

73

Amateur Radio's Technical Journal

A Wayne Green Publication

Grenada Log

Page 20

The EGG: Electronic Graphics Generator

Page 56

Heath's SS-9000

Page 107

CRASH Project for Code

Page 46

Discover Crosslinking

Page 10

New! Encoded Code: The Bottom Line

Page 46



Breakthrough in Boston: The Birth of Crosslinking

W1UKZ built this box. It's small and it works. The question is whether you're ready for it. . . . W1UKZ 10

Grenada Log

With a body-bag rig and gas from a bike, a ham hustled home the news. Here's history happening. . . . K1XR, N8RK 20

Instant Pane Relief

This is the only notch filter for windows we've ever seen. If you can figure it out, you'll beat the feedline flu. . . . KC8UD 22

Sound Off!

Here's the perfect S-meter add-on for the repeater that has everything. The higher the beep, the better the signal. . . . K3JML 28

Some Alarming Techniques

These burglar-proof circuits will stump second-story men and amaze possible thieves—as well as you. . . . WA4CCA 32

Join the Packet-Radio Revolution— Part III

Don't mess up. Packet protocols and procedures are all-important, says WA7GXD, and he's been right so far. . . . WA7GXD 36

The CW Stationmaster

Regeneration turns the worst signal into a CW symphony. And that's not all you get when you build this station accessory. . . . W4RNL 46

Top Drawer, Micro-Style

Building circuits is fun, but drawing them isn't. Let your Apple do the drafting. . . . K3LF 56

Trade Secrets of Mobile Installation

Mounting a rig in your car is not as hard as it seems. Find out how the pros do it. . . . K4TWJ 64

Around and Around and Around

There's got to be a better way to wind your coils to specs. Build the Q-meter and get the exact inductance you need. . . . N7APE 70

On the Move with 10 FM!

These modifications for Comtronix and Azden rigs will get you on your feet in a hurry. . . . W7AR 84

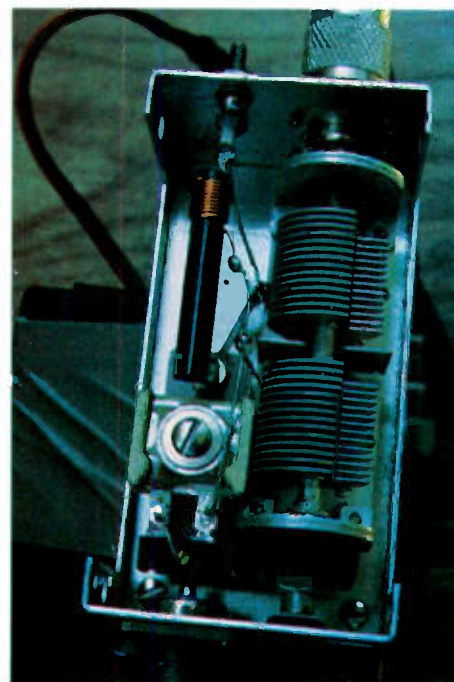

10 FM—84

Thank You for Listening

Build this simple speech expander and stop shouting. Your DX friends will thank you and the QSLs will roll in. . . . VE1BZJ 86

Secrets of Nicads

Nicad batteries will save you money. Or will they? . . . WB2FYW 88

The Edison Effect

American inventor Thomas Edison is remembered for his array of electrical firsts. But lesser known is his invention of the first wireless telegraph. . . . WB2MVK 90

Never Say Die—6
73 International—76
Corrections—94
Social Events—94
Ham Help—95,
100, 101
Circuits—96, 115
Fun!—97
RTTY Loop—97
Letters—98
Dr. Digital—99
FCC—102

Awards—104
DX—105
Review—107
New Products—110
Contests—111
Reader
Service—114
Barter 'N' Buy—117
Satellites—117
Dealer
Directory—146
Propagation—146

ICOM IC-751

The New Standard of Comparison

NEW
Competition
Grade
Transceiver!



ICOM is proud to announce the most advanced amateur transceiver in communications history. Based on ICOM's proven high technology and wide dynamic range HF receiver designs, the IC-751 is a competition grade ham receiver, a 100KHz to 30 MHz continuous tuning general coverage receiver, and a full featured all mode solid state ham band transmitter, that covers all the new WARC bands. And with the optional internal AC power supply, it becomes one compact, portable/field day package.

Receiver. Utilizing an ICOM developed J-FET DBM, the IC-751 has a 105dB dynamic range. The 70.4515MHz first IF virtually eliminates spurious responses, and a high gain 9.0115MHz second IF, with ICOM's PBT system, gives the ultimate in selectivity. A deep IF notch filter, adjustable AGC and noise blanker (can be adjusted to

eliminate the woodpecker), audio tone control, plus RIT with separate readout provides easy-to-adjust, clear reception even in the presence of strong QRM or high noise levels. A low noise receiver preamp provides exceptional reception sensitivity as required.

Transmitter. The transmitter features high reliability 2SC2904 transistors in a low IMD (-38dB @ 100W), full 100% duty cycle (internal cooling fan standard), 12 volt DC design. Quiet relay selection of transmitter LPF's, transmit audio tone control, monitor circuit (to monitor your own CW or SSB signal), XIT, and a high performance speech processor enhance the IC-751 transmitter's operation. For the CW operator, semi break-in or full QSK is provided for smooth, fast break-in keying.

Dual VFO. Dual VFO's controlled by a large tuning knob provide easy access to

split frequencies used in DX operation. Normal tuning rate is in 10Hz increments and increasing the speed of rotation of the main tuning knob shifts the tuning to 50Hz increments automatically. Pushing the tuning speed button gives 1KHz tuning. Digital outputs are available for computer control of the transceiver frequency and functions, and for a synthesized voice frequency readout.

32 Memories. Thirty two tunable memories are provided to store mode, VFO, and frequency, and the CPU is backed by an internal lithium memory backup battery to maintain the memories for up to seven years. Scanning of frequencies, memories and bands are possible from the unit, or from the HM12 scanning microphone. In the Mode S mode, only those memories with a particular mode are scanned; others are bypassed. Data may be transferred between VFO's,

from VFO to memories, or from memories to VFO.

Standard Features. All of the above features plus FM unit, high shape factor FL44A, 455 KHz SSB filter, full function metering, SSB and FM squelch, convenient large controls, a large selection of plug-in filters, and a new high visibility multi-color fluorescent display that shows frequency in white, and other functions in white or red, make the IC-751 your best choice for a superior grade HF base transceiver.

Options. External frequency controller, external PS15 power supply, voice synthesizer, computer interface, internal power supply, high stability reference crystal (less than ± 10 Hz after 1 hour), HM12 hand mic, desk mic, filter options:

SSB: FL70
CWN: FL52A, FL53A,
FL32, FL63
AM: FL33



The World System

5-STORE BUYING POWER!

SALE!

ETD ALPHA



MODEL	LIST	SALE
77DX	\$5450	\$3775
78	\$3495	\$2480
374A	\$2595	\$1860
76A	\$1985	\$1440
76PA	\$2395	\$1695
76CA	\$2695	\$1930

PRICES
F.O.B. FACTORY

KENWOOD Specials



FM "DUAL BANDER" 2M and 70CM in a single package

BUY A TW-4000A FOR \$599.95

and select **two** of the following items absolutely free!

- 1) VS-1 Voice Synthesizer. \$39.95 value.
- 2) TU-4C sub-audible tone generator. \$39.95 value.
- 3) MA-4000 Duo-band Mobile Antenna. \$44.95 value.



TS-430S TR-7950

BIG 4

CALL FOR YOUR LOW PRICES

TS-930S



w/ANTENNA TUNER
Plus 3 BONUS ITEMS

- 1) SP-930 SPEAKER
- 2) MC-60A MICROPHONE
- 3) YK-88C-1 FILTER

REG. \$2029 VALUE
\$1799 SAVE \$230.00



NEW ICOM IC-751



\$1399 PRICE
INCLUDES FREE \$160
PS-35 POWER SUPPLY

(Mounts Internally)

IDEAL PAIR FOR OSCAR 10



IC-271A

2M • 25W • ALL MODE



IC-471A

430-450 MHz • ALL MODE

CALL FOR YOUR SPECIAL PRICE



W-51
SALE \$799

W-36
CALL FOR PRICE

LM-470D
CALL FOR PRICE

KLM

KT-34A
SALE \$299

KT-34XA
SALE \$459

PRICES ARE FOB CALIF
EXCEPT FOR CERTAIN
COMBINATIONS
PLEASE INQUIRE

MIRAGE

B-3016 REG. \$239.95
SALE \$199.95

B-1016 REG. \$279.95
SALE \$249.95

B-108 REG. \$179.95
SALE \$159.95

B-23S REG. \$89.95
SALE \$79.95

B-1010 REG. \$319.95
SALE \$289.95

YAESU



FT-208R

CALL FOR
LOW PRICES
**ON HAND-
HELDS
and all
YAESU
ITEMS**



FT-708R

FT-757GX



NEW!



FT-726R

FREE SHIPMENT UPS (Surface) CONTINENTAL U.S.A.

ON MOST ITEMS THAT CAN BE SHIPPED UPS BROWN.
THERE ARE SOME EXCEPTIONS IN ALPHA, TRI-EX AND KLM

FREE PHONE 800 854-6046

9:30AM to 5:30PM PACIFIC TIME.

OVER-THE-COUNTER, 10AM to 5:30PM.

MONDAY THROUGH SATURDAY

CALIFORNIA CUSTOMERS PLEASE PHONE OR VISIT LISTED STORES

ANAHEIM, CA 92801
2620 W. La Palma.
(714) 761-3033 (213) 860-2040
Between Disneyland & Knott's Berry Farm

BURLINGAME, CA 94010
999 Howard Ave., (415) 342-5757
5 miles south on 101 from S.F. Airport.

OAKLAND, CA 94609

2811 Telegraph Ave., (415) 451-5757
Hwy 24 Downtown. Left 27th off-ramp.

SAN DIEGO, CA 92123

5375 Kearny Villa Road (619) 560-4900
Hwy 163 & Clairemont Mesa Blvd

VAN NUYS, CA 91401

6265 Sepulveda Blvd., (213) 988-2212
San Diego Fwy at Victory Blvd.

AEA • ALLIANCE • ALPHA • AMECO • AMPHENOL • ARRL • ASTRON
AVANTI • BELDON • BENCHER • BERK-TEC • BIRD • B & W
BUTTERNUT • CALLBOOK • CDE • COLLINS • CURTIS • CUSHCRAFT

DAWA • DRAKE • DX EDGE • DX ENGINEERING • EIMAC
HUSTLER • HY-GAIN • ICOM • J. W. MILLER • KANTRONICS
KENWOOD • KLM • LARSEN • LUNAR • METZ • MFJ • MICRO-LOG

MINI-PRODUCTS • MIRAGE • NYE • PALOMAR • ROBOT • ROHN
SHURE • SIGNAL-ONE • STONER • TEMPO • TEN-TEC • TRISTAO
VIEWSTAR • VOCCOM • YAESU and many more!

Prices, specifications, descriptions subject to change without notice. Calif. residents please add sales tax

**SERVING HAMS
BETTER.**

North... south... east... west.

Bob Ferrero, W6RJ
Jim Rafferty, N6RJ
other well known hams
give you courteous,
personalized
service.



**HAM
RADIO
OUTLET™**



1984 CALLBOOKS

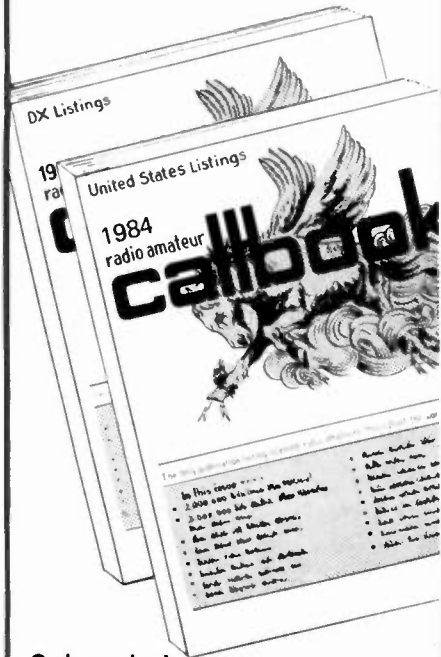

Order today!
NEW 1984
RADIO AMATEUR CALLBOOKS

Known throughout the world for accuracy, the 1984 Callbooks are a better value than ever before. The U.S. Callbook contains over 430,000 listings; the Foreign Callbook has over 400,000. More than 75,000 changes have been made in each edition since last year. Special features include call changes, Silent Keys, census of amateur licenses, world-wide QSL bureaus, international postal rates, prefixes of the world, and much more. You can't beat this value! Order your 1984 Callbooks now for earliest delivery.

	Each	Shipping	Total
□ U.S. Callbook	\$19.95	\$3.05	\$23.00
□ Foreign Callbook	18.95	3.05	22.00

Order both books at the same time for \$41.95 including shipping within the USA.

Order from your dealer or directly from the publisher. Foreign residents add \$4.55 for shipping. Illinois residents add 5% sales tax.

Keep your 1984 Callbooks up to date. The U.S. and Foreign Supplements contain all activity for the previous three months including new licenses. Available from the publisher in sets of three (March 1, June 1, and September 1) for only \$12.00 per set including shipping. Specify U.S. or Foreign Supplements when ordering. Illinois residents add 5% sales tax. Offer void after November 1, 1984.

RADIO AMATEUR
callbook INC.
Dept. B
925 Sherwood Dr., Box 247
Lake Bluff, IL 60044, USA

Tel: (312) 234-6600

\$15 DTMF DECODER \$15

The LJM2RK decoder kit converts your receiver into a special receiver or control. When a user-selected tone combination is received, the output provides a relay control for activating speakers or other devices.

INPUT: Audio from transceiver, scanner, etc.
OUTPUT: SPST (N.O.) relay.

FEATURES: Single or dual tones adjustable over the 16 digit Touch Tone range • Adjustable response time • Relay output • Manual or auto reset • Single tone ON latching with different single tone reset OFF • Operates on 12VDC • Interfacing of multiple boards for multi-digit sequential activation and reset.

APPLICATIONS: Call-up system • Repeater or commercial controls • Etc. limited only to your imagination •

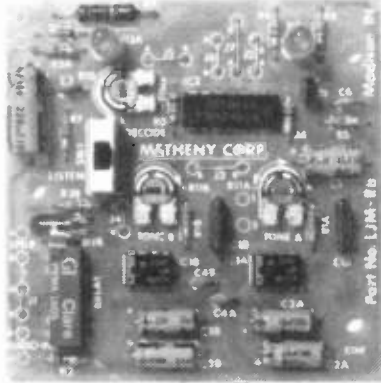

Actual Size 3"x3" - Shown Assembled

LJM2RK decoder kit includes all component, relay, and P.C. Board. . . \$15 plus \$1.50 shipping.

LJM2RC enclosure kit includes molded case, speaker, input cable. . . \$5 plus \$1.50 shipping.

For information and to order write:

THE METHENY CORPORATION
204 Sunrise Drive, Madison, IN 47250 ✓205

FILTER CASCADING

The most cost-effective way to improve the selectivity of any receiver—old or new—is to improve its IF filtering. A Fox-Tango Cascading Kit puts a high-quality steep-sided 8-pole filter in series with your present filter(s), both SSB and CW. The result is narrower Bandwidth and better Shape Factor, both of which dramatically reduce adjacent channel QRM—a necessity in today's crowded bands.

CONSIDER THESE KIT FEATURES

- Easy Installation—30 minute average.
- No drilling or switching; simple alignment.
- 16 poles of filtering yield:
Filter Shape Factor as high as 1.19.
Ultimate Rejection better than 100dB.
Works wonders on SSB; improves CW.
- Compensates for Filter Insertion loss.
- Complete Instructions, clear diagrams.
- Includes Filter and all needed parts.
- Fits all models of Series—any letter.
- All Filters 8-pole—Guaranteed One Year.

SPECIFY KIT WANTED WHEN ORDERING

YAESU FT101 \$80, FT101ZD \$75; FT107 \$80; FT901/2, \$70, FR101 \$60 (filter only). KENWOOD TS520/R599 \$75, TS820 \$75; TS830/R30/R820 \$170 (Two Filters). HEATH SB104A \$65.

Shipping \$3 (Air \$5) Overseas \$10. FL Sales Tax 5%.

In addition to the above, FOX-TANGO stocks a wide line of \$60 SSB, CW, and AM 8-pole filters for Yaesu, Kenwood, Drake R4C and 7-line, and Heathkit. Also, special filters made to order. Send specs for quote.



GO FOX-TANGO—TO BE SURE!
Order by Mail or Telephone.

AUTHORIZED EUROPEAN AGENTS
Scandinavia: MICROTEC, Makedien 26,
3200, Sandefjord, NORWAY
Other: INGOIMPEX, Postfach 24 49,
D-8070, Ingolstadt, W. GERMANY

FOX TANGO CORPORATION
Box 15944 S, W. Palm Beach FL 33416
(305) 683-9587

INFO

Manuscripts

Contributions in the form of manuscripts with drawings and/or photographs are welcome and will be considered for possible publication. We can assume no responsibility for loss or damage to any material. Please enclose a stamped, self-addressed envelope with each submission. Payment for the use of any unsolicited material will be made upon acceptance. All contributions should be directed to the 73 editorial offices. "How to Write for 73" guidelines are available upon request.

Editorial Offices:

Pine Street
Peterborough NH 03458
Phone: 603-924-9471

Advertising Offices:

Elm Street
Peterborough NH 03458
Phone: 603-924-7138

Circulation Offices:

Elm Street
Peterborough NH 03458
Phone: 603-924-9471

Subscription Rates

In the United States and Possessions:
One Year (12 issues) \$25.00
Two Years (24 Issues) \$38.00
Three Years (36 issues) \$53.00

Elsewhere:

Canada and Mexico—\$27.97/1 year only, U.S. funds. Foreign surface mail—\$44.97/1 year only, U.S. funds drawn on U.S. bank. Foreign air mail—please inquire.

To subscribe, renew or change an address:

Write to 73, Subscription Department, PO Box 931, Farmingdale NY 11737. For renewals and changes of address, include the address label from your most recent issue of 73. For gift subscriptions, include your name and address as well as those of gift recipients.

Subscription problem or question:

Write to 73, Subscription Department, PO Box 931, Farmingdale NY 11737. Please include an address label.

73: *Amateur Radio's Technical Journal* (ISSN 0745-080X) is published monthly by Wayne Green, Inc., 80 Pine Street, Peterborough NH 03458. Second class postage paid at Peterborough NH 03458 and at additional mailing offices. Entire contents copyright © 1983, Wayne Green, Inc. All rights reserved. No part of this publication may be reprinted or otherwise reproduced without written permission from the publisher. Microfilm Edition—University Microfilm, Ann Arbor MI 48106. Postmaster: Send address changes to 73, Subscription Services, PO Box 931, Farmingdale NY 11737. Nationally distributed by International Circulation Distributors.



The Bearcat® DX1000 makes tuning in London as easy as dialing a phone.

Direct access keyboard tuning brings a new level of simplicity to shortwave radio. With the Bearcat® DX 1000, dialing in the BBC in London is as easy as dialing a telephone. And you can switch from the BBC to Peruvian Huayno music from Radio Andina instantly. Without bandswitching.

Featuring the innovative microprocessor digital technology made famous by Bearcat scanner radios, the DX 1000 covers 10 kHz to 30 MHz continuously, with PLL synthesized accuracy. But as easy as it is to tune, it has all the features even the most sophisticated "DXer" could want. 10 memory channels let you store favorite stations for instant recall—or for faster "band-

scanning" during key openings.

The digital display measures frequencies to 1 kHz, or at the touch of a button, doubles as a two time zone, 24-hour digital quartz clock. A built-in timer wakes you to your favorite shortwave station. Or, it can be programmed to activate peripheral equipment like a tape recorder to record up to ten different broadcasts—any frequency, any mode—while you are asleep or at work.

The DX 1000 also includes independent selectivity selection to help you separate high-powered stations on adjacent

frequencies. Plus a noise blanking system that stops Russian pulse radar interference.

There's never been an easier way to hear what the world has to say. With the Bearcat DX 1000 shortwave radio, you have direct access to the world.

For the name of your nearest retailer dial toll-free... 1-800-SCANNER.



Frequency Range: 10 kHz to 30 MHz continuously. **Tuning:** Direct keyboard entry, selectable 3 or 24 kHz per revolution knob tuning, or manual step tuning in selectable 1-99 kHz steps. **Sensitivity:** 1.0 μ V AM, 0.5 μ V CW/SSB/FM, 1.6-30 MHz. **Image and IF Rejection:** 70 dB or more. **Memory:** 10 frequency capacity. **Frequency Stability:** Better than 100 Hz after warm-up. **Modes:** AM/LSB/USB/CW/FM. **AGC:** Selectable Fast/Slow release times. **Filter Bandwidths:** 2.7 kHz, 6 kHz and 12 kHz. **Filter Selection Independent of Mode.**

Bearcat® DX 1000 shortwave radio.

Direct Access To The World.



Electra Company
Division of Masco Corp. of Indiana
300 East County Line Road
Cumberland, Indiana 46229

W2NSD/1 NEVER SAY DIE

editorial by Wayne Green



WELL, 1984 IS HERE

It hasn't turned out much like Orwell's book, thankfully. Actually, these should be great days for hams. After all, here we are right in the early stages of the electronic revolution—something amateur radio helped in a great measure to get started. The revolution has taken some twists, so only those hams with a flexible attitude have managed to keep up with what is going on.

Indeed, I find that I have to spend a good deal of my time just trying to keep up with the onrush of technology. This means talking with people, reading several hundred technical magazines a month as well as a few books, and getting to shows—a lot of shows. They are worthwhile for me because I can see the gear, ask questions, and learn more in a short time.

Okay, you may want to know

what the bottom line is of all this activity on my part. I'll tell you... take it easy. First, as far as amateur radio goes, you may suspect that all is not well. This is heyday time for the gloom and doomers, with ARRL membership dropping like a brick, more and more dealers going bankrupt, more of our American manufacturers becoming invisible, and the sunspots diminishing.

I prefer to look on the bright side. Here we have a new OSCAR up there begging for use. We have several new modes of communication begging for activity such as packet radio, crossband repeaters, on-the-air bulletin boards—stuff like that. With low-cost computers and chips, experimenters have never had it so good. We can build circuits in an evening that would have filled several relay racks a few years ago—so let's have at it. You build 'em and I'll publish 'em—okay?

You might like to know that we're seeing some progress with some of my other ideas. I'd like to prove what can be done in high-powered education—turning out high-tech kids with a strong business education. If you think about it, you'll realize that this would be a way to give them a super start in a career. And there is some progress with my idea for getting ham clubs started in every high school in the country. Despite the obvious need for technical people, I've run into more resistance with this idea than I expected.

Now, in case you're interested in an overview of tech-

HELP WANTED

73 is currently seeking a TECHNICAL/INTERNATIONAL EDITOR. The position requires excellent written and oral communications skills, as well as a General-class or higher ticket. Experience with microcomputers would be a help. Responsibilities include participating in manuscript review, organizing and implementing special projects, and supervising our staff of foreign correspondents.

We offer a competitive salary and benefits package and excellent, informal working conditions. As you may know, Peterborough is located 75 miles from Boston in the beautiful Monadnock region of New Hampshire—a state with no sales or income tax.

Of course, we are an equal opportunity employer. If you are a non-smoker interested in this position, please forward your resume and salary requirements to: Jack Burnett, Executive Editor, 73: *Amateur Radio's Technical Journal*, Peterborough NH 03458.



QSL OF THE MONTH

This month's flashy winner, submitted by Jim Houston ZS6BUR, surely brightens up ham-shack walls around the world.

To enter your QSL card in 73's QSL of the Month contest, put it in an envelope with your choice of a book from 73's Radio Bookshop and mail it to 73, Pine Street, Peterborough NH 03458. Attn: QSL of the Month. Entries not in envelopes or without a book choice will not be eligible.

STAFF

EDITOR/PUBLISHER
Wayne Green W2NSD/1
ASST. EDITOR/PUBLISHER
Jeff DeTray WB8BTH
EXECUTIVE EDITOR
John C. Burnett

MANAGING EDITOR
Susan Philbrick
ASST. MANAGING EDITOR
Steve Jewett

EDITORIAL ASSISTANTS
Nancy Noyd
Richard Phenix

ASSOCIATES
Robert Baker WB2GFE
John Edwards K12U
Bill Gosney KE7C
Chod Harris VP2ML
Avery L. Jenkins WB8JLG
Dr. Marc Leavey WA3AJR
J. M. Nelson
Bill Pasternak WA6ITF
Peter Stark K2OAW
Robert Swirsky AF2M

PRODUCTION DIRECTOR
Nancy Salmon

ASST. TO THE PRODUCTION DIRECTOR
David Wozmak

ADVERTISING GRAPHICS MANAGER
Scott W. Philbrick

DESIGN DIRECTOR
Christine Destrempe

PRODUCTION
Lahri Bond

Patricia Bradley
Linda Drew

Michael Ford
Marjorie Gillies

Donna Hartwell
Kimberly Nadeau

Phyllis Pittet
Paula Ramsey

Anne Rocchio
Lynne Simonson

Jean Southworth
Kenneth Sutcliffe

Theresa Verville
Robert M. Villeneuve

Karen Wozmak

PHOTOGRAPHY
Thomas Villeneuve

Sandra Dukette
Nathaniel Haynes

Laurie Jennison
Sturdy Thomas

TYPESSETTING
Sara Bedell

Oariene Bailey
Marie Barker

Prem Krishna Gongala
Lynn Haines

Cynthia Letourneau
Debbie Nutting

Lindy Palmisano
Heidi N. Thomas

Sue Weller

VICE PRESIDENT/GENERAL MANAGER
Debra Wetherbee

VICE PRESIDENT/CONTROLLER
Roger J. Murphy

ASSISTANT TO THE PRESIDENT
Matthew Smith KA1IE

ACCOUNTING MANAGER
Knud Keller KV4GG/1

CIRCULATION MANAGER
William P. Howard

(603) 924-9471

RETAIL AND NEWSSTAND SALES MANAGER
Ginnie Boudreau

1-800-343-0728

ADVERTISING
(603) 924-7138

Jim Gray W1XU, Mgr.

Nancy Ciampa, Asst. Mgr.

Ross Kenyon KA1GAV

Cindy L. Molesky

Continued on page 116

ACCESSORIES



SW-2000

160-6-m 2 KW SWR/PEP-POWER Meter
Up to 3 separate directional couplers may be connected. (One SWC-3 is supplied.) Optional couplers: SWC-2 (2-m/70-cm, 200 W) & SWC-3 (160-6-m, 2 KW).

MC-85

Multi-Function Desk Top Microphone (8-pin)
700 Ω Uni-directional Electret Condenser Mic. Built-in mic-amp with output and tone control, meter, XCVR selector and UP/DOWN switch. Optional mic cables: PG-4D (4-pin), PG-4E (6-pin) & PG-4F (8-pin).

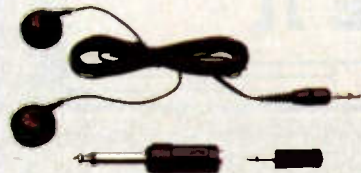

MC-80

Desk Top UP/DOWN Microphone (8-pin)
700 Ω Uni-directional Electret Condenser Mic. with "FLEX" type boom. Built-in mic-amp and UP/DOWN switch. Optional mic plug adaptors: MJ-84 (8p-4p) & MJ-86 (8p-6p).

HS-7

Micro Headphones (16 Ω)
Ultra light weight and portable ear-fitting headphones supplied with two audio adaptor plugs.



DM-81

700 kHz-250 MHz Dip Meter
All solid-state and built-in battery.



SP-50

High Quality External Mobile Speaker



TL-922A

160-15-m 2 KW PEP/1 KW DC Input Linear Amplifier
Pair of E1MAC 3-500Z tubes and excellent IMD characteristics. Perfect safety protection with blower turn-off delay circuit.

MC-55 (8P/6P)

Mobile Microphone (8-pin or 6-pin)
700 Ω Electret Condenser Mic. with flexible boom, and separate STAND-BY box built-in UP/DOWN switch and 5 minute Time-Out-Timer.



MA-4000

2-m/70-cm Dual Band Mobile Antenna
5/8 λ for 2-m and stacked 5/8 λ for 70-cm. Duplexer is supplied.



PC-1A

Phone Patch (FCC Part 68 registered)



SM-220

Station Monitor/High-Performance Oscilloscope
Pan-display capability with optional BS-8 (for TS-830S/820S/180S) or BS-5 (for TS-520 series). Transmitted waveforms and/or receiving signal waveform monitor. Built-in 2-tone generator.



SW-100A/B

A: 160-m ~ 2-m. B: 2-m ~ 70-cm. 150 W SWR/POWER/VOLT Meter
Compact design with separate coupler, ideal for mobile use. Built-in 0-20 V voltmeter.

MICROPHONES:

- MC-60A Deluxe desk top microphone with UP/DOWN switch. (8-pin) Pre-amplifier. 500/900 Ω
- MC-60N4 Deluxe desk top microphone (pre-amp. not included). (4-pin) 50 k/500 Ω
- MC-50 Desk top microphone, 50 k/500 Ω (4-pin)
- MC-48 16-key autopatch UP/DOWN microphone. (8-pin)
- MC-46 16-key autopatch UP/DOWN microphone. (6-pin)
- MC-42S Hand microphone with UP/DOWN switch. (8-pin)
- MC-35S Noise-cancelling hand microphone, 50 k Ω (4-pin)
- MC-30S Noise-cancelling hand microphone, 500 Ω (4-pin)

MICROPHONE CABLES:

- PG-4A/4B/4C For MC-60A/60N4. PG-4A(4-pin)/4B(6-pin)/4C(8-pin)
- PG-4D/4E/4F For MC-85. PG-4D (4-pin)/4E(6-pin)/4F(8-pin)

MICROPHONE PLUG ADAPTORS:

- MJ-48 (4-pin mic to 8-pin XCVR)
- MJ-84 (8-pin to 4-pin)
- MJ-86 (8-pin to 6-pin)

HEADPHONES:

- HS-6 Lightweight headphones
- HS-5 Deluxe headphones
- HS-4 Standard headphones

GENERAL PURPOSE AC POWER SUPPLIES:

- KPS-7A 13.8 VDC, 7.5A intermittent
- KPS-12 13.8 VDC, 12A intermittent
- KPS-21 13.8 VDC, 21A intermittent

ANTENNAS:

- RA-3 2-m 3/8 λ Telescoping antenna with BNC connector
- RA-5 2-m 1/4 λ /70-cm 5/8 λ Telescoping dual-band antenna with BNC connector

Other accessories:

- RD-20 Dummy load, 50 Ω , DC-500 MHz, 50 W Intermittent
- SP-40 Compact external mobile speaker
- AL-2 Lightning & static protector, 50 Ω 1 KW output
- PG-3A DC line noise filter for mobile

SERVICE MANUALS:

- Available for most transceivers, receivers, and major accessories.

NOTE: Prices and specifications of all Trio-Kenwood products are subject to change without prior notice or obligation.

KENWOOD

TRIO-KENWOOD COMMUNICATIONS
1111 West Walnut, Compton, California 90220

Blueprint for Success

THE INTERFACE

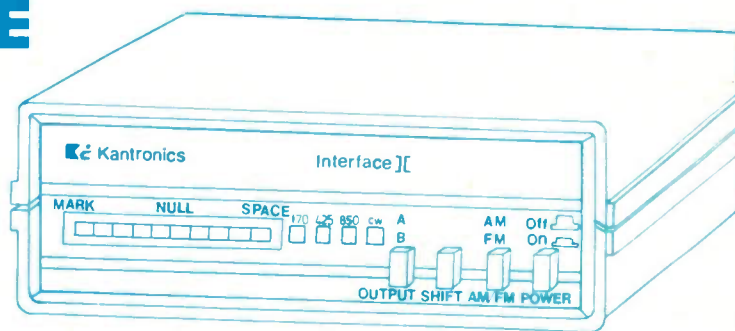
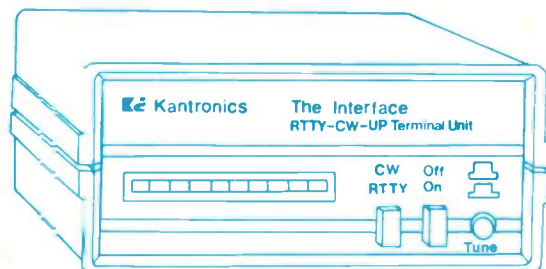

THE INTERFACE II

 Kantronics

TITLE: THE INTERFACE - INTERFACE II PROPOSAL

THE INTERFACE is the original Kantronics terminal unit that broke through the barrier of multi-computer compatibility. **THE INTERFACE** is an amateur modem for transceiver-to-computer communication. With **THE INTERFACE** and Hamsoft or Hamtext for your computer you can send and receive Morse Code, Radioteletype, and ASCII. **THE INTERFACE** is also compatible with our new software for AMTOR communication, AMTORSOFT. **THE INTERFACE** is our most popular unit combining active filtering, easy tuning, six-computer compatibility, and low price for an unbeatable package.

Suggested Retail \$139.95

INTERFACE II is the new Kantronics transceiver-to-computer interface. **INTERFACE II** features a new highly sensitive front end with mark and space filtering and a unique new tuning system. Even the most discerning operator will be surprised with the **INTERFACE II**'s ability to dig out signals in poor band conditions, and our new tuning system even displays signal fading.

X-Y scope outputs and dual interface outputs for VHF and HF connections make **INTERFACE II** compatible with almost any shack. All three standard shifts are selectable and **INTERFACE II** is compatible with the industry standard Kantronics programs: Hamsoft, Hamtext, and Amtorsoft. Step up to state of the art in computer-amateur communications with **INTERFACE II**.

Suggested Retail \$269.95

For more information see your Kantronics dealer, or contact:
 Kantronics 1202 E. 23rd Street Lawrence, KS 66044

KANTRONICS SOFTWARE

Hamsoft,™ Hamtext,™ and Amtorsoft™

MORSE 00:00:00
 TRANSMIT SPEED 25
 RECEIVE SPEED 28

.....
 ENJOY YOUR MEAL AND
 WE'LL TALK TO YOU
 REAL SOON ... 73'S ...
 WA5RGU
 WEATHER HERE IS WARM TODAY
 WITH LOTS OF SUN. ... XYL SAYS
 TIME FOR DINNER SO 73'S WØXI

Kantronics has led the amateur community in software and total computer communications systems with our original program, **HAMSOF**T. With five-computer compatibility and reasonable prices **HAMSOF**T has become the industry standard. **HAMSOF**T includes split screen display, type ahead buffer, message ports, and complete keyboard control for Morse Code, Radioteletype, and ASCII communications. With THE INTERFACE or INTERFACE II, **HAMSOF**T can make any of five computers a complete amateur communications terminal. All programs are on a ROM board, except the Apple diskette.
 VIC-20 - \$49.95, ATARI - \$49.95, APPLE - \$29.95,
 TRS-80C - \$59.95, TI-99/4A - \$99.95

HAMTEXT is our advanced CW/RTTY/ASCII program for the VIC-20, COMMODORE 64, and APPLE computers. **HAMTEXT** gives you the ability to store incoming messages in the computer's memory, transmit files directly from tape or disk, and use your computer to its fullest potential. Features like Diddle, Time Transmission, Text Transmission, Printer Outputs, and Word Wraparound, make **HAMTEXT** the program for the serious amateur. **HAMTEXT** was created with input from our users as guidelines, and with total use of the computer in mind.
Suggested Retail \$99.95

00:00:00
 PROGRAM OPTIONS
 A. RETURN TO BASIC
 B. EDIT MESSAGE PORTS
 C. SAVE MESSAGE PORTS
 D. LOAD MESSAGE PORTS
 E. SET XMIT BUFF SIZE
 F. EDIT HOLDING BUFFER
 G. SAVE HOLDING BUFFER
 H. LOAD HOLDING BUFFER
 I. SET TIME

00:00:00
 KANTRONICS AMTORSOFT
 COPYRIGHT 29 JUNE 1983

CHOOSE
 S (AMTOR SLAVE)
 M (AMTOR MASTER)
 L (AMTOR LISTENER)
 P (PROGRAM OPTIONS)
 T (T/R OPTIONS)

On January 27th, 1983, AMTOR, Amateur RadioTeletype Over Radio, became a legal mode for the amateur service. AMTOR is an essentially error-free radioteletype form of communication. **AMTORSOFT**, Kantronics' newest software package, gives your computer the ability to become an AMTOR communications terminal when used with The Interface or interface II. **AMTORSOFT** is currently available for the Apple, VIC-20, and COM-64 computers. **AMTORSOFT** brings you the newest in computer-amateur communications at an affordable price.
Suggested Retail \$89.95

For more information see your Kantronics dealer, or contact:
 Kantronics 1202 E. 23rd Street Lawrence, KS 66044

Breakthrough in Boston: The Birth of Crosslinking

*W1UKZ built this box. It's small and it works.
The question is whether you're ready for it.*

David P. Allen W1UKZ
19 Damon Road
Scituate MA 02066

Asage once said that a new idea is simply a rearrangement of old facts. This is certainly the case with crosslinking: All of the ingredients are well known and no new technology is involved. But the effect of putting them all together in a new operating mode has proven to be extraordinarily exciting to all who have par-

ticipated. Let me explain just what crosslinking is.

Fig. 1 shows diagrammatically how crosslinking works. The basic idea is for an individual amateur to configure his low-band and two-meter rigs so that three operating conditions can be maintained:

1) When the amateur keys his microphone, he transmits simultaneously on *both* a low-band frequency and a two-meter frequency. One microphone keys both rigs.

2) When the amateur *listens*, he pushes a button which feeds the audio out-

put of whichever band he is momentarily listening to into the microphone input of the other transmitter and keys that transmitter.

3) When listening to a station on the other band, he pushes a button and reverses that process. He may interrupt this back-and-forth flow at any time simply by keying his microphone.

If this all sounds like a manually-operated repeater, you are *almost* right; however, there are some very important differences. A little background will help to explain how this new operating technique emerged.

Background

For the past five years, I have had the pleasure of

conducting the East Coast Apple Net on forty meters. Every Saturday morning we gather at 9 am eastern time on 7260 kHz to chat about computers in general and Apple computers in particular. This has proven to be a very popular net since so many hams are also computer enthusiasts. Because of the general popularity of computers, I have known for a long time that we have a "lurking," voiceless audience of people who have an abiding computer interest but no amateur license. There are also many licensed amateurs who do not have low-band privileges.

"Why not," thought I, "conduct the net on *both* 40

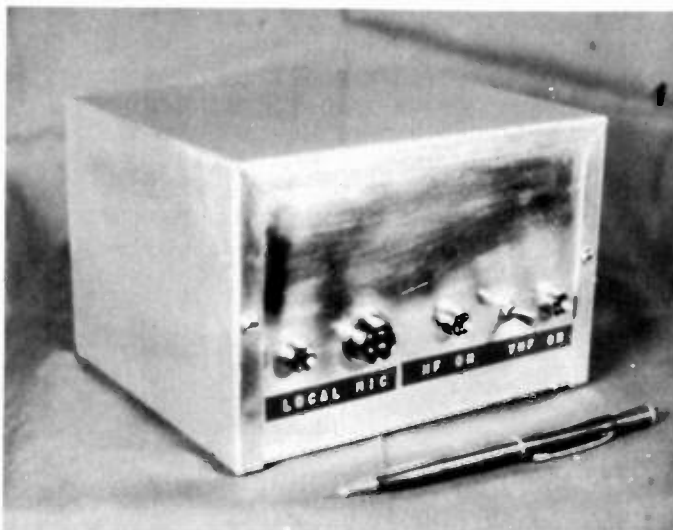

Photo A. Front view of the logic box.

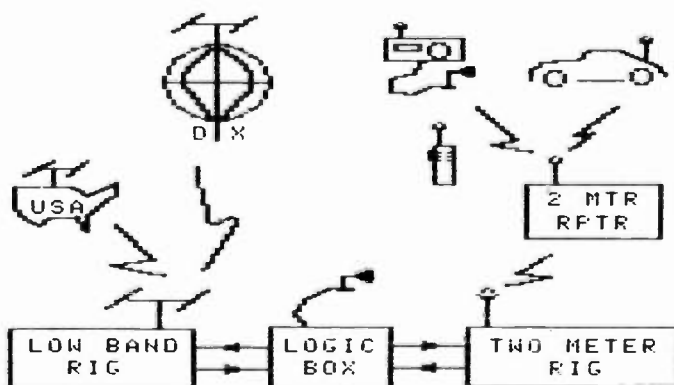

Fig. 1. Diagram of how crosslinking works.

meters and 2 meters and thereby enable a wider participation in the net?" There did not seem to be any technical reason standing in the way of this evolution. Cross-band operating is as old as amateur radio itself, and I had all the hardware (almost) necessary to try it. Just one experiment with holding microphone to loudspeaker showed two things: (1) It had great possibilities, and (2) a missing black box was needed to make it work properly.

That was the generating force for the "logic box," shown in Fig. 2. More about that later. There was another consideration which might offer a much greater handicap to carrying out this idea. It's called "FCC rules and regulations." Amateur Extra class licensees would have no problem with any conceivable permutation of operating frequencies, but how about lower-class licensees? If it were illegal for a Technician to join the net on two meters and have his voice heard on forty meters, then I was just spinning my wheels with further conjecture on this idea. It obviously was time to go to the horse's mouth.

Conversation with the administrators of amateur operations at the FCC in Washington completely dissolved any apprehensions I had about the proposed operating procedure. All amateur participants would be licensed for the frequencies upon which they were transmitting and over which they had control. All conversation relayed by my facilities was clearly covered in the definition of what I was licensed to transmit. I was not proposing a repeater-type operation, which would be both illegal on the low bands and which would allow lower-grade licensees to control emissions on frequencies for which they were not licensed. Surprise, surprise! No bureaucratic ground-breaking was involved! I was, in fact, sent

on my way with an encouraging endorsement for trying out a new operating technique. Who says the bureaucracy is never administered with good judgment and understanding!

So, the decks were cleared for action. But there was still the problem of how to oversee the net and to control the flow of transmissions. The three points defined above seemed to describe all the elements of the technique that I was looking for. I wanted to be able to switch the audio to flow in either direction from one band to another at any time. I felt that a little momentary toggle switch would allow me to perform that function best. And I wanted to be able to break into the transmission pattern at any time with my voice, so my microphone switch should override whatever mode was going on. One other corollary mode comes about from pushing the mike button. When I finish talking, *both* rigs default to the listening mode so that I can monitor both bands at any time.

Hardware

The circuit necessary to control both rigs turned out to be a little more complicated than I had thought. Fig. 2 shows the result, which I have called the logic box. Three relays are involved, one for each band control plus a third relay for my microphone keying and to provide latching for the other two relays. Since the logic of the operating called for a momentary switch closure to *open* rather than close the ground circuit of the latched-up relays (a logic negative), I inserted a simple transistor switch to invert the mechanical switch logic. Thus, either latched-up relay RY1 or RY2 can be dropped by operating the transistor switch through SX1 or by removing the latching voltage by closing the push-to-talk switch on

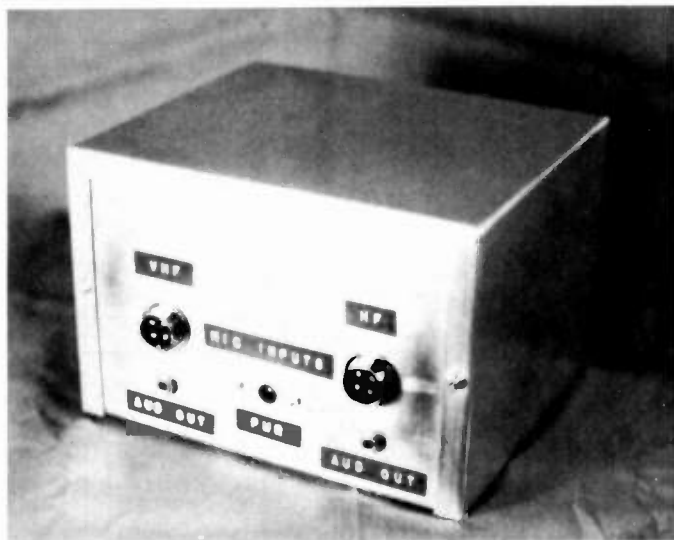

Photo B. Rear view of the logic box.

the microphone and dropping RY3.

The LEDs were put in to remind me of my last official act and clearly remind me of what the current transmission flow was. Relays were used because of the widespread variation of keying methods for the current crop of transceivers is enormous. Varying polarities and voltages are made totally irrelevant by the good old relay. I can use the logic box with any transceiver I can lay my hands on.

Photos A and B show the front and back of the logic box. The inside is a typical prototype mess (so I won't let you in), but it all works exactly as planned. I decided to use the "standard" four-pin microphone connector used by so many transceiver manufacturers and readily available at Radio Shack. The speaker audio is bridged from the transceiver at the auxiliary audio-output jack

and fed into the logic box through the mini-jack connector. Power for the relays is provided by any 9-12-volt calculator-type power supply that can furnish on the order of 200 milliamperes.

I was concerned about the varying levels of audio among the microphone and loudspeaker outputs. This turned out to be a reasonable concern. My first attempt was just to "brute-force" the audio through and see what happened. It worked, but not well. Here's what I had to do.

No ordinary microphone seems to be up to the task of feeding two rigs at once. The main problem is the widely varying input impedances of various transceivers plus the generally low output of most microphones. The solution for me was an amplified Astatic D-104 microphone. The power amplifier in this microphone turns the mike signal into a relatively

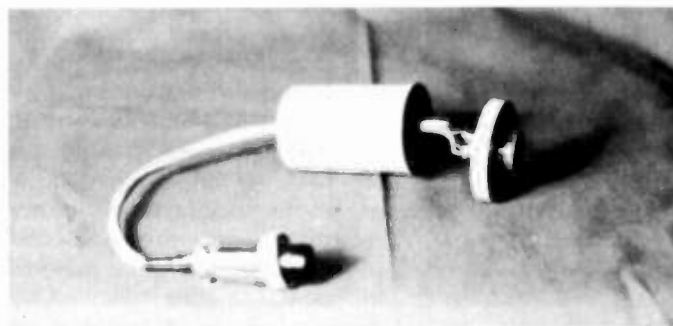

Photo C. The mini-jack connector.

Actual slow motion frames from Ham MasterTapes



1. Larry, N2NY, Lee, KA2RNV, Virginia, N2EGJ



2. Lee discharges cap



3. In slow motion it's dazzling



4. Wow. Can we see it again?

You've never seen this, like this, before this!

And you can see it—in color—again and again when you own the N2NY Ham MasterTapes.

Ever see a cap discharge in slow motion? You will on Ham MasterTapes. Ham MasterTapes can perform the dozens of complicated demonstrations necessary for a beginner's understanding of Ham Radio Theory.

Finally, a step-by-step course in Ham Radio Theory is available on color videotape. The Larry Horne N2NY Ham MasterTapes video course is a unique, effective teaching technique expertly produced by New York's leading professionals in studio and field videotape.

- Video Graphics highlight important details.
- Carefully worked-out demonstrations on video avoid the problem of getting complex gadgets to work on command in front of a class.
- Working examples of every ham radio component, device, or system covered in the FCC guide can be clearly understood.

The N2NY Ham MasterTapes give you a basic grasp of concepts that build theory background—not only for passing the FCC tests, but for understanding electronics.

The hobby has long needed better, clearer, high-tech teaching aids to help newcomers into our wonderful world of Ham Radio.

These six-hour tapes cover completely all the material needed to understand Novice and Tech/General Theory and operations, and include the new 200-question FCC syllabus used beginning September 1983.

Only \$199.95. Order direct and specify Beta or VHS format. Call or write: Larry Horne, N2NY or

Virginia Hamilton, N2EGJ at
Ham MasterTapes
136 East 31st Street
New York, N.Y. 10016 212-673-0680.



Parts List			
Quantity	Item	Description	Radio Shack #
2	RY1, RY2	4PDT relay, 12 V dc	275-214
1	RY3	SPDT relay, 12 V dc	275-243
2	Q1, Q2	NPN transistor	276-1617
1	SX1	DPDT switch, mom.	275-637
3	LED1, 2, 3	Indicating LEDs	
3	R1, R2, R3	680-Ohm resistor, 1/4 W	
2	R4, R5	10k-Ohm resistor, 1/4 W	
2	C1, C2	10-uF, 15-WV capacitor	
3		Microphone socket	274-002
2		Microphone plug	274-001
3	D1, D2, D3	Diode	276-1620
1		16-pin DIP socket (for RY3)	
2	Socket, RY1, 2	Relay socket	275-221
1		12-V-dc power supply	273-1652
1		Power-supply jack	274-1549
2		Audio jack, 1/8"	274-253

A typical drive-time round table recently found stations in Northern Ireland, England, Holland, Italy, Corsica, and Central Nigeria in a round table with five or six two-meter mobile stations on their way home from work! Another time found a one-Watt mobile station in Portsmouth, New Hampshire, talking with a station (ONØ) in the Aland Islands off the coast of Finland. His route was via a two-meter repeater in New Hampshire to my station on the south shore area in Boston, over to Europe. Not bad for one Watt!

The permutations of this technique are probably already cycling through your mind. The band combinations obviously are not limited between just 20 meters and two meters. And ragchews don't have to involve only DX stations. How many different ways can you think of which might have lots

and lots of good amateur radio fun involved, while at the same time challenging us to develop new hardware and operating techniques? How about different operating modes from just voice transmissions? A mixture, maybe...

New Techniques and Considerations

Here are some things I have learned already and some things that are as yet unresolved:

- Two-meter and DX-band operating procedures differ markedly. Two-meter operators use a speech-shorthand technique which needs modification when DX stations, some with limited English capability (and with some QRM and QSB problems thrown in), get added to the two-meter round table. DX stations seem very, very interested in the everyday experiences commonly discussed on two meters but

rarely mentioned in DX conversations. Two-meter operators need to be clear in identifying their stations, using phonetics for their call signs when necessary.

- Depending upon the skill of the operator at the host crosslinking station, rapid conversational gambits, common to two meters, can be employed. I think this type of exchange should be encouraged, but time will tell.

- Crosslink operators must be very careful not to allow transmission by unlicensed persons to enter the crosslink when stations in countries not supporting third-party traffic are involved. Since this is a brand new operating world for many Technician licensees, they are often unlikely to remember third-party proscriptions.

- All crosslink operators should keep very complete logs. This is not required by any FCC rule or regulation; it is simply to be able to reconstruct what went on for purposes of QSLing and other record keeping. How the rest of the world views the establishment of DX records for recognized purposes is yet to be established. At least one ham has started his own path toward DXCC via crosslinking.

- Amazingly enough, this technique both serves to conserve frequencies on the crowded low bands and provides new opportunities to develop greater employment of lesser-used bands, such as six meters. Clearly, six DX stations and six two-meter stations employing only one low-band frequency and two two-meter frequencies is band conservation. If the VHF frequency were on six meters, then the other part of the new equation would also be true.

- All is not just sweetness and light when new operating conditions appear. Those stations who like two-meter-repeater operation the way it is may object

strenuously to a new idea which invades their otherwise untrammelled domain. Crosslink operators can expect to be invited off some repeaters. Crosslinking can use up a lot of repeater time, and those areas where repeaters are in short supply can anticipate even greater discussion about how repeaters should be employed. Maybe repeaters will need to be established primarily for crosslinking. Crosslinking on direct VHF frequencies needs to be developed.

- In the same vein, the cordial atmosphere which normally exists on repeaters during drive time needs to be conserved. When a crosslinking control station connects with a low-band station who wishes to crosslink, what happens? If there are stations on the repeater waiting to chat, all well and good. But suppose that two-meter connections have not yet been established? What then? The crosslink control station needs to assess carefully how courteously to enter a two-meter repeater with a DX station tagging along. Sometimes, two-meter stations just don't want "foreign" stations to enter their discussions and are not prepared to modify their technique to accommodate language and listening difficulties. How to establish a new operating protocol for this new ham radio technique needs to be discussed.

Crosslinking, I suspect, may become one of the most exciting operating techniques to be adopted since the entrance of single sideband. It comes with great opportunities and a variety of operating procedures yet to be developed. It does *not* require any new hardware developments. You can begin crosslinking as soon as you return from your local Radio Shack store with less than \$20 worth of parts. If that doesn't make this idea pretty exciting, I don't know what will! ■

PARSEC COMMUNICATIONS HAS MOVED!!

New Address: 13313 Forest Hill Rd.
Grand Ledge, MI 48837

New Phone:
(517) 626-6044

6-10 P.M.
Sun. thru Thurs.



Pocket Size Radio, Perfect for Christmas.



... With Guaranteed Overnight Delivery

The TR-720 contains the latest microprocessing technology which is responsible for its amazing size (6.6" x 2.6" x 1.5") and weight (1.2 lb.). Features include 3 memory channels, 720 COM and 200 NAV channel operation, twist-off rechargeable battery pack, and multi-function LED to indicate receive signal or low battery. A full set of standard accessories including rechargeable battery, AC and DC chargers, case, flex antenna, and earphone put you straight on the air. Optional accessories are available.

The TR-720 increases the operating safety of balloons, sailplanes, and ultralights by providing communication with ground crews or ATC. It allows receipt of IFR clearances prior to engine start and is indispensable for search and rescue, forest fire fighting,

or law enforcement to coordinate aircraft operations. Sport aircraft, homebuilts, or experimental planes (even those without electrical systems) can now have reliable 720 channel communication. But perhaps the best advantage is the peace of mind that comes from having an emergency back-up transceiver.

The TR-720 comes with a full 1 year warranty with guaranteed 72 hour turnaround and is available for immediate delivery factory direct or from your local Avionics Dealer or FBO.

The TR-720, rugged, reliable communications in the palm of your hand.

\$795.00 Aircraft Owners Net
FCC and DOC Approved



Communications Specialists
426 West Taft Avenue
Orange, CA 92665-4296
(800) 854-0547 (714) 998-3021

MFJ ACCESSORIES

300 WATT ANTENNA TUNER HAS SWR/WATTMETER, ANTENNA SWITCH, BALUN. MATCHES EVERYTHING FROM 1.8 to 30 MHz.



\$99.95 MFJ-941D

NEW FEATURES

- **MFJ's fastest selling tuner packs in plenty of new features!**
- **New Styling!** Brushed aluminum front. All metal cabinet.
- **New SWR/Wattmeter!** More accurate. Switch selectable 300/30 watt ranges. Read forward/reflected power.
- **New Antenna Switch!** Front panel mounted. Select 2 coax lines, direct or through tuner, random wire/balanced line or tuner bypass for dummy load.
- **New airwound inductor!** Larger more efficient 12 position airwound inductor gives lower losses and more watts out. Run up to 300 watts RF power output. Matches everything from 1.8 to 30 MHz: dipoles, inverted vee, random wires, verticals, mobile whips, beams, balanced and coax lines. Built-in 4:1 balun for balanced lines. 1000V capacitor spacing. Black. 11x3x7 inches. Works with all solid state or tube rigs. Easy to use, anywhere.

RTTY/ASCII/CW COMPUTER INTERFACE MFJ-1224 \$99.95



Send and receive computerized RTTY/ASCII/CW with nearly any personal computer (VIC-20, Apple, TRS-80C, Atari, TI-99, Commodore 64, etc.). Use Kantronics or most other RTTY/CW software. Copies both mark and space, any shift (including 170, 425, 850 Hz) and any speed (5-100 WPM RTTY/CW, 300 baud ASCII). Sharp 8 pole active filter for CW and 170 Hz shift. Sends 170, 850 Hz shift. Normal/Reverse switch eliminates retuning. Automatic noise limiter. Kantronics compatible socket plus exclusive general purpose socket. 8x1 1/4x6 in. 12-15 VDC or 110 VAC with adapter, MFJ-1312, \$9.95.

RX NOISE BRIDGE

Maximize your antenna performance!



\$59.95 MFJ-202B

Tells whether to shorten or lengthen antenna for minimum SWR. Measure resonant frequency, radiation resistance and reactance.

New Features: individually calibrated resistance scale, expanded capacitance range (± 150 pf). Built-in range extender for measurements beyond scale readings. 1-100 MHz. Comprehensive manual. Use 9 V battery. 2x4x4 in.

INDOOR TUNED ACTIVE ANTENNA

"World Grabber" rivals or exceeds reception of outside long wires! Unique tuned Active Antenna minimizes intermod, improves selectivity, reduces noise outside tuned band, even functions as preselector with external antennas. Covers 0.3-30 MHz. Telescoping antenna. Tune, Band, Gain, On-off bypass controls.

6x2x6 in. Uses 9V battery, 9-18 VDC or 110 VAC with adapter, MFJ-1312, \$9.95.



\$79.95 MFJ-1020

POLICE/FIRE/WEATHER 2 M HANDHELD CONVERTER

Turn your synthesized scanning 2 meter handheld into a hot Police/Fire/Weather band scanner!

\$39.95

144-148 MHz handhelds receive Police/Fire on 154-158 MHz with direct frequency readout. Hear NOAA maritime coastal plus more on 160-164 MHz. Converter mounts between handheld and rubber ducky. Feedthru allows simultaneous scanning of both 2 meters and Police/Fire bands. No missed calls. Crystal controlled. Bypass/Off switch allows transmitting (up to 5 watts). Use AAA battery. 2 1/4x1 1/2x1 1/2 in. BNC connectors.



MFJ-313

MFJ/BENCHER KEYS COMBO

MFJ-422 \$99.95

The best of all CW worlds-

a deluxe MFJ Keyer in a compact configuration that fits right on the Bencher iambic paddle! MFJ Keyer - small in size, big in features. Curtis 8044 IC, adjustable weight and tone, front panel volume and speed controls (8-50 WPM). Built-in dot-dash memories. Speaker, sidetone, and push button selection of semi-automatic/tune or automatic modes. Solid state keying. Bencher paddle is fully adjustable; heavy steel base with non-skid feet. Uses 9 V battery or 110 VAC with optional adapter, MFJ-1305, \$9.95.



VHF SWR/WATTMETER

Low cost VHF SWR/Wattmeter!

MFJ-812 \$29.95

Read SWR (14 to 170 MHz) and forward/reflected power at 2 meters. Has 30 and 300 watts scales. Also read relative field strength. 4x2x3 in.



1 KW DUMMY LOAD

MFJ-250 \$34.95

Tune up fast, extend life of finals, reduce QRM! Rated 1KW CW or 2KW PEP for 10 minutes. Half rating for 20 minutes, continuous at 200 W CW, 400 W PEP. VSWR under 1.2 to 30 MHz, 1.5 to 300 MHz. Oil contains no PCB. 50 ohm non-inductive resistor. Safety vent. Carrying handle. 7 1/2x6 3/4 in.



24/12 HOUR CLOCK/ID TIMER

MFJ-103 \$34.95

Switch to 24 hour GMT or 12 hour format!



Battery backup maintains time during power outage. ID timer alerts every 9 minutes after reset. Switchable seconds readout. Elapsed timer. Just start clock from zero and note time of event up to 24 hours. Bright blue .6" digits. Alarm with snooze function. Synchronizable with WWV. Lock function prevents mis-setting. Power out, alarm on indicators. Black. 5x2x3 in. 110 VAC, 60 Hz.

DUAL TUNABLE SSB/CW FILTER

MFJ-752B \$89.95



Dual filters give unmatched performance! The primary filter lets you peak, notch, low pass or high pass with extra steep skirts. Auxiliary filter gives 70 db notch, 40 Hz peak. Both filters tune from 300 to 3000 Hz with variable bandwidth from 40 Hz to nearly flat. Constant output as bandwidth is varied; linear frequency control. Switchable noise limiter for impulse noise. Simulated stereo sound for CW lets ears and mind reject QRM. Inputs for 2 rigs. Plugs into phone jack. Two watts for speaker. Off bypasses filter. 9-18 VDC or 110 VAC with optional adapter, MFJ-1312, \$9.95.

ORDER ANY PRODUCT FROM MFJ AND TRY IT-NO OBLIGATION. IF NOT DELIGHTED, RETURN WITHIN 30 DAYS FOR PROMPT REFUND (LESS SHIPPING).

- One year unconditional guarantee • Made in USA.
- Add \$4.00 each shipping/handling • Call or write for free catalog, over 100 products.

MFJ

MFJ ENTERPRISES, INC.

Box 494, Mississippi State, MS 39762

TO ORDER OR FOR YOUR NEAREST DEALER, CALL TOLL-FREE

800-647-1800. Call 601-323-5869 in Miss. and outside continental USA
Telex 53-4590 MFJ STKV



MFJ RTTY / ASCII / CW COMPUTER INTERFACE

Lets you send and receive computerized RTTY/ASCII/CW. Copies all shifts and all speeds. Copies on both mark and space. Sharp 8 Pole active filter for 170 Hz shift and CW. Plugs between your rig and VIC-20, Apple, TRS-80C, Atari, TI-99, Commodore 64 or most other personal computers. Uses MFJ, Kantronics software and most other RTTY/CW software.



NEW!

MFJ Software plus MFJ Interface for VIC-20 or Commodore 64

(Software cartridge alone, \$49.95.
Order MFJ-1250 for VIC-20.
MFJ-1251 for Commodore 64)

\$129⁹⁵

Powerful RTTY/ASCII/CW software for VIC-20, Commodore 64.
Developed by MFJ. Cartridge plugs into expansion port.
Features split screen display, type ahead buffer, message ports,
RTTY/ASCII/CW send and receive plus much more.
Includes cable to Interface MFJ-1224 to VIC-20 or Commodore 64.

\$ 99⁹⁵
MFJ-1224

This new MFJ-1224 RTTY/ASCII/CW Computer Interface lets you use your personal computer as a computerized full featured RTTY/ASCII/CW station for sending and receiving.

It plugs between your rig and your VIC-20, Apple, TRS-80C, Atari, TI-99, Commodore 64, and most other personal computers.

Powerful MFJ software available for VIC-20 (MFJ-1250, \$49.95) and Commodore 64 (MFJ-1251, \$49.95). Features split screen display, type ahead buffer, message ports, RTTY/ASCII/CW send and receive plus more.

Uses Kantronics software for Apple, TRS-80C, Atari, TI-99 as well as VIC-20 and Commodore 64.

You can also use most other RTTY/CW software with nearly any personal computer.

A 2 LED tuning indicator system makes tuning fast, easy and positive. You can distinguish between RTTY/CW without even hearing it.

Once tuned in, the interface allows you to copy any shift (170, 425, 850 Hz and all shifts between and beyond) and any speed (5 to 100 WPM on RTTY/CW and up to 300 baud on ASCII).

Copies on both mark and space, not mark only or space only. This greatly improves copy under adverse conditions.

A sharp 8 pole active filter for 170 Hz shift and CW allows good copy under crowded, fading and weak signal conditions.

An automatic noise limiter helps suppress static crashes for better copy.

A Normal/Reverse switch eliminates retuning while stepping thru various RTTY speeds and shifts.

The demodulator will even maintain copy on a slightly drifting signal.

A +250 VDC loop output is available to drive your RTTY machine. Has convenient speaker output jack.

Phase continuous AFSK transmitter tones are generated by a clean, stable Exar 2206 function generator. Standard space tones of 2125 Hz and mark tones of 2295 and 2975 Hz are generated. A set of microphone lines is provided for AFSK out, AFSK ground, PTT out and PTT ground.

FSK keying is provided for transceivers with FSK.

High voltage grid block and direct outputs are provided for CW keying of your transmitter. A CW transmit LED provides visual indication of CW transmission. There is also an external hand key or electronic keyer input jack.

In addition to the Kantronics compatible socket, an exclusive general purpose socket allows interfacing to nearly any personal computer with most appropriate software. The following TTL compatible lines are available: RTTY demod out, CW demod out, CW-ID input, +5 VDC, ground. All signal lines are buffered and can be inverted using an internal DIP switch.

For example, you can use Galfu software with Apple computers, RAK software with VIC-20's, or Clay Abrams software with TRS-80C, N4EU software with TRS-80 III, IV. Some computers with some software may require some external components.

DC voltages are IC regulated to provide stable

AFSK tones and RTTY/ASCII/CW reception.

Aluminum cabinet. Brushed aluminum front panel. 8x1 1/4x6 inches. Uses 12-15 VDC or 110 VAC with optional adapter, MFJ-1312, \$9.95.

MFJ-1223, \$29.95, RS-232 adapter for MFJ-1224.

RTTY/ASCII/CW Receive Only SWL Computer Interface



\$ 69⁹⁵
MFJ-1225

Use your personal computer to receive commercial, military and amateur RTTY/ASCII/CW traffic.

The MFJ-1225 automatically copies all shifts (850, 425, 170 Hz shift and all others) and all speeds.

It plugs between your receiver and VIC-20, Apple, TRS-80C, Atari, TI-99, Commodore 64 and most other personal computers.

Use MFJ-1250 (\$49.95) software cartridge for VIC-20 or MFJ-1251 (\$49.95) software cartridge for Commodore 64. Use Kantronics software for Apple, TRS-80C, Atari and TI-99.

An automatic noise limiter helps suppress static crashes for better copy, while a simple 2 LED tuning indicator system makes tuning fast, easy and positive.

In addition to the Kantronics compatible socket, a general purpose socket provides RTTY out, RTTY inverted out, CW out, CW inverted out, ground and +5VDC for interfacing to nearly any personal computer with most appropriate software.

Audio in, speaker out jacks. 4 1/2x1 1/4x4 1/4 in. 12-15 VDC or 110 VAC with adapter, MFJ-1312, \$9.95.

ORDER ANY PRODUCT FROM MFJ AND TRY IT-NO OBLIGATION. IF NOT DELIGHTED, RETURN WITHIN 30 DAYS FOR PROMPT REFUND (LESS SHIPPING).

- One year unconditional guarantee • Made in USA.
- Add \$4.00 each shipping/handling • Call or write for free catalog, over 100 products.

MFJ

MFJ ENTERPRISES, INC.
Box 494, Mississippi State, MS 39762

TO ORDER OR FOR YOUR NEAREST DEALER, CALL TOLL-FREE
800-647-1800. Call
601-323-5869 in Mississippi and outside continental U.S.A. Telex 53-4590.



HUSTLER DELIVERS RELIABLE ALL BAND HF PERFORMANCE

Hustler's new 6-BTV six-band trap vertical fixed station antenna offers all band operation with unmatched convenience. The 6-BTV offers 10, 15, 20, 30, 40, and 75/80 meter coverage with excellent bandwidth and low VSWR. Its durable heavy gauge aluminum construction with fiberglass trap forms and stainless steel hardware ensures long reliability.

Thirty meter kits (30-MTK) for 4-BTV and 5-BTV are also available.



Don't miss our 30 meter excitement.
HUSTLER -
STILL THE STANDARD OF PERFORMANCE.



3275 North "B" Avenue
Kissimmee, Florida 32741

An **AMATEUR** Company

123

Nampa Satellite SYSTEMS

IDAHO'S LARGEST DEALER

introducing



MD9 - 9' Dish

Total System Design.

From the solid steel antenna to the state-of-the-art electronic receiver and hand-held control unit, Wilson gives you the most complete, integrated system you can own.

At Wilson Microwave Systems, we put the world of entertainment in the palm of your hand.

NOW ONLY

\$1695.00 F.O.B. Nampa, ID

Includes: 110° LNA · Polarizer I · 100' Cable
Wilson MD9 Dish · YM1000 Receiver



YM1000

Dealerships Available

312 12th Ave. So.
Nampa, Idaho 83651
(208) 466-6727

Wats Lines:

In State 1-800-654-1319
Out of State 1-800-654-0795

138

If you need QUARTZ CRYSTALS

—one or hundreds—

YOU NEED JAN

- high stability
- prompt service
- cost savings

**JAN
CRYSTALS**

39

- General Communication
- Industry
- Marine VHF
- Scanners
- Amateur Bands
- CB Standard
- CB Special
- Microprocessor

Call or Write

JAN CRYSTALS

P.O. Box 08017
Ft. Myers, FL 33906-6017
All Phones (813) 936-2387

BEEPERS!



**IF YOU HAVEN'T HEARD OUR BEEPERS
YOU'RE NOT LISTENING!**

What's a BEEPER? Sometimes called a "courtesy beep," both Faxscan BEEPERS add a gentle high frequency beep automatically to the beginning of each transmission and a low beep at the end. "Talk-over" is a thing of the past!

INTRODUCING BP-4 "The PRO" BEEPER. The PRO is state-of-the-art beeping! Includes a digitally-programmable timer (use it for ID or timeout warnings), an automatic "Slumber Mode" for long battery life (9V battery required—not included), and programmable volume control of the unique double 4-beep timeout warning. No speaker! Uses a piezo-transducer!

Hook-up's a snap with either model! Interfaces to virtually all modern gear. Manual supplied with each BEEPER. Available in three versions:

"A" versions are complete with case, cable, industry-standard 4-pin connectors

"B" versions are the same as above but without connectors. Add your own!

"C" versions are circuit-board models for custom installations. Perfect for repeaters or building INTO your rig

**BEEPERS ARE A
FAXSCAN EXCLUSIVE!**

BP-4 "The PRO" BEEPER BP-3 "The Original" BEEPER
A - \$79 All units are assembled, tested, A - \$69
B - \$69 carry a 90-day limited warranty. B - \$49
C - \$49 and shipped pre-paid in US. C - \$29

Ohio residents add 6% sales tax

FAXSCAN INC. 99

3148 Duff Drive • Dayton, Ohio 45418

TM



HF Transceivers:
IC-740 9-band 200w PEP Xcvr \$ 1099.00 **949⁹⁵**
plus FREE PS-740 internal power supply & \$50 Factory Rebate - until gone!

- PS-740 Internal power supply \$159.00 **149⁹⁵**
- *EX-241 Marker unit 20.00
- *EX-242 FM unit 39.00
- *EX-243 Electronic keyer unit 50.00
- *FL-45 500 Hz CW filter (1st IF) 59.50
- *FL-54 270 Hz CW filter (1st IF) 47.50
- *FL-52A 500 Hz CW filter (2nd IF) 96.50 **89⁹⁵**
- *FL-53A 250 Hz CW filter (2nd IF) 96.50 **89⁹⁵**
- *FL-44A SSB filter (2nd IF) 159.00 **144⁹⁵**
- SM-5 Electret desk microphone 39.00
- HM-10 Mobile scan microphone 39.50
- MB-12 Mobile mount 19.50

*Options also for IC-745 listed below

- IC-730 8-band 200w PEP Xcvr w/mic \$829.00 **599⁹⁵**
- FL-30 SSB filter (passband tuning) 59.50
- FL-44/A SSB filter (2nd IF) 159.00 **144⁹⁵**
- FL-45 500 Hz CW filter 59.50
- EX-195 Marker unit 39.00
- EX-202 LDA interface; 730/2KL/AH-1 27.50
- EX-203 150 Hz CW audio filter 39.00
- EX-205 Transverter switching unit 29.00
- SM-5 Electret desk microphone 39.00
- HM-10 Mobile scan microphone 39.50
- MB-5 Mobile mount 19.50

- IC-720A 9-band Xcvr/.1-30 MHz Rcvr \$ **1349.00 899⁹⁵**
- FL-32 500 Hz CW filter 59.50
- FL-34 5.2 KHz AM filter 49.50
- MB-5 Mobile mount 19.50
- IC-7072 transceiver interface, R-70 112.50

- IC-745 9 band xcvr/.1-30 MHz rcvr \$999.00 **899⁹⁵**
- PS-35 Internal power supply 160.00 **144⁹⁵**
- CF5-455K5 2.8 KHz wide SSB filter TBA
- SM-6 Desk microphone 39.00
- HM-12 Hand microphone 39.50

See IC-740 list above for other options (*)



- IC-751 9-band xcvr/.1-30 MHz rcvr \$ **1399.00 1229**
- PS-35 Internal power supply 160.00 **144⁹⁵**
- FL-52A 500 Hz CW filter 96.50 **89⁹⁵**
- FL-53A 250 Hz CW filter 96.50 **89⁹⁵**
- FL-33 AM filter 31.50
- SM-6 Desk microphone 39.00
- HM-12 Hand microphone 39.50
- External frequency controller TBA
- High stability reference crystal TBA

- Options: 720/730/740/745/751 Regular SALE
- PS-15 External 20A power supply \$149.00 **134⁹⁵**
 - EX-144 Adaptor; CF-1/PS-15 6.50
 - CF-1 Cooling fan for PS-15 45.00
 - PS-20 20A switching ps w/speaker 229.00 **199⁹⁵**
 - CC-1 Adaptor; HF radio to PS-20 10.00
 - CF-1 Cooling fan for PS-20 45.00



- Options - continued Regular SALE
- EX-310 Voice synthesizer (IC-751) 39.95
 - SP-3 External speaker 49.50
 - Speaker/phone patch (specify radio) 139.00 **129⁹⁵**
 - BC-10A Memory back-up 8.50
 - EX-2 Relay box w/marker 34.00
 - AT-100 100w 8-band automatic ant tuner 349.00 **314⁹⁵**
 - AT-500 500w 9-band automatic ant tuner 449.00 **399⁹⁵**
 - MT-100 Manual antenna tuner 249.00 **224⁹⁵**
 - AH-1 5-band mobile ant w/tuner 289.00 **259⁹⁵**
 - PS-30 20A systems power supply 259.95 **233⁹⁵**
 - GC-4 World clock 99.95 **94⁹⁵**

HF Linear amplifier

- IC-2KL 160-15m/WARC solid state linear 1795.00 **1299**

VHF/UHF Multi-modes

- IC-251A* 2m FM/SSB/CW xcvr \$749.00 **549⁹⁵**

***\$50 Factory Rebate - until gone!**

- IC-551D 80w 6m Xcvr \$699.00 **599⁹⁵**
- PS-20 20A switching ps/spkr 229.00 **199⁹⁵**
- EX-106 FM adaptor 125.00 **112⁹⁵**
- BC-10A Memory back-up 8.50
- SM-2 Electret desk microphone 39.00
- IC-451A 430-440 SSB/FM/CW Xcvr/ps 899.00 **769⁹⁵**
- IC-451A/High 440-450 MHz Xcvr/ps 899.00 **769⁹⁵**
- AG-1 15 db preamp, IC-451A/45A 89.00 **79⁹⁵**
- IC-271A 2m, 25w xcvr 699.00 **629⁹⁵**
- IC-471A 430-450 MHz, 10w xcvr 799.00 **719⁹⁵**
- PS-25 Internal power supply 99.00 **89⁹⁵**
- EX-310 Voice synthesizer 39.95
- HM-12 Hand microphone 39.50
- SM-6 Electret desk microphone 39.00

VHF/UHF FM

- IC-25A 2m, 25w, up-dn-ttp mic, grn leds \$359.00 **319⁹⁵**
- IC-25H as above, but 45 watts 389.00 **349⁹⁵**
- IC-45A 440 FM xcvr, 10w, TTP mic 399.00 **359⁹⁵**
- BU-1 Memory back-up 38.50
- IC-22U 10w 2m FM non-digital Xcvr 299.00 **249⁹⁵**
- EX-199 Remote frequency selector 35.00
- RP-3010 440 MHz repeater 999.00 **899⁹⁵**

ATTENTION CLUBS, GROUPS, etc. UHF Transceiver/Repeater SPECIAL!
 Get together and buy (10) ICOM IC-45A's at one time at the Low AES Sale Price and get the RP-3010 Repeater at 50% off List Price.

VHF/UHF multi-modes:

- IC-290H 25w 2m SSB/FM Xcvr, TTP mic \$549.00 **489⁹⁵**
- IC-560 10w 6m SSB/FM/CW Xcvr 489.00 **439⁹⁵**
- IC-490A 10w 430-440 SSB/FM/CW Xcvr 649.00 **579⁹⁵**

VHF/UHF Portables:

- IC-505 3/10w 6m port. SSB/CW Xcvr 449.00 **399⁹⁵**
- BP-10 Internal nicad battery pack 79.50
- BC-15 AC charger 12.50
- EX-248 FM unit 49.50
- LC-10 Leather case 34.95
- IC-402 432 portable SSB xcvr 389.00 **299⁹⁵**
- SP-4 Remote speaker 24.95
- IC-3PS Power supply for portables 95.00 **89⁹⁵**
- IC-20L 2m amp, 10w PEP or FM 98.00 **89⁹⁵**
- IC-30L 432 amp, 10w PEP/FM 105.00 **94⁹⁵**

1.2 GHz equipment

- IC-120 1w 1.2 GHz FM xcvr \$499.00 **449⁹⁵**
- RP-1210 10w 1.2 GHz repeater TBA
- Cabinet for RP-1210 or RP-3010 249.00

Hand-held transceivers:
New Deluxe Model - Full keyboard entry; Scanning; 10 memories; offset memories; odd offsets; 32 PL tones; batt. backup. LCD display. 3W w/std. BP-3 pack or 5W w/new opt. pack. Uses IC-2A accessories.

Deluxe Models	Regular SALE
IC-02A for 2 meters \$	319.00 289⁹⁵
IC-02AT with DTMF...	349.00 314⁹⁵
Standard Models	Regular SALE
IC-2A for 2 meters	239.50 214⁹⁵
IC-2AT with TTP	269.50 219⁹⁵
IC-3A for 220 MHz	269.95 234⁹⁵
IC-3AT with TTP	299.95 239⁹⁵
IC-4A for 440 MHz	269.95 234⁹⁵
IC-4AT with TTP	299.95 239⁹⁵

Accessories for Hand-helds: Regular

- BC-25U Extra 15-hour wall charger \$10.00
- BC-30 1/15-hour drop-in charger for BP-2/3/5 69.00
- BP-2* 450 ma, 7.2v 1w ext. time battery 39.50
- BP-3 Extra std. 250ma 8.4v 1.5w battery 29.50
- BP-4 Alkaline battery case 12.50
- BP-5* 450 ma, 10.8v 2.3w hi-power battery 49.50
- *BC-30 required to charge BP-2 & BP-5
- FA-2 Extra 2m flexible antenna 10.00
- CA-2 Telescoping 1/4-wave 2m antenna 10.00
- CA-5 5/8-wave telescoping 2m antenna 18.95
- CA-3 Extra 220 flexible antenna 9.12
- CA-4 Extra 440 flexible antenna 9.12
- CP-1 Cigarette lighter receptacle chgr for BP-3 9.50
- DC-1 DC operation module 17.50
- HM-9 Speaker/microphone 34.50
- LC-2A Leather case without TTP cutout 34.95
- LC-2AT Leather case with TTP cutout 34.95
- ML-1 2m 2.3/10w HT amp. (Reg. \$89) .. SALE **79.95**
- ML-25 2m 20w HT amp. (Reg. \$199.50) SALE **179.95**
- 3A-TTN 16-button TTP front for 2A/3A/4A 39.50
- CommSpec SS-32M 32-tone encoder 29.95
- IC-M12 12 ch Marine hand-held **SPECIAL 269.95**



Shortwave receiver Regular SALE

- R-70 100KHz-30MHz digital receiver \$749.00 **599⁹⁵**

til 12/31/83 - purchase R-70 and receive certificate for free GC-4 World Clock (\$99⁹⁵ Value) from ICOM.

- EX-257 FM unit 38.00
- IC-7072 Transceiver interface, 720A 112.50
- FL-44/A SSB filter (2nd IF) 159.00 **144⁹⁵**
- FL-63 250 Hz CW filter (1st IF) 48.50
- SP-3 External speaker 49.50
- EX-299 (CK-70) 12V option 9.95
- MB-12 Mobile mount 19.50



HOURS: Mon. thru Fri. 9-5:30; Sat. 9-3
 Milwaukee WATS line 1-800-558-0411 answered evenings until 8:00 pm, Monday thru Thursday.
Please use WATS line for Placing Orders.
 For other information, etc. please use Regular line.

Order Toll Free: 1-800-558-0411 In Wisconsin (outside Milwaukee Metro Area) 1-800-242-5195
AMATEUR ELECTRONIC SUPPLY Inc.
 4828 W. Fond du Lac Avenue; Milwaukee, WI 53216 - Phone (414) 442-4200

AES BRANCH STORES

WICKLIFFE, Ohio 44092 28940 Euclid Avenue Phone (216) 585-7388 Ohio WATS 1-800-362-0290 Outside Ohio 1-800-321-3594	ORLANDO, Fla. 32803 621 Commonwealth Ave. Phone (305) 894-3238 Fla. WATS 1-800-432-9424 Outside Florida 1-800-327-1917	CLEARWATER, Fla. 33575 1898 Drew Street Phone (813) 461-4267 No In-State WATS No Nationwide WATS	LAS VEGAS, Nev. 89106 1072 N. Rancho Drive Phone (702) 647-3114 No In-State WATS Outside Nevada 1-800-634-6227	CHICAGO, Illinois 60630 ERICKSON COMMUNICATIONS 5456 N. Milwaukee Avenue Phone (312) 631-5181 Outside Illinois 1-800-621-5802
--	---	---	---	--

Grenada Log

With a body-bag rig and gas from a bike, a ham hustled home the news. Here's history happening.

Bob Cunningham K1XR
PO Box 214
Fitzwilliam NH 03447

Tim Daniel N8RK
PO Box 485
Peterborough NH 03458

"An invasion on 20 meters?" Those were the words Steve Mendolsohn WA2DHF heard with disbelief when he answered the telephone at a little after six on the morning of Tuesday, October 25th, 1983. Over 2000 miles away on the island of Grenada, Mark Barattella KA2ORK had been up for three hours, making ham radio history. Operating from his second-floor room at the Grand Anse campus of Saint George's Medical School, Mark had become an essential link between the island and the rest of the free world.

This was how and where it began: The social and political events leading up to the rescue mission on Grenada are well known. In the days prior to October 25th, ham radio played an important but not a primary role. That all changed, however, when Mark was summoned by medical school administrators. With phone service nonexistent, the telex dead, and the extremely unusual

sound of aircraft circling overhead, Mark swung into action.

His ham gear, which had been dismantled and hidden after the days-old coup, was retrieved from its hiding place—a body bag in the school's anatomy lab. Five minutes later, KA2ORK/J37 was calling CQ on 20 meters. No response... the band was dead. Thankful for having a five-band trap dipole, Mark made a quick change to 40 meters. Tuning across the quiet band, he happened onto an early morning QSO between an operator in Texas and a K4 in Georgia.

"Break... Emergency... Break!" Naturally, the reaction was skeptical. By now Mark was hearing anti-aircraft fire in the distance. After confusion about third-party agreements was laid to rest and it was established that this was a true emergency—not a late-night bootlegger—the K4 telephoned Dr. Steve Lomazow N2DRA, Mark's QSL manager.

Due to the conversations of preceding weeks, Dr. Lomazow was more than aware that such a phone call might happen. The 40-meter frequency, however, caught him by surprise. Enlisting the help of his wife and son, Dr. Lomazow soon had a dipole connected to his rig, hastily set up near the dining room phone.

The predawn path between New Jersey and Grenada was a good one, but to ensure top-quality signals, Dr. Lomazow enlisted the aid of KC2PK, whose directional antenna and one-thousand-Watt transmitter were put on the air. There was little hesitation... KC2PK's daughter was on the island.

Mark told Dr. Lomazow that there were rumors of an invasion and asked him if he could confirm it. N2DRA's phone calls to CBS, NBC, and ABC turned up nothing. (By now conditions on 40 meters were deteriorating. The group moved to 20 meters where they set up shop on 14.250 MHz.) However, tipped off to the fact that something was happening in the Caribbean, the networks began to investigate.

Enter Steve Mendolsohn WA2DHF. His first reaction to the awakening phone call from his office, CBS Network Operations, was, "Your average invasion does not take place on 20 meters!" But after tuning in 14.250, Steve quickly changed his mind.

During KA2ORK/J37's transmissions, listeners now could not mistake the distinct sound of small-arms fire and jet aircraft. According to Steve, "It was beginning to sound like there was someone who was not just down vacationing for a DX contest!" As the word got out, hams who were close to the media were besieged with phone calls. For example, Steve logged 46 such inquiries.

As it grew light outside, in Grenada, one of Mark's fellow students used his previous military experience to monitor the activity around them. From this rooftop crow's nest, he began to identify the ships just off the beach and the aircraft overhead as belonging to the USA. Even though they were in imminent danger, Mark and the students were fascinated by the technical

expertise of the military in action.

To augment the information that they were receiving from official sources, the press desperately wanted to speak with someone on the island. With the phone and all other forms of communications dead, again, the only alternative was ham radio. Mark was inundated with on-the-air requests from the international, national, and local US media and amateur operators who were assisting the media. He refused all interviews, going so far as to deny Dan Rather any comments. (After Mark returned home, he met Mr. Rather and explained the situation and how ham radio functions.) What Mark did was to report nothing but facts. He told only of events that he could see himself or were reported to him firsthand from spotters on the roof.

Shortly after Mark started operating his Swan 500, the area lost commercial pow-

er—not an unusual event on a small Caribbean island. Prepared for this, the school had a diesel-powered generator on standby. Risking nearby gunfire, a few students made their way across campus to the generator. They fueled it, checked the oil, and started it. It had oil, but there wasn't any in reserve and it was running low. It ran for almost 18 hours before freezing up. As a last resort, they had a small Honda generator of about 500 Watts capacity. Mark put the new generator out on the balcony and started it up. After reducing his power, he started to transmit. Every time he keyed the mike, the under-powered generator groaned. However, it did the job; on-the-air signal reports were unchanged. They had enough gasoline to operate this power supply for an additional 5 to 10 hours.

It was actually needed, however, for only 3 more

hours. At that time: "It's Now!...Get Down!...Get Down Now!" Those were the words one of Mark's friends used when he was instructed to get him from his second-floor "shack." The Rangers were there and it was time to evacuate. Mark pulled the plug and headed downstairs. The rescue helicopters were arriving at the beach, four and five at a time. A line of Rangers pushed the students down the beach and into the awaiting choppers. Mark wished that he still had his rig operating, as mortar fire was coming in and the helicopters were firing their cannons back to protect the students. Over 200 people were evacuated in about 15 minutes.

After a short flight to the recently-secured airport, the group had a few hours to collect their thoughts before being flown by jet to Barbados. On Barbados, Mark was able to phone home. After

reassuring his family, top-most on his mind was letting the amateur-radio fraternity know that they were all safe. Another quick plane ride to South Carolina, and the ordeal was over.

Mark's overall impression of the entire operation was reassuring. Amateur radio proved itself again. Yes, there was malicious interference. There was also interference which was the result of some well-intentioned but nonetheless frivolous transmissions.

Licensed since his late teens, Mark epitomized the important role that young people can play in amateur radio. For KA2ORK/J37, WA2DHF, N2DRA, KC2PK, and countless others, the day 20 meters was invaded will not be forgotten soon.

The authors would like to thank WA6ITF, N2WS, WA2DHF, N2DRA, and last but not least, KA2ORK for help in researching this story. ■

AMATEUR TELEVISION

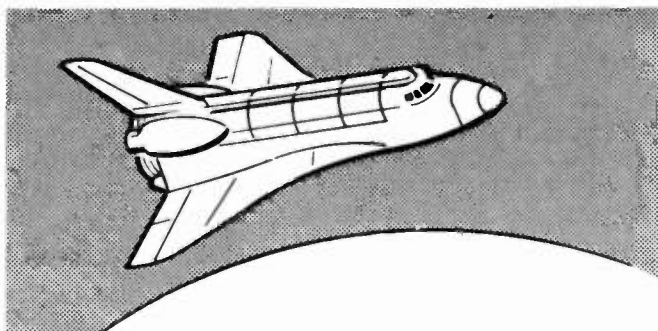

ATV TRANSMITTER/CONVERTER



\$399 delivered
TC-1 plus

- **OVER 10 WATTS PEP OUTPUT.** Crystal controlled continuous duty transmitter. Specify 439.25, 434.0, 426.25 standard or other 70 cm frequency. 2 freq. option add \$26.
- **BASE, MOBILE, or PORTABLE.** Use the builtin AC supply or external 13.8 vdc. Do parades, Marathons, etc.
- **TWO VIDEO AND AUDIO INPUTS** for camera, TVRO, VCR, or computer. Wide bandwidth for broadcast quality color video and computer graphics. Standard broadcast subcarrier sound which is heard thru the TV speaker.
- **RECEIVE ON YOUR STANDARD TVSET** tuned to channel 3 or 4. Sensitive varicap tuned TVC-2L downconverter covers simplex and repeater freq. over the whole 420-450 mHz 70 cm amateur band.
- **ATTRACTIVE 10.5 x 3 x 9 CABINET.**

FCC & NASA OKs SHUTTLE VIDEO

Want a chance at seeing W5LFL live as he works 2 meters?

It's been great hearing the audio on the various repeaters, but now, if you hold a technician class or higher license, and have a TVRO capable of receiving Satcom IR transponder 13, you can repeat the space shuttle video to your fellow hams using our TC-1 plus. Just connect the composite video and line audio from the Satellite receiver to the video and audio inputs of the TC-1. Depending on your antenna, coverage will be typically the same as 2 meter simplex. Local area hams can receive with just one of our 70 CM downconverters and an antenna.

ATV 70 cm DOWNCONVERTERS

For those who want to see the repeated shuttle video, and other ATV action before they commit to a complete station, the TVC-4 is for you. The TVC-4 contains the TVC-2 module mounted in a cabinet with AC supply ready to go. Tunes 420 to 450 mHz. Just connect 70 cm antenna and your TV set tuned to ch 3 or 4 **\$89 delivered.**

TVC-4L hotter preamp for fringe areas . . . **\$99 delivered.**
TVC-2 wired and tested module. Req. 12 vdc. MRF901 preamp stage. Varicap tuned 420-450 mHz. A low cost start at **\$49.**
TVC-2L hotter NE64535 preamp stage **\$59 delivered.**
TVC-2G GaAsFet preamp stage. Antenna mounting **\$79**

CALL OR WRITE FOR OUR CATALOG or more information on ATV antennas, transmit modules, cameras, and much, much more. See chapter 14 pg 30-32 1983 ARRL Handbook.

TERMS: Visa, Mastercard, or cash only UPS CODs by telephone or mail. Postal money orders and telephone orders usually shipped within 2 days. All other checks must clear before shipment. Transmitting equipment sold only to licensed amateurs.

(213) 447-4565 m-f 8am-6pm pst.

P.C. ELECTRONICS

Tom W6ORG Maryann WB6YSS



2522 Paxson Lane
Arcadia CA 91006

Instant Pane Relief

*This is the only notch filter for windows we've ever seen.
If you can figure it out, you'll beat the feedline flu.*

Gary L. Eldridge KCBUD
3219 Mirimar Street
Kettering OH 45409

Feeding any number of coax cables through a window from the ham shack to the antenna farm

is sometimes a problem when the window has to be kept open a slight amount to allow clearance for them. Not only does rain

blow in at times, but during the winter a tremendous amount of heat can be lost through such gaping gaps—not to mention insect invasions in the summer.

Some have taken it so far as to make a permanent installation, such as drilling holes in the side of the house, running the cables out, and then filling the holes with a weather-resistant material. That's good for home owners only.

An easier and much less

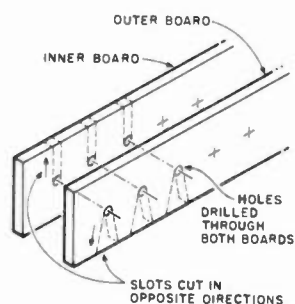

Fig. 1.

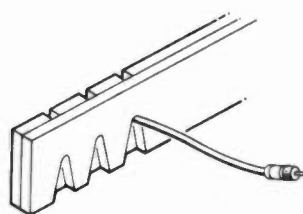

Fig. 2.

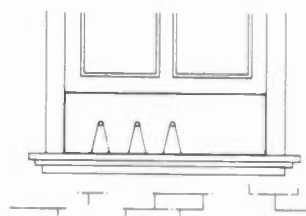
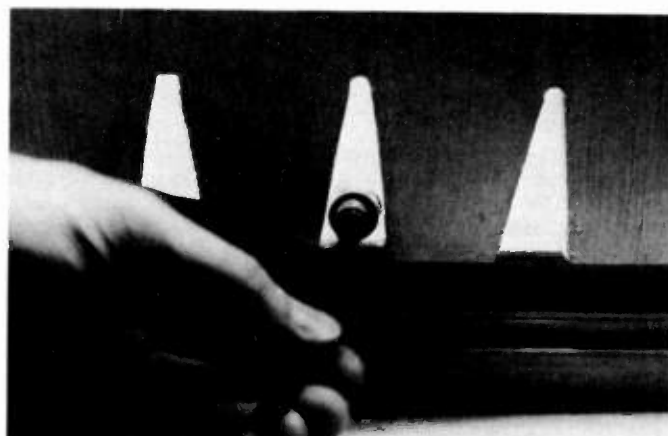

Fig. 3.



Tools needed, and finished boards.



Inserting connector through outer board.

WE SHIP WORLDWIDE

Barry Electronics Corp.

WORLD WIDE AMATEUR RADIO SINCE 1950

Your one source for all Radio Equipment!

For the best buys in town call:
212-925-7000

Los Precios Mas Bajos en Nueva York...



Barry gives the best in Commercial & Ham Gear So-to One and All- A Happy and Healthy New Year!

KITTY SAYS: WE ARE NOW OPEN 7 DAYS A WEEK.
Saturday & Sunday 10 to 5 PM
Monday-Friday 9 to 6:30 PM Thurs. to 8 PM
Come to Barry's for the best buys in town. For Orders Only Please Call: 800-221-2683



ICOM

IC-R70, IC-751, IC-730, IC-745, IC-25A/H, IC-37A
IC-45A, IC-271A, IC-2KL, IC-471A, IC-290H, IC-120



YAESU

FT-ONE, FT-980, FT-102, FT-77, FT-707, FT-230R FT-757GX
FT-726R, FT-720RU, FT-290R, FRG-7700, FT-203R



DRAKE TR-5, TR-7A, R-7A, L-7, L-15, Earth
Satellite Receiver ESR-24, THETA 9000E & 500,
EARTH SATELLITE STATION ESS-2250

We are now an Authorized
KENWOOD

Dealer

ROCKWELL/COLLINS
KWM-380

VoCom/Mirage
Tokyo Hy-Power
Amplifiers &
5/8λ HT Gain
Antennas IN STOCK

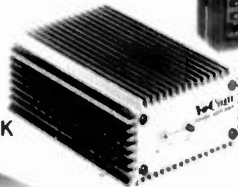

Computer Interfaces
stocked: MFJ-1224
AEA CP-1, Kantronics
Big Ham Clock/Ham Tags

KANTRONICS
Field Day 2, Mini-Reader,
Interface, Software &
Code Tapes

EIMAC
3-500Z
572B, 6JS6C
12BY7A &
4-400A



BIRD
Wattmeters &
Elements
In Stock

AEA 144 MHz
AEA 440 MHz
ANTENNAS

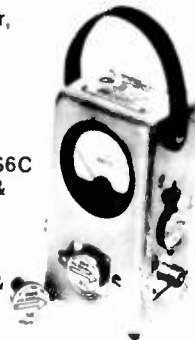

Complete Butternut Antenna
Inventory In Stock!

ROBOT 450C-800C-1200C
Color Mod Kits

Long-range Wireless
Telephone for export
In stock

**BENCHER PADDLES &
Vibroplex Keys In Stock!!**

New TEN-TEC
2591 HT, Corsair In Stock
DENTRON IS BACK IN STOCK!

SMART PATCH

CES-Simplex Autopatch 510-SA Will Patch FM
Transceiver To Your Telephone. Great For
Telephone Calls From Mobile To Base. Simple
To Use - \$319.95.



SANTEC
ST-222/UP
ST-142/UP
ST-442/UP
NEW IMPROVED



MURCH Model
UT2000B

MFJ Modcls
900, 940B, 941C, & 951D

**HAM MasterTapes—
Beta or VHS Tapes**

**DIGITAL
FREQUENCY
COUNTER**

Trionyx-
Model TR-1000
0-600 MHz
Digimax Model
D-510 50 Hz-1GHz



Tri-Ex Towers

Hy-Gain Towers
& Antennas,
and Rotors
will be shipped direct
to you FREE of shipping cost.

MAIL ALL ORDERS TO BARRY ELECTRONICS CORP., 512 BROADWAY, NEW YORK CITY, NY 10012.

New York City's LARGEST STOCKING HAM DEALER
COMPLETE REPAIR LAB ON PREMISES

"Aqui Se Habla Espanol"

BARRY INTERNATIONAL TELEX 12-7670
TOP TRADES GIVEN ON USED EQUIPMENT
STORE HOURS: Monday-Friday 9 to 6:30 PM
Parking Lot Across the Street

Saturday + Sunday 10 to 5 p.m. (Free Parking)
AUTHORIZED DIST. MCKAY DYMEK FOR
SHORTWAVE ANTENNAS & RECEIVERS.

IRT/LEX-"Spring St. Station"
Subways: BMT-"Prince St. Station"
IND-"F" Train-Bwy. Station"

Bus: Broadway #6 to Spring St.

**ORDER LINE
CALL
800-221-2683**

We Stock: AEA, ARRL, Alpha, Ameco, Antenna Specialists, Astatic, Astron, B & K, B & W, Bash, Bencher, Bird, Butternut, CDE, CES, Collins, Communications Spec. Connectors, Covercraft, Cubic (Swan), Cushcraft, Daiwa, Dentron, Digimax, Drake, ETO (Alpha), Eimac, Encomm, Heil-Sound, Henry, Hustler (Newtronics), Hy-Gain, Icom, KLM, Kantronics, Larsen, MCM (Daiwa), MFJ, J.W. Miller, Mini-Products, Mirage, Newtronics, Nye Viking, Palomar, RF Products, Radio Amateur Callbook, Robot, Rockwell Collins, Saxton, Shure, Swan, Telex, Tempo, Ten-Tec, Tokyo Hi Power, Trionyx TUBES, W2AU, Waber, Wilson, Yaesu Ham and Commercial Radios, Vocom, Vibroplex, Curtiss, Tri-Ex, Wacom Duplexers, Repeaters, Phelps Dodge, Fanon Intercoms, Scanners, Crystals, Radio Publications.

WE NOW STOCK COMMERCIAL COMMUNICATIONS SYSTEMS
DEALER INQUIRIES INVITED. PHONE IN YOUR ORDER & BE REIMBURSED.
COMMERCIAL RADIOS stocked & serviced on premises.

**Amateur Radio & Computer Courses Given On Our Premises, Call
Export Orders Shipped Immediately. TELEX 12-7670**



Guiding lines through inner board.



Lines in; window weatherproofed.

defacing method is to cut a board the same width as the window and close the window as far as possible down onto the board to make a tight fit. When a cable needs to reach outside the shack, a hole is simply drilled in the board and the cable is brought through.

With this method, I have found that almost every time I want to run a cable out the window the cable I have chosen to use inconveniently has connectors on both ends. Since a tight fit and a good seal requires that the hole in the board should be only large enough for the cable itself, that means that the connector has to be cut off before the cable can be inserted into the hole or removed from it.

However, by looking at the illustrations you should have no trouble in understanding the method I have found which facilitates a

weather-tight seal and easy insertion or removal of any size cable without having to remove the connectors.

The method employs two boards cut to the width of the window. The boards are sandwiched together and the window is closed down onto the boards. Each time a new feedline must be brought through, just drill a hole in the center of the two boards and cut slots from the holes to one edge of each board. The slots are cut in opposite directions in the two boards so that the board which faces the outside has its slot going down and the board facing inside has its slots going up.

The slots in the outside board should be cut in a wedge shape so that when the inside board is moved out of the way, the connectors on the cables can pass through the wider end of the slots without having to

remove the outer board at all. This way you can seal the outer board by caulking it or using duct tape and thus the board never has to be removed. This requires several holes and slots to be pre-cut in the outer board before it is fixed in place.

When any cable is removed, the small hole that is left behind can be filled eas-

ily with a small dab of putty, a piece of wood dowel, or cloth.

This method works well not only for coaxial feedlines but for twin-line as well since the wood helps keep the twin-line away from any metal window framing which might have some effect on the impedance of the feedline. ■

THE ONE STOP SOURCE SINCE 1959!!

COAXIAL CABLE

RG-8/U (95% BRAID-FOAM) \$235/M'
MICRO 8/U (95% BRAID-FOAM) \$115/M'
RG-213/U (96% BRAID-POLY) \$270/M'
RG-214/U (2-96% BRAIDS-POLY) \$495/M'

ROTOR CABLE

8/C HAMLINE (2-18/6-22) \$150/M'
8/C HAMLINE HD (2-16/6-18) \$340/M'

CALL COLLECT
CALL FOR LARGE QUANTITY
DISCOUNT

CONNECTORS

UHF
PL-259 57¢ ea.
UG-175/U OR 176/U .16¢
PL-258 79¢

TYPE 'N'

UG-21/BU(MALE) \$2.35
UG-27/CU(RIGHT ANGLE) \$4.45
UG-57/BU(DOUBLE MALE) \$3.15
UG-29/BU(DOUBLE FEMALE) \$3.15

✓12



cz labs

P.O. Box 95-55 Railroad Ave.
Garnerville, New York 10923

(914) 947-1554-1555

MICROWAVE COMPONENTS

25 MW EXCITER	\$49.95
45 MHZ SUBCARRIER	\$19.95
AM VIDEO MODULATOR	\$19.95
50 MW UP CONVERTER	\$149.95

GIZMO ELECTRONICS, INC.

P.O. BOX 1205
PITTSBURG, KS 66762
PH. 316-231-8171

✓229

Kansas residents 3% sales tax



MICROLOG AIR-1

Connect your computer to the air!

The "AIRWAVES" that is, thru the Microlog AIR-1, a single board terminal unit AND operating program in ROM that needs no external power supply or dangling extras to put your computer on CW & RTTY. And what a program! The famous Microlog CW decoding algorithms, superior computer enhanced RTTY detection, all the features that have made Microlog terminals the standard by which others are compared. Convenient plug-in jacks make connection to your radio a snap. On screen cross tuning indicator and audio pitch reference tone make it easy to use. The simple, one board design makes it inexpensive. And Microlog know-how makes it best! There's nothing left out with the AIR-1. "HARDWARE" front end has: AFSK, PTT, \pm CW/FSK keying

loop switch, hand key input and dual tone mark/space RTTY DEMOD plus single tone CW detector. "SOFTWARE" in onboard ROM has: split screen, large type ahead transmit buffer, automatic keyword controlled receive data storage, WRU, SELCAL printer control and user programmable memories that can dump/store on disc and tape. Full speed RTTY, 60 to 132 wpm, CW to 150 wpm, 110/300 ASCII and optional 4 mode AMTOR operation covers all the bases. If you've been waiting for the right system at the right price, or you've been disappointed with previous operating programs, your time is now. At \$199, the complete AIR-1 is your answer for VIC-20 and "64" (with 4 mode AMTOR, \$279). Join the silent revolution in RTTY/CW and get ON-THE-AIR! See it at your local dealer or give us a call at Microlog Corporation, 18713 Mooney Drive, Gaithersburg, Maryland 20879. TEL (301) 258 8400. TELEX 908153.

Note: VIC-20 is a trademark of Commodore Electronics, Ltd.

MICROLOG ✓51
INNOVATORS IN DIGITAL COMMUNICATION

SHORT DIPOLES

In selecting an antenna, choose the longest one that will fit your property. It will cost less and have wider bandwidths. All Barker & Williamson dipoles are made from rugged #14 stranded copperweld wire for strength and conductivity. Unless otherwise noted, all antennas will handle the legal power limit. These dipoles may be installed as inverted "V's" or horizontally. The tunable trap antennas are adjusted to any part of a band by sliding a tuning wire on the trap.

Model AS-80 **Only 58 ft. long**
for 80, 40, 15, 10 M **Low SWR**

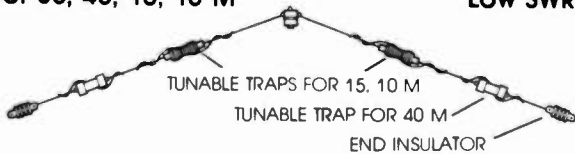

LENGTH	BANDS	DESCRIPTION	MODEL	PRICE
110 ft.	160 - 10 m	Continuous coverage antenna, SWR less than 2 from 1.8 to 30 MHz with no adjustments to antenna. 1.5 KW PEP on SSB, CW; 500 W input on AM, RTTY	AC 1.8-30	\$149.50
120 ft.	160, 80, 40 m	Low SWR on all bands, 1.5 KW PEP on SSB, CW; 500 W input on AM, RTTY.	AS-160	\$ 89.50
110 ft.	80, 40, 20, 15, 10 m	Resonant with low SWR on 80 and 40, somewhat higher SWR on 20, 15, and 10.	370-11	\$ 72.50
90 ft.	80, 40, 15, 10 m	Tunable trap antenna with low SWR on all bands. 1.5 KW PEP on SSB, CW; 500 W input AM, RTTY.	AT-80	\$ 79.50
58 ft.	80, 40, 15, 10 m	Tunable trap antenna with low SWR on all bands. 500 W Input all modes.	AS-80	\$ 99.50
55 ft.	40, 20, 15, 10 m	Resonant with low SWR on 40, 20, somewhat higher SWR on 15 and 10.	370-13	\$ 65.00
36 ft.	40, 15, 10 m	Tunable trap antenna with low SWR on all bands. 1.5 KW PEP on SSB, CW; 500 W Input on AM, RTTY.	AS-40	\$ 75.50
22 ft.	20, 15, 10 m	Tunable trap antenna with low SWR on all bands. 1.5 KW PEP on SSB, CW; 500 W input on AM, RTTY.	AS-20	\$ 75.50
30 ft.	160 m	Add-on kit to convert an 80 m dipole to 160 m. Loading coils and wire add only 15 ft. to each end of your antenna. (Not for AS-80)	AK-160	\$ 79.50
47 ft.	30 m	Add-on kits to provide 30 m or 20 m coverage to a dipole antenna. Consists of a parallel dipole and spacers.	AK-30	\$ 19.75
33 ft.	20 m		AK-20	\$ 19.75

Add \$3.00 Shipping and Handling

ALL OUR PRODUCTS MADE IN USA

BW BARKER & WILLIAMSON
 Quality Communication Products Since 1932
 At your Distributors write or call
 10 Canal Street, Bristol PA 19007
(215) 788-5581



ORBIT is the Official Journal for the Radio Amateur Satellite Corporation.

For a **SAMPLE COPY** please send \$2 to:

(AMSAT), P.O. Box 27, Washington, DC 20047.

TRIONYX INC MANUFACTURER OF ELECTRONIC TEST EQUIPMENT 600 MHZ FREQUENCY COUNTERS \$ 159.95 2 METER 5/8 WAVE HT

COMPLETE SYSTEMS

1.9 TO 2.5 GHz

BUILT ANTENNA AND VARIABLE TUNER OPERATES ON TV CHANNELS 2 THRU 6

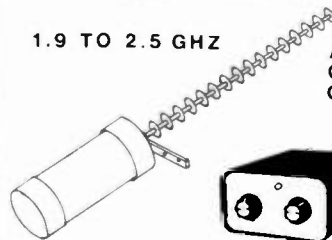

\$59.95

ALL SYSTEMS INCLUDES DETAILED INSTRUCTION

DOWN CONVERTER BOARD & PARTS KIT



9.95

VARIABLE POWER SUPPLY BOARD & PARTS KIT



9.95

ALUMINUM CABINET ALL HOLES PRE-PUNCHED **\$6.95**

MICROWAVE ANTENNA KIT \$9.95
 DOWN CONV KIT \$9.95
 POWER SUPPLY KIT \$9.95
 CABINET \$6.95
\$36.80

ALL RG59/U COAX CABLES COME WITH CONNECTOR ATTACHED

100 FT\$15.95
 75 FT\$13.95
 50 FT\$10.95
 3 FT\$2.50

TRIONYX INC

6219 COFFMAN RD. INDIANAPOLIS, IN 46268

ADD \$3.50 FOR SHIPPING

PHONE OR MAIL (317) 291 7280 291 2995



ANTENNA \$ 12.95 RUBBER DUCKS FORM \$6.95 TO \$7.95

step up to the best...

Without doubt LR-1 is the repeater value leader! Compare its outstanding performance with any repeater -- then look at its price. LR-1 features include individual die-cast shielding of receiver and transmitter plus a separately shielded 6-stage receiver prefilter for peak performance in harsh RF environments • Front panel metering of all vital functions • CW identifier • Symmetric hard limiting for clean natural audio • Low power MOS control logic • Even the cabinet is included -- just plug in and go!

LINKING? The LR-1 is also available with control circuitry for Link Transceiver operation. Now link repeater sites with the flexible control capability you've always wanted.

HIGH POWER? Our PA-75 power amplifier is the champion! Ruggedly built to give years of dependable operation in continuous duty repeater service.



Mark 3C repeaters and controllers have no equal in performance. Both units feature auto patch, reverse autopatch, autodial, 13 Morse messages and a total of 39 functions. Both feature microprocessor control and both have been proven in the field from icy Alaska to tropical Brazil. A Mark 3C supercontroller can make any repeater a super performer. The Mark 3CR repeater is in a class by itself. It combines superbly designed RF circuitry in one handsome package. It is without doubt the world's most advanced repeater!

CALL OR WRITE FOR FULL DETAILS

MICRO CONTROL SPECIALTIES

49

23 Elm Park • Groveland, Massachusetts 01834 • Telephone (617) 372-3442

Sound Off!

Here's the perfect S-meter add-on for the repeater that has everything. The higher the beep, the better the signal.

Think you've seen every kind of attachment to a repeater that there is? How about this one—an audible S-meter? If you're wondering about why in the world you would need an audible S-meter on your repeater, think about all the times that you wanted to compare rigs, optimize antenna direction or location, or just know how well you were making the repeater from a particular mobile location. If your luck was like mine, you found that no one was around at that time, or, if

they were, they couldn't stay while you fiddled around with your rotator or carried the antenna back and forth across the roof a bunch of times. And even if they did stick around, didn't you ever wonder how they could determine by ear whether you were 70% or 80% full quieting?

Well, this little circuit will solve all those problems for you. Now you can make any of those tests all by yourself and know for sure whether that last change you made helped or hurt you even if

no one's around. Generally, what it does is sample the first limiter voltage, amplify it, and feed it to a voltage-controlled oscillator which returns a beep proportional to your signal strength. The higher the beep, the stronger you are (up to full quieting). I've got mine on WR3AGU 147.81/.21 at Mehoopany, Pennsylvania, and it's been working great for about a year. It's set up to give a continuously variable tone beep between .2 μ V and 1.0 μ V. The tone frequency range is 800 Hz for .2 μ V and about 2800 Hz for 1.0 μ V.

All the other junk you see in the schematic diagram does things like delay the beep to give your receiver time to recover after transmit, set up a sample-and-hold circuit to hold the limiter voltage momentarily when you let up on the mike, and discharge that voltage after the beep is output, etc. More on that later in the circuit description. Depending on where you hook it up on your repeater, it can serve a dual purpose of indicating timer reset and signal strength.

The circuit isn't very complex and it shouldn't be hard

for anyone with the time and initiative to design a PC board for it.

Circuit Description

IC1 is a dual op amp with a very high input impedance. This is necessary so as to not load down the first limiter stage to which it will be connected. The gain of the stage is variable and is adjusted by the 1-meg-dc amp gain control. More about this adjustment later. The output of this IC is fed through D1 to the second half of IC1. D1 ensures that the 2.2- μ F tantalum capacitor is not discharged when the output of IC1a goes lower than the voltage on the 2.2- μ F capacitor.

These components form a sample-and-hold circuit which holds the voltage developed by IC1a for a short time when the input signal disappears. IC1b serves as a voltage follower/impedance transformer. Its high input impedance does not load down the 2.2- μ F capacitor and its relatively low output impedance feeds the MC4024 vco. The MC4024 is a voltage-controlled oscillator. The audio output frequency of this chip is deter-

Photo by Mike Benish K3SAE

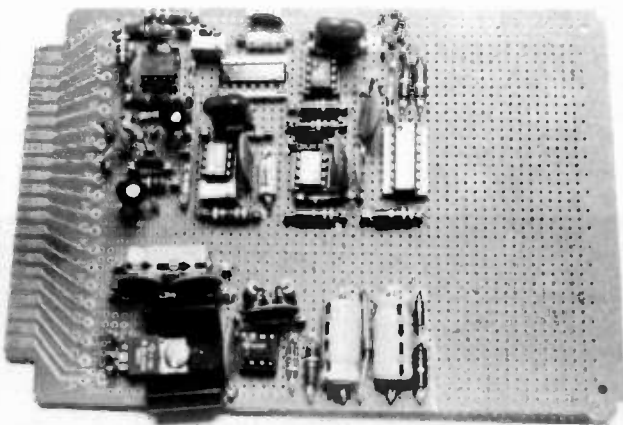

Circuit board.

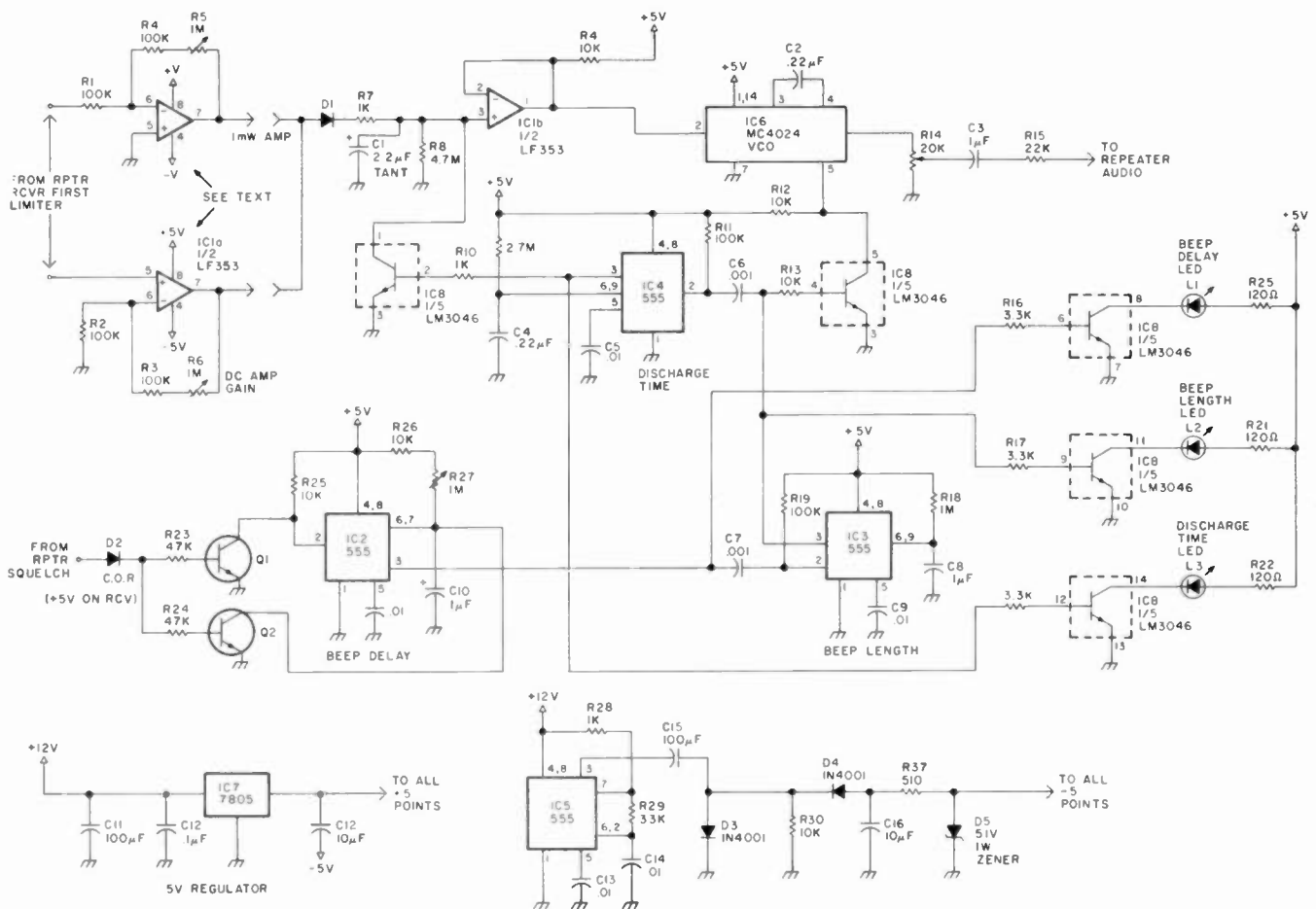

Fig. 1. Schematic.

mined by the voltage at its input. With the values shown, output frequencies between 800 and 2800 Hz will be generated when pin 5 is high.

The repeater COR is connected to the anode of D2. The COR must go above 2.0 volts on receive and remain below 1.0 volt when idle. The standard 0-volt low and 5.0-volt high is ideal. When a signal is received, IC2 (set up as a retriggerable monostable) is reset and its output is held high while a transmission is being received. When the received carrier disappears, IC2 then times out (how much later is determined by the 1-meg pot and the 1-uF capacitor) and output pin 3 goes low. This delay is to ensure that you release your mike button. Instead of an immediate return beep, a delay is introduced which allows time for receiver recovery.

When IC2 goes low, it trig-

gers IC3 which is set up as a monostable. When pin 3 of IC3 goes high, it biases on the B section of the LM3046 transistor array, bringing pin 5 of the MC4024 vco low for a finite time allowing it to output a beep. After IC3 times out, its output pin 3 goes low, shutting off the vco and triggering IC4. When IC4 is triggered, its pin 3 goes high and biases on the A section of the transistor array. This discharges the 2.2-uF tantalum and readies it for receipt and storage of the next voltage level.

The other three sections of the LM3046 transistor array are used, together with their respective LEDs, as logic monitors to indicate the status of the three timers. All five sections may, of course, be replaced by five discrete transistor devices if you wish.

The fourth 555 is used in the astable mode to convert +12 volts dc to a low-cur-

rent -5-volt supply needed for the proper operation of IC1. The 7805 is a three-terminal device used to regulate the +12 volts supplied to +5 volts needed for IC1 and other portions of this circuit.

Adjustment

There are only three adjustments to be concerned with. The one-meg pot associated with IC2 is adjusted to provide the amount of delay you would like after the carrier disappears before the beep is heard. The proper amount of time is what sounds best to you. Adjustment is best done while in actual operation.

The one-meg-dc amp gain associated with IC1a takes a bit more to adjust. If you have access to a Cushman or other service monitor with a calibrated output, things are much easier.

With a service monitor: (1) Remove the LM3046 from

its socket (you did use a socket, didn't you?). Short pins 5 and 3 of the socket with a thin jumper wire to permanently enable the MC4024. (2) Disconnect one end of the 2.2-uF capacitor. (3) Set the dc amp gain to minimum resistance. (4) Key up the repeater and adjust the 20k-level pot in the output of the vco to about 3-kHz deviation. (5) Apply a signal to the receiver which is just enough to break squelch. Adjust the dc amp gain slowly until a slight rise in tone pitch is noticed. This causes IC1a to output the dc level at this point which is needed to begin controlling the vco. Any larger signal will be further amplified and applied through IC1b to the vco, resulting in a higher tone from the vco. The stronger the signal, the higher pitched the tone.

Without a service monitor: (1) Perform steps 1, 2, 3, and 4 above. (2) Have some-

one with a very weak signal transmit. Adjust the dc amp gain as described in step 5 above.

The Input Stage

IC1a's input is connected to your repeater's first limit-

er stage. The voltage at this point will most probably increase with an increase in signal strength. In this case, the non-inverting stage configuration is used. If it is necessary to connect to a point in your first limiter where

the voltage decreases with increasing signal, then use the inverting configuration shown.

The audible S-meter has proven to be a worthwhile addition to the 81/21 repeater (WR3AGU) and I'm sure

you'll find it a useful and novel feature on your repeater.

I'll be happy to answer any questions regarding this circuit. Please include a stamped self-addressed envelope. ■

Parts List

Resistors (all 1/2 or 1/4 Watt unless stated otherwise)

R1, R2, R3, R4, R11, R19	100k	
R5, R6, R27	1 meg pot	part # TR11-1 meg \$.39
R7, R10, R28	1.0k	
R8	4.7 meg	
R9, R12, R13, R25, R26, R30	10k	
R14	20k pot	part # TR-11-20k \$.39
R15	22k	
R16, R17	3.3k	
R18	1 meg	
R20, R21, R22	120	
R23, R24	47k	
R29	33k	
R31	510	

Capacitors (all capacitors at least 12 volts dc)

C1	part # TM2.2/35	\$.51	2.2 uF tantalum
C2, C4	part # MY.22/100	\$.33	.22 uF
C3, C10	part # A1/16	\$.17	1.0 uF
C5, C9, C13, C14	part # DC.01/50	\$.08	.01uF
C6, C7	part # DC.001/50	\$.08	.001 uF
C8	part # DC.1/12	\$.12	.1 uF

C11, C15	part # A100/16	\$.24	100 uF
C12, C16	part # A10/16	\$.17	10 uF

Diodes

D1, D2, D3, D4	part # 1N4001	12/\$1.00	1N4001 or equiv.
D5	part # 1N4733	4/\$1.00	5.1 V zener

Integrated Circuits

IC1	part # LF353N	\$1.00	LF353
IC2, IC3, IC4, IC5	part # NE555V	\$.39	555
IC6	part # MC4024P	\$3.95	MC4024
IC7	part # LM340T-5	\$1.25	7805 regulator
IC8	part # LM3046N	\$1.30	transistor array

Transistors

Q1, Q2	part # 2N3392	4/\$1.00	general purpose NPN type
--------	---------------	----------	--------------------------

LEDs

L1, L2, L3	part # XC209R	5/\$1.00	general purpose LEDs
------------	---------------	----------	----------------------

All parts available from Jameco Electronics
1355 Shoreway Rd.
Belmont CA 94002

Plan Now To Attend The Most "OUT OF THIS WORLD" Event In The History Of Ham Radio!

COME TO THE ARRL 1984 NATIONAL CONVENTION IN NEW YORK, the world's greatest city, at the New York Statler July 20-22. Along with the convention's fantastic parties, technical and operating seminars, League committee meetings, banquet, DX gatherings and manufacturers' displays, you and your family can enjoy all there is to do in New York, the cultural capital of the world!

FOR A TRULY "OUT OF THIS WORLD" EXPERIENCE we'll be celebrating both the 15th Anniversary of man's first moon landing AND the first off-world amateur radio operation during the STS-9 Spacelab-1 mission. Our special guest will be astronaut **DR. OWEN GARRIOTT, W5LFL**, first ham to operate from space! You can meet W5LFL in person, at the Moon Landing Anniversary Party on Friday evening, July 20th, AND hear him speak at the Banquet on Saturday evening, July 21st.

IMAGINE, THE MOST IMPORTANT ARRL NATIONAL EVER HELD...AND YOU CAN BE THERE! Register now to assure your room and banquet reservations. For detailed information and registration forms, SASE to Mike Troy, AJ1J, R.R. 4 - Box 19C, Pound Ridge, NY 10576.

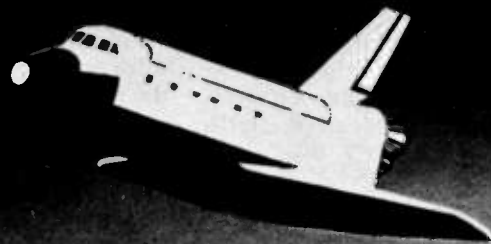

prepared by WB2GMK Advertising

ALL ITEMS ARE
 GUARANTEED OR SALES
 PRICE REFUNDED.
 PRICES F.O.B.
 HOUSTON
 PRICES SUBJECT TO
 CHANGE WITHOUT
 NOTICE.
 ITEMS SUBJECT TO
 PRIOR SALE

MADISON Electronics Supply

1508 McKinney
 Houston, Texas 77010
 *Call For Quotes
 713-658-0268
 We stock what we advertise,
 and much more.



AMATEUR COMPUTER ACCESS.

- MicroPatch™**
 model MP-20/MP-64 ... \$129.95
 The lowest priced unit available.
- AEA CP1** ... 189.95
 CP1/VIC 20 mbatext. . . Special
 CP1/COMM64 mbatext Hot Deal
Software ... 10% off Amateur
 Discount Prices
- Kantronics Interface** ... 119.95
 with HAMTEXT ... 199.95
- Kantronics AMTOR** ... 79.95
- MFJ 1224** plus new 1250
 or 1251 software for
 VIC20/COMM64 ... 129.95
- HAL CWR6850 Teletreader** ... 699.00
- New Hot AEA MicroPatch**
 COMM 64 or VIC20 ... CALL
- VHF/UHF MIRAGE B23** ... 79.00
- B3016 ... 199.00
 B1016 ... 249.00
 D1010N ... 289.00
 New A1015 ... CALL
- KDK 2030** ... 259.00
ST144uP ... 269.00
- New Santec ST142** ... CALL
ST7T ... 209.00
- Accessories in stock
- TR7950, TM201A** ... CALL
- TW4000A** ... HOT PRICE
- OSCAR FT726R** ... 699.00
- SJ726 ... 95.00
 430 Module ... 225.00
FT290/FT790 Combo ... 699.00
- TR2500** ... CALL
- FT208RA/FT708R** ... 269.00
- TenTec HT** ... 279.00
HT 1200 ... 209.00
- HF**
- Signal One Mllspec** ... 5995.00
 Accessories available.
- Rockwell-Collins**
 KVM380 ... Factory Order
- ACCESSORIES**
- TS930S** ... CALL
TS430S ... DISCOUNT
TS530S ... GREAT BARGAIN
TS830S plus free goods ... BUY!
- TenTec Corsair** ... 1020.00
- Argosy** ... 529.00
Drake TR5 ... 499.00
YAESU FT980 ... 1299.00
- FT77** ... 499.00
FT757GX ... 749.00
FT102 ... 879.00
- NYE MB-V 3kw Tuner** ... 479.00
 MB4-2 ... 399.00
 MB1-2 100 watt ... 185.00
- GE Tubes** ... STOCK
- Robot 1200c** high resolution
 color SSTV ... 1139.00
 450c Color SSTV ... 789.00
 800c/800ch RTTY/CW ... 789.00
 400c kit ... 469.00
 800c kit ... 155.00
- Heil Sound** ... 10% OFF
- Microwave Modules** ... SOON
- BIRD 43 - Elements** ... STOCK
 Call for other BIRD items!

FEATURE

- New Santec ST142** ... 299.95
 Same accessories as ST144up
- W6TOG Hearing Aids**
 Preamp board ... 29.95

ANTENNAS

- Cushcraft** Proline ... STOCK
 Cushcraft turnstile ... \$29.95
 Cushcraft D40 Rotable dipole ... 149.95
- Oscar 416TB** ... 58.00
 A14420T ... 74.00
 A14TMB ... 29.00
 As a package ... 159.00
- Belden 9913** Solid center Coax.
 foil + Braid shield ... 42¢/Ft.
 KT34A ... 308.00
 2MI3LBA ... 79.00
 144-148-13LBA ... 78.00
 420-470-18C ... 59.00
 A14410T ... 49.00
 Antenna specialists AP151.3G ... 33.00
 432-16LB ... 59.00
 68TV ... 129.00
 Explorer 14 ... CALL
 TH7DX ... DISCOUNT
 HF6V ... 125.00
 G7144 ... 108.00
 DB plus Enterprises, 2 El Quad ... 279.00
 Alpha Delta ... 10% off
 W1JC, 160/30, 160/40M dipole
 110' Long ... 69.95
 B&W AV25 Vertical Notrap ... 85.00
 Q5-QRM, coax
 Dipole, Comm. Grade 75M ... 69.95
 40M, Coax dipole ... 59.95
 Belden 8214 ... 40¢/Ft.
 9258 RG8X ... 19¢/Ft.
 8267 RG213 ... 49¢/Ft.
 Amphenol 8261 N Male ... 3.00
 831SP PL259 Silverplate ... 1.25
 UG176 ... 30¢
 HIQ dogbone insulator ... 50¢

ACCESSORIES

- Triplite 12V20A** supply ... \$99.00
- Big Ham Clocks**
 Dual LCD 12/24 hr ... 29.95
- Books:** Gliner, Radio Pub, Radio Callbook,
 ARRL, SAMS, AMECO, TAB, RIDER
- AEA MM2** ... 149.00
 CK2 ... 129.00
 KT2 ... 99.00
 BT1 ... 79.00
- Sherwood, Fox Tango** ... 10% off
- Alpha Delta** ... ASK
- Janel, Vibroplex** ... 10% off
- Coax Seal** ... 2.00
QSL Holder ... 2.00
- Bugcatcher**
 All band antenna coil ... 45.00
 Single Band Coll ... 39.00
 Valor HF mobile antennas ... 20.00 ea.
Anteco 5/8 Mag. mt. ... 25.00
Bencher ZA1A/ZA2 ... 21.00
- Paddles**
 Single Paddle ST2 ... 54.00
 Single Paddle ST1 ... 49.00

ICOM BLOWOUT

- Due to heavy buying, we have extra ICOM
 stock. Look below at these prices!
- IC490A ... \$519.00
 IC451A ... 595.00
 EX182 ... 21.00
 EX203 CW AUDIO ... 30.00
 FL63 ... 39.00
 FL30 ... 46.00
 FL45 ... 46.00
 FL52 ... 77.00
 FL53 ... 77.00
 HM10 ... 31.00
 MB12 ... 15.00
 R70 - 720A Interface ... 95.00

PARTS

- CDE .001/20KV doorknob cap ... \$1.95
Sprague 100Pf/500V Feedthru ... 1.95
Sprague 500Pf/30kv doorknob cap ... 16.00
 14, 20, 24 pin 600 Mil dip sockets,
 soldertail ... 40¢
 14, 16 pin 300 Mil ... 10¢
 20, 24, 40 Pin 600 Mil ... 25¢
 3n201 ... 10¢
 Caps to .01 Pc. ... 10¢
 Rec Tubes new surplus ... 1.00 ea.

SWL CORNER

- Bearcat DX1000** ... 499.00
 R70 ... CALL
 R2000 ... SPECIAL
 R1000 ... BUY!
 McKay Dymek ... STOCK

USED, GUARANTEED

- 90 day warranty & 6 month trade in, full value,
 for new gear.
- FT101ZD/Filter ... 595.00
 TS520 or TS520S ... 395.00 ea.
 75A4/KWS1 or 32S1/75S1 Parts ... CALL
 CX11A, clean ... 3395.00
 CX7A ... 695.00
 TS830S ... 695.00

HOT & NEW

Free upgrade book or call directory with
 new HF rig purchase. Tired of counting on
 "satisfaction" from your present dealer?
 Try us! Don't hesitate to call for a little
 radio advice, we always try to steer you
 in the right direction.

Trades welcome.

POLICIES

MasterCard, Visa, C.O.D Welcome

Note: Many companies use your money
 until the item is shipped. We hold charge
 cards, checks, until shipment. Call us
 anytime on the status of your order. All
 prices FOB Houston, subject to change,
 prior sale. Used gear sales price refunded
 if not satisfied.

- | | | | | |
|-------------|-----------|------------|-----------|---------|
| AEA | Belden | Bugcatcher | ETO-Alpha | Heil |
| Alliance | Butternut | Antennas | Finco | ICOM |
| Alpha Delta | Bird | Bencher | Fox Tango | IRL |
| Amphenol | Cushcraft | Dowkey | Gliner | Hustler |
| Anteco | CDE | Drake | GE Tubes | HyGain |

1-800-231-3057

- | | | |
|----------------|------------------|------------|
| McKay-Dymek | Rohn | Signal One |
| Nye | Rockwell-Collins | Sprague |
| Radio Callbook | TenTec | Triax |
| Rider | Telex | TAB |
| Robot | TCG | Triplet |
| | | SAMS |
| | | Vibroplex |
| | | Santec |
| | | W6TOG |
| | | Surplus |
| | | Yaesu |

Some Alarming Techniques

These burglar-proof circuits will stump second-story men and amaze possible thieves—as well as you.

The most cost-effective way to protect life and property against fire, theft, and vandalism is with an electronic alarm system. Wayne Green has been telling us for years of the market potential for amateur radio operators in the alarm business. Having once been in the alarm business, I agree with Wayne and in

this article I will share the common circuit techniques and a schematic for a simple but sophisticated residential alarm control panel.

Closed Loop or Open Loop?

For an alarm to be reliable, its operation must not be defeated by a loose connection or broken wire in the system. Most intrusion

alarms use a closed loop—a continuous loop of wire with normally-closed switches wired in series. When one of the switches is open or the metallic tape on a protected window is broken, the alarm panel responds to an open circuit on its input terminals. This type of loop is self-testing; there is only one way to make up the loop, this being with all switches closed and wires connected. Fig. 1 illustrates an example of a simple alarm control panel circuit for closed-loop operation.

An open loop consists of a chain of normally-open switches wired in parallel. Some technique for testing

the integrity must be provided, since a break in the normally-open loop would render part of the loop inoperative.

Fig. 2 illustrates the use of an end-of-line diode to monitor a normally-open loop. In this circuit an ac signal is impressed on the control-panel end of the loop. During one half of the cycle the end-of-line diode conducts, supplying current to the trouble relay. Should one of the switches close, the alarm relay would drop out, setting off the alarm circuit. Should the loop open or ac power fail, the trouble relay will drop out, alerting the operator to trouble on the

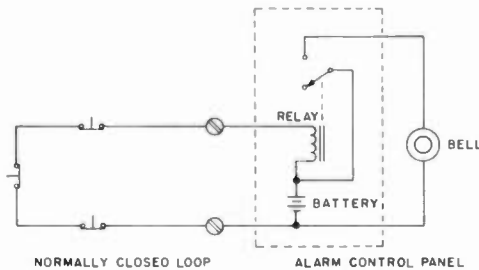

Fig. 1. Schematic of a simple closed-loop alarm using a relay, battery, and bell. The closed loop is self-testing because the loop must be made up before the alarm is turned on.

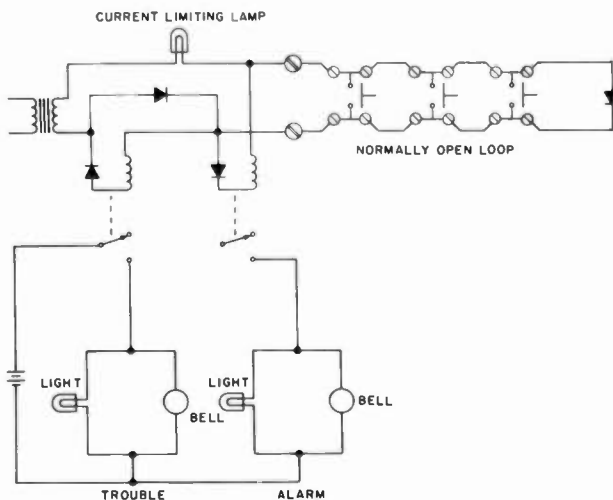

Fig. 2. Open-loop two-wire system, using end-of-line diode, relays, and ac power supply. These are used in fire-alarm systems.

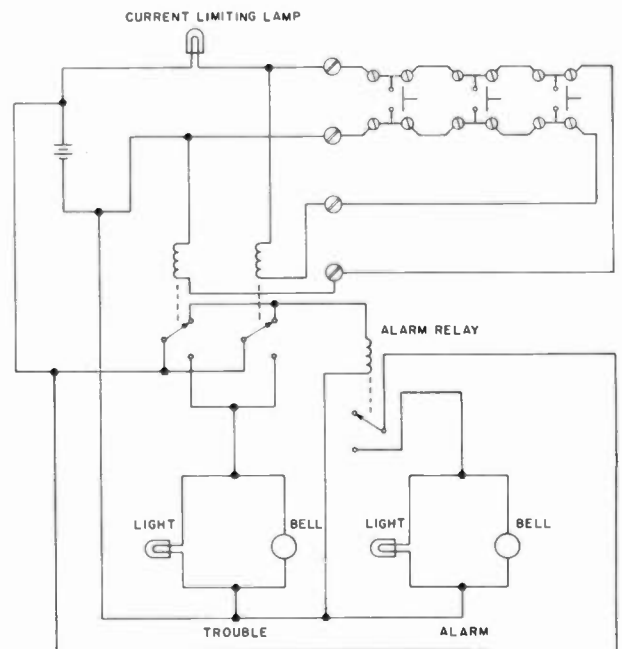

Fig. 3. Typical four-wire open-loop alarm circuit using alarm relay. These are also used in commercial fire-alarm systems.

line. There are other end-of-line techniques for detecting open-loop trouble; each has some problem and is considered not as good as a four-wire loop.

The Four-Wire Loop

A four-wire loop is shown in Fig. 3. This circuit uses two relays to sense the integrity of the loop. If either relay drops out, a trouble alarm is sounded. If the open loop is shorted, both relays drop out, as does the alarm relay.

This four-wire circuit uses a single dc power supply and may be supplied by a backup battery in case of ac power failure. It should be noted that in case of relay or power failure, this circuit will fail in the trouble or alarm mode. The normally-open switches used in this type of alarm have four sets of screws for the incoming and outgoing pairs to ensure that a switch does not get left out of the loop because of a poor connection. The open loop is normally used for fire-alarm systems which are left on continuously.

Entry and Exit

An intrusion alarm is usually turned off for part of the day and activated for part of the day. The operator must be able to turn the alarm system on and off without causing an alarm. There are two techniques for this: a high-security keyswitch mounted outside the protected perimeter and the time-delay system.

The high-security keyswitch technique uses a keyswitch with a cylindrical tumbler to bypass part of the closed loop, as shown in Fig. 4. To arm the alarm system, the operator first checks the integrity of the loop at the control panel and turns on the alarm. The operator then exits through the doors and areas bypassed by the outside keyswitch. After securing the exit door, the high-security keyswitch is opened, putting

the bypassed switches back in the loop. To enter the protected perimeter these steps are reversed; first the outside switch is closed, then the operator proceeds to the alarm panel and turns the alarm off.

Entry and exit delays may be used in low-security systems where the intruder would not expect to find an alarm system, such as in a residence. When the system is turned on, the operator has a preset exit delay period before the alarm system is armed. This period is normally adjustable from a few seconds to a couple of minutes. This gives the operator time to set the alarm and exit the perimeter without setting off the alarm.

Another delay must be provided for entry. Here the operator may break the protected perimeter and still be given time to go to the alarm-system panel and turn it off before the alarm sounds. Obviously, the intruder may be given the same opportunity to find and silence the alarm before it sounds. Fig. 5 gives us a schematic for an alarm circuit which provides for entry and exit delay.

The entry and exit delays

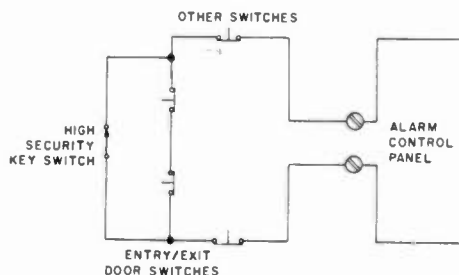

Fig. 4. Example of how a high-security keyswitch is used to bypass entry/exit doors. This type of circuit is used on commercial intrusion alarms.

are fixed by the choice of timing capacitors C1 and C2 and resistors R10 and R11 connected to IC3; with 1 megohm and 10 μ F respectively, the delay is about 14 seconds. This is about the minimum practical delay time.

Half sections of IC2 are

connected as R-S latches to hold information about the system status. System status and loop integrity are indicated by LEDs. Also included is a power supply for the system with battery backup. Normally the batteries are dry cells which are tested and replaced periodically.

Parts List

R1-R6	2.2k Ω , 1/4-Watt
R7-R9	330 Ω , 1/4-Watt
R10, R11	1 megohm, 1/4-Watt
C5, C6	4.7-uF tantalum
C1, C2	10-uF, 16-volt electrolytic
C3, C4	0.01-uF ceramic disc
D1-D3	1N4001
D4-D6	Light-emitting diode
S1-S3, S7	Normally-closed switches
S4-S6	Normally-open, momentary-contact switches
IC1, IC2	7400 quad two-input NAND; +5—pin 14, Gnd—pin 7
IC3	556 dual 555 timer; +5—pin 14, Gnd—pin 7
IC4	7805 5-V regulator
RY1	5-V low-current relay

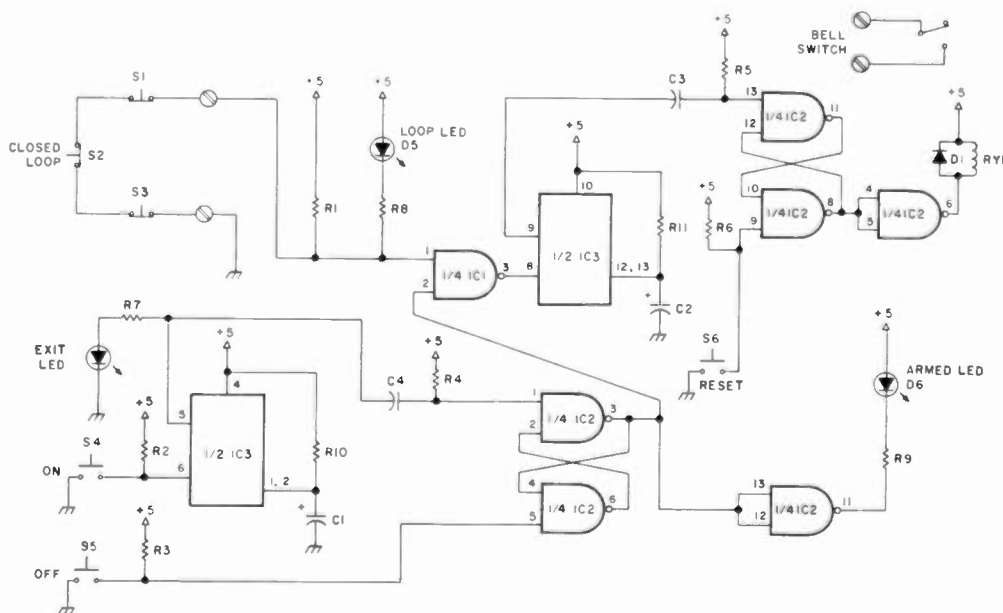

Fig. 5. Schematic diagram of an alarm control panel suitable for residential use. Entry/exit delay is included.

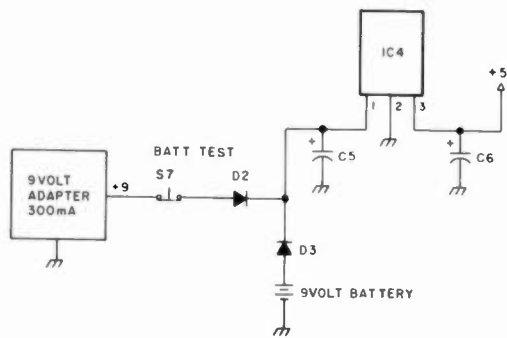

Fig. 6. Power supply for Fig. 5. The battery is usually dry cells which are periodically tested and replaced.

Summons

The systems described here all rely on a local bell to scare the intruder away and/or notify the occupants. Commercial alarms must also notify the police or fire department or some other private security office. Normally this is done over leased phone lines—pairs of wires leased from the phone company which connect the alarm panel to the central office.

In simple systems, a nor-

mal status is indicated by plus six volts dc, trouble is indicated by zero volts, and an alarm condition is indicated by negative six volts dc. In most locations, the exact nature of these signals has already been established and any new systems must conform to the existing standard. The central office receiver may vary from a plug-in zero-center meter, with latching relay and buzzer, to a small computer console which types out the name, address, and time of

any alarm. Usually a small charge is levied for the use of the central system by the city or private company.

Parts Procurement

Commercial-quality alarm components are available from Ademco, Bourns, FBI, Moose, Napco, and Universal. These units are well engineered and built like tanks to provide years of trouble-free service. Residential-quality units are available from Midex, Seeker, Eico, and Solfan. Many of these have entry and exit delays and may not be suitable for commercial use. These are available from suppliers in many metropolitan areas.

Selling the System

For those interested in making a business out of selling and installing alarm systems, the thing being sold here is security, not a bunch of alarm panels, wires, switches, lights, and bells.

The buyer wants to feel that he, his property, and his family are safe from fire, theft, and burglary. He wants his system to be reliable; if it fails to operate properly he wants it repaired immediately, even if it's 2 am. Once he has the security of an alarm system, he will not want to be without it. For this reason, alarms are usually sold with a service contract or lease. Remember: The customer probably won't know a thing about how his system operates.

There exists a good potential in many areas of the country for someone who can understand these simple circuits, organize a business, and be reliable in the installation and maintenance of alarm systems. For those not interested in a business, a do-it-yourself residential alarm offers a cheap, effective insurance against loss due to fire, theft, or burglary. ■

- ★ TECHNICAL FORUMS
- ★ ARRL AND FCC FORUMS
- ★ GIANT 3-DAY FLEA MARKET
FRIDAY, SATURDAY AND SUNDAY
- ★ NEW PRODUCTS AND EXHIBITS
- ★ GRAND BANQUET
- ★ WOMEN'S ACTIVITIES
- ★ ELECTRICAL SAFETY FORUM
- ★ SPECIAL GROUP MEETINGS
- ★ YL FORUM
- ★ PERSONAL COMPUTER FORUM
- ★ CW PROFICIENCY AWARDS
- ★ AMATEUR OF YEAR AWARD
- ★ SPECIAL ACHIEVEMENT AWARDS

ADMISSION

\$7.50 in advance, \$10 at door.
(Valid for all 3 days)

BANQUET

\$14 in advance, \$16 at door.

FLEA MARKET SPACE

\$15 in advance.
(Valid for all 3 days)

Checks for advance registration to
Dayton HAMVENTION
Box 2205, Dayton, OH 45401

DAYTON Hamvention®

April 27, 28, 29, 1984

Hara Arena and Exhibition Center — Dayton, Ohio

Meet your amateur radio friends from all over the world at the internationally famous Dayton HAMVENTION.

Seating will be limited for Grand Banquet and Entertainment on Saturday evening so please make reservations early.

If you have registered within the last 3 years you will receive a brochure in January. If not, write Box 44, Dayton, OH 45401.

Nominations are requested for Radio Amateur of the Year and Special Achievement Awards. Nomination forms are available from Awards Chairman, Box 44, Dayton, OH 45401.

For special motel rates and reservations write to Hamvention Housing, Box 1288, Dayton, OH 45402. **NO RESERVATIONS WILL BE ACCEPTED BY TELEPHONE.**

All other inquiries write Box 44, Dayton, OH 45401 or phone (513) 433-7720. Special Flea Market telephone (513) 223-0923.

Bring your family and enjoy a great weekend in Dayton.

Sponsored by the Dayton Amateur Radio Association, Inc.

812-422-0231

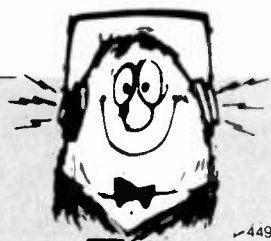

808 N. Main
Evansville, IN 47711

**The
HAM SHACK**



TEN-TEC 2591



SANTEC 142

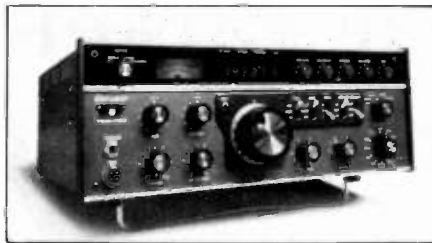

TEN-TEC CORSAIR



ICOM 745



YAESU 726R

- R3 Motor Tuned Vertical.....279.00
- 214B/214FB Boomers 14EL 2M.....75.00 each
- 32-19 Super Boomer 19EL 2M.....89.00
- ARX-2B Ringo Ranger II 2M.....39.00

- DAIWA**
- CN-520 1.8-60 MHz SWR/Pwr Mtr.....\$63.00
 - CN-620B 1.8-150 MHz SWR/Pwr Mtr.....99.00
 - CN630 140-450 MHz SWR/Pwr Mtr.....114.00
 - CN720B 1.8-150 MHz SWR/Pwr Mtr.....129.00

- DRAKE**
- TR7A Xcvr w/PS7.....\$1,495.00

ENCOMM (SANTEC)
ST-142, 222, 442
The Handhelds Still Offering the Most Features
Call for Your Discount Price

- HAL**
- DS3100/MPT/ST6000.....\$2,825.00
 - CT2200/KB2200.....945.00
 - CWR6850 Telereader.....749.00

- HY-GAIN**
- TH7 DXS 7EL Tribander.....\$375.00
 - TH5 MK2S 5EL Tribander.....319.00
 - Explorer 14 Tribander.....279.00
 - 5/8 Wave 2M Mag Mt.....22.00
 - CD45 8.5 sq ft Rotator.....119.00
 - HDR 300 25 sq ft Rotator.....435.00
 - Ham IV 15 sq ft Rotator.....195.00
 - T2X 20 sq ft Rotator.....249.00
- Free Shipping on all crank-up towers

- ICOM**
- IC-02AT Now Available.....Call
 - 751 Ultimate Transceiver.....Call
 - 745 Amazing New Transceiver.....Call
 - 730 Super Buy.....\$599.00
 - IC-2AT.....Now Only 215.00
 - 3AT/4AT Handhelds.....235.00
 - 25A new display & mic.....305.00
 - 25H 45 Watt 2M.....345.00
 - 45A 440 MHz.....335.00
 - R70 Receiver.....595.00

- KLM**
- KT34A 4EL Triband Beam.....\$299.00
 - KT34XA 6EL Triband Beam.....459.00
 - 144-148-13LBA 2M Long Boomer.....79.00

KANTRONICS
The Interface II. The brand new computer interface for
CW, RTTY, ASCII. Software Available for VIC20, C-64,
APPLE, ATARI, TR80C, TI99
Amtor Software Now Available

- LARSEN**
- NLA-150-MM 5/8 Wave 2M Mag Mt.....\$39.00

- MFJ**
- 1224 New Computer Interface.....Call
 - 941C Tuner/Meter/Ant. Switch/Balun.....\$81.00
 - 422 Keyer/BENCHER Paddle combo.....89.00
 - 313 VHF Conv for HT.....36.00
 - 989 3KW Tuner.....285.00
 - 940B Tuner/Meter/Ant. Switch.....72.00
 - 900 Tuner.....45.00
 - 401 Econokeyer.....45.00
 - 722 Filter w/notch.....63.00
 - 812 VHF Meter.....29.00
 - 816 HF Meter.....29.00
 - 1040 Deluxe Preselector.....89.00
 - 103 New 24hr Clock.....33.00

- MIRAGE**
- B1016 10/160 Preamp.....\$245.00
 - B3016 30/160 Preamp.....199.00
 - MP1/MP2 Watt Meters.....100.00

- SHURE**
- 444D Desk Mic.....\$50.00

- TEN-TEC**
- New 2M Handheld (Model 2591).....Now Available
 - Argosy II Digital.....\$535.00
 - 2KW Tuner Kit.....185.00
 - The Fantastic Corsair.....Call

- TOKYO HY-POWER**
- HL30V 2/30W Amp.....\$63.00
 - HL160V 3 or 10/160W Preamp.....295.00
 - HC2000 2KW Tuner.....295.00
 - HL82V 10/80W Preamp.....145.00
 - HL20U 2/20W UHF Amp.....105.00
 - HL45U 10/45W UHF Amp/Preamp.....175.00
 - HL90U 10/80W UHF Amp/Preamp.....305.00

- YAESU**
- FT-1 General Coverage Deluxe Xcvr.....Call
 - FT-980 Computer Aided Xcvr System.....Call
 - FT-102 160-10M w/WARC Bands Xcvr.....Call
 - FT-208R 2M Handheld.....Call

OSCAR HEADQUARTERS
Transceivers - Call for Special Package Price
ICOM 271A/471A Deluxe Base Transceivers
ICOM 290H/490A Affordable Mobile Transceivers
ICOM 402 432 MHz Transceiver
YAESU 726R/432 MHz/Duplexer

- Antennas & Amplifiers
- KLM 14C, 18C, CS2 & Stacking Frames.....Call
 - CUSHCRAFT 416TB, 144-10T, 144-20T.....Call
 - MIRAGE D1010N 432 MHz Amp/Preamp.....\$279.00
 - TOKYO HY-POWER HL90U Amp/Preamp.....305.00
 - KEN-PRO KR-500 Elevation Rotor.....169.00
 - KEN-PRO UHF/VHF Preamplifiers.....Call
 - ALLIANCE U110 Small Elevation Rotor.....49.00

Prices and Availability Subject to Change

Send SASE for our new & used equipment list.
MON-FRI 9AM-6PM • SAT 9AM-3PM

Merry Christmas from Dan, Sandi, Laura, Rick, Mary, Marconi, Dave, The Q & Harold.

Join the Packet-Radio Revolution—Part III

Don't mess up. Packet protocols and procedures are all-important, says WA7GXD, and he's been right so far.

Now that you have a background as to what packet radio is and what it takes in the way of hardware to get a packet station on the air, it is time to go into a little more detail on the communications protocols used in packet radio.

As mentioned in Part I of this series, protocol is taken to mean the formal rules governing information transfer. There are many different types of protocols used in amateur radio today. Every time you check into a net, there are procedures to follow. If you get involved in a roundtable discussion, less formal rules may apply. If you wish to use a busy repeater, there are, again, procedures to follow. In fact, any time you wish to communicate (and sometimes when you don't wish to!) there are rules. Some are formal, such as in parliamentary debate, while others are not.

In packet radio, the protocols used are designed to enable many users to access a given channel for point-to-point communication with maximum reliability. And since computers are used (the Terminal Node Controller—TNC—is a computer),

the rules must be very explicit. Because computers lack judgment, all possibilities for confusion must be defined and worked out. Thus, protocol design is a very critical part of designing a packet-radio system.

Do other amateur digital-communications systems have defined protocols? The answer is yes! In RTTY, the 5-level Murray (Baudot) code is used in the United States, while in Europe the CCIR Alphabet Number 2 is the standard. Holding a marking tone between characters, unshift-on-space, data rate (60, 67, 75, or 100 wpm)—these are all part of RTTY protocol. In ASCII, the 7-level code itself is part of the protocol, and in amateur usage, most of the applicable RTTY standards have been carried over, including such things as 170-Hz shift and the 2125/2295-Hz tone pair.

As digital communications have progressed, more rigidly-defined protocols have emerged. AMTOR, perhaps the most sophisticated RTTY system in amateur use, has evolved as an error-reducing communications system and is defined in CCIR Recommendation 476-2. In

commercial packet work, the International Standards Organization (ISO) has proposed a 7-layer model for packet-switching networks (see Fig. 1).

The first level, called the Physical Layer, deals with interfacing the user's terminal to the packet system. In the case of amateur packet radio, it is also the radio interface and the modulation scheme. While there is no standard in amateur practice at this time, there have emerged several de facto standards. RS-232 is the common interface between the packet system (usually a TNC) and the terminal. 1200 baud is the normal signaling speed on the packet side, using AFSK with 1000-Hz tone spacing using tones of 1200 Hz and 2200 Hz. Since there is no standard among amateur radio manufacturers for audio connectors or pinouts, no standard is possible for this physical interface.

The second level is the Link Layer. This deals with the actual format of the frames of information that make up a packet. It cares nothing for the data in the packet, but rigidly defines the address and control

fields as well as the flags and the Frame Check Sequence (FCS). It is at this level that amateurs have come to agreement and adopted a standard called AX.25 level two. This protocol was first publicly proposed by AMRAD and adopted, with certain modifications, at a special meeting called by AMSAT in October, 1982. It was first put on the air by Tucson Amateur Packet Radio (TAPR) on the then-new TAPR TNC in December, 1982, and has since been coded into software for the Vancouver Amateur Digital Communications Group (VADCG) TNC by Hank Magnuski KA6M and others.

The next level, the Network Layer, is the focus of much experimentation today. When implemented, it will provide for inter-group linking as well as support multiple connections for, say, a roundtable with positive frame acknowledgment.

The functions of this level overlap somewhat with level four, the Transport Layer. It is the successful operation of amateur packet radio at these levels that will herald a new era in amateur-radio communications,

opening the way for an extensive, high-speed, highly-reliable communications network on a continental scale. Experiments with Phase IIIB, HF gateways, and the like are precursors to amateur level three.

The last three layers, Session, Presentation, and Application, deal with such things as CRT screen control, character sets, and the like. Amateur packet operation has managed to blur these areas with standard usage. For example, ASCII is the normal mode of character encoding. Bulletin boards are running at level two.

In fact, the definition of the digipeater function in AX.25 level two is actually a level three "kludge" to allow limited intermediate linking. This is not necessarily bad; it just shows that amateurs tend to adopt and adapt until things suit them for the unique environment in which we operate.

At the lowest level, an RS-232 interface has become the de facto standard for communicating between a TNC and a computer or terminal. The TNC looks like a modem (Data Communications Equipment, or DCE) while the computer or terminal is defined as Data Terminal Equipment (DTE).

A Protocol-Related Problem

Even at this low level, problems may arise. What if the receive buffer in your computer gets full, or the lines you are reading start to scroll off the screen of your terminal? What if the packet channel is so clogged that the transmit buffers in the TNC are getting full? These problems are solved by the application of a *flow-control algorithm* (computerese for a method of solving a problem—hopefully one that doesn't introduce other problems!).

Flow control is handled in the TAPR TNC by both hardware and software, although the software has to recog-

nize the "hardware" solution.

In the case of the terminal (or computer—we'll use "terminal" to mean both) wanting to tell the TNC to stop sending data, the terminal may either (a) set the TNC's Request-To-Send (RTS) line false or (b) emit an X-OFF character (usually Control-S) to the TNC. In the first case, the TNC will immediately stop sending data to the terminal. In the second case, if the TNC has been told to, it will recognize the X-OFF character and cease sending data. Note that if the TNC is operating in a so-called transparent mode, only the hardware solution may be used, since in this mode the TNC passes all data, ignoring commands.

To resume data flow to the TNC, the CTS line may be set true (if the hardware control was used) or the X-ON character (typically set as Control-Q) may be sent to the TNC. (With the TAPR TNC, the X-ON and X-OFF characters may be user-defined and the default characters are given here.)

In the case of the TNC wanting the terminal to pause in sending data, it will set the Clear-To-Send (CTS) line false, returning it true when ready to again receive data from the terminal. Thus, flow control between the TNC and terminal is defined and provided for in the TAPR TNC "user interface" protocol.

The above discussion is a simple example of the sorts of problems that must be solved in defining a usable protocol for digital communications. While the details can become quite involved, the rest of this article will deal with the issues in a more general framework. The idea is not to make you an instant protocol expert but to give you some insight into the general workings of amateur digital communications with particular emphasis on the recently-

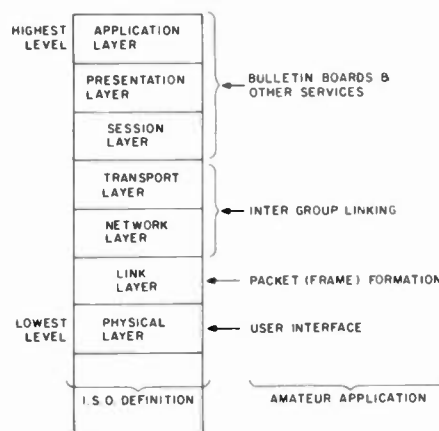

Fig. 1. ISO 7-layer protocol model.

adopted AX.25 packet-radio protocol. First, however, let's take a look at how amateur packet protocols developed.

Early Packet-Radio Protocols

At the risk of oversimplification, there basically are two ways of handling packet communications. One is to have a master-control station acting much like a net-control station in traditional amateur practice. The other is to have all stations equal, as in casual amateur operation. Not surprisingly, both methods have been used in amateur packet radio. Since the Canadians were allowed packet operation first, they implemented both first.

One system was developed in which a master-control station would *poll* each station in its list and each station would in turn pass along any traffic. The advantages are apparent: Everyone takes his turn and any potential conflicts in using the frequency are thereby resolved. The disadvantages are more subtle: How does one get on the list, and what happens if the list is long but only two or three stations are active? Do the few active users have to wait for the inactive stations to be interrogated by the master station between every transmission? And of course there may be a real problem if the master station goes down.

Another system was de-

veloped in which each station had its own identification and could attempt to access the channel at will. The possibility of "doubling" (called a *collision* in packet jargon) became real with this system, but communications were somewhat more robust because a central controller wasn't needed. And you didn't have to figure out how to get on the list.

The polling system is used in very few active packet areas now, and a variation of the second system became the de facto standard. Developed by the Vancouver Amateur Digital Communications Group, the Vancouver protocol spread with the VADCG TNC. Nearly all early work with packet radio in the United States was based on this TNC and protocol.

Features of the Vancouver Protocol

The Vancouver protocol allowed two stations to *connect* and carry on point-to-point communications with positive acknowledgment via a *handshake*. High-Level Data-Link Control—*HDLC* (see Part I of this series, September, 1983, issue of 73) was used for assembling and disassembling packet *frames*, and Non-Return to Zero Inverted (NRZI, pronounced nurzi) encoding of the data stream was used to allow clock recovery, since HDLC is a *synchronous* pro-

tol (as opposed to the asynchronous RTTY format with start and stop bits attached to every character).

In addition, this protocol allowed the use of a digipeater for allowing stations to connect that couldn't connect directly. A digipeater is similar in this respect to a voice repeater, although it is really very different. It performs the same Frame Check Sequence (FCS) on an incoming packet as any other packet station, rejecting those that are corrupted. It then generates a new, and slightly different, packet which it sends. The modifications are in the address (and possibly the control) field, much like the changing preamble in message traffic. The digipeater is thus more like an automated traffic-handling station than a repeater.

The Vancouver protocol also allowed a packet to contain multiple frames of information. Up to seven frames could be sent in one transmission, and the acknowledgment (ACK) would contain a number indicating how many frames were successfully received. This had the advantage of increasing the amount of data that could be sent in a given time period (called channel throughput) by reducing the number of times the channel had to be "turned around" to acknowledge receipt of data. At 1200 bits per second (bps), radio performance becomes the rate-limiting factor.

Finally, the Vancouver protocol provided for certain types of supervisory frames for control of the data link.

Unfortunately, there were problems, or more properly, limitations with the system. For one, only a single digipeater was allowed. What if two stations wanted to connect that needed two, or even three, intermediate relays? How could multiple stations exchange data and

still get positive acknowledgment from the other stations? What if a station found itself in range of two digipeaters (overlapping networks)?

The greatest limitation, however, was in the addressing scheme. In conformance with commercial HDLC implementations, and to allow the TNC's HDLC control chip to screen incoming packets, a single-byte addressing scheme was developed. Due to part of the HDLC standard, only seven (7) bits are allowed in an address byte, meaning only 128 addresses can exist on a given channel. The digipeater had to share in all of this, certain address fields had to be reserved for various reasons, and the result was that a maximum of 31 stations could be on a given channel.

This may not seem like a problem since that would be a very congested channel, but the hardware used required that the station's special ID code be burned into the TNC's memory. Since not everyone in an area is likely to be on at any given time, 31 addresses can be very limiting because it then implies only 31 packet stations can exist in an area, active or not. What if a visitor comes into the area with the same address as a local? Who assigns the addresses? What if a person is in range of two or more networks, and his address is used in more than one of them? The list goes on.

Dynamic Addressing

At the time TAPR was forming, the protocol issue was taken very seriously. The hardware for the TAPR TNC has provision for changing addresses, and many other parameters, by inclusion of a nonvolatile memory chip that requires no battery backup yet can be changed by the user with a simple command (see Part II of this series, October, 1983, issue of 73).

A protocol was designed that would have an "address server" to assign addresses to any stations that came on frequency. When the station checked out, its address would be removed from the active list, making room for other active users to join in. The "net-control" station would poll the users on the list from time to time to see if they were still on channel to prevent a station that had "died" from hogging an ID. The first station on a channel would become the address server, and this function could be passed on to any other station by command. Further, if a station detected the absence of the address server, it could then take over the function.

Finally, the address server would send out a broadcast message to all stations whenever a station came on or left the channel. This would allow a user to check the "system-status table" in his TNC to see who was on! It also would smooth the transition if the address server went down for any reason.

This TAPR/DA protocol is presently under continuing development and may be undergoing on-the-air tests by the time this appears in print.

Unfortunately, the protocol is fairly complex and the team implementing it in software has met with delays beyond their control. Further, adapting it to existing VADCG TNCs may be impractical without extensive modifications to that TNC.

AX.25 Level Two

In October, 1982, in conjunction with the AMSAT annual meeting, Tom Clark W3IWI called a meeting of the various packet groups to settle on some sort of level 2 protocol (the level at which the TNCs communicate with each other). The reason was very simple. With the successful launch of the Phase IIIB satellite, a digital-com-

munications channel with predictable reliability would be available. If the various packet groups were all doing their own thing, a Tower of Babel would result with no two groups speaking the same language (protocol). This would result in either (a) chaos, or (b) extreme underutilization of the channel resource. Therefore, a common protocol had to be defined sufficiently in advance of the satellite launch to allow it to be coded in software and tested on the air.

Represented at the meeting were AMRAD (Washington based), PPRS (San Francisco based), SLAPR (St. Louis based), TAPR (Tucson based), and of course, AMSAT (also Washington based). New Jersey was also represented, and the groups' membership base covered most active packet sites. Unfortunately, the various Canadian groups were unable to attend.

Several proposals were espoused, with each group defending its particular approach(es) to the problem. Tom's strategy, essentially, was to lock everyone in a room with no departure allowed until agreement was reached. Surprisingly enough, it worked! What eventually emerged from the meeting was a modified form of the AMRAD AX.25 level-two protocol, which is an adaptation of the commercial X.25 packet-switching protocol, level two.

Essentially, this protocol provides for the various functions of the earlier Vancouver protocol with a number of additional features. Point-to-point connections are allowed, with positive acknowledgment of frames. Up to seven frames may be included in a packet. Flow control between packet stations is defined, so a receiving TNC may tell a sending TNC to stop sending traffic for a while (to prevent buffer overflow). A digipeater is allowed, and its functions defined. HDLC frames are

ASTRON POWER SUPPLIES

• HEAVY DUTY • HIGH QUALITY • RUGGED • RELIABLE •

RS and VS SERIES

SPECIAL FEATURES

- SOLID STATE ELECTRONICALLY REGULATED
- FOLD-BACK CURRENT LIMITING Protects Power Supply from excessive current & continuous shorted output.
- CROWBAR OVER VOLTAGE PROTECTION on all Models except RS-4A.
- MAINTAIN REGULATION & LOW RIPPLE at low line input Voltage.
- HEAVY DUTY HEAT SINK • CHASSIS MOUNT FUSE
- THREE CONDUCTOR POWER CORD
- ONE YEAR WARRANTY • MADE IN U.S.A.

PERFORMANCE SPECIFICATIONS

- INPUT VOLTAGE: 105 - 125 VAC
- OUTPUT VOLTAGE: 13.8 VDC \pm 0.05 volts (Internally Adjustable: 11-15 VDC)
- RIPPLE: Less than 5mv peak to peak (full load & low line)

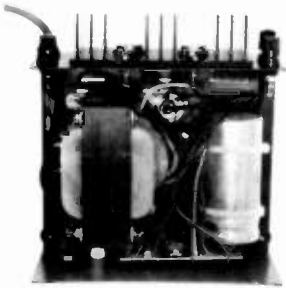

INSIDE VIEW - RS-12A



MODEL RS-50A



MODEL RS-50M



MODEL VS-50M

RM-A Series



MODEL RM-35A

19" X 5 1/4" RACK MOUNT POWER SUPPLIES

Model	Continuous Duty (AMPS)	ICS* (AMPS)	Size (IN) H X W X D	Shipping Wt. (lbs.)
RM-35A	25	35	5 1/4 x 19 x 12 1/2	38
RM-50A	37	50	5 1/4 x 19 x 12 1/2	50

RS-A SERIES



MODEL RS-7A

MODEL	Continuous Duty (Amps)	ICS* (Amps)	Size (IN) H x W x D	Shipping Wt (lbs)
RS-4A	3	4	3 3/4 x 6 1/2 x 9	5
RS-7A	5	7	3 3/4 x 6 1/2 x 9	9
RS-7B	5	7	4 x 7 1/2 x 10 3/4	10
RS-10A	7.5	10	4 x 7 1/2 x 10 3/4	11
RS-12A	9	12	4 1/2 x 8 x 9	13
RS-20A	16	20	5 x 9 x 10 1/2	18
RS-35A	25	35	5 x 11 x 11	27
RS-50A	37	50	6 x 13 3/4 x 11	46

RS-M SERIES



MODEL RS-35M

- Switchable volt and Amp meter

MODEL	Continuous Duty (Amps)	ICS* (Amps)	Size (IN) H x W x D	Shipping Wt (lbs)
RS-12M	9	12	4 1/2 x 8 x 9	13
RS-20M	16	20	5 x 9 x 10 1/2	18
RS-35M	25	35	5 x 11 x 11	27
RS-50M	37	50	6 x 13 3/4 x 11	46

VS-M SERIES



MODEL VS-20M

- Separate Volt and Amp Meters
- Output Voltage adjustable from 2-15 volts
- Current limit adjustable from 1.5 amps to Full Load

MODEL	Continuous Duty (Amps) @ 13.8VDC @ 10VDC @ 5VDC	ICS* (Amps) @ 13.8V	Size (IN) H x W x D	Shipping Wt (lbs)
VS-20M	16 9 4	20	5 x 9 x 10 1/2	20
VS-35M	25 15 7	35	5 x 11 x 11	29
VS-50M	37 22 10	50	6 x 13 3/4 x 11	46

RS-S SERIES



MODEL RS-12S

- Built in speaker

MODEL	Continous Duty (Amps)	ICS* Amps	Size (IN) H x W x D	Shipping Wt (lbs)
RS-7S	5	7	4 x 7 1/2 x 10 3/4	10
RS-10S	7.5	10	4 x 7 1/2 x 10 3/4	12
RS-10L(For LTR)	7.5	10	4 x 9 x 13	13
RS-12S	9	12	4 1/2 x 8 x 9	13
RS-20S	16	20	5 x 9 x 10 1/2	18

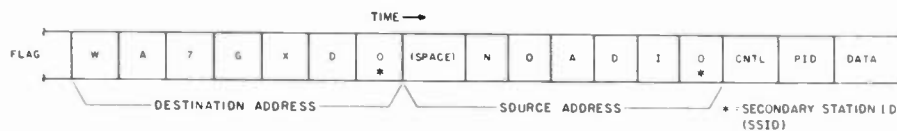

Fig. 2. Typical AX.25 non-digipeated address header.

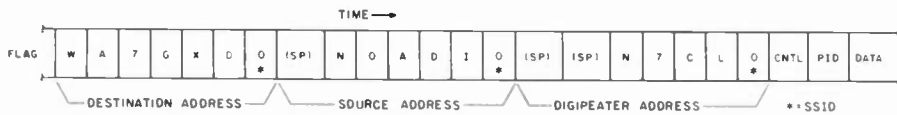

Fig. 3. Typical AX.25 digipeated address header.

used, with NRZI encoding and zero-bit stuffing.

The major differences lie in the addressing scheme. Whereas the Vancouver protocol allowed only 31 or so stations, the AX.25 system effectively allows over ten times the licensed amateur population to be active at once!

Why is this so important? Recall that the Vancouver protocol used single-byte addressing. The problem of a new packet station coming on channel becomes real when a channel exists that allows over 50% of the world's amateurs (theoretically) to have access at one time, as in the case of the Phase III satellite.

In AX.25, the amateur station callsign is encoded into a 7-byte field. This allows for a six-character callsign with an additional byte as a qualifier. This may be necessary when, for example, a packet station has multiple TNCs that must operate under one station call. This occurs fairly frequently, with some amateurs providing a bulletin-board service or a gateway station in addition to their "normal" packet station.

Both the sending station's and the intended receiving station's callsigns are in the address field, making it 14 bytes in length. A digipeater may be specified (you could be in range of multiple digipeaters), in which case its callsign must be included, making the address field 21 bytes in length.

Recognizing that future protocols may emerge, the packet group decided to ap-

pend a Protocol IDentification byte (PID) to the control field of the frame to let the receiving station know which protocol was in use, and AX.25 was assigned an identifier.

The advantages of this system are numerous. No longer must an amateur worry if another station has the same ID when he receives a packet. Many users may be accommodated (from an addressing point of view) with no effective limit. Monitoring of a channel becomes simplified, with a monitoring station able to identify (by callsign) the source and intended destination of every packet receivable at his location.

Of course, nothing is free, and AX.25 has its costs. The main problem is that the address field is quite long, being 21 bytes if a digipeater is used. At TAPR, we wanted to play with multi-hop packeting, so we allowed up to eight digipeaters to be specified. This makes for an address field of up to 70 bytes! This is a lot of overhead merely to send a zero data-length ACK.

Another limitation of AX.25 is that it doesn't allow for the typical amateur practice of roundtable discussions. Since a station may connect only to one other station, some sort of monitor mode must be enabled to see activity from other packet stations. If the "monitored" FCS is corrupted, the packet is discarded. In the case of very weak signals, it is common to miss a lot of the moni-

tored activity. Some provision must be made to accommodate this type of networking, and it will most likely take place at level three. This problem appears to be unique to amateur packet requirements at present, so we must pioneer and develop this capability.

The lack of multiple connectivity poses another problem. Suppose a station has a computer mailbox or bulletin-board service available on packet. Since only one connection can be maintained at a time, only one user can check in at a time. If others wish to check for messages, etc., they must wait until the first user disconnects. If he suffers a power outage or otherwise leaves the air without properly disconnecting, the mailbox station will lock up until reset. Thus, other users are denied access.

There undoubtedly will be further experimentation with link-level protocols, but AX.25 forms a sound basis and a common language for such development to build on.

A Typical Connection

To illustrate the functioning of packet protocol, an example of a typical connection sequence follows. (Note that in packet parlance a connection is merely establishing contact with the desired station.) Let's say that station WA7GXD wishes to connect to station N0ADI. WA7GXD would type at his terminal: C N0ADI.

A packet would be sent

that could be represented as—: FLAG : N0ADI : WA7GXD : SABM : FCS : FLAG:

Note that the destination station callsign precedes the sending station callsign. The control field SABM means "Set Asynchronous Balanced Mode," which is data-communications talk for "connect me to the other guy and treat us as equals—no one is a control station."

Assuming N0ADI is on frequency and his TNC is allowed to accept a connection request (he is not already connected with someone else), his station would respond with—: FLAG : WA7GXD : N0ADI : UA : FCS : FLAG :

In this case, the callsigns are reversed and the Unnumbered Acknowledgment (UA) is sent in the control field to ACK the connect request. At WA7GXD's terminal, the following message would be displayed: ***CONNECTED WITH N0ADI, while N0ADI's terminal would display: ***CONNECTED WITH WA7GXD. At this point the TNCs would enter the CONVERSATION mode. Now any information entered at either station will be transmitted to the other station.

When the QSO ends, one station, say N0ADI, will place his TNC in the Command Mode and enter: D WA7GXD, at which point his TNC would send out a packet like—: FLAG : WA7GXD : N0ADI : DISC : FCS : FLAG :, where DISC is the control code to disconnect, and WA7GXD's TNC would respond—: FLAG : N0ADI : WA7GXD : UA : FCS : FLAG :, and each terminal would then display: ***DISCONNECTED.

While in the connected mode, any information entered at one station's TNC will be sent to the other station and positive acknowledgment utilized to ensure that the receiving station in fact received the frame cor-

Bring Your Listening Into Focus!

FREQUENCY LISTS
SCANNING
SHORTWAVE LISTENING
UTILITIES DX'ING
SATELLITE RECEPTION
STOCK EXCHANGE
EXPERIMENTER'S WORKSHOP



352

MONITORING TIMES

135 DGG BRANCH ROAD BRASSTOWN, N.C. 28602 704-837-2214

MAKES HEADLINES

Monitoring The AWACS Net
Tracking The Great Storms
Special Report: Space Shuttle Panorama
Monitoring Nuclear Shipments
Spy Numbers Transmitter Located
New Worldwide Aeronautical Frequencies

10.50-1 year • 20-2 years • 30-3 years
Canadians please add \$9.50 per year.
Foreign subscribers please add \$9.50 per year for surface mail or \$28.00 per year for air mail.

Finally - a monthly tabloid newspaper written for you, the listener. 32 fact-filled pages on how to improve your listening post, where to hear those intriguing frequencies, home brew projects to save you \$\$\$ AND MORE!

Here's a sample of subscriber's feelings about MONITORING TIMES:
"I felt it necessary to praise you on your informative, unique paper. I subscribe to many different magazines on shortwave communications and scanning, but your publication is the one that I enjoy most of all." —Bob Blackburn, Highland, MI.
"I've found MT contains far more useful information than other magazines." —Charles Dean, Andover, KS.
"MT is a unique publication that offers something for every type of reader that is unavailable from any other hobby publication." —Nicholas Berkholtz, Minneapolis, MN.

JOIN BOB, CHRIS, NICHOLAS AND THE THOUSANDS OF OTHER ENTHUSIASTIC SUBSCRIBERS TODAY!

CALL NOW TOLL FREE 1-800-438-8155 (cont. US except NC) to place your subscription for 2 or 3 years on Mastercard or Visa. Or for a one year subscription mail your check to Grove Enterprises, Inc., 140 Dog Branch Road, Dept. D, Brasstown, NC, 28902. Office phone 704-837-9200.

FREE SAMPLE AVAILABLE UPON REQUEST

PACKET RADIO

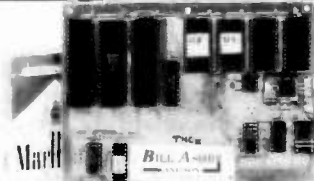

ASCII—USA/AX.25 HDLC CONVERTER

USA/AX.25 is the AMRAD approved digital format STANDARD used on amateur packet radio networks.

PAC/NET board only	\$80.00
Assembled/Tested. No ICs. 90 day warranty	
Package of all ICs except 2-2716 EPROMs	\$80.00

PAC/NET SYSTEM

PAC/NET SYSTEM \$240.00
System Tested 4.5 x 6" board complete with all ICs and programmed EPROMs personalized for each purchaser. Requires only single 8-10 volt 1/2 amp power. 1 year guarantee of hardware/software/AX.25 standard RS232 serial ASCII at any user baud rate. RS232 HDLC for 202 modem used for AFSK or direct to RF equipment for FSK.

Custom Systems Custom Programming

BILL ASHBY AND SON

K2TKN—KA2OEG 201-658-3087
BOX 332 PLUCKEMIN N.J. 07978

The Spider™ Antenna

The modern multi-band mobile antenna —switch to 10, 15, 20 or 40 meters without stopping to change resonators.

Features of the Spider™ Antenna

- The Spider™ Antenna is less than six feet high and the longest resonator projects out from the mast 24 inches. This gives a slim profile, low height and light weight, offering little wind resistance and eliminating the need for a spring mount.
- Each resonator is tuned to the desired portion of the band by a tuning sleeve which slides over the outside of the resonator.
- SWR is approximately 1:1 at the selected resonant frequency.
- Base impedance approximately 50 ohms, requiring no matching network.
- Ideal for use on vans, campers, motor homes, travel trailers; also in mobile home parks, apartment houses and condominiums.

The Spider™ Adapter converts any mono-band antenna with a half-inch mast into a modern four-band antenna.

The Spider™ Maritimer™ is the ultimate for marine use. Made of non-magnetic stainless steel and nickel-chrome plated bronze, using regular Spider™ resonators and tuning sleeves.

Accessories — Bumper, ball, angle and stud mounts. Quick disconnects. RG-58A/U coaxial cable and connectors. Ground radial systems. Copper foil and copper braid ground straps.

For further information, prices write or call!

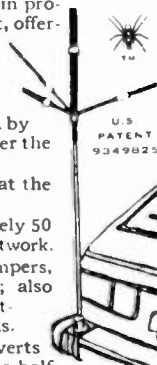

4 console displayed

MICA COMMUNICATIONS CONSOLES

4' 6" 8" Wide — 1 to 8 wide optional
L & U & Circular set ups — with optional corner table
Replaceable Front Panel — for station changes
Precisely cut panel holes — by computerized wood cutter
High station density — because no shelves are used!
Hidden accessory Shelf — for power supplies, dummy load
Puppets of all your equipment — for easy station layout

OPTIONAL ITEMS:

- Drawer Bookshelf combination — hangs under desk
- 1000 Mica's to select from — to match your decor
- Desk recessed for keyboard — optimum 26" typing height
- Desk top extensions — into panel — for apple computer or storage
- Matching dolly for floor amp's — with concealed casters
- Shelf under desk, quick access — for headphones, key Mic
- Exhaust cooling fan system — thermostatically controlled
- Wire duct, wire labels, etc.

Break Communications Systems, Inc.

5817 S.W. 21st Street, Dept. 73 • Hollywood, Florida 33023
Phone (305) 989-2371

MULTI-BAND ANTENNAS
7131 OWENSMOUTH AVENUE, SUITE 463C
CANOGA PARK, CALIF. 91303
TELEPHONE: (213) 341-5460

FOR FURTHER INFORMATION

The ARRL publishes the *Proceedings of the Second Amateur Computer Networking Conference* held in San Francisco in March, 1983. Copies are available from League Headquarters for \$9.00 postpaid. Topics covered include the complete AX.25 specification, papers on the software and hardware aspects of the TAPR TNC, and other developments such as AMRAD's HF packet modem and Sweden's SOFTNET system.

Tucson Amateur Packet Radio's *TNC Manual* covers operation of a packet station in detail. Complete information is given on the TAPR TNC, including construction and checkout. Appendices include radio hookup and the complete AX.25 specification. This manual is available from TAPR for \$20.00 postpaid in the US and Canada.

TAPR also publishes the bimonthly *Packet Status Register*, which is devoted exclusively to packet radio. Membership is currently \$12.00 per year.

AMRAD, PO Drawer 6128, McClean VA 22106, publishes the monthly *AMRAD Newsletter*, which contains columns on packet radio. Annual dues are currently \$15.00.

rectly. If the receiving station does not send the required ACK, the sender will repeat it. This goes on for up to RETRY times (RETRY being a user-entered parameter telling the TNC how many times to retry sending a packet before giving up and assuming the path no longer is usable between the stations).

The reasons that the sending station may not receive and decode an ACK are many. The receiving station may not have sent it due to (a) corrupted or garbled data bits, (b) someone else transmitting over the packet (a collision), (c) the receiving unit failed, (d) etc. The ACK may have been sent but not received correctly by the sending station for the same or other reasons.

In order to minimize the chances of a transmission getting stepped on or collided with, a station wishing to transmit will first listen and ensure that it doesn't hear any packet activity. Only then will it transmit. Further, if it is retrying a transmission, it will wait an additional *random* amount of time before transmitting. This helps ensure that two stations don't get "locked" and continually collide with each other.

If the retry count is exceeded, the station attempting to send will then report to the terminal:

```
***DISCONNECTED  
RETRY COUNT EXCEEDED.
```

Thus, the operator is kept informed of any changes in the state of the communications channel, and valuable channel time isn't wasted in continually trying to maintain contact with a station that may not even be on the air.

From the above example it can be seen that the protocol issues involved in packet radio can be very complex, but that if properly approached, the result can be extremely reliable communications and efficient sharing of amateur frequencies.

Applications

No discussion of packet radio techniques is complete without some mention of the multitude of practical applications of packet radio in the amateur environment.

Apart from FCC-mandated "advancement of the state of the radio art," packet provides unique opportunities for experimentation and public service.

Consider the aftermath of a tornado, earthquake, volcano, or other disaster. Usu-

ally, the first emergency traffic to be handled is done via amateur radio, especially if the damage is severe enough to knock out commercial lines of communication. In many cases, the traffic entered into the communications system far exceeds the ability of the system to handle it. The network becomes saturated and delays increase. It may take hours or even days to get all the messages handled.

Typically, voice or CW traffic nets are limited to a realistic rate on the order of tens of words per minute. Fatigued operators are subject to errors in copying and otherwise handling the information. As time wears on, the error rate increases.

RTTY or ASCII offers some improvement in system capacity, but errors are still likely.

On the other hand, packet offers the capability for operators to enter traffic without having to listen first (the TNC does that for them) and allows error-free communications to occur on a channel at nearly 1200 wpm (not quite 1200 due to ACK delays and the like). Multiple messages can be "in flight" at any given time, and the TNCs can sort it all out. Since the TNC likely is coupled into a computer system at some point, traffic can be passed to commercial lanes as they become available. Automatic logging of third-party traffic becomes trivial. And system capacity is on the order of 20 times that of RTTY. The capacity is even greater compared to CW or voice nets, especially when operator fatigue is considered.

As another example, consider the computer-minded amateur. Perhaps he has developed a program he wishes to share with another amateur. He can place his TNC in *transparent* mode, where it passes all data offered to it, and send a binary file dump to the other amateur, who passes it directly

to his computer. Errors are trapped before the data is passed through, so the recipient can be sure that if he receives the program, it is right.

Another system used extensively on packet right now is the bulletin board, or computerized mailbox system. Amateurs may leave messages for other amateurs or get general information items, etc.

PACSAT is a proposed system much like a bulletin board except that it will be on board a future AMSAT spacecraft. Having as much as 2 megabytes of memory, PACSAT will fly in a Low Earth Orbit (LEO) similar to OSCAR 8 or UoSAT. The PACSAT concept is a pioneering one in the use of low-cost space technology since it is far cheaper to inject a satellite into an LEO (say, via a \$10,000 Shuttle Get-Away Special) than to inject one into a geostationary slot (for a few million dollars). Further, there are many more LEO-launch opportunities than there are geosynchronous ones.

PACSAT will enable a low-power ground station with relatively unsophisticated antenna systems (a whip will do!) to leave and retrieve messages with PACSAT. Since we all don't live and work on the same schedule, PACSAT opens up a brand new opportunity for non-real-time "store-and-forward" communications.

For satellites such as AMSAT Phase III, which require a fairly complex ground station, packet offers the opportunity for several stations to share a common satellite link. By means of gateway operation, where one packet station has the needed equipment to track and communicate through the satellite, other packet stations can use the facility by operating through the gateway much like using a digipeater to increase a station's effective range. Similarly, HF and high-speed UHF/mi-

AEA Brings You The AMTOR Breakthrough

We are pleased to announce three new AMTOR products. Our new software package that will allow you to operate AMTOR with your CP-1 is called AMTORTEXT™. A complete hardware terminal unit and AMTORTEXT software plug-in cartridge for the Commodore 64 computer is called the MICROAMTOR PATCH™. We also have new applications software packages for the AMT-1 and Commodore 64 or VIC-20 computers.

NEW AMTORTEXT™

AMTORTEXT™ is a LOW COST software package that will allow the CP-1 and Commodore 64 computer to be used as a multi-mode AMTOR TERMINAL. Compare the outstanding FEATURES and PRICE of the AT-64 (AMTORTEXT for Commodore 64) to the competition:

- KEYBOARD OVERLAY instructions (eliminates constant referral to manual)
- STATUS INDICATORS on screen
- Easy to follow MENU
- ARQ, MODE A- MASTER OR SLAVE
- FEC MODE B
- MODE L (LISTEN TO MODE A)
- SPLIT SCREEN with 2000 CHARACTER TYPE AHEAD transmit buffer
- WORD MODE for error correcting with DEL KEY until space or CR is sent
- REMOTE ECHO shows characters transmitted as they are validated by other station
- easy entry of your SELCALL for automatic response to ARQ calls
- BREAK-IN MODE to interrupt sending station
- LTRS/FIGS REVERSE for assistance in MODE L synchronizing
- TEN MESSAGE BUFFERS OF 256 CHARACTERS EACH
- AMTOR timing synced to host computer internal CRYSTAL OSCILLATOR
- PROGRAMMABLE TRANSMIT DELAY can be saved to tape
- AUTOMATIC PTT
- POWERED BY HOST COMPUTER
- includes INTERFACE CABLE for AEA model CP-1 COMPUTER PATCH™



The AMTOR software TIMING ROUTINES have been written by Peter Martinez, G3PLX (father of AMTOR) which means you can be sure of having NO SYNCHRONIZING problems with other AMTOR stations adhering to the established international AMTOR standard. PROPER SYNCHRONIZATION is an ABSOLUTE must for AMTOR!

\$89.95 List \$69.95* C-64 AMTORTEXT

NEW MICROAMTOR PATCH™

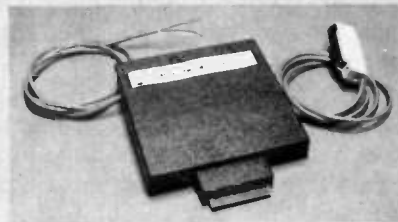

MICROAMTOR PATCH™ is a NEW LOW-COST, HIGH-PERFORMANCE AMTOR SOFTWARE/HARDWARE computer interface package. The MICROAMTOR PATCH (model MAP-64) INCORPORATES AMTORTEXT software (described above) for the Commodore 64 computer. All circuitry and software is incorporated on a single, plug-in cartridge module featuring the following:

- TRUE DUAL CHANNEL MARK AND SPACE MULTI-STAGE 4 POLE, CHEBYSHEV ACTIVE FILTERS
- AUTOMATIC THRESHOLD CORRECTION for good copy when one tone is obliterated by QRM or SELECTIVE FADING
- EASY, POSITIVE TUNING with TRIPLE LED INDICATOR
- NOT a low-cost, easily "pullable" phaselocked loop detector!!!
- SWITCH SELECTED 170 Hz or WIDE SHIFT on receive
- AUTOMATIC PTT
- demodulator circuitry powered by your 12 VDC

supply to AVOID OVERLOADING HOST COMPUTER and for maximum EMI ISOLATION • EXAR 2206 SINE GENERATOR for AFSK output • SHIELDED TRANSCIEVER AFSK/PTT INTERFACE CABLE PROVIDED • FSK keyed output.

The MicroAmtor Patch is structured for easy upgrading to the AEA CP-1 Computer Patch™ advanced interface unit without having to buy a different software package! Simply unplug the external computer interface cable (supplied with the MicroAmtor Patch) from the MicroAmtor Patch and plug it into the Computer Patch.

\$149.95 List \$129* MAP64

\$239.95 / \$199.95* MAP-64/2

The Model MAP-64/2 Incorporates the C-64 MBATEXT™ PROM on the same board with AMTORTEXT for low cost RTTY/CW/ ASCII/AMTOR operation.

The AMT-1 is the DEFINITIVE AMTOR TERMINAL UNIT which all future AMTOR units will be measured against. All you need for full AMTOR operation is a dumb ASCII terminal (or personal computer and emulation software) and a normal HF transceiver and antenna. With the AMT-1 you will receive the following features:

- SENSITIVE FM DEMODULATOR
- FOUR POLE ACTIVE RECEIVE FILTER
- TOTAL CONTROL FROM KEYBOARD or by COMPUTER PROGRAM CONTROL
- 16 LED PANADAPTOR TYPE TUNING INDICATOR
- CRYSTAL CONTROLLED AFSK MODULATOR
- RECEIVE/TRANSMIT standard RTTY
- TRANSMIT MORSE CW
- MORSE RECEIVE field installable option
- AUTOMATIC PTT
- 13 front panel LED STATUS INDICATORS
- all METAL ENCLOSURE for maximum RFI immunity
- operates from your 800 ma 12 VDC power source.



AMT-1

Shown with optional AMT-1 Console Stand, COMM-64 with CRT Monitor and cassette recorder (Not included)

\$589.95 List \$499.95* AMT-1

Applications software for C-64 or VIC-20

AEA also offers an applications software package for the Commodore VIC-20 (model AMT-1/VIC20-1) or 64 computer that is resident on a plug-in PROM CARTRIDGE and includes the INTERFACE CABLE to go between the computer and the AMT-1. KEYBOARD OVERLAY instructions are also included for easy operation without the instruction manual. The COMM-64 program (model AMT-1/C64-1) offers SPLIT SCREEN OPERATION with ten MESSAGE BUFFERS. It also offers UNATTENDED OPERATION with automatic MESSAGE RECORDING and AUTOMATIC STATION IDENTIFICATION.

\$89.95 List \$69.95*

*SUGGESTED AMATEUR DISCOUNT PRICE THROUGH PARTICIPATING DEALERS ONLY

PLEASE SEND AEA CATALOG	
Name	
Address	
City	
State	Zip

Advanced Electronic Applications, Inc.
 P.O. BOX C-2160 • LYNNWOOD, WA 98036 • (206) 775-7373 • Telex: 152571 AEA INTL



BE HEARD! GIVE YOUR HAND-HELD THE BOOST IT NEEDS!

The New Daiwa LA-2035 two meter linear amplifier.

A compact amp at a compact price
Only \$79.95 Suggested Retail.

This amplifier is designed for use with hand-held transceivers in either mobile or fixed station configurations. Because of its light weight and compact size, the LA-2035 can be mounted under the dash, under the seat, or in any other convenient location.

The LA-2035 is equipped with RF activated stand by circuitry. Easy operation. Simply connect your antenna and your hand-held to the LA-2035. Connect the LA-2035 to a suitable power supply and go.



Specifications
Band: 144-148 MHz
Mode: FM/CW/SSB
Input power: 1-3 watts

Maximum output power: 30 watts plus.
Power consumption: 13.8VDC at 5A. Max.
Dimensions: 100W x 35H x 125Dm/m
Weight: 500 grams
Coaxial input cable supplied with a BNC connector.
Output connector: SO 239



CN-520/CN-540/CN-550 Cross Needle Meters

Daiwa cross-needle convenience in a compact case
Get SWR and Power readings in a single glance.



PS-300 30A DC Power Supply

9-15 V variable 30A Max. 22A continuous
Overload protected multiple terminals



DK-200/DK-210 Electronic Keys

CW is both communication and art.
Sharpen your "fist" with Daiwa precision!



AF-606K/AF-406K All Mode Active Filters

Luxurious selectivity at an affordable price!

82



858 E. Congress Park Dr. Centerville, Ohio 45459. Phone 1-513-434-0031
Exclusive U.S. Agents for these DAIWA products. Dealer inquiry invited.

crowave links may be established with a gateway concept to allow other packet stations to utilize the resource.

Resource sharing in itself is an exciting application of packet radio. Perhaps a club is heavily involved in computing and wishes to purchase a high-capacity data-storage medium, such as a 100-megabyte Winchester drive. If the unit is networked into a packet channel, the various users may access it at will.

Of course, some of these activities, such as resource sharing, will require higher levels of protocol to be defined and developed, but the potential is there and they undoubtedly will get implemented.

Wrap-Up

This series of articles has introduced you to packet radio as it presently exists, with a short look into the an-

anticipated future. An overview was given in Part I, where certain fundamentals were presented and a packet station analyzed.

Part II went into some detail covering packet hardware, with the specific example of the TAPR TNC given. Sufficient information was presented to enable the ambitious constructor to build a TNC for packet operation (and kits are now available).

This last installment has given an overview of packet protocols and applications. While not exhaustive in any sense of the word, some history and examples have shown the types of issues involved and the present level of packet communications capability.

For further details on amateur packet radio, I encourage you to write to Tucson Amateur Packet Radio, PO Box 22888, Tucson AZ 85734-2888. ■

TUCSON AMATEUR PACKET RADIO

Complete Packet Radio Controller Kit!

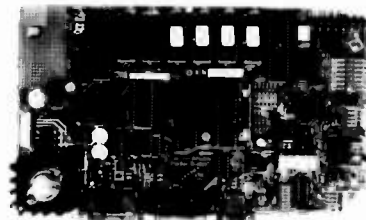

- Simple hookup and commands for the newcomer to packet!
- On-board modem designed for optimum performance with standard, unmodified transceivers.
- Retains over 60 user adjustable parameters (including call sign, terminal characteristics, etc.)—even with power removed!
- Full AX.25 and VADCG protocols—built in!
- Simultaneous operation as packet station and digital repeater—built in!
- Full duplex operation (perfect for Oscar 10)—built in!
- RS-232C (to 19.2 kboud) and Parallel Interfaces—built in!
- Parallel port optionally configurable for link status monitoring—built in!
- 32K ROM and 8K RAM—included! (expandable to 64K without modification)
- On board frequency calibration circuitry for modem—built in!
- Regulated power supply—built in!
- PC board electronically tested to assure quality!

- 200+ page manual with 50 page, heavily illustrated construction section—included!
- Hundreds of TAPR TNCs are in the field NOW!
- For background, see *Ham Radio* (July and August, 1983) and *73 Magazine* (September and October, 1983).
- Support through PSR, TAPR's bi-monthly newsletter serving a membership of over 500 amateurs worldwide!
- Introductory price \$240 (plus \$7 S&H) in the US and Canada (Arizona residents add 5% tax.)
- Manual available separately for \$18 (plus \$2 S&H) in the US and Canada (manual price creditable towards kit purchase).

Send a deposit of \$25 to secure your delivery position to:
Tucson Amateur Packet Radio (TAPR) P.O. Box 22888, Tucson, AZ 85734
(A Non-Profit Research and Development Group)

136

Note: Due to heavy demand, allow up to 90 days for delivery. Prices and specifications subject to change without notice.

TRADE IN YOUR OLD RTTY TU FOR A NEW FLESHER TU-470

The Flesher Corporation dares to make an offer you can't refuse. Now you can move up to a high quality RTTY terminal unit without throwing away money you have already invested. Your present name brand RTTY terminal unit is worth up to full retail value* when you trade up to a Flesher TU-470 priced at \$499.95. Most RTTY/CW software works with the TU-470 without modification. So while the offer lasts, call our toll free number for more information and a no-obligation estimate of your trade-in value. But act soon; this offer won't last long.

*LIMITED TO \$200.00



Here are just a few of the many fine features the TU-470 offers:

- TTL & RS-232c compatible I/O for computer remote control
- RTTY communication rates up to 300 baud
- Two tone RTTY detection with six pole active filters
- Three popular RTTY shifts
- Built-in 20 or 60 mA loop
- Signal balance circuit for single tone detection
- Threshold control
- Anti-space
- Mark hold
- Scope outputs
- Independent reverse shift controls for REC and XMIT.
- Six pole active filter CW demodulator
- Remote controlled bi-polar keying outputs for CW and PTT.

SUGGESTED RETAIL
PRICE ONLY \$499.95
(Add \$4.50 for UPS
shipping and handling in
U.S.A. plus \$1.75 for all
COD orders.



Flesher Corporation

507 Jackson • P.O. Box 976 • Topeka, Kansas 66601

Visa, Mastercard, COD, or check accepted.

For more information and sales CALL 1-800-HAM-RTTY
For service and technical CALL 1-913-234-0198

Your Ham Tube Headquarters!

TUBES BOUGHT, SOLD AND TRADED
SAVE \$\$\$—HIGH \$\$\$ FOR YOUR TUBES

Call Toll Free 800-221-0860
Tubes

3-400Z	\$85.00	7360	\$10.00
3-500Z	85.00	7735A	27.50
4-400A	80.00	8122	105.00
4CX250B	50.00	8156	12.50
572B	48.50	8643	82.50
811A	12.00	8844	26.50
813	35.00	8873	175.00
6146B	6.50	8874	185.00
6360	4.25	8877	450.00
6883B	6.75	8908	12.50

Semiconductors

MRF 245/SD1416	\$30.00	MRF 644/SD1088	19.95
MRF 454	18.95	2N3055	95.00
MRF 455	12.50	2N6084	12.50

RF Connectors

PL259	10/\$4.95	M358	2.50 ea.
PL258	10/8.95	M359	1.75 ea.
UG175/176	10/1.60	Type "N" Twist on	
UG255/u	2.50 ea.	(RG8/u)	\$4.75 ea.
UG273/u	2.25 ea.	Minimum Order \$25.00	

Allow \$3.00 min. for UPS charges

CeCo

COMMUNICATIONS, Inc.

2115 Avenue X Brooklyn, NY 11235

SERVING THE INDUSTRY SINCE 1922

Phone (212) 646-6300

Call CECo For Your CCTV Security And Color Production Requirements

Computer
Protection

KLEEN LINE[®] CONDITIONER



- Prevents:**
- Lightning Spike Damage
 - Computer Damage
 - Brownout Interruptions
 - Disruptive Line Noise
 - Program Errors

Regulator • Filter • Suppressor

KLR-250A	250 Watt Load	\$291.95
KLR-250A-1S0	250 Watt Load; Patented Filter Isolated Sockets	\$346.95
KLR-500A	500 Watt Load	\$390.95
KLR-500A-1S0	500 Watt Load; Patented Filter Isolated Sockets	\$445.95

Shipping: \$12.75 Land; \$45.50 Air

Ask Your Local Dealer

ESP Electronic Specialists, Inc.
171 South Main Street, Box 389, Natick, Massachusetts 01760

Toll Free Order Desk 1-800-225-4876

MasterCard, VISA, American Express

The CW Stationmaster

*Regeneration turns the worst signal into a CW symphony.
And that's not all you get when you build this station accessory.*

Every CW operator has (at least) two desires: to improve his ability to copy code through QRM and to be able to gauge accurately how fast he or the other fellow is sending. CRASH is a device which will enhance both abilities and provide a few extra options for the CW fan.

CRASH—Code Regenerator And Speedometer Hybrid—uses modern phase-locked-loop circuitry to provide good CW regeneration

for clear copy. In addition, it counts the code speed of both transmitted and received signals. As a bonus, the unit serves as a code-practice oscillator that permits the instructor to adjust his speed accurately.

The hybrid part of the name CRASH derives from the sources of the ideas that went into its development. WB4TYL developed a very straightforward CW speedometer, "The Confidence Builder" (73, September,

1980, p. 134). One of the drawbacks of the unit was that it did not work well with received signals, since it responded to all signals in the receiver passband. The cure for this problem emerged from W3BYM's "Golden Articulator, a CW Regenerator for Amateur Receivers" (*Ham Radio*, October, 1980, p. 64). The heart of this unit is an LM567 phase-locked-loop tone decoder with a very narrow passband. Combining the

two circuits became an easy task, since both made extensive use of LM555 timers, very handy devices indeed. The remaining chips are standard TTL ICs, plus an optocoupler and an LM386 audio amplifier.

By combining the two circuits, with additions and modifications, we achieve the following results:

- a CW regenerator with a narrow, variable frequency passband for single-signal reception;

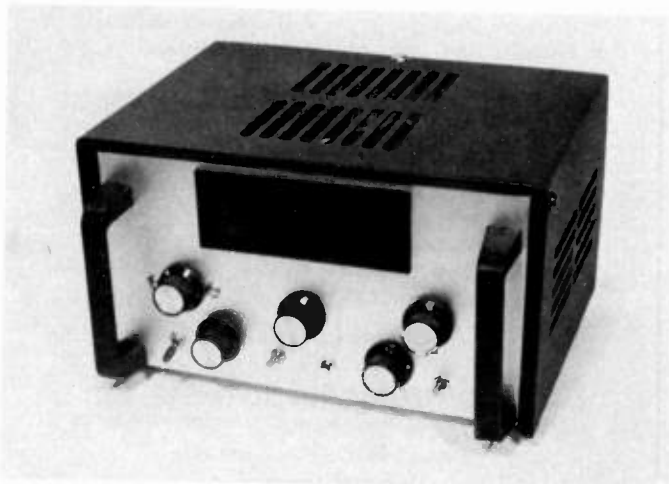

Front view of completed CRASH unit.

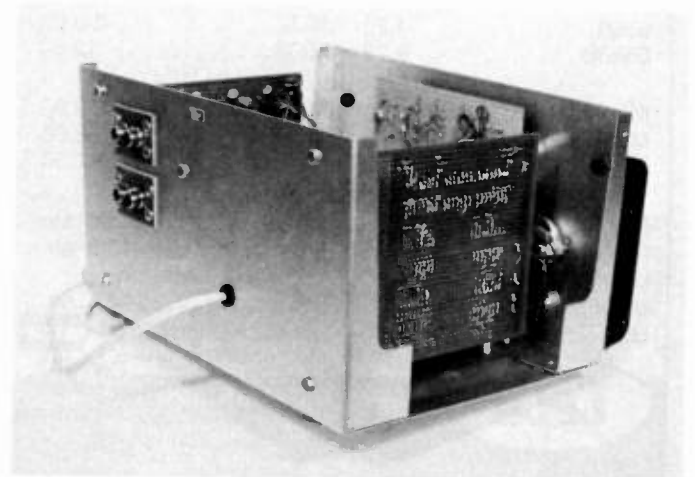

Internal view.

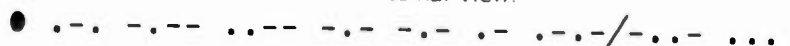

- automatic or manual return from the regenerator function to receiver audio;
- a CW speed counter which updates every five seconds;
- provision to count either transmitted or received code speed;
- a code-practice oscillator suitable for training Novices through Extra-class hams by precisely setting the practice speed;
- optically isolated keying of the unit in the CPO function;
- digital output for audio input, hence the possibility of keying other devices, such as a computer or TV readout;
- relatively simple circuitry through extensive use of 555 timers;
- a design amenable to one-stage-at-a-time building and adjustment.

Even if you do not want to copy CRASH as a total unit, there may be some useful ideas in it for other projects around the shack.

Functional Analysis

Although the circuit diagrams (Figs. 2 and 3) appear complex, the functions break down in a very direct manner. Fig. 1 provides a block diagram of the entire unit to make clear what happens to CW entering at the audio input jack. Since there are so many 555s, each has been given a functional name for easy identification.

When receiving CW, the 567 tone decoder is the first step in the signal processing. It has a very narrow bandwidth, even with high inputs: 14% of the audio frequency. Over the range of the decoder (400 to 2000 Hz) this amounts to 56 to 280 Hz, a figure excellent for CW, but also capable of producing ringing in most filter designs. Since we throw away the audio at this point and create our own in a later stage, ringing is no problem.

From the decoder, which

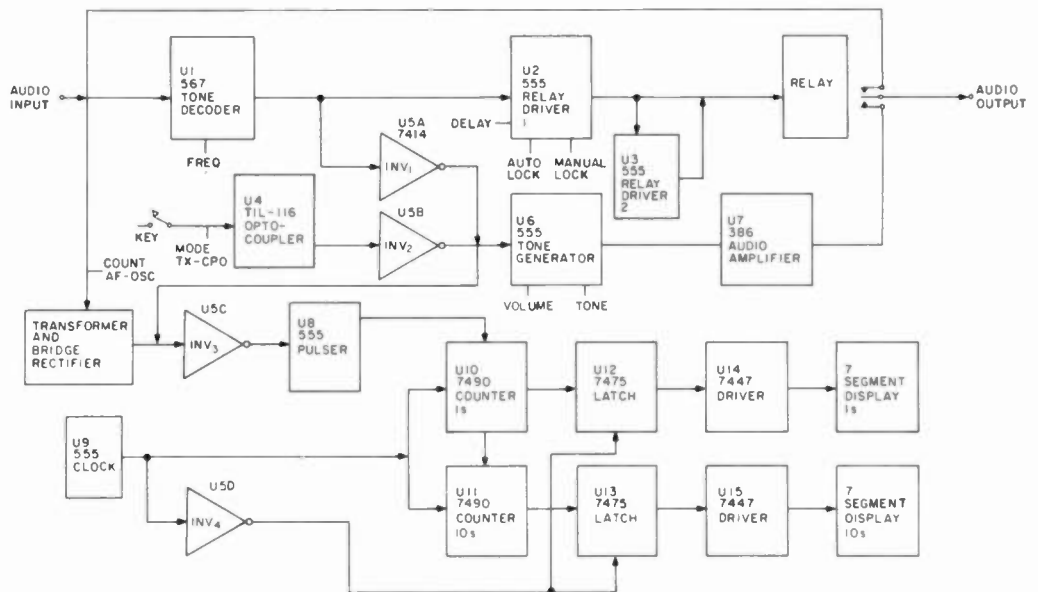

Fig. 1. Block diagram of CRASH.

produces a digital low when a signal is present, we move in three directions. One is to a tone generator (555) which produces new CW in the astable mode. Adding the LM386 amplifier lets us change the square-wave output into something a bit less harmonic-laden, but still not a pure, monotonous sine wave.

The second direction is to a pair of 555 relay drivers. The first has variable delay time and is activated by the presence of CW plus a short press of the spring-loaded toggle switch. There is also a manual switch to change from receiver audio to regenerated CW. The second relay driver has a fixed 2-second period and is activated by the first when its cycle ends. This permits time for continuing CW to reactivate the first driver, thus holding the relay in for the entire transmission.

The third direction from the decoder is to the 555 pulser which triggers the counter. For each leading edge of a dot or dash, the pulser sends a very short (10-ms) pulse which the counter section counts during a 4.7-second period. The readout provides a display of the code speed.

The counter section itself is very standard and might

be considered obsolete in the face of new combined devices available for counting and readout work. A 555 clock provides adjustable 4.7-second highs to enable counting and a brief .1-second low for resetting and latching. The 7490s build the count during the high, and their last count is latched in the 7475s by the low while the 7490s reset. The latched count is converted to 7-segment display format by the 7447s and read out on the common anode displays. The counting section runs continuously in all modes of operation of CRASH, and thus can tell us the received speed, the transmitted speed, or the CPO speed.

Back at the main board, there is a provision for switching in speaker audio to the pulser through a step-up transformer and a bridge rectifier and filter. One section of a 7414 Schmitt trigger inverter provides a sharp square signal to cue the 555 pulser. This section is most useful in checking transmitted speed by using the sidetone. Since the sidetone will rarely be in the passband of the decoder, it will not register unless we retune (a bad idea) or unless we use a wideband circuit (a better idea).

The tone generator and

pulser also can be triggered directly so that we can use the CRASH unit as a code-practice oscillator. Since all my equipment is set up for negative-voltage keying, an optoisolator/coupler (TTL-116) with a negative supply permits me to switch to the CPO mode and key a compatible voltage. The inverter provides the necessary high for the tone generator and pulser. In fact, the inverters shown but not mentioned are also placed in the circuit just to make sure that each device receives a controlling signal of the proper high or low state, as needed.

For the entire unit, a relatively simple power supply suffices. The five-volt supply needs to be very well filtered (since we are working with audio and not just digital signals) and well regulated (for TTL chips). In fact, the combined digital-audio techniques represent a second reason for calling CRASH a hybrid circuit. The negative supply is uncritical; with component adjustment, anything from -15 to -50 volts will work.

Circuit Details

Having run through the entire unit, let us look at some of the circuit details that bear mentioning, either because we might want to

experiment with them or because some caution may be in order. Fig. 2 will aid us here.

The 567 tone decoder chip is extremely versatile, and a data book will provide you with enough information to experiment with values. The frequency range of the unit with the resistor and capacitor values shown at pins 5 and 6 runs from a little over 400 Hz to just above 3000 Hz. The last thousand Hz are extremely compressed, and 2000 Hz is the useful upper limit for tuning in signals. If you prefer a different range, the frequency is determined by the formula $F_0 = 1.1/R1C1$, where R1 is the series-parallel combination of the 25k pot, the 120k resistor, and the 3.3k resistor, and C1 is .1 uF. The minimum resistance should be no less than 2k.

With most received signals, the input signal level will run above the 200-mV level at which the decoder limits and the bandwidth levels at 14%. For maximum speed of the decoder, that is, the fastest rate of cycling in response to received code, C2, the bandwidth filter should be derived from the formula $C2 = 130 \mu F/F1$, where F1 represents the lowest frequency to be used. This gives a value of .325 uF, and hence the .47-uF capacitor shown. C3, the output filter, should be about twice the value of C2 as a minimum, hence the 1-uF unit. The 1-uF feedback capacitor between pins 8 and 1 provides suppression of chatter, that is, multiple on-off cycling at the leading and trailing edges of the dots and dashes (a phenomenon which does not disturb the tone generator, but which produces some unbelievable code-speed indications). Since the highest cycling rate for the unit is given by the decoder frequency divided by 20, and since for practical purposes the highest code speed is about twice this value (in terms of

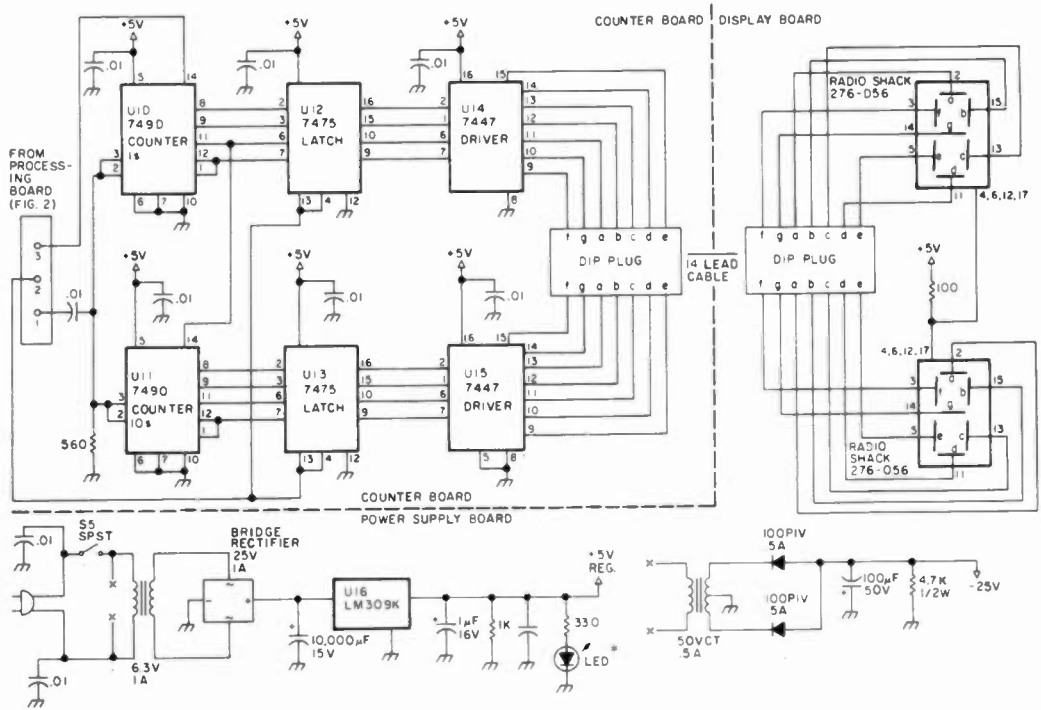

Fig. 3. Counter, display, and power supply sections of CRASH.

dots and dashes, not in terms of bauds), the values shown may be a bit low for those who listen to lower-speed code in the main. Static, which is random in tone and hence sometimes is in the passband of the decoder, may activate both the tone generator and the counter. Experimenting with values for C2 (and adjusting C3 accordingly) can overcome this at some loss of tracking at the very highest speeds. The feedback capacitor should also be enlarged in such cases.

A single 7414 chip provides all the inverters needed for the entire unit—with two left over. The 7414 inverters are Schmitt triggers which provide extremely sharp rise and fall slopes. About the only place they are essential is just preceding the pulser to sharpen the rectified audio into a good digital pulse to key the pulser cleanly. The two inverters feeding pin 4 of the tone generator could have been combined into a NAND gate (¼ of a 7400) as shown in Fig. 4, with the remaining sections used as inverters by tying together their inputs. This would have saved the use of diodes and

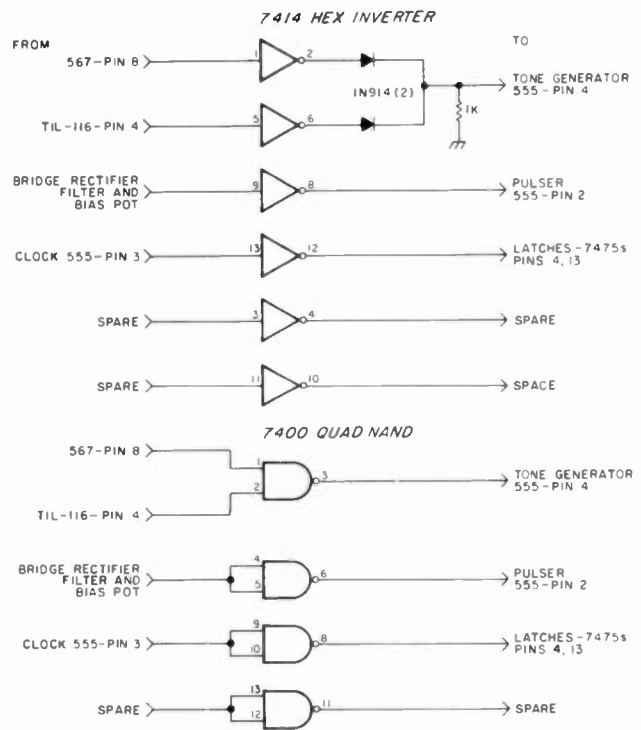

Fig. 4. Using a 7400 in place of the 7414.

the 1k ground-return resistor. Either system should work well.

All of the 555s are used in standard ways as either monostable timers or as astable oscillators. Among the monostables are the relay drivers. The first has a variable time period of .1 to 5 seconds, which is controlled from the front panel.

The second is fixed at 2 seconds. This system is more reliable than the original, which used a large capacitor across the coil of the relay. The value of the requisite capacitor will vary according to the coil characteristics; the present system makes the delay in opening the speaker to receiver audio independent of the re-

lay. The 300-Ohm resistor between the output diodes from the 555s and the relay may require some adjustment depending on the relay you have in hand. The Auto switch is a spring loaded toggle which shorts out the resistors and keys the relay when a signal has activated the first driver. Since the voltage needed to pull in a relay is greater than that needed to hold it in, the relay remains in the circuit as long as either one of the drivers is activated. The 555 is triggered faster than its output falls, so there is no noticeable voltage drop during the transition from the first to the second driver. The Manual switch allows you to hold in the relay independently of the Auto circuit.

The other monostable 555 is the pulser whose 10-millisecond pulses permit tracking of CW to a very high speed.

The tone generator is a standard audio range astable circuit for the 555. Volume and tone controls are provided on the front panel. With the values shown, tones from 200 Hz to 3000 Hz are available. Contrast this circuit, where the wave has nearly equal positive and negative halves (or nearly equal on and off times), with the clock 555, which places the large resistor value between Vcc and pin 7. Here the "on" time is very long and the "off" time very short. The 4.7-second on-time can be adjusted using a digital stopwatch (averaging several tries) or by allowing the counter to show the speed of a known transmission, such as a timed code-practice session. The 1-meg pot shown should be a miniature trimmer with 10 to 15 turns; otherwise, the adjustment will be very tricky. The .01 capacitor from the clock to the 7490s provides a count-clearing pulse that drops again through the resistor to permit gathering a new count.

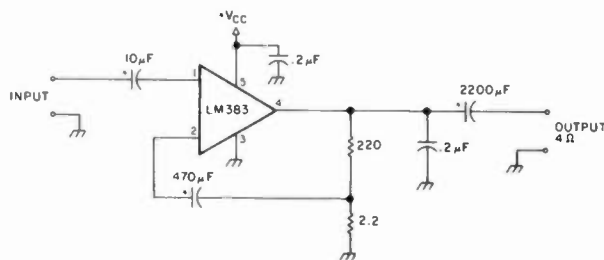

Fig. 5. An alternative audio amplifier.

The inverter provides the positive pulse to the latches to clear their old count and take on a new one for display. At the 7-segment readout, the single 100-Ohm resistor provides a simple means of lighting the units; however, brightness will vary depending on how many segments are lit simultaneously. For constant brilliance, use a 300-Ohm resistor in each lettered leg and omit the 100-Ohm unit in the supply line. Note that the lead zero is suppressed. The schematic shows the units in reverse order of visual indication—be sure to get the tens unit on the left. For common cathode displays, use 7448s instead of the 7447s and reverse the supply voltage.

Supplementing the basic circuit are a number of features. The optoisolator/coupler permits use of the unit as a code-practice oscillator. The internal LED of the TIL-116 (or just about any other available similar unit) is fed negative voltage through a multi-turn pot trigger-level adjustment. Use the minimum current that will key the output transistor cleanly, since there is little load on the circuit. The 47-Ohm resistor between the pot and the TIL-116 is a safety feature limiting the maximum current the LED can draw.

The LM386 is an extremely easy chip to use as an amplifier. It provides about a quarter Watt of power at 5 volts, far more than enough for a single CW tone. The 1-µF capacitors at the input make triangles out of the 555 square waves. Under load, these bend into hybrid

sine and square waves, which are very pleasant to listen to for long periods of CW. The series resistor and capacitor to ground in the output might be omitted at the risk of what National Semiconductor calls "bottom side fuzzies," a distortion to the negative peak of the waveform. I was able to produce this effect easily, so I recommend retaining this simple insurance of good reproduction. If you desire more power, Fig. 5 shows an alternative amplifier using the LM383. This one will fill an auditorium with sound if your speaker is big and good enough.

The transformer and bridge circuit are miniature parts, the transformer being a reversed transistor output unit for driving speakers. The diodes (like all others, except in the power supply) are 1N914 equivalents. One µF should work as the filter, but you might wish to verify first that the inverter swings cleanly and that the counter gives accurate readouts. The bias pot, another multi-turn unit, should be set for about .8 volts. More precisely, adjust it for a level that permits audio signals of moderate level to cleanly swing the inverter.

Switching within the unit may look complex, but actually is straightforward. The TX-CPO 4-pole, 2-position rotary changes several things at once. The speaker audio reaches the decoder in the TX position. In the CPO mode, the amplifier (LM386) output is switched to the speaker rather than allowing the relay to control it as in the TX mode. The key is switched from the

TIL-116 circuit (CPO) to the transmitter (TX). Finally, a pair of LEDs are switched to indicate the mode. Other switches are the two relay driver control switches, a DPDT toggle to place the audio input into the bridge and counter circuit (with LEDs to indicate what is being counted), and the power switch. One other LED appears in the decoder circuit to give a visual indication of tone-decoder signal lock and the code being received.

The power supply is normal in every respect, with an LM309K regulator in the +5-volt line. Note the heavy filtering in this supply to suppress hum. Those who work with digital circuits are accustomed to using about 3000 µF in such circuits, but audio requirements are much more stringent. The negative supply is unregulated and uses a small transformer from the junk box. Since its only function is to provide voltage and current to the optoisolator/coupler, not much of either is needed and any small transformer from 15 volts up will work. Although the LED in the TIL-116 requires only about 1.7 volts, the higher initial voltage provides room for adjustment of LED current to the lowest level that will key well.

Construction

Duplication of CRASH exactly as shown is a fairly straightforward task, but it may not be the best way for you to go. Many of the circuits can be replaced with others you prefer, and as long as each works at TTL levels, substitution should present few problems. Many extra features can be built into the unit to serve your CW needs, so before building, try modifying the design to fit your desires. After all, this is how CRASH happened in the first place—by a combination and adaption of ideas used by WB4TYL and K3BYM. The odds are

HI-Q BALUN

- For dipoles, yagis, inverted vees & doublets
- Replaces center insulator
- Puts power in antenna
- Broadbanded 3-40 MHz
- Small, lightweight and weatherproof
- 1:1 impedance ratio
- For full legal power and more
- Helps eliminate TVI
- With SO 239 connector



only \$13.95

HI-Q ANTENNA CENTER INSULATOR



Small rugged lightweight weatherproof
Replaces center insulator
Handles full legal power and more

\$6.95

With SO 239 connector

HI-Q ANTENNA END INSULATORS



Rugged, lightweight, injection molded of top quality material, with high dielectric qualities and excellent weatherability. End Insulators are constructed in a spiral unending fashion to permit winding of loading coils or partial winding for tuned traps.

May be used for

- Guy wire strain insulators
- End or center insulators for antennas
- Construction of antenna loading coils or multiband traps

\$4.95

DIPOLES

MODEL	BANDS	LENGTH	PRICE WITH HI-Q BALUN	WITH HI-Q CENTER INSULATOR
Dipole				
D-80	80,75	130	\$31.95	\$27.95
D-40	40,15	66	28.95	24.95
D-20	20	33	27.95	23.95
D-15	15	22	26.95	22.95
D-10	10	16	25.95	21.95

Shortened dipoles

SD-80	80,75	90	35.95	31.95
SD-40	40	45	32.95	28.95

Parallel dipoles

PD-8010	80,40,20,10,15	130	43.95	39.95
PD-4010	40,20,10,15	66	37.95	33.95
PD-8040	80,40,15	130	39.95	35.95
PD-4020	40,20,15	66	33.95	29.95

Dipole shorteners - only, same as included in SD models

S-80	80,75	\$11.95 pr
S-40	40	\$10.95 pr

All antennas are complete with a HI-Q Balun or HI-Q Antenna Center insulator, No. 14 antenna wire, ceramic insulators, 100 nylon antenna support rope (SD models only) rated for full legal power. Antennas may be used as an inverted V and may also be used by MARS or SWLs.

Antenna accessories—available with antenna orders
Nylon guy rope 450# test 100 feet \$4.49
Ceramic (Dogbone Type) antenna Insulators \$1.50 pr
SO-239 coax connectors .55

All prices are postpaid USA 48
Available at your favorite dealer or order direct from

Dealer Inquiries Invited
Van Gorden Engineering

BOX 21305 B, SOUTH EUCLID, OHIO 44121

Wheaton Community Radio Amateurs

HAMFEST

Sunday, January 29, 1984 (Doors open 8 a.m.)

Arlington Park Expo Center - Arlington Heights, Illinois

- Free Flea Market Tables • 100 Commercial Booths • All-in-one Building
- Acres of Clear Paved Parking • Reserved Flea Market Tables • Special Computer Section
- Tech Programs • Easy Access for Sellers (No Stairs)

TICKETS: \$3.00 in advance \$4.00 at door
Send S.A.S.E. to Wheaton Comm. Radio Amateurs P.O. Box QSL, Wheaton, IL 60187
General Info: (312) 231-7497
Talk in on 146.01/61 Mhz.

2 METER RADIOS

AZDEN PCS-300 FM HANDHELD, 3W, 8 MEM.	259.95
AZDEN PCS-4000 FM MOBILE, 25W, 16 MEM.	225.95
KDK-2030 FM MOBILE, 25W, 11 MEMORY	259.95
SANTEC ST-144 FM HANDHELD, 3.5W, 10 MEM.	262.95
TEMPO S-15 FM HANDHELD, 5W, 3 MEM.	242.95
TEMPO S-151 S-15 WITH 1/2 KEY TONE PAD.	265.95
TENTEC 2591 FM HANDHELD, 2.5W, 10 MEM.	262.95
*****SUPER SPECIAL*****	
TEMPO S-1 FM HANDHELD, 1.5W.	179.95
TEMPO S-1T S-1 WITH 1/2 KEY TONE PAD.	199.95
PRICE ON S-1 & S-1T INCLUDE 5/8 WAVE SUPER STICK II & RUBBER DUCK WHILE SUPPLY LASTS	

2 METER HANDHELD ACCESSORIES

HT-BAT SPARE BATTERY FOR PCS-300.	24.95
HT-ESH SPEAKER MIKE FOR PCS-300.	26.95
HT-IC LEATHER CASE FOR PCS-300.	26.95
ST 500B3 SPARE BATTERY FOR ST-144.	22.95
6M-3 SPEAKER MIKE FOR ST-144.	31.95
ST-LC LEATHER CASE FOR ST-144.	31.95
ST-140C AC QUICK CHARGER FOR ST-144.	26.95
ACH-15 AC QUICK CHARGER FOR S-15.	32.95
CC-15 LEATHER CASE FOR S-15.	21.95
BP-15 SPARE BATTERY FOR S-15.	25.95
HM-15 SPEAKER MIKE FOR S-15.	30.95

2 METER BASE ANTENNAS

BUTTERNUT 2MVC 5/8 WAVE TROMBONE.	29.95
BUTTERNUT 2MVC-5 5/8 SUPER TROMBONE.	34.50
CUSHCRAFT ARX2B RINGO RANGER II.	34.00
CUSHCRAFT A144-11 11 ELEMENT BEAM.	44.25
CUSHCRAFT A147-11 11 ELEMENT BEAM.	44.25
CUSHCRAFT A144-20T 20 ELEMENT TWIST.	67.95
CUSHCRAFT A147-20T 20 ELEMENT TWIST.	81.95
CUSHCRAFT 214B & 214FB 14 ELEMENT BEAM.	74.95
CUSHCRAFT 32-19 19 ELEMENT BEAM.	88.95

2 METER MOBILE ANTENNAS

AVANTI AP151-3G 1/2 WAVE "ON GLASS"	29.95
CUSHCRAFT AMS-147 MAGNET MOUNT.	27.95
CUSHCRAFT A15-147 TRUNK MOUNT.	27.95
HUSTLER SF-2 5/8 WAVE 3DB GAIN.	10.95
HUSTLER SF-142 5/8 WAVE 2DB GAIN.	28.95
HUSTLER CX-144 5/8 WAVE 3DB GAIN.	9.95

2 METER AMPLIFIERS

MIRAGE B23 FM/SSB 2W IN 30W OUT.	75.00
MIRAGE B10B FM/SSB 10W IN 30W OUT.	151.00
MIRAGE B101B FM/SSB 10W IN 160W OUT.	235.00
MIRAGE B301B FM/SSB 30W IN 160W OUT.	201.00
VJ PROD. 90L-PA FM/SSB 10W IN 90W OUT.	128.95
VJ PROD. 160L-PA FM/SSB 20W IN 160W OUT.	279.95
TEMPO S-30 FM 2W IN 30W OUT.	79.95

HF/10M/6M RADIOS

TENTEC ARGOSY 100W, SSB/CW, 10-80M.	510.00
TENTEC CORSAIR 200W, SSB/CW, 10-160M.	999.00
TENTEC OMNI-A 200W, SSB/CW, 10-160M.	799.95
AZDEN PCS-4800 10M, FM MOB., 10W, 16 MEM.	269.95
AZDEN PCS-4500 6M, FM MOB., 10W, 16 MEM.	279.95
KENWOOD TS-600 6M ALL MODE W/VOX (USED).	350.00

HF ANTENNAS

BUTTERNUT HF6V 10-80M & 30M VERTICAL.	106.75
BUTTERNUT HF6VX AS ABOVE IN SMALL BDX.	121.75
CUSHCRAFT AV-3 10-20M TRAP VERTICAL.	47.95
CUSHCRAFT AV-4 10-40M TRAP VERTICAL.	88.95
CUSHCRAFT AV-5 10-80M TRAP VERTICAL.	94.95
CUSHCRAFT 10-4CD 10M 4 ELEMENT BEAM.	101.95
CUSHCRAFT 15-3CD 15M 3 ELEMENT BEAM.	108.95

(continued)

CUSHCRAFT 20-3CD 20M 3 ELEMENT BEAM.	183.95
CUSHCRAFT 20-4CD 20M 4 ELEMENT BEAM.	257.95
CUSHCRAFT 40-2CD 40M 2 ELEMENT BEAM.	271.95
MINI-PROD HD-1 6M-20M MINI QUAD.	129.50
MINI-PROD B-24 6M-20M 4 ELEMENT BEAM.	95.50
MINI-PROD C-4 6M-20M VERTICAL.	54.50
WILSON (MACO) SY-33 10-20M 3 ELE. BEAM.	193.95
WILSON (MACO) SY-36 10-20M 6 ELE. BEAM.	226.95
WILSON (MACO) 33-6MK 40M ADD ON KIT.	67.95
WILSON (MACO) WV-1A 10-40M TRAP VERTICAL.	68.95
WILSON (MACO) GR-1 GROUND RADIAL KIT.	26.95

ROTORS & CABLES

HD-73 ALLIANCE HEAVY DUTY ROTOR.	89.00
U-100 ALLIANCE LIGHT DUTY ROTOR.	42.00
HDR-300 HYGAIN SUPER HEAVY DUTY ROTOR.	400.00
B610 B CONDUCTOR ROTOR CABLE.	PER FT. 0.17
9091 MINI RGB (RGBX) COAX.	PER FT. 0.16
9095 RG-BU SUPERFLEX COAX.	PER FT. 0.28
4063 RG-213 MIL-SPEC COAX.	PER FT. 0.28

ANTENNA SWITCHES & SWR/WATT METERS

MILLER CS-201 2 POSITION COAX SWITCH.	19.95
MILLER CS-401 4 POSITION COAX SWITCH.	61.95
MILLER CN-520 1.8-60MHz SWR/WATT.	58.95
MILLER CN-620B 1.8-150MHz SWR/WATT.	102.95
MILLER CN-720B 1.8-30MHz SWR/WATT.	144.95
MIRAGE MP-1 1.8-30MHz SWR/WATT.	99.95
MIRAGE MP-2 50-200MHz SWR/WATT.	99.95
WELZ SP-10X 1.8-150MHz POCKET SIZE.	34.95
WELZ SP-45X 140-470MHz SWR/WATT.	79.95

POWER SUPPLIES BY MACO

200A 8AMP SURGE, 6AMP INT., 4AMP CONT.	46.00
2010 12AMP SURGE, 10AMP INT., 6AMP CONT.	55.00
2020 24AMP SURGE, 20AMP INT., 12AMP CONT.	69.00
2030 36AMP SURGE, 30AMP INT., 18AMP CONT.	100.00

ANTENNA TUNERS

MFJ-900 ECONO TUNER 1.8-30MHz 200WATTS.	39.95
MFJ-901 AS ABOVE WITH 4:1 BALUN.	49.95
MFJ-941C ANTENNA TUNER/SWR METER 1:4BAL.	75.95
MFJ-962 1.5KW, ANT. SWITCH, METER, BALUN.	179.95
MFJ-982 3KW, ANT. SWITCH, METER, BALUN.	156.95
MILLER CNA1001A AUTOMATIC TUNER 200W.	294.95

COMPUTER ACCESSORIES

KANTRONICS HANSOFT FOR APPLE.	24.95
KANTRONICS HANSOFT FOR ATAR.	39.95
KANTRONICS HANSOFT FOR VIC-20.	39.95
KANTRONICS HANTEXT FOR COMMODORE 64.	82.95
KANTRONICS HANTEXT FOR VIC-20.	82.95
KANTRONICS MINI-READER CW/RTTY/ASCII.	239.95
KANTRONICS MINI-TERMINAL CW/RTTY/ASCII.	269.95
MFJ-1200 CW ONLY COMP. INTERFACE.	59.95
MFJ-1224 CW/RTTY/ASCII COMP. INTERFACE.	88.95

CLOSEOUTS

PRICES GOOD WHILE SUPPLY LASTS	
HY-GAIN TH7DX 10-20M 7 ELEMENT BEAM.	335.00
HY-GAIN TH3URS 10-20M 3 ELEMENT BEAM.	140.00
HY-GAIN HB-14 10-20M QUAD.	49.95
HY-GAIN 66-B5 6M 6 ELEMENT BEAM.	90.00
HY-GAIN 5DBB 10-80M TRAP DOUBLET.	87.00
HY-GAIN 153BA 15M 3 ELEMENT BEAM.	66.00
HY-GAIN BV 10-80M VERTICAL.	21.00
HY-GAIN 25B 2M 5 ELEMENT BEAM.	18.00
HY-GAIN 28B 2M 8 ELEMENT BEAM.	24.00
HY-GAIN 214B 2M 14 ELEMENT BEAM.	28.00
HY-GAIN HB-14 2M MAGNET MOUNT.	12.00
INNERSPACE 20 AMP POWER SUPPLY.	91.00
INNERSPACE 20 AMP METERED POWER SUPPLY.	121.00
INNERSPACE 30 AMP POWER SUPPLY.	116.00

CALL FRANK W05GZU OR JOE KASROO
FOR QUOTES ON OTHER RELATED PRODUCTS
FOB ORIGIN.



COD Available

Hours: 8:30 a.m. to 5:00 p.m. Monday thru Friday
9:00 a.m. to 2:00 p.m. Saturday - CST
Prices subject to change without notice.

Amateur
Equipment,
Accessories
& Antennas.
Export Anywhere

2317 Vance Jackson Rd.

San Antonio TX 78213

(512) 733-0334

(Toll free number 800-531-5405)



you can come up with some new design wrinkles and improvements.

Construction of the CRASH unit is a matter of taste. All will fit in a Radio Shack 9" by 5" by 6" cabinet, as the photo shows. Fig. 6 shows a sketch of a layout for inside the cabinet, while Fig. 7 suggests some board layouts by reference to the ICs. Although the prototype was built around two boards—one for processing, the other for the counter—I recommend using three. The processing board is overcrowded after circuit modification and adjustment.

Radio Shack digital experimenter boards (#276-156) for use with edge connectors (#276-1551) make convenient bases for the components, and Fig. 7 is drawn with these boards in mind. The counter board contains the 7490s, the 7475s, and the 7447s lined up in rows as in the schematic. The outputs to the display board use a 14-line DIP connector set. A slightly larger set would permit running the power and ground connections as well.

The processing board should contain the 567 decoder, the 7414 inverter chip, the 555 pulser, the 555 clock, the transformer and bridge circuit, and the TIL-116 optoisolators. A separate audio board should contain the 555 tone generator, the 386 amplifier, and the two 555 relay drivers,

along with the relay. The three boards might be mounted vertically in the case. The power supply is built on perfboard and mounted on standoffs at the bottom of the case for good weight balance. The display board also uses perf material and is held to the front panel by standoffs attached to the lugs on the bezel for the readout. Since most bezels are large enough for up to six digits and we only need two for this project, indicator LEDs (six of them) are mounted on the display board against a black foam background. This minimizes panel work and makes an effective blackout display when power is off.

Since the photo of the front of the unit was taken before the addition of the lettering, the panel control knobs are as follows, from left to right: decoder frequency, relay delay, TX-CPO switch, regenerator tone, and regenerator volume. The toggle switches along the bottom of the panel are, also left to right, ac power, auto relay, manual relay, and audio-oscillator counting. Were I to build a second version of this unit, about the only change I would make is to add a 2:1 or 3:1 vernier to the decoder frequency control, since tuning is just a bit tight at higher audio frequencies.

Because the unit mixes digital and audio functions,

it is easy to slip into digital habits and ignore the fact that ground loops and hum pickup are potential problems in layout. Besides using a high level of filtering in the +5-volt supply, some extra precautions will minimize problems. Use short ground leads and attempt to ground all parts of each circuit to a common pad or small area. Group the main audio circuits together especially the 555 tone generator and the 386 audio amplifier. Use shielded leads from input and output terminals to the boards, and between boards, for all audio lines. On each board, run a 47- μ F or 100- μ F electrolytic to ground at the power entry point and bypass each chip with at least a .01- μ F disc ceramic capacitor.

Since you will be using the unit in the presence of your transmitter and with the keyline running into the unit, good rf practice is also essential. Bypass both ac lines where they enter the case with .01- μ F disc ceramic (1000-volt units, which are getting harder to find at discount prices). Also bypass the key jack and the transmitter jack with .01 units. Since rf can instantly disable many ICs, especially at transmitter leakage power levels, the more bypassing, the better. It should not affect dc levels in the keying circuits. When you develop your own layout, be gener-

ous in this department. If in doubt, bypass it. Finally, be sure the case is at dc ground potential. Some of the anodized cases make it difficult to get a good ground contact, so be sure to use a good tooth washer at contact points.

Since this is a one-of-a-kind unit, I regret that no circuit boards are available. However, The Radio Shack epoxy experimenter boards are fun to use, and where perfboard is recommended, the wiring is easy and straightforward. The toughest problem will be to have patience during construction.

When you build the unit (if you do build one), I recommend one of two procedures. Either build the unit a stage at a time, or at least omit the power lead to every chip until it is time to check out the circuit. The first step, as in all projects, is to build and test power supplies. Once these are ready, we can work progressively through the rest of the stages.

A good place to start is with the counter board, which can be built complete, along with the seven segments of the display board. Since there are few components besides jumpers between ICs, visual inspection should prepare you for testing under power. Next, verify the clock 555 as operating by checking its output (and the output from its inverter section) with a VTVM. If all is well, connect to the counter board. Only the right (ones) digit should light and show zero (although there may be a spurious count when power is applied). For test purposes, you can key 5 volts through a resistor (say 1k) to the counter input to verify counting. If all is well, time the counter with a stopwatch. An easy way to check periods is to tap the key a few times so that the count changes at the end of the period. The

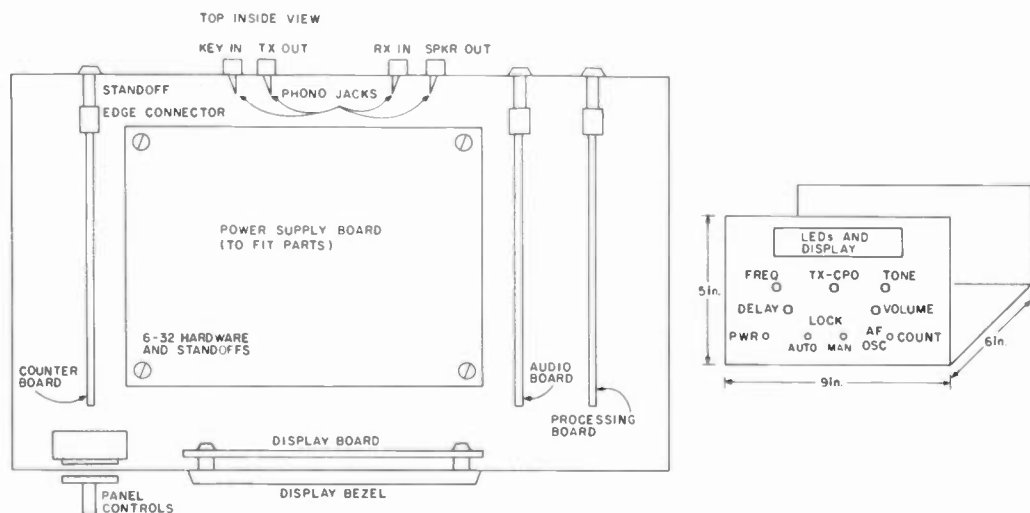

Fig. 6. General layout sketch for CRASH.

MITRONIX

MORSE CODE from MITRONIX



Turn your Radio Shack Color Computer into a complete Morse Code terminal.

MITRONIX MODEM—Interfaces the computer to your transceiver via the ROM PAC slot.

Cartridge: \$54.95

—You have your choice of 5 CW programs to pick from including:

—MITRONIX TRANSLATOR

This Machine Language program allows you to transmit & receive from 5-60 WPM. Features split-screen with reverse video receive, a 1024 character TX buffer, auto CQ, & 4 message memories.

Cassette: \$26.95

KA9FSQ PERSONAL CW MAILBOX—

Written in COLOR BASIC, this program allows you to transmit to 50 WPM, & receive to 30 WPM. In the MAILBOX mode, it will answer a CW call, get other station's call letters, message, data & time, and store it in memory for instant recall when you return. Also hard copy.

Cassette: \$21.95

For additional information and programming, write to:

Michael L. Rice, Jr. KA9FSQ
MITRONIX
5953 N. Teutonia Ave.
Milwaukee, WI 53209
(414) 466-6151

✓240

Sales please include 5% postage

There are over 1800 New Hams every month just waiting to hear from you.

In the highly competitive field of amateur radio, achieving name recognition and getting ahead of the competition are critical to a successful marketing effort. Companies that know this have turned to DCC Data Service for quality mailing lists. Through our **HAM HOTLINE** lists, these successful companies have been the first to reach the new Hams with their offers for radio equipment, accessories, magazines, technical publications and other related products and services. These names represent the latest additions to our cumulative master file of over 428,000 Radio Amateurs. The **HAM HOTLINE** service has been a proven moneymaker and an excellent supplement to magazine advertising.

SO DON'T KEEP ALL THESE NEW HAM ENTHUSIASTS WAITING. GIVE US A CALL TODAY.

Rates and Selections:

- Monthly Novice Hotline (avg. 1800 names/month) . . . \$60/M
- Upgrades and Changes (avg. 11,000 names/month) . . . \$50/M
- Last 6 Months Hotline (78,000 names) . . . \$50/M
- Cumulative files also available

DCC Data Service

1990 M Street, N.W.
Washington, D.C. 20036
(202) 452-1419



TEN-TEC 560 Corsair 9-band Digital Transceiver Regular \$1169 - Sale Price \$1029

Corsair accessories:	Regular	SALE
260 Deluxe power supply with speaker . . .	\$199.00	\$179 ⁹⁵
263 Remote VFO	199.00	179 ⁹⁵
220 2.4 KHz 8-pole crystal SSB filter	59.00	
282 250 Hz 6-pole crystal CW filter	59.00	
285 500 Hz 6-pole crystal CW filter	59.00	
288 1.8 KHz 8-pole crystal SSB filter	59.00	
214 Electret desk microphone	45.00	

TEN-TEC Corsair SPECIAL!

From September 15th, 1983 to January 15th, 1984 purchase a Corsair at our Sale Price and receive a **COUPON** for (1) **FREE** accessory **Crystal Filter** of your choice (a \$59.00 value) direct from TEN-TEC.

Also - Operate the Corsair for **30 Days**. If you are dissatisfied for any reason, you may return it to AES for **FULL CREDIT** toward other merchandise or a **FULL REFUND**, not including any Shipping Charges.



AES® STORE HOURS: Mon. thru Fri. 9-5:30; Sat. 9-3
Milwaukee WATS line **1-800-558-0411** answered evenings until 8:00 pm, Monday through Thursday.
Please use WATS line for Placing Orders
For other information, etc. please use Regular line.

Order Toll Free: 1-800-558-0411

In Wisconsin (outside Milwaukee Metro Area)
1-800-242-5195

AMATEUR ELECTRONIC SUPPLY[®] Inc.

4828 W. Fond du Lac Avenue; Milwaukee, WI 53216 - Phone (414) 442-4200

AES BRANCH STORES

WICKLIFFE, Ohio 44092
28940 Euclid Avenue
Phone (216) 585-7388
Ohio WATS 1-800-362-0290
Outside Ohio 1-800-321-3594

ORLANDO, Fla. 32803
621 Commonwealth Ave.
Phone (305) 894-3238
Fla. WATS 1-800-432-9424
Outside Florida 1-800-327-1917

CLEARWATER, Fla. 33575
1898 Drew Street
Phone (813) 461-4267
No In-State WATS
No Nationwide WATS

LAS VEGAS, Nev. 89106
1072 N. Rancho Drive
Phone (702) 647-3114
No In-State WATS
Outside Nevada 1-800-634-6227

Associate Store

CHICAGO, Illinois 60630
ERICKSON COMMUNICATIONS
5456 N. Milwaukee Avenue
Phone (312) 631-5181

15 mln. from O'Hare!

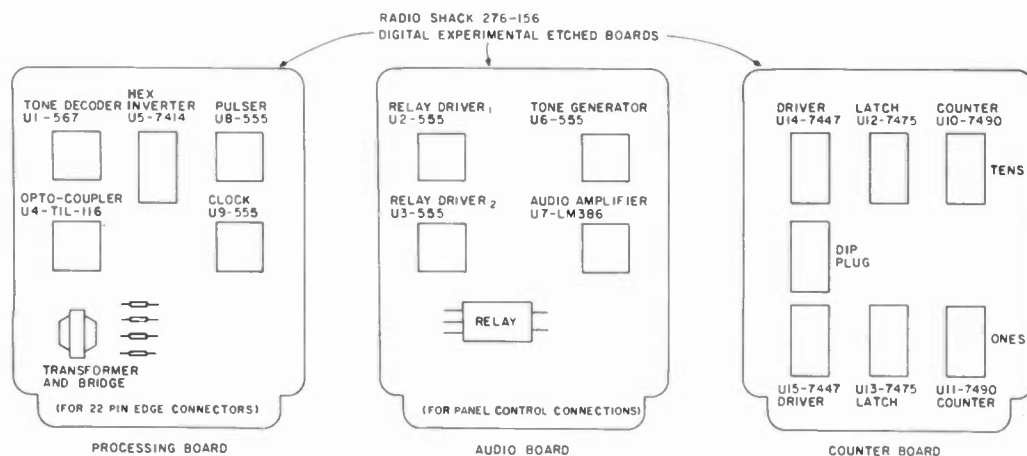

Fig. 7. Suggested board layouts for CRASH.

target for reasonably accurate code-speed readouts is 4.8 seconds per total cycle.

The next step is to verify the 555 tone generator. In the absence of the tone decoder and TIL-116 keyer, key the tone generator by applying +5 volts to pin 4. When you are satisfied with its volume and tone ranges, add the 386 amplifier. If you have a scope, you can check the waveform and adjust the capacitor network between the 555 and the 386 to suit your taste. The 555 can overdrive the 386, so check the output with a scope if you can. Adjust the coupling capacitor (shown as .02 uF in the schematic) so that the waveform just begins to flatten at full volume.

At this point, you can move in several directions according to your preference. Now is a good time to wire the TX-CPO switch and adjust the TIL-116 optoisolator/coupler. Begin with maximum resistance on the 20k multi-turn pot and reduce the resistance until pin 4 of the TIL-116 shows clean keying without hanging, as indicated by a VTVM. The object here is to get clean keying of the tone generator with minimum current to the LED. Since the inverter requires little current from the phototransistor output of the TIL-116, there is little need to overdrive the system.

We can now count our own code speed as we key

the optocoupler, since the inverter which keys the pulsar is driven. Adjust the bias 10k multi-turn pot until the output of the inverter (pin 9) also shows clean keying without hanging, as indicated on a VTVM. About .8 volts of bias will suffice, and we will readjust this control in a moment. For now, we should see our code-speed readout on the seven-segment displays every 4.8 seconds. To be sure that counting is good, key the unit a known number of times (that is, 2 to 12 or so dots) within a counting period and wait for the readout to correspond. In this way, we can check that the counter and pulsar are giving us proper performance.

At this point, wire the AF-OSC switch and the input to the transformer. The OSC position is blank, since the incoming count connection is made directly to the pulsar's inverter. Audio from the speaker, however, goes directly to the transformer through the switch to count the sidetone oscillator during transmit periods or to count received signals when the band is clear. An audio generator with a few volts output at low impedance will aid you to readjust the bias 10k pot so that the keying is clean. Weak signals may not push the voltage to the inverter high enough to trigger the inverter, but once connected to the receiver, the sidetone should key the counter easily. You may

want to tweak this adjustment later when the unit is connected to the station rig.

We have saved the tone decoder 567 for last. Using the audio generator so that the 567 has about 2 volts at its input and with the TX-CPO switch in the TX position, locate and lock the audio signal with the frequency control. 700 to 900 Hz should put the control about midrange using the series-parallel resistor combination given. If you key the audio line, the tone generator should follow without delay and the count should be accurate. If the count goes very high, even at slow keying, you probably are experiencing chatter and may want to increase the feedback capacitor between pins 8 and 1 from the 1-uF value shown. The LED from Vcc to pin 8 should also track the keying.

Assuming that all is well to this point, check the unit with on-the-air signals on a fairly clear band. If the 567 responds too readily to noise (anything from QRN to internal receiver pops), you may want to increase the values of the capacitors at pins 2 and 1 of the 567, remembering to keep the larger about twice the value of the smaller. This will slow down the response of 567. We cannot eliminate all response to noise without cutting off higher speed CW, but we can find values that will keep the counts fairly accurate and eliminate hash

from the keying of the tone generator.

At this point, the CRASH unit should be operational and ready for dial decals, case covering, and regular use in the shack.

Operation and Modification of CRASH

Operating CRASH is simple but requires some adjustment of your habits. When receiving CW, find the desired signal with the frequency control. The LED will track the code when the signal is in the passband of the 567. If the signal drifts, it is probably better to ignore the regenerator and concentrate on the station. Stable signals, however, will stay in the passband. Once the signal is acquired, use either the auto or the manual toggles to switch to the regenerator.

Since CW without QRM and QRN sounds strange at first, you may initially dislike the effect. Part of learning to like clear reception is choosing tone and volume settings that please your ears. You may find that you prefer a lower volume than with received signals, and the tone you choose may be something different from where you usually tune signals in the receiver passband. Experimenting with signals on relatively clear bands is the best way to match the unit to your preferences.

Although the 567 tone decoder accepts a wide range of input levels, receiver characteristics limit the useful range. Weak signals beyond the receiver agc limit can fade below the 567's ability to lock, and excessive volume may be accompanied by enough noise pulses to hold in the relay continuously, even without a signal. The level control can be adjusted to provide the 567 with input voltages tailored to your own habits with the receiver volume control. However, you may have to adjust receiver volume to suit the 567 if you of-

ten move from noisy bands with high signal levels, like 80 meters, to quiet bands with weak signals, such as 15 meters in the evening. Considerable experience using the CRASH unit may be needed before you settle on the final compromise setting of the level pot.

Although the unit operates well as is, CRASH is a good project for trying out new ideas. For example, Fig. 8 shows the insertion of an amplifier to isolate the audio to the speaker from the inputs of the transformer and the 567. Any amplifier which limits the voltage at the output in a controllable way should work here. Fig. 8 also shows an extra transistor in the relay circuit, in case you wish to drive relays of other than 5 volts, or in case you want to drive a heavier load.

In addition to these options, which have been tried but are not used in this version, the CRASH unit provides possibilities for exter-

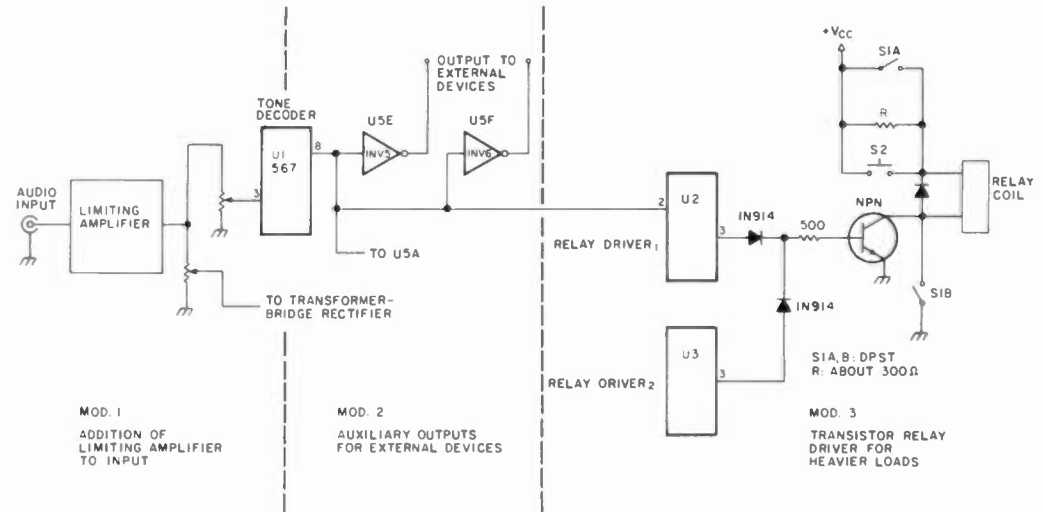

Fig. 8. Some modifications to CRASH.

nal connections. Since the 567 bandwidth is narrow and its output is digital, the unit can also be used to key other devices. Fig. 8 shows inverters as buffers to other devices, such as a MORSE-ASCII converter system for television or a computer readout of the CW. How you do this is open to many op-

tions, and a system is under development here for driving a TRS-80 III. Once you have brought the unit this far, then computer keying, automatic logging, and other station conveniences are only a dream and a soldering iron away.

In short, the CRASH unit not only works well as a CW

regenerator and code speedometer, but it also forms the basis for a number of other station options. But that is the way it usually goes with ham projects: One thing leads to another and nothing is ever finished for good. There is no telling what a good CRASH will lead to next. ■

Holiday Specials

MasterCard
Visa
ege, inc.
 13646 Jefferson Davis Highway
 Woodbridge, Virginia 22191
 (703) 494-8750

LACOMBE
 DISTRIBUTORS
 An Associate Store
 Davis & Jackson Road, P.O. Box 293
 Lacombe, Louisiana 70445
 (504) 882-5355



Call Early For Your Christmas Needs
TOLL FREE 800-336-4799

ICOM
 751: New HF Tranceiver
 271A: All-mode 2m XCVR
 Handhelds: 2AT, 3AT, 4AT with Accessories
 R 70: SWL Receiver
 745: HF XCVR/Gen Cov RCVR
 And More

TEN-TEC
 560: The New Corsair
 525D: Digital Argosy II
 2591: 2m Synth Handheld
 And More

SANTEC
 Handhelds: 2m, 220 and 440
 KDK FM2030 2m 25-watt
 WELZ Watt Meters
 TOKYO HY-POWER
 Amps & Tuners

YAESU
 980: CAT System HF XCVR
 102: 160-10M HF XCVR
 726: 2m (optional 6m, 430, 440)
 208: 2m Handheld
 290: 2m All Mode Mobile
 757: HF XCVR/Gen Cov RCVR
 And More

CALL FOR QUOTES
 Prices subject to change without notice or obligation.

RADIOS
 Kenwood, Azden, Santec, KDK Icom, Yaesu, Ten-tec, Santec

RECEIVERS
 by Panasonic, Kenwood, Bearcat, Icom, Yaesu

SCANNERS
 by Bearcat



ANTENNAS
 by Avanti, Larsen, BMW Vocom, Cushcraft KLM, Butternut, Hy-Gain Miniquad, Hustler Moseley, And More

ROTORS
 by Alliance and Telex

MFJ
 Tuners, Clocks, Converters Dummy Loads, Keyers Power Supplies, Filters And Other Accessories

MARINE & COMMERCIAL
 by Icom and Yaesu

METERS
 by Daiwa, Welz

PWR SUPPLY
 Astron

KEYERS
 by AEA & MFJ Bencher Paddles Nye-Viking Paddles

MARINE & COMMERCIAL
 by Icom and Yaesu

HEADSETS
 by Telex, Yaesu, Kenwood



PHONES
 Cordless and Regular by Freedom Phones, GTE ITT, and Cobra

SOFTWARE
 Programs for logging, propagation, and more. Ham Data, AEA (for VIC 20 and 64), Kantronics: Hamtext, Hamsoft, and Amrtoisoft Catalog available.

INTERFACES
 by MFJ, Kantronics Microlog, and AEA

INTERFACES
 by MFJ, Kantronics Microlog, and AEA

AMPS
 by Vocom, Ameritron, MFJ Amp Supply, Daiwa, Mirage

Top Drawer, Micro-Style

*Building circuits is fun, but drawing them isn't.
Let your Apple do your drafting.*

Bill Smith K3LF
RD 2, Cold Spring Creamery Rd.
Doylestown PA 18901

Using a microcomputer to assist in designing circuits is a natural. I recognized this shortly after acquiring my Apple computer and proceeded to build a library of electronic-design programs. My library covers such things as audio filters, timers, multivibrators, and many op-amp circuits. Most of the programs were entered from magazine articles such as those found in

back issues of 73. These programs are a real asset when designing or trying to "ball-park" component sizes for a particular application.

As helpful as these programs are, they have one major weakness: They have no way of displaying the circuit diagram. To make matters worse, they usually refer to components as "R1" or "C3." To find out where "C3" is located in the circuit, you have to find the article from which you entered the program and hope that the author included a circuit diagram with all of the com-

ponents labeled correctly. If you are like me, you will probably find that you lent that particular magazine to a friend who just left town for a sabbatical in South America!

Well, hang on, help is on the way. This article describes how you can incorporate that schematic diagram within your program so that it will be available at the touch of a button.

I have devised a system that uses the excellent HIRES capability of the Apple II to your best advantage. I decided that the system to be used should be fairly easy to implement; I did not want to spend hours entering a diagram for each program. I needed a system that would be flexible so that I could enter all types of electrical schematics, not just one unique circuit. Lastly, the system had to allow me to enter fairly complex circuits.

With all of these points in mind, I embarked on a six-month project to develop the system described here. I call it my "EGG" (Electronic Graphics Generator), and it really works.

The EGG is nothing more than a shapefile with up to

200 shapes and a system to map the shapes onto the HIRES screens. (Currently there are 135 shapes in the shapefile but I have set up the file to handle up to 200 for any future expansion.) The first 59 shapes are characters generated by the Apple's text generator. These shapes are used for labeling circuits and components and for any text desired on the HIRES screen with the circuit diagram. Shapes 60 through 65 are Greek letters common to electrical diagrams (such as lambda for wavelength), 66 through 99 are the actual electrical components, and the remaining shapes are used for connecting the components and drawing rectangles representing ICs.

The Apple HIRES screen dimensions are 280 points horizontal by 192 points vertical. I used these dimensions to determine the optimum size for each shape in my shapefile. Each shape is drawn within a grid that is 15 x 15 with the origin of the shape located at the center of this grid. Using these dimensions, I could accommodate 18 shapes horizontally and 12 shapes vertically for a total of 216 shapes



Fig. 1. Schematic of an active audio filter as it would appear within a program. This is typical of the type of schematic which may be incorporated in your programs.

shown, and you will find that the leads exit the grid centered on either side. By maintaining this convention throughout the shapefile, I have made it possible to draw any of the components in any of four orientations with their leads available for easy connection to the next component.

By now you should have a good idea of how the shapefile is set up. Next, I will describe how to use it to get diagrams into your programs. There are two methods. One is quick from a pro-

gramming point of view but takes longer to execute and uses more room on your diskettes. The other takes a little longer to program but executes quickly and takes little storage room.

The first method is to use the schematic draw-and-edit program accompanying this article. This program makes it very easy to draw, label, and edit a diagram. Once the diagram is drawn, the entire map of the HIRES screen is saved to disk. This method is quick. (The schematic in Fig. 1 took

about ten minutes to draw and edit using the EGG program.) The main drawback to this method is that each screen must be loaded from disk when needed. It takes about 34 sectors to store this much information, and it takes about 8 seconds to read it in from disk. This 8-second delay in the middle of a program is mildly disconcerting but certainly acceptable.

The second method is to enter into your program the necessary BASIC language statements to draw the

shapes during program execution. Using this second method to generate the diagram of Fig. 1 took less than one second during program execution but requires about thirty minutes of programming.

Using the EGG program is really quite easy as it is menu-driven and contains many useful edit commands. There are two levels of menus. The first level is used to select which HIRES screen you are interested in using and the second level allows selection of various

Program listing 1. This is the actual shapetable. This should be entered exactly as shown beginning at address hex 8000.

```

8000- 03 00 92 01 94 01 98 01
8001- A3 01 85 01 C5 01 D2 01
8002- E3 01 EB 01 F5 01 FF 01
8003- 0A 02 12 02 16 02 18 02
8004- 1E 02 27 02 36 02 3E 02
8005- 4B 02 58 02 63 02 73 02
8006- 82 02 8E 02 98 02 A6 02
8007- A9 02 AD 02 B8 02 C4 02
8008- CB 02 D5 02 E5 02 F2 02
8009- FE 02 0B 03 17 03 23 03
800A- 2F 03 3C 03 49 03 52 03
800B- 5C 03 6B 03 75 03 81 03
800C- 8F 03 9E 03 A9 03 B6 03
800D- C4 03 D2 03 DA 03 EB 03
800E- F7 03 83 04 04 03 1B 04
800F- 29 04 2F 04 3B 04 4A 04
8010- 53 04 5D 04 66 04 76 04
8011- 8D 04 93 04 B1 04 D3 04
8012- FA 04 2A 05 54 05 6F 05
8013- 8F 05 84 05 DF 05 0F 06
8014- 2A 06 3F 06 53 06 7F 06
8015- A2 06 BA 06 CF 06 EA 06
8016- 0F 07 45 07 6B 07 79 07
8017- 8B 07 A6 07 BE 07 D1 07
8018- F1 07 18 08 3C 08 59 08
8019- 08 08 97 08 AC 08 B1 08
801A- C6 08 D7 08 EC 08 01 09
801B- 0C 09 17 09 26 09 35 09
801C- 3A 09 3F 09 47 09 5C 09
801D- 53 09 69 09 7D 09 8B 09
801E- 84 09 C6 09 D9 09 E7 09
801F- FA 09 0C 0A 1A 0A 93 0A
8020- B7 0A 05 0A D2 0A DF 0A
8021- 0E 0A 0F 0A 1C 0A 24 0A
8022- 00 00 00 00 00 00 00 00
8023- 00 00 00 00 00 00 00 00
8024- 00 00 00 00 00 00 00 00
8025- 00 00 00 00 00 00 00 00
8026- 00 00 00 00 00 00 00 00
8027- 00 00 00 00 00 00 00 00
8028- 00 00 00 00 00 00 00 00
8029- 00 00 00 00 00 00 00 00
802A- 00 00 00 00 00 00 00 00
802B- 00 00 00 00 00 00 00 00
802C- 00 00 00 00 00 00 00 00
802D- 00 00 00 00 00 00 00 00
802E- 00 00 00 00 00 00 00 00
802F- 00 00 00 00 00 00 00 00
8030- 00 00 00 00 00 00 00 00
8031- 00 00 00 00 00 00 00 00
8032- 00 00 00 00 00 00 00 00
8033- 00 00 00 00 00 00 00 00
8034- 00 00 00 00 00 00 00 00
8035- 00 00 00 00 00 00 00 00
8036- 00 00 00 00 00 00 00 00
8037- 00 00 00 00 00 00 00 00
8038- 00 00 00 00 00 00 00 00
8039- 00 00 00 00 00 00 00 00
803A- 00 00 00 00 00 00 00 00
803B- 00 00 00 00 00 00 00 00
803C- 00 00 00 00 00 00 00 00
803D- 00 00 00 00 00 00 00 00
803E- 00 00 00 00 00 00 00 00
803F- 00 00 00 00 00 00 00 00
8040- 00 00 00 00 00 00 00 00
8041- 00 00 00 00 00 00 00 00
8042- 00 00 00 00 00 00 00 00
8043- 00 00 00 00 00 00 00 00
8044- 00 00 00 00 00 00 00 00
8045- 00 00 00 00 00 00 00 00
8046- 00 00 00 00 00 00 00 00
8047- 00 00 00 00 00 00 00 00
8048- 00 00 00 00 00 00 00 00
8049- 00 00 00 00 00 00 00 00
804A- 00 00 00 00 00 00 00 00
804B- 00 00 00 00 00 00 00 00
804C- 00 00 00 00 00 00 00 00
804D- 00 00 00 00 00 00 00 00
804E- 00 00 00 00 00 00 00 00
804F- 00 00 00 00 00 00 00 00
8050- 00 00 00 00 00 00 00 00
8051- 00 00 00 00 00 00 00 00
8052- 00 00 00 00 00 00 00 00
8053- 00 00 00 00 00 00 00 00
8054- 00 00 00 00 00 00 00 00
8055- 00 00 00 00 00 00 00 00
8056- 00 00 00 00 00 00 00 00
8057- 00 00 00 00 00 00 00 00
8058- 00 00 00 00 00 00 00 00
8059- 00 00 00 00 00 00 00 00
805A- 00 00 00 00 00 00 00 00
805B- 00 00 00 00 00 00 00 00
805C- 00 00 00 00 00 00 00 00
805D- 00 00 00 00 00 00 00 00
805E- 00 00 00 00 00 00 00 00
805F- 00 00 00 00 00 00 00 00
8060- 00 00 00 00 00 00 00 00
8061- 00 00 00 00 00 00 00 00
8062- 00 00 00 00 00 00 00 00
8063- 00 00 00 00 00 00 00 00
8064- 00 00 00 00 00 00 00 00
8065- 00 00 00 00 00 00 00 00
8066- 00 00 00 00 00 00 00 00
8067- 00 00 00 00 00 00 00 00
8068- 00 00 00 00 00 00 00 00
8069- 00 00 00 00 00 00 00 00
806A- 00 00 00 00 00 00 00 00
806B- 00 00 00 00 00 00 00 00
806C- 00 00 00 00 00 00 00 00
806D- 00 00 00 00 00 00 00 00
806E- 00 00 00 00 00 00 00 00
806F- 00 00 00 00 00 00 00 00
8070- 00 00 00 00 00 00 00 00
8071- 00 00 00 00 00 00 00 00
8072- 00 00 00 00 00 00 00 00
8073- 00 00 00 00 00 00 00 00
8074- 00 00 00 00 00 00 00 00
8075- 00 00 00 00 00 00 00 00
8076- 00 00 00 00 00 00 00 00
8077- 00 00 00 00 00 00 00 00
8078- 00 00 00 00 00 00 00 00
8079- 00 00 00 00 00 00 00 00
807A- 00 00 00 00 00 00 00 00
807B- 00 00 00 00 00 00 00 00
807C- 00 00 00 00 00 00 00 00
807D- 00 00 00 00 00 00 00 00
807E- 00 00 00 00 00 00 00 00
807F- 00 00 00 00 00 00 00 00
8080- 00 00 00 00 00 00 00 00
8081- 00 00 00 00 00 00 00 00
8082- 00 00 00 00 00 00 00 00
8083- 00 00 00 00 00 00 00 00
8084- 00 00 00 00 00 00 00 00
8085- 00 00 00 00 00 00 00 00
8086- 00 00 00 00 00 00 00 00
8087- 00 00 00 00 00 00 00 00
8088- 00 00 00 00 00 00 00 00
8089- 00 00 00 00 00 00 00 00
808A- 00 00 00 00 00 00 00 00
808B- 00 00 00 00 00 00 00 00
808C- 00 00 00 00 00 00 00 00
808D- 00 00 00 00 00 00 00 00
808E- 00 00 00 00 00 00 00 00
808F- 00 00 00 00 00 00 00 00
8090- 00 00 00 00 00 00 00 00
8091- 00 00 00 00 00 00 00 00
8092- 00 00 00 00 00 00 00 00
8093- 00 00 00 00 00 00 00 00
8094- 00 00 00 00 00 00 00 00
8095- 00 00 00 00 00 00 00 00
8096- 00 00 00 00 00 00 00 00
8097- 00 00 00 00 00 00 00 00
8098- 00 00 00 00 00 00 00 00
8099- 00 00 00 00 00 00 00 00
809A- 00 00 00 00 00 00 00 00
809B- 00 00 00 00 00 00 00 00
809C- 00 00 00 00 00 00 00 00
809D- 00 00 00 00 00 00 00 00
809E- 00 00 00 00 00 00 00 00
809F- 00 00 00 00 00 00 00 00
80A0- 00 00 00 00 00 00 00 00
80A1- 00 00 00 00 00 00 00 00
80A2- 00 00 00 00 00 00 00 00
80A3- 00 00 00 00 00 00 00 00
80A4- 00 00 00 00 00 00 00 00
80A5- 00 00 00 00 00 00 00 00
80A6- 00 00 00 00 00 00 00 00
80A7- 00 00 00 00 00 00 00 00
80A8- 00 00 00 00 00 00 00 00
80A9- 00 00 00 00 00 00 00 00
80AA- 00 00 00 00 00 00 00 00
80AB- 00 00 00 00 00 00 00 00
80AC- 00 00 00 00 00 00 00 00
80AD- 00 00 00 00 00 00 00 00
80AE- 00 00 00 00 00 00 00 00
80AF- 00 00 00 00 00 00 00 00
80B0- 00 00 00 00 00 00 00 00
80B1- 00 00 00 00 00 00 00 00
80B2- 00 00 00 00 00 00 00 00
80B3- 00 00 00 00 00 00 00 00
80B4- 00 00 00 00 00 00 00 00
80B5- 00 00 00 00 00 00 00 00
80B6- 00 00 00 00 00 00 00 00
80B7- 00 00 00 00 00 00 00 00
80B8- 00 00 00 00 00 00 00 00
80B9- 00 00 00 00 00 00 00 00
80BA- 00 00 00 00 00 00 00 00
80BB- 00 00 00 00 00 00 00 00
80BC- 00 00 00 00 00 00 00 00
80BD- 00 00 00 00 00 00 00 00
80BE- 00 00 00 00 00 00 00 00
80BF- 00 00 00 00 00 00 00 00
80C0- 00 00 00 00 00 00 00 00
80C1- 00 00 00 00 00 00 00 00
80C2- 00 00 00 00 00 00 00 00
80C3- 00 00 00 00 00 00 00 00
80C4- 00 00 00 00 00 00 00 00
80C5- 00 00 00 00 00 00 00 00
80C6- 00 00 00 00 00 00 00 00
80C7- 00 00 00 00 00 00 00 00
80C8- 00 00 00 00 00 00 00 00
80C9- 00 00 00 00 00 00 00 00
80CA- 00 00 00 00 00 00 00 00
80CB- 00 00 00 00 00 00 00 00
80CC- 00 00 00 00 00 00 00 00
80CD- 00 00 00 00 00 00 00 00
80CE- 00 00 00 00 00 00 00 00
80CF- 00 00 00 00 00 00 00 00
80D0- 00 00 00 00 00 00 00 00
80D1- 00 00 00 00 00 00 00 00
80D2- 00 00 00 00 00 00 00 00
80D3- 00 00 00 00 00 00 00 00
80D4- 00 00 00 00 00 00 00 00
80D5- 00 00 00 00 00 00 00 00
80D6- 00 00 00 00 00 00 00 00
80D7- 00 00 00 00 00 00 00 00
80D8- 00 00 00 00 00 00 00 00
80D9- 00 00 00 00 00 00 00 00
80DA- 00 00 00 00 00 00 00 00
80DB- 00 00 00 00 00 00 00 00
80DC- 00 00 00 00 00 00 00 00
80DD- 00 00 00 00 00 00 00 00
80DE- 00 00 00 00 00 00 00 00
80DF- 00 00 00 00 00 00 00 00
80E0- 00 00 00 00 00 00 00 00
80E1- 00 00 00 00 00 00 00 00
80E2- 00 00 00 00 00 00 00 00
80E3- 00 00 00 00 00 00 00 00
80E4- 00 00 00 00 00 00 00 00
80E5- 00 00 00 00 00 00 00 00
80E6- 00 00 00 00 00 00 00 00
80E7- 00 00 00 00 00 00 00 00
80E8- 00 00 00 00 00 00 00 00
80E9- 00 00 00 00 00 00 00 00
80EA- 00 00 00 00 00 00 00 00
80EB- 00 00 00 00 00 00 00 00
80EC- 00 00 00 00 00 00 00 00
80ED- 00 00 00 00 00 00 00 00
80EE- 00 00 00 00 00 00 00 00
80EF- 00 00 00 00 00 00 00 00
80F0- 00 00 00 00 00 00 00 00
80F1- 00 00 00 00 00 00 00 00
80F2- 00 00 00 00 00 00 00 00
80F3- 00 00 00 00 00 00 00 00
80F4- 00 00 00 00 00 00 00 00
80F5- 00 00 00 00 00 00 00 00
80F6- 00 00 00 00 00 00 00 00
80F7- 00 00 00 00 00 00 00 00
80F8- 00 00 00 00 00 00 00 00
80F9- 00 00 00 00 00 00 00 00
80FA- 00 00 00 00 00 00 00 00
80FB- 00 00 00 00 00 00 00 00
80FC- 00 00 00 00 00 00 00 00
80FD- 00 00 00 00 00 00 00 00
80FE- 00 00 00 00 00 00 00 00
80FF- 00 00 00 00 00 00 00 00

```

operating modes. From this second level you may save a HIRES screen to disk or load one into memory from disk, and you may enter a new schematic, edit one already in memory, or return to the first menu. If you select the enter or edit mode, you will next see the HIRES screen either blank or with the last schematic you put there. You also will see a small arrow and a three-digit number in the upper-left corner of the screen. The arrow indicates the rotation applied to the next shape to be drawn, and it may be turned by pressing the R key. The

three-digit number shows the shape number to plot next.

To plot a shape, move the cursor to the desired place on the screen using the I, J, K, and M keys. Enter the shape number and push P (Plot). Some other available commands are Erase, Finish, and Text. This last command puts you into the text mode so that you can add text to your schematic.

The edit commands in the text mode are similar to those in the diagram mode except that you use the CTRL key to get the function desired. To get the text onto

the screen, just type the characters desired and they will be plotted automatically. In both text and diagram modes you can move the cursor through your drawing without affecting the drawing. I have included a comprehensive set of instructions within the program and about two minutes of practice is all you will need to start diagramming. If you don't feel up to entering the EGG utility, you can always use the second method of putting the diagram into your programs.

Get some graph paper (I use paper with half-inch

squares). Position the paper with the long side horizontal and draw a grid of half-inch blocks so that you have 16 columns and 12 rows. Draw a heavy line between the second and third row from the bottom. This line is the bottom of the page 1 screen. Starting at the top left, label the first column 15, the second column 30, the third column 45, and so on until the last column is labeled 270. Starting at the top left, label the rows in a similar fashion so that the bottom row is labeled 180. Next you should make copies of this as it is your worksheet for

Program listing 2. This is a listing of the timer program discussed in the text. It works well; give it a try the next time you are playing with a 555 timer chip.

```

10 D# = "": REM D# = CONTROL D
12 P = PEEK (233)
13 IF P = 128 THEN 100
20 PRINT D#:"BLOOD SHAPEFILE 200, A#0000"
30 POKE 232,0: POKE 233,128
100 TEXT : HOME
110 P = 0
120 PRINT "    555 TIMER DESIGN PROGRAM >>>"
130 PRINT : PRINT "    <<< BILL SMITH, KJLF >>>"
140 PRINT : PRINT
150 PRINT "FIND COMPONENTS, OUTPUT KNOWN ----- 1"
200 PRINT "FIND OUTPUT, COMPONENTS KNOWN ----- 2"
210 PRINT "END PROGRAM ----- 3"
220 PRINT
230 GET A#
240 IF A# = "1" THEN 280
250 IF A# = "2" THEN 280
260 IF A# = "3" THEN 9999
270 GOTO 260
280 FOR I = 1 TO 15: PRINT : NEXT I
300 HGR
310 GOSUB 4000
320 IF A# = "1" THEN GOTO 400
340 IF A# = "2" THEN GOTO 700
360 GOTO 200
500 REM FOLLOWING PART CALCULATES RESISTOR VALUES, GIVEN OPERATING FRE
    Q, DUTY CYCLE, AND CAPACITOR VALUE
400 POKE 34,23
402 V1 = 21
403 VTAB 24
410 INPUT "FREQUENCY ":F
412 VTAB (Y1)
415 PRINT TAB( 2):F
418 VTAB 24
420 INPUT "DUTY CYCLE ( 50% ) ":D
440 IF D < = 50 THEN GOTO 420
460 IF D 100 THEN GOTO 420
455 VTAB 24: PRINT
457 VTAB (Y1): HTAB 11
469 PRINT D:"%"
480 T1 = 1 / F * D / 100
500 T2 = 1 / F - T1
510 VTAB 24: HTAB 1
511 PRINT
512 VTAB 24
520 INPUT "VALUE OF C1 IN UF ":C
530 VTAB (Y1): HTAB 16
532 PRINT C
540 R2 = T2 / (.693 * C / 1000000)
580 R1 = T1 / (.693 * C / 1000000) - R2
590 R2 = INT (R2)
600 R1 = INT (R1)
620 VTAB (Y1): HTAB 23
630 PRINT R1
632 VTAB (Y1): HTAB 32
634 PRINT R2
650 VTAB 24
660 IF R1 + R2 > 5000000 THEN PRINT "RESISTOR ARE TOO BIG "
680 INPUT "MENU OR RECALCULATE --M/R ":A#
682 IF A# = "M" THEN TEXT : GOTO 10
684 F5 = F:D5 = D:C5 = C:R5 = R1:R6 = R2
686 VTAB 21: PRINT "
687 VTAB 21
688 PRINT " :F5: TAB( 11):D5: TAB( 16):C5: TAB( 23):R5: TAB( 32):R6
690 VTAB 22: HTAB 1
691 PRINT "
694 V1 = 22
695 GOTO 403
700 REM FOLLOWING PART CALCULATES OUTPUT, ON TIME, OFF TIME, AND FREQU
    ENCY GIVEN RESISTOR AND CAPACITOR VALUES.
702 POKE 34,23
705 V1 = 21
710 REM
714 VTAB 24
720 INPUT "ENTER C1 IN UF ":C
724 VTAB (Y1): HTAB 16
728 PRINT C
730 VTAB 24
740 INPUT "ENTER R1 IN OHMS ":R1
746 VTAB (Y1): HTAB 22

```

```

748 PRINT R1
750 VTAB 24
760 INPUT "ENTER R2 IN OHMS ":R2
766 VTAB (Y1): HTAB 31
768 PRINT R2
780 T1 = .693 * C / 1000000 * (R1 + R2)
800 T2 = .693 * C / 1000000 * R2
820 D = T1 / (T1 + T2) * 100
840 D = ( INT (D * 10) ) / 10
860 F = 1 / (T1 + T2)
864 IF F < 100 THEN 880
866 F = INT (F)
870 GOTO 900
880 F = ( INT (F * 100) ) / 100
900 VTAB (Y1): HTAB 2
905 PRINT F: TAB( 10):D
907 T1 = INT (T1 * 1000000) / 1000
908 T2 = INT (T2 * 1000000) / 1000
910 VTAB 23: HTAB 1
915 PRINT "OUTPUT >>> HIGH ":T1:" MS LOW ":T2:" MS"
950 VTAB 24
955 INPUT "MENU OR RECALCULATE M/R ":A#
960 IF A# = "M" THEN 100
962 F5 = F:D5 = D:C5 = C:R5 = R1:R6 = R2
964 VTAB 21
966 PRINT "
967 VTAB 21
968 PRINT TAB( 1):F5: TAB( 10):D5: TAB( 16):C5: TAB( 22):R5: TAB( 31):
    R6
970 VTAB 23
972 PRINT "
974 VTAB 22
976 PRINT "
980 V1 = 22
990 GOTO 710
4000 REM PULSE GEN DIA.
4100 HGR
4110 SCALE = 1
4150 GOTO 4200
4200 REM >>> SUBROUTINE TO PRINT P# AS TEXT ON HIRES SCREEN
4210 P = LEN (P#)
4220 FOR I = 1 TO P
4230 IF ASC ( MID% (P#,I,1)) = 32 THEN 4260
4240 DRAW ASC ( MID% (P#,I,1)) - 31 AT X,Y
4260 X = X + 7
4270 NEXT I
4275 RETURN
4280 REM HEADER ON HIRES DRAWING
4300 P# = "
    PULSE GENERATOR DESIGN"
4310 X = 3:Y = 5: GOSUB 4210
4330 Y = Y + 9: X = 70
4340 P# = "555 TIMER CHIP"
4350 GOSUB 4210
4500 REM <<< DRAW SCHEMATIC >>>
4510 DRAW 130 AT 135,30: DRAW 107 AT 120,45: DRAW 104 AT 135,45: DRAW 1
    06 AT 150,45
4520 DRAW 102 AT 105,120: DRAW 71 AT 150,120: DRAW 74 AT 105,135: DRAW
    74 AT 150,135
4530 DRAW 107 AT 105,60: DRAW 106 AT 120,60: DRAW 69 AT 150,60
4570 DRAW 116 AT 105,75: DRAW 117 AT 120,75: DRAW 101 AT 135,75: DRAW 1
    06 AT 150,75
4580 DRAW 129 AT 75,90: DRAW 101 AT 90,90: DRAW 122 AT 105,90: DRAW 124
    AT 120,90: DRAW 108 AT 135,90: DRAW 69 AT 150,90
4590 DRAW 119 AT 105,105: DRAW 118 AT 120,105: DRAW 104 AT 135,105: DRAW
    106 AT 150,105
4600 REM <<< LABEL SCHEMATIC >>>
4650 X = 145:Y = 30:P# = "R1": GOSUB 4210
4655 X = 160:Y = 60:P# = "R1": GOSUB 4210
4660 X = 160:Y = 90:P# = "R2": GOSUB 4210
4665 X = 160:Y = 120:P# = "C1": GOSUB 4210
4670 DRAW 24 AT 131,80
4675 DRAW 23 AT 131,95
4680 DRAW 19 AT 131,110
4685 DRAW 18 AT 100,116
4690 DRAW 20 AT 92,85
4695 DRAW 21 AT 109,64
4700 DRAW 25 AT 124,64
4945 X = 35:Y = 80
4950 P# = "SIGNAL"
4955 GOSUB 4210
4960 X = 50:Y = 89
4965 P# = "OUT"
4970 GOSUB 4210
4975 P# = " FREQ DUTY C1 R1 R2"
4980 X = 3:Y = 147: GOSUB 4210
4990 P# = " HZ CYCLE UF OHMS OHMS"
4995 X = 3:Y = 155: GOSUB 4210
5999 RETURN
9999 END

```

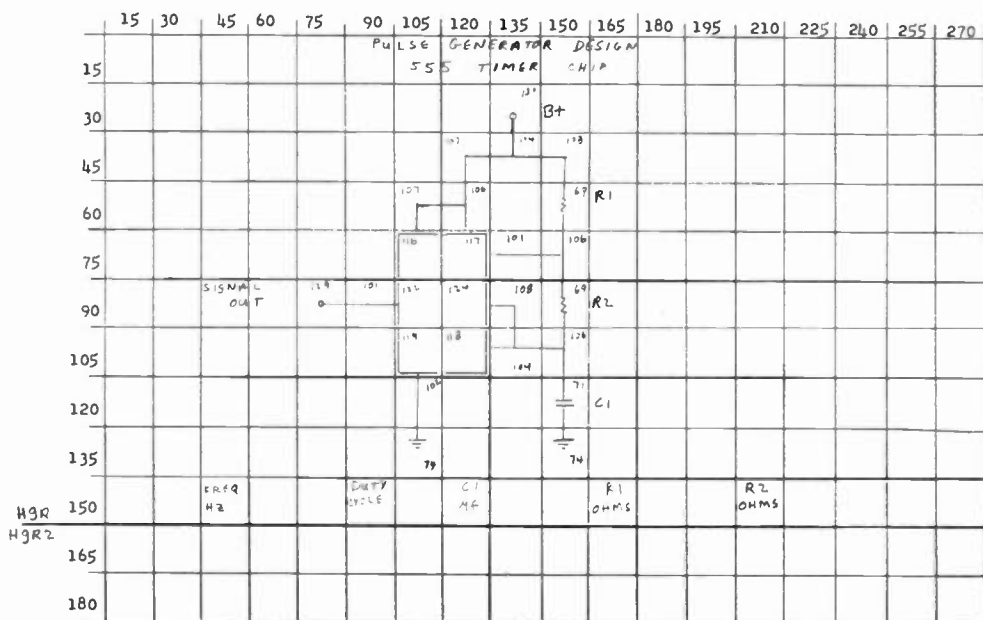

Fig. 3. Example of the worksheet discussed in the text. The diagram is that of the schematic used in the timer program listed with this article.

drawing and inputting schematics. (See Fig. 3.)

As an example of how to correctly use the worksheet, I have included my timer program in Fig. 3 and will step you through the proce-

cedure for implementing the schematic in that program. Notice that each shape making up the circuit is centered within a block so that its leads will exit in the middle of a side rather than at a cor-

ner. First, draw the diagram on the worksheet using only shapes from the shapetile. Next, label each shape with its corresponding number. Now enter any labels or text desired.

The next step is to enter the worksheet information into your program. In my example program (Program listing 2), the HIRES portion is located beginning on line 4000 and extends to the end of the program. Lines 4500 through 4590 draw the actual shapes. The easiest way to do this is draw all of the shapes on each worksheet row using one program line. This speeds up the programming process considerably when it comes to editing. Sometimes, when a row has only one shape, I will include that shape with the next row (such as line 4510 which draws the shapes for rows 30 and 45).

Lines 4200 through 4275 are a subroutine which makes the printing of text very easy. It takes the string P\$ and prints it with normal character spacing beginning at the last values of X and Y. This subroutine will allow you to input only one line of text at a time. Additional

Program listing 3. Here is the ECG draw-and-edit program listing. See text for a description of how it works.

```

100  HOME :DS# = CHR#(4): DIM N#(4): DIM M#(4)
110  FOR I = 1 TO 4:N#(I) = 17:M#(I) = "":NEXT I
120  P = PEE#(273): HCOLOR = 3: SCALE = 1
130  IF P = 128 THEN 500
140  PRINT DS#:"LOAD SHAPETILE 2000,4000"
150  POKE 312,0: POKE 313,128
160  HOME : PRINT
170  PRINT " ELECTRONIC GRAPHICS GENERATOR "
180  PRINT : PRINT " BY BILL SMITH, ECLF "
190  PRINT : PRINT : PRINT
200  PRINT "HIRES PAGE 1 - TEXT "
210  PRINT "HIRES PAGE 1 FULL SCREEN "
220  PRINT "HIRES PAGE 2 "
230  PRINT "INSTRUCTIONS "
240  PRINT "END "
250  PRINT
260  GET M# : M = VAL (M#) : PRINT
270  ON M GOTO 1000,2000,3000,4000,5000
280  GOTO 550
290  PRINT : PRINT : PRINT
300  PRINT "INPUT NEW SCHEMATIC "
310  PRINT "EDIT SCHEMATIC IN MEMORY "
320  PRINT "SAVE DIAGRAM TO DISK "
330  PRINT "LOAD DIAGRAM FROM DISK "
340  PRINT "RETURN TO MAIN MENU "
350  PRINT
360  RETURN
1000 HOME
1010 PRINT " "
1020 PRINT "HIRES PAGE 1 - TEXT "
1030 PRINT " "
1040 GOSUB 700
1050 GET M# : M = VAL (M#) : PRINT
1060 ON M GOTO 1200,1400,1500,1600,500
1070 FS# = 1: HGR : GOSUB 6000
1080 TEXT : GOTO 1000
1090 IF FS# = 1 THEN 1450
1100 PRINT : INVERSE : PRINT " NO DIAGRAM IN MEMORY " : NORMAL :
1110 FOR I = 1 TO 400: NEXT I: GOTO 1000
1120 POKE = 16300,0: POKE = 16300,0: POKE = 16297,0: POKE = 16304,
0: GOSUB 6000
1130 TEXT : GOTO 1000
1140 GOSUB 8000
1150 GOTO 1000
1160 HGR : FS# = 1: POKE = 16300,0: POKE = 16300,0: GOSUB 8100
1170 HOME : GOTO 1000
1180 HOME
1190 PRINT " "
1200 PRINT "HIRES PAGE 1 - FULL SCREEN "
1210 PRINT " "
1220 GOSUB 700
1230 GET M# : M = VAL (M#) : PRINT
1240 ON M GOTO 2200,2400,2500,2600,500
1250 FS# = 2: HGR : POKE = 16302,0: GOSUB 6000
1260 TEXT : GOTO 2000
1270 IF FS# = 2 THEN 2450
1280 PRINT : INVERSE : PRINT " NO DIAGRAM IN MEMORY " : NORMAL :
1290 FOR I = 1 TO 400: NEXT I: GOTO 2000
1300 POKE = 16304,0: POKE = 16302,0: POKE = 16300,0: POKE = 16297,
0: GOSUB 6000

```

```

1400 TEXT : GOTO 2000
1410 GOSUB 8100
1420 GOTO 2000
1430 HGR : FS# = 2: POKE = 16302,0: POKE = 16300,0: GOSUB 8100
1440 HOME : GOTO 2000
1450 HOME
1460 PRINT " "
1470 PRINT "HIRES PAGE 2 "
1480 PRINT " "
1490 GOSUB 700
1500 GET M# : M = VAL (M#) : PRINT
1510 ON M GOTO 3200,3400,3500,3600,500
1520 FS# = 3: HGR2 : GOSUB 6000
1530 TEXT : GOTO 3000
1540 IF FS# = 3 THEN 3450
1550 PRINT : INVERSE : PRINT " NO DIAGRAM IN MEMORY " : NORMAL :
1560 FOR I = 1 TO 400: NEXT I: GOTO 3000
1570 POKE = 16302,0: POKE = 16299,0: POKE = 16297,0: POKE = 16304,
0: GOSUB 6000
1580 TEXT : GOTO 3000
1590 GOSUB 8100
1600 GOTO 3000
1610 HGR : FS# = 3: POKE = 16303,0: POKE = 16300,0: GOSUB 8100
1620 HOME : GOTO 3000
1630 HOME : REM INSTRUCTIONS
1640 PRINT " " : INVERSE : PRINT " INSTRUCTIONS " : NORMAL :
1650 PRINT : PRINT : PRINT
1660 PRINT " " : INVERSE : PRINT " HIRES SCHEMATIC SHAPES " : NORMAL :
1670 PRINT : PRINT : PRINT
1680 PRINT " I " : CURSOR UP : PRINT " J " : CURSOR LEFT :
1690 PRINT " K " : CURSOR DOWN : PRINT " M " : CURSOR RIGHT :
1700 PRINT " R " : ROTATE SHAPE (SEE ARROW) : PRINT " E " :
1710 PRINT " F " : FINISH (RETURN TO MENU) : PRINT " P " :
1720 PRINT " T " : TEXT MODE : PRINT
1730 PRINT " 0 " : ENTER SHAPE NUMBER "
1740 GOSUB 4300
1750 HOME : PRINT " " : INVERSE : PRINT " INSTRUCTION " : NORMAL :
1760 PRINT : PRINT " " : INVERSE : PRINT " HIRES TEXT MODE " : NORMAL :
1770 PRINT
1780 PRINT "CTRL" : PRINT " I " : CURSOR UP : PRINT " J " :
1790 PRINT " K " : CURSOR LEFT : PRINT " L " : CURSOR RIGHT :
1800 PRINT " M " : CURSOR DOWN : PRINT
1810 PRINT " R " : ROTATE TEXT : PRINT " E " : ERA
1820 PRINT " F " : FINISH (GO TO SHAPES) : PRINT
1830 PRINT "ESC" : MOVE CURSOR ONE PIXEL ONLY : PRINT " I " :
1840 PRINT " J " : CURSOR UP : PRINT " K " : CURSOR LEFT : PRINT " L " :
1850 PRINT " M " : CURSOR RIGHT : PRINT " N " : CURSOR DOWN
1860 GOSUB 4300
1870 GOTO 500
1880 P = PEE#(1 - 16384) : POKE = 16368,0: IF P = 127 THEN RETURN
1890 GOTO 4700
1900 PRINT "5000" : END
1910 REM SUBROUTINE TO DRAW SHAPES
1920 X = 0: Y = 15: ROT = 0:0:0:0:FRZ = 0: XDRAW 66 AT 3,3: X = 12
1930 FOR I = 1 TO 4:N#(I) = "0":M#(I) = 17: NEXT I
1940 FOR I = 2 TO 4: XDRAW 17 AT X1,3: X1 = X1 + 7: NEXT
1950 C1 = 1
1960 X = X + 15: IF X = 270 THEN 6200
1970 X = 15: Y = Y + 15: IF FS# = 1 AND Y = 165 THEN Y = 15
1980 IF Y = 195 THEN Y = 15
1990 XDRAW 127 AT X,Y: IF C1 = 1 THEN C1 = 2: GOTO 6250

```

lines may be processed automatically by incrementing Y when the value of X gets to 274. Lines 4280 through 4350 print the header on the diagram using P\$ and the line 4200 subroutine. Lines 4600 through to the end are the labels for the schematic and the remainder of the text on the HIRES screen.

The schematic for my timer program is small enough so that I was able to use HIRES page 1 and use the four text lines at the bottom for my calculations. This is a very convenient set-up as I can see the diagram at the same time I am calculating values. To get the most out of the four lines below the HIRES screen, I put the column headings directly on the HIRES screen at the bottom. Most of my programs with schematics require that the calculations be displayed on page 1 of text while the schematic is on the full-screen HIRES page 2. In these programs I

include a small subroutine which allows me to flip between the schematic and the calculations. This is accomplished by checking each input to the calculations for an ESC. When one is encountered, use the "soft switches" described on pages 12 and 13 of the Apple reference manual to display the desired HIRES page. To return to the calculations, use the same system. Check for the ESC key to be depressed, then use the soft switches to display text page 1. This method will leave your calculations intact while you examine the circuit and you will have to draw the circuit only once as it is preserved unchanged.

Most of the shapes in the shapefile are self-explanatory, but there are a few requiring comments. Shape 70 is a variable resistor. If you connect a lead to the left side, it will appear as a regular potentiometer. Shape 79

PULSE GENERATOR DESIGN 555 TIMER CHIP

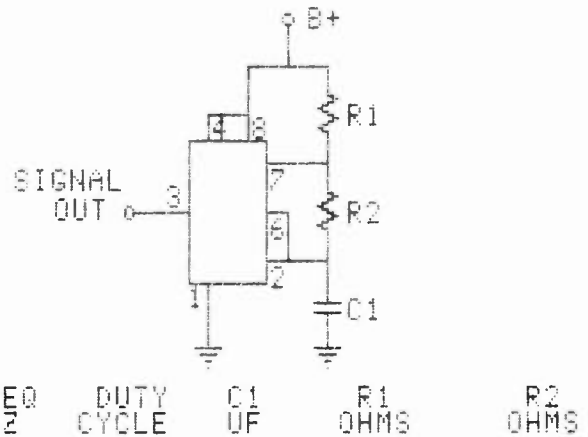

Fig. 4. Actual HIRES screen of the schematic used in the timer program. See Fig. 3 for the worksheet used to develop this schematic.

can be used for coils, transformers, or chokes. Shapes 84, 85, and 86 are leads to be used with the op amp, shape 83. Using these leads will allow you to connect the op amp to other components using the standard configuration. Shape 88 is a bridge rectifier, while shape 89 can

be used for meters and other round items.

Shapes 93 through 99 are for transistors and FETs. To draw a transistor, you must combine four shapes, but they make very nice transistors. I use shapes 116 through 119 to draw ICs.

```

6220 C1 = 1
6250 FOR I = 1 TO 15: P = PEEK ( - 16384): NEXT I
6260 POKE - 16368, 0
6300 IF P < 127 THEN 6290
6310 IF P < 175 AND P < 186 THEN GOSUB 6000
6370 IF C1 = 0 THEN XDRAW 127 AT X,Y: C1 = 1
6380 IF P < 160 THEN 6110: REM SPACE BAR
6370 IF P < 200 THEN 6380: REM PLOT
6375 IF N0 < 1 AND N0 < 132 THEN ROT = FRZ: XDRAW N0 AT X,Y: GOTO 6110

6380 IF P = 155 THEN 7000: REM ESC TO TEXT
6410 IF P = 201 THEN 6430: REM I
6415 Y = Y - 15
6418 IF Y = 0 AND FSX = 1 THEN Y = 150
6420 IF Y = 0 THEN Y = 180
6425 GOTO 6200
6430 IF P < 202 THEN 6450: REM J
6440 X = X - 15: IF X = 0 THEN X = 15
6445 GOTO 6200
6450 IF P < 203 THEN 6110: REM F
6470 IF P < 205 THEN 6490: REM M
6480 Y = Y + 15: IF Y = 165 AND FSX = 1 THEN Y = 15
6482 IF Y = 195 THEN Y = 15
6485 GOTO 6200
6490 IF P < 197 THEN 6510: REM E
6495 MZ(X / 15, Y / 15) = 0: DRAW 126 AT X,Y: XDRAW 126 AT X,Y: GOTO 6200

6510 IF P < 210 THEN 6530: REM R
6515 XDRAW 66 AT 3,3
6520 FRZ = FRZ + 16: IF FRZ = 64 THEN FRZ = 0
6528 ROT = FRZ: XDRAW 66 AT 3,3: GOTO 6200
6530 IF P < 198 THEN 6540: REM F
6535 FOR I = 0 TO B: DRAW 68 AT ((I * 5) + 3),3: XDRAW 68 AT ((I * 5) + 3),3: NEXT I: RETURN
6540 IF P = 211 THEN 6700: REM SHIFT
6599 GOTO 6200
6700 REM MOVE ROUTINE
6710 GOTO 6200
6800 N(1) = P - 159
6810 X1 = 12: V1 = 3: ROT = 0
6820 FOR I = 4 TO 2 STEP - 1: XDRAW N(I) AT X1,3: N(I) = N(I - 1): XDRAW N(I) AT X1,3: X1 = X1 + 7: NEXT I
6890 ROT = FRZ
6910 FOR I = 1 TO 4: N(I) = STR$(N(I) - 17): NEXT I
6920 N0 = N0(4) + N1(3) + N2(2): N0 = VAL(N00): ROT = FRZ
6999 RETURN
7000 REM PROCESS TEXT
7010 X2 = - 3: Y2 = 11
7070 C2 = 1
7100 X2 = X2 + 6: IF X2 < 274 THEN 7200
7120 X2 = 3: Y2 = Y2 + 8
7130 IF Y2 > 155 AND FSX = 1 THEN Y2 = 11
7140 IF Y2 > 187 THEN Y2 = 11
7200 XDRAW 68 AT X2,Y2
7210 IF C2 = 1 THEN C2 = 2: GOTO 7230
7220 C2 = 1
7230 FOR I = 1 TO 20: P = PEEK ( - 16384): NEXT I: POKE - 16368, 0
7250 IF P < 127 THEN 7200
7260 IF C2 = 2 THEN XDRAW 68 AT X2,Y2: IF C2 = 2 THEN C2 = 1
7400 IF P < 160 AND P < 221 THEN GOTO 7000
7410 IF P = 221 THEN 7120
7420 IF P < 160 THEN 7100
7430 IF P < 136 THEN 7440
7435 X2 = X2 - 6: IF X2 < 3 THEN X2 = 3

```

```

7436 DRAW 68 AT X2,Y2: XDRAW 68 AT X2,Y2: GOTO 7000
7440 IF P = 149 THEN X2 = X2 + 6: IF X2 < 275 THEN X2 = 275: GOTO 7200

7450 IF P = 137 THEN 7460
7455 Y2 = Y2 - 8: IF Y2 < 11 THEN Y2 = 11: GOTO 7200
7460 IF P = 158 THEN 7470
7465 X2 = X2 - 6: IF X2 < 3 THEN X2 = 3: GOTO 7200
7470 IF P = 159 THEN 7480
7475 X2 = X2 + 6: IF X2 < 274 THEN X2 = 274: GOTO 7200
7480 IF P = 141 THEN 7490
7485 Y2 = Y2 + 8: IF Y2 > 155 AND FSX = 1 THEN Y2 = 155: IF Y2 > 188 THEN
Y2 = 188: GOTO 7200
7490 IF P = 155 THEN 7500
7500 GET E: E = ASC(E)
7510 IF E = 73 THEN 7520
7515 Y2 = Y2 + 11: IF Y2 < 11 AND FSX = 1 THEN Y2 = 154: IF Y2 < 11 THEN
Y2 = 11
7516 GOTO 7200
7520 IF E = 74 THEN 7530
7525 X2 = X2 - 1: IF X2 < 3 THEN X2 = 3
7526 GOTO 7200
7530 IF E = 75 THEN 7540
7535 X2 = X2 + 1: IF X2 < 275 THEN X2 = 275
7536 GOTO 7200
7540 IF E = 77 THEN 7550
7545 Y2 = Y2 + 1: IF Y2 > 154 AND FSX = 1 THEN Y2 = 11: IF Y2 > 188 THEN
Y2 = 11
7546 GOTO 7200
7550 IF P = 133 THEN 7560
7555 DRAW 68 AT X2,Y2: XDRAW 68 AT X2,Y2: GOTO 7200
7560 IF P = 130 THEN 7570
7565 XDRAW 68 AT X2,Y2: GOTO 7100
7570 IF P = 134 THEN GOTO 6200
7580 IF P = 146 THEN 7600
7585 XDRAW 66 AT 3,3: FRZ = FRZ + 16: IF FRZ = 64 THEN FRZ = 0
7590 ROT = FRZ: XDRAW 66 AT 3,3: GOTO 7200
7600 GOTO 7200
7600 XDRAW P - 159 AT X2,Y2: GOTO 7100
8000 PRINT: PRINT: INPUT "ENTER FILE NAME (M FOR MENU) : " P$
8010 IF P$ = "" THEN RETURN
8020 IF FSX = 0 THEN 8140
8025 P$ = "BLOOD " + P$ + ",A$4000,L$2000"
8030 PRINT DEF: HOME: RETURN
8040 P$ = "SUSPENSE " + P$ + ",A$4000,L$2000"
8050 PRINT DEF: HOME: RETURN
8100 PRINT: PRINT: INPUT "ENTER FILE NAME TO LOAD (M - MENU) : " P1$
8110 IF P1$ = "" THEN RETURN
8120 IF FSX = 0 THEN 8150
8125 DNERR: GOTO 8190
8130 P$ = "BLOOD " + P$ + ",A$4000"
8140 RETURN
8146 RETURN
8150 P$ = "BLOOD " + P$ + ",A$4000"
8155 DNERR: GOTO 8190
8160 PRINT D$: P$
8180 RETURN
8190 PRINT: INVERSE: PRINT " FILE NOT FOUND " : NORMAL: FOR I = 1 TO 800: NEXT I
8194 IF FSX = 1 THEN GOTO 1000
8195 IF FSX = 2 THEN GOTO 2000
8196 IF FSX = 3 THEN GOTO 3000

```

WATCH FOR HAL'S NEW PRODUCTS

HAL 2304 MHz DOWN CONVERTERS (FREQ. RANGE 2000/2500 MHz)	
2304 MODEL #1 KIT BASIC UNIT W/PREAMP LESS HOUSING & FITTINGS	\$19.95
2304 MODEL #2 KIT (with preamp)	\$29.95
2304 MODEL #3 KIT (with High Gain preamp)	\$39.95
MODELS 2 & 3 WITH COAX FITTINGS IN & OUT AND WITH WEATHER-PROOFED DIE CAST HOUSINGS	
BASIC POWER SUPPLY	\$19.95
POWER SUPPLY KIT FOR ABOVE WITH CASE	\$24.95
FACTORY WIRED & TESTED	\$34.95

ANTENNAS & OTHER ACCESSORIES AVAILABLE. SEND FOR MORE INFO.

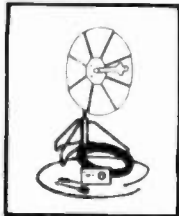

2100-2500 MHZ

*HMR-II COMPLETE UNIT
COMPLETE SYSTEM AS SHOWN. NOT A KIT, INCLUDES A PC BOARD, POWER SUPPLY, CABLES & CONNECTORS—PRE-ASSEMBLED AND TESTED. 24dB GAIN OR GREATER.

1-4 units	\$89.95 ea.
5 or more units	\$79.95 ea.

*HAM MICROWAVE RECEIVER

PRE-SCALER KITS

HAL 300 PRE	(Pre-drilled G-10 board and all components)	\$14.95
HAL 300 A/PRE	(Same as above but with preamp)	\$24.95
HAL 600 PRE	(Pre-drilled G-10 board and all components)	\$29.95
HAL 600 A/PRE	(Same as above but with preamp)	\$39.95

TOUCH TONE DECODER KIT

HIGHLY STABLE DECODER KIT. COMES WITH 2 SIDED, PLATED THRU AND SOLDER FLOWED G-10 PC BOARD, 7-567's, 2-7402, AND ALL ELECTRONIC COMPONENTS. BOARD MEASURES 3-1/2 x 5-1/2 INCHES. HAS 12 LINES OUT. ONLY \$39.95

NEW—16 LINE DELUXE DECODER	\$69.95
DELUXE 12-BUTTON TOUCHTONE ENCODER KIT UTILIZING THE NEW ICM 7206 CHIP PROVIDES BOTH VISUAL AND AUDIO INDICATIONS! COMES WITH ITS OWN TOUCH-TONE ANODIZED ALUMINUM CABINET MEASURES ONLY 2 3/4" x 3 3/4" COMPLETE WITH TOUCH-TONE PAD, BOARD, CRYSTAL, CHIP AND ALL NECESSARY COMPONENTS TO FINISH THE KIT.	PRICED AT \$29.95
NEW—16 LINE DELUXE ENCODER	\$39.95
HAL ECD—16 LINE DELUXE ENCODER INCLUDES PC BOARD, ALL PARTS & CASE	\$39.95
HAL ECD—12 LINE DELUXE ENCODER COMPLETE WITH PC BOARD, ALL PARTS & CASE	\$29.95

ACCUCKEYER (KIT) THIS ACCUCKEYER IS A REVISED VERSION OF THE VERY POPULAR WB4VVF ACCUCKEYER ORIGINALLY DESCRIBED BY JAMES GARRETT, IN QST MAGAZINE AND THE 1975 RADIO AMATEUR'S HANDBOOK \$16.95

ACCUCKEYER—MEMORY OPTION KIT PROVIDES A SIMPLE, LOW COST METHOD OF ADDING MEMORY CAPABILITY TO THE WB4VVF ACCUCKEYER. WHILE DESIGNED FOR DIRECT ATTACHMENT TO THE ABOVE ACCUCKEYER, IT CAN ALSO BE ATTACHED TO ANY STANDARD ACCUCKEYER BOARD WITH LITTLE DIFFICULTY \$16.95

BUY BOTH THE MEMORY AND THE KEYS AND SAVE
COMBINED PRICE ONLY \$32.00

PRE-AMPLIFIER

HAL-PA-19 WIDE BAND PRE-AMPLIFIER, 2-2000 MHz BANDWIDTH (-3dB POINTS), 19 dB GAIN

FULLY ASSEMBLED AND TESTED \$8.95

HAL-PA-14 WIDE BAND PRE-AMPLIFIER, 10 MHz TO 1.4 GHz, 12dB GAIN
FULLY ASSEMBLED \$12.95

CLOCK KIT—HAL 79 FOUR-DIGIT SPECIAL—\$7.95. OPERATES ON 12-VOLT AC (NOT SUPPLIED) PROVISIONS FOR DC AND ALARM OPERATION.

6-DIGIT CLOCK • 12/24 HOUR

COMPLETE KIT CONSISTING OF 2 PC G-10 PRE-DRILLED PC BOARDS, 1 CLOCK CHIP, 6 FND COMM. CATH. READOUTS, 13 TRANS., 3 CAPS, 9 RESISTORS, 5 DIODES, 3 PUSHBUTTON SWITCHES AND INSTRUCTIONS. DON'T BE FOOLED BY PARTIAL KITS WHERE YOU HAVE TO BUY EVERYTHING EXTRA. WILL RUN OFF ANY 12-VOLT AC SUPPLY. PRICED AT \$12.95

CLOCK CASE AVAILABLE AND WILL FIT ANY ONE OF THE ABOVE CLOCKS. REGULAR PRICE... \$6.50 BUT ONLY \$4.50 WHEN BOUGHT WITH CLOCK.

SIX-DIGIT ALARM CLOCK KIT FOR HOME, CAMPER, RV, OR FIELD-DAY USE. OPERATES ON 12-VOLT AC OR DC, AND HAS ITS OWN 60-Hz TIME BASE ON THE BOARD. COMPLETE WITH ALL ELECTRONIC COMPONENTS AND TWO-PIECE, PRE-DRILLED PC BOARDS. BOARD SIZE 4" x 3". COMPLETE WITH SPEAKER AND SWITCHES. IF OPERATED ON DC, THERE IS NOTHING MORE TO BUY.

PRICED AT \$16.95

*TWELVE-VOLT AC LINE CORD FOR THOSE WHO WISH TO OPERATE THE CLOCK FROM 110-VOLT AC WHEN PURCHASED WITH CLOCK KIT \$2.95

SHIPPING INFORMATION: ORDERS OVER \$25 WILL BE SHIPPED POST-PAID EXCEPT ON ITEMS WHERE ADDITIONAL CHARGES ARE REQUESTED. ON ORDERS LESS THAN \$25, PLEASE INCLUDE ADDITIONAL \$2.00 FOR HANDLING AND MAILING CHARGES. SEND 20¢ STAMP FOR FREE FLYER.

DISTRIBUTOR FOR
Aluma Tower • AP Products
(We have the new Hobby-Blox System)

HAL-TRONIX
P. O. BOX 1101
SOUTHGATE, MICH. 48195
PHONE (313) 285-1782



"HAL" HAROLD C. NOWLAND
W8ZXH

✓ 31

This allows enough room to label the pins clearly. The remainder of the shapes should be fairly self-explanatory, and if you are not sure about what a shape does, just try drawing it on your computer. If you want to add shapes to your shapefile, you should consult your Apple reference manuals and be familiar with shapetables. To conform to my system, the new shape should be drawn on a 15 x 15 grid and the origin of the shape should lie at the center (coordinates 8,8). Also remember to have all leads exit at the middle of a side. In setting up the shapetable listed here, I used a program from *Micro Magazine*, September, 1980, called "Creating Shape Tables, Improved," by Peter A. Cook.

I have listed the shapefile beginning at \$8000. Note the \$00 beginning at \$810c and extending to \$8193. These 00s are necessary for proper operation, and this is the

space set aside to address additional shapes which might be added to the end of the table in the future. If you enter this shapetable by hand, you can edit the shapes by remembering that each shape is separated by a hex 00. If you have a problem with, for example, shape #9, find the ninth set of hex 00s in the listing and you will be looking in the correct area. This shapetable is quite lengthy so I will make a copy available on disk. If you send me \$12.00, I'll send you a copy of the shapetable and the EGG utility program. In addition, I will include a copy of the timer program and a couple of copies of my worksheet. The timer program and the EGG utility are written in Applesoft BASIC and recorded using DOS 3.3. I hope you get as much utility out of my EGG as I have; it will add a whole new dimension to your programs with a minimum of effort. ■

ALL NEW H.F. 10/160 METER SOLID STATE P.L.L. TRANSCEIVER

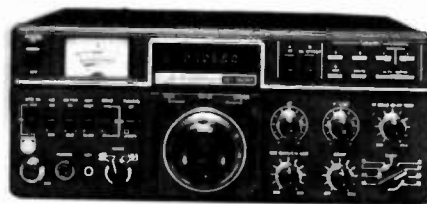

Model 10/160 M

USB-LSB

4 Memories
3 Way Auto-Scan
Includes New Bands
3-Step Tuning Speed
IF Tune ± 1 KHZ
Built-in Dual VFO
Narrow CW filter optional

CW-W CW-N

200 W. PEP (160M-12M)
100 W. PEP (10M)
Built-in Power Supply
AC-120 VAC
DC-13.8 V -Ground
External ALC & Relay
RTTY, FAX, ASCII



JUST SLIGHTLY AHEAD

1275 N. GROVE ST.
ANAHEIM, CA 92806
Cable: NATCOLGLZ

TO ORDER OR
DLR INFO. CALL
(714) 630-4541

✓ 254

NOTE: Price, Specifications subject to change without notice and obligation

TS830/TS930S IMPROVED!

Yes, spectacularly! By simply adding a *Matched Pair* of top-quality Fox Tango Filters. Here are a few quotes from enthusiastic users:

- ... makes a new rig out of my old TS830S ...
- ... VBT now works the way I dreamed it should ...
- ... Spectacular improvement in SSB selectivity ...
- ... Completely eliminates my need for CW filters ...
- ... Simple installation ... excellent instructions ...
- ... Switched filters to new 930S when I traded my old 830 ... same solid improvement!! ...

The 2.1KHz bandwidth Fox Tango SSB filters are notably superior to both original 2.7KHz BW units but especially the modest ceramic second IF; our substitutes are both 8-pole discrete-crystal construction. Compare the test results—Fox Tango Filters vs. Kenwood's:

On SSB with VBT Off—RX BW: 2.0 vs 2.4; Shape Factor: 1.2 vs 1.34; 80dB BW: 2.48 vs 3.41; Ultimate Rejection: 110dB vs 80.

On CW with VBT set for 300Hz BW—Shape Factor: 2.9 vs 3.33; Insertion Loss: 1dB vs 10dB! Chances are you won't need them but a new 400Hz CW pair is now available for those who insist on the very best CW reception.

COMPLETE KITS Only \$170 each

FTK830 or FTK930 (2.1KHz BW for SSB/CW)

FTK830 or FTK930 (400Hz BW for CW Only)

Each Includes a Matched Pair of Fox Tango Filters, all needed cables, parts, detailed instructions. Specify rig and bandwidth desired when ordering. Shipping: \$3 (COO + \$1, Air + \$2, Overseas + \$5). Florida residents: add 5% Sales Tax.

**ONE YEAR WARRANTY
GO FOX-TANGO—TO BE SURE!**
Order by Mail or Telephone.
AUTHORIZED EUROPEAN AGENTS
Scandinavia: MICROTEC, Makedlen 26,
3200, Sandefjord, NORWAY
Other: INGOIMPEX, Postfach 24 49,
D-8070, Ingolstadt, W. GERMANY

FOX TANGO CORPORATION
Box 15944S, W. Palm Beach FL 33416
(305) 683-9587



✓95

AZDEN

PHASE II TWIN ANTENNA

NEW!



- SUPER 80- POUND, 100- MPH GRAY MAGNETIC MOUNT WITH MYLAR BASE
- 5/8 WAVE FOR PHASE II SIGNAL AND
- 1/4 WAVE FOR CLOSE-IN AND RESTRICTED HEIGHT AREAS
- INSTANT CHANGE OVER
- SUPERIOR PERFORMANCE
- STAINLESS STEEL SPRING AND WHIP
- CHROME ON BRASS BASE: COMPARE!
- BOTH ANTENNAS ARE FREQUENCY ADJUSTABLE
- COMPLETE WITH 17 FEET OF FOAM COAX AND PL 259 CONNECTOR
- MADE IN USA

INTRODUCTORY PRICE:

\$29.95

COMPARE!!

TWO ANTENNAS FOR THE PRICE OF ONE!

AMATEUR-WHOLESALE ELECTRONICS

8817 SW 129th Terrace, Miami, Florida 33176

Telephone (305) 233-3631 • Telex: 80 3356

HOURS: 9 - 5 Monday thru Friday

• U.S. DISTRIBUTOR • DEALER INQUIRIES INVITED



✓243

ORDER NOW TOLL FREE

800-327-3102

CALL LONG DISTANCE ON 2 METERS

Only 10 watts drive will deliver 75 watts of RF power on 2M SSB, FM, or CW. It is biased Class AB for linear operation. The current drain is 8-9 amps at 13.6 Vdc. It comes in a well constructed, rugged case with an oversized heat sink to keep it cool. It has a sensitive C.O.R. circuitry, reliable SO-239 RF connectors, and an amplifier IN/OUT switch. The maximum power input is 15 watts.



Our products are backed by prompt factory service and technical assistance. To become familiar with our other fine products in the amateur radio market, call or write for our free product and small parts catalog.

Model 875
Kit \$109.95
Wired & Tested \$129.95



CCI Communication Concepts Inc.

2648 North Aragon Ave. • Dayton, Ohio 45420 • (513) 296-1411 ✓14



... at last ...
your shack organized!

A beautiful piece of furniture — your XYL will love it!

\$184.50 S-F RADIO DESK

Deluxe - Ready to Assemble

Designed with angled rear shelf for your viewing comfort and ease of operation.

FINISHES: Walnut or Teak Stain.

Floor Space: 39" Wide by 30" Deep

Additional Information on Request.

Checks, Money Orders, BankAmericard and Master Charge Accepted.

F.O.B. Culver City. (In Calif. Add 6% Sales Tax.)

DEALER INQUIRIES INVITED

S-f Amateur Radio Services

4384 KEYSTONE AVENUE • CULVER CITY, CALIF. 90230 — PHONE (213) 837-4870

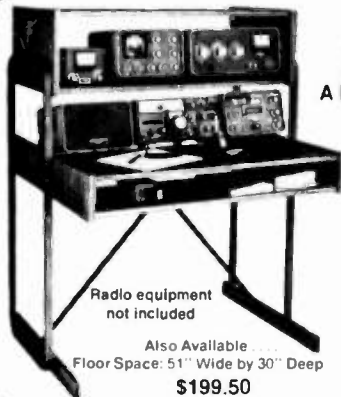

Radio equipment not included

Also Available
Floor Space: 51" Wide by 30" Deep

\$199.50

\$9

✓65

cushcraft
CORPORATION

YOUR DEALER

R & L ELECTRIC
575 MAIN STREET
HAMILTON, OH 45013
TEL. 1-513-868-6399 ✓106

Trade Secrets of Mobile Installation

*Mounting a rig in your car is not as hard as it seems.
Find out how the pros do it.*

Dave Ingram K4TWJ
Eastwood Village #1201 South
Rte. 11, Box 499
Birmingham AL 35210

Installing presently-popular amateur transceivers in the limited space of today's cars can often prove to be a hair-raising experience. While slide-in mounts and rig-hanging brackets may be readily available for some units, these mounts often place their respective rigs in

rather awkward positions. When the rig is removed from the car, the unused mount or bracket may continue to occupy vital interior room and thus further emphasize the need for a more flexible arrangement.

The mounting techniques presented in this article will attempt to alleviate those problems and provide a simple yet effective means of containing the rig in a desired location. Since the majority of mobile installations are usually more involved than merely placing a transceiver in the car,

I'll also briefly consider antenna cabling and dc power-cord routing. Amateurs following these general guidelines should be able to progress from a "stock" new car to a complete mobile installation in less than an hour's time (assuming everything needed isn't buried at the bottom of a junkbox!).

Rig Location/ Mounting Ideas

An amateur owning a large automobile with a full-width dash, bench-type seat, and no center console

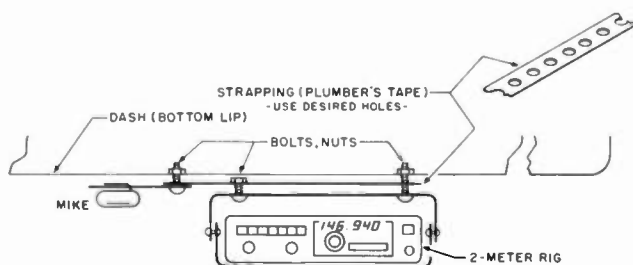

Fig. 1. Method of using strapping to mount a rig under the dash, using existing holes. Screw and nut sandwiched between the dash bottom; strapping should be short and thin for snug mounting and to prevent scratching the rig. The mike holder can be screw-mounted to one of the holes in the strapping.

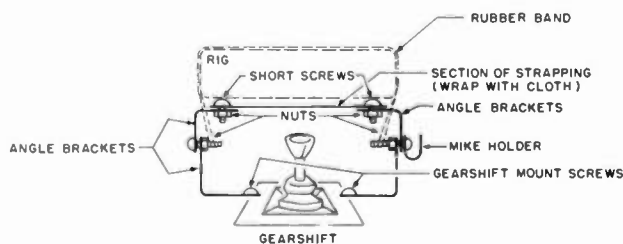

Fig. 2. Method of using hardware-store L-brackets and metal strapping for a universal mount on small autos. Rig's front sits on the covered strap and is held securely by a rubber band. Brackets may be tilted as desired.



Fig. 3. The home-brew mount. Note the power connectors for various rigs in the background.



Fig. 4. Low-band transceiver is side-slid into position with its front feet catching on the bracket. The rear of the rig is sitting on the transmission hump. The squeezed position assists in securing the rig, eliminating need for a hold-down strap.

will experience few problems mounting his rig or rigs. If existing holes in the under-dash lip don't align with the rig mounting bracket, a section of metal strapping (plumber's tape) can be used as a "hole relocator." This arrangement is shown in Fig. 1. The rig's rear area can rest lightly on the auto's carpet, if necessary, and a small chock can be used if thick carpeting blocks air flow around heat sinks.

Mounting 2-meter FM-sized transceivers (and possibly small-sized low-band transceivers) in compact autos exhibiting miniscule dash-to-transmission-hump clearance can prove to be difficult. The most logical solutions here involve using home-brew brackets and existing supports for maximum benefit. One example of this technique is shown in Fig. 2. Four L-brackets are bolted together as shown, with heavy metal strapping bolted between the upper L-brackets. The lower L-brackets are secured to the auto's gearshift mounting L-plate via existing screws. These are slightly underneath the floor shift's rubber boot in autos such as the Sunbird, Monza, Skyhawk, etc.; squeezing the

boot's bottom will reveal the screws. The upper L-brackets' size and angle of tilt can be varied as desired for proper rig positioning. In order to prevent rig scratches, cover the brackets' upper area with a couple of layers of cloth matching the auto's interior, and sew the cloth tight.

This mount can be used with a variety of rigs, depending on the particular auto's hump-to-dash clearance. A 2-meter rig, for example, can be placed on the mount and secured in place by a rubber band stretched between the long L-bracket screws. (How's that for a quick install/remove caper?) An HF rig such as the Atlas, Kenwood TS-120, etc., can also be side-slid into this bracket by positioning its front feet in front of the covered metal strap while the dash itself secures the rig from its top-side (the rig's rear then rests on the transmission hump). Other rigs can also be used with this L-bracket setup merely by securing them with a rubber band when necessary. A small towel the same color as the auto's carpet can be used to cover or camouflage the rig during brief out-of-car stops.

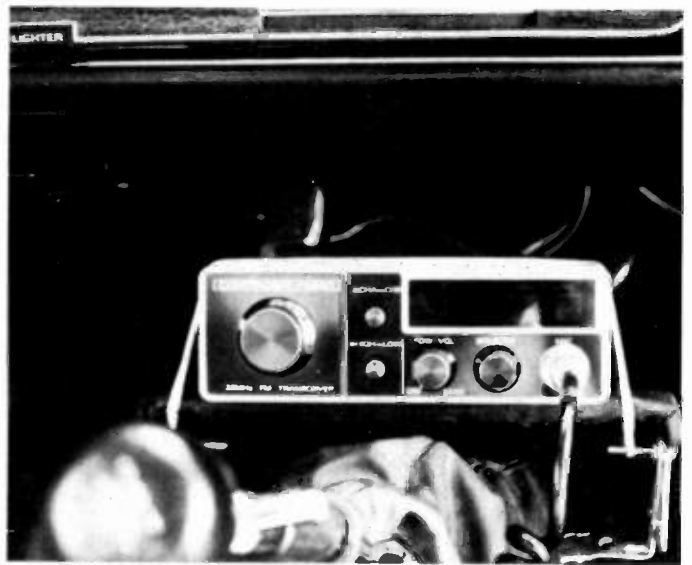

Fig. 5. This rig-mounting bracket is ideally suited to rapid installation artists. The unit is merely placed on the mount and secured with a heavy rubber band. Either top or bottom-mounted speakers can be used with this arrangement.



Fig. 6. A second (or third!) rig can be used with the bracket of Fig. 5. If front feet don't secure the rig, use a heavy rubber band. Note the mike mount on the left side of the bracket.

(Be aware, however, that any out-of-view auto is open prey to rip-off artists).

Many small and intermediate-sized autos feature bench-style seats and one-piece dashes which can support 2-meter FM rigs, but may present problems for securely supporting larger HF rigs. An effective mounting idea for these autos involves propping the HF rig between the front seat's edge and the trans-

mission's hump, securing it with a cloth-covered boat tie-down strap as shown in Fig. 7. If connecting cables dig into the carpet or if the rig's heat sink is slightly obstructed, a small piece of wood or indoor/outdoor carpet may be used for chocking. All rig cables and the tie-down strap can merely be pushed under the seat when not in use, providing a perfectly clean-looking interior. Cloth-covered tie-down straps are

GLB PACKET RADIO CONTROLLER

Now you can get in on the fun on packet radio!

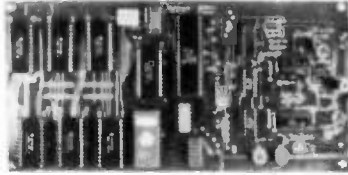

MODEL PK1
(Shown with 14K RAM and 8K ROM)

- Low cost!
- Adaptable to any transceiver
- Easy to learn, easy to use
- Nearly 50 commands
- Built-in packet Modem and CW identifier
- Use with teletype machines, computers, terminals
- RS232 serial interface—45 to 9600 baud!
- Uses both ASCII and Baudot
- Vancouver protocol—AX 25 to be released soon
- Stores received messages until requested at a later time
- Operates in "connected" and "general" modes
- Activates teletype motor to print messages
- Board accepts up to 14K of RAM
- Model PK1 can be customized for Commercial Systems.

Protocol can be changed by swapping ROM chips. Board designed to accept 6264's for up to 56K of RAM with minor modification.

Dimensions: 4.5 x 9.5 inches; 1" vertical clearance.
Power requirement: +12 VDC, approx. 200 ma.

Standard equipment includes 4K of RAM (expandable to 14K).
Model PK1, wired & tested— **\$149.95**
additional memory, installed & tested (up to 10K) **\$10/2K**
RTTY adaptor board **\$9.95**

Connecting cables & enclosure—optional

We offer a complete line of transmitters and receivers, strips, preselector-preamps, CWIDers & synthesizers for amateur & commercial use. Request our FREE catalog. MC & Visa welcome. Allow \$2 for UPS shipping.

GLB ELECTRONICS

1952 Clinton St. Buffalo, NY 14206
716-824-7936, 9 to 4

✓ 143

Two special-consideration-type mounts which may be applicable to small autos with center consoles involve mounting a mobile rig sideways on either the console or the drive-shaft tunnel right behind the rider's seat. This arrangement is illustrated in Fig. 8. Surprisingly, the front mounting often will support a large low-band rig while the rear mount supports a 2-meter rig.

Routing Cables

Today's tightly-assembled autos can prove quite challenging to cable routing, but a few tricks of the trade can simplify that situation. Antenna transmission line can easily be routed through the auto's trunk area by moving the rear seat on the rider's side and poking part of a stiff, discarded whip antenna through to the trunk. Next, tape the coaxial cable to the end of that whip and pull it into the auto's interior. (Use heavy-duty filament tape and help the cable along for first-try success.) Additional cables, if desired, can then be taped to the initial cable and pulled through in a similar manner. Routing cables on the auto's right (rider) side also is good due to the absence of steering wheel, floor pedals, etc.

The whip-antenna trick is also useful for passing power

er cords through auto fire-wall openings. The most logical and convenient opening to use is the expandable grommet through which the speedometer cable passes. Again, poke the whip into the auto's interior, tape the cable to the whip rod's tip and pull it back through the grommet, helping it as necessary.

Finally, make a composite resistance check in the following manner to ensure solid ground connections. Short the antenna's center conductor and shield at the antenna proper, then measure from the power cord's negative lead, through the auto body, through the antenna mount, and back to the center conductor of the PL-259 for less than 1 Ohm's resistance. At this point, you are ready to check alternator/battery voltage to ensure that less than 14 volts is delivered... and then connect the rig.

Conclusion

The techniques of mounting amateur gear in autos varies with each set of circumstances, yet each installation can be made easier by using ideas tried and proven by others. I hope this collection of thoughts and views will prove helpful in both the installation and operation of your existing or future mobile rigs. ■

available from boating supply or sporting goods stores, with most stores boasting on-the-spot assembly of the tie-down in any desired length. The highest price I have found on tie-downs is \$3.00 each.



Fig. 7. Mobile installation of traveling amateur W4CEC consists of an Azden 2-meter rig and Kenwood TS-120. The 120 is merely propped on the auto's seat; its tilt-down front bail secures the unit and eliminates the need for a tie-down strap. The Azden is secured, complete with bracket, by a tie-down strap hooked under the dash. Clever and convenient, and both rigs can be removed in a snap.

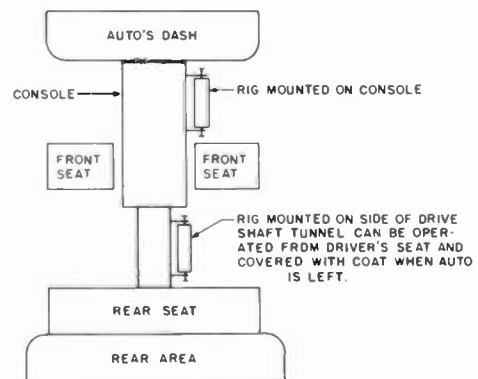

Fig. 8. Two rig-mounting locations for small autos which provide flexibility and a degree of security. Location behind rider's seat is preferred for small 2m FM units.

SAVE \$2.00 OFF THE BASIC RATE!
CHARTER OFFER



THESE COULD BE THE KEYS TO YOUR FUTURE

Unlock *all* the potential of your Commodore 64 and VIC-20* with **RUN**.

Explore... Experiment... Enjoy... Beginner and expert alike will be taken beyond the manual to the limits of their abilities. Enter your own game programs. Construct a simple hardware add-on. Broaden your scope with unique applications... And... get a 13th issue **FREE!**

Enjoy key features like these:

- Games for fun & strategy.
- Programming tips help you learn short cuts.
- Candid reviews help you make money-saving decisions.
- Programs to add to your library.
- Instructions & tutorials to increase your skills.
- Hardware & software modifications help your machine work smart.
- Unique applications broaden your scope.

Here's a system-specific magazine written with you in mind. Written by and for the reader to give time-saving, money-saving hints. You'll get instructions and tutorials to increase your skills, and candid reviews to help you make the right decisions. Most of all though, you'll have fun.



Commodore 64 and VIC-20 owners are one of the largest groups of computerists today. Enjoy the benefits of this with your own magazine. Be in control like never before. Order **RUN** today and get a 13th issue free with your prepaid order (check or credit card) of only \$17.97. Send in the coupon or call toll free 1-800-258-5473. In N.H. call 1-924-9471.

Send me a subscription to **RUN** for only \$17.97 per year. I understand that with payment enclosed or credit card order I will receive a **FREE** issue making a total of 13 issues for \$17.97. Save \$2.00 off the basic rate!

CHECK/MO MC AE VISA BILL ME

card # _____ exp. date _____

signature _____

name _____

address _____

city _____ state _____ zip _____

Canada & Mexico \$20.97; Foreign Surface \$37.97. 1 year only, US funds drawn on US bank. Foreign airmail, please inquire. Please allow 6 to 8 weeks for delivery. This offer expires January 31, 1984.

RUN • Box 954 • Farmingdale, NY 11737

341F6

Now's The Time To Buy That New Repeater!

- To Replace "The Old Klunker"*
- For That "New System" you've been Thinking about*

Spectrum's Got-

- **The widest line of Repeater/Link Equipment**
- **The Highest Performance—by far!**
- **The Finest Quality**



SCR77 Basic Repeater/link Xcvr.

new

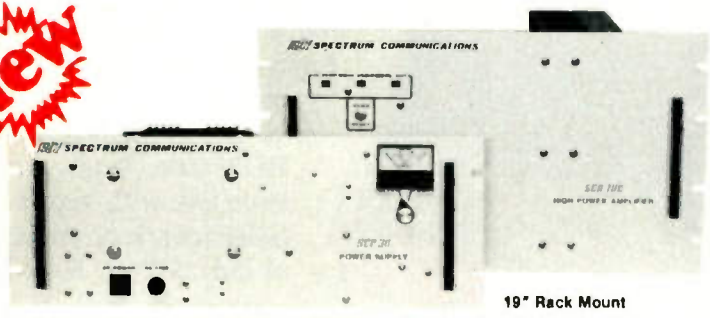

19" Rack Mount

**SCA100W UHF AMP w/companion
SCP30 30A Power Supply.
Both Super Heavy Duty! Also 150W VHF.**

There's never been a better time to buy a Spectrum Repeater or Link Equipment.

Deliveries are the fastest ever—4-5 wks. as of this writing, with some models in stock. And, with the introduction of our New 100W Repeater Amp/Pwr. Supply Package and UHF Rcvr. Helical Resonator Front End Assembly, we have the best performing, most complete line available!

Go With The Leader! Call or write today for a brochure & prices. Sold Factory Direct or through Export Sales Reps.



VHF: 15-150 Watts
UHF: 10-100 Watts
10M: 40 Watts

**SCR 4000 SUPER DELUXE REPEATER
WITH OPTIONAL CABINET & ACCESSORIES**

AVAILABLE WITH

- Autopatch, w/Reverse Patch & Land Line Control
- Touch Tone Remote Control Functions
- Various Tone & Timer Units
- "Emergency Power ID"
- Duplexers, Cabinets, Antennas, etc. for a complete system

F.C.C. TYPE ACCEPTED FOR
COMMERCIAL SERVICES



SPECTRUM
Export Orders Welcomed

1055 W. GERMANTOWN PK., DEPT S1

Spectrum Repeater Boards & Sub-Assemblies

New FL-4 UHF
Helical Resonators

These are professional "Commercial Grade" Units—Designed for Extreme Environments (–30 to 60° C.)

All Equipment Assembled & Tested. For 10M, 2M, 220 MHz, & 450 MHz

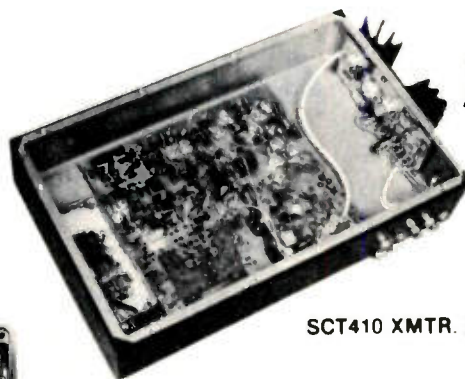

10M ALSO
AVAILABLE

SCT410 XMTR. ASSY.

COMPLETE SHIELDED RCVR. ASSY.

VHF & UHF Receiver Board
SCR 200-VHF SCR 450 UHF

- **Totally Advanced Design!**
- 8 Pole Front End Filtr. + wide dynamic range—reduces overload, spurious Resp. & IMs!
- Sens. 0.3 uV/12dB SINAD typ.
- Sel. -6dB @ ± 6.5 KHz. -130dB @ ± 30KHz (8 Pole Crystal + 4 Pole Ceramic Filtrs.
- 'S Meter', Discriminator & Deviation Mtr. Outputs!
- Exc. audio quality! Fast squeeze! w/0.0005% Crystal. ("Super Sharp" IF Filtr. also avail.)

Complete Receiver Assemblies

- Rcvr. Bd. mounted in shielded housing.
- Completely asmbld & tested, w/F.T. caps, SO239 conn.
- As used in the SCR1000 Ready to drop into your system!
- UHF Rcvr. Assy. Now Available w/Super Sharp FL-4 Helical Resonators. Greatly reduces IM & "out of band" interference!

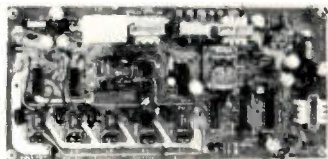

SCAP Autopatch Board

- Provides all basic autopatch functions
- Secure 3 Digit Access; 1 Aux On-Off function, Audio AGC; Built-in timers; etc. Beautiful Audio!
- O1 inhibit bd. also available
- Write/call for details and a data sheet

RPCM Board

- Used w/SCAP board to provide "Reverse Patch" and Land-Line Control of Repeater
- Includes land line "answering" circuitry

Lightning Arrester For SCAP

- Gas Discharge Tube shunts phone line surges to ground
- Handles up to 20,000 Amps!
- The Best device available to protect Autopatch equipment from lightning damage. \$14.00 + S/H.



FL-6 Rcvr. Front-End Preselector

- 6 HI Q Resonators with Lo-Noise Transistor Amp (2M or 220 MHz).
- Provides tremendous rejection of "out-of-band" signals w/out the usual loss! Can often be used instead of large expensive cavity filters
- Extremely helpful at sites with many nearby VHF transmitters to "filter-out" these out-of-band signals

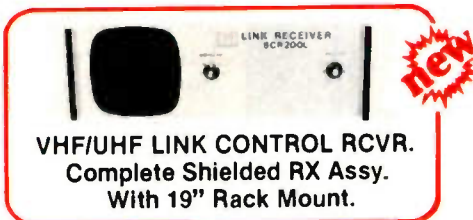

ID250 CW ID & Audio Mixer Board

- 4 Input AF Mixer & Local Mic. amp.
- PROM memory—250 bits/channel.
- Up to 4 different ID channels! AF Mute circuit.
- Many other features. Factory programmed.

CTC100 Rptr. COR Timer/Control Bd.

- Complete solid state control for rptr COR, "Hang" Timer, "Time-Out" Timer, TX Shutdown/Reset, etc.
- Includes Inputs & Outputs for panel controls & lamps

Repeater Tone & Control Bds.—For SCR1000/4000 & CTC100/ID250 only

- TMR-1 "Kerchunker Killer" or "Time Out Warning Tone" Bd.
- TRA-1 "Courtesy Tone Beeper" Board

PRM200 Power Supply Filter Cap/Regulator/Metering Board

- As used in the SCR1000 as main part of 13.8VDC/8A Pwr. Sply.

PSM-1 Repeater Power Supply Mod Kit

- For SCR1000 or ACR4000. Replaces Darlington Pass Tr. for improved reliability.

SCT110 VHF Xmtr/Exciter Board

- 10 Wts Output 100% Duty Cycle!
- Infinite VSWR proof
- True FM for exc. audio quality
- Designed specifically for continuous rptr service. Very low in "white noise"
- Spurious -70 dB. Harmonics 60 dB
- With .0005% xtal.
- BA-10 30 Wt. Amp board & Heat Sink. 3 sec. L.P. Filter & rel. pwr. sensor. BA75 75 Wt. unit also available.

SCT110 Transmitter Assembly

- SCT110 mounted in shielded housing
- Same as used on SCR1000
- Completely asmbld. w/F.T. caps. SO239 conn.
- 10, 30, or 75 Wt. unit.

SCT 410A UHF Transmitter Bd. or Assy.

- Similar to SCT110, 10 Wts. nom.
- * **Now includes "on board" proportional Xtal Osc./Oven circuitry for very high stability!**
- BA-40 40W. UHF AMP. BD. & HEAT SINK.

PCB-1 Xmtr. Power Control Board

- For SCT110 or SCT410 Exciters
- Varies B+ to control Pwr. Out
- Switchable Hi, Low, or Med. Pwr. out, locally or remotely. Adj. levels.

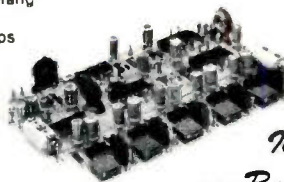

TTC 100
Touch Tone
Control Board

Interface to
any Radio or AF system!

- 3 digit ON, 3 digit OFF control of a single repeater function, or (optional) 2 functions (2 digits ON/OFF each).
- Can be used to pull in a relay, trigger logic, etc.
- Typically used for Rptr., ON/OFF, HI/LO Pwr PL ON/OFF, Patch Inhibit/Reset, etc.
- Stable anti-falsing design 5s limit on access
- For add'l function(s), add a "Partial TTC" board

COMMUNICATIONS CORP.

INQUIRE ABOUT 'SURPLUS' RX & TX BOARDS. REDUCED PRICE!

✓68

Norristown, PA 19403 • (215) 631-1710

Call, or
Send for
Data Sheets!

Around and Around and Around

*There's got to be a better way to wind your coils to specs.
Build the Q-meter and get the exact inductance you need.*

Edwin C. Miller N7APE
306 W. Court Street
Weiser ID 83672

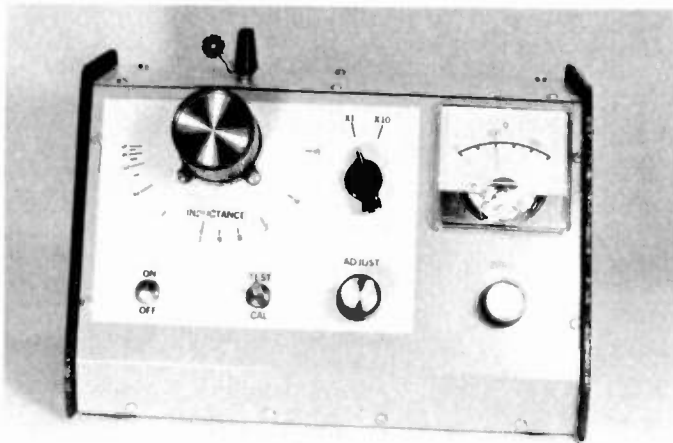

Front view of completed Q-meter.

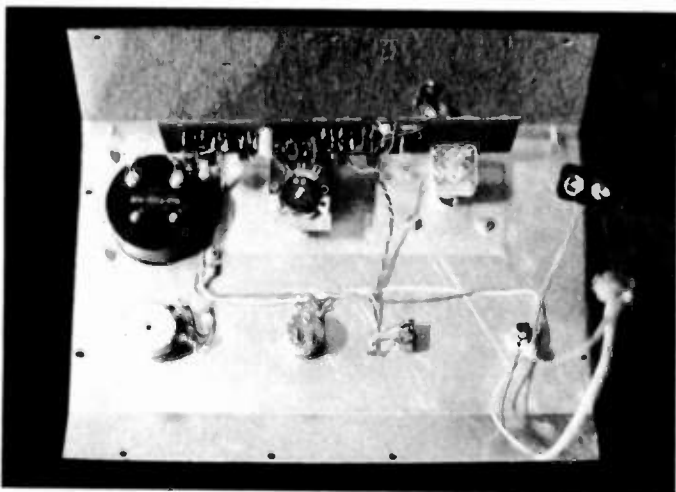

Assembled panel and top plate showing component mounting.
70 73 Magazine • January, 1984

Winding coils for a new project seems to be one of the more frightening aspects of the job. One reason may be the fear that we may not be able to duplicate the author's model. If we have a way to check each coil before it's installed, much of the apprehension is removed. A "Q"-meter will do this by measuring the coil's inductance and Q. The unit pictured is such a Q-meter that will measure inductances from .5 μH to 50 μH and Qs to 200. It's easy to build, easy to operate, and is powered by an internal 9-volt battery or wall-plug power supply.

There are four basic parts

to this Q-meter: a dual-frequency rf oscillator, an FET voltmeter, a power supply, and the tank circuit that indicates the inductor of unknown value (L_x).

Fig. 1 is the schematic. A 2N2222 transistor serves as the rf oscillator, followed by an MPF-102 JFET buffer. The range of measurement is controlled by the oscillator frequency and the tank variable capacitor. With the capacitor specified, the range is .5 to 5 μH at a frequency of 20.05 MHz, and 5 to 50 μH at 6.34 MHz. The two toroid coils resonate with C1 and C2 to produce these frequencies, and S1 determines the range in use. The buffer stage provides the neces-

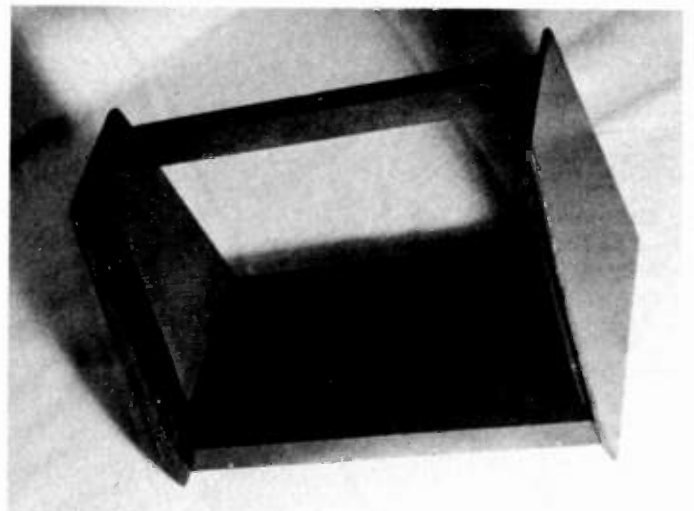

Pine and Masonite™ case for the Q-meter.

sary low impedance excitation for the tank circuit through C8. A 1N270 germanium diode (D1) rectifies the rf output of the buffer and is used to calibrate the meter before taking a measurement. A hot-carrier diode (D2) is placed across the variable capacitor and rectifies the tank circuit current to provide a dc voltage that is proportional to the Q of L_x at resonance. It is this voltage that is measured in the TEST position of S2.

The JFET voltmeter uses two MPF-102 JFETs, zeroed by R15. Full scale on the meter should be 250 microamps or less. The critical components have been selected so that the Q reading will be quite accurate if 100 is used as the calibration reference. The meter I used is calibrated from zero to 250 and is a 200-uA movement. A more sensitive meter will require using a higher resistance setting of R12, but will not affect the unit's accuracy. Qs of 250 or more are

seldom required and are difficult to obtain, so there is not much need to have a higher scale.

As for construction, there is really only one critical portion—the mounting of the tank components (C9, C10, and the terminals for L_x). At 50 uH, an inch or two of extra wire will not have much effect on accuracy,

but at .5 uH, the leads must be kept as short as possible. This is one reason for the miniature variable capacitor and small unit for C9. The terminals for L_x consist of 4-40 bolts mounted directly to the Formica™ top, using solder lugs to connect to the circuit board components and 4-40 hex nuts fastened by epoxy to small wire nuts

for holding the unknown inductor leads. Small 5-way connectors should also work fine. Although I used an import vernier dial mechanism and attached a plastic pointer, a non-reduction knob will work quite well—it's just a little harder to get right on resonance. The shaft of C10 is too short to reach the panel. It can be

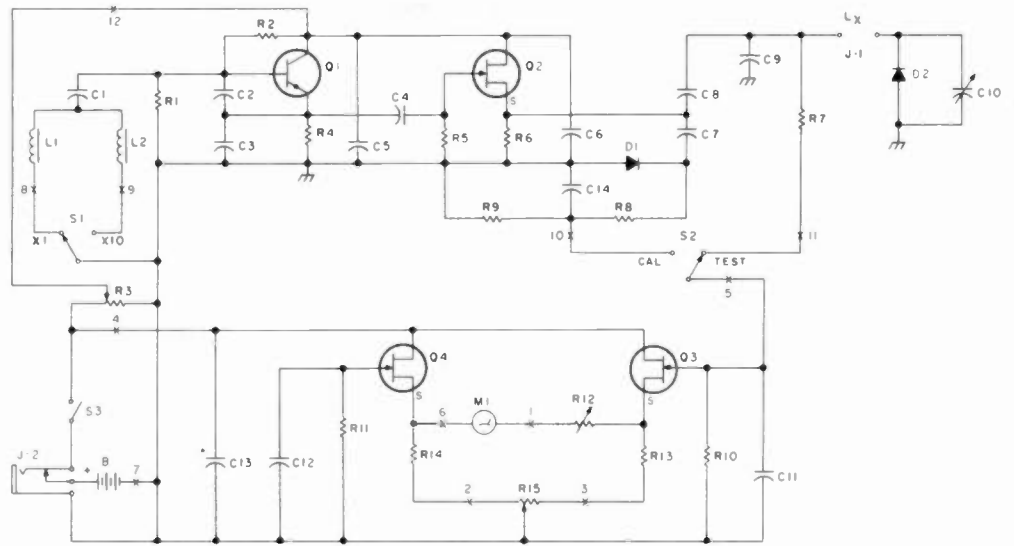

Fig. 1. Circuit schematic.

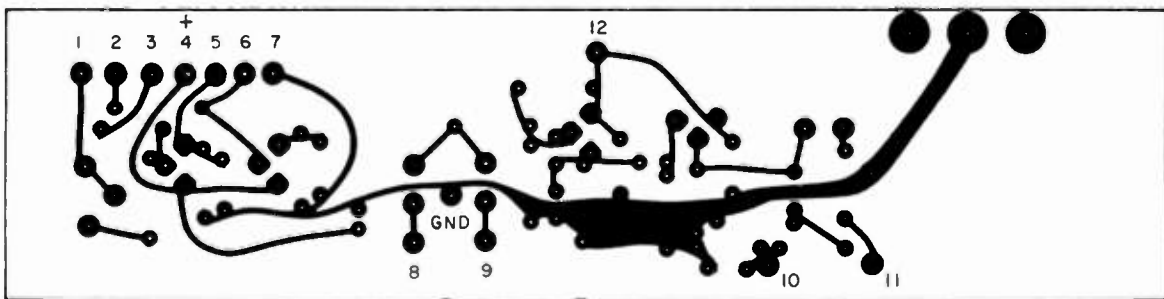

Fig. 2. Circuit board.

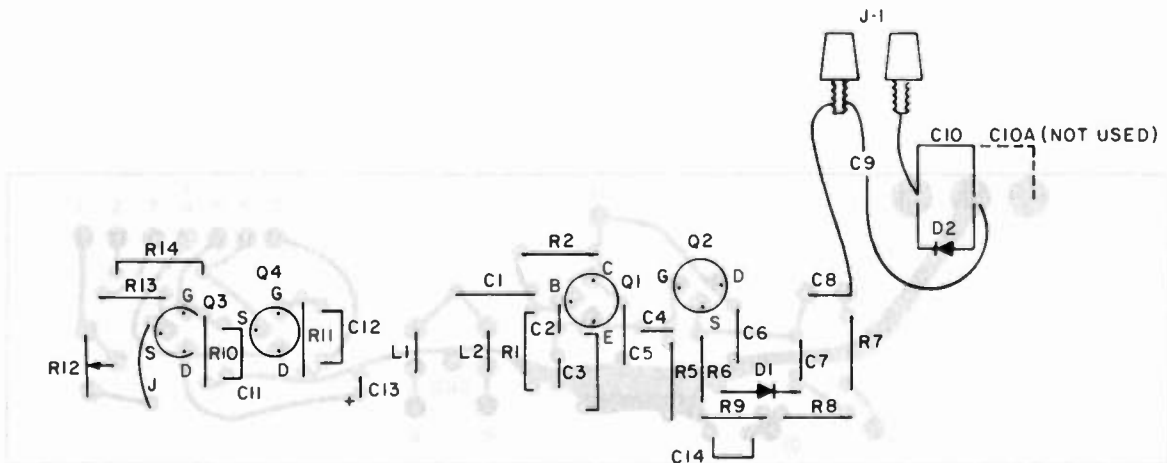

Fig. 3. Component layout, foil side view.

Parts List

C1	620-pF ceramic disc
C2, C3	68-pF NPO ceramic
C4	56-pF NPO ceramic
C5, C6,	
C11, C12	.01 ceramic disc
C7	100-pF ceramic
C8	22-pF NPO ceramic
C9	1500-pF poly
C10	138-pF variable (RS A1-234)
C13	10-uF, 25-V electrolytic
D1	1N270 germanium diode
D2	MBD-101 hot carrier diode
R1	47k, 1/4-Watt carbon
R2	100k, 1/4-Watt carbon
R3	10k linear pot
R4	1.5k, 1/4-Watt carbon
R5, R9	1-meg, 1/4-Watt carbon
R6	390-Ohm, 1/4-Watt carbon
R7, R10,	
R11	2.2-meg, 1/4-Watt carbon
R8	100k, 1/4-Watt carbon
R12	100k trimmer
R13, R14	150-Ohm, 1/4-Watt carbon
R15	2k linear standard pot
L1	1.97 uH (21 turns #24 enamel on T-37-2 toroid)
L2	19.7 uH (70 turns #32 enamel on T-37-2 toroid)
S1	SPDT rotary
S2	SPDT mini-toggle
S3	SPST mini-toggle
M1	200-uA meter (see text)
J1	Connectors for L _x (see text)
J2	Mini phone jack (normally-closed circuit)

lengthened by attaching a one-quarter-inch round metal spacer with a bolt into the capacitor's threaded shaft. An alternative would be a small flexible coupler and a piece of 1/4-inch shaft.

The total current drain is under 15 mA, so a 9-volt battery will last a long time with intermittent use. For ac operation, any rectified and filtered wall-plug supply that is rated at 4.5 to 9 volts fills the bill.

To put the Q-meter to work, set S2 to TEST, turn on the power switch, and adjust the meter to zero reading with R15. Switch S2 to CAL and set the rf level to 100 on the meter by adjusting R3. Connect the coil you want to measure, using the shortest possible leads. Reset S2 to TEST; tune C10 for maximum deflection of the meter. The reading is the approximate Q of the unknown inductor. If you cannot get any upward deflection of the meter, try the

other position of S1. If you still cannot get a reading and you are quite sure the unknown inductance falls within the range of the meter, recheck the L_x connections. A good connection is a must for reliable operation of the Q-meter.

A test coil can be made by winding about 15 turns of #24 enamel-covered wire in a T-37-2 or T-37-6 toroid. You should measure it somewhere around 1 uH with a Q of about 100. If you are satisfied with the results, you may want to mark the measured information on a tag and attach it to the inductor. It can be used later to check the performance of the meter if you should question a reading on some unknown coil.

This relatively simple project can take a lot of the fear out of coil-winding, as well as sort out unmarked small inductors and provide the identification you need. ■

MIRAGE

Mirage Communications Introduces Their 6 Meter Solid-State Amplifier A1015



10 Watts In — 150 Watts Out
\$279.95

- Built-In Rx Preamp
- All Mode-SSB, CW, FM
- Remote Keying
- DC Power 13.6 VDC at 18 Amps

- FCC Type Accepted
- 5 Year Limited Warranty
- Optional RC-1 Remote Control Available
- Made in the U.S.A.

Available at Mirage Dealers Worldwide

MIRAGE
COMMUNICATIONS EQUIPMENT, INC.

P.O. Box 1393, Gilroy, CA 95020 • (408) 847-1857



Stuck with a problem?

Our TE-12P Encoder might be just the solution to pull you out of a sticky situation. Need a different CTCSS tone for each channel in a multi-channel Public Safety System? How about customer access to multiple repeater sites on the same channel? Or use it to generate any of the twelve tones for EMS use. Also, it can be used to access Amateur repeaters or just as a piece of versatile test equipment. Any of the CTCSS tones may be accessed with the TE-12PA, any of the audible frequencies with the TE-12PB. Just set a dip switch, no test equipment is required. As usual, we're a stickler for 1day delivery with a full 1 year warranty.

- Output level flat to within 1.5db over entire range selected.
- Immune to RF.
- Powered by 6-30vdc, unregulated at 8 ma.
- Low impedance, low distortion, adjustable sinewave output, 5v peak-to-peak.
- Instant start-up.

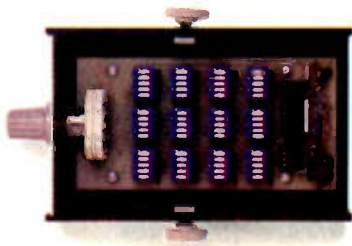

TE-12PA

67.0 XZ	85.4 YA	103.5 1A	127.3 3A	156.7 5A	192.8 7A
71.9 XA	88.5 YB	107.2 1B	131.8 3B	162.2 5B	203.5 M1
74.4 WA	91.5 ZZ	110.9 2Z	136.5 4Z	167.9 6Z	
77.0 XB	94.8 ZA	114.8 2A	141.3 4A	173.8 6A	
79.7 SP	97.4 ZB	118.8 2B	146.2 4B	179.9 6B	
82.5 YZ	100.0 1Z	123.0 3Z	151.4 5Z	186.2 7Z	

- Frequency accuracy, ± 1 Hz maximum -40°C to $+85^{\circ}\text{C}$
- Frequencies to 250 Hz available on special order.
- Continuous tone

TE-12PB

TEST-TONES:	TOUCH-TONES:	BURST TONES:
600	697 1209	600 1850 2150 2400
1000	770 1336	650 1900 2200 2450
1500	852 1477	1700 1950 2250 2500
2175	941 1633	1750 2000 2300 2550
2805		1800 2100 2350

- Frequency accuracy, ± 1 Hz maximum -40°C to $+85^{\circ}\text{C}$
- Tone length approximately 300 ms. May be lengthened, shortened or eliminated by changing value of resistor

\$89.95

✓ 15

COMMUNICATIONS SPECIALISTS

426 West Taft Avenue, Orange, California 92667
(800) 854-0547/California: (714) 998-3021



Get those
demons
downing
your
electronic
gear!

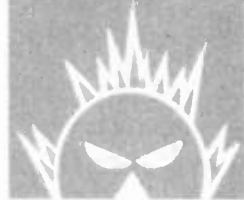

Nothing matches the MACC in voltage surge protection and component-by-component on-off control

- compact, attractive desk-top console
- eight clean AC power outlets
- individual and master on-off control
- superior three-stage auto-restore circuit with manual reset circuit breaker
- individually lighted rocker switches

Lightning striking miles away, electric motors running on the same power line, fluorescent lighting and even wind-driven snow static buildup can cause problems with delicate circuits and miniature electronic chips. But the MACC, within nanoseconds, can recognize the current disturbance, then clip it off and dissipate it, while maintaining clean current flow to your system's equipment. The MACC protects all semi-conductor, solid-state circuitry.

The MACC is designed with three 2000-amp surge discharge protection circuits — one between each of the AC input's hot, neutral and ground lines. Other surge devices may use a single 100-amp surge protector between the hot and neutral lines only. Its resettable circuit breaker adds further protection.

MACC gives you control convenience, too. It provides 8 plug-in "U" ground outlets for your components — including one "hot" outlet for a continuously powered application such as your clock. Seven "on/off" rocker switches let you control individual components. And you can turn your entire system on or off with a single master rocker switch.

ALPHA DELTA'S MASTER AC CONTROL CONSOLE PROTECTS AGAINST ALL THESE DAMAGING SURGE PROBLEMS

Problems caused in circuitry by surging and transient voltages:

- Melting of "hot spots" within semi-conductor devices
- Thermal runaway of transistors
- Welding, pitting and metal transfer on switch contacts
- Switch contact corrosion
- Insulation breakdown causing arcing of components
- Shortening of component life

The MACC is tested to IEEE pulse standards and rated at 15A, 125V-AC, 60 Hz, 1875 watts continuous

duty total for the console. A label on the unit describes the surge protection limitations.

MACC Specs

Alpha Delta Master AC Control Console

Amperage 15
Volt (AC) 125
Hertz 60

Total
Wattage 1875

Size
MACC 11" x 2-3/4" x 2-3/4"
MACC-4 5-1/2" x 2-3/4" x 2-3/4"

Shipping
Weight 4-1/2 lbs. approximately

Alpha Delta Model MACC Systems are designed to reduce the hazards of lightning-induced surges. These devices, however, will not prevent fire or damage caused by a direct stroke to an AC line or a structure. Specifications, availability and price are subject to change without notice.

Warranted against defects in materials or workmanship.

ALPHA DELTA COMMUNICATIONS, INC.

P.O. Box 571, Centerville, Ohio 45459 • (513) 435-4772



—98

current solutions to current problems



The MACC is unique in voltage surge/transient suppression and convenient, desk-top individual component control. Nothing matches the MACC in value and performance. Put one on duty on your AC line.

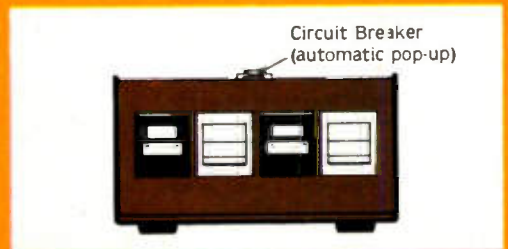
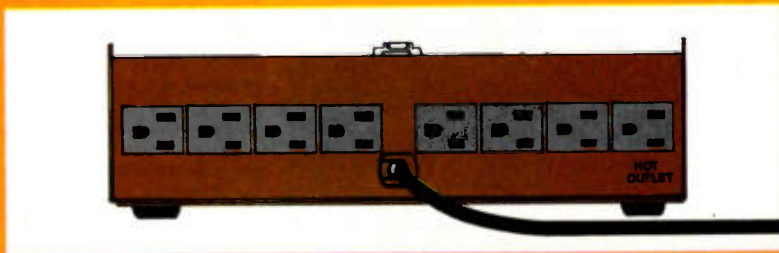

MACC only \$79.95
MACC-4 only \$59.95

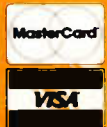

At your Alpha Delta dealer. Or in U.S., order direct, adding \$4 for postage/handling to check or money order. (Approx. shipping wt.: 4-1/2 lbs. each) MasterCard and VISA accepted. Ohio residents add Sales Tax. Sorry no C.O.D.'s

The MACC-4 is a four clean-line output version of the MACC with all the same features. It gives you a cost- and space-saving solution for your application, without sacrificing performance. Rated a full 1875 total wattage. Includes master rocker switch, three independently switchable lines, one "hot" line and resettable circuit breaker.

73 INTERNATIONAL

Each month, 73 brings you ham radio news from around the world. In this collection of reports from our foreign correspondents, we present the latest news in DX, contests, and events, as well as keep you abreast of the technical achievements of hams in other countries.

If you would like to contribute to your country's column, write to your country's correspondent or to 73: Amateur Radio's Technical Journal, Pine Street, Peterborough NH 03458, USA, Attn: Jack Burnett.



AUSTRALIA

J. E. Joyce VK3YJ
44 Wren Street
Altona 3018
Australia

In most countries, to varying degrees, amateurs are involved in emergency situations. We in Australia have an organization called Wireless Institute Civil Emergency Network, abbreviated to WICEN, that is set up as a community service in times of declared emergency situations. It is used also at several sporting events during the year as practice exercise.

However, in what we in the southern states of Australia called "The Holocaust of Ash Wednesday," practice turned to reality. It was a firestorm that spread from Adelaide in South Australia right through Victoria and up north to New South Wales—a distance of 800 miles. For us it fell, unfortunately, on the biblical Ash Wednesday, February 16th.

The states of the lower part of Australia were ripe for a bushfire. Being realistic, bushfires are a natural phenomenon here, as a lot of our trees and grasses will not germinate until bushfires have heated the seedpods to temperatures that would destroy imported trees and shrubs. The previous two seasons had been hot and dry, and on the morning of the 16th, we had a temperature of over 40° C plus strong winds of over 60 mph at some spots.

We had noticed minor bushfire smoke on the horizon during the working day but were not aware that in a few hours the whole state of Victoria with all its emergency services—and amateur radio in particular—would be put to the greatest test for decades. As you can imagine, with a country that relies largely on telephone lines strung between gum trees and wooden poles across open plains, it did not take long, once the fires got started, to burn down the gum trees and the wooden poles, leaving much of the state of Victoria with a communications problem. Added to this was the fact that most of our emergency services had only two or three crystal-locked channels of communications each.

It soon became clear that WICEN had to

be activated to back up the overloaded communications systems of the authorities. Most amateurs had been monitoring the 2-meter repeater in their area and it was not long before literally hundreds of amateurs had volunteered to go mobile or set up base stations in the affected areas. All the 2-meter repeaters were taken over for emergency use in the Melbourne area, giving us a coverage of at least 100 miles all around Melbourne. Also, we had HF set up on 80 and 40 meters for those low spots that VHF could not reach.

By the early hours of Thursday morning, February 17, WICEN was in full swing, had organized amateurs as base-receiving stations, and had dispatched mobile stations with VHF, UHF, and HF capabilities to all the disaster areas.

The sights at some of these spots were horrific, with some of the smaller towns losing 100% of their buildings. More than 2000 dwellings were totally destroyed. The loss of stock went into the thousands, and it was a pathetic sight to see hundreds of dead or dying stock, some of the badly injured ones still wandering around waiting to be shot.

Upon arriving at some of the places we were to operate from in the early stages of the operation, the scenes were not much better, with people wandering around dazed, some of them with their clothes still smoldering. Large holes burned in their coats, dresses, etc., showed how close they had come to being casualties. Even though a lot of them had lost everything they owned, their main worries were whether fathers or some other relations or friends had survived in the next town, or perhaps only 10 miles away.

With the fires still raging and the phones mostly out of operation, it was here that WICEN operators, by now located at all disaster relief centers, could really help. Welfare messages were passed, and the looks of relief on faces when messages came back that relations or friends were alright made a lasting impression on the WICEN operators, some of whom had spent up to two days with no sleep.

Some of the places of operation were a

bit hairy, to say the least, as some amateurs decided to stay in the path of the fire to relay messages. While some were set up in plush hotels with cold drinks and hot meals, others were out in the bush with cold sandwiches and hot drinks.

As a rough guide to the intensity of the fires, agricultural pipes buried two feet underground were melted and buckled beyond recognition; land that was previously flat had actually boiled and afterwards was left rough and uneven.

The wind created by the fires reached over 100 mph in some places. One instance we had reported from one of the worst-hit areas along the southern coast of Victoria was that people trying to direct traffic had to wrap arms and legs around the safety rails of a bridge to keep from being blown off.

Another aspect of fires in Australia is that the same eucalyptus oil that gives relief to people all around the world is also released during the heat of the fires. It can form into fireballs that can be up to 50 feet across and can roll along, sometimes far in advance of the main fire front. There was a sad total of 70 lives lost in these fires over a period of 2 days.

The amateur involvement did not end with the fires. Amateurs later were asked to assist in "Operation Clean-Up," when councils from most country and city areas donated men and equipment to help the fire victims remove their debris so they could start to rebuild their houses and lives. As most of these bulldozers, front-end loaders, etc., did not have two-way communications, a control center was set up and approximately 150 amateurs gave their services either at control or out with the vehicles, directing them from one site of destruction to another.

A debriefing was held for all amateurs and some of the emergency services and the result, I feel, will be a greater degree of cooperation between all concerned in any future emergencies. Also, in the media coverage of the fires, there was a fair mention of the involvement of amateur radio, and I think the general public now has a greater understanding of the role that we, as amateurs, can play in community-service ventures.

The Wireless Institute of Australia has displayed proudly on the clubroom wall in Melbourne a plaque of appreciation awarded to them for the part played by amateur radio in "The Holocaust that was Ash Wednesday."

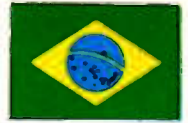

BRAZIL

Gerson Rlssin PY1APS
PO Box 12178 Copacabana
20000 Rio de Janeiro, RJ
Brazil

Carlos Vianna Carneiro PY1CC
Rua Afonso Pena 49, Apt. 701
20270 Rio de Janeiro, RJ
Brazil

CW GROUPS

CW operation has had a gradual increase in Brazil the last five years, especially on the low bands. More on forty than on eighty, we can hear a dozen stations daily between 2100 and 0300 GMT, our after-dinner time. The establishment of more than twenty CW groups did this.

Sponsoring at least one beautiful award, CW groups have provided their members with the necessary incitement to be active in CW as much as possible. Their annual contests are successful and they receive more than 95% of the logs from the participants, even when they made only a few QSOs.

Since the beginning of "73 International," we have published, little by little, the rules of some of those CW awards. Now, after six months, we are happy to say that those groups which have had their award rules published have received many more applications for their awards from abroad. And the awards are not so easy, even for us!

AWARDS

Regarding the rules of the CWRJ Award published in our column of May, 1983, please add to the CWRJ members list the following stations: PY1QN, PY1PL, PY1DUB, PY1VKA, PY1VMV, PY1ECL, PY1DWM, PY1TBW, PY1APS, PY1DMX, PY1KX, PY1QQ, PY1URO, PY1ENW, and PY1VEC. They are all very active stations and will make it easier to work the CWRJ Award.

LETTERS

We want to thank you very, very much for the letters we have received from readers of our monthly column. Besides the kindness and the most flattering terms of the letters, we are happy to know that readers are interested in Brazilian things and events.

One of them, Richard W. Randall K6ARE, collects old telegraph and wireless keys, and he is trying for one from each major part of the world. He wants an old key made in South America. The age does not make any difference, but it should be complete and in working condition. If possible, the key should be marked with the place it was made and the name of the company.

I have forwarded his letter to the CWSA CW group in the city of Santo Andre. Who can help Richard?

WIPA AWARD

Sponsored by the Grupo Praiano de CW (GPCW), the WIPA Award is available to all licensed amateurs for confirmed contacts with 10 (ten) different cities which have international ports (harbors) in at least three continents. No more than two cities for each country. For example: In Brazil, the city of Santos and the city of Rio de Janeiro. Contacts must have been made after January 1, 1983, on any amateur band. Only two-way CW mode with a minimum report of (RST) 338. No QSLs. Send GCR list of stations worked (call,



This photo, taken 100 years ago, shows the first electric plant in South America, in Campos City. Equipment came from Cleveland, Ohio, to Campos City, the pioneer in using electric light services in South America.

date, time, band, mode, and report) and 15 IRCs for mailing expenses to GPCW, PO Box 556, 11100 Santos, SP, Brazil.

Endorsements: copper label for additional 5 (five) cities, silver label for additional 15 (fifteen) cities, and gold label for additional 30 (thirty) cities.

de PY1APS

CAMPOS CITY AWARD

In 1883, a hundred years ago, using equipment coming from the Brush Electric Light Company, Cleveland, Ohio, for the first time in South America public electric light service was offered—in Campos, a Brazilian city in Rio de Janeiro State. Celebrating this event, Campos radio amateurs are sponsoring the Campos City Pioneer Award, as follows:

Available to all licensed radio amateurs, the award may be won by forming the sentence "1883-1983—Campos—Cem Anos de Iluminacao a Electricidade. Pioneira na America do Sul (meaning 1883-1983—Campos—One Hundred Years of Electric Light Service. Pioneer in South America).

Use last letters of call signs of stations reached to make the words. Contacts with two stations from Rio de Janeiro (PY1) are required, each one to substitute for one of the two dates (1883 and 1983). Contacts with stations from Campos City are valid as special QSLs to substitute for any missing letters.

Any band, any mode QSL is valid, mixed or single as well. Contacts made from January, 1983, on only. Do not send QSLs. Send log certified by amateur radio society or by two radio amateurs, stating name and call, date, QTR, report, band, and full address with zip code. Fee is 10 IRCs, and send request to Comissao Diploma Cent. Luz Elet., PO Box 391, 28100 Campos, Brazil, South America.

Submit the 62 needed QSLs in a column, in log, with the last suffix letters forming the sentence vertically.

PY2AMI BEACON PROJECT

Since April 14, 1982, a ten-Watt beacon has been permanently operating from Americana, in Sao Paulo State, at 28.300 kHz, using this message—VV VV DE PY2AMI PWR 10W ANT GP LAT 22 45 S LONG 47 16 W AMERICANA SAO PAULO. Congratulations and reports are coming from everywhere for this first 10-meter QRP beacon.

The PY2AMI call is the Brazilian hams' league, LABRE, in Americana. It was granted to the three Brazilian radio amateurs who were responsible for the transmitter and the CW identifying call message: PY2VRX Carlos Felipe, PY2FUZ Jose Roberto, and PY2CRI D'Orsay.

Reports have come from all Brazilian states, from as far as SM4KRT (Borlange, Sweden), LU9DDQ (Buenos Aires, Argentina), VE3MBN (Ontario, Canada), DF5FP (Amselwg, Germany), F3HO (Eaubonne, France); from the USA: WB1DLE, Massachusetts, N8CSR, Virginia, and KA2LEB, New Jersey; from EA8EY (Canarias Islands), GD3FLH/P (Isle of Man), GM3MHG (Ayrshire, Scotland), ZL1ATW (New Zealand), PA3BKs (Netherlands), G5AQQ (Romford, England), and many other places.

Keep an eye at 28.300 kHz and drop a QSL to PY2AMI Beacon Project, PO Box 31 or PO Box 108, 13470 Americana, Sao Paulo, Brazil, South America. Carlos Felipe, Jose Roberto, and D'Orsay will sure appreciate your report.

QRP IN BRAZIL

QRP operation in Brazil is getting a push, not only because of all the fun, not only because of new equipment and ter-

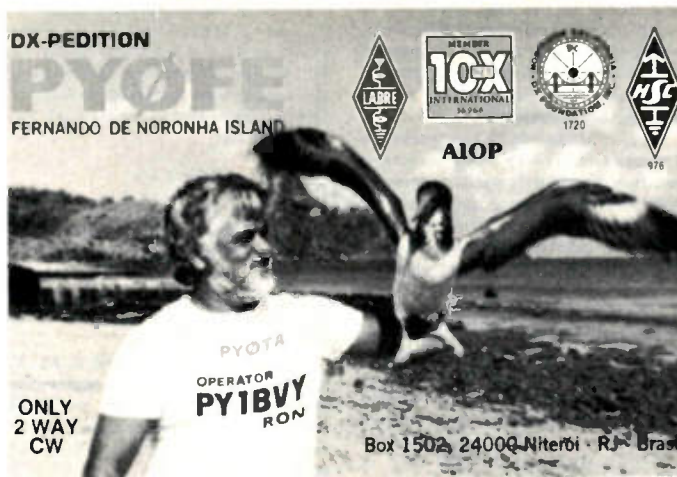

PY0FE's QSL. Ron is really fond of CW operations as you can see easily from the number of CW groups he's tied to.

rific prices, and not even because of its no-TV advantages. QRP is growing as an immediate consequence of CW groups spread all over Brazilian territory, and even a QRP group was born from this, bringing to all radio amateurs (and especially to newcomers), love for CW operation. Easy-to-build transceivers and transmitters are a very strong call to the QRP world, especially in the CW mode.

What? Still talking about a no-code license? Why don't you think big? Why don't you try to be a "real" radio amateur and join all the fun?

de PY1CC



ECUADOR

B. Patricia Recalde S. HC2PP
PO Box 511
Guayaquil
Ecuador

Last July 11, at 0728 hours, there was an aviation crash in which 119 people died. The location was four kilometers from the airport of Cuenca, the third largest city in Ecuador.

By 0745, the SAR (Servicio ala de Rescate), had an emergency net operating on 40 and 2 meters.

With the cooperation of radio amateurs, the SAR, part of the Air Force of Ecuador (FAE), was formed last year.

The area of the accident was easily covered by three repeaters, two from the Cuenca Radio Club and the other one from the Guayaquil Radio Club. The amateurs from Cuenca were at the place of the tragedy within minutes, and the reports were that there was nobody alive. At 0810, Guayaquil sent radio equipment and one amateur, by helicopter. At 0800, there were military people with amateurs from Cuenca covering the place. The repeater that was used was monitored by HC5KA, who was handling all the communication. He assigned different places for emergency handling, hospitals, Red Cross, fire department, police, and military.

At 0915 another helicopter was airborne to Cuenca from Guayaquil, and then, successively, three small planes were airborne to Cuenca. At this time, we all got to know that there were no survivors, and then our task got very sad.

We began, on 40 meters, to call relatives in different parts of the country and

to locate people who were supposed to be in that plane but apparently were not.

There was a call through 20 meters to England to tell to some people there of an Englishman who died in the accident.

At midday, the emergency was under control. The SAR had handled the emergency in an extremely organized way. But 113 dead! We hope that this kind of accident doesn't happen again.



CANADA

(Reprinted from the CARF News Service Radio News, No. 14/83, by permission of the Canadian Amateur Radio Federation, Inc.)

According to reports from maritime amateurs, the DOC has taken action against a ring of illegal radio operators by seizing equipment and dismantling antennas in New Glasgow, Nova Scotia. Among the equipment seized was amateur gear modified to operate from 6 to 25 MHz. The group operates in and out of the amateur bands, with its own call signs and QSL cards. Halifax amateurs reported that they were asked by the DOC to inform the Department of related "bootleg" activities. The enforcement action is being taken in cooperation with other countries. The DOC has not given out any details as the matter is still under investigation. Prosecutions will likely follow.

In what may be a spin-off from the recent sale of a Candu nuclear reactor to Rumania, Keith Jones VE3MH has received permission from that government to operate as VE3MH/YO in Bucharest. Keith, who works for External Affairs, was to have been on the 15-, 10-, and 20-meter bands since October 1st. The warm-up in diplomatic relations apparently resulted in this first such authority and also could account for two other firsts, both to Canadians—the issuing of a fishing license to one and permission to pursue his hobby of parachuting to another. It put Keith one up in the diplomatic community as even the US ambassador in Bucharest, who is an amateur, couldn't get the okay to operate there. Incidentally, Keith's good fortune is a one-shot special permission as there is no reciprocal operating arrangement between Canada and Rumania.

Scores of amateurs were present at the Royal Canadian Corps of Signals reunion and 80th anniversary ceremonies on

Labor Day weekend in Kingston, Ontario. More than two thousand signallers, wives, and girlfriends participated in the three days of ceremonies, banquet, and barbecue. About a thousand veterans took part in the impressive march past, making a real good show considering it was forty or more years since they had left the Vimy Barracks training center.

Unfortunately, Canadian amateurs are spectators only in a situation which would affect them directly if the FCC proposal for a no-code license goes through. A militant group calling itself the "American CB Trucking Alliance" is pressuring US legislators for a far more permissive approach to the code-free ticket than the one proposed by the FCC. The group wants all CB 11-meter operators eligible for amateur status in any new codeless license class. Most of this crew are operating illegally. US amateur organizations are meeting the FCC head-on in this one, with the perennial champion of the American amateur, Senator Barry Goldwater, leading the charge, with the assistance of other legislators.

Thanks to the assistance of the Minister of Communications, Francis Fox, three CARF handbooks are being translated into French, to be published by CARF in 1984. *The Regulations Handbook* is in the process of translation now.

Hopes may not be realized to have the ARRL DXCC list graced with a special prefix for St. Paul and Sable Islands, as they are based on the assumption that they are not under any provincial jurisdiction. They are, however, very much a part of Nova Scotia's territory, according to the federal Privy Council Office.

Regional Notes: Midwest—Norm Waltho VE5AE has taken over the VE5 QSL Bureau in addition to his other activities, including the "CARF Family Hour" on 3770 kHz at 0215 Zulu. Atlantic—Leigh Hawkes VE1ZN will be starting a CARF Regional Net soon. Ontario—Craig Howle VE3HWN, who has been very active in CARF, has resigned his directorship as he has moved to Calgary with a new job.



CYPRUS

Aris Kaponides 5B4JE
PO Box 1723
Limassol
Cyprus

NEWS FROM CYPRUS

On the 3rd and 4th of September, we had the National Field Day Contest. In this contest, three club stations took part: the Nicosia Club 5B4NC, the Larnaca Club 5B4LC, and the Paphos Technical School Club 5B4KX. Many amateurs helped in the setting up and operating of the stations, which shows that interest in amateur radio in Cyprus is growing.

All stations have sent me a report on their operations, and I start first with the Nicosia report which was sent to me by OM 5B4IT.

A few days before the start of Field Day, an initial scouting by 5B4IT and John 5B4MC around the capital, Nicosia, resulted in finding a nice hill called Kambia. Early in the morning of Field Day, 5B4NM (Marlos), 5B4MB (YL Marianna), 5B4LP (Andreas), and 5B4MF (Spyros) went to the site and installed dipoles for 10m, 15m, 20m, and 40m. They also put up a 4-band vertical antenna. Around noon,

5B4MC and 5B4IT arrived with the rest of the gear, including a Sommerkamp FT-277 and a gasoline generator. Then the antennas were tuned and all was ready for the afternoon. All sat in the shade (temperature 35° C) and had a beer and a snack. 5B4MD (George) arrived in the afternoon bringing the last supplies of food and an IC-720 transceiver.

At 1800 hours, the contest started with MF first to operate. Around 2000, the fire for the barbecue was started, but the transceiver never stopped operating. At about 2330, 5B4BD (Antonis) became quite hungry and so the charcoal fire was started again. Nobody slept that night until very early in the morning when one by one, each in turn had a short nap. Breakfast was served by 5B4MD. During the contest propagation was poor, and a final total of 937 contacts was made. Everybody in the group enjoyed both the barbecue and the contest, but it is rather difficult to decide in which order.

The Larnaca Club activities were reported to me by the main leader of the group, 5B4GJ (Erricos). The installation of the tent and generator was done by 5B4EA, 5B4GJ, and their harmonics. The site was 3 1/2 miles outside Larnaca City, by the seaside. Dipoles for 10m, 15m, 20m, and 40m were installed by 5B4DM and 5B4SP. Main operators for the contest were 5B4DM, 5B4JW, and 5B4SP. At the site, also present and helpful with operation, were 5B4EN, 5B4KY, 5B4FM, and 5B4AH, who repaired the transceiver which was used. Only 160 contacts were made due to poor propagation, and also the station was operated only until midnight Saturday and during the early morning on Sunday. According to Cyprus tradition, everybody enjoyed lots of food and drinks, such as wine, ouzo, beer, and whiskey.

The Paphos group reported to me via 2m that they set up their tent and station a few miles outside Paphos, by the seaside. The station was operated by 5B4JR (Andreas), 5B4JX (Sotos), 5B4MG (Dimitris), 5B4AI (Paul), who is also J28AI, and a group of pupils of the Paphos Technical School club station, 5B4KX. The Paphos group reports that they made around 450 contacts. So the Nicosia Club is the winner for this year's contest.

The Limassol group hopes to take part in the contest next year, and we generally hope that more Cyprus amateurs will be taking part in contests—not only local ones but also international ones.



GREAT BRITAIN

Jeff Maynard G4EJA
10 Churchfields
Wildnes WA8 9RP
Cheshire
England

THE UK SCENE

I have mentioned before the problems of intrusion on the amateur bands by illegal operators. This has usually meant CBers moving up from the crowded 27-MHz band into the bottom of our exclusive 10m band. Recently a new menace has presented itself in the form of cordless telephones.

The UK has for many years had a very restricted and tightly-controlled state monopoly of telecommunications run by British Telecom (formerly The Post Office). BT's obsession with technical excellence

and paperwork has long frustrated attempts to introduce modern telecommunications facilities (such as keyphones, call-distribution systems, mobile phones, electronic exchanges, and so on) for business and domestic use.

It is fair to say that BT has heeded the Thatcher government's desire for liberalization and competition with a more aggressive and commercial approach to its marketing. However, commercial pressures have led in the last couple of years to the widespread use of illegal telephone equipment.

Included in this category is the cordless telephone of the type consisting of a base station and remote hand-held or mobile unit. To provide full duplex communication, these crystal-controlled units operate on widely-separated transmit-receive frequencies. Most of the imported units are 1.6-2 MHz and 49.7-49.9 MHz, or 49.6-49.9 MHz and 70-70.5 MHz.

This causes interference to two amateur bands in the UK since, in addition to the international top-band allocation on 160m, we have an allocation at 4 meters (70 MHz).

With an estimated 10,000 illegal units operating in London alone and using powers up to 100-mW FM, the scale of likely interference is readily appreciated. A recent report compiled for the Radio Society of Great Britain by G3TCT has brought a measure of the problem to the attention of BT's Radio Interference Service. (Recent legislation provides for legal operation of cordless phones on 1.632-1.792 MHz and 47.45-47.554 MHz.)

DECLINE OF UK CB?

As predicted by a number of pundits, the growth in the UK CB market has not continued. CB has not and is not likely to replace hi-fi or video as the dominant consumer electronics market.

A recent statement in the House of Commons by Alexander Fletcher, Secretary of State for Trade and Industry, pointed out that although 453,000 CB licenses were issued since legalization in November, 1981, only some 285,000 are still valid. The general impression one gets from the scale (or lack) of CB advertising and the demise of most of the street-corner equipment shops suggests that UK CB is no longer significant.

NOVICE LICENSE?

The government has again rejected suggestions that a Novice amateur license be introduced to allow code-free,

minimum-technical-knowledge access to the amateur bands. It is felt that nothing should be done which would reduce the high standard of operating and technical proficiency shown to date by the Amateur Service. I doubt that few readers will disagree with that.

The RSGB breaks some new ground with the election of Bob Barrett as its president for 1984. As well as being Welsh and only in his early forties, Bob holds a class-B VHF-only call sign (GW8HEZ). Bob is the first class-B license holder to be elected for this high office.

Anyone contemplating a visit to the UK, or just interested in the latest happenings over here, might like to call the RSGB Headline News Service for some recorded comment. The number to call is 44 707 59312.

On the subject of telephone numbers, reference orbits (and other information) for UoSAT (OSCAR 9) can be heard on 44 483 61202.



GREECE

Manos Darkadakis SV1IW
Box 23051
Athens 11210
Greece

In my previous column, I mentioned the new frequencies now in use by Greek amateurs.

By the time you read this, you probably will have heard some of them working around the new bands. On 160 meters, you may find Charlie SV0AA (ex SV0WTT). Charlie is an old-timer coming from the States but living permanently in Greece—for about 20 years now. He is well known among CW operators worldwide and he is really enjoying 160 fun with his brand new Corsair from Ten-Tec and a center-loaded vertical. Of course, Charlie is not the only one down there, but he is probably the only one on CW. (If I find a solution to the antenna problem, I will certainly join him.)

There are also some SVs on 30 meters and there will be more as soon as interest grows.



INDIA

James Kalassery VU2ARL
PO Box 1446
36/677 Monastery Road
Cochin 682011
India

HIMALAYAN CAR RALLY

Photos by C. P. Ravindranath

The third Himalayan Car Rally was one of the toughest rallies in the world and therefore was indeed a challenge for the motorists. So was it also for the hams who provided communications for the organizers. They travelled over the most difficult tracks of the rally, along spine-chilling but beautiful mountain roads high up in the Himalayas.

Thirty radio amateurs from different parts of the country converged in New Delhi to take part in this hectic activity from 30th October to 6th November, 1982. While seven were stationed at the Communications Headquarters and six were mobilizing on different legs of the rally, 17 were manning nine different base stations along the 4000-km track.

Communications Headquarters was located adjacent to the headquarters of the organizers in the Hotel Maurya Sheraton, New Delhi. It was manned by VU9AID Dasan, VU9BBJ Asu, VU9NKR Naresh, VU9RX Vasant, VU9TN Ram, VU9UK Kap, and VU9YY Rayu in three shifts, with the special call VU9HRY. Changing shifts every four hours, the station was operative on 80m, 40m, 20m, and 2m all the time. Three separate dipoles for the HF bands and a 12-element yagi for VHF, all on top of the 40-meter-high hotel roof, were powered by a TS-830S, Drake TR-7, Icom 720, and a host of VHF rigs.

VU9AIR Viji, VU9FD Dinesh, VU9HSL Homi, VU9KIT Chris, VU9NA Sasi, and VU9PCD Pradeep were manning the mobile stations en route. All of them, except VU9AIR Viji, started from Bombay and came to New Delhi where they branched off in different directions. All of them were operating throughout the rally, providing most valuable support. In fact, the most adventurous, daring, and back-breaking activity of all was that of the mobilizing hams.

The base stations were located at Dehradun and Mussorie (VU9LT Ratna, VU9LR Satya, VU9BF Kaila), Nainital



Starting cars being flagged off at the Parc Ferme. The ham operators are stationed right under the banner in the background.

OWN THE WORLD WITH THE R3 NO RADIAL VERTICAL 10, 15, 20 METERS

The R3 half wavelength design eliminates the ground radial system required by other verticals. Optimum current distribution gives more efficiency and low angle radiation for DX communications.

R3 brings high performance antenna features to those living in apartments, condominiums or on small city lots. Even if you have plenty of space, R3's combination of neat appearance and DX capability make it ideal for your station. The R3 includes an integral tuner to give a perfect match across 10, 15, and 20 meters. The remote tuning feature allows easy fingertip control as you operate your station.

R3 is a complete antenna system ready to install in virtually any location from ground level to roof top.

FEATURES

- 3 dB Gain, ref $\frac{1}{4}\lambda$ whip
- No Radials
- 360° Coverage
- Integral Tuner with Remote Control Console and Indicator
- 24 Volts To Tuner
- 110 or 220 Volt Operation
- 75 ft (22.9m) Control Cable Included
- Only 22ft (6.7m) High
- 1 sq ft (.09 sq m) Space
- Self Supporting
- Stainless Steel Hardware
- Mount: Sleeve Type Fits Pipe Up To $1\frac{1}{4}$ in (4.5cm) dia
- Can Be Easily Stored and Set Up For Portable or Temporary Operation

Add up the features—you'll find that you can have ALL OF THIS PERFORMANCE without the need to buy tower, rotator and associated hardware. **R3 IS ANOTHER PRODUCT CREATED FOR THE ENJOYMENT OF YOUR HOBBY BY THE WORLD RENOWNED CUSHCRAFT ENGINEERING DESIGN TEAM.**

R3



cushcraft
CORPORATION

THE ANTENNA COMPANY
48 Perimeter Road, P.O. Box 4680
Manchester, NH 03108 USA
TELEPHONE 603-627-7877
TELEX 953-050 CUSHSIG MAN
AVAILABLE THROUGH DEALERS WORLDWIDE

(VU9SU Subi, VU9WC Sessa), Ranikhet (VU9KT Dillip, VU9VPR Vilas), Narkhanda (VU9VMJ Jadeja, VU9VRG Gopal), Manali (VU9MMA Mathew, myself), Simla (VU9SNM Subhandu, VU9XX Patil), Mandi (VU9SRJ Ramu, VU9POP Prakash), and Rai (VU9GSI Gurudev, VU9JSI Jasvinder), all along the route of the rally.

Originally, one more station was planned at Khoksar (10,000-foot altitude), but we had to cancel it since the rally itself went only up to Marhi, a little beyond Manali, due to snow-clad roads.

Most of the base stations were on HF bands. However, some operated both (Manali, Simla) and one VHF only (Narkhanda). The setup at each of the stations was decided on the basis of the survey done earlier by VU9RX Vasant.

VU9MMA and I were assigned to Manali, which was the northern tip of the rally route. At Manali the rally stopped for a night and returned from Marhi during the next day. So Manali was considered an important regrouping control point.

We were staying at the Hotel Beas, named after the snowy river flowing by its side. We had a trap dipole for 80m, 40m, and 20m supplied by VU9RX Vasant, which we put across the river (150 feet wide) at a height of about 80 feet above the water level. The other 40m and 20m combination inverted V, which I had brought along, was put up at the Parc Ferme (where the vehicles were parked for the halt), about 200 meters away from the hotel. The 3-piece, 12-element 2m ZL beam was moved around quite a bit whenever we needed it.

In spite of Manali being a very important control point, we had only one HF rig (Kenwood TS-130S) and one VHF rig (Icom IC-255A) to work with. Both of these were worked on an 80-Ah car battery which was under charge all the time.

The propagation conditions changed so rapidly that we had to keep on changing bands, one after the other, almost every hour. And very often, we had to get the assistance of hams in southern India to relay traffic. But generally 20m stayed good for the day and the other two bands were good during the night. Copy from Marhi on 2m was perfect throughout.

Until the cars started coming in on the night of November 3rd, we were operating from indoors, either relaying for some other rally station or handling traffic for the local regrouping control officials. But we had to stay outdoors almost the entire night once the cars came. And outside, it was really cold at 2° C. For many that may not seem cold, but for us who came in from far south, where the temperature varies only between 26° and 35° C, it was really very, very cold. There were many occasions while operating outdoors when we had to stop talking to breathe!

On our way back to New Delhi on November 5th, we also picked up VU9SRJ Ramu and VU9POP Prakash from Mandi, whom we had dropped there on our onward journey. In the prize-distribution ceremony (and later at the Rally Ball), to which all the participating hams were specially invited, the organizers commented on the excellent backup we all had provided for the rally. In fact, in their words, "We only organized the rally; the hams ran it!"

The whole communications network organized by the Federation of Amateur Radio Societies of India (FARSI) was steered by a committee headed by VU9AID (Chief Coordinator) and ably assisted by VU9RX Vasant and VU9TN Ram. In spite of all the difficulties with climate, food, and travel, all of us really enjoyed this activity and are looking forward to something similar again.



VU9MMA Mathew and VU9ARL James standing outdoors where they set up the station.



ISRAEL

Ron Gang 4Z4MK
Kibbutz Urim
Negev Mobile Post Office
85530 Israel

In the last edition of this column, I reported on the Israeli VHF scene and mentioned Bruno 4X4DH's pioneering work with the first OSCAR satellites.

It is with pleasure that I can write that with the successful launching and operation of AMSAT OSCAR 10, Aharon 4Z4AG, Bruno's student from the Tel Aviv Club 4X4HQ in the class of 1966, was following in his footsteps on that historic afternoon of August 6th when the satellite's transponder was turned on. The other Israeli station making contacts through the bird was that of Abe 4X4IX.

Aharon, well known in ham circles here for his high degree of technical proficiency, had his Mode B station already stand-by on the day of the launch. His gear is largely home brew—the receiving converter, transmitting amplifier, and antennas. The 70-centimeter transmitter is a Kenwood TR-9500; for receiving he uses a crossed yagi, and he transmits on a helical antenna. Aharon wants to add a low-

noise amplifier to his receiving setup to aid the weak signals. His elevational antenna rotator is also home constructed.

At the date of writing, 4Z4AG had contacted 30 countries through OSCAR 10, reporting that its apparent range from Israel is from New Zealand in the east to California in the west. California was contacted using at the time only ten Watts of CW, and the station sent him Hebrew New Year's greetings, to Aharon's great surprise! Aharon thinks that contacts with Hawaii may be possible, but only when the satellite is in a very particular position.

The amateur radio study guide, from the Open University's Center for Technological Education, mentioned here a few columns back, has at long last been published and been made available to the public. The book made its debut in August at the joint pavilion of the Israeli Amateur Radio Club and the Center for Technological Education at "Youth City" in the Tel Aviv fairgrounds.

Along with a display of the CTE's educational wares—various courses and books in the technological fields—special-events station 4X4CET was operated around the clock. Interested visitors were given explanations and encouraged to sign up for the next courses to be given at 4X4HQ. Special mention must be made of Naomi 4X6DW for her efforts in setting up the station and coercing people to operate it!

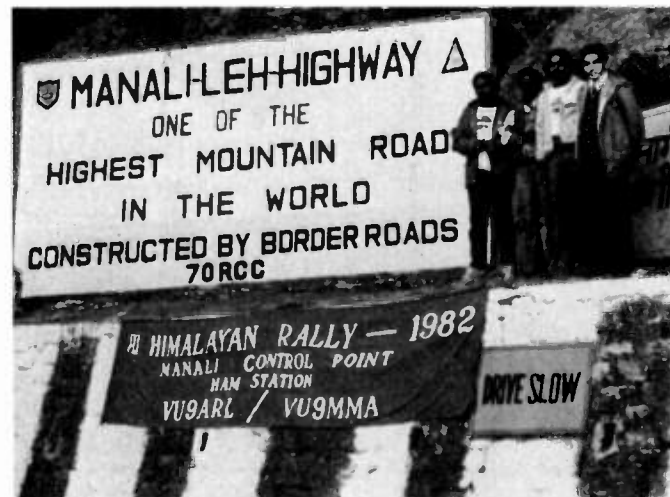

VU9MMA Mathew, VU9ARL James, and their friends just outside the hotel on the bank of River Beas.

So, after two thousand years, the first ham study book has been published in the Hebrew language. Although this well-put-together and attractive work is intended only for the grade-C Novice ticket, it is so thorough that it gives a good background for the higher-class grade-B license. The Center, so it is said, has at present no intention of putting out a higher level course. Instead, they are making available a bibliography of their other books which cover the technical topics of the grade-B exam, such that the reader of the Hebrew language will not be left high and dry when he wishes to upgrade.

The IARC Events Committee has been busy making plans, including, in May, a world conference of radio amateurs to be centered around the Israel Independence Day celebrations. Arrangements are to be made with various travel agencies and the Ministry of Communications. When more details are available, they shall be rushed to 73. In February, there is to be a national hamfest which will include the raffle of equipment and "junk" that was missing at the Annual Assembly. National Field Day is planned for the spring, March 20, 1984.

A new committee has come into being—the Contest Committee. Meeting at the QTH of Mike 4X6DF, they set for themselves the following aims: the creation of an Israeli worldwide contest, updating the rules of the Spring Contest (mentioned in the September, 1983, issue), liaison with the Ministry of Communications and foreign magazines, and the formation of a big guns all-star contest team to operate in the multi-multi class. Good luck in the contest!

On the social front, there have been meetings of both the Old-Timers, with Ozzie 4X4CW at the helm, and the Young-Timers, with Rami 4X6FH coordinating get-togethers. The Jerusalem Club, meeting on the first Thursday evening of each month, extends its invitation to all visiting amateurs. The profusion of visitors from abroad was so great at a previous meeting that the proceedings were conducted in English, under the capable leadership of Ben 4Z4AI.

I have both good news and bad news for the seekers of the coveted Jerusalem Award. First the good news: Only 8 IRCs will be required instead of 10. Secondly, 4X4JW has informed me of the following changes: Seven contacts with Jerusalem shall be needed instead of five, and three additional contacts must be made with other Israeli stations. QSLs go to 4X6AA (Dr. Milt Gordon, PO Box 4079, Jerusalem, Israel).

To help you out with this difficult award, active Jerusalem amateurs include 4X4s JW, LH, LI, RL, SO, and WP; 4Z4s JS, SM, SW, US, ZA, and ZB; 4X6s AA, BM, CJ, CQ, and GH; G3ZCZ and WB6SZB, both portable 4X. There are probably others, but these are known to me as active on HF. Check out the high end of 20 meters SSB after 2100 GMT.



ITALY

Giancarlo Martelli IQXXR
Via Bevignani, 18
00162 Rome
Italy

Nicola Sanna IQSNY, breaks his own world record from Ceuta, EA9, to Italy:

Continued on page 134

CES INTRODUCES THE NEW 510SA "SMART PATCH"

The State of the Art Simplex Interconnect

Communications Electronics Specialties introduces the CES 510SA "Smart" Simplex Autopatch, with many important new features never available before:

- Three digit control codes with user programming.
- A sophisticated toll restrict provides positive long distance lock out.
- Time-out and COR activity timers with warning beeps and digital programming.
- Rotary or DTMF dialing.
- Phone line in-use detector prevents interrupting a call in progress, and sends unique CW sequence.
- Phone ring detection logic enables unique CW sequence.
- Digital programming of the sample rate and width, and noise gate sensitivity control, for easy interfacing with most radios.

Simple and direct connections to radio.

Options available:

- Smart CW identifier with unique CW messages for each patch function
- FCC type accepted phone line coupler.
- Special tone squelch kit to operate patch through repeaters.



The 510SA — the newest advance in interconnect technology, from the innovators at:
Communications Electronics Specialties, Inc.
 Post Office Box 507 • Winter Park, Florida 32790
 (305) 645-0474 • Toll-free (for orders only): (800) 327-9956 ✓462

KENWOOD SPECIALS! - Call for Prices

Purchase a **KENWOOD TS-830S** at a **SPECIAL SALE PRICE** and receive either an **SP-230** speaker or **YK-88C** CW filter - **FREE!**

Purchase a **TR-2500** 2m or **TR-3500** 440 MHz HT at the **Low AES SALE PRICE** and receive the optional **PB-25H** HD battery - **FREE!**

KENWOOD TS-530S 9-band HF Transceiver
SPECIAL LOW PRICE!

KENWOOD TM-201A 25w, 2m FM Transceiver
SPECIAL LOW PRICE!



These are Limited Offers • Act now! - Call us for your price Today.

Order Toll Free: 1-800-558-0411

*In Wisconsin (outside Milwaukee Metro Area)
 1-800-242-5195*

AMATEUR ELECTRONIC SUPPLY[®] Inc.

4828 W. Fond du Lac Avenue; Milwaukee, WI 53216 - Phone (414) 442-4200

AES BRANCH STORES

WICKLIFFE, Ohio 44092
 28940 Euclid Avenue
 Phone (216) 585-7388
 Ohio WATS 1-800-362-0290
 Outside Ohio 1-800-321-3594

ORLANDO, Fla. 32803
 621 Commonwealth Ave.
 Phone (305) 894-3238
 Fla. WATS 1-800-432-9424
 Outside Florida 1-800-327-1917

CLEARWATER, Fla. 33575
 1898 Drew Street
 Phone (813) 461-4267
 No In-State WATS
 No Nationwide WATS

LAS VEGAS, Nev. 89106
 1072 N. Rancho Drive
 Phone (702) 647-3114
 No In-State WATS
 Outside Nevada 1-800-634-6227

Associate Store

CHICAGO, Illinois 60630
 ERICKSON COMMUNICATIONS
 5456 N. Milwaukee Avenue
 Phone (312) 631-5181

15 min. from O'Hare!

Wayne Green Books



The New Weather Satellite Handbook
All the information on the most modern spacecraft in orbit. This handbook includes material for newcomers and experienced satellite watchers. Included are hardware designs and instructions for building and operating a tracking station. One chapter covers tracking with a microcomputer. \$8.95 BK7383 131 pp.

LIVING ON A SHOESTRING

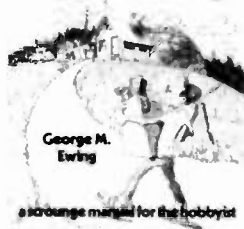

Living on a Shoestring
Save money by scrounging surplus and putting it to use. This book shows you how—at home or in the ham shack. Projects include cutting energy costs, building a dome house, constructing ham gear, transportation, and more money-saving ideas. \$7.97 BK7393 125 pp.

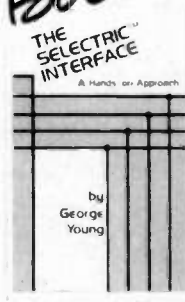

The Selectric™ Interface
You can turn an IBM Selectric I/O writer into a letter-quality printer for your computer. The Selectric™ interface gives you the programs and step-by-step instructions you need for Selectric models 2740, 2980, and Dura 1041. With slight modification, the instructions will work for various chips. \$12.97 BK7388 124 pp.

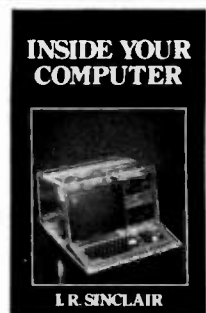

Inside Your Computer
Find out what goes on inside your machine. Inside Your Computer explains microcomputer circuits and how they work. Topics include chips, interpreters, circuits, machine language, binary numbers, algorithms, ASCII code, software, and what they all mean to the computer. Includes many photographs and schematics. \$12.97 BK7390 108 pp.

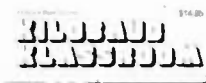

Learn Digital Electronics While Building Your Own Computer!

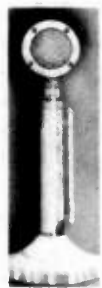

GENERAL LICENSE STUDY GUIDE

by Timothy M. Dawel N5RZ

Kilobaud Classroom
Learn electronics with this hands-on course. This collection of electronics projects starts with simple concepts and takes you on to building your own small computer. You'll learn electronics theory and get the practice you need to master digital electronics. \$14.95 BK7386 393 pp.

Study Guides
Join the hams who know what ham radio is all about. 73's study guides stress learning, not memorization, to help you study for the license exams. The General License Study Guide and the Novice License Study Guide provide all the information you need to earn a Novice or General ticket. Review questions included. **Novice License Study Guide** \$4.95 SG7357 **General License Study Guide** \$6.95 SG7358



Novice Study Tapes
It's easy to learn Novice theory from cassette. These tapes from the staff of 73 teach you what you need to know to breeze through the Novice written exam. Topics include theory, FCC regulations, operating skills, and setting up a station and getting on the air. \$15.95 CT 7300 Set of 3



Code Tapes
Mastering Morse code is easy with these code practice tapes. This series of tapes will help beginners and advanced hams get the practice they need. All cassettes are 60 minutes. **Tapes are \$4.95 each.** 5 wpm CT7305 6 + wpm CT7306 13 + wpm CT7313 20 + wpm CT7320 25 + wpm CT7325

A Guide to Ham Radio
Find out what it takes to communicate across the globe. This book answers your questions—from getting a license to setting up your station and broadcasting. You'll learn to use voice, Morse code, teletype, television, and satellites. \$4.95 BK7321 48 pp.

The Magic of Ham Radio
Learn about the special hobby of ham radio in this account from a 60-year veteran. Jerry Swank has watched radio grow from the days of Model A spark coils to microprocessors and satellites. From his experiences and those of others, he has written this entertaining and moving account of ham radio history. \$4.95 BK7312 155 pp.

Behind the Dial
You can have access to everything behind the dial, including government communications. This guide covers designing and using a receiving installation for the first 100 MHz of the radio spectrum. Included are electromagnetic spectrum, surveillance, station layout, antennas, and more. \$4.95 BK7307 57 pp.

VHF Antenna Handbook
A wealth of projects to show you how to build any kind of antenna. This book details theory, design, and construction of hundreds of VHF and UHF antennas. Included are dipoles, phased and parasitic arrays, polarized and nonresonant antennas, and more. \$5.95 BK7368 94 pp.

The Propagation Wizard's Handbook
This book by one of the best forecasters in America teaches the art of propagation forecasting. You'll read about magnetic storms, shortwave radio blackouts, long distance television, interference, and how they relate to the planets. \$6.95 BK7302 136 pp.

The Contest Cookbook
Discover the secrets of contest winners. This book covers domestic, DX, VHF, and 160-meter contests, with hints on everything from search and pounce to paperwork. You'll also learn to make 150 contacts in one hour. \$5.95 BK7308 170 pp.

SSB... The Misunderstood Mode
Discover the secrets of one of ham radio's least understood areas. This book presents several methods of sideband generation, which will let you construct a sideband generator. \$5.50 BK7351 96 pp.

World Repeater Atlas
Special price on the 1980 edition. You'll get repeater listings throughout the world indexed by location and frequency. Over 50 maps pinpoint 2000 repeaters across the U.S. Foreign listings also included. \$2.00 BK7315 274 pp.

For credit card orders, call toll-free, 1-800-258-5473. Or send your order on a separate piece of paper to: Wayne Green Books, Retail Sales, Peterborough, NH 03458. Be sure to include the book title, order number, and price. Postage and handling is \$1.50 for the first book, \$1.00 for each additional book. Foreign air mail is \$10.00 per book. Check, money order, or complete credit card information must accompany your order. If you have questions about your order, write customer service at the above address.

THE CONTINENTAL *silverline*

GUARANTEED TO OUT PERFORM

Any other Dish on the Market
or your money back*

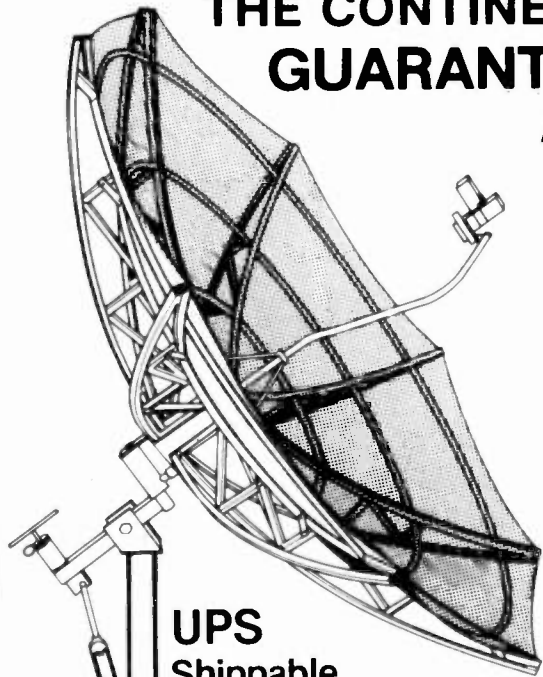

**UPS
Shippable**

While others claim to be good, we guarantee our line of antennas to out-perform any other of like size on the market. All of our 8', 10' and 12' antennas are UPS shippable. Even our 16', 20' and 24' antennas can be air shipped or taken as carry-on airline baggage. Some profitable selling points for you, the dealer, would be: *Shorter time to install on site, lightweight enough to be used with roof mounts and over a dozen colors available for even the most discriminating customer.*

*Offer good to Direct Dealers and Distributors within 7 days of purchase.

We manufacture a complete line of 8', 10', 12', 16', 20', 24' Antennas

131



**Continental
Satellite Systems**

11485 S.E. 212 Hwy.
Clackamas, OR 97015

Name _____

Address _____

City _____

State _____

Zip _____

Phone _____

Just fill in above coupon for FREE Dealer Packet or CALL 1-800-331-2774

THIS MONTH'S SPECIALS

***** LIMITED SUPPLIES *****

MUFFIN FANS (2 SIZES)

NEW \$14.95 USED \$7.95

WE ALSO CARRY A WIDE SUPPLY OF NEW & USED TEST EQUIP. COMPUTERS, MODEMS, I.C.S. COMPONENTS, TERMINALS, ETC.

BECKMAN INSTRUMENT SALE!!!!

TECH SERIES: #300...\$99.00 #310...\$122.50 #320...\$158.00
#330...\$189.00 #350...\$195.00 #360...\$230.00

HD SERIES: #100...\$139.00 #110...\$159.95

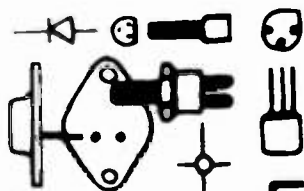

**CURRENT
ELECTRONICS**

2704 E. 22nd St.
Tucson, Arizona 85713
(602) 881-8964

For a Catalog
Please Send \$1.00
(Refunded on First order).

On the Move with 10 FM!

These modifications for Comtronix and Azden rigs will get you on your feet in a hurry.

F. W. "Andy" Anderson W7AR
8041 31 Avenue N.W.
Seattle WA 98117

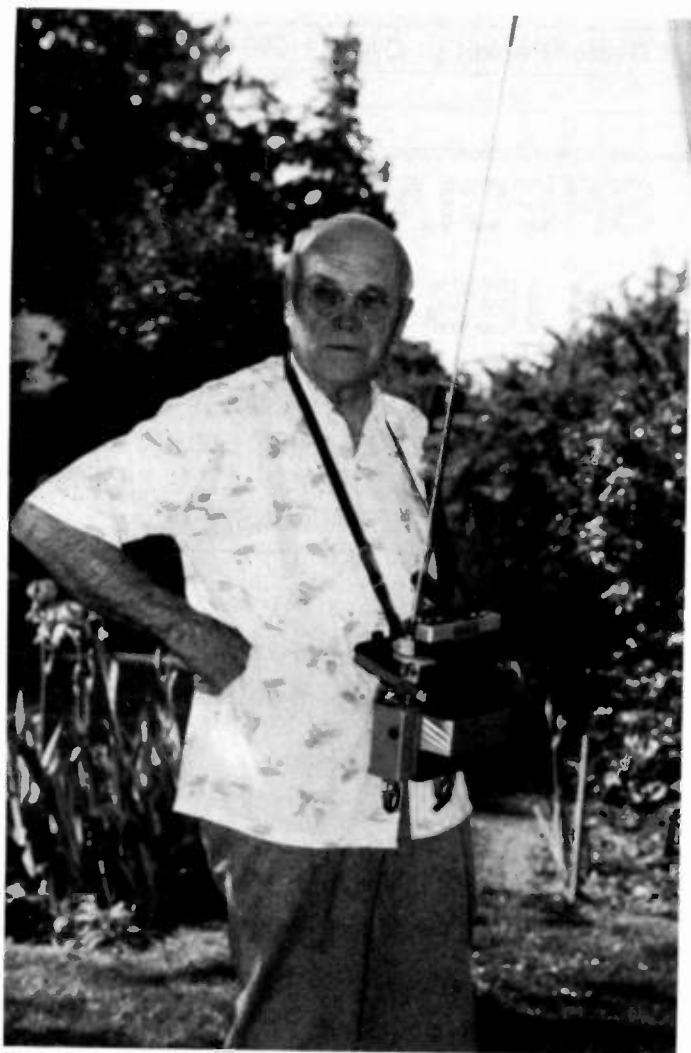

Andy and his rig.

What aspect of modern ham radio could cause a 75-year-old "recycled teenager" to tumble back into a medium which devoured his spare time as far back as 1928? The excitement and freshness of FM on ten meters did it, coupled with the fact that you can carry by shoulder strap a totally portable station feeding 14 Watts rf into a 7.9-foot whip.

Owners of transceivers like the Comtronix FM-80 and Azden may benefit from my tinkering—which included adding a 2.5-mH rf choke where the hot mike lead enters the chassis, to

kill audio squeal from rf entering the transceiver through the mike cord.

Discarding the whip which came with the Radio Shack CB kit (No. 21-941A), the ceramic cone and sturdy aluminum bracket gave me the necessary and secure antenna support. My FM-80 had two knurled screws on each side of the clamshell case, intended for U-bracket mounting under the dash. I used these screws and holes to fasten two suitably shaped 1/8-inch-thick dural plates to which not only the whip-mounting bracket could be fastened, but also the studs holding each end of



Close-up of the rig.

the Superscope tape-deck shoulder strap. In this way, no drilling of the clamshell was necessary except for the minibox mounting.

I experimented through a succession of whips to settle on a unit 7.9 feet long, consisting of a bottom section of 31 inches of 3/16" flexible aluminum rod, the upper end of which was threaded to fit an appropriate hole in the base of an 8-section telescoping whip, available for \$99 from Etco Electronics in Plattsburgh, New York. (Get on their mailing list; you'll not regret it!) This makes an extremely light, portable whip.

The heavy aluminum right-angle bracket (part of the ceramic cone insulator) was painstakingly rasped into shape and made to swivel through a short arc from a central hole with 10-32 thread screws into the dural plate. This allowed the whip to be vertical whether the FM-80 was shoulder-carried or operated from a card table outdoors.

A Bud CU-2102-B minibox was secured to the clamshell with 4-40 tapping and screws to hold the transmatch network—same as Ten-Tec's 247 unit. I settled for ten turns of No. 22 enamel on a 1/4-inch bakelite rod. The 100-pF (each section) 2-gang capacitor may be hard to come by,

although Etco has one with 45 pF per section that will work (No. 151JK, made in England). I am actually using only about 40 pF each section for an excellent 1.1:1 swr into the whip.

I dismantled several Meissner mica compression padders to come up with one 100-pF capacity feeding the whip. It was a most pleasant surprise to find that the Radio Shack Micronta 3-way CB tester (No. 21-526A) of 10-Watt rating would handle our 14 Watts (up against the pin) with no sweat. Unfortunately, the coax fittings extended out the top surface. Identical holes were drilled and reamed out the bottom; fortunately, the PC board inside could be tipped so that its coax outlets were convenient for my use.

An swr reading should always be available while walking with this rig. Two access grommet holes in the minibox permit one to make corrections for minimum swr before starting out. Hold the mike to your face in the same attitude and the swr will remain low. When the rf power meter on the FM-80 falls to mid-scale in transmit, the nicads should not be discharged further; the receiver itself should be turned off. These batteries should never be totally discharged.

I have not regretted using the BP20A-11 nicad battery pack of 2.3-Ah capacity

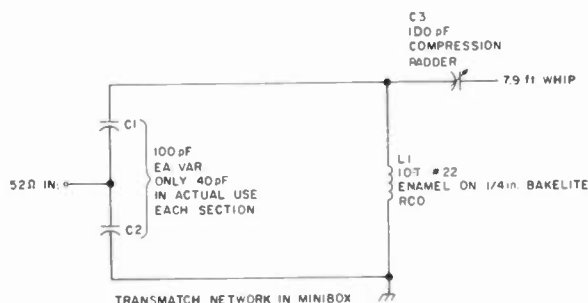

Fig. 1. Transmatch network in the minibox.

(from Alexander Mfg. Co. in Mason City, Iowa) and their 20-11 charger is guaranteed not to overcharge this unit. Fully charged in 10 hours, its 14 volts provides about three hours of operating fun. Silver duct tape secures the battery pack and swr meter case to the clamshell.

In passing, Azden/Comtronix-type transceivers intended for portable use will eventually have to go to LCD frequency/channel read-

outs since LEDs in daylight are useless.

While testing this unit in my basement workshop several feet below ground level, the whip lying horizontally, N4JB in Germantown, North Carolina, couldn't believe the circumstances for the boffo signal he copied! Operating it on a card table outdoors feeding a Cushcraft Ringo-10 right from the swr meter, the world is your oyster. See you on ten FM! ■

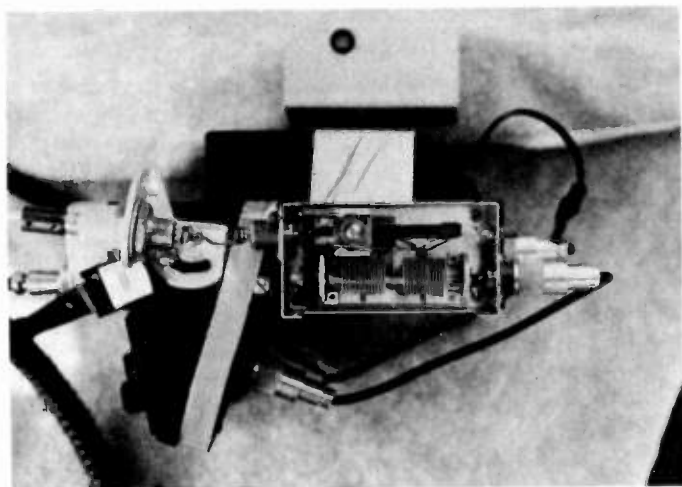

The modification of the antenna-mounting bracket.

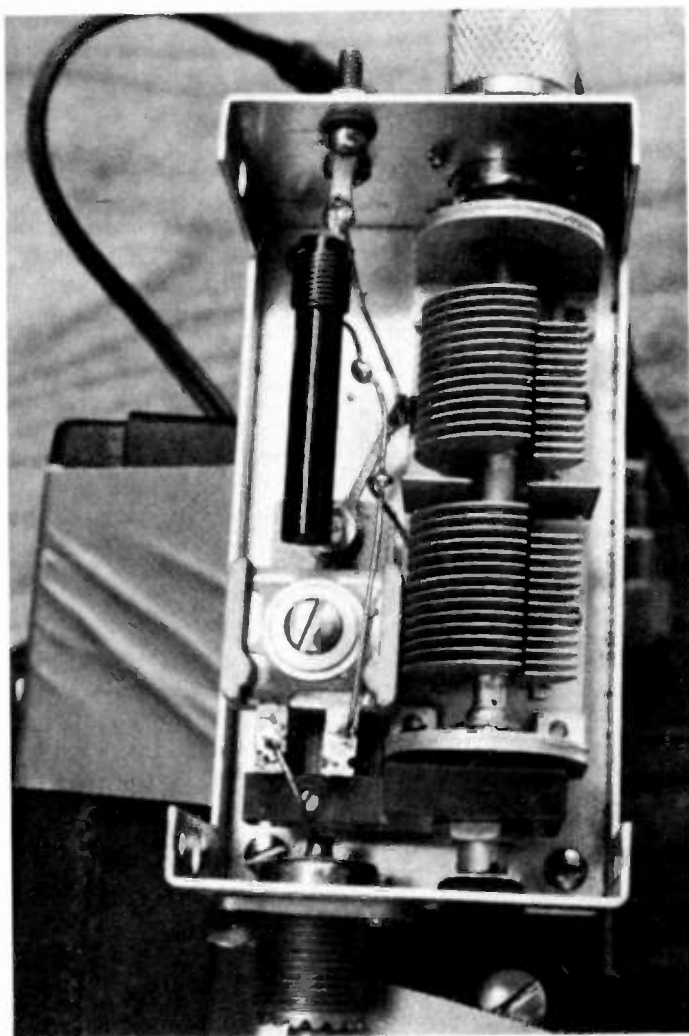

The transmatch innards in the minibox.

Thank You for Listening

*Build this simple speech expander and stop shouting.
Your DX friends will thank you and the QSLs will roll in.*

A versatile little chip called an electronic attenuator and manufactured under the brand code MC3340P is the heart of this unit. When used ahead of my old war-horse—the Heathkit SB-401 transmitter—it certainly adds a few S units when trying to make a QSO through the QRM.

In Fig. 1, the MC3340 is shown being used as a basic remote volume control. The advantage of this circuit is that the remotely located potentiometer does not need cumbersome shielded leads directly connected to a sensitive mike or other low-level audio input. When pin 2 is held high (up to +6 V dc), the audio will be fully expanded—approximately 0-dB attenuation. If the voltage at pin 2 is brought down to 3.0 V dc, 90-dB attenuation is achieved. The control potentiometer, when varied between 4k and 30k, theoretically achieves the 0-dB-to-90-dB attenuation.

Based upon these premises, the speech expander/clipper came into being.

The input transistor, Q1, is a 2N3819 and, being an FET, serves as an excellent high-impedance buffer for

the microphone and the MC3340. Transistor Q2 is a 2N1305 or similar transistor having a fairly good low-leakage coefficient. This transistor serves the purpose of dynamically varying the dc voltage at pin 2 of the MC3340.

The second chip, IC2, is a dual op amp, i.e., an LM358. Half the LM358 is used as an ac complex-non-inverting amplifier. The other half could be used to drive a VU meter or bar-graph display which can be used to monitor the audio output. However, the first half of the LM358 samples, through its pin 3, a portion of the audio output from pin 7 of the MC3340. Based upon the setting of R3, which controls the gain of the LM358, the sampled portion of the audio signal triggers a control voltage to appear at pin 1 of the LM358. This control voltage is rectified by D1 and fed to the base of Q2 which in turn controls the gain of the MC3340. Thus, the whole circuit acts as a sort of agc loop with R2 and R3 setting the attenuation thresholds.

Most of the parts are readily available at your

local Radio Shack, except for the MC3340 and possibly the LM358, for which they may have no equivalent. Any op amp could be used for IC2—the only stipulation being that it must be able to work off a single-rail supply. The prototype unit that I built used an LM741, but it required two 9-V batteries to produce the dual-rail supply. I suppose the CA3140, which is said to have a better slew rate than the 741, could have been used with a single-rail supply. However, as far as I know, the MC3340 has no equivalent. Therefore, this IC will have to be obtained from a Motorola dealer.

The printed circuit board is fairly easy to lay out and etch and should be no problem to the regular constructor. In the Heathkit SB-401, the unit can be built inboard if the VU meter/bar-graph display is not included. The unit is more accessible with plenty of scope for expansion if built as an outboard addition, in which case the male and female replicas of the microphone connectors must be obtained.

Setting up the attenuation thresholds can be done

accurately and quickly if a scope is available. If a scope is not available, plug the microphone into the input socket and clamp the leads of a pair of headphones between output connector and ground. (Do not plug the output of the unit into the transmitter.) Turn on the crystal calibrator of your receiver and adjust the audio output of the receiver for a high-pitch audio note. If the scope is available, connect it to the output connector of the unit.

Place S1 in the BYPASS position. Set R2 for minimum resistance from ground. Set R3 to minimum resistance. Set R1 to the halfway mark. Place the microphone near the receiver's speaker. If S1 has been connected appropriately, a weak tone should be heard in the headphones and a low audio trace should appear on the scope.

Now apply power to the unit and set S1 to OPERATE. If all has been connected well, you should get a significant increase in audio level at the output. Check the voltage at TP1 with a high-impedance voltmeter, preferably digital. It should

read 2.6 V dc. The voltage at TP3 should be zero or -Ve. This is the unit in full expansion mode.

Increase R3 until the voltage at TP3 goes positive approximately 1 volt. Check the voltage at TP1. It still should be showing +2.6 V dc and the scope should still be showing a healthy trace. A quick flip of S1 from OPERATE to BYPASS and back to OPERATE should show the amount of expansion.

With the voltage probe still at TP1, increase R2 until the meter shows +3 V dc. Now increase R3 until the meter reads +3.6 V dc. A reduction in the audio level at the output will be noticed and the trace on the scope will alter likewise. This is the clipping point.

If the audio source is abruptly increased and held at that level, or a loud long shout is emitted into the microphone, the result will be a sharp rise followed by a steep decline of the output signal to a constant level. This is most noticeable on the scope. The voltage at TP1 should show +4.5 V dc or higher (max. +5.2 V dc). This status is the unit in the attenuation mode.

When this has been achieved, speak at your normal level into the microphone and adjust R2 and R3 alternately until an accentuation of your voice from your normal speech level shows the peak briefly appearing and then being pulled down to the normal level. The aim of the adjustment procedure is to get that time constant between the peak and the pull-down as short as possible.

When this has been achieved, disconnect the headphones, turn off the crystal calibrator or audio source, plug the unit into the transmitter, and tune the transmitter into a dummy load. It will be found that the microphone gain control does not have to be turned up so much before the ALC cuts in. If a scope is used to monitor the transmitted audio signal, check and fine-tune R2 and R3 to suit your voice pattern and distortion threshold.

Get on the air and see how it works. Contact a distant station with the unit in OPERATE mode. Do not mention the unit, but in the course of conversation put it into BYPASS and wait for

TRY IT!

You can help us pick the "Amateur of the Year" at the 1984 Dayton Hamvention.

For details, drop a card to the address below. Do it now!

Nomination deadline is April 1, 1984.

**DAYTON HAMVENTION
ATTN: AWARDS COMMITTEE
P.O. BOX 44, DAYTON, OH 45401**

**See you at the Dayton HAMVENTION . . .
April 27, 28, 29, 1984.**

the reaction. Act accordingly.

I will be pleased to receive comments, enhancements, modifications, etc., concerning the unit and its operation.

In closing, I would like to thank G3YNB (H. Clayton) and VE1AOP (G. Coughlan) for getting me into redesigning the unit and writing this article. ■

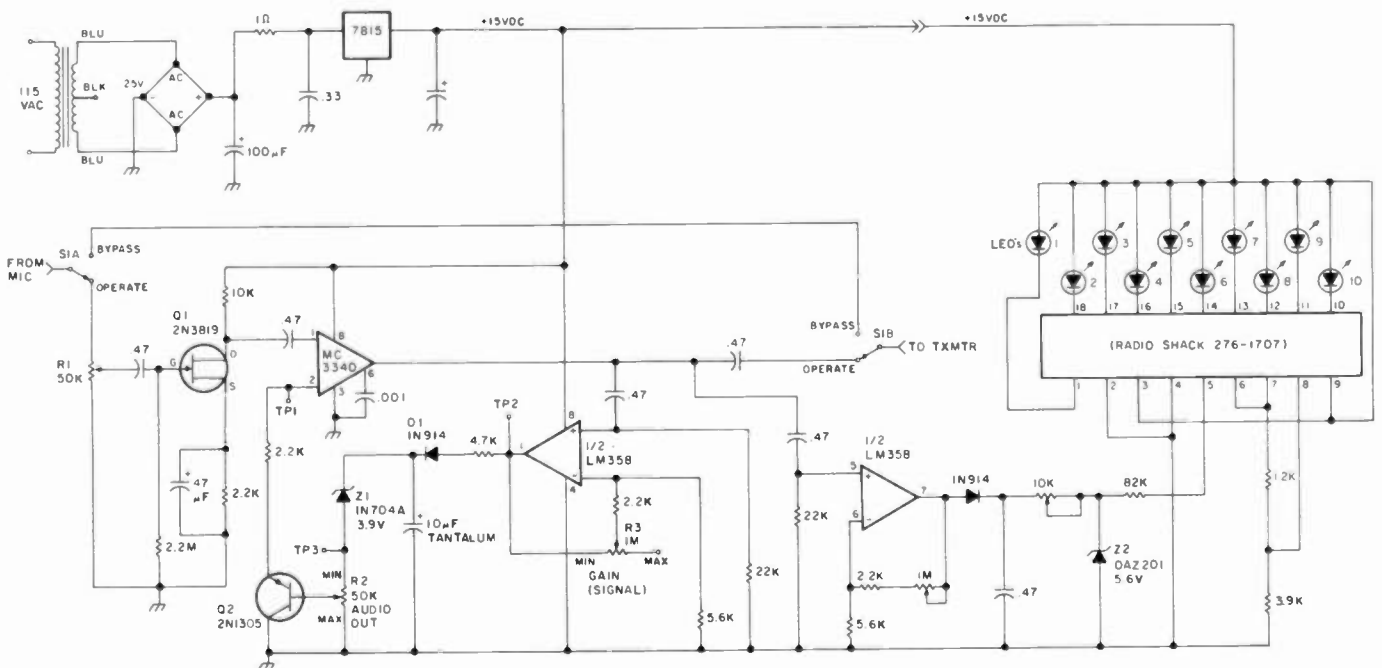

Fig. 1. Speech expander/clipper with LED bar-dot display.

Secrets of Nicads

Nicad batteries will save you money. Or will they?

You've been reading for years that nickel-cadmium batteries are the greatest thing since sliced bread for your portable gear. From one viewpoint, this is true, namely, economy. One set of nicads can be recharged many times before they have to be replaced, at a savings to the user every time they are recharged. However, there are some down sides to the use of nicads, some of which are readily apparent (lower terminal voltage, memory, downtime while charging) as well as one which is very important but not widely known: The capacity of a nicad is only about 25% that of a premium primary cell.

As an example, let's take

the AA-size cell. The commonly available AA nicad has a capacity of 450-475 milliampere hours (mAh). Gould, GE, and Radio Shack cells fall into this range. A premium alkaline AA cell from Duracell, Eveready, or Ray-O-Vac has a capacity of 1700-1900 mAh or nearly four times the capacity of the nicad. Thus, it would be necessary to recharge the nicad cell four times before you achieve any economy.

But wait. There is more to this story. We all know about the memory associated with nicads. If not fully discharged before recharging, they have a tendency to "remember" the discharge cycle, limiting the life to the remembered discharge.

Suppose you use your HT every day to and from work for a total drain of say, 150 mAh. You decide to put the charger on every night so as to have a full charge, right? Wrong. Unless you drag those batteries right down to nothing, a constant discharge/recharge of 150 mAh will result in cells with a capacity of about 150 mAh. Thus, you would have to recharge 12 times to obtain the same life as a set of premium AA cells. But that still represents some economy, doesn't it? Sure, if you are satisfied with less return on your investment than you expected.

Let's talk about the lower terminal voltage of nicads. They are 1.2 volts when fully charged. Eight cells (typical arrangement) will give you only a 9.6-volt power supply, vs. 12 volts from eight fresh

premium alkaline cells. Some HTs will provide space for 10 cells when using nicads, and some dummy cells to be used with primary batteries, but then your economy is eroded further (10 nicads vs. 8 alkalines).

Now, your 12 recharges to recover your investment becomes 15. Still an economy, sure, but not the one you thought you were getting. And if you cannot use 10 cells in your rig, think about the lower outputs, both audio and rf, when operating at the lower supply voltage.

Another consideration that you should think about is charge retention. Nicad cells will lose 10-12% of their charge per month unused, whereas alkaline cells can lose about 10-15% of

Primary	Capacity	Secondary	Capacity
AA	mAh	AA	mAh
Duracell Mn1500	1700	Gould 0.45 SC	450
Eveready E91	1600	Sanyo N450AA	450
Panasonic AM-3	1500	Panasonic NR-AA	500
C		C	
Duracell Mn1400	5000	Gould 2.0 SC	2000
Eveready	4400	Panasonic NR-C	1800
Panasonic AM-2	3900	Sanyo N2500-D	2500
D		D	
Duracell Mn1300	10,000	Gould 4.0 SC	4000
Eveready E95	9,100	Panasonic N2500-D	2500
Panasonic AM-1	9,300	Sanyo NR-d	2500

Table 1. Capacity of various batteries.

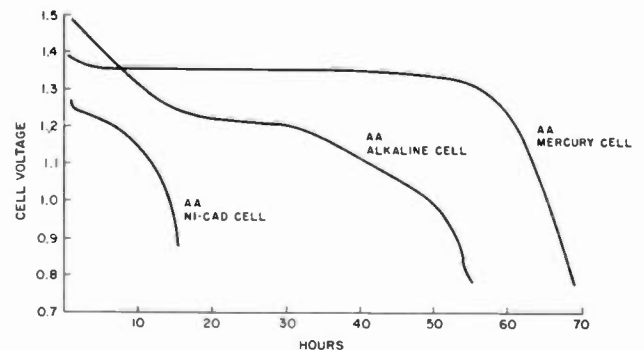

Fig. 1. Cell discharge curves. 25 Ohms continuous discharge.

rated capacity per year through shelf-discharge. Nicads are not the choice of battery to keep around in case of power failure, unless they can be trickle charged. You would be better served to keep a sack full of AA alkaline cells on the shelf for when the power goes off.

Fig. 1 shows the typical discharge curves for both alkaline and nicad cells. The curve for a typical mercury cell is also included for reference. AA mercury cells have a typical capacity of 2500 mAh, but cost nearly as much as nicads, thus are not cost-effective when compared to alkaline cells.

Table 1 is a listing of available primary and secondary cells with the manufacturer's ratings. Note the dramatic differences between cells and capacities.

Please note: I refer to premium alkaline cells. The Le-Clenche or zinc-carbon cell is not recommended for

communications products for a myriad of reasons, one of which is capacity. Manufacturers of zinc-carbon cells typically publish no data on them because of their widely varying performance.

I am not saying that nicad batteries don't have their place, but in situations where it is important to keep a radio going over the long pull, when you can't recharge (no ac outlets in the woods looking for that lost child), or in foreign countries where your 110-volt charger will not operate, the premium alkaline cell offers many real, substantial advantages that cannot be overcome by nicads. ■

References

- Gould Battery Handbook, 1973
- Eveready Battery Engineering Data, 1976
- Sanyo Cadnica Bulletin SF1542
- Panasonic Sales Brochure 20M813/10M
- Duracell Products Data Sheets

NEW!



COMPUTER RADIO MODEM

Connect your TRS-80*, Atari*, Apple*, or IBM-PC* to your radio for the ultimate in two way digital communications (CW/RTTY/ASCII).

CALL OR WRITE FOR DETAILS



(209) 667-2888

MACROTRONICS, inc. (R)

1125 N. Golden State Blvd.
Turlock, CA 95380

*TRS-80 is a registered trademark of Tandy Corp. Atari is a registered trademark of Atari Computer Inc. Apple is a registered trademark of Apple Computer Inc. IBM-PC is a registered trademark of International Business Machine Corp.

AMATEUR AND COMMERCIAL COMMUNICATION SERVICES

** Technical assistance by F.C.C. licensed technicians using the finest repair, test, and alignment equipment to give you results you can count on.

- REPAIRS
- TESTS
- INSTALLATIONS
- ALIGNMENTS
- MODIFICATIONS
- EVALUATIONS

** F.C.C. Licenses:

- General Radiotelephone (ship radar endorsed)
- Second Class Radiotelegraph (ship radar and aircraft radiotelegraph endorsed)
- Amateur Extra Class



Geff N8CE
517-626-6044



13313 FOREST HILL RD.
GRAND LEDGE, MICHIGAN 48837

HAMEG OSCILLOSCOPE



- 20 MHz Dual Trace
- Built-In Component Tester
- X-Y Operation (1:1 Ratio)
- 2 x 20 MHz, Max. 2 mV/cm
- Timebase 40 ns - 0.2 s/cm
- Trigger Bandwidth 30 Mhz

133

RFD-5

Rivendell Assoc.
DERRY, N.H. 03038 WARNER HILL (603) 434-5371



MAKE IT
EASY TO SAVE
your copies of

73 Magazine

Your magazine library is your prime reference source—keep it handy and keep it neat with these strong library shelf boxes. They are made of white corrugated cardboard and are dust resistant. Use them to keep all your magazines orderly yet available for constant reference.

Self-sticking labels are available for the following:

- | | | |
|-------------------|-------------|--------------------|
| 80 Micro | 73 Magazine | Radio Electronics |
| Microcomputing | QST | Personal Computing |
| inCider | CQ | HOT CoCo |
| Desktop Computing | Ham Radio | Interface Age |

One box (BX1000) is \$2.00, 2-7 boxes (BX1001) are \$1.50 each, and 8 or more boxes (BX1002) are \$1.25 each. Be sure to specify which labels we should send.

Call TOLL-FREE for credit card orders:

1-800-258-5473

73 Magazine

Attn: Book Sales, Peterborough, NH 03458

SHIPPING AND HANDLING CHARGES \$2.00 per order, up to and including a quantity of eight. 25¢ for each additional box ordered.

The Edison Effect

American inventor Thomas Edison is remembered for his array of electrical firsts. But lesser known is his invention of the first wireless telegraph.

The contributions that Thomas A. Edison made to the electrical world were many and are fully recognized by today's historians. His genius as a top-notch inventor is well known internationally and he is justly credited to be the most prolific and important pioneer of the electrical age. The duplex and quadruplex telegraphs, the light bulb,

the gramophone, the camera, and the movie projector are only a few of his inventions. There were many more, accounting for about 1,300 different patents at the end of his creative life.

But did you know that Edison also experimented with electromagnetic waves several years before Hertz did? ... invented an inductive railroad tele-

graph? ... invented a wireless electrostatic communication system? ... discovered and applied the thermionic vacuum emission, creating, in effect, the first two-element tube rectifier?

In 1875, while experimenting with sound vibrations produced by a magnetic vibrator and ways to transmit them over wires to distant points, he noticed

with curious amazement a peculiar light, or bright oscillating sparks, coming out of the core of the magnet. He had seen this phenomenon before in the telegraph relays and in loose filings between armatures and magnetic cores of telegraph printers, but so far attributed them to induction. These new sparks were somehow more intense and it occurred to him that they were not caused by induction. He wrote in his diary:

"We found that if we touched any part of the vibrator or magnet we got the spark. The larger the body of iron that touched the vibrator, the larger the spark. We now connected a wire to the end of the vibrating rod and we found we could get a spark from it by touching a piece of iron to it... by connecting to the gas pipe we drew sparks from it in any part of the room..."

He called this unknown electrical discharge "etheric force" or "etheric current" and conducted several randomly-directed experiments with it. It was not actually a discovery, since Joseph Henry noticed it much earlier, Faraday had speculated upon such a possibility before, and Maxwell had predicted it in 1823. Unaware of it at that time, Edi-

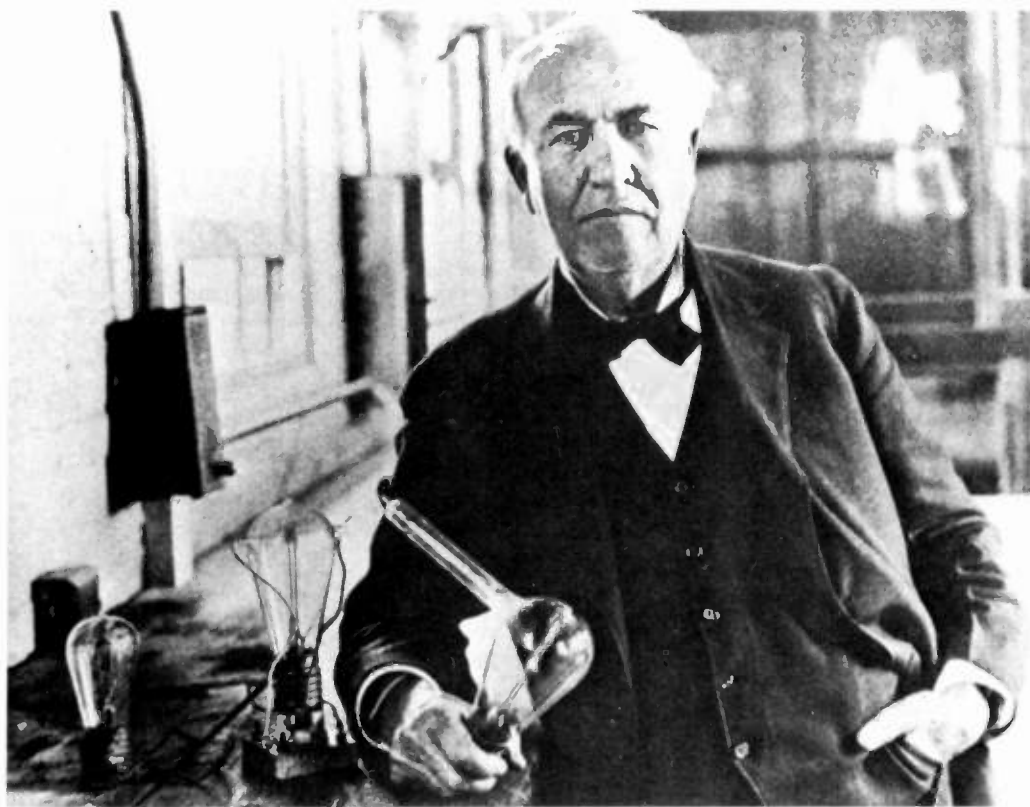

Edison with some original Edison-effect lamps.

son had been playing with electromagnetic waves.

In order to observe the new force, he constructed a "black box" with two adjustable sharp-pointed carbons and an eyepiece on top. He made public the results of his tests and since Edison was always news, the local papers reproduced his declarations, adding a bit of spice for good measure. Their words were something like this: "Mr. Edison discovered a new electric ray and predicts that someday all telegraphic and cable communications will be carried out without poles or wires."

He demonstrated his black box and etheric forces to a scientific association in New York, which brought about a few congratulations and started a turmoil of opinions—both pro and con. The news traveled as far as Europe, and in England, physicist Sylvanus Thomson declared that all was based upon known electrical principles. Oliver Lodge, distinguished man of science and later a renowned wireless pioneer, discussed the experiments and arrived at the same conclusion. Edison did not pursue his investigations much further, perhaps resentful of being criticized by these known authorities, or maybe for the lack of a practical application for the forces; he continued his inventive career in the direction of "greener" pastures.

In 1880 we find Edison at work with a novel telegraphic system, which he called the "space" or "grasshopper" telegraph. He was assisted in this project by his good friend and colleague Ezra T. Gilliland. The idea was to provide a means of communication to train travelers in the long stretches of the western plains. It made use of a special telegraph line, strung on poles at car height on the opposite side of the regular telegraph line to



Close-up of an Edison effect.

eliminate the interference from them. The receiver employed an insulated metal plate on top of the car, connected in series with the secondary winding of an induction coil, and a telephone receiver. The circuit continued through the metal wheels and track to ground. The transmitter used a battery, a telegraph key, and a high-frequency buzzer, in series with the primary of the induction coil. A send/receive switch completed the installation.

A duplicate set was to be installed at each telegraph office along the railroad line. The first tests were conducted on a small train in Staten Island NY and after a few failures and modifications, it was declared a success. Further experiments on the Lehigh Valley Railroad demonstrated the practicality of the grasshopper telegraph. It was never exploited and, although patented, apparently forgotten.

In 1855 at Menlo Park a wireless telegraphic system was developed by Edison. It used vertical masts of a hundred feet in length with metal plates on top. In his original patent he claimed to be able to communicate with points up to 3 miles distant and suggested that it could be installed on board ships,

105

Oct 8. 1883

J. E. Ott

Mr. Edison advised a working model made to indicate pressure ~~was~~ ^{was} the line, according to sketch given to me dated Oct 8. 1883. See. Book No. 204 page 67

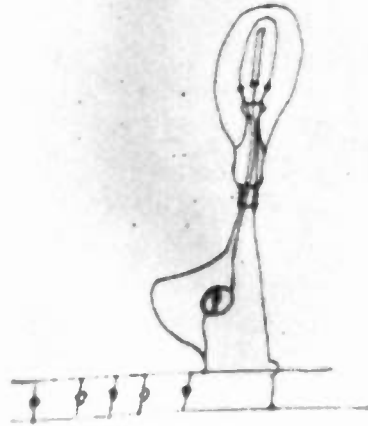

Entry in Edison's notebook showing lamp connected as a voltage indicator.

using their masts for the same purpose. He stated that communications between ships and between ships and shore could be established and collisions prevented during foggy days. As in the case of the grasshopper telegraph, the transmitter discharged an induction coil into the metal plate suspended on top of the mast. This induced a similar electrostatic charge on the plate of the receiving pole and the current thus created caused an audible click on the telephone receiver. It was never used commercially and when Edison was questioned about it, he declared with some air of mystery that, "It has been sold to a wealthy medium who wishes to communicate with the spiritual world." According to records found later, it was discovered that he had sold the patent, which also included the

grasshopper telegraph, to the Marconi Company in 1904 (patent no. 465,771).

In 1880, while testing incandescent lamps, Edison observed that particles of carbon from the filament were "carried" and deposited on the inside of the glass bulb. He also discovered that after certain periods of operation there was a thin white line, similar to a shadow, parallel to the filament but to one side. The lamps were fed with direct current and it showed that this effect was caused on the side of the filament connected to the positive side. Notes were taken but shelved for future reference since his work on lighting and power plants required his full attention at that time.

Experiments done by other scientists some years before had proven that the air, when in contact with red-hot metals, showed

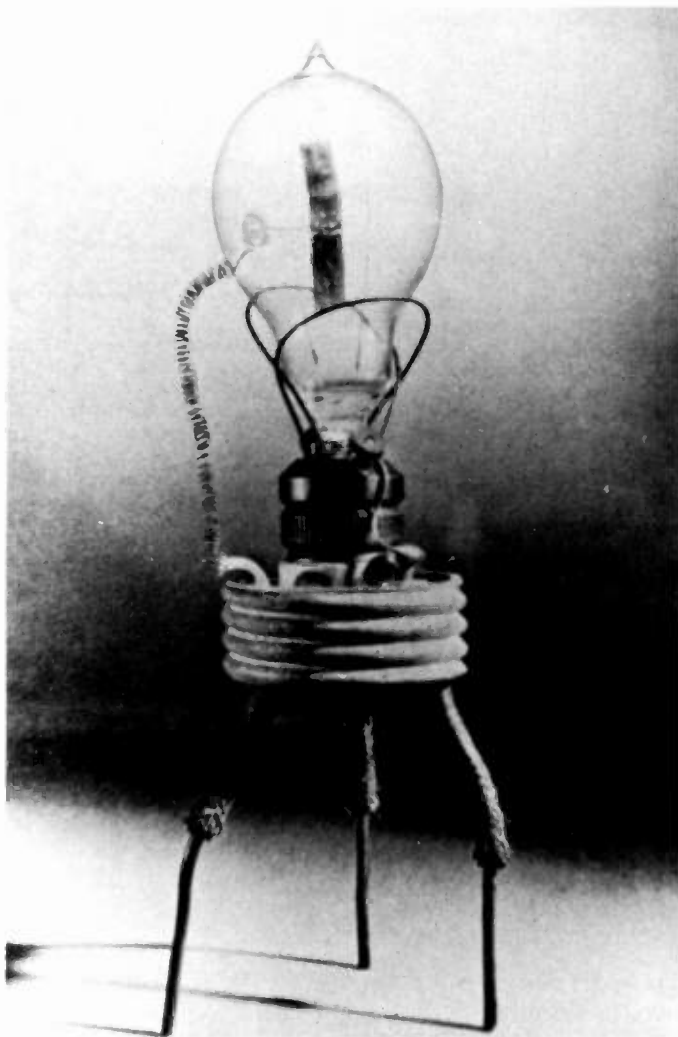

One of the Edison lamps used by Fleming in early experiments.

strange properties with regard to electrical charges. It was assumed (and sometimes emphatically affirmed) that electricity could not travel in a vacuum. Edison was aware of all these theories, but he never paid much attention to scientific assurances unless, of course, he could arrive at the same conclusions by experimentation. He was not a theoretician but a practical inventor. The question, "Was or was not the electricity the carrier of these particles of carbon?" was in his mind. He wanted an answer, he had to know and wanted to be sure.

Assuming that he installed another element inside the bulb and connected it to the positive side of the line, would it stop the flow of particles and keep the

lamp clean inside? In 1882 he sketched a bulb with the added element, but it was not until the next year that he was able to spare the time to build and test the new lamp.

The second element consisted of a platinum wire suspended between the two filament legs and insulated by the glass. When it was connected to the positive side of the line, he found that a current flow was indicated in a galvanometer connected into that circuit, but when the new element was on the negative side, there was no current indication. He did many other experiments in order to determine the best size, form, and position of the second element and found out that the best shape was a flat metal plate installed between the

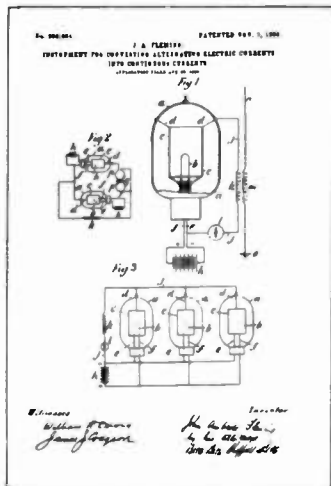

UNITED STATES PATENT OFFICE.
 JOHN AMBROSE FLEMING, OF LONDON, ENGLAND, ASSIGNOR TO THE MARCONI WIRELESS TELEGRAPH COMPANY, OF LONDON, ENGLAND.
 IMPROVEMENTS IN THE USE OF THE "VALVE" IN AN AC RECTIFICATION.
 Filed July 1, 1904.
 Patent No. 775,000.
 The nature of the invention is shown in the accompanying drawings, which are referred to by the numerals:
 Fig. 1 is a plan view of the valve.
 Fig. 2 is a plan view of the valve, showing the internal connections.
 Fig. 3 is a plan view of the valve, showing the internal connections.
 Fig. 4 is a plan view of the valve, showing the internal connections.
 Fig. 5 is a plan view of the valve, showing the internal connections.
 Fig. 6 is a plan view of the valve, showing the internal connections.
 Fig. 7 is a plan view of the valve, showing the internal connections.
 Fig. 8 is a plan view of the valve, showing the internal connections.
 Fig. 9 is a plan view of the valve, showing the internal connections.
 Fig. 10 is a plan view of the valve, showing the internal connections.
 Fig. 11 is a plan view of the valve, showing the internal connections.
 Fig. 12 is a plan view of the valve, showing the internal connections.
 Fig. 13 is a plan view of the valve, showing the internal connections.
 Fig. 14 is a plan view of the valve, showing the internal connections.
 Fig. 15 is a plan view of the valve, showing the internal connections.
 Fig. 16 is a plan view of the valve, showing the internal connections.
 Fig. 17 is a plan view of the valve, showing the internal connections.
 Fig. 18 is a plan view of the valve, showing the internal connections.
 Fig. 19 is a plan view of the valve, showing the internal connections.
 Fig. 20 is a plan view of the valve, showing the internal connections.
 Fig. 21 is a plan view of the valve, showing the internal connections.
 Fig. 22 is a plan view of the valve, showing the internal connections.
 Fig. 23 is a plan view of the valve, showing the internal connections.
 Fig. 24 is a plan view of the valve, showing the internal connections.
 Fig. 25 is a plan view of the valve, showing the internal connections.
 Fig. 26 is a plan view of the valve, showing the internal connections.
 Fig. 27 is a plan view of the valve, showing the internal connections.
 Fig. 28 is a plan view of the valve, showing the internal connections.
 Fig. 29 is a plan view of the valve, showing the internal connections.
 Fig. 30 is a plan view of the valve, showing the internal connections.
 Fig. 31 is a plan view of the valve, showing the internal connections.
 Fig. 32 is a plan view of the valve, showing the internal connections.
 Fig. 33 is a plan view of the valve, showing the internal connections.
 Fig. 34 is a plan view of the valve, showing the internal connections.
 Fig. 35 is a plan view of the valve, showing the internal connections.
 Fig. 36 is a plan view of the valve, showing the internal connections.
 Fig. 37 is a plan view of the valve, showing the internal connections.
 Fig. 38 is a plan view of the valve, showing the internal connections.
 Fig. 39 is a plan view of the valve, showing the internal connections.
 Fig. 40 is a plan view of the valve, showing the internal connections.
 Fig. 41 is a plan view of the valve, showing the internal connections.
 Fig. 42 is a plan view of the valve, showing the internal connections.
 Fig. 43 is a plan view of the valve, showing the internal connections.
 Fig. 44 is a plan view of the valve, showing the internal connections.
 Fig. 45 is a plan view of the valve, showing the internal connections.
 Fig. 46 is a plan view of the valve, showing the internal connections.
 Fig. 47 is a plan view of the valve, showing the internal connections.
 Fig. 48 is a plan view of the valve, showing the internal connections.
 Fig. 49 is a plan view of the valve, showing the internal connections.
 Fig. 50 is a plan view of the valve, showing the internal connections.
 Fig. 51 is a plan view of the valve, showing the internal connections.
 Fig. 52 is a plan view of the valve, showing the internal connections.
 Fig. 53 is a plan view of the valve, showing the internal connections.
 Fig. 54 is a plan view of the valve, showing the internal connections.
 Fig. 55 is a plan view of the valve, showing the internal connections.
 Fig. 56 is a plan view of the valve, showing the internal connections.
 Fig. 57 is a plan view of the valve, showing the internal connections.
 Fig. 58 is a plan view of the valve, showing the internal connections.
 Fig. 59 is a plan view of the valve, showing the internal connections.
 Fig. 60 is a plan view of the valve, showing the internal connections.
 Fig. 61 is a plan view of the valve, showing the internal connections.
 Fig. 62 is a plan view of the valve, showing the internal connections.
 Fig. 63 is a plan view of the valve, showing the internal connections.
 Fig. 64 is a plan view of the valve, showing the internal connections.
 Fig. 65 is a plan view of the valve, showing the internal connections.
 Fig. 66 is a plan view of the valve, showing the internal connections.
 Fig. 67 is a plan view of the valve, showing the internal connections.
 Fig. 68 is a plan view of the valve, showing the internal connections.
 Fig. 69 is a plan view of the valve, showing the internal connections.
 Fig. 70 is a plan view of the valve, showing the internal connections.
 Fig. 71 is a plan view of the valve, showing the internal connections.
 Fig. 72 is a plan view of the valve, showing the internal connections.
 Fig. 73 is a plan view of the valve, showing the internal connections.
 Fig. 74 is a plan view of the valve, showing the internal connections.
 Fig. 75 is a plan view of the valve, showing the internal connections.
 Fig. 76 is a plan view of the valve, showing the internal connections.
 Fig. 77 is a plan view of the valve, showing the internal connections.
 Fig. 78 is a plan view of the valve, showing the internal connections.
 Fig. 79 is a plan view of the valve, showing the internal connections.
 Fig. 80 is a plan view of the valve, showing the internal connections.
 Fig. 81 is a plan view of the valve, showing the internal connections.
 Fig. 82 is a plan view of the valve, showing the internal connections.
 Fig. 83 is a plan view of the valve, showing the internal connections.
 Fig. 84 is a plan view of the valve, showing the internal connections.
 Fig. 85 is a plan view of the valve, showing the internal connections.
 Fig. 86 is a plan view of the valve, showing the internal connections.
 Fig. 87 is a plan view of the valve, showing the internal connections.
 Fig. 88 is a plan view of the valve, showing the internal connections.
 Fig. 89 is a plan view of the valve, showing the internal connections.
 Fig. 90 is a plan view of the valve, showing the internal connections.
 Fig. 91 is a plan view of the valve, showing the internal connections.
 Fig. 92 is a plan view of the valve, showing the internal connections.
 Fig. 93 is a plan view of the valve, showing the internal connections.
 Fig. 94 is a plan view of the valve, showing the internal connections.
 Fig. 95 is a plan view of the valve, showing the internal connections.
 Fig. 96 is a plan view of the valve, showing the internal connections.
 Fig. 97 is a plan view of the valve, showing the internal connections.
 Fig. 98 is a plan view of the valve, showing the internal connections.
 Fig. 99 is a plan view of the valve, showing the internal connections.
 Fig. 100 is a plan view of the valve, showing the internal connections.

Copy of Fleming's US patent for use of the "valve" in ac rectification.

filaments, without any electrical connection to any of them. The current thus obtained proved to be proportional to the incandescence of the lamp, or candlepower. This lamp was patented by Edison (patent no. 3,070,311) although its commercial use or application was vague at that moment.

What he created was in reality an electronic measuring device—the first one able to demonstrate that electricity, under certain conditions, could and would travel inside a vacuum. The reason why this truth was not fully understood at the beginning was that the nature of electricity was still a mystery, as far as electronic theory was concerned.

The lamp was shown at the 1884 International Electrical Exposition in Philadelphia PA and advertised as an indicator of incandescent voltages. Due to the lack of a better vacuum, the reliability was not of the first order. This time, however, Edison's discovery was received in a more favorable mood by the electrical elite. Visitors were frankly impressed by the tests conducted by Edison in person. The renowned professor Edwin J. Houston declared prophetically that "Edison's invention would become something of great importance in the future." He

was right. Sir William Preece, Engineer-in-Chief of the British Post Office, also an induction telegraph pioneer and later Marconi's protector and collaborator, who in the past had questioned some of Edison's electrical conclusions, visited the Exposition and was sincerely moved with the two-element lamp and acquired some of them for further study and evaluation. His conclusions were published in England and a paper about the subject was read at the Royal Society in 1885. He coined the phrase "Edison effect" in recognition of Edison's achievement.

Another well-known scientist, Dr. Ambrose Fleming, recently appointed electrical consultant to the new Edison London Lighting Company, obtained several of the two-element lamps, with the purpose of using them as indicators in generator circuits—without much success.

In 1897 the British physicist, J. J. Thomson, after experimenting with the lamps, concluded that the effect was caused by the emission of "electrons," or negative electricity, which flowed from the hot filament to the cold element or plate connected to a positive potential.

Edison did not pursue

these investigations much further and his discovery lay dormant for several years, that is, until 1904. At that time Dr. Ambrose Fleming —later knighted for his discoveries in the wireless telegraphic field—was employed as technical adviser by the Marconi Wireless Telegraph Co., Ltd., in London. Fleming was searching for a better detector to be used on the receivers manufactured by that company, since the magnetic detectors currently in use lacked sensitivity. He then recalled the tests that years before he had made with the Edison-effect lamps and concluded that they could be easily adapted for that purpose. He dedicated himself to investigating the lamp in scientific detail and to improving its operation, using higher vacuum and changing the plate to a cylinder surrounding the filament. He renamed them "oscillation valves" (this is why, in

England, all vacuum tubes are still called valves) and applied for patents in England, Germany, and the United States.

Contrary to his claim, he did not invent the device, he simply used it as a high-frequency oscillation rectifier (it did not oscillate). Nor was he the first one to use it as a rectifier. Years later, as a result of litigations, his US patent was invalidated in favor of Edison's previous patent.

It did not matter very much anyway, since the Fleming valve did not make a great deal of difference as a detector of wireless signals. First, under the Marconi Company monopoly, it was supplied only to be used with their equipment and, second, it was less sensitive than the electrolytic and crystal detectors which appeared in the open market at about the same time.

We cannot deny that Dr. Fleming was a highly skilled and competent man of sci-

ence who made abundant contributions to the wireless and later radio industry. His experiments with the two-element lamps revealed facts and set standards to be considered later in their manufacture. He drew up operational curves; he used new configurations, types of filaments, and shielding schemes, and was the first one to use them in conjunction with tuned circuits. But what really revolutionized the wireless art and converted it to "radio" (1912) was the addition of a third element or "grid" by Dr. Lee De Forest, which made the bulbs capable of being used as high-frequency detectors, amplifiers, and oscillators.

It has been said that Edison did not make any great scientific discovery, but by his skill, ingenuity, and power of observation, he was able to surpass in practical achievements many scientists with broad academic backgrounds. He was a real

pioneer, perhaps the most important and imaginative of them all. He planted many seeds; others continued where he left off and a few collected the fruits. His work may not look like much to today's electronics students, where transistors, ICs, and computerized items dominate the industry, but it was the beginning—without it, radio, TV, and satellite communications would still be many years behind. * ■

References

The Saga of the Vacuum Tube, Gerald F. J. Tyne, H. W. Sams and Co., 1977.

The Edison Era, 1876-1892, Elfun Hall of History Publication, 1978.
Edison, a Biography, Matthew Josephson, McGraw-Hill, 1959.

*Other contributions made by Edison to the radio industry were the carbon microphone and the telephone receiver. The Edison battery was used as an emergency source on ships' radio stations.

PROJECT PACKS

BASED ON THE BRITISH PUBLICATION—RADIO & ELECTRONICS WORLD



DIGITAL FREQUENCY METER

Hand-held low power, fast response DFM
Frequency range 20 Hz to 150MHz
Sensitivity >50mv 20Hz-30MHz
>100mv 30MHz-150MHz
Resolution 1Hz-10KHz depending upon range
Display 5 digit LCD
Supply Voltage 9V dc
KIT Includes all parts, PCB and enclosure.
Stock No. 40-17702

\$74.50

2m CONVERTER

Low noise MOSFET circuit utilizing a 3 cavity helical filter
Frequency coverage 144-146 MHz
Output (IF) frequency 28-30 MHz
Gain 28 dB nominal
Noise Figure less than 2.0 dB
Supply voltage, current 8-16 V, 15 mA at 12 V
Input/Output impedance 50 ohm
KIT Includes all parts, PCB and enclosure
Stock No. 40-01030

\$37.50*

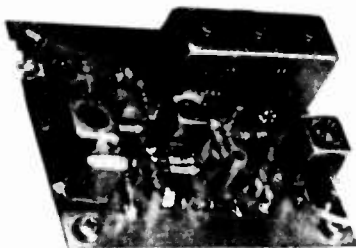

23cm CONVERTER

Low-noise low cost microwave (1240-1325) converter
Frequency coverage 1296-1298 MHz
Output (IF) frequency 28-30 MHz or 144-146 MHz
Gain 0 dB
Noise Figure 5.5 dB
Input/Output impedance 50 ohm
Supply voltage, current 10 V regulated, 96 mA
KIT includes all parts and PCB
Stock No. 40-23028 (10m output) \$43.47*
Stock No. 40-23144 (2m output) \$43.47*

UHF (70cm) CONVERTER

Low MOSFET circuit
Frequency coverage 432-434 MHz
Output (IF) frequency 28-30 MHz
Gain 28 dB nominal
Noise Figure 1.8-2.5 dB
Supply voltage, current 12V, 50mA
Input/Output impedance 50 ohm
KIT includes all parts, PCB and enclosure
Stock No. 40-01433

\$38.50*

R + EW U.S. Agent

RADIOKIT

Box 411S, Greenville, NH 03048
(603) 878-1033

*Shipping and Handling \$2.50

✓ 96



CORRECTIONS

Due to an oversight, reviews from our August and September issues were not included in our 1983 Annual Index published last month. Below is a corrected version.

TITLE	DESCRIPTION	AUTHOR	ISSUE
Advanced Computer Cont.	RC-850 Controller	WA3VUP	JAN 126
AEA	CK-2 Memory Keyer	W1XU	FEB 104
AEA	BT-1 Code Trainer	WB8JLG	MAR 104
AEA	Moscow Muffler	W1XU	MAY 120
AEA	MBA-RC Converter	N8RK	JUN 103
AEA	KT-2 Keyer/Trainer	WB8JLG	JUL 120
AEA	AMTOR TU	AF2H	NOV 98
Alden Electronics	Facsimile Recorder	W1XU	FEB 102
Autek Research	QF-1A Filter	WB8JLG	MAY 116
Azden	PCS-4000	WB8JLG	MAR 104
Blacksburg Group	Fist Fighter	W1XU	APR 103
Buckmaster Publishing	Call Directory	WB8JLG	FEB 106
Commsoft	RTTY89 Program	WB8BTH	SEP 96
Computer Applications	Pathfinder II	N8RK	JUN 104
Connect Systems	Private Patch	AG9V	NOV 99
Cushcraft	A3/A73 Tribander	AG9V	JUL 122
DGM Electronics	SRT-3000 RTTY Terminal	AA6SC	AUG 118
Dovetron	Widget	WB8JLG	MAR 107
Electronic Rainbow Inc.	Satellite TV Receiver	WB9ZNU	JAN 126
Foundation Publishing	The Rest of Ham Radio	N8RK	APR 104
Galfo	Apple RTTY Program	AE5V	APR 104
Gordon West	Code Tapes	WB8JLG	JUL 120
Hallward Products	Rad. Elec. Buyers Guide	W1XU	AUG 120
Harvey-Brain	Seychelles Saga	W1XU	JUN 104
Heath Co.	Ultrapro CW Keyboard	WBDFI	SEP 94
Heil Sound, Ltd.	HC-3 Mic Cartridge	WB8JLG	MAY 118
Hy-Gain	TH7DX Trihandler	K1XR	JUN 104
Icom	R-70 Receiver	WA2VSN	FEB 102
Icom	IC-490A Transceiver	K1KA	AUG 120
Icom	TR-720	W1XU	NOV 100
Icom	IC-751 Transceiver	WB6TOV	DEC 109
International DXers	Shortwave Equip. Review	AG9V	DEC 109
James Anderson	Ghost Fighter's Guide	N8RK	OCT 110
Kantronics	Hamsoft RTTY Program	WB8BTH	APR 102
Kenwood	Panadapter	K1XR	MAY 116
Kenwood	TS-430S	WA4BLC	JUN 102
Kenwood	TR-8400	K1KA	OCT 108
Kenwood	TR-9500	K1KA	NOV 97
Larsen	Mobile Mount	WB8JLG	APR 102
Metheny Corporation	LJN2KR Storm Alert	K9MX	JAN 128
MFJ	Econo-Tuner	WB8JLG	OCT 110
Palomar Engineers	PT-407 Antenna Tuner	WB8JLG	FEB 105
QZX Newsletter	Newsletter	WB8JLG	AUG 120
R.L. Drake Co.	9000E Comm. Terminal	W6SWZ	SEP 90
RSGB	VHF/UHF Manual	WB8JLG	JUL 119
Santec	ST-uP Handie-Talkies	W2IVS	OCT 109
Ten-Tec	Corsair Transceiver	W1XU	MAR 105
Universal Electronics	RTTY Callbooks	WB8JLG	MAR 108
Universal Software	Super-Ratt Program	N8RK	SEP 90
W.H. Natl Co.	Egbert II Program	N8RK	SEP 95
Yaesu	FT-102	WB8JLG	MAY 116

In his article "The Magical Audio Filter" (November), Jim Pepper incorrectly states that the notch frequency of Fig. 1 varies directly as R4 and by the square root of C1 and C2. However, his formula indicates that the frequency varies inversely as B4 and inversely as the square root of C1 and

C2. Thus, double R4 divides the frequency by two. Also, doubling either C1 or C2 reduces the frequency to .707 its original value.

Boyd Skillin K6MGY
Fresno CA

SOCIAL EVENTS

Listings in this column are provided free of charge on a space-available basis. The following information should be included in every announcement: sponsor, event, date, time, place, city, state, admission charge (if any), features, talk-in frequencies, and the name of whom to contact for further information. Announcements must be received by 73 Magazine by the first of the month, two months prior to the month in which the event takes place. Mail to Editorial Offices, 73 Magazine, Pine St., Peterborough NH 03458.

the river, South Bend IN. Tables are \$3.00 each in a carpeted half-acre room. The Industrial History Museum is in the same building. Four-lane highways lead to the door from all directions. Talk-in on .52/.52, .99/.39, .93/.33, .78/.18, .69/.09, 145.43, and 145.29. For more information, contact Wayne Werts K9IXU, 1889 Riverside Drive, South Bend IN 46616, or phone (219)-233-5307.

SARASOTA FL JAN 14-15

The Sarasota Amateur Radio Association will hold its 5th annual Sarasota Hamfest on Saturday and Sunday, January 14-15, 1984, at the Exhibition Hall, 801 N. Tamiami Trail (US 41), Sarasota FL. The hours on Saturday are from 8:30 am to 4:30 pm and on Sunday, from 8:30 am to 3:00 pm. Donations, good for both days, are \$3.00 in advance and \$4.00 at the door. The swap-table donation is \$12.00 for both days and includes the door donation. No one-day tables will be available and advance registrations are requested. Talk-in on 146.91/.13 primary and 146.73/.13 secondary. For advance tickets, booths, and tables, contact Dave Johnson, Jr. W4CCR, 2619 Forest Lane, Sarasota FL 33581, or call (813)-924-2525, or write Sarasota Hamfest, PO Box 3182, Sarasota FL 33578.

WEST ALLIS WI JAN 7

The West Allis Radio Amateur Club will hold its 12th annual Midwinter Swapfest on Saturday, January 7, 1984, beginning at 8:00 am, at the Waukesha County Expo Center Forum (take I-94 to Co. F, then south to FT, then west to Expo). Admission is \$2.00 in advance and \$3.00 at the door. Tables are \$3.00 in advance (reserved until 11:00 am) and \$4.00 at the door on a first-come, first-served basis. Delicious food will be available. For tickets or more information, send SASE to WARAC, PO Box 1072, Milwaukee WI 53201.

SOUTH BEND IN JAN 8

A hamfest swap & shop will be held on Sunday, January 8, 1984, at Century Center, downtown on US 33 One-way North between the St. Joseph Bank Building and

RICHMOND VA JAN 15

The Richmond Amateur Telecommunications Society will hold its Frostfest '84 Winter Amateur Radio and Computer Show on Sunday, January 15, 1984, from 8:00 am to 4:00 pm, at the Virginia State Fairgrounds, Richmond VA. All events will be indoors and general admission is \$4.00. Flea-market spaces are \$3.00 and tables are available for \$3.50. KX4Y will give Novice examinations. Doors will be open for unloading and setups beginning Saturday noon and a security guard will be on duty all night. Talk-in on 146.28/.88 and 146.34/.94. For more information, contact Bill Scruggs N4DDM at (804)-272-8206, or write Richmond Frostfest, PO Box 1070, Richmond VA 23208.

YONKERS NY JAN 22

The Yonkers Amateur Radio Club will sponsor the Yonkers Electronics Auction on Sunday, January 22, 1984, from 9:00 am to 3:00 pm, at Lemcko Hall, 556 Yonkers Avenue, Yonkers NY. Admission for buyers and sellers is \$3.00 each; children under 8 will be admitted free. New and used equipment will be auctioned and can be inspected from 9:00 am to 10:00 am. There will be plenty of seats and parking and the auction will start at 10:00 am sharp. Unlimited free coffee will be available all day. The club will charge a 10% commission on the first \$100 and 5% on the remainder on successful sales only. Talk-in on 146.265T/146.865R and .52 direct. For more information, write YARC, 53 Hay-

NEMAL ELECTRONICS

COAXIAL CABLE SALE

This Month's
Specials

Same Day
Shipping

POLYETHYLENE DIELECTRIC	
RG59/U mil spec 96% shield.....	14¢/ft.
RG213 noncontaminating 95% shield mil spec.....	36¢/ft.
RG174/U mil spec 96% shield.....	10¢/ft.
RG11U 96% shield, 75-ohm mil spec.....	25¢/ft.
RG8U 96% shield, mil spec.....	\$29.95/100 ft. or 31¢/ft.
RG6A/U double shield, 75-ohm.....	25¢/ft.
RG58AU stranded mil spec.....	12¢/ft.
RG58 mil spec 96% shield.....	11¢/ft.
LOW LOSS FOAM DIELECTRIC	
RG8X 95% shield.....	\$14.95/100 ft. or 17¢/ft.
RG59/U 70% copper braid.....	9¢/ft.
RG8U 80% shield.....	18¢/ft.
RG58U 80% shield.....	07¢/ft.
RG58U 95% shield.....	10¢/ft.
RG59U 100% foil shield, TV type.....	10¢/ft.
RG8U 97% shield 11 ga (equiv. Belden 8214).....	31¢/ft.
Heavy Duty Rotor Cable 2-16 ga. 6-18 ga.....	36¢/ft.
Rotor Cable 8-con. 2-18 ga. 6-22 ga.....	19¢/ft.

RG8U 20 ft. PL-259 ea. end.....	\$4.95
RG214U dbl silver shield 50 ohm.....	\$1.55/ft.
100 ft. RG8U with PL-259 on each end.....	\$19.95
BELDEN Coax in 100 ft. rolls	
RG58U #9201.....	\$11.95
Grounding strap, heavy duty tubular braid.....	
3/16 in. tinned copper.....	10¢/ft.
3/8 in. tinned copper.....	30¢/ft.

CONNECTORS MADE IN USA

Amphenol PI-259.....	79¢
PL-259 Teflon/Silver.....	\$1.59
PL-259 push-on adapter shell.....	10/\$3.89
PL-259 & SO-239.....	10/\$5.89
Double Male Connector.....	\$1.79
PL-258 Double Female Connector.....	98¢
1 ft. patch cord w/RCA type plugs each end.....	3/\$1.00
Reducer UG-175 or 176.....	10/\$1.99
UG-255 (PL-259 to BNC).....	\$2.95
Elbow (M359).....	\$1.79
F59A (TV type).....	10/\$2.15
UG 21D/U Amphenol Type N Male for RG8.....	\$3.00
BNC UG88C/U male.....	\$1.25
3/16 inch Mike Plug for Collins etc.....	\$1.25
UG273 BNC to PL-259.....	\$3.00

FREE CATALOG
COD add \$2.00—FLA. Res. add 5% Sales Tax

Orders under \$30.00 add \$2.00

Connectors—shipping 10% add'l, \$3.00 minimum

Cable—Shipping \$3.00 per 100 ft.

12240 NE 14th Ave., Dept. 73, No. Miami, FL 33161 Call (305) 893-3924

ward Street, Yonkers NY 10704, or phone (914)-969-1053.

**TRAVERSE CITY MI
FEB 11**

The Cherryland Amateur Radio Club will hold its 10th annual swap and shop on February 11, 1984, from 8:00 am to 1:00 pm, at the Immaculate Conception School Gym, 2 blocks south and 1 block west of the intersection of M-37 and M-22, Traverse City MI. Registration will be at the door. Talk-in on 146.25/85. For more information, call Jerry Cermak K8YVU at (616)-947-4848.

**MANSFIELD OH
FEB 12**

The Mansfield Midwinter Hamfest/Auction will be held on Sunday, February 12, 1984, beginning at 8:00 am, at the Richland County Fairgrounds, Mansfield OH. Tickets are \$2.00 in advance and \$3.00 at the door. Tables are \$5.00 in advance and \$6.00 at the door. Half tables are available. Talk-in on 146.34/94. For additional information or advance tickets and tables, send an SASE to Dean Wrasse KB8MG, 1094 Beal Road, Mansfield OH 44905, or phone (419)-589-2415.

**GLASGOW KY
FEB 25**

The annual Glasgow Swapfest will be held on Saturday, February 25, 1984, beginning at 8:00 am Central time, at the Glasgow Flea Market Building, 2 miles south of Glasgow, just off highway 31E. Admission is \$2.00 per person. There is no additional charge for exhibitors. The first table per exhibitor will be free, and extra tables will be available for \$3.00 each. There will be a large heated building, free parking, free coffee, and a large flea market. Talk-in on 146.34/94 or 147.63/03. For further information, write Bernie Schwitzgebel WA4JZO, 121 Adairland Court, Glasgow KY 42141.

**FRIDLEY MN
FEB 25**

The Robbinsdale Amateur Radio Club will hold its 3rd annual Midwinter Madness Hobby Electronics Show on Saturday, February 25, 1984, from 9:00 am to 3:00 pm, at Totino-Grace High School, 1350 Gardena Avenue NE, Fridley MN (a Minneapolis suburb). Admission is \$3.00 in advance and \$4.00 at the door. There will be manufacturers and dealers of ham, computer, satellite, and R/C gear, as well as seminars and a flea market. Talk-in on 146.52 simplex or the 147.60/00 repeater (K0LTC). For more information, contact Robbinsdale ARC, PO Box 22613, Robbinsdale MN 55422, or call Bob at (612)-533-7354.

**AKRON OH
FEB 26**

The Cuyahoga Falls ARC will hold its 30th annual electronic equipment auction and hamfest on Sunday, February 26, 1984, from 8:00 am to 4:00 pm, at North High School, Akron OH. There is easy access from the Tallmadge Avenue off-ramp of North Expressway (Rte. 8). Tickets are \$2.50 in advance and \$3.00 at the door. Some tables are available for \$2.00 or sellers may bring their own; advance reservations are advised. Talk-in on .87/27. For more details or reservations (please include an SASE), write CFARC, PO Box 6, Cuyahoga Falls OH 44222. Table reservations may also be made by calling Bill Sovinsky K8JSL at (216)-923-3830 and will be held until 9:00 am.

HAM HELP

We are happy to provide Ham Help listings free, on a space-available basis. We are not happy when we have to take time from other duties to decipher cryptic notes scrawled illegibly on dog-eared postcards and odd-sized scraps of paper. Please type or print your request (neatly!), double spaced, on an 8 1/2" x 11" sheet of paper and use upper- and lowercase letters where appropriate. Also, please make a "1" look like a "1," not an "l," which could be an "el" or an "eye," and so on. Hard as it may be to believe, we are not familiar with every piece of equipment manufactured on Earth for the last 50 years! Thanks for your cooperation.

I need a schematic and manual for Lafayette FET multimeter #99-50833. I will pay copying costs.

Keith Heryford
PO Box F
Cedarville CA 96104

I would like to hear from anyone who has successfully interfaced a Commodore VIC-1525 printer to a Hal CT-2100 communications terminal either to the ASCII printer or RS-232C serial output of the Hal terminal.

Karl Thurber W8FX
317 Poplar Drive
Millbrook AL 36054

Our club station (VE2CLL) needs schematics and service manuals for the Hallcrafters HT-45 linear and P-45 power supply.

Harold Carmichael VE2ELN
257 St. Leon St.
Quebec City
Quebec G1K 1B8
Canada

I need an up-to-date tube-checking list for a B&K Dyna-Quik Model 500 tube tester. I have the list that is attached to the top of the case but I need a more

modern list. The manufacturer says that it is out of print. Drop me a line letting me know what you have.

Gene V. Mock W4RHD
Rt. 9, Box 64-5
Fayetteville AR 72701

I need any and all technical information and manuals on the Central Electronics Model 100V transmitter. I also am interested in salvage units for parts. I will pay all expenses.

W. Van Lennep
PO Box 211
Pepperell MA 01463
(617)-433-6031

I need a copy of the tech manual/schematic of the Tektronix 535A oscilloscope. I will copy and return, or quote price for a good copy.

Hank Dean N8DOE
408 Brisbane Ave.
Westerville OH 43081

I would like to hear from anyone who has successfully changed the early Yaesu 101 6JS6 finals to 6146s.

R. F. Bricker K4CSV
PO Box 295
Fort White FL 32038

MICROWAVE PREAMPLIFIERS

Ampire 1690N:

- 1.6 to 1.8 GHz
- 25 dB gain
- 3.0 dB noise figure
- N connectors standard
- Use on GOES & METEOSAT systems

Ampire 2001:

- 2.0 to 2.6 GHz
- 20 dB gain
- 3.5 dB noise figure
- BNC connectors standard
- DC & RF cables included
- Use with microwave TV converters

Ampire 1690N	\$139 ⁹⁵
Ampire 2001	\$129 ⁹⁵
Ampire 2001N	\$149 ⁹⁵
Shipping: USA	\$2 ⁰⁰
Foreign	\$10 ⁰⁰

Data Service Company

3110 Evelyn Street
Roseville, MN 55113
612-636-9469



ALL BAND TRAP ANTENNAS!



PRE-TUNED - COMPLETELY ASSEMBLED - ONLY ONE NEAT SMALL ANTENNA FOR ALL BANDS! EXCELLENT FOR CONDOS - APARTMENTS - LIGHT - STRONG - ALMOST INVISIBLE!

FOR ALL MAKES & MODELS OF AMATEUR TRANSCEIVERS! GUARANTEED FOR 2000 WATTS SSB INPUT FOR NOVICE AND ALL CLASS AMATEURS! IMPROVED DESIGN!

COMPLETE with 90 ft. RG58U-52 ohm feedline, and PL259 connector, insulators, 30 ft. 300 ohm test decron end supports, center connector with built in lightning arrester and static discharge - molded, sealed, weatherproof, resonant traps 1" X 6" - you just switch to band desired for excellent worldwide operation - transmitting and receiving! Low SWR over all bands - Tuners usually NOT NEEDED! Can be used as inverted V's - slopers - in attics, on building tops or narrow lots. THE ONLY ANTENNA YOU WILL EVER NEED FOR ALL BANDS - WITH ANY TRANSCEIVER - NEW - NO BALUNS NEEDED!

80-40-20-15-10 -- 2 trap - 104 ft. - Model 998BUC .. \$99.95
40-20-15-10 -- 2 trap -- 54 ft. - Model 1001BUC .. \$98.95
20-15-10 meter - 2 trap - 26ft. - Model 1007BUC .. \$97.95

SEND FULL PRICE FOR POSTPAID INSURED. DEL. IN USA (Canada is \$5.00 extra for postage - clerical - customs etc.) or order using VISA - MASTER CARD - AMER. EXPRESS. Give number and ex. date. Ph 1-308-236-5333 9AM - 6PM week days. We ship in 2-3 days. ALL PRICES MAY INCREASE ORDER NOW! All antennas guaranteed for 1 year. 10 day money back trial if returned in new condition! Made in USA. FREE INFO. AVAILABLE ONLY FROM

WESTERN ELECTRONICS
Dept. A-7-1 Kearney, Nebraska, 68847



\$55 Off!
ALLIANCE
Dual-Speed
ROTOR
for HAMS

ALLIANCE HD-73 Dual-Speed rotor for Medium sized Ham antennas. Strong aluminum construction with hardened-heavy pitch steel gears & 100 ball bearings. Rated for up to 10.7 ft² wind load area & 1000 lb vertical load. 450 in/lbs starting torque. Mounts in-tower, on tower or mast; accepts 1 1/2"-2 1/2" O.D. mast. Rotates at (1) RPM for moving over a large arc or slow for peaking signals. Automatic brake system, large 3 1/2" meter, calibrated S-W-N-E-S in 10° increments. Black case, brushed aluminum front panel & bezel. 17 lbs.

Regular \$154⁹⁵ - Sale Price \$99⁹⁵

Order direct from this ad. Send Check or Money Order. For prompt shipment, Call TOLL FREE and use your MASTERCARD or VISA; COD orders accepted. Allow \$7 for UPS shipping charges in the 48 States.



AMATEUR ELECTRONIC SUPPLY

4828 W. Fond du Lac Avenue
Milwaukee, Wisconsin 53216
Phone: (414) 442-4200

Wisconsin WATS: 1-800-242-5195
Nationwide WATS: 1-800-558-0411
AES Branch Stores in: Clearwater, FL • Orlando, FL • Wickliffe, OH • Las Vegas, NV

CIRCUITS

Do you have a technique, modification, or easy-to-duplicate circuit that your fellow readers might be interested in? If so, send us a concise description of it (under two pages, double-spaced) and include a clear diagram or schematic if needed.

In exchange for these technical gems, 73 offers you the choice of a book from the Radio Bookshop, to be sent upon publication. Submit your idea (and book choice) to: Circuits, Editorial Offices, 73 Magazine, Peterborough NH 03458. Submissions not selected for publication will be returned if an SASE is enclosed.

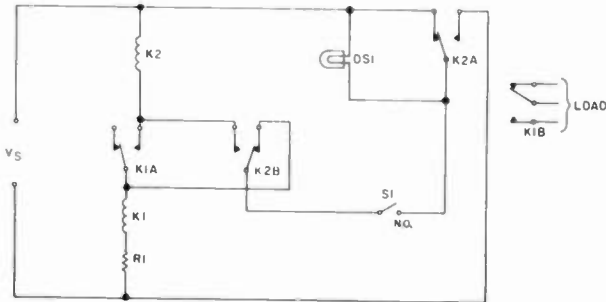

RELAY FLIP-FLOP: Here is a way to make two inexpensive DPDT relays act like an R-S flip-flop. One press of push-button switch S1 sets it; a second press resets it. Indicator DS1 shows when the circuit is set. Use contacts K1B to control the load. The two relays must have the same coil-voltage rating, which must be equal to one-half of the supply voltage, Vs. Choose R1 to reduce holding current if desired.—Terry Simonds WB4FXD, Edgartown MA.

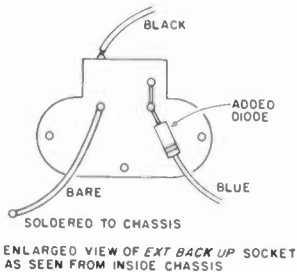

MEMORY SAVER FOR THE KENWOOD TR-7800: The Kenwood has nicad batteries to keep the memory intact when you unplug the rig. However, if you leave the power switch on when the rig is unplugged, the batteries will also try to power the rig—resulting in a very short memory life. To keep this from happening, first locate the blue wire connected to the "EXT BACKUP" socket. Remove this wire from the socket and insert a small diode between the end of the wire and the terminal to which it was formerly connected. The cathode end should be hooked up to the wire. Any small diode will do, provided it has no significant reverse current at 20 volts and as little forward resistance as possible.—H. F. Viney VE3AZX, Nepean, Ontario, Canada.

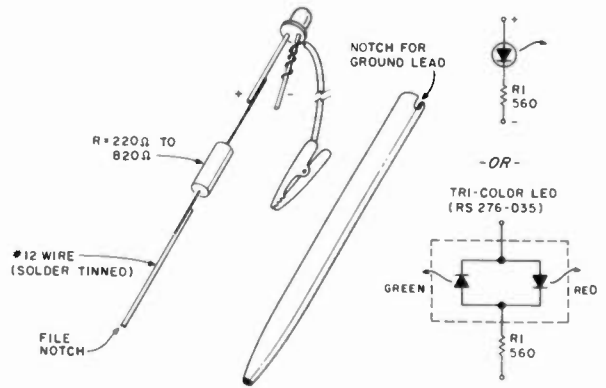

WORLD'S CHEAPEST IC TEST PROBE: The wire and resistor assembly should be about 4 inches long; work it into a ball-point pen case and glue the LED to the top. With a 560-Ohm resistor, this probe will handle up to 16 V.—Jim Hyde WB4TYL, Waycross GA.

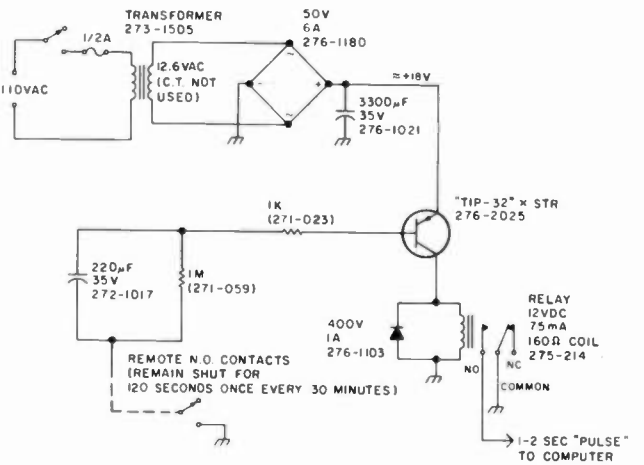

REMOTE-SWITCH TIME LIMITER: This circuit will produce a 1-2 second pulse when the remote switch contacts are closed for any length of time. When the remote switch closes, the 220-uF capacitor charges through the base-emitter junction of the transistor. The 1k resistor limits the current flow. As the capacitor charges, the current drops off until the transistor stops conducting. The on/off cycling pulls the relay in and then drops it out again. The 1-meg resistor discharges the capacitor when the remote contacts open again.—Jeffrey Blackmon W2Y1, Beavercreek OH.

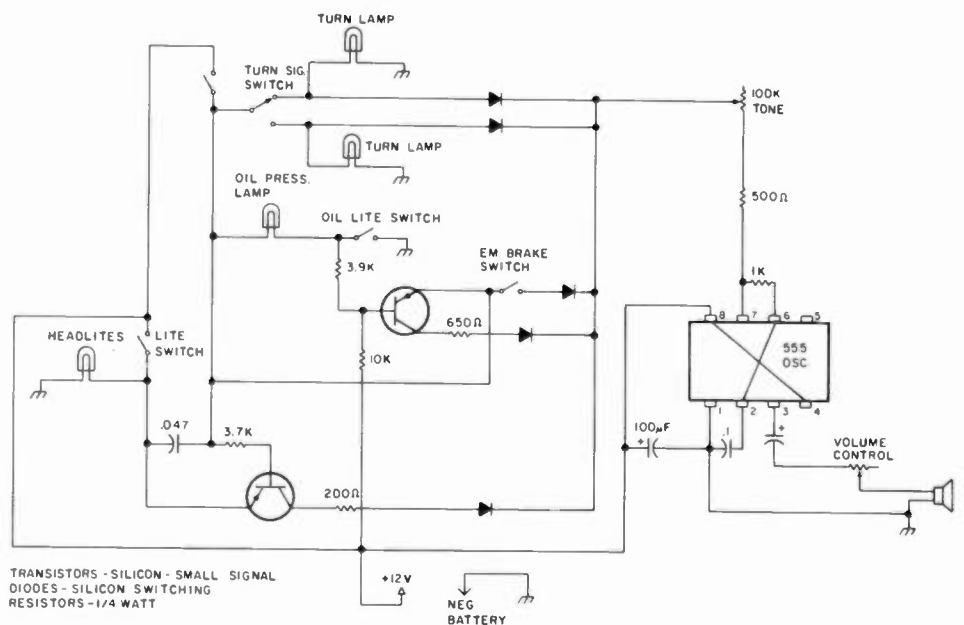

AUTOMOBILE EARLY-WARNING SYSTEM: Hook this up to your car and you will never leave your lights on again. The circuit also provides an audible turn-signal indicator, as well as warns you when your emergency brake is on. Another connection to the oil-pressure light will tell you when the pressure is low.—Keith Barrigar W7KQD, Lebanon OR.

FUN!

John Edwards KI2U
PO Box 73
Middle Village NY 11379

REPEATERS

This month's column is dedicated to the memory of WR2APG, a fine machine that died of neglect because it operated on 220 MHz instead of 2 meters. Funny, at the time I thought a repeater that specialized in RTTY, SSTV, and FAX would be successful.

ELEMENT 1— MULTIPLE CHOICE

- 1) What is a station master?
 - 1) A brand of repeater antenna
 - 2) Slang for a repeater control operator
 - 3) The name of Motorola's repeater line
 - 4) A type of phone patch
- 2) In most ham applications, Motorola's HT-220 operates on:
 - 1) 50 MHz
 - 2) 145 MHz
 - 3) 220 MHz
 - 4) 440 MHz
- 3) The Private Line subaudible tone system was invented by:
 - 1) General Electric
 - 2) RCA
 - 3) Motorola
 - 4) Kenwood

- 4) In which year did the amateur 6-meter band open?
 - 1) 1968
 - 2) 1919
 - 3) 1923
 - 4) 1945
- 5) Who invented FM?
 - 1) Colonel Perkins
 - 2) Major Armstrong
 - 3) Captain Andrews
 - 4) General Stupidity

ELEMENT 2—MATCHING

Match the past and present 2-meter transceivers with their manufacturers.

Column A	Column B
1) Carlone	A) Icom
2) Brimstone 144	B) KLM
3) Marker-Luxury (ML-2)	C) Swan
4) Voice Commander III	D) Azden
5) HR-2A	E) Motorola
6) Multi 11	F) Yaesu
7) FM-DX	G) Santec
8) HW-2036	H) General Electric
9) IC-2AT	I) Tempo
10) Metrum II	J) Kenwood
11) PCS-4500	K) RCA
12) TM-201A	L) Satan Electronics
13) 144uP	M) Heathkit
	N) Clegg

- 14) GTX-202
 - 15) FM-2X
 - 16) VHF-1
 - 17) TRX-144
 - 18) 1402 SM
 - 19) FT-221
 - 20) 13-510A
- O) VHF Engineering
 - P) Drake
 - Q) Midland
 - R) FM Laboratories
 - S) Genave
 - T) Wilson
 - U) Regency

ELEMENT 3— SCRAMBLED WORDS

Unscramble these examples of repeat-er terminology:

RMMEJA	PUSR
TCHAPTOAU	PLUDXE
PERTREEA	TILSP
LENNCHA	QUELCHS
FOFEST	PIMXSLE

THE ANSWERS

Element 1:

- 1—1 Made by Phelps-Dodge and very popular.
- 2—2 Doesn't make much sense, does it?
- 3—3 Ever notice how many "subaudible" tones really aren't?
- 4—4 Hmmm. Just a couple of years before TV.
- 5—2 Major Edwin H. Armstrong, who later killed himself when the boys at the radio networks tried to cheat him out of his royalties.

Element 2:

- 1-K, 2-L, 3-P, 4-H, 5-U, 6-B, 7-N, 8-M, 9-A, 10-E, 11-D, 12-J, 13-G, 14-S, 15-C, 16-I, 17-O, 18-T, 19-F, 20-Q.

Element 3:

(Reading from left to right) JAMMER, SPUR, AUTOPATCH, DUPLEX, RE-

PEATER, SPLIT, CHANNEL, SQUELCH, OFFSET, SIMPLEX.

SCORING

Element 1:

Six points for each correct answer.

Element 2:

One and one-half points per match.

Element 3:

Three points for each word unscrambled.

How well do you repeat?

1—20 points—Have never ventured beyond 14 MHz

21—40 points—Think that 2-meter radiation is harmful

41—60 points—Use 2 meters when the CB is broken

61—80 points—Take your HT along on dates

81+ points—Hopelessly addicted

AUTHOR'S CORNER

In these last few lines of this month's column I would like to respond to a point raised by Mark Regan of Reynoldsburg, Ohio. In a letter appearing in the August, 1983, "Letters" column, Mr. Regan claims that my comments in response to a "FUN!" poll question on religious nets proves that I wish "to deny the right of free speech to those who like to talk about ideas of a religious nature."

Not true, Mr. Regan. I certainly have no objection to bible discussions or any other sort of on-air religious activity that conforms to FCC rules. If my comment gave an anti-free-speech impression, as Mr. Regan asserts, I'm sorry. To set the matter straight, I believe in free speech for all.

RTTY LOOP

Marc I. Leavey, M.D. WA3AJR
6 Jenny Lane
Pikesville MD 21208

Happy New Year! I don't know how long I have been waiting for this year to finally arrive. I guess it has been ever since I read the book—George Orwell's, that is. But this year seems no more frightening than last, even though the technology for some of Mr. Orwell's more frightening machinery does exist. Hopefully, however, we will use this technology for good, progressive communication.

We do have a touch of "newspeak," however. Ever hear of a CBBS? How about an ABBS, Tariboard, PMS, or other such cryptic phrase? To the computer buff, these bulletin-board systems (BBS) represent the "Citizens Band" (if you will forgive the expression) of computing. They offer a source of bulletins, a pipeline for programs, and a kind of public soapbox and maildrop that is available for the cost of a phone call. It shouldn't surprise you, then, that we have our own form of BBS on the air—usually called a RTTY mailbox system.

Made possible by any of a number of microcomputers, these versatile fusions of hardware and software create a kind of, well, let's call it a repeater, which can be called up, accessed, and used much as our computer buff's BBS can. But ours is on the radio, not the telephone!

I know that you all are interested in these systems, with a representative letter this month coming from Bob Wallace

W9STA/2, in New York City. Bob writes, "Do you have any information regarding the RTTY mailboxes such as frequency, location, and how these things are accessed?"

Well, Art Santella K1VKO passes along the following information about one such system, the WA1GOO mailbox, in Rowayton, Connecticut. Art tells me that the system is on 146.580 MHz, twenty-four hours a day, idling at 60 wpm. A user accessing the machine can switch it to 100-wpm Murray or 110-baud ASCII. The machine covers a large area of Long Island and Connecticut, being located on the coastline of Long Island Sound. Operating simplex, with a Station Master antenna, Art tells me that plans are in the mill to raise the antenna to 100 feet, using a hardline feed, and a linear may be added to boost the output even more. Further down the line, a twenty-meter mailbox may be added, with a link to the VHF machine. This would give a super way to reach in and out of the Long Island area for local and DX stations.

A look at the directory on line recently shows about thirty files, including listings of computer nets, an RBBS directory, Miami weather frequencies, a W1AW schedule, various ARRL and other bulletins, several articles on RTTY and computers, and other items of interest. Even recent DX stations worked are listed, with times and frequencies, to aid other operators in their search for the rare country.

The system uses the Super-RATT™ software that we mentioned here a few

months back. Some of the commands available include the ability to save or read messages on the system disk, scan recent news or weather bulletins, look at the user file, set mode to Murray code at 45 baud (60 wpm), 74 baud, 110 baud, or ASCII at 110 baud, even the ability to look at four analog-to-digital converters. I don't know what you would use that for!

If you are interested in this system, Art would be happy to send you a full list of commands and such. Just send a business-size SASE to Art Santella K1VKO, 43 Seaview Avenue, East Norwalk CT 06855, and ask for the information on the WA1GOO mailbox. Be sure to tell him you saw it in "RTTY Loop."

A look at the mailbox on my front curb produces this letter from Roy D. Thomas KA4VVJ. Roy would like to find a source for in-depth information on several of the microprocessor chips around. He relates having information on the 6800 (a fine chip) but wants to learn more about the 8080, Z-80, 6502, and others. He also wants to know where you can buy any of these chips.

Well Roy, let's cover that last question first. Any good computer center or parts house should stock those CPU chips mentioned above, along with the support chips needed to build a functioning system. I would caution, however, that it takes a fair piece more than a chip and a power supply to make a computer. So, before you go out and buy a chip for ten bucks or so, it would do you well to read quite a bit and decide on just what you want to accomplish.

There is a raft of books out there, ranging from highly technical masterpieces of obfuscation to primers that spend hundreds of pages to teach a few elementary facts. The best bet is to read a few of the computer magazines which cover all bases, such as *Microcomputing*,

and look at back issues, which should be in any reasonably sized library, to get a grasp on the hardware involved. In the ads in these magazines you will find a great number of books on microprocessors, and many of these books will be reviewed in the magazines as well. Look them over; I am sure you will find enough information to keep you busy for some time to come.

Above all, please realize that, with few exceptions, it makes little difference which microprocessor chip is ultimately used. How well and flexibly the software is written, how well the system, once configured, will do the task at hand, and what the upward compatibility is (will it become obsolete next year?) are all valid considerations.

A thank you to you all, the readers of "RTTY Loop," is sent along by way of Barry Travis N4FNZ. Barry, you may recall, needed a hard-to-find CRT for his oscilloscope. Well you all came through, and Barry is watching dancing green lines once again.

A new request comes from Henry Kirchner KF4UW. Henry is looking for help in putting a Yaesu FT-107 on RTTY. He also would like to find a RTTY interface for the Timex/Sinclair 1000. I did not find any T/S-1000 interfaces in my review last month, Henry. But I am sure that any reader with information would be glad to drop you a note at 30 Patrick Lane, Rockledge FL 32955. Send me a copy, too, folks—thanks.

Another ham looking for help is Tom Childers WA5ZVZ. Tom has purchased a Teletype® Model 35 and plans to use it as a printer for his TRS-80C®. He is looking for help in connecting the loop supply of the teleprinter to his computer. Well, Tom, I have zip in the way of information on the Model 35; I am sure that at least one of our readers does, however, maybe even having hooked up the thing as you want to. If

so, I am sure that you will receive a note at 7189 Westbranch, Olive Branch MS 38654, very soon. If I hear anything here, I'll let you know.

In case any hams in the southern California area have never heard of SCATS (the Southern Counties Amateur Teleprinter Society), and I find that hard to believe, the club operates a two-meter repeater on 146.10/146.70 MHz, located in the north San Fernando Valley, and another repeater on 223.12/224.72 MHz on the Palo Verdes hills. These are Murray RTTY repeaters, open to all. The current president of the club is Sid Heyman WB6FFW. Interested amateurs are invited to drop a note to the editor of SCATTER, the society's newsletter, Hugh Washburn WA6IEX, 5772 Garden Grove Blvd., Sp 415, Westminster CA 92683, for more information.

I would like to take a moment to address a rather select group of readers. Any of you who are using 6800 or 6809 systems under the Smoke Signal DOS68 or DOS69 systems are invited to drop me a line with your name, address, and whatever system

details you care to offer. I am looking to get a sense of how big the DOS68/DOS69 group is compared with the FLEX bunch, so that we can see some more of our system's stuff in print. Thanks.

As I have said before, I always enjoy hearing about your experiences with the newer RTTY equipment. This month, let me present one man's experiences. Ronald Kennedy N2DWN writes: "I have been reading 'RTTY Loop' for quite some time now and with the advent of computers, interfaces, printers, and solid-state rigs, I have finally decided to plunge in.

"And when I plunge in I *plunge in!* I've acquired a Kenwood TS130S, a Kantronics Interface, and a VIC-20 computer, along with the VIC dataset, disk drive, and dot-matrix printer. Right out of the box everything worked, except the interface.

"But, not to worry, the folks at Kantronics are great people and Mr. Travis Brann stayed on the telephone with me quite some time trying to figure out why every time I plugged in the computer-to-interface cord the Kenwood went into trans-

mit mode. He finally decided that it must be a defective cable and said that he would send me a new cable.

"Not wanting to wait for the UPS truck, I pulled the cap off the game-port end of the connector and began to experiment. The wire-to-pin scheme that Travis Brann had given me said that I should be looking at the brown wire to pin 1, the red wire to pin 2, white to pin 3, green to pin 6, and black to pin 8. Not so and it's not Kantronics' fault! It's the connector itself. Pins 1, 2, and 3 (on the top side) are correct, however, on the bottom, it's a different story. The numbering order has been reversed. Therefore, by placing the green wire in the connector slot marked for pin 8 and the black in the slot for pin 6, all systems become a GO! The black wire in this cable is a double wire attached to shield, and therefore, somewhere along the line, to ground. Grounding pin 8 will activate the PTT circuit in the Kenwood and jump to transmit mode. If other hams are having problems of this nature they would do well to check the wiring to the pin in the game port.

"If you decide to use the Kantronics Interface, be careful with the operating voltage and current. If the input is not at least 12 volts at 1.5 Amps, it just won't work. If the interface can't pull enough current from the source, the entire bar graph and LED tuning light will light up and signals will not pass in either direction. Another hint for operation troubleshooting: All power must be on in order to operate. The monitor, computer, interface, transceiver, and printer (if attached) must all have power on in order to operate. Turn one of them off and the whole system will go down. According to Travis Brann it's a built-in feature."

Well, I really appreciate these Impressions of the Kantronics unit, and I am sure that those readers considering putting a computer on the air do as well. I will try to cover more of the material you ask about in the coming months. Please remember, if you would like a personal reply to a letter, enclose an SASE. Thanks. So long for now—stay tuned for next month's "RTTY Loop."

LETTERS

WINNER!

In my opinion, your recent Introduction of the "73 International" column has set your publication apart from all the others.

The use of correspondents "in country" makes the contents believable. The use of full-color national flags in the headings is a stroke of genius.

It seems to me that beyond the real service that this column provides to worldwide amateurs, it provides an insight to the correspondents' countries to the non-amateurs who may come across it. The Lord knows the world needs all the help it can get! Hope springs eternal that before long you will have correspondents in TA-, CN-, 4S-, 5R-, and perhaps even SP- and (dare I wish?) U-lands.

Finally, it is obvious that the inputs from some of the non-English-speaking correspondents have been *transliterated*, rather than *translated*. The difference is best illustrated by the line from the song: "Throw Mama from the train a kiss" (*transliteration*). The German when *translated* would be: "Throw a kiss to Mama from the train." To the thinking person, I believe this enhances the credence of the correspondents. Please don't edit them, except possibly for length.

Wayne, you have another winner!

Thomas L. Bowers III WD4CQY
Eustis FL

OFF-BASE COLUMN?

I am not given to writing letters to the editor, but after reading a column in the August issue of 73, I am moved to put in my two cents worth. The column I am referring to was part of "73 International" and was written by Roy Waite W9PQN concerning his views on amateur radio in Japan... and other non-related items.

Mr. Waite's comments made for interesting reading. Unfortunately, his statements were somewhat incomplete, incorrect, and outdated. Some were not even relevant to amateur radio.

There is a general statement that for-

eigners living in Japan often make that applies: Nothing in Japan is easy. It is a bureaucratic, red-tape, paperwork nightmare. It also makes for full employment! Mr. Waite attempted to tie Japanese procedures, rules, and regulations to the American way of doing business. That is like comparing apples to oranges. We have an outstanding country, but in my opinion, we have too liberal rules and regulations covering a wide range of rights accorded to visiting foreigners, both the legal and illegal type. But Japan is the subject here, not America.

First, it is not easy for a foreigner to obtain a license and permission to operate an amateur-radio station in Japan, but it can be done. The number doing so is quite large, surprisingly so. However, for the short-term tourist, it is almost impossible. Anyone having a valid amateur license issued by another country can apply for permission to operate on the correct form obtained from the Telecommunications Commission. The next, and often most difficult, step is finding a radio club that will allow you to use their club call sign. Only one individual at a time can use the club call sign. The other way for a foreigner to get on the air is to take the written exam in Japanese. Do that and you get your license and call sign like any other amateur. The last time I checked, the American exam was not given in Japanese—only English—so anyone who desires a regular American license must know our language.

In Japan, there are four classes of license: first class, second class, telegraphy, and telephony. First and second class can operate 100 Watts. The strict government inspection that Mr. Waite referred to plus the \$100 charge are things of the past. JARL has been given the authority to inspect and approve 100-Watt (and for first class, up to 500-Watt) stations. The modern equipment used by most amateurs makes the inspection routine.

Much has been made by Mr. Waite and others of the large numbers of Japanese who hold the lowest-class license. They

attempt to equate it to CB and a lack of technical expertise. Actually, this is not the case. The level of technical know-how among average Japanese amateurs is higher than that of the average American Novice. What is more important, technical ability and knowledge or the ability to copy CW at 12 words per minute (9 wpm for the second class, which is about equal to our General class)? In technical skills and knowledge, the holders of the lowest-level license in Japan are *not* Novices.

I also disagree with the statement that in Japan amateur radio is merely an extension of the Citizens Band, including its numerous abuses, bad manners, overcrowding, and lack of what amateur radio is all about. What is amateur radio all about anyway? It is a hobby. It is fun. It is communicating with others who enjoy the same thing. There is no requirement to do research or experiment or build homebrew equipment. The general consensus of opinion is that the more people involved with amateur radio (or any other hobby), the better off it is. More people involved means band crowding. It also means an increased likelihood of more experimenters and developers, more domestic equipment, a larger market, and a fresh infusion of "new blood" to prevent stagnation. I've heard my share of pileups and bad manners from English-speaking operators. One additional point needs to be remembered (and recognized): The holder of the license, even the telephony class, must clearly demonstrate technical knowledge... something that the stateside CB operator does not have to do. As a matter of fact, Japan has a new "sport band" in the 900-MHz range that requires no license. Putting CB up there makes more sense than in the upper HF range where ours is.

One small but important (to the few involved) aspect of amateur radio in Japan that was not covered by Mr. Waite is the KA call sign. Under an agreement between the governments of Japan and the US, amateurs who are stationed with the US military in Japan and who reside on a US military installation can be issued a special license and a KA call sign. The call sign consists of the KA prefix, a number corresponding to the part of the country where the radio is located, and by a two-letter suffix. The interesting part is that the operating privileges accorded the amateur are the same for the holder of the Novice-class US license as they are for the holder of the Extra-class ticket. In addition,

they are expanded over what is authorized in the US. For example, KA stations are granted permission to operate voice from 14.000 to 14.350 and from 21.000 to 21.450. Therefore, the holders of the KA call can legally talk with foreign stations on frequencies well outside of those normally authorized. Even a Novice, something Mr. Waite seems to think is not worth much, can talk to his heart's content with any station outside of Japan on frequencies even a US Extra ticket holder cannot use. I'm sure that must rub some "real hams" the wrong way! The two noteworthy limitations to the KA call sign are: (1) the station must be fixed-base, no mobile operations allowed (and, of course, the station must be on a US facility), and (2) no contact with Japanese stations and no third-party ops are allowed.

Unfortunately, even though the KA call signs are often listed in the call sign directory, many amateurs are not familiar with them and (1) think we are stateside or (2) don't realize that we can legally operate outside of the normal limits followed by US hams stateside.

One aspect of Mr. Waite's column that I objected to the most was the voicing of his opinions of the policies of the Japanese government. Japan is not America. His comments are best directed toward his congressman. I don't necessarily agree with many of the official or unofficial policies practiced by the Japanese government or the population at large. However, amateur radio is supposed to transcend politics. Describing the living place of the average Japanese as a "rabbit hutch" or "hovel" has no place in your magazine nor do discussions of his opinion of their attempts to protect Japanese domestic production. I have lived in Japan for the past six years and do not agree with his assessment of the living conditions of the local population... but my opinion really should not show up in print in an amateur-radio magazine any more than his should. We want to improve international relations and increase goodwill between hams, not torpedo it.

I hate to say it, but the July issue of that unnameable magazine, on page 60, gave a better summation of the Japanese license than did Mr. Waite. No politics or opinions, just the correct facts.

Thank you for your time.

Cdr. William W. Radican N7CAD/KA2WR
San Francisco CA

I wouldn't want to say that I am more qualified to comment on amateur radio for

anything else in Japan) than Cdr. Radican after his six years in Japan, but I would think that my 20+ years in Japan, having associated with Japanese hams of all classes as well as foreign hams, might give me a slight edge.

Cdr. Radican begins his essay by stating that my statements were incorrect and outdated. No way! In rechecking the column in question, I find no misstatement of fact of any kind, nor is the information outdated. My friends in the JARL (including President Hara), Ministry of Posts and Telecommunications, and CQ Ham Radio wouldn't let me down. The only fact that has changed since the column appeared (which Cdr. Radican attempts but fails to explain correctly) occurred after 73 went to press. This was the change in the rule which eliminates station inspection for stations of 100 Watts or less (previously 10 Watts or less). And this was brought about only because the American side would not sign a reciprocal agreement that required a station to be inspected prior to issuance of a license. The JARL successfully negotiated that point with the very stubborn Ministry of Posts. It has now become more probable that a reciprocal agreement will be signed, but the Japanese side still wants to charge 7,000 yen per application (equivalent to about \$28). This is not exactly reciprocity, or course, because as far as I know, most (if not all) of the major nations make no charge at all, or only a nominal charge at most. But maybe we can live with that. I am not sure the US will agree, though.

Cdr. Radican states that the JARL has been given permission to inspect first-class stations up to 500 Watts. Not true. The JARL has been given authority to waive inspections for any stations of 100 Watts or less (output power). Incidentally, inspections are not necessarily as routine as Cdr. Radican would have us believe. It depends on the inspector, the weather, if he likes the way you comb your hair, etc. Several of my Japanese friends have told me some hair-raising tales about these inspections. And you have to wait as long as six months for the inspectors to come before you can operate. A short-term visitor to Japan wouldn't even be here that long!

Cdr. Radican also states that "anyone having a valid amateur-radio license issued by another country can apply for permission to operate. . . ." Wrong! Only amateurs from America, Germany, Finland, and Ireland can do that.

Cdr. Radican states that all a foreigner has to do is to take the written Japanese exam, and if he passes it, he will get a license and call sign like everyone else. Wrong again! He will get only an operator's permit. The station and operator's license are separate in Japan. He still needs a friendly Japanese who is willing to lend a club call sign to him. But no call

sign will be assigned to the foreigner. The club call sign is owned by the Japanese, and the Japanese is in charge. The foreigner only becomes a member of that particular club. Under Japanese law, only Japanese citizens can have a call sign. Four non-Japanese have taken the Japanese test and passed, but they still had to search for a club to operate from.

Cdr. Radican disagrees with the statement that in Japan amateur radio is an extension of the Citizens Band. OK, he can disagree if he likes. But that doesn't change anything. He ought to listen to 2 meters or 15 meters some night or weekend. Maybe he would enjoy the sex tapes played on the main calling channel, deliberate repeater blocking, another "ham" telling all who will listen that he is going to masturbate on the air as he goes through all the sounds, the jeers and mocking when two English speakers want to have a QSO, guitar playing, singing, etc. Does Cdr. Radican have his head buried in the sand?

Cdr. Radican refers to the Japanese Denwakyu (whom I properly called "Novice" operators, in English). There is no doubt that the Novice operators in Japan have in the long run added new numbers to the ham population, but perhaps Cdr. Radican does not know that 42% of these new operators fail to renew their station licenses upon expiration. Of those that do renew, upon the second expiration, only 25% renew. After that, the rate continues downward. It is a case of diminishing returns. We have just a lot of people "passing through" the amateur gates and never returning after they tire of screaming and shouting and carrying on. The reason? No incentive. One can remain in the depths of the Novice world forever if he or she so chooses. Too easy to get in in the first place. Remember that anything acquired too easily is usually not cherished for long. Incidentally, many people think the large number of hams here has some real meaning, but actually, call signs are never reused; counting call signs is futile, since many operators are counted who have long ago dropped out. No one knows for sure what the real number is.

Technical skills superior to the US Novice? Yes, the questions do seem on a higher level, but remember that they are multiple choice. Memory courses are run for these budding hams the year around.

I think Cdr. Radican is correct in his statement about the new 900-MHz sport band. It is a good idea. But I am not planning to cover it, as it is outside the realm of ham radio.

Now about the US military KA stations. I covered this in the October issue of 73. Cdr. Radican seems to think that Japan and America have an agreement permitting these stations to operate. Quite the contrary. The JARL and Ministry of Posts have made it known to Japanese hams that KA stations are not hams at all and have prohibited all Japanese hams from contacting them, sub-

ject to penalties. The agreement that seems to be confusing Cdr. Radican is the Status of Forces Agreement that allows the US military to establish military communications. It is for that reason that Japan considers KA stations to be military rather than ham stations. It is not a kind Japanese government that is permitting the American KA stations full-band operation, even for US Novices. Quite the contrary.

Cdr. Radican thinks that ham radio should transcend politics. No, not when it comes to reciprocity, unfortunately. This is the real world.

Cdr. Radican states that "Nothing in Japan is easy. It is a bureaucratic, red-tape, paperwork nightmare. It also makes for full employment!" So, from that statement, I gather that Cdr. Radican would have the US imitate Japan in this regard: more red-tape and paperwork nightmares, and we will have full employment. How simple life could be, indeed! It isn't possible that some of that red tape and bureaucracy is keeping American products out of Japan, is it?

Cdr. Radican reminds me that "Japan is not America." Yes, I've noticed.

Cdr. Radican mostly objects to the voicing of my opinions of the policies of the Japanese government. Why is that? Are we to be afraid of the truth in these matters? Are my comments irrelevant to amateur radio? They certainly are not. Mr. Nakasone, the Prime Minister of Japan, does not deny me my right to criticize the government. I have written two times to Mr. Nakasone and received replies from him both times. (He answers all of his mail.) I am a member of Japanese society here, pay my taxes (heavily!), and obey the laws. Of course, I complain, and I shall continue to do so. I praise many things here, too.

My comments about Japanese life, etc., are known as "perspective sketching," and it's useful to set things in proper perspective in order to understand why things are like they are. We must not hide from the truth. I will continue to tell the truth as long as I have the strength to do so.

Cdr. Radican tells us about the various classes of Japanese licenses, etc., but we know all of that already. I hope Cdr. Radican will read the September and October issues of 73 for a fuller understanding.

Those of my Japanese friends who have read my columns so far have congratulated me on "telling the full story," as they put it. They are looking forward to a reciprocal agreement with the US as much as I am.

I enjoyed reading Cdr. Radican's letter. I just wish he would get his facts straight and put a little more trust in me. Any column I submit to 73 has been checked and double-checked carefully before submission. Items relating to law were confirmed by one of the 12 Japanese (English-speaking) attorney col-

leagues in my office. Additionally, these columns have been read by a Japanese and an American ham for "reaction" before submission to 73. I feel I owe that much to the readers of 73 and to Mr. Green. I am not infallible, of course, but in rereading the columns I have submitted to 73 thus far, I find no errors. The columns stand. Cdr. Radican has struck out.

As for that "unnameable" magazine, all I can say is that my mother stopped dishing up pabulum when I was one year old. Thereafter, I haven't cared much for it.

I am sorry Cdr. Radican didn't like my August column in 73. (Surely he won't care much for my September and October columns either.) Many people did like the columns, however, judging by my mail so far. Even my Japanese in-laws and my Japanese nephew (a budding ham) enjoyed the columns. Cdr. Radican's letter is the only negative voice I have heard.

I hope Cdr. Radican will continue reading 73 even though he doesn't find my writing to his liking. There is a large selection of fine features in 73 every month, and I think he will find many interesting articles among them, perhaps more suited to his taste.—Roy E. Walte W9PQN, Tokyo, Japan.

ELECTRONIC LUNCH

If you go to a fast-service diner, order a radio for lunch. Short-order cooks call poached eggs on toast Adam and Eve on a Raft, sometimes served with red lead (ketchup).

A radio is a tuna-fish sandwich on toast. Does anyone know why?

Carl S. Zolich AA4MI
Merriett Island FL

RELOCATED BEACON

Thank you for publishing the information on my ten-meter beacon. Unfortunately, due to the lead time for publication, the information was published after I moved. The KA1YE/B beacon has been moved to the Rochester NY area in western New York. It is about 10 miles south of the city at 43° 02' N, 77° 41' W, in grid square FN 13 of the Maidenhead grid locator system. The power is still 4 Watts, and the antenna is a dipole. The beacon is on 24 hours a day on 28.286 MHz CW.

W. Keith Hibbert KA1YE
527 Rush-Scottsville Rd.
Rush NY 14543
(716)-533-1389

DR. DIGITAL

Robert Swirsky AF2M
412 Arbuckle Avenue
Cedarhurst NY 11516

R. I. P., OSBORNE 1

I can still remember a QSO I had in April of 1981. There used to be a group of local hams that chewed the rag on 15 meters all night long. As usual, we were talking about computers.

The latest issue of Byte had just come out which, second only to receiving one's

issue of Kilobaud (now Microcomputing), was the most interesting event in a computer hacker's life. (Hackers tend to lead dull lives.) In the editorial section, there was mention of a new computer: the Osborne 1. I commented to the guys in the net: "Did you see the new computer from Osborne? It certainly is an interesting idea!"

"Bob, I can't believe you fell for that," commented Marc WB2JUF. "That thing is nothing more than an April Fool's joke!" Everyone on frequency had a good laugh,

and I conceded to Marc that I had been taken. After taking a close look at the picture of the Osborne 1, it looked as if it were a paste-up. And the silly things Byte said about it! Who in their right mind would want to put a computer under an airline seat?

After a few days passed and the Wall Street Journal carried a story on the unit, it became apparent that it was Marc, not me, who had been fooled. By now everyone knows the Osborne story. For a while they were extremely successful. The design which could have been taken for an April Fool's joke became a popular style of computer: the "transportable computer."

Unfortunately, Osborne didn't last. They announced their bankruptcy in late 1983. Competition became fierce, and mistakes were made and not corrected

until it was too late. The death of Osborne also marked the end of another phenomenon: the "garage" computer. Now, with the big guys making personal computers, multimillion-dollar ad campaigns, and consumers looking for brand names when they go computer shopping, it will be next to impossible for an individual to start his or her own computer business. The shake-out has begun.

WAKE UP, IT'S 1984

We finally made it to Orwell's infamous year. Will technology help us or ruin us? As computer hobbyists, we all have encountered anti-computer remarks and no doubt have been offended by them. How many times have you been told by a shop clerk that the computer "won't let" her do something. Or perhaps you experienced a delay at the

```

1 SOUND 1,0,0,0
2 SOUND 0,0,0,0
3 SOUND 2,0,0,0
4 SOUND 3,0,0,0
10 READ A,E
11 IF A < 0 THEN 400
20 HT = 894895 - A * 7
30 HT = HT / A
40 HT = INT (HT + 0.5)
50 LT = 894895 - E * 7
60 LT = LT / E
70 LT = INT (LT + 0.5)
100 HTH = INT (HT / 256)
110 HTL = HT - (HTH * 256)
120 LTH = INT (LT / 256)
130 LTL = LT - (LTH * 256)
200 POKE 53768,120
210 POKE 53762,HTH
220 POKE 53760,HTL
230 POKE 53766,LTH
240 POKE 53764,LTL
250 POKE 53763,230
260 POKE 53767,230
270 FOR T = 1 TO 125: NEXT T
290 POKE 53763,224:POKE 53767,224
300 GOTO 10
400 END
1000 REM : DATA STATEMENTS HERE
1010 REM : LOW TONE, HIGH TONE
9999 DATA -1,-1

```

Program listing 1. Atari DTMF.

697 770 852 941 1209 1336 1477 1633

1	X			X			
2	X					X	
3	X						X
A	X						X
4		X		X			
5		X				X	
6		X					X
E		X					X
7			X		X		
8			X			X	
9			X				X
C			X				X
*				X	X		
0				X			
1				X		X	
D				X			X

Fig. 1. DTMF frequencies in Hz. Xs indicate tones for the digits and characters on the left.

bank because "the computer was down." It's no wonder that some people seem to be against new technology. Amateur radio seems to be no different. I have received all sorts of strange comments from hams who object to the "strange noises" they hear coming from my station over two meters. Usually the objection is that the simplex frequency I am on (144.44) is for voice communications only, established by a gentlemen's agreement. To their comments, I can only respond that I am not a gentleman!

But by and large, hams are realizing that, in order to keep up with the world, a knowledge of computers is essential. In fact, computers are discussed over ham radio almost as much as the weather. I hope this trend continues.

One of the new things that computers have allowed is packet repeaters. Interest in this mode is gaining. It is nice to be able to use our spectrum more efficiently. Combined with mailbox facilities, a packet repeater is an excellent mode of communication. In the

St. Louis area, packet radio is thriving. Pete Eaton WB9FLW, president of St. Louis Area Packet Radio, reports that "packet radio is growing rapidly... In the Midwest, as well as the rest of the country." His club publishes an informative newsletter, *SLAPR Protocol*. For more information about the club and the newsletter, write to: *SLAPR Protocol*, St. Louis Area Packet Radio Club, 1309 Gloucester Dr., Edwardsville IL 62025.

"dial" the code *911, add the following data statements:

```

1500 DATA 941,1209
1510 DATA 770,1477
1520 DATA 697,1209
1530 DATA 697,1209

```

Those numbers are, of course, the tone frequencies used in the DTMF code (see Fig. 1 for the complete code).

This program can be used to create any tone that you may need. Accuracy is certainly good enough for any amateur-radio purpose. Simply put the tone frequencies you want generated on data statements. To generate single tones, eliminate the following lines: 50, 60, 70, 120, 130, 230, 240, and 260. Change line 10 to "READ A" and line 290 to "POKE 53763,224" And, of course, create your data statements accordingly. It should be possible to generate accurate RTTY and SSTV tones with the Atari—perhaps even to take a graphics screen and convert it into the proper SSTV tones. (Basic would be too slow for this; assembly language would be needed.)

ATARI DTMF

Atari home computers incorporate a built-in sound synthesizer. With commands from Basic, it is possible to make a wide range of musical notes and weird noises. As the tones are specified with an 8-bit (0-255) quantity, resolution is limited. For applications which require an accurate tone, a higher resolution is required. Atari realized that there might be a need for accurate tones and provided a way of creating them.

Atari sound is generated with a custom chip known as POKEY. Normally, one controls sound production from Basic using SOUND commands of the form SOUND a,b,c,d where a is the voice (1-4), b is the pitch (0-255), c is the distortion parameter, and d is the amplitude (0-15). The POKEY chip, however, serves other functions and has other capabilities which are not directly accessible with Basic statements. These functions can be used from Basic with the help of some POKE commands.

The program in listing 1 will generate the tones for DTMF signaling. Program logic is as follows: lines 1-4 serve to initialize the POKEY chip. All sound generation in the program is done with POKE statements, not SOUND statements. Lines 10 through 130 read in a pair of tone frequencies. From these numbers, a value is calculated which corresponds to a 16-bit integer. These numbers are split into two segments; since a byte can only hold 8 bits, 2 bytes are needed to hold the 16-bit number. The statement in line 200 tells the POKEY chip to link the sound generators in pairs: 0/1 and 2/3. Each pair becomes 1 voice that is controlled by a 16-bit (0-65535) number instead of an 8-bit (0-255) number. In addition, this POKE also makes the POKEY switch to a higher clock frequency, thus providing even more accuracy. The tones are actually switched on by lines 250 and 260. After a short delay provided by the FOR/NEXT in line 270, the tones are switched off at line 290. Line 300 starts the process all over again.

To enter the tone data, the frequencies must be placed on data statements. For example, if you wanted to have the computer

For those of you who want to experiment with Atari sound, memory locations 53761, 53763, 53765, and 53767 will be of interest to you; they are the audio-channel control registers. The most-significant three bits determine the distortion parameter, the next bit is the "forced-output" bit, and the least-significant three bits are the volume-level bits. When the forced-output bit is set to a one, the output is controlled directly with the volume bit; the speaker can be set to any one of 16 positions. Using this bit, custom waveforms can be created.

Frequency is determined with locations 53760, 53762, 53764, and 53766. The value in these registers controls the frequency of the corresponding audio generator. When two voices are linked together, the locations are taken in pairs with the higher address taking the most-significant portion of the 16-bit number.

The way to coordinate tone generation is with location 53768. For our purposes, we would be concerned with bits 6, 5, 4, and 3. When bit 6 is set to 1, channel 1 is clocked with a 1.79-MHz frequency, bit 5 does the same for channel 3. Setting bit 4 high will join channels 2 and 1; bit 3 joins channels 4 and 3. These addresses were used to produce the tones for the DTMF routine. As you see, the Atari will allow for some elaborate tone generation.

I certainly appreciate all the mail I have been receiving. So far, I have received a few interesting proposals for an amateur-radio graphics standard—I would like to hear from some more of you on this matter!

HAM HELP

I am converting a Teaberry Ranger T model 4012 CB rig for use on 10 meters. Can anyone supply a schematic or service manual?

T. Sherwood WB8QGB
PSC Box 4852
SJAFB NC 27531

I need manuals and schematics for the Yaesu YO-301 monitor scope and the Fire Bird F-200-M linear amplifier.

Mario Bledoeq
PO Box 580343
Suralco Dept. 53
Miami FL 33156

I need the manual (or a copy of it) for the Hallcrafters SR-500.

Doug Fonville
3805 33rd Street
Lubbock TX 79410

Wanted: Two YD844-A desk microphones for Yaesu radios.

John R. Bell KA9JYZ
3500-12th St.
East Moline IL 61244

I need the following coils for a National SW3 receiver: 31A (20 meters); 33A (40 meters); and coil 32. I also need National XR6 coil forms and winding information.

Walt Hill NM6L
Rt. 2, Box 323 Ailso Circle
Bishop CA 93514

Wanted: schematic and manual for the Motorola model L43GGB-1110A. I would also like to hear from anyone who has converted this set to two meters.

Ben Irvine N3CNH
Box 653 Blue Church Rd.
Coopersburg PA 18036

HAM HELP

Geloso (Italy) general-coverage (5-30 MHz) receiver, model no. G.4/218 using 9 tubes—would anyone out there have a schematic?

Maverick 6m filter, 5-section adjustable, by Gavin Instruments, Somerville NJ—I need adjustment information on this TVI filter.

I will gladly pay postage and copying costs.

John Sehring WB2EQG
PO Box 236
Oakland NJ 07436

I would like to correspond with anyone who has converted a Bunker-Ramo Telequote MDS-7 or 2210 series computer I/O station to some practical use, e.g., oscillo-

scope, RTTY monitor, etc. I also need schematics for the Hewlett-Packard 400A ac VTVM, and Hal Communications 2550 keyer. I was also told that the circuit board has provisions for adding a memory function and would like information on this, if so.

Barry Fuerst
218 Flournoy St.
Oak Park IL 60304

I am looking for a manual for the CIR Astro-200 and a parts list for the Edgecom System 3000A.

Jim Fyles WB0CZI
820 El Paso Blvd.
Denver CO 80221

I would like to contact someone who knows how to convert the computer programs for the TRS-80 which have appeared in 73 into programs for the Commodore 64. I also need schematics for an Ampex stereo amp: ASR 100, catalog #772-0056-01, s/n #5200445.

All copying and postage will be paid, but please notify me of costs in advance.

DuWain Brundage
2316B Little Valley Ct.
Birmingham AL 35216

I need manuals and schematics for the Hammarlund SP #600, the National NC #400, and the Collins R 390/URR (TM-0967-063-2010). I will pay for copying and postage.

Raul L. Martinez KA4UAT
PO Box 44-1707
Miami FL 33144

I am looking for a service manual for the Panalyzer SB3 model T-200 panoramic adapter.

Keats A. Pullen W3QOM
2807 Jerusalem Road
Kingsville MD 21087

I would like to hear from anyone who can help me interface my VIC-20 to the Icom 720 transceiver. I would like to use the VIC-20 as a frequency controller and scanner.

Robert F. Cann W4GBB
1606 Lochwood Dr.
Richmond VA 23233

I am looking for information on how to install disco lighting in stereo speakers.

Francis Turcotte
601 N. Tibbs
Indianapolis IN 46222

MULTI-BAND SLOPERS

160, 80, and 40 meters

Outstanding DX performance of slopers is well known. Now you can enjoy 2 or 3 band BIG-SIGNAL reports! Automatic bandswitching • Very low SWR • Coax feed • 2 kw power • Compact • Ground or tower feed • Hang from any support 25 ft. high or higher • Easy to install • Very low profile • Complete instructions • Immediate shipment • Check ok

3 BAND SLOPER - 160, 80, & 40 Meters - 60 ft. long	\$ 43.00	fri ppd
2 BAND SLOPER - 80 & 40 Meters - 41 ft. long	\$ 30.00	fri ppd
3-BAND NO TRAP DIPOLE - 160, 80, & 40M - 113ft. long	\$ 66.00	fri ppd
2-BAND NO TRAP DIPOLE - 80, & 40M - 84ft. long	\$ 49.00	fri ppd

FOR ADDN'L INFO on these and other unique antennas: send SASE

W9INN ANTENNAS
BOX 393-S MT. PROSPECT, IL 60056



RTTY CW ASCII
COMPUTER INTERFACE

- * BETTER RELIABILITY
- * MORE FEATURES
- * USE WITH ALL POPULAR SOFTWARE
- * L C TUNED FILTERS
- * USE WITH MOST HOME COMPUTERS

\$289.95

WRITE OR CALL FOR MORE INFORMATION:
CONTEMPORARY TECHNOLOGY, INC.
P.O. BOX 1083 • SALEM, OR 97308 • 503-399-7406

BUY! SELL! TRADE!
COMPUTER & HAM EQUIPMENT

COMPUTER* TRADER
ANNUAL SUBSCRIPTION
\$15.00

Low Ad Rates — Mailed Monthly
Foreign Subscriptions - \$30.00 Year
FREE 50 Word Classified Ad with Subscription Order

COMPUTER TRADER*
Chet Lambert, W4WDR
1704 Sam Drive • Birmingham, AL 35235
(205) 854-0271
Sample Copy — \$1.00

WESTECH ELECTRONICS

ROUTE 286, PRESQUE ISLE PLAZA
PITTSBURGH, PA 15239
(412) 733-1555



AZDEN PCS-4000 2m \$289 PCS-4300 70cm \$349 PCS-300 2m HT \$279	ICOM IC-02AT Call IC-745 Call	CUSHCRAFT A3 \$219 R3 \$269 A4 \$289	DAIWA 2M AMPLIFIERS LA-2030 30W \$69 LA-2080 60W \$125 LA-2155 150W \$265
TEN-TEC Corsair (+Free Filters) \$1019 Argosy II \$529 2501 2m HT \$289 NEW Satellite Station \$419	YAESU FT757 Call FT102 Call	BUTTERNUT HF8V \$109 2M CV-5 \$35	2KW ANTENNA TUNERS Nye MB IV 02 \$349 Ten-Tec 229 \$249 Ten-Tec 4229 (Kit) \$184
HURRY! Corsair Offer expires 1/15/84	HY-GAIN Explorer 14 \$269 30' 40m Add-on \$75 V2S \$44 14LAVQ WBS \$57 214B5 2m 14ele \$35 HAM IV Rotor \$199	KEYER PADDLES Bencher birchr \$36 \$44 Vibroplex EK-1 \$99 Vibroplex Brass Racer \$64	SWR BRIDGES Daiwa CNS20 \$59 Nye Dual Meter \$110

WESTECH ELECTRONICS is your dealer for Ten-Tec, ICOM, Yaesu, Azden, Astron, Hy-Gain, Cushcraft, Butternut, Bencher, Vibroplex, Nye-Viking, MFJ, Daiwa, Kantronics, Digimax, and more. Free shipping (UPS brown) on prepaid orders (Cashier's Check/M.O.). Prices and availability subject to change; please call for latest information.

MON., TUES., WED., 10 - 6
THURS., FRI., 10 - 8 SAT. 10 - 2

CALL (412) 733-1555

SYNTHESIZED SIGNAL GENERATOR

MADE IN USA



MODEL SG10DD
\$349.95
plus shipping

- Covers 100 to 185 MHz in 1 kHz steps with thumb-wheel dial • Accuracy 1 part per 10 million at all frequencies • Internal FM adjustable from 0 to 100 kHz at a 1 kHz rate • Spurs and noise at least 60 dB below carrier • RF output adjustable from 5-500 mV at 50 ohms • Operates on 12 Vdc @ 1/2 Amp • Available for immediate delivery • \$349.95 plus shipping
- Add-on Accessories available to extend freq. range, add infinite resolution, voice and sub-audible tones, AM, precision 120 dB calibrated attenuator
- Call for details • Dealers wanted worldwide.

VANGUARD LABS ✓311
196-23 Jamaica Ave., Hollis, NY 11423
Phone: (212) 468-2720

NICAD MEMORY ERASE — WHAT??

- Complete automatic operation
- Erases • Charges • Checks
- Rapid charges in 35 min. (typically)
- Automatically repairs shorted cells
- No dangerous heat build up
- Front panel selects up to 3 different packs
- Unlimited battery combinations with program modules (user programable)
- LED status indicators
- Supplied with universal EZ hook wire leads

Specify Voltage of Battery Pack(s) with order.
One program module included — optional modules \$2.25 each.

\$89.00 plus \$4.00 Shipping
(PA Residents add 6% sales tax)

Now Available—A commercial version of the GMS 401. Designed to charge up to and including the commercial 15 volt Nicad packs. \$139.00 plus same shipping and module cost as the GMS 401.



The GMS 401 is a complete automatic NICAD conditioner and rapid charger. Never before has this been offered anywhere at any price and it's so good it's being patented. NICAD memory characteristics must be dealt with otherwise your battery pack is not delivering all it could. The GMS 401 will automatically erase and rapid charge any type NICAD pack from 1 to 10 cells.

CONTROL PRODUCTS UNLIMITED, INC.
P.O. Box 10, Downingtown, PA 19335
215-383-6395 ✓25

FCC

Reprinted from the Federal Register

Amendment of the Commission's Rules To Allow the Use of Volunteers To Prepare and Administer Operator Examinations in the Amateur Radio Service

AGENCY: Federal Communications Commission.

ACTION: Final rule.

SUMMARY: This document amends FCC Rules to permit the use of Volunteers to prepare and administer amateur radio operator examinations. These amendments are necessary in order to maintain a viable examination program for amateur radio operators in light of FCC budgetary constraints. With a volunteer examination program, applicants will have more opportunities available to them to obtain amateur radio operator licenses.

EFFECTIVE DATE: December 1, 1983.

PART 0—(AMENDED)

1. The Table of Contents for Part 0 is amended as follows:

(a) A new § 0.484 entitled "Amateur radio operator examinations." is added.

(b) The Heading of § 0.485 is revised to read: "Commercial radio operator examinations."

2. A new § 0.484 is added to read:

§ 0.484 Amateur radio operator examinations.

Generally, examinations for amateur radio operator licenses shall be administered at locations and times specified by volunteer examiners. (See § 97.28(a)). When the FCC conducts examinations for amateur radio operator licenses, they shall take place at locations and times designated by the FCC.

3. Section 0.485 is revised to read:

§ 0.485 Commercial radio operator examinations.

Written examinations and International Morse code telegraphy examinations for commercial radio operator licenses are conducted at prescribed intervals or by appointment at locations specified in the Commission's current examination schedule, copies of which are available from any Commission field office or from the FCC, Public Service Division, Field Operations Bureau, FCC, Washington, D.C. 20554.

PART 1—(AMENDED)

4. The Table of Contents for Part 1 is amended as follows: the heading of § 1.925 is revised to read "Application for special temporary authorization, temporary permit or temporary operating authority."

5. Paragraph (a) of § 1.912 is revised to read:

§ 1.912 Where applications are to be filed.

(a) Applications for any class of new or upgraded amateur operator license shall be submitted to the examiners prior to the examination. (See § 97.28.) The examiners are required to submit the applications of persons passing their respective examinations to the Commission (for Novice Class operator licenses) or to the Volunteer-Examiner Coordinator (for all other amateur operator licenses). All other applications for amateur radio licenses shall be submitted to the Federal Communications Commission,

Gettysburg, Pennsylvania 17325. Only one copy of the application is required.

6. The heading and paragraph (e) of § 1.925 are revised to read:

§ 1.925 Application for special temporary authorization, temporary permit or temporary operating authority.

(e) Upon successful completion of an Amateur Radio Service operator examination, an applicant already licensed in the Amateur Radio Service may operate his/her amateur radio station pending issuance of his/her permanent amateur station and operator licenses by the Commission for a period of 90 days or until issuance of the permanent operator and station licenses, whichever comes first, consistent with the rights and privileges of the higher operating class for which the applicant has passed the appropriate examination element(s), provided that the applicant retains the certificate(s) issued by the examiners for successful completion of the examination element(s) at the station location, and provided that the applicant uses an identifier code provided by a VEC as a suffix to his/her present call sign.

7. Section 1.934 is revised to read:

§ 1.934 Procedure with respect to amateur radio operator license.

Each candidate for an amateur radio license which requires the applicant to pass one or more examination elements must present the examiner(s) with a properly completed FCC Form 610 prior to the examination. Upon completion of the examination, the examiner(s) will immediately grade the test papers. If the applicant is successful, the examiner(s) will forward the candidate's application to: (a) the Commission's Gettysburg, Pennsylvania facility for an application for a Novice Class operator license, or (b) a Volunteer-Examiner Coordinator (VEC) for all other classes of operator licenses. The examiners will then issue a certificate for successful completion of an amateur radio operator examination. A VEC will forward the application to the Commission's Gettysburg, Pennsylvania facility.

PART 97—(AMENDED)

8. The Table of Contents for Part 97 is amended as follows:

(a) A new § 97.28 entitled "Examination procedure." is added.

(b) The heading of § 97.27 is revised to read "Examination preparation."

(c) The heading of § 97.28 is revised to read "Examination administration."

(d) A new § 97.29 entitled "Examination grading." is added.

(e) The heading of § 97.31 is revised to read "Volunteer examiner requirements."

(f) Section 97.32 and its heading are removed.

(g) The heading of § 97.33 is revised to read "Volunteer examiner conduct."

(h) A new § 97.35 entitled "Temporary operating authority." is added.

(i) A new Subpart I is added, as follows:

Subpart I—Volunteer-Examiner Coordinators

General

- § 97.501 Purpose.
- § 97.503 Definitions.
- § 97.505 Applicability of rules.

- § 97.507 VEC Qualifications.
- § 97.509 Conflicts of interest.

Volunteer-Examiner Coordinator Functions

- § 97.511 Agreement required.
- § 97.513 Scheduling of examinations.
- § 97.515 Coordinating volunteer examiners.
- § 97.517 Written examinations.
- § 97.519 Examination procedures.
- § 97.521 Evaluation of questions.
- § 97.523 Identification of applicants passing examinations.

Authority: Secs. 4(i) and 303 of the Communications Act of 1934, as amended, 47 USC 154(i) and 303.

9. Section 97.11 is revised to read:

§ 97.11 Application for operator license.

(a) An application (FCC Form 610) for a new operator license, including an application for change in operating privileges, which will require an examination shall be submitted in accordance with the provisions of § 97.26.

(b) An application (FCC Form 610) for renewal and/or modification of license when no change in operating privileges is involved shall be submitted to the Commission's office at Gettysburg, Pennsylvania 17325.

10. Paragraph (b) of § 97.25 is revised to read as follows:

§ 97.25 Examination credit.

(b) A certificate of successful completion of an examination will be issued to applicants who successfully complete an examination element. Upon presentation of this certificate for telegraphy examination elements 1(A), 1(B) or 1(C), examiners shall give the applicant for an amateur radio operator license examination credit for the code speed associated with the previously completed element. For purposes of examination credit, this certificate is valid for a period of one year from the date of its issuance.

11. A new § 97.26 is added to read:

§ 97.26 Examination procedure.

(a) Each examination for an amateur radio operator license shall be administered at a location and a time specified by the examiner(s). Public announcement before examinations shall be made for elements 1(B), 1(C), 3, 4(A) and 4(B).

(b) The examiner(s) must be present and observing the candidate throughout the entire examination.

(c) The examiner(s) will be responsible for the proper conduct and necessary supervision during each examination.

(d) Each candidate for an amateur radio license, which requires the applicant to pass one or more examination elements, must present the examiner(s) with a properly completed FCC Form 610 on or before the registration deadline date for those examination sessions for which registration is required; otherwise, applicants shall submit FCC Form 610 at the examination session before the start of the examination(s). In cases where a registration deadline is required, it shall be specified by the VEC that issues the examination papers to the examiner.

(e) The candidate shall comply with the instructions given by the examiner(s). The examiner(s) must immediately terminate the examination upon failure of the candidate to comply with the examiner(s)' instructions.

(f) At the completion of the examination, the candidate shall return all test papers to the examiner(s).

(g) A candidate whose physical disabilities require special procedures to allow participation in examination sessions shall attach a statement to his/her application. For examinations other than Novice Class the statement shall be retained in the files of the VEC that issues the test papers. The statement for Novice Class examinations shall be retained by the examiner for one year.

The statement shall include:

(1) A physician's certification indicating the nature of the disability; and

(2) the name(s) of the person(s) taking and transcribing the applicant's dictation of test questions and answers, if such a procedure is necessary.

(h) An applicant who fails an examination element required for an amateur radio operator license shall not apply to be examined for the same or higher examination element within thirty days of the date the examination element was failed.

12. Section 97.27 is revised to read:

§ 97.27 Examination preparation.

(a) Element 1(A) shall be prepared by the examiner. The preparer must hold an Amateur Extra, Advanced, or General Class operator license. The test shall be such as to prove the applicant's ability to transmit correctly by hand key and to receive correctly by ear texts in the international Morse code at a rate of not less than five (5) words per minute. (Special procedures may be employed in cases of physical disability. See § 97.26(g).) The applicant is responsible for knowing, and may be tested on, the twenty-six letters of the alphabet, the numerals 0-9, the period, the comma, the question mark, AR, SK, BT and DN. (See § 97.29(c).)

(b) Elements 1(B) and 1(C) shall be prepared by the examiners or be obtained by the examiners from the VEC. The preparer must hold an Amateur Extra Class license. The test shall be such as to prove the applicant's ability to transmit correctly by hand key and to receive correctly by ear texts in the international Morse code at not less than the prescribed speed. (Special procedures may be employed in cases of physical disability. See § 97.26(g).) The applicant is responsible for knowing, and may be tested on, the twenty-six letters of the alphabet, the numerals 0-9, the period, the comma, the question mark, AR, SK, BT and DN. (See § 97.29(c).)

(c) Element 2 shall be designed by the examiner from PR Bulletin 1035A (latest date of issue), entitled *Questions for the Element 2 Amateur Radio Operator License Examination*.

(d) Elements 3, 4(A) and 4(B) will be designed by the FCC. The FCC will select questions for each test from the appropriate list of questions approved by the Commission (either PR Bulletin 1035 B, C, or D, latest date of issue). The FCC will provide each VEC with current examination designs. The VEC is required to hold current examination designs in confidence.

(e) PR Bulletin 1035 A, B, and C and D will be composed of questions originated by the FCC and questions submitted by amateur radio operators in accordance with the instructions in the Bulletin. Amateur radio operators holding Amateur Extra Class licenses may submit questions for any written examination element. Amateur radio operators holding Advanced Class licenses may only submit questions for Element 2 and 3. Amateur radio operators holding General Class or Technician Class licenses may only submit questions for Element 2.

13. Section 97.28 is revised to read:

§ 97.28 Examination administration.

(a) Unless otherwise prescribed by the Commission, each examination for an amateur radio operator license (except the Novice Class operator license) shall be administered by three accredited volunteer examiners. The examiners must hold Amateur Extra Class operator licenses, unless: (1) They are administering telegraphy element 1(A), in which case they may hold Amateur Extra Class, advanced Class or General Class radio operator licenses, or (2) they are administering written examination elements 2 or 3, in which case they may

hold Amateur Extra Class or Advanced Class radio operator licenses.

(b) Unless otherwise prescribed by the Commission, each examination for the Novice Class operator license shall be administered by one volunteer examiner. The examiner does not have to be accredited. The volunteer examiner must hold a current General, Advanced or Amateur Extra Class operator license issued by the Commission.

(c) Upon completion of an examination element, the examiner(s) shall immediately grade the test papers.

(d) When the candidate does not score a passing grade on an examination element, the examiner(s) shall so inform the candidate by providing the percentage of questions answered correctly, and by returning the application (see § 97.26) to the candidate. For examinations other than Novice Class examinations, the test papers, including answer sheets, shall be returned to the VEC that issued them. For Novice Class examinations, the test papers, including answer sheets, must be retained as part of the volunteer examiner's station records for one year from the date the examination is administered.

(e) When the candidate scores a passing grade on an examination element, the examiners (except for examinations for the Novice Class operator license) must issue a certificate of successful completion of the examination. This certificate must bear the VEC-issued examination identifier code (see § 97.523). This certificate is required for already-licensed applicants operating with privileges of an amateur operator class higher than that of their permanent amateur operator license (See §§ 1.925(e) and 97.04). Within one year this certificate may also be used for examination credit for elements 1(A), 1(B) or 1(C) (See § 97.25).

(f) When the candidate scores a passing grade on all examination elements required for the operator license class sought (see § 97.23), the examiners shall certify to the following information on the candidate's application form (see § 97.26):

(1) Examiners' names, addresses and amateur radio station call signs;

(2) Examiners' qualifications to administer the examination (see § 97.31); and

(3) Examiners' signed statements that the applicant has passed the required examination elements.

(g) Within ten days of the administration of a successful examination for the Novice Class operator license, the examiner shall submit the candidate's application to: Federal Communications Commission, Gettysburg, Pennsylvania 17325.

(h) Within ten days of the administration of a successful examination for the Technician, General, Advanced or Amateur Extra Class operator license, the examiners shall submit the successful candidates' applications and all test papers to the VEC that originally issued that test.

(i) The FCC reserves the right, without qualification, to:

(1) administer examinations itself; or

(2) readminister examinations (itself or under the supervision of an examiner designated by the FCC, to any person who obtained an operator license through the volunteer examination process.

14. A new § 97.29 is added to read:

§ 97.29 Examination grading.

(a) Each examination element shall be graded separately by the examiners.

(b) An applicant passes a written examination if he/she answers at least 74 percent of the questions correctly.

(c) An applicant passes a code element examination if he/she proves his/her ability to transmit correctly by hand key (straight key, or, if supplied by the applicant, any other type of hand operated key such as a semi-automatic or electronic key, but not a keyboard

keyer) and to receive correctly by ear texts in the international Morse code at not less than the prescribed speed for one continuous minute during a five-minute test period. Each five characters shall be counted as one word. Each punctuation mark and numeral shall be counted as two characters.

15. Section 97.31 is revised to read:

§ 97.31 Volunteer examiner requirements.

(a) Each volunteer examiner administering an examination for an amateur radio operator license must:

(1) Be at least 18 years of age; and

(2) Not be related to the candidate.

(b) Any person who owns a significant interest in, or is an employee of, any company or other entity which is engaged in the manufacture or distribution of equipment used in connection with amateur radio transmissions, or in the preparation or distribution of any publication used in preparation for obtaining amateur station operator licenses, is ineligible to be a volunteer examiner for purposes of administering an amateur radio operator examination. However, an employee who can demonstrate that he/she does not normally communicate with that part of an entity engaged in such manufacture or publishing is eligible to be a volunteer examiner.

(c) Each volunteer examiner shall be uncompensated for his/her services.

(d) Each volunteer administering an examination for the Technician, General, Advanced or Amateur Extra Class operator license must be accredited by the Volunteer-Examiner Coordinator (see Subpart I).

(e) The FCC will not accept the services of any person seeking to be a volunteer examiner if that person's amateur radio station license or amateur radio station operator license has ever been revoked or suspended.

16. Section 97.33 is revised to read:

§ 97.33 Volunteer examiner conduct.

A volunteer examiner who has given or certified examinations fraudulently or for monetary or other consideration is subject to revocation of his/her amateur radio station license and suspension of his/her amateur radio operator license.

17. A new § 97.35 is added to read:

§ 97.35 Temporary operating authority.

Upon successful completion of an Amateur Radio Service operator examination, an applicant already licensed in the Amateur Radio Service may operate his/her amateur radio station pending issuance of his/her permanent amateur station and operator licenses by the Commission for a period of 90 days or until issuance of the permanent operator and station licenses, whichever comes first, consistent with the rights and privileges of the higher operating class for which the applicant has passed the appropriate examination(s), provided that the applicant retains the certificate(s) issued by the examiners for successful completion of the examination(s) at the station location, and provided that the applicant uses an identifier code provided by a VEC as a suffix to his/her present call sign.

18. Paragraph (f) of § 97.04 is revised to read:

§ 97.04 Station identification.

(f) When operating under the temporary operating authority permitted by § 1.925(e) with privileges which exceed the privileges of the licensee's permanent operator license, the station must be identified in the following manner:

(1) On radiotelephony, by the transmission of the station call sign, followed by the word "temporary," followed by the identifier code(s) shown on the certificate(s) for successful completion of an amateur radio operator examination.

(2) On radiotelegraphy, by the

transmission of the station call sign, followed by the fraction bar DN, followed by the identifier code(s) shown on the certificate(s) for successful completion of an amateur radio operator examination.

19. A new Subpart I is added to Part 97 to read as follows:

Subpart I—Volunteer-Examiner Coordinators

General

§ 97.501 Purpose.

The rules in this subpart are designed to provide for the establishment of volunteer-examiner coordinators to coordinate the efforts of volunteer examiners in preparing and administering examinations for amateur radio operator licenses.

§ 97.503 Definitions.

For the purpose of this subpart, the following definitions are applicable:

(a) *Volunteer-examiner coordinator (VEC)*. An entity which has entered into an agreement with the Federal Communications Commission to coordinate the efforts of volunteer examiners in preparing and administering examinations for amateur radio operator licenses.

(b) *Volunteer examiner*. An amateur radio operator who prepares or administers examinations to applicants for amateur radio operator licenses (see § 97.30).

§ 97.505 Applicability of rules.

These rules apply to each entity that serves as a volunteer examiner coordinator.

§ 97.507 VEC Qualifications.

In order to be a VEC, an organization must:

(a) Be organized at least partially for the purpose of furthering amateur radio;

(b) Be at least regional in scope, serving one or more of the following regions:

(1) Connecticut, Maine, Massachusetts, New Hampshire, Rhode Island and Vermont;

(2) New Jersey and New York;

(3) Delaware, the District of Columbia, Maryland and Pennsylvania;

(4) Alabama, Florida, Georgia, Kentucky, North Carolina, South Carolina, Tennessee and Virginia;

(5) Arkansas, Louisiana, Mississippi, New Mexico, Oklahoma and Texas;

(6) California;

(7) Arizona, Idaho, Montana, Nevada, Oregon, Utah, Washington and Wyoming;

(8) Michigan, Ohio and West Virginia;

(9) Illinois, Indiana and Wisconsin;

(10) Colorado, Iowa, Kansas, Minnesota, Missouri, Nebraska, North Dakota and South Dakota;

(11) Alaska;

(12) Caribbean Insular areas:

Commonwealth of Puerto Rico, United States Virgin Islands (50 islets and cays) and Navassa Island; and

(13) Pacific Insular areas: Hawaii, American Samoa (seven islands), Baker Island, Commonwealth of Northern Mariana Islands, Guam Island, Howland Island, Jarvis Island, Johnston Island (Islets East, Johnston, North and Sand), Kingman Reef, Midway Island (Islets Eastern and Sand), Palmyra Island (more than 50 islets) and Wake Island (Islets Peale, Wake and Wilkes).

(c) Be capable of acting as a VEC in one or more of the regions listed in paragraph (b);

(d) Agree to coordinate all amateur radio operator examination elements for all amateur radio operator license classes;

(e) Agree not to accept any compensation from any source for its services as a VEC; and

(f) Agree to assure that for any examination every candidate qualified under these rules is registered without regard to race, sex, religion, national origin or membership (or lack thereof) in any amateur radio organization.

§ 97.509 Conflicts of interest.

An entity engaged in the manufacture or distribution of equipment used in connection with amateur radio transmissions, or in the preparation or distribution of any publication used in preparation for obtaining amateur radio station operator licenses may be a VEC only upon a persuasive showing to the Commission that preventive measures have been taken to preclude any possible conflict of interest.

Volunteer-Examiner Coordinator Functions

§ 97.511 Agreement required.

No entity may serve as a VEC until that entity has entered into a written agreement with the Federal Communications Commission to do so. The VEC must abide by the terms of that agreement.

§ 97.513 Scheduling of examinations.

A VEC will coordinate the dates and times for scheduling examinations (see § 97.26) throughout the areas where communications are regulated by the Federal Communications Commission. A VEC may also coordinate the scheduling of testing opportunities at other places. A VEC shall notify the Engineer-in-Charge of the Field Operations Bureau (FOB) District Office having jurisdiction over the area where an examination is to be held of the time, place and registration requirements for any examination. If no FOB District Office has jurisdiction over the area where an examination is to be held, a VEC shall notify the Chief of the Public Service Division of FOB in Washington, D.C., instead. In either case, this notification must be made at least 30 days in advance of the registration deadline.

§ 97.515 Coordinating volunteer examiners.

A VEC will accredit amateur radio operators, licensed by the Federal Communications Commission, as volunteer examiners (see § 97.30). A VEC will seek to recruit a broad representation of amateur radio operators to be volunteer examiners. A VEC may not discriminate in accrediting volunteer examiners on the basis of race, sex, religion or national origin. A VEC may not refuse to accredit a volunteer on the basis of membership (or lack thereof) in an amateur radio organization. A VEC must not accredit an amateur radio operator volunteering to be an examiner if:

(a) The volunteer examiner does not meet minimum statutory qualifications or minimum qualifications as prescribed by the rules;

(b) The FCC refuses to accept the voluntary and uncompensated services of the volunteer examiner;

(c) The VEC determines that the volunteer is not competent to perform the function for which he/she volunteered; or

(d) The VEC determines that questions of the volunteer's integrity or honesty could compromise the examination(s).

§ 97.517 Written examinations.

A VEC will assemble, print and distribute written examinations designed by the FCC (see § 97.27(d)).

§ 97.519 Examination procedures.

At the completion of each examination, a VEC will collect the candidates' application forms, answer sheets and test results from the volunteer examiners (see § 97.28(h)). A VEC will:

(a) Make a record of the date and place of the test; the names of the

volunteer examiners and their qualifications; the names of the candidates; the test results; and related information.

(b) Screen the application for completeness and authenticity.

(c) Forward the application within ten days of the date of the most recent examination to: Federal Communications Commission, Licensing Division, Private Radio Bureau, Gettysburg, Pennsylvania 17325.

(d) Make available to any authorized FCC representative any requested examination records.

§ 97.521 Evaluation of questions.

A VEC will be expected to evaluate the clarity and accuracy of examination questions on the basis of experience, and to bring ambiguous or inaccurate questions to the attention of the Commission, with a recommendation on whether to revise the question or to delete the question from the Commission's list of examination questions.

§ 97.523 Identification of applicants passing examinations.

A VEC must establish a unique identifier code for each testing session. This code must be a slant (/) followed by two letters from one of the following letter groups: WA through WZ, KA through KZ, NA through NZ, or AA through AL. The identifier code must be shown on the certificate for successful completion of an examination. The identifier code(s) applicable must be appended as a suffix to the licensee's call sign when the licensee operates under temporary authority granted to amateur radio operators who have passed the appropriate examination(s) for a higher class (see §§ 1.925(e) and 97.84(f)).

Use of Volunteers To Prepare and Administer Operator Examinations in the Amateur Radio Service; Correction.

AGENCY: Federal Communication Commission.

ACTION: Final rule; correction

SUMMARY: This document corrects an FCC Rule regarding Volunteer-Examiner Coordinators (VEC's) in the Amateur Radio Service. This correction is necessary in order to clarify that VEC's will not be required to coordinate amateur radio operator examinations for the Novice Class.

FOR FURTHER INFORMATION CONTACT: John J. Borkowski, Private Radio Bureau, Washington, D.C. 20554 (202) 632-4964.

Erratum

In the matter of amendment of parts 0.1 and 97 of the commission's rules to allow the use of volunteers to prepare and administer operator examinations in the Amateur Radio Service: PR Docket No. 83-27, Rm-4229.

Released: October 12, 1983.

1. On September 29, 1983, the Commission released a *Report and Order*, FCC 83-433, in the above captioned proceeding. In the *Report and Order*, the Commission amended Parts 0.1 and 97 of its Rules to allow the use of volunteers to prepare and administer operator examinations in the Amateur Radio Service.

2. At paragraph 9 of the *Report and Order*, the Commission indicated that it was adopting new rules to apply above the Novice Class, while retaining rules recently adopted in another proceeding for the Novice Class. See *Report and Order*, PR Docket No. 82-727, 48 FR 32586 (July 18, 1983). However, paragraph (d) of newly added Section 97.507 of the Rules in the Appendix would appear to require Volunteer-Examiner Coordinators (VEC's) to coordinate examinations for all classes, including the Novice Class. This was not intended.

3. Accordingly, paragraph (d) of Section 97.507 of the Rules in the

Appendix is corrected to read as follows:

§ 97.507 VEC Qualifications.

(d) Agree to coordinate all amateur radio operator examination elements for all amateur radio operator license classes except Novice Class;

Federal Communications Commission,
William J. Tricarico,
Secretary.

Amendment of the Rules To Authorize Ten Year License Terms in the Amateur Radio Service

AGENCY: Federal Communications Commission.

ACTION: Final rule.

SUMMARY: The Commission is amending Part 97 of its Rules to authorize ten year operator and station license terms and two year grace period for renewal of expired operator and station licenses in the Amateur Radio Service. The Communications Amendment Act of 1982 authorized license terms not to exceed ten years in the Amateur Radio Service. This change is necessary in order to eliminate a burden on Commission resources and a paperwork burden upon the public.

DATES: Effective December 15, 1983.

PART 97—[AMENDED]

1. Section 97.13(d) is revised to read as follows:

§ 97.13 Renewal or modification of operator license.

(d) If a license is allowed to expire,

application for renewal may be made during a grace period of two years after the expiration date. During this grace period, an expired license is not valid. A license renewed during the grace period will be dated currently and will not be backdated to the date of its expiration. Application for renewal shall be submitted on FCC Form 610 and shall be accompanied by the applicant's expired license or a photocopy thereof.

2. Section 97.47(b) is revised to read as follows:

§ 97.47 Renewal and/or modification of amateur station license.

(b) If a license is allowed to expire, application for renewal may be made during a grace period of two years after the expiration date. During this grace period, an expired license is not valid. A license renewal during the grace period will be dated currently and will not be backdated to the date of its expiration. An application for an individual station license shall be submitted on FCC Form 610. An application for an amateur club or military recreation station license shall be submitted on FCC Form 610-B. In every case the application shall be accompanied by the applicant's expired license or a photocopy thereof.

3. Section 97.59 (a) and (b) are revised to read as follows:

§ 97.59 License term.

(a) Amateur operator licenses are normally valid for a period of ten years from the date of issuance of a new, modified or renewed license.

(b) Amateur station licenses are normally valid for a period of ten years from the date of issuance of a new, modified or renewed license. All amateur station licenses, regardless of when issued, will expire on the same date as the licensee's amateur operator license.

AWARDS

Bill Gosney KE7C
Micro-80, Inc.
2665 North Busby Road
Oak Harbor WA 98277

DX AWARDS FROM CZECHOSLOVAKIA

If you've never seen the beautiful DX awards available to licensed amateurs from the Central Radio Club of Czechoslovakia, then you're in for a real treat. It has been my pleasure this past month to have received the full details of their entire awards program and they are described in the paragraphs to follow.

S6S Award

The S6S Award is afforded those amateurs who have had a QSO since January 1, 1950, with at least one station located in each of the six continents as defined by the IARU. Awards will recognize those contacts on CW, phone, and RTTY, either allband or single-band achievements. Mixed-mode contacts are recognized.

P75P Award

This award is for having worked at least 75 ITU zones as defined by the ITU Geneva Conference of 1959. All contacts

must have been made since January 1, 1960, and awards are available in three levels of achievement: 1st class—70 zones, 2nd class—60 zones, and 3rd class—50 zones. Zones may be determined in accordance with a special map made available by the Central Radio Club for a cost of 3 IRCs. Also, it is important to note that all contacts must be made with fixed stations only.

ZMT Award

To qualify for the ZMT Award, applicants must have confirmed contact since April 26, 1949, with at least one station located in each of the following 39 areas: OK1, OK2, OK3, HA, LZ, UA1, UA2, UA3, UA4, UA6, UA9, UA0, UB, UC, UD, UF, UG, UH, UI, UJ, UL, UM, UN, UO, UP, UQ, UR, DM (3 different regions determined by the last letter of the callsign), SP (3 different districts), YO (3 different districts), YU (3 different districts).

ZMT 24 Award

For those interested in pursuing the ultimate in DX endurance, the ZMT 24 Award is just for you. The requirements are exactly the same as for the basic ZMT Award detailed above, with the exception that all contacts must be made within a 24-hour period. Sound impossi-

ble? Absolutely not, but don't be discouraged if it takes you several attempts using the stopwatch!

100 OK Award

Check your QSL cards. If you can find a total of 100 OK stations, then you will qualify for the 100 OK Award. All contacts, however, must have been made on or after January 1, 1954. Endorsement stickers are available for every additional 100 stations confirmed, up to a total of 500. Stations may be worked any band, any mode.

OK SSB Award

This award requires the applicant to have two-way SSB contact with different Czechoslovak stations totaling 25 points, without a date limitation. 1 point will be scored for each QSO on the 28-, 21-, or 14-MHz bands and 2 points for each QSO on the 7- or 3.5-MHz bands. There are no mode restrictions.

As an added tip to those wishing to pursue these very respectable awards, this editor recommends that you keep a close eye on the "Contests" column in 73 magazine and consider making a few contacts during the annual OK DX Contest. Dates and times will be announced at least a month in advance of the scheduled event. The Awards Manager of the CRC also mentions that QSOs made during the contest will not require QSL confirmations. There is one stipulation, however: Application must be submitted along with your logbook entry for the OK DX Contest.

All the certificates are issued free of

charge for members of clubs or associations which accept this rule reciprocally. The fee for all others is 10 IRCs for the P75P Award and 5 IRCs for all the other awards offered by the Central Radio Club of Czechoslovakia. General certification rules apply by which contacts may be verified by two amateurs of a local club, a club official, or a notary public.

Applications shall include details for each contact, i.e., callsign, GMT, date, frequency, mode, RS(T), and any additional information required for the award. Send to Central Radio Club, Awards Manager, PO Box 69, 113-27 Praha 1, Czechoslovakia.

Slovensko Award

The DX Club of Radio Amateurs of Slovakia offers this award to all licensed amateurs who can show proof of contact with stations in the different districts (OKR) of Slovakia (OK3, OL8, OL9, OL0; districts listed below) after January 1, 1946.

Stations in countries which have a common border with Slovakia must contact 35 districts, 20 districts are required of stations in other European countries, and 10 districts are required for stations outside the European continent.

There are no band or mode restrictions. Applications with a GCR list and award fee of 5 IRCs may be sent to: Central Radio Club, PO Box 69, 113-27 Praha 1, Czechoslovakia.

Districts which qualify are: Banska, Dystrica, Bardejov, Bratislava, Bratislava-Vidiek, Cadca, Dolny Kubin, Dunajska Streda, Galanta, Hmenna,

Komarno, Kosice, Kosice-Videk, Levice, Liptovsky, Mikulas, Lucenec, Martin, Michalovce, Nitra, Nove, Zamky, Poprad, Povazska Bystrica, Presov, Prievidza, Rilmavska Sobota, Roznava, Senica, Spisska Nova Ves, Stara Lubovna, Svidnik, Topolcany, Treblsov, Trencin, Trnava, Velky Krtis, Vranov, Zvolen, Ziar nad Hronom, and Zilina.

TEN-TEN INTERNATIONAL NET AWARDS

For those of us who frequent the ten-meter band, a minute doesn't elapse that you don't hear reference being made to the Ten-Ten International fraternity.

The 10-10 organization was formed in 1962 by a group of amateurs in southern California. To this date, better than 27,000 amateurs have joined their ranks. The unique awards program for this International group was founded and managed for years by Frank Orcutt W4JQ, who is now a silent key.

To qualify for membership in Ten-Ten International and to move up on their awards ladder of achievement, you first must make contact with ten individual Ten-Ten members on the ten-meter band. From each QSO, you must obtain the station's call, 10-10 number, name, and exact QTH. Once this has been achieved, you may submit your list along with your check for US\$4.00 (includes fee for the quarterly 10-10 publication) to one of the following area or district vice presidents: Earle W1NC, Larry WA2SUH, Jim WA3RBQ, Cliff K4EKX, Grace K5MRU, Dick W6ANK, Ron WB7ADO, Del W9BPU, John N0ADJ, Mac ZL3RK (New Zealand), Art VK2BXN (Australia), August DK5UG (Europe), Jim K6PJO (DX at large).

Your application is checked against the 10-10 net roster, and if found correct, you will be issued your very own 10-10 number and Black Cat Certificate.

Once you obtain your 10-10 number, you may begin work toward various "bar" awards. The bar awards are issued in multiples of 100 individual 10-10 contacts. To apply for any bar award, you must not duplicate contacts previously claimed. In each case, submit only 100 contacts per application—no more. Each must show the callsign of the station worked, the 10-10 number, name, and exact QTH.

Award applications must show contacts in 10-10 number sequence. Applications received in any other order will be returned. There is no award fee for "bars"; however, an SASE sent along with your application is appreciated. Send to: Bill Risher WB6OMH, 10542 Lock Avon Drive, Whittier CA 90606.

This same process is repeated for the 200, 300, and 400 bar awards. Where it will end, nobody knows, for the most numbers collected to date is by Grace K5MRU, who now has 8200 confirmed.

When you reach the 500 bar, serial numbers are then assigned to each bar issued thereafter. Once the applicant reaches 1000, he or she reaches the first step in which award plaques are issued. Plaques are issued also for 2500, 5000, and 7500 contacts.

10-10 WAS Award

This award requires an applicant to make at least one contact in each state with another member of Ten-Ten International. QSL cards and sufficient postage for their safe return are to be sent with your application to WB6OMH. This award is issued only for contacts made after January 1, 1973, on any authorized mode on the ten-meter band.

The VP Certificate

To qualify for this award, a net member must have earned his or her "500 bar," at which time a VP number and certificate were assigned. The idea for the VP certificate issued here is to work at least 100 other net members who have achieved their 500 bar and who have been issued a VP serial number. To be valid, all contacts must be made between 28.500 and 28.550 MHz or above 29 MHz, with the contact lasting at least 5 minutes. As with all 10-10 awards, application must indicate the 10-10 number, callsign, name, frequency, and exact QTH. Also, a definite requirement is to list the station's VP serial number.

All contacts must be made on or after October 15, 1979, to qualify. Send your application to: Grace Dunlap K5MRU, Box 445, La Feria TX 78559.

To the best of our knowledge there is no award fee.

Lucky 13 Award

The Lucky 13 Award is to prove that your station is capable of working the entire 10-meter band. This is not a frequency-measuring test and it is not necessary to stay exactly on the prescribed frequencies. The idea here is to make contact with 13 different VP members on each 100-kHz segment of the band: 28.500, 28.600, 28.700, 28.800, 28.900, 29.000, 29.100, 29.200, 29.300, 29.400, 29.500, 29.600, and 29.690 (29.700 is the band edge, so be careful). Any mode or mixed mode is permissible. As with all awards, you must log the callsign, the VP number, the first name, the QTH, and in this case, the date and time of each contact claimed. It is not necessary to send QSLs, but you should have your list verified and mailed to: Rich Richardson QB0FQD, 960 E. Cottonwood Avenue, Littleton CO 80121.

FEARL AWARDS

I received award information from a personal friend of mine, Glenn KABGW (WB7SPD), who used to reside here on

Whidbey Island and is stationed with the US Navy in Masawa, Japan. Glenn urges those seeking the awards being offered by the Far East Auxiliary Radio League (FEARL) to be careful to only count contacts with KA stations in Japan and not to include those in the continental United States.

Glenn mentioned a couple of nets which may assist those wishing to meet the award requirements in a minimum of time. 14.284 MHz is the golden frequency on Sundays at 0200Z and Wednesdays at 1200Z.

All FEARL awards are available for \$1.00 or 7 IRCs, which must be sent with your application to: Far East Auxiliary Radio League, Attention: Awards Manager, c/o Sam Fleming KA2SF, GARH-ID-GS-M NCS Japan, APO San Francisco CA 96343.

Worked Fifteen KA Stations

To qualify for the WFTKAS Award, applicants must work a minimum of at least 15 KA stations located in Japan or Okinawa. Stateside KA stations do not count. There are no mode or band restrictions nor are there any date limitations. General certification rules apply, with proper logbook data.

KA Rag-Chewers Club

This award certifies that the applicant has presented evidence of having had a rag chew with a KA station in the Orient for a period of not less than thirty minutes. There are no band, mode, or date limitations. To apply, merely give general logbook data including the time your QSO began and ended. GCR apply.

Rag-Chewer Supreme

Should you be longwinded and were fortunate enough to enjoy an hour-long QSO with a KA station in the Orient, then the Rag-Chewer Supreme award is designed especially for you. To apply, merely provide logbook data and the appropriate award fee of \$1.00 or 7 IRCs. GCR apply.

KA Roundtable Award

To qualify for this award, the applicant must establish and maintain two-way amateur-radio communication with at least two KA stations in the Orient on the same frequency at the same time for a minimum of thirty minutes. There are no special band or mode endorsements. Date is not a factor. GCR apply.

Shortwave Listener Award

For the shortwave listeners, FEARL presents this award for having heard and rendered a signal report to the operators of at least two KA stations in the Orient. Applicants merely send general logbook data and the appropriate award fee when applying.

Islands, a highly successful assault on Malpeo, increasing activity from China, and dozens of other amateur operations.

What do we see ahead for 1984? Radio propagation will continue to decline. The sunspot numbers are already well below their peak levels of the late '70s and early '80s, and they will fall still further this year. This regular pattern of worsening propagation is familiar to DXers of more than 10 years standing. The old-timers will remember the slow days of the mid-'70s when sporadic E and trans-equatorial propagation provided what little DX excitement there was, and DXing hours were spent fighting the static on the lower frequencies and calling long CQs on apparently dead bands.

1984 probably will not be the bottom of

UTICA NY

The Utica Amateur Radio Club will operate special-event station K2IQ, commemorating its 50th anniversary, from 1700Z February 11 to 2200Z February 12, on SSB, 25 kHz from the upper edge of the 40-, 20-, and 15-meter bands, and 25 kHz from the upper edge of the 40-meter Novice band. QSL with SASE and contact number for an attractive certificate to: K2IQ, PO Box 71, Utica NY 13503.

SNOWFLAKE MADNESS

The Michigan Technological University Amateur Radio Club and the Copper Country Radio Amateur Association announce a radio celebration of their Winter Carnival festivities in the northernmost part of Michigan's upper peninsula.

Tech's Winter Carnival is probably the most spectacular winter festival in America with snow sculptures, ice hockey, dog-sled racing, skiing, and other festive events.

In association with the Copper Country Chamber of Commerce, we are issuing a certificate to all amateurs who make contact with any participating ham in the Copper Country between 0000 February 2 and 0000 February 8, 1984.

Only one contact is required to get a certificate. Frequencies are 3.630, 7.090, and 14.095, RTTY; 3.705, 7.085, 14.085, 21.085, and 28.185, CW; and 3.930, 7.285, 14.305, 21.385, and 28.685, phone. On CW listen for CQ Winter Carnival.

Send your QSL along with three 20¢ stamps (for postage and handling) to: Howard Junkin N8FHF, 106 W. South Avenue, Houghton MI 49931.

HOSARC SPECIAL-EVENT STATIONS

The Hall of Science Amateur Radio Club will issue a commemorative certificate to anyone working a HOSARC club station on January 15 from 1400 to 2300 UTC, in conjunction with HOSARC's 11th anniversary. Stations using the call WB2JSM will operate CW in the first 25 kHz of the Novice bands of 40, 15, and 10 meters. Stations using the call WB2ZZD will operate SSB in the first 25 kHz of the General phone bands of 40, 20, 15, and 10 meters. QSL with a large SASE (40¢ or 1 IRC) to HOSARC, PO Box 131, Jamaica NY 11415, or to WB2YXB, club QSL manager.

PUNXSUTAWNEY PA

The Punxsutawney, Pennsylvania, Amateur Radio Club will commemorate Groundhog Day on Sunday, January 29, 1984, from 10 am to 5 pm on 7.230 and 14.290. For a certificate send an SASE to Cliff WB3GAD, RD #6 Box 211, Punxsutawney PA 15767.

DX

Chod Harris VP2ML
Box 4881
Santa Rosa CA 95402

HAPPY NEW YEAR

The start of a new year brings reflection and anticipation: reflection on the events of the past twelve months and anticipation for the coming year. It is a time to think back on coveted successes and

missed opportunities, a time to consider what you will be doing over the next year.

1983 was a good year for DX. Not a great one; the sunspot numbers continued to fall, shortening band openings and weakening signals. But 1983 also saw some excellent DX from many corners of the globe.

Among the DX highlights were not one but two DXpeditions to Inhabitable Heard Island, the disaster in the Spratly

the current sunspot cycle. The 1986-8 period is a more likely candidate for that dubious honor. However, the sun can be fickle, and it can decrease activity dramatically or flare up and provide some good DXing. But the overall trend in 1984 will be down.

Those DXers bitten by the DX bug in the past few years, however, will be hard pressed. The tremendous increase in the number of amateurs worldwide and especially the number of DXers, since the last sunspot minimum, is unprecedented. Many thousands of amateurs turned on to DX at a time when 10 Watts into a wet noodle could be heard around the world. The amateur radio equipment of today is significantly advanced over that of ten years ago, facilitating such communications.



Jim Smith VK9NS plans a 1984 DXpedition to Kermadec Island, north of New Zealand. Jim led the Heard Island DX Association trip to Heard last year. (Photo via The DXers Magazine)

The effects of these factors of declining sunspots and large numbers of avid DXers can be seen already. When a DX station comes on the band, a pileup often begins even if the station is not particularly rare. The large number of DXer mice chasing the increasingly elusive DX cheese makes it very difficult for foreign stations to have satisfying contacts. This trend will only worsen.

For the many thousands of amateurs who have started chasing DX since 1978, 1984 will be a year of decision. Should I upgrade my station to remain competitive in the increasingly-difficult DX world? Should I try to tough it out with my present equipment, meekly accepting diminishing results? Or should I forget about DX for a few years and turn to satellite operation or stamp collecting?

The hard-core DXer will rise to the challenge, improving his station and operating techniques to ensure DX success. And the DXer will have considerable assistance in this task. Again in 1984, as in the past years, a number of hard-working and dedicated amateurs will be traveling to choice DX locations around the world to hand out contacts to the "Deserving DXers."

THE DX ADVENTURE

Some of the most rewarding aspects of DXing are the wonderful people who devote so much of their own time and money to sponsor, organize, and operate on DXpeditions to the rarer amateur spots in the world. Without the dedication and persistence of these amateurs, the DX world would be dull indeed. And a fine example of this respected breed is Jack Binder KB7NW.

An avid traveler, Jack had moved to Australia in 1969 with his English wife, Jude. A few years later, the Binder family, including two young sons, set sail in their home-built *Banyandah* (which is Aboriginal for "Home on the Water"). And that's what the yacht was to the family of four: their only home. For eight years the family cruised the Pacific, covering more than 60,000 miles. Jack and Jude took turns teaching their boys using materials from a cooperative stateside school. The parents supplemented the traditional curriculum with extra lessons in marine biology,

botany, and geography, based on their travels.

The Binders kept their expenses to the minimum (there was no need of clothes on the boat or uninhabited islands, for example), but they did need a source of cash for foodstuffs, supplies, and repairs. Sometimes Jack worked on land for a short time, but in 1978 he turned to charter trips for income. And one of his early charters was a DXpedition to Mellish Reef, off Australia.

Jack's next DXpedition would be enough to turn most hams away from this pastime: Jack's yacht was fired upon as it approached Amboyna Cay, in the Spratly Islands, in 1979. The Binders escaped without being hit, unlike the Germans in the more recent attempt. Several members of that DXpedition figured Brunei VS5 was exciting enough, but Jack and two other hams returned to the Spratlys, setting up and operating on Barc Canada Reef. Since then, Jack's wanderlust and DX spirit have led him to Palmyra, Kingman, Tokelau, and back to Mellish Reef.

The Binders called a temporary halt to their odyssey in 1982 and placed their yacht in a regular school for the first time in their lives. Meanwhile, Jack earned some much-needed funds by piloting a charter vessel around the Great Barrier



Desecheo from the air. Two Puerto Rican amateurs hope to activate KP4/D this month. (WF4ATF photo)



Lloyd W6KG and Iris W6QL Colvin swing through South America on the 1983-4 Yasme trip. (Photo via The DXers Magazine)

Reef. "It's an unalterable fact of life that it costs money to live, no matter how idyllic the life-style or how basic and down-to-earth one lives," Jack explains.

Jack makes it very clear that this land-based existence is not permanent. "My one and only true love will always be expeditions. There is something about them that's hard to put down in words. Something about conceiving the idea, then putting it into action, following it through in every tiny detail until the speck of land shows on the horizon and the operators get down to business. It's out and out adventure, but with a purpose."

Now, 1984, the Four Js (Jack, Jude, Jerome, and Jason) are on the open ocean again. The planned itinerary includes the Solomon Islands (H44), the Philippines (DU), Singapore (9V), and the Seychelles (S7) on the way to the western Indian Ocean. The DX targets there are Mayotte (FH), Girosio (FR), and Juan de Nova (FR). In late spring or early summer.

A host of other DXpeditions are scheduled for early 1984. A group of Venezuelan amateurs intend to land on tiny Aves Island in the Caribbean. Aves

(YV0), about 125 miles southwest of Montserrat, is so low to the water that high waves and tides preclude landing for much of the year. Also on tap for the coming year is another trip to Clipperton Island (FO) by a collection of Tahitian and stateside hams. And Jim Smith VK9NS (see photo) of Heard-Island fame is putting together a scientific and amateur operation on Kermadec Island (ZL/K). Closer to home, the Colvins are on the move again, and a couple of Puerto Rican amateurs are shooting for Desecheo (KP4/D)—see details, below.

YASME SAILS AGAIN

Once again, Lloyd and Iris Colvin, W6KG and W6QL (see photo), are DXpeditioning, this year concentrating on South America where contacts may be plentiful but QSLs rare. The Colvins are sailing under the auspices of the Yasme Foundation, the nonprofit group which has been sponsoring DXpeditions for many years. The name, Yasme, comes from the yacht of that name on which Danny Well sailed for many DXpeditions twenty years ago.

The Colvins customarily set up a substantial station in each country where they operate, including beam antennas and amplifiers. They thus present a consistent signal and are quite easy to work. Also, the Colvins stay at each location for several weeks, working 5-10,000 QSOs, which gives DXers with very modest stations ample opportunity for a contact. And the Yasme Foundation QSL system is excellent.

Look for the Colvins (with portable calls or calls ending in KG or QL) toward the low ends of the bands, especially the lower frequencies. Send QSLs to Yasme Foundation, Box 2025, Castro Valley CA 94546.

DESECHEO

Two amateurs from Puerto Rico plan a DXpedition to tiny Desecheo Island in the Caribbean this month. Jose Maldonado WP4ATF and Rodolfo HI3RST/KP4 are aiming for the first week in January for

their three-day operation. They will use their own call signs with the designator /D. They solicit contributions and QSLs via Box 449, Palmer PR 00721.

Descheo was one of the last DXCC "countries" admitted under the "separate administration" rule which has since been eliminated. The island is a wildlife refuge only a few miles west of Puerto Rico. Its refuge status was the reason for its separate-country designation by the ARRL, but this same status also restricts travel to the island. The Fish and Wildlife people don't want dozens of hams swarming over their island, littering with beer cans and coax cable bits. Consequently, only a few amateur DXpeditions have operated from the island, starting with Bob Dennison W0DX.

The well-run International DX Foundation DXpedition to Descheo two years ago cleaned up most of the demand for KP4ID, but then, the definition of a rare country is "the one you don't have," regardless of how easy it is to work. Hopefully, the operators will spend some time on the lower frequencies to take advantage of the good propagation from that part of the world and to meet the increasing demands for 40-, 80-, and 160-meter DX contacts.

KEEPING INFORMED

There is a major difference between

working a DXpedition versus contacting a resident of the country. In the latter case, the timing probably is not very important. If you don't work him this time, you might tomorrow, or next week, or next year. But you don't get a second chance with many DXpeditions. How long do you think it will be before hams return to Heard Island?

DXpeditions give DXers a great shot at the DX contact, and in many cases provide the only way for radio contacts. After all, many of these DXCC "countries" are totally uninhabited. Many are uninhabitable over the long term, and only the limited stay of a DXpedition provides DXers with a shot at them.

So the DXpedition will *not* be there next week, or next year. It may be years before that particular "country" again attracts a DXpedition. Thus the DXer cannot afford to miss the contacts offered by the DXpeditioners. If you hibernated through the Heard Island activity last year, you probably won't get another shot at it for many years.

Real DXers understand that keeping informed on a timely basis is an essential part of successful DXing, especially as the sunspots decline and the pileups increase on the few remaining DX stations.

The chief way of keeping abreast of the DX world is through the radio; active

amateurs who talk to and listen to their fellow DXers will know who is on now, who is supposed to be coming on, and where. There is no substitute for activity. But there are aids which make DXing more effective and enjoyable.

Your local radio club can be an excellent source of DX information. Keeping in touch with other DXers in your area is like having extra pairs of ears. You can be keeping an eye on 20 meters while a fellow DXer across town is watching 40. A quick call over VHF FM keeps both hams informed.

Many areas of the country have taken this a step further by organizing DX clubs. The larger DX clubs sponsor repeaters dedicated to DX and DXers. Now with dozens of ears out, little DX slips by. A DX station can tell when his presence is broadcast over a DX repeater easily. He first works one station in an area, say San Francisco. Then, a couple of minutes later, another DXer from the same region calls. Then stations from all over the Bay area are in the pileup!

Of course, the flow of information must go both ways. The DXer should share his success with the other members of the club and not simply take advantage of the hard work of others. And the DX club prob-

ably has many other tasks which need help: meetings, newsletters, repeater maintenance, etc. So one way you can continue your DX success is to join and support your local radio club.

Other useful sources of DX information are the DX bulletins. DX columns in the major amateur radio magazines (such as this one) have lead times too long for the kind of timely information needed in the DX world. You need to know what is on now, and for that a weekly DX news sheet can be well worth the money.

So to help you keep up-to-date in the DX world in 1984, the two major weekly DX bulletins are offering a free subscription to a couple of lucky readers of this column. Send your QSL card (and maybe a photo of you and your shack) to VP2ML, Box 4881, Santa Rosa CA 95402 by January 31, 1984. I'll pull a couple of cards out of my hat and present the lucky winners with a one-year subscription to *The DX Bulletin* or *QRX DX*.

If you can't wait and you aren't lucky enough to have your card pulled out of the hat, you can subscribe directly. Send \$28.00 for a one-year subscription to *QRX DX*, Box 4072, Richardson TX 75080, or to *The DX Bulletin*, Box 873, Vernon CT 06066.

REVIEW

THE HEATHKIT SS-9000

From the time about two years ago that I had the opportunity to try out a prototype of the SS-9000, I have looked forward with anticipation to seeing it on the market. While the unit has many features attractive to the SSB operator, it should have special appeal to the computer-oriented operator who likes to jump from band to band and frequency to frequency in search of a good QSO or rare DX. The CW operator can take advantage of two extremely effective narrow filters in addition to the above-mentioned computer capabilities.

A floppy disk that demonstrates some of the capabilities of the unit's controller is shipped with it. The disk utilizes interaction between the computer, the operator, and the SS-9000 during the demonstration. The program that controls the unit during operation is within the unit itself, in the controller circuit, however. As a consequence, only a terminal is required, and any computer used must be reconfigured as a terminal if it is to be used to control the SS-9000. I used a Heathkit H-89 computer to run the demo disk and then had to go into the cabinet to change a jumper cable to use it as a terminal. In effect, I was dedicating the computer to use with the SS-9000 alone. My guess is that anyone who wants to control his unit with a keyboard will opt for some inexpensive terminal rather than restricting the use of his home computer to transceiver control.

Terminal Functions

The unit is programmed to remember and display both the frequencies last shown on the two frequency displays and the one stored in memory on each band. If I inadvertently bandswitch to one of these bands, the displays (and terminal print-out) will return to the appropriate band

limit and the stored frequencies will be lost. In order to be used, the frequencies must be retrieved by the terminal.

The terminal also controls and indicates the frequency within each band to which the receiver and transmitter have been toggled. Two push-buttons centered under the middle of the two frequency displays do this switching in the manual mode. The indicators for toggling on the unit are red LEDs for transmit and green LEDs for the receive frequencies. The displayed and remembered frequencies for each band can be established by either terminal or manual control at any time.

Some other functions the terminal can control and indicate are:

- Passband shift in 100-Hz steps—as many as 600 Hz down and 400 Hz up
- Bandswitching
- Scan rate
- Transmitter/Receive
- Mode: LSB, USB, CW wide, CW medium (400 Hz), CW narrow (200 Hz), and RTTY (400 Hz)

During operation on any given band, the operator has the ability to preset all of

these functions in anticipation of operating on another band.

Shared Functions: PLL Tuning

The phase-locked-loop tuning is deadly accurate to the 100-Hz steps by which it changes. No supplementary frequency standard is necessary. PLL with 100-Hz resolution introduces a problem in bringing two or more transceivers to the identical frequency. I can be as much as 50 Hz off while attempting to zero beat another signal with the SS-9000. The other station with stepless tuning might have to make up the difference. The SS-9000 CW operator might become a little frustrated with this dependence on the other operator if he is a purist. Fifty- or ten-Hertz resolution would lessen the problem of frequency matching, but for most operators the higher resolution is probably unnecessary.

Scan Rate

PLL tuning makes it practicable for the manufacturer to offer tuning up or down the band at almost any desired rate. This rate can be determined for the SS-9000 by the setting of four DIP switches. Since access is gained to these switches by removing the cover of the unit (nine screws), I probably won't change them often. On the other hand, if I'm operating with the terminal, I need only to punch S = 1 (to 16) to vary the manual scan rate through its whole range.

Memories

The practicality of the memories comes out when I'm looking for a QSO on whatever band is open. I'll flip the rig on to hear immediately a sector of a band that I have last used. Nothing new there, but I have also two other segments of the band that I can check out with two punches of a button. This happens without my losing the first frequency in the process. I can tune up or down from any of the three spots if I hear nothing interesting. If I hear a station in QSO that I might like to talk with when he finishes, I commit his frequency to memory—not my memory but the memory of the SS-9000—and resume searching for a CQ or someone finishing a QSO. If I don't find either, I can check back on the QSO with a punch of a button, and if it's still underway, resume searching with another punch.

If somehow I hear a second hot prospect for a later QSO, I can leave the one display on that second station and toggle the receiver over to the other display to continue searching. Then if I want to take a quick listen for activity on the other band, the three selections are preserved in memory.

Bandswitching

On the SS-9000, changing bands with the front-panel bandswitch can be made to activate an antenna switch for each selection. There is a plug on the back that will connect the unit directly to the Heathkit antenna switching relay. This function can, of course, be adapted to other antenna switches.

Bandswitching by computer or terminal control is another capability of this unit. A motor switches bands as well as antennas if this is desired.

On this unit, the bandswitch hung up at times when I attempted to rotate it counterclockwise manually. This could have damaged the switch if I had strong-armed it. This is because the teeth that engage during computer-controlled bandswitching are not quite separated adequately on this particular motor assembly. I expect that a call or a letter to the company could bring a new assembly in the mail. Since the assembly is located in a housing that

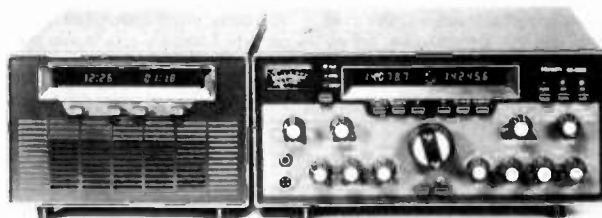

Photo A. The Heathkit SS-9000.

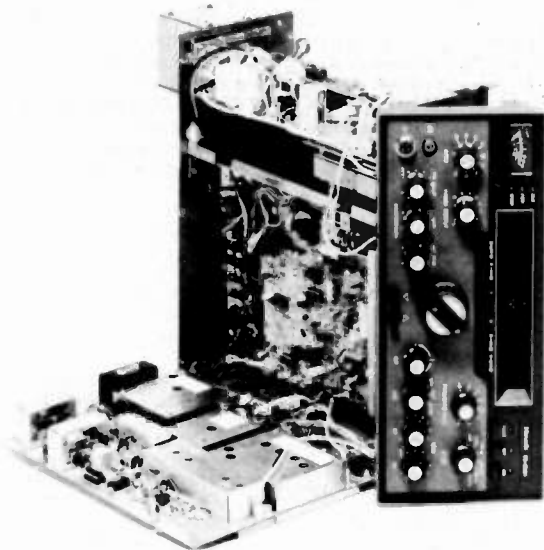

Photo B. Bottom view of the SS-9000.

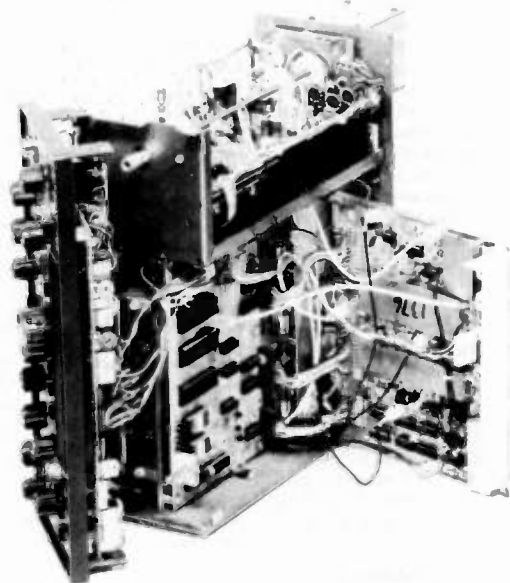

Photo C. Top view of the SS-9000.

extends from the back of the unit behind the bandswitch shaft. It would not be difficult for me to replace.

Receiving

True to the numbers given in the manual, the bandpass filter and CW filters are extremely effective. The effectiveness of the SSB bandpass filter can be demonstrated easily with a turn of the bandpass shift switch during reception with a strong interfering signal parked close by. All I sacrifice for this filtering are some of the lows of the received operator's voice, or some of the highs. Being able to drop a strong unwanted signal off the side of the bandpass plateau can result in a significant increase in intelligibility of the wanted signal.

CW Operation

Using the CW narrow filter, I can drop a strong interfering signal 100 Hz or more away down to a level at which I can copy a desired signal through it. This means, too, that the strong signal is far enough down the filter passband skirt that the agc is not triggered to the point that the weak signal doesn't get amplified adequately. In fact, the filtering is such that I am able to copy CW with the comfort of agc leveling of the desired signal almost without exception since the CW filtering renders harmless the signal-killing effect of the agc from strong stations. Another nice feature of the narrower filters is the lack of ringing I experienced. This is an especial advantage while copying high-speed CW. The SS-9000's filtering is the cleanest I have heard in this regard.

Since I'm not a musician and don't have perfect pitch, I have the same problem with the SS-9000 that I have with any other transceiver. I can't tell by ear when I have the desired signal at the offset frequency of 800 Hz. It's easy to tell by peaking the signal with the S-meter with the narrow CW filter switched in if there is no interference and/or fading. It's almost impossible otherwise to tune the transmitter exactly to the frequency of the received station without an outside reference tone.

Being able to tune as closely as possible to another signal with one's own trans-

mitter is important. It minimizes the amount of band space taken up, it's easier for others to break in, one doesn't have to retune for each signal in a round robin, and it minimizes leap-frogging. I attempt to minimize my contribution to the problem by using a cheap audio frequency standard: a musician's pitch pipe. I tune the note of the desired signal to F-sharp, 800 Hz. Then my signal and at least one other are on the same frequency.

Transmitter

Front-panel controls in addition to the shared transceiver controls of band and frequency are: power output, VOX delay, speech compression, and microphone gain. Power output can be read directly from the multi-function meter as the power control is varied. These are all that are needed to control SSB transmissions from contact to contact. Speech compression, if desired, is switched on and turned up until compression indicated on the meter on voice peaks gives the same excursion of the needle as depressing the tune button while the meter is switched to read power. That's probably the most complicated maneuver necessary to learn to be able to take full advantage of the SSB feature of this unit. Microphone gain also is turned up on voice peaks until the meter, switched to ALC indication, shows some ALC action.

VOX delay, compression, and microphone gain may need to be varied from operator to operator, justifying the location of the controls on the front panel. Three other controls will need to be set, but not adjusted as frequently as the front-panel controls. These are: CW side-tone level, anti-trip, and VOX gain. Adjustment of these is made through the right side panel.

Power Supply

The companion power supply to the SS-9000 will operate with inputs in the 120- and 240-V-ac ranges to provide 13.8 V dc with sophisticated regulation and protection. It has high-temperature protection from heat, sink sensing, surge-current protection, and short protection. Tripping the last of the three will require resetting the on-off switch. The first two react by reducing power-supply output to safe levels until the condition reverses itself. The power-amplifier transistors of the SS-9000 are provided protection from excess current flow by these power-supply circuits as well as by power-output-controlling circuitry that is heat-sink temperature dependent, and by high vswr cutback circuitry.

The power-supply cabinet contains the speaker for the unit and two clocks, each settable by its own two front-panel buttons. The clocks will operate with either 12- or 24-hour format. The readouts are green vacuum fluorescent tubes, as are the frequency displays on the SS-9000.

Summary

Setting the SS-9000 up for operation on SSB and CW was as straightforward as could be. I did not make use of the RTTY mode, but RTTY sending and receiving should be optimally simple also. A 400-Hz RTTY filter position is provided in the mode switch as well as the usual LSB.

The several controls that must be dealt with in order to operate SSB are easily set using the owner's manual. Front-panel-control changes, such as power output, VOX delay, compression, and microphone gain are extremely simple with the multi-function metering provided at the touch of a button.

Operating the SS-9000 with an amplifier is easily arranged. After stringing a phono-plugged cable for the relay and the ALC voltage, I just punched the tune button and screwdriver-adjusted the ALC level in the back panel to limit the amplifier current properly by limiting drive power.

I had to get used to operating CW without QSK, coming from a rig that has a carrier-operated relay (COR). It was good discipline for me to attempt to keep my transmissions short. Rumor has it that it was felt the frequency synthesizer loops might be too unstable while using the COR in this unit with high-speed CW. As you can tell from the advertisements, only very recently have manufacturers developed confidence enough in their designs to offer full break-in operation with PLL tuning, Heathkit included.

Conclusion

I very much enjoyed indulging in fantasies about how I could take advantage of the unique features of this rig. One idea most appealing was to buy some cheap high-lying property in my local telephone-calling area or within UHF range and set up the SS-9000 right in the middle of a huge antenna farm. A terminal with modern control the unit, and I could operate from any convenient room in the house.

The capability of terminal control rather than computer and software control appeals to me. I'm eager to develop applications for personal computers in my life, but I'm not enthusiastic about dedicating a PC to a single use. If the feature of terminal control and the concept of a quality-built, sensitive, selective, adaptable transceiver appeal to you, give the SS-9000 serious consideration.

For further information, contact the Heath Company, Benton Harbor MI 49022. Reader Service number 484.

Dave Learned W8DFI
Benton Harbor MI

WHAT DO YOU THINK?

Have you recently purchased a new product that has been reviewed in 73? If you have, write and tell us what you think about it. 73 will publish your comments so you can share them with other hams, as part of our continuing effort to bring you the best in new product information and reviews. Send your thoughts to Review Editor, 73: *Amateur Radio's Technical Journal*, Peterborough NH 03458.

A BOOK ON AMTOR: WHAT, WHY, AND HOW

AMTOR means AMateur Teletype Over Radio and provides almost error-free

transmission and reception of messages. A form of RTTY that uses a seven-bit (Moore) code, TOR has been in use by both land-based and sea-based stations for several years but has been adopted by amateurs only recently.

The International Telegraphic Union Report CCIR 476-2 (1978) formed the basis for the 1983 FCC approval of AMTOR, and provides a set of operating standards and procedures.

And now, because of the relative newness of AMTOR to the amateur-radio fraternity and because some of the introductory articles that appeared in amateur magazines have been missed by amateurs who may be interested in trying out this new mode of communication, Phil Anderson W0XI has put out a neat, soft-cover publication called *Introduction to and the Operation of AMTOR*.

The table of contents lists a preface and introduction and chapters entitled *Why AMTOR*, *Basic Equipment*, *Basic Operating Procedures*, *An Operating Example: AMTORSOFT* (Copyright 1983 by Kantronics, Inc.), and *Theory of Operation, AMTOR*; there also is an appendix which includes chapters on a "Brief History of AMTOR," a table of the AMTOR code, and references.

The author uses cartoons in an early chapter to relate the reader to the idea of AMTOR, showing how interference can be minimized through repetition of the message and how an acknowledgement of message received is an important element of the system.

The booklet describes how essentially error-free communication can result in spite of fading, interference, and the use of low power by either or both stations in a two-way circuit. It shows the reader what equipment is required, basic operating procedures, where to find and how to tune AMTOR, how to establish contact, how to send and receive messages, and provides dozens of other vital pieces of information that one will want to know when beginning. Retail price of this 37-page booklet is \$3.50.

For further information, contact *Kantronics, Inc.*, 1202 East 23rd Road, Lawrence KS 66044.

Jim Gray W1XU
73 Staff

THE J. C. LABS ACTION MONITOR

The first thing you'll ask yourself—as I did—is, "Why hasn't someone done that before?"

The Action Monitor is one of those devices that is simple, neat, and effective... besides which it is *needed!* Let me give you an example.

How many of you have a scanner or monitor that has to be left unattended much of the day (or night)? There may be something that comes over the monitor that you want to know, or even have to know... yet you can't be there.

How about a DX station that you have been waiting for on a spot frequency, but you have to go to work and may never know whether it ever showed up?

If you've ever worried about not getting that vital message, or capturing that signal that you wanted, the Action Monitor by J. C. Labs is for you. Here's how it works.

The Action Monitor is actually a VOX unit that operates a built-in switch to turn on a tape recorder or other recording device. You attach the speaker output of your receiver or scanner to the input terminals of the Action Monitor by a pair of wires. These can be audio wire, zip cord, or even a shielded pair, although it isn't

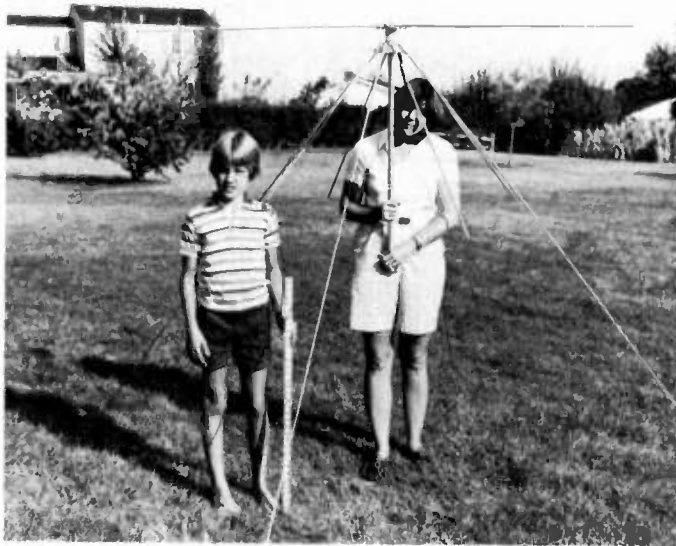

Photo A. The yardstick held by Alex Torres indicates size of the disccone held by Joan Torres.

necessary to go to shielded wire unless you want to.

Next, you attach one of the output leads of the Action Monitor to the tape recorder's push-to-talk input jack by means of the mating plug already furnished; and finally, you attach the other output lead to the tape recorder's microphone input jack by means of the mating plug also furnished. Now you are ready to record.

There is an ON-OFF switch on the Action Monitor. In the OFF position, the Action Monitor is not functional and your scanner or receiver functions normally—that is, without recording anything. Now comes the good part: You turn the switch to ON and you set the tape recorder to the RECORD position. Then tune in a signal on the receiver and watch what happens. As soon as the signal is received, the Action Monitor automatically turns the tape recorder on, and it records the received signal.

In case you wonder about it turning off too soon and missing a reply, Jim Casamassa of J. C. Labs has that all figured out: He provides a two-second delay in the Action Monitor so that it doesn't shut the recorder off immediately. Thus, if there is another signal following the first one by a short delay it also is picked up. Neat, huh?

Okay, how well does it work, you'd like to know? *It works just great!* My thing, for instance, is monitoring the aircraft bands. I like to listen to the commercial airliners call in to the Boston Air Traffic Control Center, so I merely hook up my aircraft monitor receiver to the Action Monitor, and let it record while I am away from home.

In case you wonder why I do that, let me say that it's not mere curiosity. I happen to be a pilot who uses radio communications in my aircraft. Aircraft radio procedure is short, terse, clipped, and *fast*. It takes a bit of getting used to, and you have to mentally gear up to understand it... particularly when you receive instructions to make a complicated approach. I find that the only way for me to be able to understand these rapid-fire contacts is to practice, practice, and practice listening, and the Action Monitor is the perfect way to do it simply and painlessly. I can get a tape full of information over a period of a day's time, so that when I get home in the evening, I can listen to the tape and hear what has happened while away. Best of all, I can replay the tape again and again to get that important practice.

Your use of the Action Monitor may be somewhat different than mine, of course, but that doesn't mean it will be less use-

ful. A friend of mine listens to those "secret" frequencies where nothing happens for hours—even days—at a time. Then, suddenly, there is a burst of information. The Action Monitor is there, ready as always, to catch and record the transmission. Clandestine-radio monitors will find the Action Monitor to be absolutely necessary for their purposes—it is a valuable tool that saves time and money.

Speaking of which, you ought to know that the Action Monitor costs only \$39.95 (plus \$2.00 shipping and handling)—an extremely affordable price, in this writer's opinion, for something that is as useful and simple as this device. As I said in the beginning, why hasn't it been done before?

Oh, yes, one more thing: The Action Monitor comes complete with 9-V battery for powering the VOX circuit. While the battery seems to last forever, it is possible to use an ac adapter to furnish the necessary direct current. J. C. Labs furnishes one that is suitable for use with the Action Monitor for \$8.95, as an optional accessory, plus a \$1.00 shipping and handling charge.

For more information, contact J. C. Labs, PO Box 183, Wales WI 53183; (414) 547-7987. Reader Service number 482.

Jim Gray W1XU
73 Staff

A NEW DISCONE ANTENNA FOR AMATEUR SERVICE

For the past twenty years, the disccone antenna has been a very popular item among military communicators, and until recently, the only source for such antennas was the military surplus business. But things are changing, and in the last few months, TET (Taniguchi-Engineering-Traders, Yokohama, Japan) has introduced a disccone antenna for amateur use.

The useful frequency range of the antenna is an impressive 50 to 480 Megahertz continuous. That's one of the biggest payoffs of a disccone: about an octave worth of bandwidth. TET claims that the swr anywhere in the useful frequency range is less than 1.5:1. Let me tell you, I tested the antenna at 146 MHz, 220 MHz and 450 MHz, and the worst swr obtained was 1.3:1—a very impressive performance.

The gain of the antenna is given at 3 dBi, and in a quick comparison between a quarter-wave vertical whip and the disccone, the disccone came out ahead by 2.8 dB. Considering that the measurement was relatively crude (even though it was done in an anechoic chamber), I probably would go along with the specifications given by TET.

Maximum power limit on this jewel is 500 Watts. The most impressive part of the antenna is the way it was built. The metal used is high-quality aluminum and the hardware used is all stainless steel. Assembly of the antenna took me about one hour (that includes two long-distance telephone interruptions) after figuring out the conversion from metric to inches (my tape measure is in inches). Mechanically, the antenna is about as strong as a mule, yet the unit only weighs 6.5 pounds.

The longest element, part of a radial, is 2200 mm (86.6"). This seven-foot radial is needed for 50-MHz operation. Photo B shows the top of the disccone, and Photo C shows the insulator between the driven elements and the reflectors. It is made of a very hard and durable plastic, solid, and about 2 inches in diameter.

The antenna can be mounted on top of an HF monobander or tribander. It has about the same performance as a Ringo Ranger but much wider frequency operating range. This antenna will work very well

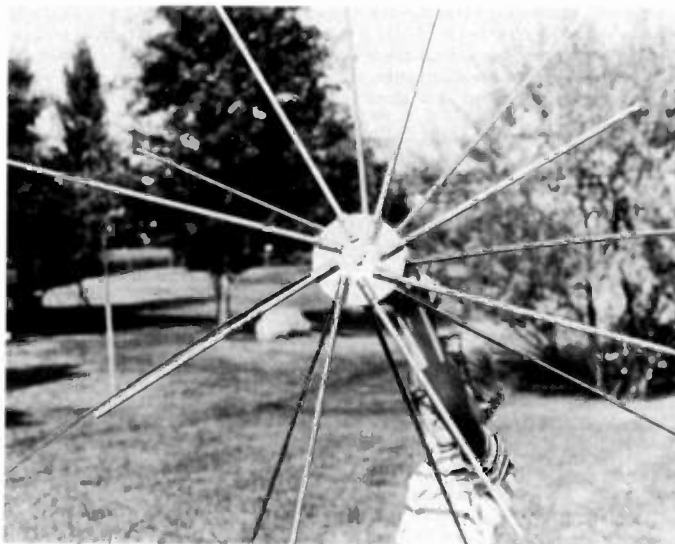

Photo B. Top view of the disccone.

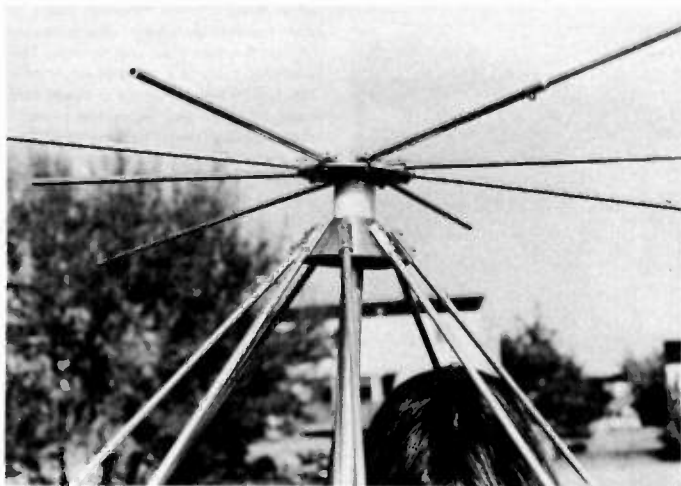

Photo C. The two discs of the disccone, top (radiator) and bottom (ground-plane reflector).

on 2 meters, 220 MHz, and 450 MHz; it is vertically polarized, which makes it compatible with repeaters and FM simplex operation.

The angle of radiation is relatively low, at approximately 15° from the horizontal plane. Fig. 1 shows the angle of radiation relative to a quarter-wave vertical antenna. The GD-X2 is made with a metal coupling that mounts on the top of the SO-239 connector to protect such a connector from the weather.

For those of you willing to take the

plunge, the antenna is now available from US TET distributors. (I bought this one from Sultronics, Inc., Xenia, Ohio.) The antenna was bought by DARA (Dayton Amateur Radio Association) for evaluation purposes; it was given as a door prize at one of the association meetings.

We paid the standard price of \$79.95 for the antenna. Considering the wide bandwidth, the rugged construction, and its performance, the price is very good. The alternative would be to build three antennas and three feedlines plus connectors.

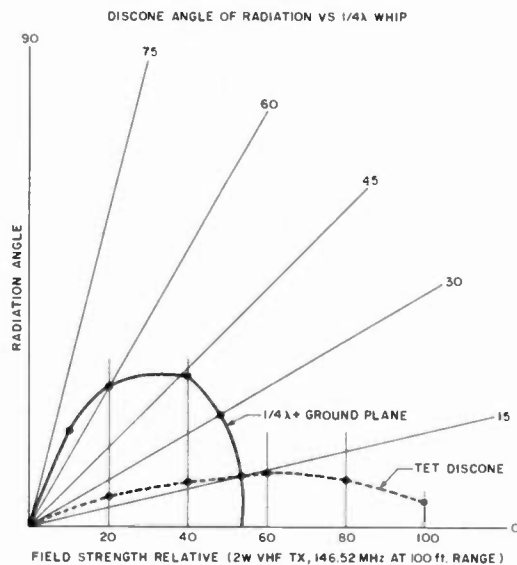

Fig. 1. Angle of radiation relative to a quarter-wave vertical.

The disccone comes ahead financially after making the tradeoff.

For further information, contact TET Antenna Systems, 1924-E W. Mission Road, Escondido CA 92025; (714)-743-7025. Reader Service number 483.

Al Torres KP4AQI
Technical Chairman
Dayton Amateur Radio Assn.

References

1. TET Antenna Systems, GD-X2 Instruction Manual.
2. ARRL Radio Amateur Handbook, 1983 edition, p. 20-16 to 20-18.
3. Kraus, J. D., *Antennas*, McGraw-Hill Book Co., New York NY, 1950, p. 420-422.
4. ARRL Antenna Handbook, 1976 edition, p. 57.

NEW PRODUCTS

AEA RTTY SOFTWARE

AEA has released several new RTTY software packages for the Commodore machines. The MBAText is an advanced Morse, Baudot, and RTTY package for the VIC-20 or C-64, and includes a keyboard overlay for easy operation. The program includes RTTY and ASCII speed-estimate mode, as well as automatic speed tracking and lock-on capabilities. Dedicated function keys, message buffers, and hard-copy and magnetic media storage all make for easy, full-capability operation.

The AEA Micropatch™ is a low-cost Morse, Baudot, and ASCII software/hardware interface package. The Micropatch incorporates the MBAText software ROM, and adds dual-channel mark and space Chebyshev active filters. Automatic threshold correction makes for good copy when one tone is obliterated by QRM or selective fading. Several shifts are switch-selectable, and the triple-LED indicator creates an easy-tuning environment.

AEA has also produced two AMTOR products, the AMTORText™ and the MicroAMTOR Patch™. AMTORText will allow the Commodore 64 to be used as an AMTOR terminal with all the features. The menu-driven program makes it easy to run, and comes complete with SELCALL, ARQ, and break-in operation capabilities.

Combine the AMTORText program with high-quality hardware, and you get MicroAMTOR Patch. Four-pole active filters, automatic PTT, and an EXAR 2206 sine generator make this interface capable of copying through severe QRM.

For more information, contact *Advanced*

Electronic Applications, Inc., PO Box C-2160, Lynnwood WA 98036; (206)-775-7373.

BHC'S NEW BHC— THE BIG HAM CLOCK

BHC, Inc., has just introduced their Big Ham Clock, the latest of large liquid-crystal display clocks in small packages. The clock has two large (5 1/8" tall) LCD modules, one for local time (12- or 24-hour type) and one for GMT. Each clock module can be programmed for your desired combination of: month/day, hours/minutes, seconds, and set to WWV (hack).

Each of the big modules will run one to three years on the replaceable battery. Both modules are mounted in a black anodized desk-top frame.

The Big Ham Clock is available from amateur radio dealers and distributors, or

may be ordered directly from BHC, Inc., 1716 Woodhead, Houston TX 77019. Reader Service number 477.

NEMAL'S SATELLITE CONTROL CABLE

Nemal Electronics International, Inc., has just introduced a new type of combination cable designed for the satellite television industry. As a supplier of cable, connectors, and SMATV products to the satellite television market for over seven years, Nemal has responded to a need for an all-purpose cable for TVRO installations.

Consisting of nine individual conductors plus a 96% copper-shielded RG59/U coaxial line, the Nemal SCC (Satellite Control Cable) provides for all the requirements of most TVRO equipment in one direct burial cable. On the nine conductors, there are five #22-gauge standard copper, two 22-gauge shielded with a third drain wire, and two #18-gauge wires. All wires are color coded to industry standards for easy identification.

Nemal SCC is available in 500- and 1000-foot rolls, as well as by the foot. For

additional information, please contact *Nemal Electronics International, Inc., 12240 N.E. 14th Avenue, North Miami FL 33161; (305)-893-3924.* Reader Service number 478.

INFORMATION PACKETS BY H. STEWART DESIGNS

H. Stewart Designs recently announced the availability of its design-information packet for a unique indoor antenna called the DX Hidden Asset Loop Antenna. This antenna is intended for use by apartment and condo dwellers, and others who are frustrated by antenna space restrictions. An antenna made from the information supplied has a vertically-polarized omnidirectional radiation pattern ideal for working mobiles and for DXing.

Intended for mounting in an attic or crawl space (and outdoors, too, if you should be lucky enough to have roof space available) a DX Hidden Asset Loop Antenna built for the ten-meter band would be only 40 inches tall and 55 inches in diameter. It is electrically balanced, independent of ground, and does not require radials or a ground connection.

Constructed from wire and other simple, readily-available materials, the DXHA looks like two four-foot halos arranged in a horizontal plane, mounted one above the other and separated by a little over three feet. The two loops are joined by two vertical wires spaced a few inches apart, and the coax feedline attaches to the center of one of the wires. Radiation is mainly from the verticals and, possibly, the antenna could be thought of as top-and-bottom-loaded radiators, although that has not been suggested by the literature.

If made from aluminum tubing and supported by some PVC pipe, it would appear as if the antenna could be self-supporting and well suited to outdoor mounting. H. Stewart Designs gives the construction for a wire-and-wood antenna but suggests that other possibilities exist. The informa-



BHC's Big Ham Clock.

tion package contains drawings, tables of dimensions, diagrams, and assembly/tuning instructions for several popular high-frequency amateur bands from two through fifteen meters.

We at 73 will be putting together a ten-meter version for evaluation and will report results in the Product Review section within a few months. Meanwhile, for further information, contact H. Stewart Designs, PO Box 643, Oregon City OR 97045. Reader Service number 481.

GUIDE TO RTTY FREQUENCIES

Interest in monitoring RTTY signals in the shortwave spectrum has caught the fancy of thousands of hams and SWLs. Receiving RTTY signals has been greatly simplified through the use of computer technology and stable HF receiving equipment. In keeping pace with this explosive growth, the second edition of the *Guide to RTTY Frequencies* has double the amount of information and number of pages as the 1980 first edition.

Compiled and edited by O. P. Ferrell, the *Guide to RTTY Frequencies* details the frequency, callsign, location, power, speed, and shift, plus schedules of over 5000 RTTY stations and frequencies in use. The book is conveniently divided into two separate lists: the first by frequency, the second a reverse list by callsign. Included in the lists are military, weather, aeronautical, embassy, press, traffic, and coastal RTTY stations and nets. This is the most comprehensive listing of RTTY stations ever published.



Microtec's dc-dc converter.

The introductory text provides an overview of the techniques of RTTY reception with short articles on Russian Cyrillic, Hellschreiber, test signals, and an explanation of how to use the station lists. RTTY newscasts are given special consideration in the *Guide*. For the first time in print, the *Guide to RTTY Frequencies* gives definitive schedules, details on beam headings, "silent days," special shift patterns, etc. The author gives some advice on buying equipment just to copy RTTY newscasts, pointing out that the number of RTTY newscasts that can be monitored in North America has been

steadily decreasing although activity in all other services is expanding.

For more information, contact Giffer Associates, Inc., 52 Park Avenue, PO Box 239, Park Ridge NJ 07656; (201)391-7887. Reader Service number 476.

A 25-W AMPLIFIER FOR TWO METERS

Ham Industries, Inc., which recently expanded its product line, has announced the availability of its first ham product, the PA-25, a very compact 25-Watt amplifier for the 2-meter band.

Weighing 8 ounces, the PA-25 can be attached to a hand-held or mounted to a car dashboard with the accessory mounts included. It will boost output power up to 6 times for a hand-held transceiver. An adapter cord allows plugging into a cigarette lighter, or a separate power supply can be used.

To order, or to obtain further information, contact Ham Industries, Inc., Inspection Products Division, 835 Highland Rd., Macedonia OH 44056, (212)467-4256. Reader Service number 479.

THE MICROTEC 50DC1235 DC-DC CONVERTER

Magnum Distributors, Inc., has introduced another power-conversion product, the model 50DC1235, designed and manufactured by Microtec, Inc.

The model 50DC1235 is a commercial-grade, high-efficiency, high-current, continuous-duty, dc-dc converter. Specifications: 18-50-V-dc input, 13.8-V-dc output at 30 A. Continuous, 35 A intermittent (35 A continuous with forced air cooling); regulation: line 0.1% temp. 0.5%; output ripple and noise: less than 5 mV rms at max. load; efficiency: 83-90% input and output protection; size: 13.5" x 3.25" x 4.5"; weight: 5 lbs.; construction: all non-ferrous, 1 year warranty. Complete specifications upon request.

For additional information and pricing, contact Magnum Distributors, Inc., 1000 S. Dixie Hy. W. #3, Pompano Beach FL 33060; (305)785-2002. Reader Service number 480.

CONTESTS

Robert Baker WB2GFE
15 Windsor Dr.
Atco NJ 08004

3RD ANNUAL 40-METER WORLD SSB CHAMPIONSHIP 0000Z to 2400Z January 7, 1984

SPONSORED BY:

73: Amateur Radio's Technical Journal.

MISCELLANEOUS RULES:

Work as many stations as possible on 40-meter phone during the specified times of allowable operation. The same station may be worked once. Crossmode contacts will not count. Single-operator stations may operate a total of 16 hours. All multi-operator stations may operate the entire 24-hour period. Off periods must be noted in your log(s) and on your summary sheet. Off periods are no less than 30 minutes each.

OPERATOR CLASSES:

(A) Single operator, single transmitter, phone only. (B) Multi-operator, single transmitter, phone only.

EXCHANGE:

Stations within the continental 48 United States and Canada transmit an RS report and state, province, or territory. All other stations, including Alaska and Hawaii, transmit RS report and DX country.

POINTS:

5 QSO points for contacts with WVE sta-

tions located within the continental 48 United States and Canada. All other contacts score 10 points each. List points for each contact on your log sheet(s).

MULTIPLIERS:

1 multiplier point is earned for each US state, 48 maximum (a District of Columbia contact may be substituted for a Maryland multiplier), each Canadian province or terri-

tory (13 maximum), and DX country (excluding the continental US and Canada).

FINAL SCORE:

Total QSO points times total multiplier points equals claimed score.

CONTEST ENTRIES:

Each entry must include a contest log, a dupe sheet, a contest summary, and multiplier checklist. We recommend that contestants send for a copy of the contest forms. Send an SASE to the contest address listed below.

CONTEST DEADLINE:

Each entry must be postmarked no later than February 12, 1984.

DISQUALIFICATIONS:

Omission of any required entry form, operating in excess of legal power, manipulating of contest scores or times to achieve a score advantage, or failure to omit duplicate contacts which would reduce the overall score more than 2% are all grounds for immediate disqualification. Decisions of the contest committee are final.

AWARDS:

Contest awards will be issued in each operator class in each of the continental 48 United States, Canadian provinces and territories, and each DX country represented. A minimum of 100 QSOs must be worked to be eligible for contest awards.

CONTEST ADDRESS:

To obtain entry forms or to submit an entry, contact: 40-Meter Contest, Dennis Younker NE6I, 43261 Sixth Street East, Lancaster CA 93535.

3RD ANNUAL 75-METER WORLD SSB CHAMPIONSHIP 0000Z to 2400Z January 8, 1984

SPONSORED BY:

73: Amateur Radio's Technical Journal.

MISCELLANEOUS RULES:

Work as many stations as possible on 75-meter phone during the specified times of allowable operation. The same station may be worked once. Crossmode contacts will not count. Single-operator stations may operate a total of 16 hours. All multi-operator stations may operate the entire 24-hour period. Off periods must be noted in your log(s) and on your summary sheet. Off periods are no less than 30 minutes each.

THE TSRAE BNE

NEWSLETTER OF THE MONTH

"The A. R. club publication that tries to be different." That's the self-proclaimed motto of The Triple States Radio Amateur Club's *TSRAE BNE*, this month's contest winner. How are they different from most other newsletters?

Well, sure, they have news about club members and news about hamfests and special events. News about past and future happenings. "The Trading Post" classifieds. Some paid advertising. News (and a coupon) about a new Novice class. FCC and ARRL news. Articles (September Issue) such as "Simulated Disaster Turns into the Real Thing" and "Helping the FCC at Midnight!" News about the newsletter itself—editorial and subscription info. Letters to the Editor. News "From the Editor's Desk" for readers. Some photos of hams in action. ARES news. A League membership application. More news.

Get the picture? News, news, news—crammed into this 24-page single-spaced issue. Editor Ralph McDonough KBAN's club doesn't get this award for news, though. They get it for taking the time and an awful lot of space to congratulate and recognize club members for their personal and club efforts. They try to be different by doing this and we feel that they more than succeed.

Our congratulations go out to Ralph, his helpers (however unsung), and *TSRAE* for a job very well done.

To enter your club's newsletter in 73's Newsletter of the Month Contest, send it to 73, Pine Street, Peterborough NH 03458, Attn: Newsletter of the Month.

OPERATOR CLASSES:

(A) Single operator, single transmitter, phone only. (B) Multi-operator, single transmitter, phone only.

EXCHANGE:

Stations within the continental 48 United States and Canada transmit an RS report and state, province, or territory. All other stations, including Alaska and Hawaii, transmit RS report and DX country.

POINTS:

5 QSO points for contacts with WVE stations located within the continental 48 United States and Canada. All other contacts score 10 points each. List points for each contact on your log sheet(s).

MULTIPLIERS:

1 multiplier point is earned for each US state, 48 maximum (a District of Columbia contact may be substituted for a Maryland multiplier), each Canadian province or territory (13 maximum), and DX country (excluding the continental US and Canada).

FINAL SCORE:

Total QSO points times total multiplier points equals *claimed* score.

CONTEST ENTRIES:

Each entry must include a contest log, a dupe sheet, a contest summary, and multiplier checklist. We recommend that contestants send for a copy of the contest forms. Send an SASE to the contest address listed below.

CONTEST DEADLINE:

Each entry must be postmarked no later than February 12, 1984.

DISQUALIFICATIONS:

Omission of any required entry form, operating in excess of legal power, manipulating of contest scores or times to achieve a score advantage, or failure to omit duplicate contacts which would reduce the overall score more than 2% are all grounds for immediate disqualification. Decisions of the contest committee are final.

AWARDS:

Contest awards will be issued in each operator class in each of the continental 48 United States, Canadian provinces and territories, and each DX country represented. A minimum of 100 QSOs must be worked to be eligible for contest awards.

CONTEST ADDRESS:

To obtain entry forms or to submit an entry, contact: 75-Meter Contest, Jose A. Castillo N4BAA, 1832 Highland Drive, Amelia Island FL 32034.

**RATS NEST AND CROOKED STICK IV
2100Z January 8 to
0100Z January 9**

This antenna experimenter's contest sprint is sponsored by the Issaquah Amateur Radio Club. A Rats Nest and Crooked Stick antenna is 100 feet maximum of single-conductor wire (solid or stranded), any configuration. Feedline will not have to count as part of the 100 feet unless it is coaxial cable. Antenna height is limited to 20 feet at the center of high current, i.e., center of dipole, center of quad, base of 1/4-wave vertical. Transmitter power shall be 250 Watts or less (dc input).

CALENDAR

Jan 7	73 40-Meter World SSB Championship
Jan 8	73 75-Meter World SSB Championship
Jan 14-15	73 160-Meter World SSB Championship
Jan 14-15	Hunting Lions In the Air Contest
Jan 14-15	ARRL VHF Sweepstakes
Jan 20-22	A5 Was SSTV Contest
Jan 21-22	North Dakota QSO Party
Jan 27-29	CQ Worldwide 160-Meter DX Contest—CW
Jan 28-29	Michigan YL QSO Party
Jan 28-Feb 5	ARRL Novice Roundup
Feb 4-5	South Carolina QSO Party
Feb 4-5	Arizona QSO Party
Feb 4-5	Vermont QSO Party
Feb 4-5	Zero-District QSO Party
Feb 11-12	Dutch PACC Contest
Feb 18-19	American Radio Club International DX Contest
Feb 18-19	YL-SSB Commo System QSO Party—Phone
Feb 18-19	ARRL DX Contest—CW
Feb 24-26	CQ Worldwide 160-Meter DX Contest—SSB
Feb 25	RTTY World Championship
Mar 3-4	ARRL DX Contest—Phone
Mar 17-18	YL-SSB Commo System QSO Party—CW
Mar 17-18	Bermuda Contest
Mar 17-18	Spring QRP CW Activity Weekend
Jul 13-15	A5 International SSTV-DX Contest
Aug 11-12	New Jersey QSO Party
Aug 24-27	A5 North American UHF FSTV-DX Contest
Sep 22-23	Late Summer QRP CW Activity Weekend

FREQUENCIES:

CW—21.060 to 21.200 MHz.
SSB—21.350 to 21.450 MHz.

EXCHANGE:

Name, location (QTH), type of antenna, IARC member—yes or no.

SCORING:

CW contact—21.060 to 21.099 MHz, 5 points; CW contact—21.100 to 21.200 MHz, 10 points; SSB contact—21.350 to 21.450 MHz, 2 points.

A station may be contacted once on SSB and once on CW. Each dupe the contest committee finds is penalized by a loss of 10 points.

Bonus points awarded as follows: each new state worked, 3 points; worked all seventh-call-area states (8), 50 points; worked all states (50) 75 points; each new call area worked, 5 points; worked all ten US call areas, 35 points; 7 or more CW contacts, 25 points; 15 or more CW contacts, 75 points; each DX contact (KH6, KL7, VE, XE, JA, etc.), 5 points.

CATEGORIES:

1. Non-IARC member using a Rats Nest and Crooked Stick antenna. 2. IARC member using a Rats Nest and Crooked

Stick antenna. 3. IARC member using a conventional base-station antenna. 4. A station making contact with three IARC members during contest.

AWARDS:

In each of the above categories 1, 2, and 3: A. High overall score. B. High CW score (without bonus). C. High SSB score (without bonus). D. High Novice/Technician score. E. Participant (1 hour or more operation).

In category 4: "Rat Catcher" certificate.

ENTRIES:

By February 1, 1984, submit summary sheet—points per mode, bonus points earned, total points earned, name, call, address, complete description of antenna and equipment used, license class. Log sheet—time, call, frequency, mode, exchange.

For Rat Catcher entries, submit log sheet showing three contacts with Issaquah Amateur Radio Club members during contest.

All correspondence must include an SASE sent to: Issaquah Amateur Radio Club, Bob Farnworth KB7NV, 6822 131st Ave. S.E., Bellevue WA 98006. All decisions of the contest committee will be final.

**5TH ANNUAL 160-METER WORLD SSB CHAMPIONSHIP
0000Z January 14, 1984 to
2400Z January 15, 1984**

SPONSORED BY:

73. Amateur Radio's Technical Journal.

OBJECT:

To work as many stations as possible on 160-meter phone in a maximum of 32 hours allowable contest time. Multi-operator stations may operate the entire 48-hour contest period. Stations may be worked only once.

ENTRY CATEGORIES:

(A) Single operator, single transmitter, phone only. (B) Multi-operator, single transmitter, phone only.

EXCHANGE:

Stations within the continental US and Canada transmit RS report and state or province/territory. All others transmit RS report and DX country.

POINTS:

5 QSO points for contact with WVE stations contacted within the continental 48 United States and Canada. All other contacts earn 10 points each.

MULTIPLIERS:

1 multiplier point will be earned for each of the continental United States, 48 maximum (a District of Columbia contact may be substituted for a Maryland multiplier), each of the Canadian provinces/territories (13 maximum), and each DX country outside the continental 48 United States and Canada.

FINAL SCORE:

Total QSO points times total multiplier points equals *claimed* score.

CONTEST ENTRIES:

Each entry must include log sheets, dupe sheet for 100 or more contacts, a contest summary, and a multiplier check sheet.

ENTRY DEADLINE:

All entries must be postmarked no later than February 19, 1984.

DX WINDOW:

Stations are expected to observe the DX window from 1.825-1.830 MHz as mutually agreed by top-band operators. Stations in the US and Canada are asked not to transmit in this 5-kHz segment of the band. During the contest, all WVE stations are requested to utilize only those frequencies from 1.808-1.825 and 1.830-1.900 MHz.

DISQUALIFICATIONS:

Disqualification may result if a contestant omits any required entry form, operates in excess of legal power authorized for his/her given area, manipulates operating times to achieve a score advantage, or fails to omit duplicate contacts which reduce the overall score more than 2%. Decisions of the contest committee are final.

AWARDS:

Contest awards will be issued in each entry category in each of the continental United States, each Canadian province/territory, and each DX country. A minimum of 100 QSOs must be worked to qualify.

CONTEST ADDRESS:

To obtain information or entry forms (enclose an SASE) or to submit a contest entry, contact: 160-Meter Contest, Harry Arsenault K1PLR, 603 Powell Avenue, Erie PA 16505.

RESULTS

1983 ARIZONA QSO PARTY

Arizona Stations

Call	QTH	Score
*K6LL	Yuma County	75,468
*KB7KZ	Pima County	16,965

Non-Arizona Stations

*W5PWG	Texas	200
W5WG	Louisiana	170

* Certificate winner

HUNTING LIONS IN THE AIR CONTEST

Starts: 1200 GMT January 14
Ends: 1200 GMT January 15

The contest is sponsored by Lions Clubs International and coordinated by Lions Club Rio de Janeiro Arpoador, Brazil. Participation in the contest is open to all duly licensed radio operators, Lion and non-Lion. There are two modes: phone and CW. Participation in both modes is allowed but points are counted separately. All amateur stations participating must operate within their licensing regulation. Separate categories will exist for single operators and radio clubs/societies. Multi-operators may participate as long as they do not operate simultaneously with the same callsign. However, each callsign used must be listed on the log.

Use all bands, 80, 40, 20, 15, and 10 meters. Only one QSO with the same station on each band may be counted. Remember that phone and CW are counted separately!

EXCHANGE:

RS(T) and sequential QSO number. When a contact is made with any Lion, Leo, or Lioness, the name of the club contacted should be clearly identified.

SCORING:

QSOs within the same continent count 1 point while those between different continents count 3 points. Score 1Q extra bonus points for each QSO with a member of a Lion, Lioness, or Leo Club from a different country or 5 points within the same country. Score 20 bonus points for a QSO with a member of the Lions Club Rio de Janeiro Arpoador. Contacts between Brazilian stations and members of the Arpoador club will count only 5 extra points. Contacts between members of the Arpoador club will not count any bonus points.

AWARDS:

For single-operator entries, Lions Clubs International will present trophies for first, second, and third places on both modes. Fourth through tenth places will receive plaques. In addition, each participant sending a log with a minimum of 5 contacts will receive a special certificate. The contest committee will also select and reward the most active Lions Club participating in the contest.

ENTRIES:

Keep a separate log for each mode. Each participant will note in the log the callsign and information exchanged. Confirmation of contacts will be made by comparing the logs of the participants. Participants should send their logs by airmail no later than Feb. 5 to: Contest Committee, Hunting Lions in the Air, Lions Club of Rio de Janeiro Arpoador, Rua Sao Francisco Xavier #246, Apt. 407, 22550 Rio de Janeiro, RJ, Brazil.

A5 WAS SSTV CONTEST

Starts: 1800 EDT January 20
Ends: 1800 EDT January 22

This is the 3rd annual contest sponsored by A5 ATV Magazine. The object is to work as many different US states as possible on the video mode. All contacts must be in video form with a minimum of callsign and RSV signal reports sent and received. Count 10 points per SSTV QSO regardless of location, with 100 points awarded for each new state. Contacts with Alaska or Hawaii on SSTV count 500

points. Top scorer will receive a free 3-year subscription to A5 ATV Magazine with 1-year subscriptions going to District leaders. All entrants will receive a special gold specialized-communications certificate suitable for framing. Logs must be sent to: Contest Manager, A5 ATV Magazine, PO Box H, Lowden IA 52255. Indicate state and score on the front of the envelope. Logs and photos sent will be returned at the close of the contest judging period. Results should be published in the March or April, 1984, issue of A5 ATV Magazine.

NORTH DAKOTA QSO PARTY 0000 to 0800 and 1600 to 2400 GMT January 21 0800 to 1600 GMT January 22

Sponsored again by the Red River Radio Amateurs of Fargo ND. Work stations once per band and mode.

EXCHANGE:

RS(T) and state, province, country, or North Dakota county.

FREQUENCIES:

Phone—1835, 3905, 7280, 14295, 21380, 28580.

CW—1810, 3540, 7035, 14035, 21035, 28035.

Novice—3725, 7125, 21125, 28125.

SCORING:

Phone contacts count 10 points, CW 20 points, and RTTY 50 points. North Dakota stations count an additional 100-point bonus for working five Novices. North Dakota stations multiply score by total of states, provinces, and countries worked. Others multiply by the number of North Dakota counties worked (max 53).

ENTRIES & AWARDS:

Certificates to state, province, and country winners. Plaque to North Dakota winner and highest scorer outside North Dakota. Mail logs by February 28th to: Mike Beaton KD9A, 2267 Flickertail Dr., Fargo ND 58103. Include a large SASE for results.

CQ WORLDWIDE 160-METER CONTEST-CW

Starts: 2200 GMT January 27
Ends: 1600 GMT January 29

Operating classes include both single and multi-operator (maximum of 5 ops per station).

EXCHANGE:

RST plus QTH, and state for USA, province for Canadian.

SCORING:

Contacts with stations within own country are 2 points, other countries but same continent are 5 points, other continents are 10 points. KH6 and KL7 are considered countries.

Multipliers are each US state, VE province, and DX country. USA and Canada are not country multipliers. However, there are three VE1 provinces: New Brunswick, Nova Scotia, and Prince Edward Island. Final score is total QSO points times the sum of the multipliers. Maritime-mobile scoring will be determined by the location.

AWARDS:

Certificates to the top scorers in each class in each US state, VE province, and DX country. Special plaques are also

being awarded for top USA, Europe, and world scores.

PENALTIES:

Three additional contacts will be deleted from the score for each duplicate, false, or unverifiable contact removed from the log. A second multiplier will also be removed for each one lost by this action.

Violation of the rules and regulations pertaining to amateur radio in the country of the contestant or the rules of the contest, unsportsmanlike conduct, or taking credit for excessive duplicate contacts or multipliers will be deemed sufficient cause for disqualification. Disqualified stations or operators may be barred from competing in CQ contests for a period of up to three years.

ENTRIES:

Sample log and summary sheets may be obtained from CQ by sending a large SASE with sufficient postage to cover your request. It is not necessary to use the official form, you can use your own. Logs should have 40 contacts per page and show time in GMT, numbers sent and received, and separate columns for QSO points and multipliers. Indicate the multiplier only the first time it is worked.

Include a summary sheet with your entry showing the scoring and other essential information, and a signed declaration that all rules and regulations have been observed. Mailing deadline for CW entries is Feb 28. Logs can be sent directly to the 160 Contest Director, Don McClenon N4IN, 3075 Florida Avenue, Melbourne FL 32901, USA. Alternatively, they can be sent to CQ 160-Meter Contest, 76 North Broadway, Hicksville NY 11801, USA. Please indicate "CW" on the envelope!

MICHIGAN YL QSO PARTY

Starts: 1800 GMT January 28
Ends: 1800 GMT January 29

Sponsored by The Auto State Young Ladies (TASYLs). No crossband, net, or repeater QSOs are allowed. Each station can be contacted only once.

EXCHANGE:

RS(T), QTH, and TASYL number (for members).

SCORING:

Score one point per QSO and multiply by 2 if on CW. Multiply again by 2 if TASYL member. Multiply QSO points by number of different ARRL sections and DX countries worked.

ENTRIES:

Send logs to TASYL President Carol Hall WD8DQG, 4651 Cardinal Dr., Mt. Pleasant MI 48858. Entries must be received by February 25th.

The TASYL Certificate may also be earned during the QSO Party for working TASYL members. Charter members 1 thru 50 count 2 points while all other members count 1 point. Michigan stations need 15 points while others only need 10 points. To apply for the award, send a signed and dated log showing the date and time of contacts, callsigns, frequencies, RST, and TASYL numbers. Certification giving date and QTH must be on the original application and signed by one of the following: 2 licensed amateurs, General-class or higher (non-family), one official of a recognized club, or a notary public. Include \$1 to cover mailing costs, etc., and submit applications to Carol Hall WD8DQG, 4651 Cardinal Drive, Mt. Pleasant MI 48858.

3RD ANNUAL RTTY WORLD CHAMPIONSHIP 0000Z to 2400Z February 25, 1984

SPONSORED BY:

73 Amateur Radio's Technical Journal and The RTTY Journal.

OPERATOR CLASSES:

(A) Single operator, single transmitter (B) Multi-operator, single transmitter.

ENTRY CATEGORIES:

(A) Single band. (B) Allband, 10-80 meters.

EXCHANGE:

Stations within the 48 continental United States and Canada must transmit RST and state or province/territory. All others must transmit RST and consecutive contact number.

MISCELLANEOUS RULES:

The same station may be worked once on each band. Crossmode contacts do not count. Single-operator stations may work 16 hours maximum while multi-operator stations may operate the entire 24-hour period. Off times are no less than 30 minutes each and must be noted in your log(s).

QSO POINTS:

5 QSO points for contacts with WVE stations located within the continental United States and Canada. 10 QSO points for all other contacts.

MULTIPLIER POINTS:

1 multiplier point is awarded for each of the 48 continental United States (a District of Columbia contact may be substituted for a Maryland multiplier), Canadian provinces/territories, and DX countries worked on each band (excluding US and Canada).

FINAL POINTS:

Total QSO points times total multipliers equals claimed score.

CONTEST ENTRIES:

Entries must include a separate log for each band, a dupe sheet, a summary sheet, a multiplier checklist, and a list of equipment used. Contestants are asked to send an SASE to the contest address for official forms.

ENTRY DEADLINE:

All entries must be postmarked no later than April 15, 1984.

DISQUALIFICATIONS:

Omission of the required entry forms, operating in excess of legal power, manipulating scores or times to achieve a score advantage, or failure to omit duplicate contacts which would reduce the overall score more than 2% are all grounds for immediate disqualification. Decisions of the contest committee are final.

AWARDS:

Contest awards will be issued in each entry category and operator class in each of the US call districts and Canadian provinces/territories, as well as in each DX country represented. Other awards may be issued at the discretion of the awards committee. A minimum of 25 QSOs must be worked to be eligible for awards.

CONTEST ADDRESS:

RTTY World Championship, c/o The RTTY Journal, PO Box RY, Cardiff CA 92007.

ADVERTISERS

*Please contact these advertisers directly.
To receive full information from our advertisers please complete the postage-paid card.

R. S. No.	Page	R. S. No.	Page	R. S. No.	Page	R. S. No.	Page
* AE/Advanced Electronic Applications	43, 110	117 Communications Specialists, Inc.	15	33 Hamtronics, NY	144, 145	62 Ramsey Electronics	141, 143
127 Advanced Computer Controls	132	* Computer Trader	101	303 Heath Company	131	133 Rivendell Associates	89
98 Alpha Delta Communications	74, 75	140 Contact East	119	484 Heath Company	107	150 Royal	117
* Amateur Communications, Etc.	51	37 Contemporary Technology, Inc.	101	123 Hustler, Inc.	18	* RUN Magazine	67
* Amateur Electronic Supply	19, 53, 81, 95	317 Continental Satellite Systems	83	* ICOM	Cov. II	65 S-F Amateur Radio Services	63
243 Amateur-Wholesale Electronics	63	25 Control Products, Unlimited	101	482 J. C. Labs	109	500 73	
109 Analog Technology	118	87 Current Electronics	83	39 Jan Crystals	18	Dealer Ad	132
* ARRL National Convention	30	141 Cushcraft Corp.	79	354 Jensen Tools	118	Moving	132
* Astron Power Supplies	39	106 Cushcraft Corp.	63	* Kantronics	8, 9, 108	Subscriptions	119, 130
447 BHC, Inc.	110	* DCC Data Service	53	* Kenwood	7, Cov. IV	68 Spectrum Communications	68, 69
* BMG Engineering	119	346 Data Service	95	220 Lunar Electronics	118	436 Spectrum International, Inc.	137
11 Barker & Williamson, Inc.	26	* Dayton Hamvention	34, 87	82 MCM Communications	44	* Spider Antenna	41
305 Barry Electronics	23	425 Doppler Systems	142	9 MFJ Enterprises	16, 17	483 TET/Sultronics	109
* Barter 'N' Buy	117, 119	* EGE, Inc.	55	48 MHz Electronics	120-129	224 Teltone	118
* Bill Ashby & Son	41	120 Electra Company	5	* Macrotronics, Inc.	89	449 The Ham Shack	35
* Blacksburg Group	137	18 Electronic Specialists, Inc.	45	45 Madison Electronics	31	205 The Metheny Corp.	4
* Break Comm. Systems, Inc.	41	135 Encomm, Inc.	133	480 Magnum Distributors, Inc.	111	104 Trionyx Industries	26
* Butternut Electronics	131	22 Esoteric Engineering	119	51 Micro Control Specialties	27	136 Tucson Amateur Packet Radio	44
12 CZ Labs	24	22 Fair Radio Sales	119	* Mirage Communications	72	* University Microfilms	118
462 CES, Inc.	45	99 Faxscan	18	258 Missouri Radio Center	137	* Van Gorden Engineering	51
111 Ceco Communications, Inc.	45	23 Flesher Corp.	45	240 Miltronix	53	311 Vanguard Labs	101
13 Coin International	119	88 Fox-Tango Corp.	4	* Moler Antenna, Inc.	119	* W9INN Antennas	101
14 Communications Concepts, Inc.	63	147 Fox-Tango Corp.	119	352 Monitoring Times	41	135 WELZ	133
15 Communications Specialists, Inc.	73	95 Fox-Tango Corp.	63	138 Nampa Satellite Systems	18	145 Wayne Green Books	82
34 Communications Specialists, Inc.	139	178 Galaxy Electronics	118	254 National Comm. Group Co.	62	* Wayne Green Shelf Boxes	89
		476 Giffler Associates	111	412 Nema Electronics	94	* Westcom	132
		229 Gizmo Electronics	24	478 Nema Electronics	110	* Westech Electronics, Inc.	101
		143 GLB Electronics	66	137 Nuts & Volts	118	80 Western Radio Electronics	95
		481 H. Stewart Designs	110	* Orbit Magazine	26	* Wheaton Hamfest	51
		31 Hal-Tronix	62	* P. C. Electronics	21	* Wheeler Applied Research Lab	118
		479 Ham Industries, Inc.	111	4 Parsec Communications	89	107 Woodall & Associates	118
		101 Ham Masters Tapes	13	* Parsec Communications	14	83 Yaesu Electronics	Cov. III
		* Ham Radio Outlet	3	* R & L Electric	63		
				61 Radio Amateur Callbook, Inc.	4		
				96 Radiokit	93		

73

BOOKS, ETC.

To order, complete the postage-paid card, or itemize your order including detailed credit card information or check and mail to: 73 Magazine/Mail Order Dept./Peterborough NH 03458.

Catalog#	Item	Price	Catalog#	Item	Price	Catalog#	Item	Price	Catalog#	Item	Price
73300	73 BACK ISSUE—BEFORE JULY 1980	\$ 3.00	BK7309	CHALLENGE OF 160	\$ 4.95	BK7310	OWNER REPAIR OF RADIO EQUIPMENT	\$ 7.95	SG7358	STUDY GUIDE—GENERAL CLASS	\$ 6.95
73350	73 BACK ISSUE—JULY 1980 THRU OCT 1981	\$ 3.50	BK1011	CMOS COOKBOOK	\$10.50	BK1185	THE PRACTICAL HANDBOOK OF FM REPEATERS	\$12.95	BK1190	THE TEN METER FM HANDBOOK	\$ 4.95
73350P	73 BACK ISSUE—NOV 1981 TO PRESENT	\$ 3.50	CT7305	CODE TAPE—5 WPM	\$ 4.95	BK7302	PROPAGATION WIZARD'S HANDBOOK	\$ 6.95	LB7360	TEST EQUIP LIB V2—AUDIO TESTERS	\$ 4.95
73005	73 BACK ISSUE—5 YOUR CHOICE	\$10.75	CT7306	CODE TAPE—6 WPM	\$ 4.95	QW0250	OSL CARDS—STYLE W—250	\$ 8.95	LB7361	TEST EQUIP LIB V3—RADIO EQUIP	\$ 4.95
73010	73 BACK ISSUE—10 YOUR CHOICE	\$16.00	CT7313	CODE TAPE—13 WPM	\$ 4.95	QW0500	OSL CARDS—STYLE W—500	\$13.95	LB7362	TEST EQUIP LIB V4—IC TEST ED	\$ 4.95
73025	73 BACK ISSUE—25 YOUR CHOICE	\$27.00	CT7320	CODE TAPE—20 WPM	\$ 4.95	OX0250	OSL CARDS—STYLE X—250	\$ 8.95	BK7387	TEXTEDIT—WORD PROCESSING KIT	\$9.97
73125	73 BACK ISSUE—25 OUR CHOICE	\$14.00	CT7325	CODE TAPE—25 WPM	\$ 4.95	OX0500	OSL CARDS—STYLE X—500	\$13.95	DS7387	TEXTEDIT DISK	\$19.97
	Add \$7.50 per order for shipping		CT7325P	CODE TAPE—25 WPM	\$ 4.95	OX0250	OSL CARDS—STYLE X—250	\$ 8.95	BK7348	TOOLS & TECHNIQUES	\$ 4.95
BK1196	ALL ABOUT CUBICAL QUAD ANTENNAS	\$ 5.95	CT7394	CODE TAPES (ANY FOUR ABOVE)	\$15.95	BK1199	THE RADIO AMATEUR ANTENNA HANDBOOK	\$ 6.95	BK1063	TTL COOKBOOK	\$ 4.95
BK7384	ANNOTATED BASIC VOL 1	\$10.95	BK1241	THE COMPLETE SHORTWAVE LISTENER'S HANDBOOK	\$ 9.95	BK1044	RF & DIGITAL TEST EQUIPMENT	\$ 6.95	BK1064	TVI COOKBOOK	\$ 9.95
BK7385	ANNOTATED BASIC VOL 2	\$10.95	BK7308	THE CONTEST COOKBOOK	\$ 5.95	BK1016	73 DIPOLE & LONG WIRE ANTENNAS	\$ 5.50	BK7382	UNDERSTANDING & PROGRAMMING MICROCOMPUTERS	\$10.95
BK1197	BEAM ANTENNA HANDBOOK	\$ 5.95	BK7381	40 COMPUTER GAMES	\$ 7.95	BK1000	SHELF BOX—1	\$ 2.00	BK7368	VHF ANTENNA HANDBOOK	\$ 5.95
BK7307	BEHIND THE DIAL	\$ 4.95	BK7386	KILOBAUD KLASROOM	\$14.95	BK1001	SHELF BOXES—2 7	\$1.50 each	BK1198	VHF HANDBOOK FOR RADIO AMATEURS	\$ 6.95
			BK7312	MAGIC OF HAM RADIO	\$ 4.95	BK1002	SHELF BOXES—8 AND UP	\$1.25 each	BK1202	WORLD PRESS SERVICE FREQUENCIES	\$ 7.95
			BK7340	THE NEW HOBBY COMPUTERS	\$ 2.47	BK1200	SIMPLE LOW COST WIRE ANTENNAS FOR RADIO AMATEURS	\$ 6.95	BK1184	WORLD RADIO TV HANDBOOK	\$16.50
			BK7383	THE NEW WEATHER SATELLITE HANDBOOK	\$ 8.95	BK7311	SOME OF THE BEST FROM KILOBAUD	\$10.95	BK7315	WORLD REPEATER ATLAS	\$ 2.00
			CT7300	NOVICE THEORY TAPES	\$15.95	BK7351	SSB THE MISUNDERSTOOD MODE	\$ 5.50			
						SG7357	STUDY GUIDE—NOVICE CLASS	\$ 4.95			

SHIPPING AND HANDLING CHARGES \$1.50 for the first book, \$1 for each additional book for US delivery and foreign surface \$10 per book for foreign airmail

CIRCUITS

Do you have a technique, modification, or easy-to-duplicate circuit that your fellow readers might be interested in? If so, send us a concise description of it (under two pages, double-spaced) and include a clear diagram or schematic if needed.

In exchange for these technical gems, 73 offers you the choice of a book from the Radio Bookshop, to be sent upon publication. Submit your idea (and book choice) to: Circuits, Editorial Offices, 73 Magazine, Peterborough NH 03458. Submissions not selected for publication will be returned if an SASE is enclosed.

STOP THAT ICOM BUZZ: If your IC-45A has been buzzing through the speaker or has been commanding itself to start or stop scanning, here is a simple fix. The regulator (IC-2) on the main board is the power supply for the whole radio. If it is not securely attached to the heat sink and if the board on which it sits is not firmly attached to the framework, the regulator filter will not function correctly. This will allow a buzz into the 8-V supply and will false the CPU into thinking that there was a command. Buzz may also occur in the audio. By tightening the four screws holding IC-2 to the heat sink, the filter will be allowed to work again. Some of the screws have a tendency to loosen, so a periodic check of them is in order.—Rick Bates WA6NHC, Petaluma CA.

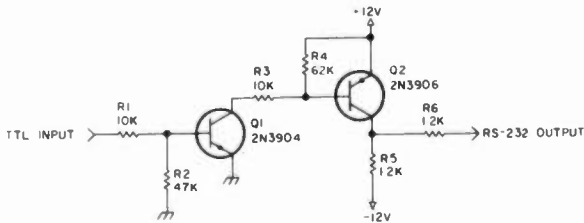

SIMPLE TRANSISTOR TTL-TO-RS232 INTERFACE: This circuit can be used for driving an RS232 printer or RTTY interface from your computer or digital circuit. Transistor Q2 is the ± 12 -V switch, which is driven by Q1. When the TTL input is low (mark condition), Q1 is turned off, which allows Q2 to be turned off. The RS232 output rests at -12 volts (mark condition). When the TTL input is logic high (5 V), Q1 turns on and drives the base of Q2, turning it on. The RS232 output will then go to approximately $+12$ V (space condition). Resistor R6 maintains a current limit in the event of an RS232 output short circuit. If the output were shorted without R6 in the circuit, the switch transistor Q2 would quickly burn out. The total cost of this simple interface is 32 cents.—Scott M. Freeberg WA9WFA, Ft. Atkinson WI.

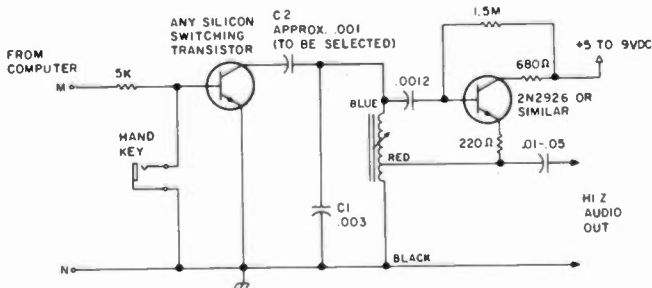

RTTY OSCILLATOR FROM ORGAN PARTS: Using a tapped coil from the tone generator in a Conn organ, this circuit will generate the necessary 1275 and 1445 tones for RTTY. The coil I used (no. 57013) produced F sharp in the sixth octave; it should be available from a Conn organ repairman. Other coils may be used instead, but you must change the value of C2 to get the correct frequency. The circuit itself is a standard Hartley oscillator, and the coil adjustment is a standard 6-32 nut. Be sure to finish tuning in the tightening mode to ensure mechanical stability.—Wm. Bruce Cameron WA4UZM, Temple Terrace FL.

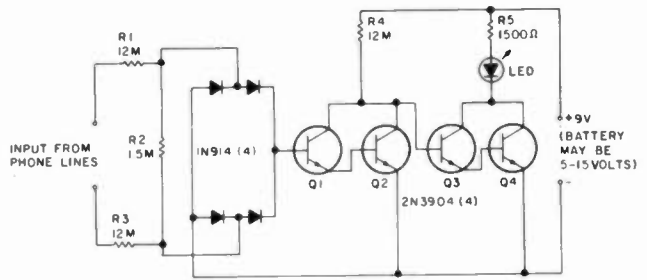

TELEPHONE OFF-HOOK INDICATOR: How many times have you started to dial a phone number only to find that the line was already in use? This visual indicator will signal when another person is dialing or talking on an extension and also provides a visual ring indicator. The LED flickers when the phone is ringing or being dialed. It glows steadily when the phone is off the hook. R1 and R2 isolate the system from the phone lines. They form a voltage divider with R3. The divider output feeds switch Q1-Q2. The switch senses less than 2 μ A which the system draws from the phone line. That small current drops about three volts across R2 which keeps Q2 turned on. That keeps the second switch, Q3-Q4, and the LED turned off. But when the phone is taken off the hook, the line voltage falls, Q1-Q2 turns off, and Q3-Q4 turns on and lights the LED. Voltage changes caused by ringing and dialing also affect the switching, causing the LED to flicker.—Evert Fruitman W7RXV, Phoenix AZ.

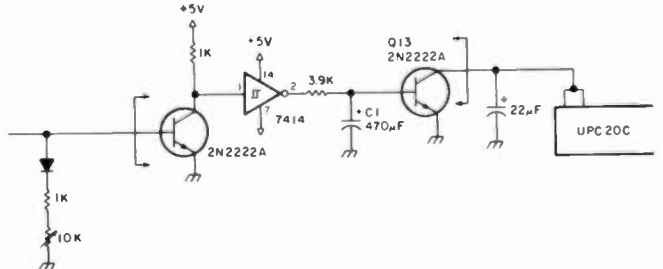

FAST-ATTACK SQUELCH: This circuit was designed to provide a high-performance squelch for a nearby repeater which uses an IC-22A as a receiver. The Schmitt trigger provides a little hysteresis where it takes more signal energy to open the squelch than it takes to close it. Replace Q13 with a 2N222A in a TO-18 package, and leave the base lead out of the circuit board so that a wire can be attached to it later. C1 must be greater than 100 μ F to eliminate popping noise around the squelch threshold, but the other parts values are not critical.—Robert C. Lee WB0UBL, North Liberty IA.

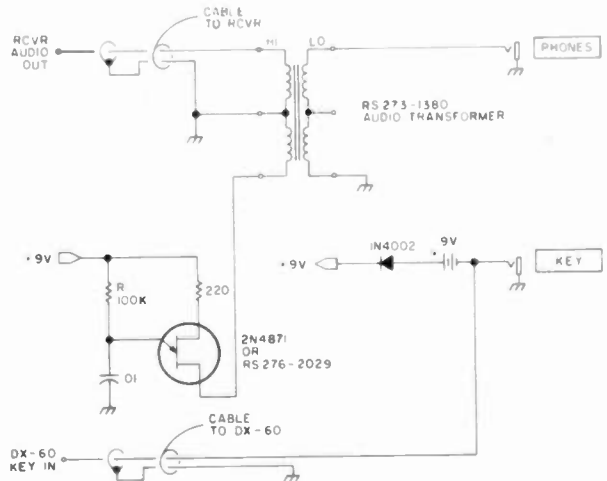

CW SIDETONE FOR THE DX-60: Here's a simple circuit which will work with any receiver and create a sidetone when you are keying the DX-60. Transformer T1 is an audio transformer. The unijunction transistor used as an oscillator may be any type; a 2N4871 or RS 276-2029 are good choices. Battery drain is practically nil, so a power switch is not needed, and you can change the pitch of the sidetone by changing the value of R.—Terry Simonds WB4FXD, Edgartown MA.

W2NSD/1 NEVER SAY DIE

editorial by Wayne Green

from page 6

nology, I'll let you know what's going on. In computers, the big push is for lap micros—the size of a ream of paper, but a lot lighter. This editorial is being written on a Tandy 100 lap computer.

The first system on the market along this line was the Sony Typecorder. But after almost a two-year lead on the field, Sony dropped the ball. An old CB manufacturing firm in Japan went the next step, producing the Tandy 100. This came out last spring, made by Kyocera.

Oddly enough, I described this computer in rather good detail when I gave a talk at the Atlanta Hamfest in 1976. Later that year, I went over the idea with K. Mishi, the editor of *I/O* magazine in Japan. He, I am told, worked with Kyocera on its development. My part has probably been forgotten by now, but then, I'm used to that. It was my idea for splitting channels onto videotape which brought the first breakthrough by Ampex back in 1948. I'm sure that my idea has been long forgotten, but it was the one thing they needed to get started with videotape. At the time, I was working as a television engineer for WPIX in New York. I attended a TV seminar and talked with the engineers at Ampex. They explained that they were only able to get part of the needed bandwidth on tape, so I suggested heterodyning the frequencies down to where they could be put on tape and then putting the frequencies back together again later. They tried it and soon after we had 2" videotape from Ampex. No one even said thanks.

The lap computer is going to be a very big business, with opportunities for small firms to develop accessories and software for them—thousands of firms. But the next step is one which should be duck soup for hams—getting rid of the umbilical cord so these small computers can access a nearby com-

puter system and use its storage, disks, and so on.

The next step, as I have written before, is a communications system which will allow all the desktop and lap computers to almost instantly communicate with each other. Something along the line of our repeater systems, which would receive messages, check them for errors and roger them, then pass them along to the addressee, complete with a return roger of the message receipt, is so obvious that it will have to happen.

In a few years, any of us who want to will be able to communicate with anyone anywhere from anywhere. It won't make any difference if I am walking along the street, shopping in Singapore, or in New Hampshire on a ski slope—I'll be able to type or talk a message and have it delivered in a second or two anywhere to anyone.

This is going to change business beyond recognition. It is going to have a profound effect on education. We can't even imagine what it will do for personal relationships. Oh, busy people will have to have filters built into the system. When my business was small I was available by phone at any time of the day or night. Today I'd be driven crazy with stockbrokers wanting to help me with my "portfolio" and investment counselors wanting to help me with my estate—not to mention people with investment ideas for my money and so on.

This communications demand is going to call for hundreds of thousands or even millions of technicians, engineers, and scientists to develop, manufacture, sell, install, operate, and service the systems it will take to do all this. It's mind-boggling in concept. We'll be using fiber optics, lasers, microwaves, satellites, and anything else we can invent to speed things up and make them less expensive. Amateurs are in a beautiful spot to get in on this bonanza. We can develop the

communications system to do these things on our ham bands and then get started with small businesses, taking advantage of what we've developed. Or, we can bicker over the Morse code, get into pileups fighting for DX, and jam nets. I'm not sure these activities are any more beneficial to the world—or to amateur radio—than sitting back with two six packs of 807s and watching football on television.

The potential is there. My magazines can help you take advantage of that potential. Indeed, it is as a direct result of the pressures at Dayton, where hundreds of hams pleaded for a good Commodore magazine, that we've launched *RUN*. The first issue is due out in December and it looks as if it will sell well over 100,000 copies right off the bat.

I have a bunch more magazines in various stages of getting started just in case you don't smoke and are interested in getting involved in high-tech publishing. Some are in computers, some aren't.

Speaking of new magazines, while in Munich for the huge systems show (24 big buildings full of computer exhibits), we had a launching party for *PC Welt*, a German version of our sister magazine, *PC World*. Then on to Tokyo for the Data Show and the launching of a PC magazine there. A day later in Singapore, at a third computer show, it was *Computerworld Asia* getting started. And finally, after flying around the world and covering 32,000 miles in ten days, Comdex in Amsterdam and the launching of *Micro/Info*, a Dutch micro magazine—an other associated publication of ours. Whew, what a trip!

With sunspots diminishing for several more years, DX is going to be harder to work and our higher bands are going to be of less interest. This seems like the ideal time for us to get cracking on new technologies—to experiment with new modes of communications and pioneer them.

Will we see automatic identification of rigs this year? It's certainly within our current level of technology to do this, complete with a reader on every receiver which will instantly read out the call of the received station—or even search for a desired station prefix.

With the development of pack-

et communications, we may start having automatic message handling. We could have done that thirty years ago when I first started working with digital communications on the ham bands, but our national organization has done little to encourage such changes—and much to discourage them.

I'll be continuing to get on 20m as much as I can—and 2m from the various cities I visit. Sure, I'll be at Dayton this year. I don't know which other hamfests I'll make as yet. I've gotten to a lot of shows in the last year—consumer electronics shows in Tokyo, Seoul, Taipei, Hong Kong, and Vegas—computer shows in Anaheim, Tokyo, Taipei, Singapore, Munich, Amsterdam, Atlanta, Boston, New York, and so on. This year I'll be hitting more hamfests—hope to see you.

INTERNATIONAL CORRESPONDENTS

First, I'd like to thank the hundreds of readers who have called or written to say that this feature is a favorite. We have 52 countries with correspondents and need more. I'll do what I can to find 'em as I travel, but you can help, too, by mentioning it over the air to some of the more interesting DX operators you get to know.

Some of the columnists have a tough job getting the information through—such as from Poland, for example. We really appreciate the job they're doing.

We have a truly international hobby and this column helps to bring us all together. We're interested in news of expeditions, special operations, certificates, how visitors can get permission to operate, how easy or difficult it is to get a license for locals, and so on.

With its international column, 73 has become the first international ham magazine.

PRICE INCREASE

With a substantial increase in the international distribution of 73—increased by 35,000 copies—we've had to increase the cover price from \$2.495 to \$2.50 so as not to drive foreign newsstands right out of their minds. We had enough trouble in America—worth every minute of it, by the way.

Speaking of DX, have you chosen a DX operator to send a subscription to?

BARTER 'N' BUY

73 CLASSIFIED ADVERTISING

RATES

Individual (non-commercial) 15¢ per word
 Commercial 50¢ per word

Prepayment by check or money order is required with your ad. No discounts or commissions are available. Please make your payment to 73. Rates for multiple insertions are available on request.

ADVERTISING COPY

Advertising must pertain to amateur radio products or services. No special layouts or positions are possible. All advertising copy must be submitted type-written (double-spaced) and must include full name and address. Copy limited to 100 words, maximum. Count only words in text. Address, free.

73 cannot verify advertising claims and cannot be held responsible for claims made by the advertiser. Liability will be limited to making any necessary correction in the next available issue. 73 reserves the right to reject any copy deemed unsuitable.

DEADLINES

Copy must be received in Peterborough by the 5th of the second month preceding the cover date. If copy is received after the deadline, it will be scheduled to run the following month, unless specifically prohibited by the advertiser.

MATERIALS

Send to Advertising Department, 73, Elm Street, Peterborough NH 03458.

WYOMING-UTAH RANCH LAND. 10 acres. \$60 down, \$60/month. FREE information, maps, photographs. Trade equity for ham gear, home computer, test equipment, etc. Owner—Mike Gauthier K6ICS, 9550-B—Gallatin Rd., Downey CA 90240. BNB001

QSL MANAGER ALBUM™. Beautiful leather-grained vinyl ring binder for displaying 240 of your prized QSL cards. 30-day guarantee. \$18.95 ppd or send stamp for flyer. Walter Beaton WD8DVC, 3780 Cecilia Ave., Cleveland OH 44109. BNB009

SATELLITES

Amateur Satellite Reference Orbits

Date	OSCAR 8		RS-5		RS-6		RS-7		RS-8		Date
	UTC	EQX	UTC	EQX	UTC	EQX	UTC	EQX	UTC	EQX	
Jan 1	0014	94	0001	226	0122	253	0000	229	0124	245	1
2	0018	95	0155	257	0107	251	0149	258	0121	246	2
3	0022	96	0150	257	0052	249	0140	257	0118	246	3
4	0027	97	0145	257	0036	247	0130	256	0115	247	4
5	0031	98	0139	257	0021	244	0120	255	0112	248	5
6	0035	100	0134	257	0005	242	0111	254	0109	249	6
7	0040	101	0129	257	0149	269	0101	253	0107	250	7
8	0044	102	0123	258	0133	267	0052	252	0104	250	8
9	0048	103	0118	258	0118	265	0042	252	0101	251	9
10	0053	104	0113	258	0102	262	0032	251	0058	252	10
11	0057	105	0107	258	0047	260	0023	250	0055	253	11
12	0101	106	0102	258	0032	258	0013	249	0052	254	12
13	0106	107	0057	259	0016	255	0003	248	0050	255	13
14	0110	109	0051	259	0001	253	0153	277	0047	255	14
15	0114	110	0046	259	0144	280	0143	276	0044	256	15
16	0119	111	0041	259	0129	278	0133	275	0041	257	16
17	0123	112	0035	259	0113	276	0124	274	0038	258	17
18	0127	113	0030	260	0058	274	0114	273	0035	259	18
19	0132	114	0024	260	0042	271	0104	273	0033	259	19
20	0136	115	0019	260	0027	269	0055	272	0030	260	20
21	0140	116	0014	260	0012	267	0045	271	0027	261	21
22	0002	92	0008	260	0155	294	0036	270	0024	262	22
23	0006	93	0003	261	0140	292	0026	269	0021	263	23
24	0010	94	0157	291	0124	289	0016	268	0018	263	24
25	0015	95	0152	291	0109	287	0007	267	0016	264	25
26	0019	96	0147	291	0053	285	0156	296	0013	265	26
27	0023	97	0141	291	0038	282	0146	295	0010	266	27
28	0028	98	0136	291	0022	280	0137	294	0007	267	28
29	0032	99	0131	292	0007	278	0127	294	0004	268	29
30	0036	101	0125	292	0150	305	0117	293	0001	268	30
31	0041	102	0120	292	0135	303	0108	292	0158	299	31
Feb 1	0045	103	0115	292	0120	300	0058	291	0156	300	1
2	0049	104	0109	292	0104	298	0048	290	0153	301	2
3	0054	105	0104	293	0049	296	0039	289	0150	302	3
4	0058	106	0059	293	0033	294	0029	288	0147	303	4
5	0102	107	0053	293	0018	291	0020	287	0144	303	5
6	0107	108	0048	293	0003	289	0010	286	0141	304	6
7	0111	110	0043	293	0146	316	0000	286	0139	305	7
8	0115	111	0037	294	0130	314	0150	315	0136	306	8
9	0120	112	0032	294	0115	312	0140	314	0133	307	9
10	0124	113	0027	294	0100	309	0130	313	0130	307	10
11	0128	114	0021	294	0044	307	0121	312	0127	308	11
12	0133	115	0016	294	0029	305	0111	311	0124	309	12

See List of Advertisers on page 114

MOBILE IGNITION SHIELDING. Free literature. Estes Engineering, 930 Marine Drive, Port Angeles WA 98362. BNB006

DEALERS IN SURPLUS test instruments, microwave equipment, and components. **WANTED:** late test equipment (H.P., TEK, G.R., Narda, etc.), waveguide diagonal coax components. Immediate needs: H.P. K382A, R382A, S382C, 432A; G.R. 874 and 900-series coax items. Request want list. ELECTRONICS, 1423 Ferry Avenue, Camden NJ 08104. Telephone (609)541-4200. BNB015

WANTED: Early telegraph instruments for my collection. Keys, sounders, call boxes, registers, meters, and related items including pre-1910 paper. Larry Nutting WD6DTC, 5957 Yerba Buena, Santa Rosa CA 95405. BNB018

COLOR COMPUTER owners—call (212) 441-2807 for FREE color computer hardware and software catalog or write to Spectrum Projects, 93-15 86 Drive, Woodhaven NY 11421. BNB023

FOURTH ANNUAL Ohio State Convention and Flea Market: Join in the even bigger "Cincinnati ARR L '84," February 25 and 26. Activities for hams and electronics enthusiasts: forums, meetings, vendors, Wouff Hong, women's activities, banquet, hospitality suite, more. Sure cure for "cabin fever." Hospitality suite Friday and Saturday nights. The \$5 convention registration includes all convention awards. Flea market is \$4/space for two days—ham and electronics items, only. Write: Cincinnati ARR L '84, POB 11300, Cincinnati OH 45211 or telephone (513) 825-8234. Vendor and exhibitor inquiries invited. BNB024

KENWOOD 7625 2-meter transceiver, synthesized/memory, 25 Watts, \$135. Kenwood TS-130V, \$75. Turner Plus Two amplified mike, \$35. D-104 amplified mike, \$35; unamplified, \$25. Vista IV 4-Amp unregulated 12-volt power supply, \$16. Earl W. Long KA0MOE, Box 955, Joplin MO 64802-0955. No telephone calls please. BNB025

FREE SAMPLE—send stamp. Buy/sell radio, computer equipment in "Electronic Exchange," Box 486E, Forest Lake MN 55025. BNB026

CABLE, CONNECTORS, Fittings, 50 & 75 Ohms. Bought storage room full new ham/cable TV hardware. Send SASE & \$50 for big list. Pete WB3BQO, 329 Little Ave., Ridgway PA 15853. BNB027

DXERS—DX headings centered on YOUR QTH. \$3.00 pp. KENTRONICS, PO Box 586, Vernon AL 35592. BNB028

AZDEN SERVICE MANUALS, PCS 3000 and PCS 300—\$5.00 each; PCS 4000—\$9.00. N.P.S., 1138 Boxwood, Jenkintown PA 19046. BNB029

WANTED: Cash paid for used SPEED RADAR EQUIPMENT. Write or call: Brian R. Esterman, PO Box 8141, Northfield IL 60093; (312)251-8901. BNB030

MILITARY RADIO GEAR turns me on—I particularly crave more German, Japanese WW2 gear, UK sets, type #18, 21, 22, 48, Canadian RCAF AR-6, other non-US items. Also US types GRC-109, PRC-1 through 5, RAX, RBD, RBM, TRC-2, 10, others through 1950s, except post-1945 FM/VHF. I collect/restore/operate this vintage gear, so please dig out those dusty green and black boxes, accessories, manuals, etc. Tnx! Hugh Miller KA7LXY, 11206-1 NE, Seattle WA 98125. BNB031

RTTY FDM DEMODULATORS. FDM RTTY exists on satellites. FM SCA broadcast subcarriers (e.g., Commodity News Service), and HF radio. Four solid-state synthesized models, NSA surplus, new-used, \$50 to \$350. Call/write for brochure. Electrovalue Industrial, Inc., Box 376-WF, Morris Plains NJ 07950; (201)267-1117. BNB032

PALOMAR ELECTRONICS CORPORATION EQUIPMENT REPAIR—2 techs, factory-trained. FCC-licensed, experienced, professional. Also available—Palomar equipment service manual—covers over 30 models. Communications Service, PO Box 3262, Escondido CA 92025. BNB033

ATLAS RADIO REPAIR—Specializing in the 180-210x-215x. Factory-trained, fast, experienced, reasonable. Payne Communications, PO Box 977, Vista CA 92083. BNB034

RTTY FOR THE T199/4a. Mini-memory required. Mark and space tones are internally generated in send mode. TU is needed for receive only. \$17.95. Mark Schmidt, 4661 Lark Dr., Beale AFB CA 95903. BNB035

PSST! HEY, wanna make professional-quality printed circuit boards? One or more in only 60 minutes. Simple, inexpensive, new system. Free 1984 catalog. PINCOR, 530 Palace, Aurora IL 60506; (312)896-0015. BNB036



ROYAL

CONTACT-80 MARK-II TRS-80 MOD. III-IV

"RTTY your TRS-80 with CONTACT-80!"

SOFTWARE FEATURES, DISK & CASSETTE VERSIONS: BAUDOT-ASCII-MORSE • Morse AUTOSYNC, FIST-FIXER • TRI-SPLIT screen • "Unlimited" STORED MSG sizes • AUTO BUFFER ALLOCATION • HARD-COPY • AUTO-ID'ing • TIME/DATED X-missions • NAME-LINE • AUTO DIDDLE • Scrn COUNTERS-CLOCK-OSCILLOSCOPE • CLOCK KEYING • K/B ROLL-OVER-REPEATING KEYS • Fast flexible I/O • Full EDITING using "word processing techniques".

ADDITIONAL DISK VERSION FEATURES: SAVE-LOAD-KILL-DIR • AUTO-MONITOR • File REVIEW 2-way MSG SELCALL, a "PERSONAL MSO" • AUTO-LOAD.

With CONTACT-80 INTERFACE (1-KHz CW Tone DECODER, mates with any stand-alone TTY Terminal Unit.) \$199

With MFJ-1224 RTTY/CW COMPUTER INTERFACE, P/S and Royal MFJ ADAPTER. **A COMPLETE FULL FEATURE SYSTEM!** \$239 Guaranteed • Include Amateur CALLSIGN • POST PAID

ROYAL, 407 Conkle Rd., Hampton, GA 30228 ✓ 150 Tel. (404)946-9314

MASTER MORSE CODE IN DAYS

No other company dares tie such a claim to a complete money back guarantee! How can we keep doing it year after year?

BECAUSE IT WORKS!

Ask any of the more than 1000 CODE QUICK hams—from novice to extra—they will tell you how CODE QUICK worked for them. Scores write us, "Thanks for CODE QUICK—if only I had known about it when I started..."

Designed by a Doctor of Education, CODE QUICK is an amazing breakthrough. It trades dead end conventional methods for the thrill of virtual overnight success. Instead of a confusing maze of dits and dahs, each letter begins to call out its own name—like magic! Your growth will amaze everyone!

Don't delay another day! Send \$39.95 for five power-packed cassettes, visual impact cards, and original guide in a beautiful vinyl case. Completion qualifies you for a free upgrade bonus including FCC type code tests.

Full cash refund if you don't master code much faster than you dream possible!

Always shipped in 24 hours. Calif. add 6% sales tax.

Order Today or Free Details from:
Wheeler Applied Research Lab
1608 Nogales St., Suite 235
Rowland Heights, CA 91748



THE
BEST PLACE
To Look For
New & Used
Equipment
Buy-Sell-Trade
Our 4th Year

NUTS & VOLTS MAGAZINE

PO BOX 1111-G • PLACENTIA, CA 92670
(714) 632-7721 ✓137

JOIN THOUSANDS OF READERS
NATIONWIDE, EVERY MONTH

U.S.A. SUBSCRIPTIONS

\$ 7.00 - 1 YR. 3RD CLASS MAIL

\$12.50 - 1 YR. 1ST CLASS MAIL

\$25.00 - LIFETIME - 3RD CLASS



With Free Classified Ad



PRECISION PROCESSING



The E-CLIPS Model III

Provides total dynamic range control
with very low distortion

- Selectable processing modes—envelope compression or peak limiting
- Variable high and low frequency response equalization
- Five segment LED display
- Easy to install and use with any transmitter/transceiver

Introductory price—\$189.95 ppd.

For brochure with complete technical specifications contact:

ANALOG TECHNOLOGY

P.O. Box 8964 • Fort Collins, CO 80525 ✓109

FREE CATALOG



NEW!
CATALOG OF
HARD-TO-FIND
PRECISION TOOLS

✓354

Also contains test equipment
plus wide selection of
tool kits and cases

Jensen's new catalog is jam-packed with more than 2000 quality items. Your single source for hard-to-find precision tools and tool kits used by electronic technicians, scientists, engineers, instrument mechanics, schools, laboratories and government agencies. Send for your free copy today!



JENSEN TOOLS INC.

7815 S. 46TH STREET PHOENIX, AZ 85040

NEW! CW & RTTY SOFTWARE

Send and receive CW or RTTY with my programs and your Model I, III, or IV TRS-80 computer. **NO HARDWARE OR TUNING IS REQUIRED!** All I/O is done via the cassette ports and cable. Get great results! Order from Gary Woodall, WD9ECD. Model I or III CW is \$24.95, Model III RTTY is \$34.95. Please add \$2.50 handling on each order.

WOODALL & ASSOCIATES

P.O. BOX 284

Plainfield, IN 46168

(317) 271-2565 (Mon-Sat)



✓107

this publication
is available in
microform

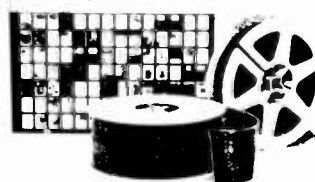

University Microfilms International

300 North Zeeb Road
Dept. P.R.
Ann Arbor, MI 48106
U.S.A.

18 Bedford Row
Dept. P.R.
London, WC1R 4EJ
England

NEW! MULTI-CHANNEL MICROWAVE

Complete Antenna Systems from \$69⁹⁵

Full 800 Mhz Range
Tune 1.9-2.7 Ghz
Includes all
ITFS Channels

DEALERS WANTED

COO's and Credit Card
Orders call TOLL FREE
1-800-247-1151

GALAXY ✓178
ELECTRONICS
6009 N. 61 Avenue
Glendale, AZ 85301
1-602-247-1151

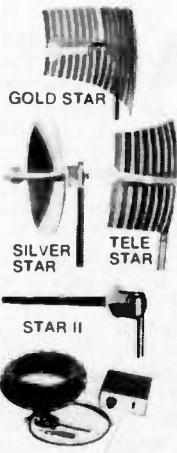

New Life for Tired Receivers



Lunar's line of RF actuated in-line receiving preamplifiers can spark up that otherwise dead band. Missing those weak ones? Become an elephant with new ears. Models available from 28-220 MHz bands. Simply insert between your transceiver and antenna, apply 12 VDC and enjoy. Standard SO-239 connectors on RF ports - BNC available. Typical performance at 144 MHz: 1.4 dB NF 10 dB gain. Low noise performance from Lunar - simply, the best.

LUNAR
electronics

2775 Kurtz Street, Suite 11
San Diego, Ca 92110
(619) 299-9740 • Telex 181747

✓220

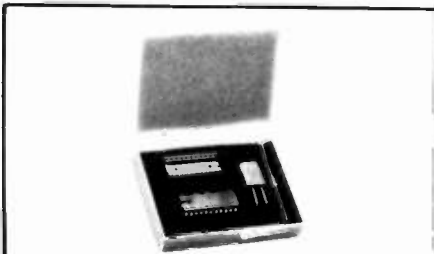

New CMOS DTMF Chip Kit

Teltone's TRK-957 Kit makes it easier and less expensive to breadboard a low-power, central office quality DTMF detection system. All you need is a power source from 5 to 12 VDC. The sensitivity, wide dynamic range, noise immunity, and low-power consumption make the TRK-957 ideal for telephone switching, computer, and remote control applications. The TRK-957 DTMF Kit is only \$24.75. To order call:

(800) 227-3800, ext. 1130.

TELTONE

✓224

ANNOUNCING 73 CLASSIFIEDS
BARTER 'N' BUY

Beginning with the December Issue, 73 will accept classified advertising. Individual and non-commercial rates—15¢ per word; commercial rates—50¢ per word; prepaid by check or money order. Ads must pertain to amateur radio products or services, and must be submitted typewritten, double-spaced, 100 words maximum. Include full name and address in ad; telephone number optional. Copy must be received in Peterborough by the 5th of the second month preceding cover date. Example: December issue ad must be in our hands by October 5th. Ads received after deadline will be run in the next issue. Direct all material and inquiries to:

BARTER 'N' BUY
73 ADVERTISING DEPARTMENT
Elm Street, Peterborough,
New Hampshire 03458.
Telephone: (603) 924-7138

N8BKR Introduces the...
E Field Displacement Antenna

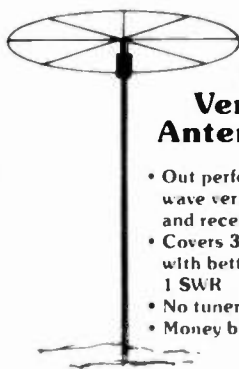

**A 16 Ft.
80 Meter
Vertical
Antenna**

- Out performs any 60 ft. 1/4 wave vertical on transmit and receive
- Covers 3.5 to 4.0 MHz with better than 1.5 to 1 SWR
- No tuner needed
- Money back guarantee

Send S.A.S.E. for more information to:

MOLER ANTENNA CORP.
2623 Morris Lane • Girard, OH 44420
(216) 530-2059

Free Tool Catalog

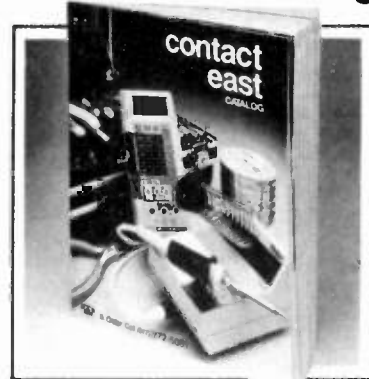

Thousands of hard-to-find products for building, testing, and repairing electronics. Everything is easy to order by phone or mail, ready for immediate delivery. **Contact East—Dept. 0235**
7 Cypress Drive, Burlington, MA 01803
In a hurry to receive your catalog?
Call (617) 272-5051.

**Subscription
Problem?**

73 does not keep subscription records on the premises, therefore calling us only adds time and doesn't solve the problem.

Please send a description of the problem and your most recent address label to:

73 Amateur Radio's
Technical Journal

Subscription Dept.
PO Box 931
Farmingdale, NY 11737

WARC for FT-101/901

Modernize any model of the original FT-101 Series by adding all three WARC bands for RX and TX!

- Use 10 MHz now; be ready for the others.
 - Increase resale value of your rig.
 - Easy installation, detailed instructions.
 - Includes all crystals, relays, etc.
 - Tested, fool-proof design for all but 'ZD.
- FT-101 WARC Kit #4N **ONLY \$25.**
FT-901 WARC Kit #4J (30M only) **ONLY \$10.**
Shipping \$3 (Air \$5). Florida sales tax 5%.

GO FOX TANGO — TO BE SURE!



Order by Mail
or Telephone

For other great Yaesu modifications get the top-rated FT Newsletter. Still only \$8 per calendar year (US), \$9 Canada, \$12 Overseas.

FOX TANGO CORPORATION

Box 15944S • W. Palm Beach, FL 33416
(305) 683-9587

**RADIO
DIRECTION FINDER**
The SuperDF

Inexpensive kit and assembled units for use with Hand-Held, Mobile, or Base Station. 100 to 260 MHz or 200 to 550 MHz with one antenna. Non-ambiguous. No overloading. Use with unmodified HT, scanner, or transceiver. No attenuator or "S" meter needed. Can DF signals below the noise. Averages out local reflections while mobile-in-motion. Used by FCC, US Army, State of California, Coast Guard Aux. Prices start at \$125. For details send SASE to: **BMG Engineering, 9935 East Garibaldi, Temple City, Cal. 91780.**

YOU EARNED YOUR CALL!

NOW DISPLAY IT PROUDLY
IN A TOP QUALITY
LACOSTE-TYPE KNIT SHIRT.

ONLY \$14.00 With your call in rich embroidery.

\$1.50 extra for first name. Choose from 10 great colors: rust, cream, brown, green, yellow, navy, lt. blue, aqua, white, and black.

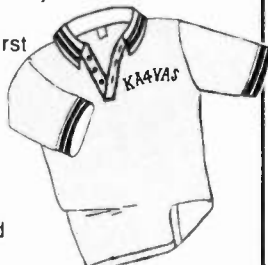

Adult sizes only S-M-L-XL Club and dealer inquiries invited. Please add \$2.00 for P/H. Make check or money order payable to:

Coin Int'l Inc.
7861 SW 53rd Ave.
Miami, FL 33143
(305) 662-6900



13

Allow 4 weeks for delivery. Fl. residents add sales tax

CIRCUIT BOARD SALE

RS-232C Serial Line Monitor LED Indicators show activity and polarity of the 7 most common signals. DB-25 male and female connectors mount directly on circuit board to form a compact 2" x 3" unit. Mounts in series with your RS-232C cable. Kit includes all parts, directions and tips for use. Commercial quality, double-sided fiberglass board with plated through holes. Assembled and tested (SLM-1) 29.95
Kit (SLM-1K) 21.95
Board only (SLM-1NB) 6.95

Power Supply Board Provides +5, +12 and -12 volts at 1 amp for your ham radio project. Uses 78xx series positive voltage regulators. Needs 2 transformer windings, 18-24 volts (1 center tapped). 3.50" x 4.50" Assembled and Tested (PS-1) 21.95
Kit (Less Xfms) (PS-1K) 16.95
Board only (PS-1NB) 4.95

STD Bus Mother board Single-sided fiberglass mother board. An excellent foundation for your STD bus computer. Mounts 12 of our 56 pin connectors. Provide your own card cage and save hundreds of dollars. 3.80" x 7.80" Mother Board (MB-1) 15.95
Connectors (C56-125-ST) 3.00
MB-1 and 12 connectors (MB-SPC) 45.00

Please add \$2.00 per order shipping and handling. CA residents include tax.

Esoteric Engineering Incorporated
PO Box 33692, San Diego, CA 92193
(619) 569-7868

UHF POWER AMP

AM-6155/GRT (ITT 3212) 225-400 Mhz RF amp,



50W output from 4-10W input using Elmac X651Z; silver-plated cavity in removable drawer. Requires 115/230 VAC & 20 VDC. 7x19 1/2x18" 75 lbs. sh. Used-not tested, excellent condition: **\$149.50**

R-392 RECEIVER, 0.5-32 Mhz AM-CW in 32 bands; mechanical digital tuning. 2-4-8 KHz bandwidth; 100 KHz calibrator. 25 tubes; requires 24 VDC 5 amps. 11 1/2x14 1/2x11", 60 lbs. sh. Used-repairable, **\$135**. Chkd., **\$200**. Manual, partial repro: **\$15**. LS-166 speaker, **\$10.95**. 24 VDC 6 AMP Supply, for R-392 — no connector, used: **\$25**.

TEKTRONIX 516 DUAL TRACE SCOPE, DC-15 Mhz response with 5" CRT. Sensitivity 0.05-20 v/div and Sweep 0.2 usec-2 sec/div calibrated; Square-wave Calibrator 0.05-100 volts. Requires 115 VAC 60 Hz. 13 1/2x9 3/4x21 1/2", 50 lbs. sh. Used-repairable **\$165**. Checked **\$225**. Prices F.O.B. Lima, O. • VISA, MASTERCARD Accepted. Allow for Shipping • Send for New FREE CATALOG '83 Address Dept. 73 • Phone: 419/227-6573

FAIR RADIO SALES ✓22
1016 E. EUREKA • Box 1105 • LIMA, OHIO • 45802



EIMAC 4CX10,000D/8171 with SK300 and SK1306 . \$1200.00
 SK300 and SK1306 Only. \$ 350.00
 (These are all new not used.) Limited Supply.

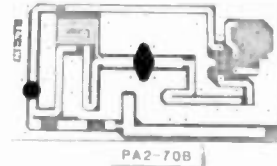
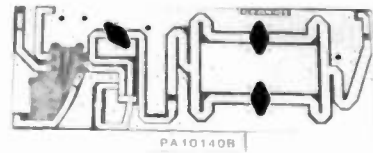

KJM ELECTRONICS, INC. VHF AMPLIFIER PC BOARDS AND RF TRANSISTOR KITS.
 Model PA2-70B RF power Input 2watts at 144 to 148MHz output 70watts 13.5vdc at 10amps.
 \$49.99 with data PC Board Only \$14.99
 MODEL PA10140B RF power Input 10watts at 144 to 148MHz output 140watts 13.5vdc at 18amps.
 \$89.99 with data PC Board Only \$19.99

GENEVA CALCULATOR WATCH

This attractive watch has the following modes:
 Normal Time Setting,
 Calendar Setting,
 Daily Alarm Time Setting,
 Weekly Alarm Time Setting,
 Chronograph,
 Calculator.



Featured in Black Plastic \$18.99 or Featured in Stainless Steel \$29.99

SILICON DIODES

MR751	100vdc	6Amps	10/\$5.00	100/\$38.00
MR510	1000vdc	3Amps	10/\$3.75	100/\$24.00
HEP170	1000vdc	2Amps	20/\$2.00	100/\$15.00
1N3209	100vdc	15Amps	\$2.00	10/ \$15.00
BYX21/200	200vdc	25Amps	\$2.00	10/ \$15.00
1N2138A	600vdc	60Amps	\$5.00	10/ \$40.00
DS85-04C	400vdc	80Amps	\$10.00	10/ \$80.00
1N3269	600vdc	160Amps	\$15.00	10/\$120.00
275241	300vdc	250Amps	\$20.00	10/\$175.00
7-5754	300vdc	400Amps	\$30.00	10/\$250.00
RCD-15	15KVDC	20ma.	\$3.00	10/ \$20.00
SMFR20K	20KVDC	20ma.	\$4.00	10/ \$30.00
1N4148	signal		30/\$1.00	100/ \$3.00

FEED THRU SOLDER RF CAPACTORS

470pf +-20%
5/\$1.00 or 100/\$15.00 or 1000/\$100.00
1000pf/.001uf +-10%
4/\$1.00 or 100/\$20.00 or 1000/\$150.00

E PROMS

2708 1024x1	\$2.00 each
2716 2048x8	\$4.00 each
27L32/25L32	\$10.00 each

FAIRCHILD 4116 16K DYNAMIC RAMS 200ns. Part # 16K75

25 For \$25.00 or 100 For \$90.00 or 1000 For \$750.00

HEWLETT PACKARD MICROWAVE DIODES

1N5711	(5082-2800)	Schottky Barrier Diodes	\$1.00 or 10 for \$ 8.50
1N5712	(5082-2810)	" " "	\$1.50 or 10 for \$10.00
1N6263	(HSCH-1001)	" " "	\$.75 or 10 for \$ 5.00
5082-2835		" " "	\$1.50 or 10 for \$10.00
5082-2805	Quad Matched	" " "	per set \$5.00 or 10 for \$40.00

For information call: (602) 242-3037

Toll Free Number
 800-528-0180
 (For orders only)

MHz electronics

"All parts may be new or surplus, and parts may be substituted with comparable parts if we are out of stock of an item."

PRICES SUBJECT TO CHANGE WITHOUT NOTICE

"MIXERS"

WATKINS JOHNSON WJ-M6 Double Balanced Mixer

LO and RF 0.2 to 300MHz	IF DC to 300MHz	\$21.00
Conversion Loss (SSB)	6.5dB Max. 1 to 50MHz	
Noise Figure (SSB)	8.5dB Max. .2 to 300MHz	WITH DATA SHEET
Conversion Compression	same as above	
	8.5dB Max. 50 to 300MHz	
	.3dB Typ.	

NEC (NIPPON ELECTRIC CO. LTD. NE57835/2SC2150 Microwave Transistor

NF Min F=2GHz	dB 2.4 Typ.	MAG F=2GHz	dB 12 Typ.	\$5.30
F=3GHz	dB 3.4 Typ.	F=3GHz	dB 9 Typ.	
F=4GHz	dB 4.3 Typ.	F=4GHz	dB 6.5 Typ.	

Ft Gain Bandwidth Product at Vce=8v, Ic=10ma. GHz 4 Min. 6 Typ.
 Vcbo 25v Vceo 11v Vebo 3v Ic 50ma. Pt. 250mw

UNELCO RF Power and Linear Amplifier Capacitors

These are the famous capacitors used by all the RF Power and Linear Amplifier manufacturers, and described in the RF Data Book.

5pf	10pf	18pf	30pf	43pf	100pf	200pf	1 to 10pcs.	\$1.00 ea
5.1pf	12pf	22pf	32pf	51pf	110pf	220pf	11 to 50pcs.	\$.90 ea
6.8pf	13pf	25pf	33pf	60pf	120pf	470pf	51 up pcs.	\$.80 ea
7pf	14pf	27pf	34pf	80pf	130pf	500pf		
8.2pf	15pf	27.5pf	40pf	82pf	140pf	1000pf		

NIPPON ELECTRIC COMPANY TUNNEL DIODES

		MODEL 1S2199	1S2200	\$7.50
Peak Pt. Current ma.	Ip	9min. 10Typ. 11max.	9min. 10Typ. 11max.	
Valley Pt. Current ma.	Iv	1.2Typ. 1.5max.	1.2Typ. 1.5max.	
Peak Pt. Voltage mv.	Vp	95Typ. 120max.	75Typ. 90max.	
Projected Peak Pt. Voltage mv.	Vpp Vf=Ip	480min. 550Typ. 630max.	440min. 520Typ. 600max.	
Series Res. Ohms	rS	2.5Typ. 4max.	2Typ. 3max.	
Terminal Cap. pf.	Ct	1.7Typ. 2max.	5Typ. 8max.	
Valley Pt. Voltage mv.	VV	370Typ.	350Typ.	

FAIRCHILD / DUMONT Oscilloscope Probes Model 4290B

Input Impedance 10 meg., Input Capacity 6.5 to 12pf., Division Ratio (Volts/Div Factor) 10:1, Cable Length 4Ft., Frequency Range Over 100MHz.

These Probes will work on all Tektronix, Hewlett Packard, and other Oscilloscopes.

PRICE \$45.00

MOTOROLA RF DATA BOOK

Lists all Motorola RF Transistors / RF Power Amplifiers, Varactor Diodes and much much more.

PRICE \$7.50

For information call: (602) 242-3037

Toll Free Number
800-528-0180
(For orders only)

MHz electronics

"All parts may be new or surplus, and parts may be substituted with comparable parts if we are out of stock of an item."

PRICES SUBJECT TO CHANGE WITHOUT NOTICE

RF TRANSISTORS, MICROWAVE DIODES

TYPE	PRICE	TYPE	PRICE	TYPE	PRICE	TYPE	PRICE
2N1561	\$ 25.00	2SC1678	\$ 2.00	M1134	\$ 16.90	MSC1821-3	\$125.00
2N1562	25.00	2SC1729	20.00	M9579	7.95	MSC1821-10	225.00
2N1692	25.00	2SC1760	1.50	M9588	7.50	MSC2001	40.00
2N2957	1.55	2SC1909	4.00	M9622	7.95	MSC2223-10	200.00
2N2857JANTX	4.10	2SC1946	36.00	M9623	9.95	MSC3000	50.00
2N2857JANTXV	4.10	2SC1946A	40.00	M9624	11.95	MSC3001	50.00
2N2876	13.50	2SC1970	2.50	M9625	17.95	MSC73001	50.00
2N2947	18.35	2SC1974	4.00	M9630	18.00	MSC82001	40.00
2N2948	13.00	2SC2166	5.50	M9740	29.90	MSC82014	40.00
2N2949	15.50	2SC2237	32.00	M9741	29.90	MSC82020	40.00
2N3375	17.10	2SC2695	47.00	M9755	19.50	MSC82030	40.00
2N3553	1.55	A50-12	25.00	M9848	37.00	MSC83001	50.00
2N3632	15.50	A209	10.00	M9850	16.90	MSC83005	100.00
2N3733	11.00	A283	5.00	M9851	20.00	MT4150	14.40
2N3818	5.00	A283B	6.00	M9887	5.25	MT5126	POR
2N3866	1.30	AF102	2.50	MEL80091	25.00	MT5596/2N5596	99.00
2N3866JAN	2.20	AFY12	2.50	MM1550	10.00	MT5768/2N5768	95.00
2N3924	3.35	BF272A	2.50	MM1552	50.00	MT8762	POR
2N3927	17.25	BFR21	2.50	MM1553	50.00	NB02136	2.50
2N3950	25.00	BFR90	1.00	MM1614	10.00	NE13783	POR
2N4012	11.00	BFR91	1.65	MM1943/2N4072	1.80	NE21889	POR
2N4041	14.00	BFR99	2.50	MM2608	5.00	NE57835	5.70
2N4072	1.80	BFT12	2.50	MM3375A	17.10	NE73436	2.50
2N4080	4.53	BFW16A	2.50	MM4429	10.00	TRW	
2N4127	21.00	BFW17	2.50	MM8000	1.15	PR78637	POR
2N4427	1.30	BFW92	1.50	MM8006	2.30	PT3190	POR
2N4428	1.85	BFX44	2.50	MM8011	25.00	PT3194	POR
2N4430	11.80	BFX48	2.50	MPP102	.45	PT3195	POR
2N4957	3.45	BFX65	2.50	MPSU31	1.01	PT3537	7.80
2N4959	2.30	BFX84	2.50	MRA2023-1.5	42.50	PT4166E	POR
2N5090	13.80	BFX85	2.50	MR208	16.10	PT4176D	POR
2N5108	3.45	BFX86	2.50	MR212	16.10	PT4186B	POR
2N5109	1.70	BFX89	1.00	MR223	13.25	PT4209	POR
2N5160	3.45	BFY11	2.50	MR224	15.50	PT4209C/5645	POR
2N5177	21.62	BFY18	2.50	MR231	10.92	PT4556	24.60
2N5179	1.04	BFY19	2.50	MR232	12.07	PT4570	7.50
2N5216	56.00	BFY39	2.50	MR233	12.65	PT4577	POR
2N5583	3.45	BFY90	1.00	MR237	3.15	PT4590	POR
2N5589	9.77	BLX67	15.24	MR238	13.80	PT4612	POR
2N5590	10.92	BLX68C3	15.24	MR239	17.25	PT4628	POR
2N5591	13.80	BLX93C3	22.21	MR245	35.65	PT4640	POR
2N5637	15.50	BLX87A	8.94	MR247	35.65	PT4642	POR
2N5641	12.42	BLX88C3	13.08	MR304	43.45	PT5632	4.70
2N5642	14.03	BLY94C	21.30	MR309	33.81	PT5749	POR
2N5643	15.50	BLY351	10.00	MR314	28.52	PT6629	POR
2N5645	13.80	BLY568C/CF	30.00	MR315	28.86	PT6709	POR
2N5646	20.70	C458-617	25.00	MR316	POR	PT6720	POR
2N5651	11.05	C4005	20.00	MR317	63.94	PT8510	POR
2N5691	18.00	CD1899	20.00	MR420	20.00	PT8524	POR
2N5764	27.00	CD2188	18.00	MR421	36.80	PT8609	POR
2N5836	3.45	CD2545	25.00	MR422A	41.40	PT8633	POR
2N5842/MM1607	8.45	CTC3005	100.00	MR427	17.25	PT8639	POR
2N5849	20.00	<u>Dexcel GaAs FET</u>		MR428	46.00	PT8659	POR
2N5913	3.25	<u>DXL3501A-PT00F</u>	49.30	MR433	12.07	PT8679	POR
2N5916	36.00	<u>Fujitsu GaAs FET</u>		MR449/A	12.65	PT8708	POR
2N5922	10.00	FSX52WF	58.00	MR450/A	14.37	PT8709	POR
2N5923	25.00	GMO290A	2.50	MR453/A	18.40	PT8727	29.00
2N5941	23.00	HEP76	4.95	MR454/A	20.12	PT8731	POR
2N5942	40.00	HEPS3002	11.40	MR455/A	16.00	PT8742	19.10
2N5944	10.35	HEPS3003	30.00	MR458	20.70	PT8787	POR
2N5945	11.50	HEPS3005	10.00	MR463	25.00	PT9783	16.50
2N5946	14.40	HEPS3006	19.90	MR472	1.00	PT9784	32.70
2N6080	10.35	HEPS3007	25.00	MR475	3.10	PT9790	56.00
2N6081	12.07	HEPS3010	11.34	MR476	2.00	PT31962	POR
2N6082	12.65	<u>Hewlett Packard</u>		MR477	14.95	PT31963	POR
2N6083	13.25	IFET2204	112.00	MR492	23.00	PT31083	POR
2N6084	15.00	35821E	38.00	MR502	1.04	PTX6680	POR
2N6094	11.00	35826B	32.00	MR503	6.00	RCA	
2N6095	12.00	35826E	32.00	MR504	7.00	40081	5.00
2N6096	16.10	35831E-H31	30.00	MR509	5.00	40279	10.00
2N6097	20.70	35831E	30.00	MR511	10.69	40280	4.62
2N6105	21.00	35832E	50.00	MR515	2.00	40281	10.00
2N6136	21.85	35833E	50.00	MR517	2.00	40282	20.00
2N6166	40.24	35853E	71.50	MR559	2.05	40290	2.80
2N6201	50.00	35854E	75.00	MR605	20.00	40292	13.05
2N6304	1.50	35866E	44.00	MR618	25.00	40294	2.50
2N6459	18.00	HXTR3101	7.00	MR628	8.65	40341	21.00
2N6567	10.06	HXTR3102	8.75	MR629	3.45	40608	2.48
2N6680	80.00	HXTR5104	30.00	MR644	27.60	40894	1.00
2SC703	3.00	HXTR6104	68.00	MR646	29.90	40977	10.00
2SC756A	7.50	HXTR6105	31.00	MRP816	15.00	62800A	60.00
2SC781	2.80	HXTR6106	33.00	MRP823	20.00	RE3754	25.00
2SC1018	1.00	J310	.70	MRP901 (3) Lead	1.00	RE3789	25.00
2SC1042	12.00	TRW		MRP901 (4) Lead	2.00	RF110	25.00
2SC1070	2.50	JC02000	10.00	MRP904	2.30	S50-12	25.00
2SC1239	2.50	JC02001	25.00	MRP911	3.00	S3006	5.00
2SC1251	12.00	JC04045	25.00	MRP961	2.30	S3031	5.00
2SC1306	2.90	<u>Motorola Comm.</u>		MRP004	2.10	SCA3522	5.00
2SC1307	5.50	M1131	8.50	MS261F	POR	SCA3523	5.00
2SC1424	2.80	M1132	11.95	MSC1720-12	225.00	PRICE ON REQUEST = POR	

Toll Free Number
800-528-0180
(For orders only)

"All parts may be new or surplus, and parts may be substituted with comparable parts if we are out of stock of an item."

For information call: (602) 242-3037

PRICES SUBJECT TO CHANGE WITHOUT NOTICE

MHz electronics

GaAs, TUNNEL DIODES, ETC.

PART	PRICE	PART	PRICE	PART	PRICE
MA47100	\$ 3.05	MRF503	\$ 6.00	PT4186B	\$ POR
MA47202	30.80	MRF504	7.00	PT4209	POR
MA47771	POR	MRF509	5.00	PT4209C	POR
MA47852	POR	MRF511	8.65	PT4566	POR
MA49558	POR	MRF605	20.00	PT4570	POR
MB4021	POR	MRF629	3.47	PT4571	POR
MBD101	1.00	MRF644	23.00	PT4571A	POR
MDO513	POR	MRF816	15.00	PT4577	POR
MHW1171	42.50	MRF823	20.00	PT4590	POR
MHW1182	48.60	MRF901	3.00	PT4612	POR
MHW4171	49.35	MRF8004	2.10	PT4628	POR
MHW4172	51.90	MS261F	POR	PT4640	POR
MHW4342	68.75	MT4150 Fair.	POR	PT4642	POR
MLP102	25.00	MT5126 Fair.	POR	PT5632	POR
MM1500	32.32	MT5481 Fair.	POR	PT5749	POR
MM1550	POR	MT5482 Fair.	POR	PT6612	POR
MM1552	50.00	MT5483 Fair.	POR	PT6626	POR
MM1553	50.00	MT5596 Fair.	POR	PT6709	POR
MM1614	10.00	MT5764 Fair.	POR	PT6720	POR
MM2608	5.00	MT8762 Fair.	POR	PT8510	POR
MM3375A	11.50	MV109	.77	PT8524	POR
MM4429	10.00	MV1401	8.75	PT8609	POR
MM8000	1.15	MV1624	1.42	PT8633	POR
MM8006	2.30	MV1805	15.00	PT8639	POR
MO277L	POR	MV1808	10.00	PT8659	POR
MO283L	POR	MV1817B	10.00	PT8679	POR
MO3757	POR	MV1863B	10.00	PT8708	POR
MP102	POR	MV1864A	10.00	PT8709	POR
MPN3202	10.00	MV1864B	10.00	PT8727	POR
MPN3401	.52	MV1864D	10.00	PT8731	POR
MPN3412	1.00	MV1868D	10.00	PT8742	POR
MPSU31	1.01	MV2101	.90	PT8787	POR
MRA2023-1.5 TRW	42.50	MV2111	.90	PT9790	41.70
MRF212/208	16.10	MV2115	1.55	PT31962	POR
MRF223	13.25	MV2201	.53	PT31963	POR
MRF224	15.50	MV2203	.53	PT31983	POR
MRF237	3.15	MV2209	2.00	PTX6680	POR
MRF238	12.65	MV2215	2.00	RAY-3	24.99
MRF243	25.00	MWA110	7.45	40081	POR
MRF245	34.50	MWA120	7.80	40281	POR
MRF247	34.50	MWA130	8.25	40282	POR
MRF304	43.45	MWA210	7.80	40290	POR
MRF315	23.00	MWA220	8.25	RF110	25.00
MRF420	20.00	MWA230	8.65	SCA3522	POR
MRF421	36.80	MWA310	8.25	SCA3523	POR
MRF422	41.40	MWA320	8.65	SD1065	POR
MRF427	16.10	MWA330	9.50	SS43	POR
MRF428	46.00	NEC57835	5.30	TP1014	POR
MRF450/A	13.80	ON382	5.00	TP1028	POR
MRF453/A	17.25	PPT515-20-3	POR	TRW-3	POR
MRF454/A	19.90	PRT8637	POR	UT0504 Avantek	70.00
MRF455/A	16.00	PSCQ2-160	POR	UT0511 Avantek	75.00
MRF458	19.90	PT3190	POR	V15	4.00
MRF463	25.00	PT3194	POR	V33B	4.00
MRF472	1.00	PT3195	POR	V100B	4.00
MRF475	2.90	PT3537	POR	VAB801EC	25.00
MRF477	11.50	PT4166E	POR	VAB804EC	25.00
MRF502	1.04	PT4176D	POR	VAS21AN20	25.00

For information call: (602) 242-3037

Toll Free Number
800-528-0180
(For orders only)

"All parts may be new or surplus, and parts may be substituted with comparable parts if we are out of stock of an item."

MHz electronics

PRICES SUBJECT TO CHANGE WITHOUT NOTICE

COAXIAL RELAY SWITCHES SPDT

Electronic Specialty Co./Raven Electronics FSN 5985-556-9683 \$49.00
 Part # 25N28 Part # SU-01
 26Vdc Type N Connector, DC to 1 GHz.

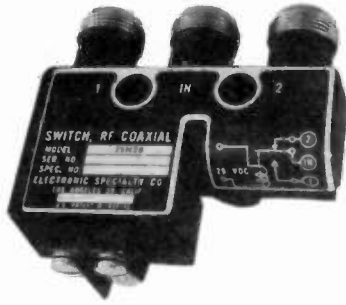

Amphenol
 Part # 316-10102-8
 115Vac Type BNC DC to 3 GHz.

FXR
 Part # 300-11182
 120Vac Type BNC DC to 4 GHz.
 FSN 5985-543-1225

FXR
 Part # 300-11173
 120Vac Type BNC Same
 FSN 5985-543-1850

\$29.99

\$39.99

\$39.99

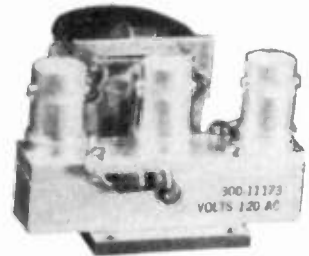
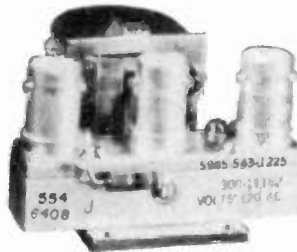
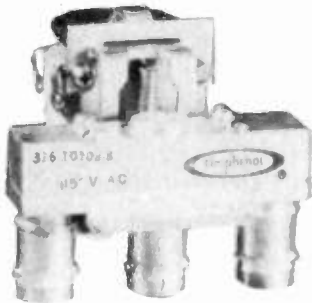

BNC To Banana Plug Coax Cable RG-58 36 inch or BNC to N Coax Cable RG-58 36 inch.

\$7.99 or 2 For \$13.99 or 10 For \$50.00

\$8.99 or 2 For \$15.99 or 10 For \$60.00



SOLID STATE RELAYS

P&B Model ECT1DB72 5vdc turn on
 PRICE EACH \$5.00

Digisig, Inc. Model ECS-215 5vdc turn on
 PRICE EACH \$7.50

Grigsby/Barton Model GB7400 5vdc turn on
 PRICE EACH \$7.50

120vac contact at 7amps or 20amps on a 10"x 10"x .124 aluminum. Heatsink with silicon grease.

240vac contact 14amps or 40amps on a 10"x 10"x .124 aluminum. Heatsink with silicon grease.

240vac contact at 15amps or 40amps on a 10"x 10"x .124 aluminum. Heatsink with silicon grease.

NOTE: *** Items may be substituted with other brands or equivalent model numbers. ***

MHz electronics

"All parts may be new or surplus, and parts may be substituted with comparable parts if we are out of stock of an item."

For information call: (602) 242-3037

Toll Free Number
800-528-0180
 (For orders only)

PRICES SUBJECT TO CHANGE WITHOUT NOTICE

RECALL PHONE MEMORY TELEPHONE WITH 24 NUMBER AUTO DIALER

The Recall Phone Telephone employs the latest state of art communications technology. It is a combination telephone and automatic dialer that uses premium-quality, solid-state circuitry to assure high-reliability performance in personal or business applications. \$49.99

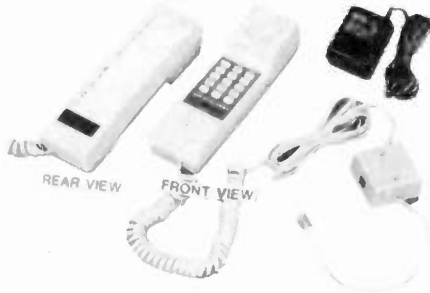

ARON ALPHA RAPID BONDING GLUE

Super Glue #CE-486 high strength rapid bonding adhesive. Alpha Cyanoacrylate. Set-Time 20 to 40 sec., 0.7fl.oz. (20gm.) \$2.00



TOUCH TONE PAD

This pad contains all the electronics to produce standard touch-tone tones. New with data.

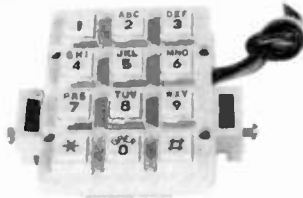

\$9.99 or 10/\$89.99

MITSUMI UHF/VHF VARACTOR TUNER MODEL UVE1A

Perfect for those unscrambler projects. New with data.



\$19.99 or 10/\$149.99

INTEGRATED CIRCUIT

		1 to 10	11up
MC1372P	Color TV Video Modulator Circuit.	\$ 4.42	\$2.95
MC1358P	IF Amp., Limiter, FM Detector, Audio Driver, Electronic Attenuator.	5.00	4.00
MC1350P	IF Amplifier	1.50	1.25
MC1330A1P	Low Level Video Detector	1.50	1.15
MC1310P	FM Stereo Demodulator	4.29	3.30
MC1496P	Balanced Modulator/Demodulator	1.50	1.25
LM565N	Phase Locked Loop	2.50	2.00
LM380N14	2Watt Audio Power Amplifier	1.56	1.25
LM1889N	TV Video Modulator	5.00	4.00
NE564N	Phase Locked Loop	10.00	8.00
NE561N	Phase Locked Loop	10.00	8.00

FERRANTI ELECTRONICS AM RADIO RECEIVER MODEL ZN414 INTEGRATED CIRCUIT.

Features:

1.2 to 1.6 volt operating range., Less than 0.5ma current consumption. 150KHz to 3MHz Frequency range., Easy to assemble, no alignment necessary. Effective and variable AGC action., Will drive an earphone direct. Excellent audio quality., Typical power gain of 72dB., TO-18 package. With data. \$2.99 or 10 For \$24.99

NI CAD RECHARGEABLE BATTERIES

AA Battery Pack of 6 These are Factory New. \$5.00

SUB C Pack of 10 2.5Amp/Hr. \$10.00

Gates Rechargeable Battery Packs

12vdc at 2.5Amp/Hr. \$11.99
12vdc at 5Amp/Hr. \$15.99



MOTOROLA MRF559 RF TRANSISTOR

hfe 30min 90typ 200max.
ft 3000mhz
gain 8db min 9.5typ at 870mhz
13db typ at 512mhz
output power .5watts at 12.5vdc
at 870mhz.

\$2.05 or 10/\$15.00

For information call: (602) 242-3037

Toll Free Number

800-528-0180

(For orders only)

PRICES SUBJECT TO CHANGE WITHOUT NOTICE

MHz electronics

"All parts may be new or surplus, and parts may be substituted with comparable parts if we are out of stock of an item."

"SOCKETS AND CHIMNEYS"

EIMAC TUBE SOCKETS AND CHIMNEYS

SK110	Socket	\$POR
SK300A	Socket For 4CX5000A,R,J, 4CX10,000D, 4CX15,000A,J	\$520.00
SK400	Socket For 4-125A,250A,400A,400C,4PR125A,400A,4-500A,5-500A	260.00
SK406	Chimney For 4-250A,400A,400C,4PR400A	74.00
SK416	Chimney For 3-400Z	36.00
SK500	Socket For 4-1000A/4PR1000A/B	390.00
SK600	Socket For 4CX250B,BC,FG,R,4CX350A,F,FJ	51.00
SK602	Socket For 4CX250B,BC,FG,R,4CX350A,F,FJ	73.00
SK606	Chimney For 4CX250B,BC,FG,R,4CX350A,F,FJ	11.00
SK607	Socket For 4CX600J,JA	60.00
SK610	Socket For 4CX600J,JA	60.00
SK620	Socket For 4CX600J,JA	66.00
SK626	Chimney For 4CX600J,JA	10.00
SK630	Socket For 4CX600J,JA	66.00
SK636B	Chimney For 4CX600J,JA	34.00
SK640	Socket For 4CX600J,JA	36.00
SK646	Chimney For 4CX600J,JA	71.00
SK700	Socket For 4CX300A,Y,4CX125C,F	225.00
SK711A	Socket For 4CX300A,Y,4CX125C,F	225.00
SK740	Socket For 4CX300A,Y,4CX125C,F	86.00
SK770	Socket For 4CX300A,Y,4CX125C,F	86.00
SK800A	Socket For 4CX1000A,4CX1500B	225.00
SK806	Chimney For 4CX1000A,4CX1500B	40.00
SK810	Socket For 4CX1000A,4CX1500B	225.00
SK900	Socket For 4X500A	300.00
SK906	Chimney For 4X500A	57.00
SK1420	Socket For 5CX3000A	650.00
SK1490	Socket For 4CV8000A	585.00

JOHNSON TUBE SOCKETS AND CHIMNEYS

124-111/SK606	Chimney For 4CX250B,BC,FG,R, 4CX350A,F,FJ	\$ 10.00
122-0275-001	Socket For 3-500Z, 4-125A, 250A, 400A, 4-500A, 5-500A	(pair)15.00
124-0113-00	Capacitor Ring	15.00
124-116/SK630A	Socket For 4CX250B,BC,FG,R, /4CX350A,F,FJ	55.00
124-115-2/SK620A	Socket For 4CX250B,BC,FG,R, /4CX350A,F,FJ	55.00
	813 Tube Socket	20.00

CHIP CAPACITORS

.8pf	10pf	100pf*	430pf
1pf	12pf	110pf	470pf
1.1pf	15pf	120pf	510pf
1.4pf	18pf	130pf	560pf
1.5pf	20pf	150pf	620pf
1.8pf	22pf	160pf	680pf
2.2pf	24pf	180pf	820pf
2.7pf	27pf	200pf	1000pf/.001uf*
3.3pf	33pf	220pf*	1800pf/.0018uf
3.6pf	39pf	240pf	2700pf/.0027uf
3.9pf	47pf	270pf	10,000pf/.01uf
4.7pf	51pf	300pf	12,000pf/.012uf
5.6pf	56pf	330pf	15,000pf/.015uf
6.8pf	68pf	360pf	18,000pf/.018uf
8.2pf	82pf	390pf	

PRICES: 1 to 10 - .99¢ 101 to 1000 .60¢ * IS A SPECIAL PRICE: 10 for \$7.50
 11 to 50 - .90¢ 1001 & UP .35¢ 100 for \$65.00
 51 to 100 - .80¢ 1000 for \$350.00

TUBE CAPS (Plate)

HR1, 4	\$11.00
HR2,3, 6 & 7	13.00
HR5, 8	14.00
HR9	17.00
HR10	20.00

WATKINS JOHNSON WJ-V907: Voltage Controlled Microwave Oscillator \$110.00

Frequency range 3.6 to 4.2GHz, Power output, Min. 10dBm typical, 8dBm Guaranteed.
 Spurious output suppression Harmonic (nf₀), min. 20dB typical, In-Band Non-Harmonic, min. 60dB typical, Residual FM, pk to pk, Max. 5KHz, pushing factor, Max. 8KHz/V, Pulling figure (1.5:I VSWR), Max. 60MHz, Tuning voltage range +1 to +15volts, Tuning current, Max. -0.1mA, modulation sensitivity range, Max. 120 to 30MHz/V, Input capacitance, Max. 100pf, Oscillator Bias +15 +/-0.05 volts @ 55mA, Max.

Toll Free Number
800-528-0180
(For orders only)

"All parts may be new or surplus, and parts may be substituted with comparable parts if we are out of stock of an item."

MHz electronics

For information call: (602) 242-3037

PRICES SUBJECT TO CHANGE WITHOUT NOTICE

TUBES

TYPE	PRICE	TYPE	PRICE	TYPE	PRICE
2C39/7289	\$ 34.00	1182/4600A	\$500.00	ML7815AL	\$ 60.00
2E26	7.95	4600A	500.00	7843	107.00
2K28	200.00	4624	310.00	7854	130.00
3-500Z	102.00	4657	84.00	ML7855KAL	125.00
3-1000Z/8164	400.00	4662	100.00	7984	14.95
3B28/866A	9.50	4665	500.00	8072	84.00
3CX400U7/8961	255.00	4687	P.O.R.	8106	5.00
3CX1000A7/8283	526.00	5675	42.00	8117A	225.00
3CX3000F1/8239	567.00	5721	250.00	8121	110.00
3CW30000H7	1700.00	5768	125.00	8122	110.00
3X2500A3	473.00	5819	119.00	8134	470.00
3X3000F1	567.00	5836	232.50	8156	12.00
4-65A/8165	69.00	5837	232.50	8233	60.00
4-125A/4D21	79.00	5861	140.00	8236	35.00
4-250A/5D22	98.00	5867A	185.00	8295/PL172	500.00
4-400A/8438	98.00	5868/AX9902	270.00	8458	35.00
4-400B/7527	110.00	5876/A	42.00	8462	130.00
4-400C/6775	110.00	5881/6L6	8.00	8505A	95.00
4-1000A/8166	444.00	5893	60.00	8533W	136.00
4CX250B/7203	54.00	5894/A	54.00	8560/A	75.00
4CX250FG/8621	75.00	5894B/8737	54.00	8560AS	100.00
4CX250K/8245	125.00	5946	395.00	8608	38.00
4CX250R/7580W	90.00	6083/AZ9909	95.00	8624	100.00
4CX300A/8167	170.00	6146/6146A	8.50	8637	70.00
4CX350A/8321	110.00	6146B/8298	10.50	8643	83.00
4CX350F/8322	115.00	6146W/7212	17.95	8647	168.00
4CX350FJ/8904	140.00	6156	110.00	8683	95.00
4CX600J/8809	835.00	6159	13.85	8877	465.00
4CX1000A/8168	242.50*	6159B	23.50	8908	13.00
4CX1000A/8168	485.00	6161	325.00	8950	13.00
4CX1500B/8660	555.00	6280	42.50	8930	137.00
4CX5000A/8170	1100.00	6291	180.00	6L6 Metal	25.00
4CX10000D/8171	1255.00	6293	24.00	6L6GC	5.03
4CX15000A/8281	1500.00	6326	P.O.R.	6CA7/EL34	5.38
4CW800F	710.00	6360/A	5.75	6CL6	3.50
4D32	240.00	6399	540.00	6DJ8	2.50
4E27A/5-125B	240.00	6550A	10.00	6DQ5	6.58
4PR60A	200.00	6883B/8032A/8552	10.00	6GF5	5.85
4PR60B	345.00	6897	160.00	6GJ5A	6.20
4PR65A/8187	175.00	6907	79.00	6GK6	6.00
4PR1000A/8189	590.00	6922/6DJ8	5.00	6HB5	6.00
4X150A/7034	60.00	6939	22.00	6HF5	8.73
4X150D/7609	95.00	7094	250.00	6JG6A	6.28
4X250B	45.00	7117	38.50	6JM6	6.00
4X250F	45.00	7203	P.O.R.	6JN6	6.00
4X500A	412.00	7211	100.00	6JS6C	7.25
5CX1500A	660.00	7213	300.00*	6KN6	5.05
KT88	27.50	7214	300.00*	6KD6	8.25
416B	45.00	7271	135.00	6LF6	7.00
416C	62.50	7289/2C39	34.00	6LQ6 G.E.	7.00
572B/T160L	49.95	7325	P.O.R.	6LQ6/6MJ6 Sylvania	9.00
592/3-200A3	211.00	7360	13.50	6ME6	8.90
807	8.50	7377	85.00	12AT7	3.50
811A	15.00	7408	2.50	12AX7	3.00
812A	29.00	7609	95.00	12BY7	5.00
813	50.00	7735	36.00	12JB6A	6.50

NOTE * = USED TUBE

NOTE P.O.R. = PRICE ON REQUEST

"ALL PARTS MAY BE NEW, USED, OR SURPLUS. PARTS MAY BE SUBSTITUTED WITH COMPARABLE PARTS IF WE ARE OUT OF STOCK OF AN ITEM.

NOTICE: ALL PRICES ARE SUBJECT TO CHANGE WITHOUT NOTICE.

For information call: (602) 242-3037

Toll Free Number
800-528-0180
(For orders only)

"All parts may be new or surplus, and parts may be substituted with comparable parts if we are out of stock of an item."

MHz electronics

PRICES SUBJECT TO CHANGE WITHOUT NOTICE

"FILTERS"

COLLINS Mechanical Filter #526-9724-010 MODEL F455Z32F

455KHz at 3.2KHz wide. May be other models but equivalent. May be used or new, \$15.99

ATLAS Crystal Filters

5.595-2.7/8/LSB, 5.595-2.7/LSB
8 pole 2.7KHz wide Upper sideband. Impedance 800ohms 15pf In/800ohms 0pf out. 19.99

5.595-2.7/8/U, 5.595-2.7/USB
8 pole 2.7KHz wide Upper sideband. Impedance 800ohms 15pf In/800ohms 0pf out. 19.99

5.595-.500/4, 5.595-.500/4/CW
4 pole 500 cycles wide CW. Impedance 800ohms 15pf In/800ohms 0pf out. 19.99

9.0USB/CW
6 pole 2.7KHz wide at 6dB. Impedance 680ohms 7pf In/300ohms 8pf out. CW-1599Hz 19.99

KOKUSAI ELECTRIC CO. Mechanical Filter #MF-455-ZL/ZU-21H

455KHz at Center Frequency of 453.5KC. Carrier Frequency of 455KHz 2.36KC Bandwidth.
Upper sideband. (ZU) 19.99
Lower sideband. (ZL) 19.99

CRYSTAL FILTERS

NIKKO	FX-07800C	7.8MHz	\$10.00
TEW	FEC-103-2	10.6935MHz	10.00
SDK	SCH-113A	11.2735MHz	10.00
TAMA	TF-31H250	CF 3179.3KHz	19.99
TYCO/CD	001019880	10.7MHz 2pole 15KHz bandwidth	5.00
MOTOROLA	4884863B01	11.7MHz 2pole 15KHz bandwidth	5.00
PTI	5350C	12MHz 2pole 15KHz bandwidth	5.00
PTI	5426C	21.4MHz 2pole 15KHz bandwidth	5.00
PTI	1479	10.7MHz 8pole bandwidth 7.5KHz at 3dB, 5KHz at 6dB	20.00
COMTECH	A10300	45MHz 2pole 15KHz bandwidth	6.00
FRC	ERXF-15700	20.6MHz 36KHz wide	10.00
FILTECH	2131	CF 7.825MHz	10.00

CERAMIC FILTERS

AXEL	4F449	12.6KC Bandpass Filter 3dB bandwidth 1.6KHz from 11.8-13.4KHz	10.00
CLEVITE	TO-01A	455KHz±2KHz bandwidth 4-7% at 3dB	5.00
	TCF4-12D36A	455KHz±1KHz bandwidth 6dB min 12KHz, 60dB max 36KHz	10.00
MURATA	BFB455B	455KHz	2.50
	BFB455L	455KHz	3.50
	CFM455E	455KHz ±5.5KHz at 3dB, ±8KHz at 6dB, ±16KHz at 50dB	6.65
	CFM455D	455KHz ±7KHz at 3dB, ±10KHz at 6dB, ±20KHz at 50dB	6.65
	CFR455E	455KHz ±5.5KHz at 3dB, ±8KHz at 6dB, ±16KHz at 60dB	8.00
	CFU455B	455KHz ±2KHz bandwidth ±15KHz at 6dB, ±30KHz at 40dB	2.90
	CFU455C	455KHz ±2KHz bandwidth ±12.5KHz at 6dB, ±24KHz at 40dB	2.90
	CFU455G	455KHz ±1KHz bandwidth ±4.5KHz at 6dB, ±10KHz at 40dB	2.90
	CFU455H	455KHz ±1KHz bandwidth ±3KHz at 6dB, ±9KHz at 40dB	2.90
	CFU455I	455KHz ±1KHz bandwidth ±2KHz at 6dB, ±6KHz at 40dB	2.90
	CFW455D	455KHz ±10KHz at 6dB, ±20KHz at 40dB	2.90
	CFW455H	455KHz ±3KHz at 6dB, ±9KHz at 40dB	2.90
	SFB455D	455KHz	2.50
	SFD455D	455KHz ±2KHz, 3dB bandwidth 4.5KHz ±1KHz	5.00
	SFE10.7MA	10.7MHz 280KHz ±50KHz at 3dB, 650KHz at 20dB	2.50
	SFE10.7MS	10.7MHz 230KHz ±50KHz at 3dB, 570KHz at 20dB	2.50
	SFG10.7MA	10.7MHz	10.00
NIPPON	LF-B4/CFU455I	455KHz ±1KHz	2.90
	LF-B6/CFU455H	455KHz ±1KHz	2.90
	LF-B8	455KHz	2.90
	LF-C18	455KHz	10.00
TOKIN	CF455A/BFU455K	455KHz ±2KHz	5.00
MATSUSHIRA	EFC-L455K	455KHz	7.00

SPECTRA PHYSICS INC. Model 088 HeNe LASER TUBES

POWER OUTPUT 1.6MW.	BEAM DIA. .75MM	BEAM DIR. 2.7MR	8KV STARTING VOLTAGE DC
68K OHM 1WATT BALLAST	1000VDC ±100VDC	At 3.7MA	\$59.99

ROTRON MUFFIN FANS Model MARK4/MU2A1

115 VAC	14WATTS	50/60CPS	IMPEDENCE PROTECTED-F	88CFM at 50CPS	\$ 7.99
105CFM at 60CPS	THESE ARE NEW				

MHz electronics

PRICES SUBJECT TO CHANGE WITHOUT NOTICE

Toll Free Number
800-528-0180
(For orders only)

"All parts may be new or surplus, and parts may be substituted with comparable parts if we are out of stock of an item."

For information call: (602) 242-3037

HEWLETT PACKARD SIGNAL GENERATORS

606A	50KHZ to 65MHZ in 6 bands $\pm 1\%$ Output level adjustable 0.1uV to 3V into 50 ohms. Built-in crystal calibrator. 400 - 1000HZ modulation.	\$ 650.00	616B	Same as above but later model.	\$ 600.00
606B	Same as above but has frequency control feature to allow operation with HP 8708A Synchronizer.	\$1100.00	618B	3.8 to 7.66GHZ range, with calibrated output and selection of pulse-FM or square wave modulation.	\$ 600.00
608C	10MHZ to 480MHZ, 0.1uV-1V into 50 ohms, AM, CW, or pulse modulation, calibrated attenuator.	\$ 500.00	618C	Same as above but later model.	\$2200.00
608D/1S510	10MHZ to 420MHZ, 0.1uV-0.5V into 50 ohms, $\pm 0.5\%$ accuracy, built-in crystal calibrator, AM-CW or pulse output.	\$ 375.00	620A	7 to 1GHZ range, with calibrated output and selection of pulse-FM or square wave modulation.	\$ 750.00
608E	Improved version of popular 608C. Up to 1V output. Improved stability, low residual FM.	\$1450.00	620B	Same as above but later model.	\$2200.00
608F	10MHZ to 455MHZ in 5 bands $\pm 1\%$ frequency accuracy with built-in crystal calibrator. Can be used with HP 8708A Synchronizer. Output continuously adjustable from .1uV to .5V into 50 ohms.	\$1100.00	626A	10 to 15GHZ, 10mw output power with calibrated output and pulse-square wave or FM modulation.	\$4200.00
612A	450-1230MHZ, 0.1uV-0.5V into 50 ohms, calibrated output.	\$ 750.00	8708A	Synchronizer used with 606B, 608F. The synchronizer is a phase-lock frequency stabilizer which provides crystal-oscillator frequency stability to 430MHZ in the 608F signal generator. Phase locking eliminates microphonics and drift resulting in excellent frequency stability. The 8708A includes a vernier which can tune the reference oscillator over a range of $\pm 0.25\%$ permitting frequency set stability to 2 parts in 10 to the seventh. Provides a very stable signal that satisfies many critical applications.	(With HP 606B or 608F) \$ 350.00 (Without) \$ 450.00
614A	900-2100MHZ with many features including calibrated output and all modulation characteristics.	\$ 500.00	EMC-10	ELECTROMETRICS EMC-10 RFI/EMI RECEIVER Low frequency analyzer covering 20HZ to 50KHZ frequency range. Extendable to 500 KHZ in wideband mode.	\$2500.00
616A/1S403	Direct reading and direct control from 1.8 to 4.2GHZ. The H.P. 616A features ± 1.5 dB calibrated output accuracy from -3127dBm to -dBm. The output is directly calibrated in microvolts and dBm with continuous monitoring. Simple operation. Frequency diode accuracy is $\pm 1\%$ and stability exceeds 0.005% / C change in ambient temperature. Calibrated attenuator is within ± 1.5 dB over entire output band. 50 ohm impedance unit has internal pulse modulation with rep rate variable from 40 HZ to 4KHZ, variable pulsewidth (1 to 10uSec) and variable pulse delay (3 to 300uSec). External modulating inputs increase versatility.	\$ 375.00	NF-105F	Empire Devices Field Intensity Meter. Has NF-105/TA, NF-105/TX, NF-105/T1, NF-105/T2, NF-105/T3. Covers 14KHZ to 1000MHZ.	\$2100.00

ALL EQUIPMENT CARRY A 30 DAY GUARANTEE.
EQUIPMENT IS NOT CALIBRATED.

UNEX LABORATORIES THS-2 FLEXICOM HEADSET.

These headsets come with data to hook up to a ICOM radios and many other equipment.
Perfect for Airplanes, Helicopters, Mobile Radios, or Just the Telephone.
These Are Factory New In Sealed Boxes. Limited Supply Only \$69.95



\$69.95

ORDERING INSTRUCTIONS

DEFECTIVE MATERIAL: All claims for defective material must be made within sixty (60) days after receipt of parcel. All claims must include the defective material (for testing purposes), our invoice number, and the date of purchase. All returns must be packed properly or it will void all warranties.

DELIVERY: Orders are normally shipped within 48 hours after receipt of customer's order. If a part has to be backordered the customer is notified. Our normal shipping method is via First Class Mail or UPS depending on size and weight of the package. On test equipment it is by Air only, FOB shipping point.

FOREIGN ORDERS: All foreign orders must be prepaid with cashier's check or money order made out in U.S. Funds. We are sorry but C.O.D. is not available to foreign countries and Letters of Credit are not an acceptable form of payment either. Further information is available on request.

HOURS: Monday thru Saturday 8:30 a.m. to 5:00 p.m.

INSURANCE: Please include 25c for each additional \$100.00 over \$100.00. Uninsured Parcel only.

ORDER FORMS: New order forms are included with each order for your convenience. Additional forms are available on request.

POSTAGE: Minimum shipping and handling in the US, Canada, and Mexico is \$2.50 all other countries is \$5.00. On foreign orders include 20% shipping and handling.

PREPAID ORDERS: Order must be accompanied by a check.

PRICES: Prices are subject to change without notice.

RESTOCK CHARGE: If parts are returned to MHZ Electronics due to customer error, customer will be held responsible for all extra fees. Will be charged a 15% restocking fee, with the remainder in credit only. All returns must have approval.

SALES TAX: Arizona must add 5% sales tax, unless a signed Arizona resale tax card is currently on file with MHZ Electronics. All orders placed by persons outside of Arizona, but delivered to persons in Arizona are subject to the 5% sales tax.

SHORTAGE OR DAMAGE: All claims for shortages or damages must be made within 5 days after receipt of parcel. Claims must include our invoice number and the date of purchase. Customers which do not notify us within this time period will be held responsible for the entire order as we will consider the order complete.

OUR 800 NUMBER IS STRICTLY FOR ORDERS ONLY
NO INFORMATION WILL BE GIVEN. 1-800-528-0180.

TERMS: DOMESTIC: Prepaid, C.O.D. or Credit Card

FOREIGN: Prepaid only, U.S. Funds—money order or cashier's check only

C.O.D.: Acceptable by telephone or mail. Payment from customer will be by cash, money order or cashier's check. We are sorry but we cannot accept personal checks for C.O.D.'s.

CONFIRMING ORDERS: We would prefer that confirming orders not be sent after a telephone order has been placed. If company policy necessitates a confirming order, please mark "CONFIRMING" boldly on the order. If problems or duplicate shipments occur due to an order which is not properly marked, customers will be held responsible for any charges incurred, plus a 15% restock charge on returned parts.

CREDIT CARDS: WE ACCEPT MASTERCARD VISA AND AMERICAN EXPRESS.

DATA SHEETS: When we have data sheets in stock on devices we do supply them with the order.

MHZ electronics



For information call: (602) 242-3037

2111 W. CAMELBACK ROAD
PHOENIX, ARIZONA 85015

Toll Free Number
800-528-0180
(For orders only)

"All parts may be new or surplus, and parts may be substituted with comparable parts if we are out of stock of an item."

Save 28% off the basic 1 year rate!

A year of 73

\$17.97

THE SPIRIT OF

73

Stay in Step
with Amateur Radio's
Technical Journal

Amateur Radio's Technical Journal

A Wayne Green Publication

73 keeps you up to date on what's happening in the ham world. For only \$17.97, 73 gives you a year of:

•**CONSTRUCTION PROJECTS**—73 publishes more easy-to-build projects than any other ham magazine.

•**73 INTERNATIONAL**—Get reports from 73 correspondents around the globe. Amateur radio is a worldwide pastime and 73 is your source for international news.

•**NEW PRODUCTS**—73 gives you reports on state-of-the-art amateur-radio equipment. In 1982 alone, 73 introduced 137 pieces of newly-available ham gear!

•**REVIEWS**—From keyers to transceivers to tuners, you'll save money with 73's first-hand equipment evaluations.

•**DXING**—Get the best DX column there is. 73 columnist Chod Harris VP2ML provides tips for newcomers, profiles of the hams behind those famous call signs, and constant DXpedition updates. Don't miss it!

•**NEVER SAY DIE**—W2NSD's controversial editorials have livened up the ham scene for more than 22 years. Is he right or wrong? "Never Say Die" lets you be the judge.

•**HAM HELP**—Thousands of readers have had their problems solved through a query published in 73's "Ham Help" column. Need a hard-to-find part, schematic, or owner's manual? Ham information of any kind? Let 73 help!

Get the information you need for better hamming.

Get into the spirit of 73!



YES!

I would like a year of 73 for \$17.97.

I understand that with payment enclosed or credit card information, I will receive a FREE issue making a total of 13 issues for \$17.97. (Full year sub-price usually \$25.00!)

Check/M.O. MC VISA AE Bill Me \$17.97 for 12 issues.

Card # _____ Exp. Date _____

Signature _____

Name _____

Address _____

City _____ State _____ Zip _____

Canada & Mexico, \$20.97 1 year only. US funds drawn on US bank.
Foreign Surface, \$37.97. 1 year only. US funds drawn on US bank.
Foreign Airmail please inquire. Please allow 6-8 weeks for delivery.

341F6

73: Amateur Radio's Technical Journal • Box 931 • Farmingdale, NY 11737

**BUTTERNUT
ELECTRONICS
COMPANY**

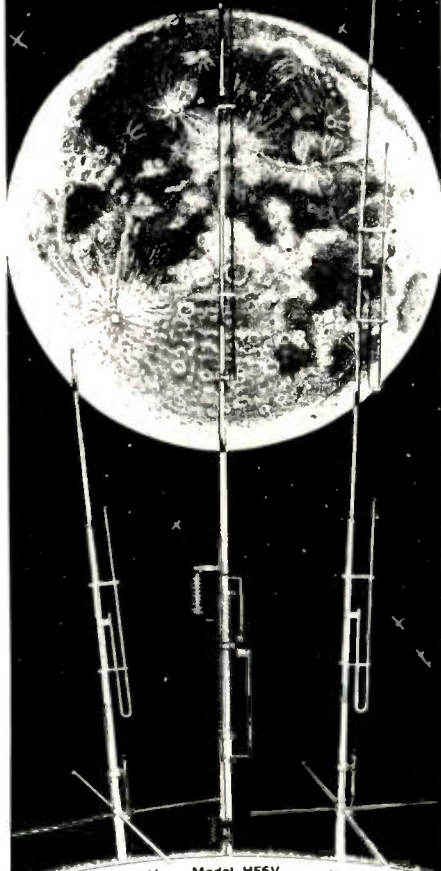

**THE
WINNERS**

Model HF6V - Completely automatic bandswitching 80 through 10 plus 30 meters. Outperforms all 4- and 5-band "trap" verticals of comparable size. Thousands in use worldwide since December '81! 160 meter option available now; retrofit kits for remaining WARC bands coming soon. Height 26 ft/7.8 meters; guying not required in most installations.

Model 2MVC "Trombone" - omnidirectional collinear gain vertical for 2 meters having the same gain as "double- $\frac{1}{2}$ A" types, but the patented "trombone" phasing section allows the radiator to remain unbroken by insulators for maximum strength in high winds. No coils "plumber's delight" construction and adjustable gamma match for complete D.C. grounding and lowest possible SWR. Height 9.8 ft/2.98 meters

NEW
Model 2MVC-5 "Super-Trombone" - Same advanced features as the basic 2MVC but a full wavelength taller with additional "Trombone" phasing section for additional gain. Height 15.75 ft/4.8 meters

All BUTTERNUT ANTENNAS use stainless steel hardware and are guaranteed for a full year. For further information on these and other BUTTERNUT products write for our FREE CATALOG!

**BUTTERNUT
ELECTRONICS**
405 E. Market St. Lockhart, TX 78644

Build a "Supershack"



From QRP to SSB, Heath leads the way with high tech products that perform.

- **SS-9000** microprocessor-based, solid-state Deluxe HF Transceiver with nine band operation.
- **HD-8999 UltraPro™** CW micro-controlled keyboard. Send letter perfect code at up to 99 WPM.
- **HW-5400** Synthesized HF SSB/CW Transceiver. Our lowest cost, high tech transceiver.
- **HL-2200** 2kW Linear Amplifier. The lowest cost-per-watt in 2k linears.
- **Plus dozens of other high tech amateur products and accessories.**
- **New HFT-9 QRP Antenna Tuner** gives operators an exact transmatch, when every watt counts in a low-power QSO. An enjoyable, kit with our famous guarantee: "We won't let you fail!"



See our complete amateur radio line including the new Tunable Active Audio Filter, RTTY Terminal Interface, Smart Outlet Box and more.

Over 50 value-priced products for the well-equipped hamshack. See them on display at a nearby Heathkit Electronic Center!



Get more information in the **FREE CATALOG**

Please send me the new, expanded 104-page Heathkit Catalog.

Mail to: Heath Company, Dept. 011-132
Benton Harbor, MI 49022

Name _____
Address _____
City _____
State _____ Zip _____

Heathkit
Heath
Company

AM-439

RC-850 REPEATER CONTROLLER

Feature of the Month

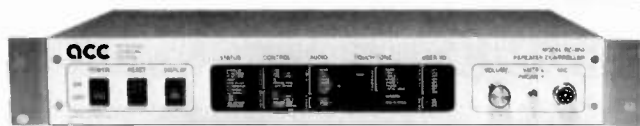

THE SCHEDULER

The RC-850 Repeater Controller is changing what repeaters are all about. The SCHEDULER, one of its many innovative features, puts your repeater on "Autopilot" for fully automatic scheduled operation.

Of course, the Scheduler easily handles your day to day control op chores, such as shutting down certain functions at night, changing the timeout timer for rush hours... but that's just the beginning.

"We have a weather radio storm alert connected to our '850 over-the-air alarm," reports VE3MEG. "The scheduler disables the alarm at the weekly test time so we don't have false alarms."

WB6KHP tells us that, "My 220 repeater has a 2 meter remote base, and the scheduler links us up weekly for Westlink and our club's 2 meter net. The '850 also reminds us of our 'Net tonight, 8:30' with a tail message for a few hours before the net."

Automatic net and meeting reminders, scheduled control of the remote bases and links, full control op capability and more. How would you use the Scheduler on your repeater?

The 850's Scheduler makes life easy for control ops and offers consistent, predictable operation for users. New in our Version 2.0 software, it's an example of how your '850 controller will never become obsolete.

MAKE YOUR REPEATER A WHOLE NEW ANIMAL WITH THE RC-850 REPEATER CONTROLLER

Call or write for detailed specifications

acc advanced computer controls, inc.

10816 Northridge Square • Cupertino, CA 95014 • (408) 749-8330 -127

RF TRANSISTORS

FRESH STOCK - NOT SURPLUS

2-30 MHz					
P/N	Net	Match/Pr	P/N	Net	Match/Pr
MRF412	\$18.00	\$39.00	MRF455	\$13.50	\$30.00
MRF421	27.00	58.00	MRF455A	13.50	30.00
MRF450	12.50	28.00	MRF458	18.00	40.00
MRF450A	12.50	28.00	MRF492	20.00	43.00
MRF453	15.00	33.00	SRF2072	15.00	33.00
MRF435A	15.00	33.00	SRF2769	15.00	33.00
MRF454	16.50	36.00	CD2545	18.50	40.00
MRF454A	16.50	36.00	CD3424	19.00	41.00

High Gain Matched Pairs & Quads Available					
P/N	Net	P/N	Net	P/N	Net
MRF406	\$14.50	MRF475	\$ 5.00		
MRF422	39.50	MRF476	3.50		
MRF433	14.50	MRF477	13.00		
MRF435	42.00	SD1407	37.00		
MRF449	14.50	SD1487	28.00		
MRF449A	14.50	S10-12	14.50		

VHF & UHF TRANSISTORS					
Type	Mount	Rating	MHz	Net/ea.	
MRF238	(s)	30W	145-175	\$13.00	
MRF240	(s)	40W	145-175	15.00	
MRF245	(f)	80W	130-175	27.00	
MRF247	(f)	80W	130-175	27.00	
MRF492	(f)	70W	27-50	20.00	
SD1416	(f)	80W	130-175	29.50	
SD1477	(f)	125W	130-175	37.00	
SD1441	(f)	150W	130-175	83.50	
2N6081	(s)	15W	130-175	7.75	
2N6082	(s)	25W	130-175	9.75	
2N6083	(s)	30W	130-175	9.75	
2N6084	(s)	40W	130-175	12.00	
2SC1955	—	1W	130-175	15.00	
2SC2289	—	5W	130-175	20.00	
MRF641	(f)	15W	430-470	18.00	
MRF644	(f)	25W	430-470	21.50	
MRF646	(f)	45W	430-470	24.50	
MRF648	(f)	60W	430-470	33.50	

Technical Assistance and cross-reference information on CD, PT, RF, SRF & SD P/N's; Call our Engineering Dept. (619) 744-0728
 WE SHIP SAME DAY C.O.D. or VISA/M.C.
 Minimum Order \$20.00 Add \$3.50 Shipping
 RF Parts Catalog Avail. OEM & Quantity Discounts
 ORDERS ONLY: 800-854-1927



WESTCOM

1320 Grand Ave. San Marcos
 California 92069 (619) 744-0728

MOVING?

Let us know 8 weeks in advance so that you won't miss a single issue of 73.

Attach old label where indicated and print new address in space provided. Also include your mailing label whenever you write concerning your subscription. It helps us serve you promptly. Write to:

73 Amateur Radio's Technical Journal
 Subscription Department P.O. Box 931 Farmingdale NY 11737

- Extend my subscription one additional year for only \$17.97
 Payment enclosed Bill me

Canada & Mexico \$20.97/1 year only US Funds drawn on US bank. Foreign Surface \$37.97/1 year only US Funds drawn on US bank. Foreign Airmail, please inquire.

If you have no label handy, print OLD address here.

Name _____

Address _____

City _____ State _____ Zip _____

print NEW address here:

Name _____

Address _____

City _____ State _____ Zip _____

Dealer...
BELL

Selling 73 will make money for you. Consider the facts:

Fact 1: Selling 73 increases store traffic—our dealers tell us that 73 is one of the hottest-selling amateur radio magazines on the newsstands.

Fact 2: There is a direct correlation between store traffic and sales—increase the number of people coming through your door and you'll increase sales.

Fact 3: Fact 1 + Fact 2 = INCREASED SALES, which means more money for you. And that's a fact.

For information on selling 73, call 800-343-0728 (in New Hampshire call 1-924-9471) and speak with Ginnie Boudrieau, our bulk sales manager. Or write to her at 73, 80 Pine St., Peterborough, NH 03458.

73 Amateur Radio's Technical Journal

80 Pine Street Peterborough, NH 03458

800-343-0728

WELZ



SP-600

SP-600

Select 1 of 3 sensors by soft touch switch. Three wide bandwidth sensors cover 1.6-500MHz. **\$159.00**
 RS-1: 1.6-60MHz 0-2kW RS-2: 1.6-150MHz 0-200W RS-3: 130-500MHz 0-200W

SP-200

Two position antenna switch and indicators. Three power ranges to 1kW, 1.8-160MHz. **\$107.00**

SP-400

Three band sensors (2m, 220, 450MHz), 10 percent accuracy, 0-150W CW, LED power range indicators. **\$109.00**

Distributed by
Encomm, Inc.
 2000 Avenue G, Suite 800, Plano, Texas 75074
 Phone (214) 423-0024 TLX 79-4783 ENCOMM DAL

WELZ

DUMMY LOADS

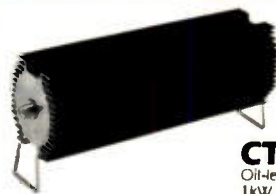

CT-300
 Oil-less aircooled,
 1kW peak for 3 min.,
 300W avg. DC-250MHz
\$68.00

CT-150

Oil-less aircooled,
 400W peak for 3 min.,
 150W avg. DC-250MHz
\$46.00



CT-15A
 50W peak, 15W avg.
 SO-239 Screw-on dummy
 DC-500MHz, VSWR < 1:1.2
\$12.00

CT-15N

50W peak, 15W avg.,
 Type N Dummy Load,
 DC-500MHz, VSWR < 1:1.1
\$21.00



SURGE SUPPRESSOR



CA-35A
 Contains replaceable,
 chip-type surge
 voltage protector.
 Low loss, low VSWR.
 DC-500MHz, 350V breakdown.
\$22.00

COAXIAL SWITCH

CH-20N

Two-way coaxial switch
 SO-239 type connector.
 DC-900MHz, 1kW power.
\$54.00



TERMINATION POWER METERS



TP-05X
 BNC connector,
 5W talkie checker.
 Field calibratable,
 3W avg. Dummy Load,
 1W center. 50-500MHz
\$21.00

TP-25A

25 watt version of
 TP-05X for mobile use.
 Larger Dummy Load.
 50-500MHz
\$40.00



All prices are suggested retail and subject to change.

Distributed by
Encomm, Inc.
 2000 Avenue G, Suite 800, Plano, Texas 75074
 Phone (214) 423-0024 TLX 79-4783 ENCOMM DAL

WELZ

SP-250



SWR & POWER METERS

SP-250

Low-profile, economy 2kW wattmeter. 1.6-60MHz bandwidth. 3W SWR sensitivity. Three ranges. A Best Buy! **\$75.00**

SP-15M

1.8-150MHz, 200 watt, low-profile wattmeter. VSWR, FWD PWR, REF PWR, 1.5W SWR sensitivity. Great for mobile HF. **\$60.00**

SP-45M

VHF-UHF to 100 watts. 3W sensitivity for SWR, 10 percent accuracy. All metal shielded construction. **\$85.00**

Distributed by
Encomm, Inc.
 2000 Avenue G, Suite 800, Plano, Texas 75074
 Phone (214) 423-0024 TLX 79-4783 ENCOMM DAL

✓ 135

73 INTERNATIONAL

from page 80

1914 km on 1296 MHz and 1663 km on 10 GHz!

Last summer that worldwide-known GHz DXer bettered a fantastic world record of 1166 km on 10 GHz from Sagunto, Spain, to Italy. On July 2nd, Nicola joined I0SC and I0KBL in Ceuta. With them was Bernardo EA5RK. Nicola's car hauled a trailer with gear for 144 MHz, HF, and the GHz transceivers.

They met many hams from Ceuta, EA9LT, EA9GH, EA9KF, EA9LV, and EA9GH, who gave their assistance, providing permission to install the setup and the antennas on the Ceuta lighthouse, 400 feet above sea level.

● July 4—Nicola starts with two QSOs on 144 MHz MS, contacting I4BXN and F6FHI.

● July 5—There is an E-sporadic aperture: Nicola contacts on 144 MHz several YUs and is with signals far in excess of S9. These are the first EA9-YU QSOs in history. At 1507Z, a contact is established on

1296 MHz with I8TUS/8. The QRB is 1914 km, a world record.

● July 6—At 1052, an ES contact with 9H1CG, a new one on 144 between EA9 and 9H. Then dozens of ES contacts with Italy and Yugoslavia. The signals are terrific: The S-meter is pinning up to full scale. At 1804, another new one with G4JJE; then, at 1845, G4TAP (first QSO EA9-GI); at 1847, EI2CA, and at 1917, GW8FKB (two new ones with EA9).

● July 7—A one-hour opening on 1296 and many QSOs with Sicily. I0HOC/I79 displays in Ceuta a signal of S9+20. Giuseppe has gone portable from Rome to Sicily just to try the contact!

Then the magic moments: At 1600, the contact is established with fair signals with IW0BCU/I79, France, with a QRB of 1621 km! After seven minutes, again the record with I0NLK/I79. The entire Roma Microwave Gang was in Sicily to attend the I0SNY enterprise.

Three hours after the record is filed, a new contact with I0NLK/IE9, Isle of Ustica, brings the record to 1663 km, almost 500 km more than the 1982 record from

ITALIAN CALL AREAS	
I1, IK1, IW1*	Liguria and Piemonte (N.W. Italy)
I2, IK2, IW2	Lombardia (N. Italy)
IX1, IW1	Valle d'Aosta (N.W. Italy)
I3, IK3, IW3	Veneto (N.E. Italy)
IN3, IW3	Trentino Alto Adige (N.E. Italy)
IV3, IW3	Friuli Venezia Giulia (N.E. Italy)
I4, IK4, IW4	Emilia (N. Italy)
I5, IK5, IW5	Toscana (C. Italy)
I6, IK6, IW6	Marche and Abruzzi (C.E. Italy)
I7, IK7, IW7	Puglia (S.E. Italy)
I8, IK8, IW8	Molise (S.E. Italy)
I8, IK8, IW8	Basilicata, Calabria, Campania (S. Italy)
IT9, IW9	Sicily (S. Italy)
I0, IK0, IW0	Lazio (C.W. Italy)
I0, IK0, IW0	Umbria (C. Italy)
IS0, IW0U	Sardinia (W. Italy)

* The IW prefix is for special no-code license, 144 MHz and up.

Sagunto to Rome. The day is not ended, as IW0BHN is contacted on 10 GHz: 1603 km, not a record but great DX!

● 9 and 10 July—The team is now in Morocco and gets several new contacts from that country on 144 and 432 MHz. But the most interesting QSO is the contact with I0HOC/I79 on 1296: two hours of conversation with steady signals of S9+40 dB, full scale! Nicola then tries FM: S9+40 again!

Too many bureaucratic difficulties in

Morocco, so I0SNY and his friends leave for Perugia, the nice, historical, small city where he lives, in central Italy.

Boys, let's see what he will do next summer!

ITALIAN ISLANDS AWARD (IIA)

The Italian Islands Award is issued by ARI (Associazione Radioamatori Italiani) to all radio amateurs and SWLs worldwide. The award can be obtained on the following frequencies and with the follow-

ITALIAN ISLANDS AWARD

List of the Islands and points. (To save space, only the points achieved on the HF bands are indicated. There is a different point scale for the contacts on other bands (VHF, UHF, up 3 GHz). The complete point table can be requested from the ARI Award Manager with an SASE.

Isole Liguri—IA4		Ogliera	2
Palmaria	2	Ortano	2
Tino	3	Palmarola	1
Tinetto	4	Remaiolo	2
Gallinara	3	Scoglietto	2
Bergeggi	2	Sedia Paolina	2
Arcipelago Ponziano—IB0		Scoglio Africa	3
Ponza	1	Topi	2
Gavi	2	Triglia	1
Botte	5	Gorgona	2
Cappello	5	Montecristo	3
Formiche	5	Pianosã	2
Le Galere	5	Cerboli	2
Mezzogiorno	5	Falconcino	2
Palmarola	3	Santa Lucia	2
Platti	5	Capraia	1
S. Stefano	2	Giannutri	2
Ventotene	1	Giglio	1
Zannone	2	Argentorola	3
Arcipelago Napoletano—IC8		Formica Burano	2
Ischia	1	Formiche	2
Procida	1	Isola Rossa	2
Li Galli	4	Isolotto	3
Nisida	4	Sparviero	2
Vivara	1	Arcipelago delle Eolie—ID9	
Capri	1	Lipari	1
Isola di Ustica—IE9		Allicudi	1
Ustica	1	Filicudi	1
Banco Apello	2	Canna	5
Colombara	2	Montenassari	3
Medico	2	Panarea	3
Isole Pelagie—IG9		Basiluzzo	3
Lampedusa	2	Battara	3
Lampione	3	Dattilo	5
Linosa	3	Formiche	3
Isola Conigli	5	Lisca Bianca	3
Isola di Pantelleria—IH9		Lisca Nera	3
Pantelleria	1	Panarelli	3
Arcipelago Toscano—IA5		Spinazzola	3
Elba	1	Salina	1
Corbella	2	Stromboli	1
Gemini	2	Strombolcchio	2
Meloria	2	Vulcano	1
		Arcipelago delle Egadi—IF9	
		Asinelli	5

Porcelli	5	Molarotto	5
Favignana	1	Mortorio	5
Formica	2	Mortoriotto	5
Galeotta	5	Pagliosa	4
Maraone	2	Pecora	4
Preveto	5	Pedrami	4
Levanzo	1	Piana di Alghero	4
Marettimo	1	Porri	4
Arcipelago Cheradi—IJ7		Prorotola	4
San Paolo	2	Rossa	4
San Pietro	2	Rossa di Bosa	4
Isole Tremiti—IL7		Ruja	4
San Domino	1	Scoglio Businco	5
San Nicola	1	Corona Niedda	5
Caprara	2	Scoglio Forani	5
Cretaccio	2	Scoglio Paganetto	5
Pianosa	4	Tavolara	2
Arcipelago della Maddalena—IM0		Arcipelago Cagliari—IM0	
Maddalena	1	Cavoli	4
Barrettini	2	Corno	4
Biscie	2	Il Toro	2
Budelli	2	La Vacca	2
Cana	4	Mai di Ventre	2
Caprera	1	Meli	4
Cavalli	3	Ogliastra	4
Corcalli	2	Piana S. Pietro	4
La Presa	2	Quirra	4
Monaci	2	Ratti	4
Piana	2	Rossa Teulada	4
Porruggia	2	San Macario	4
Porco	2	San Pietro	1
Ratino	2	Sant'Antioco	1
Razzoli	2	Serpentara	4
Santa Maria	2	Tuaredda	4
Santo Stefano	2	Varigioni	4
Spargi	2	Isole di Oristano—IM0	
Spargiotto	4	Scoglio La Ghinghetta	5
Asinara	2	Scoglio Mangiabarche	5
Cappuccini	4	Scoglio Pan di	
Della Bocca	4	Zuccheru	5
Figarolo	4	Sardegna—IS0	
Foradada	4	Sardegna	1
Delli Nibani	4	Sicily—IT9	
Poveri	4	Sicily	1
Isolotto Rossa	4	Minor Islands	
Le Camere	4	Prefix I3	1
Le Soffi	4	Prefix IV3	1
Maddalena Alghero	4	Prefix I7	3
Marmorata	4	Prefix I8	1
Molara	2	(Sicilian)	
		Prefix IT9	4

ing modes: Frequencies: HF, VHF, UHF, microwaves above 3 GHz. Modes: SSB, CW, mixed, RTTY.

To obtain the award, the amateurs/SWLs must work/hear Italian islands to obtain the following score: DX—10 points; EU—20 points; Italy—40 points.

Contacts are valid starting from January 1, 1970.

Points must be calculated following the list (see box). Different islands of the same archipelago can be contacted, and the points achieved added up. The same island of the same archipelago can be worked on different bands and modes, i.e., five different contacts with the same island but on five different bands count 5 x points assigned to that island.

Honor Roll—This endorsement is achieved with a minimum of 60 points.

5BIIA—To obtain this award, 10 contacts must be made with islands or groups of islands on 5 HF bands.

The IIA must be requested from the ARI Award Manager, Via Scarlatti 31, 20124 Milano, Italy. It is not necessary to send QSL cards; a list log-formed is sufficient. The QSL cards must be in the possession of the applicant and should be sent if requested by the Award Manager.

Fee: Any application must be sent with US \$8.00 or 30 IRCs.



KOREA

J. Michael Wengert HL9KT
c/o ABC News
CPO Box 2961
Seoul
Korea

Amateur radio operators in Korea were surprised recently to receive letters from the "Korean Radio Operators Association," a group of professional radio operators, requesting them to mail fees to the organization and to make their stations available for inspection. Apparently, the Korean Ministry of Communications (MOC), which is responsible for issuance of all commercial and amateur radio licenses and for inspection of all classes of radio transmitting stations, has decided that the annual inspection required for all amateur stations for license renewal will be conducted by the professional organization and not by KARL (Korean Amateur Radio League). KARL had all but announced that they would soon be taking over inspection of amateur stations from the MOC. The reason for turning over the inspection responsibility to an outside organization was given as the "excessive workload" imposed by the growing number of new ham stations in Korea.

This decision from the MOC was yet another blow to KARL, which already was smarting from suspicion and criticism from its members following a procurement scandal. Early this year, a general-affairs director of KARL was relieved of his official duties when it was learned that his position was used to gain exclusive import rights for Japanese-made transceivers for a certain Korean import company whose president was a close friend of the KARL president, National Assemblyman Lee Min Sup. Lee was not directly implicated in the matter, but the incident has yet to be resolved to the satisfaction of KARL members as Lee repeatedly overruled attempts by individual members to bring up the matter for discussion at the KARL annual meeting last April.

Other matters for which KARL is under attack by its members include high fees charged for membership compared to that of other countries. Membership in the League is compulsory for all amateur radio operators in Korea and annual dues must be paid up in advance (US\$30) before the KARL president's seal may be applied to applications for annual renewal of the station licenses. The annual inspection fee comes to another \$22 (average). This, coupled with high customs duty and local taxes, makes amateur radio in Korea a pastime for rich people.

Attempts by KARL to get mobile/portable operation reinstated have failed. A League source, who prefers to remain anonymous, blames Korea's security agencies for blocking the proposal.

Although the total number of amateurs in Korea is on the increase, the number of active hams, especially on the HF bands, is not increasing proportionately. Korea has a Radiotelephone Class license (no-code Novice) which permits phone operation on 80, 40, 15, and 10 meters plus VHF and is relatively easy to get. As a result, many Koreans soon lose interest, sell their rigs, and buy microcomputers, a phenomenon observed in neighboring Japan which also has a box-top, no-code license.

HL9 operation by United Nations Command-affiliated personnel continues, but attempts to get on the new Phase III band are thwarted by the unavailability of 430 MHz. More on the HL9s and the American Radio Club in Korea next month. 73 from the Land of the Morning Calm.



LIBERIA

Brother "Don" Donard, Steffes, C.S.C.
EL2AL/WB8HFY
Brothers of the Holy Cross
St. Patrick High School
Monrovia
Republic of Liberia

What is a developing country—in amateur radio?

This question is under consideration by a committee of the Region I Division Conference of The International Amateur Radio Union. When this question has been decided, they will study a proposal "To establish a means of funding, and guidelines for effective operation for the Promotion of Amateur Radio in the Developing Countries."

Here is another quote: "... for example, in Liberia there are 67 licensed amateurs of which 26 are members of the Liberian Radio Amateur Association (LRAA). Of the 67, only 10 are indigenous Liberians."

Here in Monrovia, we have just finished a course in amateur radio. Out of a hundred and twenty students who registered for the course, twenty-six came in to sit for the examination. Of these, four passed the General test and four passed the Novice test.

We are a developing country. There is no lack of interest, and the data given above is enough evidence of that. The data given above might also be an indication of the handicaps under which we and the students must work. It takes a lot of courage for a high school student or an adult to study amateur radio without a textbook or a code oscillator.

We are very much encouraged by the fact that the Region I Conference is aware of our problems and is actively engaged in an effort to solve them. They propose to set up a resource center that will make available all kinds of instructional materials. They will stock printed materials that are either donated or that are obtainable free of charge and will appropriate an ongoing fund to purchase instructional materials and to pay shipping charges. They are even exploring the possibility of providing instructors if they are not otherwise available.

This is an ambitious idea but it can

work, and if it is handled in the manner in which amateurs traditionally handle their undertakings, it will indeed do what it is supposed to do. It will succeed.

One can only guess what is happening in other developing countries, but here in Liberia there is real promise of progress. We have, at the present time, five places, all of them school locations run by missionaries, where there is one (in some cases more) dedicated person ready to conduct classes in amateur radio even under existing conditions. If we can apply to the Region I committee, or to anyone else for that matter, for essential teaching materials, it would increase very much the effectiveness of our work.



MEXICO

Mark K. Toutjian XE1MKT
Apartado Postal 42-048
06470 Mexico, D.F.

MEXICO'S NATIONAL EMERGENCY NET

DIRECTOR

National Emergency Coordinator

Special Events Coordinator

VHF Coordinator

Public Relations Coordinator

Treasurer

Secretary

Region # 1

North Baja Calif.

Sinaloa

South Baja Calif.

Sonora

Region #2

Chihuahua

Durango

Region #3

Coahuila

Nuevo Leon

Tamaulipas

San Luis Potosi

Zacatecas

Region #4

Jalisco

Aguascalientes

Michoacan

Guanajuato

Nayarit

Region #5

Mexico City

Hidalgo

Mexico State

Queretaro

Region #6

Chiapas

Morelos

Guerrero

Oaxaca

Region #7

Puebla

Tlaxcala

Tabasco

Veracruz

Region #8

Campeche

Quintana Roo

Yucatan

MEXICO'S NATIONAL EMERGENCY NETWORK

One of the many activities that has been developed over the years here in Mexico, as in many countries, is the cooperation among many ham radio operators during catastrophes, natural disasters, and airplane accidents, as well as work on problems with mobiles (auto and maritime). In 1943, a communications net known by the name of The Emergency Chain of Ham Radio Operators of the Southeast was established in order to provide auxiliary services along the coast of the Gulf of Mexico, principally in the State of Veracruz. It was formally accepted in 1949 due to the aid of many national hams.

Later on, in 1960, a group of ham operators who were members of the Mexican Radio Experimenters League undertook the labor of forming a nationwide emergency network that would also be tied in with emergency networks in other countries. Frequencies were then established (see box for current frequencies being used). This National Emergency Network was fully organized finally by 1963. One of today's most leading authorities or representatives of the network is Pablo A. Mooser XE1SR who serves as president of the Mexican Radio Experimenters League at the present.

Organizational Structure

In order for this National Emergency Network to function well, it is obvious that an administrative staff is very necessary (see box). This is composed of its director and six additional positions in order to coordinate things fully. Under this administrative staff, the country is divided into eight different regions or zones, each with its own Regional Coordinator. Within each region or zone there are various states, each with its own State Coordinator. These coordinators have in mind the development of special programs for members of the net so as to be able to function efficiently under most emergency situations. (This is very similar to emergency networks in other countries.) The structure may be of use to some of you who plan on organizing an emergency network in your own country where ham activities are starting to boom.

Certificates Available from the Network

Mexico's National Emergency Network

EMERGENCY FREQUENCIES OF THE MEXICAN NATIONAL EMERGENCY NET

Phone	Code
3,680 MHz	3,690 MHz
7,020 MHz	7,060 MHz
14,040 MHz	14,120 MHz
21,060 MHz	21,180 MHz
50,040 MHz	50,040 MHz
144,500 MHz	144,500 MHz

encourages new membership and more cooperation by means of authorizing three different certificates yearly. This is done by calculating individual attendance figures during each year. First, one has to be a member of the net. This organized transmission takes place daily at 2100 GMT on 3.690 MHz and on the 2nd and 4th Sundays of each month at 1000 GMT on 7.060 MHz. (The frequency chart shows frequencies to use when disaster strikes; they are used frequently for get-togethers.)

1) The first certificate is available for having attended 50 sessions with the net during the year (once a week).

2) The second certificate is available for having attended 150 times during the year (three times a week).

3) The third and last certificate is available for having been on frequency and reported your call 300 times during one year (six times a week).

The National Emergency Network can and has already presented different members with special certificates upon having participated in and resulting in outstanding performances during emergencies, catastrophes, or in special situations requiring aid.

You are possibly asking yourself: "How can I be a member?"

Membership

In order to become a member, you must have attended at least 24 sessions of the net during a year (at least once every two weeks). This certificate is valid for one year and is renewable upon attending another 24 sessions as mentioned above.

As was mentioned, many activities are planned by the National Emergency Net each year, and here I could mention that the different radio clubs throughout the country work in harmony with the net and also plan special events such as DXpeditions and other activities for the advancement of ham technology.

Special Note to Regional and State Coordinators in Mexico

Upon planning your future activities, I would appreciate it very much if you would send me an outline of such events and other pertinent information that may be of interest to 73 readers! Gracias!



THE NETHERLANDS

Henk Meerman PD0DDV
Zandvoortterweg 33
2111 GR Aerdenhout
The Netherlands

FIFTEENTH DNAT

From the 26th to the 28th of August of this year, the DNAT was held. The DNAT means Deutsch-Niederlandische Amateurfunktag (the German-Dutch Amateur Radio Days).

These days are organized by two Dutch amateur radio unions and one German, namely the VERON, the VRZA, and the DARC.

This annual Dutch-German meeting was held this year for the 15th time, in the beautiful city of Bad Bentheim, which is located near Almelo (The Netherlands), just a few kilometers over the Dutch border in Germany. Every year the Dutch and German hams and their families come from miles around to meet one another in Bentheim.

This year also the DNAT was a great success and hundreds of hams were pres-



The flea market at Bad Bentheim.

ent. Also yours truly was there with his YL to see what was on the program this year.

My first pleasure was to fill up the tank of my car with much cheaper German gas. The difference is about thirty cents a liter! My second pleasure was to find a good camping spot near Bentheim. The thought of taking a hotel during these days you can forget, because all the hotels are fully booked. Anyway, I was glad that I took my tent along because we had extremely high temperatures for our kind of climate and for this time of the year.

We arrived at Bentheim on Friday evening, and because I was a bit tired of my work and I have to drive from the west side of my country to the east side, we had a few drinks and went to sleep.

The next morning my YL, friends, and I checked in at the DNAT office, located in the DARC (German Amateur Radio Club) building. We paid our registration fee and received badges with the DNAT sign. By paying the fee, entrance to all activities was free. We even had free entrance to the Bentheimer Casino and we could visit the Amateur Radio Museum. We also drove out of town and went to the castle of Bentheim. Afterwards we had a look at the flea market; you never know what bargains might be found.

So we took a very close look at all the stands. The place was so crowded that I and my friends kept in contact via our HTs—otherwise we would have lost each other. Since we all came in one car, the thought of losing one other was not a pleasant idea!

There was much to see, from pieces of junk to complete HF lines with reasonable price tags. I bought some spare tubes for some receivers; the price of one tube was one mark. What can you buy for one mark these days?

After the flea market full of "sonderangebot," as the Germans call it, we had a look in the large school building where a number of German dealers had their stands. All the big names in ham equipment were present, and often these dealers had special DNAT prices. We bought some antenna stuff.

In the evening we went to a large hamfest in the garden of the castle of Bentheim, where we could dance to the music of a combo. On Sunday morning we packed up our things and went home again. It all was a great success, and I promised myself and my YL that we'll be there again next year.

NEW RULE

A new rule in Dutch amateur radio license conditions requires that all hams make a complete inventory of all the

transmitters they own. This list has to be in the station's logbook and must include serial numbers, date of selling or purchase, type of equipment, power output, and name and address from whom the rig was bought and to whom the rig was sold. So, in the future, all Dutch hams will need an accountant to keep papers in order. (H)



NEW ZEALAND

Des Chapman ZL2VR
459 Kennedy Road
Napier
New Zealand

This month I shall explain about the birth of the Amateur Radio Emergency Corps of the New Zealand Association of Radio Transmitters.

THE 1931 EARTHQUAKE

"There can be, at this time, no more topical or important subject than the calamitous earthquake that has almost razed to the ground the towns of Napier and Hastings. The day of February 3rd, 1931, will remain for long a day of grief and consternation for the country as a whole, even as for years the date '79 A.D.' was significant for the annihilation of the cities of Herculaneum and Pompeii by Vesuvius."

So went the editorial from *Break-In* for the month of February, 1931. It goes on to extol the feats of two local Hawkes Bay amateur radio enthusiasts from Napier and Hastings who were able to transmit messages to the outside world of the tragedy of that day. ZL2GE (George Tyler) and ZL2BE (Jim Mills) provided the only communications links with places outside the earthquake-affected area in those early few hours after the first shocks at 10:50 that morning.

There were some other radio stations on board ships in the harbor which were able to call for help, too, but the amateur stations were operating from the centers of the two stricken cities. Both stations were battery operated and had contact with other amateur stations. Early in the emergency, the New Zealand Post and Telegraph Department requisitioned the amateur stations at Napier and Hastings as well as an amateur station in Wellington so that there were communications links available for emergency traffic in the

first 24 hours after the calamity and until the telegraph and telephone lines were repaired and normal communications were restored.

THE RADIO EMERGENCY CORPS

That very briefly indicates the happenings of the 1931 February day when the earthquake struck. As a direct result of the success of the earthquake amateur radio communications network, the New Zealand Association of Radio Transmitters formed the Radio Emergency Corps in March, 1932.

Previously, about 1930, as a result of suggestions at a Headquarters meeting, a form of communications network was set up under the name of the Guard System and introduced in March, 1931. Guard stations were rostered two nights each week to operate a traffic net between HQ and the Branches of NZART. Rosters were published in *Break-In* and the *NZART Journal*, and the Guard System operated from 6:30 pm to 10:00 pm, Monday to Friday, and 6:00 pm to 11:00 pm, Saturday and Sunday.

It was intended that in times of an emergency, all Guard Stations would stand by for the Control Guard Station in the District affected by the emergency and handle any traffic as required. This Guard System gave the members practice in handling messages on the air and established a link between HQ and the Branches. The system was most successful, and many messages were transmitted and received every week on a scheduled basis. However, in due course, the New Zealand Post and Telegraph Department, the regulatory body in New Zealand, decided this message service was contrary to the radio regulations governing the amateur service here (no third-party traffic allowed), so NZART discontinued the Guard System.

About the same time as the Guard System was being formulated, a Christchurch group of amateurs under Norm Laugeson ZL3AS assisted by Hugh Simpson ZL3CF, Jack Elliott ZL3CC, and Les Hurrell ZL3BG had set up a group in that area able to go into action in an emergency at short notice should the necessity arise. But because the Christchurch group was part of the Radio Society of Christchurch and the Third District Transmitters Association, the two clubs catering to the local budding radio enthusiasts of the 30s, they were not part of the NZART message-handling system, although most of the group were members of the NZART. The Third District RTA in due course merged with the NZART to form the Christchurch Branch.

With the termination of the Guard System, Norm Laugeson, then a Vice-President of NZART, put forward a proposal to HQ for an emergency radio communications scheme, and in February, 1932, the proposal was adopted by the Executive of NZART, and amateur stations were asked to form themselves into local Sections of the Radio Emergency Corps, each self-contained but affiliated to the national body of emergency stations at Headquarters. Thus, the Radio Emergency Corps was formed.

The response from amateurs throughout the country was tremendous. A constitution was produced, and by March, 1932, nine Sections had been formed and a National REC Field Day was held to test the emergency network; 27 amateur stations and approximately 50 operators participated in that first successful Field Day.

The Field Day organization consisted of at least three stations, a Guard Relay Station (Base Station today), a Zone Station (Field Headquarters today), and an Outpost Station (or stations)—the same title today. Stations were to organize and ex-

MISSOURI RADIO CENTER 1-800-821-7323

KENWOOD TS-430S



- All Bands
- Dual VFO's
- General Coverage
- 8 Memories
- 200 Watts

ICOM NEW IC-745

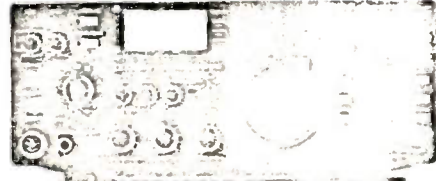

- General Coverage Receiver
- 1.8 to 30 MHz
- Fantastic Buy

YAESU -NEW FT-77



- Extremely Compact
- 3.5 to 30 MHz
- 200 Watts
- Inexpensive

ANTENNA SALE

CUSHCRAFT

A-3	\$215
A-4	\$285
R-3	\$275
AV-5	\$ 98
214-FB	\$ 79
32-19	\$ 94
40-2CD	\$285

HY-GAIN TOWERS

HG37SS	\$ 649
HG52SS	\$ 919
HG54HD	\$1429
HG70HD	\$2339
HG50MTS	\$ 749

LARSEN CALL

BUTTERNUT

HF6V	\$109
— KLM —	
KT34A	\$299
KT34XA	\$449
144-148LBA	\$ 69

AEA CALL

HY-GAIN

TH5MK2S	\$318
TH7DXS	\$378
TH3MK3S	\$218
TH3JRS	\$158
TH2MKS	\$138
18AVT/WS	\$ 94
18HTS	\$335
V2S	\$ 37
EXPLORER 14	\$275
30/40 METER KIT	\$ 79

ANIXTER-MARK

HW-3 TRIBAND MOBILE \$34

Call "TOLL FREE" For All Antennas & Accessories

2900 N.W. VIVION RD. / KANSAS CITY, MISSOURI 64150 / 816-741-8118

ALL HF BANDS!



The SLINKY DIPOLE® Antenna

A broadband, low SWR dipole that really works in apartments, small yards, attics, anywhere a small antenna is a must. Indoors or out, you can work ANY HF BAND, including 10 MHz. No gimmicks or add-ons. Imagine 80M in as little as 24 ft.! Complete kit and instructions, plus 50 ft. of coax. Easy to set up and adjust. More information available - just call or write.

Blacksburg Group
Box 242 Suite 500
Blacksburg, Virginia 24060
703/951-9030

\$67.95 postpaid (in U.S.A.)
Money Back Guarantee
Virginia residents
add 4% sales tax

WORK THE U.H.F. BANDS

Add a transverter or converter to your existing 10m, 6m or 2m equipments. Choose from the largest selection of modules available for DX, OSCAR, EME, ATV

TRANSVERTERS



- MMT 50-144 \$189.95
 - MMT 144-28 \$179.95
 - MMT 432-28 (S) \$269.95
 - MMT 439-ATV \$349.95
 - MMT 1296-144 \$339.95
- OTHER MODELS AVAILABLE write for details

POWER AMPLIFIERS

all models include RF VOX & Low Noise RX Pre-Ampl. (no pre-amp in MML432-100)

2 Meters:	100W output	MML144-100-LS	1W or 3W in	\$254.95
	100W output	MML144-100-S	10W input	\$264.95
	50W output	MML144-50-S	10W input	\$214.95
	30W output	MML144-30-LS	1W or 3W in	\$109.95
	25W output	MML144-25	3W input	\$114.95
432 MHz:	100W output	MML432-100	10W input	\$399.95
	50W output	MML432-50	10W input	\$239.95
	30W output	MML432-30-L	1W or 3W in	\$199.95
1268-1296 MHz:			Coming soon. Watch for details.	

ANTENNAS (incl. 50 ohm balun)

- 2 Meter J-Beams: 12.3 dBd gain
- 8 over 8 Horizon'l pol D8-2M \$63.40
- 8 by 8 Vertical pol D8-2M-vert \$76.95
- 1250-1300 MHz Loop-Yagi 1296-LY \$44.95
- 70 cm/MBM 48 \$75.75
- 70 cm/MBM 88 \$105.50



Send 36¢ stamps for full details of all our VHF/UHF items.

- Pre-selector filters
- Pre-amplifiers
- Antennas
- Low-pass filters
- Transverters
- Crystal Filters
- Varactor triplers
- Converters



Spectrum International, Inc.
Post Office Box 1084S
Concord, Mass. 01742 USA



change messages during the exercise, up and down the network. The Guard Relay Stations handled the messages between each District and distributed the messages for their own District to the Zone Stations, which retransmitted them to the Outpost Stations. Zone and Outpost Stations were operated at a portable location, on battery power.

The pace of the organization of the Radio Emergency Corps continued to quicken, and in June, 1932, negotiations were completed with the New Zealand Post and Telegraph Department for the allocation of special call signs and wavelengths for the Emergency Service to use during practices and emergencies. As this step had finally cemented the setting up of the REC of NZART, Headquarters, through an editorial in *Break-In*, paid tribute to the untiring efforts of Norm Laugeson ZL3AS and Wally Ashbridge ZL2GP of Wellington, in formulating and founding the REC. Headquarters expressed the gratitude of all ZL amateur operators and the community at large for all the work these two men, and others closely associated with them, had done to set up an organization that was to become well known in the future.

Wally Ashbridge, a professional communications man in the New Zealand Army and the officer in charge of the Guard System, was appointed the first Commanding Officer of the REC. The collaboration between Wally Ashbridge and Norm Laugeson, professionally a detective in the NZ Police, is obvious today when one observes that there is very little difference between the basic organization of the present day emergency network systems and that which they formulated over 50 years ago. Truly a great tribute to the organizational abilities of these two men and their assistants.

The honor of the first operation went to the Christchurch group which went into action in January, 1932, in response to a request from Wally Ashbridge to provide some radio communications for search parties at an alpine tragedy in the Southern Alps. They made ready a group of four Christchurch amateurs, complete with transmitters, receivers, and suitable rations for one week in the field, within one hour of the request being received. They were to set up a communications net between the search parties in the Alps and the Telegraph office at Bealy, the headquarters for the search, some 15 miles distant. Although the missing trampers' bodies were found before the team was able to set up the communications net, it ably demonstrated the way REC was going to work in emergencies.

In July, 1932, the new REC held another Field Day with the newly allotted call signs and wavelengths. In all, 11 Sections operated with the "E" calls very similar to those we use today, but only two-letter ones for obvious reasons. The present three-letter call signs were introduced in the early 50s. At this 1932 Field Day, the frequencies used were between 100 and 105 meters, and these were found to be useful but not successful in some areas. The Field Day was a great success, and Wally Ashbridge declared that all Sections were fit to operate on emergency duties any time the need should arise. All Sections agreed that the exercise had been a successful one, but some felt that a frequency change could improve the communications between some of the Basic Stations.

By February, 1933, a new constitution and organization plan was approved by Headquarters and duly circulated to all members. The 1933 format and organization is still basically the same as given in

our modernized AREC Manual in use today.

Over the years, the AREC has participated in many searches and rescues, severe floodings on both North and South Islands, air crashes, earthquakes, land subsidances, and marine searches. The Amateur Radio Emergency Corps of today is still the same as our founders intended—to provide emergency communications during times of national calamity or tragedy, and to provide readily organized mobile transmitting and receiving stations, equipment, and operators to function at short notice should they be required—except that the equipment we use today has changed drastically from that used in former times.

Today, when Search and Rescue Headquarters requires it, we are able to put teams into operation with portable and base stations to assist with all manner of emergency and rescue operations, whether it be in the city, the bush, mountainous terrain, or at sea.

In contrast with the 1932 Field Day statistics mentioned previously, and 51 years later, the 1983 Field Day statistics were: 59 Sections operated 266 Field Day stations, manned by 491 operators, on 80, 40, and 2 meters, and sent and received over 12,000 messages during the 6-hour period of the exercise.

AWARDS

Last month I made mention of a special award to commemorate the 100th birthday of Hastings City. Here are details.

The City of Hastings Centennial Award is open to all amateurs worldwide on all bands and all modes; the period of the award will be from 0001 hours GMT, February 1, 1984, until 2400 hours GMT, February 29, 1984 (*one month only*). Applicants for the award must complete two-way contacts with Hastings stations or members of the Hastings Branch number 13 of NZART as follows: overseas stations—3 contacts, any band, any mode; ZL stations—5 contacts, any band, any mode.

No QSL cards are required; just send a detailed list of the contacts, verified by another amateur operator, to the Awards Manager, PO Box 609, Hastings, New Zealand, with US\$2.00 or IRC equivalent, to receive the handsome colored certificate.

Hastings is a city of about 50,000 population situated in the province of Hawkes Bay on the east coast of New Zealand's North Island. The area is favored with a good climate and is surrounded by some of the most fertile land in the country. Hastings is the center of a great and expanding food- and meat-processing industry and one of the most prolific fruit- and grape-growing districts in New Zealand; it justly earns the name, "The Fruit Bowl of New Zealand."

Hastings was constituted a town district in 1833, and in 1886 achieved borough status. The earthquake of 1931, followed by raging fires, caused great loss of life and reduced the town to ruins. The manner in which the city was rebuilt is a tribute to the citizens of that day. In 1956, the borough was proclaimed a city. The motto on the City Arms signifies the harmony between city and countryside.

So to all certificate hunters and readers of 73, best of luck with this special award. Remember, it is available only for contacts during the month of February, 1984.

By my calculations, this column should be appearing in the January issue of 73, so I take this opportunity of wishing all readers belated Christmas greetings and the very best of luck for the coming year. For those of you in the northern hemisphere, you are in the depth of your winter season at this festive time while we, down under, are enjoying mid-summer temperatures

and our summer holidays, as well as the festive season.

In New Zealand, most large manufacturing businesses curtail their operations at Christmas time, closing from about December 23rd until around January 15th, except for maintenance staff, so we here all have our summer holidays at that time. The schools close for their summer vacation about December 15th and do not resume until February 1st, the equivalent of the US/Canadian July/August school holiday closing.

I hope everyone had a Happy Christmas and a joyous New Year and that Father Christmas brought you something worthwhile for the shack this year!



PAPUA NEW GUINEA

Siegl Freymadl P29NSF

PO Box 165

Rabaul

Papua New Guinea

Lae is the capital of the Morobe Province, one of the twenty provinces of Papua New Guinea. The Morobe Province is located in the northeastern part of New Guinea. Lae, the administrative center of the province and also the industrial metropolis of the entire country, is situated on the Huon Gulf. It is the gateway to the Markham Valley. The population of Lae is approximately 65,000. In Lae we have the country's foremost technological institution: the Papua New Guinea University of Technology, commonly known as Unitech.

The amateur population of Lae is seven, four of whom are on the staff of Unitech (three in the Electrical Engineering Department). P29BR, P29LC, P29MC, and P29NL are Unitech staff. Husband and wife team P29JH and P29NWJ, John and Betty, are with the P and T Training College and are active from Lae. George P29NCB makes up the seventh member of Lae's amateur population; all are expatriates.

Unitech attracts students from all provinces of Papua New Guinea—indeed, from a number of South Pacific countries. What better forum for promoting and advertising amateur radio and thus increasing the number of PNG nationals who are amateurs? In November, 1982, P29BR, P29LC, P29MC, and P29NL put their heads together and decided to offer radio amateur classes to interested students. To publicize amateur radio, a lunch-time demonstration was organized with P29BR bringing his rig along and demonstrating it. The exercise also was written up in the campus newspaper, the *Reporter*. The response was tremendous, and more than 100 students enrolled for amateur radio classes. Thus the Unitech Amateur Radio Club (UARC) was formed and it has the call sign P29HT. The club is affiliated with the Papua New Guinea Amateur Radio Society.

P29BR, P29LC, P29MC, and P29NL give freely of their spare time and provide three hours of tuition per week in CW, theory, and regulations. Practical projects, such as building Morse-code oscillators, are included. P29BR records CW tapes for the weekly classes and on one occasion he decided to take the prepared tapes home. The following morning Bill discovered that his house had been burgled during the night but that the only things missing were the plastic bag containing the tapes,

a pair of jeans, and a packet of cheese. A very selective thief, and one who will be bewildered by the strange sounds on the tapes!

The turnover of young hopefuls in the amateur radio classes is large; not many have the staying power, but generally 20 students attend and it is hoped that a number of those will attempt the Novice examinations the next time they are given.

Last year, Bill P29BR went on a visit to the United States and while there approached the ARRL regarding the possibility of donations of equipment and/or publications to help the students at the Unitech Amateur Radio Club; the oral response was positive. Bill also visited the Asla Foundation, and the Area Director for the Pacific Islands there offered assistance with postage expenses for sending material. An official reply was subsequently received from the ARRL which expresses unwillingness to deal directly with the Unitech Amateur Radio Club and appeared willing to have donations handled only through the Papua New Guinea Amateur Radio Society. There can be no questioning the ability of the staff and their supervision at the Unitech Amateur Radio Club. There also cannot be any doubt that future PNG amateurs are more likely to come from Unitech than anywhere else in the country. Why then this reluctance on the part of the ARRL to deal with UARC directly?

It is hoped that several of the students will be successful in the next Novice exams and that a number of PNG nationals will be on the air after that. Another consideration is the application fee which has to be paid six weeks prior to the exam. In the event of any students finding the fee beyond their means, the UARC is willing to come to the rescue out of club funds. We wish the UARC every success in their undertaking!

On July 14, 1983, the Post and Telecommunication Corporation in PNG sent out letters to all amateur radio station licensees introducing the new frequencies available as from that date. Full-call operators have the authorization to operate on all the new frequency bands. Limited amateur radio stations are permitted to operate on all new frequency bands above 30 MHz, and for Novice amateur radio stations there is no change in operating frequencies.



POLAND

Jerzy Szymczak
78-200 Białogard
Buczka 2/3
Poland

POLISH ETHER CARRIES SOUND AGAIN

On January 1, 1983, martial law in Poland was suspended. Polish hams expected to begin their usual activity. But no gain without pain. Renewing licenses was faced with official difficulties, and the commencement of reissuing them did not take place in January as it had been announced.

At the beginning of 1983, letters of application—printed forms submitted by petitioners to District Verification Boards—were still being brought up to date. At the end of January, 1250 applications were confirmed, and on April 1 over 1700. The Presidium of PRAA (Polish Radio Amateurs Association) was informed that



Plug-In Bumper Crop

From the fertile grounds of Communications Specialists comes our fresh harvest of direct CTCSS plug-ins to spade through valuable installation time and cultivate profits. They're available for most popular mobiles, portables, and repeater panels, and all incorporate our industry standard, field programmable TS-32.

Just call our sales or engineering departments toll free from anywhere in the USA (including California) and reap what we've sown.

**COMMUNICATIONS
SPECIALISTS** ✓ 34
426 West Taft Avenue, Orange, CA 92667
714/998-3021 Entire USA 800/854-0547



licenses of club radio stations would be handed over to them in April and those of individual radio stations at the turn of the second and third quarters of this year. Better late than never.

Negotiations with authorities brought changes of these provisions. For the sake of the annual International competition, the SP DX Contest, it was promised that licenses would be delivered in March, 1983. And really, 460 individual and 70 club licenses were given. Well, it's a long lane that has no turning. Poles are in the ether again.

A problem is how well this process will continue. At the sixth PRAA director's meeting last April, the president of the association urged patience and calm but encouraged hams to continue to press for more action, through regular channels. He predicted that radio amateur activity would reach a normal level in a few months.

The president has also expressed regret at the new limitations placed on Polish hams and for the State Radio Surveillance.

It was hoped that by the end of 1983, the action of bringing licenses up to date would have been completed. How many Polish hams will be able to use their calls in 1984 when the National Congress of PRAA takes place, nobody knows. But some of them are presently in the ether, so enter upon a conversation with them!



SWEDEN

Rune Wande SM0COP
 Frejavagen 10
 S-155 00 Nykvarn
 Sweden

SVALBARD EXPEDITION

A Swedish group of four made a second expedition in the summer of 1983 to the Svalbard Islands in the Arctic Ocean. The group members do this entirely of personal interest on their own vacation time. Two members of the group were ham operators, Kjell SM2AZH and Sigvard SM2EJE.

The purpose of this expedition was to study the flora and fossils. Svalbard has an interesting history and has a geological structure of scientific importance. From the ham-radio point of view, the first trip in 1982 was no success. The radio equipment got damaged by water during transportation between islands in high winds.

The Islands of Svalbard (prefix JW) belong to Norway. They are about 1,100 kilometers (700 miles) from the North Pole. The summer temperature reaches refrigerator level. The islands have no permanent residents, but boats stop there when the harbors are free of ice. Svalbard has been the base for many Arctic expeditions. The Norwegians began mining coal there in the 1890s.

Kjell and Sigvard were active from Svalbard using their home calls JW between July 20 and August 4, 1983. In case you were lucky enough to work them, use their Callbook addresses for the QSL.

The equipment for the expedition was sent in advance on a ship for coal transportation. The group itself flew out of Tromsø (Norway) to their base in Longyearbyen on Svalbard. The radio equipment consisted of a Kenwood TS-120V, the low-power version of this well-known transceiver, and a Heathkit HW-8 for backup. For power, they used two batteries

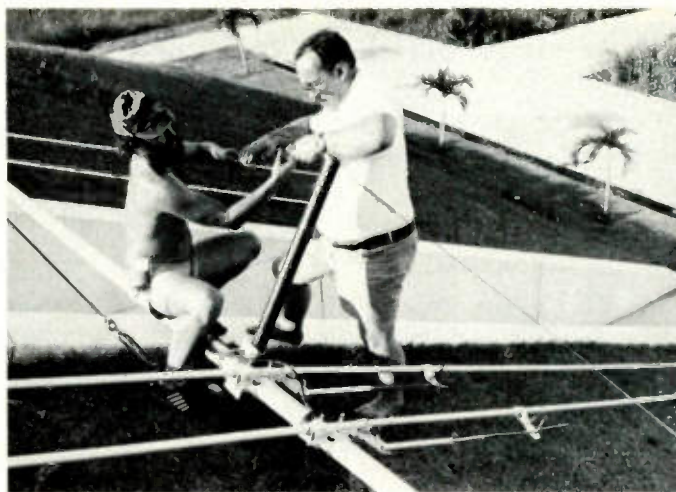

Jean H51ANV/ON8JA (left) and Hans H51BG secure the supporting truss on the 20/15-meter (full-size) beam. Note the gamma match, using aluminum piping, plastic hose, and an inner core of copper tubing for the driven elements.

rated at 60 Ah which they charged by a gasoline generator. The antennas for 7 and 14 MHz were verticals, and a dipole was used for 3.5 MHz.

The propagation that far north is very poor on the low bands during the summer season. This is due to two months of daylight and sunshine 24 hours a day. They managed to contact northern Norway and northern Sweden on 40 meters, however, although 20 meters was the best band. A few good openings towards the US and South America stirred up some pileups.

Anyway, hamming was not the main purpose for this expedition, so the QSO rate was low. Because of the frequent change of location and transport between islands in a rubber boat, operating time was limited. But wherever hams go and for whatever reason, they surely bring ham radio with them. Kjell and Sigvard and the two other members of this expedition must have had a unique vacation to remember!

NRAU MEETING IN STOCKHOLM

The Nordic Radio Amateur Union was

formed in 1935 with the purpose of working for common Nordic interests for the radio amateurs. Through the NRAU there is a valuable dialogue between the leagues in the Nordic countries. Meetings are held annually. The next one is taking place in Stockholm on January 14-15, 1984. The NRAU runs a very low-budget operation, and to make it possible for representatives from distant Iceland (TF) and Faroe Islands (OY) to attend, the other larger leagues try to sponsor them.

Contributions from the Nordic Council, an organization founded in 1952 by the Nordic parliaments for improvement for Nordic cooperation, have been applied for. Unfortunately, no financial support has been received in previous years. Let us hope that they are more obliging this time.

One major subject for discussion at the NRAU meeting is the common Nordic license. This has been worked on for years, but still only regular reciprocal rules apply. Crossing borders between Nordic countries does not require a passport, and you have to be observant even to see the customs house, but still do not even bring the 2-meter hand-held over the border unless you have a valid guest license. Hopefully, this situation will be solved eventually so that it will be as easy to operate from different Nordic countries as it is between the USA and Canada.



THAILAND

Tony Waltham H51AMH
 c/o Bangkok Post
 U Chuliang Building
 Bangkok 10500
 Thailand

Most countries have their national radio society, and in Thailand the "magic" acronym is RAST, standing for the Radio Amateur Society of Thailand, which has been representing amateur radio activity in Thailand since its founding in November, 1963.

In addition to holding regular club meetings on the first Sunday of each month, to which all visiting radio amateurs are heartily welcomed, it has organized many other activities and has represented Thailand in the field of amateur radio on numerous occasions.

Highlights have been the Southeast Asia Network conventions in 1977 and again last year. Also, club representatives have endeavored to attend every major international conference on amateur radio, such as the World Administrative Radio Conference held in Geneva, IARU regional meetings such as the Manila conference in April, 1982, and the World Communications Year conference in Tokyo in September, and the World Amateur Radio International Conference.

Club meetings regularly vote on routine IARU motions, and full international representation is maintained through the club secretary. The address for all correspondence (as well as for the QSL bureau) is PO Box 2008, GPO, Bangkok 10501, Thailand.

A most encouraging aspect of amateur radio in Thailand has been the recent upsurge in interest among Thais in the hobby and its related aspects. Up until 1971, which coincided with the American presence in Vietnam, the society regulated membership to a maximum of 50. This was largely so that it could be in a posi-



The antenna is nearly ready for the H50HS Seantel-contest operation.

RAMSEY

THE FIRST NAME IN ELECTRONIC TEST GEAR



NEW FROM RAMSEY 20 MHz DUAL TRACE OSCILLOSCOPE

Unsurpassed quality at an unbeatable price, the Ramsey oscilloscope compares to others costing hundreds more. Features include a component testing circuit that will allow you to easily test resistors, capacitors, digital circuits and diodes • TV video sync filter • wide bandwidth & high sensitivity • internal graticule • high quality rectangular CRT • front panel trace rotator • Z axis • high sensitivity x-y mode • very low power consumption • regulated power supply • built-in calibrator • rock solid triggering • high quality hook-on probes

\$399.95 high quality hook-on probes included



RAMSEY D-1100 VOM-MULTITESTER

Compact and reliable, designed to service a wide variety of equipment. Features include • mirror back scale • double-jeweled precision moving coil • double overload protection • an ideal low cost unit for the beginner or as a spare back-up unit

\$19.95

test leads and battery included



RAMSEY D-2100 DIGITAL MULTITESTER

A compact easy to use unit designed to operate like a pro. Featuring • 3 1/2 digit LCD • low BAT. indicator • all range overload protection • overrange indication • auto-polarity • Transistor tester • dual-slope integration • vinyl carrying case

\$54.95

hFE test leads, battery & vinyl carrying case included

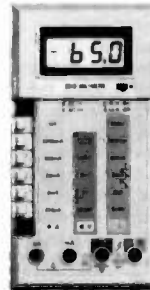

RAMSEY D-3100 DIGITAL MULTIMETER

Reliable, accurate digital measurements at an amazingly low cost • In-line color coded push buttons, speeds range selection • abs plastic tilt stand • recessed input jacks • overload protection on all ranges • 3 1/2 digit LCD display with auto zero, auto polarity & low BAT. indicator

\$59.95

test leads and battery included



CT-70 7 DIGIT 525 MHz COUNTER

Lab quality at a breakthrough price. Features • 3 frequency ranges each with pre amp • dual selectable gate times • gate activity indicator • 50mV @ 150 MHz typical sensitivity • wide frequency range • 1 ppm accuracy

\$119.95

wired includes AC adapter

CT-70 kit \$99.95
BP-4 nicad pack 8.95



CT-90 9 DIGIT 600 MHz COUNTER

The most versatile for less than \$300. Features 3 selectable gate times • 9 digits • gate indicator • display hold • 25mV @ 150 MHz typical sensitivity • 10 MHz timebase for WWV calibration • 1 ppm accuracy

\$149.95

wired includes AC adapter

CT-90 kit \$129.95
OV-1 0.1 PPM over timebase ... \$59.95
BP-4 nicad pack 8.95



CT-125 9 DIGIT 1.2 GHz COUNTER

A 9 digit counter that will outperform units costing hundreds more. • gate indicator • 24mV @ 150 MHz typical sensitivity • 9 digit display • 1 ppm accuracy • display hold • dual inputs with preamps

\$169.95

wired includes AC adapter

CT-125 kit \$149.95
BP-4 nicad pack 8.95



CT-50 8 DIGIT 600 MHz COUNTER

A versatile lab bench counter with optional receive frequency adapter, which turns the CT-50 into a digital readout for most any receiver • 25 mV @ 150 MHz typical sensitivity • 8 digit display • 1 ppm accuracy

\$169.95

wired

CT-50 kit \$139.95
RA-1 receiver adapter kit 14.95



DM-700 DIGITAL MULTIMETER

Professional quality at a hobbyist price. Features include 26 different ranges and 5 functions • 3 1/2 digit, 1/2 inch LED display • automatic decimal placement • automatic polarity

\$119.95

wired includes AC adapter

DM-700 kit \$99.95
MP-1 probe set 4.95



PS-2 AUDIO MULTIPLIER

The PS-2 is handy for high resolution audio resolution measurements, multiplies UP in frequency • great for PL tone measurements • multiplies by 10 or 100 • 0.01Hz resolution & built-in signal preamp/conditioner

\$49.95

wired includes AC adapter

PS-2 kit \$39.95



PR-2 COUNTER PREAMP

The PR-2 is ideal for measuring weak signals from 10 to 1,000 MHz • flat 25 db gain • BNC connectors • great for sniffing RF • ideal receiver/TV preamp

\$44.95

wired includes AC adapter

PR-2 kit \$34.95



PS-1B 600 MHz PRESCALER

Extends the range of your present counter to 600 MHz • 2 stage preamp • divide by 10 circuitry • sensitivity 25mV @ 150 MHz • BNC connectors • drives any counter

\$59.95

wired includes AC adapter

PS-1B kit \$49.95

ACCESSORIES FOR RAMSEY COUNTERS

Telescopic whip antenna—BNC plug \$ 8.95
High impedance probe, light loading 16.95
Low pass probe, audio use 16.95
Direct probe, general purpose use 13.95
Tilt ball, for CT-70, 90, 125 3.95



PHONE ORDERS CALL
716-586-3950

TELEX 466735 RAMSEY CI

TERMS: • satisfaction guaranteed • examine for 10 days; if not pleased return in original form for refund • add 6% for shipping and insurance to a maximum of \$10.00 • overseas add 15% for surface mail • C.O.D. add \$2.50 • orders under \$10.00 add \$1.50 • NY residents add 7% sales tax • all kits have a 90 day parts warranty. Wired units have a one year parts & labor warranty.



RAMSEY ELECTRONICS, INC.
2575 Baird Rd.
Penfield, N.Y. 14526

tion to control the activities of what was at that time a hobby mostly pursued by American servicemen based temporarily in Thailand. But with the gradual withdrawal of American forces, the complexion of the club began to change. More Thais joined, and now the society has about 600 registered members, of which 90 percent are Thai—a far cry from the late 1960s when the hobby had caught the imagination of few Thais.

This upsurge can be attributed to several factors, not the least being enthusiasm shown by the Post and Telegraph Department and personally by the department's director-general, Police Major-General Suchart P. Sakhol, who addressed one very-well-attended RAST meeting in 1981.

It would also be appropriate to credit the society's former president, the late Brigadier-General Kamchai Chotikul HS1WR, for his lifelong dedication to the hobby. He also did much to popularize amateur radio and to increase club membership. All club members, as well as his many friends in amateur radio circles, were deeply saddened at his death in June, 1982.

The society has, of course, continued on its course of promoting the hobby and doing its best to popularize amateur radio and its self-educational aspect in this era of rapid technological advances, especially in the field of communications. As an example of this, the club has embarked on a course of teaching computer applications in amateur radio, since the integration of microcomputing and amateur radio is inevitable and they are compatible.

The society also has conducted other educational courses, including Morse code, and especially in teaching the electronic principles and operating procedures required for the Thai equivalent of a Technician's license for two-meter operation.

The Thai PTT has shown great enthusiasm for amateur radio, especially in the light of constraints relating to national security apparently imposed from outside the Communications Ministry. The department has also shown cooperation in authorizing special-event stations on the HF amateur bands for such occasions as major contests and for the Southeast Asia Network Convention in November, 1982.

RAST was thus able to operate an HF station for the Seanet contest in August this year as well as to take part in the All Asia DX Contest (CW section) that same month. Arrangements also were made for the CQ WW phone and CW contests in October and November.

In operating these contests, the club was most grateful to the Asian Institute of Technology on the outskirts of Bangkok which has endorsed our applications to

Class	Qualified for license	Test for technical knowledge	Test for operating knowledge	Test on regulations	Morse Code send and receive (wpm)
B		75	65	65	12
A		65	65	65	6
C		50	65	65	N/A
Upgrade from A to B		75	—	—	12
Upgrade from C to A		65	—	—	6
Upgrade from C to B		75	—	—	12

Table 1. Percent-correct and wpm scores needed to qualify for licenses, by class and subjects.

Class	Number	PC of Total	PC Increase 1982-1983
B	26,944	56.1	5.1
C	20,254	42.2	1.6(!)
A	822	1.7	37.0
Total	48,020		4.0

Note: The A license has been in existence for only 2 years, and the major reason for the low increase in class C licenses has been due to license holders upgrading to higher license classes. Also note a bad sign: The total increase of 4 percent was down over the previous year's increase of 6.6 percent.

Table 2. Distribution of total number of licenses, by class, and percent increases.

operate on campus and which kindly offered the use of its premises for these club events. In this way, experienced amateur radio operators have been able to demonstrate several aspects of the hobby to those without firsthand experience.

For example, for both contests, club members constructed their own full-sized yagi beam antennas for the 10-, 15-, and 20-meter bands using entirely locally-available aluminum piping and other hardware. The antennas were up and in the air and getting 5 and 9 plus reports all within the space of two afternoons of work by a team of five hams: HS1AHT, who supervised the project, and HS1ALP, HS1BG, HS1ANV, and HS1AMH (yours truly).

The club also issues a much-coveted award, the Siam Award. This is granted to amateur radio stations and SWLs who have submitted evidence (endorsed log extracts) of contacts with Thai amateur radio stations in at least six of the nine call areas as well as the HS0 prefix which signifies a special-event operation. Alternatively, evidence of contacts with 10 different HS stations also qualifies for the award. Applicants should enclose US\$5.00 or the equivalent in IRCs to cover the return postage of the award.

The situation regarding operating on HF on a routine basis has not changed since my September, 1983, column, but those who are looking for Zone 26 or Thailand on 10, 15, 20, 40, or 80 meters should listen for a pileup for the call HS0HS, the special-event station, during a major contest.



WEST GERMANY

Mitchell B. Wolfson DJ0QN
Furtweg 18d
D-8044 Lohhof
Federal Republic of Germany

With the hullabaloo concerning the FCC proposal for a code-free license, I felt that it would be appropriate to illustrate how such a license has been approached here in Germany. Before going into the code-free license specifically, let's get a general overview into the German licensing structure first.

There are only three license classes in Germany, A, B, and C. The B license is your all-purpose ticket, giving you full privileges on all bands with a maximum peak power of 750 Watts on 80 meters through 1.2 GHz, and with reduced power on 160 meters, the WARC bands, and the UHF bands 2.3 GHz and above.

The A license is similar to the present Technician-class license in the States, with full VHF/UHF privileges, and with CW from 3520-3600 and 21090-21150, plus full 10-meter phone privileges. Maximum peak power is 150 Watts for bands up to 1.2 GHz. This class of license can be recognized by callsigns beginning with DH.

The third class of license is the class C, the code-free license. This class of license carries all VHF/UHF privileges from 2 meters and up, with a maximum peak power of 75 Watts.

As for the exam itself, the biggest surprise is that there is actually only one exam for all three license classes! The difference between the three license classes lies in the score received on the exam, combined with the code speed tested. It is quite possible for an applicant for a class C license to pass the exam with a score qualifying him for a B license, with only the CW exam lacking. Judging by the number of technically-inclined individuals with class C licenses, I would assume that this situation occurs quite often.

Table 1 illustrates the four parts of the German amateur-radio examination along with the score (in percent) needed to qualify the applicant for a specific license class. Note that the class C license requires the applicant to score only 50 percent on the technical portion, which certainly makes this license class relatively easy to obtain.

Now come the big questions: What is the split between the three license classes and what is the impact of the class C license?

As of January 1, 1983, there were 48,020 licensed amateurs in the Federal Republic of Germany. The split and increase over January 1, 1982, is shown in Table 2.

Now for a bit of editorializing: I have to admit that I accepted the concept of a code-free license with trepidation. Having operated in the USA for nine years before moving to Germany six years ago, I could not bring myself to accept that the class C operators were anything more than a bunch of lids.

Having now had time to let it sink in, plus having been active in club activities, I have come to think otherwise. When I look around at my fellow club members, I see that a number of truly invaluable people are class C holders. There's the club newsletter editor, the member teaching a Basic course, others interested in building equipment for the club station, etc. Many of the other members are ex-C licensees, such as our club president and the one before him. In looking outside our little group, I also see class C licensees active in repeater groups, writing technical articles for amateur magazines, etc.

When you go up to one of the present or previous class C license holders and ask specifically if they would have bothered to have learned CW to get their licenses, the answer could be a "yes," or "no," or a "maybe," but in general they feel that it would have been an unnecessary hindrance. It really is too difficult to speculate on this point, but I'd hate to think about losing many invaluable fellow amateurs just due to the Morse code.

As for the lids on 2 meters with a California-size amateur population with very few repeaters to operate on, the incidence of turkeys is amazingly low when put into perspective. Remembering what it was like in California makes me appreciate the true professionalism many German class C holders exhibit.

Will it work in the States? In my opinion, only you can make it work. If you will accept a code-free licensee as one of your own and try to understand that he or she may be able to contribute to your club in some way, you will find that the Morse code does not really make one a better person. Quite the contrary, many of the young people now interested in computers or electronics would make great amateurs. Do you really want to have to force them all to learn the code? In Germany, we don't and it works!

DIRECTION FINDING?

- ★ Doppler Direction Finding
- ★ No Receiver Mods
- ★ Mobile or Fixed
- ★ Kits or Assembled Units
- ★ 135-165 MHz Standard Range



- ★ Circular LED Display
- ★ Optional Digital Display
- ★ Optional Serial Interface
- ★ 12 VDC Operation
- ★ 90 Day Warranty

New Technology (patent pending) converts any VHF FM receiver into an advanced Doppler Direction Finder. Simply plug into receiver's antenna and external speaker jacks. Use any four omnidirectional antennas. Low noise, high sensitivity for weak signal detection. Kits from \$270. Assembled units and antennas also available. Call or write for full details and prices.

DOPPLER SYSTEMS,

5540 E. Charter Oak, (602) 998-1151
Scottsdale, AZ 85254

425

We now have available a bunch of goodies too good to bypass. Items are limited so order today

716-586-3950

Call your Phone Order in Today. TERMS: Satisfaction guaranteed or money refunded. C.O.D. add \$2.50. Minimum order \$6.00. Orders under \$10.00 add \$1.50. Over 6% for postage, insurance, handling. Overseas add 15%. N.Y. residents add 7% tax.

**MINI KITS - YOU HAVE SEEN THESE BEFORE NOW
HERE ARE OLD FAVORITE AND NEW ONES TOO.
GREAT FOR THAT AFTERNOON HOBBY.**

FM MINI MIKE



A super high performance FM wireless mike kit! Transmits a stable signal up to 300 yards with exceptional audio quality by means of its built in electret mike. Kit includes case, mike, on-off switch, antenna, battery and super instructions. This is the finest unit available.

FM-3 Kit \$14.95
FM-3 Wired and Tested 19.95

Color Organ

See music come alive! 3 different lights flicker with music. One light each for high, mid-range and lows. Each individually adjustable and drives up to 300 W runs on 110 VAC.

Complete kit, ML-1 \$8.95

Video Modulator Kit
Converts any TV to video monitor. Super stable. Tunable over ch 4-6. Runs on 5-15V accepts std video signal. Best unit on the market! Complete kit VO-1 \$7.95



Led Blinky Kit
A great attention getter which alternately flashes 2 jumbo LEDs. Use for name badges, buttons, warning panel lights, anything! Runs on 3 to 15 volts. Complete kit, BL-1 \$2.95

Super Sleuth
A super sensitive amplifier which will pick up a pin drop at 15 feet! Great for monitoring baby's room or as general purpose amplifier. Full 2 W rms output runs on 6 to 15 volts, uses 8-45 ohm speaker. Complete kit, BN-9 \$5.95

CPO-1
Runs on 3-12 Vdc 1 watt out. 1 KHZ good for CPO Alarm, Audio Oscillator. Complete kit \$2.95

FM Wireless Mike Kit

Transmits up to 300' to any FM broadcast radio. Uses any type of mike. Runs on 3 to 9V. Type FM-2 has added sensitive mike preamp stage.

FM-1 kit \$3.95 FM-2 kit \$4.95

Whisper Light Kit

An interesting kit, small mike picks up sounds and converts them to light. The louder the sound, the brighter the light. Includes mike, controls up to 300 W, runs on 110 VAC. Complete kit, WL-1 \$6.95

Tone Decoder

A complete tone decoder on a single PC board. Features 400-5000 Hz adjustable range via 20 turn pot, voltage regulation, 567 IC. Useful for touch-tone burst detection, FSK, etc. Can also be used as a stable tone encoder. Runs on 5 to 12 volts. Complete kit, TD-1 \$5.95

Siren Kit

Produces upward and downward wail characteristic of a police siren. 5 W peak audio output runs on 3-15 volts, uses 3-45 ohm speaker. Complete kit, SM-3 \$2.95

60 Hz Time Base
Runs on 5-15 VDC, Low Current (2.5 ma), min. month accuracy. TB-7 Kit \$5.50
TB-7 Assy \$9.95

Universal Timer Kit

Provides the basic parts and PC board required to provide a source of precision timing and pulse generation. Uses 555 timer IC and includes a range of parts for most timing needs.

UT-5 Kit \$5.95

Mad Blaster Kit

Produces LOUD ear shattering and attention getting siren like sound. Can supply up to 15 watts of obnoxious audio. Runs on 6-15 VDC. Complete kit, MB-1 \$4.95

CLOCK KITS

Your old favorites are here again. Over 7,000 Sold to Date. Be one of the gang and order yours today!

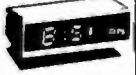

Try your hand at building the finest looking clock on the market. Its satin finish anodized aluminum case looks great anywhere, while six .4" LED digits provide a highly readable display. This is a complete kit, no extras needed, and it only takes 1-2 hours to assemble. Your choice of case colors: silver, gold, black (specify).
Clock kit, 12/24 hour, DC-5 \$24.95
Clock with 10 min. ID timer, 12/24 hour, DC-10 \$29.95

For wired and tested clocks add \$10.00 to kit price. SPECIFY 12 OR 24 HOUR FORMAT

SATELLITE TV KIT



image rejection, fully tunable audio to recover "hidden" subcarriers, divide by two PLL demodulator for excellent threshold performance, tight tracking AFC to assure drift free reception, and of course, full 24 channel tunable coverage. Build your satellite TV system around the R2B, close to ten thousand others already have and now it's available in kit form at a new low price. Order yours today.

THE POPULAR SAT-TEC RECEIVER IN KIT FORM!

NEW, LOWER PRICES!

Featured in a Radio Electronics magazine cover story (May 82), the reliable R2B Sat-tec TV receiver is now operating in thousands of locations. The R2B is easy to build, pre-circled boards with screened component layout assures accurate component placement and the critical IF section and local oscillator are pre-assembled and aligned! All parts are included for the R2B: attractive case, power supply, descriptive operating manual as well as complete assembly instructions. Features of the receiver include: dual conversion design for best

A complete Satellite TV System requires a dish antenna, LNA (low noise amplifier), Receiver and Modulator.
R2B Receiver Kit \$295.00
R2B Receiver, Wired and Tested \$395.00
120" K LNA \$295.00
RM3 RF Modulator \$49.95
Prices include domestic UPS shipping and insurance

PARTS PARADE

IC SPECIALS

LINEAR

301	\$.35
324	\$1.50
380	\$1.50
555	\$.45
556	\$1.00
565	\$1.00
566	\$1.00
567	\$1.25
741	10/\$2.00
1458	\$.50
3900	\$.50
3914	\$2.95
8038	\$2.95

TTL

74S00	\$ 4.40
7447	\$ 6.50
7475	\$ 5.50
7490	\$ 5.50
74196	\$1.35

SPECIAL

11C90	\$15.00
10116	\$ 1.25
7209	\$17.50
7207A	\$ 5.50
7216D	\$21.00
7107C	\$12.50
5314	\$ 2.95
5375AB/G	\$ 2.95
7001	\$ 6.50

CMOS

4011	\$.50
4013	\$.50
4046	\$1.85
4049	\$.50
4059	\$9.00
4511	\$2.00
4518	\$1.35
5639	\$1.75

Resistor Ass't
Assortment of Popular values - 1/4 watt. Cut lead for PC mounting, 1/2" center. 1/2" leads bag of 300 or more \$1.50

Crystals
3 579545 MHZ \$1.50
10 00000 MHZ \$5.00
5.248800 MHZ \$5.00

Switches
Mini toggle SPDT \$1.00
Red Pushbuttons N/O 3/\$1.00

AC Adapters
Good for clocks, nicad chargers, all 110 VAC plug one end.
8.5 vdc @ 20 mA \$1.00
16 vac @ 160mA \$2.50
12 vac @ 250mA \$3.00

Earphones
3' leads, 8 ohm, good for small tone speakers, alarm clocks, etc. 5 for \$1.00

Solid State Buzzers
small buzzer 450 Hz, 86 dB sound output on 5-12 vdc at 10-30 mA TTL compatible. \$1.50

Slug Tuned Coils
Small 3/16" Hex Slugs turned coil, 3 turns. 10 for \$1.00

AC Outlet
Panel Mount with Leads 4/\$1.00

CAPACITORS
TANTALUM
Dipped Epoxy
1.5 uF 25V 3/\$1.00
1.8 uF 25V 3/\$1.00
22 uF 25V 3/\$1.00

DISK CERAMIC
01 16V disk 20/\$1.00
1 16V 15/\$1.00
001 16V 20/\$1.00
100pF 20/\$1.00
047 16V 20/\$1.00

FERRITE BEADS
With info and specs \$5/\$1.00
6 Hole Bead \$1/\$1.00

READOUTS

FND 359 4 C C	\$1.00
FND 507/510 5 C A	1.00
MAN 72/HP7730 33 C A	1.00
HP 7651 43 C A	2.00

Sockets
8 Pin 10/\$2.00
14 Pin 10/\$2.00
16 Pin 10/\$2.00
24 Pin 4/\$2.00
28 Pin 4/\$2.00
40 Pin 3/\$2.00

DC-DC Converter
-5 vdc input prod. 9 vdc @ 30ma
-9 vdc produces -15 vdc @ 35ma \$1.25

Ceramic IF Filter
Mini B.W. \$1.50 ea.

25K 20 Turn Trim Pot \$1.00
1K 20 Turn Trim Pot \$.50

Trimmer Caps
Sprague 3-40 pf Stable Polypropylene 50 ea.

TRANSISTORS

2N3904 NPN C-F	\$15.100
2N3906 PNP C-F	\$15.100
2N4403 PNP C-F	\$15.100
2N4410 NPN C-F	\$15.100
2N4916 FET C-F	4/\$1.00
2N5401 PNP C-F	5/\$1.00
2N6028 C-F	4/\$1.00
2N3771 NPN Silicon	\$1.50
Power Tab PNP 40W	3/\$1.00
Power Tab PNP 40W	3/\$1.00
MPF 102/2N5484	\$.50
NPN 3904 Type T-R	\$0.82.50
PNP 3906 Type T-R	\$0.82.50
2N3055	\$.80
2N2946 UJT	3/\$2.00

Diodes
5.1 V Zener 20/\$1.00
1N914 Type 50/\$1.00
1KV 2Amp 8/\$1.00
100V 1Amp 15/\$1.00

Crystal Microphone
Small 1" diameter 1/2" thick crystal mike cartridge \$7.75

Mini RG-174 Coax
10 ft. for \$1.00

Coax Connector
Chassis mount BNC type \$1.00

9 Volt Battery Clips
Nice quality clips 5 for \$1.00
Rubber Grommets 10 for \$1.00

Parts Bag
Asst of chokes, disc caps, tantal resistors, transistors, diodes, MICA caps etc. sm bag (100 pcs) \$1.00 ig bag (300 pcs) \$2.50

Connectors
6 pin type gold contacts for mA-1003 car clock module price .75 ea.

Leds - your choice, please specify
Mini Red, Jumbo Red, High Intensity Red, Illuminator Red 8/\$1
Mini Yellow, Jumbo Yellow, Jumbo Green 6/\$1

Varactors
Motorola MV 2209 30 PF Nominal cap 20-80 PF - Tunable range -.50 each or 3/\$1.00

25 AMP 100V Bridge \$1.50 each
Mini-Bridge 50V 1 AMP 2 for \$1.00

Audio Prescaler

Make high resolution audio measurements, great for musical instrument tuning, PL tones, etc. Multiplies audio UP in frequency, selectable x10 or x100 gives 01 Hz resolution with 1 sec gate time! High sensitivity of 25 mv, 1 meg input z and built-in filtering gives great performance. Runs on 9V battery, all CMOS.
PS-2 kit \$29.95
PS-2 wired \$39.95

600 MHz PRESCALER



Extend the range of your counter to 600 MHz. Works with all counters. Less than 150 mv sensitivity specify -10 or -100.
Wired, tested, PS-1B \$59.95
Kit, PS-1B \$44.95

30 Watt 2 mtr PWR AMP

Simple Class C power amp features 8 times power gain. 1 W in for 8 out, 2 W in for 15 out, 4 W in for 30 out. Max output of 35 W, incredible value, complete with all parts, less case and T-R relay.
PA-1, 30 W pwr amp kit \$22.95
TR-1, RF sensed T-R relay kit 6.95

MRF-238 transistor as used in PA-1 8-10db gain 150 mhz \$11.95

Power Supply Kit
Complete triple regulated power supply provides variable 6 to 18 volts at 200 ma and +5 at 1 Amp. Excellent load regulation, good filtering and small size. Less transformers, requires 6.3 V 1 A and 24 VCT.
Complete kit, PS-3LT \$6.95

RF actuated relay senses RF (1W) and closes DPDT relay
For RF sensed T-R relay TR-1 Kit \$6.95

OP-AMP Special

BI-FET LF 13741 - Direct pin for pin 741 op amp, but 500,000 MEG input z, super low 50 pa input current, power drain.
50 for only \$9.00

Regulators
7812 \$1.00
7815 \$1.00
7905 \$1.25
7912 \$1.25
7915 \$1.25

Shrink Tubing Nubs
Nice precut pcs of shrink size 1" x 1/8" shrink to 1/4". Great for splices 50/\$1.00

Mini TO-92 Heat Sinks
Thermalloy Brand 5 for \$1.00
To-220 Heat Sinks 3 for \$1.00

Opto Isolators - 4N28 type \$1.00 ea.
Opto Reflectors - Photo diode + LED \$1.00 ea.

Molex Pins
Molex already precut in length of 7. Perfect for 14 pin sockets. 20 strips for \$1.00

CDS Photocells
Resistance varies with light. 250 ohms to over 3 meg 3 for \$1.00

THE MOST AFFORDABLE REPEATER

ALSO HAS THE MOST IMPRESSIVE PERFORMANCE FEATURES

(AND GIVES THEM TO YOU AS STANDARD EQUIPMENT!)



JUST LOOK AT THESE PRICES!

Band	Kit	Wired/Tested
10M, 6M, 2M, 220	\$680	\$880
440	\$780	\$980

Both kit and wired units are complete with all parts, modules, hardware, and crystals.

CALL OR WRITE FOR COMPLETE DETAILS.

Also available for remote site linking, crossband, and remote base.

FEATURES:

- SENSITIVITY SECOND TO NONE; TYPICALLY 0.15 μ V ON VHF, 0.3 μ V ON UHF.
- SELECTIVITY THAT CAN'T BE BEAT! BOTH 8 POLE CRYSTAL FILTER & CERAMIC FILTER FOR GREATER THAN 100 dB AT \pm 12KHZ. HELICAL RESONATOR FRONT ENDS. SEE R144, R220, AND R451 SPECS IN RECEIVER AD BELOW.
- OTHER GREAT RECEIVER FEATURES: FLUTTER-PROOF SQUELCH, AFC TO COMPENSATE FOR OFF-FREQ TRANSMITTERS, SEPARATE LOCAL SPEAKER AMPLIFIER & CONTROL.
- CLEAN, EASY TUNE TRANSMITTER; UP TO 20 WATTS OUT (UP TO 50W WITH OPTIONAL PA).

HIGH QUALITY MODULES FOR REPEATERS, LINKS, TELEMETRY, ETC.

HIGH-PERFORMANCE RECEIVER MODULES

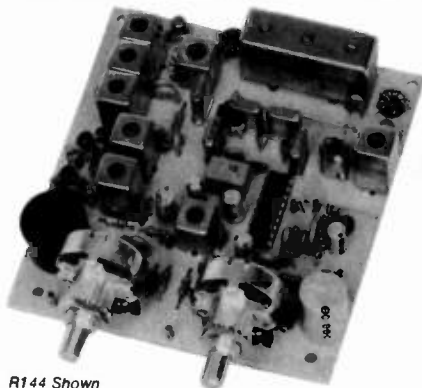

R144 Shown

- **R144/R220 FM RCVRs** for 2M or 220 MHz. 0.15 μ V sens.; 8 pole xtal filter & ceramic filter in i-f, helical resonator front end for exceptional selectivity, more than -100 dB at \pm 12 kHz, best available today. Flutter-proof squelch. AFC tracks drifting xmtrs. Xtal oven avail. Kit only \$138.
- **R451 FM RCVR** Same but for uhf. Tuned line front end, 0.3 μ V sens. Kit only \$138.
- **R76 FM RCVR** for 10M, 6M, 2M, 220, or commercial bands. As above, but w/o AFC or hel. res. Kits only \$118. Also avail w/4 pole filter, only \$98/kit.
- **R110 VHF AM RECEIVER** kit for VHF aircraft band or ham bands. Only \$98.
- **R110-259 SPACE SHUTTLE RECEIVER**, kit only \$98.

TRANSMITTERS

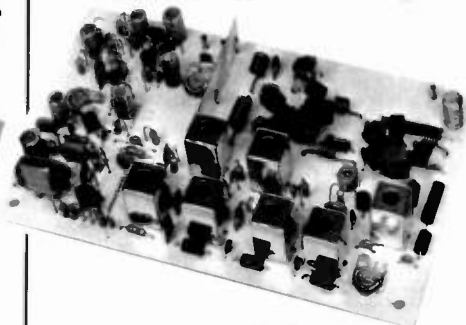

- **T51 VHF FM EXCITER** for 10M, 6M, 2M, 220 MHz or adjacent bands. 2 Watts continuous, up to 2 1/2 W intermittent. \$68/kit.



- **T451 UHF FM EXCITER** 2 to 3 Watts on 450 ham band or adjacent freq. Kit only \$78.
- **VHF & UHF LINEAR AMPLIFIERS.** Use on either FM or SSB. Power levels from 10 to 45 Watts to go with exciters & xmtg converters. Several models. Kits from \$78.
- **A16 RF TIGHT BOX** Deep drawn alum. case with tight cover and no seams. 7 x 8 x 2 inches. Designed especially for repeaters. \$20.

ACCESSORIES

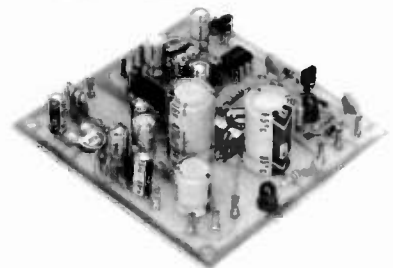

- **COR KITS** With Audio mixer, speaker amplifier, tail & time out timers. Kit only \$38.
- **CWID KITS** 158 bits, field programmable, clean audio, rugged TTL logic. Kit only \$68.
- **DTMF DECODER/CONTROLLER KITS.** Control 2 separate on/off functions with touchtones[®], e.g., repeater and autopatch. Use with main or aux. receiver or with Autopatch. Only \$90
- **AUTOPATCH KITS.** Provide repeater autopatch, reverse patch, phone line remote control of repeater, secondary control via repeater receiver. Many other features. Only \$90. Requires DTMF Module.

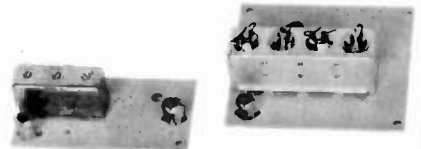

- **HELICAL RESONATOR FILTERS** available separately on pcb w/connectors.
 - HRF-144 for 143-150 MHz \$38
 - HRF-220 for 213-233 MHz \$38
 - HRF-432 for 420-450 MHz \$48

hamtronics [®]

NEW LOW-NOISE PREAMPS RECEIVING CONVERTERS TRANSMIT CONVERTERS

New low-noise microwave transistors make preamps in the 0.9 to 1.0 dB noise figure range possible without the fragility and power supply problems of gas-fet's. Units furnished wired and tuned to ham band. Can be easily retuned to nearby freq.



Models LNA(), P30 and P432 shown

Model	Tunable Freq Range	Noise Figure	Gain	Price
LNA 28	20-40	0.9 dB	20 dB	\$39
LNA 50	40-70	0.9 dB	20 dB	\$39
LNA 144	120-180	1.0 dB	18 dB	\$39
LNA 220	180-250	1.0 dB	17 dB	\$39
LNA 432	380-470	1.0 dB	18 dB	\$45
LNA 800	470-960	1.2dB	15 dB	\$45

ECONOMY PREAMPS

Our traditional preamps, proven in years of service. Over 20,000 in use throughout the world. Tuneable over narrow range. Specify exact freq. band needed. Gain 16-20 dB. NF = 2 dB or less. VHF units available 27 to 300 MHz. UHF units available 300 to 650 MHz.

- P30K, VHF Kit less case \$18
- P30W, VHF Wired/Tested \$33
- P432K, UHF Kit less case \$21
- P432W, UHF Wired/Tested \$36

P432 also available in broadband version to cover 20-650 MHz without tuning. Same price as P432; add "B" to model #.

HELICAL RESONATOR PREAMPS

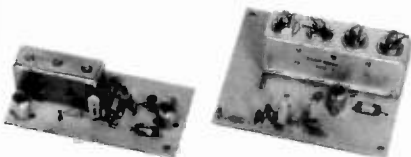

Our lab has developed a new line of low-noise receiver preamps with helical resonator filters built in. The combination of a low noise amplifier similar to the LNA series and the sharp selectivity of a 3 or 4 section helical resonator provides increased sensitivity while reducing intermod and cross-band interference in critical applications. See selectivity curves at right. Noise figure = 1 to 1.2 dB. Gain = 12 to 15 dB.

Model	Tuning Range	Price
HRA-144	143-150 MHz	\$49
HRA-220	213-233 MHz	\$49
HRA-432	420-450 MHz	\$59
HRA-()	150-174MHz	\$69
HRA-()	450-470 MHz	\$79



Models to cover every practical rf & if range to listen to SSB, FM, ATV, etc. NF = 2 dB or less.

	Antenna Input Range	Receiver Output
VHF MODELS	28-32	144-148
	50-52	28-30
Kit with Case \$49	50-54	144-148
Less Case \$39	144-146	28-30
Wired \$69	145-147	28-30
	144-144.4	27-27.4
	146-148	28-30
	144-148	50-54
	220-222	28-30
	220-224	144-148
	222-226	144-148
	220-224	50-54
	222-224	28-30
UHF MODELS	432-434	28-30
	435-437	28-30
Kit with Case \$59	432-436	144-148
Less Case \$49	432-436	50-54
Wired \$75	439.25	61.25

SCANNER CONVERTERS Copy 72-76, 135-144, 240-270, 400-420, or 806-894 MHz bands on any scanner. Wired/tested Only \$88.

SAVE A BUNDLE ON VHF FM TRANSCEIVERS!

FM-5 PC Board Kit - ONLY \$178 complete with controls, heatsink, etc. 10 Watts, 5 Channels, for 2M or 220 MHz.



Cabinet Kit, complete with speaker, knobs, connectors, hardware. Only \$60.

REPEAT OF A SELLOUT!

While supply lasts, get \$60 cabinet kit free when you buy an FM-5 Transceiver kit. Where else can you get a complete transceiver for only \$178

For SSB, CW, ATV, FM, etc. Why pay big bucks for a multi mode rig for each band? Can be linked with receive converters for transceive. 2 Watts output vhf, 1 Watt uhf.

	Exciter Input Range	Antenna Output
For VHF,	28-30	144-146
Model XV2	28-29	145-146
Kit \$79	28-30	50-52
Wired \$149	27-27.4	144-144.4
(Specify band)	28-30	220-222*
	50-54	220-224
	144-146	50-52
	50-54	144-148
	144-146	28-30

For UHF,	28-30	432-434
Model XV4	28-30	435-437
Kit \$99	50-54	432-436
Wired \$169	61.25	439.25
	144-148	432-436*
	*Add \$20 for 2M input	

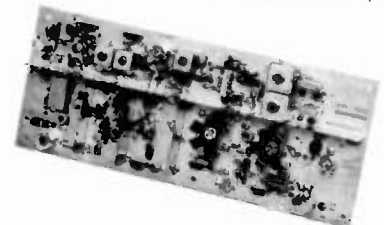

VHF & UHF LINEAR AMPLIFIERS. Use with above. Power levels from 10 to 45 Watts. Several models, kits from \$78.

LOOK AT THESE ATTRACTIVE CURVES!

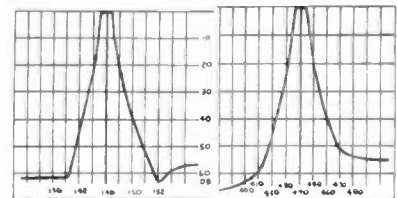

Typical Selectivity Curves of Receivers and Helical Resonators.

IMPORTANT REASONS WHY YOU SHOULD BUY FROM THE VALUE LEADER:

1. Largest selection of vhf and uhf kits in the world.
2. Exceptional quality and low prices due to large volume.
3. Fast delivery; most kits shipped same day.
4. Complete, professional instruction manuals.
5. Prompt factory service available and free phone consultation.
6. In business 21 years.
7. Sell more repeater modules than all other mfrs. and have for years. Can give quality features for much lower cost.

- Call or Write for FREE CATALOG
- (Send \$1.00 or 4 IRC's for overseas mailing)
- Order by phone or mail • Add \$3 S & H per order ✓³³ (Electronic answering service evenings & weekends) Use VISA, MASTERCARD, Check, or UPS COD.

hamtronics, inc.

65-A MOUL RD. • HILTON NY 14468
Phone: 716-392-9430

Hamtronics® is a registered trademark

DEALER DIRECTORY

Culver City CA

Jun's Electronics, 3919 Sepulveda Blvd., Culver City CA 90230, 390-8003. Trades 463-1886 San Diego, 827-5732 (Reno NV).

Fontana CA

Complete lines ICOM, DenTron, Ten-Tec, Mirage, Cubic, Lunar, over 4000 electronic products for hobbyist, technician, experimenter. Also CB radio, landmobile. Fontana Electronics, 8625 Sierra Ave., Fontana CA 92335, 822-7710.

San Jose CA

Bay area's newest amateur radio store. New & used amateur radio sales & service. We feature Kenwood, ICOM, Azden, Yaesu, Ten-Tec, Satec & many more. Shaver Radio, Inc., 1378 So. Bascom Ave., San Jose CA 95128, 998-1103.

New Castle DE

Factory Authorized Dealer! Yaesu, ICOM, Ten-Tec, KDK, Azden, AEA, Kantronics, Satec. Full line of accessories. No sales tax in Delaware. One mile off I-95. Delaware Amateur Supply, 71 Meadow Road, New Castle DE 19720, 325-7728.

Bloomington IL

Rohn Towers—Wholesale direct to users, 23% to 34% discount from dealer price. All products available. Write or call for price list. Also we are wholesale distributors for Antenna Specialists, Regency, and Hy-Gain. Hill Radio, 2503 G.E. Road, PO Box 1405, Bloomington IL 61701-0887, 663-2141.

Boise ID

Rocky Mountain area's newest ham dealer. Call RJM first for AEA, Azden, KDK, Ten-Tec, Butternut, Cushcraft, and more! RJM Electronics, 4204 Overland, Boise ID 83705, 343-4018.

Preston ID

Ross WB7BYZ has the largest stock of amateur gear in the Intermountain West and the best prices. Call me for all your ham needs. Ross Distributing, 78 So. State, Preston ID 83263, 852-0630.

Littleton MA

The reliable ham store serving NE. Full line of ICOM & Kenwood, Yaesu HTs, Drake, Daiwa, B&W accessories. Curtis & Trac keyers, Larsen, Hustler, Telex/Hy-Gain products, Mirage amps, Astron P.S., Alpha Delta protectors, ARRL & Kantronics instruction aids. Whistler radar detectors. Full line of coax fittings. TEL-COM Electronic Communications, 675 Great Rd. (Rt. 119), Littleton MA 01460, 486-3400/3040.

Ann Arbor MI

See us for products like Ten-Tec, R. I. Drake, Dentron and many more. Open Monday through Saturday, 0830 to 1730. WB8VGR, WB8UXO, WD8OKN, and W8RRP behind the counter. Purchase Radio Supply, 327 E. Hoover Ave., Ann Arbor MI 48104, 668-8696.

Livonia MI

Complete photovoltaic systems. Amateur radio, repeater, satellite, and computer applications! Call Paul WD8AHO. Encon Photovoltaics, 27600 Schoolcraft Road, Livonia MI 48150, 523-1850.

Hudson NH

Look!—hams, SWLs, and experimenters: parts, books, gear, antennas, towers. Call for quotes. Polcari's ELECTRONICS CENTER, 61 Lowell Road (Route 3A), Hudson NH 03051, 883-5005.

Albany, New York UPSTATE NEW YORK

Kenwood, ICOM, Ten-Tec, Belden, Cushcraft, Larsen, Hustler, ARRL, Hy-Gain, B&W, MFJ, Mirage. New and used equipment. Serving the amateur community since 1942. Adirondack Electronics, Inc., 1991 Central Avenue, Albany NY 12205, 456-0203 (one mile west of Northway exit 2W).

Columbus OH

The biggest and best ham store in the Midwest featuring Kenwood and other quality products with working displays. We sell only the best. Authorized Kenwood service. Universal Amateur Radio, Inc., 1280 Aida Dr., Reynoldsburg (Columbus) OH 43068, 966-4267.

Stigler OK

T199/4-4A Basic. Extended Basic. Assembly Language Programs. CV Transceiver, CW Practice, DX, 1010, WAS, SSTV, Hamkid's Programs, ACS Computer Programs, Box 368, Stigler OK 74462, 967-2034.

Scranton PA

ICOM, Bird, Cushcraft, Beckman, Fluke, Larsen, Hustler, Antenna Specialists, Astron, Avanti, Belden, W2AU/W2VS, AEA, Vibroplex, HamKey, Amphenol, Sony, B&W, Coax-Seal, Cover Craft, J.V. Miller/Daiwa, ARRL, Ameco, Shure. LaRue Electronics, 1112 Grandview St., Scranton PA 18509, 343-2124.

Dallas TX

IBM PC/Apple aftermarket products; hobbyists' electronics project kits; \$50.00 complete modem kit, subscription/satellite TV decoder kits, EPROM programmer/duplicator, popular memory IC testers, data sheets, application notes, and more than 6000 parts in stock. Semiconductors, discretes, video products, tools. Please write for your free literature/catalog. Independent Electronics, 6415-06 Airline Rd., Dallas TX 75205.

Baltimore/Washington

Avantek transistors, amplifiers, oscillators, and LNAs. Coaxial cable and connectors. Blonder Tongue dealer with Microwave laboratory. Applied Specialties, Inc., 10101G Bacon Drive, Beltsville MD 20705. Wash. 595-5393, Balt. 792-2211, 7:30 am to 6:00 pm, Monday thru Friday.

DEALERS

Your company name and message can contain up to 25 words for as little as \$150 yearly (prepaid), or \$15 per month (prepaid quarterly). No mention of mail-order business or area code permitted. Directory text and payment must reach us 60 days in advance of publication. For example, advertising for the April '84 issue must be in our hands by Feb. 1st. Mail to 73 Magazine, Peterborough NH 03458. ATTN: Nancy Ciampa.

PROPAGATION

J. H. Nelson
4 Plymouth Dr.
Whiting NJ 08759

EASTERN UNITED STATES TO:

	GMT:	00	02	04	06	08	10	12	14	16	18	20	22
ALASKA	7A	7	7	7	3A	3A	3A	3A	3B	7A	14A	21A	21
ARGENTINA	14	7	7B	7B	7	7	14	21	21A	21A	21A	14A	21
AUSTRALIA	14A	14B	7B	7B	7B	7B	14	14A	14	14A	21A	21A	21A
CANAL ZONE	7A	7	7	7	7	7	7A	14A	21	21A	21A	14	14
ENGLAND	7	7	3A	3A	3A	7B	14	21	21A	14	7	7	7
HAWAII	14A	14	7	7	7	7	7	7B	14	21	21A	21A	21A
INDIA	7	7B	7B	7B	7B	7B	14	14A	14B	14B	14B	14B	7B
JAPAN	14A	7B	7B	7B	7	7	7	7B	7B	7B	7B	14	14
MEXICO	14	7	7	7	7	7	7A	14	21	21A	21A	21A	21
PHILIPPINES	14	7B	7B	7B	7B	7B	7B	14B	14B	14B	14B	14B	14
PUERTO RICO	14	7	7	7	7	7	14	21	21A	21A	21	14A	14
SOUTH AFRICA	14	7	7	7	7B	7A	14A	21	21A	21A	21	14	14
U. S. S. R.	7	7	3A	3A	3A	7A	7A	7A	21	14	7B	7B	7
WEST COAST	14	14	7	7	7	7	7	14	21	21A	21A	21	21

CENTRAL UNITED STATES TO:

ALASKA	14	7	7	3A	3A	3A	3A	3A	7A	14A	21	21A	21A
ARGENTINA	14	7	7B	7B	7	7	7A	14A	21	21A	21A	21	21
AUSTRALIA	21	14	7B	7B	7B	7B	7B	14	14A	21A	21A	21A	21A
CANAL ZONE	14	7	7	7	7	7	7A	14A	21	21A	21A	21	21
ENGLAND	7	7	3A	3A	3A	3B	14B	14A	21A	14	7B	7B	7B
HAWAII	21	14	7	7	7	7	7	7	7	14	21	21A	21A
INDIA	14	7B	7B	7B	7B	7B	7B	14B	14B	14B	14B	14B	7B
JAPAN	14A	14B	7B	7B	7	7	7	7	7B	7B	14B	14A	14A
MEXICO	14	7	7	7	7	7	7	14	21	21A	21A	21	21
PHILIPPINES	21	7B	7B	7B	7B	7B	7	7	14B	14B	14B	14B	14
PUERTO RICO	14	7	7	7	7	7	7A	14A	21A	21A	21	14A	14
SOUTH AFRICA	14	7	7	7	7B	7B	7A	14	21	21A	21	14	14
U. S. S. R.	7B	7	3A	3A	3A	7B	7B	14	14	7B	7B	7B	7B

WESTERN UNITED STATES TO:

ALASKA	14	7A	7	3A	3A	3A	3A	3A	7	7A	21	21A	21A
ARGENTINA	21	14	7B	7B	7	7	7B	14	21	21A	21A	21A	21A
AUSTRALIA	21A	14A	14	14	7B	7B	7B	7B	14	21	21A	21A	21A
CANAL ZONE	14A	7	7	7	7	7	7	14	21	21A	21A	21A	21A
ENGLAND	7B	7	3A	3A	3A	3B	7B	14B	21A	14	7B	7B	7B
HAWAII	21A	14A	14	7	7	7	7	7	14	21	21A	21A	21A
INDIA	14	14	7B	7B	7B	7B	7B	7B	14B	14B	14B	14B	7B
JAPAN	21A	14	7B	7B	7	7	7	7	7	7B	14	21	21
MEXICO	14	14	7	7	7	7	7	7	14A	21A	21	21	21
PHILIPPINES	21A	14A	14B	7B	7B	7B	7	7	14B	14B	14B	14B	14
PUERTO RICO	14A	14	7	7	7	7	7	14	21	21A	21A	21	21
SOUTH AFRICA	14	7	7	7	7B	7B	7B	14	21	21A	21	14	14
U. S. S. R.	7B	7	3A	3A	3A	7B	7B	7B	14	7B	7B	7B	7B
EAST COAST	14	14	7	7	7	7	7	14	21	21A	21A	21	21

A = Next higher frequency band may also be useful.
B = Difficult circuit this period.

First letter = night waves. Second = day waves.
G = Good, F = Fair, P = Poor. * = Chance of solar flares.
= Chance of aurora.

NOTE THAT NIGHT WAVE LETTER NOW COMES FIRST.

JANUARY

SUN	MON	TUE	WED	THU	FRI	SAT
1	2	3	4	5	6	7
F/F	FIG	FIG	F/F	F/F	G/G	G/G
8	9	10	11	12	13	14
F/F	FIG	FIG	F/F	FIG	G/G	G/G
15	16	17	18	19	20	21
F/F	FIG	G/G	G/G	F/F*	P/F*	P/F
22	23	24	25	26	27	28
F/F	FIG	G/G	G/G	F/F*	P/F*	P/F
29	30	31				
F/F	F/F	P/F				

YAESU FT-726R TRIBANDER

NEW GALAXIES OF PERFORMANCE ON VHF AND UHF

FULL DUPLEX!!

SATELLITES!!

SCATTER!!

FM!!

EME!!



The New Yaesu FT-726R Tribander is the world's first multiband, multimode Amateur transceiver capable of full duplex operation. Whether you're interested in OSCAR, moonbounce, or terrestrial repeaters, you owe yourself a look at this one-of-a-kind technological wonder!

Multiband Capability

Factory equipped for 2 meter operation, the FT-726R is a three-band unit capable of operation on 10 meters, 6 meters, and/or two segments of the 70 cm band (430-440 or 440-450 MHz), using optional modules. The appropriate repeater shift is automatically programmed for each module. Other bands pending.

Advanced Microprocessor Control

Powered by an 8-bit Central Processing Unit, the ten-channel memory of the FT-726R stores both frequency and mode, with pushbutton transfer capability to either of two VFO registers. The synthesized VFO tunes in 20 Hz steps on SSB/CW, with selectable steps on FM. Scanning of the band or memories is provided.

Full Duplex Option

The optional SU-726 module provides a second, parallel IF strip, thereby allowing full duplex crossband satellite work. Either the transmit or receive frequency may be varied during transmission, for quick zero-beat on another station or for tracking Doppler shift.

High Performance Features

Borrowing heavily from Yaesu's HF transceiver experience, the FT-726R comes equipped with a speech processor, variable receiver bandwidth, IF shift, all-mode squelch, receiver audio tone control, and an IF noise blanker. When the optional XF-455MC CW filter is installed, CW Wide/Narrow selection is provided. Convenient rear panel connections allow quick interface to your station audio, linear amplifier, and control lines.

Leading the way into the space age of Ham communications, Yaesu's FT-726R is the first VHF/UHF base station built around modern-day requirements. If you're tired of piecing together converters, transmitter strips, and relays, ask your Authorized Yaesu Dealer for a demonstration of the exciting new FT-726R, the rig that will expand your DX horizons!

Price And Specifications Subject To
Change Without Notice Or Obligation

YAESU
The radio.



83

483

YAESU ELECTRONICS CORPORATION 6851 Walthall Way, Paramount, CA 90723 • (213) 633-4007
YAESU CINCINNATI SERVICE CENTER 9070 Gold Park Drive, Hamilton, OH 45011 • (513) 874-3100

"Comm-packed."

**BIG performance...
small size...
smaller price!!!**

TR-2500

The TR-2500 is a compact 2 meter FM handheld transceiver featuring an LCD readout, 10 channel memory, lithium battery memory back-up, memory scan, programmable automatic band scan, Hi/Lo power switch and built-in sub-tone encoder.

TR-2500 FEATURES:

- **Extremely compact size and light weight**
Measures 66 (2-5/8) W x 168 (6-5/8) H x 40 (1-5/8) D. mm (inches). Weighs 540 grams (1.2 lbs) with Ni-Cd pack.
- **LCD digital frequency readout**
Shows frequencies and memory channels, four "Arrow" indicators.
- **Ten channel memory**
Nine memories for simplex or ± 600 kHz offset. "M0" memory for non-standard split frequency repeaters.
- **Lithium battery memory back-up**
(Estimated 5 year life.) Maintains memory when Ni-Cd pack is fully discharged or removed.



- **HI/LOW power selection**
2.5 watts or 300 mw.
- **Memory scan**
Scans only channels in which frequency data is stored.
- **Programmable automatic band scan**
Upper and lower frequency limits and scan steps of 5-kHz and larger.
- **UP/DOWN manual scan**
- **Built-in tuneable sub-tone encoder**
Tuneable (variable resistor) to desired CTCSS tone.
- **Built-in 16-key autopatch encoder**
- **"SLIDE-LOC" battery pack**
- **Repeater reverse switch**
- **Keyboard frequency selection**
- **Extended frequency coverage**
Covers 143.900 to 148.995 MHz in 5-kHz steps.
- **Optional power source**
Using optional MS-1 mobile or ST-2 AC charger/power supply, radio may be operated while charging. (Automatic drop-in connections.)



Actual size

- **High impact plastic case**
- **Battery status indicator**
- **Two lock switches**
Prevent accidental frequency change and accidental transmission.

Standard accessories include:

- Flexible antenna with BNC connector
- 400 mA H Ni-Cd battery pack
- AC charger

Optional accessories:

- ST-2 Base station power supply/charger (approx. 1 hr.)
- MS-1 13.8 VDC mobile stand/charger/power supply



TR-3500

70 CM FM Handheld

- 440-449.995 MHz in 5-kHz steps
- TX OFFSET switch keyboard programmable ± 5 kHz to ± 9.995 MHz
- 1.5 W/300 mW HI/LOW power switch
- Auto. squelch position on squelch control
- Tone switch for TU-35B optional programmable CTCSS encoder
- Other features include 10 memories, lithium battery memory back-up, programmable automatic band scan, memory scan, UP/DOWN manual scan, repeater reverse, 16-key autopatch, keyboard frequency selection, slide-lock battery.

- VB-2530 2-M 25 W RF power amp. w/cables, mtg. brkt. (TR-2500 only)
- TU-1 Programmable CTCSS encoder (TR-2500 only)
- TU-35B Programmable CTCSS encoder (mounts inside TR-3500 only)
- PB-25 Extra 400 mA H Ni-Cd battery
- PB-25H Heavy-duty 490 mA H Ni-Cd battery
- DC-25 13.8 VDC adapter.
- BT-1 Battery case for manganese/alkaline AA cells
- SMC-25 Speaker-microphone
- LH-2 Deluxe leather case
- BH-2A Belt hook
- RA-3 m 3/8" telescoping antenna (for TR-2500).
- WS-1 Wrist strap
- EP-1 Earphone

More information on the TR-2500 and TR-3500 is available from all authorized dealers of Trio-Kenwood Communications, 1111 West Walnut Street, Compton, California 90220.

KENWOOD

...pacesetter in amateur radio

Specifications and prices are subject to change without notice or obligation.