

73 Magazine

for Radio Amateurs

- 30 **The Rites of Spring**
—Dayton does it again
.....N1AUI, WB8BTH, KA1HY
- 36 **One Step at a Time: Designing Your Own Ham Gear**
—part II.....W4RNL
- 44 **Top-Banding the DX-60B**
—put a classic rig on a classic band.....WB1ASL
- 48 **Forward into the Past!**
—a solid-state restoration project for a vintage BC receiver.....W5JJ
- 52 **ADDSCAN**
—now you can be two places at once.....WB9FSC
- 56 **Flat Cells are No Fun!**
—build a battery status monitor.....WA3ENK
- 58 **When Plus Goes Minus**
—a 555-based negative power supply.....Minchow
- 60 **Depolarize that Power Supply!**
—positive or negative grounds won't bother you any more.....AA6C
- 64 **Transform Noisy Fluorescents**
—“temporary” solution.....W2OLU
- 66 **Early Radio Detectors—A Backward Glance**
—pulling rf from the ether was (and is) no easy trick.....W5JJ
- 70 **Sheathe Thyself**
—a cheap trick to pull on old rubber duckies
.....W48WTE
- 72 **CB to 10**
—part XXVI: the Cobra 132.....WA1UQC
- 74 **FT-227 Update**
—more mods for the Fox-Tango set.....WA1GPO
- 78 **“That’s the Way It Was . . .”**
.....K2VGV
- 80 **All About Coordinated Universal Time**
—GMT has become UTC, but the reasons for using it are as valid as ever.....WA7NEV
- 82 **Don’t Be a dB Dummy!**
—use a pocket calculator to deal with decibels
.....McMahan
- 84 **The Sweet Sounding Probe**
.....W7BBX
- 91 **Silence is Golden**
—reassemble noisy transformers to eliminate hum
.....Powell
- 92 **1 Welcome to the ‘80s**
—Radio Shack and Macrotronics make computerized operation a reality.....K3PUR
- 106 **The Multi-Media Bench Tester**
—this audio/visual device will test your diodes, SCRs, transistors, and more.....WD4KFF
- 108 **CB to 10**
—part XXVII: new life for SSB CB rigs.....N6SD
- 118 **Build the ZL Paddle**
—brass with class.....ZL2GA
- 120 **Repeater Time-Out Warning**
—put time on your side (relatively speaking)
.....KA6A
- 122 **CB to 10**
—part XXVIII: double your channels in SSB conversions.....WB2EQG
- 124 **Ham Economics: Selling Used Gear**
—be wily.....K5CA
- 125 **A Final Solution**
—make life easy for your filaments.....W4ANL
- 128 **The NMX Relay Deceiver**
—pull in those 24-V relays with a mere 12 V
.....W9NMX
- 130 **Who Needs SSB?**
—using your FT-101 on 10m AM.....K8JS
- 132 **Like to See My Etchings?**
—chemical technique keeps your property at home.....W6OJJ
- 134 **A Low-Life Antenna**
—tune in on the life below 500 kHz.....AB5S
- 148 **The Don Nobles Descramblers**
—listen to what you’re not supposed to hear
.....WA4PYQ



Never Say Die—4, Looking West—10, RTTY Loop—12, DX—14, Leaky Lines—16, Ham Help—16, 155, 169, Letters—18, OSCAR Orbits—21, Contests—22, Awards—24, New Products—26, Social Events—150, Corrections—160, FCC—161, Dealer Directory—193, Propagation—193.

Henry



...STILL THE TOP FAMILY IN LINEAR AMPLIFIERS

IT'S A FACT... HENRY RADIO STILL PRODUCES THE BROADEST LINE OF SUPERIOR QUALITY AMPLIFIERS IN THE WORLD. WHETHER FOR AMATEUR RADIO, COMMERCIAL OR MILITARY USE, WE OFFER A CHOICE OF FIELD PROVEN STATE-OF-THE-ART UNITS TO FIT THE REQUIREMENTS AND BUDGETS OF THE MOST DISCRIMINATING USER.

The 1KD-5...the newest member of the famous Henry Radio family of fine amplifiers. And we're still convinced that it's the world's finest linear in its class. The 1KD-5 was designed for the amateur who wants the quality and dependability of the 2KD-5 and 2K-4A, who may prefer the smaller size, lighter weight and lower price and who will settle for a little less power. But make no

mistake, the 1KD-5 is no slouch. Its 1200 watt PEP input (700 watt PEP nominal output) along with its superb operating characteristics will still punch out clean powerful signals...signals you'll be proud of. Compare its specifications, its features and its fine components and we're sure you will agree that the 1KD-5 is a superb value at only \$695.

The 2KD-5 We have been suggesting that you look inside any amplifier before you buy it. We hope that you will. If you "lift the lid" on a 2KD-5 you will see only the highest quality, heavy duty components and careful workmanship...attributes that promise a long life of continuous operation in any mode at full

legal power. The 2KD-5 is a 2000 watt PEP input (1200 watt PEP nominal output) RF linear amplifier, covering the 80, 40, 20, and 15 meter amateur bands. It operates with two Elmac 3-500Z glass envelope triodes and a PI-L plate circuit with a rotary silver plated tank coil. Price \$945.

HENRY AMPLIFIERS ARE ON DISPLAY AT THE FOLLOWING DEALERS

A G L Electronics Inc.
Clearwater, **FLORIDA**
A.R.C. Electronics Inc.
Shreveport, **LOUISIANA**
Amateur-Wholesale Electronics
Miami, **FLORIDA**
Associated Radio Communications
Overland Park, **KANSAS**
The Base Station
Concord, **CALIFORNIA**
Castle Marina Inc.
Greenup, **KENTUCKY**
Communications Center Inc.
Lincoln, **NEBRASKA**

Communications Technology Group
Oceanside, **NEW YORK**
Communications World Inc.
Hinckley, **OHIO**
Conley Radio Supply
Billings, **MONTANA**
Custom Electronics
Boise, **IDAHO**
Doc's Communications
Lookout Mountain, **TENNESSEE**
Douglas Electronics
Corpus Christi, **TEXAS**
Earl Distributing Co.
Idaho Falls, **IDAHO**
Electronics Inc.
Salina, **KANSAS**
Gismo Communications
Rock Hill, **SOUTH CAROLINA**

HI Inc.
Council Bluffs, **IOWA**
H. R. Electronics
Muskegon, **MICHIGAN**
Hamtronics Inc.
Trevose, **PENNSYLVANIA**
Hobby Electronics Center
College Park, **GEORGIA**
Industrial Distributing Co.
Dallas, **TEXAS**
Kryder Electronics
Oklahoma City, **OKLAHOMA**
N & G Distributing Corp.
Miami, **FLORIDA**
Norbill's Electronics Inc.
Springfield, **MASSACHUSETTS**
P.A.C.E. Engineering
Tucson, **ARIZONA**

Quad Electronics Co.
Pensacola, **FLORIDA**
Radio Wholesale
Columbus, **GEORGIA**
Radio World
Oriskany, **NEW YORK**
Radios Unlimited
Somerset, **NEW JERSEY**
Shaver Radio
San Jose, **CALIFORNIA**
Slep Electronics Co.
Otto, **NORTH CAROLINA**
Stephens Electronics
Corpus Christi, **TEXAS**
Tufts Electronics
Medford, **MASSACHUSETTS**
Universal Amateur Radio Inc.
Columbus, **OHIO**

And don't forget the rest of the Henry family of amateur amplifiers...The 2K-4A, the Tempo 2002 high power VHF amplifier and the broad line of top quality solid state amplifiers. Henry Radio also

offers the 3K-A and 4K-Ultra superb high power H.F. amplifiers and a broad line of commercial FCC type accepted amplifiers for two way FM communications covering the range to 500 MHz.



11240 W. Olympic Blvd., Los Angeles, CA 90064 213/477-6701
931 N. Euclid, Anaheim, CA 92801 714/772-9200
Butler, Missouri 64730 816/679-3127

NEW TOLL FREE ORDER NUMBER: (800) 421-6631
For all states except California
Calif. residents please call collect on our regular numbers.

✓ 34

Henry Radio

Prices subject to change without notice.

Announcing the Heathkit VF-7401 2-meter FM Digital Scanning Transceiver



TWO METER DIGITAL SCANNING TRANSCEIVER



6.33

HEATHKIT
VF-7401

LED indicates 5 kHz position.

The 0 kHz/5 kHz Switch gives you an effective choice of 800/2-meter channels in 5 kHz steps.

Dim/Bright Switch for bright illumination of frequency read-out and meter for daytime, and lower intensity for safe mobile operation at night.

The Manual/Scan Switch lets you choose your frequency manually, or have the VF-7401 find an active channel for you.

Lock/Latch Switch. In Scan Latch mode, a channel latch-up signal inhibits scan circuits when signal is detected, and the 7401 stays on that frequency. If it detects a 4-8 second break in received signal, scanning resumes. In the Scan-Lock mode, once the receiver scans to a signal, it remains on that channel until reset.

Optional Micoder II Microphone/Auto Patch Encoder lets you phone through repeaters with auto patch input. Draws power from the 7401, so no mike battery is necessary.

The Squelch Control also functions as the receiver's sensitivity control to step scanning only upon reception of "full-quieting" signals, skipping the weak ones.

The 100 kHz Selector button controls the VF-7401's tuning in 100 kHz increments. The 7401's 1 MHz Selector button lets you choose any 1 MHz segment of the 2-meter band.

The 10 kHz Selector advances in 10 kHz steps. In Scan, as it recycles from "S" to "C," it also causes the 100 kHz readout to advance by one digit. Depress once to resume scan function.

More features that make the VF-7401 the 2-meter rig that belongs in your shack and vehicle

No more searching through repeater guides while roving in unfamiliar territory - your new Heathkit VF-7401 will find the active channels for you. It will even alert you to band openings. You're going to enjoy building your VF-7401... and you're going to love using it. The VF-7401, the ultimate 2-meter rig... from the more than 200 Hams at Heath.

- Adjustable, 15-watt (nominal), solid-state, narrow-band FM Transceiver. Fully synthesized digital circuitry provides full-band coverage without need for added crystals.

- All-new, state-of-the-art circuits provide the exciting, exclusive features of 1 MHz bandwidth scanning, and Scan Lock/Latch capability on 2-meters.
- A receiver hotter than Heath's HW-2036A features dual-gate MOSFET front-end to minimize overload and adjacent-channel interference.
- "Power-up" on a pre-programmed frequency of your own choice, such as your favorite repeater.
- Convenient detachable mike using 4-pin connector.

- Power to the Micoder II Microphone (if used) eliminates need for a battery.
- Sturdy SO-239 rear-panel antenna jack.
- Chassis-mounted power and external speaker plugs.
- Improved synthesizer, eliminating need for panel mounted sync lock light.
- Tuning for Power Amplifier and output power level adjustment is accessible without removing case.
- Capability of mobile or base operation (with Model VFA-7401-1 AC Power Supply - 13.8 V at 4A nominal, transmit).



SEND FOR FREE CATALOG

The new VF-7401 is featured in the latest Heathkit Catalog. For a free copy write: Heath Company, Dept. D11-674, Benton Harbor, MI 49022. Or visit the nearest Heathkit Electronic Center in the U.S. or Canada where Heathkit products are displayed, sold and serviced. See the white pages of your phone book for location. In the U.S., Heathkit Electronic Centers are units of Veritechnology Electronics Corporation.

This device has not been approved by the Federal Communications Commission. This device is not, and may not be, offered for sale or lease, or sold or leased until the approval of the FCC has been obtained.



Heathkit®

THERE'S MORE FOR THE HAM AT HEATH!

Info

Manuscripts

Contributions in the form of manuscripts with drawings and/or photographs are welcome and will be considered for possible publication. We can assume no responsibility for loss or damage to any material. Please enclose a stamped, self-addressed envelope with each submission. Payment for the use of any unsolicited material will be made upon acceptance. All contributions should be directed to the 73 editorial offices. "How to Write for 73" guidelines are available upon request.

Editorial Offices:

Pine Street
Peterborough NH 03458
Phone: 603-924-3873

Advertising Offices:

Elm Street
Peterborough NH 03458
Phone: 603-924-7138

Circulation Offices:

Elm Street
Peterborough NH 03458
Phone: 603-924-7296

Subscription Rates

In the United States and Possessions:
One Year (12 issues) \$25.00
Two Years (24 issues) \$38.00
Three Years (36 issues) \$53.00

Elsewhere:

Canada—\$27.00/1 year only, U.S. funds. Foreign surface mail—\$35.00/1 year only, U.S. funds. Foreign air mail—\$62.00/1 year only, U.S. funds.

To subscribe, renew or change an address:

Write to 73 Magazine, Subscription Department, PO Box 931, Farmingdale NY 11737. For renewals and changes of address, include the address label from your most recent issue of 73. For gift subscriptions, include your name and address as well as those of gift recipients. Postmaster: Send form #3579 to 73 Magazine, Subscription Services, P.O. Box 931, Farmingdale, NY 11737.

Subscription problem or question:

Write to 73 Magazine, Subscription Department, PO Box 931, Farmingdale NY 11737. Please include an address label.

73 Magazine (ISSN 0098-9010) is published monthly by 73, Inc., 80 Pine Street, Peterborough NH 03458. Second class postage paid at Peterborough NH 03458 and at additional mailing offices. Copyright (c) 1980 by 73, Inc. All rights reserved. No part of this publication may be reprinted or otherwise reproduced without written permission from the publisher. Microfilm Edition—University Microfilm, Ann Arbor MI 48106.

W2NSD/1 NEVER SAY DIE

editorial by Wayne Green

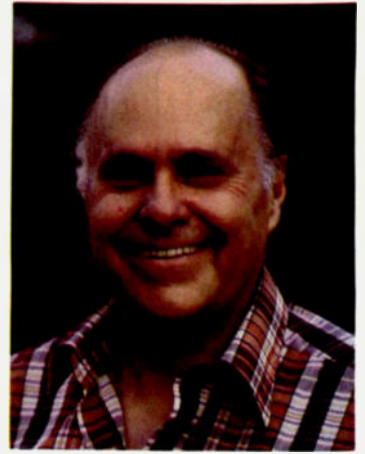

BOYCOTT

The Russian ham stations may clam up a bit after the recent bout with Dave Clark K8MPF. He was on 15 meters talking to RZ3AJA, a special Olympic prefix station, and he explained to them about the US boycott of the Olympics, much to their amazement. They expressed frustration and this was echoed by several other Russian stations which broke in on frequency. The Russians seem not to have any idea that their country has actually invaded Afghanistan and thus they were astounded to learn of the US boycott in retaliation.

This could throw quite a crimp in the Russian plans. It appears that they were going to field quite a bunch of ham stations using the special "R" calls in order to promote the Moscow '80 Olympics and that they had an objective of talking with every US amateur... and others around the world.

Dave suggests that it would be appropriate for US amateurs to refrain from contacting these special Olympic stations, but that normal contacts with Russian stations be encouraged since this is one of the few ways for information to reach the people of that country.

The text of a letter sent by Dave to Dr. Zbigniew Brzezinski follows:

March 26, 1980

Dr. Brzezinski
White House
Washington DC 20500
Dear Dr. Brzezinski:

As requested by your office on March 25, 1980, I'm submitting the following communication detailing events that occurred via amateur radio contacts I had with Soviet amateurs during the afternoon of March 25th.

Contacts with Soviet amateurs are most common; however, few of their amateurs discuss issues beyond stating location, name, signal report, weather, and descriptions of their radio equipment. Most of the Soviet amateurs are interested in exchanging QSL cards and do so through the Central Radio Club, Box 88, Moscow.

On March 25th, Soviet station RZ3AJA contacted me and the usual exchange was made with some notice on my part that this individual was fluent in English. I inquired as to the special call prefix RZ3 and got a detailed explanation of how the special prefixes were a part of Olympics '80 to be held in Moscow. He further

explained, as most amateurs are aware, that several prefixes have been assigned with R (instead of the normal U) especially for the Olympics. He further explained in detail about the preparations Moscow is making for the Olympics and that amateur radio will play an important part through special calls and awards for contacting these designated prefixes.

I explained to this amateur that the US probably would not be attending the Olympic events and the reasons for this action by our government. Not only did the station I was contacting show obvious emotional reaction, but he also was joined by several other Soviet stations who expressed great frustration with my comments.

It is my opinion that USSR amateur radio operators will continue to combine this popular hobby with an effort to promote Moscow '80. These stations have as an objective talking with and exchanging data regarding Moscow '80 with the more than 400,000 US amateurs as well as thousands of amateurs around the world.

It seems appropriate, therefore, that US amateurs be asked to refrain from communications with the special Moscow '80 R prefixes and their associated activities. A news release from your office would make an immediate impact on hundreds of Soviet stations seeking exchanges with US amateurs.

Normal communications with the Soviet U prefixes should be encouraged since amateur radio does provide a system of direct communication to all parts of the world regardless of political relations. Amateur radio should not be restricted by

NO TAXES!

Looking for a job? 73 is currently seeking applicants for one of its top staff positions. In addition to being a non-smoker, the qualified candidate will be a ham with an outstanding knowledge of electronics, an excellent command of the English language, and experience as a working journalist. We offer a competitive salary, fine fringe benefits, and excellent working conditions—as well as the opportunity to live and work in beautiful, tax-free New Hampshire. Interested parties should respond with resumes to: Director of Personnel, 73 Magazine, Elm Street, Peterborough NH 03458.

TS-120S...a big little rig.



Optimum HF performance in a compact package

TS-120S

Exciting and perfect for mobile or ham-shack use! The unique, all solid-state, HF SSB/CW TS-120S transceiver produces a hefty signal and offers many great features in a very attractive, compact package.

TS-120S FEATURES:

- **Easy operation**
No final dipping or loading, no transmit drive peaking, and all of 10 meters...and receives WWV on 15 MHz. VFO covers 50 kHz above and below each 500-kHz band, for expanded operation
- **Five bands, plus WWV**
Transmits and receives on 80/75, 40, 20, 15, and all of 10 meters...and receives WWV on 15 MHz. VFO covers 50 kHz above and below each 500-kHz band, for expanded operation
- **IF shift**
Passband tuning, to remove adjacent-frequency interference and sideband splatter

- **High power**
Runs 200 watts PEP (160 watts DC) input on 80-15 meters, 160 watts PEP (140 watts DC) input on 10 meters. LSB, USB, and CW. Built-in cooling fan and protection circuit
- **Built-in digital frequency display**
Six-digit display with 100-Hz resolution. No recalibration needed when switching bands or modes. Indicates RIT shift and CW transmit/receive shifts. Green fluorescent tubes eliminate viewing fatigue. Analog subdial, too, for backup display
- **Innovative single-conversion PLL system**
Eliminates need for heterodyne crystal element for each band. PLL lock frequency, CAL marker signal, and counter clock circuit use single reference frequency crystal. Simplifies circuitry, improves overall stability. Also improves transmit and receive spurious characteristics.
- **Built-in VOX**
For convenient SSB operation, as well as semi-break-in CW with sidetone

- **Very compact and lightweight**
Measures only 3-3/4" high x 9-1/2" wide x 11-9/16" deep, and weighs only 5.6 kg (12.3 lbs). A perfect size for convenient mobile operation and rugged enough for either mobile or portable use, with all the desired features for optimum ham-shack operation as well.
 - **Effective noise blanker**
Eliminates ignition noise
 - **Built-in 25-kHz marker**
Accurate frequency reference for calibration
 - **Versatile front-panel meter**
Functions as S-meter on receive and as I_c meter and ALC meter (for adjusting microphone gain) on transmit
- See the big little TS-120S rig and matching accessories at your Authorized Kenwood Dealer today!

NOTE: Price, specifications subject to change without notice and obligation.

MATCHING ACCESSORIES FOR FIXED-STATION OPERATION:

- PS-30 base-station power supply (remotely switchable on and off with TS-120S power switch)
- SP-120 compact external speaker
- VFO-120 remote VFO
- MC-50 50 k Ω /500 Ω desk microphone
- **Other accessories not shown:**
 - YK-88C CW filter (500 Hz)
 - PC-1 phone patch
 - HC-10 world digital clock
 - HS-5 and HS-4 headphones
 - TL-922A linear amplifier
 - AT-120 compact antenna tuner
- MC-30S and MC-35S noise-cancelling hand microphones
- MB-100 mobile mounting bracket



Staff

EDITOR/PUBLISHER
Wayne Green W2NSD/1

MANAGING EDITOR
John Burnett

ASSISTANT MANAGING EDITOR
Susan Philbrick

EDITORIAL ASSISTANTS
Nancy Noyd
Richard Phenix

PRODUCTION MANAGER
Noel Self WB1ARP

ASSISTANT PRODUCTION MANAGER
Robin Sloan

ART DEPARTMENT

Steve Baldwin
James Butler
Tedd Cluff
Robert Drew
Bruce Hedin
Kenneth Jackson
Clare McCarthy
Michael Murphy
Dion Owens
Patrice Scribner
Susan Symonds
John White

BOOK PUBLICATIONS
Jim Perry

BOOK PRODUCTION
Emily Gibbs
Chris Brown N1AUI

PHOTOGRAPHY
Bill Heydolph
Terrie Anderson

TYPESETTING
Barbara Latti
Sara Bedell
Mary Kinzel
Karen Podzycki

EXECUTIVE VICE PRESIDENT
Sherry Smythe

CORPORATE CONTROLLER
Alan Thulander

ASSISTANT PUBLISHER
Jeffrey DeTray WB8BTH

EXECUTIVE ASSISTANT
Leatrice O'Neil

ACCOUNTING MANAGER
Knud Keller KV4GG/1

DATA ENTRY
Cathy DeSilva

CIRCULATION MANAGER
Debra Boudrieau

ASSISTANT CIRCULATION MANAGER
Barbara Block

CIRCULATION
Pauline Johnstone

BULK SALES MANAGER
Ginnie Boudrieau

SHIPPING
Phil Rodier
Bill Barry
Bryan Hastings KA1HY

RECEPTIONIST
Pat Graham

ASSOCIATES

Robert Baker WB2GFE
Sanger Green
Dave Ingram K4TJWJ
Larry Kahaner WB2NEL
Joe Kasser G3ZCZ
Bill Pasternak WA6ITF
John Schultz W4FA
Peter Stark K2OAW

ADVERTISING
(603) 924-7138

Nancy Ciampa, Mgr.

government sanction since it provides emergency communication in times of crisis and need.

Your comments and feelings concerning this issue will be communicated to the major amateur radio publications and organizations.

Respectfully,
(s) Dave Clark K8MPF
2508 Rusridge
Kalamazoo MI 49007

Having visited and operated from Afghanistan (YA1NSD), I can understand the anger about the Russian invasion of those people who have visited this primitive country. I doubt if hopes for a Viet Nam-like problem will be realized. Yes, the Afghans are independent and fierce, but they do not have the endless supplies and training that the troops from North Viet Nam had behind them... unless the US manages to cook something up. That seems very unlikely, since we are not on that good terms with the surrounding countries. No, I think Afghanistan will go the way of Hungary and Czechoslovakia.

Should we contact the special events stations? I'm inclined to go along with Dave on this and boycott them. But I do think that it is important to bypass Pravda and talk directly with the other Russian hams to explain why our country has taken this unusual stand.

PHOOTLOOSE PHOTOGRAPHER WANTED

Perhaps you have seen some of the dirty grimy pictures accompanying DX articles in some of the other ham magazines. I think it's about time for DXpeditions to get the press they should have. Believe me, if I weren't tied down, I'd be volunteering to go out there and take the pictures and write the articles. Unfortunately, I have discovered that I really can't do everything.

Is there an Extra Class (or even Advanced) with a good background in photography and writing who might be available to accompany DXpeditions as a stringer for *73 Magazine*? We would pay the travel expenses... anywhere in the world... in return for top-notch articles for *73* with good photographs.

The line starts at the right.

One of the problems I have encountered on DXpeditions is the lack of foresight on the part of the other DXpeditioners. They get so wrapped up in what they are doing and what has to be done that they forget the importance of documentation. The Documentation Officer on a DXpedition should not be required to carry, lift, haul, erect, or otherwise spend his valuable documentation time doing routine work. He should be busy working out angles for pictures, setting up shots, making tape recordings, making notes, and planning the movies of the trip.

By the time you have worked out a 16mm movie, covered the trip with a color 35mm transparencies, and shot plenty of black and white 35mm photos, plus made notes for the article and tape recordings of interesting background, there is little time left except for some operating... mostly at night.

I managed to shoot a 16mm film of the 1958 Dxpediton to Navassa... which everyone fought me on at the time. Later, the film was in tremendous demand—and I still get calls for it. Having learned my lesson, I did not take a movie camera on the 1972 DXpedition to Navassa, but covered it as best I could with 35mm color shots. It isn't the same. In the future, I would go back to 16mm or else use a good video recorder.

On my DXpeditions to Africa, the Middle East, Asia, and the Pacific, I really didn't have time to shoot enough movie film to make it worthwhile to show. The 35mm slides were shown to dozens of clubs and at hamfests and conventions all around the world. I tried a Super-8 camera on one trip, but will never do that again in a case when I want first-rate films.

If I am able to find someone with the time and experience to go out on DXpeditions, we will be able to do a first-rate job of publishing articles on these trips... and perhaps come up with some film or tape which can be used on television.

JAPAN MAGAZINES

Though my ability to read Japanese is somewhat limited (I know one Kanji character so far), there is enough English for me to get quite a kick out of getting the Japanese *CQ Ham Radio* magazine every month. It is enormous, usually well over 500 pages, and packed with beautiful color pictures of the latest in Japanese ham gear. They have many more hams than we... perhaps twice as many active hams... so their market for ham gear is much larger than ours. The result of this is that they have a far greater selection of ham gear than we do.

A few of the Japanese firms are exporting their equipment for sale here and we are familiar with them. But there are a lot more smaller firms which are



Rol Anders K3RA, president of the Baltimore Amateur Radio Club (BARC), introduced W2NSD/1 at the Greater Baltimore Hamboree and Computerfest in Timonium MD. Photo by W3VBM.

Continued on page 158



*Simply...
the Best*

ICOM AMERICA, INCORPORATED
2112 116th Avenue N.E., Bellevue WA 98004, (206) 454-8155
3331 Towerwood Dr., Suite 307, Dallas, TX 75234, (214) 620-2780

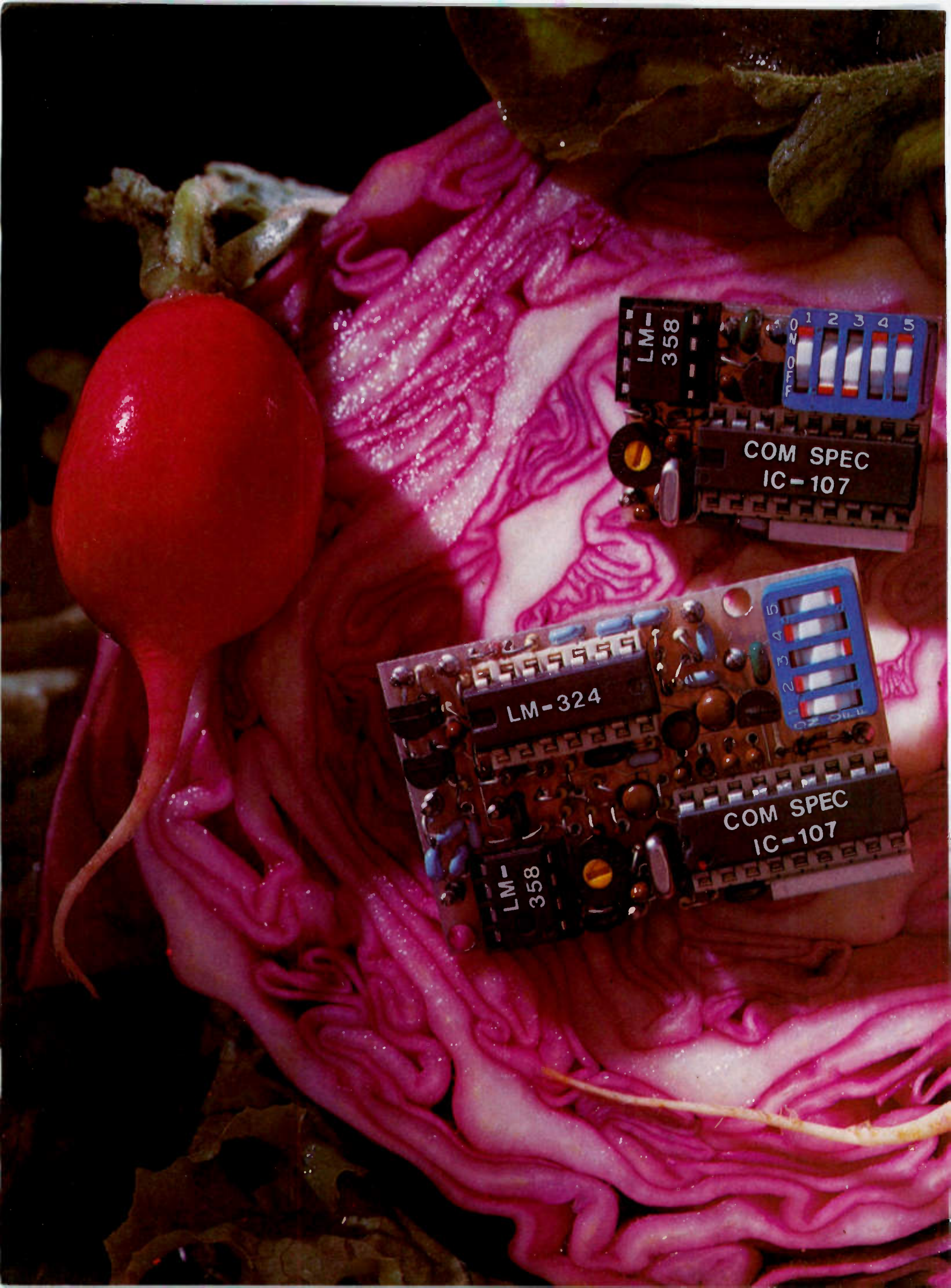

LM-358

COM SPEC
IC-107

1 2 3 4 5

0 2 0 1 L

LM-324

COM SPEC
IC-107

1 2 3 4 5

0 2 0 1 L





A fresh idea!

Our new crop of tone equipment is the freshest thing growing in the encoder/decoder field today. All tones are instantly programmable by setting a dip switch; no counter is required. Frequency accuracy is an astonishing $\pm .1$ Hz over all temperature extremes. Multiple tone frequency operation is a snap since the dip switch may be removed. Our SS-32 encode only model is programmed for all 32 CTCSS tones or all test tones, touch-tones and burst-tones.

And, of course, there's no need to mention our 1 day delivery and 1 year warranty.



TS-32 Encoder-Decoder

- Size: 1.25" x 2.0" x .40"
- High-pass tone filter included that may be muted
- Meets all new RS-220-A specifications
- Available in all 32 EIA standard CTCSS tones

SS-32 Encoder

- Size: .9" x 1.3" x .40"
- Available with either Group A or Group B tones

Frequencies Available:

| Group A | | | |
|---------|----------|----------|----------|
| 67.0 XZ | 91.5 ZZ | 118.8 2B | 156.7 5A |
| 71.9 XA | 94.8 ZA | 123.0 3Z | 162.2 5B |
| 74.4 WA | 97.4 ZB | 127.3 3A | 167.9 6Z |
| 77.0 XB | 100.0 1Z | 131.8 3B | 173.8 6A |
| 79.7 SP | 103.5 1A | 136.5 4Z | 179.9 6B |
| 82.5 YZ | 107.2 1B | 141.3 4A | 186.2 7Z |
| 85.4 YA | 110.9 2Z | 146.2 4B | 192.8 7A |
| 88.5 YB | 114.8 2A | 151.4 5Z | 203.5 M1 |

- Frequency accuracy, $\pm .1$ Hz maximum - 40°C to + 85°C
- Frequencies to 250 Hz available on special order
- Continuous tone

| Group B | | | | | | |
|-------------|--------------|------|--------------|------|------|------|
| TEST-TONES: | TOUCH-TONES: | | BURST-TONES: | | | |
| 600 | 697 | 1209 | 1600 | 1850 | 2150 | 2400 |
| 1000 | 770 | 1336 | 1650 | 1900 | 2200 | 2450 |
| 1500 | 852 | 1477 | 1700 | 1950 | 2250 | 2500 |
| 2175 | 941 | 1633 | 1750 | 2000 | 2300 | 2550 |
| 2805 | | | 1800 | 2100 | 2350 | |

- Frequency accuracy, ± 1 Hz maximum - 40°C to + 85°C
- Tone length approximately 300ms. May be lengthened, shortened or eliminated by changing value of resistor

Wired and tested: TS-32 \$59.95, SS-32 \$29.95



COMMUNICATIONS SPECIALISTS

426 West Taft Avenue, Orange, California 92667
(800) 854-0547 / California: (714) 998-3021



Looking West

Bill Pasternak WA6ITF
24854-C Newhall Ave.
Newhall CA 91321

It's about 2:00 pm Pacific time or thereabouts. We are at 35,000 feet somewhere above Kansas aboard a Boeing 727 jetliner headed home to Los Angeles. We left Dayton about an hour ago and will shortly be landing in Kansas City for about a 45-minute layover. Seated next to me is Joe Merdler N6AHU, and a few rows toward the front of the aircraft is Dr. Wayne Overbeck N6NB and his XYL. It's been quite a hectic weekend for all of us, but a special one for Joe and Wayne. We are returning from the 1980 Dayton Hamvention, and what made it special for Joe and Wayne were the awards presented to them at last night's banquet. In case you have not yet heard, Wayne Overbeck was named "Ham of the Year" because of his continuing contributions to the overall picture of amateur radio communications. DARA's "Special Achievement Award" for 1980 went to Joe, for his leadership in the fight against malicious interference in amateur communications.

By the way, this is the first time in the history of these awards that two amateurs from the same call district (other than "8"-land) have been chosen to receive awards in the same calendar year. Even more coincidental, both are residents of the San Fernando Valley and both are members of the same amateur radio club. What's really important is that DARA saw fit to honor both these men for their outstanding contributions to the amateur service; I cannot think of any two people who were more deserving of such honors. To both, Looking West offers its heartiest congratulations.

Joe and I decided to fly in together, and the flight to Dayton was far better than this one going home. When I booked our tickets, I was told that the aircraft on the return trip would be a "wide-body" Lockheed 1011, but for some reason this smaller plane is what showed up. When we left the other evening, we had a Boeing 747 for the main leg of the trip and spent only 45 min-

utes on board a smaller plane for a connecting flight out of Chicago. Not that there is anything wrong with a 727, except trying to sleep on it. That's where a 747 or 1011 is really nice, and what I need right now is about 10 hours of sleep. Oh, well, one cannot win them all, can one?

Next month, we will have a complete story about the Hamvention, but right now I want to tell you a bit about the truly wonderful people who were our hosts during the past three days. We arrived in Dayton the morning of April 25th at about 9:00 am local time. Waiting for us were two of the nicest people I have ever had the pleasure of meeting: Bob McKay N8ADA and Bob Roettele W8UNV. Both are active DARA members, and both worked very hard to make Hamvention '80 the overwhelming success it turned out to be. We loaded our bags into Bob Roettele's red station wagon and headed to our hotel, only to learn that our rooms would not be available till about noon. Undaunted, Bob McKay suggested that we head over to his house for breakfast. Let me tell you, it was some breakfast! I literally "pigged out." Bob's wife whipped up the biggest platters of bacon and eggs I have ever seen, and did so in what must have been record time. Boy, can that lady cook!

Since it would still be a while before we could get into our rooms, Joe decided to see if he could hear his friend Dave Gardner K6LPL, who at that time was operating a DXpedition from Johnson Island in the Pacific. We swung Bob's beam out in that direction, but Joe never did hear Dave. Sometime during all this, I must have dozed off, because the next thing I remember was Joe telling me it was time to try again at the hotel. This time the room was ready, and while Joe and the two Bobs headed out to the Hara Arena, I elected to catch up on some lost sleep. Having been to Dayton before, I kind of knew that this might be the best approach. I had slept for 3 hours between Los Angeles and Chicago, but this darn hypoglycemia I suffer from really requires about 8 hours of sleep so that I can function

properly for the next 16.

It was about 6:00 pm local time when Joe returned, and he had with him yet another Bob. This was his cousin Bob Merdler K8AQA from Saginaw, Michigan. Joe introduced us, and we took off for dinner.

It was when we returned that I finally met Noel and Marilyn McKeown and their 8-month-old daughter. Noel is WB8QQC and was the General Chairman of Hamvention '80. Ever meet someone for the first time and feel you have known him for a lifetime? That's the way it was with Noel and Marilyn. I can only say that in my book, they are super. So, while Bob and Joe hit the snore shelf, Noel, Marilyn and I, along with a number of other members of DARA, sat in the DARA suite talking into the wee hours of the morning. I never did get much sleep that night, but I had, as you know, taken precautions to cover just such a happening. About 1:00 am, Noel and Marilyn excused themselves, since they both had to be at the arena early to open for the next day's events, so we rambled downstairs to the hotel's pub with the rest of the crew. As I sipped my Diet-Rite Cola and chatted with Vic Stauder WA2KOO/8 and the rest of the people, I knew deep inside that I had made new friendships that would last a lifetime. Vic was interested in possibly videotaping some of next year's convention, and we spent a good two hours debating the pros and cons about how to do this.

Saturday morning at about 8:00 am, Bob picked us up and we headed out to the Hara Arena, stopping along the way for a rather healthy midwest breakfast. I thought we would be among the first to arrive, but I was in for a rude awakening. By the time we arrived, the parking lots were loaded with cars bearing callsign plates from almost every state in the Union. If there is a gasoline shortage, you would never have known it here. The place was buzzing with activity. Since Joe was not scheduled to speak till noon, I left him in Bob's capable hands and made my way toward the flea market. I had a specific destination and a specific person to meet with.

You have not seen an amateur radio flea market until you see the one at the Hamvention. This year, they opened the flea mar-

ket a day earlier than usual, and by mid-Friday it was already packed full. By the time I arrived on Saturday, it was both unbelievable and breathtaking. There is no way I can tell you how many buyers and sellers there were. Maybe DARA has figures on this, but if the place was crowded in 1976 when I last attended, it was twice as crowded this year. Even with the mass of humanity I had to wade through, it took only 10 minutes to locate the person for whom I was searching. After all, how many people come to the Hamvention with a 10-meter ground plane on a push-up mast? I had been told to watch for this "landmark" by its owner and had spotted it almost immediately. Its owner was Bob Heil K9EID of Marissa, Illinois.

In the past year, Bob and I have become friends over the phone, though we had yet to eyeball. Actually, Wayne Green sort of introduced us by suggesting that I give Bob a call in early 1979. That phone call led to many others and finally to our meeting face-to-face at Dayton. Bob is the guy who put the town of Marissa on the map with regard to amateur radio. As he explains it, Marissa has about 2,000 residents of which close to 170 are active amateur radio operators. Virtually all of these are members of "MARC," the Marissa Amateur Radio Club, one of the most active radio clubs in the nation. They own one of the most elaborate amateur repeater systems in the nation, with satellite receivers, satellite transmitters, and remote links to other bands—including 10-meter SSB! How was this accomplished? That's for Bob to tell, and the story is told partially in a slide show that MARC makes available which details the development of WD9GOE... "The Mighty Marissa Machine." I've seen this slide and audio tape presentation, and it's one worthy of showing at any radio club meeting. I suggest that you contact MARC at PO Box 68, Marissa IL 62257, for information on its availability.

Back to the narrative. I arrived at Bob's van and was introduced to his wife Judy and another friend of theirs who made the 400-plus-mile trek to the Hamvention together. Bob's latest interest is getting more people on

Continued on page 167

enter the new world of TEN-TEC

OMNI-Series C



new features, new performance + all 9 hf bands

NEW — ALL 9 HF BANDS. Full coverage from 160 through 10 Meters. Ready to go, with crystals supplied for seven bands (crystals for 18 and 24.5 MHz bands available when bands are ready for use).

ALL SOLID-STATE. From the pioneer.

BROADBANDED. From the pioneer.

NEW 3-MODE, 2-RANGE OFFSET TUNING. Another TEN-TEC first... (1) Offset Receiver Tuning, (2) Offset Transmitter Tuning and (3) Offset Transceiver Tuning. None other has it. For complete flexibility, to meet all needs, fine tuning or DX. 2-ranges: ± 500 Hz or ± 4 kHz.

OPTIMIZED RECEIVER SENSITIVITY. For an ideal balance between dynamic range and sensitivity... from $2 \mu\text{V}$ on 160 to $0.3 \mu\text{V}$ on 10 Meters.

NEW OPTIMIZED BANDWIDTH. Seven response curves—four for SSB, three for CW. Standard i-f filter is an 8-pole 2.4 kHz crystal ladder type. Options include a 1.8 kHz 8-pole crystal ladder type, a 500 Hz 8-pole CW filter and a 250 Hz 6-pole CW filter. Switch an optional filter from the front panel to put it in series for up to 16 poles of filtering. And the standard CW active audio filter has 450 and 150 Hz bandwidths for added attenuation. New toggle switches select i-f and audio filtering. Selectivity for any situation.

BUILT-IN NOTCH FILTER. Variable null eliminates unwanted signals and carriers in a pass band from 200 Hz to 3.5 kHz with a notch depth of more than 50 dB.

NEW BUILT-IN NOISE BLANKER. Standard equipment. New 2-pole monolithic crystal filter handles big signals easily, makes impossible locations usable.

GREATER DYNAMIC RANGE. Better than 90 dB, typically. Reduces front-end overload and distortion. Plus a PIN diode switchable 18 dB attenuator on the RF gain control.

NEW "HANG" AGC. Smoother operation. **2-SPEED BREAK-IN.** "Fast" or "Slow" speeds. "Fast" for instant, full break-in. "Slow" has a longer mute time before receiver is actuated for working crowded bands with heavy QRM and for mobile.

WWV RECEPTION. On the 10 MHz band. **DIGITAL READOUT.** 6 shielded 0.43" LEDs with 5 in red, the 6th (100 Hz) in green.

SEPARATE RECEIVING ANTENNA CAPABILITY. Use with separate components, instant break-in linears, or transverters.

"S"/SWR METER. Easy-to-read. Electronically switched.

200 WATTS INPUT. On all bands, when used with 50 ohm load. Proven, conservatively rated design. Fully warranted for first year, pro-rata warranty for five extra years! **100% DUTY CYCLE.** Full power hour after hour without fail. Ideal for RTTY, SSTV or any hard usage.

BUILT-IN VOX AND PTT. Smooth VOX with 3 front panel controls. And PTT control at both front and rear panel jacks.

BUILT-IN PHONE PATCH JACKS. Easy interface to speaker and microphone signals.

BUILT-IN CW ZERO-BEAT SWITCH. Puts you on exact frequency of a station being worked without being on the air.

BUILT-IN ADJUSTABLE SIDETONE. Vary pitch and volume for easy listening.

ADJUSTABLE THRESHOLD AUTOMATIC LEVEL CONTROL. From low power to full output with full ALC control.

FRONT PANEL CONTROL OF LINEAR OR ANTENNA. Auxiliary bandswitch terminals on rear panel permit simultaneous control of external relays or circuits.

AUTOMATIC SIDEBAND SELECTION. And you can reverse it with the mode switch.

SUPER AUDIO. A TEN-TEC trademark. Proper shaping plus low distortion.

IMPECCABLE SIGNAL. Clean. Easily exceeding FCC requirements, thanks to meticulous design, fine components, and conservative ratings.

HIGH STABILITY. Deviation is no more than 15 cycles per degree temperature change after warm-up.

HIGH ARTICULATION KEYING. 2½ msec rise and decay time for sharp, clean keying.

BUILT-IN SPEAKER. Built into the bottom of the cabinet shell. Compression-loaded for better quality and higher efficiency. External speaker connections on rear panel.

PLUG-IN CIRCUIT BOARDS. For easy removal if needed.

FUNCTIONAL STYLING. Dark front panel, convenient control groupings, "clamshell" cabinet, full shielding, and easier-to-use size: 5¼" h x 14¼" w x 14" d.

POWER. Operates on 12-14 VDC for mobile or storage battery use. For 117 VAC use, an external supply is required.

FULL ACCESSORY LINE. Model 217 500 Hz CW filter \$55, Model 219 250 Hz CW filter \$60, Model 218 1.8 kHz SSB filter \$55, Model 243 Remote VFO \$139, Model 255 Power Supply/Speaker \$169, Model 280 Power Supply \$139, Model 645 Dual Paddle Keyer \$85, Model 670 Single Paddle Keyer \$34.50, Model 234/214 Speech Processor & Condenser Microphone \$163, Model 247 Antenna Tuner \$69. All in matching color.

Model 546 OMNI-Series C \$1189

See your TEN-TEC dealer, or write for full details.

TEN-TEC, INC.
SEVIERVILLE, TENNESSEE 37862
EXPORT 5715 LINCOLN AVE. CHICAGO, ILL. 60646

RTTY Loop

Marc I. Leavey, M.D. WA3AJR
4006 Winlee Road
Randallstown MD 21133

This month, the spotlight shifts from the home-brew to the commercial. We shall begin examining "store-bought" RTTY equipment available to the amateur. I plan to cover only equipment I have bought and used personally or been able to get my hands on for a while. I will not echo manufacturers' spec sheets or promotional literature; that would be a disservice to you all.

I guess it is best to start with something popular that many of you have had experience with. We have been talking about demodulators for a few months, and one of the most popular commercial demodulators of recent times is the ST-6, manufactured by HAL Communications Corp., Urbana, Illinois 61801. Now, HAL has come out with many new models, with all kinds of bells and whistles, but the ST-6 has been the anchor for many a RTTY enthusiast.

You can trace the ancestry of the ST-6 back to at least August,

1965, when Irv Hoff W6FFC, then K8DKC, published a description of his "Mainline TT/L FSK Demodulator" in *QST*. Although built with tubes and requiring a hefty power supply to match, this is the granddaddy of the ST-6, with most of the same operating features. The design was upgraded in a few years to the TT/L-2, and then solid state appeared. Irv went to work and a whole series of begats ran from the ST-1 to the ST-6, the latter published in *Ham Radio*, January, 1971.

The ST-6 uses 709 operational amplifiers throughout and employs well-designed Butterworth input filters. As supplied, it comes equipped for 850-Hz and 170-Hz operation; 425-Hz operation is available as an option. The filters are quite narrow, which allows for sharp selectivity under difficult conditions. By straddle tuning, shifts of ten Hz to 1100 Hz are copyable with a stock unit. Autostart, however, is functional only on the nominal shifts.

Using the ST-6 is relatively straightforward. The loop connector is a molex™ plug on the

rear skirt and provides the standard 60-mA loop current. An RS-232 output is also available and may be used to drive a video display or transmitting FSK circuit. A key jack is provided which, when used with the FSK output, can provide narrow-shift CW identification. The teleprinter may be plugged into a switched ac receptacle, also on the rear skirt.

A signal is tuned in by peaking the built-in meter so that minimum flicker of the needle is observed. The meter deflects upward for both mark and space, so when the signal is tuned correctly, assuming equal strengths for mark and space, the deflection remains constant. Alternately, a conventional oscilloscope may be connected to a jack and a cross pattern used for tuning. The demodulator may be used in "FM" (limiter) or "AM" (limiterless) mode. The autostart only works when the limiter is on FM.

Now, a few problems. Many people buy the ST-6 as a kit. The circuit is assembled mostly on several printed circuit boards, so this is not too much of a chore. But, wiring at least seven (more if extra shifts or AFSK is added) edge connectors is hard enough without being forced to use the wire supplied. Typically,

a coil of fine stranded wire is supplied, all one color. If you like your eyes and plan to assemble this kit, go out and find some multi-colored wire to do the connectors with and ditch what they send you. Almost every mistake I have seen in an ST-6 built from kit form (and there have been quite a few) has been traced to an error in wiring those edge connectors, an error that could have been prevented, or at least found easily, if coded wiring was used. I mentioned that a discriminator for 425-Hz shift is available. This shift is a common commercial shift, but is rarely used in amateur work. Nonetheless, the front panel is marked for all three shifts. If you have only two, 850 Hz and 170 Hz, the switch used has a different arc, so the pointer lines up with neither label. A neater way would be to stamp the case for two shifts and offer an escutcheon to users to the three-shift option. Finally, I am not fully versed enough on the circuit to know why, but it sure would be nice to be able to use autostart while in limiterless mode. As it is, the machine runs open without a signal in limiterless mode, while in limiter (FM) there is mark-hold.

Continued on page 163

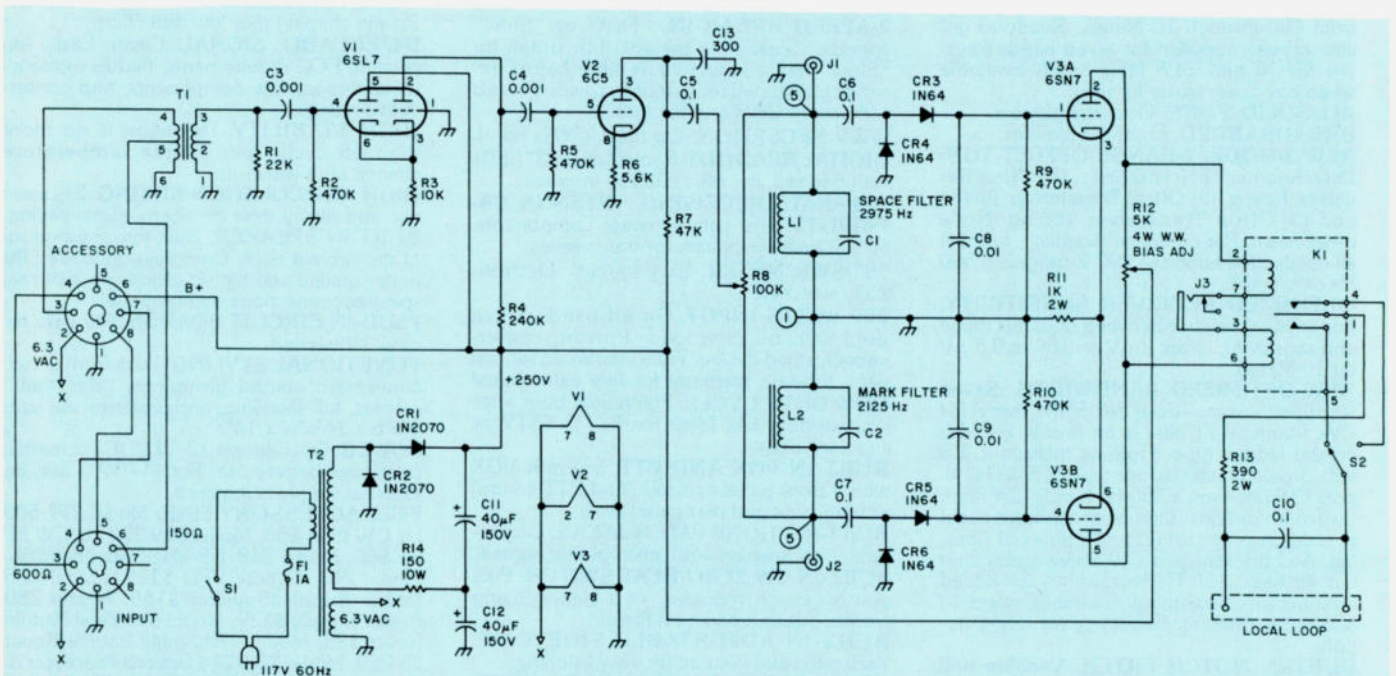

Fig. 1. The Twin Cities TU: Parts List. C1—0.033 mF, approx., to resonate with L1 to 2975 cycles. C2—0.066 mF, approx., to resonate with L2 to 2125 cycles. C3, C4—500 V, disc ceramic. C5, C6, C7, C10—400 V, paper. C8, C9—500 V, disc ceramic. C11, C12—electrolytic. C13—500 V, mica. CR1, CR2—400 pIV silicon diode. CR3, CR4, CR5, CR6—1N64 or 1N69 diode. F1—1 Ampere, 250 V fuse. J1, J2—Auto radio antenna jacks, Motorola type. J3—Phone jack, closed circuit, with insulating washers. K1—255 A polar relay. L1, L2—88 mH toroid telephone loading coil. R1—½ Watt. R2, R5, R9, R10—½ Watt. R3—½ Watt. R4—½ Watt. R6—½ Watt. R7—½ Watt. R8—potentiometer, linear taper. R14—wire-wound. S1—SPST toggle switch. S2—SPDT toggle switch. T1—150/600 to 19,000 Ohm, surplus; #GH-1202-2. T2—150 V @ 50 mA, 6.3 V @ 2 A, Stancor PA-8421. V1—6SL7 tube. V2—6C5 tube. V3—6SN7 tube.

WHEN OUR CUSTOMERS TALK... WE LISTEN.



John Fail, KL7GRF/6
Long Beach, CA



Vernelle "Red" Irwin, K9KUW
Kenney, IL

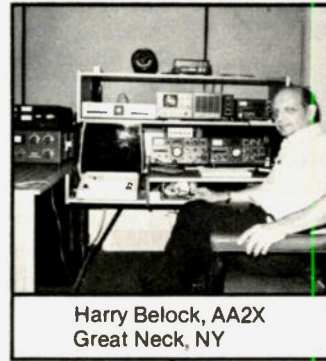

Harry Belock, AA2X
Great Neck, NY

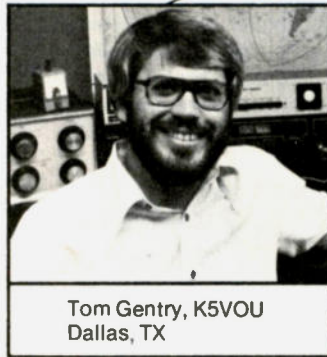
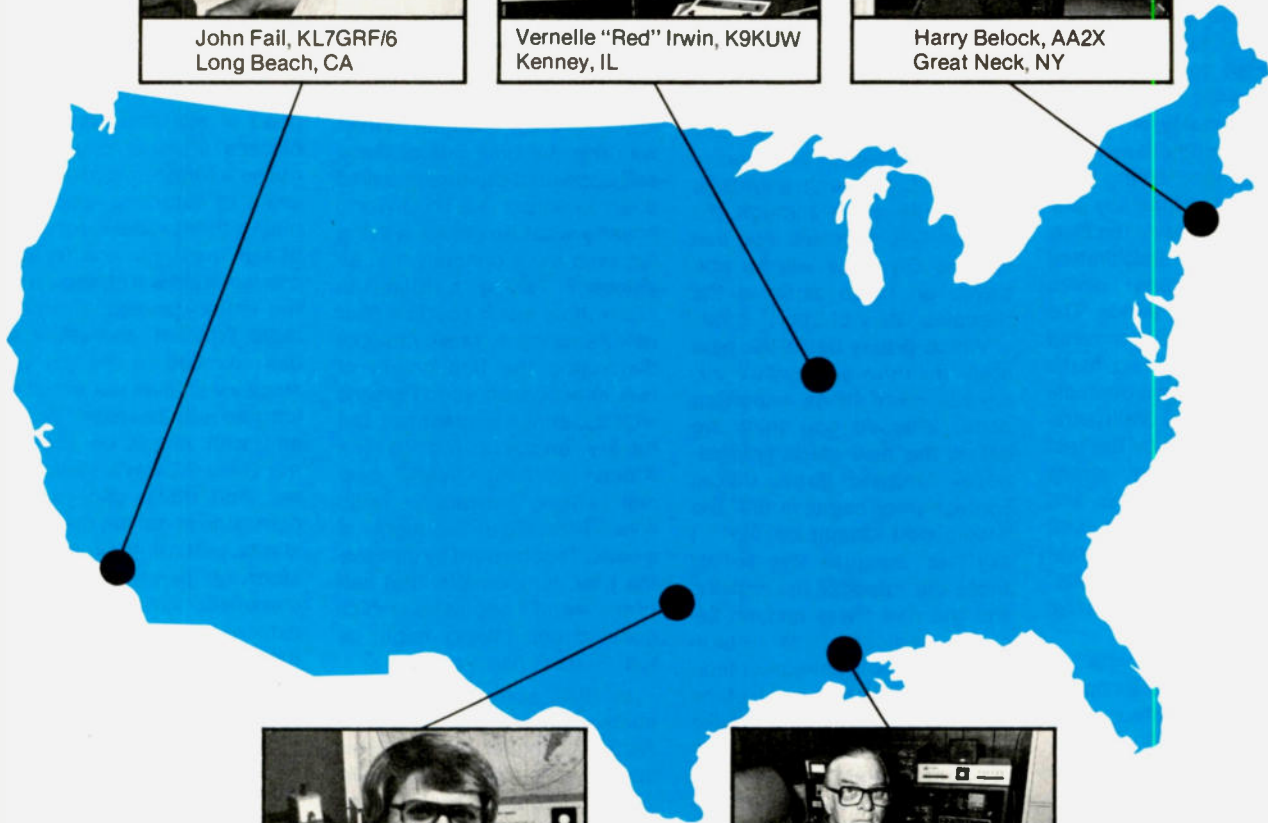

Tom Gentry, K5VOU
Dallas, TX

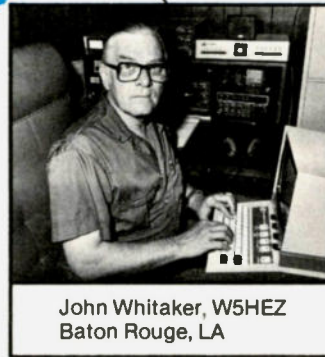

John Whitaker, W5HEZ
Baton Rouge, LA

And we respond with unexcelled RTTY equipment.

One reason RTTY equipment designed by HAL is always state-of-the-art quality is our open channel of communications with customers.

We *want* to hear the "What if's..." and "How about's..." that come from active and dedicated RTTY operators. Our engineers have combined

customer ideas with their own to create the most advanced equipment features and capabilities in the industry.

It adds up to greater enjoyment of RTTY operation and a dependability factor backed with a full one-year warranty.

Write or give us a call. We'll be glad to send you our new RTTY catalog.



HAL COMMUNICATIONS CORP.
Box 365
Urbana, Illinois 61801
217-367-7373

For our European Customers Contact:
Richter & Co., D3000 Hannover 1
Transradio SA, 6816 Bissone/Lugano

James D. Cain K1TN
306 Vernon Avenue
Vernon CT 06066

DXING IN THE EIGHTIES

Unlike other phases of amateur radio, DXing depends on the world political situation and on each country's relationship with other countries. A world war is the extreme example when amateur radio simply ceases to exist. Luckily, this has not happened for nearly forty years. Otherwise, during times of political normalcy, when only three or four world crises are in progress at a time, DXing is affected but not completely precluded. In 1980, there's the Russian "woodpecker," that dratted over-the-horizon radar which trashes various HF bands. The woodpecker has engendered worldwide anger among hams since it is the greatest obstacle to DXing in memory. The frustration is compounded by the fact that the woodpecker comes from a country which has, and encourages, a dynamic amateur radio program. In addition, that same country was "on our side" at the World Administrative Radio Conference.

Another example of what we are going to face in the coming decade is that amateur radio may no longer be the international diplomat it has been in recent years, at least not from America's point of view. Already this year, several expeditions have been mounted to rare DXCC countries by non-US amateurs after attempts to operate from the same spots by Americans have been flatly turned down. Take Europeans in Africa, for example, or Canadians in Asia. Where one sells arms of war to another country, amateur radio operators are inevitably present and likely to obtain permission to operate if anyone can. The US has traded businessmen/hams in Iran for Naval personnel/hams on Diego Garcia. Now Iran is rare and VQ9s are everywhere.

QST published its May issue with a full-color cover photo of radio operations for the Winter Olympics at Lake Placid, New York, in February, 1980. That is wonderful publicity for amateurs, but, since mostly ama-

teurs read QST, we wonder why that cover was chosen. Hams worldwide will get that issue of QST just as the last hopes for the Summer Games in Moscow are dying. A few copies of QST make their way to the USSR, too. We are sure the May issue will be allowed in, as the propaganda value will be great. If some sort of "alternate games" are held this summer, will amateur radio be there? Would amateur radio have played a part in the Moscow Games? As a matter of fact, it already does, in the form of special amateur radio call-signs being used by amateurs in the USSR. And wait until their QSL cards come through the various QSL bureaus: You can bet the Olympics will be portrayed on those cards in the "People's Glory of Sport" motif.

Which brings us to the next step in this somewhat circuitous route to an important point. Why do you think we called the new IARU (International Amateur Radio Union) contest which began in 1977 the "Radiosport Championship"? I say "we" because this author wrote the rules for the activity, and the name was chosen because "radiosport" is a term used in the Communist-bloc countries as well as much of the rest of the world. It seemed like a nice change from the wrung-out term "contest." It was an attempt to show support for the concept of "radiosports," which in many countries means strap-

ping a radio on one's back, running miles and miles, stopping at certain checkpoints to make contacts, and hoping to finish the course or find the hidden transmitter first, before one's heart bursts. Try to forget that in North America a transmitter hunt means climbing into a gas-guzzling automobile with a case of beer and a couple thousand dollars worth of commercial radio equipment.

Listen to the talk on 20 meters among hams ostensibly furthering international goodwill—amateurs in the "have" countries talking to amateurs in other "have" countries about their next six-month tour of still another "have" country. When was the last time one of these self-appointed diplomats asked a radio contact in a Third-World country what he did for a living (or, even more remotely, got an answer)? Telling a friend in Japan how much you like your new Kenwood or Yaesu radio, or discussing the fine points of fuel injection on your Porsche with a German is great fun, but hardly encouraging to the African with his "WARC Special" single conversion radio who is listening in. We might put a better foot forward by discussing how, for example, that half of the world's population which goes to bed hungry might be fed. Or don't hams care?

In 1970, author Alvin Toffler stunned the world with his book *Future Shock*; he followed it this spring with *The Third Wave*, which reminds us that his predictions ten years ago are coming true and that those who roll

with the punches of a changing society and a changing world will make it; those who don't, won't. If a DXer burns wood for heat, cuts his driving, grows a garden, starts a business because the industrial state no longer seems relevant (much less efficient), how can that DXer continue operating his radio station in the same manner as when times were simpler?

For years we have heard amateur radio's leaders tell us that our ability to communicate around the world is a unique privilege to be guarded and cherished. Indeed. But it is also a privilege to be utilized in the best possible manner for the good of mankind. Speaking to citizens of other countries remains a thrill to us, after twenty years of hamming, and will remain a thrill probably for the rest of our lives. But the topics of conversation will change, as will the entire concept of amateur radio. Why not? Everything else has changed in the ten years since we walked out of college, long-haired, bearded, drafted, and with lumps on the head from Mayor Daley's storm troopers. And those who yearn for ham radio to remain the one last stable part of their lives in a storm of change had best look elsewhere. Amateur radio is a personal, human reflection of the other parts of our psychological makeup. The old-timers on the bands who hoot at thoughts such as these will not be around ten years hence to witness the changes they oppose. Pity. The changes are inevitable.

Already, signs are on the horizon. There is an entirely new breed of DXers on the bands, a crop of neophytes spawned by the League's training program of a few years ago. They don't think like we "old-timers" do. They didn't come up through the ranks of DX-20 transmitters and "All American Five" blooper shortwave radios, those stations where finally working a G3 on 20 CW was worthy of a three-day celebration and a news item in the local paper ("13-Year-Old Boy Earns FCC Radio License"). Nowadays, get a ticket, hook your FT-101 to a trap vertical, and make DXCC in a month. And that's great! But such a growing up in radio results in an attitude which removes much of the mystique of wireless communications and, ultimately, an atti-

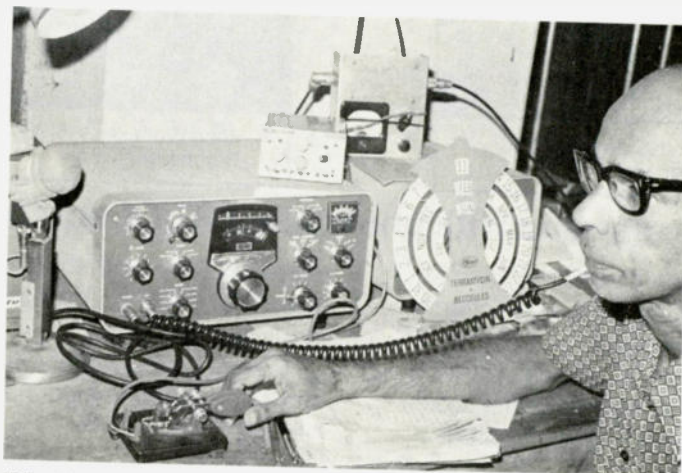

Kris VU2KMK is very active on 20-meter CW almost daily, looking for the North Americans. The SB-101 is hooked to a dipole and usually puts a good signal into the States and Canada. Thanks to Doug Hendricks N7UT, who is manager for VU2KMK QSLs, for sending the photo.

tude toward DXing which took some of us decades to cultivate. Oh, the newcomers still listen to their elders on the bands; witness the KA1 "calling CQ ten and carefully tuning for any possible call." No matter he has a locked-in transceiver and his "any possible callers" are fully aware that he is on 10 meters without being told! He/she is sure to wish us best of best regards (best 73s) and he/she will learn. If we do the teaching.

So the bands are sounding different: newcomers, hippies, lists, hams who don't know the code, operators tied into computers or playing chess, outcasts from the amateur radio establishment. Not everyone on the bands voted for Nixon, has short hair, holds a job, is male, has freedom of choice, and is married with 2.3 children, a dog, and a station wagon. Talk to a ham in San Francisco and odds are one in three he/she isn't even heterosexual. But who cares? Let's talk!

An important person in amateur radio passed away in April

and we should record his passing. Jim Fisk W1HR, Editor-in-Chief of *Ham Radio* and *Ham Radio Horizons* magazines, succumbed to a heart attack on April 18, 1980, at age 45. Jim was a true ham: technically knowledgeable, devoted to amateur radio, and active on more frequency bands than most of us know exist. Jim was a founding father of *Ham Radio* magazine twelve years ago, and he was known for his ability to convince reluctant basement experimenters to publish their findings in the amateur press. Jim's last goal was DXCC Honor Roll, and he had worked four new countries in the last week of his life. People like this are hard to find, and W1HR's void will be difficult to fill.

We ran a photo last month of Nao Akiyama JH1VRQ, one of Japan's most active and avid hams. Nao's home was destroyed by fire early in April, and he lost most of his valued radio records. Nao was overseas liaison officer for the Japan DX Radio Club, and he correspond-

ed with most of us who are into DXing. Please. You may remember working JH1VRQ in the past few years, in contests especially. Look him up in your log and get some QSLs off to him c/o the JARL bureau in Tokyo. Think where you would be if your collection of DX cards was wiped out by a personal disaster. Thanks.

There was plenty of good news on the DX front in April, 1980. Herewith a rundown.

You read our report on the Heard Island VK0RM operation last month. The good news is that Jim Smith P29JS and Dave Gardner K6LPL are both interested in planning a full-blown operation from this remote island late this year or early next. The accompanying box has the letter from P29JS regarding this. P29JS has thus far expended considerable effort on behalf of DXers and he seems likely to be in a position where he could pull off a full-bore expedition. How badly you want to work Heard depends on how close you are to the Honor

Roll and how much you might want to be on the Honor Roll a couple of years from now.

Speaking of K6LPL, Dave operated from Johnston Island /KH3 in April and did an exemplary job. We listened to Dave for a long period of time, and no matter who he worked, chit-chat was at an absolute minimum. It was always rush, rush, rush. Dave started his expedition by firing up 26 hours after he departed the infamous Fresno DX Convention and operated SSB despite a cold of what sounded to be monumental proportions. Dave was all business, which is what counts in an operation of this kind. It is great to know that Dave's injuries while on Palmyra as K6LPL/KH5 last January have apparently healed enough to enable his Johnston operation. QSLs for this one to Joe Merdler N6AHU, who is, by the way, associated with the Personal Communications Foundation. Those of you not familiar with the PCF

Continued on page 166

Heard Island DX Association
c/o PO Box 2053
Konedobu
Papua, New Guinea

73 DX Column

Dear OM,

Anybody who has followed the recent activation of Heard Island will be disappointed in the misfortune suffered by the people involved. Even if all had gone well, the size and duration of the operation (interspersed as it was with the requirements of a scientific expedition) meant that the total of anticipated contacts would not exceed around 1000 QSOs.

Prior to VK0RM, Heard Island had not been activated for 8-10 years and has never been the subject of a full-blown DXpedition. It is intended to try to change this situation within the next 10 months.

The Heard Island DX Association has been formed for the purpose of activating Heard Island.

A considerable amount of research has already been done in conjunction with the scientific expedition which took place in March this year. During the coming months, further work involving the necessary logistics to support a serious amateur DXpedition to Heard Island will continue.

The Australian authorities concerned have indicated that there would be no serious objection to a well-planned, well-founded, and good-intentioned amateur DXpedition. It is intended that the association will offer a place in the team to a professional scientist to carry out research on Heard Island over the duration of the DXpedition.

It is anticipated that the team will consist of a number of experienced "contest-type" operators who, while capable of dealing with the tremendous demand that exists for Heard Island, will have the capability of offering other skills which will contribute to a successful operation.

The financing of any major operation invariably creates

problems; the costs of mounting this DXpedition will be considerable. Many people and DX groups have indicated a tremendous interest in the activation of Heard Island and offers of assistance have been numerous.

Funding of the 1980-81 DXpedition will be based on the following criteria:

- (a) Each member of the amateur team will be required to contribute to the expedition fund.
- (b) Individual donations will be accepted.
- (c) Offers of financial assistance from the various amateur radio societies, radio clubs, and DX groups will be accepted.
- (d) Residue of funds accrued after completion of QSL commitments.

A trust account has been established by the founder members of the Heard Island DX Association to account for the funds received, and receipts will be issued for all contributions.

In the unlikely event of the DXpedition not taking place as scheduled, all donations will be either refunded or allocated to another DXpedition or worthy charity. In either event, all donors will be notified personally.

Firm offers of radio equipment have already been received, but no offers of ancillary equipment, antennas or power supplies, etc., have as yet been solicited.

Owing to weather conditions, the time slot available is mid-December to mid-February. As you can see, the time factor to allow an operation to take place in 1980 is very limited.

We thank you for your cooperation and assistance in helping us to activate one of the most difficult and rare DX countries in the world today.

73,
Jim Smith P29JS
President
Heard Island DX Association

Leaky Lines

Dave Mann K2AGZ
3 Daniel Lane
Kinnelon NJ 07405

RTTY, to me an arcane, mysterious mode that I deliberately avoided for years, has finally gotten to me. I had sidestepped it on the theory that since inanimate objects are unpredictably perverse, I would rather not have any truck with it. People are bad enough, but at least they can be dealt with to some extent, however slight. But when you're dealing with machines and gadgets, the only way to overcome their occasional idiosyncrasies is to take a sledge to them.

How does one capture the attention of a dumb machine? You can slug a recalcitrant jackass over the head with a two by four. But you cannot do anything with a malfunctioning machine. You might just as well bay at the moon!

As I say, I avoided teletype™ like the plague. But in recent months, several of my buddies, the more affluent ones, had bought themselves Pets, Apples, TRS-80s, and the like, and a few even went for those dandy little DS3100 ASR jobs. All at once, I found that I was left with two or three guys to talk with; the rest were all pounding on the "green keys." It frustrated me no end. When I did run into them once in a while, they were patronizing, uppity, and positively revolting!

So, notwithstanding my natural aversion to the mode, I was forced to get in on the action. It was strictly a case of peer pressure and keeping up with the Joneses.

I latched onto an old clunker . . . a Model 15. It had its problems. As I've already implied, what I know about teletype you could put into an eyedropper, with room to spare. So every bug that gave me trouble became a major crisis. I had to seek help on practically every one of them, and I suppose I exposed myself for what I really am: a rather non-technical person. One of my friends, while on the phone with me, said that he had monitored one of my QSOs in which I was attempting to make head or tail out of someone's explanation about loop circuits and scathingly asked me, "Hey, Dave,

where did you get your license . . . at Sears & Roebuck?" I know that he was just trying to be funny, but it cut me to the quick. I mean, I can look at a diagram of a Hartley or Colpitts oscillator and identify it . . . I can recite Ohm's Law and the Square of Turns Ratio . . . I know the formulae for inductive and capacitive reactance and know the difference between a Lissajous figure and a lecher line. But RTTY is something else again.

It's the frightening intricacy of the thing. It has more wheels, cogs, cams, ratchets, levers, escapements, springs, sprockets, pawls, pivots, bearings, shafts, bushings, idlers, and other gadgets and widgets than anything I've ever tackled since I surreptitiously dismantled our old Seth Thomas when I was about eleven (and got the worst trouncing of my life from my righteously indignant father). RTTY is a formidable and diabolical challenge indeed, especially to one who, like me, is all thumbs.

Then, too, this machine had not been in service for quite a spell, and a great deal of the old grease had dried out pretty badly and was of the hardness and consistency of well-aged Portland cement. Have you ever tried to remove a blob of old dried-up bubble gum from the seat of your blue serge pants? Well, that's what it's like to clean up that ancient, dessicated grease in a Model 15.

Moreover, at least ten families of spiders, moths, and other wildlife had made their domiciles in that machine, and I found some artifacts within that indicated that at least one small boy must have used it as a repository for some of his prized possessions. A few marbles, a small pocketknife with a broken blade, a size 8 snelled Eagle Claw fishhook, two baseball cards (Johnny Mize and "Lucky" Jack Lohrke, which suggest that this particular kid must have been a Giants fan fast approaching middle age by this time), and a red cardboard cylindrical Daisy BB container holding a few old-fashioned kitchen matches. I believe that I've gotten all of his stuff out of the machine, but you never can tell. It's possible that I've missed

some items which will turn up later.

I needed a terminal unit, of course. I hung around the house for days on end, hoping to intercept the UPS man so that the XYL wouldn't find out that I'd ordered one COD. I figured that I could tell her I'd traded some old stuff in the basement for it, just as I'd done when I got my linear amplifier and the 2-meter FM rig. But, of course, the damned thing had to arrive during a brief ten-minute hiatus when I was out of the house. She made out the check for \$238.95, and on the stub, in very neat handwriting, she wrote, "What nerve!!!"

As close as I can figure it, that TU has cost me about 400 bucks to date, counting the new handbag, the gloves, the two tickets to "Evita," and the restaurant after the show. I'll never order a piece of gear COD again . . . that I promise you.

RTTY operators generally prepare what is known as a "brag tape." It is simply a rundown of the station equipment and is pretty much standardized; most of them are fairly similar. I was delighted to learn, however, that there are a couple of guys who rebel at the conventional and show their disdain by running tapes which are much different. This represents the sort of iconoclasm dear to my heart . . . to me, there's nothing worse than a stuffed shirt who never whistled in a library. Sacred cows often get booted in the tail, and this brightens my day. After hearing many squares denouncing these non-conformists in rather harsh terms, I couldn't possibly avoid making up an unconventional brag tape. This is the way mine will go.

The transmitter here is a Multi-Elmac 67, driving 6 UV201's. The tubes are installed in small tomato paste cans

which are placed in large tomato cans, and the outer jacket holds sufficient water to act as a cooling chamber. (If desired, Chianti may be substituted.)

The receiver is a Sky Buddy, and the antenna (Beverage type) is composed of 144 beer cans (Coors), soldered end to end, mounted on the outhouse roof. The metallic slats from a venetian blind, grounded to the radiator grille of a 1926 Essex Super-Six, act as a counterpoise.

The terminal unit consists of a pair of close-mounted salad forks activated by a series-tuned Mixmaster paddle which can be simultaneously utilized to whip up custards or cake batter, thus saving electrical energy.

The reperf utilizes the services of a Mexican alien fruit picker. He punches the tape by doing the Mexican hat dance on it while wearing a pair of Lee Trevino's old golf shoes.

We have no pix to transmit at the moment, but the puncher has volunteered to talk to his brother, a distributor who exports Tijuana bibles into the US, among other Mexican products, mainly agricultural in nature. Before long, we hope to have on hand a good selection of RTTY pix such as Tillie and Mac, Maggie and Jiggs, Ella Cinders, Popeye, Lil Abner and Daisy Mae, etc.

I'd like to see anybody top that. That's the sort of brag tape that'll make people sit up and take notice. But as far as those pix are concerned . . . forget it; it's just a gag. But, incidentally, if you know anyone who owns any of those old 8-pagers, see if you can get him to Xerox a few and send them to this QTH. I haven't seen any of those since way back in high school . . . har, har!

Ham Help

I am interested in—in fact, "desperate" for—information from anyone who has solved TVI in conjunction with cable HBO units. QSOing with other hams, I find this seems to be a nationwide problem for amateurs.

The unit used locally is made by Magnavox and tuned to chan-

nel 4.

I have tried all the usual methods, such as shielding, grounding, and filtering, with little success. All and any solutions will be greatly appreciated.

Harry Umphenour WD9IVY
1127 W. Nebraska Ave.
Peoria IL 61604

Buy Direct from the Tri-Ex[®] Factory

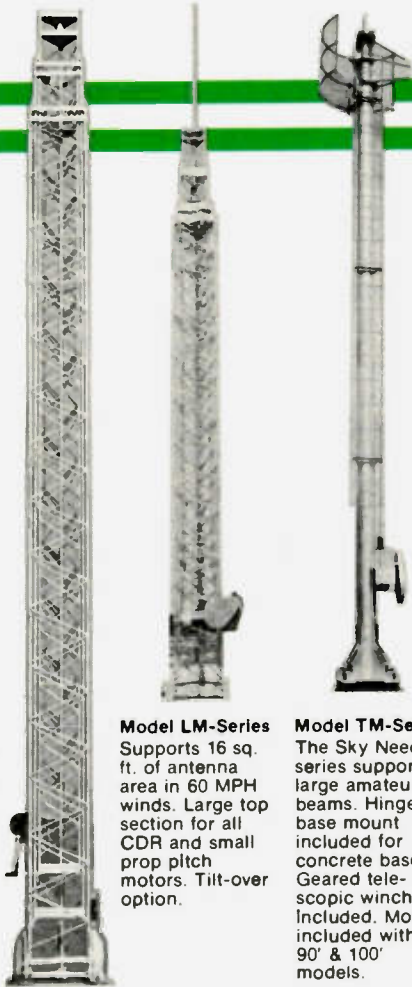

Model W-Series
Supports 9 sq. ft. of antenna area in 50 MPH winds. CDR rotator mounting plate in top section. Rigid base mount included.

Model LM-Series
Supports 16 sq. ft. of antenna area in 60 MPH winds. Large top section for all CDR and small prop pitch motors. Tilt-over option.

Model TM-Series
The Sky Needle series supports large amateur beams. Hinged base mount included for concrete base. Geared telescopic winch included. Motor included with 70', 90' & 100' models.

Come to Tri-Ex for innovative tower design and engineering! Our towers are famous all over the world for their strength, stress and wind resistance. Now you can buy a superior Tri-Ex tower at **FACTORY SAVINGS!**

Choose your metal. Towers can be fabricated in steel to ASTM Specifications with hot-dipped galvanized finish (done after construction so that inside surfaces are zinc-coated, too). Or in Triexium[™], our lightweight, corrosion resisting, high-strength light alloy.

Tri-Ex HAM towers are available self-supporting or guyed; take your choice. The W series of crank-up towers, the LM series of crank-up/tilt-over towers and the TM sky needles are self-supporting.

Use your charge power to buy your tower. Tri-Ex honors Visa and Master Charge credit cards. **If you have questions about tower accessories or which size tower is right for your antenna, call Bill Salerno, his technical sales know-how is ready to serve you.**



7182 Rasmussen Ave., Visalia, CA 93277

Save 25% on the best towers made!

*Call me!
73 Bill Salerno*



W2ONV

**TOLL FREE
800-526-5277
in New Jersey
201-279-7528
CALL NOW**

or



USE THIS HANDY ORDER FORM

Mail to Tri-Ex Tower Corp.
7182 Rasmussen Avenue, Visalia, CA 93277

Name

Street

City State Zip

Check Enclosed Visa  M/C 

Card # Expires

Bank # Signature

| Model Number | Nested Height | Extended Height | Wind Load or 50 MPH Antenna Load | Factory Direct Price |
|---------------------|---------------|-----------------|----------------------------------|----------------------|
| ED 40* | 13' 0" | 40' | 6.0 Sq. Ft. † | \$ 346.00 |
| MW 35** | 20' 5" | 35' | 9.5 Sq. Ft. ‡ | 435.00 |
| MW 50** | 20' 10" | 50' | 8.6 Sq. Ft. ‡ | 668.00 |
| MW 65** | 21' 3" | 65' | 5.0 Sq. Ft. ‡ | 913.00 |
| W 36** | 20' 6" | 36' | 9.0 Sq. Ft. | 546.00 |
| W 51** | 21' 0" | 51' | 9.0 Sq. Ft. | 844.00 |
| WT 51.. | 21' 0" | 51' | 9.0 Sq. Ft. | 923.00 |
| W 67** | 22' 0" | 67' | 9.0 Sq. Ft. | 1,816.00 |
| LM 237** | 20' 6" | 37' | 16.0 Sq. Ft. | 1,064.00 |
| LM 354** | 21' 0" | 54' | 16.0 Sq. Ft. | 1,537.00 |
| LM 470** | 23' 6" | 70' | 16.0 Sq. Ft. | 2,826.00 |
| LM 470D** Motorized | 23' 6" | 70' | 16.0 Sq. Ft. | 3,221.00 |
| TM 490** Sky Needle | 28' 0" | 90' | 37.8 Sq. Ft. | 10,560.00 |

*Triexium[™]

**Also available in Triexium. Please consult factory for prices.

†When properly guyed 2 positions.

‡Roof bracket or guyed at 1st level.

NOTE: All products FOB Visalia, CA. Prices and specifications subject to change without notice. Ninety day limited warranty. California residents add sales tax.

LETTERS

PRC

The accompanying article may give 73 readers an idea of where ham radio stands, or stood, in China when I was there. There are so many background cultural and political problems to be overcome. Decision-making is always done as a committee. I think the quickest way to a license would be a quid pro quo. If an American businessman who was a ham had something they really wanted, the subject could be broached.

While I was there, they asked me to extend my stay and I go to some other plants to work on the instrumentation. I told them I would if they would give me the temporary license. They didn't and I didn't... sort of! They would not give me my travel papers, visa, or passport when it was time for me to go. I ended up putting in an extra two months I had not counted on! I probably could have refused to go to work and they would have either locked me up or expelled me from the country. My company finally sent another guy, so they let me go. Needless to say,

I'm not with that company any more! We had a few loud discussions over that deal when I finally got back! The Chinese are difficult, frustrating people to deal with. They are very clever and it is foolish to underestimate them. They respect strength, ability, cleverness, and patience. I don't think there is any one man or woman, outside of the Chairman himself, who can give permission to operate.

You may not hear me on with a JY8 call... I'm in Arabia! There is a MARS station in Dhahran, but I'm about 130 miles from it out in the desert. I'm trying to arrange a time to find it and the guy in charge of it, and a time I can get in there. We work a minimum of 60 hours a week. Our only day off is Friday, the Moslem holy day. We work a lot of the Fridays anyway. I never did get it arranged last year, but perhaps this year I'll get lucky. I did read the article about Jordan in the January, '80, issue of 73. Perhaps I can route myself through there on one of my turnaround leaves.

I have read 73 over the past 15 years and have always enjoyed

it. I wrote an article, "The Protector," that was published in 73 some 10 or 12 years ago.

Don McCoy WA0HKC
Dhahran, Saudi Arabia

BY1HKC!... ALMOST

Assignment to China! The call from the home office reached me while I was on a job in Fresno. This was early fall in 1976. At that time, few Americans had penetrated the Bamboo Curtain. I was in field service for an instrumentation company and had already been a portable 7, 6, 5, 3, and 2 that year. Perhaps a little smooth talking and there I would be, BY1HKC. I sent off a quick note to Wayne Green; he answered and said my chances were a million to one, but if I succeeded, he would lend me a portable station. First step completed!

Three days after leaving Denver, I got off a train in the city of Tsang Chou, in Hopei Province. Tsang Chou is south-east of Peking and north of Tsingtao, where they make the beer! My destination was an anhydrous ammonia plant where I would start up and take care of the plant instrumentation until the Chinese took over. They billeted me in a "guest house" with nine other Americans and ten Europeans. These men had various other start-up duties.

An interpreter was assigned to me and I went to work. The job kept me very busy out in the field. I'm interested in languages, so I learned some Mandarin Chinese from my interpreter and the people I worked with. Before I left, they gave me a small "Chairman Mao" medal for taking the time to learn.

After a month or so, when I was pretty well known, I started making inquiries about amateur radio. I asked middle-aged people and especially the technical men I dealt with on a daily basis. I had some QSL cards with me and showed them also. No one professed to knowing what I was talking about. After a week or two of casual questions, the guest-house manager sent for my interpreter and me. He said he had heard of my questions and interest in amateur radio. What specifically did I want to know? I told him I would like to be issued a temporary license to operate a station from the guest house. I went on to explain that it was not political in nature, on-

ly a hobby. I told him I could arrange to have equipment flown in, and also that I would like to be issued the call BY1HKC to coincide with my own call, WA0HKC. I mentioned the calls so there would be no mistake in my request.

Mr. Yang, the manager, said perhaps he could arrange a meeting with the man in charge of radio for the Tsang Chou district. My hopes soared!! Mr. Yang and I had spent Christmas Day on a six-hour trip in a freezing mini-bus. We exchanged many ideas and thoughts. By the end of the trip, we had a mutual respect for each other. I had found a man's job did not indicate his position in party hierarchy, so perhaps Mr. Yang was in a position to help my cause.

About a week later, we were again summoned to a guest-house meeting room. Mr. Yang introduced us to a Mr. Wo, a man about 65 or so. After the ceremonial tea and small talk, we got down to business. Mr. Wo was the man in charge of the radio district. I gave him one of my QSL cards. Yes, he did know about amateur radio, but it had been many years since he had thought of it. Mr. Wo said he had received my request through Mr. Yang. He had contacted his superiors in Peking and "due to the differences in our social systems," Peking had refused my request. Mr. Wo seemed genuinely sorry he couldn't help me. Naturally, I asked Mr. Wo if he had ever been a ham himself, and he said something like "working for the social system has taken most of his time." I did not want to make an issue of the question in front of Mr. Yang, so we both smiled, like two conspirators. Perhaps Mr. Wo was making the answer fit the circumstance. Mr. Wo mentioned they had a radio training system for school children to communicate between schools. He said that may lead to amateur radio again. I never saw any evidence of that in Tsang Chou, but perhaps in the larger cities it was true, or maybe something got twisted in the translation.

The China National Technical Import Co. (CNTIC) was the sponsoring agency for us. All non-Chinese foreigners (they consider Chinese-Americans, Chinese-South Americans, etc.,

Continued on page 164

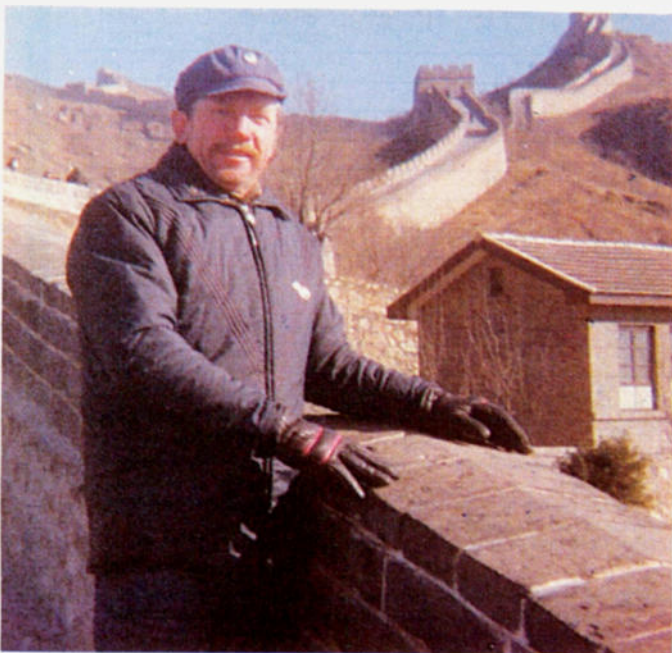

Don McCoy WA0HKC at the Great Wall of China near Peking.

73 Magazine

IS GIVING YOU TIME TO FIGHT INFLATION



73 Magazine is increasing its cover price (and subscription price) on July 1, 1980. *BUT* we would like to give you time *TO FIGHT INFLATION* . . . subscribe or renew your present subscription from now until July 18, 1980, and receive 73 at *THE OLD RATES*.

Keep 73 Magazine, with its informative articles and controversial editorials, coming to your doorstep for \$15.00/1 year; \$30.00/2 years and \$45.00/3 years. You could *SAVE* as much as 57% by subscribing (or renewing) for three years at \$1.25 per copy . . . that's \$1.70 *LESS* than the new cover price. With the July issue the new subscription prices will be \$25.00/1 year; \$38.00/2 years and \$53.00/3 years . . . *SO HURRY . . . SEND IN THE COUPON TODAY AND FIGHT INFLATION.*

**ALL PREVIOUS SUBSCRIPTION OFFERS TO 73 MAGAZINE
ARE VOID ON JULY 18, 1980.**

YES, I'LL TAKE THE TIME TO FIGHT INFLATION

- New Subscription Renewal (please affix an address label from your most recent magazine)
 1 year/\$15.00 2 years/\$30.00 3 years/\$45.00
 Payment Enclosed Bill: Me Master Charge VISA Amerex

Card # _____ Expire Date _____
Signature _____ Interbank # _____
Name/Label _____
Address _____
City _____ State _____ Zip _____

73 Magazine

Canadian—\$15.00 1 year only, US funds ● Foreign—\$26.00 1 year only, US funds

THIS CARD EXPIRES JULY 18, 1980.

PO BOX 931 ● FARMINGDALE NY 11737

307B6

THE GIANT

AZDEN®

COMPANY

REVOLUTIONIZES THE STATE OF THE ART

AWE AND AZDEN INTRODUCE THE BRILLIANT NEW PCS-2000

MICROCOMPUTER CONTROLLED

SUPERIOR COMMERCIAL GRADE 2 METER FM TRANSCEIVER

NOT \$550.00

SUMMER SALE

\$299⁰⁰

REG. \$369.00

NOT \$550.00

SUMMER SALE

\$299⁰⁰

REG. \$369.00



COMPARE THESE FEATURES WITH ANY UNIT AT ANY PRICE



- **FREQUENCY RANGE:** Receive and transmit: 144.00 to 147.995 MHz, 5Khz steps + MARS-CAP CAPABILITY BUILT IN (142-149.995 MHz).
- **ALL SOLID STATE-CMOS PL DIGITAL SYNTHESIZED.**
- **SIZE: UNBELIEVABLE! ONLY 6 3/4" x 2 3/8" x 9 3/4". COMPARE!**
- **MICROCOMPUTER CONTROLLED:** All scanning and frequency-control functions are performed by microcomputer.
- **DETACHABLE HEAD:** The control head may be separated from the radio for use in limited spaces and for security purposes.
- **SIX-CHANNEL MEMORY:** Each memory is re-programmable. Memory is retained even when the unit is turned off.
- **MEMORY SCAN:** The six channels may be scanned in either the "busy" or "vacant" modes for quick, easy location of an occupied or unoccupied frequency. **AUTO RESUME. COMPARE!**
- **FULL-BAND SCAN:** All channels may be scanned in either "busy" or "vacant" mode. This is especially useful for locating repeater frequencies in an unfamiliar area. **AUTO RESUME. COMPARE!**
- **INSTANT MEMORY-1 RECALL:** By pressing a button on the microphone or front panel, memory channel 1 may be recalled for immediate use.
- **MIC-CONTROLLED VOLUME AND SQUELCH:** Volume and squelch can be adjusted from the microphone for convenience in mobile operation.
- **ADDITIONAL OFFSETS:** Provides three additional offset values: +0.4 MHz, +1 MHz and +1.6 MHz. Other offsets may also be obtained.
- **25 WATTS OUTPUT:** Also 5 watts low power for short-distance communication.
- **DIGITAL S/R F METER:** LEDs indicate signal strength and power output. No more mechanical meter movements to fall apart!
- **LARGE 1/2-INCH LED DISPLAY:** Easy-to-read frequency display minimizes "eyes-off-the-road" time.
- **PUSHBUTTON FREQUENCY CONTROL FROM MIC OR FRONT PANEL:** Any frequency may be selected by pressing a microphone or front-panel switch.
- **SUPERIOR RECEIVER SENSITIVITY:** 0.28 uV for 20-dB quieting. The squelch sensitivity is superb requiring less than 0.1 uV to open. The receiver radio circuits are designed and built to exacting specifications, resulting in unsurpassed received-signal intelligibility.
- **TRUE FM, NOT PHASE MODULATION:** Transmitted audio quality is optimized by the same high standard of design and construction as is found in the receiver. The microphone amplifier and compression circuits offer intelligibility second to none.
- **OTHER FEATURES:** Dynamic Microphone, built in speaker, mobile mounting bracket, external remote speaker jack (head and radio) and much, much more. All cords, plugs, fuses, microphone hanger, etc. Included. Weight: 6 lbs.
- **ACCESSORIES:** 15' REMOTE CABLE.....\$29.95. CS-6R A/C POWER SUPPLY.....\$49.95. TOUCHTONE MIC. KIT.....\$39.95. EXTERNAL SPEAKER.....\$18.00.

AMATEUR-WHOLESALE ELECTRONICS ORDER NOW TOLL FREE

8817 S.W. 129th Terrace, Miami, Florida 33176
Telephone (305) 233-3631 • Telex: 80-3356
HOURS: 8-6, Mon. - Thur.

1-800-327-3102

U.S. DISTRIBUTOR
DEALER INQUIRIES INVITED

CREDIT CARD HOLDERS MAY USE OUR TOLL FREE ORDERING NUMBER.

OSCAR Orbits

Courtesy of AMSAT

Any satellite placed into a near-Earth orbit suffers from the cumulative effects of atmospheric drag. The much publicized descent of the Skylab space station was a graphic demonstration of these effects.

The OSCAR satellites are subject to atmospheric drag, of course, and the present period of intense solar activity has accentuated the problem. During this period, our sun has been expelling huge numbers of charged particles, some of which find their way into the Earth's upper atmosphere, increasing the density (and thus the drag) there. It is through this region that the OSCARs must pass. OSCAR 8, in a lower orbit than OSCAR 7, is the more seriously affected of the two.

If the drag factor is not considered when OSCAR calculations are performed, long-range orbital projections will be in error. For example, by the end of 1979, OSCAR 8 was more than 20 minutes ahead of some published schedules. The nature of orbital mechanics is such that extra drag on a satellite causes it to move into a lower orbit, resulting in a shorter orbital period. Thus, the satellite arrives above a given Earthbound location earlier than predicted.

Using data supplied to us by Dr. Thomas A. Clark W3IWI of AMSAT, the equatorial crossing tables shown here were generated with the aid of a TRS-80™ microcomputer. The tables take into account the effects of atmospheric drag and should be in error by a few seconds at most.

The listed data tells you the time and place that OSCAR 7 and OSCAR 8 cross the equator in an ascending orbit for the first time each day. To calculate successive OSCAR 7 orbits, make a list of the first orbit number and the next twelve orbits for that day. List the time of the first orbit. Each successive orbit is 115 minutes later (two hours less five minutes). The chart gives the longitude of the day's first ascending (northbound) equatorial crossing. Add 29° for each succeeding orbit. When OSCAR is ascending on the other side of the world from you, it will descend over you. To find the

equatorial descending longitude, subtract 166° from the ascending longitude. To find the time OSCAR 7 passes the North Pole, add 29 minutes to the time it passes the equator. You should be able to hear OSCAR 7 when it is within 45 degrees of you. The easiest way to determine if OSCAR is above the horizon (and thus within range) at your location is to take a globe and draw a circle with a radius of 2450 miles (4000 kilometers) from your QTH. If OSCAR passes above that circle, you should be able to hear it. If it passes right overhead, you should hear it for about 24 minutes total. OSCAR 7 will pass an imaginary line drawn from San Francisco to Norfolk about 12 minutes after passing the equator. Add about a minute for each 200 miles that you live north of this line. If OSCAR passes 15° east or west of you, add another minute; at 30°, three minutes; at 45°, ten minutes. Mode A: 145.85-95 MHz uplink, 29.4-29.5 MHz downlink, beacon at 29.502 MHz. Mode B: 432.125-.175 MHz uplink, 145.975-925 MHz downlink, beacon at 145.972 MHz.

At press time, OSCAR 7 was scheduled to be in Mode A on odd numbered days of the year and in Mode B on even numbered days. Monday is QRP day on OSCAR 7, while Wednesdays are set aside for experiments and are not available for use.

OSCAR 8 calculations are similar to those for OSCAR 7, with some important exceptions. Instead of making 13 orbits each day, OSCAR 8 makes 14 orbits during each 24-hour period. The orbital period of OSCAR 8 is therefore somewhat shorter: 103 minutes.

To calculate successive OSCAR 8 orbits, make a list of the first orbit number (from the OSCAR 8 chart) and the next thirteen orbits for that day. List the time of the first orbit. Each successive orbit is then 103 minutes later. The chart gives the longitude of the day's first ascending equatorial crossing. Add 26° for each succeeding orbit. To find the time OSCAR 8 passes the North Pole, add 26 minutes to the time it crosses the equator. OSCAR 8 will cross the imaginary San Francisco-to-Norfolk line about 11 minutes after crossing the equator. Mode A: 145.85-95 MHz uplink, 29.4-29.50 MHz downlink, beacon at 29.400 MHz. Mode J: 145.90-146.00 MHz uplink, 435.20-435.10 MHz downlink, beacon on 435.090 MHz.

OSCAR 8 is in Mode A on Mondays and Thursdays, Mode J on Saturdays and Sundays, and both modes simultaneously on Tuesdays and Fridays. As with OSCAR 7, Wednesdays are reserved for experiments.

OSCAR 7 ORBITAL INFORMATION FOR JULY

| ORBIT # | DATE | TIME (GMT) | EQ. CROSSING (DEGREES WEST) |
|---------|------|------------|-----------------------------|
| 25737 | 1 | 0159:28 | 99.8 |
| 25749 | 2 | 0049:47 | 83.8 |
| 25762 | 3 | 0144:02 | 97.4 |
| 25774 | 4 | 0043:21 | 82.3 |
| 25787 | 5 | 0137:36 | 95.9 |
| 25799 | 6 | 0036:55 | 88.7 |
| 25812 | 7 | 0131:10 | 94.3 |
| 25824 | 8 | 0030:29 | 79.1 |
| 25837 | 9 | 0124:44 | 92.7 |
| 25849 | 10 | 0024:03 | 77.6 |
| 25862 | 11 | 0118:18 | 91.2 |
| 25874 | 12 | 0017:37 | 76.0 |
| 25887 | 13 | 0111:52 | 89.6 |
| 25899 | 14 | 0011:11 | 74.5 |
| 25912 | 15 | 0105:27 | 88.8 |
| 25924 | 16 | 0004:45 | 72.9 |
| 25937 | 17 | 0059:01 | 86.5 |
| 25950 | 18 | 0153:16 | 100.1 |
| 25962 | 19 | 0052:35 | 84.9 |
| 25975 | 20 | 0146:50 | 98.5 |
| 25987 | 21 | 0046:09 | 83.4 |
| 26000 | 22 | 0140:24 | 96.9 |
| 26012 | 23 | 0039:43 | 81.8 |
| 26025 | 24 | 0133:58 | 95.4 |
| 26037 | 25 | 0033:17 | 80.2 |
| 26050 | 26 | 0127:32 | 93.0 |
| 26062 | 27 | 0026:51 | 78.7 |
| 26075 | 28 | 0121:06 | 92.2 |
| 26087 | 29 | 0020:25 | 77.1 |
| 26100 | 30 | 0114:40 | 90.7 |
| 26112 | 31 | 0013:59 | 75.5 |

OSCAR 8 ORBITAL INFORMATION FOR JULY

| ORBIT # | DATE | TIME (GMT) | EQ. CROSSING (DEGREES WEST) |
|---------|------|------------|-----------------------------|
| 11835 | 1 | 0139:56 | 77.4 |
| 11840 | 2 | 0001:33 | 52.9 |
| 0006:22 | 3 | 0006:22 | 54.1 |
| 0011:11 | 4 | 0011:11 | 55.3 |
| 0016:00 | 5 | 0016:00 | 56.5 |
| 0020:48 | 6 | 0020:48 | 57.8 |
| 0025:37 | 7 | 0025:37 | 59.0 |
| 0030:26 | 8 | 0030:26 | 60.2 |
| 0035:15 | 9 | 0035:15 | 61.4 |
| 0040:03 | 10 | 0040:03 | 62.7 |
| 0044:52 | 11 | 0044:52 | 63.9 |
| 0049:41 | 12 | 0049:41 | 65.1 |
| 0054:29 | 13 | 0054:29 | 66.3 |
| 0059:18 | 14 | 0059:18 | 67.6 |
| 0104:06 | 15 | 0104:06 | 68.8 |
| 0108:54 | 16 | 0108:54 | 70.0 |
| 0113:43 | 17 | 0113:43 | 71.2 |
| 0118:31 | 18 | 0118:31 | 72.5 |
| 0123:19 | 19 | 0123:19 | 73.7 |
| 0128:07 | 20 | 0128:07 | 74.9 |
| 0132:55 | 21 | 0132:55 | 76.1 |
| 0137:43 | 22 | 0137:43 | 77.4 |
| 0142:31 | 23 | 0142:31 | 78.6 |
| 0147:19 | 24 | 0147:19 | 79.8 |
| 0152:07 | 25 | 0152:07 | 81.0 |
| 0156:55 | 26 | 0156:55 | 82.2 |
| 0201:43 | 27 | 0201:43 | 83.4 |
| 0206:31 | 28 | 0206:31 | 84.6 |
| 0211:19 | 29 | 0211:19 | 85.8 |
| 0216:07 | 30 | 0216:07 | 87.0 |
| 0220:55 | 31 | 0220:55 | 88.2 |

OSCAR 8 ORBITAL INFORMATION FOR AUGUST

| ORBIT # | DATE | TIME (GMT) | EQ. CROSSING (DEGREES WEST) |
|---------|------|------------|-----------------------------|
| 26125 | 1 | 0108:14 | 89.1 |
| 26137 | 2 | 0007:33 | 74.0 |
| 26150 | 3 | 0101:48 | 87.6 |
| 26162 | 4 | 0001:07 | 72.4 |
| 26175 | 5 | 0055:22 | 86.8 |
| 26188 | 6 | 0149:37 | 99.6 |
| 26200 | 7 | 0048:56 | 84.4 |
| 26213 | 8 | 0143:11 | 98.0 |
| 26225 | 9 | 0042:30 | 82.9 |
| 26238 | 10 | 0136:45 | 96.5 |
| 26250 | 11 | 0036:04 | 81.3 |
| 26263 | 12 | 0130:19 | 94.9 |
| 26275 | 13 | 0029:37 | 79.7 |
| 26288 | 14 | 0123:53 | 93.3 |
| 26300 | 15 | 0023:11 | 78.2 |
| 26313 | 16 | 0117:27 | 91.8 |
| 26325 | 17 | 0016:45 | 76.6 |
| 26338 | 18 | 0111:01 | 90.2 |
| 26350 | 19 | 0010:19 | 75.0 |
| 26363 | 20 | 0104:34 | 88.6 |
| 26375 | 21 | 0003:53 | 73.5 |
| 26388 | 22 | 0058:08 | 87.1 |
| 26401 | 23 | 0152:24 | 100.7 |
| 26413 | 24 | 0051:42 | 85.5 |
| 26426 | 25 | 0145:57 | 99.1 |
| 26438 | 26 | 0045:16 | 83.9 |
| 26451 | 27 | 0139:31 | 97.5 |
| 26463 | 28 | 0038:50 | 82.4 |
| 26476 | 29 | 0133:05 | 96.0 |
| 26488 | 30 | 0032:24 | 80.8 |
| 26501 | 31 | 0126:39 | 94.4 |

OSCAR 7 ORBITAL INFORMATION FOR AUGUST

| ORBIT # | DATE | TIME (GMT) | EQ. CROSSING (DEGREES WEST) |
|---------|------|------------|-----------------------------|
| 12267 | 1 | 0042:29 | 63.8 |
| 12281 | 2 | 0047:17 | 65.0 |
| 12295 | 3 | 0052:04 | 66.2 |
| 12309 | 4 | 0056:52 | 67.5 |
| 12323 | 5 | 0101:39 | 68.7 |
| 12337 | 6 | 0106:26 | 69.9 |
| 12351 | 7 | 0111:13 | 71.1 |
| 12365 | 8 | 0116:01 | 72.3 |
| 12379 | 9 | 0120:48 | 73.6 |
| 12393 | 10 | 0125:35 | 74.8 |
| 12407 | 11 | 0130:22 | 76.0 |
| 12421 | 12 | 0135:09 | 77.2 |
| 12435 | 13 | 0139:56 | 78.4 |
| 12448 | 14 | 0144:43 | 79.6 |
| 12462 | 15 | 0149:30 | 80.8 |
| 12476 | 16 | 0154:17 | 82.0 |
| 12490 | 17 | 0159:04 | 83.2 |
| 12504 | 18 | 0203:51 | 84.4 |
| 12518 | 19 | 0208:38 | 85.6 |
| 12532 | 20 | 0213:25 | 86.8 |
| 12546 | 21 | 0218:12 | 88.0 |
| 12560 | 22 | 0222:59 | 89.2 |
| 12574 | 23 | 0227:46 | 90.4 |
| 12588 | 24 | 0232:33 | 91.6 |
| 12602 | 25 | 0237:20 | 92.8 |
| 12616 | 26 | 0242:07 | 94.0 |
| 12630 | 27 | 0246:54 | 95.2 |
| 12644 | 28 | 0251:41 | 96.4 |
| 12658 | 29 | 0256:28 | 97.6 |
| 12672 | 30 | 0301:15 | 98.8 |
| 12686 | 31 | 0306:02 | 100.0 |

2 METER AMPLIFIER

CLASS C
PA 1-10

\$79.95



Works with all hand held and portable units. ✓ 324
1-3 watts in, 10-25 watts out, 4MHz band width.
Operates from 12-14 VDC. Solid state RF switching.

THS ELECTRONICS
RD 1, Box 195, Greene, NY 13778
Phone 607-656-8071

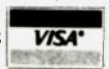

ALL BAND TRAP ANTENNAS!

PRETUNED - COMPLETELY ASSEMBLED - ONLY ONE NEAT SMALL ANTENNA FOR UP TO 8 BANDS - EXCELLENT FOR CONGESTED HOUSING AREAS - APARTMENTS - LIGHT - STRONG - ALMOST INVISIBLE!

FOR ALL MAKES & MODELS OF AMATEUR TRANSCEIVERS - TRANSMITTERS - GUARANTEED FOR 200 WATTS SSB 1000 WATTS CW INPUT FOR NOVICE AND ALL CLASS AMATEURS!

COMPLETE AS SHOWN WITH 90 FT. RG58U-52 ohm feedline, and PL259 connector, insulators, 30 FT. 300 Ω test decoupler and supports, center connector with built in lightning arrester and static discharge - molded, coated, weatherproof, permanent traps (TPO) - you just switch to band desired for excellent worldwide operation - transmitting and receiving! WT. LESS THAN 8 LBS.

160-80-40-20-15-10 bands 4 trap --- 169 ft. with 90 ft. RG58U - connector - Model 100S0U ... \$99.95
80-40-20-15-10 bands 4 trap --- 91 ft. with 90 ft. RG58U coax - connector - Model 100B0U ... \$95.95
40-20-15-10 bands 4 trap --- 48 ft. with 90 ft. RG58U coax - connector - Model 100C0U ... \$92.95
20-15-10 bands 4 trap --- 23 ft. with 90 ft. RG58U coax - connector - Model 100Z0U ... \$89.95

SEND FULL PRICE FOR POST PAID INSURED DEL. IN USA (Canada \$5.00 extra for postage - clerical - customs - etc.) or order using VISA Bank Americard - MASTER CHARGE - AMER. EXPRESS. Give number and ex. date. Ph 1-308-236-8333 9AM - 5PM week days. We ship in 2-3 days. ALL PRICES WILL INCREASE - SAVE - ORDER NOW! All antennas guaranteed for 1 year. 10 day money back wtd if returned in new condition! Made in USA. FREE INFO. AVAILABLE ONLY FROM.

WESTERN ELECTRONICS ✓ 80 Dept. A7-7 Kearney, Nebraska, 68847

ALL BAND TRAP ANTENNAS!

Contests

Robert Baker WB2GFE
15 Windsor Dr.
Atco NJ 08004

**IARU RADIOSPORT
CHAMPIONSHIP**
Starts: 0000 GMT July 12
Ends: 2400 GMT July 13

GHOST TOWN DXPEDITION

A group of amateurs from the Gallatin Han. Radio Club will be on the air from 1800 GMT Saturday, July 5th, until 1800 GMT Sunday, July 6th, from Bannack, Montana. Presently a ghost town, Bannack was the first capital of the territory of Montana. The DXpedition will use the call-sign W7ED and operate on 7235 kHz SSB, 14060 kHz CW, 14285 kHz SSB, and 21360 kHz SSB (plus or minus 5 kHz). Specially printed certificates loaded with historical information will be sent to those sending QSL cards, an SASE, and \$1 to help defray printing costs. Requests should be sent to: Bannack DXpedition, 417 Staudaer Street, Bozeman MT 59715.

All amateurs worldwide, in single-operator and multi-operator/single-transmitter categories, are eligible. No multi-transmitters are allowed. Separate categories of competition for single-operator stations will include the following: CW only, phone only, and mixed phone/CW. In the single-operator category, one person performs all operating and logging functions. Use of spotting nets is not permitted. Multi-operator single-transmitter stations must observe a 10-minute-per-band rule: If a contact is made on a band, the transmitter must remain on that band for at least the next 10 minutes.

A maximum of 36 hours may be used for single-operator en-

tries. Off times must be at least 30 minutes in length. There is no time limit for multi/single stations. Use all amateur bands, 160 through 2 meters. Each station may be worked once per frequency band, regardless of mode. Crossband contacts are not allowed. Contacts made by retransmitting either or both stations do not count for contest purposes.

EXCHANGE:

Signal report (RST) and ITU zone. Please note that ITU zones are not the same as the ARRL zones. See page 74 of the May issue of QST for a list of ITU zones by callsign prefixes.

SCORING:

Contacts within one's own ITU zone count 1 point, outside one's own ITU zone but within one's own continent count 3 points, and outside of one's own continent count 5 points. The multiplier is the sum of the number of different ITU zones worked on each band. Final score equals the number of QSO points times the zone multiplier.

AWARDS:

A certificate will be awarded to the highest-scoring CW-only, phone-only, and mixed-mode entrant in each ARRL section, each ITU zone, and each DXCC country. In addition, achievement-level awards are available for making 250 QSOs, 1000 QSOs, and/or making a total of 50 or more multipliers. In the case of multiple award levels achieved, only the highest award will be issued. Additional awards may be made at the discretion of each country's IARU member society.

ENTRIES:

All entries worldwide are to be sent to IARU Headquarters, Box 500, Newington CT 06111, USA. All US and Canadian entrants must use official log sheets and summary sheets or a reasonable facsimile. Entries must be accompanied by dupe sheets if 200 or more QSOs were made. Entries must be postmarked no later than August 25th. An entry received after mid-October may not be in time to be included in the printed results. All entries become the property of the IARU and none can be returned. In cases of dispute, the decisions of the IARU/ARRL Awards Committee are final. Each entrant agrees to be bound by the provisions as well as the intent of the contest announcement, the regulations of his licensing

authority, and the decisions of the IARU/ARRL Awards Committee. Incomplete or illegible entries will be classified as check logs. Usual disqualification rules apply!

MAINE QSO PARTY
Starts: 1600 GMT July 19
Ends: 2000 GMT July 20

Sponsored by the Portland Amateur Wireless Association, the contest is open to all. Stations may be worked once on each band and mode. CW and phone count as the same contest and Maine stations may work other Maine stations.

EXCHANGE:

QSO number, RS(T), and QTH. Maine stations send county; others send state, province, or country.

FREQUENCIES:

SSB - 1815, 3930, 7280, 14280, 21380, 28580.

CW - 1805, 3560, 7060, 14060, 21060, 28060.

Novice - 3725, 7125, 21125, 28125.

SCORING:

Complete QSOs count 3 points. Out-of-state stations multiply the total number of QSO points by the number of Maine counties contacted (maximum of 16). Maine stations multiply the total number of QSO points by the sum of Maine counties, states, provinces, and countries.

ENTRIES & AWARDS:

Certificates will be awarded to the top scorer in each area. A Worked All Maine Award is available to any station that contacts all 16 Maine counties.

Logs should show date and time in GMT, band, and emission. Logs, summary sheet, and requests for info on the WAM award should be sent by September 1st to: Joe Blinick K1JB, Portland Amateur Wireless Assoc., PO Box 1605, Portland ME 04104.

**WORKED ALL BRITAIN
CONTEST - LF CW**
Starts: 0900 GMT July 20
Ends: 2200 GMT July 20

This is the 4th of the five Worked All Britain contests for this year. The remaining contest is shown in the calendar.

All contacts must be made on CW using the 160- through 40-meter amateur bands. There must be a one-hour break shown in the logs. The maximum op-

Continued on page 170

Calendar

| | |
|-----------|------------------------------------|
| Jul 1 | Canada Day Contest |
| Jul 5-6 | Ghost Town DXpedition |
| Jul 12-13 | IARU Radiosport Championship |
| Jul 19-20 | Maine QSO Party |
| Jul 19-20 | SEANET DX Contest - CW |
| Jul 19-20 | QRP Summer Contest |
| Jul 20 | Worked All Britain Contest - LF CW |
| Jul 26-28 | County Hunters Contest - CW |
| Aug 1-7 | SWOT QSO Party |
| Aug 2-3 | ARRL UHF Contest |
| Aug 2-3 | Illinois QSO Party |
| Aug 9-10 | European DX Contest - CW |
| Aug 16-18 | New Jersey QSO Party |
| Aug 16-18 | Rhode Island QSO Party |
| Aug 23-24 | All Asian DX Contest - CW |
| Aug 31 | Worked All Britain Contest - VHF |
| Sep 13-14 | European DX Contest - Phone |
| Sep 13-14 | ARRL VHF Contest |
| Sep 13-14 | Pennsylvania QSO Party |
| Sep 13-15 | Washington State QSO Party |
| Sep 14 | North American Sprint |
| Sep 27 | DARC Corona 10-Meter RTTY Contest |
| Sep 27-28 | Delta QSO Party |
| Oct 4-5 | California QSO Party |
| Oct 4-5 | ARRL Simulated Emergency Test |
| Oct 11-12 | ARRL CD Party |
| Nov 1-2 | ARRL Sweepstakes - CW |
| Nov 8-9 | European DX Contest - RTTY |
| Nov 8-9 | IPA Contest |
| Nov 9 | International OK DX Contest |
| Nov 15 | DARC Corona 10-Meter RTTY Contest |
| Nov 15-16 | ARRL Sweepstakes - Phone |
| Dec 6-7 | ARRL 160-Meter Contest |
| Dec 13-14 | ARRL 10-Meter Contest |
| Jan 18 | FRACAP Worldwide Contest |

ATR-6800



a taste
of luxury
in
amateur
radio

```
R TTY 0060                      15:15:41 EST
*****
AR4G AB4G OE K3ICH K3ICH
GOOD SIGS HERE IN MARYLAND TOO JOHN.

THE RTTY GEAR HERE IS THE NEW MICROLOG ATR-6800 SYSTEM
PROGRAMMED TO CALL "CO" AND LISTEN FOR MY CALL SIGN.
I WAS POURING A CUP OF COFFEE IN THE KITCHEN WHEN YOU
ANSWERED MY "CO".
THE "ATR" HEARD "K3ICH" WHEN YOU CAME BACK TO ME AND
KEYED MY ALERT BEEPER!!!
IT THEN AUTOMATICALLY RETURNED THE CALL WHICH GAVE ME
TIME TO GET TO THE RADIO.
SO JOHN, YOU'RE NOW TALKING TO CHARLIE (HUMAN) INSTEAD
OF THE ATR-6800 ... HI ... HI ...
*****
DK CHARLIE, GOOD SIGNAL DOWN HERE IN FLORIDA.
YOU MUST TELL ME MORE ABOUT THE AUTO RESPONSE/CO
MACHINE ..... IT MUST BE A MICROLOG (??) .....
```

The best of both worlds . . . a simple, easy to use video system for CW/RTTY/SSTV and an automatic computer station control.

Learn a few keyboard commands; plug in your transceiver and you're on the air with performance that leaves the others "in the noise." With the program permanently stored in ROM, there's no need to fumble with loading. To get it going, you just turn it on!

The complexity of its operation is up to you; the capability is there when you need it. Use the computer mode to add a new dimension to your station's operation. It virtually obsolete-proofs the system for future developments by allowing direct control or modification

of all operating parameters in all modes. With battery backup memory it will remember your ID, stored messages and special programs.

SLOW SCAN TV? Sure, why didn't you say so? It's easy with the ATR-6800, our SSTV program outputs standard tones for sending characters and computer graphics. Compose a full screen and transmit it, just like you would on RTTY!

ATR-6800 with 9" monitor \$1995 00

Ask your dealer or drop by. MICROLOG CORPORATION, 4 Professional Drive, Suite 119, Gaithersburg, MD 20760, Telephone (301) 948-5307.

MICROLOG ✓ 51

INNOVATORS IN DIGITAL COMMUNICATIONS



"BRAND NEW"

CHAMPION MESSAGE MEMORY KEYS

Model TE-292

\$125.95

Features:

- State-of-the-Art CMOS Circuitry
- Choice of Message Storage
 - A. Six 50 character messages
 - B. Twelve 25 character messages
 - C. 27 combinations of message C. programming.
- Records at any speed—plays at any speed.
- Memory operating LED
- Use for daily QSO or contests

PLUS:

- Self-completing dots and dashes
- Both dot and dash memory
- Iambic Keying with any squeeze paddle
- 5-50 w.p.m.
- Speed, volume, tone, tune and weight controls
- Sidetone and speaker
- Low current drain CMOS battery operation—portable
- Rear panel Jack for auxiliary power
- Deluxe quarter-inch jacks for keying and output
- Keys grid block and solid rigs
- WIRED AND TESTED FULLY GUARANTEED—LESS BATTERY

\$89.95

Features: Model TE-284

- State-of-the-Art CMOS Circuitry
- Three choices of Message Storage
 - A. Two (50 character each) message storage
 - B. Four (25 character each) message storage
 - C. One 50 character and two 25 character message storage
- Records at any speed—plays at any speed
- Memory operating LED
- Use for daily QSO or contests



PLUS:

- Self-completing dots and dashes
- Both dot and dash memory
- Iambic Keying with any squeeze paddle
- 5-50 w.p.m.
- Speed, volume, tone, tune and weight controls
- Sidetone and speaker
- Low current drain CMOS battery operation—portable
- Deluxe quarter-inch jacks for keying and output
- Keys grid block and solid rigs
- WIRED AND TESTED FULLY GUARANTEED—LESS BATTERY



MESSAGE MEMORY KEYS

Model # TE201

\$69.95

Features:

- Advanced CMOS message memory
- Two (50 char each) message storage
- Repeat function
- Records at any speed—plays back at any speed
- Longer message capacity
- Example send CQ CQ CQ DX de WB2YJM WB2YJM K—then play second message on contact—de WB2YJM QSL NY NY 579 579 Paul Paul K
- Use for daily QSOs or contests

PLUS:

- State-of-the-art CMOS keyer
- Self-completing dots and dashes
- Both dot and dash memory
- Iambic keying with any squeeze paddle
- 5-50 wpm
- Speed, volume, tone, tune and weight controls
- Sidetone and speaker
- Low current drain CMOS battery operation—portable
- Deluxe quarter-inch jacks for keying and output
- Keys grid block and solid state rigs
- WIRED AND TESTED FULLY GUARANTEED—LESS BATTERY



Model # TE144

\$59.95

Features: Deluxe CMOS Electronic Keyer

- State-of-the-art CMOS circuitry
- Self-completing dots and dashes
- Both dot and dash memory
- IAMBIC keying with any squeeze paddle 5-50 wpm
- Speed, weight, tone, volume tune controls & sidetone and speaker
- Semi-automatic "bug" operation & straight keying—rear panel switch
- Low current drain CMOS battery operation—portable
- Deluxe quarter inch jacks for keying and output
- Keys grid block and solid state rigs
- Wired and tested—fully guaranteed—less battery

MODEL TE133—same as TE144 with wgt and tone control internal, less semi-auto keying. **\$49.95**

MODEL TE122—same as TE133 less wgt, tune, solid state keying **\$36.50**

AT YOUR DEALER OR SEND CHECK OR MONEY ORDER.

Plus \$2.00 S/H NY Res add tax

TRAC

**ELECTRONICS, INC
1106 RAND BLDG.
BUFFALO NY 14203**

VLF Converter



- New device opens up the world of Very Low Frequency radio.
- Gives reception of the 1750 meter band at 160-190 KHz where transmitters of one watt power can be operated without FCC license.
- Also covers the navigation radio-beacon band, standard frequency broadcasts, ship-to-shore communications, and the European low frequency broadcast band.

The converter moves all these signals to the 80 meter amateur band where they can be tuned in on an ordinary shortwave receiver.

The converter is simple to use and has no tuning adjustments. Tuning of VLF signals is done entirely by the receiver which picks up 10 KHz signals at 3510 KHz, 100 KHz signals at 3600 KHz, 500 KHz signals at 4000 KHz.

The VLF converter has crystal control for accurate frequency conversion, a low noise rf amplifier for high sensitivity, and a multipole filter to cut broadcast and 80 meter interference.

All this performance is packed into a small 3" x 1 1/2" x 6" die cast aluminum case with UHF (SO-239) connectors.

The unique Palomar Engineers circuit eliminates the complex bandswitching and tuning adjustments usually found in VLF converters. Free descriptive brochure sent on request.

"VLF Converter \$59.95 in U.S. and Canada. Add \$3.00 shipping/handling. California residents add sales tax."



ORDER YOURS NOW!

Palomar Engineers

BOX 455, ESCONDIDO, CA 92025
Phone: (714) 747-3343

New Products

ROBOT RESEARCH INTRODUCES LOW-COST IMAGE-PROCESSING SCAN CONVERTER

A new low-cost image-processing scan converter for interfacing between computers or microcomputers and TV cameras and monitors has been introduced by Robot Research, Inc.

Designated the Robot Model 650, the unit has a $256 \times 256 \times 6$ MOS frame-store memory which permits a picture to be frame-grabbed from a television camera and supplied to the computer on a random access basis. One picture element (pixel) can be moved every 63.5 microseconds. Frame-grab memory contents are viewed on a television monitor at all times. Frame-grab memory contents may be replaced from the computer on a random access basis.

Image data may be quantified or enhanced since the computer can also write new data into the frame-grab memory. This data may be derived from the data previously taken from the memory or may be entirely new data. As frame-grab memory data is altered by the computer, the displayed image on the monitor also changes.

The unit may be programmed with assembler or high-level languages, and by using multiple Model 650s may be daisy-chained to a single computer. Interface with either 16 bit minicomputers or microcomputers is available by means of different interface boards.

For further information, contact: *Robot Research, Inc., 7591 Convoy Court, San Diego CA 92111.* Reader Service number 479.

MICROPROCESSOR- CONTROLLED REPEATER

A line of repeaters covering the 144, 220, and 450 MHz bands has just been introduced by Micro Control Specialties. The new Mark 3CR repeaters combine all the features of the popular Mark 3C repeater controller plus transmitter, receiver, and power supply in a rack-mount cabinet ready for immediate service. The microprocessor-based repeater provides 39 tone-accessible functions including autopatch, autodial, redial, reverse patch, external outputs, and secure control operator commands. Crystal-controlled digital tone decoding ensures stable and reliable function access. To keep users informed of its status, the repeater generates 13 different Morse messages, several of which are custom programmed to user specifications. Basic repeater operations such as time-out, tail, and ID timing are also directed by the microprocessor so that the repeater can discriminate intelligently against noise and kerchunkers. Several of these operations can be modified remotely by command functions.

The repeater receiver uses dual-gate MOSFETs in both rf amplifier and mixer stages for high sensitivity (20-dB quieting

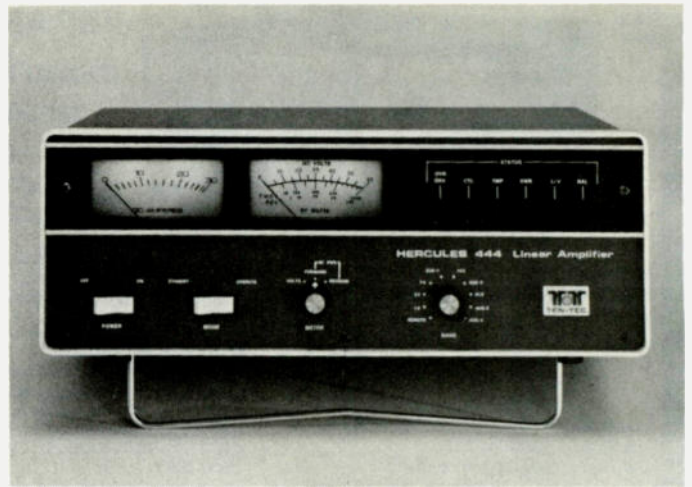

TEN-TEC's Hercules 444 linear amplifier.

with only 0.25 uV of input signal) and freedom from overload in the presence of 1/2-volt signals. Crystal filtering and double conversion are both used to obtain 65-dB rejection of off-frequency signals, so the repeater is well suited for use in hostile rf environments.

Transmitter output is 2 Watts, but optional amplifiers are available to increase the power output to any desired level. Transmitter and receiver oscillators are temperature-compensated to meet commercial frequency stability requirements. The audio circuits combine generous amounts of feedback with symmetrical clipping for virtually transparent audio quality.

For further information, write *Micro Control Specialties, 23 Elm Park, Groveland MA 08134.* Reader Service number 482.

TEN-TEC INTRODUCES NEW LINEAR AMPLIFIER

TEN-TEC has offered the

amateur radio world another "first" in its new Model 444 "Hercules" kW linear amplifier — it's the first solid-state unit with instant break-in.

Absolutely no tuning is required — in fact, there are no tuning knobs! The sleek front panel of the amplifier has just four switches (power, mode, meter, and band). Behind the 444 black-out upper panel are two large meters which light up when ac power is turned on. One meter measures collector current, while the other measures collector voltage or power (forward or reverse). Also on the black upper panel are six status indicators with LEDs that light up to show a condition (overdrive, improper control switch setting, heat sink temperature, swr, overvoltage/overcurrent, and rf output balance). Any condition will shut down the amplifier when set limits are exceeded.

The design of the Hercules 444 uses two 500-Watt push-pull transistor amplifier modules,

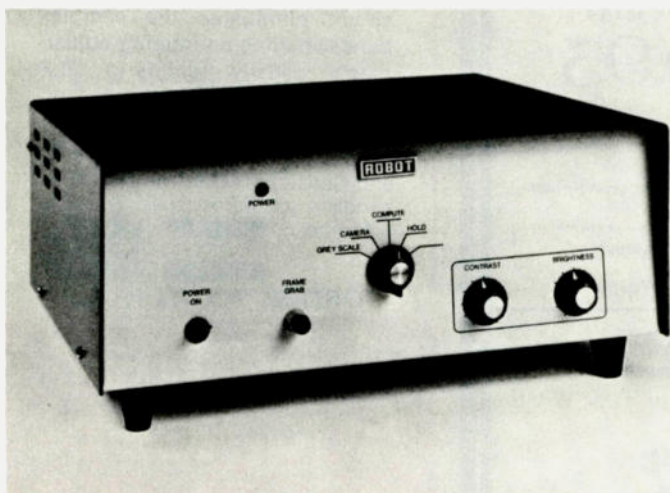

Robot Research's Model 650 scan converter.

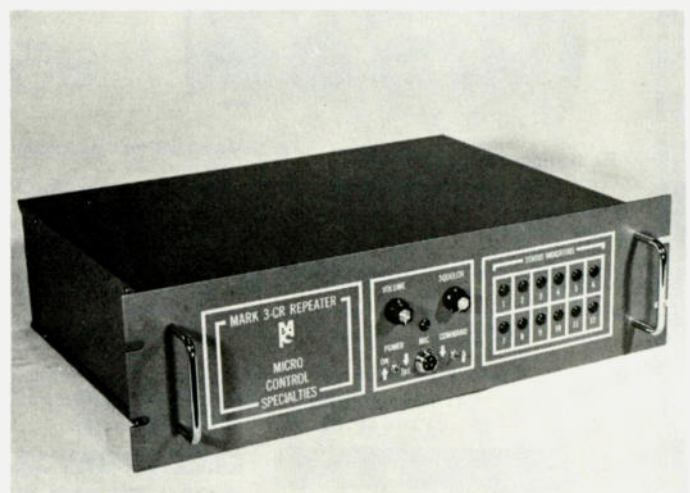

Micro Control Specialties' Mark 3CR repeater.

The Question we seem to get most often from our customers:

"WHEN IS ICOM COMING OUT WITH A HAND-HELD?"

ICOM IC-2A SYNTHESIZED 2 METER HAND- HELD

FEATURES YOU'VE WANTED

- 800 T/R Channels. Synthesized.
- 1.5 Watt Output High/Low Power Battery Saving Switch to .15 Watt.
- Separate built in Speaker & Mic. Excellent audio quality.
- Compact. About the size of a dollar bill.
- Variable size NiCd Power Pack, 3 sizes available to suit your needs. (250 MA standard). Makes the IC-2A the most compact synthesized HT on the market.
- ICOM level Receiver Performance-ICOM Quality Receiver in a compact package (.2uv/20db typical)
- Optional Tone Pad, Desk Charger, Speaker/Mic available.
- With slip on/slip off Bottom NiCd Pack, you can vary the size of the HT from about 116 mm high to 175 mm high. Easy to carry extra Snap-on packs with you for extended trips.



Actual size: Cut out and put the ICOM IC-2A in the palm of your hand.

BACK VIEW
±600 kHz offset
simplex/duplex
Hi/lo power



TOP VIEW

BNC antenna connector
"Rubber Duckie"
standard

transmit indicator
squelch
volume control



on/off
5 kHz channel selection
10 kHz channel selection
speaker/mic jack



ICOM AMERICA, INC.
2112 - 116th Avenue NE
Bellevue, WA 98004
3331 Towerwood Dr., Suite 307
Dallas, TX 75234

THE ANSWER IS: NOW!

All 800 channels of it!

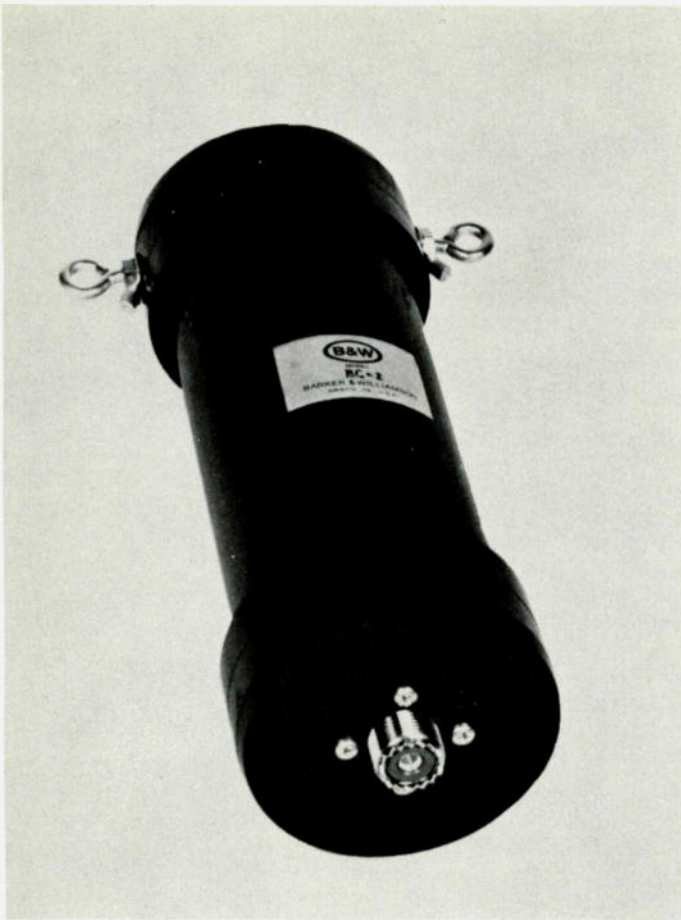

B & W's Model BC-1 balun.

operating at 45 V dc at 22.2 A, typically providing 600 Watts rf output from the hybrid output combiner. Driving power required is 50 Watts, typical. Frequency coverage is 1.8 MHz through 21.5 MHz, with provision for four auxiliary bands. Duty cycle is continuous for SSB voice modulation, 50% for CW or RTTY (keydown time is 5 minutes max.). Continuous carrier operation is possible at reduced output. ALC voltage is

negative, starting at zero, and is adjustable. Both input and output impedances are 50 Ohms, unbalanced.

The separate power supply, housed in a utility-type enclosure, provides approximately 45 V dc at 24 Amperes. The supply uses a tape-wound transformer and choke to reduce size and weight (50 lbs.). A unique automatic line voltage correcting circuit (patent applied for) eliminates the possibility of applying

too high a voltage to the final transistors. This new regulating innovation is highly efficient since it only becomes operative under low voltage conditions.

For further information, write or call *TEN-TEC, Inc., Highway 411 East, Sevierville TN 37862.*

B & W's BC-1 BALUN

Barker & Williamson, Inc., has announced a new product for the radio amateur, the Model BC-1 balun. Its features include impedance of 50 Ohms unbalanced to 50 Ohms balanced, frequency of 1.8-30 MHz, and 2.5 kW to 5 kW PEP. For further information, contact: *Barker & Williamson, Inc., 10 Canal Street, Bristol PA 19007; (215)-788-5581.* Reader Service number 478.

TRAC'S MODEL TE-292 MEMORY KEYS

Containing all CMOS ICs, including three CMOS RAM chips, this unit offers twenty-seven possible combinations of messages. The Master Memory switch selects a RAM. With that RAM, you can have two 50-character messages, four 25-character messages, or one 50- and two 25-character messages. A second and third position for the Master Memory switch allows the above choices twice more.

In all, there are six possible 50-character messages and twelve 25-character messages available, for a total of 27 choices. Blank spaces may be recorded while the message is playing. An LED tells when the message is operating. This keyer contains deluxe quarter-inch jacks for both keying and output, and operates on a single 9-volt battery.

For further information, contact *TRAC Electronics, Inc., 1106 Rand Bldg., Buffalo NY 14203.* Reader Service number 481.

KANTRONICS' SIGNAL ENFORCER™ DUAL AUDIO FILTER FOR CW, SSB, RTTY, ASCII AND AM

A frequency-agile, dual audio filter that will reduce or eliminate signal interference to any one of five common modes has just been introduced by Kantronics. To provide ultimate versatility in a single accessory, the Signal Enforcer™ uses two independently tunable filters to team up on signal interference to CW (continuous-wave), single-sideband, AM, radioteletype and ASCII computer transmissions.

The Signal Enforcer's two state-of-the-art filters have both notch and peak capabilities. That means they can be used either to reduce signals on all but a selected frequency (peaking) or to eliminate signals on a selected frequency where interference is present (notching). Because they are independently tunable, one filter can notch out an interfering signal or noise source while the other filter peaks up the signal being copied.

The filters can be operated in series on separate frequencies to notch and peak, or they can be teamed to make a super peak or super notch filter. In series, the filters can even be used to notch two frequencies at once. Series operation of the Signal Enforcer is called cascading. The filters can also be used in parallel to peak two frequencies at once.

In the cascade mode, for example, one filter can be used to peak a weak CW signal while the other is used to notch out a nearby foreign AM broadcast station. Also in the cascade mode, the Signal Enforcer can act as a doubly potent single filter to peak or notch individual frequencies. Operated in the

Continued on page 156



TRAC's Model TE-292 memory keyer.

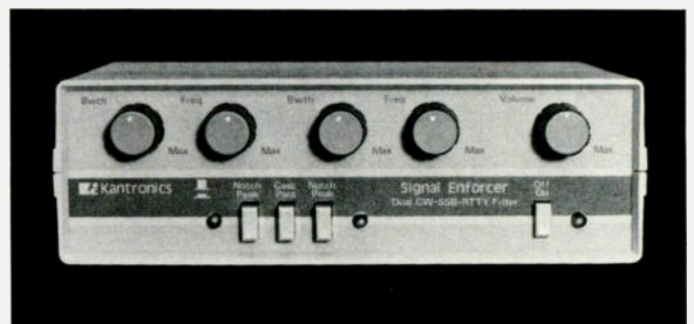

Kantronics' Signal Enforcer™.

Move over imports, here's the new TEN-TEC

DELTA

the notable change in hf transceivers



All new, all **nine** hf bands and only \$849!

DELTA — the symbol of change—the name of a great new TEN-TEC transceiver. A transceiver for changing times, with new features, performance, styling, size and value.

TOTAL SOLID-STATE. By the world's most experienced manufacturer of hf solid-state amateur radio equipment.

ALL 9 HF BANDS. First new transceiver since WARC. 160-10 Meters including the three new hf bands (10, 18 & 24.5 MHz). Ready to go except for plug-in crystals for 18 and 24.5 MHz segments (available when bands open for use).

SUPER RECEIVER. New, low noise double-conversion design, with 0.3 μ V sensitivity for 10 dB S+N/N.

HIGH DYNAMIC RANGE. 85 dB minimum to reduce overload possibility. Built-in, switchable, 20 dB attenuator for extreme situations.

SUPER SELECTIVITY. 8-pole monolithic SSB filter with 2.4 kHz bandwidth, 2.5 shape factor at 6/60 dB points. And optional 200 Hz and 500 Hz 6-pole crystal ladder filters. Eight pole and 6-pole filters cascade for 14 poles of near ultimate skirt selectivity. Plus 4 stages of active audio filtering. To sharpen that i-f response curve to just 150 Hz bandwidth. 4-position selectivity switch.

BUILT-IN NOTCH FILTER. Standard equipment. Variable, 200 Hz to 3.5 kHz, with notch depth down to -50 dB. Wipes out interfering carriers or CW.

OFFSET TUNING. Moves receiver frequency up to ± 1 kHz to tune receiver separately from transmitter.

"HANG" AGC. For smoother, clearer, receiver operation.

OPTIONAL NOISE BLANKER. For that noisy location, mobile or fixed.

WWV RECEPTION. Ready at 10 MHz.

"S"/SWR METER. To read received signal

strength and transmitted standing wave ratio. Electronically switched.

SEPARATE RECEIVER ANTENNA JACK. For use with separate receiving antenna, linear amplifier with full break-in (QSK) or transverters.

FRONT PANEL HEADPHONE AND MICROPHONE JACKS. Convenient.

DIGITAL READOUT. Six 0.3" red LEDs.

BROADBAND DESIGN. For easy operation. Instant band change—no tuneup of receiver or final amplifier. From the pioneer, TEN-TEC.

SUPER TRANSMITTER. Solid-state all the way. Stable, reliable, easy to use.

200 WATTS INPUT. On all bands including 10 meters (with 50 ohm load). High SWR does not automatically limit you to a few watts output. Proven, conservatively rated final amplifier with solid-state devices warranted fully for the first year, and pro-rata for five more years.

100% DUTY CYCLE. All modes, with confidence. 20 minutes max. key-down time. Brought to you by the leader in solid-state finals, TEN-TEC.

QSK — INSTANT BREAK-IN. Full and fast, to make CW a real conversation.

BUILT-IN VOX AND PTT. Smooth, set-and-forget VOX action plus PTT control. VOX is separate from keying circuits.

ADJUSTABLE THRESHOLD ALC & DRIVE. From low level to full output with ALC control. Maximum power without distortion. LED indicator.

ADJUSTABLE SIDETONE. Both volume and pitch, for pleasant monitoring of CW.

SUPER STABILITY. Permeability tuned VFO with less than 15 Hz change per F° change over 40° range after 30 min. warmup—and

less than 10 Hz change for 20 Volt AC line change with TEN-TEC power supply.

VERNIER TUNING. 18 kHz per revolution, typical.

SUPER AUDIO. A TEN-TEC trademark. Low IM and HD distortion (less than 2%). Built-in speaker.

SUPER STYLING. The '80s look with neat, functional layout. "Panelized" grouping of controls nicely human engineered for logical use. New, smaller size that goes anywhere, fixed or mobile (4 $\frac{3}{4}$ "h x 11 $\frac{3}{8}$ "w x 15"d). Warm, dark front panel. Easy-to-read contrasting nomenclature. Black "clam-shell" aluminum case. Tilt bail.

MODULAR/MASS-TERMINATION CONSTRUCTION. Individual circuit boards with plug-in harnesses for easy removal if necessary. Boards are available.

FULL ACCESSORY LINE. All the options: Model 282 200 Hz CW filter \$50; Model 285 500 Hz CW Filter \$45; Model 280 Power Supply \$139; Model 645 Dual Paddle Keyer \$85; Model 670 Single Paddle Keyer \$34.50; Model 247 Antenna Tuner \$69; Model 234/214 Speech Processor & Condenser Microphone \$163; Model 215 PC Ceramic Microphone \$34.50. Model 283 Remote VFO. Model 287 Mobile Mount, and Model 289 Noise Blanker available soon.

Experience The Notable Change In HF Transceivers, Experience DELTA. See your TEN-TEC dealer or write for full details.

 **TEN-TEC, INC.**
SEVIERVILLE, TENNESSEE 37862
EXPORT 5715 LINCOLN AVE. CHICAGO ILL. 60646

The Rites of Spring

— Dayton does it again

Chris Brown N1AUI
Jeff DeTray WB8BTH
Bryan Hastings KA1HY
73 Magazine Staff

“Dayton, huh? Boy, I sure wish I were going along with you. I’ve always wanted to see that

one. They say there is nothing like it.”

As the van rolls west through the long Pennsylvania night, the chatter on most two-meter repeaters within range is of Dayton. Not the city, but the institution that has become a rite of spring for thousands of hams—the Dayton Hamvention.

“Say, you’re about on the edge of this machine. If you drop down to the nine/one machine, you can take it clear into Ohio. Have a good trip and I hope you enjoy Dayton. Maybe I’ll see you there during the week-end. Seventy-threes.”

The Dayton Hamvention has become the granddad-

dy of all ham gatherings. In sheer size, it is larger than many of the towns its participants come from. And they come from all call areas of the US and Canada, and from many European and South American countries. They come to be part of the Dayton magic. When you go to Dayton, you don’t just see it, you live it. From the crowded exhibition halls to the spacious 10-acre flea market, from the business-like technical forums to the freewheeling evening bar scene, Dayton is ham radio at its most intense. It allows the ham total immersion in his hobby. For these three late April days, a ham can eat, sleep, and drink ham radio as he can at no other

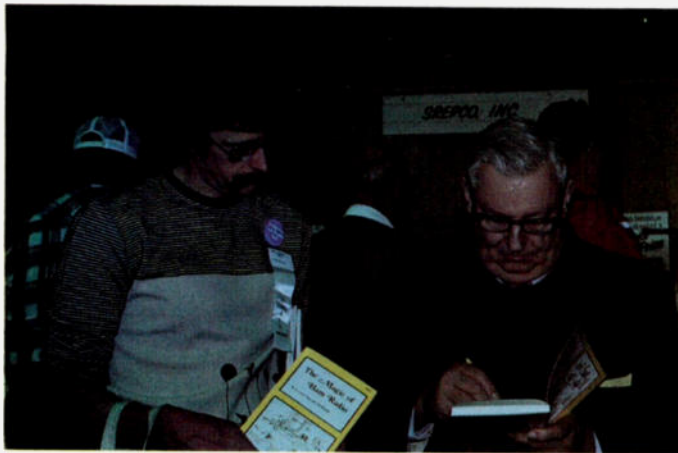

Jerry Swank WBHXR autographs the first copies of his new book, *The Magic of Ham Radio*, a 73 publication. Chris Brown N1AUI, one of the book’s editors, looks on.

Photo by Dan Tkach WB8OBD



time or place. He's at Dayton, and it's another world.

But why Dayton? Why this out-of-the-way rather bland mid-western city? It seems a long drive from anywhere, especially the population centers of either coast. Except for its proximity to the R. L. Drake Company in nearby Miamisburg, it has no distinguishing features a ham would find significant. Why then did over twenty-five thousand hams make the annual pilgrimage to Dayton this year in spite of a lousy economy, an energy shortage, and a viciously enforced fifty-five-mile-an-hour speed limit on the nation's interstate highway system? To answer that question, you have to know what Dayton is.

There are actually four Dayton's. Each is distinct and offers its own unique flavor. When added together, the whole is much greater than the sum of the individual parts.

The Hall

One Dayton is manufacturers and dealers. The huge Hara Arena is wall to wall equipment—the newest releases, the latest gadgets. Magazines, badge-makers, and booksellers, too, jammed shoulder to shoulder in a delightful pot-

pourri of electronic madness, and it's all for sale.

When the gates open at 8:00 am, the people who have been waiting in line for an hour or more flow into the arena with a vengeance. Once inside, the river of humanity fragments like so much white water as each person, with his own velocity and direction, heads for the booth of his dreams. For many, Collins/Rockwell is the stuff of dreams.

Booth is not the right word for what Collins/Rockwell has attempted to construct. Environment is more accurate. Their potted plants and lush carpets provide an air of artificial luxury amidst the chaos of the main exhibition hall. Collins knows their clientele.

Engineers in three-piece suits wait to courteously answer questions and provide specifications. They carefully rationalize to the curious why their new three-thousand-dollar transceiver, steeped in tradition, costs twice as much as its imported counterparts. Traffic ebbs and flows throughout the day in the Collins environment. The engineers grow tired of the same questions, the incessant CW coming from a nearby booth, and the heat.

In another part of the arena, the Kenwood booth,

staffed by eight Japanese engineers and countless factory reps and salesmen, does a brisk business. Every conceivable Kenwood unit made is on display. Plans for new models are secretly divulged as service gripes are efficiently attended to. There are no potted plants at Kenwood—just customers, radios, and all those Japanese engineers who don't seem to mind incessant CW or redundant questions and who always look cool.

Collins and Kenwood. America and Japan. The parallels extend beyond the hobby.

The Flea Market

Dayton is also the most

legendary electronic flea market in the country, maybe the world. Acres of used PC boards, vintage Motorolas, surplus scrap, and nearly-new Kenwoods. Peopled by carney hucksters, off-duty engineers, forty-year veterans, and kids in search of their first rig, the flea market is the people's Dayton.

"What can you do with a 48-pole relay?"

"Who cares? The price was right!"

"It runs off 28 volts, ya know."

"So... I'll figure out something."

For the bargain-hunter, the Hamvention's flea market is heaven on Earth. There is at least one of



Why is this man smiling? This is Bob Heil K9EID, who has just discovered that his CB-to-10-meter FM conversions are selling like hot cakes. Bob has authored several articles for 73.





Lunch at the flea market is a spartan affair.



The medium is the message.



Getting there is half the fun—and expense.

everything in that ten-acre communications cornucopia. Perhaps the only item not for sale was one huckster's personal supply of Coors, cases of which were stacked a dozen high atop his van and guyed like a Rohn tower.

Don't plan to see the flea market in an afternoon—a day and a half is more like it. If you're conducting a serious search for something, you'd do well to carry along a notebook so you can remember just where you saw that mint Gonset Communicator or Viking Thunderbolt.

Comparing prices is fun, too. You'll see an amazing value on a one-of-a-kind item only to walk ten paces and find the same gizmo \$5 cheaper. That is the flea market.

There was a guy who had five SB-101s. Five. How he

ever accumulated that many he would not say. A good-looking pair of Drake twins went for \$900. Some nut dressed as an Arabian oil sheik, scimitar in hand, drove a hard bargain as he dickered over price through his Budweiser-equipped interpreter. One made as much sense as the other.

The master of understatement was the guy who was trying to unload a rusted-out military-surplus transceiver that had been air-dropped without a chute. His attached cardboard tag read "\$5—Needs some work."

The flea market is an electronic junkyard and a living history of ham radio: For some, memory lane; for others, the sideshow at Dayton's three-ring circus.

A Sunday Forum

Another Dayton is

forums—this year, thirty in all. Everything from QRP operation to OSCAR, extraterrestrial radio signals to Earth-based malicious interference. Contests, ATV, the FCC, VHF, DX, Westlink, and WARC. At Dayton, there is a forum for everyone, a quiet respite in a hectic day. A classroom experience for those long out of school or a chance to ask questions and get answers from someone you've only read about.

John Johnston is in the hot seat today. As Chief of the Personal Radio Branch of the Federal Communications Commission, he has come to the Dayton Hamvention to conduct a forum. The subject of his forum is, simply, "The FCC." Meeting room number one is filled with the curious and the angry when he arrives. The government's adversary relationship with the ham is obvious as he fields questions like a middleweight fending off jabs to the head.

"Why don't you guys give tests at hamfests anymore like you used to? What are we paying our taxes for, anyhow?"

"Who the hell thought up the new callsign assignment system? And why?"

The questions keep coming as John Johnston bobs and weaves his way through the forum offering hope

here, rationalizing Commission actions there. Always on the defensive, he does his best to pacify the crowd. He has come to Dayton as a representative of the federal government. This is a particularly bad weekend to be placed in that role. Three days earlier, other representatives of the federal government had failed in their attempt to rescue the American hostages in Iran and had given an international display of technical incompetence.

The hams at John Johnston's forum are tired of the stalemate in Iran, of bureaucratic incompetence, of the federal government. This weekend John Johnston is a victim of bad timing.

People abruptly rise and leave throughout John Johnston's forum once they have their say. Having the bureaucracy's ear, one on one, for a few moments, seems to satisfy them. As they leave, others hurry to take their places, hoping there is still time to air their pet peeves. A microphone circulates through the crowd and verbose hams have no trouble verbalizing their feelings.

"What is the FCC going to do about these damn repeater-jammers? There is a guy in my town we'll deliver to you in a basket if you'll put him away for awhile. Why haven't you people



The Coors tower: slightly askew, but operational on all bands.



One of several exhibition areas within the huge Hara Arena.

done anything about this mess?"

"Why are the questions on your exams so confusing? Some sound as if they are written by PhDs."

After two hours, John Johnston has had enough. He says there is only time for a few more questions. There are many more hands up in the air and many more questions wanting answers. Good-naturedly, he carries on through the long afternoon . . . bobbing and weaving . . . bringing the bureaucracy to the people.

Kansas City DXers

Finally, Dayton is people. When the arena doors close for the evening, the bars and restaurants come alive. Manufacturer and club hospitality suites are busy every evening. On Friday night, an FM Bash; on Saturday, a banquet with two thousand guests. People are a major part of the Dayton experience.

The Kansas City DXers are hard-core. Their hospitality suite on the fifth floor of the Downtown Stouffers has been buzzing with activity since the door opened at 6:00 pm. Now, well past 11:00, it is still crowded with people three deep at the cash bar.

"Hey, who wants to take the CW QRM test? It's a real bear. C'mon, you guys; it'll separate the men from the boys. Twelve different DX

calls in fifteen seconds in heavy QRM. Let's do it!"

Other guests in the suite stir self-consciously as three teenagers cautiously approach the corner of the large table where a cassette recorder waits.

"We'd like to take it."

"Well, well. Alright, boys. Sit right down. Here are the rules. You get one shot and one shot only. Write your calls on top of your paper and get ready."

The suite grows silent as the young ops try to get comfortable, try to calm down. The tape begins and fills the room with a deafening hash of CW. Bent over their copy pads, the boys try to look serious, though their furtive glances at one another telegraph the hopelessness of their situation throughout the room. The tape ends. The test is over.

"Let's see how you did. No, no, there's one, no, no. Well, one out of twelve. Not bad."

The others did not get any.

"Not exactly a championship score. But come back and try next year. We'll be here. We're always here."

The young op who managed to pull one DX call out of the mess on the tape watches as his name and score are duly recorded on the score sheet tacked to the wall. Proud of his achievement, he lingers for



Oil for technology! The sheik and his interpreter drive a hard bargain in the flea market.

a moment before shuffling out the door and back to his parents' room.

"Okay, okay. Who wants to see the slides of the VP1 expedition? Or how about the Monster Quad slides? We haven't seen them lately. Come on, you people, it's early. Hey, get those VP1 slides loaded. Boy, what a trip that was! Even got an OSCAR QSO from there."

The bar is busy again and the crowd jostles for position as the slide projector is readied for the Nth time. The first slide hits the screen in the beautiful turquoise and blue hues of the Caribbean.

"Now this sandy spit of earth is one of the rare ones. VP1-land. You can see our 20-meter beam behind that palm on the left of the grass

hut. Quite a shack, huh? We were lucky it didn't rain. Getting that antenna up was something else. Had to use bamboo mast for the thing, but it worked like a charm. Amazing what you can do with some spit and coax. Next slide!"

The slides click on; in the darkened hospitality suite, the tinkle of ice-filled glasses is a soothing counterpoint to the host's staccato monologue. The Kansas City DXers like what they do. They are hard-core.

All of this is Dayton. And more. Eight free bus lines operated by the Hamvention running throughout the city for those needing transportation. For three days, the busiest repeater in the country, the largest one-day CPR course ever given. Awards for "Ham Of The

this publication is available in microform



Please send me additional information.

University Microfilms International

300 North Zeeb Road
Dept. P.R.
Ann Arbor, MI 48106
U.S.A.

18 Bedford Row
Dept. P.R.
London, WC1R 4EJ
England

Name _____
Institution _____
Street _____
City _____
State _____ Zip _____

Year" and "Special Achievement" won by Californians; hot dogs, beer, too few hotel rooms, too many exhibitors on the waiting list.

Why the Dayton Hamvention has become popular is a bit of a mystery to current Hamvention organizers. They do concede that being the first major ham convention each spring is a factor in their

success.

The Dayton Amateur Radio Association is not mystified by the running of the Hamvention, though. This totally volunteer group, with minimal support from their city, manages to stage a most professional convention, the scale of which would give pause to many larger organizations.

The 1980 Hamvention

staff was headed by General Chairman Noel McKeown WB8QQC. McKeown is a fortyish practicing attorney from Xenia, Ohio, with a flair for organization and a sense of humor. The squeaky toy duck he has attached to his HT antenna makes him easy to spot in a crowd. He was the first ham back on the local two-meter repeater after the disastrous tornado which leveled much of his home town, and now he maintains his cool despite being in his first year as Chairman. Reluctant to delegate authority, he places himself at the center of the organizational maelstrom. While accessible to all of his people, he is firm in his resolve to maintain decision-making control and responsibility. His HT is never quiet as he strolls through the arena like a general on the battlefield—more tables are needed here; there is a power failure there. All problems find rapid solutions in Noel McKeown's Hamvention.

Self-effacing, he characterizes his role as merely that of a shoulder to cry on. In a sense, he is right, for he does not work alone. Thirty-two people are listed in the official program as staff and hundreds more have contributed time and effort.

Hamvention planning begins in May each year. Consequently, twelve months are taken up with organizational work. Endless rounds of meetings, critiques, and strategy sessions run throughout fall and winter. For the Dayton Amateur Radio Association, the effort pays off.

This year the Hamvention had close to twenty thousand gate customers at six dollars a head and more than six thousand pre-registered ones. Almost two hundred exhibitors in the main arena paid \$180 for

each booth space. In addition, hundreds of flea-marketers bought space for the weekend at thirteen dollars a spot. The Saturday evening banquet, a tradition for many conventioners, was a sellout with two thousand in attendance.

If the Association's communication van is any indication of the profitability of running the Hamvention, the return is worth the trouble. Their Drake-equipped 30-foot motor home is an impressive sight.

The Dayton Hamvention is profitable for the exhibitors, too. One large dealer has reported six-figure business over the Dayton weekend, and smaller operations making badges, selling books, and hawking electronic kits show up year after year along with the ever-efficient State of Ohio tax agents.

What the future holds in store for the Dayton Hamvention is on the minds of the organizers. The declining economy and tight money situation does not bode well for expensive equipment-oriented hobbies like ham radio. Whether the Dayton Hamvention will continue to grow in size, as it has for the past five years, is difficult to say. There were indications that business had slowed this year in comparison to last. As the economy goes from bad to worse, tough times may be ahead for the Dayton Hamvention.

For the present, the Dayton Hamvention rolls on as the biggest and most successful ham gathering in the country. One can only hope that as inflation chips away at the non-essentials that make life worth living, people will be reluctant to let go of what they hold dear: opening day at the ballpark, fishing season, the Dayton Hamvention. After all, rites of spring should die hard. ■



Flotsam and jetsam: electronic and otherwise.

**YOU ARE LOOKING AT
EVERYTHING
THAT IS NOT ON SALE
THIS MONTH
AT HAM RADIO CENTER**

**FOR BEST PRICE – FAST DELIVERY
CALL TOLL - FREE**

1-800-325-3636

HAM RADIO CENTER ✓ 32
8340-42 Olive Blvd. • P.O. Box 28271 • St. Louis, MO 63132



One Step at a Time: Designing Your Own Ham Gear

— part II

In Part I of this article, I covered the first three parts of a seven-part step-by-step process, taking us from design to building and testing. Here are the other four parts.

Parts Acquisition

Acquiring parts for the project may be the most frustrating stage in the entire design process. Part of the problem stems from the variety of components now available. Not too long ago, say about twenty years, we could build what we wanted from coils, capacitors, resistors, tubes, sockets, transformers, wire, and jacks. Plus a cabinet, necessitated by the advent of television. Thousands of transistor types and a growing number of IC types now make it impossible for one dealer to carry everything. Handling costs have risen so that locally-available parts in blister packaging are expensive. Fewer mail-order houses wish to fool with open bins of resistors or with a small order. Fortunately, the situation seems to be improving for many kinds of parts, and a few individuals have begun to specialize in parts for rf. If only hams had not decided to build more than just transmitters and receivers; now they insist on keyers,

frequency counters and readouts, synthesized vfos, and even computers. Little wonder parts dealers cannot keep up.

Parts ordering will involve several orders to different houses. It is useful to try to be as complete as possible in the initial order, since many houses have a minimum order. Of course, it is inevitable that you will forget to order one small, but crucial, part available only from a company with a \$20 minimum, but then what better time to stock up on everything for the next project?

It is possible to divide parts into three types: crucial, needed, and desirable. Crucial parts are those without which an entire circuit may need to be replaced with another. The inability to obtain a special power transistor may require rethinking the entire set of amplifier stages. The unavailability of a specified power transformer may require you to redesign the whole power supply, e.g., to shift from a bridge rectifier circuit to a full-wave center-tap circuit.

Needed parts are those whose absence may require some circuit or construction modifications. Changing from toroids to slug-

tuned coils may require giving thought to shielding and the consequences of lower Q.

Desirable parts are those which, in your design and with respect to your objectives, may have adequate, easily-available substitutes which will do the job just about as well. A vfo with silver-mica capacitors rather than polystyrene ones will work satisfactorily in some units (not subject to great temperature changes).

The point in making these distinctions is to determine the order in which you acquire parts. To receive all the desirable parts for a circuit and to fail to obtain the crucial one amounts to filling the parts bins of your shack for use in another circuit.

Besides acquiring parts in the priority of crucial first and desirable last, you should buy in two steps. First, purchase all the major components. Then think about matters such as chassis and cabinet. To discover that your transformer and circuit board require a 4"x 5"x 6 1/4" cabinet when you have just bought a 4"x 5"x 6" cabinet only adds a spare aluminum case to all those extra parts

you just put in the junk box. If possible, put off buying chassis and case until after the next stage (planning the layout). Then you will be sure that everything will fit. (But do not feel bad about violating this advice; nearly everyone does. I have three or four small boxes and cabinets awaiting projects designed just to fill them up.)

Layout Planning

Many builders follow the rule of breadboarding all circuits before building a final version of a piece of equipment. If you are one of these persons, then you will want to jump ahead to the stages of building and testing before working through this one, even though some of the general points here can ease potential problems in breadboarding. Modern construction techniques permit many types of equipment to be breadboarded and built simultaneously. Using a perfboard or circuit board as a sub-chassis means that the builder can perfect parts of a total unit one at a time and then—if the breadboarding method is also a sound building method—simply install the working subunits into the overall case. Whatever your particular building

technique, giving plenty of thought as well as pencil and paper to planning the physical layout of your equipment will ease the construction process.

There is no one best way to build equipment for oneself. Our skills vary. Some enjoy metal work, others want to minimize it; some enjoy the finishing process of paint and decals, others use blank panels; some love to make up circuit boards, others prefer perfboard techniques or the use of terminal strips. And, in fact, there is no set way for the actual construction process to proceed. Therefore, with attention to some cautions given below in the section on building, choose the type of construction which you can do best. Just as building a piece of equipment increases our knowledge of electronics, however, building also can increase our building skills; do not hesitate to try a new technique. As a hedge against messing up your project, you might first experiment with the technique on a small project in order to learn the basic skills and discover the main pitfalls. But if you have never etched a circuit board or bent your own chassis or wound your own coils, acquiring skills such as these can add to your building and designing skills by opening up new possibilities. Construction of a piece of equipment should not be outside your abilities just because the mechanical work is difficult. Besides, there may be hams in your area who can help you learn or who may do the work expertly for you. Trading skills is an old and honored ham custom.

Before you perform the first mechanical task, work through the placement of the parts. There are two levels to this planning task: circuitry and cabinetry.

Circuitry and the interconnection of circuitry requires attention to the placement of parts and leads on each subassembly, whether that be a tube socket, terminal strip, circuit or perfboard, or a chassis. The use of subassemblies on boards is recommended wherever possible because it will permit independent testing of the circuits involved, replacement of a small part of the project in case of a major snafu, and easier maintenance after the unit is complete. In laying out parts of the circuits, pay special attention to the following items:

1. Signal paths: Are they as short and direct as possible? Are input and output leads isolated as much as possible? Are there minimal crossovers?

2. Components: Are they going to be securely fastened? Will they interact (e.g., are coils—except for toroids—at 90-degree angles to each other or shielded)? Will they all fit?

3. Dc paths: Are they neatly routed? If wire, are they bundled into cables? If PC board or perfboard, do the runs avoid capacitive coupling to signal paths?

4. Switches and controls: Are leads short unless they carry only dc? Is necessary shielding planned for?

5. Crossovers: Do circuit paths cross over (either on one side of a board or on alternate sides) in ways to create undesired coupling? Are connecting cables between boards isolated with respect to dc and signal? Are subunits isolated either by position or shielding?

Cabinetry includes not just the overall case of the unit, but chassis and other substructure considerations which go into making up a total unit as well. Among the things you should think about are the following:

1. Power supplies: Are

they positioned for adequate mechanical support of transformers and chokes? Is ac isolated from lines into which hum might be coupled?

2. Major parts placement: Is the size and weight distribution well balanced for mechanical support and operating ease? Is there sufficient room around these major parts for associated circuitry, shielding (where needed), and mechanical supports?

3. Mechanical supports: Are dials, vfos, and other units with movable electronics or mechanics adequately supported for stable, unbreakable operation? Will shafts or mounting brackets of controls or subunits interfere with other subunits of the equipment?

4. Maintenance: Are subunits mounted so that they are easily removed for maintenance? Are test points accessible for metering? Are parts mounted to the main frame or chassis accessible for replacement?

5. Controls and jacks: Are controls placed for ease of operation without confusion? Are jacks for input and output conveniently placed? Are fuses and line cords accessible without interference to operation?

The last set of questions, concerning the use of panel-mounted controls and jacks, should open the builder to new ideas. Most builders try to emulate commercial construction, even to the point of putting the same items on the front and rear panels. Remember, however, that this piece of equipment is being custom-built by you for you. That means that you have freedom to choose just where each control, jack, fuse, or cord will go. If you are building a CW transmitter, there is no general good reason for putting the key jack on the

rear panel, even though almost every commercial transceiver and transmitter has it there. Where you place it should depend upon what you need from the equipment by way of operating ease, convenience, and design necessity. In principle, there is no reason not to use the top and sides of the unit, as well as the front and rear, for controls and jacks. The decision whether or not to use a surface is determined by your objectives, circuit constraints (e.g., high-impedance rf leads), and mechanical constraints (e.g., a box having only independent front and rear panels).

Consideration of the unit's panels brings up another matter. Earlier, we mentioned that you might want to review your objectives throughout the design process. Now, before getting to the stage of actually building the equipment, is a good time to perform the review. In your design of circuit blocks and in your research and selection of circuits, you may well have unconsciously changed some of the objectives through your decisions. In laying out the parts, you are made aware of most of the elements of operational ease of the equipment. If these thoughts are not among your objectives, you should add them now, after thinking through carefully what you want in this department. After all, you expect to operate with the equipment for a far longer period than it will have taken to design and build it.

Circuit Interaction: Shielding and Isolation

Although many of the points to be made about shielding and circuit isolation have been mentioned in the course of these design hints, it may pay to look at the subject as a whole. Planning the layout

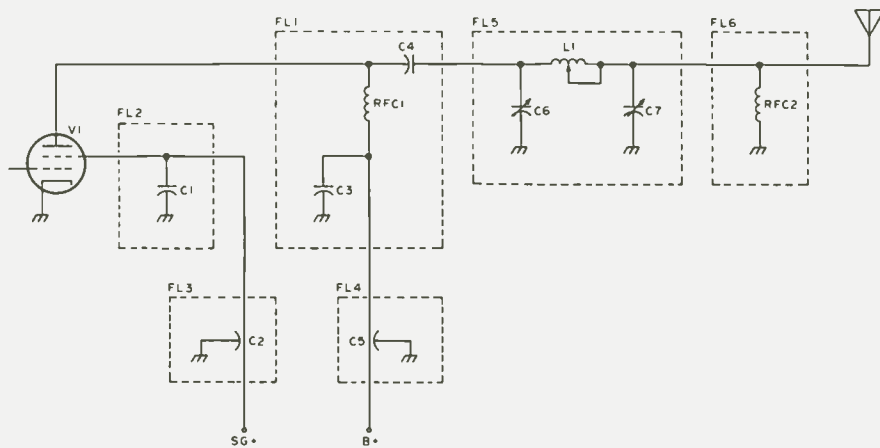

Fig. 6. This figure illustrates thinking about the output circuit of a typical power amplifier circuit as a collection of filters. FL1 consists of C3, C4, and RFC1, which separate the dc and rf. FL2 and FL3 also separate dc and rf, sending the latter to the chassis ground. C2 is a feedthrough capacitor, used where dc enters the amplifier enclosure. FL4, consisting of C5, has a similar function for the plate voltage. FL5, consisting of C6, L1, and C7, is a pi-network which passes rf energy at the frequency to which it is tuned and attenuates energy at all other frequencies, including harmonics and spurious frequencies. FL6, RFC2, is a back-up filter: Should C4 break down and permit dc to the output, RFC2 will route it to ground and blow a fuse rather than let it appear at the antenna where it might pose a danger to the operator or bystanders. It is not only possible, but also useful, to think of most circuits and circuit elements as filters which separate energy into two or more paths. Such analysis makes us aware of the fact that each type of energy (dc, ac, af, rf, etc.) must have a complete path, and that good design has a proper route for each type of energy at every point in a circuit. For example, bypassing energy to ground is a proper route for af and rf energy which we do not want at some point in a circuit.

of parts provides an excellent opportunity to forecast all the possible difficulties you might encounter from circuit interaction.

The most common type of equipment to suffer from unwanted circuit interaction is rf gear, either transmitters or receivers. Station accessories also come into play since they might have to work in an environment of stray rf fields or rf energy carried to the unit by power or interconnecting lines. However, almost any type of equipment—audio, digital, test, etc.—can suffer from improper energy transfer. Therefore, the following list of places to think about may help you predict and take preventive action against trouble spots.

1. Power entry: Look out for possible line surges, rf on the power lines, voltage spikes, etc. Any of these items can kill solid-state devices or interrupt proper operation. Bypassing, voltage limitation, and other

usual handbook-type preventatives should be employed.

2. Dc lines: Check for possible signal coupling, whether rf, af, or digital. Separating lines is effective for some troubles. Extensive bypassing can avoid other problems. In digital gear, there may be simultaneous pulsing on several devices which pulls a heavy current load, thereby reducing the supply voltage to individual devices for an instant. This may cause a device to operate erratically.

3. Parts placement: Look for parts interaction due to placement and positioning. Capacitive coupling should be suspected everywhere until you are satisfied that it is minimal. Inter-coil coupling possibilities should arouse your suspicions. Additional coupling in switches is another suspect.

4. Shield placement: Be sure that your shielding efforts are adequate to the needs. Using additional

screws, adding tops to enclosures, being sure shields extend beyond the edges of components they shield, making sure cables have good chassis grounds for their shields—these points should all be remembered, as well as others which handbooks can provide in detail.

5. Electronic isolation: Check all filter chokes and bypass capacitors to see that they are where they should be and that they are of the proper value. Coupling capacitors associated with rf chokes and bypass capacitors, as in Fig. 6, form a type of filter. A filter may be defined as any device which separates energy into two or more paths. If the coupling capacitor, say in a power amplifier, is too small, rf will be forced into the dc lines. If the choke or bypass capacitors are of the wrong values, they will aid rf in reaching the power supply. From there, rf can travel to everywhere else that you do not want it. Use

feedthrough capacitors for running power into any enclosed subunit. Add further filtering if you think rf might be a problem. Check each circuit for each stage to be sure that all filtering (and this includes things as simple as tuned circuits) is adequate. The list of electronic isolation techniques is far longer than this note can give a hint of. The key thought is this: Be thorough! Every problem you anticipate in advance is one less problem you will face later and one less circuit to be needlessly torn apart after you build it.

Building and Testing— One Stage At A Time, Cumulatively

Building your well-designed piece of equipment is not just a matter of good construction practice. Certainly, you should always adhere to the practices which the handbooks and various articles show. Practicing the skills of mounting components, soldering, cabling dc leads, and the like should be part of every project. They will vary in part with the type of construction that you choose. The reason these practices will not be reviewed here is that you should have thought through them in the preceding stage of selecting circuits, acquiring parts, and planning your layout.

The actual process of building is one of putting these practices to use in a way that will best ensure that your unit will function as desired. This happens for the home builder only if he combines building and testing and takes one stage at a time. Remember that your project is not a kit, engineered to be repeated in the home. Kit manufacturers can have you work on widely separate subunits of the kit at the same time because they have made the unit work a number of times already. For you, the

home builder, this is the first time. Therefore, to be sure that every subunit will contribute to the whole in a way to meet your design specifications, you must build and test them as you go along.

Besides, it is much easier this way. One reason for suggesting earlier that you build in terms of subunits was to permit you easily to accomplish this step-by-step procedure. A good way to think of the building and testing procedure is to call it "circuit adjustment." You will be combining your circuit parts in order to make a circuit work. Notice that you will not be building and then seeing if the unit works. Instead, you are going to do what you must to make it work. Often we think of adjustment as changing the setting of a potentiometer, a variable capacitor, or a slug-tuned coil. But, every change made in the value of a bias resistor—even if it means taking out a fixed-value part and putting in another—is also a circuit adjustment.

Among the other replacement adjustments you may have to make are these: replacing an active device with one having higher/lower gain, adding chokes and bypasses, rerouting leads, rewinding coils, replacing capacitance-division networks, changing resistor and/or capacitor values in timing circuits, altering supply voltages, revising ground paths. And these are only a few of the possibilities. Luckily, you will have to consider only a few of these possibilities for any one stage that you build and test. If you have thought through the earlier stages of design, the number of possible adjustments will be minimal. (But remember that Murphy lurks in the background to make a liar out of me.)

Before getting to the building process itself, let's

spend a moment thinking about test equipment. Most hams would love to have a completely-equipped laboratory but do not have the cash or the space to put one together. Short of that ideal, what equipment is the most necessary? The answer to this question will vary with the kind of project you are building. The two most basic instruments for every project, however, are the VTVM and the VOM. The VTVM is for voltage and resistance measurements. The VOM is for current measurements. If your project deals with rf, then you should have an rf probe for the VTVM. In addition, a grid-dip oscillator permits pre-adjustment of tuned circuits and a basket full of other handy tests. A good gdo also will function as a sensitive wavemeter to sniff out spurious emissions. Oscilloscopes and frequency counters are useful, but if you are just beginning to put your workshop together, save them for later and begin with the essentials.

For digital work, the VTVM and the VOM are still basic. A digital probe to indicate device logic state is handy, but a scope is probably the best item to determine the pulse trains and shapes. Thus, if your projects are going to be mostly digital, then a scope takes much higher priority on the test equipment list.

Finally, you should have a variety of signal sources and signal decoders. That is, a variety of oscillators and receivers. If you are building a transmitter, an allband receiver—however inexpensive—can be extremely useful: It can tell you where your oscillator signals are (as well as if they exist), and the S-meter can help you peak up a circuit. For receivers, you need signals for rf, i-f, and af testing. Often these can be made up from junk-box parts as

you go along. Lab-grade generators may be more accurate, but they are also many times more expensive. The cheap and easy way is usually more than good enough to get a unit fully and satisfactorily functioning. If you then want to perfect adjustment to the last gnat's hair, there is usually a well-equipped ham in the area, or perhaps a friendly technical school, a serviceman, or even a set-up at a hamfest.

With these thoughts in mind, let's begin the process of building and testing. Begin always with the power supply. Beginning here has several advantages. First, power becomes available to all the stages. Second, you can run your dc cabling around the chassis or case before adding other parts. Third, you can assure yourself that all requirements for regulation, ripple, and load capability are going to be met.

The next stage depends upon the unit you build. In general, there are only receivers and transmitters, that is, signal generators and signal decoders. Test equipment, such as frequency counters and oscilloscopes, are simply special types of decoders. Function generators and audio oscillators are in a family with transmitters. Therefore, there are only two building progressions you have to think about.

For decoders or receivers, begin with the output stage. In a receiver, this will usually be the audio stages; in a counter, it will be the visual readout. Whatever the device, it is usually easy to provide inputs to check the proper output of the stage. All other stages will work progressively into this one. If you are not sure this stage works, then when you build another, you will not know which of the two stages needs adjustment. If it does work, then your po-

tential problems are cut in half. The trick is to work backwards toward the input to the unit, testing each circuit and each subunit as you go. This does not mean you may not want to alter something in a later stage after adding the earlier ones. It does mean that you will have the best chance of making the entire unit function as you planned.

For transmitters and other signal generators, begin at the opposite end. A CW transmitter might begin with the vfo. Once this works, move to the heterodyne oscillators and mixer. Finally, tackle the amplifier trains. For an SSB transmitter, you might begin with the audio stages. Then work on the carrier generator. Next comes the balanced modulator, the sideband filters, the vfo, the mixer, the heterodyne oscillators and mixer, and finally the amplifier stages.

In all of your work, add accessories last. VOX, electronic T-R switches, sidetone monitors, and the like are all additions to the basic unit and should be deferred until you are sure the basic unit functions correctly. On the other hand, be sure you distinguish between accessories and essentials. Although a blocked-grid keying network is not part of the signal generation train, it is essential to a CW transmitter and should be developed with the main part of the rig. Likewise, avc, if essential to a receiver design, should be begun as soon as you reach the stage from which it is derived.

Figs. 7 and 8 illustrate the progressive building process for two small projects. The order of building and testing can be altered somewhat. You might begin on a receiver with the high-band converters, using an available receiver to check them out, but the general principles given here are a

sound way to begin your thinking. If you vary them, you should be clear in your own mind just why you are departing from them and what advantages you will gain.

Circuit Interaction: Spurious Oscillations and Emissions

While building and testing each stage of the unit, you should be aware of circuit problems which might occur and what corrective actions you can take at this stage of the design process. Most of them have to do with oscillation and the mixing of oscillations. In transmitters, we refer to harmonics, parasitics, and spurious emissions. In receivers, we tend to think of "birdies." Whatever we call the effects, there are only a few basic causes and cures. Here is a starter list.

1. Amplifiers on a high: The wire leads and the com-

ponents associated with an amplifier can produce oscillations at some unpredictable very high frequency. This is true of both tube and solid-state amplifiers. When building an amplifier, check it in operation with a sensitive wavemeter tuned through the range from 50 to 200 MHz. If you detect any oscillations, the usual methods of adding parasitic suppressors to the plate leads of power tubes or adding a ferrite bead to the collector lead of a transistor will usually take care of the problem.

2. Amplifiers on a low: Transistor amplifiers are subject to low-frequency oscillations (which are not a problem with tubes). Additional bypassing with values from .1 to 1 uF in the collector supply lead will usually eliminate this problem.

3. Spurious mixing: Mod-

ern equipment, especially for rf, usually contains several oscillators. There is no telling where, in all the circuitry, that signals from them may mix and produce new frequencies either in or out of the ham bands. Careful shielding of circuitry and rf leads will often cure this problem by ensuring that signals go only to the stages in which they are supposed to be mixed. Spurious mixing of signals can result from rf getting into dc lines from improper lead dress, as well as from direct radiation. Thus, there may be several things to check.

4. Harmonics: Oscillators have harmonics which may cause problems. The harmonics may produce direct output or they may mix with other signals to produce new signals. In receivers, these new products can show up as "birdies," i.e., steady or warbling tones that show up at a certain

point on the dial. In transmitters, the products, if in the ham band to which the amplifier is tuned, can show up as a well-amplified signal, but not in the place you think you are operating. If you encounter any of these problems, check the harmonic frequencies of all oscillators and see if any mixed combination might produce the problem. The cure may involve shielding and lead dress, but a trap, placed in the output of the offending oscillator and tuned to the troublesome harmonic, can often eliminate the difficulty.

The list of possible problems could be extended. In transmitters, standard precautions against harmonics should be used. In one form or another, these precautions apply to all signal generators. In receivers or decoders, precautions should be taken at the input or early in the equipment to pre-

Fig. 7. Stages in the construction of a low-power solid-state CW transmitter for 40 meters. a) Building and testing the power supply. b) Building and testing the 7-MHz vfo and buffer stage. c) Adding a tuned amplifier and testing for feedback to the vfo. d) Adding a keying transistor to key the buffer and amplifier. e) Adding a second power amplifier and half-wave filter; testing power levels and signal purity. f) Adding a CWX circuit to provide power with the first dit and delay removal of power for 1 second after transmission is complete; acts as a T-R switch.

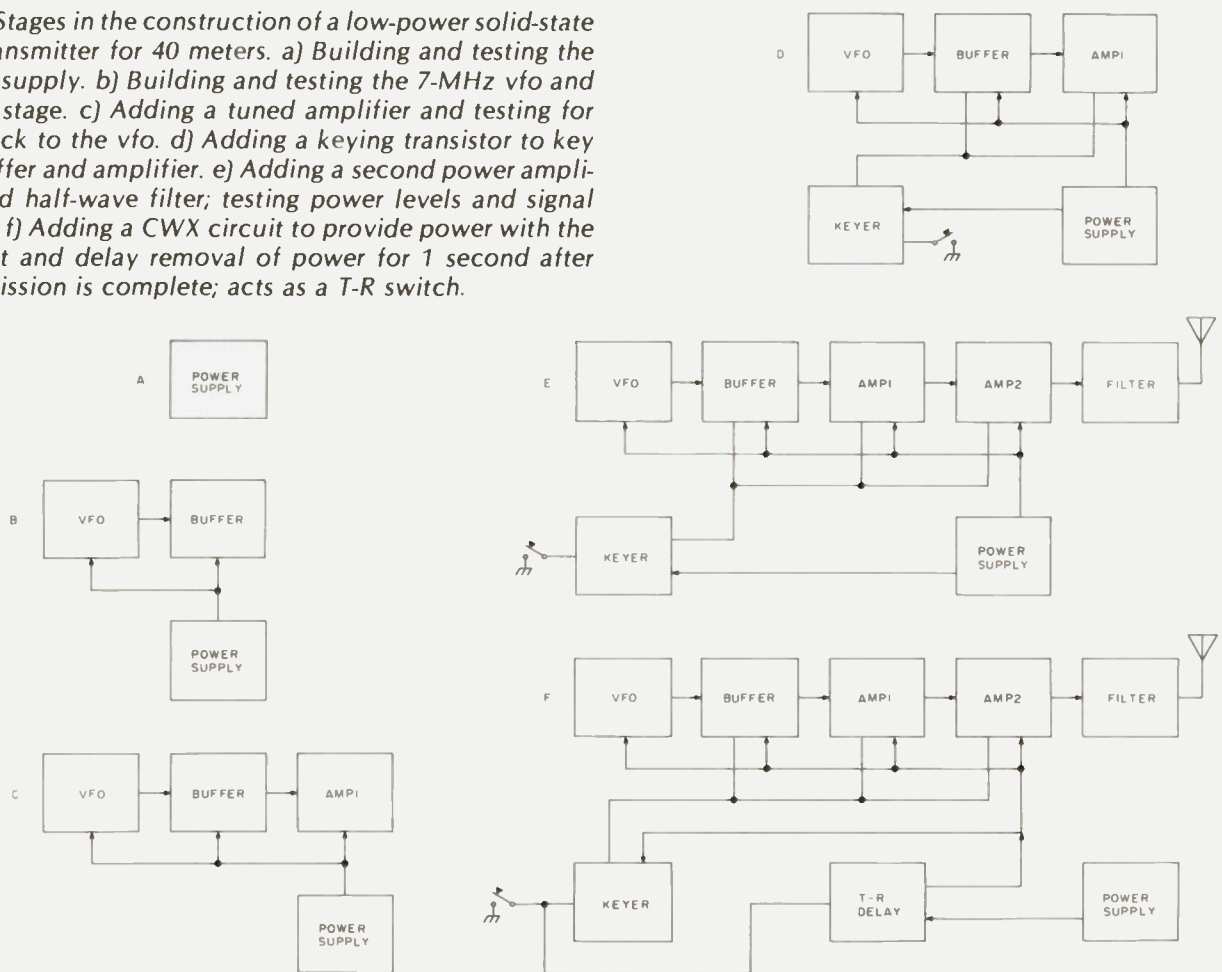

vent all but the desired signal from appearing in the output, either as a false signal or as a mixing or distortion product.

The essence of this list, however, is to make you aware of some typical problems that show up in the building process, problems which have simple cures which may be added to the circuit without affecting its main function. If you clean up each stage as you proceed, then you cut down the possible causes of such problems. In transmitters, they ordinarily will be caused by the new stage itself or by the new stage in combination with the preceding stage. In receivers, the problems are usually traceable to oscillators mixing somewhere. The simple cures will take care of better than ninety percent of the cases. And the procedure of building a stage at a time will usually make locating and curing the problem an easy matter.

The effect of building and testing as you go, one stage at a time, is that you accumulate a functioning unit. If you attend not only to the fact of a circuit's functioning but also to its sensitivity, output level, and all the other factors you noted down while designing the unit, the final adjustment will yield a piece of equipment ready for use. Close the lid, label the switches and controls, clean the handling smudges from the case, and begin using your equipment. The only question left will be your satisfaction: Will it be greater the first time it works or when you suddenly realize a year later that it still works and as well as many commercial pieces of equipment?

There is one other question: What will you want to build as your next project?

Before closing, we should take one more look at the notebook you have been accumulating as the

design process proceeded. By now, it not only has a collection of objective lists, block diagrams, circuits, and notes, but also has layout drawings and other notes you entered while adjusting the circuits you built. At this point, it will pay to add the following:

1. A clean schematic of the final unit, just as you finished it. This drawing can be broken up into sections according to the subunits you built, or it can be a single large drawing. The subunit system of drawing does tell you where every part is, and this may help you later when your clear memory has dimmed because you have been building other pieces of equipment.

2. Clear drawings of the front panel, rear panel, and chassis or subunit layouts, just as you finally built them. These can replace some of your earlier sketches (but save those earlier sketches if they contain ideas that may be useful to other projects).

3. Notes on the typical operation of the unit. For transmitters, this may include tune-up procedures, neutralization procedures, and the like. For receivers, this list might contain the effects of controls and their interaction, the most useful ways to null out unwanted signals, and other operating procedures.

4. Notes on signal and dc voltages and device currents. These notes, which can also be entered onto the schematic diagram, provide a record of what conditions are normal for the unit. If you ever have to troubleshoot the unit, they can help you locate a trouble source fast.

The purpose of these notes is twofold. First, they aid you in any later servicing and maintenance work. Second, they provide operating notes should you ever sell or give away the

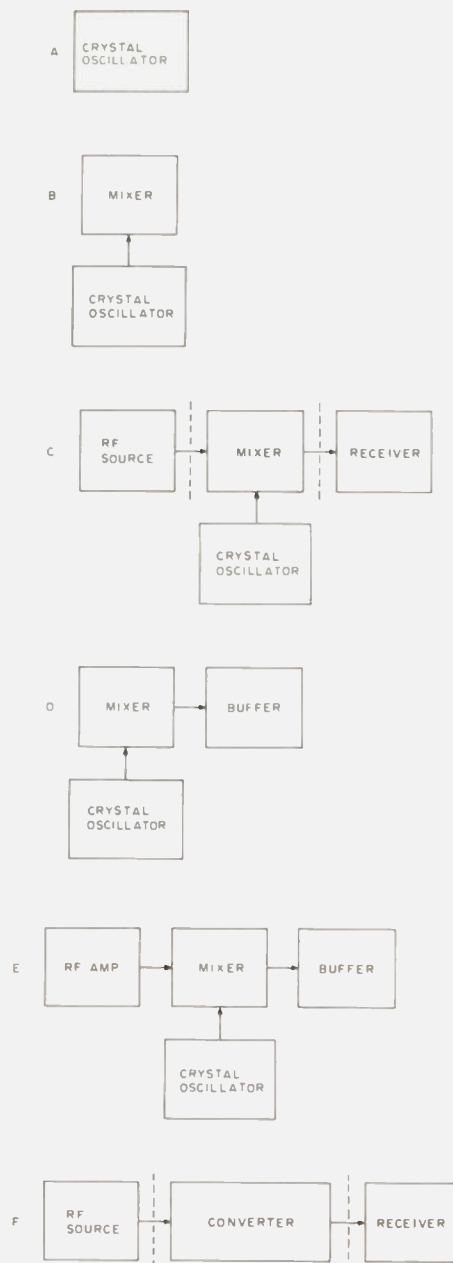

Fig. 8. Stages in the construction of a 10-meter converter. a) Building and testing of the crystal oscillator; without the oscillator, no conversion will be possible. b) Adding the mixer. c) Testing the basic converter for mixer alignment. d) Adding a buffer/i-f amplifier with low gain and low-impedance output. e) Adding an rf amplifier for additional gain. f) Testing the complete converter, noting operating voltages and performance figures for future reference. Although this procedure looks elaborate for a small project, it is, or should be, the natural procedure for a project such as this. Unlike building a kit, there is no point at which I could say that the unit worked right the first time. In fact, even at stage f, when the unit was working well, I decided to see if I could make it work better by controlling the rf stage with avc derived from the receiver.

unit. There is a third possible use: If you ever have the urge to write up the project for a ham magazine, you will have all the information at your fingertips.

The main purpose of this

article has been to develop a step-by-step thinking process so that a new General class ham can move from soldering circuits to designing his own equipment. It is based on the premise that

Visa/MC welcomed. Money back if not satisfied.
8-POLE FILTER BANDWIDTHS IN STOCK

| CRYSTAL FILTER | CW (Hz) | | | | | SSB-AM (kHz) | | | | | |
|-------------------|--|--|-----|-----|-----|--------------|-----|-----|-----|-----|----------------|
| | 125 | 250 | 400 | 500 | 600 | 800 | 1.6 | 2.1 | 2.4 | 6.0 | 8.0 |
| YAESU | \$55 EACH | | | | | | | | | | |
| *FT-101/F/FR-101 | ✓ | ✓ | ✓ | ✓ | ✓ | ✓ | ✓ | ✓ | ✓ | ✓ | ✓ |
| *FT-301/FT-7B/620 | ✓ | ✓ | ✓ | ✓ | ✓ | ✓ | ✓ | ✓ | ✓ | ✓ | ✓ |
| *FT-901/101ZD/107 | ✓ | ✓ | ✓ | ✓ | ✓ | ✓ | ✓ | ✓ | ✓ | ✓ | ✓ |
| FT-401/560/570 | ✓ | ✓ | ✓ | ✓ | ✓ | ✓ | ✓ | ✓ | ✓ | ✓ | ✓ |
| FT-200/TEMPO I | ✓ | ✓ | ✓ | ✓ | ✓ | ✓ | ✓ | ✓ | ✓ | ✓ | ✓ |
| KENWOOD | \$55 EACH | | | | | | | | | | |
| *TS-520/R-599 | ✓ | ✓ | ✓ | ✓ | ✓ | ✓ | ✓ | ✓ | ✓ | ✓ | • 2nd IF \$125 |
| *TS-820/R-820 | ✓ | ✓ | ✓ | ✓ | ✓ | ✓ | ✓ | ✓ | ✓ | ✓ | for R-820 only |
| HEATH | \$55 EACH | | | | | | | | | | |
| ALL HF | ✓ | ✓ | ✓ | ✓ | ✓ | ✓ | ✓ | ✓ | ✓ | ✓ | ✓ |
| DRAKE | FOR PRICES SEE NOTES | | | | | | | | | | |
| R-4C | GUF-1 Broad 1st IF Superior Shape Factor/Ult Rej \$65 ✓ | | | | | | | | | | |
| | GUF-2 Narrow 1st IF ✓ + pcb w sw relays \$90 | | | | | | | | | | |
| | 2nd IF ✓ Plug in type ✓ \$65 | | | | | | | | | | |
| | GUD Product Detector pcb w relay double balanced type \$30 | | | | | | | | | | |
| COLLINS: | SPECIAL \$125 EACH | | | | | | | | | | |
| 75S-3B/C | ✓ | EQUALS OR EXCELS \$400 COLLINS UNIT | | | | | | | | | |

FOX-TANGO CRYSTAL FILTERS

Fox Tango Corporation, sponsor of the 4000 member, eighth year old International Fox Tango Club for owners of Yaesu amateur radio equipment, announces the expansion of its quality line of eight pole crystal filters and related accessories to include not only popular models produced by Yaesu but also those of Kenwood, Heath, Drake and Collins.

Noting that most manufacturers of amateur radio equipment were content to supply relatively few filters to supplement the SSB unit supplied as standard equipment, and these as extra cost options of six poles or even less, Fox Tango decided it was time to offer the worldwide amateur fraternity true "freedom of choice" by making available a variety of filter types and bandwidths never previously obtainable or adaptable to their rigs. For example, for its popular FT-101 line, Yaesu offered only a single 600 Hz bandwidth CW filter for direct installation, and while a 6000 Hz AM filter could be bought, it could be used only

by sacrificing the CW filter whose spot it pre-empted. Both optional Yaesu filters were of six pole construction. By contrast, for the same set, Fox Tango now offers 250, 500, 600, 1800, 2100, and 6000 Hz bandwidths—all carefully designed and manufactured eight pole units made up of specially treated Hi-Q high quality quartz crystals. Moreover, to compensate for the lack of space in the original design for more than one optional filter, Fox Tango offers inexpensive diode switching boards (both single and dual types) for most Yaesu and Kenwood models which permit the addition of up to three filters more than those for which the manufacturer provided room. Thus owners of older models can "update" their sets either by the "drop-in" installation of superior filters to supplant original units or can supplement them by adding selectable bandwidth filtering, often using switches already existing on front panels. All filters are custom made to perfectly match the sets for which they are designed, both physically and electronically so installation is a simple matter of

tightening two nuts and soldering two connections. Fox-Tango filters are guaranteed on a money back or replacement basis, as preferred, for one year.

The following filters are currently available for the brands indicated.

Yaesu FT 101 (to F), FR-101, FT 301, FT 7B, FT 901/101Z, FT 200, FT 401. Bandwidths 250, 500, 600, 1800, 2100, 6000 Hz.

Kenwood TS 520/R 599, TS 820/R 820. Bandwidths 250, 400, 1800, 2100.

Heath All Bandwidths 250, 400, 1800, 2100 Hz.

Drake R-4 C only Broad 1st (1.6 or 8 kHz BW) Narrow 1st (1.600 or 800 Hz BW) with relays for switching from broad to narrow 1st for CW only. Very sharp 2nd (1.6) (plugs in) 125 Hz Product detector kit converts existing units to superior double balance type.

Collins 75S 3B/C. For superior CW, 250 Hz bandwidth.

Reprinted from 73 Magazine

F T **Get the BEST for Less!**

Yaesu Heathkit Kenwood Drake Collins

Whether your SSB rig is old or new, there is no easier or essentially less expensive way to significantly upgrade its performance than by improving its IF passband filtering. FOX-TANGO filters are made of specially-treated high-Q quartz crystals, affording excellent shape factors and ultimate rejection exceeding 80 dB. They are custom made for drop-in installation, matching perfectly, both physically and electronically. Our Diode Switching Boards make possible (now or in the future) the addition of a variety of switch-selectable filters affording superior variable bandwidth without the need to buy an expensive new model. If you want the best for less, you'll buy FOX-TANGO. Just tell us the bandwidth(s) desired for your make and model.

*DIODE SWITCHING BOARDS available to permit 1, 2 or more filters than those for which manufacturer provides room. SPECIFY make and model.

Single-filter type: \$12 Airmail postpaid
 Dual-filter type: \$21 Airmail postpaid

Florida residents add 4% (sales tax) (FOREIGN ADD \$3 per filter)

clear thinking is nine-tenths of the battle to successful design and building. The steps given here are aids to clear thinking. As such, they have no magic. As you progress in the art of design, you will begin to alter them to suit your own individual way of going about things. More and more of the work will become natural and require fewer checklists and notes. But having a workable system to begin with can make the process of growth more rapid and more successful. I hope that this article will aid the process and encourage you to design and build.

The thought process described here is also useful to those who do not plan to build, however. The stages of thinking can help you to evaluate commercial equipment. By thinking through your objectives in having a piece of equipment, it becomes

clear as to what features are important to you and which are extras you can do without. By looking at a manufacturer's literature, you can learn how he has designed the equipment to fulfill those functions, and what circuits he has chosen to satisfy each block sub-function. Examining the parts layout and the construction techniques, with an eye on what advantages he wanted to gain and what potential problems he wanted to overcome, can teach you much about the interaction of the electronic and physical dimensions of radio equipment. All of this will not only make you a more intelligent buyer, but it will also aid your understanding of the equipment as you operate it and perform maintenance upon it. And this can add a new satisfaction to your experience in amateur radio. ■

"WORLD FRIENDSHIP THROUGH AMATEUR RADIO"

SEANARC '80

SEATTLE NATIONAL AMATEUR RADIO CONVENTION

26th NATIONAL ARRL CONVENTION

July 25 - 27, 1980
Seattle, Washington

ENJOY THE 26th NATIONAL ARRL CONVENTION
 IN THE BEAUTIFUL PACIFIC NORTHWEST

SEMINARS, DISPLAYS, LADIES PROGRAMS, FORUMS AND MAJOR
 EQUIPMENT EXHIBITORS WILL HIGHLIGHT THIS GATHERING AT
 THE SEA-TAC AIRPORT RED LION MOTOR INN.

Roy Neal, K6DUE, of NBC News will be the featured Saturday night banquet speaker.

Vic Clark, W4KFC will explain the results of WARC-79 and what it means to the future of amateur radio.

Meet ARRL President Harry Dannals W2HD, and other ARRL officials.

For Program and Registration Materials
 Write:
 1980 ARRL NATIONAL CONVENTION COMMITTEE
 P. O. Box 68534, SEATTLE, WASHINGTON 98168



FT-707 is shown with optional FV-707DM VFO & Scanning Microphone



THE FT-707 "WAYFARER"

The introduction of the "WAYFARER" by Yaesu is the beginning of a new era in compact solid state transceivers. The FT-707 "WAYFARER" offers you a full 100 watts output on 80-10 meters and operates SSB, CW, and AM modes. Don't let the small size fool you! Though it is not much larger than a book, this is a full-featured transceiver which is ideally suited for your home station or as a traveling companion for mobile or portable operation.

The receiver offers sensitivity of .25 μ V/10 dB SN as well as a degree of selectivity previously unavailable in a package this small. The "WAYFARER" comes equipped with 16 poles of IF filtering, variable bandwidth and optional crystal filters for 600 Hz or 350 Hz. Just look at these additional features:

FT-707 with Standard Features

- Fast/slow AGC selection
- Advanced noise blanker
- Built-in calibrator
- WWV/JJY Band
- Bright Digital Readout
- Fixed crystal position
- 2 auxiliary bands for future expansion
- Unique multi-color bar metering—monitors signal strength, power output, and ALC voltage.

FT-707 with Optional FV-707DM & Scanning Microphone

- Choice of 2 rates of scan
- Remote scanning from microphone
- Scans in 10 cycle steps
- Synthesized VFO
- Selection of receiver/transmitter functions from either front panel or external VFO
- "DMS" (Digital Memory Shift)

Impressive as the "WAYFARER" is its versatility can be greatly increased by the addition of the FV-707DM (optional). The FV-707DM, though only one inch high, allows the storage of 13 discrete frequencies and with the use of "DMS" (Digital Memory Shift) each memory can be band-spread 500 KHz. These 500 KHz bands may be remotely scanned from the microphone at the very smooth rate of 10 Hz steps.

The FT-707 "WAYFARER" is a truly unique rig. See it today at your authorized Yaesu Dealer.

YAESU ✓83
The radio.



YAESU ELECTRONICS CORP., 6851 Waltham Way, Paramount, CA 90723 • (213) 633-4007
YAESU ELECTRONICS Eastern Service Ctr., 9812 Princeton-Glendale Rd., Cincinnati, OH 45246

Top-Banding the DX-60B

— put a classic rig on a classic band

After having my interest in 160 meters kindled by reports of increased activity and by reading a number of articles in recent magazines concerning the "top band," I decided that I, too, wanted to share in some of the excitement.

Because my present HF transceiver does not include that long-forgotten range of frequencies, I considered either buying a new

transceiver or building a transmitter and using my Hammarlund HQ-145A receiver. After investigating the purchase of a new transceiver, I decided that that would best be put off until financially better times. Regarding the building of a transmitter, there appeared to be many schematics available, but the parts for the higher power units seemed to be difficult to

obtain. I thought I would like to learn a little more about the band by operating with higher power before going QRP.

One day while I was operating RTTY with my Heathkit™ DX-60B on 20 meters, it suddenly occurred to me that the DX-60B might not be too difficult to convert to 160 meters. After looking at the assembly manual and sche-

matic, I realized that I was right. And, not only would the transmitter give me 90 Watts on CW, but it also would give me AM phone ability. This mode is still pretty popular on 160.

The DX-60B cost about \$90 new and was designed for Novice and General use. The inclusion of AM phone made the transmitter obsolete before its time, and many still can be purchased through classified ads and flea market sales for around \$30-\$40.

Since the circuit of the DX-60B uses a crystal oscillator, driver, and amplifier in the rf stages, only two tuned circuits must be changed to use the unit on 160 meters. With the 160-meter conversion added, the transmitter can be used on all bands, 40-10 meters, but the case will have to be opened and jumpers added to use the transmitter on 80 meters. Since the only other use I have for the transmitter is on RTTY and I very seldom leave 20 meters on that mode, this was not much of an inconvenience for me.

The modification involves the removal of coils L2 and L3. These coils have to be taken completely out of the unit to make their

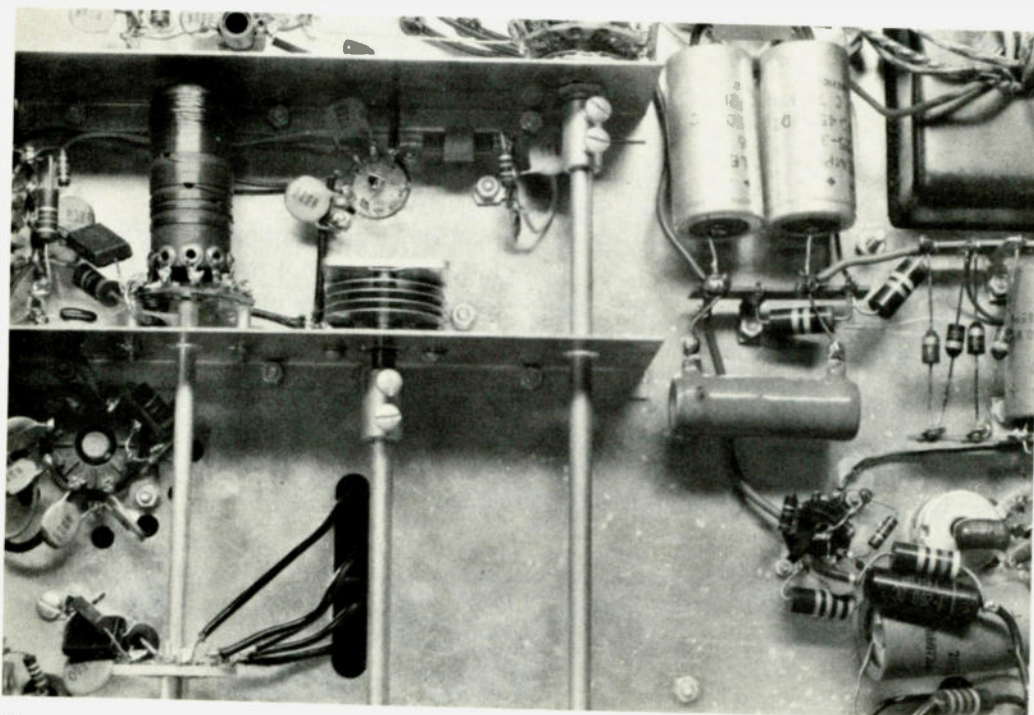

Photo A. Bottom view of the DX-60B. Coil L2 with the additional coil winding is at the upper left. The additional capacitor across C21 can be seen at the lower left.

modification possible.

After the removal of coil L2, drill another hole in the coil form as close as possible to the end of the form away from the mounting terminals. This hole should be in line with the hole farthest from the solder terminals.

Unsolder the wire from the terminal connected to the 80-meter switch contact. This is the wire which comes from the hole farthest from the terminals. Pull the wire back through the hole. Then insert a short piece of bare large-diameter wire into the hole. Bend the wire inside the coil form so that it cannot be withdrawn. Attach the wire which was unsoldered from the terminal to this large-diameter wire on the coil, taking up all of the slack. Also attach one end of an enamel-covered #26 AWG wire to the large-diameter wire. Continue winding this piece of #26 wire around the coil form in the same direction as the original coil. This additional coil should consist of 40 turns and must be scramble-wound to fit in the space between the large-diameter wire and the new hole. After winding the 40 turns, feed the wire through the new hole and down through the coil form to where the original wire was unsoldered from the 80-meter switch terminal. Solder this new wire to the terminal. The large-diameter wire will be used as a shorting terminal to restore the transmitter to 80-meter operation. L2 can now be reinstalled into the unit as it was originally.

Remove coil L3 by unsoldering the wires on the bandswitch under the chassis. Then unsolder the wire from variable capacitors C22, C23, and C24 and the wire from the low-pass filter at the coil.

Drill a new hole in the coil form at the end closest to the mounting lugs and in

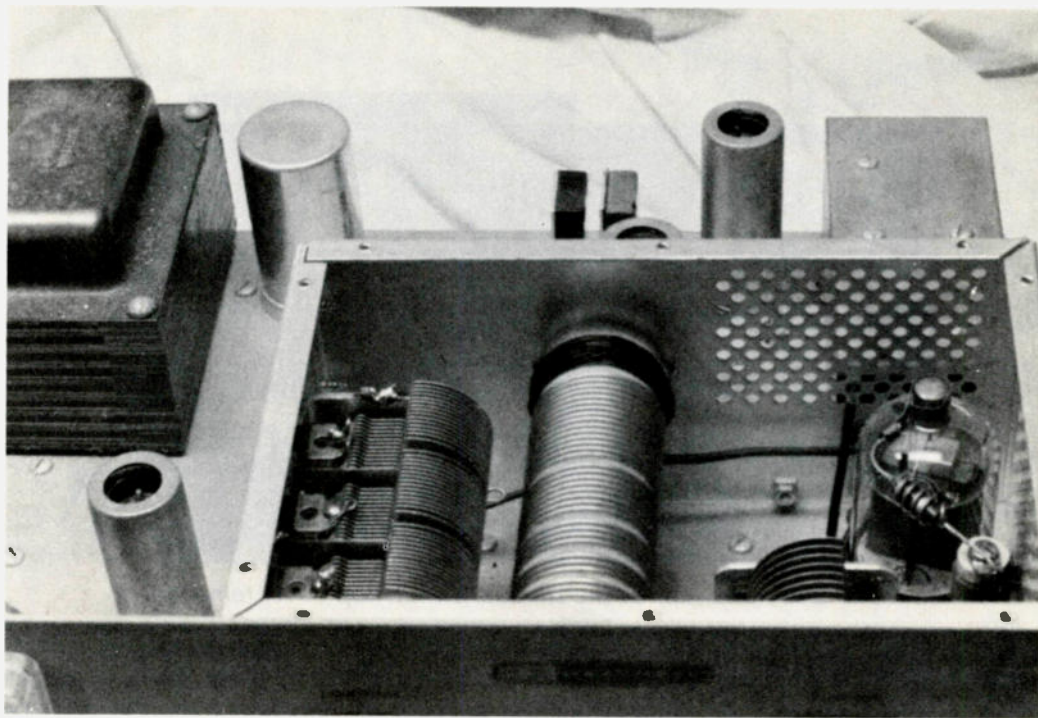

Photo B. The new winding on L3 shows in this top view of the DX-60B. The additional capacitor across C22, C23, and C24 is not shown, but the solder point is shown on the frame at the rear of the capacitor.

line with the coil terminals. Make sure that this hole is not closer to the end of the coil form than the end of the mounting lugs. This is to ensure that the new coil which is to be wound will not short on the mounting lugs. Again insert a bare, large-diameter wire through the hole and bend it inside the coil form. This wire can be bent in a loop on the outside of the form. It will act as a terminal for the 160-meter coil.

Bend the wire coming from the 80-meter terminal of the coil out at a right angle to the coil so that when the coil is remounted it will point toward capacitors C22, C23, and C24. Also, solder a length of #18 AWG enamel-covered wire to the 80-meter coil terminal. Wind 35 turns of this #18 wire on the form between the 80-meter coil terminal and the new terminal at the end of the coil, in the same direction as the original coil. Again, this section will have to be scramble-wound to fit in the space. Make sure that this wire does not touch either

mounting lug at the end of the coil. Solder both terminals.

Attach a length of insulated #12 AWG wire to the new terminal and bend it so that it will fit through the opening in the chassis to the switch when the coil is remounted. Then reinstall the coil.

An extension may have to be soldered onto the wire from capacitors C22, C23, and C24 so that it can be

soldered to the new terminal. Also, solder the wire from the low-pass filter to the new terminal. Under the chassis, solder all the wires back to the switch in the same order in which they were unsoldered. The new wire from the new coil terminal is soldered to the 80-meter switch terminal.

Make sure the wire from the 80-meter terminal on the coil is not touching the

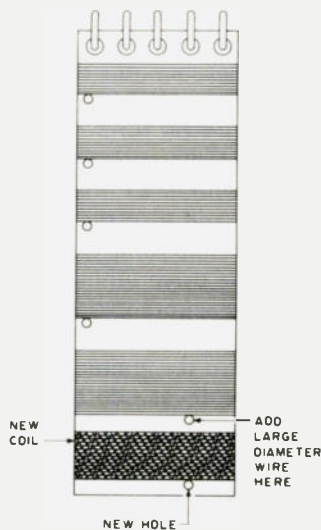

Fig. 1. Modification of L2.

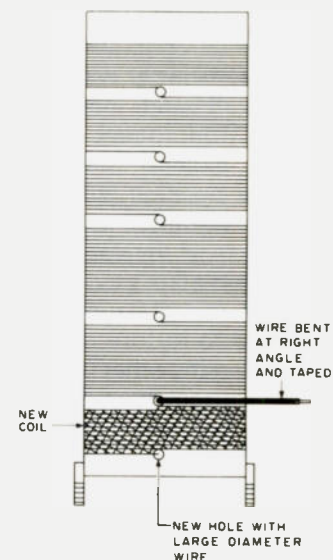

Fig. 2. Modification of L3.

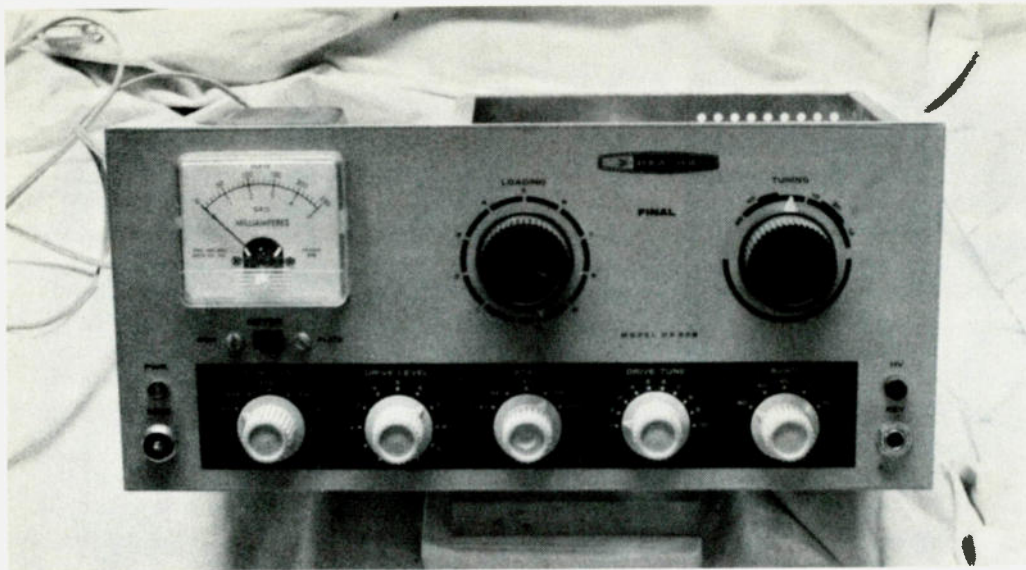

Photo C. A front view of the DX-60B with its top cover removed.

capacitors or ground. A small piece of plastic electrical tape can be placed over the exposed end of the wire, and then the wire can be bent under the coil.

Locate the 68-pF capacitor (C21) under the chassis. This capacitor is connected from the bandswitch. Place a 50-pF capacitor in parallel with this capacitor.

This completes the conversion. If the transmitter does not load correctly on 160 meters, an additional capacitance may be needed across capacitors C22, C23, and C24. This capacitor can be soldered from the terminal of one of the capacitors directly to the frame of the capacitor. Try about 500 pF at 1000 working volts to start.

The transmitter will now work on all bands indicated on the front panel bandswitch, except that the 80-meter position will now be the 160-meter position. (Of course, if the capacitor was added across C22, C23, and C24, it will have to be removed to restore correct loading on the other bands.)

To resurrect 80-meter operation, three steps must be taken. A shorting wire must be connected from the junction of the new coil and the original coil of L2 to the 80-meter terminal on the bandswitch. The wire from

the 80-meter terminal of coil L3, which was bent and taped, must be connected to the wire from capacitors C22, C23, and C24 to the coil. And the 50-pF capacitor must be removed from across the 68-pF capacitor near the bandswitch.

Let's get back to 160-meter operation. Install a 160-meter crystal in any one of the four crystal positions. Connect a dummy load of 50-Ohm impedance to the antenna jack at the back of the transmitter. After the set warms up in the standby position, check to make sure you have the crystal selector switch in the correct position. Set the drive level to about 2½ on the front panel. The final tuning capacitor should be set in the 80-meter region, and the final loading capacitor should be turned fully counterclockwise. Set the meter switch to the grid position and turn the function switch to tune. Quickly rotate the drive tuning control for maximum grid reading, then set this reading to 2.5 mA on the meter using the drive level control. At this point, use a good receiver to check the output of the oscillator. Listen on the 160-meter band for the purity of the oscillation and then check 80 meters

for the harmonic, which should be down in signal strength from the primary frequency on 160 meters. If for some reason there was a wiring error in the conversion of the driver tuned circuit (L2), it is possible that the driver could be acting as a doubler and putting out most of its signal in the 80-meter region. Therefore, if the 80-meter signal is stronger than the 160-meter signal, go back and check the wiring of L2. (As a point of fact, Heathkit suggests the use of 160-meter crystals in this transmitter for use on the 80-meter band—before modification, of course.)

If all seems to check out all right up to this point, you can proceed with the tune-up.

Set the meter switch to the plate position and turn the function switch to the AM position. Quickly rotate the final tuning control to obtain a dip or minimum plate-current reading on the meter. Next, set the function switch to the CW position and, while maintaining minimum plate current with the final tuning control, start increasing the loading with the final loading control. With an indication of 100 mA, the transmitter will be running at 75 Watts input, and with a

reading of 150 mA, the input power will be 90 Watts. At this point, if you cannot get sufficient loading to achieve the desired input power, that capacitor which we discussed before will have to be added across capacitors C22, C23, and C24. Begin with either 500 pF or 1000 pF at about 1000 working volts. This should allow you to load the transmitter to its maximum power.

After you have the loading straightened out, again switch the meter switch to grid position and set the drive level to 2.5 mA on the meter. Again, check the plate current and reset your dip with the final tuning control. Then set the function switch to standby.

To transmit on CW, merely insert a key in the key jack, and when you are ready to transmit, switch the function control to the CW position.

To transmit on AM phone, remove the key and connect a high-impedance microphone to the microphone jack. When ready to transmit, turn the function switch to the AM position.

I've had many happy hours operating the DX-60B on 160 meters and I am sure you will, too. With the use of the proper antenna, it will perform beautifully and give you a signal you can be proud to radiate.

The one drawback to the rig as described in this article is that it is crystal controlled. I have added a home-brew vfo which can be plugged right into the DX-60B, and with this accessory, operation was made much more pleasant and contacts became easier to initiate. In a future article, I will describe this vfo, which cost only a few dollars to construct, but added so much to the rig.

But, even when you are rockbound, the DX-60B can give you many enjoyable hours exploring the "top band." ■

TET[®]

ANTENNA SYSTEMS

1-800-654-3231

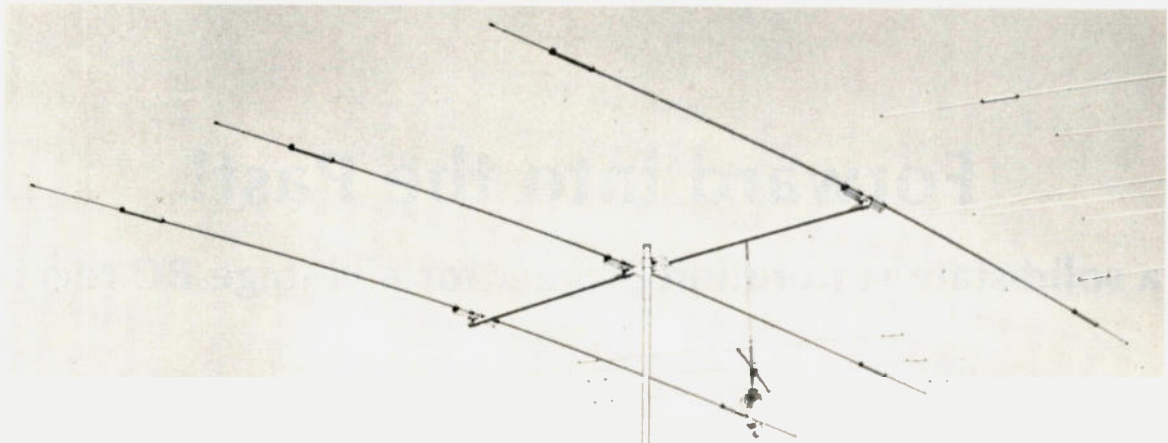

TE33SP COMPACT SIZE, MULTIPLE DRIVEN ELEMENTS

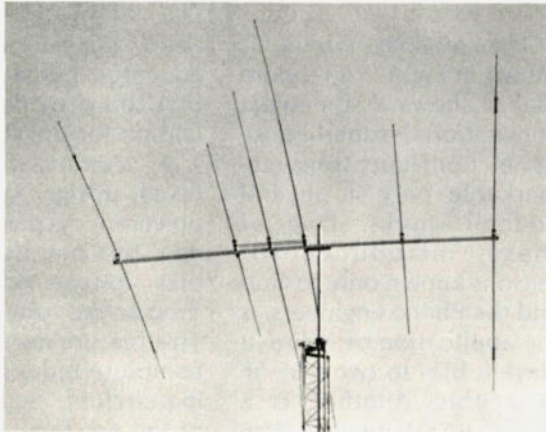

3F36DX FULL SIZE DRIVEN ELEMENTS



TET, the leader in wideband antenna design, is proud to announce a totally new concept in antenna design with the all new TE33SP. The TE33SP employs two driven elements to achieve previously unattainable performance from a triband yagi. Power is applied to the radiator and coupled through a rigid phasing line operates in conjunction with a specially engineered printed circuit board to provide the required phase shift for full sized performance on each band. This multi element drive network, combined with Hi Q traps provides greatly improved performance and true wide band operation. 1.5:1 VSWR bandwidth is at least 1 MHz on ten meters. Fifteen and twenty meters can be expected to produce VSWR of less than 1.5:1 from edge to edge.



The TET 3F36DX and 3F37DX triband beams provide excellent performance across the complete spectrum of the 10, 15 and 20 meter amateur bands. High performance is accomplished through the use of a full sized driven element for each band combined with efficient Hi Q traps for the parasitic elements. No Phone and CW settings with the 3F36DX and 3F37DX. Full band coverage is possible even with the new all solid state transceivers. You can expect VSWR below 1.5:1. The 3F36DX and 3F37DX are fed directly with a single 50 ohm coaxial line. No baluns or difficult to adjust matching networks are used.

TET invites you to compare our performance data against that of other antenna manufacturers. TET, the leader in wideband antenna design, offers superior performance at an affordable price. Join the crowd and switch to TET.

| | BAND | ELE- MENTS | ELE- MENTS PER BAND | MAX PWR | VSWR | IMPEDANCE | MAX ELEMENT LGTH | BOOM LGTH | TURN- ING RADIUS | WIND SURFACE AREA | WIND LOAD @80 mph | MAST SIZE | WT |
|--------|----------|---------------|------------------------------|------------|-----------|-----------|------------------------|--------------|------------------------|-------------------------|-------------------------|--------------|----------|
| TE33SP | 14/21/28 | 3 | 3 | 2KW | BELOW 1.5 | 50Ohm | 27' | 13'2" | 15' | 5.1 sq ft. | 102 lb. | 2" | 29.5 lb. |
| 3F36DX | 14/21/28 | 6 | 3/4/4 | 2KW | BELOW 1.5 | 50 Ohm | 34'5" | 16'5" | 17'3" | 9.58 sq ft | 191 lb. | 2" | 46.3 lb. |
| 3F37DX | 14/21/28 | 7 | 3/5/5 | 2KW | BELOW 1.5 | 50 Ohm | 34'11" | 24'8" | 17'5" | 11.3 sq ft | 226 lb. | 2" | 55 lb. |

Call Factory for ANTENNA GAIN dBd and FRONT TO BACK RATIO.

TET FACTORY DIRECT PRICE

| | |
|--------|-----------|
| 3F36DX | \$ 199.95 |
| 3F37DX | \$ 249.95 |
| TE33SP | \$ 154.95 |

LIMITED TIME ONLY

CALL TOLL FREE 1-800-654-3231



✓73

TET U.S.A., INC.



425 HIGHLAND PARKWAY, NORMAN, OKLAHOMA 73069 TEL: 405-360-6410

Forward into the Past!

— a solid-state restoration project for a vintage BC receiver

What do you do when you have an old broadcast receiver mounted in a beautiful console cabinet and you can't buy tubes for it? Why, you convert it to solid state!

A friend approached me with just such a project. He had a Philco broadcast and shortwave receiver, one that his grandfather had used when living on a farm. It was battery-operated, using 1.4-volt series tubes, but powered from a six-volt storage battery and deriving its plate voltage by

means of a vibrator. He wanted its appearance unchanged. That meant leaving the tubes (all shot) in their sockets. It also meant using the original coils and tuning capacitors, as he wanted the dial calibration to remain meaningful.

After some hesitation, I undertook the job. The actual man-hours were not recorded, but they would not truly be indicative of the task, because I pursued many false trails before arriving at the circuit ultimately used.

The original circuit is shown in Fig. 1. You'll note that it shows a somewhat conventional superheterodyne configuration, remarkable only in several oddball quirks. One of these, introduced for reasons known only to God and the Philco engineers, is the application of a direct-current bias to two 0.05- μ F capacitors. Another, is a third winding on the second intermediate-frequency transformer which carries bias to the screen-grid of the tube in

that stage. A semi-educated guess would be that this provided neutralization for the stage.

In common with the usual design of battery-powered receivers of its day, this one derived grid bias voltage from the IR drop across tube filaments. This feature necessitated a complete redesign of biasing circuits, including that of the agc bus.

The job was tackled in three stages. Really, four, if you count the power supply. I took the coward's way out, and bought one from Radio Shack! (It was their catalog no. 22-124.)

The first element is illustrated in Fig. 2, which shows the frequency-conversion stage only. This stage required more work than all others combined. It was a hellcat, pure and simple! The difficulty lay in getting the oscillator to perform properly over the desired frequency spectrum.

As shown, the original converter tube was replaced by two transistors, one as the "first detector" (as we used to call them) and the other as the local oscillator. The original

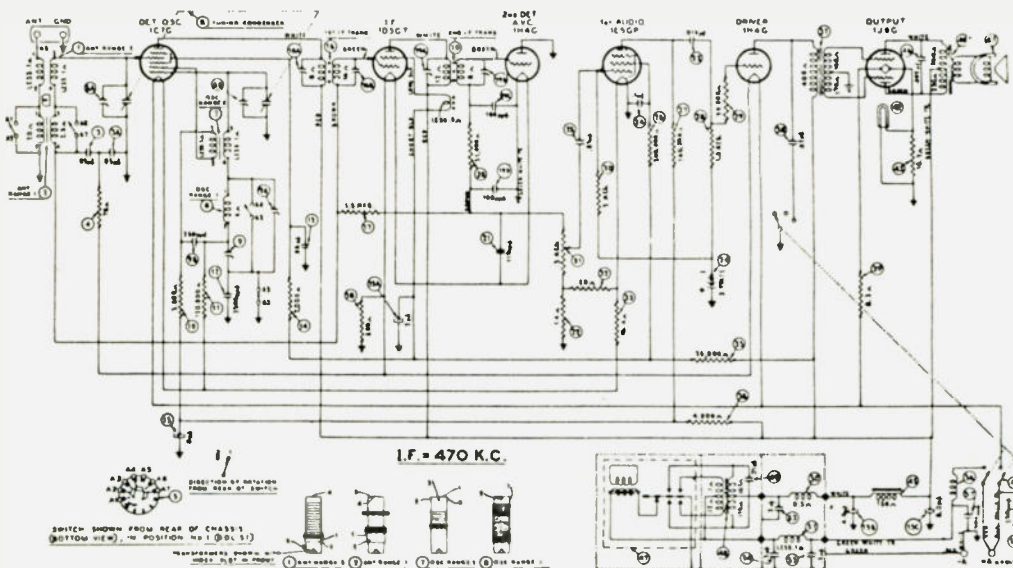

Fig. 1.

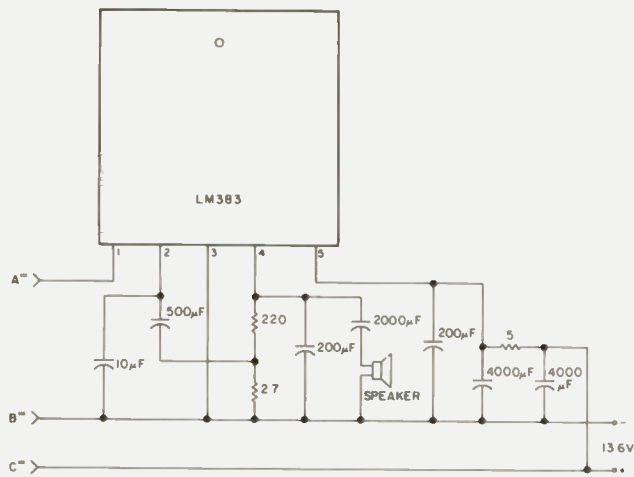

Fig. 4. Audio power amplifier uses Radio Shack LM383.

oscilloscope. Then the level of the input signal was advanced until distortion was observed on an audio voltage crest. The value of the resistor was adjusted until, when overloaded with audio input, the stage went into limiting simultaneously on both positive-going and negative-going peaks.

It was noticed that this stage developed an excessive hum when the gain control was set at zero signal input. The addition of a 1k-Ohm resistor in series with the gate cured the hum.

An audio power amplifier IC seemed the logical way to go for the final stage. The LM383, Radio

Shack no. 276-703, looked like a reasonable choice; one was purchased and installed. It required a certain amount of fiddling before operation was satisfactory. It appeared that a very low output impedance was essential for its power supply; also, filtering requirements were rigorous. I added a pi-section low-pass filter of two 4000-uF capacitors, and a 5-Ohm resistor. This helped, but did not entirely eliminate, a residual hum. What remained had to be tolerated.

As mentioned previously, a 13.6-V power supply was procured from Radio Shack. Other than being slightly lacking in filtering, it seems to be quite adequate.

With all its frustrations, the job was interesting and very challenging. Some of the problems were solved

by means surely not elegant—more by brute force than nicety.

A number of lessons were learned, some the hard way! For instance, it pays to experiment with a number of bipolar transistors even in an audio stage. The differences in behavior were marked. There seems to be little difference among RCA 40673, Sylvania ECG 222, and Motorola HEP F2004 dual-gate insulated-gate FETs.

Don't be tempted to use any 40-year-old capacitors! Be suspicious of old resistors, too. Be lavish with contact cleaning spray. Don't attempt to use a bipolar transistor with a coil-plus-capacitor combination designed for use with a vacuum tube.

And, above all, don't hesitate tackling a conversion job. It can be done! (The owner agrees!)■

HAM-KEY™ RADIO TELEGRAPH SENDING DEVICES



Model **HK-3M**
\$19⁹⁵

- * Deluxe straight key
- * Anti-tip bracket. Can't tip
- * Heavy base. No need to attach to desk

Add \$2.00 Shipping & Handling.

- * Navy type knob
- * Smooth action

CC-3P shielded cable & plug for HK-3M \$2.49.

Add \$.50 Shipping & Handling.

Model AT-B anti-tip bracket only, to convert any HK-3 to HK-3M.
\$2.99 Postpaid



Model **HK-1** **\$29⁹⁵**

Add \$2.00 Shipping & Handling.

- * Dual lever squeeze paddle
- * For use with all electronic keyers
- * Heavy base with non-slip rubber feet
- * Paddles reversible for wide or close finger spacing

CC-1P shielded cable & plug for HK-1 \$3.75

Add \$.75 Shipping & Handling.

Model HK-2, same as HK-1 but less base for incorporation in your own keyer. \$19.95

Add \$1.00 Shipping & Handling.

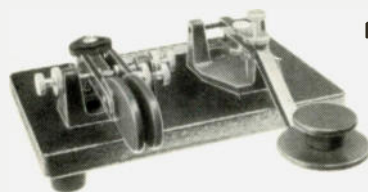

Model **HK-4**
\$44⁹⁵

Add \$2.00 Shipping & Handling.

- * Combination HK-1 & HK-3 on same base
- * Straight key may be used conventionally or as a switch to trigger a memory.

CC-1/3P Shielded cable with plugs for HK-4 \$5.99.

Add \$1.00 Shipping & Handling



Model **HK-5A** Electronic Keyer

\$69⁹⁵

Add \$2.00 Shipping & Handling.

- * Iambic circuit for squeeze keying
- * Self completing dots & dashes
- * Dot & dash memory
- * Built-in sidetone
- * Battery operated with provisions for external power
- * Uses Curtis 8044 keyer chip
- * Grid block or direct keying
- * Speed, volume, tone & weight controls on front panel
- * Use with HK-1 or HK-4

Order direct or from your favorite dealer. ✓ 30

The **HAM-KEY** Co.

P.O. Box 28271

St. Louis, MO 63132

Phone TOLL-FREE 1-800-325-3651



Call 1-203-667-0811 ORDER YOURS TODAY!

NEW EQUIPMENT SPECIALS

| | | |
|-----------------------------------|-----------|------------------------------------|
| ATLAS | | ICOM |
| RX-110 Rcvr. | \$ 169.00 | IC2A List: \$229.50 Call for Quote |
| MM-110 Mobile Mnt. | 27.00 | IC2AT List: \$249.50 " |
| ALLIANCE | | 255A List: \$389.00 " |
| HD-73 | 99.00 | 260A List: \$489.00 " |
| BIRD | | 551 List: \$449.00 " |
| Model 43 "On Sale" Call for Quote | | 551D w/PS20 List: \$849.00 " |
| CUSHCRAFT | | 251A List: \$699.00 " |
| ATB-34 | 229.00 | KENWOOD |
| A-3 | 169.00 | 120S, 180S, 520SE, TR-9000, |
| ATV-5 | 89.00 | TR-7800, TR2400 Call for Quote |
| ATV-4 | 79.00 | ROHN |
| ATV-3 | 39.00 | 25G Towers & Accessories |
| 32-19 | 77.00 | 20' to 25' Off |
| 214B | 59.00 | ROBOT |
| 214FB | 59.00 | Model 400 |
| 617-6B | 169.00 | \$ 649.00 |
| A50-5 | 59.00 | SWAN |
| A147-4 | 23.00 | TB-3HA Tribander |
| A147-11 | 34.00 | 10-40V Vertical |
| A147-20T | 58.00 | |
| ARX-2 | 34.00 | YAESU |

| | | |
|-------------------------------|--------|-----------------------------|
| HEATHKIT | | TEN-TEC |
| SB-110 6 meter Xcvr. w/HP-23B | 329.00 | Triton II Xcvr. w/CW Filter |
| Power Supply | 49.95 | Triton IV Xcvr. w/CW Filter |
| HA-202A 2 meter Amp/40 watts | | Omni D Xcvr. |
| ICOM | | Century 21 CW Xcvr. |
| IC-3PA D.C. Supply/Spkr. | 49.00 | |
| KENWOOD | | YAESU |
| TS-600 6 meter Xcvr. | 499.00 | FT-901DE "Demo" w/FM option |
| NATIONAL | | installed - full warranty |
| NCX-5 Xcvr. w/Power Supply/ | 339.00 | FTdx-560 Xcvr. |
| Spkr. | | FT-620B 6 meter Xcvr. |
| NCX-3 Xcvr. w/Power Supply/ | 249.00 | FT-7 Xcvr. |
| Spkr. | | FT-127RA w/YM-22 TT Mike |

| | |
|-------------------------------|--------|
| ANTENNA PACKAGES | |
| Cushcraft ATB-34 Tribander w/ | 339.00 |
| Alliance HD73 Rotor | |
| Cushcraft A-3 Tribander w/ | 259.00 |
| Alliance HD73 Rotor | |
| Hygain TH3 Jr. Tribander w/ | 229.00 |
| Alliance HD-73 Rotor | |
| Hygain TH3MK3 Tribander w/ | 279.00 |
| Alliance HD-73 Rotor | |
| Hygain TH5DX Tribander w/ | 309.00 |
| Alliance HD-73 Rotor | |

| | |
|-------------------------------|-----------|
| STANDARD | |
| 146 2 meter HT w/TTP, nicads, | \$ 179.00 |
| case, charger | |

| | |
|--------------------------------|--------|
| TEMPO | |
| Tempo One Xcvr. w/Power Supply | 379.00 |
| and Spkr. | |

USED EQUIPMENT

| | | |
|---|---------|--------------------------------|
| DENTRON | | COLLINS |
| DTR-2000L | 1199.00 | R390A .5 - 32 Mhz Rcvr. w/ |
| Clipperton L | 639.00 | case |
| DTR-1200L | 609.00 | 75S-3B Rcvr. |
| GLA-1000B | 359.00 | 75S-3 Rcvr. |
| DTR-3KA Call for Quote | | KWM-2 (Round) w/516F-2 PS |
| MT-3000A | 359.00 | KWM-2 (Round) |
| AT-3K | 239.00 | 949.00 |
| AT-1K | 139.00 | DRAKE |
| RT-3000 | 274.00 | T-4X Xmtr. w/AC-4 Power Supply |
| W2-PEP | 149.00 | T-4XB Xmtr. w/AC-4 " |
| Jr. Monitor | 74.00 | TR-4 Xcvr. w/AC-4 Power Supply |
| DRAKE | | R-4A Rcvr. |
| TR7/DR7 Xcvr. List: \$1549 - Call for Quote | | FF-1 Fixed Freq. Adapt. |
| HYGAIN | | 418.00 |
| TH3 Jr. | 139.00 | 458.00 |
| TH3 Mk 3 | 189.00 | 478.00 |
| TH5 DX | 219.00 | 279.00 |
| TH6DXX | 269.00 | 39.00 |
| 12AVQ | 35.00 | DENTRON |
| 14AVQ/WB | 58.00 | HF-200A Xcvr. w/HF-ACS, Power |
| 18AVT/WB | 87.00 | Supply Spkr., Mike |
| | | Clipperton L Amp. |
| | | 450.00 |
| | | HALLICRAFTERS |
| | | SX-111 Rcvr. |
| | | 129.00 |
| | | FPM-300 Xcvr. |
| | | 329.00 |

We Sell and Service the Following New and Used Equipment:

| | | |
|------------|-----------|-------------------|
| Aida | DSI | Mirage |
| Alliance | ETO Alpha | Mosley |
| Ameco | Ham Key | Murch |
| ARRL | Hustler | PIPO |
| Atlas | Hy-Gain | Robot |
| Benchner | ICOM | Rohn |
| Bird | JW Miller | Saxton Wire |
| B & W | KDK | Shure |
| Callbook | KLM | SST Electronics |
| CDE | Larsen | Swan |
| CES | MFJ | Telex |
| Covercraft | Microlog | Ten Tec |
| Cushcraft | | TET Antennas |
| Dentron | | Trac |
| Drake | | Unadilla |
| | | VHF Engineering |
| | | Vibroplex |
| | | Wilson |
| | | Wilson Commercial |
| | | Yaesu |



WE TAKE PHONE ORDERS OR SHIP C.O.D.

Call
or Write
for your
super quote
today!



VISA

WE EXPORT
(Sub-Dealers
wanted in
foreign countries)

THOMAS COMMUNICATIONS

95 Kitts Lane, Newington, Conn. 06111
"Near ARRL Headquarters"

Call: 203-667-0811

OPEN MON.-FRI. 10:5:30 • Sat. 10-4.

EASY DIRECTIONS: Rt. 15 South - 2 blocks past McDonald's (Berlin Turnpike)

SUB-DEALER INQUIRIES INVITED! (Send letterhead for complete package)

ADDSCAN

— now you can be two places at once

Daniel P. Bohi WB9FSC
3910 Sterling Road
Downers Grove IL 60515

One major drawback in owning an older crystal-controlled 2-meter rig is having to listen only to whatever you have your channel selector turned to. The end result is missed contacts and a very tired hand from switching the channel selector switch back and forth. After starting at the front of my rig and scratching my head in frustration, a thought occurred to me: "Hmm, a scanner would be nice . . ."

The features of this scanner include LED indication of the active channel, channel-lockout switches, and an LED busy-channel indicator/COR. Junk-box-variety components can be used, although not everyone has a 4017 counter chip lying around his junk box. All transistors are 2N2222s, diodes are 1N914s, and LEDs are whatever looks nice. I built my prototype on perfboard; construction is fairly straightforward. The scanner consists of 4 main sections: clock, inverter/COR, counter, and diode crystal switching.

Converting the crystal deck in the receiver to im-

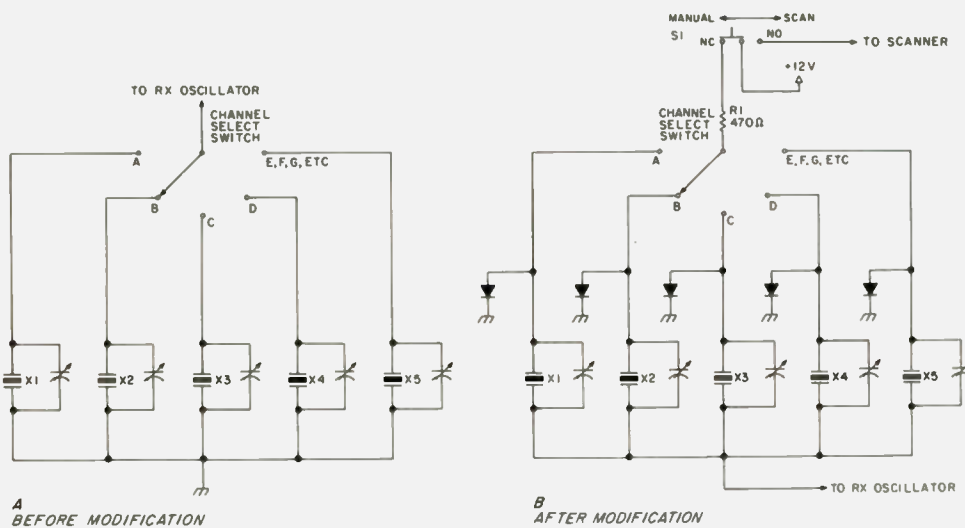

Fig. 1. (a) Crystal deck before modification. (b) After modification.

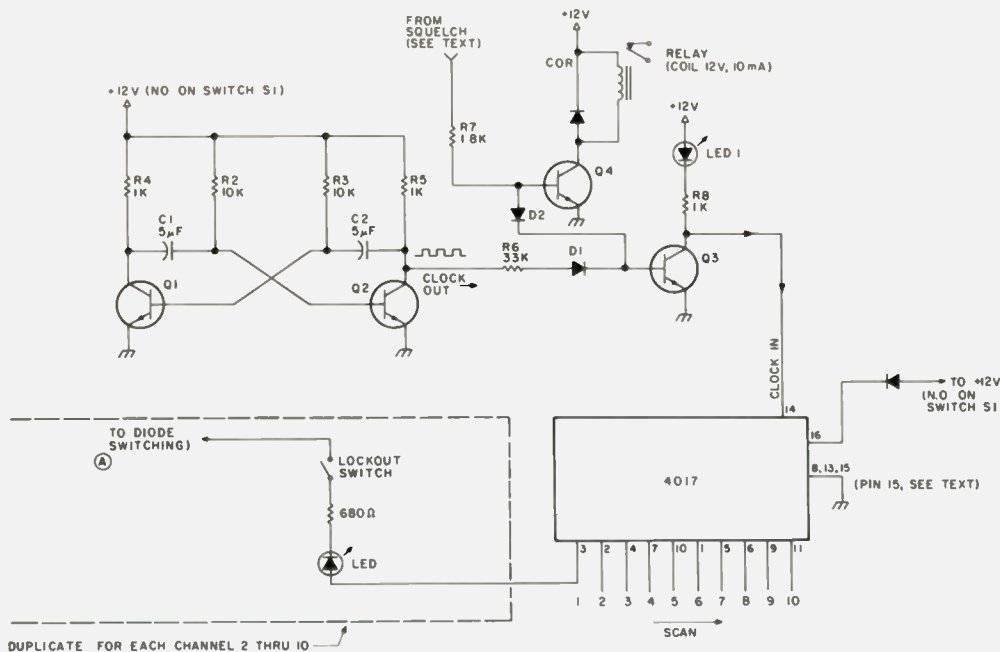

Fig. 2. Scanner schematic.

plement diode switching is the first thing on the agenda. This not only will make it possible to connect up the scanner, but also will make it possible for remote switching of channels if desired, as switching is accomplished by switching a voltage rather than the oscillator leads themselves.

This conversion will work on almost any rig in which RX oscillator crystals have one side grounded, as do my Wilson WE-224 and most other makes. On most rigs, this ground is one long common-to-all-crystals bus—see Fig. 1(a).

First, lift the ground connection from this bus. If the ground is made via the screwheads from the screws that hold the deck in, you may have to file some foil away around them. Next, disconnect the RX oscillator input lead from the channel-selector-switch wiper and connect this lead to the common bus for the crystals that you just finished isolating from ground. Now, connect a 470-Ohm resistor between the wiper on the channel-select switch and the NC connection on S1.

Installation of the switching diodes is next—see Fig. 1(b). Connect the cathode end of each diode to the side of each crystal that connects to the channel-selector switch and bus all of the anodes to ground. Keep all leads short. Find a +12-volt source in your radio and connect the wiper of S1 to it. If everything checks out so far, connect the radio to power and fire it up—it should work normally. Disconnect power.

The inverter/COR consists of Q3 and Q4. Transistor Q3 supplies pulses to the counter from the clock and keeps the clock pulses from advancing the counter when a squelch voltage ap-

pears. Since a squelch voltage from the radio is necessary to stop the scanning when a signal is present, now's a good time to pull out your schematic, if you haven't already. Find the squelch section. Most FM transceivers have a "noise" squelch, in which "noise" present at the discriminator is amplified and rectified into a dc bias voltage to turn a transistor "on," squelching the receiver. When a signal is present, the noise at the discriminator "quiets," removing the bias and un-squelching the receiver. Locate this switching transistor and find its collector. This is where the squelch voltage for the scanner is taken. Transistor Q4 is the optional COR and can be omitted if not needed. Or, leave it in to sound a buzzer, key a transmitter, or whatever.

The clock consists of Q1-Q2, which is an astable multivibrator whose frequency is determined by the time constant of the 10k resistor and 5-uF capacitor. With these values, the clock runs at about 15 Hz, which is about one and a half scans a second if 10 channels of scan are implemented. A 555 timer could have been substituted for the clock to lower the parts count, but I didn't have one lying around the shack at the time and I'm a cheap-skate, anyway.

The 4017 CMOS counter/divider does the counting. For each positive-going pulse from Q3, it advances 1 count. When it reaches count 10, it resets and starts over. The 4017 is a nifty chip in that it has a special "reset" pin. Using this feature, it is possible to use it not only as a count-to-ten counter, but also as a $\div 9$, $\div 8$, $\div 7$, etc. For example: If your rig has only 6 channels, take count 7 (pin 5) and connect it to the reset terminal (pin 15). In this

RF POWER

ONE BILLION WATTS IN STOCK



Your One Stop Source for RF Power Tubes and Transistors

RF IS BUSTING OUT ALL OVER

| | | | |
|----------------------|----------|-------------|--------|
| 8877/3CX1500A7 | \$300.00 | 6MJ6 | \$3.83 |
| 811A | 9.00 | 6146B | 5.50 |
| 572B | 28.50 | 8950 | 6.25 |
| 3-500Z | 95.00 | 8236 | 22.00 |

RF Transistors

SD1451 — 60W 2-30Mhz 12.5V Flange 12.00 (excellent for 100W linears = to MRF 453)

RF 13 — 50W 2-175Mhz 12.5V Stud type 12.50 (Premium replacement for MRF 450A and 2N6084)

RF 33 — 70W 2-30Mhz 12.5V Stud Type 13.50 (Premium replacement for MRF 455A)

MINIMUM ORDER \$25.00
CALL TOLL-FREE 800-645-2322 (N.Y. State 516-536-8868)



RF Gain, Ltd.

342

100 Merrick Road
Rockville Centre, New York 11570

way, it will scan to 6, then reset on the seventh count. If you want your rig to scan 10 channels, simply ground the reset pin.

Theory of Operation

The output of clock Q1-Q2 is fed into the base of inverter Q3. The output of Q3 goes high with every low count of the clock. The output of Q3 is fed into the 4017 counter, and for each count of the clock in which the output of Q3 goes from low (about 1 V) to high (12 V), the counter advances its count by 1, making it "scan." Each output of the counter is connected through an LED, lockout switch, limit resistor, and switching diode to ground. As each output goes high, each respective switching diode is forward biased, effectively grounding one side of the crystal, connecting the crystal momentarily to the RX oscillator circuit.

If there is a signal on that channel, there will be a voltage available at the squelch circuit. This squelch voltage will make Q3 conduct, forcing Q3's output to stay low, which stops the 4017 from advancing with the clock to the next count and locking it on the active channel. Diodes D1-D2 isolate the clock voltage from the squelch and vice versa. LED 1 is just a visual indication that the clock is counting during scanner operation and works as a carrier indicator when the scanner is disabled.

Conclusion

Why listen to one channel at a time when you can listen to ten at a time? This setup is especially nice on business and vacation trips when you don't know which channels are used locally. Monitor them all and find out! ■

WILSON SYSTEMS TOWERS

— IN STOCK —

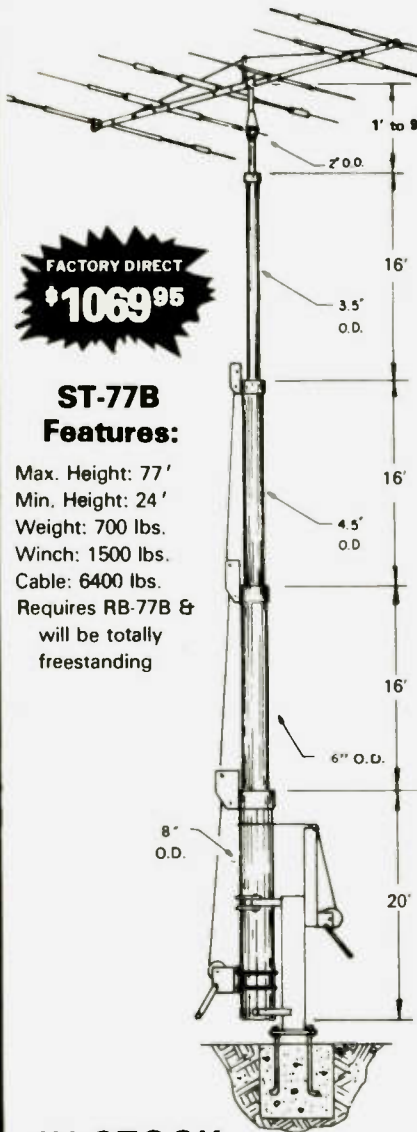

ST-77B Features:

Max. Height: 77'
Min. Height: 24'
Weight: 700 lbs.
Winch: 1500 lbs.
Cable: 6400 lbs.
Requires RB-77B & will be totally freestanding



MT-61B Features:

Max. Height: 61'
Min. Height: 23'
Weight: 450 lbs.
Winch: 1200 lbs.
Cable: 4200 lbs.
No Guys required when mounting against house.
For completely freestanding installation, use RB-61B or FB-61B below.

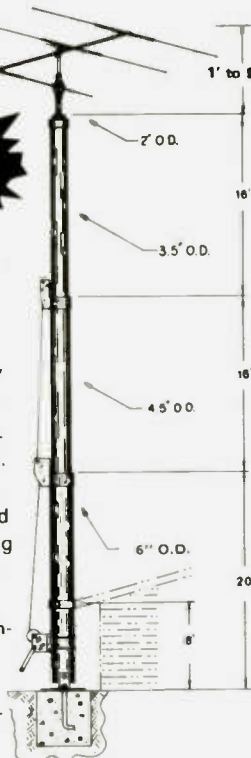

TT-45B Features:

Max Height: 45'
Min. Height: 22'
Weight: 250 lbs.
Winch: 1200 lbs.
Cable: 4200 lbs.
No Guys required when mounting against eve of house.
For completely freestanding installation, use RB-45B or FB-45B below.

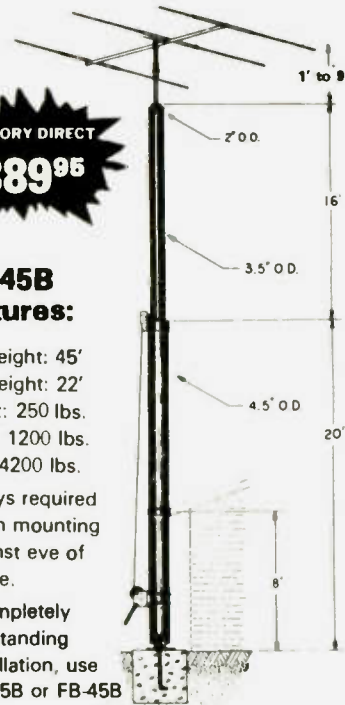

| WIND LOADING | | | |
|--------------|--------|---------|-------------------------------------|
| Tower | Height | Sq. Ft. | Square Footage Based on 50 MPH Wind |
| ST-77B | 69 | 18 | |
| | 77 | 12 | |
| MT-61B | 53 | 18 | |
| | 61 | 12 | |
| TT-45B | 37 | 18 | |
| | 45 | 12 | |

| BASE CHART | | |
|------------|-----------------|--------|
| TOWER | WIDTH | DEPTH |
| TT-45B | 12" x 12" | 30" |
| FB-45B | 30" x 30" | 4 1/2' |
| RB-45B | 30" x 30" | 4 1/2' |
| MT-61B | 18" x 18" | 4' |
| FB-61B | 3' x 3' | 5 1/2' |
| RB-61B | 3' x 3' | 5 1/2' |
| ST-77B | See Below | Bases |
| RB-77B | 3 1/2' x 3 1/2' | 6' |

Wilson Systems uses a new high strength carbon steel tube manufactured especially for Wilson Systems. It is 25% stronger than conventional pipe or tubing. The tubing size used is: 2" & 3 1/2" .095; 4 1/2" & 6" .125; 8" .134. All tubing is hot dip galvanized. Top section is 2" O.D. for proper rotor and antenna mounting.

The TT-45B and MT-61B come complete with house bracket and hinged base plate for against-house mounting. For totally freestanding installation, use either of the tilt-over bases shown below.

The ST-77B cannot be mounted against the house and must be used with the rotating tilt-over base RB-77B shown below.

IN STOCK

TILT-OVER BASES FOR TOWERS

FIXED BASE

The FB Series was designed to provide an economical method of moving the tower away from the house. It will support the tower in a completely free-standing vertical position, while also having the capabilities of tilting the tower over to provide an easy access to the antenna. The rotor mounts at the top of the tower in the conventional manner, and will not rotate the complete tower.

FB-45B . . 112 lbs. . . \$179.95
FB-61B . . 169 lbs. . . \$259.95



ROTATING BASE

The RB Series was designed for the Amateur who wants the added convenience of being able to work on the rotor from the ground position. This series of bases will give that ease plus rotate the complete tower and antenna system by the use of a heavy duty thrust bearing at the base of the tower mounting position, while still being able to tilt the tower over when desiring to make changes on the antenna system.

RB-45B . 144 lbs. . \$249.95
RB-61B . 229 lbs. . \$334.95
RB-77B . 300 lbs. . \$499.95



Tilting the tower over is a one-man task with the Wilson bases. (Shown above is the RB-61B. Rotor is not included.)

ORDER
FACTORY DIRECT
1-800-634-6898

Prices Effective 7-1-80 to 7-30-80

W S I WILSON
SYSTEMS, INC.

4286 S Polaris Ave Las Vegas, Nevada 89103

WILSON SYSTEMS, INC. MULTIBAND ANTENNAS

WV-1A **\$59⁹⁵**
FACTORY DIRECT

**4 BAND
TRAP VERTICAL
(10 - 40 METERS)**

No bandswitching necessary with this vertical. An excellent low cost DX antenna with an electrical quarter wavelength on each band and low angle radiation. Advanced design provides low SWR and exceptionally flat response across the full width of each band.

Featured is the Wilson large diameter High-Q traps which will maintain resonant points with varying temperatures and humidity.

Easily assembled, the WV-1A is supplied with a hot dipped galvanized base mount bracket to attach to vent pipe or to a mast driven in the ground.

NOTE: Radials are required for peak operation. (See GR-1 below)

SPECIFICATIONS

- 19' total height
- Self supporting — no guys required
- Weight — 14 lbs.
- Input impedance: 50 Ω
- Powerhandling capability: Legal Limit
- Two High-Q traps with large diameter coils
- Low angle radiation
- Omnidirectional performance
- Taper swaged aluminum tubing
- Automatic bandswitching
- Mast bracket furnished
- SWR: 1.1:1 or less on all bands

GR-1 **\$14⁹⁵**

The GR-1 is the complete ground radial kit for the WV-1A. It consists of 150' of 7/14 stranded aluminum wire and heavy duty egg insulators, instructions. The GR-1 will increase the efficiency of the WV-1A by providing the correct counterpoise.

33-6 MK **\$59⁹⁵**

Now you can have the capabilities of 40-meter operation on the SYSTEM 36 and SYSTEM 33. Using the same type high quality traps, the 40-meter addition will offer 150 KHZ of bandwidth at less than 2:1 SWR. The new 33-6 MK will fit your present SY36, SY33, or SY3 and use the same single feed line. The 33-6 MK adds approximately 15' to the driven element of your tri-bander, increasing the tuning radius by 5 to 6 feet. This addition will offer an effective rotatable dipole at the same height of your beam.

SY-40A
\$349⁹⁵

- ★ 3 MONOBANDERS on 1 Boom
- 4 elements on 20 mtrs FULL SIZE
- 4 elements on 15 mtrs
- 5 elements on 10 mtrs

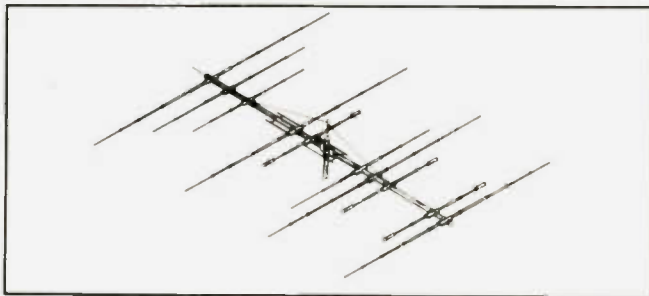

The System 40A is the answer to the DXer who does not have space to stack monobanders yet wants the advantages they offer. Through the use of a switchable matching unit, only one feed line is required and complete coverage of both the phone and cw bands are available with only one setting.

SPECIFICATIONS

| | | | | | |
|----------------------|----------------|----------------------|------------|----------------------------|-------------|
| Max. Pwr. Input..... | Legal Limit | Matching Method..... | Split Beta | Surface Area..... | 12.1 sq.ft. |
| VSWR @ Res..... | 1.2:1 | F/B Ratio..... | 25 db | Wind Loading @ 80 mph..... | 309 lbs. |
| Impedance..... | 50 ohm | Boom..... | 2" x 26' | Assem. Weight..... | 75 lbs. |
| Feed Method..... | Balun Supplied | Longest Element..... | 36' | Shipping Weight..... | 84 lbs. |
| | | Turning Radius..... | 22'6" | | |

SY-36
\$214⁹⁵

A trap loaded antenna that performs like a mono-bander! That's the characteristic of this six element three band beam. Through the use of wide spacing and interlacing of elements, the following is possible: three active elements on 20, three active elements on 15, and four active elements on 10 meters. No need to run separate coax feed lines for each band, as the bandswitching is automatically made via the High-Q Wilson traps.

Designed to handle the maximum legal power, the traps are capped at each end to provide a weather-proof seal against rain and dust. The special High-Q traps are the strongest available in the industry today.

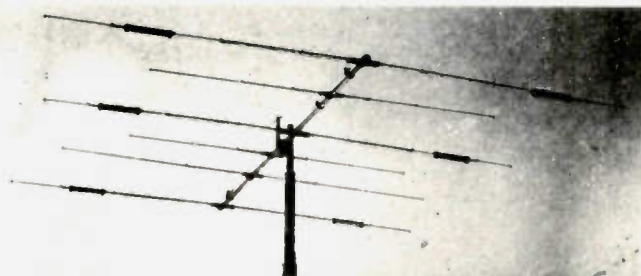

SPECIFICATIONS

| | | | | | |
|--------------------------|-----------------|----------------------------|-----------------|--------------------------------|--------------------------|
| Band MHz..... | 14-21-28 | Boom (D.D. x Length)..... | 2" x 24' 2 1/2" | Wind Loading @ 80 mph..... | 215 lbs. |
| Maximum power input..... | Legal Limit | No. of Elements..... | 6 | Maximum wind survival..... | 100 mph |
| Gain (dBD)..... | Up to 9 dB | Longest Element..... | 29' 6 1/2" | Feed method..... | Coaxial Balun (supplied) |
| VSWR @ resonance..... | 1.3:1 | Turning Radius..... | 18'6" | Assembled weight (approx)..... | 53 lbs. |
| Impedance..... | 50 ohm | Maximum mast diameter..... | 2" | Shipping weight (approx)..... | 62 lbs. |
| F/B Ratio..... | 20 dB or better | Surface area..... | 8.6 sq. ft. | | |

SY-33
\$159⁹⁵

Capable of handling the Legal Limit, the SYSTEM 33 is the finest compact tribander available to the amateur. Designed and produced by one of the world's largest antenna manufacturers, the traditional quality of workmanship and materials excels with the SYSTEM 33.

New boom-to-element mount consists of two 1/8" thick formed aluminum plates that will provide more clamping and holding strength to prevent element misalignment. Superior clamping power is obtained with the use of a rugged 1/4" thick aluminum plate for boom to mast mounting. The use of large diameter High-Q Traps in the SYSTEM 33 makes it a high performance tri-bander and at a very economical price. A complete step-by-step illustrated instruction manual guides you to easy assembly and the lightweight antenna makes installation of the SYSTEM 33 quick and simple.

SPECIFICATIONS

| | | | | | |
|--------------------------|-------------|----------------------------|-------------|--|----------|
| Band MHz..... | 14-21-28 | Boom (D.D. x length)..... | 2" x 14'4" | Wind loading at 80 mph..... | 114 lbs. |
| Maximum power input..... | Legal Limit | No. of elements..... | 3 | Assembled weight (approx)..... | 37 lbs. |
| Gain (dBD)..... | Up to 8 dB | Longest element..... | 27'4" | Shipping weight (approx)..... | 42 lbs. |
| VSWR at resonance..... | 1.3:1 | Turning radius..... | 15'9" | Direct 52 ohm feed — no balun required | |
| Impedance..... | 50 ohms | Maximum mast diameter..... | 2" O D | Maximum wind survival..... | 100 mph |
| F/B Ratio..... | Up to 20db | Surface area..... | 5.7 sq. ft. | | |

**ORDER
FACTORY DIRECT
1-800-634-6898**

Prices Effective 7-1-80 to 7-30-80

**W S I WILSON
SYSTEMS, INC.**

4286 S. Polaris Ave., Las Vegas, Nevada 89103

Prices and specifications subject to change without notice.

Flat Cells are No Fun!

— build a battery status monitor

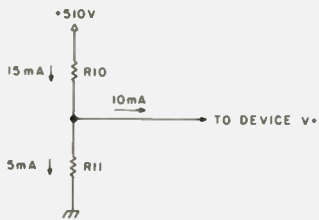

Fig. 1. $510 \text{ V}/15 \text{ mA} = R10 + R11 = 34\text{k}$. $R10 = (510 \text{ volts} - 10 \text{ volts})/15 \text{ mA} \approx 33\text{k}$; $R11 = 34\text{k} - 33\text{k} = 1\text{k}$. Therefore, $R10 = 33\text{k}$ and $R11 = 1\text{k}$.

With the sales of two-meter rigs on the rise (most powered by 12 V dc), many hams are finding themselves with a great deal of battery-operated equipment around the shack. Sure, many of us have 12-volt power supplies that can almost be used for arc welding, but quite a few people have battery back-up for emergency service. Add calculators, radios,

digital voltmeters, clocks, toys, tape recorders, and photographic equipment and you have a scene that makes Eveready grin from ear to ear.

The pilot light/voltage monitor will not extend the life of or eliminate the need for any batteries. What it will do is give you plenty of warning that the old power source just ain't what she used to be. As an added bonus, it will tell you that the device is on, and it will do it at very little cost.

Circuit Operation

Trimmer resistor R1 sets the voltage threshold of the device. As long as the voltage applied to the circuit is greater than this threshold, zener diode D1 will conduct, causing transistor Q1 to saturate. This keeps pin 10 of inverter 1 in a logic 1 or high-voltage state.

Inverters 2 and 3 form a low-frequency oscillator (2 Hz or so) which would normally cause the LED to

blink at a slow rate. The LED will not blink, however, as long as pin 10 remains high. The reason for this is that diodes D2 and D3 form an OR gate and inverter 1 continuously applies a 1 to D2, which passes (ORs) the continuous 1 to light the LED regardless of D3's input.

When the voltage falls below the voltage threshold, pin 10 falls to logic 0 (about zero volts). With the constant 1 removed from D2, the pulses from inverters 2 and 3 are ORED through D3 and the LED will flash. The flash rate can be adjusted by changing C1, R5, or R6.

Construction and Component Substitution

Almost any type of construction can be used including printed circuit or perfboard. The only restriction is that the LED must be placed in a position that is clearly visible.

The value of the zener is not critical. Its voltage

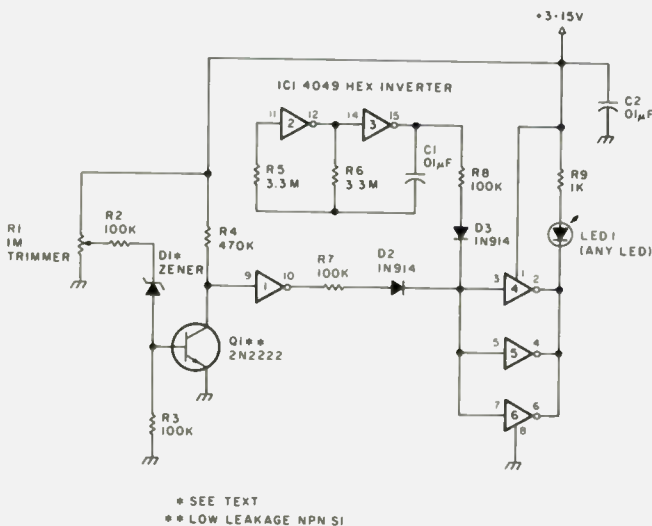

Fig. 2. Pilot light/voltage monitor.

rating must be less than the voltage threshold that you wish to have, however. You can't fire a 5-volt zener with 3 volts. Ideally, the zener should have a sharp knee, but the prototype worked with any one that was tried.

By itself, the pilot light/voltage monitor will operate from about 3 volts to 15 volts. Much higher voltages can be monitored by using a voltage divider. Do not try to regulate the voltage divider!

For example, assume that you wished to monitor a 510-volt flash battery. Calculate R10 and R11 as shown in Fig. 1.

Works nicely on paper, doesn't it? Well, it would work if you can afford 15 mA. Stop and calculate the power drawn from the battery. $510\text{ V} \times 0.015\text{ A} = 7.65\text{ Watts!}$

Which brings me to my final point. The device

needs about 10 mA to operate. A voltage divider needs a few mA. Make sure you can spare the current! A nine-volt transistor radio battery cannot spare 10 mA. AA, C, or D cells can. Nicads or a car battery certainly can. As a wise man once said, "Look before you solder," or something to that effect.

Adjustment

Adjustment is quite simple. Using a variable power supply or a voltage divider, adjust the voltage to your desired threshold. Turn the trimmer pot, R1, until the LED is constantly on. Slowly back the pot off until the LED begins to blink. Try raising and lowering the supply voltage to make sure the device operates at the desired threshold.

As an added precaution against battery failure, buy some stock in a good battery company. ■



**Germtown
Amateur
Supply,
Inc.**

MEMPHIS, TENNESSEE

NO MONKEY BUSINESS!

- (A) Complete Service Facilities
- (B) Good Deals on most Brands
- (C) Shipping within 24 Hours
- (D) All inquiries handled by Active Hams with over 20 years experience in ham radio

CALL TOLL FREE
1-800-238-6168

IN TENNESSEE, CALL 901-452-4276
MONDAY - SATURDAY 8:30-5:30
FOR YOUR SPECIAL.

Write: 3202 Summer Ave., Memphis, Tennessee 38112

NEW MFJ *DELUXE* Versa Tuner II

\$129.95 buys you one of the world's finest 300 watt antenna tuners with features that only MFJ offers, like . . . dummy load, SWR, forward, reflected power meter, antenna switch, balun. Matches everything from 1.8 thru 30 MHz: coax, random wires, balanced lines.



MFJ's Best Versa Tuner II . . .
Solid American Quality

\$129⁹⁵

This is MFJ's best Versa Tuner II. And one of the world's finest 300 watt (RF output) tuners.

The MFJ-949 *Deluxe Versa Tuner II* gives you a combination of quality, performance, and features that others can't touch at this price . . . or any price.

PERFORMANCE: You can run your full transmitter power output — up to 300 watts RF output — and match your transmitter to any feedline from 1.8 thru 30 MHz whether you have coax, balanced line or random wire.

FEATURES: A 200 watt 50 ohm dummy load lets you tune up for maximum performance.

A sensitive meter lets you read SWR with only 5 watts and both forward and reflected power in two ranges (300 and 30 watts).

A flexible antenna switch lets you select 2 coax lines direct or thru tuner, random wire or balanced line and dummy load.

A large efficient airwound inductor 3 inches in diameter gives you plenty of matching range and less losses for more watts out.

1:4 balun, 1000 volt capacitors, SO 239 coax connectors. Binding post for balanced line, random wire, ground, 10x3x7 inches.

QUALITY: Every single unit is tested for performance and inspected for quality. Solid American construction, quality components.

The MFJ-949 carries a full one year unconditional guarantee.

Order from MFJ and try it — no obligation. If not delighted, return it within 30 days for a re-

fund (less shipping).

To order, simply call us toll free 800-647-1800 and charge it on your VISA or Master Charge or mail us a check or money order for \$129.95 plus \$4.00 for shipping/handling.

Don't wait any longer to tune out that SWR and enjoy solid QSO's. Order your *Deluxe Versa Tuner II* at no obligation, today.

CALL TOLL FREE . . . 800-647-1800

Call 601-323-5869 for technical information, order/repair status. Also call 601-323-5869 outside continental USA and in Mississippi.

MFJ ENTERPRISES, INC.
BOX 494, MISSISSIPPI STATE, MS 39762

When Plus Goes Minus

— a 555-based negative power supply

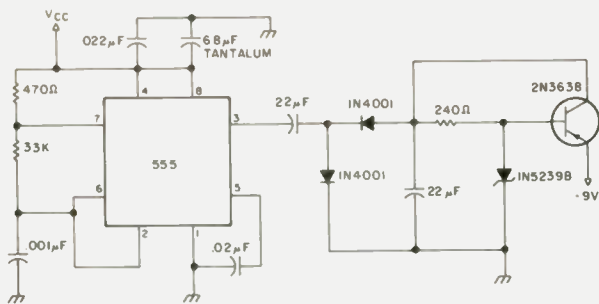

Fig. 1. Original -9-volt power supply.

Hubert E. Minchow
1065 Lynnwood Avenue NE
Renton WA 98055

Recently, I had to make an extensive modification to a number of identical pieces of equipment. As a result of the modification, the power supply in these sets, which had originally been designed to furnish only regulated 5 volts, had to be revised to also deliver +9 volts and -9 volts. The ±9-volt supplies did not require as stiff regulation as the 5-volt line, and the current demand for

the two supplies was less than 20 mils.

Since rebuilding the power supply by replacing the power transformer with one which had windings of the correct voltages for the three supplies and adding the components for complete power supplies would be costly in time, material, and space, I looked for a more economical way to obtain the plus and minus

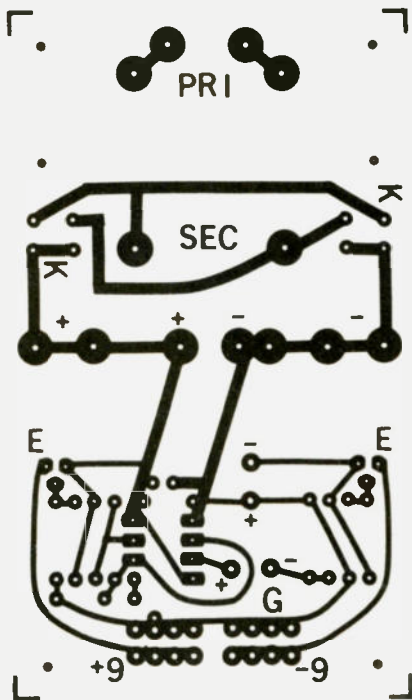

Fig. 2. PC board layout.

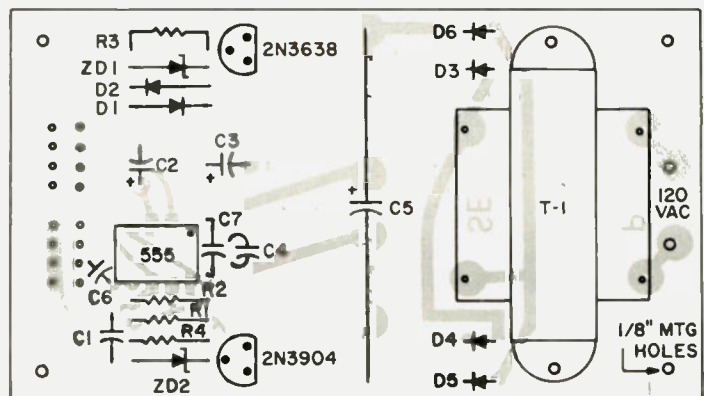

Fig. 3. Component layout.

supplies.

As the input voltage to the 5-volt regulator (at the filter capacitor) was about 12 volts, the positive 9 volts could be obtained by connecting a series resistor and a zener diode to the filter capacitor. This became the +9-volt power supply for the cost of two small components.

Now to the remaining problem, a -9-volt supply. There have been a number of dc-to-dc power supplies made where a low dc voltage is transformed into a higher dc voltage. Usually this is done by using the low dc voltage to power an audio oscillator and then raising the output voltage of the oscillator to the desired level with an audio transformer. This voltage is then rectified and filtered and becomes the dc output voltage.

Although the circuit is usually used to manufacture a voltage of the same polarity as the original supply voltage, there isn't any reason why one couldn't recover a voltage of the opposite polarity.

The entire problem was even simpler than it first appeared. Since the 12 volts at the filter capacitor could be used to power the audio oscillator and give an output voltage close to 12 volts from the circuit, there would be no need to use an audio transformer to boost the voltage. This kept the required number of components to a minimum and saved some space. Once again, a series resistor and a zener diode would be used to establish the -9-volt level.

A circuit was designed for the -9-volt supply using the well-known 555 IC timer as the audio oscillator. See Fig. 1. The 555 is able to supply currents of up to 150 mA, so it is

operating well within its ratings at 20 mA. The output voltage is 1½ to 2 volts less than the supply voltage at pin 8 (and inverted), but still high enough that a stable -9 volts can be obtained with a Vcc of 12 volts. To ensure that a varying load would not upset the regulation of the zener diode, a 2N3638 transistor was added to the circuit to carry the load current. As the load current flows through the transistor rather than the series resistor, the voltage across the zener diode remains very constant. The regulation of the -9-volt supply is very good.

The 555 audio oscillator was designed to operate at over 20 kHz in this circuit, so filtering requirements would be minimized. The purpose of the parallel combination of a 0.022-µF disc capacitor and a 6.8-µF tantalum capacitor at pin 8 of the 555 is to suppress the extraneous pulses usually emitted by a 555. These, or a similar combination of capacitors, really control the unwanted pulses. The two capacitors have to be connected close to pin 8 to be effective.

The positive and negative 9-volt supplies were built on a small printed circuit board and placed in the equipment cabinets with a minimum of problems. The negative power supply proved so effective and trouble-free that I later constructed a positive and negative 9-volt power supply to replace those ±9-volt battery combinations frequently called for with many op amp circuits.

I used a 12-volt power transformer sold by Radio Shack, along with a number of other Radio Shack parts, and built the supply on a 2" × 3.5" single-sided printed circuit board. Fig. 2 is the foil pattern for this power

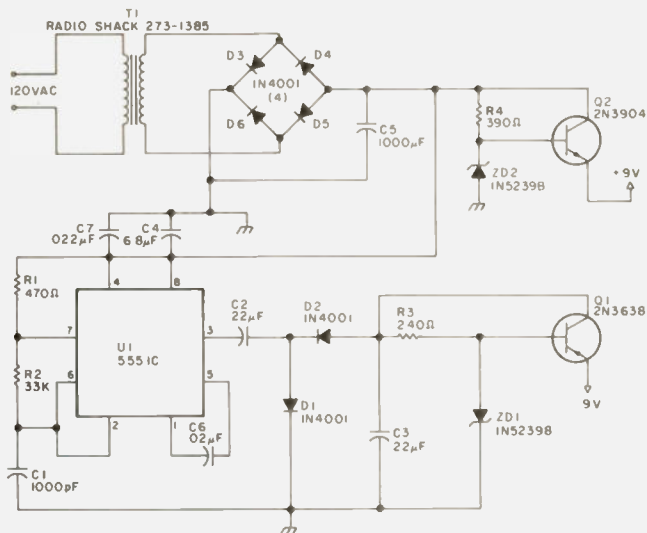

Fig. 4. Complete plus and minus 9-volt power supply.

supply and Fig. 3 is the component layout. Fig. 4 is the schematic of the positive and negative power supply.

The transistors shown in the plus and minus regulators can be replaced by others with a higher current rating if one wants to draw

more current from either supply. The 555 will furnish about 60-70 mA with the components shown in Fig. 4. About the same amount of current can be taken simultaneously from the positive regulator without overloading the transformer. ■

★ YOU ASKED FOR IT ★

A COMPLETE REPEATER STARRING THE MARK 3C SUPERCONTROLLER



ALL the unique features which make Mark 3C the acclaimed leader in repeater control —

- Autopatch
- Reverse patch
- Autodial
- 40 Functions
- 13 Morse messages
- Custom tail messages
- Digital tone decoding
- Microprocessor control

MARK 3-C CONTROLLER \$995.

AND NOW, even the repeater is built in —

- Receiver sens. 0.25 UV
- Super crisp audio
- Transmitter output 2W

PLUS options —

- Power amplifiers (pick your level)
- Sub-audible tone
- Control receivers

MARK 3CR REPEATER
144-220 \$1595.

Call or write for specifications

MICRO CONTROL SPECIALITIES (617) 372-3442
23 Elm Park, Groveland, Ma. 01834

✓ 49

Depolarize that Power Supply!

— positive or negative grounds won't bother you any more

Being in the 2-way radio service business, I see many of the same failures over and over again. One of the more common is the case of reversed power polarity, particularly in mobile installations. Avoidable? Sometimes, yes, certainly, when due to lack of attention during the installation. Sometimes there is confusion about which is the "hot" lead—the red or the black. Sometimes, the problem just isn't avoidable, e.g., when the radio is to be swapped among vehicles. For some reason, the

problem seems most often to afflict hams who take their radios along on business trips and get power from the cigarette lighters in rented cars.

The problem prompted design of a simple modification which steers the proper polarity to the radio while at the same time avoids shorting the battery—which blows the fuse if present or the wiring if a fuse is not present.

Radios come in two flavors, as far as power polarity is concerned: dedicated ground (usually described

as "12-V negative ground only" or equivalent) and floating ground (usually described as "12-V positive or negative ground" or equivalent). The only technical difference is whether or not one of the power leads—usually the negative—is connected to the radio chassis. Some radios have only a single power terminal (usually the positive) with the return made through the case and mounting hardware to the vehicle frame. These can be used only in negative-ground systems unless modified as described below. The Midland 13-513 synthesized 220-MHz rig is one popular radio which is designed for negative ground only.

The other, so-called "non-polarized" types of radios have floating power inputs in which both the positive and the negative

power leads are dc-isolated from the chassis. As long as the positive lead goes to B+ and the negative lead goes to B-, all is well. One of these connections is most conveniently made via the vehicle frame; which connection may be so-made depends on whether the vehicle has a positive or negative ground electrical system, and which connection actually is made may not be clear when using a cigarette lighter plug—especially if the power cord coming from it is all one color.

The polarity-protection modification is slightly different for a dedicated-ground radio than for a floating-ground radio. To determine what kind of radio you have, measure the resistance between each of the power leads and the chassis. This test

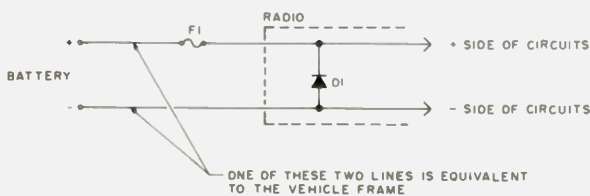

Fig. 1. Typical primary power circuit.

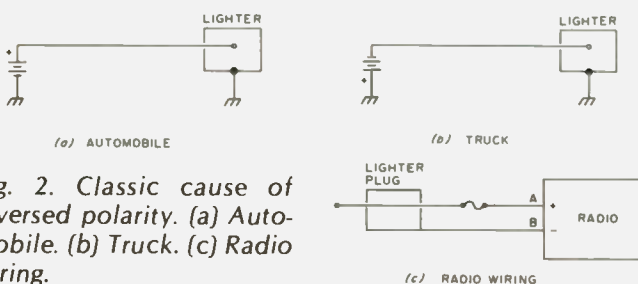

Fig. 2. Classic cause of reversed polarity. (a) Automobile. (b) Truck. (c) Radio wiring.

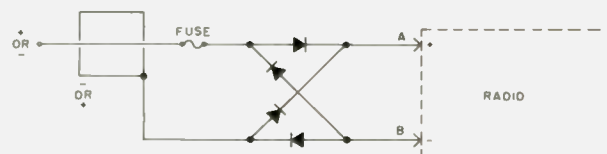

Fig. 3. Depolarizing circuit. Diodes should have a current rating greater than the fuse value.

should be made with the radio out of the vehicle, and the power switch ON. If either terminal shows direct continuity, you have a dedicated-ground radio.

The basic primary power supply for a typical mobile radio looks something like Fig. 1. If battery polarity is correct, the diode is back-biased and looks like an open circuit. If the polarity is reversed, the diode is forward-biased and looks like a short circuit. This presumably blows the fuse and protects the radio. (If the forward current rating of the diode is greater than the fuse value, the fuse may blow before the diode itself is damaged. This is not always the case, however, and even a brief period of reversed polarity may cause the diode to open, leaving the radio with no protection.) The diode in Fig. 1 is often called the "protective diode."

What we'd like to do comes down to the situation shown in Fig. 2. We'd like to take the radio with its power cord shown in Fig. 2(c), plug it into either of the cigarette lighter sockets in Fig. 2(a) or Fig. 2(b), and have it work properly. The cigarette lighter is shown for example only; the same principles apply if a slide mount or hard wiring is used. The ground symbol is used to denote the vehicle frame because this is, in fact, the way vehicles are wired.

What we need to do is to come up with a way such that no matter what the polarity is at the lighter socket, the radio will see B+ on lead A in Fig. 2(c), and B- on lead B in Fig. 2(c). This is done quite simply by arranging four steering diodes in a bridge, as shown in Fig. 3.

The diodes are not critical, but they must be able to carry the current drawn by the radio in the worst

case. Any of the 1N4000-series diodes will work well for radios up to 10 Watts or so. It is best if the diodes have a forward-current capacity of perhaps twice the fuse value, just in case of a catastrophic short in the radio. This will help ensure that the fuse blows before any diodes fail, and that there will be that many fewer parts to replace. Since the protective diode isn't needed any more, it can be cannibalized for use in the bridge.

The bridge may be built anywhere in the power line, inside the radio, or even inside the cigarette lighter plug. I favor building it inside the radio because it makes for neater external wiring and also assures that the bridge is between the fuse and the radio. This allows the fuse also to protect against breakdown in the bridge itself, which is not the case if the bridge is built into the lighter plug.

The battery voltage seen by the radio is reduced by about 1.5 volts (two diode drops), but performance has not been degraded on any of the radios I have so modified. The voltage reduction is only about 10%.

For floating-ground radios, that's all there is to it. For dedicated-ground radios, however, one additional modification is required to prevent a dc-return path through the antenna wiring, i.e., the coax shield. If you are using a magnetic mount (such that the shield doesn't touch the vehicle frame), this final step is not necessary. It is advised in any case, however, just for the additional protection. Dc-isolation in the coax can be achieved very simply by the use of a small capacitor as shown in Fig. 4. The capacitor will block dc power, but is transparent to rf. The value of the capacitor is not



Fig. 4.

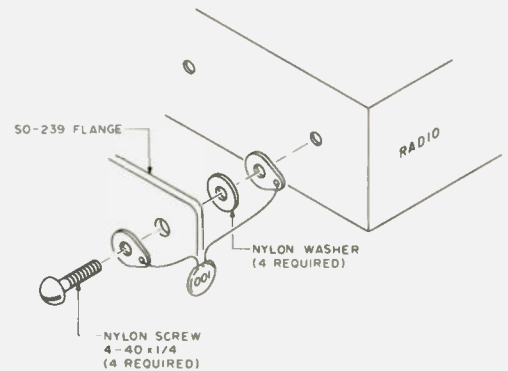

Fig. 5. Dc-isolation of standard SO-239 antenna jack.

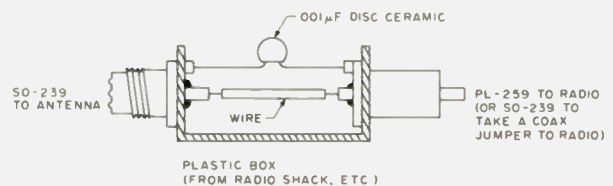

Fig. 6. Dc-isolation in antenna line.

critical, but it should be a ceramic type for low rf loss.

The easiest way I have found to obtain this isolation with a standard SO-239 connector is as follows:

1. Remove the four metal screws holding the SO-239 flange to the radio chassis.

2. Install four nylon screws through the SO-239 flange, through nylon washers, to the case. Connect the capacitor across one of the nylon washers as shown in Fig. 5.

I have found that size 4-40 nylon machine screws fit the original sheet-metal screw holes very well, so nuts and lockwashers are not needed.

Some radios do not use the flanged SO-239 connector, and have a single-hole mount version of the SO-239. In this case, I suggest making a coupling as shown in Fig. 6. The plastic box can be very small and

can be mounted right on the radio.

Keeping in mind that the objective is to keep the radio case isolated from power ground, it follows that the case must not be allowed to touch the vehicle frame. This can be done in a variety of ways, of which the simplest is just to lay the radio on the seat beside you. This is probably what you do anyway, when you often move it from one vehicle to another. For other mounting arrangements, appropriate substitution of nylon for metal hardware will do the job. In many newer vehicles, the dashboard is plastic so that you needn't worry about mounting the radio even if you use the standard metal hardware.

Finally, many radios have a power connector on the rear apron—not just wires coming out. If you build the diode bridge inside the radio, as recommended, you'll also be pro-

MOVING?

Let us know 8 weeks in advance so that you won't miss a single issue of 73 Magazine.

Attach old label where indicated and print new address in space provided. Also include your mailing label whenever you write concerning your subscription. It helps us serve you promptly. Write to:

73 magazine

Subscription Department
P.O. Box 931
Farmingdale NY 11737

- | | |
|---|---|
| <input type="checkbox"/> Address change only | <input type="checkbox"/> Payment enclosed |
| <input type="checkbox"/> Extend subscription | |
| <input type="checkbox"/> Enter new subscription | <input type="checkbox"/> Bill me later |
| <input type="checkbox"/> 1 year \$18.00 | |

If you have no label handy, print OLD address here.

AFFIX LABEL
Name _____ Call _____
Address _____
City _____ State _____ Zip _____

print NEW address here:

Name _____ Call _____
Address _____
City _____ State _____ Zip _____ 301B55

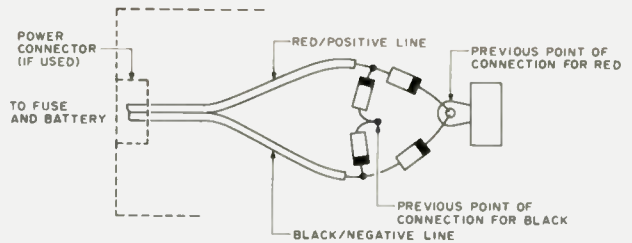

Fig. 7. How to add the bridge inside the radio.

tected even if the mating power connector is somehow reversed at the radio. A pictorial diagram of how to make the modification inside the radio is shown in Fig. 7. Here is a step-by-step procedure:

1. Remove the red and black leads from their termination points inside the radio.

2. Connect two diodes (banded end) to the point from which you removed the red (positive) lead.

3. Connect the free end of one diode to the red lead, the free end of the other diode to the black lead.

4. Connect two diodes (unbanded end) to the point from which you removed the black lead (this may be the chassis itself).

5. Connect the free end of one diode to the red lead, the free end of the other diode to the black lead.

And there you have a very simple modification which is impossible to defeat and will positively protect your equipment. The only remaining question, it seems to me, is why this isn't the way radios are built at the factory in the first place. ■

New 2 Meter Avanti Mobile Antenna

Mounts on glass — no holes!

- Receives and transmits through glass.
- Superior performance equivalent to 5/8 wave.
- Superior radiation full Omni-Directional.

It's easy to install — No holes to drill, no magnet to scratch the paint, no clamps. Uses an especially developed epoxy adhesive that secures antenna to window like a 1/4" bolt. The capacity coupling box is simply attached with a special adhesive tape to inside of window. Worried about crimping or corroding coaxial cables? It's all inside and out of sight.

Models also available for 220 MHz and 450 MHz.
AH 151.3G SPECIFICATIONS

| | |
|---|------------------------|
| Gain | Equivalent to 5/8 wave |
| 2 meter V S W R Band Width | Better than 1.5:1 |
| Maximum power | 150 watts |
| Nominal Impedance | 50 Ohms |
| Chrome plated casting. Stainless Steel hardware. Swivel whip holder | 33" |
| Height | |
| Performance and Mechanical Patents Pending | |

Buy one from your nearest AVANTI dealer. If your dealer does not have one in stock, have him call the following toll free number and we will ship him one within 24 hours:

(800) 323-9429

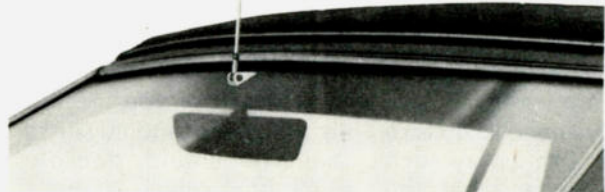
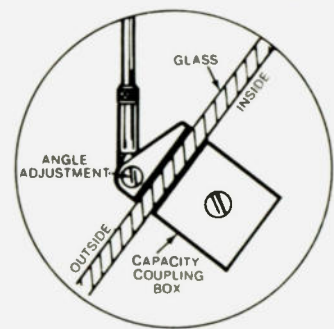

See Avanti's other new amateur mobile and base antennas. Write for new catalog today.

Send 50¢ for handling and postage

avanti antennas

Avanti Research and Development, Inc.,
340 Stewart Ave., Addison, IL 60101
© 1979 In Canada: Lenbrook Ind., Scarborough, Ontario M1H 1H5

Tomorrow's Technology—Here Today!

THE YAESU FT-207R

The "horse-and-buggy" days of crystal-controlled handies are gone! Yaesu's engineers have harnessed the power of the microprocessor, bringing you 800 channels, digital display, memory, and scanning from a hand-held package. Only with Yaesu can you get these big performance features in such a compact package.

- 4 bit CPU chip for frequency control.
- Keyboard entry of all frequencies
- Digital frequency display.
- 800 channels across 144-148 MHz.
- Up/Down manual scan, or auto scan for busy/clear channels. 10 kHz scanning steps.
- Five channels of memory
- Priority channel with search-back feature.
- Keyboard lock to prevent accidental frequency change.
- Memory backup
- ± 600 kHz or odd repeater splits.
- Display ON/OFF switch for battery conservation.
- Equipped with rubber flex antenna, wallmount battery charger, earphone, shoulder strap, and belt clip.
- Switchable RF output 2.5 watts (minimum) or 200 mW
- Earphone for private listening
- 2 Tone (Touchtone[®]) Input from Keyboard
- Highly reliable LED frequency display (works in cold temperatures and does not fade with age)

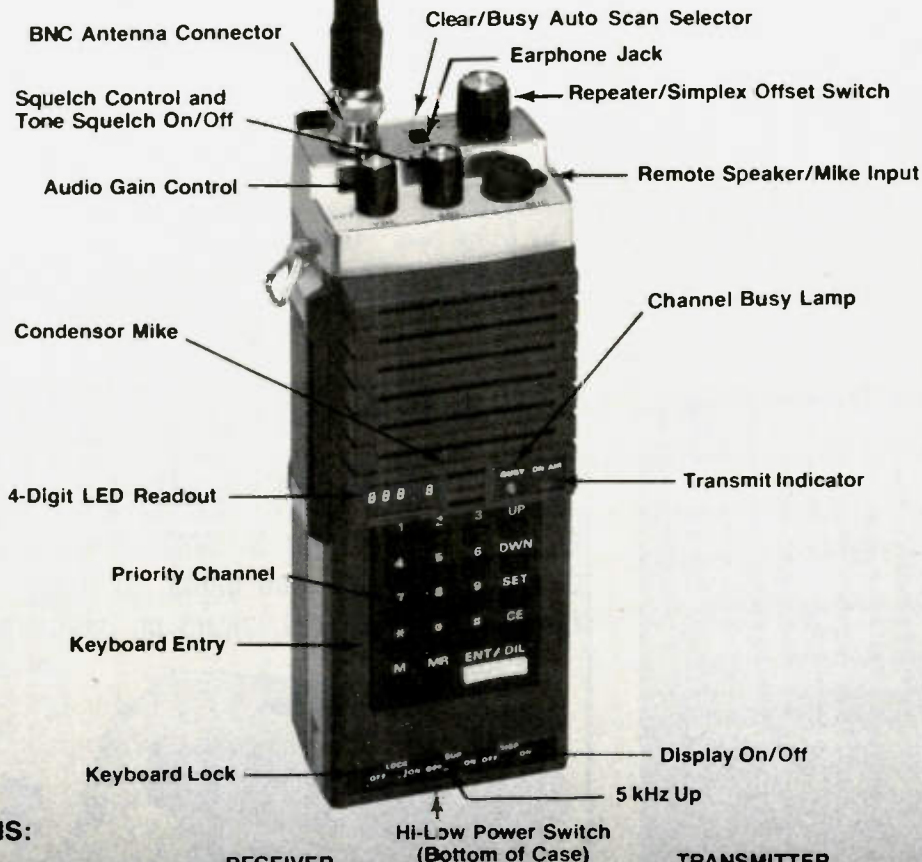

SPECIFICATIONS:

GENERAL

Frequency coverage: 144-148 MHz
Number of channels: 800
Emission type: F3
Batteries: NiCd battery pack
Voltage requirement: 10.8 VDC $\pm 10\%$, maximum
Current consumption:
 Receive: 35 mA squelched (150 mA unsquelched with maximum audio)
 Transmit: 800 mA (full power)
Case dimensions: 68 x 181 x 54 mm (HWD)
Weight (with batteries): 680 grams

RECEIVER

Circuit type: Double conversion superheterodyne intermediate frequencies.
 1st IF = 10.7 MHz
 2nd IF = 455 kHz
Sensitivity: 0.32 μ V for 20 dB quieting
Selectivity: ± 7.5 kHz at 60 dB down
Audio Output: 200 mW at 10% THD

Price And Specifications Subject To Change Without Notice Or Obligation

TRANSMITTER

Power Output: 2.5 watts minimum /200mW
Deviation: ± 5 kHz
Spurious radiation: -60 dB or better
Microphone: Condenser type (2000 ohms)

OPTIONS

LC-C7 Leather Carrying Case
 YM-24 Remote Speaker/Microphone
 Tone Squelch Unit
 NB-P9 Battery Pack
 NC-2 Quick Charger

YAESU
The radio.



180

Transform Noisy Fluorescents

— “temporary” solution

I had a very bad case of QRN recently, from an old fluorescent fixture in the operating room. I did not have time to replace the tubes in the fixture. It

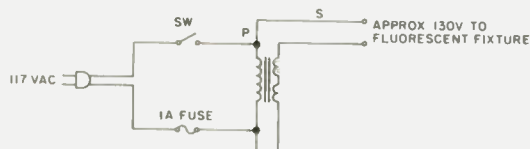

Fig. 1. The transformer can be any spare transformer that will supply approximately 10 to 12 volts ac. This can be accomplished by using a single winding, or by using two windings in series, such as 6.3 and 6.3 volts. In order to “add up,” the windings must be properly polarized. Otherwise, a lowered voltage will result.

was in the middle of a DX contest, and the stores were closed for most of the contest weekend.

I noticed that most of the noise originated when the ac line dropped slightly below the rated 117 volts. So why not boost the ac input to the tired fluorescent lamp and for the time being eliminate the noise from the fixture?

For the moment, an old Variac™ was pressed into service and the noise disap-

peared.

It would be unwise to keep such an expensive setup in operation indefinitely for such a purpose, however, so this modification seems to represent a compromise between expediency and sound engineering practice. See Fig. 1.

This is recommended solely as a temporary cure, of course, but who is to say how long “temporary” is? ■

TWO REALLY GREAT ANTENNAS

THE JOYSTICK VFA (Variable Freq. Antenna) claims unbeaten scoring over commercial and/or conventional antennae.

- Simple, rapid erection
- Not only 6-band but CONTINUOUS 0.5 – 30Mhz., incl. BC & MARS
- Omni-directional
- Substantially Harmonic FREE
- 1,000,000 miles per watt, world record!
- Poor QTH's enhanced! CLIFF DWELLERS DREAM ANTENNA!
- QUOTE from RADIO ZS (South Africa) “A remarkable antenna with great possibilities. Its physical size makes confined space operation a practical proposition”.

SYSTEM 'A' \$110.00

150 W.P.E.P. &/or Receiving only

SYSTEM 'J' \$130.00

500 W.P.E.P. &/or Improved Q Factor Receive

UP-DATE FOR THE EIGHTIES
NEW JOYMASTER

You get all the JOYSTICK VFA top-notch capability plus the JOYMASTER BONUS of EARTH INDEPENDENCE. This new system gives you TUNED ARTIFICIAL EARTH radials on ham bands 80 thru 10. Now snap your fingers at 99% of QTH problems!

SYSTEM 'JM1' \$147.00

150 W.P.E.P. &/or Receiving only

SYSTEM 'JM2' \$162.00

500 W.P.E.P. &/or improved Q Factor Receive

JOYSTICK VFA OWNERS, update your system to JM1/JM2 for \$86.00 and \$101.00, respectively. Rush Master-charge/Visa no. or check or request FREE literature. All goods assemble easily from the pack — then you have your REALLY COMPACT ANTENNA SYSTEM. Matching ATU's. Air mail cost incl.

PARTRIDGE ELECTRONICS LTD

8, Partridge House,

G3CED Broadstairs, Kent, England. G3VFA
Tel: 011 44 0843 62535

Please send all reader enquiries directly

NEW MFJ SOLID STATE

24 HOUR DIGITAL CLOCK

Eliminate converting to GMT. Pleasant **BLUE** easy-on-eyes display. Bright .6 inch digits. **ID** timer. Alarm, snooze, lock functions. Power out, alarm on indicators. Assembled.

Pleasant Blue Display is easy-on-eyes.
Bright .6 inch digits.
Built-in ID timer.



\$29⁹⁵

The MFJ-101 is a new all solid state 24 hour digital clock. Just set it to GMT and forget about converting to GMT.

Pleasant **blue** .6 inch digits (like TS-820S) are easy-on-eyes and bright enough to see clear across your room.

ID timer alerts you every 9 minutes after you tap ID/doze button.

Set alarm to remind you of SKED or simply to wake you up in morning. Has alarm on indicator.

Fast/slow set buttons make setting time and alarm simple.

Lock function prevents missetting time/alarm. Digits flash if power is interrupted. Rugged black plastic case. Brush aluminum front/top panel.

UL approved. 110 VAC. 50/60 HZ switch for USA, Europe, Japan and other countries. Use

220/240 VAC with optional AC adapter. 6x2x3 in.

Order from MFJ and try it — **no obligation.** If not delighted, return it within 30 days for refund (less shipping). One year limited warranty by MFJ.

Order today. Call toll free 800-647-1800. Charge VISA, MC or mail check, money order for \$29.95 plus \$3.00 shipping/handling for MFJ-101.

Don't wait any longer to enjoy the convenience of reading GMT time directly.

CALL TOLL FREE ... 800-647-1800

Call 601-323-5869 for technical information, order/repair status. Also call 601-323-5869 outside continental USA and in Mississippi.

MFJ ENTERPRISES, INC.
BOX 494, MISSISSIPPI STATE, MS 39762

CALL TOLL FREE
1-800-228-4097

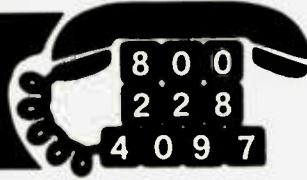

They won't last long AT THIS INTRODUCTORY PRICE

16 Channels
 30-54 MHZ
 140-180 MHZ
 410-514 MHZ
 Digital Clock
 Date Display
 110 V. AC or 12-16 V. DC
 1 Year Warranty
 Seek Rate: Fast 10ch/sec
 Slow 5 ch/sec



INTRODUCING THE
J.I.L. SX-100 SCANNER

**BRIGHT GREEN 9 DIGIT
 FREQUENCY DISPLAY**

Ext. Antenna Jack
 Ext. Speaker Jack
 Large Top Mounted Speaker
 Mobile Mounting Bracket
 Scan Rate: Fast 8 ch/sec
 Slow 4 ch/sec
 Scan delay time variable 0-4 sec.

HURRY

ONLY 102 UNITS TO SELL AT THIS PRICE ALL UNITS FACTORY FRESH
Mfg. List \$399.00 UNBELIEVABLY PRICED AT A LOW \$179.95



**IN 1970 A COMPUTER THIS
 POWERFUL COST \$125,000.
 NOW, TEN YEARS LATER
 YOU CAN OWN IT
 FOR LESS THAN \$1,000.**

Not only has the price of computers come well within the reach of most people, the computers themselves have improved remarkably.

With the Atari® 800™ Personal Computer System, you'll be running programs yourself in just a few hours.

You'll be able to evaluate your investment options with confidence. Organize your family finances. Simplify all sorts of bookkeeping and accounting activities. And have endless fun playing computer games.

LIST \$999 CALL FOR PRICE



NEW SHURE 44D
 Dual Impedance
 Normal/Vox Slide Switch
 Adjustable Height
 Mfg. List \$90.00
SAVE AT ONLY \$49.95



PANASONIC RF-4900
 General Coverage Receiver
 List \$549.95
Ours \$399.95



KENWOOD TR-2400
 2 Mtr. Hand Held
 144-148 MHZ
 List \$395.00
CALL FOR PRICE

CUSHCRAFT

| | | |
|-----------|---------------------------------|-----------|
| ATB-34 | 4-Element Triband Beam | \$ 219.95 |
| ATV-4 | 40-10 mtr Trap Vertical | 84.95 |
| ATV-5 | 80-10 mtr Trap Vertical | 89.95 |
| ARX-2 | 2-mtr "Ringo Ranger" | 32.95 |
| A-3219 | 19-Element 2-mtr "Boomer" | 74.95 |
| A-214B | 14-Element 2-mtr "Boomer" | 56.95 |
| A-214FB | 14-Element 2-mtr FM "Boomer" | 56.95 |
| A-228FB | 28-Element 2-mtr FM Power Pack | 179.95 |
| A-147-11 | 11-Element 2-mtr FM Beam | 32.95 |
| A-147-22 | 22-Element 2-mtr FM Power Pack | 95.95 |
| ARX-450 | 450 MHz "Ringo Ranger" | 32.95 |
| A-144-10T | 10-Element 2-mtr "Oscar" ant. | 39.95 |
| A-144-20T | 20-Element 2-mtr "Oscar" ant. | 56.95 |
| A-432-20T | 20-Element 432 MHz "Oscar" ant. | 49.95 |

LOWEST PRICES IN THE COUNTRY ON ANTENNAS
HY-GAIN — CUSHCRAFT — MOSLEY — HUSTLER

| | HY-GAIN | Regular | Special |
|----------|-------------------------------|----------|----------|
| TH80KX | Super Thunderbird | \$329.95 | \$239.95 |
| TH3MK3 | 3 el. 10-15-20M beam | 222.95 | 166.95 |
| TH3JR | 3 el. 10-15-20M beam | 186.95 | 126.95 |
| Hy-Quad | 2 el. 10-15-20M Quad | 274.95 | 206.95 |
| 206BA | 5 el. "Long John" 20M beam | 329.95 | 239.95 |
| 156BA | 5 el. "Long John" 15M beam | 199.95 | 146.95 |
| 106BA | 5 el. "Long John" 10M beam | 129.95 | 99.95 |
| 204BA | 4 el. 20M beam | 249.95 | 186.95 |
| 204MK5 | 5 el. conversion kit | 96.95 | 79.95 |
| 153BA | 3 el. 15M beam | 89.95 | 79.95 |
| 103BA | 3 el. 10M beam | 74.95 | 59.95 |
| 402BA | 2 el. 40M beam | 239.95 | 189.95 |
| BN 86 | Balun for beam antennas | 15.95 | 15.95 |
| TH2MK3 | 2 el. 10-15-20M beam | 149.95 | 119.95 |
| 18HT | Hy-Tower 80-10M vertical | \$359.95 | \$269.95 |
| 18AVT/WB | 80-10M Trap vertical | 106.95 | 84.95 |
| 14AVD/WB | 40-10M Trap vertical | 69.95 | 57.00 |
| 12AVO | 20-10M Trap Vertical | 42.95 | 34.95 |
| 14RMQ | Roof Mounting kit (verticals) | 33.95 | 29.95 |
| 58DQ | 80-10M Trap doublet | 106.95 | 89.95 |
| 28DQ | 80-40M Trap doublet | 59.95 | 49.95 |
| 66B | 6 el. 6M beam | 119.95 | 99.95 |
| 20J | 3 el. 2M beam | 15.95 | |
| 206 | 5 el. 2M beam | 21.95 | |
| 208 | 8 el. 2M beam | 29.95 | |
| 214 | 14 el. 2M beam | 34.95 | |
| LA.1 | Deluxe lightning arrestor | 59.95 | 49.95 |
| TH5DX | 5 el. 10-15-20 M Beam | 269.95 | 199.95 |

We Export
 ALL PRICES SUBJECT TO CHANGE

Communications Center

443 N. 48th, Lincoln, Nebraska 68504

In Nebraska Call (402) 466-8402



Early Radio Detectors— A Backward Glance

—pulling rf from the ether was (and is) no easy trick

If you wondered why the more modern nomenclature, demodulators, is not used in the title, there's a reason. The very first detectors were simply that: means of detecting the presence of radio-frequency energy. Also, the

use of the term indicates that this article will not be concerned with demodulators for frequency-modulated signals.

Heinrich Rudolf Hertz made the first and the simplest detector. He just bent a dipole antenna

around into a circle, leaving a tiny air gap between the two ends. When radio-frequency energy of the frequency at which the (circular) dipole resonated was present, he could (in a dark room) see a minute spark.

Edouard Branly gets the credit for the next step in the art of detecting the presence of radio waves. In 1890, he received a patent on a device which permitted the operation of a local relay by means of wireless waves. It was crude but good. The principle was elementary. A glass tube was filled with loose iron filings (later iron plus nickel), and wires were stuck into each end. The loose filings were a poor conductor of the direct-current voltage applied in a series circuit made up of the voltaic battery, a relay, and the iron filings, but when radio-frequency energy was routed through the glass tube, the filings stuck together (cohered). In that state, they

conducted the direct current quite well, causing the relay to actuate. But if the radio-frequency energy was turned off, the filings remained cohered. If you wanted to detect the dots and dashes of radiotelegraphy, it was necessary to keep the filings agitated so that they would de-cohere as soon as the rf signal ceased. This problem was solved easily by using a buzzer with a clapper that tapped the coherer tube.

Crude as it was, Branly's coherer was used widely for many years. One reason for its continued use was the fact that the relay could be used to produce "hard copy." It was quite easy to have the relay actuate a pen poised over a strip of paper being pulled slowly underneath. Another reason for its continued use was the fierce competition between rival "wireless" communication companies. They shared no inventions. Each protected its

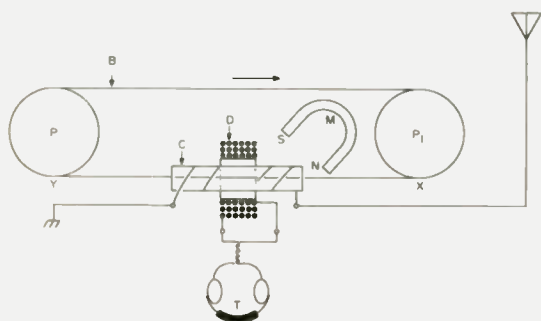

Fig. 1. The magnetic detector. An endless band (B) consisting of a number of fine strands of iron wire is passed over two pulleys, P and P1, one of which is turned slowly by clockwork. This causes the band to move in the direction indicated by the arrow. The band is made to pass through a small glass tube, C, around which is wound a single layer of insulated wire. This wire carries the incoming rf signal. The second coil, D, is wound over the solenoid. It conducts the recovered audio to the headphones, T. The magnet, M, is placed near the band, which moves from point X to point Y. Note that the north pole of the magnet is close to the band.

own. Not a one had a really good system, yet each had some devices that were superior to similar ones being used by other communication companies.

Curiously, the next four types of detectors were introduced rather closely together—approximately in the period between 1904 and 1906. The least known of these was the Marconi magnetic detector. It was a somewhat complex device. A loop of multi-strand iron wire was pulled by clockwork through a circular path that involved passing through a glass tube. (More on that glass tube later.) Just before the moving wire went into the glass tube, it passed through the magnetic field of the north pole of a permanent magnet. That magnetic field induced a weak south-pole type of magnetism into the small segment of wire immediately under it. The segment continued its way into the tube, to be followed, of course, with more magnetized segments.

The glass tube merits additional description. A single-layer coil was wound directly upon the tube. The two ends of this solenoid were attached to the radio-frequency tuner (or directly to the antenna and ground in the basic systems). Over the solenoid, another coil, one with many turns and many layers, was wound. A pair of headphones was attached to the multi-layer coil. As the magnetized wire was pulled through the tube, any "wireless" signal applied to the solenoid (which acted as a primary of a transformer having a single-turn secondary, the moving wire) induced a magnetic field into the wire. This field caused an abrupt reversal of the weak polarization of that segment of wire. The field created by this reversal cut the many turns of the multi-layer coil, creating a current that actuated the head-

phones.

This form of detector seems to have performed acceptably well on Marconi's system of wireless communication. It must be remembered that Marconi used only spark transmitters. These emitted discontinuous waves, Type B emission. There is no record of how it might have performed on voice-modulated, tone-modulated, or key-modulated continuous waves (Type A emission).

Another type of detector, this one a true demodulator, was the thermionic diode. It was discovered by Thomas A. Edison, who never pursued any possible application for his discovery. An English scientist, John Ambrose Fleming, was more imaginative. He recognized that the diode made an excellent rectifier for radio-frequency signals. It is not known just who first became aware of the fact that rectification enabled the demodulation of most types of radio signals. For some reason, the thermionic diode did not come into common use until the 1930s. It was, and is, an excellent detector. Perhaps it is the requirement of filament power that caused it to be ignored in favor of much less reliable types of signal rectifiers.

In this same time period, the electrolytic detector was introduced by some long-forgotten inventor. It used a tiny platinum wire, only 0.0002" in diameter, which was carefully lowered so as to just touch the surface of the liquid in a small cup. The liquid was either nitric or dilute sulphuric acid. Rectification took place at the junction between wire and acid. It was an effective detector, but it had one great drawback: It required a stable platform. That one fault ruled it out of the shipboard market, which was one of the best markets for wireless gear.

The last of the four, the crystal detector, seems to have been developed simultaneously by several persons, although Greenleaf Whittier Pickard often is given credit for its invention. There were many types of rectifying crystals used. Some detectors used two crystals in contact with each other. (One wonders if these were PN junctions?) Most used some variety of a point contact. Often this was the renowned "cat-whisker," a small and springy wire, usually brass, that made tenuous contact with a spot on the surface of the crystal. The proper spot had to be found by careful search. Once found (and retained, an even more difficult undertaking!), it provided maximum audible signal from the incoming radio waves. A few varieties of crystals needed direct current through their junctions for best operation. It is quite possible that some of these actually oscillated, conceivably on the tunnel-diode principle. Such claims were made, although the principle of operation was only guessed at.

All of the multitude of crystal detectors shared one common characteristic: Their sensitivity varied inversely with their stability!

Coming several years after the introduction of the previously-mentioned detectors, the triode vacuum tube, Lee DeForest's famous audion, did not immediately displace the older types. There were several explanations. Audions were very hard to obtain. They were not sold outright, but came with DeForest equipment and were replaced (at a high price) only if the defective audion was returned! They also were expensive and had a life span that was unpredictable but all too often distressingly brief!

Audions were used in two differing types of detection techniques. One, the bias detector, required biasing the grid into a non-linear portion of the $E_c I_p$ curve. This form of demodulation did not provide maximum sensitivity, but did constitute a detector capable of coping with strong signals without causing excessive distortion. The most favored method of using a triode as a demodulator was as a "grid-leak detector." The actual principle of this type of operation was dual in nature. That is, the grid and cathode, in conjunction with the grid-blocking capacitor and the grid resistor, constituted a diode rectifier ("detector"). As these elements also were parts of the triode tube, they, plus the plate, also constituted an audio amplifier. The combination of detection and amplification in one vacuum tube resulted in sensitivity that far outstripped all competitors.

All rectifier-type demodulators worked satisfactorily for receiving discontinuous-wave (spark) and modulated continuous-wave signals, but were useless for extracting intelligence from key-modulated (make-and-break modulation) continuous-wave radiotelegraph signals.

Continuous-wave signals were generated by several means. Probably the first was the Fessenden arc. Carefully-controlled arcs could produce an excellent continuous wave. So could the Alexanderson high-frequency alternator. The vacuum tube, after it became commonly available in the early 1920s, was the choice of both experimenters and commercial users for low-power and even medium-power continuous-wave generation, although arcs and alternators continued to be used in high-

RAPID MOBILE CHARGER

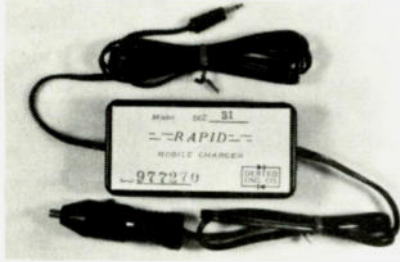

Charge your handheld radio off 12 volt source in 4-6 hours. Will not overcharge your batteries due to automatic shut-off circuitry.

Equipped with a cigarette lighter plug on the input side and the appropriate charging plug on the output side.

CORD LENGTHS ALLOW FOR CONVENIENT USE WHILE CHARGING!

Models available now for the Kenwood TR2400, the Yaesu 207R Tempo S1, Wilson Mark II and the Wilson Mark IV. Other models available also please call or write for more info.\$29.95

Order by mail or phone. All orders add 5% shipping, C.O.D. add additional \$1.15 Bac/Visa/MC. Ohio Res. add 4 1/2% Tax
Phone (513) 731-7220

✓ 330

DE **DEBCO ELECTRONICS**
P.O. BOX 9169
CINCINNATI, OHIO 45209

powered stations for many years.

Perhaps the first attempt to "demodulate" continuous-wave radiotelegraphy was by use of a "tikker" (yes, that is the correct spelling!). Before describing just what a tikker is, let's consider why one was needed. When a continuous-wave signal is rectified, the result is a direct-current pulse the length of the dot or dash of CW radiotelegraphy. This is not suitable for actuating headphones or for audio amplification. The steady dc pulse must be transformed into some sort of audible signal. A simple way of doing this is to interrupt or break up that dc pulse several hundred times a second. That is what a tikker does. It's a mechanical interrupter.

Reginald Aubrey Fessenden invented the heterodyne detector. He used a low-power arc as a local os-

cillator. This continuous wave was combined in a non-linear device such as a crystal detector, with an incoming key-modulated continuous-wave signal. By making the former a few hundred Hz higher (or lower) in frequency than the latter, an audible beat note was produced.

A regenerative vacuum-tube detector can be operated in an oscillating state. Slightly detuned from the frequency of an incoming CW radiotelegraph signal by, say, 750 Hz, it develops its own heterodyne note. (This is called autodyne reception.) A regenerative detector therefore can be used to demodulate spark signals, tone-modulated continuous-wave signals, voice-modulated continuous-wave signals, and key-modulated continuous-wave signals. Truly it's the universal detector! ■

INSTRUMENTS YOU CAN COUNT ON...

- 4 1/2 DIGIT MULTIMETER/THERMOMETER
- FREQUENCY COUNTERS TO 1.3 GHz
- PRECISION DIGITAL THERMOMETER
- CAPACITANCE METER

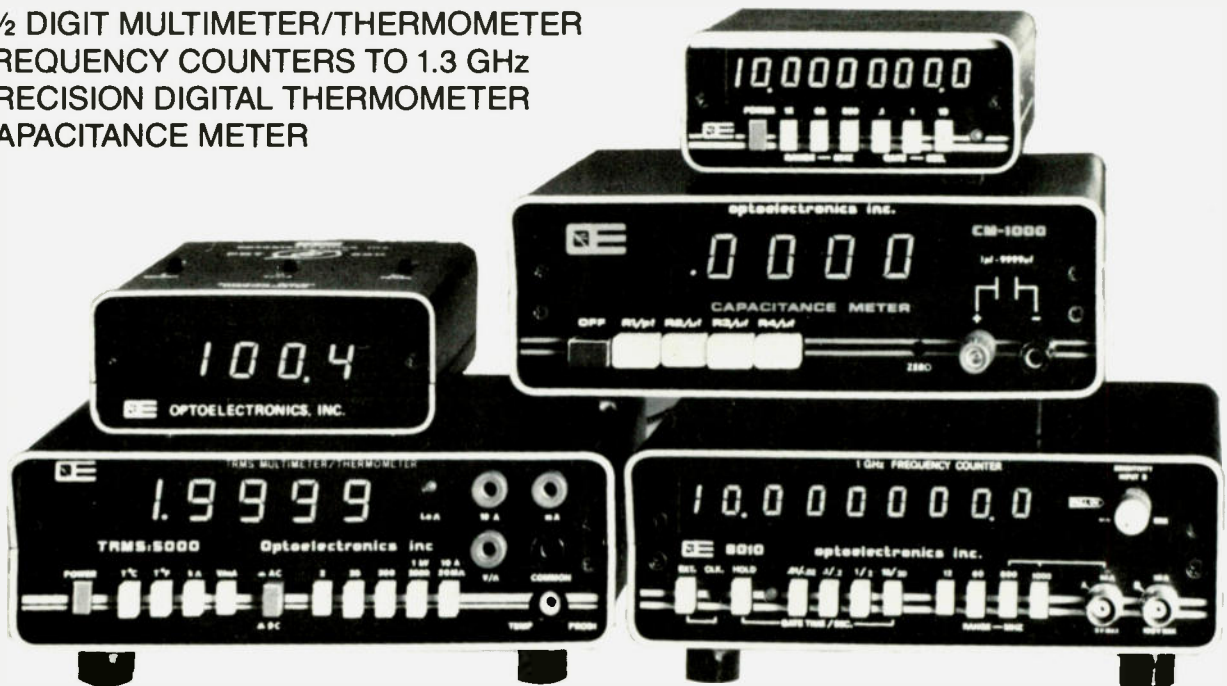

FOR ORDERS, INFORMATION OR A CATALOG WRITE OR PHONE **800-327-5912**
FROM FLORIDA PHONE (305) 771-2050/771-2051



Optoelectronics inc

5821 N.E. 14 AVE. FT. LAUDERDALE, FL. 33334

✓ 55

THE BEST



TS-520SE



FT-101ZD



TR-7800



TR-7



IC-251A

TOP OF THE LINE. NUMBER ONE!

IF YOU'RE THE TYPE OF PERSON THAT WILL SETTLE FOR NOTHING LESS, WE'VE GOT WHAT YOU'RE LOOKING FOR — TOP OF THE LINE FROM THE TOP LINES. WE OFFER MORE THAN JUST THE RIGS — SUPER SERVICE AFTER THE SALE. CALL US SOON FOR A QUOTE ON YOUR NEXT RIG.

ORDER TOLL FREE!

800-845-6183



G.I.S.M.O. ✓27

2305 CHERRY ROAD
ROCK HILL, S.C. 29730

Service Department
Call 803-366-7158

Sheathe Thyself

— a cheap trick to pull on old rubber duckies

For over two years I have been the proud owner of a Wilson 1402-SM HT,

and after an incredible amount of hard use and abuse, I have only two pet-

ty gripes: (a) the funny little round accessory connector that steadfastly refuses to mate with anything in my junk box, and (b) the early-model rubber flex antenna. More about (a) another time.

Please note that it isn't the pesky "F" connector that I'm complaining about. I know some hams prefer to replace it with a BNC-type, but I've never had any trouble with it. One good feature is that it allows you to match up your HT to all kinds of inexpensive cable-TV hardware. My problem was more basic—the relatively fragile skin of the rubber ducky itself.

After a couple of months of hard use, the antenna started to assume an odd angle when mounted on the rig, and the rubber skin began to look twisted and lumpy. Finally, pieces of the skin began to peel off, exposing the helical copper coils inside. The antenna still worked fine, but it looked terrible and the exposed end began to snag on clothing and poke passers-by in the face (Photo A). Small urchins would point and snicker and attempts to

repair the damaged mess with silicone rubber weren't helpful. No matter how it was patched and dipped, it still looked as though it had been stuck in a pencil sharpener by mistake or used to flog armadillos.

The catalogs do list replacements, but at prices running upwards from ten dollars. The solution was a piece of heavy rubber automotive hose with an inside diameter of 3/8" (NAPA #H-176).

An 8" length of this costs fifty cents at a local parts store, but a piece probably could be scrounged for free at a friendly gas station. Of course, lighter neoprene tubing or plastic shrink material could work, but this stuff fits perfectly down over the "F" connector as well and is incredibly tough. Also, a standard 1/2" PVC pipe cap is a snug friction-fit over the top end (see Fig. 1).

Note that the hose fits flush against the top of the HT, completely covering the connector. To install or remove, simply pinch the tubing against the knurled fitting inside, and the whole thing unscrews as a unit. Rf



Photo A. Before. The beat-up rubber ducky before installing the replacement covering.

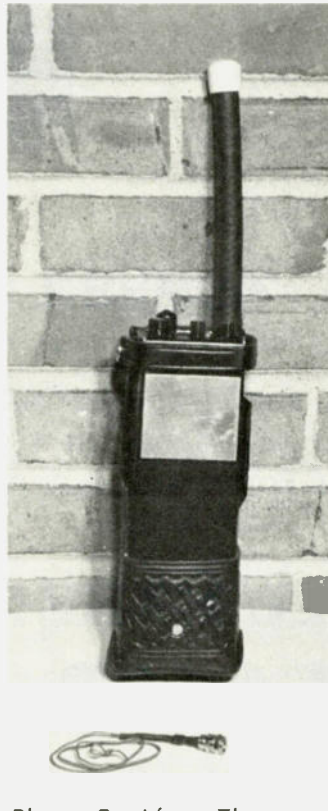

Photo B. After. The automotive hose is now in place, with the 1/2" PVC pipe cap glued over the open end. Note the compact size of the rolled-up "Floppy Duck" (bottom).

losses through the material are slight; I can still stand on a hilltop and work the VE3SSM repeater fifty miles away and performance is about the same as the original antenna or the bare spring.

For far-fringe operating, the "Floppy Duck" (Fig. 2) is just the ticket, especially for HTs like the Wilson 1402 which do not have an internal telescoping whip. All it is is a replacement "F" connector and a quarter wavelength of hookup wire which is the right gauge to make the bare conductor snugly fit the center hole of the female fitting on the HT. The wire is held in place with a dab of silicone rubber, and a piece of 1/8" staple is crimped over the insulation to hold it in place. A couple of scraps of shrink-tubing are slipped over the outer flange of the "F" fitting and shrunk in place with a light bulb. The

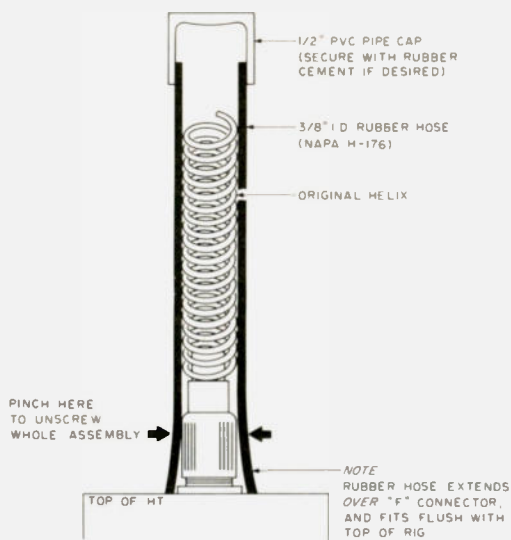

Fig. 1.

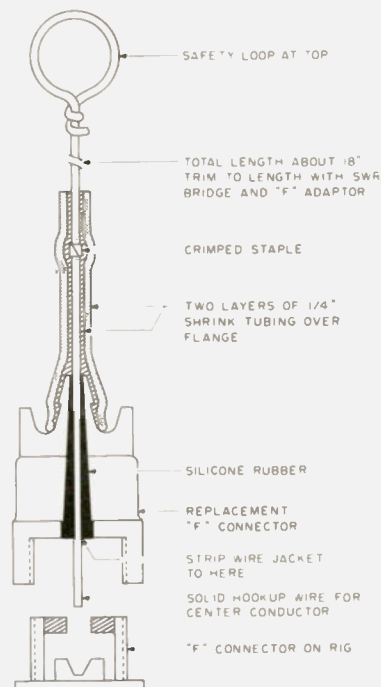

Fig. 2.

resulting antenna can be rolled up to about the size of a stick of gum (see Photo B) and tucked away in a corner of the HT case until

needed. Performance is dramatically better than with the rubber ducky, and the antenna can easily be taped to a bus or train window for

operating while traveling. Cost is negligible; the connectors come in packs of two for 59¢ or so at stores like Radio Shack. ■

THE V-J PRODUCTS...

wired for sound

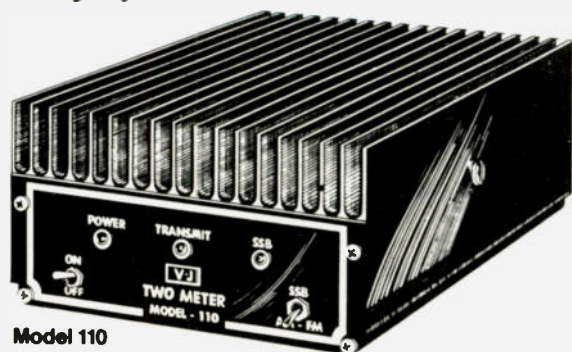

Model 110
List: \$199.00

and
how!

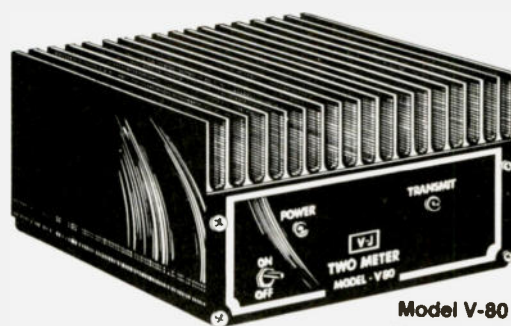

Model V-80
List: \$119.00

In fact, each V-J Products 2 meter amplifier is HAND WIRED. The model 110 with 140 watts out, or the V-80 with 80 watts both feature parasitic coils delicately hand balanced to resonance. And each unit is individually tested and burned in. The heat sink, which totally surrounds each unit, insures cool operation with the cleanest FM or SSB signal on the air. Warranty? You Bet! 90 days on the power transistors and 1 full year on all other components. You can buy a 2 meter amplifier anywhere, but the V-J Products model 110 and V-80 are only available at:

Call for quote!

MADISON

Electronics Supply, Inc.

1508 McKinney, Houston, Texas 77002, (713) 658-0268

Ask about the V-J 30 amp
Power Supply coming soon

CB to 10

— part XXVI: the Cobra 132

The latest changes in the FCC rules which prohibited the sale of new 23-channel CB sets has made quite a few of these sets available at very low prices. This was because the manufacturers had to unload their surplus and also because CBers wanted to move up to the new 40-channel models.

I have been reading with interest all of the articles in *73 Magazine* on conversion of CB sets to 10 meters. I had a Cobra 132 on the shelf which was built by a Japanese manufacturer for B & K. (The same manufacturer built very similar radios for other companies; they were the Tram

Diamond-60 and the Browning LTD.)

With the 10-meter band being so open in recent months, and the number of QRP stations I have heard with great signals, many well over S-9, I decided that I would modify the Cobra and get in on the action from the mobile myself.

Before you attempt this mod, I highly recommend that you get a Sams Photo-fact.[®] This will give you all the needed information such as part locations and alignment test points and procedures. The one needed for this conversion is CB-54, June, 1974.

There were several

objectives in my conversion. Number one was good 10-meter SSB coverage, and I chose 28.5 to 29.1 MHz. Next was to have continuous coverage with the vco, with enough overlap to cover the spacing caused by the former radio control channels which were located between several of the original 23 channels.

This conversion is set up for the Cobra 132 mobile or the Cobra 135 base station radio, each of which uses the late-version synthesizer, PAC-4231. With the very close similarities of the Tram Diamond-60 and the Browning LTD, I am sure one can use the basics of this conversion to modify these sets up to 10 meters, also.

The parts that have to be changed are listed in Table 1.

To install the new local oscillator crystals that re-

place the X311, 12.8 MHz crystal, a miniature SPDT toggle switch and a 3-30 pF trimmer capacitor must be added. I will leave it up to you as to where you want to mount the switch. Once that is decided, install as per the switch diagram.

The next step is to enable the blank channel between 22 and 23. With the case off, place the set upside down with the channel selector set on this blank channel. If you look at the back wafer of the channel selector switch, you will see the notched-out portion of the switch. On my set there is a purple wire from the synthesizer board connected to the switch terminal that is supposed to enable this channel. Take a short piece of no. 18 wire and solder one end to the switch terminal. With the other end of this wire, form a contact on the center, bottom portion of the channel selector

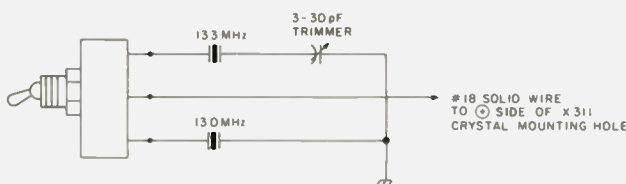

Fig. 1. Switch diagram.

| Crystals | Remove | Install |
|----------|------------|--|
| X301 | 15.965 MHz | 17.300 MHz |
| X302 | 16.015 MHz | 17.350 MHz |
| X303 | 16.065 MHz | 17.400 MHz |
| X304 | 16.115 MHz | 17.450 MHz |
| X305 | 16.165 MHz | 17.500 MHz |
| X306 | 16.215 MHz | 17.550 MHz |
| X311* | 12.8 MHz | 13.0 MHz = 28.5-28.8 MHz range 13.3 MHz = 28.8-29.1 MHz range |

Table 1. Parts to be changed. (* — See text.)

switch. Glue this in place with a hot glue gun. Be careful not to get any glue on the contact portion of the switch. This may seem a bit crude, but it enabled me to get an extra 10 kHz of coverage that would have been lost unless I changed the whole channel switch.

On the synthesizer board, connect a short between TP302 and TP303, mode switch set to USB. Connect a frequency counter between TP303 and TP304. Adjust per Table 2.

Remove the frequency counter from between

TP304 and TP303 and connect to TP309 and TP305. Set the Voice Lock for center frequency. Select the 13.0 MHz oscillator crystal and adjust L301 cw for the proper frequency. Select the 13.3 MHz crystal and adjust the 3-30 pF trimmer for the proper frequency.

Remove the short and the frequency counter. Connect up a dummy load wattmeter. Select channel 23, also select the lower oscillator crystal, AM mode, and adjust T301 through T305 for maximum out on transmit. Next, ad-

just T14, T15, L3, and C116 for maximum rf out.

Select USB mode, inject 10-mV 2-tone test signal to the audio input; and adjust L2, L5, T1, T2, T3, T4, T5, T6, T16, and L8 for maximum rf output. Adjust R136 for maximum power out, but observe proper linearity to prevent distortion. This is the ALC adjustment; you should have about 8- to 15-Watts PEP out. This completes the transmitter adjustment.

Next, tune in a weak signal source, NB off, and adjust T7, T8, T9, T10, and T11 for maximum sensitivity. The last adjustment is for the Voice Lock range.

Adjust R331 and R326 almost maximum clockwise. Adjust R329 almost maximum counterclockwise. Don't go too far or some instability will occur. This will give you about a 15-to-20-kHz range, which allows total overlap between channels.

Well, that's about it for the conversion. I am sure there are several other ways as far as crystal selection goes, but this one worked for me. The antenna I use is a base-loaded trunk-mount CB antenna that is retuned for 28.6. Good luck with your conversion; hope to work you QRP mobile on 10.73. ■

Table 2.



Radio equipment
not included

Also Available . . .
Floor Space: 51" Wide by 30" Deep
\$192.50

... at last ... your shack organized!

A beautiful piece of furniture — your XYL will love it!

\$16450 S-F RADIO DESK Deluxe - Ready to Assemble

Designed with angled rear shelf for your viewing comfort and ease of operation.

FINISHES: Walnut or Teak Stain.

Floor Space: 39" Wide by 30" Deep

Additional Information on Request.

Checks, Money Orders, BankAmericard
and Master Charge Accepted.

F.O.B. Culver City. (In Calif. Add 6% Sales Tax.)

___ DEALER INQUIRIES INVITED ___

65

SF

S-f Amateur Radio Services

4384 KEYSTONE AVENUE • CULVER CITY, CALIF. 90230 — PHONE (213) 837-4870

FT-227 Update

— more mods for the Fox-Tango set

One of the more popular two-meter transceivers, offering 4-MHz coverage and a single memory channel at a reasonable price, is the Yaesu FT-227R. This article describes some simple modifications which expand the range and versatility of the transceiver.

Two-Channel Scanner

There are a number of commercially-available scanners which will adapt the 227R to scan a segment

of two meters from one- to four-MHz wide. These are extremely useful if you travel, but for local use they stop on every active channel and are not satisfactory for monitoring specific frequencies. The scanner shown in Fig. 1 is a simple circuit designed to scan between the frequency stored in memory and the one shown on the display. All the circuitry is contained on a single circuit board which mounts internally in place of the

tone squelch option.

The front-panel tone-squelch switch is used to activate the scan function. The scanner derives its power from the PLL control board (PB1773A) and utilizes COS/MOS integrated circuits for low power consumption. In order to understand fully the operation of the scanner, you should be familiar with the switching arrangement used in the 227R to select the memory. Fig. 2 shows a simplified diagram for the

front-panel push-button switches and their connections to the PLL control board. From this diagram, it's evident that S5 switches 5 volts to either the manual or the memory recall lines.

Electronically switching 5 volts between these two lines will cause the radio to scan. The scanner operation is described as follows: IC1A and IC1B function as an oscillator, the frequency of which is determined by R1 and C1, Fig. 1. IC2 divides the oscillator frequency by a factor of 1024 to derive the 2-Hz signal which toggles IC3, the PLL controller flip-flop.

When S2 is closed, the input to IC1C is held high, forcing its output low, permitting the flip-flop to toggle. When a signal is detected, the input of IC1D is pulled low by Q115, the output of the inverter goes high, resetting IC2. This prevents IC3 from being clocked and locks the PLL control board on the active channel.

The relationship between the output of the flip-flop and the manual/memory recall inputs is shown in Fig. 3. Note the

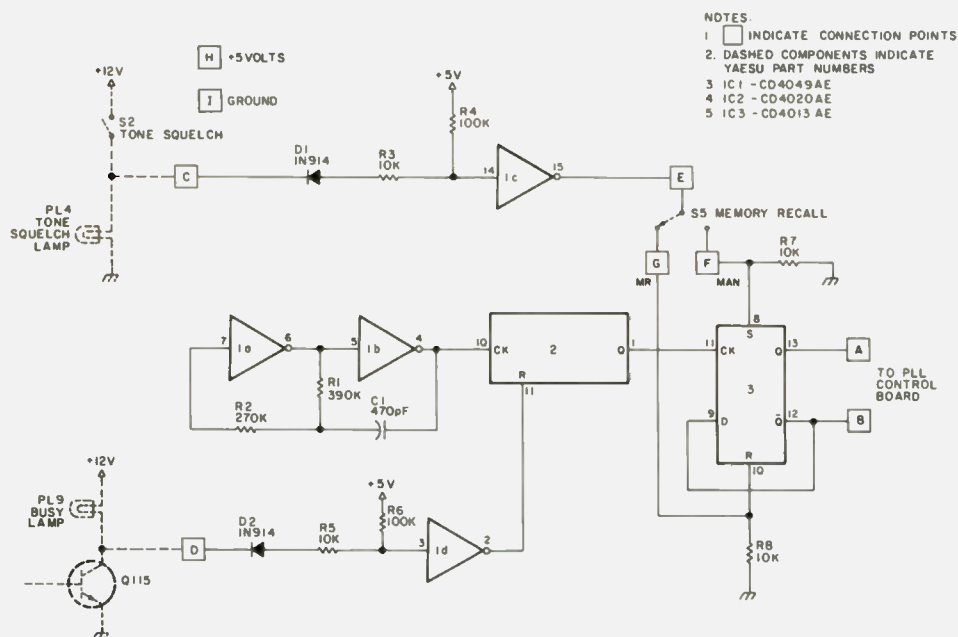

Fig. 1. Scanner diagram.

circuitry on the inputs of IC1C and IC1D. R4 and R6 are pull-up resistors forcing the nominal outputs of the inverters to be low. D1 and D2 are blocking diodes required for isolation since the switches and the indicator lamps operate from 12 volts. R3 and R5 are current limiters.

When operating in the manual mode, S2 is open and IC1C "sees" the low resistance of the indicator lamp (PL4) to ground, setting the output of IC1C high. This high level is switched by S5 between the set and reset pins of IC3 to control the Q and \bar{Q} outputs. A high on the set input causes Q to be high and \bar{Q} low; a high on the reset results in Q low and \bar{Q} high. This retains the normal operation of the MR switch (S5), which allows you to switch manually between the memory and the display.

The circuit board mounts foil side up in place of the tone squelch option; a full-size layout is shown in Fig. 4. Fig. 5 is the parts placement diagram. The connections from the circuit board to the 227R are made as follows: Refer to Figs. 1, 2, and 5.

1. Move the red/white wire from the center of S5B to the center of S3B. Break the connection from the center of S5B into the circuit board.

2. Disconnect the gray/white wire from the front of S5B.

3. Disconnect the yellow/white wire from the rear of S5B.

4. Wire the scanner as follows:

(A) Connect to the gray/white wire which was removed from the front of S5B.
 (B) Connect to the yellow/white wire which was removed from the rear of S5B.
 (C) Connect to the center of S2A.

(D) Connect to the switched side of the busy lamp (PL9).
 (E) Connect to the center of S5B.
 (F) Connect to the front of S5B in place of the gray/white wire.
 (G) Connect to the rear of S5B in place of the yellow/white wire.
 (H) Connect to the +5-volt line on the PLL control board.
 (I) Connect to ground on the PLL control board.

The switched side of PL9 can be found using a voltmeter with a common pin as a probe. On a 12-volt scale, measure between ground and determine with the probe which of the lamp wires is switched to ground when the busy

- NOTES
 1 CHANGES AND ADDITIONS ARE SHOWN IN DASHED LINES
 2 ALL SWITCHES SHOWN IN THE OUT POSITION
 3 D1 & D4 1N914
 1N3605, OR
 1N4004

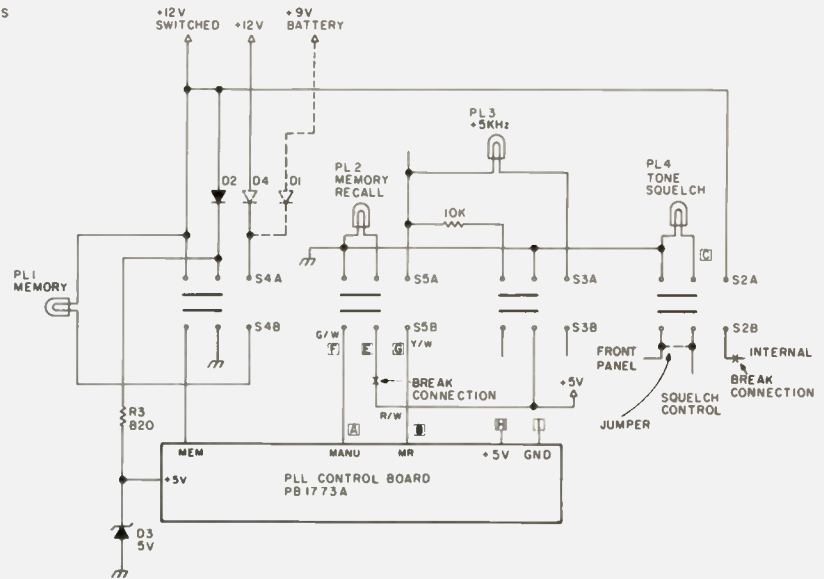

Fig. 2. Simplified switching diagram showing modifications.

| MODE | Q | \bar{Q} |
|--------|---|-----------|
| MANUAL | I | O |
| MEMORY | O | I |

I = HIGH + 5 VOLTS
 O = LOW + GROUND

Fig. 3. Truth table for flip-flop output.

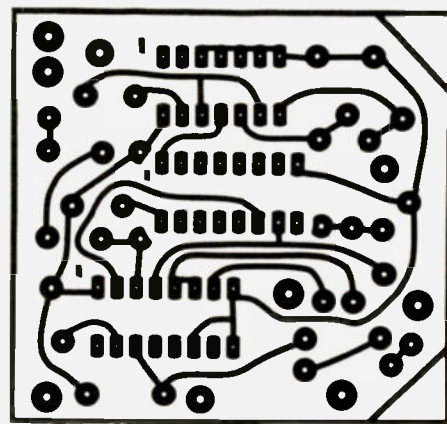
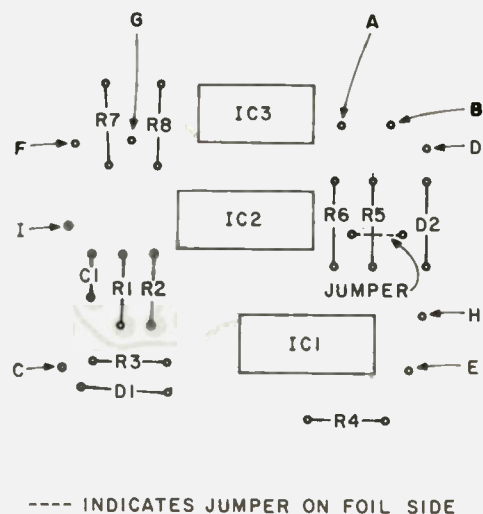

Fig. 4. Foil side.



---- INDICATES JUMPER ON FOIL SIDE
 LARGE PADS MATCH TONE SQUELCH MOUNTING HOLES

Fig. 5. Component side.

lamp is on. Splice into that wire and connect to point D. When in the scan mode,

the front-panel squelch control is inoperative and the squelch level is set by

NOTES.
 1. ALL DIMENSIONS
 IN INCHES
 2. MAKE 90° BEND AT
 DOTTED LINE

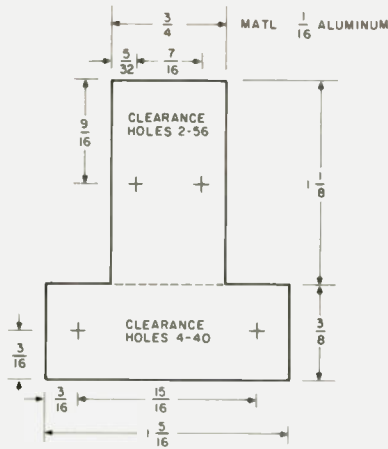

Fig. 6. Battery mounting bracket. Keystone no. 93 battery clip required.

an internal control. To make the front-panel control operative, remove the wire from the rear of S2B and place a jumper between the front and center connections of the switch, Fig. 2.

To test the scanner, set a frequency into memory with the scan switch off. Select a second frequency on the display and depress

the scan switch (S2). The display should now alternate between the two frequencies at a 2-Hz rate. Opening the squelch should inhibit the scanning action.

Other Changes

A second modification to the 227R permits the memory to be retained when power is removed.

The dashed components shown in Fig. 2 are the only components added. They are mounted (soldered) directly to S4. Fig. 6 is the battery bracket. This mounts internally at the rear of the 227R between the slide switches and the coax connector. The bracket is designed to mount using the holes for the ground lugs from the transmitter printed circuit board. When a frequency is stored in memory and the radio is connected to a 12-volt supply, D1 is reverse-biased and the power to the PLL control board is supplied through D4. This voltage is regulated to 5 volts by R3 and D3. When the input voltage falls below 9 volts, D1 conducts, supplying voltage to the regulator thus retaining the memory. Current drain from the battery under these conditions is about 4 mA. When storing the radio

for long periods of time, the battery can be switched off by disabling the memory feature (S4).

One final change permits the 227R to operate above 148 MHz. This is useful when the 227R is being used as a driver for a varactor tripler to the 450-MHz band. Removing diodes D701 and D702 from the PLL control board will expand the frequency coverage to 149.995 MHz.

This completes my list of modifications to the Yaesu FT-227R. They have been in use for some time now and I have not experienced any problems. Comments and inquiries will be answered provided an SASE is enclosed. Acknowledgements go to Bob Wagner W1HWU for his ideas and suggestions, and to my XYL, Deb WB1DRS, for the typing. Good luck, and have fun with your new 227R! ■

ASCII MORSE RTTY

MONITOR \$149.

(12" B&W)
 (Optional)

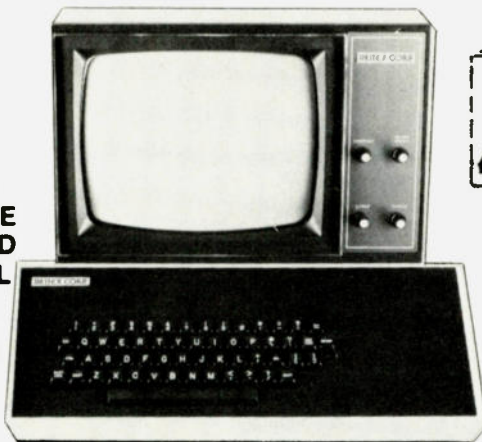

SKT-100 COMPLETE KEYBOARD TERMINAL

\$375. KIT
 (Less Monitor)
 Assembled \$430

ALSO AVAILABLE:

SCT-100 STAND ALONE VIDEO BOARD

Assembled & Tested \$215.

Full Kit \$175. Partial Kit \$115.

ABM-200 ASCII BAUDOT MORSE CONVERTER \$189.

XITEX CORP.

9861 Chartwell Drive
 Dallas, Texas 75243 (214)349-2490

MC/VISA ORDER BY PHONE
 Prices subject to change without notice.

COMPUTER



Features

- ASCII & BAUDOT
- Auto Sync. 1-150 WPM CW
- Narrow & Wide Shift TU
- Microcomputer Interface

TRANSCIVER



AFSK/KEY
 (SEND)

AUDIO
 (COPY)

SERIAL
 LOOP or RS232



Key
 Input
 Key Optional

UDT 170 UNIVERSAL DATA TRANSCIVER

Converts any ASCII or Baudot TTY® or Video Terminal into a multiple band rate data transceiver for RTTY and Morse operation. (Boards sold separately)

Reg. \$549

INTRODUCTORY PRICE \$479

WHY GET ON FAST SCAN ATV ?

- You can send broadcast quality video of home movies, video tapes, computer games, the shack, etc., at a cost that is less than slowscan. Requires only a technician class or higher.
- Really aids public service communications for parades, RACES, CAP searches, weather watch, marathons, etc.
- DX is about the same as 2 meter simplex - 15 to 100 miles.
- ATV uses broadcast standards. No special converters needed. Receive full color and sound on a regular TV set.

TC-1 TRANSMITTER/CONVERTER



ALL IN ONE BOX READY TO OPERATE \$399 delivered U.S. Plug in any closed circuit camera, antenna, mic., and TV set and you are on the air. Contains the basic four modules, AC supply, and T/R switch. Full color and sound. Specify xmtr freq and TV ch 2 or 3.

GET A BUDDY ON SPECIAL 2 for \$750 ppd.
HITACHI HV62U CAMERA \$239 ppd

Build Your Own System with The Basic Four Modules

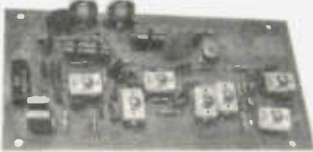

1. TXA5-3 ATV EXCITER/MODULATOR \$85 ppd
This wired and tested module is designed to drive the Motorola MHW-710 module in the PA5 10 watt linear amp. The crystal in the 100 MHz region keeps harmonics out of two meters for talk back. The video modulator is full 8 MHz for computer graphics and color. Requires 13.8 vdc reg @ 70 ma. Tuned with xtal on 439.25, 434.0, or 426.25 MHz. Two Freq version add \$30.



2. PA5 10 WATT ATV POWER MODULE \$79 ppd
The PA5 will put out 10 watts RMS power on the sync tips when driven with 80 mw by the TXA5 exciter. 50 ohms in and out, plus bandwidth for the whole band with good linearity for color and sound. Requires 13.8 vdc regulated @ 3 amps.



3. FMA5 AUDIO SUBCARRIER GENERATOR \$25.00 ppd
Puts audio on with your camera video just as broadcast TV does at 4.5 MHz. Puts out up to 1 v p-p to drive the TXA5 or VM-2, 3, or 4 modulators. Requires low Z mic (150 to 600 ohms), and +12 to 18 vdc @ 25 ma. Works with any xmtr with 5 MHz video bandwidth.



4. TVC-1B ATV DOWNCONVERTER \$49.50 ppd
Very sensitive MRF901 (1.7 db NF) preamp and double balanced mixer module digs out the weak ones but resists intermods and overload. Connects between uhf antenna and TV set tuned to channel 2 or 3. Tunes 420 to 450 MHz. Requires +12 to 18 vdc @ 20 ma. Super sensitive TVC-1C with NE64535 preamp (.9db NF) preamp \$79.50 ppd



TVC-4 ATV DOWNCONVERTER \$85.00 ppd
This is a packaged version of the TVC-1B converter with internal power supply. Has BNC input and F output connectors. Also available with the NE64535 for \$115 ppd. Size 5 1/4 x 2 1/2 x 7 inches.

PACKAGE SPECIALS

TXA5-3, PA5, FMA5, and TVC-1B
BASIC MODULE PACKAGE \$225 ppd

OPTIONS:

- 2 frequency exciter add \$30
- NE64535 low noise downconverter . add \$30
- Packaged TVC-4 downconverter . . . add \$35
- Less TVC-1B downconverter . . subtract \$40

SEND SELF ADDRESSED STAMPED ENVELOPE FOR COMPLETE CATALOG AND ATV INFO. We have all your ATV needs: Antennas, Cameras, Repeaters, Video Monitors, Preamp, Linears, Test Equipment, and more. 19 years in ATV. Check, Money Order or Credit Card by mail. Credit Card orders call (213) 447-4565



Maryann
WB6YSS

P.C. ELECTRONICS ✓ 57

2522 PAXSON
ARCADIA, CA 91006

Tom
W6ORG



"That's the Way It Was . . ."

Do you recall your first introduction to radio? Do you remember what led you to become an amateur radio operator?

It was in the early 1920s; I was about five years old. I lived in Philadelphia, Pennsylvania, on a street that was narrow and short. There were about fifteen one-family houses on the street. There were two gas-operated lamp posts on either end of the street. The lighting in the homes also was gas.

In a corner of one of the rooms in our house was a workbench strewn with wires, tubes, insulators, batteries, tools, and many other objects that were pertinent to the construction of radios. At the time, it all meant nothing to me, not knowing to what use they were put.

I could always find my father puttering around in that corner. I can recall him using the terms peanut tubes, aerial, and also distant stations. Another term that always stood out in my mind was his referral to KDKA.

One day as he was at the bench, I heard him call excitedly to my mother. I remember him telling her that he had just heard a station from California. He placed the earphones on my head, also, and I heard music.

In time, he constructed many receivers using various circuits to improve the

reception, and received many more distant stations.

My next vivid recollection of radio was in 1926 when the Dempsey-Tunney fight was held. People were crowding in front of my house, listening to it. My father had set up a loud-speaker on the window sill.

In 1927, we moved to Brooklyn, New York. I attended the local public school. When I was in junior high school, I became the operator of the movie projector, which used carbon arc light. I still had no interest in following my father's footsteps—in dabbling with radio construction. However, I did become an SWL, and kept a log of the radio stations I heard.

In 1939, I was introduced to amateur radio by a young lad who was my next-door neighbor, Lou W2MGX. He assisted me with the construction of a transmitter for 160 meters. My receiver was a National SW-3. I tried to make a contact, but without success. I became disillusioned and took the transmitter apart. (By the way, I had no license to legally operate a transmitter.)

During World War II, I worked for Bendix. I was the final tester for landmine detectors. There I gained a better knowledge of electronics. I still had no ambition to get interested in ham radio.

In 1955, I worked for a company that was located in the same building with Eico, and met some of the Eico employees. One of them was a ham. Once again, I was fired with enthusiasm to become an amateur radio operator.

Not knowing any hams in my neighborhood, I was at a disadvantage. How could I find a ham who would help me acquire my license? I purchased a *Callbook* and proceeded to thumb through the pages, looking for a ham close to my house. Success! I found one two blocks away.

I jotted down his name, address and call, and went to visit him. I was greeted at the door by his wife. I introduced myself and explained my desire. She called her husband and told him what I wanted. His name was Ray and his call was W2DIU. I was taken aback when I met him. Ray was blind and also wore a hearing aid. His wife, Judy, was also a ham. Her call was K2KBQ.

Ray helped me learn the code and taught me the theory for the Novice license. In a few months, I got my license and was issued the call KN2VGV. That was October, 1956.

Ray would not permit me to get on the air until I built a transmitter. I made the chassis from sheet aluminum and the cabinet of sheet metal. For parts, I

cannibalized old radio receivers and television sets. The remainder of the parts I purchased on Cortlandt Street—affectionately known as "Radio Row." I also had to wind the coils. My receiver was a Hallcrafters S-40. I had very little success getting contacts. I was not permitted to erect an antenna on the roof. I tried loading the window screens, the bed-springs, and stringing wires throughout the apartment.

A few years later, I moved to another location. There I was permitted to install an antenna. I had a three-element beam for 10, 15, and 20 meters, a dipole for 40 meters and a 5-element beam for 6 meters. I was now able to enjoy amateur radio to my heart's content, to work DX and to try for WAS. I also had gotten my General.

I have had my trials and tribulations being a ham. TVI complaints, letters from the FCC, feedlines cut, telephone calls in the wee hours of the night, and various other annoyances. But I persevered through it all. I am enjoying ham radio, to my great content.

I am retired and spend a great deal of time teaching those who want to become amateur radio operators. My greatest joy is when my students call and tell me they passed their test and have received their call-signs. ■

Dual filtering comes of age.

Kantronics' state-of-the-art **Signal Enforcer**[®] introduces quality and versatility to variable-frequency/variable-bandwidth dual filtering

At last, you can have the ultimate operating edge with a tunable, dual filter that looks as good inside as it does outside and operates with the precision only quality engineering can offer.

The Kantronics Signal Enforcer[™] takes a one-two approach to knocking out interference to CW, radioteletype, single-sideband, ASCII and AM audio signals.

The Dual-Filter Approach

With the dual-filter approach, the Signal Enforcer can be used to maximize one signal (peaking) while it minimizes an interfering one (notching). It can also peak two frequencies at once, which is great for RTTY or ASCII signals, or it can notch two frequencies at once. The Signal Enforcer filters can even be teamed to offer a super-notch or super-peak single filter.

No Groping in the Dark

The operator is in total control with the Signal Enforcer, choosing not only the frequencies he wants to filter (from less than 100 Hz to over 3000 Hz) but the bandwidth as well (from less than 30 Hz to over 1000 Hz).

Because the Signal Enforcer is an audio filter, it works with the output of any receiver, regardless of coverage, and doesn't require internal connections.

Two tuning eyes on the Signal Enforcer front panel make locating signals for filtering easy even during crowded band conditions. The tuning eyes are LED indicators that find the heart of signals and blink with them so you know which signals you are filtering.

You Won't Groan When You Look Inside

Once you get past the attractive tan, cream and brown case, you'll still be happy when you inspect the Signal Enforcer inside. It was designed to operate with precision.

The boards, components, engineering design and craftsmanship are all first-rate. Glass/epoxy boards, dlp soldering and preci-

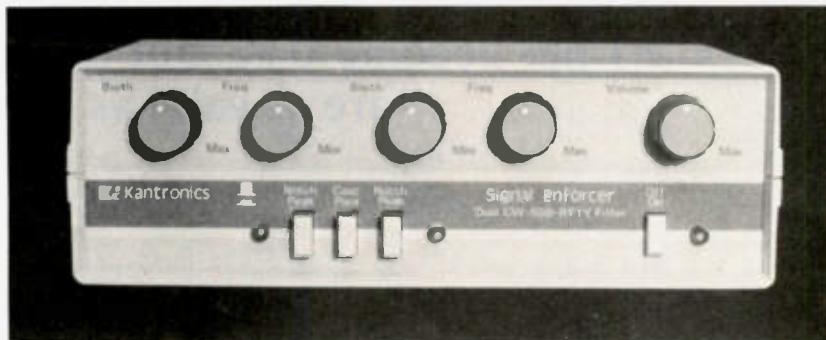

sion components are standard equipment. The Signal Enforcer was also designed for almost immediate turn-around should repair ever be needed. The circuits are divided by function and are replaceable with new modules by factory engineers. We don't have to make you wait while we find a problem.

Internal Power Supply

The Signal Enforcer has its own internal power supply. It is switchable for 230 VAC or 115 VAC at anywhere between 50 to 60 Hz. A back-panel connection will accept 12 to 18 VDC as well.

Full-Year Warranty

Kantronics is so confident of the Signal Enforcer, it backs up each unit with a 12-full-months warranty from the time of purchase. Defects due to workmanship or materials during the warranty period will be cheerfully repaired as quickly as possible at no cost to you other than the postage to send the unit in. We'll also be around to help you after your warranty expires.

Fifteen-Day Trial

Try a Signal Enforcer from us for 15 days to see what you think. We think you'll find it one of your most valuable pieces of station equipment. Many of our over 40 authorized dealers in the United States, Canada, England, Argentina, West Germany and the Netherlands will make you this same offer. (But check with them, first!) If

you're not satisfied, send the Signal Enforcer back in perfect order and we'll return your money less shipping and handling costs.

Specifications

Filtering: two identical filters, both providing peak and notch capabilities. Both filters are independently variable in frequency and bandwidth. **Modes:** The filters may be operated in parallel or cascade modes. Regardless of mode, both filters can peak or notch. **Bandwidth:** continuously variable from less than 30 Hz to over 1000 Hz. Once set, bandwidth remains constant regardless of frequency changes. **Frequency Range:** from less than 150 Hz to over 3000 Hz. **Audio Power Output:** 2 Watts maximum - variable through volume control. **Power Requirements:** 115 VAC or 230 VAC at 50 to 60 Hz or external 12-18 VDC source. **Inputs:** signal input, external DC input. **Outputs:** external speaker, external headphones, demodulator output. **Indicators:** Power, one tuning eye for each filter. **Size:** 2½" by 8" by 6". **Suggested Retail Price:** \$189.95 plus \$3.00 shipping/handling. Allow three weeks delivery from factory.

Kantronics
(913) 842-7745

1202 E. 23rd Street
Lawrence, Kansas 66044

All About Coordinated Universal Time

— GMT has become UTC, but the reasons for using it are as valid as ever

It is popularly called Greenwich Mean Time (GMT) and is now named Coordinated Universal Time (UTC), but is it universal? Universal time is a system that allows a person in one time zone to indicate the timing of an event to a person in another time zone without having to know which time zone that person is in.

For instance, if you received a QSL card from a ham in each of the twenty-four different time zones, and each ham used his local time on the card, it would be necessary for you to know the difference in hours between your time zone and each of the twenty-four. If they all

used UTC correctly, it would be necessary for you to know only the difference between your time zone and UTC. If your log was kept in UTC, you could look them up directly—a much simpler process. This is especially pertinent when you have many QSLs to locate in the log.

I speak from experience. In the aftermath of my NT7HEL operation, I was deluged with QSLs. It was very exciting finding a post office box full of cards every day. Exciting, that is, until I started checking the dates and times on the cards with those in my log and found many that didn't match. With over a thousand entries to hunt

through, I found myself slipping the hard-to-find contacts on the bottom of the pile.

Out of all of the cards received in the first month—they were still coming in eight months later—the following statistics emerged: 24% did not use UTC and 16% used it incorrectly. An interesting sidelight: 278 foreign QSLs were received, and every one used UTC and used it correctly! The two main incorrect uses of UTC were: Failure to advance the date when going past 2400 (UTC midnight), and adding an extra hour unnecessarily to UTC when converting from daylight saving time.

Let's look at these two errors. They both involve a misunderstanding of the mechanism of UTC. In order to convert from local time to UTC it is necessary to know the difference in hours between your time zone and the time zone centered on Greenwich, England. (See Table 1.) Using the Eastern Time zone as an example: We add 5 hours to Eastern Standard

Time to arrive at Coordinated Universal Time. Note that 7 pm EST is midnight (2400) in Greenwich. The same is true of 6 pm CST, 5 pm MST, and 4 pm PST. UTC time recorded after that hour should carry the next day's date and not your local date.

An example:

June 15, 1977—6 pm EST is
June 15, 1977—2300 UTC.
June 15, 1977—8 pm EST is
June 16, 1977—0100 UTC.

The error involving daylight saving time occurs when one uses the same time-zone difference as was used when converting standard time to UTC. Consider the fact that when your time zone changes to daylight saving time, you are in effect moving one time zone to the east (see Table 1 again). Using the Eastern Time zone again: During Eastern Daylight Saving time you add 4 hours to local time to arrive at UTC instead of 5.

One of the easiest ways to keep on top of Coordinated Universal Time is to have a 24-hour clock in the shack and keep it set to

| Time Zone | Abbreviation | Hours To Add |
|-------------------------------|--------------|--------------|
| Atlantic Standard Time | AST | 4 |
| Eastern Daylight Saving Time | EDST | 4 |
| Eastern Standard Time | EST | 5 |
| Central Daylight Saving Time | CDST | 5 |
| Central Standard Time | CST | 6 |
| Mountain Daylight Saving Time | MDST | 6 |
| Mountain Standard Time | MST | 7 |
| Pacific Daylight Saving Time | PDST | 7 |
| Pacific Standard Time | PST | 8 |
| Hawaiian Standard Time | HST | 10 |

Table 1. Local-time-to-UTC conversion.

UTC. Digital-readout clocks are now accurate, dependable, and cheap. Use this clock for logging purposes. When it passes 2400, you should change the date in your log to the next day.

One way to remove any doubt is to tune in WWV, WWVH, or CHU regularly, since the time signals on these stations are reported in UTC. When you can't raise any of the above stations, a quick call to 303-499-7111 (Colorado) will get you exactly the same information that is being broadcast on WWV. Interstate telephone calls are very inexpensive after 5 pm local time.

Relative to Daylight Saving Time, an Indian friend of mine compares it to a squaw cutting a foot off of one end of a blanket and sewing it on to the other end to make it longer. The state of Arizona apparent-

ly agrees with this philosophy, since we follow standard time all the year around.

What happened to the cards that I slipped to the bottom of the NT7HEL pile earlier? I converted the local times to UTC and found most of those. The rest required a search of the log, entry by entry, until they were found. A few never were.

Need another reason to use UTC? Some DX stations and their QSL managers will not search through a long list of contacts looking for your call. If you are not in the log where your card says to look, you are out of luck! Since the QSLs you send out are an attempt to convince the other guy that you really want one of his cards, why not make it as easy as possible for him to reply? Use Coordinated Universal Time! ■

NEW!!

ATTENTION MOBILE HAMS

15 METER MOBILE TRANSCEIVER CW & USB

NCG 15SB



THE QRP RIG WITH THE **BIG RIG SOUND** ACTIVE NOISE BLANKER—RF GAIN—CW SWITCH—SQUELCH—MIC GAIN—DIGITAL FREQUENCY DISPLAY—HI/LO POWER SWITCH—13.8 VDC 5A POSITIVE OR NEGATIVE GROUND.

DEALER INQUIRY INVITED.

NCG Co. ✓ 318

1275 N. GROVE ST.
ANAHEIM, CALIF. 92806 (714) 630-4541

NEW MFJ Deluxe Keyer has Speed Readout

Socket for external Curtis memory, random code generator, keyboard. Uses Curtis 8044 IC. Gives you dot-dash memories, weight, speed, volume, tone controls, speaker. Sends iambic, automatic, semi-automatic, manual. Reliable solid state keying, RF proof.



BRAND NEW

**Speed Readout Meter
lets you read to 50 WPM.
Socket for Curtis memory,
random code generator, keyboard.**

\$79⁹⁵

The new MFJ-408 Deluxe Electronic Keyer II is based on the proven Curtis 8044 IC keyer chip. **Speed readout meter** lets you read sending speed to 50 WPM. **Socket** (optional cable with plug, \$3.00) lets you use external Curtis memory, random code generator, keyboard (available from Curtis Electro Devices).

Sends iambic, automatic, semi-automatic, manual. Use squeeze, single lever or straight key. **Iambic operation** with squeeze key. **Dot-dash insertion.** **Semi-automatic "bug" operation** provides automatic dots and manual dashes.

Dot-dash memory, self-completing dots and dashes, jam-proof spacing, instant start. **RF proof.**

Ultra-reliable solid-state keying: grid block, cathode, solid state transmitters (-300 V, 10 ma. max, +300 V, 100 ma. max).

All controls are on front panel: speed, weight, tone volume, function switch. Smooth linear speed control. 8 to 50 WPM.

Weight control adjusts dot-dash space ratio; makes your signal distinctive to penetrate QRM.

Tone control. Room filling volume. Built-in speaker. Ideal for classroom teaching.

Function switch selects off, on, semi-automatic/manual, tune. Tune keys transmitter for tuning.

Completely portable. Operates up to a year on 4 C-cells. 2.5 mm phone jack for external power (6 to 9 VDC). Optional AC adapter \$7.95.

Eggshell white, walnut sides. 8x2x6 inches.

Stereo phone jack for key, phono jack outputs. **OPTIONAL BENCHER IAMBIC PADDLE.** Dot and dash pad-



dles have fully adjustable tension and spacing. Heavy base with non-slip rubber feet eliminates "walking." \$39.95.

Order from MFJ and try it — no obligation. If not delighted, return it within 30 days for refund (less shipping). **One year unconditional guarantee.**

Order today. Call toll free 800-647-1800. Charge VISA, MC or mail check, money order for \$79.95 plus \$3.00 shipping for MFJ-408 keyer and/or \$39.95 plus \$3.00 shipping for Bencher paddle.

CALL TOLL FREE ... 800-647-1800

For technical information, order/repair status, in Miss., outside continental USA, call 601-323-5869.

MFJ ENTERPRISES, INC.
BOX 494, MISSISSIPPI STATE, MS 39762

Don't Be a dB Dummy!

— use a pocket calculator to deal with decibels

For those of us who face the all-important test for that license, take heart! Working with gain and loss with dBs isn't all that hard. Trying to remember a dB table is a pain for some, including me.

Those people endowed with a "smart" calculator have no problem. You can keep your dB table on a program card and can take a break while the calculator does all the work.

If you have an old TI number-cruncher with a square root key, there might be an easier way.

Step 1 is to remember the binary number system. That shouldn't be too hard;

everyone can count to two. (See Table 1.)

Bear with me a minute. I don't want to lose you at this point (I lost myself the first time around). Just below the zeros, number from 0 to 10, starting with the LSB at the right as in Table 2.

All that is left is to figure the cube root of the binary number. It sounds hard, but turns out to be fairly easy.

For example, to figure 8 dB (power ratio), take the cube root of 256. Now, take a wild guess of 6 and enter that in the calculator. Now hit the times (X) button once. Enter 256, hit the

square root button twice and the times (X) once. Once again enter 256, hit the square root button twice and the times (X) once. By repeating this several times, you end up with 6.3495986, or approximately 6.35. The actual power gain is 6.31. While the figure from the calculator is not exact, it is close enough when you set it down for the test.

The actual dBs for power ratio vs. the calculator's answers are shown in Table 3.

Now, if you want to be really sneaky and figure the

voltage or current ratio, all you have to do is take the square root of the power ratio. Figuring any ratio higher than 10 dB is a snap. Take the corresponding number between one and ten. If you want to find the 13 dB power ratio, take the 3 dB power ratio of 2.00 and move the decimal point to the right one place. For 15 dB, use the 5 dB ratio, etc.

Now that dB tables are no longer giving you headaches, go on to bigger and better things. Field gain, transistor parameters, Q of a dipole, etc., etc. ■

| | | | | | | | | | | |
|------|-----|-----|-----|----|----|----|---|---|---|---|
| 1024 | 512 | 256 | 128 | 64 | 32 | 16 | 8 | 4 | 2 | 1 |
| 0 | 0 | 0 | 0 | 0 | 0 | 0 | 0 | 0 | 0 | 0 |

Table 1.

| | | | | | | | | | | |
|------|-----|-----|-----|----|----|----|---|---|---|---|
| 1024 | 512 | 256 | 128 | 64 | 32 | 16 | 8 | 4 | 2 | 1 |
| 0 | 0 | 0 | 0 | 0 | 0 | 0 | 0 | 0 | 0 | 0 |
| 10 | 9 | 8 | 7 | 6 | 5 | 4 | 3 | 2 | 1 | 0 |

Table 2. Bottom row is dBs.

| dB | Power Ratio | Calculator |
|----|-------------|------------|
| 0 | 1.00 | 1.00 |
| 1 | 1.26 | 1.26 |
| 2 | 1.58 | 1.59 |
| 3 | 2.00 | 2.00 |
| 4 | 2.51 | 2.52 |
| 5 | 3.16 | 3.17 |
| 6 | 3.98 | 4.00 |
| 7 | 5.01 | 5.03 |
| 8 | 6.31 | 6.35 |
| 9 | 7.94 | 8.00 |
| 10 | 10.00 | 10.07 |

Table 3.

FORMULA FOR 2 METER FM ENJOYMENT

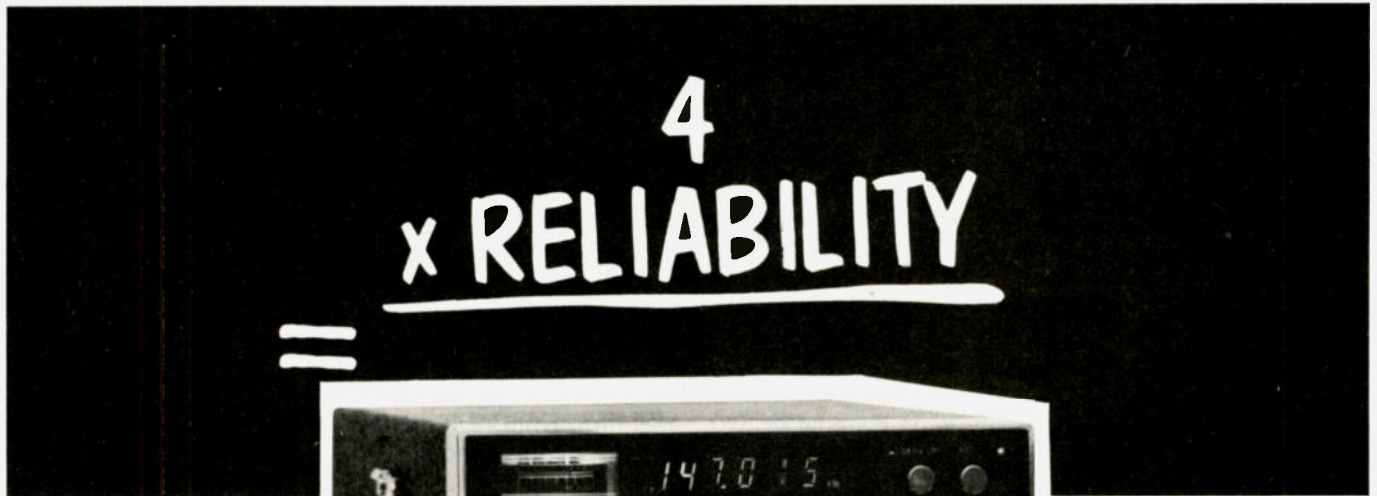

CLEGG FM-88

\$329.95

143-149 MHz

.25 uv sensitivity

mobile mount & microphone included

25 Watts (variable)

Provisions for non-standard splits
(CAP, MARS, etc.)

Optional AC power supply available

THAT'S CORRECT!!!

We are convinced that the FM-88 is four times more reliable than the other 2 meter rigs being offered. To prove it to you, we are supplying the FM-88 with *four times* more warranty than supplied with other models—One full year instead of the normally expected 90 days.

While there are radios on the market that offer lots of "gadgets"—our past experience

Phone 1 (800) 233-0250 today to order your FM-88 or to request a detailed brochure describing this fantastic transceiver & related accessories.

has been that simplicity of operation & elimination of unnecessary "Bells & Whistles" actually removes the causes of many failures being experienced with such transceivers.

If you are shopping for a new 2 meter transceiver, don't you owe it to yourself to go with a radio that has proven itself with thousands of hours of reliable, "On the Air" operation?

The FM-88 is also available with an 800 channel, programmable scanner—order model FM-88S—\$429.95



Clegg

Communications Corp.
1911 Old Homestead Lane
Greenfield Industrial Park East
Lancaster, PA 17601
(717) 299-7221

The Sweet Sounding Probe

This threshold-settable audio logic probe has been a must through many TTL and CMOS digital projects for the past few years. With this unit, the user can hear a logic 1 level and also determine the voltage of that logic 1 level to within a few tenths of a volt over a range of from about 2.2 to 12 volts. It is reliable, uses very few parts (none hard to find), and can be assembled

easily in an evening or two for about \$15.

The heart of the unit is a popular high-input impedance op amp (741C) which is used as a voltage comparator. Referring to Fig. 1, a reference voltage is applied to the noninverting op amp input by R8. When the voltage applied to the inverting input of U2 exceeds the reference voltage, the output voltage of U2 pin 6

will drop from near V_{cc} to about 3 volts. Since U2 is operated in an open-loop configuration (no feedback resistor from the output to the inverting input), action of the op amp approaches that of a Schmitt trigger, but without the usual hysteresis. D6-D8 and R4 limit base current to, and ensure positive cutoff of, Q1. The collector of Q1 then rises and turns on U1, a 555

audio oscillator. When the probe voltage falls below the U2 pin 3 reference voltage or when the probe is unconnected, U2 pin 6 rises, saturating Q1 and turning the audio oscillator off.

Power is furnished by a conventional full-wave rectifier bridge composed of D1-D4 and a +12-volt voltage regulator, U3. The unit may be powered from an external +12-volt source at J2 if desired; however, if the polarity-protection diode, D5, is included, the V_{cc} supplied to the reference-voltage pot, R2, may be somewhat lower (about +11.4 volts), which will affect the voltage calibration slightly. D5 may be bypassed, if desired.

The entire unit was constructed on a 3" x 3" etched PC board which accommodates all components within the heavy outline in Fig. 1. Alternatively, perfboard construction can be used.

Calibration is done after the unit is constructed. With a known voltage applied to the probe as shown in Fig. 2, make a series of calibrated settings with the power supply at one-volt intervals and apply dry transfer numbers under R8 in the appropriate locations where the audio transition just occurs. Finish with a light coat of acrylic spray for protection, and you're in business with one of the handiest ever accessories for your workbench. ■

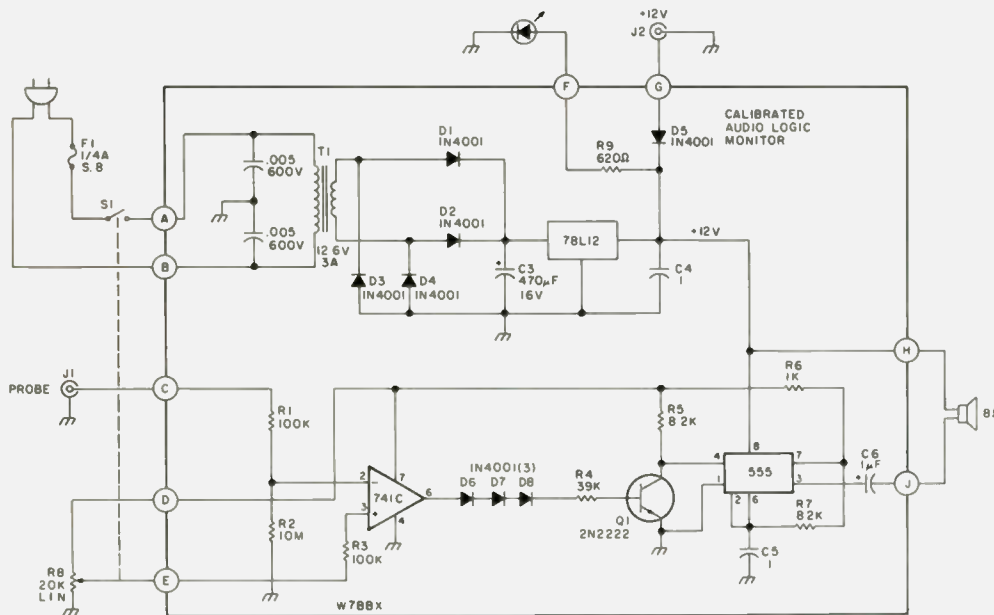

Fig. 1. Schematic diagram.

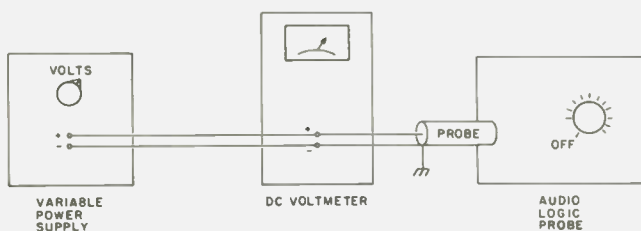

Fig. 2. Calibration connections.

SCR 4000

*The Feature -
Packed 450 MHz
Repeater!*

- 35W typ. Output
- Low Noise/Wide Dynamic Range 8 Pole Filtr. Front End for Excellent Sensitivity & Rejection of IM's & Spurious Responses.
- Sensitivity: 0.3 μ V Typ./12 dB SINAD
- 12 Poles of Filtering -For Incredible Selectivity! > -115dB 115dB @ \pm 25K-Hz

- Receiver Discriminator & Deviation Meter Functions!
- Ultra-High Stability Transmitter Crystal Oscillator/Oven.
- Plus-All of the Many Other Features Found in the SCR1000 VHF Repeater-Full Metering, Lighted Status Indicators/Control Push-buttons, Btry. Pwr. Input, AC Pwr. Supply, CW IDer, etc., etc.



180 Day Warranty

Shown in Optional Cabinet

**SCR1000 IS FCC TYPE ACCEPTED
for Commercial Services**

The SCR4000 UHF FM Repeater incorporates all of the many desirable repeater control, test and operating features which have been requested by our customers over the past several years. It includes the latest 'State of the Art' transmitter and receiver boards which were specifically designed for UHF Repeater application. The rest of the unit is basically the same as our tried and proven SCR1000 VHF Repeater, which has an excellent reputation for performance and reliability throughout the world! Only the very finest quality 100% 'Commercial Grade' designs & components are used throughout.

No cheap "Kit Type" Boards are used in any of our gear!

Of course, all of our Repeaters are available with a complete line of options and accessories... such as: Full Autopatch/Reverse Patch/Land-Line Control; Touch-Tone Control of various repeater functions; "PL"-CTCSS; "Emergency Pwr. I.D."; various Courtesy Tone and Timer units, etc. **PLUS**—the finest Duplexers, Cabinets, Antennas, Cables, etc.

The SCR4000 and SCR1000 are sold factory direct or through Foreign Sales Reps — at prices which are only about 1/2 that of the "big two" names in 2-way radio! **Get your order in A.S.A.P.!**

COMMERCIAL MOBILE & BASE TRANSCEIVERS - For U.S. or Export Markets

new

PCL250 25 W. Mobile Unit

- "Super Rugged" Housing Solid 1/8" Thk. Aircraft Aluminum!



"Professional Communications Line"

- 136-174 MHz & 220-240 MHz (450 soon).
- 6 channels.
- 0.35 uV Rcvr.
- 8 Pole Crystal Filtr.
- Beautiful Audio—RX & TX.
- Very Reasonable Price!
- Built-in AC Power Supply.
- Front Panel Status Indicator Lights.
- Optional Revr. Scanning Function Available

- Very attractive woodgrain housing.



FCC TYPE ACCEPTED—PARTS 21, 91, 90



Commercial Business
Radio Dealer
Inquiries Invited

SPECTRUM COMMUNICATIONS

Write or call for Data Sheets, prices, etc. ● Export orders—Contact our International Dept.
1055 W. Germantown Pk., Dept. S7 ● Norristown PA 19401 ● (215) 631-1710

LUNAR ELECTRONICS 3RD ANNIVERSARY SALE

SAVE 10% ON LUNAR'S TRANSVERTER MODULES

The Lunar line of modules allow a new concept in VHF/UHF operations. Combining appropriate modules allows you to construct a high performance system suitable for EME and weak signal work, contesting, or local work. □ The basic system consists of a Down Converter and an Up Converter module. Adding the appropriate Local Oscillator module will put you on the desired band. Improvements to this basic system are accomplished by adding amplifiers to both sides to attain the desired performance level. To change bands, merely changing the LO module (and the bandpass filter) will give you a new band with the same basic specs. □ Modules are packaged in well-shielded enclosures. Interconnections between modules are accomplished using the SMA-type microwave connectors and appropriate coax. Power requirements are 24VDC, with a 12V to 24V inverter module to be available soon for those requiring mobile operation. □ Write for free descriptive literature.

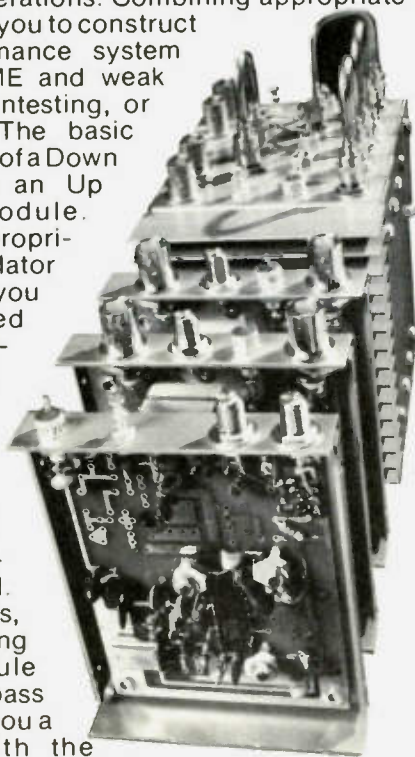

10% DISCOUNT ON ALL LUNAR PRODUCTS THROUGH JULY 31, 1980



2785 Kurtz Street, Suite 10
San Diego, CA 92110
Telephone: (714) 299-9740
Telex: 181747

Louis N. Anciaux
WB6NMT

Louis N. Anciaux, WB6NMT stands behind every product he makes at Lunar Electronics.



All Lunar products are designed and manufactured under the direct supervision of Louis Anciaux, head of Lunar Electronics. While Lunar maintains a complete QA department, Louis controls the final check-out. If it's not right, it's not shipped.

That's why, in amps, pre-amps, and transverter modules, Lunar is considered the standard of the industry. As in all ham products, you get what you pay for... that's why Lunar is your best buy.

LUNAR LINEARIZED AMPLIFIERS

One reason our Linearized amp/pre-amp combos are the best selling amps in the amateur market is the superior linearity our units exhibit in the SSB mode. To be "Linear," the amplifier's output signal must be an exact reproduction of the input signal, with only the power level changed.

Lunar is the originator of the LINEARIZED process, and all of our amps exhibit this by the very small amount of side-splatter produced. Others may attempt to copy us. But, why buy a copy when you can have the original.

2 Meter Amps

40 to 160 watt power output. From \$124⁹⁵

For 220 MHz

25 to 140 watt power output. From \$159⁹⁵

For 6 Meters

50 to 120 watts. From \$199⁹⁵

Commercial and other special frequencies available

LUNAR TRANSVERTER MODULES

The addition of Lunar Transverter Modules to your present transceiver in various combinations expands your station's coverage from HF through UHF.

FOR COMMUNICATION CAPABILITY

Adding Lunar Transverter Modules to your present transceiver allows you to include working Oscar Phase III, exploring 220MHz SSB, or many other present and future uses of amateur radio.

FOR AMATEUR TV (ATV)

Special Lunar Transverter Modules can allow you to transmit/receive 440 MHz ATV signals from/to Channel 3 I.F.

AMATEUR RADIO ASTRONOMY

Lunar can provide you with modules for receiving noise from the sky (make your own sky noise chart), or from the sun (plot occurrences of flares). We even have modules that receive the weather satellite transmissions (they can be connected to your home computer for a weather map print-out on your CRT display).

LUNAR RECEIVING PRE-AMPLIFIERS

These ultra-performance receiving pre-amps are suitable to the most demanding needs where low noise figure is important. Uses include all types of weak signal work such as EME, Tropo, Iono and Meteor Scatter, Satellite Communications, Radio Astronomy, weak, etc. Absolutely the highest quality construction and components.

Models for all amateur bands through 1296 priced from \$35⁹⁵



2785 Hartz Street #10
San Diego, CA 92110

(714) 299-9740 TELEX: 181 747

LUNAR ELECTRONICS 3RD ANNIVERSARY SALE

SAVE 10% ON ALL LUNAR PRODUCTS

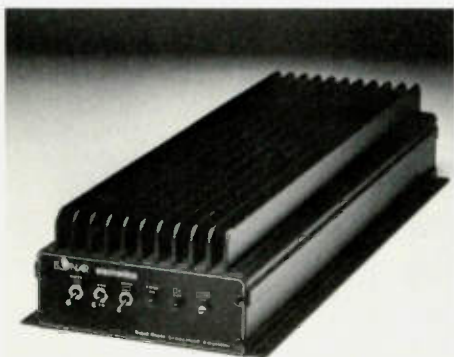

LUNAR'S LINEARIZED AMPS & PREAMPS

The only truly linearized amplifiers on the market today. Considered the standard of the industry.

LINEARIZED—ACCEPTS ALL MODES

- Low Power Input Yields nom 9-10 dB gain
- Covers Entire Amateur Band w/o Tuning (2MHz-50MHz Model)
- Built-in Receive Preamp
- Automatic T-R Switching
- Exceeds FCC R&O 20777 Requirements of -60 dB
- Variable T-R Delay for SSB/CW use
- Preamp & Power Amp Independently Controllable
- Preamp nom 9 dB gain 1.9 dB Overall NF
- One Year Warranty-90 days on Power transistors

28-432 LOW NOISE FIGURE RECEIVING PREAMPLIFIERS

These ultra-performance receiving preamplifiers are suitable to the most demanding needs where low noise figure is important. Uses include all types of weak signal work such as EME, Tropo & Ionosphere Scatter, Satellite Communications, Radio Astronomy, Meteor Scatter, etc.

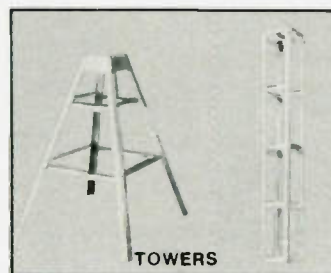

TOWERS

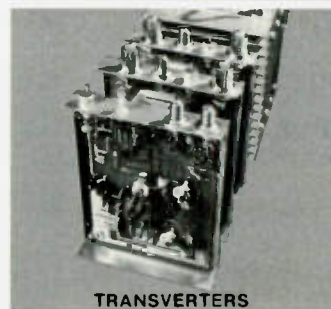

TRANSVERTERS

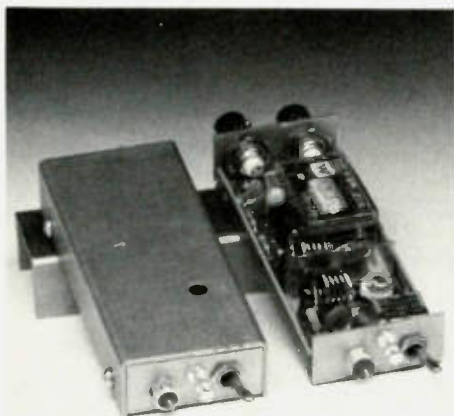

AMPLIFIERS

For a limited time only, V.A.R. pays the U.P.S. shipping on your new Lunar equipment.

VINEYARD AMATEUR RADIO ✓86

Art (WA6OYS)—Sales and Service—Jay (WB6YQN)
4407 Vineyard, Oxnard, CA 93030, (805) 485-0942

FOR YOUR VISA AND MASTERCARD ORDERS ONLY CALL

Nationwide 24-hour order line
1-800-854-2003, Ext. 873

California 24-hour order line
1-800-522-1500 ext. 873

The shipping is free... the call is free...
ORDER NOW!

DISCOUNT PRICES ON QUALITY HAM GEAR

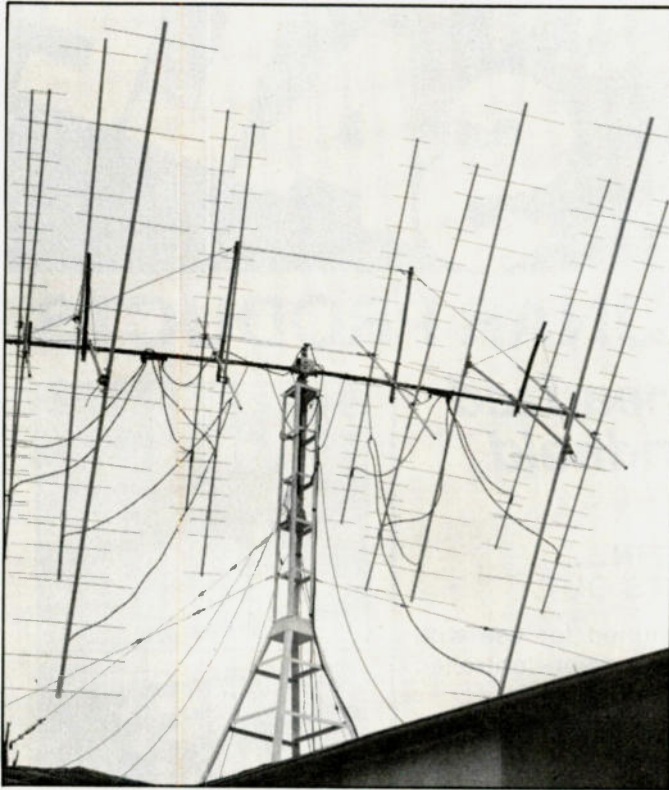

YAGI ANTENNAS

NMT-11 for 144 & 220

- Handles legal power.
- Lightweight at 4 kg.
- 31 degree beamwidth.
- High efficiency performance.
- Easily arrayed for increased gain.
- Low VSWR, under 1.2:1 at resonance.

RIW 19 for 432 MHz

- Outperforms all others.
- 24 degree beamwidth.
- Handles legal power.
- Low VSWR, under 1.2:1 at 432 MHz.
- Easily arrayed for increased gain.
- Lightweight at 1.3 kg.

Call for M&M's special prices on all antennas.

LINEAR TRANSVERTERS FROM SOTA



We are the exclusive U.S. Distributor for these high quality transverters from SOTA Communications Systems Ltd.

- 432 MHz transverter for Phase III
- 15 watt output
- Under 2 dB NF
- 1296 MHz transverter
- 2W output.
- 28 or 144 MHz IF available

**CALL FOR
SPECIAL
PRICES**

✓ 26

HF/SSB 5 BAND TRANSCIVER SS-105



- Covers 80M, 40M, 20M, 15M and 10M.
- Power output:
Model SS-105S: 10 watts.
Model SS-105D: 100 watts.

- Includes separate transceiver input and output connection.
- Modes: SSB, CW, and FM 10 watt model only (optional).
- Weighs only 3 kg (6.6 lbs.)

\$499⁹⁵

Write for free brochure.

M&M RF DISTRIBUTORS

2285 KURTZ ST., #4, SAN DIEGO, CA 92110
P.O. BOX 82183, SAN DIEGO, CA 92138

CALL (714) 299-9741

LUNAR ELECTRONICS 3RD ANNIVERSARY SALE

SAVE 10% ON ALL LUNAR PRODUCTS

Lunar's New 2M4-40P Linearized Amplifier makes your handheld transceiver a GIANT!



**1 to 4 WATTS IN...
10 to 40 WATTS OUT.**

Specifically designed for use with the new micro-processor-controlled hand-helds.

- Linearized: Use with any mode, including SSB.
- Coverage: Entire 144-148 MHz band plus approx. +500 KHz either end for MARS.
- Rated RF Power Levels: RF power gain is nom. 10 dB + 1 dB. Input drive 1/2-5 W at 13.6 VDC. 1 dB compression occurs at 4W drive.
- Preamplifier: Receiving pre-amplifier rated 10 dB gain nominal, 1.9 dB NF nom, 1.5 dB NF typical.
- Impedences: input and output impedences are nom. 50 ohms.

\$129⁹⁵
(Less 10%)

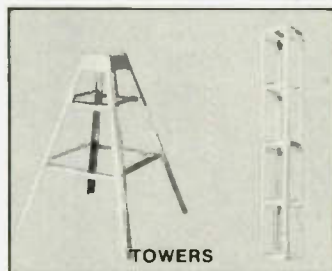

TOWERS

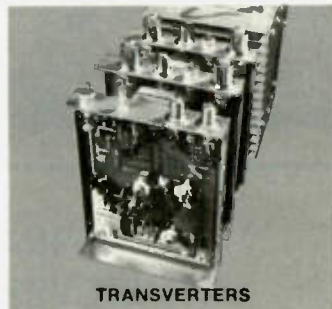

TRANSVERTERS

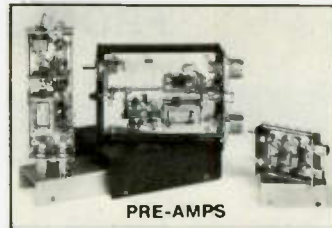

PRE-AMPS

**New Jersey's fastest growing Ham Store.
Stocking most major brands**

RADIOS UNLIMITED

1760 Easton Ave. (Rte. 527)
P.O. Box 347
Somerset, N.J. 08873

201-469-4599



343

Silence is Golden

— reassemble noisy transformers to eliminate hum

Radio Shack provides the experimenter/builder with a convenient, relatively inexpensive source of power transformers. These transformers are available in a good selection of voltage and current ratings and many are in use by builders of electronic gizmos. I have used several of these transformers over the years with good success.

Unfortunately, many of the transformers have, or develop, an annoying problem—they hum, and loudly at that. At first I assumed it was the way I was mounting them, but insulating the transformers with rubber strips, dipping them in glue, etc., did not help. Finally, when the 12-volt, 300-mA transformer in my alarm clock kept me awake half the night, I took some drastic action.

Taking the transformer apart, I immediately found the cause of the hum. It seems that the people who make Radio Shack transformers feel that it is not necessary to interleave the laminations on some of their transformers. They simply slip all the E-shaped pieces through the bottom of the winding bobbin and then place a laminated bar of the straight pieces across the top of the transformer. This technique is excellent for making 60-Hz buzzers, but not transformers. Not all Radio Shack transformers are made this way, but many, especially the smaller ones, are.

I tried gluing the laminations together, which worked for a while, but, sooner or later, the hum returned. The final solution was quite successful and is described here.

If your transformer hums, the chances are that it has the type of construction described above. Remove the outer metal band that holds everything together. Remove the E-shaped laminations from the bobbin winding assembly and separate the individual laminations. Although the lamination assembly is shellacked, the pieces can be separated easily by slipping a thin knife between them. Take care not to bend the laminations as this will lower the efficiency of the transformer.

Once all the laminations are separated, replace the E-shaped ones alternately from the top and bottom of the bobbin and winding assembly. Now replace the straight pieces in the spaces between the E-shaped laminations. Use a

speck of glue to hold the end straight piece on, if necessary. Tap the assembly lightly with a hammer to line up the laminations. Replace the metal outer band and squeeze everything together as tightly as possible. The transformer should operate quietly now.

I have modified several of the transformers in this manner, and none of them hums now. Although the procedure may sound time-consuming, it actually takes only about 15 minutes and it is well worth it. As an added benefit, the no-load primary current also is reduced by interleaving the laminations. On a particular 12-volt, 300-mA transformer, the no-load current dropped from 55 mA to 35 mA and the transformer operates considerably cooler. Enjoy the silence! ■

HAMFEST & JUNE 28 & 29, 1980
TRI-CITIES, WASH.

- ★ Nationally-known guest speaker
- ★ Saturday evening banquet
- ★ Special "Field Day" station
- ★ Camping facilities available
- ★ Family activities for all ages
- ★ Displays, lectures, contests, tours, +

★ For more information, write:
Tri-City Hamfest
P.O. Box 563
Richland, WA 99352

COMPUTER FAIR

Welcome to the '80s

— Radio Shack and Macrotronics make computerized operation a reality

If you are tired of fighting the SSB QRM and bored with computer games, checkbook balance programs, and biorhythms, maybe it's time for you to try some new modes of communication and make your computer an integral part of your station.

Macrotronics, P.O. Box 518, Keyes CA 95328, has developed a ham interface board which will directly tie the PET or TRS-80 computer to your ham equipment and provide auto CW/RTTY operation. The mechanical kluge, better

known as the noisy Teletype[®] machine, with its polar relays, rotating switches, and permeating odor of lubricant, has been replaced by the electronic keyboard and video CRT.

As with any new development in the throes of trying to get the product on the market in a timely manner, there are always some bugs which slip by. Perhaps the hardest part of business, and definitely the most important, is how the manufacturer reacts in supplying supplementary fixes and information to his customers.

The Macrotronics M-80 Ham Interface is designed to be used with the Radio Shack TRS-80 computer, and the M-65 model is designed for the PET unit. The interface can be supplied for either Level I or Level II with 4K or 16K RAM. With 4K, you lose the capability of 10 message registers, which allow the pre-entered contents of up to 255 characters each, to be transmitted in the send mode by entering only the message number. Fig. 1 is a picture of the completed board. The ac adaptor has been replaced with a shielded 12-volt transformer to ensure enough current to supply the accessory filter/amp board described later. The specifications for the interface are listed in Table 1. It is available in kit form for \$99, or ready-to-use at \$129. This price includes a board of good quality, all components and integrated circuits, board edge-connector for various signals to and from your ham equipment, six-inch ribbon cable and 40-pin TRS-80 external bus connector, ac adaptor, and a cassette containing the machine language and BASIC programs.

Some of the units were shipped without documen-

tation—a fate for most hams surpassed only by the unavailability of parts for their DX-35 or Benton Harbor Lunchbox. The kit I received contained a preliminary manual and schematic, with a note from Ron Lodewyck N6EE to the effect that there were some bugs in the software and the board had been reworked due to a problem with the RS-232 input—so the schematic was not correct. This is all to be rectified in the future.

After assembling the various components on the circuit board, I turned my attention to the ribbon cable and 40-pin bus connector. Connector problems are well known to TRS-80 experimenters—there aren't any. That is, there weren't until recently, and Macrotronics had the same problem. The connector supplied was of the no-strip, place, hold, cuss, position-cover, push-and-pray variety. Needless to say, such connectors are an exercise in futility, providing only binary operation—shorted pins or no connection. Hooking up the completed interface between the receiver output and the computer produced no smoke

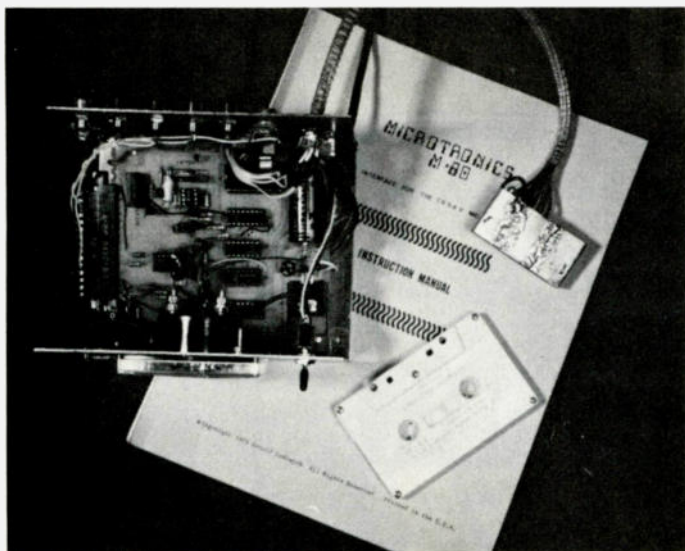

Fig. 1. Macrotronics M-80 Ham Interface.

but some other interesting anomalies. The computer could not be initialized when the interface was connected and the power on, but rather filled the screen with ROM character contents. With the converter power off, the computer could be initialized and the programs loaded, but as soon as the interface power was turned on the CRT screen would begin filling with -D-D from bottom right to left, line per line, until the screen was full, at which time the computer would hang.

Tracing back from the output on the board showed that the 7367 IC was never triggering the output. This IC requires a logic level low from the demultiplexer, which requires the correct DCBA code to be supplied by the A0-A3 lines of the computer bus. A checkout of the demultiplexer on the Heath Digital Design breadboard showed that all was in order on the chip. Numerous calls to Ron at Macrotronics only substantiated the fact that the computer and interface were not talking to each other.

The input signal line D0 is port 2 on the TRS-80 bus, and by writing a two-line input loop to check this port for each clock strobe, you can tell whether the port is receiving data by the value which appears on the screen (port 2 is assigned a value of 254). Since the schematic only tended to confuse the actual wiring layout, the board was returned to Macrotronics. Three weeks later I received the returned interface with a note saying that there had been an extra jumper wire installed on the board—no charge. They also included a new 40-pin connector with solder terminals, definitely worth the hassle of returning the board.

With fingers crossed, the retest proved successful.

Subsequent experimentation without the schematic showed that the hex inverter originally shown as a signal output buffer is not used, the output coming directly from the 7367. Changing the circuit to allow operation according to the schematic brought back the original problems, so now I know the cause and effect.

M-80 Capabilities

As the program begins, the operator selects either Morse or Baudot RTTY. If Morse is selected, the operator then initializes the send and receive speed between 10 and 100 words per minute. The software then places the system in Morse Send Mode with keyboard entry options for transfer to Morse Receive Mode, Change Character/Word Spacing, Change Speed, Transfer to RTTY Send Mode, Create a Canned Message, Send a Pre-entered Canned Message, Code Practice, Change CW Output Keying Mode (negative or positive), Change to 32 Characters Per Line (double-sized letters), or Return to 64 Characters Per Line Mode. Special CW characters such as AR, SK, AS, and KN also are available by pressing special keys on the keyboard which are not normally used in Morse code. The code practice mode allows Morse code practice by generating random characters or words from memory, made audible through the sidetone oscillator already on the circuit board (you supply the speaker). You also can practice sending by connecting a key to the key jack terminals.

In the RTTY mode, the operator may select Auto CW ID, Reverse Mark/Space, Change Baud Rate (initialized at 60 wpm), Create or Send a Canned Message, Turn Off Unshift-On-Space, Select 32 Char-

| | |
|-----------------------------|---|
| Power Required | 110-volt ac adapter supplied |
| External Connections | 15-pin edge connector supplied Inputs/outputs: Phase locked loop LED Receiver audio + 5-volt power LED Key or TU input RS-232 input (± 12 -volt) Ground TTY current loop keyer Negative-voltage solid-state switch Positive-voltage solid-state switch Sidetone out to speaker DIP relay, common DIP relay, normally open DIP relay, normally closed Computer bus (ribbon cable and connector supplied) |
| Software | Cassette supplied, with machine and BASIC programs |
| Required Memory | Will run with 4K at limited capability |
| Options | CW at 10-100 wpm send/receive RTTY at 60, 66, 75, 100 wpm send/receive 10 CW/RTTY message registers Auto CW ID on RTTY Sidetone oscillator Code practice mode with random word generation |
| Price | Kit: \$99, wired: \$129 Available for PET, TRS-80, Apple, and Sorcerer computers |

Table 1. Macrotronics M-80 Ham Interface specifications.

acters Per Line, or Return to 64 Characters Per Line Mode.

Three main points become evident very quickly when attempting CW operation:

1. The human ear and brain are vastly superior to a computer for copying hand-sent Morse.

2. The computer is vastly superior to the human brain and hand (fist) for sending Morse.

3. The majority of CW operators do not send steady, well-spaced manual Morse code.

According to the Macrotronics specifications, the computer should copy the selected speed within ± 10 wpm. However, this figure assumes that the character spacing and word separation do not change appreciably. Many fists are impossible to copy due to

short dashes or lack of space between characters and words. If the speed is relatively stable and the dot/dash ratio is good, the computer will display the data as continuous characters (most often the case). Try a 60-minute CW contact sometime, and see if you can detect a change between the first and final transmission. Electronic keyers are very forgiving, and even the paddle-operated types are relatively easy to copy as long as the operator does not try to send 25 wpm or more. A good keyer and experienced operator make for armchair copy. The phase locked loop input to the interface provides a very narrow bandwidth as long as the back-to-back diodes are not overdriven. There are also input terminals for a terminal unit (TU) or de-

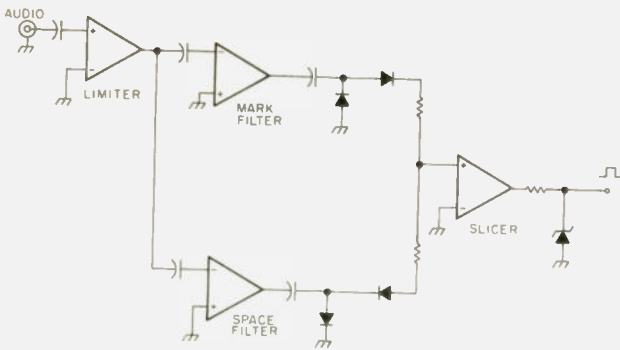

Fig. 2. RTTY terminal unit.

modulator (dc output) should you already have one.

To transmit in the CW mode you need only to connect the key input jack of your transmitter to the appropriate terminal on the interface board connector. In the send mode, all characters are entered from the keyboard just like a typewriter, and an input buffer allows convenient typing ahead. Then sit back and watch the screen as the memory contents are transmitted over the airwaves. Returning to receive mode entails pressing the CLEAR then ENTER keys; returning to send mode calls for only the CLEAR key. However, as long as there is a signal on the input port in the receive mode, the interrupt will not be recognized.

Thus, if there is noise below the signal but high enough to trigger the phase locked loop, you must have a method of interrupting the interface input or lowering the signal level to change modes.

Operating RTTY is similarly simple. The receiver must be tuned to the space frequency (via the receiver RIT control) and the phase locked loop trimmer on the interface board set for a convenient frequency between 800 and 2200 Hertz. Some receiver audio sections favor a lower range of audio frequencies. The trimmer needs to be set only once for both CW and RTTY and is not too critical since you can always move the signal within the passband of the phase locked loop by tuning the receiver

slightly. When you are tuned on the space frequency of a RTTY signal, the phase locked loop LED will blink. When the transmitting station is idle, the LED will not light unless you are tuned to the mark frequency. As noted in Table 1, there are numerous outputs for use in adapting a transmitter for FSK operation. Copy in the RTTY mode is relatively good, although it sometimes appears that the software misses a shift and a line or so of figure characters is printed.

CW/RTTY Operation

As supplied, the M-80 interface requires only a connection to the receiver audio output, transmitter key jack, TRS-80 bus, and ac wall socket for initial CW operation. For RTTY operation, you must have a transmitter with FSK capability (or AFSK—but no AFSK oscillator is supplied) or be willing to modify your transmitter/transceiver for FSK operation. Since FSK is a mode requiring 100 percent duty cycle, most transmitters and amplifiers will not take kindly to FSK operation at full output. However, if your transmitter/amplifier runs relatively cool,

and you are not bothered with replacing output tubes on a regular basis, you normally can operate FSK at 50 percent input power or more without trouble. If you have added a fan for final cooling you may be able to run slightly more power. In any event, if you decide to modify, keep transmissions short and check the final tube current to note any change from the tune-up value.

There are three main problem areas in obtaining reliable CW/RTTY copy via electronic means: QRN—Man-made and atmospheric noise; QSB—Fading; and QRM—Adjacent channel interference.

Generally speaking, the narrower the passband filter used, the better the noise figure. However, there is a point of diminishing returns where strong signals cause ringing or oscillation and the transmitting oscillator drifts out of the passband of the filter. More important than the filter bandwidth at the 3-dB points is the skirt response, or the common 6/60-dB figure which gives an indication of the actual filter out-of-passband signal-rejection capabilities. Atmospheric noise may be considered as broadband noise for our purposes since, if it is found in one portion of the band, it also will be prominent in the rest of the band.

Normally, we operate on the band which has the longest propagation for the time of day. Therefore, when we are relegated to 80 and 40 meters late at night, there probably is no other band open, and we have to make do with any noise which may be present. A good filter will help to minimize both noise and adjacent channel interference. However, regardless of the quality of the i-f filter used in the reception of CW/RTTY signals, there still are many times when

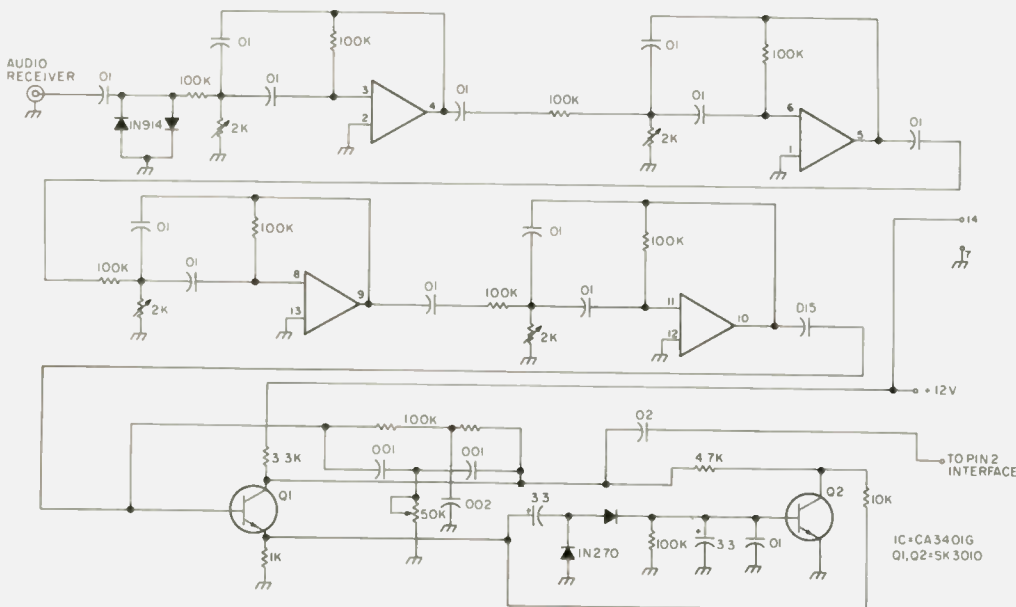

Fig. 3. Filter/amp schematic.

the noise level approaches the desired signal level (or vice versa) or somebody starts calling CQ within 100 Hertz of the signal we are trying to copy. The only hope of improving copy in these situations is to use a variable frequency filter. Those receivers which incorporate variable width and Q filters in the last i-f are easier to use. If you are going to operate CW/RTTY with your computer, I recommend an active variable audio filter of the type which installs either between the volume control and first audio stage or attaches directly to the receiver-speaker terminals. These filters normally have low-pass, null, and peak or narrow bandpass modes and controls which allow you to vary the width of the passband as well as placing the desired signal on one side of the filter skirt and the interference on the other, thereby increasing the signal level and decreasing the interference level. Any noise which gets to the phase locked loop will cause loss of "sync" and garbage to be printed on the screen. Therefore, it becomes important to maintain as good a signal-to-noise ratio as possible.

Probably the only thing worse than an intermittently fading signal is one which fades below S5 when the noise level is S3-5. When there is no appreciable noise present but strong fading, the computer will leave a space when a signal not strong enough to drive the phase locked loop is present. If there is noise which manifests itself only when the signal fades, the computer will print garbage when fading occurs. A strong adjacent signal will also produce a loss of the desired signal, and, if close enough in frequency, will cause the phase locked loop to select the signals alternately (another garbage mode).

Processing of the audio signal prior to its application to the interface, such as in a terminal unit, can be done to produce either an audio input to the phase locked loop or a dc level to the terminal unit input on the interface board. The terminal unit input is logic level high, or 1 for mark and low for space. In reality, only the low input level is recognized since the normal circuit state is high. This means that dual-processing channels, one for mark and one for space, are not necessary. The main goals for either the audio or dc unit should be to:

1. Maintain a filter bandwidth of approximately 100 Hertz.

2. Process a low-level audio signal just above the noise level and provide a signal to the interface which can be reliably copied.

3. Minimize signal fading effects on the interface unit.

You will notice that I did not say anything directly about noise. Processing a signal which is intermittently subject to noise becomes a long and expensive design procedure and is more effectively accomplished in the front end of the receiver in the first i-f section. The aim here is to do the best we can to increase the chance of good copy without a full blown, i.e., expensive, terminal unit. To this end, the receiver should have reasonably good agc and noise circuitry to start with. Although we do not have to worry about receiving the mark frequency, if we are copying a signal with 170 Hertz shift, the mark frequency is relatively close to the space frequency, and a wide passband allowing both frequencies to get through may cause desensitization of the phase locked loop circuitry. Similarly, since we do not need the mark frequency, the interface

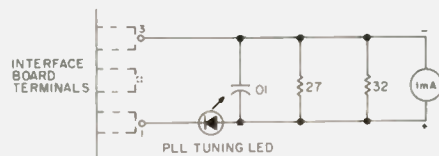

Fig. 4. M-80 board modification for tuning meter.

will copy any frequency shift.

Both methods, audio and dc, were tried. If both mark and space frequencies were required, the method illustrated in Fig. 2 would have the advantage of producing a constant output level for either mark or space by driving the slicer positive or negative. However, since we are interested only in the space frequency, to use the dc method the terminal unit must maintain a constant high when there is no space signal, and low or ground when the space frequency is present. In addition to the extra circuitry required to meet this criterion, no advantage was found in noise immunity. It requires a healthy gain figure to increase the amplitude of a marginal input signal to a level which will drive the diodes which rectify the audio into a 10-volt dc level to drive the slicer. Accomplishing this, we still need some method of maintaining this level as the signal fades.

Add-On Filter/Amp

With the experience gained testing the dc method and the nice operating characteristics of the phase locked loop in the interface, it was decided to stick with straight audio to the phase locked loop input. The circuit of Fig. 3 will provide reliable copy for signals just barely discernible on the S-meter. The CA3401G is available from James Electronics, 1021 Howard Avenue, San Carlos CA 94070. Other op amps may be used, and those requiring dual-supply voltages will provide more gain for fewer stages. Circuit layout is not critical, but components making up each filter network (100k, .01 uF, 2k) should not be mounted too close to an adjacent network. The gain can be adjusted by changing the .01 coupling capacitors higher for more gain. The .01 capacitors in the filter network are poly film or mylar™. Transistor Q1 serves as a final shaping stage to adjust the symmetry of the output wave.

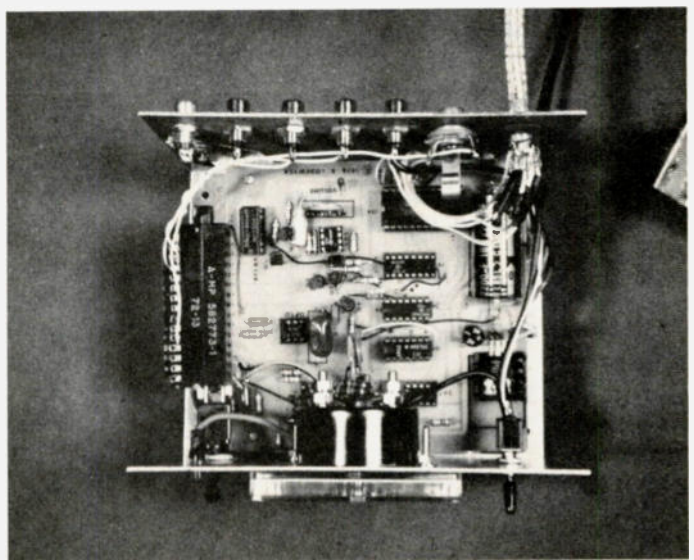

Fig. 5. CW/RTTY converter with the cover removed.

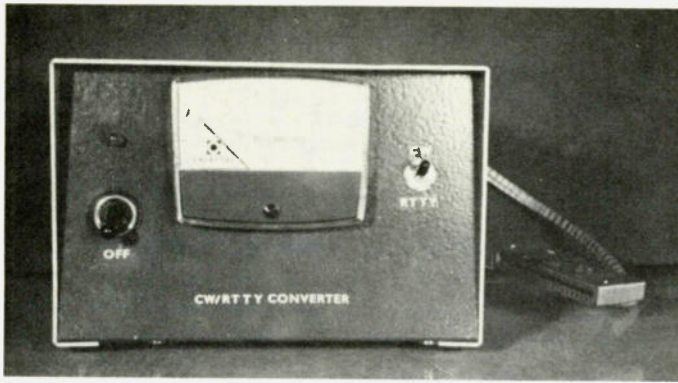

Fig. 6. The front panel of the converter.

Transistor Q2 provides a small amount of gain control on Q1. Slow fading of over three S units will be compensated by this stage.

Fig. 4 shows a modification to the interface board circuit which allows the installation of a 1 milliamperere meter to show signal level and make tuning easier than by trying to watch the brightness of the LED. Output level of the filter/amp circuit should limit at approximately 0.6 volt peak-to-peak. Tune each filter section for about 1200 Hertz, then recheck with the scope attached to filter output and interface input. Do not overdrive the filter with the signal generator. In operation, adjust receiver audio, after tuning in a signal, just slightly higher than the level required to drive the meter to maximum. Too high an input level will change the filter response and decrease the noise trigger threshold.

Fig. 5 shows the filter/amp and interface board with power transformer tucked into an enclosure ready to be added to the

station equipment. The 5-volt power indicator LED has been removed from the board and placed on the front panel, as seen in Fig. 6. The CW/RTTY switch shown is not required for normal operation. Note that the six-inch ribbon cable has been replaced with six shielded cables tied together and 12 inches long. (See Notes at the end of this article.) The 40-pin connector has been enclosed in brass stock which is grounded to the cable shields and to the computer ground bus via stranded wire. The brass enclosure is held to the connector by two short pieces of no. 14 wire which fit through holes carefully drilled through the solid portion at each end of the connector. A narrow piece of brass stock is soldered over the middle seam where the ends of the brass enclosure come together. Fig. 7 shows the rear panel with input/output jacks. Only those functions of the interface board utilized in my station were brought out to the rear panel jacks. The wiring is shown in Fig. 8.

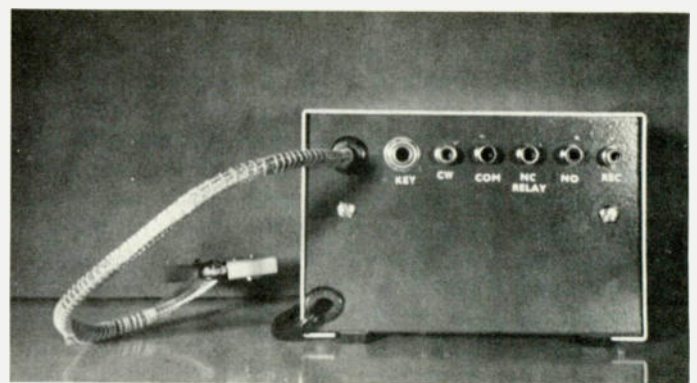

Fig. 7. The rear panel of the converter.

FSK for the FT-101

It is interesting to note that, with the M-80 interface, the same amount of data can be transmitted in the CW mode as with a 100 wpm teletype station. However, since not everyone has updated his equipment to microprocessor- or computer-oriented operation yet, we still need the capability of contacting stations using teletype equipment. Modifying the Yaesu FT-101 for FSK operation is relatively simple, and the same method should be applicable to most transceivers employing receiver incremental tuning. In normal FSK operation the space frequency is 850 or 170 Hertz below the carrier frequency. The lower shift gives better noise immunity and is utilized by most ham RTTY stations. Fig. 9 shows the modifications made to the FT-101, and Fig. 10 shows how the enclosure is mounted to the side of the transceiver. In Fig. 11, the mods are completed, and the equipment is ready for on-the-air testing.

To perform the modification, remove the bottom cover and unsolder the leads going to the clarifier terminal on the vfo case (two green wires). Solder a short length of hookup wire from pin 11 of the accessory plug, and attach a dc jack to the other end. A test-lead jack works well. If you use your rig portable, and have the accessory output in use in the shack, the plug must remain installed during portable operation because it contains a factory-installed jumper. By adding a dc jack, the converter can easily be disconnected for taking the transceiver out for remote operation.

out to the front corner of the transceiver on the side which has the handle attached. This is where the enclosure will be mounted.

Bring two wires from the location of the vfo terminals to the same side of the rig. Solder one to the vfo clarifier terminal and the other to the vfo regulated 6-volt terminal (blue wire and resistor). Install two more wires from the side of the rig to the external vfo socket. All five wires will enter the chassis in the bottom corner beside the capacitor trimmer board. When spread singly and wrapped with tape, there should be enough clearance so that the bottom cover does not have to be altered.

Solder one of these wires to pin 2 of the external vfo socket and the other to pin 3. (All of these pins normally should be unused.) Solder a short piece of hookup wire to pin 11 of the accessory plug, and attach a dc jack to the other end. A test-lead jack works well. If you use your rig portable, and have the accessory output in use in the shack, the plug must remain installed during portable operation because it contains a factory-installed jumper. By adding a dc jack, the converter can easily be disconnected for taking the transceiver out for remote operation.

If you do not have a plug for the external vfo socket, they are available at most

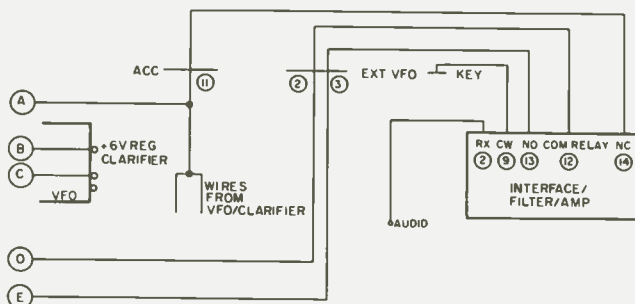

Fig. 8. Interchassis wiring.

supply houses. Be careful, however, when soldering leads to the plug, since the pin connections are probably different than the socket numbers. The single-pole double-throw miniature toggle switch allows normal operation when the converter is disconnected—such as in portable or mobile use. When the interface is connected to the rig, the switch will not affect normal operation since the normally closed contacts of the DIP relay on the interface board make the “normal” connection.

The momentary-action push-button allows tuning on the space frequency for test purposes when in the RTTY mode. When using the tune push-button, the wiring to the DIP relay on the interface board is shorted at the switch. The lack of the wire resistance will make the clarifier voltage high and cause a 40- to 50-Hertz high reading. This could be compensated by a resistance at the switch, but since it is used only for testing and we are aware of the resulting high reading which will vary from band to band, no extra components were added.

All circuitry is enclosed in an LMB 3-1/2 × 2-1/8 × 1-5/8 box which is mounted to the lower right side of the FT-101, using the existing screw hole. (The original screw was replaced with one slightly longer to ensure a solid mounting and a good ground connection.)

The hole for the mounting screw in the LMB box is made toward the top of the side of the box with the overlapping lips. The bottom of the box is held steady by a small angle which is screwed to the front side of the box with the opposite end of the angle resting on the front panel of the transceiver just inside the protruding edge of the rig. An 8-connection terminal strip was used to solder the incoming wires

and various switch lugs. The wires enter the box through a rubber grommet on the rear of the box. The RTTY bandswitch is a miniature, single-section, 2-pole, 5-position type.

After the circuit and wiring have been completed, make up cables and connect the converter interface/filter/amp to the FT-101. Attach frequency counter leads to transceiver counter leads to chassis and through a .01 microfarad capacitor to the rf output jack on the rear of the transceiver chassis. This jack provides an rf output from the driver stage. Set the FT-101 bandswitch for 80 meters and tune into a dummy load at a frequency of about 3.6 MHz with a carrier level of 2, as noted on the panel behind the carrier level control. When tuned, reduce the carrier level to just enough to give a stable reading on the frequency counter and set the frequency at 3.625170 MHz.

Allow the equipment to warm up for at least 30 minutes before beginning calibration. Set the RTTY bandswitch for 80 meters, the Normal/RTTY switch to RTTY, leave the FT-101 Mode switch in the Tune position, and activate the transceiver with the MOX/PTT/VOX switch in the MOX position. Recheck the carrier frequency, then short the Common and Normally Open plugs at the interface. Adjust the frequency at the 80-meter trimmer in the mod box for a frequency of 3.62500 MHz. If the three wires to the DIP relay jacks on the rear of the converter are unplugged, a double alligator clip may be used to short the Common and Normally Closed wires for carrier frequency reading and the Common and Normally Open wires for adjustment of the space frequency. Repeat frequency adjustment until no improvement is noted; normally this is with-

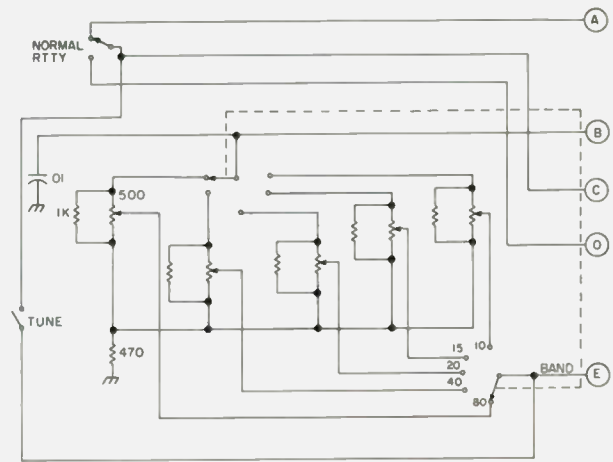

Fig. 9. FT-101 FSK modifications.

in 5-6 Hertz. Return the FT-101 switch to the PTT position. Adjust other bands for 170 Hertz below carrier in the same manner, remembering to set the RTTY bandswitch and change the shorting alligator clip for the desired carrier or space frequency.

The frequencies for the space frequency on the other bands are 7.090, 14.090, 21.090, and 28.090 MHz. These are in the portion of the bands normally operated by RTTY. Set the carrier frequency 170 Hertz higher to make trimmer adjustment to 0000 kHz easier. Before replacing the bottom cover, move the frequency counter to the vfo output terminal and check to see if the frequency is the same with the clarifier off and on, in the zero position.

If a difference is noted, adjust the trimmer located in back of the clarifier control until the frequencies coincide.

Modified FT-101 Operation

For CW operation with the computer ready, place the MOX/PTT/VOX switch on the FT-101 to VOX, the Mode switch to CW, and the computer will control send and receive. For RTTY operation, you are required to send your callsign in CW at least every 10 minutes. The M-80 software provides a register in which you can store ID information which is sent in CW when the CLEAR, SHIFT, and # keys are pressed. However, this output comes from the CW Keyer output of the interface which must be grounded for FSK operation with

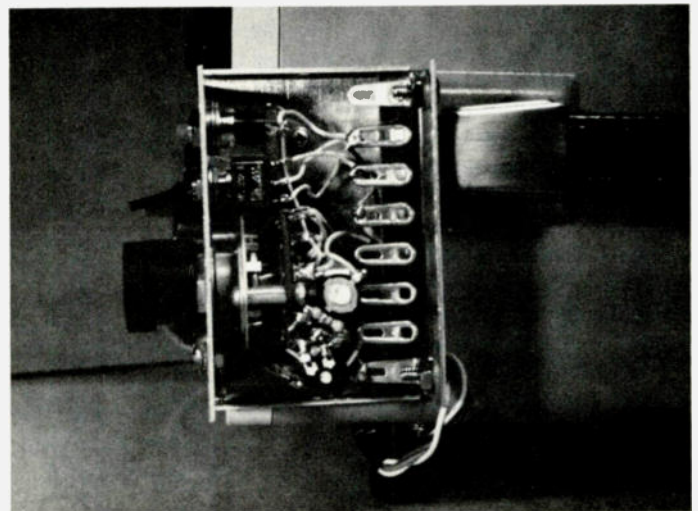

Fig. 10. FT-101 FSK modification box.

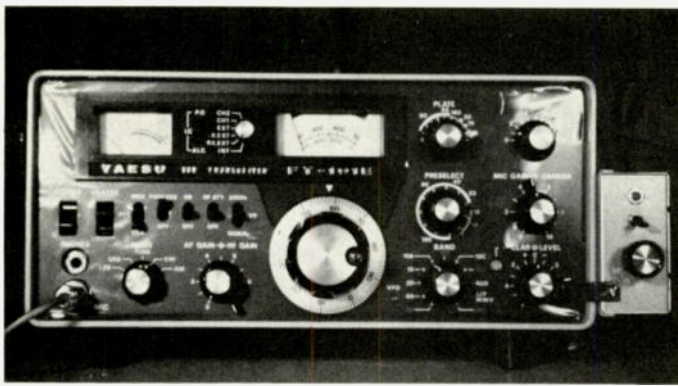

Fig. 11. FT-101 ready for FSK.

the FT-101 Mode switch in CW position. The easiest way around this problem is to place the FT-101 Mode switch in the Tune position, the RTTY bandswitch to the desired band, the RTTY/Normal switch to RTTY, and activate the transceiver with the MOX/PTT/VOX switch in the MOX position. This procedure also gets rid of the annoying sidetone oscillator output. After pressing the applicable keys for CW ID and seeing the words CW ID FOLLOWS appear on the screen, move the Mode switch to the CW position, and the contents of register O will be sent in CW. Return the Mode switch to the Tune position and the MOX/PTT/VOX switch to PTT and you are ready to copy. This procedure is much easier than using a hand key with a shorting bar.

TRS-80 RFI Notes

Like most computers, the TRS-80 emits a lot of RFI at different frequencies, depending upon the software operation being performed at any particular time. Since the 1.77 MHz clock is divided down, birdies can be expected just about anywhere in the spectrum. Unfortunately, at my location the antenna is only about 40 feet from the operating position and computer. I can tell what portion of a particular program is executing just by listening to the bleeps and warbles be-

ing radiated by the computer to the antenna and through the ham gear. The worst problem is probably on 15 meters, neglecting the VHF scanner.

Individual parts of the system were checked for extent of radiation and possible simple solutions. One problem which had me talking to myself for awhile was manifested by a 24-hour digital clock which displays UCT and is situated within an ac distribution box and 12-volt power supply. I first noticed that every once in a while, the clock would be fast, sometimes as much as 10 minutes. I checked the drivers (60-Hertz line clock) and the display with a stopwatch, and day-to-day comparisons would show little change until all at once it would be fast again. Although the thought had crossed my mind that the computer might be triggering the clock circuit, I had moved the computer power plugs to a different outlet. To make a long story short, at the time I was working on "Sorcerer," a game program from *Kilobaud Magazine*. It appeared that every time the program called a subroutine, the digital clock had a good chance of receiving an extra strobe for the seconds pulse! Changing the wall plug did not help much since they were both on the same circuit.

The CRT display is transformerless and radiates in

the lower part of the HF spectrum, but doesn't appear to be a problem unless you are working 160 meters. The video/sync/sweep lines from the monitor have only one shielded lead and do put out some radiation. Surprisingly, the keyboard/computer only radiates at the output/input connections. When a cable is attached to any of these jacks, it performs just like an antenna.

The following modifications dropped the interference level from a maximum of S7-8, in the worst case, to S2:

1. Shielded power supply leads.
2. Shielded all leads to monitor.
3. Replaced ribbon cable with shielded leads.
4. Installed 110-volt isolation transformer in monitor to supply ac for display and keyboard/computer power supply.

Conclusion

In this article I have tried to present an evaluation of the Macrotronics M-80 interface for those amateurs who may be interested in working CW/RTTY with a PET or TRS-80 computer. The filter/amp will serve as the minimum piece of equipment to help provide better copy. With a variable audio peak filter between the receiver output and filter/amp, operation has been found to be better than anticipated, with the ability to copy signals which don't move the needle on the S-meter, minimum noise interference, and lack of adjacent channel interference or QRM unless the signal is over S9 and within 50 Hertz of the desired station in frequency. The transceiver modifications presented should be applicable to the majority of ham transceivers, and are relatively easy to implement without affecting re-

sale value of the equipment.

Macrotronics Update

Since this article was originally authored, Macrotronics has available a new software package featuring deluxe RTTY/ASCII with split screen capability. The price of \$99 also includes two new integrated circuits incorporating a PTT capability. Modification to the M-80 circuit board is minimal and the software offers so many additional capabilities that the operator will be hard pressed to remember how to use them all.

In addition, the M-80 kit is no longer offered; the ready-to-use board now lists at \$149 with software cassette. I recommend ordering a catalog from Macrotronics before making a decision on what to purchase. They also offer a filter/demodulator board if you prefer not to build your own. ■

Notes On Connecting the M-80 Interface and Computer

The specifications for the demultiplexer integrated circuit used in the Ham Interface state that the cable length should be limited to six inches. Since such a short cable tends to make placement of equipment difficult and contributes to the breaking of the individual leads where they enter the board or connector, different lengths of cable were painstakingly tried utilizing W1AW bulletins as a reference signal. At 36 inches no abnormal effects were noted on CW. However, RTTY reception was degraded to about 30 percent copy on W1AW, to less than 10 percent on other stations. Still unexplained were the errors which repeated on a regular basis, such as the same extra letter every time the same word appeared, or the same apparent misspelling on the word "OSCAR." As the cable was shortened, the error rate decreased to the point where, at 12 inches, no measurable difference was noted from the six-inch length. All cables were individually shielded and laced together.

Radio Bookshop

The Magic of Ham Radio

by Jerrold Swank
W8HXR

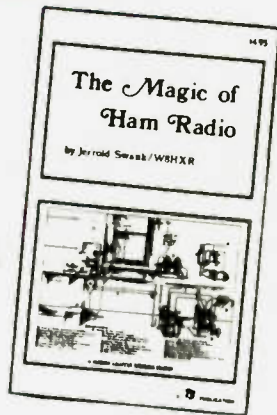

NEW from 73!

Under various call signs, Jerry Swank W8HXR has been heard on the ham bands since 1919. He has watched amateur radio grow from the days of Model A spark coils to an era of microprocessors and satellite communications. In *The Magic of Ham Radio*, Jerry gives his account of our hobby during the past six decades.

W8HXR has often been where the action is. Jerry has responded to calls for help from earthquake-stricken Managua and tornado-ravaged Xenia. Antarctica, one of man's loneliest outposts, has been a bit less lonely, thanks to Jerry's tireless phone patching efforts. Drawing on his own colorful experiences and those of many other hams, Jerry has compiled this word-picture of what ham radio was and is.

It has been said that any sufficiently advanced technology is indistinguishable from magic. Ham radio fits this description quite well. In what other activity is it possible to meet people, reunite them with loved ones, even save their lives without actually seeing those you've helped? Yes, there *is* something magical about ham radio, and we hams are the magicians. Order BK7312 \$4.95.*

*Use the order card in the back of this magazine or itemize your order on a separate piece of paper and mail to: 73 Radio Bookshop • Peterborough NH 03458. Be sure to include check or detailed credit card information, no C.O.D. orders accepted. Add \$1.00 handling charge. Note: Prices subject to change on books not published by 73 Magazine. Questions regarding your order? Please write to Customer Service at the above address. Please allow 4-6 weeks for delivery.

BW-2630 Battery Tool



BW-2630 \$19.85*
BT-30 \$ 3.95*
BT-2628 \$ 7.95*

BW-2630 BATTERY TOOL

The new BW-2630 is a revolutionary battery powered wire-wrapping tool. The tool operates on 2 standard "C" size NiCad batteries (not included) and accepts either of two specially designed bits. Bit model BT-30 is for wrapping 30 AWG wire onto .025" square pins; BT-2628 wraps 26-28 AWG wire. Both produce the preferred "modified" wrap.

Designed for the serious amateur, BW-2630 even includes both positive indexing and anti-overwrapping mechanisms — features usually found only in industrial tools costing five times as much. Pistol grip design and rugged ABS construction assure performance and durability. In stock at local electronic retailers or directly from

OK Machine & Tool Corporation
3455 Conner St., Bronx, N.Y. 10475 U.S.A.
Tel. (212) 994-6600 Telex 125091 ✓ 54

Minimum billings \$25.00, add shipping charge \$2.00
New York State residents add applicable tax

X-RATED

**OUTPERFORMS
ALL commercially
available tribanders
AND many monoband
systems, too!**

KT-34 UPGRADE KITS AVAILABLE
WRITE FOR COMPLETE DETAILS OR
SEE YOUR LOCAL KLM DEALER

KLM's KT-34X

20, 15, & 10M — FOR THE MATURE HAM ONLY

KLM 17025 LAUREL RD., MORGAN HILL, CA 95037. (408) 779-7363 ✓40

AN INVITATION

July 1, 1980, the cover price of *KILOBAUD MICROCOMPUTING* is going up to \$2.95. Inflation has finally hit. BUT, we would like to extend you an *INVITATION TO BEAT INFLATION . . . SUBSCRIBE OR RENEW* your present subscription from now until July 18, 1980, *AT THE OLD RATES.*

Don't miss an issue of the industry's most complete and informative journal by letting this *SAVINGS* pass by . . . fill out the coupon below today. This price increase makes all other Kilobaud Microcomputing subscription offers void on July 18th . . . so hurry and *BEAT THE 18% INFLATION.*

TO BEAT INFLATION

OF COURSE, I'LL BEAT INFLATION . . .

- New Subscriber Renewal (please affix an address label from your most recent magazine)
 1 year/\$18.00 2 years/\$30.00 3 years/\$45.00
 Payment enclosed Bill: Me Master Charge VISA Amerex

Card # _____ Expire Date _____

Signature _____ Interbank # _____

Name/Label _____

Address _____

City _____ State _____ Zip _____

Canadian—\$18.00, 1 year only, US funds. Foreign—\$23.00, 1 year only, US funds. Please allow 6-8 weeks for processing

THIS CARD EXPIRES JULY 18, 1980

KILOBAUD MICROCOMPUTING PO BOX 997 FARMINGDALE NY 11737

307B6



**MAKE MONEY...
SELL
MAGAZINE**

73

Selling 73 Magazine, the ham radio magazine that offers quality and quantity, brings the ham into your store. Once through the door you can sell him anything.

Plus . . . you make a profit selling "73". Newsstand price is \$2.95 and you pay only \$1.97 an issue (that's the standard dealer discount of 33 1/3%). You make 98¢ on each issue sold.

For information on selling 73 Magazine call 603-924-7296 and speak with Ginnie Boudrieau, our Bulk Sales Manager. Or write to her at 73 Magazine, 80 Pine Street, Peterborough, NH 03458.

Our dealers are telling us that "73" outsells them all . . . so call today and join the dealers who make money with 73 Magazine.

73 magazine

80 Pine Street, Peterborough, NH 03458

NEW

Traditional
Wire-Wrapping

JUST WRAP

Wire-Wrapping

WHY CUT?
WHY STRIP?
WHY NOT . . .

JUST WRAP™

WIRE WRAPPING TOOL

• AWG 30 Wire
• .025" Square Posts
• Daisy Chain or Point To Point
• No Stripping or Slitting Required
• JUST WRAP™
• Built In Cut Off
• Easy Loading of Wire
• Available Wire Colors:
• Blue, White, Red & Yellow

FATEDED U.S.A.
FOREIGN PATENTS PENDING

JUST WRAP TOOL WITH ONE 50 FT ROLL OF WIRE

| COLOR | PART NO. | U.S. LIST PRICE |
|--------|----------|-----------------|
| BLUE | JW B | \$14.95 |
| WHITE | JW W | 14.95 |
| YELLOW | JW Y | 14.95 |
| RED | JW R | 14.95 |

REPLACEMENT ROLL OF WIRE 50 FT.

| | | |
|--------|-------|---------|
| BLUE | RJW B | \$ 2.98 |
| WHITE | RJW W | 2.98 |
| YELLOW | RJW Y | 2.98 |
| RED | RJW R | 2.98 |

JUST WRAP-UNWRAPPING TOOL

| | |
|------|---------|
| JW 1 | \$ 3.49 |
|------|---------|

* Minimum billings \$26.00, add shipping charge \$2.00/New York State residents add applicable tax

OK Machine & Tool Corporation

3456 Conner St., Bronx, N.Y. 10476 U.S.A.
Tel. (212) 994-6600 Telex 125091

OK M & T CORP JW 1 PAT. PEND.

If you enjoy driving, you're going to get a **COMPUCRUISE**. Once you see what it can do, you just won't be able to live without it.



This gadget fits into most dashboards... no strain even in a tiny sports car like the Mazda RX-7... and once you have it, every trip is like flying a 747. The darned thing tells you the time, how fast you're going, how far you've been on this trip or since the last regassing, how many miles per gallon you're getting, either at the instant or the average on the trip... or gallons per hour at the moment or for the trip... temperature outside... inside (or coolant temperature, if you prefer)... oh, it has an elapsed time for the trip, a stop watch, lap time, an alarm... how much further for your trip, how many gallons more the trip will take, how much longer for the trip at your present average speed... yes, it gives you your average speed for the trip. You prefer it in metric, no strain... liters remaining, etc. Did we mention that it also has cruise control either at a speed set on the control board or at whatever speed you are traveling? The Compucruise will keep you busy and entertained during any trip... telling you more than you will ever want to know.

The Compucruise is not difficult to install... though it does connect to everything except the cigarette lighter. Until you've tried computerized travel, you haven't found out how much fun driving can be. It will work on any car not having fuel injection... and there is a front-wheel drive accessory gadget available for only \$4.40-#P001 (regularly \$5.50).

The price for the Compucruise is regularly \$199.95... and a bargain at that price. We'll sell you one of these fantastic gadgets for \$159.95 with cruise control (Model 44-#P002), and \$127.95 without (Model 41-#P003). Send money... and start having fun!

MOM'S

MAIL ORDER MICROS ✓53
Dept. 773 • PO Box 427 • Marlboro NH 03455
Phone: (603) 924-3041†

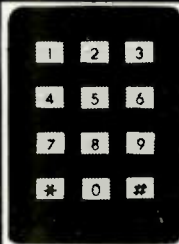

Steal Stopper

Ever had your car stolen?
The first reaction is one of disbelief...
... you know it was right there!

What you want is a modern combination lock on your ignition... The Steal Stopper. It's easy to install and almost impossible to defeat. You can by-pass it, if you want, for parking attendants or a car wash. Other than that, you get a secret four digit code and only will then be able to start the car... even if you have the keys in the ignition.

This protection retails for \$50... but we have a special for you at \$39.95. Don't procrastinate. Order #P004.

Note: This product works best on Detroit cars. Mazda RX7 owners must order additional module, #P008, which costs \$8. The Steal Stopper can be modified for Mercedes, Porsche, Ferrari, or other high performance European cars by returning unit to manufacturer with \$3. They promise quick modification and return.

MAGIC LIGHT BULB SAVER

If you've got a light bulb you need our MAGIC L.B.S., which increases the life expectancy of a new bulb 93 times!... and saves you 44% on energy costs. Regularly \$2.50... MOM's price is \$1.99 each. #LS001.

POLY-88 ACCESSORIES

- 1 Software on 5 1/4" — This is system software that requires a PolyMorphic Disk Controller in a System 88 Cabinet. #D002S-\$100.
- 1 Electric Pencil-#D003-\$80

MOM'S SOFTWARE SPEED READING COURSE

Could be the most important program you'll ever buy.

A tachistoscope simulation which enables the user to increase reading and comprehension speeds. A must for any TRS-80 16K Level II owner. Only \$5 per cassette. Order #R2001.



PANASONIC TAPE DECKS

Panasonic RS261 US Stereo Cassette Decks — with auto-stop, record level adjust, VU meters, used condition; all have had heads replaced and aligned. #T001-\$50.

Panasonic RS260 US Stereo Cassette Decks — same as above, but also has bias switch for chrome tapes. #T002-\$50.

COMPUCOLOR HARDWARE

- 2 Compucolor Computer 8001 (use as computer or 75 MHz Color Monitor) — 8K RAM, BASIC and DOS in ROM, good condition. #S025S-\$1400 each. **SPECIAL PRICE.**
- 2 Compucolor MiniFloppy — 5 1/4 inch, good condition. #S026S-\$500 each. **SPECIAL PRICE.**
- 4 Compucolor 8K RAM card — Static RAM, good condition. #S027S-\$190 each. **SPECIAL PRICE.**
- 3 Compucolor Floppy Tape Drive — Uses eight-track cartridges, good condition. #S028S-\$60 each. **SPECIAL PRICE.**

ALS-80

- 13 ALS-80 Operating system — This system requires 12K RAM from D000 to FFFF; as well as either the SOLOS or CUTTER monitor; It includes an Assembler/Editor. #D018-\$11.60 each.

POLYMORPHIC HARDWARE

- 6 PolyMorphic Video Terminal Interface — Memory mapped video for S-100 bus, good to excellent condition. #S044-\$150 each.
- 1 **SPECIAL PRICE** PolyMorphic S-100 Cabinets — Nice 5 slot S-100 mainframe, good to excellent condition. #D049 — \$248 each.

PROCESSOR TECH SOFTWARE

- 2 Processor Tech Extended Disk BASIC — This is full disk BASIC on 8" disk for HELIOS II disk controllers with PTDOS and greater than 16K. #D015S-\$70 each.
- 4 Extended Cassette BASIC — This includes all file operations, advanced functions for doing more than playing games; for SOLOS, CUTTER, and CONSOL Monitors. #D016-\$22 each.
- 16 BASIC 5 from Processor Tech — This is a simple BASIC for a SOLOS, CUTTER, or CONSOL Monitor and 8K of RAM. #D013-\$11.60 each.
- 4 Processor Tech GAMEPAC for above BASIC — Various simple games. #D014-\$10.00 each

ABACUS

- 56 S-100 Edge Connector — Gold Contacts, new. #D050-\$2 each.

TDL ZAPPLE

- 3 TDL ZAP 1K Monitor — Simple monitor. #D0073S-\$10.

LIMITED SUPPLY 73 MAG. AUG. '79

Contains controversial article "You Can Watch Those Secret TV Channels." Order #M001-\$5 each. (Plus shipping and handling.)

IMSAI PARALLEL I/O CARDS

- 1 IMSAI Parallel I/O card 4-4 — Four parallel ports, S-100, excellent condition. #D0093S-\$176.

IMSAI SERIAL I/O CARDS

- 2 IMSAI Serial I/O card 2-1 (kit) — One serial port, full control RS-232 control, S-100, new. #D0092S-\$90.

ICOM DISK DRIVE ACCESSORIES

- 1 ICOM PROM and 8" Disk for SOL FDOS — This disk requires an ICOM S-100 Disk Controller installed in an S-100. #D031S-\$150.
- 1 ICOM CP/M on 8" Disk for S-100 — Requires an ICOM S-100 controller in an S-100 cabinet. #D032S-\$90.
- 2 ICOM FDOS-II on 8" Disk for S-100 — Requires an ICOM S-100 cabinet, no documentation. #D033S-\$170 each.
- 1 ICOM FDOS-II on 5 1/4" Disk for S-100 — Requires an ICOM S-100 Mini-Floppy Controller in an S-100 cabinet. #D034S — \$155.

IMSAI SOFTWARE

- 2 IMSAI IMDOS V2.02 on 8" Disk for S-100 — No documentation but this is apparently IMSAI's version of CP/M for S-100 systems with an IMSAI Disk Controller. #D0056S-\$75 each

PROCESSOR TECH SOL

- 4 SOL Computers — 8K RAM Monitor, S-100, excellent condition. #D004S-\$950 each.
- 17 TREK-80 on cassette for SOL — This is one of the best real time space games available today; needs 8K. #D005-\$11 each.

CASIO'S NEW C-80 CALCULATOR CHRONOGRAPH



has lightweight attractive ruggedly built black plastic water-tight case and band, regular digital watch features of hours, minutes, seconds, AM/PM and day on display PLUS two time zones, calendar and a 4 function calculator! You've seen it advertised in the Wall Street Journal for \$75... MOM's price is only \$49.95. Hurry, our supply is limited... order #PC80 now.

5% EXTRA DISCOUNT

for orders with checks or money orders (see "TERMS" for details).

HEAD ALIGNMENT KIT

Best cassette recorder tape head alignment kit available. Solves loading problems. #K001-only \$9.95.

HONEYWELL

- 15 Honeywell ASR-33 Communications Consoles with TTY, paper tape reader and punch. Used, working when removed from service. Shipped freight collect or you pick up. Weight 300 lbs. \$375. Order #P006S.

SPECIAL 10% DISCOUNT
FROM LIST PRICES
SCOTT ADAMS ADVENTURES
FOR TRS-80 • SORCERER • APPLE

MOM'S



SALE

MAIL ORDER MICROS ✓ 53
Dept. 773 • PO Box 427 • Marlboro NH
03455
Phone: (603) 924-3D41

#1 ADVENTURELAND
YOU'LL WANDER THROUGH AN ENCHANTED LAND ENCOUNTERING WILD ANIMALS AND MAGICAL BEINGS WHILE YOU TRY TO RECOVER LOST TREASURES
Order #SA001T for TRS Level II 16K
#SA001S for Sorcerer 16K #SA001A for Apple 24K—\$13.45 each, on cassette

#2 PIRATE ADVENTURE
SAIL TO TREASURE ISLAND AND TRY TO RECOVER LONG JOHN SILVER'S LOST TREASURES
Order #SA002T for TRS Level II 16K, #SA002S for Sorcerer 16K #SA002A for Apple 24K—\$13.45 each, on cassette

#3 MISSION IMPOSSIBLE ADVENTURE
SAVE THE WORLD'S FIRST AUTOMATED NUCLEAR REACTOR WHEN YOU COMPLETE YOUR MISSION
Order #SA003T for TRS Level II 16K #SA003S for Sorcerer 16K #SA003A for Apple 24K—\$13.45 each, on cassette

#4 VOODOO CASTLE
SAVE COUNT CRISTO FROM THE FIENDISH CURSE OR FOREVER BE DOOMED—BEWARE THE VOODOO MAN
Order #SA004T for TRS Level II 16K #SA004S for Sorcerer 16K #SA004A for Apple 24K—\$13.45 each, on cassette

#5 THE COUNT
LOVE AT FIRST BYTE FROM YOUR BIG BRASS BED IN TRANSYLVANIA
Order #SA005T for TRS Level II 16K #SA005S for Sorcerer 16K #SA005A for Apple 24K—\$13.45 each, on cassette

#6 STRANGE ODYSSEY
YOU'RE MAROONED AT THE GALAXY'S EDGE AND DISCOVER RUINS OF AN ANCIENT ALIEN CIVILIZATION AND TRY TO COPE WITH UNEARTHLY TECHNOLOGIES WHILE YOU AMASS FABULOUS TREASURES
Order #SA006T for TRS Level II 16K #SA006S for Sorcerer 16K #SA006A for Apple 24K—\$13.45 each, on cassette

#7 MYSTERY FUN HOUSE
FIND YOUR WAY THROUGH THE STRANGEST FUN HOUSE BEFORE THE WEIRD PARK CLOSES
Order #SA007T for TRS Level II 16K #SA007S for Sorcerer 16K #SA007A for Apple 24K—\$13.45 each, on cassette

#8 PYRAMID OF DOOM
AN EGYPTIAN TREASURE HUNT THROUGH A NEWLY UNCOVERED PYRAMID COMPLETE WITH AN ANCIENT CURSE
Order #SA008T for TRS Level II 16K #SA008S for Sorcerer 16K #SA008A for Apple 24K—\$13.45 each, on cassette

TDL SOFTWARE-DISK

- 1 TDL FDOS & SuperBASIC on 8" Disk—This requires an ICOM Disk Controller and at least 20K of memory, plus a ZAPPLE Monitor in an S-100 Cabinet (Altair, IMSAI, etc.) #D0065S-\$125.
- 1 TDL System Software on 5 1/4" disk—This set of system software requires a North Star Disk Controller, and a TDL Systems Monitor Board I, and consists of 12K BASIC, Relocator/Linking Loader, Z-80 Editor, and Text Processor. #D0066S-\$170.
- 1 TDL System Software on 5 1/4" disk—This is the same as above, but does not require the Systems Monitor Board I. #D0067S-\$190.
- 1 TDL System Software on 5 1/4" disk—Again, as above, but requires a HELIOS Disk Controller and the TDL Systems Monitor Board II (not I). #D0068S-\$170.

CALLBOOKS 10% OFF

J5-CX01—was \$16.95, now \$15.25
DX-CX02—was \$15.95, now \$14.35

WAMECO S-100 Bare Computer Boards

| | | Retail | MOM'S Price | |
|-------|---------|--|-------------|--------------|
| 10 ea | CPU-1 | 8080 CPU Board | 26.95 | 22.95 #LP001 |
| 10 ea | MEM-1A | 8K Memory Board (2102) | 25.95 | 21.95 #LP002 |
| 10 ea | Mem-2 | 16K Memory Board (2114) | 26.95 | 22.95 #LP003 |
| 10 ea | EPROM-2 | 2708/2716 EPROM Board | 25.95 | 21.95 #LP004 |
| 10 ea | EPROM-1 | 1702 EPROM Board | 25.95 | 21.95 #LP005 |
| 10 ea | RTC-1 | Real Time Clock | 23.95 | 20.50 #LP006 |
| 10 ea | QM-9 | The Little Mother (9 slot) | 30.95 | 26.50 #LP007 |
| 10 ea | QM-12 | The Quite Mother (12 slot) | 34.95 | 29.95 #LP008 |
| 5 ea | FDC-1 | Floppy Disk Board | 42.95 | 36.95 #LP009 |
| 7 ea | FPB-1 | Front Panel IMSAI size) | 44.50 | 37.95 #LP010 |
| 1 ea | EPROM-1 | 1702 EPROM Board (asmbld) without EPROMS | 49.95 | 42.50 #LP011 |

BRAND NEW* TRS-80's and accessories at FANTASTIC SAVINGS

| | | | |
|---|---------------------|-----------------------------------|-----------------|
| LEVEL II 16K COMPLETE..... | \$690 #TRS-001X | FRICITION MODEL PRINTER..... | \$870 #TRS-005S |
| 16K EXPANSION UNIT..... | \$400 #TRS-002S | TRACTOR FOLD MODEL PRINTER..... | \$1350 #TRS-006 |
| 32K EXPANSION UNIT..... | \$525 #TRS-003 | LINE PRINTER III (AND CABLE)..... | \$1550 #TRS-007 |
| DISK DRIVES(Specify which drive you want) | \$425 each #TRS-004 | MOD II 64K..... | \$3400 #TRS-008 |

TRS TERMS: Shipment normally within one week of receipt of your order. Microcomputer accessories may take three extra weeks to ship. Personal checks take additional two weeks to clear bank. ADD \$2.50 PER ITEM FOR HANDLING. Everything will be sent to you with UPS freight charges COLLECT. Sorry, no credit card purchases or extra discounts on TRS-80 items.

**NOT UPGRADED USED OR RECONDITIONED LEVEL I's WITH OLD KEYBOARDS BUT BRAND SPANKING NEW TRS-80's IN FACTORY CARTONS WITH FULL FACTORY WARRANTY! COMPARE PRICES AND QUALITY AND ORDER FROM MOM'S.*

SIMULATED SURVEILLANCE VIDEO SYSTEMS

Since the video camera systems are totally psychological, that is, the visibility and suggestion of video cameras is what deters the thief's desire to steal, all that is really needed is a device that appears to be a functioning video camera. The SSV System provides the businessman with the same deterrent to crime as real systems at a fraction of the cost, because the cameras and alarm boxes are empty of electronics, but would-be crooks don't know this, and SSV Systems are extremely realistic in detail. Some scan back and forth and all have red neon lights. They feature easy installation, mount on any wall, have metal construction throughout, with wrinkle finish paint, all aluminum lens barrel with f-stops, footage markings, and convex optics, simulated coaxial cable and wall plate, manufacturer's unconditional guarantee, plus warning stickers included with all orders.

SVS 900 Scanning camera features 155 degree scanning action, long-life quiet, 1 rpm motor, only \$100 (regularly \$119.95) catalog #P0010. SVS 880 stationary camera is adjustable to any angle for fixed view coverage with mounting brackets and hardware, only \$50 (regularly \$58.95) catalog #P0011; or go first class with the SVS-2000, which has a soft blue finish with satin mylar trim only \$105 (regularly \$124.95) catalog #P0012, the stationary version is only \$55 (regularly \$62.95) catalog #P0013. Alarm boxes are only \$20 (regularly \$24.95) catalog #P0014 and complete your look of having real surveillance equipment installed at your business, home or office.

ASK MOM

For details of October 1980 Asian and European Electronics Tours. See January and February Wayne Green editorials in 1980 73 Magazine. Info #002. No charge.

IMSAI SOFTWARE

- 2 IMSAI IMDOS V2.02 on 8" Disk
- ★ for S-100—No documentation, but this is apparently IMSAI's version of CP/M for S-100 systems with an IMSAI Disk Controller. #D0056SS-\$75 each.

MOUNTAIN HARDWARE

- 7 Mountain Hardware AC Controller—Remote AC outlet control, S-100, new. #D040S-\$90 each.

5% EXTRA DISCOUNT

for orders with checks or money orders (see "TERMS" for details).

VECTOR GRAPHIC S-100

- 3 Vector Graphic ROM/RAM card
- ★ —12K empty ROM sockets, 1K RAM, excellent condition. #D0078S-\$100.

VERBATIM MINI DISKS

For TRS-80, Pet, Apple (Please specify which)
10 PACK—ONLY \$24.50
#P007 MOM's offers the Best for Less... Again!

HEURISTICS SPEECH LAB

- 1 Heuristics Speech Lab—S-100, used, fair condition. #S042S-\$90 as is. **SPECIAL PRICE.**

SPECIAL PRICE includes more than 20% discount.

• Indicates extra price reduction since last ad.
Quantities are limited, immediate refund if ordered item is no longer available.

TERMS: FOB Marlboro, NH USA. Limited stock; everything guaranteed as described; you pay postage on returns. PRINT orders clearly. Minimum order \$12.50 plus \$2.50 shipping and handling charge in USA only. **DOUBLE THAT ELSEWHERE.** Orders over \$50 add 5% for shipping in Continental USA; 10% elsewhere (We will refund excess.) We ship UPS or insured mail where possible. No COD's please. Send US funds by check or money order. 5% DISCOUNT on CASHIER'S CHECKS, MONEY ORDERS or CHECKS (2 weeks delay in shipping for checks to clear) or if you have cash buy a money order or cashier's check, and send it instead of cash. Credit card orders do not get the discount. For credit card purchases, list AE, MC or VISA, number, and expiration date. Mail to MOM'S, Department 773, PO Box 427, Marlboro NH 03455.

Condition of Inventory:
New = original container
Excellent = new, but not in original container
Good = tested or used in store

↑ Phone answered by machine. Orders taken with credit cards. Questions answered by mail. Please leave your name and address.

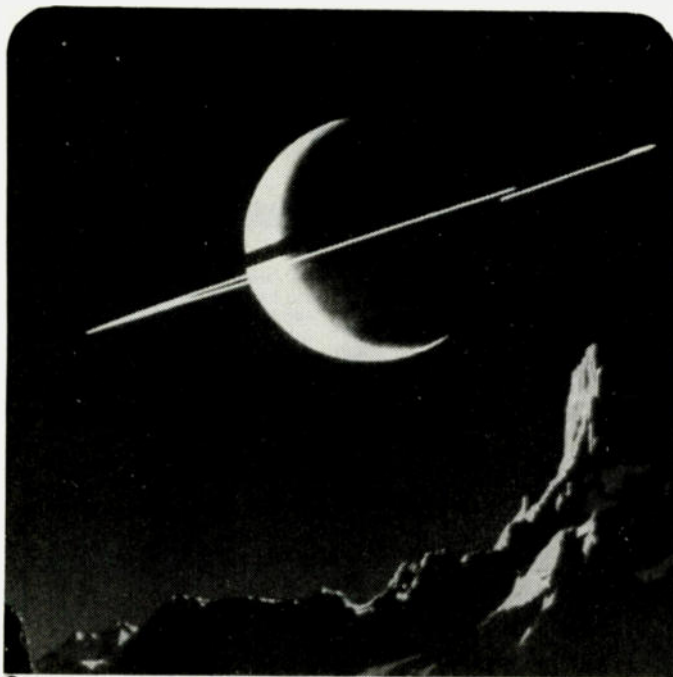

DECIDE NOW ... BECAUSE THE PRICES ARE GOING UP.

If you haven't made up your mind whether to subscribe to 80 Microcomputing ... NOW IS THE TIME. July 1, 1980 the cover price is increasing to \$2.50 and along with it the subscription prices are going up. BUT, 80 Microcomputing is giving you from now until July 18, 1980 to SUBSCRIBE OR RENEW AT THE OLD RATES.

SUBSCRIBE TODAY to the industry's only complete journal for the users of the TRS-80* at the old rates of \$15.00/1 year; \$24.00/2 years and \$36.00/3 years. Don't wait and have inflation hit again and pay the new rates of \$18.00/\$30.00/\$45.00.

OF COURSE, I'LL BEAT INFLATION

- New Subscriber Renewal (please affix an address label from your most recent magazine)
- 1 year/\$15.00 2 years/\$24.00 3 years/\$36.00
- Payment enclosed Bill: Me Master Charge
 Visa Amerex

Card # _____

Signature _____

Expire Date _____ Interbank # _____

Name/Label _____

Address _____

City _____

State _____ Zip _____

Canadian: \$15.00, 1 year only, US funds. • Foreign: \$20.00, 1 year only, US funds. • Please allow 6-8 weeks for processing.

THIS CARD EXPIRES JULY 18, 1980

ALL previous subscription offers to 80 Microcomputing are void July 18, 1980.

80 microcomputing™

PO BOX 981 FARMINGDALE NY 11737

*a trademark of Tandy Corporation

307B6

JULY SPECIALS

11C05 1 GHz, pre. Special \$59.95
ATF 417 pre-amp net Special \$19.95
MRF 901 UHF transistors, 1 GHz
Special \$ 3.95

COMPLETE KITS: CONSISTING OF EVERY ESSENTIAL PART NEEDED TO MAKE YOUR COUNTER COMPLETE. HAL-600A 7-DIGIT COUNTER WITH FREQUENCY RANGE OF ZERO TO 600 MHZ. FEATURES TWO INPUTS; ONE FOR LOW FREQUENCY AND ONE FOR HIGH FREQUENCY; AUTOMATIC ZERO SUPPRESSION. TIME BASE IS 1.0 SEC OR .1 SEC GATE WITH OPTIONAL 10 SEC GATE AVAILABLE. ACCURACY ± .001%. UTILIZES 10-MHZ CRYSTAL 5 PPM.

COMPLETE KIT.....\$129

HAL-300A 7-DIGIT COUNTER WITH FREQUENCY RANGE OF ZERO TO 300 MHZ. FEATURES TWO INPUTS; ONE FOR LOW FREQUENCY AND ONE FOR HIGH FREQUENCY; AUTOMATIC ZERO SUPPRESSION. TIME BASE IS 1.0 SEC OR .1 SEC GATE WITH OPTIONAL 10 SEC GATE AVAILABLE. ACCURACY ± .001%. UTILIZES 10-MHZ CRYSTAL 5 PPM.

COMPLETE KIT.....\$109

HAL-50A 8-DIGIT COUNTER WITH FREQUENCY RANGE OF ZERO TO 50 MHZ OR BETTER. AUTOMATIC DECIMAL POINT. ZERO SUPPRESSION UPON DEMAND. FEATURES TWO INPUTS; ONE FOR LOW FREQUENCY INPUT, AND ONE ON PANEL FOR USE WITH AN INTERNALLY MOUNTED HALTRONIX PRE-SCALER FOR WHICH PROVISIONS HAVE ALREADY BEEN MADE. 1.0 SEC AND .1 SEC TIME GATES. ACCURACY ± .001%. UTILIZES 10-MHZ CRYSTAL 5 PPM.

COMPLETE KIT.....\$109

PRE-SCALER KITS

HAL 300 PRE.....\$14.95
(Pre-drilled G10 board and all components)

HAL 300 A/PRE.....\$24.95
(Same as above with preamp)

HAL 600 PRE.....\$29.95
(Pre-drilled G10 board and all components)

HAL 600 A/PRE.....\$39.95
(Same as above but with preamp)

TOUCH TONE DECODER KIT

HIGHLY STABLE DECODER KIT. COMES WITH 2 SIDED, PLATED THRU AND SOLDER FLOWED G-10 PC BOARD, 7-567's, 2-7402, AND ALL ELECTRONIC COMPONENTS. BOARD MEASURES 3 1/2" x 5 1/2" INCHES. HAS 12 LINES OUT. ONLY \$39.95

DELUXE 12-BUTTON TOUCHTONE ENCODER KIT utilizing the new ICM 7206 chip. Provides both VISUAL AND AUDIO indications! Comes with its own two-tone anodized aluminum cabinet. Measures only 2 3/4" x 3 3/4". Complete with Touch-Tone pad, board, crystal, chip and all necessary components to finish the kit.

PRICED AT.....\$29.95

For those who wish to mount the encoder in a hand-held unit, the PC board measures only 9/16" x 1 3/4". This partial kit with PC board, crystal, chip and components.

PRICED AT.....\$14.95

ACCUKEYER—MEMORY OPTION KIT THIS ACCUKEYER MEMORY KIT PROVIDES A SIMPLE, LOW COST METHOD OF ADDING MEMORY CAPABILITY TO THE WB4VVF ACCUKEYER. WHILE DESIGNED FOR DIRECT ATTACHMENT TO THE ABOVE ACCUKEYER, IT CAN ALSO BE ATTACHED TO ANY STANDARD ACCUKEYER BOARD WITH LITTLE DIFFICULTY. \$16.95

ACCUKEYER (KIT) THIS ACCUKEYER IS A REVISED VERSION OF THE VERY POPULAR WB4VVF ACCUKEYER ORIGINALLY DESCRIBED BY JAMES GARRETT, IN QST MAGAZINE AND THE 1975 RADIO AMATEURS HANDBOOK. \$16.95

ACCUKEYER—MEMORY OPTION KIT—TOGETHER ONLY \$32.00

6-DIGIT CLOCK • 12/24 HOUR

COMPLETE KIT CONSISTING OF 2 PC G10 PRE-DRILLED PC BOARDS, 1 CLOCK CHIP, 6 FND 359 READOUTS, 13 TRANSISTORS, 3 CAPS, 9 RESISTORS, 5 DIODES, 3 PUSH-BUTTON SWITCHES, POWER TRANSFORMER AND INSTRUCTIONS. DON'T BE FOOLED BY PARTIAL KITS WHERE YOU HAVE TO BUY EVERYTHING EXTRA.

PRICED AT.....\$12.95

CLOCK CASE Available and will fit any one of the above clocks. Regular Price ... \$6.50 But Only \$4.50 when bought with clock

SIX-DIGIT ALARM CLOCK KIT for home, camper, RV, or field-day use. Operates on 12-volt AC or DC, and has its own 60-Hz time base on the board. Complete with all electronic components and two-piece, pre-drilled PC boards. Board size 4" x 3". Complete with speaker and switches. If operated on DC, there is nothing more to buy.*

PRICED AT.....\$16.95

Twelve-volt AC line cord for those who wish to operate the clock from 110-volt AC. \$2.95

SHIPPING INFORMATION

ORDERS OVER \$15.00 WILL BE SHIPPED POSTPAID EXCEPT ON ITEMS WHERE ADDITIONAL CHARGES ARE REQUESTED. ON ORDERS LESS THAN \$15.00 PLEASE INCLUDE ADDITIONAL \$1.00 FOR HANDLING AND MAILING CHARGES. SEND SASE FOR FREE FLYER.



"HAL" HAROLD C. NOWLAND
WBZXH

HAL-TRONIX ✓31

P. O. BOX 1101
SOUTHGATE, MICH. 48195
PHONE (313) 285-1782



Heavy Favorite

Hustler's 5-BTV™ five band vertical antenna.

Made heavier for better performance and quality. Heavier optimum Q traps assure accurate and permanent resonance for greater bandwidth. Heavier solid one-inch fiberglass trap forms give optimum electrical and mechanical stability.

One setting provides total band coverage from 10 through 40 meters with SWR of 1.6:1 or better at band edges, and up to 100 kHz on 75/80 meters.

Easy to assemble and install. Features high strength heat treated seamless aluminum construction throughout, plus heavy duty stainless steel hardware. Feed with any length 50 ohm coax.

For the BIG difference in performance, it's the Hustler 5-BTV antenna.

Clearly the choice of those who know quality.

HUSTLER INC. ✓ 305

3275 North B. Ave. • Kissimmee, Florida 32741

GET READY FOR PHASE III with KLM

We've got the whole package!

The time to prepare is NOW. Whether you're already serious about satellite communications, or considering the new Phase III worldwide DX opportunities for the first time, **KLM** has what you'll need.

A prime example is our 420-450 MHz 18 element Circular Polarized antenna. Designed for optimized communications through OSCAR 9, the 420-450-18C puts the lid on flutter and multi-path fading. And, with its typical **KLM** broadband response, the 18C also meets the critical needs of DX'ers, ATV'ers, and the 440-450 FM group. Totally new engineering and construction techniques put the **KLM 420-450-18C** head and shoulders above any competition. The optional CS-2 circularity switcher delivers fingertip control of circularity (RHC-LHC) right to your shack!

We didn't stop with the 18C. There's our Echo 70 transceiver, PA15-110CL linear power amplifier, 144-150-16C circular antenna and switcher, elevation and azimuth rotators, preamps and converters, "Great Little Towers," and more. **YOUR SATELLITE STATION IS AS CLOSE AS YOUR KLM DEALER.** Give him a call. For complete information contact:

KLM's 420-450-18C

✓ 40

KLM P. O. Box 816, Morgan Hill, CA 95037

The Multi-Media Bench Tester

— this audio/visual device will test
your diodes, SCRs, transistors, and more

After admiring the qualities of the new transistor testers on the market and realizing that I could not afford one, I decided to construct my own.

The new breed of transistor testers possessed several qualities that I liked:

1) The ability of testing a device without having to know whether it is a PNP or an NPN.

2) Being able to test the device when the collector, emitter, or base leads are not known.

3) Getting both an audio and a visual response from the tester.

After several weeks of trial and error and several prototypes, the final product was very satisfactory, and produced additional features that have made it

the ultimate in portable test equipment.

Theory of Operation

The quad two-input NAND gates (7400) are connected so that three of the gates act together as an oscillator with the frequency (about 15 kHz) determined by the 1- μ F capacitor. The final gate acts as a buffer/driver.

The 15-kHz output is fed into a 7490 decade counter which is connected in a divide-by-ten configuration. The 15-kHz signal also is used to provide base bias, or base driving signal, when S1 is closed while S2 is switched to R1 or R2.

The output of the 7490 decade counter, a signal of approximately 1.5 kHz, is fed to the clock input of one of the J-K flip-flops. The Q output is externally tied to the clock input of the remaining J-K flip-flop. The frequency at this point is about 750 Hz.

The Q output of the second flip-flop is attached to the collector of the transistor under test through the use of an alligator clip. The \bar{Q} output is connected through two paralleled LEDs (connected back to back) and an 8-Ohm speaker to the emitter of the transistor under test.

S2 determines the base current by selecting either a 470-Ohm series resistor or a 4.7k resistor. The 470-Ohm resistor would be used to test transistors with a low gain. The other half of S2 acts as an on-off switch.

Construction

Any method of construction may be used. Of the several transistor testers

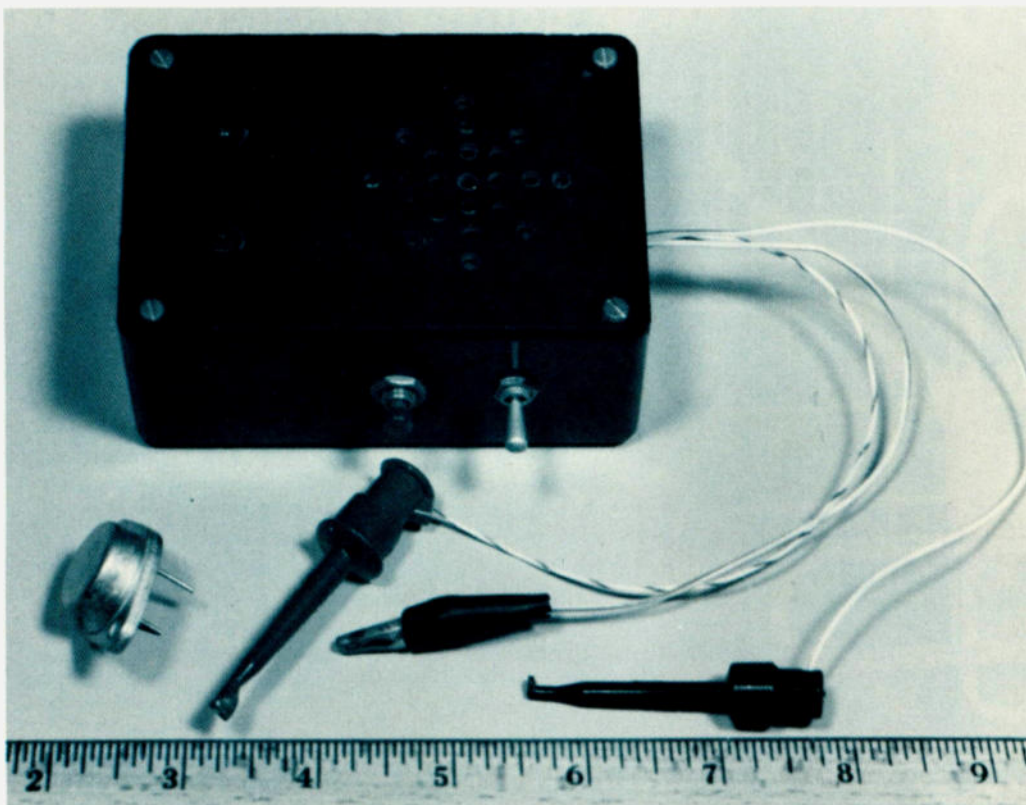

The finished transistor tester.

that have been built by others (using my design), some were wire-wrapped, some were soldered point-to-point, and some were actually built on a prototype PC board.

All you need is a suitable box to house the device, a battery pack, and a few hours for construction. If you are careful, the tester can be built for under \$10.

How It Works

The Q and \bar{Q} outputs of the J-K flip-flop are alternating from high to low at a rate of 750 Hz; thus, at one instant the Q output would be positive and the \bar{Q} output would be zero. To the transistor under test, this would look as if the collector is positive and the emitter is negative. If the transistor is an NPN, then the positive pulses from the base lead (when S1 is depressed) would turn the transistor on, thus allowing current to flow through the speaker and the LEDs.

When the Q output is zero and the \bar{Q} output is positive, this would correspond to a negative on the collector and a positive on the emitter of the transistor under test. If this transistor is a PNP, then the negative pulses (periods when the signal is at zero) from the base lead would turn the transistor on, allowing current to flow through the LEDs and through the speaker.

Because of the fact that Q and \bar{Q} are changing at a rate of 750 Hz, a tone is produced by the speaker (if a good transistor is being tested). The loudness of the tone depends upon the gain of the transistor.

How To Use It

1) When used as a continuity tester, the red and black leads are used. Continuity between these two leads will result in a tone being produced by the speaker (S2 must be on).

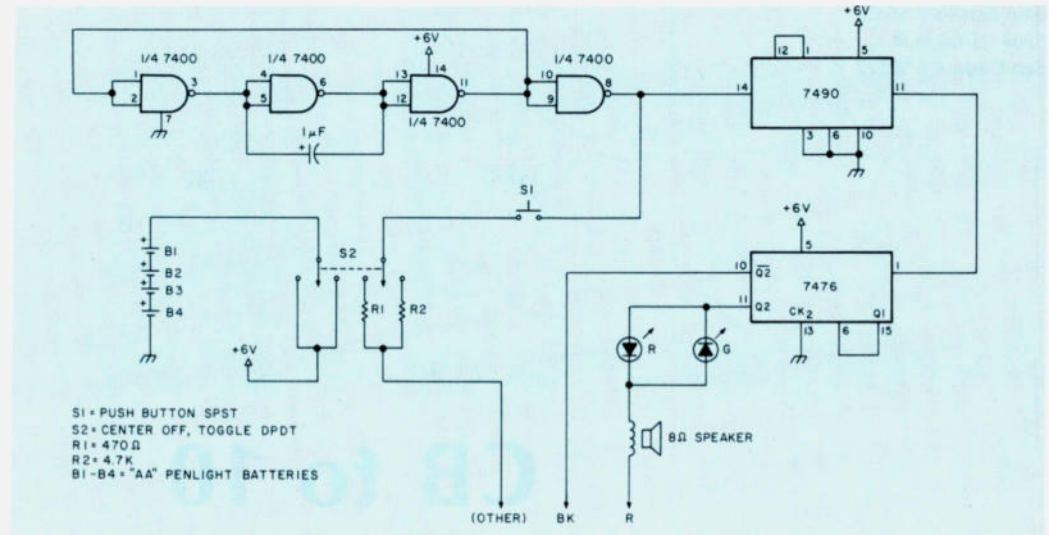

Fig. 1. Transistor tester schematic diagram.

2) To check diodes, each diode is connected between the red lead and the black lead. A good diode will stop current flow in one direction, thus lighting only one LED (S2 must be on). Possible test results are: tone and one LED lit—diode is good; tone and both LEDs lit—diode is shorted; no tone and no LED lit—diode is open.

Note: If collector and emitter leads are not known, the tester will test the transistor anyway, even if collector and emitter connections are backwards.

3) To check transistors, the red lead is connected to the collector, the black lead is connected to the emitter, and the blue lead to the base (press S1 with S2 on). The results could be: a tone (when S1 is depressed) indicates a good transistor; a tone (prior to S1 being depressed) indicates: 1) with one LED lit—transistor is connected wrong, or 2) with both LEDs lit—transistor is shorted. No tone (when S1 depressed) indicates an open transistor.

To determine if a transistor is a PNP or an NPN, remove the collector lead and place it on the terminal occupied by the blue lead (S2 must be on). If the red LED lights—NPN; green LED lights—PNP.

4) To check junction FETs, connect the red lead to the drain, the black lead to source, and the blue lead to the gate (S2 must be on—indications will be the same as for a bipolar transistor).

5) To check SCRs, connect the red and black leads to the anode and cathode (red and black leads can be reversed), and connect the blue lead to the gate. Depress S1—S2 must be on. Possible results are: tone and one LED lit—SCR good; tone and both LEDs lit—SCR shorted; no tone or LED lit—SCR open; tone and one LED lit before S1 is depressed—SCR connected wrong.

6) To use as an audio signal generator, switch S2 into either position (on) and

a 750-Hz square wave will be available between the red and black leads. The square wave output produces usable harmonics up into the VHF region. More uses for the ultimate transistor tester will be found by experimenting further. I have also used it to test TRIACs and UJTs.

In conclusion, it seems that commercial technicians are often wary of using something that does not have a meter on the front of it. I have used this device for over a year and I haven't been misled once—I trust it.

I finally realized that I had something special when one of my co-workers asked me to check an SCR on my tester, because the \$179 shop transistor tester would not check it. ■

Parts List

| Quantity | Description |
|----------|--|
| 1 | 7400 Quad 2-input NAND gates. |
| 1 | 7490 Decade counter. |
| 1 | 7476 Master-slave J-K flip-flop. |
| 1 | SPST Momentary contact n/o push-button switch. |
| 1 | DPDT Center-off toggle switch. |
| 1 | Red LED. |
| 1 | Green LED. |
| 1 | 8-Ohm Speaker (small). |
| 1 | 1.0- μ F Capacitor. |
| 1 | 470-Ohm, 1/4-Watt resistor. |
| 1 | 4700-Ohm, 1/4-Watt resistor. |
| 4 | AA Penlight batteries. |
| 1 | Battery holder for above. |
| 1 | Suitable box and hardware. |

CB to 10

— part XXVII: new life for SSB CB rigs

This article will describe the conversion of three 40-channel, phase-locked loop SSB transceivers to 10 meters. The three rigs are the Midland model 79-893, the original model of the President Grant, and the Cobra 138XLR. This conversion allows operation on almost the entire 10-meter band, from 28.04 MHz to 29.70 MHz. However, due to the Q of the tuned circuits, the output power and

receiver sensitivity are maximized only over a range of about 600 kHz. This conversion also allows direct read-out of the operating frequency to 5 kHz.

Most CB conversions consist of changing some crystals, retuning the rig, and modifying the clarifier so that it changes the transmitter as well as the receiver frequency. When I first converted my Midland, this is how I did it, but I

soon became dissatisfied with the results.

A Discussion of the Changes

The first problem is trying to tune a range of 10 kHz with the clarifier. It can be done, but usually the frequencies are spread out on one end of the range and bunched up at the other end. This makes tuning difficult while driving and, in some cases, frequency in-

stability can be caused. In one case I know of, frequency modulation was noticed at some settings of the clarifier. To avoid this problem, I rewired the LSB circuitry so that it operated in the USB mode but was offset from the normal USB frequency by 5 kHz. This allows me to tune the rig in 5-kHz steps instead of 10-kHz steps, which reduces the tuning range needed by the clarifier to 5 kHz. You lose the ability to operate in LSB, but in the year I have used my rig, I have heard only one LSB signal on 10 meters and I didn't really want to talk to him anyway.

The second problem was the limited frequency range allowed by the 40-channel selector switch plus the missing channels that were set aside for radio control operation. There were too many stations I couldn't contact because they were slightly out of my tuning range in one of the radio-control channels. Then there were the times I

Photos by Marcia Bradsher



Photo A. The Midland, showing the BCD switch in place of the rotary switch. Notice that the switch is reading 850, which is an operating frequency of 28.50 MHz.

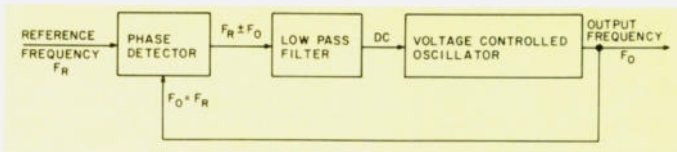

Fig. 1. Block diagram of a simple phase-locked loop.

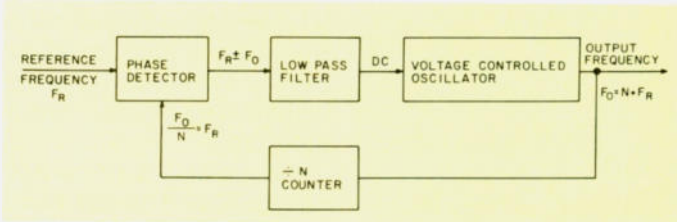

Fig. 2. Block diagram of a more versatile phase-locked loop.

wanted to QSY up 10 kHz to avoid QRM, but I didn't know whether I was going up 10 kHz or 20 kHz. Worse yet, I could go down 20 kHz when switching from channel 23 to channel 24. I made up a chart of frequencies vs. channels, but it was difficult to read while driving along the freeway at 55. Clearly, there had to be a better way, and I think I found it. By replacing the 40-channel selector switch with a binary-coded decimal (BCD) thumbwheel switch, the above problems were eliminated and, as a bonus, if the crystal frequencies are selected right, the switch reads out the actual operating frequency.

Another change I made was to replace a zener-diode voltage-regulator circuit with a 723 voltage regulator. This was to prevent a slight frequency shift caused by the input voltage changing. This change was made only on the Midland, as the other two rigs did not exhibit the problem. It would be a good idea to check your rig out in your car to see if you have a problem before making this change. It may not be needed.

The last change I made was to increase the output power. After about ten months of operating on 10 meters, I found the output power to be less than 5 Watts. By disabling the

automatic load control and pruning the output coils, I was able to increase the output power to 10 Watts.

Understanding the Phase-Locked Loop Circuit

To understand how this conversion works, you must first understand how a phase-locked loop frequency synthesizer works. Fig. 1 is a block diagram of a simple phase-locked loop. Two frequencies enter the phase detector: the reference frequency, F_R , and the output frequency, F_O . The output of the phase detector is the sum ($F_R + F_O$) and difference ($F_R - F_O$) of the two inputs. When the two input frequencies are equal, $F_R - F_O = 0$ and the output of the phase detector contains a dc component. The low-pass filter rejects the sum frequency and passes the dc component. The dc component in turn controls the voltage-controlled oscillator (vco) output frequency to keep it the same as the input frequency, F_R . For example, if F_O tries to increase above F_R , the dc component changes in such a way as to decrease F_O ; if F_O tries to decrease below F_R , the dc component changes in such a way as to increase F_O . The preceding explanation is for a very simple phase-locked loop where $F_O = F_R$. If you need F_O to be greater than F_R , then the circuit of Fig. 2 can be used.

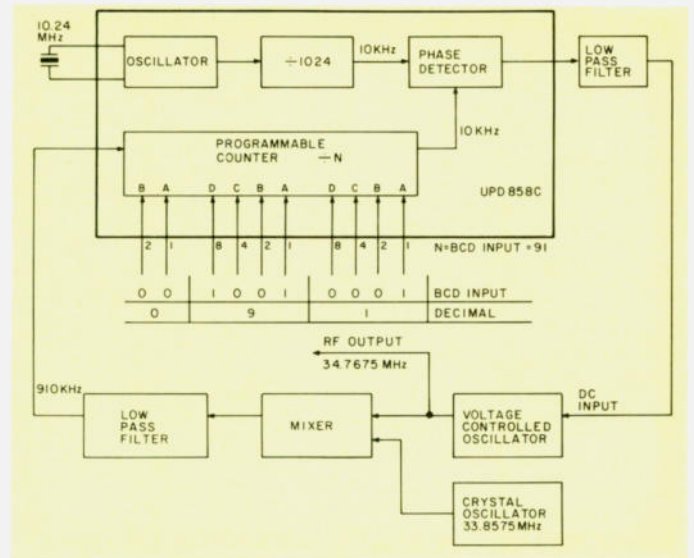

Fig. 3. Block diagram of the Midland 79-893, President Grant, and Cobra 138XLR phase-locked loop.

The output frequency of the circuit shown in Fig. 2 is N times F_R , or $F_O = NF_R$. The counter divides F_O by N : $F_O/N = NF_R/N = F_R$. Therefore, the two inputs to the phase detector are the same frequency just as they were in the previous explanation. In all other respects, the two phase-locked loops are the same. By adding the divide-by- N counter in the feedback loop, the phase-locked loop is made much more versatile. For a given reference frequency, the output can be any multiple within reason. Also, if N can be changed, then the output can be changed, in steps equal to F_R . For a more detailed explanation of PLL theory, see references 1 and 2.

The phase-locked loop for these three rigs is a bit more complicated. The block diagram for this PLL is shown in Fig. 3.

The frequencies shown are generated for USB channel 1 operation on the CB band. The operation of this phase-locked loop is as follows. The 10.24-MHz output of the reference oscillator is divided by 1024 to give a reference frequency of 10 kHz into the phase detector. For channel 1 operation in the CB band,

the programmable counter divides by 91. Since the output of the counter must be 10 kHz (the same as F_R), the input to the counter is 910 kHz. The crystal oscillator is fixed at a frequency of 33.8575 MHz. Therefore, the vco output frequency is 34.7675 MHz, or 910 kHz higher. For transmitting, the 34.7675 MHz is mixed with 7.8025 MHz to get the 26.965-MHz channel 1 output. For receiving, the incoming 26.965 MHz is mixed with the 34.7675 MHz to get the difference frequency of 7.8025 MHz, which is the receiver i-f.

To change channels, the programmable counter divisor must be changed. Since the output of the counter is always 10 kHz, the channel separation will be 10 kHz. For example, for channel 2 operation, the programmable counter divides by 92. This forces the input of the counter to be 920 kHz; thus the output of the vco must be 34.7775 MHz, or 920 kHz greater than the crystal oscillator. This raises the operating frequency to 26.975 MHz, or an increase of 10 kHz.

The control input to the programmable counter must be a binary-coded decimal (BCD) value equal

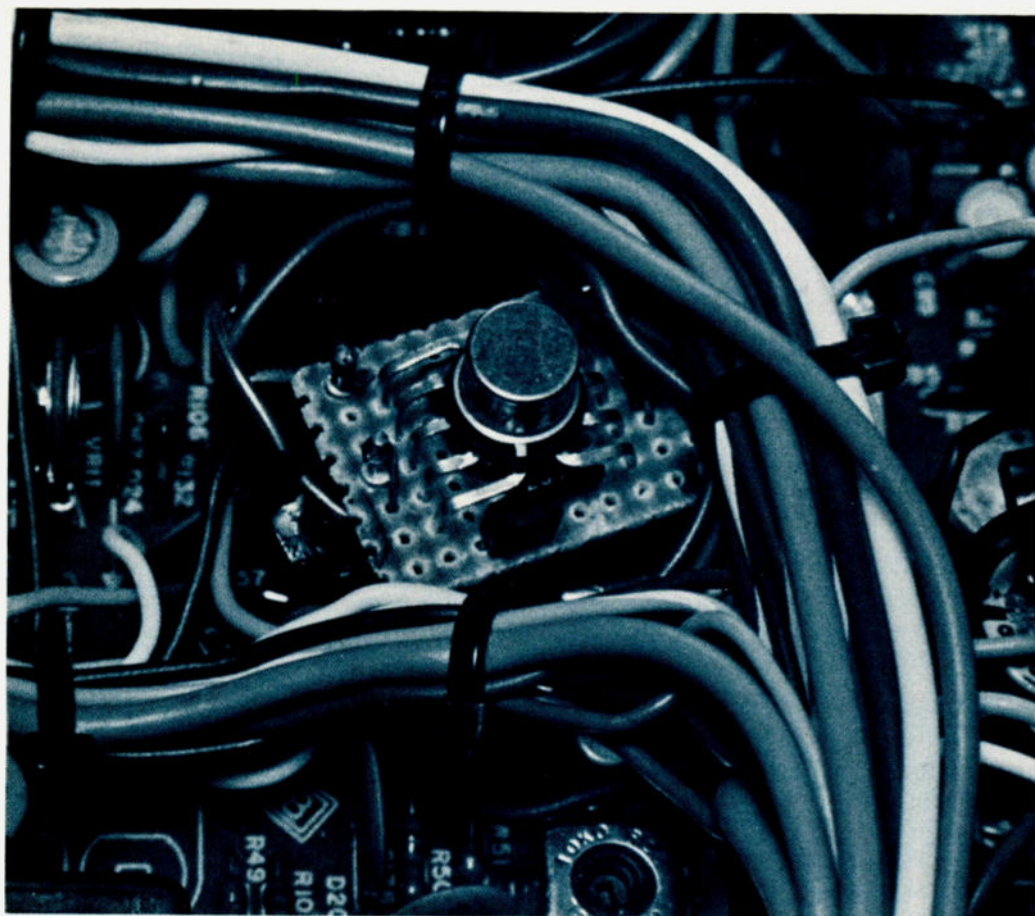

Photo B. This shows the placement of the 723 voltage regulator in the Midland.

to the number you want to divide by. In BCD, it takes 4 inputs to represent each decimal number. Each of these 4 inputs represents some power of 2. Fig. 4 explains how the BCD values represent the decimal numbers 0 through 9. To find the equivalent decimal value from the BCD value, simply add together the values that the 1s represent (a 1 is +4.7 V into a pin, and a 0 is 0.0 V into a pin). For example, decimal 5 has a BCD number of 0101. This yields

$$[8(2^3) \times 0] + [4(2^2) \times 1] + [2(2^1) \times 0] + [1(2^0) \times 1] = 0 + 4 + 0 + 1 = 5.$$

There are 10 inputs to the programmable counter. These inputs represent two decimal digits that range from 0 through 9 and one digit that ranges from 0 through 3. Thus, the range of the divisor is from 0 to 399. In this rig, you never want to divide by less than 4, so the actual range is from 4 to 399. The BCD input portion of the programmable counter is shown in

Fig. 5 with some examples of inputs.

Since each bit of the least significant digit changes the frequency by 10 kHz, the total range of frequencies that can be switched is almost 4 MHz. We need a range of only 1.7 MHz for 10-meter operation.

For normal CB band operation, the 40-position selector switch provides the BCD inputs from BCD 091

for channel 1 through BCD 135 for channel 40. The selector switch skips over BCD 94, 99, 104, 109, and 114. It also skips over BCD 118 and 119, but it then reinserts them after BCD 120. A close examination of a frequency allocation chart for the CB band will show which frequencies these represent.

To get all the frequency channels, and to get them in the correct order, I replaced the 40-channel selector switch with a 3-digit BCD thumbwheel switch. The switches I selected are back-lighted, which is very handy for night operation. I bought my switches from MHz Electronics, 2111 W. Camelback Road, Phoenix AZ 85015. They sold for \$2.00 a section, at the time, and you will need 3 sections. The lamps are +5 V, so wire them in series and use +12 V for lamp excitation. Make sure the switches you use are of the 10-position BCD type.

These rigs start at BCD 91 for the lowest channel, but there is no reason why you have to start there. In fact, if you start at BCD 50 for 28.50 MHz, then the BCD switch will read the actual operating frequency. The right-hand switch changes the operating frequency in 10-kHz steps from 0 to 90 kHz; the middle switch changes the operating frequency in 100-kHz steps from 0 to 900 kHz; the left-hand switch changes the

| D | C | B | A | POWER OF 2 | ACTUAL VALUE |
|----------------|----------------|----------------|----------------|---|--------------|
| 2 ³ | 2 ² | 2 ¹ | 2 ⁰ | | |
| 8 | 4 | 2 | 1 | | |
| 0 | 0 | 0 | 0 | 0.8 + 0.4 + 0.2 + 0.1 + 0.0 + 0.0 + 0.0 + 0.0 | 0 |
| 0 | 0 | 0 | 1 | 0.8 + 0.4 + 0.2 + 1.1 + 0.0 + 0.0 + 0.0 + 1.1 | 1 |
| 0 | 0 | 1 | 0 | 0.8 + 0.4 + 1.2 + 0.1 + 0.0 + 0.0 + 2.0 + 0.2 | 2 |
| 0 | 0 | 1 | 1 | 0.8 + 0.4 + 1.2 + 1.1 + 0.0 + 0.0 + 2.1 + 0.3 | 3 |
| 0 | 1 | 0 | 0 | 0.8 + 1.4 + 0.2 + 0.1 + 0.4 + 0.0 + 0.0 + 4 | 4 |
| 0 | 1 | 0 | 1 | 0.8 + 1.4 + 0.2 + 1.1 + 0.4 + 0.0 + 0.1 + 5 | 5 |
| 0 | 1 | 1 | 0 | 0.8 + 1.4 + 1.2 + 0.1 + 0.4 + 2.0 + 0.6 | 6 |
| 0 | 1 | 1 | 1 | 0.8 + 1.4 + 1.2 + 1.1 + 0.4 + 2.1 + 0.7 | 7 |
| 1 | 0 | 0 | 0 | 1.8 + 0.4 + 0.2 + 0.1 + 8.0 + 0.0 + 0.0 + 8 | 8 |
| 1 | 0 | 0 | 1 | 1.8 + 0.4 + 0.2 + 1.1 + 8.0 + 0.0 + 1.1 + 9 | 9 |

ALL OTHER VALUES ARE FORBIDDEN

Fig. 4. BCD-to-decimal conversion for 1 digit.

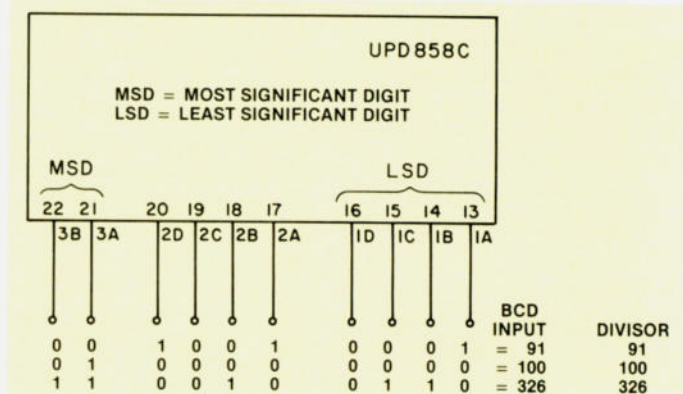

Fig. 5. Examples of BCD inputs to the programmable counter.

operating frequency in 1.0-MHz steps from 28 MHz to 29 MHz. The left-hand switch is restricted to this range because that is all that is needed for 10-meter operation. In fact, all the even number positions on the left-hand switch will give an operating frequency from 28.0 MHz to 28.99 MHz and all the odd number positions will give an operating frequency from 29.00 MHz to 29.99 MHz. This is because only the least significant bit of this switch is wired up.

To change in 5-kHz steps, a two-position switch is required to switch between the two crystal oscillators. Since there will be no LSB operation after the rig is modified, you can use the mode switch to give the 5-kHz steps. After the conversion, the AM position will give AM operation in 10-kHz steps. The USB position will give USB operation in 10-kHz steps and the LSB position will give USB operation in 10-kHz steps, but 5 kHz below the USB frequencies.

To accomplish this, change the LSB crystal to 11.934167 MHz, change the USB crystal to 11.935833 MHz, and the AM crystal to 11.933333 MHz. The crystal oscillators are followed by a frequency tripler.

The Differences in the Rigs

The circuit boards for all three of these rigs are made by the Uniden Company. The PC board layout is identical for the President Grant and the Cobra 138XLR, but they may not use the same components. The Midland has a different PC board layout, but the schematics for the three rigs are identical except for a few minor differences. The component reference designators for the Grant and the 138XLR are the same, but in the Midland they are numbered differently even though the schematics are

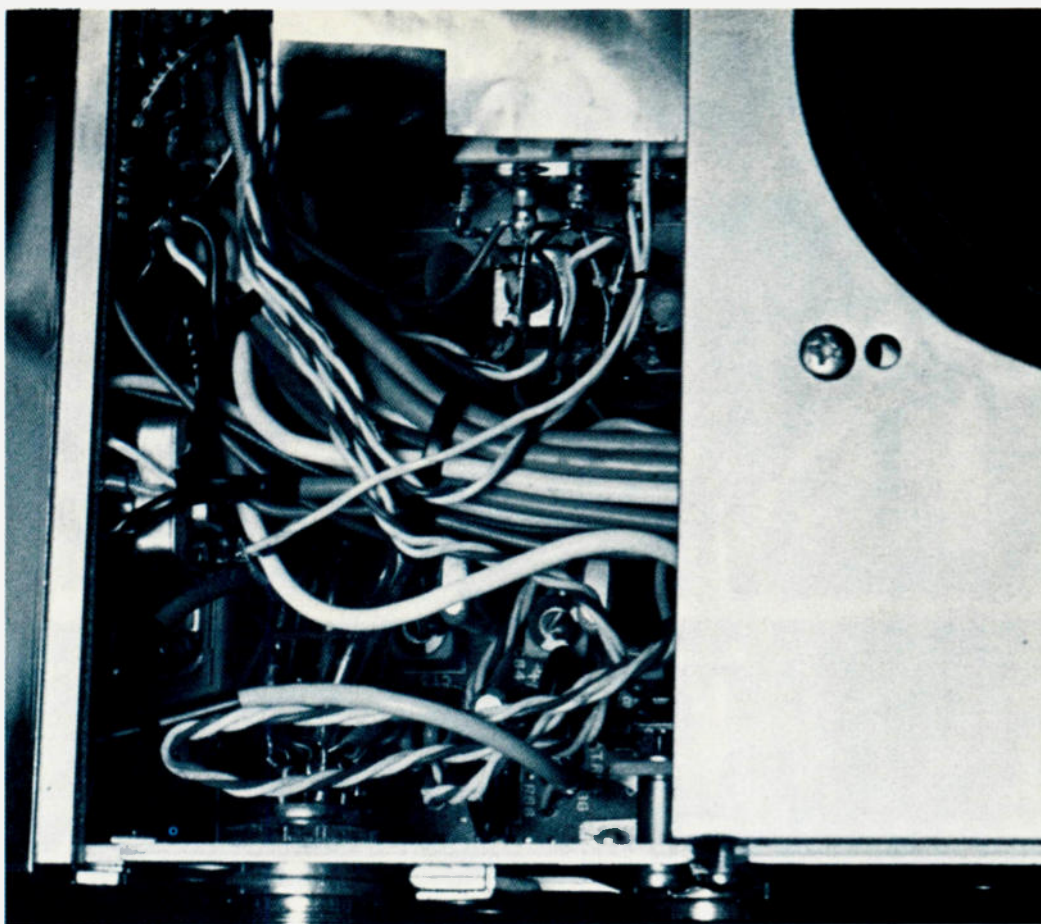

Photo C. This view of the Midland shows the placement of the diodes for the LSB and AM changes. The arrows point to the diodes added.

almost the same.

The Midland also has an enclosed metal box to shield the PLL circuitry, whereas the other two have only a metal strip on the PC board for a shield. The front panels and switches are also different for all three of the rigs. The Midland was the only rig modified to put the switch on the front panel. On the other two rigs, the switch was mounted external to the rig. If you have a Grant or 138XLR and wish to mount the switch on the front panel, be sure the switch clears everything before cutting any holes. I have not done this and do not know if it will fit, but there should be no problem.

After I had converted the Grant, I found that the newer Grants on the market do not use the UPD858 IC in the phase-locked loop. This new model can be identified by the fact that it has a

presettable channel 9 switch. The frequency range of the newer Grant can not be extended because the PLL IC has built-in safeguards to prevent this. I can not be certain that the manufacturer will not change the other rigs in the same way. Make sure the rig you get for conversion uses a UPD858 in the phase-locked loop.

Circuit Details of the Changes

Before attempting this

conversion, you will need a copy of the maintenance manual or Sams Photofact® for your rig. The Sams Photofact for each of the three rigs is available.

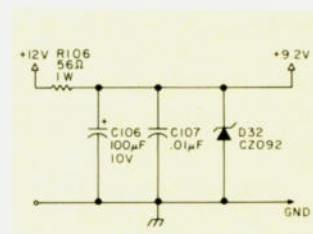

Fig. 6(a). Original regulator circuit.

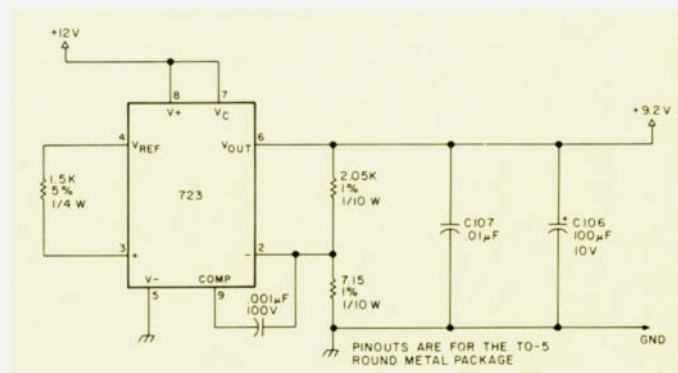

Fig. 6(b). The 723 regulator circuit.

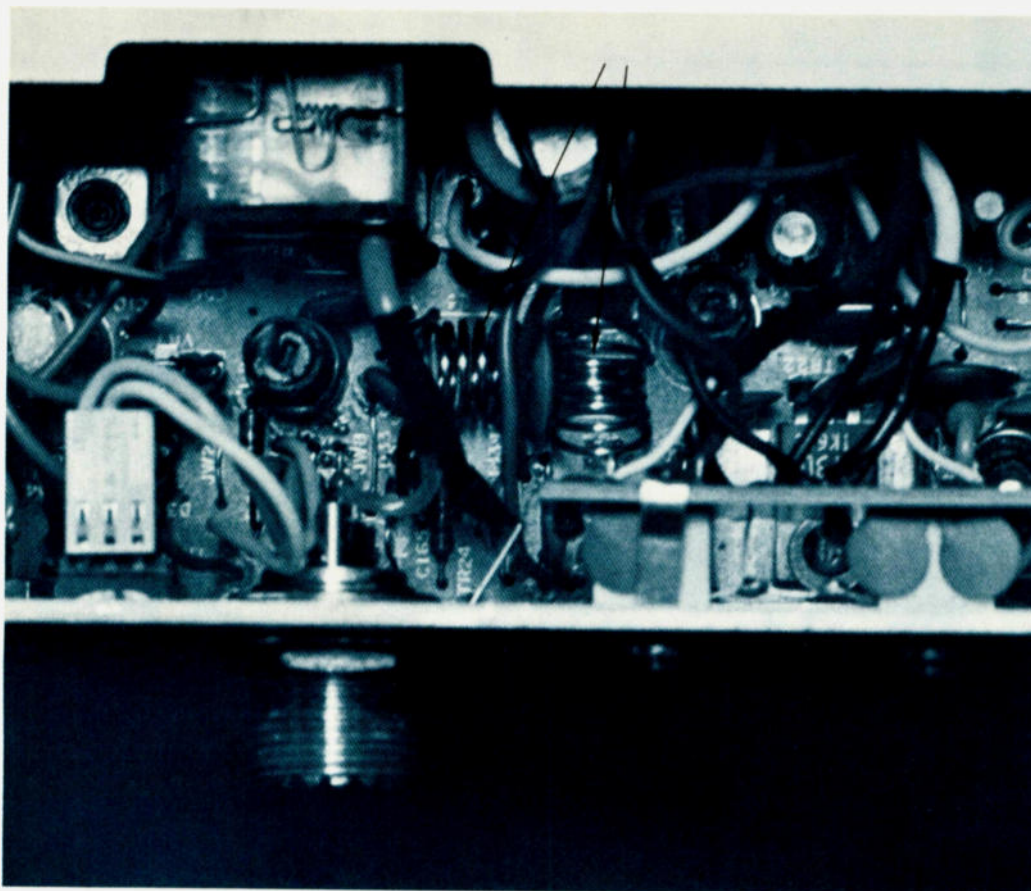

Photo D. Arrows point to the two coils (L28 and L29) in the President Grant in which the turns were spread apart. In the Midland, the turns of L5 and L6 should be spread in the same way.

I will first describe the changes for the Midland, then I will describe those for the Grant and the 138XLR. The actual circuit changes for all three rigs are the same, but the manner in which they are accomplished and the reference designators are different for the Midland.

MIDLAND 79-893 CONVERSION

Voltage Regulator Change

Note: If the operating fre-

quency of your rig does not change with varying input voltage in your installation, this change is not needed.

Remove D32 (CZ092) and R106 (56-Ohm, 1 W) shown in Fig. 6(a). Add the 723 voltage-regulator circuit shown in Fig. 6(b). Mount the parts on a small piece of perforated epoxy board and attach to the PC board with short jumper wires. My regulator is suspended above the chassis by the leads and

insulated with black electrical tape.

Clarifier Change

Remove D24 (1S2473) and save it for later use. Lift the end of R61 (100 Ohms) that connects to the +9.2-V bus that originates at D39. Connect the loose end of R61 to the +9.2-V bus that originates at pin 6 of the 723 regulator just added. If the regulator wasn't added, connect the loose end of R61 to the +9.2-V bus that originates at D32.

Output Power Change

Remove D33 (1S2473) and save it for later use. Spread the turns of L5 and L6 apart. The spreading distance is not critical. Remove one turn from L7.

Phase-Locked Loop Change

To accomplish these changes, you will need new crystals. The frequencies required are 11.934167 MHz

for the LSB position, 11.935833 MHz for the USB position, and 11.933333 MHz for the AM position. The Midland uses solder leads on the crystals, whereas the other two rigs use plug-in crystals.

The crystals are available from Jan Crystal Co., 2400 Crystal Drive, Fort Myers FL 33901. Order the CB-type crystals with a tolerance of $\pm 0.0025\%$. They were priced at \$3.50 each for fewer than 10, or \$3.25 each for 10 or more, in the 1978 catalog numbered 21. Order the HC-18-type holder for the Midland 79-893 and the HC-25-type holder for the President Grant and Cobra 138XLR. When ordering, include the following information on the rig: manufacturer's name, model, crystal frequency, holder type, and a copy of Fig. 7 to ensure that the crystal is cut properly.

Note that the Sams Photofact for Midland uses the same reference designators for parts inside the PLL and parts on the chassis. To avoid the confusion of this duplication, the Midland maintenance manual adds 500 to each of the reference designators in the phase-locked loop. I will follow this practice also, so each of the parts referred to in the phase-locked loop will be numbered between 501 and 599.

The PLL is enclosed inside a shielded box which must be removed from the PC board before the crystals can be replaced. Mark and remove the wires from the shielded box feed-throughs. Unsolder the shielded box tabs from the bottom of the PC board. The tabs must be completely clean of solder and flux before the box can be removed. Once the box is free, the wires to the 40-position switch can be disconnected from the switch. Use these wires to connect to the new switch.

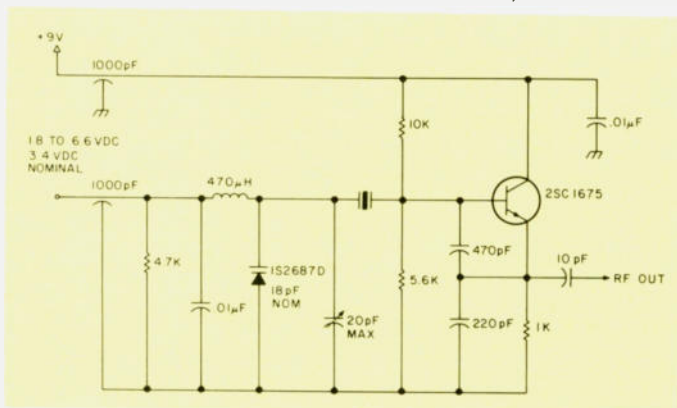

Fig. 7. Crystal-oscillator schematic.

The new crystals can now be soldered in place. Put the 11.934167-MHz crystal at X502, the 11.933333-MHz crystal at X503, and the 11.935833-MHz crystal at X504.

Remove R530 (1k Ohm) from the bottom of the PLL PC board. This resistor will not be used later. Pin 19 of the 858 IC is grounded on the PC board. This pin will be used, so it will have to be isolated from ground. Use a sharp knife to cut the circuitry between pin 19 and ground, then add a 4.7k, 5%, 1/4-W resistor and a .01-uF capacitor in parallel from pin 19 to ground. Add a short jumper between pin 19 and the solder pad that has the violet wire connected to it. This completes the changes to the phase-locked loop. It can now be resoldered to the main PC board and the wiring reconnected.

Front-Panel Change

Remove the knobs and the four small screws at the sides of the panel and remove the panel. If you are careful, all the work can be accomplished without removing the wires. Remove the 40-position channel-selector switch from the steel frame. You will need to cut a clearance hole in the steel frame for the BCD switch, but make sure it lines up with the hole in the front panel, and don't cut completely through the frame since it is needed for support. Carefully mark the front panel for the size of hole to fit your switches. The front panel is made of plastic with a thin sheet of metal glued to the front, so use caution while drilling and filing.

You will probably need an indentation on the right-hand side of the hole in order to be able to change positions on the right-hand switch section. Try the switch out before permanently attaching it to the panel. I used glue to hold

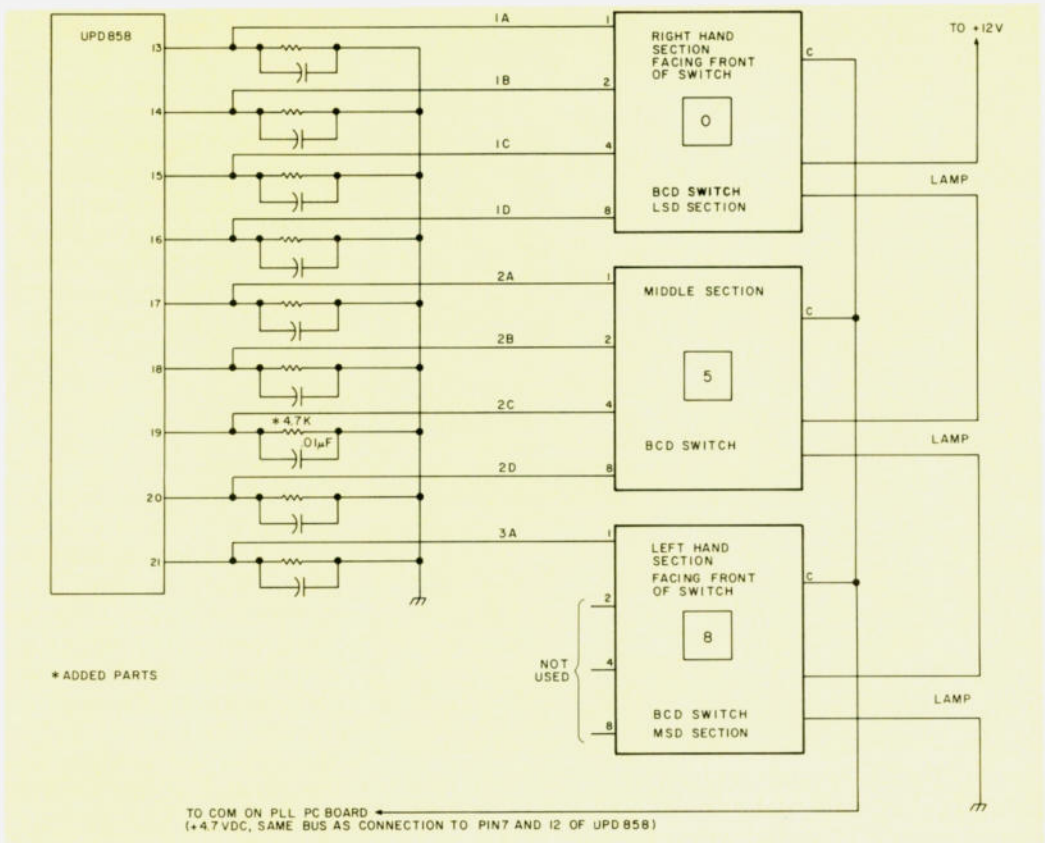

Fig. 8. PLL-to-BCD switch wiring.

my switch in position. Make sure everything clears before gluing the switch in position. To allow clearance in the back, I had to cut some of the PC board away from the backs of the switches. Leave enough printed circuit to solder the wires to. Before remounting the front panel, wire between the PLL and the switch as shown in Fig. 8.

LSB Change

Remove D50 (1S2473), which is mounted on the underside of the main PC board, and replace it with a piece of wire. Save the diode for later use. Remove the red wire between L1 and C539 on the PLL shield. Remove the brown wire between L2 and C542 on the PLL shield. Using two of the diodes previously removed, attach one anode to C539 and the other anode to C542. Tie the two cathodes together and wire them to L2. Do not remove the wires that go to the mode switch. Fig. 9 shows the details of this change.

AM Change

Add the remaining 1S2473 diode in series with the blue wire going to C541 on the phase-locked loop shield. Attach the cathode to C541 and the blue wire to the anode. Remove the cathode of D43 from S403A and connect it to C541. Connect a wire between L1 and D43 anode as shown in Fig. 10.

This completes the wiring changes for the Midland. However, if you study

the photograph of the front of the rig (Photo A), you will notice some differences that haven't been explained. I will describe these changes briefly but will not go into detail since they are not required to make the rig operate on 10 meters. They are easy to implement if you wish to incorporate them.

There are three toggle switches, one for tone, one for CB/PA, and one for noise blanker on or off. I

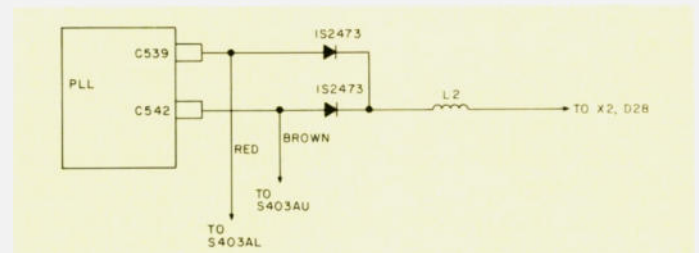

Fig. 9. PLL wiring for LSB.

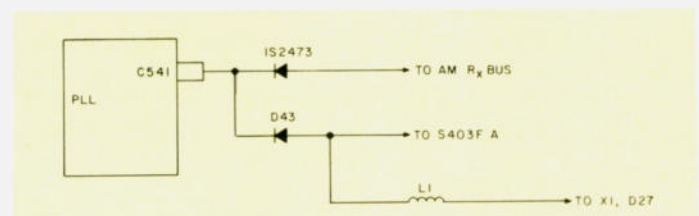

Fig. 10. PLL wiring for AM.

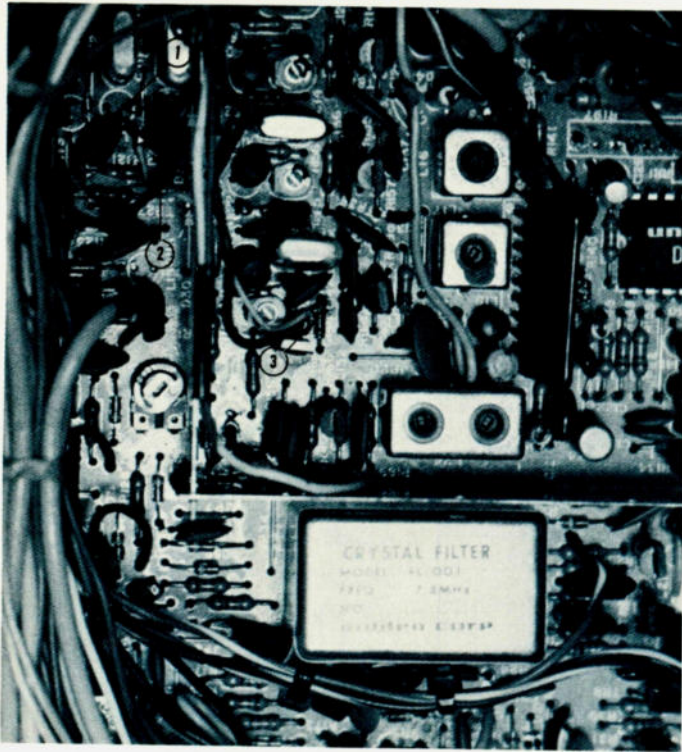

Photo E. Details of some of the President Grant changes show here. Arrow #1 points to L13, #2 to L12, and #3 to where jumper JP11 was located originally. D38 is located between L12 and the shield.

wired around each of these switches to get a low tone, CB operation, and the noise blanker on all the time. I used one of the switches to control a remote homebrew linear. Another switch is used to switch between the two crystals to give the 5-kHz steps. The other switch is to select the internal BCD switch or an external BCD switch mounted in the dash. I use an external BCD switch most of the time because the rig is mounted in the glove compartment.

PRESIDENT GRANT AND COBRA 138XLR CONVERSION

Clarifier Change

Remove D30 (1S2473) and save it for later use. Lift the end of R119 (100 Ohms) that connects to the +9.2-V bus that originates at D28. Connect the loose end of R119 to the +9.2-V bus that originates at D44.

Output Power Change

Remove D46 (1S2473) and save it for later use.

Spread the turns of L28 and L29 apart. The spreading distance is not critical. Remove one turn from L30.

Phase-Locked Loop Change

Unplug the original crystals from X3, X4, and X6 and plug in the new crystals. X3 receives the 11.93533-MHz crystal, X4 receives the 11.934167-MHz crystal, and X6 receives the 11.933333-MHz crystal. For information on how to order the new crystals, see the PLL change for the Midland.

Remove D40 and save it for later use. Use a sharp knife to cut the printed circuit between pin 19 of IC7 and ground, then add a 4.7k-Ohm resistor and .01- μ F capacitor in parallel between pin 19 and ground. Remove both ends of the flat wire cable between the 40-position channel-selector switch and the PLL. Mount the BCD switch and wire it to the PLL as shown in Fig. 8.

LSB Change

Locate L12 and L13. Lift

the lead nearest the metal shield of each of these coils. Lay each of the coils on its side to expose the holes the leads were removed from. Using two of the diodes previously removed, solder the anode of one into one of the exposed holes and the anode of the other into the second exposed hole. Solder both cathodes to the exposed lead of L12.

AM Change

Lift the cathode of D38 and bend the lead over to touch the exposed lead of L13. Remove jumper JP11. It is located near C148 and X6. Replace JP11 with the remaining diode. Place the cathode toward the front of the rig. Solder one end of a jumper to the cathode of this diode and solder the other end to L13 and the cathode of D38.

This completes the wiring changes for the Grant and 138XLR.

Retuning for 10 Meters

All that remains is to retune to the 10-meter band. Following the instructions should allow you to operate between 28.50 MHz and 29.10 MHz. The following test equipment will be required for the retuning: a 50-MHz frequency counter, a 12-V power supply, an rf generator for the 10-meter band, a VTVM with an rf probe, a 10-W rf power meter, and a 10-W dummy load. To keep from blowing your final transistor, never plug in the mike unless the dummy load is connected to the antenna connector. This procedure assumes that the rig was operating correctly before the changes were made.

The alignment procedure for all three rigs is identical except for the reference designators. I will list the Midland reference designator in the text of the procedure, and the reference designators for the Grant

and 138XLR will immediately follow in parentheses.

Alignment of Phase-Locked Loop

Remove the mike from the rig; set the BCD switch to 850; set the clarifier to the 10 o'clock position; set the mode switch to the AM position.

Note: The following adjustments are to components within the shield.

1) Connect the rf probe of the VTVM to TP502 (TP6), which is the secondary of L509 (L24). Adjust L508 (no coil exists) and L509 (L24) for a maximum indication on the VTVM. The indication may be less than 1 volt.

2) Connect the dc input of the VTVM to TP501 (TP7), which is pin 4 of IC501 (collector of TR35). Adjust L507 (L17) to obtain 2.0 V dc on the VTVM. Set the BCD switch to 870.

3) Connect the rf probe of the VTVM to Local Out (TP8), the secondary of L506 (L16). Adjust L506 (L16) for a maximum indication on the VTVM.

4) Connect the frequency counter to Local Out (TP8). Adjust CT503 (CT6) to obtain 36.5000 MHz. Set the mode switch to the LSB position. Adjust CT502 (CT5) to obtain 36.5025 MHz. Set the mode switch to the USB position. Adjust CT504 (CT4) to obtain 36.5075 MHz.

For the above adjustments, the clarifier (voice lock) position will affect the frequency reading. Also, the setting of CT502 (CT5), CT503 (CT6), and CT504 (CT4) will affect the range of the clarifier. You will need to check the range of the clarifier after you have adjusted CT502 (CT5) and CT504 (CT4) to ensure that you can vary the frequency more than 5 kHz and that the bands overlap when switching between USB and LSB. If the clarifier range is incorrect, readjust CT502 (CT5) and CT504 (CT4) until

it is correct. On mine, the 10 o'clock position on the clarifier was the best choice for adjusting CT502 (CT5) for a frequency of 36.5025 MHz and CT504 (CT4) for a frequency of 36.5075 MHz. Decreasing the value of R132 (R116) slightly will also increase the range of the clarifier.

All of the following adjustments are to components mounted on the main PC board.

Alignment of the Carrier Oscillator

Remove the mike from the rig. Set the BCD switch to 870. Set the mode switch to the LSB or USB position.

1) Connect the rf probe of the VTVM to TP2 (TP9). Adjust T8 (no coil exists) for a maximum indication of the VTVM.

2) Connect a frequency counter to TP2 (TP9). Adjust CT3 (CT2) to obtain 7.8025 MHz. Set mode switch to

the AM position. Adjust CT2 (CT3) to obtain 7.8000 MHz or as close as is possible to 7.8 MHz.

Alignment of the Receiver

Remove the mike from the rig. Set the BCD switch to 870. Set the mode switch to LSB. Set the squelch to minimum. Set the rf gain to maximum.

1) Connect an rf source to the antenna connector and adjust it to 28.70 MHz. Adjust the signal level to give an S-1 to S-3 indication on the S-meter. Adjust the clarifier for a 1-kHz beat note.

Adjust T7 (L3), T6 (L4), T5 (L5), T4 (L8), and T3 (L7) for a maximum indication on the S-meter. Reduce the rf signal to keep the indication below S-5 on the S-meter.

Alignment of the Transmitter

Connect the mike to the rig. Set the BCD switch to 870. Set the mode switch to

the AM position. Connect the rf wattmeter and dummy load to the antenna connector.

1) Key the mike and adjust T13 (L39), T10 (L37), L10 (L32), and L7 (L30) for a maximum indication on the wattmeter. A sharp steady whistle into the mike when in the USB or LSB position should give an indication of about 10 Watts on the wattmeter. If you have a receiver that will receive the third harmonic of the output signal, you can adjust L8 (L27) to minimize the third harmonic.

This completes the alignment. All that remains is to connect an antenna to the rig and get an on-the-air report.

Results

I have operated for over a year mobile with a 102-inch whip and have had hundreds of QSOs. I have worked all states and many

foreign countries in a period of less than 8 months, with less than 10 Watts. I always receive good reports on the audio quality of the rig, and I sometimes get signal reports of S-9 or greater, but this is rare.

Operating QRP can be frustrating at times, but the contacts you make are more enjoyable, and operating with low power is more of a challenge. Converting a CB rig to 10 meters is an inexpensive method of getting on 10 mobile. With sunspots at their peak, you can be assured of many hours of enjoyable QRP operation. CU on 10. ■

References

1. Bob Marshall WB6FOC, "Phase-Locked Loops," *Ham Radio*, July, 1978, p. 54.
2. *Signetics Analog Data Manual*, Signetics Corporation, Sunnyvale CA, 1977.
3. David Gray WB8ZBA, "A 2-Meter Frequency Synthesizer," *QST*, August, 1978, p. 11.



BECKMAN 3 1/2-DIGIT MULTIMETER MODEL TECH 310

COMPLETE MULTIMETER CAPABILITY:

DC VOLTS: 100 μ V TO 1500 V
AC VOLTS: 100 μ V TO 1000 V rms
RESISTANCE: 0.1 OHMS TO 20 MEGOHMS
DC CURRENT: 100 nA TO 10 A
AC CURRENT: 100 nA TO 10 A
DIODE/SEMICONDUCTOR TEST FUNCTION.
CONTINUITY FUNCTION - INSTA-OHMS [TM].
COMPLETE OVERVOLTAGE PROTECTION.
LOW-POWER OHMS IN ALL RESISTANCE RANGES.

FULLY EQUIPPED WITH THE FOLLOWING:
9-VOLT BATTERY, A SPARE FUSE, SAFETY-DESIGNED TEST LEAD SET, OPERATOR'S MANUAL AND BECKMAN'S FULL ONE-YEAR WARRANTY.

OPTIONAL ACCESSORIES AND PRICES:

TECH 310 DIGITAL MULTIMETER \$140.00
DC-202 DELUXE CASE 24.00
VC-201 VINYL CASE 10.00
DL-241 DELUXE TEST LEAD KIT 10.00
TL-242 TEST LEAD SET [AS SUPPLIED] ... 6.00
RF-221 RF PROBE 35.00

LaRUE ELECTRONICS ✓41
1112 GRANDVIEW STREET
SCRANTON, PENNSYLVANIA 18509
PHONE [717]343-2124

Completely Free
Standing Towers

TELE TOW'R

PAT. NO. 4,151,534

40' MODEL

Model 40 (extends from 21' to 40')

List \$259.10

55' MODEL

Model 55 (extends from 21' to 55')

List \$473.97

Breakover Model

40 (extends from 23' to 40' with breakover at ground level)

List \$440.62

Breakover Model

55 (extends from 23' to 55' with breakover at ground level)

List \$661.75



All steel constructed.

Concrete sleeve available for all models.

✓72

TELE-TOW'R MFG. CO., INC.
P.O. Box 3412 • Enid, OK 73701
405-233-4412

For your TRS-80
send & receive
CW/RTTY



FEATURES

- Auto Send & Receive RTTY & CW
- Connects to TRS-80 User Port & Key-head phone jacks
- 10 message memories 255 char. ea.
- Uses builtin PLL or external TU
- Includes hardware, cassette & manual
- Morse tutorial-10 lessons-corrects mistakes simplest, fastest way to learn the code
- Morse practice-random 5 letter words
- Auto numbering contest keyer
- Interactive graphics custom PIX
- Autotransmitter control PTT
- Requires Level II Basic & 16K RAM

- M80 Software, PC Board, Manual \$149
- CM80 As above in Cabinet \$279
- TM80 As above plus demodulator & AFSK \$499
- M800 Adds advanced RTTY to M80, CM80 / TM80 \$99

PET, APPLE, SORCERER versions available

Write or call for complete catalog



MACROTRONICS, inc. ^{✓44} (R)

1125 N. Golden State Blvd. / Suite G
Turlock, CA 95380 (S)
(209) 667-2888 / 634-8888

California residents add 6% tax

We are experiencing telephone difficulties, please keep trying.



NEW!

from Barker & Williamson, Inc.

**Model 422-2 Two Meter TVI,
Harmonic Filter.**

A quality filter in a
small package.

Power capability to 175
watts FM-AM—350
watts PEP

Size:
3" L × 1 3/8" × 1 3/8"

SO239 Connectors

Impedance 50/75 ohms

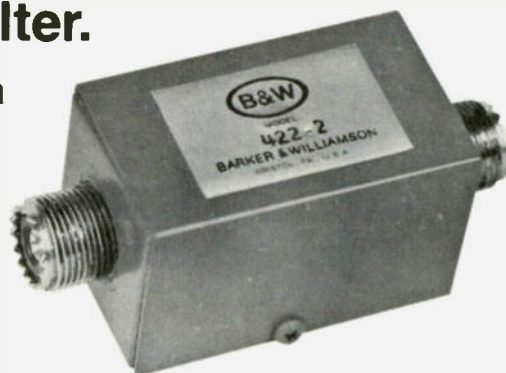

See your Dealer or Write:

Barker & Williamson, Inc.
10 Canal Street
Bristol, Pa. 19007



✓11

ECONOMICAL RTTY

Flesher Corp offers a selection of compact, economical RTTY equipment and accessories unequalled in quality

or function for the price. Flesher units are designed with minimum space requirements in mind, too. Call or write today for our free 1980 catalog of affordable kits, wired units and accessories.



FLESHER CORP ✓23

P.O. Box 976 • Topeka, Kansas 66601 • 913 • 234 • 0198
Distributors in Canada and Australia

All Solid-State! BASE STATION amplifiers

160 THRU 2 METERS
80 WATTS-600 WATTS



RF POWER LABS, INC.

21820 87th S.E., Maltby Industrial Village,
Woodinville, WA 98072, (206) 481-8833
Telex No. 32-1042

MFJ SUPER CW/SSB FILTERS



✓47
\$59⁹⁵
MFJ-721

MFJ-721 SUPER SELECTOR CW/SSB FILTER gives 80 Hz BW, steep SSB skirts, noise limiting. **CW Filter** gives 80 Hz BW. No ringing. 8 poles give super steep skirts (60 dB down one octave from center freq. of 750 Hz). No tunable filter can match performance. BW: 80, 110, 150, 180 Hz. Reduces noise up to 15 dB.

SSB Filter improves readability. Reduces splatter, hiss, static, noise, hum. IC active filter has 375 Hz highpass cutoff; 2.5, 2.0, 1.5 KHz (36 dB/octave) lowpass cutoffs.

Works with any rig. AM, SSB, CW. Plugs into phone jack. 2 watts for speaker. Inputs for 2 rigs. Speaker and phone jacks. Phones disable speaker. OFF bypasses filter. 9-18 VDC, 300 ma. 5x2x6 inches. Optional AC adapter, \$7.95.

Switchable noise limiter for impulse noise; trough clipper removes background noise.

Simulated stereo for CW lets ears, brain reject QRM. Yet, hear off frequency calls.

Tunable Filter

Instantly zero in SSB/CW signals with tunable peak, notch, lowpass filter.



✓47
\$59⁹⁵
MFJ-751

MFJ-751. Peak, notch or lowpass signals, zero in with freq. control, adjust bandwidth for minimum QRM. Double tuned for extra steep skirts.

Linear freq. control tunes 300 to 3000 Hz. Output is constant as bandwidth is varied flat to 40 Hz. Tight notch to 70 db. 5x2x6 in.

Hear off frequency calls with simulated stereo.

Works with any rig. Plugs in phone jack. 2 watts for speaker. 110 VAC or 9-18 VDC, 300 ma. One year unconditional guarantee.

MFJ-721 has 4 CW stages for super steep skirts. Best for CW. **MFJ-751** is best for general use when versatility is more important.

Order from MFJ and try it. If not delighted return within 30 days for refund (less shipping). One year unconditional guarantee. **Order today.** Call toll-free 800-647-1800, charge VISA, MC. Or mail check, money order. Add \$3.00 shipping.

CALL TOLL FREE ... 800-647-1800

Call 601-323-5869 for technical information, order/repair status. Also call 601-323-5869 outside continental USA and in Mississippi.

MFJ ENTERPRISES, INC.
BOX 494, MISSISSIPPI STATE, MS 39762

Build the ZL Paddle

— brass with class

After gaining my New Zealand Post Office Grade 2 license, I decided to set myself up for CW as the license gave me 160m, 80m, 6m, and 2m, plus several other frequencies and most modes.

I had recently built a keyer and looked at the possibility of building a paddle key. After reading several magazine articles concerned with both CW and paddle keys, I came up with this design which is a

mixture of several other designs.

I was extremely pleased with the prototype and gave it to my father, Fred ZL2AMJ, who used it to make CW tapes for some

beginners who are now hams. The second key built, which was a little more advanced than the first, I gave to my uncle, Hugh ZL2BHK. After this, I got paddle key-making down to a fine art.

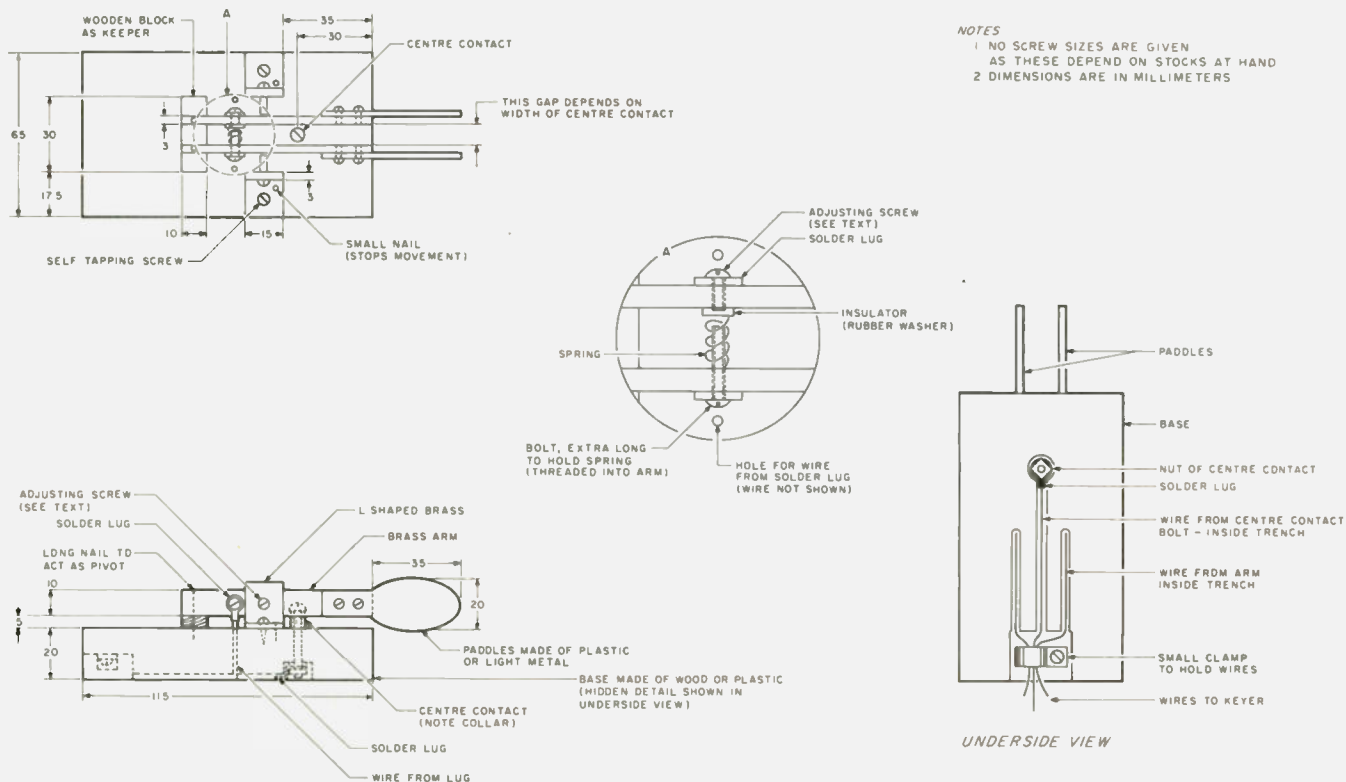

Fig. 1. A simple paddle key.

Construction Details

It is an easy key to build and anyone with a slight knowledge of metalwork should be able to produce a key to be proud of.

Perhaps the hardest part of the construction is the drilling of the vertical holes through the ends of the arms. To do this, a vise or a jig must be used to hold the arm straight, and the drill bit should be put in a drill press to keep the hole vertical. Also, with most of the holes, a center-punch hole must be punched to guide the drill. Note also that it may be necessary to put hexagonal nuts on the adjusting Ls.

The method of wiring is but one of many and can easily be changed to suit your own desires. The spring used came out of a ballpoint pen. Note also that the center contact has a collar around it, and that the contact's head is

round.

The base is made extra long so that a clamp or other fastener can be used—or the wires going to the keyer can be wound around it. If the key were being used in a permanent situation, then the extra length of base could be cut off and the key screwed or nailed down.

Finishing Details

When finished, it is a good idea to take the key apart, clean all the brass with either steel wool or some type of chemical cleaner, and then spray with clear lacquer to hold fast the shine. The base can be painted or varnished, depending on the type of material used. A plastic frame or box over the key will protect it from dust.

So have fun, and you can end up with the proper end product which people will admire. ■

MEMORY KEYS BREAKTHROUGH!

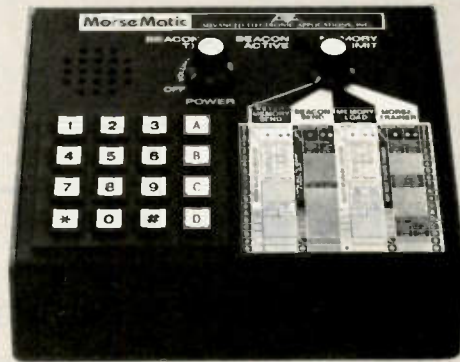

The remarkable AEA Morsematic memory keyer has 33 fantastic features including two AEA designed microcomputers, up to 2,000 character memory, automatic serial number and four different modes.

Get the Facts.

Learn the other 30 features simply by contacting Advanced Electronic Applications, Inc., P.O. Box 2160, Lynnwood, WA 98036. Call 206/775-7373.

AEA Brings you the Breakthrough!

✓ 2

the direct connection

AVANTI • ASTRON • ALLIANCE • ATLAS • ALPHA • BIRO • CUSHCRAFT • COLLINS • COE • DRAKE • DENTRON • HY-GAIN • HUSTLER • ICOM • KLM • KENWOOD • MOSLEY • MICRO-LOG • MOR-GAIN • MIRAGE • MFJ • PALOMAR ENG. • SWAN • TEN-TEC • TAYLOR • TRI-EX • TELE-TOW'R • UNIVERSAL • UNARCO-ROHN... ALL THESE AND MORE

MIDCOM ELECTRONICS, INC.
2506 S. BRENTWOOD BOULEVARD
ST. LOUIS, MISSOURI 63144 ✓ 52



1-800-325-3609

MO. RESIDENTS CALL COLLECT 314-961-9990

Repeater Time-Out Warning

— put time on your side (relatively speaking)

In the November, 1978, issue of 73, there was an article by WB4CEO describing some circuits using the 555 integrated circuit timer chip. After reading his article, it occurred to me that this IC could be utilized for a useful circuit for amateurs who operate

through repeaters on 2m FM. Using three 555 chips (or one 555 and one 556), it is possible to build a circuit that would warn an operator when the time-out circuitry of the repeater is about to drop the repeater carrier.

This article will describe

a circuit for this purpose, giving details of its operation and an explanation of how each 555 chip is interfaced with the others. This time-out warning circuit has an adjustable timing interval so that it can be used on different repeaters, and is operated from a nine-volt battery.

The time-out warning circuit consists of three parts, each using one 555 timer chip. The first timer chip measures a specific time interval which has been adjusted to be slightly less than the timer interval of the repeater. At the end of this interval, a pulse is generated which triggers a second timer circuit. The second timer supplies power to an audio oscillator (the third 555 chip) for a short, fixed duration. The result is a short audio tone at the end of a time interval specified by the operator. The entire circuit requires only a handful of parts, and can be assembled for under five dollars.

The actual circuit for a 30-second to 3-minute adjustable timing interval is shown in Fig. 1. This version of the circuit uses one 556 and one 555, but the same circuit can be obtained by using three 555 chips. The circuit of Fig. 1

works as follows: The operator presses a momentary-contact SPST switch (START) connected to pin 6 of the 556 chip (trigger). This begins the timing interval of the monostable multivibrator built from the left side of the 556 chip. During the timing interval, the normally low output of the multivibrator (pin 5) is high. The timing interval is determined by the RC combination of the 100-uF capacitor and the 180k resistor and 1 megohm potentiometer. For this combination of values, the interval is variable between 25 and 175 seconds. The output (pin 5) of this part of the circuit is high. The timing interval is determined by the RC combination of the 100-uF capacitor and the 180k resistor and 1 megohm potentiometer. For this combination of values, the interval is variable between 25 and 175 seconds. The output (pin 5) of this part of the circuit is high.

The right side of the 556 chip is also in a monostable multivibrator configuration and serves as the driver for the audio oscillator. The output of this multivibrator has a fixed-interval duration of slightly greater than 0.6 seconds. This duration is determined by the 2-uF capacitor and the 220k resistor. The trigger input (pin 8) for this multivibrator is taken from the output of the first multivibrator through a 0.01-uF capacitor. The voltage waveform of pin 8 is shown also in Fig. 2. The

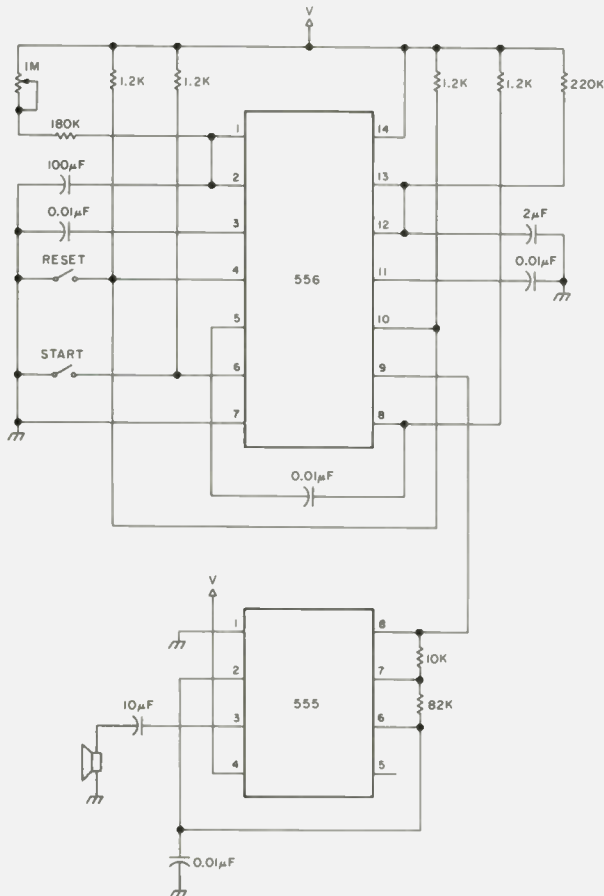

Fig. 1.

0.01-uF capacitor differentiates the first stage output waveform and puts the generated pulses across the input (trigger) of the second multivibrator. The positive pulse at the start of the interval is ignored by the second stage, while the negative pulse at the end of the interval triggers the second stage. The output of the second multivibrator (pin 9) is normally low, but goes high for a duration of about 0.6 seconds. This voltage waveform is also shown in Fig. 2.

The third stage of this circuit is simply an audio oscillator. The output frequency is about 900 Hz and the oscillator is powered directly from the output of the second multivibrator.

To use the circuit, the operator adjusts the interval to be 5 or 10 seconds less than the repeater timer and presses the START but-

ton at the beginning of each transmission. When the tone sounds, he has just enough time to pass the conversation. If he finishes sooner, he presses the RESET button which immediately returns the output of the first multivibrator to its normal low value. Pin 10 of the 556 is the reset pin for the second multivibrator, and the short circuit between pins 4 and 10 allows the RESET button to return both timer outputs to their original low value. Without the short circuit between these pins, the tone will sound both at the end of the timing interval and when the RESET button is pressed.

Appropriate changes in the values for the timing resistors and capacitors would allow this circuit to be used for other timing applications. Some examples are: as an oven timer, as a 10-minute ID remind-

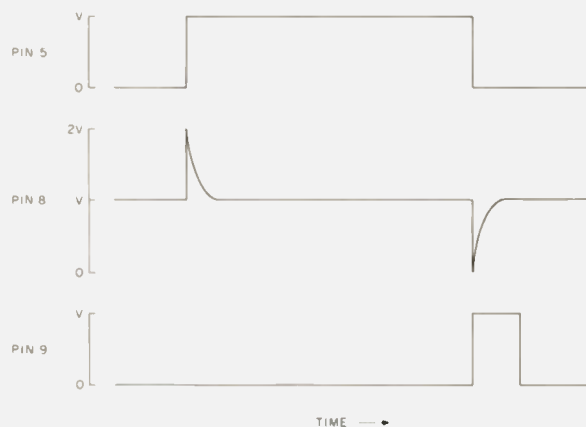

Fig. 2.

er, or even as a delay circuit for an automobile windshield wiper. For mobile operation, the START and RESET buttons could be wired directly into the microphone or connected to the microphone button so as to START when the microphone button is pressed and RESET when the button is released. Such an arrangement would allow for complete-

ly automatic mobile operation.

This circuit was designed for Walter WD6EBW, who is blind and confined for the most part to a wheelchair. Amateur radio, and particularly 2m FM, is his principal pastime. With this circuit, he can avoid being "timed out" on the repeaters he uses. Other blind amateurs also may find this circuit useful. ■

HAM-KEY™ RADIO TELEGRAPH SENDING DEVICES



Model **HK-3M**
\$19⁹⁵

- * Deluxe straight key
- * Anti-tip bracket. Can't tip
- * Heavy base. No need to attach to desk

Add \$2.00 Shipping & Handling.

- * Navy type knob
- * Smooth action

CC-3P shielded cable & plug for HK-3M \$2.49.

Add \$.50 Shipping & Handling.

Model AT-B anti-tip bracket only, to convert any HK-3 to HK-3M. \$2.99 Postpaid

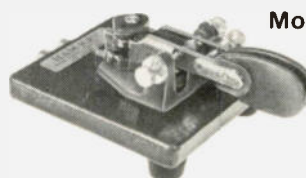

Model **HK-1** **\$29⁹⁵**

Add \$2.00 Shipping & Handling.

- * Dual lever squeeze paddle
- * For use with all electronic keyers
- * Heavy base with non-slip rubber feet
- * Paddles reversible for wide or close finger spacing

CC-1P shielded cable & plug for HK-1 \$3.75

Add \$.75 Shipping & Handling.

Model HK-2, same as HK-1 but less base for incorporation in your own keyer. \$19.95

Add \$1.00 Shipping & Handling.

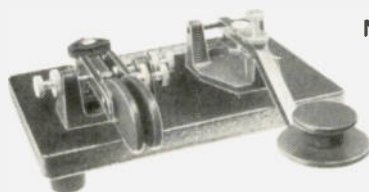

Model **HK-4**
\$44⁹⁵

Add \$2.00 Shipping & Handling.

- * Combination HK-1 & HK-3 on same base
- * Straight key may be used conventionally or as a switch to trigger a memory.

CC-1/3P Shielded cable with plugs for HK-4 \$5.99.

Add \$1.00 Shipping & Handling



Model **HK-5A** Electronic Keyer

\$69⁹⁵

Add \$2.00 Shipping & Handling.

- * Iambic circuit for squeeze keying
- * Self completing dots & dashes
- * Dot & dash memory
- * Built-in sidetone
- * Battery operated with provisions for external power
- * Uses Curtis 8044 keyer chip
- * Grid block or direct keying
- * Speed, volume, tone & weight controls on front panel
- * Use with HK-1 or HK-4

Order direct or from your favorite dealer. ✓ 30

The **HAM-KEY** Co.

P.O. Box 28271

St. Louis, MO 63132

Phone TOLL-FREE 1-800-325-3651



CB to 10

— part XXVIII: double your channels in SSB conversions

In the course of converting several different types of SSB CB rigs for 10-meter amateur use, I've come up with a simple, no-cost modification which will *double* the number of channels available on these rigs. The idea seems to be applicable to almost all

types of SSB CB transceivers, whether they use crystal-plex or synthesized circuits for frequency generation. Instead of having 23 (or 40) channels spread at 10-kHz intervals, you'll wind up with 46 (or 80) channels at about a 5-kHz spacing. And, if you modify the

delta-tune circuit found on most of these rigs to swing ± 2.5 kHz, you'll have just about continuous coverage on 10 meters. Sounds too good to be true? Read on!

The seed of the idea comes from the fact that *all* 10-meter SSB activity is on upper sideband. Therefore, the lower sideband function of the transceiver will never be needed and can be deactivated at no loss. Now the upper and lower sideband signals are generated by one or more carrier oscillators, sent to a balanced modulator (gets rid of the carrier), and then to a filter which selects the desired sideband and rejects the other, unwanted, sideband. Sideband selection is accomplished by shifting the carrier oscillator frequency in such a way as to place the desired sideband *inside* of the filter's bandpass and the unwanted sideband *outside* of the bandpass. See Fig. 1.

Note that the carrier is shifted by about 3 kHz, to put the desired sideband into the filter's passband. This means that the signal's actual frequency will be shifted by the same amount, i.e., changing sidebands also would move you by 3 kHz. To keep the signal on the

same frequency (channel) regardless of the sideband selected, these rigs all shift another oscillator somewhere in the frequency generation chain by 3 kHz, but in the opposite direction. This exactly cancels out the frequency shift caused by the sideband change.

Suppose that we rewire the sideband selector switch so that the carrier oscillator ran in upper sideband mode at all times but left the other frequency shifters intact. Then, switching from USB to LSB still would give us a USB signal, but shifted in frequency by 3 kHz, providing a new set of 23 (or 40) channels offset between the original channels. Further, it is usually possible to readjust the USB frequency shifter up (or down) in frequency a kHz or so and the LSB frequency shifter down (or up) a kHz also, by means of the built-in trimmers. This results in about 5-kHz spacing between the two sets of channels with practically gap-free coverage.

Then, dig into the delta-tune circuit, modify it for ± 2.5 -kHz swing, and rewire it (if necessary) to make the delta-tune function on transmit as well as receive. That's all, folks! ■

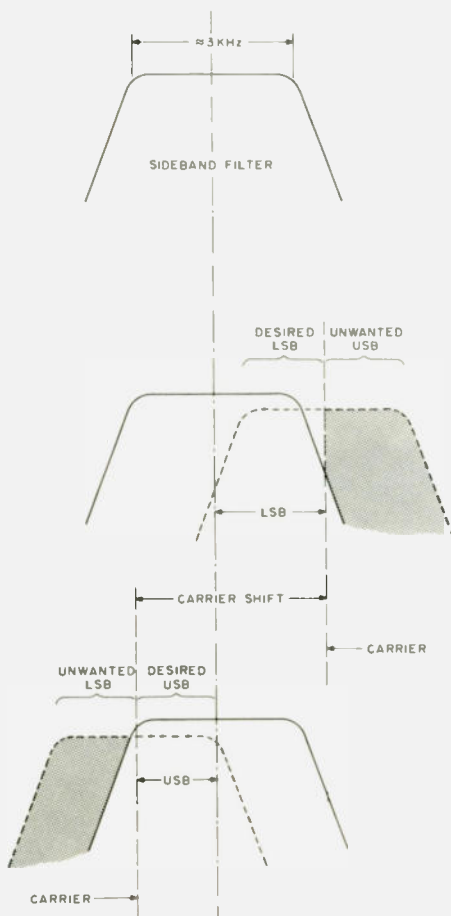

Fig. 1.

ATTN: MOBILE HAMS

VOLT-I-CATOR®

END BATTERY ANXIETY

Plugs into your cigarette lighter to test

- Battery Voltage Regulator
- Alternator

MINI DIAGNOSTIC METER

- Shop accuracy in precision instrument
- Easy to read color coded dial Swivels for easy viewing
- Rugged case—guaranteed against defects
- Designed for any 12 volt negative ground system
- Simple instructions included



OVER 100,000 SOLD

\$16.95

\$2.00 Shipping and Handling
1 year guarantee
CA add 8% tax

Never again get stuck with a dead battery. Know in advance if your battery is weak... if your alternator is undercharging... if your regulator is overcharging. Avoid costly—and dangerous—breakdowns.

J&J Enterprises W6HSY ^{✓341}
P.O. Box 18 • Grass Valley, CA 95945

JULY SUPER SALE!
From: **DIGITREX**
ELECTRONICS COMPANY
✓18
PA-19 Wideband Preamplifier

- 2 to 200 MHz Bandwidth (-3dB Points)
- 19dB Gain!
- 50 Ohms Input & Output Impedance
- Tiny PC Board Size (7/8" x 1-5/8")
- Absolutely No Tuning Required
- Extremely Stable
- Draws only 20MA @ 12VDC
- Great Way to Increase Sensitivity of Receivers, Counter, etc.
- Fully Assembled and Tested
- Instructions Provided, Full Warranty



only ~~\$8.95~~
+ 50 Shipping/Handling

PS-600 600 MHz Prescaler

- Provides +10 and +100 TTL Level Output
- 75 MV RMS Input Sensitivity
- Built in 5 Volt Regulator Allows Use at B-12 VDC @ 90-110 MA.
- Tiny PC Board Size (1-1/4" x 1-3/8")
- Fully Assembled and Tested
- Instructions Provided, Full Warranty



only ~~\$28.95~~
ppd
\$23.95

New PS-1250 1.25GHz Prescaler

complete pc board ~~\$79.95~~ ppd

COD Orders Accepted **\$39.95**

4412 Fernlee

Royal Oak, Michigan 48073

Phone 313-651-9247

NEW MFJ-525

RF SPEECH PROCESSOR

True RF Speech Processing. Up to 4 times more average SSB power. Powerful natural sounding speech punches thru QRM. Works with any rig. Plugs between mic and rig.

Powerful natural sounding processed speech punches thru QRM. Plugs between mic and rig.



\$119.95
BRAND NEW

The MFJ-525 gives you up to four times (6db) more average SSB power on all bands with true RF Speech Processing. Powerful natural sounding speech punches thru QRM and DX pile ups.

Gives you more average SSB power increase per dollar than a linear or beam. Combine with linear and beam for ultimate

Ideal for mobile and ORP. Vastly improves phone patching. Eliminates flat topping, splatter.

Complete SSB transmitter-receiver system: Micro phone audio is converted to SSB, clipped, filtered and converted back to audio for rig's mic input.

Plugs between mic, rig. No internal connections.

Two color VU meter aids in setting clipping level.

Clipping level control. Output level control.

ON-OFF/BYPASS switch. LED indicates power on.

4 pin mic jack. Shielded output cable has push-to-talk line. Uncommitted 4 pin mic plug supplied.

Input, output RFI filtering, ferrite beads, careful layout, PC ground plane, RFI coating on side panels. 110 VAC or 12 to 18 VDC. 6x2x6 inches.

Order from MFJ and try it — no obligation. If not delighted, return it within 30 days for refund (less shipping). One year unconditional guarantee.

Order today. Call toll free 800-647-1800. Charge VISA, MC or mail check, money order for \$119.95 plus \$3.00 shipping for MFJ-525.

Don't wait to punch thru QRM with powerful natural sounding processed speech, order today.

CALL TOLL FREE ... 800-647-1800

Call 601-323-5869 for technical information, order/repair status. Also call 601-323-5869 outside continental USA and in Mississippi. ✓47

MFJ ENTERPRISES, INC.
BOX 494, MISSISSIPPI STATE, MS 39762

Signalcrafters Presents The Most Advanced Automatic Computing Power Meters In Amateur Radio!

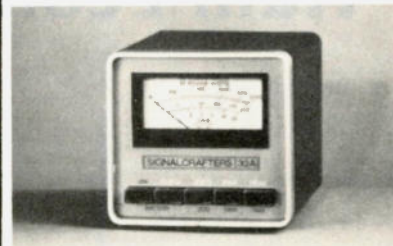

MODELS 31 and 32*

Our portable Models 31 and 32 feature the same state-of-the-art technology that is incorporated in their Big Brother, the Model 30. Never again will you have to bother with SWR "calibrate" controls and switches! Signalcrafters' custom integrated circuit makes power and SWR measurement a "hands-off" operation by automatically computing SWR. The result is unparalleled accuracy and ease of operation.

FEATURES:

- **CUSTOM IC**—Computes SWR from the level sensed on the transmission line independent of the power level. This analog computer operates over a range of only one watt to the full scale of the meter with unequal accuracy.
- **RUGGED TAUT-BAND METERS**—Provide accuracy and readability that must be seen to be appreciated.
- **HEAVY DUTY CABINETS**—Handsome heavy duty metal cabinets complement virtually every transceiver on the market today.
- **TWO MODES—PEAK OR AVERAGE**—The amateur may choose between either peak or average power readings.
- **POWER REQUIREMENTS**—Due to the advanced low current design, battery life is truly outstanding, making this meter a natural for portable or field day operation. Uses standard 9 volt battery or 120V AC with optional AC adaptor.
- **ATTRACTIVE AFFORDABLE PRICING**
Model 31A (0 to 200w)
31B (0 to 20w)
..... only **\$149.00**
Model 32A (0 to 200w, 0 to 2000w)
32B (0 to 20w,
0 to 200w)
✓66 only **\$169.00**

SIGNALCRAFTERS, INC.®

5460 BUENA VISTA DRIVE
SHAWNEE MISSION, KANSAS 66205
913/262-6565; TELEX 42-4171

All Signalcrafters products are designed, engineered, and produced in the U.S.A. Prices include shipping to all U.S.A. VISA and Master Charge accepted. Kansas Residents please add 3% percent.

Ham Economics: Selling Used Gear

—be wily

*Donald Wiseman K5CA
1208 Plantation Dr.
Dickinson TX 77539*

So it's springtime, and you are chomping at the bit for that new chrome super-duper Belchfire-8 rig pictured so beautifully in the color ads. You look at old faithful on the table in front of you, knowing that buying the new super-chrome model will require relinquishing old faithful in the most favorable manner. (Basically, this means that you will want to somehow make the move with the smallest possible outlay of your cash!)

Now, there are two ways of managing the exchange. First (and requiring the least effort for the owner), you can look for a dealer who will trade. Be aware, however, that the dealer is in business to make money. He doesn't really want your old rig, and he has to plan for contingencies in the cleaning, repairing, and marketing of the used equipment before he can realize his profit. In other words, he will either offer you the lowest possible price for your rig or else will not allow you a discount on the new item, in order to make the deal attractive to him—not you!

The other route to take is that of selling your rig and then buying the new one. This takes some work, but is well worth the trouble. Why? Simply because you will get the best market price for your equipment; then, with cash in hand, you can negotiate for the best discount prices for the new gear—a double savings to you. How does one go about creating this magic? There are a few relatively simple steps to take which will put you on the right track. Let's look at these one at a time.

First, what price to set? Unfortunately, with ham gear there is no "Blue Book" available, such as exists for used autos. You will have to do a little investigating on your own. Check the ads in the magazines for similar equipment. Visit the local stores. Take note of the prices asked. After establishing the current popular pricing, adjust it upward or downward according to the actual condition of your equipment. Take into account both appearance and function. Based on this, set three prices in your mind:

1. The asking price—this is the price you will advertise; it's what you think the rig should bring on the market, based on your re-

search.

2. The negotiating price—this price is the one you will work to in negotiations with potential buyers.

3. The lowest price—this is absolutely the lowest price you will accept. Never, never, never go below this price in your negotiations.

The next steps to take are those of clean-up and check-out. This takes some elbow grease, but is well worth the effort. Most gear will look very much better after a simple clean-up with some warm water and mild detergent. Simply clean off the panel, knobs, cabinet, and accessories. Shine it up as well as you can. Now, make sure the gear is working—simple things such as making sure pilot lights are all on, switches all work, etc., should be taken care of. Nothing will unsell or drop the price of a rig faster than poor appearance or the unexpected failure of some operating feature.

Now, display the rig for your prospective buyers. Here, let's assume the item is a major piece of equipment. For goodness sake, clean up your operating table and even your shack. Try to have adequate lighting so the buyer can see what he is shopping for. If you have another, newer,

similar piece of equipment, hide it! Otherwise you will quickly draw interest to it and not to your sale item.

Advertising comes next. Fortunately, most hams have many possibilities here. List with the local ham networks. Many have "bulletin boards" and welcome listings. Write a simple ad to go in your local club paper. Place a card on the club bulletin board. Many suppliers have bulletin boards—place an ad card there. If you want even more coverage, send an ad to the national magazines. When writing the ad, describe the features of the equipment in a positive way. However, make sure the ad is honestly stated. Remember, as you choose the extent of advertising, that dealing long distance puts both parties in some jeopardy. Where it's reasonable, the local market seems to be a more comfortable place to do business.

Let's assume you have followed the previous steps and have had a prospective buyer call. Remember, you know your piece of equipment better than anyone else in the world and are in a strong bargaining position. You have a good piece of equipment for which you

want a fair price. Remember also, at this point, your three prices. These are the cornerstone of your negotiation. Never reduce your stated price unless there is a firm counter offer. Many times the other party will say something such as: "What is your lowest price?" or "Can't you drop the price a bit?" without making an offer himself. Should you lower the price on this basis, you have

simply reduced your asking price before starting to negotiate. If your prospect is serious and makes an offer, the negotiation range is established, and then you may haggle a bit before reaching agreement. Again, keep in mind your prices; be careful not to fall back too far.

Assuming you reach agreement, there is one more piece of advice. Be careful about payment.

Cash is preferred; a cashier's check and certified check are acceptable. A personal check is a dangerous thing, be very cautious if you are offered payment by this method. Unless you are personally familiar with, and completely trust, the individual who offers payment in this manner, don't accept a personal check.

Well, you've done it. You've cleaned up, mar-

keted, and sold old faithful. You've got a handful of bills in your hand and are ready to invade the local emporium to pick up your new super-duper Belch-fire-8 rig. Just keep in mind what we have gone over, because now you are on the opposite side of the table. Use your knowledge to find what you want at the best price for you. By working both ends of the game, you are a two-time winner! ■

Harry Longrich W4ANL
Rte. 1, CV-9
Fredericksburg TX 78624

A Final Solution

— make life easy for your filaments

Having just purchased a new 3-500Z for my home-brew linear, I resolved that the empty feeling in my pocketbook warranted a bit of conservation on my part. When you turn on the filament switch on your linear, nasty things happen, like 14.1 Amperes flowing through a cold fila-

ment. That's quite a jolt in anybody's language. Most linears have a separate filament transformer, and therein lies a simple solution for the calm, cool, and conservative treatment for your 3-500Z (or a pair of them).

Our local hardware store had a sale on 600-Watt,

110-volt ac light dimmers. Inserting this dimmer in series with the primary of the filament transformer will provide a variable transition to rated operating temperature. You can control the warm-up period to suit your operating habits. This particular dimmer has a push-pull on-off switch which is coupled to the SCR. Bypassing this switch is no problem and allows you to use the existing filament on-off switch on your linear. The dimmer is marked "RFI filtered," but at low settings (about 1 to 2 volts), I was

able to detect a very low level of hash at 14 MHz. When the tube was brought up to operating temperature, no trace of hash was heard.

Mount the dimmer wherever convenient. I had to mount mine on the outside of the linear cabinet because I did not have room inside. If you should install it inside, the usual precautions for adequate RFI shielding should be observed. Fig. 1 is a schematic of my installation. Credit must be given to W4YFS for suggesting this idea. ■

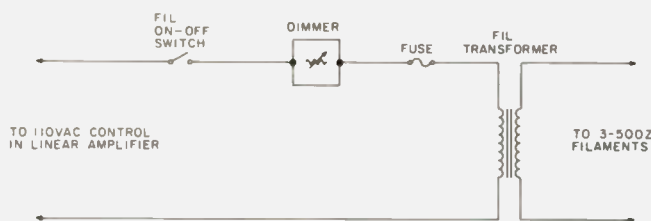
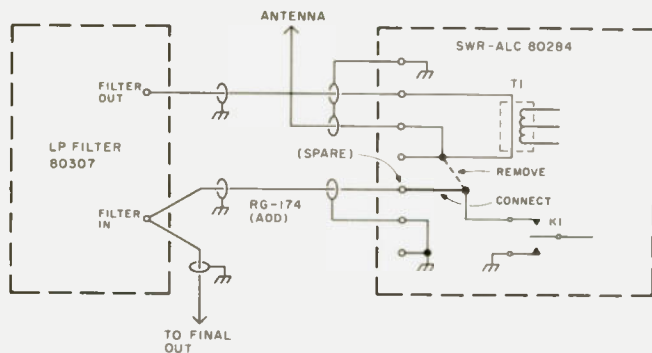

Fig. 1.

Triton IV Quick Trick



With the rf pollution being what it is in this metropolitan area, my Ten-Tec Triton IV (Model 540/544) did not do very well with regard to front-end selectivity. I did not try to analyze all of the beats, buzzes, and assorted crud coming in on the various bands, but all of the broadcast, TV, FM, paging, micro-

wave, and VHF communication stations in the area certainly were suspected.

An external low-pass filter (below 30 MHz) will do a pretty good job of cleaning up the bands, but why have this add-on equipment when a good set of low-pass filters is built in for the transmitter section? These filters also cut off just above each band, so why leave the receiver open to possible HF interference below 30 MHz as would be the case when using the single external filter?

My modification is rather simple. Move the receiver pick-up point from the output of the transmitter section low-pass filter to the input of it. This change is shown in the diagram. The bands are now clean of spurious crud and the excellent sensitivity is not affected by receiving through the filter on any band. ■



Organize your shack with a **CLUTTERFREE MODULAR CONSOLE \$179.95**

- Large, 42" H x 57" W x 29"D
- Strong groove-construction
- Mar-resistant wood grain finish
- Options, drawers & face plate
- For ham or home computer
- Visa and Master Charge

CLUTTERFREE MODULAR CONSOLES ✓89

P.O. Box 5103 Tacoma, WA 98405
(206) 572-8570 9 a.m.—5 p.m.
(206) 759-1611 Evenings

DIGI-DIAL Adaptor

Kit \$49.95
Assembled \$64.95

Turns any frequency counter into an absolutely accurate digital display! Inexpensive! With continual display of both transmit AND RECEIVE MODE frequencies — as fast as you turn your transceiver dial.

Operation requires only a connecting cable to transceiver Variable Frequency Output plug. Translates VFO output to 2 thru 2.500 MHz. No internal connections or modification necessary. Illustrated manual included. 3½" x 3" x 2" deep.

Power options: (A) + 5 volts or 12V. 12 ma or less; Z in-hi greater than 10k; Z out-to-less than 50 ohms. (B) The DD Adaptor has its own DC rectification and filtering system, connect any 6.3 V centertap transformer.

Specify your rig: Heathkit HW 100-101-104, SB series 15 m/c; Kenwood TS-520, 900, J-599, R-599, Yaesu FT101 (E)(E) series, FT-300, 400, Series, FTDX-560; Drake TR4 (c), Twins; Hallicrafter FPM-300, Mark III; Tempo One; Galaxy V, GT550.

**DaringOn
Industries**

P.O. Box 7492 ✓344
University Station
Provo, UT 84602
801-375-3902/374-1547

Update your rig to convenience

IRON POWDER and FERRITE PRODUCTS

AMIDON
Associates ✓334

Fast, Reliable Service Since 1963

Small Orders Welcome

Free 'Tech-Data' Flyer

Toroidal Cores, Shielding Beads, Shielded Coil Forms
Ferrite Rods, Pot Cores, Baluns, Etc.

12033 OTSEGO STREET, NORTH HOLLYWOOD, CALIFORNIA 91607

Radio World

CENTRAL NEW YORK'S FASTEST GROWING HAM DEALER

Featuring Yaesu, Icom, Drake, Ten-Tec, Swan, DenTron, Midland, KDK, MFJ, Microwave Module, Tempo, Astron, KLM, Hy-Gain, Mosley, Larsen, Cushcraft, Hustler, Mini Products, Bird, DSI, Mirage, Vibroplex, Bencher, Info-Tech, Universal Towers, Callbook, ARRL, Astatic, Shure. We service everything we sell! Write or call for quote. You Won't be Disappointed. We are just a few minutes off the NYS Thruway (I-90) Exit 32

**ONEIDA COUNTY AIRPORT TERMINAL BUILDING
ORISKANY, NEW YORK 13424**

Warren K2IXN Call Toll Free: 1-800-448-7914 Bob WA2MSH New York State Residents Call: 315-337-2622 or 315-337-0203

2 watts QRP go a long way!

Rockhound®



Two full watts CW output! Choose 40 or 80 meter models. Weighs less than 6 ounces. Crystal control, 12-15 VDC. \$25.95

8040 B

Covers the Novice portions and more on 40 and 80 meters for CW receiving. Only 3" by 5" by 7" and 24 ounces! \$89.95

Freedom®

Free yourself from crystals with this VFO for 40, 80 and 15 meters. Great for many old transmitters! \$64.95

Please add \$2 per order, or \$3 for combinations, for shipping/handling.



Kantronics
(913) 842-7745
1202 E. 23rd Street
Lawrence, Kansas 66044

Microcraft's New Morse-A-Word

Eight character moving display.
Built-in code practice oscillator.
Excellent for learning Morse Code.
Complete — no CRT or expensive extras needed.
Decodes audio CW signals from your receiver's speaker and displays letters, numbers, punctuation and special Morse characters as the code is received.



MORSE-A-WORD Kit with 4 character readout MAWK-4 \$149.95
MORSE-A-WORD Kit with 8 character readout MAWK-8 \$169.95
MORSE-A-WORD wired & tested with 8 character readout . . . MAWF \$249.95

Send check or money order. Use your VISA or Master Charge. Add \$3.50 shipping and handling for continental U.S. Wisconsin residents add 4% State Sales Tax.

Microcraft Corporation Telephone: (414) 241-8144
P. O. Box 513G, Thiensville, Wisconsin 53092

ASCII MORSE RTTY

MONITOR \$149.
(12" B&W)
(Optional)



SKT-100 COMPLETE KEYBOARD TERMINAL \$375. Kit (Less Monitor) Assembled \$430

COMPUTER



SERIAL LOOP or RS232

Features

- ASCII & BAUDOT
- Auto Sync. 1-150 WPM CW
- Narrow & Wide Shift TU
- Microcomputer Interface

TRANSCEIVER



AFSK/KEY (SEND)

AUDIO (COPY)

Key Input  Key Optional

ALSO AVAILABLE:

SCT-100 STAND ALONE VIDEO BOARD
Assembled & Tested \$215.
Full Kit \$175. Partial Kit \$115.

ABM-200 ASCII BAUDOT MORSE CONVERTER \$189.

XITEX CORP.
9861 Chartwell Drive
Dallas, Texas 75243 (214)349-2490

MC/VISA ORDER BY PHONE
Prices subject to change without notice.

UDT 170 UNIVERSAL DATA TRANSCEIVER
Converts any ASCII or Baudot TTY® or Video Terminal into a multiple band rate data transceiver for RTTY and Morse operation. (Boards sold separately) Reg. \$549

INTRODUCTORY PRICE \$479

The NMX Relay Deceiver

— pull in those 24-V relays with a mere 12 V

Here's a way to make use of those 24-V dc relays that you find at hamfests and in surplus stores. Often you'll see high-quality rf relays or transfer switches at very reasonable prices. The problem is having to build a separate power supply to actuate them.

There is a way to operate them from 12-V dc: It uses the idea that a relay takes less voltage to hold up than it does to pull in. Also, the

scheme saves current by not wasting unnecessary power when the relay is pulled up.

Looking at Fig. 1, S1 applies 12-V dc to the relay when it is closed, through S2C, which goes to ground. This probably will pull the relay up, although sluggishly. While we are looking at the circuit, notice that capacitor C is charging to +12-V dc through R1, S2A, and S2B. If we operate S2 at the same time that we close

S1, look what happens: S2A disconnects the + end of C from the power supply and grounds it. S2B and S2C unground the negative end of C and the coil, respectively, and connect them together. The coil now has +12-V dc on its top end and -12-V dc on the lower end. Now, the -12-V dc is not the negative end of the positive supply, but is another voltage in series, adding to the power supply voltage to give 24-V dc—at least until the capacitor discharges. See Fig. 2.

Now we have a problem when the capacitor discharges to zero and tries to charge in the other direction, and the voltage across the coil goes to zero because the capacitor is in

series with it. This method is impractical, but it should illustrate the principle of the circuit that we'll look at next.

In Fig. 3, we have replaced some of the switches with a diode. C charges from the supply as before. Simultaneously, S1 and S2 are closed. S1 applies +12-V dc to the top end of the coil, S2 grounds the + end of C, and the negative end of C applies -12-V dc to the lower end of the coil. D1 is reverse-biased by the negative voltage from C. Now, instead of C charging in the opposite direction after it discharges to zero, D1 conducts and holds the coil in with +12-V dc from the power supply. When S1 and S2 open, the cycle repeats. The method is not without its faults. R1 must be made smaller and smaller to speed up the recharging of C, which limits the speed of operation. If you try to operate it too quickly, it won't get the full kick, since C won't have time to charge fully.

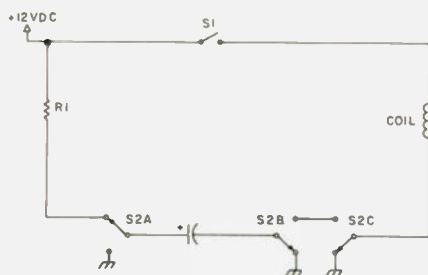

Fig. 1.

| Coil Resistance | Coil Current | R1 | R2 and R3 | C |
|-----------------|--------------|----------|-----------|---------|
| 24 Ohms | 1.0 A | 120 Ohms | 220 Ohms | 4000 uF |
| 600 Ohms | 40 mA | 3k Ohms | 5.6k Ohms | 200 uF |

Table 1.

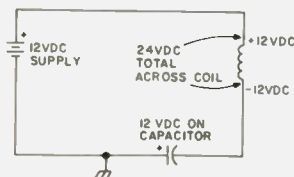

Fig. 2.

Now we have a functioning circuit. Not the most practical—so look at Fig. 4. This is the same as Fig. 3 except that S2 is replaced by Q1 and R2. Now when S1 closes, R2 causes base current to flow in Q1 and turns it on, grounding the + end of C.

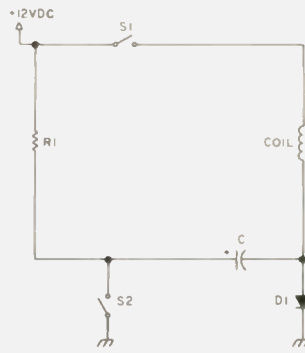

Fig. 3.

There is only one more improvement to be made. The circuit of Fig. 4 requires a floating contact for S1. A PNP power transistor can replace S1 as in Fig. 5. R3 and S3 control the base current in Q2, turning it on and operating the relay when S3 is closed. Another possibility would be to use an NPN power transistor with an optocoupler at Q2.

D1 can be a 1N4002 or almost any silicon rectifier, Q1 can be a 2N3055 or TIP-41, or almost any NPN silicon power transistor capable of handling the

current of the relay coil. Q2 could be a TIP-42.

This circuit will operate a relay, of course, but it will not power anything which requires 24-V dc continuously, like an ART-13. One possible use for the circuit would be flashing a 12-V dc bulb. The extra voltage warms the filament up quickly and gives a bright flash.

The typical values in Table 1 were arrived at by figuring on a 0.1-second

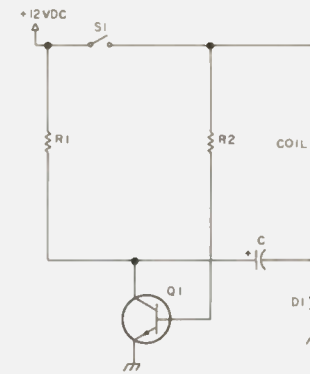

Fig. 4.

time constant for the boost to pull the relay up, and a 0.5-second time constant for C to recharge. To give a longer boost, increase the size of C. To speed the recharging, decrease the size of R1, but if you make R1 too small, the current will blow Q1 when it conducts. Note that some current is wasted through R1 when Q1 conducts, so you may not want to use this where current drain is critical, as in portable

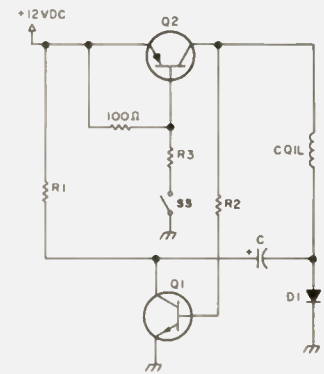

Fig. 5.

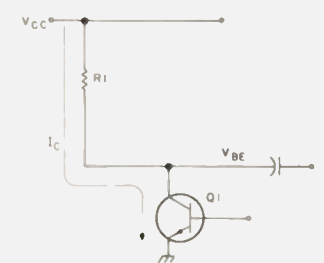



Fig. 6. Too much current through R1 when Q1 is conducting will blow Q1.

operation. See Fig. 6 for more on this. ■

NOW - THE NEW



AMCODER

IT'S EVEN BETTER!!!

4" x 2 3/8" x 6"

- Still only 40hz wide Single signal - no QRM/QRN reception. Immune to impulse (ignition) noise
- Still tape quality audio with TTL compatible signal for computer interface applications. No noise appears in the AMCODER output
- NOT A FILTER! Its CW regeneration
- NOW - dig into the noise for the weak ones without front end overload with our new AGC module. No locking on noise.
- No mods to your gear. Just plug into phone Jack. Speaker or phone outputs with bypass switching when not in use. No external power required
- 26DB dynamic range (5 to 6S unit fade margin) with AGC module when properly adjusted
- Constant level input to the AMCODER regardless of receiver audio level with either S-1 or 30 over 9 signals. (Works on phone signal levels too) with the AGC module.
- Still reduced operator fatigue, variable frequency acquisition, 400-1400hz and variable frequency output tone (and smoother)
- Still variable output level for station speaker or head phones

Complete kit (Less AGC option) (Cabinet included) \$79.95

AGC Module (only FWT) for older AMCODERS 29.95

AGC Module (Only FWT) for new AMCODERS 29.95

New AMCODER Factory wired & tested 94.95

With AGC Module installed 119.95

Foreign - Add \$20.00 - all in U.S. Funds.

Ship your old AMCODER to AMC for updating and installation of AGC module - we pay for return shipping 32.50

VISA & Mastercharge Accepted
Maryland residents - add 5% Sales Tax
Write for brochure or check reader info card

AMC ENGINEERING
P.O. Box 427
Jessup, Md. 20794

Phone: 301-799-7741

ALDELCO ELECTRONICS COMPANY

RF DEVICES

| | |
|----------------------------|--------------------------|
| 2N5913 1.7W 175 MHz \$1.70 | 2N6080 4W 175 MHz 5.40 |
| 2N3866 1W 400 MHz 1.25 | 2N6081 15W 175 MHz 8.45 |
| 2N5589 3W 175 MHz 4.75 | 2N6082 25W 175 MHz 10.95 |
| 2N5590 10W 175 MHz 7.80 | 2N6083 30W 175 MHz 11.75 |
| 2N5591 25W 175 MHz 10.95 | 2N6084 40W 175 MHz 13.30 |

OVERVOLTAGE PROTECTION OV-12 Provides protection from runaway Power Supply Voltage. Triggers @ 16V 25 Amp rated, 1 piece moulded unit for 12 Volt DC fused Power Supply \$8.95 OV-5 for 5 Volt PS triggers at 7V \$9.95

ACCUKEYER KIT. Similar to Handbook version. Includes PC Board, IC's, Sockets & all parts. Includes sidetone on board, Iambic operation dot dash memory. Only \$21.95

NEW MEMORY KIT. 1056 bit memory expandable to 4224 bits. 1 2102 supplied. Additional chips \$1.25 each. Led indicator. Adaptable to other keyers. Uses 5VDC. Only \$21.95

Dual digital 12 or 24 HOUR CLOCK KIT. NOW WITH A NEW WALNUT WOOD GRAIN CABINET Model ALD 5-W Six Big 0.5 Displays Only \$52.95 12 or 24 Hour Operation — Each Clock controlled separately Freeze Feature for Time Set — Easy assembly for clock and Cabinet

5 x 7.3 dot matrix display 3.95

Handle Talkie collapsible whip ant. BNC 8.95

ALARM CLOCK KIT Six 0.5 LED Display Readouts Elapsed Time indicator 12 Hour Format with 24 Hour Alarm Snooze feature AM/PM indicator Power Supply power failure indicator Only \$21.95
12 or 24 Hour Clock Kit 0.5 Display LED S \$19.95
Wood Grain Cabinet \$4.95

TUNABLE AMATEUR TV CONVERTER Receive Fast Scan ATV in the 420 MHz Band with any TV Set. Low noise high gain Amplifier stage with Varactor Tuned input and output. Built-in 110 VAC Supply Two Tone Walnut & Beige Cabinet measuring 1-7/8" x 4-1/4" x 4-1/8" Factory Wired & Tested 2 Year Warranty Only \$59.95

Lunch Counter Kit (boards & front panel only) \$14.50

| | |
|---------------------------|----------------------------|
| 11C90 Prescaler \$19.95 | 1 MHz crystal \$ 7.95 |
| 74C925 Multiplex \$15.95 | 10-60 PF trimmer \$.60 |
| F9368 Drivers (2) \$15.95 | 704 displays, each \$ 1.25 |
| Resistor Kit \$ 1.75 | Capacitor Kit \$ 6.00 |

Add 6% for Shipping, Min. Order \$10.00. Out of USA send Certified Check or Money Order. Include Postage.

ALDELCO

2789 A Milburn Avenue, Baldwin, NY 11510
(516) 378-4555

✓ 300 Send 1st class stamp for our catalog





JAN CRYSTALS

HOLD THE FREQUENCY

- CB
- CB standard
- 2 meter
- Scanners
- Amateur Bands
- General Communication
- Industry
- Marine VHF
- Micro processor crystals

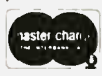
Send 10¢ for our latest catalog. Write or phone for more details.

JAN CRYSTALS   easy to charge ✓ 39

2400 Crystal Drive
Ft. Myers, Florida 33907
all phones (813) 936-2397

Who Needs SSB?

— using your FT-101 on 10m AM

Low-power "channelized" 10 meter activity is certainly on the increase. Most of it consists of recrystallized (recycled?) CB rigs operating between 28.8 to 29.4 MHz. So far, the majority of these stations are using the AM mode.

FT-101 owners may want to try a little of this, too, as an interesting diversion. Turn the MODE switch to AM, and adjust the CARRIER control for 150 mA plate current. Also, adjust the MIC GAIN to the level

where your voice barely kicks the plate current upward. That's what the owner's manual says.

But, wait a minute. Unless your FT-101 is equipped with an AM filter ("CB version"), you may run into an interesting nuisance. Assuming that your CLARIFIER is at the OFF or ZERO position, if you zero-beat the AM carrier in either the TUNE or CW mode and then switch back to AM, the AM station's audio will be severely distorted due to the SSB filter's narrow

passband.

Or, if you instead leave your FT-101 in the AM mode and tune for a peak S-meter reading, you will actually see two peaks close together. That is probably caused by filter passband ripple. Which peak do you tune for? Actually, either peak will work. However, one of the peaks will center your signal better into the other station's (ex-CB rig) somewhat broad i-f passband. It can be confusing to try to remember which peak is which.

A Better Way

Instead, tune for a zero-beat on the CW or TUNE modes, with the CLARIFIER set at ZERO or OFF. Now switch back to AM, turn on the CLARIFIER, and set the CLARIFIER to minus one kHz. This is the first mark to the right of the CLARIFIER's zero-center mark. Setting up the CLARIFIER like this for AM is easier with the "B" or "E" models because of the separate ON-OFF switch. After you do it this way a couple of times, you will see how it eliminates any mental guesswork.

Many CBers and their lobbyists are hungrily looking at "vast, seemingly empty" ten meters. Maybe they should listen a little more—above 28.8 MHz when the skip is in. That's where some of the action is!

I'll gladly answer inquiries accompanied by an SASE. ■

The CONNECTION™

Radio Communications on All TRS-80's
with or Without an Expansion Interface—
For ONLY \$249⁰⁰!

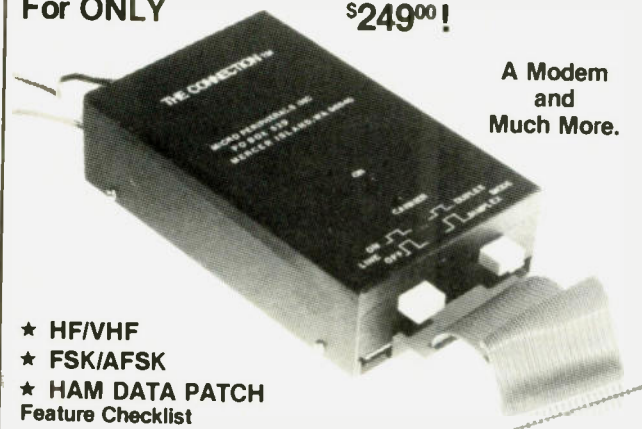

A Modem
and
Much More.

- ★ HF/VHF
 - ★ FSK/AFSK
 - ★ HAM DATA PATCH
- Feature Checklist

- Direct connection between all TRS-80's (Level I 4K to Level II, 48K) and the telephone network without acoustic coupling.
- RS-232 input / output operates printers and other serial interface devices.
- Accurate performance at 300 baud (Bell 103 compatible).
- Connects to two-way radio equipment for computer communications "over the air".
- Supplied with software and documentation. Extensive optional software available.

For more information or to order:
The Microperipheral Corp.
P.O. Box 529 • Mercer Island, WA 98040
(206) 454-3303

✓ 338

TRS-80* is a registered trademark of Tandy Corp.

TMCONNECTION is a trademark of The Microperipheral Corp.

Sentry Crystals...

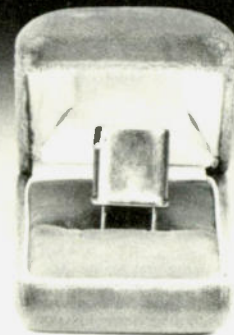

A Work Of Art.

Why settle for an imitation?

Policemen, firemen, E.M.S. and private citizens all depend on good, clear communication. That's why Sentry builds crystals better than they have to be—they're built to exceed Mil-Spec standards. Sentry produces the highest quality, gold-plated crystals available.

world. Just call Sentry's toll free number (800-654-8850) and you're in business with the crystals you need to get the job done right, the first time, in a very short time.



✓ 333

You don't have to wait for a
Sentry Crystal . . .

to come halfway around the

Sentry

When it comes to
**AMATEUR
RADIO QSL's...**



it's the
ONLY BOOK!
US or DX Listings

1980
callbooks

Here they are! The latest editions. World-famous Radio Amateur Callbooks, the most respected and complete listing of radio amateurs. Lists calls, license classes, address information. Loaded with special features such as call changes, prefixes of the world, standard time charts, world-wide QSL bureaus and more. The new 1980 Radio Amateur Callbooks are available now. The U.S. Edition features over 400,000 listings, over 120,000 changes from last year. The Foreign Edition, over 315,000 listings, over 90,000 call changes. Place your order now.

| | Each | Shipping | Total |
|---|---------|----------|---------|
| <input type="checkbox"/> US Callbook | \$16.95 | \$1.75 | \$18.70 |
| <input type="checkbox"/> Foreign Callbook | \$15.95 | \$1.75 | \$17.70 |

Order both books at the same time for \$34.65, includes shipping.

Order from your favorite electronics dealer or direct from the publisher. All direct orders add \$1.75 for shipping. Illinois residents add 5% Sales Tax.



SPECIAL LIMITED OFFER!
Amateur Radio
Emblem Patch
only \$2.50 postpaid

Pegasus on blue field, red lettering. 3" wide x 3" high. Great on jackets and caps. Sorry, no call letters.

ORDER TODAY!

✓61

RADIO AMATEUR
callbook INC.



925 Sherwood Drive
Lake Bluff, IL 60044

TRS-80/RTTY The Crowning Touch ROM-116

Amateur RTTY Operating System

* MODES: RTTY (ASCII or BAUDOT) * CW *

* REAL-TIME CLOCK: 24 hour clock * Automatic updating * Time display includes day, month and year.

* SPLIT-SCREEN VIDEO: 12 lines receive text * 3 lines transmit text or pre-typing a message * 1 line display, real-time clock * Status displayed continuously * Word-wrapping.

* TWO SERIAL PORTS PROVIDED: Port "A" - Interfaces to internal or external terminal unit * RS-232, TTL and 60 ma. * ASCII/BAUDOT * Baud rates of 60, 66, 75, 100 wpm, or 110, 300, 600, 1200, 2400, 4800 and 9600 baud * Mode/baud rate keyboard selectable any time * BAUDOT/ASCII feature wide range of speeds compatible now and in the future. Port "B" RS-232/20ma * Baud rates of 110, 300, 600, 1200, 2400, 4800 and 9600 * Supports any 8-level serial printer or modem * Baud rate keyboard selectable * Expansion interface not required for operation of serial printer or modem.

* BUFFERS: 7.5K Main text buffer * Pre-typed messages up to 7.5K possible. * 2.5K general purpose buffer * Program with CQ, TEST, CALL SIGNS, CONTEST MESSAGES, BRAG TAPES, ETC. * Loadable from cassette * Contents may be saved to cassette * 1/4K Call sign buffer * Program with any message (call signs, etc.).

* AUTOMATIC CW/ID: At the start/end of each transmission * Every 10 minutes * Provision for quick break (no ID).

* TRANSMITTER CONTROL: Transmitter turns on/off automatically via software control * Provisions made for quick break.

* OTHER FEATURES: WRU * RY/FOX tests * Repeat last transmission. * SELCAL: Selcal saves all or selected transmissions to cassette tape, serial printer or both.

* SOFTWARE PROVIDED: 2 RTTY Programs (Cassette/Disk version) * ASCII/BAUDOT Driver routines (permits use of "LLIST" and "LPRINT" commands from basic) * CW send/receive program.

* HARDWARE REQUIREMENTS: TRS-80 with 16K RAM * External terminal unit recommended (Fletcher TU-170, ST-6 etc) * AFSK/FSK unit.

* Board size 6x8, cabinet size 7x10x3.

INTRODUCTORY PRICE **\$240**

less cabinet

CROWN ✓16
MicroProducts

P. O. Box 892

Marysville, Washington 98270
206-659-4279 / 206-659-9512

*A Trademark of The Tondy Corp.

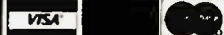

Completely Free
Standing Towers

TELE TOW'R

PAT. NO.

4,151,534

40' MODEL

Model 40 (extends from 21' to 40')

List \$259.10

55' MODEL

Model 55 (extends from 21' to 55')

List \$473.97

Breakover Model

40 (extends from 23' to 40' with breakover at ground level)

List \$440.62

Breakover Model

55 (extends from 23' to 55' with breakover at ground level)

List \$661.75

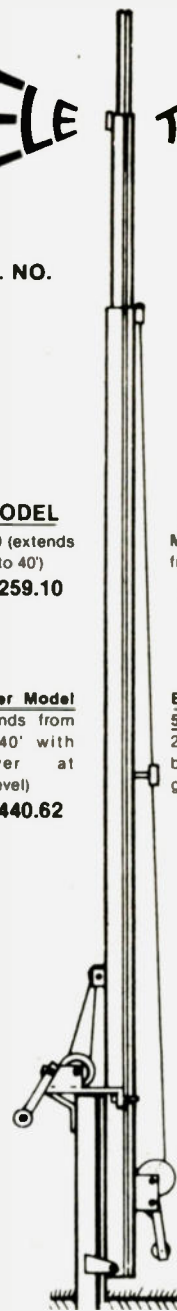

All steel constructed.

Concrete sleeve available for all models.

✓72

TELE-TOW'R MFG. CO., INC.
P.O. Box 3412 • Enid, OK 73701
405-233-4412

Like to See My Etchings?

— chemical technique keeps your property at home

Have you ever lent out one of your tools and then wondered where it was when, later, you needed it? You begin to think, to try to remember who might have borrowed it. As time goes on you start inquiring, but no one seems to know anything about it. Probably, your tool has wound up in the bottom of somebody's tool box mixed with all the others. It now "belongs" to that somebody, although there has been no dishonest intent involved.

About 15 years ago at some exhibit, I saw a

method of engraving metal by electrolysis that intrigued me and I tried it to see if it worked. I was so pleased with the results that I engraved my name on all my tools.

Here is the way it works—engrave your name by the use of a typewriter. No, you don't place the tool in the typewriter, you type your name on a mimeograph stencil and, by electrolysis, engrave it on the tool. The engraver is very simple to build.

The engraver is made up as shown in Fig. 1: a block of wood (any size that you

wish) with a dowel for a handle. The dowel has a hole drilled down through the center to receive a wire which is soldered to the copper electrode. The felt pad is used to retain the electrolyte and is held in place with a rubber band.

After you have assembled the etcher, try it out on a scrap piece of metal. First, wet the felt pad with water, then squeeze it so it's just damp, and then apply some electrolyte. Connect one lead from the transformer to the work and the other to the etcher. Place the stencil on the

work, turn on the power, then place the etcher on the stencil using moderate pressure and hold for about 20-30 seconds. Lay the etcher aside and, holding one corner of the stencil with one hand, peel the stencil back, being careful not to displace it.

Examine the etch to see whether it needs more time or not. If it is too weak, either reposition the stencil so that it will be in the exact place and etch some more or try again on a fresh spot. (If you don't think it was etched, just try to remove it with steel wool or sandpaper! You'll be surprised how deep it really is.)

This method of using ac will just engrave the metal, but suppose that you would like a little contrast. By using dc, you have about the same principle as electroplating: removing the metal from one electrode and applying it to another. There is only one addition needed, and that is a small rectifier hooked in series with the lead going to the work.

When I first started to engrave my tools, I made up an electrolyte made up of 1 tablespoon of table salt in one pint of water. This provides enough conductivity between the electrode and the work. It works fine on ferrous metals, but when I tried it on aluminum, I was unable to obtain a dark impres-

Photos by Bill Trackler KA6BDB

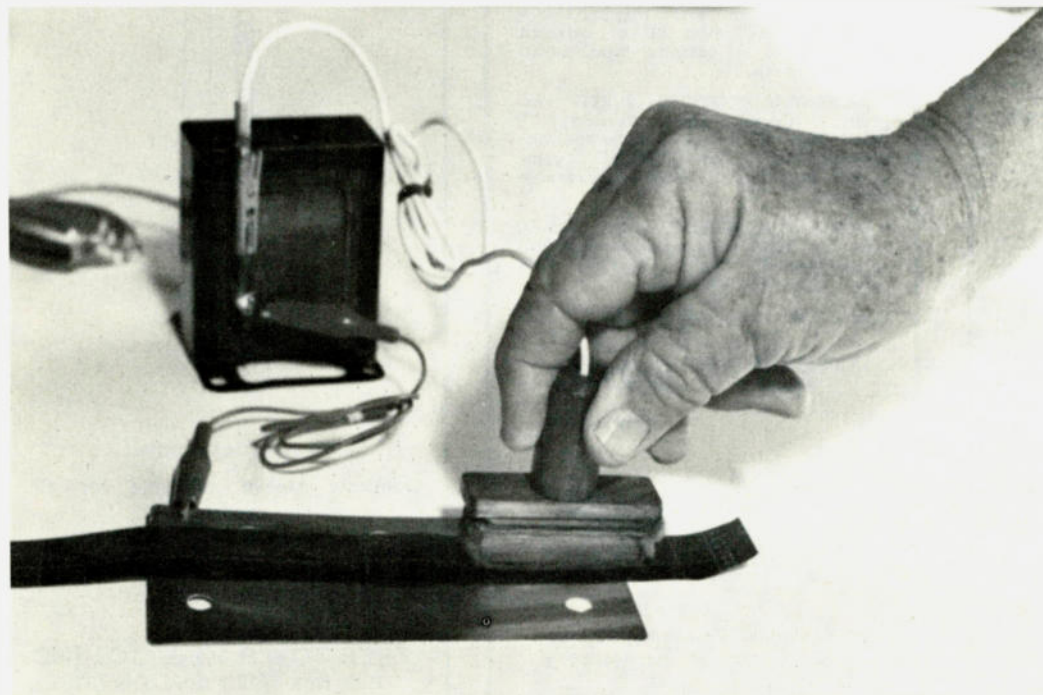

Photo A.

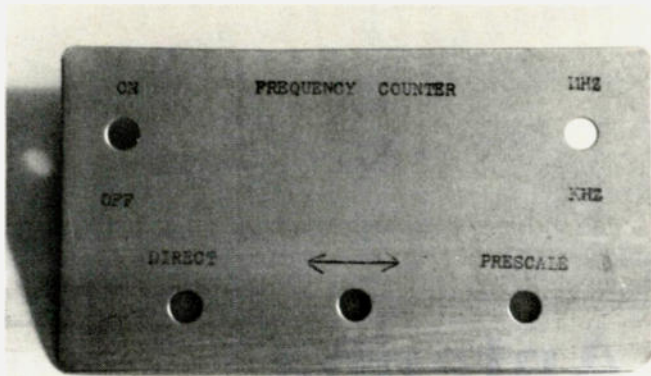

Photo B.

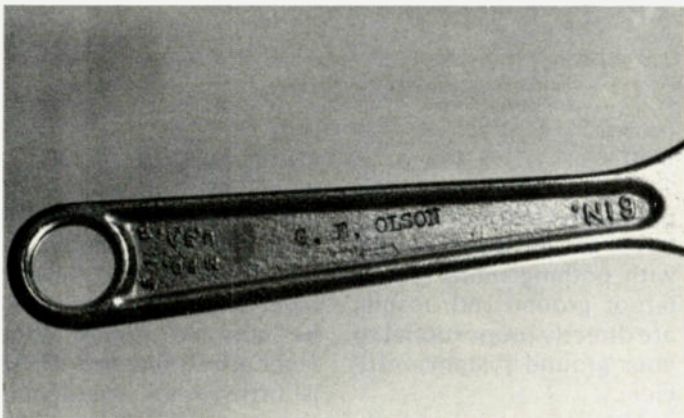

Photo C.

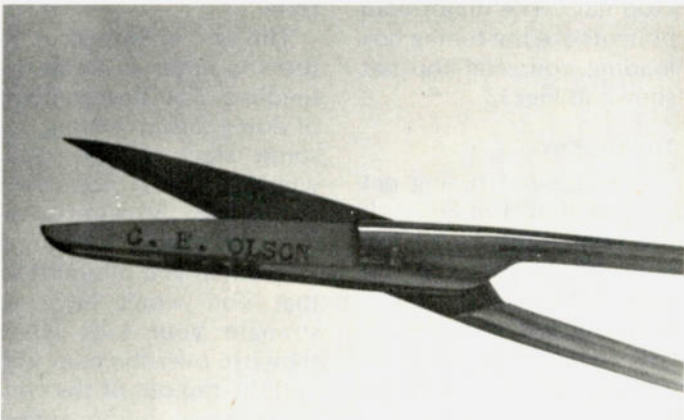

Photo D.

sion. I experimented with several types of salts, but was unable to obtain the desired results. So, I thought I would try an acid. I had some muriatic acid which I had planned to use to clean my driveway, so I diluted it 4 parts water to 1 part acid and that did the trick. I recommend using rubber gloves, but this solution seems so weak that it does not have

any detrimental effects on the parts of the etcher. A rip-off artist will attempt to destroy marks which he believes will identify ownership. To beat him at his game, use a mark which is not too obvious, something which resembles a serial or model number. This may be done by using the last two groups of your social security number—or your

MODEL TR70A
ATV RECEIVING CONVERTER, 420-450 MHz

- TUNABLE—vernier tuned, 420 to 450 MHz
- HIGH PERFORMANCE—low noise RF preamp, mosfet mixer, mosfet IF amp. [Ch2 or 3 out]
- SELF-CONTAINED—including power supply
- 1 YEAR WARRANTY
- PRICE: \$ 88.00 [includes shipping. Add \$ 1.15 for COD shipment]

To order, or receive detailed information, write us or call us at 1-812-336-4775

APTRON LABORATORIES
 PO BOX 373, BLOOMINGTON, INDIANA, 47402

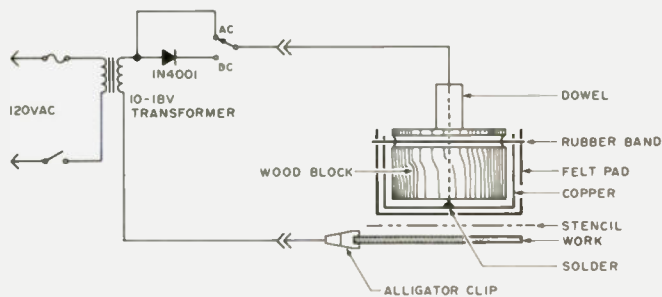

Fig. 1.

first initial plus the number: G-40-459. It is a good idea to contact your local police and ask about the procedure for registering your ID with them. You also can etch parts locations on your chassis and names of controls on your panels. If you have an artistic touch, you can make special designs on your panels. Just use a fine ball-point pen and draw the design on the stencil. If the design is a large one, just increase the size of your etcher.

Ham radio is frowned upon by many XYs, but don't give up; show her that through your hobby you can do interesting things that she can appreciate. As I said, if you have an artistic touch, you could, for example, come up with some sort of a plaque. This she might award to one of her bridge players. And if she is the one who has the artistic touch, you can make another etcher for her! Make her happy and get off the hook! ■

A Low-Life Antenna

— tune in on the life below 500 kHz

There has been a resurgence of interest in the low-frequency bands (0-500 kHz) of late among many radio amateurs. Twenty-four hour weather broadcasts, navigational beacons, standard time broadcasts, the license-free 160-190 kHz communications band, as well as many other services residing in this lowest end of the spectrum, make it a very special challenge to the active amateur.

Unfortunately, many ex-

perimenters shy away from LF due to the misconception that antennas for this band must be gigantic to work well. I have spent several years experimenting in this band, using all shapes and forms of antennas, but I have found the antenna described here to be an excellent performer, as well as being practical and of low construction cost.

Description

There are three basic rules to follow in designing a low-frequency antenna.

1. It must be vertical. A horizontal antenna of any practical size on this band is a real exercise in frustration and will perform about as well as a dummy load.

2. It should use a tuning network of some kind. Antennas on this band are very high Q devices, and some kind of tuning arrangement will be of great

help.

3. It should have a good ground system. Although I have gotten good results with nothing more than a 6-foot ground rod, results are directly proportional to your ground system's efficiency.

The antenna is basically a center- and base-loaded vertical with a capacitance "top hat." The major components are the tuning box, loading coil, and top hat, shown in Fig. 1.

Tuning Box

A suggested tuning network is shown in Fig. 2. In this configuration, the tuning is all done by the variable capacitor, C1. C2-C5 are switched into the circuit to give the capacitor an effective range of 0-2365 pF. If you happen to have a switch with more than five contacts on it, you can extend this range, but I do not recommend

going overboard. L1 is wound on a 2.5-inch-diameter, 5-inch-long form (I used a large pill bottle), using about #28 wire. Several layers may be required, but be sure to secure each layer as it is finished. There is little more maddening than to finish 299 turns and then have your winding go flying off the end of the form.

The coil is tapped at 50 turns in order to tie in the feedline. The best method of doing this is to bring out some slack at the 50th winding, twist together, and solder. Be sure to secure the tap to a terminal strip when you mount it so that you won't have to strangle your kids when they trip over the coax and pull the tap out of the coil. If you have another rotary switch on hand, you can tap the coil at several other places to give even more tuning range.

The manner of mounting components in the tuning box is a matter of personal preference as, at this frequency, long leads do not show an appreciable inductance (within reason, of course).

The network can be mounted in the shack, but in most cases this would require a long horizontal run to the first standoff sup-



Fig. 1. Antenna.

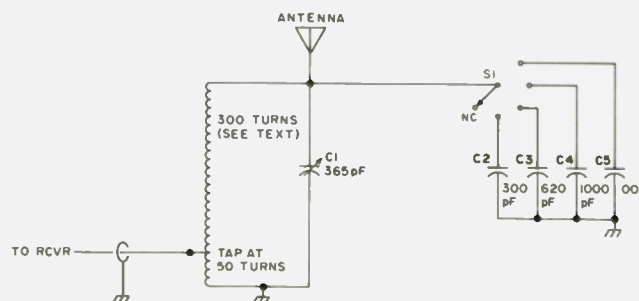

Fig. 2. Tuning box.

porting the end of the vertical element. As much of the antenna as possible must be kept vertical.

Loading Coil

The loading coil is constructed from a 4-foot length of 1.5-inch PVC pipe available from any hardware store. Start the winding six inches in from the end and wind to within six inches of the other end. This leaves enough space at either end to secure the vertical wire elements. Alternate every six inches with close- and wide-spaced winding. I don't know why, but this seems to work better than using consistently close- or wide-spaced winding. Have patience!

I was able to secure the enameled wire I needed by going to a TV repair shop and getting some old television yokes. These contain a lot of #24-28 wire that can be gotten out with little effort. The owner of the TV shop gave me the bad yokes just to get them out of his way.

Always keep a piece of electrical tape close at hand to secure the winding should you have to get up from the table. When the winding is finished (if you haven't gone crazy by now), cover the entire length with electrical tape and plug the ends to keep the bugs and other undesirables out.

Top Hat

The top hat's function is to increase the antenna's capacitance to its ground plane, thus increasing its efficiency. My top hat was constructed from two 2-foot-diameter loops of coat-hanger wire joined at right angles, with a brace down the center to support the weight of the rest of the antenna. (See Fig. 1.)

Installation

Fig. 3 shows my method of installation. This system

was chosen simply because the tree was in the right place and tall enough, and I have a friend who is good at climbing 75-foot tall sweet gum trees. (Not recommended!) You can erect your LF antenna by likewise sloping it up any kind of support, of course. Use the bow-and-arrow trick or just throw a rock up there with a string tied to it. (A case of cool 807s to the first one to do that!) Use your own ingenuity; just keep the antenna as vertical as possible.

Ground System

I recommend an 8-foot ground rod with a minimum of four radials, each about 20 feet long. The more ground, the better. However, you can get surprisingly good results with no radials at all. The tuning network does not have to be mounted directly on the ground. Remember, we are talking about low frequency.

Some Results

The antenna is at its best between 50 and 500 kHz, the most active part of the band. Fourteen states have been logged on TWEB stations (24-hour aviation weather stations). Some of the best DX has been CUT in upper Michigan—227 kHz, MF in southern Florida—365 kHz, LE in North Carolina—350 kHz, and CMH in Ohio—391 kHz. None of these was even faintly detectable with a standard loop antenna.

On occasion, I have copied beacon TUK in New England on 194 kHz with a solid signal. However, it is my understanding that this is a high-power beacon. (Most TWEB stations run about 100-1000 Watts.)

Performance on the 160-190 kHz band is really super. By the way, if you mount the transmitter right at the base, this is a legal and effective antenna for use on this band. WWVB

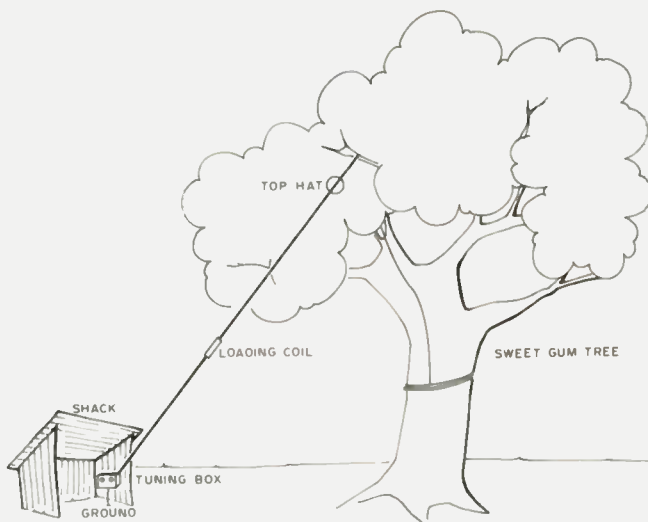

Fig. 3. The AB5S installation.

on 60 kHz is much more readable with this system than with the loop.

Conclusions

I have found this antenna to be a real winner for anyone interested in long-wave work who will put forth the effort to construct it. Many refinements

can yet be made, I am sure, and I hope those of you who construct this system will try your own ideas. By the time you read this, my beacon, AB5S, should be back on 188 kHz, using this antenna. I will gladly answer any questions with an SASE. Good luck, and see you on long-wave! ■

FREE RF TESTER DESIGN

You may be losing up to half the output from your vertical, omnidirectional antenna simply because of RF spillover. We'll send you a design for a simple RF tester that can help you find out. We'll also send you details on the amazing AEA Isopole that virtually eliminates RF spillover and can help multiply your power in all directions on the horizon relative to an ideal half-wave dipole or other non-decoupled "gain" antennas.

Get the Facts.

Contact Advanced Electronic Applications, Inc., P.O. Box 2160, Lynnwood, WA 98036. Call 206/775-7373.

✓2

AEA Brings you the Breakthrough!

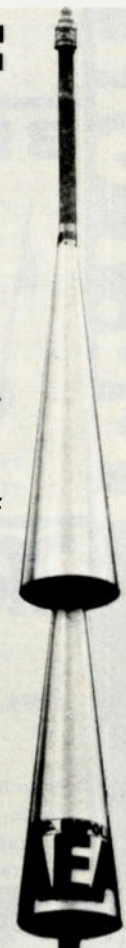

Electronic Department Store

CATALOG



KENWOOD



TR7600: 2m FM XCVR. 10 watts, LED readout, 144-147.995. Fully synthesized, any repeater offset possible, memory channel.

TR7600 VHF XCVR **\$375.00**
 BLC 10/70 VHF Power Amplifier **149.95**



TOTAL REGULAR PRICE **\$524.95**
 SALE PRICE **\$424.95**

Vhf engineering

SAVE \$100.00



Unarco-Rohn

COMPLETE 25G TOWER PACKAGES

50' Guyed Tower: Includes top section, 4 regular sections, base plate, rotor plate, 50' guy wire, 2 guy assemblies with torque bars, 3 concrete guy anchors and other miscellaneous hardware.

TOTAL REGULAR PRICE **\$594.02**
 SALE PRICE **464.02**

SAVE \$130.00

50' Bracketed Tower: Includes top section, 4 regular sections, base plate, rotor plate and universal house bracket.

TOTAL REGULAR PRICE **\$366.15**
 SALE PRICE **266.15**

SAVE \$100.00



BECKMAN



If you've ever been troubled by a faulty multimeter — or had one that wasn't quite up to the tougher jobs — your troubles are over

Choice of Models
 The TECH 310 has all above features, 7 functions, 29 ranges, plus 0.25% Vdc accuracy.
 The TECH 300 has a 0.5% Vdc accuracy and all the above features, but without Insta-Ohms™ continuity function or the 10 amp current ranges

Complete Multimeter Capability
 DC volts: 100 μ V to 1500V
 AC volts: 100 μ V to 1000V rms
 Resistance: 0 Ω to 20M Ω
 DC current: 100nA to 10A (TECH 310)
 100nA to 2A (TECH 300)
 AC current: 100nA to 10A (TECH 310)
 100nA to 2A (TECH 300)
 Diode/Semiconductor test function
 Continuity function (TECH 310)

TECH 300 — \$110
 TECH 310 — \$140

TUFTS TEN-TEC



574



570

TUFTS NOVICE EXCLUSIVE

Purchase your Century 21 (570 or 574) from us and have up to one year to apply the full purchase price towards a model 540, 544, 545, or 546 when you upgrade your station.

TEMPO KLM YAESU



Syncom S1 with TTP:
 From Tempo — the world's first synthesized 800 channel handheld transceiver. Includes battery pack, charger, telescoping antenna — and 800 channels!

FT207R:
 From YAESU — 2m FM XCVR. Handheld completely synthesized, digital readout, keyboard access, 2 watts, 4 memories and much more.



KLM PA2-25B Power Amplifier: 2 watts in, 25 watts out.

PACKAGE 1

Tempo S1 w/TTP **\$339.00**
 KLM PA2-25B Power Amplifier **92.95**

Total Regular Price **\$431.95**
 SALE PRICE **\$396.95**
 SAVE \$35.00

PACKAGE 2

FT207R Synthesized 2m handheld **\$399.00**
 KLM PA2-25B Power Amplifier **92.95**

Total Regular Price **\$491.95**
 SALE PRICE **\$441.95**
 SAVE \$50.00



KENWOOD

...pacesetter in amateur radio



TS520SE

TS520SE: 160-10 meters, 200 watts P.E.P., speech processor, noise blanker, excellent sensitivity and minimum cross-mod.

5BTV

TS520SE **\$629.95**
 Hustler 5BTV Vertical **139.95**

TOTAL REGULAR PRICE **\$769.90**
 SALE PRICE **\$649.90**

SAVE \$120.00

ATB34



TS520SE **\$629.95**
 ATB34 Cushcraft TriBander **\$289.95**

TOTAL REGULAR PRICE **\$919.90**
 SALE PRICE **\$769.90**

SAVE \$150.00



KENWOOD



TL922A: 2kW P.E.P., 160-15 meters, 3-500Z tubes.

TL922A: **\$1199.00**
 MBII Tuner **295.00**

Total Regular Price **\$1494.00**
 Sale Price **\$1294.00**

SAVE \$200.00



Model 43



MBII TUNER:

3kW, 160-10 meters.

TL922A: **\$1199.00**
 Bird Model 43 **\$201.00**

with 2500H element and carrying case

Total Regular Price **\$1400.00**
 Sale Price **\$1200.00**

SAVE \$200.00

CALL AND CHECK OUR GREAT DEALS ON ALL YOUR AMATEUR RADIO NEEDS.

DIAL: 1-617-391-3200

Stock items shipped within 24 hours. Prices subject to change. Limited quantity on some items.

TUFTS ELECTRONIC

TELE. 1-617-391-3200

CATALOG Electronic Department Store



OSCAR

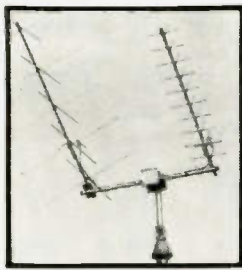

OSCAR Satellite Communications

Cushcraft offers complete antenna systems for OSCAR satellite communications on 2m and 70 cm. On 145 MHz, the 10 element mast antenna (5 vertical elements, 5 horizontal) yields up to 10 dB dBS gain. For greater performance on 2m, choose the 20 element 145 MHz mast (10 vertical elements plus 10 horizontal) providing up to 13.6 dBS gain. For greater performance on 70 cm, choose the 20 element 145 MHz mast which offers 13.6 dBS gain. The half-power beamwidth of these antennas has been optimized for reliable satellite communications with minimum trailing requirements. All test antennas come complete with coaxial matching harness for selectable horizontal, vertical, or circular polarization. Match 50 ohm feedlines.

ATV-5

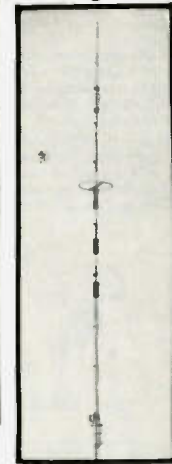

This tapered vertical antenna system has been engineered for five-band operation on 80m-10m. The high Q traps are carefully optimized for wide operating bandwidth. 2:1 SWR bandwidth with 50 ohm feedline is approximately 1 MHz on 10m, more than 500 kHz on 15m and 20m, 160 kHz on 40m and 75 kHz on 80m. Instructions are provided for selective resonance to your preferred part of the band. CW or SSB. Built-in coaxial connector takes PL-750. Nominal height: 293 inches. Rated at 2000 watts PEP on all bands.

Two Meter Boomers

Whether you use the stock for the 2:1 32 19 or the compact 2:1 model, 2m Boomers are your best choice. They offer the maximum gain available for their boom length (see table below). They feature trigon reflectors for additional front to back ratio and clearer patterns. All stainless steel hardware and heavy gauge heat treated aluminum are used throughout. Whatever your choice of 2m activity, the Boomer will fill your needs. For FM use the 228FB or 214FB. For QWSSB on the low end use 218 or 214B. For EME, DX or just reliable QSO, Boomer will perform for you.

Six Meter Boomers

The new 6m Yagi offers more boom, more gain and fewer elements. Designed for the low end of the band, the 6m Boomer has Cushcraft's typical attention to detail. The Boomer's balanced feed with helix and extra heavy duty mechanical construction. The secret behind its superior performance and light weight is special element spacing and boom lengths.

Specifications

| Model | 32 19 | 214B | 214FB | 228FB | 617-6B |
|----------------------------|---------|---------|---------|---------|--------|
| Frequency Range (MHz) | 144-148 | 144-148 | 144-148 | 144-148 | 50-50 |
| Forward gain (dBS) | 18.2 | 15.2 | 15.2 | 18.2 | 14 |
| Front to back ratio (dB) | 24 | 24 | 24 | 24 | 30 |
| Element Spacing (inches) | 2x14 | 2x17 | 2x17 | 2x17 | 2x19 |
| Element Spacing (degrees) | 2x17 | 2x18 | 2x18 | 2x18 | NA |
| Side lobe attenuation (dB) | -80 | -80 | -80 | -80 | -80 |
| Element mass (grams) | 1.21 | 1.21 | 1.21 | 1.21 | 1.21 |
| Impedance (ohms) | 50 | 50 | 50 | 50 | 50 |
| Resistance (ohms) | NA | NA | NA | NA | NA |
| Element diameter (inches) | 14 | 10 | 10 | 10 | NA |
| Element length (inches) | 12 | 8 | 8 | 8 | 8 |
| Element weight (lb) | 22 | 15 | 15 | 15 | 34 |
| Longest element (inches) | 40% | 40% | 38% | 38% | 13% |
| Turning radius (ft) | 11 | 7.5 | 7.5 | 9.5 | 1.7 |
| Windload (lb/ft) | 3.5 | 1.7 | 1.7 | 4.0 | 4.8 |

On this page Tufts brings you...
Cushcraft
Save Your Radio

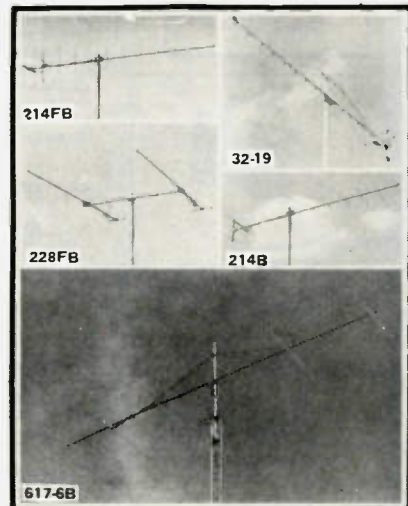

Skywalker

ALL PRICES SHOWN ARE LIST PRICES!
CALL FOR SPECIAL PACKAGE PRICING!

Skywalker

3 and 4 Element Single Band Yagis

Skywalker

More contacts, less trailing, less interference and a better signal at the other end are goals with the Skywalker series of single band Yagis. The 10dB forward gain of the 4 element models will put you first in line. See the chart for all the details. Heavy wall heat treated 6063 T832 aluminum tubing, ruggedly plated steel fasteners, and carefully formed aluminum brackets. Assembly is a breeze with the new Cushcraft Boom Assembly Marking System.

| Model Number | 32-4CD | A33-3 | A33-4 | A33-5 | 3CD-3 | 3CD-4 | 3CD-5 |
|----------------------------|-------------|-------------|-------------|-------------|-------------|-------------|-------------|
| Frequency Range (MHz) | 14.15-14.18 | 14.15-14.18 | 14.15-14.18 | 14.15-14.18 | 28.35-28.38 | 28.35-28.38 | 28.35-28.38 |
| Forward gain (dBS) | 14.5 | 14.5 | 14.5 | 14.5 | 14.5 | 14.5 | 14.5 |
| Front to back ratio (dB) | 30 | 30 | 30 | 30 | 30 | 30 | 30 |
| Element Spacing (inches) | 12 | 12 | 12 | 12 | 12 | 12 | 12 |
| Element Spacing (degrees) | 12 | 12 | 12 | 12 | 12 | 12 | 12 |
| Side lobe attenuation (dB) | -40 | -40 | -40 | -40 | -40 | -40 | -40 |
| Element mass (grams) | 15 | 15 | 15 | 15 | 15 | 15 | 15 |
| Impedance (ohms) | 50 | 50 | 50 | 50 | 50 | 50 | 50 |
| Resistance (ohms) | NA | NA | NA | NA | NA | NA | NA |
| Element diameter (inches) | 12 | 12 | 12 | 12 | 12 | 12 | 12 |
| Element length (inches) | 12 | 12 | 12 | 12 | 12 | 12 | 12 |
| Longest element (inches) | 41 | 40 | 38 | 36 | 35 | 33 | 31 |
| Turning radius (ft) | 20 | 20 | 15.4 | 14.6 | 14 | 13 | 12 |
| Windload (lb/ft) | 8 | 7 | 5 | 4.5 | 4 | 3.5 | 3 |

ATB-34

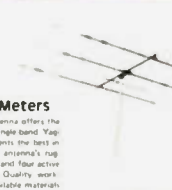

ATB-34

ATB-34 - 10-15-20 Meters

The Cushcraft ATB 34® 3 band antenna offers the maximum performance of a single band Yagi on 10m, 15m, and 20m, and represents the best in state of the art antenna design. The antenna's rugged construction, broad bandwidth, and four active elements give superb performance. Quality workmanship and the use of the best available materials give an estimated wind survival rating of 90 mph. Forward gain is 7.5 dBS on all bands, front to back ratio is nominally 30 dB on 20m, 22 dB on 15m, and 18 dB on 10m. Nominal input impedance = 50 ohms. VSWR is 1.5:1 or less at resonance.

PRICE LIST

| MODEL | DESCRIPTION | LIST PRICE | MODEL | DESCRIPTION | LIST PRICE |
|-----------------------------|-----------------------------------|------------|--|---|------------|
| BOOMER ANTENNAS | | | | | |
| 32 19 | 144-148 MHz, 19 element, 2:1 | 89.95 | ARX 2x | 135-170 MHz, Ranger Kit | 18.95 |
| 214B | 144-148 MHz, 14 element, 2:1 | 69.95 | ARX 200 | 220-275 MHz, Ringo Ranger | 39.95 |
| 214FB | 144.5-148 MHz, 14 element, 2:1 | 69.95 | ARX 450 | 475-450 MHz, Ringo Ranger | 39.95 |
| 228FB | 144.5-148 MHz, 78 element, 2:1 | 219.95 | FM STACKING KITS | | |
| 617-6B | 50-50 MHz, 6 element, 1:1 | 199.95 | A147SK | Vert. Pol. for two A147 A | 19.95 |
| BOOMER STACKING KITS | | | | | |
| 32SK | Stacking Harness & P.D. 2 Boomers | 39.95 | A215SK | Stacking Kit for two A215 | 18.95 |
| 124DK | Quad Stacking Kit, 4 Boomers | 389.95 | A220VPR | Vert. Pol. for two A220 11 | 29.95 |
| 27SK | Stacking Harness & P.D. 2 Boomers | 36.95 | A147SK | Stacking Kit for two A147 11 | 18.95 |
| 728DK | Quad Stacking Kit, 4 Boomers | 369.95 | A147VPR | Vert. Pol. for two A147 11 | 12.95 |
| 278VPR | Vert. Pol. Kit for two Boomers | 89.95 | A448SK | Stacking Kit for two A448 6 or 11 | 29.95 |
| PO 2 | Power Divider, 2 Boomers | 19.95 | A448VPR | Vert. Pol. for two A448 6 or 11 | 19.95 |
| PO 4 | Power Divider, 4 Boomers | 29.95 | BLITZBUGS | | |
| MULTI-BAND ANTENNAS | | | | | |
| ATB 34 | Three Band 4 element Beam | 289.95 | LAC 1 | Car. Lightning Arrester | 4.95 |
| ATV 3 | Three Band Trapped Vertical | 49.95 | LAC 2 | Car. Lightning Arrester | 4.95 |
| ATV 4 | Four Band Trapped Vertical | 99.95 | TRAP ANTENNAS | | |
| ATV 5 | Five Band Trapped Vertical | 109.95 | A147 3B | Three Element Beam & Bracket | 21.95 |
| SKYWALKER BEAMS | | | | | |
| 20-4 CD | 14 MHz, 4 element (2 custom) | 299.95 | A144 10T | 115 MHz, 10 element | 49.95 |
| REPLACES | | | | | |
| 20-3 CD | 14 MHz, 3 element, A14 3 | 199.95 | A144 20T | 145 MHz, 20 element | 69.95 |
| 15-4 CD | 21 MHz, 4 element, A23 4 | 119.95 | A132 20T | 430-436 MHz, 20 element | 59.95 |
| 15-3 CD | 21 MHz, 3 element, A21 3 | 99.95 | VHF/UHF BEAMS | | |
| 10-4 CD | 28 MHz, 4 element, A28 4 | 89.95 | A50 3 | 50 MHz, 3 element beam | 89.95 |
| 10-3 CD | 28 MHz, 3 element, A28 3 | 69.95 | A50 5 | 50 MHz, 5 element beam | 119.95 |
| MOBILE ANTENNAS | | | | | |
| AMS 147 | 110-148 MHz, Scamless Magnet Mt | 29.95 | A50 10 | 50 MHz, 10 element beam | 209.95 |
| ATS 147 | 148-148 MHz, Scamless Trunk Mt | 29.95 | A144 11 | 144 MHz, 11 element beam | 39.95 |
| AMS 200 | 220-275 MHz, Scamless Magnet Mt | 29.95 | A430 11 | 432 MHz, 11 element beam | 37.95 |
| ATS 200 | 220-275 MHz, Scamless Trunk Mt | 29.95 | VHF/UHF STACKING KITS | | |
| A147 A | 144-148 MHz, 4 element | 26.95 | A155SK | Stacking Kit for two A155 | 18.95 |
| A147 B | 144-148 MHz, 20 element | 87.95 | A50 5SK | Stacking Kit for two A50 3/A50 5 | 29.95 |
| A147 22 | 148-148 MHz, 22 element | 119.95 | A50 10SK | Stacking Kit for two A50 3/A50 5/A50 10 | 109.95 |
| A220 7 | 220-275 MHz, 7 element | 29.95 | DX 120 | 144 MHz, 12 element | 49.95 |
| A220 11 | 220-275 MHz, 11 element | 37.95 | DX 200 | 220 MHz, 20 element | 89.95 |
| A448 B | 448 MHz, 8 element | 26.95 | DX 420 | 432 MHz, 12 element | 119.95 |
| A448 11 | 448 MHz, 11 element | 37.95 | DX ARRAY BEAMS | | |
| AFM 440 | 440-450 MHz, Four Pole | 89.95 | DX 18N | 1.1 Beam for DX 120 | 18.95 |
| AR 2 | 135-170 MHz, Ringo | 64.95 | DX 28N | 1.1 Beam for DX 200 | 16.95 |
| AR 6 | 50-54 MHz, Ringo | 59.95 | DX 48N | 1.1 Beam for DX 420 | 16.95 |
| AR 20 | 220-275 MHz, Four Pole | 24.95 | DX ARRAY 40 ELEMENT STACKING KITS | | |
| AR 440 | 440-450 MHz, Four Pole | 39.95 | DX 140 | Stacking Kit for two DX 120 | 159.95 |
| AR 2 | 135-170 MHz, Ringo | 24.95 | DX 440 | Stacking Kit for two DX 420 | 69.95 |
| AR 6 | 50-54 MHz, Ringo | 39.95 | DX 48N | 40 ELEMENT STACKING KITS | 299.95 |
| AR 20 | 220-275 MHz, Ringo | 39.95 | DX 180 | Stacking Kit for two DX 120 | 179.95 |
| AR 450 | 440-450 MHz, Ringo | 39.95 | DX 480 | Stacking Kit for two DX 420 | 179.95 |



\$19995

The full power, full performance 20-15-10m beam.

Enjoy the thrill of working rare DX. Increase the pleasure of your daily contacts with A3 interference reducing front-to-back ratio. Use your linear amplifier with confidence with our new high power traps.

6 METER BEAMS



3 - 5 - 6 - 10 ELEMENTS

| Description | 3 element | 5 element | 6 element | 10 element |
|-----------------|-----------|-----------|-----------|------------|
| Model No | A50 3 | A50 5 | A50 6 | A50 10 |
| Boom Length | 6 | 12 | 20 | 24 |
| Longest Element | 11.7 | 11.7 | 11.7 | 11.7 |
| Turn Radius | 6 | 7.6 | 11 | 13 |
| Feed Gain | 7.5 dB | 9.5 dB | 11.5 dB | 13 dB |
| F:B Ratio | 20 dB | 24 dB | 26 dB | 28 dB |
| Weight | 7 lbs | 11 lbs | 18 lbs | 25 lbs |

3/4, 1-1/4, 2 METER BEAMS



| Model No | A144 7 | A144 11 | A220 11 | A430 11 |
|--------------------|--------|---------|---------|---------|
| Description | 7m | 2m | 11m | 11m |
| Elements | 7 | 11 | 11 | 11 |
| Boom Length | 98 | 144 | 102 | 57 |
| Weight | 4 | 6 | 4 | 3 |
| Fwd Gain | 11 dB | 13 dB | 12 dB | 13 dB |
| F:B Ratio | 26 dB | 28 dB | 28 dB | 28 dB |
| Fwd. Loss @ 100 ft | 42 | 42 | 42 | 42 |
| SWR @ Freq | 1 to 1 | 1 to 1 | 1 to 1 | 1 to 1 |

DEPARTMENT STORE TUFTS

P.O. Box 27, Medford, Mass., 02155

Electronic Department Store CATALOG

On this page Tufts brings you . . .

**Telex
NPC
Unarco-Rohn**



Headphone Jack Box

Ham Clubs, field day contest operation. No more jury rigs for multiple headphones. Six 1/4" phone jacks with individual volume controls, 4 foot cord with 1/2" phone plug.

\$14.30

PROFESSIONAL HEADPHONES & HEADSETS BOOM MIC HEADSETS

For the ultimate in communications convenience and efficiency select a boom mic headset. Long-time favorites of professional communications, boom mic headsets allow more personal mobility while always keeping the mic properly positioned for fast, precise voice transmission. Boom microphones are completely adjustable to allow perfect positioning. And, boom headsets leave both hands free to perform other tasks.

All modes are supplied with "close talking" microphones to limit ambient noise pick-up and provide superior intelligibility. Each model as a convenient, inline push-to-talk switch, which can be wired for either push-to-talk relay control or mic circuit interrupt for voice operated transmitters. The switch may be used as a momentary push-button or it can be locked in the down position. All models have tough, flexible, 8 foot cords which are stripped and tinned, unterminated.



CM-610



CM-1210



CM-1320



CM-1320-S



PC-100



HTC-2



HMC-2



HTC-91

TELEX



C-610



C-1210



C-1320

| MODEL | C-610 | SWL-610 | C-1210 | C-1320 | CM-610 | CM-1210 | CM-1320 | CM-1320S | PC-100 | HTC-2 | HMC-2 | HFC-91 |
|--|-------------------|-------------------|-------------------|-------------------|-------------------|-------------------|-------------------|------------------|---------------|----------------|----------------|----------------|
| Headphone Sensitivity Ref 0002 Dynes/cm ² @ 1mW input, 1kHz | 103dB SPL ±5dB | 103dB SPL ±5dB | 103dB SPL ±3dB | 105dB SPL ±5dB | 103dB SPL ±5dB | 103dB SPL ±3dB | 105dB SPL ±5dB | 105dB SPL ±dB | | | | |
| Headphone Impedance | 3.2 20 ohms | 2000 ohms | 3.2 20 ohms | 3.2 20 ohms | 3.2 20 ohms | 3.2 20 ohms | 3.2 20 ohms | 3.2 20 ohms | 8 200 ohms | 3.2 20 ohms | 3.2 20 ohms | 3.2 20 ohms |
| Microphone Frequency Response | | | | | 50 8000 Hz | 50 8000 Hz | 50 8000 Hz | 50 8000 Hz | 50 1200 Hz | 100 3000 Hz | 100 3000 Hz | 100 3000 Hz |
| Microphone Impedance | | | | | High | High | High | High | Low | Low | Low | Low |
| Microphone Sensitivity Below 1 volt/microbar at 1 kHz | | | | | 51 dB ±5 dB | 51 dB ±5 dB | 51 dB ±5 dB | 51 dB ±5 dB | | | | |
| PRICE: | \$10.45 | \$12.25 | \$29.70 | \$41.80 | \$47.20 | \$62.75 | \$75.25 | \$59.95 | \$18.95 | \$24.50 | \$15.50 | \$9.90 |



| MODEL | NET PRICE | MODEL | NET PRICE |
|-------|-----------|-------|-----------|
| 12V4 | \$19.95 | 104R | \$49.95 |
| 102 | \$24.95 | 108RA | \$79.95 |
| 107 | \$28.95 | 108RM | \$99.95 |
| 103R | \$39.95 | 109R | \$149.95 |



MODEL 109R

NPC 25 Amp Regulator Power Supply 4 Way Protected Output Voltage and Current Meters

Extra heavy duty unit quality converts 115 volts AC to 13.6 volts DC - 200 millivolts, 10 amps continuous, 25 amp max. All solid state. Features dual current overload protection and thermal protection. Ideally suited for operating mobile Ham radio and linear amplifiers in your home or office. Excellent bench power supply for testing and servicing of mobile communications equipment.

| Output Voltage | 13.6 VDC | 13.6 VDC |
|------------------------|-----------|------------|
| Current Regulation | ±1% | ±1% |
| Regulator Noise | 50 mV RMS | 100 mV RMS |
| Transient Response | 20 ohms | 20 ohms |
| Current Continuous | 10 Amp | 10 Amp |
| Current Max | 25 Amp | 25 Amp |
| Overvoltage Protection | ±5 V | ±5 V |
| Thermal Shutdown | 150 °C | 150 °C |

Case 41 (19" x 10" x 8") (D) Shipping Weight 14 lbs.

MODEL 107

NPC 4 Amp Power Supply 6 Amp Max. Solid State. Overload Protection



Functions identically in converting 115 volts AC to 12 volts DC. 4 amps continuous, 6 amp max. Enables anyone to enjoy CB radio, car 8 track cartridge, cassette player or car radio in a home or office.

Case 3 (10" x 4" x 5") (D) Shipping Weight 3 lbs.

MODEL 12V4

NPC 1.75 Amp Power Supply 3 Amp Max.



Functions identically in converting 115 volts AC to 12 volts DC. Ideally suited for most applications including 8 track stereo, burglar alarm, car radio and cassette tape player within power rating.

Case 3 (10" x 4" x 5") (D) Shipping Weight 3 lbs.

MODEL 108RM

NPC 10 Amp Regulated Power Supply 1 Way Protected Output Voltage and Current Meter

The heavy duty unit quality converts 115 volts AC to 13.6 volts DC - 200 millivolts, 8 amps continuous, 10 amp max. All solid state. Features dual current overload protection and thermal protection. Ideally suited for operating mobile Ham radio and linear amplifiers in your home or office. Excellent bench power supply for testing and servicing of mobile communications equipment.

| Output Voltage | 13.6 VDC | 13.6 VDC |
|------------------------|-----------|------------|
| Current Regulation | ±1% | ±1% |
| Regulator Noise | 50 mV RMS | 100 mV RMS |
| Transient Response | 20 ohms | 20 ohms |
| Current Continuous | 8 Amp | 8 Amp |
| Current Max | 10 Amp | 10 Amp |
| Overvoltage Protection | ±5 V | ±5 V |
| Thermal Shutdown | 150 °C | 150 °C |

Case 4 (11" x 10" x 8") (D) Shipping Weight 14 lbs.

MODEL 103R

NPC 4 Amp Regulated Power Supply 1 Way Protected Output Voltage and Current Meter

Converts 115 volts AC to 13.6 volts DC - 200 millivolts. Handles 2.5 amps continuous and 4 amp max. Ideally suited for applications where no Ham and CB stability are important such as CB transmission, small Ham radio transmitter, and high quality night track car stereo. Can also be used to trickle charge 12 volt car batteries.

| Output Voltage | 13.6 VDC | 13.6 VDC |
|------------------------|-----------|------------|
| Current Regulation | ±1% | ±1% |
| Regulator Noise | 50 mV RMS | 100 mV RMS |
| Transient Response | 20 ohms | 20 ohms |
| Current Continuous | 2.5 Amp | 2.5 Amp |
| Current Max | 4 Amp | 4 Amp |
| Overvoltage Protection | ±5 V | ±5 V |
| Thermal Shutdown | 150 °C | 150 °C |

Case 3 (10" x 4" x 5") (D) Shipping Weight 3 lbs.



MODEL 104R

NPC 6 Amp Power Supply Regulated Dual Overload Protection

Converts 115 volts AC to 13.6 volts DC - 200 millivolts. Handles 4 amp continuous and 6 amp max. Ideally suited for applications where no Ham and CB stability are important such as CB transmission, small Ham radio transmitter, and high quality night track car stereo. Can be used to trickle charge 12 volt car batteries.

| Output Voltage | 13.6 VDC | 13.6 VDC |
|------------------------|-----------|------------|
| Current Regulation | ±1% | ±1% |
| Regulator Noise | 50 mV RMS | 100 mV RMS |
| Transient Response | 20 ohms | 20 ohms |
| Current Continuous | 4 Amp | 4 Amp |
| Current Max | 6 Amp | 6 Amp |
| Overvoltage Protection | ±5 V | ±5 V |
| Thermal Shutdown | 150 °C | 150 °C |

Case 3 (10" x 4" x 5") (D) Shipping Weight 3 lbs.



MODEL 102

NPC 2.5 Amp Power Supply 4 Amp Max. Solid State Overload Protected

Converts 115 volts AC to 12 volts DC. 2.5 amps continuous, 4 amp max. Enables anyone to enjoy CB radio, car 8 track cartridge, cassette tape player or car radio in a home or office.

| Output Voltage | 12 VDC | 12 VDC |
|------------------------|-----------|------------|
| Current Regulation | ±1% | ±1% |
| Regulator Noise | 50 mV RMS | 100 mV RMS |
| Transient Response | 20 ohms | 20 ohms |
| Current Continuous | 2.5 Amp | 2.5 Amp |
| Current Max | 4 Amp | 4 Amp |
| Overvoltage Protection | ±5 V | ±5 V |
| Thermal Shutdown | 150 °C | 150 °C |

Case 3 (10" x 4" x 5") (D) Shipping Weight 3 lbs.

Unarco-Rohn

COMPLETE 25G TOWER PACKAGES

50' Guyed Tower: Includes top section, 4 regular sections, base plate, rotor plate, 50' guy wire, 2 guy assemblies with torque bars, 3 concrete guy anchors and other miscellaneous hardware.

TOTAL REGULAR PRICE \$594.02
SALE PRICE 464.02

SAVE \$130.00

50' Bracketed Tower: Includes top section, 4 regular sections, base plate, rotor plate and universal house bracket.

TOTAL REGULAR PRICE \$366.15
SALE PRICE 266.15

SAVE \$100.00



Tel. 1-617-391-3200

TUFTS ELECTRONIC

CATALOG Electronic Department Store



A Warner Communications Company

All items in stock for immediate delivery.

ATARI® 800™ PERSONAL COMPUTER SYSTEM



ATARI 800

The ATARI 800 is a top-of-the-line personal computer system. Its expandable memory, advanced peripheral components, comprehensive software library, and modular design assure that it will never become obsolete.

Whether it's for business and household management, education, or entertainment,

the ATARI 800 can be tailored to specific needs and has been designed to change as those needs change. This "timeless" computer system can be used by people with no previous computer experience, although it doesn't compromise capability for the sophisticated user.

SOFTWARE LIBRARY

The hardware which makes up the ATARI 800 Personal Computer System is only half the story.

The other half is ATARI's complete software library. You get a full choice of ROM cartridge, tape cassette, and diskettes that give you complete control in shaping your computer's character and applications. For data management. For problem solving. For education. For fun and games.

You can even create and apply your own programs. ATARI's BASIC Language cartridge gives you direct access to your computer's central processing unit, memory and color, sound and file transfer capabilities. So you can design, write and implement your own programs. Or modify existing ones to suit your needs. Easily. Even if you've never talked to a computer before.



ATARI® 830™ MODE M



ATARI® 850™ INTERFACE MODULE



JOYSTICK CONTROLLERS



PADDLE CONTROLLERS



ROM PROGRAMS



CASSETTE PROGRAMS

ANNOUNCING A NEW GENERATION OF PERSONAL COMPUTERS BY ATARI®



ATARI 820 Printer (Optional)

High resolution, dot-matrix impact printer uses inexpensive, standard roll paper. Prints more than 2,000 characters per minute to provide permanent printed records of program listings and program results.



ATARI 410 Program Recorder

Comes supplied with your ATARI 800 Personal Computer. The program recorder gives you the ability to utilize any ATARI pre-recorded tape cassette program. It also lets you store your own programs on audio cassette tapes. It can store up to 100K bytes per 60 minute tape.



ATARI Memory Modules (Optional)

Unique 8K and 16K plug-in RAM modules let you instantly expand your computer's internal memory up to 48K.



ATARI 810 DISC DRIVE (Optional)

Uses standard 5 1/4" diskettes to add up to 88K bytes of rapid access information storage for each diskette. As many as four 810 Disk Drive units can be operated simultaneously and accessed individually.

ATARI® 400™ PERSONAL COMPUTER SYSTEM



ATARI 400

The ATARI 400 Personal Computer is just that: a computer that you can use. It's easy to own. And easy to operate. Even if you've never used a computer before.

But don't let its simple operation fool you. The ATARI 400 is a full-fledged general purpose computer that can go a long way towards simplifying your complex life.

All you have to do is pick a program from ATARI's comprehensive library of plug-in cartridge and cassette tape software. Everything from small business management to home finance and computerized education. Plus some of the most challenging, most exciting computer games ever.

The system

The ATARI 800™ system provides easy access to a wide variety of household information. Uses such as music composition, electronic art, and household security control are all planned applications for the ATARI 800 system. The educational and entertainment value built into the system is endless.

For professional use, the ATARI 800 is expandable to keep up with the needs of most small businesses, and with the needs of large businesses where the central computer is overloaded.

Business & household management

- **Personal Financial Management** Income and expense record keeping keyed to rapid retrieval for income tax purposes
- **Record Keeping** Books, records, serial numbers, insurance policies
- **Charge Account Management** (With check printing)
- **Personal Capital Investment Management** Stocks, bonds, real estate, with stock quotation service
- **Mailing List/Address Book** (With printing)
- **Computerized Appointment Calendar**
- **Inventory Management**
- **Accounts Payable**
- **Touch-typing Trainer**
- **Payroll**

Educational applications

The exclusive ATARI 800 Educational Library on audio digital cassettes, contains over 20 subjects, including:

- Algebra
- Economics
- Auto Mechanics
- Sociology
- U.S. History
- Zoology
- Counseling Procedures
- Vocabulary Builder
- Basic Psychology
- Spelling
- Spanish
- Accounting
- Carpentry
- Great Classics
- Statistics
- Basic Electricity
- World History

Direct interaction with the computer takes place through the keyboard, television screen, and speaker. This running dialogue between the user and the computer is highlighted by immediate feedback on accuracy and understanding.

Entertainment applications

The ATARI 800 is capable of playing sophisticated thinking and action games. The Entertainment Program Library consists of:

Thinking games

- Chess
- Backgammon
- Business Simulations
- Stock Market Simulation
- Space Adventure
- Strategy Games

Action games

- Four-Player Basketball
- Superbug™ Driving Game
- Game of Life
- Super Breakout™

P.O. Box 27, Medford, Mass., 02155

DEPARTMENT STORE TUFTS

Electronic Department Store CATALOG

On this page Tufts brings you . . .
YAESU

YAESU



FT-1012D

High-Performance HF Transceiver
Today's technology, backed by a proud tradition, is yours to enjoy with the all new FT-1012D HF SSB/CW transceiver. This no-compromise rig includes variable IF bandwidth, digital plus analog frequency display, a built-in RF speech processor, and a wide receiver dynamic range. The FT-1012D may be used with all of the FT-901 series accessories, providing such exciting features as a scanning external VFO, memory, VHF and UHF coverage, and extensive monitoring capability.

FT-101Z

Top Performance for the Budget-Minded Amateur
If economy is an important consideration, and you don't need the frequency counter and digital display, then choose the FT-101Z. The precision VFO gear mechanism is coupled to an easy-to-read analog display, providing resolution to greater than 1 kHz. All other features — the variable IF bandwidth, rf speech processor, superb noise blanker, VOX — are identical to the FT-1012D.



YC-500

500 MHz Frequency Counter
The YC-500 utilizes advanced IC techniques and a dual range system to provide accurate 8 digit readout to cover 500 MHz. Both MHz and kHz indications can be selected with ease over this range with a flip of a switch on the front panel. A built-in ac and dc supply enables complete portability, and a double sided epoxy circuit board ensures stable and accurate operation with reliability for many years.



FT-127RA — 220 MHz FM
FT-227RB — 144 MHz FM
FT-627RA — 50 MHz FM

Scanning Memorizers

The FT-127RA, FT-627RA, and FT-227RB FM transceivers allow scanning and expanded memory coverage for the demanding VHF FM operator. Both feature up/down scanning capability, with control from the microphone, the scanner will also search for a busy or clear channel, if you wish. Four memory channels are also available — two for simplex channels, three for repeater channels, and one for a split of up to 4 MHz.



FT-7B

HF Mobile Transceiver
The all-solid state FT-7B provides power and performance for the amateur on the move. The rugged transistor final amplifier stage operates at an input power of 100W for SSB and CW, 25W for AM. The YC-7B optional frequency display provides safe indication of your operating frequency from your dash board, steering column, or other convenient location.



NEW FROM YAESU FT-707 — "WAYFARER"

The FT-707 offers you a full 100W output on 80-10m and operates SSB, CW, and AM modes. This full-featured transceiver is ideally suited for your home station or as a traveling companion for mobile or portable operation.

FEATURES:

- Fast/slow AGC selection
- Advanced noise blanker
- Built-in calibrator
- WWV/JJY Band
- Bright Digital Readout
- Fixed crystal position
- 2 auxiliary bands for future expansion
- Unique multi-color bar metering — monitors signal strength, power output, and ALC voltage.



FT-901 DM

Our Top-of-the-line Transceiver
Unparalleled receiver performance, combined with state-of-the-art transmitter features, makes our top-of-the-line FT-901DM the ham's dream, at home or away. The receiver features continuously variable IF bandwidth, rejection tuning, a CW audio peak filter, and industry-leading dynamic range. The transmit side includes a built-in Curtis 8044 IC keyer, RF speech processor, and a 10-second "TUNE" mode timer, which prevents damage to your finals caused by excessive key-down time while tuning.



FT-625RD

All-Mode 6m Transceiver
The FT-625RD is designed for today's demanding 6m operator. Built into every FT-625RD are an rf speech processor, a high-performance noise blanker, and ±1 MHz repeater split for FM buffs. Available as an option is Yaesu's exciting memory unit, allowing storage and recall of any frequency.

CPU-2500R

2m FM Transceiver with CPU
The age of computers has exploded onto the amateur scene with the announcement of the new CPU-2500R 2m FM transceiver. Controlled by a 4-bit central processing unit (CPU), the CPU-2500R contains a scanner, 4 memory channels, manual or automatic tone burst generation, an optional sub-audible tone squelch, and 25W output across the band.



| MODEL | DESCRIPTION | PRICE |
|-----------|--|-----------|
| FT-901DM | 160-10m xcvr | \$1459.00 |
| FT-1012D | 160-10m xcvr | 895.00 |
| FT-101Z | Analog Version | 749.00 |
| | UHF TRANSCEIVER | |
| FT-720RU | 440-450 FM xcvr | 499.00 |
| | SOLID STATE HF XCVRs | |
| FT-7B | 80-10m 100W | 675.00 |
| FT-107M | 160-10m SSB/CW/AM w/o DMS & memory | 1045.00 |
| FT-707 | 80-10m 200W | TBA |
| | VHF TRANSCEIVERS | |
| CPU2500RK | FM mobile keyboard | 585.00 |
| FT-127RA | 200 MHz AutoScan | 479.00 |
| FT-207R | 2m Syn. 3W Handie | 399.00 |
| FT-225RD | 2m with Digital | 895.00 |
| FT-227RB | 2m/4 Mem. w/YM-22 | 425.00 |
| FT-625RD | 6m All Mode xcvr | 895.00 |
| FT-627RA | 6m 4 Memory xcvr | 399.00 |
| | SOLID STATE RECEIVERS | |
| FRG-7 | Communications | 370.00 |
| FRG-7000 | All Band HF | 655.00 |
| | LINEAR AMPLIFIER | |
| FL-2100ZA | 160-15m | 599.00 |
| | ACCESSORIES ALL MODELS | |
| YH-55 | Headset | 15.00 |
| FF501dx | Lo pass filter | 34.00 |
| QTR-24D | Quartz Clock | 49.00 |
| | TEST EQUIPMENT | |
| YC-500J | 500 MHz 10 PPM | 239.00 |
| YC-500S | 500 MHz 1 PPM | 399.00 |
| YC-500E | 500 MHz 0.02 PPM | 537.00 |
| YS-2000 | 2000W Peak Reading SWR Bridge | 95.00 |
| | ACCESSORIES FOR 901/101Z Series (All items can be used with the 101Z Series except * Items.) | |
| FA-9 | Fan | \$ 20.00 |
| FM-901* | FM Adapter | 45.00 |
| KY-901* | Keyer Unit | 45.00 |
| MU-901* | Memory Unit | 124.00 |
| DC-901* | DC-DC Converter | 60.00 |
| SP-901 | Speaker | 35.00 |
| SP-901P | Speaker/Patch | 74.00 |
| FTV-901R | Transverter w/2m | 455.00 |
| " | 2m adapter only | 154.00 |
| " | 6m adapter only | 110.00 |
| " | 70 cm adapter only | 255.00 |
| YO-901 | Monitor w/scope | 515.00 |
| YR-901 | Code/RTTY Decoder | 730.00 |
| FV-901DM | Synthesized VFO | 415.00 |
| FC-901 | Antenna Tuner | 199.00 |
| XF8.9HC | CW Filter | 45.00 |
| XF8.9B* | AM Filter | 45.00 |
| DC-1012D | DC-DC Converter | 60.00 |
| ZD-1 | Analog Readout | 150.00 |
| FV-101Z | Remote VFO | 175.00 |
| | ACCESSORIES FOR VHF EQUIPMENT | |
| PB-1424 | Marker Unit | 50.00 |
| PB-1555 | Tone Squelch Unit | 30.00 |
| MMB-4 | Mobile Unit for (620B & FT-221) | 23.00 |
| MMB-5 | Mobile Mount (227R) | 8.00 |
| FP-4 | 4 Amp Pwr. Supply | 50.00 |
| FP-12 | 12 Amp Pwr. Supply/Spkr (2500RK) | 132.00 |
| MU225/625 | Memory Unit for (225RD & 625RD) | 165.00 |
| XF10.BHC | CW Filter (625RD) | 45.00 |
| XF10.BHS | SSB Filter (625RD) | 45.00 |
| FSP-1 | Remote Speaker | 21.00 |
| FTS-64 | 64 Tone Switchable CTCSS/Burst Encoder | 80.00 |
| FTS-32ED | 32 Tone CTCSS Programmable Encoder/Decoder | TBA |
| | ACCESSORIES FOR 101 SERIES | |
| FTV-250 | 2m Transverter | 275.00 |
| FA-9 | Fan | 20.00 |
| XF-30B | AM Filter | 40.00 |
| XF-30C | CW Filter | 40.00 |
| DC-1 | DC-DC Converter | 50.00 |
| YO-101 | Monitor Scope | 320.00 |
| YC-601B | Digital Readout | 235.00 |
| SP-101B | Speaker | 25.00 |
| | ACCESSORIES FOR HAND-HELD XCVRs | |
| NC-1A | 15 hr. Drop-in Charger | \$ 46.00 |
| NC-2 | 3 hr. Drop-in with Power Supply | 90.00 |
| PA-1 | Mobile Battery Eliminator | 39.00 |
| LCC202 | Leather Carry Case | 35.00 |
| TC-202 | Top Cover | 3.95 |
| NBP-9 | Battery Pack | 23.00 |
| NC-9B | 15 hr. Wall Mount Charger | 10.00 |
| YM-24 | Speaker Mic | 32.00 |
| FBA-1 | Battery Sleeve | 8.00 |
| LCC-7 | Leather Carry Case | 35.00 |
| TA-2 | Telescope Antenna | 8.50 |
| FTS-32E | Syn. 32 Tone CTCSS/Burst Encoder | 40.00 |
| | ACCESSORIES FOR SOLID STATE XCVRs | |
| FP-12 | 12 Amp Speaker with Power Supply | 132.00 |
| YC-7B | Digital Readout Counter | 110.00 |
| FP-107 | Internal Power Supply | 139.00 |
| FP-107E | External Power Supply | 145.00 |
| DMS-107 | Digital Memory Shift | 125.00 |
| FC-107 | Antenna Tuner | 139.00 |
| FV-107 | Remote VFO | 125.00 |
| SP-107 | Speaker | 29.00 |
| SP-107P | Speaker/Patch | 67.00 |
| FTV-107R | Transverter w/2m | 284.00 |
| " | 6m Adapter only | 110.00 |
| " | 70 cm Adapter Only | 255.00 |

TEL. 1-617-391-3200

TUFTS ELECTRONIC

CATALOG Electronic Department Store



from Barker & Williamson

On this page Tufts brings you . . .
B&W

NEW & DIFFERENT

FROM BARKER & WILLIAMSON, INC.

Barker & Williamson Model 370-11, Broad Band Dipole Antenna with built-in rugged construction for long life.



Class 2 50-30 MHz (including the 12, 17 and 30 meter bands. Only 80 feet long!) Can be used as a stepping or for top antenna.
Support structure assembled with high tensile strength steel copper clad wire, 50B RG code cable and PL-259 connector.
Kit number 2 5149.95 S. & W. P. P.

5-BAND TRAP DIPOLE (80 thru 10 meters) Power rated 2k WPEP approx. 110 ft. span

Complete with: wire, traps, end insulators, 50 ft. RG-8/U, PL-259 connector, heavy-duty cast aluminum and steatite center connector.



Pre-assembled:
Model 370-11 Kit (illustrated):
— \$64.95 Model 370-12 — \$54.95

| Model Number | Dia. | TPI | Wire Size (AWG) | Length of Coils (Inches) | PRICE | Model Number | Dia. | TPI | Wire Size (AWG) | Length of Coils (Inches) | PRICE |
|--------------|-------|-----|-----------------|--------------------------|--------|--------------|-------|-----|-----------------|--------------------------|--------|
| 404T | 1/2 | 4 | 18 | 2 | \$2.20 | 1404T | 13/4 | 4 | 14 | 10 | \$7.10 |
| 406T | 1/2 | 6 | 18 | 2 | 2.33 | 1406T | 13/4 | 6 | 14 | 10 | 5.01 |
| 408T | 1/2 | 8 | 18 | 2 | 2.33 | 1408T | 13/4 | 8 | 14 | 10 | 5.12 |
| 410T | 1/2 | 10 | 18 | 2 | 2.42 | 1410T | 13/4 | 10 | 16 | 10 | 5.23 |
| 416T | 1/2 | 16 | 20 | 2 | 2.53 | 1416T | 13/4 | 16 | 18 | 10 | 5.36 |
| 432T | 1/2 | 32 | 24 | 2 | 2.75 | 1432T | 13/4 | 32 | 24 | 10 | 5.65 |
| 504T | 5/8 | 4 | 16 | 2 | 2.20 | 1604T | 2 | 4 | 12 | 10 | 9.60 |
| 506T | 5/8 | 6 | 18 | 2 | 2.27 | 1606T | 2 | 6 | 14 | 10 | 9.71 |
| 508T | 5/8 | 8 | 18 | 2 | 2.33 | 1608T | 2 | 8 | 14 | 10 | 9.82 |
| 510T | 5/8 | 10 | 18 | 2 | 2.46 | 1610T | 2 | 10 | 16 | 10 | 9.94 |
| 516T | 5/8 | 16 | 20 | 2 | 2.53 | 1616T | 2 | 16 | 18 | 10 | 10.14 |
| 532T | 5/8 | 32 | 24 | 2 | 2.66 | 2004T | 2 1/2 | 4 | 12 | 10 | 10.90 |
| 604T | 3/4 | 4 | 16 | 2 | 2.10 | 2006T | 2 1/2 | 6 | 12 | 10 | 11.01 |
| 606T | 3/4 | 6 | 18 | 2 | 2.17 | 2008T | 2 1/2 | 8 | 12 | 10 | 11.12 |
| 608T | 3/4 | 8 | 18 | 2 | 2.30 | 2010T | 2 1/2 | 10 | 16 | 10 | 11.23 |
| 610T | 3/4 | 10 | 18 | 2 | 2.37 | 2404T | 3 | 4 | 10 | 10 | 13.17 |
| 616T | 3/4 | 16 | 20 | 2 | 2.42 | 2406T | 3 | 6 | 12 | 10 | 13.28 |
| 632T | 3/4 | 32 | 24 | 2 | 2.61 | 2408T | 3 | 8 | 14 | 10 | 13.40 |
| 804T | 1 | 4 | 16 | 3 | 2.31 | 2410T | 3 | 10 | 14 | 10 | 13.50 |
| 806T | 1 | 6 | 18 | 3 | 2.45 | 195-1 | 3 | --- | --- | --- | 52.38 |
| 808T | 1 | 8 | 18 | 3 | 2.52 | 195-2 | 3 | --- | --- | --- | 61.02 |
| 810T | 1 | 10 | 18 | 3 | 2.56 | 3204T | 4 | 4 | 8 | 10 | 69.39 |
| 816T | 1 | 16 | 20 | 3 | 2.73 | 3206T | 4 | 6 | 10 | 10 | 70.74 |
| 832T | 1 | 32 | 24 | 3 | 2.78 | 3208T | 4 | 8 | 12 | 10 | 67.23 |
| 1004T | 1 1/4 | 4 | 14 | 10 | 6.17 | 3210T | 4 | 10 | 12 | 10 | 68.58 |
| 1006T | 1 1/4 | 6 | 14 | 10 | 6.33 | 4004T | 5 | 4 | 8 | 10 | 83.16 |
| 1008T | 1 1/4 | 8 | 16 | 10 | 7.17 | 4006T | 5 | 6 | 10 | 10 | 84.78 |
| 1010T | 1 1/4 | 10 | 18 | 10 | 7.33 | 4008T | 5 | 8 | 12 | 10 | 86.94 |
| 1016T | 1 1/4 | 16 | 20 | 10 | 7.48 | 4010T | 5 | 10 | 12 | 10 | 90.45 |
| 1032T | 1 1/4 | 32 | 24 | 10 | 7.89 | 4804T | 6 | 4 | 8 | 10 | 92.34 |
| 1204T | 1 1/2 | 4 | 14 | 10 | 6.36 | 4806T | 6 | 6 | 10 | 10 | 99.36 |
| 1206T | 1 1/2 | 6 | 14 | 10 | 6.79 | 4808T | 6 | 8 | 12 | 10 | 100.98 |
| 1208T | 1 1/2 | 8 | 16 | 10 | 7.17 | 4810T | 6 | 10 | 12 | 10 | 108.00 |
| 1210T | 1 1/2 | 10 | 18 | 10 | 7.24 | | | | | | |
| 1216T | 1 1/2 | 16 | 20 | 10 | 7.50 | | | | | | |
| 1232T | 1 1/2 | 32 | 24 | 10 | 7.82 | | | | | | |

PI-DUX® Coils
High Precision air wound coils for band switching, pi-network final amplifiers.

AIR-DUX® Air Wound Coils
Uniflate push coils from 1/4 inch to 6 inches diameter, 2 inches to 18 inches long, 4 to 30 turns per inch, up to 24 AWG.

COAXIAL SWITCHES AND ACCESSORIES

for antenna selection and RF switching



| MODEL | SWITCHES DESCRIPTION | PRICE |
|--------|---|---------|
| 375 | PROTAX switch. Grounds all except selected output circuit. 6 Outputs. | \$19.75 |
| 376 | PROTAX switch. Grounds all except selected output circuit. Sixth switch position grounds all outputs. 5 Outputs. | |
| 377 | Coaxial Antenna Relay | 19.75 |
| 550A | Antenna/RF Coax Switch. 5 Outputs. | 22.50 |
| 550A-2 | Antenna/RF Coax Switch. 2 Outputs. | 17.50 |
| 551A | Special 2-pole, 2-position switch used to switch any RF device in or out of series connection in a coaxial line. 2 Outputs. | 14.95 |
| 556 | Bracket only, for wall mounting of radial connector switches. | 17.95 |
| 590 | Antenna/RF Coax Switch. 5 Outputs. | .95 |
| 590G | Grounds all except selected output circuit. 5 Outputs. | 18.50 |
| 592 | Antenna/RF Coax Switch. 2 Outputs. | 18.50 |
| 593 | Single pole, 3 position Antenna RF/Coax Switch. | 17.75 |
| 594 | O.P.D.T. Antenna /RF Coax Switch. Interchanges two outputs between two inputs. | 17.50 |
| 595 | Grounds all except selected output circuit. 6 Outputs. | 18.25 |
| | | 21.50 |



Model 333 dummy load watt meter - Favorite Lightweight Portable - 250 WATT RATING - Air Cooled. Ideal field service unit for mobile 2-way radio - CB, marine, business band. Best for QRP amateur use, CB, with zero to 5 watts full scale low power range.

Frequency Range: DC to 300 MHz
VSWR: Less than 1.3:1 to 230 MHz
Power Range: 250 watts intermittent
Wattmeter Ranges: 0.1, 0.5, 0.125, 0.250
Connector: SO-239
Size: 4" x 7" x 8"
Shipping Weight: 2 lbs.
Price: \$38.90



High Power - 1000 WATT RATING - Oil Cooled - model 334A dummy load wattmeter. Our most popular combination unit. Handles full amateur power. Meter ranges individually calibrated. Can be panel mounted.

Frequency Range: DC to 300 MHz
VSWR: Less than 1.3:1 to 230 MHz
Power Range: 1000 watts CW intermittent
Warning light: signals maximum heat limit
Wattmeter Ranges: 0.1, 0.100, 0.300, 0.1000
Input Connector: SO-239 (hermetically sealed)
Size: 4" x 7" x 10"
Shipping Weight: 12 lbs.
Price: \$175.00

Model 374 dummy load watt meter - Top of the Line 1500 WATT RATING - Oil Cooled. Our highest power combination unit. Rated to 1500 watts input (intermittent). Meter ranges are individually calibrated for highest accuracy.

Frequency Range: DC to 300 MHz
VSWR: Less than 1.3:1 to 230 MHz
Power Range: 1500 watts DC intermittent
Warning light: signals maximum heat limit
Wattmeter Ranges: 0.1, 0.50, 0.300, 0.1500
Input Connector: SO-239 (hermetically sealed)
Size: 4" x 8" x 10"
Shipping Weight: 12 lbs.
Price: \$28.95



Wide range attenuator - Model 371-1. Seven rocker switches provide attenuation from 1 dB to 61 dB in 1-dB steps. Switches are marked in dB, 1-2-3 5 10-20 20. Sum of actuated switches (IN position) gives attenuation. With all switches in OUT position, there is NO insertion loss. Attenuator installs in coaxial line using UHF connectors.

Power Capacity: 50 watts
VSWR: 1.3:1 maximum, DC to 225 MHz
Impedance: 50 ohms
Attenuation: 1 dB dB, DC to 80 MHz
0.1 dB dB, 10 dB DC to 160 MHz
0.1 dB dB, 1.0 dB DC to 225 MHz
Size: 4" x 7" x 2 1/2"
Shipping Weight: 1 1/2 lbs.
Price: \$59.50

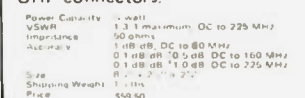

DEPARTMENT STORE TUFTS

P.O. Box 27, Medford, Mass., 02155

Electronic Department Store CATALOG

NEW! GRANDMASTER MEMORY KEYS

At \$139.95 this MFJ-484 GRANDMASTER memory keyer gives you more features per dollar than any other memory keyer available — and Here's Why . . .



- WEIGHT CONTROL TO PENETRATE**
PULL TO COMBINE MORSES
A AND B FOR 1, 2 OR 3 FIFTY
CHARACTER MESSAGES
- MESSAGE BUTTONS SELECT DESIRED 25 CHARACTER MESSAGES**
- REPEATS MEMORY IN USE TO BE CARRYING**
- MEMORY SELECT:** POSI-
TIONS 1, 2, 3 ARE EACH
SPLIT INTO MEMORY SEC-
TIONS A, B, C, D (UP TO
TWELVE 25 CHARACTER
MESSAGES). SWITCH COM-
BINES A AND B POSITION
* LIGHTS YOU 100, 75, 50
OR 25 CHARACTERS BY
PRESSING BUTTONS A, B,
C OR D
- LEDs (4) SHOW WHICH MEMORY IS IN USE AND WHEN IT ENDS**
- TONE CONTROL:** PULL TO TUNE
TNDL. POWER ON/OFF
- DELAY REPEAT CONTROL:** (0 TO 2 MINUTES) PULL FOR AUTO REPEAT
- LED INDICATES DELAY REPEAT MODE**
- | |
|---|
| MFJ-484 Grandmaster Memory Keyer. Up to twelve 25 character messages plus a 100, 75, 50, or 25 character message. 139.95 |
| MFJ-482 Grandmaster Memory Keyer. Four 25 or a 50 and two 25 character messages. 99.95 |
| MFJ-481 Grandmaster Memory Keyer. Two 50 character messages. 79.95 |
| HK-1 Optional Squeeze Key. 29.95 |

PROFESSOR MORSE

MFJ-410 Professor Morse. Random code generator/keyer. Morse code teaching computer. Sends alpha only or alphanumeric, full feature Curtis keyer, speed readout, delay for spacing letters up to three seconds. 149.95

TELEPHONE PATCHES

MFJ-624 Crisp clear professional sounding audio, Vu meter for monitoring line level and for nulling for maximum separation of transmitter and receiver, easy patch in patch out connections. 59.95

MFJ-620 Same as MFJ-624 except without meter. 49.95



MFJ-40T ORP Transmitter

\$29.95

MISCELLANEOUS

- | | |
|--|-------|
| MFJ-202 RF Noise Bridge. | 59.95 |
| MFJ-1030BX Receiver Preselector. | 49.95 |
| MFJ-200BX Frequency Standard. | 29.95 |
| MFJ-40T ORP Transmitter. | 29.95 |
| MFJ-40V Companion ORP VFO for 40T | 29.95 |
| CPO-555 Code Practice Oscillator | 17.95 |
| TK-555 Optional Telegraph Key. | 1.95 |



LSP-520BX

\$49.95



LSP-520BX II

\$59.95

SPEECH PROCESSOR

- MFJ-525** RF Speech Processor. Plugs between microphone and rig. Powerful natural sounding speech. Vu meter for adjustment of processing, 4 pin mic jack, 6 dB more average SSB power, use with any rig and any mic, push button on-off/bypass. 119.95
- LSP-520BX II** Logarithmic Speech Processor. Deluxe model. 59.95
- LSP-520BX** Logarithmic Speech Processor. 49.95



CMOS-8043 Electronic Keyer
State of the art design uses CURTIS-8043 Keyer-on-a-chip

\$54.95

- Built-in Key • Dot memory • Iambic Alpha
- Full auto external squeeze key • 0-50 WPM • Sideband and spread • Speed variable tone weight controls • Ultra reliable solid state keying • 4 pin mic jack • 4 position switch for TUNE • OFF • ON • SIDETONE OFF
- Useful 4 preset keys • 2.5, 16, 31.4, 4 dashes

ELECTRONIC KEYS

- | | |
|--|-------|
| MFJ-8044IC Deluxe Keyer. Dot and dash memory. | 69.95 |
| MFJ-404 Econo Keyer. Built-in paddle, plus extras. | 59.95 |
| MFJ-402 Econo Keyer. Built-in paddle. | 44.95 |
| MFJ-400 Econo Keyer. External Key. | 49.95 |
| MFJ-408 New Deluxe Electronic II, speed readout meter, socket for Memory, random code generator, keyboard. 8044IC keyer chip dot and dash memory. Up to 50 WPM. | 79.95 |
| BY-1 Bencher Deluxe Iambic Paddles. Heavy steel base, non-skid feet. | 39.95 |

MFJ ENTERPRISES DELUXE Versa Tuner II



BRAND NEW

- | |
|--|
| MFJ-984 Deluxe 3kW Versa Tuner IV. SWR, forward-reflected wattmeter, rf ammeter, dummy load, antenna switch, balun, 3kW PEP. 299.95 |
| MFJ-982 3kW Versa Tuner IV. 7 position antenna switch, balun, 3kW PEP. 199.95 |
| MFJ-981 3kW Versa Tuner IV. SWR, forward-reflected wattmeter, balun, 3kW PEP. 199.95 |
| MFJ-980 3kW Versa Tuner IV. Built-in balun, 3kW PEP. 169.95 |
| MFJ-962 1.5 kW Versa Tuner III. SWR, forward-reflected wattmeter, 6 position antenna switch, balun, 1.5kW PEP. 169.95 |
| MFJ-961 1.5kW Versa Tuner III. 6 position antenna switch, balun for balanced lines, 1.5kW PEP. 149.95 |
| MFJ-949 Deluxe Versa Tuner II. Ultimate in antenna tuners: SWR, dummy load, forward-reflected wattmeter, front panel antenna switch, balun, 300W output. 129.95 |
| MFJ-941B Versa Tuner II. Improved model with SWR/wattmeter, antenna switch, balun, mobile mounting bracket, 300W output. 79.95 |
| MFJ-940 Versa Tuner II. SWR/wattmeter, antenna switch, no balun, no mobile mount, 300W. 69.95 |
| 700-0014 Mobile mount for MFJ-940. 3.00 |
| MFJ-945 Versa Tuner II. With SWR/wattmeter and mobile mounting bracket, less 6 position antenna switch, 300W. 69.95 |
| MFJ-944 Versa Tuner II. With antenna switch and mobile mounting bracket, less SWR/wattmeter, 300W output. 69.95 |
| MFJ-943 Versa Tuner II. Less SWR/wattmeter, antenna switch mounting bracket, 300W output. 59.95 |
| MFJ-901 Versa Tuner. Matches anything. Coax, random wires, balance lines, 200W output. 49.95 |
| MFJ-900 Econo Tuner. Matches coax and random wires, 200W. 39.95 |
| MFJ-16010 Random Wire Tuner. For random and long wires, 200W. 29.95 |

24-HOUR DIGITAL CLOCK SOLID-STATE



\$29.95

24 HOUR DIGITAL CLOCK

MFJ-101 24 hour digital clock, totally solid state, 6" blue display (like TS-820S), ID time, lock function (prevents accidental missetting of time). 29.95

These MFJ active filters are the most copied in industry.

CWF 201 MFJ SUPER CW FILTER SBF 201 MFJ SSB FILTER



\$29.95 each

SSB/CW FILTERS

- | |
|--|
| MFJ-752 Dual tunable SSB/CW active filter Signal Enhancer II. 2 noise limiters, inputs for 2 rigs, 110VAC or 12 VDC. 79.95 |
| MFJ-751 Tunable SSB/CW active filter Signal Enhancer. 110VAC or 12 VDC. 59.95 |
| MFJ-721 Super CW/SSB Filter. 2W amplifier, noise limiters, inputs for 2 rigs. 12VDC or 110VAC with optional AC adapter. 59.95 |
| MFJ-720 Deluxe Super CW Filter. 2W amplifier, 12VDC or 110VAC with optional AC adapter. 44.95 |
| CWF-28X Super CW Filter. 29.95 |
| SBF-28X Single Sideband Filter. 29.95 |
| AC Adapter 12 VDC, 200 mA. 7.95 |
| CWF-2PC Same wired and tested PC board as in CWF-28X with 4 position switch. 19.95 |
| SBF-2PC Same wired and tested PC board as in SBF-28X with 4 position switch. 19.95 |
| AC Adapter 6 VDC, 300 mA. 7.95 |

TELE. 1-617-391-3200

TUFTS ELECTRONIC

CATALOG Electronic Department Store

Bearcat



\$299.00

BEARCAT 220

Aircraft, Marine, Public Service. The 220 adds features and advanced sophistication.

- Aircraft and Marine - press button to search entire Aircraft Band, another for Marine
- 7 Bands - Low, High, UHF, UHF-T, 2m amateur and 75 CM Ham - plus the Aircraft Band
- 20 Channels - scan up to 20 frequencies or either of two banks of 10 channels each
- Automatic Search - Selective Scan Delay - Automatic Lock-Out - Patented Track Tuning - Manual Scan Control - Single Antenna
- Priority - automatically samples designated channel every two seconds
- AC/DC operation

NEW!

\$149.95



BEARCAT™ FOUR-SIX THIN SCAN™

More bands, more channels - more scanning capabilities than other Hand-Helds.

- 4 Bands (Low, High, UHF and UHF-T)
- 6 Channels - more monitoring capacity
- "Rubber Ducky" Antenna
- Belt Clip frees hands while monitoring
- 8 channels per second scan speed
- Automatic or manual scanning
- Individual channel lock-outs
- Portable - weighs only 12 ounces
- Battery operated (6 Vdc)

BEARCAT 211

More capabilities - more refinements. The 211 sets a new standard for synthesized scanners.

- 6-Band coverage - Low, High, Gov't., UHF, UHF-T and the amateur Ham Band.
- 18 channel monitoring.
- Digital Electronic Clock
- Variable Scan Speed - 5 or 15 channels per second
- Deluxe Keyboard, Synthesized Programming
- Automatic Search - Selective Scan Delay - Automatic Lock-Out - Patented Track Tuning - Manual Scan Control - Hold for stopping on frequencies while searching - Single Antenna
- Decimal Display
- Auto Squelch factory-set for optimum reception
- AC/DC operation



BEARCAT 300 \$499.95

Service Search
Over 2100 pre-programmed frequencies.

- 11 Service Search categories arrange stored frequencies into "interest" groups - Police, Fire, Marine, HAM, Emergency, Telephone, Government, Forestry, Industrial, Transportation and Aircraft.
- 50 Channels/5 bands
- 7 Bands (Low & High VHF, UHF, and UHF-T, AM Aircraft, 2m & 75 CM Amateur)
- Non-volatile memory, AC/DC
- Automatic Search with Hold & Resume functions
- Patented Selective Scan Delay
- Vacuum Fluorescent Decimal-Display with Dimmer Control
- Speed Control
- Quartz Clock
- Patented Track Tuning
- Direct Channel Access
- Automatic Squelch

On this page Tufts brings you...
Bearcat
DAIWA (J. W. Miller)



\$299.00

BEARCAT 250

The most advanced synthesized scanner in Bearcat history.

- 50 channels can be programmed in 5 banks of 10 channels each; 6 Bands
- Search/Store locates and remembers active frequencies
- Search/Recall displays "found" frequencies in sequence
- Automatic Count of action on each channel
- Search Direction for easy operations
- LED Clock
- Non-Volatile Memory - Priority - Auxiliary Control - Twin Scan Speeds - Manual Scan - Automatic Squelch - Scan Delay - Track Tuning - LED Clock - more.
- AC/DC operation



\$279.00



\$219.55

BEARCAT 210

The one that pioneered synthesized scanning - and unlocks new channels of communication.

- No crystals to buy - full 6-band coverage.
- Keyboard programming makes frequency selection as easy as punching a push-button telephone.
- Decimal display and exclusive rolling zeros to show what's being programmed and monitored.
- Automatic search for finding new frequencies.

\$65.95



\$20.95

Coaxial Switches
2 Position/Model CS-201
4 Position/Model CS-401

SWR & Power Meters

Models CN-720, CN-620 and CN-630
Professionally engineered cavity construction.
Power Rating: 2.5kW PEP, 1kW CW
Impedance: 50 Ohms
Connectors: SO-239
Insertion Loss: Less than 2 dB
VSWR: 1:1.2
Maximum Frequency: 500 MHz
Isolation: Better than 50 dB at 300 MHz; better than 45 dB at 450 MHz; adjacent terminal.
Unused Terminals grounded.

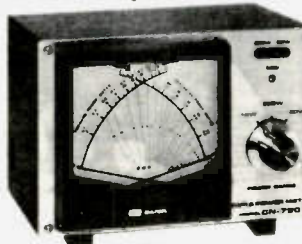

CN-720 \$166.95

DAIWA



\$105.00 RF-660



\$135.95 RF-440

RF Speech Processor

Models RF-400 & RF-660
Increases talk power with splatter free operation. RF clipping assures low distortion. Simply install between microphone and transmitter.
Talk Power: Better than 6 dB
Frequency Response: 300-3000 Hz at 12 dB down.
Distortion: Less than 3% at 1 kHz, 20 dB clipping.
Power Requirement: RF-440 self contained. AC power supply: RF-660 13.5Vdc external supply.

CN-720 and CN-620

Frequency Range: 1.8-150 MHz
SWR Detection Sensitivity: 5W min.
Power: 3 Ranges (Forward, 20/200/100W) (Reflected, 4/40/200W)



\$140.50 CN-620

Interference Filters from J. W. Miller

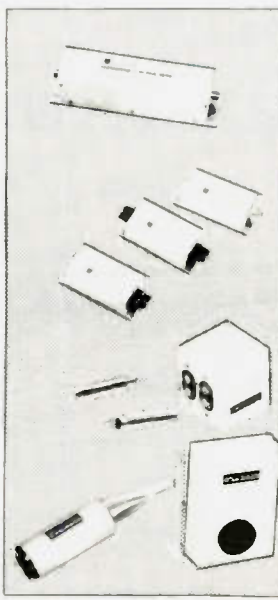

Low Pass Filters

Eliminate or greatly reduce interference to TV receivers by radio amateur stations when installed in antenna lines of those transmitters. Input and output impedance 50 ohms. Insertion loss: 3dB max. VWSR 1:2.1. Attenuation greater than 75 dB above 411 MHz.
C 511 T 25 W AM 50 W PEP SSB \$19.50
C 514 T 1000 W AM 2000 W PEP SSB \$26.80

High Pass Filters

When installed in the antenna, eliminate or greatly reduce front end overload interference to TV or FM receivers caused by amateur radio transmitters and other high frequency radio services. Filter attenuates signals below 40 MHz by a power factor greater than 1,000,000:1. Impedance C 513 T 1: 75/300 ohm
C 513 T2 75/75 ohm, C 513 T3 300/300 ohm \$10.18 \$10.18

Audio Interference Filters

Eliminate interference caused in your audio equipment by radio amateur transmitters and other radio services. C 505 R installs in the input lines of audio equipment. Consists of 1 pair. C 506 R installs in speaker lines. Unit will take care of stereo speaker system. \$5.07 \$6.67

AC Power Line Filters

Eliminate or reduce interference to radio amateur receivers, TV's and radios, and prevent radio signals from entering power line.
C 508 L 3 section LC filter, 3 A max \$ 8.33
C 509 L 5 section LC filter (for more severe interference) 5 A max \$18.35

CN-630
Frequency Range: 140-450 MHz
Power: 2 Ranges (Forward 20/200W) (Reflected 4/40W)

CN-630
\$139.00



P.O. Box 27, Medford, Mass., 02155

DEPARTMENT STORE TUFTS

Electronic Department Store CATALOG

FINCO STINGER VHF/UHF Antennas

On this page Tufts brings you . . .
Finco Stinger **Hitachi**
Ham-Key **Alliance**



10 meter

STINGER A 10-4 DESCRIPTION
 The model Stinger A 10-4 is a wide spaced, full size, high gain four element 10 meter, monobander, designed for optimum DX performance. Utilizing the exclusive Stinger Series square boom construction, the A 10-4 is light enough to be easily erected for an additional 3 dB gain yet strong enough to withstand the most adverse weather conditions. The highly efficient gamma match system easily withstands 2,000 watts P.E.P. of power and maintains a relatively low V.S.W.R. across the entire 10 meter amateur band.

SPECIFICATIONS - A 10-4

| ELECTRICAL | MECHANICAL |
|-------------------------|------------------|
| Forward Gain | 10 dB |
| Front to Back Ratio | 20dB |
| V.S.W.R. (at resonance) | 1.1 |
| V.I.W.R. (at resonance) | 1.1 |
| Half Power Beam Width | 40° |
| Bandwidth | 50 MHz |
| Impedance | 50 Ohms |
| Matching System | Adjustable Gamma |

\$62.95



8 meter

STINGER A 8-5 DESCRIPTION
 The model Stinger A 8-5 is a highly directional 8 meter five element beam specifically designed for maximum forward gain with a "no compromise" front to back ratio. The elements are constructed of high tensile strength aluminum tubing plus the exclusive Stinger square boom and bracket assemblies. For maximum power transfer and low V.S.W.R., a carefully designed gamma matching assembly capable of withstanding 2,000 watts P.E.P. is incorporated. Wide element spacing insures optimum DX performance and good operating efficiency across the entire 80 to 90 MHz 8 meter band. The square boom allows optional vertical mounting for accessing 8 meter repeaters.

SPECIFICATIONS - A 8-5

| ELECTRICAL | MECHANICAL |
|-------------------------|------------------|
| Forward Gain | 11 dB |
| Front to Back Ratio | 20dB |
| V.S.W.R. (at resonance) | 1.1 |
| V.I.W.R. (at resonance) | 1.1 |
| Half Power Beam Width | 40° |
| Bandwidth | 50 MHz |
| Impedance | 50 Ohms |
| Matching System | Adjustable Gamma |

\$46.50



6 and 2 meter

STINGER A 6-3 DESCRIPTION
 The model Stinger A 6-3 is a 3 element high gain 6 meter beam antenna. A 6-3 but especially designed for the casual 6 meter DXer. It is an excellent application for portable use as it disassembles into a compact package. Due to the units light weight and multiple mounting options, it is ideal for double stacked and quad stacked arrays for 12, 18, and 24 dB gain. The A 6-3 is rated at 2,000 watts P.E.P. and incorporates a square boom and high tensile strength aluminum elements.

SPECIFICATIONS - A 6-3

| ELECTRICAL | MECHANICAL |
|-------------------------|------------------|
| Forward Gain | 9.0 dB |
| Front to Back Ratio | 10 dB |
| V.S.W.R. (at resonance) | 1.1 |
| V.I.W.R. (at resonance) | 1.1 |
| Half Power Beam Width | 40° |
| Bandwidth | 50 MHz |
| Impedance | 50 Ohms |
| Matching System | Adjustable Gamma |

\$30.00



6 and 2 meter

STINGER A 6-2 DESCRIPTION
 The model Stinger A 6-2 is a truly remarkable combination 6 and 2 meter beam designed for optimum performance on both bands yet only requiring ONE transmission line. This is accomplished through the use of exclusive gain elements to accomplish dual band operation with no sacrifice to either band. **(NO SWITCHING REQUIRED!)** On 2 meters the A 6-2 has 6 collinear elements - equivalent to three 1/2 lambda elements - spaced side by side - thus giving outstanding performance. Maximum forward gain is insured on 6 meters through the use of four wide spaced elements. The heavy duty Stinger construction is used throughout so that the antenna will withstand 120 mph wind plus other loads. The A 6-2 is ideal for mounting on the same mast as your 12 meter or other antenna thus easily opening up the popular 10 and 2 meter VHF communication.

SPECIFICATIONS - A 6-2

| ELECTRICAL | MECHANICAL |
|-------------------------|------------------|
| Forward Gain | 6 meters 9.0 dB |
| Front to Back Ratio | 2 meters 12.0 dB |
| V.S.W.R. (at resonance) | 1.1 |
| V.I.W.R. (at resonance) | 1.1 |
| Half Power Beam Width | 40° |
| Bandwidth | 50 MHz |
| Impedance | 50 Ohms |
| Matching System | Adjustable Gamma |

\$74.95

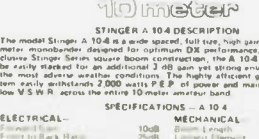

2 meter

STINGER A 2-10 DESCRIPTION
 The model Stinger A 2-10 is a high performance wide spaced ten element 2 meter beam designed for the serious VHF operator. Utilizing the Stinger construction features, the A 2-10 is almost undetectable on meter what weather conditions are encountered. Complete coverage of the 2 meter band and low V.S.W.R. is insured through the use of non-linear spaced elements that also achieving maximum forward gain. Power rating - 2,000 watts P.E.P. The A 2-10 can be mounted for vertical polarization, thereby making the antenna quite useful in repeater stations. An additional base of the A 2-10 can be easily added for even greater gain and front to back ratio.

SPECIFICATIONS - A 2-10

| ELECTRICAL | MECHANICAL |
|-------------------------|------------------|
| Forward Gain | 13.8 dB |
| Front to Back Ratio | 20dB |
| V.S.W.R. (at resonance) | 1.1 |
| V.I.W.R. (at resonance) | 1.1 |
| Half Power Beam Width | 40° |
| Bandwidth | 144 to 148 MHz |
| Impedance | 50 Ohms |
| Matching System | Adjustable Gamma |

\$44.95

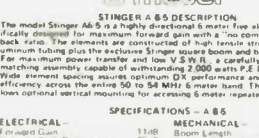

2 meter

STINGER A 2-8 DESCRIPTION
 The model Stinger A 2-8 is a five element high gain antenna similar to the A 2-10 but having a slightly less of a profile. The A 2-8 finds excellent application as a portable antenna as it disassembles into a very compact package. Like the A 2-10, the antenna can be mounted for vertical polarization or weather repeater or general coverage work. Construction of the Stinger antenna features insure optimum DX performance and good operating efficiency under adverse weather conditions. Power rating 2,000 watts P.E.P.

SPECIFICATIONS - A 2-8

| ELECTRICAL | MECHANICAL |
|-------------------------|------------------|
| Forward Gain | 10.5 dB |
| Front to Back Ratio | 10 dB |
| V.S.W.R. (at resonance) | 1.1 |
| V.I.W.R. (at resonance) | 1.1 |
| Half Power Beam Width | 40° |
| Bandwidth | 144 to 148 MHz |
| Impedance | 50 Ohms |
| Matching System | Adjustable Gamma |

\$27.95

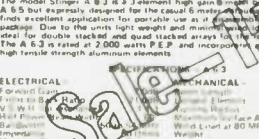

2 meter

STINGER A 2-2 DESCRIPTION
 The model Stinger A 2-2 is a two element dual polarization 2 meter antenna designed for OSCAR communications or where switching from horizontal to vertical polarization is required. The A 2-2 can even be phased to operate on both horizontal and vertical polarization at the same time. This is not only an OSCAR work but gives your station versatility for ground communication.

SPECIFICATIONS - A 2-2

| ELECTRICAL | MECHANICAL |
|-------------------------|------------------|
| Forward Gain | 9.4 dB |
| Front to Back Ratio | 10 dB |
| V.S.W.R. (at resonance) | 1.1 |
| V.I.W.R. (at resonance) | 1.1 |
| Half Power Beam Width | 40° |
| Bandwidth | 144 to 148 MHz |
| Impedance | 50 Ohms |
| Matching System | Adjustable Gamma |

\$46.50

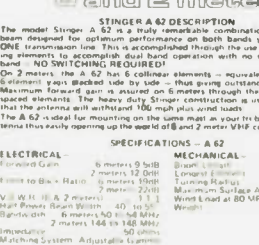

1 1/4 meter

STINGER A 1-1/4 DESCRIPTION
 The model Stinger A 1-1/4 is a two element 1 1/4 meter 120 MHz high performance beam designed for all 120 MHz communication needs. Designed to be mounted in either the vertical or horizontal plane, the A 1-1/4 is adaptable to OSCAR, repeater, or general communication work. Incorporating the Stinger heavy duty elements, boom and boom support assemblies, the antenna easily withstands 120 mph wind loads under 1/4 lambda test conditions. A low loss gamma matching system insures a low V.S.W.R. and is power rated at 1,000 watts.

SPECIFICATIONS - A 1-1/4

| ELECTRICAL | MECHANICAL |
|-------------------------|------------------|
| Forward Gain | 13.8 dB |
| Front to Back Ratio | 20dB |
| V.S.W.R. (at resonance) | 1.1 |
| V.I.W.R. (at resonance) | 1.1 |
| Half Power Beam Width | 40° |
| Bandwidth | 220 to 226 MHz |
| Impedance | 50 Ohms |
| Matching System | Adjustable Gamma |

\$32.95

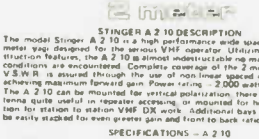

2 meter

STINGER A 2-10 DESCRIPTION
 The model Stinger A 2-10 is a high performance wide spaced ten element 2 meter beam designed for the serious VHF operator. Utilizing the Stinger construction features, the A 2-10 is almost undetectable on meter what weather conditions are encountered. Complete coverage of the 2 meter band and low V.S.W.R. is insured through the use of non-linear spaced elements that also achieving maximum forward gain. Power rating - 2,000 watts P.E.P. The A 2-10 can be mounted for vertical polarization, thereby making the antenna quite useful in repeater stations. An additional base of the A 2-10 can be easily added for even greater gain and front to back ratio.

SPECIFICATIONS - A 2-10

| ELECTRICAL | MECHANICAL |
|-------------------------|------------------|
| Forward Gain | 13.8 dB |
| Front to Back Ratio | 20dB |
| V.S.W.R. (at resonance) | 1.1 |
| V.I.W.R. (at resonance) | 1.1 |
| Half Power Beam Width | 40° |
| Bandwidth | 144 to 148 MHz |
| Impedance | 50 Ohms |
| Matching System | Adjustable Gamma |

\$44.95

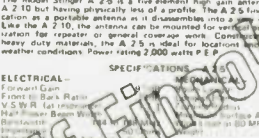

2 meter

STINGER A 2-8 DESCRIPTION
 The model Stinger A 2-8 is a five element high gain antenna similar to the A 2-10 but having a slightly less of a profile. The A 2-8 finds excellent application as a portable antenna as it disassembles into a very compact package. Like the A 2-10, the antenna can be mounted for vertical polarization or weather repeater or general coverage work. Construction of the Stinger antenna features insure optimum DX performance and good operating efficiency under adverse weather conditions. Power rating 2,000 watts P.E.P.

SPECIFICATIONS - A 2-8

| ELECTRICAL | MECHANICAL |
|-------------------------|------------------|
| Forward Gain | 10.5 dB |
| Front to Back Ratio | 10 dB |
| V.S.W.R. (at resonance) | 1.1 |
| V.I.W.R. (at resonance) | 1.1 |
| Half Power Beam Width | 40° |
| Bandwidth | 144 to 148 MHz |
| Impedance | 50 Ohms |
| Matching System | Adjustable Gamma |

\$27.95

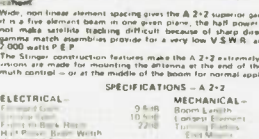

2 meter

STINGER A 2-2 DESCRIPTION
 The model Stinger A 2-2 is a two element dual polarization 2 meter antenna designed for OSCAR communications or where switching from horizontal to vertical polarization is required. The A 2-2 can even be phased to operate on both horizontal and vertical polarization at the same time. This is not only an OSCAR work but gives your station versatility for ground communication.

SPECIFICATIONS - A 2-2

| ELECTRICAL | MECHANICAL |
|-------------------------|------------------|
| Forward Gain | 9.4 dB |
| Front to Back Ratio | 10 dB |
| V.S.W.R. (at resonance) | 1.1 |
| V.I.W.R. (at resonance) | 1.1 |
| Half Power Beam Width | 40° |
| Bandwidth | 144 to 148 MHz |
| Impedance | 50 Ohms |
| Matching System | Adjustable Gamma |

\$46.50

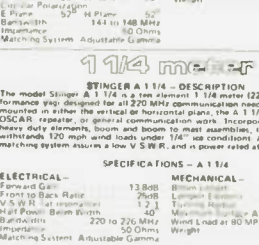

1 1/4 meter

STINGER A 1-1/4 DESCRIPTION
 The model Stinger A 1-1/4 is a two element 1 1/4 meter 120 MHz high performance beam designed for all 120 MHz communication needs. Designed to be mounted in either the vertical or horizontal plane, the A 1-1/4 is adaptable to OSCAR, repeater, or general communication work. Incorporating the Stinger heavy duty elements, boom and boom support assemblies, the antenna easily withstands 120 mph wind loads under 1/4 lambda test conditions. A low loss gamma matching system insures a low V.S.W.R. and is power rated at 1,000 watts.

SPECIFICATIONS - A 1-1/4

| ELECTRICAL | MECHANICAL |
|-------------------------|------------------|
| Forward Gain | 13.8 dB |
| Front to Back Ratio | 20dB |
| V.S.W.R. (at resonance) | 1.1 |
| V.I.W.R. (at resonance) | 1.1 |
| Half Power Beam Width | 40° |
| Bandwidth | 220 to 226 MHz |
| Impedance | 50 Ohms |
| Matching System | Adjustable Gamma |

\$32.95

HITACHI OSCILLOSCOPES



Model HK-3M

\$19.95

Single and dual trace, 15 and 30 MHz. All four high sensitivity Hitachi oscilloscopes are built to demanding Hitachi quality standards and are backed by a 2-year warranty. They're able to measure signals as low as 1mV/division (with X5 vertical magnifier). It's a specification you won't find on any other 15 or 30 MHz scope. Plus: X-axis modulation, trace rotation, front panel X-Y operation for all four scope models, and X10 sweep magnification. And, both 30 MHz oscilloscopes offer internal signal delay lines. For ease of operation, functionally-related controls are grouped into three blocks on the color coded front panel.

- V-302 30 MHz Dual Trace **\$850.50**
- V-301 30 MHz Single Trace **\$670.50**
- V-152 15 MHz Dual Trace **\$625.25**
- V-151 15 MHz Single Trace **\$490.50**

HAM-KEY

Model HK-4

\$44.95

Combination HK-1 & HK-3 on same base. Straight base may be used conventionally or as a switch to trigger a memory.

Model HK-5A Electronic Keyer

\$69.95

Man Curtis 8044 keyer chip. Great tone and speed tuning. Speed, volume, tone & weight controls on front panel. Use with HK-3 or HK-4. Battery controlled with provisions for external power.

RADIO TELEGRAPH SENDING DEVICES

Model HK-1

\$29.95

Dual lever squeeze pulser. For use with all electronic keyers. Heavy base with non slip rubber feet. Pulser interchangeable for wide on/off finger spacing.

Model HK-5A Electronic Keyer

\$69.95

Man Curtis 8044 keyer chip. Great tone and speed tuning. Speed, volume, tone & weight controls on front panel. Use with HK-3 or HK-4. Battery controlled with provisions for external power.

ALLIANCE



Model HD-73 HEAVY-DUTY ROTATOR

\$99.00

with exclusive Dual-Speed Control!

For antennas up to 10.7 sq. ft. of wind load area. Mast support bracket design permits easy centering and offers a positive drive no-slip option. Automatic brake action cushions stops to reduce inertia stresses. Unique control unit features DUAL-SPEED rotation with one five-position switch. SPECIFICATIONS: Max. wind load bending moment - 10,000 in.-lbs. (side-thrust over-turning); Starting torque - 400 in.-lbs.; Hardened steel drive gears; Bearings - 100-3/8" diameter (hardened); Meter - D'Arsonval, tail band (back-lighted). There's much, much more.

Tel. 1-617-391-3200

TUFTS ELECTRONIC

CATALOG Electronic Department Store

On this page Tufts brings you . . .

Datong Fox
Bencher Bird



DATONG ELECTRONICS LIMITED



FL1 . . . Frequency-Agile Audio Filter

MODEL FL1

Frequency - Agile Audio Filter

The Datong Frequency-Agile Audio Filter is intended primarily for post-detector signal filtering in RF and LF communications receivers for SSB and CW. It offers an unusually versatile combination of benefits to the user including:

For the SSB operator:

- Fast automatic suppression of interfering heterodyne whistles in the range 280-3000 Hz by a unique search-lock-and-track notch filter. The tracking notch can be left in circuit with no audible effect until a whistle appears in which case the whistle will 'disappear' within typically one second.

- A continuously adjustable audio 'window' or a variable-width notch to improve reception in the presence of other off-tune SSB, RTTY or SSTV signals.

For the CW operator:

- Continuously variable center-frequency (280-3000 Hz) and bandwidth (25-1000 Hz) for perfect matching of receiver passband to changing band conditions, sending speeds, and personal preference.
- Flat-topped, steep-skirted response shape for optimum ease of tuning combined with excellent noise rejection.
- Linear tuning law with bandwidth independent of frequency and gain independent of bandwidth for natural 'feel'.



ASP . . . Automatic Speech Processor

ASP

Automatic Speech Processor

The ASP internally generates its own SSB signal and processes it up to 30 dB. This processed signal is demodulated and delivered to your rig's mic input with fully automatic AGC control of both input and output level.

ASP Features:

- Installs between mic and transmitter!
- No need to open the rig!
- Push button selection of processing

- Harmonic distortion - less than 0.5% at 1 kHz.
- Internal tone generator allows easy and accurate initial adjustment - no scope needed.
- Selectable HiZ or LoZ mic input.
- Operates from 12 Vdc internal or external.
- Size 7 1/4" x 1 3/4".
- For use in PTT (non-VOX) operation.

MODEL D-70

Morse Tutor

The Morse Tutor provides a highly effective new way to practice Morse code reception at all levels of skill. It provides an unlimited supply of precision Morse at the turn of a switch, plus a built-in oscillator for sending practice.

D70 Features:

- Produces random five character groups. You can choose all letters, all figures, or mixed.
- Calibrated variable speed (6 1/2-37 wpm) and variable delay (up to 3 seconds) between letters for optimum learning efficiency. This delay facility means that right from the start you can learn each letter and number as it ought to be learnt, that is with the dots and dashes within a letter fast enough to form a complete sound pattern, but with a long delay between each letter. As you improve you simply reduce the delay between letters.
- Internal loudspeaker, plus personal ear-piece for private listening.

PRICE

| | |
|-----------------------------------|----------|
| ASP Automatic Speech Processor | \$259.95 |
| FL-1 Frequency Agile Audio Filter | 219.95 |
| UC-1 UP Converter | 379.95 |
| D-70 Code Tutor | 159.95 |
| DATEST I | 189.95 |
| DATEST II | 169.95 |
| D-75 | 179.95 |
| RFC M RF Clipper Board Assembly | 59.95 |
| M100 | 20.00 |

BIRD
Electronic Corporation

\$99 VHF model 4362 (140-180 MHz)
\$99 HF model 4360 (18-30 MHz)



the indispensable
BIRD 43
THRULINE
WATTMETER



The 4360, 4362 HAM-MATE Directional Wattmeters are insertion type instruments for measuring forward or reflected power in 50-ohm coaxial transmission lines. They are direct dependants of the model 43 THRULINE Wattmeter - the professional standard of the industry - and will accurately measure RF power flow under any load condition. Each wattmeter is made up of a precisely machined section of 50-ohm line, a rotatable sensing element and meter calibrated in watts, all mounted in a high impact plastic housing. It is this type of solid construction and the directional THRULINE coupling circuit, without toroids, that account for the superiority of the HAM-MATE Wattmeters.

| Power Range | Frequency Bands (MHz) | | | | | |
|-------------|-----------------------|-------|---------|----------|------------|--|
| | 2-30 | 25-50 | 100-250 | 700-1000 | 4000-10000 | |
| 5-watts | 5A | 5C | 5D | 5E | | |
| 10-watts | 10A | 10C | 10D | 10E | | |
| 25-watts | 25A | 25C | 25D | 25E | | |
| 50-watts | 50A | 50C | 50D | 50E | | |
| 100-watts | 100A | 100C | 100D | 100E | | |
| 250-watts | 250A | 250C | 250D | 250E | | |
| 500-watts | 500A | 500C | 500D | 500E | | |
| 1000-watts | 1000A | 1000C | 1000D | 1000E | | |
| 2500-watts | 2500A | | | | | |
| 5000-watts | 5000A | | | | | |

| | | |
|---|--|----------|
| MODEL 43 | | |
| Elements (Table 1) 2-30 MHz | | \$135.00 |
| Elements (Table 1) 25-1000 MHz | | 50.00 |
| Carrying case for Model 43 & 6 elements | | 42.00 |
| Carrying case for 12 elements | | 28.00 |
| | | 17.00 |

READ RF WATTS DIRECTLY! (Specify Type N or SO239 connectors) 0.45 - 2300 MHz, 1-10,000 Watts ±5%, low insertion VSWR - 1.05. Unequaled economy and flexibility. Buy only the element(s) covering your present frequency and power needs, add extra ranges later if your requirements expand.



The Bencher Ultimate Paddle . . . a dual lever, iambic keyer paddle that will increase your speed, accuracy & operating comfort.

- **ADJUSTABLE CONTACT POINT SPACING** - Precision screw adjustments on each set of contacts make exact settings easy. Contact posts are split and locked by set screws, eliminating the need for locknuts.
- **WIDE RANGE OF TENSION ADJUSTMENT** - Tension on finger knobs is maintained by a long expansion spring. Dual screw adjustments adjust spring tension to match your "fist."
- **SELF ADJUSTING NEEDLE BEARINGS** - Keying shafts pivot in nylon bearings that "float" on machined brass fittings. Spring tension prevents free play and slop, eliminates contact bounce and backlash.
- **SOLID SILVER CONTACT POINTS** - The contact points are solid silver for a lifetime of flawless keying.
- **PRECISION-MACHINED COMPONENTS** - Main frame, contact posts, spring post and bearing ring are all machined from solid brass . . . polished and chrome plated for durability and rich appearance. The Bencher Paddle looks as good as it works!
- **HEAVY STEEL BASE; NON-SKID FEET** - Finished in an attractive black wrinkle finish (chrome plating optional), the base measures 9.5cm x 10.2cm x 1.3cm thick. It weighs 1 kilogram, and with its non-skid rubber feet is as solid as a rock.

Model BY-1 Standard Black Base . . . \$42.95. Model BY-2 Polished Chrome Base . . . \$52.95.

BENCHER, INC.



First is the Fox XK. It reads all bands and tucks away on the visor.



Our remote (RW) unit is "out of sight" when installed. Out of sight in performance, too.



And now there's Superfox!

The first remote superheterodyne radar warning system. Superfox has 10 times the sensitivity capability of any conventional radar detector. It is ideal for custom installations.

PRICE LIST

| Order No. | Description | Price |
|-----------|--|----------|
| 60 | Fox XK All band detector w/self contained aural/visual alarm | \$109.00 |
| 60-2 | Fox XK (RW) All band detector w/remote control, water proof | \$139.00 |
| 60-3 | Super Fox Super-Heterodyne remote radar warning system | \$299.95 |

P.O. Box 27, Medford, Mass., 02155

Electronic Department Store CATALOG

On this page Tufts brings you...
Tempo
Palomar Engineers

PALOMAR ENGINEERS



ANTENNA TUNER

Here is a new tuner that puts more power into your antenna, works from 160m-10m, handles full legal power and then some, and works with coax, single wire and balanced lines. And it lets you tune up without going on the air.

All tuners lose some rf power, mostly in the inductance coil and the balun core. To avoid this we switched from No. 12 wire for the main inductor to copper tubing. It can carry ten times the rf current. And we've moved the balun from the output, where it almost never sees its design impedance, to the input where it always does. Thus more power to your antenna.

The biggest problem with tuners is getting them tuned up. With three knobs to tune on your transceiver and three on the tuner and ten seconds to do it (see the warning in your transceiver manual) that's 1 1/2 seconds per knob. We have a better way; a built in 50 Ohm noise bridge that lets you set the tuner controls without transmitting. And a switch that lets you tune your transmitter into a dummy load. So you can do the whole tuneup without going on the air. Saves that final, cuts QRM.

\$299.95



TEMPO
the first in synthesized portables gives you the broadest choice at the lowest price

TEMPO

PRICE LIST

| | |
|--|----------|
| Tempo S-5 | \$299.00 |
| Tempo S-5 with touch tone pad | \$339.00 |
| 12 Button touch tone pad (not installed) | 39.00 |
| 16 Button touch tone pad (not installed) | 48.00 |
| Tone burst generator | 29.95 |
| CTCSS sub-audible tone control | 29.95 |
| Rubber flex antenna | 8.00 |
| Leather holster | 16.00 |
| Cigarette lighter plug mobile charging unit | 6.00 |
| Matching 30 watt output 13.8 VDC power amplifier (S30) | 89.00 |
| Matching 80 watt output power amplifier (S80) | 149.00 |
| Tempo S-2 | \$349.00 |
| Tempo S-2 with touch tone pad | \$399.00 |
| Tempo S-1 | \$259.00 |
| Tempo S-1 with touch tone pad | \$289.00 |

... the new S-5

- ★ The only synthesized hand-held offering 5 watts output. (Switchable for 1 or 5 watt operation)
- ★ The same dependability as the time proven S-1. Circuitry that has been proven in more than a million hours of operation.
- ★ Heavy duty battery pack.
- ★ Telescoping whip antenna.
- ★ Ni-cad battery pack, charger.
- ★ External microphone capability.

the Tempo S-2

- ★ Tempo is first again. This time with a superior quality synthesized 220 MHz hand-held transceiver. With an S-2 in your car or pocket you can use 220 MHz repeaters throughout the U.S. It offers all the advanced engineering, premium quality components and exciting features of the S-1. The S-2 offers 1000 channels in an extremely lightweight but rugged case.

If you're not on 220 this is the perfect way to get started. With the addition of the S-25 (25W output) or S-75 (75W output) Tempo solid state amplifier it becomes a powerful mobile or base station. If you have a 220 MHz rig, the S-2 will add tremendous versatility. Its low price includes an external microphone capability, heavy duty ni-cad battery pack, charger, and telescoping whip antenna.

Tempo S-1

- ★ The first and most thoroughly field tested hand-held synthesized radio available. 800 channels in the palm of your hand.
- ★ Simple to operate. (You don't need a degree in computer programming).
- ★ Heavy duty battery pack allows more operating time between charges.
- ★ External microphone capability.

R-X NOISE BRIDGE \$55.00



- Learn the truth about your antenna.
- Find its resonant frequency.
- Find R and X off-resonance.
- Broadband 1-100 MHz.
- Simple to use. — Self contained.

VLF CONVERTER \$59.95



- New device opens up the world of VLF radio.
- Converts VLF to 80 meters. For use with any shortwave receiver covering 3.5 - 4 MHz.
- Advanced design for simple operation, high performance.
- Gives reception of the 1750 meter band.
- Also covers navigation radiobeacons, WWVB, ship to shore, and LP broadcast band.

LOOP ANTENNA

Loop Amplifier \$67.50
Plug-in loops \$47.50 ea.



- Plug-in loops available for:
1600-5000 KHz (160/80 meter amateur bands)
550-1600 KHz (Broadcast Band)
150-550 KHz (VLF, 1750 meter band)
40-150 KHz (WWVB, Lorain)
10-40 KHz (Omega)
- Nulls out interference

IC KEYS \$97.50



- Sends Manual, Semi-Automatic, Full Automatic, Dot Memory, Dash Memory, Squeeze and Iambic.
- More Features than any other keyer. Built-in sidetone speaker, speed and volume controls.
- Fully Adjustable contact spacing and paddle tension. The perfect paddle touch will Amaze you.
- Battery Operated. Heavy shielded die-cast metal case. 3-lb. steel base.
- By the World's oldest manufacturer of electronic keys.

FREQUENCY STANDARD \$42.50

- 100, 50, 25, 10 and 5 KHz. Markers selectable by panel switch.
- Crystal controlled.
- A true secondary frequency standard.
- Square Wave Signal. Rich harmonics usable from 5 KHz to 50 MHz.
- Sharp Clear Output. Exclusive Circuit suppresses unwanted markers.
- Battery Operated. No line cord. Self contained battery.



RF TRANSFORMER \$42.50

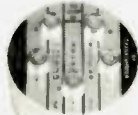

- Full 2000 watt CW (5-kw PEP).
- Matches 32, 28, 22, 18, 12, 8, 5 ohm antennas.
- For all verticals and mobile whip antennas.
- Smaller size. Higher efficiency.
- RF ferrite toroid core.

500 W. RF TRANSFORMER \$35.00



- Full 500 watt CW capability. No time limit.
- Convenient switch selection of impedance taps.
- Small size. High efficiency.
- RF ferrite toroid core.

CW FILTER \$39.95



- Steep skirts. No ringing.
- Simulated stereo technique filters QRM. Improves copyability of CW signals.
- 80 Hz bandwidth.
- Eight pole IC filter.

ALL BANDS PREAMPLIFIER \$89.50



- Tunes 1.8 to 54 MHz. Covers ALL amateur bands 160 to 6 meters. ALL shortwave broadcast bands.
- For receivers AND transceivers.
- Up to 20 db gain.
- Peps up that tired receiver.
- Reduces image and spurious response.

BEAM BALUN \$47.50



- 3 Kw CW, 6 Kw PEP input power.
- U bolt for 2" boom.
- 1:7 - 30 MHz.
- 1:1 or 4:1 ratio available.
- All stainless steel hardware.

MODEL 2K BALUN \$42.50



- 3 Kw CW, 6 Kw PEP input power.
- Replaces center insulator.
- 1:7 - 30 MHz.
- 1:1 or 4:1 ratio available.

MODEL 1K BALUN \$22.50



- 1.5 Kw CW, 3 Kw PEP input power.
- Replaces center insulator.
- 1:7 - 30 MHz.
- 1:1 or 4:1 ratio available.

PALOMAR ENGINEERS

TUFTS ELECTRONIC

TEL. 1-617-391-3200

The Don Nobles Descramblers

— listen to what you're not supposed to hear

With the proliferation of programmable scanning receivers capable of tuning in virtually any land mobile frequency at the whim of the user, law-enforcement agencies have been hard put to find ways

to protect their privacy. Every time a new security technique is devised, some enterprising individual will devise a way to defeat it!

For many years, one of the favorite methods to encrypt speech has been fre-

quency inversion. Just as an incoming frequency is mixed with an oscillator in a superheterodyne receiver to produce another frequency, the speech inverter mixes normal speech with a tone to produce a different

frequency which is transmitted as scrambled speech. This sounds to the unaided listener like a side-band signal badly out of whack!

To decode the inverted speech, however, one merely has to pass the encrypted speech back through a device similar to the one that inverted it in the first place. This process will re-invert the inverted speech; in other words, the voice spectrum has gone a full 360 degrees—first out of phase, then back in phase again, so to speak.

Several manufacturers produce speech decoders, but one name stands prominently against the field: Don Nobles.

The Nobles descramblers are certainly straightforward enough. The scrambled speech is extracted from the speaker output of the scanner and fed into a 1496 double-balanced mixer. There it is mixed with a reference frequency injected by a sine-wave oscil-



Photo A. The D-12 scramble decoder shown working here with a Bearcat 210 scanner.

lator. The resultant inverted audio is passed on to a Motorola 1306P amplifier and out to the user's speaker.

Because virtually any reference tone can be used by the transmitting agency to encrypt their voice transmissions, all speech-inversion decoders have a potentiometer to control the frequency of the local reference oscillator to match the original inversion frequency.

Nobles has taken a proven circuit and used it in his various models. The D-12 (Photo A) is the standard version designed to hook to a conventional scanner. It features a front-panel toggle switch for the dual purpose of turning the unit on and off and bypassing the decoder when switched off to allow normal speech to be fed from the scanner to the speaker.

The TUNE control adjusts the frequency of the internal reference oscillator, varying the baseband of the audio until the recovered speech sounds normal. Once set, this control is usually forgotten. Most law-enforcement agencies like to leave their speech inverter codes set to one particular frequency to avoid the confusion which would arise from constant changing. Some agencies, however, code several scrambler settings, referring to RED or a number to signify the particular code they are switching to. If this is the case, the listener may wish to rotate his Nobles TUNE control until the speech is normal and mark the position on the panel for later reference.

The descrambler is powered by a standard nine-volt transistor radio battery which is held to the back of the decoder cabinet by a small spring clamp. A three-conductor cable protrudes from the back of the cabinet to allow attach-

ment to the monitor receiver. In virtually all cases, a simple plug attachment chosen to mate with the radio is all that will be necessary to defeat the internal speaker. An extension speaker will have to be supplied by the user; otherwise, internal speaker rewiring will be necessary to utilize the receiver's built-in speaker.

A miniature edition of the D-12 is available as the P-20 "Pocket Pal" (Photo B); it is designed to attach to pocket scanners with a minimum of bulk. Measuring a scant 2" x 2" x 3" (approximately), it does the job neatly.

Comments regarding the

hookup and operation of the P-20 are the same as for the D-12. Both units give a fine accounting of themselves in actual use.

Finally, I would like to mention a handy additional accessory from Don Nobles: the TM-100 Tapemate (Photo C). It is designed to record telephone conversations directly into a tape recorder. Automatic activation of the recorder's remote jack is provided by the TM-100 when the telephone handset is lifted from the cradle. Yes, it's legal, and it is useful for verifying orders and recording crank calls.

All of these clever Nobles innovations are in-

expensive and reliable. The Tapemate is \$24.95; the scramble decoders are somewhat more. For further information, check with your local radio equipment supplier or write Don Nobles Electronics, Route 7, Box 610, Hot Springs AR 71901. ■

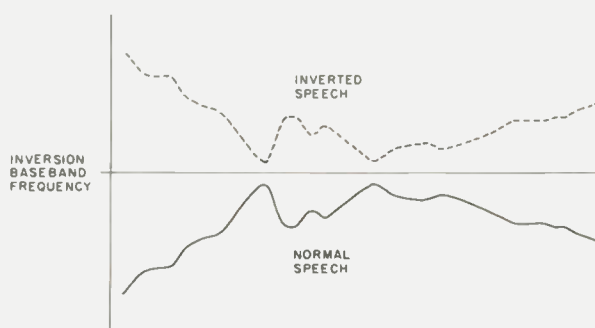

Fig. 1. Simplified representation of common speech inversion.



Photo B. The tiny P-20 is designed to fit against a pocket scanner like this Midland.

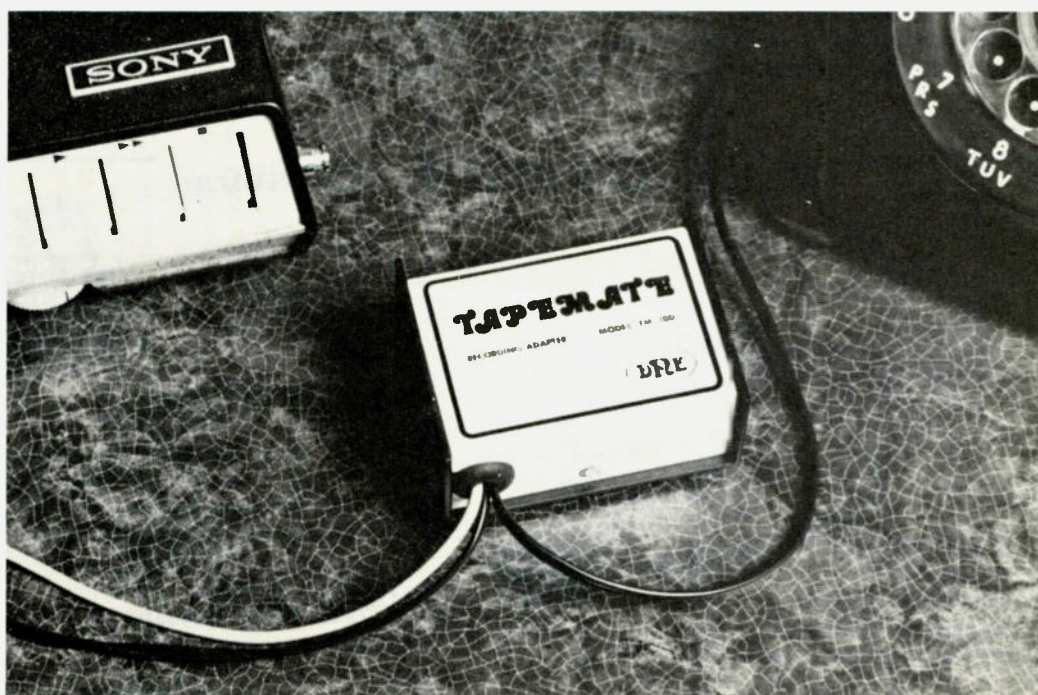

Photo C. The TM-100 Tapemate automatically activates a tape recorder when the telephone handset is lifted from its cradle.

Social Events

Listings in this column are provided free of charge on a space-available basis. The following information should be included in every announcement: sponsor, event, date, time, place, city, state, admission charge (if any), features, talk-in frequencies, and the name of whom to contact for further information. Announcements must be received two months prior to the month in which the event takes place. They should be sent directly to Editorial Offices, 73 Magazine, Pine Street, Peterborough NH 03458, Attn: Social Events.

INDIANAPOLIS IN JUL 1

The Central Indiana Section of IEEE and the corresponding IEEE Computer Society Chapter will hold the fifth annual IEEE Indy Microcomputer Show on Tuesday, July 1, 1980, from 9:30 am to 8:00 pm at the Sheraton Motor Inn East, located at I-465 and SR-67 in Indianapolis. There will be exhibits, demonstrations, and technical seminars addressing the engineering, industrial, scientific, medical, business, and personal applications of microcomputer systems.

HARRISBURG PA JUL 4

The Harrisburg RAC Annual Firecracker Hamfest will be held on Friday, July 4, 1980, at the Shellsville VFW Picnic Grounds.

Take exit 27 off I-81 north of Harrisburg at PA route 39, then follow the signs for one mile or call for talk-in information. There are shade trees and a pavilion. Parking for 1,000 cars will be available. Food will be available or bring your own picnic. Admission is \$3.00; XYLs and children are free. Tailgating is \$1.50. Many valuable prizes will be awarded.

BURLINGTON ONT CAN JUL 5

The Burlington Amateur Radio Club will hold its 6th annual Ontario Hamfest 1980 on Saturday, July 5, 1980, at the Milton Fairgrounds, just south of the intersection of Highways 401 and 25 (Exit 39). General admission is \$3.00; children and ladies are free. Pre-registration before June 15, 1980, is \$2.00. Gates will open Friday, July 4, 1980, at 12:00 noon and Saturday, July 5, 1980, at 7:00 am. The flea market opens at 8:00 am and tables are free. There will be camping available and food and prizes. Talk-in on 147.81/.21 VE3RSB. For information, write BARC, Box 836, Burlington ONT, CAN L7R 3Y7.

OAK CREEK WI JUL 12

The South Milwaukee Amateur Radio Club will hold its annual Swapfest '80 on Saturday, July 12, 1980, at the American

Legion Post #434, 9327 S. Shepard Avenue, Oak Creek WI. Admission is \$2.00 and includes a happy hour with free beverages. Prizes include a \$100 first prize, a \$50 second prize, and a variety of other prizes. Activities will begin at 7:00 am and continue until 5:00 pm. Parking, a picnic area, and hot and cold sandwiches, as well as liquid refreshments, will be available on the grounds. Overnight camping is also available. Talk-in on 146.94. More details, including a map, may be obtained from the South Milwaukee Amateur Radio Club, Inc., Robert Kastelic WB9TIK, Secretary, PO Box 102, South Milwaukee WI 53172.

INT'L PEACE GARDENS MANITOBA JUL 12-13

The International Peace Garden Hamfest will be held on July 12-13, 1980, at the International Peace Garden on the North Dakota/Manitoba, Canada, border. Featured will be a flea market and various activities for hams and their families. Registrations will be taken on both days for door prizes and there will be a free breakfast for those who register on Sunday. For more information, contact the committee chairmen, VE4LB and WA0LPV.

CHARLESTON SC JUL 12-13

The Charleston Amateur Radio Society will hold the

Charleston Hamfest on July 12-13, 1980, at the Omar Shrine Temple. General admission is \$3.50, which includes one prize ticket. Additional prize tickets are \$2.00 each or 5 for \$5.50. Children 12 years old and under will be admitted free. Flea market tables are \$5.00 and commercial booths are \$35.00, which includes 2 admission tickets. Saturday's prize is an Icom IC-2A synthesized 2-meter handie-talkie. Sunday's grand prize is a Kenwood TS-120S; second prize is an Azden PCS 2000 2-meter rig. There will be refreshments, ladies' activities and a hospitality room available. Talk-in on 146.34/.94, 146.16/.76, and 146.19/.79 for general use. For more information, contact the Charleston Hamfest Committee, PO Box 30643, Charleston SC 29407, or phone (803)-747-2324/563-2523.

INDIANAPOLIS IN JUL 13

The Indianapolis Amateur Radio Convention and Hamfest will be held on Sunday, July 13, 1980, at the Marion County Fairgrounds. For further information, write Indianapolis Amateur Radio Association, Box 11086, Indianapolis IN 46201.

HIBBING MN JUL 13

Five amateur radio clubs in northern Minnesota are sponsoring the Iron Range Hamfest on Sunday, July 13, 1980, from 9:00 am until 5:00 pm at the St. Louis County Fairgrounds, Hib-

50 144 REPEATERS 220 450 Mhz

Hi Pro Mk I



OPTIONS

- Duplexers
- Basic auto patch
- Matching cabinet
- .0005% High stability crystals

50 MHz \$889.95 450 MHz 899.95
144 or 220 MHz 799.95

New and Improved
Receiver
and Transmitter

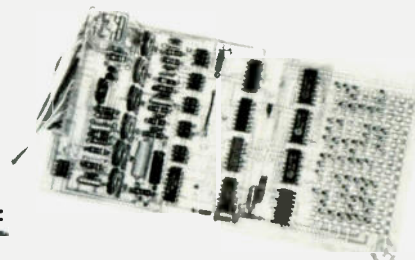

Available Separately:

COR Identifier: All on one board, programmable, Fully adjustable, time out (.5-7 min.), hang time (0-1 min.), identifier (1-10 min.), tone, speed, volume, L.E.D. outputs, low current drain CMOS logic, plugs for easy installation and removal plus much more. \$89.95

Basic Repeater \$599.95

2M 130-175 MHz Basic Repeater for 2 meters with all the features of the Hi Pro MkI less the power supply and front panel controls and accessories.

PA Res. add 6% tax
PLUS SHIPPING

Maggtore Electronic Laboratory

845 WESTTOWN RD. WEST CHESTER, PA. 19380 PHONE 215 436-6051

bing MN. Camping facilities with electrical and water hook-ups are available for \$3.50 per night. There are other accommodations available close by. Features will include a flea market, games for XYLs and children, door prizes, including a grand prize of a Yaesu FT-202 hand-held transceiver, and indoor displays. Tables for the flea market are free and lunch will be available. Talk-in on .19/.79.

**WILKES-BARRE PA
JUL 13**

The Broadcasters' Amateur Radio Club will hold its third annual hamfest on July 13, 1980, from 9:00 am to 4:00 pm at the Pocono Downs Race Track, Rte. 315, Plains Twp., 1 1/2 miles north of Wilkes-Barre PA. Admission is \$2.50, XYLs and children are free, and there will be no additional charge for sellers. Gates will open at 8:00 am for set-up. There will be unlimited outdoor and indoor space, refreshments, prizes, a free FM clinic, and ac power available. Talk-in on 147.66/.06 and 146.52 simplex. For more information, contact Charles Baltimore WA3NUT, BARC, 62 South Franklin Street, Wilkes-Barre PA 18773, or phone (717)-823-3101.

**WAUKESHA WI
JUL 19**

The Kettle Moraine Radio Amateur Club (KMRA) will hold its annual hamfest on Saturday, July 19, 1980, beginning at 7:00 am, at the Badger Raceway, Waukesha WI. The Badger

Raceway is located west of Dousman on U.S. 18, 3 1/2 miles from the intersection of I-94 and State Highway 67. There will be overnight camping on the grounds on Friday. Tickets are \$1.50 in advance and \$2.00 at the door. Talk-in on 146.52, 52.525, and 28.650 MHz. For additional information and advance tickets, write KMRA Hamfest, 108 Shepard Ct., Mukwonago WI 53149.

**CARY NC
JUL 19**

The Cary Amateur Radio Club will hold its 8th annual Mid-Summer Swapfest on Saturday, July 19, 1980 (rain or shine), at the Cary Lions Club Shelter (next to the Cary Senior High School). Gates will open at 9:00 am. There will be an auction (no fees) from 1:00 pm to 2:00 pm. Prize drawings will be held from 2:00 pm to 2:15 pm and will include a Kenwood TS-520SE, a Yaesu FT-202 with nicads and charger, a CDE Tailtwister* rotor, a Hy-Gain TH3 Sr., and others. Registration is \$3.00. Tables will be rented or bring your own. Talk-in on 146.28/.88 and 146.52/.52. For

more information, write CARC, Box 53, Cary NC 27511.

**BLYTHERVILLE AR
JUL 19-20**

The 1980 Arkansas Army MARS Convention will be held on July 19-20, 1980, at the National Guard Armory, Highway 61 south, Blytheville AR. Registration is \$7.50 and includes a catfish supper and pancake breakfast. Talk-in on 148.01 and .07/.67. For more information, contact Richard Duncan WB5CNV/AAR6SH, 209 Wilson Street, Dell AR 72426.

**MONACA PA
JUL 20**

The Beaver Valley Amateur Radio Association will hold its third annual hamfest on Sunday, July 20, 1980, at the Community College of Beaver County from 9:00 am to 5:00 pm. Registration is \$2.00 each or 3 for \$5.00; children under 12 will be admitted free. Refreshments will be available, as well as free parking, indoor vendor space, and a paved outdoor flea market. There will be a drawing at 4:00 pm and door prizes all

day, including a first prize of a Kenwood TS-520SE transceiver, a second prize of a Kenwood TS-2400 synthesized hand-held, and a third prize of a Cushcraft ATB-34 triband beam. Talk-in on 146.25/.85 WR3AAA, 223.26/.86 WR3AAA, and 146.52 simplex. For further information and advance registration, contact either Gary Mohrbacher WB3FKE, 3417 47th Street, New Brighton PA 15066, (412)-843-9546, or Adam Horniak WB3JZN, 182 Edgewood Street, Aliquippa PA 15001, (412)-378-9667.

**WRIGHTSTOWN NJ
JUL 20**

The West Jersey Radio Amateurs, Inc., hamfest will be held on July 20, 1980, at McGuire AFB, Wrightstown NJ, from 9:00 am to 4:00 pm. Admission is \$2.50 and advance orders receive an additional chance at door prizes. Spouses and children are free. Tailgate or table space is \$2.50 per space; bring your own table. Refreshments and activities will be available. Door prizes will be awarded continuously and a

COPY CW. RTTY. ASCII



with OHIO SCIENTIFIC'S C1-P Computer

- Send & Receive CW
- Retain All Functions of C1-P 8K Computer

RTTY Receive Program \$19.95
 CW Transceive Program 19.95
 ASCII Transceive Program .. Coming

- All Programs Supplied On Cassette Complete With Interfacing Schematics and Instructions.

Parts Kit for Interface 19.95
 C1-P 8K RAM Computer 379.00
 C1-P 8K Complete with Interface Installed, Wired, and Tested .. 429.00

COMPUTER SYSTEMS

3763 Airport Blvd. • Mobile, AL 36608

(205) 344-7448 ✓ 340

Dealer Inquiries Invited



SCANNERS:

KENWOOD TR7400A, TR7600, & TR7625, TEMPO (RESERVED), KDK 2015R, KDK 2016A, ICOM IC225, MIDLAND 13-510, 13-513, CLEGG FM-28, COMTRONX, YAESU FT227R

- AED continues to expand its line of quality scanners.
- All of AED's scanners are custom designed to install completely inside of their respective rigs.
- Installation is simple. Unlike other competitive products all AED scanners are designed so that it is totally unnecessary to cut any wires inside your rig during installation.
- All P.C.B.s are silk-screened and tin plated for easier and more effective soldering.
- The kit comes complete with all parts and a detailed instruction manual including schematics.
- In the scanner OFF mode the rig operates normally. In the scanner ON mode the scanner locks on an occupied frequency, pauses for a preset time (about 5 sec.) and then resumes scanning (except 225).
- The frequency being scanned is displayed on the digital readout (except 225).
- This gives you the ability to eavesdrop all over the band without lifting a finger. When you hear something interesting, you flip the switch to the LOCK mode and the rig is ready to transmit.

KIT PRICE..... 39.95
PREASSEMBLED, REG. .. 59.95
NOW.. 49.95

**10 METER FM
—THE NEW FRONTIER**

The AED FM ADAPTER is now available

- The AED adapter converts existing HF transceivers to transmit on 10 meter FM.
- To use the adapter you are required to have an HF SSB transceiver and a 2 M FM transceiver or receiver.
- The AED kit consists of 2 P.C. boards. Both boards are designed to fit entirely inside your HF rig. (Each board measures 1" x 2")
- One board serves as the modulator which FM's your existing HF transceiver's VFO.
- The second board is a receiver adapter which converts your HF transceiver's I.F. to a 2M frequency. This will allow you to receive noise free 10M FM on your 2M transceiver.
- This modification can be disabled with the on-off switch supplied with the kit.
- The kit comes complete with all parts and a detailed instruction manual (crystal not included). Specify transceiver I.F.

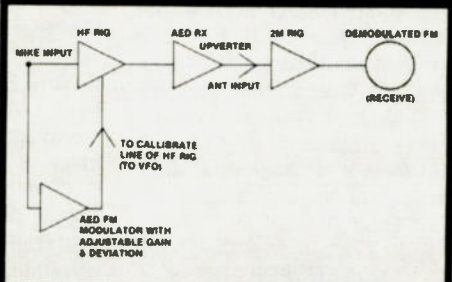

KIT PRICE..... 39.95
PREASSEMBLED..... 49.95

Special \$10.00 off

All Preassembled items.

AED ELECTRONICS

750 LUCERNE RD., SUITE 120 DEPT. A
 MONTREAL, QUEBEC, CANADA H3R 2H6
 TEL. 514-737-7293

INCLUDE \$1.50 FOR

POSTAGE AND HANDLING PER ITEM



major door prize of a 2-meter transceiver will be drawn at 3:30. Talk-in on .52 and 146.925. Advance tickets are available from club members or send an SASE to Mary Lou Shontz WB2QIU, 107 Spruce Lane, Route 16, Mt. Holly NJ 08060. For additional information, call Mark Millman N2ME at (609)-871-6691.

**WASHINGTON MO
JUL 20**

The Zero-Beaters ARC will sponsor the Washington Hamfest on Sunday, July 20, 1980, at the Washington Fairgrounds, Washington MO. There will be prizes and good buys for the ham, and bingo and a candy scramble for other family members. Features will include a commercial dealer exhibit, a large traders' row, and delicious food. Talk-in on .52 simplex. For more information on tickets, prizes, and camping, write ZBARC, Box 24, Dutzow MO 63342.

**MCKEESPORT PA
JUL 20**

The Two Rivers Amateur Radio Club will hold its annual hamfest on Sunday, July 20, 1980, at the Penn State University McKeesport Campus, McKeesport PA. A flea market will be held outside on the hard surface and car spaces will be \$5.00. There will be food and drink, door prizes, and free admission. Talk-in on 146.22/.82.

**GOLDEN CO
JUL 20**

The RMRL will hold its annual Field Day Demonstration and Swapfest on Sunday, July 20, 1980, at 10:00 am at Karl Ramstetter's (WA0HJZ) Ranch. It is located on top of Guy Hill, Highway 93, Golden CO. Signs will be posted. There will be door prizes. It would be appreciated if everyone would make his contribution to the potluck lunch by bringing his favorite dish and chairs and/or blankets. Soft drinks will be provided. Talk-in on .34 and .94.

**LOGANSPOUR IN
JUL 20**

The Cass County Amateur Radio Club's third annual hamfest will be held on Sunday, July 20, 1980, from 7:00 am to 4:00 pm at the 4-H Fairgrounds. Go north of Logansport on Highway 25, turn right at Road 100, and follow the QSY signs. Advance

tickets are \$1.50; \$2.00 at the gate. Outside setup is free; undercover is \$1.00. Bring your own tables. Free overnight camping, refreshments, and door prizes will be available. Talk-in on 146.52 and Logansport Repeater 147.78/.18. For information, write Roy E. Mannikko WB9PKN, 530 North Cicott Street, Logansport IN 46947.

**CANTON OH
JUL 20**

The Canton Amateur Radio Club and the Tusco Amateur Radio Club will hold the 6th annual Hall of Fame Hamfest on Sunday, July 20, 1980, at the Nimishillen Grange near Louisville OH, just off of Route 62, East of Canton OH. Admission is \$2.50 in advance and \$3.00 at the gate. Talk-in on .52/.52, .19/.79, and .72/.12. For reservations and information, contact Max Lebold WA8SHP, 10877 Hazelview Avenue, Alliance OH 44601, or phone (216)-821-8794.

**DETROIT LAKES MN
JUL 20**

The Detroit Lakes Amateur Radio Club will hold its 4th annual picnic and swapfest on Sunday, July 20, 1980, from 10:00 am to 4:00 pm at Long Lake Park, 1½ miles west of Detroit Lakes on Highway 10. Tickets for the drawing are \$1.00. Picnic and swap tables will be available. Talk-in on 146.22/.82 and 146.52/.52. For additional information, contact Russ Berger N0ARZ, 1406 Long Avenue, Detroit Lakes MN 56501.

**BELVIDERE IL
JUL 20**

The annual Big Thunder ARC Hamfest will be held on Sunday, July 20, 1980, at the Boone County Fairgrounds. There will be a large indoor facility and plenty of outdoor space available, as well as camping after 6:00 pm on Saturday. Talk-in on 146.52 simplex and 147.375 repeater. For more information, write Mike George, 6159 Broadway, Belvidere IL 61008.

**RAPID CITY SD
JUL 25-27**

The Black Hills Amateur Radio Club will hold its 1980 South Dakota Hamfest and Picnic on Friday, July 25, through Sunday, July 27, 1980, at the

Surbeck Center, South Dakota School of Mines campus, Rapid City SD. Registration will be \$6.50 before July 1st, and \$7.00 after July 1st and at the door beginning at 4:00 pm on Friday, July 25th. Door prizes will be awarded along with a pre-registration prize. There will be forums, tours, exhibits, a transmitter hunt, a flea market, contests, and YL activities. Flea-market tables are free. A Sunday noon meal will be catered and tickets will be available at the door. Assistance will be provided in obtaining lodging or trailer parking facilities. Talk-in on 146.34/.94, or contact W0BLK. To pre-register or obtain further information, contact Black Hills Amateur Radio Club, PO Box 1014, Rapid City SD 57709.

**OKLAHOMA CITY OK
JUL 25-27**

The Central Oklahoma Radio Amateurs will hold the Oklahoma State ARRL Convention and "Ham Holiday" on July 25-27, 1980, at Lincoln Plaza, 4445 Lincoln Boulevard, Oklahoma City OK. The program will include an ARRL forum and technical talks. In addition, a full program is scheduled for the ladies. Pre-registration will be \$5.00 if received before July 19. After that date, it will be \$6.00. A special award is being given to encourage pre-registration. There will be many other awards. Adequate rooms are available for commercial exhibitors and flea market swappers. Unlimited parking space is also available. Mail your registration to CORA, PO Box 15013, Oklahoma City OK 73155.

**SEATTLE WA
JUL 25-27**

The 26th National ARRL Convention will be held on July 25-27, 1980, at the SEA-TAC Airport Red Lion Motor Inn, 18740 Pacific Highway South, Seattle WA 98188. Basic registration is \$7.00 before July 1, 1980, \$9.00 after that date; additional family registration is \$6.00, \$7.00 after July 1, and student registration is \$7.00. Features will include prize drawings, forums, displays and new equipment exhibits, tours, and much more. Roy Neal K6DUE of NBC News will be the featured Saturday-night banquet speaker. For additional details, write John H. Brown W7CKZ, Promotion Chairman, SEANARC '80, PO Box 68534,

Seattle WA 98168.

**NASHVILLE TN
JUL 27**

The Nashville Hamfest will be held on Sunday, July 27, 1980, beginning at 8:00 am CDT at the National Guard Armory, Sidco Drive, Nashville TN. Admission is \$1.00 and tables are \$3.00. Refreshments will be available and the hamfest will be all indoors. Talk-in on .90/.30. For more information, contact Radio Amateur Transmitting Society (RATS), PO Box 2892, Nashville TN 37219.

**WEST FRIENDSHIP MD
JUL 27**

The Baltimore Radio Amateur Television Society will hold its annual BRATS Maryland Hamfest on Sunday, July 27, 1980, at the Howard County Fairgrounds, just off I-70 and Route 32 at Route 144, West Friendship MD. Beginning at 8:00 am, activities will be held rain or shine. Talk-in on .63/.03, .16/.76, and .52 simplex. For information or table reservations, write BRATS, Box 5915, Baltimore MD 21208.

**YELLOWSTONE
AUG 1-3**

The Wyoming-Idaho-Montana-Utah Amateur Radio Council will hold its Yellowstone National Amateur Radio Convention on August 1-3, 1980, at the convention center in West Yellowstone MT. The convention will feature a full program starting Friday morning and running through Sunday. Activities will include forums, contests, crafts, movies, swap tables, dealers, banquets, and much more. There are hotel-motel accommodations available adjoining the convention center and RV parks and campgrounds close by. There are airports and gas available in West Yellowstone. For more information, write WIMU, PO Box 20116, Salt Lake City UT 84120.

**MACON MO
AUG 2**

The Tri-County ARC, NEMO ARC, and Macon County ARC will hold the 2nd annual North Central Missouri Hamfest on Saturday, August 2, 1980, from 9:00 am to 5:00 pm at the Macon County Fairgrounds Park, Highway 63 south, Macon MO. There will be free parking, an enclosed

area for commercial displays, food available on the grounds, and YL activities. Tailgaters are welcome. Tickets for the prize drawing will be available for \$1.00 each at the door. The major prize will be either a color TV, an allband receiver, or a hand-held two-meter transceiver. Talk-in on 146.52, 147.69/.09, and 146.07/.67. For more information, contact Charles Coy WB0ENV, 601 McKinley, Moberly MO 65270.

JACKSONVILLE FL AUG 2-3

The Jacksonville Hamfest Association is pleased to announce that the 1980 Jacksonville Hamfest and ARRL Florida State Convention will be held on August 2-3, 1980, at a new location, the Orange Park Kennel Club at the intersection of I-295 and US Highway 17. Advance registration is \$3.00 and is available from Jacksonville Hamfest, 1249 Cape Charles Avenue, Atlantic Beach FL 32233. Price at the door will be \$3.50. A large indoor swap mart will be featured, with tables available at \$5.00 per day. The table reservations can be ordered from Andy Burton WA4TUB, 5101 Younis Road, Jacksonville FL 32218. Interesting programs and forums are planned, as well as door prizes and many manufacturer and dealer exhibits. Plenty of family activities are available close by. The headquarters hotel is the Best Western located just across the street from the hamfest. Special rates of \$23.00 single and \$28.00 double are available; reservations should be made through the local number (904)-264-1211 to get the low rates. A special DX-ers' forum and dinner banquet will feature a Spratly Island presentation by Stu Woodward K4SMX. Also, Bill Barr N4NX will present a show on the VP2KC world record effort of over 32 million points in the CQ WW contest (1979). Reservations for the banquet can be obtained for \$11.50 each by writing N4KE, 258 Wesley Road, Green Cove Spring FL 32043. For the fly-in ham, Herlong Airport is the closest landing site. Free weekend parking and rental automobiles are available. Phone (904)-783-2805 for more information. For more general information, write JHA, 911 Rio St. Johns Drive, Jacksonville FL 32211.

LEVELLAND TX AUG 3

The Hockley County Amateur Radio Club and the Northwest Texas Emergency Net will sponsor their 15th annual picnic and swapfest on Sunday, August 3, 1980, beginning at 8:00 am at the city park in Levelland TX. This is an event for the entire family. A \$3.00 registration fee is requested but not required. Lunch will begin at 12:30 pm with a bring-your-own-picnic-basket lunch. There will be swapping all day, with tables provided. Talk-in on 146.28/.88.

ANGOLA IN AUG 3

The Steuben County Radio Amateurs will hold their 22nd annual FM Picnic and Hamfest on Sunday, August 3, 1980, at Crooked Lake, Angola IN. Admission is \$2.00. There will be prizes, picnic-style BBQ chicken, inside tables for vendors and exhibitors, and overnight camping (with a fee charged by the county park). Talk-in on 146.52 and 147.81/.21.

BURLINGTON VT AUG 9-10

The Burlington Amateur Radio Club will hold its annual International Hamfest on August 9-10, 1980, at the Old Lantern Campground, 14 miles south of Burlington VT. Admission is \$4.00. Planned events include a flea market, commercial exhibitors, interesting and useful door prizes, and the traditional Can-Am tug-of-war. Talk-in on .34/.94. For more information, contact Hap Preston W1VSA, PO Box 312, Burlington VT 05402.

CEDARTOWN GA AUG 10

The Cedar Valley Amateur Radio Club will hold its annual Cedar Valley Hamfest on August 10, 1980, from 8:00 am to 4:00 pm at the Polk County Fairgrounds, on US 278, two miles east of Cedartown GA. There will be food, drinks, and prizes. Talk-in on 147.72/.12 (WR4AZU). For more information, contact Jim T. Schliestett W4IMQ, Secretary, Cedar Valley ARC, PO Box 93, Cedartown GA 30125, or phone (404)-748-5968.

ST. CLOUD MN AUG 10

The St. Cloud Radio Club will hold its annual hamfest on

August 10, 1980, at the Whitney Park Senior Center from 9:00 am until 5:00 pm. There will be free overnight camping available one mile from the site at the Sauk Rapids Lions Park. Food will be available and Uncle Tom's (W0CF) chili will be featured. There will be a swapfest and prizes. For more information, write William (Bill) R. Zins WA0OTO, RR 4, St. Cloud MN 56301 or phone (612)-253-3428.

LEXINGTON KY AUG 10

The Bluegrass Amateur Radio Society will hold its annual ARRL Central Kentucky Bluegrass Hamfest on August 10, 1980, starting at 8:00 am at the Fasig-Tipton Sales Paddock, Newton Pike, Lexington KY. Admission is \$3.00 in advance and \$3.50 at the gate. This fee includes parking. There will be grand prizes, hourly door prizes, indoor exhibits and distributors, a paved outside flea market, and food service will be available. Talk-in on 146.16/.76. For details, write Bluegrass Hamfest, Attention: Edward Bono WA4ONE, 2077 Dogwood Drive, Lexington KY 40504.

WILLOW SPRINGS IL AUG 10

The Hamfesters Amateur Radio Club will hold its 46th annual hamfest on Sunday, August 10th, 1980, at Santa Fe Park, 91st and Willow Springs Road, Willow Springs IL (near Chicago). Gates will open at 6:00 am. Tickets at the gate are \$3.00 each or \$2.00 each in advance. There will be free coffee for the early birds, games for the kids, prizes for the YLs, and the world-famous shoppers' row. Children under fifteen are free. For more information and advance tickets, send an SASE and a check to Hamfesters Amateur Radio Club, PO Box 42792, Chicago IL 60642.

OAKLAND NJ AUG 16

The Ramapo Mountain Amateur Radio Club will hold its annual flea market on Saturday, August 16, 1980, at the American Legion Hall, Oak Street, Oakland NJ. Indoor tables are \$5.00 and tailgating is \$3.00. There is no admission fee for buyers. Refreshments will be available on the premises. Talk-in on 147.49/146.49 WR2AHD or

146.52 simplex. For advance reservations and information, call Bud Hauser WA2JUO at (201)-797-8471 or (201)-791-0589.

FT BRAGG NC AUG 16-17

The Cape Fear Amateur Radio Society's 4th annual hamfest will be held on August 16-17, 1980, at the Main Officers' Club, FT. Bragg NC. Tickets are \$1.00 in advance and \$2.00 at the door. There will be 9,000 square feet of air conditioned space available. Prizes will include a TS-120S, a triband beam, a handie-talkie, and a rotor. There will be a Saturday night social and a QCWA luncheon meeting on Sunday. Talk-in on 146.31/.91, 147.93/.33, and 146.52. Send an SASE to Marie Presler WA4YMM, PO Box 35171, Fayetteville NC 28303, for tickets.

NORTH HAVEN CT AUG 16-17

The South Central Connecticut Amateur Radio Association will hold its Super Scarafest '80 on August 16-17, 1980, at the Ramada Inn, at Exit 12 of I-91, North Haven CT 06473. Booths will be available. Features will include a ham and computer flea market, an auction, special events for non-ham spouses and children, and drawings for prizes throughout the show. Prizes will include a solid-state low-band transceiver, a synthesized two-meter HT, a micro-computer, and a 600-MHz frequency counter. Admission will be \$4.00, pre-registration before July 1, and \$5.00 at the door for both days. Talk-in on 146.01/146.61. For further information, write Super Scarafest '80, PO Box 5265, Hamden CT 06518, or call Jeff Wayne K1YLV at (203)-281-6038 between 9:00 am and 9:00 pm EST.

HUNTSVILLE AL AUG 17

The North Alabama Hamfest will be held on Sunday, August 17, 1980, at the Von Braun Civic Center in Huntsville AL. Admission is free. There will be prizes, exhibits, forums, an air-conditioned indoor flea market, and ladies' activities. Tours of the Alabama Space and Rocket Center are available for the family. A hamfest supper will be held on Saturday night. A limited number of camping sites with hookups are available at the

VBCC on a first-come-first-served basis. Flea market tables are available for \$3.00. Talk-in on 3.965 and .34/.94. For more information, write NAHA, PO Box 423, Huntsville AL 35804.

WARREN OH AUG 17

The Warren Amateur Radio Association will hold its 23rd hamfest on August 17, 1980, at Trumbull Branch, Kent State University. There will be five acres of flea market, tech forums, DX programs, inside dealer displays, and XYL activities. For further information, QSL to WARA, PO Box 809, Warren OH 44482.

BEAR DE AUG 17

The Fifth Annual New Delmarva Hamfest will be held on Sunday, August 17, 1980, at Gloryland Park, Bear DE. Admission will be \$2.00 in advance and \$2.50 at the gate. Tailgating will be \$2.50 and tables under the pavilion, \$4.00. Prizes, food and drinks will be available. Talk-in on .52 and .13/.73. For more information, send an SASE to Stephen Momot K3HBP, 14 Balsam Road, Wilmington DE 19804. Make checks payable to Delmarva Hamfest, Inc.

REND LAKE IL AUG 17

The Shawnee Amateur Radio Association Hamfest will be held on August 17, 1980, at the North Marcum access area on Rend Lake in southern Illinois. Complete recreational facilities, including beach and campsites, will be available. Talk-in on 146.25/.85, 146.52, and 3.925.

TACOMA WA AUG 23-24

The Radio Club of Tacoma (W7DK) will hold its annual Hamfair on August 23-24, 1980, at the campus of Pacific Lutheran University, 122nd and Park Avenue. Registration is \$4.00 and the banquet is \$6.00. Events include a flea market, door prizes, commercial displays, a banquet, a loggers' breakfast, seminars, and much more. Talk-in on .88/.28. For additional information, contact Joe Winter WA7RWK, 819 No. Mullen, Tacoma WA 98406 or phone (206)-759-9857.

LA PORTE IN AUG 24

The annual LaPorte County

Hamfest will be held, rain or shine, on Sunday, August 24, 1980, at the County Fairgrounds on Highway 2, west of LaPorte IN (50 miles SE of Chicago). There will be an outdoor paved flea market area, indoor tables at \$1.00 each, and overnight trailer hookups available on site for early birds. Advance tickets are \$2.00. For reservation or information, send an SASE to PO Box 30, LaPorte IN 46350.

MARYSVILLE OH AUG 24

The Union County Amateur Radio Club will hold its fourth annual Hamfest-80 on Sunday, August 24, 1980, at the fairgrounds in Marysville OH. There will be a free gate until 10:00 pm Saturday; then admission is \$2.00 each or \$1.50 in advance. Features will include free overnight camping, free movies Saturday night, breakfast served all night until 10:00 am Sunday, many prizes, including a Kenwood TR-2400, a flea market, ARRL forums, and MARS and FM meetings. For more information or advance tickets, write UCARC, 13613 US 36, Marysville OH 43040, or phone (513)-644-0468.

SEWELL NJ AUG 24

The Gloucester County ARC will hold its second annual hamfest on Sunday, August 24, 1980, from 8:00 am to 3:00 pm at Gloucester County College, Tanyard Road, Sewell NJ. Tickets are \$2.00 in advance, \$2.50 at the door, and dealers' and tailgaters' admission is \$5.00. Tailgaters can set up at 7:00 am and indoor and outdoor spaces will be available. There will be food and prizes. Talk-in on .52 and .78/.18. For information and tickets, contact Bob Grimmer KN2QWO, 229 William Avenue, Barrington NJ 08007.

SYDNEY NS AUG 29-SEP 1

The Sydney Amateur Radio Club will host the 1980 Maritime Convention, Ham Ceilidh 80, on Labor Day weekend, August 29 - September 1, 1980, at the Isle Royale Hotel, Sydney, Cape Breton Island, Nova Scotia, Canada. There will be plenty of free parking and shopping for the ladies. The program will include many items of interest and will cater to amateurs along with their XYLs. Friday evening, August 29, will be a special event with registration and a ham get-together. For more in-

formation, contact the Sydney Amateur Radio Club, Box 1051, Sydney, Cape Breton, Nova Scotia CAN B1P 6J7.

GEORGETOWN IL AUG 30-31

The Illiana Repeater System, Inc., amateur radio club will hold its 11th annual Danville, Illinois, Hamfest, Saturday and Sunday, August 30-31, 1980, at the Georgetown, Illinois, Fairgrounds. Advance gate donations are \$1.50 per adult; \$2.00 at the gate, with children 14 years and younger free. Activities will include two days of flea markets, commercial exhibitors, RTTY setups, an Antique Wireless Association display, a home-brew builders contest, a USAF MARS station, and other interests. Meals and refreshments will be served both days and overnight camping facilities are available. For more information or advance tickets, send an SASE to Illiana Repeater System, Inc., PO Box G, Catlin IL 61817.

PECATONICA IL AUG 31

The third annual Rockford Hamfest and Illinois State ARRL Convention will be held at the grand exhibition hall at the Winnebago County Fairgrounds at Pecatonica, just west of Rockford on US Route 20. Tickets are \$2.00 in advance or \$2.50 at the gate and are available from any RARA member. They may also be obtained by mail by writing to RARA, PO Box 1744, Rockford IL 61110 and including a business-size SASE. Food and campsites (with electric and sanitary hookups) will be available, as well as plenty of free parking. For flea market dealers, there will be 300 tables available at a nominal charge. There will be speakers and forums, demonstrations and discussions, and prizes. Talk-in on 146.01/.61 Rockford repeater, or 146.52.

MARSHALL MI AUG 31

On Sunday, August 31, 1980, from 8:00 am to 5:00 pm, "Historic Marshall's" 72/12 E. S. Team will hold its Trunk 'n Trailer Bash on the whole block of 615 S. Marshall Avenue, Marshall MI (1830 site of Michigan's capitol and governor's mansion). The donation is \$2.00, spaces are \$5.00, and inside space is 50 cents a foot. There will be free parking and a huge consignment area

for the mini-swapper. For further information, send an SASE to K8UCQ, 110 Perrett, Marshall MI 49068.

PENSACOLA FL AUG 31

The Five Flags Amateur Radio Association, Inc., will hold its 1980 Ham-A-Rama on August 31, 1980, from 8:00 am to 4:00 pm at the Pensacola Municipal Auditorium, Pensacola FL. Admission will be \$1.00 and swap tables will be available for \$5.00 each. Additional information can be obtained by writing to the FFARA, PO Box 17343, Pensacola FL 32522.

MELBOURNE FL SEP 6-7

The Platinum Coast Amateur Radio Society will hold its 15th annual hamfest and indoor swap-and-shop flea market on September 6-7, 1980, at the Melbourne Civic Auditorium. Admission is \$3.00 in advance and \$4.00 at the door. Swap tables are \$5.00 per day. There will be food and plenty of free parking available, as well as awards, forums, and meetings. Talk-in on .25/.85 and .52/.52. For reservations, tables, and information, write PCARS, PO Box 1004, Melbourne FL 32901.

SOUTH DARTMOUTH MA SEP 7

The South Eastern Massachusetts Amateur Radio Association will hold its annual picnic and flea market on Sunday, September 7, 1980, from 9:00 am until 4:00 pm at the Stackhouse Fairgrounds, Faith Street, South Dartmouth MA. The rain date will be September 14, 1980. Sales space is \$6.00 and tables for rent are \$4.00. There will be free parking, entertainment, and food and beverages for sale. Talk-in on 147.60/147.00 or CB channel 11. For information, write SEMARA, PO Box P-105, South Dartmouth MA 02748, or phone (617)-997-3674 or (617)-994-4838.

VALPARAISO IN SEP 14

The Porter County Amateur Radio Club, Inc., will hold its annual hamfest on September 14, 1980, at the Porter County Fairgrounds, Valparaiso IN. Featured will be a flea market, technical sessions, door prizes, and bingo. Food will be available. Advance tickets are \$1.50 and

tickets at the gate are \$2.00. There will be dealers and commercial exhibitors, as well as free indoor and outdoor space. Gates will open at 6:00 am. Talk-in on 147.96/.36 and 146.52. For tickets and information, write Charles Baker W9SUN, PO Box 251, Portage IN 46368.

**LOWER BURRELL PA
SEP 21**

The Skyview Radio annual swap and shop will be held on September 21, 1980, at Sokol Camp, Lower Burrell PA, from 12:00 noon to 4:00 pm. Registration is \$1.00 per ham, and XYLS, YLs, and children are free. There will be plenty of parking and lots of shade. Talk-in on .04 and .64. For more information, send an SASE to Jim Jackson K3VRU, RD 1, Box 7A, Apollo PA 15613.

**PHILADELPHIA PA
SEP 25-28**

National Computer Shows (formerly Northeast Expositions) will hold the Mid-Atlantic Personal and Business Computer Show from Thursday, September 25, through Sunday, September, 1980, at the Philadelphia Civic Center, Philadelphia PA. Show hours are: Thursday through Saturday, 11:00 am to 9:30 pm and Sunday, 11:00 am to 6:00 pm. General adult admission is \$5.00. For further information, contact National Computer Shows, PO Box 678 Brookline Village MA 02147, or phone (617)-524-0000.

**FINDLAY OH
SEP 27**

The Findlay Radio Club will hold its 38th annual Findlay Hamfest on Sunday, September 27, 1980, at a new location, the Hancock Recreational Center, just east of I-75 exit 161, on the north edge of Findlay, 40 miles south of Toledo. Tickets are \$2.00 in advance and \$2.50 at the door. Reserved tables are \$2.50 per half. There will be forums on Saturday evening and setup Sunday at 5:00 am. Main prizes are a TS-120S with supplies, two TR-2400s, and an AT-120 matcher. For tickets, information, and reservations, send an SASE to PO Box 587, Findlay OH 45840.

**ELMIRA NY
SEP 27**

The 5th annual Elmira International Hamfest will be held at

the Chemung Country Fairgrounds on September 27, 1980. Featured will be an ARRL Forum and talk by Atlantic Division Director Jesse Bieberman W3KT. Also on the agenda is a similar forum and discussion with officials from the Federal Communications Commission's Buffalo NY office. There will be a free outdoor flea market and some indoor space, as well as several electronics dealers from across the northeast. The usual abundance of prizes and good food will be part of this year's event once again. Gates open at 8:00 am. Advance sale tickets are available from John Breese WA2FJM, 340 West Avenue, Horseheads NY 14845 at \$2.00 each (save a dollar per ticket off the gate price!). Talk-in on 147.96/.36, 146.10/.70, and .52 simplex.

**TYSONS CORNER VA
SEP 27-28**

The National Capitol DX Association will sponsor DXPO 80 on Saturday and Sunday, September 27-28, 1980, at the Ramada Inn, junction of Rte. 7 and I-495, Tysons Corner VA. Saturday's half-day session will include Phase I of the DXPO Program, an Attitude Adjustment Party, and a banquet with prizes and surprises. Sunday's session will feature Phase II of the DXPO Program. Unless you have previously attended DXPO, write to Dick Vincent K3AO, Rte. 1, Box 230, Bryantown MD 20617, for more information. If you have any program suggestions, contact John Boyd W4WG, 8424 Reflection Lane, Vienna VA 22180.

**ADRIAN MI
SEPT 28**

The Adrian Amateur Radio Club will hold its 8th annual

hamfest on Sunday, September 28, 1980, at the Lenawee County Fairgrounds, Adrian MI. Featured will be prizes, games and programs. Tables are available for \$5.00 per 8-foot space, \$3.00 per 4-foot space, \$1.00 per 8-foot trunk space, and \$2.00 for an inside space for your table. Talk-in on 146.31/.91 and 146.52. For ticket and table information, write Adrian Amateur Radio Club, Inc., PO Box 26, Adrian MI 49221, or call Bob and Sally Fay of Sword Enterprises at (517)-263-3592.

**ERIE PA
SEP 28**

The Radio Association of Erie, Inc., will hold its HAMJAM 1980 on Sunday, September 28, 1980, at the Rainbow Gardens at Waldameer Beach Park, Erie PA. Hours are from 9:00 am to 5:00 pm. The \$3.00 admission fee includes a chance for the main prizes, hourly door prizes, and a free cup of coffee. Featured will be commercial displays, huge outdoor flea market (\$1.00 per car space), large indoor display area (tables available at \$5.00). Food will be available on site. Talk-in on 146.34/.94 (primary) and 146.22/.82 (secondary). For information about overnight parking and other details, write Lee Robinson WA3HJC, HAMJAM Chairman, PO Box 844, Erie PA 16512.

**BOULDER CO
SEP 28**

The Boulder Amateur Radio Club will hold Barcfest '80 on September 28, 1980, beginning at 9:00 am at the Boulder National Guard Armory, North Broadway, at the city limits, Boulder CO. There will be an auction and a snack bar. Admission is \$2.00 per family and includes a door prize drawing

and swap space. Talk-in on 146.10/.70 and .52/.52. For further information, contact Mark Call N0MC, 4297 Redwood Ct., Boulder CO 80301, or phone (303)-442-2616.

**CHICAGO IL
OCT 16-19**

National Computer Shows (formerly Northeast Expositions) will hold the Midwest Personal and Business Computer Show from Thursday, October 16, through Sunday, October 19, 1980, at McCormack Place, Chicago IL. Show hours are: Thursday through Saturday, 11:00 am to 9:30 pm and Sunday, 11:00 am to 6:00 pm. General adult admission is \$5.00. For further information, contact National Computer Shows, PO Box 678 Brookline Village MA 02147, or phone (617)-524-0000.

**FRAMINGHAM MA
NOV 9**

The Framingham Amateur Radio Association will hold its annual fall flea market on Sunday, November 9, 1980, at the Framingham Police Station Drill Shed, Framingham MA. Admission is \$1.00 and sellers' tables are \$6.00. Sellers are advised to pre-register. Doors will open at 9:00 am. Talk-in on .75/.15 and .52. For more information or to register, contact Ron Egalka K1YHM, FARA, PO Box 3005, Saxonville MA 01701, or phone (617)-877-4520.

**BOSTON MA
NOV 20-23**

National Computer Shows (formerly Northeast Expositions) will hold the Northeast Personal and Business Computer Show from Thursday, November 20, through Sunday, November 23, 1980, at Hynes Auditorium, Boston MA.

Ham Help

I need any information on hints, kinks, and modifications for the Yaesu FT-101E. I am willing to pay.

**Brian Stoll N8AFX
3025 Brockman
Ann Arbor MI 48104**

Greenpeace, the anti-whaling organization, is in need of a San Francisco Bay area site for its ham station. The site must be

able to accommodate a tower, a large log periodic antenna and high power. Those with a site or suggestions should contact me at the address below.

**Dick Dillman N6VS
435 Utah Street, No. 4
San Francisco CA 94110
Phone: (415)-864-6320**

I need a blower motor assembly P/N DEB067-A01 and power

transformer P/N PU015-A01 (Waterman Products Co., Inc., Philadelphia PA) for an OS-51/USM-24C oscilloscope. I will pay a reasonable price for these parts.

**Elmer H. Melvin WA8DJY
5050 New Market Road
Hillsboro OH 45133**

I need a schematic and/or circuit information for a suitable noise-blanker circuit to use in a Hammarlund HQ-180A receiver.

**Robert F. Cann W4GBB
1606 Lochwood Drive
Richmond VA 23233**

New Products

from page 28

parallel mode, the two filters can be used to peak the mark and space signals used in RTTY and ASCII transmissions.

Because the Signal Enforcer is an audio filter, it can be hooked in line with the audio output of a receiver so that no connections inside the receiver are necessary. It can be used in line with the receiver speaker, headphones output, or other audio outputs from the receiver. The Signal Enforcer will drive up to 2 Watts through an 8-Ohm speaker. The audio output is adjusted through a volume control.

Each Signal Enforcer filter has its own "tuning eye" indicator, peak/notch switch, bandwidth control, and frequency control. The tuning eyes are LED indicators that make tuning fast and simple. Each tuning eye

has its own very narrow filter. When one of the Signal Enforcer filters is tuned to the heart of a signal, its tuning eye will blink simultaneously with the signal's audio output. Under crowded band conditions, it is very difficult to tune signals without the aid of the tuning eyes. The Signal Enforcer is the only filter that offers that essential feature on both filters.

The high quality of the filters allows the bandwidth to remain constant once it has been set by the operator, regardless of the frequency tuned to. The filters are continuously variable in bandwidth from less than 30 Hz to over 1000 Hz. Their audio-frequency range runs from less than 150 Hz to over 3000 Hz.

Ultimate serviceability has been designed into the Signal Enforcer. If service or repair is needed, the modular design will

allow for nearly immediate replacement and turn-around. All internal boards, components, and craftsmanship are of the highest quality.

Front-panel controls on the Signal Enforcer include POWER, POWER INDICATOR, VOLUME, BANDWIDTH 1, BANDWIDTH 2, FREQUENCY 1, FREQUENCY 2, TUNING EYE 1, TUNING EYE 2, PEAK/NOTCH switch 1, PEAK/NOTCH switch 2 and PARALLEL/CASCADE mode switch. Back-panel inputs include SIGNAL INPUT (RCA jack) and DC INPUT (2.5mm jack). Back-panel outputs include EXTERNAL SPEAKER (3.5mm phone jack), EXTERNAL HEADPHONES (1/4" phone jack), and RTTY DEMODULATOR OUTPUT (RCA jack). The Signal Enforcer has its own internal power supply and can be run from 115 V ac at 60 Hz, 220 V ac at 50 Hz or from an external 12 to 18 V dc power source.

The Signal Enforcer is in a tan, cream, and brown enclosure about 2 1/2" by 8" by 6". It comes with operator's manual and all necessary connectors used on the unit.

For further information, contact: *Kantronics, Inc., 1202 E. 23rd Street, Lawrence KS 66044.*

KLM'S SSV 80-40-15

The SSV 80-40-15 is the latest addition to KLM's series of vertical multiband antennas, featuring broadband response on 80, 40, and 15 meters. The SSV is freestanding, with the lower half made up of three electrically-active tripod legs. Excellent DX is possible because the configuration of the legs contributes to a low angle of radiation on each band. Two of the legs are hinged at the base, allowing the SSV to be easily raised by two men. Only modest base preparations are needed. The upper half of the SSV is a single telescoping whip section. It is quite flexible and survives high winds by bending over to reduce its own wind load. Although the SSV stretches over 60 feet above ground, no guying is necessary. Its overall weight is only 88 lbs., and the nominal feed impedance is 50 Ohms.

A full 1/4-wave resonance is possible on 80 meters through the use of one tripod leg and the upper whip section. The adjustable tip allows the SSV to be tuned from below 3.5 MHz to 6.5 MHz, in 300-kHz steps, at 1.5:1

vswr or better.

The 40-meter resonance is quite broad thanks to the effective diameter of the base 1/4 wave (two of the tripod legs). Wide-range tuning is possible from 6.5 MHz on up. Performance on 40 meters appears better than a standard ground-mounted 1/4-wave vertical because shock excitation of the 80-meter section improves the radiation pattern.

Performance of the 1/4-wave 15-meter section is also improved by shock excitation of the 80-meter section. The vswr curve is very broad, with little change from band edge to band edge. Performance approaching a full 1/4-wave vertical is also possible on 160 meters simply by adding inductance at the base of the antenna.

Experimental uses for the SSV abound. A wind spectrum vswr plot shows three more naturally occurring resonances that fall very close to the three new HF bands authorized at WARC '79 (10, 17, and 24 MHz) and are usable with slight retuning.

High-quality materials are used throughout the SSV. All aluminum tubing is drawn seamless 6063-T832 alloy. Tough fiberglass insulators are used to insulate the SSV from ground and insulate the resonant sections. Base mounting anchor plates are supplied.

For more information, contact *KLM Electronics, Inc., PO Box 816, Morgan Hill CA 95037; (408)-779-7363.* Reader Service number 480.

NEW HUSTLER FIVE-BAND TRAP VERTICAL FIXED STATION ANTENNA

Hustler recently introduced the new Model 5-BTV, a five-band trap vertical fixed station antenna. The unit covers 10, 15, 20, 40, and 80 meters (tunable to 75 meters). The 5-BTV consists of the popular Hustler Model 4-BTV, RM-80-S resonator, and spider assembly, in one UPS-shipable carton.

In restricted or unlimited space locations, the Hustler 5-BTV delivers top signal performance, consistent contacts, five-band operation, and complete coverage. Use one feedline of any convenient length. Switching or matching devices are not required.

The total antenna length is 25'5"; it is constructed of the

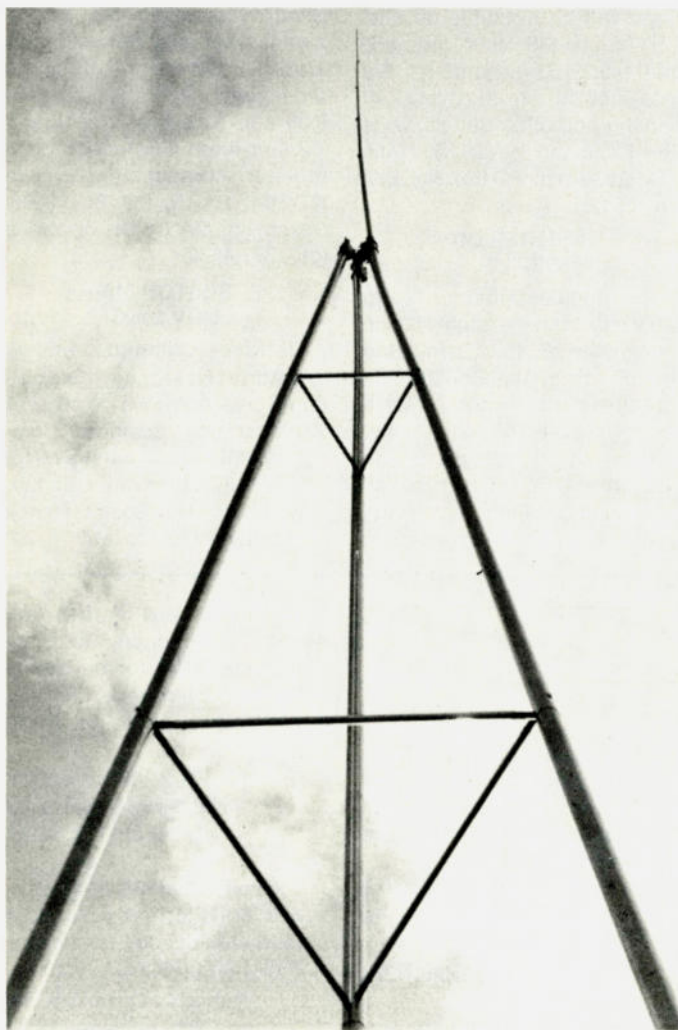

KLM's SSV 80-40-15.

finest quality heat-treated seamless aluminum and all stainless steel hardware. Mounts to any 1 1/4" o.d. vertical support. Vswr is better than 1.6:1 at band edges and up to 100 kHz bandwidth on 75 or 80 meters. Power capability is the full legal limit on SSB and CW. For further information, contact: *Hustler, Incorporated, 3275 North B Avenue, Kissimmee FL 32741*. Reader Service number 477.

NEW BEARCAT® POCKET SCANNER HAS FOUR BANDS, SIX CHANNELS

Weighing a mere 10 ounces and measuring just 2 3/4" wide by 1" thick, the new Bearcat® Four-Six ThinScan™ pocket scanner recently introduced by Electra Company is designed as a reliable, high-performance scanner especially for the fireman, paramedic, or other professional on the move. Small enough to slip easily into a shirt pocket, the little unit nevertheless can receive any mix of six channels on four bands (high and low VHF, UHF, and UHF "T" public service bands). It scans the six crystal-controlled frequencies at the rate of fifteen channels per second and has built-in scan delay. The radio also features Electra's patented Track Tuning on UHF for optimum performance across the entire band. Each channel has a lockout control to permit the listener to bypass those not of current interest. A SCAN/MANUAL function switch lets the user select and hold any of the six channels manually; LED indicators show the channels being scanned.

Ruggedly constructed to take the punishment of on-the-go professional service, the trim new pocket scanner has easy-to-operate recessed controls, an anodized aluminum front panel, and flexible rubber ducky antenna (an interchangeable wire antenna is also supplied). Extremely versatile, the radio will operate from external power as well as from internal batteries. It also has provision for an optional external battery charger, earphone, and external speaker. Complete information on the new unit is available from Bearcat retailers or directly from *Electra Company, PO Box 29243, Cumberland IN 46229*. Reader Service number 476.

NEW HY-GAIN AMATEUR CATALOG INCLUDES MORE THAN 100 PRODUCTS

Hy-Gain, a division of Telex Communications, Inc., has published a new 24-page catalog featuring over 100 base and mobile antennas, towers, rotators, microphones, headphones, boom mike headsets, and accessories for the amateur radio operator.

A full line of desk and hand mikes, the new HDR300 antenna rotator, and a series of seven crank-up antenna towers are the newest additions to the Hy-Gain amateur offerings. The catalog contains detailed specifications on all products, including swr curves on all base antennas.

For a copy of this catalog (#AM 2504), contact: Kit Kitterer, *Hy-Gain, Division of Telex Communications, Inc., 8601 Northeast Highway Six, Lincoln NE 68505*. Reader Service number 484.

HUSTLER 2-METER FIXED STATION MOUNTING KIT

A new mounting kit, Model MKR-2, is now available for converting Hustler's line of series-fed mobile VHF antennas to fixed station operation. With the appropriate VHF antenna installed and tuned, the MKR-2 is ideally suited for temporary field day use or permanent installation for local QSOs.

The MKR-2 radial kit consists of a heavy-duty zinc-plated mast



Bearcat's new Four-Six ThinScan pocket scanner.

bracket and hardware with three 19" decoupling radials for correct feedpoint impedance. It accepts any VHF antenna with a standard 3/8" x 24 thread.

For further information, contact: *Hustler, Incorporated, 3275 North B Avenue, Kissimmee FL 32741*. Reader Service number 483.

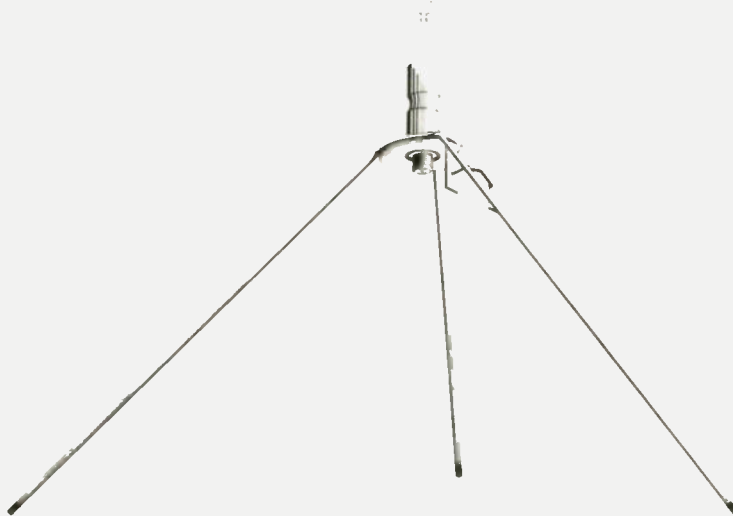

Hustler's new MKR-2 mounting kit.

W2NSD/1 NEVER SAY DIE

editorial by Wayne Green

from page 6

visible only in the Japanese magazines. When you visit over there, you find that some of these firms would like to export equipment to be sold here, but they are too small to set up the necessary sales offices and a repair center.

Those hams who join Sherry and me on the October tour of the Orient will have a chance to meet some of the smaller manufacturing firms in Japan (as well as Korea, Taiwan, and Hong Kong) and look into the possibility of importing ham gear for sale here. For instance, how many of you have seen a Sugi-yama Electric 850 transceiver? It goes from the 1.8 MHz to 144 MHz bands! It has SSB, AM, CW, and FM modes, VOX, and so forth.

Not even the old Cortlandt Street complex of radio stores in New York came close to the mind-boggling collection of electronics and computer stores in the Akihabara section of Tokyo. You'll never be the same.

If interested, drop a line to Sherry for details. The trip costs a bit over \$2,000, and that includes first-class hotels, all transportation, entry to consumer electronics shows in four countries, and more banquets (great banquets) than you may be able to handle.

POSTERS

COMMUNICATIONS by AMATEUR RADIO

As a result of the lessons learned by the group at Colorado Springs which provided the communications for the 1979 National Sports Festival, we rushed to make some posters which could be displayed by ham groups indulging in similar public service efforts. If we don't

blow our own trumpet and make sure that both the general public and the media know that amateur radio is providing the communications for an event, our secret will be well kept and golden opportunities to improve the image of amateur radio will be lost.

A package of ten of these cards is available for the token payment of \$2 to cover the cost of packing and shipping. This will not cover the cost of setting the type, making the artwork, making the negative, spotting the negative ready for use, making the printing plates, printing the posters, the cardboard stock, the time spent in planning the project, the cost of advertising and promoting the availability of the posters, and other such expenses. Who would pay a buck apiece to make this a paying project?

FREE MESSAGE SERVICE

To Anywhere in the United States

Via Amateur Radio

Where groups are not only providing communications for an event, but also providing a message service for the participants, this poster may be needed. If so, please mention it and a couple of these will be substituted in the above package (ten posters, \$2). Of course ten of these are also available for the usual \$2 handling. Let's make sure that everyone knows that amateur radio is providing the service.

SBE DIES

Another of the ham firms which went for the CB gold has bitten the dust. This is Sideband Engineers (SBE), once a well-known ham name. While ham sales are not doing wonderfully, they are a bowl of cherries when compared with CB equipment sales.

By the way, if any hams are

having problems with manufacturers, even if they are in Chapter 11, they may be able to get help via the California State Consumer Protection Agency in Sacramento.

NEW HAMPSHIRE AUCTION

One of the livelier ham clubs in New Hampshire is the Interstate Repeater Society (hate the acronym) of Derry. In the past, they have held their yearly auction in the winter, but the coincidence of major snowstorms and their auction date finally convinced them to change it to early spring.



The auction was held this March near Manchester at the Bedford Sheraton convention facility. Hams packed the place. A lot of used ham gear changed hands. Here we see the auction in full swing.



Hams of all ages kept the bidding going on a wide variety of ham gear, test equipment, home-built rigs, and just plain junk... much of which we will probably see at the next New England auction.



Here are the Tufts booth and Chuck Martin WA1KPS. Tufts had a lot of everything with them, but the sales were mostly small items... quite a bit different from 1979, when many big ticket items sold and the net sales were almost double those of this year. One fact is inescapable: It is a lot more difficult to sell this year.



Don Poulin W1MXC managed to keep up with the activity at the ARRL booth. Don is one of the organizers of the popular Boxborough hamfest which will be along in October.

CASIO WATCH

When I visited Hong Kong last year, one of the exhibits in the consumer electronics show had a relatively inexpensive digital watch with a calculator built in. This could have been sold in the US for around \$150 and looked like a winner to me... particularly when compared with the almost identical Seiko at about double that price.

The watch also had a stopwatch function, the day and date, plus an alarm. It was the gadget lover's delight. The calculator function required a ball pen or pencil to operate the keys, but this wasn't all that much of a drawback. Of course, this developed at a time when I switched over to those Pilot Razor Point plastic-tipped pens... which were completely incompatible with the watch. That's the way life goes... I'm almost used to it.

Once you have a calculator watch, you would be surprised at how many things come up which need instant calculation... particularly if there is an appreciative audience. Great toy, but rather clumsy to use.

Then, just recently, ads appeared for the new Casio calculator watch. Sherry did some fast work and rustled up one for me to try out. Fantastic! Here was a calculator with buttons I could operate with my fingers... with ease! Casio came up with a little circuit which makes it so that even if my finger touches a second button as I press down, only the first button touched will function and others are ignored.

The Casio C-80 is half the price of the Mikado... is backed by a major organization, so service should be a snap... weighs perhaps one third the weight of the older calculator watches (you won't believe how

light it is), has the stopwatch function built in, even with lap time . . . keeps the day and date for you . . . and has two times . . . 12 hours and 24 hours. You can set the two times separately so that when you are traveling you have one on the time at home . . . or a ham can keep one on Greenwich time and the other on local time.

Casio has come a long way in the last year or two. I now find myself carrying the Casio watch, an MQ-1 calculator/watch pocket unit, and a Melody-80 musical calculator/watch . . . all by Casio. The MQ-1 is great for calculating date and time differences as well as normal calculations. The Melody-80 plays long, involved tunes and gets people who haven't heard one before all excited.

And every time I use my calculator watch or pull out one of the other Casio calculators, I offer a prayer of thanks to Mort Kahn W4KR, who I feel made this all possible. Also, some credit should go to Bill Orr W6SAI, and his part in making possible the move of the world's electronics industries to Japan from our shores. Bill, too, had a lot to do with this, the way I see it.

Surely I am exaggerating when I suggest that one or two hams may have been largely responsible for the loss of billions of dollars in the sales of electronic equipment such as television sets, hi-fi systems, ham equipment, CB equipment, calculators, and digital watches. To me, there seems to be quite a clear-cut connection between the events which seem to have brought about this world change in manufacturing and marketing.

To trace the path which led us

to where we are, it is easier to start from the present and work our way back. First, let's start with the ham population we have today. We now have under 400,000 licensed amateurs, of which less than half are active. In Japan, they have over 500,000 licensed amateurs of which over 400,000 are said to be active. I think this is significant.

Had the growth of amateur radio in the US not stopped in 1963 for over a ten-year period, we might today have an amateur population of around 1,680,000 with over one million active. Would this really make any difference in the ability of our country to develop and market electronic products?

You better believe it! It is no coincidence that the technological development of countries is proportional to the number of hams in those countries. All you have to do is think about the situation for a moment and you'll realize that while our technical colleges turn out engineers, few of them have any real interest in electronics . . . or else they would be hams.

I don't know about you, but I've known a lot of non-ham engineers and few have been worth the powder to blow them to hell. While about 80% of the hams who get their licenses in their teens go on to work in the electronics or communications industry, only a relatively small percentage go on to get their engineering degrees. Most of them enter the work force as technicians.

I would hesitate to say that Sam Harris W1FZJ was a typical technician, but he certainly was representative of the better of the breed. Sam was the chap who built the first working para-

metric amplifier. He built it to work on six meters and it revolutionized the radar equipment of the time. The fact is that the bulk of the technical development work in electronics is being done by technicians. And an amazingly high percentage of these chaps who live and breathe electronics are hams . . . and started their careers as hams.

What would be the state of the art in electronic developments in the United States if we had twice as many engineers and technicians as Japan in our labs and factories? I don't think there is any way in the world that I would be wearing a Casio watch, watching a Sanyo portable television, and listening to a Sansui stereo. Nor would I be carting around a Sony cassette recorder and a Sony stereo portable cassette player.

I believe that the stopping of the growth of amateur radio in 1963 has resulted in the loss of much of the electronics industry in our country and has cost us billions of dollars in lost sales over the last ten years.

So how do W4KR and W6SAI fit into this picture? Well, Mort Kahn was elected as director of the League in the late '50s and it was he, I believe, who engineered the coup which suddenly retired Budlong, the general manager. This left Mort firmly in control of the League, which he ran from his position as Hudson Division Director until he apparently got bored with it.

The League proposals in 1963, pushed through, I understand, by Kahn, and vigorously promoted by Orr, called for taking away most of the phone bands from most of the hams. The plan so dismayed everyone

that growth stopped and sales of ham gear dropped to about 15% of their previous level . . . leading to the bankruptcy or disappearance of Hallicrafters, National, Hammarlund, Harvey Wells, and most of the other firms in the ham business. This also knocked out about 75% of the ham dealers and brought to an end the sale of parts through electronics stores in the quantities we had previously known.

For over ten years amateur radio was in the doldrums, with zero to negative growth. Only the popularity of FM and repeaters, the establishment of study classes organized by the repeater clubs, and the growing popularity of CB brought an end to this stagnation.

The electronics industry was particularly hard hit by the shutting off of technicians and truly creative engineers because the average age of the newcomer to amateur radio increased substantially through this period and far fewer of the new hams were entering the field for career work. The teenager in high school who gets involved with amateur radio has an 80% likelihood of getting into electronics in some way . . . the chap in his 30s and 40s, coming in via CB and ham classes, already has a career and is unlikely to make a career change at this time of life . . . so the result has been that even though the amateur ranks have been growing slowly over the last five years, a much smaller percentage of the new hams have been going into industry. The result of all this has been an electronics industry in the US which has had a negligible infusion of ham-technicians and ham-engineers, while the Japanese industry has been



10% DISCOUNT
Off List

64K 1 Drive \$3499.00

No Taxes on Out Of State Shipments

Immediate Shipment From Stock

AUTHORIZED
TRS-80® DEALER A301

COMPUTER SPECIALISTS

| | |
|---|-----------------|
| Popular 16K Level II System | \$ 715.00 |
| 26-1145 RS-232 Board | 84.00 |
| 26-1140 "O" K Interface | 254.00 |
| 26-1160 Mini Disk | 424.00 |
| 26-1171 Telephone Modem | 169.00 |
| Fast 100 CPS Centronics 730 Printer | 675.00 |
| Highly Reliable Laba 5 1/4" Drives | 375.00 |
| Versatile Laba Interface, 8" Drives and IBM Hard Drives | Call For Prices |

1-800-841-0860 Toll Free Order Entry
MICRO MANAGEMENT SYSTEMS, INC. 313

DOWNTOWN PLAZA SHOPPING CENTER
115 C SECOND AVE. S.W.
CAIRO, GEORGIA 31728
GA. PHONE NO. (912) 377-7120

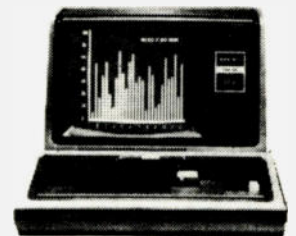

15% DISCOUNT
Off List

84K Level 11 \$527.00

Full Factory Warranty on All Items Sold.

Largest Inventory in the S.E. U.S.A.

Corrections

growing to enormous proportions, fueled by youngsters with radio and electronics deep in their hearts.

In case you have any question about the Japanese getting started in amateur radio early, all you have to do is take a look at any of the Japanese ham magazines . . . which, by the way, are twice the thickness of ours . . . and you'll see hundreds of pages of pictures of ham clubs, most of them packed with teenagers. Their ham clubs go out for DXpeditions, special outings, fox hunts, and jamborees—and they are having a ball with amateur radio. The seed of destruction is planted early, in high school, and the result is that most of them are seriously infected with the ham bug and try to make it as contagious as possible.

In the June issue of 73, I had a picture of the development lab at Yaesu, showing a couple dozen of their technicians and engineers. I wonder if we could get together that many such people in the US, even if we emptied out every US ham manufacturer's test labs.

WHAT CAN BE DONE?

Since it was the development of two or three thousand repeater clubs which got club license classes going back in the mid '70s and thus got amateur radio back into a growth mode for a while, I suspect that it will again be the clubs which will be able to turn the tide and get amateur growth back into the high schools. It won't happen by accident. Clubs will have to set this as a goal and it will take a lot of work to get our hobby into a growth pattern of around 15% or more. We have a lot of catching up to do if we want to have any electronics industry at all in twenty years.

Both Kahn and Orr are getting along in years and something should be done by Japan to give them recognition for the fantastic change they have helped bring about. I'll drop a note to the editor of *CQ Ham Radio*, the leading Japanese magazine, and see what can be done to right this oversight.

Meanwhile, if you are interested in getting one of those Casio C-80 watches, look for ads for it in 73 . . . I hope you enjoy this gadget as much as I do mine . . . and think often and kindly of Kahn and Orr.

In the program listing which accompanied my article "Antenna Engineer" (May, 1980), line 700 shows two left brackets (]).

These should be up arrows (↑).
Dennis Mitchell K8UR
30-5 Briarwood Lane
Marlboro MA 01752

Several component designations were not included in the schematic which accompanied my article ("Fun with Fozzle") which appeared in your June issue. Enclosed is the complete schematic.

Howard F. Batie W7BBX
Herndon VA

01-07

4027B

4075B

4081B

4027B

4075B

4027B

4048B

Revised Fig. 1, "Fun with Fozzle."

Please note that a new line 152 in my article ("Prefix Challenge," June, 1980) will save a lot of misery for beginner users of the program, a conclusion I came to after seeing my fellow

hams use it at a club meeting. The new line should be:
152 PRINT: PRINT "IF 'READY'
SHOWS, ENTER CONT TO
GO ON": PRINT
Also, changing the number 19

to 38 in line 3, column 3 of page 108 will correct a misleading suggestion that would mess up a graphic.

Ron Gunn AG6P
Livermore CA

FCC

Reprinted from the Federal Register.

47 CFR Part 97

[Gen. Docket No. 80-136; RM-2910; RM-2939; RM-3281; RM-3302; FCC 80-183]

Amending Rules Concerning Station Identification Requirements

AGENCY: Federal Communications Commission.

ACTION: Notice of Proposed Rulemaking.

SUMMARY: The FCC proposes to amend station identification requirements in the Amateur Radio Service. The present rule requires amateur radio stations to identify the station with which contact was made, at the end of the transmission. The proposal would eliminate this requirement for all communications except those involving international third party traffic. The adoption of this proposal would reduce channel usage, and would permit amateur radio operators to complete their transmissions in less time.

DATES: Comments must be received on or before July 16, 1980 and Reply Comments must be received on or before August 15, 1980.

ADDRESS: Federal Communications Commission, Washington, D.C. 20554.

FOR FURTHER INFORMATION CONTACT: John Johnston, Private Radio Bureau, (202) 254-6884.

Adopted: March 31, 1980.

Released: April 9, 1980.

In the matter of Amendment of Part 97.84(a) of the Amateur Radio Service Rules. PR Docket No. 80-136, RM-2910, RM-2939, RM-3281, RM-3302.

1. The Commission has before it four petitions for rulemaking separately filed by James R. Sebolt in 1977, John C. Kanode on behalf of the Potomac Valley Radio Club in 1977, Arlington R. Kaeding in 1978, and Stephen R. Mann in 1978. The petitioners request that the Commission consider simplifying the identification requirements for amateur radio stations. 47 CFR 97.84.

2. Section 97.84(a) of the Amateur Radio Service Rules and Regulations provides that:

(a) An amateur station shall be identified by the transmission of its call sign at the beginning and end of each single transmission or exchange of transmissions and at intervals not to exceed 10 minutes during any single transmission or exchange of transmission of more than 10 minutes of duration. Additionally, at the end of an

exchange of telegraphy (other than teleprinter) or telephony transmissions between amateur stations, the call sign (or generally accepted network identifier) shall be given for the station, or for at least one of the group of stations with which communication was established.

Two petitioners request that the Commission eliminate completely the requirement that amateur radio operators identify the station with which they were in contact, at the end of the transmission. The third petitioner also favors elimination of this requirement, except that he would retain the restriction for international third party communications. The fourth petitioner requests that this requirement be eliminated where the entire exchange of communication lasts less than one minute. In addition, one petitioner requests that the rules be amended to allow stations completing an exchange in less than one minute to identify themselves at any time during the exchange, rather than at the beginning and end of each transmission.

3. FCC monitoring observers sample transmissions in progress, as well as the beginning or end of transmissions. For this reason, the proposal to allow identification at any time during a transmission lasting less than one minute rather than at the beginning and end of transmission, cannot be adopted. If adopted, this proposal would preclude FCC monitoring observers from identifying the transmitting station, if, for instance, the observer began monitoring the transmission after the identification was given.

4. The petitioners, and others who have filed comments pursuant to the Public Notices released by this Commission, advance the following arguments for amending § 97.84(a)'s requirement that amateur radio operators identify the station with which they were in contact, at the end of the transmission.

(1) Each station is required to identify its own transmission; therefore there is no need to require stations to also identify each other.

(2) The removal of this restriction would reduce channel usage, and therefore reduce channel congestion.

(3) This amendment would benefit United States amateur radio operators engaged in contest operations by increasing the number of communications that could be completed within a set period of time.

(4) The Amateur Radio Service is the only

radio service where station operators are still required to identify the station with which contact has been made. A similar requirement was deleted from the Citizens Radio Service Rules in 1975. 54 F.C.C. 2d 841, 40 FR 33667 (1975).

Proposal

5. The Commission proposes to delete the requirement that amateur radio stations identify the station with which they were in contact for all transmission except those involving international third party communications.¹

International third party communications are excluded from the scope of the proposed amendment because of the Commission's obligation to enforce the International Radio Regulations. Article N30/41, No. 6355/1561 of the International Radio Regulations provides, in part, that "... [i]t is absolutely forbidden for amateur stations to be used for transmitting international communications on behalf of third parties." The United States does have bilateral agreements with 29 countries which permit third party traffic, but with regard to other countries, the prohibition is still applicable. Without the identification requirement presently imposed by our rules, enforcement of the prohibition would be very difficult.

6. We are also proposing to extend requirement that radio stations identify the station with which they were in contact where international third party communication is involved, to teleprinter communications. Heretofore, teleprinter had been excluded from this requirement, but there appears to be no reason not to require this type of identification, especially where the requirement would strengthen the enforcement mechanism available to the Commission, and only minimally impact the licensee.

7. Our proposal is not limited to only those transmissions which last less than one minute. The arguments advanced in favor of that proposition (i.e. that contest operations would be enhanced "...") extend to the less restrictive proposal we have adopted as well.

8. In view of the above, the petitions proposing to simplify station identification requirements in the Amateur Radio Service are adopted to the extent that they are not inconsistent with this Notice. All proposals contained in the petitions which are inconsistent with this Notice are denied. The proposed amendment of the

¹ See the Appendix for the complete text of the proposed amendment.

Commission's rules, as set forth in the attached appendix below, is issued pursuant to the authority contained in Section 4(i) and 303(r) of the Communications Act of 1934, as amended.

9. Pursuant to the applicable procedures set forth in § 1.415 of the Commission's rules, interested persons may file comments on or before July 16, 1980, and reply comments on or before August 15, 1980. All relevant and timely comments will be considered by the Commission before final action is taken in this proceeding. In reaching its decision, the Commission may take into consideration information and ideas not contained in the comments, provided that such information or a writing indicating the nature and source of such information is placed in the public file, and provided that the fact of the Commission's reliance on such information is noted in the Report and Order.

10. In accordance with the provisions of § 1.419 of the Commission's rules, an original and 5 copies of all statements, briefs, or comments shall be furnished the Commission. All comments received in response to Notice of Proposed Rule Making will be available for public inspection in the Docket Reference Room in the Commission's Office in Washington, D.C.

11. Regarding questions on the matters covered in this document contact John B. Johnston, Rules Division, (202) 254-6884.

Federal Communications Commission.

William J. Tricarico,

Secretary.

Appendix

I. Part 97 of the Commission's Rules is amended as follows:

1. In § 97.84, paragraph (a) is amended and paragraph (h) is added to read as follows:

§ 97.84 Station identification.

(a) Each amateur radio station shall give its call sign—

(1) When it begins or ends each single transmission or exchange of transmissions, and

(2) At least every ten minutes during a transmission or exchange of transmissions.

... ..
(h) At the end of an exchange of third party communications with a station located in a foreign country, each amateur radio station shall also give the call sign of the station with which third party communications was exchanged.

[FR Doc. 80-11308 Filed 4-14-80; 8:45 am]

BILLING CODE 6712-01-80



Tempo Handheld! 800 CHANNEL SYNTHESIZED TRANSCEIVERS

| | | |
|------|----------|----------------|
| S-1 | \$232.80 | 2 Meter |
| S-1T | \$260.90 | With Tone Pad |
| S-2 | \$315.00 | 220 MHz |
| S-2T | \$359.00 | With Tone Pad |
| S-5 | \$264.50 | 2 Meter 5 Watt |
| 2-5A | \$299.95 | With Tone Pad |

Amateur equipment accessories & antennas,
Amateur & commercial repair service.

GOD'S USA. Export anywhere.



✓ 301

2317 Vance Jackson Rd. San Antonio, TX 78213
(512) 734-7793

Subscription Problem?

73 Magazine does not keep subscription records on the premises, therefore calling us only adds time and doesn't solve the problem.

Please send a description of the problem and your most recent address label to:

73 Magazine
Subscription Dept.
PO Box 931
Farmingdale, NY 11737

Thank you and enjoy your subscription

Stretch YOUR HAM RADIO-S S S •• WE SELL SATISFACTION At a DISCOUNT!

Call or Write:

✓ 339

J-T ELECTRONICS SUPPLY, INC.
14 JUPITER PLACE # 117
PLANO, TEXAS 75074
(214) 424-0515

•TEN-TEC • MFJ • BENCHER • JANEL
• RAMSEY 600 Mhz COUNTERS
• KLM AMPLIFIERS
• B & W, MANY OTHERS

OPEN: 12 00 - 8 00 WEEKDAYS
9 00 - 5 00 SATURDAY

SIDEWALK SALE -
LAST SAT OF EVERY MONTH

Awards

from page 24

with news about the charitable Morokulien (SJ9WL/LG5LG) activity, the unique "state" on the Norwegian-Swedish borderline, east of Oslo, featuring radio calls LG5LG and SJ9WL and a lot more.

Recognizing the independence of this area, the Morokulien activities have been stimulated to benefit the handicapped radio amateurs in Norway and Sweden. Likewise, applicants for the Morokulien Award find their donated award fees going to aid these less fortunate people... a cause all of us can be proud to have assisted.

The Morokulien Award

This unique DX award is available to licensed amateurs and SWLers. Only contacts after July, 1968, will count. Applicants are asked not to send QSL cards. GRC apply. Europeans should contact LG5LG and SJ9WL on two bands and on different days for a total of four days of operation.

All other applicants must work each of these same two stations, each on a different day.

You may forward your application to the attention of Ulf Strandberg LA2ZN, Konglev. 3, N-2200 Kongsvinger, Norway. Please be sure to enclose an award fee of US \$3.00 or 8 IRCs. Additional contributions are most appreciated.

DX AWARD FROM ROMANIA

The Romanian Radioamateur Federation takes pleasure in announcing the YO DX Club Award available to amateurs and SWL stations the world over.

YO DX Club Award

To qualify for the YODXC Award, applicants in Europe need to confirm contact with five (5) YO DX Club members; stations outside Europe need confirm only two (2) YO DX Club membership contacts. All QSOs must be made after August 23, 1949, and may be made on any mode or combination of modes and any band in the HF, VHF, or UHF segments.

To apply, have your list verified by at least two amateurs

and send your list with US \$1.00 or 7 IRCs to: F R R (YODXC), PO Box 1395, R 76100 Bucuresti 5, Romania.

As of January 1, 1978, the following YO DX Club members count towards this award:

YO2: ABW, AVP, BA, BB, BN, BS, BU, BV, CD, FP, GL, GZ, IS, KAB, KAC, KAR, QY, RA, VB, VF.

YO3: AAJ, AAQ, AC, AVE, BAA, CR, DZ, FF, FU, JF, JU, JW, KAA, KBC, KSD, NN, QK, QO, RD, RF, RG, RK, RO, RX, VN, YZ.

YO4: ASG, CS, CT, HW, KAK, KBJ, KCA, WO, WU, XF.

YO5: AFJ, AMO, ATV, AUG, AVN, AY, BQ, DS, KAD, KAU, KLA, LC, LD, LP, NB, NU, NZ, UW.

YO6: ADM, AW, EX, KAF, KAL, KBA, KBM, LG, UX, XI.

YO7: BI, DL, DO, KAJ, NA, NM, VS.

YO8: AGZ, CF, DD, FZ, GF, KAE, KAN, KGA, ME, MH, OK, OP, RL.

YO9: APJ, ASS, BGV, CN, EM, GP, HH, HI, HT, IA, IF, KAG, KPD, VI, WL.

YO0: ITU, YR0A.

In YO land, the suffix for the same licensed ham is the same for any prefix.

DX AWARDS FROM THE RADIO CLUB OF PARAGUAYO

From the Radio Club of Paraguay comes a very nice letter from their Awards Manager, Elio Donna ZP5CE. Elio enclosed the complete awards portfolio offered by this South American organization and we'll review each one individually.

The All Mediterranean Countries Award

The AMCA is given for confirmed contacts with Mediterranean countries in three levels of achievement: Class A—41 countries; Class B—30 countries; Class C—20 countries. A ZP contact is obligatory in any class of award. The following list of prefixes qualify as valid contacts: A2, A5, AC3, C31, CP, HA, HB, HBO, HV, JT, LX, OE, OK, TL, TT, TZ, UC2, UD6, UG6, UH8, UI8, UL7, UM8, UO5, XT, XW8, YA, ZE, ZP, 3D6, 4U1, 5U7, 5X5, 7P8, 7Q7, M1 (9A), 9J2, 9N1, 9U, 9X.

All Zone 11 Prefix Award

The AZ 11 PX Award is given

for confirmed contacts with prefixes in CQ Zone 11 as follows: Class A—30 prefixes; Class B—19 prefixes; Class C—12 prefixes.

ZP1 to ZP9, PY1 to PY0, and the special prefixes used for WPX contests are the only prefixes which qualify for this very difficult award.

The Tropics of Cancer and Capricorn Award

The TCCA Award is afforded to those applicants who confirm contact with countries touched by the Tropics of Cancer and Capricorn boundaries. A ZP contact is obligatory for this award. For Class A, 28 country contacts are required from the list below. Class B requires 20 countries; Class C requires 12 countries.

Tropic of Cancer: S2/3, BV, BY, EA9, KH6, A4, A6, SU, TZ, C6, VU, XE, XZ, 5A, 5T5, 5U7, 7X, 7Z.

Tropic of Capricorn: A2, CE, C9, LU, PY, VK, ZP, ZS, ZS3, 5R8.

The Diploma Sud-America

The DSA Award is given for contacts with countries located in ITU Zones 12, 13, 14, 15, 16, and 73 as follows:

Class A—33 DX Countries and 6 ITU Zones.

Class B—25 DX Countries and 6 ITU Zones.

Class C—18 DX Countries and 5 ITU Zones.

Countries which are qualifying contacts are:

Zone 12—FY, HC, HC8, HK, HK0 (Malpelo), OA, PZ, 8R, YV, CP1/8/9.

Zone 13—PY6/7/8, PY0 (Fernando de Noronha), PY0 (St. Peter, St. Paul).

Zone 14—CE1/2/3/4/5, CE0X, CE0Z, CP2/3/4/5/6/7, ZP, CX, LU-A/U/Y.

Zone 15—PY1/2/3/4/5/9, PY0 (Trinidad Island).

Zone 16—CE6/7/8, VP8 (Falkland), LU-V/W/X.

Zone 73—KC4USP, LU-Z, CE9AA/AM, VP8 (Graham Land), VP8 (Georgia), VP8 (So. Orkney), VP8 (So. Sandwich), VP8 (So. Shetland).

Diploma Paraguay

The DP Award is given for confirmed contacts with 5 different ZP stations. Stations in South America are required to contact 15 ZP operators.

Worked All ZP

The WAZP Award is being offered to amateurs making at

least one confirmed contact with ZP stations in each of the ZP call districts, ZP1-ZP9.

Diploma Departamentos del Paraguay

The DDP is given for confirmed contacts with the Nation's Capital and different departments into which Paraguay is divided. Class A requires 20 contacts; Class B requires 16 contacts; Class C requires 12 contacts.

Departments by prefix are:

ZP1—Boqueron, Chaco, Nueva, Asuncion.

ZP2—Alto, Pte. Hayes.

ZP3—Amambay, Concepcion.

ZP4—Canendiyu, San Pedro.

ZP5—Asuncion (Nation's Capital).

ZP6—Central, Cordillera, Paraguari.

ZP7—Caaguazu, Caazapa, Guaira.

ZP8—Misiones, Neembucu.

ZP9—Alto Parana, Itapua.

Contacts must be made on or after May 15, 1952, to qualify for any of the awards sponsored by the Radio Club of Paraguay. A certified list of contacts with a fee of 5 IRCs for each award should be sent to: Elio Donna ZP5CE, Award Manager, RC Paraguayo, PL Box 512, Asuncion, Paraguay.

3905 CENTURY CLUB AWARDS

Representing the 3905 Century Club, Bill Herbert WA2ZYM writes to share with us the various awards available to amateurs who frequent their net operation.

The 3905 Century Club is basically a WAS (Worked All States) Net which grew out of the old Bicentennial Net on 80 meters back in 1976. The net now operates daily on 40 and 80 meters, 0100-0500 on 7.233 MHz and 0500-0800Z on 3.905.

Naturally, as time went on, it became apparent that an awards program of some kind was in the offing. As amateurs work each other on the band, they gather a point per contact. Once 100 points are earned, you become a full-fledged member of the club and are issued a certificate to illustrate your affiliation.

As members continue their contacts on the net, several levels of achievement are recognized, with the ultimate being the 1,000 Point Award, which is certainly no overnight venture.

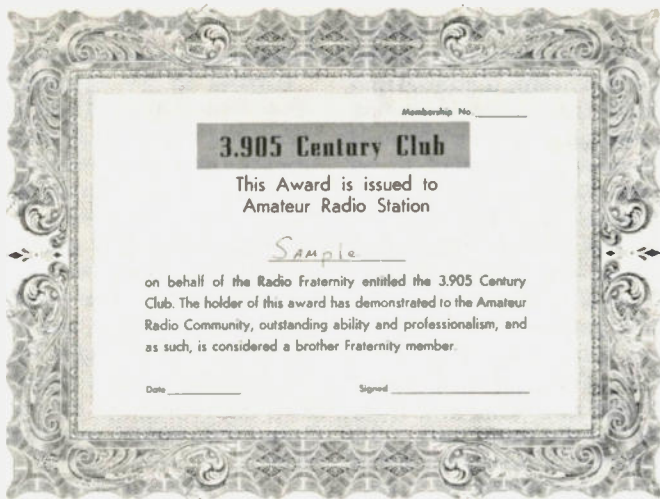

Among the certificates afforded net participants is the 3905 Century Club State Capitols Award, which requires the applicant to contact at least 35 state capital cities. Endorsements are given for 40, 45, and the maximum of 50 state capitals worked on the sponsor net.

HAROAA AWARDS

We believe the many long hours of dedicated operation should not go unnoticed, nor should the high degree of enthusiasm of amateur radio operators go neglected in their pursuit of self-set goals. That is why we have an awards column in this magazine and why I introduce to you the awards and certificates made available by HAROAA.

As we review each one individually, we find that all their awards are of high quality and will make a very impressive ad-

dition to any radio shack.

GRC apply in making application for any HAROAA awards. Each award is assessed two dollars (\$2) each or 5 IRCs. At your request, special endorsements will be added for CW, SSB, RTTY, SSTV, FM, QRP, All YL, or Single Band. There is no date restriction on contacts made and satellite contacts are permitted.

HAROAA DX Award

The most popular of all HAROAA achievement awards, the applicant is awarded recognition for contacting 10 DX stations. Endorsements are also given for 25/50/75/100/200 and 500 DX contacts. Keep in mind we are not speaking of DX countries, but instead DX "contacts," which makes this award unique.

Great Lakes Award

This award requires one con-

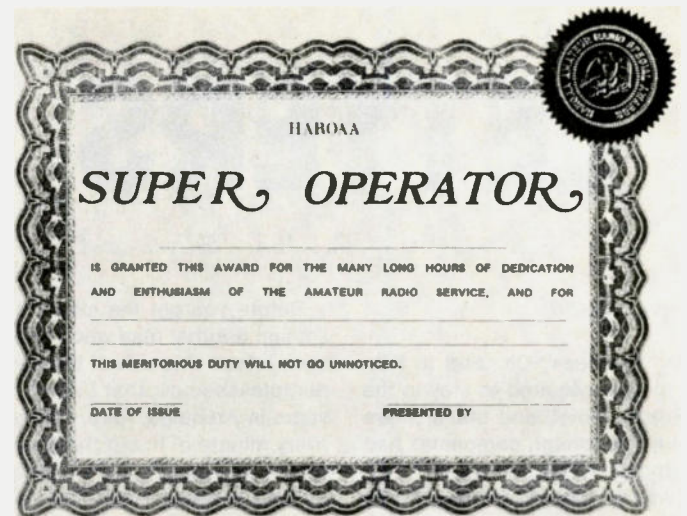

tact from each state bordering the Great Lakes—New York, Pennsylvania, Ohio, Michigan, Indiana, Illinois, Wisconsin, and Minnesota.

Insomnia Award

This award is earned for communicating with a single amateur station anywhere in the world for a minimum of one hour between the hours of 1:00 and 5:00 am. Truly a super conversation piece for any ham shack.

Super Certificate Hunters Award

This award is designed for the serious certificate hunter. To earn this award, you must have a minimum of ten amateur radio awards in your possession. Simply list these awards on your application and note the certificate number of each. Special endorsements are given for your collection of 25, 50, 75, 100, and 100 plus.

Official Traffic Handler Award

This award is a self-issued achievement, allowing you to display the fact that you are indeed an official handler of radio traffic.

HAROAA Super Operator Award

This certificate is rendered for those providing a service on behalf of amateur radio, such as weather observer, public service, emergency, helping a new ham, providing communications for a community function, etc. The requirements are for the applicant to briefly describe the event or service and the officials at HAROAA will determine whether it deserves this special recognition.

For your personal copy of HAROAA award program rules or to apply for any awards presented here, write: HAROAA Awards Program, PO Box 341. Hinckley, Ohio USA 44233.

RTTY Loop

from page 12

In summary, the ST-6 kit, currently selling for under \$300 with all options, represents a good, solid demodulator that most amateurs will find entirely adequate to their needs. Careful assembly (this is not a Heath-kit™) will pay off in a valuable addition to the RTTY station.

For the last several months, I have been mentioning a firm, Teleprinter Arts, Ltd., that has had trouble filling orders. We are in the process of helping to straighten out some of the problems and hopefully will have more to report in a month or so.

In the meanwhile, anyone who has had any problems with Teleprinter Arts, Ltd., is urged to drop me a note describing your experiences. Include as much detail as possible, and an SASE for reply.

A letter here from Robert F. Kramer, Alliance, Ohio, relates the problems with progress. Robert has a Twin Cities TU and would like to construct narrow-shift 170-Hz filters for it. For those of you unfamiliar with the unit, the Twin Cities TU was, of course, named for the twin cities of Minneapolis and St. Paul. Using three tubes, a dual

triode, an amplifier, and a keyer, this was a simple design that was around in several forms for many years. Fig. 1 is a diagram of an early version which used octal-based tubes and a polar relay! Anyway, the mark and space filters are conventional 88-mH toroids, paralleled with a small capacitor to resonate at the mark and space frequencies of 2125 Hz and 2975 Hz, respectively. Typical values for these capacitors would be 0.066 uF and 0.033 uF. With 170-Hz shift, the mark frequency remains the same, so only a new space filter, tuned to 2125 + 170 Hz (2295 Hz), is needed. Start with a nominal 0.06 uF and work around until the filter is tuned. Remember, the marked value and the actual value of small ca-

pacitors is sometimes different by a factor of 50% or more!

According to my informal sources, RTTY Loop readers inundated the Stark RTTY Group out in Massillon, Ohio, with mail. I hope that this is an indication of the interest in RTTY operation in general. Let me know what is happening where you are, what repeaters are available for RTTY or ASCII, and I will pass it along to the immediate world. Here in Megalopolis (the Baltimore-Washington area to the uninitiated), for example, try 147.81/21 for communication over the AMRAD repeater. This 300-baud ASCII repeater links amateur radio to a CBBS. If I ever get a rig on up there, maybe we can chat; meanwhile, drop me a line at the above address.

ou rooms don't ever profit
lousy manuscripts from lat
burh
you
I insist that you print ev
tell Ma Bell that she shou

LETTERS

from page 18

as "overseas" Chinese) in Peking were required to stay in the Peking Hotel, and that's where the few foreign companies had offices. During my time in China, I was in and out of Peking five or six times, but only stayed a few days while awaiting papers and trains to other points. The CNTIC might be a good place to start a ham request, especially if you're in a good bartering position. If you were around the Peking Hotel for extended periods, you might have the opportunity to meet officials who could help, too. Of course, nothing is done quickly in China, so unless help comes from an unexpected source, it may be some time before we hear a BY on the air again.

RESTRICTIONS

I appreciated many of the remarks in the editorial in the May issue of 73 regarding ham activity and band use. I got my ticket in the fall of '38 and was on CW for about a year. I am very glad of it. I later built a 160 rig from broadcast radio parts, put up a 1/4-wave against ground, and had a lot more fun, even. Got my class "A" license and converted the rig over to 75 phone a few months before Pearl Harbor. So, I hope that we do get all of 160 back.

Wouldn't it be nice if we had all of 20? Yes, we are banned from phone below 14,200, supposedly to give the foreigners, the Canadians and the Mexicans, elbow room. So, listen to 14,150 to 14,200. A QSO here, a QSO there, but plenty of room for more DX contacts. Listen from 14,200 up. A bedlam of noise. When you can decipher anything, you often hear two guys a few hundred miles apart talking to one another. Listen higher up. Try 14,325 to 14,350. Now you'll hear the foreigners! They say 15 is the phone-patch band! Listen to 14,325 to 14,350 at night!

Before you get the idea that I'm just another man who's only seen it from this side of the border, please know that I spent 6 years in Arequipa, Peru. I loved every minute of it, but that's another story. But I did have plenty of time to listen to 20 and see what was going on. The same observation could be made—few QSOs going on between 14,100 and 14,200, but things mighty crowded from 14,200 up. Why can't we use phone from 14,100 up? If anyone thinks CW is not on the wane, listen from 14,100 to 14,200 and then see how many more CW QSOs are going on below 14,100.

It is too much to expect of human nature to hope that the block-heads who use 20 for local contacts are going to change. They live in all countries. But wouldn't it be nice if we did not have such artificial restrictions as we do? Can anything be done about it?

I enjoyed the May issue. Keep them coming.

George Brumley K0WTM
Wichita KS

RADIOSPORT

While recently engaged in a QSO with SV0AE on 15m (for my first SV-land contact), an otherwise enjoyable experience was marred by the proverbial woodpecker beginning its periodic search for food on the band. As if its S9 + 20 signal was not bad enough, the + 40 that Kim was getting at his end was that much worse. Of course this is nothing new to anyone who operates on 15 or 20, but in the midst of our lamentations over the assassination of a fine QSO, a discussion of the various protests that had been attempted (and totally ignored) took place in between the staccato beat of the obnoxious bird. An idea emerged, however, which could possibly be considered as a means of dealing with this problem, or at least sending a stronger message of disapproval than has been done up to this point.

In order to attract the attention of a centralized, bureaucratic establishment, some point of leverage is necessary in order to make at least someone in the organization feel like their particular ox is about to be goaded. Then they can at least serve as a sounding board for your own viewpoint, but one that is heard from the inside. I won't go into all the details of how the USSR government fits this pattern, but such a point of leverage was suggested to me as I recalled something else I had read. In the April, 1980, QST, there was an excerpted reprint of an article written by V. Bondarenko, chief of the Central Radio Club (of Box 88 infamy) of the USSR. In this article, there was expressed a point of view concerning amateur radio which I found to be quite different from anything I had previously considered. Mr. Bondarenko, in referring to contest participation, noted that "Radiosport is . . . becoming one of the mass military-applied forms of sport." He went on and proposed a series of measures to encourage and assist Soviet "snipers of the airwaves" in their quest "to struggle seriously for superiority in the international sports arena." (What was that one, by the way, about non-political Olympics?)

With this sort of a viewpoint, perhaps there should be a rules addition for the major contests which penalized or even disqualified amateurs when their government deliberately and consciously, as a matter of state policy, engaged in actions in violation of ITU rules to the detriment of the amateur radio service on one or more bands. If desired, such a rule could even be made applicable (if deemed desirable) to violations of the recently revised WARC sections applying to the 7-MHz band. The effectiveness of such a move would be subject to a lot of uncertainty, given the scale of priorities of the Soviet government, but at least it would be doing something other than talking, which has gotten nothing at all accomplished.

I'm not sure this could or should be done, but at least it should be discussed, and possibly this may serve to stimulate a much more effective response to this continuing problem.

John S. Walker N0BOT
Brookings SD

K06JM

Relative to my letter published in the April 73 and the mystery of my call K6JM being used by a television translator at Gillette, Wyoming: The mystery has since been resolved.

A letter from the TV station's manager explained that there had been a typo on the license, and subsequently this was corrected to K06JM. A letter from the FCC Public Radio Division admitted to nothing, but confirmed that K06JM was legitimate.

I was unaware that translators associated with TV stations were being issued alphanumeric calls similar to ham calls, which also confused the Wyoming amateurs who brought this to my attention.

I am enclosing an excellent letter from K2PG which fully explains the allocation of TV translator calls and their resemblance to ham calls.

Peter Lovelock K6JM
Santa Monica CA

Peter A. Lovelock K6JM
1330 California Avenue
Santa Monica CA 90403

Dear Mr. Lovelock:

I have read your letter in the April issue of 73 and find it to be quite interesting. I am a broadcast technician at WABC-TV in New York and have some information for you regarding call-signs. The call-sign K06JM is a legitimate call-sign for a television broadcast translator (repeater) station. Translator call-signs consist of a W prefix for stations east of the Mississippi River (K for stations west of it), a two-digit numeral indicating the output channel, and a two-letter suffix issued systematically. K06JM is a ten-Watt translator which transmits on channel 6. According to Parts 2 and 74 of the FCC Rules and Regulations, translators operating on channels 2 through 9 use a zero as the first digit in the call-sign, giving a two-digit numeral to avoid confusion with amateur call-signs. When the translator in Gillette was using "K6JM" as its call-sign, either the FCC made a typo in issuing the translator license or the engineer responsible for setting up the system misinterpreted K06JM as K6JM.

Television translators do not originate programs. They operate by receiving and filtering the

signal of the primary station, heterodyning it up or down to the desired output channel, and amplifying the signal after passing it through a bandpass filter. Some translators ID automatically using Morse code as narrowband FM tone modulation on the visual carrier. When the translator does not have an automatic ID, the primary station must ID the translator periodically when giving its own ID. VHF translators are limited to 10 Watts in the west and 1 Watt in the east, while UHF translators are permitted 100 or 1000 Watts, depending upon the channel used. WABC-TV operates a 1000-Watt translator with input on channel 7 and output on channel 66. Its call sign is W66AA and it covers areas of Upper Manhattan and the Bronx which receive horrible ghosting from the World Trade Center. (The New York stations still transmit from the Empire State Building, as permission to move to the World Trade Center has gotten bogged down in red tape.) I hope that this information proves helpful to you.

Philip E. Galasso K2PG
Iselin NJ

MORE YASME

We concluded our operation as HI6XQL (10,000 QSOs) the first of April after the WPX Contest and returned to the United States, concluding a one-half year extended YASME DXpedition as J3ABV, VP2SAX, J6LOO, J7DBB, VP2K 1H, and HI6XQL. We were actually "on the air" four months of that time and made 55,000 QSOs. Our equipment, a Yaesu 901DM transceiver, an SB-230 amplifier, and a TH3 beam, plus doublets, worked fine with no major failures.

During the next several months, we will give talks at a number of ham meetings throughout the USA. We plan to resume our YASME DXpedition travels in the fall.

Please pass the following two items on to all ham publications and ham clubs for information and publication.

1. Do you need the countries of Desecheo or Kamaran? There is an easy way to work either of these countries. We will go there and promise to work you if you can get permission for us to enter and operate amateur radio

in either country.

2. The YASME Foundation, at its annual Board of Directors Meeting, established a YASME Award and passed the following resolution: "A beautiful and unusual certificate will be awarded free of charge to any amateur presenting proof (QSLs) verifying contact with the holders of 30 different YASME DXpedition calls, including any calls held by YASME Officers or Directors, past or present."

Dick McKercher W0MLY is the custodian of the YASME Award, and applications (QSLs) can be sent directly to him. Please include a list of the QSL cards sent.

Lloyd Colvin W6KG
Iris Colvin W6QL
Castro Valley CA

METROPLEX

The New York City Metropolitan Area's most sophisticated system of inter-linked repeaters has entered Phase II of its operations and improved its own high standards.

Metroplex was conceived in January, 1978, by K2KLN and WB2MGB to: establish repeaters on all allocated FCC frequencies; use all available modes; provide 24-hour emergency communications; and provide a forum for east coast and worldwide amateur radio operators via a 2-meter/10-meter FM link. Club members have already contacted over 35 countries on 4 continents through the 10-meter link. Autopatch facilities are completely computerized and are part of a large long-distance network which includes trunk-lines, satellites, and emergency speed-dial numbers.

Growing every day, Metroplex has over 400 members, including 50 overseas amateur radio operators! Club meetings are the second Wednesday of each month, 8 pm, Firehouse No. 4, Fort Lee, New Jersey.

Listen to Metroplex FM everywhere on 29.640 MHz/29.540 in, and on 145.450/144.850, 223.720, and 443.950, or write PO Box 237, Leonia NJ 07605. You may also call the 24-hour club phone, (201)-592-1579, to request an information package.

Hank Goldman WA2OVG
New York NY

ORDINARILY IGNORED

I believe in giving credit where it is due. I recently passed the Extra class code and theory and hopefully I won't have to do any more studying. I just want you people at *73 Magazine* to know what I think of your code tapes: Great!! The 20+ got me through the Extra and your beginner's tape procured (I love that word) a Tech license for my wife.

I'm sure you get lots of complaints and criticisms, so I thought I'd let you know that not all of us think that Wayne is a radical big-mouthed SOB.

The cliché of "the squeaking wheel gets the grease" describes some of your methods. If nothing else, the editorials generate a little controversy and stimulate people to discuss and think about things they would ordinarily ignore.

Grover Conde WA7USI
Granger WY

ALPINE COUNTY

Attention county hunters! The Antelope Valley ARC, Lancaster, California, is planning a DXpedition to Alpine County August 16 and 17, 1980. All bands, modes, and county hunter nets will be used. It will be operated under K6OX. All QSLs via K6GXO; SASE or IRCs necessary. All plans are subject to change because of weather and availability of gasoline.

Alexes Hourigan WD6GVL
Secretary, Antelope Valley ARC
Lancaster CA

SHORT IDEAS

Couple of short ideas: One—a Novice page or section each month. If you don't promote Novices, where will future hams come from? Second—In a very prominent place each and every month, a notice in good wording for all hams when they order QSLs from whomever to please put their county on the card. It is bad enough for US hams to go back through many cards received as a Novice or whatever to find out the county of origin; it must be pure hell for our foreign friends on the bands. Your wording of the notice would be better than any I could dream up, but it is a very important point for many of us.

Keep up the good work and fine editorials. You and your staff are dedicated to promoting ham radio, not greenback collecting as in Newington.

Earl Turner KA2DLK
Niverville NY

SOARING

Amateur radio station WB2VPY will be on the air July 1-10, 1980, as a special events station celebrating the 50th Anniversary of Soaring, in Elmira NY, the Glider Soaring Capital of America.

We will operate on 80 through 10 meters SSB. On July 1-3, 7-10, hours will be 2100Z until ?, and there will be continuous operation during the 3-day holiday, July 4-6.

QSL with a legal-size SASE for a beautiful certificate to WB2VPY, National Soaring Museum, RD #3, Elmira NY 14903.

John L. Wilcox Sr. WA2DHZ
Pine City NY

EYE-BALLS

The 3905 Century Club operates nets that basically are for WAS and other club-issued awards on both 75 meters and 40 meters, 357 nights a year. We have additional nets that operate less frequently on both of the above bands, plus a twice-weekly 80-meter CW net. We have about a thousand members spread through every state, the majority of the Canadian provinces, and many Caribbean and Western Atlantic islands.

We hold annual "eye-ball QSOs"—this year, "Eye-Ball III, East" will be in Bowling Green KY on August 8-10; "Eye-Ball III, West" will be held one week later, in Cimarron CO. In 1981, we will have a "Big Eye-Ball QSO" somewhere in the mid-USA.

Early each year, we elect our corporate President and Vice-President "on the air." We print a quarterly newsletter, the *Centurion*.

I would be delighted to furnish any further information.

T. L. Bowers
Public Relations/Editor,
Centurion
Star Route 1, Box 1424
Eustis FL 32726

DX

from page 15

might want to keep this in mind: If you ever have a legal hassle with the Town Board about your "monstrous aeriels," have your attorney contact the PCF for legal advice.

More, more, more. We couldn't work them fast enough in April. Your scribe (that's a quaint term, isn't it?) stood at 293 countries worked the first of April and at the end of the month had 297! Terrific! Next on the list (pardon the term) was TZ4AQS. The primary, original operator of this station was a Belgian national with limited experience who had done a fine job of handling the demand for this African country since last autumn. His home-town pal ON6BC had merely taken care of the QSL demand until April, when ON6BC made the airplane journey from Belgium to West Africa for a stint at the mike and key. Jan Deneker ON6BC finished up on 16 April with 11,000 contacts from Mali, many of them on 40 and 80 meters. Jan took a couple of days off for a sightseeing tour of the surrounding territory, but still spent many days at a hot radio working the masses. The QSLs go to ON6BC.

The next big show (not necessarily in big-show order) was an operation by several hams from West Germany on Glorioso Island, off the west coast of Africa. DK9KX, DF3KX, DJ5RT, DJ6SI, and DJ3NG used the calls FR0ACB/G (on CW) and FR0ACC/G (on SSB), operating five transceivers on battery power into two beam and two ground-plane antennas. They stayed on Glorioso only a few days, but appear to have cleaned up much of the demand for this very rare spot.

Prior to Glorioso, the German team operated from Mayotte as FH0FLP and FH0ACB, and they were scheduled to put in a few days afterward from the Comoros D68. All QSLs for these operations go to Dieter Loeffler DK9KD, PO Box 620 260, 5000 Koeln 60, Federal Republic of Germany.

N6DX, JA1BK, and N2KK mounted a Pacific expedition in April to Fijis 3D2DB, Tonga A35DX, Niue and Wallis (calls

not known at presstime), and Samoa 5W1CF. Their operations were concentrated on 6 meters with some HF activity, since the general demand for these spots is not as great as for, say, Glorioso. QSLs to JA1BK, Kan Mizoguchi, Central PO Box 231, Tokyo 100-91, Japan.

An operation from Aves Island which was to use the call YV0USB was postponed from the CQ WPX SSB weekend at the end of March until later in April, but was still not heard from at that time. There has not been an operation from Aves ("Bird Island") for several years.

JE6NEM and JE6NLL had planned to put Okino Torishima 7J1 back on the bands in June, but they postponed their trip until at least October. By that time, the ARRL may have deleted this "country" from the DXCC list. First activated in 1976, Okino Torishima is a spit of rock so small and so seldom above water that the Japanese had to mount a complex, expensive operation including the construction of steel platforms to keep the operators and their radios out of the water. Although this construction has been left in place, future operations still involve complex logistics.

LX1BW and DJ5CQ put New Caledonia on the air in April (FK0BW and FK0CQ), followed by proposed stops at Norfolk and Lord Howe Islands. They are just leaving FK as this is written. QSL to Rudi Mueller DJ5CQ, 23 Alter Main, D-8601 Ebing, FRG.

The International DX Foundation (PO Box 117, Manahawkin NJ 08050) is a small group of DXers who are using their own funds plus membership fees (\$25/year) to put rare spots on the air. John Ackley KP2A operated from the Maldives as 8Q7AL in early April, then as 4S7DX from Sri Lanka. From there, he joined N2OO, VS5TX, and N2CW to operate East Malaysia 9M6MU followed by Brunei VS5KV. Manufacturers who loaned equipment to IDXF included Bencher (paddles), DenTron (amplifiers and tuners), and MFJ (keyers), while Yaesu, Hy-Gain, and KLM provided discounts on purchased equipment. QSLs for the Asian operations should be sent as

follows: 4S7DX to WB2VFT, 8Q7AL to K2TJ, VS5OO or VS5KV to N2OO, and 9M6MU to N2CW. Do not send QSLs to the PO Box in Manahawkin!

Iris Colvin W6QL and Lloyd Colvin W6KG concluded a half-year extended YASME expedition early in April. Their operations included Grenada J3ABV, St. Vincent VP2SAX, St. Lucia J6LOO, Dominica J7DBB, St. Kitts VP2KAH, and the Dominican Republic HI6XQL. During the period, they were on the air about four months and, using a Yaesu FT-901DM, Heath SB-230, and a TH3 beam, they made 55,000 contacts. From now through this fall, the Colvins will be traveling stateside, speaking at conventions and club meetings. They will operate from Desecheo and/or the Kamarans if someone can find a way for them to get operating permission!

The YASME Foundation has established a YASME Award which will be awarded free to any amateur presenting QSLs verifying contact with the holders of thirty different YASME DXpedition calls, including any calls held by YASME officers or directors, past or present. Dick Mc-Kercher W0MLY is custodian for that award. All QSLs for contacts with YASME operations go to The YASME Foundation, PO Box 2025, Castro Valley CA 94546.

Several brief operations took place from Cocos Island off the coast of Costa Rica in April; the call signs used were TI9s CF, CC, JVA, and XXX. There was no advance warning to any of the bulletins and consequently many missed their chance to work TI9. The operations did take place on weekends, which helped. QSL to Carlos M. Fonseca Q. TI2CF, Box 4300, San Jose, Costa Rica.

SV1JG and SV1IW put Mount Athos on the air once again in mid-April; their operation had been rumored for some time, but no direct word resulted in doubt as to exactly when and where to look for them. Their signal from Mt. Athos was very weak, making it especially difficult for US and Canadian west coast stations to work them. Mt. Athos is still very much needed among this group of DXers, although hardly any serious east coast DXers have missed one operation or another from the "Holy Mountain." QSL Box 3751,

Athens.

QSLs for last fall's Equatorial Guinea 3C1AA and Annobon 3C0AB operations went into the mail in April; if you haven't received yours by now, another request to EA4LH might be in order.

April departures: Jim Bullington N4HX from Chad (TT); ZS2MI from Marion Island; ZK1DR from South Cooks; PP0MAG from Trindade after two solid months of CW only; TZ4AQS from Mali.

The Northern California DX Foundation has, according to K6SSJ, shipped a beam, coax, rotator, and cable to Khartoum, Sudan, and it should be set up and operating now, with rigs supplied by the ITU. They were supposed to use the call 6T1YP from the Children's Youth Palace building, which was donated and constructed by the government of North Korea. Martti Laine OH2BH visited and operated in early June and then planned additional air time from Southern Sudan ST0. No QSL info available at this time.

A news release concerning the operation of the US fourth call area QSL bureau came out in late March. There are actually two bureaus for the call area, which is the largest with some 60,000 amateurs. Unfortunately, only about 5200 of them maintain envelopes on file. The amount of unclaimed DX cards on file in January, 1980, if piled in one stack, would be nearly 50 feet high, according to Art Nevins WA4NTP, Bureau Manager. Although the official sponsor is the Sterling Park Amateur Radio Club of Virginia, the volunteer workers in the bureau come from all over the 1300-square-mile Northern Virginia region. Three dozen bureau volunteers process over 60 pounds of cards each week with seasonal peaks of up to a hundred pounds a week. A pound is about 150 cards.

At the present US minimum wage, the bureau volunteers provide more than \$16,000 of free labor each year. And this is only one call area! Art says the three biggest headaches at his bureau are DXers who don't keep envelopes on file, envelopes with insufficient postage, and wrong size envelopes. Each bureau has certain specific requirements for users and you should check with your own bureau to find out exactly what they want. None of them ask for

much and they all offer a lot in return.

Next month will be QSL managers list time. Meanwhile, a very complete list of over 4000 managers is available for \$1.75 US/Canada/Mexico or \$2.80 overseas airmail from J. O'Brien, Electronics Enterprises, 6606 Fifth St., Rio Linda CA 95673. A yearly subscription is also available for this list, which is updated monthly. This particular listing is the latest to start up, the O'Briens having

taken over from WB0MSZ. Several other publications listing managers are advertised in the various amateur magazines.

The 1980 International DX Convention at Fresno CA was a sellout. No details at this time except that Larry KS6DV won three Hy-Gain monoband yagis.

That just about wraps up April, 1980—certainly a month to remember with the concentrated operating of TZ4AQS, Glorioso, East Malaysia, Mt. Athos, many of the Pacific

Islands, Trindade, and more. Band conditions were generally superb with 90 percent of the days rated High Normal or Above Normal.

Looking ahead to July, no major expeditions have as yet been announced, which is not unusual since the summer months in the Northern Hemisphere are usually pretty devoid of expeditions. But it pays to be prepared; if you take your beam(s) down for refurbishing, better keep a

trap vertical or something operational in case of an "emergency" like China or whatever coming on! Last month we expounded on summertime propagation conditions; you might want to re-read that, check the bands out, and send us a report card. And keep those photos and notes coming in, too. Thanks and good DX.

All the information for this column came from the weekly *DX Bulletin* out of Vernon CT.

Looking West

from page 10

10-meter FM, and to that end he has developed a neat little kit which uses a CB transceiver board and a "Bob Heil"-developed modification kit to put it on that mode. For about \$50, the world of 10-meter FM can be yours, in a neat little package that works well and takes very little time to get on the air. Bob was doing a "land-office" business selling these goodies from his spot at the flea market.

I had two reasons I wanted to meet with Bob. First, as stated earlier, was the chance to eyeball a person for whom I have a great deal of personal admiration. Also, we had to set up some plans for the then upcoming ARCH convention in St. Louis. That's another one I will be attending and talking at. Oh, yes, I probably forgot to mention that one of the main reasons for my trek to Dayton was to speak at the Hamvention about the Westlink Radio Network. More about this later on.

During the time I was with Bob, Joe and his cousin Bob located us and we soon departed for the innards of the arena so that Joe could give his seminar on malicious interference and how to combat it and I could audiotape it. As I was setting up, a chap whose name escapes me at the moment asked if I could find someone who could provide more light so that he could videotape Joe's presentation. He had with him a Panasonic color camera and portable VHS recorder, but no portable lighting equipment. A quick search revealed that there was no way to get higher intensity on the house lights, but where there is

a will, there is always a way. I noticed that on a table almost directly in front of the speakers' rostrum there was one of those overhead projectors used for thin-film slides. With a handkerchief over the lens to diffuse the light, it made a dandy portable source of luminance. My friend with the video equipment had the illumination he needed.

One of the things you learn quickly in covering news using audio tape is never to depend on the house PA providing a place to connect a tape recorder. This time was no exception, but we had come prepared with a mike of our own and enough cable to reach the recorder. If you ever plan to do any recording at a convention, meeting, or the like, keep this in mind. A good, low-impedance dynamic mike with 30 to 50 feet of cable is all but a necessity. I usually carry an SM-61 mike and two 20-foot cables fitted with type XLR connectors. At the end going into the recorder, I transform from the balanced mike line to the unbalanced recorder input, thus getting the best quality audio with minimum hum induced by long mike line runs. This is standard procedure in both broadcasting and public address system work. True, it's the expensive way to go, but the quality of audio you get is worth it. My recorder is a Panasonic RQ-309S cassette unit that operates on both 110 V ac and internal batteries, thus affording a maximum of flexibility under differing conditions. The recorder features automatic recording-level control and automatic end-of-tape shutoff, which makes for almost hands-off operation. The ALC is a godsend when record-

ing non-professional speakers who are not aware of the proper way to "play a microphone." Another necessity is a roll of what is called "gaffer's tape." It's just like ducting tape and is very valuable in attaching your mike to the PA mike and holding down mike lines so that you do not cause someone to trip over them. With the equipment described above, you can get some excellent recordings for an investment of about \$175, the microphone being the most expensive investment.

Once Joe's presentation was concluded, he, his cousin, and I spent the rest of the day browsing around the convention itself. There was a plethora of new equipment to see, touch, and wish for. We spent the afternoon doing just that. It was when I arrived at the *Ham Radio Magazine* booth that I learned some very sad news. There on the counter were copies of a special edition of *HR Report* which told of the untimely passing of Jim Fisk W1HR, editor of *Ham Radio* and *Ham Radio Horizons*. This news just about knocked me off my feet. I cannot claim to have known Jim very well. I had met him on several occasions at hamfests, conventions, and other meetings, and I always felt that there was something very special about him. He was one of those rare people who had devoted himself to amateur radio and had become a very important part of the amateur radio community in the nation and the world. On the evening of April 18th, at about 8:00 pm, Jim suffered a heart attack from which he never recovered. He will be missed by many of us, and the mark he left on the amateur community will long be remembered. A short time later I located *HR's* publisher, Skip Tenney, and ran the hardest interview I

have ever been forced to do. I was almost in tears as I asked what had happened and recorded the answers. Sometimes covering the news is not a very easy job. Sometimes it really hits home.

Soon after, Joe and Bob caught up with me and told me they were heading back to the hotel. I told them I would meet them there later and went back out into the flea market with Noel, interviewing him and those who stopped us as we proceeded though the crowds, up one aisle and down another. I had parked my attache case containing my recording kit at the DSI booth with Dennis Romack WA6OYI, and at this point was using a smaller Craig pocket cassette machine more suited for field interviews. About 5:00 pm, Noel, Marilyn, and I took off for a quick trip to Xenia to take the baby to her grandparents who would be babysitting. We then went back to the hotel to get ready for the banquet.

The hotel we were staying at was directly across from the Dayton Convention Center where the banquet was to be held. We quickly changed into our formal attire and headed across the street in the hope of getting a good table. Joe and Wayne would be on the dais, but I needed to find a spot which would permit me to record from the house PA system, since there would be no way to run my own mike lines here. As it turned out, we were not the only 6th call district amateurs at the affair. Almost immediately we ran into Dave Bell W6AQ, who produces "Hams' Wide World," "Moving Up To Amateur Radio," and the newly-released "World of Amateur Radio." Dave was filming in Ohio that week and was able to slip away to get to the Hamvention and the banquet.

All I can say for the banquet was that the food was good, the awards ceremony beautifully done, and the entertainment excellent. The latter was provided by another old friend, Jean Shepherd K2ORS. I doubt if I have to say any more. Anyone who has ever heard "Shep" on the radio, on TV, or in person knows exactly where I am coming from. Jean is by far one of the nation's truly great humorists, and I have been a devoted fan of his since I first heard his program on WOR radio in New York many years ago. The last time I had spoken with him was on the WA2SUR repeater in New York back in 1971. It was both a pleasure and a thrill to get reacquainted again after all these years. Earlier in the day, we had spent about an hour or so talking about the old days back in NYC while standing around the Hamvention headquarters, but listening to him that evening really brought back the past. I closed my eyes, leaned back, and just listened. I was reliving many happy hours of long, long ago.

After the banquet, we adjourned to the DARA suite, at which time I excused myself for about an hour. I had my job to do at this point. On a bunch of tape cassettes was the story of the 1980 Dayton Hamvention. Somehow, I had to condense this material into a 2-minute story, write a script, choose my actuality material, and put it all together. I closed the connecting door and went to work. I had no way of editing tape on the fly, so all I could do was list the actuality cuts to be used and note the outcues, running times, and insert points for Bill Orenstein KH6IAF. I would be feeding the story to Bill over the phone so that he could get it on the upcoming Westlink newscast. Sixty minutes later, I was ready to record the "anchor track" and then feed Bill. I had asked Vic earlier if he would "voice" the story for me and he had agreed. However, when I cornered him, he told me he would be back shortly. He was, and with a rather big surprise. A few minutes after Vic returned, Jean joined us. It was then Vic told me that he had asked Jean if he would "voice" the report and that Jean had agreed to do it. At about 1:00 am Dayton time, we recorded the last track, and by 2:00 am the entire package had been fed

to Bill via the phone. At that point, I went horizontal.

In the morning, this morning, which came all too soon, we packed our bags and checked out. Our flight back to LA would leave at about 4:30 that afternoon EDST, so along with our hosts, we headed back for a last few hours at the convention. Besides, I still had my own presentation to make about the Westlink Radio Network.

Our talk consisted of a 15-minute slide and sound presentation narrated on tape by Westlink anchorperson Jim Davis KA6IUH, followed by a 45-minute "question and answer" session. This was the first time I had used the slide show, and I am glad it was so well received. We will be presenting it again at the ARCH convention and will soon have it available on VHS videocassette for free loan to interested groups nationwide.

I recognize the terrain below. We have already made the stop in Kansas City and are about 30 minutes out of Los Angeles. It's been a whirlwind weekend and I have only one job left. That's transferring all these mental notes onto paper for you to read. It's been four years since my last Hamvention. A lot has happened in that time—some good, some bad. But for the past 72 hours it's been the thrill of a lifetime, and this very personal column is my way of saying thanks to a very wonderful bunch of people who put on one of amateur radio's greatest annual events. My thanks to DARA and especially to one Noel, his wife Marilyn, a Vic, a Larry, and two guys named Bob. Special thanks to Jean Shepherd K2ORS for becoming the Hamvention correspondent for Westlink and to everyone else who made this weekend happen. I will never forget any of you.

BOB, DAVE, AND RM-3618

You are about to read a request for rulemaking submitted to the FCC by Bob Thornburg WB6JPI and David Faraone WA6KOS. If you are a repeater user or owner, this rulemaking request will eventually have a profound effect on your day-to-day amateur operation. It was submitted because of a sequence of events that transpired over a year's time that perhaps began with a letter I sent to the FCC requesting a clarification

of the rules and regulations in regard to a number of aspects of repeater operation.

You might remember the letter I speak of. We printed it in the column and have mentioned it from time to time. I have yet to receive an answer to it, even though a number of congressional leaders secured promises that an answer would be forthcoming. Early this year, the engineer in charge of the FCC's Long Beach, California, facilities announced that henceforth the licensee of a repeater would be held responsible for the content of communications over a repeater. This announcement was greeted with mixed emotions in the Los Angeles amateur community. Some amateurs felt that such action was long overdue, while many others were adamant in their opposition. Many amateurs, especially repeater owners, felt that such an interpretation of Part 97 might lead to an end of open repeater operation in this area. A large cross section of their userships echoed this sentiment.

Talking about a problem and acting on it are two entirely different things. While many talked a blue streak, two amateurs decided to take decisive action on the matter. Working together with input derived from both Part 97 and the local amateur community, Bob Thornburg and Dave Faraone prepared a formal request for rulemaking which asks a specific clarification of Part 97. It was assigned the designation RM-3618 and had a commentary cutoff date of April 30th.

Whether you agree or disagree with what follows is unimportant. The regulatory changes caused by it will affect you, and you should be aware of what might be coming in the future.

February 19, 1980

Federal Communications
Commission
Washington DC

We request the following changes to Part 97 of the Rules and Regulations of the Federal Communications Commission be considered:

We are proposing the rules be clarified to ensure that equity in responsibility be maintained clearly and unambiguously making the repeater owner to not be responsible (under cer-

tain conditions) for the subject content retransmitted by his repeater. The repeater owner/trustee will still be responsible for the technical operation of the repeater and be responsible in those areas where the repeater is the origin of a rules violation. But for those cases where a violation originates from stations other than the repeater station, the repeater licensee/trustee is not to be held responsible even if his repeater retransmits the violation.

We have been repeater owners and operators for several years and have endured numerous changes to those paragraphs of Part 97 that regulate and control repeaters. We have observed with enthusiasm the relaxation of those rules recognizing the stability and maturity of the repeater technology and its management. The concept of automatic repeaters which released the repeater owner from full-time control and monitoring was a significant meaningful advancement. This concept has been successful. The public service allowed by having 24-hour availability as well as the on-line emergency facilities has been documented in many thousands of examples.

The intent of automatic repeaters was to support the ongoing concept of deregulation by allowing the responsible amateur to "do his thing" without severe and restrictive rules and regulations. Clearly, the intent of the commission in this area of rulemaking was to relax the previous strict control and monitoring regulations. It has been successfully demonstrated that the privilege of repeaters was not abused and that the availability of automatic repeaters has better served the public.

Recently, the FCC enforcement branch here in Los Angeles (Long Beach) has stated that it will hold the repeater owner responsible for the subject content of signals retransmitted by automatic repeaters. We are not taking exception with his right to take this position, as Part 97 is quite ambiguous in this area. Nowhere could we find this subject addressed (either way) in Part 97. Therefore, we are not requesting a change, per se, to Part 97, but rather an unambiguous clarification to the repeater rules.

The clarification is justified by three distinct considerations.

First, the repeater owner cannot realistically control the subject content of repeater transmissions. It only takes one word or one note of music to have a violation. The technical control provisions of the repeater could not possibly respond to preclude retransmissions of these signals. It is not fair or equitable to impose responsibility in areas where control or prevention cannot exist or is impractical.

The second consideration is the very concept of automatic repeaters. The rules clearly release the repeater licensee/trustee from full-time control. This allowance states that the control does not have to be in "real time" and the implication is clear that the word-by-word content control is not required or intended. (See 97.85(e).)

The third consideration is a clear statement of intent of the FCC made in response to comments to Docket 21033. Quoting from page 7, paragraph 19:

In Docket 21033, we proposed to take the next logical step and end the requirement for a separate license for repeaters. This was done in recognition that the original function of repeater licensing, namely, the stabilization of a new situation, had been served. However, the petitioners in this docket argued that a repeater license is still necessary and still serves a function. The expressed fear is that the situation will become chaotic if any amateur, Technician class or above, can set up a repeater. However, the state of affairs at present

is that any amateur, Technician class or above, can set up a repeater simply by checking off the appropriate box on Form 610 and waiting for a repeater license. There is simply no longer any practical purpose being served by the licensing process. We should also note that some amateurs have also expressed the fear that without separate repeater licenses, amateurs that operate their primary stations as repeaters might place their primary station license in jeopardy for rule violations committed by users of the repeater. In this regard, the commission intends to treat the repeater users as being primarily liable for operational rule violations, and will look to the repeater licensee only to the extent that he fails to meet this obligation to provide adequate control of his repeater. As a practical matter, our enforcement efforts in the past have proceeded on this basis. In many instances, we have worked with repeater licensees in tracking down users who commit rule violations through the repeaters.

Additional concepts that may be considered are that in all cases the party originating the radio transmission is still responsible and that the request presented here specifically excludes any situation where the repeater itself is the originator of a violation. **THERE IS ALWAYS A RESPONSIBLE PARTY FOR ALL RADIO TRANSMISSIONS.** With this request, the responsibility

for radio transmissions and any retransmissions, desired or not, become the sole responsibility of the originating operator.

Additionally, and in reverse argument, if the repeater is responsible for retransmission content, then the control operator must act as judge and jury on subjects such as what is profane or what constitutes broadcasting, etc. Most of these concepts are difficult for a court of law to interpret, much less the average repeater owner or control operator. The rationale that only continuing or severe or repeated "violations" would inflict action against the repeater owner is inappropriate, as a violation is a violation and quantity, time span, or intent do not make a violation. Either the first profane word is a violation or there is no violation even for the 100th profane word.

The specific change we are proposing is in two parts. First, we propose adding a paragraph to section 97.3 DEFINITIONS:

Repeater User: The repeater user is defined as a radio operator utilizing a repeater for radio communications.

Secondly, we propose to add paragraph (f) to 97.85:

(f) It is the responsibility of the repeater licensees to maintain technical standards as specified by the rules pertaining to automatic control or by control using a control operator. It is the responsibility of the repeater user to ensure that emissions originating at his station are in accordance with the rules as provided in 97.112 through 97.129 re-

spectively. The content of a signal being automatically retransmitted by a repeater, in the automatic mode, is solely the responsibility of the originating station, not the repeater licensee.

This request for rulemaking is submitted by:

Robert Thornburg WB6JPI
PO Box 6022
Blue Jay CA 92317
(714)-629-5111, x-3738
David A. Faraone WA6KOS
1103 S. Ambridge
Anaheim CA 92806
(714)-776-2384

While it is too late for you to file comments on RM-3618, its authors definitely want to know your feelings on it, and they have, as you will note, provided addresses and telephone numbers where they may be contacted. If you do write to them, please send us a copy of your letter so that we may excerpt from it in future columns.

Also, if you are planning to submit a rulemaking request on any matter, the example shown herein is one of the best guides that you can use. It was well prepared and documented and is exactly the way such a request should be submitted. Whether or not you agree with RM-3618 is not the important issue. Far more important is that you be aware of it. I freely admit that I have certain reservations over some portions of it. However, if it helps clear away some of the ambiguity that now permeates the rules and regs, then it's definitely a positive step. We will keep you abreast of the progress of this RM as it wends its way through the Washington rulemaking mill.

Ham Help

I am presently in ACI in Florida and I have been having a little problem with trying to get any electronics/radio courses in here. I am very highly interested in amateur radio and am presently doing what I can to get my Novice ticket while here.

I am serving four years and I don't know when I will be granted parole, but I'm trying to do something with my life. I always

have been interested in radio communications and I like to build and operate my own equipment. Up to late, my projects have been mostly flea-powered FM transmitters and such. I have built a few transmitters, receivers, preamps, and linears, and am awaiting the day when I have my ticket in hand before I will use this equipment.

But back to the story at hand.

Since I am in prison, I have not been allowed to enjoy my hobby, and I sure do miss working with electronics. I tried to get permission to get an HF receiver, but they are afraid that such equipment would be hazardous to the security of the institution. They don't realize that the receiver would not be capable of receiving their police frequency of 45.520 MHz. I would just like to be able to monitor the activity on the amateur bands and learn in the process. I have also tried to get a code-practice oscillator — to no avail. They don't see

how such a small device would be of any help to me. It is too bad there are no hams working here that I know of—maybe they could help convince the staff here of my good intentions.

If anyone out there can help me convince them of the good of amateur radio, please write to me. The only literature on the subject I have is my subscription to 73. It is a lifesaver for me, as radio is my future. Thank you.

Norman R. Boyce, Jr.
PO Box 699, B-73
Sneads FL 32460

Contests

from page 22

erating time is 12 hours of the 13-hour period. Operating classes include: single- or multi-operator, single- or multi-band, and SWL. In the case of multi-operator, only one transmitter may be used at any time. There is a special section for mobile operators.

EXCHANGE:

RST, QSO number from 01, WAB area and county. Book numbers and districts may be requested, but are not mandatory as part of the exchange.

SCORING:

Score 5 points for each completed QSO. Stations may be worked on other bands for extra points.

Multippliers for UK contestants are each WAB area and each overseas country (DXCC list). In addition, Alderney, Guernsey, Jersey, and Sark count as separate countries. The remainder of G, GD, GI, GM, and GW count as one multiplier only.

Multippliers for overseas contestants are each WAB area, county, and each G prefix (G, GD, GM, and GW). Multippliers count on each band, i.e., a station worked on three bands = 3 multipliers.

For mobile entries, every contact made from a different area will count five points, but the multiplier counts once only (i.e., mobile station X from ten different areas: score is 10 times 5 points, but only one multiplier for the mobile station).

AWARDS:

Certificates for the leading contestant in each class or entry. For awards, each G prefix is separate. There will be certificates issued to the leading contestants from each DXCC country and also to SWLs. Certificates for 2nd and 3rd will be issued if there are 10 or 25 entries from a particular country or call area.

ENTRIES:

Logs must show the title of the contest, name and full postal address of contestant, QSO details, total points claimed, multipliers claimed, and the full details of all operators when multi-operator entry is submitted. Logs must be sent to the contest manager:

R. L. Senter G4BFY, 27 Station Road, Thurnby, Leicester LE7 9PW, England.

Entries must be postmarked not later than one calendar month following the date of the contest and must be received by the contest manager not later than 40 days following the said contest. A signed declaration that the station was operated in accordance with the current licensing conditions must accompany all entries. It is a condition of entry that the decision of the WAB Contest Manager and the WAB Committee shall be absolute in the case of dispute. For SWLs, all stations logged must be participating in the contest and giving serial numbers which must be logged. The results will be notified to the RSGB and the Contest Manager will supply a detailed sheet on receipt of an SAE on or after November 1st.

SWOT QSO PARTY

Starts: 0000 GMT August 1
Ends: 2359 GMT August 7

Participants may use as much of the contest period as they wish during the third annual SWOT QSO Party. All licensed amateurs with operating privileges on two meters are eligible to participate. Contacts must be made on either CW or SSB. A station may be worked once on each mode for QSO score. You can count a portable or mobile station only once on each mode even though you may have worked him while he was in two or more geographic units. Contacts must be made direct without the aid of satellites, repeaters, or retransmissions of any kind. EME (moon-bounce) contacts may be counted if they otherwise meet all requirements. All contacts must be made from one geographic unit. Portable or mobile stations operating from several geographic units may, however, claim the highest score made from a single unit.

EXCHANGE:

The following information must be exchanged to qualify for contact credit:

1. Callsigns.
2. Geographic designator (unit)—This will consist of a four- or five-digit number indicating the geographic loca-

tion of the station in latitude and longitude rounded down to the next whole number. (Example: W7CKL located at 32 degrees 7 minutes north and 110 degrees 55 minutes west would send 32110.) Non-competing stations may be counted for contact and multiplier credit if they give their location with enough specificity that the competing station can determine the geographic designator.

3. SWOT suffix "X"—SWOT members will add the suffix "X" to the geographic designator to indicate SWOT membership; this will provide the additional multiplier as indicated under scoring.

SCORING:

The final score equals the sum of SWOT member and non-member credits computed as follows: The total SWOT member QSOs multiplied by the number of different geographic units they were located in multiplied by 2 equals the total SWOT member credit. The total non-SWOT member QSOs multiplied by the number of different geographic units they were in equals the non-SWOT member credit.

ENTRIES & AWARDS:

The person with the highest final score will receive the 1980 SWOT Trophy. Certificates will be awarded to the highest scorer in each ARRL section in which more than one entry is made. In the event of ties, the entry with the earliest postmark will be the winner. Winners will be announced in the *SWOT Bulletin* at the earliest possible date. Logs should not be submitted unless requested. Send a summary sheet postmarked not later than September 1st to: Val Taylor W7CKL, 3849 N. Houghton Road, Tucson AZ 85715. The summary sheet should include: name, callsign, address, ARRL section, SWOT membership number (if a member), # SWOT member stations worked and # geographic units they were in, total non-SWOT credit, final score.

ILLINOIS QSO PARTY

Starts: 1800 GMT August 2
Ends: 2300 GMT August 3

Sponsored by RAMS, the Radio Amateur Megacycle Society. Use all bands, CW and phone, with a rest period from 0500 GMT to 1200 GMT on August 3rd. The same station may be worked on each band and mode. No repeater contacts

are allowed.

EXCHANGE:

RS(T) and state, province, country, or IL county.

FREQUENCIES:

Any frequency, but look for most activity: about 60 kHz from low end on CW; about 3975, 7275, 14275, 21375, and 28675 on phone; and about 25 kHz from the low end of each Novice band, especially on the hour and half hour.

SCORING:

One QSO point per contact or two points if the other station is a Novice or Technician in a Novice band. Illinois stations multiply QSO point total by the total number of states (50 max.), VE/VO call areas (10 max.), and no more than 5 non-W/K/VE/VO DX countries worked for a maximum of 65 multipliers. Additional DX contacts count for QSO points, but not for additional multipliers. Illinois portables or mobiles away from normal QTH may add 200 to final score for each county of operation from which 10 or more contacts were made. Non-Illinois stations multiply QSO points by the number of Illinois counties worked. Only Illinois stations may be counted for QSO points. Non-Illinois stations may also take extra bonus multipliers for each group of 8 QSOs with the same county.

AWARDS:

Certificates to the top 3 Illinois scorers in single-op, multi-op, multi-multi, portable out of home county, mobile, Novice, and CW Technician categories. For out-of-staters, awards go to top scorers in similar categories in each state, province, or country from which 2 valid entries are received. Club participation awards given per ARRL SS rules. Other awards may be given if deemed worthy and decisions of the contest committee are final.

ENTRIES:

Logs must be legible and be submitted along with a summary sheet listing all claimed multipliers and calculations of score. Operator(s) name, address, call, and operation category must be typed or printed clearly. Include a business-size stamped addressed envelope for return of results. Entries must be postmarked no later than September 15th and sent to: RAMS/K9CJU, 3620 N. Oleaner Avenue, Chicago IL 60634.

New SATELLITE
For the TV home.



Supersharpest Reception—Color Like Never Before
Get over 50 channels of television directly from the satellite! HBO, Showtime, the Superstations, and sports from around the world!

Works Anywhere!

Buy complete or build and save. Our book tells everything! Send \$7.95 today or call our 24 hr. C.O.D. Hotline! (305) 869-4283

SPACECOAST RESEARCH ✓ 310
P.O. Box 442, Dept. G, Altamonte Springs, FL 32701

SYNTHESIZED SIGNAL GENERATOR



• Covers 100 to 179.999 MHz in 1 kHz steps with thumb-wheel dial • Accuracy .00001% at all frequencies • Internal frequency modulation from 0 to over 100 kHz at a 1 kHz rate • Spurs and noise at least 60dB below carrier • RF output adjustable from 50 to 500mv across 50 ohms • Operates on 12vdc @ 1/2 amp • Price \$299.95 plus shipping
In stock for immediate shipping. Overnight delivery available at extra cost. Phone: (212) 468-2720. ✓ 311

VANGUARD LABS
196-23 Jamaica Ave. Hollis, NY 11423

CB to 10 METER
10 METER CONVERSION KITS FOR CB RADIOS AM-FM & SSB

- Kits for over 300 Models of CB Radios
- Low Cost from \$10.00
Easy to Install with All Instructions
Tune-Up Procedure Alignment
- KITS FOR MOST POPULAR UNITS
Over 5,000 Satisfied Customers
- Write or Call Today for Our Free 1980 Catalogue

AMERICAN CRYSTAL SUPPLY COMPANY
PO Box 638
W Yarmouth, MA 02673
(617) 771-4634 ✓ 7

Radio Amateurs!

AZDEN PCS-2000
2 Meter \$289.95 (MARS-CAP KIT SOON)

AZDEN PCS-2800
10 Meter \$289.95

SWAN ASTRO 102BX
160-10 Meters \$1051.60
Astro 150 \$814.00
100 MX \$615.96

TEN-TEC OMNI C NEW1 \$1025.50
TEN-TEC OMNI D \$965.25

Six others lower priced

Amateur equipment accessories & antennas. COD, USA. Export Anywhere. Amateur & commercial repair service.

2317 Vance Jackson Rd. San Antonio, TX 78213
(512) 734-7793 ✓ 301

MILITARY SURPLUS WANTED

Highest prices ever on recent U.S. Military surplus, especially on Collins equipment or parts. We Pay freight. Call collect for high offer. (201) 440-8787. 35 Ruta Court, S. Hackensack, N.J. 07606

Our 18th Year

SPACE ELECTRONICS CO. ✓ 317

AN/APR-4Y AM & FM Receiver—115 Volts 60 Cycle for Frequencies 38 to 4000 megacycles \$79.50 (Tuning Units Available P.U.R.)

AN/ART-13 Transmitter for 80, 40, 20 and 10 meters 100 Watts Output on AM, CW & MCW With all tubes \$59.50

SCR-522 TRANSMITTER-RECEIVER 100-156 mc Crystal Controlled on 4 Channel Excellent condition All tubes \$42.50

ARC-5 TRANSMITTER with all tubes and crystal Brand new (BC 457-4 5 3mc BC 458-5 3-7mc) \$16.95

AC POWER SUPPLY for above transmitter completely wired and tested New \$26.50

R-2B/ARC-5 VHF RECEIVER Crystal Controlled on 4 channels 100-156 MC Excellent used cond \$27.50

T-23/ARC-5 VHF Transmitter Crystal Controlled on 4 channels 100 156 mc New \$29.50

OM-32 Dynamotor, New \$3.95

R-23/ARC-5 RECEIVER 190-550 KC continuous tuning used, with all tubes \$16.95

ARR-2 RECEIVER 234-238 MC. New \$10.95

Write for catalog—send 50¢ for postage.
Write for low prices on all types of tubes.

Terms: F.O.B. NYC. 25% deposit with order balance COD or remittance in full. Subject to prior sale and price change

G & G Radio Electronics CO. ✓ 302
45-47 WARREN ST.
NEW YORK, NY 10007 Ph. 212-267-4605

URFI
(UNIVERSAL RECEIVED FREQUENCY INDICATOR)



Digitize your receiver's dial with the DIAL SPOTTER. Adapts to most Communication Receivers with simple connection to VFO. From \$149.95 Write for Data Sheet.

GEMINI INSTRUMENTS INCORPORATED
Box 205, Larchmont, NY 10538 ✓ 24

ATTENTION

EXPERIMENTER DESIGNER MANUFACTURER
HFT OFFERS YOU
ENGINEERING SERVICES - MINIMODULE PRODUCTS
AUDIO THROUGH 250 MHz

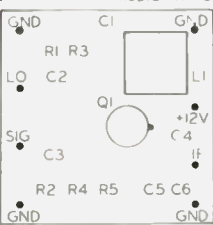

RF PREAMPLIFIERS
DUAL GATE FET MIXERS
IF AMPLIFIERS
AUDIO AMPLIFIERS
WWW RECEIVERS
TUNING GEAR FOR
COMPRESSIVE AUDIO AMP.
SSB GENERATOR
RF POWER AMPLIFIERS
POWER SUPPLIES
KITS

CATALOG ITEMS IN TWO WEEKS OR LESS
QUICK TURN AROUND ON SPECIALS
CATALOG & DESIGN MANUAL \$3.95 REFUND ON 1ST PURCHASE
DETAILED SPECIFICATIONS
APPLICATION NOTES
DESIGN DATA ON

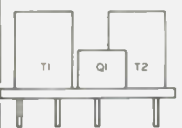

RF PREAMPLIFIERS, MIXERS,
SPURIOUS SIGNALS, RECEIVER
PARAMETERS, AUDIO COMPRESSION,
& OTHER DATA
SHORT FORM CATALOG ON REQUEST

HFT INC ✓ 304
158 West 9th St
Deer Park NY 11729

225-400 Mhz CONVERTER
AM-914/TRC Amplifier-Converter



Originally used with military R-417 receiver for the 225-400 Mhz range. Continuous tuning of RF and oscillator; 30 Mhz I.F. Has tubes 5670 and 4/6J4. See 7/80 CQ for R. Grove's conversion of this unit. 7 1/2 x 6 1/2 x 9 1/2, 17 lbs. sh.

wt. Used, repairable \$34.95

AC LINE FREQUENCY METER
48-52 and 58-62 Hz 100-150 VAC using ten leads. 3 1/2" round; sealed. H.H. Sticht mfg. 2 lbs. sh.
wt. #974-9364, unused \$27.95

TMC MSR-4 (CV-591) SSB Converter
for use with 2-32 Mhz receivers having 455 KHz IF's. USB, LSB, AM, CW, FSK, and FAX. Input voltage 0.1 to 10 V-rms. Requires 115/230 VAC 50-60 Hz. 5 1/4 x 19 x 13 1/2, 28 lbs. sh. Used, repairable \$145.00

Prices F.O.B. Lima, O. • VISA, MASTERCARD Accepted.
Send for our New FREE SURPLUS CATALOG Today!
Address Dept. 73 • Phone: 419/227-6573

FAIR RADIO SALES ✓ 22
1016 E. EUREKA • Box 1105 • LIMA, OHIO • 45802

Lynda Says . . . We want your Used Equipment.

That's right . . . We have Kenwood, Yaesu, Icom, Henry Radio, Tempo, DenTron, Drake, Swan, Ten-Tec and so much more to offer. We are a Ham Radio Company in the Empire State. And watch for the Grand Opening in our New York City, Madison Avenue Showroom. Also New Jersey. Come in, call or write at any hour for free brochures. Export inquiries are invited.



Ten-Tec Omni Series B

Ten-Tec D Transceiver. 160-10 Mtrs. Digital Readout. Four position CW/SSB Filter. 200 Watts SSB. Regularly sells for \$1,119.00/WOW Call for Price. Delta Transceiver — 200 Watts SSB/CW 1.8-30 MHz. Call for prices on all Ten-Tec.



Swan 100MX Solid-State. 10-80 Mtrs. 235 Watts SSB power with noise blander. Regularly sells for \$699.95/Now \$549.00.



Kenwood TS120S. 80-10 Mtrs. Digital Readout. Analog Dial, 200 Watts SSB power. Reg. \$699.00/Call for all Kenwood Prices.

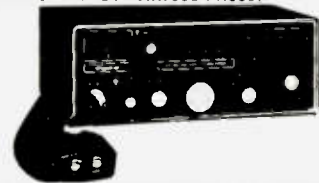

Swan Astro 150 VRS Tuning 10-80 Mtrs. 235 Watts SSB. Fully Microprocessor Controlled frequencies. Regularly sells for \$925.00/Now \$765.00



NCX 1000 Transceiver. 10-80 Mtrs. 1 kW SSB, AM, CW, RIT Control. Speech Clipper. Built-in P.S. Much more. Regularly sells for \$1,695.00/Now \$1,495.00.



Kenwood TS180S with DFC. 160-10 Mtrs. 200 Watts. Digitally Tuned Memory. Regularly \$1,149.95/Call for Special Prices.



Drake TR7/DR7. Reg. \$1,495.00/Call for Drake Prices.

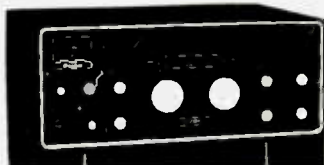

Swan 102BX Transceiver. Dual PTO's 235 Watts SSB & CW. 1.8-30 MHz. I.F. Passband Tuning. Tunable Notch filter, much, much more. Regularly sells for \$1,195.00/Now \$995.00.

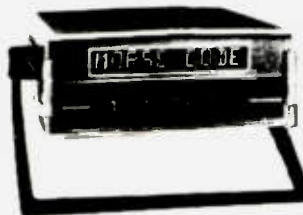

Icom IC255A. 143.800-148.195 MHz. 5 Channel Memory with Scan. 25 Watts. Reg. \$399.00/Call for all Icom Products.



CDE Tailtwister Rotor TX2
Reg. \$379.00/Now \$249.00

Kantronics Field Day TTY Code Reader. Reg. \$449.00/Now \$360.00.

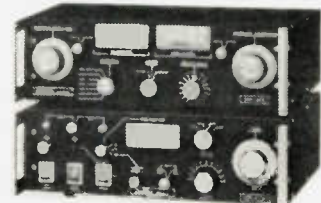

DenTron DTR3KA/DTR1200L Linear and Antenna Tuner. Call for prices on all DenTron products.



Communications
Technology
Group, Incorporated®

448 Merrick Road Oceanside, N. Y. 11572 (516) 536-5724
1708 Rockaway Avenue Lynbrook, N. Y. 11563

Telex 640-596/TWX 510-225-7536

7294 N.W. 54 STREET
MIAMI, FLORIDA 33166

SEC SURPLUS ELECTRONICS CORP.

PHONE: (305) 887-8228
TWX: 810-848-6085
WHOLESALE - RETAIL

| <p>SO239 10/\$5.00 100/\$35.00 50/\$20.00 1000/\$300.00</p> | <p>CB SPECIAL Brand new printed circuit board assembly. Used in all HyGain 40 Channel CB transceivers. Fits many other manufacturers' units also. Squelch pot/volume control/channel selector switch not included. Board Dimensions 6" x 6 1/2" 1-9 - 7.50 ea. 50-99 - 6.00 ea. 10-49 - 6.50 ea. 100-up - 5.50 ea.</p> | | <p>TRIMMER CAPS Can fit in your watch 3.5-20 pF & 5-30 pF \$.75 ea., 2/\$1.25 5/\$3.00</p> | | | | | | | | | | | | | | | | | | | | | | | | | | | | | | | | | | | | | | | | | | | | | | | | | | | | | | | | | | | | | | | | | | | | | | |
|--|---|---|---|------------|-------|-------------------|-------------|-------------|-------------|--------------|--------------|-----|-------------------|------------|-------------|-------------|------------|------------|----------|-------------------|-------------|--------------|--------------|------|---------|-------------|-----|--------|----------|---------|----------|-----|----|------|---------|----------|-----|--------|------|---------|---------|-----|--------|----------|---------|----------|-----|----|----------|---------|-------|-----|--------|----------|---------|-------|------|--------|----------|---------|-------|------|--------|----------|---------|------|------|--------|------|---------|--|---|---|
| <p>PL259 Amphenol .60¢ ea.</p> | <p>CB SPECIAL W/40 ch SW same as above 1-9 \$10.50 ea. 50-99 \$9.00 ea. 10-49 \$9.50 ea. 100-up \$8.50 ea.</p> | | <p>POLY FOAM COAX 50 Ohm Low Loss = to RG174 \$.45/100' \$3.00/50'</p> | | | | | | | | | | | | | | | | | | | | | | | | | | | | | | | | | | | | | | | | | | | | | | | | | | | | | | | | | | | | | | | | | | | | | | |
| <p>E. F. Johnson S Meter Edge Meter 250 UA. Fits in 5/8" x 1-3/8" hole MTG holes on each end 1-1/4" behind panel. Black scale 0-5 bottom 1-20 top \$1.25 ea. 5/\$5.00</p> | <p>Serviceman Special New Hy-Gain 40ch CB Less Case. Speaker & Knobs (as is) \$14.95 ea NEW Hy-Gain Remote 40ch CB Less Case. Speaker & Control Mic (as is) \$14.95 ea</p> | | <p>ULTRASONIC TRANSDUCER Detects sound above the range of human hearing! Transmits & receives \$2.50 ea. 5/\$10.00</p> | | | | | | | | | | | | | | | | | | | | | | | | | | | | | | | | | | | | | | | | | | | | | | | | | | | | | | | | | | | | | | | | | | | | | | |
| <p>E. F. Johnson Signal Strength Meter 200 UA 2 1/4" x 2 1/4" Sq. mounts in 1 1/4" hole 1" behind panel. Scale 1-30 db top 0-5 bottom. \$4.95 ea 5/\$20.00</p> | <p>ASTATIC T-UG8-D104 PREAMP Desktop microphone w/crystal element 3 Pin Plug \$35 ea.</p> | <p>NEW E.F. Johnson Power Mic/Less Cord. Desktop Style \$19.95 ea</p> | <p>MAGNETIC PICK UP TRANSDUCER Converts motion to ac voltage without mechanical linkage 1/4" x 2" w/6' shielded cable \$4.95 ea.</p> | | | | | | | | | | | | | | | | | | | | | | | | | | | | | | | | | | | | | | | | | | | | | | | | | | | | | | | | | | | | | | | | | | | | | | |
| <p>PANEL METERS \$4.00 ea 2 for \$7.00 25-0-25 dc Volts } 2 1/4" x 3" 0-25 dc Volts } 0-50 ac Volts } 2 1/4" x 2 1/4" -Shunt Required-</p> | <p>8 Position Dip Switches 16 pin (AMP) \$1.50 ea. 10/\$13.50</p> | <p>15' MODEM CABLES 10#22ga wire w/shield, DB25P conn & DB51226-1 cover on one end \$5.50 ea. 10/\$50.00</p> | <p>25' MODEM CABLES 13#22ga wire w/shield, DB25P conn & DB51226-1 cover on one end \$6.50 ea. 10/\$60.00</p> | | | | | | | | | | | | | | | | | | | | | | | | | | | | | | | | | | | | | | | | | | | | | | | | | | | | | | | | | | | | | | | | | | | | | | |
| <p>Double Row/Wire Wrap .100 25 pins \$3.49 ea 10/\$30.00 30 pins \$3.96 ea 10/\$32.00 50 pins \$5.43 ea 10/\$45.00</p> | <p>12 Vdc RELAY SPST 35 Amp Contacts Open Frame Rugged, great for mobile use \$4.50 ea 5/\$20.00</p> | <p>12 Vdc RELAY SPST Open Frame 5 Amp Contacts Mfg-Magnecraft \$1.50 ea 4/\$5.00</p> | <p>SOLDERLESS TEST PROD (BLACK) Threaded type, molded handle \$.40 ea. 10/\$3.50</p> | | | | | | | | | | | | | | | | | | | | | | | | | | | | | | | | | | | | | | | | | | | | | | | | | | | | | | | | | | | | | | | | | | | | | | |
| <p>Double Row/Solder Eyelet .156 6 pins \$1.10 ea 10/\$ 9.00 15 pins \$1.55 ea 10/\$12.50 22 pins \$2.08 ea 10/\$17.00 43 pins \$3.66 ea 10/\$30.00</p> | <p>22 pins/Double Row/Dipped Solder .156 \$2.08 ea 10/\$17.00</p> | <p>22 pins/Double Row/Wire Wrap .156 \$2.44 ea 10/\$19.00</p> | <p>USED MUFFIN FANS 3 blades, 110VAC, 4 1/4" sq. \$5.95</p> | | | | | | | | | | | | | | | | | | | | | | | | | | | | | | | | | | | | | | | | | | | | | | | | | | | | | | | | | | | | | | | | | | | | | | |
| <p>C & K SWITCHES PART # MOVEMENT 7101 ON/NONE/ON SPST 7103 ON/OFF/ON SPST 7108 ON/NONE/(ON) SPST 7201 ON/NONE/ON DPDT \$1.00 EA 6 FOR \$5.00</p> | <p>12 V DC Horn 2" diameter x 1 1/4" deep .75 each 3/\$2.00</p> | <p>100 ASSORTED DISC CAPS (FULL LEADS) 20 EA OF 5 DIFFERENT VALUES \$2.00 PER PACK</p> | <p>CW MINI SLIDE SW DPDT .15 ea. 10/\$1.25</p> | | | | | | | | | | | | | | | | | | | | | | | | | | | | | | | | | | | | | | | | | | | | | | | | | | | | | | | | | | | | | | | | | | | | | | |
| <p>6 TV GAMES ON (1) CHIP Gen Instr AY-3-8500-1 28 Pin Plastic Case EVERYDAY LOW PRICE \$7.50 ea</p> | <p>Autronic Elect Auto Alarm Easy installation Independent circuits solid state 12V neg ground \$5.00 ea.</p> | <p>White Porcelain Egg Insulator 1 1/2" x 1" 50¢ ea. 3 for \$1.25</p> | <p>ALL STAR AIR VARIABLE 24-275 pF .75 ea.</p> | | | | | | | | | | | | | | | | | | | | | | | | | | | | | | | | | | | | | | | | | | | | | | | | | | | | | | | | | | | | | | | | | | | | | | |
| <p>ASSORTED ELECTROLYTICS</p> <table border="1"> <thead> <tr> <th>VALUE/MFD</th> <th>VOLTS</th> <th>DIA</th> <th>LENGTH</th> <th>PRICE</th> </tr> </thead> <tbody> <tr><td>63,000 @</td><td>15V</td><td>3"</td><td>x 5 1/2"</td><td>4.00 ea</td></tr> <tr><td>10,000 @</td><td>20V</td><td>1 1/2"</td><td>x 5 3/4"</td><td>3.00 ea</td></tr> <tr><td>2,700 @</td><td>25V</td><td>1 1/4"</td><td>x 2 1/4"</td><td>2.00 ea</td></tr> <tr><td>2,900 @</td><td>25V</td><td>1 1/2"</td><td>x 2"</td><td>2.00 ea</td></tr> <tr><td>3,000 @</td><td>25V</td><td>1 1/2"</td><td>x 4 1/2"</td><td>2.00 ea</td></tr> <tr><td>18,000 @</td><td>25V</td><td>2"</td><td>x 4"</td><td>3.00 ea</td></tr> <tr><td>21,000 @</td><td>25V</td><td>2 1/2"</td><td>x 3"</td><td>3.00 ea</td></tr> <tr><td>1,000 @</td><td>50V</td><td>1 1/4"</td><td>x 3 1/4"</td><td>2.50 ea</td></tr> <tr><td>34,800 @</td><td>50V</td><td>3"</td><td>x 5 1/2"</td><td>3.00 ea</td></tr> <tr><td>450 @</td><td>75V</td><td>1 1/4"</td><td>x 2 1/4"</td><td>2.00 ea</td></tr> <tr><td>500 @</td><td>100V</td><td>1 1/2"</td><td>x 3 1/2"</td><td>2.00 ea</td></tr> <tr><td>240 @</td><td>300V</td><td>1 1/4"</td><td>x 2 1/4"</td><td>2.00 ea</td></tr> <tr><td>50 @</td><td>450V</td><td>1 1/4"</td><td>x 2"</td><td>2.00 ea</td></tr> </tbody> </table> | VALUE/MFD | VOLTS | DIA | LENGTH | PRICE | 63,000 @ | 15V | 3" | x 5 1/2" | 4.00 ea | 10,000 @ | 20V | 1 1/2" | x 5 3/4" | 3.00 ea | 2,700 @ | 25V | 1 1/4" | x 2 1/4" | 2.00 ea | 2,900 @ | 25V | 1 1/2" | x 2" | 2.00 ea | 3,000 @ | 25V | 1 1/2" | x 4 1/2" | 2.00 ea | 18,000 @ | 25V | 2" | x 4" | 3.00 ea | 21,000 @ | 25V | 2 1/2" | x 3" | 3.00 ea | 1,000 @ | 50V | 1 1/4" | x 3 1/4" | 2.50 ea | 34,800 @ | 50V | 3" | x 5 1/2" | 3.00 ea | 450 @ | 75V | 1 1/4" | x 2 1/4" | 2.00 ea | 500 @ | 100V | 1 1/2" | x 3 1/2" | 2.00 ea | 240 @ | 300V | 1 1/4" | x 2 1/4" | 2.00 ea | 50 @ | 450V | 1 1/4" | x 2" | 2.00 ea | <p>Extralytic 4800 µF at 7.5 VDC 1 1/4" length x 1" diameter \$3.00 each 50 µF at 200 VDC 1 1/4" length x 3/4" diameter \$2.00 each</p> | <p>CAPS RADIAL LEADS 2200 uF @ 16V .25 ea. 10/\$2.00</p> | <p>RED SEVEN SEGMENT DISPLAY TIL 322P \$1.00 ea.</p> |
| VALUE/MFD | VOLTS | DIA | LENGTH | PRICE | | | | | | | | | | | | | | | | | | | | | | | | | | | | | | | | | | | | | | | | | | | | | | | | | | | | | | | | | | | | | | | | | | | | | |
| 63,000 @ | 15V | 3" | x 5 1/2" | 4.00 ea | | | | | | | | | | | | | | | | | | | | | | | | | | | | | | | | | | | | | | | | | | | | | | | | | | | | | | | | | | | | | | | | | | | | | |
| 10,000 @ | 20V | 1 1/2" | x 5 3/4" | 3.00 ea | | | | | | | | | | | | | | | | | | | | | | | | | | | | | | | | | | | | | | | | | | | | | | | | | | | | | | | | | | | | | | | | | | | | | |
| 2,700 @ | 25V | 1 1/4" | x 2 1/4" | 2.00 ea | | | | | | | | | | | | | | | | | | | | | | | | | | | | | | | | | | | | | | | | | | | | | | | | | | | | | | | | | | | | | | | | | | | | | |
| 2,900 @ | 25V | 1 1/2" | x 2" | 2.00 ea | | | | | | | | | | | | | | | | | | | | | | | | | | | | | | | | | | | | | | | | | | | | | | | | | | | | | | | | | | | | | | | | | | | | | |
| 3,000 @ | 25V | 1 1/2" | x 4 1/2" | 2.00 ea | | | | | | | | | | | | | | | | | | | | | | | | | | | | | | | | | | | | | | | | | | | | | | | | | | | | | | | | | | | | | | | | | | | | | |
| 18,000 @ | 25V | 2" | x 4" | 3.00 ea | | | | | | | | | | | | | | | | | | | | | | | | | | | | | | | | | | | | | | | | | | | | | | | | | | | | | | | | | | | | | | | | | | | | | |
| 21,000 @ | 25V | 2 1/2" | x 3" | 3.00 ea | | | | | | | | | | | | | | | | | | | | | | | | | | | | | | | | | | | | | | | | | | | | | | | | | | | | | | | | | | | | | | | | | | | | | |
| 1,000 @ | 50V | 1 1/4" | x 3 1/4" | 2.50 ea | | | | | | | | | | | | | | | | | | | | | | | | | | | | | | | | | | | | | | | | | | | | | | | | | | | | | | | | | | | | | | | | | | | | | |
| 34,800 @ | 50V | 3" | x 5 1/2" | 3.00 ea | | | | | | | | | | | | | | | | | | | | | | | | | | | | | | | | | | | | | | | | | | | | | | | | | | | | | | | | | | | | | | | | | | | | | |
| 450 @ | 75V | 1 1/4" | x 2 1/4" | 2.00 ea | | | | | | | | | | | | | | | | | | | | | | | | | | | | | | | | | | | | | | | | | | | | | | | | | | | | | | | | | | | | | | | | | | | | | |
| 500 @ | 100V | 1 1/2" | x 3 1/2" | 2.00 ea | | | | | | | | | | | | | | | | | | | | | | | | | | | | | | | | | | | | | | | | | | | | | | | | | | | | | | | | | | | | | | | | | | | | | |
| 240 @ | 300V | 1 1/4" | x 2 1/4" | 2.00 ea | | | | | | | | | | | | | | | | | | | | | | | | | | | | | | | | | | | | | | | | | | | | | | | | | | | | | | | | | | | | | | | | | | | | | |
| 50 @ | 450V | 1 1/4" | x 2" | 2.00 ea | | | | | | | | | | | | | | | | | | | | | | | | | | | | | | | | | | | | | | | | | | | | | | | | | | | | | | | | | | | | | | | | | | | | | |
| | <p>15' MODEM CABLES 14#22ga wire w/shield, DB25P conn & DB51226-1 cover on one end \$6.00 ea. 10/\$55.00</p> | <p>SOLDER LUG-TYPE CAPS 50 UF @ 350V 1" D x 3" L 50 UF @ 450V 1" D x 2 1/2" L 50 UF @ 450V 1" D x 3" L 60¢ EA. 5 FOR \$2.50</p> | <p>BOURNS' EDGE MOUNTING 5K pot single turn 3345W series \$1.50 ea.</p> | | | | | | | | | | | | | | | | | | | | | | | | | | | | | | | | | | | | | | | | | | | | | | | | | | | | | | | | | | | | | | | | | | | | | | |
| | <p>15' MODEM CABLES 10#22ga wire w/shield, DB25S conn & DB51226-1 cover on one end \$6.50 ea. 10/\$60.00</p> | <p>EFJ CRYSTAL OVENS 6V/12V 75° \$5.00 ea.</p> | <p>12 VOLTS @ 1/2 AMP Filament transformer 1 1/2" x 2" x 1" \$1.50 ea.</p> | | | | | | | | | | | | | | | | | | | | | | | | | | | | | | | | | | | | | | | | | | | | | | | | | | | | | | | | | | | | | | | | | | | | | | |
| | | <p>IC SOCKETS Cambion Gold Plated Wire Wrap 14 pin .35 ea 10/\$3.00 16 pin .38 ea 10/\$3.30</p> | <p>CTS DP6P ROT SWITCH .50 ea. 5/\$2.00</p> | | | | | | | | | | | | | | | | | | | | | | | | | | | | | | | | | | | | | | | | | | | | | | | | | | | | | | | | | | | | | | | | | | | | | | |
| | | <p>COMCO XTAL FILTER 23/8" x 1" x 3/4" 13KC BW \$10.00 ea.</p> | <p>AXIAL LEAD ELECTROLYTIC CAPACITORS</p> <table border="1"> <tbody> <tr><td>2 uF @ 15V</td><td rowspan="5">}</td><td rowspan="5">12 ea. for \$1.00</td></tr> <tr><td>10 uF @ 15V</td></tr> <tr><td>20 uF @ 15V</td></tr> <tr><td>50 uF @ 15V</td></tr> <tr><td>2.2 uF @ 25V</td></tr> <tr><td>3.3 uF @ 25V</td><td rowspan="5">}</td><td rowspan="5">15 ea. for \$2.00</td></tr> <tr><td>1 uF @ 35V</td></tr> <tr><td>2 uF @ 150V</td></tr> <tr><td>25 uF @ 25V</td></tr> <tr><td>3 uF @ 50V</td></tr> <tr><td>5 uF @ 50V</td><td rowspan="3">}</td><td rowspan="3">10 ea. for \$2.00</td></tr> <tr><td>10 uF @ 50V</td></tr> <tr><td>250 uF @ 25V</td></tr> <tr><td>100 uF @ 50V</td><td></td><td></td></tr> <tr><td>50 uF @ 75V</td><td></td><td></td></tr> </tbody> </table> | 2 uF @ 15V | } | 12 ea. for \$1.00 | 10 uF @ 15V | 20 uF @ 15V | 50 uF @ 15V | 2.2 uF @ 25V | 3.3 uF @ 25V | } | 15 ea. for \$2.00 | 1 uF @ 35V | 2 uF @ 150V | 25 uF @ 25V | 3 uF @ 50V | 5 uF @ 50V | } | 10 ea. for \$2.00 | 10 uF @ 50V | 250 uF @ 25V | 100 uF @ 50V | | | 50 uF @ 75V | | | | | | | | | | | | | | | | | | | | | | | | | | | | | | | | | | | | | | | | | | | | | | | |
| 2 uF @ 15V | } | 12 ea. for \$1.00 | | | | | | | | | | | | | | | | | | | | | | | | | | | | | | | | | | | | | | | | | | | | | | | | | | | | | | | | | | | | | | | | | | | | | | | |
| 10 uF @ 15V | | | | | | | | | | | | | | | | | | | | | | | | | | | | | | | | | | | | | | | | | | | | | | | | | | | | | | | | | | | | | | | | | | | | | | | | | |
| 20 uF @ 15V | | | | | | | | | | | | | | | | | | | | | | | | | | | | | | | | | | | | | | | | | | | | | | | | | | | | | | | | | | | | | | | | | | | | | | | | | |
| 50 uF @ 15V | | | | | | | | | | | | | | | | | | | | | | | | | | | | | | | | | | | | | | | | | | | | | | | | | | | | | | | | | | | | | | | | | | | | | | | | | |
| 2.2 uF @ 25V | | | | | | | | | | | | | | | | | | | | | | | | | | | | | | | | | | | | | | | | | | | | | | | | | | | | | | | | | | | | | | | | | | | | | | | | | |
| 3.3 uF @ 25V | } | 15 ea. for \$2.00 | | | | | | | | | | | | | | | | | | | | | | | | | | | | | | | | | | | | | | | | | | | | | | | | | | | | | | | | | | | | | | | | | | | | | | | |
| 1 uF @ 35V | | | | | | | | | | | | | | | | | | | | | | | | | | | | | | | | | | | | | | | | | | | | | | | | | | | | | | | | | | | | | | | | | | | | | | | | | |
| 2 uF @ 150V | | | | | | | | | | | | | | | | | | | | | | | | | | | | | | | | | | | | | | | | | | | | | | | | | | | | | | | | | | | | | | | | | | | | | | | | | |
| 25 uF @ 25V | | | | | | | | | | | | | | | | | | | | | | | | | | | | | | | | | | | | | | | | | | | | | | | | | | | | | | | | | | | | | | | | | | | | | | | | | |
| 3 uF @ 50V | | | | | | | | | | | | | | | | | | | | | | | | | | | | | | | | | | | | | | | | | | | | | | | | | | | | | | | | | | | | | | | | | | | | | | | | | |
| 5 uF @ 50V | } | 10 ea. for \$2.00 | | | | | | | | | | | | | | | | | | | | | | | | | | | | | | | | | | | | | | | | | | | | | | | | | | | | | | | | | | | | | | | | | | | | | | | |
| 10 uF @ 50V | | | | | | | | | | | | | | | | | | | | | | | | | | | | | | | | | | | | | | | | | | | | | | | | | | | | | | | | | | | | | | | | | | | | | | | | | |
| 250 uF @ 25V | | | | | | | | | | | | | | | | | | | | | | | | | | | | | | | | | | | | | | | | | | | | | | | | | | | | | | | | | | | | | | | | | | | | | | | | | |
| 100 uF @ 50V | | | | | | | | | | | | | | | | | | | | | | | | | | | | | | | | | | | | | | | | | | | | | | | | | | | | | | | | | | | | | | | | | | | | | | | | | |
| 50 uF @ 75V | | | | | | | | | | | | | | | | | | | | | | | | | | | | | | | | | | | | | | | | | | | | | | | | | | | | | | | | | | | | | | | | | | | | | | | | | |

TERMS: All material guaranteed • If for any reason you are not satisfied, our products may be returned within 10 days for a full refund (less shipping). Please add \$3 for shipping and handling on all orders. Additional 5% charge for shipping any item over 5 lbs. COD's accepted for orders totaling \$50.00 or more. All orders shipped UPS unless otherwise specified. Florida residents please add 4% sales tax. Minimum order \$15.00.

EQUIPMENT / COMPONENTS / WIRE & CABLE / ACCESSORIES

SEMICONDUCTORS SURPLUS

2822 North 32nd Street/Unit -1 Phoenix, Arizona 85008 (602) 956-9423

We accept checks, MasterCharge, and Visa

Prices subject to change without notice



ORDERING INSTRUCTIONS

Check, money order, credit cards, or COD orders welcome. (Mastercharge and VISA only)
 No personal checks or certified personal checks for foreign countries accepted. Money order or cashier's check in U.S. funds only. No COD available to any foreign country. Letters of credit are not acceptable. COD's by UPS will be charged a \$2.00 handling charge plus shipping. COD by mail will be charged \$1.00 handling charge, plus COD charges by post office, plus shipping. Minimum shipping by UPS is \$2.00 and 35¢ insurance per \$100.00. Please allow extra shipping charges for heavy items. All parts returned due to customer error will be subject to a 15% restock charge. Claims must be made within ten (10) days after receipt of parcel. All requests must include defective material, invoice number and date.

\$10.00 MINIMUM ORDER plus shipping. ORDERS LESS THAN THIS MINIMUM WILL BE RETURNED UNPROCESSED. Thank you.

See December issue of 73 Magazine for first 10 pages of our catalog.

WE ACCEPT MASTERCHARGE, VISA, CHECKS, AND C.O.D.'s PHONE IN YOUR ORDER
 NO ORDERS WILL BE ACCEPTED UNDER \$10.00, NOT INCLUDING SHIPPING!

| | | |
|---|---|--|
| MOTOROLA 2N914/ 8342-2 10/\$1.00 | 5 V 5 Amp REGULATOR #78H05KC \$4.29 each | 2708 E-PROM TMS4116-20JDL 200NS Low power 16K \$ 7.00 TMS2516/2716 450NS Single voltage \$23.95 |
| GE 2N5819/ 34E2516 10/\$1.00 | RCA POWER TRANSISTORS NPN TO-3 CASE #RCS258 Vceo 60 20 Amps Vce 4 250 Watts \$2.99 each | CINCH DB51226-1 CONNECTOR COVERS \$1.10 ea. NEW DB25S RS232 CONNECTORS 4.90 ea. USED DB25P RS232 CONNECTORS 2.50 ea. USED DB25S RS232 CONNECTORS 3.00 ea. |
| MOTOROLA MICRO-T NPN TRANSISTORS MMT70 Pkg. of 5 \$2.00 | TRW RF TRANSISTORS PT3551C 15 W output 12.6 VDC @ 175 MHZ Same as 2N6081 but has no stud. \$3.50 each or 10/\$29.00 | NEW POWER SUPPLYS STANDARD POWER INCORPORATED Model SPS-120-5 5 VDC @ 12 Amps 7' long x 5' high x 7' deep \$59.95 each |
| MOTOROLA MICRO-T NPN TRANSISTORS MMT74 700 MHZ 12 V \$1.00 MMT2857 1000 MHZ 15 V 1.99 FMT2060 1000 MHZ 10 V 1.25 | MOTOROLA IC's MC1550G \$1.50 MC1590G 6.00 MC4024P 3.82 MC4044P 3.82 | NEW MICROLAB/FXR WAVEGUIDE SWITCHES Model RQ-A62 X-Band \$89.99 each |
| NEW RF TRANSISTORS CTC CD3495 \$10.99 CTC CD3435 20.10 CTC A50-12 20.10 MRF902 12.50 MRF455 12.65 MRF455A 12.65 MRF454 17.99 MRF454A 20.10 MRF452 25.00 MRF240 12.00 MRF238 11.00 | FERRITE ROD 3-30 MHZ 1/4" x 7 1/2" \$2.99 each | WATKINS-JOHNSON COMPACT YIG FILTERS Model WJ-614-15 7.40 to 12.12 GHz \$59.95 each |
| GERMANIUM PNP POWER TRANSISTORS TO-3 CASE #GP1600 will replace the 2N1529 - 2N1560 Cev/BVCEs 75 V Cev/BVECO 60 Ebv/BVEBO 40 Collector current 15A 150W \$3.99 each or 10/\$29.00 12 V 5 Amp REGULATOR #LAS1512A/78H12KC \$5.50 each | DUAL ELEMENT FUSE Slow Blow 3 Amp 3AG Type 8/\$1.00 | MOTOROLA HIGH FREQUENCY TRANSISTORS AND DIODES MRF901 NPN 2.5dB @ 1.0 GHz \$ 3.99 each MRF902 NPN 2.0dB @ 1.0 GHz 12.50 each MRF911 NPN 12.5dB @ 1 GHz 4.99 each MBD101 1.99 each MB1101 4.99 each HP2835/1N5711 1.99 each |
| | NEW TRANSCO COAX RELAYS SPDT 28 VDC #13730 \$39.95 each | SPECIAL |
| | NEW RF SWITCHES by MICROWAVE ASSOCIATES #MA-7501-DNM \$69.95 each | L.E.D. DIGITAL CLOCKS made by SPARTUS Sold AS IS. NO RETURNS. All 'work' but have minor problems. Can also be used as spare parts or to experiment with. Take a chance for only \$4.99 each. "Work" = plug it in and the LED's light up |

We now have available a bunch of goodies too good to bypass. Items are limited so order today

Call Your Phone Order in Today

**MINI KITS - YOU HAVE SEEN THESE BEFORE NOW
HERE ARE OLD FAVORITE AND NEW ONES TOO.
GREAT FOR THAT AFTERNOON HOBBY.**

| | | | | |
|---|---|--|--|---|
| <p>FM MINI MIKE</p>  <p>A super high performance FM wireless mike kit! Transmits a stable signal up to 300 yards with exceptional audio quality by means of its built in electret mike. Kit includes case, mike, on-off switch, antenna, battery and super instructions. This is the finest unit available.</p> <p>FM-3 Kit \$14.95 FM-3 Wired and Tested 19.95</p> | <p>Color Organ</p> <p>See music come alive! 3 different lights flicker with music. One light each for high, mid-range and lows. Each individually adjustable and drives up to 300 W runs on 110 VAC.</p> <p>Complete kit, ML-1 \$8.95</p> | <p>Video Modulator Kit</p> <p>Converts any TV to video monitor. Super stable, tunable over ch. 4-6. Runs on 5-15V, accepts sid video signal. Best unit on the market! Complete kit VO-1 \$7.95</p> | <p>Led Blinky Kit</p> <p>A great attention getter which alternately flashes 2 jumbo LEDs. Use for name badges, buttons, warning panel lights, anything! Runs on 3 to 15 volts. Complete kit, BL-1 \$2.95</p> | <p>Super Steuth</p> <p>A super sensitive amplifier which will pick up a pin drop at 15 feet! Great for monitoring baby's room or as general purpose amplifier. Full 2 W rms output, runs on 6 to 15 volts, uses 8-45 ohm speaker. Complete kit, BN-9 \$5.95</p> |
| | <p>CPO-1</p> <p>Runs on 3-12 Vdc 1 wall out, 1 KHZ good for CPO. Alarm, Audio Oscillator. Complete kit \$2.95</p> | <p>Siren Kit</p> <p>Produces upward and downward wail characteristic of a police siren. 5 W peak audio output, runs on 3-15 volts, uses 3-45 ohm speaker. Complete kit, SM-3 \$2.95</p> | | |

CLOCK KITS

Your old favorites are here again. Over 7,000 Sold to Date. Be one of the gang and order yours today!

Try your hand at building the finest looking clock on the market. Its satin finish anodized aluminum case looks great anywhere, while six 4" LED digits provide a highly readable display. This is a complete kit, no extras needed, and it only takes 1-2 hours to assemble. Your choice of case colors: silver, gold, black (specify).

Clock kit, 12/24 hour, DC-5 **\$24.95**
Clock with 10 min. ID timer, 12/24 hour, DC-10 **\$29.95**
Alarm clock, 12 hour only, DC-8 **\$29.95**
12V DC car clock, DC-7 **\$29.95**

For wired and tested clocks add \$10.00 to kit price. SPECIFY 12 OR 24 HOUR FORMAT

| | | |
|---|--|--|
| <p>FM Wireless Mike Kit</p>  <p>Transmits up to 300' to any FM broadcast radio, uses any type of mike. Runs on 3 to 9V. Type FM-2 has added sensitive mike preamp stage.</p> <p>FM-1 kit \$3.95 FM-2 kit \$4.95</p> | <p>Whisper Light Kit</p> <p>An interesting kit, small mike picks up sounds and converts them to light. The louder the sound, the brighter the light. Includes mike, controls up to 300 W, runs on 110 VAC. Complete kit, WL-1 \$6.95</p> | <p>Tone Decoder</p> <p>A complete tone decoder on a single PC board. Features 400-5000 Hz adjustable range via 20 turn pot, voltage regulation, 567 IC. Useful for touch-tone burst detection, FSK, etc. Can also be used as a stable tone encoder. Runs on 5 to 12 volts. Complete kit, TD-1 \$5.95</p> |
| <p>Universal Timer Kit</p> <p>Provides the basic parts and PC board required to provide a source of precision timing and pulse generation. Uses 555 timer IC and includes a range of parts for most timing needs.</p> <p>UT-5 Kit \$5.95</p> | <p>Mad Blaster Kit</p> <p>Produces LOUD ear shattering and attention getting siren like sound. Can supply up to 15 watts of obnoxious audio. Runs on 6-15 VDC.</p> <p>MB-1 Kit \$4.95</p> | <p>60 Hz Time Base</p> <p>Runs on 15 VDC. Low current (2.5 ma) 1 min month accuracy. TB-7 Kit \$5.50 TB-7 Assy \$9.95</p> |

Car Clock

The UN-KIT, only 5 solder connections

Here's a super looking, rugged and accurate auto clock, which is a snap to build and install. Clock movement is completely assembled - you only solder 3 wires and 2 switches, takes about 15 minutes! Display is bright green with automatic brightness control protocol - assures you of a highly readable display day or night. Comes in a satin finish anodized aluminum case which can be attached 5 different ways using 2 sided tape. Choice of silver, black or gold case (specify).

OC-3 kit, 12 hour format **\$22.95**
OC-3 wired and tested **\$29.95**

| | |
|--|---|
| <p>Calendar Alarm Clock</p> <p>The clock that's got it all! 6-5" LEDs, 12/24 hour, SNOOZE, 24 hour alarm, 4 year calendar, battery backup and lots more. The super 7001 chip is used. Size 5x4x2 inches. Complete kit, less case (not available) \$34.95</p> | <p>Under Dash Car Clock</p> <p>12/24 hour clock in a beautiful plastic case features 6 jumbo RED LEDs, high accuracy (0.01%), easy 3 wire hookup, display blanks with ignition and super instructions. Optional dimmer automatically adjusts display to ambient light level. DC-11 clock with mtg. bracket \$27.95 kit DM-1 dimmer adapter \$2.50 Add \$10.00 Assy. and Test</p> |
|--|---|

Video Terminal

A completely self-contained, stand alone, dot-matrix terminal. Requires only an ASCII keyboard and TV set to become a complete terminal unit. Features are: single XTAL controlled sync and baud rates (to 9600), complete computer and keyboard control of cursor, parity error control and display, accepts and generates serial ASCII plus parallel keyboard input. The 6416 is 64 char. by 16 lines with scrolling upper and lower case (optional) and has 85 232 and 20ma loop-in/loops-out on board. Kits include sockets and complete documentation.

RE 6416 terminal card kit (add \$60.00 for wired unit) **\$189.95**
Lower Case option **\$19.95**
Power Supply **\$14.95**
RF Modulator kit **\$7.95**

PARTS PARADE

IC SPECIALS

| <p>LINEAR</p> <p>301 \$1.35 324 \$1.50 380 \$1.50 555 \$1.45 556 \$1.00 565 \$1.00 566 \$1.00 567 \$1.25 741 10/\$2.00 1458 \$1.50 3900 \$1.50 3914 \$2.95 8738 \$2.95</p> | <p>TTL</p> <p>74S00 \$1.40 7447 \$1.65 7475 \$1.50 7490 \$1.50 74196 \$1.35</p> | <p>Resistor Ass't</p> <p>Assortment of Popular values - 1/4 watt. Cut lead for PC mounting, 1/2" center, 1/2" leads, bag of 300 or more \$1.50</p> | <p>Crystals</p> <p>3579545 MHZ \$1.50 10 00000 MHZ \$5.00 5 248800 MHZ \$5.00</p> | | | | | | | | | | | | | | | | | | |
|---|--|--|--|----------|----------|--------------|-------------|--------------|-----------------------------|---------------------|--------------------------------|------------------------|---------------------|------------------------------|--------------------------|---------------------|--------------------------------|------------------------|--|-----------------------------------|--------------------------|
| <p>CMOS</p> <p>4011 .50 4013 .50 4046 \$1.85 4049 .50 4059 \$9.00 4511 \$2.00 4518 \$1.35 5639 \$1.75</p> | <p>SPECIAL</p> <p>11C90 \$15.00 10116 \$1.25 7208 \$17.50 7207A \$5.50 7216D \$21.00 7107C \$12.50 5314 \$2.95 5375AB/G \$2.95 7001 \$6.50</p> | <p>Switches</p> <p>Mini toggle SPDT \$1.00 Red Pushbuttons N/O 3/\$1.00</p> | <p>AC Adapters</p> <p>Good for clocks, nicad chargers, all 110 VAC plug one end.</p> <p>8 5 vdc @ 20 mA \$1.50 16 vdc @ 160mA \$2.00 12 vdc @ 250mA \$3.00</p> | | | | | | | | | | | | | | | | | | |
| <p>FERRITE BEADS</p> <p>With info and specs 15/\$1.00 6 Hole Balun Beads \$81.00</p> | <p>Sockets</p> <p>8 Pin 10/\$2.00 14 Pin 10/\$2.00 16 Pin 10/\$2.00 24 Pin 4/\$2.00 28 Pin 4/\$2.00 40 Pin 3/\$2.00</p> | <p>Earphones</p> <p>3' leads, 8 ohm, good for small tone speakers, alarm clocks, etc. 5 for \$1.00</p> | <p>AC Outlet</p> <p>Panel Mount with Leads 4/\$1.00</p> | | | | | | | | | | | | | | | | | | |
| <p>TRANSISTORS</p> <p>2N3904 NPN 15/\$1.00 2N3906 PNP 15/\$1.00 2N4403 PNP 15/\$1.00 2N4410 PNP 15/\$1.00 2N4516 FET 4/\$1.00 2N5401 PNP 5/\$1.00 2N5402 C-F 4/\$1.00 2N3771 NPN Silicon 15/\$1.00 2N5179 UHF NPN 3/\$2.00 Power Tab NPN 40W 3/\$1.00 Power Tab PNP 40W 3/\$1.00 MPP 102/2N5484 5/\$1.00 NPN 3904 Type 50/\$2.50 PNP 3906 Type 50/\$2.50 2N3055 8/\$1.00 2N2646 UJT 3/\$2.00</p> | <p>Diodes</p> <p>5.1 V Zener 20/\$1.00 1N914 Type 50/\$1.00 1KV 2Amp 8/\$1.00 100V 1Amp 15/\$1.00</p> | <p>Slugs Tuned Coils</p> <p>Small 3/16" Hex Slugs turned coil 3 turns 10 for \$1.00</p> | <p>Capacitors</p> <table border="1"> <tr> <th>TANTALUM</th> <th>ALUMINUM</th> <th>DISK CERAMIC</th> </tr> <tr> <td>Ogged Epoxy</td> <td>Electrolytic</td> <td>01 16V DIA 20/\$1.00</td> </tr> <tr> <td>1.5 uF 25V 3/\$1.00</td> <td>1000 uF 16V Radial 1.50</td> <td>1 16V 15/\$1.00</td> </tr> <tr> <td>1.8 uF 25V 3/\$1.00</td> <td>500 uF 20V Axial 1.50</td> <td>100 16V 20/\$1.00</td> </tr> <tr> <td>.22 uF 25V 3/\$1.00</td> <td>150 uF 16V Axial \$1.00</td> <td>100pF 20/\$1.00</td> </tr> <tr> <td></td> <td>10 uF 15V Radial 10/\$1.00</td> <td>047 16V 20/\$1.00</td> </tr> </table> | TANTALUM | ALUMINUM | DISK CERAMIC | Ogged Epoxy | Electrolytic | 01 16V DIA 20/\$1.00 | 1.5 uF 25V 3/\$1.00 | 1000 uF 16V Radial 1.50 | 1 16V 15/\$1.00 | 1.8 uF 25V 3/\$1.00 | 500 uF 20V Axial 1.50 | 100 16V 20/\$1.00 | .22 uF 25V 3/\$1.00 | 150 uF 16V Axial \$1.00 | 100pF 20/\$1.00 | | 10 uF 15V Radial 10/\$1.00 | 047 16V 20/\$1.00 |
| TANTALUM | ALUMINUM | DISK CERAMIC | | | | | | | | | | | | | | | | | | | |
| Ogged Epoxy | Electrolytic | 01 16V DIA 20/\$1.00 | | | | | | | | | | | | | | | | | | | |
| 1.5 uF 25V 3/\$1.00 | 1000 uF 16V Radial 1.50 | 1 16V 15/\$1.00 | | | | | | | | | | | | | | | | | | | |
| 1.8 uF 25V 3/\$1.00 | 500 uF 20V Axial 1.50 | 100 16V 20/\$1.00 | | | | | | | | | | | | | | | | | | | |
| .22 uF 25V 3/\$1.00 | 150 uF 16V Axial \$1.00 | 100pF 20/\$1.00 | | | | | | | | | | | | | | | | | | | |
| | 10 uF 15V Radial 10/\$1.00 | 047 16V 20/\$1.00 | | | | | | | | | | | | | | | | | | | |
| <p>25 AMP 100V Bridge \$1.50 each</p> <p>Mini-Bridge 50V 1 AMP 2 for \$1.00</p> | <p>Crystal Microphone</p> <p>Small 1" diameter 1/2" thick crystal mike cartridge \$7.75</p> | <p>OC-OC Converter</p> <p>-5 vdc input prod -9 vdc @ 30ma -9 vdc prod/uces -15 vdc @ 35ma \$1.25</p> | <p>Ceramic IF Filters</p> <p>Mini ceramic filters 7 kHz B.W. 455 kHz \$1.50 ea.</p> | | | | | | | | | | | | | | | | | | |
| <p>Parts Bag</p> <p>Ass't of chokes, disc caps, tantal resistors, transistors, diodes, MICA caps, etc. sm bag (100 pc) \$1.00 lg bag (300 pc) \$2.50</p> | <p>Coax Connector</p> <p>Chassis mount BNC type \$1.00</p> | <p>9 Volt Battery Clips</p> <p>Nice quality clips 5 for \$1.00 1/2" Rubber Grommets 10 for \$1.00</p> | <p>Trimmer Caps</p> <p>Stable 3-40 pf Polypropylene .50 ea.</p> | | | | | | | | | | | | | | | | | | |
| <p>Leds - your choice, please specify</p> <p>Mini Red, Jumbo Red, High Intensity Red, Illuminator Red 8/\$1 Mini Yellow, Jumbo Yellow, Jumbo Green 6/\$1</p> | <p>Veractors</p> <p>Motorola MV 2209 30 PF Nominal cap 20-80 PF - Tunable range - .50 each or 3/\$1.00</p> | <p>Shrink Tubing Nubs</p> <p>Nice pre-cut pcs of shrink tube 1" x 1/2" Shrink to 1/4" Great for splices 50/\$1.00</p> | <p>Mini TO-92 Heat Sinks</p> <p>Thermalloy Brand 5 for \$1.00 To-220 Heat Sinks 3 for \$1.00</p> | | | | | | | | | | | | | | | | | | |

Audio Prescaler

Make high resolution audio measurements, great for musical instrument tuning, PL tones, etc. Multiplies audio UP in frequency, selectable x10 or x100, gives 01 Hz resolution with 1 sec gate time! High sensitivity of 25 mv 1 meg input z and built-in filtering gives great performance. Runs on 9V battery, all CMOS.

PS-2 kit **\$29.95**
PS-2 wired **\$39.95**

600 MHz PRESCALER



Extend the range of your counter to 600 MHz. Works with all counters. Less than 150 mv sensitivity, specify -10 or -100.

Wired, tested, PS-1B **\$59.95**
Kit, PS-1B **\$44.95**

30 Watt 2 mtr PWR AMP

Simple Class C power amp features 8 times power gain, 1 W in for 8 out, 2 W in for 15 out, 4W in for 30 out. Max output of 35 W, incredible value, complete with all parts, less case and T-R relay.

PA-1, 30 W pwr amp kit **\$22.95**
TR-1, RF sensed T-R relay kit **6.95**

MRF-238 transistor as used in PA-1 8-10db gain 150 mhz **\$11.95**

Power Supply Kit

Complete triple regulated power supply provides variable 6 to 18 volts at 200 ma and .5 at 1 Amp. Excellent load regulation, good filtering and small size. Less transformers, requires 6.3 V 1 A 1 and 24 VCT. Complete kit, PS-3LT **\$6.95**

RF actuated relay senses RF (1W) and closes DPDT relay.

For RF sensed T-R relay TR-1 Kit **\$6.95**

OP-AMP Special

BI-FET LF 13741 - Direct pin for pin 741 compatible, but 500,000 MEG input z, super low 50 pa input current, low power drain.

50 for only **\$9.00** 10 for **\$2.00**

| | |
|--------------------|--------------------|
| 78MG \$1.25 | 7812 \$1.00 |
| 79MG \$1.25 | 7815 \$1.00 |
| 723 \$1.00 | 7905 \$1.25 |
| 309K \$1.15 | 7912 \$1.25 |
| 7805 \$1.00 | 7915 \$1.25 |

Opto Isolators - 4N28 type

Opto Isolators - Photo diode + LED **\$1.00 ea.**

Molex Pins

Molex already pre-cut in length of 7. Perfect for 14 pin sockets. 20 stripe for **\$1.00**

CDS Photo Cells

Resistance varies with light. 250 ohms to over 3 meg **3 for \$1.00**



SPECTRONICS, INC.

1009 Garfield St., Oak Park, Illinois • 60304

(312) 848-6777 ✓67

OUR BEST-SELLING MULTI-BAND!



AS LOW AS
\$73⁷⁵

- One half the length of conventional half-wave dipoles
- Multi-band, Multi-frequency
- Maximum efficiency — no traps, loading coils, or stubs
- Fully assembled and pre-tuned — no measuring, no cutting
- All weather rated — 1 KW AM, 2.5 KW CW or PEP SSB
- Proven performance — more than 10,000 have been delivered
- Permit use of the full capabilities of today's 5-band xcvrs
- One feedline for operation on all bands

80-40HD/A 80/40 Mtr bands (69) 77.25 c
 75/40HD/A 75/40 Mtr bands (66) 73.75 c
 75-10HD/A 75/40/20/15/10 Mtr (66) 89.95 c
 80-10HD/A 80/40/20/15/10 Mtr (69) ... 94.95 c

BARGAIN FAVORITES!

Famous "W2AU" Balun

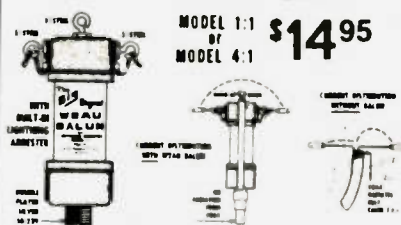

MODEL 1:1 or MODEL 4:1 **\$14⁹⁵**

1. HANDLES FULL 2 KW PEP AND THEN SOME. Broad Banded 3 to 40 Mc
2. HELPS TYPICAL PROBLEMS By Reducing Coax Line Radiation
3. NOW ALL STAINLESS STEEL HARDWARE. 50239 Double Silver Plated
4. IMPROVES F/B RATIO By Reducing Coax Line Pick-Up
5. REPLACES CENTER INSULATOR. Withstands Antenna Pull of Over 600 Lbs.
6. BUILT-IN LIGHTNING ARRESTER. Helps Protect Balun — Could Also Save Your Valuable Gear
7. BUILT-IN HANG-UP HOOK. Ideal For Inverted Vees, Multi-Band Antennas, Dipoles, Beam and Quads

NOW BEING USED BY ALL BRANCHES OF THE U.S. ARMED FORCES, FAA, RCA, CIA, CANADIAN DEFENSE DEPT. PLUS THOUSANDS OF HAMS THE WORLD OVER

Comes in 2 models: 1:1 matches 50 or 75 ohm unbalanced (coax line) to 50 or 75 ohm balanced load 4:1 model matches 50 or 75 ohm unbalanced (coax line) to 200 or 300 ohm balanced load

Model 1:1 \$14.95 Model 4:1 \$14.95

MODEL 595 **BW**
\$22⁵⁰



Our most popular switch. 6 position, grounds all except selected output circuit. Can be mounted on wall, on desk, or almost anywhere. Good to 150MHz. Wt. 2 lbs.

IMPROVE YOUR RECEPTION!



MODEL PLF-2 **AMECO ALL-BAND PREAMP!**
\$49⁹⁵

- 6-160 Meters
- 20+ dB Gain
- Low Price

MODEL PLF-2 ... Improves weak signals as well as image and spurious rejection of most receivers. Direct switching to rec or preamp. Includes pwr supp. 117 VAC wired & tested **\$49.95**
 MODEL PLF-2E ... 240 VAC 50-60 Hz operation **\$54.95**
 MODEL PT-2 ... For transceiver use. Continuously tunable from 6 to 160 meters. Features dual-gate FET transistor amplifier for improved receiver sensitivity and low noise figure. Requires no transceiver modifications and can handle up to 250W transceiver output. 117 VAC 60 Hz. **\$74.95**
 MODEL PT-2E ... 240 VAC 50-60 Hz operation **\$79.95**

2 METER ANTENNAS at BARGAIN PRICES!!

hy-gain 3 db GAIN MAGNETIC MOUNT
 ONLY **\$19.⁹⁵**
 Model 287 Wt. 2.5 lbs.

An economical alternative to drilling a hole. A magnetic antenna by a name you can trust at a low, low price.

Model 286 Same but trunk lid. \$15.95 b

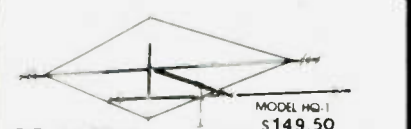

MODEL HQ-1 **\$149.50**
CRAMPED FOR SPACE? **Mini-Products, Inc.**

Then you want the antenna that's known around the world for its small size and superior performance... The Multiband HYBRID QUAD for 6-10-15 & 20 meters. • FEED LINE—50 OHMS

- WING SPAN—11 FT.
- BOOM—54 INCHES LONG
- WIND AREA—1.5 SQ. FT.
- 1200 WATTS P.E.P. INPUT TO FINAL



2 MTR DUCKIES

- Model HM-4. Has 5/16" 32 thread. Fits Motorola HT's, ICOM IC215 and Standard 146A **\$7.00**
- Model HM-5. Same as above, but with PL-259 connector **\$7.00**
- Model HM-226. Same, with TNC connector for Wilson 1405 **\$18.50**
- Model HM-227. Same, but with BNC connector termination **\$12.00**
- Model HM-228. With F connector for Wilson 1402 & Tempo **\$11.50**

At last! An inexpensive, omni directional, 144-148 MHz, 1/2 wave antenna. Fits 1 1/4" mast, 50 ohm imp. A good antenna at a very affordable price.



ONLY **\$29⁹⁵**

MFJ-101 24 HOUR SOLID STATE DIGITAL CLOCK.

AVERAGE SHIPPING COST GUIDE

(Continental U.S.) Items sent UPS whenever possible. Please estimate the shipping charges for your order. Any excess payment over 25c will be refunded or credited. Underpayment will be billed or sent collect. For insurance add 25c for each \$100.00 value over the first \$100.00

| WT. CALL AREA | ESTIMATED WEIGHT CODING | | | |
|---------------|-------------------------|-------|-------|-------|
| 1 lb | 1.2 | 1.4 | 1.7 | 2.0 |
| 5 lbs | 1.50 | 2.00 | 2.50 | 3.00 |
| 10 lbs | 2.25 | 3.25 | 4.25 | 5.25 |
| 20 lbs | 3.50 | 5.00 | 6.50 | 8.00 |
| 30 lbs | 5.00 | 7.00 | 9.00 | 11.00 |
| 50 lbs | 8.00 | 12.00 | 16.00 | 20.00 |

After the price of each item you will find a letter (i.e., 1B 90). To make it easier to figure shipping costs, these letters indicate the approximate weight of the item as follows:

| | |
|-------------------|--------------|
| a. Less than 1 lb | b. 10-30 lbs |
| c. 1-5 lbs | d. 30-40 lbs |
| e. 5-10 lbs | f. 40-50 lbs |
| g. 10-20 lbs | |

NOTE: INTERNATIONAL ORDERS write for Proforma Invoice. ITEMS MARKED * will be sent track collect.

AZDEN ★ NEW! ★ AZDEN ★ NEW! ★ AZDEN ★ NEW! ★ AZDEN

THE GIANT **AZDEN**® COMPANY

REVOLUTIONIZES THE STATE OF THE ART

AWE AND AZDEN. INTRODUCE THE BRILLIANT NEW PCS-2800

MICROCOMPUTER CONTROLLED

SUPERIOR COMMERCIAL GRADE

10 METER
FM TRANSCEIVER

INTRODUCTORY
PRICE

\$299⁰⁰

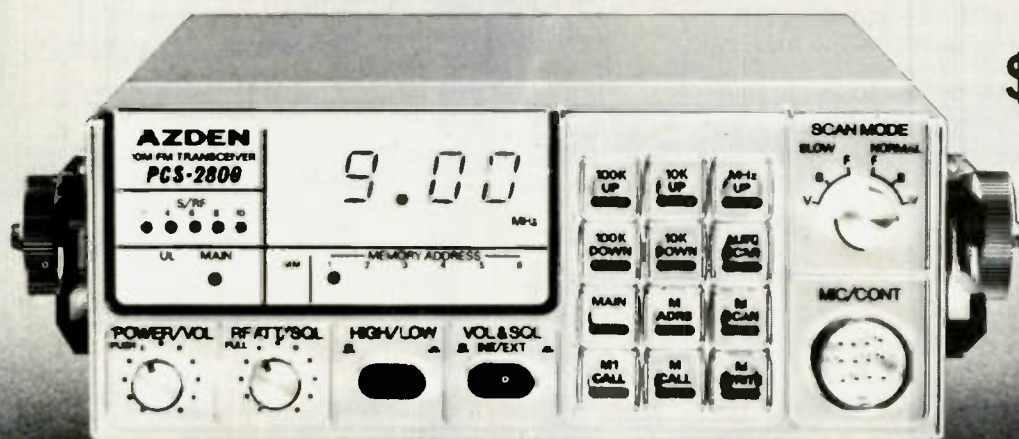

COMPARE THESE FEATURES
WITH ANY UNIT AT ANY PRICE

- **FREQUENCY RANGE:** Receive and transmit: 28.000 to 29.995 MHz, 10KHz steps with built-in +100 KHz repeater offset.
- **ALL SOLID STATE-CMOS PL DIGITAL SYNTHESIZED.**
- **SIZE: UNBELIEVABLE! ONLY 6 3/4" x 2 3/8" x 9 3/4" COMPARE!**
- **MICROCOMPUTER CONTROLLED:** All scanning and frequency-control functions are performed by microcomputer.
- **DETACHABLE HEAD:** The control head may be separated from the radio for use in limited spaces and for security purposes.
- **SIX-C-HANNEL MEMORY:** Each memory is re-programmable. Memory is retained even when the unit is turned off.
- **MEMORY SCAN:** The six channels may be scanned in either the "busy" or "vacant" modes for quick, easy location of an occupied or unoccupied frequency. **AUTO RESUME. COMPARE!**
- **FULL-BAND SCAN:** All channels may be scanned in either "busy" or "vacant" mode. This is especially useful for locating repeater frequencies in an unfamiliar area. **AUTO RESUME. COMPARE!**
- **INSTANT MEMORY-1 RECALL:** By pressing a button on the microphone or front panel, memory channel 1 may be recalled for immediate use.
- **MIC-CONTROLLED VOLUME AND SQUELCH:** Volume and squelch can be adjusted from the microphone for convenience in mobile operation.
- **DIRECT FREQUENCY READOUT:** LED display shows operating frequency, NOT channel number. **COMPARE!**
- **TEN (10) WATTS OUTPUT:** Also 1 watt low power for shorter

- distance communications. LED readout display power select on when transmitting.
- **DIGITAL S/R F METER:** LEDs indicate signal strength and power output. No more mechanical meter movements to fall apart!
- **LARGE 1/2-INCH LED DISPLAY:** Easy-to-read frequency display minimizes "eyes-off-the-road" time.
- **PUSHBUTTON FREQUENCY CONTROL FROM MIC OR FRONT PANEL:** Any frequency may be selected by pressing a microphone or front-panel switch.
- **SUPERIOR RECEIVER SENSITIVITY:** 0.28 uV for 20-CB audio. The squelch sensitivity is superb requiring less than 10 uV to open. The receiver audio circuits are designed and built to exacting specifications, resulting in unsurpassed received-signal intelligibility.
- **TRUE FM, NOT PHASE MODULATION:** Transmitted audio quality is optimized by the same high standard of design and construction as is found in the receiver. The microphone amplifier and compression circuits offer intelligibility second to none.
- **OTHER FEATURES:** Dynamic Microphone, built-in speaker, mobile mounting bracket, external remote speaker jack (rear and radio) and much, much more. All cords, plugs, fuses, microphone hanger, etc. Included. Weight 6 lbs.
- **ACCESSORIES:** 15' REMOTE CABLE...\$29.95. FMPS-4R A/C POWER SUPPLY...\$39.95. TOUCHTONE MIC. KIT...\$39.95. EXTERNAL SPEAKER...\$18.00.

AMATEUR-WHOLESALE ELECTRONICS ORDER NOW TO CALL FREE

8817 S W 129th Terrace, Miami, Florida 33176
Telephone (305) 233-3637 • Telex: 80-3356
HOURS: 8-6, Mon. - Thurs.

U.S. DISTRIBUTOR
DEALER INQUIRIES INVITED

1-800-327-3102

CREDIT CARD HOLDERS MAY USE OUR TOLL FREE ORDERING NJM3ER.

Low Cost...High Performance

DIGITAL MULTIMETER



\$99.95 WIRED

Low cost, high performance, that's the DM-700. Unlike some of the hobby grade DMMs available, the DM-700 offers professional quality performance and appearance at a hobbyist price. It features 26 different ranges and 5 functions, all arranged in a convenient, easy to use format. Measurements are displayed on a large 3½ digit, ½ inch high LED display, with automatic decimal placement, automatic polarity, and overrange indication. You can depend upon the DM-700, state-of-the-art components such as a precision laser trimmed resistor array, semiconductor band gap reference, and reliable LSI circuitry insure lab quality performance for years to come. Basic DC volts and ohms accuracy is 0.1%, and you can measure voltage all the way from 100 μv to 1000 volts, current from 0.1 μa to 2.0 amps and resistance from 0.1 ohms to 20 megohms. Overload protection is inherent in the design of the DM-700, 1250 volts, AC or DC on all ranges, making it virtually goof proof. Power is supplied by four 'C' size cells, making the DM-700 portable, and, as options, a nicad battery pack and AC adapter are available. The DM-700 features a handsome, jet black, rugged ABS case with convenient retractable tilt bail. All factory wired units are covered by a one year limited warranty and kits have a 90 day parts warranty.

Order a DM-700, examine it for 10 days, and if you're not satisfied in every way, return it in original form for a prompt refund.

Specifications

DC and AC volts: 100 μv to 1000 Volts, 5 ranges
 DC and AC current: 0.1 μA to 2.0 Amps, 5 ranges
 Resistance: 0.1Ω to 20 megohms, 6 ranges
 Input protection: 1250 volts AC/DC all ranges fuse protected for overcurrent
 Input impedance: 10 megohms, DC/AC volts
 Display: 3½ digits, 0.5 inch LED
 Accuracy: 0.1% basic DC volts
 Power: 4 'C' cells, optional nicad pack, or AC adapter
 Size: 6"W x 3"H x 6"D
 Weight: 2 lbs with batteries

Prices

| | |
|------------------------------------|---------|
| DM-700 wired + tested | \$99.95 |
| DM-700 kit form | 79.95 |
| AC adapter/charger | 4.95 |
| Nicad pack with AC adapter/charger | 14.95 |
| Probe kit | 3.95 |

TERMS: Satisfaction guaranteed or money refunded. COD, add \$1.50. Minimum order \$6.00. Orders under \$10.00, add \$.75. Add 5% for postage, insurance, handling. Overseas, add 15%. NY residents, add 7% tax.



600 mHz COUNTER



\$99.95 WIRED

The CT-70 breaks the price barrier on lab quality frequency counters. No longer do you have to settle for a kit, half-kit or poor performance, the CT-70 is completely wired and tested, features professional quality construction and specifications, plus is covered by a one year warranty. Power for the CT-70 is provided by four 'AA' size batteries or 12 volts, AC or DC, available as options are a nicad battery pack, and AC adapter. Three selectable frequency ranges, each with its own pre-amp, enable you to make accurate measurements from less than 10 Hz to greater than 600 mHz. All switches are conveniently located on the front panel for ease of operation, and a single input jack eliminates the need to change cables as different ranges are selected. Accurate readings are insured by the use of a large 0.4 inch seven digit LED display, a 10 ppm TCXO time base and a handy LED gate light indicator.

The CT-70 is the answer to all your measurement needs, in the field, in the lab, or in the ham shack. Order yours today, examine it for 10 days, if you're not completely satisfied, return the unit for a prompt and courteous refund.

Specifications

Frequency range: 10 Hz to over 600 mHz
 Sensitivity: less than 25 mv to 150 mHz
 less than 150 mv to 600 mHz
 Stability: 1.0 ppm, 20-40 °C, 0.05 ppm/°C TCXO crystal time base
 Display: 7 digits, LED, 0.4 inch height
 Input protection: 50 VAC to 60 mHz, 10 VAC to 600 mHz
 Input impedance: 1 megohm, 6 and 60 mHz ranges 50 ohms, 600 mHz range
 Power: 4 'AA' cells, 12 V AC DC
 Gate: 0.1 sec and 1.0 sec LED gate light
 Decimal point: Automatic, all ranges
 Size: 5"W x 1½"H x 5½"D
 Weight: 1 lb with batteries

Prices

| | |
|------------------------------------|---------|
| CT 70 wired + tested | \$99.95 |
| CT 70 kit form | 75.95 |
| AC adapter | 4.95 |
| Nicad pack with AC adapter/charger | 9.95 |
| Telescopic whip antenna - BNC plug | 7.95 |
| Tilt bail assembly | 3.95 |

ramsey electronics

✓ 62 BOX 4072, ROCHESTER, N.Y. 14610
 PHONE ORDERS CALL
 (716) 271-6487

SEMICONDUCTORS & MORE!

While the CompuPro™ and Musikit™ lines continue to be our big sellers, we haven't forgotten that we started in this business by offering good parts at a good price. Now with our volume buying, the parts and prices are even better... and just wait until you see our socket special!

1A/TO-220 VOLTAGE REGULATORS

| | | |
|-------|-------|--------|
| 7805 | + 5V | \$1.38 |
| 7806 | + 6V | 1.38 |
| 7808 | + 8V | 1.38 |
| 7812 | + 12V | 1.38 |
| 7815 | + 15V | 1.38 |
| 7818 | + 18V | 1.38 |
| 7824 | + 24V | 1.38 |
| 7905 | - 5V | 1.49 |
| 7906 | - 6V | 1.49 |
| 7908 | - 8V | 1.49 |
| 7912 | - 12V | 1.49 |
| 7915 | - 15V | 1.49 |
| 7918 | - 18V | 1.49 |
| 7924 | - 24V | 1.49 |
| LM317 | + adj | 2.25 |

LINEAR ICS

(H = round, M = minidip,
D = dip, K = power package)

| | |
|-------|--------|
| 201H | \$0.55 |
| 201M | 0.55 |
| 301H | 0.40 |
| 301M | 0.30 |
| 304H | 0.83 |
| 305H | 0.58 |
| 308H | 1.10 |
| 308M | 0.55 |
| 309K | 1.38 |
| 311H | 0.87 |
| 311M | 0.56 |
| 316H | 2.75 |
| 324D | 1.65 |
| 339D | 1.65 |
| 373D | 3.25 |
| 377D | 1.76 |
| 380D | 1.05 |
| 380M | 0.94 |
| 381D | 1.65 |
| 382D | 1.27 |
| 531M | 1.38 |
| 540H | 3.02 |
| 556D | 0.66 |
| 565D | 1.05 |
| 566M | 1.71 |
| 567M | 1.05 |
| 703M | 0.94 |
| 706D | 1.05 |
| 709H | 0.39 |
| 723D | 0.61 |
| 733H | 0.94 |
| 741H | 0.39 |
| 741M | 0.28 |
| 747D | 0.74 |
| 748H | 0.36 |
| 1496D | 0.99 |
| 1556H | 1.65 |
| 1556M | 1.65 |
| 1558M | 0.61 |
| 3026H | 1.38 |
| 4136D | 2.15 |
| 4195K | 2.48 |
| 4250M | 1.32 |
| 4558M | 0.61 |
| 4739D | 1.82 |
| 4741H | 0.55 |

TRANSISTORS AND FETS

| | | |
|---|-----------------------------------|----------|
| Special! Gen purp NPN (sim 2N3904) | 100/\$7.95 | |
| Special! Gen purp PNP (sim 2N3908) | 100/\$8.95 | |
| 2N2221 | NPN TO-18 unmarked | 7/\$1.00 |
| 2N2222 | PNP TO-18 unmarked | 5/\$1.00 |
| 2N2907A | PNP plastic house # | 5/\$1.00 |
| 2N3055 | NPN TO-3 house# | 1/\$0.75 |
| 2N3904 | NPN TO-105 house # | 5/\$1.00 |
| 2N3906 | PNP TO-105 house # | 5/\$1.00 |
| 2N4124 | 30V/350 mW TO-92 | 3/\$1.00 |
| 2N4304 | TO-18 plastic N-JFET gen purp | 2/\$1.00 |
| 2N4400 | NPN plastic house # | 5/\$1.00 |
| 2N4917 | PNP TO-106 | 5/\$1.00 |
| 2N4946 | NPN TO-106 | 6/\$1.00 |
| 2N5227 | PNP TO-92 30V | 6/\$1.00 |
| 2N5306 | NPN TO-92 darlington | 3/\$1.00 |
| 2N5449 | NPN | 6/\$1.00 |
| 2N5484 | RF N-JFET | 3/\$1.00 |
| D41D1 | PNP TO-220 1A max | 1/\$0.50 |
| D44C4 | NPN TO-220 4A/55V | 1/\$0.75 |
| D45C4 | PNP TO-220 4A/55V | 1/\$0.75 |
| D45H8 | PNP TO-220 10A/60V | 3/\$2.00 |
| MPS3694 | NPN gen purp | 4/\$1.00 |
| FPT100 | Phototransistor | 1/\$0.50 |
| FET-2 | Dual N-JFET TO-18 sim 2N4416 | 3/\$1.00 |
| FET-3 | Dual N-JFET lo noise audio | 2/\$1.00 |
| FET-6 | Gen purp dual gate MOSFET house # | 3/\$2.00 |

74LS TTL

| | |
|---------|--------|
| 74LS00 | \$0.34 |
| 74LS01 | 0.34 |
| 74LS02 | 0.34 |
| 74LS04 | 0.38 |
| 74LS05 | 0.44 |
| 74LS08 | 0.34 |
| 74LS10 | 0.34 |
| 74LS11 | 0.40 |
| 74LS12 | 0.34 |
| 74LS14 | 2.20 |
| 74LS15 | 0.40 |
| 74LS20 | 0.34 |
| 74LS21 | 0.40 |
| 74LS22 | 0.40 |
| 74LS26 | 0.48 |
| 74LS27 | 0.42 |
| 74LS30 | 0.34 |
| 74LS32 | 0.46 |
| 74LS33 | 0.60 |
| 74LS37 | 0.48 |
| 74LS38 | 0.48 |
| 74LS42 | 1.56 |
| 74LS47 | 1.68 |
| 74LS48 | 1.68 |
| 74LS74 | 0.54 |
| 74LS75 | 0.82 |
| 74LS76 | 0.50 |
| 74LS86 | 0.58 |
| 74LS109 | 0.62 |
| 74LS123 | 1.70 |
| 74LS125 | 0.87 |
| 74LS126 | 0.87 |
| 74LS132 | 1.50 |
| 74LS136 | 0.69 |
| 74LS138 | 1.87 |
| 74LS139 | 1.87 |
| 74LS151 | 1.66 |
| 74LS154 | 2.10 |
| 74LS155 | 1.87 |
| 74LS157 | 1.57 |
| 74LS160 | 2.20 |
| 74LS161 | 2.18 |
| 74LS162 | 2.20 |
| 74LS163 | 2.18 |
| 74LS168 | 3.75 |
| 74LS169 | 3.75 |
| 74LS173 | 2.08 |
| 74LS174 | 2.05 |
| 74LS175 | 1.95 |
| 74LS181 | 3.50 |
| 74LS192 | 3.05 |
| 74LS195 | 1.87 |
| 74LS221 | 1.70 |
| 74LS240 | 2.50 |
| 74LS241 | 2.50 |
| 74LS244 | 2.50 |
| 74LS257 | 1.95 |
| 74LS258 | 2.02 |
| 74LS266 | 0.69 |
| 74LS273 | 2.91 |
| 74LS283 | 2.02 |
| 74LS365 | 0.88 |
| 74LS366 | 0.88 |
| 74LS367 | 0.88 |
| 74LS368 | 0.88 |
| 74LS386 | 0.69 |
| 80LS95 | 0.88 |
| 80LS96 | 0.88 |
| 80LS97 | 0.88 |
| 80LS98 | 0.88 |
| 81LS95 | 2.10 |
| 81LS96 | 2.10 |
| 81LS97 | 2.10 |
| 81LS98 | 2.10 |

SOLDERTAIL SOCKET ★ SPECIAL ★

Now that you've got the ICs, get some sockets at a fantastic price!

| | | | | | |
|---------|-----------|---------|-----------|---------|-----------|
| 14 pin: | 50/\$4.95 | 20 pin: | 40/\$4.95 | 28 pin: | 30/\$4.95 |
| 16 pin: | 50/\$4.95 | 24 pin: | 30/\$4.95 | 40 pin: | 20/\$4.95 |
| 18 pin: | 50/\$4.95 | | | | |

16K DYNAMIC RAM SPECIAL: 8/\$69!

Expand Memory in TRS-80* -I and -II, as well as machines made by Apple, Exidy, Heath H89, newer PETs, etc. Low power, high speed (4 MHz). Add \$3 for 2 dip shunts plus TRS-80* conversion instructions.

*TRS-80 is a trademark of the Tandy Corporation.

THE COMPUPRO "RAM" SERIES OF STATIC MEMORY

Recommended for commercial, industrial, and scientific applications. 4/5 MHz standard operation, no dynamic timing problems, meets all IEEE specifications, low power/high speed chips used throughout, extensive bypassing, careful thermal design.

NOTE: Most CompuPro boards are available in unkit form (sockets, bypass caps pre-soldered in place), assembled, or qualified under the Certified System Component (CSC) high-reliability program (200 hour burn-in, 8 MHz operation, even lower power than standard boards).

| S-100 STANDARD MEMORY | | unkit | asam | CSC |
|---|--|-------|-------|--------|
| 8K RAM IIA | | \$169 | \$189 | \$239 |
| 16K RAM X-16 | | \$329 | \$379 | \$479 |
| 24K RAM XX-24 | | \$449 | \$499 | \$599 |
| 32K RAM X-32 | | \$599 | \$689 | \$789 |
| S-100 EXTENDED ADDRESSING MEMORY | | | | |
| (16/24 address lines; addressable on 4K boundaries) | | | | |
| 16K RAM XIV | | \$299 | \$349 | \$429 |
| SBC/BLC MEMORY | | | | |
| 32K RAM XI | | n/a | n/a | \$1050 |

TERMS: Cal res add tax. Allow 5% shipping; excess refunded. Orders under \$15 add \$1 handling. VISA®/Mastercard® orders (\$25 min) call our 24 hour order desk at (415) 582-0836. COD OK with street address for UPS. Sale prices good through cover month of magazine; other prices are subject to change without notice.

GODBOUT

GODBOUT ELECTRONICS
Bldg. 725, Oakland Airport, CA 94614

FREE FLYER: This ad is only the tip of the iceberg; our catalog tells the rest of story. Add 41 cents in stamps for 1st class delivery. Outside USA, include \$2 to cover postage (refundable with order). Thank you for your business!

ASSOCIATED RADIO

913-381-5900

8012 CONSER BOX 4327

OVERLAND PARK, KANSAS 66204



CALL US WITH YOUR REQUIREMENTS
AMERICA'S NO. 1 Real Amateur Radio Store



**(Associated Wants to TRADE - BUY - SELL
GOT YOUR BEST DEAL? THEN CALL US AT
913-381-5900 - NO TRADE? ASK FOR EXT. 12)**

**NOTE: SEND \$1.00 FOR OUR CURRENT CATALOG
OF NEW AND RECONDITIONED EQUIPMENT.**

***ALSO WE PERIODICALLY PUBLISH A LIST OF
UNSERVICED EQUIPMENT AT GREAT SAVINGS.
A BONANZA FOR THE EXPERIENCED OPERATOR.
TO OBTAIN THE NEXT UNSERVICED BARGAIN LIST,
SEND A SELF ADDRESSED STAMPED ENVELOPE.**

20% DISCOUNT

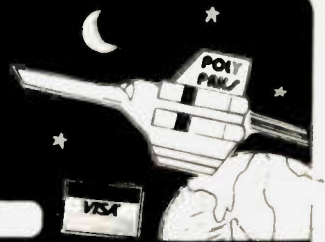

Take 20% Off The Total Price Of Any Item(s) Shown Below

- 20-MOTORS MOTORS, asstd. sizes speeds & types, 1.5-12 volts, (#2551A) \$2.99
- 200-LONG LEAD DISCS, prime, marked caps, assorted material, (#2598) 2.99
- 100-PLASTIC TRANSISTORS, untested, TO-92, asst. types (#2604) 2.99
- 50-SLIDE SWITCHES, various shapes, sizes, and types, (#2726) 2.99
- 75-TRANSISTOR ELECTROLYTICS, epoxy encapsulated, asst. values, (#2747) 2.99
- 25-HALF WATTERS, 100%, color-coded resistors, asst. values, (#3046) 2.99
- 25-SLIDE VOLUME CONTROLS, various values & types, for Hi-Fi, etc. (#3057) 2.99
- 50-UPRIGHT ELECTROS, 100%, assorted values & voltages, marked, (#3226) 2.99
- 20-ROCKER SWITCHES, white rockers, DPDT, solder lugs, 125V 4A, (#3302A) 2.99
- 50-MINI POTS, pc style, single turn, assorted values, (#3345) 2.99
- 20-JUMBO RED LEADS, 3V 10 mA, 100% good material, red dome lense, (#3369) 2.99
- 3-SOUND TRIGGERS, sound activated amp, SCR triggered, on 3" board, (#3625) 2.99
- 50-TRANSISTOR SOCKETS, assortment may include: TO-19, 5, 66, 3, etc. (#3845) 2.99
- 100-CABLE TIES, 4" non-slip white plastic, like Ty-wap, (#5218) 2.99
- 150-FEEDTHRU CAPS, assorted types & sizes, for RF, UHF, etc. (#5668A) 2.99
- 250-WATT RESISTORS, asst. carbons, carbon films, some 5'sers, (#5797A) 2.99
- 100-PLESSY CAPS, ceramic blocks in assorted sizes & values, (#6221) 2.99
- 30-HOBBY LEADS, assorted types & colors, mostly dims, some good, (#6225) 2.99
- 200-PC-SEMICON SPECIAL, assorted semis of all types. Untested material, (#3300) 2.99
- 100-TTLs, 7400 series, incl. gates, flip-flops, etc. untested, (#6226) 2.99
- 5-BRASS LOCKS, with key, 1 1/2" long, for doors, windows, etc. (#6253) 2.99
- 250-MOLEX SOCKETS, "on-a-strip", make your own pc sockets, (#6255) 2.99
- 100-DTL IC's, mostly dual JK flip flops, marked, 100% prime, (#6444) 2.99
- 200-ONE WATTERS, asst. 1W resistors, mostly carbons, some 5'sers, (#6284) 2.99
- 40-INSTRUMENT KNOBS, for half round shafts, some w/ pointers, (#6498) 2.99
- 15-DIGIT READOUTS, flat pak w/bubble gum, 120" high, 14 pin, (#5558) 2.99
- 10-ASST. READOUTS, various types, colors, and styles, (#5862) 2.99
- 15-5 JUMBO LEADS, assorted styles and colors, all new & 100%, (#2079) 2.99
- 4-0-3" DIGITS ON A DISC, com. cathode, mltpls, w/bubble gum, (#1887) 2.99
- 6-8-1/2 DIGIT LED DISPLAY, 1/8" high digits, com. cathode, 2V, 25 mA (#H009) 2.99
- 8-INCANDESCENT READOUTS, asst. 5 & 6 volt, 5/16" high, com. anode, (#6645) 2.99
- 4-0-5" READOUTS, red FND 507, common anode, PC leads, 7-seg. LED, (#2950) 2.99
- 2-RUBBER DUCKIE, scanner antenna, VHF-Hi, 1/8" threaded stud, (#6137) 2.99
- 15-THUMBWHEEL TRIM POTS, snap-in type, assorted values, (#6299) 2.99
- 50-RCA PHONO PLUGS, popular audio/speaker plugs, 100% material, (#3293) 2.99
- 200-PREFORMED HALF WATTERS, resistors, color coded, asst (#6246) 2.99
- 25-CRYSTALS, assorted types, some H6/U, some frequency marked, (#6256) 2.99
- 150-SUBMINI IF TRANSFORMERS, asst. may include: otc, antenna, etc. (#6259) 2.99
- 60-SQUARE OHM RESISTORS, prime resistors, asst. values, grab 'em! (#6261) 2.99
- 30-MICRO MINI REED SWITCHES, 1" long, for alarms, relay systems, etc. (#6263) 2.99
- 200-PC-CAPACITOR SPECIAL, asst. mylars, polys, micas, etc. 100% good, (#6264) 2.99
- 20-PUSHBUTTON ALARM SWITCH, SPST, momentary, NC, w/hardware, (#6267) 2.99
- 500-PC-HARDWARE SURPRISE, (approx.) 1 lb. asst. screws, washers, etc. (#6271) 2.99
- 30-9V BATTERY CLIPS, snap connector, coded, insulated leads, (#6286) 2.99
- 6-WATCH CUTS, 5-function, LED style, assorted sizes, untested, (#6287) 2.99
- 10-HEAVY DUTY LINE CORDS, white, 2 cond., 6 ft. 16 gauge, (#6292) 2.99
- 20-SINGLE PIN LEADS, green, micro style, 3V 10mA, 100%, (#6293) 2.99
- 40-LED TRANSISTOR SOCKETS, "snap-in", 3 pc leads, for TO-5, 18 46, etc. (#6297) 2.99
- 200 PRECISION RESISTORS, 1/4W, 1%, axial (#2428) 2.99
- 5-SETS-COMPUTER TAPE HEADS, play/recorder & erase sets, digital appl. (#6646) 2.99
- 3-SHIELDED AUDIO CABLES, 2 cond., with RCA plugs at each end, (#6412) 2.99
- 6-Y ADAPTER, shielded, 2 motorola plugs to 1 motorola jack, (#5974) 2.99
- 200-HI-QUALITY RESISTORS, asst. carbons, some metallic, some 5'sers, (#6627) 2.99
- 40-RADIO TV KNOBS, various styles, shapes, & colors, w/ w/o shafts, (#6628) 2.99
- 20-PANEL SWITCHES, assorted rotary, micro, slide etc. (#6629) 2.99
- 30-PAIRS-RCA PLUGS & JACKS, popular for Hi-Fi, speakers, etc. (#6630) 2.99
- 100-IN914 SWITCHING DIODES, 4 nec, axial, glass, untested, (#6632) 2.99
- 4-2N3055 NPN TRANSISTORS, 115 watts, 15 amps, TO-3, 100% material, (#6633) 2.99
- 80-UPRIGHT MYLAR CAPS, incl. asst. epoxy, plastic, polystyrene, etc. (#6634) 2.99
- 20-NE-2 BULBS W/RESISTOR, neon, plugs right into 110 VAC, (#6620) 2.99
- 100-1/2 WATT METAL FILM, asst. resistors, color-coded, axial leads, (#6621) 2.99

- 50-5CRs & TRIACS, assorted values, 10 Amp TO-220, untested, (#6337) \$2.99
- 1-CB CONVERTER, receives CB on car radio, 12 VDC operation, (#5193) 2.99
- 40-EDGE CONNECTORS, asst. 4 & 6 pin, 2-sided, pc leads, (#6364) 2.99
- 20-6 CELL BATTERY HOLDERS, for AA size cells, 9V clip receptacle, (#6386) 2.99
- 60-THERMAL FUSES, break at 257 F. 14 gauge axial leads, (#6367) 2.99
- 4-0-8" HOBBY READOUTS, 4 digit panels, Com. Cathode, untested, (#6384) 2.99
- 25-TINY SLIDE SWITCH, only 3/7" cube, SPDT, PC leads, (#6385) 2.99
- 50-TO-5 TRIACS, 50-600 prv., 3 lead TO-5 cans, 60%+ yield, (#6321) 2.99
- 30-PLASTIC POWERS, 25 watt, npr & pnp, 50-200 hv/bv, TO-220, (#6327) 2.99
- 100-2 WATT RESISTORS, assorted carbons, films, etc. some 5'sers, (#6238) 2.99
- 10-MICRO LED DISPLAYS, 4 tiny 0.1" digits, 12 pin, mltpls, (#5064) 2.99
- 25-MAGNETIC DISCS, Plastalloy 13/16 dia. x 1/8" discs, (#6294) 2.99
- 150-PLUGS & SOCKETS, assorted types & styles, wide variety, (#3527) 2.99
- 15-PA-263 PC BOARDS, for GE PA-263 stereo amps, pre-etched, (#2013) 2.99
- 40-STEREO INDICATORS, tiny red 1.5V bulbs, for Hi-Fi replacement, (#6244) 2.99
- 40-800V 1A RECTIFIERS, type IN4006, epoxy, axial leads, (#6245) 2.99
- 4-2A 500W BRIDGES, silicon, full wave rectifiers, TO-5 case, (#6248) 2.99
- 10-QUAD PHONO JACKS, 4 RCA jacks on 2 x 1 1/2" Bakelite strip, (#6249) 2.99
- 50-MODULAR SWITCHES, by Centralab, "push-on" DPDT, 6PDT, etc. (#3150A) 2.99
- 150-"4000" RECTIFIERS, IN4000 series, may include: 50 to 1000V, (#2417) 2.99
- 1-1-R. DIODE, 5-9 watts, hetero-junction coas, for Pulse mode, (#6445) 2.99
- 200-BULLPLATES, asst. resistor-capacitor networks, various values, (#6282) 2.99
- 150-METAL CAN TRANSISTORS, asst. 2N n's in TO-5, 1, 18, some unmarked, (#2603) 2.99
- 24-1M-340T VOLTAGE REGULATORS, untested TO-220, may incl. 5-24V, (#2635) 2.99
- 150-POLYSTYRENE CAPS, assorted types, styles, & sizes, all good, (#2729) 2.99
- 100-PLASTIC LENSES, assorted styles, & colors, (#6266) 2.99
- 250-CERAMIC CAPS, asst. tubulars, NPO's, temp. coefficient, etc. (#5839) 2.99
- 60-THERMISTORS, various types & styles, neg. coefficient, 100%, (#4089) 2.99
- 25-IC SOCKETS, asst. 24, 28, & 40 pin sockets on G-10 board, (#6380) 2.99
- 25-MINI PLUG & CABLE SETS, 3.5mm plug, 6" insulated 2 cond. leads, (#6269) 2.99
- 20-RCA PHONO JACKS, popular HiFi jack on a Bakelite strip, (#6230) 2.99
- 250-PRE-FORMED DISCS, caps w/leads for PC use, mixed values, (#2605) 2.99
- 50-AXIAL ELECTROS, asst. values, volts, sizes, What a buy!, (#3227) 2.99
- 100-METALLIC RESISTORS, mostly 1/2 watters, asst. val. 1-5% tol. (#6280) 2.99
- 100-POWERS POWERS, 3 to 7 watt power resistors, (#6281) 2.99
- 15-IGNITION SUPPRESSION CAPS, for auto radios, decks, etc. 0.5 mf (#6224) 2.99
- 200-COILS & CHOKES, asst. RF, OSCIF, and praking types, (#6283) 2.99
- 50-POWER TAB TRANSISTORS, plastic NPN, TO-220, asst. types, untested, (#2425) 2.99
- 24-SKINNYY TRIM POTS, multi & single turn, asst. values & types, (#6285) 2.99
- 30-HOBBY OPTO COUPLERS, untested, mini DIP, 1500V isolation, (#6269) 2.99
- 15-LINE CORDS, heavy-duty, 18 gauge, 6" molded plug, 2-cond., (#6499) 2.99
- 100-METALIZED 1/4 WATTERS, assorted values, preset for PC appl. (#6622) 2.99
- 40-IN4148 SWITCHING DIODES, 4 nec, 100V, 10 mA, axial, 100%, (#6623) 2.99
- 10-2N3055 HOBBY TRANSISTORS, manu. fallout, TO-3, U-test, (#6624) 2.99
- 3-1H FARAD LYTICS, 1000 mf, 200 WV, FP can caps, 4" x 1-5/8" dia. (#6625) 2.99
- 2-FOTO FLASH CAPS, 600 mf, 360 WV, 3-1/2" x 1" dia. photographic apps. (#6626) 2.99
- 3-TO-3 HEATSINKS, heavy duty aluminum, 1-3/4" x 1-3/4" x 1-1/4" (#6613) 2.99
- 20-TANTALUM ELECTROS, asst. axial mini's, sealed & marked, (#6614) 2.99
- 8-CALCULATOR CHIPS, various makers, numbers, and functions, (#6615) 2.99
- 6-ASST. LAMP ASSEMBLIES, for lamps, leds, etc. asst. types & colors, (#6616) 2.99
- 100-NYLON SPACERS, interesting variety of spacers, washers, etc. (#6617) 2.99
- 10-MINI TRIM POTS, asst. types, may be ganged, various values, (#6618) 2.99
- 12-PHOTO CELLS, asst. sizes & types, may incl. "pancake", duals, etc. (#6619) 2.99
- 100-DIPPED SILVER MICAS, incl. asst. values, some red "silvers", (#6631) 2.99
- 60-SOLDERLESS TERMINALS, asst. spade & push-ons, for #12-20 wire, (#6635) 2.99
- 5-ASST. EDGE CONNECTORS, various sizes, # of pins, & spacing, (#6647) 2.99
- 2-COMPUTER TAPE HEADS, 2 channel, read/write, for cassette mech. (#6152) 2.99
- 100-TUBULAR CAPS, asst. hi-quality tubulars, various values, (#6254) 2.99
- 150-TERMINAL STRIPS, asst. screw and solder lug types, (#6251) 2.99
- 150-MICA CAPS, popular values by assorted manufacturers, (#6265) 2.99
- 30-NE-2 BULBS, neon, for 110 VAC, requires resistor, (not incl.) (#2613) 2.99

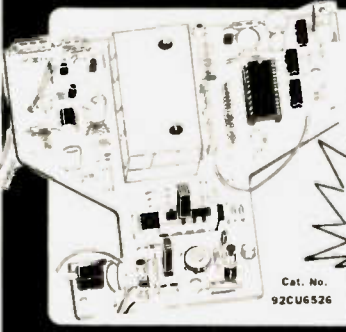

TANK BATTLE TV GAME CHIP & BOARD SET

\$14.88

You're commanding Sherman class tank on patrol Suddenly there's an explosion to your right You've been sighted by the enemy Quickly you swing your turret and Fire Poly Paks brings back the thrill of armored combat in a 28 pin DIP with General Instrument's AY-3-8700-1 Tank Battle Game Chip and board set. The initial response for this item was so phenomenal that we've been searching the world over to replenish our already depleted stock. Finally in the far reaches of Hong Kong - SUCCESS! But to avoid disappointment, order Now... they sold out before... and they'll sell out again! Boards have shielded PCB/ demulator section. In \$4.95 value alone! ICs, transistors, caps, etc. Chip capabilities: Two independently controllable tanks which explode & fragment w/when hit by shells or mines. 3 forward & reverse speeds. Realistic tank motor, track squeak, and explosion sounds, automatic on-screen scoring, (in color), and more! Tank game chip is 100% Guaranteed. With a little ingenuity and perhaps a few parts, you can recreate history's great tank battles in the comfort of your home. Size: 8 1/2 x 6 5/8 x 1 1/4. Wt.: 8 oz.



TANK GAME CHIP LESS BOARD
 • General Instrument's AY-3-8700-1
 Cat. No. 92CU6505
\$9.95



COMPACT CONDENSOR BOOM MIKE

- Space Efficient
- Practical Overhead "Boom" Design
- Minimizes Sound Coloration

\$3.50

Supply Voltage: 9V, Sensitivity: -63 dB @ 1 KHz. (typ) Frequency Response: 19-18 KHz Imped: 3.3K ohms @ 1 KHz. Size: 5/8" dia. x 1-1/8" With Spec.

Cat. No. 92CU6374

Return of a Repeated Sellout!

40 Channel CB BOARD

Cat. No. 92CU5554

From His Own Boards have Heatsinked 9 Watt Amp Chip, Rf & Mixer, 100% tested, and 100% reliable. May be used for 10 meter conversion. (see continuing series CB to 10 in 73 magazine Size: 6 x 6 x 2 1/2" Wt: 9 oz.



Only **\$14.88**

Could Convert To 10 Meters

ORDERING DEADLINE: September 1, 1980
 Discount To Be Taken BEFORE Postage Is Added. ✓58
 HOW TO ORDER
 SEND FOR FREE CATALOG
POLY PAKS
 P.O. BOX 942-A7
 SO LYNNFIELD, MA 01940
 We honor MASTERCARD, VISA, check, and C.O.D. Order by phone or mail. Minimum order \$10. Please state Cat. No. & description, name & month of magazine. POSTAGE: USA: add \$3. CANADIAN: add \$5. FOREIGN: add \$10. US funds. Excess will be returned. OPEN ACCOUNTS: (must be listed & rated in D & B) (Min. \$25) Net. 30 PHONE: (617) 245-8828. C.O.D. ORDERS: Payment must be made in Cash, Postal Money Order, or Certified Check. C.O.D. charges will be added to the order.

MHz electronics ✓48

1900 MHz to 2500 MHz DOWN CONVERTER

This receiver is tunable over a range of 1900 to 2500 mc and is intended for amateur radio use. The local oscillator is voltage controlled (i.e.) making the i-f range approximately 54 to 88 mc (Channels 2 to 7).

| | |
|--|----------|
| PC BOARD WITH CHIP CAPACITORS 13 | \$44.99 |
| PC BOARD WITH ALL PARTS FOR ASSEMBLY | \$79.99 |
| PC BOARD ASSEMBLED AND TESTED | \$120.00 |
| POWER SUPPLY KIT | \$44.99 |
| POWER SUPPLY ASSEMBLED AND TESTED | \$69.99 |
| YAGI ANTENNA 4' LONG APPROX. 20 TO 23 dB GAIN | \$59.99 |
| YAGI ANTENNA 4' WITH TYPE (N, BNC, SMA Connector) | \$64.99 |
| 2300 MHz DOWN CONVERTER | |
| Includes converter mounted in antenna, power supply, antenna, 75' and 3' RG59 cable with connectors, 75 to 300 ohm adapter, Plus 90 DAY WARRANTY | \$299.99 |
| OPTION #1 MRF902 in front end. (7 dB noise figure) | \$349.99 |
| OPTION #2 2N6603 in front end. (5 dB noise figure) | \$400.00 |
| 2300 MHz DOWN CONVERTER ONLY | |
| 10 dB Noise Figure 23 dB gain in box with N conn. Input F conn. Output | \$149.99 |
| 7 dB Noise Figure 23 dB gain in box with N conn. Input F conn. Output | \$169.99 |
| 5 dB Noise Figure 23 dB gain in box with SMA conn. Input F conn. Output | \$189.99 |
| DATA IS INCLUDED WITH KITS OR MAY BE PURCHASED SEPARATELY | \$15.00 |

Shipping and Handling Cost:

Receiver Kits add \$1.50, Power Supply add \$2.00, Antenna add \$5.00, Option 1/2 add \$3.00, For complete system add \$7.50.

Replacement Parts:

| | | | |
|--------|---------|----------------|-------------------|
| MRF901 | \$5.00 | MBD101 | \$2.00 |
| MRF902 | \$10.00 | .001 chip caps | \$2.00 |
| 2N6603 | \$12.00 | PC Board only | \$25.00 with data |

3.7 to 4.2 Gc SATELLITE DOWN CONVERTER

70 MHz i-f (30 MHz @ 3 dB) 10 dB min. IMAGE REJECTION

15 dB max. Noise Figure 15 dB Gain

ASSEMBLED AND TESTED WITH N OR SMA CONNECTOR FOR INPUT AND F CONNECTOR FOR OUTPUT

\$499.99

I-F AMPLIFIER FOR ABOVE 70 MHz

45 dB Gain — 30 MHz @ 3 dB — ASSEMBLED AND TESTED F CONNECTOR

\$129.99

DEMOD FOR ABOVE 70 MHz

COMPOSITE VIDEO OUTPUT (NO RF) — ASSEMBLED AND TESTED

\$159.99

We no longer accept Bank Cards.

PLEASE SEND POSTAL MONEY ORDER, CERTIFIED CHECK, CASHIER'S CHECK OR MONEY ORDER.
 PRICES SUBJECT TO CHANGE WITHOUT NOTICE. WE CHARGE 15% FOR RESTOCKING ON ANY ORDER.
 ALL CHECKS AND MONEY ORDERS IN US FUNDS ONLY.

ALL ORDERS SENT FIRST CLASS OR UPS.

ALL PARTS PRIME AND GUARANTEED.

WE WILL ACCEPT COD ORDERS FOR \$25.00 OR OVER, ADD \$1.50 FOR COD CHARGE.

PLEASE INCLUDE \$1.50 MINIMUM FOR SHIPPING OR CALL FOR CHARGES.

(602) 242-3037

(602) 242-8916

WE ALSO ARE LOOKING FOR NEW AND USED TUBES,
 TEST EQUIPMENT, COMPONENTS ETC.

WE ALSO SWAP OR TRADE.

FOR CATALOG SEE JANUARY, 1980, 73 Magazine, 10

Pages.

**2111 W. Camelback
 Phoenix, Arizona 85015**

FAIRCHILD VHF AND UHF PRESCALER CHIPS

| | | |
|----------------|--|--------|
| 95H90DC | 350 MHz Prescaler Divide by 10/11 | \$9.50 |
| 95H91DC | 350 MHz Prescaler Divide by 5/6 | 9.50 |
| 11C90DC | 650 MHz Prescaler Divide by 10/11 | 16.50 |
| 11C91DC | 650 MHz Prescaler Divide by 5/6 | 16.50 |
| 11C83DC | 1 GHz Divide by 248/256 Prescaler | 29.90 |
| 11C70DC | 600 MHz Flip/Flop with reset | 12.30 |
| 11C58DC | ECL VCM | 4.53 |
| 11C44DC/MC4044 | Phase Frequency Detector | 3.82 |
| 11C24DC/MC4024 | Dual TTL VCM | 3.82 |
| 11C08DC | UHF Prescaler 750 MHz D Type Flip/Flop | 12.30 |
| 11C05DC | 1 GHz Counter Divide by 4 | 74.35 |
| 11C01FC | High Speed Dual 5-4 input NO/NOR Gate | 15.40 |

WISPER FANS

This fan is super quiet, efficient cooling where low acoustical disturbance is a must. Size 4.66" x 4.66" x 1.50", Impedance protected, 50/60 Hz. 120 Vac. \$9.99

TRW BROADBAND AMPLIFIER MODEL CA615B

Frequency response 40 MHz to 300 MHz
Gain: 300 MHz 16 dB Min., 17.5 dB Max.
50 MHz 0 to -1 dB from 300 MHz
Voltage: 24 volts dc at 220 ma max. \$19.99

CARBIDE — CIRCUIT BOARD DRILL BITS FOR PC BOARDS

Size: 35, 42, 47, 49, 51, 52 \$2.15
Size: 53, 54, 55, 56, 57, 58, 59, 61, 63, 64, 65 1.85
Size: 66 1.90
Size: 1.25 mm, 1.45 mm 2.00
Size: 3.20 mm 3.56

CRYSTAL FILTERS: TYCO 001-19880 same as 2194F

10.7 MHz Narrow Band Crystal Filter
3 dB bandwidth 15 kHz min. 20 dB bandwidth 60 kHz min. 40 dB bandwidth 150 kHz min.
Ultimate 50 dB: Insertion loss 1.0 dB max. Ripple 1.0 dB max. Ct. 0 + / - 5 pf 3600 ohms. \$5.95

MURATA CERAMIC FILTERS

Models: SFD-455D 455 kHz \$3.00
SFB-455D 455 kHz 2.00
CFM-455E 455 kHz 7.95
SFE-10.7 10.7 MHz 5.95

TEST EQUIPMENT — HEWLETT PACKARD — TEKTRONIX — ETC.

Hewlett Packard:

| | | |
|------|--|-----------|
| 491C | TWT Amplifier 2 to 4 Gc 1 watt 30 dB gain | \$1150.00 |
| 608D | 10 to 420 mc .1 uV to .5 V into 50 ohms Signal Generator | 500.00 |
| 612A | 450 to 1230 mc .1 uV to .5 V into 50 ohms Signal Generator | 750.00 |
| 614A | 900 to 2100 mc Signal Generator | 500.00 |
| 616B | 1.8 to 4.2 Gc Signal Generator | 400.00 |
| 618B | 3.8 to 7.2 Gc Signal Generator | 400.00 |
| 620A | 7 to 11 Gc Signal Generator | 400.00 |
| 623B | Microwave Test Set | 900.00 |
| 624C | Microwave Test Set | 950.00 |

| | | |
|-------|-------------------------------------|---------|
| 8691A | 1 to 2 Gc Plug In For 8690A Sweeper | 800.00 |
| 8692A | 2 to 4 Gc Plug In For 8690A Sweeper | 800.00 |
| 8693A | 4 to 6 Gc Plug In For 8690A Sweeper | 800.00 |
| 8742A | Reflection Test Unit 2 to 12.4 Gc | 1800.00 |

Tektronix:
190B 350 kHz to 50 mc Oscillator 150.00

Alltech:
473 225 to 400 mc AM/FM Signal Generator 750.00

Singer:
MF5/VR-4 Universal Spectrum Analyzer with 1 kHz to 27.5 mc Plug In 1200.00

Keltek:
XR630-100 TWT Amplifier 6 to 12.4 Gc 100 watts 40 dB gain 9200.00

Polarad:
2038/2436/1102A
Calibrated Display with an SSB Analysis Module and a 10 to 40 mc Single Tone Synthesizer 1500.00

RF TRANSISTORS

| TYPE | PRICE | TYPE | PRICE | TYPE | PRICE |
|-------------|---------|---------------|--------|----------------|---------|
| 2N1561 | \$15.00 | 2N5590 | \$6.00 | MM1550 | \$10.00 |
| 2N1562 | 15.00 | 2N5591 | 10.35 | MM1552 | 50.00 |
| 2N1692 | 15.00 | 2N5637 | 20.00 | MM1553 | 56.50 |
| 2N1693 | 15.00 | 2N5841 | 4.90 | MM1601 | 5.50 |
| 2N2632 | 45.00 | 2N5842 | 8.83 | MM1602/2N5842 | 7.50 |
| 2N2857JAN | 2.45 | 2N5843 | 14.38 | MM1607 | 8.85 |
| 2N2876 | 12.35 | 2N6545 | 11.00 | MM1661 | 15.00 |
| 2N2880 | 25.00 | 2N5764 | 27.00 | MM1669 | 17.50 |
| 2N2927 | 7.00 | 2N5842 | 8.85 | MM1943 | 3.00 |
| 2N2947 | 17.25 | 2N5849 | 19.50 | MM2605 | 3.00 |
| 2N2948 | 15.50 | 2N5862 | 50.00 | MM2608 | 5.00 |
| 2N2949 | 3.90 | 2N5913 | 3.25 | MM8006 | 2.15 |
| 2N2950 | 5.00 | 2N5922 | 10.00 | MMC0918 | 1.00 |
| 2N3287 | 4.30 | 2N5942 | 46.00 | MMT72 | .61 |
| 2N3294 | 1.15 | 2N5944 | 7.50 | MMT74 | .94 |
| 2N3301 | .75 | 2N5945 | 10.90 | MMT2857 | 2.68 |
| 2N3302 | 1.05 | 2N5946 | 13.20 | MRF304 | 43.45 |
| 2N3304 | 1.48 | 2N6080 | 5.45 | MRF420 | 20.00 |
| 2N3307 | 10.50 | 2N6081 | 8.60 | MRF450 | 11.85 |
| 2N3309 | 3.90 | 2N6082 | 9.90 | MRF450A | 11.85 |
| 2N3375 | 6.75 | 2N6083 | 11.80 | MRF454 | 20.10 |
| 2N3553 | 1.45 | 2N6084 | 13.20 | MRF456 | 16.95 |
| 2N3755 | 7.20 | 2N6094 | 5.75 | MRF475 | 5.00 |
| 2N3816 | 6.00 | 2N6095 | 10.35 | MRF476 | 5.00 |
| 2N3866 | 1.09 | 2N6096 | 19.35 | MRF502 | .49 |
| 2N3866JAN | 2.70 | 2N6097 | 28.00 | MRF504 | 6.95 |
| 2N3866JANTX | 4.43 | 2N6136 | 18.70 | MRF509 | 4.90 |
| 2N3924 | 3.20 | 2N6186 | 36.80 | MRF511 | 6.60 |
| 2N3925 | 6.00 | 2N6265 | 75.00 | MRF901 | 5.00 |
| 2N3927 | 11.50 | 2N6266 | 100.00 | MRF5177 | 20.70 |
| 2N3950 | 26.25 | 2N6439 | 43.45 | MRF8004 | 1.44 |
| 2N4072 | 1.70 | 2N6459/PT9795 | 18.00 | PT4166B | 3.00 |
| 2N4135 | 2.00 | 2N6603 | 12.00 | PT4571A | 1.50 |
| 2N4261 | 14.80 | 2N6604 | 12.00 | PT4612 | 5.00 |
| 2N4427 | 1.09 | A50-12 | 25.00 | PT4628 | 5.00 |
| 2N4429 | 7.50 | BFR90 | 5.00 | PT4640 | 5.00 |
| 2N4430 | 20.00 | BLY568C | 25.00 | PT8659 | 10.72 |
| 2N4957 | 3.50 | BLY568CF | 25.00 | PT9784 | 24.30 |
| 2N4958 | 2.80 | CD3495 | 15.00 | PT9790 | 41.70 |
| 2N4959 | 2.12 | HEP76/S3014 | 4.95 | SD1043 | 5.00 |
| 2N4976 | 19.00 | HEPS3002 | 11.30 | SD1116 | 3.00 |
| 2N5090 | 6.90 | HEPS3003 | 29.88 | SD1118 | 5.00 |
| 2N5108 | 3.90 | HEPS3005 | 9.95 | SD1119 | 3.00 |
| 2N5109 | 1.55 | HEPS3006 | 19.90 | TA7993 | 75.00 |
| 2N5160 | 3.34 | HEPS3007 | 24.95 | TA7994 | 100.00 |
| 2N5179 | .80 | HEPS3010 | 11.34 | TRWMRA2023-1.5 | 42.50 |
| 2N5184 | 2.00 | HEPS5026 | 2.56 | 40281 | 10.90 |
| 2N5216 | 47.50 | HP35831E/ | 40282 | 40282 | 11.90 |
| 2N5583 | 4.43 | HXTR5104 | 50.00 | 40290 | 2.48 |
| 2N5589 | 4.60 | MM1500 | 32.20 | | |

CHIP CAPACITORS

| | | | |
|-------|-------|--------|--------|
| 1pf | 27pf | 220pf | 1200pf |
| 1.5pf | 33pf | 240pf | 1500pf |
| 2.2pf | 39pf | 270pf | 1800pf |
| 2.7pf | 47pf | 300pf | 2200pf |
| 3.3pf | 56pf | 330pf | 2700pf |
| 3.9pf | 66pf | 360pf | 3300pf |
| 4.7pf | 82pf | 390pf | 3900pf |
| 5.6pf | 100pf | 430pf | 4700pf |
| 6.8pf | 110pf | 470pf | 5600pf |
| 6.2pf | 120pf | 510pf | 6800pf |
| 10pf | 130pf | 560pf | 8200pf |
| 12pf | 150pf | 620pf | .010mf |
| 15pf | 160pf | 660pf | .012mf |
| 16pf | 180pf | 820pf | .015mf |
| 22pf | 200pf | 1000pf | .018mf |

We can supply any value chip capacitors you may need.

PRICES

1 to 10 \$1.99
11 - 50 1.49
51 - 100 1.00
101 up POR

POR = CALL FOR PRICE

ATLAS CRYSTAL FILTERS FOR ATLAS HAM GEAR

- 5.52-2.7/8
- 5.595-2.7/6/U
- 5.595-500/4/CW
- 5.595-2.7/LSB
- 5.595-2.7/USB
- 5.645-2.7/8
- 9.0USB/CW

YOUR CHOICE \$24.95

ALARM CLOCK KITS: 4 Digit .5"

Here it is! The first of several quality kits we have been asked for: Here is what you get — unbelievable as it may sound...

- 1 National - 5375AA Clock Chip
- 1 Bowmar Clock Stick Readout (L.E.D.) 4 digit - 1/2"
- 13 Transistors
- 2 Push Buttons for time set
- 2 Toggle Switches for alarm
- 1 Filter cap
- 4 1N4000 series diodes
- 1 1N4148
- 2 Disc caps
- 29 Resistors
- 1 Transducer (Speaker) for Alarm
- 1 LED Lamp for alarm indicator

ORDER
KIT
CK-100AC

NEW!
\$9.99

P.C. Board \$2.25
Plug In Transformer \$1.50
CASE \$3.50

D.C. MODEL

Same as above except it includes 60 Hz timebase.

This Kit Includes:

- 1 National 5375AA Clock Chip
- 1 Bowmar Clock Stick Readout - (L.E.D.) 4 digit - 1/2"
- 12 Transistors
- 2 Push Buttons for time set
- 2 Disc caps
- 27 Resistors
- 1 MOV
- 1 60 Hz time base

ORDER
KIT
CK-100DC

NEW!
\$12.75

P.C. Board \$2.25
CASE \$3.50

MICRO MINI TOGGLE SWITCHES



99¢
EACH

*****CABLE TIES*****
MAKE YOUR PROJECTS "NEAT + TIDY" 4" CABLE TIES AT A FANTASTIC PRICE. GET THIS BARGAIN AND "TIE" IT DOWN! \$2.00 for 100 or better yet \$15.00 for 1000

5-14 V.D.C. BETTER BEEPER

Two audio oscillator—a low frequency pulse oscillator—either or both audio frequencies can be shifted (warbled) or pulsed on and off. Constant tone capability. Any combination of pulses and warbles or tones. 1 7/8" DX 1 3/4" ALARMS—TOYS—TESTING—ETC. Complete kit \$3.55 or 3 for \$9

RCA SENSITIVE GATE TRIAC

TO-5 CASE. HOUSE #40531
ALSO SAME AS T2300D.
2.5 AMPS 400 PIV



5 FOR \$1.19

Perfect for Dimmers, Color Organs, etc.
PC LEADS

5 VOLT REED RELAY

An absolutely fantastic item. Compare this price with any advertiser. While They Last.
\$1.10
Turns on at 10 MA. Drops out at 5 MA.



We bought 350,000 LED's. And you get the savings. Reds, greens, yellows, orange, small, medium, large. Bags of 25 - mixed \$2.75. That's only 11¢ each. Compare this bargain up to twice our price.

FACTORY PRIME
BI - Polar LED 59¢ ea. or 10 for \$5

LAB-BENCH VARIABLE POWER SUPPLY KIT \$15.99 KIT

5 to 20 VDC at 1 AMP. Short circuit protected by current limit. Uses IC regulator and 10 AMP Power Darlington. Very good regulation and low ripple. Kit includes PC Board, all parts, large heatsink and shielded transformer. 50 MV. TYP. Regulation.

NATIONAL SEMICONDUCTOR

"COLOSSUS JR." JUMBO CLOCK MODULE

MA1013
BRAND NEW!

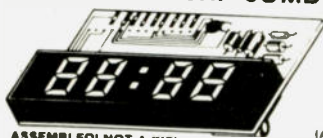

\$8.50
2 FOR \$15

- Bright 4 digit 0.7" LED Display
- Complete-Add only Transformer and Switches
- 24 Hour Alarm Signal Output
- 12 Hour Real Time Format
- 50 or 60 Hz Operation
- Power Failure Indication
- LED Brightness Control
- Sleep and Snooze Timers
- Alarm "on" and PM Indicators
- Direct Drive - No RFI
- Direct Replacement for MA1012
- Comes with Full Data

ASSEMBLED! NOT A KIT!
MANUFACTURER'S CLOSEOUT!

PERFECT FOR USE
WITH A TIMEBASE

TOSHIBA POWER AUDIO AMP

5.8 WATTS RMS Typical Output. 50 to 30,000 HZ ± 3 DB. For CB's, tape decks, PA's, etc. Works off of a single supply voltage from 10.5 to 18 VDC. 10 Pin plastic DIP with special built in heat sink tab. Perfect for use on 12VDC. With Data. **\$3.99 each**

16K DYNAMIC RAM CHIP WORKS IN TRS-80 OR APPLE II

16K X 1 Bits 16 Pin Package Same as Mostek 4116-4 250 NS access 410 NS cycle time. Our best price yet for this state of the art RAM 32K and 64K RAM boards using this chip are readily available. These are new fully guaranteed devices by a major mfg.

VERY LIMITED STOCK!
"MAGAZINE SPECIAL"
8/\$79.50

60 HZ CRYSTAL TIME BASE

\$4.95 (Complete Kit)
Uses MM5369 CMOS divider IC with high accuracy 3.579545 MHz Crystal. Use with all MOS Clock Chips or Modules. Draws only 1.5 MA. All parts, data and PC Board included 100 Hz. same as above, except \$5.95

CLOCK MODULE OPTIONS

MA 1008 A and D MA1013
Switches and pot for all options
Includes:
5 push buttons
1 toggle
1 10K pot
Alarm Parts (including high impedance transducer) Much more efficient than a speaker
Transducer only (unbelievably loud) \$1.10

SILICON POWER SOLAR CELLS

2 Inch Dia Approx 5 VDC at 500 MA in sunlight. Factory new units not rejects as sold by others. Series for higher voltage parallel for higher current. Converts solar energy directly to electricity. **LIMITED QUANTITY. \$5.99 ea.**

SONY 23 WATT AUDIO AMP MODULE

#STK-054. 23 WATTS SUPER CLEAN AUDIO. 20 HZ to 100 KHZ ± 2 DB HYBRID, SILICON, SELF-CONTAINED MODULE. ONLY 1 1/4 x 2 1/2 IN. WITH DATA.

COMPARE AT UP TO TWICE OUR PRICE! **\$6.50 each**

FAIRCHILD PNP

"SUPER TRANSISTOR"
2N4402 TO-92 Plastic Silicon PNP Driver High Current VCEO-40HF-50 to 150 at 150 MA FT-150 MHZ A super "BEEFED-UP" version of the 2N3906

8 FOR \$1.19

SOUND ACTIVATED SWITCH

Not a kit. Already assembled. Clap your hands and turn on lights, music boxes, coffee pots, etc. Full spec sheet with each unit.

69¢ 10 for \$5.50

Digital Research: Parts

(OF TEXAS)

P.O. BOX 401247 • GARLAND, TEXAS 75040 • (214) 271-2461

TERMS: Add 50¢ postage, we pay balance. Orders under \$15 add 75¢ handling. No C.O.D. We accept Visa, MasterCard and American Express cards. Tex. Res add 5% Tax. Foreign orders (except Canada) add 20% P&H. 90 Day Money Back Guarantee on all items.

GET ON PHASE THREE FOR MUCH LESS THAN YOU THINK!

These Low Cost SSB TRANSMITTING CONVERTERS

Let you use inexpensive recycled 10M or 2M SSB exciters on UHF & VHF!

- Linear Converters for SSB, CW, FM, etc.
- A fraction of the price of other units; no need to spend \$300 - \$400!
- Use with any exciter; works with input levels as low as 1 mW.
- Use low power tap on exciter or simple resistor attenuator pad (instructions included).
- Link osc with RX converter for transceiver.



XV4 UHF KIT — ONLY \$99.95

28-30 MHz in, 435-437 MHz out; 1W p.e.p. on ssb, up to 1½W on CW or FM. Has second oscillator for other ranges. Atten. supplied for 1 to 500 mW input, use external attenuator for higher levels.

Extra crystal for 432-434 MHz range..... \$5.95
XV4 Wired and tested \$149.95

XV2 VHF KIT - ONLY \$69.95

2W p.e.p. output with as little as 1mW input. Use simple external attenuator. Many freq. ranges available.

| MODEL | INPUT (MHZ) | OUTPUT (MHZ) |
|-------|--------------------|--------------------|
| XV2-1 | 28-30 | 50-52 |
| XV2-2 | 28-30 | 220-222 |
| XV2-4 | 28-30 | 144-146 |
| XV2-5 | 28-29 (27-27.4 CB) | 145-146(144-144.4) |
| XV2-7 | 144-146 | 50-52 |

XV2 Wired and tested \$109.95

XV28 2M ADAPTER KIT - \$24.95

Converts any 2M exciter to provide the 10M signal required to drive above 220 or 435 MHz units.



NEW! COMPLETE TRANSMITTING CONVERTER AND PA IN ATTRACTIVE CABINET

Far less than the cost of many 10W units!

Now, the popular Hamtronics® Transmitting Converters and heavy duty Linear Power Amplifiers are available as complete units in attractive, shielded cabinets with BNC receptacles for exciter and antenna connections. Perfect setup for versatile terrestrial and OSCAR operations! Just right for phase 3! You save \$30 when you buy complete unit with cabinet under cost of individual items. Run 40-45 Watts on VHF or 30-40 Watts on UHF with one integrated unit! Call for more details.

| MODEL | KIT | WIRED and TESTED |
|-----------------------------|----------|------------------|
| XV2/LPA2-45/Cabt (6M or 2M) | \$199.95 | \$299.95 |
| XV4/LPA4-30/Cabt (for UHF) | \$229.95 | \$349.95 |

IT'S EASY TO ORDER!

- Write or phone 716-392-9430 (Electronic answering service evenings & weekends)
- Use Credit Card, UPS COD, Check, Money Order
- Add \$2.00 shipping & handling per order

Easy to Build FET RECEIVING CONVERTERS

Let you receive OSCAR and other exciting VHF and UHF signals on your present HF or 2M receiver



- NEW LOW-NOISE DESIGN
- ATTRACTIVE WOODGRAIN CASE
- Less than 2dB noise figure, 20dB gain

| MODEL | RF RANGE | OUTPUT RANGE |
|---------|---------------------------|-----------------------|
| CA28 | 28-32 MHz | 144-148 MHz |
| CA50 | 50-52 | 28-30 |
| CA50-2 | 50-54 | 144-148 |
| CA144 | 144-146 | 28-30 |
| CA145 | 145-147-or-144-144.4 | 28-30 27-27.4 (CB) |
| CA146 | 146-148 | 28-30 |
| CA220 | 220-222 | 28-30 |
| CA220-2 | 220-224 | 144-148 |
| CA110 | Any 2MHz of Aircraft Band | 26-28 or 28-30 |
| CA432-2 | 432-434 | 28-30 |
| CA432-5 | 435-437 | 28-30 |
| CA432-4 | 432-436 | 144-148 |

Easily modified for other rf and if ranges.

| STYLE | VHF | UHF |
|----------------------|---------|---------|
| Kit less case | \$34.95 | \$49.95 |
| Kit with case | \$39.95 | \$54.95 |
| Wired/Tested in case | \$54.95 | \$64.95 |

Professional Quality VHF/UHF FM/CW EXCITERS

- Fully shielded designs
- Double tuned circuits for spurious suppression
- Easy to align with built-in test aids



| | | |
|---------|-------------------------|---------|
| T50-50 | 6-chan, 6M, 2W Kit | \$44.95 |
| T50-150 | 6-chan, 2M, 2W Kit | \$44.95 |
| T50-220 | 6-chan, 220 MHz, 2W Kit | \$44.95 |
| T450 | 1-chan, 450 MHz, ¼W Kit | \$44.95 |

See our Complete Line of VHF & UHF Linear PA's

- Use as linear or class C PA
- For use with SSB Xmtg Converters, FM Exciters, etc.

| | | |
|---------|------------------------|----------|
| LPA2-15 | 6M, 2M, 220; 15 to 20W | \$59.95 |
| LPA2-30 | 6M, 2m; 25 to 30W | \$89.95 |
| LPA2-40 | 220 MHz; 30 to 40W | \$119.95 |
| LPA2-45 | 6M, 2M; 40 to 45W | \$119.95 |
| LPA4-10 | 430MHz; 10 to 14W | \$79.95 |
| LPA4-30 | 430MHz; 30-40W | \$119.95 |

See catalog for complete specifications

Call or Write to get FREE CATALOG With Complete Details

(Send 4 IRC's for overseas mailing)

HAMTRONICS® IS A REGISTERED TRADEMARK

FAMOUS HAMTRONICS PREAMPS

Let you hear the weak ones too!
Great for OSCAR, SSB, FM, ATV. Over 14,000 in use throughout the world on all types of receivers.



- NEW LOW-NOISE DESIGN
- Less than 2 dB noise figure, 20 dB gain
- Case only 2 inches square
- Specify operating frequency when ordering

MODEL P-30 VHF PREAMP, available in many versions to cover bands 18-300 MHz.

MODEL P432 UHF PREAMP, available in versions to cover bands 300-650 MHz.

| STYLE | VHF | UHF |
|----------------------|---------|---------|
| Kit less case | \$12.95 | \$18.95 |
| Kit with case | \$18.95 | \$26.95 |
| Wired/Tested in Case | \$27.95 | \$32.95 |

NEW VHF/UHF FM RCVRs

Offer Unprecedented Range of Selectivity Options

- New generation
- More sensitive
- More selective
- Low cross mod
- Uses crystal filters
- Smaller
- Easy to align

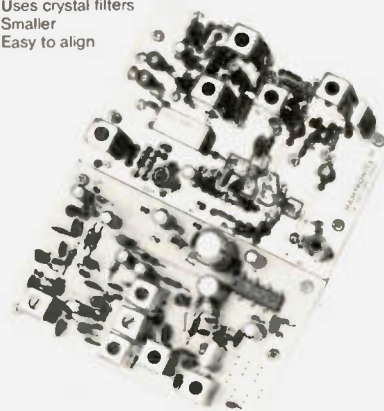

R75A* VHF Kit for monitor or weather satellite service. Uses wide L-C filter. -60dB at ± 30 kHz..... \$69.95

R75B* VHF Kit for normal nbfm service. Equivalent to most transceivers. -60dB at ± 17 kHz, -80dB at ± 25 kHz... \$74.95

R75C* VHF Kit for repeater service or high rf density area. -60dB at ± 14kHz, -80dB ± 22kHz, -100dB ± 30kHz... \$84.95

R75D* VHF Kit for split channel operation or repeater in high density area. Uses 8-pole crystal filter. -60dB at ± 9kHz, -100dB at ± 15kHz. The ultimate receiver!... \$99.95

* Specify band: 10M, 6M, 2M, or 220 MHz. May also be used for adjacent commercial bands. Use 2M version for 137 MHz WX satellites.

R450() UHF FM Receiver Kits, similar to R75, but for UHF band. New low-noise front end. Add \$10 to above prices. (Add selectivity letter to model number as on R75.)

A14 5 Channel Adapter for Receivers..... \$9.95

NEW R110 VHF AM RCVR

AM monitor receiver kit similar to R75A, but AM. Available for 10-11M, 6M, 2M, 220 MHz, and 110-130 MHz aircraft band \$74.95. (Also available in UHF version.)

hamtronics, inc.

65J MOUL RD · HILTON, NY 14468

BULLET ELECTRONICS

P.O. Box 401244-E Garland, TX. 75040 (214) 278-3553

SUPER SUMMER SPECIALS!



SLIDE SWITCH ASSORTMENT

An outstanding bargain. Includes miniature and standard sizes and multiposition units. All new first quality, name brand switches. Try one pack and you'll reorder more: **SPECIAL — 12 for \$1.20** (Assortment)



1/2W RESISTOR ASSORTMENT

A good mix of 5% and 10% values in both full lead and PC lead devices. All new, first quality.



(Asst.) 200 pieces/ 2.00

XAN SUPER DIGITS

.6" JUMBO LED
7 SEGMENT
RED

.99

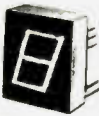

6920 COMMON ANODE
6640 COMMON CATHODE

NOW A SUPER READOUT AT A SUPER BUY! These are factory fresh prime LED readouts, not seconds or rejects as sold by others. Compare our price and send for yours today, but hurry, the supply is limited!
SPECIFY: COMMON ANODE OR COMMON CATHODE

ULTRASONIC RELAY KIT

Invisible Beam Works Like A Photo Electric Eye. **COMPLETE KIT** All Parts & PC Board. Use Up To 25 Ft. Apart.
\$21.50

Optional entry delay and Alarm Timeout Circuit will source or sink up to 200 MA DC.

\$3.95

AUTO/VAN CLOCK KIT

- 12 Hr. Format
- 6 Digit 1/2" LED Readouts
- Quartz XTAL Timebase
- Alarm & Snooze Options
- Noise Filtering
- Easy Assembly • 12 VDC
- 4 5/8" x 3" x 1 1/2"
- All Parts!

\$16.95

ZULU II CLOCK KIT X-RATED!

WITH CALENDAR
AND NOX** CIRCUIT

19.95

LESS CASE
ACCESSORIES

Custom High Impact Molded Case with Ruby Lens. Available in Blue or Tan.

\$6.50

117 VAC to 12 VDC Transformer.

\$1.35

*9V Battery Not Included

- X-TRA VALUE:** All the components and high quality plated G-10 PC Boards are provided.
X-TRA CARE IN DESIGN: Easy Assembly! Large open layout
X-CELLENCE IN IDEAS: 5 years of designed products for the amateur radio market.
X-CELLENCE IN INSTRUCTIONS: Clear step-by-step instructions with quality illustrations and schematic
X-TRA FEATURES: There has never been a clock kit with so many features — at any price!
- Unit operates on either 12 VAC or 12 VDC.
 - On board **QUARTZ XTAL TIMEBASE** or 60Hz AC line freq. can be used
 - Automatic **BATTERY BACKUP**
 - Reads true **24 HOUR TIME** and **31 DAY CALENDAR**.
 - **Unique NOX** CIRCUIT** activates readouts with a handclap followed by the date for 4 seconds. Or they can be turned on constantly.
 - When used mobile readouts blank when ignition is off.
 - Special **NOISE SUPPRESSION** and battery reversal circuits
 - Bright 1/2" LED's show hours, minute and seconds

Sound Effects Kit

The **SE-01 Sound Effects Kit** is a complete kit, all you need to build a programmable sound effects machine except a battery and speaker. Our kit is designed to really ring out the **TI 76477 Sound Chip**. Only the SE-01 provides you with additional circuitry that includes a **PULSE GENERATOR, MUX OSCILLATOR** and **COMPARATOR** to make more complex sounds a snap. We help you in building the kit with a clear, easy-to-follow construction manual and we show you how to easily program the unit. Other dealers will sell you the chip or a "kit" of parts but you are on your own to do the most difficult part...make neat sounds! Within a short time after you build the SE-01 you can easily create **Gunshots, Explosions, Space Sounds, Steam Trains** and much more. We think the **Bullet SE-01** is the best deal on the market but don't ask us — ask the 15,000 happy SE-01 owners!
Complete Kit With Quality Plated PC Board **\$17.50**
(Less battery & speaker)

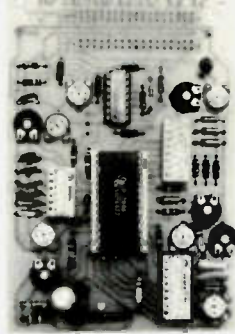

Users Group Notes: Includes additional programming charts plus quarterly updates **\$5.00**

7 WATT AUDIO AMP KIT

SMALL SINGLE HYBRID IC AND COMPONENTS FIT ON A 2" x 3" PC BOARD (INCLUDED). RUNS ON 12VDC GREAT FOR ANY PROJECT THAT NEEDS AN INEXPENSIVE AMP. LESS THAN 3% THD @ 5 WATTS COMPATIBLE WITH SE-01 SOUND KIT **\$5.95**

*2N5191
NPN

**SILICON
POWER
TRANSISTOR**



V_{ceo} = 60V Pd 40W
IC = 4A
H_{fe} 25-100
@ 1.5A
*HSE #

3/\$1.00
100/\$25.00

PN2222 (2N2222A)

**MOST POPULAR NPN
GEN. PURPOSE
TRANSISTOR.**

TO - 90 V_{ceo} = 40V
Pd = 5W
H_{fe} = 100 - 300

10/\$1.00 100/\$9.00

THE PERFECT TRANSFORMER

117VAC primary, 12VAC secondary @ 200ma
Great for all your CMOS, or low power TTL projects. PC board mount.



99¢ ea. 3/\$2.50

Size: 1.5" W x 1.25" D x 1.25" H

AY3-8910 PROGRAMMABLE SOUND GENERATOR

The AY3-8910 is a 40 pin LSI chip with three oscillators, three amplitude controls, programmable noise generator, three mixers, an envelope generator, and three D/A converters that are controlled by 8 BIT WORDS. No external pots or caps required. This chip hooked to an 8 bit microprocessor chip or Buss (8080, Z80, 6800 etc.) can be software controlled to produce almost any sound. It will play three note chords, make bangs, whistles, sirens, gunshots, explosions, bleets, whines, or grunts. In addition, it has provisions to control its own memory chips with two IO ports. The chip requires +5V @ 75ma and a standard TTL clock oscillator. A truly incredible circuit.

\$14.95 W/Basic Spec Sheet (4 pages)

60 page manual with S-100 interface instructions and several programming examples, **\$3.00 extra**

OVP-2 OVERVOLTAGE PROTECTOR 6.95

Provides cheap insurance for your expensive equipment. Trip voltage is adjustable from 3 to 30 volts. Overvoltage instantly fires a 25A SCR and shorts the output to protect equipment. Should be used on units that are fused. Directly compatible with the PS-12 and PS-14. All electronics supplied. Drilled and plated PC board.

PARTS

| | | |
|-----------|---------------------------|--------|
| LM3046 | (CA3046) Xistor Array | 75 |
| RCA 40430 | 400V 6A TRIAC TO-66 | 75 |
| CA3086 | RCA Xistor Array | 80 |
| LM567 | Tone Decoder | 99 |
| CD4046 | PLL CMOS | 99 |
| LM3302 | Quad Comparator | 89 |
| 25C 1849 | High Freq NPN TO-92 | 6/1.00 |
| MPS A 20 | NPN General Purpose | 8/1.00 |
| TL490 | Bar/Graph Driver w/specs | 2.50 |
| 7812 | 12V 1A Regulator | 99 |
| 7805 | 5V 1A Regulator | 99 |
| 78M05 | 5V 1/2A Reg. TO-5 (Hse #) | 60 |
| LM3911 | Temp Transducer w/specs | 1.10 |
| 555 | Timer IC | 49 |
| 2N6028 | P.U.T. w/specs | 50 |
| IL-1 | Opto Isolator w/specs | 60 |
| LM380 | 2W Audio IC w/specs | 50 |
| LM377 | Dual LM380 w/specs | 1.09 |
| TIP-30 | PNP Power TO-220 | 3/1.00 |

NEW! MUSIC FOR YOUR EARS

Bullet's **Electronic Music Machine™** Kit has a single 28 Pin Microprocessor Chip with ROM that has been programmed to play the first 8 to 10 notes of the 25 popular tunes listed below. Each tune can easily be addressed individually or played sequentially at the push of a button. The 3 chime sequences are activated at any time by separate switch closures so when used as a doorbell, one door can play songs while two others will play different chimes. The unit has a **5 watt audio Amp** and will run on either **12VAC** or **12VDC**. Optional 117VAC transformer is available. Construction is very simple, works with any 8 or 16 ohm speaker, or horn speaker. (Not Included) Tunes can be remotely programmed using a single rotary switch. (not included), if desired

Complete Kit \$16.95 Transformer \$1.35

For Operation on 117VAC

Tunes: Toreador * William Tell * Hallelujah Chorus * Star Spangled Banner * Yankee Doodle * America, America * Deutschland Leid * Wedding March * Beethoven's 5th and 9th * Hell's Bells * La Vien En Rose * Star Wars Theme * Clementine * Augustine * Jingle Bells * God Save The Queen * Colonel Bogey * Marsellaise * O Sole Mio * Santa Lucia * The End * Blue Danube * Brahms Lullaby * Westminster Chime * Simple Chime * Descending Octave Chime.

★ CALL OR WRITE TODAY FOR FREE CATALOG ★

- * NO C.O.D.
- * SEND CHECK, M.O., OR CREDIT CARD #
- * PHONE ORDERS ACCEPTED ON VISA/MASTER CHARGE ONLY (214) 278-3553

P
O
L
I
C
I
E
S

- * ADD 5% FOR SHIPPING
- * ORDERS UNDER \$10 ADD .75 HANDLING
- * TEX. RES. ADD 5% TAX
- * FOREIGN ORDERS (EXCEPT CANADA ADD 10% (20% FOR AIRMAIL).

RADIO BOOKSHOP

LICENSE STUDY GUIDES & TAPES

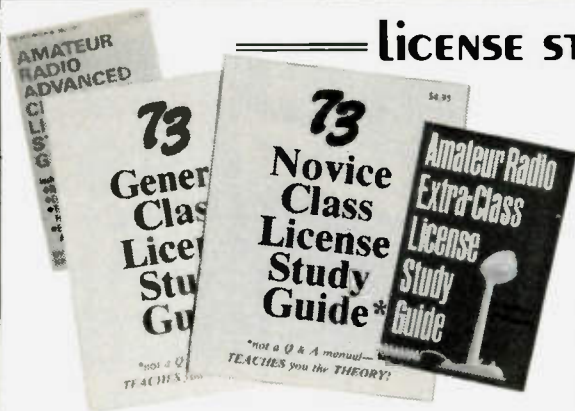

• **NOVICE STUDY GUIDE—SG7357**—Here is a completely new study guide and reference book for the potential ham. This is not a question/answer memorization course. Electronic and radio fundamentals are presented and explained in an easy-to-understand fashion, preparing the beginner for the Novice exam. Includes the latest FCC amateur regulations, as well as application forms. Easily the best path into the exciting world of ham radio! \$4.95.*

• **GENERAL CLASS STUDY GUIDE—SG7358**—A complete theory course for the prospective General or Technician. This reference explains transistor, amplifier, and general radio theory, while preparing the Novice for the "big" ticket. After getting your ticket, you'll use this guide again and again as an electronics reference source. Not a question/answer guide that becomes dated when the FCC updates the amateur exams. \$5.95.*

• **ADVANCED CLASS LICENSE STUDY GUIDE—SG1081**—Ready to upgrade your license? To prevent retaking the FCC theory exam, you need the 73 Advanced theory guide. SSB, antenna theory, transmitters, and electronics measuring techniques are covered in detail in this easy-to-follow study guide. Special modes and techniques, such as RTTY, are also treated. An engineering degree is *not* necessary to master the Advanced theory—try this book before visiting the examiner's office! \$6.95.* (Published by TAB Books previous to recent changes in FCC exam material.)

• **EXTRA CLASS LICENSE STUDY GUIDE—SG1080**—Before going for your 1 x 2 call, it pays to be a master of the Extra class electronics theory. This study guide is the logical extension of the 73 theory course. All the theory necessary to pass the exam is presented. Antennas, transmission lines, swr are discussed, as well as noise, propagation, and specialized communication techniques. This book is not a classroom lecture or memorization guide, but rather a logical presentation of the material that must be *understood* before attempting the Extra exam. Save yourself a return trip to the FCC and try the 73 method first! \$5.95.*



NOVICE THEORY TAPES Startling Learning Breakthrough



• **NOVICE THEORY TAPES—CT7300**—Startling Learning Breakthrough. You'll be astounded at how really simple the theory is when you hear it explained on these tapes. Three tapes of theory and one of questions and answers from the latest Novice exams give you the edge you need to breeze through your exam. 73 is interested in helping get more amateurs, so we're giving you the complete set of our tapes for the incredibly low price of **ONLY \$15.95.***

Scientists have proven that you learn faster by listening than by reading because you can play a cassette tape over and over in your spare time—even while you're driving! You get more and more info each time you hear it. You can't progress without solid fundamentals. These four hour-long tapes give you all the basics you'll need to pass the Novice exam easily. You'll have an understanding of the basics which will be invaluable to you for the rest of your life! Can you afford to take your Novice exam without first listening to these tapes? Set of 4—\$15.95.*

These tapes were made previous to recent changes in FCC rules. These minor changes do not affect the *theory* involved. A new set of tapes reflecting these rule changes is being developed. Expected availability is June 1980.



SSTV

• **SLOW SCAN TELEVISION TAPE—CT7350**—Prize-winning programs from the 73 SSTV contest. Excellent for Demo! \$5.95.*



73 CODE TAPES

Any Four Tapes For \$15.95! *
\$4.95 Each! *

"GENESIS"

5 WPM—CT7305—This is the beginning tape for people who do not know the code at all. It takes them through the 26 letters, 10 numbers and necessary punctuation, complete with practice every step of the way using the newest blitz teaching techniques. It is almost miraculous! In one hour many people—including kids of ten—are able to master the code. The ease of learning gives confidence to beginners who might otherwise drop out.

"THE STICKLER"

6+ WPM—CT7306—This is the practice tape for the Novice and Technician licenses. It is made up of one solid hour of code, sent at the official FCC standard (no other tape we've heard uses these standards, so many people flunk the code when they are suddenly—under pressure—faced with characters sent at 13 wpm and spaced for 5 wpm). This tape is not memorizable, unlike the zany 5 wpm tape, since the code groups are entirely random characters sent in groups of five.

"BACK BREAKER"

13+ WPM—CT7313—Code groups again, at a brisk 13 per so you will be at ease when you sit down in front of the steely-eyed government Inspector and he starts sending you plain language at only 13 per. You need this extra margin to overcome the panic which is universal in the test situations. When you've spent your money and time to take the test, you'll thank heavens you had this back-breaking tape.

"COURAGEOUS"

20+ WPM—CT7320—Code is what gets you when you go for the Extra class license. It is so embarrassing to panic out just because you didn't prepare yourself with this tape. Though this is only one word faster, the code groups are so difficult that you'll almost fall asleep copying the FCC stuff by comparison. Users report that they can't believe how easy 20 per really is with this fantastic one hour tape.

"OUTRAGEOUS"

25+ WPM—CT7325—This is the tape for that small group of overachieving hams who wouldn't be content to simply satisfy the code requirements of the Extra Class license. It's the toughest tape we've got and we keep a permanent file of hams who have mastered it. Let us know when you're up to speed and we'll inscribe your name in 73's CW "Hall of Fame."

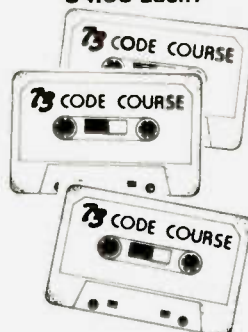

*Use the order card in the back of this magazine or itemize your order on a separate piece of paper and mail to: 73 Radio Bookshop • Peterborough NH 03458. Be sure to include check or detailed credit card information. No C.O.D. orders accepted. *Add \$1.00 handling charge. Note: Prices subject to change on books not published by 73 Magazine. Questions regarding your order? Please write to Customer Service at the above address. Please allow 4-6 weeks for delivery.

FOR TOLL FREE ORDERING CALL 1-800-258-5473

Radio Bookshop

73 TECHNICAL LIBRARY

● **BEHIND THE DIAL**—BK7307—By Bob Grove. Get more fun out of shortwave listening with this interesting guide to receivers, antennas, frequencies and interference. \$4.95.*

● **THE CHALLENGE OF 160**—BK7309—is the newest book in the 73 technical library, dedicated to 160 meter operating. Si Dunn provides all necessary information to get started on this unique band. The all-important antenna and ground systems are described in detail. The introduction contains interesting photos of Stew Perry's (the King of 160) shack. This reference is a must for new and experienced "Top Band" operators. Price: \$4.95.*

● **IC OP-AMP COOKBOOK**—BK1028—by Walter G. Jung. Covers not only the basic theory of the IC op amp in great detail, but also includes over 250 practical circuit applications, liberally illustrated. 592 pages, 5½ x 8½, softbound. \$12.95.*

● **THE POWER SUPPLY HANDBOOK**—BK7305—Need a power supply for a gadget you're building? In the **POWER SUPPLY HANDBOOK** there are dozens ready-to-build, plus detailed steps for designing your own. There are circuits and parts lists for all kinds of supplies, ranging from simple DC types to highly stable regulated versions. If you need a circuit to convert a DC voltage to a higher or lower voltage, turn DC into AC, or AC to DC—then this is the book you need. With more than 400 pages, you should be able to find just the circuit you need. Without a doubt one of the best power supply source books available, compiled by the editors of 73. \$7.95.*

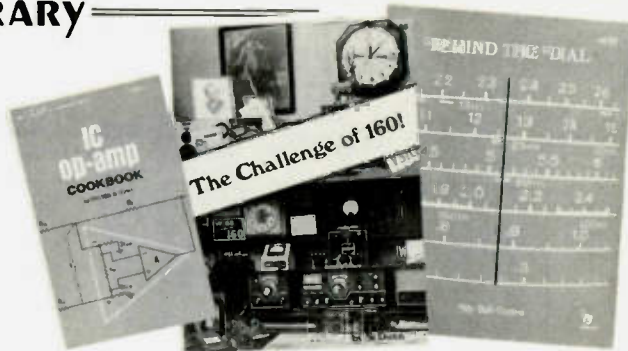

● **INTRODUCTION TO RTTY**—BK7380—A beginner's guide to radioteletype including teletypewriter fundamentals, signals, distortion and RTTY art. You can be a RTTY artist! A 73 publication. \$2.00.*

● **THE NEW RTTY HANDBOOK**—BK7347—is a new edition and the only up-to-date RTTY book available. The state of the art has been changing radically and has made all previous RTTY books obsolete. It has the latest circuits, great for the newcomer and expert alike. \$5.95.*

● **PROPAGATION WIZARD'S HANDBOOK**—BK7302—by J. H. Nelson. When sunspots riddled the worldwide communications networks of the 1940's, John Henry Nelson looked to the planets for an answer. The result was a theory of propagation forecasting based upon interplanetary alignment that made the author the most reliable forecaster in America today. The book provides an enlightened look at communications past, present, and future, as well as teaching the art of propagation forecasting. \$6.95.*



● **SSB . . . THE MISUNDERSTOOD MODE**—BK7351—by James B. Wilson. Single Sideband Transmission . . . thousands of us use it every day, yet it remains one of the least understood facets of amateur radio. J. B. Wilson presents several methods of sideband generation, amply illustrated with charts and schematics, which will enable the ambitious reader to construct his own sideband generator. A must for the technically-serious ham. \$5.50.*

● **MASTER HANDBOOK OF HAM RADIO CIRCUITS**—BK1033—This is an encyclopedia of amateur radio circuits, gleaned from past issues of 73 Magazine and carefully selected according to application. You'll find many you've never seen before, some new twists on the tried and true, and several that have been long forgotten but are well worth remembering. Where your interest ranges from ragchewing to EME, from CW to slow-scan TV, from DX to county nets, this handbook will be a welcome addition to your shack. \$8.95.*



● **WEATHER SATELLITE HANDBOOK**—BK7370—Simple equipment and methods for getting good pictures from the weather satellite. Antennas, receivers, monitors, facsimile you can build, tracking, automatic control (you don't even have to be home). Dr. Taggart WB8DQT. \$4.95.*

● **TOOLS & TECHNIQUES FOR ELECTRONICS**—BK7348—is an easy-to-understand book written for the beginning kit builder as well as the experienced hobbyist. It has numerous pictures and descriptions of the safe and correct ways to use basic and specialized tools for electronic projects as well as specialized metal working tools and the chemical aids which are used in repair shops. \$4.95.*

● **THE CONTEST COOKBOOK**—BK7308—reveals the secrets of the contest winners (Domestic, DX and specialty contests), complete with photos and diagrams of equipment used by the top scorers. Find out how to make 150 contacts in one hour. \$5.95.*

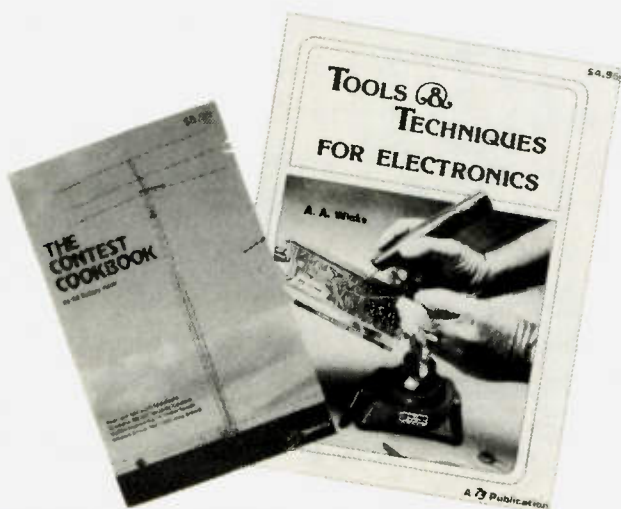

* Use the order card in the back of this magazine or itemize your order on a separate piece of paper and mail to: 73 Radio Bookshop • Peterborough NH 03458. Be sure to include check or detailed credit card information. No C.O.D. orders accepted. * Add \$1.00 handling charge. Note: Prices subject to change on books not published by 73 Magazine. Questions regarding your order? Please write to Customer Service at the above address. Please allow 4-6 weeks for delivery.

FOR TOLL FREE ORDERING CALL 1-800-258-5473

Radio Bookshop

TEST EQUIPMENT

● **RF AND DIGITAL TEST EQUIPMENT YOU CAN BUILD**—BK1044—Rf burst, function, square wave generators, variable length pulse generators—100 kHz marker, i-f and rf sweep generators, audio osc, af/rf signal injector, 146 MHz synthesizer, digital readouts for counters, several counters, prescaler, microwave meter, etc. 252 pages. \$5.95.*

● **VOL. I COMPONENT TESTERS**—LB7359—... how to build transistor testers (8), diode testers (3), IC testers (3), voltmeters and VTVMs (9), ohmmeters (8 different kinds), inductance (3), capacity (9), Q measurement, crystal checking (6), temperature (2), aural meters for the blind (3) and all sorts of miscellaneous data on meters ... using them, making them more versatile, making standards. Invaluable book. \$4.95.*

● **VOL. II AUDIO FREQUENCY TESTERS**—LB7360—... jam packed with all kinds of audio frequency test equipment. If you're into SSB, RTTY, SSTV, etc., this book is a must for you ... a good book for hi-fi addicts and experimenters, too! \$4.95.*

● **VOL. III RADIO FREQUENCY TESTERS**—LB7361—Radio frequency waves, the common denominator of Amateur Radio. Such items as SWR, antenna impedance, line impedance, rf output and field strength; detailed instructions on testing these items includes sections on signal generators, crystal callibrators, grid dip oscillators, noise generators, dummy loads and much more. \$4.95.*

● **VOL. IV IC TEST EQUIPMENT**—LB7362—Become a troubleshooting wizard! In this fourth volume of the 73 TEST EQUIPMENT LIBRARY are 42 home construction projects for building test equipment to work with your ham station and in servicing digital equipment. Plus a cumulative index for all four volumes of the 73 TEST EQUIPMENT LIBRARY. \$4.95.*



THE WELL-EQUIPPED HAM SHACK

NEW!

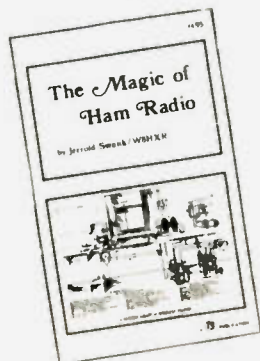

● **THE MAGIC OF HAM RADIO**—BK7312—by Jerrold Swank, W8HXR begins with a brief history of amateur radio and of Jerry's involvement in it. Part 2 details many of ham radio's heroic moments. Hamdom's close ties with the continent of Antarctica are the subject of Part 3. In Part 4 the strange and humorous sides of ham life get their due. And what of the future? Part 5 peers into the crystal ball. \$4.95.*

● **A GUIDE TO HAM RADIO**—BK7321—by Larry Kahaner WB2NEL. What's Amateur Radio all about? You can learn the basics of this fascinating hobby with this excellent beginner's guide. It answers the most frequently asked questions in an easy-going manner, and it shows the best way to go about getting an FCC license. A Guide to Ham Radio is an ideal introduction to a hobby enjoyed by people around the world. \$4.95.*

● **HOW TO BUILD A MICROCOMPUTER—AND REALLY UNDERSTAND IT**—BK7325—by Sam Creason. The electronics hobbyist who wants to build his own microcomputer system now has a practical "How-To" guidebook. This book is a combination technical manual and programming guide that takes the hobbyist step-by-step through the design, construction, testing and debugging of a complete microcomputer system. Must reading for anyone desiring a true understanding of small computer systems. \$9.95.*



● **LIBRARY SHELF BOXES**—These sturdy white, corrugated, dirt-resistant boxes each hold a full year of 73, *Kilobaud Microcomputing* or *80 Microcomputing*. With your order, request self-sticking labels for any of the following: 73, *Kilobaud Microcomputing*, *80 Microcomputing*, *CQ*, *QST*, *Ham Radio*, *Personal Computing*, *Radio Electronics*, *Interface Age*, and *Byte*. Order 1—BX1000—for \$2.00*; order 2-7—BX2002—for \$1.50 each*; order 8 or more—BX1002—for \$1.25 each*.

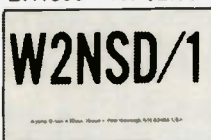

Style Y



Style W

● **QSL CARDS**—73 turns out a fantastic series of QSL cards at about half the cost of having them done elsewhere because they are run as a fill-in between printing books and other items in the 73 Print Shop. 250 Style W—QW0250—for \$8.95*; 500 Style W—QW0500—for \$13.95*; 250 Style X—QX0250—for \$8.95*; 500 Style X—QX0500—for \$13.95*; 250 Style Y—QY0250—for \$8.95*; 500 Style Y—QY0500—for \$13.95.* Allow 6-12 wks. for delivery.



Style X

● **BACK ISSUES**—Complete your collection; many are prime collectables now, classics in the field! A full collection is an invaluable compendium of radio and electronics knowledge!

Single back issue—ST0000—\$3.00*;
25 our choice—ST2500—\$12.00*;
25 your choice—ST2501—\$25.00*;
5 your choice—ST0500—\$8.75*;
10 your choice—ST1000—\$14.00*.

● **FREE BACK ISSUE CATALOGS** are yours for the asking ... specify 73 Magazine and/or *Kilobaud Microcomputing* back issue catalog when you send your name and address to us on a postcard.

● **OWNER REPAIR OF RADIO EQUIPMENT**—BK7310—Frank Glass K6RQ shares over 40 years of operating, servicing, and design experience in this magazine which ranges from the elementary to the highly technical written for the top engineers in the field. It is written in narrative style on the subjects of electronic servicing, how components work, and how they are combined to provide communication equipment. This book will help you understand the concepts required to service your own station equipment. \$7.95.*

*Use the order card in the back of this magazine or itemize your order on a separate piece of paper and mail to: 73 Radio Bookshop • Peterborough NH 03458. Be sure to include check or detailed credit card information. No C.O.D. orders accepted. *Add \$1.00 handling charge. Note: Prices subject to change on books not published by 73 Magazine. Questions regarding your order? Please write to Customer Service at the above address. Please allow 4-6 weeks for delivery.

FOR TOLL FREE ORDERING CALL 1-800-258-5473

Radio Bookshop

● **73 DIPOLE AND LONG-WIRE ANTENNAS**—BK1016—by Edward M. Noll W3FQJ. This is the first collection of virtually every type of wire antenna used by amateurs. Includes dimensions, configurations, and detailed construction data for 73 different antenna types. Appendices describe the construction of noise bridges, line tuners, and data on measuring resonant frequency, velocity factor, and swr. \$5.50.*



● **THE GIANT BOOK OF AMATEUR RADIO ANTENNAS**—With the **GIANT Book of Amateur Radio Antennas**—BK1104—by your side, antennas will become the least of your worries. Over 450 pages of design ideas, theory and reference data make this book live up to its title. The 7 chapters cover everything from basic antenna theory through designs for DIY accessories, as well as dozens of antenna designs. Whether planning to build or buy, design or admire, test or enjoy a ham antenna—this is the book for you. From the editors of 73; published by Tab Books. 8.95.*

● **73 VERTICAL, BEAM AND TRIANGLE ANTENNAS**—BK1069—by Edward M. Noll W3FQJ. Describes 73 different antennas for amateurs. Each design is the result of the author's own experiments covering the construction of noise bridges and antenna line tuners, as well as methods for measuring resonant frequency, velocity factor, and standing-wave ratios. 160 pages. \$5.50.*

● **VHF ANTENNA HANDBOOK**—BK7368—The **NEW VHF Antenna Handbook** details the theory, design and construction of hundreds of different VHF and UHF antennas... A practical book written for the average amateur who takes joy in building, not full of complex formulas for the design engineer. Packed with fabulous antenna projects you can build. \$5.95.*

● **PRACTICAL ANTENNAS FOR THE RADIO AMATEUR**—BK1015—A manual describing how to equip a ham station with a suitable antenna. A wide range of antenna topics, systems, and accessories are presented giving the reader some food for thought and practical data for construction. Designed to aid the experienced ham and novice as well. Only \$9.95.*

● **TTL COOKBOOK**—BK1063—by Donald Lancaster. Explains what TTL is, how it works, and how to use it. Discusses practical applications, such as a digital counter and display system, events counter, electronic stopwatch, digital voltmeter and a digital tachometer. \$9.50.

● **CMOS COOKBOOK**—BK1011—by Don Lancaster. Details the application of CMOS, the low power logic family suitable for most applications presently dominated by TTL. Required reading for every serious digital experimenter! \$10.50.*

● **TVT COOKBOOK**—BK1064—by Don Lancaster. Describes the use of a standard television receiver as a microprocessor CRT terminal. Explains and describes character generation, cursor control and interface information in typical, easy-to-understand Lancaster style. \$9.95.*

● **RTL COOKBOOK**—BK1059—by Donald Lancaster. Explains the how and why of RTL (Resistor-Transistor Logic) and gives design information that can be put to practical use. Gives a multitude of digital applications ranging from the basic switch to the sophisticated counter. 240 pages; \$6.50.*



● **HOBBY COMPUTERS ARE HERE!**—BK7322—If you want to come up to speed on how computers work... hardware and software... this is an excellent book. It starts with the fundamentals and explains the circuits, the basics of programming, along with a couple of TVT construction projects, ASCII-Baudot, etc. This book has the highest recommendations as a teaching aid for newcomers. \$4.95.*

● **THE NEW HOBBY COMPUTERS**—BK7340—This book takes it from where **Hobby Computers Are Here!** leaves off, with chapters on Large Scale Integration, how to choose a microprocessor chip, an introduction to programming, low cost I/O for a computer, computer arithmetic, checking memory boards, a Baudot monitor/editor system, an audible logic probe for finding those tough problems, a ham's computer, a computer QSO machine... and much, much more! \$4.95.*

● **HOW TO MAKE MONEY WITH COMPUTERS**—In 10 information-packed chapters, Jerry Felsen describes more than 30 computer-related, money-making, high profit, low capital investment opportunities. \$15.00.* (BK1003)

● **BASIC NEW 2ND EDITION**—by Bob Albrecht. Self-teaching guide to the computer language you will need to know for use with your microcomputer. This is one of the easiest ways to learn computer programming. \$6.95.* (BK1081)



*Use the order card in the back of this magazine or itemize your order on a separate piece of paper and mail to: 73 Radio Bookshop • Peterborough NH 03458. Be sure to include check or detailed credit card information. No C.O.D. orders accepted. *Add \$1.00 handling charge. Note: Prices subject to change on books not published by 73 Magazine. Questions regarding your order? Please write to Customer Service at the above address. Please allow 4-6 weeks for delivery.

FOR TOLL FREE ORDERING CALL 1-800-258-5473

DEALER DIRECTORY

Fontana CA

We carry the following: ICOM, Midland, Amcom, DenTron, KLM, Swan, Drake, Ten-Tec, Wilson, SST, MFJ, Hy-Gain, Lunar, Nye-Viking, B&W, Redi-kilowatt, CushCraft, Mosley, Big Signal, Pipco, etc. Full Service Store Fontana Electronics, 8628 Sierra Ave., Fontana CA 92335, 822-7710.

San Jose CA

Bay area's newest Amateur Radio store. New & used Amateur Radio sales & service. We feature Kenwood, ICOM, KDK, Yaesu, Ten-Tec, VHF Engineering & many more. Shaver Radio, Inc., 1378 So. Bascom Ave., San Jose CA 95128, 998-1103.

Denver CO

Experimenter's paradise! Electronic and mechanical components for computer people, audio people, hams, robot builders, experimenters. Open six days a week. Gateway Electronics Corp., 2839 W. 44th Ave., Denver CO 80211, 458-5444.

Uncasville CT

Cushcraft, Bencher, Hy-Gain, Telex, Barker & Williamson, Nye-Viking, Hustler, MFJ, Callbook, Murch, Unadilla, OK, Saxton, ARRL Books, Used equipment, Electronic parts and accessories, free catalog. Donovan Electronics, Inc., 2510 Norwich, New London Tpke, Uncasville CT 06382, 848-3434.

New Castle DE

ICOM, Ten-Tec, Swan, KDK, NDI, Tempo, Wilson; Authorized dealer: 1 mile off I-95. No sales tax. Delaware Amateur Supply, 71 Meadow Road, New Castle DE 19720, 328-7728.

Columbus GA

KENWOOD—YAESU—DRAKE

The world's most fantastic amateur show-room! You gotta see it to believe it! Radio Wholesale, 2012 Auburn Avenue, Columbus GA 31906, 561-7000.

Boise ID

Adzen, Amidon, Ameco, ARRL, B&W, Callbook, Collins, CushCraft, Dentrone, Hustler, ICOM, Jim-Pak, KDK, MFJ, NPC, Nye, Sams, SST, Swan, Ten-Tec, Wanzer, Wilson. Custom Electronics, 1209 Broadway, Boise ID 83706, Bob W7SC 344-5084.

Preston ID

Ross WB7BYZ, has the Largest Stock of Amateur Gear in the Intermountain West and the Best Prices. Call me for all your ham needs. Ross I Distributing, 78 So. State, Preston ID 83263, 852-0830.

Terre Haute IN

Your ham headquarters located in the heart of the midwest. Hoosier Electronics, Inc., 43B Meadows Shopping Center, P.O. Box 2001, Terre Haute IN 47802, 238-1456.

Littleton MA

The ham store of N.E. you can rely on. Kenwood, ICOM, Wilson, Yaesu, DenTron, KLM amps, B&W switches & wattmeters, Whistler radar detectors, Bearcat, Regency, antennas by Larsen, Wilson, Hustler, GAM. TEL-COM Inc. Communications & Electronics, 675 Great Rd., Rt. 119, Littleton MA 01460, 486-3040.

Laurel MD

Kenwood, Drake, ICOM, Ten-Tec, Swan, Dentrone, Tempo and many ham accessories. Also computers by Apple and Exidy. Call toll free 1-800-638-4486. The Comm Center, Inc., Laurel Plaza—Rt. 198, Laurel MD 20810.

St. Louis MO

Experimenter's paradise! Electronic and mechanical components for computer people, audio people, hams, robot builders, experimenters. Open six days a week. Gateway Electronics Corp., 8123-25 Page Blvd., St. Louis MO 63130, 427-6116.

Camden NJ

X-band (& other frequencies) Microwave Components & Equipment. Laboratory Grade Test Instruments, Power Supplies, 1000's in stock at all times, BUY & SELL all popular makes—HP, GR, FXR, ESI, Sorensen, Singer, etc. Lectronic Research Labs, 1423 Ferry Ave., Camden NJ 08104, 541-4200.

Syracuse—Central NY

We deal, we trade, we discount, we please! Yaesu, Ten-Tec, Cushcraft, Drake, Dentrone, KLM, Midland, B&W, ICOM, Hygain, Swan, Amcom, Telco, Mirage, DSI etc. Complete 2-way service shop! Ham-Bone Radio (Div. Stereo Repair Shop) 3206 Erie Blvd. East, Syracuse NY 13214, 446-2266.

Syracuse—Rome—Utica NY

Featuring: Yaesu, ICOM, Drake, Atlas, Dentrone, Ten-Tec, Swan, Tempo, KLM, Hy-Gain, Mosley, Wilson, Larsen, Midland Southwest Technical Products. You won't be disappointed with equipment/service. Radio World, Oneida County Airport-Terminal Building, Oriskany NY 13424, 337-2622.

Phila. PA/Camden NJ

Waveguide & coaxial microwave components & equipment. Laboratory grade test instruments, power supplies. Buy, sell & trade all popular makes, HP, GR, FXR, ESI, Sorensen, Singer, etc. Lectronic Research Labs., 1423 Ferry Ave., Camden NJ 08104, 541-4200.

Houston TX

Experimenter's paradise! Electronic and mechanical components for computer people, audio people, hams, robot builders, experimenters. Open six days a week. Gateway Electronics Inc., 8932 Clarkcrest, Houston TX 77063, 978-6575.

San Antonio TX

Complete 2 way service shop. Call Dee, W5FSP. Selling Antenna Specialists, Avanti, Azden, Bird, Hy-gain, Standard communications, Genave, Henry, CushCraft, Hustler, ICOM, KDK, MFJ, Nye, Shure, Swan, Tempo, Ten-Tec and others. Appliance & Equipment Co., Inc., 2317 Vance Jackson Road, San Antonio TX 78213, 734-7793.

Port Angeles WA

Mobile RFI shielding for elimination of ignition and alternator noises. Bonding straps. Components for "do-it-yourself" projects. Plenty of free advice. Estes Engineering, 930 Marine Drive, Port Angeles WA 98362, 457-0904.

DEALERS

Your company name and message can contain up to 25 words for as little as \$150 yearly (prepaid), or \$15 per month (prepaid quarterly). No mention of mail-order business or area code permitted. Directory text and payment must reach us 60 days in advance of publication. For example, advertising for the September issue must be in our hands by July 1st. Mail to 73 Magazine, Peterborough NH 03458. ATTN: Nancy Ciampa.

propagation

by
J. H. Nelson

EASTERN UNITED STATES TO:

| | GMT: | 00 | 02 | 04 | 06 | 08 | 10 | 12 | 14 | 16 | 18 | 20 | 22 |
|--------------|------|-----|-----|----|----|----|----|-----|-----|-----|-----|-----|-----|
| ALASKA | 14 | 14 | 14 | 7 | 7 | 7 | 7 | 7 | 14 | 14 | 14 | 14 | 14 |
| ARGENTINA | 21 | 21 | 14A | 14 | 14 | 7 | 14 | 21 | 21 | 21 | 21 | 21 | 21 |
| AUSTRALIA | 21 | 14 | 14 | 14 | 7B | 7B | 7 | 7 | 7B | 14 | 14A | 14A | 14A |
| CANAL ZONE | 21 | 14A | 14 | 14 | 7 | 7 | 14 | 21 | 21 | 21A | 21A | 21A | 21A |
| ENGLAND | 14 | 14 | 7A | 7 | 7 | 14 | 21 | 21 | 21 | 21 | 21 | 21 | 21 |
| HAWAII | 21 | 14 | 14 | 14 | 7B | 7B | 7 | 7 | 14 | 14 | 14 | 21 | 21 |
| INDIA | 14A | 14 | 14 | 7B | 7B | 7B | 14 | 14 | 14 | 14 | 14 | 14 | 14A |
| JAPAN | 21 | 14 | 14 | 7B | 7B | 7B | 7B | 14B | 14 | 14 | 14 | 14 | 14A |
| MEXICO | 21 | 14A | 14 | 14 | 7 | 7 | 7A | 14 | 14 | 14 | 14 | 21 | 21 |
| PHILIPPINES | 14 | 14 | 14 | 7B | 7B | 7B | 7B | 14 | 14 | 14 | 14 | 14 | 14 |
| PUERTO RICO | 21 | 14 | 14 | 7 | 7 | 7 | 14 | 14 | 14 | 14 | 21 | 21 | 21 |
| SOUTH AFRICA | 7B | 7B | 7B | 14 | 14 | 21 | 21 | 21 | 21A | 21A | 14A | 14A | 14A |
| U. S. S. R. | 14 | 14 | 7 | 7 | 7 | 7A | 14 | 14 | 14 | 14A | 14A | 14A | 14A |
| WEST COAST | 21 | 14A | 14 | 14 | 7 | 7 | 7A | 14 | 14A | 21 | 21 | 21 | 21 |

CENTRAL UNITED STATES TO:

| | GMT: | 00 | 02 | 04 | 06 | 08 | 10 | 12 | 14 | 16 | 18 | 20 | 22 |
|--------------|------|-----|-----|----|----|-----|----|----|----|-----|-----|-----|-----|
| ALASKA | 14 | 14 | 14 | 7A | 7 | 7 | 7 | 7 | 14 | 14 | 14 | 14 | 14 |
| ARGENTINA | 21 | 21 | 14A | 14 | 14 | 7 | 14 | 21 | 21 | 21 | 21 | 21 | 21 |
| AUSTRALIA | 21 | 21 | 14 | 14 | 14 | 7B | 7 | 7 | 7 | 7B | 14 | 14A | 14A |
| CANAL ZONE | 21 | 14A | 14 | 14 | 7 | 7 | 14 | 21 | 21 | 21A | 21A | 21A | 21A |
| ENGLAND | 14 | 14 | 7 | 7 | 7 | 7 | 14 | 14 | 14 | 14A | 14A | 14A | 14A |
| HAWAII | 21 | 21 | 14 | 14 | 7 | 7 | 7 | 14 | 14 | 14 | 21 | 21 | 21 |
| INDIA | 14 | 14 | 14 | 7B | 7B | 7B | 14 | 14 | 14 | 14 | 14 | 14 | 14 |
| JAPAN | 21 | 14 | 14 | 14 | 7B | 7B | 7B | 14 | 14 | 14 | 14 | 14 | 14A |
| MEXICO | 14 | 14 | 7 | 7 | 7 | 7 | 7 | 14 | 14 | 14 | 14 | 14 | 14 |
| PHILIPPINES | 14 | 14 | 14 | 14 | 7B | 7B | 7B | 14 | 14 | 14 | 14 | 14 | 14 |
| PUERTO RICO | 21 | 14A | 14 | 14 | 7 | 7 | 14 | 14 | 14 | 14A | 14A | 14A | 14A |
| SOUTH AFRICA | 7B | 7B | 7B | 7B | 7B | 14B | 14 | 21 | 21 | 21 | 14 | 14 | 14 |
| U. S. S. R. | 14 | 14 | 7 | 7 | 7 | 7 | 7A | 14 | 14 | 14 | 14 | 14 | 14 |

WESTERN UNITED STATES TO:

| | GMT: | 00 | 02 | 04 | 06 | 08 | 10 | 12 | 14 | 16 | 18 | 20 | 22 |
|--------------|------|-----|-----|-----|-----|-----|----|----|-----|-----|-----|-----|-----|
| ALASKA | 14 | 14 | 14 | 7 | 7 | 7 | 7 | 7 | 14 | 14 | 14 | 14 | 14 |
| ARGENTINA | 21 | 21 | 14A | 14 | 14 | 7 | 14 | 21 | 21 | 21 | 21 | 21 | 21 |
| AUSTRALIA | 21 | 21A | 21A | 21 | 14 | 14 | 14 | 7 | 7 | 7B | 14 | 14 | 14 |
| CANAL ZONE | 21 | 14A | 14 | 14 | 7 | 7 | 14 | 14 | 21 | 21 | 21A | 21A | 21A |
| ENGLAND | 14 | 14 | 7 | 7 | 7 | 7 | 14 | 14 | 14 | 14 | 14 | 14 | 14 |
| HAWAII | 21A | 21A | 21 | 14A | 14 | 14 | 7A | 14 | 14 | 14 | 21 | 21 | 21 |
| INDIA | 14 | 14 | 14 | 14 | 14B | 7B | 7B | 14 | 14 | 14 | 14 | 14 | 14 |
| JAPAN | 21 | 14A | 14 | 14 | 14 | 14 | 7B | 7B | 14 | 14 | 14 | 14 | 14A |
| MEXICO | 14A | 14 | 14 | 7 | 7 | 7 | 7 | 14 | 14 | 14 | 14A | 14A | 14A |
| PHILIPPINES | 14A | 14 | 14 | 14 | 14 | 14B | 7B | 14 | 14 | 14 | 14 | 14A | 14A |
| PUERTO RICO | 21 | 14A | 14 | 14 | 7 | 7 | 14 | 14 | 14 | 14A | 21 | 21 | 21 |
| SOUTH AFRICA | 7B | 7B | 7B | 7B | 7B | 14 | 14 | 14 | 14A | 14A | 14 | 14 | 14 |
| U. S. S. R. | 14 | 14 | 7 | 7 | 7 | 7 | 7 | 14 | 14 | 14 | 14 | 14 | 14 |
| EAST COAST | 21 | 14A | 14 | 14 | 7 | 7 | 7A | 14 | 14A | 21 | 21 | 21 | 21 |

- A = Next higher frequency may also be useful
- B = Difficult circuit this period
- F = Fair
- G = Good
- P = Poor
- SF = Chance of solar flares

July

| sun | mon | tue | wed | thu | fri | sat |
|-----------|-----------|-----------|-----------|-----------|-----------|-----------|
| | | 1 | 2 | 3 | 4 | 5 |
| | | G | G | G | G | G |
| 6 | 7 | 8 | 9 | 10 | 11 | 12 |
| G | G | G | G | G | G | F |
| 13 | 14 | 15 | 16 | 17 | 18 | 19 |
| F | G | G | G | G | G | G |
| 20 | 21 | 22 | 23 | 24 | 25 | 26 |
| G/SF | P/SF | P/SF | F | G | G | G |
| 27 | 28 | 29 | 30 | 31 | | |
| G | F | F | G | G | | |

List of AdvertisERS

To receive full information from our advertisers please complete the following postage-paid card.

| R.S. No. | Page | R.S. No. | Page | R.S. No. | Page | R.S. No. | Page |
|----------|--|----------|---|----------|---|----------|--|
| 3 | AED Electronics..... 151 | 31 | Hal Comm. Corp..... 13 | 338 | Microperipheral Corp..... 130 | 481 | Trac Electronics..... 28 |
| 6 | AMC Engineering..... 129 | 31 | Hal-Tronix..... 104 | 52 | Mid Com Electronics, III Inc..... 119 | * | Tri-City Hamfest..... 91 |
| 2 | Adv. Elect. Applications..... 119, 135 | 30 | The Ham-Key Co..... 50, 121 | 318 | National Comm. Group Co..... 81 | 335 | Tri-Ex Tower..... 17 |
| 300 | Aldelco..... 129 | 32 | Ham Radio Center..... 35 | 54 | OK Machine & Tool..... 99, 101 | 77 | Tufts Radio Electronics..... 136-147 |
| 5 | Amateur-Wholesale Elect..... 20, 178 | 33 | Hamtronics, NY..... 187 | 55 | Optoelectronics, Inc..... 68 | 311 | Vanguard Labs..... 171 |
| 7 | American Crystal Supply..... 171 | 303 | Heath Co..... 3 | 57 | P.C. Electronics..... 77 | 86 | Vineyard Amat. Radio/Lunar..... 88 |
| 334 | Amidon Associates..... 126 | 34 | Henry Radio..... Cov. II | * | Palomar Engineers..... 25 | 80 | Western Electronics..... 21 |
| 301 | Appli. & Equip. Co., Inc..... 161, 171 | 305 | Hustler, Inc..... 105 | * | Partridge Electronics..... 64 | * | Wilson Sys., Inc..... 54, 55 |
| 8 | Apron Laboratories..... 133 | 477 | Hustler, Inc..... 156 | 58 | Poly Paks..... 183 | 82 | Xitex Corp..... 76, 127 |
| * | Associated Radio..... 182 | 483 | Hustler, Inc..... 157 | 59 | Quest Electronics..... 172 | 83 | Yaesu Electronics Corp..... Cov. III, 43, 63 |
| 10 | Avanti Research & Develop..... 62 | 484 | Hy-Gain Div. of Telex Comm., Inc..... 157 | 342 | RF Gain, Ltd..... 53 | | |
| 11 | Barker-Williamson..... 116 | | | 63 | RF Power Labs, Inc..... 117 | | |
| 478 | Barker-Williamson..... 28 | * | ICOM..... 7, 27 | 61 | Radio Amateur Callbook..... 131 | | |
| 12 | Bullet Electronics..... 188 | 341 | J & J Enterprises..... 123 | * | Radio World..... 127 | | |
| 13 | Clegg..... 83 | 339 | J-T Electronics Supply, Inc..... 161 | 343 | Radios Unltd./Lunar..... 90 | | |
| 89 | Clutterfree Modular Consoles..... 126 | 38 | Jameco Electronics..... 181 | 62 | Ramsey Electronics..... 176, 179 | | |
| 14 | Comm. Center, NE..... 65 | 39 | Jan Crystals..... 129 | 479 | Robot..... 26 | | |
| 15 | Comm. Specialists..... 8, 9 | 40 | KLM Electronics..... 100, 105 | 65 | S-F Amateur Radio Services..... 73 | | |
| 85 | Comm. Tech. Group..... 173 | 480 | KLM Electronics..... 156 | * | Seattle National Amateur Radio Convention..... 42 | | |
| 340 | Computer Systems..... 151 | * | Kantronics..... 28, 79, 127 | 64 | Semiconductors Surplus..... 175 | | |
| 16 | Crown Micro Prod..... 131 | * | KB Microcomputing..... 100 | 333 | Sentry Mfg. Co..... 130 | | |
| 344 | DarrinOn Industries..... 126 | * | Kenwood..... Cov. IV, 5 | * | 73 Magazine..... 19, 34, 161, 189-192 | | |
| 330 | Debco Electronics..... 68 | 41 | LaRue Electronics..... 115 | 66 | Signalcrafters, Inc..... 123 | | |
| * | Digital Research Parts..... 186 | 43 | Lunar Electronics..... 86, 87 | 317 | Space Electronics..... 171 | | |
| 18 | Digitrex..... 123 | 47 | MFJ Enterprises..... 57, 64, 81, 117, 123 | 309 | Spacecoast Research..... 171 | | |
| * | 80 Microcomputing..... 104 | 48 | MHz Electronics..... 184, 185 | 67 | Spectronics, Inc..... 177 | | |
| 476 | Electra Co..... 157 | 26 | M & M RF Distributors..... 89 | 68 | Spectrum Comm..... 85 | | |
| 22 | Fair Radio Sales..... 171 | 53 | MOM's..... 102, 103 | 69 | Surplus Electronics..... 174 | | |
| 23 | Flesher Corp..... 117 | 44 | Macrotronics..... 116 | 73 | TET, USA..... 47 | | |
| 323 | Fox-Tango Corp..... 42 | 45 | Madison Electronics Supply..... 71 | 324 | THS Electronics..... 21 | | |
| 302 | G&G Radio Elect. Co..... 171 | 46 | Maggiore Electronic Lab..... 150 | 72 | Tele-Tow'r Mfg. Co..... 116, 131 | | |
| 27 | G.I.S.M.O..... 69 | 49 | Micro Control Specialties..... 59 | 484 | Telex Comm., Inc..... 157 | | |
| 24 | Gemini Instrument Co..... 171 | 482 | Micro Control Specialties..... 26 | * | Ten-Tec, Inc..... 11, 26, 29 | | |
| 25 | Germantown Amat. Supply..... 57 | 313 | Micro Management Systems..... 159 | 75 | Thomas Comm..... 51 | | |
| 28 | Godbout Electronics..... 180 | 50 | Microcraft Corp..... 127 | 76 | Trac Electronics..... 25 | | |
| 304 | HFT, Inc..... 171 | 51 | Microlog Corp..... 23 | | | | |

*Please contact these advertisers directly.

73 magazine peterborough, n.h. 03458

Books, ETC.

To order, complete the following postage-paid card, or itemize your order including detailed credit card information or check and mail to: 73 Magazine/Mail Order Dept./Peterborough NH 03458.

| Catalog # | Item | Price | Catalog # | Item | Price | Catalog # | Item | Price |
|-----------|---|---------|-----------|--|-------------|-----------|---------------------------------|---------|
| BK1016 | 73 DIPOLE & LONG WIRE ANTENNAS | \$ 5.50 | BK1028 | IC OP AMP COOKBOOK | \$12.95 | BK7351 | SSB THE MISUNDERSTOOD MODE | \$ 5.50 |
| ST0000 | 73 BACK ISSUE | \$ 3.00 | BK7380 | INTRO TO RTTY | \$ 2.00 | CT7350 | SSTV TAPE | \$ 5.95 |
| ST2500 | 73 BACK ISSUES—25 OUR CHOICE | \$12.00 | BK7312 | MAGIC OF HAM RADIO | \$ 4.95 | SG1081 | STUDY GUIDE—ADV CLASS | \$ 6.95 |
| ST0500 | 73 BACK ISSUES—5 YOUR CHOICE | \$ 8.75 | BK1033 | MASTER HANDBOOK OF HAM RADIO CIRCUITS | \$ 8.95 | SG1080 | STUDY GUIDE—EXTRA CLASS | \$ 5.95 |
| ST1000 | 73 BACK ISSUES—10 YOUR CHOICE | \$14.00 | BK7340 | THE NEW HOBBY COMPUTERS | \$ 4.95 | SG7358 | STUDY GUIDE—GENERAL CLASS | \$ 5.95 |
| ST2501 | 73 BACK ISSUES—25 YOUR CHOICE | \$25.00 | CT7300 | NOVICE THEORY TAPES | \$15.95 | SG7357 | STUDY GUIDE—NOVICE CLASS | \$ 4.95 |
| BK1081 | BASIC NEW 2ND EDITION | \$ 6.95 | BK7310 | OWNER REPAIR OF RADIO EQUIPMENT | \$ 7.95 | LB7359 | TEST EQUIP LIB V1—COMP TESTERS | \$ 4.95 |
| BK7307 | BEHIND THE DIAL | \$ 4.95 | BK7305 | POWER SUPPLY HANDBOOK | \$ 7.95 | LB7360 | TEST EQUIP LIB V2—AUDIO TESTERS | \$ 4.95 |
| BK7309 | CHALLENGE OF 160 | \$ 4.95 | BK1015 | PRACTICAL ANTENNAS FOR THE RADIO AMATEUR | \$ 9.95 | LB7361 | TEST EQUIP LIB V3—RADIO EQUIP | \$ 4.95 |
| CT7305 | CODE TAPE—5 WPM | \$ 4.95 | BK7302 | PROPAGATION WIZARD'S HANDBOOK | \$ 6.95 | LB7362 | TEST EQUIP LIB V4—IC TEST EQ | \$ 4.95 |
| CT7306 | CODE TAPE—6 + WPM | \$ 4.95 | QW0250 | OSL CARDS—STYLE W—250 | \$ 8.95 | BK7348 | TOOLS & TECHNIQUES | \$ 4.95 |
| CT7313 | CODE TAPE—13 + WPM | \$ 4.95 | QW0500 | OSL CARDS—STYLE W—500 | \$13.95 | BK1063 | TTL COOKBOOK | \$ 9.50 |
| CT7320 | CODE TAPE—20 + WPM | \$ 4.95 | QX0250 | OSL CARDS—STYLE X—250 | \$ 8.95 | BK1064 | TVT COOKBOOK | \$ 9.95 |
| CT7325 | CODE TAPE—25 + WPM | \$ 4.95 | QX0500 | OSL CARDS—STYLE X—500 | \$13.95 | BK1069 | VERTICAL BEAM & TRIANGLE ANTNS | \$ 5.50 |
| CT7394 | CODE TAPES (ANY FOUR ABOVE) | \$15.95 | QY0250 | OSL CARDS—STYLE Y—250 | \$ 8.95 | BK7368 | VHF ANTENNA HANDBOOK | \$ 5.95 |
| BK7308 | THE CONTEST COOKBOOK | \$ 5.95 | QY0500 | OSL CARDS—STYLE Y—500 | \$13.95 | BK7370 | WEATHER SATELLITE HANDBOOK | \$ 4.95 |
| BK7304 | GIANT BOOK OF AMATEUR RADIO ANTENNAS | \$12.95 | BK1044 | RF DIGITAL TEST EQUIPMENT | \$ 5.95 | | | |
| BK7322 | HOBBY COMPUTERS ARE HERE | \$ 4.95 | BK7347 | RTTY HANDBOOK | \$ 5.95 | | | |
| BK7325 | HOW TO BUILD A MICROCOMPUTER & REALLY UNDERSTAND IT | \$ 9.95 | BK1059 | RTL COOKBOOK | \$ 6.50 | | | |
| BK1003 | HOW TO MAKE MONEY WITH COMPUTERS | \$15.00 | BX1000 | SHELF BOX—1 | \$ 2.00 | | | |
| | | | BX1001 | SHELF BOXES—2-7 | \$1.50 each | | | |
| | | | BX1002 | SHELF BOXES—8 AND UP | \$1.25 each | | | |

READER SERVICE

73 Magazine, P.O.B. 2739, Clinton, IA 52735

This card is valid until October 31, 1980.

Please help us to bring you a better magazine—by answering these questions:

I. What is your age?

- A. under 18
- B. 18-22
- C. 23-40
- D. 41-60
- E. over 60

II. ARRL

- 1. Love it
- 2. Don't care
- 3. Hate it

III. If you are not a subscriber please circle number 500.

Reader Service: Return this card to receive full information on the products advertised in this issue. Refer to the ad. You will find numbers near the logo of each advertiser. Each represents the advertiser's individual Reader Service Number. Circle the corresponding numbers on one of the cards on this page, include your name, address & zip, and drop in a mailbox. In 4-6 weeks you'll hear from the advertiser directly.

| | | | | | | | | | | | | | | | | | | | |
|-----|-----|-----|-----|-----|-----|-----|-----|-----|-----|-----|-----|-----|-----|-----|-----|-----|-----|-----|-----|
| 1 | 6 | 11 | 16 | 21 | 126 | 131 | 136 | 141 | 146 | 251 | 256 | 261 | 266 | 271 | 376 | 381 | 386 | 391 | 396 |
| 2 | 7 | 12 | 17 | 22 | 127 | 132 | 137 | 142 | 147 | 252 | 257 | 262 | 267 | 272 | 377 | 382 | 387 | 392 | 397 |
| 3 | 8 | 13 | 18 | 23 | 128 | 133 | 138 | 143 | 148 | 253 | 258 | 263 | 268 | 273 | 378 | 383 | 388 | 393 | 398 |
| 4 | 9 | 14 | 19 | 24 | 129 | 134 | 139 | 144 | 149 | 254 | 259 | 264 | 269 | 274 | 379 | 384 | 389 | 394 | 399 |
| 5 | 10 | 15 | 20 | 25 | 130 | 135 | 140 | 145 | 150 | 255 | 260 | 265 | 270 | 275 | 380 | 385 | 390 | 395 | 400 |
| 26 | 31 | 36 | 41 | 46 | 151 | 156 | 161 | 166 | 171 | 276 | 281 | 286 | 291 | 296 | 401 | 406 | 411 | 416 | 421 |
| 27 | 32 | 37 | 42 | 47 | 152 | 157 | 162 | 167 | 172 | 277 | 282 | 287 | 292 | 297 | 402 | 407 | 412 | 417 | 422 |
| 28 | 33 | 38 | 43 | 48 | 153 | 158 | 163 | 168 | 173 | 278 | 283 | 288 | 293 | 298 | 403 | 408 | 413 | 418 | 423 |
| 29 | 34 | 39 | 44 | 49 | 154 | 159 | 164 | 169 | 174 | 279 | 284 | 289 | 294 | 299 | 404 | 409 | 414 | 419 | 424 |
| 30 | 35 | 40 | 45 | 50 | 155 | 160 | 165 | 170 | 175 | 280 | 285 | 290 | 295 | 300 | 405 | 410 | 415 | 420 | 425 |
| 51 | 56 | 61 | 66 | 71 | 176 | 181 | 186 | 191 | 196 | 301 | 306 | 311 | 316 | 321 | 426 | 431 | 436 | 441 | 446 |
| 52 | 57 | 62 | 67 | 72 | 177 | 182 | 187 | 192 | 197 | 302 | 307 | 312 | 317 | 322 | 427 | 432 | 437 | 442 | 447 |
| 53 | 58 | 63 | 68 | 73 | 178 | 183 | 188 | 193 | 198 | 303 | 308 | 313 | 318 | 323 | 428 | 433 | 438 | 443 | 448 |
| 54 | 59 | 64 | 69 | 74 | 179 | 184 | 189 | 194 | 199 | 304 | 309 | 314 | 319 | 324 | 429 | 434 | 439 | 444 | 449 |
| 55 | 60 | 65 | 70 | 75 | 180 | 185 | 190 | 195 | 200 | 305 | 310 | 315 | 320 | 325 | 430 | 435 | 440 | 445 | 450 |
| 76 | 81 | 86 | 91 | 96 | 201 | 206 | 211 | 216 | 221 | 326 | 331 | 336 | 341 | 346 | 451 | 456 | 461 | 466 | 471 |
| 77 | 82 | 87 | 92 | 97 | 202 | 207 | 212 | 217 | 222 | 327 | 332 | 337 | 342 | 347 | 452 | 457 | 462 | 467 | 472 |
| 78 | 83 | 88 | 93 | 98 | 203 | 208 | 213 | 218 | 223 | 328 | 333 | 338 | 343 | 348 | 453 | 458 | 463 | 468 | 473 |
| 79 | 84 | 89 | 94 | 99 | 204 | 209 | 214 | 219 | 224 | 329 | 334 | 339 | 344 | 349 | 454 | 459 | 464 | 469 | 474 |
| 80 | 85 | 90 | 95 | 100 | 205 | 210 | 215 | 220 | 225 | 330 | 335 | 340 | 345 | 350 | 455 | 460 | 465 | 470 | 475 |
| 101 | 106 | 111 | 116 | 121 | 226 | 231 | 236 | 241 | 246 | 351 | 356 | 361 | 366 | 371 | 476 | 481 | 486 | 491 | 496 |
| 102 | 107 | 112 | 117 | 122 | 227 | 232 | 237 | 242 | 247 | 352 | 357 | 362 | 367 | 372 | 477 | 482 | 487 | 492 | 497 |
| 103 | 108 | 113 | 118 | 123 | 228 | 233 | 238 | 243 | 248 | 353 | 358 | 363 | 368 | 373 | 478 | 483 | 488 | 493 | 498 |
| 104 | 109 | 114 | 119 | 124 | 229 | 234 | 239 | 244 | 249 | 354 | 359 | 364 | 369 | 374 | 479 | 484 | 489 | 494 | 499 |
| 105 | 110 | 115 | 120 | 125 | 230 | 235 | 240 | 245 | 250 | 355 | 360 | 365 | 370 | 375 | 480 | 485 | 490 | 495 | 500 |

Name _____

Address _____

City _____ State _____ Zip _____

73 Magazine • July 1980

BOOKS

73 Magazine, Pine Street, Peterborough, N.H. 03458

Please send me the following 73 products:

| Qty. | Catalog # | Title | Unit Price | Total |
|------|-----------|-------|------------|-------|
| | | | | |
| | | | | |
| | | | | |
| | | | | |
| | | | | |
| | | | | |
| | | | | |
| | | | | |
| | | | | |
| | | | | |

Add \$1 shipping/handling _____

Total _____

Please allow 4-6 weeks for delivery.

No C.O.D. orders accepted.

Enclosed \$ _____ Check M.O.

Bill: AE MC Visa

Card # _____ Exp. date _____

Signature _____ Interbank # _____

Name _____

Address _____

City _____

State _____ Zip _____

SUBSCRIPTION

73 Magazine P.O. Box 931 Farmingdale, N.Y. 11737

73 subscribers
Beat the July 1st
Rate Increase
Subscribe now

New subscription Renewal

1 year—\$15 2 years—\$30 3 years—\$45

Enclosed \$ _____ Check M.O.

Bill: MC Visa AE me

This Card Expires July 18, 1980

Card # _____ Exp. date _____

Signature _____ Interbank # _____

Name _____

Address _____

City _____ State _____ Zip _____

Canada \$15 per year US funds

Other foreign \$26 one year only US funds

307B9

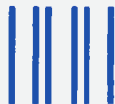

NO POSTAGE
NECESSARY
IF MAILED
IN THE
UNITED STATES

BUSINESS REPLY CARD

FIRST CLASS PERMIT NO 73 PETERBOROUGH NH 03458

POSTAGE WILL BE PAID BY ADDRESSEE

73 MAGAZINE
Subscription Dept.
POB 931
Farmingdale NY 11737

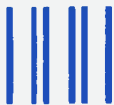

NO POSTAGE
NECESSARY
IF MAILED
IN THE
UNITED STATES

BUSINESS REPLY CARD

FIRST CLASS PERMIT NO 73 PETERBOROUGH NH 03458

POSTAGE WILL BE PAID BY ADDRESSEE

73 MAGAZINE
Peterborough
NH 03458

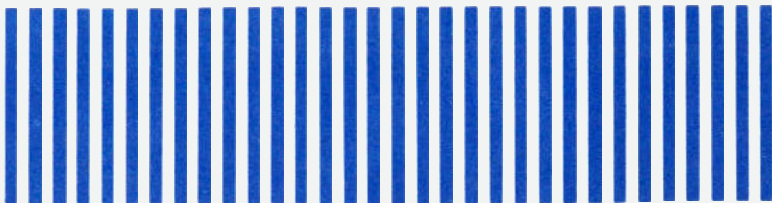

NO POSTAGE
NECESSARY
IF MAILED
IN THE
UNITED STATES



BUSINESS REPLY CARD

FIRST CLASS PERMIT NO. 217 CLINTON IA 52735

POSTAGE WILL BE PAID BY ADDRESSEE

73 MAGAZINE
POB 2739
Clinton IA 52735

Att. Mail Order

DOUBLE YOUR PLEASURE



Versatility Plus . . . Work Both 2 and 3/4 Meters With Yaesu's New FT-720R

The FT-720R series is a compact VHF/UHF mobile transceiver that harnesses the incredible power of the microprocessor to bring you top-operating flexibility. Start with the FT-720R Control Head, then add either the 10 watt FT-720RU 440 MHz or 25 watt FT-720RVH 2 meter RF Deck. You can clamp the Control and RF Deck together or use an optional remote cable to hide the RF Deck. The best news is still to come! By using the optional S-72 Switching Box and two remote cables, you can use a single Control Head for operation with both the 440 MHz and 2 meter decks, giving you a high-performance two band FM station for your car or home. Compare the features below, then ask your dealer for a demonstration of the fabulous FT-720R series. . . another winner from the performance leader . . . Yaesu.

- Four simplex/repeater memory channels, plus receive-only memory channel.
- Scanning controls on microphone with search for busy or clear channel.
- Optional 32 tone CTCSS module for accessing private repeaters.
- Colorful, easy-to-read LED power output/S meter.
- Built-in 1800 Hz tone generator.
- Priority channel with search-back feature.
- Pause feature that holds, then restarts scan, on busy or clear channels.
- Digital display of last four digits of operating frequency.
- Single Control Head may be used for operation on both 440 MHz and 2 meters via optional switching box and remote cables.
- Extremely compact size, light weight.

| FT-720RVH | Specifications | FT-720RU |
|-------------------|--------------------|--------------------|
| 144.00-147.99 MHz | Frequency Coverage | 440.00-449.975 MHz |
| 10 kHz | Synthesizer Steps | 25 kHz |
| 25 watts | Power Output | 10 watts |
| .32 uV for 20 dB | Sensitivity | 0.5 uV for 20 dB |
| quieting | | quieting |
| ±6 kHz (-6dB) | Selectivity | ±12 kHz (-6dB) |
| ±12 kHz (-60 dB) | | ±24 kHz (-60 dB) |

Price And Specifications Subject To
Change Without Notice Or Obligation

YAESU
The radio.



480

YAESU ELECTRONICS CORP., 6851 Walthall Way, Paramount, CA 90723 ● (213) 633-4007
YAESU ELECTRONICS Eastern Service Ctr., 9812 Princeton-Glendale Rd., Cincinnati, OH 45246

Easy selection.

15 memories/offset recall, scan, Touch-Tone[®], priority



TR-7800

Kenwood's remarkable TR-7800 2-meter FM mobile transceiver provides all the features you could desire for maximum operating enjoyment. Frequency selection is easier than ever, and the rig incorporates new memory developments for repeater shift, priority, and scan, and includes a

built-in autopatch Touch-Tone[®] encoder. Ask your Authorized Kenwood Dealer about the exciting TR-7800.

NOTE: Price, specifications subject to change without notice and obligation.

 **KENWOOD**
...pacesetter in amateur radio

TRIO-KENWOOD COMMUNICATIONS INC.
1111 WEST WALNUT / COMPTON, CA 90220