

73 Magazine

for Radio Amateurs

- 30 **A DXer's Dream Vacation**
—try sunny Montserrat WB6JPZ
- 36 **Close Encounters**
—the eyes of Texans are upon them K8NQN
- 44 **The Schizophrenic Triangle**
—a split-personality radiator WA4JTJ
- 48 **From CW to Computers**
—a digital modulation primer N6RY
- 56 **A 28¢ Touchtone™ Mod**
—something for (almost) nothing W9CGI
- 60 **Space Age Surplus**
—your own Saturn V? Endress, Endress
- 64 **An X-Band Transceiver**
—more 10-GHz fun W1SNN
- 82 **SSTV Recorder Controller**
—replaces your index finger K3JML
- 90 **Receiver Diseases**
—and how to cure them K4IPV
- 96 **Autophasing for WEFAX**
—preserve your mental health Cawthon
- 105 **The Lunch Counter**
—eat it up WA4PIN
- 114 **Confessions of a Stripper**
—confirmed junker tells all K5GNZ
- 118 **Tuned Feeders and Other Good Stuff**
—who needs coax? W0VM
- 126 **Build a Realistic S-Meter**
—“you're S9 + 40, OM!” DJ3NW
- 130 **Wow! A Good Portable Receiver!**
—thanks, Panasonic! WA2EJT
- 132 **The XITEX Video Terminal**
—a quiet alternative to your Model
15 AH6AQ
- 136 **Light Up Your Life**
—the 2036 glows digital WA4NUE
- 142 **High Seas Adventure—Ham Style**
—part III WA6FEI
- 148 **Whither Microcomputers?**
—a pro looks ahead WB2HJD
- 152 **SSTV Meets SWTPC: Part 2**
—micro-enhanced pictures K6AEP
- 160 **A Multi-Memory Morse Machine**
—using a Motorola micro WA8TIW
- 164 **“This is Your Computer Speaking”**
—how to dial up your micro Sorrels
- 170 **RTTY with the KIM**
—one more step VE1AKL
- 174 **DX Delight**
—a do-it-all program WA4VQD, N3NN
- 182 **Big Max Attacks**
—it's W2DU vs. K4KI, in the battle of the
bazooka W2DU
- 192 **The Packet Radio Revolution**
—pioneers, take note! VE2PY
- 200 **This Voltage Standard Is Precise!**
—and makes calibration a snap WB6NTR
- 206 **The 22S Goes Digital**
—add 7-segment displays KH6IEL
- 212 **WARC '79 Preview**
—showdown in Geneva WA9MZS
- 216 **The “Flim-Flam” Factor**
—another biased article WA2SUT/NNN0ZVB
- 222 **Build the Flexi-Filter**
—a very active device W3QVZ
- 226 **The Klassic Kilowatt**
—four 811As do it K4TWJ
- 230 **Ham Radio Goes to School**
—10-year-olds love it N2CF
- 234 **What's Your uF?**
—a six-digit answer K5BTV
- 250 **Fail-Safe**
—protecting repeater batteries WA7DPX
- 256 **Code-Practice Oscillators**
—an exhaustive report W6GXN
- 270 **PCs Are Easy**
—step-by-step details VE3CGE
- 274 **The Games People Play**
—why not hams? WB3EUG
- 287 **An Improved HV Tube Socket**
—easy modification Miller



Shown with accessory touch tone pad

800

channels in the palm of your hand

**Tempo presents the
S1 SYNCOM...the world's
first synthesized 800
channel hand held
transceiver**

This amazing pocket sized radio represents the year's biggest breakthrough in 2-meter communications. Other units that are larger, heavier and are similarly priced can offer only 6 channels. The SYNCOM'S price includes the battery pack, charger, and a telescoping antenna. But, far more important is the 800 channels offered by the S1.

The optional touch tone pad shown in the illustration adds greatly to its convenience and we have available a 30 watt solid state power amplifier designed to give the SYNCOM S-1 the flexibility of operating as a mobile and base station as well.

SPECIFICATIONS

Frequency Coverage: 144 to 148 MHz
 Channel Spacing: Every 5 KHz
 Power Requirements: 9.6 VDC
 Current Drain: 17 ma - standby 400 ma - transmit
 Batteries: Ni-cad battery pack included
 Antenna Impedance: 50 ohms
 Dimensions: 40 mm x 62 mm x 165 mm (1.6" x 2.5" x 6.5")
 RF Output: Better than 1.5 watts
 Sensitivity: Better than .5 microvolts

SUPPLIED ACCESSORIES

Telescoping whip antenna, ni-cad battery pack, charger.

OPTIONAL ACCESSORIES

Touch tone pad, tone burst generator, CTCSS chips, Rubber flex antenna.

Price ... \$349.00 (or with touch tone pad ... \$399.00)

Tempo also offers a complete line of solid state power amplifiers, pocket receivers, the FMH-2, 5 & 42 portables, the VHF/ONE PLUS mobile transceiver, and the FMT-2 & FMT-42 remote control mobile transceiver. All available from Tempo dealers throughout the U.S. Call or write for full information.

11240 W. Olympic Blvd., Los Angeles, Calif. 90064 213/477-6701
 931 N. Euclid, Anaheim, Calif. 92801 714/772-9200
 Butler, Missouri 64730 816/679-3127

Henry Radio

Prices subject to change without notice.

THE SWITCH IS ON!

Not only is the big move to switch to the Wilson Mark Series of Mini-Hand-Held Radios, but now the switch is on the Mark!

Wilson Electronics, known for setting the pace in 2m FM Hand-Helds, goes one step beyond!

AT NO EXTRA CHARGE: all Mark Series Radios now will include a switch for you to control the power of operation. This will enable you to use the high power when needed, then later switch to low power to conserve battery drain for extended operation.

IN ADDITION: all Mark Series Radios now have an LED Battery Condition Indicator conveniently mounted on the top plate. A quick peek will reassure you of a charged battery in the radio.

Wilson hand-helds have been known world-wide for exceptional quality and durable performance. That's why they have been the best selling units for years.

Now the Mark Series of miniature sized 2-meter hand-helds offers the same dependability and operation, but in an easier to use, more comfortable to carry size . . . fits conveniently in the palm of your hand.

The small compact size battery pack makes it possible to carry one or more extra packs in your pocket for super extended operation time. No more worry about loose cells shorting out in your pocket, and the economical price makes the extra packs a must.

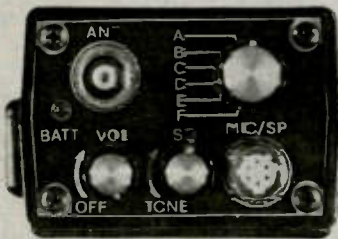

Conveniently located on top of the radio are the controls for volume, squelch, accessory speaker mike connector, 6 channel switch, BNC antenna connector and LED battery condition indicator.

Optional Touch Tone™ Pad available.

To obtain complete specifications on the Mark II and Mark IV, along with Wilson's other fine products, see your local dealer or write for our Free Amateur Buyer's Guide.

Prices and specifications subject to change without notice.

— NOW SWITCHABLE —
MARK II: ≈ 1 & 2.5 watts
MARK IV: ≈ 1 & 4.0 watts

SPECIFICATIONS

- Range: 144-148 MHz
- 6 Channel Operation
- Individual Trimmers on TX and RX Xtals
- Rugged Lexan® outer case
- Current Drain: RX 15 mA
- TX - Mark II: 500 mA
- TX - Mark IV: 900 mA
- 12 KHz Ceramic Filter and 10.7 Monolithic Filter included.
- 10.7 MHz and 455 IKz IF
- Spurious and Harmonics: more than 50 dB below carrier
- BNC Antenna Connector
- .3 Microvolt Sensitivity for 20 dB Quieting
- Uses special rechargeable Ni-Cad Battery Pack
- Rubber Duck and one pair Xtals 52/52 included
- Weight: 19 oz. including batteries
- Size: 6" x 1.770" x 2.440"
- Popular accessories available: Wall Charger, Mobile Charger, Desk Charger, Leather Case, Speaker Mike, Battery Packs, and Touch Tone™ Pad.



Illustrated is Wilson's BC-2 Desk Top Battery Charger shown charging the Mark Series Unit or the BC-4 Battery Pack only.

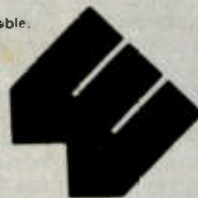

Consumer Products Division

Wilson
Electronics Corp.

4288 South Polaris Avenue • P. O. Box 19000 • Las Vegas, Nevada 89119
 Telephone (702) 739-1931 • TELEX 684-522

Staff

EDITOR/PUBLISHER
Wayne Green W2NSD/1

EXECUTIVE VICE PRESIDENT
Sherry Smythe

ASSISTANT PUBLISHER
Jeffrey D. DeTray WB8BTH/1

ADMINISTRATIVE ASSISTANT
Dotty Gibson

MANAGING EDITOR
John C. Burnett

ASSISTANT MANAGING EDITOR
Susan G. Philbrick

NEWS EDITOR
Gene Smarte WB6TOV/1

BOOK PUBLICATIONS
Beth Weston

PRODUCTION MANAGER
Lynn Panciera-Fraser

ART DEPARTMENT
Craig Brown
Gayle Cabana
Bob Drew
Bruce Hedin
Carl Jackson
James Lamothe
Dion Owens
Noel R. Self WB1ARP
Robin M. Sloan

PRINTING
Gary Steinbach
Dan Morgan

PHOTOGRAPHY
Bill Heydolph
Tedd Cluff

TYPESETTING
Barbara J. Latti
Sara Bedell
Sharon Demmerle
Mary Kinzel
Holly Walsh

BOOKKEEPER
Knud E. M. Keller KV4GG/1

CIRCULATION
Barbara Block
Laura Barnicle

DATA ENTRY
Mary Kinzel
Denise Loranger

DIRECTOR OF MARKETING
Robert R. LaPointe

BULK SALES MANAGER
Judy Waterman

SHIPPING
Ethan Perry
Bill Barry
Michelle Walsh

RECEPTIONIST
Doni Jarvis

ASSOCIATES
Robert Baker WB2GFE
E. H. Barnett WB0IX
Schley Cox WB9LHO
Tom DiBlase WB8KZD
Terry Fox WB4JFI
W. Sanger Green
Dave Ingram K4TWJ
Larry Kahaner WB2NEL
Joe Kasser G3ZCZ
Bill Pasternak WA6ITF
John Schultz W4FA
Waller Scott K8DIZ
Peter Stark K2OAW
Bill Turner WA0ABI

COMPUTER PROGRAMMING
Richard J. Dykema
Ron Cooke WB9WHX

CUSTOMER SERVICE
Florence Goldman
Joyce Tarr
Ellen Blanchard

ADVERTISING
Aline Coutu
Marcia Stone
William G. York
Nancy Ciampa

W2NSD/1 NEVER SAY DIE

editorial by Wayne Green



WARC DOOM AND GLOOM

Well, here we are with all sorts of exciting things going on technically in amateur radio, and Wayne Green is preaching doom. One day I'm up on a mountain working with Chuck WA1KPS to make some record-breaking contacts on 10.5 GHz and a couple days later I'm talking to a group of hams at an ARRL convention about the possible loss of most or all of our ham bands.

With the coming microcomputer explosion in amateur radio, the development of packet radio transmissions, the development of practical double sideband systems, and a host of other exciting technical developments, it's obvious that technically things have never looked better.

With the coming International Telecommunications Union (ITU) conference at Geneva next October, never have things looked worse for the allocation of ham bands. I hope, even more than you, that I am just a worrywart... and it may turn out that my worries are needless.

Having been one of the official U.S. delegates to the 1959 ITU conference (the last full conference), I am quite aware of the pressures on amateur radio allocations at that time. We held our frequencies only because of a miracle. No such miracle seems possible next time.

After a visit to 20 countries in Africa and Asia, I wrote an editorial in 73 outlining what I had found. That was in 1966, and I found that few countries had any real use for amateur radio or any understanding of the value of the hobby to their country. Many were so upset over even the concept of third-party traffic that they were

unable to evaluate amateur radio reasonably.

After talking with amateurs in these countries, I came up with a proposal that amateur radio societies around the world try to encourage emerging nations to encourage the use of amateur radio as a way to develop the technicians and engineers so badly needed in small countries. Nothing whatever came of this until I sold His Majesty King Hussein on the concept in 1970 and he implemented it immediately.

In 1971, the ARRL went to the ITU to try to hold on to our ham satellite frequency allocations. There, according to the report in QST, they found that the majority of the countries of the world were opposed to amateur radio and they lost every ham satellite microwave allocation we had... some 237,000 MHz of them. Down the tubes went any hope for worldwide ham communications via satellite other than on the smallest scale.

Once it became clear to me that there was no way that I could get the ARRL or IARU to approach the countries which would in all probability shoot down our allocations at WARC, I tried first with some editorials in 73 to encourage businessmen who were amateurs to carry the ball. Nothing happened.

The only hope that I could see left was to get a group of the people who had the most to lose financially, the ham industry, to take some action. When the FCC actions on linear amplifiers got so ridiculous that something really had to be done, the ham manufacturers did start trying to form an association. They tried to cooperate with the ARRL, but found themselves undercut and sabotaged at every turn by

a League in fear of any organization other than the ARRL.

Had it not been for the ARRL refusing to cooperate with ARMA, the manufacturer's association, we might not have lost the linear amplifier battle with the FCC. The fact was that amateur radio put on a disorganized response, while EIA had its act together and clobbered us. A large part of the disorganization was directly due to the League counsel and its weakening of the ARMA impact. The ARRL testimony was one of the most inept performances I have ever seen and was so bad the FCC Commissioners were laughing over it.

Yes, I've been an ARRL member for over 40 years, but I still get annoyed at the pitiful leadership amateur radio has to suffer. The "leaders" are third-rate bureaucrats without a hope of achieving second rate. They are protected by a group of directors who, for the most part, are afraid to offend the bureaucrats.

The ARRL likes to pose as a democracy, but they are much more like a dictatorship. Think about it. Members don't get to vote for the officers at all, only the directors... just like in Russia. The directors (politburo) vote for the officers. A dictatorship is a one-party system, just like the ARRL. Why is there only one party? Because the dictatorship destroys any possible challengers. The ARRL has had a long history of doing whatever it takes to keep any other organizations from gaining strength. Their latest coups have been their jobs on the QCWA and ARMA.

How did they get at ARMA?

Continued on page 112

The evolution of the MLA

When the MLA-2500 was first introduced it was a new concept in high performance amplifiers. Low and sleek yet powerful enough for the military. Some wondered . . . needlessly.

A promise kept.

The MLA-2500 promised 2000 watts PEP input on SSB. A heavy duty power supply. Two Eimac 8875's. And as thousands of Amateurs across the world have proven, the MLA-2500 delivers!

Now DenTron is pleased to bring you **The new MLA-2500 B.** Inherently the same as the original MLA-2500, the B model includes all of the above specifications plus a few refinements. New high-low power switching for consistent efficiency at both the 1KW and 2KW power levels, and 160 - 15 meters.

Tested and proven.

What better test for an amplifier than the Clipperton DXpedition? Even after 32,000 QSO's, and an accidental dunk in the ocean, the same 3 MLA-2500's are still amplifying other rare DXpeditions around the world — listen for them.

Convinced? Isn't it time you owned the amplifier that powered Clipperton and thousands upon thousands of radio stations throughout the world?

MLA-2500 B \$899.50.



DenTron[®]
Radio Co., Inc.

2100 Enterprise Parkway
Twinsburg, Ohio 44087
(216)425-3173

WINTER '78/79 PRODUCT LINE

*Novice or Advanced...
you can own the world's most
popular transceiver*



AT-200

The AT-200 is an antenna tuner, but it's also much more. It's an antenna switch, an SWR bridge and an in-line wattmeter. The AT-200 reduces the clutter and increases the operating efficiency of your

SP-520

station... and at a surprisingly moderate price. The SP-520 matching speaker offers improved sound in a handsome cabinet. The DG-5 option gives you your exact frequency, while

TS-520S & DG-5

transmitting and receiving, in large easy to read digits by mixing the carrier, VFO, and heterodyne frequencies. The VFO-520 remote VFO is a perfect match for your TS-520S and provides maximum

operating flexibility. The TV-502S 2-meter transceiver produces 8 watts on SSB and CW. It easily hooks up to the TS-520 and TS-820 series transceivers, providing an inexpensive method of get-

TS-520S

THE TS-520S SERIES LITERALLY TOOK THE AMATEUR WORLD BY STORM. NO OTHER RADIO EVER CAUGHT ON SO FAST AND THE REASONS ARE OBVIOUS... EXCELLENT PERFORMANCE CHARACTERISTICS, DEPENDABILITY, FLEXIBILITY, AND A VERY SOLID VALUE FOR THE PRICE. AND NOW THE TS-520S SERIES OFFERS THE MOST COMPLETE LINE OF ACCESSORIES AVAILABLE.

FULL COVERAGE TRANSCEIVER

The TS-520S provides full coverage on all amateur bands from 1.8 to 29.7 MHz. Kenwood gives you 160 meter capability, WWV on 15.000 MHz., and an auxiliary band position. And with the addition of the TV-506 transverter, your TS-520S can cover 160 meters to 6 meters on SSB and CW.

OUTSTANDING RECEIVER SENSITIVITY AND MINIMUM CROSS MODULATION

The TS-520S incorporates a 3SK35 dual gate MOSFET for outstanding cross modulation and spurious response characteristics. The 3SK35 has a low noise figure (3.5 dB typ.) and high gain (18 dB typ.) for excellent sensitivity.

NEW IMPROVED SPEECH PROCESSOR

An audio compression amplifier

gives you extra punch in the pile ups and when the going gets rough.

VERNIER TUNING FOR FINAL PLATE CONTROL

A vernier tuning mechanism allows easy and accurate adjustment of the plate control during tune-up.

FINAL AMPLIFIER

The TS-520S is completely solid state except for the driver and the final tubes.

Kenwood has employed two husky S-2001A (equivalent to 6146B) tubes. These rugged, time-proven tubes are known for their long life and superb linearity.

HIGHLY EFFECTIVE NOISE BLANKER

An effective noise blanking circuit developed by Kenwood that virtually eliminates ignition noise is built into the TS-520S.

RF ATTENUATOR

The TS-520S has a built-in 20 dB attenuator that can be activated by a push button switch conveniently located on the front panel.

PROVISION FOR EXTERNAL RECEIVER

A special jack on the rear panel of the TS-520S provides receiver signals to an external receiver for increased station versatility. A switch on the rear panel determines the signal path... the receiver in the TS-520S or any external receiver.

CW-520 — CW FILTER (OPTION)

The CW-520 500-Hz filter can be easily installed and will provide improved operation on CW.

AMPLIFIED TYPE AGC CIRCUIT

The AGC circuit has three positions (OFF, FAST, SLOW) for optimum operation on CW.

AC POWER SUPPLY

The TS-520S is completely self-contained with a rugged AC power supply built-in. The addition of the DS-1A DC-DC converter (optional) allows for mobile operation of the TS-520S.

EASY PHONE PATCH CONNECTION

The TS-520S has two convenient RCA phono jacks on the rear panel for PHONE PATCH IN and PHONE PATCH OUT.

The TS-520S retains all of the features of the original TS-520 that made it tops in its class: RIT control • B-pole crystal filter • Built-in 25 kHz calibrator • Front panel carrier level control • Semi-break-in CW with sidetone • VOX/PTT/MOX • TUNE position for low power tune up • Built-in speaker • Built-in cooling fan • Provisions for four fixed frequency channels • Heater switch.



VFO-520S TV-502S

ting on the 2-meter band. The TV-506 is an equally practical way of getting on the 6-meter band, providing 10 watts on SSB and CW.

The SM-220 is an extremely useful and unique station

TV-506

monitor. It allows you to monitor your transmissions, monitor incoming signals and monitor the amount and strength of band activity* and performs as a general purpose 10 MHz oscilloscope, as well.

*With BS-5 or BS-8 pan display option.

SM-220

The TS-820S... known worldwide as the Pacesetter. Amateur Radio Operators universally respect its superb quality, proven through thousands of hours of operating time under all environmental conditions. The TS-820S has every feature any Amateur could desire for operating enjoyment, on any band from 160 through all of 10 meters.



You can always tell who's running a TS-820S. Its superb quality stands out from all the other rigs on the band... and when the QRM gets heavy, the TS-820S's adjustable RF speech processor, utilizing a 455-kHz circuit to provide quick-time-constant compression, will get the message through. RF negative feedback is applied from the final to the driver to improve linearity, and third-order products are at least -35 dB. Harmonic spurious emissions are less than -40 dB and other spurs are less than -60 dB. RF input power is 200 W PEP on SSB, 160 W DC on CW, and 100 W DC on FSK. Receiver sensitivity is better than 0.25 μ V for 10 dB S/N. The TS-820S is known for its superb receiver selectivity, and its famous IF shift easily eliminates heavy QRM. That's why the TS-820S is the DXer's choice.

See your local Authorized Kenwood Dealer today.

TS-820S

The Perfect Station



SP-820

TS-820S

VFO-820

TV-502S

TV-506

SM-220



T-599D

*The R-599D and T-599D...
...now less than \$1,000*

Kenwood developed the T-599D transmitter and R-599D receiver for the most discriminating Amateur

The T-599D transceiver is solid-state with the exception of only three tubes, has built-in power supply and full metering. It operates CW, LSB, USB and AM and, of course, is a perfect match to the R-599D receiver.

The R-599D is the most complete receiver ever offered. It is entirely solid-state, superbly reliable and compact. It covers the full Amateur band, 10 through 160 meters, CW, LSB, USB, AM and FM.

Your station isn't complete if it doesn't include the R-820



R-820

Introducing the ultimate in receiver design ... the Kenwood R-820.

With more features than ever before available in a ham-band receiver. This triple-conversion (8.33 MHz, 455 kHz, and 50 kHz IFs) receiver, covering all Amateur bands from 160 through 10 meters, as well as several shortwave broadcast bands, features digital as well as analog frequency readouts, notch filter, IF shift, variable bandwidth tuning, sharp IF filters, noise blanker, stepped RF attenuator, 25 kHz calibrator, and many other features, providing more operating conveniences than any other ham-band receiver. The R-820 may be used in conjunction with the Kenwood TS-820 series transceiver, providing full transceive frequency control.

Additional features include: A monitor switch which allows the user to hear his own voice when using associated transmitter. Either VFO control or crystal control on four selectable frequencies. Digital hold ... locks counter and display while VFO is tuned to another frequency ... facilitates return to "hold" frequency. RIT/notch control ... RIT allows receiver to be tuned off frequency, while not affecting transmit frequency when in transceive mode with TS-820S. Notch control tunes notch within IF passband for eliminating interference. Interfering signal remains notched even when IF shift is utilized. Built-in crystal calibrator, settable to WWV, provides signal every 25 kHz. Noise blanker/level control ... for maximum reduction of noise interference. A transceive/separate switch enables receive VFO to control the receiver and TS-820 (or TS-820S) frequency (or the TS-820 VFO to control both), or, of course, both can function independently.



TL-922A

the most versatile pair on the air

If you have never considered the advantages of operating a receiver/transmitter combination ... maybe you should. Because of the larger number of controls and dual VFOs the combination offers flexibility impossible to duplicate with a transceiver.

Compare the specs of the R-599D and the T-599D with any other brand. Remember, the R-599D is all solid-state (and includes four filters). Your choice will obviously be the Kenwood.



R-599D

KENWOOD
...pacesetter in amateur radio

10 WATT ...KENWOOD OFFERS A CHOICE



NEW

TR-7600 ...THE RADIO THAT REMEMBERS

Every feature you could possibly want in a 2-meter FM rig is available now in the Kenwood TR-7600 and RM-76 Microprocessor Control Unit

The new TR-7600 gives you...

- Full 4-MHz coverage (144.000-147.995 MHz) on 2 meters • 800 channels • Dual concentric knobs for fast frequency change (100-kHz and 10-kHz steps) • 5-kHz offset switch • MHz selector switch... for desired band (144, 145, 146, or 147 MHz) • Mode switch for operating simplex or for switching the transmit

- frequency up or down 600 kHz for repeater operation... or for switching the transmitter to the frequency you have stored in the TR-7600's memory (while the receiver remains on the frequency you have selected with the dual knobs) • Memory channel... with simplex or repeater (plus or minus 600 kHz transmitter offset) operation • Digital frequency display (large, bright, orange LEDs) • UNLOCK indicator... an LED that indicates transceiver protection when the frequency selector switches are improperly positioned, or the PLL has malfunctioned • 10 watts RF

output (switchable to 1 watt low power) • Noise-cancelling microphone • Compact size (only 6-7/16 inches wide, 2-7/16 inches high, and 9-3/16 inches deep)

The RM-76 Microprocessor Control Unit provides more operating features to the TR-7600 2-meter FM transceiver than found in any other rig! With the RM-76 Microprocessor Control Unit attached to your TR-7600, you can...

- Select any 2-meter frequency • Store frequencies in six memories • Scan all memory channels • Automatically scan up all frequencies in 5-kHz steps • Manually scan up or down in 5-kHz steps • Set lower and upper scan frequency limits • Reset scan to 144 MHz • Stop scan (with HOLD button) • Cancel scan (for transmitting) • Automatically stop scan on first busy or open channel • Operate on MARS (143.95 MHz simplex only) • Select repeater mode (simplex, plus transmit frequency offset, minus offset, or any of six memory transmit offsets) • Select transmit offset (1 MHz/600 kHz)

The Microprocessor Control Unit's display indicates frequency (even while scanning) and functions (such as autoscans, lower scan frequency limit, upper scan limit, error, and call channel).

Subject to FCC approval



TS-700SP SP-70 VFO-700S

Still the same fine, time proven rig. But now with the simple addition of a plug-in crystal, the TS-700SP will be able to utilize the new repeater sub-band (144.5 to 145.5 MHz). Still features all of the fine attributes of the TS-700S: A digital frequency display, receiver pre-amp, VOX, semi-break in, and CW sidetone. Of course, it's all mode, 144-148 MHz, VFO controlled... and Kenwood quality throughout.

Features: 4 MHz band coverage (144 to 148 MHz) • Automatic repeater offset capability on all FCC authorized repeater subbands including 144.5-145.5 MHz • Simply dial receive frequency and radio does the rest... simplex, repeater, or reverse. Same features on any of 11 crystal positions • Transmit/Receive capability on 44 channels with 11 crystals • Operates all modes: SSB (upper and

lower), FM, AM and CW • Digital readout with "Kenwood Blue" digits • Receiver pre-amp • Built-in VOX • Semi break-in on CW • CW sidetone • All solid-state • AC and DC capability • 10 watts RF output on SSB, FM, CW • 3 watts on AM • 1 watt FM low-power switch • 0.25 μ V for 10 dB (S+N)/N SSB/CW sensitivity • 0.4 μ V for 20 dB quieting FM sensitivity.

OR **25 WATT** OUTPUT



TR-7400A

The fully-synthesized TR-7400A 2-meter FM transceiver operates on 800 channels and features repeater offset over the entire 144-148-MHz range, dual frequency readout, six-digit display, and subaudible tone encoder and decoder. RF output is at least 25 watts!

The TR-7400A 2-meter FM transceiver provides fully synthesized operation, including 600-kHz repeater offsets, over the entire 144-148-MHz range. It can operate on any of 800 channels, spaced 5 kHz apart. RF output is at least 25 W, and typically 30 W. A low power position produces 5-15 W (adjustable). Included is a dual frequency readout with large six-digit LED display plus a dial readout. The sub-

audible CTCSS signaling feature may be used on transmit and receive, or transmit only. Optional tone-burst modules are available. Receiver sensitivity is better than 0.4 μ V for 20 dB quieting. Large, high Q, helical resonators minimize interference from outside the band. A two-pole 10.7-MHz monolithic crystal filter provides excellent selectivity. Intermodulation distortion is down more than 66 dB, spurious rejection is better than -60 dB, and image rejection is better than -70 dB.

See your local Authorized Kenwood Dealer today, for a demonstration of the fantastic TR-7400A.



TS-600

Experience the excitement of 6 meters. The TS-600 all mode transceiver lets you experience the fun of 6 meter band openings. This 10 watt, solid state rig covers 50.0-54.0 MHz. The VFO tunes the band in 1 MHz segments. It also has provisions for

fixed frequency operation on NETS or to listen for beacons. State of the art features such as an effective noise blanker and the RIT (Receiver Incremental Tuning) circuit make the TS-600 another Kenwood "Pacesetter"

TRIO-KENWOOD COMMUNICATIONS INC.
1111 WEST WALNUT/COMPTON, CALIFORNIA

 **KENWOOD**
...pacesetter in amateur radio



Give your signal extra muscle

TL-922A

The Kenwood name has grown to represent the finest Amateur Radio equipment available. The TL-922A linear amplifier carries on that tradition. As a linear it gets your signal through today's crowded bands and provides the power to reach those far away places with ease. And because it's Kenwood you can count on its dependability. The TL-922A is FCC type accepted. It runs the full legal limit on all ham bands from 160-15 meters and is compatible with most amateur excitors. Contact your nearest Authorized Kenwood Dealer for complete specifications and the best deal.

WHY SHOULD THE TL-922A BE PART OF YOUR STATION? COMPARE THESE FEATURES AND SPECS...THE ANSWER WILL BE OBVIOUS.

Instant heating filaments — The 3-500Z tubes require no warm up period. Just turn it on and go!

Time delay fan circuit — Even after you turn the TL-922A off, the super quiet fan continues to work for approximately 2 minutes to greatly extend tube life.

Adjustable ALC output voltage — Lets you tailor the ALC voltage to your exciter.

Standby position — Provides amplifier bypassing without having to turn the AC power off.

Two independent safety interlocks — One disconnects

AC line voltage and the second shorts B+ to ground when tripped.

Vernier plate control — For smooth, easy tune-up.

Diecast side panels—Includes functional carrying handles for easy transportation.

Thermal protection of power transformer — Amplifier automatically switches to standby if power transformer temperature exceeds 145°F.

Tuned Input Circuit — Means improved spurious characteristics.

Line voltage selector — Easily switched between 120 and 240 VAC.

Multimeter — Reads high voltage, relative output or grid current (selectable).

Plate Current Meter — Separate meter allows continuous monitoring of plate current.



For the best in world listening

R-300

Dependable operation, superior specifications and excellent features make the R-300 an unexcelled value for the shortwave listener. It offers full band coverage with a frequency range of 170 kHz to 30.0 MHz • Receives AM, SSB and CW • Features large, easy to read drum dials with fast smooth dial action • Band spread is calibrated for the 10 foreign broadcast bands, easily tuned with the use of a built-in 500 kHz calibrator • Automatic noise limiter • 3-way power supply system (AC/Batteries/External DC) ... take it anyplace • Automatically switches to battery power in the event of AC power failure.

Escape the rat race... try 440 MHz FM!



TR-8300

How would you like to work an uncrowded frequency... hear signals with less noise... or use a sophisticated repeater or remote base with better coverage? 440 MHz is the answer. It will surprise you. It will penetrate buildings where 2 meters won't, and often you can even work out from underground garages... where 2 meters is dead. Best of all, it's easy to get on 440 MHz (70 cm)... with a Kenwood TR-8300 transceiver. High quality is critically important on VHF bands, and the TR-8300 is just what you need to meet all technical requirements.

- 10 watts RF output (switchable to 1 watt)
 - 23 crystal-controlled channels (3 supplied)
 - 445.0-450.0 MHz transmit range
 - 442.0-447.0 MHz receive range
 - Transmitter and receiver adjustable over any 5-MHz segment from 440 to 450 MHz
 - 5-section helical resonator and 2-pole crystal filter in IF to reject intermod
 - SWR protection in final amplifier
 - Excessive-voltage and reverse-polarity protection circuits
 - 0.5 μ V for 20 dB quieting sensitivity
 - Better than -60 dB spurious radiation
 - 20 kHz (-6 dB), 40 kHz (-70 dB) selectivity
 - Monitor switch that lets you check modulation and frequency "netting"
 - Call CH switch that activates optional CTCSS (subaudible tone) function
 - Large S meter
- Move up to 440 MHz today... with a Kenwood TR-8300... for more reliable communications!*

Fine equipment that belongs in every well equipped station

HF LINES

- 820 Series**
 TS-820S... TS-820 with Digital Installed
 TS-820... 160-10 m Deluxe Transceiver
 YG-88A... 6-kHz AM filter for R-280
 YG-455C... 500-Hz CW filter for R-820
 YG-455CN... 250-Hz CW filter for R-820
 DG-1... Digital Frequency Display for TS-820
 VFO-820... Deluxe Remote VFO for TS-820/820S
 SP-820... External speaker with audio filters
 CW-820... 500 Hz CW Filter for TS-820/820S
- 520 Series**
 TS-520S... 160-10 m Transceiver
 DG-5... Digital Frequency Display for TS-520 Series
 VFO-520... Remote VFO for TS-520 and TS-520S
 SP-520... External Speaker for 520/820 Series
 CW-520... 500 Hz CW Filter for TS-520/520S
 DK-520... Digital Adaptor Kit for TS-520
- 599D Series**
 R-599D... 160-10 m Solid State Receiver
 T-599D... 80-10 m Matching Transmitter
 S-599... External Speaker for 599D Series
 CC-29A... 2-meter Converter for R-599D
 CC-69A... 6-meter Converter for R-599D
 FM-599A... FM Filter for R-599D

HF ACCESSORIES

- TL-922A... 160-15 m kilowatt linear amplifier
 SM-220... Station monitor, 10-MHz scope

- BS-8... SM-220 pan display for TS-820 Series
 BS-5... SM-220 pan display for TS-520 Series
 AT-200... 200-W antenna tuner, SWR/power meter, switch
 DS-1A... DC-DC Converter for 520/820 Series

SHORT WAVE LISTENING

- R-300 General Coverage SWL Receiver

VHF LINES

- TS-600... 6 m All Mode Transceiver
 TS-700SP... 2 m All Mode Digital Transceiver
 VFO-700S... Remote VFO for TS-700S
 SP-70... Matching Speaker for TS-600/700 Series
 VOX-3... VOX for TS-600/700A
 TR-7400A... 2 m Synthesized Deluxe FM Transceiver
 TR-7600... 2 m FM transceiver with 800 channels and memory

- RM-76... Remote Controller for TR-7600 with six memories, scanning
 TR-8300... 70 CM FM Transceiver (450 MHz)
 TV-506... 6-m Transverter for 520/820/599 Series
 TV-502S... 2-m Transverter for 520/820/599 Series

POPULAR STATION ACCESSORIES

- HS-4... Headphone Set
 MC-30S... low-impedance mobile noise-cancelling microphone
 MC-35S... high-impedance mobile noise-cancelling microphone
 MC-50... Desk Microphone
 PS-6... Power Supply for TR-8300
 PS-8... Power Supply for TR-7400A

Trio-Kenwood stocks a complete line of replacement parts, accessories, and manuals for all Kenwood models.

MORE ACCESSORIES:

Description	Model #	For use with
Repeater Subband Kit	RSK-7	TS-700A/S
Rubber Helical Antenna	RA-1	TR-2200A
Telescoping Whip Antenna	T90-0082-05	TR-2200A
Ni-Cad Battery Pack (set)	PB-15	TR-2200A
4 Pin Mic. Connector	E07-0403-05	All Models
Active Filter Elements	See Service Manual	TR-7400A
Tone Burst Modules	See Service Manual	TS-700A; TR-7400A
AC Cables	Specify Model	All Models
DC Cables	Specify Model	All Models



The Kenwood HS-4 headphone set adds versatility to any Kenwood station. For extended periods of wear, the HS-4 is comfortably padded and is completely adjustable. The frequency response of the HS-4 is tailored specifically for amateur communication use. (300 to 3000 Hz, 8 ohms).



The MC-50 dynamic microphone has been designed expressly for amateur radio operation as a splendid addition to any Kenwood shack. Complete with PTT and LOCK switches, and a microphone plug for instant hook-up to any Kenwood rig. Easily converted to high or low impedance. (600 or 50k ohm).

TRIO-KENWOOD COMMUNICATIONS INC.
 1111 WEST WALNUT/COMPTON, CA 90220

ou goons don't ever proof
lousy manuscripts from bat
burn the rock
you liars
I insist that you print ev
tell Ma Bell that she shou

LETTERS

QUASI PRIMA DONNA

Once, as an untutored, not-yet-jaded youth of 15, I had the temerity to write the editor of QST suggesting that the ARRL lend "Gil" to the Government of India, where his wretched li'l yo-yos doing all the li'l no-nos could be used to far greater advantage on birth control propaganda posters.

The resulting correspondence has been long misplaced, but be assured, all hell broke loose; as I saw it in 1955, anyway.

Now I freely confess to being a nostalgia freak and, in hindsight, some "Gil" illustrations are their own reward. It was in September of this year, however, that I found that the gates of hell can still be flung open on command, and while they couldn't really do much to a kid of 15, it will really amaze you what can be done to a married, professional fellow of 38.

Right now, you're probably wondering what this has to do with the price of opium in Macao. Stay with me and I shall enlighten you.

When Wayne Green was the editor of CQ I thought it was the neatest and funniest magazine in the world. (I was a *very* arcane kid.) After joining the Navy in 1957, *suffering* through ET school at Treasure Island (in the winter), and being assigned to the fleet, I looked forward to my CQs every bit as much as letters from my steamy girl friend. Now I realize this sounds bizarre on the face of it, but if you are fortunate enough to know an old-time ham with a storeroom full of old radio magazines, be prepared to see some ham cartoons worthy of the name. It's been years since a sample of this genre has brought much more than a "yeechh" out of me. It also goes without saying that his "jack-em-up" editorials were about the same, but somehow not so pessimistic, and far more entertaining. But we all march to the clock and that, really, is the whole point of what I'm trying to get to.

How emotional have I gotten? Well, I've gotten so emotional that I shot off a hot telegram to Mr. Richard Baldwin W1RU, using not *one* of the seven dirty words, but express-

ing my feeling strongly.

Please be advised that such a course is not for the faint-hearted, but the only fair comparison between me and the late Arnold Stang is glasses.

To get Mr. Baldwin's attention (i.e., to let him know I did not survive by scouring alleys for unbroken pop bottles), I mentioned my company's name and the position I occupy. This was a mistake—whether mine or his is not yet clear.

I am not a member of the ARRL anymore, which is wrong, I suppose, because it puts me somewhat in the position of a rock thrower.

The reason I'm not is simply because the illusion of a retarded bear cub swatting incompetently at a newly found appendage is quite torturous. Allow me to digress.

I am employed by a hallowed, old-line radio company (okay—the first 3 letters of which is the same as hallowed, and deservedly; that's as far as I go) that receives gratis copies of all the ham and related monthlies.

To thine own self be true. I read these on breaks and at lunch—I guess I'll never grow up—and have become somewhat emotional about WARC '79.

I wanted to get his attention to possibly start a dialogue or, more to the point, to do his damn job instead of being some sort of quasi prima donna fiddling while our frequencies burn.

What happened was totally unexpected. The League Poohbah is not a Pooh-Bear, he is a Nixonian treasure, and I now have the questionable distinction of being on Richard's enemies list, with a vengeance.

A. On Saturday, September 16, I got a *personally-dictated letter* from W1RU telling me he "does *not* respond to correspondence personally calling him a son of a bitch"—which was not really true. Hang on. The telegram will be printed, regardless of the accuracy or inaccuracy of the statement. (I know the concept here is torturous.) This was the first non-response.

B. I was greeted at noon, on Monday, September 18, with a Xerox copy of a letter guaranteed to catch fire when ex-

posed to light, written by W1RU to the President of my company, the text of which I cannot relate verbatim, presented by my boss.

W1RU pulled out *all the stops* to get me fired in the sleaziest, most innuendo-peppered misuse of personal power I have ever had the misfortune to read. The very inaccuracy and overkill of the attempt, in our times of universal free-ha-ha, literally saved me. I am truly fortunate to work for some fine, decent human beings. This was the second non-response.

I guess this is where I should say that, gee, it's only a hobby, folks. But it's much more than that. I've been caught up in the mystique and adventure of ham radio like few others. I personally feel that the Arabian nights I have spent over the warm smell of communications equipment, listening to and talking with people the world over, and looking out of my window at the starry early-morning sky, have shaped my personality. I truly don't know what I would have done in the 1800s—my great-great uncle was a renowned gunfighter (Will Stokes), but I don't think that would have been my calling. It's just lucky to be here today, with the apparatus existent to fly your fancies according to your innermost, gut-wrenching needs.

Now, to that telegram. Being worked up over losing all this to a bunch of people who don't even have the wherewithal to utilize it, I said:

If Wayne Green's September editorial is even 10% correct, you SOB's should be dismembered and thrown to a pack of wild dogs.

Terry Staudt W0WUZ
Company Title

This is a good old Colorado saying used sparingly to express true disgust. There is also some humor there that evidently loses itself when put in print, especially to plastic people of the job set.

I sincerely hope, as does Lew McCoy, Wayne, and Johnny Johnson, that the ARRL gets its act together in time to properly present our incomparably-just cause.

Terry Staudt W0WUZ
Ft. Worth TX

TAKE A LICKING?

Many of my friends are "wheels" in CCIR, URSI, IEEE, etc. Just two weeks ago there was an international meeting of URSI (Intl Sci Radio Union) in Helsinki. One of my old college buddies is a commission chairman (in charge of matters relating to radio noise, man-made and natural). He told me, in

passing, that he's afraid the hams are going to take a licking at WARC—something similar to what Wayne has been writing about. This friend of mine had recently talked to Dick Kirby. In fact, he had put together a panel wherein Kirby and several other spectrum managers talked. Also, my friend last year edited an entire IEEE volume on spectrum management, including articles on WARC.

Well, I happened to telephone the ARRL the next day and asked to speak to the guy in charge of WARC relations. It turned out to be Bruce Johnson, whom I don't know. Anyway, Johnson assured me that my friend (who's worked as a radio engineer for Stanford Research Institute for 20 years... and has had very close contact with CCIR, etc.) is all wrong.

Also, Johnson had never heard of URSI! He wasn't sure he'd heard of the IEEE Spectrum Management group. The ARRL had turned down Stanford Research Institute's proposal to do a study for the ARRL which could also be used by third-world countries to support ham needs in the HF and VHF spectra.

Johnson was also sure that anything that goes on at international meetings such as URSI can't affect WARC since all countries have already decided on their plans. (This is B.S., since many third-world countries are in limbo.)

In any case, the message I got was that the ARRL is all set. They know all that's worth knowing, and guys like me, who worked for the National Bureau of Standards CRPL back when Johnson was in grammar school, are to be tolerated but not listened to.

By the way, W1FYM just told me that Bruce Johnson had promised to join us for our 1978 Field Day QRP-computerized operation. Two days before Field Day, W1FYM asked about Johnson and somebody at the ARRL told him, "Oh, Johnson's not going with you guys. He had the chance to go to Pennsylvania and work Field Day with some *real* big shots..." Johnson didn't even bother to tell us.

Plus ça change...

C. Stewart Gillmor W1FK
Higganum CT

SRRL?

I'll preface the following with the fact that I have been a member of the ARRL for most of my 22+ years as a ham. Have you heard about the latest attempt to set up a dictatorship by the Board of Direc-

tors of the League? It was bad enough when they stripped Mary W7QGP of the right to run as Washington SCM. Now they have taken on the entire League membership of the Northwestern Division: Alaska, Idaho, Montana, Oregon, and Washington.

In case you did not hear about the latest news from Newington, here goes: Mary was to run against the incumbent, Bob Thurston W7PGY, for Director. It seems that the Executive Committee decided against allowing the members of the Division to democratically decide who is the better candidate. Instead, they "postponed" the election and gave W7PGY the position until after the election is "decided." The election has been postponed until the current litigation between Mary and the League is completed. If that litigation takes another two years, then Bob Thurston will have been the *appointed* Director for his entire term of office!

I wrote to Dick Baldwin, but do not expect any answer, unless it is a form letter. I will *not* resign from the ARRL, as they may not be doing much, but a little is better than nothing with WARC coming up next year. Anyway, to paraphrase the letter to W1RU, "Welcome to the Soviet Radio Relay League!"

Keep up the fight. We need some voices in the wilderness against the fuddy-duddies in Newington, and you do a better job than Cowan does in CQ. Oh yes, Wayne. "Looking West" is a good column, but contrary to what Californians believe, there is a lot more to the west coast than 6 Land!

Jerry Ostrer W7EMX
Vancouver WA

ROSE-COLORED GLASSES

I just finished reading a letter to you from Carl Manion W4BDC in the September, 1978, issue of 73. In his letter, Mr. Manion was highly critical of your stand against some ARRL policies, and of similar policies of the other ham magazines.

I have been reading all of the "big four" ham rags (except CQ) now for twenty years, or since the first issue of each respective magazine, and I want you to know that *this* Kentuckian totally agrees with your opinions and especially with your right to express them. Perhaps the reason QST, et al, remains silent in respect to Wayne Green and 73 is the old "let's ignore him and maybe he'll go away" theory. Or then, again, maybe it's because they know they have no defense against the truth.

I applaud you and your staff

for being the *leader* in ham magazines. There's no doubt about it . . . 73 is way out in front. Please don't stop keeping us informed of the *truth*, even when it sometimes hurts.

In closing, let me say that I am sure that for each renewal you don't receive from people in Mr. Manion's league, you will get three or four from those who welcome the truth and don't see ham radio as a wonderful hobby through a pair of rose-colored glasses.

Michael W. Babb N4PF
Louisville KY

ENEMIES NOT NEEDED

Jam 10 GHz police radar? If we lose this band, you will receive a bill for my two Gunnplexers. With friends like you, amateur radio doesn't need enemies. Just because someone writes an article doesn't mean you have to print it.

Steve Noll WA6EJO
Ventura CA

REALLY WEIRD

This reader has held a Class A (Advanced class) ticket since June of 1939 and therefore qualifies as something of an old-timer.

You are correct in that the ARRL has made some mistakes. The first was in not battling the FCC (if necessary) to the end when the Class A subbands were opened to all General class tickets. This problem was remedied when "incentive" licensing was restored, even though this ham lost some privileges until this year when he finally went up for Extra class and upgraded. The other mistake was in not doing everything to prevent amateur licenses which omitted the 13 wpm code test.

There are certainly many excellent technical men with Technician class licenses, but that is not the point. The reader whose letter appeared in your Letters column a few issues ago stating that the code bands will eventually be opened wide to phone simply is too much of a "young squirt" to know the score. No matter how much advancement is made in the art, as the number of hams increase and, hence, increase the QRM, the ham bands will eventually become like the CB channels are today. That is the day this ham will tear up his license. Even the opening of all CW subbands would not prevent this. Developing 13 wpm or more in CW is not that difficult, and, once a ham reaches it, most enjoy CW contacts immensely. When the QRM be-

comes completely unbearable at some time in the future, the logical move would be to narrow down the phone bands and increase the CW spectrum such as we had when the entire 40 meter band was CW only. In this way, ham radio will continue successfully—especially with the terrific new CW filters on the market.

Wayne, despite the mistakes of the ARRL, some of your counter-proposals are really weird! Not all, but some. Lay off the ARRL, but continue your suggestions, if you desire.

John B. Broughton AD4I
Charleston SC

SEMANTICS

The recent article, "New Life for Double Sideband?", deserves some comment. This article was in the August, 1978, issue of 73.

First of all, the author is engaging in semantic exercises when he says that the carrier of an AM signal is not changed by the modulating process. It is true, of course, that mathematical analysis and a spectrum analyzer will show that the carrier is unchanged when modulation occurs. Nevertheless, examination of the modulated wave on an oscilloscope clearly shows that the amplitude of the output wave does vary with the audio input. Whether or not you call that the carrier or not is up to the reader, but amplitude variation of the output certainly does occur. Similarly, in FM, the frequency of the output wave certainly varies, while the actual carrier frequency itself remains constant, and varies in amplitude. Again, the whole thing depends upon the definition of certain terms. In my view, the original 1976 article by K1IO on this subject created more confusion than it cleared up.

Similar semantic problems occur in the author's discussion about the detection of DSB. Most authors of texts in communications theory use the terms "synchronous, product, and coherent" to mean the same thing in describing detectors. Also, the author of the article in question says that a product detector only works with SSB. This just isn't true. Both theory and practice prove that a good product detector works well on AM, and I have used my product detector for years to pick up AM. Actually, a good product detector will dig AM out of the noise when a regular envelope detector won't do the job. Also, a simple product detector *will* work on DSB, and most authorities agree that understandable speech will

come out of such a detector even if the inserted carrier is as much as 30 Hz away from the proper value. Actually, the carrier can be derived from a DSB signal by a process of squaring, filtering and frequency division, without use of the PLL, although the PLL is probably the best method.

In another word error, the author says that an AM detector is nothing but a mixer. This is wrong, since to mix something you need at least two inputs, and an ordinary AM detector has only one input. Here again, the meaning of words is involved.

At least five stereo AM systems have been proposed, each with its own advantages and disadvantages. Whether or not these will prove to be successful depends on many economic and technical factors, as the author points out.

James N. Thurston W4PPB
Clemson SC

COMMUNICASTING

Just as early experimental work performed by amateur radio operators evolved into the broadcasting industry, so, too, may a new service evolve called "communicasting." Based on experience from amateur radio repeater operation, a petition was filed in January, 1977, by WA2RPC of the Center for Advanced Study in Education of the Graduate School of CUNY with W2KPK for a new "Community Educational Radio Fixed Service" (RM-2846). This service would employ the communicasting concept.

Communicasting utilizes a low-power community repeater station which can transmit audio and video signals a distance of thirty miles or more from a high antenna. Signals can input the repeater from many parts of the community and the output can be transmitted on an unused UHF TV channel for anyone to receive. The petitioners and others filing comments had additionally requested that these low-power facilities be exempted from conforming to rigid broadcast standards in order to minimize costs.

In a recent "Memorandum Opinion and Order" on RM-2846, the FCC praised the communicasting concept and made it part of a broad "Inquiry into the Future Role of Low-Power Television Broadcasting and Television Translators in the National Telecommunications System" (Notice of Inquiry in BC Docket No. 78-253). The FCC stated that, "The petition and comments by others

Continued on page 102

RTTY Loop

Marc I. Leavey, M.D. WA3AJR
4006 Winlee Road
Randallstown MD 21133

How did the old song go, "Letters, we get letters . . ."? Well, so do I, and this month I'll dip into the mailbag and see what kind of items are brought forth.

Chris Sheridan, of Yonkers, New York, sends along a tape and notes that the printing on the tape shifts from letters to figures, but that the transmitted print appears correct. In order to diagnose this problem, you must be able to read the perforations directly on the punched tape. Teletype® has been nice and standardized the format in which the tape is punched. Looking at the tape from the top, perforations are for bit 1, bit 2, sprocket, bit 3, bit 4, and bit 5. Furthermore, typing reperforators put the typed character six places behind the punched representation. Looking at the tape that was sent (I'm sorry that there is no way to reproduce it for publication), the printing reads: "WEL 8-)3?.6". Looking at the perforations, one sees that what should have been the second "L" of "WELL," 01001 binary, has been changed to 11011, presumably by a noise pulse. This is the code for FIGURES and was responsible for the shift in case on the tape. I assume that your page printer is equipped with the "downshift on space" feature that returns the carriage to LETTERS after a space. Thus, the space after the "WEL" would have returned printing to the normal mode.

Chris also asks three questions echoed by many other hams, with details only slightly changed. He wants to know:

1. Do you recommend the Kenwood (he has the TS-520) or, to you, which is the best receiver/transmitter to use for RTTY?

2. Is the HAL ST-5 good, or should I try for a better unit?

3. Do you have any recommendations for a linear?

Being of a conservative and frugal nature, the answer to

your first question, to me at least, is obvious. If you have a station that works on SSB or CW and you can get it on RTTY, use it! There probably is no "best" RTTY rig any more than there is a "best" SSB rig or "best" two meter FM transceiver. If there were one clearly superior rig, it would quickly eclipse all others on the market. The presence of variety provides for an individual's taste, and what is great for you may be rotten for me, and vice versa. Similarly, to those of you using inexpensive demodulators, such as the HAL ST-5 or Flesher 170, as long as they perform within your expectations, use them! It will become painfully obvious when you try to do more than these otherwise fine units can do. There is no reason to discard a perfectly good piece of equipment merely because it does not meet someone's arbitrary description of "the best." I'm going to punt on the linear question. I don't use one myself, but I guess like anything else, any clean linear that can be run key-down, all right with decreased specs, is fine. Get what you can afford that will make you happy. I hope that kind of puts the philosophy of equipment procurement into the proper perspective.

While it's not strictly RTTY, I'm a sucker for DX requests, and from a fellow physician, I find it hard to refuse. P. P. Kurian, M.D. VU2PP, needs help in setting up an SSTV rig in India. He notes that he is particularly interested in an Atlas 210X or equivalent, and something on the order of a Robot 400 converter. Anyone who can help is invited to write him at: Dr. P. P. Kurian MBBS, MD, Kelachandra Medical Centre, Chingavanam-686531, Tf. Res. 396, Hosp. 334, Kottayam Dt. Kerala, S. India.

While we're on the subject of help, all you whale lovers may be interested in a request from the Greenpeace Foundation of America. They need help in getting an LO15C Intellex Systems teleprinter on 60 wpm. Richard

What I had in mind was something like a conventional VOM, but with a small speaker to give an audio clue as to what the needle was doing.

Roger Deran
21 Betty Drive
Santa Barbara CA 93105

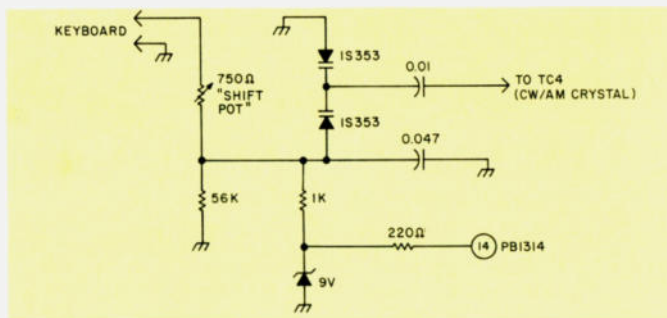

Fig. 1. FT-101B FSK.

Dillman N6VS notes the machine was made by Standard Elektrik Lorenz, AG. Write him at 240 Fort Mason, San Francisco, CA 94123, if you can help. The whale will thank you, I'm sure.

For those of you within the sphere of influence of Harrisburg, Pennsylvania, I have a note here from Bob Marzari WA3AVX about the WR3ACO RTTY repeater. It seems as though the machine has just had its second birthday, and the "parents" celebrated by equipping it with a new machine. With a Super Stationmaster at 1600 feet above sea level atop Blue Mountain, and 25 W erp, the signal covers the surrounding area well. Digital input and output is provided by a system built by local hams. Bob tells me that they are planning a link with the Eagleville, Pennsylvania, repeater, northwest of Philadelphia. This sounds like a super idea, and with the possibility of ASCII lingering as of this writing, RTTY repeaters could become the first step to turning any RTTY station into a computer terminal.

Somehow, it wouldn't seem right to have a column without at least one diagram. This month's is provided by Dick Beagell WD8CEB. Dick notes that by carefully following the directions given in the manual for the Yaesu FT-101B, RTTY could be generated. Only one problem: it was upside down! Fig. 1 is the circuit Dick came up with. He notes that, as in many other keyer circuits, the keying contacts must be "dry," that is, outside of the loop. This means that in order to get local copy while transmitting, usually a good idea unless you are a perfect speller, you should either use a polar relay to key the transmitter, or a magnetic reed relay, as described here several months ago. Dick says that adjusting TC4 and the shift pot should allow 170-Hz shift without any problems. He built his on a small terminal strip and mounted it to the "FIXED XTAL" board on top of the VFO.

Does anyone know what ever happened to the RTTY Journal and the New Jersey Green

Keys? Several readers have written to say that they cannot get mail to these publications and wonder if they still exist. I don't know, myself. Do any of you?

Many, many, many readers have asked me a variation of the "Where can I buy a frammszacher?" question so, somewhat against my better judgment, I have decided to pass along that information about RTTY sources that crosses my desk. Van W2DLT runs a joint known as Teletypewriter Communications Specialists. They sell and rent just about anything in Teletype, Baudot, Murray, ASCII, or what have you. See their ad in 73 or Kilobaud, or drop them a note at 550 Springfield Avenue, Berkeley Heights NJ 07922. Another outfit, Typetronics, reachable at Box 8873, Ft. Lauderdale FL 33310, sends along an eight-page list of equipment available. It appears they have machines, parts and accessories for Teletype and Kleinschmidt machines. I'm sure they would be happy to send you a list, too!

A tip of the hat to Bill Bennett K3TNM, Bill Richarz WA4VAF, and Ric Cooney WB3DJV, all of whom have let me know that the RTTY receiving program published here in July is up and running at their stations. In answer to their, and others', questions, modular sending and stunt-box programs are under development, and will be published as soon as I am 100% convinced that they are bug-free. For those still having problems with that program, the one bug that creeps up with fast terminals has been patched, and the program should work with any terminal of 300 baud or faster. The updated source listing (Ver. 3.1) is still available for an SASE and one dollar to cover copying costs.

Other hams have let me know there is a wide range of equipment in use out there, from the most elementary to highly-sophisticated microprocessors. We've heard from Model 15s and Digital Group stations. I'm still compiling a list of what you send in, and when it looks presentable, I'll let you all in on it . . . right here, in RTTY Loop!

Ham Help

Where can I obtain a continuity tester that produces an audible tone which changes with resistance? I am presently using a bell taped to a battery, but of course this does not provide the information a variable tone would.

What I had in mind was something like a conventional VOM, but with a small speaker to give an audio clue as to what the needle was doing.

Roger Deran
21 Betty Drive
Santa Barbara CA 93105

The Computerized Mobile Elite

The World's Best 2 meter Mobile Team.



ICOM's superior mobile IC-245/SSB teams up with the new RM2 to provide the most versatile, convenient and high quality 2 meter mobile station available anywhere. The IC-245's outstanding LSI performance, controlled by the RM2's microprocessor frequency selection and multi-frequency memory storage, puts full-band coverage speed and accuracy right where you want it — at your fingertip.

With remarkable compactness, outstanding stability, and Amateur Radio's most advanced computer technology, ICOM's Mobile LSI Team makes all others, new and old, seem obsolete. Now incremental step programming and instant recall memories are added to the IC-245's fully synthesized, multi-mode mobile operation.

The IC-245/SSB alone, even before the introduction of the RM2 remote microprocessor, has proven itself to be the most versatile 2 meter mobile radio made. With quality features like two built-in VFO's, which can handle splits of 600 KHz and 1 MHz easily, the IC-245 is the full-feature, top quality radio that every 2 meter mobile Ham wants.

Those Hams who have sought out the best and who are now operating with the IC-245 often report their satisfaction to us. Here is just some of the feedback ICOM has received on the IC-245:

"A really flexible radio. SSB has very good copy over long distance when mobile: tested at 25 miles so far."

Richard, K0GHC

"Beautifully made radio: and the signal reports have been great."

Donley, N6CD

"Exceptional receiver; and simple to use while mobile."

Clark, WD6AVT

"Very pleased with design and construction."

Horace, K3KT

"Your equipment is excellent keep it coming."

Gary, WD8CAO

"Very pleased with unit."

Kenneth, W3EMT

"Excellent Equipment."

Tom, WB7SAB

"A great rig to get into 2 meters with. It's super!"

Edward, W6OSV

All ICOM radios significantly exceed FCC regulations limiting spurious emissions.

HF/VHF/UHF AMATEUR AND MARINE COMMUNICATION EQUIPMENT

DISTRIBUTED BY:



ICOM

ICOM WEST, INC.
Suite 3
13256 Northrup Way
Bellevue, Wash. 98005
(206) 747-9020

ICOM EAST, INC.
Suite 307
3331 Towerwood Drive
Dallas, Texas 75234
(214) 620-2780

ICOM CANADA
7087 Victoria Drive
Vancouver B.C. V5P 3Y9
Canada
(604) 321-1833

DX

Chuck Stuart N5KC
5115 Menefee Drive
Dallas TX 75227

Here it is December already, and it appears that good old Saint Nick will be bringing plenty of exotic DX to the deserving. Of course, there is no need to ask if you've been good or not. That just comes naturally with being a DXer. You are one of the chosen few.

A couple of months back, in the October column, we laid out our ideas and plans for what we hoped to be able to do with this column. This included a monthly DXer profile, lots of pictures, stories on the latest DXpeditions, and much more. Mostly, we want to give you something we feel has been missing in the DX columns presently available—a column with pictures and stories about the DXers rather than the DX. Of course, we will continue to keep you up to date on "what's happening," but it's the personal side we're looking for.

To do this, we need your help. Let us hear from you. Tell us what we are doing right and what you feel could be done better. Send pictures of yourself and your station. Black and white or color—we can print either one. Let us know whom you would like to see in the DX Profile. We need lots of input from the readers. The more input we receive, the better job we can do and the better the column will be. Merry Christmas.



Lenny Mendel K5OVC, as a member of the New York City Police Department's Elite Emergency Squad. He seems to be saying, "What do you mean I'm not in the Clipperton log?"

DX PROFILE

This month's DX Profile is on one of the best known and most popular DXers around, Lenny Mendel K5OVC.

Lenny first became interested in amateur radio while attending a technical vocational high school in New York City. He was first licensed while still a junior in high school in 1945, but due to the war, he received no call at that time. By the time Lenny graduated from high school, he had earned a commercial radiotelephone license as well as first and second class radiotelegraph licenses. He had also received the call W2OVC.

After a hitch in the Coast Guard as a radio operator aboard a Coast Guard cutter and a short tour as a commercial radio operator on a seagoing tug, Lenny joined the sales staff of Harrison Radio in New York City.

In 1951, Lenny joined the New York City Police Department and became a member of the Elite Emergency Squad. Today this department is known as SWAT. If there is a better training ground for the twenty meter wars, we can't think of one. In 1971, he retired, completing twenty years of service.

1972 was not one of Lenny's best years. He was sued by five of his neighbors for a cool one million dollars. They not only claimed TVI, but charged Lenny with maliciously operating his radio and causing severe damage to their health from staying awake all night waiting for his

tower to fall on their heads. The case made it all the way to the New York State Supreme Court before it ended without the neighbors getting a cent. Lenny and his wife Norma feel that they never could have made it through this period in their lives without the moral and financial support provided by their many friends.

It was during that time that Lenny became good friends with Bud W5WZN and several other Arkansas DXers. When the Arkansas DX Association held a special meeting for Ahmed AP2AH, Lenny and Norma decided it would be a perfect time to visit Arkansas and meet some of their many friends in that area. After a short visit, during which time they fell in love with Hot Springs, Lenny and Norma put their New York house on the market and moved to Arkansas. Lenny does admit, though, that before they signed the papers on their new home, he set up a rig in the driveway just to make sure he could get out okay from that location. Now there is a man who has his priorities straight.

Lenny says that DXing from Arkansas is just great. You have a good shot to Asia and the Pacific, but it gets a little rough toward Europe. Regardless of the conditions, Lenny has earned 5BWAS, 5BDXCC, Single Band WAZ, and is waiting for cards from 6O1FG and HZ1BX/8Z4 to bring his confirmed DXCC total to 319 countries.

Lenny's equipment includes a Drake T4XC, R4B, and a Henry 2k linear. Antennas consist of a KLM 5-element Big Stick on twenty and a Wilson Duo-bander for ten and fifteen.

Lenny and his wife Norma, a native of Wakefield, Mass., have three children. Ken is a doctor at Columbia Presbyterian Hospital in New York City. Kathy Ann teaches eighth grade in Humble, Texas, and the youngest, Jo-Ann, is a junior at Lake Hamilton High School who plans to become a lawyer. None is interested in amateur radio.

Lenny is one of the real gentlemen in a highly competitive hobby. The next time you hear K5OVC on the air, give him a call. You'll be glad you did.

DX NOTEBOOK

Nigeria—5N2NAS

Ron Veelik WA6LTH forwarded a letter he recently received from Kunle 5N2NAS, secretary of the Nigerian Amateur Radio Society, explaining the present situation concerning amateur radio operation in Nigeria. In November, Emergency Regulation Decree No. 24 of 1966 was lifted. Prior to this, it was un-

lawful to bring amateur radio equipment into Nigeria and few if any new licenses were being issued, especially to foreigners. Now, with the lifting of Decree No. 24, it is again possible for foreigners to obtain operating permission. If you are interested in operating from Nigeria, write to Oyekunle Ajayi, Nigerian Amateur Radio Society, PO Box 2873, Lagos, Nigeria. Tell them when you are coming, how long you plan to be there, and where you will be staying. If you stay in Apapa or Lagos, you can receive permission to operate from the club station, 5N2NAS. Present club members are 5N2AAJ, 5N2AAE, 5N2AAK, 5N2AAV, 5N2ESH, and 5N2NAS. Kunle states that the NARS members are vitally interested in WARC '79, and he feels that we need well-disciplined radio amateurs around the world to justify the use of our old and new frequencies.

Sable Island—VGW-211

The ARRL has refused to accept contacts with VGW-211 for DXCC credit, citing DXCC rule number 6 as the reason. Rule number 6 states that "All contacts must be made with amateur stations working in the authorized amateur bands or with other stations licensed to work amateurs." The discredited contacts were made August 8th and 9th. Later contacts made while the station was signing VE1MTA are acceptable.

Thailand—HS1AIV

"Chester" XV5AC from a few years back has returned to southeast Asia and is now signing HS1AIV. Located in Bangkok, Chester has all the equipment from XV5AC and then some. In addition to full kilowatt amplifiers, he has stacked ten meter beams, stacked fifteen meter beams, two TH6DXXs, and the big Telrex six-element twenty meter beam. On the lower bands, a two-element forty meter beam and phased verticals on eighty do the trick. Chester also reports room for a 160 meter antenna and plans to do a lot of operating on the lower bands this winter. Chester will be there for a least four years and has plans for a few multi-multi contest efforts as soon as he has the station set up to his liking and all the bugs worked out.

Sri Lanka—4S7

There are presently two list-type operations involving 4S7 stations. 4S7EA meets WB9OQU Monday and Wednesday on 14247 at 2330Z. QSL to WB9OQU. 4S7JD meets

Continued on page 74

DSI COMMUNICATIONS SERIES

1.3GHz — 1GHz — 700MHz



MODEL C1000 10Hz to 1GHz

\$399⁹⁵ • AUTO ZERO BLANKING
• AUTO DECIMAL POINT

Accuracy . . . that's the operational key to this rugged advanced design Model C1000 1GHz frequency counter . . . a significant achievement from DSI. That's because you get1 PPM 0° to 40°C proportional oven time base . . . Built in 25DB preamplifier with a 60DB adjustable attenuator . . . x10 & x100 audio scaler which yields .01 Hz resolution from 10Hz to 10KHz equivalent to 10 sec. & 100 sec. Gate Time . . . Selectable .1 & 1 sec. time base and 50 ohms or 1 meg ohm input impedance . . . Built-in battery charging circuit with a Rapid or Trickle Charge Selector . . . Color keyed high quality push button operation . . . All combined in a rugged black anodized (.125" thick) aluminum cabinet. The model C-1000 reflects DSI's on going dedication to excellence in instrumentation for the professional service technician, engineer, or the communication industry.

MODEL C700 50Hz to 700MHz

\$299⁹⁵ • AUTO ZERO BLANKING
• AUTO DECIMAL POINT

ALL NEW! ALL UNPARALLELED DSI QUALITY! The model C 700 700 MHz frequency counter features2 PPM 0° to 40° C proportional oven time base . . . 25db preamplifier with a 60db adjustable attenuator. Built in battery charger with a rapid or trickle charge selector . . . Combined in a rugged (.125" thick) aluminum cabinet makes the C700 ideal for the communication industry and professional service technician.

3600A OWNERS: Up date your 3600A frequency counter to a C 700 includes, new back board, .2PPM proportional oven, 25db preamplifier, rugged .125" thick aluminum cabinet, order 3600A-700. Unit must be returned to DSI factory for modification.

DSI — GUARANTEED SPECIFICATIONS — FACTORY ASSEMBLED — MADE IN USA

Model	Frequency Range	Proportional Oven Accuracy Over Temperature	50Hz To 75MHz	75MHz To 500MHz	500MHz To 1GHz	Number Of Digits	Size Of Digits	Power Requirements	Size
C700	50Hz to 700MHz	2PPM 0° to 40° C	5CMV	10MV	NA	8	.5 Inch	115 VAC-BATT 8 to 15VDC	3"H x 8"W x 6"D
C1000	10Hz to 1GHz	1PPM 0° to 40° C	2CMV	1MV	>50MV	9	.5 Inch	115VAC-BATT 8 to 15VDC	4"H x 10"W x 7½"D

— All Units Are Factory Assembled, Tested And Carry A Full 5 Year Limited Warranty —

• NO EXTRA COSTS •

FREE Shipping anywhere in U.S.A. & Canada. All other countries, Add 10%.

Strongest warranty in the counter field.
Satisfaction Guaranteed.

See Your Dealer

OR

Call Toll Free (800) 854-2049 DSI Instruments, Inc.

California Residents, Call Collect (714) 565-8402

VISA • MC • AMERICAN EXPRESS • CHECK • MONEY ORDER • COD

7914 Ronson Road, No. G, San Diego, CA 92111

Model C 700 **\$299.95**

3600A-700 Factory update (3600A only)

Includes Labor & Re-Calibration **\$124.95**

Model C 1000 **\$399.95**

Opt. 01 1.3 GHZ (C1000 only) **\$ 99.95**

Opt. 02 .05 PPM 10MHz Double Oven 0° to 50° C Time Base (C1000 only) **\$129.95**

Opt. 03 20 Hr. rechargeable

Battery Pack **\$ 29.95**

Ant. 210 Telescopic Ant./BNC Adapter **\$ 9.95**

New Products

NEW 6M TRANSCEIVER FROM YAESU

With the six meter amateur band heading into an era of worldwide DX similar to that enjoyed by hams in the 1950s, Yaesu Electronics has announced the availability of their new all-mode six meter transceiver, the FT-625RD.

The state-of-the-art transceiver offers USB, LSB, AM, CW, and FM, with 25 Watts SSB PEP, 25 Watts FM/CW, and 10 Watts AM output.

An rf speech processor is built-in, and a 600-Hz CW filter is available as an option, as is the memory storage unit, which allows recall of any frequency with just the flick of a switch when installed. The latter is ideal for watching a beacon or calling frequency during marginal openings.

Digital readout is accurate to 0.1 kHz. Analog readout in the model FT-625R, at slightly less cost, is better than 1 kHz. VOX, PTT, semi-break-in CW with sidetone, and a clarifier for Rx or Tx/Rx are all included in the circuitry. For FM repeater use, the transceiver features standard ± 1 MHz repeater offset, programmable tone burst encoder, squelch, and a discriminator zero center meter. Alternative repeater splits may be accommodated through an optional crystal or the optional memory unit.

A built-in power supply accommodates all line voltages, with taps for 100/110/117/200/220 and 234 V ac 50/60 Hz or dc voltages from 11.5 to 16 V dc, negative ground, 5.7 Amps transmit and 0.7 Amps receive.

The transceiver measures 280 (W) x 125 (H) x 300 (D) mm and weighs just 9 kg. For a

detailed 4-color brochure, see your nearby authorized Yaesu dealer or write to: *Yaesu Electronics Corp., PO Box 498, Paramount CA 90723*. Reader Service number Y1.

LAFAYETTE INTRODUCES NEW 6-BAND COMMUNICATIONS RECEIVER

Lafayette Radio Electronics Corporation has introduced a new 6-band communications receiver with a wide range of features—the BCR-101. The unit receives international and local shortwave, marine, amateur, CB, and AM broadcasts.

Features of the BCR-101 include: a drum-type tuning dial with separate calibrated bandspread tuning on three bands; a 50/500 kHz marker tone (crystal-calibrated circuit); variable bandwidth; an adjustable noise blander; a built-in front-mounted speaker; and a tracking control and dual conversion receiver for maximum sensitivity across each band.

The receiver is available through any of the more than 400 Lafayette stores and dealers in the US or by mail order. Lafayette, a leading designer and distributor of consumer and commercial electronics products, also has an industrial sales division and an extensive direct mail operation.

For further information, contact: *Lafayette Radio Electronics Corporation, 111 Jericho Turnpike, Syosset NY 11791*. Reader Service number L18.

PE-100 TWO-TONE SEQUENTIAL ENCODER

Communications Specialists has announced another new product, the PE-100 Two-Tone Sequential Encoder.



Lafayette's BCR-101 6-band communications receiver.

This desktop encoder is capable of producing up to 100 individual paging codes, or may be programmed for 90 paging codes and 10 group call codes. Measuring 8.5" x 7.0" x 3.75" high, this unit features a high-visibility LED readout display, a 12-button miniature keyboard, and automatic transmitter keying with an LED indicator.

This unit is completely solid state and uses digitally-synthesized tone frequencies for high stability and accuracy. It is powered by low voltage ac which is obtained from an external step-down transformer furnished with the unit, or it may be powered by any unregulated 8 to 16 V dc source at 400 mA.

It is available in all EIA tone frequencies from 268.5 Hz to 3906.0 Hz, with a frequency accuracy of ± 1 Hz maximum throughout the full operating range. Frequency stability is .1 Hz from -30° C. to $+85^{\circ}$ C.

This unit is compatible with most two-tone sequential systems, such as Quick Call II, Type 99, 1 + 1, etc. Output connections include isolated DPDT

relay contacts rated at 1 A.

A one year warranty is provided when the unit is returned to the factory for repair. For further information, contact: *Communications Specialists, 426 West Taft Avenue, Orange CA 92667; (714)-998-3021, (800)-854-0547*. Reader Service number C6.

MORSE CODE TRANSCEIVER USING SINGLE CHIP MICROCOMPUTER INTRODUCED BY XITEX

Xitex Corporation of Dallas, Texas, has just introduced a Morse code transceiver designed around a preprogrammed single chip microcomputer for the generation and reception of Morse code signals using a standard ASCII or Baudot terminal (such as the Xitex model SCT-100).

The microcomputer's on-chip 2048-byte ROM contains both the send and copy algorithms, plus a software UART with multiple ASCII and Baudot rates. All timing signals are generated internally from a single external 4 MHz crystal. This not only reduces system costs, but also virtually



Yaesu's new FT-625RD 6m transceiver.



Communications Specialists' PE-100 Two-Tone Sequential Encoder.



The MRS-100 Morse code transceiver from Xitex.

eliminates RFI generation or susceptibility.

The copy portion of the device provides automatic synchronization from 1 to 150 wpm, while it is continuously computing and displaying the corresponding wpm value.

The send mode features include precise control of the output Morse wpm rate in unit increments from 1 to 150 wpm, plus a 32-byte FIFO buffer which can be edited prior to transmission.

Another feature permits both send and copy operation in a unique "RTTY emulate" mode. This permits the transmission of a 60-character ASCII subset

using standard Morse codes plus "new" codes defined for special symbols and control characters (such as line feed, space, carriage return, etc.).

The MRS-100 Morse transceiver is available from authorized distributors or directly from Xitex.

All inquiries should be made to: Xitex Corporation, 13628 Neutron, PO Box 402110, Dallas TX 75240; (214)-386-3859. Reader Service number X1.

WIRE "CLIP AND STRIPTM" TOOL

The new CAS-130 "Clip and StripTM" tool for wire-wrapping

wire cuts and strips 30 AWG (0.25-mm) wire nick-free and hides in the palm of your hand. Just insert the wire into the jaws, squeeze the tool to cut off excess wire, and pull the wire through the precision stripping blade. The result is a precise, uniform 1-inch (25-mm) strip-off length ready for wire-wrapping. The one-piece cutting mechanism and precision blade ensure dependability and ease of operation. For KynarTM and all PVC type insulations, the tool

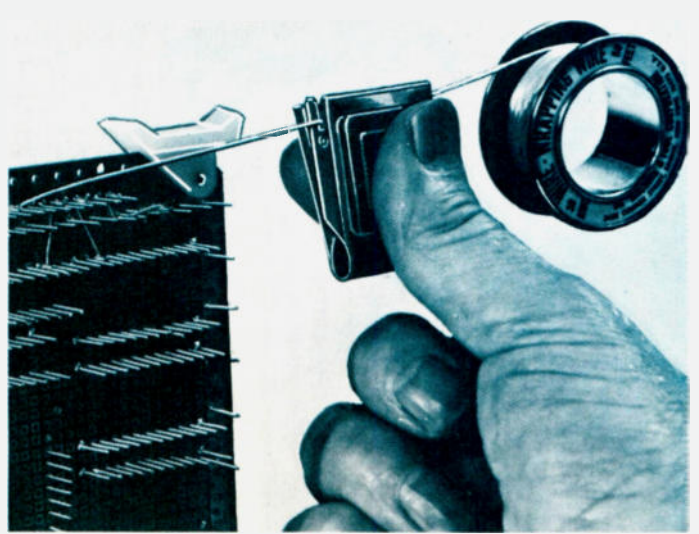

OK's new "Clip and StripTM" tool.

is in stock at your local electronics store or available directly from OK Machine and Tool Corporation, 3455 Conner Street, Bronx NY 10475. Reader Service number O5.

THE QUIK-KEY

The QUIK-KEY is certainly like no other keyer paddle I've seen or used. Basically, it is two straight keys mounted

Continued on page 147

NEW! RTTY DEMODULATOR

A RTTY DXers' Dream



FSK-1000

At IRL, we believe that the RTTY ham should be limited by his skill as an operator—not by his demodulator. The FSK-1000 was conceived and specifically engineered for use on the crowded HF ham bands, to give the serious DXer, contest operator, or MARS station a competitive edge when the QRM gets rough. For those who desire top-of-the-line performance, the FSK-1000 offers:

- Optional three shift AFSK keyer
- Optional Baudot/ASCII Video driver
- Positive dynamic range indicator
- Internal loop supply
- Dual mode autostart
- True limiterless operation over wide dynamic range
- Ultra-sharp selectable-bandwidth filters for each tone—wide = 100 Hz; narrow = 55 Hz
- Accurate tuning accomplished with individual meters for mark and space channels
- Decision level correction circuitry

Write for complete specifications. Compare our features and our price. We think you'll agree that the FSK-1000 is the logical choice for cost-effective high performance RTTY.

introductory price \$397.00
FOB



TEL.# 614-864-2464

2686 SOUTHBRIDGE DRIVE
COLUMBUS OH 43224

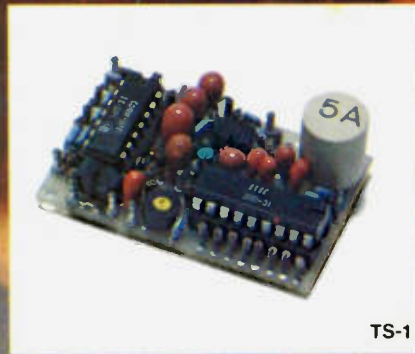

TS-1

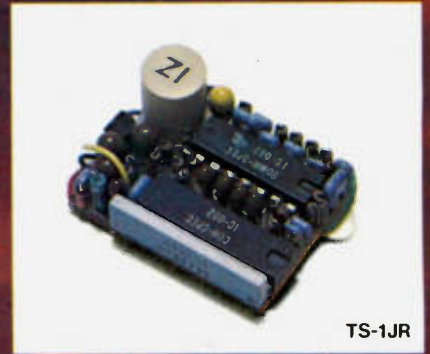

TS-1JR



PE-2



SD-1

THE DAWNING

The age of tone control has come to Amateur Radio. What better way to utilize our ever diminishing resource of frequency spectrum? Sub-audible tone control allows several repeaters to share the same channel with minimal geographic separation. It allows protection from intermod and interference for repeaters, remote base stations, and autopatches. It even allows silent monitoring of our crowded simplex channels.

We make the most reliable and complete line of tone products available. All are totally immune to RF, use plug-in, field replaceable, frequency determining elements for low cost and the most accurate and stable frequency control possible. Our impeccable 1 day delivery is unmatched in the industry and you are protected by a full 1 year warranty when our products are returned to the factory for repair. Isn't it time for you to get into the New Age of tone control?

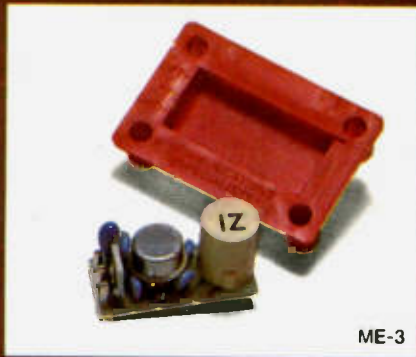

ME-3

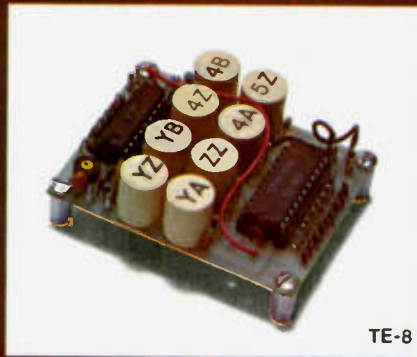

TE-8



TE-12



SD-1

OF A NEW AGE.

TS-1 Sub-Audible Encoder-Decoder • Microminiature in size, 1.25" x 2.0" x .65" • Encodes and decodes simultaneously • **\$59.95** complete with K-1 element.

TS-1JR Sub-Audible Encoder-Decoder • Microminiature version of the TS-1 measuring just 1.0" x 1.25" x .65", for hand-held units • **\$79.95** complete with K-1 element.

ME-3 Sub-Audible Encoder • Microminiature in size, measures .45" x 1.1" x .6" • Instant start-up • **\$29.95** complete with K-1 element.

TE-8 Eight-Tone Sub-Audible Encoder • Measures 2.6" x 2.0" x .7" • Frequency selection made by either a pull to ground or to supply • **\$69.95** with 8 K-1 elements.

PE-2 Two-Tone Sequential Encoder for paging • Two call unit • Measures 1.25" x 2.0" x .65" • **\$49.95** with 2K-2 elements.

SD-1 Two-Tone Sequential Decoder • Frequency range is 268.5 - 2109.4 Hz • Measures 1.2" x 1.67" x .65" • Momentary output for horn relay, latched output for call light and receiver muting built-in • **\$59.95** with 2 K-2 elements.

TE-12 Twelve-Tone Sub-Audible or Burst-Tone Encoder • Frequency range is 67.0 - 263.0 Hz sub-audible or 1650 - 4200 Hz burst-tone • Measures 4.25" x 2.5" x 1.5" • **\$79.95** with 12 K-1 elements.

ST-1 Burst-Tone Encoder • Measures .95" x .5" x .5" plus K-1 measurements • Frequency range is 1650 - 4200 Hz • **\$29.95** with K-1 element.



COMMUNICATIONS SPECIALISTS

426 West Taft Avenue, Orange, CA 92667
(800) 854-0547, California residents use: (714) 998-3021



Editor:
Robert Baker WB2GFE
15 Windsor Dr.
Atco NJ 08004

CONTESTS

ARRL 160 METER CONTEST
Starts: 2200 GMT Friday,
December 1
Ends: 1800 GMT Sunday,
December 3

The annual ARRL 160 Meter Contest is open to all amateurs on CW only. Multi-operator work is permitted and scores will be listed separately in the results, but they will not be eligible for certificates.

EXCHANGE:

RST and ARRL section or country.

SCORING:

QSOs with amateurs in an ARRL section count 2 points; QSOs with amateurs not in an ARRL section are worth 5 points. DX-to-DX QSOs do not count. Multiplier is the total number of ARRL sections (74), VE8, and foreign countries worked.

AWARDS:

Certificates will be awarded for section and non-WIVE country high scores. Division high scores will have their section award endorsed with an appropriate seal.

FORMS:

It is suggested that contest forms be obtained from the ARRL, 225 Main St., Newington CT 06111. Checksheets are not required, but a penalty of 3 additional contacts will be made for each duplicate contact.

These rules were taken from last year's contest. For complete

rules, see the November issue of QST.

VU2 DX CONTEST—GARDEN CITY CONTEST
Starts: 1200 GMT
Saturday, December 2
Ends: 1159 GMT
Sunday, December 3

The Bangalore ARC and the Viswesvariah Industrial and Technological Museum invite all amateurs to participate in the contest this year. Only two bands are specified, the 20 and 40 meter bands for all contacts, on CW only! Only one type of entry is permitted, single operator. A station may be worked once on each band; VUs may contact other VUs. Valid points can be scored by contacting stations not in the contest provided complete RST exchanges are made and logged. VU stations will work the world and vice versa!

EXCHANGE:

RST and serial QSO number of three digits or more.

SCORING:

Each completed QSO counts one point, with the following multipliers: Power-output multipliers—10 Watts and below = 5; up to 50 Watts = 3; above 50 Watts = 1. DX multipliers—Asia = 1; Europe, including UK, Africa, and Australia = 2; North and South America = 3.

Note: For all islands con-

tacted, for the purpose of multipliers, the nearest continent/mainland will be taken into account. Contacts with maritime-mobile or aircraft-mobile stations do not qualify for DX multipliers. Contacts with other portable or mobile stations count as fixed stations.

ENTRIES AND AWARDS:

All entries must be post-marked no later than Dec. 31, 1978, and addressed to:

Bangalore Amateur Radio Club, VU2ARC, PO Box 5053, Bangalore, 560 001 India. There is no entry fee, and the entry must be a true copy of the actual log for the contest period. Three prizes will be awarded to the three highest scorers. A special award will be given by the Federation of Amateur Radio Societies of India. All DX stations who contact 20 or more VU2 stations will be issued a "Garden City Cer-

RESULTS

RESULTS OF THE 1978 FRENCH CONTEST
(Listed by call, number of points, and number of QSOs)

CANADA

A1	VE3KZ	361030	232
	VE2EHF	72896	113
	VE2WA	66430	70
	VE3BR	21200	53
A3	VE3KZ	516420	349
	VE2OG	201880	206
	VE2AFC	124976	119

TERRE NEUVE

A1	VO1AW	105480	130
A3	VO1AW	5267	25

U.S.A.

A1	W1	W1BWS	13108	48
		W1OPJ	10980	38
W2	A1	W2FAS	100036	118
		W2GKZ	62243	96
		K2PF	12870	39
		N2CM	11284	41
	A3	F2YS/W2	183084	162
		K2PF	360	6
W3	A1	W3ARK	154700	155
		W3HDH	51968	91
		N3RL	6720	28
		WB3DBI	360	6
	A3	N3RL	5500	25
		W3MR	9212	35
		WB3DBI	40	2
W4	A1	N4NX	138240	144
		WB4ENI	10528	39
		W4YN	9360	36
		AA4RR	22854	60
		WB4WHE	120	4
	A3	N4NX	5000	25
		WA4LOF	2381	17
W5	A1	K5UR	20898	50
	A3	K5RF	1000	10
W8	A1	N8BB	82871	108
		W8DSO	11780	38
		W8VSK	5940	27
		WB8VWV	40	2
	A3	K8MN	15640	46
		WB8TGS	490	7
W9	A1	W9OA	56154	115
		K9WA	14490	49
	A3	WA9FZQ	34833	69
		W9LKI	26789	63
		W9TLU	6120	36
		W9SS	9090	30
W0	A3	W0CDC	7364	32

CALENDAR

Dec 1-3	ARRL 160 Meter Contest
Dec 2-3*	International Island DX Contest TOPS CW Contest VU2 DX Contest Alexander Volta RTTY DX Contest Telephone Pioneers QSO Party EA Contest—Phone
Dec 2-4	Connecticut QSO Party
Dec 3	Flatland Farmer 10-X QSO Party
Dec 9-10	ARRL 10 Meter Contest EA Contest—CW HA-DX
Dec 16-17	SOWP Christmas CW QSO Party
Dec 24	HA5-WW
Jan 1	ARRL Straight Key Night
Jan 6-7	ARRL CD Party—Phone
Jan 13-14	ARRL CD Party—CW ARRL VHF Sweepstakes
Jan 27-28	ARRL Simulated Emergency Test
Jan 28-29	Classic Radio Exchange French Contest—CW
Feb 24-25	French Contest—Phone

* = described in last issue.

AMPLIFY CHRISTMAS

Vhf engineering
BLUE LINE AMPLIFIERS

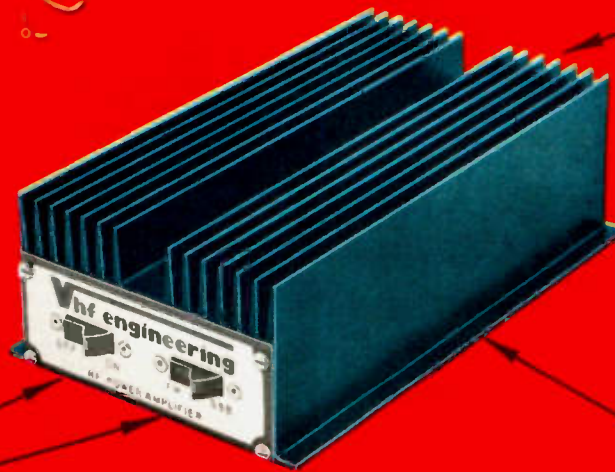
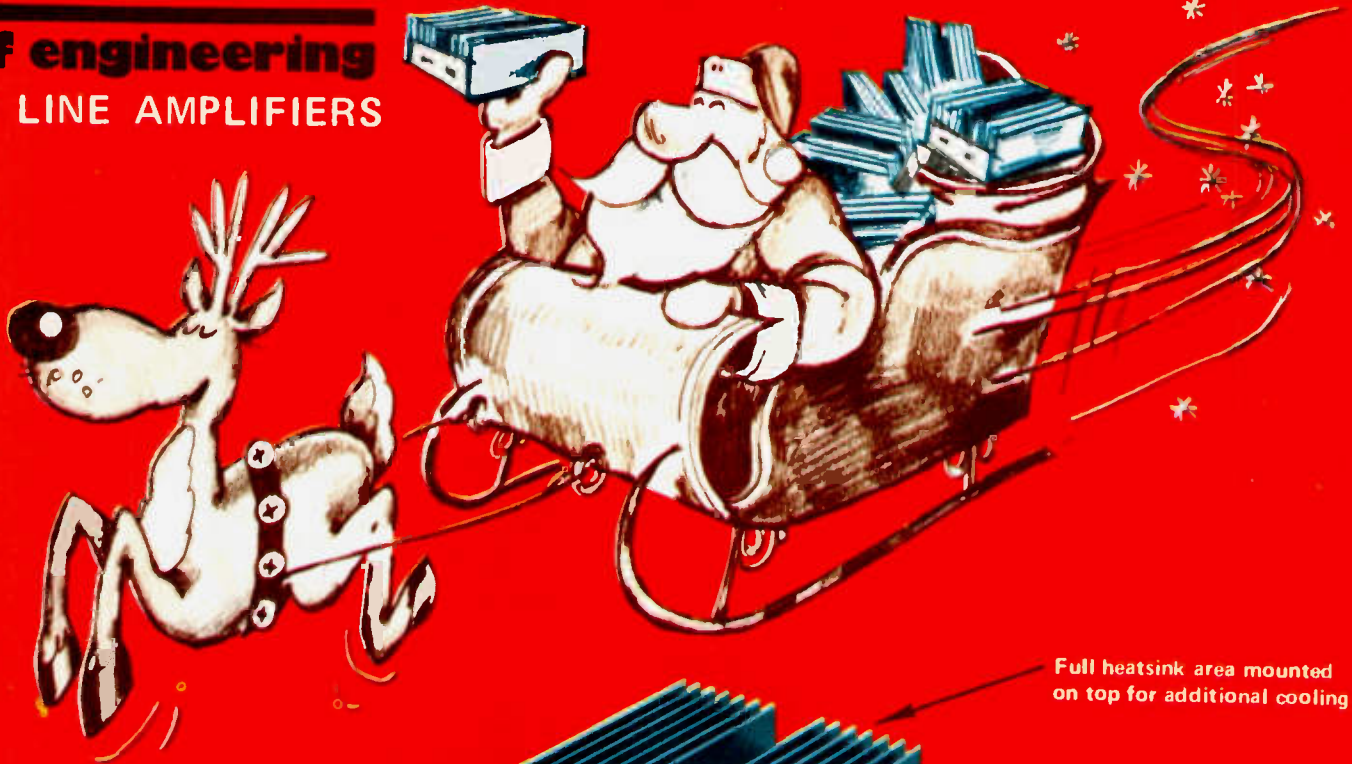

Attractive, blue anodized finish.

Full heatsink area mounted on top for additional cooling

Rugged, one piece aluminum extrusion.

High quality power switch and mode switch on front panel.

Designed for ease of mounting.

MODEL	BAND	EMISSION	POWER INPUT	POWER OUTPUT	WIRED AND TESTED PRICE
BLC 10/70	144 MHz	CW-FM-SSB/AM	10W	70W	\$149.95
BLC 2/70	144 MHz	CW-FM-SSB/AM	2W	70W	169.95
BLC 10/150	144 MHz	CW-FM-SSB/AM	10W	150W	259.95
BLC 30/150	144 MHz	CW-FM-SSB/AM	30W	150W	239.95
BLD 2/60	220 MHz	CW-FM-SSB/AM	2W	60W	164.95
BLD 10/60	220 MHz	CW-FM-SSB/AM	10W	60W	159.95
BLD 10/120	220 MHz	CW-FM-SSB/AM	10W	120W	259.95
BLE 10/40	420 MHz	CW-FM-SSB/AM	10W	40W	159.95
BLE 2/40	420 MHz	CW-FM-SSB/AM	2W	40W	179.95
BLE 30/80	420 MHz	CW-FM-SSB/AM	30W	80W	259.95
BLE 10/80	420 MHz	CW-FM-SSB/AM	10W	80W	289.95

F.O.B. Binghamton. Prices and specifications are subject to change. Export prices are slightly higher.

FEATURES

- High efficiency means low current drain.
- Broad band design (no tuning).
- Direct 12 volt DC operation.
- Indicator lamps for On/Off and FM/SSB.
- Relay switching (allows you to put amplifier in or out of circuit at the flip of a switch).
- Insertion loss of less than 1 dB.
- 90 day limited warranty on parts and labor.



V5

Vhf engineering



DIVISION OF BROWNIAN ELECTRONICS CORP.

320 WATER STREET / BINGHAMTON, N.Y. 13901 / Phone 607-723-9574

tificate." For QRP multiplier, a signed statement from the local club's secretary or president is mandatory. The ruling of the Contest Committee (VU2ARC/VU2VTN) is final in any instance of doubt.

ALEXANDER VOLTA RTTY DX CONTEST

Starts: 1200 GMT Saturday, December 2

Ends: 1200 GMT Sunday, December 3

Two-way RTTY contacts between stations of the same country are not valid. All 2-way RTTY contacts with stations in one's own zone will count 2 points; those outside one's own zone count for points in ac-

cordance with the exchange points table. All 2-way RTTY contacts made on 7 MHz are worth double; those on 3.5 or 28 MHz are worth triple points. Stations may only be worked once per band. A multiplier of one is given for each country contacted on each band. Total score is total exchange points times the total number of multipliers times the total number of QSOs. Italian bonus points are added last—1000 points for each I/IS/IT contact on all bands. Note: Each US, Canadian, and Australian district will be considered a separate country! Exchange consists of message number, RST, and zone. Use one log per

band. Logs must be received before Jan. 20, 1979, to qualify (advisable to use air mail). Send logs and score sheets to: A. V. RTTY DX Contest Committee, SSB & RTTY Club, PO Box 144, 22100 Como, Italy.

This contest is open to SWL RTTYers as well, and the same rules apply as used for transmitting stations; a separate results table will be made for these entries. In addition, points and positions achieved in this contest will be valid for inclusion in the "World RTTY Championship" for 1978.

TOPS CW CONTEST

Starts: 1800 GMT Saturday, December 2

Ends: 1800 GMT Sunday, December 3

General call is "CQ QMF." Entry classes for single/multi-operator. Use the 3.5-to-3.6 MHz band. Look for USA Novices between 3.7 and 3.75 MHz. Use low end of band for DX-CW only!

EXCHANGE:

RST and serial number from 001.

SCORING:

Contacts with own country = 1 point; each call area in W/K, VE/VO, VK, and UA counts as a separate country. Contacts with stations in same continent count 2 points, other

Continued on page 72

RESULTS

RESULTS OF THE 1978 MICHIGAN QSO PARTY MICHIGAN RESULTS

(Listed by Call, Score and County)

Call	Score	County	Achievement
W8PBO	69,040	Macomb	Trophy Winner
K8IF	60,080	Livingston	Certificate
K8RO	48,080	Oakland	Certificate
WB8TRY	36,560	Wayne	Certificate
K8KA/8	35,259	Osceola	Certificate
K8DD	33,456	St. Clair	Certificate
W8LAQ	31,746	Eaton	Certificate
W8JKU	27,744	Oakland	
WD8JOF	20,460	Genesee	Certificate
N8UM	19,992	Washtenaw	Certificate
WB8SLQ	18,312	Macomb	
W8QGP	17,580	Hillsdale	Certificate
WD8CQN	17,353	Genesee	
WB8YWG	17,100	Shiawassee	Certificate
N8UM/8	16,632	Wayne	
WB8MTD	15,080	Jackson	Certificate
WD8ITV	14,899	Macomb	
K8SJQ	14,688	Lapeer	Certificate
WD8LRR	14,460	Genesee	
WB8SVI	14,274	Macomb	
WD8ITS	13,986	Oakland	
WB8ZME	13,542	Macomb	
K8OT	12,660	Saginaw	
K8KQJ/8	12,250	Oakland	
WD8ECT	11,440	Wayne	
W8ETH	9,020	Oakland	
WD8DKM	8,695	Bay	
WD8AAE	7,866	Marquette	Trophy—UP
K8DAC	6,930	Saginaw	Multi-Op
WA8VEB	6,650	Oakland	
N8WW	6,480	Macomb	
WD8QVB	6,407	Macomb	
WA8MAM	5,940	Menominee	Multi-Op
N8RW	4,560	Saginaw	
WD8OKL	4,532	Bay	
WB8ZJL	4,176	Macomb	
N8HT	3,924	Genesee	
WB8BNN	3,478	Van Buren	Certificate
W8HW	3,317	Genesee	
N8MK	3,102	Saginaw	
WD8IKZ	2,997	Oakland	
W8WVU	2,952	Lenawee	Certificate
WB8AUN	2,800	Macomb	
W8WVU/8	2,376	Cheboygan	Certificate
WB8NXN	2,244	Oakland	
WD8OLC	943	Genesee	
WB8LWS	792	Macomb	
K8BWC	595	Saginaw	
W8YL	532	Lenawee	

WA8EFF	496	Macomb	
WD8QNM	442	Macomb	
WA8TOF	300	St. Clair	
WD8NNM	72	Macomb	
K3KX/m8	17,493	6 Cos.	Certificate
W8VSK/m8	3,672	4 Cos.	
WB8FEZ	2,349	Genesee	Plaque (VHF)
WD8LID	144	Lapeer	VHF
WD8KEO	21	Genesee	VHF

CLUB SCORES

1. L'Anse Creuse ARC—266,450 Club Trophy (4th Straight Year)
2. Central Mich. Contesters—62,971
3. Saginaw Valley ARA—36,542
4. Central Mich ARC—31,746
5. Sawyer ARA—7,866

OUT OF STATE RESULTS

(Listed by State, Call, and Total QSO Points)

State	Call	Score	Achievement
CAL.	WB6DQR	20	Certificate
CONN.	W1VH	1,848	Certificate
DEL.	W3JZA	640	Certificate
GA.	WB4RUA	2,525	Certificate
ILL.	K9BG	5,032	Certificate
	WB9SMU	3,861	
	W9QWM	2,783	
	K9CW	1,050	
	K9GL	192	
IND.	K9NN	6,996	Certificate
	N9BU	1,029	
IOWA	WB0UCP	4,026	Certificate
LA.	W5WG	1,881	Certificate
MD.	W3BHE	6,630	Certificate
	W3PYZ	6,400	Certificate
MINN.	WA0QIT	7,912	Certificate
MO.	WB3JAP/0	1,218	Certificate
NEV.	W7HI	416	Certificate
N.J.	WB2LBV	5,254	Certificate
	N2VA	1,098	
	WA2BYX	96	
N.Y.	N2RT	4,366	Certificate
	WA2OTC	3,422	
	W2EY	980	
N.C.	WD4BEJ	416	Certificate
	N4GF	108	
OH.	WD8CGR	2,889	Certificate
	K8BBH	2,714	
PA.	K3NB	4,433	Certificate
	WA3ZAH	779	
	W3FVU	30	
TEX.	W5KLB	2,002	Certificate
	N5QQ	224	
WISC.	WB9PVI	1,771	Certificate
	K9GDF	765	
	WB9KAR	70	
ONT.	VE3DAP	8,034	Trophy
	VE3CDK	8,000	Trophy
	VE3BR	5,115	Certificate

CT-50 FREQUENCY COUNTER



**Outstanding
Performance
at an
Incredible
Price**

DESCRIPTION: The CT-50 is a versatile and precision frequency counter which will measure frequencies to 60 mHz and up to 600 mHz with the CT-600 option. Large Scale Integration, CMOS circuitry and solid state display technology have enabled this counter to match performance found in units selling for over three times as much. Low power consumption (typically 300-400 ma) makes the CT-50 ideal for portable battery operation. Features of the CT-50 include: large 8 digit LED display, RF shielded all metal case, easy pushbutton operation, automatic decimal point, fully socketed IC chips and input protection to 50 volts to insure against accidental burnout or overload. And, the best feature of all is the easy assembly. Clear, step by step instructions guide you to a finished unit you can rely on. Use the order blank below or call us direct and order yours today!

SPECIFICATIONS:

- Frequency range: 5 Hz to 65 mHz, 600 mHz with CT-600
- Resolution: 10 Hz @ 0.1 sec gate, 1 Hz @ 1 sec gate
- Readout: 8 digit, 0.4" high LED, direct readout in mHz
- Accuracy: adjustable to 0.5 ppm
- Stability: 2.0 ppm over 10° to 40° C, temperature compensated
- Input: BNC, 1 megohm/20 pf direct, 50 ohm with CT-600
- Overload: 50VAC maximum, all modes
- Sensitivity: less than 25 mv to 65 mHz, 50-150 mv to 600 mHz
- Power: 110 VAC 5 Watts or 12 VDC @ 400 ma
- Size: 6" x 4" x 2", high quality aluminum case, 2 lbs
- ICS: 13 units, all socketed
- CT-600: 600 mHz prescaler option, fits inside CT-50
- CB-1: Color burst adapter, use with color TV for extreme accuracy and stability, typically 0.001 ppm

OPTIONS:

CB-1 option: The CT-50 time base may be locked to an external frequency standard. The television networks maintain extremely accurate atomic based frequency standards to maintain color tint on TV programs. These standards are typically accurate to one part in 10 to the 12. By locking the CT-50 to one of these network standards, we are able to get super accuracy. The CB-1 adapter interfaces a standard color TV receiver to the CT-50 so that one can take advantage of the TV network frequency standards. The CB-1 requires connection to a color television for operation.

CT-600 option: The CT-600 prescaler option enables the CT-50 counter to measure frequencies as high as 600 mHz with sensitivity in the 20 to 150 mv range, depending upon frequency. Typical sensitivity at 150 mHz is 25 mv. The CT-600 mounts on the same PC board as the CT-50, no extra boxes or PC boards are required. The scaler utilizes a state of the art ECL IC chip and two transistor pre-amplifier, thus eliminating the need for external pre-amp devices.



CT-50, 60 mHz Counter Kit	\$89.95
CT-50 WT, 60 mHz counter, wired, tested	159.95
CT-600, 600 mHz prescaler option for CT-50, add	29.95

ACCESSORIES

DC probe, direct input, general purpose type	\$12.95
High impedance probe, does not load circuit	15.95
Low pass probe, used when measuring audio	15.95
High pass probe, reduces low freq pickup	15.95
VHF flexible rubber antenna, BNC connector	12.95
Color burst adapter, for calibration, high accuracy typically 0,001 ppm accuracy, stability	14.95

Ramsey Electronics
Box 4072 716-271-6487
Rochester, NY 14610 ✓ RB



78

Quantity	Description	Price
	Shipping, handling, insurance	\$5.00
	N.Y. state residents, add tax	
	Total	
Name _____		
Address _____		
City _____ State _____ Zip _____		

ramsey electronics

Box 4072 Rochester NY 14610 (716) 271-6487

A DXer's Dream Vacation

— *try sunny Montserrat*

*Alan Adler WB6JPZ
2500 Granville
Los Angeles CA 90064*

It was another typical pileup on twenty meters: lots of stations blasting away at the rare one, hoping for that all-important signal report which sig-

nifies another successful try. But this time we were at the other end and the hundreds of calls were for us. All we could do after it was over was grin at each other at the thrill of for once being the sought-after instead of the seekers. We were, for eight days, VP2MJE. We had been lifted out of the anonymity of our previous existence as Alan Adler WB6JPZ and Stuart Sokolin W6MJE. For once in our careers as ham radio operators, we were DX.

The idea for our expedition really started more as a dream or wish rather than a carefully planned and well thought-out expedition. After suffering through numerous DX pileups, we started daydreaming about how nice it would be to go on a DX-pedition ourselves. Lacking tremendous financial resources and a great deal of time, we resigned ourselves to more daydream-



Arrival at the Montserrat airport: Stuart Sokolin W6MJE, left; Ruby Bramble VP2MGB, center; Alan Adler WB6JPZ, right.

ing. We still hoped one day to strike out on a trip to some exotic DX location —possibly some island. Our opportunity came sooner than we expected.

A small ad in the back of a ham periodical told of a house which was available for rent complete with tower, quad, and linear amplifier. The house was located on a small obscure island in the Caribbean, British West Indies. The island was Montserrat, of which we knew absolutely nothing. Everybody we asked about the island also knew nothing about its location or geographical layout. Being intrigued by the mystery surrounding the island, we began to investigate the possibility that this might be a place for our first expedition. We inquired further about how to get to the island and where it was actually located. Travel agencies were no help and we had to do the research on our own. After calling numerous airlines, we finally found a way to get down to the island, which involved the use of three separate flights. After careful research, we decided that this was the opportunity for which we had been searching. Both Stu and I could afford the trip to the island, and we would be able to operate without the hassle of taking along an antenna system or linear. The problem of a rig was solved by using my FT-101B, an excellent rig for traveling. We decided that this was the place to try our hand at being DXpeditioners.

Immediately we wrote to the owner of the house to inquire about the availability and cost of rental and the procedure for obtaining a license. We received a detailed reply from Doc Beverstein VP2MZ, who was delighted with our interest in operating from the island



Mountain view on the way to Plymouth, showing typical scenery of the island.

and arranged for us to stay in the house from September 24, 1977, to October 2, 1977. The rent was very reasonable, well below that of a similar stay in the local hotel. Once the reservations were finalized, we set out to organize our forth-

coming trip. First, a letter was sent to one of the hams on Montserrat to obtain a license. Here we were helped by Ruby Bramble VP2MGB. She was able to apply for our license under standard reciprocal agreements, and would be

waiting at the airport to help us through customs.

We set out from Los Angeles on September 23, leaving for New York at 10:00 pm Los Angeles time. Upon arrival at Kennedy International Airport, we had to wait six hours for



Operating position. Alan Adler, left, and Stuart Sokolin, right.

MONTSERRAT

BRITISH WEST INDIES

VP2MJE

QSO WITH	MONTH	DAY	YEAR	GMT	RST	BAND
	SEPT.		1977			3.5 - 7
	OCT.					14 -21 -28
2 WAY SSB-CW	EQUIP: FT101B-SB200-2EL QUAD - SLOPER					

QSL VIA W6EL

73's
Stu & Al

W6MJE: Stuart Sokolin
WB6JPZ: Alan Adler

Sample Montserrat QSL card.

our connecting flight to Antigua. After arriving in Antigua on a very hot and humid afternoon, we had to wait another four hours for our flight to Montserrat. On our last flight, we crowded into a hot, steamy, ancient DC-3 somewhat reminiscent of a Mexican bus ride, and took off (thankfully) for Mont-

serrat. Fifteen minutes later, we stumbled off the plane, clutching our equipment, and headed for customs. We encountered little difficulty at the customs office once Ruby presented the officer with our Montserrat amateur license.

Our route to the house was short, but strewn with

holes, ruts, and other obstacles such as stray cows. The house itself was isolated and surrounded by thick undergrowth topped with beautiful flowers, making a very picturesque scene. The inside of the house was very nice, with a separate living room, kitchenette, and two bedrooms. The ham station was in one

of the bedrooms, which had an unobstructed view of the ocean. The house was on a hill overlooking the ocean, and the trade winds from the Caribbean kept the whole house cool. Both Stu and I were overwhelmed by our surroundings. Seeing it all, we decided that life as a DXer might not be so bad after all.

Eager to set up, we piled the equipment onto a table and started to hook up the maze of wires necessary for our operation. Our equipment consisted of my Yaesu FT-101B transceiver, the FV-101B external vfo, the SB-200 linear amplifier, and our portable cassette recorder. Our antennas were a Hy-Gain quad on a 70-foot tower and sloping dipoles for 80 and 40 meters. We had a first-rate island setup.

After an hour of setting up equipment and fixing the sloping dipoles, knocked over by a recent tropical storm, we were ready to make our appearance on the air. In order to generate maximum exposure, we started on 20 meters with the quad pointed toward the United States. The response was astounding. Within seconds of starting operations, we had a tremendous pileup of state-side hams. To be on the other end of a pileup this size was the most exciting ham radio operation that either Stu or I had ever experienced. It was instant popularity!—and quite different than being just another California station. Fortunately, both of us had planned, months in advance, the techniques we would use in handling large pileups, and soon we were handling the callers smoothly and quickly.

In order to assure everybody an equal chance of contacting us, we decided to keep the exchanges to a minimum. For example, during our heavi-

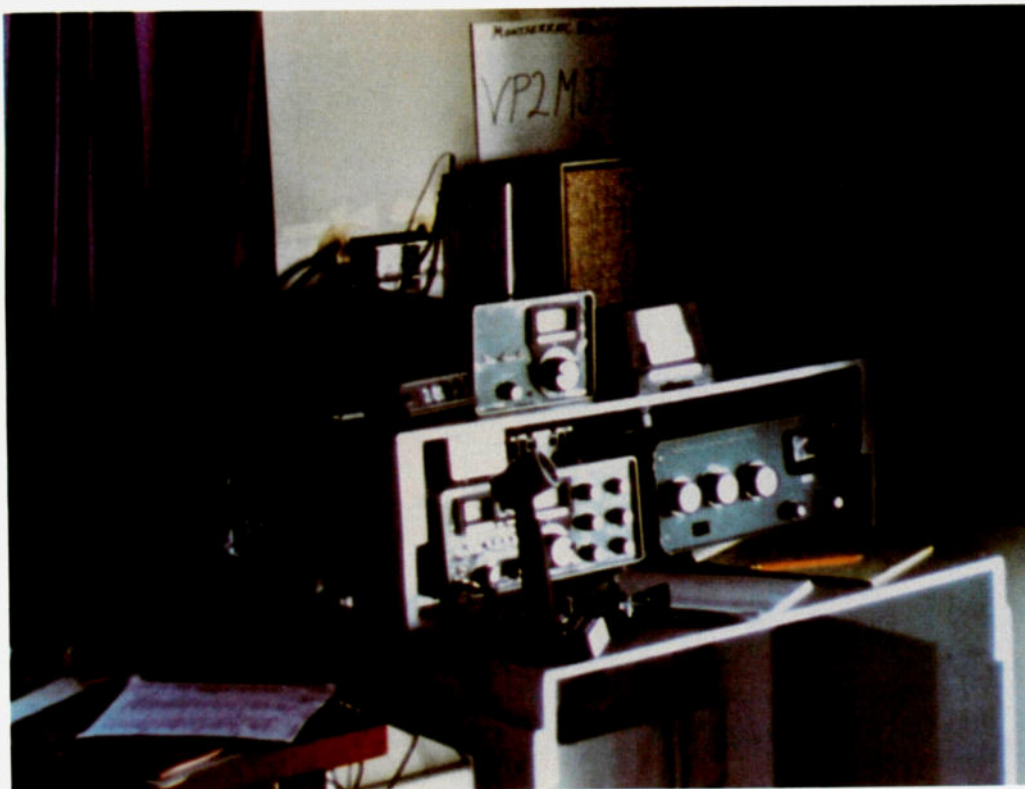

View of operating area. Equipment shown: Yaesu FT-101B, FV-101B, and Heath SB-200 linear.

est pileups we would only ask for call sign and signal report. We would not stand by for anyone's friends at any time, so as to be fair to all hams, and we would not use lists of any kind when dealing with the pileups. In order to give areas of poorer propagation a chance, we took periodic standbys to listen for the weaker stations. The overall operating manners of the stateside stations in pileups were quite commendable. We had very little deliberate interference. The hams would stand by while we were in contact with each station, and there was very little tail-ending. When we asked for standbys to the areas with poorer propagation, we got good cooperation and minimum QRM. Score an "excellent" for American amateurs in our pileups.

The European pileups were much harder to control. The European hams usually did not stand by while we contacted a station, and the interference was much greater. These reactions may have been a result of the language barrier or of a lack of experience in large pileups. Still, we had many good contacts into the European area.

After our hectic opening night of operation, we finally realized that we would need some supplies if we were going to survive a week on the island, so we set out on a mini-expedition into Plymouth, the one and only town on the island. We piled into our small taxi and raced over mountainous roads past beautiful hills and lush green valleys to the main market. Driving in Montserrat is a real experience in survival. First, they drive on the opposite side of the road, as in England. Second, the roads are narrow and rugged, with lots of blind curves



This is a view of the town square in Plymouth.

and thousand-foot drop-offs. Third, everyone drives as if he were trying to win the Monaco Grand Prix. It's very exciting to see if you can make it to town and back without an accident with another driver or with one of the many large cows wandering about. Planning on a long siege at the radio, we stockpiled such necessities as cases of soft drinks (at an amazingly low 10¢ per bottle), packs of candy bars, eggs, Heineken beers, and other essential foods needed for good health. After loading the car with munchies, we decided to walk around town and do some sightseeing. The village was very quaint and all the people were quite friendly. Upon our return to the house, we decided to see if there was any activity yet on 15 or 10 meters.

The pileups on 20 meters seemed like a picnic compared to the response we got on 15 meters. We were inundated with calls from all areas of the United States as well as Canada, and with an equal number of calls from the European stations. We

had no idea where to point the quad first, since wherever we aimed the antenna we were barged with calls. Stu and I took turns operating and logging, trying to work as many stations as possible, but we could not handle all of the response.

We finally had to reluctantly leave 15 meters to take advantage of an opening on 10 meters. I think half of the world followed us to 10 meters. If you think 10 meters is a dead band, just listen to a DX station give one CQ. I believe we attracted every ham within 6,000 miles. We were working stations at the rate of three per minute until a sudden power failure on the island took us off the air. After the power had been restored, we checked the band but found that the propagation had gone down considerably. Taking a quick count of our brief 10 meter debut, we found that we had contacted over 200 stations in about one hour. We had also contacted over 300 stations on 15

for our first try on that band.

Almost collapsing from exhaustion, we stumbled out to our patio overlooking the Caribbean and revived our spirits with several cold drinks from our spacious, well-stocked refrigerator. The life of a DXer can truly be grueling, we thought, as we relaxed on the front porch, enjoying the cool trade winds. Then, gathering courage, we went back into the shack and looked at the log to see how many extra QSL cards we would have to fill out for our moment of glory. Sobered by the thought of increased writing, we decided to concentrate on our two expedition goals: first, to obtain enough countries for DXCC; second, to work all states.

Shunning massive pileups for the moment, no matter how ego-gratifying, we exerted all our efforts toward obtaining a maximum country total. We tried 40 meters for nighttime DX, but found the band cluttered by broadcast stations, making communications impossible.



View of 70-foot tower and Hy-Gain quad. This was shot on the approach to the house.

Our 80 meter nighttime operation proved much more successful and we were able to work several of the European countries. We were also able to spend some time in the Russian portion of the 80 meter band, working many of the Russian stations which could not come up to the regular DX area of the band. During the daytime we concentrated primarily on 15 and 10 meters, getting excellent propagation into the Mideast, Asia, and Oceania. Longpath to these areas was also quite effective and was the only way we were able to contact stations in the Asian zones.

Being able to operate in the foreign band, a privilege denied to us in the United States, helped immensely in contacting new countries. We were able to avoid much of the QRM and congestion of the American band and were also able to contact stations which operate primarily in the foreign band. Split operation also was made more efficient by our ability to listen in the DX portion of the American

band but transmit below the band edge. Operating in this portion of the band was an experience we really miss, now that we are back in the United States.

We were surprised to find that, at the end, when all was totalled, we had not only met our goal of 100 countries, but had exceeded it by a large margin. The total country count finished at 143 worked, including all continents. We had also obtained contacts with all 50 states, the most difficult being Alaska and the last being South Dakota. Lest anyone think that all we did was hunt for specific states and countries, let me add that in our eight days of operation, we contacted more than 3,300 stations.

After eight days of operation, we reluctantly packed for our trip back to California. We were sad to leave the island. Though we would not miss the giant bugs that attacked us every night, nor the sugar ants that competed with us for food, we would miss the beautiful weather, the friendly people, the help

and support of local hams, and, most of all, the notoriety of being a sought-after DX station. We were about to be transformed back from pileup-makers into pileup-seekers. Stu and I were ready to stay indefinitely, but we had no choice because the house no longer belonged to us. A new occupant was eagerly waiting for us to leave so that he could taste the action that we had enjoyed. The weather was perfect as we left for Antigua to meet our connecting flight back to New York.

As luck would have it, we arrived in Antigua just in time to watch our connecting flight take off for New York, which started off a whole chain of missed flights, so we had plenty of time to sit around airports and reflect on the experiences of our first expedition. We listened quite a bit to cassette tapes that we made of our operation and enjoyed reliving the pileups. Both of us agreed that it was well worth the trip to Montserrat to understand first-hand the workings of a DXpedition. The experience gained on the receiving end of a big pileup is invaluable. It helps one's discipline in operating procedures, and it makes one appreciate the difficult time that DX stations have in sorting out the numerous calls which seem to blend into one continuous buzz.

When we arrived back in Los Angeles, our QSL manager, Sheldon Shallon W6EL, presented us with the first of a number of large shopping bags full of QSL cards. After looking through hundreds of cards sent for our VP2MJE operation, we have learned what will expedite a return card and what will slow a card down. For example, it is surprising the number of people who send cards

with local time indicated, instead of the universally accepted GMT. A DX station, which has no idea of what CDST or MDST means, will simply throw away a card not in GMT, and the poor ham who worked so hard in that pileup will never get his card. We've received cards which have been an hour or more off of the correct time, and some have come through with no time indicated at all. Also, people who send cards to a QSL manager with no SASE, expecting to get a card back immediately, will be lucky to get a card back through the bureau in a year, if at all. Some cards came with the wrong date, and with a log containing 3,300 contacts, it is impossible to spend time looking for that contact. Above all, make sure that every DX card you send is in GMT with the correct date and time, and is legibly written. Luckily, however, most of the cards sent to us were done properly, so we were able to locate them quickly in the log and send them out in a reasonable period of time.

Both Stu and I have agreed that the expense and time involved in an expedition such as ours is well worth it, and we feel that any ham who has the opportunity to go on an expedition should not hesitate. One need not go to the rarest spots of the world to enjoy the excitement of being a DX station. We were neither the first nor the last of the stations visiting Montserrat, but every ham who has been there has enjoyed the excitement of being on the other end of the pileups and there is plenty of action on all bands. Other islands could offer the same opportunities. DXpeditioning is a unique experience which can be appreciated only by those who have tried it. ■

TWO OF THE THREE BEST THINGS IN LIFE COME FROM EDGECOM . . .



SYSTEM 3000A

Featuring: Twenty front-panel-programmable memory channels . . . Memory channel scanner . . . Band scanner . . . Two priority channels . . . Any transmitter offset . . . Full coverage (144-147.995 MHz) in 5 kHz steps . . . Memory channel monitor . . . Advanced microcomputer-controlled PLL synthesizer with electronic push-button tuning . . . Extraordinary receiver with five-pole front-end and ten-pole IF . . . 25 Watts output (adjustable) . . . MARS/CAP coverage optional (142-150.99 MHz) . . . Small, light weight . . . Full TWO-YEAR WARRANTY . . . An incredible bargain at \$549.

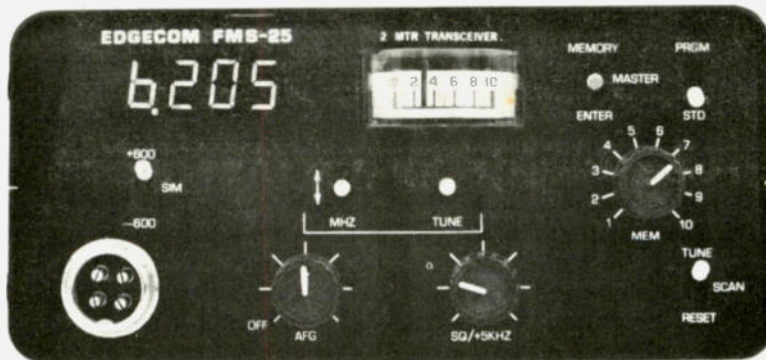

FMS-25

Features: Ten front-panel-programmable memory channels . . . Built-in band scanner . . . Any transmitter offset . . . Full 144-147.995 MHz in 5 kHz steps . . . Advanced microcomputer-controlled PLL frequency synthesizer . . . Electronic push-button tuning . . . The same fantastic receiver and transmitter as System 3000A . . . Full TWO-YEAR WARRANTY . . . Low price: \$439.

SYSTEM 3000A/FMS-25 . . . PERFORMANCE TO CHALLENGE YOUR IMAGINATION

See them at selected dealers or write for more information.

Edgecom Inc. ✓E19

2909 Oregon Ct—A3, Torrance CA 90503 (213) 533-0433

Close Encounters

— *the eyes of Texans are upon them*

Something strange was moving up there! Across the glittering star fields of a moonless Texas night it crept, a small orange light, pulsating slightly and growing brighter. Abruptly, it changed direction. Reddish now, it proceeded at right angles to its former course, away from the smudge of light on the horizon that marked a distant city.

A flight controller hunched intently over his radarscope. Its eerie glow illuminated an expression of amazed disbelief. A silent whistle escaped from his pursed lips. An 80° turn at 16,000 mph and out of range already? Involuntarily, his throat muscles tensed to speak to the pilot of the only plane on the scope, then relaxed. Who would believe him? Probably an equipment malfunction, he thought. Yet stories told by old-timers, stories at which he had scoffed, began to filter into his mind.

Much lower now, the object skimmed slowly over an area of rough terrain. A lone car probed the dark

county road with high beams. Nearing the crest of a hill, it switched to low as a glare showed someone was coming. The beer net on 34/94 was pleasant company. Suddenly there was only dead silence. Worse yet, the engine and headlights had quit at the same moment!

Too busy braking to question the source, the driver was thankful for the light as he brought the car to a stop on the berm. But now the approaching blaze looked like a jet-propelled magnesium flare. Just as it seemed that it must smash right into the car, it was up and over and off into the sky behind. And a ham sat quietly, shaking for five minutes before realizing that the engine was running, the headlights were on, and the repeater was chattering away as though nothing had happened. "What was *that*?" was still his only thought.

At that moment, not far away, as it had all day, every day for months, a unique laboratory waited to answer that question. Near the very limit of their sensitivity, recording instruments deviated slightly

from the norms of their tireless monitoring. Inside a low building, pale by starlight against the dark hillside, electrons surged through microcircuitry. A minicomputer swiftly executed its intricate series of commands. An alarm shrilled, alerting duty personnel. Quickly all posts were manned, and the sophisticated technology of the only known scientific facility in the world dedicated solely to UFO research was ready for what might come.

Still adjusting headsets, observers manning three phototheodolites at widely separated locations on the 400-acre site scanned the stars for one that moved, waiting for instructions. They were not long in coming. "Magnetic anomaly, 270 degrees, increasing in intensity. Stand by." Inside the laboratory, the director studied the endless white tongue of paper extruding slowly from the chart recorder. Eight fine lines were being penned on it, measuring the output of various sensors. Periodic blips indicated time signals being received on 60 kHz from WWVB. Two of the

channels were now showing deviation well above their baselines. Attention shifted expectantly to the color video terminal.

From high atop a tower rising into the darkness above a nearby building, powerful radar pulses were sweeping a 12-mile radius. For several rotations there was no unusual return. Then, "Radar lock-on!" As coordinates of the UFO were relayed to the field observers, excited cries doubled in the headsets. "Got it! Orange lenticular object, moving in fast."

All three phototheodolites were now tracking the object. Each operator concentrated on keeping the image of the UFO centered on an illuminated spot in his aiming scope, while shaft encoders on the pan-and-tilt heads of the telescopic cameras were feeding coordinates into the computer. At the same time photographic evidence was being collected, data sampled from each of the three locations every few seconds was being processed into a video display. The UFO's path was seen superimposed over an im-

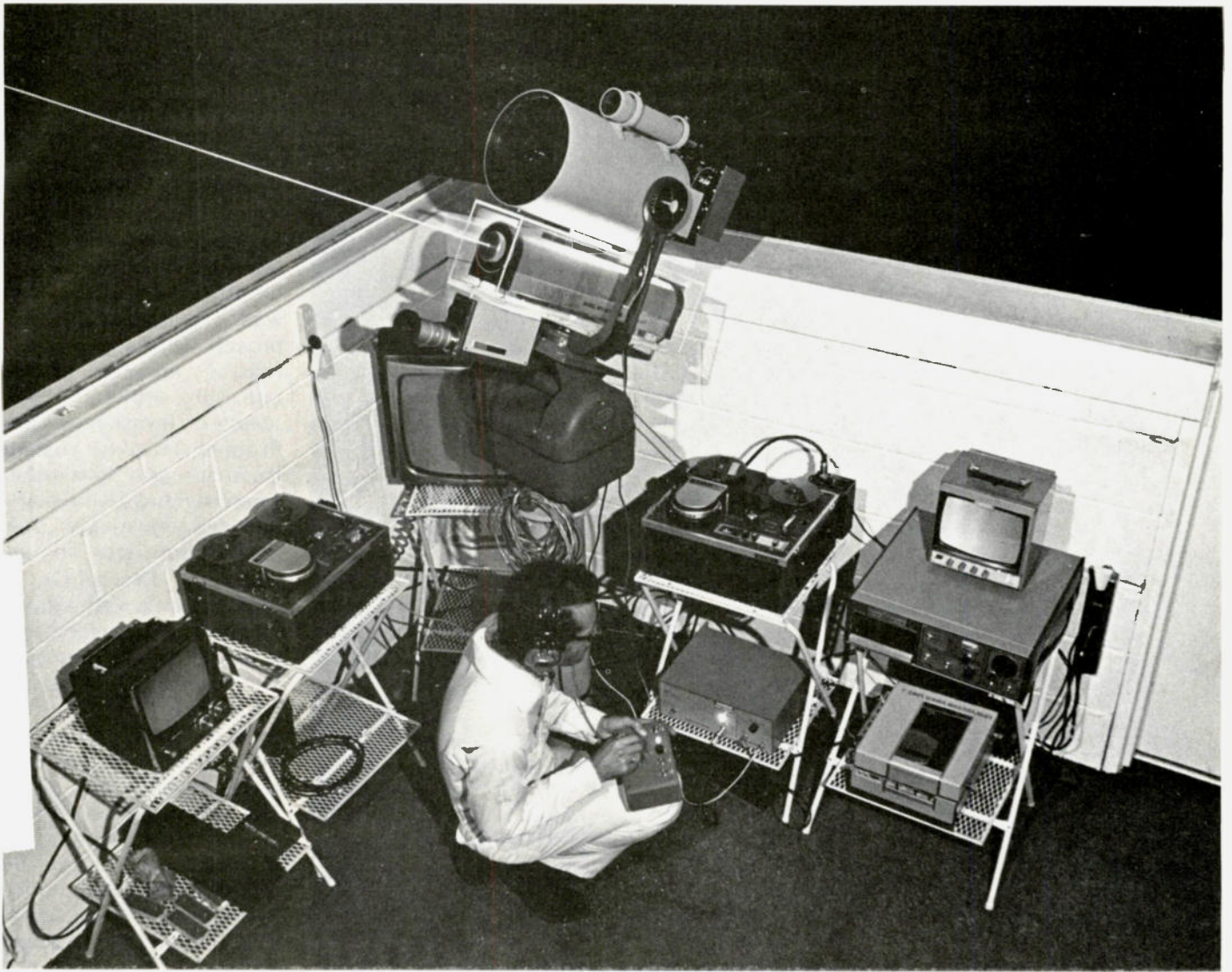

Photo A. Laser beam made visible by water vapor refraction pierces the night from the UFO light-pulse experiment apparatus at the Laboratory for Instrumented UFO Research near Austin, Texas. Capable of transmitting up to 2.5 million bits of response-test data per second, this red-light laser device can also be used to measure UFO distance and test the hypothesis that light beams may be bent in the vicinity of some UFOs.

age of the area beneath it. Actual distance readings were being printed out for permanent record.

Busy as it was, though, the computer was also performing a number of other vital functions. As the vidicon operator focused on the approaching UFO, it measured the arc subtended by the image and computed the size of the object. It also computed the visibility radius of the object, and retrieved the names and phone numbers of ARGUS volunteers who should be able to see it. Several telephone lines were being pulsed with the dual tones so familiar to

autopatch users, and sleepy voices began answering phones shrilling on bedside stands miles away. As each answered, the name and phone number was printed out and the volunteer heard, "This is an Operation ARGUS alert! Please do as you were instructed."

Suddenly wide awake, the observers hastily pulled on clothes, jammed feet into shoes, and grabbed binoculars and cameras on the run. This night they were not to be disappointed. Here was UFO event-sharing on a silver platter, in contrast to the ordeals suffered by

our friends in "Close Encounters" on the silver screen.

Unlike the movie, the scenario we have imagined is hardly fantasy. This laboratory actually exists. At this very moment, whatever the time, its equipment is scanning the sky, waiting for the real thing to happen. This is where history may be made—Project Starlight International, or PSI.

In the rattlesnake-infested hill country northwest of Austin, Texas, accessible only by four-wheel drive, lies the 400-acre site of the Laboratory for Instrumented UFO Research,

a facility unique in the world. At this remote location, field research is conducted for Project Starlight International, a research division of the Association for the Understanding of Man, which is a nonprofit educational organization based in Austin. PSI's purpose? To document scientifically and irrefutably the existence of UFOs. Ray Stanford, founder and managing director, is an acknowledged expert in the field of UFO research. Author of *Socorro "Saucer" in a Pentagon Pantry*, he conducted a fascinating and well-documented investigation of the Socorro,

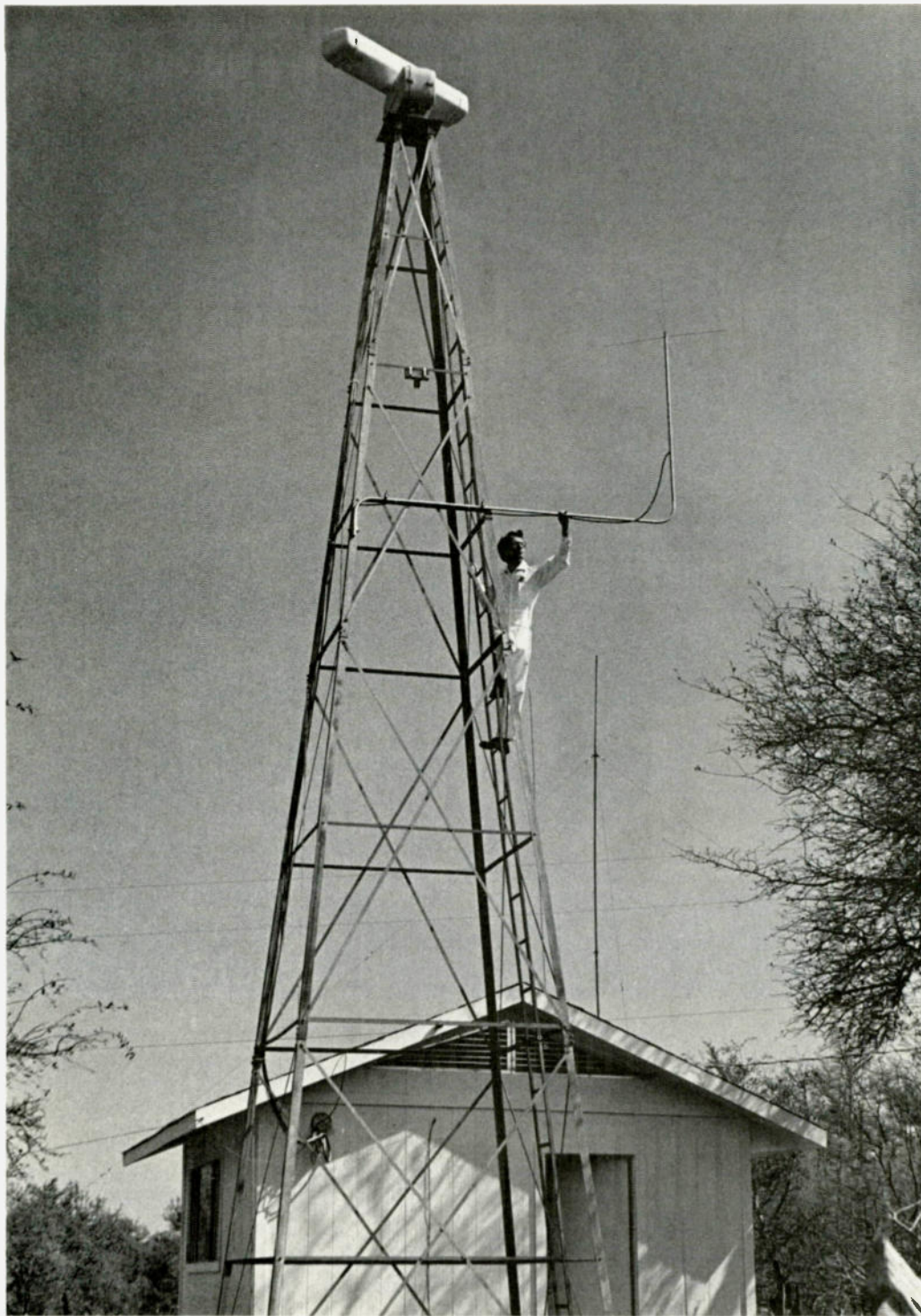

Photo B. PSI's Operation ARGUS radar and radio-frequency monitoring laboratory. With a radius of 12 miles, this radar unit will provide UFO distance data for Operation ARGUS, a computer-centered tracking system of highly sophisticated design covering a range of 472 square miles.

New Mexico, landing of April 24, 1964. According to Stanford, there is no known research facility in the world dedicated to UFO investigation which even approaches the sophistication and capability of PSI.

This high-powered re-

search effort is directed by a professional astronomer, Dr. Daniel H. Harris, Ph.D., from the University of Arizona. Dr. Harris, something of a modern pioneer, is the first scientist to accept a full-time paid position in UFO research. Right now, final touches are be-

ing completed on the most sophisticated of the equipment, and the laboratory will be fully operational. Much of the equipment is already scanning Texas skies twenty-four hours a day. And a most impressive array of scientific goodies it is indeed.

What are the prospects for irrefutably documenting a close encounter? Much better than you might think, as witness the photographs showing only one of several UFOs observed at the site. But wouldn't it be better to go to the UFOs rather than hope they appear at one location? Actually, that was the historical approach. During the green fireball episode in the late '40s and early '50s, teams of investigators for Project Twinkle rushed from one area to another where sightings were being reported. Invariably, they arrived too late to see anything. The UFOs, it seems, didn't wait around for them. PSI decided that it would be more productive to establish a permanent laboratory with sophisticated equipment and man it around the clock, seven days a week. The other option is still open, however. A vital core of instruments can be transported on short notice by four-wheel-drive van to any location where it might be needed.

Until now, most UFO research has been anecdotal. Witnesses of past events could be interviewed and second- or third-hand information could be correlated. Infrequently, a fortuitous amateur photograph, usually of very poor quality, might turn up. Or perhaps a bit of soil from a purported landing site could be secured for analysis. Immense effort went into analyzing and rehashing data of this kind, and there is a lot of it. UFOCAT, the computerized files associated with the Center for UFO Studies, now contains over 60,000 close encounters. And Ted Bloecher has indexed over 1500 close encounters of the third kind, in which contact with entities was reported.

However, there was no way to study UFOs directly and scientifically. Like the weather, lots of people talked about UFOs, but nobody did anything about them—except for the military, which was busy trying to shoot them down.

Scientific voices have cried in the wilderness almost from the beginning of the modern UFO era in World War II, urging serious investigation. Back in 1968, the House Committee on Science and Astronautics held a hearing on UFOs. Dr. Garry C. Henderson, then project leader on the lunar surface gravimeter/surveying system, proposed an implemented plan to acquire hard facts about the existence and nature of UFOs. He even detailed the instruments which should be used. And Carl Sagan, an astronomer who is as outspoken an advocate of the well-inhabited universe theory as he is a skeptic about UFOs, has said that anyone really interested in the supposed phenomenon should use high-quality instrumentation to probe its nature. Finally, someone is doing just that!

PSI is equipped to study a broad range of physical effects which might be associated with UFOs. Their objective is to gather a maximum range of hard data and to disseminate this information quickly to members of the scientific community. At a local level, larger numbers of people, probably including some hams, will be able to share in UFO events through Operation ARGUS.

The Greeks, as usual, had a word for it. Argus was a character in Greek mythology who had eyes all over his body to make him a good watchman. At the Laboratory for Instrumented UFO Research, ARGUS stands for Automated Ringup on Geo-

located UFO Sightings, and we have illustrated how it might work in practice. But there is a lot more to scientific UFOlogy than this.

UFOs have been reported to cause magnetic, radio-frequency, electrostatic, and gravitational effects, as well as temperature changes, barometric disturbances, and sounds. PSI's automatic recording equipment therefore includes three magnetometers and a gravimeter, as well as a microbarometer, an electrometer, and a sky camera activated by magnetometer deviations. An ambient microphone records voice input and audio effects, while a highly-directional microphone can handle distant sounds. The eight-channel, sensor-activated chart recorder displays low-frequency data up to 150 Hz correlated with universal time from WWVB. Radio-frequency scanners and recorders also incorporating UTC input cover the rest of the spectrum.

A computer-interfaced magnetometer system has been completed which will process field-effect data. Newly-designed sensors with 60-Hz filters respond up to 700 Hz and are oriented in three dimensions. Thus a three-dimensional video model of the magnetic field around a UFO can be displayed, showing each component in a different color. Pulsations or changes in light emitted by a UFO can be monitored by an electronic system utilizing solid-state sensors having a bandwidth of 10

Ray Stanford, Managing Director
Project Starlight International (PSI)
PO Box 5310
Austin TX 78763

Walter Andrus, Director
Mutual UFO Network (MUFON)
103 Oldtowne Road
Seguin TX 78155

Dr. J. Allen Hynek, Director
Center for UFO Studies (CUFOS)
924 Chicago Avenue
Evanston IL 60202

William Spaulding, Director
Ground Saucer Watch (GSW)
13238 North 7th Drive
Phoenix AZ 85029

Dr. Dennis W. Hauck, Director
International UFO Registry (IUFOR)
PO Box 1004
Hammond IN 46325

James Lorenzen, Director
Aerial Phenomena Research Organization (APRO)
3910 East Kleindale Road
Tucson AZ 85712

Table 1. Major UFO research organizations.

MHz.

OZMA and CYCLOPS are strange-sounding names for serious projects funded by the U.S. government to search for intelligent life in space. Possible communications from selected stars have been monitored. SETI, Search for Intelligent Life, is an ongoing NASA project which is developing designs for a very large system of antennas and computers for the purpose of contacting extraterrestrial life. Since NASA scientists are convinced of the importance of such endeavors, PSI has not neglected this aspect of UFO research. Are UFO intelligences, if they exist, capable of or interested in exchanging intelligent communication? To answer this question, a

modulatable Liconix 605M helium-neon laser has been installed which can transmit voice, code, or television signals. Any modulated light response which a UFO might make to the laser signals can be detected as sound or as a TV image.

Radio transmissions other than noise have not been reported from UFOs. Disruption of radio transmission and reception, on the other hand, is frequently reported. This is why laser light rather than rf was chosen for a communication experiment. According to many reports, what appear to be coherent light beams of various colors have been projected from UFOs. And searchlight beams directed at UFOs have been seen to bend sharply, due perhaps

DAY	BAND	MHz	UTC	EST	NET CONTROL	QTH
Saturday	40	7.237	1200	0800	N1JS	MA
Saturday	75	3.975	1300	0900	WA9ARG	IL

Table 2. MUFON amateur radio SSB nets—weekly.



Photo C. An early prototype program display on Operation ARGUS's color video terminal, showing simulated UFO tracking over a computerized topographic map. Tracking and laboratory instrument data is automatically displayed below the map.

to some field effect or variations in atmospheric density. These are phenomena worthy of investigation for which the laser equipment could be used. In addition, the system can be adapted to determine the distance of an object with extreme accuracy using reflected laser light.

As you might expect, photographic documentation is an important aspect of the laboratory program. UFOs within range will find that they are captured on 35mm moving picture film. A Super-8mm sound movie camera with a 1-to-12 ratio zoom lens is also available. From various stations at the site, three automatically synchronized 35mm cameras, one of which is equipped with a diffraction grating for spectral studies, record any UFO event. High-resolution, close-up images of objects being tracked can be obtained

using Schmidt-Cassegrain telescopes of 2,110mm and 1,250mm focal lengths, as well as a 240mm telephoto lens on the 35mm movie camera.

UFOs have often been reported to investigate new or unusual light patterns on the ground. Some have responded to lights flashed or directed at them. For this reason, a light pattern response experiment has been devised, although it is rarely used. A hundred-foot circle consisting of ninety-one 150-Watt spotlights contains a single light in its center. Solid-state circuitry and a microprocessor make it possible to sequence the lights in any desired pattern, or even to mimic the light patterns of a UFO.

K12XBJ, the only known radar facility in the world dedicated exclusively to UFO research, was licensed by the FCC on June 8, 1977. Although it is

planned to install a more effective system for broad-range sky coverage when funds permit, the present Raytheon Model 1700 covers a 12-mile radius with 360-degree rotation. Operating on 9375 MHz, its 7.5 kW pulses can detect reflective objects up to 20 degrees above the horizon.

How big was the UFO? This easy-sounding question is one of the most difficult to answer accurately when a sighting has occurred. Was the object very large and far away, or was it small but close to the observer? Few people run around with optical range finders in their pockets, and it is rare that a UFO passes in front of some background object which can provide a distance reference. At PSI, however, Operation ARGUS can determine distance electronically by radar. Not all UFOs reflect radar signals, apparently,

but this poses no problem. Accurate horizontal and vertical coordinate data from shaft-encoders on optical tracking equipment can be triangulated by the computer to provide actual distance, horizontal distance, and altitude. If the area of an image can be measured, the size of the object can then be computed from the distance data.

When a UFO is being tracked, the ARGUS computer has been programmed to select from its memory of 472 square miles of terrain that sector of a full-color topographic map over which it determines the object to be passing. The path of the UFO then appears on the video display superimposed over the image of the terrain. Sequentially-tracked positions are indicated by successive letters or numbers. The entire episode, correlated against UTC, can be retrieved from computer memory for later study. Ground objects over which the UFO passed or hovered as well as possible landing sites will thus be a matter of record. They can be examined for evidence later, if the UFO departs before a mobile unit can reach the site.

We've had a look at the GUS of Operation ARGUS, which is primarily technological. The AR, automated ringup, deals with people, for it is in this way that local volunteers can get involved. Ray Stanford terms this aspect of the operation "UFO event-sharing." Here is a concept of great potential to us as amateur radio operators, wherever we may live. As a movie, "Close Encounters" was great entertainment and could even be considered educational in some respects. But, fantasy aside, what is the actual status quo with regard to UFO knowledge at the

present time?

To be honest about it, there is a great diversity of opinion on the subject. UFOlogists, many of whom have been investigating the phenomenon for thirty years, present a spectrum of opinion. Some take the position that little or nothing is known concerning the true nature of the UFO. Official government interest vanished with the dissolution of Project Bluebook and the issue of the infamous "Condon Report," which as much as denied their existence. On the other hand, a number of authorities believe that the reason for governmental disinterest, including the recent refusal of NASA to reopen the field for investigation, is that they already know all about UFOs. In his book, *Situation Red: The UFO Siege*, Leonard Stringfield builds a strong circumstantial case that intact spacecraft have been recovered from crash sites, and that extraterrestrial humanoids have been autopsied. If so, it now appears unlikely that military authorities will voluntarily expose these facts to public view. However, a lawsuit filed by one UFO group against a government agency under the Freedom of Information Act could produce evidence of such concealment.

Between these viewpoints, one finds many theories about the nature of the UFO. Some UFOlogists believe that the phenomena may be psychic in nature. Others think UFOs are a mass neurosis, a psychological projection from the race mind. A few like the idea that they are a control mechanism, designed to influence human evolution in the manner we saw dramatized in the movie "2001." Most, however, believe the evidence points to hardware from

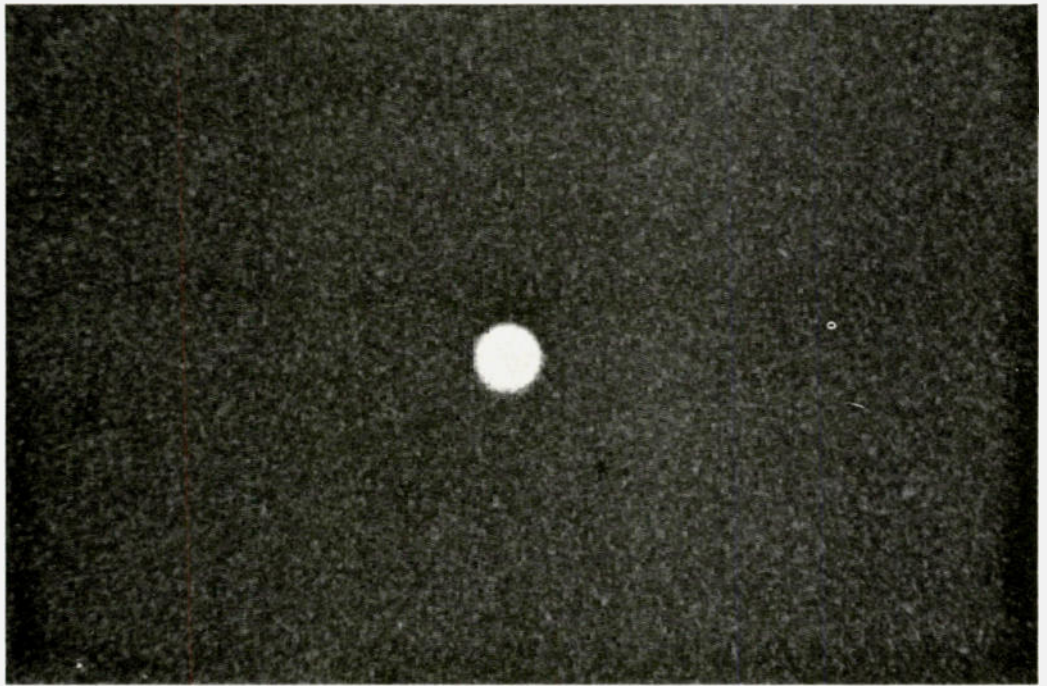

Photo D. Second-generation print of possible UFO which hovered for nearly 10 minutes beginning at 8:58 pm on December 10, 1975. Tri-X film, 5-second exposure with 300mm f/4 lens. Forty-eight photos were obtained during this event, which occurred prior to installation of PSI's more sophisticated equipment.

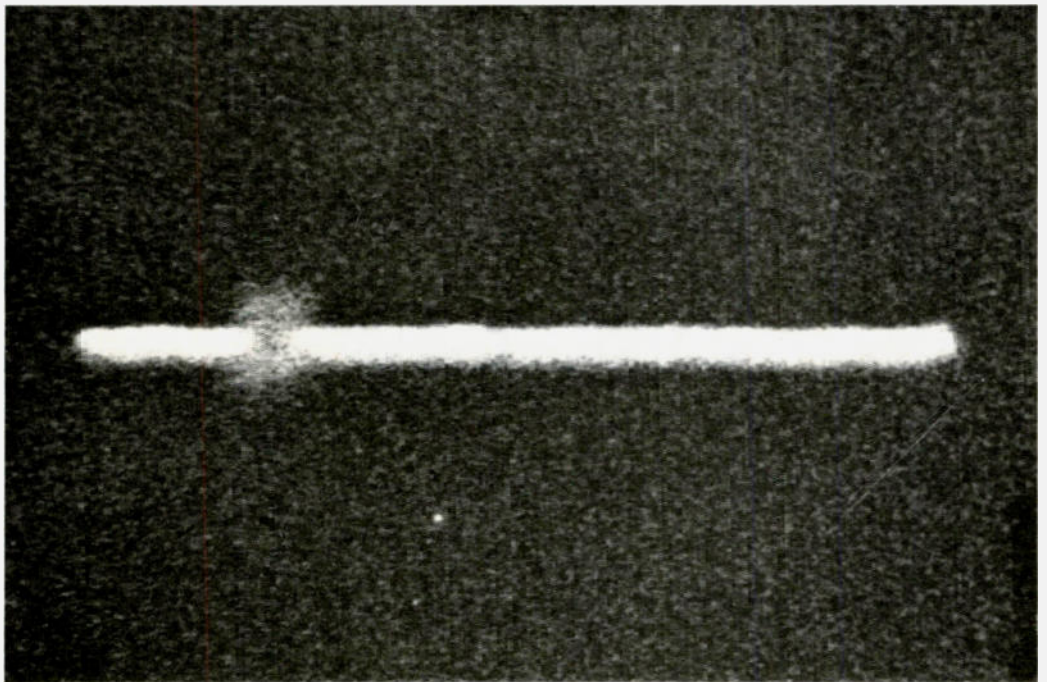

Photo E. Second-generation print of same object as Photo D moving off to left during 8-second exposure. Note strange burst-like effect not apparent to observers. Approximately 9:09 pm, Tri-X film with 300 mm f/4 lens. Typical of those taken by the PSI staff during the December 10, 1975, event, the photos are encouraging but not considered definitive concerning the nature of UFOs.

outer space, vehicles from some distant star system which operate through space/time in a manner we cannot yet comprehend. It is this hardware aspect of

UFOs which renders them susceptible to instrumental investigation. We may be on the way to answering what UFOs are, but the questions of where they

are from and why they are here will ultimately have to be answered as well.

Where, then, does all this leave us, as interested citizens who want to know

the truth? And what can we do to help, or to be prepared when the next "flap" or wave of activity once more fills our skies with something strange?

There are things we can all do. For those fortunate enough to live in the vicinity of Austin, training and participation in PSI activities as a volunteer might be possible. The expense of supporting a research effort such as this suggests a way in which we might contribute. As radio amateurs, however, we have unique qualifications for participating in UFO event-sharing on a national as well as a local level.

We can keep informed through groups which correlate and communicate information, such as the Center for UFO Studies. Dr. J. Allen Hynek, Chairman of CUFOs, was technical advisor for the

production of "Close Encounters." Much of the realism of this film can be attributed to the case information he was able to provide. We can also join or support investigatory groups such as MUFON or GSW, for example. MUFON amateur radio nets meet weekly. On Saturday mornings at 1200 UTC, the 40 meter section meets on 7237 kHz, and the 75 meter section meets at 1300 on 3975.

Every section of the country has investigators trained by some organization to investigate UFO incidents. They are often interviewed by the media. Most of them would be more than happy to speak at a radio club meeting, or to know that local hams are ready to help during a local UFO flap. Many of them need education in the tremendous capabilities amateur radio has for

tracking and reporting sightings and landings. Repeater groups in particular may be interested in learning who to call and what to do if UFOs appear in their area. So the relationship can be one of mutual benefit. Getting qualified investigators to the site of a UFO incident, while it is still in progress if at all possible, is the key to solving the mystery. The government agencies can offer no help, since they have officially declined to investigate UFOs. The police, if they do anything at all, generally report the incident to the Center for UFO Studies via their hotline. Ultimately, news of the incident may filter down from there to the headquarters of one of the investigatory groups such as MUFON. A local investigator is finally informed and hopefully reaches the scene. By then, the UFO and most of the

evidence is long gone. Wouldn't it be much more efficient if hams knew who to contact in their own area to report an encounter? And a call on the 2 meter repeaters in any city ought to furnish plenty of tracking observers or witnesses in a hurry. We can't all have a Project Starlight International in our backyard, but we do have an HT, a mobile, or a low-band rig and know how to communicate. We also have some technical training which helps in describing a UFO and its effects. Working together, we can solve the UFO problem.

Current UFO activity has recently shifted from South America to Australia. The lull in sightings in the U.S. may end at any time. UFOs, the eyes of Texas are upon you! And we'll be keeping ours open, too. ■

DC



POWER!

Rugged, High Quality DC Power

SPECIAL FEATURES

- Solid state electronically regulated
- Fold-back current limiting protects power supply from excessive current and continuous shorted output
- Crowbar over voltage protection on all models
- Three conductor power cord
- One year warranty
- Made in U.S.A.
- Maintain regulation and low ripple at low line input voltage and rated load
- Heavy duty heat sink
- Chassis mount fuse

PERFORMANCE SPECIFICATIONS

Input voltage: 105 - 125 VAC
Output voltage: 13.8 VDC \pm 0.05 volts
Ripple: less than 5 mV peak-to-peak worst case (full load and low line)
Regulation: \pm .05 volts no load to full load and low line to high line

Shipping Weights
 RS 7A 8# RS 20A 22#
 RS 12A 17# RS 35A 33#

Technical data and specifications subject to change without notice.

FOUR POWERFUL MODELS

RS-7A

5 A Continuous
 7 A Intermittent
 Recommended for
 50 W amps and 30
 watt transmitters

\$49.95

RS-20A

16 A Continuous
 20 A Intermittent
 Recommended for
 125 W amps

\$94.95

RS-12A

9 A Continuous
 12 A Intermittent
 Recommended for
 90 W amps and 50-
 W transmitters

\$72.95

RS-35A

25 A Continuous
 35 A Intermittent
 Recommended for
 250 W amps

\$136.95

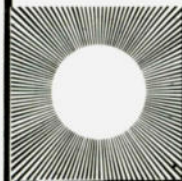

WESTCOM

ENGINEERING W17

1320 Grand Avenue
 California 92069

San Marcos
 (714) 744-0728

THE INCREDIBLES FROM EDGECOM ... NOW AT TOWER ELECTRONICS

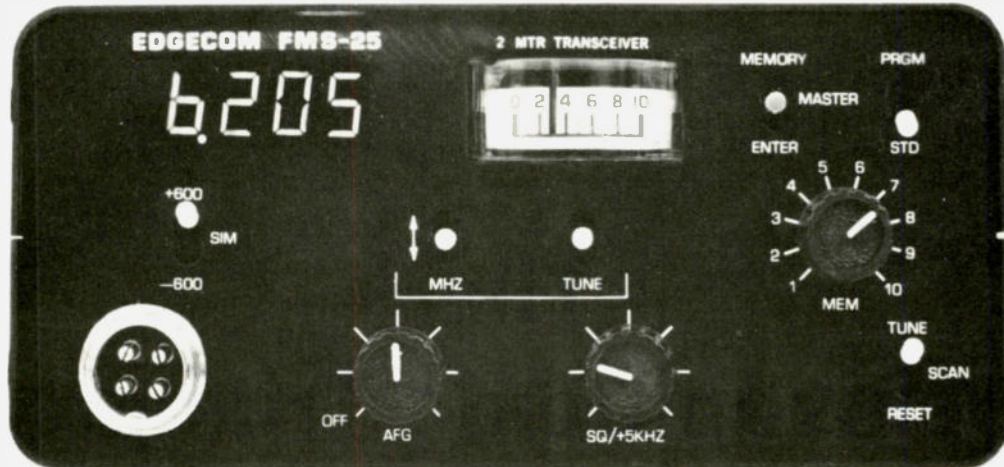

FMS-25

Designed to be the perfect mobile rig, the FMS-25 provides you with the same outstanding receiver and transmitter as the System 3000A plus several operating features that provide the utmost in mobile operating convenience. Ten front-panel-programmable memory channels, a built-in band scanner, any transmitter offset, full coverage (144-147.995 MHz), electronic push-button tuning and an advanced PLL synthesizer are just a few of the operating features that make the FMS-25 a fantastic rig. At the low price of \$439 it leaves all the others behind.

TOWER ELECTRONICS CORP.

✓T44

24001 ALICIA PARKWAY
MISSION VIEJO, CALIFORNIA 92675

(714) 768-8900

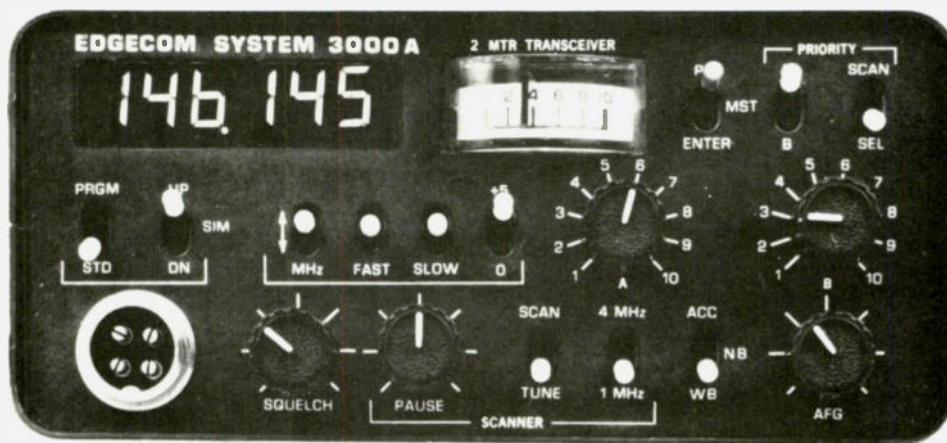

SYSTEM 3000A

The incomparable System 3000A starts by giving you a receiver with absolutely unequalled performance. The five-pole front-end provides virtually intermod-free reception, even in the most populated areas. Images are at least -60 dB and desensing a minimum of -100 dB. The ten-pole IF filters make adjacent-channel interference a thing of the past (-80 dB at 15 kHz). Add a transmitter that gives you 25 Watts of power, fully adjustable, and advanced PLL synthesizer and you have a pretty good rig. But Edgecom didn't settle for "pretty good." System 3000A also features: Twenty memory channels, a memory channel scanner, a band scanner, any transmitter offset, two priority channels, memory channel monitor, electronic push-button tuning and a full TWO-YEAR WARRANTY. These, and all of the other fine features of System 3000A make it a pretty incredible rig. And at the bargain price of \$549, you're getting much more than your moneys worth.



The Schizophrenic Triangle

— a split-personality radiator

Freddy Brown WA4JTJ
RFD 1, Box 267
Scottsville KY 42164

If you're interested in a multiband, inexpensive, easily built wire antenna system with DX capabilities, then here it is. It's inexpensive because it is made of available ma-

terials, such as wire and small variable capacitors for the matching section. This also contributes to the ease of construction. Because the antenna has a dual personality, or is bi-banded, I call it "schizophrenic."

The triangle antenna is a single loop of wire fed by a gamma match. In fact, the loop has two gamma matches (one for each band of operation). I first

built a 40m triangle as described by Byron Self WB6UFW.¹ I operated this antenna for about a year with excellent results. A loop is very wide-banded. In fact, by use of the gamma match, the swr of this antenna never exceeded 1.3:1 at the band edges. The 40 meter loop is 1 wavelength long (140 ft.). After realizing this closed antenna loop would probably resonate with 15

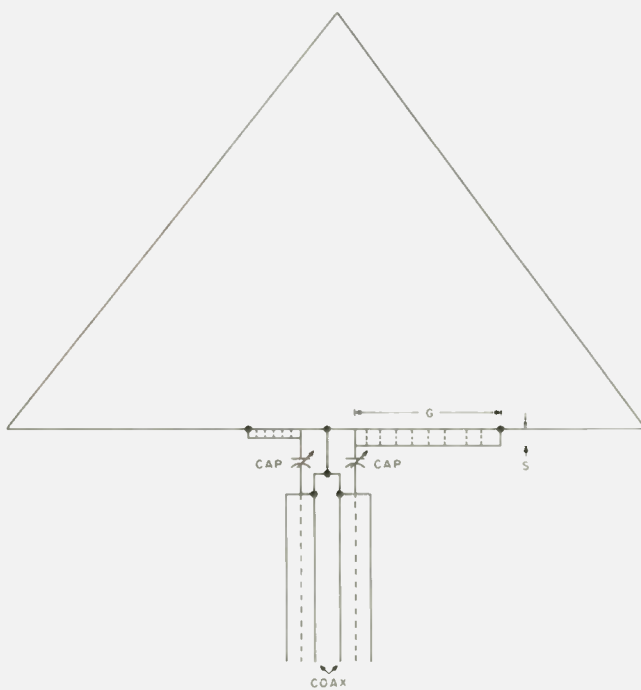

Fig. 1.

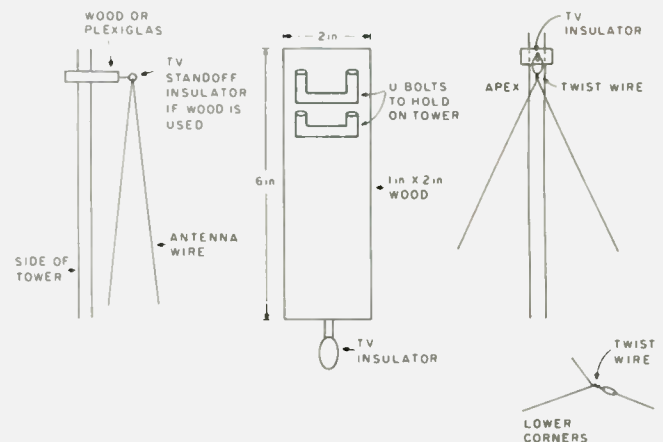

Fig. 2.

MFJ INTRODUCES NEW SUPER CW/SSB FILTERS

This new MFJ-721 Super Selector CW/SSB Filter gives you 80 Hz BW, steep SSB skirts, noise limiting, 2 watts for speaker plus more.



BRAND NEW \$59⁹⁵

This New MFJ-721 Super Selector CW/SSB Filter gives you a combination of performance and features available only from MFJ:

- Razor sharp 80 Hz non-ringing CW filter
- Steep skirt SSB filter
- Selectable peak and trough noise limiting
- Plugs in phone jack
- Two watts for speaker
- Simulated stereo reception
- Inputs for 2 rigs
- Speaker and phone jacks
- Auxiliary 2 watt amplifier, 20 dB gain.

The CW filter gives you 80 Hz bandwidth and extremely steep skirts with no ringing for razor sharp selectivity. Lets you hear just one CW signal on the crowded Novice bands.

Bandwidth is selectable: bypass, 80, 110, 150, 180 Hz. Response is 60 dB down one octave from center freq. for 80 Hz BW. Center freq. is 750 Hz. Up to 15 dB noise reduction.

8 pole active IC filter. Low Q cascaded stages eliminates ringing. Hand matched components.

The SSB filter dramatically improves readability by optimizing audio bandwidth to reduce

sideband splatter, remove low and high pitched QRM, hiss, static crashes, background noise, and hum.

Makes listening for long periods pleasurable and less fatiguing. Ideal for contest and DX

IC active filter includes 375 Hz highpass cut-off plus selectable lowpass cutoffs at 2.5, 2.0, 1.5 KHz (36 dB per octave rolloff).

Switchable automatic noise limiter for impulse noise; trough clipper removes background noise.

For Simulated Stereo, the raw signal goes to one ear and the filtered signal to the other. The signal appears in both ears and the QRM in only one. The ears and brain reject QRM yet off-frequency calls can be heard. Requires stereo phones.

Switch selects one of two rigs. OFF position connects speaker to rig. Speaker disables when phones are used. Requires 9 to 18 VDC, 300 ma. max. 5x2x6 inches. Optional AC adapter is \$7.95. Order yours now.

This New MFJ-720 Deluxe Super CW Filter gives you 80 Hz BW, no ringing, 2 watts out.

Same 8 pole Super CW Filter as in MFJ-721. 80 Hz BW, extremely steep skirts with no ringing for razor sharp selectivity. Selectable BW: 80, 110, 180 Hz. Center freq. 750 Hz. Automatic noise limiter. Plugs in phone jack to drive speaker to 2 watts. 2x4x6 in. Requires 9-18 VDC, 300 ma. max. Optional AC adapter, \$7.95.

BRAND NEW

\$44⁹⁵



These MFJ active filters are the most copied in Industry.

CWF-2BX MFJ SUPER CW FILTER

S8F-2BX MFJ SSB FILTER

\$29⁹⁵ each



But performance is not copied. Only MFJ hand selects components so the center frequency of each CW stage is within one Hz of each other.



CWF 2BX and the S8F 2BX are the same CW and SSB filter as in the MFJ 721 but less speaker amplifier and noise

limiter. Plugs in rig to drive phones or connect between audio stage for full speaker operation. Uses 9 V battery 2x3x4 inches

For Orders, Call Toll Free

800-647-1800

ORDER TODAY BY MAIL OR CALL TOLL FREE 800-647-1800 AND CHARGE IT ON VISA OR MASTER CHARGE. Order any product from MFJ and try it. If not delighted, return it within 30 days for a prompt refund (less shipping). One year unconditional guarantee. Add \$2.00 shipping/handling. For order/repair status, in Mississippi and outside continental USA, call 601-323-5869.



MFJ ENTERPRISES, INC.

P. O. BOX 494 MISSISSIPPI STATE, MISSISSIPPI 39762 ✓ M52



It's easier

Dx'er
Contester • Trafficman
Ragchewer

Telex headphones and headsets make it easier to enjoy the hobby. Whether you prefer lightweight or full cushioned comfort, there's a high performance Telex product that will help make you a better operator. See yours...at better ham outlets everywhere, or write...

✓ H4
hy-gain.electronics
DIVISION OF TELEX COMMUNICATIONS, INC.

8601 NORTHEAST HWY 6 LINCOLN NE 68505 USA
telephone 402 467 5321 telex 48 4324

Europe: 22 rue de la Legion-d'Honneur 93200 St Denis France
telephone 820-95 46. telex 63-0013

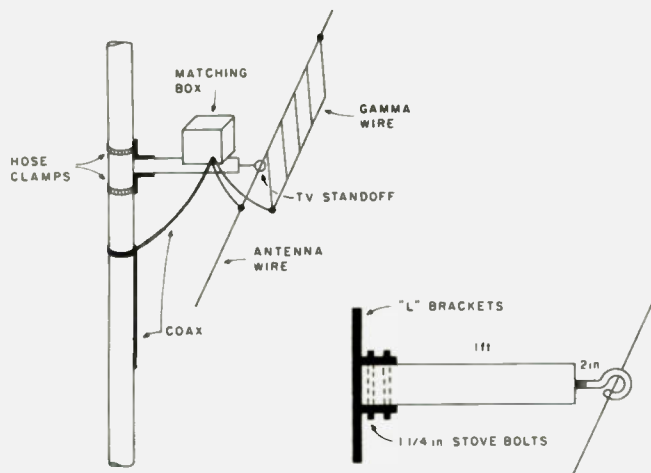

Fig. 3.

meter (21 MHz) excitation, I proceeded to build a 15m gamma match and attach it directly to the antenna. The same results were obtained on 15 meters — low swr and very wide bandwidth. Adding the second gamma match didn't alter the performance of the original antenna.

Shortly afterwards, I constructed a triangle loop for 80 and 10 meter operation. I simply computed the loop length for the middle of the low frequency band by using the formula: $1000/f(\text{MHz})$. For example, $1000/3.6 = 278 \text{ ft}$. This is 1 wavelength for 80 meters and 8 wavelengths for 10 meters.

Construction Notes

I'm including diagrams from Byron's article to aid in the construction of the wire loop and gamma matches. These are Figs. 2-4. Fig. 1 shows the "schizophrenic" triangle with gamma matches attached. Solder the braid of the two 50- or 75-Ohm coaxial lines to the center of the loop. Solder the center conductor of the coax to one side of the capacitor and the gamma wire to the other side of the capacitor. I used a plastic freezer box to house the capacitor and applied silicone rubber sealant to waterproof the holes made

by the exiting wires. I used a standard close-spaced 365 pF broadcast band capacitor, which has not arced yet with my 180 W transmitter.

Final Notes

I installed both loops on my 60-foot tower (Fig. 5), leaving room at the top for TV, 2 meters, and maybe a yagi or two later on. The loops should be kept as close to equilateral triangles as possible. Of course, I couldn't do this with the 80 meter loop on my 60-foot tower. Therefore, I stretched the horizontal side to 122 ft., and each slanting leg was 78 ft. long. This put the horizontal leg about 10 ft. above ground and the apex at the top of my tower. The whole loop is tilted a few degrees off vertical. I would expect that tilting the triangle would result in a lower angle of radiation.

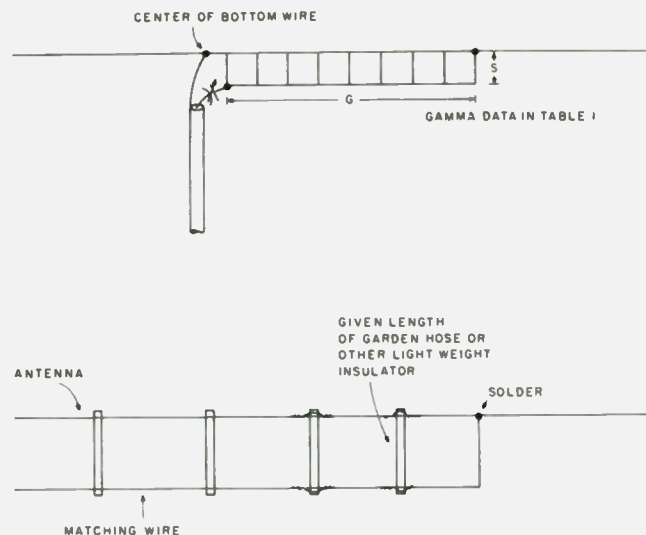

Fig. 4.

One last point. A good antenna switch in the shack is desirable for quick band changes. ■

Reference

1. Self, "The 40-Meter Triangle," *QST*, Vol. LX, No. 5, May, 1976.

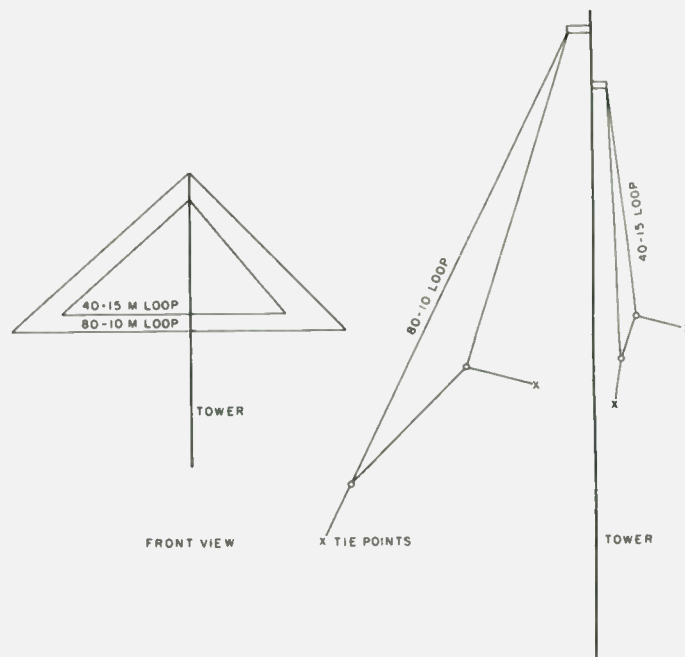

Fig. 5.

Loop information		Gamma data		Capacitor (pF)
Band	Loop length for middle of band	G	S	
80	277'9"	96"	6"	300
40	141'	73"	4"	200
20	70'5"	35"	2"	100
15	47'2"	27"	1.5"	75
10	35'8"	18"	1"	50
6	19'11"	10"	1"	30
Combinations	Loop length	Gamma data		Resonant frequencies
40m and 15m	141'	same as above		40m—7.100 MHz 15m—21.277 MHz
80m and 10m	277'9"	same as above		80m—3.6 MHz 10m—28.830 MHz

Table 1.

Cohoon Amateur Supply

NOW STOCKING THE INCREDIBLES



- Twenty Memory Channels
- Memory Scanner
- Band Scanner
- Two Priority Channels
- Memory Channel Monitor
- Bargain Price: \$549

EDGECOM SYSTEM 3000A

- Ten Memory Channels
- Band Scanner
- Any Transmitter Offset
- Full Coverage
- Small/Light Weight
- Only \$439



EDGECOM FMS-25

Both of these outstanding 2m FM transceivers offer you an unbelievable receiver, 25 Watts of power (adjustable), and advanced microcomputer-controlled frequency synthesizer, electronic push-button tuning, any transmitter offset and a FULL TWO-YEAR WARRANTY. Call, write or come in and compare for yourself. Find out why the Edgecom SYSTEM 3000A and FMS-25 are called the incredibles.

**Cohoon
Amateur
Supply**

✓ C95

Hwy. 475 Trenton, Kentucky 42286

502-886-4534

From CW to Computers

—a digital modulation primer

You're sitting in your easy chair discussing the fine points of raising begonias with the bunch on 3914 when something sounding a great deal like the soundtrack from the "Texas Chainsaw Massacre" begins to put a decided cramp in your rag chewing style. The group is divided on whether it is SSTV, Teletype™, facsimile, or just the Russians at it again. Whatever it is, you decide, it is at least 50 kHz wide, and bound to be part of the computer conspiracy incited by 73 and its I/O section. Bunch of whippersnappers and their confounded digital modulation!

Digital modulation is

nothing new, having been started by Samuel F. B. Morse and others quite some time ago. Lately, however, it has grown into something quite removed from the days of manually sent Morse code and of clanking, noisy, mechanical teleprinters. Integrated circuits have made complicated signal processing simple, or at least small, and computers are now available at a price within reasonable reach. Lots of hams like you have found that there is a great amount of fun in programming and playing with microcomputers. After the initial hardware debugging and the game playing which follows, you

remember your temporarily-forgotten transceiver and begin to wonder how you can hook your new toy to your old one. And while you're wondering that, you also wonder what the output of your transmitter will be and how many "Sunday Afternoon Begonia Appreciation Nets" will be doomed by your next computer-driven transmission.

The FCC stands in the way of complete havoc, leaving you only a few loopholes. Presently, they only allow two types of digital modulation for general use. One is good old Morse code, and the other is the Baudot teleprinter code. The Baudot code is a five-bit code with definite legal speed restrictions; International Morse is not limited in speed at all. Receipt of Morse by ear is limited to perhaps 100 or so, and there is a group of operators who specialize in running speeds like that for their own fun and amusement. But your computer is much better equipped to send and receive Morse than the human brain, and with a small amount of restraint on your part, you should be

able to run Morse much faster than 100 wpm and still not convince the FCC that it should pass new, even more restrictive laws to slow you down once again. To help you gain an appreciation for the bandwidths of the signal you may create when you digitally modulate your transmitter, I have made a few measurements to indicate what you might expect, both for speeds and codes now permitted, and some that might be allowed on the air

Types of Digital Modulation

The most familiar type of digital modulation is probably CW. This is called continuous wave, because it normally isn't, to help the confusion. It is better to call it A1, which means on-off amplitude keying. In case you haven't checked lately, it is still being used in the amateur bands.

A modification of CW is A2. This is tone-modulated AM. Usually this is used for code practice to allow the use of simple receivers. Its chief identifying characteristic is its inefficiency. It uses lots of transmitter power without paying you back in signal-to-noise

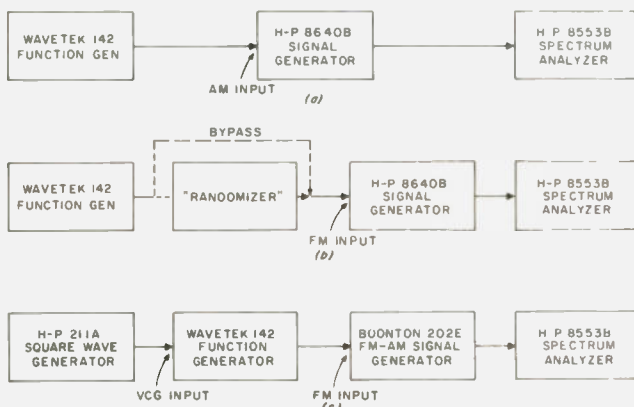

Fig. 1(a). A1 measurement setup. Carrier set to 7 MHz. (b). F1 measurement setup. Carrier set to 20 MHz. (c). F2 measurement setup. Carrier set to 55 MHz.

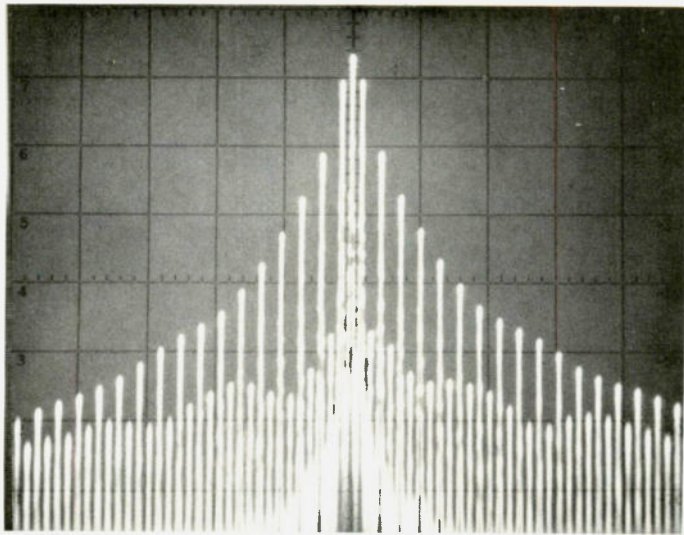

Fig. 2. CW signal at 300 bps with steady dots. Scale: 1 kHz per division.

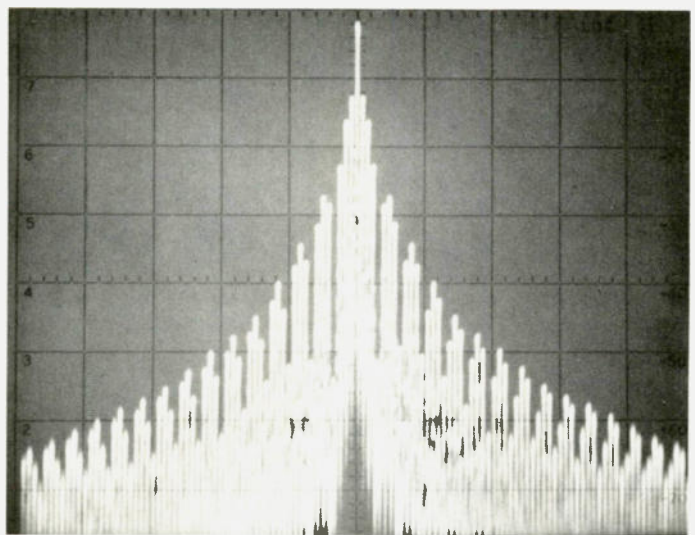

Fig. 3. CW signal at 300 bps with steady dashes. Scale: 1 kHz per division.

ratio. Let's let this one die a natural death.

Lots of hams are now active on Teletype™, using FSK. This is designated F1, which stands for telegraphy by frequency shift keying. The key-down or marking condition is noted by one frequency, and the key-up or spacing condition is noted by another. Normal practice on the HF bands is to use a shift, or frequency difference, of 170 Hz. This has largely replaced the use of 850-Hz shift by hams.

As in the case of CW, FSK has a counterpart called AFSK-FM, which is tone-modulated FM, designated F2. Audio tones are shifted by the teleprinter keyboard (or computer) output, and these tones then are used to modulate a standard FM transmitter. This is in widespread use on many FM repeaters designed specifically for the enjoyment of RTTY enthusiasts.

Since the FCC groups phase modulation with frequency modulation, you would probably not be stretching things too much to suppose that you could use PSK, or phase-shift keying, and call it F1. I have never seen any amateur use of PSK, probably because of the difficulties

in demodulating it. It may not be totally suitable for use where the propagation medium is unstable, causing multiple paths between two locations and the accompanying fading and rapid phase rotation.

For these reasons, I will limit myself to looking at only three types of signals: CW, FSK, and AFSK-FM. I'll show you what present signals probably look like, and give you a few glimpses into what the future may allow on the amateur bands to enhance your digital modulation pleasure.

Before we begin, one idea is very important. That is a concept called frequency scaling. What this means is that the spectra of digital signals will be unchanged, except for frequency scale, if you change both the rate of modulation and the frequency shift, if any, in the same proportion. For example, the spectrum of a transmitter with FSK of 170-Hz shift and 45.45 bit per second modulation will look identical to that from a transmitter with 17-kHz shift and 4545 bit per second modulation, except that the spectrum will be blown up in the frequency scale by 100 times. This trick was used in all of the

examples that follow, to allow the spectrum analyzer to be swept over wider frequency ranges at higher sweep speeds, using wider detector bandwidths than would have been possible. In other words, I used sleight-of-hand to produce the spectrum photographs. The scaling factor used was 100, except for the F2 spectra (scaled by 10 times).

Morse Code

International Morse consists of dots, dashes, and three different lengths of spaces. Dashes are (supposed to be) exactly three times as long as a dot, as is

the space between letters. The space between dots and dashes is the same length as a dot, and space between words is seven times this length. Each dot period represents one binary digit or bit of information.

In order to produce the spectrum for a CW signal, we need to know the relationship between the speed in words per minute and the signaling rate in bits per second (sometimes called a baud). The FCC uses a standard word composed of 50 bits.¹ Therefore, one word per minute corresponds to 50 bits per minute or 0.8333 bps.

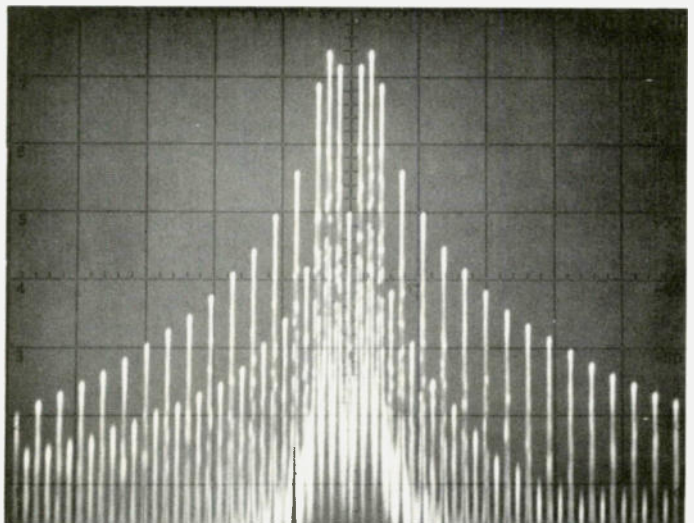

Fig. 4. 600-Hz shift FSK Morse at 300 bps with steady dots. Scale: 1 kHz per division.

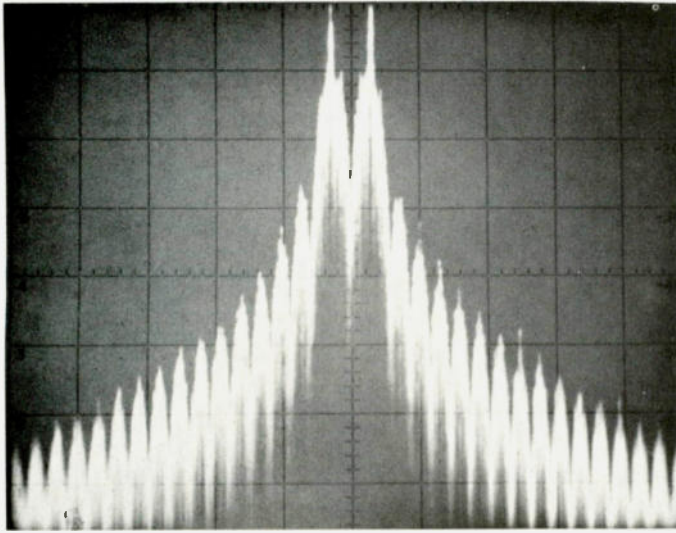

Fig. 5. 600-Hz shift FSK Morse at 300 bps with random keying. Scale: 1 kHz per division.

Somewhat arbitrarily, I have chosen a signaling speed of 300 bps, which translates to 360 wpm. This seems pretty fast, but we'll see that the transmitted bandwidth is within reason. And because of the scaling property, you can get a good idea what bandwidth will be produced by slower speeds.

The FCC rules contain an assortment of formulas for calculating *necessary bandwidths*.² This is an indication of the width of the signal that must be transmitted and received in order to obtain a reasonable replica of the desired signal. For A1,

$BW = B \times K$, where B is the signaling rate in bps and K is an empirical constant set equal to 5 for fading circuits (aren't they all?). From this we get a necessary bandwidth of 1500 Hz. This is admittedly an approximation, but at least it gives us an indication that we won't need to cover up more than one "Begonia Net" if we inadvertently fire up our rig on the wrong frequency.

Fig. 1(a) shows the measurement setup used to generate the A1 spectra. The function generator produces square waves which are used to AM the high frequency signal

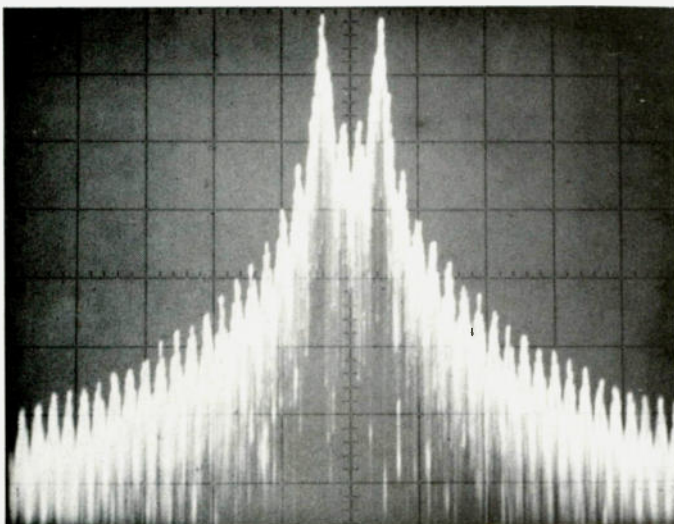

Fig. 7. 170-Hz shift FSK at 45.45 bps with random bits. Scale: 200 Hz per division.

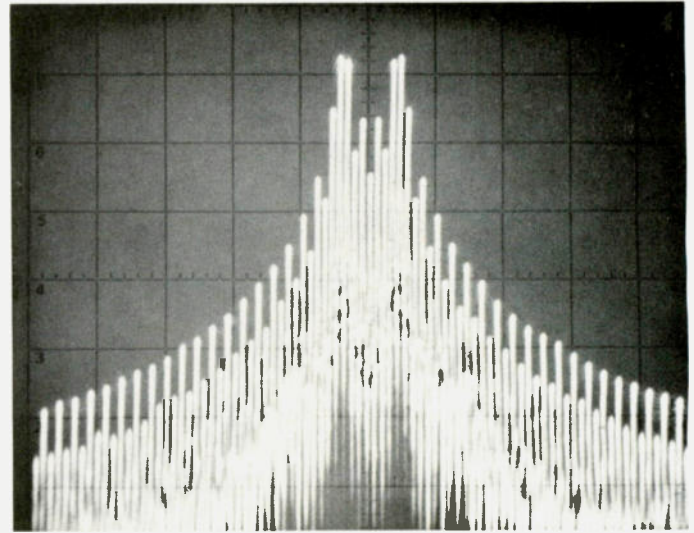

Fig. 6. 170-Hz shift FSK at 45.45 bps with alternating 1s and 0s. Scale: 200 Hz per division.

generator. The spectrum analyzer looks directly at the output of the signal generator at around 7MHz. For dashes, the function generator is set to produce rectangular waves with a 3:1 duty cycle at half the frequency used for dots.

Fig. 2 shows the resulting spectrum for steady dots and Fig. 3, for steady dashes. All the spectrum photographs are taken with the top line of the graticule indicating the level of the unmodulated carrier. Vertical calibration is 10 dB per division for all of the spectra. These two pictures have a frequency scale of 1 kHz per division.

Fig. 2 has a series of fine lines at multiples of the keying rate (150 Hz = 300 bps for dots). Note that every other line is at a much lower level than the preceding line. This is a characteristic of the spectrum of square waves. All of the even-order harmonics of a square wave are theoretically zero. Because of slight imperfections in the symmetry of modulation, the even-order harmonics do appear, but still at a reduced level. It is worth noting that the shape of both sidebands is nearly identical, and is in fact the same shape as the spectrum of

the modulating waveform. This is true only for amplitude-modulated signals, and definitely not for frequency-modulated ones.

In order to make a comparison of bandwidths, we have to choose some definition of bandwidth. The FCC specifies allowed *occupied bandwidths* for all commercial services. This is defined as the frequency bandwidth which leaves only 0.5% of the average power above and 0.5% below its frequency limits. This is easy to calculate by adding up the power in the carrier and each sideband, until 99% of the total power is exceeded.³ For signals that do not have identifiable discrete sidebands, a good approximation of the occupied bandwidth is to take the bandwidth at the -27-dB (0.2% of carrier power) points of the spectrum. This allows a quick estimate of the transmitted signal bandwidth, without the mess of numerically adding up all of the areas under the spectral curve.

For Fig. 2, the occupied bandwidth is 1500 Hz, which is the same number calculated for the necessary bandwidth. To simplify comparison of the bandwidths of the dif-

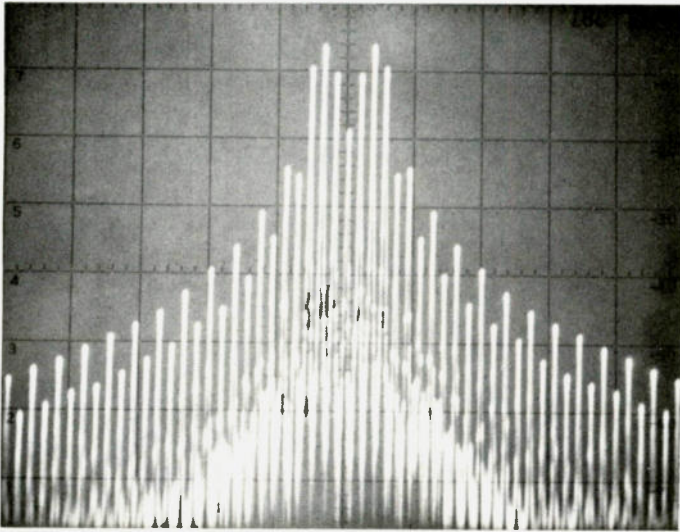

Fig. 8. 170-Hz shift FSK at 74.2 bps with alternating 1s and 0s. Scale: 200 Hz per division.

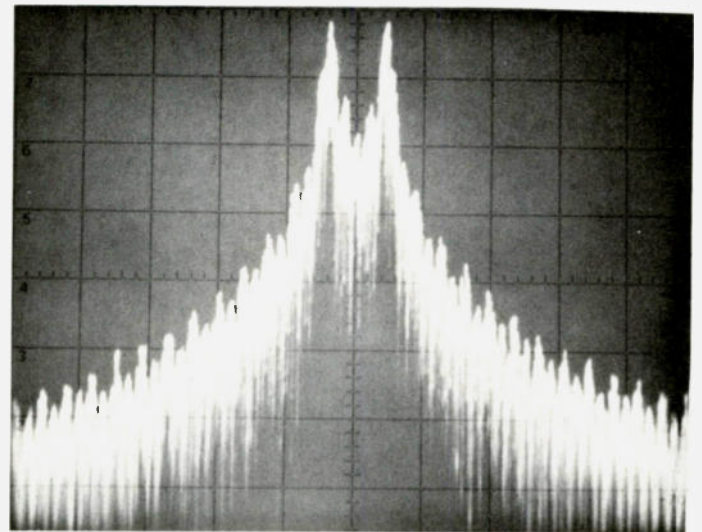

Fig. 9. 170-Hz shift FSK at 74.2 bps with random bits. Scale: 200 Hz per division.

ferent spectra, Table 1 shows the calculated and measured bandwidths for all of the measured emissions.

Fig. 3 has twice as many lines as Fig. 2 since the sending rate for dashes is exactly half that for dots. Every fourth line of dash spectrum is attenuated sharply. This is due to the 3:1 duty cycle, and can be proved mathematically if desired. (As they say in the textbooks, "It can be easily shown that...")

Frequency Shift Morse

To some, the thought of Morse code sent by other than on-off keying is a bit strange. If you have ever listened to the Morse identifications required by the FCC for RTTY stations, you can see that it is sometimes difficult to copy code when sent with FSK. The human ear is well equipped to take care of the problems inherent in receiving A1, but a machine is not. The biggest problem for the machine is what to do while the key is up. The noise present during this period is a source of confusion to most demodulators. Many detectors use a phase-locked receiving technique, so the momentary absence of signal means a loss of lock

and the need to reacquire lock at the beginning of the next dot or dash.

FSK has a signal present at all times during the transmission. This allows the demodulator to operate without interruption. The problem is now shifted to the transmitter, which has to produce output on a 100% duty cycle. However, for a given key-down transmitter power, an FSK system with proper shift will provide a 3-dB advantage over the on-off keyed system. If you are really worried about the power, you can drop the output of the transmitter to one-half of what you were running on CW and still be in good shape for transmission errors.

Since we're setting up things from scratch, we are free to pick the shift at random, with the only requirement being that we stay within the 900 Hz maximum specified by the FCC. Since the data rate is 300 bps, let's pick 600 Hz for the shift. This would allow us to use audio tones of 1200 Hz and 1800 Hz. These tones are centered nicely in the audio pass-band of a normal SSB transmitter and have the added advantage that they are all multiples of 300 Hz, which would make it easy

to generate the tones with a digital frequency divider synchronized with the oscillator used to make the code.

The formula for the necessary bandwidth for F1 is given by the FCC as: $BW = 2.6D + 0.55B$, where D is the peak deviation (one-half the shift) and B is the signaling rate in bps. For the case at hand, $BW = 945$ Hz.

The measurement setup for FSK signals is shown in Fig. 1(b). The function generator output is connected to the FM input of the signal generator, either directly or via the *randomizer*. The randomizer is

a 25-stage shift register with feedback taps arranged in such a way as to generate a *pseudo-random sequence* that is $2^{25} - 1$ long (33,554,431 bits) before the pattern repeats. The randomizer makes the modulation more realistic, since sending continuous dots doesn't convey much information. Steady dots tend to create the worst case for transmitted bandwidth, too.

Fig. 4 shows the spectrum with Morse dots at 300 bps with 600-Hz shift. The frequency scale is the same as in the previous photos. Except for the

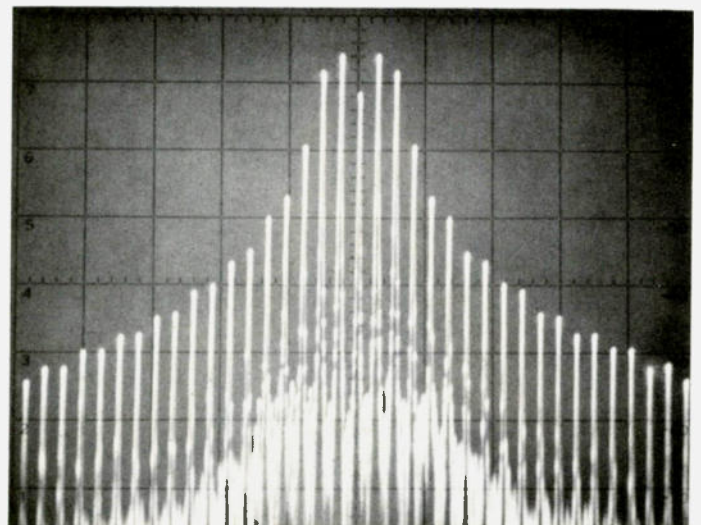

Fig. 10. 170-Hz shift FSK at 110 bps with alternating 1s and 0s. Scale: 200 Hz per division.

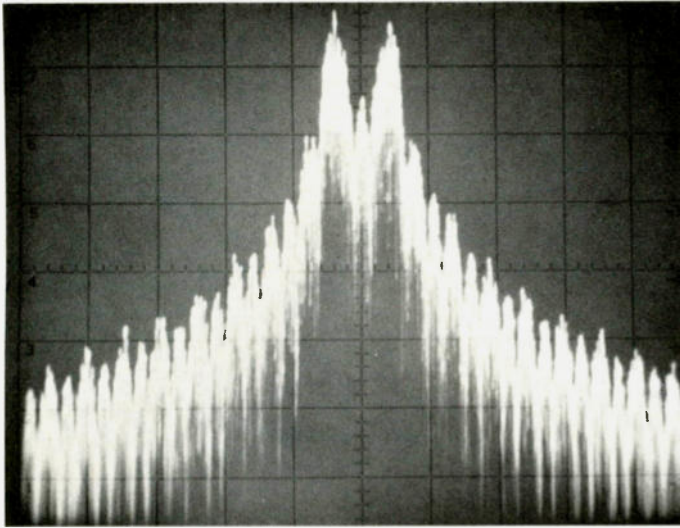

Fig. 11. 170-Hz shift FSK at 110 bps with random bits. Scale: 200 Hz per division.

tendency of the spectral lines to bunch up in the region of the resting mark and space frequencies, there are many similarities between the A1 and F1 spectra. The occupied bandwidth is again 1500 Hz, which is almost 60% larger than the necessary bandwidth for F1. At frequencies well away from the carrier, the sideband levels of the two spectra are nearly identical.

Fig. 5 shows the effect of the randomizer. The discrete spectral lines are gone, and are replaced with noise-like spectral lobes. It is interesting that the spacing of the lobes is

the same as the major lines in the spectrum of dot modulation. The bandwidth is nearly the same as with dots, but the level of the sidebands several kilohertz away is somewhat lower, due to the increase in low-frequency components in the bit stream at the expense of the high-frequency components, which is caused by the randomizing process.

FSK and Teleprinter Codes

The most common use of F1 is in sending text messages between mechanical teleprinters. The FCC has specified that the

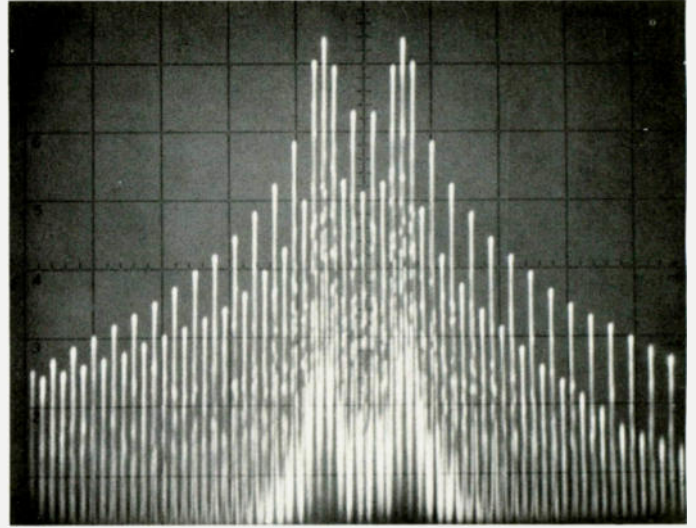

Fig. 12. 1200-Hz shift FSK at 300 bps with alternating 1s and 0s. Scale: 1 kHz per division.

code to be in general use by amateurs is the 5-bit Baudot code, named after Emile Baudot, the man who pioneered the concept of printing telegraphy. As used by amateurs, it is a *start-stop* or *asynchronous* code, since it does not require an external synchronizing clock. The equipment is synchronized on a character-by-character basis by using a start bit, which is always a space, and a stop pulse, which is always a mark, to frame the character. The start bit is the same length as each of the five information bits. The stop pulse in Baudot is normally a minimum of 1.42 times as long as the other bits. It can be as long as desired, since the resting condition between characters is the marking state. For computer use, the stop pulse is often made two times as long as the others, for convenience in timing.

A second code authorized by the FCC for limited use (presently on OSCAR) is called ASCII. That stands for the *American Standard Code for Information Interchange*. It is similar in concept to the Baudot code, but consists of a start bit, seven information bits, a parity bit (for error checking), and one or two stop

bits. Normally, two stop bits are used when the signaling rate is less than 300 bps, and one is used when the rate is greater than 300 bps. Because it has seven information bits instead of five as in Baudot, ASCII has a greater number of possible code combinations. Many of these are used in making upper and lower case alphabetic characters, but there are also a number of control codes not found in Baudot at all. Because of its greater versatility, ASCII is preferred for communications with computers.

Another possible code that might be used for computer communications is straight binary numbers. Transmitting a start bit, eight information bits, and a stop bit would allow sending binary numbers equivalent to decimal numbers from zero to 255. Although meaningless to (normal) humans, the computer uses these numbers for machine language programs and data. Alas, the FCC does not at present permit the use of this type of data, since it is neither Baudot nor ASCII.

You may be curious about the number of words per minute that are produced by a given bit

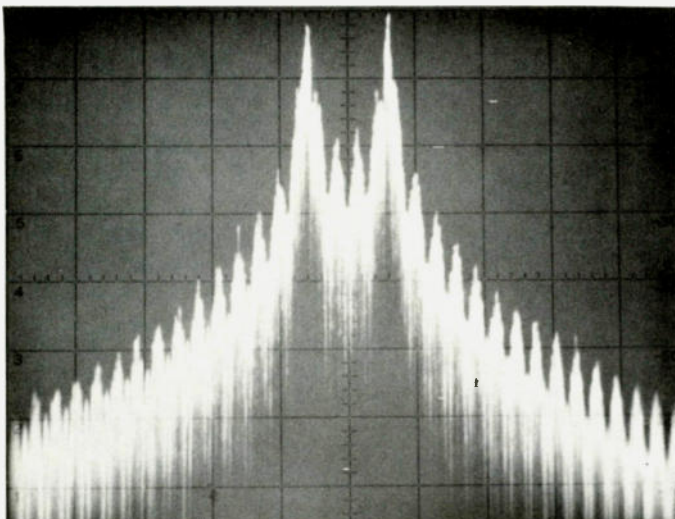

Fig. 13. 1200-Hz shift FSK at 300 bps with random bits. Scale: 1 kHz per division.

rate using Baudot and ASCII. If we assume that a word consists of five characters and a space between words, the speed in wpm for Baudot is 1.35 times the signaling rate. For ASCII with two stop bits, it is 0.91 times the bit rate, and for ASCII with one stop bit, it is equal to the bit rate. Compare this to 1.2 times the bit rate for Morse. It's interesting to note that Baudot is the most efficient of the codes mentioned, in terms of words per bit.

Standard amateur practice at present is to use 170-Hz shift on FSK. (The origin of this number is probably as obscure as that for the 1.42-unit stop pulse!) This has almost completely replaced the use of 850-Hz shift because of improved resistance to interference and selective fading when using 170-Hz shift. Another shift which may be of future interest is 1200-Hz shift. This exceeds present FCC limits, but is in wide use for medium speed telephone data sets and for cassette tape storage of computer programs by hobbyists using the "Kansas City standard." The KC standard normally is used at 300 bps and has been successfully used by computer amateurs for program exchange via long distance telephone as well as by magnetic tape. It is quite possible that it might be usable for rf transmission as well.

The speeds used for the measurements were 45.45 bps (60 wpm Baudot), 74.2 bps (100 wpm Baudot), 110 bps (100 wpm ASCII), and 300 bps (KC standard). Calculated and measured bandwidths are given in Table 1. The measured spectra are shown in Figs. 6 through 13. The first of each pair of photos represents steady alternating 1s and 0s, and the second photo shows the

effect of a pseudo-random bit pattern. The photos for the narrow shift signals are made with 200 Hz per division on the frequency scale to allow adequate resolution. The 1200-Hz shift spectra are again at 1 kHz per division.

Notice that, generally, the spectra do not have any lines at what would be the resting mark or space frequencies. This will only be the case where the signaling rate and the shift are integer multiples (e.g., 300:1200 or 300:600). The point of this is that you may not be justified in saying that an FSK signal looks just like two oscillators that are being alternately switched off and on. That should make the purists scratch their heads a bit.

AFSK On FM

Lastly, we will look at the spectrum that you might see coming forth from the antenna connector on your two meter rig when you are putting FSK tones into the microphone jack. The measurement setup is shown in Fig. 1(c). Only two cases are considered: 170-Hz shift at 45.45 bps using tones of 2125 Hz and 2295 Hz, and 750-Hz shift at 45.45 bps using tones of 2125 Hz and 2975 Hz. Peak deviation of the rf carrier was set to 5 kHz in both cases. The use of 850-Hz shift is still common on VHF, probably because of MARS influences. On VHF, there is probably no significant difference between the two shifts in terms of performance, since signal-to-noise ratios are normally very good, and errors in transmission are rare.

There really isn't much difference in the bandwidths, either, as Table 1 shows. The use of 850 shift tones carries with it the disadvantage that the amplitudes of the sidebands at some distance

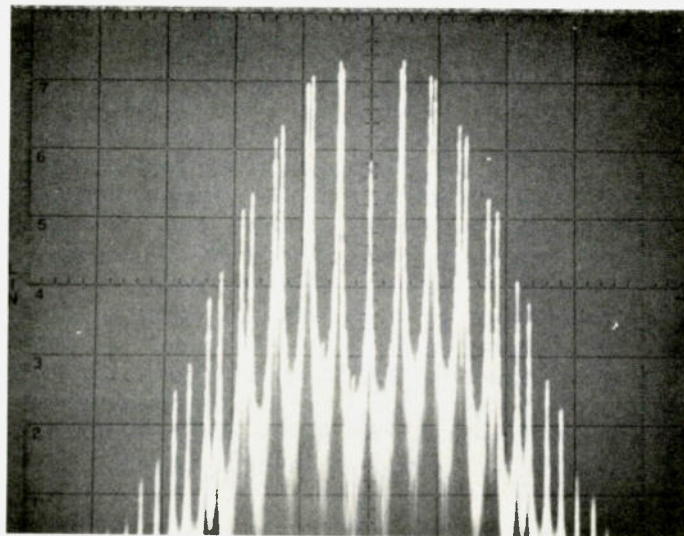

Fig. 14. 170-Hz shift AFSK-FM at 45.45 bps with alternating 1s and 0s. Peak FM deviation is 5 kHz. Scale: 5 kHz per division.

from the carrier do not diminish as quickly as those for the 170 shift tones.

Bandwidth Reduction

The measured spectra are laboratory creations, but they should reflect with some accuracy how actual transmitted signals will appear. It is likely that real signals may be slightly narrower in bandwidth than those shown. Normal CW transmitters employ some filtering in the keying circuits to reduce the tendency to generate "key clicks." These clicks are

just the low level sidebands seen in the photos at some distance from the carrier. The filtering in the transmitter makes the spectrum of the keying waveform fall off much more rapidly and reduces interference with nearby stations.

Amateurs who generate FSK signals by putting audio tones into SSB transmitters may restrict the transmitted bandwidth, also. The SSB filter in the i-f circuit will sharply attenuate signals which might otherwise extend beyond the edges of the

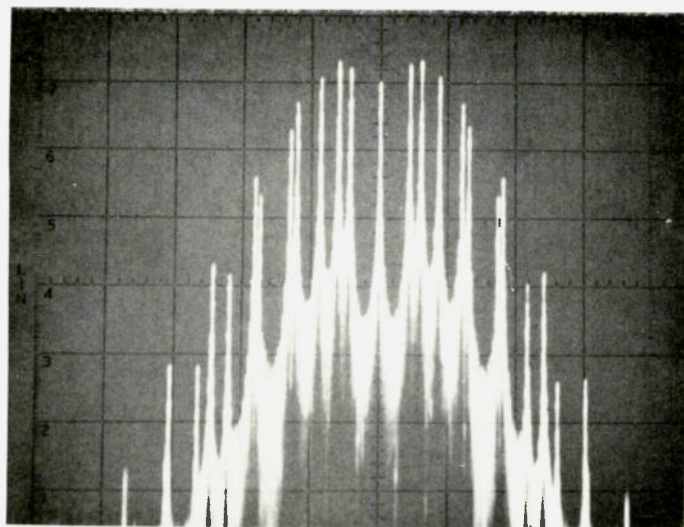

Fig. 15. 850-Hz shift AFSK-FM at 45.45 bps with alternating 1s and 0s. Peak FM deviation is 5 kHz. Scale: 5 kHz per division.

filter. This is especially true in the case of FSK Morse or future use of Kansas City standard signals, since their bandwidths approach that of the SSB filter. Intentional filtering may be added at audio frequencies between the AFSK generator and the transmitter input to accomplish the same result.

Filters which reduce the bandwidth of FSK signals (or any FM signal) tend to introduce an AM compo-

nent to the signal. If the filtered signal then passes through a transmitter circuit that acts to partially limit the signal, such as an overdriven output stage, the AM component may be removed and the bandwidth widened once again. What this means is that if filters are added to intentionally reduce the transmitted bandwidth, they will not be completely effective unless they follow non-linear circuits.

Someday...

The FCC may give us a chance to use all of these emissions to improve computer communications, and communications in general, as well. Although a phone transmitter may seem simple by comparison, when the signal-to-noise ratio is poor, digital systems give superior performance. Mother Bell has already made the decision to convert the vast majority of her switching

systems to *pulse code modulation* to take advantage of the ease of routing long-distance conversations with logic ICs instead of relays. PCM requires a rather large bandwidth, but makes sense in the upper UHF region through the optical wavelengths.

The "Begonia Net" may not soon be running PCM in place of lower sideband, but a "Worked All 8080s Award" for computer-equipped hams running CW at 360 wpm may not be far off. ■

Fig.	Bps	Shift, Hz	Nec. BW, Hz	Occ. BW, Hz	-27 dB BW, Hz
2	300	0	1500	1500	900
3	300	0	1500	750	900
4	300	600	945	1500	1500
5	300	600	945	-	1400
6	45.45	170	246	318	318
7	45.45	170	246	-	315
8	74.2	170	262	371	371
9	74.2	170	262	-	380
10	110	170	282	330	440
11	110	170	282	-	360
12	300	1200	1725	2100	2100
13	300	1200	1725	-	2200
14	45.45	170	14590	13770	17000
15	45.45	850	15590	17000	17850

Table 1. Bandwidth summary.

References

1. Lizee, Gaspard, "Speed Standards for International Morse Code," *Ham Radio*, April, 1973, p. 68.
2. FCC Rules and Regulations, Volume 2, Subpart C, Section 2.202.
3. Guentzler, Ron, "RTTY Signal Bandwidth," *RTTY Journal*, April, 1977, p. 5.
4. *ITT Reference Data for Radio Engineers*, p. 23-8, Indianapolis, Howard W. Sams, 1975.

A *Christmas* MESSAGE TO ALL...

In this Christmas season, when our thoughts and desires are turned toward material possessions, we offer, for your consideration, one possession of lasting value which will truly satisfy an inner hunger.

There is an area of human desire that can only be satisfied by our Heavenly Father. We can attempt to satisfy this area in our life with material possessions, but it will not be successful.

The Bible tells us in Psalms 37:4, 5; "Delight thyself also in the Lord, and He shall give thee the desires of thine heart. Commit thy way unto the Lord; trust also in Him, and He shall bring it to pass". (KJV)

Jesus tells us in the Gospel of John that He is the way, the truth and the life. If we believe this, follow His teachings and obey His commands, we may ask any request of Him and it will be granted. He has told us this so we will be filled with His joy.

His way for our life will fulfill our desires and solve the complex and confusing problems of this life. Jesus said, "I am come that they might have life, and that they might have it more abundantly". John 10:10b (KJV)

God's plan for our life makes us a complete person through Jesus Christ. Please accept His love and have a blessed Christ-centered holiday season.

"73" from the gang

MATAC M71

RD 1 • BOX 185A • FRANKLIN, PA 16323

IF YOU HAVEN'T USED EDGECOM EQUIPMENT, YOU JUST HAVEN'T LIVED

SYSTEM 3000A

- 20 Memory Channels
- Any Transmitter Offset
- Memory Scanner
- Band Scanner
- Two Priority Channels
- Memory Channel Monitoring
- Only \$549



FMS-25

- Ten Memory Channels
- Band Scanner
- Any Transmitter Offset
- Full Coverage
- Low Price: \$439

Both the System 3000A and FMS-25 provide you with an extraordinary receiver (five-pole front-end, ten-pole IF), 25 Watts of output power, advanced PLL synthesizer with electronic push-button tuning, small size, light weight and a full TWO-YEAR WARRANTY. Call, write or visit us for more information on these incredible 2m transceivers from Edgecom. It's time you really started to live.

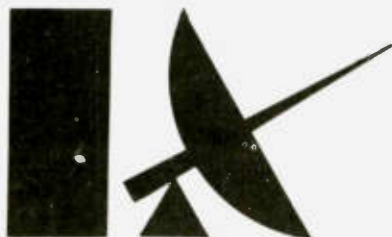

**VHF
COMMUNICATIONS** ✓ V18

915 N. MAIN ST. JAMESTOWN NEW YORK 14701
[716] 664-6345

A 28¢ Touchtone™ Mod

— something for (almost) nothing

*David J. Brown W9CGI
RR 5, Box 39
Noblesville IN 46060*

Repeater owners, remote control users, and touchtone™ fans in general—take note! This article will show you how to get 24 decoded functions (on 16-key TT pad systems with A, B, C, D) or 19 decoded functions (on 12-key TT pad systems with 10 numbers, the *, and the # only) from your present 16- or 12-function systems—and very inexpensively.

Depending on how you decode your TT tones at the receiving end, this modification will cost you from 28¢ to 76¢ at January, 1978, prices on TTL logic (source is Poly Paks®). Since nearly all the up and working systems use 567 tone decoders that output

a low for a decoded number (as do many other systems), and these lows are inverted before the low group/high group ANDing to get a single function, I will concentrate on those systems. Mine is shown in Fig. 1. By just comparing it to yours, you can tell what may be missing on yours. I have duplicated my TT decoder section for clarity. It has nothing to do with whether you can get the extra 7 or 8 functions, and is shown only because I use an extra enable/disable function line on TT decoding. This is not required, so, if your system uses the more common two-input gating system, don't fret.

Since I already had all of the ICs with letter designations, and half of IC-D wasn't being used, I only had to use unused func-

tions of ICs already there, except for adding ICs 1 and 2. While we are on ICs 1 and 2, I will add that they may be 7400s if you want TTL-compatible outputs for your extra added functions. If you want uncommitted outputs to run outside-world devices (small low-voltage/current relays, etc.), as I did, you use 7403s with no wiring changes on the sockets. This is nice if you later change your mind or want four of one and four of the other.

To explain the system, first let me cover normal TT decoding. For any valid TT tones, you will have one decoded low group and one decoded high group as TTL lows on the inverter (ICs A and B) input lines. Depending on the function, this will be a high on one of the L1 to L4 points, and a high on one of the H1

to H4 points. This will 2/3 enable one of the 3-input gates in IC-E through J. The common line you see connected to all of the gates in IC-E through J must go high to finish the decode enabling. Example: If this line is high and we receive a low group 697 Hz tone and a 1209 Hz high group tone, L1 and H1 will be high, and the number 1 will be decoded (TT).

As for how that common line gets high, please take the above example again. A low on IC-A-1, causing a high on IC-A-2 and L1, half enables IC-1-1. Since this is a TT tone we are receiving, there is also a high group tone (1209 Hz), and, if there is a high group tone (as there is for any valid TT tone), IC-C-8 is high. Invert this through IC-B-11 to 10 to HTT for a low. That low is applied to IC-D-10 and

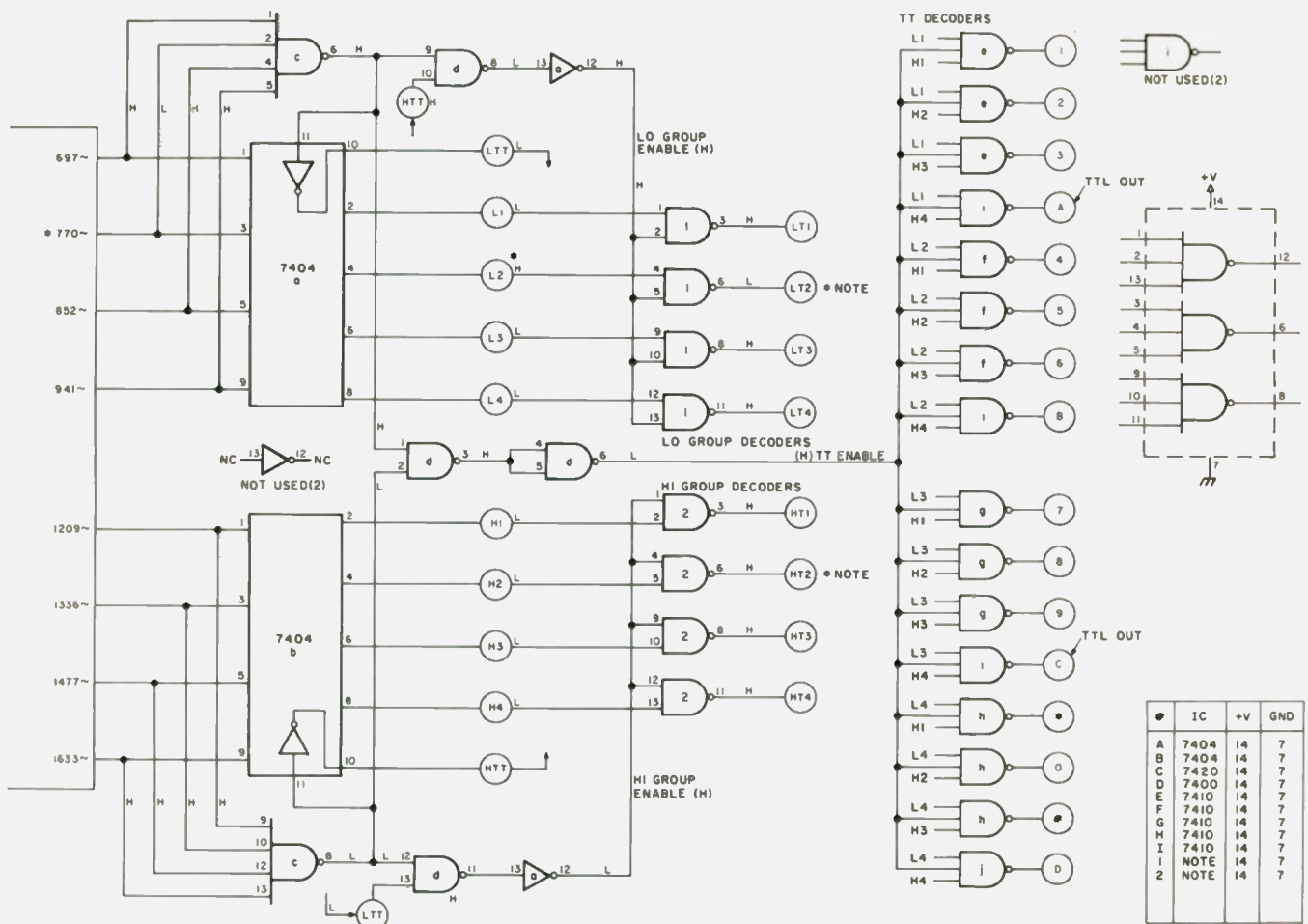

Fig. 1. *Note: ICs 1 and 2 can be 7400 for TTL outputs or 7403 for uncommitted collector outputs.

disables IC-D-8 (high), through IC-A-13 to 12 (low), and disables all the single low tone group decoders, IC-1. When a low group tone is also present (as with any valid TT tone), following IC-C-6 (high), through IC-A-11 to 10 (low) and LTT, to IC-D-13 disables IC-D-11 (high), through IC-A-13 to 12 to all of IC-2, disabling all the high tone group single tone decoders.

Going back to IC-C-6 and IC-C-8 (both high on TT), these highs go to IC-D-1 and IC-D-2 to form a low at IC-D-3. The last gate in IC-D is wired as an inverter and causes the low at IC-D-3 to be a high at IC-D-6. This 1/3 enables all the TT decoders and says a valid 2 tone TT signal is present. Since we chose the example of 697 Hz and 1209 Hz (TT function 1), the low group (697 Hz) fully decoded as a high goes to 1/3 of a gate in IC-E, and the high

group (1209 Hz) fully decoded as a high goes to another 1/3 of the same gate in IC-E. Along with the TT enable high, this causes the function 1 to go low and the TT number 1 is decoded.

If you follow the asterisk in Fig. 1, I have shown also the single tone (770 Hz) decoding. All the little L and H characters indicate low and high, respectively, and refer to gate or line status for this one particular (770 Hz) example. You will see that, with the high group tone of any kind missing, IC-C-8 is low, disabling all the TT decoders via IC-D-2 (low) and IC-D-3 (high), through inverter IC-D-4 and 5 to 6 (low). The missing high group tone and IC-C-8 (low), through inverter IC-B-11 to 10 (high) and HTT, causes IC-D-10 to be high. Since there is a low group tone (770 Hz), IC-C-6 is high and enables the

other half of IC-D-9 and 10 to 8 and makes IC-D-8 low. Inverted through IC-A-13 to 12 (high), all the low single-tone decoders are 1/2 enabled. Since the low-group-only tone is 770 Hz, IC-A-3 is low and IC-A-4 is high and enables the other half of IC-1-4. This causes a low at IC-1-6 and a fully decoded 770 Hz function at IC-1-6.

I confess to a bit of foxy maneuvering at this point. This whole business (seeing as all I had to add were ICs 1 and 2) was done originally to detect the independent high and low tone group decodings and only light LED indicators. It was not until the unit was all built and running that I decided why not use these extra functions to do things on the receiving end with a bit of extra circuitry to define single tone versus TT pair tones. It greatly reduces the necessary

hardware to handle station keeping such as changing from tight to loose squelch on the repeater receiver and resetting the time-out timer if someone over-talks it. That way, none of the original 12 or 16 functions are used up or confused, like on an autopatch repeater. These can be used as completely separate functions.

While I am covering bits of honesty, I should mention how this whole thing works from the sending end. Following Fig. 2 should help. This is nothing more than the face of a TT pad. As long as you push single buttons, you get dual TT tones corresponding to the key pressed. If you push any adjacent pair of keys on a standard TT pad, you get only the single tone for that row or column. Following Fig. 2, if any pair of the column keys such as (1-4), (4-7), or

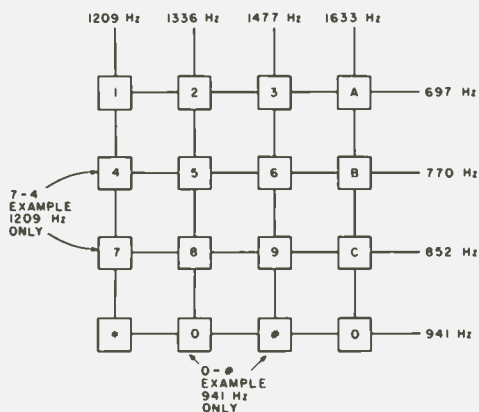

Fig. 2.

(7-*) are pushed, that column tone results. Columns produce the high tones, going from lowest to highest as you go left to right [i.e., left column = 1209 Hz through right column (if present A, B, C, D) = 1633 Hz]. Any row pair that is pushed produces a low group tone, going lowest to highest as you go top to bottom (i.e., top row = 697 Hz through the bottom row = 941 Hz). A row pair example to get 941 Hz would be (*-0), (0-#), or (#-D). Any pair example in a row or pair in a column seems to work, but adjacent pair keys are easier to hit and better insurance that you have both keys down.

As for rules to follow when sending, be sure to hit and depress both keys of a pair at the same time and release at the same time. If you hit one key and then add another, you will get a TT tone and single tone sequence not desired in this decoder. Changing the decoding further, you could put this to advantage in two-number systems. The Indianapolis 16/76 machine has a very interesting and helpful system function that is TT-tone controlled. By pushing the series 71 through 79 (excluding 77) TT numbers, a tape is played back to you giving you one track of 8 possible tracks worth of prerecorded messages. As you might guess, the number 7 fol-

lowed by 6 (76) gives you all the information about the 16/76 machine operations and format. Adding more housekeeping functions could be done by adding another full two-number set decoder group (quite a few ICs) and using the 10s or 80s, etc., numbers just as the 70s are now used for the tapes. Just as easily, and for much less expense, at least 7 more functions could be added by my method with no changes made out in the field by the sending stations.

The sequence 7-6 would still be a decoded 7-6 and activate the tape that explains 16/76. Using the 7-4 for a single tone example, since they are a column pair, and 7-6 is neither a column nor a row pair, if 7-4 is pushed in sequence form, the 74 tape would still play. If the 7-4 were pushed together, however, a single tone of 1209 Hz (left column) would result, causing a low decoded at HT-1 in Fig. 1. This could be used for whatever you like.

Since I have used our 16/76 machine which Indy amateurs are quite proud of for an example, please allow me to issue an invitation and a couple of words of warning/advice/help. Should you pass through our town (or within about a 25-mile range), and want to dial up the tapes, you must observe two simple rules. The first is: The dial-up on-

ly works if preceded immediately (without dropping carrier between) by audio. A valid and appreciated by us (and the FCC) way of doing this is: Using my call only as an example—"This is W9CG1 accessing tapes." Send first TT (7) for about 1 second, then send second TT (any but 0 or 7) for about 1 second, then drop carrier. To allow for any of the emergency-type break-ins that might occur, the tape was done so it can be "talked over," i.e., if another station has emergency traffic, and a tape is playing, he has only to key the mike and start talking, and the audio on the tape is dropped below him by several dB. The next rule is: Please allow 45 seconds minimum between the end of the last tape message sent and the next request to allow for rewinding of the 8-track player system. Thank you.

Into every life a little rain might, if not will, now and then fall. I confess, I do not know what happens when the newer so-called (but not) TT pads are used that are little keyboards and IC generators (Heath Micoder™ and keyboard and Motorola TT-type tone IC, etc.). Pushing two keys at once in these systems produces results I can't begin to predict, having never owned or even operated one. You can only try it and see. I am reasonably sure that the manufacturer would not be so careless as to allow a catastrophic failure to occur on a two-key press, since it is so easy to do it accidentally, but you may get one or the other of the dual TT tones, or not any tone at all—instead of the single tone desired. Systems considering my add-on decoders should poll their members using it for the number of "non-real" TT pads or the results of two key press actions on the "non-real" TT

pads, or keep these as station housekeeping control tones for use by control stations having real TT pads.

For the miniscule cash outlay, this system modification has been infinitely handy to me for use as everything from a troubleshooting aid to a high/low tone pass filter alignment aid and a free (almost) station control. In my opinion, it would pay to use the 7403s for both ICs 1 and 2 and connect the outputs up to +5 volts through limiting resistors and LEDs, even if you are going on to TTL inputs. This still gives a ground or +5 volts output usable as a TTL input and adds the ability to monitor what is going on in the few parts the average system will have to add on. You then have a visible panel status indicator (on when that single tone function is decoded).

While I can't imagine anyone finding trouble with this that I can help with (i.e., I can't show you a solder splash, short, etc.), I remain, as always, at your service for an SASE. The wiring for the TT decoder portion (7410s) is not given on each IC-E through J, but does appear in Fig. 1 for a single 7410 for two reasons: This is not part of the modification and new system, and, if you duplicate it, you can hand wire it to suit your own board layout and fill in your own numbers on a copy of the page from this magazine. I muttered the first time I saw this in another article using a lot of ICs but it worked out beautifully for me, and the copy of the nice neat schematic from the magazine with my numbers neatly penned in is now a unique diagram for my particular board—great for troubleshooting. I hope this works out well for you, also, if you are duplicating the whole system of Fig. 1. ■

EDGECON SYSTEM 3000A AND FMS-25 ... PERFORMANCE THAT CHALLENGES YOUR IMAGINATION



SYSTEM 3000A: 144-147.995 MHz FM transceiver that features: • Twenty front-panel-programmable memory channels • Memory scanner • Band scanner • Any transmitter offset • Memory channel monitoring • Two priority channels • Extraordinary receiver • 25 Watts output • American made • Full two-year warranty • \$549.



FMS-25: Uses the same fantastic receiver and transmitter as System 3000A. Features: • Ten front-panel-programmable memory channels • Built-in band scanner • Full coverage in 5 kHz steps • Electronic push-button tuning • Any transmitter offset • Wired for commercially available Touchtone microphones • American made • Full two-year warranty • Only \$439.

Minimum \$3.00 for shipping & handling on ALL ORDERS.

Prices FOB Medford MA. MA residents add 5% sales tax.



Radio Electronics
209 Mystic Avenue
Medford MA 02155
(617) 395-8280 ✓ T45

Space Age Surplus

— your own Saturn V?

*Bill and Katha Endress
1128 Marygon Street
Kissimmee FL 32741*

With the tremendous advances made in electronics and the termination of the Saturn and certain other space programs, today's surplus "junkie" has a whole new world to explore. Let us take a trip to a local surplus store and see what kinds of goodies a computer hobbyist, turned bargain hunter, can find. There is a super surplus store in Orlando, Florida, called Skycraft Parts And Surplus. It is owned and operated by Bob Fiedler, and it has a wide variety of

both government and industry surplus.

In years past, a trip to your local electronic surplus store meant hours spent gazing at racks of armed forces hardware. These units were usually transmitters, receivers, and transceivers. They came in shockproof heavy-duty cases, and the components were sprayed with varnish to protect them from the elements. The units were designed to withstand a war. They operated from various power sources that usually operated at 400 Hz. Numerous articles filled the magazines on how to convert this surplus to civilian uses.

The surplus that one finds today can be divided

into two broad categories: tube surplus and solid state surplus. The older tube surplus is characterized by vacuum tubes and generally larger physical dimensions. Most of this equipment was used by the military, with only a smattering of industrial surplus.

Unless you have interests in the ham field or you need a particular device for a specialized application, my advice to you is to stay away from tube surplus. Even if you buy one of these units with the thought of stripping it for parts, you will still come out losing. In these units, most of the capacitors are quite old, the resistors won't be precision resistors, and the power

supply components will be designed for the higher voltages necessary to operate vacuum tubes.

The newer surplus is an outgrowth of the tremendous advances made in industry and the termination of several of our space programs. We can divide this newer surplus into two sub-categories: space hardware and industrial hardware.

With the advent of the space shuttle, two important things have happened that have released and will continue to release great quantities of space hardware into the surplus market. The first thing that has happened is the termination of the Saturn program. Most of the electronic hardware that was



Entrance to shop.

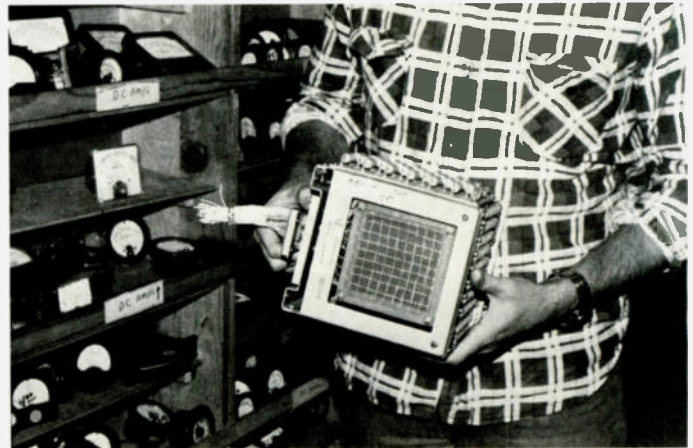

Core memory.

used in the Saturn program was designed specifically for that program and cannot be converted to the space shuttle program.

The second major factor in the release of space hardware is in the cost effectiveness of the space shuttle. Once the shuttle becomes operational, sometime in the early 1980s, all of the NASA and most of the military satellite launches will be performed by the shuttle. The reason for this is that it will be millions of dollars cheaper to launch the reusable shuttle rather than expendable boosters. Both NASA and the military are already planning the shutdown of most of their launch support facilities at both the eastern and western test ranges. This will assure us of a continuing supply of space hardware coming on the market.

Industrial surplus is mainly the result of the tremendous expansion of technology in the electronics industry in this country over the last decade. With the development of integrated circuits and large scale integration, transistorized equipment is becoming obsolete. This has become even more evident in recent years as energy costs have shot sky-high. Transistorized equipment requires not only a greater amount of operat-

ing energy than the newer ICs, but also, if the unit is large, it needs substantial amounts of cooling energy as well. With new technology becoming available to industry every year, more and more equipment is becoming available to the surplus "junkie."

The important difference between the older tube-type surplus and the newer transistorized surplus is that the power supplies for the transistorized hardware usually operate on 110 volt, 60 Hz power sources. These power supplies provide well-filtered low-voltage, high-ampere outputs. Another big bonus is that, in many cases, when you plug in a newer unit and turn it on, it works! No tricky conversions are necessary.

Let us take a look at some ways to help you select pieces of equipment to stretch your surplus dollar further. Equipment is sold in four different stages of assembly: individual components, circuit boards, partially disassembled units, and intact units. The surplus shop pays someone to disassemble the intact units into saleable portions. The more work he puts into a unit by taking it apart, the more you will have to pay for the components.

Individual Components

You can usually find any

value of capacitor or resistor in any quality or size among the individual parts sold by the surplus store. You may have to look a little harder for the particular transistor or IC that you need. When buying transistors and ICs, remember that you are buying used or factory second items in most cases. This may be fine for breadboarding circuits or for noncritical circuits, but do you really want it in a critical circuit? Most merchandise in the surplus store is sold as is, no refunds or exchanges. Individual components can be a good buy to help you breadboard a new circuit, but, generally, this is the most expensive way to purchase surplus.

While checking out the individual parts area, look for unusual items. I recently paid \$15.00 for a 12K ferrite core memory unit. I'm not sure just what I will do with it yet, but, in the meantime, it makes an excellent paper weight!

Circuit Boards

I have mixed emotions about buying circuit boards. Sometimes you can find a real bargain, but you can also find a lot of junk. Skycraft Parts has bins of circuit boards to choose from, priced at three or four for \$1.00. You can even buy a barrelful for \$10.00. The boards may

be populated with transistors, ICs, or even core memory. The capacitors are usually quality capacitors and the resistors are, in many cases, 5% precision or better.

Whenever I buy a circuit board, I buy only those boards that I can pick out and examine before the purchase is made. I usually pick out premium boards and therefore pay premium prices. One of my favorite purchases was a circuit board that I paid \$7.00 for. It had no electronic components on it at all. It was instead covered with over one hundred 14- and 16-pin wire-wrap sockets. This put my cost at less than 7 cents per socket. I also managed to save most of the wire, adding further to my savings!

When picking out circuit boards, try to have a definite goal in mind before you even enter the store. Do you need ICs, or perhaps heat sinks? Are you after resistors, or are you looking for reed relays? Once you know what you want, you will be in a better position to buy the circuit boards containing the components that you need, and not just a lot of junk.

When I look at circuit boards, I look at the ones with lots of ICs. I check to see if they are of the 7400 or TTL series of ICs and whether or not they are in

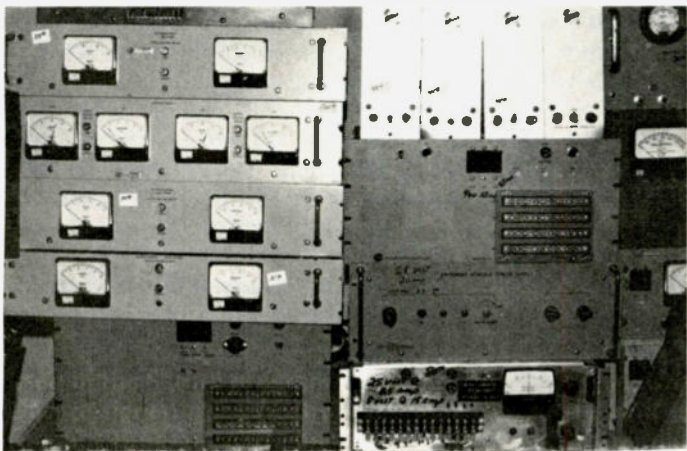

Power supplies.

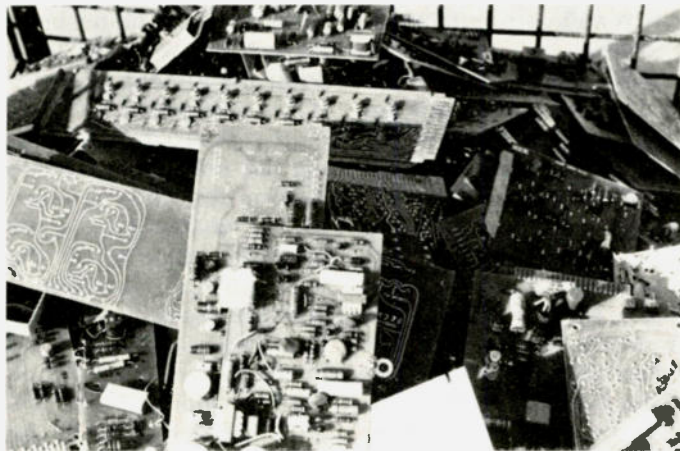

Circuit boards.

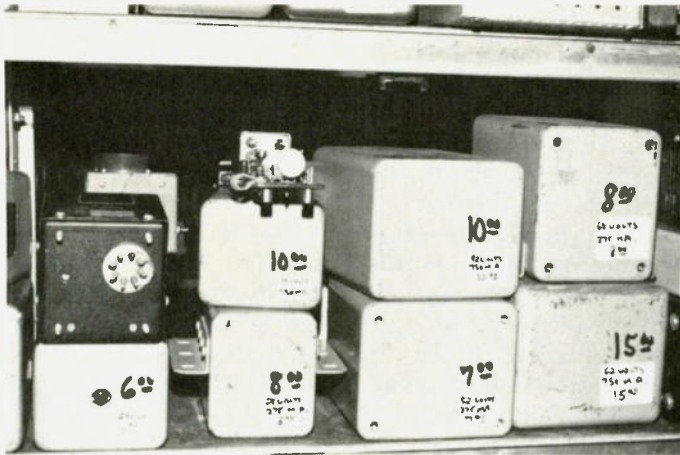

Power supplies and transformers.

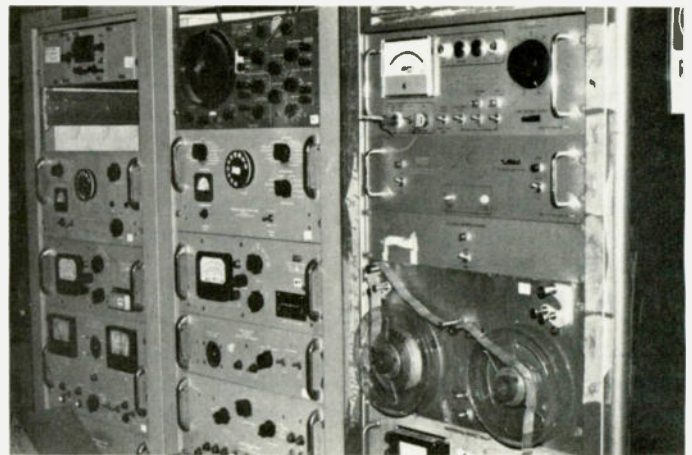

Complete units.

sockets. I have paid as much as \$14.00 for just one circuit board, but it was covered with fully socketed 7400-series ICs.

Partially Disassembled Units

This is where I start to get turned on. Partially disassembled units include such items as power supplies, circuit board card cages, diode assemblies, switch and light panels, and a whole host of other goodies. If you are in the market for switches or lights, or other items in a quantity, this is the best way to go. You don't pay the cost of someone completely disassembling the unit as with individual components. On the other hand, you aren't paying for a lot of excess baggage either. Among the partially disassembled units, you can usually find power supplies to fit both your power needs and your budget.

When purchasing a power supply, check to see if the input and output terminals are clearly marked. You can purchase the best power supply available only to find it is useless if you don't know which input and output connections to make. All you can do then is strip it for parts. I don't recommend this. Any supply having the quality components necessary for use in computer circuits is usually in working condi-

tion. You will pay a premium price for these units. This is too expensive a way to go just for parts.

Intact Units

This is my favorite way to buy surplus. If you shop wisely, you can get more for your money here than in any other form of surplus buying. Not only can you get your money's worth out of the parts' value, but many times you can also find working units.

When shopping for completely assembled units, I look for several things. First, I check to see if it was put together with nuts and bolts, as opposed to rivets. Not only do nuts and bolts ease disassembly, but you also end up with a good assortment of hardware when you are done. Most of the newer units use circuit boards and plug-in modules. You usually end up with a card cage suitable for a home brew project in addition to a good assortment of parts. If it is possible to remove a circuit board before buying the unit, do so. While looking at the board, check to see what precision the resistors are, whether the unit uses ICs or transistors, and the overall construction and condition of the board. These can all be used as indicators of the quality and the age of the unit.

Occasionally I will find a

unit that uses transistor sockets for its transistors. Check to see if the power supply is visible. If so, look for a heavy-duty transformer, large electrolytic capacitors, and heavy-duty power transistors mounted on large heat sinks. Also look to see if there is a line cord with a conventional plug. These are all indications of a heavy-duty power supply that might still be in working order. Check the front panel to see if it contains a meter to check the performance of the power supply or gives a hint of the voltages put out by the power supply. While at it, check for fuses. Many times the output voltages are protected by fuses. These may also give you an indication of the output voltage and current. Above all, when checking out a unit for possible purchase, check the price and ask yourself, "If the unit is stripped for parts, will I get my money's worth in parts alone?" Unless the store owner is willing to let you plug in the unit to see if it is operational, never assume a unit is in operating condition.

Even if the unit lights up, the only thing you should assume is that the power supply works. Take along your voltage meter and check whatever you can in the store. I recently heard of a local electronics firm that sold 20 Tektronix

oscilloscopes to a surplus dealer for \$90.00 each. The only catch was that the CRT was burned out in each scope and a replacement CRT would cost \$1200.

I tend to prefer space hardware over industrial hardware. These units use only the highest quality components. Most of the contacts are gold-plated and many of the soldering posts are silver-plated for better connections. Also, since these units are on the market because of a phaseout, many of the units are still in working condition.

While many of the items for sale in a surplus store have changed over the last few years, one thing remains: You can still spend hours browsing the shelves of your favorite surplus store in search of that ultimate bargain. ■

Oddly enough, only a few of the many surplus houses around the country are well enough organized to advertise, so most of them are unknown except to a few local hams and experimenters. If you have a surplus store which hams, computer hobbyists, or experimenters might find of value, please send the name, address, and phone number to us and we'll publish it. Also include the name of the proprietor.
—Wayne.

EDGECOM'S FMS-25 . . . THE FANTASTIC 2M FM MOBILE RIG



Edgecom's FMS-25 2m FM transceiver is nothing short of ideal for 2m mobile operation. Ten front-panel-programmable memory channels provide you with fingertip convenience for recalling your favorite frequencies, the microcomputer-controlled PLL frequency synthesizer gives you full coverage with any transmitter offset using push-button tuning, and the built-in band scanner lets you automatically tune the band. Add to these features an absolutely superior receiver, 25 Watts of output power and you have a combination that provides unexcelled performance at the low price of \$439.

FOR THE ULTIMATE IN FLEXIBILITY, THE INCOMPARABLE SYSTEM 3000A



The Edgecom SYSTEM 3000A 2m FM transceiver provides unequalled performance, incredible flexibility and several features that go beyond the imagination. Twenty front-panel-programmable memory channels, a memory scanner, a band scanner, two priority channels, any transmit offset, electronic tuning, 25 Watts of output power and the superior Edgecom receiver are a few of the several outstanding features that make the System 3000A the forerunner in the state-of-the-art in amateur communications.

MIDCOM

We'll Make You Glad You're A Ham
ELECTRONICS, INC. ✓ M62

Call Collect Now to Order (314) 961-9990

2506 S. BRENTWOOD BOULEVARD
ST. LOUIS, MISSOURI 63144

An X-Band Transceiver

— more 10-GHz fun

The system described in the following paragraphs is made up of surplus microwave components and other equipment used in the home and mobile station here at W1SNN. Only one piece is

described for construction because the main components are now available to amateurs and made for amateur frequencies. The device we will construct is not too difficult to make, but several pieces will re-

quire the use of a lathe. The method used to control the frequency of the Gunn diode oscillator in the transceiver is not new. It is often used in radio astronomy equipment although in that

endeavor, spectral purity of the rf output is far superior to that achieved here at W1SNN. Many amateurs have used the same idea in days past to control klystron local oscillators for their

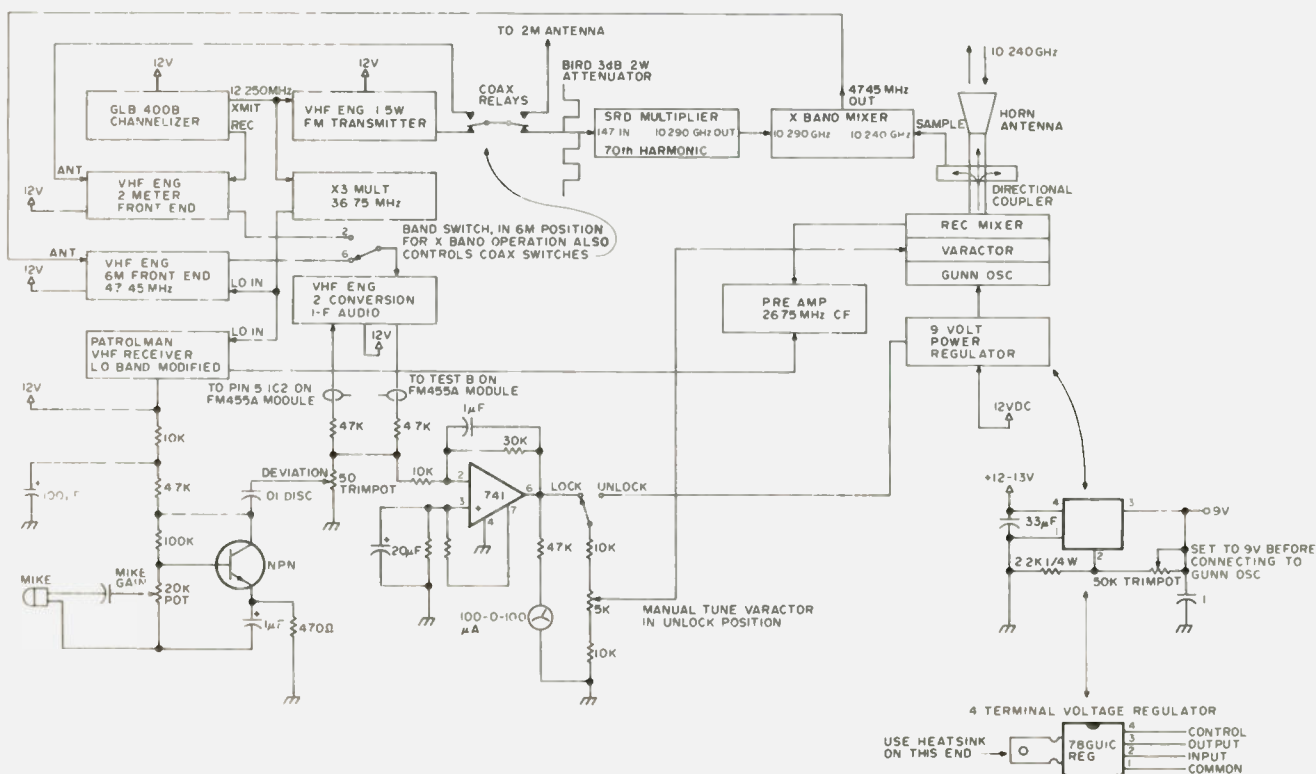

Fig 1. Block diagram and simplified schematic of 10 GHz synthesizer.

receivers. Let us examine a block diagram of my approach (Fig. 1). I hope you will come up with better ways to do the trick, since we need more activity on 10.250 GHz.

It starts out with a GLB-400B channelizer. The GLB drives a 1.5 Watt two meter transmitter and receiver and an appropriate two meter antenna through two coaxial relays which allow the use of the two meter gear for liason when setting up on X-band during field days. The other output of the second coaxial relay feeds into a comb generator containing a step recovery diode (SRD) or snap varactor which generates the appropriate X-band harmonic.

The comb generator receives its power for harmonic generation by setting the GLB transmit output to 12.250 MHz, which is multiplied up to 147 MHz through the VHF Engineering 1.5 Watt two meter transmitter. The output comb from the SRD or snap varactor produces a usable output at 10.242 GHz. This output is fed into a microwave hybrid mixer and mixed with a sample of the Gunn oscillator's output through a directional coupler to produce an i-f output at 47.45 MHz.

A VHF Engineering six meter front end set at 47.45 MHz serves as the second conversion to the 10.7 MHz i-f input of the two meter receiver i-f amplifier and associated circuits. The i-f input of the two meter receiver can be switched to either the two meter front end or the one on six for liason use, or for synthesizing the X-band transmitter. The six meter LO input comes from the 12.250 MHz output of the GLB through a tripler. The 10.7 MHz i-f is further converted down to 455 kHz where the discriminator output voltage is fed into a servo amplifier. The servo

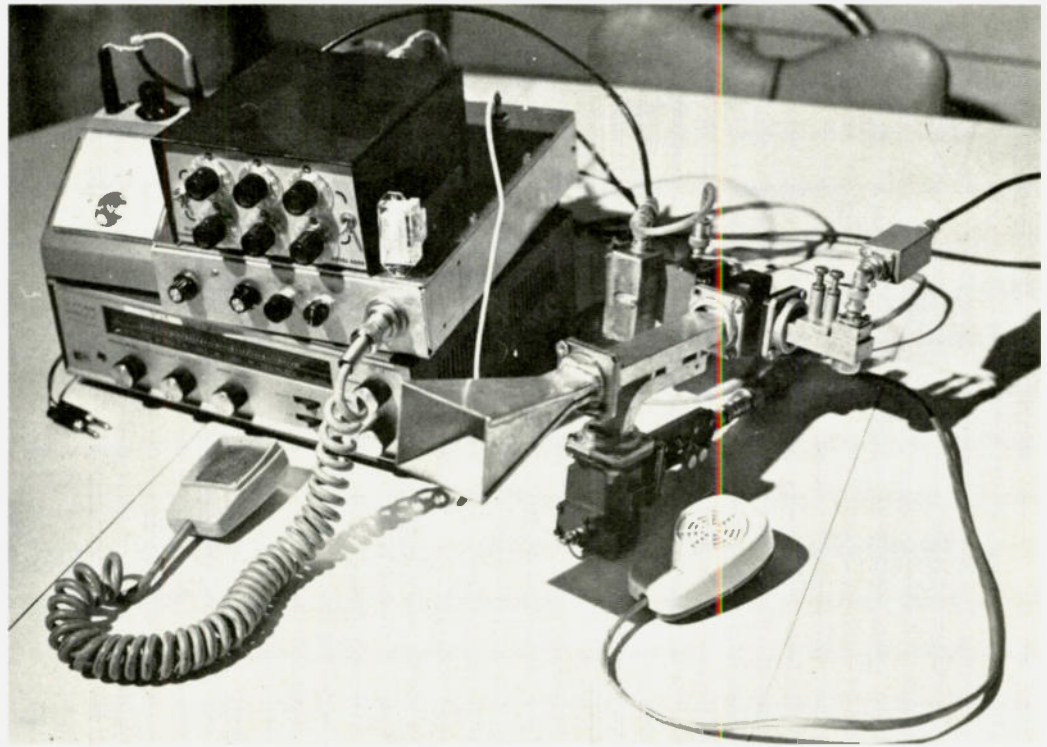

The X-band phase locked rig set up on the kitchen table photo studio. The meter on the left is used for tuning up. The GLB sets on top of the two and six meter receiver. The 1.5 Watt two meter rig is in the same chassis. The box that hangs on the right-hand detector mount is a preamplifier. On the left, a small box contains the servo and modulation electronics.

electronics are complete with an integrator and are used to tune a varactor mounted in the Gunn oscil-

lator cavity. Thus, the system becomes locked to the GLB channelizer.

A second receiver is

made up by modifying an old Radio Shack two-band Patrolman police monitor.

This receiver, which is

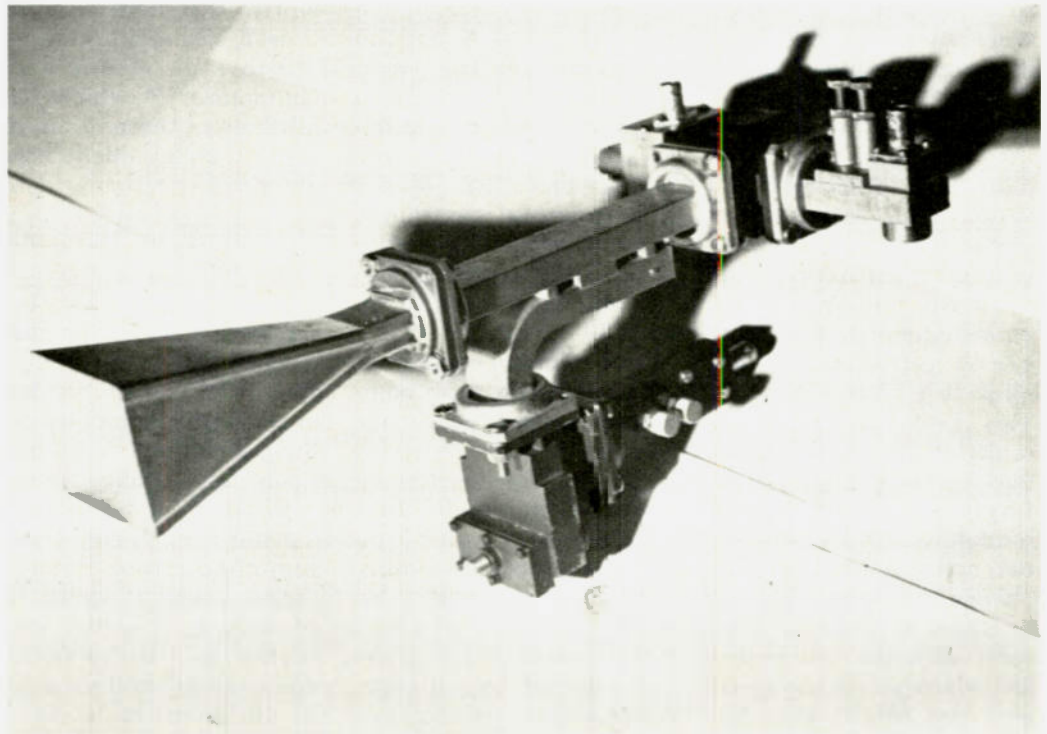

The rf plumbing stripped of all the electronics. On the right is the receiver detector which feeds into a circulator. On the left is a Gunn oscillator. The large square unit fastened to it is the varactor used to tune the Gunn oscillator.

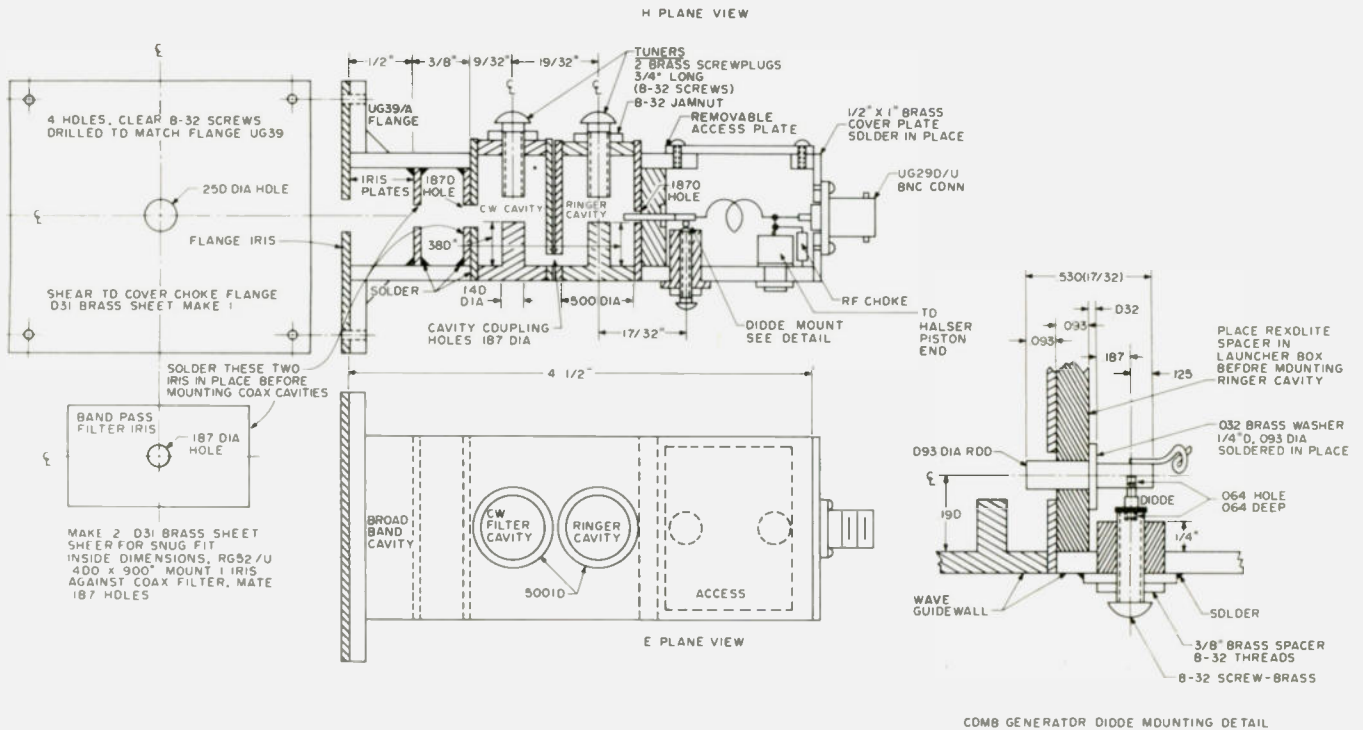

COMB GENERATOR DIDDE MOUNTING DETAIL

Fig. 2. Harmonic generator construction details.

tunable (or frequency controlled by the GLB synthesizer through the same tripler used above) is used as the receiving i-f system at 26.75 MHz when locked to, or at, frequencies that can be tuned across the X-band range. Modification requires the addition of a preamplifier that would match the output of the receiving mixer to get the noise figure down to a useful level. This receiver does not have any band-narrowing filters in its i-f system (10.7 MHz) and is ideal for the searching that is required for stations that obviously will not be on your frequency. It also has 12-volt capabilities which allow it to work in the car. This receiver could be replaced by another six meter converter and VHF Engineering i-f audio module as is used in the two meter setup. Until this change is made, we will continue to make our contacts with the old police job which so far has given excellent results over the short-path QSOs with WA1NWF. Its bandwidth is wide enough that once the signal is captured, small

drifts can be compensated for by readjustment. It is not an easy task to make contact with another station unless you both are locked on the same frequency, so a tunable receiver, for the time being, is a must. Another amateur, who is using a similar idea, has a police scanner in use as the search receiver. The crystal oscillator has been modified to be tunable and is scanned in the same manner that it would be if it were crystal controlled. This provides a fully-automated scanning system so he can drink his Coors™.

The microwave plumbing used in this set is composed of pieces either gathered from surplus houses or constructed by the author. It is quite a task to make a Gunn-diode oscillator/mixer assembly such as the one used in this system. The frequency control of the oscillator is accomplished by voltage-controlling a microwave varactor located within the oscillator cavity. A ferrite isolator, acquired from a police radar set, and incor-

porated with the tunable crystal mount completes the mixer half of the unit. The construction of these devices is a formidable task unless a well-equipped microwave test facility and a large amount of machine work can be accomplished. Therefore, it would be worth the constructor's time if he incorporated a Microwave Associates Gunnplexer™ which has all three of these items, as well as an excellent horn antenna.

The Comb or Harmonic Generator

Snap varactor or step recovery diodes are names given to these semiconductors by two of the leaders in this field. Undoubtedly there are other names, but, since this article started with these nomenclature, we will keep them. These semiconductors have a property which, regardless of what it is called, performs as follows: An epitaxial diffused varactor is designed to store a charge when it conducts in its forward direction. It conducts for a very short time until this charge is

pushed out by the driving rf signal. Then the conduction ceases very quickly. This is called the "lifetime" and is a way to measure the period that the varactor will store a charge, and the snap-time (or step-time, as it is also called) ceases. These diodes sometimes require an external bias, but ours will be used in the self-bias mode.

The effects described produce a series of pulses, which cause, in our generator, the first cavity to "ring," producing a train of damped waves at a microwave frequency. The output of the "ringer" cavity is then directed into a second cavity, which, by virtue of its high Q, propagates a more CW-like signal to its output termination. In the unit described for construction, these cavities are coaxial for the first two, and waveguide bandpass cavities for the last two. Needless to say, much care will be required in the construction of the unit. See Fig. 2 for details.

The diodes can be obtained from many manufacturers. Two are listed, with references, at the con-

clusion of the article. The two references are certainly worth the reader's inspection in regard to future generator construction.

The parts required for this section are easily obtained. They consist of a three-inch section of copper "small X" waveguide (RG-52/U), two 1/2-inch i.d. sections of brass pipe with 1/32-inch wall thickness, and four end-plugs for these pipes that must be machined and drilled to size. Also required are a cover, UG-39B/U, which is soldered to one end of the waveguide, and a small brass box which is constructed from another section of the same waveguide. Construction of this unit should be easily accomplished from the mechanical drawings. The iris coupling consists of holes found near the bottom of each coaxial cavity. The plate used to cover the choke flange, which is the output of the harmonic generator, is the frequency controlling element of the fourth filter, a waveguide bandpass filter.

The tuning screws found on the top of the waveguide must have the large plates loaded to make sure that firm connection is made to the wall of the waveguide. Once adjusted, the jam nuts can be firmly set since no further adjustment will be required, but be sure that the nuts squeeze into the lock washers.

Begin construction of the SRD assembly by marking off the two holes for the circular cavities. These two holes are drilled through the waveguide walls and are spaced double the thickness of the pipe wall, so the material left in the edges of these two holes will be removed. It is best to drill both holes with a smaller drill and then line-ream out the remainder of the material un-

til a tight fit is achieved. The two pieces of 1/2-inch tubing should now touch each other on one side.

Insert each of the cavity tubes into the holes so that the two iris slots near the bottom of each tube face each other. At the center of each of these cavities, the holes shown in the drawings should face the open ends of the waveguide. These are the exit irises of each of the coaxial filters. Next, install the bottom plug which should be the machined piece which makes up the coaxial post for each cavity. All of these pieces should be turned on a lathe so that they provide a very tight fit into the tubing. Make sure that the plug ends of these cavities are parallel to the bottom wall of the waveguide and that the iris holes near the bottom are facing each other. Install the top plugs, which have the tuning studs, into the top of each coaxial cavity. These, too, should be machined for a very tight fit.

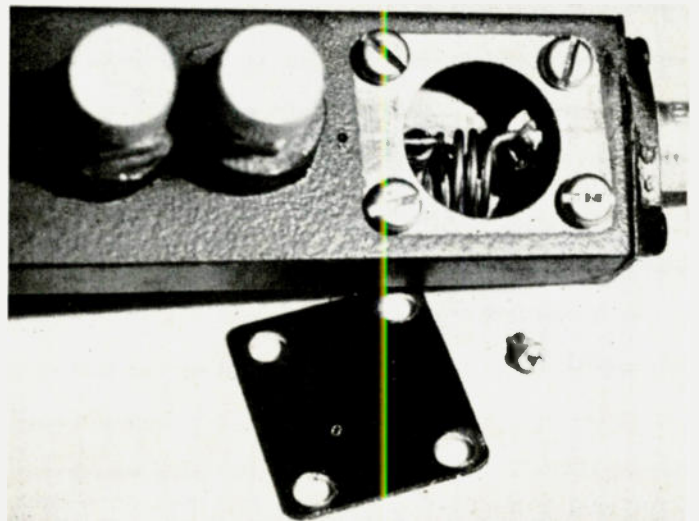

This view shows where the piston capacitor is located. The SRD is in the foreground near the inspection plate.

When all of these parts are aligned and you are sure of the correct positioning as shown in the drawing, gently heat the assembly to a temperature that will cause soft solder to run, apply flux to each joint, and run in the solder. Use only a very small

amount of solder; just enough to make a good electrical joint. Let the unit cool before attempting the next step.

On one end of the waveguide, install the inside rectangular iris plates as shown. Then install the output flange on the end of

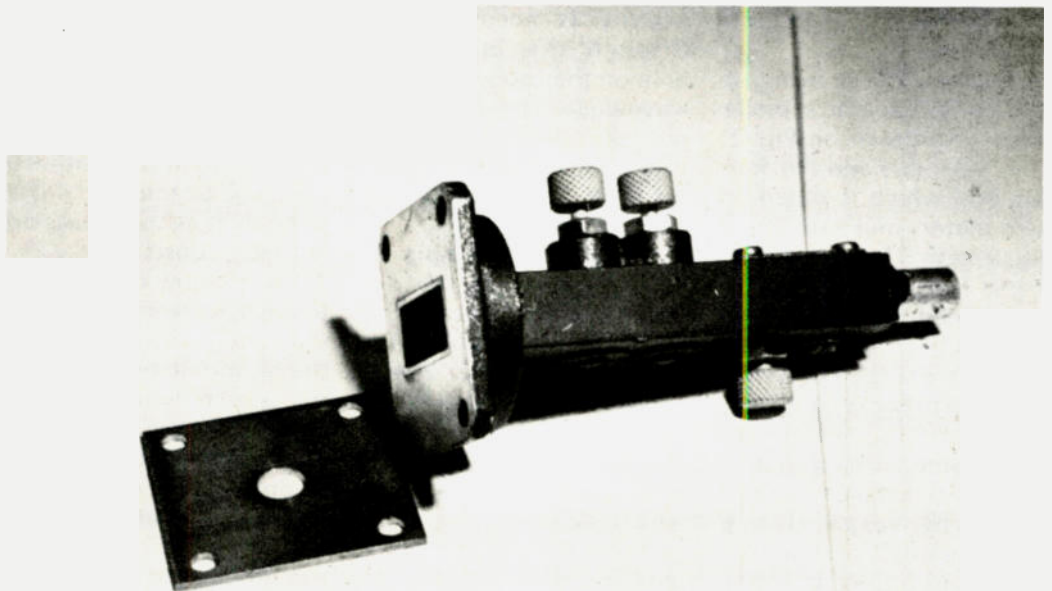

Side view of the SRD comb generator which provides the harmonics for mixing. The two tuners on the top of the waveguide are inserted into the tops of the coaxial cavities. On the bottom, the SRD mounting stud is in view and just behind it is the piston capacitor tuning plug.

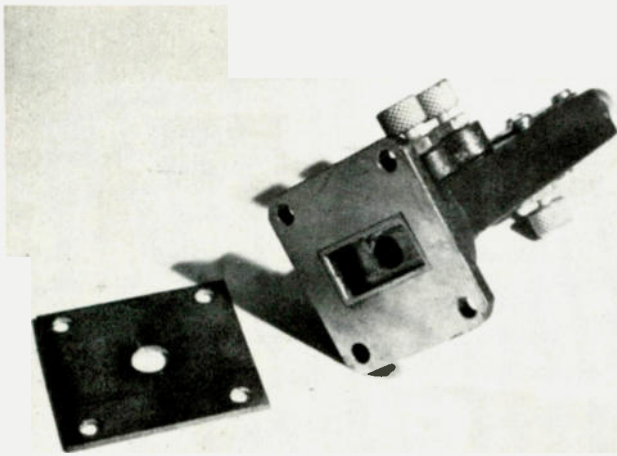

Front view of the comb generator shows the second internal iris which forms half of the bandpass filter. The large flat plate near the flange is the output iris which makes up the second half of the bandpass filter. It is held in place by the mounting screws which fasten the whole unit to the directional coupler.

the waveguide. Again heat the assembly, flux the iris plates and the flange, and apply solder. Care should be taken not to overheat the waveguide such that the cavity assemblies are disturbed. A four-cavity assembly has been completed and is now ready for installation of the SRD and rf launcher.

Examine the drawing of the comb generator diode mounting detail on Fig. 2. This assembly and the driving coil which is tuned to two meters make up the rf launcher. These components must be carefully assembled prior to installing the SRD in place. This diode is a small pill which has a form factor known as "style 31" in the microwave semiconductor trade. To install it, place the end with the large flange near the small circular protrusion into the end of the prepared 8-32 screw, after the screw has been run up through the threaded bushing so that it's just visible. The hole in the end of this screw should accept the diode with a little resistance. Do not push sideways on the diode or you will fracture the seal.

When installed, run the screw into the bushing so that the other end of the diode engages with the launcher line. The launcher should have a matching hole drilled into it in the correct place. DO NOT tighten the diode—just a firm fit will do. All of this activity is accomplished through the inspection hole on the top wall of the waveguide. The diode cannot take much heat, so any soldering of the launcher rod must be done before its installation.

When the assembly is completed, replace the access plate and connect the output of the two meter gear through the attenuator shown in the drawing. This pad will reduce the output of the transmitter to about 0.5 Watts which is all that is required to drive the diode. It can take only slightly more power, so take care!

Put the output of the comb generator into a wavemeter and detector. The detector will have to drive a very sensitive meter if the output is to be seen. There should be at least 20 microamperes output and should be indicated at the

frequency described.

If a smaller indication is shown, it should improve when the tuning screws on the top of each cavity are adjusted. The frequency meter should be left on the prescribed frequency of 10.240 GHz. Adjust the output coaxial cavity, which is the one nearest to the flange, for maximum and then peak-up the ringer. It is possible to be 147 MHz higher or lower since this is a comb generator, so watch the frequency meter. If a spectrum analyzer is available, as was to the author, little problem will be encountered in adjusting for peak output, but if not, it will require judicious observation of the frequency detected by the frequency meter cavity. When it is correctly adjusted, one very large peak right on frequency can be measured. When it is slightly off peak, a number of peaks will be observed when the frequency meter is tuned through the desired output. With a little practice, full output will be assured. When adjustments are completed, be sure to tighten the two jamb nuts that are on the tuning screws. No further adjustment will be required if it is done right as these nuts do not work loose.

We are now ready to try to lock up the system to the channelizer, hook up the harmonic generator to the system, and determine that all of the servo connections and indicators are in order. Turn on the system and look at the center scale tuning meter. It should be right on the line. To prove it is locked, and will also lock again, open the lock/unlock switch and watch the meter swing one way or the other and then snap back to center when the switch is closed. With the lock switch closed on the search receiver, you should be able to hear

yourself when you speak into the mike. Full duplex can be used on this frequency.

The circuitry shown for the power supply, servo electronics, and modulator are simple and should give little trouble. The output from the VHF Engineering i-f strip discriminator should be used as recommended from the manufacturer for driving a microammeter. The meter, however, is replaced with the circuitry shown, and then the meter will be connected to a new set of connections.

Modulation of the varactor requires a little care. Very little modulation is needed as full FM is used. If you are working a station that uses a wideband receiver, then a greater swing will be required. However, if you are working one that has a system like the one described, then the deviation must be adjusted to fit his receiver using the deviation control.

Tests throughout the fall have gone on with this rig. It is portable, by virtue of its several boxes, and gets hauled up on Prospect Hill in Waltham on Sunday afternoons. Prearranged contacts have been made over 30-mile paths with little difficulty.

Plans for another rig of the same type to be used for expeditions are in the works. It would be interesting to see what can be done at greater ranges, which I know are done commercially. It's quite a thrill to hear full quieting on top of a hill with a lot of old junk plumbed together. I hope you will enjoy the same results on your own expeditions. ■

References

- Hewlett-Packard Application Notes #920 and #928
- Step Recovery Diode, HP 5082-0830
- Microwave Associates Snap Varactor, MA 43004

CALL TOLL FREE

1-800-228-4097

FOR EDGECON . . .



THE INCOMPARABLE SYSTEM 3000A

- TWENTY FRONT-PANEL-PROGRAMMABLE CHANNELS.
- TWO BUILT-IN SCANNERS
- MEMORY-CHANNEL MONITOR.
- ANY TRANSMITTER OFFSET.
- FULL TWO-YEAR WARRANTY.

LIST PRICE ONLY \$549

THE FMS-25 . . . ONLY \$439



- BUILT-IN SCANNER
 - TEN FRONT-PANEL-PROGRAMMABLE MEMORY CHANNELS
 - ANY TRANSMITTER OFFSET
 - ELECTRONIC PUSH-BUTTON TUNING
 - 25 WATTS OUTPUT
 - SUPERIOR INTERMODULATION PERFORMANCE
- FMS-25 . . . PERFORMANCE THAT CHALLENGES YOUR IMAGINATION**

■ ■ ■ ■ ■ LOOK! ■ ■ ■ ■ ■

HOURS: Monday - Friday 8 a.m. - Midnight
 Saturday 8 a.m. - 8 p.m.
 Sunday Noon - 8 p.m.

Communications Center

The Radio Store

✓ C96



443 N. 48th, Lincoln, Nebraska 68504

In Nebraska Call (402) 466-8402



Faces, Places



In recognition of her outstanding support of radio amateurs in their state, Alabama hams presented this plaque to Mrs. Edith M. Parker at the Central Alabama Hamfest in September. Mrs. Parker was in charge of issuing amateur radio car tags from 1962 until her retirement in July of this year.



T. S. Ganesh VU2TS (left) and his seventeen-year-old SWL nephew, Janardhan, competed in August's 1000-mile Karnataka-1000 Motor Rally, organized by the Bangalore (India) Motor Sports Club. What you can't see in this view is the sign painted on the bike's seat: "73 FROM RADIO AMATEURS."



Craig McCartney WA8DRZ/9 was one of the Chicago Area Radioteletype Repeater System's members who manned the booth at the Chicago FM Club's annual Radio Expo this past fall.



At the Veteran Wireless Operators Association's annual banquet in New York on May 20, Jack R. Popple (left) presented the Marconi Memorial Gold Medal to Bob "Whitey" Doherty K1VV for his efforts in conjunction with the Marconi 75th Anniversary Amateur Radio Commemorative Station, KM1CC.



These central Ohio amateurs helped raise over two thousand dollars for charity last spring, when they assisted with the fourth annual Reynoldsburg bike-a-thon. Pictured left to right are Dr. B. Morgan Heflin WA8UVR, Randy Mitchell WD8AXY, Vernon Holland WD8NAU, Joe Hahn WD8NBA, Malt Brown WB8WKZ, Dick Carr WA4BIH, Dennie Roe WA8HPW, John Vollmer WB8UIF, and Mac Ceschiat K8ZQS.

EDGECOM SYSTEM 3000A

AND FMS-25...



INCOMPARABLE PERFORMANCE

AND FLEXIBILITY

SYSTEM 3000A



INCREDIBLY PRICED AT \$549

- Twenty Front-Panel-Programmable Memory Channels
- Any Transmitter Offset
- Built-In Memory Scanner
- Built-In Band Scanner
- Memory Channel Monitor
- Superior Receiver
- 25 Watts Output (adjustable)
- American Made/FULL 2-YEAR WARRANTY

FMS-25

- Ten Front-Panel-Programmable Memory Channels
- Built-In Band Scanner
- Same Fantastic Receiver/Transmitter as System 3000A
- Any Transmitter Offset
- Push-Button Tuning
- American Made/Full 2-Year Warranty

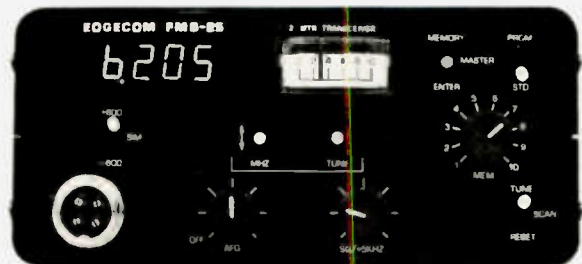

BARGAIN PRICED AT \$439



✓ A64



Aureus Electronics Inc.
 1415 North Eagle
 Naperville IL 60540
 (312) 420-8629



CONTESTS

from page 28

continents = 5 points. Contacts with HQ station GW8WJ or GW6AQ count 25 points. Total score is total number of QSO points times number of prefixes worked (as per WPX award rules).

ENTRIES:

Send logs not later than Jan. 31 to: Peter Lumb G3IRM, 14 Linton Gardens, Bury Saint Edmunds, Suffolk IP33 2DZ, United Kingdom. IRCs appreciated for contest results.

CONNECTICUT QSO PARTY

Starts: 2000 GMT Saturday, December 2

Ends: 0200 GMT Monday, December 4

Rest Period: 0500 to 1200 GMT December 3

The Candlewood ARA invites all amateurs to participate in the annual CT QSO party. Phone and CW are considered to be the same contest. Stations may be worked once on each band and mode, including

OSCAR as a separate mode. Novices will please identify themselves by "JN" unless "N" is part of their call. Out-of-state portables and mobiles operating in CT are requested to identify themselves as such. CT mobiles operating in other than their home counties will receive special certificates provided they make at least 20 out-of-state QSOs. Mobiles count as a separate station in each county. Counties certificates will be awarded to each station working all 8 CT counties.

EXCHANGE:

QSO number, RS(T), and ARRL section or CT county.

FREQUENCIES:

SSB—3927, 7250, 14295, 21370, 28540.

CW—40 kHz up from bottom of each band.

Novices—3725, 7125, 21125, 28125.

SCORING:

Non-CT stations multiply total number of CT QSO points by number of CT counties worked (8 max.). CT stations multiply total number of QSO

points by number of ARRL sections and provinces. Additional DX contacts count for QSO points, but only one DX multiplier is allowed overall. W1QI, the club station, will be operating CW on odd hours and SSB on even hours, and counts as 5 points on each band and mode. Novice QSOs count 2 points while OSCAR QSOs count 3 points each.

ENTRIES:

Logs must show category, date, time (GMT), calls, numbers, mode, bands, QSO points, and claimed scores. Separate certificates for single and multi-operator stations, and all logs should show which class applies. Enclose a large SASE for results. Send logs, postmarked by Jan. 3, to CARA, c/o Fred Porter W1VH, 169 Carmen Hill Rd. #2, New Milford CT 06776.

FLATLAND FARMER 10-X QSO PARTY

Starts: 1200 GMT Sunday, December 3

Ends: 2400 GMT

Sunday, December 3

This is the first DX QSO party sponsored by an individual chapter of the 10-X International Net, Inc., the Flatland Farmer Chapter. Score one point per QSO if said station does not have a Flatland Farmer certificate, two points if they hold a Local or Associate certificate number (station will have an "L" or "A" after the certificate number). All first state

or first DX certificate holders will be worth 2 points for a QSO. If the station is a Charter member certificate holder, score 3 points per QSO.

SPECIAL:

On this date and this date only, any station who does not hold a Flatland Farmer certificate can qualify for one by having two QSOs with any two stations who have a Flatland Farmer certificate, regardless of whether that station is a Charter, Local, or Associate member. Stations wishing to obtain their basic certificate should send request, listing the two QSOs, \$1.00, and two first class stamps to: Lou Reik WB9YJE, 804 Commercial Street, Danville IL 61832.

ENTRIES:

Logs must have date, call letters, name, QTH, 10-10 number, and Flatland Farmer number, if any. Logs to be postmarked by Jan. 15 and mailed to: Mike Reik WB9YJF, 304 McKinley Street, Westville IL 61883. Results of the contest will be published in the spring 10=10 bulletin, and other amateur publications.

AWARDS:

A certificate will be issued to the 1st, 2nd, and 3rd place winners in each US call area, including KH6 and KL7. All other call areas will be considered DX and a certificate will be issued for 1st, 2nd, and 3rd place. In addition, a special award will be given to the person anywhere in the world who scores the highest point total.

RESULTS

RESULTS OF 10-10 SUMMER QSO PARTY JULY 15-16, 1978

TOP TEN

K0GU	1317/2358
K0LT	805/1481
W0PEL	781/1433
TI2NA	771/1356
WA5JDU	687/1272
W0CP	649/1215
W4ORH	648/1186
N0CP	613/1137
WD5CSK	583/1104
K5CWB	582/1089

CHAPTER STANDINGS

1. Colorado	11081/20704
2. Minute Man	5629/10721
3. Bay Area	3839/7201
4. Land O' Lincoln	2934/5455
5. Gateway	2740/5326
6. City of Lights	2447/4607
7. Plainsman	2202/4196
8. North Star	2164/4125
9. Sky Blue Waters	2115/4060
10. White House	2081/3940

U.S. DISTRICT LEADERS

1. WA1UZH	505/953
2. K2DEG	407/751
3. WB3FAF	418/769
4. W4ORH	648/1186
5. WA5JDU	687/1272
6. WB6JPY	444/804
7. K7PVZ	470/833
8. WD8DPB	236/446
9. WA9PQY	464/850
0. K0GU	1317/2358
KG KH6ITD/KG6	107/144
KH KH6JTL	389/693
KA KA6HF	90/132

DX LEADERS

Central America & Caribbean	
TI2NA	771/1356
South America	
LU6DWZ	231/418
Europe	
DF1XG	124/140
Asia	
JA3XOG	61/105
New Zealand	
ZL1BQD	260/440
Australia	
VK2NET	383/661

CANADIAN LEADERS

VE1 VE1BNN	508/910
VE2 VE2DZO	324/603
VE3 VE3JAR	271/519
VE4 VE4ADG	219/414
VE6 VE6BBC	54/102
VE7 VE7CMT	255/459

Flatland Farmer Chapter 10-X International Net, Inc.

Amateur Radio Station



CERTIFICATE IS ISSUED
FOR PROVEN AND SINCERE EFFORTS TO PROMOTE
FRIENDSHIP, GOODWILL, AND OUTSTANDING COMMUNICATIONS
ON 10-METERS.

Certificate Number

Chapter Head

Date

Awards Manager

NET FREQ. 28 745 MHZ
Sundays 1900 hrs. Local Time

There will be no multipliers used or consideration given for multi-operators.

The normal requirements for the award are a total of 10 points as follows: Charter members (#01C-24C) = 5 points; Local members (#101L-500L) = 2 points; Associate members (#501A and up) = 1 point. Submit your request with \$1.00 and two first class stamps to the certificate manager, Lou Reik WB9YJE (see above for address).

SODBUSTER AWARD

The Sodbuster Award is the newest award. It is a 3- x 2 1/2-inch self-sticking award that is to be placed on your basic certificate. This award requires 50 points. This award in itself will be worth 3 points. The point breakdown for the Sodbuster Award is as follows: Charter members are worth 5 points; Local members are worth 3 points; first staters and first DX are worth 2 points; all other Associate members are worth 1 point. Submit your request along with 3 first class stamps to the certificate manager, Lou Reik WB9YJE.

For those interested in the Flatland Farmer Chapter, it meets each Sunday night at 1900 hours local IL time on 28.745 MHz.

ARRL 10 METER CONTEST

Starts: 1200 GMT

Saturday, December 9

Ends: 2359 GMT

Sunday, December 10

The contest is open to all amateurs worldwide. All QSOs must take place on 10 meters, and OSCAR QSOs are valid. Each station can be worked on phone-to-phone and CW-to-CW, and anyone can work anyone. All CW contacts must be made between 28.0 and 28.5 MHz, unless working through OSCAR. When operating on 10 meters, please avoid the OSCAR downlink frequencies. **CLASSES:**

Entries will be classified as either single- or multiple-operator stations. Multiple-transmitter stations are not allowed. **EXCHANGE:**

All WIVE stations will send RS(T) and state or province. Others will send RS(T) and consecutive serial number starting with 001. Stations that are not land-based will send RS(T) and ITU Region (1, 2 or 3). The District of Columbia is counted as part of Maryland. **SCORING:**

Each completed QSO counts 2 points, or 4 points if with a W or K Novice. The multiplier is the sum of the total number of states, Canadian call areas (max. 9), ARRL countries (not US or Canada), and ITU regions

from non-land-based stations. Final score is the sum of the QSO points times the total multiplier.

AWARDS:

A certificate will be awarded to the highest-scoring single-operator station in each section, Canadian call area, and foreign country. Region awards for non-land-based stations and awards for multi-operator and Novice stations will be issued if warranted. **FORMS:**

It is suggested that contest forms be obtained before the contest from the ARRL, 225 Main St., Newington CT 06111; include an SASE. Checksheets are not required, but a penalty of 3 additional contacts will be made for each duplicate contact.

These rules were taken from last year's contest. For complete rules, see the November issue of QST.

1978 CW CHRISTMAS PARTY

The Society of Wireless Pioneers (SOWP) is planning a membership Christmas on-the-air CW QSO Party for the weekend of December 16 and 17, 1978. The party will cover the full GMT period to allow members around the world to participate.

All members with amateur licenses are being encouraged to take part. The call will be CQ SOWP. While there will be no certificates or other awards given—everyone who takes part will be a winner by having an opportunity to renew old friendships, establish new ones, and continue a camaraderie developed over the years.

Suggested frequencies for the party are between 50 and 60 kHz up from the low end of each amateur band. Novices should consider the middle of each Novice band. Additional information about this party and the Society can be obtained from the Party Coordinator, Bill Willmot K4TF, 1630 Venus Street, Merritt Island FL 32952.

ARRL STRAIGHT KEY NIGHT

0100-0700 GMT

Monday, January 1

Check QST for any changes in the rules!

Basically, rules require the use of a straight key only. Send "SKN" instead of "RST" during QSOs, to help identify contest stations. On 80-40-20 meters, try 060 to 080 kHz up from the bottom edge of the band. On Novice bands, try 10 kHz up from the bottom of the Novice band. After the contest period, send a list of calls of the stations contacted during the contest period, plus your vote for the best fist heard. Please mail entries as soon as possi-

THE 73 MAGAZINE 10 METER AWARDS

The return of vigorous solar activity means that 10 meters is once again a band to be reckoned with. Of Sol's 11-year cycle of sunspot production is about to hit a peak, with the result that QRP 10 meter DX is possible.

Now's the perfect time to convert that old CB rig to 10 (or buy a brand new one from Bristol or Standard) and join the fun. We've had many articles showing you just how easy a CB-to-10 conversion really is. To give you an added incentive, 73 is offering two nifty Certificates of Achievement for 10 meter channelized communications.

For domestic types, there is the 10-40 Award. This one should be pretty easy—just work 40 of the 50 states. The DX Decade Award goes to DXers who work 10 or more foreign countries with a channelized 10 meter rig. We have endorsement stickers, too—the whole bit.

To give everyone an equal shot at award #1, only contacts made October 1, 1978, or after will be valid.

Well, don't just sit there. Get out your soldering iron, order some crystals, and put that CB rig on 10. This is going to be fun, so don't miss out!

RULES

1) All contacts must be made in the 10 meter amateur band using channelized AM equipment. Both converted Citizens Band equipment and commercially-produced units (such as those available from Bristol Electronics and Standard Communications) may be used.

2) To be eligible for award credit, all contacts must be made October 1, 1978, or after.

3) The 10-40 Award is available to applicants showing proof of contact with stations in at least 40 of the 50 United States. A special endorsement sticker will be available to those working all 50 states.

4) The DX Decade Award is available to applicants showing proof of contact with at least 10 foreign countries. Endorsement stickers will be awarded for 25, 50, 75, and 100 countries.

5) A log of stations worked, with the date, time, and type of equipment used for each contact, must be submitted when applying for each award or endorsement.

6) Each application for an award or endorsement must be accompanied by a signed statement that all claimed contacts are valid. No QSL cards need be sent, but they must be in the possession of the applicant.

7) To cover costs, a fee of \$5.00 must accompany each application for the 10-40 or DX Decade Award. The fee for endorsement stickers will be \$2.00 each.

8) All award applications should be mailed to: Chuck Stuart N5KC, 5115 Menefee Drive, Dallas TX 75227.

ble to the ARRL, 225 Main Street, Newington CT 06111.

SLOW SCAN TELEVISION NEWS

Amateur Television Magazine is now offering a series of award certificates for SSTV activity ranging from a basic award through several levels of difficulty to a Master Scanner Award. The beginning level certificate requires the SSTV operator to have confirmed five SSTV contacts on each of any five ham bands, a total of 25 contacts. The bands used for all the levels may be any combination of the contestant's choosing. Additional awards are available for working increasing numbers of stations on increasing numbers of bands. Each certificate is 8 x 11 inches and suitable for framing. ATV Magazine will publish the names and calls of each certificate holder as issued with each award numbered consecutively. The various

award levels are as follows: 5 SSTV QSOs on each of any 5 bands = 25 contacts total; 6 SSTV QSOs on each of any 6 bands = 36 contacts total; 7 SSTV QSOs on each of any 7 bands = 49 contacts total; 8 SSTV QSOs on each of any 8 bands = 64 contacts total; 9 SSTV QSOs on each of any 9 bands = 81 contacts total; 10 SSTV QSOs on each of any 10 bands = 100 contacts total.

In addition to the normal frequency bands, the use of OSCAR may be used as 2 bands for any two OSCAR modes, i.e., 5 contacts via 450/144 OSCAR would count as 1 band for the basic certificate.

Applicants should send proof of QSOs and \$1.00 for postage for each award to: SSTV Master Scanners Awards, PO Box 1347, Bloomington IN 47401. Allow two weeks for processing and award preparation. SSTV contacts must have been made after Sept. 1, 1978, to qualify!

from page 20

W4KPK daily on 14210 at 1200Z. QSL to K4MQG.

South Shetlands—CE9AT

CE9AT meets WA2HNE daily on 21335 at 1600Z. Tune in about a half hour earlier to get your call on the list. US, VE, and XE stations can QSL to CE2BIO, Antarctic Department, Naval Post Office, Valparaiso, Chile. Include an SASE with 15¢ USA postage.

Svalbard—JW7FD

Rag has been showing in the 14200 to 14250 slot on twenty meters after 1000Z. Between 1700 and 1800Z he moves to fifteen meters, sometimes visiting the Africana Net on 21355. QSL to LA5NM.

Tonga—A35CR

Clark plans to be in Tonga for about a year as a member of the Peace Corps. Look for him around 14240 most days after 0700. QSL to Box 147, Nuku' Alofa, Tonga.

Walvis Bay

The Northern California DX Foundation has indicated a willingness to supply a beam and equipment for an operation if it can be assured that it will be a duly licensed operation, there being some doubt whether one of the previously heard stations did have a valid Walvis Bay license. South Africa continues to insist that Walvis Bay is their territory and has been for over 100 years. Namibia, on the other hand, has only been administered since its capture by the Germans during World War I. This will all be worked out eventually, so work them if you hear them and worry later.

Rhodes—SV0

SV0WTT has been trying to get permission from the Greek licensing authorities for an operation from Rhodes Island in the Dodecanese group. While the US has a reciprocal licensing agreement with Greece, it is still difficult to get permission to operate from Rhodes and just about impossible to get permission to operate from Mount Athos. In the meantime, Jack can usually be found around 7003 from 2230 and 21003 after 0300Z. Give him a call and you'll get the latest word on Rhodes.

United Arab Emirates—A6XB

A month or so back, we reported that all A6 operations had ceased. Apparently this is

not completely true. Vernon Dameron K1DRN, QSL manager for A6XB for the past seven years, says that from the QSL cards he is receiving for A6XB, there is still plenty of activity. CW operation is completely forbidden though, so any A6s you hear on CW are phony.

Brunei—VS5XU

Look for this one from 1300Z daily in the 14200 to 14210 slot. A good operator, he stays away from lists and generally works by call districts. QSL via DL1DL.

East Malaysia—9M8HG

CW contacts can be made with this rare one near 14003 around 1300Z and near 21025 after 1500Z. QSL to Horace Cray, PO Box 2242, Kuching, Sarawak, East Malaysia.

Iraq—YI1BGD

Magid seems to have settled into a regular routine operating transceive on 14310 after 2100Z. Although handicapped by a weak antenna and low power, he continues to do a terrific job and show a lot of patience, seldom losing his cool. At the end of each Friday session, a list is taken by districts for the following week's session. QSL to Box 5864, Baghdad, Iraq.

Lord Howe Island—VK2AGT

Dick can usually be found around 14225 from 0600 to 0700Z, especially on Wednesdays. He is looking for Nebraska, Utah, and Wyoming to fill out his WAS. QSL to Dick Hoffman, Lord Howe Island, N.S.W. 2829, Australia.

Mongolia—JT1BF

On almost daily from 1100 to 1400Z. UW0NE is the list-taker and MC. QSL to PO Box 6, Vladivostok, USSR.

BITS AND PIECES

The Johnson Island Radio Club has received a number of cards for contacts with KJ6DL, operator Henry, during the period July 18 to August 1. KJ6BZ reports that this station is unknown and cards are being returned.

A show of hands at the DX Forum at DXPO 78 showed that 98% of those present favored making the DXCC awards pure by disallowing any cross-mode contacts. A majority also favored dropping the "separate administration" clause from the DXCC country criteria. This is the clause that gave us 4U1TU/4U1UN and Sable

Island.

There are three different groups from as many countries planning future Bovet action.

The TF6M operation garnered 10,800 QSOs in 85 hours. They worked 121 countries on five continents, including all states but Hawaii.

Some new prefixes have been announced. These include J4 for Greece and J3 for Guinea Bissau.

Congratulations to W5OPC, WA5KGQ, and WB5OJO for providing a vital communications link to the *Double Eagle II* during the first-ever transoceanic balloon crossing. Amateur radio proved to be the only method of communications when a faulty transmission cable aboard the balloon knocked out the commercial frequency equipment. A special QSL will be sent to all those lucky enough to make contact.

By the time you read this, the new beam supplied by the Northern California DX Foundation should be up and in operation at 4U1UN.

As of the end of July, total licensed amateurs in the United States numbered 348,561, up 8.5% in the last year.

Jacky F6BBJ, one of the top French DXers, has been looking toward the Red Sea and the islands off East Africa for some possible DXpedition action around the end of the year. Other Frenchmen closer to home have been eyeing St. Barthelemy Island north of Guadeloupe for possible DXpedition action if DXCC approval can be obtained.

Volunteer examiners are needed by the FCC to administer amateur examinations to blind and physically handicapped applicants. Contact your local FCC office for more information.

Rules and application blanks for the World Radio W-100-N, Worked 100 Nations Award, can be obtained by sending an SASE to World Radio, 2120 28th Street, Sacramento CA 95818.

The DXAC recently vetoed DXCC status for the Republic of Sealand. The Republic of Sealand is an old British air-defense radar tower similar to a drilling tower, located just off the English coast. It was purchased by a group hoping to turn it into a gambling casino. They issued passports, minted stamps, and even had their own currency. Apparently it was a good idea because another group invaded Sealand and captured it by force. The original group then rearmored and recaptured Sealand and imprisoned the invaders' leader. After all this, the DXAC still said no.

Bill A35WL will be returning to New Zealand soon, but while on Tonga, he has been conducting radio classes. Hopefully, one of the graduates will remove A35 from your needed list.

Last month, we mentioned the possibility of a future DXpedition to Oneo Island in the South Pacific. For those of you trying to find it on your map, look northwest of Pitcairn and west of Henderson Island.

There is a report that Iraq and Saudi Arabia have signed an agreement concerning their neutral zone, so if you haven't worked 8Z4, now is the time.

FG7AS does QSL—sometimes a year late, but he does QSL. On that same subject, there is a report out of Moscow that the USSR QSL Bureau is running out of funds and must cut back on their manpower. This will mean an even longer wait for those needed Russian QSLs.

HH2MC advises that there are now 17 members in the Port-au-prince Radio Club. Haiti has applied for IARU membership and is waiting for action to be taken on its application.

Baruch 4Z4TT plans to head back into the Pacific before next summer. VR1 is a possible stop. Let him know if you have any favorites.

Congratulations to K1DG on winning the 1978 Bermuda DX Contest and the all-expense-paid trip to Bermuda that goes to the winner. K3DH was the top scorer in the third call district for the 5th straight year.

Alex 3B8DA reports making better than 10,000 contacts from 3B9 and some 5,000 from 3B6.

The September issue of *National Geographic* had an article on JA1QFW's solo walk to the North Pole.

KM6FC left Midway Island last October and headed for Maine. Len logged better than 23,000 QSOs during his stay. Two operators remain at KM6BI. KM6BI contacts before July, 1978, go to W8TIZ; afterwards, to W5RU at the Delta DX Association.

It is reported that the VU Bureau has gone bankrupt and folded operations. It might be prudent to seek a direct QSL route for VU contacts.

It seems there will be no ZS6QU/ZS3 QSLs forthcoming. ZS6QU first reported that an office girl had accidentally dumped the incoming QSLs into the wastebasket. Those who tried again received only silence for their efforts.

Jack K9OTB has ceased QSL operations for FP8DX/FP8ML and FP8HL. He will still help you for contacts with FP8DX/FP8ML and his own call,

NEW

for '78

The FM Deviation Meter Anyone Can Afford

\$189

less batteries and crystals

ECM-5B MK-II fm modulation meter

- Now used by the U.S. Government in over 50 locations
- All new unbreakable A.B.S. cabinet
- 0-6 kHz peak reading linear scale
- Operates 25 MHz to 500 MHz
- Crystal controlled for easy operation
- Audio/Scope output with earphone
- Options: NICAD power PAK \$34.95
Charger \$39.95

Write or call for complete information. Send check or money order for \$189. Shipping prepaid in U.S. Indiana residents add 4% sales tax. Crystals \$7.95 each.

ECM Corporation
412 N. Weinbach Ave.
Evansville IN 47711
812-476-2121 E1



Radio equipment not included

Floor Space: 39" Wide 30" Deep

4384 KEYSTONE AVENUE • CULVER CITY, CALIF 90230 — PHONE (213) 837-4870

... at last ...

your shack organized!

A beautiful piece of furniture — your XYL will love it!

\$13995 S-F RADIO DESK Deluxe - Ready to Assemble

Designed with angled rear shelf for your viewing comfort and ease of operation.

FINISHES: Walnut or Teak Stain.

Also available in Unfinished Birch, \$124.95.

Additional Information on Request.

Checks, Money Orders, BankAmericard and Master Charge Accepted.

F.O.B. Culver City. (In Calif. Add 6% Sales Tax.)

✓ S33

S-F AMATEUR RADIO SERVICES

HIGH PERFORMANCE CONVERTER AND PRE-AMP FOR

OSCAR

UHF Converter



Model
C-432A (408)

\$5995

- Converts 432 or 435 MHz to 29 MHz. (Be sure to specify the input frequency you want)
- 2 tuned RF stages using low noise J-FETs eliminates the need for a separate UHF pre-amp
- Special RCA dual-gate MOSFET mixer gives good conversion gain and minimum cross modulation
- High frequency quartz crystal oscillator and multiplier stages use 1.2 GHz transistors for maximum efficiency
- Conversion gain is more than 20 dB (typically 25 dB) therefore assuring you 1 microvolt sensitivity when used with an average communications receiver
- Just connect a simple turnstile antenna (see Nov. '77 of 73 Magazine) and a 12 volts DC power source (only 30 mA required) and you're ready to receive.

SEE OUR OTHER PRODUCTS IN THE FULL PAGE AD OF THE DECEMBER 1977 ISSUE OR WRITE FOR CATALOG SHEET.

Low Noise • High Gain Pre-Amp For 29 MHz.



Model
201-29

\$2995

- 35 to 40 dB power gain at 29 MHz with a noise figure of only 2.0 dB and a bandwidth of 1 MHz.
- Makes reception of OSCAR possible even with low cost receivers or old receivers with poor sensitivity at 29 MHz.
- Two RF stages using dual-gate MOSFETs
- Manual gain control and provision for AGC
- Requires 12 volts DC at 10 mA.

For immediate shipment of either item call (212) 468-2720 or mail your order with payment plus \$1.00 for air mail to:

VANGUARD LABS
196-23 Jamaica Ave.
Hollis, NY 11423

✓ V1

REGULATED POWER SUPPLY

- Fully regulated, dual protected, 13.8 volts
 - Illuminated on/off switch
 - Hammer-tone metal case

33 Amp (30 Amp continuous) \$119.95
20 Amp (16 amp. cont.) \$74.95
8 Amp (6 amp. cont.) \$39.95

TIMES CABLE

RG-8U - 100' multiples 18c/ft.
RG-213U - (Non-contaminating jacket)
- 100' multiples 22c/ft.
1/2" Aluminum Jacketed hardline - 75 ohm,
1000' rolls only 29c/ft.
PL259 connectors 25/50c ea.
or 100/45c ea. POSTPAID

UNIVERSAL TOWERS

SUPER DISCOUNTS —

S.A.S.E. for brochure and prices!

Send S.A.S.E. for additional information. Include shipping charges with check or money order. (Ohio residents add 4 1/2% sales tax)

JRS ELECTRONICS ✓ JB
P.O. Box 1893—Cincinnati, Ohio 45201

FAST SCAN ATV

ALL YOU NEED IN ONE BOX



Show the shack, home movies, computer games, etc. Connect to the ant. terminals of any TV set, add a good 450 antenna, a camera, and you are there ...

- 10 Watts peak RF output. Specify 434.0 or 439.25 MHz
- Subcarrier sound with plenty of mic gain for distance pick-up.
- 8 MHz bandwidth, high resolution necessary for computer alphanumeric and color.
- Tuneable converter covers 420 to 450. (Covers CH 2, 3)
- Contains AC to 12VDC regulated 3 AMP power supply.
- Only \$399.00 direct mail. Check, Money Order, VISA. Send S.A.S.E. for catalog of ATV Modules and PC Boards.

P.C. ELECTRONICS

Maryann WB6YSS 2522 PAXSON Tom W6ORG
ARCADIA, CA 91006

Radio World

CENTRAL NEW YORK'S FASTEST
GROWING HAM DEALER



YAESU FT 901DM



YAESU CPU 2500RK

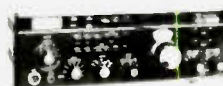

DRAKE TR7 DR7



ICOM IC 701

Featuring Yaesu, Icom, Drake, Atlas, Ten-Tec, Swan, Dentron, Pace, Palomar, Alda, Midland, Wilson, KDK, MFJ, Microwave Module, Standard, Tempo, Astron, KLM, Hy-Gain, Mosley, Larsen, Cushcraft, Hustler, Mini Products, Universal and Tristao Towers. We service everything we sell! YOU WON'T BE DISAPPOINTED.

We are just a few minutes off the
NYS Thruway (I-90) Exit 32

ONEIDA COUNTY AIRPORT TERMINAL BUILDING
ORISKANY, NEW YORK 13424

Warren K2IXN 315-337-2622 or 315-337-0203 Bob WA2MSH

FP0YY.

VU2ANI became a silent key in 1976 and several are searching for his logs. K6TWT doesn't have them.

W0BW is trying to get confirmation on contacts with CR6OB in November, 1975, and D2ACK in July, 1976. Any assistance would be appreciated.

NOVICE CORNER

Last month, we talked about the incoming QSL bureaus and how to make sure you received any QSL cards directed to you via that route. This month, we will discuss the best way to send QSLs. Whether you QSL direct, via the bureau, or through a QSL manager, you'll want to be able to pick the best route for that particular card. Best route in this case means the one that is the most likely to produce a card in return, not necessarily the cheapest or even the fastest. Remember, confirming the contact is the result we are after.

QSL managers are almost always the best route to go. If the station you work has a QSL manager, then you can usually be assured of a fast confirmation. Sometimes problems develop like logs getting lost or an inexperienced QSL manager not realizing the scope of the task he has undertaken, but generally QSLing via a QSL manager will produce the fastest results. Here is the way it works: After looking up the QSL manager's address, fill out a QSL in the normal manner, but make sure that your call is written on the report side of the card. QSL managers don't like to have to stop and flip a card over to see who sent it. That can be very time-consuming. Next comes the SASE. SASE stands for self-addressed stamped envelope and that's exactly

what it is. Address the envelope in the normal manner, except address it to yourself and don't forget to stamp it. Now, when the QSL manager fills out your card, he just drops it into the SASE, seals it, and mails it back to you. Some QSL managers like to have the call of the DX station and the date and time of the contact written in the lower left-hand corner of the envelope. This helps them to file your envelope until the logs arrive from the DX station. If the QSL manager is located outside the United States, skip the postage stamp and drop a one dollar bill in the envelope. There are other ways, such as using IRCs or foreign postage, but a dollar bill generally produces the best results.

If no QSL manager exists for a particular station, then the next best route is direct to the station's home QTH. If the station accepts direct QSLs, he will usually pass you his address during the contact. This is generally a PO box number, so it is no problem to pass. Since the DX station receives many QSL requests, he will usually return your QSL via the bureau unless you enclose an SAE along with the usual dollar bill. Again, IRCs or foreign mint stamps can be used, but the dollar bill produces the best results. IRCs, which can be purchased at your local post office, are too expensive and are not always accepted in some countries. One thing can be said for foreign mint stamps. Once you stick them on your SAE, they are useless to the DX station for any purpose other than to return your card. One thing must be kept in mind when considering direct QSLing. If the DX station says to QSL via the bureau or via his QSL manager, there may be a reason that he doesn't want

cards sent directly to him. In some countries, the ownership and use of a radio transmitter can cause problems with the local authorities. Receiving mail addressed to an amateur radio station from all over the world would be a dead giveaway. It's always best to follow the QSL instructions given by the DX station. They will usually produce the best results.

The slowest, but by far the least expensive, method of QSLing is via the bureau. In many cases, such as the Iron Curtain and Soviet countries, QSLing via the bureau is the only way. The best way to QSL via the bureau, especially if you have many cards going to several different countries, is to ship them all in one bundle to one of the outgoing QSL bureaus.

If you belong to the ARRL, you can send your cards along with one dollar and the label from your last issue of QST to the ARRL Outgoing QSL Bureau. A shortcoming of the ARRL bureau is the fact that they will only forward QSLs to countries which have an incoming QSL bureau. Many countries have only a few hams and do not support a QSL bureau. In fact, of the 319 "countries" currently recognized for DXCC contacts, the ARRL Outgoing QSL Bureau will forward cards to only about 160. Fortunately, there are several good commercial QSL forwarding services that will forward your cards anywhere for about 5¢ per card. W3KT is one. There are several others.

In summation, of the three QSLing methods we have discussed, the QSL manager is almost always the best route, followed by direct QSLing, and then the bureau. In all cases, it is best to follow the QSL instructions given by the DX station himself. Good luck.

QSL INFORMATION

A6XP—see text
FK8AH—Robert Garbe, Aviation Civile, La Tontouta, New Caledonia
FP8DH—K9OTB
FP8YY—K9OTB
H5AW—ZS6AW
HZ1BS/8Z4—OE6EEG
J20BL—F6BFN
KJ6DI—see text
KM6BI—see text
OJ0MA—OH0NA
PW0PP/PY0RO—W1DA
ST2HF—G4GFI
TJ2P—see text
VGW-211—see text
VK9ZR—VK2BJL
ZD7WT—W3KT or via SARL
3B6DA/3B9DA—3B8DA
3B8YY—K5YY/K5QHS
3B9ZZ—K4YT
5N2NAS—see text

Thanks to the *West Coast DX Bulletin*, Long Island DX Association, and *World Radio Magazine* for much of the preceding information.

STATEMENT OF OWNERSHIP, MANAGEMENT AND CIRCULATION (Required by 39 U.S.C. 3685). 1. Title of publication, 73 Magazine. 2. Date of filing, Oct. 1, 1978. 3. Frequency of issue, Monthly. A. No. of issues published annually, 12. B. Annual subscription price, \$15. 4. Location of known office of publication (Street, City, County, State and ZIP Code) (Not printers), Pine Street, Peterborough, Hillsboro County, N.H. 03458. 5. Location of the headquarters or general business offices of the publishers (Not printers), Pine Street, Peterborough, Hillsboro County, N.H. 03458. 6. Names and complete addresses of publisher, editor and managing editor. Publisher (Name and Address), Wayne Green, Peterborough, N.H. 03458. Editor (Name and Address), Wayne Green, Peterborough, N.H. 03458. Managing Editor (Name and Address), John Burnett, Peterborough, N.H. 03458. 7. Owner (If owned by a corporation, its name and address must be stated and also immediately thereunder the names and addresses of stockholders owning or holding 1 percent or more of total amount of stock. If not owned by a corporation, the names and addresses of the individual owners must be given. If owned by a partnership or other unincorporated firm, its name and address, as well as that of each individual must be given.) Name, 73 Inc., Peterborough, N.H. 03458. Wayne Green, Peterborough, N.H. 03458. 8. Known bondholders, mortgagees, and other security holders owning or holding 1 percent or more of total amount of bonds, mortgagees or other securities (If there are none, so state) Name, none. 9. For completion by nonprofit organizations authorized to mail at special rates (Section 132.122, PSM). The purpose, function, and nonprofit status of this organization and the exempt status for Federal income tax purposes (Check one) Not applicable. 10. Extent and nature of circulation. (X) Average No. copies each issue during preceding 12 months. (Y) Actual No. copies of single issue published nearest to filing date. A. Total No. copies printed (Net Press Run) (X) 77,550 (Y) 80,000. B. Paid circulation 1. Sales through dealers and carriers, street vendors and counter sales (X) 13,590 (Y) 14,585. 2. Mail subscriptions (X) 56,290 (Y) 58,547. C. Total paid circulation (Sum of 10B1 and 10B2) (X) 69,880 (Y) 73,132. D. Free distribution by mail, carrier, or other means samples, complimentary, and other free copies (X) 740 (Y) 820. E. Total distribution (Sum of C and D) (X) 70,620 (Y) 73,957. F. Copies not distributed 1. Office use, left over, unaccounted, spoiled after printing (X) 5,840 (Y) 6,048. 2. Return from news agents (X) 1,090 (Y) None. G. Total (Sum of E, F1 and 2—should equal net press run shown in A) (X) 77,550 (Y) 80,000. 11. I certify that the statements made by me above are correct and complete. Signature and title of editor, publisher, business manager, or owner Robert R. LaPointe, Business Manager.

Ham Help

I need a manual and/or schematic for the Multiphase Exciter Model 20-A made by Central Electronics, Inc., during the 1950s. I will copy, and return in good condition.

A. McGinnis WA2DTQ
55 Patton St.
Iselin NJ 08830

I am indeed very, very sorry that I waited this long to thank you for publishing my letter in the August issue.

It seems that when it rains, it pours. (I hate to use an old saying.) In August, I suddenly found that I had some friends,

for I suddenly received a few letters and coils, and being partially blind, it took about 2 weeks to discover that my letter was in the magazine, and then to find it. In addition to this, I was studying to get my Novice ticket, and I can announce that on September 1, 1978, I became WD0???

Anyway, I'm also busy setting up my shack and figuring out the best way to put up my antenna, and it is creating some problems. Somehow I'll be able to be on the air when my license arrives. However, whenever I get some time, I've

been slowly trying to get my telephone together, and with luck, I should have it working soon.

So, again I want to thank you, and all the other people who have been so kind to me, and have done so much to help me. So, thank you, and I'll hear you all on the air shortly.

Ron Peterson WD0???
Route 1, Box 151
Clear Lake MN 55319

I would be interested in talking to anyone who has developed a simple, chirp-free CW keying circuit for the Kenwood TR-7400A so that the transceiver can be used for 2 meter OSCAR work.

John Mollan WA7ATU
7805 NE 147th Ave.
Vancouver WA 98662

**QUASAR VIDEO
TAPE RECORDER
SALE!**

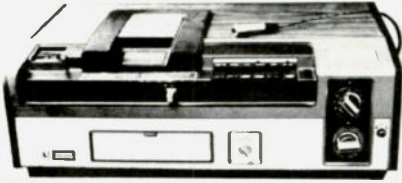

We are constantly testing ham and other electronic equipment for review in 73 Magazine. In order to be able to keep this not inexpensive project going we have to sell off the equipment used for test. Most of it has been used for a few days and is in every way as good as new. In many cases it is better than new since 95% of the equipment failures come within the first few hours of operation.

In this case we are running a series of tests of VTR systems, using them for regular, ham TV, SSTV, and even micro-computer programming tests. One of the best we've found so far is the Quasar system, but we still have to go on and test the RCA, JVC, and many other systems . . . so our Quasar is up for sale. We paid well over \$1,000 for the Quasar . . . used it for a few days and have gone on to test more systems.

Quasar VTR System special like new \$675.

73 MAGAZINE
Peterborough NH 03458

Major Credit Cards Accepted.

FREQUENCY STANDARD

RAINBOW INDUSTRIES

PROVIDES STRONG, PRECISE MARKERS EVERY 1 MHz, 500, 250, 100, 50, 25, 10, 5, 2.5, 1 KHz, 500, 250, 100, 50, 25 Hz WELL INTO THE VHF RANGE.

- ★ USE AS MARKER GENERATOR FOR HAM RECEIVERS
- ★ OSCILLOSCOPE TIME BASE CALIBRATOR
- ★ C-MOS IC CONSTRUCTION
- ★ POWER REQUIREMENTS 6.5 V to 15 V at 15 ma. (9 V Radio Battery excellent)
- ★ ZERO TO WWV



See July 78 '73 page 146 for more information.

COMPLETELY ASSEMBLED IN CABINET

\$3995

Please Add Postage

WIRED PC BOARD

\$2495

Board Size 3 1/4" x 2 1/2"

EDGE CONNECTOR INCLUDED

P. O. BOX 2366 INDIANAPOLIS, IND. 46206

DOVETRON

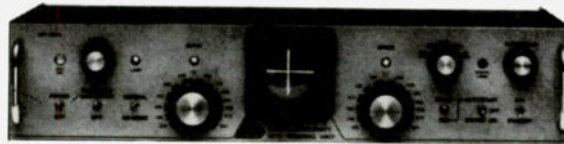

MPC-1000C

Multipath Correction In-Band Diversity & AFSK Tone Keyer

Amateur Net: \$545.00

Standard features include CONTINUOUSLY tuneable Mark and Space channels (1000 Hz to 3200 Hz), Dual Mode (MARK or FSK) Autostart and internal high level neutral loop keyer (20 to 60 ml). Both EIA and MIL FSK outputs are provided for direct interface to microprocessor and video terminal peripherals.



MPC-1000CR

Signal Regeneration & Speed Conversion

Amateur Net: \$645.00

A front panel switch permits internal TSR-200 Signal Regenerator-Speed converter assembly to electronically "gear-shift" between 60, 67, 75 and 100 WPM. All incoming and outgoing signals are regenerated to less than 0.5% bias distortion. Also available with DIGITAL Autostart (TSR-200D): Amateur Net: \$695.00



MPC-1000R/TSR-500

Dual UART Regeneration, Speed Conversion, 200 Char. Memory, Word Correction & DIGITAL Autostart

Amateur Net: \$895.00*

The MPC-1000R/TSR-500 provides Preloading and Recirculation of the 200 character FIFO Memory, a keyboard-controlled Word Correction circuit, Variable Character Rate, Tee Dee Inhibit, Blank/LTRS Diddle, a Triple Tone-Pair AFSK Tone Keyer and a Character Recognition/Speed Determination DIGITAL (DAS-100) Autostart mode.

*The MPC-1000R is also available without a TSR assembly and functions as a MPC-1000C with a Triple Tone-Pair AFSK Tone Keyer. This "Basic-R" permits future expansion with a TSR-100, TSR-200, TSR-200D or TSR-500 by simply lifting the lid and plugging in the appropriate TSR assembly: Amateur Net (Basic-R): \$595.00

Your QSL will bring complete specifications, or call: 213-682-3705.



627 FREMONT AVENUE
(P. O. BOX 267)
SOUTH PASADENA, CA. 91030

✓ D23

✓ Reader Service—see page 323.

**FT-227
"MEMORIZER"
OWNERS: SCANNER KIT**

- Selectable sweep width (up to full band)
- Scans *only* the portion of band you select
- Scans at the rate of 200 kHz per second
- Switch modification on mike allows you to scan past, or lock on, any occupied frequency
- Complete kit with detailed instructions
- Installs *inside* rig; no obtrusive external connections
- Rig can easily be returned to original condition whenever desired
- Scans to preset limits and reverses
- Automatic bypass of locked frequency in 3 1/2 seconds unless you press lock-on switch

Kit \$34.95 [add \$1.50 postage & handling]
pre-assembled and tested \$54

**IC22S SCANNERS ALSO AVAILABLE
KIT \$34.95;
PRE-ASSEMBLED AND TESTED \$54
[add \$1.50 postage & handling]**

DEALER INQUIRIES INVITED

AED ELECTRONICS
750 LUCERNE RD SUITE 120
MONTREAL QUEBEC CANADA
H3R 2H6
TEL 514 737 7293

✓ A60

**JUST GETTING ON THE AIR?
See Adirondack for**



- New Equipment
- Used Gear
- Friendly Advice

ADIRONDACK Radio Supply

185-191 West Main Street • P.O. Box 88
Amsterdam, N.Y. 12010 Tel. (518) 842-8350
Just 5 minutes from N.Y. Thruway - Exit 27

More Economical RTTY



The ST-5000 from HAL

The HAL ST-5000 sets the pace for an economical demodulator/keyer for radio-teletype (RTTY). All the features you need for reception and transmission of HF and VHF RTTY are here.

The demodulator features a hard-limiting front end, active filter discriminator, and active detector circuitry for wide dynamic range. Autostart and motor control circuitry make for easy VHF and HF autostart operation.

Convenient front panel switches are provided for 850 and 170 Hz shift, normal or reverse sense, autostart on/off, print - line or local, and power on/off. 425 Hz press transmissions may also be copied with the ST-5000. High voltage 60 ma. loop output as well as low level RS-232 compatible output are provided by the demodulator.

The audio keyer section of the ST-5000 generates stable, phase-coherent audio tones. Transmission is a simple matter of applying these tones to your HF SSB or VHF FM transmitter.

The ST-5000 is housed in an attractive blue and beige cabinet and is backed by the HAL Communications one year warranty.

For complete specs on the HAL ST-5000, write or call HAL today.

\$275.00



HAL Communications Corp., Box 365, 807 E. Green St.
Urbana, Illinois 61801 • Telephone (217) 367-7373

DUPLEXERS

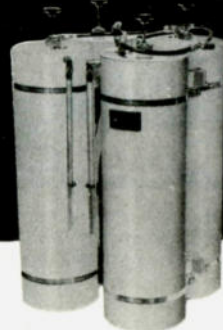

US PATENT
4080601

✓ W15

OUR NEW BANDPASS-REJECT DUPLEXERS WITH OUR EXCLUSIVE

BpBr CIRCUIT*

... provides superior performance, especially at close frequency spacing.

Models available for all Ham bands. Special price for Amateur Repeater Clubs

CALL OR WRITE FOR DETAILS:

WACOM PRODUCTS, INC.



Box 7307
Waco, Texas 76710
817/776-4444

The **ONLY** thing you need to know about

Quartz Crystals

is: **1-405-224-6780**

- Best delivery plus Emergency Service with Guaranteed Delivery
- Highest Quality with gold MIL-C-3098 Process
- Ask for Sentry Technology Manual

And, order Toll Free 1-800-654-8850

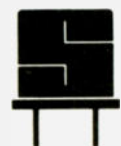

SENTRY

✓ S3 Crystal Park
Chickasha, Oklahoma
73018

Swan SWR-3 \$14.50
 Swan SWR HFM-200 44.95
 Swan SWR WMM-200 44.95

Authorized dealer for:
 TEN — TEC — Swan — Yaesu
 — ICOM — Drake — Wilson —
 Astatic — Tempo — KDK —
 Robot — Dentron — Alpha —
 Astron and SAY Power Supplies
 CDR — Kirk Quad — Nye Viking
 Mosley — Hy-Gain and Others:
call for special prices



universal amateur radio inc. ✓ U6



1280 AIDA DRIVE
 COLUMBUS, OHIO
 (Reynoldsburg) 43068

(614)-866-HAMS

CHRISTMAS SPECIALS

Gift Certificates — Any amount
 QTR-24 clocks
 By Yaesu \$29.95
 Headsets YH-55
 By Yaesu 14.95
 Bencher Paddle BY-1 39.50
 Regency Weather Alarm
 Monitor Radio 39.95
 Code Practice Set
 Key & Oscillator 20.95

*All the above items
 prepaid and shipped
 via U.P.S.*

Build Your Own CW Keyboard Keyer



Save Over \$175

QSL for full details

ECM

ECM Corporation,
 412 N. Weinbach Ave.,
 Evansville, IN 47711
 812-476-2121 ✓ E1

ALL BAND TRAP ANTENNAS!



PRETUNED - COMPLETELY ASSEMBLED -
 ONLY ONE NEAT SMALL ANTENNA FOR
 UP TO 6 BANDS! EXCELLENT FOR CON-
 GESTED HOUSING AREAS - APARTMENTS
 LIGHT - STRONG - ALMOST INVISIBLE!

FOR ALL MAKES & MODELS OF AMATEUR
 TRANSCEIVERS - TRANSMITTERS -
 GUARANTEED FOR 2000 WATTS SSB
 1000 WATTS CW. FOR NOVICE AND ALL
 CLASS AMATEURS!

COMPLETE AS SHOWN with 90 ft. RG58U-52 ohm feedline, and PL259 connector, insulators, 30 ft. 300 lb. test dacron end supports, center connector with built in lightning arrester and static discharge - molded, sealed, weatherproof, resonant traps 1"X6" - you just switch to band desired for excellent worldwide operation - transmitting and receiving! WT. LESS THAN 5 LBS.

160-80-40-20-15-10 bands 2 trap---138 ft. with 90 ft. RG58U - connector - Model 777BU ... \$54.95
 80-40-20-15-10 bands 2 trap --- 102 ft. with 90 ft. RG58U - connector - Model 998BU ... \$49.95
 40-20-15-10 bands 4 trap --- 54 ft. with 90 ft. RG58U coax - connector - Model 1001BU ... \$48.95
 20-15-10 bands 2 trap --- 26 ft. with 90 ft. RG58U coax - connector - Model 1007BU ... \$47.95

SEND FULL PRICE FOR POST PAID INSURED DEL. IN USA. (Canada is \$5.00 extra for postage - clerical - customs - etc.) or order using VISA Bank Americard - MASTER CHARGE - AMER. EX - PRESS. Give number and ex. date. Ph 1-308-236-5333 9AM - 6PM week days. We ship in 2-3 days. PRICES MAY INCREASE SO - ORDER NOW AND SAVE! All antennas guaranteed for 1 year. Money back trial! Made in USA. FREE INFO. AVAILABLE ONLY FROM.

WESTERN ELECTRONICS ✓ W18 Dept. A7-12

Kearney, Nebraska, 68847

NEW!

\$36.50 plus \$1.50 s/h
 NY res. add tax



FEATURES: CMOS ELECTRONIC KEYS

- State-of-the-art CMOS circuitry
- Self completing dots and dashes
- Dot and dash memory
- Iambic keying with any squeeze paddle
- 5-50 WPM
- Speed, volume, tone controls, side tone and speaker
- Low current drain CMOS-battery operation
- Deluxe quarter-inch jacks for keying and output
- Handsome eggshell white base—woodgrain top
- Compact and portable—1-7/8 x 4-1/4 x 6-1/4
- Grid block keying
- Wired and tested—fully guaranteed—less battery

**BRAND
NEW!**

\$25.95 plus \$2.00 s/h
 NY res. add tax

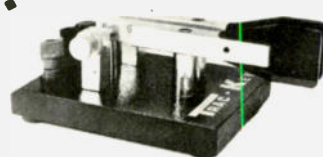

FEATURES:

- Twin paddle squeeze key
- Extra heavy base—non skid feet
- Adjustable contact spacing
- Touch tension—comfort keying
- Smooth friction free paddle movement
- Handsome crinkle finish base and rich red paddles
- Five way binding posts
- Use with TRAC CMOS keyer or any keyer

TRAC - KEY

✓ T18 **TRAC**

ELECTRONICS, INC
 1106 RAND BLDG.
 BUFFALO NY 14203

Ham Help

I would like to provide a little feedback in regard to my request (May, 1978) for information on the 8326 tube and the Hallicrafters SR500. I found out that 8326s are available from CeCo for \$22 each. They are rated at 50-Watt plate dissipation. A direct replacement is the 6DQ5; however, it has only a 24-Watt plate dissipation, so be real careful on tune-ups. The 6146B was not recommended as a replacement. I got 28 replies plus one phone call on that one. My second request was about a K-W crystal and I

got 11 replies telling me that K-W Manufacturing, PO Box 508, Prague OK 74864, made the crystal. When I sent them the bad crystal, they sent me a new one at no charge! Ham Help really works! Thanks.

**Marvin Moss W4UXJ
Atlanta GA**

I've got the kind of problem that will require the help of real hams. I have only held my Novice license a short time, and, so far, I have only been able to acquire a few books, magazine articles, etc. I have not yet been able to meet any of the local hams, and my personal knowledge level and technical resources are still very limited. But, nevertheless, I am determined to help a friend who is blind enter the exciting world of ham radio.

I would very much appreciate hearing from anyone who may have ideas or information on operating aids, and any advice at all on methods or procedures of teaching the blind. Thank you.

**Jack Beckwith WB7VBC
624 W. Linden
Caldwell ID 83605**

I am writing in the hope that someone might be able to give me some advice or possibly direct me to someone that might be of assistance. My wife and I are going to Cayman Brac, Cayman Islands, in January. The purpose of the trip is a diving vacation with underwater photography. Anyway, the other night I got the bright idea to take along a radio. A day or two later, I sent off a request for a license. Now comes the problem — weight? We are allowed a mere 47 lbs. With diving and photography equipment I'm afraid the toothbrush will have to be a lightweight one! Does anyone know of an operation on Brac? Or, can anyone come up with a solution... short of not taking my wife's diving equipment. Thanks for the help.

**John Aubrey W5EQ
1113 N. 58th Terr.
Fort Smith AR 72904**

I am building a receiver, and I need a subminiature audio transformer, such as those found in small transistor radios, with a 10,000-Ohm primary and a 1,000-Ohm secondary. Also, I must obtain a special item from a store in Regina, Saskatchewan. I would greatly appreciate hearing from any Canadian ham who could

be of assistance in obtaining it.
**Paul Hoegstrom WD8OTW
5962 S. Park Blvd.
Parma OH 44134**

I need information to convert a Motorola MICOR T53RTN1190A to ham and/or MARS 2 meter frequencies. I also need data on the SC-946 handset. Thanks.

**Frank Nollette KA0AOJ
5228 Clark
Richards-Gebaur AFB MO
64030**

I need a schematic diagram and service manuals for an Icom DV-21 digital vfo, a National HFS receiver, an Amplidyne Labs model C14 220-MHz converter, and a Centimeg 432-MHz converter.

**Jung Y. Lem KB6BO
5222 Coringa Dr.
Los Angeles CA 90042**

I need help. I bought a Mostek integrated tone receiver chip, #MK5102(n)-5, but I can't get it to do anything but look back at me from my table. I need help specifically for the input and output circuits.

**Norman E. Rosenspan
64 Berry Avenue
Staten Island NY 10312**

73

Study Guides
and
Code Tapes —
The Best Available

see page 316



HEARING AIDS!

An ancient amateur proverb has it that: "If you can't hear them, you can't work them."

That's one reason why our linearized amplifier/preamplifier combinations are the fastest selling amps in the amateur radio market. Not only do they provide you with 9 dB (almost 2 "S" units) of increased signal at the other guys' receiver; but, they also provide you with a greatly improved capability to read his signal. Our transmitting amp/preamp combos don't just give more output power; they also provide

you with the increased sensitivity you need to make those contacts that you've never made before. Remember, the other guy may not have a Lunar amp/preamp yet. Our better than 2 dB noise figure indicates that Lunar has achieved the practical limit at 2 meters for any local noise conditions you might have. Whether you're bouncing signals off the moon or trying to pick up a noisy signal in your car, Lunar's preamp in our bi-linear amplifier is the best "hearing aid" you can have.

LINEARIZED AMPLIFIERS

Accepts all modes. Power ranges from 50 to 250 watts, frequencies from 50 MHz to 220 MHz.
From \$199.95

RECEIVING PREAMPS

For the most demanding needs where low noise figure is important. Medium and high gain models now available for frequencies 28 to 450 MHz.
From \$34.95

LUNAR DEALERS ARIZONA: Communication Sales, 6727 N. Central, Phoenix 85022 • P.A.C.E. 1720 W. Wetmore Tucson 85705 • CALIFORNIA: Buddy Sales, 18552 Sherman Way, Reseda 91335 • American Radio, 2695 Mission Village Road San Diego 92123 • C.B.A. Electronics, 22010 S. Wilmington Ave. #105, Carson 90745 • H.E.M.E.C., 217 W. Gutierrez Street, Santa Barbara 93101 • Henry Radio, 11240 W. Olympic Blvd. Los Angeles 90064 • Henry Radio, 931 N. Euclid, Anaheim 92601 • H.R.O., 2620 W. La Palma, Anaheim 92601 • H.R.O., 5255 Sycamore Blvd., Van Nuys 91401 • H.R.O., 5375 Kearny Villa Road, San Diego 92123 • H.R.O., 999 Howard Ave., Burlingame 94010 • Fontana Electronics, 6620 Sierra Ave., Fontana 92335 • Lon Electronics, 457 Broadway, Chula Vista 92010 • Tower Electronics, 24001 Alcaia Parkway, Mission Viejo 92675 • DELAWARE: Delaware Amateur Supply, 711 Meadow Road, Newcastle 19720 • FLORIDA: Help Radio, 1955 Liberty Street, Jacksonville 32206 • Wal-Ga Shops, 500 Bufl View Drive, Bellare Berths 33540 • GEORGIA: Radio Wholesale, 2012 Auburn Ave., Columbus 31906 • KANSAS: Revcom, 6247 N. Hydraulic, Wichita 67219 • Wheel's Communications, 15001 Marlin Road, Olathe 66061 • KENTUCKY: Wave Radio & TV, Box 152, Irvine 40336 • MAINE: Spectrum International, Box 1084, Concord 01742 • MARYLAND: Tycal Communications, Rt. 3, Mt. Airy 21094 • MISSOURI: Henry Radio, 211 N. Main, Butler 64730 • NEW JERSEY: Radios Unlimited, 1760 Easton Ave., Somerset 08854 • Allen Communications, 5 Ocean Terrace, Hermans Beach 08739 • NEW YORK: Am-Com, N. Utica Shopping Center, Utica 13502 • NORTH CAROLINA: Telecom, 4348 Kaurerstraße Rd., Kaurerstraße 27284 • OHIO: Universal Amateur Radio, 1280 Auda Drive, Reynoldsburg 43068 • OKLAHOMA: Brodie Electronics Co., 2537 Edgewood Drive, Moore 73160 • OREGON: The Watt Shop, 1017 Madala Ave., Oregon City 97045 • Midcan Ham Sales, 1309 Skipper Ave., Eugene 97404 • PENNSYLVANIA: Maggiore Electronics Ltd., 845 Westown Road, West Chester 19380 • SOUTH CAROLINA: Maury's VHF-UHF, 253 Providence Square, Greenville 29615 • TEXAS: Madson Electronics, 1508 McKinney, Houston 77002 • Bellare Electronics Supply, 5200 Bellare Blvd., Bellare 77401 • WASHINGTON: C-Comm, 6115 15th Ave. N.W., Seattle 98107 • Amateur Radio Supply Co., 6213 13th S., Seattle 98108 • AUSTRALIA: Emona Electronics, Room 208/661 George St., Sydney NSW 2000 • ENGLAND: SOTA, 29 Cherry Vale, Woburn, Leppool L25 5PX • GERMANY: Ing. Hannes Bauer, KG, Postfach 1060, 8600 Bamberg • JAPAN: Tama Electronics, Komayama Bldg. 2F, 515 Higashi-cho, Niigata, Tokyo 177 • PORTUGAL: Germano Lopes & Cia. da Av. Fernao de Magalhães, 860 Porto • VENEZUELA: Panamericana de Comunicaciones, Apdo 78093 Caracas 107 • NEW ZEALAND: Southern Cross Electronics, 26 Southern Cross Road, Kolumarama Auckland



Best of Season's Greetings to all amateurs everywhere!



Lunar would like to hear from you as to what products you think we ought to be providing for you. Drop us a line with your ideas
Louis Anciaux • W8BNT

Social Events

HAZEL PARK MI DEC 3

The Hazel Park Amateur Radio Club will hold its 13th annual Swap & Shop on Sunday, December 3, 1978, from 9:00 am to 3:00 pm, at Hazel Park High School, Hazel Park, Michigan. Prizes include a TS-520S, HW-2036A with Micoder™, and a Bird Model 43 wattmeter with element. Admission is \$1.00. There will be food, door prizes, and free parking. Reserved table space is 75¢ per foot. Talk-in on 146.52. For details, send an SASE to Robert Numerick WB8ZPN, 23737 Couzens, Hazel Park MI 48030.

SOUTH BEND IN JAN 7

The Repeater Valley Hamfest Swap & Shop will be held on Sunday, January 7, 1979, at the New Century Center on US 31 in South Bend, Indiana. This event will be held indoors with food service available. An automobile museum and art center are in the same building. Tables are \$3.00. Talk-in on 146.13/.73, .34/.94, and .52/.52; 147.99/.39, .93/.33, .84/.24, and .69/.09. For information, contact Wayne Werts K9IXU, 1889 Riverside Drive, South Bend IN 46616; (219)-233-5307.

RICHMOND VA JAN 14

The Richmond Amateur Telecommunications Society will hold its Frostfest-II on January 14, 1979, at the Bon Air Community Center in Richmond, Virginia. Talk-in on .28/.88, .34/.94, and .52. There will be a technical symposium, a drawing, and a home-brewers' contest with two divisions, over 18 and under. FCC exams will be administered starting at 10:00 am. To take the exam, mail Form 610 at least five days prior to the Fest to the address below. Commercial exhibitors are by invitation only. There will be an indoor flea market with one table for \$2.50 and outdoor tailgate space for \$1.00. Admission is \$2.50. For information, contact the Richmond Amateur Telecommunications Society, PO Box 1070, Richmond VA 23208.

SOUTHFIELD MI JAN 21

The Southfield High School Amateur Radio Club will hold its 14th annual Swap & Shop on Sunday, January 21, 1979, at Southfield High School, Southfield, Michigan, at 10 Mile and Lasher. Admission is \$2.00. For information, send an SASE to

Robert Younkens, 24675 Lasher Rd., Southfield MI 48034, or call (313)-354-8210.

MIAMI FL JAN 27-28

The Dade Radio Club presents the 19th annual Tropical Hamboree and ARRL South Florida Convention on January 27-28, 1979, in Miami, Florida. Over one hundred exhibitor booths, a giant flea market, and several technical and group sessions will operate simultaneously in completely separate areas of the Flagler Dog Track Auditorium building. With the Convention immediately following the Miami Board Meeting, most Division Directors and HQ officials will be present for the ARRL general session. Extensive free parking, including overnight space for RVs, is available on the grounds. Pre-registration is \$3.00; \$4.00 at the door. For up-to-date information, booth space, flea market table space, RV parking space reservations, and hotel rates, write DRC Hamboree, PO Box 350045, Riverside, Miami FL 33135.

MANSFIELD OH FEB 11

The Mansfield midwinter hamfest/auction will be held on February 11, 1979, in a heated building at the Richland County Fairgrounds in Mansfield, Ohio. There will be prizes and a flea market. Doors will open to the public at 8:00 am. Talk-in on 146.34/.94. Advance tickets are \$1.50; \$2.00 at the door. For information, contact Harry Fritchen K8HF, 120 Homewood, Mansfield OH 44906, or phone (419)-529-2801 or (419)-524-1441.

LANCASTER PA FEB 18

The 7th annual Lancaster hamfest will be held on Sunday, February 18, 1979, at the Guernsey Sales Pavilion, US Rt. 30 & PA Rt. 896, Lancaster, Pennsylvania. Doors will open at 8:00 am and there will be a prize drawing at 2:00 pm. Admission is \$3.00, and table reservations are \$2.00 in advance. There is a new, larger indoor flea market area. Food and soft drinks will be available. Talk-in on 146.01/.61. For further information, contact SERCOM, PO Box 6082, Rohrerstown PA 17603.

DAVENPORT IA FEB 25

The Davenport Radio Amateur Club will hold its hamfest

on February 25, 1979, at the Masonic Temple in Davenport, Iowa. Admission is \$2.00 in advance, \$2.50 at the door. Refreshments and tables will be available. Talk-in on .28/.88 and .52. For further information, send an SASE to John S. Birmingham WB0QCC, 2022 Brown Street, Davenport IA 52804.

LIVONIA MI FEB 25

The Livonia Amateur Radio Club would like to announce that the 9th annual LARC Swap 'n Shop will be held on Sunday, February 25, 1979, from 8:00 am to 4:00 pm, at the new location of Churchill High School in Livonia MI. Tables, door prizes, refreshments, and free parking will be available. Talk-in on 146.52 simplex. Reserved table space of 12-foot minimum is available. For further information, send an SASE to Neil Coffin WA8GWL, c/o Livonia Amateur Radio Club, PO Box 2111, Livonia MI 48151.

VERO BEACH FL MAR 17-18

The Treasure Coast Hamfest will be held on March 17-18, 1979, at the Vero Beach Community Center, Vero Beach, Florida. Activities will include prizes, drawings, and a QCWA luncheon. Admission is \$3.00 per family. Talk-in on 146.13/.73, 146.52/.52, and 222.34/223.94. For information, write PO Box 3088, Vero Beach FL 32960.

WAUKEGAN IL MAR 25

The Libertyville and Mundelein Amateur Radio Society will hold its second annual Lamarsfest on Sunday, March 25, 1979, at the J. M. Club, 708 Greenwood Ave., Waukegan, Illinois. Doors will open at 7:00 am. There will be plenty of free parking, door prizes, and a large indoor flea market for radio and electronic items. Tables will be available at \$4.00 each. Advance tickets are \$1.50; \$2.00 at the gate, with children under 10 free. Hot lunch will be available and there will be plenty of commercial exhibits and demonstrations. Talk-in on 146.94. For further information, write LAMARS (include SASE, please) at 1226 Deer Trail Lane, Libertyville IL 60048, or call (312)-367-1599.

MUSKEGON MI MAR 30-31

The Muskegon Area Amateur Radio Council is sponsoring the ARRL Great Lakes Division Convention and Hamfest at the Muskegon Community College in Muskegon, Michigan, on March 30-31, 1979. This event will feature manufacturers' ex-



hibits, technical forums, and a large swap shop. Ample parking and dining facilities are available. Friday evening at the Muskegon Ramada Inn, there will be a "Ham Hospitality" with libation courtesy of the MAARC and a Wouf Hong initiation. For additional information, contact MAARC, PO Box 691, Muskegon MI 49443, or H. Riekels WA8GVK; (616)-722-1378/9.

NATCHEZ MS APR 1

The Old Natchez ARC Hamfest will be held on Sunday, April 1, 1979, at the Natchez Convention Center, Natchez, Mississippi. The event will be indoors and air-conditioned. There will be free admission and swap tables. Talk-in on 146.31/.91 and 146.52. For information, write ONARC, 1226 Magnolia Avenue, Natchez MS 39120.

UPPER HUTT NZ JUNE 1-4

The 1979 Annual Conference of the New Zealand Association of Radio Transmitters will be held on June 1-4, 1979, at Upper Hutt, New Zealand. Visitors are welcome to attend this conference. For registration forms, contact the Secretary, 1979 Conference Committee, PO Box 40-212, Upper Hutt NZ.

LOUISVILLE KY JUN 29-JUL 1

The Louisville Area Computer Club will hold its 4th annual Computerfest™ 1979 on June 29 through July 1, 1979, at the Bluegrass Convention Center, Louisville, Kentucky. Activities include a flea market, seminars, and exposition, as well as activities for the entire family. Seminar and exposition admission is \$4.00. Pre-registered Ramada Inn guests (\$29.00, single; \$34.00, double) receive free admission. For advance mail information, write Computerfest '79, Louisville Area Computer Club, PO Box 70355, Louisville KY 40270, or phone Tom Eubank, Chairman, at (502)-895-1230.

SSTV Recorder Controller

—replaces your index finger

C. A. Kollar K3JML
1202 Gemini St.
Nanticoke PA 18634

This article describes a device which will make the recording of a picture from a scan converter or SSTV camera more convenient. At present, using the Robot 400 scan converter,

the procedure I use generally goes like this: The closed circuit TV camera is adjusted for proper focus and picture content. A frame is then snatched by the 400 and entered into its

memory according to instructions in the manual. Once entered into the memory, the picture can be recorded for future playback by putting "transmit select" in "memory"

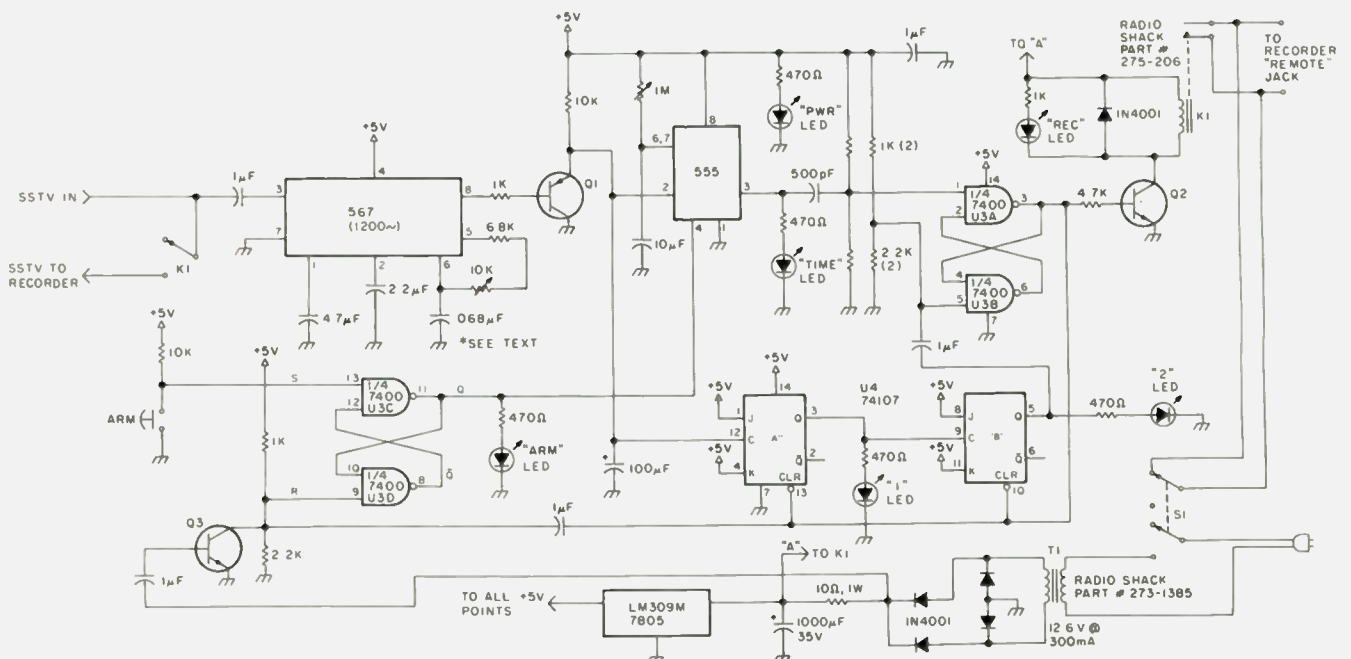

Fig. 1. SSTV tape recorder synchronizer. Q1—any general-purpose PNP silicon transistor; Q2—any general-purpose NPN silicon transistor.

and recording the resulting SSTV signal from the audio cable plugged into the "to tape" jack on the back of the 400.

This is where the tape recorder comes into play. Up to now, the procedure I followed was to watch the FSTV monitor for a blink indicating the end of one frame and the beginning of another. At this point, I would count seven seconds (a complete frame takes about eight seconds) and engage the tape recorder. This ensured that the 1200 Hz reset pulse at the end of the frame would be captured on tape to ensure proper vertical sync for the next complete frame. I then would watch very closely for three more winks, indicating that three complete frames had been recorded. After the third wink, the tape recorder would be disengaged. Three frames is the usual amount sent by SSTVers to try to ensure copy of the video through QRM. The disadvantage to this system is the necessity of watching for a wink, counting seven, engaging the tape recorder, counting three more winks (4 including the one immediately after engaging the tape recorder), and then disengaging the tape recorder. A momentary distraction can result in missing the sync pulse and starting in the middle of a frame or recording more or less than three frames.

With an SSTV camera, lighting and focus are first set up as usual. Then you must wait until the scan gets near the bottom of the frame, at which time you engage the tape recorder. Next, you must observe three complete frames and then stop the tape recorder. As with the 400, engaging the tape recorder when the scan is near the bottom ensures that the sync pulse for the first frame you will record will

also be captured on tape.

Enter the SSTV tape recorder synchronizer. With this device, all you do is enter the picture into the 400 memory, set the transmit selector on the 400 to "memory," press the "arm" button on the synchronizer, and go about your business. The synchronizer will turn on your tape recorder at the proper time to capture the initial sync pulse, record three complete frames, and shut

off automatically. There's no need to get cross-eyed watching for winks on your fast-scan monitor. With an SSTV camera, hit the arm button as soon as focus and lighting are set up, and the synchronizer will do the rest—no more counting frames.

Circuit Description

Initially, the circuit is in a standby condition where pin three of the 7400 (see Fig. 1) is low. This turns off

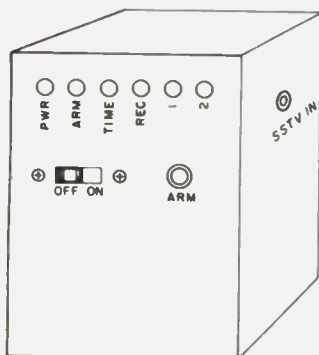
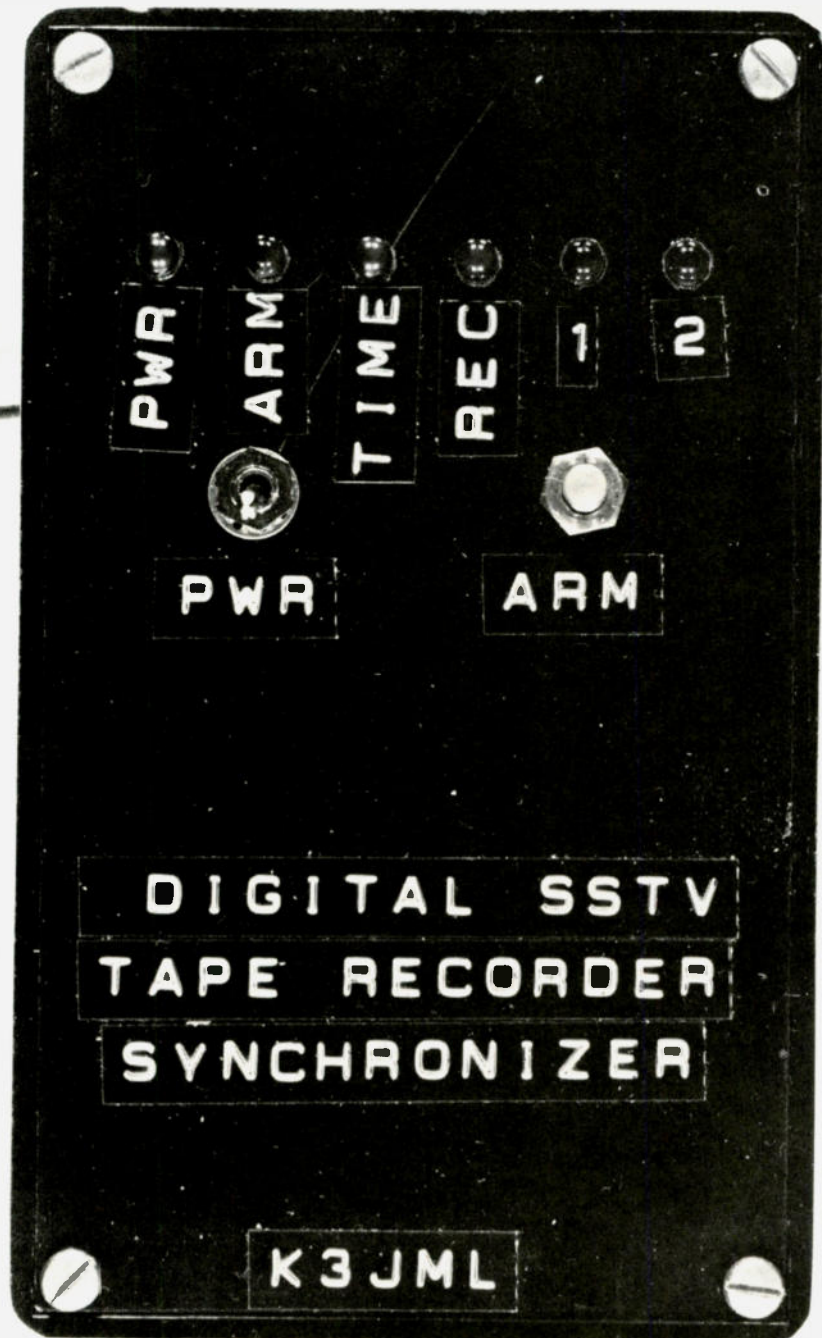
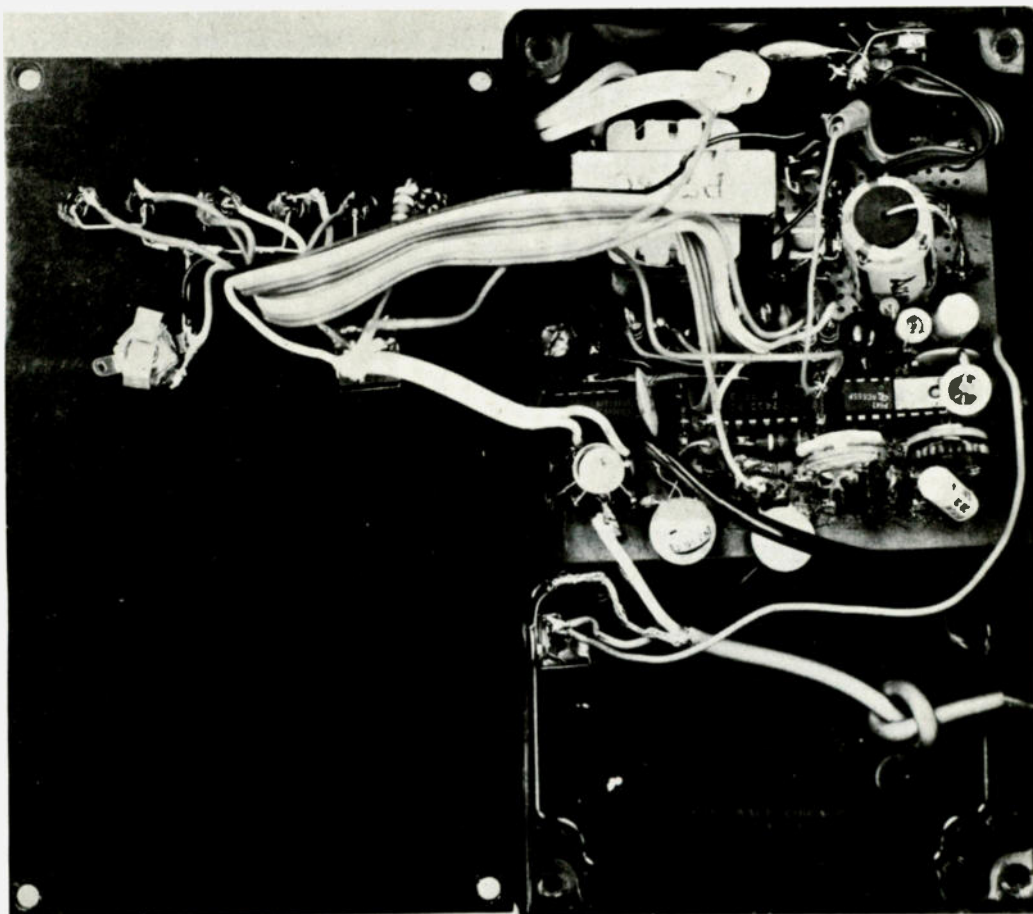

Fig. 2. Suggested front panel layout.



Front panel layout of the prototype.



Enclosure opened to reveal the perfboard construction and parts layout.

Q2, de-energizing the relay. It also grounds pins 10 and 13 of U4, resetting the flip-flops to zero. The R-S flip-flop consisting of U3C and U3D is in the state where pin 11 (Q output) is low. This grounds pin 4 of the 555, disabling it. This initial state is ensured by Q3, which momentarily grounds pin 9 of U3D when power is applied. The circuit is set into operation by depressing the arm push-button, which now makes U3C, pin 13 low, which causes pin 11 of U3C as well as pin 4 of the 555 to go high, enabling the timer and lighting the arm LED.

SSTV audio is fed to pin 3 of the 567 decoder through a .1 uF capacitor. The output of the decoder (pin 8) is normally high and goes low whenever a 1200 Hz reset pulse is detected. This turns on Q1, bringing pin 2 of the 555, pin 12 of the 74107, and the positive end of the 100 uF capacitor

to ground. The 100 uF capacitor is necessary to prevent the 74107 from counting more than once, because of glitches, during the duration of the reset pulse. When pin 2 of the 555 goes low momentarily, its output (pin 8) goes high, lighting the LED for a time determined by the 1 meg pot and 10 uF capacitor connected to pins 6 and 7. In this case, it is set up for seven seconds. At the end of seven seconds, pin 3 goes low, pulling the end of the 500 pF capacitor to ground, which in turn pulls pin 1 of U3A to ground momentarily. This sets the R-S flip-flop U3A/U3B, making pin 3 high. This high turns on Q2, pulling in the relay which turns on your tape recorder. It also makes pins 10 and 13 of the 74107 high, enabling the dual J-K flip-flop, U4.

U4 will now count the next four reset pulses (the initial reset pulse and also

the next three indicating three complete frames) supplied by the 567 decoder whenever it sees 1200 Hz. On the fourth reset pulse, indicating the end of the third complete frame, U4B, pin 5 goes low, bringing one end of the .1 uF capacitor connected to it to ground. This in turn applies a momentary ground to pin 5 of U3B, resetting the flip-flop, and pin 3 goes low. When pin 3 goes low, Q2 stops conducting, and the relay drops out, stopping the tape recorder. Pin 3 of U3A also pulls pins 10 and 13 of U4 to ground, resetting the flip-flops to zero and disabling them. At the same time, pin 3 of U3A pulls one end of the .1 uF capacitor connected to pin 9 of U3D to ground, thereby applying a momentary ground to pin 9, resetting the flip-flop U3C/U3D. Pin 11 of U3C goes low and disables the 555 timer.

The LEDs, placed as they

are, give an indication of proper circuit operation for maintenance and operation of this unit. One set of contacts on K1 removes SSTV audio from the tape recorder when its remote input becomes disengaged by the synchronizer so as not to record anything during the time the recorder is coming to a stop.

Initial Setup

There are only two adjustments to be made to place the synchronizer into operation—the 1200 Hz decoder and the 555 timer. The 1200 Hz decoder can be set up in one of two ways. Method #1 is to connect a frequency counter with a high-impedance input between pin 5 and ground and adjust the 10k pot connected to pin 6 of the 567 for 1200 Hz. Method #2 is accomplished by connecting a VOM, VTVM, or scope to pin 8 of 567. While applying an accurate 1200 Hz, adjust the pot mentioned above until you see the meter drop suddenly to zero. You will notice a small amount of play in the rotation of the pot between the points where the voltage is zero and where it is 5 volts. The pot should be set at the middle of this range. The 555 timer is set up by observing the LED connected to pin 3 of the 555. Disconnect the 500 pF capacitor connected to pin 3, press the arm button, and the arm LED should light. Momentarily short pin 2 of the 555 to ground; the time LED should light for a period of time and then go out. Adjust the 1 meg pot connected to pin 6 of the 555 so that the light stays lit for 7 seconds. Reconnect the 500 pF capacitor. Initial adjustment is now complete.

Operation

Connect the output of your SSTV camera to "SSTV in" on the syn-

chronizer, or, if using the Robot 400, insert a picture into the memory of your scan converter. Connect the output of the scan converter to "SSTV in" on the synchronizer. Connect "SSTV to recorder" to the auxiliary input on your tape recorder. Connect "to recorder remote" to your recorder remote jack. Your recorder motor functions should be normal (S1 off). Put S1 on, and note that the power LED lights. Put your recorder into the record mode; your recorder motors should not operate. Depress the arm push-button; the arm LED should light. The very next 1200 Hz reset pulse that arrives should light the time LED. After 7 seconds, the time LED goes out momentarily, the record LED should light, the relay should pull in, and your recorder should start. In sequence, on arrival of the 1200 Hz

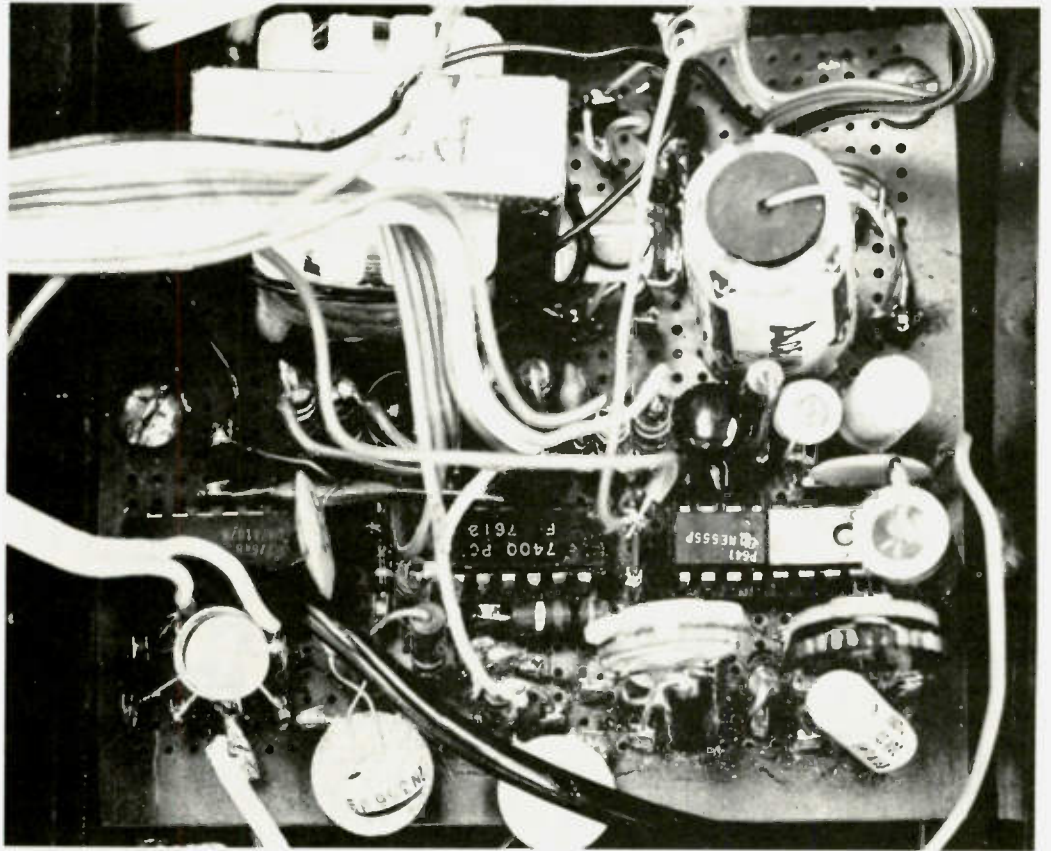

Close-up of the perboard and core wiring.

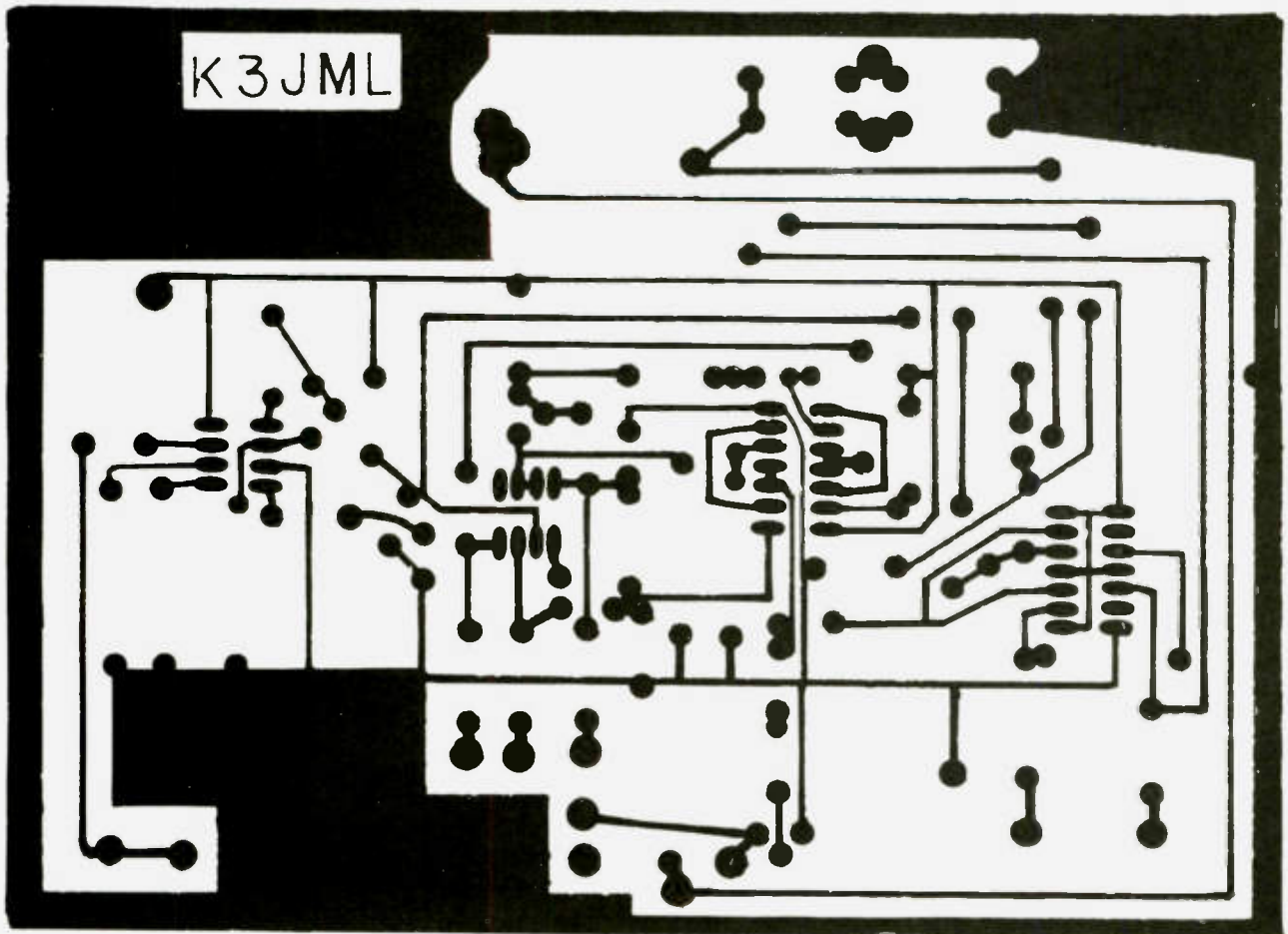

Fig. 3. PC board.

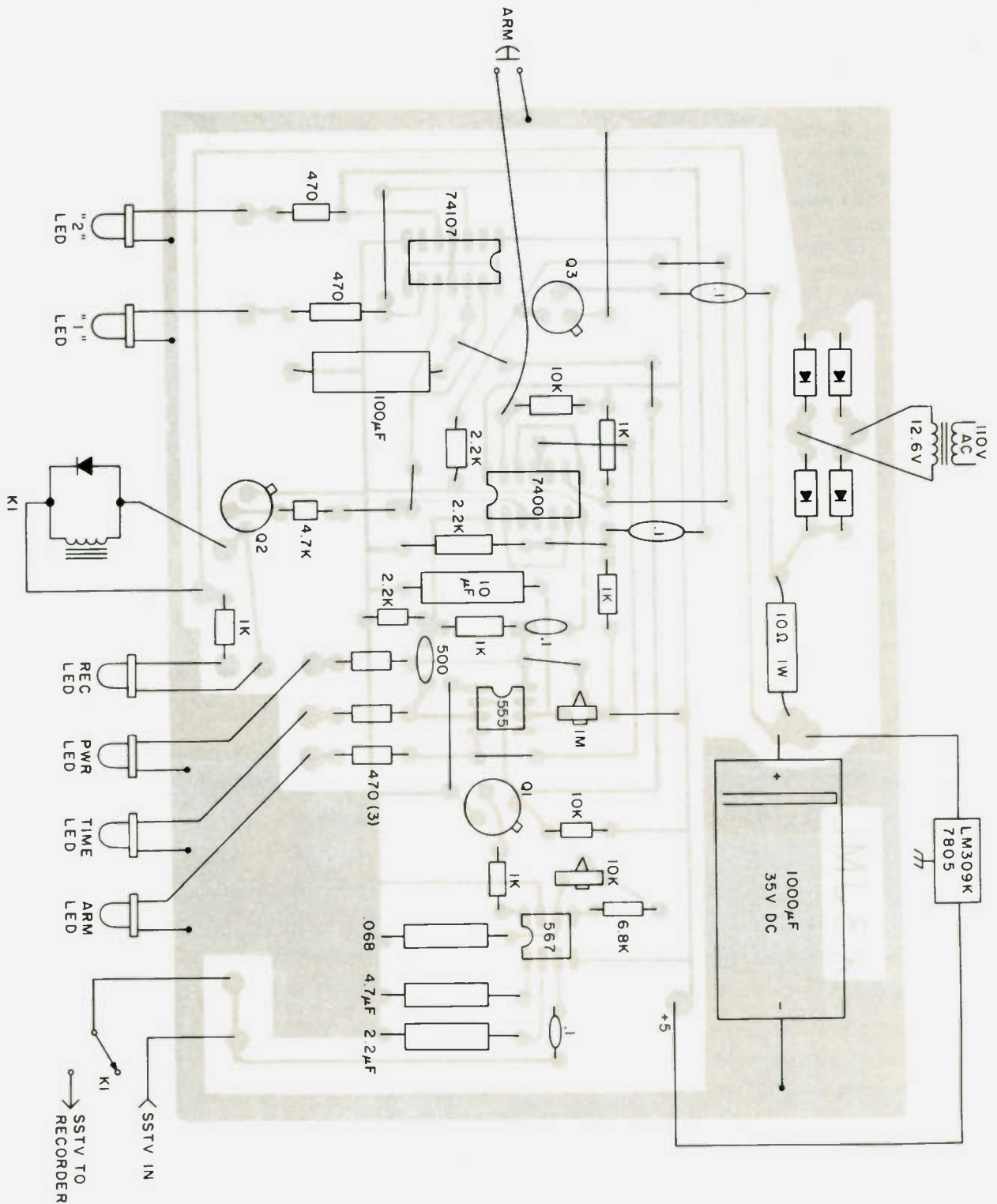

Fig. 4. Component layout.

sync pulses, the "1" LED, the "2" LED, and both the "1" and "2" LEDs should light. Eight seconds after the "1" and "2" LEDs light, all LEDs except the power LED should go out, and the recorder will stop.

Comments

Fig. 2 is the suggested

panel layout for the synchronizer. Parts layout is not critical as long as good wiring practice is followed. All parts are off-the-shelf items available at most electronic stores. The .068 capacitor connected to pin 6 of the 5676 decoder should be a good quality mylar to avoid problems

with the decoder drifting off frequency.

Please note that the photos of the synchronizer are of the prototype, in which perfboard was used to build the circuit. The circuit may be built in this fashion, or the full-scale PC layout shown in Fig. 3 may be used instead. If the PC

layout is used, a suitable housing will have to be chosen to accommodate it.

My sincere thanks and appreciation go to Joe W7SI for the photos and to Stan K3ETN for the PC layout. Questions regarding this project will gladly be answered when an SASE is included. ■

SST T-4 ULTRA TUNER

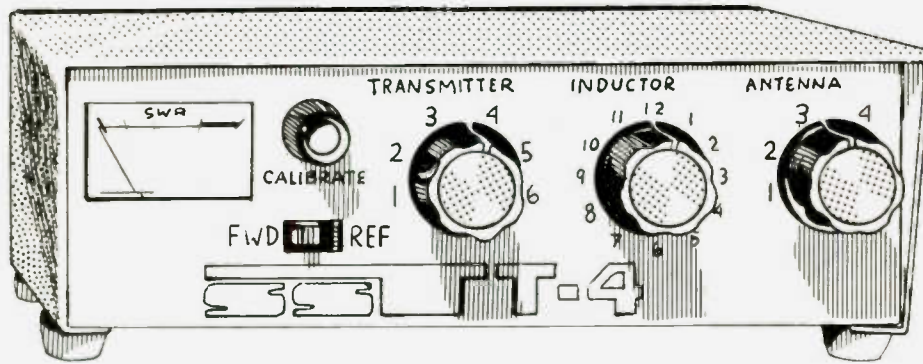

ULTRA TUNER DELUXE

The new SST T-4 Ultra Tuner Deluxe matches any antenna---coax fed or random wire on all bands (160-10 meters). Use it with your dipole, vertical, beam, etc. It works with any transceiver.

Tune out the SWR on your antenna for more efficient operation of your rig. One antenna can even be used for all bands. The SWR on mobile whips can be tuned out from inside your car.

An easy-to-read two color meter scale provides convenient indication of SWR for easy tuning. A back panel antenna switch allows you to select between two coax fed antennas, a random wire, or tuner bypass.

The SST T-4 Ultra Tuner Deluxe is compatible with any rig---solid state or tube. It's compact size (9" x 2-1/2" x 5") makes it ideal for mobile, portable, or home operation. Features an attractive bronze finished enclosure and exclusive SST styling.

Features:

- Matches any antenna - coax fed or random wire. 1.8-30 MHz.
- 300 watt output power capability.
- SWR meter.
- Antenna switch on back panel.
- Efficient tapped inductor.
- 208 pf. 1000v. capacitors for flexible, reliable operation.
- Johnson binding posts. Four SO-239 connectors.
- Made in USA.

Compare features, quality, and price---SST antenna tuners are your best value. This is our seventh year of manufacturing compact antenna tuners.

Available now at your SST dealer or order direct---information on following page.

✓S10

only \$69.95



ELECTRONICS

P.O. BOX 1 LAWDALE, CALIF.
90260 (213) 376-5887

SWR Power Meters



COMBINATION SWR/ FIELD STRENGTH METER
Measures SWR up to 3:1, or higher. Meter has sensitive movement and easy-reading two-color scale. 5% accuracy. 52 ohms impedance. SO-239 female coaxial connectors. 6" high x 2" wide x 2 3/4" deep. Model SWR-A **\$14.95**

MINI SWR METER

Small size makes this the perfect mobile or portable meter. Sensitive meter with easy-to-read two-color scale. Metal case 1-5/8" x 2-1/8" x 2-1/8". Model SWR-B **\$12.95**



POWER/SWR/F.S. METER
Measures SWR and power on 0-10 and 0-100 watt ranges. Good up to 225 MHz for SWR function, up to 148 MHz for power functions. Accuracy: 5% on SWR, 10% on power functions. 2" x 4 3/4" x 2 1/4". Model SWR-C **\$26.95**



DUAL METER SWR BRIDGE
Shows output power and reflected power simultaneously. Can be used as reference power meter, too. Wide scale, easy-to-read meter faces. Dual meters make antenna tuner adjustments a snap. Good through 175 MHz. May be left in-line up to 2,000 watts. Model SWR-D **\$29.95**

POWER SUPPLY

Laboratory grade 12V 10 amps continuous, 15 amps intermittent. Output regulation: .02%. Ripple: less than .5 mv. Overtemperature, overcurrent, and overvoltage protected. 16 lbs. 0-71°C. Special purchase at fraction of regular price. Additional information on request. Model PS-1 **\$94.00**

SST T-1 RANDOM WIRE ANTENNA TUNER

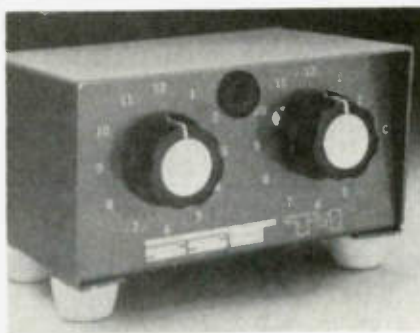

**ONLY
\$29.95**

All band operation (160-10 meters) with any random length of wire. 200 watt output power capability—will work with virtually any transceiver. Ideal for portable or home operation. Great for apartments and hotel rooms—simply run a wire inside, out a window, or anyplace available. Efficient toroid inductor for small size: 4-1/4" x 2-3/8" x 3", and negligible loss. Built-in neon tune-up indicator. SO-239 connector. Attractive bronze finished enclosure.

The Original Random Wire Antenna Tuner ... in use by amateurs for 7 years.

SST T-3 MOBILE IMPEDANCE TRANSFORMER

**ONLY
\$19.95**

Matches 52 ohm coax to the lower impedance of a mobile whip or vertical. 12-position switch with taps spread between 3 and 50 ohms. Broadband from 1-30 MHz. Will work with virtually any transceiver—300 watt output power capability. SO-239 connectors. Toroid inductor for small size: 2-3/4" x 2" x 2-1/4". Attractive bronze finish.

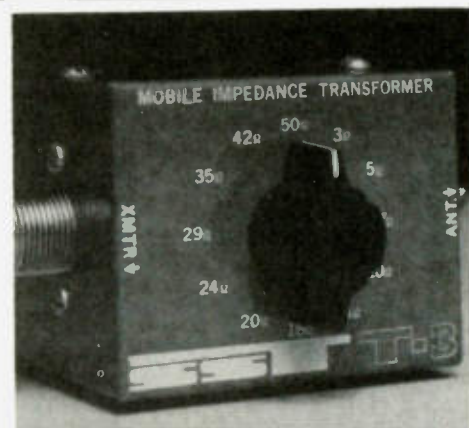

SST A-1 VHF AMPLIFIER KIT ONLY

\$29.95 \$49.95 wired and tested.

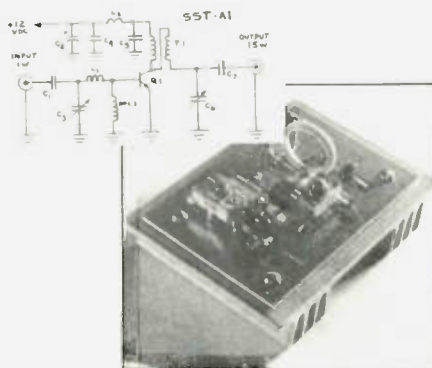

1 watt input gives you 15 watts output across the entire 2 meter band without re-tuning. This easy-to-build kit (approx. 1/2 hr. assembly) includes everything you need for a complete amplifier. All top quality components. Compatible with all 1-3 watt 2-meter transceivers. Short and open protected—not damaged by high SWR.

Kit includes:

- Etched and drilled G-10 epoxy solder plated board.
- Heat sink and mounting hardware. All components—including pre-wound coils. Less case.
- Top quality TRW RF power transistor.
- Complete assembly instructions with details on a carrier operated T/R switch. (COR switch parts \$10 ppd.).

SSS

ELECTRONICS

P.O. BOX 1 LAWNOALE, CALIF.
90260 · (213) 376-5887

✓S10

SST T-2 ULTRA TUNER

The SST T-2 Ultra Tuner has become the standard tuner the world over. The original SST concept of offering compact antenna tuners with maximum versatility began seven years ago with the production of the first SST tuner. No one has matched the SST line for years of dependable operation, quality, and value. The top-of-the-line SST T-2 Ultra Tuner is the standard—at any price.

**ONLY
\$39.95**

THE STANDARD TUNER



CHECK

THESE FEATURES:

Tunes out SWR on any coax fed antenna as well as random wires. Works great on all bands (80-10 meters) with any transmitter running up to 200 watts power output.

Increases usable bandwidth of any antenna. Tunes out SWR on mobile whips from inside your car.

Uses efficient toroid inductor and specially made capacitors for small size: 5¼" x 2¼" x 2½". Rugged, yet compact. Negligible line loss. Attractive bronze finished enclosure. SO-239 coax connectors are used for transmitter input and coax fed antennas. Convenient binding posts are provided for random wire and ground connections.

TO ORDER:

If not available from your dealer, order direct by mail or phone. Please add \$2 for shipping and handling (\$5 for Airmail worldwide). Calif. residents, please add sales tax. COD, Master Charge, and VISA orders accepted.

GUARANTEE:

All SST products are guaranteed for 1 year. In addition, they may be returned within 10 days for a full refund (less shipping) if you are not satisfied for any reason.

CALL (213) 376-5887 OR 379-9572 TO
ORDER C.O.D., VISA OR MASTER CHARGE

OR SEND TO: SST ELECTRONICS,
P.O. BOX 1, LAWNSDALE, CALIF. 90260

NAME _____
STREET _____
CITY _____ STATE _____ ZIP _____
MODELS DESIRED: TOTAL ENCLOSED
\$ _____

OR CHARGE TO: VISA M.C. C.O.D.
CARD # _____ EXP. DATE _____

WE ACCEPT



Receiver Diseases

— and how to cure them

*Joseph J. Carr K4IPV
5440 South 8th Road
Arlington VA 22204*

Two identical transceivers need repairs. One is completely dead—no sound, no lights, nothing works. The other works

well, except that, on receive, a static-like “frying-eggs” sound is heard occasionally, and it is capable of drowning out

all but S9+ signals. Which of these will be the hardest to troubleshoot?

Many inexperienced troubleshooters pick the

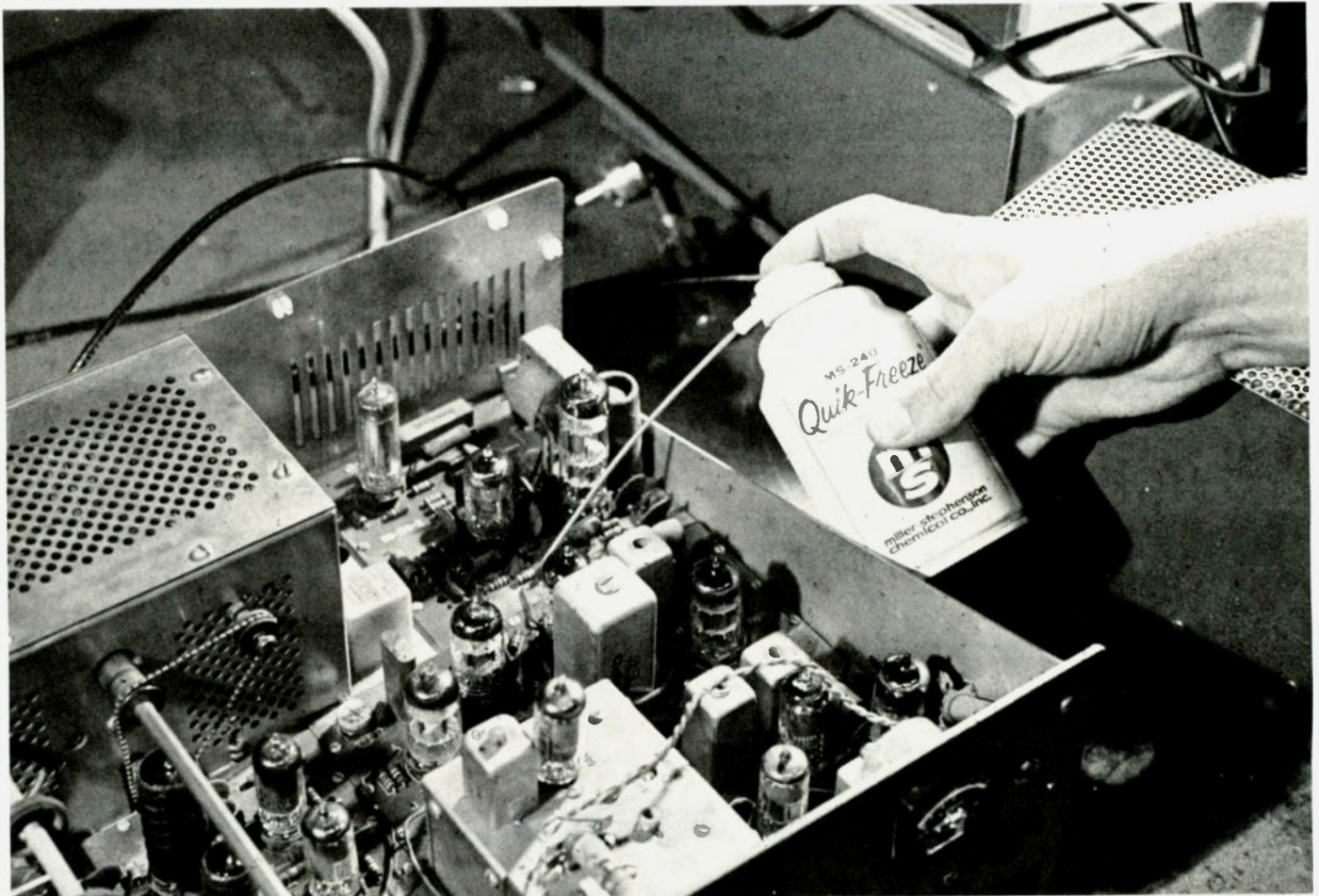

Photo A. Freon cool spray (available at most electronic wholesalers) will cool off the circuit and help locate bad components.

dead receiver/transceiver, probably because the symptoms hint at some catastrophic failure. Dead receivers, whether the dial lights come on or not, are usually relatively easy to troubleshoot. Even if smoke has rolled out of the innards (some say especially), the problem of locating the faulty part(s) is actually pretty easy.

It is the more subtle problems that tend to snap your mind clean out of its socket! The static, pops, hisses, and miscellaneous oscillations and grumbings that a defective receiver is capable of generating are often rather difficult to pin down, especially in a short period of time. The professional servicer who hears a customer making such a complaint will often as not utter a silent "Oh, no!" and say a private prayer because he knows that such problems can take a lot of time, and there is a limit to how much of a labor fee the market will bear.

In this article, I will examine some of the causes of noises and the troubleshooting techniques appropriate to each by taking you through several case histories. These troubles have occurred in amateur, CB, and commercial communications receivers, plus a few million times in consumer equipment, so they are all but universal.

Case No. 1 A High-Pitched Whistle

Some years ago, I had to service a vacuum-tube receiver that had a high-pitched whistle superimposed on the audio output. In receivers, this could be caused by any number of devilish faults, but, in this case, it was relatively easy to pin down the section of the receiver at fault because the noise did not go away when the audio gain control was set to mini-

mum. If anything, the apparent amplitude went up because of an improved signal-to-noise ratio.

The trouble in this case turned out to be in the power supply powering the audio preamplifier stages. A panel-mounted neon lamp (Fig. 1) was used as the power-on indicator, and this lamp was connected into the dc power supply, rather than in series with a 150k-Ohm resistor across the ac line as is normally done. The circuit designer apparently tried to gain a little dc voltage regulation with the lamp, forcing it to serve a dual function, thereby saving money.

The circuit (Fig.1) contained series resistances R1 and R2 to drop the voltage to the level required by the neon bulb and to limit current through the bulb so that a catastrophic burn-out was prevented.

Capacitors C1, C2, C3, and C4 serve to decouple the stages being powered, while all but C3 also serve to filter out the 120-Hertz ripple component left by the rectifier. Capacitor C3 is of a lower value than the others and is usually a disc ceramic, mica, mylar, or even paper-type, rather than an electrolytic.

The technique of using a small-value disc ceramic capacitor in parallel with a high-value electrolytic seems ridiculous on first glance, but becomes more valid when you realize that many electrolytics (especially older types) are as effective as a block of wood at higher frequencies. The low-value capacitor becomes necessary even in some audio amplifiers and with i-f amplifiers with as low as a 50 kHz operating frequency. It is certainly most advisable if the stage powers a 455 kHz or higher i-f amplifier.

In the receiver with the "high-pitched whistle," the problem was that C4 had

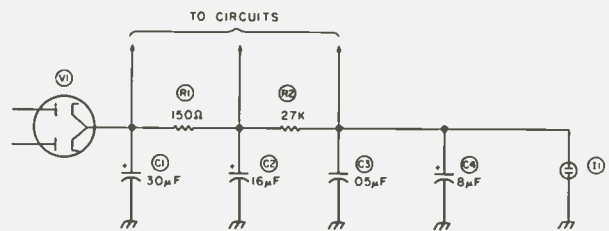

Fig. 1. An amplifier power supply using a neon glow lamp.

opened up. This allowed the now undecoupled stages to go into a low-frequency motorboating oscillation and also allowed I1-R2-C3 to operate as a neon relaxation oscillator. The frequency of oscillation is set by the time constant of R2-C3 and the firing potential of neon lamp I1. The symptom was a nauseating combination of a whistle modulated by a low-frequency motorboating oscillation.

Case No. 2 Noisy Plate Loads

Many amateur receivers, as well as other equipment used by amateurs both in and out of their ham radio hobby, may tend to develop a sound that is often typified as "frying eggs" or "sizzling." This is especially prevalent in equipment that is allowed to take on moisture by being (often improperly) stored for a long time in a humid climate.

Some amplifier stages are resistor/capacitor coupled, so the plate load resistor of the first stage in a cascade chain will be a resistor. Still other amplifiers, such as the rf and i-f amplifiers in the receiver, are coupled through tuned rf transformers (see Fig. 2). In either case, internal arc-

ing of the plate load, be it resistor or rf transformer, will be propagated through the following stages as a signal. In most cases, the result is the classic frying-eggs sound of a continuous arc, or thunder crashes of static of an intermittent arc.

In a multiple-i-f amplifier receiver or multi-stage audio amplifier, this noise can be a little difficult to locate, but a little "trick of the trade" can reduce the agony. In the case of both types of amplifier, you can troubleshoot by removing the tubes from their sockets one by one, until the noisy stage is found. A replacement tube will usually eliminate the tube from suspicion. With the power turned off and the tube out of the socket, connect a 10k-Ohm, 1-Watt resistor between the plate pin of the tube and power supply ground. This maneuver will draw "plate" current through the load resistor or transformer and will create the frying-eggs sound if that load is defective. If no trouble is found, go to the next stage back toward the input and repeat the procedure.

Of course, if the bad plate load is a resistor, then it should be replaced when

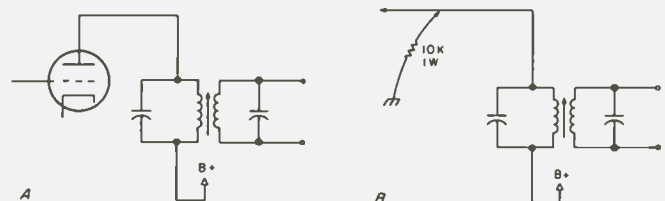

Fig. 2. (a) Vacuum tube i-f amplifier plate circuit. (b) A 10k-Ohm, 1-Watt resistor to ground will tell the tale.

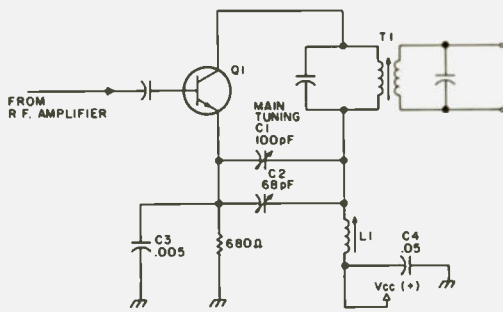

Fig. 3. High humidity over long times will cause the trimmer to arc.

found. But, in the case of i-f transformers, it might be worth attempting to repair—a luxury that amateurs can afford. This is not merely desirable, but becomes mandatory if the receiver is a few years old or the manufacturing company is no longer in business.

Very carefully pry apart the metal tabs holding the shield onto the transformer form and expose the coils and capacitors. Be very careful and work slowly, because sometimes the coil form has adhered to the shield and will be pulled from its mounting if the shield is pulled off vigorously before the wires and form are freed. Carefully examine the fine wires with a tiny screwdriver or toothpick to see that they are actually soldered to the wire tabs or i-f can terminals. Oddly enough, an unsoldered joint at this point may work for years before being jarred loose or before an oxide layer forms to break the connection.

Other sources of problems are the resonating capacitors across each coil. If they are disc ceramic, tubular ceramic, or mica types, then they may be easily replaced. But most i-f transformers use a fixed mica compression capacitor molded into the plastic base. There is no firm advice on how to repair such transformers. Try finding the metal tab leading from the capacitor

to the terminal lug to which the coil is soldered. In most cases, it will appear to be one piece with the lug, but close examination reveals that it is actually a sandwich assembly. If you can cut this tab, even if a little of the plastic base must be melted to gain access, then you are in luck. Otherwise try forming a new terminal in one of the unused spots on the mounting, or obtain a new transformer.

Some old-timer electronic supply houses, especially those with a large TV-shop clientele, may have an old 455-kHz i-f transformer for sale. Alternatively, find a dealer (or mail order direct) who sells J. W. Miller products. They offer a line of i-f transformers that may be exactly what is required or can be modified to meet your needs with little effort. In fact, it is possible that J. W. Miller made the original under contract to the receiver manufacturer!

Case No. 3 Shorted Trimmer Capacitors

Fig. 3 shows a converter stage (combination mixer and local oscillator) from a mobile receiver made several years ago. Transistor Q1 serves as both the local oscillator and the mixer in a superheterodyne design. Transformer T1 is the i-f transformer, while coil L1 is in the tuning circuit of the oscillator, along with C1 and C2. Capacitors C3

and C4 are used mainly for bypassing.

The trimmer capacitor (C2) is a compression mica variable and will suffer from the same problems as the fixed mica compression capacitors in the i-f amplifier. These will occasionally arc internally despite the relatively low voltage applied to the transistor. The result is the same sort of frying-eggs sound as before, but it is not always so easily found.

In this case, once the i-f transformer and L1 connections are eliminated, a 0.01 uF disc capacitor is inserted in series with the trimmer to block dc. If the arcing disappears, or is significantly reduced, then replace the trimmer capacitor. Do not be tempted to leave the apparently restored capacitor in the receiver because 1) dial calibration is now incorrect and 2) the trimmer will eventually fail more and kill the set. The trimmer was, after all, shorted, if only with a high resistance.

Case No. 4 Pn Junctions

Another noise source peculiar to solid-state rigs is any pn junction that becomes reverse biased. In a complex circuit, there may be several such junctions whose loss does not completely kill the receiver's operation, so noise results.

If a pn junction becomes reverse biased, it can produce a hiss-like "white noise." This phenomenon is used as the basis for a couple of popular amateur antenna bridges. In the circuit of Fig. 4, there is a noise generator made from a reverse-biased pn junction, in this case, a diode. If an oscilloscope with a wideband vertical amplifier were connected across terminals A-B, you would see a lot of "grass" on the CRT screen.

It sometimes happens

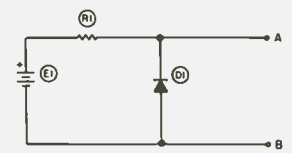

Fig. 4. Diode noise generator.

that faults in capacitors, changed values in resistors, or certain other circuit defects can cause a junction to become reverse biased without completely upsetting the dc operation of the rest of the circuit. Consider the circuit of Fig. 5. This circuit operates from a dual-polarity power supply in which Vcc is positive to ground and Vee is negative to ground. The circuit also has a differential input stage in which the signal is applied to the base of transistor Q1A, and the operating characteristics of Q1B are held constant by a fixed resistor network.

In one problem involving this type of circuit, capacitor C1 became leaky (not a direct short, but a high resistance short) and that substantially reduced the contribution of Vcc (+) to the bias voltage appearing at point A. This caused the base-emitter potential of Q1B to become reversed, making the b-e junction into a noise generator, which sees Q1A effectively as a common-base amplifier followed by the rest of the high gain stages in the chain.

Case No. 5 Noisy Transistors

There is a possibility that a normally-biased transistor will become noisy and drown out signals being received. If the transistor is located in a low-level stage close to the input, then the gain of the following stages makes the problem even worse. Most of the time, the noise is of the familiar frying-eggs variety with a few extra

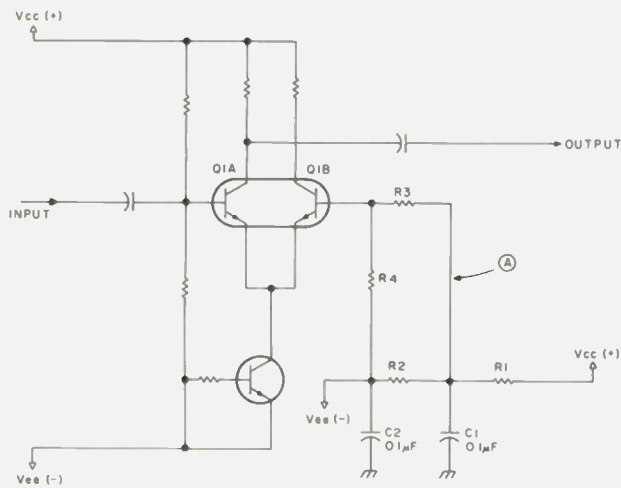

Fig. 5. Transistor wideband preamplifier.

pops and fizzes thrown in for good measure.

Most of the time, the type of noise I am talking about is sensitive to heat. By making the circuit hotter, you can often create the noise (almost at will), while making it colder will cause the noise to disappear for awhile. It seems, though, that most common thermal troubleshooting techniques cover too much area of the circuit at one time.

For example, take the common aerosol freon "circuit cooler" or "freeze spray" (see Photo A) used by many professional servicers. It can help pinpoint the location of bad components very quickly, if you can keep from spraying it on too many components at once. The same holds true for most heat sources used by servicers.

What is needed is a means for concentrating the cold or heat on one component at a time. One solution is the use of one of those oversize pieces of "spaghetti" tubing that seems to be in everybody's junk box from the times when a "universal" assortment was purchased. Simply cut one to three inches of tubing to fit snugly over the transistors or resistors under suspicion. If cooling is your goal, the tubing allows you to concentrate

the spray only on the suspect component.

For heat treatment, simply place a small incandescent pilot lamp (#47 for 6-volt and #1892 for 12-volt are suitable) in the open end of the tubing, and connect it to a battery or dc supply. It has been my experience that truly heat-caused defects will show up within about three to five minutes under the lamp. Most of them will succumb to the increased heat in less than one minute.

Case No. 6 "It Goes Dead When Hot (or Cold)"

A solid-state transceiver was brought in for repair, and the owner complained that it worked in the morning, but not in the afternoon. This problem is not actually a noise problem, but is so common and so closely related to problem number 5 that it bears some attention.

Solid-state circuits can be quite sensitive to the thermal environment, hot and cold. Normally operating transistors will operate over a wide range of temperatures, but, when certain defects show up, then they become abnormally sensitive to changes in temperature.

During the summer, your mobile rig might work prop-

erly on the way to work in the morning, but when returning home in the late afternoon will simply refuse to do anything right. The problem is that the car was sitting in the hot sun all day long, and the interior is very hot. Until the air conditioner cools off the rig, the problem will remain. One car manufacturer's radio division measured the interior temperatures of cars sitting in the 90° F (32° C) Indiana sun for four hours at almost 160° F (71° C). Marginal solid-state devices might quit working under such conditions.

Winter gets in its licks, too. A complaint is sometimes heard that the rig does not work until the car is halfway to work. By that time, the car's heater has warmed the rig up to a temperature range where it will work. If you think this is a problem limited to those in the northern states and Canada, then keep in mind that I am a K4, and I have seen this problem on many occasions.

Both problems succumb to the same troubleshooting techniques as were used to find noise in case number 5. First, heat or freeze spray a large area, such as one corner of the chassis or an entire printed circuit board. Go to successively smaller areas until you are at the component level.

Case No. 7 Internal Component Arcing

Some noises can show up in the loudspeaker as a result of internal arcing resistors, capacitors, transformers, and the like. These can be miserably difficult to find. Even when the arcing is audible to the naked ear, without the loudspeaker, it seems to come from several components at once.

One effective technique for locating the arcing

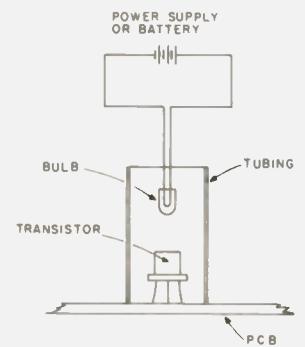

Fig. 6. A short length of "spaghetti" tubing will concentrate heat from lamp or mist from freeze spray on only one component at a time.

component is to use a long, thin section of rubber or neoprene tubing. Hold one end in your ear while using the other end as a probe to find the arcing component. The tubing will transmit a barely audible click loudly to your ear.

Actually, where possible, I prefer to use a modified medical stethoscope for this purpose. Although the professional type used by physicians and intensive care nurses is quite expensive, cheaper types are available in home "blood pressure kits" and in mail-order catalogues such as Edmund Scientific of Barrington NJ. Even one from a two-dollar child's "play doctor" kit will be sufficient.

If you use a medical stethoscope, be sure to remove the metal bell or end piece. This will serve to both localize the source of arcing and prevent you from getting an electrical shock in the case of inadvertent contact.

It will be necessary to scan the whole component in many cases because the lumen of the tubing is so small that the device becomes very directional. In fact, the resolution of this technique is so good that you can often tell which end of a paper or mylar capacitor contains the arc! ■



DRAKE UV-3 multi-band



Designed and manufactured in the U.S.A.

UNIQUE in the world of UHF/VHF FM!

The Model 1346 Drake UV-3 (144-220-440 MHz) is fully synthesized to 5 kHz on each of the three bands—and is completely bandswitched from the front panel.

The rear panel provides a separate SO-239 coax connector for each band, offering flexibility in choice of antenna.

UNIQUE—This one unit covers it all! It's like having three synthesized FM transceivers in a single box—and all at a super price.

- Model 1346** Drake UV-3 (144-220-440) \$795.00
- Model 1504** Drake PS-3 AC Power Supply . . . \$ 89.95
- Model 1525** Drake 1525EM Encoding Mike . . \$ 49.95
- Model 1330** UMK-3 Remote Trunk-Mount Kit \$ 69.95

Note: Other models are also available.

synthesized fm system

For the serious amateur who...

- considers fm a vital part of a total communication system
- needs multi-band coverage in a single transceiver
- needs to continuously scan-monitor a priority amateur repeater dedicated to public service, weather, or DX alerts
- needs extra programmed channels for quick selection, in addition to the synthesizer...

The Drake UV-3 provides it all!

- Continuous priority channel scan
- Remote trunk operation (optional)
- Four extra diode-programmed channels on each band
- All three bands in a single bandswitched unit, or start with basic models and add extra band-modules later
- Non-standard offsets available for each band

The Priority Channel Scan

You can diode-program your priority channel in one of the fixed channel positions. It can be con-



tinuously monitored from any other synthesized or fixed channel. If you're operating on the priority channel, or another programmed fixed channel, you can also scan-monitor any synthesizer frequency you choose.

The Extra Diode-Programmed Channels

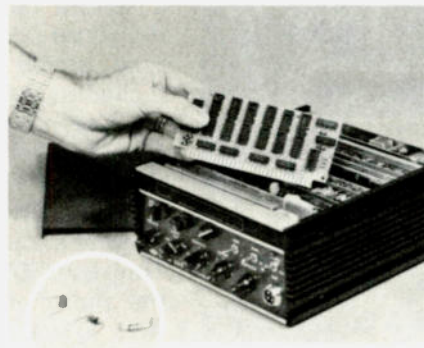

You can diode-program up to four fixed channels, with their offsets, for each band. This feature allows super-quick selection of favorite channels. The five-kHz synthe-

sizer operates independently of these programmed channels. And best of all, soldering is not necessary for programming. The program board has special sockets mounted on it for direct insertion of diodes. We even provide the diodes.

Remote Trunk Mount Kit

The control panel of every UV-3 removes for installation in the UMK-3 Remote Kit. This provides for safety, as well as easy installation in small cars where under-dash space is limited.

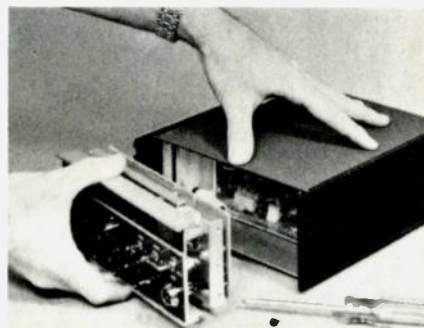

✓D11

Write for a fully illustrated brochure on the Drake UV-3 System.

R. L. DRAKE COMPANY



540 Richard St., Miamisburg, Ohio 45342
Phone: (513) 866-2421 • Telex: 288-017

✓ Reader Service—see page 323.

Autophasing for WEFAX

—preserve your mental health

This article will introduce you to a method of automatically positioning the sync pulse, or margin, in GOES WEFAX pictures. It is a well-known fact among weather satellite amateurs that one can go practically nuts trying to manually position the margin of a picture. Even if you do succeed in getting the horizontal sync on the

left edge of the paper, the strain on one's nervous system is simply too great. Inevitably, the phasing period at the start of the picture just seems too short.

Before I gave up hope, I got the idea of making the machine phase itself. After all, why shouldn't the machine do all the work? With that thought in mind,

the following circuits were developed. The schematics appear in Figs. 1-5. The result was a phasing circuit that has proved that it can easily place the picture sync in the same spot each time a photo is made. This will help any operator's blood pressure remain normal while he's using his facsimile machine.

Take a look at Fig. 1. This circuit has the function of a simple comparator. As the picture drum rotates, a small alnico magnet is attached to the drum so that it passes close by a small relay solenoid on each revolution. The resulting pulse of current is used to operate a transistor switch. Transistor Q1 squares up the pulse and inverts it. Also, Q1 clamps the pulse to TTL voltage levels. You must make sure, however, that you have enough voltage coming from the solenoid to forward bias Q1. It may be necessary to move the solenoid closer to the magnet. With Q1 operating, U1A restores the pulse to its original phase relation and drives J1 and also U2, pin 1.

If there were a sheet of

photographic paper on the drum, and you had its edge at the centerline of the magnet, would the pulse from U1A mark the edge of the paper? Unfortunately, this is not true. There is some phase shift introduced by the magnet and solenoid arrangement. You could put in a variable phase shifting network before Q1 to counteract this, but it is much easier to simply measure the shift and offset the paper edge. This need only be done once, and a permanent mark can be placed on the drum corresponding to the picture edge. I will discuss later, in the calibration procedure, just how this is done. For now, let's assume the pulse from U1A is coincident with the picture edge.

The other input to U2 is the sync pulse transmitted during the WEFAX phasing period. Connector J2 is attached to Fig. 5's U4B, pin 7, in my article "Attention, Weather Watchers! — advanced circuitry for WEFAX processing" (73, October, 1978). The signal on U4B, pin 7 is the output of the 1700 Hz low-pass

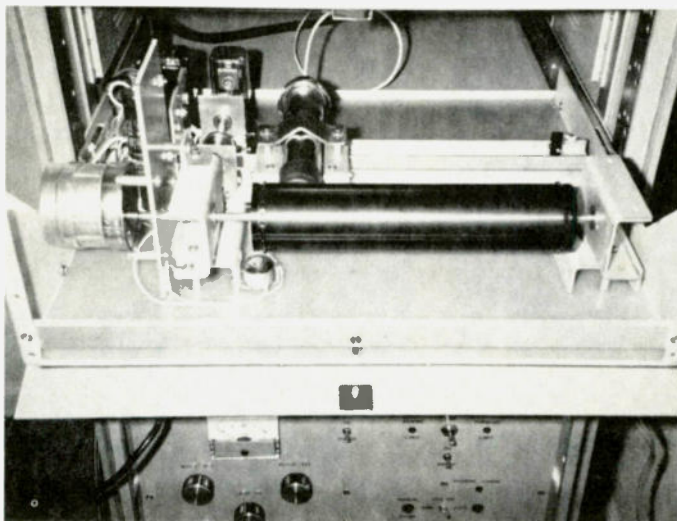

Photo A. Photograph of the author's drum recorder. Note the position of the solenoid. The magnet is epoxied to the left side of the drum. The forward and reverse limit relays are in the back corner. They remove power from the lamp carriage when a forward or reverse limit is sensed. Also, they light a corresponding indicator on the panel below the recording head.

video filter. During the GOES WEFAX picture phasing period, the white set pot, R52, is set to give a pulse rising from -0.5 V dc to ground at U4B, pin 7. This will be the correct white current setting for the GOES WEFAX. Meanwhile, back in Fig. 1, U3A accepts the -0.5 V dc-to-ground sync pulse and buffers it. The second section of U3, U3B, converts the sync pulse into a TTL-compatible waveform.

Now, we can finally talk about U2. IC U2 has only one purpose in life. Its output sits high as long as the sync pulse in the WEFAX phasing period and the picture edge pulse, from U1A, are not overlapping in time. Assume, for the moment, that the picture drum is turning in phase lock with the satellite video. Usually, some time difference exists between the actual picture edge and the satellite sync pulse. This indicates that the picture is not phased properly. If an error in time exists, U2, pin 3 is high. I call this a phasing error. If U2, pin 3 happened to be low, the picture phase would be okay.

If U2, pin 3 is high, you need some way of reducing the time difference between the two pulses to zero. One way is to slightly reduce the frequency of the phase locked 60 Hz going into M1 in Fig. 1. If this happens, the picture edge pulse on U2, pin 1 will slowly drift or roll when compared with the WEFAX phasing period pulse at U2, pin 2. Eventually, the two pulses will cross, and both inputs to U2 are high. At this moment, M1 must be phase locked back on the satellite subcarrier so that the picture edge will drift no further. The phasing would then be accomplished.

The method of reducing the speed of M1 slightly is seen in Fig. 2. I use a pro-

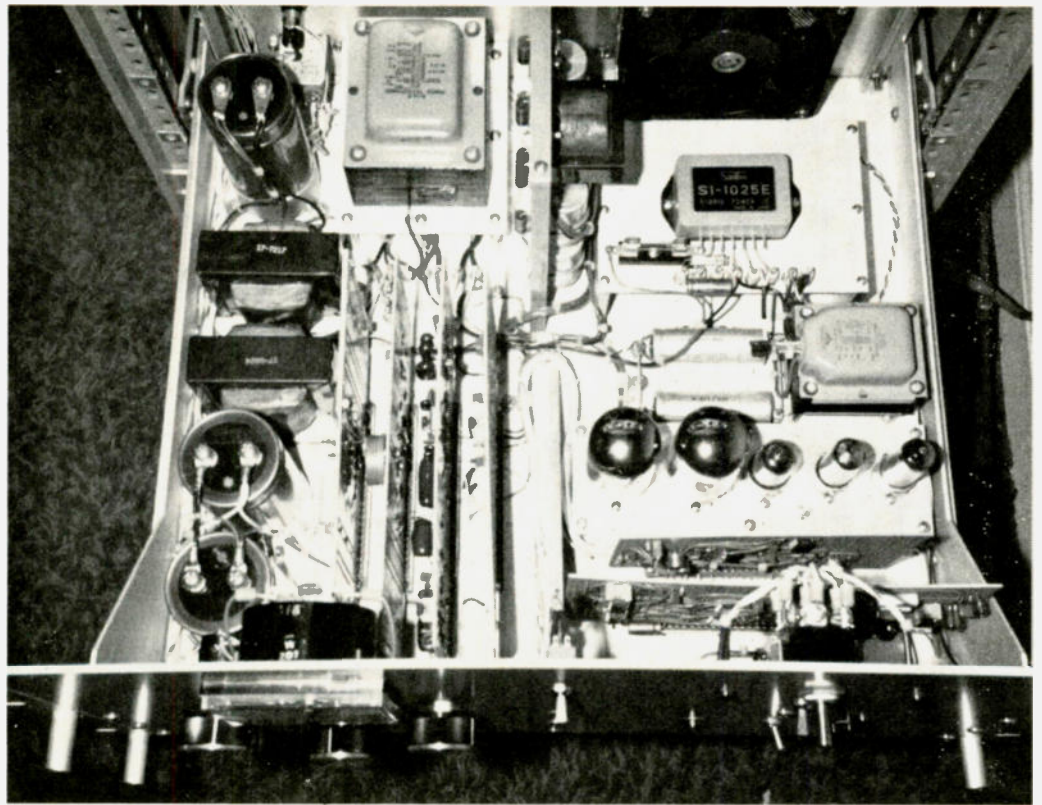

Photo. B. This is an inside view of the unit seen below the recorder head in Photo A. The two cards at the right front are the auto-phasing circuits. The S1-1025E power amp is on the heat sink in the right corner. The transformer in front of it is T1. A 300 V dc power supply for the R11-68 is on the subchassis and it uses five tubes. The five-inch fan at the back keeps things cool. My video processing circuits are built on the four cards at the left side of the chassis. The meter is the lamp current indicator.

grammable divider to control the speed of M1. ICs U5 and U6 comprise the

divider. The divider is capable of dividing the 2400 Hz reference, from

Fig. 4, by 40 or 41. Normally, when the picture phase is okay, U2, pin 3 is low.

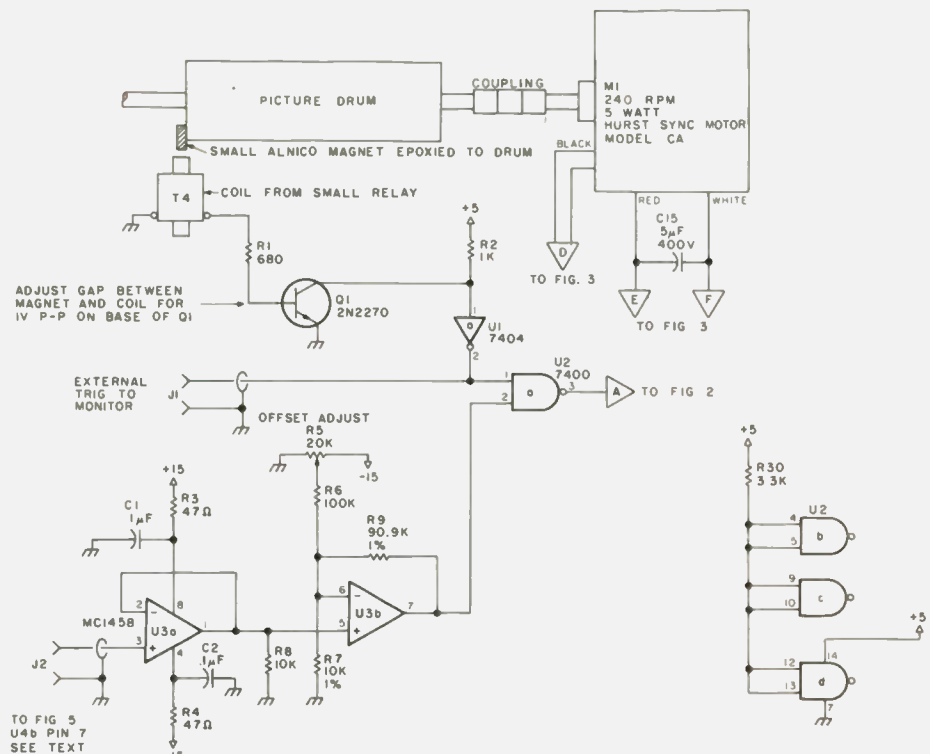

Fig. 1. Sync comparator.

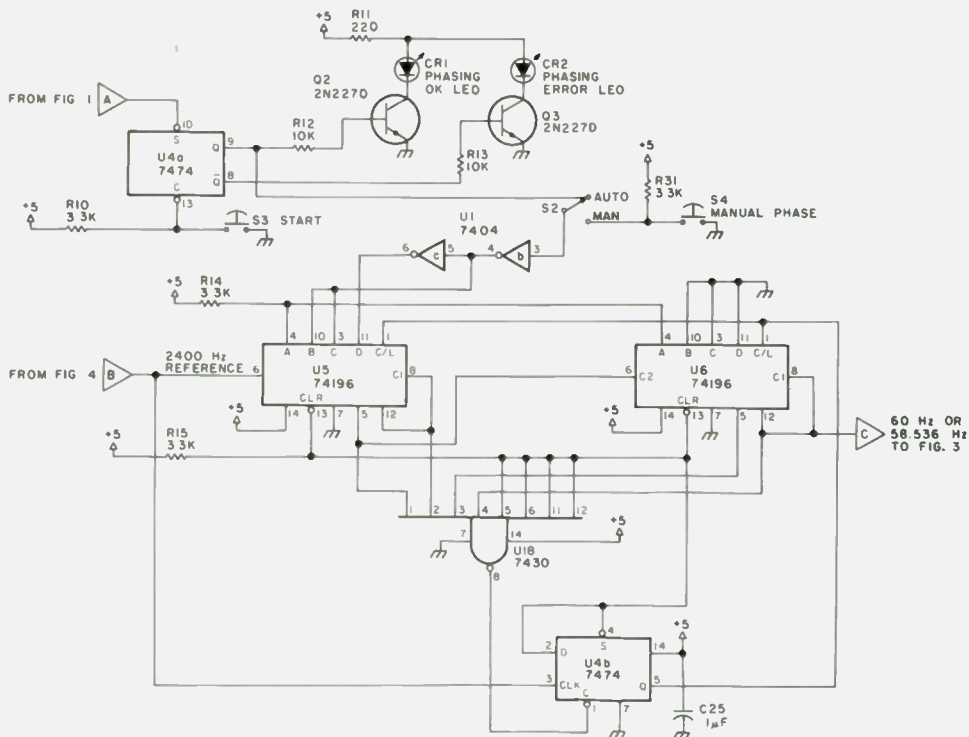

Fig. 2. Programmable divider.

This sets the Q-output on flip-flop U4A to one. The phasing-okay LED, CR1, now lights, and the correct bi-quinary word is loaded into the divider to do division by 40. U6, pin 8 now supplies a 60 Hz locked reference to the low-pass

filter in Fig. 3 and, in turn, to the motor amplifier.

As soon as the WEFAX phasing period starts, it is necessary to test the picture phase. At this moment, the start button, S3, is depressed and flip-flop U4A is cleared. The

phasing-effort LED will now come on, and the programmable divider is instructed to divide by 41. The picture edge pulse begins to drift slowly now with respect to the reference, since the drum slowed down. The drum

motor is now running at 58.536 Hz. IC U2 is now looking for the time when the two pulses will cross. The frequency of 58.536 Hz provides a slow enough drift so that the two pulses do not happen to miss each other. Also, it is slow enough so that the results obtained are repeatable. That is, it puts the margin in the same place each time. As soon as the two pulses cross, U2, pin 3 switches low and U4A is set. The phasing-okay LED now comes on, and division by 40 is loaded again into the divider. The synchronous motor, M1, jumps extremely fast to the proper speed so that the margin remains properly phased.

You now have the picture phasing accomplished with a minimal amount of work on your part. Perfectionists should be able to eliminate the start button by utilizing a 300 Hz band-pass filter to detect the picture start tone. This start tone immediately precedes the phasing period. The filter could feed a peak detector and, in turn, charge a capacitor. Next, the voltage on the capacitor could be sensed by a voltage comparator and used to fire a one-shot. The one-shot could control U4, pin 13. I haven't incorporated this into my system, since I have chosen not to eliminate myself entirely from the process.

Now, suppose I had chosen to manually phase the picture, or, for some reason, I missed the phasing period. The phasing switch, S2, is set to manual. The manual phase button, S4, is simply held depressed. At this point, a monitor oscilloscope is necessary. The scope must have its timebase set to 250 ms, and then it must be externally triggered by the pulse on J1. Also, the satellite video is supplied to the scope's vertical

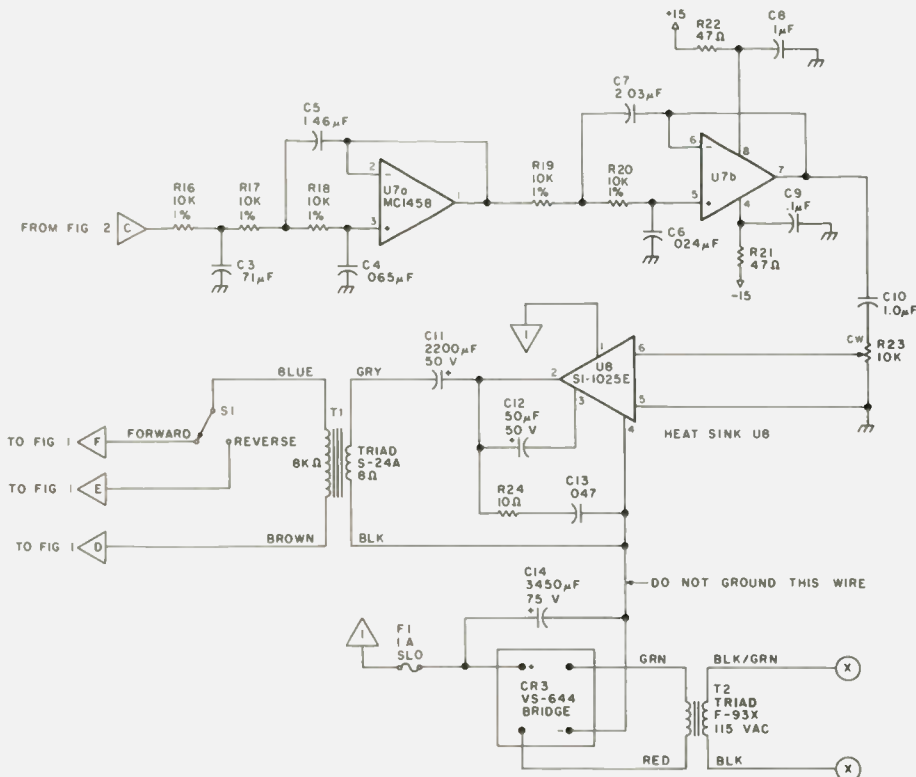
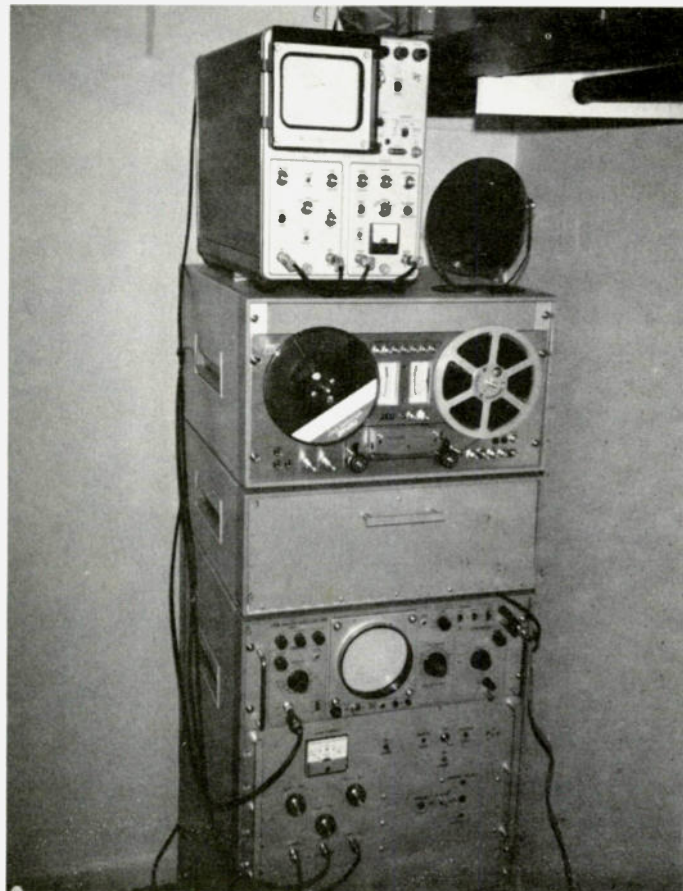

Fig. 3. 70 Hz low-pass filter and power amplifier.

Photo C. This is an overall view of the author's GOES WEFAX station. The scope on the top is a customized Tektronix 561B. It is used in conjunction with the Tektronix C-27 camera to make 4 by 5 Polaroid™ prints of WEFAX pictures. The tape deck is seen in the rack below the 561. Below the tape deck is the drum recorder in its protective enclosure. The door opens down and the machine slides out. The scope below this is used as a waveform monitor. It is used for manual phasing and checking signal quality. Below the monitor is the machine that powers the drum recorder head. It does the video and sync processing. Also, it contains the power amplifiers for the motors. My receivers are housed in a separate rack and were not shown here. I use a 200-channel synthesized radio for 136-138 and a double-conversion custom-built receiver for GOES.



amplifier. The scope screen now depicts what is happening on the paper drum one line at a time. If the position the sync pulse takes during auto-phase is known, you can manually move it there now by holding down the manual phase button, S4. When the pulse arrives on its desired position, S4 is simply released.

Finally, the input frequency for the programmable divider, U5, pin 6, is generated in Fig. 4. To begin, a 2.4 MHz oscillator module was purchased from International Crystal Mfg. Co. The 2.4 MHz TTL square wave is buffered by

U1D and U1E. ICs U9, U10, and U11 divide the 2.4 MHz down to 2400 Hz. During real-time operation, the 2400 Hz is fed directly to the programmable divider by S5. Also, it may be recorded on tape via capacitor C39 for playback later. During playback, the 2400 Hz that was recorded on tape locks up U12. U12 is a phase locked loop chip that has its vco adjusted to free run on 2400 Hz by R29. The purpose of U12 is to compensate for any speed variation in the tape deck and also to provide a clean signal for the programmable divider.

There you have it; you

now have a complete state-of-the-art phasing system for the new GOES WEFAX broadcasts.

Calibration Procedure

First of all, check the wiring before applying power.

These circuits should work the first time if the wiring is okay. After giving everything a thorough going over, turn on the power supply. Check to see that the voltage levels are correct and that the ripple is

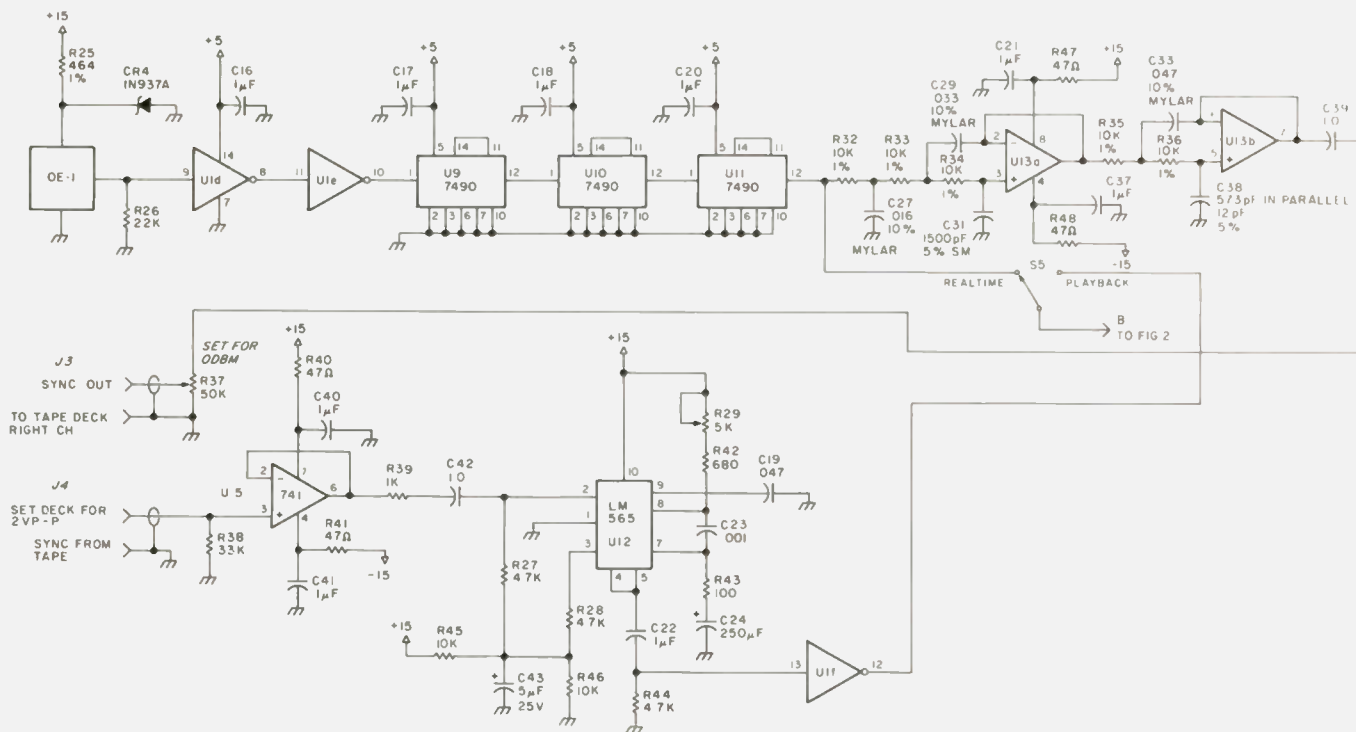

Fig. 4. Sync generator.



Photo D. This is an example of a properly phased GOES WEFAX picture. It was received and processed by the equipment in Photo C.

low. The ripple should only be several mV p-p. Next, measure the voltage between U8, pin 1 and U8, pin 4. With R23 adjusted fully CCW, the voltage should be about 50 V dc. Now, connect a dc-cou-

pled scope to U11, pin 12 and check for a 2400 Hz square wave. Connect a counter to U1E, pin 10 and check the oscillator, OSC-1, for 2,400,000.0 Hz. Move the counter over to U1F, pin 12, and, with S5 in real time and J4 disconnected, adjust R29 for 2400 Hz. Switch S2, the phasing switch, to manual and connect the counter to U6, pin 8. You should read 60 Hz.

Next, depress the manual phase button, and the counter should read 58.536 Hz. This checks the divider. Release the manual phase button and connect a VOM, on a high ac voltage range, across the blue and brown wires on the secondary of T1. Adjust R23 CW until 117 V ac is read on the meter. M1 should now be

running. Next, move your dc-coupled scope to the base of Q1. Check the amplitude of the pulse from the magneto. You need at least 1 volt peak to ensure that Q1 turns on. The positive half cycle will forward bias Q1. If the pulse level is too low, move the solenoid in closer to the magnet. Move the probe to the collector and check for a TTL pulse of approximately 10 ms duration. The inversion of this pulse will be on J1.

It is now necessary to use a GOES WEFAX signal. A prerecorded signal will be desirable. With the circuits completed and tested, as described in "Attention, Weather Watchers!", connect J2 to U4B, pin 7 in the video filter. Switch both function switches to playback, start the tape, and adjust the white set pot for a pulse that rises from -0.5 V dc to ground during the phasing period at U4B, pin 7. Next, adjust R5 in Fig. 1 for a zero-to-five-volt pulse on U3B, pin 7. Finally, with S2 in auto, start the tape at the beginning. The phasing-okay LED should be on as the drum spins. As soon as the phasing period starts, check the picture phasing by pressing the start button. The error LED will now come on and will remain on until the two pulses cross. When the two pulses cross, the phasing-okay LED will come on, indicating that phasing was accomplished.

I mentioned earlier that there is a phase shift introduced by the magnet and the coil that offsets the true picture edge about an inch or so. The easiest way to correct this is to find the point on the drum that corresponds to the actual picture edge. To do this, you will need to load the drum with photographic paper and place the paper's edge in line with the magnet's centerline. Now, start the

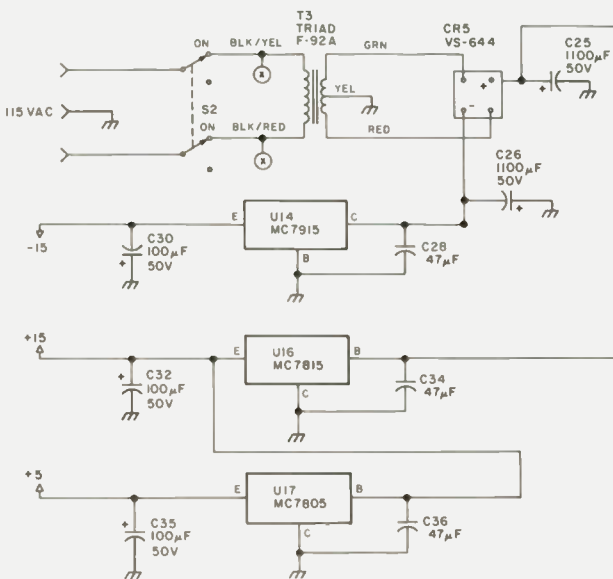

Fig. 5. Power supply.

Parts List

C1	.1 uF, 50 V monolytic (mono)	R14	3.3k, ¼ W 10%
C2	.1 uF, 50 V mono	R15	3.3k, ¼ W 10%
C3	.71 uF, 100 V mylar*	R16	10k RN55 1%
C4	.065 uF, 100 V mylar*	R17	10k RN55 1%
C5	1.46 uF, 100 V mylar*	R18	10k RN55 1%
C6	.024 uF, 100 V mylar*	R19	10k RN55 1%
C7	2.03 uF, 100 V mylar*	R20	10k RN55 1%
C8	.1 uF, 50 V mono	R21	47 Ohm, ¼ W 10%
C9	.1 uF, 50 V mono	R22	47 Ohm, ¼ W 10%
C10	1.0 uF, 50 V mono	R23	10k, 1 W wire-wound 20-turn pc pot
C11	2200 uF, 50 V electrolytic	R24	10 Ohm, ¼ W 10%
C12	50 uF, 50 V electrolytic	R25	464 Ohm RN60 1%
C13	.047 uF, 100 V mylar	R26	22k, ¼ W 10%
C14	3450 uF, 75 V electrolytic	R27	4.7k, ¼ W 10%
C15	.5 uF, 400 V (supplied with M1)	R28	4.7k, ¼ W 10%
C16	.1 uF, 50 V mono	R29	5k Ohm, 1 W wire-wound 20-turn pc pot
C17	.1 uF, 50 V mono	R30	3.3k Ohm, ¼ W 10%
C18	.1 uF, 50 V mono	R31	3.3k Ohm, ¼ W 10%
C19	.047 uF, 100 V 10% mylar	R32	10k RN55 1%
C20	.1 uF, 50 V mono	R33	10k RN55 1%
C21	.1 uF, 50 V mono	R34	10k RN55 1%
C22	.1 uF, 50 V mono	R35	10k RN55 1%
C23	.001 uF, 50 V mono	R36	10k RN55 1%
C24	250 uF, 25 V electrolytic	R37	50k, 1 W wire-wound 20-turn pc pot
C25	1100 uF, 50 V electrolytic	R38	33k, ¼ W 10%
C26	1100 uF, 50 V electrolytic	R39	1k, ¼ W 10%
C27	.016 uF, 10% mylar	R40	47 Ohm, ¼ W 10%
C28	.47 uF, 50 V mono	R41	47 Ohm, ¼ W 10%
C29	.033 uF, 50 V 10% mylar	R42	680 Ohm, ¼ W 10%
C30	100 uF, 50 V electrolytic	R43	100 Ohm, ¼ W 10%
C31	1500 pF 5% silver mica	R44	4.7k, ¼ W 10%
C32	100 uF, 50 V electrolytic	R45	10k, ¼ W 10%
C33	.047 uF, 50 V 10% mylar	R46	10k, ¼ W 10%
C34	.47 uF, 50 V mono	R47	47 Ohm, ¼ W 10%
C35	100 uF, 50 V electrolytic	R48	47 Ohm, ¼ W 10%
C36	.47 uF, 50 V mono	S1	SPDT 120 V toggle
C37	.1 uF, 50 V mono	S2	DPDT 120 V toggle
C38	573 pF in parallel with 12 pF 5% silver mica	S3	SPST push-button
C39	1.0 uF, 50 V mono	S4	SPST push-button
C40	.1 uF, 50 V mono	S5	SPDT toggle or rotary switch
C41	.1 uF, 50 V mono	T1	TRIAD S-24A 8-Ohm-to-8k-Ohm, 15 W
C42	1.0 uF, 50 V mono	T2	TRIAD F-93X
C43	5 uF, 25 V electrolytic	T3	TRIAD F-92A
CR1	1.7 V, 20 mA LED	T4	solenoid from a relay—I use a coil from a model KRP11AG Potter and Brumfield.
CR2	1.7 V, 20 mA LED	U1	SN7404
CR3	VS-644 bridge rectifier assembly, 600 V @ 2 A	U2	SN7400
CR4	1N937A	U3	MC1458
CR5	VS-644	U4	SN7474
F1	1 Amp slow blow	U5	SN74196
J1	BNC female chassis mount connector	U6	SN74196
J2	BNC female chassis mount connector	U7	MC1458
J3	BNC female chassis mount connector	U8	Sanken S1-1025E hybrid power IC. An S1-1020 is a good substitute.
J4	BNC female chassis mount connector	U9	SN7490
M1	240 rpm 5-Watt synchronous Hurst motor model CA	U10	SN7490
Q1	2N2270	U11	SN7490
Q2	2N2270	U12	LM565
Q3	2N2270	U13	MC1458
R1	680 Ohm, ¼ W 10%	U14	MC7915CP
R2	1k Ohm, ¼ W 10%	U15	LM741
R3	47 Ohm, ¼ W 10%	U16	MC7815CP
R4	47 Ohm, ¼ W 10%	U17	MC7805CP
R5	20k 1-Watt wire-wound 20-turn PC pot	U18	SN7430
R6	100k, ¼ W 10%	OSC1	International Crystal Mfg. Co. OE-1 oscillator module.
R7	10k RN55 1%		
R8	10k RN55 1%		
R9	90.9k RN55 1%		
R10	3.3k, ¼ W 10%		
R11	220 Ohm, ¼ W 10%		
R12	10k Ohm, ¼ W 10%		
R13	10k Ohm, ¼ W 10%		

*The desired value is obtained by paralleling two or more capacitors. Use a good quality capacitor. The value doesn't have to be exactly on the calculated value shown.

drum, turn on the tape deck, and wait for the phasing period to start. As soon as it begins, depress the start switch and allow the machine to phase. Next, switch on the lamp and allow part of the picture to expose. Remove the paper and develop it. Note the position of the sync on the paper. Place the developed picture back on the drum the same way it came off. Make a small mark on the

drum corresponding to where the sync is on the paper. Remove the paper and scribe a line on the drum where the mark is. This line is to be used to indicate where the paper's edge will go from now on each time the drum is loaded.

Load the drum with a fresh sheet of paper and place its edge along the new line. Remake the tape-recorded picture once

more. Allow the drum to phase automatically. This time when the phasing is accomplished, the sync will be positioned at the edge of the photo. If you make pictures in the reverse direction, a phasing mark will have to be located for the opposite direction, also. To do this, the above process will have to be repeated. When you finish, there will be one mark on the drum for

pictures made in the forward direction and one for the reverse direction.

Please take careful note of the photos showing my station. Details of the solenoid and magnet may be seen in the picture of the recorder. Good luck in getting your system on the air. If you have come this far, I am sure you have quite a station by now. If you have any questions, please include an SASE. ■

LETTERS

from page 15

suggest an imaginative and potentially beneficial public service television concept and that this type of communications activity is one which deserves considerable attention in the overall inquiry."

The FCC requested comments in BC Docket No. 78-253 from all interested parties. These comments are due (original and six copies) at the FCC, Washington DC 20554, by December 11, 1978.

S. E. Pillar W2KPQ
President
Communicating Association
of America, Inc.
Syosset NY

FRESH VIEWPOINT

Being an active amateur for three years and hoping to be one for at least another thirty, I feel inclined to respond to your criticism of the ARRL. From my Novice days on, I have been brought up on the thinking and ways of the League. On the whole, this organization has been superb in helping me grow in the hobby. Many new things have come about, and ham radio is still around because of the League.

At this point, the accolades end and the real essence of my correspondence surfaces. In the beginning, you and your magazine really rubbed me the wrong way, and, as usual, I merely discarded your commentaries. Well, I guess everyone grows up, and after many hours of mental soul-

searching and objective meditation, I finally saw the light.

Mr. Green, thank you very much for providing about the only fresh viewpoint in a too-long monopolized field. It seems that we hams have become far too complacent in our thinking. This is undoubtedly a very dangerous and unhealthy situation.

Although there are points of disagreements in our thinking, at least you have spurred my mind to realize the presence of other possibilities. I now read the rebuttals you receive from other hams and can see the fear I once experienced. I can only urge all my counterparts to just stop for a few minutes and examine their way of thinking.

Ham radio is going through an amazing period of change and growth, and it certainly needs more than one voice to express its needs. I personally wish you good luck in your attempts concerning the upcoming WARC, and thanks again.

Michael A. Roscoe K3VK
Sharon PA

ATLAS CLASS

In the past, you've printed letters from WA5TUM and AA6US commending Atlas Radio and their service. All I can say about Atlas service is, "FANTASTIC."

On September 20, my Atlas 350-XL became inoperative. I called Clint Call at Atlas and, after describing the problem, Clint told me to send the 350-XL and p/s to Steve Crossman at Communications Specialties in

Erie PA, collect. The units were shipped via UPS that day and on September 27 at 6:30 pm, my 350-XL was back on the air at my QTH. Not only was the rig repaired, but it was updated with the latest modifications, all for no cost or shipping charges.

I can't praise all of the personnel at Atlas too much, as they are not only gracious, but helpful to the nth degree. Atlas Radio is setting a precedent and building up a reputation that is going to be hard to beat.

Now, a few words about 73. It's in a class by itself. Were it not for 73, K2QHI would have been relegated to "appliance-operator" status a long time ago, but the plethora of construction articles keeps my hands busy and my soldering irons hot. Keep up the good work, Wayne.

Michael Stefanik K2QHI
Garfield NJ

WHICH MAGAZINE?

After reading the letters in a few of the past issues, I feel compelled to write in answer. I have subscribed to both 73 and QST for the past three years, and wish to ask (and answer) a few questions about these publications:

In which magazine can you find the most useful articles, divergent points of view, letters printed on both sides of a question, letters attacking the magazine as well as praising it? In 73. In which will you find a publishing philosophy which accepts opposing points of view, which screens its advertisers for reliability, which will accept letters proposing almost anything? In 73. In which will you find editorials which most likely are representative of a majority of its readers, if not of amateurs in general, and which doesn't "flip-flop" on the issues? In 73.

In which will you find a

multitude of column inches devoted to relatively useless columns, and claims of representation of the amateur while trumpeting nonrepresentative views? In QST. In which will you find the most apologies for a bumbling FCC, and the most "official reportage" with the least member input? In QST. Which magazine can usually be relied upon to review a "new" product long after it has been on the market, or to fail to reply to a proposal or letter? QST.

I don't for a moment begrudge these fellow amateurs their opinions, and I applaud your printing of them, but I just can't figure out what's so great about the League. It has its good points, just as 73 has its bad points, but on the balance, I'll take 73 anytime.

R. J. Edmunds WB2BJH
Kinnelon NJ

QTHING

For many years I have been thinking of writing to the various amateur magazines on the following subject, but kept putting it off. However, I'm finally getting around to it.

I have been on the air about fifty years. During that time, when I called a CQ, I have always given my location (QTH) since I felt many amateurs wanted to know where the call was coming from, and there is always the chance they might have phone-patch traffic for my location.

Back in the old days, when someone signed W1, W2, W3, etc., one always had a general idea of his location, but with the complete jumble in call assignments by the FCC recently, one does not know if the call is from their next-door neighbor or from Timbuktu.

I would like to suggest that a movement be started by the various magazines to have

Continued on page 116

NEW! MFJ INTRODUCES THE GRANDMASTER MEMORY KEYERS

At \$139.95 this MFJ-484 GRANDMASTER memory keyer gives you more features per dollar than any other memory keyer available — and Here's Why . . .

WEIGHT CONTROL TO PENETRATE ORM. PULL TO COMBINE MEMORIES A AND B FOR 1, 2, OR 3 FIFTY CHARACTER MESSAGES.

MESSAGE BUTTONS SELECT DESIRED 25 CHARACTER MESSAGES.

RESETS MEMORY IN USE TO BEGINNING.

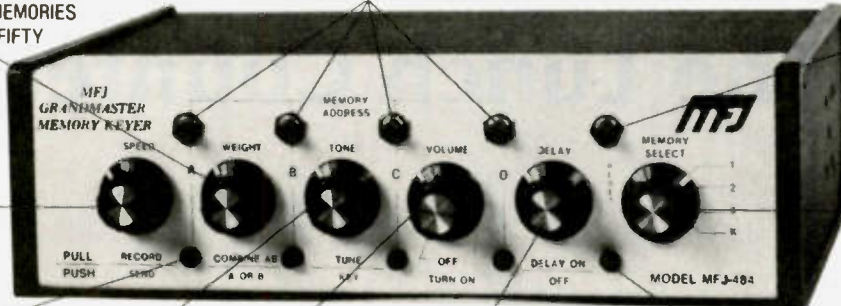

SPEED CONTROL, 8 TO 50 WPM. PULL TO RECORD.

MEMORY SELECT: POSITIONS 1, 2, 3 ARE EACH SPLIT INTO MEMORY SECTIONS A, B, C, D (UP TO TWELVE 25 CHARACTER MESSAGES). SWITCH COMBINES A AND B. POSITION K GIVES YOU 100, 75, 50, OR 25 CHARACTERS BY PRESSING BUTTONS A, B, C, OR D.

LEDs (4) SHOW WHICH MEMORY IS IN USE AND WHEN IT ENDS.

TONE CONTROL. PULL TO TUNE.

VOLUME CONTROL. POWER ON-OFF.

DELAY REPEAT CONTROL (0 TO 2 MINUTES). PULL FOR AUTO REPEAT.

LED INDICATES DELAY REPEAT MODE.

NOW YOU CAN CALL CQ, SEND YOUR QTH, NAME, ETC., ALL AUTOMATICALLY.

And only MFJ offers you the MFJ-484 Grandmaster memory keyer with this much flexibility at this price.

Up to twelve 25 character messages plus a 100, 75, 50, or 25 character message (4096 bits total).

A switch combines 25 character messages for up to three 50 character messages.

To record, pull out the speed control, touch a message button and send. To playback, push in the speed control, select your message and touch the button. That's all there is to it!

You can repeat any message continuously and even leave a pause between repeats (up to 2 minutes). Example: Call CQ. Pause. Listen. If no answer, it repeats CQ again. To answer simply start sending. LED indicates Delay Repeat Mode.

Instantly insert or make changes in any playing message by simply sending. Continue by touching another button.

Memory resets to beginning with button, or by tapping paddle when playing. Touching message button restarts message.

LEDs show which 25 character memory is in use and when it ends.

Built-in memory saver. Uses 9 volt battery, no drain when power is on. Saves messages in memory when power loss occurs or when transporting keyer. Ultra compact, 8x2x6 inches.

PLUS A MFJ DELUXE FULL FEATURE KEYER. Iambic operation with squeeze key. Dot-dash insertion.

Dot-dash memories, self-completing dots and dashes, jamproof spacing, instant start (except when recording).

All controls are on front panel: speed, weight, tone, volume. Smooth linear speed

control. 8 to 50 WPM.

Weight control lets you adjust dot-dash space ratio; makes your signal distinctive to penetrate ORM.

Tone control. Room filling volume. Built-in speaker.

Tune function keys transmitter for tuning.

Ultra reliable solid state keying: grid block, cathode, solid state transmitters (-300 V, 10 ma. max., +300 V, 100 ma. max.). CMOS ICs, MOS memories. Use 110 VAC or 12 to 15 VDC. Automatically switches to external batteries when AC power is lost.

OPTIONAL SQUEEZE KEY

for all memory keyers. Dot and dash paddles have fully adjustable tension and spacing for the exact "feel" you like. Heavy base with non-slip rubber feet eliminates "walking". \$29.95 plus \$2.00 for shipping and handling.



THIS MFJ-482 FEATURES FOUR 25 OR A 50 AND TWO 25 CHARACTER MESSAGES.

- Speed, volume, weight, tone controls
- Combine memory switch
- Repeat, tune functions
- Built-in memory saver

\$99⁹⁵

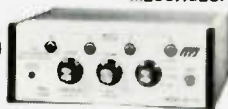

Similar to MFJ-484 but with 1024 bits of memory, less delay repeat, single memory operating LED. Weight and tone controls adjustable from rear panel. 6x2x6 inches. 110 VAC or 12 to 15 VDC.

THIS MFJ-481 GIVES YOU TWO 50 CHARACTER MESSAGES.

- Repeat function
- Tune function
- Built-in memory saver

\$79⁹⁵



Similar to MFJ-482 but with two 50 character messages, less weight controls. Internal tone control. Volume control is adjustable from rear panel. 5x2x6 inches. 110 VAC or 12 to 15 VDC.

For Orders Call toll-free 800-647-1800

Order any product from MFJ and try it. If not delighted, return within 30 days for a prompt refund (less shipping).

Order today. Money back if not delighted. One year unconditional guarantee. Add \$2.00 shipping/handling.

For technical information, order/repair status, in Mississippi, outside continental USA, call 601-323-5869.

Order By Mail or Call TOLL FREE 800-647-1800 and Charge It On

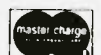

MFJ ENTERPRISES, INC.

P. O. BOX 494

✓ M52

MISSISSIPPI STATE, MISSISSIPPI 39762

The Lunch Counter

— eat it up

*Johnny C. Chestnut WA4PIN
801 N. Ramona Avenue
Indialantic FL 32903*

*John L. Wolcott W4CCX
490 E. Riviera Blvd.
Indialantic FL 32903*

The Lunch Counter project was designed, from start to finish, as a ham

project with ham specifications. Its primary goals were that it:

- 1) be technically up to date;
- 2) be easy to build;
- 3) use readily-obtainable parts; and
- 4) involve easy case fabrication.

As you may have already surmised from the name, the entire project was conceived and designed during a series of eyeball QSOs over lunch. A few evenings were used to build the prototype.

All of the participants work in electronics in some capacity, but none of the work was done within our respective fields of expertise. As an example, we elected our professional program manager to be the prototype technician, on the theory that the experience would be good for him. While only two of us wrote this article, acknowledgement is given to WA4QGE for mechanical design, WB4GDP for

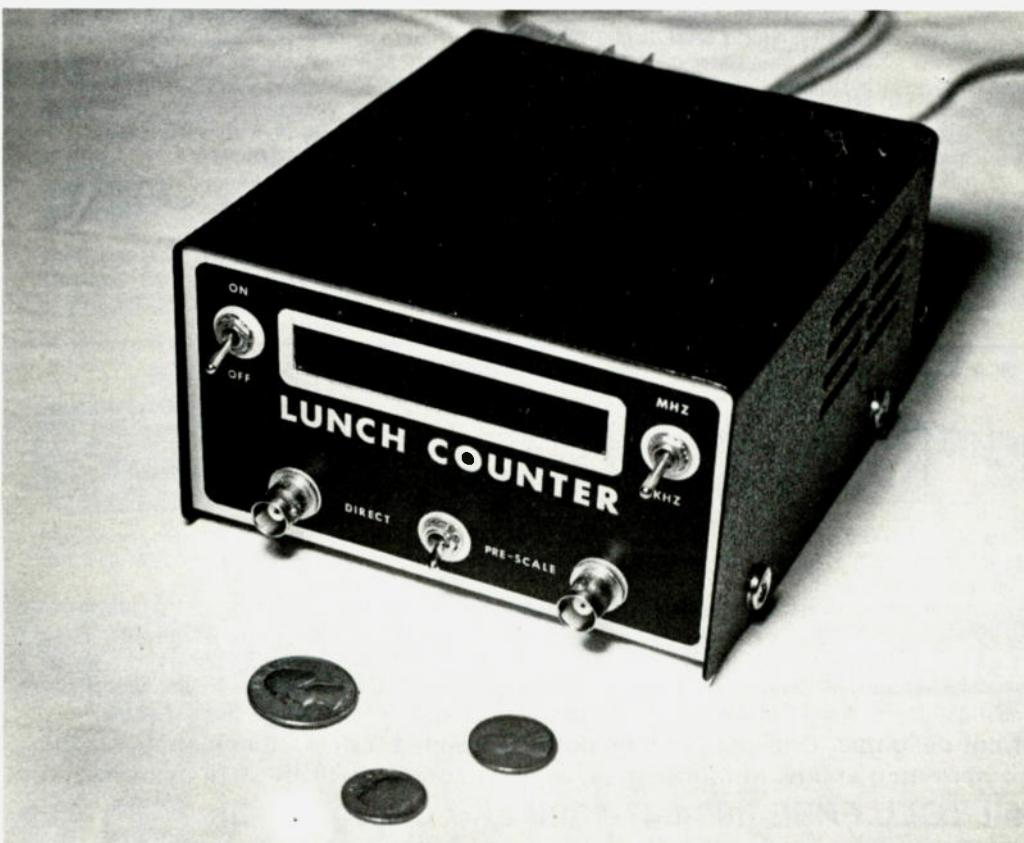

The finished Lunch Counter.

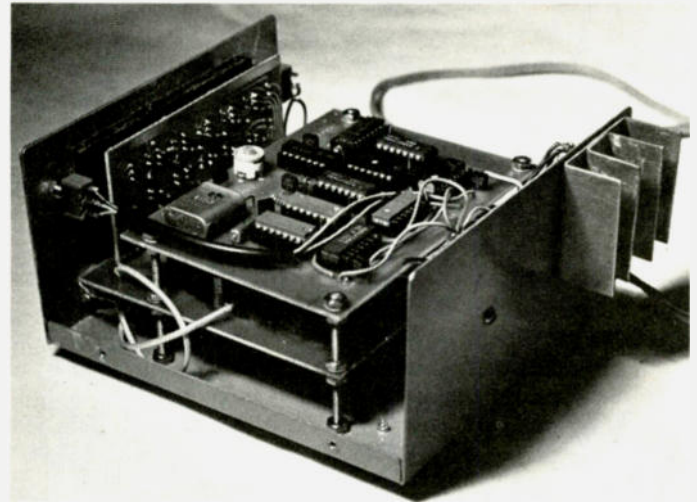
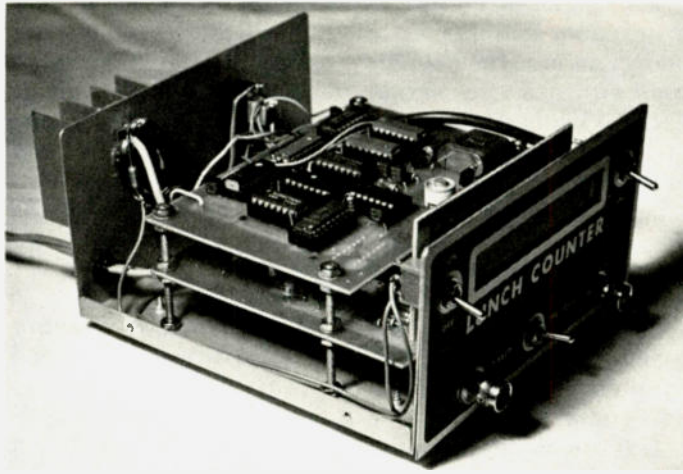

Interior views showing construction details and PC board mounting.

layout and drafting, and WB4UDI and WB4WWI for parts procurement.

We made a detailed evaluation of advertisements for available frequency counters. It soon became obvious that the art of digital frequency counters has progressed remarkably in the past few years as the newer integrated circuits have become available. As the semiconductor wizards pack more circuitry into an integrated circuit, the overall size goes down, the device capability goes up, and, best of all, the cost goes down. After all frequency counter ads and construction articles were reviewed and summarized, our appetites demanded the best features from each, and, of course, no one counter met all our desires.

Specifications

At this point, we developed a target specification which would satisfy all of us.

- 1) Cost—cheap, to fit a ham's pocketbook.
- 2) Display—six digits, big enough to read.
- 3) Frequency range—from audio (touchtone™ pads) through all the popular amateur bands (1.8 MHz to 450 MHz).
- 4) Sensitivity—sufficient for most solid-state rigs,

but not sensitive enough to produce unnecessary counting on noise (10 mV to 25 mV).

5) Accuracy— ± 10 Hz to ± 100 Hz is usually fine for most amateur purposes. A good quality crystal can be adjusted to better than 10 parts per million and will easily meet these criteria.

6) Stability—stable over the temperature range encountered in the ham shack. We did not expect to use it outside of normal room temperatures. Long-term stability should be good enough to maintain accuracy between calibration checks, which are six months to one year for most users.

7) Size—small enough to fit in the palm of the hand, but large enough to have an easy-to-use front panel.

8) Power—12 V dc was the choice of most of us who participated in the development. Most new solid-

state rigs operate on 12 V dc, and a 110 V ac power supply is easy to build for those who desire it.

Design

The design that evolved over many lunch hours is shown in the block diagram in Fig. 1. The circuit was divided into three functional boards—timing, counter, and display. The timing board contains the oscillator, dividers, and timing to control the counter board. The counter board contains the six decade counters, latches, and seven-segment display drivers. In addition, it has the input amplifiers and high-frequency prescaler. The display board holds the six LED displays. Power requirements are met by the use of a three-terminal regulator to obtain 5 V dc from an 8-16 V dc supply.

Schematic details began with the selection of the

74C925 as the workhorse of the counter. This is a new counter chip which has a full four stages of counter built in with the necessary latch, seven-segment decoders, and LED drivers. It also multiplexes the output drivers, thus greatly simplifying the wiring to the displays. Comparing this single 16-pin integrated circuit to an equivalent set of conventional four-digit TTL counters, twelve integrated circuits, twenty-eight resistors, and twenty-eight wires to the display are now replaced with one integrated circuit, seven resistors, four transistors, and eleven wires to the display board.

Since the design criteria called for a six-digit counter, two more stages must be added. By using 74LS90 counters for these stages, the frequency range of the basic counter

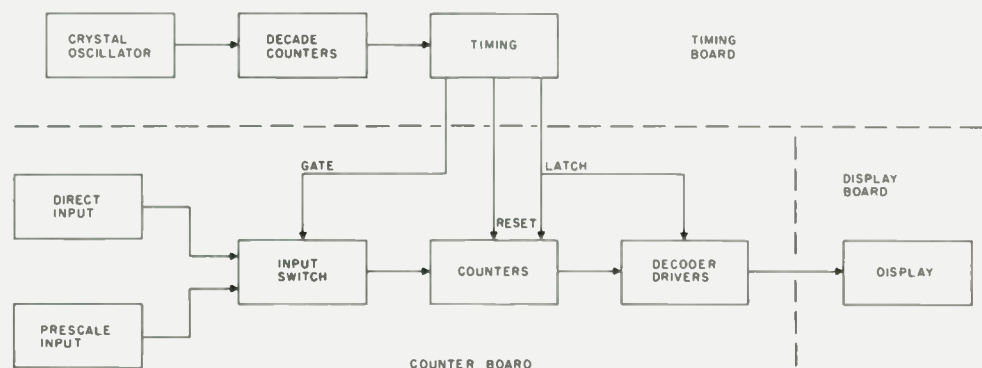
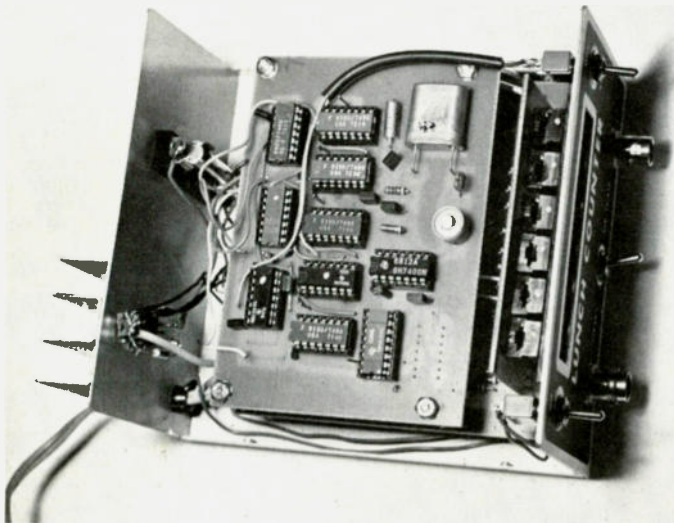

Fig. 1. Lunch Counter block diagram.



Top view showing parts layout of timing board.

will cover to 50 MHz. The associated latch and decoder/LED drivers for these two stages use 9368s. This device saves a couple of integrated circuits by combining the latch, decoding, and driving functions, but the resistors and wiring to the LEDs are cumbersome when compared to the multiplexed 74C925. It must be noted that the digit "9" on the 9368 and the 74C925 are decoded differently.

The input stages to the counter are either the amplifier, for direct input, or the divide-by-10 prescaler. A front panel switch is used to select the direct input or the prescaler through a 74LS00 gate so that the high-frequency signal path is always from one integrated circuit to

the next. The DIRECT/PRE-SCALE switch only switches a dc control voltage. The 11C90 prescaler was selected because its frequency range exceeds 500 MHz. It also has the ECL-to-TTL conversion built in and therefore does not require additional transistors for level conversion. The prescaler divides the high-frequency input by 10, so its output is within the 50-MHz range of the basic counter. In this process, the last digit is dropped from the count, and the decimal point is therefore moved one place to the right.

The function of the timing board is to generate the timebase and control functions for the counter. An accurate gate is required

which will allow the counter to count its input for a known period. The counter uses either a one-second gate for kilohertz or a one-millisecond gate for megahertz. The timing board also provides latch and reset pulses to update the display. The latch pulse updates the display with the previous count, and the reset pulse clears the counters prior to starting a new count.

Our original design used a 1.3-MHz crystal because we already had a few available. The first stage following the oscillator was a 74L193 programmed to divide by 13. After we completed the printed circuit board artwork, the plan to make the Lunch Counter into a club project developed. At this point, we modified the artwork to permit the use of a more readily available 1.0-MHz crystal as an option.

The power supply is simply a 3-terminal regulator bolted to the rear of the chassis with the bypass capacitors soldered directly to the terminals and a solder lug under the mounting screw. We used a small heat sink to reduce the regulator temperature, but several have been built using just the chassis for a heat sink with good results.

A parts list for the Lunch

Counter is included with this article. The parts are easily available through advertisers listed in any of the ham radio magazines, such as 73. The 11C90 and 74C925 are the most expensive parts and the 9368s come in a close third.

Construction

Construction is very straightforward. Printed circuit board assembly should be started with the jumpers on the component side, followed by the integrated circuit sockets, and then the remaining components. The display board is mated to the counter board with cutoff resistor leads or bits of hookup wire bent at a right angle. Both boards may be mounted in the cabinet with long bolts and stand-offs. Wiring between boards, the switches, inputs, and power supply completes the wiring. The boards are then mounted in the cabinet and the LEDs lined up with the window.

The case is widely available through Radio Shack stores. A silk-screened front panel gives the unit a professional appearance and makes the construction easy. Cutting the rectangular hole in the front panel may be the most difficult part for some builders. A nibbling tool

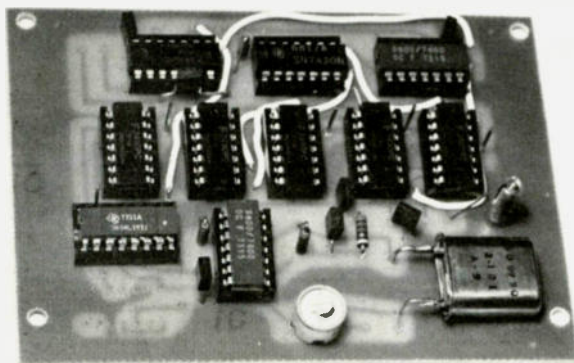

Timing board — component side.

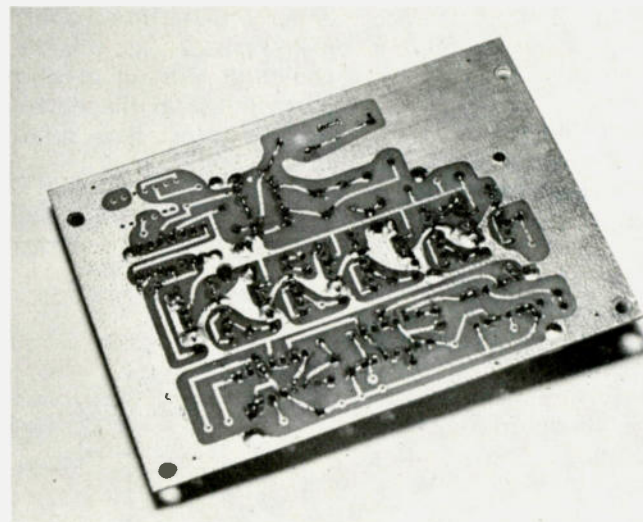

Timing board — foil side.

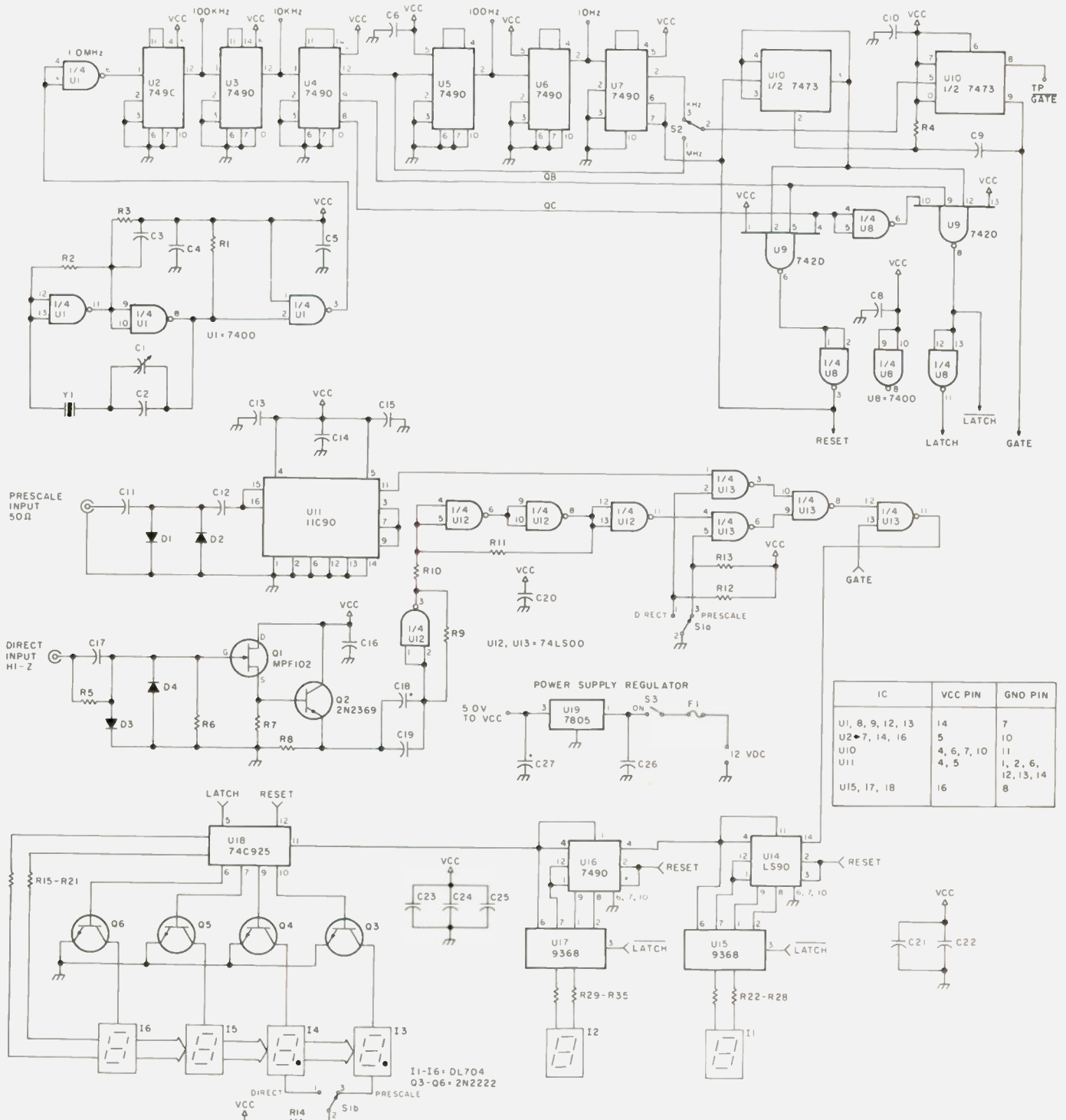

Fig. 2. Schematic.

does a good job on this hole. Some of us used a Dremel tool to cut out the hole. We then glued a red piece of Plexiglas™ to the back side of the hole.

Suggested Wiring Sequence

1. Jumpers under sockets — 10 total.
2. Sockets — remove unused pins from display sockets.

3. All other on-board jumpers.

4. All other components.
5. Mount display board to counter board.
6. Wiring between boards.
7. Mount front panel on cabinet; drill holes and cut window.
8. Mount PC boards in cabinet.
9. Complete mechanical assembly.
10. Complete wiring.

Calibration

The only alignment required is to put the oscillator exactly on frequency. We made provisions for a fixed padder (C2) in parallel with the trimmer (C1) to be used if necessary. If the oscillator adjusts to the exact frequency with the trimmer alone, C2 is not needed. If the oscillator frequency is too high with the trimmer, C1, fully

meshed, C2 should be added to lower the frequency. Note that a low oscillator frequency will result in a high count when using the frequency counter. The most accurate alignment method is to use the counter to count a known laboratory frequency standard. A frequency above 10 MHz is preferred to obtain the best accuracy. Alternate calibration

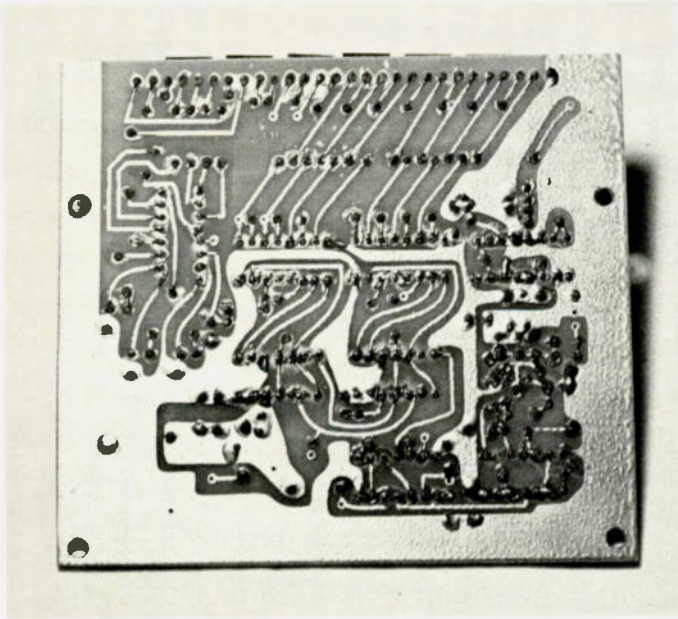

Counter board — foil side.

sources would be a 100-kHz crystal calibrator or an oscillator zero beat to WWV. Also, there have been several magazine articles on using the TV color burst frequency as an accurate standard.

Troubleshooting

The counter should read all zeros (the last digit may read 1) with no input signal. If it does not, the following sequence of troubleshooting is suggested:

1. Double check all jumpers and wiring.
2. Check for 5 V dc on each IC as per pin connection table on the schematic.
3. If individual segments of one or more LEDs do not light, check the display by

interchanging LEDs, and check wiring and solder joints on the display and counter boards.

4. If one LED does not light, check the corresponding driver IC and/or transistor.

5. If the display lights but does not reset, check the following:

- a. Check the oscillator by connecting a scope to pin 6 of U1. You should see a 1-MHz square wave.
- b. Check the GATE pulse by connecting a scope to pin 9 of U10. You should see a 1-ms square pulse (MHz-kHz switch in MHz).
- c. Check the LATCH pulse by connecting a

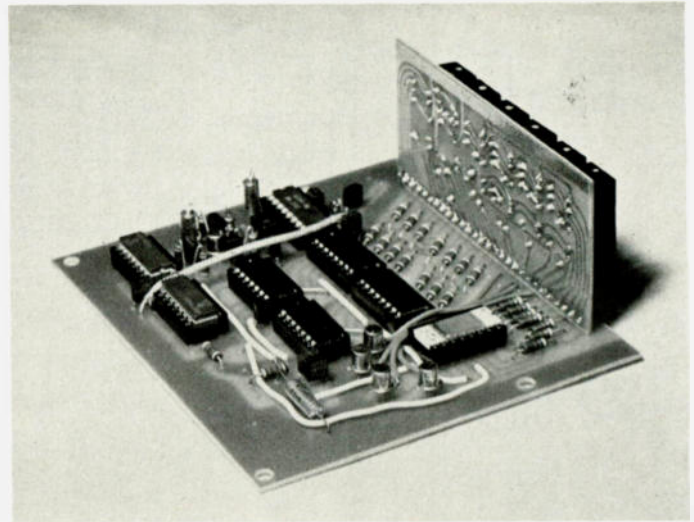

Counter and display boards showing parts layout.

scope to pin 11 of U8. You should see a 0.1-ms square pulse every 2 ms.

d. Check the RESET pulse by connecting a scope to pin 3 of U8. It should look exactly like the LATCH pulse.

e. Check for correct GATE, LATCH, LATCH, and RESET pulses on LC2.

6. If the display lights but does not count, check the following:

a. Connect the 100-kHz test point to the DIRECT input. Put the DIRECT/PRE-SCALE switch in DIRECT and check for a 100-kHz square wave at pin 4 and pin 11 of U13. The display should read 000.100 with the MHz-kHz switch in MHz.

b. Move the input signal to the PRE-SCALE input, put the DIRECT/PRE-SCALE switch in PRE-SCALE, and check for a 10-kHz square wave at pin 1 and pin 11 of U13.

c. Check for a 10-kHz square wave at pin 14 of U14 and a 1-kHz square wave at pin 4 of U14.

d. Check for a 1-kHz square wave at pin 14 of U16 and a 100-Hz square wave at pin 4 of U16.

cies under 50 MHz. The timebase switch may be set to either the MHz or kHz position. The decimal point on the readout is located after the third digit to correspond to MHz or kHz. In the kHz position, the least significant digit is 0.001 kHz or 1 Hz. When reading frequencies above 1 MHz, you can read to the nearest kHz in the MHz position, then switch to the kHz position and read the last three digits to the nearest Hertz.

Between 50 MHz and 500 MHz, you must use the prescaled input. The prescaler divides the input frequency by 10 and does not display the least significant digit. Therefore, the decimal point is moved one place to the right to properly index the display. By using the MHz/kHz switch, a prescaled frequency can be displayed to the nearest 10 Hertz.

Accuracy, temperature stability, and long-term drift of any counter are only as good as the crystal timebase. Most reasonably-accurate 1-MHz crystals can be trimmed to exactly 1 MHz with a little care, so the initial accuracy will depend on the facilities you have for calibration. Temperature stability and long-term drift depend on the crystal quality and the

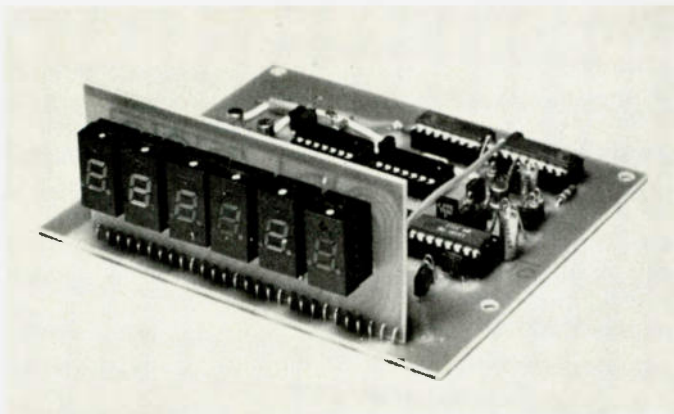

Display and counter boards showing LEDs and mounting technique.

Use

The direct input is generally used for frequen-

oscillator circuit. In the counters we built, these two effects were less than 0.0005% over normal room temperature. After all, we did not intend to use the counter at temperatures where we do not function well. For greater stability, a high-quality crystal and oven can be used.

The sensitivity of the Lunch Counter was measured as 10 mV up to 50 Mhz in the direct mode and 50 mV up to 500 MHz in the prescale mode. This is sufficient to measure most transmitters using a short antenna on the input, without a direct connection. The most important caution is not to overcouple to the counter. Excessive input causes multiple counts and a reading much higher than expected. Of course, if you couple too much energy into the input, you can damage the input circuitry. Diodes are provided across the inputs to reduce this possibility.

As the word of our project spread through the local club, it was soon apparent that a counter was of universal interest. As a result, boards were made available, and more than 50 were constructed by members of the Platinum Coast Amateur Radio Society.

We had a lot of fun designing and building the Lunch Counter. We have met our goals of a simple-to-build counter with excellent specifications, and it has generated a lot of interest as a local club project. By using a good case and a good-looking front panel, any ham should be able to make a professional-looking piece of test equipment like the ones which are now indispensable in our shacks.

The three printed circuit boards, a 0.020-inch-thick aluminum silk-screened front panel with adhesive

back, and documentation are available from Johnny

Chestnut, 801 N. Ramona Avenue, Indialantic FL

32903, for \$12.50 post-paid. ■

Parts List

	Size	Quantity
Capacitors		
C1	10-60 pF trimmer	1
C17	100 pF	1
C9	0.001 uF ceramic disc	1
C3, C4, C11, C12, C15, C20, C22, C24	0.01 uF ceramic disc	8
C6, C7, C8, C10, C14, C16, C19, C21, C23	0.1 uF ceramic disc	9
C26	0.22 uF, 50 V	1
C27	1 uF, 10 V tantalum	1
C18	4.7 uF, 10 V tantalum	1
C5, C13, C25	10 uF, 10 V tantalum	3
C2	*Selected at test	1
Diodes		
D1-D4	1N4148	4
Displays		
I1-I6	DL-704	6
Transistors		
Q1	MPF-102	1
Q3-Q6	2N2222	4
Q2	2N2369	1
Resistors (all 1/4-Watt)		
R15-R21	120 Ohms	7
R2	150 Ohms	1
R8	220 Ohms	1
R22-R35	390 Ohms	14
R9, R10, R14	470 Ohms	3
R1, R3	680 Ohms	2
R7, R12, R13	4.7k Ohms	3
R11	15k Ohms	1
R4	47k Ohms	1
R5	100k Ohms	1
R6	1.8 megohms	1
Switches		
S3	SPST	1
S2	SPDT	1
S1	DPDT	1
ICs		
U11	11C90	1
U1, U8	7400	2
U12, U13	74LS00	2
U9	7420	1
U10	7473	1
U2-U7, U16	7490	7
U14	74LS90	1
U18	74C925	1
U19	7805	1
U15, U17	9368	2
Crystal		
Y1	1 MHz, 0.001% tolerance, 30 pF parallel resonant	1
PC boards		
LC1	Clock and timing	1
LC2	Counter	1
LC3	Display	1
Miscellaneous		
Archer #270-253 (Radio Shack)	Cabinet	1
	RG-174	18"
	BNC panel connector	2
	Red plastic window	1
	Test lead (BNC - alligator clips)	1
	Power cord and connector	1
	Strain relief	1
	14-pin DIP sockets	20
	16-pin DIP sockets	4
	#4 hardware	assorted
	Fuse and holder (1 Amp)	1
F1	*C2 (silver mica) may be used if C1 is not sufficient to calibrate the crystal; otherwise it should be omitted (approximate value is 60 pF).	

The Full Spectrum of VHF

SCR 1000 - Standard of Comparison

In Repeaters - Now Available with Autopatch

- and Many Other Options!



Optional Cabinet \$130.00

*Now in Use
Around the
World!*

**FCC TYPE ACCEPTANCE
For Commercial Services
NOW PENDING!**

The SCR1000/SCAP Combination — A New Dimension in Autopatch Repeater Performance

2M & 220 MHz



Now Spec Comm has taken the hassle out of putting an autopatch repeater on the air! The SCR1000/SCAP is a fully self-contained 30 watt repeater with built-in autopatch and land line control. You simply plug in the phone line, hook up the duplexer, and you're on the air! The usual months of problems are eliminated! The SCR1000/SCAP has been meticulously engineered to provide the smoothest performing patch together with a positive land line control of the repeater. Just look at all these features:

Features:

- Normal patch, or secure "reverse" patch
- 3 digit anti-falsing access — single digit disconnect
- 3 digit on-off control of repeater transmitter
- 4 sec. time limit on access
- Built-in adjustable time-out function — patch shuts down in 30-90 sec. if no carrier is received
- Wide range AGC on audio input and output
- User can mute phone line audio simply by keying his mic button — prevents embarrassing language from being repeated
- Patch access and repeater control — either over the air or over the land line

The SCR 1000/SCAP is a complete Autopatch Repeater — fully assembled, set-up and checked-out in our lab. As with all Spec Comm products, all workmanship and components are of the very highest quality. The price? A very reasonable \$1700.00. (\$2195 w/ WP641 Duplexer). Get your order in A.S.A.P.!

180 Day Warranty

Call or write today and get the details!



SPECTRUM

Export Orders — Contact Shere in our Int'l. Dept.

1055 W. Germantown Pk., Dept. S12

/FM Repeater Equipment

The SCR 1000 "Dream Machine" System is Continually Being Improved - and Expanded!

Recent Improvements

- New, More stable, 'low-noise' transmitter exciter
- Improved Rcvr. Front-End & I.F. Selectivity. (FL-6 Preselector & 8 Pole Crystal Fltr. now Standard!)
- New, greatly expanded memory CW IDer. (Up to 4 different IDs as an option!)
- Improved Power Supply long-term reliability.

SCR1000 System Options

- Full Autopatch, 'Reverse-Patch'/Rprtr. landline control.
- Touchtone™ Control of various rprtr. functions. (e.g. Rprtr. or "PL" ON/OFF, HI/LO Pwr., etc.)
- "PL"; Multi-Freq.; HI/LO Pwr.; 10 Pole Xtal Fltr.; Up to 4 IDs; Timer Reset Tone; TX Xtal Oven.
- 60-70 Wt. Transmitter
- Duplexers, Cable, Antennas, Cabinets, etc. Please inquire.

We feel the SCR1000 is **simply the finest repeater available**. It is often compared to other (lesser featured) units selling for 3X the price! This 30 Wt. unit has a very sensitive & selective receiver, and its superb repeat audio quality is famous for "sounding like direct"! Included is a built-in AC Supply, CW IDer, full metering & lighted status indicator/control push-buttons, crystals, local mic, etc. Also provided are jacks for Emergency Power, Remote Control, Autopatch, Aux AF In, etc.

The Spec Comm Repeater System ... a sound long-term investment—for those who demand the finest! An excellent value at \$1150.00. (\$1065.00 w/o Preselector.) Available only by direct factory order.

SPEC COMM REPEATER BOARDS, SUB-ASSEMBLIES & ACCESSORIES

SCR100 BOARD

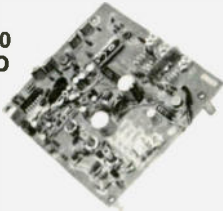

SCR100 Receiver Board

- Wide dynamic range! Reduces overload, 'desense', and IM.
- Sens. 0.3 uV/20 dB Qt. typ.
- Sel. -6dB @ ± 6.5 KHz, -90dB @ ± 30KHz, (-110dB w/opt. 8 Pole Fltr.) 10 Pole Fltr. Avail.
- 'S Meter' Output.
- Exc. audio quality! Fast squeeze! \$125.00 w/xtal. 8 Pole Fltr. (Highly recommended.) \$15.00

SCR100 Receiver Assembly

- SCR100 mounted in shielded housing
- Same as used on SCR100C
- Completely asmbld. w/F.T. caps, S0239 conn., AF GAIN POT, etc. \$195.00

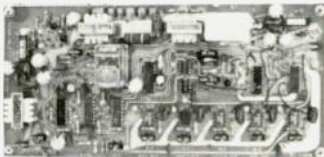

SCAP Autopatch Board

- Provides all basic autopatch functions
- See features on opposite page. \$225.00

RPCM Board

- Used w/SCAP board to provide "Reverse Patch" and land-line control of rprtr
- Includes land line "answering" circuitry. \$79.95

WP641 Duplexer

- Superior Band Pass/Band Reject design
- Provides great rejection of "out-of-band" signals
- Extremely easy to adjust
- -93dB typ. isolation. \$495.00 (fully ckd. out w/SCR1000).

All equipment assembled & tested. For 2M & 220 MHz.

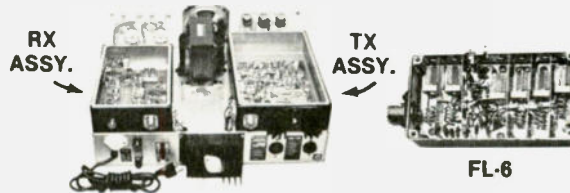

FL-6 Rcvr. Front-End Preselector

- 6 section filter with FET preamp.
- Provides tremendous rejection of "out-of-band" signals w/out the usual loss!
- Extremely helpful at sites with many nearby VHF transmitters
- Gain: apx. 10 dB
- Selectivity: -20 dB @ ± 2.0 MHz; -60 dB @ ± 6 MHz (typ.)
- \$85.00

TRA-1 Timer Reset Annunciator Board

- Puts out a tone "beep" on rprtr. xmtr. apx. 1 sec. after rcvd. signal drops — thus allowing time for breakers
- Resets rprtr. time-out timer when tone is emitted
- Adjustable time delay and tone duration
- Used with CTC100 and ID100/250
- \$20.95 (Add \$18.00 for inst. & ck. out in SCR1000)

CTC100 COR/Timer/Control Board

- Complete COR circuitry
- Carrier 'Hang' & T.O. Timers
- Remote xmtr. ON/OFF control
- Provision for panel control switches & lamps
- 100% Solid State CMOS logic
- Many other features \$35.00

ID250 CW ID & Audio Mixer Board

- Adjustable ID tone, speed, level, timing cycle
- 4 Input AF Mixer & Local Mic amp.
- COR input & xmtr. hold circuits.
- CMOS logic; PROM memory—250 bits/chan.
- Up to 4 different ID channels!
- Many other features. Programmed \$65.00 (1 chan.) Add'l Chan. \$6.00 ea.
- Local MIC: \$18.95

SCT 110 BOARD



SCT 110 Xmitter/Exciter Board

- 7 or 10 Wts. Output
- Infinite VSWR proof
- True FM for exc. audio quality
- New Design — specifically for continuous rprtr. service
- Very low in "white noise"
- Spurious -70 dB
- With .0005% xtal. \$135.00
- BA-10 30 Wt. Amp board & Heat Sink, 3 sec. LPF & rel. pwr. sensor. \$51.95

SCT110 Transmitter Assembly

- SCT110 mounted in shielded housing
- Same as used on SCR1000
- Completely asmbld. w/F.T. caps, S0239 conn.
- 7 or 10 Wt. unit \$199.95. Add \$68.00 for 30 Wt. unit

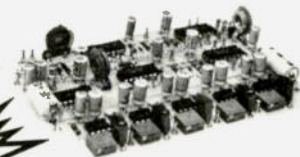

TTC100 TOUCHTONE™ CONTROL BOARD

TTC100 Touchtone™ Control Board

- 3 digit ON, 3 digit OFF control of a single repeater function. Or, 2 functions ON (2 digits each) with 1 digit (each) OFF.
- Can be used to pull in a relay, trigger logic, etc.
- Typically used for Rprtr. ON/OFF, HI/LO Pwr., P.L. ON/OFF, etc.
- Stable, anti-falsing design.
- \$85.00 (\$110.00 inst. & ckd. out in SCR10000.)



COMMUNICATIONS

MOBILE/PORTABLE TRANSCEIVERS ALSO AVAILABLE. 5-25 Wt., 2M & 220 MHz!

Norristown, PA 19401 • (215) 631-1710

Send for Data Sheets!

(Ship./Handl. — \$3.50. PA residents add 6% tax)

W2NSD/1 NEVER SAY DIE

editorial by Wayne Green

from page 4

Well, ARMA was in serious need of some activity which would be of benefit to the entire ham industry as a way of attracting members. They were formed to fight the linear amplifier nonsense, but this was of interest only to a few manufacturers, so ARMA meetings were small . . . very small.

Both as a rallying effort for ARMA and as a response to the threat of the 44 African nation black bloc which could well eliminate all amateur allocations at WARC, I convinced ARMA to try to support a mission to Africa. ARMA voted overwhelmingly to support the plan.

ARMA decided to put the job of writing the letter asking for support from both the industry and individual amateurs in the hands of two chaps from *Ham Radio* magazine. I expressed

concern over this, for the ARRL/HR connection is hardly any secret. ARMA members seemed to feel that this was too important a matter to suffer any political shenanigans.

Unfortunately, it turned out that I was right again. Not only did the letter never get written (that was four months ago), but the promised piece in *HR Reports* asking for support also did not appear. *HR Reports* did print a short put-down of the idea and then later resorted to outright lies to try to back this up, saying that the ARMA directors had voted against the African plan.

Should we only lose a small part of our allocations, I hope that indignation will run high enough so amateurs will get busy and get some better ARRL directors elected and have them get an executive search firm to find someone with business background and a

history of honesty to manage the League. Having this \$5 million empire in the hands of incompetents is a crime which could very possibly lose us the whole ball of wax.

If we lose everything, then the problem will have been neatly solved. No amateur radio, no League, and some people will be on welfare at the general public expense instead of ours.

While I am writing about the League, I wonder if you knew that their Hartford convention last year ended up with a profit which went into the ARRL kitty. Some \$3,000, I understand. Would this have been better invested in lower admission charges which might have encouraged younger hams to come to the show?

There has been some criticism of the board action to authorize the short-term borrowing of about a quarter million dollars to help pay the day-to-day League expenses. Despite record income, the ARRL has been racking up record losses. Instead of figuring out how to make their books better so they will sell more, they are responding by laying off people. Indeed, many of their best people have recently jumped ship . . . Dunkerly, the Whites, McCoy,

etc. Laying off people will only empty some of those new and expensive offices they just built and are now trying to pay for.

Amateur radio is growing at a high rate and we see this in 73 in an increase in both subscriptions and advertising. The recent issues have been the largest in our history and we have been doing everything we can to get more people to work here, while ARRL has been firing their people.

We need people to work in our book department to prepare books for publication. Every time we get someone trained for this, the 73 staff grabs them to work on the magazine, leaving us shorthanded for book preparation again. We need people interested in marketing, advertising, drafting, a good technician to help test ham gear, layout and pasteup people, plus a lot more help with our microcomputer magazine and software plans. We are nearing a staff of 100 now and are projecting 200 by late next year and 300 in 1980.

If amateur radio should get killed, 73 would have to become an experimenter magazine and would undoubtedly shrink a lot. We don't know what the possibilities are for 180 kHz low-power communications . . . or

DEALER DIRECTORY

Fontana CA

We carry the following: ICOM, Midland, Amcom, DenTron, KLM, Swan, Drake, Ten-Tec, Wilson, SST, MFJ, Hy-Gain, Lunar, Nye-Viking, B&W, Redi-kilowatt, Cush Craft, Mosley, Big Signal, Pipo, etc. Full Service Store Fontana Electronics, 8628 Sierra Ave., Fontana CA 92335, 822-7710.

Santa Clara CA

Bay area's newest Amateur Radio store. New & used Amateur Radio sales & service. We feature Kenwood, ICOM, Wilson, Yaesu, Atlas, Ten-Tec & many more. Shaver Radio, 3550 Lochinvar Avenue, Santa Clara CA 95051, 247-4220.

Denver CO

Experimenter's paradise! Electronic and mechanical components for computer people, audio people, hams, robot builders, experimenters. Open six days a week. Gateway Electronics Corp., 2839 W. 44th Ave., Denver CO 80211, 458-5444.

New Castle DE

Paul WA3QPX, Rob WA3QLS—Serving amateurs in southern New Jersey, Delaware, and Maryland with the largest stock of amateur equipment and accessories in Delaware. Delaware Amateur Supply, 71 Meadow Road, New Castle DE 19720, 328-7728.

Tell them you saw
their name in 73

Boise ID

Alliance, Amcom, CIR, Cushcraft, Dentrion, Edgcom, ICOM, Hustler, KDK, MFJ, NPC, NYE, SST, Ten-Tec, Wilson. Custom Electronics, 1209 Broadway, Boise ID 83706, Bob W7SC 344-5084.

Preston ID

Ross WB7BYZ, has the Largest Stock of Amateur Gear in the Intermountain West and the Best Prices. Call me for all your ham needs. Ross Distributing, 78 So. State, Preston ID 83263, 852-0830.

Bloomington IL

Retail—wholesale distributor for Rohn Towers—antennas by Cush Craft, Antenna Specialists, KLM, Wilson, Hy-Gain. Transceivers by Tempo, Regency, Wilson, Amcom. Also business and marine radios. Hill Radio, 2503 G.E. Rd., Bloomington IL 61701, 663-2141.

Terre Haute IN

Your ham headquarters located in the heart of the midwest. Hoosier Electronics, Inc., 43B Meadows Shopping Center, P.O. Box 2001, Terre Haute IN 47802, 238-1456.

Littleton MA

The ham store of N.E. you can rely on. Kenwood, ICOM, Wilson, Yaesu, DenTron, K1M amps, B&W switches & wattmeters, Whistler radar detectors, Bearcat, Regency, antennas by Larsen, Wilson, Hustler, GAM. TEL-COM

Inc. Communications & Electronics, 675 Great Rd. Rt. 119, Littleton MA 01460, 486-3040.

Laurel MD

We stock Drake, Ten-Tec, Wilson, ICOM, DenTron, Tempo, Hy-Gain, Midland, Mosley, Hustler. 40-page ham catalog available for \$1.00 (refundable with 1st purchase)—write for cash quote! The Comm Center, Inc., Laurel Plaza, Rte. 198, Laurel MD 20810, 792-0600.

St. Louis MO

Experimenter's paradise! Electronic and mechanical components for computer people, audio people, hams, robot builders, experimenters. Open six days a week. Gateway Electronics Corp., 8123-25 Page Blvd., St. Louis MO 63130, 427-6116.

Camden NJ

X-Band (& other frequencies) Microwave Components & Equipment. Laboratory Grade Test Instruments, Power Supplies, 1000's in stock at all times, BUY & SELL all popular makes—HP, GR, FXR, ESI, Sorensen, Singer, etc. Electronic Research Labs, 1423 Ferry Ave., Camden NJ 08104, 541-4200.

Syracuse NY

We Deal, We Trade, We Discount, We Please! Yaesu, Kenwood, Drake, ICOM, Ten-Tec, Swan, DenTron, Midland, Cush Craft, KLM, Hy-Gain, etc. Complete 2-way service shop! Ham-bone Radio (div. Stereo Repair Shop) 3206 Erie Blvd. East, Syracuse NY 13214, 446-2266.

Syracuse-Rome-Utica NY

Featuring: Yaesu, ICOM, Drake, Atlas, DenTron, Ten-Tec, Swan, Tempo, KLM, Hy-Gain, Mosley, Wilson, Larsen, Midland Southwest Technical Products. You won't be disappointed with equipment/service. Radio World, Oneida County Airport-Terminal Building, Oriskany NY 13424, 337-2622.

Souderton PA

Tired of looking at ads ??? Come and try our new and used equipment yourself—personal advice from our staff's 60 years combined ham experience. Electronic Exchange, 136 N. Main St., Souderton PA 18964, 723-1200.

Port Angeles WA

Mobile RF1 shielding for elimination of ignition and alternator noises. Bonding straps. Components for "do-it-yourself" projects. Plenty of free advice. Estes Engineering, 930 Marine Drive, Port Angeles WA 98362, 457-0904.

DEALERS

Your company name and message can contain as many as 25 words for as little as \$150 yearly (prepaid), or \$15 per month (prepaid quarterly). No mention of mail or business or area code permitted. Directory text and payment must reach us 45 days in advance of publication. For example, advertising for the March issue must be in our hands by January 18th. Mail to 73 Magazine, Peterborough NH 03458, ATTN: Aline Coutu.

what might be developed in underground communications. Would amateurs shift to 11 meters and the HF band? The CB repeater band would get a good workout, for sure.

These are bad thoughts, so in general I agree with the ARRL leaders and their approach . . . "they can't kill amateur radio!" Keep thinking those happy thoughts.

With or without an amateur radio magazine, our microcomputer magazine will be continuing to grow. Plus, we have two more magazines in the works and the Instant Software project, so we will be growing in size even if amateur radio does disappear. Having been an avid ham for some 40 years, I'll sure hate to lose it. It's been a big part of my life.

During the last 40 years, I've talked with amateurs in well over 300 countries and visited them in almost 100. I've had fun with RTTY, NFM, SSTV, SSB, moonbounce, OSCAR, microwaves, repeaters, and a whole lot of rag chewing. I'll never forget the pileups I ran into from many rare spots or the thrill of pioneering new modes.

If things should go against us, how soon would the axe fall? As near as I can figure, even if we lost everything, it would take several years before we would actually be put off the air. We would still get a lot of action from our new rigs . . . and some of the newest stuff is fantastic. We would not be out of business until our government ratified the ITU agreement. With no lobby in Washington to express our concern over this matter, Congress might not waste too much time, particularly if the EIA were in there pushing against us. Yet even when Congress acts

quickly, it can take years.

Can the U.S. simply drop out of the ITU? If amateurs lose frequencies, you can be sure that commercial and military interests will also lose them wholesale, so we won't be the only group burnt. How practical is it to consider trying to go it alone and not have to toady to the African countries? Well, we've been having the same problem with the U.N. and we haven't dropped out of that yet, no matter how miserable they make it. The ITU is a branch of the U.N., by the way. It seems unlikely that we would pull out, no matter how revolting the consequences.

So far I've had nothing but comments of agreement on my evaluation of the situation. I know the ARRL disagrees, but no one in the ARRL has come up with any good reasons for disagreeing. Others claim that I have been guilty of understating the seriousness of the situation. If anyone has any words of cheer, the pages of 73

are wide open. Let's know if you have any data which changes the picture. We really need a change.

WHAT ABOUT NEXT YEAR?

While December is best known for offering us Christmas, a holiday to which I am not partial, it also includes, at no extra cost, New Year's Eve. Whee.

Since a birthday gets only a small celebration, it is not quite as traumatic as the New Year, where it is made clear that everything and everybody is now a year older. It is a time for introspection. Let's mull over amateur radio, putting the last year into perspective and seeing what we have going for us for 1979.

My recent experiences with the relatively simple 10.5-GHz rigs is indicative of some of the fun that lies in store for the adventurous. Bandwidth is not a problem at these frequencies, so we can use such microwave links for television, data

transfer, or whatever we want to cook up. Of course, the sad fact that we have lost this incredible band for satellite use through blundering at Geneva is something we will have to live with as long as we have amateur radio. It didn't seem quite as important when there was nothing much available in equipment to use on these bands, and therefore they were of interest only to a tiny group of hams with machine shops and incredible patience. Now, with relatively simple and inexpensive equipment coming available, we will begin to feel the pinch and begin to really understand what has been lost . . . forever.

The sunspots have been coming back in spurts, just as our propagation editor said they would. Incidentally, Nelson was the *only* professional in this field to make such a prediction, so I'm sure he's sitting back with a smug look

Continued on page 246

Iron Powder and Ferrite TOROIDAL CORES

Wide selection - Large stock
Fast, one-day service
Technical data with each order
Write for free Tech-Data-Flyer

AMIDON
A26 Associates

12033 Otsego Street, North Hollywood, Calif. 91607

In Germany: Elektronikladen, Wilhelm - Mellies Str. 88
4930 Detmold 18, West Germany.



IN STOCK!

THE REVOLUTIONARY NEW YAESU 2-METER FM LINE

CPU-2500RK



"The Ultimate Rig"
Microprocessor controlled, 25 watt, keyboard-entry transceiver.
Amateur net \$585.00

FT-202R



"Best Buy" 2-meter hand-held. Compact, lots of extras.

Amateur net \$199.00

FT-227RA



"Full-Featured Plus." Four memories, Autoscan remotely controlled from mike. Tone burst.
Amateur net \$399.00

For immediate delivery, best price . . .

TOWER ELECTRONICS

T44

24001 Alicia Parkway
Mission Viejo, CA 92675
Phone 714/768-8900



Hours:
Tues thru Fri 10 am - 7 pm
Saturday: 9 am - 5 pm
Sunday: Noon - 4 pm

Yeasu service and repair specialists.

Confessions of a Stripper

— *confirmed junkor tells all*

Which are you? The “junkee” is a collector of odds and ends, an impulse buyer, a pack rat — don’t throw it away, you might be able to use it sometime. The “junkor” strips everything now and gets rid of the excess — if he can’t use it, he throws it away — he can always get another one, the junk yard or surplus house is full of them.

If you are an experimenter, you probably fit into one of the categories. Articles about stripping surplus equipment are commonplace among the old issues of many magazines, articles on how to strip a TV set and get usable parts for the do-it-yourself projects, or stripping particular GI units easily acquired to obtain the necessary parts for a specific project. But every article assumes that you know what to do with the residue of the stripped unit after the project is complete, or that parts desired are removed. It’s

assumed that the “junk” will be thrown away. Don’t do it. You can save yourself a little cash and also do your thing for ecology.

Stripping or junking is, in reality, an art form. I have seen salvage metal buyers who can handle a hammer and chisel like an experienced sculptor. The required removal of a frozen nut or bolt to separate a valuable piece of equipment from an indescribable or unworthy piece of metal requires talent if damage is to be negligible. In the first place, a professional cannot spend a lot of time in dismantling equipment. His time and profit margin isn’t that much. His methods may be crude, but, when it counts, he has the delicate touch of an artist.

When removing the parts you desire for the project you have in mind, go one step further. Completely strip down the unit at the same time. This will keep storage

problems from arising.

Lay out the tools you will need and have a seat. There are many ways to keep parts separated. It depends on how much stripping you intend to do. The cheap way is to gather a bunch of milk cartons. Cut them in half and wash them out. Use as many as you need.

A tool caddy is advisable, loaded with every tool imaginable. Stay away from unsoldering items when stripping. Save those until later when you are ready to use them. Cut them out with a pair of large diagonal pliers. A great time-saver is the use of nut-drivers, spintites, etc. These do not preclude the use of a socket set at times, but normally they will suffice in most cases when the nuts are securing terminal strips and/or transformers, tube sockets, and other nut-and-bolt secured items. Allen wrenches are a must for knobs and gear drives where needed. Nothing is more aggravating than

being midway into a stripping project and finding a gear that is preventing the removal of an entire mechanism. All that’s required is the correct Allen wrench . . . and you don’t have it.

If the equipment being stripped is small, then the tool complement can follow in order. Electronic equipment tools used for dismantling and repairing equipment may be all that’s necessary. If the equipment is large, additional tools may be required.

If the item is a piece designed strictly for military application, then there will be some specially designed screws, nuts, and bolts that should be removed with a hammer and chisel. Leave them until last. Even if you have the special tool, don’t waste your time. You wouldn’t want to use them in a project anyway.

Wiring harnesses do not serve any purpose unless you need hookup wire. Removing

the entire harness at one time is sometimes easier than removing and disconnecting each item as it is stripped. If the terminal strips and associated plugs are not wanted, then leave them connected and remove the entire wiring assembly by unscrewing, unbolting, and cutting. When this is out of the way, all other parts are easily accessible, and dismantling is much easier.

A reminder here about the removal of transformers: Trace the wiring and mark the connections before removing. Many will follow the standard color code of black for primary, red for secondary high voltage, red and yellow for center tap, and green for filament, but don't count on it. Some artistic devils can get hold of the design and color leads to look like modern art. Trace the wiring just to be sure before disconnecting the transformer. The same thing applies to any item that has more than two leads and depends on any type of color code for identification.

There are always some limitations each do-it-yourself technician places upon himself. It may be coil winding or some other technical item that requires special equipment or a lot of time to build and is easily acquired for a small sum of money at the local parts house. Another example is tube sockets. The common seven- and nine-pin sockets can be reused if you are willing to take the time to clean the individual pins after removal from the chassis being stripped.

The most usable items that you can remove in quantity will be the resistors and capacitors. You will never have enough of these items. The more you get, the more you find you will need. Removal of these items can be done rather speedily.

Where tube sockets and terminal strips are not important, a fast method of removal is to cut the tabs of the terminal strips and sockets



The junkie who saves everything needs a place to put it. If you are an organized junkie, pigeon holes, like these, are ideal. If not, it may take a month to find a particular item.

instead of the resistor wires and capacitors. You can remove the solder and small piece of connection later. This also allows for further and faster stripping.

The junkie has arrived at his destination. All reusable parts have been removed and all that remains is a bunch of wire and assorted metal chassis bits and pieces. The junkor's turn is next. The junkor will take the same piece of equipment and spend just a few minutes and accomplish the same thing. He will get his desired part and either throw the rest away or store it for later use, or strip it to the point where a salvage metal buyer will accept it. There are many hobbyists who enjoy stripping as much as they do building. If that is your forte, then make it pay.

You must acquire a most important tool to keep with you at all times — a magnet. This will aid you no matter where you beg, borrow, buy, or steal your material. Separation of the different types of metal (copper, iron, steel, stainless steel, bronze, etc.) is a must. Also, to make it worthwhile, don't attempt to

sell the metals until you have a sizable amount. Of course, it depends on the type of metal. Where ten pounds of clean copper wire may bring you four dollars, the same ten pounds of aluminum may bring one dollar and sixty cents (\$1.60) at fifteen cents per pound. The prices may fluctuate from day to day, but usually not more than a few cents a pound, although prices for clean copper in past years has risen to over a dollar a pound and fallen back to as low as thirty cents a pound.

Clean metals will bring as much as 200 percent more than what are known as "dirty metals." Dirty metals are those that still have screws, bolts, rubber, weather stripping, or other materials which are still attached.

For speed, the hammer-and-chisel technique is used. The simplest way is to take the chisel and hold it with a pair of pliers. This eliminates split fingers, but it does not eliminate the tiny slivers of metal that occasionally fly from the head of the chisel. Gloves and a pair of safety goggles, if you don't wear glasses, should be used if you

intend to do much chiseling.

When you have everything removed, check the metal with your little magnet. Anything it will stick to is iron and should be removed. This is the main purpose of the magnet. Of course, the magnet will not indicate the presence of brass or copper which should also be separated. Yellow-colored metal will indicate brass, while the reddish varieties are more likely copper. Stainless steel and lead also bring a nice scrap price.

You can throw away the tube sockets, crushed coils, resistors and capacitors not saved, and knobs (unless they have brass inserts). A smart blow from a hammer will crack away the outer plastic covering of the knob and leave a clean piece of brass. Don't expect much from your iron; that will be on the low end of the pay scale (two or three cents a pound). When you have accumulated thirty or forty pounds or more of copper, brass, aluminum, etc., you might be surprised at the price it will bring. Remember to keep it separated and free of iron.

One last reminder: Wire

must be completely clean of all insulation and attachments, including plugs, clips, brackets, etc. This, of course, is your highest paying metal, so extra care should be taken. In most states, the method of burning the insulation off the wire is forbidden due to the pollutants released by some electronic insulation, although this does not stop many illegal smelter operations and backyard burners. The backyard burners (bar-

becue pits) usually get away with it because of the small amount cleaned (ten to fifteen pounds) at a time.

The junkor should be aware of the copper content of television yokes, motors, and, last but not least, transformers. Average transformers with an open core winding will contain between thirteen and eighteen percent of the total weight in copper. Again, the easiest method of stripping a transformer is to

burn it. If it's an enclosed transformer, remove the outer cover and throw it in the fire, if regulations permit. One alternative is to remove the wire by hand. This can be a difficult and time-consuming chore if it is an iron-core transformer with inserts shaped like the letter W. The easiest method is to saw through the inserts and slip them out, leaving the wire to be unraveled by hand.

There are many other

ways to accomplish the same stripping procedures discussed in the preceding paragraphs, but whatever method you discover that's easiest for you to use, do it. Not only will you pocket a little extra cash, but a lot of that old metal will find its way back into circulation, and someday your efforts may be remembered as the only thing that saved the beer can.

May you chisel your way to glory. ■

ou rooms don't ever profit
lousy manuscripts from that
burner took a year to
you liked it, but it is
I insist that you print or
tell Ma bell that she shou

LETTERS

from page 102

everyone give their QTH as well as their call sign. I'm sure most of the old-timers feel the same way.

Russell A. Garlin W5UKA
Albuquerque NM

MORE MICODER MODS

Re the Micoder™ articles in the July, 1978 (page 90 by K3MPJ), and August, 1978 (page 168 by W4CUG), issues of 73:

Getting rid of the 555 timers for tone generation is easier than building a PC board and buying all the parts, that is, unless you have a well-stocked junk box. Heath has a kit to make the Micoder into a Micoder II. It is not very expen-

sive and includes all the parts. It uses the Mostek chip and TV color crystal.

Also, to get rid of the 9-volt battery, which just doesn't last very long at all, I did it a little more easily than K3MPJ. Unless they have changed the coiled cord in later models, it contains an extra black wire. It is connected to ground at each end with the shield. I used the same zener setup that MPJ did, except I put the zener and resistor where the cord comes into the radio and used the extra black wire for the power conductor. There was no change in the fine audio quality of the Micoder or 2036. As a side benefit, the Micoder is somewhat lighter without the battery.

I hope this will be of interest

to others who might want to make these modifications.

Oscar A. Hoyt III K5UBS
Dallas TX

JAPANESE JACKPOT

Japanese folklore says that there is a jackpot day in each month. The day I find 73 Magazine in the mail box is the day for me.

I especially liked your article "Radio Row Revisited" in the past August issue. I would like to make an addition to Brad's statement that "a large portion of the gear on display here is aimed at the lucrative Japanese Novice market: ten Watts maximum, phone only, 80, 40, 15, and 10 meters and VHF."

The Japanese version of the FCC has regulations applicable to four different amateur radio licenses.

1. Novice: Bands and modes same as the regulations.
2. Telegraph class: Same as Novice plus CW.
3. Second class: 3-500Z x 2, maximum.
4. First class: Henry 4K-Ultra,

and up.

I have never seen a ten-Watt rig, except at a ham shop display, and in my own shack when I was a Novice.

Mitch H. Ono JF3JJK
Otsu City, Japan

WONDERFUL RESPONSE

About a year ago our club asked you for a donation for our first club raffle. The response was wonderful and the raffle became a great success. Our goal was modest: \$200 for the treasury. We surpassed that with your help.

As a club sponsored by the Nassau County Department of Parks and Recreation, we do not charge any membership dues or fees. The modest treasury helps keep us on the air, and in postage. We are not asking for a hand again, but we may do so in the future.

Please pass on the word that students are always welcome in our Novice and General/Advanced classes each Monday at 7:30 pm.

Gene Blanck
East Meadow NY

Corrections

It was called to my attention that one reader thought that there was the possibility of eye damage from the use of the Instant Engraving system described in the July issue (Letters, September, 1978, p. 127). He cites the fact that carbon arc lights are used to generate ultraviolet radiation for use in exposing photosensitive materials. Of course, some form of eye protection is to be used under those conditions. The key words are carbon arc.

Please note the third column

on page 59 (July, 1978), "... the voltage should be kept below the point where an arc can be struck and maintained." Photo D shows the rod glowing from simple I²R heating, not the veritable inferno contained in an arc. The light given off during the engraving process should be no more or less harmful than that of any other incandescent light of similar light value. As in any incandescent light source, a considerable amount of energy is dissipated in the form of heat,

with only a small portion used to generate visible or invisible radiation.

I regret any confusion that there may have been concerning the above point.

Evert Fruitman W7RXV
Phoenix AZ

Please note a correction to my article "Triple Threat," which appeared in your October issue. On page 133, line 2, column 2 should read "leled phono or phono".

Ralph E. Delligatti K3CMT
Gaithersburg MD

Ham Help

I would like to know if anyone knows of a commercially run school which a person can attend in order to learn how to obtain an amateur radio license.

Carl M. Sullivan
RR 24, Box 383
Terre Haute IN 47802

I need a schematic and/or manual for the Harris-Interdata COPE 1035 Selectric-based terminal. I will pay for photocopy and shipping.

Jeff Duntemann WB9MQY
6208 N. Campbell Ave.
Chicago IL 60659

Announcing



HENRY RADIO'S **1KD-5**

A BRAND NEW MEMBER OF THE FAMOUS HENRY RADIO FAMILY OF FINE AMPLIFIERS

The 2KD-5 and 2K-4 linear amplifiers completely fulfill the needs of discriminating amateurs who want the very best and are willing to pay the price. But we have long felt that many amateurs would be satisfied with less power if they could still have the same high quality and dependability.

The 1KD-5 fulfills that need beautifully.

- Quality that is unmatched in any other linear in its class. The same high standards of engineering and construction as the 2KD-5 and 2K-4. Heavy duty components guarantee years of trouble free, dependable performance.
- Smaller and lighter. Weighs about 27 pounds less... easier to take along on vacation trips and DXpeditions.
- Less expensive. If your budget is limited, but you still want a GOOD quality linear to kick your signal way up, with sharp, clear signals, the 1KD-5 will give you just about everything you want... and without sacrificing quality.

GENERAL INFORMATION

The 1KD-5 is a 1200 watt PEP Input (700 watt PEP nominal output) RF linear amplifier, covering the 80, 40, 20 and 15 meter amateur bands. (10 meters on units shipped outside the U.S.)

Tube Complement: Eimac 3-5000Z glass envelope triode operating in a grounded grid circuit.

ALC Circuit: ALC Circuit to prevent overdrive from high power exciters, also boosts average talk power.

Type of Emission: SSB, CW, RTTY or AM

Antenna Relay: DC relay system for hum-free operation, requires shorting contact to ground during transmit to key amplifier into transmit.

Power Output Indicator: Self-contained relative RF power meter.

Tank Circuit: Pi-L plate circuit with a rotary silver plated tank coil for greatest efficiency and maximum attenuation of unwanted harmonics.

Input Circuits: Cathode Pi input matching circuits for maximum drive and linearity.
Power Supply: Conservative power supply with solid state rectifiers for reliable, long term operation.

Dimensions: 8.75" high x 14" wide x 15" deep.

Weight: 27 pounds.

Price \$895.00

2K-4 floor console linear amplifier... still the "workhorse" of Amateur Radio. Engineering, construction and features second to none. Provides a long life of reliable service while its heavy duty components allow it to loaf along at full legal power. \$1095.00

2KD-5 desk model linear amplifier... lighter, more compact and less expensive, but still a heavy duty, high quality linear that will operate at full legal power month after month for years to come. \$895.00

Tempo 2002 amplifier for 2-meter operation. 2000 watts PEP input on SSB or 1000 watts input on FM or CW. \$745.00

Tempo VHF/UHF solid state power amplifiers for use in most land mobile applications. Call or write for list of models available.

Tempo 100AL10 VHF linear amplifier. Power output of 100 watts (nom.) with only 10 watts (nom.) in. \$209.00

3K-A linear amplifier (for export and military use only) Superior quality, extremely reliable. At least three kilowatt PEP input on SSB... 2000 watt PEP output. \$1495.00

4K-ULTRA linear amplifier (for export and military use only) For the most demanding operation... SSB, CW, FSK or AM. For general coverage operation from 3.0 to 30 MHz, but can be modified for operation on frequencies up to 100 MHz. 100 watts drive delivers 4000 watts PEP input. \$3250.00

All of the above except the 2002, 3K-A & 4K-ULTRA are available at Tempo dealers throughout the U.S.

11240 W. Olympic Blvd., Los Angeles, Calif. 90064 213/477-6701
931 N. Euclid, Anaheim, Calif. 92801 714/772-9200
Butler, Missouri 64730 816/679-3127

Henry Radio

Prices subject to change without notice.

Tuned Feeders and Other Good Stuff

— *who needs coax?*

As you know, other things being equal, the success of your amateur radio station depends upon the quality of its antennas. Is your antenna a coax-fed dipole?

If so, why? Is it because it is the easiest kind of antenna to put up and get on the air with? Is it because it can be brought into the house through one small hole? Is it because other kinds of

antennas seem complicated and difficult to understand?¹

From on-the-air descriptions of antennas, one gets the impression that most amateurs feed their antennas with coax. This was not always so. Before coax existed, amateur operators designed and built excellent antennas using open-wire tuned feeders. Some antennas used no feeders at all.

The purpose of this article is to present some "antenna axioms" along with some basic antenna theory and to explain how to use these ideas to build effective antennas that are not fed with coax. (Coax is used only between the transmitter and the antenna tuner.) Building and experimenting with antennas is fun and good experience.

Antenna Axioms

1. The antenna system should be resonant at the frequency being used.

2. The rf from the transmitter must be effectively put into the antenna.

3. "There is no substitute for height." The higher the antenna, the better. The high-current part (or parts) of the antenna should be as high as possible.

4. Other things being equal, full-length antennas work better than do shorter antennas that have been made "electrically longer" by means of "loading coils."

5. Quarter-wavelength vertical antennas use a good ground or group of quarter-wavelength radials for the other half of the antenna. Radials buried in the ground are often used. The greater the number of radials, the better the antenna works. At easy-to-attain heights, vertical antennas have a lower angle of radiation than do horizontal antennas. This makes them good for DX.

6. The transmitter's harmonics should be prevented from getting into the antenna.

Basic Antenna Theory and Applications

A half-wave resonant antenna has high voltage rf on its ends and high rf current in its center. (See Fig. 1.) The antenna can be fed rf voltage at one end, or it can be fed rf current in its center. (A half-wave antenna fed in its center by coax is a current-fed antenna.) An antenna can be voltage-fed by bringing one end into the shack and connecting it to a parallel-tuned "antenna tank" tuner



"Vertical zepp" antenna for 20 meter CW.

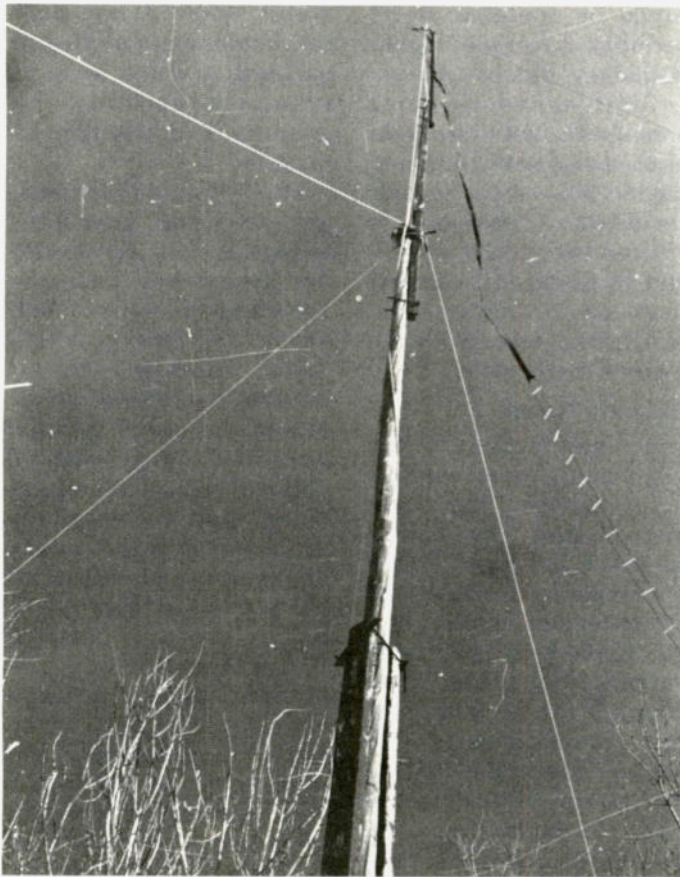

Tuned doublet antenna 66 feet either side of center.

which is link-coupled to the transmitter. The tuner is composed of a coil and variable capacitor which will tune to the frequency of the transmitter. The rotating plates of the variable capacitor are connected to ground. The stator plates will be "hot" with rf voltage, and the end of the antenna is connected to the stator plates. One side of a neon tube is connected to the antenna to indicate the presence of rf voltage when the coil is tuned to resonance. (See Fig. 2.) The antenna should go out from the shack and be strung up as high as possible. (The length of a resonant half-wave antenna is found by applying the formula: Length in feet =

468/frequency in megahertz.) If the antenna length is for one of the lower frequency amateur bands, it can be used on its harmonics for the higher frequency bands. (An antenna 132 feet long, for use on the 3.5 MHz band, will also work on 7 MHz, 14 MHz, 21 MHz, and 28 MHz by tuning the antenna tuner to these higher frequencies. Plug-in coils can be used for the various bands.)

An antenna may be current-fed if the center of the antenna is brought into the shack. In this case, the coil

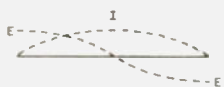

Fig. 1. Rf voltage and current distribution of a half-wave resonant antenna.

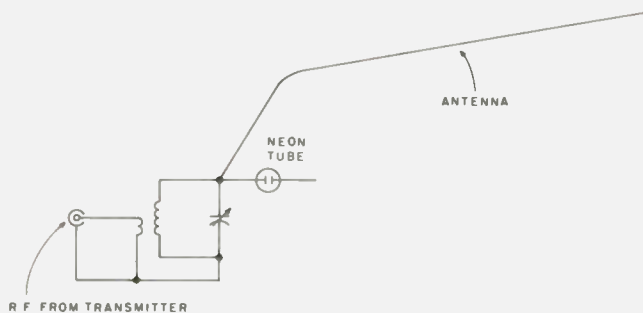
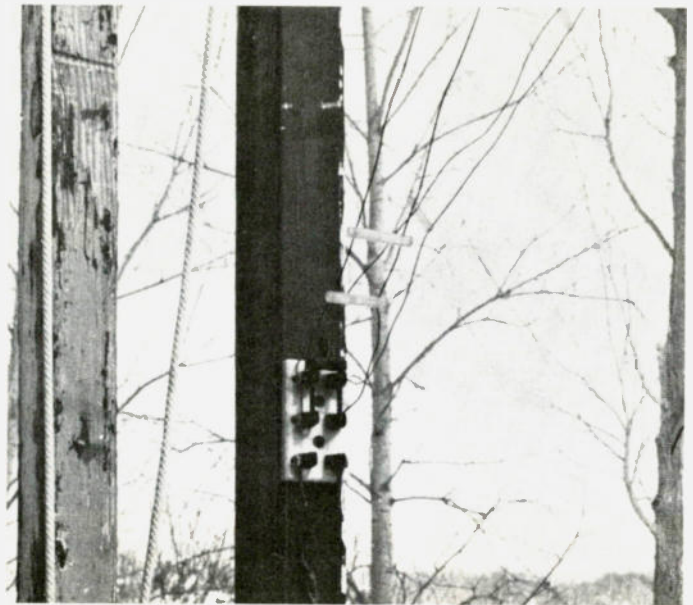

Fig. 2. Feeding rf voltage to the end of a resonant antenna (parallel-tuned coil to give rf voltage).



Antenna grounding switch on tuned doublet's feeders. The switch is in place for use on the air.

and variable capacitor are connected in series with each other and in series with the rf "center ends" of the antenna. (See Fig. 3.) This kind of antenna can be conveniently used if the shack is on the second floor of a house. One half of the antenna can be vertical and the other half of the antenna can slant down and out. (Two-by-fours, or furring strips screwed together with a long bamboo fishpole on top, make a good support for a vertical wire.) This kind of antenna illustrates the principle of series tuning for rf current. The endfed antenna utilizes the principle of parallel tuning for rf voltage.

When an endfed antenna is used on its harmonics, provision can be made for lengthening the antenna in-

side the shack to make it work better on the harmonics.²

It is good to have your antenna as high and in the clear as possible. For this, a means of feeding the rf to the antenna through wires is necessary. (See Axioms 2 and 3.) There are several kinds of wire transmission lines that can be used. The most efficient transmission line is the open-wire type. (Efficient means with the least loss per hundred feet of line.) Next most efficient is the transmitter-type twinlead. After this are the other kinds of twinlead (TV twinlead). The least efficient transmission lines are the small-diameter coaxial cables such as the RG-58/U and the RG-59/U.³

Before coax was available, zeppelin-type ("zepp") tuned feeders were often used to take the rf from the shack to the

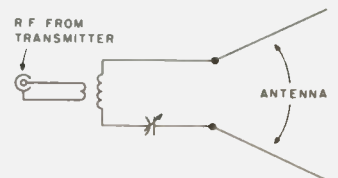
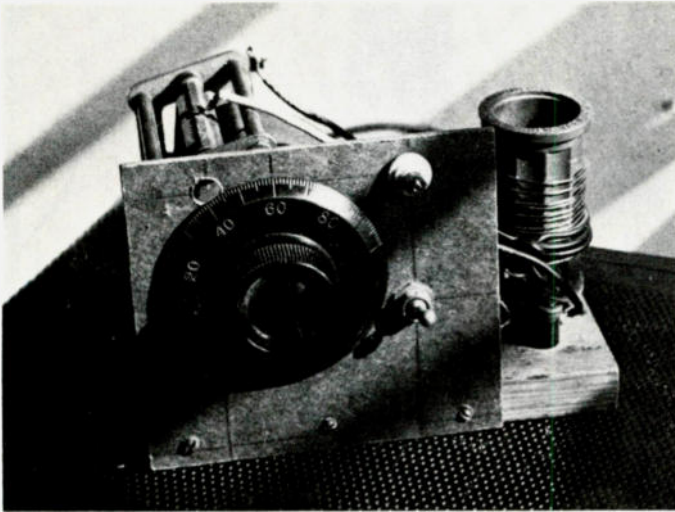

Fig. 3. Feeding rf current into the center of a half-wave resonant antenna (series tuning for rf current).



"Single-ended" antenna tank tuner for endfed (voltage) antennas (switch for transmitter or receiver, etc.).

antenna. The "zepp" antenna consisted of a resonant antenna that was fed by an antenna that was a half-wavelength long, folded back on itself, and fed rf current. In the case of a dirigible or zeppelin, the antenna was suspended below the airship, as in Fig. 4. When used in an amateur radio station, the tuned feeders go up from the shack to the end of the antenna. (See Fig. 12.) Electrically, the tuned feeders are an antenna folded back on itself, and one end of the tuned feedline is connected to one end of the antenna. The other end of the feedline is not connected to anything, except, of course, the insulators that support it. There is no rf radiated from the tuned feeders because the rf field of one feeder cancels the rf field of the other feeder. The length of the zepp

antenna itself should be 5% longer than $468/f(\text{MHz})$ because of "end effects."⁴ The "tuned doublet" is another type of antenna that uses tuned feeders.⁵ This antenna is better balanced than the zepp because both ends of the tuned feeders are connected to the antenna, each to the same length of wire. (See Fig. 5.) The tuned doublet can be used on harmonics of its fundamental length. Furthermore, it has a gain of about 1.9 dB at right angles to the antenna when it is tuned to its second harmonic. The antenna also has some gain, as compared to a dipole, when it is used on higher harmonics at angles less than 90 degrees from the antenna. If the station can have only one antenna, a tuned doublet would be an excellent allband antenna. Cut for the lowest frequency band to be used, it

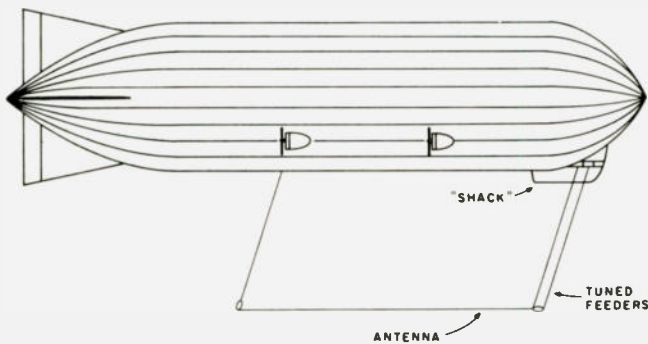

Fig. 4. The original "zepp" antenna.

would be operated on its harmonics for the higher frequency bands.⁶ An excellent tuned doublet antenna 66 feet either side of 65-foot open-wire tuned feeders was used in several field day contests. It worked well on 80, 40, 20, and 15 meters. (It was not tried on 10 meters, but probably would have worked there, also.)⁷

Antenna Tuners

A tuned feeder antenna system requires an antenna tuner between the transmitter and the tuned feeders.⁸ The most simple antenna tuner for balanced tuned feeders consists of a coil tuned by a split-stator variable capacitor, link-coupled to the output of the transmitter. The feeders are connected to the stator plates of the variable capacitor. (See Fig. 6.) The coil and capacitor should be of such values as may be tuned to the transmitter's frequency. (Plug-in coils can be used to change bands.) This tuner works well if the length of the antenna and its feeders is such that the ends of the feeders in the shack should be fed rf voltage. However, with other feeder lengths, variable capacitors must be placed in series with the feeders, and you have the tuner of Fig. 7. Since tuned feeders are of the same length (balanced), the series-variable capacitors are ganged together and tuned with one dial. (These capacitors must be electrically insulated from each other when ganged.) This tuner (with plug-in coils for changing bands) makes possible the use of tuned feeders of practically any convenient length. A neon tube connected to one stator of the split-stator variable capacitor (or leaning against one or both of them) helps in the initial tune-up of the antenna system. A field strength

meter located not near the antenna tuner should be used, and the antenna system tuned for the greatest field strength indication.

With this antenna tuner, an swr meter connected between the transmitter and the antenna tuner may show a rather high swr, but, when the field strength meter shows the highest reading, the swr will be the lowest. The use of coax-fed antennas and the limited impedance output range of many transmitters have made amateurs worry about swr, and nearly all hams use swr meters. To reduce the swr between the transmitter and the antenna tuner, a large variable capacitor can be added in series with the primary coil of the tuner.⁹ This enables the operator to obtain a very low swr reading, if this is necessary to make either him or his transmitter happy. (See Fig. 8.) This tuner worked so well on field days that one of the field day operators called it the "old reliable" antenna tuner. (This was even before the variable capacitor was added in series with the primary.) In the "old reliable" tuner, a two-turn coil made of number 12 house-wiring wire is used for the primary. This wire is stiff enough to hold itself in place. The primary coil's diameter is larger than that of the plug-in coils, and these coils are plugged in right through the primary coil. (See Fig. 9 and photograph.) Another tuner has plug-in coils with

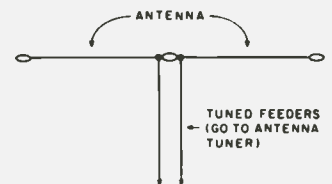

Fig. 5. Centerfed tuned doublet antenna (often incorrectly called a "centerfed zepp").

a separate primary for each secondary. This tuner works well, but the swr is not quite as low as with the "old reliable" antenna tuner.

This type of tuner, especially if built with junk box or scrounged parts, is inexpensive but effective. Some other tuners such as the DenTron Super Tuner™ (\$129.50) or the Universal Transmatch of the ARRL *Antenna Book* work well with tuned feeder antenna systems, but the "old reliable" tuner does it with a lower swr.

Some amateurs may object to having to adjust the three dials on the antenna tuner. In practice, after C2 and C3, on one dial, and C4 are adjusted, only C1 must be readjusted when moving from one part of a band to another.

The drawings and diagrams in Figs. 10 through 17 show the dimensions and arrangements of a few non-coax-fed antennas.

Many other tuned feeder antenna systems can be designed. Use your thinking and imagination. Although open-wire feedline is the best kind to use, good quality 300-Ohm twinlead works very well. It can be brought into the house under a window without having to drill holes.

For lightning protection, provision should be made for grounding the feedline outside of the house when the antenna is not in use.

A balanced feeder antenna tuner such as the "old reliable" will work as the series tuner for the "center of the antenna in the shack" arrangement by opening out the plates of the split stator variable capacitor and tuning with the ganged series-variable capacitors. This kind of tuner can also be used for voltage feeding the end of an antenna in the shack. Short out one of the split stator variable capacitors

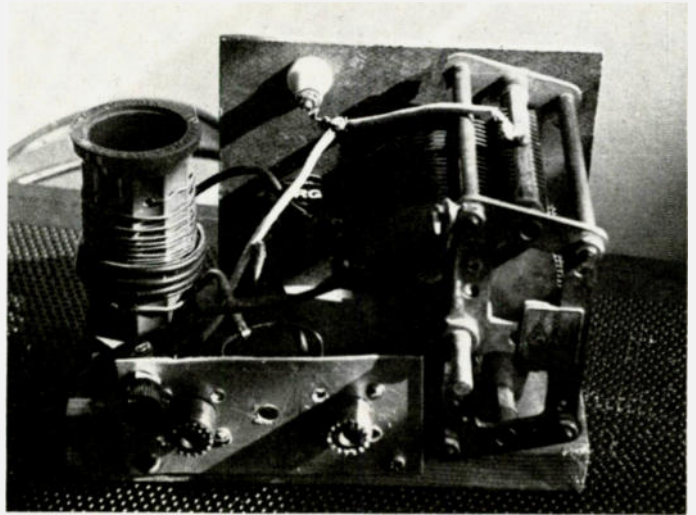

Back view of single-ended voltage-fed tuner. This shows two coax connectors switched from the front.

and connect the antenna to the stator plates of the other side of the variable capacitor. A neon tube, one side of which is connected to the antenna, will indicate the rf voltage when the coil is tuned to resonance at the transmitter's frequency.

You may ask, "Why should I go to all the bother of building a three-dial antenna tuner and a tuned feeder antenna system?" "What does a tuned feeder system accomplish that is not accomplished with my present antenna?" One important accomplishment of a balanced tuned feeder system is that it can be tuned to exact resonance at any frequency in any band for which the antenna is designed. For example, the 80 meter band extends from 3500 kHz to 4000 kHz. The resonant length for 3500 kHz is over 133½ feet. The resonant length for 4000 kHz is only 117

feet. A coax-fed antenna of one length cannot be resonant at both ends of the band. With a centered doublet, using tuned feeders, the antenna system can be made resonant in any part of the band, thus fulfilling the requirement of Antenna Axiom 1.

Another important feature of a tuned feeder antenna system is that the rf is effectively taken from the transmitter to the antenna (Antenna Axiom 2).

Another advantage of a tuned feeder antenna system is that the antenna tuner effectively prevents transmitter harmonics from getting into the antenna and being radiated (Axiom 6). Coax-fed dipoles, coax-fed trap dipoles, coax-fed parallel dipoles, and coax-fed trap vertical antennas all accept and

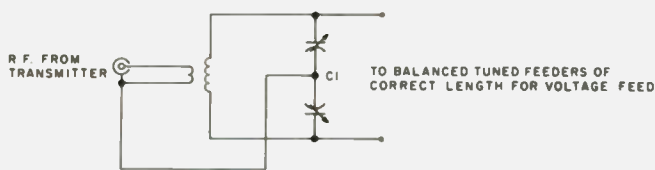

Fig. 6. Antenna tuner to voltage-fed balanced tuned feeders.

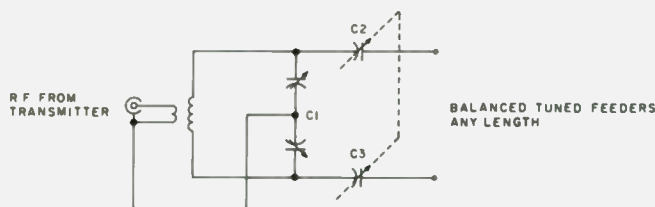

Fig. 7. Antenna tuner for balanced tuned feeders any length.

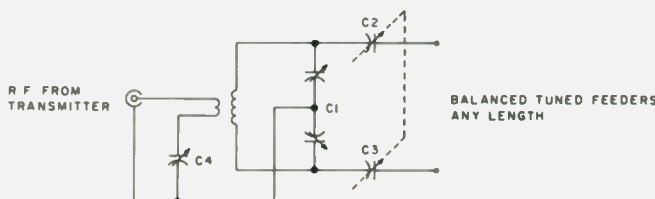

Fig. 8. Antenna tuner for balanced tuned feeders any length, with a variable capacitor in series with the primary to reduce the swr between the transmitter and the tuner.

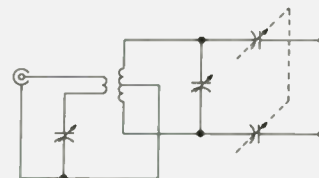

Fig. 8(a). Using a center-tapped coil in place of the split stator capacitor to obtain a balanced rf output.

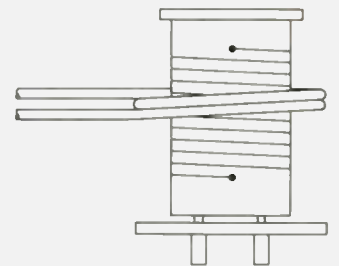

Fig. 9. Antenna coil plugged in through the heavy wire self-supporting primary coil.



"Old reliable" antenna tuner — front view. This shows the neon tube and the 80 and 15-10 meter coils.

radiate any transmitter harmonics that are in a band for which the antenna is designed, and which are in the transmitter's output.¹⁰

Multiband operation is effectively accomplished with a tuned feeder antenna system. An antenna,

designed for a lower frequency band, is used on harmonically-related higher frequency bands by tuning the feeders to the harmonic frequencies.¹¹

With a good antenna tuner, feeder length is not critical. This makes possi-

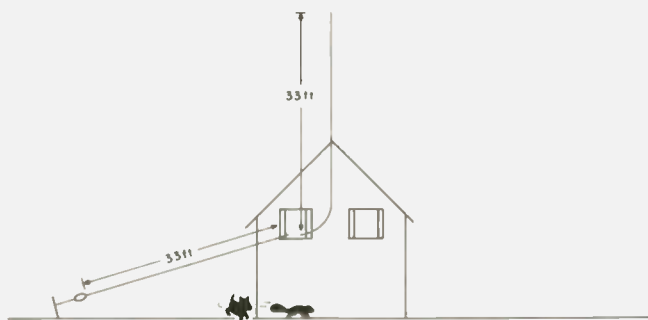
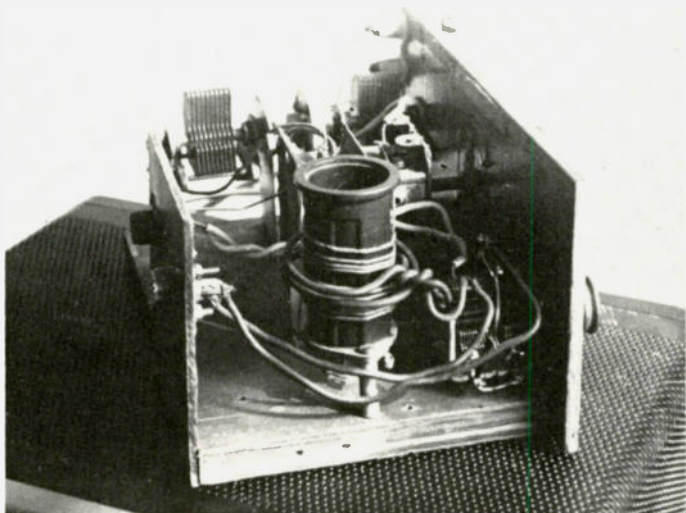

Fig. 10. 33-ft. vertical and 33-ft. "slanter" coming into a second-story shack. Series tune both for 40 meter operation (Fig. 3). For 20 meters, voltage-feed the vertical part only (Fig. 2). For 15 meters, feed both parts in series (Fig. 3). The antenna can also be made to work on 80 meters by using a large coil in the series tuning arrangement.



"Old reliable" antenna tuner — side view. This shows the plug-in coil arrangement.

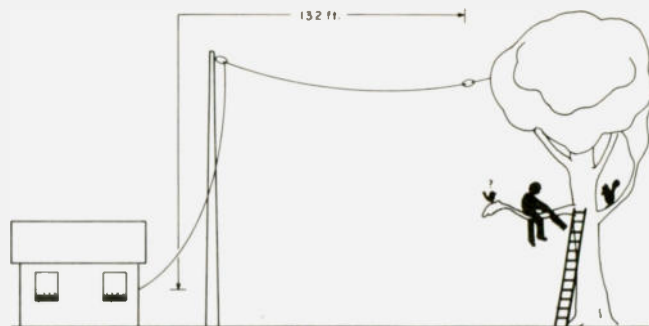

Fig. 11. An in-the-shack endfed antenna. Use parallel-tuned coil with plug-in coils for each band (Fig. 2). This will work on 80 meters and higher frequency bands on harmonics. See reference 1 for means of lengthening the antenna for harmonic operation.

ble high antennas. (Antenna Axiom 3).

Tuned feeders can be used with good results to feed vertical and ground-

plane antennas that are half vertical and half horizontal.¹²

Tuned feeders have worked very well with a Hustler 4BTV

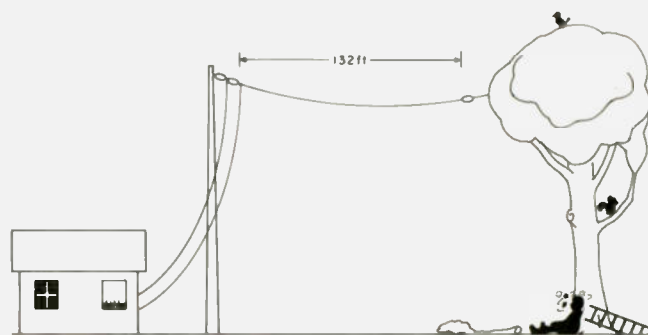
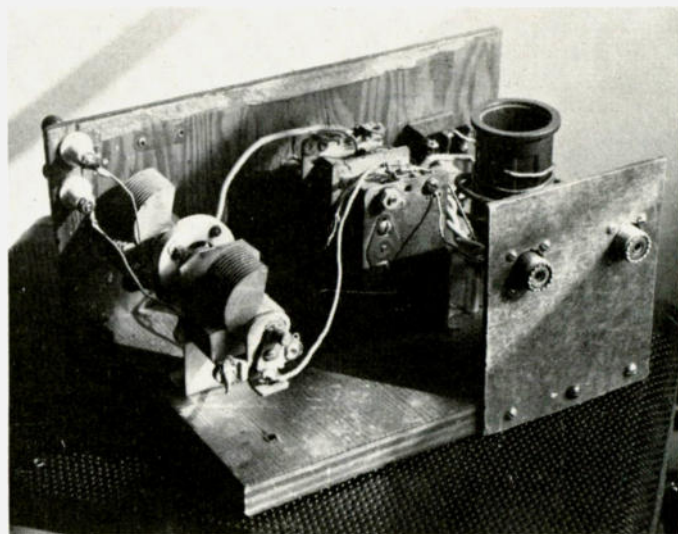
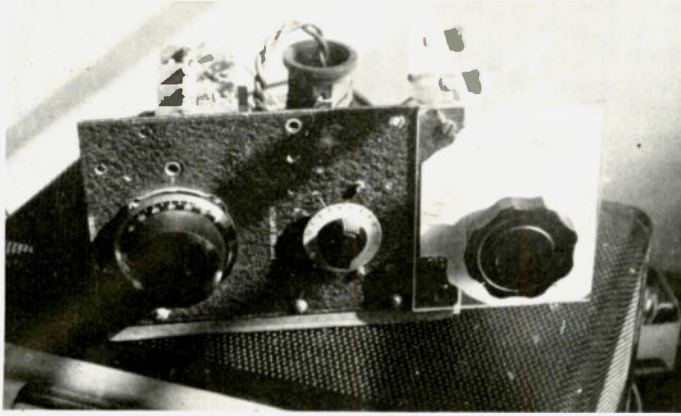

Fig. 12. Endfed "zepp" antenna for 80 meters (CW). Use balanced feeder tuner. This will work on higher frequency bands (harmonic operation). Tune feeders to the frequencies of the higher frequency bands. A centered antenna 66 feet on each side of center tuned feeders would be better, if all parts of the 80 meter band are to be used (both CW and phone).



"Old reliable" antenna tuner — back view. The two coax connectors and front switch are for switching the tuner between receiver and transmitter or for switching between two transmitters.



Another antenna tuner with primary coil which plugs in.

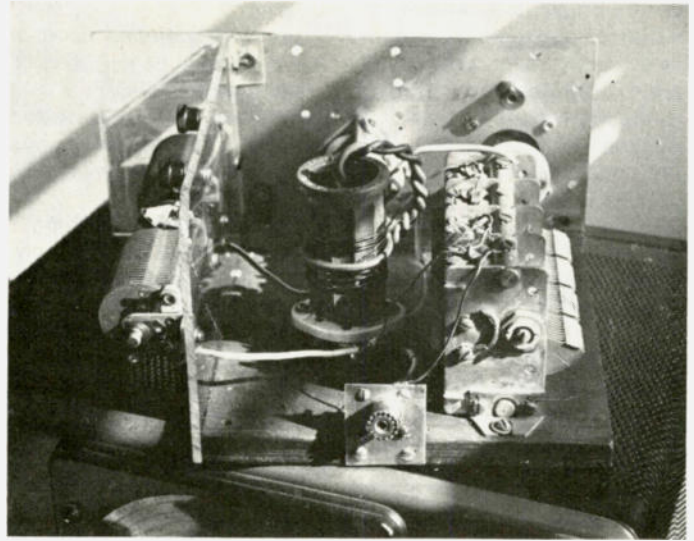

Back view of the other antenna tuner.

trap vertical antenna.

For amateurs who like to talk (or boast) about their low swr, the swr between the transmitter and the antenna tuner can be reduced to a very low

value on all bands with careful adjustment of the tuner.

Tuned feeders are the best kind to use with some kinds of beam antennas. For example, to use a W8JK

flattop beam on its harmonics, tuned feeders must be used. Tuned feeders make it possible to use V-beams on several frequency bands.¹³

If the radiating element of a rotating beam antenna is fed with tuned feeders, it can be tuned to exact resonance on the frequency being used. This will make the antenna work better on both the phone and the CW frequencies.

If you want to be able to have good QSOs on any frequency within an amateur band, if you want to eliminate any fear of harmonic radiation, and if you want a larger percentage of your calls to result in QSOs, use an antenna tuner and an antenna centered with tuned feeders. You will be pleased with the results. ■

References

1. "Simple Dipole Antennas," Jim Fisk W1HR, *Ham Radio Horizons*, January, 1978, pages 18 through 26, is an excellent article on coax-fed antennas. It describes several antennas, including parallel dipoles and trap dipoles. Much useful data is presented. However, starting on page 21 is a section called "Simple multiband antennas." This states, "There's no doubt that the most efficient (and simplest) multiband antenna is a half-wave dipole cut to resonate at the lowest operating frequency, centered with open-wire transmission line through an antenna tuner."
2. The theory of the need for extra length is beyond the scope

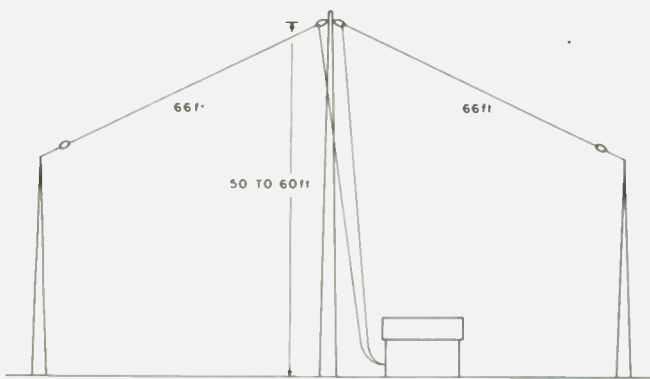

Fig. 13. 80 meter tuned doublet operated on harmonics for the higher frequency bands. Use balanced feeder tuner. This is the best all-around antenna for multiband use. (This is the W8BVU/WØVM field day antenna.)

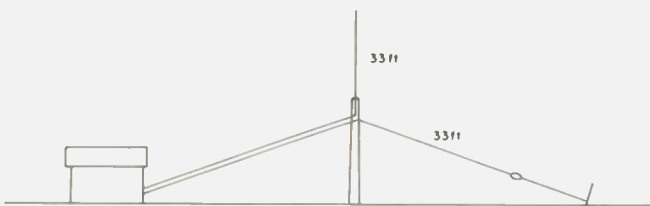

Fig. 14. Vertical "slanter" tuned doublet for 40, 20, and 15 meters. Use balanced feeder antenna tuner. It also works on 80 meters with the 80 meter antenna coil in the tuner. Several "slanters" could be used and spaced radially to make a ground-plane antenna for 40, 20, and 15 meters.



Fig. 15. Ground-plane antenna for 20, 15, and 10 meters. Use balanced feeder antenna tuner.

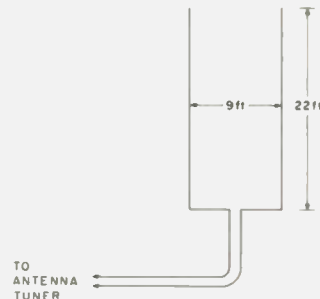

Fig. 16. A vertical "endfire" bidirectional beam antenna for 20, 15, and 10 meters. Use balanced feeder antenna tuner.

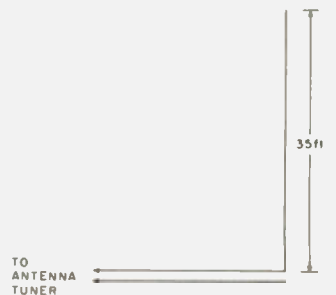

Fig. 17. A "vertical zep" for 20 meter CW. Strung on two bamboo fishpoles taped together, this antenna has worked into Europe from St. Louis, Missouri, using a Ranger 1, with only 80 Watts dc input to the final stage. The antenna was at ground level and the feeders went down a few feet into the shack.

of this article. For a practical means of changing the antenna's length inside the shack, see "A 'Stretcher' for Endfed Multiband Wires," Howard J. Hanson W7MRY, QST, July, 1972, page 32.

3. "Why Coax?" by Ed Wagner G3BID, 73 *Magazine*, November, 1971, page 96, and *Understanding Amateur Radio*, 2nd ed., ARRL, chart on page 121.

4. See *The Radio Handbook*, 1939 edition, page 425, "flattop length." Also see page 424, Fig. 12, "The evolution of a zepp

antenna."

5. See *Understanding Amateur Radio*, 2nd ed., pages 122, 123, "'Open-wire' Feeders," and page 264, "The Center-fed Dipole." (This antenna has often been erroneously called a "centerfed zepp.")

6. See "Gee, What's a Zepp?" Charles G. Miller W3WLX, July, 1975, 73 *Magazine*, page 111, and the ARRL *Antenna Book*, pages 179 and 180, "Centerfed Antennas."

7. See "A Field Day to Remember," William R. Stocking W8BVU, 73 *Magazine*, June,

1969, page 44.

8. A "transmatch" is a form of antenna tuner.

9. For this capacitor, a two- or three-section broadcast band variable capacitor with all sections connected in parallel can be used. I had no swr meter for many years and used a neon bulb and field strength meter to tune the antenna system to resonance. The variable capacitor in series with the primary coil was added after I obtained the swr meter. Now, as do other hams, I keep the swr as low as possible.

10. See the ARRL *Antenna Book*, page 188, "Harmonic Radiation from Multiband Antennas."

11. See ARRL *Understanding Amateur Radio*, 2nd ed., page 123, "Multiband Operation" and the ARRL *Antenna Book*, page 179, "Centerfed Antennas."

12. See the ARRL *Antenna Book*, page 187, "Combining Vertical and Horizontal Conductors."

13. See the ARRL *Antenna Book*, page 174, "Feeding the V."

Looking West

from page 18

to go ahead and prosecute such a case? To get them to say: Here is an individual that we want to take the time to prosecute?

"There have been some interesting things that we have learned in working on this one case. The first questions they have asked (federal authorities) is if there are any tapes of the individual. It is my opinion that although section 605 of the Communications Act of 1934 states that the privacy provision does not apply to amateur communications, and I have not researched it, this distinction is invalid. There is no rational basis to hold that a communication by a police officer on a radio is private and cannot be revealed to a third party and that what I say via a two meter repeater need not be held so. Still, when you get down to the prosecution of these cases, you are asked if you have any tapes. Therefore, I have recommended to several repeater owners who have tape-logging systems (or volunteers recording people among the usership) that when jamming starts tapes be made and a log (written) be kept and it all be documented. It's a lot of work, admittedly.

"I'm presently in the process of meeting with the FCC in Long Beach (California) to find out just what they will want from the amateur to go ahead and take these cases. However, when you get down to it, it's going to be basically the amateur's job. You will get a lot of lip service, a lot of excuses, and if you convince the FCC to prosecute, then you have to convince the U.S. Attorney to act. Believe me, this takes pressure. Pressure is the only thing the U.S. Attorney knows (under-

stands). In our ranks, we have such pressure. We have amateurs who are correspondents for all phases of the media, including major newspapers and television networks. Amateur radio has got to learn how to make use of the members of the service. Believe me. A phone call from a nationally-prominent news correspondent can make a world of difference as to whether a case is prosecuted. This is one idea. There can be no general rule. However, let's phrase a few items for you to think about.

"Let's first explore how we can get the government to act. Number one, you must document what has taken place. You must have tape recordings of the individual and his activities. It also must be more than once (thereby creating a definite pattern of behavior).

"You must have a DFing crew. In cases of repeater jamming, this task belongs to four or five (dedicated) people. While other groups might assist, your central group should be four or five people of the type who would turn in their own mother if need be. This is because you have situations where people (DFers) spend time trying to disprove the identity of a jammer if it turns out to be a friend. Also, you must have security (total) within your group, since premature announcements or leaks can ruin such activities (prejudice future litigation). One does not sit down at a poker table, lay out one's hand to full view, and then start betting. Handling malicious interference is just that. It's a question of playing your cards just right and knowing when to make the right move.

"Once you have set that

hypothesis, you can then proceed to build your case. Document it. You must actually document exactly how you did your DFing. When you get into the prosecution of such a case, the federal authorities are going to ask this. Also, you must be able to show that your DF equipment is working accurately, and how you arrived at your conclusions.

"One other thing that I would strongly urge those into DFing for this purpose to do is keep an accurate map of all of their bearings, their location when taken, the date, and the time. This can present a pattern and prove a case. Once you have all this, you then have a basis to go to the FCC and request their help. As I said earlier, we are currently meeting with the Long Beach FCC office, coordinating our efforts so that all this work by amateurs will not be wasted.

"It is my opinion that the U.S. Attorney has been instructed by the Attorney General that amateur radio cases of the type involving malicious interference are lowest-case priorities. I think you must face the fact that this is what their feeling is. They feel you are treading in an area of First Amendment rights. . .

"Therefore, it is important to have some way of protecting yourself—that is the most important thing.

"There are many other things that can be done, but now is not the time to go into detail. My purpose here was to throw out some ideas for you to consider.

"We take tests; we learn rules; we are told that there are certain fines for violating the law. We are basically law-abiding. However, there is that small percentage of people I prefer to call mentally demented who say, 'If I can't talk, then nobody will talk,' or who enjoy swearing and the jamming that prevents others from talking. Those are my

ideas. They will be developed further. I did not become an amateur to put up with that stuff, and I don't think that I should be afraid to turn on my radio in the car when my wife and particularly my child is there."

The above was transcribed from a tape recording made on September 23, 1978, at the ARRL Southwestern Division convention in San Diego, California. They are the statements of a man who cares, and very closely echo my views. In the near future, copies of this talk and others at the special six-hour seminar will be made available through the seminar sponsors. Watch your normal amateur media outlets and this column for further information. Comments on Joe's ideas can be directed to him through this column. LW will continue watch on this topic until the amateur service rids itself of this menace to its continued existence.

THE GROWING WELL DEPARTMENT

Thanks to William Oliver Grieve W7WGW, I have some interesting news concerning two meter activity in Arizona. First, congratulations to W7WGW on being elected as secretary of the Amateur Radio Council of Arizona. We at LW wish him well in this position. Oliver owns WR7AFC (147.60/.00) and WR7AHJ (147.87/.27) in the Phoenix area.

Now, how many repeaters would you imagine that a state like Arizona plays host to on two meters? Well, unless I have counted wrong, the new list shows 53 such machines, including the first two inverted tertiary allocations on 146.745/.145 and 146.865/.265. Judging by this list, one should be able to go just about any place in Arizona these days and have two meter communica-

Continued on page 134

Clegg is FM Headquarters!

No one else offers the wide selection of VHF FM Transceivers that you'll find at Clegg.



Clegg FM-DX
40+ Watts—
Synthesized
Made in USA
"THE BEST"

Clegg FM-28
25 Watts—
Synthesized
"Second only to
the FM-DX"

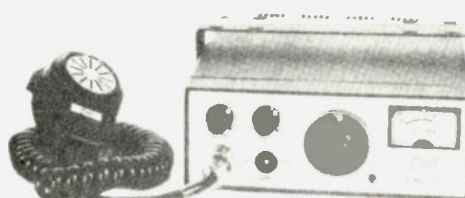
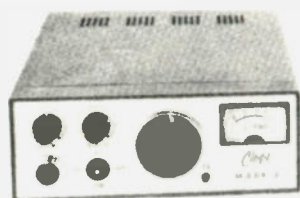

Clegg MARK 3 and FM-76
12 Channel coverage.
Select 144 or 220 MHz
"For the budget minded"

But if you have another brand in mind we can supply any of the other fine FM or Multi-Mode Transceivers and Hand Helds manufactured by YAESU, ICOM, WILSON, DRAKE—and at very competitive prices. And we service them all!



Yaesu CPU-2500R



Yaesu FT-625RD & FT-225RD



WILSON Mark II



ICOM IC-211

Whatever your needs in FM or Multimode Transceivers, Hand Helds, Antennas, etc., call your friends at Clegg, using our new departmentalized telephone system.

ORDERS AND QUOTES: TOLL FREE 1-800-233-0250

SERVICE DEPARTMENT: TOLL FREE 1-800-233-0337

ENGINEERING, PURCHASING, ADMINISTRATION AND ACCOUNTING: 1-717-299-7221

And—let us fill your antenna requirements:

- Towers, Masts & Hardware
- Rotators & Cables
- Coax & Connectors
- HF, VHF, UHF Beams & Mobile Antennas
- Multi-Band Dipoles
- Traps & Baluns

Clegg

Communications Corp.
1911 Old Homestead Lane
Greenfield Industrial Park East
Lancaster, PA 17601

✓ C3

Build a Realistic S-Meter

— “you’re S9 + 40, OM!”

Ralf Beyer DJ3NW
Opferkamp 14
33 Braunschweig-Waggum
Germany

What is the most fixating item in the ham shack when you have tuned in a signal? The S-meter! Do you trust it? No!

These are hypothetical answers to these questions, but chances are great that this would be the response if someone were asked to investigate the role of the S-meter in many of today’s receivers. All of us have had our own experiences with S-meters, but a general trend can be observed centering around

four major problems:

1. Many S-meters show nearly accurate readings in the vicinity of the S9 mark.
2. Many S-meters indicate much higher S-values than appropriate for signals stronger than S9.
3. Many S-meters are insensitive to signals below S3 or S4: (“I can copy you S4 though you are not moving the needle.”)
4. Many S-meters indicate much lower S-values than appropriate when SSB or CW is received. (“Say aah or press the key, so I can read the meter.”)

Correspondence with an equipment manufacturer showed that he was well informed about these problems. But experience

shows that manufacturers are reluctant to invest in this field because of increased cost and, more important, because radio amateurs have willingly accepted the S-meters as they are and because they have no opportunity to check the calibration in most cases. A simple method is presented to solve the aforementioned problems at moderate cost. The method described is applicable to both i-f or af signal based S-meter circuits. However, af signal processing was chosen for the sake of simplicity. A Heath SB-301 receiver was used as the test vehicle.

The Basic Idea

A block diagram of the suggested S-meter circuit is shown in Fig. 1. The af signal of the receiver, taken in front of the af gain control, is the input signal for this circuit. It is routed to a buffer to provide isolation from the receiver to keep the characteristics of the receiver unchanged. The signal is then amplified to a level which allows a diode in the rectifier circuit which follows to conduct even during small amplitudes of the input signal. If the rectifier output is connected to an S-meter and if the amplifier has a high enough gain to produce a

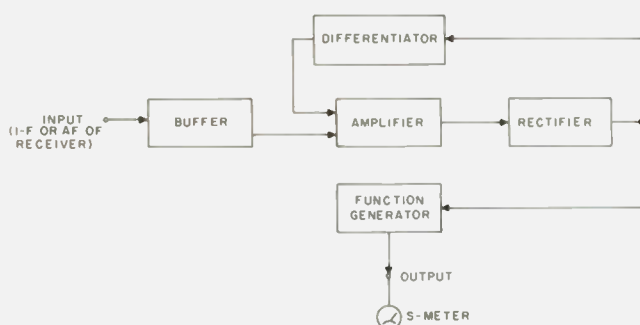

Fig. 1. Block diagram of the S-meter circuit.

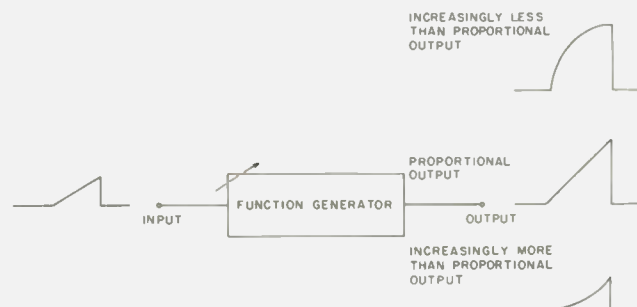

Fig. 2. Possible output waveforms which may be obtained from a simple variable function generator using a ramp waveform as the input.

reasonable output even for a small signal amplitude input, the circuit discussed so far would already be adequate to cope with S-meter problem No. 3 (inadequate sensitivity for weak signals). However, for most receiver agc characteristics, the gain of the amplifier would be too high now for larger input signal amplitudes. This would cause the S-meter to indicate a much higher S-value than appropriate, presenting S-meter problem No. 2 (sensitivity too high for strong signals).

Therefore, a so-called function generator is placed between the rectifier and the S-meter. A function generator is a device which produces an output signal that can be any function of its input signal. For example, a signal of linearly increasing amplitude (ramp) at the function generator input may be converted by the function generator to a signal which is proportional or increasingly more or less than proportional to the input signal (Fig. 2).

It is obvious that problem No. 2 can be solved if a function generator with a degressive (increasingly less than proportional) input/output transfer function is placed between the rectifier and the S-meter. The selection of an appropriate transfer function depends, of course, on the transfer function between the receiver antenna input and the rectifier output (determined mainly by the gain control characteristics of the receiver) and on the layout of the S-meter scale. Both, however, can be matched to each other by the function generator so that signals at the receiver antenna terminal which range, for example, from S1 to S9 +60 dB are correctly indicated by the S-meter.

With the system described so far, it is possible to

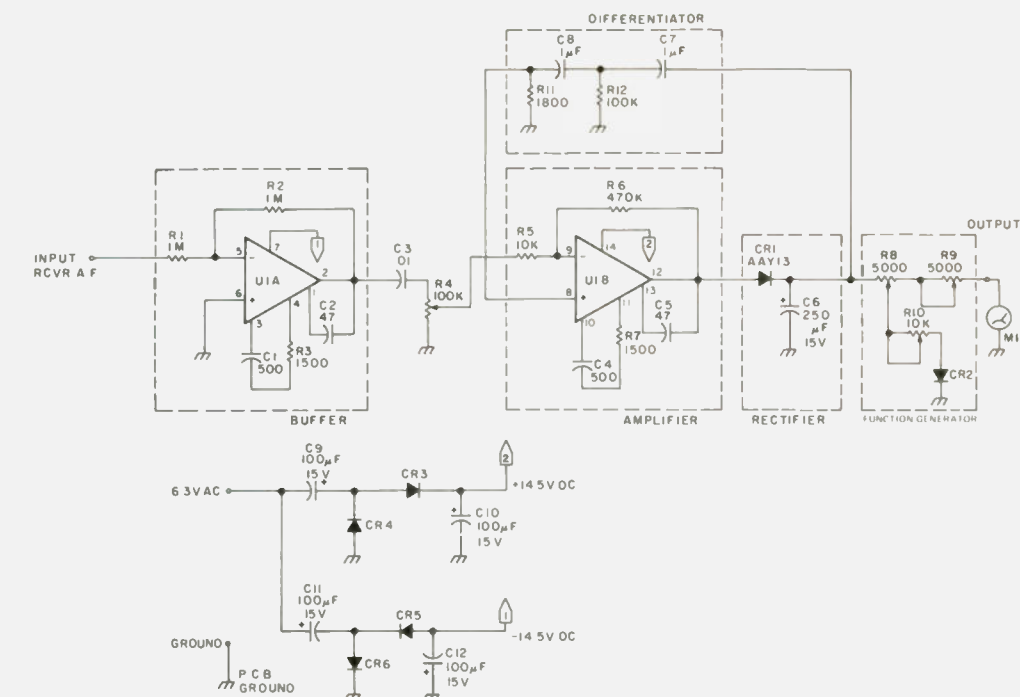

Fig. 3. Schematic diagram of the S-meter circuit and power supply. CR2 is a low forward-bias germanium diode, Siemens RL32g or equivalent. CR3 through CR6 are BAY18 diodes or equivalent. M1 is a 1 mA, 100-Ohm internal resistance unit. U1 is an MC1437L dual op amp or equivalent.

obtain an accurate indication of the signal strength for static (key-down) signals. Keyed or modulated signals, however, make the needle fluctuate which makes reading the meter difficult (problem No. 4). A large capacitor in the rectifier circuit would help, of course, to make the meter needle more steady. But the limited output power of the amplifier, its output impedance, the impedance of the rectifier, and the inertia of the moving coil in the S-meter form a low-pass filter which prevents the needle from reaching the same position for CW/SSB reception as for an identical key-down condition. And, a large capacitor makes the S-meter similarly less responsive in the other direction, too, because the decay time constant is also increased. This prevents the S-meter from showing a quick dip when comparing barefoot/linear operation or when looking for a minimum in antenna radiation pattern tests.

In order to overcome this problem, some form of

“quickening” of the rectifier output signal or the meter needle movement is required. This can be achieved by feeding the rectifier output signal into a differentiator whose output signal is then fed back to the input of the amplifier (Fig. 1). Now, let us assume that a signal at the input of the circuit shown in Fig. 1 produces a positive signal at the rectifier output. Then an increasing amplitude of the input signal produces a positive slope of the rectifier output signal, too. The differentiator connected to the rectifier output also produces a positive signal at its output which is proportional to the slope of the rectifier output signal. And, because this signal is fed back to the input of the amplifier, the differentiator output signal drives the rectifier output signal to a higher level, temporarily giving the rectifier output signal and the meter needle the desired “extra punch” in the right direction.

For a decreasing amplitude input signal in Fig. 1, one would expect a similar effect which, however, would drive the meter needle in the opposite direction because the differentiator output signal is negative for a negative slope of the input signal amplitude. This would cancel the desired effect just achieved, so nothing would be gained. But because of the fast attack/slow decay characteristics of the rectifier circuit, a rising amplitude input signal produces a positive and much steeper slope of the rectifier output signal than a drop of the input signal amplitude. A drop in signal amplitude produces a negative but much shallower slope of the rectifier output signal. For a constant amplitude input signal in Fig. 1, the differentiator is inactive, of course, and does not affect the remaining part of the circuit.

The Circuit

A schematic diagram of the S-meter circuit is

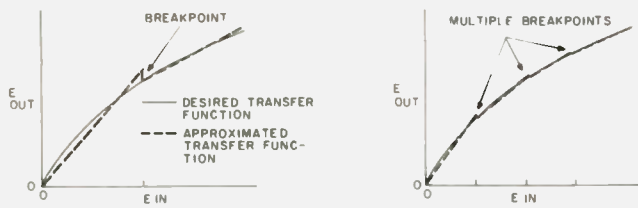

Fig. 4. Approximation of a desired transfer function by a function generator having a single breakpoint, Fig. 4(a), and multiple breakpoints, Fig. 4(b).

shown in Fig. 3. A dual operational amplifier is used for both the buffer and the amplifier. Both amplifiers are frequency compensated by means of C1, R3, C2, and C4, R7, C5, respectively, as recommended in the manufacturer's data sheet. The required supply voltage of ± 15 V dc is provided by two voltage-doubling rectifier circuits connected to the 6.3 V ac filament supply of the receiver.

The af signal of the receiver, taken from a point preceding the volume control potentiometer, is connected to the input terminal of the circuit. A shielded cable is recommended for this connection. The buffer, U1A, which follows provides a high input impedance to the receiver so that the af circuit of the receiver is not affected. The buffer output signal is coupled to the amplifier, U1B. The input to this amplifier is controlled by trimmer potentiometer R4. This potentiometer is

adjusted such that a maximum signal amplitude of $S9 + 60$ dB at the antenna terminal of the receiver causes the output amplitude of amplifier U1B to just reach the limits of linear operation, i.e., approximately ± 12 volts. Of course, potentiometer R4 can be adjusted so that the amplifier is driven into its output limitation for signals greater than $S9 + 40$ dB or so in order to contribute to the desired degressive transfer behavior of the S-meter circuit. However, it was not found necessary in the case of the SB-301 receiver. The amplified af signal is then rectified by the rectifier circuit which follows. A germanium diode is recommended for this circuit. The rectifier output is a dc signal which represents the amplitude of the rf signal at the antenna terminal of the receiver. The function generator which follows modifies this signal in order to match its slope to the graduation of the

S-meter scale.

The Function Generator

Fig. 3 shows the diagram of a simple function generator with one so-called "breakpoint." The breakpoint determines the amplitude of the signal applied to the generator input at which the input/output transfer function of the generator is switched from an initial slope to the final slope. Diode CR2 in Fig. 3 acts as the switch. For an ideal switch with normally open contacts and contacts closed when a signal of given amplitude is applied to the function generator input, the transfer function which can be obtained is shown as a broken line in Fig. 4(a). For a given impedance of the S-meter, the generator transfer function would be controlled by R8 and R9 (Fig. 3) alone up to the breakpoint. But, when the breakpoint is reached, the switch is closed and R10 is effective. The amplitude of the generator output signal is immediately reduced to a lower level (which is not desired), but the steepness of the slope of the resulting transfer function is also reduced, which gives a first-order approximation of the desired transfer function as shown in Fig. 4(a). For a closer approximation of the desired transfer function, more breakpoints (switches) are required as shown in Fig. 4(b). However, as the diode CR2 in Fig. 3 is not an ideal switch, and because it becomes only gradually conductive, the diode characteristic can be used to advantage, thereby eliminating the need for multiple discrete breakpoints.

Fig. 5 presents the range of calculated transfer functions which can be obtained with the function generator shown in Fig. 3. The slope of the transfer function depends on the characteristics of diode

CR2, of course. The diode shown in Fig. 3 was taken from the junk box, but comparable results can be obtained with other germanium-type diodes which have a low forward bias of $U_D = 200$ mV at $I_D = 0.2$ mA and $U_D = 350$ mV at $I_D = 1$ mA.

The Differentiator

"Quickening" of the S-meter is achieved by feeding back the output of the twofold differentiator shown in Fig. 3 to the input of the amplifier. The output can be adjusted by means of R12. This type of adjustment was found to be more convenient than changing capacitors C7 or C8. Furthermore, the terminating resistor, R11, at the non-inverting input of amplifier U1B was kept constant by this method in order to avoid ill effects on the remaining circuit.

As an ordinary S-meter indicates the average current flowing through the meter with respect to time, the amount of "quickening" is determined by the average amplitude of the differentiator output signal. The average amplitude of a signal, however, is determined by its average deviation from zero. Positive deviations are counted positive and negative deviations are counted negative. Fig. 6 presents two computed output functions of the differentiator shown in Fig. 3 obtained for identical inputs and different values of R12. It can be seen that a large value of R12 increases the (positive) average amplitude of the differentiator output signal and thereby the amount of "quickening." Optimum "quickening" is determined by a number of factors such as the time constants of the rectifier circuit, the damping of the S-meter, and so on. A value of 100k Ohms for R12 was found to be optimum when

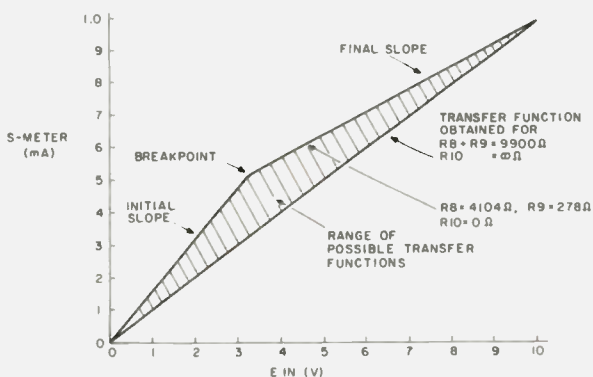

Fig. 5. Range of transfer functions which can be obtained with the function generator and the S-meter of Fig. 3. Values of R10 range from zero to an indefinitely large value and R8 and R9 adjusted for full-scale output (1mA) at maximum input (10 volts).

the circuit was installed in a Heath SB-301 receiver. Compared to the indication of the S-meter for a key-down signal from a transmitter, this value of R12 produced an almost identical indication on the meter when SSB (processed and unprocessed speech) was used and only a slightly higher one for CW.

Construction

The circuit shown in Fig. 3 was built on a 65mm × 65mm (2½-inch × 2½-inch) Vectorboard. Helitrim™ potentiometers were used for all potentiometers because they are small and convenient to adjust. All other components are miniature size. A socket was used for U1. The board has four terminals: ground, 6.3 V ac, receiver af, and S-meter. The board was mounted at the back of the front panel of the SB-301 receiver by means of a mounting bracket held by the screw in the upper right-hand corner of the panel. A shielded cable was used for the connection between the "hot" end of the receiver af gain control and the input terminal of the circuit.

Alignment

A signal generator and an attenuator are required which can provide an unmodulated signal on all bands of interest within the range of S1 through S9 + 60 dB. A signal amplitude of 50 microvolts at the 50 Ohm antenna terminal may be used for S9 and half the amplitude (-6 dB) of the preceding S-value for the next lower S-value, i.e., 25 microvolts for S8 and so on [1 dB = 20 · log(Vout/Vin) for the attenuator]. Some signal generators are calibrated to produce a signal of given amplitude if the generator output is unterminated (open). Others are calibrated for an output terminated with 50 Ohms.

One should be sure which type of generator is on hand before the alignment is started.

First, the receiver should be checked to be in good condition and for uniform gain on all bands of interest. With the rf gain control set to maximum gain, agc on, mode switch set to USB, LSB, or CW, and the receiver tuned for maximum input to the S-meter circuit, each band should be checked to note what signal amplitude at the antenna terminal of the receiver produces a given beat note amplitude at the af input of the S-meter circuit. For the SB-301, identical beat note amplitudes were obtained on all bands with an input signal variation of less than ±1 dB (±1/6 S-unit).

Next, the receiver should be checked for uniform gain in all modes. It was noted, for example, that for a constant signal amplitude at the antenna terminal of the SB-301, a somewhat higher beat note amplitude was obtained when the receiver was switched from LSB to USB. The reason for this was a higher signal amplitude of the bfo crystal used in the USB mode. A potentiometer across the terminals of this crystal was used to reduce the bfo output amplitude in this mode so that a uniform receiver gain was obtained for both USB and LSB modes. No separate CW filter was installed in the SB-301 which may have a passband attenuation different from the SSB filter. And because the USB crystal is also used for CW in the SB-301, an identical receiver gain was obtained in the CW mode, too.

Next, the function generator is aligned. This should be done on a band on which the receiver has an average gain compared to all other bands. Three parameters of the function

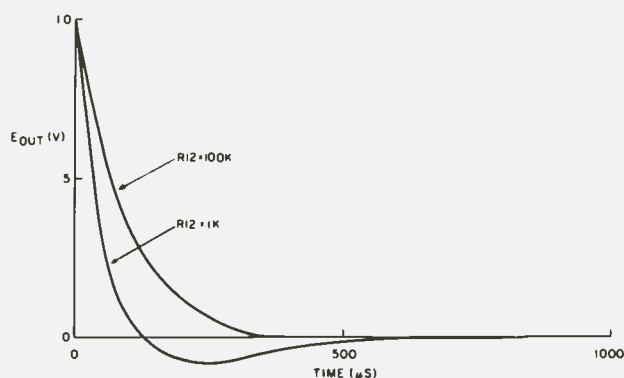

Fig. 6. Calculated response of the differentiator in Fig. 3 to a 1-volt positive-going pulse using different values of R12.

generator transfer function can be adjusted within given limits (see Fig. 5): the initial slope (primarily controlled by the sum of R8 and R9), the input voltage at which the breakpoint occurs (primarily controlled by the ratio of R8 to R9), and the final slope (primarily controlled by R10). It is generally possible, therefore, to adjust the transfer function of the generator so that it passes through one given point of the desired transfer function left of the breakpoint and through two other given points right of the breakpoint. At other points, there may be a deviation of the transfer function which can be implemented from the desired one. But the trick is to find those three reference points of the desired transfer function to which the function generator can be adjusted almost perfectly, while the average deviation at all other points is reduced to a minimum. For the SB-301, such points were found at S5 (left of the breakpoint) and S9 and S9 + 40 dB (both right of the breakpoint). By an iterative process, R8, R9, and R10 were adjusted so that for appropriate signals at the antenna terminal of the receiver, the S-meter showed accurate S-readings at these points and a maximum deviation of about ±2 dB (±1/3 S-unit) at all other points. The average

deviation was less than that and negligible for signals below S9 + 10 dB.

Conclusions

In 1969, the S-meter circuit was installed in a SB-301 receiver and has provided stable operation since then. No realignment has been necessary so far, but annual checks of the receiver are recommended. It is helpful, therefore, to keep a record of the S-meter readings which can be obtained with the internal crystal calibrator of the receiver on all bands. Any deviation from these values which may occur later indicates that the performance of the receiver, the S-meter circuit, or the calibrator is degraded and that there is something to be done.

The S-meter problems listed in the introduction were solved satisfactorily and the S-meter reports became more meaningful and objective. This is particularly useful for relative reports, e.g., a comparison of barefoot/linear operation or antenna checks. Absolute reports may be accompanied by a short statement on the antenna used, on topographical peculiarities, and on the accuracy of the S-meter. But simply spoken, it is a real pleasure to give that low-power or faraway station a better and accurate report and not to fool others with unrealistic S9 + 20 dB reports. ■

Wow!

A Good Portable Receiver!

—thanks, Panasonic!

Photo by Robert Hinman WA2DIZ

Joseph W. Long WA2EJT
Chemistry Dept.
Broome Community College
Binghamton NY 13902

The Panasonic RF-2200 is a unique multiband receiver and should be of great interest to many amateurs. The receiver tunes standard broadcast AM and FM and is general coverage in the shortwave spectrum from 3.9 to 28 MHz (more about the shortwave frequency limits later on).

There are several items which make this receiver of so much potential interest. The first concerns the shortwave section. The coverage is in 6 bands, each 4 MHz wide, which are tuned with a linear dial scale calibrated every 10 kHz and which can be read to within about 3 kHz

throughout the whole shortwave spectrum.

There are two built-in crystal calibrators, one at 0.5 MHz and one at 0.125 MHz, with which the dial may be very accurately calibrated. When calibrated at the appropriate spot, any frequency throughout its range may be dialed up with the volume off. Turning up the receiver volume will bring in the station if it can be heard. Shades of the R-390/51 J Collins general-coverage receivers!

The vfo tunes over 4 MHz, but, even with this range, the dial is surprisingly linear. For example, my RF-2200 on band SW 3 (12-16 MHz), when calibrated at 12 MHz, has a dial error of no more than 10 kHz all the way up to 15.5 MHz. The 16.0 MHz point is off by about 20 kHz.

Turning on the calibrators automatically disconnects the antenna, turns on the bfo, and declutches the linear dial so that there are no points to offset. That's just about like it's done in my Collins R-391.

The receiver also has an excellent product detector tuning meter and rf gain control, making it great for use within the ham bands. Also useful are a wide/narrow i-f selectivity switch (narrow is not very narrow), separate bass and treble controls, and a two-speed dial.

The SW section of the RF-2200 is very hot, and the built-in whip antenna brings in all manner of signals. The receiver is advertised as tunable from 3.9 to 28 MHz, but mine actually goes all the way down to 3.5 MHz, with the dial getting rather

nonlinear. It also tunes above 28 MHz—to just above 28.5 MHz.

For \$140, you don't get everything, of course, and the receiver does have some deficiencies which must be mentioned. First, there is a slow drift during reception of CW and SSB signals which is independent of frequency. The instruction manual suggests that the bfo be turned on 5 minutes early for "wonderful CW and SSB reception." This suggestion is helpful, but there remains a slow drift even after long periods. Since the problem does appear to be caused by drift in the bfo circuit, I suspect that it could be cured fairly easily.

Another deficiency is a dead space in the tuning gears. This is only dead space; the signals do not keep going the wrong way when you reverse direc-

tions; they just don't change at all. The effect is noticeable only on CW and SSB. Even at low speed, the tuning is a bit fast for CW and SSB—a very delicate touch is required. Otherwise, the feel of the tuning is really excellent and smacks of quality.

In the higher SW bands, the rf gain control pulls the signals quite a bit. I actually rather like this deficiency, as it can be used as a fine tuning control.

A fourth problem is the presence of an unusual kind of spurious signal. When very strong CB signals are tuned in on band 6 (24-28 MHz), they can still be heard on band 5 (20-24 MHz) at the same points on the dial. It sounds as though there is some sort of leakage in the hfo chain in the front end. This does not seem to be a serious problem; the only place I have noticed it is with very strong CB signals.

A test which it occurred to me to make just as I write this is for mechanical stability. A good rap on the side of the set, or a two-inch (5.08 cm) drop test will not throw the receiver off from zero beat. Amazing!

There are many comments which are important regarding the AM and FM bands on the receiver. The AM reception is excellent. It is extremely sensitive, and it seems much less susceptible to noise pickup than most other receivers. For example, in my office at work I can regularly receive WQXR from New York City (over 100 miles away), while other radios from the same spot can barely get the local Binghamton stations through all of the fluorescent light noises. This noise immunity really amazes me; I wish I could explain it.

The dial is calibrated every 20 kHz on the BC band and is quite accurate; the greatest error on my



2200 is about 10 kHz around the middle of the band. This is infinitely better than the calibration on most other transistor radios I've seen.

The AM antenna may be swiveled. It's on the top of the radio, is calibrated in degrees, and may be used for amateur direction-finding. When I've tried it, all I was able to prove was that Binghamton, New York, is somewhere in the middle of the Atlantic.

I have saved one of the nicest sections of the receiver for last: the FM band. FM on this set is truly outstanding. It is about the hottest FM receiver I've ever heard; it outshines my \$700 McIntosh FM tuner in this regard. One evening, my girl friend and I logged stations from Syracuse, Utica, Scranton, and Wilkes Barre on the built-in whip antenna from a location where other portables can hear the local stations and nothing more. The 2200 has very few spurious responses on FM, many fewer than I have ever seen on any other FM portables.

The FM selectivity is also outstanding. Binghamton is blessed with two

very powerful stations on 98.1 and 99.1 MHz, yet WBRE in Wilkes Barre, on 98.5 MHz (about 70 mountainous air miles away and very weak), can be tuned in easily. FM dial readings may be estimated quite accurately, using the built-in logging scale, to about plus/minus 0.3 MHz.

The audio in the set is of first quality. The receiver produces several Watts of very clean sound. Everyone who has heard it agrees that it sounds unbelievably good. This high-quality audio is, of course, somewhat wasted on the AM and SW bands.

The receiver will play on internal batteries (4 D cells, included) or on 110 volts by plugging in the line cord. Battery life is very long.

The packaging of the radio is very nice. It has an attractive but rugged plastic case, the controls are well and plainly marked, and a momentary-on dial light is included for nighttime spy radio listening. I understand that an extensive service manual is available for \$3.50, which can be obtained from Panasonic service centers.

I became hooked on the

set when I got to play with one my baby brother had purchased and was raving about. After fiddling with my 2200 (when they should have been working), two of my co-workers rushed out to buy their own and a third is thinking of how he might slip one past his wife. The 2200 disease is very contagious!

The set should be available from dealers well stocked in Panasonic gear. The prices seem to range from about \$117 at 47th Street Photo in NYC (which is usually out of stock) to \$138, which I paid at a discount store here in Binghamton.

This little box is a real jewel. It is unique in the high quality of all three of its bands. Its "new technology" SW circuitry and tremendous audio make it a set that any receiver buff, as well as many others, will want to own.

I would like to emphasize that I have nothing to do with the Panasonic company (I wish I did!) and that this article is unsolicited. The article is just an attempt to provide an honest report on a nice piece of gear to people who may be interested. ■

The XITEX Video Terminal

*—a quiet alternative
to your Model 15*

I have been in RTTY for about two years and have decided to do something about all the noise in the shack caused by the Model 15 printer. I visited a fellow ham and looked at his video terminal and knew at once that video was the course to follow.

We Air Force types are not what you would call "rolling in the money," so I looked for some type of kit to assemble. I took my search to the usual monthly publications, but this proved to be in vain, as everything appeared to be encoded in ASCII and we hams must transmit in Baudot. As my search proceeded, I still wasn't having very much luck, until, one day, I spotted an advertisement in 73. Reading further, I was impressed with the fact that this video terminal would interface in ASCII and Baudot. This video ter-

minal is the SCT-100, by XITEX, P.O. Box 20887, Dallas, Texas 75220.

Not only does this 5" by 10" board speak both ASCII and Baudot, but also I won't have to hock my ham gear to be able to afford it. Now whenever the FCC decides to let hams use ASCII, or I figure out what computers do, I will be ready.

This video board has the capability for serial ASCII or Baudot, full X-Y cursor control, 128 characters including upper and lower case, 16 lines by 64 characters, S-100 compatibility, and operates on 7 V dc unregulated or 12.5 V ac at one Amp. The SCT-100 single-card terminal interfaces directly to any computer or modem having serial ASCII or Baudot capability. It requires only the addition of an ASCII keyboard and a TV monitor or modified TV

set. It's available in two kit forms or prewired and tested.

Well, I have to admit that all this looked good to me, but I am just a ham and I don't know much about computers, keyboards, etc. This was solved, however, by a call to the factory. After talking to them a bit and asking a few very elementary questions, I ordered a prewired and tested unit, and now, at last, I am on the way to ridding myself of a lot of noise. I ordered a keyboard kit from a parts distributor, so now I am into this thing wholeheartedly.

As fate would have it, the keyboard arrived first, so, at once, I went off to my local parts supplier, purchased two chassis, and picked up a copy of the *TVT Cookbook*. I would definitely recommend this little book to anyone attempting any video terminal project. Now, I sup-

pose one can put the keyboard and the terminal board in the same chassis; however, I often like to do things the hard way.

The keyboard was a cinch to assemble, only taking about one hour. I checked it out and it performed okay. The messy part is cutting the chassis and causing small bits of metal to fly all over the shack. I performed a few measurements, cut the hole in the keyboard chassis, and installed the keyboard. It looked okay except for all the scratches that were added to the outside of the chassis. So out the door I went to the local hardware store for some contact paper to give the whole thing that "wood-grain look." After applying this to the chassis, it looked a lot better. I also installed wooden wedges to give the keyboard the proper angle for ease in typing . . . I don't think this

step will improve my typing, but it looks better.

Next, I moved to the chassis that would house the video terminal board. I installed a 12.5 V ac transformer and a 5-Ohm resistor to supply approximately 8 V ac to the on-board supply. The SCT-100 has a 5 V dc regulated one-Amp power supply on board, and this is enough to power the video board and the keyboard. However, if your keyboard requires -12 V dc, you will need to add a -12 V dc supply. I must point out that the parts are not critical and most can be obtained from the average junk box.

The next move was to tiptoe upstairs and kidnap my daughter's 12" TV for modification to a video monitor. This TV video monitor was used on a time-share basis until Christmas when we purchased another one for her. I used the guidelines from the *TVT Cookbook* to modify the TV. My only catch was that the TV turned out to be a hot chassis set. This problem was solved by using two old TV transformers and tying their 6.3 leads together to make an "el cheapo" isolation transformer.

At last the UPS package arrived, and it was time for the task of tying all the components together. First, you should read all the instructions; then the same instructions should be read again and again. I know the first thing one usually does is to cast aside the instructions and proceed full speed ahead. This may be okay for some people, but not me. As I have said before, I often do things the hard way.

Now that the instructions seemed clear, I made all the connections that would be required. I planned for the future and made the provisions for RS-232 and a 60 mA loop. There is one point here that



I would like to bring up. There are some voltage points called E3, 4, and 5. These are used to connect either an external 5 V dc supply or approximately 7 V dc to the on-board regulator, or to strap the on-board supply to the circuit. This is not clear in the instruction, and one can look at the diagram to

make the connections.

Now for the moment of truth. I hooked up the video monitor and powered up. This produced a screen full of garble, so I cycled the power switch and the screen cleared up and the cursor moved to home. The instructions make clear that if clearing is encountered, a capacitor

change is in order.

Next I jumpered the RS-232 in/out ports together and plugged the keyboard in for keyboard checkout, first checking all the key functions in ASCII and then proceeding with the Baudot checkout. The Baudot mode had no letters. After reading all the directions, I strapped my

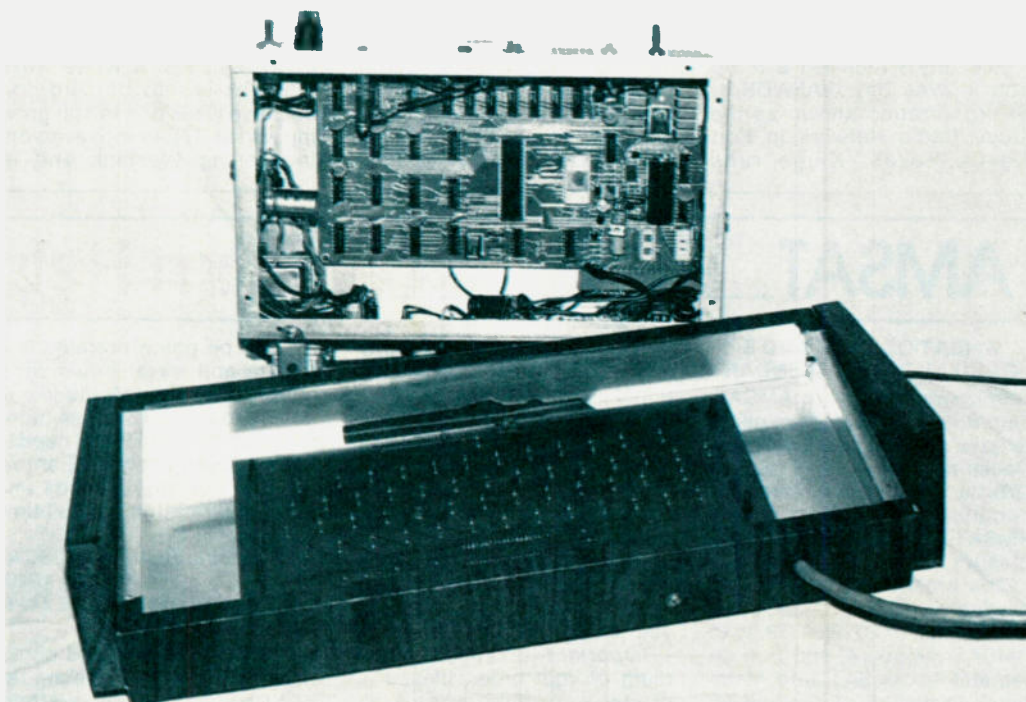

keyboard for upper case only and the Baudot functioned normally.

I proceeded with the 60 mA loop checkout. This was one point that bothered me, as the max of 80 mA in current and voltage of 180 V dc is also called for in the instructions. Most loop supplies run between 150 and 170 V dc, and this does not leave much margin for relay or keyboard spikes. I called the folks at XITEX

and discussed this situation with John McCrady. We agreed that the circuit should be beefed up. He recommended a TIP-48 for Q5 and changing D9 to at least 1000 volts at one Amp. I received his permission to install transistor sockets, and then I proceeded with the modification. After all the modifications were made to the 60 mA loop, it checked out fine and has given me no problems.

I next turned on the rig, called CQ, and had my first "video RTTY" contact. It was very nice not to hear the "klunk" of the old Model 15. I will keep the Model 15, as I like to copy the RTTY pix on the weekends.

I would like to say that, in dealing with radio suppliers for the last 8 years, I have never worked with a nicer or more helpful company than XITEX. I wish to thank John McCrady and

Bob Farrier for all their assistance.

I have included some photos of my project. One could make the project smaller, but I chose to have space for maintenance and future expansion.

The SCT-100 provides the RTTY or microcomputer hobbyist with an inexpensive video terminal. As for the RTTY hams, it provides the ability for transition to ASCII when it is permitted. ■

Looking West

from page 124

tion. Not that many years ago, when I last drove across the country, the only real "western" activity was here in California. Not so today. Two meters and all FM relay subbands continue to grow. Arizona is an excellent example of this.

LET'S LINK AGAIN DEPARTMENT

About a year ago, LW ran a story titled "Linking America." It told about Sam Davis WA1GQY and some cross-country repeater linking he had spearheaded. Sam no longer resides here in California, and since his departure little has happened along these lines. It was fun when it was done, but it never caught on to any great extent.

Recently I received a letter from Wayne Day WA5WDB of an organization known as the Kluge Radio Network in Fort Worth, Texas. Kluge runs

WR5ARL on 147.015/.615, a system that serves the Dallas/Fort Worth metroplex. Wayne describes ARL as being that area's first "California Split" system (inverted tertiary) and the first to provide autopatch service to that area. Further, while the name "Kluge" came from the odd assortment of equipment utilized to place the original machine into operation, things are far better these days. The current ARL system boasts a 100-Watt Micor into a DB 4 bay at 385'.

The reason we mention this is that Kluge is interested in picking up where "Linking America" left off. They are equipped to link via telephone interconnect to two repeaters at any given time. The only prerequisite is that one be further east and one be west. They literally have the ability to act as a switching point to permit coast-to-coast repeater links. Also, it works quite well; I have seen many times when ARL has linked to the WA6VQP/RPT (ex-

WR6AWQ) repeater here in Los Angeles. Having spoken with Wayne and his "Kluge" associates on many occasions, I'm in a position to tell you that they are one swell group of people. They are interested in expanding the concept of repeater interlinking with any interested system in the United States or Canada. Therefore, if your desires go in that direction, you should contact WA5WDB at the following address: R. Wayne Day WA5WDB, 2501 Taxco Road #662, Fort Worth TX 76116.

Systems interested in linking directly to the west coast should contact the Westlink Radio Network, 12731 Rajah Street, Sylmar CA 91342. For those of you who are trying to remember where they heard the name "Westlink" before, it is the same group that produces the weekly Repeater News QSTs now heard on over 150 repeaters throughout the nation. In that regard, Westlink recently celebrated its first birthday. As I write this, Westlink is into its 53rd consecutive week and is still growing. We at 73 join with everyone in wishing Westlink and its

creator/network director Jim Hendershot a very happy first anniversary.

THE WELL-SEASONED GREETINGS DEPARTMENT

Next year, amateur radio faces its greatest challenge, in the form of the World Administrative Radio Conference. Will we be here next year? Will amateur radio exist at all in 12 months? Your guess is as good as mine. With the unfortunate decision by ARMA not to back an international trade mission to the underdeveloped nations, we are left with but one hope. We can only pray that this time the ARRL has done its homework and that through their efforts we will come through WARC unscathed. A year from now, I hope we don't see a one page issue of 73 which simply reads: "The World Has Canceled Amateur Radio."

Sharon and I would like to take this opportunity to wish each of you a Merry Christmas or Happy Chanukah, and above all, we would like to extend our best wishes for a Happy New Year. Not just for all of you, but for the future of amateur radio as well.

AMSAT

AMSAT-OSCAR 7 AND 8 ORBITAL DATA CALENDAR

In cooperation with AMSAT, Skip Reymann W6PAJ expects to have available, by the end of November, an AMSAT-OSCAR Orbital Predictions calendar containing all orbits of the AMSAT-OSCAR 7 and 8 satellites for 1979.

The orbital calendar will be available, postpaid, for \$5.00 (U.S. funds) or 20 IRCs (\$3.00 to AMSAT members, and free on request to AMSAT Life Members). Overseas orders will be airmailed.

From outside the U.S., payment may be made by international postal money order, or by checks made out in U.S. funds, or by U.S. currency. Send orders to AMSAT or to: Skip Reymann W6PAJ, PO Box 374, San Dimas CA 91773.

Orders may also be charged to VISA or Master Charge. (Be sure to provide your account number and expiration date on your charge card.)

Important—to speed up handling of your order, please include a gummed, self-addressed label.

Ham Help

I will be going portable in a pickup and travel trailer for a couple of years. I would like to get in touch with other hams who operate from RVs. I need to learn about generators, antennas that work on HF bands, and other information for full-time RVing.

**Ronald L. Headley WD8QAZ
PO Box 18406
Cleveland Hts. OH 44118**

I have a lot of toroid cores, most of which I believe are ferrite. I would like to know if there is a simple, unsophisticated,

easy way to ballpark their permeability figure, μ . I'd like to do it without a lot of fancy test gear, too. I am attempting to put together a small QRP linear amp for the HF band, and it requires some broadband rf transformers to be made out of ferrite cores having a permeability figure of about 900+ per core. If anyone has any knowledge on this subject, I would be most grateful to hear about it.

**Rick Christensen
Rt. 3, Box 630
Provo UT 84601**

TEN-TEC CENTURY 21 GOES DIGITAL!

Century 21, the exciting 70-watt, 5-band CW transceiver that surprised everyone with its super performance and low cost, has another surprise for you. A second model with digital readout (and a mod kit for those who would like to convert their dial model). Both Models 570 and 574 have the same unique circuitry that has won raves from everyone — both have the same fine features:

- Direct Frequency Readout (Model 574: 5 red LED digits, 0.3" high, accurate to nearest 1 kHz. Model 570: marked in 5 kHz increments from 0-500 kHz, MHz markings for each band displayed, tuning rate typically 17 kHz per tuning knob turn.
- Full Break-In • Full Band Coverage on 3, 5, 7, 14, 21 MHz Bands, 1 MHz on 28 MHz Band • 70 Watts Input • Total Solid-State • Receives SSB and CW • Receiver Sensitivity 1 μ V • Instant Band Change, No Tune-up • Offset Receiver Tuning • 3-Position Selectivity • Adjustable Sidetone Level
- Linear Crystal-Mixed VFO • Overload Protection • Built-In AC Power Supply • Black & Gray Styling • HWD: 6 $\frac{1}{8}$ " x 12 $\frac{1}{2}$ " x 12", 15 $\frac{1}{2}$ lbs. • Matching Accessories

THE RECEIVER. Double-Direct-Conversion. Easy tuning. Just select the frequency and set the audio level. Excellent cross-modulation characteristics. Offset tuning so you can tune either side of zero beat to reduce QRM. Front panel control selects one of 3 selectivity curves: 2.5 kHz for SSB reception, 1 kHz for normal CW, and 500 Hz for when the QRM gets rough. Plus separate AF and RF controls, headphone jack, and built-in speaker.

THE TRANSMITTER. Total solid-state. Push-pull Class C final amplifier. Individual low-pass filters are switched into the antenna line to reduce unwanted radiations, minimize TVI. No tune-up needed when changing frequencies or bands. And *full break-in* allows incoming signals to be heard between transmitted characters. Now CW is real conversation!

THE VFO. Common to receiver and transmitter. Permeability tuned. Linear scale on model 570; 5-5.5 MHz basic frequency is crystal-mixed to the desired frequency so bandwidth and stability are the same on all bands (crystals included for 3.5, 7, 14, 21, and 28-28.5 MHz segment of the 10 meter band).

THE POWER SUPPLY. Built in, AC operated, and regulated. Monitors current demand, shuts down automatically when necessary for protection. Lighted input current meter shows proper Drive setting.

MATCHING ACCESSORIES. Model 277 Antenna Tuner/SWR Meter. Model 670 Electronic Keyer, 6-50 wpm, self-completing characters. Model 276 Calibrator for markers at every 25 and 100 kHz. Model 273 Crystal for 28.5-29 MHz. Model 1170 12 VDC Circuit Breaker for mobile operation of models 574 and 570.

574 Century 21 Digital Transceiver	\$399.00
570 Century 21 Non-Digital Transceiver	\$299.00
277 Antenna Tuner/SWR Meter	\$ 85.00
670 Century 21 Keyer	\$ 29.00
276 Century 21 Calibrator	\$ 29.00
273 Crystal for 28.5-29 MHz	\$ 5.00
274 Digital Mod. Kit for Model 570	\$ 90.00
1170 DC Circuit Breaker	\$ 8.75

See both Century 21 surprises at your TEN-TEC dealer — or write for full details.

TEN-TEC, INC.
SEVIERVILLE, TENNESSEE 37862
EXPORT 5715 LINCOLN AVE., CHICAGO, ILL. 60646

THE SECOND SURPRISE OF THE CENTURY: DIGITAL



Light Up Your Life

— the 2036 glows digital

Paul Bales WA4NUE
Gregory's Trailer Pk., Lot #12
Bristol TN 37620

When I bought my HW-2036, the first thing I noticed was the fact that you couldn't see what frequency you were on at night in the car. This disadvantage was soon taken care of by adding a

digital readout. This project has probably been made already, but for those who have not heard of it, this article is for you.

The readout is a very simple and straightforward project. The switches that are used to set the frequency on the radio are BCD-type, binary-coded decimal switches. This makes the building of a digital readout very simple. All

that is needed to build the readout are three BCD decoder ICs and six seven-segment readouts. Of course you will need a case to put it in, 470-Ohm resistors for current limiting, and some ribbon cable for connections of the readout to the radio. I used a connector on the cable in order to disconnect the readout from the radio so I could simply disconnect

the readout and remove the radio. This way the readout can be left mounted in the vehicle. You can also mount the readout on top of or below the radio and leave the readout connected all the time.

In building the readout, you can either use a printed circuit board or a breadboard-type of parts holder. I first used the breadboard and several other hams have done the same. But for a real neat and good-looking project, I suggest you use the printed circuit board. The first two digits are hard-wired to read out only these two digits. This is done by connecting 470-Ohm resistors, one side to ground and the other side to the associated pins on the readouts, which, by the way, are common-anode-type, and positive 5 volts to pins 3 and 14.

The ICs used are SN7447 or equivalent. These are common-anode decoder ICs. If you start from the top of the BCD switch in the radio and count down 1 through 4, this will correspond to the inputs on the ICs as follows: Pin 1 on the IC is pin 3 on the BCD switch, pin 2 goes to pin 2



on the switch, pin 6 of the IC goes to pin 1 on the switch, and pin 7 of the IC connects to pin 4 of the switch. The same connections are made on each of the ICs. Connecting the ICs to the radio gives the next three digits. Now, on the sixth digit, which is the 0/5-kHz readout, the switch in the radio has its center connection wired to ground. So in order to make the readout read what is needed, run a wire from the top connection on the switch to one side of five 470-Ohm resistors, and the bottom connection to one side of six 470-Ohm resistors. To make one readout read two different numbers, four of the segments are used to make both digits. Strap the resistors as shown to come out with four single leads to connect to the readout. For the 5, connect the 4 leads to pins 1, 2, 8, and 10, then connect the last resistor to pin 11. This will give a 5 on the readout. For the 0, four of the pins are already connected. Connect the two remaining resistors to pins 7 and 13. For ease of replacing readouts or ICs, the use of

IC sockets is very helpful. The readouts I used were Radio Shack part number 276-053; however, the MAN 72 readout from Poly Paks® will work just fine. Now, to place the decimal, use a 470-Ohm resistor from ground to pin 6 of the fourth readout. The readouts I used have a left-hand decimal point, so the fourth readout is used for the proper placement of the decimal.

The positive 5 volts is also taken from the radio. The 2200-Ohm resistors on the synthesizer board which are used to connect the BCD switches to the board have positive 5 volts on the back side of each one. This is the side opposite the switches. Connect a wire from this point and run it to the readout. A switch may be installed on the readout to turn it on and off. In order to protect the 5-volt supply in the radio, install a ½-Amp fuse in line with the 5 volts. The circuit draws 274 milliamps, so a ½-Amp fuse is fine. Connect all pins 3, 14, and 16 on the ICs to 5 volts and connect pin 8 of the ICs to ground.

The layout of parts is not

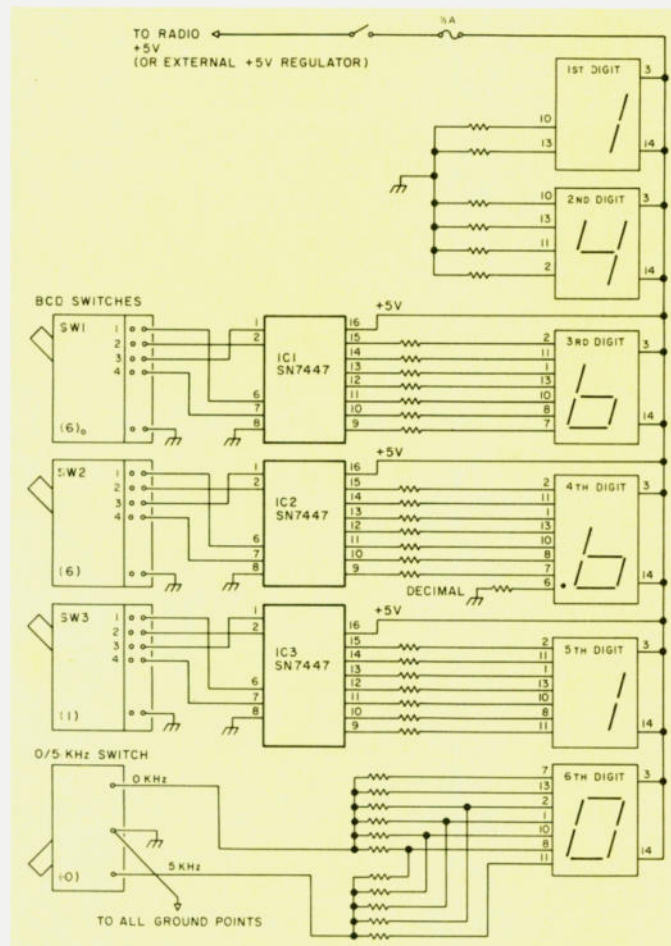
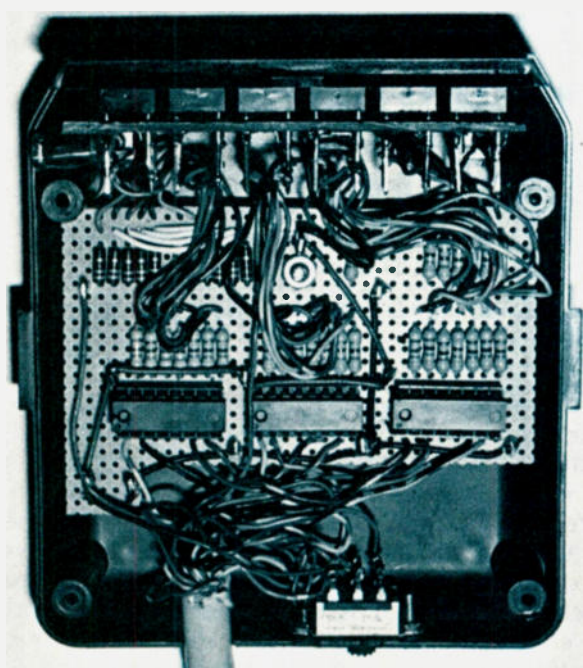

Fig. 1. Digital readout for Heath HW-2036. All resistors are 470 Ohms. ICs are Radio Shack SN7447s or equivalent. Readouts are common-anode Radio Shack #276-053 or equivalent (e.g., MAN 72). Connection of +5 volts in radio is on back side of 2200-Ohm resistor on synthesizer board.

critical, so any arrangement is fine. The ribbon cable is easily routed down the side of the radio and

out through the opening at the back of the radio on the bottom. The cable can then be connected to a



Top front view

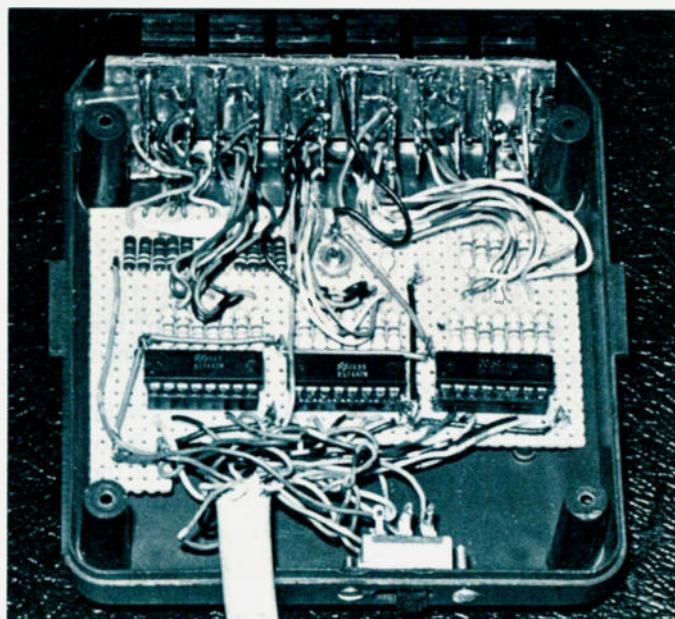

Top rear view.

The parameters of the Palomar PTR-130k are the outer perimeters of logic technology.

Never before has any transceiver approached the capabilities of the Palomar PTR-130k!

It's the first completely multi-functional transceiver ever made available to the public!

The Palomar PTR-130k is a miniaturized mobile transceiver

capable of operating in 100 cycle resolution from 100 KHz to 30 MHz in all modes of transmission and reception. Instant frequency selection is available with the touch of a finger.

The Palomar PTR-130k.

technology is pure space age... the price is strictly down-to-earth. Send for our full color brochure to:

Palomar Electronics Corporation
665 Opper Street
Escondido, CA 92025
Telephone: (714) 746-2666



TECHNOLOGY AT THE SPEED OF SOUND

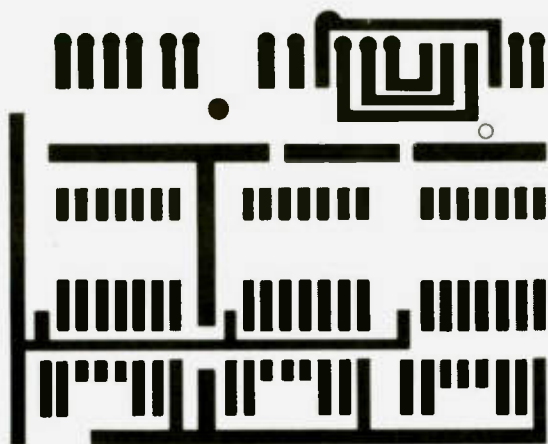

Fig. 2. PC board.

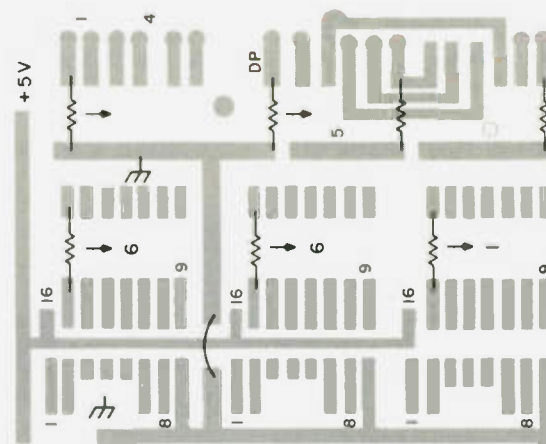

Fig. 3. Component layout (foil side view). Strap ground wire with 24 gauge.

connector or to the readout, if desired. There is a total of 16 wires used, so a 15-pin connector can be used if the ground wire from the readout is connected to chassis ground on the radio. The case I used to mount the parts in was a Radio Shack readout case. It is small and easy to mount and is large enough

to easily mount the board and readouts inside with room to spare.

I hope this article will be of help to the many hams who own one of these fine rigs. My readout has been in service for months now and has given no trouble. It is very nice to be able to see what frequency you are on without having to

turn on the inside light of the vehicle. I hope that no one thinks that I stole their idea; it was not intended, I assure you. The project is easy to build and takes a very short time. I think you will enjoy it as much as I have enjoyed building and using it.

Something I forgot to

mention: You can also use an external 5-volt regulator instead of the 5 volts from the radio; however, in my opinion, this would be an added expense and involve more parts than necessary for the readout to be a simple and not expensive attachment for the HW-2036. ■

MADISON ELECTRONICS SUPPLY, INC.

1508-B McKINNEY
713/658-0268

HOUSTON, TEXAS 77002
Nites 713/497-5683

NEW! EXCITING! BREAKTHROUGH! YAESU FRG-7000 Shortwave Receiver



\$655.00

*The Most Exciting
Shortwave Receiver
Since the HRO!*

(Call for Quotes)



ANTENNAS

Model OJA-146

TWO METER AMATEUR BAND 146-148MHz

- NO GROUND PLANE REQUIRED
- USE FIXED, MOBILE, OR PORTABLE
- 5dB GAIN OVER ISOTROPIC IN MOST MOBILE APPLICATIONS
- OVERALL LENGTH: LESS THAN 64 INCHES
- COLLAPSIBLE TO 22 INCHES. MAY BE PACKED IN SUITCASE FOR THOSE OUT-OF-TOWN TRIPS
- STEEL WHIP AND ADAPTER INCLUDED FOR MOBILE AND FIXED APPLICATIONS
- VSWR: LESS THAN 1.2:1

PRICE \$39.95 UPS Prepaid
220 MHz — \$37.95 450 MHz — \$37.95

**CALL FOR FAST QUOTES
SPECIAL ORDERS WELCOME**

TERMS: All prices FOB Houston. Prices subject to change without notice. All items Guaranteed. Some items subject to prior sale. Send letterhead for Amateur dealers price list. Texas residents add 6% tax. Please add postage estimate.

W5GJ, W5MBB, K5AAD, N5JJ, W5IMJ, AG5K, WD5EDE, K5ZD, WD5ABR, WA5TGU, WD5BDX, W55AYF, K5RC, K5BGB

Have A Nice Day!
DLA



JINGLE BELL SPECIALS



OMNI-J & heavy duty magnet mount complete	\$49.95
TRIEX W-51 FT Self Support Tower (Reg. \$825.00) Your Cost (F.O.B. California)	\$725.00
Tonna F9FT Antennas 144/16el	\$79.95
RIW 432/19el	\$59.95
KLITZING VHF-UHF Amplifiers	
2M 10W In — 100W OUT	\$198.00
432 10W In — 50 W Out	\$198.00
BIRD 43 & Slugs, Stock, UPS Paid	Call
Microwave Modules 432-28S, UPS Paid	\$298.00
Telrex TB5EM, In Stock	\$415.00
NEW Palomar Engr. Transceiver Preamp	\$89.50
Bencher Paddles . . . \$39.95; Chrome	\$49.95
ETO 76 Amplifiers	Stock
Lunar 6M-2M-220 In Line Preamps	\$49.95
Lunar 2M Amp 10-80 with Preamp, UPS Paid	\$189.95
Janel QSA-5	\$41.95
CDE HAM-3 . . . \$129.00; HAM-X	\$249.00
VHF Engrs. blue line amps	Stock
Cetron 572B	\$27.95
Raytheon 572B	\$24.95
Motorola HEP 170	\$0.29 ea.
Mallory 2.5A/1000 PIV Epoxy Diode	\$0.19 ea.
Aerovox 1000PF/500V Feed thru	\$1.95
GE 6146B/8950	\$7.95
Technical books: AMECO, ARRL, Sams, TAB, Rider, Radio Pub., Callbook, Cowan, many others	Call
NEW BELDEN 9405 (2#16) (6#18) 8 wire Rotor Cable, heavy duty for long runs	\$0.26/ft.
8448, Std. 8-wire Rotor	\$0.16/ft.
9888, double shield RG8 Foam	\$0.39/ft.
8214, RG8 Foam	\$0.25/ft.
8237, RG-8	\$0.21/ft.
8267, RG-213	\$0.25/ft.
Amphonor Silver Plate PL259	\$0.59
TIMES 1 1/2" Foam Hardline \$0.60/ft	Connectors \$15.00 ea.
7/8" Hardline \$1.50/ft.	Connectors \$25.00 ea.
BERKTEK RG-8X, 52 ohm, KW	\$0.16/ft.
Consolidated HD-18 Ga. Galv. Tower, 10 Sec.	\$29.95
Robot "Slow Scan" Now In Stock	Call
Alliance HD73 Rotor	\$109.95

LATE SPECIAL: All FINCO Amateur Antennas — 10% off list in stock

THIS MONTH'S SPECIAL

ICOM IC-280 \$395.00

16 ELEMENTS — F9FT — 144 MHz



*The 'Tonna' You've been
hearing about*

144/146 MHz SWR 1.2:1
50 ohms Wt. 4.4 kg.
length 6.4 m. Horiz./Vert.
Horizontal aperture 2 x 16° (-3 dB)
Vertical aperture 2 x 17° (-3 dB)

\$79.95

9 Element 144-146 \$39.95
4 Element 144-146 \$32.95

MADISON ^{M35} ELECTRONICS SUPPLY, INC.

1508-B McKINNEY
713/658-0268

HOUSTON, TEXAS 77002
Nites 713/497-5683

BI-LATERAL

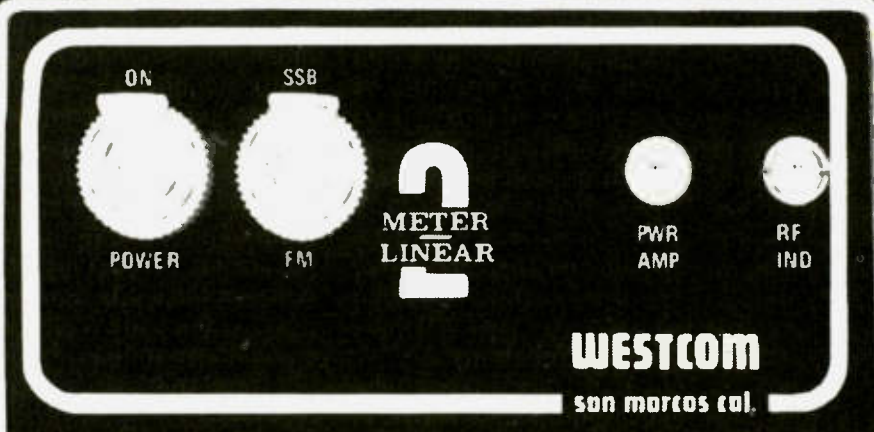

DIGS OUT THE WEAK SIGNAL AND BOOSTS THE POWER !!!

Now Westcom gives you twice the advantage... a low noise receiver preamplifier and an output power amplifier, all in the same package! No modification of your transceiver is required since it's all in one high performance, low cost unit. The low noise U310 J-FET yields 12dB gain, 2dB NF, and the receive amp may be used independent of power amp. This unit is a natural for OSCAR uplink or long haul weak signal TROPO work. Available in 90w or 125w.

- An add-on unit, no internal connections or adjustments required to associated equipment
- Standard Amplifiers operate FM, Linear Models operate all modes: SSB, FM, AM, RTTY, CW.
- Diffused emitter ballasting resistors achieve extreme ruggedness under severe operating conditions
- Withstands 20:1 VSWR under specified operating conditions
- "Microstrip" design provides high stability and optimum performance over wide bandwidth
- Factory adjusted, no tuning required
- Mobile mounting bracket included
- RF sensing T/R switching, adjustable drop-out delay (SSB/CW Mode)
- Remote keying capability
- Thermally coupled biasing
- Reverse Voltage protected
- Detachable fused power connector
- Conservatively rated with oversized heat sink
- Compact: 4 1/8 x 5 1/2 x 2 5/8
- Red LED Indicators for monitoring DC and RF
- One year material and workmanship limited warranty

MODEL NO. (two meter)	INPUT POWER (watts)	MINIMUM OUTPUT W. (at max input)	MAXIMUM CURRENT 13.8 VDC	PRICE
FM Mode				
2m 15x70	5-15	70	8	\$119.95
2m 15x90	5-15	90	11	\$134.95
2m 25x125	10-25	125	18	\$164.95
All Mode-Linearized				
2m 15x70L	2-15	70	8	\$129.95
2m 15x90L	2-15	90	11	\$149.95
2m 25x125L	5-25	125	18	\$179.95
All Mode-Linearized with pre-amp				
2m 15x90BL	2-15	90	11	\$179.95
2m 25x125BL	5-25	125	18	\$209.95

* Linear; AM, CW, FM, SSB, RTTY. Linear models work well with low power transmitters of 2-3 watts to yield 30-40w output. Size: 4 1/8 x 5 1/2 x 2 5/8

If not available from your local dealer, contact:

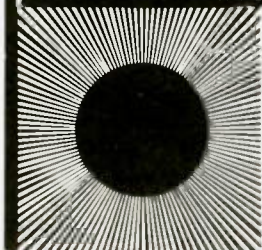

WESTCOM

ENGINEERING ✓ W17

1320 Grand Avenue San Marcos
California 92069 (714) 744-0728

CURTIS LSI's help you

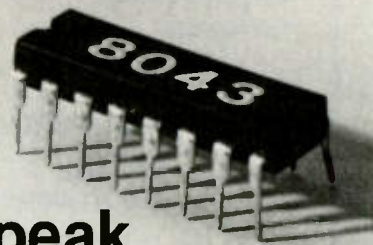

speak MORSE

- ★ 8044; Keyer-On-A-Chip* (Replaces 8043) . \$14.95
Apr '75 HR, Feb '76 OST, Radio Hdbk '75, Apr Hdbk '77-78
 - ★ 8044-3; IC, PCB, Socket, Manual 24.95
 - ★ 8044-4; Semi-Kit 54.95
 - ★ 8045; Morse Keyboard-On-A-Chip IC . . . 59.95
 - ★ 8045-1; IC, PCB, FIFO, Sockets, Manual . . 89.95
 - ★ 8045-2; Semi-Kit 159.95
 - ★ 8046; Instructokeyer-On-A-Chip 49.95
 - ★ 8046-1; Semi-Kit 79.95
 - ★ 8047; Message Memory-On-A-Chip IC . . . 39.95
 - ★ 8047-1; IC, PCB, RAM, Sockets, Manual . . 69.95
(add \$1.75 on above for postage and handling)
 - EK-430; CMOS Keyer* (Feb '76 OST) 124.95
 - IK-440A; Instructokeyer* (Mar '76 OST) . . . 224.95
* now with dash memory as standard
- System 4000 Ham Computer (see Jan '78 OST) (write)

Curtis Electro Devices, Inc.
(415) 964-3136
Box 4090, Mountain View, CA 94040

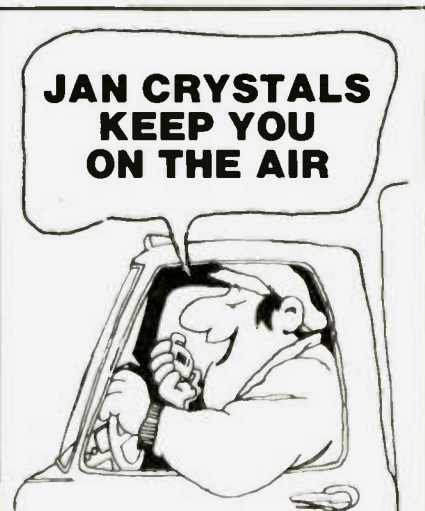

- CB
- CB standard
- 2 meter
- Scanners
- Amateur Bands
- General Communication
- Industry
- Marine VHF
- Micro processor crystals

easy to charge

Send 10¢ for our latest catalog
Write or phone for more details
2400 Crystal Drive
Ft. Myers, Florida 33901
all phones (813) 936-2397 ✓ J2

Hustler: The First Family of mobile amateur two meter antennas!

None can come close to us on the road. The Hustler family has a strong tradition of quality. Our performance gives you everything you want including maximum range, improved gain and better SWR at resonance.

Ours' is a lasting tradition, too. Hustler antennas are made of only the finest stainless steel and chrome plated components. So you get longer service life.

Quality. Performance. Dependability. Durability. It's all in the Hustler family. . .the First Family of two meter mobile amateur antennas.*



BBLT-144A



CGT-144



HT-144



SPS-144

*Most models available in 1-1/4 meters.

Clearly the choice of those who know quality.

new·tronics corporation

15800 Commerce Park Dr. • Brookpark, Ohio 44142

High Seas Adventure — Ham Style

— part III

Photos by Jules Wenglare W6YO

James E. Seidel WA6FEI
1066 N. Westside St.
Porterville CA 93257

"Commercial broadcast stations and 40 meter harmonics literally dominated the 20 meter band. No stateside signals were heard for several days. Very little was heard from anywhere."

That was the comment Jules Wenglare W6YO made about his amateur radio activities in the South China Sea during his 10-month around-the-world cruise. He had set sail from Freeport in the Bahamas five months earlier aboard the *Yankee Trader*. In a few days the ship would stop at still another exotic port: Singapore.

The *Trader* docked in Singapore on July 18, 1977. "There were countless numbers of ships in the bay," said Jules, "making it very difficult to get dock space. The city looked very beautiful from the waterfront."

After customs clearance, the passengers were allowed to go ashore. Jules contacted Doctor Charan

9V1NR at his dispensary, and later went to his home. While there, he had a chance to get on the air for some ham contacts.

After an eyeball QSO with another ham, Bud 9V1OI, Jules purchased a ticket at the airport and flew to Bangkok, Thailand, where he met Bill HS1AGU, and a former co-worker from Delano, Dean Bartelet.

During the weekend in Bangkok, Jules went to the coast. He said he saw many "water scooters" being used. They are a very popular sport here and something one just wouldn't think people on the other side of the world would be doing. And the traffic in Bangkok? "It was bedlam," Jules mentioned, "with motor scooters, bikes, rickshaws, taxis, and wagons everywhere."

On Sunday, Jules contacted Dieter HS1ALG, an electronics professor at Bangkok University. At Dieter's apartment, they got on the air for some good DX. One nice chat was with Bill W7PHO, a well-known ham in the DX-world from Seattle.

While Jules was here, he learned that there is no official licensing in Thailand. A person interested in becoming a ham must join a radio club and then be issued a call through the club. Kam HS1WR runs the show.

After a five-day enjoyable stay in Bangkok, Jules took a two-hour flight back to Singapore. Upon arrival, he learned that the ship's stay had been extended a few more days in port. This gave him a chance to do a little more visiting.

Bud 9V1OI and his wife, Jan, hosted Jules for dinner one night. Jan, whom Jules complimented about being an excellent cook, would like to open a Chinese restaurant in southern California after Bud retires. From the way Jules praised her cooking, especially the chicken wings in a special sauce, I'm sure her restaurant would be a great success.

Bud lives in a 20-story apartment building and his beam is about 280 feet above ground. This sure makes for good DXing. Jules got some air time and

again talked to John W6UZ back in Delano. He said the DX was very good.

Jules went to the post office and had this to say: "Mailing letters in Singapore was a chore. You always had to wait in a long line. Boy, they weighed every letter, wrote down the price, and then gave you a stamp separately for every card or letter. On postcards, you had to stick on an air mail sticker. Both the stickers and postage stamps had very little glue on them. You'd stick 'em down and they'd come off. They had glue bottles all over and you'd get glue all over your fingers, and, oh, what a mess."

When the *Trader* was in Tahiti, the ship's radar went out, and the replacement part caught up with the ship in Singapore. Jules assisted in its installation. It arrived at the proper time.

When leaving Singapore and sailing through the straits, two extra crew members had to serve as lookouts on the bridge because there were so many other ships coming

and going. Half of them didn't have lights. "It was a nightmare," Jules said. "We were thankful that the radar was working again."

As the *Trader* sailed toward Penang, Jules said the DX was good only in the evening. When the ship got closer to Penang, he made contact with Mal 9M2MW and tried to advise him that the ship would be in port in the morning. The signals were too weak, but Harry K6MOO heard both of them very clearly, and instead of a 100-mile direct contact, a round-trip relay of over 15,000 miles was made.

After the *Trader* anchored at Penang on August 3, Jules went to the post office. While he was standing in line with some of the other passengers, this fellow came in and asked another American if he knew Jules. Well, Jules was standing only a few feet away. It was Eshee 9M2FK, whom he had worked earlier when at sea. They left the post office and called Mal 9M2MW, who met them; later, all three went back to the ship. They got on 40 meters and worked several of the local hams who were on a net.

One of the trips Jules took here was up the side of Penang Mountain. As one of the cable cars goes up, another one comes down. They both use the same single tracks. About midway up, the tracks divide into passing tracks. (There had better be no mistakes here.) From the top, Jules could see the two bright lights aboard the *Yankee Trader*, some five miles away in the straits.

Mal 9M2MW and his wife, Patricia, also hosted Jules one night for dinner. Mal is interested in Teletype™ and has several pieces of RTTY

equipment, some of which is home brew. While he was here, he met Chong 9M2DJ and Tan 9M2DW.

Jules, along with some other hams, helped in taking down Mal's mast and tri-band antenna. The weather and corrosion had attacked the connections and the swr was getting high. He said it was a miracle that they got it down in one piece, due to the small area in the backyard.

While here in Penang, Jules visited the home of Eshee 9M2FK, who works for the port authority. His radio shack, located in the back of his home, is a very neat layout. In his portfolio of awards and certificates, Jules found an award from the Northern California DX Club.

The time had finally arrived for Jules to leave Penang. Within a few hours after setting sail for Colombo, he contacted a ham at Clark Air Force Base in the Philippines. He received the satellite weather report for the area which showed pretty good weather. Later, he got into Reunion Island (FR7) for an unusual contact, and then several U.S. stations. He also talked to John 4S7JD, the manager of the Voice of America radio station in Sri Lanka.

For the next few days, Jules filled several pages of his logbook working stations all over the world. He said he even had a perfect contact with an American at the embassy in Brasilia, Brazil. He also checked into the SEANET (South East Asia Net), which, at the time, was being run by Carl S79R, in the Seychelles. Also, one evening, Jules worked about seven 4S7s; a couple of them were at the home of John 4S7JD.

On August 13, the *Trader* pulled into Colombo, Sri Lanka (formally Ceylon), after sailing five days from Malaysia. Most of the

passengers set out for various parts of the country, but Jules had personal guides waiting for him at the dock. It was John 4S7JD and Shanti 4S7WP, a radio operator aboard a tanker out of Colombo.

Since Jules was to be the house guest of John 4S7JD for the duration of his stay here, that's where he went. Jules and John had first worked each other when John was in Liberia back in 1965. This was the first time they had ever met in person and they had plenty to talk about, having mutual friends in the VOA.

John had invited many of the hams over to his home to meet Jules. About 6:00 pm, they began to arrive. Jules met the following: Fernando 4S7BC; Senevi 4S7SW, whom Jules had worked in the past years and on the way over; Vasanth 4S7VG; Ernest 4S7EA; Guru 4S7PG; and Paddy 4S7PB.

The following are excerpts from a tape recording made in John's home on August 14, 1977, of some of the hams who were visiting with Jules. This first one, Jules said, is Paddy 4S7PB.

"Right now we're here with 4S7 hams, and Jules W6YO is with us. He wants me to say a few words to start with. May I say a very

good evening to all the gang in the Northern and Southern California DX Clubs, and I wish I were with you as I was some time back, ten years ago — in fact, 1967. Wish you all the best in good propagation for the next umpteen years. Bye-bye."

"Good evening, my brother hams in California. This is Ernest 4S7EA with Jules and my brother hams here at 4S7JD's shack. I will say '(couldn't catch the phrase)' to you all. Which is, in our own lingo, 'May your life be long.' That is how we say it. It's very nice meeting Jules and I have had the pleasure of meeting many W6s on Charlie Willie. I look forward to meeting you once again, especially my friend Jules, when he goes back home. Bye for now. 73."

"Hello boys, this is 4S7 Baker Charlie speaking. I was very happy to work my good friend Jules some days ago. He's my own age. I'm very happy to know that (laughter). Our rigs, as you know, are mostly home brew and mine is also a home-brew one. I've been getting quite a number of stations with really good signal strength. Wish you all the best till we possibly meet you on the band again. Cheerio."

(4S7SW) "Hello, my



What you see is almost all of the town of Dzaoudzi, Mayotte, French Comoros. It was here in a little 8-room hotel where Jules operated with the call of FH0YO.

friends in the United States. I've been having a nice time with Jules over here. There are altogether about seven hams here; we're all having a nice time. That's about all from here. I'll pass this over to my good friend, Victor George."

"Good evening, friends, this is 4S7 Victor George and we are having a very fine time with old man Jules here. I would hope to meet many of the boys on the air very soon. 73 and wishing you an eyeball from Sri Lanka. 4S7VG, off."

A couple of days later, Jules was invited to the home of Shanti 4S7WP for a four- or five-course dinner that Jules said was very delightful.

Shanti showed Jules a VP9BM QSL card dated 1955. VP9BM is a former call held by Jules when he was living in Bermuda. "I guess Shanti was my first 4S7," Jules mentioned, "and I was his first VP9. It was great to see the card." He also had cards from Don W6BVM and Leon W6BYH from Delano, Jules's home town. On top of that was a Delano Amateur Radio Club certificate, #45, dated 23 of July, 1955, for working five of the club members.

One day, at John's home, Jules met Soma 4S7YL and her OM, Wick 4S7WA. They talked about DX and she presented Jules with an eyeball QSL card and a kiss on the cheek. Jules had also worked her when she was 8Q6AC in the Republic of Maldives.

Before Jules left Colombo, John took him out of town about 20 miles to the Voice of America transmitter site, one of several located in different countries around the world. Since Jules had only recently retired from the VOA in Delano, this was almost like being at home.

All visits to the various

countries and islands must, sooner or later, come to an end. Many hams were met on Sri Lanka, and the memories will always be pleasant.

After the *Trader* set sail for the Maldives, Jules got on the air and worked some good DX. Contacts were made with KZ5KN, Canal Zone, and VP2MH, Montserrat. Another good QSO was held with Bill W7PHO, and later with Father Moran 9N1MM, in Nepal.

The *Trader* dropped anchor at 5:15 pm on Thursday, August 25, about a half mile off shore at Male, Maldives, an island group off the tip of India, and only a few degrees north of the equator.

One of the first things Jules did was to check about operating amateur radio from the island. A customs official told him that no radio transmissions of any type were allowed from the island or from a ship in the harbor. It was strictly prohibited. Jules was very disappointed.

With only 48 hours here, one might as well enjoy it, so Jules did a little shopping and sight-seeing. He also did some more snorkeling. He said the fish were very beautiful, and even got to touch some of them. The water was so clear one could see a hundred feet away.

On the last day in port, Jules went to the Telecommunications Department to see what the requirements were to get permission to operate here. Jules was "shocked" when Mohamed Ismail Maniku, Director of Telecommunications, gave him permission to operate in the Maldives. Jules asked Maniku if he would like to become a ham. He said yes. Jules said he would do everything possible to help him become an amateur radio operator.

Jules asked if other hams

could operate from the island and was told that they could. There are no customs or great formalities necessary.

Jules could have received an 8Q call, but with only a few hours remaining before the ship left the island, there wasn't time to wait, so he was given permission to operate as W6YO/8Q. He worked all continents within two hours after returning to the ship and getting on the air. He would have liked more air time, but the ship was about to sail.

For the March, '77, issue of *73 Magazine*, I wrote the article "Pitcairn Island—an inside look at VR6TC." I mailed a copy to Jules and he received it in Tahiti. Before leaving the Maldives, he gave that copy to Maniku. I'm sure he read it from cover to cover.

The ship left at 4:00 pm and Jules worked a lot of stations en route to the Seychelles. He worked a PY, 9Y4, VK, and many Europeans, as well as many stateside contacts.

In issue #8 of the *Trader Tales* newsletter, Jules wrote: "Good ole Uncle Sam is at our service. Here around the Indian Ocean, GI 'hams' at Clark Air Force Base and the Subic Bay U.S. Navy base, both the Philippines, and with the U.S. Navy at Diego Garcia in the Chagos Archipelago, pass on to me the latest weather data for requested areas, gathered from weather satellites. In the Pacific, the Honolulu and Guam satellite service was even 'phone-patched' to me directly from, and to, the weather plotting station.

"In the Indian Ocean, this service was provided through the generosity of one particular amateur radio station, WA4RQK/VQ9. Jim, the operator there, has been most helpful; this is, I believe,

because we are 'Yanks.'

"Another great service we have all around the world, and particularly here in the Indian Ocean, is the SEANET, which stands for South East Asia Net, with participating amateur radio operators surrounding the Indian Ocean, and a 'net control' station which supervises all 'hams' checking in, to offer any possible assistance over the air or to relay telephone calls. This net control station is being handled by a most outstanding and capable person by the name of Carl Reder S79R, who makes his home in Victoria on Mahe Island, Seychelles (our next port of call). Carl can instantly remember the 'handle' of any one he has contacted before, and there are several dozen stations who check in every evening."

Six days of sailing brought the *Trader* to Victoria, Seychelles. Jules met Carl and spent a great deal of time with him going to various places on the island. They visited a religious high-power short-wave broadcast station and Jules stated that the 300-foot towers and antennas were all out in the water — a very unusual setup. Jules even had the opportunity to watch some speedboat and yacht races. An unusual treat for an area such as this.

Time never stands still, so the time had come to depart from yet another island. After getting to sea, Jules made contact with Jim WA4RQK/VQ9 and received the weather report for their trip to Mombasa, Kenya. He also made contact with Ted 5Z4OT, in Nairobi, whom he hoped to visit upon arrival. He talked to Ray 5Z4PR, also in Nairobi, and was invited to stay at his place for a visit. He even gave Jules two phone numbers to call when the

ship docked. Another contact was with a Cape Town ham whom he will meet when the *Trader* arrives in South Africa.

Once every 24 hours while at sea during this around-the-world cruise, Jules had to take the wheel (helm) for two hours. One morning while doing so, he said, "We could hear birds chirping away. I was wondering, gosh, we're 500 miles away from land and a bird's here?" Later that morning, someone saw a bird up in Jules's antenna. All of a sudden it dropped and fell into the ocean alongside the ship. No one could understand what had happened until they looked up again and saw one of the bird's wings stuck in the antenna. Jules said, "It must have gotten wedged in one of the corners of the wire and fiberglass outrigger supporting the antennas."

No matter where you might be in this world, there is always time for being a volunteer instructor for Novice class students. The *Yankee Trader* on the high seas is no exception. Jules started a Novice code class with three students, and every afternoon at 3 o'clock he gave three-quarters of an hour of code practice. All of his students, at this stage of the trip, were very enthused about getting an amateur radio operator's license. Jules said they were doing pretty well.

When the *Trader* arrived at Mombasa, Kenya, many of the passengers headed for the interior to visit some of the preserves and parks. Jules headed inland, also.

When he took the bus to Nairobi, he had hopes of seeing 19,340-foot Mount Kilimanjaro in Tanzania, near the border of Kenya. Unfortunately, the weather didn't cooperate; it was overcast. The trip, some 300 miles, was on a

narrow bumpy road. The dust was terrible. Jules expected to see numerous wild animals, but only a few were actually seen.

When he arrived in Nairobi he called Ron 5Z4RG, and later they met. Ron took Jules out to their coffee plantation where he met Philomena 5Z4PG, Ron's XYL. He got some air time and had a long QSO with a close friend, Frank W6KPC, on 15 meters. Jules said, "He had a very good signal, but no other 6s were heard." He enjoyed a hot bath and delightful dinner Phil had prepared.

The next day, in downtown Nairobi, Jules met Ted 5Z4OT, and they had a very nice chat. While here in town, he said he walked so much just sight-seeing that his feet became sore and swollen. He also took a four- to five-hour tour of a wild game preserve 20 miles from town. He left that night for the return trip to Mombasa and it rained most of the way back.

Jules had purchased an antique brass washbasin (he called it a spittoon) as a souvenir and was carrying it when the following occurred about a block from the gate to the docks:

"A fellow came up from behind me and grabbed for my wristwatch. With both hands, he pulled down, but I didn't have an expanding band and it wouldn't come loose. I gripped it and held on when it slipped to my hand. He pulled me over and I fell to the road, tore my trousers, and got a bruise on my knee. It scratched my wrist, too, from the sharp wristband. I swung at him with the spittoon, but I missed him. I'd liked to have dented his head with it. He ran across the street. Luckily, I got away without getting beaten up or having my wallet or camera stolen."

Jules reported the incident, but that's about all



This is Cape Agulhas, southernmost tip of Africa. The unusual feature is in the whitecap water seen between the rocks. It is the dividing point for the Indian Ocean on the left and the Atlantic Ocean on the right...

that could be done. It was quite an experience, especially when you're about to leave the country and head for another port.

Two days out of Mombasa, the passengers were treated to what you might call "porpoises on parade." It was a spectacular display of porpoises, mostly in front of the ship. There were hundreds of them leaping in and out of the water in their acrobatic swimming and playful jumps.

Since the *Trader* arrived at Mutsamudu, Anjouan Island, Independent Comoros, in the evening, Jules decided to stay on board. The following day he took a bus tour of the island and saw many of the plants from which perfume is made. He even took a tour of a perfume factory where flowers are processed and a liquid is extracted from them. From this liquid, a perfume is made. "The tour," Jules said, "was quite enjoyable." That evening the ship set sail for an overnight trip to Mayotte Island, French Isles de Comoros.

When Jules was in Miami, he had asked the captain about stopping at the Comoros since it wasn't

a scheduled stop. The captain said he was agreeable and would like to. In issue #9 of the *Trader Tales*, Jules wrote another short piece titled, "Perfume Islands Attract Ham Operator."

"The Comoro Islands were first called the Perfume Islands, for they attracted perfume merchants to buy the strong-scented oil extracted from the ylang-ylang tree flowers.

"Today, the islands have another attraction to the hams around the world: a rare island country. This inspired me to operate my radio equipment ashore in a small hotel overlooking the bay at Dzaoudzi, Mayotte. On September 26 and 27, in the wee hours of morning, during fair conditions, in less than five hours, I made 318 contacts, mostly with stateside stations. Many thanks from myself, and I'm sure from the lucky ones who made a QSO, to Yvon Segueiney for issuing me the license and call FHØYO, Al Fox, an American visiting Mayotte who helped in the operation, and especially Captain Paul Maskell, skipper of the *Yankee Trader*, for stopping here."

Long before the *Trader*



Mac ZS1LK and Jules W6YO beside the Yankee Trader, docked in Cape Town, South Africa. Mac is one of many hams Jules met while here in this very beautiful country.

arrived at Mayotte, Jules had contacted Al VP2LOX/MM1 by radio and talked to him about getting a license to operate from the island. When the ship docked, Al was there to meet him. He had received the call of FHØFX for himself and FHØYO for Jules. They were all set for an amateur radio DXpedition.

After a stop to see Al's yacht and meet his XYL, Eva, they headed for the only local hotel (8-room) and started getting things ready for the special operation. They obtained a ladder to get up on the roof and dipoles for both 15 and 20 meters were installed. The low ends were tied to a rock down on the beach. Everything was set up out on the balcony.

The first QSO on 20 SSB at 1200 UTC (3:00 PM local time) as FHØYO, Mayotte, Comoro Islands, was W3NX, 5 × 7 both ways, followed by YBØAAU, W3LMA, and then W3KT. The first hour produced

nearly 60 QSOs. Jules said he worked into Central America very well, but only picked up one station in Australia. It was Merv VK4MW, whom he had met several months earlier during a visit to that country. Most of the QSOs as FHØYO were on 20 meters; a total of 228 contacts were made.

Operation on 15 meters was with the call of FHØFX. There were 90 contacts made here before the band folded. Jules stated that most of the stateside contacts were from the 3rd, 4th, and 5th districts. He missed "Worked All Continents" by one: the one closest to his location — South Africa.

"I was working split, transmitting with an FT-101 down on 14.195 and tuning with the Atlas around 200 to 220. Later in the evening," Jules stated, "I was tuning above 275, still transmitting on 195.

"I even worked a station running 1 Watt; W8OK got me to stand by for him. The

station was W8ILC. It was something. He was 3 × 2.

"Most of the reports we were giving were 5 × 7. We received some 20 over S9 reports, with 20 meters being much better in signal reports than 15."

I personally don't know if any other hams have gone to Mayotte and operated, but from the appearance and success of what Jules did, this sounds like an excellent spot for an extended DXpedition. The *Trader* was here for less than 24 hours and they did pretty well with what time was available, thanks to Yvon FH8CY, Director of Telecommunications, who was responsible for issuing the calls.

After leaving the island, the *Trader* sailed toward the Juan de Nova Island group in the Mozambique Channel. From there, they turned and headed for Tulear, Madagascar. When the ship arrived, Jules went into town but didn't do too much. The next day, officials restricted everyone

to the ship, so the following day they shoved off for Cape Town, South Africa.

At this point in the trip, Jules mentioned that the three Novice students he had been doing pretty well—about 5 wpm on the code. They would be ready for their tests by the time the *Trader* reached South America.

The bands were very good here at sea. He had a QSO with Bill ZS1ER, whom he had contacted on other occasions. Jules planned on visiting Bill when the ship arrived in Cape Town.

Another contact was with a ham at 37,000 feet. It was Fred W7UKG/AM3 aboard a 747 en route from Seattle to Tokyo. He was somewhere between Alaska and Siberia. It was a good, long QSO.

"Oh, it was a beautiful sight," Jules said, "coming in to see Table Top Mountain, Lion's Head, Signal Hill, and the terrific skyline of Cape Town. The large buildings could be seen for miles and miles. It is just a tremendous-looking city. The harbor reminds you of Rio de Janeiro; kind of a round horseshoe bay. Fantastic! There were dozens of cranes about 200 feet high, and large tanker ships. You couldn't count them all. It was nice to get in."

It was Sunday morning, October 9, when the *Trader* moved up to a pier near the yacht club in Cape Town. "Believe it or not," Jules said, "on the dock was Bill ZS1ER. He was the first one to shake hands with me before we even had the gangplank down."

Bill, along with his XYL and two boys, took Jules down the coast to the Cape of Good Hope and Cape Agulhas, southernmost tip of Africa, for a nice view of the country. They had a really nice day and even drove to a hill and saw all the night lights of Cape

Town. On another day, Bill and his family took Jules up the coast for an all-day trip where he met Mac ZS1LK and family. Jules stayed at Mac's home and they got in a little air time. Mac is quite active on 2 meters as well as the HF bands.

Jules said Mac has a little two-year-old son, Jamie, who really took to him. He said, "We really made friends—the cutest little fellow you ever wanted to see."

Mac took Jules to the yacht club, where a lot of people asked him a number of questions since he was from the U.S. While they were there, "The first leg of the around-the-world yacht race from England came in," Jules commented. "There were some beautiful yachts."

Jules also met Dick W6OZ, the radio operator off a large freighter from

New Orleans. Later, Jules took him aboard the *Trader* for a visit. They even had breakfast aboard Dick's ship one morning.

Another ham Jules met was Danie ZS1X. He went to his home which was right on the beach. A very picturesque location. Danie does a lot of experimenting with ham equipment. His XYL was about to get her ham license.

The word apparently got out about Jules being in Cape Town, and a lot of operators wanted to meet him personally. "I met quite a few hams. They always seemed to be coming around. There was," Jules commented, "a continuous stream of them."

Jules was impressed with the modern buildings in the city. He mentioned that they have modern freeways and overpasses. The train station is as beautiful

and more modern than Jules had seen in the states. This is a very progressive city. The people were very polite and courteous. The shops had a very good selection of souvenirs. Jules even had a T-bone steak at the Town House, the first since leaving the states back in February. The dinner was a little over \$4.00.

"The hams here were sure nice," Jules said, "particularly Mac ZS1LK and Bill ZS1ER." Mac came to see Jules off at 11 o'clock on October 21. They had some coffee out on the deck while having their final eyeball QSO. Mac was one of the last to leave the *Trader* before she set sail for St. Helena.

It was some 1,700 miles to Jamestown, St. Helena, from Cape Town, South Africa. Before the *Trader* arrived, she had sailed some 25,143 miles in this

10-month around-the-world cruise. For Jules Wenglare W6YO, it would be another adventure in yet another country. It would also be a location for another DXpedition for Jules as ZD7YO.

In three parts, I have covered eight months of travel with Jules aboard the *Yankee Trader* on the high seas and the ports of call visited. In part IV, the *Trader* will sail another 5000 miles and stop at another dozen locations. Jules will meet and participate with other hams in celebrating 40 years as a ham for Vic PY7AN in Recife, Brazil.

On the island of Carriacou, Jules eats part of an apple. Within a few minutes his mouth and throat began to burn. He later learns that it was poisonous. In fact, the toxic apple has been fatal to small children. ■

New Products

from page 23

side-by-side on a small, 2-1/8" x 5" x 1-1/8" base of satin chrome with a black plastic top. The big difference between the QUIK-KEY and conventional keyer paddles is that it is manipulated by downward pressure, as with a straight key, instead of by horizontal pressure.

One of the problems I've always had with keyer paddles is that the way I bang away while sending, the paddle skates about on the operating desk. Short of screwing the paddle down solidly as I do with a straight key, I simply haven't been able to keep one in the same spot without holding it down with my other hand. To my delight, the QUIK-KEY has eliminated that problem. The combination of the weighted base and downward pressure when manipulating the keying levers makes for very stable operation. Even with the way I thump it about, the QUIK-KEY stays in place.

Another impressive feature of the QUIK-KEY is its physical appearance. Quality materials and precision machining make

for smooth operation and good looks. Personalizing each paddle with the operator's call is a nice, attractive touch.

The QUIK-KEY is connected the same as other paddles and works with any keyer, including iambic ones. If you've been using a bug or conventional keyer paddle, you may find that it takes a while to get used to using the QUIK-KEY because of the vertical movement of the keying levers. Once you do make the transition, though, you'll undoubtedly be impressed by its operation. And if you go directly from using a straight key to the QUIK-KEY, chances are you'll wonder why you didn't switch sooner. Tension and finger spacing are adjustable.

Of course, some operating surfaces will provide better adhesion than others, but in using the QUIK-KEY on a variety of surfaces it was always much more stable than either of my conventional keyer paddles, mostly by the proverbial country mile.

The QUIK-KEY may be ordered direct for \$39.95 plus \$2 postage. QUIK-KEY, PO Box

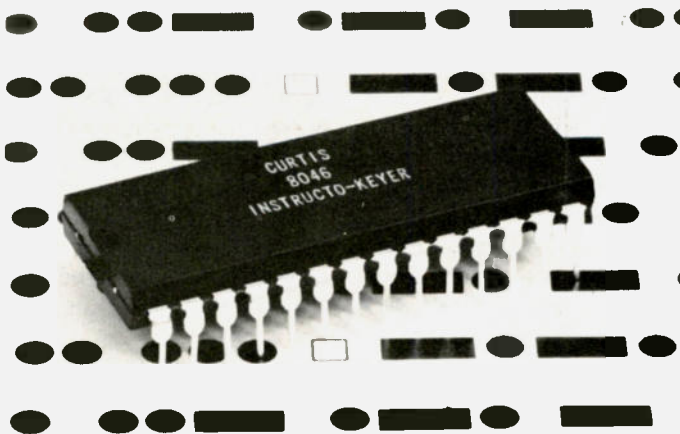

The new 8046 28-pin CMOS IC from Curtis.

73, Katonah NY 10536. Reader Service number Q6.

Morgan W. Godwin W4WFL
Peterborough NH

SINGLE IC SPEAKS RANDOM MORSE

Using the new Curtis 8046 28-pin CMOS QSLI (Quite Large Scale Integration) IC, you can construct a random Morse code practice generator with features similar to the popular IK-440A Instructokeyer.

The 8047 requires one external 256 x 4 ROM (Read Only Memory) and an 8043- or

8044-based keyer to provide completely random Morse characters for speed improvement practice from 6 to 50 wpm. Output is either alphabet-only (Novice practice) or alphanumeric with punctuation. A typical sequence might look like this: "Q, TSA LVT-BEVYL Z/A EE 73D."

Variable extended spacing between letters and letter groups is also provided for slow speed study (characters at 13 wpm, words at 6 wpm, for ex-

Continued on page 158

Whither Microcomputers?

—a pro looks ahead

*Charlene Babb Knadle WB2HJD
316 Vanderbilt Parkway
Dix Hills NY 11746*

Computers are definitely the wave of the future. So says Hans Napfel WB2ZZB, who should know. Not only does he work with them at Fairchild, where he oversees 28 people, most of whom are engineers, but he also has been studying them since the early 60s at home, through all stages of their development. And he knows what applications are planned for them in the foreseeable future. No one, he says, can be unaffected by computers. They are a part of everyone's

life, and this will be increasingly true.

Hans designed and built a small "dedicated" computer (one restricted to performing certain functions) in 1973. It was built with the best components available at the time—resistors, transistors, capacitors, and some integrated circuits—and had no microprocessor (a group of integrated circuits formed into a single component). But most amateur computing did not really begin until more than a year later, when 8008s—the first microprocessing chips—appeared on the market. Now amateur computing is a rapidly-growing hobby, one which Hans nevertheless believes is still in its infancy. (The fact

that the "Personal Computing '77 Trade Fair" at Atlanta drew 140 exhibitors and more than 5,000 people on its first day bears this out.)

The personal computer is industry's answer to the general demand for involvement with computers. It is diminutive in size, can read from already-prepared tapes to carry out a program, or the operator can write in his or her own programs.

Technical people will find computers extremely useful as a tool, Hans believes. Indeed, it was Hans's technical needs as a radio amateur that created his interest in computers

and caused him to begin working with them. "Now," Hans says, "my computer runs my radio station." Not the limited-function computer of 1973, but a second model, built in 1975, which Hans affectionately calls "The Blue Max." It is a general computer, programmable for many things. The Blue Max (which is named for its attractive azure front panel) takes up less than a square foot of space (quite a contrast from the behemoths of the sixties, which were also awkward to use). Max can provide automatic-repeat CW when Hans wants to run a test. It makes contact with a

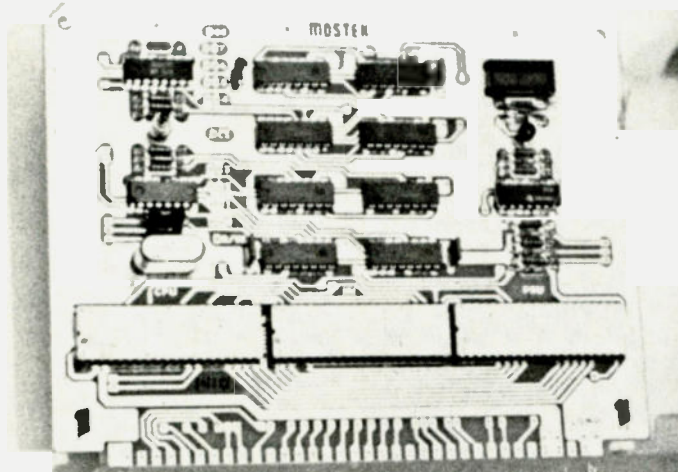

A commercial microprocessor. This type of simple computer will soon monitor the condition of your car.

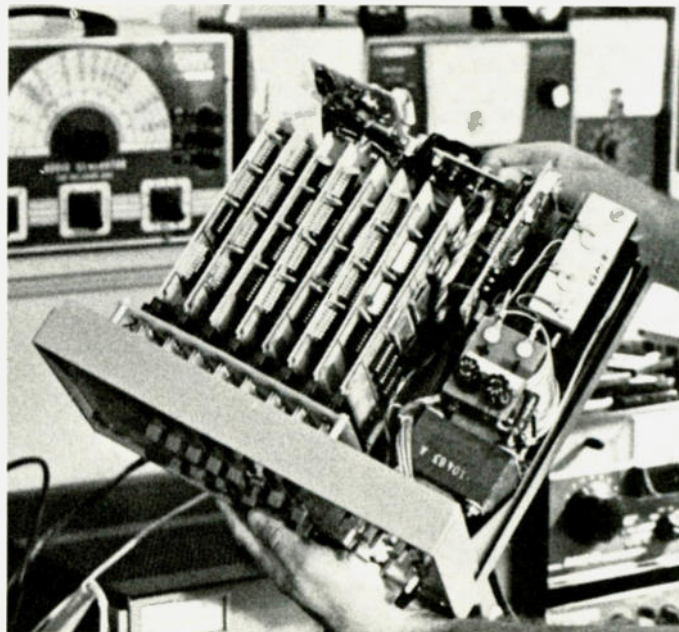

Inside "The Blue Max."

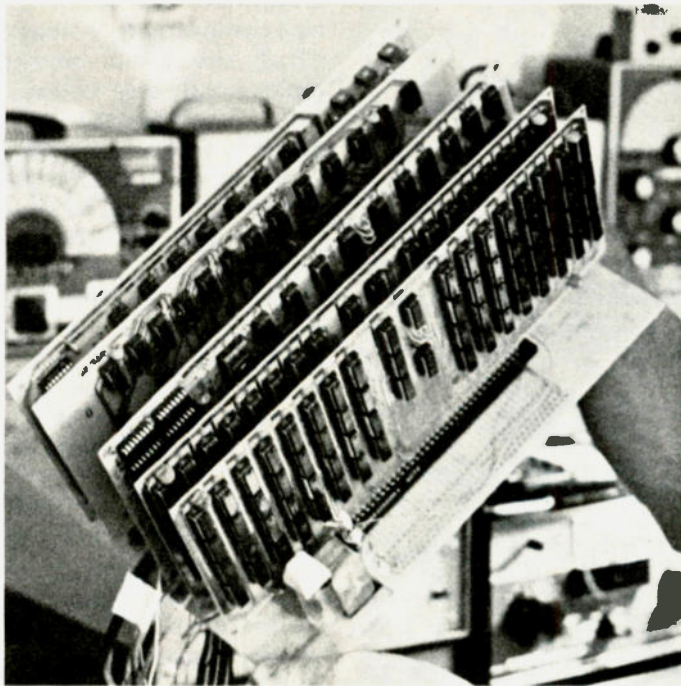

The uncompleted new computer, containing \$2000 worth of modified commercial boards.

friend on schedule, with or without Hans's presence, and records the Morse code answer received, which it prints, in words, either on the attachable television screen or by radioteletype, or both, as Hans has instructed. It prints the received message at exactly the same speed as the sender gives it.

Hans's computer is helpful to him in other ways with amateur radio. It keeps track of his QSLs for him so that he does not have to wonder whether the contact he's just made should be asked for one. (A bulging QSL file shows why this is helpful!) It keeps track of call-letter changes. And it can be asked to print out all the "Charlies," all the W5s, or whatever.

Indeed, with a capability of handling 200,000 full instructions (not bits) per second (yes, that's per second), Hans's computer can be asked to remember anything. Hans uses it during contests to keep his log and to eliminate duplications in the log. "It is also useful for field days,"

he says, "to keep you from repeating stations worked."

Hans also recommends computers as a good way to practice Morse code. For not only does the computer send perfect code every time, at whatever speed you desire, but it also can show you the dots and dashes on screen simultaneously, thus giving you the benefit of involving two senses instead of just one. And it can be programmed to increase the speed gradually, if you wish.

There are other interesting computer applications for the radio amateur. For instance, the moonbouncer will find it "indispensable," Hans says, to keep the antenna positioned at the moon. When a ham with a parabolic dish is not at home, a computer can sense the weather and wind and rotate the dish for the least amount of wind resistance.

Hans and three of his friends are working on an even better computer than The Blue Max. It, too, is homemade, but is com-

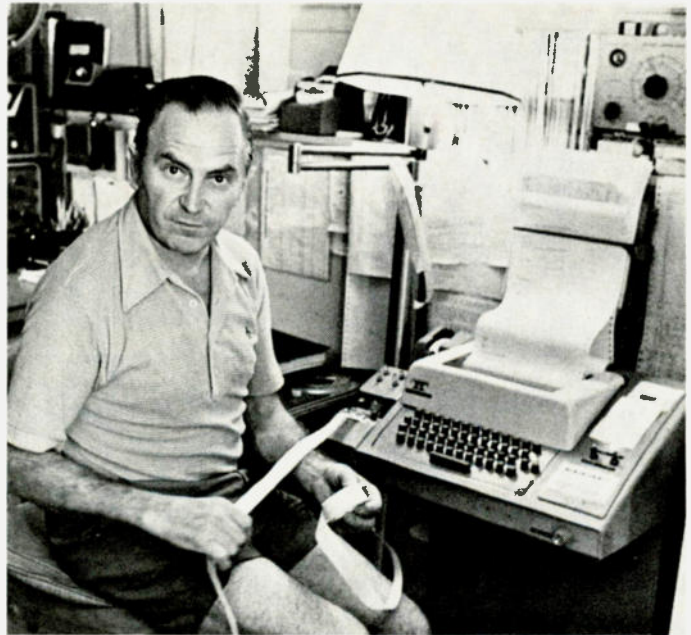

Hans's computer terminal Model 33 ASR punches out a taped program.

posed of commercial boards that the four men have modified. (For Max, Hans designed even the routine things.) Hans and his friends are taking care to program their computers the same way and with the same language (they have settled on "super BASIC"), so that they can exchange programs and communicate with each other effectively. The computers can use audio cassettes as well as paper tape. Punch cards, Hans says, are almost obsolete in personal computing. (In addition to paper tape and punch cards, Hans's computer can work from a "floppy disk," with the addition of a floppy bit memory unit. This attachment records information on a flexible record called a "floppy disk," and thus gives Hans quick access to what is now peripheral-memory material, freeing space in the computer's central memory. These disks, too, are transferable—easily mailed.)

When this system is complete, Hans says, it will not only run his radio station, but his whole house as well. Already, Max orga-

nizes important dates for him. It tells him when to pay certain bills; it will monitor the water temperature and control the pump and filter of his in-ground backyard pool; it tells him when to send birthday and anniversary cards and when to buy gifts. How does it do this? Not by waiting for Hans to call up its memory. When Hans looks into his conveniently-located ham room each morning, there is the day's message right on the screen—blinking to get his attention.

"A computer can handle anything to do with numbers," Hans says. "Using it unclutters your memory and makes life easier." Indeed. If Hans should be late for a class or fail to acknowledge an occasion, it will not be because he was not informed! Max lets him know the flagging date—the day it is necessary to know—if an event is coming up. And Hans can call for a review of the coming month, if he so desires.

The computer is also useful as a telephone directory. It may take a few hours to prepare the program, but to update it later



As Hans taps out instructions, they appear on the screen at the top of the rack. Simultaneously, the Teletype™ machine on the left makes a printout.

will only take seconds. And you can get the number by first name only, last name only, or even by call letters.

Having a computer in the home can be beneficial to non-hams, too. Hans's twelve-year-old daughter, Claudia, uses it for games, for educational math workouts, and to make musical programs. She will soon have a remote terminal in her room. There is already a remote unit in the kitchen, where Hans's wife, Lisa, bones up on her French.

But the computer can do more. It can adjust the thermostat in the house, for instance. It could even be made to do this "intelligently," by monitoring the outside and inside temperatures and "deciding" how to adjust the inside accordingly. This could be important when one is away, especially in winter when pipes could freeze, but when an Indian summer could allow a

lower-than-usual inside temperature. The computer could also be made to turn lights on and off, water plants, feed the dog, play music, and control air conditioning.

The family car will not be unaffected by computers. "In the next two years," Hans says, "cars will have computers to control gas mileage (by noting speed vs. vacuum vs. temperature and keeping the car running at maximum efficiency by optimizing the fuel mixture) and to monitor the condition of the car (letting you know if a light is not working, for instance). In fact, a few cars even have computers now." Signals to the driver will be shown on one light-emitting-diode display, not by means of six or eight meters as we now often see in a car. A computer-controlled warning system will sound a buzzer to alert a speeding or sleeping driver (erratic wheel movements will in-

dicade that the car has left the pavement).

Computers will eventually revolutionize grocery shopping. One could make selections at home, visually (even comparing prices from store to store, right at your own kitchen terminal), and then go to the store to pick up the waiting order. Or it could be delivered to your door. Food, by this system, could be dispensed directly from warehouses. And computers (microprocessors) already control microwave ovens and teaching machines.

But computers will never make it big in the classroom, Hans feels, because "teachers are too threatened by machines. Machines are potentially authority-shattering. What if something goes wrong that the teacher can't fix?" Still, Hans feels that computers could be used by schools successfully as tutors for drill and routine work, if they are housed in

a separate room overseen by a competent technician. "But they will never replace teachers," he says.

For handicapped people, they will be especially important, Hans says, becoming the ears of deaf people and eyes of the blind. Already, speaking computers like the one owned by Pete Motyl K1PXE can be purchased. And in the health field, they are already indispensable, but will become more so.

"And by 1985 or 1990, every house will have its own minicomputer," Hans says. It will be used as an "intelligent" security system (those who live in each house will not set off the alarm), as a telephone answering service and directory (indeed, all forms of paper directories may soon be obsolete), as well as for energy management, bookkeeping, scheduling, providing educational drill, and playing games.

"What about using them to communicate with outer space?" I asked Hans.

His eyes twinkled at the unexpected thought.

"They would be essential in a space colony," he answered, "to monitor the station's life-support system and relative positions, and to keep track of supplies. But to communicate with other intelligences in outer space? Let me put it this way: I'm a hardware realist."

For Hans, that's not a limitation. "I keep up with what's being discovered," he says, "and I just take it one step further. That's what makes the difference." In fact, Hans advances the state of computer art through his hobby, then takes his knowledge to the job, where he educates others.

In a pursuit requiring perseverance and thoroughness, Hans's philosophy is clearly the one that works. ■

visit our new retail location

TOLL FREE 1 (800) 423-5633
CA., AK., HI., (213) 893-8202

BRAND
NEW

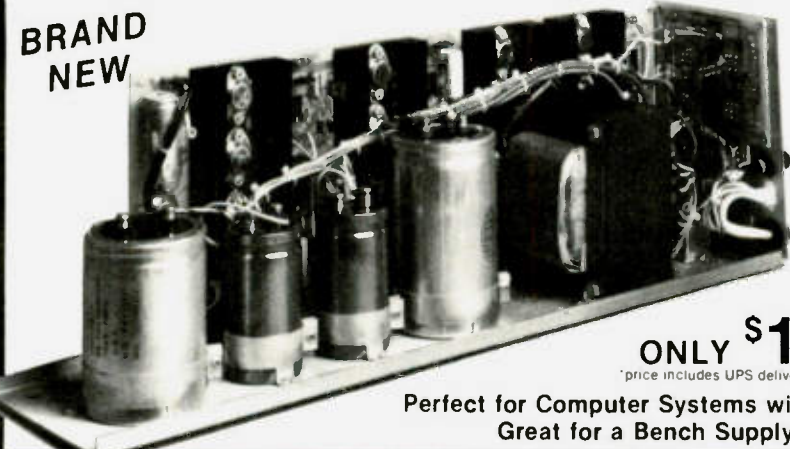

COMPUTER POWER SUPPLY

Output Specifications
under continuous current loads

- 5 Volts @ 17 Amps ± 2%, 50 mv ripple & noise maximum*
- 5 Volts @ 1.25 Amps ± 5%, 50 mv ripple & noise maximum
+ 12 Volts @ 3 Amps ± 3%, 150 mv ripple & noise maximum
- 12 Volts @ 2.75 Amps ± 3%, 150 mv ripple & noise maximum
+ 24 Volts @ 3.5 Amps ± 5%, 150 mv ripple & noise maximum
- 5 Volt supply has remote sensing and overvoltage protection

Input

115VAC or 230 VAC, 48-63 Hz, complete with standard 115VAC 3 wire line cord

We made a fantastic buy on these BRAND NEW Tele-Dynamic power supplies. They are shipped to you in the original factory cartons. Take advantage of this great offer and pay only a fraction of a large computer manufacturer's acquisition cost. Supply is limited, we suggest you phone your order in.

ONLY \$129.95*

*price includes UPS delivery in the continental US

Perfect for Computer Systems with Discs.
Great for a Bench Supply.

CONTINENTAL SPECIALTIES CORPORATION

Logic Probes and Digital Pulsers



LOGIC PROBES

CSC logic probes are the ultimate tool for breadboard design and testing. These hand held units provide an instant overview of circuit conditions. Simple to use, just clip power leads to circuit's power supply, set logic family switch to TTL/DTL or CMOS/RTL. Touch probe to test node. Trace logic levels and pulses through digital circuits. Even stretch and latch for easy pulse detection. Instant recognition of high, low or invalid levels, open circuits and nodes. Simple, dual level detector LEDs tell it quickly, correctly. HI (Logic "1") LO (Logic "0"). Also incorporates blinking pulse detector, e.g., HI and LO LEDs blink on or off, tracking "1" or "0" states at square wave frequencies up to 1.5 MHz. Pulse LED blinks on for 1/2 second during pulse transition. Choice of three modes to meet individual requirements, budget, project and speed of logic circuits.

MODEL LP-1
Hand held logic probe provides instant reading of logic levels for TTL, DTL, HTL or CMOS. **Input Impedance:** 100,000 ohms. **Minimum Detectable Pulse:** 50 ns. **Maximum Input Signal (Frequency):** 10 MHz. **Pulse Detector (LED):** High speed train or single event. **Pulse Memory:** Pulse or level transition detected and stored.
CSC Model LP-1 Logic Probe - Net Each \$44.95

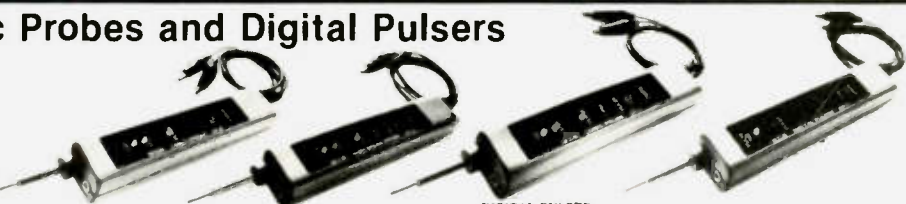

DIGITAL PULSER

The ultimate in speed and ease of operation. Simply connect clip leads to positive and negative power, then touch DP's probe to a circuit node, automatic polarity sensor detects circuit's high or low condition. Inpress the pushbutton and trigger an opposite polarity pulse into the circuit. Fast troubleshooting includes injecting signals at key points in TTL, DTL, CMOS or other popular circuits. Test with single pulse or 100 pulses per second via built in dual control push button; button selects single shot or continuous modes. LED indicator monitors operating modes by flashing once for single pulse or continuously for a pulse train. Completely automatic, pencil size labfield pulse generator for any family of digital circuits. **Output:** Tri state. **Polarity:** Pulse sensing auto polarity. **Sync and Source:** 100 mA. **Pulse Train:** 100 pps. **LED Indicator:** Flashes for single pulse, stays lit for pulse train.
CSC Model DP-1 Digital Pulser - Net Each \$74.95

MODEL LP-2
Economy version of Model LP-1. Safer than a voltmeter. More accurate than a scope. **Input Impedance:** 300,000 ohms. **Minimum Detectable Pulse:** 300 ns. **Maximum Input Signal (Frequency):** 1.5 MHz. **Pulse Detector (LED):** High speed train or single event. **Pulse Memory:** None.
CSC Model LP-2 Logic Probe - Net Each \$24.95

MODEL LP-3
High speed logic probe. Captures pulses as short as 10 ns. **Input Impedance:** 500,000 ohms. **Minimum Detectable Pulse:** 10 ns. **Maximum Input Signal (Frequency):** 50 MHz. **Pulse Detector (LED):** High speed train or single event. **Pulse Memory:** Pulse or level transition detected and stored.
CSC Model LP-3 Logic Probe - Net Each \$69.95



LOGIC MONITOR 1

Trace signals through all types of digital circuits. Unit clips over any DIP IC up to 16 pins. Each of its 16 contacts connects to a single bit level detector that drives a high intensity, numbered LED readout activated when the applied voltage exceeds a fixed 2 V threshold. Logic "1" turns LED on, logic "0" keeps LED off. A power seeking gate network automatically locates supply leads and feeds them to the LM's internal circuitry. Saves minutes, even hours in design, troubleshooting, debugging of equipment. **Voltage Threshold:** 2 V ± 0.2 V. **Input Impedance:** 100,000 ohms. **Input Voltage Range:** 4.5 V max across any two or more inputs. **Current Drain:** 200 mA at 10 V. **Size:** 4" l x 2" w x 1.75" d when open. **Weight:** 3 ozs.
CSC Model LM-1 Logic Monitor - Complete \$59.95

LOGIC MONITOR 2

Provides greater versatility and precision in testing all types of digital circuits. The fully insulated power supply and selectable trigger threshold let you match the precise characteristics of the logic family under test, permitting more accurate measurements. The connector/displays unit clips over any DIP IC up to 16 pins. The power supply module contains the precision reference power supply and logic family selector switch. Operation is simple. Set the threshold switch to the proper logic family. Connect back clip lead to circuit ground. For CMOS circuitry, the red clip is connected to circuit positive or Vcc. The clip module is then clipped over the IC and the LED display instantly gives the logic states of all pins. **Logic Thresholds:** CMOS, 70% of circuit Vcc; HTL, 7.5 V; TTL, 2.4 V; DTL, 1.6 V; RTL, 1.2 V. **Maximum Viable Input Frequency:** 30 KHz at 50% duty cycle. **Size:** Test Clip, 4" l x 2" w x 1.75" d when open; Power Module, 6" w x 5.63" d x 3" h max. **Total Weight:** 20 ozs. **Power Required:** 117 VAC, 50-60 Hz, 10 W; also available for 220 VAC, 50, 60 Hz at slight higher price.
CSC Model LM-2 Logic Monitor - Complete \$129.95

Digital IC Testers and COUNTER



MAX 100 PORTABLE FREQUENCY COUNTER
MAX 100 is a portable, high precision frequency counter that sets new standards in performance and value. In a compact, portable case, it gives you continuous readings from 20 Hz to a guaranteed 100 MHz, with 8 digit accuracy. Fast readings with 1/6 sec. update and 1 sec. sampling rate. Precise readings, derived from a crystal-controlled time base with 3 ppm accuracy. High sensitivity readings from signals as low as 30 mV, with diode-overload protection up to 200 V peaks. Input signals over 100 MHz automatically flash the most significant digit, and to indicate low battery condition and extend battery life, the entire display flashes at 1 kHz.

SPECIFICATIONS
Frequency Range: 20 Hz to 100 MHz; guaranteed: 110 MHz typical. **Gate Time:** 1 sec. **Resolution:** 1 Hz. **Accuracy:** ± 1 count + time base error. **Input Impedance:** 1 megohm shunted by 56 pf. **Coupling:** AC. **Sine Wave Sensitivity:** 30 mV RMS at 50 MHz. **Internal Time Base Frequency:** 3.579545 MHz crystal oscillator. **Stability:** ± 3 ppm at 25° C. **Temperature Stability:** Better than 0.2 ppm/°C. **0.50° C. Max. Aging:** 10 ppm/year. **Display:** Eight 0.6" LED digits. **Lead Zero Blanking:** Decimal point appears between 6th and 7th digit when input exceeds 1 MHz. **Overflow:** With signals over 99,999,999 Hz, most significant left hand digit flashes, allowing readings in excess of 100 MHz. **Display Update:** 1/6 sec. plus 1 sec. gate time. **Low Battery Indicator:** When battery supply falls below 6.6 VDC, all digits flash at 1 Hz. **Power Required:** Internal, 6" AA cells; external, 110 or 220 VAC charger/eliminator, auto cigarette lighter adapter or 3.2 V VDC external supply. **Battery Charging:** 12-14 hrs. **Size:** 1.75" h x 5.63" w x 7.75" d. **Weight:** Less than 1.5 lbs., with batteries.
CSC Model MAX-100 Frequency Counter - Net Each \$134.95

MAX-100 ACCESSORIES

- Model 100-CLA - Mobile charger eliminator. Net Each \$ 3.95
- Model 100-CA1 - 110 VAC charger eliminator. Net Each 9.95
- Model 100-CA2 - 220 VAC charger eliminator. Net Each 9.95
- Model 100-IPC - Input cable with clip leads. Net Each 5.95
- Model 100-LLC - Low loss tap off 14.95
- Model 100-MWA - Mini whip antenna 3.95
- Model 100-CC - Carry case 9.95

DIP JUMPERS

FLAT RIBBON CABLE ASSEMBLIES WITH DIP CONNECTORS

- Available with 14, 16, 24 and 40 contacts.
- Mate with standard IC sockets.
- Fully assembled and tested.
- Integral molded-on strain relief.
- Line-by-line probeability.



MATERIALS
DIELECTRIC: UL recognized glass filled polyester.
CONTACTS: Non-corrosive copper alloy 770.
CABLE: All cable conductors are #29 AWG stranded 7/36 tin coated copper with vinyl insulation. All cable is grooved top and bottom for easy test down.

A P Dip Jumpers are the low-cost, high-quality solution for jumpering within a PC board; interconnecting between PC boards, backplanes and motherboards; interfacing Input/Output signals; and more.

All assemblies use rainbow cable. Standard lengths are 6, 12, 18, 24 and 36 inches.

ACE • All- for fast, solderless, circuit Evaluator plug-in circuit building and testing

Just plug in any components with leads to 032" dia. Interconnect with solid wire up to 20 ga. Assembled models too!

Model	No. Pins	IC Family	Bits	Price	Board Size (inches)	Power
200 (assm)	728	8195-51	2	2	4.9x16x5.9/16	\$18.95
204 (assm)	872	8195-51	8	2	4.9x16x5.9/16	28.95
201K (assm)	1032	1214-51	2	2	16 x 7	14.95
202 (assm)	1224	1014-51	8	2	4.9x16x7	34.95
218 (assm)	1760	1814-51	10	2	6.1x27x7.1/8	48.95
221 (assm)	2712	2714-51	28	4	6.9x18	59.95
236 (assm)	3648	3614-51	36	4	10.1x4x5.1/4	79.95

IC TEST CLIPS

- TC-14 3 in. \$4.50
- TC-16 3 in. \$4.75
- TC-16 flts 14 & 16 Pin Dips.

SALE PRIORITY ONE ELECTRONICS

16723S Roscoe Blvd. Sepulveda, CA 91343

Terms: VISA MC BAC check Money Order C O D U S Funds Only CA residents add 6% sales tax. Minimum order \$10.00. Orders less than \$75.00 include 10% shipping and handling, excess refunded. Just in case please include your phone no. Good thru 1978

DOUBLE-ENDED DIP JUMPERS

No. Contacts	Length 6"	Length 12"	Length 18"	Length 24"	Length 36"
14	924106 6 R \$2.41	924106 12 R \$2.61	924106 18 R \$2.82	924106 24 R \$3.02	924106 36 R \$3.23
16	924116 6 R \$2.05	924116 12 R \$2.25	924116 18 R \$2.45	924116 24 R \$2.65	924116 36 R \$2.85
24	924126 6 R \$4.15	924126 12 R \$4.50	924126 18 R \$4.85	924126 24 R \$5.20	924126 36 R \$5.50
40	924136 6 R \$6.93	924136 12 R \$7.52	924136 18 R \$8.11	924136 24 R \$8.70	924136 36 R \$9.88

SINGLE-ENDED DIP JUMPERS

No. Contacts	Length 6"
14	924102 36 R \$2.33
16	924112 36 R \$2.59
24	924122 36 R \$4.00
40	924132 36 R \$6.71

Send for our latest brochure

phone orders welcome (213) 893-8202

OEM and institutional inquiries invited

visit our new retail location

14116/416 16K Ram's 8 for \$98.00 for APPLE, TRS-80, EXPANDO-RAM

visit our new retail location

visit our new retail location

SSTV Meets SWTPC: Part 2

—micro-enhanced pictures

Clayton W. Abrams K6AEP
1758 Comstock Lane
San Jose CA 95124

In the first part of my article, I acquainted you with the hardware and the basic concepts. Now, let's discuss the software.

The software was the most complex part of the project, but the most fun. I think the most important point I should make is that the software is a replace-

ment for hardware logic. The use of software is more repeatable and reliable than hardware logic.

Another point is that the timings are very critical. If you try to execute this program on another 6800 system without a 1.7971-MHz clock crystal, changes will have to be made. I will identify the memory locations which will have to be altered. If the clock is much slower than the SWTPC, the program may

not work.

The programming was written with a top-down approach, with the extensive use of subroutine calls (JSR and BSR). The frequent use of up to 4 nested subroutines was used. This makes the program easier to write, debug, and change. Additionally, self-modifying code was used. If you plan to install this program on PROM, don't—unless you plan to execute it elsewhere in RAM mem-

ory. Self-modifying code means that as the program executes, it changes itself. This type of code is difficult to debug, but the end result is that a program can be written to run in less memory. All subroutines using self-modifying code restore themselves upon completion. So don't hit reset in the middle of an operation unless you are willing to reload the program.

Another concept used is to call certain routines frequently. This also makes sense and saves memory. A typical routine called frequently is DEL2 which is a program delay which is used to transmit pixels. A few large blocks of memory were left free for expansion. Fig. 1 shows how memory is organized. Locations below address 101 were left free because of the direct addressing capability of the 6800. This could be very useful in future enhancements.

I will discuss each of these routines on an individual basis, and explain how the algorithms work. But first, a few basic concepts should be discussed.

```
ENHANCE SSTU PROGRAM
1. TEST
2. RECEIVE
3. CONTRAST
4. BINARY
5. NEGATIVE
6. ZOOM
7. TRANSMIT
8. NOISE
9. PRINT
?

*****
THIS ROUTINE SELECTS THE SSTU
PROGRAM ENHANCEMENT OPTIONS
*****
```

Visit our new retail location!

CALL FREE 1 (800) 423-5633
CA., AK., HI., (213) 893-8202

Visit our new retail location! CALL FREE 1 (800) 423-5633

Visit our new retail location! Visit our new retail location!

+ 9.704

NLS

1c SALE

LM3A 3 dig 1% DC \$134.00
LM3.5A 3 1/2 dig .5% DC \$158.50
LM40A 4 dig .1% DC \$209.00
LM4A 4 dig .03% DC \$250.00

- Rechargeable batteries and charger included
- Measures DC Volts, AC Volts, Ohms and Current
- Automatic polarity, decimal and overload indication
- Rechargeable batteries and charger
- Measures DC Volts, AC Volts, Ohms and Current
- Automatic polarity, decimal and overload indication
- No zero adjustment and no full-scale ohms adjust
- Battery-operated — NiCad batteries; also AC line operation.
- Large LED display for easy reading without interpolation
- Size: 1 9/16" x 2 7/8" x 4" D
- Parts & labor guaranteed 1 year
- Tilt stand option \$3.50
- Leather case \$20.00

Purchase any of the LM series Meters and buy the LEATHER CASE for 1c

NLS

\$318.

MS-15 MINISCOPE With Rechargeable Batteries & Charger Unit

- 15 megahertz bandwidth
- External and internal trigger.
- Time base — .1 microsec. to 0.5 Sec/div. 21 settings ± 3%
- Battery or line operation
- Automatic & line sync modes
- Power consumption < 15 watts
- Vertical Gain — 01 to 50 Vidiv 12 settings ± 3%
- Weaving area 1 1/2" x 1 3/8"
- Cable Area 2 7/8" x 6 4/8" x 7 5/8" D 3 pounds
- Parts & Labor guaranteed 1 year
- 10 x 13 1/2 mag probe
- Leather carrying case

PROBE 1C
PROBE 1C with the purchase of SCOPE and the MENTION of this MAGAZINE

NLS

\$27.
\$45.

MS-215 Dual Trace Version of MS-15 \$435.

3 LEVEL GOLD WIRE WRAP SOCKETS

Sockets purchased in multiples of 50 per type may be combined for best price

	1-24	25-49	50-99	100-249	250-999	1K-5K
8 pin*	.41	.38	.35	.31	.27	.23
14 pin*	.39	.38	.36	.32	.29	.27
16 pin*	.43	.42	.39	.35	.32	.30
18 pin	.63	.58	.54	.47	.42	.36
20 pin	.80	.75	.70	.63	.58	.53
22 pin*	.90	.85	.80	.70	.61	.57
24 pin	.90	.84	.78	.68	.63	.58
28 pin	1.10	1.00	.90	.84	.76	.71
40 pin	1.50	1.40	1.30	1.20	1.04	.89

All sockets are GOLD 3 level closed entry. End and side stackable. 2 level Solder Tail Low Profile. Tin Sockets and Dip Plugs available. CALL FOR QUOTATION

SALE S-100 BUS EDGE CONNECTORS

\$100 WWG 50 100 Cont. 125 cts 3 LEVEL WIRE WRAP Q25 64 posts on 250 spaced rows. GOLD plated
1.4 \$9 10.24
84.00 \$3.75 \$3.50

\$100 STG 50 100 Cont. 125 cts DIP SOLDER TAIL on 250 spaced rows for VECTOR and MAIL motherboards. GOLD plated
1.4 \$9 10.24
84.00 \$3.75 \$3.50

R681 3 50 100 Cont. 125 cts PERCED SOLDER EYELET tails GOLD
17.35

R684 3 22 44 Cont. 156 cts PERCED SOLDER EYELET tails GOLD
14.71

Other Popular Edge Connectors

R644 G 22 44 Cont. 156 cts PERCED SOLDER EYELET tails GOLD plated
1.4 \$9 10.24
83.00 \$2.75 \$2.80

ATTN: OEM'S and Dealers, many other connectors available call or quotation

LIQUID CRYSTAL DIGITAL CLOCK-CALENDAR

- For Auto. Home, Office
- Small in size (2 1/2" x 1 1/2")
- Push button for seconds release for date
- Clocks mount anywhere with either 3M double sided tape or VELCRO, included
- 2 MODELS AVAILABLE
- LCD 101, portable model runs on self-contained batteries for better than a year
- LCD 102, runs on 12 Volt system and is back lighted
- LCD 101 or LCD 102 your choice

\$34.95..

Clear data stand for \$2.00

8803 MOTHER BOARD FOR \$100 BUS MICRO-COMPUTERS

- Includes 12 tantalum capacitors for S-100
- 12 buses and 191 lead mounting spaces
- Using Side Mount Components use bare epoxy glass with white markings for component locations
- One extra glass board with 2 ounce copper solder plated and 038 diam for fine line leads
- Solder mask with solder windows on etched circuits to avoid accidental short circuits
- Mounts 191 components with 100 contacts (2 rows on 125 centers with 250 row spacing)
- Vector part number: R681-2 or R681-10 (replaces 2 pin connectors to smaller mother board like expansion)
- Includes etched circuits and instructions for optional active bus lead or floating terminations
- Large buffers - 74 and GND (10 AMPS) ± 17v or 16V (10 AMPS). Current ratings are per MIL STD 275 with 10°C rise
- Fits in Vector pin enclosures
- Fits in MS-AI-8080 microcomputer as expansion board

Price: \$29.50

Vector Plugboards

8800V
Universal Microcomputer processor plugboard use with S-100 Bus. Complete with heat sink & hardware 5.3 x 10 x 1 1/2

1-4	5-9	10-24
\$19.95	\$17.95	\$15.95

Same as 8800V except plain less power buses & heat sink

1-4	5-9	10-24
\$11.95	\$13.46	\$11.95

3677 9.6" x 4.5"
\$10.90

3677-2.6.5" x 4.5"
\$9.74

3662 6.5" x 4.5"
\$7.65

3662-2 9.6" x 4.5"
\$11.45

Gen Purpose D.I.P Boards with Bus Pattern for Solder or Wire Wrap Epoxy Glass 1/16" 44 pin con spaced 156

3690-12 CARD EXTENDER
Card Extender has 100 contacts-50 per side on 125 centers-Attached connector is compatible with S-100 Bus Systems. \$25.00
3690 6.5" 22/44 pin-158 ctrs. Extenders \$12.00

2708 8K 450 ns EPROM FACTORY PRIME \$ 9.00 EA. 25 + Call For Price

14 & 16 PIN GOLD 3 LEVEL WIRE WRAP SOCKETS

14 - G3 100 for \$30.00
16-G3 100 for \$30.00
50 of each for \$32.00

Sockets are End & Side stackable. closed entry

1/16 Vector BOARD .042 dia holes on 0.1 spacing for IC's

Phenolic

PART NO	SIZE	1-9	10-19
64P44XXXP	4.5x6.5"	\$1.49	1.34
169P44XXXP	4.5x17"	\$3.51	3.16

Epoxy Glass

64P44	4.5x6.5"	\$1.70	1.53
84P44	4.5x6.5"	\$2.10	1.89
169P44	4.5x17"	\$4.30	3.87
169P84	8.5x17"	\$7.65	6.89

ELITE WIRE

Wraps insulated wire on Q25 square posts **FOUR TIMES FASTER**

P180
With two 100' spools of 28 ga wire
\$24.50

P180 AT
Includes charger, extra \$75.00

NO PRE STRIPPING! NO PRE CUTTING! SPOOLED WIRE

The spooled wire passes through the tool past a slitting edge next to the wrap post. A narrow longitudinal cut is made in the insulation where it precedes the square post (mark the barrel opening) - marked by the wrap edge (mark the 28 gauge contact).

SLIT-N-WRAP WIRE
NO. 28 GAUGE INSULATED WIRE, 100' SPOOLS
WR 2 28g 3 Core WR 3 28g 3 Core WR 2 28g 3 Core WR 3 28g 3 Core

P.C. BOARD HOLDER 315
PRICE: \$16.95

315-S same as 315 but with 14" bar to accommodate "S100" boards
PRICE: \$17.95

HORIZONTAL JAW VISE HEAD 304
PRICE: \$12.95

STANDARD VISE HEAD 303
PRICE: \$12.95

WIDE OPENING VISE HEAD 306
PRICE: \$12.95

PANAVISE TILTS, TURNS, AND ROTATES TO ANY POSITION. IT HOLDS YOUR WORK EXACTLY WHERE YOU WANT IT.

PANAVISE

LOW-PROFILE BASE PRICE: \$11.95

STANDARD BASE PRICE: \$11.95

VACUUM BASE PRICE: \$16.95

SPECIAL \$49.95

Perfectly balanced fluorescent lighting with precision magnifier lens. For profit technicians & hobbyist. Has die cast protective shade. Inst. start 3 diopler lens 42 inch.

with 18 fluorescent tubes (not included)

Colors: Gray or Black

2708 8K 450 ns EPROM FACTORY PRIME \$ 9.00 EA. 25 + Call For Price

14 & 16 PIN GOLD 3 LEVEL WIRE WRAP SOCKETS

14 - G3 100 for \$30.00
16-G3 100 for \$30.00
50 of each for \$32.00

Sockets are End & Side stackable. closed entry

Vector WRAP POST
for .042 dia holes (all boards on this page)
T-44 pkg 100 \$ 2.28
T-44 pkg 1000 \$14.00
A-13 hand installing tool \$ 2.80

Send for our latest brochure

PRIORITY ONE ELECTRONICS

16723S Roscoe Blvd Sepulveda, CA 91343

Terms: VISA MC BAC, check, Money Order C.O.D. U.S. Funds Only. CA residents add 6% sales tax. Minimum order \$10.00. Orders less than \$75.00 include 10% shipping and handling, excess refunded, just in case please include your phone no.

phone orders welcome (213) 893-8202

OEM and institutional inquiries invited

SC-5 With Rechargeable Batteries & Charger Unit \$98

Features include: • By using the new NLS SC-5 Prescaler the range of the FM 7 Frequency Meter which is 10 Hz to 60 MHz may be extended to 512 MHz (the upper VHF & UHF frequency bands). • The FM-7 utilizes an LED readout providing 7 digit resolution. • The FM-7 can be calibrated to an accuracy of 0.00001%. • The SC-5 is accurate to one part per million. • Each unit has 30 millivolts sensitivity, is battery powered and has a charger unit included. • Dimensions of each are 1 9/16" x 2 1/8" x 3 9/16" D. • The units may be obtained separately or as a Frequency Duo. • Parts & Labor guaranteed 1 year

MA1003 CAR CLOCK
Price Breakthrough! \$17.50
Bright Green Fluorescent Display Crystal Time Base Assembled, just add switches and 12 VDC

SPECIAL
14CS2 100 for \$14.99
16CS2 100 for \$16.99
14 pin CS2 10 for \$2.99
16 pin CS2 8 for \$2.99

These low cost DIP sockets will accept both standard width plugs and chips. For use with chips, the sockets offer a low profile height of only .125" above the board. These sockets are end stackable

24 PIN DIP PLUGS WITH COVERS
3 / \$1.00
40 / \$10.00

Visit our new retail location! 4116/416 16K Ram's 8 for \$98.00 for APPLE, TRS-80, EXPANDO-RAM

MEMORY LOCATIONS (HEX)	
0	
NOT USED	0101
TEST - ADC	0185
RECVPX - RECEIVE PICTURE	0226
PPRIN - PRINT PICTURE	02F4
TRANS - TRANSMIT PICTURE	044F
NEG - NEGATIVE PICTURE	0494
BIN - BINARY PICTURE	04F5
ZOOM - MAGNIFY X2	05F8
CONT - ADD CONTRAST	0732
NOISE - REMOVE NOISE	07EC
NOT USED	0F01 (START ADDRESS)
MONIT - MONITOR PROG	0FC1
PICTURE PIXELS (1000 - 2FFF)	

Fig. 1. SSTV program memory map.

Programming Concepts

The most important concept to understand is the programming format of the analog interface. Fig. 2 shows the bit structure of the PIA ports, and which bits are used to control various functions. As you can see from the format, the program will only function properly with the hardware connected to correct PIA bits as shown in Fig. 2. The other concept which must be understood is the format of the pixels in memory. These concepts are used throughout the subroutine descriptions and must be understood to code the program in another language.



Subroutine Descriptions

The following is a description of each major subroutine used. The routines will be referred to by their program label.

Test

This routine is by far the easiest to understand. This routine can be used by entering an analog input into the special analog card.

If you apply 0 volts and hit a number key on the computer keyboard, a zero should appear on the TV screen. Also, an SSTV frequency of 1500 Hz should be generated. If 4.9 volts is applied to the card, an F will appear on the TV screen, and a 2300 Hz frequency will be generated when a number key is pressed. If a nonnumeric key is pressed, the program will return to the monitor. The flowchart for this routine is shown in Fig. 3.

PPRIN

This routine prints an ASCII character picture of the pixels in computer memory. The program is written for the SWTPC PR-40 printer. This printer has only 40 columns. In order to print a complete SSTV picture, 120 columns were printed on three pages, and every other line (64). When these three pages are joined together, a complete picture was formed. A total of 7 characters was printed, which represent the 16 gray levels of a picture. I'm sure the character selection can be improved upon. The selection was subjectively chosen, with little experimentation. One point was clear: A character for each gray level was not the way to go. This technique produced poor picture quality. Fig. 4 shows a flowchart of PPRIN. Table 1 is a list of gray level vs. character and memory location. This table allows the user to experiment with the various ASCII codes.

TRANS

This routine is used throughout the program to transmit regular and enhanced SSTV pictures. The routine is easy to use. Once selected, a message appears on the screen which asks for a keyboard response of 0 to F, where 1 to F will be the number of

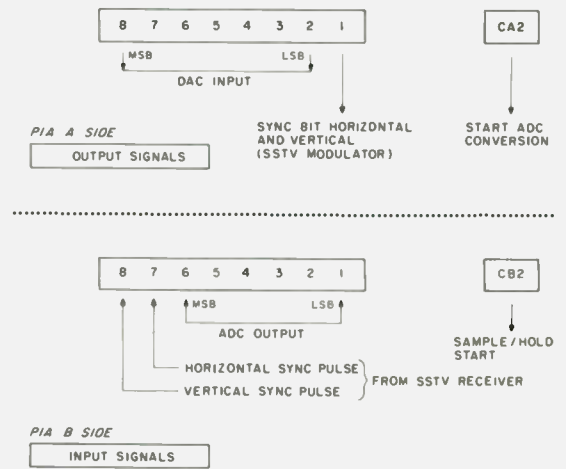

Fig. 2. SSTV enhancement program programming format.

pictures transmitted. If 0 is selected, the picture memory buffer will be filled with a gray-scale pattern of 16 gray levels. These gray levels will appear as vertical bars on the SSTV monitor. This allows the receiver to adjust his contrast and brightness. After memory is loaded, the next message asks for the number of loops for the transmission. The response should be 1 to F, where F is 15. This routine assumes the 60-Hz SSTV video will be transmitted. For those of you who wish to transmit 50-Hz video, the delay constant at location 01C9 should be changed from 20 hex to 10 hex.

This routine uses self-modifying code, and six NOP instructions were assembled into the program. These NOP are modified by other routines to enhance pixels and allow a minimum duplication of code. Fig. 5 shows a flowchart of the most important transmit routine. A total of 7 subroutines are used during the transmis-

sion of a picture.

RECVPX

This routine receives slow scan pictures pixels and places them into memory. The routine is simple to use. Once the option is selected, the first message which appears on the screen asks if you wish to

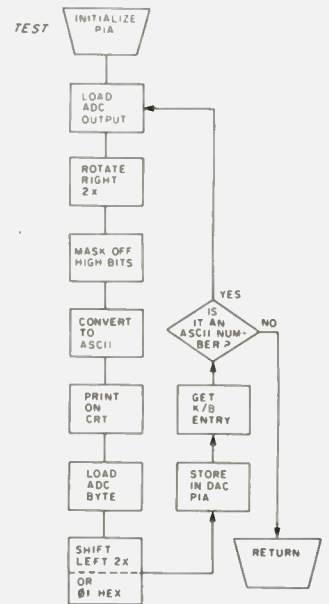

Fig. 3. TEST routine. Test analog card routine flowchart.

Memory Location	ASCII Code	Print Character	Gray Level
231,2	23 23	#	F,E
233,4	4F 4F	O	D,C
235,6	5C 5C	/	B,A
237,8	2A 2A	*	9,8
239,A	3D 3D	=	7,6
23B,C	3A 3A	:	5,4
23D,E	3A 20	: space	3,2
23F,240	20 20	space	1,0

Table 1. Gray level vs. ASCII character value.

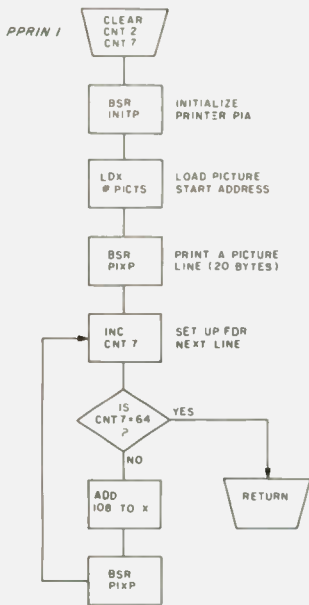

Fig. 4. PPRIN routine. Print a SSTV picture flowchart: CNT 2 = pixel counter and CNT 7 = line counter.

receive 50- or 60-Hz video. Your response should be 50 or 60. Upon the detection of a vertical sync pulse by the program, the 8K of memory will be loaded with 16k pixels in 8.3 seconds. One point should be noted: The program assumes that 128 lines will be received. If the picture received has less, the program will continue to receive video until memory is filled. Therefore, part of the top of the next picture will be in memory if the original picture has less than 128 lines.

Fig. 6 shows the main receive routine. This function is easily accomplished by modifying the code in TRANS to execute a 1's complement of each pixel before it is transmitted. The transmit routine is then executed and negative pictures are produced.

Upon completion of this routine, the code is restored to NOPs in TRANS. As a result, the picture in computer memory is not altered.

BIN

This routine produces binary pictures. Binary pictures are a reduction of the 16 gray levels pixels to 2. If the pixel in memory is 8 or higher, an F gray level is transmitted. If the level is 7 or lower, a 0 is transmitted. The routine like BIN modifies the code in TRANS to jump out of the routine, modify the pixel to 0 or F, and transmit it. The code is restored after execution to NOPs. If you wish to experiment with the gray level clip level, the code at locations 04D8,E7 can be changed from 80 to another value. Computer memory is not altered by the use of this routine.

In both BIN and NEG, the program asks for the number of picture loops between 1 and F. If you respond with a zero, the program will loop 255 times. To recover from this condition, hit reset and load a low ASCII number into CNT 10 (02F4). Then type G, and the program will return after the count you have just entered is decremented to zero.

ZOOM

Zoom was one of the most interesting routines to code. This routine allows selection of 5 locations of the picture which will be magnified by a factor of 2. The locations are selected by answering a TV message with the computer keyboard by selecting 0 to 4. This zoom capability allows magnification of any portion of the SSTV picture without the use of complex hardware which is used in commercial systems. The zoom locations on the picture are selected in the program by loading the index

register with the upper left hand corner pixel address and branching to the TRZ routine (056D). The following demonstrates how it works:

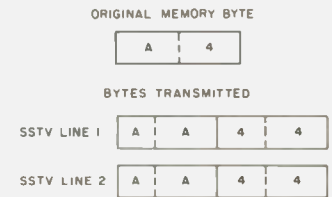

As you can see, all that is required is to transmit each pixel twice and then transmit the same pixel line in memory again. The resultant picture shows contouring, but this can be expected.

The memory locations, picture locations, and hexadecimal values are listed in Table 2. By simple program changes, you can experiment on where you would like to zoom in on the picture. This routine calls six other routines, and Fig. 7 shows the TRZ routine which is the main routine. Computer memory is not altered as a result of execution of this routine.

CONT

CONT is a routine which adds contrast to the SSTV picture. The routine functions best when the picture is very dark and contains few white areas. The routine makes the picture lighter, and if a high-contrast enhancement is selected, a binary effect will be achieved.

When the routine is selected, the first selection will be the number of transmit loops after enhancement. After this selection, the number of times of enhancement is selected (2 to F). Fig. 8 illustrates the computer algorithm used. The routine first finds the darkest pixel value in a routine called FIND. This routine scans 10 lines in the center of the picture for the darkest pixel value. The

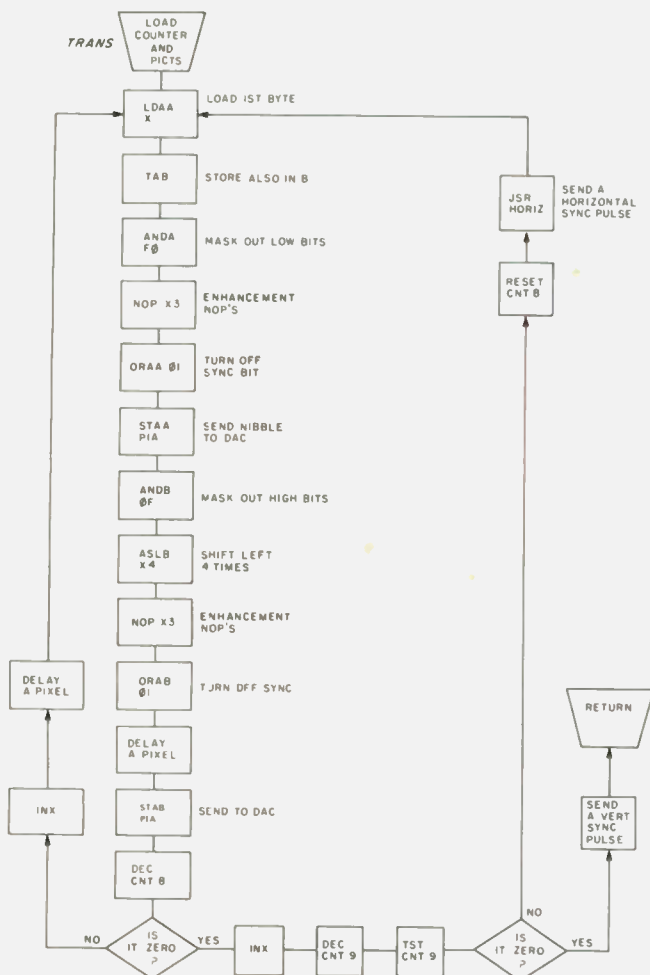

Fig. 5. TRANS routine. Transmit a SSTV picture flowchart: CNT 8 = pixel count (64) and CNT 9 = line count (128).

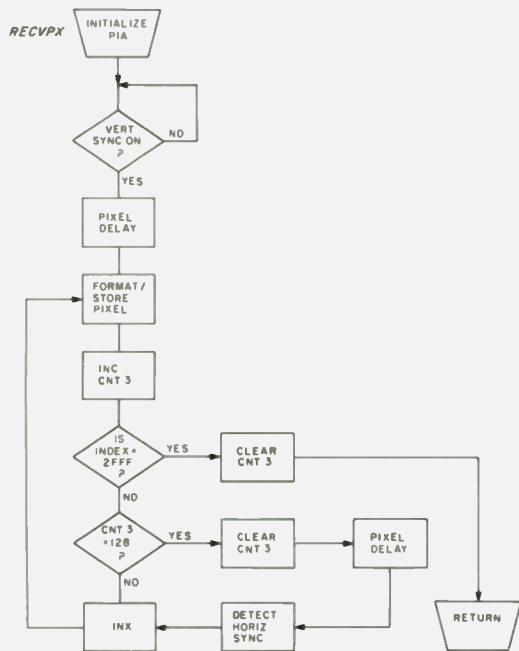

Fig. 6. RECVPX routine. Receive an SSTV picture flowchart: CNT 3 = pixel count.

dark routine then subtracts this value from almost all of the 16k pixels in memory along with multiplying the results by the enhancement number selected. This new value is compared to see if it is greater than F. If so, an F is placed in memory. If it is less than F, the results are placed in memory.

The bottom 8 lines of the picture are not enhanced,

and since many pictures are generated by scan converters, this area was left alone. Fig. 9 is a flowchart of the dark routine which shows how some of the calculations are made.

NOISE

This routine removes random noise from the SSTV picture received. This is accomplished by an averaging technique. Pix-



Fig. 8. Enhancement selection.

els, as received by the microprocessor, are averaged together with those in memory. By use of this technique, random noise can be reduced by the square root of number of pictures received. When executed, this routine asks first for the number of noise pictures to be received. A value of 1 to F can be selected. The program will then ask for a selection of 50- or 60-Hz video. The response to the query should be 50 or 60.

This routine also calls 4 other routines and the main line routine is contained in Fig. 10. This routine is similar to RECVPX in operation, except for the averaging routines. Since more computer overhead is used, different delay constants were selected.

MONIT

This routine is used to select the program options. Upon completion of each routine, the program jumps back into MONIT. The pro-

gram should be started at the beginning of this routine (0F01). This is accomplished by loading A048,9 with 0F01 and typing G. When this is done, a menu will appear on the TV screen. The routine calls INIT (01B6) initializes

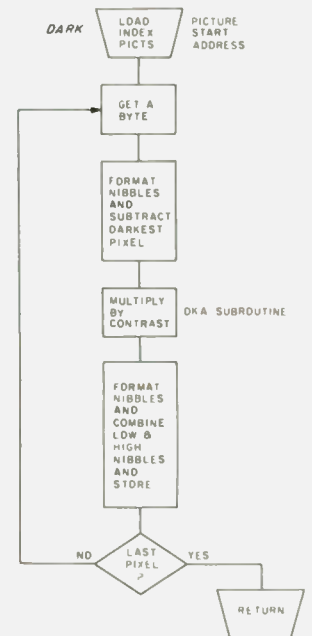

Fig. 9. DARK Routine. Calculate a new pixel contrast level flowchart.

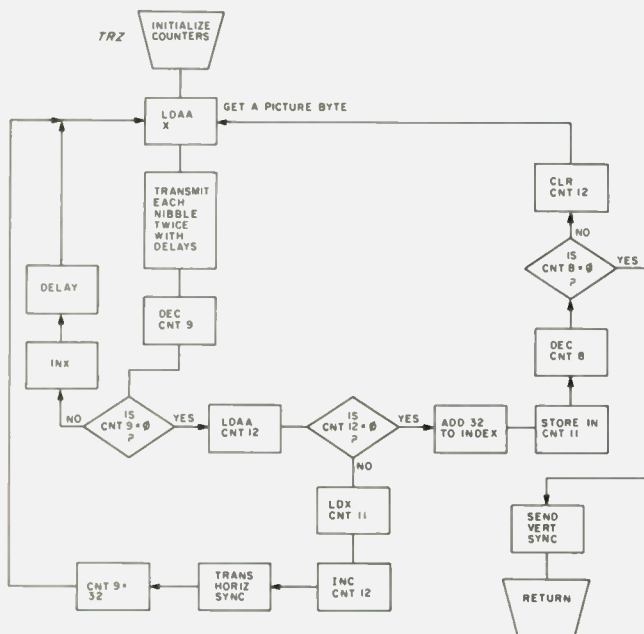

Fig. 7. ZOOM Routine. Transmit a SSTV picture with a 2 X magnification flowchart: CNT 8 = 64 lines/picture, CNT 9 = 32 bytes/picture line, CNT 12 = line count storage, and CNT 11 = index register storage.

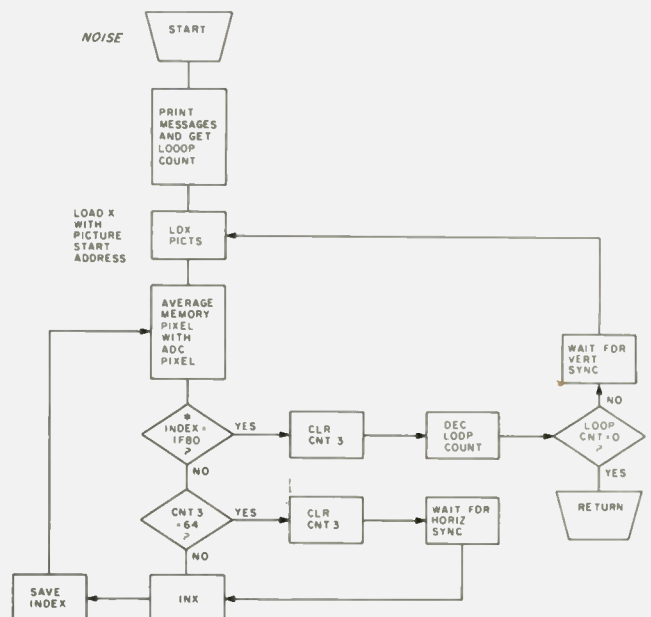

Fig. 10. NOISE Routine. Receive successive SSTV pictures and average flowchart CNT 3 = pixel counter. *Value was fine-tuned due to program overhead.

SSTV Enhancement Program Object code.

```
0100 00 BD 01 B6 8D 22 46 46 84 0F 8D 41 8D 4B B6 01
0110 27 48 48 84 F0 8A 01 B7 80 10 BD E1 AC 84 F0 81
0120 30 27 E1 7E 0F 01 04 00 FF 01 F1 CE 80 10 86 3F
0130 A7 03 86 37 A7 03 86 38 A7 01 86 30 A7 01 B6 01
0140 26 BD 01 CD A6 02 B7 01 27 FE 01 F1 39 84 0F 8B
0150 30 81 39 23 02 8B 07 39 00 B7 01 58 CE 01 6C BD
0160 E0 7E B6 01 58 BD E1 D1 B6 01 58 39 10 16 53 41
0170 4D 50 4C 45 20 41 4E 41 4C 4F 47 20 53 49 47 4E
0180 41 4C 0A 0D 04 00 7F 01 85 BD 06 F7 BD 02 15 CE
0190 10 00 86 08 8D 37 8D 3D 7C 01 85 8C 2F FF 27 0A
01A0 F6 01 85 C1 40 27 06 08 20 EC 7E 0F 01 7F 01 85
01B0 8D 18 8D 3F 20 F1 CE 80 10 86 FF A7 00 86 30 A7
01C0 01 4F A7 02 86 37 A7 03 39 20 B6 01 C9 4D 27 03
01D0 4A 20 FA 39 00 BD 01 28 49 49 84 F0 B7 01 D4 86
01E0 29 8D EA BD 01 28 46 46 84 0F F6 01 D4 1B A7 00
01F0 39 00 00 FF 01 F1 CE 80 10 A6 02 84 40 27 0A C6
```

```
0200 0F 5D 27 0D 5A 8D C3 20 F8 A6 02 84 40 27 FA 8D
0210 B9 FE 01 F1 39 36 B6 80 12 84 80 27 F9 B6 80 12
0220 84 80 26 F9 32 39 00 00 8D 17 8D 39 8D 49 7E 0F
0230 01 23 23 4F 4F 5C 5C 2A 2A 3D 3D 3A 3A 3A 20 20
0240 20 7F 02 26 7F 02 27 8D 79 CE 10 00 8D 3B 7C 02
0250 27 B6 02 27 81 40 27 0C 86 6C B7 02 E3 BD 02 E4
0260 8D 27 20 EA 39 7F 02 26 7F 02 27 8D 60 8D 5E 8D
0270 5C CE 10 15 8D D6 39 7F 02 26 7F 02 27 8D 4E 8D
0280 4C 8D 4A CE 10 29 8D C4 39 A6 00 08 7C 02 26 8D
0290 0F B6 02 26 81 14 27 02 20 EF 7F 02 26 39 00 00
02A0 FF 02 9E 16 44 44 44 44 44 87 02 AF CE 02 31 A6 00
02B0 C4 0F F7 02 B6 E6 00 37 8D 15 33 17 8D 11 FE 02
02C0 9E 39 CE 80 18 C6 FF E7 00 C6 3F E7 01 86 0D CE
02D0 80 18 A7 00 C6 37 E7 01 C6 3F E7 01 6D 01 2A FC
02E0 E6 00 39 00 4F F6 02 E3 F7 02 EE 08 4C 81 00 27
02F0 02 20 F8 39 00 CE 03 25 BD E0 7E BD E1 AC 81 30
```

```
0300 27 12 BD 04 3F B7 02 F4 8D 6E 7A 02 F4 7D 02 F4
0310 27 10 20 F4 BD 03 FC CE 03 5D BD E0 7E BD E1 AC
0320 20 E0 7E 0F 01 10 16 4C 4F 4F 50 20 50 49 43 54
0330 2E 20 4F 52 20 4F 52 41 59 20 53 43 41 4C 45 0A
0340 0D 30 3D 47 2E 53 2E 2C 4C 4F 4F 50 20 50 49 43
0350 54 28 31 20 54 4F 20 46 29 0A 0D 3F 04 10 16 45
0360 4E 54 45 52 20 4C 4F 4F 50 53 28 31 20 54 4F 20
0370 46 29 0A 0D 3F 04 00 00 8D 40 CE 10 00 A6 00 16
0380 84 F0 01 01 01 8A 01 B7 80 10 C4 0F 58 58 58 58
0390 01 01 01 CA 01 BD 04 33 F7 80 10 7A 03 76 7D 03
03A0 76 26 12 08 7A 03 77 7D 03 77 26 03 8D 33 39 8D
03B0 0E 8D 13 20 C8 08 8D 7B 20 C3 86 80 B7 03 77 86
03C0 40 B7 03 76 39 5D 4F B7 80 10 86 04 F6 03 C5 5A
03D0 5D 27 02 20 FA 4A 4D 27 02 20 F1 86 01 B7 80 10
03E0 39 4F B7 80 10 86 1E F6 03 C5 5A 5D 27 02 20 FA
03F0 4A 4D 27 02 20 F1 86 01 B7 80 10 39 CE 10 00 7F
```

```
0400 03 76 7F 03 77 86 FF 8D 20 80 11 7C 03 76 F6 03
0410 76 C1 10 27 02 20 F0 7C 03 77 F6 03 77 C1 80 27
0420 05 7F 03 76 20 DF 7E 03 17 C6 04 A7 00 08 5A 5D
0430 26 F9 39 36 B6 01 C9 4D 27 03 4A 20 FA 32 39 37
0440 16 C4 F0 C1 40 27 04 84 0F 20 02 80 37 33 39 86
0450 43 B7 03 82 CE 84 F0 FF 03 83 86 53 B7 03 90 CE
0460 C4 F0 FF 03 91 CE 03 5D BD E0 7E BD E1 AC 8D CF
0470 B7 02 F4 BD 03 78 7A 02 F4 27 02 20 F6 86 01 B7
0480 03 82 B7 03 83 B7 03 84 B7 03 90 B7 03 91 B7 03
0490 92 7E 0F 01 86 7E B7 03 82 B7 03 90 CE 04 D7 FF
04A0 03 83 CE 04 E6 FF 03 91 CE 03 5D BD E0 7E BD E1
04B0 AC 8D 8C B7 02 F4 BD 03 78 7A 02 F4 27 02 20 F6
04C0 86 01 B7 03 82 B7 03 83 B7 03 84 B7 03 90 B7 03
```

```
04D0 91 B7 03 92 7E 0F 01 81 80 23 02 20 04 4F 7E 03
04E0 85 86 F0 7E 03 85 C1 80 23 02 20 04 5F 7E 03 93
04F0 C6 F0 7E 03 93 00 00 CE 03 5D BD E0 7E BD E1 AC
0500 BD 04 3F B7 02 F4 CE 05 4E BD E0 7E BD E1 AC 81
0510 30 27 12 81 31 27 13 81 32 27 14 81 33 27 15 81
0520 34 27 16 20 E1 CE 10 00 20 12 CE 10 20 20 0D CE
0530 18 10 20 08 CE 20 00 20 03 CE 20 1F FF 04 F5 8D
0540 2C 7A 02 F4 27 05 FE 04 F5 20 F4 7E 0F 01 10 16
0550 53 45 4C 45 43 54 20 5A 4F 4F 4D 20 41 52 45 41
0560 20 28 30 2D 34 29 0A 0D 3F 04 00 00 00 8D 50 FF
0570 05 6A A6 00 B7 06 58 8D 54 BD 04 33 8D 4F BD 04
0580 33 8D 55 BD 04 33 8D 50 7A 03 77 27 06 08 BD 04
0590 33 20 DF B6 05 6C 81 01 27 0D FE 05 6A 7C 05 6C
05A0 BD 03 C6 8D 22 20 CB 8D 3E FF 05 6A 7A 03 76 27
05B0 0A 8D 14 BD 03 C6 7F 05 6C 20 B7 8D 03 E1 39 7F
05C0 05 6C 86 40 B7 03 76 86 20 B7 03 77 39 86 06 5B
05D0 84 F0 8A 01 B7 80 10 39 F6 06 5B C4 0F 58 58 58
05E0 58 CA 01 F7 80 10 39 37 C6 21 08 5A 26 FC 33 39
05F0 CE 06 29 BD E0 7E BD E1 AC 81 30 27 F3 81 31 27
```

```
0600 EF BD 04 3F 4A B7 06 5A CE 03 5D BD E0 7E BD E1
0610 AC BD 04 3F B7 02 F4 BD CE A3 8D 40 BD 03 78 7A
0620 02 F4 27 02 20 F6 7E 0F 01 10 16 45 4E 54 45 52
0630 20 43 4F 4E 54 52 41 53 54 20 49 4D 50 52 4F 56
0640 45 4D 45 4E 54 0A 0D 58 20 54 49 4D 45 53 28 32
0650 20 54 4F 20 46 29 0A 0D 3F 04 00 00 CE 10 00 A6
0660 00 16 C4 0F 44 44 44 44 44 80 06 A1 F0 06 A1 F7 06
0670 A2 8D 1C B7 06 5B B6 06 A2 8D 14 16 B6 06 5B 48
0680 48 48 48 1B A7 00 08 8C 2C FF 27 02 20 D1 39 F6
0690 06 5A B7 06 96 8B 00 5A 26 F8 81 0F 23 02 86 0F
06A0 39 00 00 7F 06 A2 7F 0F 32 F7 0F 33 86 0F B7 06
06B0 A1 CE 18 10 A6 00 16 C4 0F F7 06 A2 44 44 44 44
06C0 F6 06 A1 11 22 03 B7 06 A1 B6 06 A2 11 22 03 B7
06D0 06 A1 08 7C 07 32 B6 07 32 81 20 27 02 20 D5 7F
06E0 07 32 7C 07 33 B6 07 33 81 0A 27 0A 86 20 B7 02
06F0 E3 BD 02 E4 20 BE 39 CE 07 20 BD E0 7E BD E1 AC
```

```
0700 81 35 27 06 81 36 27 0D 20 ED 86 20 B7 01 E0 86
0710 13 B7 07 E6 39 86 29 B7 01 E0 86 18 B7 07 E6 39
0720 10 16 35 30 20 4F 52 20 36 30 20 48 5A 20 3F 20
0730 04 00 00 00 7F 01 85 CE 07 98 BD E0 7E BD E1 AC
0740 81 30 27 F0 BD 04 3F B7 02 F4 8D AB CE 10 00 BD
0750 02 15 FF 07 32 BD 01 28 FE 07 32 A6 00 8D 5E BD
0760 07 E4 BD 01 28 FE 07 32 A6 00 8D 62 8D 76 7C 01
0770 85 8C 2F 80 27 12 B6 01 85 81 40 27 03 08 20 D2
0780 7F 01 85 BD 01 F3 20 F5 7F 01 85 7A 02 F4 7D 02
0790 F4 27 02 20 B7 7E 0F 01 10 16 45 4E 54 45 52 20
07A0 4E 55 4D 42 45 52 20 4F 46 20 4E 4F 49 53 45 20
07B0 50 49 43 54 55 52 45 53 0A 0D 3F 04 00 F6 01 27
07C0 54 54 C4 0F 44 44 44 44 1B 44 07 07 BC 39 F6 01
07D0 27 54 54 C4 0F 84 0F 1B 44 F6 07 BC 48 48 48 48
07E0 1B A7 00 39 37 C6 0F 5A 5D 26 FC 33 39 00 00 00
```

```
0F00 00 BD 01 B6 CE 0F 45 BD E0 7E BD E1 AC B7 0F 00
0F10 84 F0 81 30 26 EB B6 0F 00 84 0F 4D 27 E3 CE 0F
0F20 27 08 08 08 4A 4D 26 F9 6E 00 7E 01 01 7E 01 86
0F30 7E 05 F0 7E 04 94 7E 04 4F 7E 04 F7 7E 02 F5 7E
0F40 07 34 7E 02 28 10 16 45 4E 48 41 4E 43 45 20 53
0F50 53 54 56 20 50 52 4F 47 52 41 4D 0A 0D 31 2E 20
0F60 54 45 53 54 0A 0D 32 2E 20 52 45 43 45 49 56 45
0F70 0A 0D 33 2E 20 43 4F 4E 54 52 41 53 54 0A 0D 34
0F80 2E 20 42 49 4E 41 52 59 0A 0D 35 2E 20 4E 45 47
0F90 41 54 49 56 45 0A 0D 36 2E 20 5A 4F 4F 4D 0A 0D
0FA0 37 2E 20 54 52 41 4E 53 4D 49 54 0A 0D 38 2E 20
0FB0 4E 4F 49 53 45 0A 0D 39 2E 20 50 52 49 4E 54 0A
0FC0 0D 3F 04 00 00 00 00 00 00 00 00 00 00 00 00 00
```

the PIA. The PIA must be initialized for the analog card to function properly.

Program Delay Constants

As discussed earlier, if a different CPU clock speed

is used, different program delay constants should be used. These constants are as shown in Table 3.

These program constants are exactly like hardware timers and single-

shots. I selected them by trial and error. I loaded a number into them and then viewed an SSTV picture. The number was then finetuned for the best picture quality.

MIKBUG Considerations

The program assumes that MIKBUG will be used. The following MIKBUG routines were used throughout the program:

E07E—Output an ASCII character string

E1D1—Output one ASCII character

E1AC—Input one ASCII character

The program also assumes the special Analog Card is

Keyboard Entry	Memory Location	Value (hex)	Location
0	0526,7	1000	upper l/h corner
1	052B,C	1020	upper r/h corner
2	0530,1	1810	center
3	0535,6	2000	lower l/h corner
4	053A,B	201F	lower r/h corner

Table 2. Memory locations vs. picture locations.

plugged into the Mother Board at address 8010 in the SWTPC MP-68. The program address assigned to the printer is 8018 (locations 02C3, 4 and 02D0, 1). A fully-commented source listing of my program is so large that I could not expect it to be published. If you wish a copy, send me \$8.00 to cover the reproduction and mailing costs. If you are outside the USA, please include more

postage for airmail. Also, if you decide to write, please include a SASE.

Acknowledgements

I would like to thank Mike Talent W6MXV for his help in interfacing the MXV-100 SSTV monitor and for his technical review of my project. Additionally, I would like to thank M. S. Schlosser, Vice President of Spatial Data Systems for providing a

copy of his *Handbook of Image Processing*, and allowing me to refer to it. ■

Program Label	Program Location	Current Value	Program Use
MSEC1	0126	04	ADC conversion
MSEC2	01C9	20,10 (50 Hz)	Transmit delay
PUL1	03C5	5D	Horiz pulse width
—	03E6	1E	Vert pulse width
—	0200	0F	Missing horiz pulse width delay time
—	01E0,070B	29,20 (50 Hz)	RECVPX delay
—	0716		
—	0710,071B	18,13 (50 Hz)	NOISE delay
—	07E6		

Table 3. Program delay constants.

New Products

from page 147

ample).

Another feature is an analog output to directly indicate code speed in wpm on a 1 mA movement meter.

For additional information, write: *Curtis Electro Devices, Inc., Box 4090, Mountain View CA 94040*, or call (415)-964-3136. Reader Service number C90.

HEUER INTRODUCES WORLD'S SMALLEST DIGITAL MULTIMETER

Heuer has announced the availability of a microminaturized digital multimeter, the DMM 2000, for industrial field service measurement applications. Introduced earlier this year at the Newcom '78 show in Las Vegas, the new instrument is the smallest, thinnest, most compact digital multimeter available anywhere. It weighs less than 3 ounces (or 80 grams), including probe and batteries, and measures 100 x

40 x 14 mm (4" x 1.87" x 0.55") for the base unit, and 100 x 20 x 12 mm (4" x 0.78" x 0.47") for the standard probe.

The LCD display assures a high degree of legibility for on-the-job service for computer systems, business machines, telephone exchanges, data transmission systems, radios, and TVs. The instrument provides four measuring ranges for every mode: dc up to 1000 volts and ac up to 700 volts, ac and dc current up to 2 A, and resistance up to 20 megohms, with a typical accuracy of 0.5% on the dc range.

Heuer was capable of developing such a small multimeter because the company combined the microminaturization used in its watch manufacture with advanced multi-layer ceramic substrate techniques.

Two major technical features of the Heuer multimeter are its true rms (root mean square) measurement of the ac range

and complete shielding against rf and other types of interference, which assures accuracy and error-free reading even in radio and TV applications. Another technical feature is the special design of the probe and hook for easy accessibility while testing high-density circuit boards. A choice of accessories, including special probes for high voltage, high current, and temperature measurement, is also available.

The exclusive permanent identification of the measuring mode on the LCD display and the remote control of measuring mode and range on the probe simplify operation of the multimeter, and assure error-free readout of the results. Up to 100-hour battery life is provided for the DMM 2000 by four small watch batteries of 1.5 V each. An additional advantage of the unit for field service application is its high electronics reliability and sturdy mechanical construction. The unit is delivered in a handsome carrying case which includes measuring cable, spare probe point, batteries, and fuses.

The DMM 2000, however, is

not designed for professional use alone. With this unit, the electronics enthusiast has at his disposal a measuring and servicing instrument which suits his requirements, considering its ease of operation and sturdy construction.

The DMM 2000 marks the entrance of Heuer into the field of microelectronic instrumentation. Heuer is a 100-year-old Swiss pioneer in high-precision chronographs, stopwatches, and electronic timing devices.

For additional information, contact: *Hans J. Kueffer, Heuer Time & Electronics, 960 South Springfield Avenue, Springfield NJ 07081*. Reader Service number H30.

SD-1 TWO-TONE SEQUENTIAL DECODER

A new product announced by Communications Specialists is the SD-1 Two-Tone Sequential Decoder. This product is micro-miniature in size, measuring just 1.2" x 1.67" x .65" high, and will fit all mobile units and most portables.

It uses plug-in field-replace-

Continued on page 204

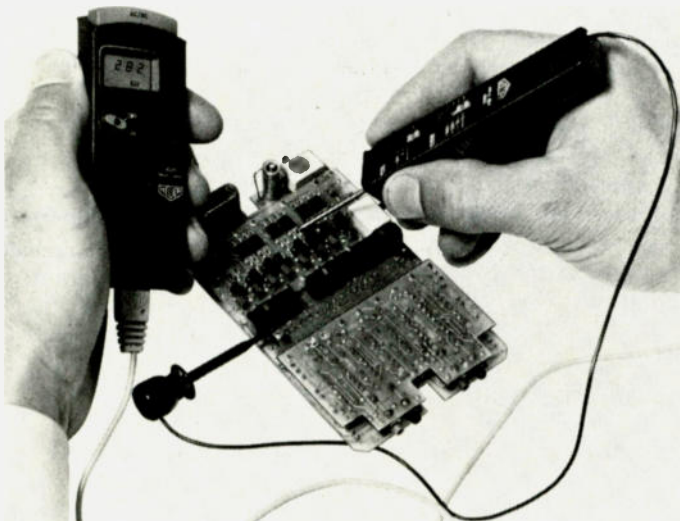

The DMM 2000 multimeter from Heuer.

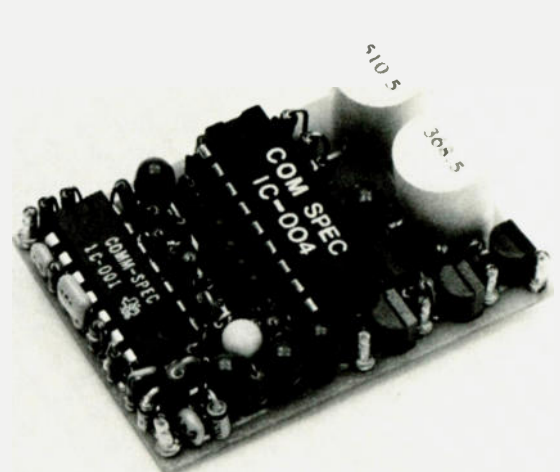

The SD-1 Two-Tone Sequential Decoder from Communications Specialists.

Bearcat® 250 Features:

- **50 Channels/5 banks**—Program 50 frequencies from infinite frequency combinations. Designate certain banks for specific types of activity; for example, use bank 1-10 for Police, 11-20 for Secret Service, 21-30 for Drug Enforcement Agencies, etc.
- **5-Band Coverage**—Includes Low and High VHF bands, UHF and 2 meter plus ¼ meter amateur bands. With special programming techniques, this unit can monitor additional frequencies not published in factory specifications.
- **Self-Destruct**—In case your scanner falls into enemy hands, you can electronically erase up to 64 frequencies in storage memory with only two key strokes.
- **Search/Store**—"Hands-off" automatic search operation that locates and remembers active frequencies.
- **Search/Recall**—Used in conjunction with search, displays frequencies found in search/store sequence.
- **Communications Electronics™**—quality control approval rating #1. Our highest quality grade for technologically sophisticated equipment.
- **Crystalless**—Without ever buying a crystal, you can select from all local frequencies by simply pushing a few buttons.
- **Priority**—Samples programmed priority frequency on channel 1 every 2 seconds regardless of other scanner operations—important for professionals who must monitor a certain frequency.
- **Time**—Brilliant digital LED clock—will display hours, minutes and seconds. Extremely accurate!
- **Count**—Frequency traffic analysis may be easily recorded to keep track of potentially hostile forces. Automatically counts numbers of transmissions on each channel to determine the most active frequencies.
- **Non-Volatile Memory**—No batteries required to retain memory even when scanner is unplugged. MNOS integrated circuit utilized for memory.
- **Scrambler/Tape Audio Output**—Top secret cryptographic messages may be received and decoded by connecting the Bearcat 250's audio output jack to a correctly keyed decoding device even if it utilizes the National Bureau of Standards Data Encryption Standard.
- **Small Size**—The Bearcat 250's small physical size lends itself to a wide variety of applications. When used with a battery power supply and a tape recorder the Bearcat 250 may be easily concealed in an attaché case for unattended, unobtrusive surveillance.
- **Auxiliary**—On/Off control of auxiliary equipment (tape deck, alarm, light motor) when transmissions occur on programmed channels. Now, law enforcement agents can activate a tape recorder by remote control when a "body mike" transmission is received.
- **Speed**—Choice of either 15 or 5 channels per second scan speed for closer monitoring of desired frequencies.
- **Limit**—Sets the upper and lower frequencies of the user controlled search range.
- **Birdie-Lockout**—Avoid annoying scanner lockup during search mode. Scanner will skip over any programmed birdies!
- **Search Direction**—Determines in which direction search goes for faster return to desired frequencies.
- **Direct Channel Access**—Move directly to desired channel without stepping through all channels.
- **Automatic Squelch**—Factory-set squelch automatically blocks out unwanted noise.
- **Decimal Display**—Shows frequency and channel number as well as programmed function.
- **Deluxe Keyboard**—Makes frequency and feature selection easy for simple programming.
- **Patented Track Tuning**—Receive frequencies across the full band without adjustment. Circuitry is automatically aligned to each frequency monitored.
- **Selective Scan Delay**—Adds a two-second delay to prevent missing transmissions when "calls" and "answers" are on the same frequency.
- **Extended Frequency Coverage**—With special programming techniques, the Bearcat 250 can monitor 125-146 MHz and 399-420 MHz in addition to the normal frequencies without special modifications.
- **Simple Programming**—Simply punch in on the keyboard the frequency you wish to monitor.
- **Space Age Circuitry**—Custom integrated circuits a Bearcat tradition in scanning radios.
- **Rolling Zeros**—This Bearcat exclusive tells you which channels your scanner is monitoring.
- **UL Listed/FCC Certified**—In addition to the #1 rating from Communications Electronics™, the UL and FCC certification assures you of quality design and manufacture.

The new Communications Electronics Bearcat® 250 is an incredible scanning radio offering the scanning professional and the knowledgeable scanning enthusiast more monitoring capabilities, more frequency versatility, than any other scanning monitor available today.

It uses patented Bearcat integrated circuitry, so there's never a crystal to buy. With pushbutton ease, up to 50 channels can be programmed in five banks of ten channels each. The keyboard is easy to comprehend, simple to use. All functions are instantly displayed in bright LED numbers and letters.

All programmed frequencies and pertinent scan instructions are memorized in an electronic memory that operates even when the unit is unplugged from wall power—there is no need for batteries.

Not only will the Bearcat 250 capture more scanning action, it will "remember" where and how often it heard that action. Now it's easy to identify which frequency is used most often. It will search automatically through a selected frequency range and memorize in its search memory up to 64 active frequencies. To determine what frequencies were found during the search store mode, simply push the recall button and they will be displayed one at a time. Press the enter key and any of these frequencies is entered automatically into the scan memory.

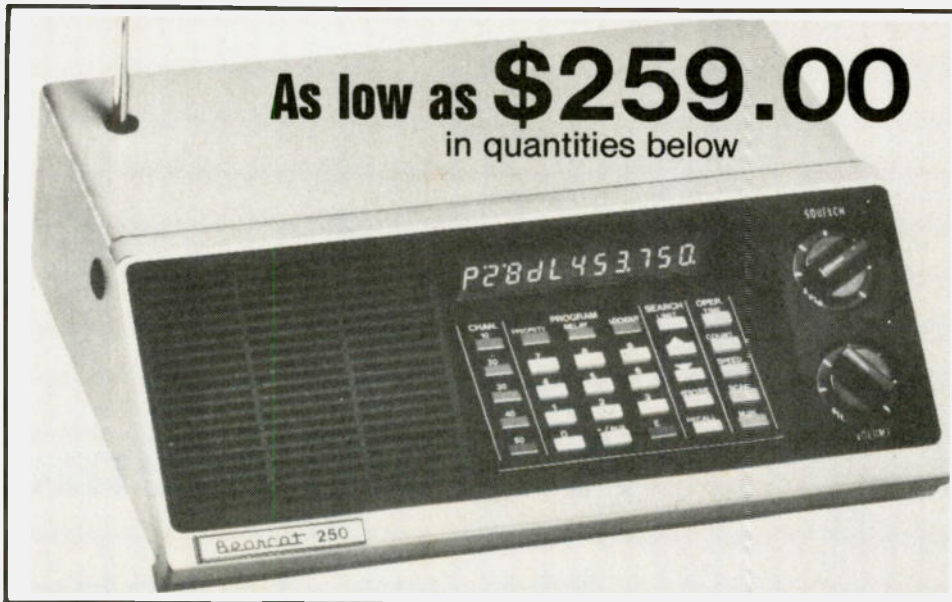

Bearcat® 250 Specifications

Frequency Reception Range

Low Band	32-50 MHz
VHF Band	146-174 MHz
UHF Band	420-512 MHz

Extended frequency range

With special programming techniques the Bearcat 250 will also cover the following frequencies with a reduction in sensitivity.

VHF Band	125-146 MHz
UHF Band	399-420 MHz

Scanner Dimensions

27.0 cm Wide x 7.6 cm High x 19.4 cm Deep
(10 5/8" Wide x 3" High x 7 1/2" Deep)

Scanner Weight

2.27 Kilograms (5 pounds)

Shipping Weight

3.14 Kilograms (7 pounds)

Power Requirements

(Note: 220 Volt AC Export model may be available April, 1979)
110-130 V ac 60 Hz 15 Watts
12-15 V dc 8 Watts

Audio Output

At least 2.0 Watts rms

Antenna

Telescoping (supplied)

Scan Rate

15 or 5 channels per second

Sensitivity

0.4 microvolts for 12dB SINAD on VHF bands. UHF band slightly less.

Selectivity

Better than
-60dB ± 25 KHz

Audio Quality

The BC-250's audio is more noise-free and suffers less distortion than the Bearcat 210 by a margin of 10 dB or more.

Image Rejection

The Bearcat 250 rejects image frequencies by at least 8 dB better in all bands than the Bearcat 210.

Connectors

External antenna and speaker, AC & DC Power, Auxiliary control output, tape audio output.

Accessories

Vehicle mounting bracket and hardware, AC & DC power cords.

The Communications Electronics™

Bearcat 250 even has an automatic count function that remembers how often any or all programmed frequencies were activated by transmissions while scanning. This will help you determine the value of your frequency selections. The Bearcat 250 will literally search and seize active frequencies.

An important feature for professionals who must monitor a specific frequency is the priority channel, Channel 1. If desired whatever frequency is programmed for this channel will be sampled every two seconds anytime the set is turned on.

COMMUNICATIONS ELECTRONICS™ ✓ C5

Box 1002, Ann Arbor, Michigan 48106 U.S.A.

THE INCREDIBLE, NEW BEARCAT 250 SCANNER.

LEADING THE WAY TO REAL EXCITEMENT

The Bearcat 250 has an auxiliary output feature which can be programmed to actuate external devices such as a light, alarm, motor, etc.

ONE-YEAR LIMITED WARRANTY

With your Bearcat 250, we will send all accessories, a complete set of simple operating instructions and a one-year limited warranty. If service is ever required, just send your receiver to one of our approved national service centers. When you purchase your scanner from Communications Electronics, you're buying from the world's leader in no-crystal scanners. We've sold more synthesized scanners than any other company.

NO OBLIGATION 31 DAY TRIAL

Test our Bearcat 250 for 31 days before you decide to keep it. If you do, you'll own the most sophisticated and technologically advanced scanner in the world. If for any reason you are not completely satisfied, return it in new condition with all accessories in 31 days, for a courteous and prompt refund (less shipping charges).

ADVANCED YET UNCOMPLICATED

Besides all the advanced features that put the Communications Electronics™ Bearcat 250 light years ahead of any other scanning radio, it has the superior engineering and "standard" features that have made Bearcat the greatest selling scanner in America. Bearcat's patented track tuning insures full band coverage for maximum reception. And a single electronically switched antenna eliminates the need for an additional low band antenna. A detailed service manual is also available for \$15.00 postpaid.

BUY WITH CONFIDENCE

The Communications Electronics™ Bearcat 250 is an extraordinary scanning instrument that provides virtually any scanning function that the most professional monitor could require. The Bearcat 250 lets those who need to know, know more. To get the fastest delivery of your super synthesized Bearcat 250, send or phone your order directly to our Bearcat Scanner Distribution Center™. Mail orders to Communications Electronics, Box 1002 - Department WG12, Ann Arbor, Michigan 48106 U.S.A. Send \$319.00 plus \$5.00 for U.P.S. shipping or \$9.00 for U.P.S. air shipping (Michigan residents please add 4% sales tax). Foreign orders invited at a slightly higher cost. International customers, please read special shipping information (in our catalog) before ordering. Further price discounts are available to quantity buyers. Suggested list price is \$399.95 but you can get 6 Bearcat 250's @ \$309.00, 12 units @ 299.00, 24 units @ \$289.00, 48 units @ \$279.00, 96 units @ \$269.00, 252 units and up @ 259.00. Add \$15.00 for each 6 scanners ordered for U.P.S. U.S. ground shipping. Add \$195.00 shipping charge for each 6 scanners, on international shipments, or write for a pro-forma invoice. If you have a Master Charge or Visa card you may call and order toll free 800-521-4414 to place a credit card order. If you are outside the U.S. or in Michigan dial 313-994-4444. All order lines at Communications Electronics™ are staffed 24 hours.

Since this Bearcat scanner is the most popular unit ordered through our Scanner Distribution Center™, you must order your Bearcat 250 today at no obligation, to assure prompt delivery.

Autoprogramming™ Scanner Distribution Center™ and CE logos are trademarks of Communications Electronics™. Bearcat® is a registered trademark of Masco Corporation of Indiana. Copyright © 1978 Communications Electronics™

BEARCAT



ORDER YOUR BEARCAT 250 TODAY!

A Multi-Memory Morse Machine

— using a Motorola micro

Kenneth D. Leininger WA8TIW
11101 Pacton St.
Utica MI 48087

This program, a dual-function aid to sending Morse code, was written on Motorola's MEK6800D2 evaluation kit. Not only is the function useful, but valuable experience is to be gained in writing a pro-

gram which exercises the PIA. (No matter how large or small your system, you can't "control the world" without first stirring those I/O lines to life!)

As previously indicated, this program does two jobs: It emulates the logic of an automatic keyer, and also allows the fully-automatic transmission of one of five prepro-

grammed messages. All eight lines on the "A" side of the user's PIA are utilized: two for the dot and dash contacts of the keyer, one for the output to the keying-relay buffer, and one for each of the five message-select push-buttons. Fig. 1 indicates how simple a schematic becomes once a microprocessor system is used to displace combinational logic.

expansion of the kit to 512 bytes by adding two 6810 chips in the sockets provided is necessary for the message buffer. Of course, one could utilize the optional ROM areas on the kit once the application and messages were suitably developed.

Initialization

The program is executed at location 001D. As indicated by Fig. 2 and Program A, the PIA is configured, then the letter "k" is sent to acknowledge a functioning system. Just how the dits and dahs are formed will be discussed shortly. Each PIA line assigned as an input looks like a standard TTL input, complete with internal pull-up resistor. Bit 0, the output line, has insufficient power to directly drive the keying relay, a problem easily overcome with the use of a common-emitter amplifier.

The program runs in the 256 bytes of RAM provided in the "barefoot" kit, but

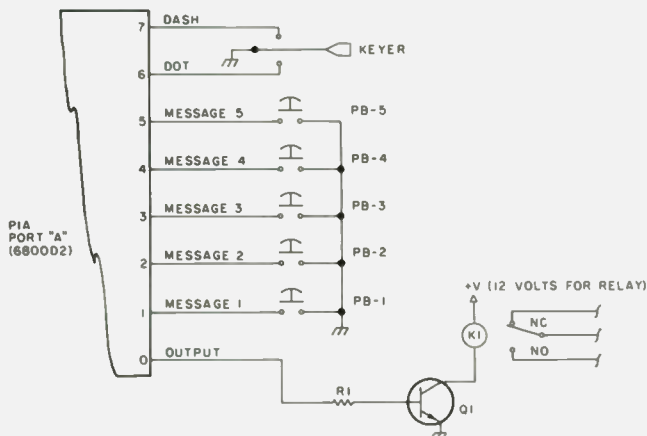

Fig. 1. Code system schematic diagram.

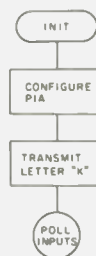

Fig. 2. System initialization.

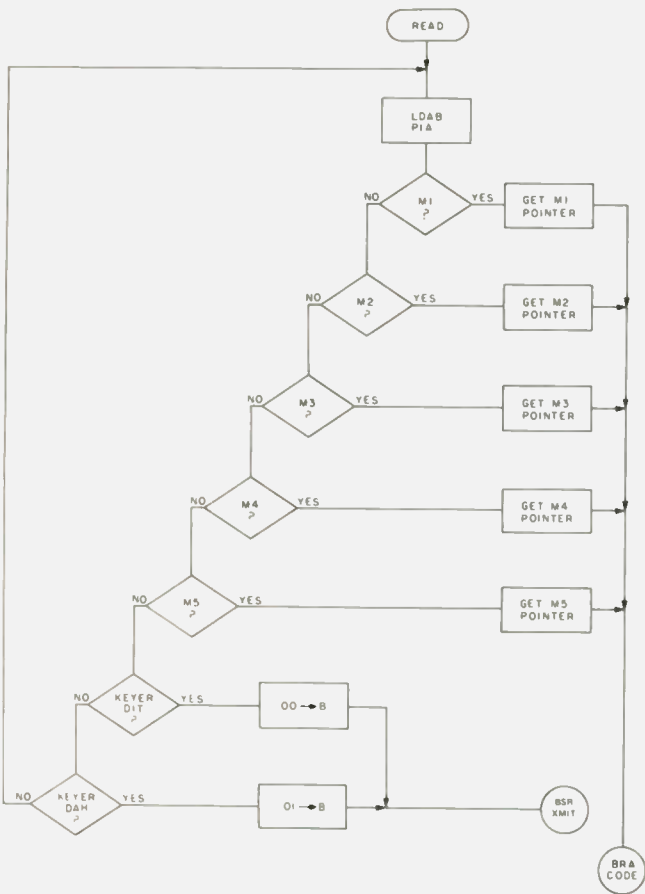

Fig. 3. Input polling routine flowchart.

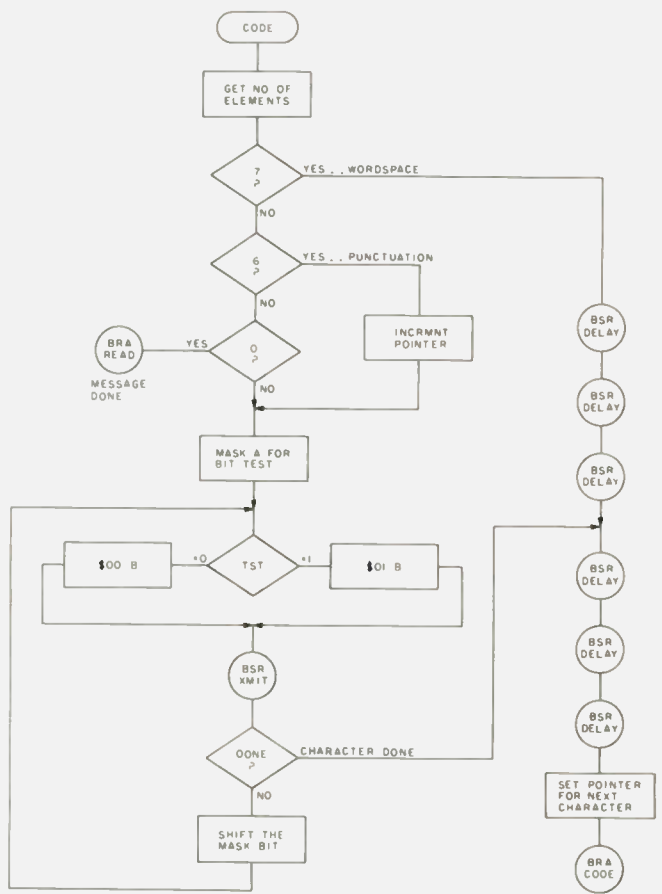

Fig. 4. Morse code routine flowchart.

Character	Code	Character	Code	Character	Code
0	FD	I	02	AR	55
1	7D	J	74	Slash	95
2	3D	K	A3	Period*	06
3	1D	L	44	Period	54
4	0D	M	C2	Comma*	06
5	05	N	82	Comma	CC
6	85	O	E3	Question*	06
7	C5	P	64	Question	30
8	E5	Q	D4	Wordspace	07
9	F5	R	43	Halt	00
A	42	S	03		
B	84	T	81		
C	A4	U	23		
D	83	V	14		
E	01	W	63		
F	24	X	B4		
G	C3	Y	94		
H	04	Z	C4		

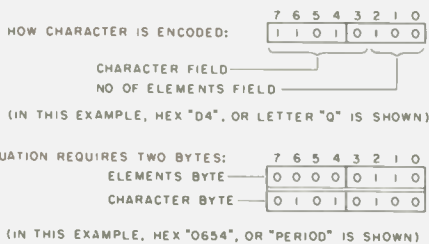

Fig. 5. Digitizing the Morse code.

PIA Polling

This portion of the program, illustrated in Fig. 3 and Program B, reads the input lines of the PIA (bits 1 through 7) and then se-

quentially compares the bit pattern with each legal pattern expected: five patterns for the five preprogrammed messages, and two for the keyer input. If

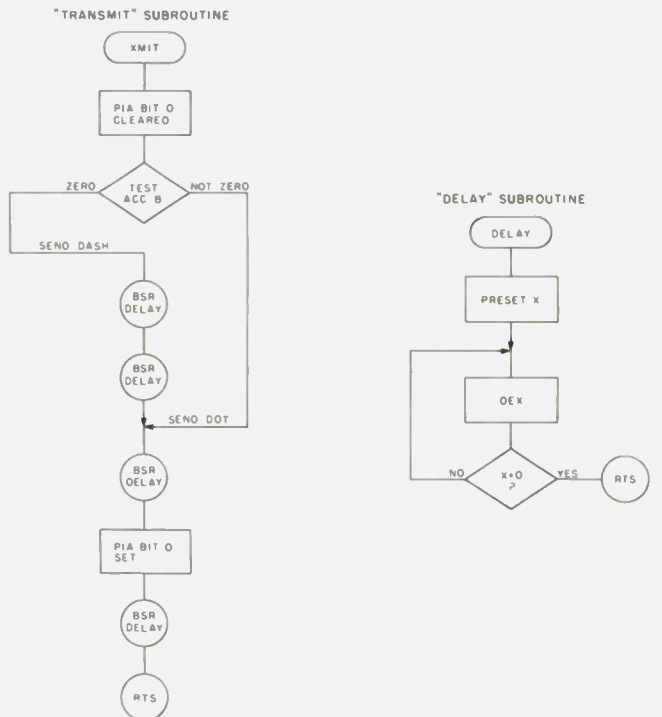

Fig. 6. Transmit and delay flowcharts.

quentially compares the bit pattern with each legal pattern expected: five patterns for the five preprogrammed messages, and two for the keyer input. If

all inputs remain high, the polling routine continuously repeats the check. If a particular message is selected, however, the grounded input is de-

LOCATION	CODE	LABEL	SYMBOL	COMMENT	LOCATION	CODE	LABEL	SYMBOL	COMMENT
00	1700	PRESET		VALUE DETERMINES CODE WFM	75	C6 07	CODE	LDA B ##07	MASK ACC B
02	0100	MESS1		POINTS TO START OF TEXT 1	77	E4 00		AND B 0,X	GET BITS 0,1,AND 2
04	0109	MESS2		POINTS TO START OF TEXT 2	79	D7 0F		STAB ELDEC	SAVE # OF ELEMENTS
06	0123	MESS3		POINTS TO START OF TEXT 3	7B	C1 07		CMP B ##07	SEVEN ELEMENTS?
08	0148	MESS4		POINTS TO START OF TEXT 4	7D	27 25		BEQ WRDSP	IF SO, DO WORDSPACE
0A	0151	MESS5		POINTS TO START OF TEXT 5	7F	C1 06		CMP B ##06	SIX ELEMENTS?
0C	0000	CRRT		1 POINTER FOR CURRENT CHAR	81	27 06		BEQ PUNCT	THEN PUNCTUATION
0E	0000	MSKST		BIT TEST MASK STORE AREA	83	C1 00		CMPB ##00	ZERO ELEMENTS??
0F	0000	ELDEC		ELEMENTS PER CHAR REGISTER	85	26 03		BNE CONT	IF SO, DONE.
					87	20 AE		BRA READ	GO BACK TO POLLING
					89	08 08	FUNCT	INX	LOOK AT NEXT CHAR
1D	7F 8005	INIT	CLR CRA	CLEAR CRA	8A	DF 0C	CONT	STX CRRT	SAVE POINTER
20	86 01		LDA A ##01	BIT 0 OF PIA IS OUTPUT	8C	86 80		LDA A ##80	SET BIT 7 (MASKBIT)
22	H7 8004		STA A PIA	SET BIT 0 OF DDR	8E	97 0E	TEST	STA A MSKST	SAVE AT MASKSTORE
25	86 04		LDA A ##04	SET BIT 2	90	5F 00		CLR B	GET READY FOR CODE
27	H7 8005		STA A CRA	SELECTS PIA PERIPH REG	91	A5 00		BIT A 0,X	TEST AN ELEMENT
2A	C6 01	READY	LDA B ##01	SET B TO 01	93	27 01		BEQ SUB	IF 0, DO DOT. IF 1, DO DASH
2C	BD 00C0		JSR XMIT	SEND DASH	95	5C 00		INC B	PREP "B" FOR CHAR
2F	5F 00		CLR B	CLEAR ACC B	96	8D 28	SUB	BSR XMIT	EXECUTE ELEMENT
30	BD 00C0		JSR XMIT	SEND DOT	98	7A 000F		DEC ELDEC	ONE LESS ELEMENT
33	5C 00		INC B	SET B TO 1 AGAIN	9B	27 0D		BEQ CHRSP	IF ZERO, DO CHAR SPACE
34	BD 00C0		JSR XMIT	SEND DASH	9D	96 0E		LDA A MSKST	GET MASK BACK
					9F	44 00		LSR A	SHIFT BIT TO RIGHT
					A0	DE 0C		LDX CHRSP	GET POINTER BACK
					A2	20 EA		BK TEST	GO TO TEST
					A4	8D 36	WRDSP	BSR DELAY	SIX DELAY UNITS
					A6	8D 34		BSR DELAY	SENT BETWEEN WORDS
					A8	8D 32		BSR DELAY	CALLED BY "07".
					AA	8D 30	CHRSP	BSR DELAY	THREE DELAY UNITS
					AC	8D 2E		BSR DELAY	SENT AFTER EACH
					AE	8D 2C		BSR DELAY	CHARACTER
					B0	DE 0C		LDX CRRT	GET POINTER
					B2	08 00		INX	INCREMENT FOR NEXT
					B3	DF 0C		STX CRRT	SAVE POINTER
					B5	20 BE		BRA CODE	GET BACK; DO NEXT CHAR

Program A. System buffers, vectors, and initialization.

LOCATION	CODE	LABEL	SYMBOL	COMMENT
37	C6 FE	READ	LDA B ##FE	SET READ MASK
39	F4 8004		AND B PIA	AND PIA INTO ACC B
3C	C1 FC	TEST1	CMP B ##FC	COMPARE B WITH 'F'
3E	26 04		BNE TEST2	IF #, DO TEST 2
40	DE 02		LDX MESS1	POINT TO MESSAGE 1
42	20 31		BRA CODE	RUN MESSAGE
44	C1 FA	TEST2	CMP B ##FA	COMPARE B WITH 'F'
46	26 04		BNE TEST3	IF #, DO TEST 3
48	DE 04		LDX MESS2	POINT TO MESSAGE 2
4A	20 29		BRA CODE	RUN MESSAGE
4C	C1 F6	TEST3	CMP B ##F6	COMPARE B WITH 'F'
4E	26 04		BNE TEST4	IF #, DO TEST 4
50	DE 06		LDX MESS3	POINT TO MESSAGE 3
52	20 21		BRA CODE	RUN MESSAGE
54	C1 EE	TEST4	CMP B ##EE	COMPARE B WITH 'E'
56	26 04		BNE TEST5	IF #, DO TEST 5
58	DE 08		LDX MESS4	POINT TO MESSAGE 4
5A	20 19		BRA CODE	RUN MESSAGE
5C	C1 DE	TEST5	CMP B ##DE	COMPARE B WITH 'D'
5E	26 04		BNE TEST6	IF #, DO TEST 6
60	DE 0A		LDX MESS5	POINT TO MESSAGE 5
62	20 11		BRA CODE	RUN MESSAGE
64	C1 BE	TEST6	CMP B ##BE	COMPARE B WITH 'B'
66	26 03		BNE TEST7	IF #, DO TEST 7
68	5F 00		CLR B	PREP B FOR "DIT"
69	8D 55		BSR XMIT	TRANSMIT A "DIT"
6B	C1 7E	TEST7	CMP B ##7E	COMPARE B WITH '7'
6D	26 C8		BNE READ	IF #, GO BACK TO READ
6F	5F 00		CLR B	PREP B FOR "DAH" BY
70	5C 00		INC B	SETTING TO 01
71	8D 4D		BSR XMIT	TRANSMIT A "DAH"
73	20 C2		BRA READ	GO TO READ

THIS ROUTINE POLLS THE PIA (BITS 1 THRU 7) AND DISTRIBUTES CONTROL AS FUNCTION OF OPERATOR INPUT TO THE PIA.

Program B. Input polling routine.

ected, the index register is loaded with the starting location of the respective message text, and then a branch to "CODE" (location 0075) is executed. When the message is complete, "CODE" returns execution to the beginning of the polling routine. If the keyer is operated, then the

dot or dash contact is detected and Accumulator B is respectively cleared or set. This accumulator is then handed to the "XMIT" subroutine whose job it is to make nice clean self-completing dits and dahs. After a single dit or dah, a "return from subroutine" instruction returns execu-

Parts List

K1	Relay, Sigma 65F-1A-12DC or equivalent
PB-1 through PB-5	Switch, push-button-type, NO momentary-contact*
Q1	HEP 234 or equivalent
R1	1k, 1/4 W

*Note: Because relay is energized during system reset, the relay output is taken off the normally closed contacts.

THIS ROUTINE CONVERTS A HEXADECIMAL ENCODED MORSE MESSAGE INTO REAL TIME MORSE CODE.

Program C. Morse code routine listing.

LOCATION	CODE	LABEL	SYMBOL	COMMENT
C0	86 FE	XMIT	LDA A ##FE	MASK A: BIT 0 OFF
C2	B4 8004		AND A PIA	AND PIA INTO A
C5	B7 8004		STA A PIA	PIA BIT 0 NOW LOW
C8	5D 00		TST B	IF ACC B IS ZERO;
C9	27 04		BEQ DOT	EXECUTE DOT
CB	8D 0F	DASH	BSR DELAY	OTHERWISE DO A DASH
CD	8D 0D		BSR DELAY	(A DASH IS THREE UNITS
CF	8D 0B	DOT	BSR DELAY	LONG; A DOT IS ONE)
D1	86 01		LDA A ##01	SET PIA BIT 0 BY
D3	BA 8004		ORA A PIA	UTILIZING THE "OR"
D6	F7 8004		STA A PIA	FUNCTION
D9	8D 01		BSR DELAY	COMPLETE THE DOT/DASH
DB	39 00		RTS	RETURN FROM SUBRTNE
DC	DE 00	DELAY	LDX PRESET	THIS IS THE DELAY
DE	09 00	DEC	DEX	SUBROUTINE. VARY CODE
DF	26 FD		BNE DEC	SPEED BY MODIFYING
E1	39 00		RTS	X PRESET AT LOC 00.

Program D. Transmit and delay subroutines.

tion to the polling routine.

Digitizing the Morse Code

The real challenge, of course, was to teach the machine to speak "Morse." Essentially, the system obtains a character (a byte of data from the message text) and performs a bit test, starting at the MSB. A "1" is translated into a dash and a "0" into a dot. Knowledge of the number of dits and dahs in a particular Morse character is required in order to tell the program when to stop shifting the bit test across the data byte. This is accomplished by indicating the number of elements in the three least significant bits of the data byte. As

shown in the flowchart in Fig. 4 and the listing in Program C, the A and B Accumulators are masked so that Accumulator B receives the number of elements. Accumulator B is then stored at "ELDEC," a memory location which is decremented every time a Morse element is completed. Fig. 5 indicates how the Morse code is encoded into the previously described format. As usual, exceptions exist, and they deserve some explanation. The format is useful for a Morse character which contains from one to five elements. Punctuation requires special handling. Therefore, if Accumulator B picks up the integer "06,"

then that particular byte is skipped: The six-bit character is found at the next location in the text. Two other special cases exist, one for inserting just spaces, and one for terminating the message. These situations, again detected in Accumulator B, are illustrated on the "CODE" flowchart.

Morse Code Generation

Subroutine "XMIT" (Fig. 6 and Program D) handles the actual formation of and output for the dits and dahs. The timing for character generation is performed by a delay loop located at 00DC. The pre-set value is conveniently located at 0000. An initial value of hex 1700 sets the keyer and message generator speeds at about 13 wpm. A dot consists of one unit of time of output "on" followed by an identical unit of time of output "off." A dash consists of

three units of time of output "on" followed by a single unit of time of output "off." The contents of Accumulator B at the time of the call indicate the desired element (00:dot; 01:dash). The output, PIA bit 0, is cleared to assert output "on". This prevents a keydown situation during system reset.

Setup

Loading the messages for the automatic sender consists of converting the text of the message into hexadecimal and storing

it. (Armed with only an evaluation kit, this is a manual job!) The starting address of each message is then stored in the message-vector area starting at location 0002. The current program can only support five message vectors, but there is no reason (other than memory constraints) why a multitude of messages could not be stored; simply changing a vector would then pull a new text string into the foreground. A series of "Vs" or the word "test" repeated several times makes a nice brief

message around which the code speed may be optimized. Fig. 7 illustrates a group of encoded messages.

Operation

Start the machine by executing at 001D. The letter "k" in Morse should acknowledge start-up. At this point, the keyer may be used, or any one of five messages may be sent by momentarily depressing the appropriate push-button. Once started, a message will proceed until completion. ■

Message	Starting Location	Code
1. CQ CQ CQ	0100	A4 D4 07 A4 D4 07 A4 D4 07
2. DE WA8TIW K	0109	83 01 07 63 42 E5 81 02 63 07 A3 00
3. QTH IS UTICA, MICH. ES NAME IS KEN	0123	D4 81 04 07 02 03 07 23 81 02 A4 42 06CC 07 C2 02 A4 04 0654 07 01 03 07 82 42 C2 01 07 02 03 07 A3 01 82 00
4. EIGHT DITS	0148	01 01 01 01 01 01 01 01 00
5. QRZ QRZ QRZ	0151	D4 43 C4 07 D4 43 C4 07 D4 43 C4 00

Fig. 7. Sample message set.

You can't go wrong with a **Mobile 2.**

With 5/8 wave ready, all we left out was a high price.

Now available in both 5/8 and 1/4 wavelengths, the **Mobile 2** antennas are great for 2 meters, 220 MHz or 440 MHz bands.

The original **Mobile 2** mounts to your trunk lid. The **Mobile 2** magnetic grabs on almost anywhere, and stays put. Even when passing big trucks.

Both antennas come with all cable, connectors and hardware in one package.

Either way, you can't go wrong with a **Kantronics Mobile 2.**

magnetic
\$19.95

trunk
\$11.95



KANTRONICS ✓K13
The Lightweight Champs.

1202 East 23rd Street
Lawrence, Kansas 66044 Phone: 913-842-7745
We accept Visa, Master Charge, check and money orders.



Swan 100MX

ALLIANCE ROTOR SPECIAL

HD 73 \$99.95



ICOM IC211

ATLAS • DRAKE • ICOM • SWAN • TEMPO • HY-GAIN •
DENTRON • WILSON • STANDARD • KLM • CUSHCRAFT •
B&W • PIPO • LARSEN • BENCHER • NYE • WESTCOM •
ALLIANCE • MFJ • TELEX • NEW-TRONICS • FINCO •
ROHN • W2AU • HAM-KEY • AND MANY MORE •

((DISCOUNT PRICES ON ALL ABOVE ITEMS))

Before you buy your next HAM RADIO—STOP—and take time to call us. We offer the lowest prices in the U.S.A. Charge it, VISA OR MASTERCARD, or we will ship C.O.D.

RON
(716) 235-7716

Mon-Fri 10 to 3
and 6 to 9

JIM
(716) 235-7540

**Amateur Radio
of Rochester, Inc.** ✓A51

1185 Scottsville Rd. Rochester, New York 14624

“This is Your Computer Speaking”

— *how to dial up your micro*



Completed modem number one.

*Jerry Sorrels
6266 Banner Ct.
Riverside CA 92504*

A modem, now that's what I need for my 6800 system! But how about one that has auto answer? Auto answer lets you dial up your phone, and, when it rings, the modem will answer and connect your computer to the phone line. Now you, or someone else, can operate your computer from a remote terminal and modem.

I decided on using Motorola's MC6860 modem IC, and being a fairly-stingy-with-a-buck person, its availability, features, and \$14.95 price are what sold me.

After spending a week thinking, I decided on the features for my first modem. It was going to do everything the chip was capable of. This overkill approach does have its advantages when you're not positive about what you're going to do with it or connect it to.

Two months later, when the smoke finally cleared, I had built two modems. One was a do-everything, interface-to-almost-everything, and the other was a minimum-parts version, with most of the features.

This article will be about a combination of my two modems which will have the following features: 0-300 baud, self-test, full duplex, originate and answer modes, compatible

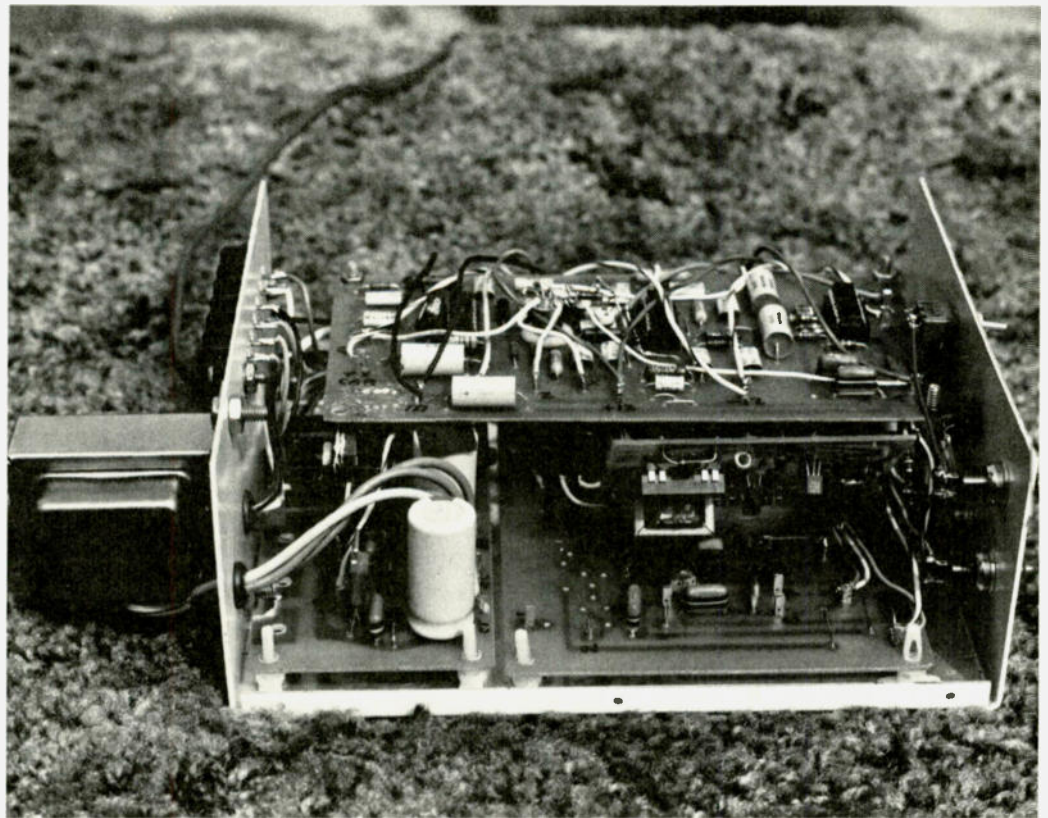

Inside view of my first modem (note internal coupler board mounted at angle to fit in case).

with various systems via TTL or RS-232 levels, and auto answer and disconnect. My total cost, for all new parts, was under \$70, including the case and power supply.

Some Theory

This modem uses audio frequency shift keying (AFSK); data to be sent is converted to audio tones. If the modem is in the originate mode, a logic 0 (space) is sent as a 1070 Hz tone (2025 Hz, if in answer mode), and a logic 1 (mark) is sent as a 1270 Hz tone (2225 Hz if in answer mode); see Table 1. This might seem a little confusing, but it works just fine. These frequencies are standard for low-speed data communication.

This modem is composed of several logical sections. First is the interface to the telephone company line (see the schematic, Fig. 1). This interface must be able to match the characteristic impedance of the phone line,

usually 900 Ohms, to the modem. It must provide dc isolation from the telephone line and, for automatic answer, must be able to detect when the phone is ringing and be able to answer and terminate the call.

The filter (see Fig. 2) passes only the frequencies 1070 Hz to 1270 Hz when in the answer mode and 2025 Hz to 2225 Hz when in the originate mode. The filter is needed because, in full duplex operation, the modem is transmitting and receiving at the same time, and the signals must be separated. The limiter, IC3, takes the sine wave from the filter and changes it into a symmetrical square wave of a TTL-compatible level. The demodulator in the modem IC compares each half-cycle of this square wave against the crystal-controlled timebase to determine if the incoming frequency is a mark or space. The threshold detector, IC4, is used to tell

the modem IC that the input signal entering the limiter is above the minimum detectable level.

The 6860 modem IC is the brains behind the outfit. It takes care of modulation, demodulation, and the hand-shaking signals to establish, maintain, and terminate the data link. Another section is the interface to the computer or terminal. There is a fair amount of flexibility here due to the 6860 signal levels being TTL-compatible. Depending on the exact use you plan for the modem, it can be tailored to fit. In my case, I converted some of the signals to RS-232; all of them could be converted if desired.

How It Works

IC1 is placed in the answer mode when its pin 19 is grounded. This is done by the ring detector when your phone rings or by pushing the answer switch. This causes IC1, pin 4 to go high, operating RL1, which

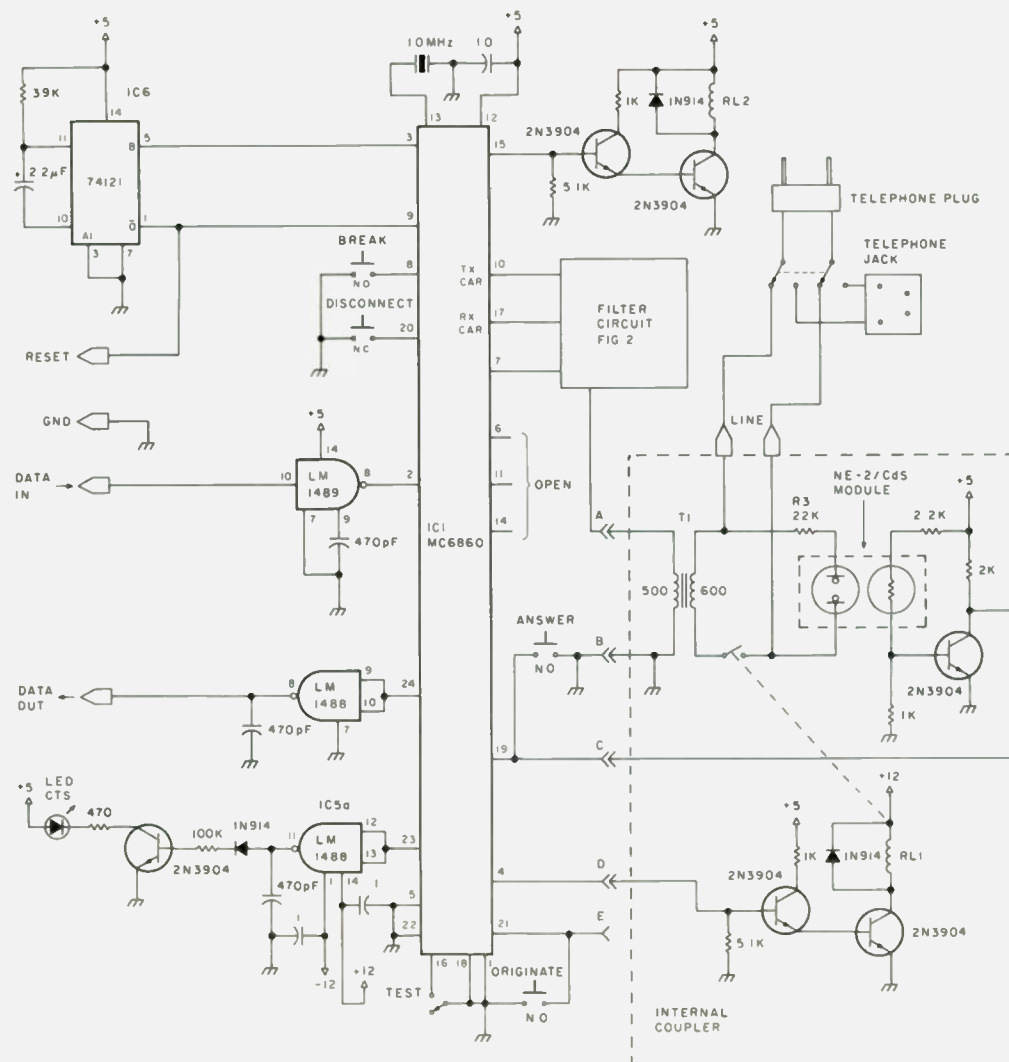

Fig. 1. Main schematic with internal coupler.

connects the modem and answers the call. At the same time, IC1, pin 15 goes low; this places RL2 in the proper position to select the answer mode filter. When IC1 detects the mark tone from the other modem, pin 23 goes low; this turns on the clear-to-send (CTS) LED.

The originating mode is initiated when the originating switch is pushed, causing IC1, pin 21 to go low. Next, pin 4 goes high, closing RL1, connecting the modem to the phone line. At the same time, pin 15 goes high, operating RL2 and selecting the originating filter. When IC1

detects the mark tone from the answering modem, it will send out its mark tone from pin 10 to the transmit buffer, T1, and out to the line. Now the CTS LED will light, indicating "ready to exchange data."

If IC1, pin 16 is held low, the modem is placed in the self-test mode. The demodulator is changed to the modulator frequency and loops back to the terminal whatever is typed in.

When a break (150 ms space) is received by the modem, IC1, pin 3 is clamped high and stops data exchange. This positive-going level triggers a one-shot, IC6, which sends

a negative pulse to IC1, pin 9, automatically releasing the break condition. This negative pulse is also sent to my SWTP 6800 computer's MRST line. This gives the remote terminal the ability to operate the computer's hardware reset by sending a break.

Construction Tips

I built the modem on four printed circuit boards, consisting of the following circuits: the internal coupler, the filter, limiter, and threshold detector, the modem IC and RS-232 chips, and the power supply. You can use whatever construction technique you prefer. I always socket all integrated circuits. This time I had to replace the 24-pin socket with one of better quality; it caused all sorts of problems, so be-

ware! I guess if I had socketed the sockets, I might not have had that problem!

I made the ring detector by laying an NE-2 lamp on top of a flat cadmium sulfide cell and using hot-melt glue at each end of the lamp to hold them together. Then I wrapped black electrical tape around them to keep out the ambient light. The first one I made didn't work. I found that some NE-2 lamps require about 100 V ac before they light. Next I took apart a neon pilot lamp assembly. It had an internal 22k resistor in series with the neon lamp; this combination worked. The series resistor, R3, can be from 22k up to 220k, depending on the wattage rating of the lamp. Pretest your neon-resistor combination to make sure it will light on approximately 70 V ac. I bought the cadmium cell at a surplus store; it's about 3/4-inch square and 1/4-inch thick (any similar configuration you can come up with should work okay). There are also commercial neon/CdS modules available, such as the Clairex DLM 3120A Photomod.

RL1 is an SPST 12 V dc relay with a 1k Ohm coil, mounted in a 14-pin IC package. A suitable 5 V relay could be used if connected to the 5 V supply.

RL2 is a DPDT 5 V relay with a 100-Ohm coil, mounted in a TO-5 package. You should be able to use any similar relays. In my second modem, I left out RL2 and just used a DPDT switch, mounted between the originate and answer push-buttons. This made construction a lot easier, without losing any real features.

IC5a is just used for inversion to save a transistor.

I used a 500- to 600-Ohm transformer for T1. The ideal value for the side that connects to the phone line

Data	Originate	Answer
0 Space	1070 Hz	2025 Hz
1 Mark	1270 Hz	2225 Hz

Table 1. FSK transmit frequency.

is 900 Ohms. The side of T1 connected to terminals A and B can be anything between 500 and 1k Ohms, but, whatever value it is, R1 (connected to pin 1 of IC2a) should be adjusted to match it.

All the frequency-determining resistors in the originating and answer filters should be 1%. All the .01 uF capacitors should be 5% or better, mylar or polystyrene.

A lot of phone companies require you to rent (from them) a coupling device when connecting external equipment to their lines. There are several types of coupling devices that will give the same auto answer and disconnect features as the internal coupler described here. One is a CBS data coupler which has RS-232-compatible signals. If you use one of these, the optional data coupler interface (see Fig. 3) is used in place of the internal coupler. This circuit will provide the RS-232 levels needed by the phone company's CBS data coupler. R1 should be changed to a 600-Ohm resistor, because the customer sides of their couplers are 600 Ohms.

Testing and Adjustment

The modem's handshaking signals should be tested first. Connect a small high-impedance speaker (100 Ohm) or frequency counter to the line terminals of the modem. Turn on the power and push the answer push-button; you should hear a 2225 Hz tone. The level can be adjusted by R2.

Next, connect an audio oscillator across the speaker and apply a 2225 Hz signal, push the originate push-button and, if you left out RL2, change the filter switch to originate. You should hear the modem send out a 1270 Hz tone, and the clear-to-send (CTS) LED will light. Next,

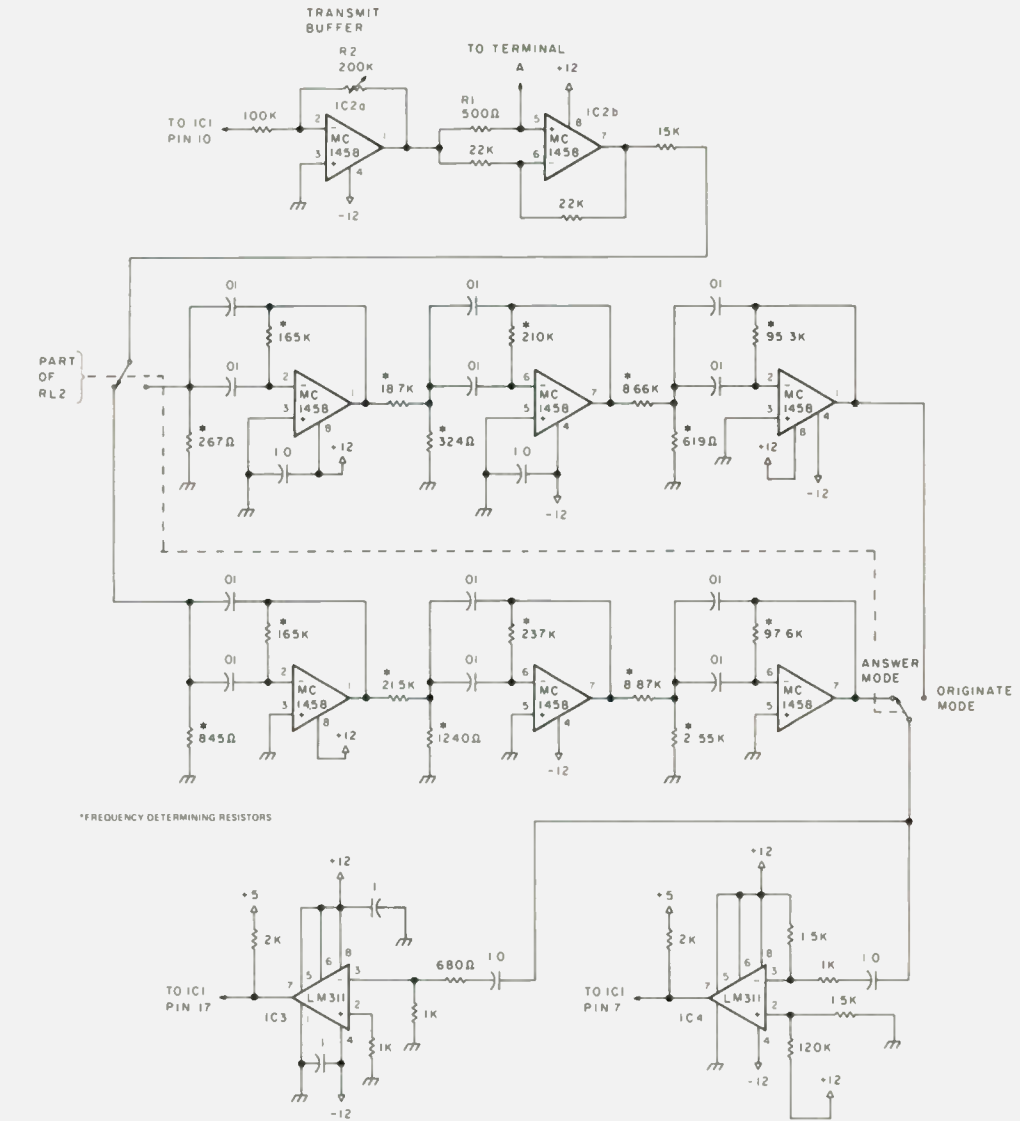

Fig. 2. Filter circuit.

push the break push-button; the modem should send a 150 ms 1070 Hz tone every time this switch is pushed. Now push the disconnect switch; the modem will send a 3-second 1070 Hz tone, the CTS LED will go off, and the modem will stop sending.

The transmit level (R2) will be adjusted next. Dial up a friend and have him leave his phone off the hook. With the modem line terminals connected across the phone line, push the answer push-button and hang up your phone, or operate the line switch to the modem. You have 17 seconds to measure the signal level across the phone line with an ungrounded meter. Use the output jack or connect a

0.1 uF capacitor in series with the meter and adjust R2 for a level of -15 dBm, 0.14 V rms, or 0.39 V p-p.

Next have your friend call you back, but, before he does, the modem should be on and connected to the phone line, and, if you left out RL2, place the filter switch in the answer position. When he calls, the phone should ring once. If it does, wait a few seconds and pick up your phone. The modem should be sending out a 2225 Hz tone. If the phone keeps ringing, the ring detector is not working.

To test the data section, connect the data in and out to something that speaks RS-232 at 300 baud or less. The modem does not care about format; it converts

to tones anything that comes into it. I used my SWTP CT 1024 terminal. Turn on the modem and push the answer switch. Turn on the test switch. Now the CTS LED will light, and what you type on the keyboard will be looped back and printed on the screen. If you installed the manual filter switch, change it to the originate position (this is one of the things that RL2 does automatically). This is about all the testing you can do until you find someone else with a modem or build two like I did!

Interface and Operation

I connected the modem to my system by paralleling it across the CT 1024 data in and out lines. This

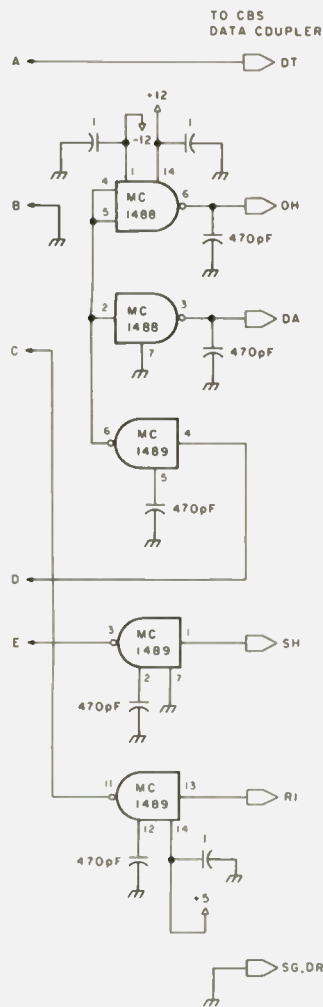

Fig. 3. Optional CBS data coupler interface.

way, it acts like another terminal that can access the computer over the phone line.

To use the modem as a terminal only, like talking to a time-share computer, just connect it to the terminal and disconnect the rest of the system.

When using modems, a point to remember is that one end must be in the originate and the other in the answer mode; it does not really matter which.

The hand-shaking tones can be lost for up to 17 seconds before the connection will be lost, but data sent when the CTS LED is off will be lost.

During actual use, if you are the originating modem, dial the number you want, and it will be answered by a person or a modem. If you hear a tone, you have 17 seconds to push your

originate switch and hang up or change your line switch to the modem. When your modem detects the tone, it will send out its mark tone; then the CTS LED will light, and the data can now be exchanged.

If you are talking to an SWTP computer whose MRST line is connected to the reset terminal, sending a break will reset the computer to its Mikbug™ operating system. Operating the disconnect push-button will cause the modem at the other end to hang up.

Also remember that, if the modem is on and connected to the phone line, it will answer all calls you get. It could be someone not expecting to get a 2225 Hz tone in his ear, and they could report your phone out of order. The best thing would be if you had a separate phone line just for the modem.

For my acid test, I left one modem at home and the computer loaded with games; the other I took

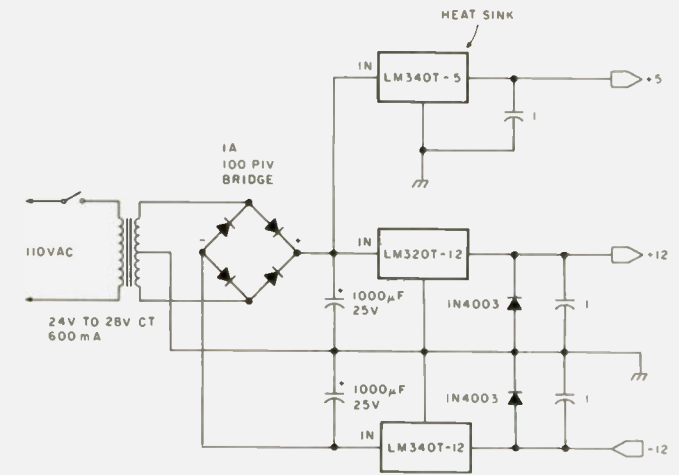

Fig. 4. Power supply.

with my terminal over to a friend's home. I dialed up the computer, and we played games for four hours; it worked great! Imagine what I could do with a floppy back at the computer! ■

References

1. Felsenstein, Lee, "Build Pennywhistle, the Hobbyist's Modem," *Popular Electronics*, March, 1976.
2. Lancaster, Don, *TV Typewriter Cookbook*.

3. Motorola MC6860L data sheet.
4. De Lavne, Jon, "Low-speed Modem System Design Using the MC6860," Motorola Application Note AN-747.
5. Nash, Garth, "Low-speed Modem Fundamentals," Motorola Application Note AN-731.
6. Lange, Ron, "Build the \$35 Modem," *Kilobaud*, November, 1977.
7. Stark, Peter, "Solid State Telephone Ring Relay," *73 Magazine*, April, 1974.
8. Whipple, Spenser, "Basic Telephone Systems," *73 Magazine*, April-June, 1975.

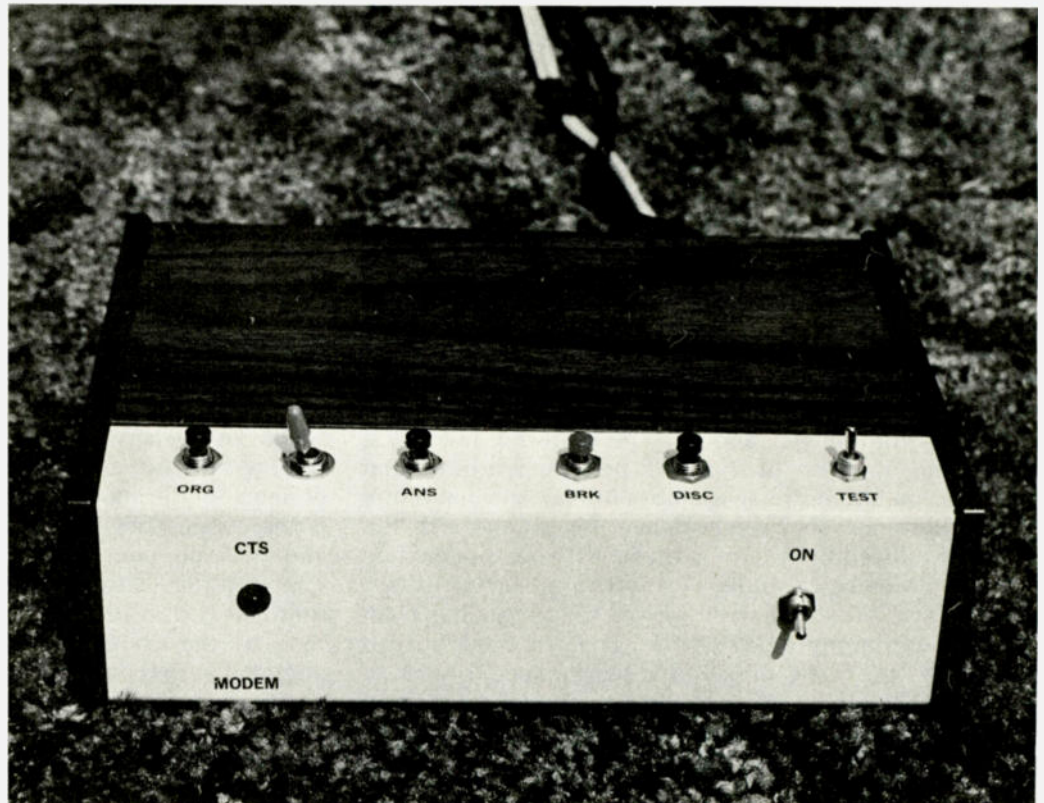

Close-up of modem number two. Everything was built on one circuit board. This does not have the auto answer feature.

The Small Computer Magazine

Kilobaud Magazine, aimed at the computer hobbyist and small businessman who wants to learn the fundamentals of computers, is an ongoing ENCYCLOPEDIA OF COMPUTING growing in size and information every month. The complete encyclopedia includes over 4000 pages on:

Programs to help you with your system...
News of new hardware and software...
Evaluations of new hardware you may be interested in getting...
Thought-provoking articles...
The key to having fun with your computer...
Hints on how to save money with microcomputers...
Hints on how to make it rich using your computer...
Information exchanges for hobbyists...
and more...

Kilobaud believes that hobby computing is the forerunner of small business computing, home computing, and widespread educational uses. To stay in touch with what's happening day to day in the world of computing, or if you are just getting into computers, or if you are just getting interested, Kilobaud is for you. It's written to be understandable for beginners and interesting for experts. As a special offer to new subscribers, fill out the coupon for your subscription, and if you like, get your encyclopedia started with some of our back issues. If you take full advantage of this offer, you'll save \$50!!

As a limited offer to new subscribers, Kilobaud will send you the following with a subscription to Kilobaud...

One-year subscription for \$18 (25% off the cover price)
Three-year subscription for \$45 (37½% off the cover price)
Up to 10 back issues (our choice) to get your encyclopedia started, at \$1.50 each (50% off, save up to \$15)
A Kilobaud Binder, as advertised, for \$5.50 (you save \$1)
That's a savings of up to \$40—for the most comprehensive encyclopedia of computing available.

Fill out the attached coupon today (be sure to tell us how many back issues you want).

You need not send money now; we'll bill you later if you like (the back issues and your binder will be sent after invoice has been paid).

Please Rush My Subscription To Kilobaud and Start My Encyclopedia of Computing...

- One Year @ \$18
 Three Years @ \$45
_____ Back Issues (up to 10, our choice) @ \$1.50 ea.
Qty. _____
_____ Kilobaud Binder @ \$5.50

Total Enclosed Bill Me
 Master Charge Visa Card # _____ Exp. date _____

Signature _____

Name _____
Address _____
City _____ State _____ Zip Code _____

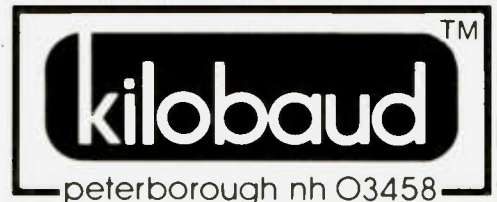

S12 B

RTTY with the KIM

— one more step

<u>Lower case</u>	<u>Upper case</u>
0300 40 letters	0320 40 letters
0301 4B K	0321 28 (
0302 51 Q	0322 31 I
0303 55 U	0323 37 7
0304 20 figures	0324 20 figures
0305 4A J	0325 27 '
0306 57 W	0326 32 2
0307 41 A	0327 2D -
0308 58 X	0328 2F /
0309 46 F	0329 2I !
030A 59 Y	032A 36 6
030B 53 S	032B 00 bell
030C 42 B	032C 3F ?
030D 44 D	032D 24 \$
030E 5A Z	032E 22 "
030F 45 E	032F 33 3
0310 56 V	0330 3B ;
0311 43 C	0331 3A :
0312 50 P	0332 30 0
0313 49 I	0333 38 8
0314 47 G	0334 26 &
0315 52 R	0335 34 4
0316 4C L	0336 29)
0317 0A Line feed	0337 0A Line Feed
0318 4D M	0338 2E .
0319 4E N	0339 2C ,
031A 48 H	033A EA nop
031B 80 Space	033B 80 Space
031C 4F O	033C 39 9
031D 0D CR	033D 0D CR
031E 54 T	033E 35 5
031F 40 blank	033F 40 blank

Modified character set.

Without a doubt, the KIM-1 microcomputer has to be one of the slickest little rigs on the computer market. It is being put to work on all types of ham-oriented applications. It is decoding Morse and RTTY and transmitting Morse and RTTY, and all of this with only the 1K of memory that comes with the unit. (8080, eat your heart out.) At the time I was first seeing all of these articles (in *73 Magazine*, of course), I did not have a computer and was having a terrible time deciding on just what I should get. After seeing Wilfred Gregson's article (September, 1977) on "Receiving RTTY with the KIM" and several others, I decided on buying my namesake.

When I first tried Wilfred's program, I was amazed at what I was see-

ing. Even with the 7-segment display, the words were very easy to distinguish. I was quite heavily involved in RTTY at the time, so I had a terminal unit. I found the KIM-1 much more tolerant of the various things that affect RTTY. Such things as distortion of the character pulses that would drive the old Model 19 crazy did not seem to bother KIM very much. I was also using a HAL DS-3000 version 2 in my RTTY operations. For anyone familiar with this unit, they will know that besides featuring the Baudot code, it is an ideal computer terminal in the ASCII position. It was only logical that I should want the KIM to deliver the RTTY to the HAL terminal so I would not have to struggle with the 7-segment display. This is the basis of this article. It may



Germantown Amateur Supply, Inc.

MEMPHIS, TENNESSEE

NO MONKEY BUSINESS!

- (A) Complete Service Facilities
- (B) Good Deals on most Brands
- (C) Shipping within 24 Hours
- (D) All inquiries handled by Active Hams with over 20 years experience in ham radio

CALL TOLL FREE
1-800-238-6168

IN TENNESSEE, CALL 901-452-4276
MONDAY - SATURDAY 8:30-5:30
FOR YOUR SPECIAL.

Write: 3202 Summer Ave., Memphis, Tennessee 38112

CUSTOM TRANSFORMERS

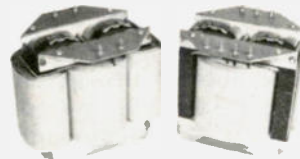

HEAVY DUTY REPLACEMENT TRANSFORMERS

ALPHA A77D Power	\$135	HEATH DX-100 Modl	\$ 95
BTILK-2000 Plate	\$135	HEATH HX-10 Power	\$ 95
COLLINS 30S-1 Power	\$215	HEATH SB-220 Plate	\$125
COLLINS KWS-1 Plate	\$135	HENRY 2K Plate	\$150
COLLINS 516F-2 Power	\$ 95	HENRY 2K-2 Power	\$155
DENTRON 160-10L Power	\$125	HENRY 2K-4 Power	\$165
DRAKE L4B Plate	\$165	HENRY 3K-A Plate	\$165
GONSET GSB-100 Power	\$ 95	HENRY 3K-A DC Choke	\$ 85
GONSET GSB-201 Power	\$135	EFJ T-BOLT Plate	\$125
H-CRAFTERS HT-32 Power	\$ 95	EFJ 500 Modulation	\$ 95
H-CRAFTERS HT-37 Power	\$ 95	EFJ 500 DC Choke	\$ 75
HEATH DX-100 LV Power	\$ 95	NATL NCL-2000 Plate	\$125

OFF-THE-SHELF SPECIALS

PLATE XFMR:	2400 VAC @ 1.5A ICAS 220/240 PRI-4 1LB	\$150
PLATE XFMR:	3000 VAC @ 1.5A CCS 230 PRI-60LB	\$195
PLATE XFMR:	3000 VAC @ 0.7A ICAS 115/230 PRI-27LB	\$115
PLATE XFMR:	3500 VAC @ 1.0A ICAS 115/230 PRI-4 1LB	\$150
PLATE XFMR:	4000/4600 VAC @ 1.5A ICAS 230 PRI-60LB	\$195
PLATE XFMR:	6000 VCT @ 0.8A CCS 115/230 PRI-4 1LB	\$150
FILMT XFMR:	5.0 VCT @ 30A 117 PRI-9.5LB	\$ 30
FILMT XFMR:	7.5 VCT @ 21A 117 PRI-9.5LB	\$ 30
FILMT XFMR:	7.5 VCT @ 55A 115/230 PRI-14.6LB	\$ 65
FILMT XFMR:	7.5 VCT @ 75A 115/230 PRI-20.2LB	\$ 95
FIL CHOKE:	30 AMP Bifilar Wound on 1/2" x 7" rod	\$ 9
DC CHOKE:	8.0 Henries @ 1.5 AMP DC 4 1LB	\$150
SWG CHOKE:	5-30 Henries @ 1.0 AMP DC 23LB	\$100

ALL TRANSFORMERS & CHOKES GUARANTEED FOR 24 MONTHS
Many others also available. Write for free list or quote on any custom transformer, choke, or saturable reactor.

Peter W. Dahl Co.

4007 Fort Blvd. • El Paso, Texas 79930
Telephone (915) 566-5365 or (915) 751-4856

IN ELECTRONICS HAS THE LINE...

DIP/IC INSERTION TOOL WITH PIN STRAIGHTENER

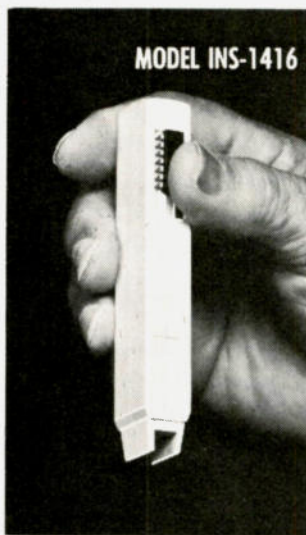

STRAIGHTEN PINS

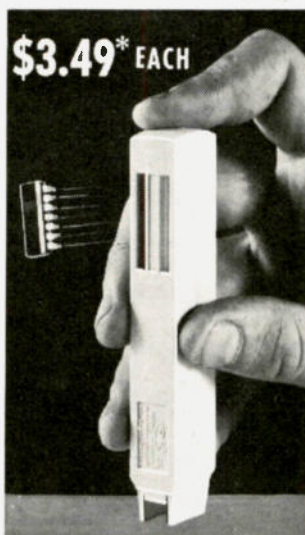

\$3.49* EACH

RELEASE

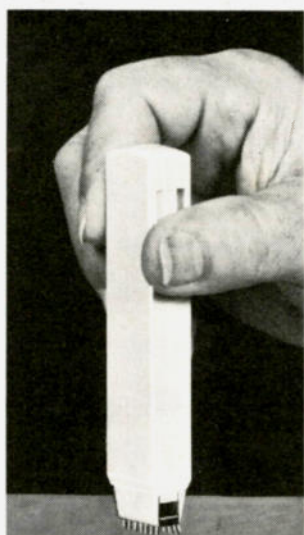

PICK-UP

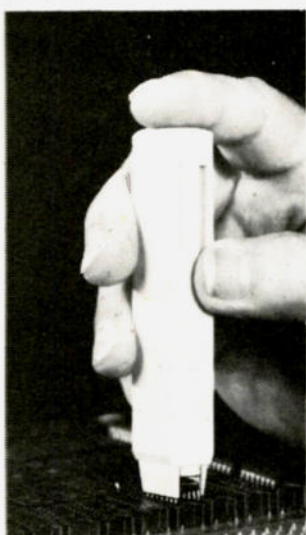

INSERT

* MINIMUM ORDER \$25.00, SHIPPING CHARGE \$1.00, N.Y. CITY AND STATE RESIDENTS ADD TAX

OK MACHINE AND TOOL CORPORATION

3455 CONNER STREET, BRONX, NEW YORK, N.Y. 10475 U.S.A.
PHONE (212) 994-6600 TELEX NO. 125091

seem rather ironic to receive ASCII on a video terminal that already can receive in Baudot, but this is aimed at the computer hobbyist who would like to print RTTY on his Model 33 or on his ASCII terminal and does not have normal Baudot provisions.

I guess you could call this a glorified ASCII-to-Baudot converter, but to

say that would be an injustice. Not only will you get the full upper and lower case, but you will also get something called "unshift on space." What this means is that if you are in upper case Baudot and you receive a space code, the unit will automatically shift back to lower case. This might not seem like much, but in the presence

of severe noise and fading, this is a blessing in disguise. Here you will have the RTTY printer that many dream about. If you take the trouble to get this going, you will be in for some very artful RTTY pictures.

After studying the program, the first thing that I had to do was to get the OUTCH subroutine in

there somewhere. With this come the necessary changes to the lookup table so that the characters that are OUTCHed will be the corresponding ASCII characters. One of the first problems that was encountered was interference with the command detection. For example, if I put the ASCII code for space, 20_h, in location

Program listing.

0200	A9	7F	LDA imm 7F	0265	24	E7	BIT,z 00E7		
0202	8D	41	17	STA abs 1741	0267	10	07	BPL branch to figures encode	
0205	A0	06	LDY imm 06	0269	A9	00	LDA imm 00		
0207	A2	09	LDX imm 09	026B	85	E4	STA,z 00E4 letters command		
0209	A9	00	LDA imm 00 Put Ltrs in the ltrs/figs byte	026D	4C	81	02	JMP to finish	
020B	85	E4	STA,z 00E4	0270	50	07	BVC bell		
020D	2C	00	17	BIT 1700 Look for a start bit	0272	A9	20	LDA imm 20	
0210	30	03	BPL branch if detect start	0274	85	E4	STA,z 00E4		
0212	4C	0D	02	JMP 020D Look again.	0276	4C	81	02	JMP to the finish
0215	A9	0F	LDA imm 0F set the first time delay	0279	A9	01	LDA imm 01 BELL		
0217	8D	07	17	STA abs 1707	027B	8D	01	17	STA abs 1701
021A	A9	00	LDA imm 00 clear new char. register	027E	8D	00	17	STA abs 1700	
021C	85	E7	STA,z 00E7	0281	A9	15	LDA imm 15 FINISH set for the third delay		
021E	A9	10	LDA imm 10 set bit position register	0283	8D	07	17	STA imm 1707	
0220	85	E5	STA,z 00E5	0286	2C	07	17	BIT 1707 look	
0222	2C	07	17	BIT 1707 Is first delay finished ?	0289	30	03	BMI back	
0225	30	03	BMI branch if yes.	028B	4C	86	02	JMP	
0227	4C	22	02	JMP if not back to 0222 and wait	028E	A9	00	LDA imm 00	
022A	A9	14	LDA imm 14 set timer for second delay	0290	8D	00	17	STA 1700	
022C	8D	07	17	STA abs 1707	0293	4C	0D	02	JMP
022F	2C	07	17	BIT 1707 is timer finished?	0296	EA	NOP		
0232	30	03	BMI branch if yes	0340	85	E0	STA,z 00E0 save " A "		
0234	4C	2F	02	JMP if not, go to 022F and wait	0342	86	E1	STX,z 00E1 save " X "	
0237	2C	00	17	BIT Read the state of Input 1700	0344	85	E2	STY,z 00E2 save " Y "	
023A	10	06	BMI if it is " 0 " , do not load	0346	C9	80	CMP imm 80 is this a space code ?		
023C	A5	E7	LDA,z load the bit at 00E7	0348	F0	18	BEQ if so, then go to 0362		
023E	05	E5	ORA,z 00E5	034A	C9	00	CMP imm 00 is this a bell code ?		
0240	85	E7	STA,z 00E7	034C	F0	19	BEQ if so, then go to 0367		
0242	46	E5	LSR,z 00E5 shift bit position register	034E	C9	20	CMP imm 20 is this a " FIGS " code		
0244	A5	E5	LDA,z 00E5 check for all 5 baudot char.	0350	F0	1C	BEQ if so, then go to 036C		
0246	C9	00	CMP imm 00	0352	C9	40	CMP imm 40 is this a " LTRS " code ?		
0248	F0	03	BEQ all finished ?	0354	F0	1A	BEQ if so, then go to 036C		
024A	4C	2A	02	JMP to 022A	0356	20	A0	1E	JSR OUTCH send character to terminal
024D	A5	E7	LDA,z 00E7 letters / figures prefix	0359	A5	E0	LDA,z 00E0 Restore " A "		
024F	05	E4	ORA,z 00E4	035B	A6	E1	LDX,z 00E1 Restore " X "		
0251	A8	TAY index for lookup	035D	A4	E2	LDY,z 00E2 Restore " Y "			
0252	85	E3	STA,z 00E3	035F	4C	5C	02	JMP back to main program	
0254	B9	00	03	LDA abs,y	0362	A9	00	LDA imm 00 unshift on space routine	
0257	85	E7	STA,z 00E7	0364	85	E4	STA,z 00E4		
0259	4C	40	03	JMP to output to terminal routine	0366	A9	20	LDA imm 20 space routine	
025C	24	E7	BIT,z 00E7 check for a command	0368	4C	56	03	JMP to OUTCH at 0356	
025E	10	03	BPL to function	036B	A9	07	LDA imm 07 bell routine		
0260	4C	81	02	JMP to finish	036D	4C	56	03	JMP to OUTCH at 0365
0263	06	E7	ASL,z 00E7 Decode letters function	0370	A9	00	LDA imm 00 NULL routine		
				0372	4C	56	03	JMP to OUTCH at 0356	

031B, the command detection part of the program would sense this as a FIGS command and all the characters received after that would be upper case.

Therefore, for all the commands, space, and bell codes in the table, there is another part in the output routine that will look for these and insert the correct ASCII codes for the function. After these modified codes are sent to the terminal, they are changed back to their original value so the command detection will function properly. See locations 0340_h through 0374_h for this function. The values for FIGS and LTRS that are output to the terminal are simply nulls because we do not want the terminal to print anything on these commands. If these were not changed to nulls, the terminal would space, 20_h on a FIGS command, or output the character @, which

is 40_h on a LTRS command.

The next step in the modification was the deletion of all unnecessary steps in the program, such as the display and all the software that supports that function. This also included the "MOVE" and "SETX" parts in the original program. You will see that I also eliminated the tuning part from the original because I have a terminal unit with complete tuning facilities. If you were to use the PLL on the KIM for your terminal unit, you would have to add this on at the beginning. So do not forget to change the necessary commands for input from the PLL circuit and pin 8 on the applications connector.

I used a high-speed Potter and Brumfield reed relay to control data on pin 8, but I would suggest the photo-coupler as the best method. If you are not a

RTTY advocate and do not have a terminal unit, there are several units on the market now which, for their price, cannot be beaten. Many of these do not come with the high-voltage loop supply which the mechanical units such as the Model 19 require, but this is just fine. We do not require the high pull-up voltage that these old beasts required. Remember we are modern! All you need is the current to light the LED on the coupler. This eliminates one major expense of a terminal unit. If you are serious about this at all, you really should invest in one of these cheap terminal units. You will receive some fantastic art and see some of the most enjoyable QSOs that you could ever want to see. You can then really enjoy the mode and not be plagued with the errors caused by QRM and QRN. I hope that this article

will just be the start of a whole RTTY operating system for the KIM-1 owner, featuring all the luxuries of this "receive" article and also some very desirable transmit functions, like large memory buffer for typing faster than the output rate, correction and editing of transmitted data before it is actually transmitted, and more important, very little extra hardware.

Also, if you are thinking of a computer, I hope I have added just one more plug for the KIM-1. You will be able to copy all RTTY at all standard speeds, just by changing the bit in the timer. I would also like to talk to people who are KIM-1 owners; I usually hang out about 14.090 on Sunday at 1400Z. So please give me a holler and maybe we can trade information on this and other programs.

Oh, yes, anybody have a floppy on a KIM? ■



WIRE WRAPPING TOOL

For AWG 30, .025" (0,63mm) sq. post, "MODIFIED" wrap, positive indexing, anti-overwrapping device

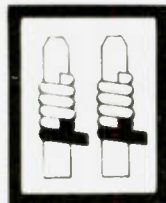

✓05

OK MACHINE & TOOL CORPORATION

3455 Conner St. Bronx, N.Y. 10475 / (212) 994-6600 / Telex 125091

NEW

HOBBY-WRAP
Model BW-630



Battery
**wire
wrapping
tool**

\$34⁹⁵
(batteries
not included)
ONLY
**COMPLETE WITH BIT
AND SLEEVE**



DX Delight

— a do-it-all program

Editor's Note: WA4VQD will provide a full listing of data for US and world cities and all DX countries to all those who request such and enclose a legal-size SASE.

Calculating Great Circle distances and antenna bearings to various points around the world by hand, even with a calculator, is tedious and time-consuming. Here is a program that does it for you. By entering a set of coordinates, you can get the

distance and bearing to any other point in the world. Using the data compiled and supplied here with the program will yield tables to major US cities and all the DX countries on the American Radio Relay League (ARRL) countries list.

How It Started and Credits Due

When I started selling selected pieces of amateur radio gear to pay for my growing computer system, my ham radio colleagues always came up with the old familiar "What will it do?" or "I'd build one of those computers if I could find a use for it." I had a canned five-minute dissertation on the virtues and potential applications for my system which I could immediately recite. This usually quieted them, but I wanted a good amateur radio application to prove that my computer could "really do something."

I got the idea for this program from Ed Mehnert N3NN while he was giving a talk on DXing to our local Twin Base Amateur Radio Club. Ed mentioned that he had developed a computer program written in BASIC on a time-sharing system which allowed him to calculate the distance and bearing to the DX countries. At that moment, the

light bulb in my head came on. "If it will work on a time-sharing BASIC system, it will work on my IMSAI," I said to myself. Then I knew I had found a good ham radio program for my computer. With Ed's blessing, I rewrote his program and used the extensive data he compiled on the DX locations to come up with this program.

The General Theory and Calculations

Any edition of *The ARRL Antenna Book* features a section on finding directions. This includes a description of the calculations for Great Circle distances and bearings between any two points in the world. These are based on two formulas using trigonometric functions.

For distance: $\cos D = \sin A \sin B + \cos A \cos B \cos L$

For bearing: $\sin R = \cos B \csc D \sin L$ *

A = your latitude in degrees.

B = the latitude of the distant location in degrees (latitudes in the Northern Hemisphere are positive and those in the Southern Hemisphere are negative).

L = longitude difference between the two

*The American Radio Relay League, *The ARRL Antenna Book*, Twelfth Ed., Newington, Connecticut, 1970, p. 284.

GREAT CIRCLE BEARINGS AND DISTANCES PROGRAM

DO YOU NEED INSTRUCTIONS? - YES OR NO
? YES

THIS PROGRAM CALCULATES GREAT CIRCLE DISTANCES IN STATUTE MILES AND KILOMETERS AND BEARINGS BETWEEN YOU AND THE REST OF THE WORLD. LATITUDES IN THE NORTHERN HEM ARE POSITIVE AND SOUTHERN HEM ARE NEG. LONGITUDES IN THE EASTERN HEM ARE POSITIVE AND WESTERN HEM ARE NEGATIVE. ALWAYS USE DEGREES WITH DECIMAL PARTS - NO MINUTES AND SECONDS.

WHAT IS YOUR NAME AND CALL LETTER?
? JAN HEISE - WA4VQD
WHAT IS YOUR LOCATION (HOME QTH)?
? MONTGOMERY, AL
WHAT IS THE LATITUDE OF THIS LOCATION?
? 32.3

WHAT IS THE LONGITUDE OF THIS LOCATION?
? -86.3
SELECT THE FUNCTION YOU WANT AND ENTER THE NUMBER

- 1 = GLOBAL GRID CENTERED ON YOUR LOCATION (LAT EVERY 15 DEGREES & LONG EVERY 30 DEGREES)
- 2 = BEARINGS AND DISTANCES TO MAJOR US CITIES
- 3 = BEARINGS & DISTANCE TO DX LOCATIONS FROM THE ARRL COUNTRIES LIST - LISTED BY CALL PREFIX
- 4 = BOTH US CITIES AND DX LIST.
- 5 = BEARINGS & DISTANCE TO USER SELECTED POINTS.
- 6 = ENTER NEW CENTRAL LOCATION
- ? = TERMINATE THE PROGRAM!!!

? 5

ENTER DISTANT LOCATION DESIGNATION
? PARIS, FRANCE

ENTER LATITUDE OF DISTANT POINT.
? 48.83

ENTER LONGITUDE OF DISTANT POINT.
? 2.33

DISTANCE FROM MONTGOMERY, AL TO PARIS, FRANCE IS 4522 MILES.
THAT DISTANCE IS 7277 KILOMETERS.
BEARING TO PARIS, FRANCE IS 46 DEGREES.

DO YOU WANT OTHER POINTS CALCULATED? YES OR NO

? NO

Fig. 1 Sample run of program instructions.

BEARINGS AND DISTANCES TO MAJOR US CITIES

CITY	MILES	K/M	BEARING
ANCHORAGE	3423	5509	325
ATLANTA	149	240	47
BANGOR-ME	1276	2053	42
BIRMINGHAM	88	142	341
BOISE-ID	1793	2885	304
BOSTON	1089	1753	46
CHARLOTTE	374	602	56
CHEYENNE	1191	1917	306
CINCINNATI	481	774	12
CLEVELAND	684	1101	20
COLUMBIA-SC	328	528	68
DALLAS	612	985	276
DENVER	1160	1867	301
DES-MOINES	758	1220	330
DETROIT	714	1149	14
GREAT-FALLS	1678	2700	316
HONOLULU	4403	7086	280
HOUSTON	577	929	255
INDIANAPOLIS	518	834	1
JACKSONVILLE	310	499	115
KANSAS-CITY	661	1064	318
KNOXVILLE	288	463	27
LAS-VEGAS	1660	2671	287
LITTLE-ROCK	383	616	297
LOS-ANGELES	1842	2964	282
LOUISVILLE	409	658	5
MEMPHIS	288	463	313
MIAMI	569	916	141
MILWAUKEE	745	1199	353
MINN-ST.PAUL	950	1529	339
MINOT	1348	2169	329
NASHVILLE	264	425	354
NEWINGTON-ARRL	990	1593	45
NEW-ORLEANS	270	435	235
NEW-YORK	895	1440	46
NORFOLK	654	1052	57
OKLAHOMA-CITY	679	1093	292
OMAHA	820	1320	322
PETERBOROUGH-73	1069	1720	43
PHILADELPHIA	815	1312	46
PHOENIX	1491	2399	279
PITTSBURG	660	1062	30
PORTLAND	2136	3437	306
RAPID-CITY	1219	1962	316
ST.LOUIS	496	798	334
SALT-LAKE-CITY	1535	2470	300
SAN-FRANCISCO	2064	3322	291
SEATTLE	2158	3473	310
TAMPA	374	602	142
WASHINGTON-DC	693	1115	46
WICHITA	7594	12221	357

Fig. 2. Sample run of US cities list.

locations. In this program, $L = L1 - L2$, where $L1$ is your longitude and $L2$ is the distant location. Longitudes in the Eastern Hemisphere are positive and those in the Western Hemisphere are negative.

D = distance in nautical miles or minutes of an arc. One Great Circle arc is 60 nautical miles and 1 min. = 1 nautical mile = 1.15078 statute miles. In this program, the output is converted to both statute miles and kilometers.

R = the direction of the distant location from you in degrees east or west of

north or south.

What this means is that the result will be between -90 and $+90$ degrees. This must then be converted to $0-359$ degrees. For example, a raw bearing of 17 could mean $0 + 17$, $180 - 17$, $180 + 17$ or $360 - 17$. Thank goodness for the computer to keep track of all the signs.

Most BASIC interpreters do not have arcsin and arccos functions; therefore, the arctangent function is used to get $\cos R$ and $\sin R$ in the formulas back into degrees based on the following relationship:

DX LISTING CENTERED FROM MONTGOMERY, AL FOR JAN HEISE -WA4VOD

	DX PREFIX	MILES	K/M	BEARING
1	A2C	8338	13418	101
2	A35	6818	10972	252
3	A4X	7727	12435	38
4	A6X	8156	13125	37
5	A7X	7580	12198	41
6	A9X	7451	11991	40
7	AC3	8328	13402	5
8	AC4	8164	13138	2
9	AP	7902	12717	24
10	BV	8074	12993	332
11	BY-N	7241	11653	343
12	BY-CTR	7671	12345	351
13	BY-S	8430	13566	337
14	C21	7151	11508	278
15	C31	4691	7549	53
16	C5A	4511	7260	90
17	C6A	618	995	124
18	C9M	8743	14070	92
19	CE	4628	7448	166
20	CE9-ANTR	8450	13599	180
21	CE0A	4372	7036	203
22	CE0X	4049	6516	173
23	CE0Z	4599	7401	174
24	CM	694	1117	157
25	CM	4438	7142	66
26	CP	3539	5695	158
27	CR3	5552	8935	111
28	CR4-NOW-D4	4064	6540	91
29	CR5	5583	8985	96
30	CR6-NOW-D2	7424	11947	95
31	CR7/C9M	8743	14070	92
32	CR8-DEL	9869	15882	302
33	CR9	8409	13533	337
34	CR10-DEL	9869	15882	302
35	CT	4231	6809	61
36	CT2	3332	5362	67
37	CT3	3898	6273	69
38	CX	5004	8053	155
39	D2A	7424	11947	95
40	D4	4064	6540	91
41	D62B	8903	14328	77
42	DL-DEL	4709	7578	43
43	DA-WEST	4709	7578	43
44	DM-EAST	4826	7766	39
45	DU	8703	14006	327
46	EA	4445	7153	57
47	EA6	4812	7744	55
48	EAB	4078	6563	74
49	EA9-CEUTA	4410	7097	62
50	EA9/R-DEL	4332	6971	76
51	EA9/S-DEL	4332	6971	76
52	EA0-DEL	6549	10539	86
53	EI	4048	6514	44
54	EL	5169	8318	92
55	EP	6969	11215	34

Fig. 3. Sample run of DX countries list.

```

3000 DATA ANCHORAGE,61,-150,ATLANTA,33.75,-84.4
3005 DATA BANGOR-ME,44.8,-68.8,BIRMINGHAM,33.5,-86.8
3010 DATA BOISE-ID,43.6,-116.2,BOSTON,42.4,-71
3015 DATA CHARLOTTE,35.2,-80.8,CHEYENNE,41.2,-104
3020 DATA CINCINNATI,39.1,-84.5,CLEVELAND,41.9,-81.9
3025 DATA COLUMBIA-SC,34,-81,DALLAS,32.8,-96.8,DETROIT,42.3,-83,HOUSTON,29.7,-95.2,INDIANAPOLIS,39.8,-86.2,LOS-ANGELES,34,-118.2,MIAMI,25.8,-80.2,MINN-ST.PAUL,44.9,-93.1,NEW-YORK,40.7,-74,PHILADELPHIA,39.9,-75.1,PHOENIX,33.4,-111.5,PITTSBURG,40.4,-79.9,PORTLAND,45.5,-122.7,RAPID-CITY,40.4,-103.1,SEATTLE,47.7,-122.3,ST.LOUIS,38.6,-90.2,SALT-LAKE-CITY,40.7,-111.8,SAN-FRANCISCO,37.8,-122.5,SPRINGFIELD,37.2,-90.5,TAMPA,28.2,-82.4,WASHINGTON-DC,38.9,-77,WINNIPEG,49.9,-99.1
3030 DATA DENVER,39.7,-105,DES-MOINES,39.1,-90.5,HOUSTON,29.7,-95.2,INDIANAPOLIS,39.8,-86.2,LOS-ANGELES,34,-118.2,MIAMI,25.8,-80.2,MINN-ST.PAUL,44.9,-93.1,NEW-YORK,40.7,-74,PHILADELPHIA,39.9,-75.1,PHOENIX,33.4,-111.5,PITTSBURG,40.4,-79.9,PORTLAND,45.5,-122.7,RAPID-CITY,40.4,-103.1,SEATTLE,47.7,-122.3,ST.LOUIS,38.6,-90.2,SALT-LAKE-CITY,40.7,-111.8,SAN-FRANCISCO,37.8,-122.5,SPRINGFIELD,37.2,-90.5,TAMPA,28.2,-82.4,WASHINGTON-DC,38.9,-77,WINNIPEG,49.9,-99.1
3035 DATA DETROIT,42.3,-83,HOUSTON,29.7,-95.2,INDIANAPOLIS,39.8,-86.2,LOS-ANGELES,34,-118.2,MIAMI,25.8,-80.2,MINN-ST.PAUL,44.9,-93.1,NEW-YORK,40.7,-74,PHILADELPHIA,39.9,-75.1,PHOENIX,33.4,-111.5,PITTSBURG,40.4,-79.9,PORTLAND,45.5,-122.7,RAPID-CITY,40.4,-103.1,SEATTLE,47.7,-122.3,ST.LOUIS,38.6,-90.2,SALT-LAKE-CITY,40.7,-111.8,SAN-FRANCISCO,37.8,-122.5,SPRINGFIELD,37.2,-90.5,TAMPA,28.2,-82.4,WASHINGTON-DC,38.9,-77,WINNIPEG,49.9,-99.1
3040 DATA HONOLULU,21.3,-155.5,LOS-ANGELES,34,-118.2,MIAMI,25.8,-80.2,MINN-ST.PAUL,44.9,-93.1,NEW-YORK,40.7,-74,PHILADELPHIA,39.9,-75.1,PHOENIX,33.4,-111.5,PITTSBURG,40.4,-79.9,PORTLAND,45.5,-122.7,RAPID-CITY,40.4,-103.1,SEATTLE,47.7,-122.3,ST.LOUIS,38.6,-90.2,SALT-LAKE-CITY,40.7,-111.8,SAN-FRANCISCO,37.8,-122.5,SPRINGFIELD,37.2,-90.5,TAMPA,28.2,-82.4,WASHINGTON-DC,38.9,-77,WINNIPEG,49.9,-99.1
3045 DATA TAMPA,28.2,-82.4,WASHINGTON-DC,38.9,-77,WINNIPEG,49.9,-99.1
3050 DATA ANCHORAGE,61,-150,ATLANTA,33.75,-84.4,BOISE-ID,43.6,-116.2,BOSTON,42.4,-71,CHARLOTTE,35.2,-80.8,CHEYENNE,41.2,-104,CINCINNATI,39.1,-84.5,CLEVELAND,41.9,-81.9,COLUMBIA-SC,34,-81,DALLAS,32.8,-96.8,DETROIT,42.3,-83,HOUSTON,29.7,-95.2,INDIANAPOLIS,39.8,-86.2,LOS-ANGELES,34,-118.2,MIAMI,25.8,-80.2,MINN-ST.PAUL,44.9,-93.1,NEW-YORK,40.7,-74,PHILADELPHIA,39.9,-75.1,PHOENIX,33.4,-111.5,PITTSBURG,40.4,-79.9,PORTLAND,45.5,-122.7,RAPID-CITY,40.4,-103.1,SEATTLE,47.7,-122.3,ST.LOUIS,38.6,-90.2,SALT-LAKE-CITY,40.7,-111.8,SAN-FRANCISCO,37.8,-122.5,SPRINGFIELD,37.2,-90.5,TAMPA,28.2,-82.4,WASHINGTON-DC,38.9,-77,WINNIPEG,49.9,-99.1
4495 DATA 7X,36,3,8P6,12.5,-59.5,80,4,73,8R1,7,-59
4500 DATA 8Z,29,47,9A1,44,12,9G,5.5,0,9H,36,14,9J,-16,28
4505 DATA 9K,29,48,9L1,8,-13.5,9M-EAST,1.5,110.5
4510 DATA 9M-WEST,3,101.5,9N,27,85,9O,-5,15,9U,-3,29.5
4515 DATA 9V1-SING,1,104,9X,-2.5,30,9Y4-TR&TOB,10.5,-61
4999 DATA ENDDATA,2,2
9999 END

```

Fig. 4. Portion of data statements from main program.

$$X = \arctan \frac{\sin X}{\cos X} =$$

$$\arctan \frac{\sqrt{1 - \cos^2 X}}{\cos X}$$

$$\text{or } \arctan \frac{\sin X}{\sqrt{1 - \sin^2 X}}$$

Radians are used in performing the calculations rather than degrees. The following formulas are used to convert degrees to radians and vice versa:

$$\text{Radians} = \frac{\text{Degrees} \times \pi}{180}$$

$$\text{Degrees} = \frac{\text{Radians} \times 180}{\pi}$$

The degrees must be entered in decimal form for this program and not in minutes and seconds.

The Program Description

The program was built in a modular manner with a "menu-type selection" of the function desired. Each function uses the same calculations which are all in one subroutine. This makes the program easy to modify. By taking out the appropriate block of call and print instructions and data, you can eliminate unwanted functions. I used straightforward BASIC commands and avoided any known unique characteristics of my system. Numerous remark statements were used to help clarify the program.

The instructions from the beginning up to 400

give you the option to get instructions, then input the data for your location, and finally select which function you desire. As you can see from Fig. 1, the following functions are available from the menu:

1. This option prints a global grid centered on your location. This allows you to make your own world map centered on your location. These azimuthal maps can be purchased centered on a few of the major cities such as Chicago or New York, but this function provides the data necessary to make one for any central location.
2. This option prints the

distances and bearings to over fifty selected US cities using the data provided in the program. You can add more if you wish.

3. This option prints the distances and bearings to all the DX countries on the ARRL countries list. These are listed alphabetically by radio call area prefix.
4. This option gives the cities list, automatically followed by the DX list.
5. This option allows you to enter any distant locations at the terminal and get the distance and bearing in return.
6. This option restarts the program at the point where you input the cen-

Main program listing.

```

:0 PRINT "GREAT CIRCLE BEARINGS AND DISTANCES PROGRAM"
:2 REM - PROGRAMMED BY JAN A. HEISE, WA4VQD, NOV 77.
:5 PRINT
:6 PRINT "DO YOU NEED INSTRUCTIONS? - YES OR NO"
:5 INPUT I$
:7 IF I$="NO" THEN 165
100 PRINT "THIS PROGRAM CALCULATES GREAT CIRCLE DISTANCES IN"
110 PRINT "STATUTE MILES AND KILOMETERS AND BEARINGS BETWEEN"
120 PRINT "YOU AND THE REST OF THE WORLD. LATITUDES IN THE"
130 PRINT "NORTHERN HEM ARE POSITIVE AND SOUTHERN HEM ARE NEG."
140 PRINT "LONGITUDES IN THE EASTERN HEM ARE POSITIVE"
150 PRINT "AND WESTERN HEM ARE NEGATIVE. ALWAYS USE DEGREES"
160 PRINT "WITH DECIMAL PARTS - NO MINUTES AND SECONDS."
165 PRINT
170 PRINT "WHAT IS YOUR NAME AND CALL LETTER?"
175 INPUT LINE N$
180 PRINT "WHAT IS YOUR LOCATION (HOME QTH)?"
185 INPUT LINE U$
190 PRINT "WHAT IS THE LATITUDE OF THIS LOCATION?"
195 INPUT A
:200 REM - CONVERT A TO RADIANS
:205 LET A1=A*3.14159/180
:210 PRINT
:220 PRINT "WHAT IS THE LONGITUDE OF THIS LOCATION?"
:240 INPUT L1
:250 LET J=0
:252 LET F=0
:255 GOSUB 2000
:260 PRINT "SELECT THE FUNCTION YOU WANT AND ENTER THE NUMBER"
:265 PRINT
:270 PRINT "1 = GLOBAL GRID CENTERED ON YOUR LOCATION"
:275 PRINT " (LAT EVERY 15 DEGREES & LONG EVERY 30 DEGREES)"
:280 PRINT "2 = BEARINGS AND DISTANCES TO MAJOR US CITIES"
:285 PRINT "3 = BEARINGS & DISTANCE TO DX LOCATIONS FROM THE"
:290 PRINT " ARRL COUNTRIES LIST - LISTED BY CALL PREFIX"
:292 PRINT "4 = BOTH US CITIES AND DX LIST."
:295 PRINT "5 = BEARINGS & DISTANCE TO USER SELECTED POINTS."
:300 PRINT "6 = ENTER NEW CENTRAL LOCATION "
:305 PRINT "7 = TERMINATE THE PROGRAM!!!"
:307 PRINT
:310 INPUT S
:312 PRINT
:315 ON S GOTO 400,515,605,510,700,50,9999
400 GOSUB 2000
401 PRINT "GREAT CIRCLE COORDINATES CENTERED ON ";U$
405 PRINT
410 PRINT "PROGRAMMED FOR ";N$
430 PRINT
435 PRINT "LATITUDE LONGITUDE MILES KILOMETERS BEARING"
437 PRINT "-----"
440 FOR L2 = -180 TO 180 STEP 30
450 FOR B=-90 TO 90 STEP 15
460 GOSUB 1000
465 PRINT TAB3;B;TAB11;L2;TAB22;D1;TAB30;D2;TAB44;R2
468 REM - CHECK THE LINE COUNTER.
469 LET K=K+1
470 IF K=55 THEN 485
475 NEXT B
480 NEXT L2
482 GOTO 250
485 GOSUB 2000
490 PRINT "LATITUDE LONGITUDE MILES KILOMETERS BEARING"
491 PRINT "-----"
495 GOTO 475
500 REM - 500 NUMBERED STATEMENTS READ THE FIRST SET OF DATA
502 REM - WHICH CONTAINS THE US CITIES DATA AND PRINTS LIST.
508 REM - F IS A FLAG TO SEE IF BOTH CITIES & DX LIST ARE
509 REM - DESIRED. IF YES ENTER AT 510 & F=1.
510 LET F=1
514 REM - 515 IS ENTRY POINT FOR CITIES ONLY (F=0 PRESET)
515 GOSUB 2000
520 PRINT "CITIES LISTING CENTERED ON ";U$;" FOR ";N$
:25 PRINT
:30 PRINT "BEARINGS AND DISTANCES TO MAJOR US CITIES"
:35 PRINT
:40 PRINT TAB5;"CITY";TAB15;"LAT/LONG MILES K/M BEARING"
:45 PRINT"-----"
550 LET K=K+1
559 REM - READ DATA & CHECK FOR END OF FILE.
:60 READ M$,B,L2
:65 IF M$="ENDATA1" THEN 597
:69 REM - GO PERFORM THE CALCULATIONS
:70 GOSUB 1000
:75 PRINT M$;TAB13;B;"/";L2;TAB28;D1;TAB35;D2;TAB43;R2
580 IF K=55 THEN 590
585 GOTO 550
590 GOSUB 2000
:95 GOTO 540
:96 REM - IS FLAG SET FOR BOTH CITIES AND DX LIST?
:97 IF F=1 THEN 614
598 RESTORE
599 GOTO 250
600 REM - 600 NUMBERED STATEMENTS READ THE SECOND SET OF
602 REM - DATA WHICH IS THE DX COUNTRIES LIST DATA.
603 REM - 605 TO 610 FIND THE END OF THE FIRST DATA.
605 READ M$,B,L2
608 IF M$ = "ENDATA1" THEN 614
610 GOTO 605
614 GOSUB 2000
615 PRINT "BEARINGS TO DX LOCATIONS ON ARRL COUNTRIES LIST"
620 PRINT "DEL - MEANS A COUNTRY DELETED FROM ARRL LIST"
625 PRINT
630 PRINT "DX LISTING CENTERED FROM ";U$;" FOR ";N$
635 PRINT
640 PRINTTAB5;"DX PREFIX LAT/LONG MILES K/M BEARING"
645 PRINT"-----"

```

tral location data. This is useful when you are preparing several lists for different locations—for all your ham friends.

7. This option simply terminates the program.

The 400-series statements all correspond to option one, which is to print the global grid. Nested loops are used to perform the calculations with the latitude incremented by 15 degrees at a time from -90 to +90, while the longitude is varied from -180 to +180 in increments of 30 degrees.

The 500-series statements are used to perform option two, which is to print the US cities list (see

Fig. 2). A flag (F) is used to determine if lists of both cities and countries are desired. The 3000-series data statements contain the cities data used with this option. The program looks for "ENDATA1" in the city field to tell it there are no more cities. The data is then restored for use again, and the program either goes back to the menu or on to prepare a DX country list.

The 600-series statements correspond to option three, which is to prepare the DX countries list (see Fig. 3). If the entry here is from the menu, the program first reads the data and looks for "EN-

DATA1" in the country field. This means it must read through all the cities data, but since no calculations are performed, virtually no time is lost. The data for the DX countries list is contained in the 4000-series data statements (see Fig. 4). When this data is reached, the program operates just as it did for the cities. It looks for an "ENDATA2" in the country field to indicate it has reached the end of the countries data. The program then returns to the menu.

The 700-series statements compose the routine used to calculate individually-entered distant

points. This routine is set up in a loop, which allows you to continue to calculate individual points until you desire to return to the menu.

The 1000-series subroutine performs all the calculations. The subroutine can be used as a stand-alone program if desired. It requires that A, B, L1, and L2, which I have previously discussed, be provided. It returns the following results: D1 = the distance in miles; D2 = the distance in kilometers; R2 = the bearing in degrees. All of these are rounded to the nearest integer.

In the routine, L is calculated and then

```

650 LET K=K+1
655 LET J=J+1
660 READ M$,B,L2
665 IF M$="ENDATA2" THEN 696
670 GOSUB 1000
675 PRINTJ;TAB5;M$;TAB15;B;"/";L2;TAB29;D1;TAB36;D2;TAB45;R2
680 IF K=55 THEN 690
685 GOTO 650
690 GOSUB 2000
695 GOTO 640
696 RESTORE
699 GOTO 250
/00 REM - THE 700 NUMBERED STATEMENTS MAKE UP THE ROUTINE TO
/01 REM - CALCULATE USER ENTERED COORDINATES ONE AT A TIME.
/05 PRINT "ENTER DISTANT LOCATION DESIGNATION"
/15 INPUT LINE M1$
/20 PRINT
/25 PRINT "ENTER LATITUDE OF DISTANT POINT."
/35 INPUT B
/40 PRINT
/45 PRINT "ENTER LONGITUDE OF DISTANT POINT."
/55 INPUT L2
/60 GOSUB 1000
/65 PRINT
/70 PRINT "DISTANCE FROM ";M$; " TO ";M1$; " IS ";D1;" MILES."
/71 PRINT "THAT DISTANCE IS ";D2;" KILOMETERS."
/72 PRINT "BEARING TO ";M1$; " IS ";R2;" DEGREES."
/75 PRINT
/80 PRINT "DO YOU WANT OTHER POINTS CALCULATED? YES OR NO"
/85 PRINT
/90 INPUT T$
/95 IF T$ = "YES" THEN 705
/99 GOTO 250
1000 REM - 1000 SERIES SUBROUTINE PERFORMS ALL CALCULATIONS.
1001 LET L=L2-L1
1002 REM - X IS A FLAG FOR TESTING L
1003 LET X=0
1005 REM - BRING L WITHIN RANGE -180 TO 180
1010 IF L<-180 GO TO 1025
1015 IF L>180 GO TO 1035
1020 GOTO 1040
1025 LET L=L+360
1030 GOTO 1100
1035 LET L=L-360
1040 IF L<0 THEN 1100
1045 LET X=1
1100 REM - CONVERT L AND B TO RADIAN
1110 LET B1 = B*3.14159/180
1115 LET L = L*3.14159/180
1119 REM - COMPUTE THE DISTANCE ANGLE
1120 LET P=COS(L)*COS(A1)*COS(B1)+SIN(A1)*SIN(B1)
1125 LET P1=ATN(SQR(1-P*P)/P)
1130 LET P2=P1+180/3.14159
1134 REM - DISTANCE ANGLE MUST BE POSITIVE IF NOT ADD 180
1135 IF P2<0 GOTO 1145
1140 GOTO 1150
1145 LET P2=P2+180
1149 REM - COMPUTE DISTANCE
1150 LET D1 = INT(P2*60+1.15152+.5)
1151 LET D2=INT(D1*1.6093+.5)
1154 REM - COMPUTE THE BEARING ANGLE.
1155 LET R=COS(B1)*SIN(L)/SIN(P1)
1160 LET R1=ATN(R/SQR(1-R*R))
1164 REM - CONVERT BEARINGS TO DEGREES ROUNDED TO NEAREST INT
1165 LET R2=INT((R1+180/3.14159)+.5)
1168 REM - DETERMINE WHAT QUADRANT THE BEARING ANGLE IS IN AND
1169 REM - ADJUST THE DEGREES.
1170 IF ABS(R)>.999998 THEN 1500
1175 IF ABS(R)<.00174 THEN 1600
1180 LET B2=(B+.1) * 3.14159/180
1185 LET R3=COS(L)*COS(A1)+COS(B2)+SIN(B2)*SIN(A1)
1190 LET R4=ATN(SQR(1-R3*R3)/R3)
1200 LET R6=COS(B2)*SIN(L)/SIN(R4)
1205 IF X=1 THEN 1240
1210 IF ABS(R6) > ABS(R) THEN 1230
1215 LET R2=360-ABS(R2)
1220 GOTO 1700
1230 LET R2 = 180+ABS(R2)
1235 GOTO 1700
1240 IF ABS(R6) < ABS(R) THEN 1255
1245 LET R2 = 180-ABS(R2)
1250 GOTO 1700
1255 LET R2 = ABS(R2)
1260 GOTO 1700
1500 IF X=1 THEN 1530
1510 LET R2 = 270
1520 GOTO 1700
1530 LET R2=90
1540 GOTO 1700
1600 IF ABS(L) > 178 THEN 1640
1605 IF B<A THEN 1630
1610 LET R2=0
1620 GOTO 1700
1630 LET R2=180
1635 GOTO 1700
1640 IF B>A THEN 1630
1645 GOTO 1610
1700 RETURN
2000 REM - THIS ROUTINE PRINTS BLANK LINES AFTER EVERY 55
/001 REM - LINES OF DATA SO PAPER CAN BE CUT STANDARD SIZED.
2005 PRINT
/006 PRINT
2007 PRINT
2008 PRINT
2009 PRINT
2010 PRINT
2011 PRINT
2012 PRINT
/020 K=0
2030 RETURN

```

brought into the range of -180 to +180 degrees. All angles are then converted into radians and plugged into the formula to compute the distance angle. The bearing angle is then computed.

The rest of the calculations ensure that the bearing angle is placed in the correct quadrant. For most angles, the procedure is to take a slightly incremented point (0.1 degree) from the original angle and compare the sines of the original and incremented angles. The original angle is placed in the correct quadrant depending on whether the sine increased or decreased. For any L that is positive, the bearing angle will be in quadrant I or II, and for any negative L, it will be in quadrant III or IV. Keeping this in mind, you can see that the incremental test will tell you whether to add or subtract

the bearing angle from 0 or 180 degrees to give you the final bearing angle.

Before the incremental test is performed, angles which are so small that the test could put them into the next quadrant are sorted out and simply rounded off. Since $\sin(0) = 0$ and $\sin(90) = 1$, the following procedure is used:

If the sine is positive and very close to 1, then angle = 90 degrees; if the sine is negative and very close to 1, then angle = 270 degrees; if the sine is positive and very close to 0, then angle = 0 degrees; if the sine is negative and very close to 0, then angle = 180 degrees.

Once the distances and the bearing angle have been calculated, the routine returns to the calling segment where the results are printed.

The 2000-series subrou-

tine merely prints blank lines and new page headers to keep the output in a page size format. A counter (K) is used in each option. It calls the new page routine after every 55 lines of data are printed.

Sidelines and Miscellaneous Information

The complete program with all the cities and DX countries data requires about 14K of user memory. By omitting remark statements and some of the "frills," you can cut the size down considerably. By using DATA statements such as I did in this program, you can easily add new cities or make changes to the countries list.

The version listed here prints out the latitude and longitude of the cities and DX countries. After a few initial runs to verify the data, I went to a new version in which I stopped

printing the latitude and longitude for each location.

Entering the data may look like an enormous task, but to me it was well worth it. Hams can buy listings similar to these from commercial sources, but they usually cost about \$10.00. Your local amateur radio club members may be more than willing to compensate you for your efforts.

A feature which I plan to add to my program is an alphabetical listing of major cities around the world. *The World Almanac* gives the latitude and longitude for a long list of North American cities as well as several world cities. I use maps in the *Rand McNally World Atlas* for obtaining the latitude and longitude for other locations.

I hope that this program will be as useful to others as it has been to me. ■



BRITT'S
2-Way Radio Service

2508 North Atlanta Road
Belmont Hills Center
Smyrna,
Georgia 30080
Phone (404) 432-8006

B29

North Georgia's
only
Authorized
Yaesu Dealer

Yaesu	Kenwood
Mosley Antenna	Vibroplex keys
Cush-Craft	B & W
Rohn-Tower	Swan meters
C.D.E. Rotors	Hustler
Shure	United Clocks and tuners
Call Books	ARRL Books
M F J	Saxton

TPL 2 Meter Amplifiers
Complete service facilities
Call toll free 1-800-241-9961

SLEP SPECIALS

RADIO RECEIVERS, TRANSCEIVERS

- R-390/JRR Receiver, tunes 500 kHz through 30.5 MHz, digital tuning, dual rf, audio filters, 19" rack mount, 115 V/60 Hz \$495.00
- R-390A/JRR Receiver, tunes 500 kHz thru 30.5 MHz digital tuning, mechanical filters, 19" rack mount, 115 V/60 Hz 595.00
- R-389/JRR VLF Receiver tunes 15 kHz thru 1500 kHz, 19" rack mount, digital tuning, 115 V/60 Hz 550.00
- HAMMARLUND SP-600JX Receiver, tunes 500 kHz thru 34 MHz, 19" rack mount, 115 V/60 Hz 375.00
- R-388/JRR Receiver, military version of the 511-3, tunes 500 Hz to 30.5 MHz, 19" rack mount, 115 V/60 Hz 375.00
- R-392/JRR Receiver tunes 500 kHz thru 32 MHz digital tuning, mechanical filters, in cabinet size 11-1/2" H x 14" D x 11" L, takes 28 volts dc - 5 Amps to operate 275.00
- COLLINS RT-594/ARC-38A Aircraft Transceiver 2.0 thru 25 MHz, synthesized channels 35, 250 (20 preset), 100 Watts PEP 5S8, FSK AM, CW, size 24" L x 15-1/2" W x 7-3/4" H, weight 65 lbs., requires 28 volt dc power supply 145.00
- MODEL VOX-2 technical material corp variable frequency oscillator tuneable 2 thru 64 MHz even controlled, 115 V/60 Hz 85.00

TEST EQUIPMENT

- COLLINS 479T-2 VOR/MLS Signal Generator 108-135.9 MHz and 329.3-335 MHz, output signals include VOR, LOC, glideslope G 1000 CPS operated 28 V dc portable or bench power source 225.00
- TS-510A Signal Generator, military version of HP608D, 10-420 MHz AM, CW, Pulse, built-in calibrator 425.00
- TS-497/JRR Signal Generator, 2-400 MHz, 100,000 Microvolts, calibrated output, 400, 1000, Hz modulation 225.00
- AN/JRM-25 Signal Generator, 10 kHz thru 50 MHz, AM/CW, MOD 400 G 1 kHz, rf output D-2 V, or D-1 V precision 50 Ohm stop attenuator 285.00
- SG-12 FM Signal Generator, 20-100 MHz in 5 bands, rf output .5 uV to .5 V, deviation 0-100 kHz in 3 ranges, internal modulations 185.00
- SG-3 FM Signal Generator 50-400 MHz in 3 bands, rf output .1 to .1 V, variable 50 Ohm attenuator, deviation 0-150 kHz in 3 ranges, internal modulation 385.00
- HP 302A Wave Analyzer 125.00
- TS-1379/U SPECTRUM ANALYZER range 0-30 MHz in 6 bands, 5" crt display, 8 sweep widths from .15 to 30 kHz sweep rate 1 sec. to 10 sec. Has fast sweep mode for rapid tuning, dynamic range 60dB, solid state 385.00
- ARM-5A military version of the ARC H-14 OMNI signal generator 285.00
- TS-1100/U Transistor Test Set, portable, perfect for testing transistors 65.00
- SG-24/TRM-3 Sweep Generator 265.00
- HP 17A Klystron Power Supply 65.00
- HP-100D Frequency standard Generator 10 Hz, 100 kHz, 1 kHz, built-in scope 85.00

All equipment shop tested, satisfaction guaranteed or money refunded. Send check, M.C. or VISA, FOB Otto, NC, phone (704) 524-7519.

SLEP ELECTRONICS COMPANY
P.O. Box 100, Hwy. 441, Dept. 73
OTTO, NORTH CAROLINA 28763

S4

Now you have a friend in the business!



Planning to purchase a new Transceiver?
or a new Amplifier —
or an Antenna?

Talk it over with your friends at Clegg!

Shopping for Price?
Looking for Reliable Service?
Want Professional Advice?

Your friends at Clegg offer all this, and more!

We want to be your Friend. Let us prove it! Call us today using our new departmentalized telephone system.

ORDERS AND QUOTES: TOLL FREE 1-800-233-0250
SERVICE DEPARTMENT: TOLL FREE 1-800-233-0337
ENGINEERING, PURCHASING, ADMINISTRATION
AND ACCOUNTING: 1-717-299-7221

Clegg

Communications Corp.
1911 Old Homestead Lane
Greenfield Industrial Park East
Lancaster, PA 17601

✓ C3

INSTANT SOFTWARE™

*IMP™ for **TRS-80** ONLY \$7.95 ea.

Level I on one side, Level II on the other



● **SPACE TREK II**—by KB1 (for the TRS-80™) This Space Trek game will challenge the most skillful and careful player. As commander of the Enterprise, you must defend the galaxy against enemy Klingon warships using your arsenal of phasers and photon torpedoes to best advantage. The Enterprise is also equipped with impulse power for moving within the quadrant, and warp power for jumping from quadrant to quadrant. \$7.95 Order no. 0002R.

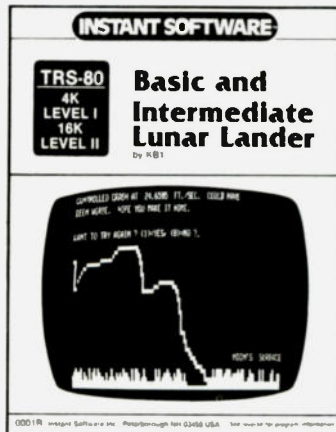

● **BASIC LUNAR LANDER/INTERMEDIATE LUNAR LANDER**—by KB1 (for TRS-80™) Your automatic landing system has malfunctioned and you are forced to make a manual landing. Taking control at 15,000 feet, the pilot's success requires precise manipulation of the lunar lander's retro-rockets. After mastering the basic game, the able commander will be taxed by the difficult intermediate program \$7.95. Order no. 0001R.



● **BEGINNER'S BACKGAMMON/KENO**—by Fred Schild and KB1 (for the TRS-80™) You will never be in need of a backgammon companion again! Schild's program is designed for the newcomer to the game, but the computer's steady play will challenge the careless expert. KENO is a popular Las Vegas gambling game. As in many games of chance, the odds are against you, but when you win you can win big \$7.95 Order no. 0004R.

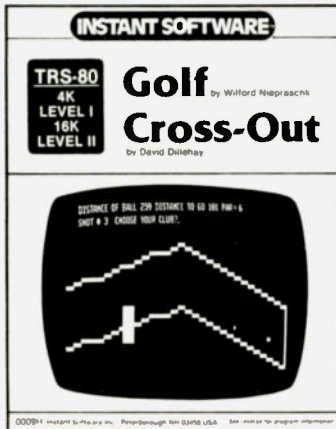

● **GOLF/CROSS-OUT**—by Wilford Niepraschk and David Dillehay. Playing golf on a computer? You bet and frustrating, too. You have your choice of seven clubs—three irons, three woods, a chip and a putter. The program has 18 different fairways, each diabolically designed. You have to pick the right club and angle for hitting the ball or else you end up in the woods or a trap. The green calls for putting skill. The program has excellent graphics and you'll have a ball . . . golf ball. CROSS-OUT is the old peg puzzle, but in computer form. You have to jump pegs, removing each one jumped. The idea is to end up with but one peg, and that one in the middle hole. The program will rate your skill at the end of each try. \$7.95. Order no. 0009R.

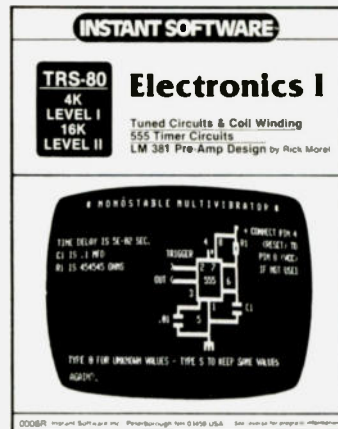

● **ELECTRONICS I** by Rick Morel. With this group of five programs you will be able to design coils for radio circuits, calculate the component values for tuned circuits, design preamplifiers using the LM-381 IC and timer circuits, either monostable or astable using the 555 timer IC. Coils can be designed with the use of tables or special calculators, but they are difficult to use. This package has a coil designing program which is simple to use and the computer does all the work. There is also a program for designing tuned circuits, audio or radio frequency—fixed or variable frequency. The LM-381 program draws the circuit diagram and gives you the component values for your needs. It will calculate any unknown values for you. The two 555 programs do the same, giving you the diagrams for either one-shot timers or astable timing systems (clocks). It will do all the calculations for you, providing times or component values. These programs are not only helpful around any workshop or lab, they also are wonderful for teaching the fundamentals of electronics to newcomers. \$7.95. Order no. 0008R.



● **HAM PACKAGE I** by Rick Morel and D. A. Lien. This group of eight programs (we like to give you plenty) will be of frequent help to any experimenter or ham operator. OHM'S LAW CALCULATIONS SERIES CAPACITANCES FREQUENCY VS REACTANCE PARALLEL CAPACITANCES SERIES RESISTANCES DIPOLE DESIGN PARALLEL RESISTANCES YAGI DESIGN. These programs draw the circuits or antennas involved and let you fill in the pertinent data, giving you the dimensions, etc. This series of programs is not only an excellent way to learn the fundamentals of electronics and the handling of simple formulas, they will also be of constant use in any workshop or ham shack. \$7.95 Order no. 0007R.

INSTANT SOFTWARE™

*IMP™ for **PET**

INSTANT SOFTWARE™
for your **PET**

INSTANT SOFTWARE™
for your **PET**

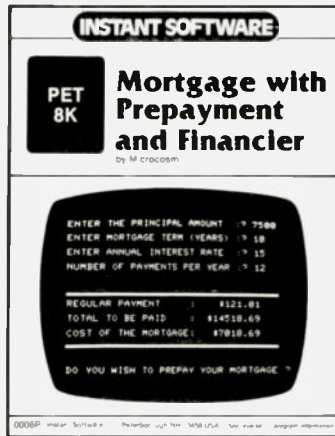
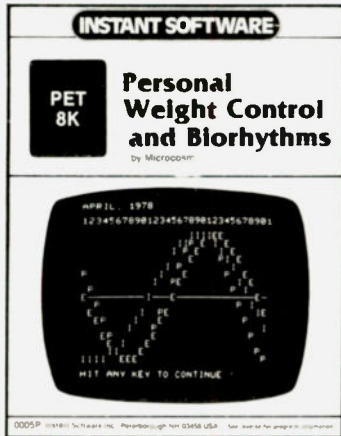

● **PERSONAL WEIGHT CONTROL/BIORHYTHMS**

—by Microcosm (for the PET™) Here's a program that will let you chart any individual's biorhythm cycle showing physical, emotional, and intellectual highs and lows. If your neighbors find out you've got it, they will never leave you in peace. **PERSONAL WEIGHT CONTROL** is a must for the diet-conscious. Once your ideal weight has been determined, the program will calculate the correct daily caloric intake necessary to reach your goal over a certain time period. \$7.95. Order no. 0005P.

● **MORTGAGE WITH PREPAYMENT OPTION/FINANCIER**

—by Microcosm (for the PET™) Before you go to the bank, calculate your mortgage payment schedule and find out what you can afford. You will learn how much prepayments save, and can easily compare the true costs of variations in interest. **FINANCIER** is actually three programs in one and is guaranteed to make you a financial wizard. In part I you'll learn to tell which investments will pay off! Part II calculates annual depreciation schedules, providing rates, amounts, and salvage values which is great when tax time rolls around. The final section figures costs of borrowing, payment terms, and remaining balances on loans of all sizes. \$7.95. Order no. 0006P.

\$7.95 ea.

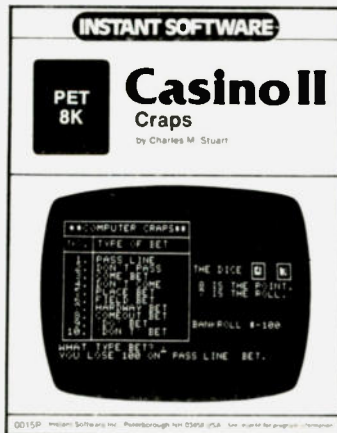
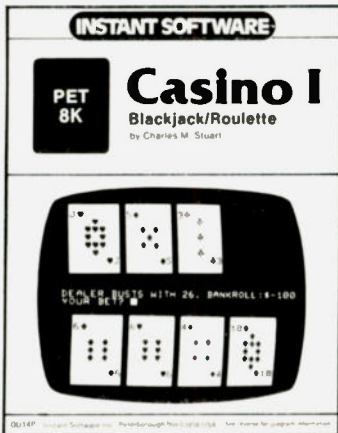

● **CASINO I** by Charles M. Stuart—There are blackjack games galore, but not many of them are so dependable that you can rely on them to prepare to make your fortune at Vegas. This blackjack program is not only fun to play, it is also tutorial and allows you to try every combination which you could play at the MGM Grand Hotel in Las Vegas.

There are several systems which will beat the house at blackjack, so before you go investing your cash in a get rich quick attempt, try it your system on this program and see how it does in actual practice.

Roulette programs are more difficult to find, yet this is another very popular casino game—and one you'll want to get some experience with before you venture to go up against the professionals at Vegas. Remember that there are a lot of people who have worked out systems to beat the house at these games and they make a comfortable living going to Vegas every now and then to rebuild their fortunes.

This roulette program is tutorial and gives you the odds on each type of bet.

All you need is the expertise and a little luck to go along with it and you'll pay for your computer in no time. \$7.95. Order no. 0014P.

● **CASINO II** by Charles M. Stuart—Yes, there are a lot of craps programs around—so why should you buy this one? The big difference is that this one is not just a crap game, it is also a tutorial program which will give you the odds on every type of bet so you can steer clear of the idiot bets that impoverish the unwary. Did you know that there are bets which give the house as little as 0.8% advantage? It takes precious little luck to overcome such a slight edge—but you have to know where to find these bets before you can use them.

If you use this program to get experienced with craps you should be able to walk away from any craps table a winner. Once you know what bets to make and are able thereby to take the best advantage of lucky streaks, betting lightly to wait through the lean times, you'll have quite an edge.

This program uses the exact rules used at the MGM Grand Hotel in Las Vegas, so you'll be playing under actual gambling house conditions. You should be able not only to pay for the program, but also for your computer system the next time you go to Vegas or Atlantic City. \$7.95. Order no. 0015P.

Send me the following Instant Software:

Quantity	Catalog	Program name	Unit Cost	Total cost
			\$7.95	
			7.95	
			7.95	
			7.95	
		Shipping		\$1.00
		Total order		

Check Money Order VISA AMEX

MasterCharge Expiration date _____

Card No. _____

Name _____

Address _____

City _____ State _____ Zip _____

Instant Software Inc. Peterborough, NH 03458
Dept. S11

Big Max Attacks

—it's W2DU vs. K4KI,
in the battle of the bazooka

M. Walter Maxwell W2DU
PO Box 215
Dayton NJ 08810

Several years ago I was faced with a perplexing question: Why the popularity of the so-called double bazooka, while *my* bazooka showed no vital signs other than those expected of a simple half-wave dipole? So, I performed an autopsy.

The startling results of the postmortem examination were published in *Ham Radio*,¹ and the graveside rites were reported in *QST*.² Since then, it has been generally conceded that the burial was justified. Nevertheless, William Vissers K4KI has taken exception. Believing my account of the death to be exaggerated, and the burial premature, he exhumed the bazooka and reexamined it. However, due to unsuspected errors in his examination, he con-

cluded *incorrectly* that it still lives. I will uncover these errors so that it can be quickly reburied.

The *73 Magazine* article³ reporting his reexamination of the double bazooka (a *misnomer* for the coaxial dipole) discloses some interesting and valuable information. But it's unfortunate that some portions of the article are misleading, and others are totally incorrect (particularly the major conclusion), making it impossible for the uninitiated to separate fact from distortion.

My paper in *Ham Radio*¹ analyzes the impedance characteristics of the coaxial-dipole antenna, clarifying the conditions under which its coaxial stubs either will or will not enhance the impedance bandwidth of a dipole. My analysis shows why coaxial stubs connected in parallel with the dipole terminals

cannot provide a worthwhile or *significant* improvement in bandwidth for the effort expended (even with stubs of *optimum* impedance), *unless the feedline impedance is considerably higher than the usual 50 Ohms*.

Errors in the Reexamination Technique

Mr. Vissers agrees that my conclusion is valid for a *free-space* environment. Nevertheless, because he miscalculated the effect of the "big difference" between free-space and near-earth antennas, his contention that the thin-wire, free-space dipole used in my analysis doesn't represent antennas operated near earth is incorrect. In addition, through a fortuitous combination of other errors, he has been misled to believe that the shunt stubs *will* provide a significant enhancement of dipole bandwidth that they

can't provide in free space, by simply operating the coaxial dipole near earth.

On the contrary, just the opposite is true; the broad-banding effect of the stubs is *less* when the antenna is near earth than when it is in free space, not greater. In view of Mr. Vissers' seemingly plausible presentation, how can this be? Don't his graphs showing *swr* prove that the stubs are working? Indeed they don't. With all due respect to Mr. Vissers, I regret having to point out errors in his treatment of antenna fundamentals that caused the *swr* graphs in both Figs. 8 and 9 to be in serious error. And these erroneous *swr* curves misled him to the catastrophic conclusions that the bandwidth performance of his coaxial dipole is *significant*, and that the stubs perform better near earth than they do in free space.

In examining the reasons why he arrived at conclusions that are directly opposite to the facts, we will discover why the free-space, thin-wire antenna data used in my analysis is relevant to antennas near earth. Furthermore, since mistreatment of the fundamental concepts has generated confusion far beyond the realm of the coaxial-dipole antenna, I feel compelled to discuss the mistreated concepts in sufficient depth to clarify the confusion.

Validity of the Thin-Wire, Free-Space Dipole

To begin, let's consider the criticism concerning thin wire for the dipole radiating elements. The statement that there is no such thing as "thin-wire" coaxial cable has no meaning, because there is no reference defining what "thin" is. He has simply misinterpreted "thin" to mean *vanishingly* thin, instead of following the standard practice of specifying finite thickness of radiators in terms of wavelength λ . On the contrary, the antenna terminal impedances used throughout my analysis are based specifically on diameter D of the outer conductor of RG-58/U coax, where $D = 0.140$ inches $= 0.0000445\lambda$ at 3.75 MHz, which is indeed a "thin wire" at this frequency (see page 50¹). And in asserting that there is a "big difference" in the effect on bandwidth between free-space and near-earth conditions, Mr. Vissers must have overlooked my *measured, near-earth* data appearing on page 48 in the *Ham Radio analysis*,¹ and in *QST*.² The difference in the effect between these two conditions will be explored in detail later on.

Improper Selection of Q Spells Trouble in Fig. 8

Next, let's examine the

three swr curves appearing in his Fig. 8. He used these curves as the "theoretical" basis for his conclusion that the coaxial stubs in the dipole are contributing significantly to bandwidth. However, because of an improper selection of Q for antennas near earth, these swr curves are incorrect—the true values are more than double those shown. Thus, the basis for his conclusion falls apart. All of the swr values in Fig. 8 were calculated based on resonant antenna reactances X_{La} and X_{Ca} (which were unwisely obtained from Q) in his Fig. 2. By incorrectly assuming a Q of 10, the resulting 400 Ohms obtained for reactances X_{La} and X_{Ca} is less than half the true value of the resonant reactances found in antennas having the dimensions of a typical coaxial dipole resonant at 3.75 MHz (length $L = 125$ feet, and diameter $D = 0.140$ inches). Using the incorrect 400 Ohms as the basis for the swr calculations resulted in the optimistic, but *impossibly-low* swr values in Fig. 8. Ironically, when this error in reactance is corrected, and the affected arithmetic recalculated, the resulting swr values are nearly the same as those obtained in my analysis. Thus a conclusion similar to mine must also follow. Directly related to the improper choice of Q in determining the value of X_{La} is the contention that Q is lower when an antenna is near earth than when it is in free space. The opposite is actually true. I will show later how Q was used improperly, why it is unwise to obtain X_{La} from Q , and why Q is *higher* when an antenna is near earth than when it is in free space. I will also outline a procedure for calculating the value of X_{La} from the L/D ratio, which entails less chance for error than when

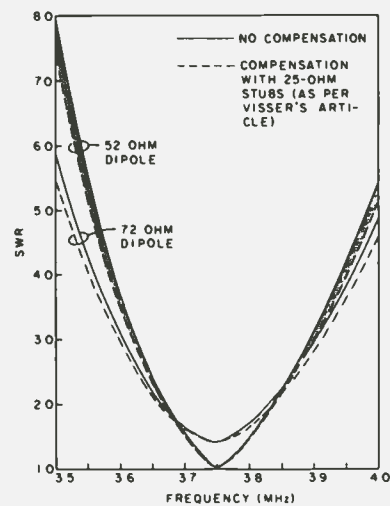

Fig. 1.

using Q .

Obtaining Corrected Value of X_C for Swr Calculations

So let's ignore Q momentarily, and start with the basic length-to-diameter ratio $L/D = 125'/0.140'' = 10,714$. From this ratio, which determines antenna inductance L_a and capacitance C_a in his Fig. 2 (detailed procedure comes later), we obtain the correct value of 846 Ohms for reactances X_{La} and X_{Ca} at the 3.75-MHz resonant frequency, instead of the incorrect 400 Ohms shown in Fig. 2. Using $X_{La} = 846$ Ohms in calculating the off-resonance antenna reactance X_C at 3.5 MHz yields 117 Ohms, in contrast to the 55.24 Ohms in Fig. 3. It's too bad this error wasn't detected early on by simply checking the 55.24 Ohms in a universal graph of antenna resistance and reactance versus radiator length (or frequency), with L/D ratio as a parameter. Such a graph appears in the *ARRL Antenna Book*, and in many textbooks on antennas, such as Jordan and Balmain,⁴ Schelkunoff,⁶ or King⁷ (and in Figs. 2 and 4 of my analysis¹). Another way of confirming the error will be disclosed later.

Because of the simplified procedure used to ob-

tain it, this corrected off-resonance reactance of 117 Ohms is still only an approximate value. To calculate antenna-terminal impedances that agree more closely with the measured data requires more complex mathematical procedures, such as those of Schelkunoff⁶ or King,⁷ from which universal impedance graphs are generated. Thus from King we obtain a more accurate and realistic off-resonance antenna reactance: $X_C = 108$ Ohms at 3.5 MHz for our L/D ratio (see Table 2).

Impact of Wrong X_{La} from Improper Selection of Q

To confirm the catastrophic impact on the conclusion, let's now compare the results using the correct reactance with those using the incorrect reactance. First, using the corrected value of reactance, $X_C = 108$ Ohms with resistance R_a of 40 Ohms, we get a realistic swr of 7.75:1 at the antenna terminals at 3.5 MHz instead of the impossibly-low 3.27:1 shown in his Figs. 3 and 8. Why is the 3.27 impossibly low? Because to obtain a raw, uncompensated swr of only 3.27:1 at 3.5 MHz with $R_a = 40$ Ohms, it would require a dipole diameter of 3.1 inches—22 times larger than the 0.14" diameter of RG-

58/U coax. Remember, RG-58/U is a thin radiator at 3.5 MHz!

Second, a 7.75:1 swr agrees closely with data obtained during hundreds of my measurements of similar conditions using a General Radio rf impedance bridge, Model GR-1606A (also see Borton,⁹ Fig. 2). In contrast to the $\pm 10\%$ accuracy specified for the swr indicator mentioned in the 73 Magazine article (which cannot indicate reactance), the General Radio bridge has an accuracy capability of measuring resistance to within $\pm 1\%$, and reactance to within $\pm 2\%$.

Third, re-solving the parallel circuit problem of his Fig. 5 using the corrected reactance, $X_C = 108$ Ohms, instead of 55.24 Ohms, confirms the catastrophe, because the original compensated resistance of 116 Ohms (which yielded the 2.33:1 swr) now becomes 331.6 Ohms when the parallel-circuit reactance is canceled (using a shunt reactance X_L of 122.8 Ω , instead of 85.3 Ω). With a 331.6- Ω resistance terminating a 50- Ω line, the uncompensated 7.75:1 swr is reduced only to 6.63:1 (vs. 2.33:1!).

In proportion to the frequency difference, the corrected impedance, $Z_a = 40 - j108$ Ohms (7.75 swr), agrees closely with my measured data appearing in the 80 meter example on page 48 in my *Ham Radio* analysis,¹ and in QST²: At 3.55 MHz (50 kHz closer to resonance), I measured $Z_a = 50 - j90$ Ohms (5.04 swr). With perfect compensation the parallel-circuit resistance is 212 Ohms, reducing the 5.04 swr to 4.24. Thus the amount of mismatch reduction is also proportional. In addition, at 3.5 MHz I measured $Z_a = 48 - j110$ Ohms (6.90 swr). Note the close agreement with the corrected impedance, $Z_a = 40 -$

$j108$ Ohms, especially the 110-Ohm reactance component. Bear in mind that both my data were measured with the GR-1606A rf bridge, and the corrected data represent near-earth conditions. Thus the errors in the Vissers data are confirmed. And in view of the close agreement between the data of these near-earth antennas and the free-space data appearing in Figs. 2 and 9b of my analysis,¹ the criticism of using free-space data in my analysis is clearly unjustified. More on this later.

Procedure for Obtaining X_{La} (and Q) from the L/D Ratio

Let's now see how the resonant antenna reactance, X_{La} , is calculated from the L/D ratio, from which we'll see the difficulties both in obtaining X_{La} from Q and in making an accurate assumption of Q unless X_{La} is already known. The basic antenna characteristic from which values of antenna inductance L_a and capacitance C_a may be obtained for use in the equivalent-series RLC circuit of Mr Vissers' Fig. 2 is the average characteristic impedance, Z_0 . Antenna Z_0 is determined uniquely by the physical dimensions of the radiator. The value of Z_0 may be obtained from the length-to-diameter ratio, L/D, using the expression $Z_0 = 120 (\log_e 2L/D - 1) = 120 (\log_e 3000/0.140 - 1) = 1076.7$ Ohms (equation 1). Antenna inductance L_a and capacitance C_a may now be obtained from the expressions³ $L_a = Z_0/8f_r$ (equation 2) and $C_a = 2/\pi^2 f_r Z_0$ (equation 3), where f_r = resonant frequency. Since L_a and C_a are both dependent on L/D and Z_0 , both the inductive reactance, X_a , at resonance and the equally negative capacitive reactance, X_{Ca} , are also dependent on L/D and Z_0 . Multi-

plying the expression in equation 2 by $\omega = 2\pi f$, we get the simple expression for obtaining X_{La} : $X_{La} = \pi Z_0/4 = 0.7854 Z_0 = 845.64$ Ohms (equation 4). [Knowing Z_0 , here is the other check method Vissers could have used to detect his reactance error, which also confirms that the correct antenna reactance (X_a) at 3.5 MHz is around 110 Ohms, not 55 (when resonant at 3.75 MHz). This method uses the well-known expression $X_a = -Z_0 \cot l^\circ$. At 3.5 MHz, the electrical half length $l = 90^\circ \times 3.5/3.75 = 84^\circ$. Thus, $X_a = -1076.7(\cot 84^\circ) = -113.6$ Ohms.]

Antenna Q can now be determined from X_{La} and resonant resistance R_a using the expression³ $Q = X_{La}/R_a$ (resonant) (equation 5). Observe in equation 4 that resonant resistance R_a (which is affected by proximity to ground) does not appear in determining the resonant inductive reactance X_{La} ; thus X_{La} is independent of R_a . However, since X_{La} at resonance is determined by L/D, it is relatively constant, having only a slight variation with height above ground. In equation 5 we see that Q is dependent on X_{La} , and also varies inversely with the value of R_a at resonance. Since R_a at resonance varies appreciably with height, decreasing as height decreases below 0.2λ , Q thus increases as the antenna height decreases. Since Q and R_a both vary with antenna height, we can't assume to know the value of either Q or R_a at some arbitrary height for the purpose of determining X_{La} , unless accurate measurements of both Q and R_a are taken. Most amateurs don't have the equipment to perform these measurements with sufficient precision to yield a good value for X_{La} . And herein lies the

key to Mr. Vissers' error: He has implied that the assumptions for his R_a and Q were based on his measurements. Although his assumption of $R_a = 40$ Ohms is realistic, his $Q = 10$ is not, because this combination yields the erroneous $X_{La} = 400$ Ohms, a value that can't exist with an L/D ratio of 10,714 at 3.75 MHz. However, since it is so easy to determine the accurate length and diameter of the radiating element, why not obtain X_{La} directly from L/D as described above? This way we avoid the uncertainties accompanying any attempt to determine X_{La} from R_a and Q. So let's now correlate some pertinent values based on the correct value of X_{La} (846 Ohms, obtained earlier from L/D), which will emphasize the importance of obtaining the correct value of X_{La} , if calculations based on this value are to have validity.

Why a Q of 10 Is Incorrect

The resonant resistance R_a of our RG-58 coaxial dipole in free space with an L/D ratio of 10,714 is 72 Ohms (73.13 Ohms when $L/D = \infty$, see King⁷), and the value of X_{La} from equation 4 is 846 Ohms. Thus, from equation 5, the free-space Q of the dipole is $846/72 = 11.75$. However, when the antenna is at a height where R_a is reduced to 40 Ohms, the Q increases to $846/40 = 21.15$, in contrast to Mr. Vissers' value of 10. On the other hand, if this arbitrarily-chosen Q of 10 were realistic with an $R_a = 40$, the value of X_{La} really would be 400 Ohms. However, this Q of 10 would have come from a free-space $Q = 10 \times 40/72 = 5.56$, which defines an entirely different antenna. In fact, as stated earlier, a value for X_{La} of 400 Ohms at 3.75 MHz requires that diameter $D = 3.1$ inches,

22 times thicker than that of RG-58/U, for an L/D = 487. To use Mr. Vissers' own words, that is a big difference!

Effect of Height on Antenna Q

The subject of antenna height and its effect on Q is another area of concern in the 73 Magazine article,³ because two conflicting concepts appear that are rather puzzling. On one hand, he used the expression $Q = X_{La}/R_a$ (equation 5), and its inversion $X_{La} = R_a \times Q$, which state correctly that when R_a decreases, Q increases. On the other hand, "after much thought" concerning the results of his measurements, he concluded that because of the unavoidable losses incurred when the antenna is near ground, the Q is lower than when the antenna is in free space. This conclusion is puzzling, because it is well known that when dipole height is less than 0.2λ , the antenna resistance, R_a , is less than the free-space value. Since equation 5 shows that Q varies inversely with R_a , antenna Q near ground becomes higher than the free-space value, rather than lower. This discrepancy in his conclusion, and the erroneous assumption that $Q = 10$, raises serious questions concerning the measuring equipment, technique, and evaluation of the data.

Now, the matter in which R_a changes with height over actual ground (in contrast to perfectly-conducting ground) is complicated by several factors, including the dissipative losses he mentioned. However, the actual value of R_a is determined by the integrated effect of all the contributing factors in any given set of ground-proximity conditions. Thus the value $R_a = 40$ Ohms includes the effect of these losses, and R_a and X_{La}

determine the Q actually existing under those conditions. On the other hand, if the ground were perfectly conducting, the mutual coupling between the antenna and its ground-reflected image would be greater for the same height, due to the absence of the ground losses. When height is less than 0.2λ , this larger coupling results in a lower value of R_a , and a correspondingly higher Q than when the antenna is over actual ground. Perhaps he really meant that because of the ground-associated losses, the Q of an antenna over actual ground is lower (and the R_a higher) than if it were over perfectly-conducting ground. In any event, the Q of an earth-oriented antenna is higher, not lower, than the same antenna in free space. Thus, it is not true that "because earth-oriented antennas have a lower Q" they yield a greater degree of bandwidth improvement using shunt-stub compensation than those in free space.

Ignoring Feedline Attenuation Spells Trouble in Fig. 9

Let's now examine Fig. 9, which is called the "proof of the pudding." The experimental data of Fig. 9 is said to prove that the coaxial dipole is working, because it is said to correlate with the theoretical data of Fig. 8 (which we have shown to be erroneous), and because "it indicates that the swr improvement is even better than the calculations predicted." Unfortunately, Fig. 9 provides no such proof. On the contrary, Fig. 9 reveals that he shares a widespread misconception concerning the correlation between theoretical and practical aspects of antenna systems evaluation. In reality, the graph in Fig. 9 proves only that the swr values shown are those

measured at the input to a feedline, and that some amount of change in swr at the load (antenna) resulted from changing the stub conditions. Regardless of the caption, the graph reveals no quantitative data whatever concerning swr at the antenna, because the true dipole swr values are masked by an unknown feedline attenuation between the line input and the antenna terminals. It's like trying to identify a pea beneath a mattress, because we know both from the corrected calculated data and from measurements that the true values of dipole swr are nearly $2\frac{1}{2}$ times larger than those shown in Fig. 8.

Necessity for Line-Attenuation Data

If the swr is measured at the feedline input simply to ascertain transmitter loading conditions, then line-attenuation data is unnecessary. On the other hand, if the line-input measurements are for ascertaining the matching conditions at the antenna, then feedline-attenuation data is absolutely essential. The attenuation data is needed to obtain the input-output proportionality factor required to calculate the magnitude of the reflection coefficient (mismatch) at the load from that measured at the input. But no attenuation data is given for the curves

in Fig. 9. Thus the numbers on the scale labeled "MEASURED SWR" are meaningless with respect to swr at the antenna, because their mathematical relation to the antenna terminals is unknown. If the line attenuation were zero (which it isn't), then the curves, as labeled, would represent the true swr values of the antenna. On the other hand, if the attenuation were 2.06 dB, then the 2.85:1 swr of curve A at 3.5 MHz would represent the recalculated 7.75:1 swr appearing at the antenna terminals. Thus, to indicate swr at the antenna, the scale factor of the "MEASURED SWR" scale must be tailored to fit the line input-output proportionality factor obtainable only from the line attenuation. A procedure for obtaining this proportionality factor is outlined (with solved examples) in Appendix 4 of my analysis in *Ham Radio*.¹

The data in Table 1 illustrates the necessity of attenuation data, showing, for example, that by simply increasing the line attenuation from 2.06 to 3.18 dB, a 2.85:1 swr would still appear at the feedline input with the far end either short circuited, or left open circuited. In other words, by measuring at the line input, one could not distinguish between the separate loads of either zero Ohms or an infinitely-high

With Line Attenuation <i>a</i>	Swr at Line Input	
	When Load $Z_L = 40-j108$ Ohms	When Load $Z_L = SC$ (0 Ohms) or OC (∞ Ohms)
0.0 dB	7.75	∞
0.25	6.36	34.8
0.5	5.40	17.4
1.0	4.17	8.7
1.5	3.41	5.85
2.0	2.90	4.42
2.06	[2.85]	4.30
3.0	2.26	3.0
3.18	2.18	[2.85]
4.0	1.89	2.32
5.0	1.64	1.92

Table 1. SC = short circuit; OC = open circuit.

resistance.

Murphy Nearly Scored, but Two Wrongs Don't Make a Right

The fortuitous similarity of the incorrect theoretical data in Fig. 8 and the meaningless measured data in Fig. 9 is unfortunate and misleading because, for those unfamiliar with the effects of line attenuation, the comparison of these figures supports the widespread misconception that measurements at the line input directly indicate conditions at the antenna. And indeed, this misconception trapped Mr. Vissers into the most catastrophic error in his coaxial-dipole projects, because it misled him to believe that his stubs were performing well, even though they were performing as described in my *Ham Radio* analysis. By ignoring the effect of feedline attenuation, the accidental agreement between the low-swr values of Fig. 9 measured at the line input, and the unsuspected, incorrect, theoretical antenna swr data in Figs. 3 and 8, misled him to believe that both graphs were correct and valid antenna terminal data, and that the measured data supported the theoretical data. On the contrary, if he had calculated in the effect of the feedline attenuation on the line-input swr values of Fig. 9, he would have obtained values of dipole swr that are vastly greater than those of Fig. 8 at the corresponding frequencies. This discrepancy would have alerted him to go back and find the initial error (the wrong value of X_{La}) in calculating the Fig. 8 data. This is the second opportunity at which the error could have been detected. Had the error been detected at either point, the case for the coaxial dipole would have evaporated. Unfortunately, it is fairly

common to see published curves purporting to show measured antenna bandwidth characteristics, without providing any feedline attenuation information. Such curves convey no more clues to truth in antenna performance than Mr. Vissers' Fig. 9, so he is not alone.

In addition to line attenuation, there are other factors that contribute to misleading indications when measuring swr at the line input. More often than not, swr-indicator readings are somewhat lower than the real swr values appearing at the line input. And with the coaxial dipole, the external dielectric covering on the coax-cable radiator causes a mild increase in antenna bandwidth, from the combination of increased antenna capacity C_a and additional ohmic loss due to dissipation in the dielectric. (I raised this point in *QST*.²) These factors make it impossible to calculate the true terminal impedance and swr of the dielectric-covered dipole (for Fig. 8) with any degree of certainty, although the swr is certain to be somewhat less than the 7.75:1 that we calculated previously for a bare wire of $D = 0.14$ inches. The best way to find out for sure is to determine the attenuation of the feedline used in obtaining the data for Fig. 9, re-measure the data with an accurate impedance bridge, and then perform the calculation to transfer the swr values at the feedline-input terminals to the antenna terminals.

Impedance Relations in Free Space Versus Near Earth

Let's now return to the discussion concerning the effect of free-space versus near-earth conditions in relation to antenna impedance and bandwidth, to

discover why Mr. Vissers' belief that the coaxial dipole performs better near earth is erroneous. He agrees with the conclusion in my analysis that the reactance shunting used in the coaxial dipole is ineffective for increasing bandwidth when the dipole is in free space and fed with 50-Ohm feedline. However, he believes this technique is effective with lower antenna resistance, R_a , as found in 80 meter antennas at normal heights. Unfortunately, in expecting an improvement in the broadbanding capabilities of reactance shunting by reducing resistance R_a from the free-space value of 72 Ohms to around 40 Ohms, he is overlooking two basic principles of impedance matching, one underlying the shunt-reactance method of increasing the bandwidth, and the other concerning the minimum-swr resistance in a complex load impedance. The vital aspects of the shunt-reactance method that were overlooked are disclosed in my *Ham Radio* analysis¹ (page 50), and the minimum-swr resistance principle is described in a paper I published in *QST*.⁶ However, the following discussion may be helpful in clarifying the conflict.

In the conventional method of matching, antenna resistance R_a , at resonance, is usually nearly equal to the line impedance, Z_C . Typically, R_a can be anywhere from 40 to 72 Ohms when $Z_C = 50$ Ohms (a 1.4:1 mismatch is considered insignificant). With this nearly one-to-one ratio between the line and load impedances at resonance, the mismatch rises continuously on either side of resonance, because the ratio between the two impedances increases, due to the increasing reactance, X_a . Now if we simply add reactance shunting to the

antenna terminals to cancel the antenna reactance, the shunt reactance cannot perform effectively in reducing the mismatch off resonance, as long as the impedance ratio is already nearly one-to-one at resonance. The reason is because the shunt reactance cannot yield a significant reduction in the off-resonant antenna impedance—it can only exchange a reactive terminal impedance for a nearly-equal resistive impedance. Thus the impedance ratio remains high, and as I explained in the analysis and illustrated with a numerical example in *QST*,² when the feedline-to-antenna impedance ratio is high, the mismatch is nearly the same whether the antenna terminal impedance is reactive or resistive. Thus the shunting is ineffective, as shown in Fig. 10B in my analysis, and in Fig. 1 in this article.

On the other hand, consider the relationship where the feedline-to-antenna impedance ratio is within the range where the shunt-reactance method can perform effectively. By using a feedline of higher impedance, increased by a factor of two-to-one or more (and accepting a similar compromise in mismatch at resonance), the ratio between the reactive off-resonant antenna impedance and the line impedance is reduced proportionally. With this lower off-resonance impedance ratio, the exchange of a reactive load impedance for a resistive impedance resulting from the reactance shunting now yields a significant reduction of off-resonance mismatch, as Fig. 4 of my analysis shows.

The Crucial Factor in the Resistance Versus Off-Resonance-Mismatch Relationship

The crucial factor in this

relationship is this: The vital reduction of the off-resonant, line-to-antenna impedance ratio obtained by increasing the line impedance cannot be duplicated by reducing the antenna resistance R_a unless the antenna reactance X_a is also reduced proportionally, because it is mainly the off-resonance reactance that causes the high antenna impedance. Naturally this inherent reactance cannot be reduced unless the radiator itself is redesigned. So when the resistance is reduced without also reducing the reactance, the off-resonance impedance relationship is entirely different from that obtained by increasing the line impedance.

To discover how reducing only the resistance R_a affects mismatch, let's experiment with a dipole. Starting with $R_a = 72$ Ohms at resonance, we'll make a series of frequency excursions to the ends of the band, and at each successive excursion we'll reduce only the resistance, so that all values of R_a versus frequency are lower than those of the preceding excursion. The result is that at any frequency where the swr exceeds about 2:1, the mismatch and swr become LARGER as the resistance becomes LOWER. And the greater the swr, the less improvement reactance shunting can provide, for the reason explained earlier. So while the mismatch improvement by reactance shunting is already insignificant when $R_a = 72$ Ohms (as Mr. Vissers agrees), it becomes worse when $R_a = 40$ Ohms, not better.

It is true that reducing the resonant antenna resistance from 72 to 40 Ohms improves the inherent match slightly in the region near resonance

(from 1.44 down to 1.25:1). However, this is not the region where mismatch reduction is needed; the reduction is needed in the regions toward the band ends, where the inherent, uncompensated swr exceeds 2:1, and it is in these regions where Mr. Vissers' theory fails, and where the shunt-reactance method cannot provide significant improvement for a thin dipole when fed with a 50-Ohm feedline.

The relationship between resistance and off-resonance mismatch is shown in Fig. 1 (a graph from data of Table 2, which will be explained shortly), where we can see the significant difference in the way dipole swr changes between frequencies near resonance and those nearer to the band edges, depending on whether the antenna resistance R_a at resonance is 52 Ohms or the free-space value of 72 Ohms. With the 52-Ohm antenna the match is nearly perfect at resonance, and thus remains somewhat better than the 72-Ohm antenna out to around a 2:1 swr. However, at frequencies where the swr is greater than 1.7:1 below resonance, and 2.2:1 above resonance, the match is consistently worse with the 52-Ohm antenna. From calculations not shown in Table 2, the match quality of an antenna having a 40-Ohm resonant R_a deteriorates much more rapidly than the 52-Ohm antenna, especially near the band-edge frequencies where we need the mismatch reduction the most.

The Basis for the Graphs and Tables

The swr values appearing in Fig. 1 and Table 2 were calculated from the terminal impedances of both a free-space and an earth-oriented dipole, with

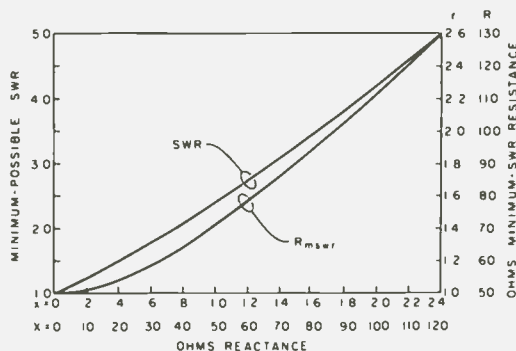

Fig. 2.

three different stub-matching conditions for each: 1) no stubs; 2) 25-Ohm stubs; and 3) optimum stubs. To make a valid comparison of the mismatches associated with these different stub conditions requires authentic impedance data. Because dipole resistance R_a changes significantly with frequency (see Table 2), it is improper to calculate the mismatches using a constant resistance $R_a = 40$ Ohms across the band (as Mr. Vissers has done). Therefore, the free-space data appearing in Fig. 1 and Table 2 is authentic impedance data taken from King,⁷ the same as used in my analysis.¹

For the earth-oriented impedance data, resistance values of $R_a = 20$ Ohms were selected for each corresponding frequency, to allow for the mutual coupling to the image dipole. The constant 20-Ohm difference between free-space and earth-oriented resistance versus frequency represents only a small compromise with the actual change in mutual resistance R_m across the band, and the $R_a = 20$ -Ohm values closely represent those obtained with the reflection coefficient of average ground. Exceptionally high ground conductivity beneath the antenna is required to obtain values much less than 40 Ohms anywhere within the band at any height us-

ing a straight dipole, although lower values can be obtained with inverted-Vs having included angles of considerably less than 180 degrees. The $R_a = 20$ -Ohm values include 68 Ohms at 4.0 MHz, 52 Ohms at resonance, down to 38.5 Ohms at 3.5 MHz.

At average 80 meter antenna heights, the mutual reactance X_m is small, so the change in terminal reactance X_a with height is negligible, as confirmed by extensive measurements. Therefore the same values of X_a were used in both the free-space and earth-oriented conditions. Of course, earth-oriented impedances vary with location. However, the impedances selected as previously described are typical of the average amateur situation, and are valid for demonstrating the general relationship between antenna resistance and mismatch (both with and without stubbing). In other words, measured values are not expected to repeat the data in Table 2 exactly, but in general the improvements due to stubbing will be fairly proportional to those appearing in Table 2. It should be kept in mind, as explained earlier, that with 50-Ohm feedline, the ratio of off-resonance antenna-to-feedline impedance is too high for the stubbing to have a significant effect.

However, it should be clearly understood that the

Table 2 values showing swr improvement are the precise values that will result strictly from the shunt reactance alone for the given impedance conditions—no greater improvement than this can be obtained from the shunting itself, because the calculations based on pure, lossless reactance yield precise answers. However, if measured values do indicate a significantly greater amount of improvement than shown in Table 2 under the same conditions of uncompensated impedance, it means that additional phenomena are also contributing to the effect obtained with lossless stubs. Such phenomena include ohmic loss of the stubs which we haven't considered (the actual stubs aren't lossless), and the effect of the external dielectric, which is a separate contribution that is practically impossible to predict. But remember, any such "improvement" resulting from ohmic loss represents power that isn't radiated.

The Minimum-Swr-Resistance Principle

When a load terminating a feedline is resistive, as in an antenna operating at resonance, the mismatch between the line and the load impedances is found by simply dividing the larger impedance by the smaller. However, as with all amateur antennas, when the load is the complex impedance $Z_a = R_a + jX_a$ of an antenna operating off resonance, the relationship between line impedance Z_c and mismatch is no longer a simple one. So appreciation of the swr values in Fig. 1 and Table 2 is understandably difficult. Directions for calculating the swr values are outlined in Appendices 1 and 2 of my analysis,¹ but textbook study is required for an in-depth apprecia-

tion of the concepts. However, although not well known among amateurs, the minimum-swr-resistance⁸ principle provides an elegant means for correlating complex load impedance with feedline impedance in a way that provides an unusual viewpoint in appreciating the effect of resistance on the match quality when the load contains reactance. So let's examine the minimum-swr-resistance principle.

In a series complex load impedance, Z_L , comprising a resistance R and reactance X , if the resistance is varied but the reactance is not, there is a single value of resistance, R_{mswr} (called the minimum-swr resistance), that will cause the load to produce a minimum of mismatch when terminating a generator or line. Unless $X = 0$, R_{mswr} will be greater than the line impedance Z_c . When the component values in the load are normalized to the line impedance Z_c (yielding $R/Z_c = r$, and $X/Z_c = x$), the value of the normalized minimum-swr-resistance $r_{mswr} = \sqrt{x^2 + 1}$ (equation 6).⁸ When the load $Z_L = R_{mswr} + jX$, the mismatch value equals the sum of the normalized components of the load; i.e., $swr = r_{mswr} + x$ (equation 7).⁸

This principle tells us that for a given value of reactance, X , in a load in series with resistance R_{mswr} , any change in resistance (either higher or lower) will cause the swr to rise. For example, let's find the value of R_{mswr} for a reactance $X = 50$ Ohms with a 50-Ohm line, and compare the mismatch the combination produces with the mismatches from two other impedances having the same reactance, but one having a higher resistance and the other a lower resistance. Thus, $Z_L = R_{mswr} + j50$ Ohms, and

by normalizing becomes $z = R_{mswr} + j1.0$. The value of r_{mswr} (determined solely from x) is $\sqrt{x^2 + 1} = \sqrt{1^2 + 1} = \sqrt{2} = 1.414$. De-normalizing, $R_{mswr} = 50 \times 1.414 = 70.71$ Ohms, so the desired impedance is $Z_L = 70.71 + j50$ Ohms. The swr produced by this impedance is $r_{mswr} + x = 1.414 + 1 = 2.414$, the minimum-possible swr when $X = Z_c = 50$ Ohms. (This treatment works only when $r = r_{mswr}$.) Now, using the expressions from Appendices 1 or 2 in my analysis¹ to calculate the swr produced by general complex load impedances, we find that impedances $Z_L = 50 + j50$ and $100 + j50$ both yield the identical value of $swr = 2.618:1$, which is higher than the minimum-possible 2.414:1 produced by the impedance $70.71 + j50$ Ohms. Additional calculations show that as the resistance goes either lower than 50 Ohms or higher than 100 Ohms, the swr continues to rise above 2.618:1. For example, $Z_L = 25 + j50$ yields 4.266:1, and $125 + j50$ yields 2.962:1. However, note that the swr rises slowly as R increases above 100 Ohms, but rises rapidly when R decreases below 50 Ohms.

This minimum-swr-resistance principle is completely general, working for any value of reactance X and line impedance Z_c . Thus we have a powerful tool for investigating any complex antenna-terminal impedance Z_a as the load for determining which direction the swr will go with a change in resistance R_a . Fig. 2 contains a plot of R_{mswr} versus reactance X (including the normalized values for x) for values of X from zero to 120 Ohms with a line impedance Z_c of 50 Ohms. For convenience, the corresponding minimum-possible-swr values are also plotted. To

use the graph in determining whether the swr will rise or fall with a given change in antenna resistance R_a , we first determine the reactance component X_a of the antenna impedance. From either the graph, or equation 6, we then find the corresponding minimum-swr-resistance, R_{mswr} . If resistance R_a is lower than R_{mswr} , raising the value of R_a will reduce the swr (until $R_a = R_{mswr}$), and vice versa. If R_a is higher than R_{mswr} , raising the value of R_a will increase the swr, and vice versa. Since R_{mswr} is 50 Ohms when $X = 0$, R_{mswr} does not go lower than 50 Ohms. Thus if resistance R_a is less than 50 Ohms, increasing the value of R_a will decrease the swr for whatever the value of reactance X_a , including $X_a = 0$. However, to reach the minimum-possible swr when any reactance is present, resistance R_a must be higher than 50 Ohms, and the greater the reactance, the higher resistance R_a must be raised.

Verification Using the Minimum-Swr-Resistance Principle

Turning now to Table 2, the values of minimum-swr-resistance R_{mswr} listed there (from the data of Fig. 2) are the values which yield the lowest possible mismatch when in series with the corresponding reactance X_a at the indicated frequency. In other words, if resistance R_{mswr} for the corresponding reactance were to replace the actual antenna resistance R_a , we would obtain the lowest swr that is possible with that particular reactance X_a in the circuit. The values of the corresponding minimum-possible swr are also listed in Table 2.

In using this technique to confirm our previous conclusions based on calculated values of swr, let's first examine the con-

FMHz	Antenna Impedance Components'					Mismatch or Swr					
	Resistance		Ohms React.	Ohms Resis.	Min.-Possible	Uncompensated dipole		Compensated with 25Ω stubs		Compensated with optimum stubs	
	R_a	R_a-20	X_a	R_{mswr}	Swr	Free-Space	Near-Earth	Free-Space	Near-Earth	Free-Space	Near-Earth
	R_a	R_a-20	X_a	R_{mswr}	Swr	R_a	R_a-20	R_a	R_a-20	R_a	R_a-20
3.5	58.5	38.5	108.00	119.0	4.54	5.84	8.00	5.50	7.50	5.16	6.83
3.55	60.8	40.8	-86.50	99.9	3.73	4.27	5.53	4.04	5.19	3.71	4.58
3.6	63.4	43.4	-64.79	81.8	2.93	3.05	3.68	2.92	3.49	2.67	3.03
3.625	64.75	44.75	-53.94	73.55	2.55	2.58	2.98				
3.65	66.1	46.1	-43.08	66.0	2.18	2.18	2.39	2.12	2.30	1.97	2.03
3.675	67.6	47.6	-32.24	59.5	1.83	1.86	1.92				
3.69	68.5	48.5	-25.74	56.24	1.64	1.70	1.68				
3.7	69.1	49.1	-21.40	54.4	1.52	1.62	1.54	1.60	1.50	1.54	1.38
3.75	72.0	52.0	0	50.0	1.00	1.44	1.04	1.44	1.04	1.44	1.04
3.8	75.1	55.1	21.92	54.6	1.53	1.71	1.53	1.69	1.50	1.69	1.49
3.825	76.6	56.6	32.80	59.8	1.85	1.95	1.86				
3.85	78.2	58.2	43.58	66.3	2.20	2.24	2.23	2.19	2.15	2.14	2.05
3.9	81.3	61.3	65.24	82.2	2.95	2.95	3.11	2.85	2.97	2.74	2.77
3.95	84.8	64.8	87.15	100.5	3.75	3.81	4.17	3.61	3.96	3.51	3.69
4.0	88.0	68.0	109.24	120.1	4.59	4.83	5.42	4.61	5.13	4.47	4.87

Table 2.

ditions at 3.825 MHz. At this frequency the lower-height ($R_a - 20$, or 52-Ohm) antenna yields a slightly better match near resonance because its 52-Ohm resonant resistance is nearer to the 50-Ohm line impedance than the 72-Ohm free-space antenna. From Table 2, at 3.825 MHz, $X_a = 32.8$ Ohms, and the minimum-swr-resistance $R_{mswr} = 59.8$ Ohms. If the actual resistance $R_a - 20$ were 59.8 Ohms, the swr would be 1.85:1, the lowest swr possible with 32.8 Ohms of reactance in the circuit. However, at this frequency the actual resistance $R_a - 20 = 56.6$ Ohms nearly equals the minimum-swr resistance, yielding a 1.86:1 swr for the 52-Ohm antenna (only slightly higher than the minimum), in contrast to the higher value $R_a = 76.6$ Ohms for the free-space antenna, with a 1.95:1 swr. This explains why the 52-Ohm antenna yields a slightly better match than the 72-Ohm antenna at this frequency.

On the other hand, at 3.5 MHz the minimum-swr-resistance technique demonstrates rather dramatically why the off-resonance mismatch in-

creases when the antenna resistance at resonance is reduced. Again from Table 2, at 3.5 MHz the reactance $X_a = -108$ Ohms is shown to require a resistance R_{mswr} of 119 Ohms to obtain the lowest-possible swr, which is 4.54:1. The free-space and near-earth dipole resistances at 3.5 MHz are 58.5 Ohms and 38.5 Ohms, respectively. Thus, the free-space resistance is 60.5 Ohms below the optimum 119 Ohms, which increases the swr to 5.84:1. However, with the 38.5-Ohm resistance of the near-earth antenna, the swr has soared to 8.0:1, because the 38.5-Ohm resistance is 20 Ohms lower yet than the free-space value, or 80.5 Ohms below the optimum value. Now, since the free-space value of 58.5 Ohms is already 60.5 Ohms below the optimum value of R_{mswr} of 119 Ohms, it is clearly evident that to obtain a lower swr than the free-space value of 5.84:1, the resistance R_a must be increased, rather than decreased. Moreover, an examination of all remaining data points listed in Table 2 reveals that the values of R_{mswr} and minimum-possible swr confirm the direction in which

every value of dipole swr changed resulting from a corresponding change in dipole resistance R_a .

As an additional point of interest, compare the curves appearing in Fig. 8 of the *73 Magazine* article¹ with those of my Fig. 1, and note the asymmetric shape of my swr curves with respect to the center frequency of 3.75 MHz. While the (+) and (-) reactances, X_a , are almost symmetrical (see Table 2), the values of swr below center are higher than those at the same difference in frequency above center. The reason is that resistance R_a is decreasing below center, and increasing above, and the swr values are simply following the minimum-swr-resistance principle. On the contrary, the Vissers curves are unrealistically symmetrical, because in his swr calculations the constant value $R_a = 40$ Ohms was used (incorrectly) across the entire band.

Conclusion

In comparing the swr curves of the 72-Ohm and 52-Ohm antennas in my Fig. 1, it is evident that no great dramatic difference exists between them. However, these two curves

represent the effect of the "big difference" that was asserted to exist between my free-space 72-Ohm dipole and a dipole near earth. This is the "big difference" that was predicted would change the insignificant stub contribution in my "irrelevant" free-space coaxial dipole into a workable, worthwhile contribution by "bringing the dipole down to earth." Obviously, the dramatic change that was predicted doesn't materialize, and the positions of the curves in my Fig. 1 indeed show that the dipole near earth is even less effective than when in free space. Thus, despite Vissers' statement to the contrary, these curves more than justify the use of free-space data in my analysis that enables the amateur to recognize the conditions under which the stubs in a coaxial dipole will or will not provide a worthwhile improvement in bandwidth.

Perhaps not everyone will agree on just what constitutes a worthwhile, significant improvement in swr. So if anyone decides the meager improvement shown in Fig. 1 and Table 2 is worth the constructional effort and cost required to

obtain it with shunt stubs, fine and dandy. But if you appear to be measuring considerably more bandwidth at the antenna than indicated in Fig. 1, you are quite likely to be fooling yourself. Remember that unwanted ohmic losses can raise an otherwise-low terminal resistance, thus reducing the swr via the minimum-swr principle, but at the expense of losing power to heat. In any case, as a professional antenna engineer, my boss would hand me my head on a platter within seconds if I seriously presented him with this shunt-stub method as a viable solution to the 80 meter broad-banding problem when using 50-Ohm feedline. ■

Addendum

Mr. Vissers raised an important point concerning Borton's work,⁹ in that my analysis failed to mention the swr differences Borton

obtained between a coaxial dipole and the bow-tie antenna constructed from galvanized wire. There are two reasons why I omitted reference to this topic: First, my article was already too long. More importantly, several cloudy issues concerning both of these antenna forms need clarifying before I can discuss them knowledgeably.

For example, in the coaxial dipole: What precise, quantitative effects result from the external dielectric covering? Well, Z_0 , X_{La} , and Q are all reduced by the resulting increase in antenna capacitance C_a . But how much? Does this yield an efficient increase in bandwidth? And how much does the dielectric covering increase the dissipation loss, reducing the efficiency while raising the terminal resistance and reducing the swr? As I stated in *QST*,² further in-

vestigation is necessary.

Concerning the galvanized wire, the higher resistance of the zinc covering is probably causing the lower swr, but more investigation is required here also: What is the thickness of the galvanizing? Is it greater than the rf skin depth at 4 MHz? If so, what is the total series surface resistance at rf? Compared to copper? Enough to account for the difference in swr? Does the magnetic effect of the iron in the wire influence the phase velocity of the rf wave? So far, I have been unable to pursue these questions. I had planned future collaboration with Borton for further investigation into the rf properties of galvanized iron wire. I regret that such collaboration is no longer possible, because Dwight Borton recently became a silent key. I will think of him as I proceed alone.

References

1. Walter Maxwell W2DU, "A Revealing Analysis of the Coaxial-Dipole Antenna," *Ham Radio*, August, 1976, p. 46.
2. Walter Maxwell W2DU, "The Broad-Band Double-Bazooka Antenna—How Broad Is It?," *QST*, September, 1976, p. 29.
3. William Vissers K4KI, "Build A Double Bazooka," *73 Magazine*, August, 1977, p. 36.
4. Jordan and Balmain, *Electromagnetic Waves and Radiating Systems*, 2nd Edition, Prentice-Hall, Englewood Cliffs NJ, p. 548. (Caution: Values shown are for monopole; multiply by 2 for dipole.)
5. *Ibid.*, p. 388.
6. Schelkunoff and Friis, *Antennas, Theory and Practice*, Wiley, 1952, pp. 436-455.
7. Ronald W. P. King, *Theory of Linear Antennas*, Cambridge University Press, Cambridge MA, p. 176.
8. Walter Maxwell W2DU, "Another Look At Reflections," Part 5, *QST*, April, 1974, p. 161, equation 11.
9. Dwight Borton W9VMQ, "Wide-Bandwidth Bow-Tie Antenna for 80 Meters," *Ham Radio*, May, 1975, p. 56.

Choosy People LOVE Standard!



C-6500 Solid State, Synthesized Receiver

Covers Broadcast Band From 0.5 to 30 MHz

The C-6500 is capable of receiving AM, CW, USB and LSB. Synthesizer design affords unusual stability and digital dial accuracy. Drift-cancelling 1st mixer injection system provides 30 tunable ranges, covering the entire broadcast band starting at 500 kilohertz through 30 megahertz, from a single 10 MHz crystal oscillator. This ensures the frequency stability necessary for excellent SSB reception. Operates from internal batteries or AC mains.



✓S18

**Standard
Communications**

Standard Communications Corp. • P.O. Box 92151, Los Angeles, CA 90009

January 27-28, 1979



ARRL Convention & 19th Annual TROPICAL HAMBOREE

**FLAGLER DOG TRACK
Miami, Florida**

Pre-Registration
\$3.00

FREE PARKING
INCLUDING OVERNIGHT SPACE FOR
COMPLETELY SELF-CONTAINED RV'S

P.O. Box 350045, Riverside Sta.
Miami, Fla. 33135

BARKER & WILLIAMSON

INTRODUCES

PI-DUX® Coils

High-precision, air-wound coils for band-switching, pi-network final amplifiers.



Model 195-1 rated to 1 KW PEP
Model 195-2 rated to 2 KW PEP.
Send for application data...

Also ...

AIR-DUX® Air Wound Coils

Uniform-pitch coils from 1/2 inch to 6 inches diameter, 2 inches to 10 inches long, 4 to 32 turns per inch, no. 8 to no. 24 AWG.



Typical air-dux coil.

2 New Coaxial Switches for wall or desk mounting

Model 593—Single pole, 3-position



Grounds unused positions.

Model 594—DPDT

Interchanges two outputs between two inputs.



Power rated 2 KW PEP Current rating 5 A VSWR @ 50 ohms—1.3:1 max. to 150 MHz Insertion loss and crosstalk negligible.

Also New this Year ...

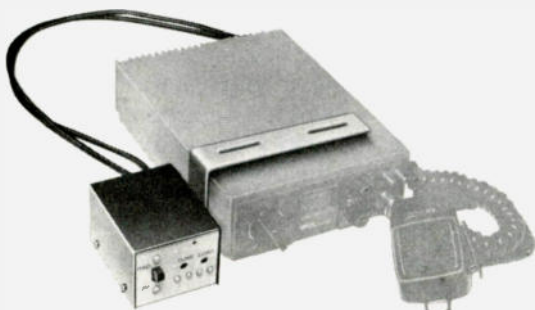

AT-200 Mobile Matcher for 2 meters

lets you avoid advertising you have a rig in the car by matching your car's entertainment receiver antenna to your transceiver.

Made in U.S.A. by



Trap Dipole Antennas

5-Band (80 thru 10)
Model 370-11 pre-assembled
Model 370-12 kit
4-Band (40 thru 10)
Model 370-13 pre-assembled
Includes end insulators, 50 ft RG-8/U, PL-259 connector.
Low VSWR, power to 2 KW PEP.



BARKER & WILLIAMSON, INC. 10 Canal Street • Bristol, Pennsylvania 19007

✓ B23

(215) 788-5581

The Packet Radio Revolution

—pioneers, take note!

Editor's Note: Shortly before press time, the Canadian authorities announced the creation of a new "Amateur Digital Radio Operator's Certificate," a no-code license allowing certain experimenter privileges, including packet radio, in the amateur bands above 1.8 MHz. Certain portions of the 220 and 440 MHz bands have been reserved exclusively for packet transmissions.

Robert T. Rouleau VE2PY
1050 Churchill
Montreal, Quebec
Canada H3R 3B6

Not with a bang, but with sort of a swish, the "packet" revolution began. On May 31, 1978, the Montreal Amateur Radio Club sent the first amateur packets. The face and sound of amateur radio will never be the same again. Space-age radio arrived for amateurs. Our communications will be faster, more accurate, more reliable, and use less spectrum.

If you haven't heard of packet radio, don't be surprised. It is new. Don't look

in the *Handbook* or your favorite ham magazine, either. You'd have more luck researching doctoral theses for information. Right now, there are about two dozen packet systems up and running in the world. None of them are amateur and none of them contemplate the number of users that an amateur radio system would.

Packet radio is a name given to the time-division multiplexing of a radio channel. Large numbers of users can share one channel without QRM or hassles. Users don't even know that they are sharing the channel with anyone else. The name "packet" is

derived from the fact that each message is sent in a package. It has three parts: the address and return address called the "header," the data or message part, and the "trailer," which is an error-detection scheme.

You can compare packet radio to a sort of instant electronic mail service. Each packet is a postcard. You put your message on the card, address it, and put on the return address. You then slip it in a mail slot which is your amateur radio station. If your message is too long for one postcard, then you'll just send a series of them. Once you slip it in the mail slot, the system delivers the card for you, or if it can't, it returns the card automatically.

How can so many users share one channel? Speed. Packets are sent from 25 to 25,000 times faster than amateur RTTY. Let's compare packet RTTY to the amateur kind. To send a

one-line message on 60 wpm Teletype™, you need about 10 seconds, and no one else can use the channel. The simple packet system we'll see later only takes 1/4 of a second to do the same thing. The other 9-3/4 seconds could be used for other messages, up to 40 of them, in fact.

How does it go so fast? There are two explanations. First, instead of using the channel while each letter is sent, we wait until the whole line is complete and send it in a burst. Second, the baud rate for our system is 2000 instead of 45 for amateur Teletype. It also fits in the same bandwidth! This is not a contradiction—we just use better modulation schemes which are capable of sending more information in the same bandwidth.

You are probably saying, "Why all this packet nonsense? It's just a faster Teletype setup." Not at all! You haven't heard the half

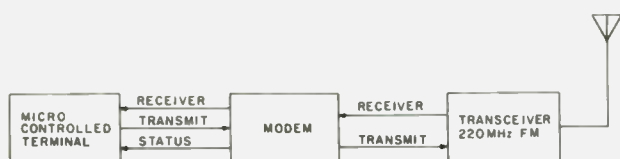

Fig. 1. Block diagram showing component arrangement of a typical packet radio station.

of it yet. The good part is still to come. Packets are digitally encoded. This means that anything that can be "digitized" can be sent in the packet: voice, RTTY, slow-scan, television, telemetry—you name it. Packet radio encompasses all modes! That's why we call the "message" part of the packet the data. It could be any one of a million things. But, that's not *all* the good stuff.

Since packets are in a digital format, they can be read and understood by simple computers. What if we had a microprocessor setup at a VHF repeater? The repeater could read the address on your packet and, if it was out of town, switch on a link transmitter and relay it towards its destination. Now if we had microprocessor-controlled repeater links all across the country, your packet could be delivered anywhere within the range of a repeater. Packets make this kind of network easy. We are now working on the design of a packet net called AMPAC (amateur packet), which will make this possible. Since packets contain an error-detection scheme at the end, checking a message to verify that it is intact is easy. If the packet was damaged, we could ask for a repeat automatically if our terminals were programmed to do so.

Let's look at a few of the applications for packet radio. On the HF bands, I bet the RTTY operators would like to have a system this fast which automatically calls for repeats of packets damaged by QRM and fading. For once, the copy would be clean all the way. The same would be true for the slow-scan TV crowd. The image would form line-by-line and with no snow! Moonbouncers already use a kind of burst technique.

Your terminal would be programmed to send a packet, and then wait a predetermined length of time for a return message. If the return message didn't come, the original message would be repeated until it did. It could also log the callsigns and time that transmission was completed. Satellites are a natural for packets. The time-sharing aspect makes the satellites available to more people, and the communications are more reliable. The list is almost endless, and that's what makes packet so good.

If you've read this far, you probably want to know exactly how packet radio works. First of all, you will need a microprocessor-controlled terminal, which could be a TV typewriter or Teletype machine for hard copy. We'll look at a packet Teletype system to see how it works. You type out your message and the address of the receiving station. The terminal will fill in your call and address as well as do the error-detection calculations. When this is complete, it will be sent automatically. At the other end, a terminal will receive the packet and look at the address. If the packet is addressed to someone else, the terminal will dump it. Otherwise, it will check for transmission errors and, if the message is intact, the terminal will print it out or display it on the screen. It will also send an acknowledgement back to you. If it didn't arrive intact, it will send a negative acknowledgement. Your terminal, on seeing a negative acknowledgement, or "NAK," will retransmit the packet again, and will do so until it gets through or it is instructed to give up.

What if two terminals send at once? The packets collide and are wiped out. In this case, your terminal won't get the acknowl-

edgement it is expecting, so it sends the packet again, and does so until it gets the acknowledgement it wants or is told to stop. To prevent two terminals from sending packet after packet at the same time, each terminal is instructed by its microprocessor to wait a random length of time before sending the packet again. The delay in our case would be from 1 to 4 seconds. Since the delay is random, and all the terminals have this routine built in, the chances of a second or third collision are very small.

The rules that the terminals follow are called the protocol. This term will be familiar to the computer people. The protocol makes every user feel as if he is the only one on the channel. You don't know that it is being shared. There is no QRM and no hassles. The protocol, which is written into the program of the microprocessor controlling your terminal, can be as simple or as complicated as you wish. The fancy ones make the system even more efficient and maximize the capacity of the channel, but involve more memory and software. The key is to make sure that all users of the local net play by the same rules.

The hardware you'll need is not fancy. A microprocessor, a keyboard input/output device, a radio, and a modem are all that is required. Our system runs on 220-MHz FM and uses the Western or Sangamo Model 201 modem, running at 2000 baud. We used this one because it was available surplus and was cheap. We run 220 because that's the only band in Canada we are allowed to use for packet right now. The radio feeds the modem which feeds the terminal. The modem outputs phase-

shift keying using an 1800-Hertz tone so it can go right in the microphone jack. The output can come from the speaker line or, if you're fussy, right from the discriminator to the modem. The modem is RS-232 standard, so hooking it up to the computer is no problem. See Fig. 1.

We have only touched the surface of packet radio and its applications. Before you go any further, however, you will have to either move to Canada or convince the FCC that American amateurs should be allowed to use packet radio as well. As far as I know, Canada is the only country which is permitting amateurs to experiment with packet. I doubt that it will stay this way for very long. The prognosis is for amateurs to develop the first really large packet network on VHF and UHF which will be copied by commercial operations shortly afterward. Our satellites will be the proving ground for more packet techniques, and I bet commercial stations will be looking over our shoulders. Again, amateurs are getting into the act first. Who else could supply millions of free man-hours of research and development to the world? Right now there are a few centers doing research on packet radio. Stanford Research Institute is one, for instance, and while they may be better qualified than we are, we sure outnumber them!

Here, in Montreal, the few of us who have formed AMPAC will be pushing the technique for all it's worth. We are talking to AMSAT to get permission to use their satellites as well as negotiating with our government to get more packet privileges. We would be happy to talk to anybody who is interested in packet radio. ■

CALL TOLL FREE 1-800-633-3410

PUT YOURSELF ON TWO METERS FOR CHRISTMAS



KENWOOD TR-7600 . . .
The radio that remembers

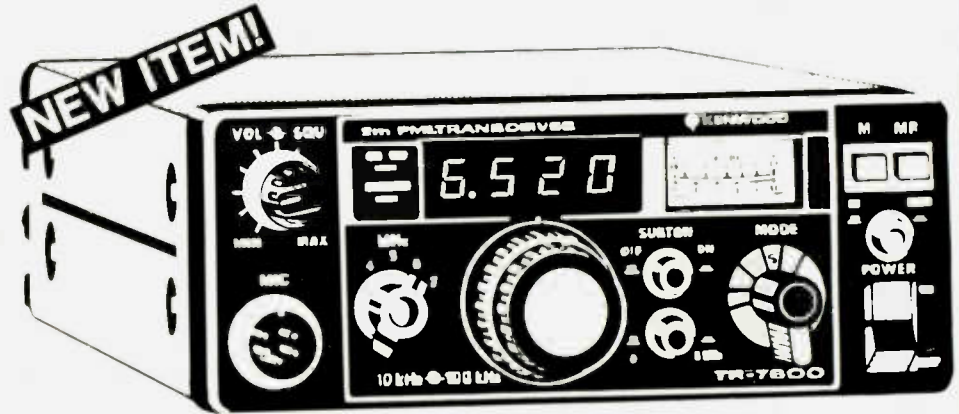

The all new Kenwood TR-7600 is packed with all the features you could want in a 2-meter FM rig. Combining it with the optional RM-76 Microprocessor Control Unit provides twenty-four operating features. Alone it gives full 4-MHz coverage (144.000-147.995 mhz), 800 channels, dual concentric knobs for fast frequency change, 10 watts RF output or 1 watt low power, memory channel with simplex or repeater offset (600 khz/1 mhz), and large, bright orange LED display. Adding the RM-76 Microprocessor Control Unit provides more operating features than are found in any other rig! With the RM-76 you can: Select any 2-meter frequency, store frequencies; automatically stop on first busy or open channel, Select simplex or repeater offset, Scan memories, Operate on Mars (143.95 mhz), and set upper and lower scan frequency limits. Rm-76 has digital display indicating frequency and function.
Price to be announced.

RM-76 Microprocessor Unit optional

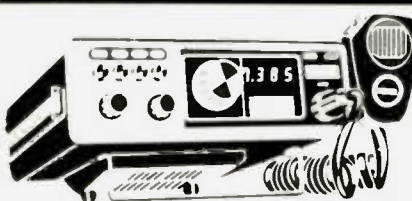
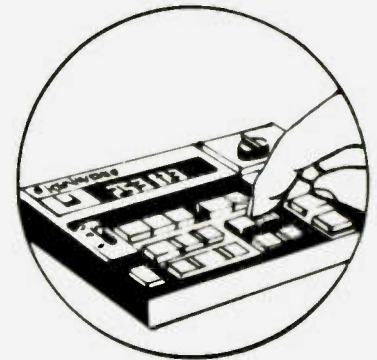

YAESU FT227RA
The "Memorizer" transceiver

Provides 4 memories, finger touch control on mic scans entire 2 meter band for a clear or busy channel, provision for 800 digital Phase Lock Loop channels 144-148 mhz, channel memory, tone burst repeater operation, digital LED, and 10 watt/1 watt output.

429.00 Call for quote today.



YAESU CPU-2500 RK
2 meter FM transceiver

This ultimate transceiver has keyboard mic for remote input, scanning control, aux. repeater split selection, and two-tone input for auto-patch or control link. Controlled by a central processing unit, 800 channels, channel memory, and an automatic scanner search. Freq. 144 to 148 MHz.

585.00 Call for quote today.

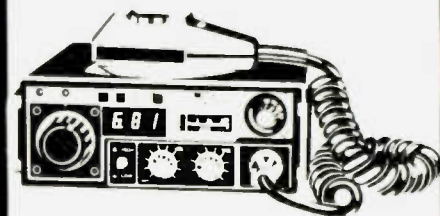

ICOM IC-280
Remotable 2-meter FM mobile transceiver

Freq. 143.90-148.11 mhz, power 10 watt/1 watt, 13.8 VDC at 2.5 amps, can detach and remotely mount the main PLL control head, with microprocessor, can store 3 freqs., and has digital LEDs.

453.00 Call for yours today.

Remember, you can Call Toll Free: 1-800-633-3410 in the U.S.A. or call 1-800-292-8668 in Alabama for our low price quote. Store hours: 9:00 AM til 5:30 PM, Monday thru Friday



Long's Electronics



METER CHRISTMAS WARMTH



CALL TOLL FREE 1-800-633-3410



SWAN SWR-1A power meter and SWR bridge

Frequency range 3.5 to 150 MHz • Compact and lightweight for portable or mobile use • Capable of handling 1,000 watts RF and measures 1:1 to infinity VSWR

29.95 Call for yours today



SWAN WM-2000 in-line wattmeter

Frequency 3.5 to 30 MHz. 3 scales: 0-200, 1000 and 2000 watts. VSWR scale permits reading from 1:1 to 3:1. Uses two SC-239 connectors.

64.95 Call for yours today

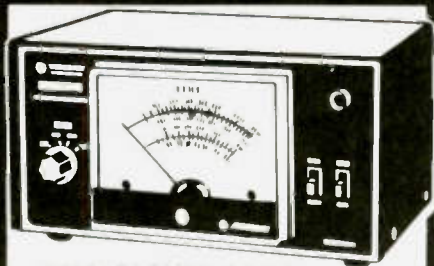

SWAN WM-3000 precision PEAK/RMS wattmeter

Read forward or reflected power with maximum accuracy from 3.5 to 30 MHz. RMS readings available with the flick of a switch. Four scales from 0 to 2000 watts. Requires 117 VAC power source.

87.95 Call for yours today.



DENTRON W-2 wattmeter

The W-2 lets you read forward and reflected watts at the same time.

- Forward watt scale: 2000 or 200
- Reflected watt scale: 200 watts • Low insertion loss • Frequency range: 1.8 to 30 MHz • Accuracy: 5% • two SC-239 connectors • Sensor box may be extended 4 feet.

99.50 List. Call for quote

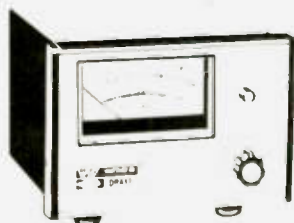

DRAKE WH-7 HF wattmeter

Has a frequency of 1.8-54 MHz, a power range 0-20, 200, and 2000 watts full scale. Features a direct scale readout for VSWR. Sensing element can be located remotely up to 3 ft. away. Connectors SO-239. Line imp. 50 ohms resistance.

89.00 Call for yours today.

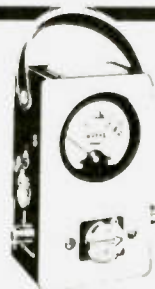

BIRD MODEL 43 Thruline® watt meter

50 ohms nominal impedance VSWR with UHF connectors 1.05 max • Expanded scales of 25, 50 & 100 permits direct reading from 100 Mw to 10,000 watts

125.00 Call for yours today

BIRD plug-in elements for the Model 43

Frequency Bands in MHz

Power Range	Frequency Bands in MHz				
	2-30	25-60	100-250	200-500	400-1000
5W	5A	5C	5D	5E	
10W	10A	10C	10D	10E	
25W	25A	25C	25D	25E	
50W	50H	50A	50C	50D	50E
100W	100H	100A	100C	100D	100E
250W	250H	250A	250C	250D	250E
500W	500H	500A	500C	500D	500E
1000W	1000H	1000A	1000C	1000D	1000E
2500W	2500H				
5000W	5000H				

H-Elements (2-30 MHz) **44.00 ea.**

A-C-D-E-Elements (25-1000 MHz) **38.00 ea.**

Call Toll Free for yours today

Remember, you can Call Toll Free: 1-800-633-3410 in the U.S.A. or call 1-800-292-8668 in Alabama for our low price quote. Store hours: 9:00 AM til 5:30 PM. Monday thru Friday



Long's Electronics

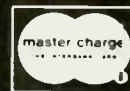

MAIL ORDERS: P.O. BOX 11347 BIRMINGHAM, AL 35202 • STREET ADDRESS: 2808 7TH AVENUE SOUTH BIRMINGHAM, ALABAMA 35233

CALL TOLL FREE 1-800-633-3410

SEND MERRY CHRISTMAS



DRAKE 1525 EM microphone

The auto-patch encoder and microphone are a single unit, fully wired and ready to use • High accuracy IC tone generator, no frequency adjustments • High reliability Digitran® keyboard • Power for tone encoder from transceiver via mike cable • Encoder audio level adjustable from 1 mV to 5 mV with internal potentiometer • Low output impedance • 4-pin plug.

49.95 Call for yours today.



SHURE 444 desk microphone

Has PTT switch, adjustable head height, solid construction. Freq: 300 to 3000 Hz, Omnidirectional polar pattern, Controlled magnetic mic element. High impedance: 50K ohms.

35.00 Call for yours today.



SHURE 414A hand-held mic

Ideal for your mobile transceiver. One-half the size of most hand mikes. Has an omnidirectional polar pattern. Frequency response: 400 to 4000 Hz. High impedance. output level: 54.5 dB. Controlled magnetic mic element designed for SSB. High impedance: 50K ohms.

25.00 Call for yours today.



KENWOOD MC-35S dynamic mic

The MC-35S is a 50K ohms impedance, dynamic hand held mic. A 2-position switch lets you operate in a quiet mobile or fixed station or select noise cancelling for use in high ambient noise environments. MC-30S same as MC-35S but 500 ohms. low impedance for TR-7400 7500

29.00 Call for yours today



KENWOOD MC-50 desk microphone

This dynamic mike is designed expressly for amateur radio operation • PTT & LOCK switches • Converts from HI to LOW impedance • Unidirectional • Mike plug for instant hook-up to any Kenwood rig.

45.00 list. Call for quote.



YAESU YD-148 dynamic microphone

This is a super value buy. It features switchable 600/50K ohms impedance, a locking push to talk switch, a flexible neck that adjusts for operator comfort, and comes wired with a 4-pin plug.

30.00 Call for yours today.



TELEX ProCom II Electret mobile microphone

"Broadcast quality" — "clarity and crispness," describe the audio of the electret. Useable in low or high impedance. 1.4 volt battery (included) also powers the 10dB amplifier.

29.95 Call for yours today



Remember, you can Call Toll Free: 1-800-633-3410 in the U.S.A. or call 1-800-292-8668 in Alabama for our low price quote. Store hours: 9:00 AM til 5:30 PM, Monday thru Friday



Long's Electronics



MAIL ORDERS: P.O. BOX 11347 BIRMINGHAM, AL 35202 • STREET ADDRESS: 2808 7TH AVENUE SOUTH BIRMINGHAM, ALABAMA 35233

RECEIVE CHRISTMAS NEWS

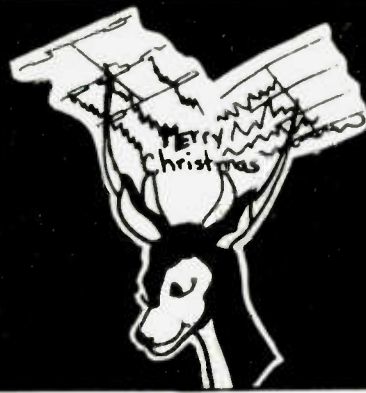

CALL TOLL FREE 1-800-633-3410



HY-GAIN TH3MK3 Super 3-element tribander

Gain 8dB • Front-to-back ratio 25 dB • SWR (at resonance) less than 1.5:1 • Frequency 10, 15, and 20 meters • Power rating: maximum legal limit • Longest element 27' • Boom length 14' • Wind load at 80 m.p.h., 131 lbs. • Surface area 5 10 sq. ft Balun BN-86 recommended 15.95.

219.95 Call for quote.

HYGAIN 14AVQ/WB 10-40 antenna

Features: • Taper swaged seamless aluminum construction • Omnidirectional performance • Auto band switching • Wide band performance with one setting • Hy-Q traps with large diameter coils • 12" double-grip mast bracket • Low angle radiation • SO-239 connector • 50 ohm input impedance.

67.00 Call for yours today.

HUSTLER 4-BTV vertical antenna

The 4-BTV HF fixed station four bander features 10, 15, 20, and 40 meter coverage, switching or matching devices not required, RM 75 option may be added for 75 meter coverage, 21'5" long, 2000 watts PEP power rating, bandwidth SWR 1.6:1 or better at band edges. Guaranteed easy assembly.

99.95 Call for quote.

LARSEN LM-MM-150K 2m 3/8 mag mount antenna

The 3/8 wave length 2 meter antenna consists of a 49" stainless steel rod, quadruple plated, and coil for use between 144-174 MHz • A full 3dB gain over a 1/4 wave length antenna. Magnet guaranteed permanent in ordinary use • Full capacitance coupling • Complete with 12' of RG-58 A/U coax & coax connector.

38.45 Call for yours today.

CUSH CRAFT ATB-34HF 4-element beam

• Covers 10, 15, & 20 meters • High-Q coax traps rated for 2KW power • Direct 52 ohm feed thru 1-1 balun • Turn radius 18'9" • Wind survival 90 mph.

249.95 Call for quote.

CUSH CRAFT ARX-2 2m antenna

Cush Craft has created another first by making the world's most popular 2m antenna twice as good! • Three 1/2 waves in phase and a 1/8 wave matching stub • Extremely low angle of radiation for better signal coverage • Tunable over a broad frequency range • Matched to 52 ohm coax.

32.95 Call for yours today.

ANTLER A-280 2m mobile antenna

The A-280 is as close to the ideal antenna as you can get. Features • Precision tuned coil • 47" tapered 17-7 stainless steel whip • VSWR less than 1.3 • Certified 3 dB gain • Magnetic mount has root-top stability to withstand winds up to 100 MPH.

29.95 Call for yours today.

Remember, you can Call Toll Free: **1-800-633-3410** in the U.S.A. or call **1-800-292-8668** in Alabama for our low price quote. Store hours: 9:00 AM til 5:30 PM. Monday thru Friday.

VISA

Long's Electronics



CALL TOLL FREE 1-800-633-3410

HEAR CHRISTMAS GREETINGS

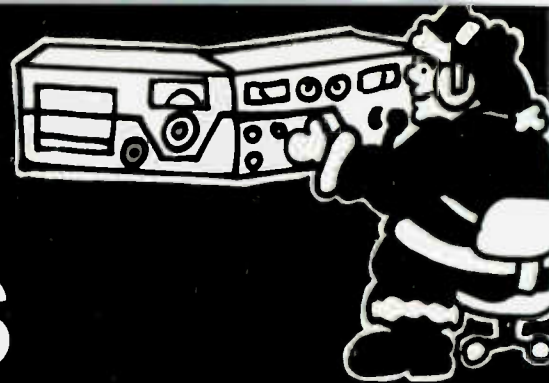

TELEX CM 1320-S single earpiece headset

If you prefer a single earpiece headset, choose this top quality one. This has a ceramic, boom microphone, high impedance, mobile operation, and a choice of DX-peditions.

57.25 Call for yours today.



TELEX



TELEX C-1320 headphone

"Top of the line" fully cushioned, audiometric type drivers are ultra-sensitive - DX'ers choice. 20-20,000 Hz. Low impedance 8-20 ohms.

39.80 Call for yours today.



TELEX CM-1320 headset

This is Telex's best headset. It's the top of the line with a ceramic, boom microphone, high impedance 50K, and the choice of DX-peditions. Don't wait. Order today.

71.70 Call for yours today.



TELEX HMC-2 lightweight headphones

These headphones are feather-weight aluminum. The underchin tone arms direct signals into the ear. Great for contests 1.2 ozs., 100-3000 hz., low impedance, and 8-20 ohms.

13.85 Call for yours today.



TELEX Mobile "FM"

VHF House or Mobile-high performance audio on transmit and receive. Fet amplifier, low Z microphone. Earphone 8 ohms — in-line PTT.

59.95 Call for yours today.



KENWOOD HS-4 headphones

For extended periods of wear, the HS-4 is comfortably padded and completely adjustable. Frequency response is 300 to 3000 Hz, 8 ohms, just right for amateur radio use.

19.50 Call for yours today.



YAESU YH-55 headphone set

Comes equipped with a soft pad for long hours of listening with maximum comfort. Compatible with all Yaesu equipment. 8 ohms impedance.

15.00 Call for yours today.

Remember, you can Call Toll Free: **1-800-633-3410** in the U.S.A. or call **1-800-292-8668** in Alabama for our low price quote. Store hours: 9:00 AM til 5:30 PM, Monday thru Friday



Long's Electronics



STUFF STOCKINGS WITH ACCESSORIES



CALL TOLL FREE 1-800-633-3410

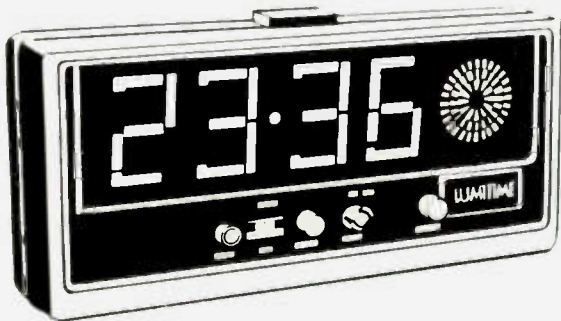

LUMITIME CC-24 24 hour digital clock

The CC-24 is the perfect addition to any ham shack. Large 2 inch digital display makes telling time easy at a glance. • 24 hour alarm with 8-10 min. snooze button can also be used as a station ID buzzer. • 110 volts A/C operation.

29.95 Call for yours today.



YAESU SP-101PB speaker/phone patch

The SP-101-B features: • A shaped response speaker from 300 to 3000 Hz • Built-in hybrid phone path with individual gain controls • VU meter. Full VOX operation • Receiver input impedance: 4 or 600 ohm • Output impedance: 600 ohm or high impedance.

67.00 Call for yours today.

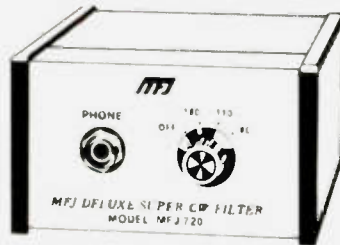

MFJ-720 Deluxe Super Filter

This brand new filter has selectable band width, 8 pole active IC filter, razor sharp selectivity, automatic noise limiter, plugs in phone jack, two watts for speaker, and 80 Hz BW, no ringing.

44.95 Call for yours today.

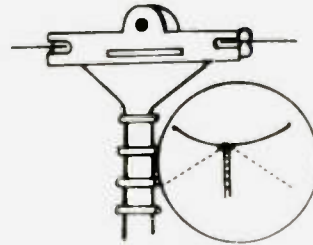

DENTRON All Band Doublet antenna

• Has a total length of 130 feet (14 ga. stranded copper) • Center fed through 100 ft. of 470 ohm PVC covered balanced transmission line • Assembly complete • Tune 10 thru 160 with one antenna • (Requires antenna tuner).

24.50 Call for yours today.

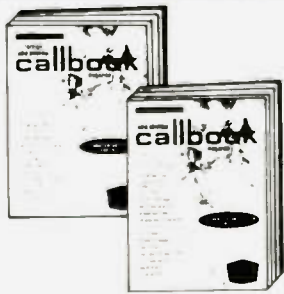

1979 CALL BOOK

U.S. edition contains over 350,000 listings & has over 1,000 pages. Foreign edition: over 280,000 listings, over 900 pages.

15.95 U.S.

14.95 foreign. Call for yours today.

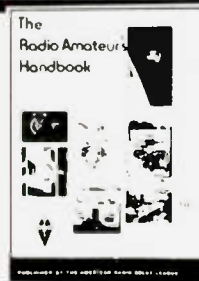

THE RADIO AMATEUR'S HANDBOOK

Published by the ARRL. This is the standard manual of amateur radio communication. 1979 is the fifty-fifth edition of an indispensable handbook for all hams.

9.75 Call for yours today.



COVER CRAFT dust covers

Made of tough, clear vinyl plastic with a "pearlized" texture finish. All seams are machine stitched for maximum strength. Keep your equipment clean and it will need less maintenance. We carry covers for Kenwood, Yaesu, Icom, Drake, Ten-Tec, CDE, and Dentron.

4.95 most sizes.

Remember, you can Call Toll Free: 1-800-633-3410 in the U.S.A. or call 1-800-292-8668 in Alabama for our low price quote. Store hours: 9:00 AM til 5:30 PM, Monday thru Friday.



Long's Electronics



This Voltage Standard Is Precise!

--and makes calibration a snap

Do you sometimes wish you had a stable voltage source for calibrating your DVM or the vertical amplifier of your dc scope, a source that would remain rock stable

for months or years? Such an instrument is usually expensive to build or buy because it uses exotic components such as standard cells and perhaps a complex voltage divider to pro-

vide various output potentials. The voltage standard described here may suit your need perfectly, as it provides an exceptionally stable output voltage using ordinary off-the-shelf parts, and an unconventional "circular" voltage divider, using the minimum possible number of precision resistors, provides convenient switch-selected output voltages.

The unit is powered by two 9-volt batteries, and the output voltage is 0-10 volts in 10 millivolt steps, although finer voltage divisions may be obtained by adding stages to the voltage divider. A microammeter is connected in series with the output so that the instrument may be used to directly measure dc voltage.

Output stability is about $\pm 0.04\%$ over a battery-voltage range of 6-9 volts. This tolerance can be reduced virtually to zero if you elect to use a power source better regulated than batteries.

Thermal stability, over the range of temperatures normally encountered in the laboratory, is more or

less perfect, depending on your choice of parts. Admittedly, the unit must be calibrated against an accurate voltage standard or DVM but, once set, it will remain stable more or less indefinitely, depending again on your choice of parts. Accuracy of the switch-selected output voltages depends on the tolerance of the resistors you decide to use in the voltage divider. We have specified 0.1% resistors, so we get 0.1% accuracy. If you use 0.01% resistors, you will get 0.01% accuracy, but they will cost a lot more. Output resistance of the instrument is several thousand Ohms, but we will discuss means to circumvent the effect of loading on output voltage.

How It Works

Fig. 1 is a simplified diagram of the voltage standard, showing how the use of a "circular" voltage divider minimizes the number of resistors needed to obtain 1001 different output voltages. This article, as far as we know, is the first published application of the author's novel development. In a conven-

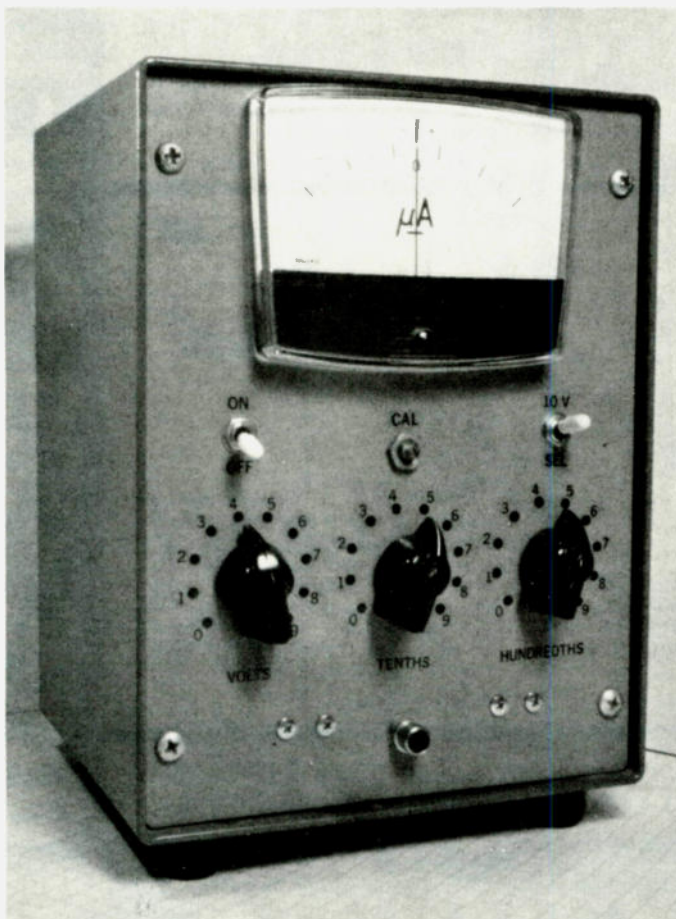

tional voltage divider, the input voltage is applied across the entire network, and output is selected from the constituent resistors—but a disproportionately large number of resistors or a complex switching scheme is needed to get a large number of output voltages. In the circular voltage divider, the output voltage is taken from a fixed point, and this potential is selected by changing the location to which the input voltage is applied. This scheme simplifies the requisite switching and minimizes the number of resistors needed. In Fig. 1, the digit beside each resistor corresponds to the voltage obtained when that resistor is connected. Output in this example would be 6.43 volts.

The general rule applying to resistor values in the circular divider is this: Ten resistors are used in each ring except the last, which has eleven. The resistors in each ring are 1.1 times the value of the ones in the preceding ring. Thus, if you wanted an additional stage to get steps of 1 millivolt, you would substitute, for the terminating resistor R_T , another ring, containing 11 resistors of 1330 Ohms each. How did we know what value to start with in the first ring? Well, if too small, the selected resistor will unduly load the power supply. But making it, and all the other resistors, larger will proportionally increase the output resistance of the divider.

If you want to build the simplest possible divider, you can omit the selector switches and use alligator clips where we have shown arrows. To use the instrument as a voltmeter, connect the voltage to be measured at "unknown E," and set the clips to obtain a null on the meter. The unknown voltage then corresponds to the digits beside

the selected resistors.

Fig. 2 is a schematic of the instrument, except for the divider. The stable voltage source consists of field effect transistors (FETs) Q1 and Q2, and resistor R1. The FETs are connected in series, forming a very high impedance current source which develops the reference voltage across R1. This means of obtaining a stable potential has not been widely exploited and, indeed, it is little known even among FET manufacturers. The reference voltage, E_R , depends on FET Q2, ordinarily turning out to be somewhere between 1 volt and 3.5 volts. You don't have much control over this parameter unless you individually select the 2N3819. But E_R is remarkably stable with changes in battery voltage and can be made almost completely independent of temperature by the selection of R1, as described later.

To get 10 volts for the divider, E_R is amplified by op amp IC1, whose gain is set by the selection of feedback resistor R3 and the adjustment of CAL trimmer R4. The S5556/MC1456 op amp was chosen for its low bias current (about 30 nanoamperes), its excellent temperature stability, and its reasonable price. To further enhance temperature stability, emitter-follower Q3 obviates any loading on IC1 and thereby keeps the op amp cool. Capacitor C1 suppresses any tendency to oscillate.

The divider uses three two-pole, 10-position selector switches to perform the function of the alligator clips suggested for Fig. 1, selecting 1000 different output voltages (0-9.99 volts).

Referring again to Fig. 2, setting switch S2 to SEL applies the selected voltage to the output circuit. The 1001th voltage, 10 volts, is obtained in the 10 V posi-

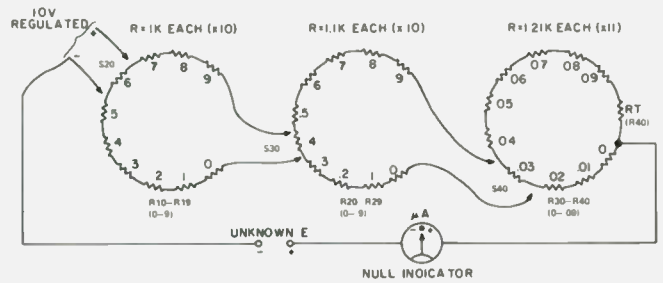

Fig. 1. Simplified schematic of voltage standard. In the "circular" voltage divider, the resistors in each ring are 1.1 times the value of the ones in the preceding ring. A microammeter, used as a null indicator, provides a means for directly measuring dc voltage.

tion. The potential selected by S2 is applied to output jack J1 through microammeter M1. The time constant R5-C2 and germanium diodes CR1 and CR2 protect the meter movement from slamming when J1 is connected to a voltage much different from the one selected. Resistor R6, in turn, protects the diodes from burn-out when the selected voltage happens to be 0 volts. In this case the divider output is at common and, without R6, any voltage on J1 would be applied directly across one of the diodes.

Output resistance of the divider is about 1000 Ohms. The output resistance of the unit is,

therefore, this value in series with R5, R6, and the microammeter, for a grand total of 2000 to 5000 Ohms, depending on the meter resistance. Therefore, the instrument cannot be loaded without loss of accuracy. Even a 1-megohm load could drop the output voltage as much as 0.5%. We will deal with this problem under "Operation." On the other hand, if you can tolerate a higher output resistance, you would be well advised to make all the resistors in the divider much larger in value. They should all be increased by the same factor, say by 10 or even 100 times. This would make the current in the first divider ring proportionally lower,

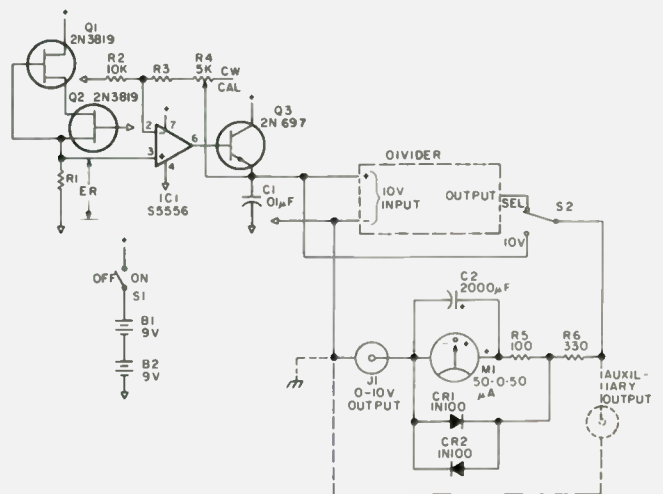
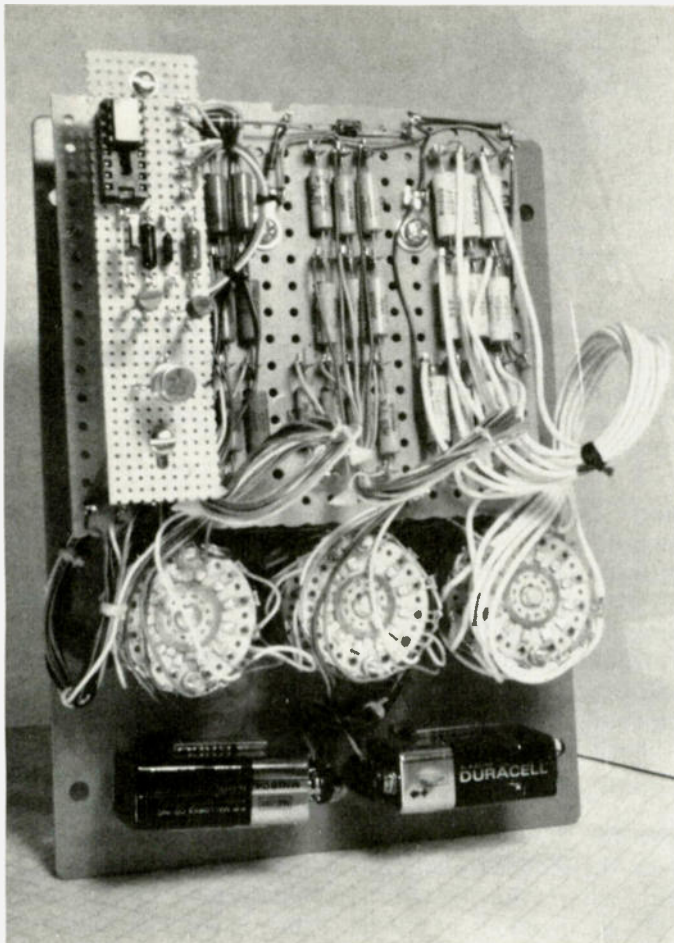

Fig. 2. Schematic of precision voltage source and output circuit of instrument. Inexpensive 2N3819 FETs provide an extremely stable reference voltage, amplified to 10 V by IC1 and Q3. Output voltage is applied to J1. Microammeter null indicator is protected from slamming by RC circuit and diodes.



Interior view of instrument. All parts are mounted on back of the front panel. The divider resistors are located on a perfboard mounted on the meter terminals. The precision voltage source subassembly is built on another perfboard mounted to the first.

alleviating problems of stray voltage drops and greatly increasing battery life. However, it would also reduce meter deflection, so you might have to

employ a more sensitive movement.

If you wish to bypass the various resistances of the output circuit, you can add the auxiliary output jack

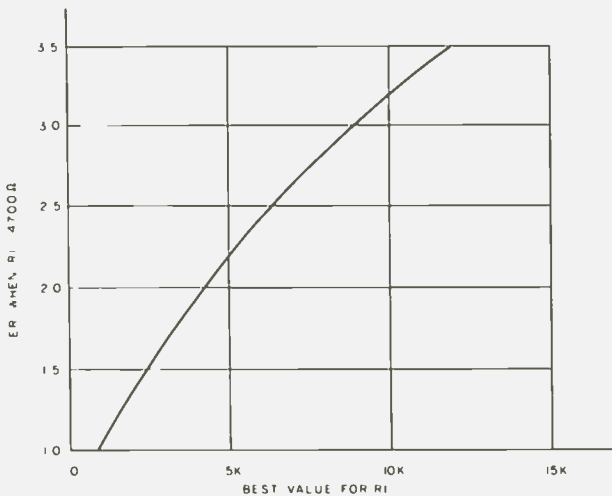

Fig. 3. Graph of R_1 vs. E_R when R_1 is 4700 Ohms approximates optimum value for new R_1 . Exact value for best temperature stability can be determined by heat test. (See text, "Adjustment.")

shown in dashed lines. This addition also provides access, when S_2 is in the 10 V position, directly to the 10-volt source, whose resistance is practically zero and which can, therefore, be loaded heavily with virtually no loss of voltage.

Choice of Parts

Temperature stability depends on your choice of R_1 - R_4 . For best results, precision resistors should be used for R_1 - R_3 , not because these resistances are critical, but because precision types are less affected by time and temperature than composition. Film or wirewound units are a good choice. However, the values of R_1 and R_3 will be selected as described under "Adjustment," the former for best temperature independence and the latter to set the output voltage. For this selection process, you can use ordinary composition resistors, and later replace them with the precision variety. For best stability and ease of adjustment, R_4 should be a multi-turn trimmer, either wirewound or cermet. A shaft lock is desirable. Precision resistors must be used in the divider and, as we have indicated earlier, a closer tolerance than we have specified will provide more accurate output voltages. Any general purpose, silicon NPN transistor may be substituted for the 2N697 specified at Q3.

If you have a mathematical bent and wish to interpolate the meter reading to estimate potentials falling between the positions of "hundredths" switch S_{30} , you may wish to use a more sensitive meter (say, 10-0-10 microamperes). In this case, CR_1 and CR_2 will introduce a troublesome non-linearity, so you may wish to use silicon diodes or back-to-back zeners for

a higher threshold voltage. If you want the meter to respond faster, you can use a smaller value for C_2 . Either change, though, will cause the meter to slam harder.

Any hookup wire used in the divider section of the instrument must be no smaller than No. 22. Smaller wire would develop voltage drops that degrade accuracy. If you have decided to add a fourth or fifth stage to the divider, you should carefully consider the effect of contact resistance in the voltage selector switches. It might be necessary to procure special switches made for this sort of application.

Construction

The voltage standard can be built in any convenient enclosure. As shown in the photos, all parts in the author's prototype, including the batteries, were mounted on the backside of the front panel of an instrument housing. The divider resistors are located on a perfboard mounted to the meter terminals. You can, instead, mount the resistors directly on the switch terminals, but this will much complicate matters if you have to correct wiring errors or later decide to change the divider resistors for ones having different values or tolerances. The precision voltage source is constructed on a smaller perfboard mounted to the first by spacers.

Do not use the chassis as the common conductor. Instead, use wire leads between components. The common conductor may then be connected to the chassis, but at one point only. If the connector you plan to use at J_1 is somewhat difficult to insulate, as many jacks are, you may make the chassis connection at this point, as shown by the dashed symbol in

Fig. 2. This connection, however, creates an obscure but potent hazard. Due to manufacturing defects, an occasional 9-volt battery has an internal short circuit between one terminal and the case. If the battery case is touching the chassis and the common conductor is also connected to the chassis, the battery will be shorted and may explode! Therefore, as in any equipment using 9-volt batteries where the case is grounded, it is smart to insulate the battery holders from the case. Solder carefully. Rosin joints introduce stray voltage drops.

As we mentioned earlier, the values of resistors R1 and R3 will be individually selected. For now, however, temporarily install 4700 Ohms at R1 and 18,000 Ohms at R3.

Adjustment

The adjustment procedure has two main parts. First, R1 must be selected for best temperature stability, and then R3 must be selected to yield 10 volts from the dc amplifier. To select R1, proceed as follows:

1. Set S1 to ON.
2. Measure voltage E_R across 4700-Ohm resistor R1.
3. Find the best value for the new R1 from Fig. 3, and replace R1 with this value.
4. If you are using a DVM of at least 4½ digits, you can now verify temperature stability by touching the tip of a hot soldering iron to Q2 for about 3 seconds. Reference voltage E_R should not vary more than a few millivolts. If it does, correct the value of R1 as needed.

To select R3, you need only a reasonably accurate voltmeter such as a typical VOM. Then, to trim R4 to exactly 10 volts, you will

need either an accurate DVM (preferably 4½ digits or more), or a precision voltage source such as a standard battery, having a known terminal potential up to 10 volts. If you don't need perfect calibration, however, instead of a standard battery you can use a brand new Mallory Duracell Type MN-1604, which has an open-circuit potential close to 9.32 volts. Do not use as a standard either of the batteries powering the instrument because its load drops the voltage too much. To select R3, proceed as follows:

1. Set CAL trimmer R4 to its mid-position.
2. Set S2 to 10 V.
3. Connect the voltmeter between common and the arm of S2, or to the auxiliary output jack if you have one.
4. Select R3 to get a reading as close to 10 volts as possible.
5. If using a DVM, adjust R4 to get 10.000 volts. This step ends your adjustment procedure. Otherwise, proceed to step 6.
6. Set S2 to SEL.
7. Set the selector switches to correspond to the voltage of the standard battery.
8. Connect the standard battery to J1, plus to the meter side, minus to common.
9. Adjust R4 to zero the meter.

Operation

The voltage standard has two main uses, as a 0-10-volt dc voltmeter or as a precision voltage source. To use the instrument as a dc voltmeter, proceed as follows:

1. Set S1 to ON.
2. Set S2 to SEL.
3. Set voltage selector switches S10, S20, and S30 to approximate the voltage you wish to measure. If you can't estimate this unknown

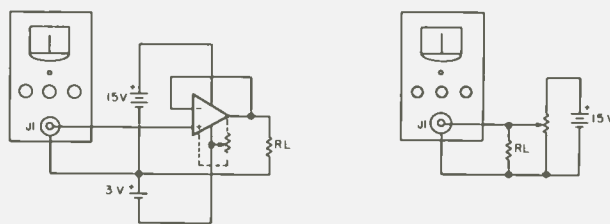

Fig. 4. Two methods to avert the effect of loading on output voltage.

voltage, set the switches to 5.55 volts.

4. Connect the unknown voltage to J1, plus to the meter side and minus to common.
5. Set voltage selector switches S10, S20, and S30 to zero the meter as nearly as possible. The switch settings now correspond to the unknown potential. (If the unknown turns out to be

exactly 10 volts, the meter will of course zero with S2 set at 10 V.) If the meter needle is not exactly at zero, then the unknown is a few millivolts different from the setting of "Hundredths" switch S30. You might try interpolating to estimate the difference, but if you have used 0.1% resistors in the divider,

Parts List

(for divider of Fig. 1)

R10-R19	1,000-Ohm, 0.1%, ¼-Watt precision resistor
R20-R29	1100-Ohm, 0.1%, ¼-Watt precision resistor
R30-R40	1210-Ohm, 0.1%, ¼-Watt precision resistor
S10, S20, & S30	2-pole, 10-position rotary switch

Note: 0.1% resistors described above are available at \$1 each from Cal-State Electronics, 5222 Venice Bl., Los Angeles CA 90019. Add \$1.50 for shipping (UPS). California residents please add 6% sales tax.

Parts List

(for electronics of Fig. 2)

B1, B2	9-volt battery
C1	0.01 uF capacitor
C2	2000 uF, 3-volt electrolytic capacitor
CR1, CR2	1N100 germanium diode
IC1	S5556/MC1456 op amp (preferably by Signetics)
J1	phono receptacle or other suitable 2-conductor jack
M1	50-0-50 dc microammeter
Q1, Q2	2N3819 field effect transistor (Texas Instruments)
Q3	2N697 transistor
R1	1%, ¼-Watt precision resistor; value selected. See text, "Choice of parts." Temporarily use 4700-Ohm composition-type.
R2	10,000 Ohm, 1%, ¼-Watt precision resistor
R3	1%, ¼-Watt precision resistor, value selected. See text, "Choice of parts." Temporarily use 18,000-Ohm composition-type.
R4	5k panel-mounting trimmer potentiometer
R5	100-Ohm, 10%, ¼-Watt resistor
R6	330-Ohm, 10%, ¼-Watt resistor
S1	SPST toggle switch
S2	SPDT toggle switch
Misc.	22-gauge hookup wire for divider, perfboard, push-in terminals, IC socket, battery clips, battery holders, cabinet, etc. To select R1 and R3, a supply of 5% composition resistors, or a resistor-substitution ("decade") box in the range of 1000 Ohms to 100,000 Ohms is required. See separate parts list for divider.

remember that your reading will only be accurate within 0.1 percent of the indicated voltage anyhow.

As a voltage source, a typical use of the instrument is in the calibration of a voltmeter. It is especially valuable, for example, to check the linearity of a DVM. However, the voltage source application may involve loading complications. The input resistance of a typical

DVM is 100 or 1000 megohms, so it should give you no such problem. Given a load of lower resistance, though, say a 20,000-Ohm-per-volt VOM, you must either mathematically allow for the load or avert its effect entirely. In the former course, you are on your own, but with the latter, we can offer a couple of methods: As shown in Fig. 4, you can either decouple the voltage standard output through an op

amp voltage follower, or create a bridge with the use of a pot.

In the method of Fig. 4(a), an op amp is connected as a voltage follower to relieve the load on the voltage standard output. For best accuracy, you should choose an op amp that has provisions for nulling its offset and which is rated for low offset-current.

The method of Fig. 4(b) is simpler and cheaper

though not as convenient. In this method, the voltage standard is one leg of a bridge, the other being provided by a potentiometer that matches the voltage set by the standard. With this scheme, once having set the voltage selector switches to the potential you want, simply adjust the pot to zero the meter. For smoothest adjustment, the resistance value of the pot should be one half to one tenth R_L . ■

New Products

from page 158

able K-2 frequency-determining elements, available in all EIA tone frequencies from 268.5 Hz to 2109.0 Hz.

Power requirements are 6 to 16 V dc unregulated at 10 mA. Reverse polarity and over-voltage protection are built-in. All connections to the board are made with push-on connectors, and color-coded wires are furnished.

The SD-1 may be driven by the discriminator, by the audio stages, or from the speaker circuit. Switched outputs include momentary high current closure to ground for horn relay, a latched high current closure for a call light, and a latched low current, high voltage pull-away from ground to unmute the receiver.

The unit is completely immune to rf and comes complete with universal mounting hardware. A full one year warranty

applies when the unit is returned to the factory for repair.

For further information, contact: *Communications Specialists*, 426 West Taft Avenue, Orange CA 92667; (714)-998-3021, (800)-854-0547. Reader Service number C6.

YAESU'S FT-225RD 2M TRANSCEIVER

A new state-of-the-art 2 meter all-mode transceiver, the FT-225RD, has been added to Yaesu's quality line of amateur radio equipment.

The new transceiver covers the entire 4 MHz and provides for USB, LSB, CW, FM, and AM. Power output is variable, 1-25 Watts. Squelch, VOX, PTT, semi-break-in CW with sidetone, and tone burst are standard features of the FT-225RD. A superb noise blanker permits mobile SSB operation, and a discriminator center meter allows precise zeroing on FM

signals. Repeater splits are the standard 600 kHz; however, any split up to 1 MHz is possible with optional crystals. Provision has been made for up to eleven (11) fixed channels using optional crystals.

The transceiver utilizes high quality plug-in circuit boards throughout, and an optional memory unit enables the storage and recall of any frequency within the range of the unit. This allows instant programmable QSY to a favorite repeater or calling frequency with just a flick of the switch. The digital frequency is accurate to 0.1 kHz (or to 1 kHz with the FT-225R, which offers the analog dial readout only at slightly less cost).

A built-in power supply provides taps for operation on 100/110/117/200/220 and 234 volts 50/60 Hz. Dc operation covers 11.5 to 16 volts, negative ground at 6.5 Amps on transmit, 1.2 Amps on receive. The transceiver measures 280 (W) x 125 (H) x 315 (D) mm and weighs only 9.0 kg.

An attractive four-color brochure is available at your

nearby authorized Yaesu dealer or from *Yaesu Electronics Corporation*, 15954 Downey Avenue, PO Box 498, Paramount CA 90723. Reader Service number Y1.

ECONOMY HAND TOOL CRIMPS BELDEN 8281 CABLE

AMP Special Industries' Coax Economy Stamped Hand Tool line has been expanded to include Belden 8281 cable, a popular 75-Ohm video cable used by television studios, broadcasting systems, and test equipment. Designed to crimp UHF and BNC connectors on the Belden 8281 cable, this quality SUPER CHAMP™ hand tool is lightweight and economical. Its features include a guide on the tool body for strip dimensions in all coax series—standard, economy, single, or dual crimp. The handles are cushioned for greater comfort.

For more information, contact: *AMP Special Industries*, Valley Forge PA 19482. Reader Service number A70. SUPER

Continued on page 253



The FT-225RD 2m transceiver from Yaesu.



AMP Special Industries' new SUPER CHAMP hand tool.

UNFORTUNATELY...



**Radio
equip-
ment
doesn't
grow
on
trees!**

You have worked hard for your money—don't gamble when you buy that next rig, antenna or even accessories. Contact C&A where they have been serving the amateur and commercial market for almost two decades. C&A can offer you the best prices plus the assurance that they will be there to back up your purchase with their staff of experienced LICENSED technicians and a genuine desire to add your name to their long list of satisfied customers.

CALL OR WRITE for all your needs to:



C&A Electronic Enterprises

Distributors of Commercial and Amateur Radio Equipment ✓c88

Two locations to serve you better:

22010 S. Wilmington Ave., Suite 105
Carson, CA 90745
(213) 834-5868

5773 Overland
Boise, Idaho 83705
(208) 377-5274

The 22S Goes Digital

— add 7-segment displays

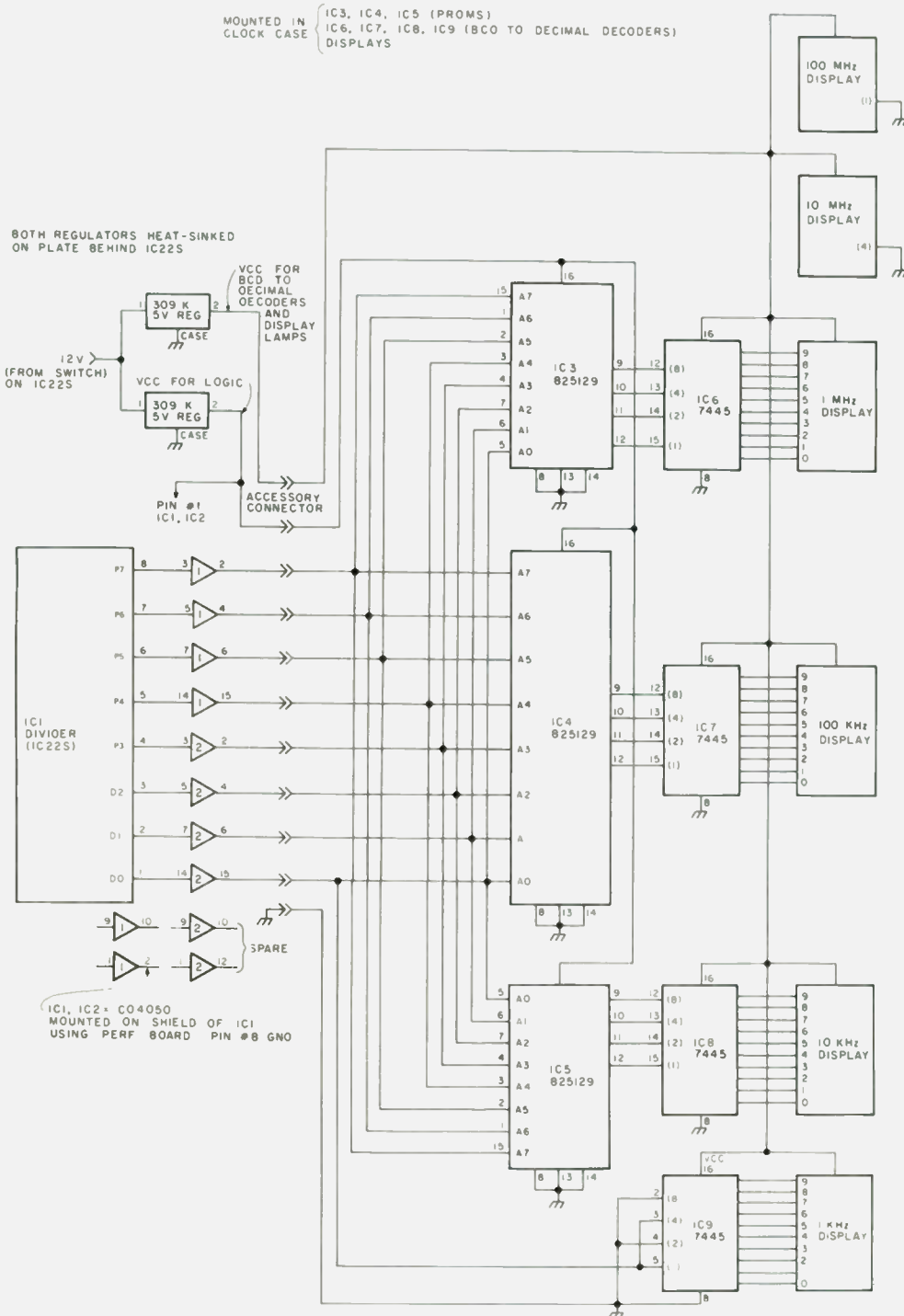

Fig. 1. IC-22S frequency display schematic diagram.

Raymond E. Thompson KH6IEL
2040 Komo Mai Drive
Pearl City HI 96782

Although very popular since its introduction by Icom, one big problem with the IC-22S is that it is so darn hard *not* to add modifications. Funny, but with a crystal-controlled 2 meter transceiver, the thought of adding additional channels seldom enters your mind. Six, fifteen, or twenty-four channels or whatever was originally supplied seems adequate. When you own an IC-22S, you can program any frequency you like with diodes. Frequency selection with only one knob is a great feature which really adds a lot to operating convenience. That's where the problem comes in. The 23 channels that you can select don't seem to be enough. Something keeps you trying to think of different methods of getting more channels. Several easy ones come to mind right away: adding an eight-level DIP switch, using toggle switches to add 15, 30, or 45 kHz to the programmed frequency, or adding a second matrix board and using the previous high/low power switch as a selector. All of these have one common drawback: You have to memorize switch settings or use charts, tables, etc., to know what frequency you are operating on. Even the mode switch can cause

problems if you forget that some of your programmed channels are simplex rather than repeaters. What is needed is a direct frequency readout.

That is the subject of this article. A direct frequency display for the IC-225. It works on receive or transmit and converts whatever binary code you have at the divider input in the IC-225 to a direct-reading frequency.

Programming the diode matrix board for a particular frequency has been covered in several articles and in the operating manual, so I won't go into any of that. The circuit for the frequency readout can be broken down into two functions. First, we must convert the eight-level binary code in the IC-225

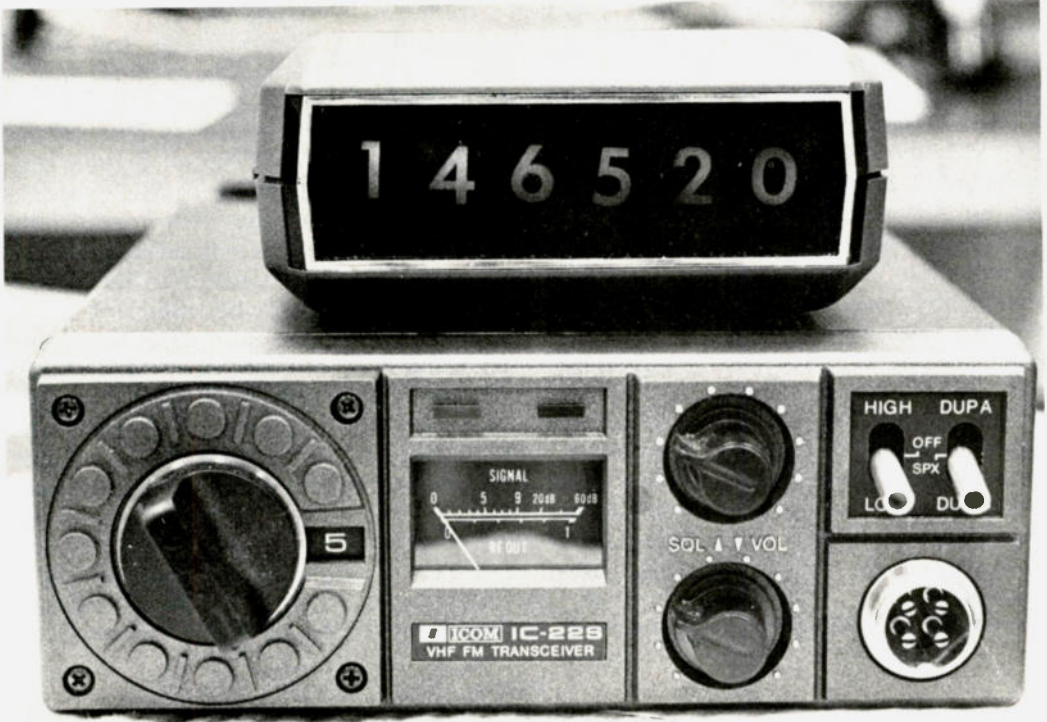

The clock case used to enclose the display fits very nicely on top of the IC-225. No question as to what frequency channel 5 is on this IC-225.

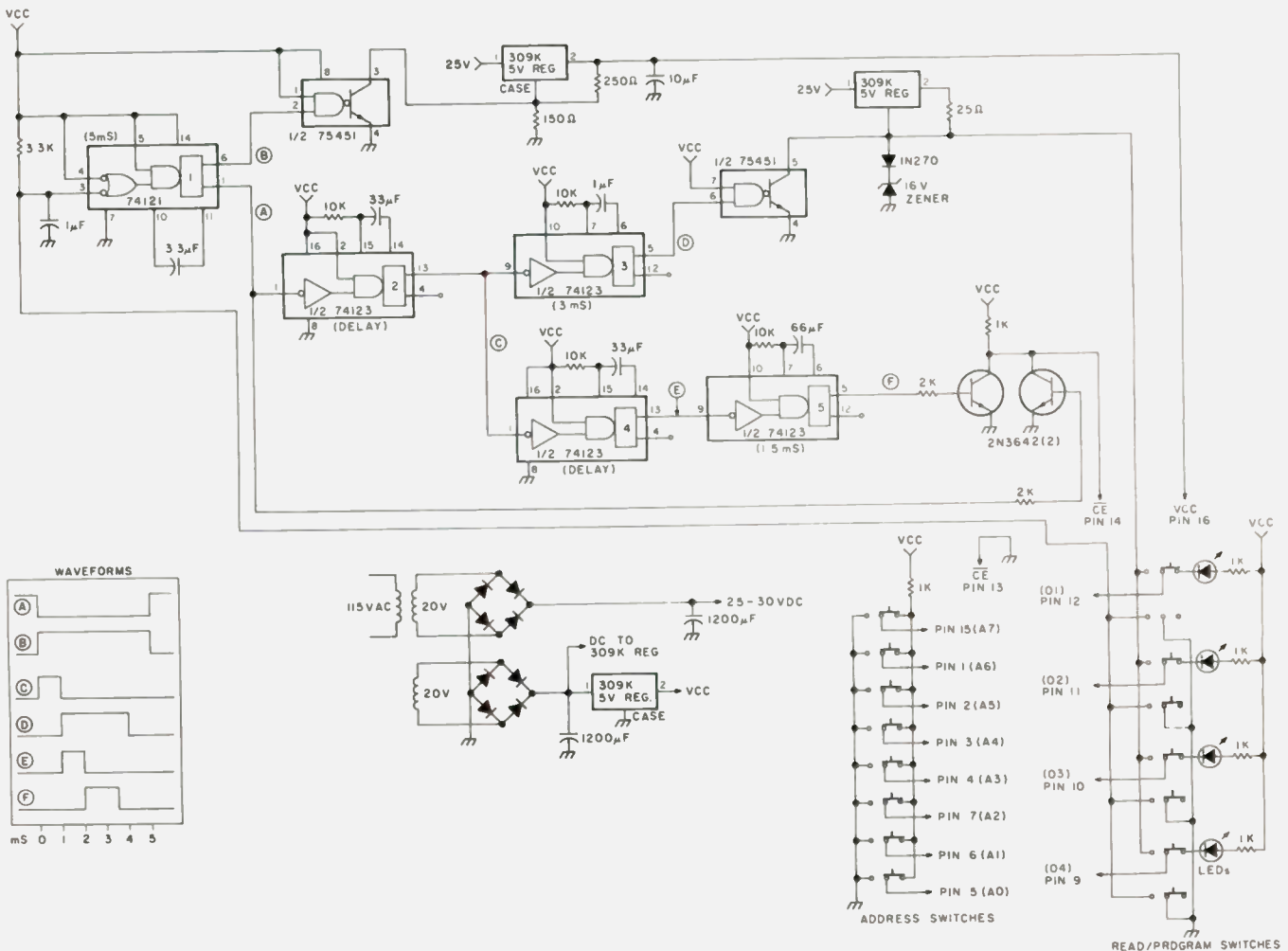

Fig. 2. Manual programmer from Signetics for 82S129 PROM.

divider into the appropriate BCD code for frequency. Second, we have to convert the BCD code to a visual display of frequency. "Why two steps and not just one?" you might be asking. It's simpler using two steps. We have eight inputs to convert to twenty-two outputs. Two for the MHz (6 and 7) and ten for both the 100 kHz and 10 kHz positions (1-10). If we use seven-segment LEDs, this cuts our requirements down to fifteen. Eight inputs must be converted to fifteen outputs. No such device is available.

Instead of looking at all

three displays together, and by looking at each one separately, we come up with eight inputs and seven outputs for the 10 and 100 kHz digits. This is still a pretty expensive thing and beyond using simple gate logic. If we use a standard BCD-to-seven-segment decoder ahead of each display, we have cut our requirements to eight inputs with four outputs. Now we are getting somewhere! Any 256 x 4-bit converter would work, one for each display digit. That's it. Tie three 256 x 4-bit PROMs, with their inputs in parallel, to standard decoders to drive the

display digits!

Looking at the schematic diagram (Fig. 1), IC1 and IC2 are simply hex buffer converters. They get the CMOS binary divider outputs down to TTL where we can use them. Since only eight are needed, there are four unused buffers which could be used for some other purpose. I used the 82S129 PROM for two reasons. A 256 x 4-bit device was required and the 82S129 PROM cost was only \$2.50 from S.D. Sales. The PROM for the MHz position (IC3) has to be programmed to produce a 5, 6, 7, or 8 with the appropriate binary input. Likewise, IC4

must be programmed to output the proper BCD code in the 100 kHz position of the frequency readout. IC5 is for the 10 kHz numbers.

Let's look at 146.520 MHz to see how this works out. 146.520 has the binary address of 142. This is found in the owner's manual or can be calculated by several means. So, we need the binary address code of 142 to be changed to a BCD code representing 146520. The hundreds and tens of MHz (1 and 4) will never change, so they can be either hardwired in the display or forgotten about. IC3 (MHz) is programmed

Program chart. 145.350—148.035

Address	IC3								IC4			IC5			
	128	64	32	16	8	4	2	1	8 4 2 1	8 4 2 1	8 4 2 1	107	108	109	
064	0	1	0	0	0	0	0	0	0101	0011	0101	0101	0110	0000	0001
065	0	1	0	0	0	0	0	1	0101	0011	0110	0110	0110	0000	0010
066	0	1	0	0	0	0	1	0	0101	0011	1000	0110	0110	0000	0100
067	0	1	0	0	0	0	1	1	0101	0011	1001	0110	0110	0000	0101
068	0	1	0	0	0	1	0	0	0101	0100	0001	0110	0110	0000	0111
069	0	1	0	0	0	1	0	1	0101	0100	0010	0110	0110	0000	1000
070	0	1	0	0	0	1	1	0	0101	0100	0100	0110	0110	0001	1000
071	0	1	0	0	0	1	1	1	0101	0100	0101	0110	0110	0001	0011
072	0	1	0	0	1	0	0	0	0101	0100	0111	0110	0110	0001	0100
073	0	1	0	0	1	0	0	1	0101	0100	1000	0110	0110	0001	0110
074	0	1	0	0	1	0	1	0	0101	0101	0000	0110	0110	0001	0111
075	0	1	0	0	1	0	1	1	0101	0101	0001	0110	0110	0001	1001
076	0	1	0	0	1	1	0	0	0101	0101	0011	0110	0110	0010	0000
077	0	1	0	0	1	1	0	1	0101	0101	0100	0110	0110	0010	0010
078	0	1	0	0	1	1	1	0	0101	0101	0110	0110	0110	0010	0011
079	0	1	0	0	1	1	1	1	0101	0101	0111	0110	0110	0010	0101
080	0	1	0	1	0	0	0	0	0101	0101	1001	0110	0110	0010	0110
081	0	1	0	1	0	0	0	1	0101	0110	0000	0110	0110	0010	1000
082	0	1	0	1	0	0	1	0	0101	0110	0010	0110	0110	0010	1001
083	0	1	0	1	0	0	1	1	0101	0110	0011	0110	0110	0011	0001
084	0	1	0	1	0	1	0	0	0101	0110	0101	0110	0110	0011	0010
085	0	1	0	1	0	1	0	1	0101	0110	0110	0110	0110	0011	0100
086	0	1	0	1	0	1	1	0	0101	0110	1000	0110	0110	0011	0101
087	0	1	0	1	0	1	1	1	0101	0110	1001	0110	0110	0011	0111
088	0	1	0	1	1	0	0	0	0101	0111	0001	0110	0110	0011	1000
089	0	1	0	1	1	0	0	1	0101	0111	0010	0110	0110	0100	0000
090	0	1	0	1	1	0	1	0	0101	0111	0100	0110	0110	0100	0001
091	0	1	0	1	1	0	1	1	0101	0111	0101	0110	0110	0100	0011
092	0	1	0	1	1	1	0	0	0101	0111	0111	0110	0110	0100	0100
093	0	1	0	1	1	1	0	1	0101	0111	1000	0110	0110	0100	0110
094	0	1	0	1	1	1	1	0	0101	1000	0000	0110	0110	0100	0111
095	0	1	0	1	1	1	1	1	0101	1000	0000	0110	0110	0100	1001
096	0	1	1	0	0	0	0	0	0101	1000	0011	0110	0101	0101	0000
097	0	1	1	0	0	0	0	1	0101	1000	0100	0110	0101	0101	0010
098	0	1	1	0	0	0	1	0	0101	1000	0110	0110	0101	0101	0011
099	0	1	1	0	0	0	1	1	0101	1000	0111	0110	0101	0101	0101
100	0	1	1	0	0	1	0	0	0101	1000	1001	0110	0101	0101	0110
101	0	1	1	0	0	1	0	1	0101	1001	0000	0110	0101	0101	1000
102	0	1	1	0	0	1	1	0	0101	1001	0010	0110	0101	0101	1001
103	0	1	1	0	0	1	1	1	0101	1001	0011	0110	0110	0110	0001
104	0	1	1	0	1	0	0	0	0101	1001	0101	0110	0110	0110	0011
105	0	1	1	0	1	0	0	1	0101	1001	0110	0110	0110	0110	0100
106	0	1	1	0	1	0	1	0	0101	1001	1000	0110	0110	0110	0101

for a BCD 6 (0110). IC4 (kHz) at address 142 is programmed for an output BCD 5 (0101). Likewise IC5 (10 kHz) at address 142 is programmed to a BCD 2 (0010). The kHz position does not require a PROM for conversion because anytime D0 is low, we want a 0, and when it's high, we want a 5. In this case, the binary number is 142 (10001110), so we read a 0. D0 is the last digit of the binary or the least significant. For address 142, we'll have IC3 = 6, IC4 = 5, IC5 = 2, and D0 = 0. As another example, take a look at 146.010 MHz. The binary address

for this frequency is 108 or 01101100. Here we'll want IC3 = 0110, IC4 = 0000, IC5 = 0001, and D0 = 0.

The second function is changing the BCD outputs to a display reading. I just happened to have a six-digit display that I had been wanting to use, so I used 7445 BCD-to-decimal decoders. LEDs and appropriate decoders would work nicely and would probably be the logical choice if you didn't already have some other type of readout display.

Programming the PROMs was my first experience with PROMs. Until this time, I just didn't have a

need to get into this. I was a little leery about attempting it, but I soon found out that it wasn't that hard. I did follow the manufacturer's circuit recommendations and the PROMs were programmed without difficulty. I built the required programmer circuit into my Heathkit® IC Tester, since the IC socket and all the switches were already there. I had to modify my IC Tester in order to do this; however, I won't go into any details of the modification. I will just include the circuit recommendations from the chip manufacturer. I will have to agree with others that

patience and care are the main things you must have when you are manually programming a PROM. The manufacturer also included waveforms to be used with automatic programming.

The programmer circuit (Fig. 2) appears at first to be a little involved, but is really pretty straightforward. The complete cycle takes 5 milliseconds and is controlled by one-shot 1. Its resting state causes the case of the 5-volt regulator to be grounded through 1/2 of the 75451, which puts Vcc for the PROM at 5 volts. With the address switches set to the desired

152	1 0 0 1 1 0 0 0	0110	0110	0111	198	1 1 0 0 0 1 1 0	0111	0011	0110
153	1 0 0 1 1 0 0 1	0110	0110	1000	199	1 1 0 0 0 1 1 1	0111	0011	0111
154	1 0 0 1 1 0 1 0	0110	0111	0000	200	1 1 0 0 1 0 0 0	0111	0011	1001
155	1 0 0 1 1 0 1 1	0110	0111	0001	201	1 1 0 0 1 0 0 1	0111	0100	0000
156	1 0 0 1 1 1 0 0	0110	0111	0011	202	1 1 0 0 1 0 1 0	0111	0100	0010
157	1 0 0 1 1 1 0 1	0110	0111	0100	203	1 1 0 0 1 0 1 1	0111	0100	0011
158	1 0 0 1 1 1 1 0	0110	0111	0110	204	1 1 0 0 1 1 0 0	0111	0101	0101
159	1 0 0 1 1 1 1 1	0110	0111	0111	205	1 1 0 0 1 1 0 1	0111	0100	0110
160	1 0 1 0 0 0 0 0	0110	0111	1001	206	1 1 0 0 1 1 1 0	0111	0100	1000
161	1 0 1 0 0 0 0 1	0110	1000	0000	207	1 1 0 0 1 1 1 1	0111	0100	1001
162	1 0 1 0 0 0 1 0	0110	1000	0010	208	1 1 0 1 0 0 0 0	0111	0101	0001
163	1 0 1 0 0 0 1 1	0110	1000	0011	209	1 1 0 1 0 0 0 1	0111	0101	0010
164	1 0 1 0 0 1 0 0	0110	1000	0101	210	1 1 0 1 0 0 1 0	0111	0101	0100
165	1 0 1 0 0 1 0 1	0110	1000	0110	211	1 1 0 1 0 0 1 1	0111	0101	0101
166	1 0 1 0 0 1 1 0	0110	1000	1000	212	1 1 0 1 0 1 0 0	0111	0101	0111
167	1 0 1 0 0 1 1 1	0110	1000	1001	213	1 1 0 1 0 1 0 1	0111	0101	1000
168	1 0 1 0 1 0 0 0	0110	0110	0001	214	1 1 0 1 0 1 1 0	0111	0110	0000
169	1 0 1 0 1 0 0 1	0110	1001	0010	215	1 1 0 1 0 1 1 1	0111	0110	0001
170	1 0 1 0 1 0 1 0	0110	1001	0100	216	1 1 0 1 1 0 0 0	0111	0110	0011
171	1 0 1 0 1 0 1 1	0110	1001	0101	217	1 1 0 1 1 0 0 1	0111	0110	0100
172	1 0 1 0 1 1 0 0	0110	1001	0111	218	1 1 0 1 1 0 1 0	0111	0110	0110
173	1 0 1 0 1 1 0 1	0110	1001	1000	219	1 1 0 1 1 0 1 1	0111	0110	0111
174	1 0 1 0 1 1 1 0	0111	0000	0000	220	1 1 0 1 1 1 0 0	0111	0110	1001
175	1 0 1 0 1 1 1 1	0111	0110	0001	221	1 1 0 1 1 1 0 1	0111	0111	0000
176	1 0 1 1 0 0 0 0	0111	0110	0011	222	1 1 0 1 1 1 1 0	0111	0111	0010
177	1 0 1 1 0 0 0 1	0111	0110	0100	223	1 1 0 1 1 1 1 1	0111	0111	0011
178	1 0 1 1 0 0 1 0	0111	0111	0110	224	1 1 1 0 0 0 0 0	0111	0111	0101
179	1 0 1 1 0 0 1 1	0111	0111	0111	225	1 1 1 0 0 0 0 1	0111	0111	0110
180	1 0 1 1 0 1 0 0	0111	0111	1001	226	1 1 1 0 0 0 1 0	0111	0111	1000
181	1 0 1 1 0 1 0 1	0111	0111	0000	227	1 1 1 0 0 0 1 1	0111	0111	1001
182	1 0 1 1 0 1 1 0	0111	0111	0010	228	1 1 1 0 0 1 0 0	0111	1000	0001
183	1 0 1 1 0 1 1 1	0111	0111	0011	229	1 1 1 0 0 1 0 1	0111	1000	0010
184	1 0 1 1 1 0 0 0	0111	1000	0101	230	1 1 1 0 0 1 1 0	0111	1000	0100
185	1 0 1 1 1 0 0 1	0111	0001	0110	231	1 1 1 0 0 1 1 1	0111	1000	0101
186	1 0 1 1 1 0 1 0	0111	0001	1000	232	1 1 1 0 1 0 0 0	0111	1000	0111
187	1 0 1 1 1 0 1 1	0111	0001	1001	233	1 1 1 0 1 0 0 1	0111	1000	1000
188	1 0 1 1 1 1 0 0	0111	0010	0001	234	1 1 1 0 1 0 1 0	0111	1001	0000
189	1 0 1 1 1 1 1 1	0111	0010	0010	235	1 1 1 0 1 0 1 1	0111	1001	0001
190	1 0 1 1 1 1 1 0	0111	0010	0100	236	1 1 1 0 1 1 0 0	0111	1001	0011
191	1 0 1 1 1 1 1 1	0111	0010	0101	237	1 1 1 0 1 1 0 1	0111	1001	0100
192	1 1 0 0 0 0 0 0	0111	0010	0111	238	1 1 1 0 1 1 1 0	0111	1001	0110
193	1 1 0 0 0 0 0 1	0111	0010	1000	239	1 1 1 0 1 1 1 1	0111	1001	0111
194	1 1 0 0 0 0 1 0	0111	0011	0000	240	1 1 1 1 0 0 0 0	0111	1001	1001
195	1 1 0 0 0 0 1 1	0111	0011	0001	241	1 1 1 1 0 0 0 1	1000	0000	0000
196	1 1 0 0 0 1 0 0	0111	0011	0011	242	1 1 1 1 0 0 1 0	1000	0000	0010
197	1 1 0 0 0 1 0 1	0111	0011	0100	243	1 1 1 1 0 0 1 1	1000	0000	0011

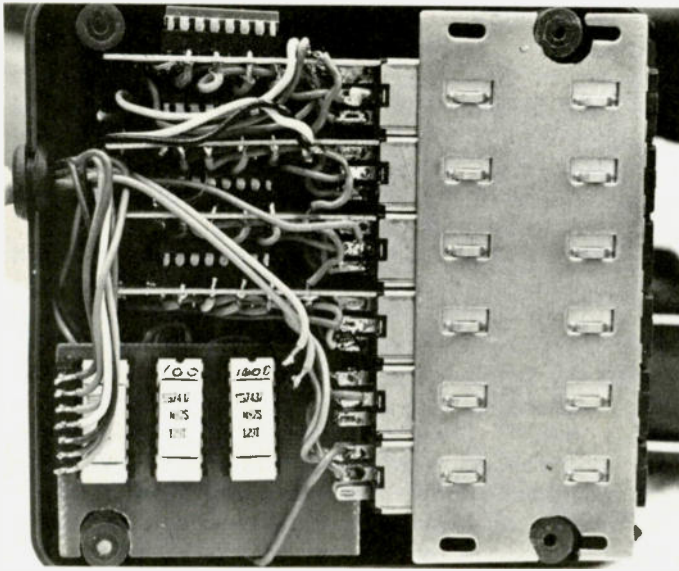

The three PROMs in the lower left leave plenty of room for the four decoders and display lamps. This clock case would be almost empty if LEDs had been used.

address, flipping any one of the output switches starts the 5 ms cycle. The case of the regulator is ungrounded, which raises Vcc up to 8.75 volts and starts one-shot 2 for a 2 ms delay. Following the delay, one-shot 3 is turned on for 3 ms. This removes the ground from the regulator and selected output pin, which lets this go to 17 volts. It also starts delay one-shot 4 which operates one-shot 5 after 1 ms delay. One-shot 5 raises the chip enable pin for 1.5 ms. The waveforms are indicated on the diagram. The output

switch is returned to the read position and another output to be programmed to a one at this address will run the cycle again.

I started my programming with IC3. To get started and check my procedures, I put in address 1 (00000001). With all output switches in the read position, the LEDs remained off, indicating a 0000 in the output. I toggled the switch for output 1 (pin 12). The circuit ran through its operation and was now reading a 1. Leaving the address switches at 00000001, I flipped each of the other

output switches and, sure enough, they now read 1111. (With this circuit, just toggling the desired output switch from read to program and back again is all that is required to program a 1 into the output. Nothing could be easier.) I had just programmed a BCD 15 into address 1. This didn't matter because the first address that I was going to need was 108. So with 108 as the address (01101100), all I had to do was program a BCD number 6 (0110). I programmed these outputs (pins 11 and 10) to ones. When I switched to another address, my outputs went to 0000. Returning to 108, I had my BCD 6, big as life. I then went down through the remaining addresses, programming the appropriate BCD 6 or 7. In fact, I decided to program the appropriate BCD number all the way from 64 through 243, just because my IC-22S would operate in this range.

IC4 and IC5 were not as straightforward because they have a lot of changes in their outputs. To keep from getting confused, I made up a chart which gave me the outputs for each PROM. Numbering from 64 through 243, I put down the eight-bit binary address and then the appropriate BCD number for each PROM. Before changing to the next address, I checked the chart against my LEDs to make certain that I had the right BCD number programmed. Making the output a 1 is easy, but once you toggle the switch, it's a 1, and if you toggle the wrong switch at that address, you are in trouble.

One suggestion I have is to mark each PROM with some kind of identification after being programmed. They all look alike and are much easier to visually identify than to look up the output codes in your programmer to tell the dif-

ference, once they are programmed. I marked mine by the number of kHz.

I placed the PROMs, decoders, and displays all together in a small clock cabinet. This kept my interface cable down to 11 wires. I used perfboard and point-to-point wiring. IC1 and IC2 are mounted close to the divider and add circuit. I used ribbon cable from the converter outputs to the accessory jack. If power is connected through the two spare pins of the power cable, the original 9-pin socket is adequate. Removing the original 9-pin socket and replacing it with a 24-pin connector would be a lot better. Once you use all 9 pins for a frequency display, you will certainly need more pins to add channels, or a scanner, or an external meter, or something. I couldn't find a 24-pin connector locally, so I enlarged the opening and put in a 36-pin Waldom connector.

When soldering connections to the pins of the divider, use care. The inputs for the converters could be taken from the matrix board (D0 through D7) rather than the divider (D0 through P7) which would be easier to get to. If this is done, in order to make the frequency read correctly, two CD4008 full-adders would have to be placed ahead of the PROMs and operated with the DP line. I gained access to the divider inputs (D0 through P7) by removing the matrix board, removing the 3 mounting screws and one threaded stand-off, and turning the board up so I could get to the pins of the IC1 divider. The wires were soldered onto pins 1 through 8 of IC1 and run toward the rear of the transceiver. These wires run under the board out to the perfboard for IC1 and IC2. I put my outputs of the converters on one side of

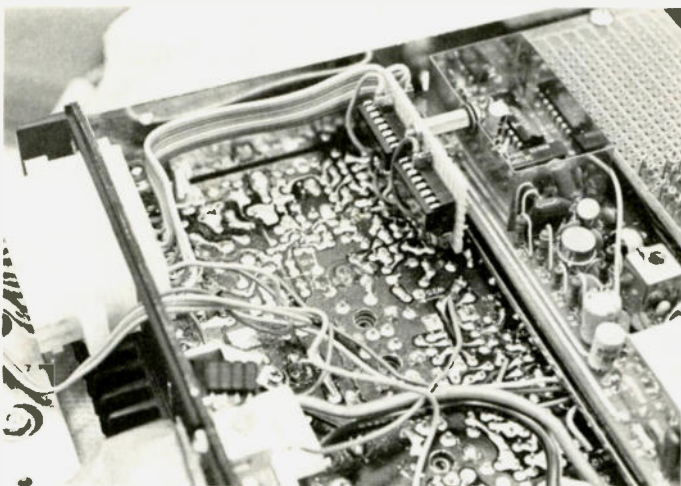

IC1 and IC2 are shown mounted on the shield using a stand-off. The added accessory connector on the left leaves plenty of spare connectors for other goodies.

the perfboard and the inputs on the other side, which helped in keeping the installation neat. My display lamps and drivers draw a little over 600 mA, so I used two separate 5-volt regulators. I mounted these on a metal plate with heat sinks. The plate is mounted to the back of the IC-22S with stand-offs. The logic doesn't draw much current so, depending on the display requirements, one regulator might do the job. The display can be mounted on top of the IC-22S or any easily readable position.

Since the binary code present at the divider is always present and converted to a frequency read-out on the display, there are no adjustments or alignments. I checked each section for proper operation as they were put together. The display and drivers were checked by

substituting a BCD number into each frequency position. The PROMs of course were checked during programming and the converters were checked to make certain that they faithfully followed the binary number in the divider. Once connected together, the job is completed.

At first, I tried to make use of all that room around the speaker. So I made a shield with a copperclad board over the main board and mounted the shield very close to the main board. This caused problems by changing the tuning of the output circuit. Moving the ICs up next to the divider and removing my shield board solved the problem. I mention this because, at first glance, it appears that mounting the hex buffers near the accessory socket is a good idea, but it isn't. I used flat ribbon cable and kept it up

and away from the rf circuits.

Because of the numerous variations possible, I'm sure that each frequency display addition will be

done a little differently. This article outlines one way that it can be done, so hopefully it will inspire you to put one together for your IC-22S. ■

Photos by Jan Kaneshiro

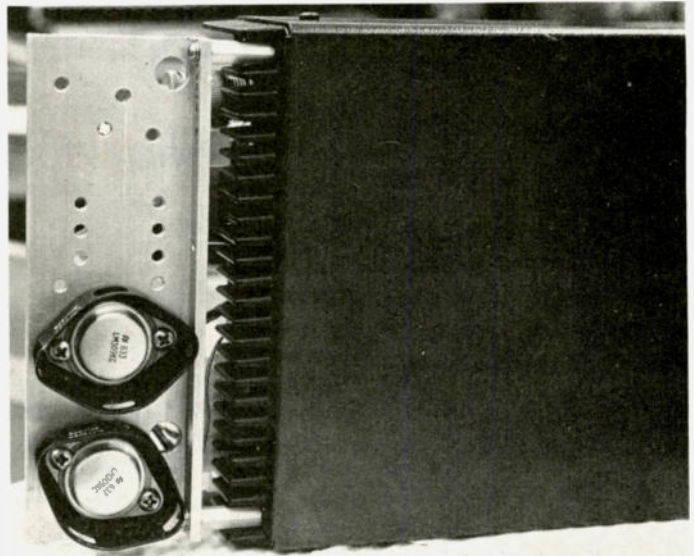

The two 5-volt regulators add a little length to the transceiver but operate quite coolly being mounted on this plate with stand-offs.

The RF testing kit for professionals.

The WATT-KIT puts RF equipment testing all together. Kit consists of a Type 1000 RF Directional Wattmeter, 100 watt plug-in elements to measure from 25 MHz to 1 GHz, UHF connector, two-foot patch cable with connectors and luggage style carrying case. Available with 100 watt dry terminating load.

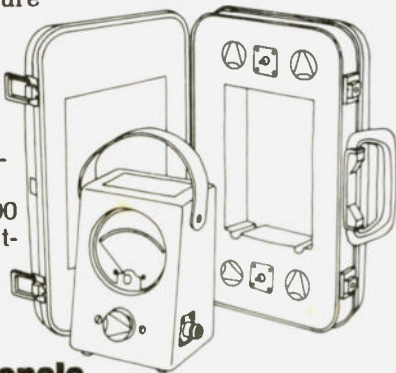

Wattmeters for professionals.

For the name of your local distributor call toll free 800-341-9678

GS DIELECTRIC COMMUNICATIONS
A UNIT OF GENERAL SIGNAL
RAYMOND, MAINE 04071 • TEL 207 655 4555 • 800 341 9678

NEW Electronic Keyers!

By Famous Katsumi™ of Japan and Globalman—USA



EK-121

\$64.95, both units, ppd

- MODEL EK-121**
- Built-in paddle
 - Self completing dots, dashes
 - Dot memory
 - 4 penlight cells req. or 4-6 V dc
 - Speed, weight control
 - Transistor output keying, 150 V, 1 Amp, dc
 - Uses external side tone oscillator (G 100)
 - LED keying light monitor
 - Auto or semi-auto keying
 - Size: 8" L x 4" W x 2" H
 - Weight: 2.2 lbs. (1 kg)

MODEL EK-150

- Squeeze or std keying w/dot memory
- Built-in paddle
- Built-in slide tone w/tone & volume control, speaker, headphone jack
- Switch for auto or semi-auto keying
- Heavy-duty transistor output keying, 150 V, 2 Amps dc & high speed relay, 700 V, 500 mA
- Operates on ac 100-120 V/50-60 kHz or 7-13.5 V dc
- Size: 5" W x 3" H x 7" D
- Weight: 4.4 lbs. (2 kg)



EK-150

\$99.00 ppd.



MK-1024

\$169.95 ppd.

- MODEL MK-1024 PROGRAMMABLE MEMORY !!**
- 4 Independent 256 bits or one 1024 bit long message memories. Push-buttons—select & start
 - Built-in paddle
 - Squeeze (A/R/B/C) keying, dot memory
 - Built-in sidetone w/tone & volume control, speaker, headphone jack
 - Semi- or automatic keying
 - Heavy-duty transistor switch keys 150 V at 2 Amps dc, also relay keying for max. 700 V, 500 mA
 - Operates on ac 100-120 V/220-240 V, 50-60 kHz or external 9-14 V dc
 - Size: 5 1/2" W x 3" H x 8" D
 - Weight: 5 lbs. (2.3 kg)

Free spec. sheets all items, incl.
G-700 Code practice osc. \$6.50
MC-701 Speech Processor \$39.95
SWR meters to 150 MHz, other items.

➤ G23 GLOBALMAN PRODUCTS

W6PHIA (714) 533-4400
Mail Address Telex 678-496
P.O. Box 246G
El Toro, Calif. 92630

WARC '79 Preview

—showdown in Geneva

The World Administrative Radio Conference (WARC) will reconvene in Geneva, Switzerland, on September 24, 1979. It is scheduled to last ten weeks at the International Telecommunication Union headquarters' complex.

The last WARC was held in Geneva during 1959. Delegates from over 100 countries attended to discuss and revise regulations that govern the international use of the radio spectrum. Regional conferences have been held since then to review matters such as the handling of third-party traffic.

To understand how amateur radio as a hobby fits into the global scheme of things, one should be aware of the purpose and workings of the ITU. Their negotiations will lead to a treaty that will have an enormous effect on how the communication services of the world will function.

History of the ITU

The ITU has existed for over 100 years and is the oldest of agencies that are affiliated with the United Nations. It first operated as a separate body until the UN absorbed it in an agreement signed in 1947. It was

organized mainly to help regulate the use of the electric telegraph, which was made available to the public during the mid-1800s.

Various treaties were negotiated between the nations of Europe. The governments had to face difficulties that would have to be overcome. When Prussia, in 1848, decided to link its capital with places on the borders of its kingdom, it had to conclude at least 15 treaties with the German states to obtain the rights of passage needed for the building of telegraph lines.

The International Telegraph Convention was signed during the 1865 Paris Conference by 20 countries. These nations made up the International Telegraph Union, which was the original name of the ITU.

Then, in 1895, the first successful wireless transmissions signaled the greatest revolution in the history of telecommunications: the invention of radio. It was first regarded as a radically advanced form of telegraphy. Radio spread across the international scene more rapidly than the telegraph had.

With the rapid use of radio as a form of com-

munication, it became clear that international regulations were needed to accommodate it. This became apparent in 1902 when Prince Henry of Prussia was returning across the Atlantic from a visit to the United States. He attempted to send a courtesy message to President Roosevelt. It was refused by the operator of a U.S. coastal station because the radio equipment on the ship was of a different type and nationality than that of the shore station. As a result of this incident, the German government called for, and convened, the 1903 Berlin Radio Conference.

In three years, another conference was held where the first international radio regulations incorporated the principle that ships and coastal radio stations must accept messages from each other.

The first World War greatly stimulated the development of radio, and in the early 1920s, the International Broadcasting Radio Service began. A new problem became how to share the radio frequencies to avoid the inevitable interference between stations. Even today, the global responsibility for radio frequencies remains

one of the ITU's heaviest and most vital jobs.

It was not until the ITU conference of 1927 that a reference to the Amateur Radio Service was made: private experimental stations. The Washington, D.C., meeting allocated bands of frequencies to all of the various radio services, including maritime, broadcasting, and ham radio. Hams had been operating in the U.S. before this year but were now officially recognized by the world community.

During the second World War, broadcasting brought the fact home to everyone that radio waves respected no geographical boundaries. It was apparent that much wider world agreements would have to be drawn up for radio.

Radio Conference Procedure

The upcoming conference's purpose is to review the regulations currently in effect and to devote the proceedings to those needing revision. By the time the official delegations assemble in Switzerland, governments would have already firmed up their positions with the aid of private organizations and citizen groups. Their views will have

CALL A.R.S.O.N. NOW!

615 868-4956

for the Best DEALS

Amateur Radio Supply of Nashville, Inc.

615 South Gallatin Road, Madison, Tennessee 37115 ✓ A40

best prices · best service · best trades



CDE Rotor Specials

Shipping included to Cont. U.S.A.
 Ham III rotor \$124.00
 Ham III rotor plus 100 ft. rotor cable \$139.00
 Ham III rotor plus 100 ft. each - rotor cable and best RG-8U foam coax \$162.00
 T2X Talltwister \$229.00
 Send cashiers check or M.O.

SPECIAL DEMO SALE

The following are NEW Close-outs, New displays, Demos, etc. Most are factory-sealed, all carry New warranties. Limited quantity. First come, first served.

ICOM

IC-245 2M FM \$399.00
 IC-245/SSB 2M all mode 575.00
 IC-211 2M all mode 725.00
 IC-701 Dig HF XCVR 1400.00

KENWOOD

TS 820S Xcvr 975.00
 TS 520S Xcvr 565.00
 SM 220 Scope 289.00
 TR 7400A 2M FM 379.00
 TS 700SP 2M all mode 625.00

TEN-TEC

544 Dig Xcvr 715.00
 540 Xcvr 579.00
 570 CW Xcvr 259.00
 574 Dig Xcvr 339.00

WILSON

Mark II 2M hand held 199.00
 Mark IV 2M hand held 229.00

YAESU

FT 901DM 1175.00
 FT 901DE 999.00
 FT 901D 999.00
 FT 101F 669.00
 FT 101EE 615.00
 FT 101EX 569.00
 FT-7 HF Mobile 449.00



YAESU FT 901 DM
 Call for yours today.



TS-820S KENWOOD
 Deluxe 1.8 - 30 MHz Transceiver



Kenwood
 7400A 25 watts
 Fully syn. 2M FM
 Call for Super Quote

Call us for:
 Drake TR7 & Ten-Tec OMNI
 The best antenna deals.
SUBDEALERS WELCOME
 We're burning to make "hot" deals

STORE HOURS
 Mon. - Fri. 9 AM - 5 PM
 Sun. 1 PM - 6 PM

MASTER CHARGE & VISA ACCEPTED



The Memorizer



Yaesu FT 227R
 Fully Syn 2M FM

TRY OUR SERVICE DEPT.
 Send your rig complete with PS and Manuals via U.P.S. to us and will put it into top shape FAST.

SPECIAL USED SALE

30-Day guarantee. Limited quantities. First come first served.

DRAKE

R4C RCVR	\$379.00
T4XC Trans	379.00
TR4CW/RIT XCVR	549.00
R4-A RCVR	299.00
T4-X Trans	299.00
TR-3 XCVR	325.00
MS-4 Spkr	19.00
AC-4 AC Supply	85.00
DC-4 DC Supply	85.00

ICOM

IC 22A FM 2M Xcvr	125.00
IC 21A & DV-21 2M	349.00
IC 22S 2M FM	209.00

KENWOOD

T-599A Trans	269.00
R-599A Rcvr	269.00
T-599D Trans	399.00
R-599D Rcvr	399.00
TV502 2M Transverter	169.00
TV506 6M Transverter	169.00
TS 700A 2M all mode	399.00
TS 502S 160-10M Xcvr	539.00

HEATHKIT

SB-230 Linear amp	299.00
HW 101 & PS & Spkr, Mic	369.00
SB-300	189.00

YAESU

FR AX400 Rcvr	249.00
FL AX400 Trans	249.00
FR 101SD dig Rcvr	449.00
FL 101 Trans	419.00
Yaesu FT 101EE 160-10M	519.00

been submitted to the Secretariat of the ITU and published in a single book of proposals. Copies then would have been circulated to all member nations to enable each delegation to know what everybody else is thinking.

In the U.S., negotiation of the treaty is exclusively the responsibility of our State Department. Various working groups have been meeting for the past two years hashing out what they think should be the final U.S. proposal. The Federal Communications Commission considers these views, and adds to this their outlook. They then publish notices of proposals. Eventually, the FCC will come up with their final position paper and hand it to the State Department to begin the diplomatic process.

Much of the nitty-gritty negotiations are taking place now and the actual ITU WARC will seem anticlimactic.

Let's examine the makeup of the people who can attend these world meetings. Official voting delegates from the various nations have not yet been selected but soon will be. If the makeup of the last conference in 1959 can be any indication of what to expect, countries will include various governmental department heads who will administer radio law back home. In our case, the military brass would be included along with people from the FCC.

Representatives of private companies can participate along with people from international radio organizations. They can act as observers only after obtaining the approval of the participating governments. They can look on from the audience but cannot actively have a say in

polycymaking decisions.

On opening day, distinguished members will be seated in a large room of the ITU building to carry out the formal opening ceremonies. A chairman will be selected who will organize committees that will meet separately to take up the various issues that brought them there. Each nation will register members for participation in the discussion groups. They will be meeting near Geneva during the length of the assembly. Toward the end of the conference, members will once again assemble en masse to vote on the new international radio law.

In addition to committee meetings, there are plenty of social functions to attend. Much arm twisting is done in between the wine and the cheese dip. The diplomatic officials of the world do have a tradition of combining business with pleasure. Where else but in Geneva, which is the world headquarters of our many organizations (Red Cross,

Boy Scouts, etc.) that serve humanity, should such splendid parties be thrown. These occasions are legal ground for the conference's observers to confer with the delegates on various matters.

When the treaty is concluded and the officials approve, then it is up to each member nation to ratify the agreement. In the U.S., our Senate has to approve the final document. Our services in the communications field do not have to abide by the new regulations until our government makes it law. One ratification process took our officials in Washington several years to give it their seal of approval. Until ratification, we continue to operate under the present treaty.

U.S. Preparations

U.S. Preparations have been actively under way since 1975 at the Department of State, the Federal Communications Commission, and the Office of Telecommunications Policy (now known as the

National Telecommunications and Information Administration). The FCC is charged with primary responsibility for developing non-federal user requirements. The NTIA is primarily responsible for federal government requirements.

The FCC and NTIA are developing the different needs and requirements of the U.S. spectrum users through close consultation with each other and with the State Department. Industry and general public interests have been solicited by means of a series of public Notices of Inquiry, issued by the FCC. Eight Notices of Inquiry have been issued and additional Notices may be released in the future. The Notices treat different aspects of WARC planning, most notably changes in the international table of frequency allocations.

How Much Can World Politics Affect Amateur Radio Bands?

There has been speculation on how other nations

United Nations Photo



Headquarters of the International Telecommunication Union in Geneva, Switzerland.

view amateur radio. The concern seems to be focussed on how third-world governments place their communications priorities. At the time of past WARC's, many of these nations were colonies of the western nations and the voting power of these colonies was held by their respective ruling countries. The situation has changed enormously since the 1959 WARC; the number of independent nations has increased dramatically. In September of 1979, 154 nations will cast votes on the many issues facing WARC. Many of them will be nations which were not yet independent at the time of the last WARC. The balance of power has shifted.

These new nations are rapidly reaching the period when their development creates economic and social needs to fill. As their domestic and foreign goals become clear, amateur radio may not be so important to them when compared with commercial, military, and governmental interests.

If you look through the list of those who hold amateur licenses in developing nations, you'll find that many of the licenses are held by foreign nationals. In some nations, you'll find native-born hams in the government or military, but not in the population at large. Most African authorities consider hamming to be a "white man's hobby" and they discourage the population from getting involved with it. In many cases, licenses simply are not issued to natives of these nations.

Can world politics hinder amateur radio? This is a hard situation to get a handle on. One would think that the U.S.S.R. bloc

might be against ham radio, but in 1959 a very curious thing happened. Most of the ITU members were attempting to slice up the ham bands and even threaten amateur radio's existence. Then, with the aid of the Communist votes and our hemispheric friends, we gathered enough support to salvage the service without losing a kilohertz!

Last time we went into the conference not asking for anything special, like the expansion of our bands. WARC '79 may see us asking for additional bands due to some services moving up to communication satellites and thus abandoning many shortwave frequencies. We may hear some countries suggest that CB should become a world service and share the ham bands with us. The political situation being played out at the U.N. and its agencies may spill over to Geneva. This would put the western world into opposition with the third world just because it is the fashionable thing to do. A 44-nation African bloc appears ready to vote for a set of world frequency allocations which will mean drastic cuts in the amateur bands. Many other third-world governments will probably follow this lead.

We do have strong support in some countries, including at least one in Africa. Liberia is a staunch advocate of ours because of the way ham radio aided that country during an epidemic. Central and South American governments know of our value in providing disaster and emergency communications. We do have friends who will stand by us, but the world is changing and only time will tell what will happen. ■

Call for the famous HAM-KEY.

JUST DIAL **1-800-325-3636**
TOLL FREE



Model HK-1

- Dual-lever squeeze paddle
- Use with HK-5A, or any electronic keyer
- Heavy base with non-slip rubber feet
- Paddles reversible for wide- or close-finger spacing

\$29⁹⁵



Model HK-2

- Same as HK-1, less base for incorporation in own keyer

\$19⁹⁵



Model HK-3

- Deluxe straight key
- Heavy base...no need to attach to desk
- With navy type knob

\$16⁹⁵

Model HK-3A

- Same as above less base

\$9.95

Extra: navy type knob only **\$2.75**



Model HK-4

- Combination of HK-1 and HK-3 on same base
- Base only with rubber feet
- Terminals, red or black. \$.75 each

\$44⁹⁵

Model HK-5A
Electronic Keyer

- New Cabinet Colored-Keyed to Match most modern radio equipment
- Iambic Circuit for squeeze keying
- Self-completing dots and dashes
- Curtis 8044 I.C. Keyer Chip
- Battery operated with provision for external power
- Built-in side-tone monitor
- Grid block or direct keying

\$69⁹⁵

NEW DOT AND DASH MEMORY



- Speed, volume, tone and weight controls all mounted on front panel
- For use with external paddle, such as HK-1 or HK-4
- Can be used as Code practice oscillator with straight-key, such as HK-3

Same day shipment...PREPAID
So order today direct or from your favorite dealer

HAM RADIO CENTER

8340-42 Olive Blvd • PO Box 28271 • St. Louis, MO 63132

The "Flim-Flam" Factor

—another biased article

Alexander MacLean WA2SUT/NNNØZVB
18 Indian Spring Trail
Denville NJ 07834

Having trouble understanding things about transistors that you think ought to be understandable? It's been a long time since anyone has said much about tubes and maybe things are not as clear as they could be. Or, perhaps there is such a wide gulf between tubes and transistors that you despair of ever making sense out of it all.

There is a reason for all

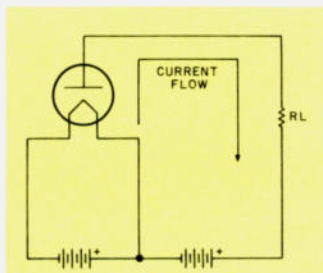

Fig. 1. Fleming valve (diode).

this, although rarely spoken of in electronics circles. There is no official word for it, but for the purposes of this article, it will be referred to as the "flim-flam" factor. The flim-flam factor is the amount by which the electronics industry has deliberately made understanding more difficult for non-electronic reasons.

To explain this, it will be necessary to go back and fold, spindle and mutilate a bit of electronics history.

In the beginning, there was the Edison effect, named after Mr. Edison, who noticed the effect. What he noticed was that after a while, the glass of his light bulb would become darkened by something. This was found to be caused by electrons

given off by the lamp's filament. In time, this led to the Fleming valve, which consisted of a filament and a separate metal plate, the anode. Current would flow from the filament to the anode, as in Fig. 1. This is the basic tube rectifier, detector, or diode. RL limits the current in the circuit. Otherwise the diode would draw too much and be destroyed.

DeForest is credited with the addition of the third element of the tube, the grid, which was able to control the flow of current between the filament and the anode. This created the basic triode as in Fig. 2. It is the basis for most of the electronic circuits in use today.

I am told that it was possible to make the diode amplify, but the triode's ability to amplify was the key to the whole show.

In time, other elements

were added to the tube to improve its abilities. The screen and suppressor grids and the indirectly-heated cathode allowed for higher gain and better stability than the triodes then had. In a well-designed circuit, they did work better. That's in a well-designed circuit. You could have a poor design and they worked lously. However, it was something new. The thing to remember is, while it was an improvement, there was nothing these tubes could do that the triode couldn't. It was just an improvement. To sell the new tubes, they had to destroy the old ones. A great deal was written and promulgated about how poor a practice it was to use triodes, but the fact is there are many applications where it is still more desirable to use a triode tube. They have made improvements in them over

the years, too. However, the bad name stuck and that is important for the narrative. Why will be explained a bit later, but it is necessary to stop a moment and talk about bias, what it is and why it is.

The triode amplified. So did the later tubes. You put a little signal in one side and a big signal comes out the other. Wonderful! But there were a few little problems.

Ideally, you want a clear relationship between the input and the output. For example, if the gain of the stage was 100, then 0.1 volt in should get you 10 volts out, and 0.2 volts in get you 20, and so forth. Unfortunately, it didn't work that way. The input-output ratio was not a straight line. It was a curved line.

Fig. 3 shows the problem. The grids of most tubes must be minus with respect to the filament (or cathode) and there is only a small area over which the relationship is linear. At one minus point, the tube cuts off, and at the other extreme, it draws its maximum current (saturation point), usually ruining the tube. The center part of the line is the so-called "linear" portion of the curve. This is the usable part. You have to place the input signal where you want it on that line.

Now then, how do you establish the point on the line? This is done with "bias." Bias is a fixed voltage introduced to the tube, apart from the signal, to establish the reference point on the tube's response curve, around which the signal will vary.

Some circuits use a bias voltage at the grid as in Fig. 4. However, we are really talking about two tube elements. You can either make the grid negative or make the cathode more positive than the grid as in Fig. 5(a). This could be done with an actual fixed

voltage or the tube can be "self"-biased. Fig. 5(b) shows a cathode resistor and capacitor. The resistor raises the cathode above ground potential, making it more positive than the grid, and the capacitor passes signal variations around the resistor so the bias remains constant. This is one of the most common forms of tube bias in use. You will see it in many receiver stages and many parts of a transmitter.

One of the most confusing things about bias is that there seem to be several kinds. There are, but it's simple once you get the hang of it. There are three basic classes of bias in use and one common subclassification. There is class A, class B, and class C.

Fig. 3 shows class A bias. It means that the tube is biased to the center of the most linear part of its curve. The output waveform is the most accurate following of the input waveform possible. When biased to that point, the tube will also draw current at all times, even when there is no signal present. This is not the most efficient use of the tube, but it produces the most undistorted output available. It is usually used at low af and rf levels.

If the tube were to be biased so that it rested right at the cutoff point, no current would flow. This would be class B, as in Fig. 6. Many audio power amplifiers use this bias with two tubes in push-pull. Each tube takes one half of the input signal so that the output is still a faithful rendition of the input. Thus, more of the power used appears as output rather than just dissipated as heat by the tube.

This is commonly done in many tube-transmitter AM modulator sections. A single class B tube is often used as an rf power amplifier stage. It takes little

drive, mostly just a signal voltage, and has good power gain. For rf, and even small audio amps, it is still considered a linear amplifier. The output is proportional to the input and the output distortion is minimal.

An amplifier that is biased beyond the cutoff point would be operating class C. It has to be driven into conduction (Fig. 7). However, the available output is higher than the other two and represents greater tube efficiency. Unfortunately, the output wave is distorted and non-linear. The output is really just one of the peaks of the input signal. It's no good at all for audio or linear amplification of an rf signal.

Class C is the favored output stage for a CW or FM transmitter. The tuned circuit's flywheel effect smooths out the waveform and you get a good signal output.

There is a common way of deriving the bias voltage for class C operation which may not be easily recognizable as such. This is grid leak bias, which is common in oscillator circuits, circuits like the regenerative receiver and small rf power amplifier stages.

It is shown in Fig. 8(a) and (b). Here's what is going on. Class C is non-linear, a distortion of the signal, but the input signal voltage also gets rectified by the grid to cathode diode combination. This produces a dc potential across the resistance which

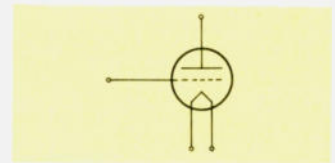

Fig. 2. Triode.

is smoothed by the capacitance in the circuit. As the current requirement is very small, this is enough to bias the tube.

There is one problem. It requires an input voltage to get the bias. If the input voltage or drive should be cut off in a stage like an rf power amplifier, it would lose its bias and draw excessive current. This is why it's only used with simple transmitters. A high power amplifier would have some form of protective bias or cutoff circuit to protect the tube. With transistors, if you cut off the bias, you cut off the transistor and usually this is no problem. (That's with the normal bipolar type.)

The common subclass of bias is class AB. This is a class B stage that is biased towards cutoff, but not all the way. This smooths out the crossover point in the two-tube (push-pull) circuit and also works better with the one-tube amplifier. It draws some current when there is no signal, but it improves the linearity of the amplifier.

Let's review. Class A is biased to the midpoint of the linear portion of the tube curve, draws current at all times, amplifies the whole input signal with minimum distortion, and is the least efficient use of power.

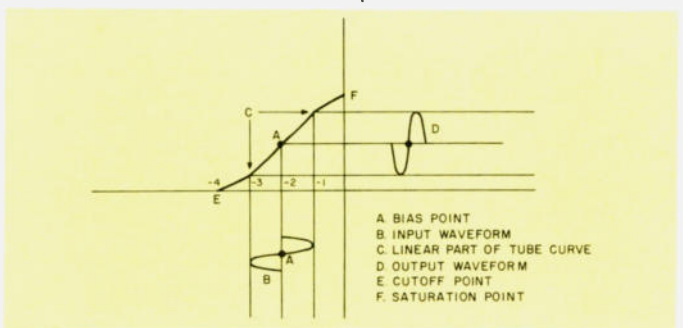

Fig. 3. Triode class A bias point.

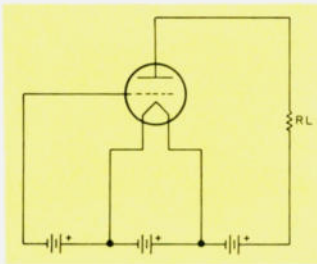

Fig. 4. Triode voltage polarities.

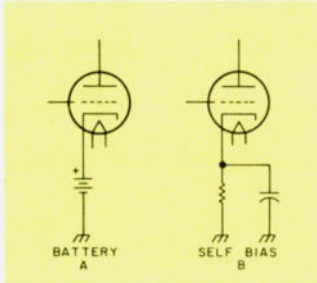

Fig. 5. Cathode bias.

Class B is biased to the cutoff point of the tube curve, draws current only when there is a signal applied, amplifies only part of the input signal per tube (one half), has an output that is proportional to the input, and is considered a linear amplifier. It is also a more efficient use of power.

Class C is biased beyond the cutoff point, only draws current and has output when driven into conduction, amplifies a smaller portion of the input signal (less than half), has the largest and most distorted output, and is not considered a linear amplifier. It is the most efficient use of the available power.

Class AB is a variation of the class B amplifier that is not fully biased to cutoff. It draws some current at all times, is more efficient than class A, but less than

class B, and is less distorted than class B.

That's it for tube bias classes. There is one other thing about tube bias which should be mentioned. Most tubes will cut off with sufficient minus bias.

There is, however, one kind of tube that was designed so that it would not cut off in operation. This is the remote-cutoff tube (Fig. 9). This was designed for stages like rf and i-f amplifiers where AVC (automatic volume control) action is desired. A strong signal would bias a normal tube to cutoff and the set would go dead. The remote-cutoff tube does not cut off. It just continues to reduce the gain. Strictly speaking, that is not a class of bias, but it does have an odd tube curve and function.

Now then, we come to transistors. Here's where we start to have troubles. Once again the flim-flam factor appears.

The transistor was a triode—nothing more. Not only that, it was a triode with all the troubles the tube triode had and a few more that tubes never thought of. It was the new toy that had to be sold and a great deal of effort went into making it seem like anything but a triode. All the bad things they said about triodes came back to haunt them. And they were trying to do all the things with a triode that they were using multi-element tubes for.

There were a few problems. In a well-designed

circuit, a transistor can be a reliable circuit element, but many of the circuits were not designed well and got worse as they aged. This quickly gave transistors a well-deserved bad name. They had oversold their reliability and rushed into production with too many transistor circuits riding right on the edge of their technology. To sell them, they worked very hard to disassociate transistors from anything to do with tubes, particularly the triode.

As far as possible, new terms were given and even new ways of arranging the schematics so that transistor schematics often have circuit elements in different positions than a tube schematic would. All this overlooked one simple thing: There are far more similarities between tubes and transistors than there are differences. We will need to fill in just a few more tube items before we can fill in the blanks. There were some factors which were deliberately drawn to widen the gulf between the two when, in fact, they are just opposite ends of the same stick.

Way back, it was thought that the tube grid did not draw current, particularly in the class A amplifier stage and the early regenerative stages and so forth. One theory held that bias was a static charge, a potential difference as at the poles of a battery (which often supplied the bias voltage). While the voltage appeared as a static charge at

the poles of the battery and at the tube elements, no actual current flowed. It was not, in that sense, a complete circuit.

But unless the Supreme Court has declared Ohm's Law to be unconstitutional, grids draw current. All grids draw current.

The problem was that the grid resistance might be several million Ohms and the voltage only a few volts. The current was so slight that it couldn't be measured without upsetting the circuit.

Much has been made of saying that the tube is a voltage-operated device and the transistor is current-operated, as if this was something different. Bunk! There is voltage and current floating around in both of them. You can't have one without the other, no matter who says what. Why then is there the big problem? It's a matter of impedance and sloppy wording. Here, we will have to use impedance and resistance interchangeably because we are dealing with both the static dc voltages and the signal voltages.

It is a matter of convenience to speak of the tube circuit as voltage-operated and the transistor as current-operated because of the resistance involved. For convenience, think of it as an amount of power, even though it may be small. The tube circuit has a high resistance. The signal is higher voltage, which means that the current will be very small. The equivalent signal in a tran-

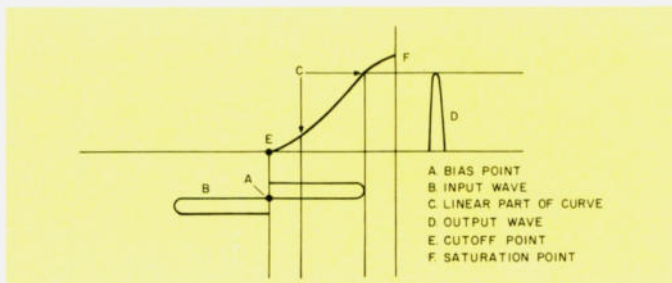

Fig. 6. Class B bias.

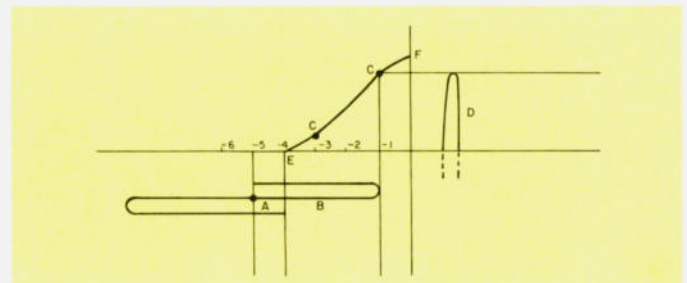

Fig. 7. Class C bias.

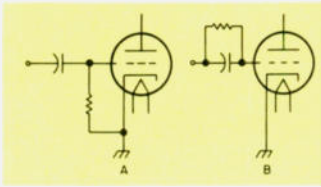

Fig. 8. Grid-leak bias.

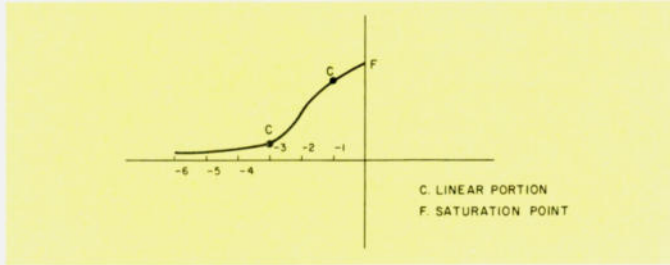

Fig. 9. Typical remote-cutoff tube curve.

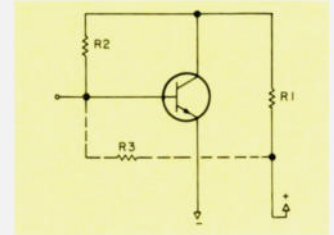

Fig. 10. A simple transistor bias circuit.

sistor is across a lower resistance, which means that the voltage on it will be smaller but the current higher.

You have seen this before with antennas. An end-fed wire is a high impedance point, which means a high voltage point but low current. A dipole is a low impedance feed-point, which means a lower voltage but a high current. That's all you have with tubes and transistors. Just a matter of convenience when speaking of signal transfer. There is voltage and current associated with both circuits.

You will also see signal sources referred to as a current source or a voltage source. It's the same thing. The voltage source will be higher impedance and the current source will be lower.

Now we come to the matter of transistor bias. The classes of bias are the same for transistors as for tubes, and the definitions hold true for them, too. The transistor also has a linear portion of its "current-transfer" curve, and a cutoff point. We do have to make a distinction, though. Here, we are speaking of the normal bipolar transistor, not the field-effect type which will be dealt with later.

While the classes of bias are the same, they are arrived at in a slightly different manner. Even though the transistor is on the other end of the stick from the tube, in one way it behaves exactly opposite from the tube.

If you look at the tube curve, you will notice that when a tube receives zero

bias, it will draw the maximum current, which can be unhealthy. The tube must be biased just to sit there. The transistor is just the opposite. Without bias, it will just sit there and be cut off. The trick is how you bias it.

Look at the circuit in Fig. 10. Resistor R1 is the load resistance for the transistor. It has the same function as the tube load resistance (RL). R2 and R3 are different ways to introduce bias to the transistor. R2 is one of the more stable ways to do it. Transistors are prone to a number of screwball bad habits. Thermal runaway is one. When it gets hot, it draws more current and gets hotter and draws even more current and pfffft!

Either resistor will allow a certain amount of bias current to flow in the base circuit, which is how the transistor gets biased.

R2 gets the current from the collector resistor. If the stage draws more current, the voltage drops and the current drops through R2, helping to stabilize the collector current. That is a simplified circuit, but it would work as a simple amplifier.

Fig. 11 shows a few more resistors in there. R3 is the emitter resistor which is usually bypassed. It also has a stabilizing effect on the stage. Often its value is similar to many small signal tube stages, although it is not exactly the equivalent of the cathode resistor. R4 is something like a load on the grid, but also helps the stability of the stage. Its value is usual-

ly in the range of one-tenth the value of R2.

Now we come to the name-games people play. With the modern tube, you have the cathode, the grid, and the anode or "plate." Diodes have long had a cathode and an anode, but, when they got to the transistor, they had to think up some new names and came up with emitter, base, and collector. That's not too bad, just a little farfetched.

Then came field-effect transistors (FETs). They are the ones that think they are tubes. We get back to voltage-operated again. Also they wanted to disassociate them from those nasty old transistors that gave so much trouble.

FETs are compared to tubes because they are a comparatively high impedance device, more like tubes than transistors. The words "field effect" are used because it is the field of the input signal voltage that makes them work. They seem much more like tubes than bipolar transistors. It would never do to use the same names for their new toy, so they came up with source, gate and drain. How imaginative!

You still have the same classes of bias possible and bias is accomplished with FETs much the same way it is with tubes.

There are applications with some tubes and FETs that don't use an external bias. These are small-signal amplifier stages. The usual high load resistance limits the current as well as providing the load. The tiny input signal to the stage has the effect of riding in a

linear portion of the curve over a short distance. Even so, the tube does provide a tiny amount of self-bias, too.

Which brings us back to the beginning. The transistor is just another kind of triode. Tube and transistor bias do the same job for the same reason. They just do it somewhat differently.

A tube is biased by applying a negative voltage to the grid or by making the cathode more positive than the grid.

A bipolar (ordinary) transistor is biased by applying a small current to the base, or by biasing the emitter with respect to the base.

An FET is biased roughly the same way a tube is biased. The voltage and currents will be smaller, though.

The FET either biases the gate negative or the source positive with respect to the gate, if an N-type, the reverse if a P-type.

While this discussion has been a little shy on numbers and practical applications, it should help you make sense of the more detailed descriptions of tube and transistor theory: a backbone upon which to hang more detail. ■

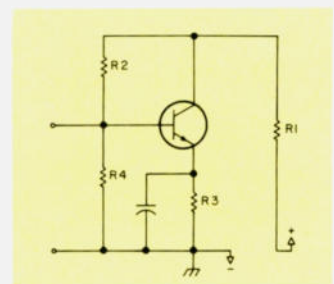

Fig. 11. Conventional transistor bias arrangement.

YOU ASKED FOR IT YOU GOT IT DSI QUIK-KIT®

550 MHZ COUNTER KIT Performance You Can Count On



OPERATES ON

- Batt 6-C Size
- DC 8.2 To 14.5 VDC
- AC Batt. Eliminator

\$99.95

MODEL 3550 KIT

DSI OFFERS THE BEST OF TWO WORLDS . . .

An unprecedented DSI VALUE . . . in a high quality, LSI Design, 550 MHZ frequency counter kit. And, because it's a DSI innovation, you know it obsoletes any competitive makes, both in price & performance. The basic 550 MHZ counter & time base are factory assembled, tested and burned-in. The problems of bad LEDs, IC's, capacitors, are a thing of the past with DSI QUIK-KIT®. But you can take pride in assembling the power supply, PC mounted selector switch, input connectors, and the final mechanical assembly of your 550 MHZ counter, into its' handsome cabinet. **GO WITH THE LEADER . . . BUY A DSI FREQUENCY COUNTER KIT. SAVE TIME & MONEY AND BE ASSURED IT WILL WORK THE FIRST TIME.**

SPECIFICATIONS

Time Base TCXO 1PPM 65° to 85°F
 Frequency Range 50HZ to 550MHZ
 Resolution 1HZ to 55MHZ, 10HZ to 550MHZ
 Gate Time 1 second - 1/10 second
 Sensitivity 25MV 150 & 250MHZ 75MV 550MHZ
 Display Eight 1/2-inch LEDs
 Input Two SO239 Connectors
 Power 6C-Size Batt., 15HR, or 8.2VDC to 14.5VDC
 Current 150 Ma standby 300 Ma operational

3550 KIT INCLUDES

- Pre-assembled, tested counter board
- Case, power supply, connectors, hardware
- Built-in prescaler & preamp
- Gate Light - Automatic Zero Blanking
- Automatic Decimal Point
- One to two hours assembly time
- One Year Warranty on all parts
- All new parts - not factory seconds or surplus

3550 Kit	\$99.95
T-101 Telescopic Antenna	3.95
AC-9 Battery Eliminator	7.95
Cigarette Lighter DC Adapter	2.95

TERMS: Orders to U.S. and Canada, add 5% to maximum of \$10.00 per order for shipping, handling and insurance. To all other countries, add 15% of total order. California Residents add 6% State Sales Tax

SEE YOUR LOCAL DEALER
OR

CALL TOLL FREE (800) 854-2049

California Residents, Call Collect (714) 565-8402

DSI INSTRUMENTS, INC.

7914 Ronson Road No. G, San Diego, CA 92111

VISA • MC
AMERICAN EXPRESS
CK • MONEY ORDER
COD

ARE YOU ON FREQUENCY?

BE ON FREQUENCY WITH DSI



MODEL 3600A .5PPM 17° - 37°C
\$199⁹⁵

- AUTO ZERO BLANKING
- AUTO DECIMAL POINT
- INCLUDES ANTENNA

SAVE SHOP COSTS WHEN ADJUSTING XTALS
 MEET YOUR QSO ON FREQUENCY EVERY TIME

The 3600A and 3550W Frequency Counters represent a significant new advancement, utilizing the latest LSI Design . . . which reflects DSI's ongoing dedication to excellence in instrumentation, for the professional service technician and amateur radio operator. Before you buy a DSI instrument you know what the specifications are. We publish complete and meaningful specifications which state accuracy over temperature and sensitivity at frequencies you need. And we guarantee those specifications in writing.

MODEL 3550W TCXO

\$149⁹⁵

- INCLUDES INTERNAL BATTERY HOLDER
- SAME AS 3600A LESS OVEN
- SEE SPECIFICATIONS BELOW

MODEL 3700 .2PPM 0° - 40°C
\$269⁹⁵

- AUTO ZERO BLANKING
- AUTO DECIMAL POINT
- INCLUDES ANTENNA

PORTABLE! TAKE IT TO THE MOUNTAINS OR
 USE IT MOBILE — TAKE IT WITH YOU ON FIELD DAY

ALL NEW! ALL UNPARALLELED DSI QUALITY! The model 3700 700MHz frequency counter features . . . **.2 PPM** 0° to 40° C proportional oven time base . . . Built in battery trickle charger less batteries . . . Combined in a rugged (.125" thick) aluminum cabinet makes the 3700 ideal for the communications industry, professional service technicians, and sophisticated amateur radio operators.

3600A OWNERS: Update your 3600A frequency counter to a 3700 includes . . . **.2 PPM** proportional oven, rugged .125" thick aluminum cabinet, order 3600-A - 3700. Unit must be returned to DSI factory for modification.

DSI — GUARANTEED SPECIFICATIONS — MADE IN USA

Model	Frequency Range	Accuracy Over Temperature	@ 146MHz	@ 220MHz	@ 450MHz	Number of Readouts	Size of Readouts	Power Requirements	Size
3700	50Hz - 700MHz	Proportional Oven .2 PPM 0° - 40°C	10MV	10MV	50MV	8	.5 Inch	115 VAC or 8.2 - 14.5VDC	3"H x 8"W x 6"D
3600A	50Hz - 600MHz	Oven .5 PPM 17° - 37°C	10MV	10MV	50MV	8	.5 Inch	115VAC or 8.2 - 14.5VDC	2½"H x 8"W x 5"D
3550W	50Hz - 550MHz	1 PPM 65° - 85°F	25MV	25MV	75MV	8	.5 Inch	115VAC or 8.2 - 14.5VDC	2½"H x 8"W x 5"D

— ALL UNITS ARE FACTORY ASSEMBLED, TESTED AND CARRY A FULL 1 YEAR WARRANTY —

- NO EXTRA COSTS •

FREE Shipping anywhere in U.S.A. and Canada.
 All other countries, add 10%.

*Strongest warranty in the counter field.
 Satisfaction Guaranteed.*

See Your Dealer or

Call Toll Free: (800) 854-2049
DSI INSTRUMENTS, INC.

California Residents, Call Collect: (714) 565-8402

VISA • MC • AMERICAN EXPRESS • CHECK • MONEY ORDER • COD
 7914 RONSON ROAD, #G, SAN DIEGO, CA 92111

Model 3700	\$269.95
3600A - 3700 Factory Update (3600A Only) Includes Labor & Re-Calibration	\$ 99.95
Model 3600A	\$199.95
Model 3550W	\$149.95
Option 03 20-Hr. Rechargeable Battery Pack	\$ 29.95

Build the Flexi-Filter

—a very active device

Donald Morar W3QVZ
3663 Hipsley Mill Road
Woodbine MD 21797

Ever have need for an active filter with tunable multiple outputs, i.e., high-pass, low-pass, bandpass, and a very sharp rejection

notch? The filter described is a "state variable filter" (svf). The svf described here has an operating frequency of 6 Hz to 60 kHz. A good discussion of this type of filter may be found in the *IC Op-Amp Cookbook* by Walter Jung and the *Active Filter Cookbook* by Don Lancaster. This svf

uses 5 op amps. Four of the op amps are contained in the quad 3403 unit and U5 is a single LM318. (See Fig. 1.)

Functionally, the state variable filter uses three or four op amps. Two op amps, U2 and U3, are connected as inverting integrators in cascade. The output of the second op amp integrator is unity gain, and is inverted and fed back to the input of the first integrator, U2. There is also a feedback loop from the first integrator back to its own input to provide a controllable amount of damping.

The input summing stage, U1, combines oscillatory feedback, damping, and input signals. If U1 has properly scaled input and feedback resistors, you can independently control circuit gain, frequency, and damping. The function of U5 is to correct the bandpass output phase so all three outputs will be out of phase at resonance, and increase the gain of the bandpass channel by about 3 dB, thereby making the gain of all three outputs equal within their respective passbands. From

Jung's *IC Op-Amp Cookbook*, page 337, for the circuit in question: Given f_1 , Q_1 , and H_o (passband gain), select C1 (C2). $R_1 = 1/(2\pi f_c C_1)$. Choose R3, $R_4 = QR_3$, $R_7 = R_6Q/H_{obp}$. Example: $f_c = 723$ Hz, $Q = 20$, $H_o = Q$. If $R_1 = R_2$ and $C_1 = C_2$ and $R_5 = R_6 = R_7 = R_8 = 10k$, $f_c = 1/(2\pi R_1 C_1)$, $Q = R_4/R_3$, $H_{obp} = R_6/R_7(Q)$, $C_1, C_2 = 1/(2\pi R_1 f_c) = .022$ μ F for $R_1, R_2 = 10k$.

Construction

As can be seen from the accompanying photos, the unit is housed in a Bud sloping-panel cabinet, Model AC1613. A piece of single-clad phenolic board was utilized. An isolated-pad drill mill was used to produce isolated pads through which Vector "Mini-Klip" pins were pressed in and soldered. The layout and wiring are not critical.

Filter Measurements and Operation

The operating controls of the filter are self-explanatory and may be observed in the accompanying photos. The curves in Fig. 2 were made as described in the block

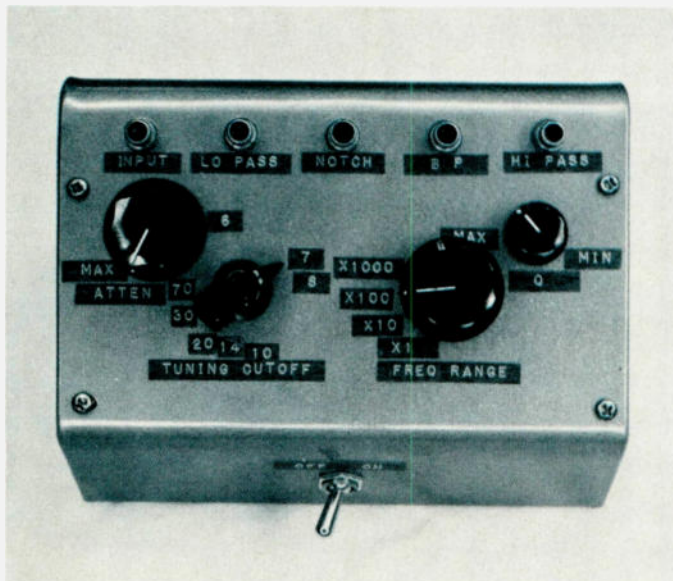

The various control functions and input/output connections can be seen in this photo. The various filter functions are available simultaneously at the various phono jacks. For those only interested in general communications use, the top and bottom frequency ranges may not be wanted. In this case, only two values of C1 and C2 would be required. .022 and .0022 μ F capacitors could yield a range of 60 to 7000 Hz.

diagram of Fig. 2. The audio oscillator output was set at 100 mV at a frequency of 1 kHz. The filter attenuator was then adjusted to produce 250 mV output. Setting 250 mV = 0 dB, the low-pass filter curve was plotted. As indicated in Fig. 2, the Q control must be adjusted by trial and error for the smoothest (without peaking) roll-off. The roll-off was also observed with a swept 70 to 10,000 Hz audio signal applied to the filter (see Appendix). The Q control could then be adjusted by watching the scope presentation for optimum roll-off shape. The same routine was used in the plotting of Fig. 3. The change in the setup in the plotting of Fig. 4 involved changing the tuning control to 1.5 kHz and the Q control to near minimum. The tuning control must be very carefully set at 1.5 kHz or an asymmetrical plot will result. Examination of the 6 dB points of the notch plot shows a Δf considerably under 100 Hz. Fig. 5 setup conditions were 10 mV filter input with the filter attenuator adjusted to yield 40 mV at the bandpass output jack. The tuning control was rechecked for an accurate 1.5 kHz setting and the Q control was set near maximum. This curve indicates a Δf substantially less than 200 Hz. When this filter was built, no attempt was made in matching the resistor and capacitor values in the tuning circuits (components with asterisks in schematic). An improvement in maximum selectivity may be possible by doing this, for those concerned with obtaining optimum selectivity.

Filter Tests

I have made a number of listening tests on my Kenwood R-599 receiver with the filter interposed between the receiver output

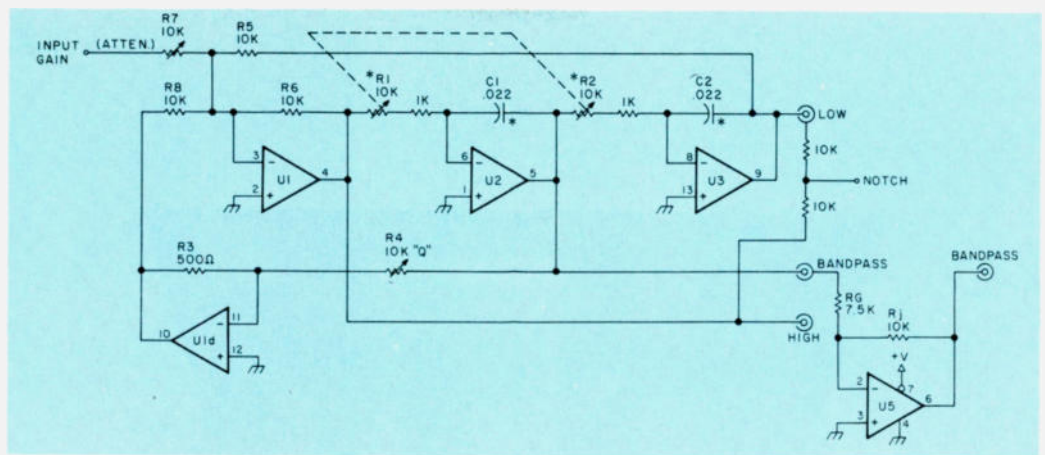

Fig. 1. Versatile audio filter schematic diagram + V = pin 14; - V = pin 7. U1, U2, U3, U4 = 3403 quad unit. U5 = LM318. Tune with *R1, R2 = ganged 10k pot. If *C1, C2 = .022 uF, $f_c = 723$ N, with R1, R2 maximum. Range switch not shown. C1, C2 = .022, .22, and 2.2 uF.

(headphones jack) and a pair of low-impedance headphones. The filter will produce as much as 2 volts rms output into a low-impedance headphone load with only a few mV rms input at the bandpass output jack of the filter, with the filter attenuator set at minimum. One can then listen to sideband signals with typical QRM situations and hear the effect of the low-, high-, or bandpass filters by varying the filter tuning and Q controls. The notch output was very effective in rejecting CW signal interference when listening to phone signals. The receiver output was also fed through the filter to a separate audio power amplifier driving a speaker to compare more directly with the receiver's own speaker output. There was definite improvement in the clarity of reception of various phone signals (SSB) by juggling the tuning and Q controls and listening at various filter output jacks. The filter was not as selective as the Kenwood fixed-tuned CW filter regarding CW reception, but was definitely superior as an adjustable phone filter. The Kenwood SSB selectivity position is a low-pass filter rolling off rapidly beyond 2.5 kHz. While generally satisfactory, under extreme conditions of QRM,

the audio filter afforded definite improvement in speech intelligibility and reduction of prolonged listening fatigue.

Another interesting application for the audio experimenter would be as an audio sweep marker. By interposing the filter be-

tween the audio preamp output and power amp input and applying a swept audio signal to the audio system, the rejection notch would appear on the scope presentation as a narrow notch in the sweep. The position and depth of this marker would be a func-

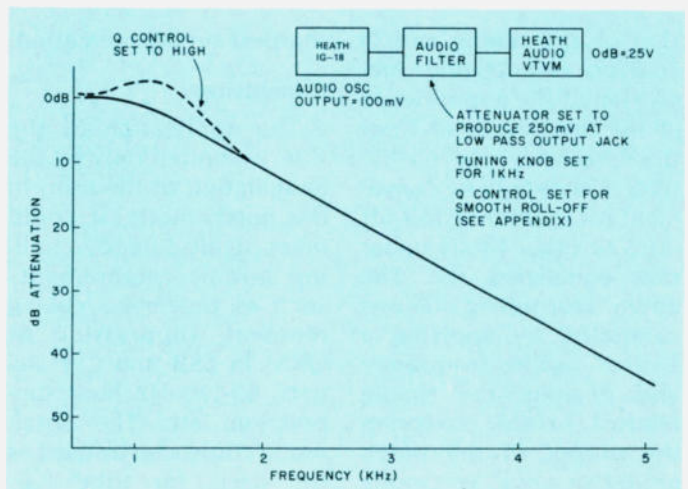

Fig. 2. Low-pass filter characteristics.

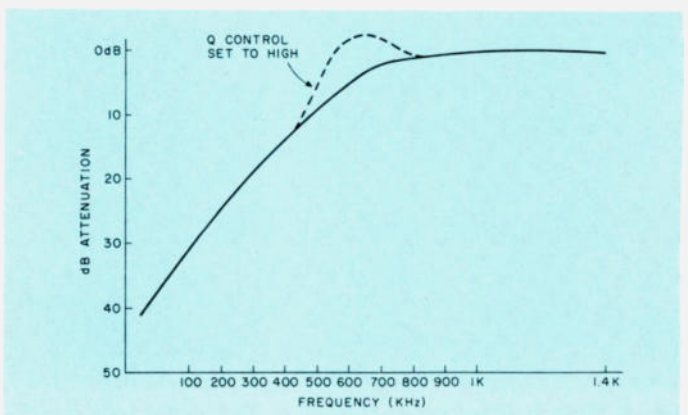
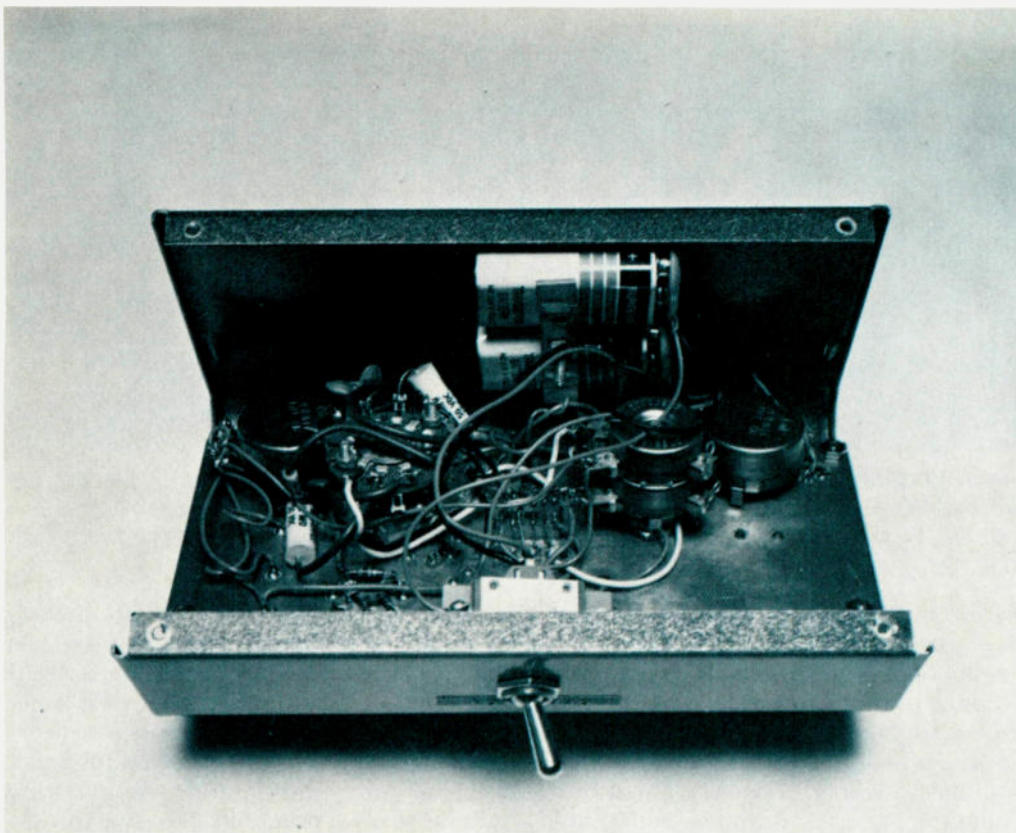

Fig. 3. High-pass filter characteristics. The same test conditions as Fig. 1 were used except for 250 mV at the high-pass filter output jack.



Bottom view shows copper-clad phenolic board construction as explained in text.

tion of the tuning and Q controls respectively. Any portion of the audio sweep could then be read from the frequency dial on the filter. This would be convenient for measuring roll-off rates of other filters under test, equalizers, etc. The audio filter tuning dial was calibrated by applying a known audio frequency and peaking the tuning control (while observing the output in the notch mode) for a null. This mode was used since it has the

sharpest tuning indication.

Conclusion

The application of the filter is limited only by the imagination of the user. In the notch mode, it could meet highly selective nulling circuit requirements such as tape-beep cueing removal, suppression of QRM in SSB and CW signals, 60-120 Hz hum suppression, etc. The notch mode could also be used as the basis for total harmonic distortion analysis

measurements. The state variable filter makes available an active filter with high stability, predictability, and wide tuning range at a very moderate cost and relatively easy construction.

Appendix

A measurement was made (data not included) which consisted of applying a swept audio signal to the audio filter. The source was a "Clarkstan" sweep frequency phonograph transcription played back

through a very flat Empire phono pickup. The filter was connected at the output of the audio power amplifier and an oscilloscope was connected to examine each filter output mode. The characteristics of the sweep record were a Δf of 70 to 10,000 Hz, at a 20 Hz sweep rate. The effect of the Q control of the high- and low-pass filters' roll-off rates was observed. The roll-off rate could be controlled (increased or decreased) by the Q control, but a setting yielding a smooth roll-off was set to plot Figs. 2 and 3. Higher settings of the Q control were employed when plotting the bandpass mode, Fig. 5. The dotted lines in the plots of Figs. 2 and 3 indicate the effect of raising or lowering the Q control settings. High-Q operation really only pertains to the bandpass mode. As can be seen, an excessive Q setting produces a hump or peaking in the low- and high-pass modes near the cut-off frequencies. Excessive Q in the notch mode likewise reduces notch selectivity. A Q value of $\sqrt{2}/2$ theoretically produces minimal peaking (Butterworth response). For those desiring more detailed design information on the state variable filter, as well as other types, a copious amount of data is available in the aforementioned books by Jung and Lancaster. ■

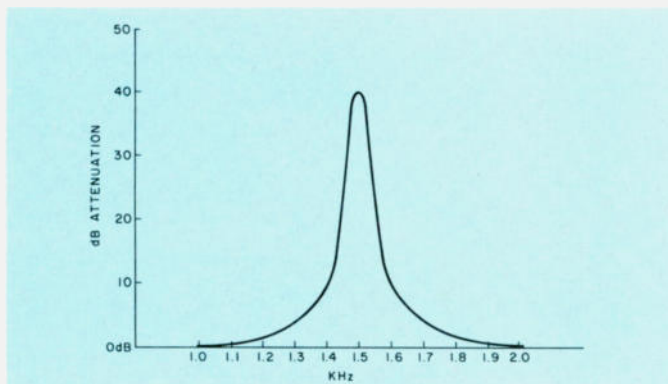

Fig. 4. Notch filter characteristics. The same test conditions as in Fig. 1 were used except the tuning was set for 1.5 kHz and Q control was set for best notch (near minimum Q setting). See Appendix.

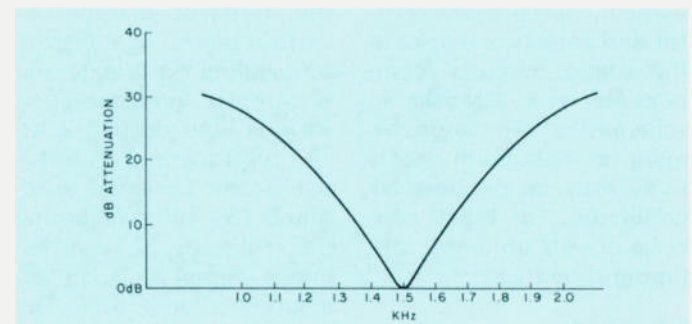

Fig. 5. Bandpass filter characteristics. The same test conditions as Fig. 1 were used except 10 mV input to filter, attenuator set for 40 mV output for bandpass output jack, tuning control peaked at 1.5 kHz, Q control set near maximum. See Appendix.

Happy Days ARE HERE Again!

When it comes to . . .
**FAST DELIVERY,
 HONEST DEALING &
 PROMPT DEPENDABLE**
"S-E-R-V-I-C-E"
 We don't just advertise it —
WE GIVE IT!

DENTRON ML-2500
 160 thru 10 Meter Amplifier



REG. \$899⁵⁰

While they last . . . Only \$799^{50*}

CDE HAM-III

New/Improved
 Heavy Duty
ROTORS
 NOW
 ONLY

\$129.95
 with Control
 (LESS CABLE)

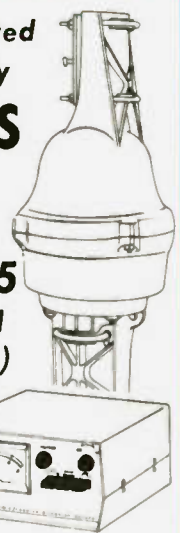

**SPECIAL
 TRI-BAND
 BEAM OFFER**

MAIL AND
 TELEPHONE
 ORDERS
"WELCOMED"
 . . . They're our
 business!!



SAVE 10% PLUS

10% "CASH" SAVINGS NOW IN EFFECT on these popular TRI-BAND BEAMS! AND . . . with "PACKAGE" PURCHASE of selected TRI-BANDERS . . . you can BUY A NEW CDE

HAM-III ROTOR for LESS THAN ONE HUNDRED DOLLARS! LIMITED — ORDER NOW & SAVE! CALL or WRITE TODAY . . . *TERMS: "CASH" means CHECK, MONEY ORDER or C.O.D.

MAKE/MODEL		REGULAR PRICE	SPECIAL "CASH" PRICES*	
			BEAM ONLY	BEAM & ROTOR
CUSHCRAFT ATB-34	4-Element / 2-KW	\$259.95	\$209.95	\$319.95
HY-GAIN TH3-JR.	3-Element / 300W	\$144.50	\$129.95	\$242.50
HY-GAIN TH3-MK3	3-Element / 1KW	\$219.95	\$179.95	\$289.95
HY-GAIN TH6-DXX	6-Element / 2KW	\$296.95	\$246.95	\$349.95
MOSLEY TA-33-JR	3-Element / 1KW	\$151.85	\$136.50	\$247.50
MOSLEY TA-33	3-Element / 2KW	\$206.50	\$185.00	\$294.50
MOSLEY TA-36	6-Element / 2KW	\$335.25	\$299.95	\$399.95
MOSLEY CL-33	3-Element / 2KW	\$232.50	\$209.00	\$317.25
MOSLEY CL-36	6-Element / 2KW	\$310.65	\$279.50	\$384.50
WILSON SYSTEM I	4-Element / 2KW	\$274.95	\$224.95	\$329.95
WILSON SYSTEM II	3-Element / 2KW	\$219.95	\$179.95	\$289.95

FREIGHT: ALL SHIPPING CHARGES "COLLECT" — F.O.B. WATERTOWN!



Write today for our latest Bulletin/Used Equipment list.

Burghardt
 INC.
AMATEUR CENTER

"America's Most Reliable Amateur Radio Dealer"

PHONE NO. (605)-886-7314 P.O. BOX 73 WATERTOWN, SOUTH DAKOTA 57201

The Klassic Kilowatt

— four 811As do it

*Dave Ingram K4TWJ
Eastwood Village No. 604N
Rt. 11, Box 499
Birmingham AL 35210*

One of the most popular rf amplifier circuits in use by today's amateurs is a grounded-

grid configuration of 811A tubes. Four of these tubes can provide the basis of a flexible and economical amplifier which uses readily available parts, operates from home brew 110-volt power supplies, and is only 2 dB weaker than a large, power-consuming 2 kW unit. My previous ex-

periences with "legal limit" amplifiers have been a combination of back-breaking power supplies, special 220 V ac lines, elaborate cooling systems, and offensive TVI. Few problems have been experienced with this 811A amplifier, however, and I still have plenty of power for competitive operation

in DX pileups.

The circuit (Fig. 1) of my amplifier is not a new design. It has been used (and proven!) in equipment for several years. A very similar circuit is used in the Collins 30L-1 linear amplifier. The difference in my unit is its layout and design for station compatibility. Rather than using a surplus



Front view of classic amplifier shows R.L. Drake cabinet and knobs. Illuminated Heathkit-type meter is modified to read amplifier plate current, grid current, and relative output.



Classic amplifier in service and operating normally. The 4 811As add a soft glow to any ham shack. Room is dimly illuminated for slow scan TV operations.

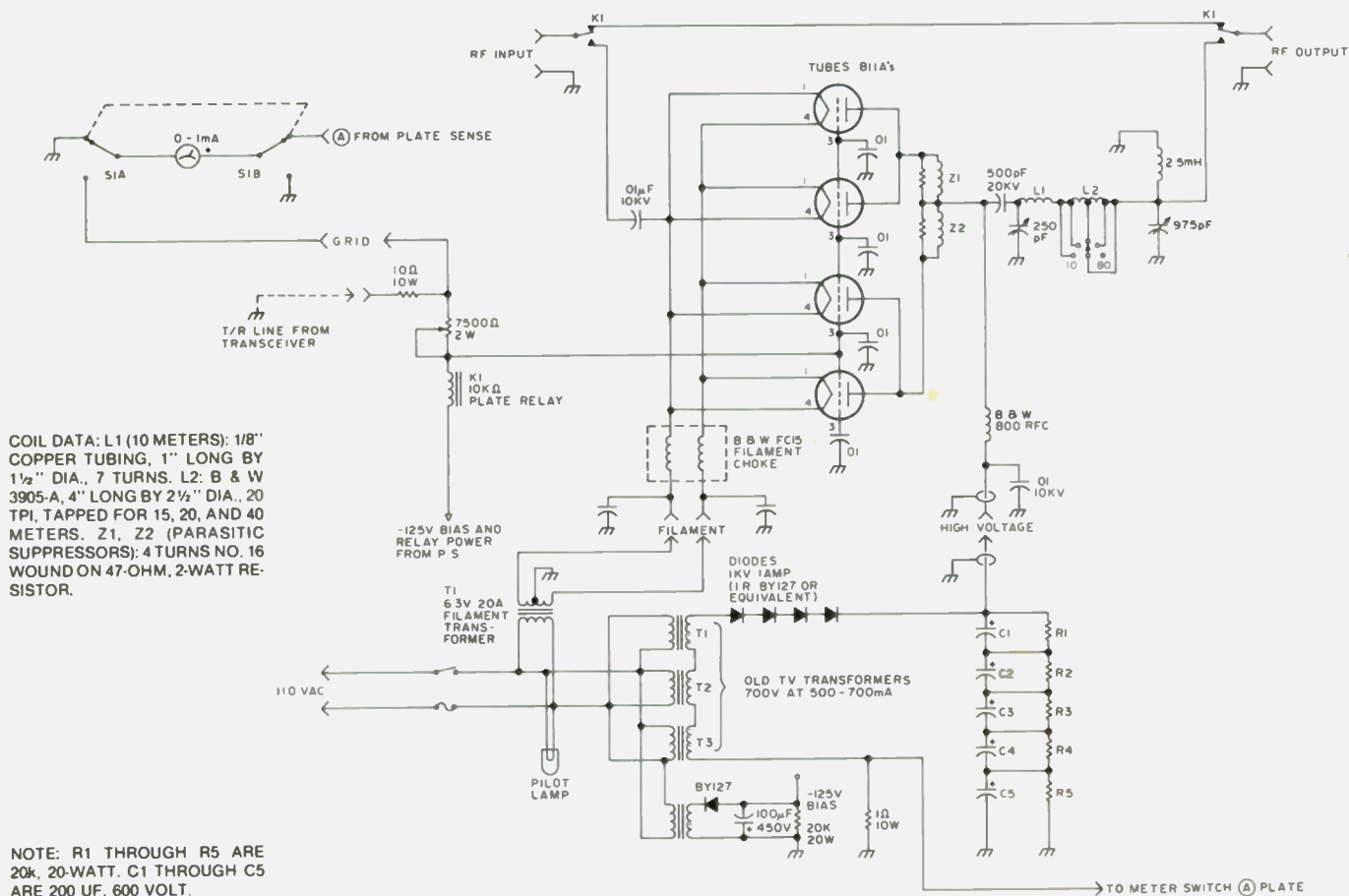

Fig. 1. Classic rf amplifier schematic diagram.

enclosure for the amplifier, an empty cabinet that matched my transceiver was purchased directly from the manufacturer. Matching knobs were also purchased from the same manufacturer. In addition to working beautifully, the completed amplifier blends perfectly with my other station equipment. The overall result (which includes similarly matched slow scan TV gear) is a "commercial" appearing setup that's enjoyable to own and operate. The information presented in this article is intended to serve as a guideline for others desiring to construct amplifiers, antenna tuners, monitors, etc., which may also match their particular setup.

Amplifier Mechanical Details

The amplifier's 811As are mounted horizontally in the cabinet and all input circuitry is mounted in the

811As' rear-supporting chassis. A bottom plate is fitted to this chassis, thus totally isolating input and output signals. This design eliminates the necessity of neutralizing the amplifier. Four pieces of 3-inch metal channel (I used Seezac plates) are fitted together and used as a framework for the amplifier. The upright rear chassis and front panels are bolted to this frame, as shown in Fig. 2. All the amplifier's output circuitry is mounted in the center of this "free air" space. Exact size of the vertically mounted rear chassis and metal framework varies with the specific cabinet used to house the amplifier. A small minibox, with holes for the front panel meter and incoming wires, is used as an rf-proof meter case. The meter switch and the meter's pilot lamp are also enclosed by this case. The plate-tuning and load capacitors are surplus units

which mount directly to the amplifier's front panel. A 10 meter tank coil is mounted between the plate-tuning capacitor and bandswitch, while the larger tank coil mounts behind the bandswitch. Both coils are supported by their leads. A small phonograph motor fan, mounted on the amplifier's left side, cools the tubes during use. Sub-chassis mounting of the 811As is accomplished by using long screws and spacers, as shown in Fig. 3. A similar arrangement permits all rear panel amplifier connections to protrude through the removable rear chassis plate.

Due to the high temperatures produced inside 811As during normal service, their rectangular-shaped plates should be situated vertically for structural support, as shown in Fig. 4. This will prevent a hot filament from falling against a grid

or plate.

A local sheet metal shop cut and drilled the amplifier's front panel for five dollars. I merely painted the panel to match my TR-4 and mounted it on the amplifier. The amplifier's framework is directly mounted in the bottom part of the TR-4 cabinet, and a thin piece of extruded aluminum covers the inside of this bottom to prevent TVI. The rectangular slots in the bottom part of the cabinet would allow rf to "leak out," but the round holes in the extruded aluminum prevent rf leakage.

Amplifier Circuit Details

As previously mentioned, the basic circuit of this amplifier has been in use by amateurs for several years. Similar circuits have also appeared in many amateur publications and handbooks. The minor variations of components in each schematic are

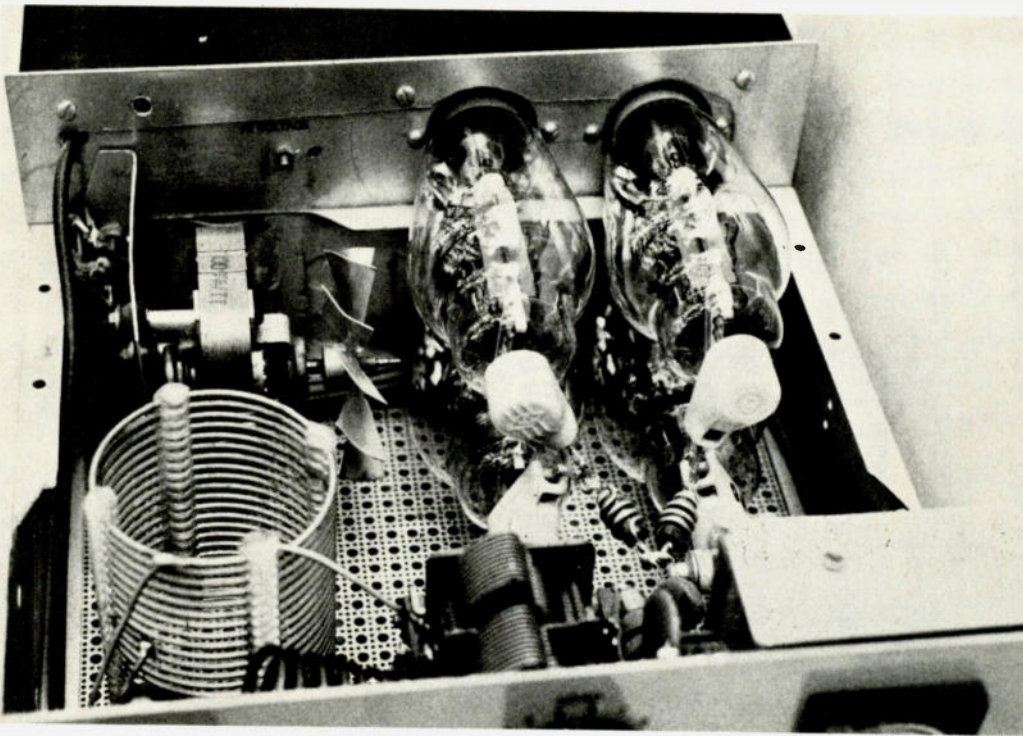

Interior view of kilowatt amplifier reveals layout of components discussed in text. Note extruded aluminum lining in bottom of cabinet for TVI reduction.

prime examples of the amplifier's flexibility. While some 811A circuits include tuned inputs, my unit simply feeds incoming rf directly to the 811A filaments through a .01 uF capacitor. Naturally, tuned inputs for each band can be included if desired. Suitable filament chokes which may be used with the amplifier are the B&W FC15A and FC25A or Amidon's new filament choke kit. The filament choke in my particular amplifier is an SB-200 replacement type obtained from Heath-kit.

Although a B&W 851 tank coil and bandswitch assembly may be used in this amplifier, I used a 4-inch section of B&W 3905 coil stock and a separate 10 meter coil. Approximate tap positions for each band were located using a grid-dip meter. Then, exact positions were located by moving these taps ± 3 turns and noting the corresponding change in output power. Presently, the amplifier's 20 meter output power is 750 Watts. The bandswitch is a relatively heavy-duty unit obtained at a hamfest bargain

table. Any porcelain switch with large contacts should work equally well.

T-R switching and 811A biasing is accomplished through the use of a -125 V dc divider network, which consists of a sensitive 10k Ohm plate relay and a 7500 Ohm pot. This network is ungrounded during receive, thus applying approximately -125 volts to the 811A grids as cut-off bias. When the transceiver's relay grounds this T-R line, tube bias is reduced to approximately -4 volts. The pot should be adjusted to produce 60 or 70 mA of idling current on the 811As (transmit mode with no input driving signal), and the amplifier is ready for action.

Power Supply Details

Operating voltages for the amplifier are furnished by a home-brew power supply built in two mating chassis. A sketch of this unit is shown in Fig. 5. Three large series-connected TV transformers are mounted inside the bottom chassis. The filament transformer, bias-supply transformer, and power control relay are also mounted in this chassis. The series rectifier and filter capacitor board is mounted on top of this chassis. The upper chassis provides a "top" for the power supply. It is cut and fitted with corrugated aluminum for ventilation. The two chassis are held together by a front panel and a steel strap screwed into the rear of both pieces. A sheet of heavy perforated aluminum also covers the bottom chassis, thus serving as a bottom cover for the power supply. A "whisper fan" is mounted above the power supply to provide additional cooling.

Operation

Amplifier tune-up is straightforward and follows conventional plate-tuning techniques. Remember to use minimum rf drive when initially loading the amplifier to avoid high off-resonance plate current. If you have any old 811As, this initial tune-up time is ideal for their use. Once the amplifier is working properly, you can make a chart of the load and plate settings and output

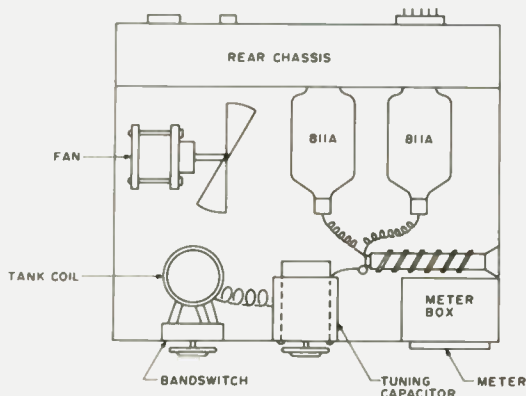

Fig. 2. Top view of component layout in kilowatt amplifier.

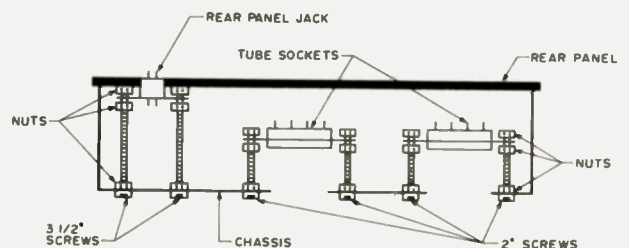

Fig. 3. Mounting arrangement for tube sockets and parts used in the amplifier.

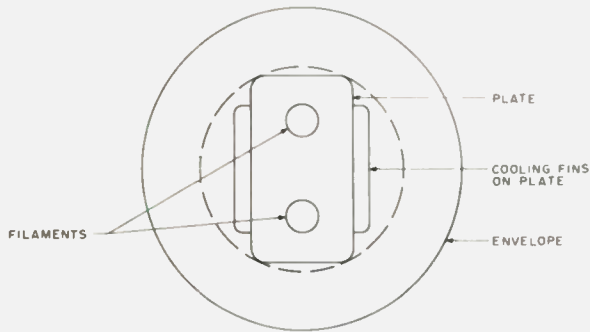

Fig. 4. End view of 811A as seen from front panel. The filaments should be positioned as shown. The top of the illustration corresponds to the top of the amplifier.

power level for each band. This chart will serve two purposes: It will help keep you from running the plate current more than 50 mA off resonance and it will help you realize when the finals eventually begin to lose output.

Typical operating parameters of my amplifier are 1700 volts at 800 mA on 20 meters, producing 750 Watts output. These rf levels are possible because

grounded-grid amplifiers allow the driving power to directly add with the output power.

Conclusion

As this article illustrates, the 811A amplifier is one of the most versatile and inexpensive amplifiers that an amateur can build and operate. The concept of separating rf and power supply sections is also quite appealing to

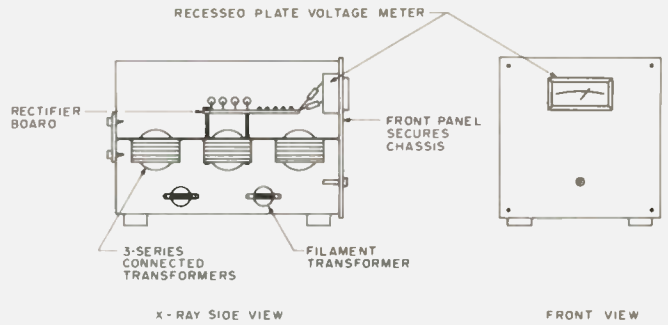
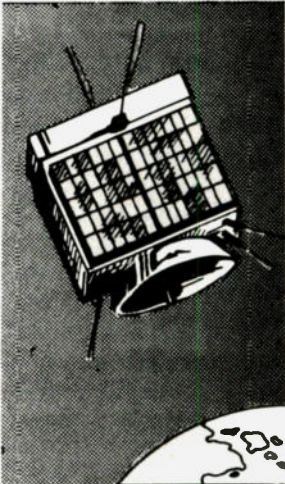

Fig. 5. Power supply cabinet arrangement.

many amateur setups. The time-proven circuit is easily adapted to one's particular station arrangement, thus producing a reliable finished product which can be enjoyed for many years. Recently, I purchased a new R. L. Drake TR-4 CW transceiver and considered purchasing a new linear amplifier also. After several weeks of deliberation, I concluded that my seven-year-old 811A amplifier couldn't be beat. I replaced tubes and filter capacitors, cleaned it

like new, and it's now ready for another seven years' service. What more could one ask?

I would like to thank Erskine Jackson W4CEC for his assistance in the design and layout of this amplifier. Erskine's ingenuity was the prime contributing factor to the amplifier's professional results. Thanks also to Robert Perkins of Birmingham AL for special processing of the photographs used in this article. ■



There's a new, eighth OSCAR satellite in orbit, and the AMSAT team helped put it there! Your help is needed for future satellites. Join AMSAT and support the new, advanced Phase III series of OSCARs, engineered to provide communications over transcontinental distances for hours at a time.

Send \$10 membership dues to AMSAT, P.O. Box 27, Washington, D.C. 20044. Life membership is available for a tax-deductible donation of \$100 or more, payable in quarterly installments if you wish.

Phase III satellite solar cells may be sponsored for \$10 each, and we'll send you a certificate specifying the cells you are sponsoring.

For a tax-deductible contribution of \$1,000 or more, we'll even inscribe your name on a plaque to be placed in orbit aboard the Phase III spacecraft for posterity, and we'll send you a replica honoring your contribution.

Dues and contributions may be charged to VISA or Master Charge. Phone us at (202) 488-8649.

Radio Amateur Satellite Corporation
P.O. BOX 27, WASHINGTON, D.C. 20044
AMSAT
AMSAT MEMBER

50 144 REPEATERS 220 450 Mhz

Now with courtesy beep and beacon capability.

Available Separately:

COR Identifier: All on one board, programmable, Fully adjustable, time out (.5-7 min.), hang time (0-1 min.), identifier (1-10 min.), tone, speed, volume, L.E.D. outputs, low current drain CMOS logic, plugs for easy installation and removal plus much more. \$79.95

OPTIONS

- Duplexers
- Basic auto patch
- Matching cabinet
- .0005% High stability crystals

Hi Pro Mk I



50 MHz \$789.95 450 MHz 799.95
144 + 220 MHz \$699.95 PLUS SHIPPING PA Res. add 6% tax

Maggtore Electronic Laboratory
845 WESTTOWN RD. M36
WEST CHESTER, PA. 19380 PHONE 215 436-6051

Ham Radio Goes to School

—10-year-olds love it!

*William L. Lazzaro N2CF
11 Jefferson Street
Highland Mills NY 10930*

"Hey, Mr. Lazzaro, we got Maine! Our RST was 579, and the guy didn't believe us when we told him we were only 10 years old."

Teaching fifth-grade youngsters at Montebello Elementary School in Suffern, New York, has been an exciting experience for me. But when I introduced my students to amateur radio, my vocation as a teacher took on incredibly exciting dimensions.

I began my introduction

to amateur radio one day without prior announcement. It was in December, 1975, and I had just purchased a new Yaesu FT-101B. I obtained permission from the principal to put up a 40 meter dipole and I was in business! As the children came into school that day, their attention focused on the gray box in the corner of the room. Ten-year-olds are curious souls and they had many questions about it. Finally, the moment arrived for our first QSO. I went back to the rig, grabbed the mic, and called my first CQ. That CQ has echoed in the halls of Montebello School for the last three years. Little

did I know at the time that I was ushering in a new era of excitement for those elementary-school students.

In that first year of operation from my classroom, we worked 17 states. All my students received QSL cards from gracious amateurs and everyone had a chance to talk over the air.

It wasn't long before my students wanted to know how they could become hams. I explained the FCC requirements for the Novice license, but I personally felt 10-year-olds were just too young to get a license.

Since fifth-graders enjoy secret codes and ciphers, I introduced my students to

Morse code. To my utter amazement, all my students loved it! Many learned it so well they could communicate effectively in code. The year ended in June with sad faces as my students and I realized our exciting year with ham radio was ending.

The next September, I began teaching radio theory and Morse Code long before I brought in my rig. Our year was very successful in making contacts, but the children loved the code the best! The proficiency exhibited by the majority of my students amazed all who witnessed it. We had sent Morse code with flags from mountaintop to mountaintop while

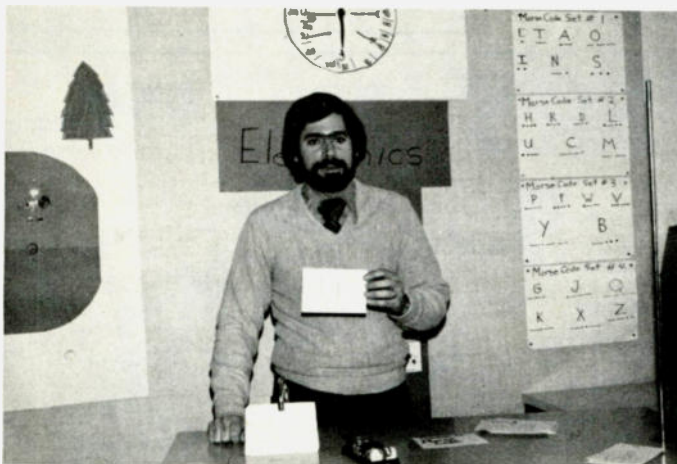

I found flash cards to be a valuable teaching aid for reviewing material already taught.



Boys and girls exhibit equal enthusiasm and proficiency as operators.

hiking, and we sent messages across a lake at night using flashlights while camping. We even made some on-the-air CW contacts! I was now convinced that the average 10-year-old could learn the code and use it proficiently.

As September, 1976, rolled around, my attitudes toward the possibility of 10-year-olds getting licensed were changing. One of my first-year students had gone to get his General class license! He skipped the Novice license, stating it was too easy! (Presently he is in ninth grade and holds an Extra class license with a 1 x 2 callsign to boot!)

I taught my students the code and I operated portable from my classroom with the FT-101B. As spring came, I had a group of six students, three boys and three girls, who were most proficient at code and who wanted to be hams. I decided to see how much theory they could learn. We began classes at noon hour and recess. They learned quickly as long as I taught them in little steps and on one topic at a time. We reviewed constantly what I had already taught. (Later I was to find out that flash cards would be of great help in reviewing.) In May, all six took their Novice exams and passed!

The realization that I had a problem now became apparent. I had six 10-year-old licensed radio amateurs on my hands and no gear for them to use, save a CW QRP rig I had built. It was ludicrous to think a fifth-grader could finance his own station, so I began the search for funding for ham radio equipment to be located at school.

My principal alerted me to the possibility of a donation from our Parent-Faculty Association. It

seemed that they had had an unusually successful year at fund-raising and they were looking for a gift to present to the school.

I wrote out a detailed proposal for the station equipment I needed and I planned an extracurricular program for a ham radio club. I presented my plan to several members of the PFA executive board and I received a chilly response. I would have to convince the PFA that my plan was worthy of their support if I was to get the funding I requested.

An invitation to speak at a PFA meeting gave me my opportunity to "sell" ham radio. After carefully planning my presentation, I gave it to them with all the enthusiasm of an ardent amateur radio operator! As the meeting ended, I not only had gained the funding I requested, but I also had many offers of help! Even some of the mothers asked if they could get their own ham licenses through my program!

I was thrilled! My dream of having an amateur radio club station at school was going to be a reality. Unfortunately, I was to learn that several problems would have to be solved before my dream came to fruition.

The first difficulty I experienced was finding gear. I had received enough money to purchase a low-cost used SSB transceiver. My first inclination was to check the classified ads in ham magazines. There was nothing listed at that time which was suitable. Then I began calling dealers, hoping to find a trade-in. I contacted more than ten dealers and none of them had a thing. At this point I became aware of the severe scarcity of low-cost used ham gear.

I wondered if I'd be able to find appropriate equipment in my budgeted price



Brian WB2QOV demonstrates the way it's done.

range. My search led me to a brokerage firm. They had a Heathkit HW-100 listed. I snatched it up immediately and considered myself lucky.

Setting up the station was relatively easy. I attached 2 x 4s about eight feet high to protrusions on the roof of the school, and I strung up my dipoles. As I ran my transmission lines, I wondered about the line loss. Each transmission line had a run of 200 feet and we couldn't afford anything better than RG-58/U coax.

My concerns were calmed, however, as I loaded the forty meter dipole and worked several stations with good reports.

It was difficult to contain my excitement any longer. Although it was only August, I called together

my vacationing Novices for a club station christening.

We met together after nearly two months without any CW practice. As we sent our first CQ with the club station, six nervous Novices, armed with pencils and paper, crowded around the HW-100 anxiously waiting for a contact.

Suddenly we heard the sweetest sound any ham can hear! Our callsign was being sent to us in pure dc notes. It was music to our ears!

The excitement of that moment quickly turned into a mild panic as rusty minds struggled to copy the callsign being sent to us. "I didn't get that." "He's sending too fast." "What's —...?" "I can't remember." These words



Several YLs log another QSO made from our club station, WB2RZP.

filled the station as nervous hands wrote the message being sent to us.

Once it was our turn to transmit, another problem developed. "What should I say, Mr. Lazzaro?" was the question asked of me. As I hurriedly wrote out a message format, I began to realize that I still had a lot to teach these newcomers. CW abbreviations and operating format were not required material to get a license, yet they were essential to know. I had to teach these Novices this material and fast.

Later I prepared a wall chart of a typical QSO and another with common CW abbreviations. We worked together to learn both. Once this was accomplished, I thought my problems were solved. Not so!

For some time, my students made hit-or-miss contacts. Sometimes they achieved complete QSOs

and other times they only received the callsign of the other station. Then the percentage of incomplete contacts or no contacts began to outstrip completed QSOs. The log showed remarks like "lost transmission" and "QRM." I decided to go on the air myself and see if the rig was working properly. I made a contact immediately and had a complete QSO without any difficulty. I was sure the rig worked.

That week I made arrangements to actually be in the ham shack while the Novices went on the air. After only a few minutes, I realized the problem. They were sending CQ at about thirteen words per minute. When a station answered them at that speed, no one could receive it, since their code speed was still well below thirteen wpm.

We set up a verbal rule

stating: "Send only as fast as you can receive." That corrected our problem.

The logbook began filling up with completed QSOs. We even began collecting QSL cards at a high rate of speed.

After-school Novice classes commenced in October of 1977. By February, 1978, we had ten more Novices, with more on the way.

Today the Novices are operating at lunch and recess for one hour a day. Those who have taken their exams and are waiting for the results act as third parties when the Novices operate. These future hams are getting actual on-the-air experience while learning what they will need to know as operators.

My program has arrived at almost a self-perpetuating point. There are children at all levels, with those children at the higher

level helping those at a level below them.

The excitement generated by our ham station has been incredible. Students are signing up for my Novice classes in droves (I had 35 in the fall). Children talk about their ham radio contacts instead of talking about television shows. At recess, children send code to each other using buzzers instead of playing games.

It should be noted that of twenty-six Novice operators, there are ten YLs. I made it a point to encourage both sexes equally. It has paid off!

Montebello School hasn't been the same since that first CQ in 1975. We are now looking ahead to upgrading and the joys of General class operation. But can ten-year-olds get a General class license? I wonder. Here we go again! ■

free

Our famous value-packed mail order catalog filled with thousands of Amateur Radio items. Now ready to roll and yours for the asking... Call Tufts today for prompt delivery of your Amateur Radio needs from our tremendous inventory. Let us show you why Tufts is the leader in mail order sales.

Our crew of 100% hams, very competitive prices, and reliable modern service facilities ensure your complete satisfaction. Call toll free daily 9-9 and Saturday 9-6. 1-(800) 225-4428.

TUFTS
Radio Electronics

✓T3

**209 S Mystic Avenue
Medford MA 02155
1-(800)225-4428**

1-(617)395-8280

NEW

**THE
BANTAM
DIPOLE**



**30-day money back
guarantee. \$59.95,
plus UPS shipping**

**THE
COMM
CENTER**

Send S.A.E. for spec sheet
U.S. patent pending
Dealer inquiries invited

✓C75

**Laurel Plaza—Rte 198
Laurel MD 20810 301-792-0600**

The HF BANTAM DIPOLE is a truly portable all-band miniature dipole complete with its own carrying case and mast/hardware to mount on a camera tripod (3/8" x 24" adaptor available). High performance is obtained on 80-10 meters at its normal 13 foot length or the same antenna may be shortened to 7 feet for 75-10 meter coverage. Polarization is quickly interchangeable from horizontal to vertical. No ground system necessary. The BANTAM DIPOLE is ideal for camping, traveling, mountaintopping, apartment living, or if you're stuck with building code restrictions. Construction is of high quality 6061-T6 aluminum and stainless steel hardware.

DRAKE • ICOM • TEN-TEC • TEMPO • Wilson

Midland's 13-510 Is One Great 2-Meter Mobile. Our 13-510A Is Even Better!



- NEW!** The 13-510A P.L.L. synthesizer delivers 1,200 frequencies between 143.00 and 149.00 MHz . . . the full 2-meter band, plus MARS.
- NEW!** The 13-510A will operate with up to a 6 MHz split between TX and RX frequencies.
- NEW!** The 13-510A microphone connector is pre-wired for your Touch-Tone® encoding microphone.
- NEW!** The 13-510A has a 7-pin accessory connector for your Touch-Tone® dial, tone-burst generator or discriminator meter. *Touch-Tone is a registered trademark of AT&T.
- NEW!** The 13-510A is compatible with available popular CTCSS continuous tone-coded squelch system accessories.
- NEW!** The 13-510A has 3 transmitter outputs: 1, 10 and 25 watts.

Midland's 13-510, with its commercial-type modular construction, earned its reputation as one tough 2-meter FM mobile. Now Midland has made the 13-510A an even more versatile performer!

The 13-510A P.L.L. synthesizer splits the 6 MHz spread between 143.00 and 149.00 into 600 discrete frequencies, and a 5 KHz up-shift delivers 600 more for a total of 1,200 . . . shown directly on the digital display. In addition, there's access to 4 available offsets for repeater operation on ± 600 Hz with crystals supplied or up to 6 MHz spread with your crystals installed. Inside the 13-510A, there's a highly sensitive (0.3 μ V), highly selective (-70 dB at ± 15 KHz) dual conversion receiver with

dual gate MOSFET RF and mixer stages, crystal filter in the 1st IF, ceramic filter in the 2nd IF, and helical resonators in the RF amplifier.

The transmitter is conservatively rated for 25 watts output, switchable to 1 or 10 watts for repeaters, and uses direct FM modulation to deliver natural sounding audio.

Other features making Midland's 13-510A the one to look at include automatic protection circuit for the output transistor, internal DC filtering and polarity protection, a deep-finned heat sink for the power transistors, and electronic switching that needs no mechanical maintenance. Mobile mounting bracket, base stand and push-to-talk microphone are included.

CHECK OUR SPECS:

RECEIVER. Type: dual conversion superheterodyne. 1st IF frequency: 16.9 MHz. 2nd IF frequency: 455 KHz. Sensitivity: Less than 0.5 μ V for 20 dB quieting (0.3 μ V for 12 dB SINAD). Spurious response: -60 dB. Squelch threshold: Less than 0.3 μ V. Modulation Acceptance: ± 7.5 KHz. Selectivity: -70 dB at ± 15 KHz. Audio output power: 1.5 watts at 8 ohms.

TRANSMITTER. Outputs: 1, 10, 25 watts. Frequency deviation: Adjustable 3 - 16 KHz (normal 5 KHz). Audio Input: 600 ohms. Modulation system: Direct FM. Spurious Radiation: Less than -60 dB below carrier.

GENERAL. Power: 13.8 volts DC, negative ground. Current drain: Transmit, 2 - 7 amps.; receive, 0.8 amps. average. Antenna impedance: 50 ohms. Unit size: 2-5/8" x 6-13/16" x 9-5/8". Unit weight: 6.6 lbs.

Want to know more? See your
Amateur Radio Dealer for Midland Quality

- P.L.L. "220" MOBILE
- CRYSTAL "220" MOBILE
- ANTENNAS & ACCESSORIES

... or write for free full-color brochures. ^{M41}

MIDLAND[®]
INTERNATIONAL

P.O. Box 1903, Kansas City, Missouri 64141

What's Your uF?

— a six-digit answer

The following project yields a simple but accurate digital meter to measure capacitance values from 1 pF to 999999 pF (1.0 uF).

Theory of Operation

The theory of operation is based on the equation $I = C(dv/dt)$. Rearranging the equation, $C = I(dt/dv)$, where C is pF, I is microamperes, dt is increments of one μ s, and dv is change of voltage in volts across the capacitor.

In other words, if a counter chip were to count the time it took a given capacitance to charge from a constant current source to some fixed voltage level, that count would be equivalent to the capacity being measured. A block diagram in Fig. 1 further describes the operation.

The start-measurement switch drains the charge from the capacitor under measurement and diverts the constant current

source to ground. Also, the 1 MHz pulses are not allowed to accumulate in the counter.

Upon activating the start-measurement switch, the capacitor begins charging. The counter is accumulating the one microsecond pulses, and the race is on. The capacitor charge voltage, upon reaching the threshold of the count-inhibit line of the counter, prevents the counter from accepting any more 1 MHz pulses. Therefore, the contents of the counter can be displayed directly as the value of the capacitance being measured.

Returning to the equation one last time and assuming an example, examine what capacitance is represented in the following (where $I = 5$ microamperes = 5×10^{-6} Amp; $dt = 47$ microseconds = 47×10^{-6} sec.; and $dv = 5$ volts):

$$C \text{ pF} = [(5 \times 10^{-6}) / (47 \times 10^{-6})] / 5$$

$$= (235 \times 10^{-12}) / 5 \text{ pF} \\ = 47 \text{ pF}$$

So far, theory shows the approach to be a workable idea. To reduce this theory to actual practice, the use of the schematic shown in Fig. 2 resulted in being able to measure capacitance to within $\pm 5\%$, or ± 1 pF, whichever is greater, from 1 pF to 999999 pF (1.0 microfarad). Now those unmarked capacitors can be accurately measured and their values displayed digitally.

The Schematic

The key to the simplicity of the capacitance meter is the MK50395N six-decade counter manufactured by Mostek. This counter performs the tasks of counting up or down, is presettable, has a compare register that provides an equal output when the counter contents equal the register contents, and also provides seven-segment and BCD output data. The list of features continues, but those interested can get the data sheet by writing Mostek, Box 169, Carrollton TX 75006.

The 1 MHz oscillator is arranged using U1, CMOS NAND gates, and is a standard design. Since extreme accuracy was not a requirement, no frequency trim-

ming or special crystal tolerance is specified. This should simplify and lessen the expense of the components. U2 provides the control functions necessary to operate the meter.

Linear amplifier A1 is a dual bi-fet high input impedance amplifier. A1 is wired to drive a constant current (adjustable by R4) through the capacitor being measured. Amplifier A2 is used as a comparator so that, when the output of A1 reaches a predetermined voltage, A2 switches its output from zero volts to V+. This action prevents further counts from accumulating in the MK50395 counter. The diodes from digit strobe lines on the counter feed preset counter BCD inputs A and D. This results in digit 6 down to digit 3 having a 9 preset into it. Digit 2 is loaded with an 8, and digit 1 (LSD) is loaded with zero. The BCD inputs have internal pull-down resistors, so a zero will be loaded into the unconnected BCD input ports. More on this in the calibration sequence.

A single-pole three-position break-before-make switch is used to provide the control sequence for the unit. On the schematic, position A is the

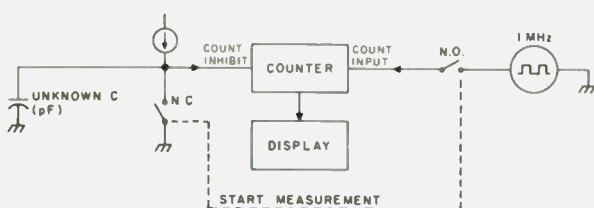

Fig. 1.

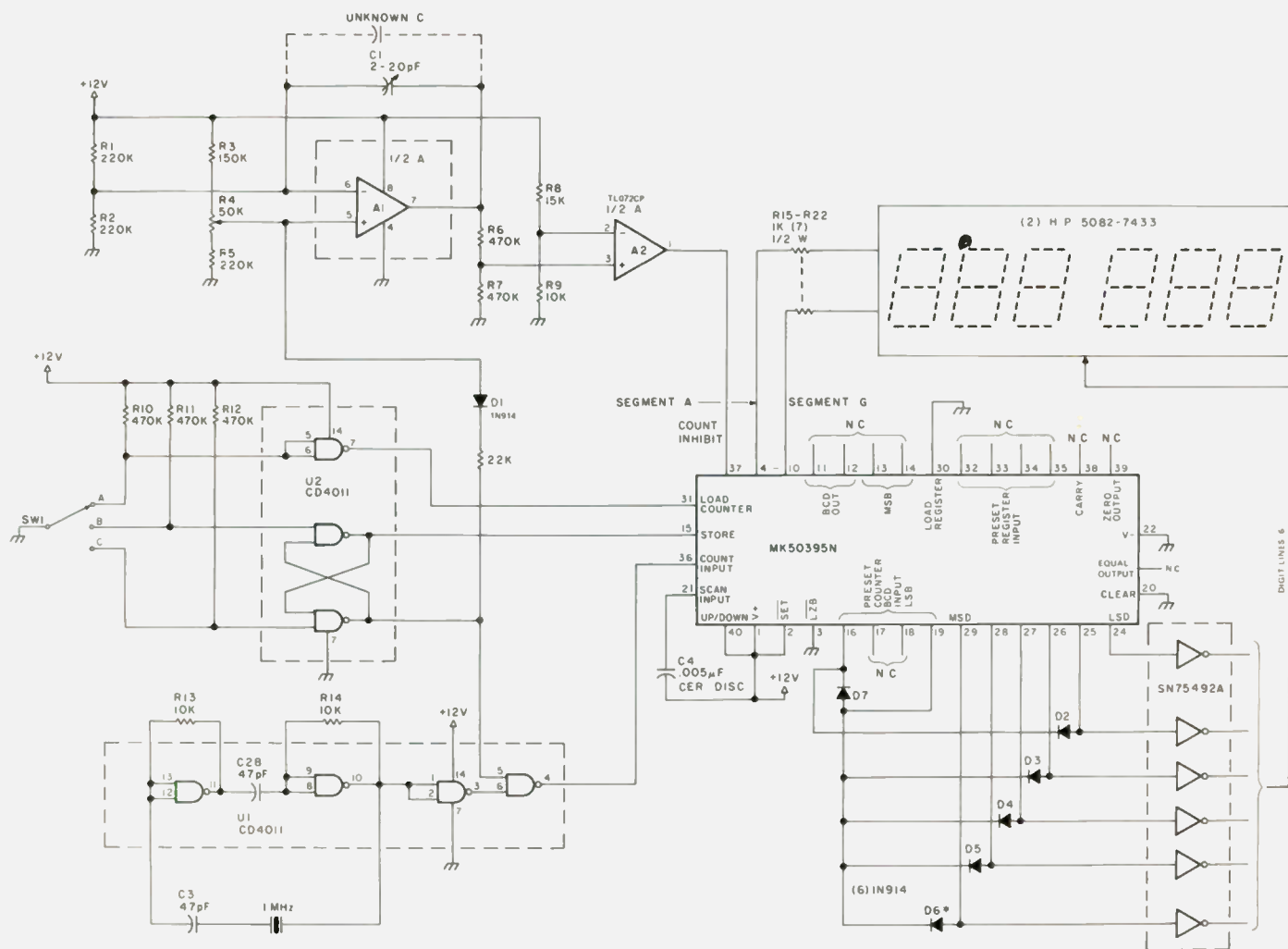

Fig. 2. Note: Capacitors are silver mica unless otherwise specified. Resistor values are 10%, 1/4 Watt unless otherwise specified.

starting point. While in position A, the counter is being loaded with 99980.

Position B stores the data in the counter display after a capacitor measurement.

Position C initiates a measurement.

Upon returning to position A, the value of the capacitor measured will be stored for display and the counter preset for the next measurement.

The unit utilizes leading zero suppression, so, when the counter contains all zeros, the display will show only one zero when turned on.

Calibration

Calibration is accomplished in two steps: high value and stray. 1,000 pF 5% silver mica or other

high-value close-tolerance units may be used for the initial setting. Since most capacitors are $\pm 20\%$ tolerance units, extreme accuracy is not a requirement, and the silver mica units will provide sufficient accuracy if closer tolerance units are not available. 1,000 pF to 10,000 pF values are preferred for calibration.

Attach the known-value capacitor to the input terminals. Apply power, and switch from A to C with SW1. The display will read some value. Adjust R43 until 1,000 pF ± 15 pF is shown. This completes step one.

The next calibration sequence will zero out the stray capacity. Adjust trimmer capacitor C1 for minimum capacity. With

no capacitor connected to the unit, switch from A to C. Some number will show on the display (999992 on test unit). This represents the preset number loaded into the counter plus the stray capacity. This value must be zeroed out, so small capacitor values can be measured. Zeroing the stray is accomplished by adjusting the trimmer C1 until the meter reads zero when switching from A to C.

Upon completion of zeroing out the stray value, return to the 1,000 pF capacitor and readjust if necessary to bring the unit into calibration.

General

A digital display can produce some distracting observations. As an exam-

ple, measuring a 5,000 pF (.005 uF) capacitor may produce a reading of 5040 pF one time and 4995 the next time. Remember, even though that appears to be a large value, it represents a $\pm 0.9\%$ accuracy. Since the majority of capacitors are $\pm 20\%$, this unit allows measurement of those unmarked capacitors sufficiently accurate for most applications.

Two last comments concern the constant current source. The accuracy of this type of capacity meter depends on the constant current source. Improvement in this area will improve overall performance. Secondly, any capacitor that is "leaky" will give a reading that is not representative of its true value. ■

WE HAVE WHAT YOU NEED AT...



YD-844
Dynamic Mike

YAESU

ADVANCED COMMUNICATION EQUIPMENT



QTR-24
World Clock



Left to right — FRG-7, Solid State Synthesized Communications Receiver • FR-101 Digital, Solid State Receiver • SP-101B, Speaker • FR-101, Digital Solid State Receiver • FL-101, 100 W Transmitter • FL-2100B, 1200 W PEP Input Linear Amplifier

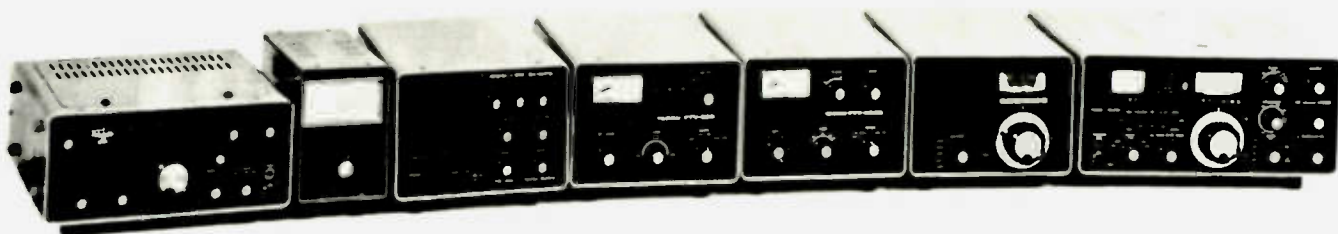

Left to right — FT-620B, 6 Meter Transceiver • YP-150, Dummy Load Wattmeter • YO-101, Monitor Scope • FTV-250, 2 Meter Transverter • FTV-650, 6 Meter Transverter • FV-101B, External VFO • FT-101F 160-10M Transceiver



Left to right — YC-601, Digital Frequency Display • YC-355D, Frequency Counter • FP-301, AC Power Supply • FT-301S Digital, All Solid State Transceiver • FV-301, External VFO • FT-225RD, 144-148 All Solid State All Mode Transceiver



USED GEAR • TRADE UP • FREE UPS SHIPPING ON PREPAID ORDERS

\$2,000,000 HAM INVENTORY

HAMTRONICS - WHERE THE HAM IS KING

THE LOWEST POSSIBLE PRICES



THE PACESETTER IN AMATEUR RADIO

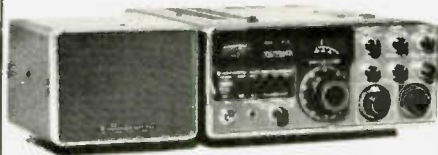

TS-700SP \$759.00

2M ALL MODE BASE/MOBILE TRANSCEIVER. SSB (upper and lower), FM, AM and CW. AC and DC. 4 MHz band coverage (144 to 148 MHz). Dial in receiver frequency and TS-700A automatically switches xmitter freq. 600 KHz for repeater operation. Xmit, Rcv capability on 44 Ch. with 11 xtals.



TR-7400A \$449.00

2M MOBILE TRANSCEIVER. Synthesized PLL. Selectable output, 25 watts or 10 watts. 6 Digit LED freq. display. 144-148 MHz, 800 CH. in 5 KHz steps. 600 KHz repeater offset. Continuous tone-coded squelch (CTSC). Tone Burst.



TS-820S \$1249.00

SSB TRANSCEIVER. PLL RF Monitor Noise Blanker. Digital hold locks counter & display at any frequency, but allows VFO to tune normally. True RF compressor adjustable speech processor. IF shift control. RF attenuator. VOX, GAIN, ANTIVOX and VOX delay controls. RF negative feedback. Optional digital readout. DRS Dial. High stability FET VFO.



TS-520S \$799.00

SSB TRANSCEIVER. Proven in the shacks of thousands of discriminating hams, field day sites, DX and contest stations and mobile installations. Superb engineering and styling.

SP-520 \$33.00

Optional external speaker for better readability.

TV-502S \$299.00

TRANSVERTER. Puts you on 2M the easy way. 144-145.7 MHz or optional 145-146 MHz.



R-820 — INTRODUCING— \$1099.00

THE ULTIMATE IN RECEIVER DESIGN... THE KENWOOD R-820. With more features than ever before available in a ham band receiver. This triple conversion (8.33 MHz, 455 kHz, and 50 kHz IFs) receiver, covering all Amateur bands from 160 through 10 meters, as well as several shortwave broadcast bands, features digital as well as analog frequency readouts, notch filter, IF shift, variable bandwidth tuning, sharp IF filters, noise blanker, stepped RF attenuator, 25 kHz calibrator, and many other features, providing more operating conveniences than any other ham band receiver. The R-820 may be used in conjunction with the Kenwood TS-820 series transceiver, providing full transceive frequency control.



MC-50 \$45.00

Dynamic microphone designed expressly for amateur radio operation. Complete with PTT and LOCK switches, and a microphone plug. (600 or 50k ohm)



S-5990-\$25.00 R-5990-\$499.00 T-5990-\$499.00

COMMUNICATIONS RECEIVER. 1.8 to 29.7 MHz, WWV and CB band. 50 MHz, 144 MHz converter optional. Stable VFO & oscillator for 5 fixed channels. 1 KHz dial readout. Xtal filters (SSB/8 pole, CW/8 pole, AM/6 pole). Squelch. S meter. Noise blanker.

SSB TRANSMITTER. 3.5 to 29.7 MHz. Stable VFO. 1 KHz dial readout. 8 pole Xtal filter. AM Xmission available. Built-in AC pwr supply. Split frequency control available.



VFO-820 \$175.00

Designed exclusively for use with TS-820. RIT circuit and control switch. Fully compatible with optional digital display.

VFO-520 (Not Shown) \$149.00

Solid State Remote VFO. RIT circuit with LED indicator.



SM-220 \$349.00

KENWOOD'S SM-220 STATION MONITOR. The SM-220's unexcelled versatility allows you to monitor your transmissions, monitor incoming signals, and monitor the amount and strength of band activity* and performs as a general-purpose 10 MHz oscilloscope, as well.



R-300 \$279.00

ALL BAND COMMUNICATIONS RECEIVER. AC, batteries or external DC. 170 KHz to 30 MHz in 6 bands. Foreign broadcasts or ham radio in AM, SSB and CW. Dual gate MOS/FET transistors & double conversion. Band spread dial. 500 KHz marker.

THE BIG 'H' FOR ALL YOUR HAM NEEDS!

CALL JIM TITUS FOR FREE QUOTES ON TOLL FREE NO. 800-523-8998

HAMTRONICS

DIVISION OF TREVOSE ELECTRONICS
4033 Brownsville Rd • Trevoise, Pa. 19047
(215) 357-1400/(215) 757-5300

WE HAVE WHAT YOU NEED AT...



DRAKE®

KNOWN FOR QUALITY THROUGHOUT THE WORLD



RECEIVERS

DSR-2	VLF-HF Digital Synthesized SSB, AM, CW, ISB, RTTY	\$3200.00
R-4C	C-Line, HF, 160-10M	\$699.00
4NB	Noise Blanker for R-4C	\$74.00



TRANSMITTER

T-4XC	C-Line, HF, 160-10M	\$699.00
-------	---------------------	----------



TRANSCIVERS

TR-7	Transceiver	\$1100.00
DR-7	Digital Readout	\$195.00
RV-7	Remote VFO for TR7	\$195.00
FA-7	Fan for TR-7	\$25.00
MS-7	Speaker for TR-7	\$33.00
7077	Dynamic Desk Mike for TR7	\$45.00
34PNB	Plug-in Noise Blanker for TR-4 Series	\$100.00



LINEAR AMPLIFIER

L-4B	Linear and w/power supply & tubes	\$995.00
------	-----------------------------------	----------



MATCHING NETWORKS

MN-4C	Antenna Matching Network. 200W	\$165.00
MN-2000	Antenna Matching Network. 1000W	\$250.00
W-4	RF Wattmeter, 1.8 to 54 MHz	\$79.00
WV-4	RF Wattmeter, 20 to 200 MHz	\$89.00
7073	Hand-Held Microphone	\$19.00
7075	Desk Top Microphone	\$45.00
1525EM	Push-button Encoding Microphone	\$49.95
HS-1	Head Phones	\$10.00
AA-10	10W, 2M Amplifier	\$49.95
TV-300-HP	300 ohm High Pass TV Set Filter	\$10.60
TV-75-HP	75 ohm High Pass TV Set Filter	\$13.25
TV-42-LP	Transmitter Low Pass Filter. 100W	\$14.60
TV-3300-LP	Transmitter Low Pass Filter. 1000W	\$26.60
TV-5200-LP	Transmitter Low Pass Filter. 1000W. 100W, 6M	\$26.60



USED GEAR • TRADE UP • FREE UPS SHIPPING ON PREPAID ORDERS

\$2,000,000 HAM INVENTORY

HAMTRONICS-WHERE THE HAM IS KING

THE LOWEST POSSIBLE PRICES

COLLINS AMATEUR EQUIPMENT



KWM-2A TRANSCEIVER **\$3533.00**
 Unmatched for mobile and fixed station applications. 175W on SSB, 160W on CW. Switch select up to 14 optional Xtals. Can be used for RTTY. Filter type SSB generation. Automatic load control. Inverse RF feedback. Reimability-tuned variable oscillator.



75S-3C RECEIVER **\$3000.00**
 Sharp selectivity. SSB, CW and RTTY. Single control rejection tuning. Variable BFO. Optional mechanical filters for CW, RTTY and AM. 2.1 KHz mechanical filter. Zener regulated oscillators. 3-position AGC.



32S-3A TRANSMITTER **\$3250.00**

Covers all ham bands between 3.4 MHz and 30 MHz. Nominal output of 100 W. 175 W, SSB and 160 W CW. Dual conversion. Automatic load control. RF inverse feedback. CW spotting control. Collins mechanical filter.



312B-3 SPEAKER
\$95.00



312B-4 SPEAKER CONSOLE
\$648.00



312B-5 VFO CONSOLE
\$1616.00



516F-2 AC POWER SUPPLY
\$440.00



302C-3 DIRECTIONAL WATT METER
\$493.00



DL-1 DUMMY LOAD
\$270.00

CALL JIM TITUS FOR FREE QUOTES ON TOLL FREE NO. 800-523-8998

HAMTRONICS

DIVISION OF TREVOSE ELECTRONICS
 4033 Brownsville Rd • Trevose, Pa. 19047
 (215) 357-1400 / (215) 757-5300

THE BIG 'H' FOR ALL YOUR HAM NEEDS!

WE HAVE WHAT YOU NEED AT...

BIRD THRULINE® WATTMETER



MODEL 43

- BUY ONLY THE ELEMENTS YOU NEED AND ADD EXTRA RANGES AT ANY TIME
- READ RF WATTS DIRECTLY

**Table 1
STANDARD
ELEMENTS**

Power Range	Frequency Bands (MHz)					
	2-30	25-60	50-125	100-250	200-500	400-1000
5 watts	—	5A	5B	5C	5D	5E
10 watts	—	10A	10B	10C	10D	10E
25 watts	—	25A	25B	25C	25D	25E
50 watts	50H	50A	50B	50C	50D	50E
100 watts	100H	100A	100B	100C	100D	100E
250 watts	250H	250A	250B	250C	250D	250E
500 watts	500H	500A	500B	500C	500D	500E
1000 watts	1000H	1000A	1000B	1000C	1000D	1000E
2500 watts	2500H					
5000 watts	5000H					

**Table 2
LOW-
POWER
ELEMENTS**

1 watt	Cat. No.	2.5 watts	Cat. No.
60-80 MHz	060-1	60-80 MHz	060-2
80-95 MHz	080-1	80-95 MHz	080-2
95-125 MHz	095-1	95-150 MHz	095-2
110-160 MHz	110-1	150-250 MHz	150-2
150-250 MHz	150-1	200-300 MHz	200-2
200-300 MHz	200-1	250-450 MHz	250-2
275-450 MHz	275-1	400-850 MHz	400-2
425-850 MHz	425-1	800-950 MHz	800-2
800-950 MHz	800-1		

WE HAVE A COMPLETE STOCK OF ALL BIRD WATTMETERS AND SLUGS

ATLAS



210X	Transceiver. 10-80M. 200W	765.00	DD6-XL	Digital Dial Readout for 350-XL	229.00
215X	Transceiver. 15-160M. 200W	765.00	305	Plug-In Auxiliary VFO. For 350-XL	155.00
DMK	Deluxe Mtg. Kit for 210X & 215X	55.00	311	Plug-In Auxiliary Crystal Oscillator for 350-XL	135.00
220CS	AC Console for 210X & 215X	155.00	350-PS	AC Pwr Supply w/Spkr & Phone Jack for 350-XL	229.00
350-XL	Transceiver. SSB. Solid State. 10-160M. 350W.	1195.00	DMK-XL	Mobile Mounting Bracket for 350-XL. Easy Plug-In	65.00



USED GEAR • TRADE UP • FREE UPS SHIPPING ON PREPAID ORDERS

\$2,000,000 HAM INVENTORY

HAMTRONICS-WHERE THE HAM IS KING

THE LOWEST POSSIBLE PRICES

NYE VIKING



No. 114-310-003 \$9.65



No. 114-310-004GP \$50.00



No. 114-404-002 \$20.75

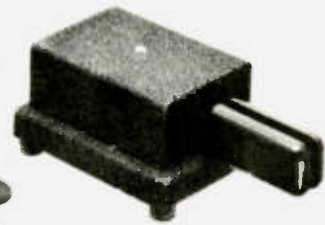

No. SSK-1 \$23.95



No. 250-46-1 \$36.50



No. 250-46-3 \$46.50



No. 250-20-1 \$19.95



No. MB2-1 \$315

NPC

2.5 AMP



12CB4 29.95

4 AMP



103R 39.95

6 AMP



104R 49.95

12 AMP



108 RM
\$104.95



25 AMP

109R 159.95

VIBROPLEX



"PRESENTATION"
72.50

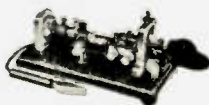

"ORIGINAL"
49.95



"LIGHTNING BUG"
49.95

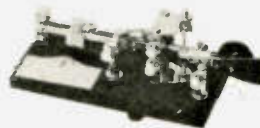

"CHAMPION"
46.50



VIBRO-KEYER
46.50

CALL JIM TITUS FOR FREE QUOTES ON TOLL FREE NO. 800-523-8998

HAMTRONICS

DIVISION OF TREVISE ELECTRONICS
4033 Brownsville Rd • Trevose, Pa. 19047
(215) 357-1400 / (215) 757-5300

THE BIG 'H' FOR ALL YOUR HAM NEEDS!

WE HAVE WHAT YOU NEED AT...

DenTron The MT-3000A

SPECIFICATIONS:

- Power handling capability in excess of 3 KW PEP
- Front Panel Antenna Switch with 5 Antenna Inputs plus Tuner bypass position
- Built-in 50 Ohm—250 Watt dummy load
- Dual Wattmeters
- Compact: 5 1/4" x 14" x 14", 18 pounds
- Continuous Tuning 160-10 meters
- 3 Core Heavy-Duty Balun

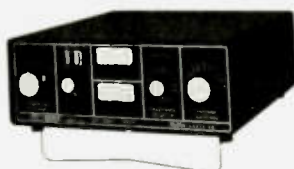

349.50

The evolution of the MLA



When the MLA-2500 was first introduced it was a new concept in high performance amplifiers. Low and sleek yet powerful enough for the military. Some wondered... needlessly.

A promise kept.

The MLA-2500 promised 2000 watts PEP input on SSB. A heavy duty power supply. Two Eimac 8875's. And as thousands of Amateurs across the world have proven, the MLA-2500 delivers!

Now DenTron is pleased to bring you The new MLA-2500B. Inherently the same as the original MLA-2500, the B model includes all of the above specifications plus a few refinements. New high-low power switching for consistent efficiency at both the 1KW and 2KW power levels, and 160-15 meters.

Tested and proven.

What better test for an amplifier than the Clipperton DXpedition? Even after 32,000 QSO's, and an accidental dunk in the ocean, the same 3 MLA-2500's are still amplifying other rare DXpeditions around the world—listen for them.

Convinced? Isn't it time you owned the amplifier that powered Clipperton and thousands upon thousands of radio stations throughout the world?

MLA-2500B \$899.50



DenTron Super Tuner

160-10 Meters
Balanced Line,
Coax, Random
or Long Wire

Maximum Power Transfer, Xmitter to Antenna.

1 KW Model \$129.50

3 KW Model \$229.50

If they copy the quality, they can't meet the price.

The original DenTron Super Tuner. The original MT-3000A. And now DenTron brings you the original MT-2000A, an economical, full-power tuner designed to handle virtually any type of antenna.

The sleek styling and low profile of the MT-2000A is beautiful, but be assured that it's only a part of the excitement you'll derive from the MT-2000A. The MT-2000A is designed and engineered using heavy-duty all-metal cabinetry, and high quality American components throughout.

When you consider the MT-2000A's unique features: 5 1/4" H x 14" D x 14" W, front panel coax bypass switching, front panel lightning protection antenna grounding switch, 3KW PEP, and the ability to match coax, random wire and balanced feedline, we're sure you'll decide to buy an American original and stay with DenTron.



DenTron

MT-2000A \$199.50

DenTron JR. MONITOR™ Antenna Tuner



Continuous tuning from 1.8-30 MHz. 300 watt power capability. Forward reading relative output power meter—simply tune JR. MONITOR™ controls for maximum RF output on the meter. Built-in balun. Mobile mounting bracket. Ceramic rotary 12-position switch. Capacitor spacing 1000 volts. Tapped toroid inductor. Antenna inputs: coax unbalanced SO 239, random wire, balanced feed line 75-660 ohm. Weight: 2 1/2 pounds.

\$79.50

Big Dummy w/coolant



\$29.50

All Band Doublet



This All Band Doublet or inverted Type Antenna covers 160 thru 10 meters. Has total length of 130 feet (14 ga. stranded copper) although it may be made shorter if necessary. This tuned Doublet is center fed through 100 feet of 450 ohm PVC covered balanced transmission line. The assembly is complete. Add rope to the ends and pull up into position. Tune with the DenTron Super Tuner and you're on 10 through 160 meters with one antenna! Now just for the DenTron All Band Doublet.

\$24.50

DenTron W-2 PAD IN LINE WATTMASTER

Read forward and reflected watts at the same time



Tired of constant switching and guesswork?

Every serious ham knows he must read both forward and reverse wattage simultaneously for that perfect match. So upgrade with the DenTron W-2 Dual in line Wattmaster.

\$99.50

USED GEAR • TRADE UP • FREE UPS SHIPPING ON PREPAID ORDERS

\$2,000,000 HAM INVENTORY

HAMTRONICS - WHERE THE HAM IS KING

THE LOWEST POSSIBLE PRICES

TEN-TEC INC.

TRITON IV EQUIPMENT



TRANSCEIVERS

MODEL 540-200W, SSB/CW
3.5 - 30 MHz \$699.00

MODEL 544- DIGITAL, 200W
SSB/CW, 3.5 - 30 MHz
\$869.00

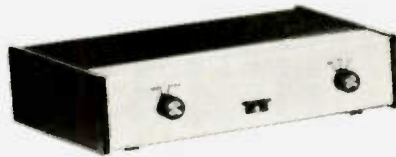

MODEL 240 \$110.00
ONE - SIXTY CONVERTER



MODEL 242 \$179.00
REMOTE VFO

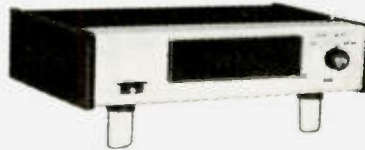

MODEL 244 \$197.00
DIGITAL READ OUT/COUNTER



MODEL 262-M \$145.00
DELUXE POWER SUPPLY

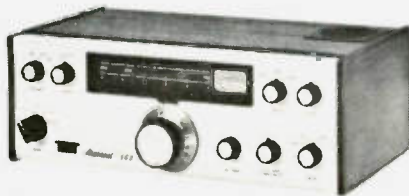

ARGONAUT

MODEL 509 \$369.00
SW, SSB/CW, 3.5-30 MHz

LINEAR AMPLIFIER

MODEL 405 \$159.00
100W, 3.5 - 30 MHz

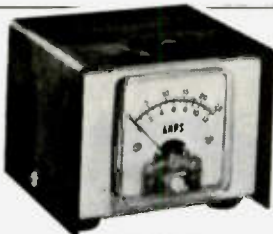
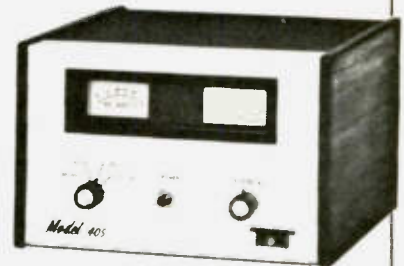

AMMETER
207 \$14.00



XTAL CALIBRATOR
206-A \$29.00

KEYERS

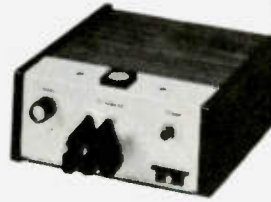

ELECTRONIC KR-50
\$110.00



ELECTRONIC KR20-A
\$69.50



ELECTRONIC KR-5A
\$39.50

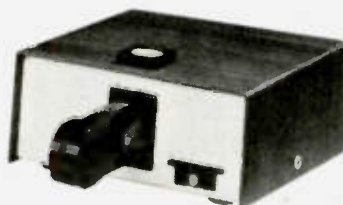

KR-2A \$17.00



KR1-A \$35.00

CALL JIM TITUS FOR FREE QUOTES ON TOLL FREE NO. 800-523-8998

HAMTRONICS

DIVISION OF TREVISE ELECTRONICS
4033 Brownsville Rd • Trevose, Pa. 19047
(215) 357-1400/(215) 757-5300

THE BIG 'H' FOR ALL YOUR HAM NEEDS!

WE HAVE WHAT YOU NEED AT...



ICOM

VHF/UHF AMATEUR & MARINE EQUIPMENT



VHF/UHF AMATEUR & MARINE EQUIPMENT

IC-245. SSB 146 MHz FM 10W x CVR. LSI synthesizer with 4 digit LED readout. Xmit & Rev frequencies independently programmable. 60 dB spurious attenuation.

\$545.00

IC245SSB.....**\$689.95**

IC-215. 2 METER FM PORTABLE. Three narrow filters for superb performance. 3W or 400 mW. 15 CH. capacity. MOS FET RF Amp & 5 tuned ckt. S-meter front panel.

\$239.00



\$265.00



IC-502. 6 METER SSB & CW PORTABLE XCVR. Includes antenna & battery pack. 3W PEP & stable VFO for fun & FB QSO's. Covers first 800 KHz of 6M band, where most activity is.



IC-211

IC-211. 4 MEG. MULTI-MODE 2M XCVR. 144-145 MHz on SSB & CW, plus 146-147 MHz on FM. Work AMAT OSCAR six or seven. LSI synthesizer with 7 digit LED. MOS FET RF Amp, 5 helical cavities, FET mixer & 3 I.F. filters.

\$850.00

\$1650.00



IC701 W/POWER SUPPLY & MIKE • Dual Independent UFO's Built-in • 100 Watts Output • All HF Bands, 160-10M • Fully Synthesized Tuning • Continuously Variable Bandwidth • Double Balanced Schottky Diode 1st Mixer • RF Speech Processor • VOX; Fastbreak in CW; RIT; AGC; Noise Blanker; Full Metering •

IC280.....**\$480.00**



IC-21A. 146 MHz FM 10W XCVR. MOS FET RF Amp & 5 helical resonator filter, plus 3 I.F. filters. IDC modulation control. Variable output pwr: 500 MW to 10W Front panel discriminator meter. SWR bridge. 117 VAC and 13.6 VDC pwr supplies.

\$399.00

DV-21. DIGITAL VFO. Use with IC-21A to complete 2M band.

\$299.00

IC-202. 2 METER SSB PORTABLE XCVR. Puts sideband in your hand! Internal C batteries or external 12 VDC. 3W PEP. True I.P. noise blanker. 144.0, 144.2 on two other 200 KHz bands, selectable. Hamtronics stocks 145.2 and 145.8-146.0 MHz for calling frequency & satellite band.

\$275.00



IC-30A. 450 MHz FM LOW XCVR. 1W or 10W. Low noise MOS-FET RF Amp & 5 section helical filter. 22 CH. capacity. S-meter & relative power output meter. IDC modulation control.

\$440.00

CALL JIM TITUS FOR FREE QUOTES ON TOLL FREE NO. 800-523-8998

\$2,000,000 HAM INVENTORY

HAMTRONICS-WHERE THE HAM IS KING

THE LOWEST POSSIBLE PRICES



— TRANSCEIVERS —



Single-Sideband Transceiver
350B \$649.95



350D \$749.95

Full 300 Watts PEP input on single-sideband • Selectable 80 or 100 Hz CW audio filter • Built-in AC power supply • Built-in 25 kHz crystal calibrator for model 350A • Meets or exceeds all FCC specifications for purity of emissions.

Model 350D has the same specifications and characteristics as the Model 350A except the unit comes with a built-in digital frequency display with readout to 100 Hz as standard equipment.

HF 700S \$699.95
HF 700S/SS16B \$799.95

— POWER SUPPLIES —



Precision power supplies provide all input required by Swan transceivers. DC converters adapt the AC power supplies for mobile or portable use to a standard 12 V automobile battery

- Power supplies are ideal for temporary operation, such as vacations, short trips, remote installations and emergencies
- Swan power supplies are designed for long reliable service.

PSU-3 Universal Power Supply • 115/230 VAC • Built in Speaker \$175.95
117 x AC Economical AC Power Supply w/out cabinet or speaker \$129.95

— ACCESSORIES —



510X 10 Channel Crystal Controlled Oscillator \$69.95
VX-2 Plug-in VOX \$49.95
FP-4 Phone Patch \$69.95
SS16-B 16 Poll Filter Kit \$99.95

— METERS —



WM6200 In-line Precision Wattmeter for 2M. 2 Scales to 200 W. Reads SWR \$87.95
FS-2 SWR & Field Strength Meter \$19.95
SWR-3 Pocket SWR Meter \$14.95
SWR-1A Relative Power Meter & SWR Bridge \$29.95
FS1 Pocket Field Strength Meter \$13.95
WM1500 In-line Wattmeter. 4 Scales to 1500W. 2 to 50 MHz \$74.95
WM2000A Peak Reading SWR Wattmeter... \$89.95

NEW! 100 MX Mobile Transceiver



The 100 MX Mobile Transceiver is completely solid state and incorporates state-of-the-art design and styling.

The receiver sensitivity is better than 0.35 uv at 50 ohms for 10 db signal plus noise-to-noise ratio for all bands. Audio output is four watts into four ohm load. Audio bandpass response is 300 to 3000 Hertz. Provisions for an external speaker or headphones are on the rear panel and a gimbal-type mobile mount is included as standard equipment.

THE BIG 'H' FOR ALL YOUR HAM NEEDS!

CALL JIM TITUS FOR FREE QUOTES ON TOLL FREE NO. 800-523-8998

HAMTRONICS

DIVISION OF TREVOSE ELECTRONICS
4033 Brownsville Rd • Trevose, Pa. 19047
(215) 357-1400/(215) 757-5300

W2NSD/1 NEVER SAY DIE

editorial by Wayne Green

from page 113

these days, having proven his theories rather spectacularly. Spots mean better DX, so the DX brethren are up to here in countries. They can't stop worrying about WARC and the coming 1979 ITU plenipotentiary conference which has the power to completely delete all amateur frequency allocations.

Where we actually stand as far as gaining, holding, or losing frequencies goes is more of a matter of belief than one of certainty, since no one can know for sure which way the critical African 44-vote black bloc will go. That's the bunch which wiped out our 237,000 MHz of satellite microwave channels in 1971. Oddly enough, time has not seemed to increase their enthusiasm for giving up what they consider their frequencies for a white man's hobby.

The ARRL complacency is reassuring to many amateurs. A reading of the report in *QST* of what happened in 1971 when the ARRL went to the ITU at Geneva to preserve our ham satellite frequencies and lost virtually everything might dispell some of that complacency. Well, since it is now far too late to do anything about it, why fret more. Let's just wait and see. If we come out okay, we saved a lot of needless worry. If we lose our shirts, then we can indulge in an orgy of recriminations. I'm not sure how the League will work things around to put the blame on me, but they managed it with "incentive licensing," so I have a profound respect for their ability to rewrite history and get gullible amateurs to buy it.

Rather than spend a lot of time on WARC, I see the ARRL tied up with a whole rash of petty squabbling. Their persecution of Mary Lewis and their dedication to preventing her from being the first woman ARRL director has resulted in a lawsuit. Their insurance scheme has come a cropper and must be taking a lot of time to hassle. Then there is a suit pending with Al Ogden, challenging the ARRL to put up or shut up on keeping Technicians from holding office in the League. The ARRL Foundation mess is coming apart, despite

heroic efforts to cover up the situation... which is tied in with the almost total inaction on solving the real WARC problems.

Recent efforts to try to scuttle the Canadian Amateur Radio Federation have been tying up many HQ staffers. CARF seems to be weathering the battle rather well and we see more and more Canadians resisting the carpetbaggers from south of their border. They still have time to harass hams who write in with a beef. One recent sample was Terry Staudt, who wrote to Baldwin with a complaint and for his trouble found Baldwin trying to get him fired rather than answer his complaints.

ARMA (the Amateur Radio Manufacturer's Association) members got uptight over the ARRL Code of Ethics. They didn't object to the concept, only the jamming of it down their throats. They called Baldwin on the carpet and demanded some explanation for the *QST* editorial claiming heavy industry support for the scheme. Baldwin, according to the industry people I've talked with, came out a liar in their estimation. He was totally unable to back up his editorial with facts. The industry is further very upset over the new ARRL push to set the prices to be charged for ham gear and to force manufacturers to have a sample unit tested in the ARRL labs before it can be advertised in *QST*. It's the arrogance that really gets to the industry people.

If the League would spend a fraction of the time they invest in petty harassing of hams who are critical of them and in making life difficult for the industry, they would have plenty of time to attend to the more important matters such as WARC, and I don't mean the relatively insignificant WARC meetings in Washington. The votes of the other 153 countries are going to determine what amateur radio is like in the 80s, not what happens in Washington.

ARMA members were astounded when Noel Eaton (ARRL-IARU) reported to them in Atlanta this year that nothing whatever had been done or was in prospect to approach the 44-vote African black bloc to try to get their support for amateur

radio at WARC. It appears that the whole future of amateur radio is being left entirely to chance. Good luck.

ARRL BUSINESS

If the ARRL isn't busy trying to cope with the WARC situation, then what are they doing... besides trying to cut expenses by firing people? Oh, they're busy with a multitude of problems... such as the insurance program which seems to be giving them more and more troubles. They may really be in the soup on that one. Then there is the project to try to stop Mary Lewis from getting to be the first woman ARRL director... this seems to be getting into court. The incumbent, Thurston, has been a terrific yes-man, so he would be a serious loss to HQ, particularly since Mary is the kind of person who does not knuckle under easily... as they've found. Another big time waster is the HQ battle to prevent a Technician class ham from getting elected as a vice director. Al Ogden, a Technician, is challenging this bias in a court case. Then there is Terry Staudt, a ham who had the gall to write Baldwin with a beef and who, for his trouble, found the League trying to get his employers to fire him! And, despite monumental efforts to cover it up, the mess with the ARRL Foundation just won't die. Ask your director about some of these incidents the next time he comes to your club... and let me know what he says.

With ARMA in disarray after their African plan was destroyed, the League is back to business as usual. ARMA has been trying to come up with some ideas on other things they might do which would attract members, such as working up a ham industry exhibit for use at trade shows, but this seems to be leaving the smaller firms cold since they would get little benefit from it. ARMA, having no paid staff, has to depend on volunteer time from industry people. In general, this is in very short supply, for most industry leaders are already spread thin trying to keep up with their own work. The lack of any significant benefits to firms supporting ARMA has kept down paid memberships, thus making it impossible to have a paid staff. Until ARMA comes up with a convincing goal which will benefit the entire industry, it is going to have tough sledding and be a sitting duck for ARRL pot-shooting.

COWAN PROMISES

On page 1 of the October, 1976, issue of *CQ*, Dick Cowan said, "... *CQ* has slipped badly in both circulation and adver-

tising." He went on to say that this had happened because he was preoccupied with S9 and other more profitable publishing ventures. He points out that "it would be very expensive and time-consuming to rebuild it." Next he says he has the money, the manpower, and the know-how to rebuild *CQ*, and, by God, he intends to do just that.

Okay, here we are two years down the pike. All that money, manpower, and know-how have resulted in a magazine that is hardly different from two years ago, running about six or eight articles an issue (like *Ham Radio Horizons*). There has been no noticeable change except for a slight increase in advertising, and that is due primarily to the yeoman efforts of Jack Gutzeit.

Far from being first, as promised, *CQ* is running neck and neck with *Ham Radio Horizons* for last place... getting ads out of sympathy more than performance. This sympathy can be costly. One advertiser complained to me that he had run an ad and been incredulous at the reader service response. He was had, he felt, for sending out catalogs costing him nearly \$1,000 and the results were virtually nil. Would he re-run his ad for half price? No way!

The secret to having a good magazine is no secret at all. You pay authors well and you pay them promptly, not after they have to sue you for payment. This will bring you the cream of the crop. It will also bring you plenty of readers who will respond by buying from your advertisers. You really have to share the money with the authors, not take it all and put it into trains and yachts.

There is no real secret to putting out a good magazine and getting hams to read it. You have to give good value... interesting articles and lots of 'em. To get these, you must pay money... funny how a quick check for an article seems to motivate people.

EXCITING THE FCC

The latest catalog from Henshaw's, 7622 Wornall, Kansas City MO 64114, should get some people at the FCC in an uproar. They have three stores, the others in Independence and Ft. Worth, and they are *not* ham stores. The catalog is strictly CB, but with two items marked as being for amateurs. These are items you won't find in a ham store catalog. There on the back cover you'll find an ad for an "amateur" CW transmitter. It says, "Illegal to modify for use as a CB linear." This gem is a 125-Watt CB linear disguised as a 10m ham transmitter. As long as I see ads like that right out in front of the CBers, I have

The LEADER In the Northwest!



ATLAS • ICOM • KENWOOD • YAESU

Come to ABC Communications today for the best solution to your particular communication requirements, whether they be Amateur, Two-way Business Band, VHF Marine or Police Scanner.



ATLAS Transceiver 210X
80 thru 10M

ATLAS Transceiver 215X (not shown)
160 thru 15M



DENTRON MT-3000A
Deluxe Tuner

DENTRON 160-10 AT (not shown)
Super Tuner



KENWOOD Transceiver
TS-820S 160 thru 10M



KENWOOD Transceiver
TS-520S 160 thru 10M



KENWOOD 2M FM
TR-7400A



NATIONWIDE TOLL FREE NUMBER

1-800-426-6937

washington state: 1-800-562-7625



ICOM Transceiver 2M FM
SSB IC 211



ICOM Transceiver 2M FM IC 245



YAESU 901 DM



YAESU HF SSB 160 thru 10M
FT 101F or FE



ABC
COMMUNICATIONS

✓ A46

17550 15TH AVE. N.E. • SEATTLE, WASH. 98155 • (206) 364-8300

We also handle Wilson, Cushcraft, Hy-Gain, Antenna Specialists, KLM, etc.

Attention Washington residents: Come on in for excellent service in our complete Communications Repair Shop.

Write or call for SPECIAL tower, rotor, antenna package! Tri-Ex, Rohn, Wilson Towers. Shipping Info: F.O.B. Seattle via UPS, truck, or parcel post.

Washington residents add sales tax.



Other locations: (Walk-in customers only) • Bellevue — 12001 N. E. 12th • Everett — 4610 Evergreen Way • Open Mon. thru Sat.

no confidence that the FCC has any intention of making their CB and ham linear rules stick. Oh, ham dealers selling amplifiers which cover 10m to hams will get the full treatment from the FCC, but CB dealers selling CB linears under the most transparent of covers will be ignored by the FCC.

The other gem from Henshaw's is a 10.5-GHz police radar jammer which is called an "amateur transmitter." The ad goes on to say that, "This may be illegal to use as a police radar jammer." This \$400 gadget can be set to indicate speeds of 20, 30, 40, 55, or 60 mph on police radar. Here we go again!

SPEAKING OF 10.5 GHZ

When Microwave Associates came out with their cute little 10 GHz units a couple of years ago, I got quite interested and urged our then editor to get a couple and play with them. He did and wrote them up, but didn't ever offer to let me in on the fun. Then, when he left, the 10 GHz stuff left with him, so I missed out completely.

Well, almost completely. Chuck WA1KPS of Tufts Electronics recently got a pair of the units and added the i-f strips which turn them into transceivers. Since I have one of the more accessible mountains just up the street (actually, the mountain had a lot to do with my picking this location when we moved up here 16 years ago), Chuck got one of the transceiver units into my hands for some tests. The first test was between Pack Monadnock (NH) and Blue Hill (MA).

I had it easy, having only to pack the 10 GHz rig and a couple of HTs in the 73 van and head up the road. The road goes right to the very top. I then climbed up into the fire tower and set up my system, coordinating it on 223.5 MHz simplex. Chuck had a more difficult time, having to carry everything up from a parking lot to the top of his mountain, a 20-minute hike. It was worth the trouble, for the signals came through full quieting over the 58-mile path.

All is not beer and skittles for the pioneer. I forgot to bring gloves and the wind was icy cold up there in the framework of the fire tower, so I about got frostbite. It was worth it once we got the two rigs tuned to each other. This is no simple matter when your hands are cold and the wind is blowing you around.

As I was driving back down the mountain, fired with the enthusiasm of success, I got to thinking about Pack Monadnock. I've spent many a night on that mountain working far-

off repeaters . . . particularly back about ten years ago when there weren't so many of them. From that location I had no problem working repeaters in Maine, Vermont, Massachusetts, and even down into Connecticut. I couldn't quite make any Rhode Island repeaters except under better than average conditions. Why not see what DX we could work on 10.5 GHz?

Chuck is a sucker for anything to do with amateur radio, so a few days later he was taking a day off from the store and heading for Mt. Ascutney in Vermont (they have a splendid 76 repeater on Ascutney). Again I pooped on up the Pack and coordinated via first 2m, then 223.5 MHz until we made the contact on 10.5! Again Chuck had quite a hike to the top, carrying the 10.5 rig plus his HTs. It was even colder than the previous contact and it took about 15 minutes before we finally got everything tuned up right and had full quieting clean signals. We were afraid for a while that we might not make it. The distance was only 52 miles, but it was over some very rough terrain.

Well, the day was still early, so why not drive on over to Maine and up to the top of Mt. Agamenticus, near Ogunquit. Chuck climbed back down Ascutney, packed everything in his van, and drove clear across New Hampshire and to the top of Agamenticus. This was a 68.5-mile hop, so it would be stretching the ability of the tiny rigs. We were using them barefoot, with only the little horn antenna which Microwave Associates furnishes.

By late afternoon, Chuck was on top of Agamenticus and I was back up on the fire tower on the Pack, listening carefully and aiming the rig at where I thought his mountain should be. Once Chuck heard me calling and tuned me in, I was able to aim the rig a bit better and peak the signals to perhaps an S-7. Hmm, that made three states on 10.5 GHz. Not a record, but not bad.

A couple days later, Chuck was off to Rhode Island for another try. This time we were looking at a 69-mile path, but with some formidable mountains right along the route. Chuck first had to get permission to climb the tower on the hill (there are no mountains in Rhode Island). This turned out to be a production in itself. Then, when he got there, he had to climb the hill, which took on the proportions of a mountain. Next he had to climb the cement base of one leg of the tower and work his way up the tower framework until he got to the ladder at the 20-foot level. From there it was a bit easier,

climbing the wet and very cold tower in the wind, holding on to the rig with one hand, pockets bulging with the HTs, and holding on very, very tight with the other all the way up to the 150-foot level.

While Chuck was trying to aim the rig and not fall off the tower, his fingers gradually freezing in spite of his gloves, I was getting cold clear through up on the Pack. I was, as usual, inadequately dressed and without gloves. The wind was cold and brisk, and the entire top of the mountain was engulfed in a thick cloud. We tried to get through, but even the 223.5 HTs were not doing very well. We were doomed by the clouds, if not by anything else. Those 10.5 GHz signals drop dead in clouds or even in rain, so we really didn't expect to make it. We didn't.

Chuck has been going over the maps looking for a hill in Connecticut which might have a good line-of-sight path to the Pack. The fire warden on the Pack says you can see Ragged Mountain in Connecticut on a clear day, so perhaps we'll make it.

Oddly enough, we had not yet worked New Hampshire, so one recent Sunday Chuck packed everything into his van and headed up here. After visiting the Pack to see how visible some of the mountains were up north, he headed for Mt. Washington. There was no time to lose since the road to the top would be closing the next day for the winter. The auto-road people warned that the top of the mountain was in a cloud with 250-foot visibility. Well, perhaps it would blow off and we'd make it.

After allowing Chuck enough time to reach Mt. Washington (6,288 feet, the highest point in New England), I called him on the Mt. Washington repeater on 67. He was stuck at the base, waiting out a long line of cars waiting to pay the \$7.50 toll. I'd had to wait almost a half hour to get up the Pack, this being a Sunday at the peak of the fall foliage.

Eventually, he got through the toll gate and made it to the top of the mountain. It was still socked in, so I had little hope for a contact. We had measured the path on the map and it was 106 miles, which seemed a lot for the tiny rigs. We set up anyway, with me in gloves and a heavy jacket for a change. I was only braving temperatures in the 40s, while Chuck had 15° and a 40 mph wind. We tried to get through until frostbite started to set in on Washington. The top of the mountain was iced over with rime ice and the clouds were still heavy.

After the three and a half hour

drive, a half hour wait in line, and the long drive to the top, plus the fact that this would be the last chance to try the path until next summer, Chuck was not about to give up without one more try. He set up in the parking lot, maybe a couple hundred feet down from the top, and we worked at it. The clouds parted for a moment and there it was . . . "W2NSD, this is WA1KPS." I acknowledged it and we had a contact. It's funny, but you can hear your own voice coming through the system when you have a contact. This was a weak one and didn't last but a couple of minutes before the clouds were in again and it was lost. I could always tell just how well Chuck was tuning in my signal by how clearly I could hear my voice coming back.

Next spring, when we see a particularly clear day in prospect, perhaps we will again head for the mountains. I measure 150 miles between Mt. Greylock in Massachusetts and Mt. Washington. I'll bet we can make it. In the meanwhile, you can be sure that we'll be working on Connecticut and Rhode Island. The very eastern edge of New York might just be reachable, too. Who's worked seven states on 10.5 GHz?

SOME NEVER LEARN DEPARTMENT

While on the one hand many amateurs are trying to get the FCC to live up to its promise to deregulate amateur radio, on the other a few amateurs are trying to tie us up again with more rules. I seriously doubt if any of the amateurs who went through the FCC repeater rules screw-up are in any way involved with the present move to try again for repeater regulation by the Commission.

The sooner amateur groups stop trying to solve their problems by getting more rules from the FCC and tackle their problems directly, the more we will be in control of our future. What amateurs who are pushing for more regulations are saying is that they don't want to either take the time or make the effort it requires to solve their problems.

Yes, I am all too familiar with the repeater situation where any amateur can set up a repeater and mess things up for hundreds of others. I also know there are some reasonable solutions to this problem for those who tackle the situation with determination.

The first step is for the local repeater council to decide what has to be done. If there is an uncoordinated repeater in the area, get the other repeater

Continued on page 254

CALL TOLL FREE

1-800-228-4097
Communications Center
 443 N 48th Street ✓CSB
 Lincoln, Nebraska 68504
 In Nebraska Call (402)466-8402

1-800-634-6227
Communications Center
West
 1072 N. Rancho Drive
 Las Vegas, Nevada 89106
 In Nevada Call (702)647-3114

Antenna Sale!



18HT



CUSHCRAFT
ATB-34

MOSLEY CL-36

HY-GAIN		Regular	Special
TH6-DXX	Super Thunderbird	\$296.95	\$ 209.95
TH3-MK3	3 ele. 10, 15, 20 Mtr. beam	219.95	169.95
Hy-Quad	2 ele. Quad 10, 15, 20 Mtr.	229.95	189.95
TH3-Jr.	3 ele. 10, 15, 20 Mtr. beam	144.50	129.95
18 HT	Hy-Tower 10-80 Mtr. Vertical	299.95	239.95
14AVQ/WB	10-40 Mtr. Trap Vertical	67.00	57.00
18AVT/WB	10-80 Mtr. Trap Vertical	97.00	84.95
203	3 ele. 2 Mtr. beam	14.95	
205	5 ele. 2 Mtr. beam	16.95	
208	8 ele. 2 Mtr. beam	24.95	
214	14 ele. 2 Mtr. beam	31.95	

MOSLEY		Regular	Special
Classic 33	3 ele. 10, 15, 20 Mtr. beam	232.50	189.95
Classic 36	6 ele. 10, 15, 20 Mtr. beam	310.65	249.95
TA-33	3 ele. 10, 15, 20 Mtr. beam	206.50	169.95
TA-36	6 ele. 10, 15, 20 Mtr. beam	335.25	279.95
TA-33 Jr.	3 ele. 10, 15, 20 Mtr. beam	151.85	129.95
TA-40KR	40 Mtr. add on	92.25	74.95

CUSHCRAFT		Regular	Special
ATB-34	4 ele. 10, 15, 20 Mtr. beam	259.95	209.95
ARX-2	2 Mtr. Ringo Ranger	36.95	32.95
A147-20T	2 Mtr. Twist	59.95	52.95
A144-10T	10 ele. Twist 2 Mtr.	39.95	32.95
A144-20T	20 ele. Twist 2 Mtr.	59.95	52.95

HUSTLER		Regular	Special
4BTV	10-40 Mtr. Trap Vertical	99.95	82.95
RM-75	75 Meter Resonator	15.50	13.50
RM-75s	75 Meter Super Resonator	30.00	26.50
G6-144-A	6 db. 2 Mtr. Base Colinear	67.55	57.95

WILSON		Regular	Special
System One	5 ele. 10, 15, 20 Mtr. beam	274.95	239.95
System Two	4 ele. 10, 15, 20 Mtr. beam	219.95	189.95

CDE ROTORS		Price
Ham III		\$125.00
T2X Tail Twister		\$225.00



RINGO
RANGER

4BTV

**We carry all major brands of ham radios
 AT DISCOUNT PRICES**

Yaesu — Kenwood — Drake — ICOM — Dentron —
 Ten-Tec — Swan — Tempo — Midland — E.T.O. — Wilson



Fail-Safe

—protecting repeater batteries

Most repeater owners want to have a battery on the repeater so that the system will continue to function during a power failure. But the problem is, how do you keep the battery charged up so it will work when you need it?

The following circuit came about as the result of a need for a battery charging circuit for our .37/97 repeater in Casa Grande, Arizona. The following capabilities were needed on the charger:

1. Normal charging —

turn charger on at approximately 12.5 V and off at approximately 15 V.

2. Low-voltage fail-safe in the event of charger failure, approximately 11.5 V.

3. Overvoltage fail-safe in the event of malfunction in charger turn-off sensing, approximately 15.5 V.

4. Battery connected to 110 V ac line only during charging period.

The obvious question that comes to mind is, "Why not just float the bat-

tery?" In my experiences as a two-way service technician, I have found that the majority of lightning-caused damage is because of lightning hits on the commercial power line. With this in mind, it was figured that the probability of damage would be greatly reduced if the battery were only hooked to the charger for the 2 to 3 hours per week when it was charging. If you don't expect to ever get hit with lightning at your site or if you like to gamble, then

skip this article and jump over to the next one. However, if you are a natural pessimist like myself, read on. (Remember Murphy's Laws: If it can possibly go wrong, it will. If it is impossible for anything to fail, it still will.) Another reason for using the type of charging described here is one of battery life. A battery that is on a continual float is likely to go bad much faster than one that is charged and recharged on a regular basis. The following circuit contains all of the features previously described.

Circuit

The circuits for sensing charger turn-on, charger turn-off, and low-voltage disconnect make use of three sections of a Motorola MC3302 quad voltage comparator. This device provides a TTL-compatible output that is at a high state when the inverting input is below the reference voltage (on the noninverting input). When the voltage on the inverting input is equal to or higher than the reference voltage, the output switches to a low state. The reference voltage is supplied by an MC7805CP regulator chip. Potentiom-

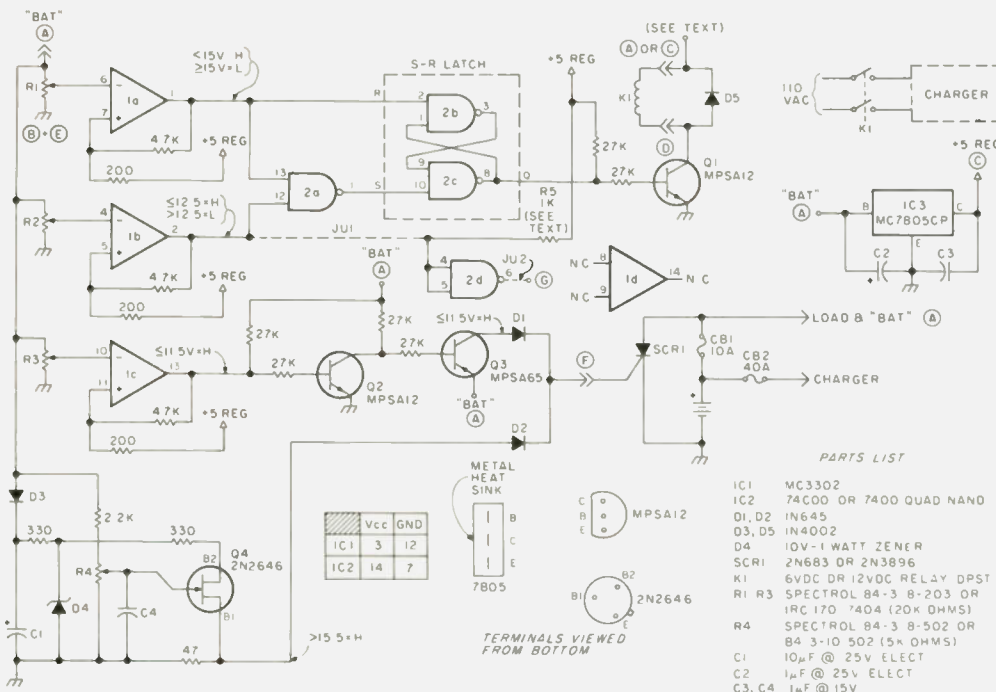

Fig. 1. All fixed resistors are 1/4-Watt, 10%. The PC board mates with a 15-pin edge connector.

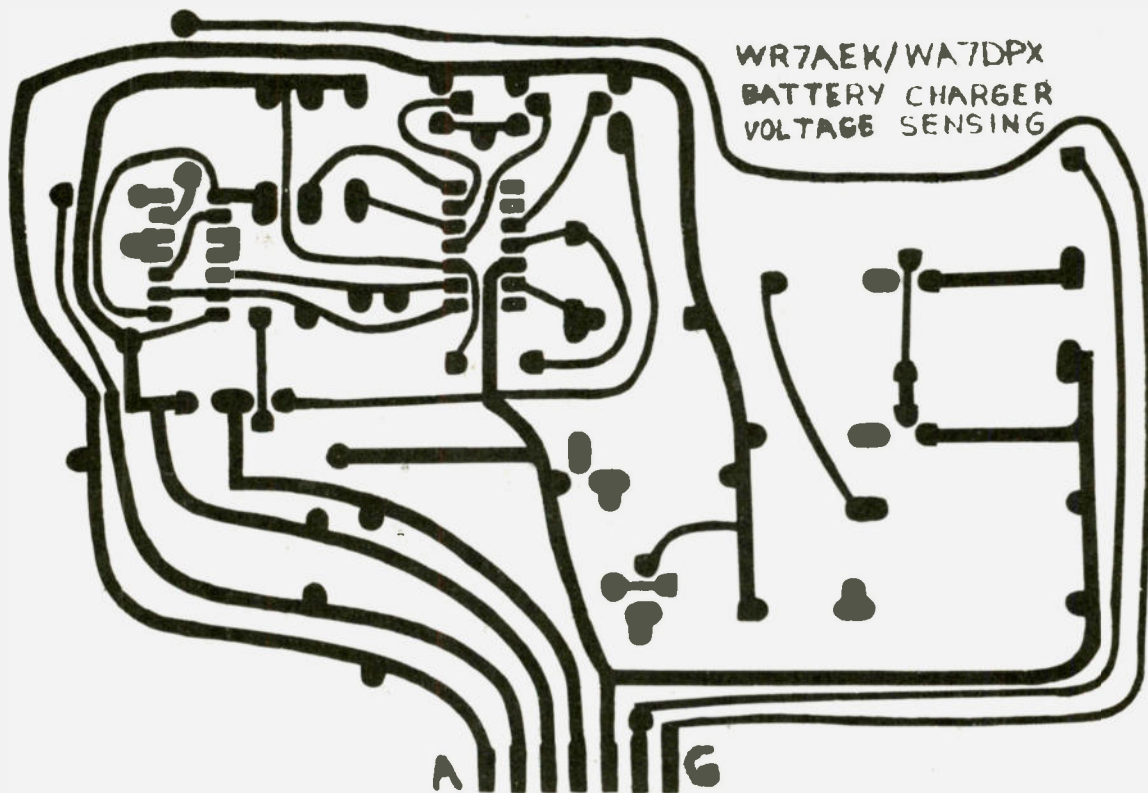

Fig. 2. PC board.

eters R1 and R2 are used to set the switching levels for the voltage comparators. (Both pots act as voltage dividers across the battery voltage.) (See Fig. 1.)

The output of the comparators (1A and 1B) are hooked to a NAND gate (1/4 of a 7400 IC section, 2A) which drives two more sections of the 7400 chip (2B and 2C). Sections 2B and 2C are hooked in what is called a set-reset latch configuration (abbreviated S-R latch). The device is effectively an on-off switch (an electronic latching relay, if you will).

When a low is applied to the set (S) input, the output (Q) goes high and stays high. The Q output will stay high even though the low on the S-input is removed. To "turn off" the latch, a low is applied to the reset (R) input. The output will stay low even though the low on the S-input is removed. The Q-output drives an MPS-A12 Darlington amplifier transistor (Q1) which acts as a relay driver.

Because of the extremely high gain of the MPS-A12 ($H_{FE} = 20,000$), the device works very well at TTL levels. The device is capable of switching a 500 mA load. Q1 drives relay K1 which is used to switch the 110 V ac line to the battery charger. A relay with a good gap between the normally-open contacts should be used so that line surges (i.e., lightning hits) will not jump across the gap.

Let's look at the action of the circuit during a typical discharge and recharge cycle. The logic states for the output switching points are shown on the schematic to make it easier to follow. Starting at a full charge, both outputs (pins 1 and 2 of IC1) are low; hence K1 is turned off (the S-R latch is reset by the low on the R-input (pin 2, IC2)). As the voltage drops below 15 V, output pin 1 switches high, placing a high on one input of NAND gate 2A (pin 13). Input 2 of IC2 is still low, since the voltage is

still over 12.5 V. When the voltage drops below 12.5 V, IC1B output (pin 2) switches high. We now have both gates of NAND gate IC2A high. This causes its output (pin 11) to go low. This low makes the S-R latch output (Q) go high, turning on Q1, which pulls in K1. K1 turns on the charger. As the battery charges, the output of IC1B goes low when the voltages go over 12.5 V. The battery will continue to charge until it reaches 15 volts. At this point, IC1A output will go low. When this happens, the S-R latch is turned off by the low on the R-input (pin 2, IC2B). Q goes low, which turns off K1 and disconnects the charger.

The remaining two sections of the circuit (IC1C and Q4) are the low-voltage and overvoltage protection fail-safe circuits. The circuits are referred to as fail-safe because a failure that actuates either circuit will result in the battery being disconnected from all circuits, and the charger will be discon-

nected from the ac line. This results in a "safe" condition where the battery cannot be damaged by excessive discharge or overcharge. Either of these conditions is a major fault that requires technical attention. Consequently, a nonreversible disconnect (blowing circuit breaker CB1, which must be manually reset) was chosen to accomplish the job.

The low-voltage section of the circuit uses the third section of IC1 as the sensing element. Operation is the same as IC1, A and B. When the voltage goes below 11.5 V, the output of IC1C goes high through D1 to the gate of SCR1. The high on the gate causes SCR1 to fire, placing a short across the circuit breaker and battery, which, of course, causes the circuit breaker to open. Since the coil of K1 is actuated by the battery voltage, the relay cannot pull in to connect the charger to the 110 V ac line.

The remaining section is

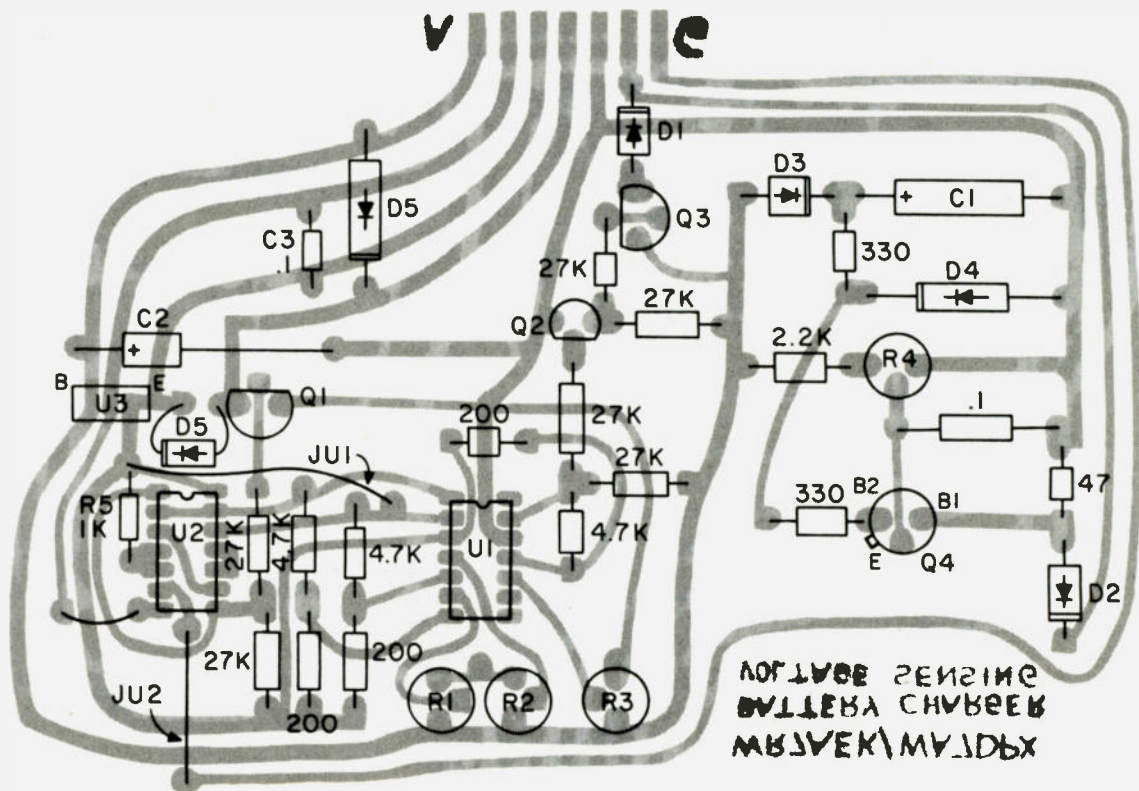

Fig. 3. Component layout.

the overvoltage protection circuitry. This is a conventional "crowbar" circuit. D3 and C1 act to suppress negative transients which might trigger the circuit. When the voltage exceeds 15.5 V, the gate of the UJT (Q4) fires, causing a positive pulse to be generated at base one of Q4. The pulse is coupled through D2 to the gate of SCR1, which blows the circuit breaker as previously described.

Output G is an optional output used to drive a tone generator. The purpose of this option is to place a tone on the repeater transmitter to indicate that the battery is below 12.5 volts and is not getting charged. This warning will give you time to correct the problem before the battery drops to 11.5 V and is shut off by the low-voltage protection circuit. Fig. 4 shows an example of an oscillator that could be used for this option. If you want to use this feature, jumpers JU1 and JU2 should be installed and

resistor R5 omitted. If the option is not used, jumpers JU1 and JU2 should be left out and R5 installed. Do not install the jumpers and the resistor, as damage could result to the comparator IC.

Circuit Adjustments

The voltage levels stated were found to be correct for the battery we were using (a 200 Ah battery). However, you should check your specific battery to determine the limits you want to set. The main voltage to watch is the "full-charge" turn-off. The logical thing to assume is that, when the battery hits 13.8 V, it is fully charged. That's wrong! The battery must be brought to a point above that for it to take a full charge.

The best way to determine this voltage is to discharge your battery. Run it down to about 12.5 volts. This should show a "high red" area on your hydrometer. Now charge the battery at the rate you intend to use in your system. Take regular

hydrometer readings until the battery shows in the "green" on the float. Check the voltage at this point. This is your full-charge turn-off voltage. When the charger is disconnected, you should read approximately 13.8 V with no load on the battery. The other voltage levels stated should be adequate to prevent damage to the battery.

The easiest way to set up the voltage comparators is with a variable voltage power supply connected to the "BAT" terminal (pin A) of the circuit. Connect a VOM (12 V dc scale) to pin 1 of IC1. Set the power supply for 15 volts. Adjust R1 until the voltage on the VOM changes from high to low (approximately 5 V to less than .5 V). Drop the voltage to about 14 V dc. Run the voltage back up to 15 V. Make fine adjustments on R1 until the output switches to a low at exactly 15 V. There will be a very distinct switch from high to low at the output switching points.

Move the VOM to pin 2 of IC1. Repeat the procedure, but set R2 for a switching point of 12.5 V dc. Repeat this again using IC1 pin 13 and 11.5 V dc. (Disconnect the gate of SCR1 to prevent it from firing.) Adjust R3. The remaining adjustment is on the overvoltage circuits. Connect the VOM (3 V scale) to D2 cathode. Adjust R4 for a voltage increase (to approximately 1 volt) at 15.5 volts. Run the voltage back and forth a few times to check the setting. The firing voltage should be a very distinct point. Reconnect the gate of SCR1.

After making all adjustments, give the circuit a final smoke test. Start at 15 V. The relay (K1) should be unenergized. Increase to 16 V. The circuit breaker should open. Drop to 15 V. Kill the power and reset the breaker. Drop the voltage slowly. At 12.5 V, K1 should pull in. Run the voltage back up. At 15 V, K1 should open. Drop the voltage down to 11.5 V. At this point, the circuit

breaker should open and K1 should open. Be sure your power supply has enough current to blow the circuit breaker.

Construction

The value for CB1 should be chosen to meet the requirements of your particular station. The SCR listed is sufficient to handle at least a 25 Amp breaker. If a fuse is used instead of a breaker, a smaller SCR could probably be used. Be sure to tie all unused inputs of IC2 to +5 V through a 1k resistor. It is recommended that a 74C00 CMOS chip be used for IC2 because of the higher immunity to falsing that it has as compared to the 7400. The extra 15¢ for the CMOS chip shouldn't kill you unless you plan to make two or three gross of these circuits. All other areas of construction

should be pretty straightforward. The circuit can be built on a PC board (see Fig. 2) or perfboard, whichever suits your needs.

The printed circuit board was set up so that either a 12 V dc or 6 V dc relay could be used for K1. If a 12 V dc relay is used, diode D5 should be installed with the cathode connected to the 12 V line or battery (base of U3). If a 6 V dc relay is used, the cathode of D5 should be connected to the regulated 5 V dc line (E of U3). The high side of the relay coil would be connected to +12 V dc (pin A of card) or +5 V dc (pin C of card) as required. Do not omit diode D5. This diode is used to suppress the counter EMF developed when K1 is turned off. The low side of the relay and the anode of D5 are always

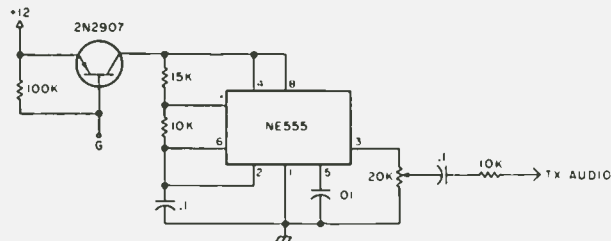

Fig. 4.

connected to pin D of the card.

Fig. 2 is a full-size drawing of the PC board. Fig. 3 shows the parts layout for the PC board.

Parts can be obtained from a number of the advertisers in 73. However, to save you time and probably money, arrangements have been made with Tri-Tek, Inc., to provide all of the parts (including PC board) in a kit form. You can, of course, order the entire kit or just the parts you need. The entire kit

can be ordered by asking for a "WR7AEK battery charger kit." (This doesn't include board or parts for the oscillator option.) The entire kit costs \$24.00. (It includes SCR1, but not CB1 or the edge connector.) The PC board alone is \$8.00.

I have made every effort to make the text and schematics as complete as possible. If you have a problem with the circuit that I can help you with, drop me a letter. I will make every effort possible to answer your questions (SASE, please). ■

New Products

from page 204

W6TOG RECEIVER MODIFICATION KIT

It wasn't until I began using a new FT-901DM that I finally concluded that my trusty FT-101B could stand some improvement in the receive mode. With the two rigs tuned to the same signal, and the antenna switched back and forth between them, it became quite apparent that the FT-901DM was much livelier. I was also able to copy weak signals very close to extremely loud signals that all too often were impossible to pull out with the FT-101B. Happily, as I was pondering the situation and wondering what might be done to punch up the older rig's performance, one of the W6TOG FT-101 series receiver modification kits arrived in the mail from S-F Amateur Radio Services.

My long-standing reluctance to go mucking about in the densely-packed solid-state innards of modern rigs was quickly overcome by the discovery that only four small components and three simple steps were involved in the

modification. The fact that things can be quickly and easily restored to their original state was also reassuring.

According to the instruction sheet, the purpose of the modification is to "improve the receiver sensitivity and help eliminate receiver blocking due to local signals." That sounded exactly like what I was looking for, so, taking screwdriver and soldering iron in hand, I proceeded to install the modification kit in my FT-101B.

The installation procedure is quite simple. You locate the receiver rf board, remove it, find the rf amplifier transistor (Q1), and replace it with one of the transistors from the modification kit. Then you locate foil track 8 on the board and solder one end of the pair of back-to-back diodes supplied with the kit to the track. The other end of the diode pair is soldered to foil track 7. The rf board is then plugged back into the unit and the high frequency i-f board is removed. Find the receiver second mixer transistor (Q2) and replace it with the remaining transistor from the kit. Replace the board in the transceiver and

the modification is complete. The entire process is quite straightforward and takes only a few minutes.

In some instances, you may find that after making the modification you will have to reapek the receiver section. If you do, be sure to carefully follow the instructions in the alignment section of your owner's manual. The time spent properly tweaking things up will be amply rewarded later by improved performance.

The installation of the W6TOG receiver modification kit has clearly improved the performance of my FT-101B. It's livelier than ever before, and I'm now able to copy signals that would have been very difficult, if not outright impossible, to pull out of the crud in the past. The decision as to whether or not you should make this modification to your own rig is one you will have to make for yourself, and depends largely on the sort of operating you do and the conditions you are confronted with when on the air. To help you decide, you may want to write to S-F Amateur Radio Services for a copy of the combination information sheet and order form.

In addition to the FT-101 series, there are receiver modification kits available for

the FR-101 series, TS-520, TS-520S and TS-820/820S. There is also the "MAGICOM" processor modification kit which converts the TS-820 speech processor from an rf compressor to an rf clipper.

W6TOG receiver modification kit prices are: TS-520, \$27.50; TS-520S, \$32.50; TS-820/820S, \$34.50; FT-101 series, \$32.50; FR-101 series, \$34.50. The "MAGICOM" processor modification kit for the TS-820 is \$27.50. All prices are postpaid from S-F Amateur Radio Services, 4384 Keystone Avenue, Culver City CA 90230; (213)-837-4870. Reader Service number S33.

Morgan W. Godwin W4WFL
Peterborough NH

S-F RADIO DESK

I used to set up my first rig on a small folding card table each time I wanted to operate, and then disconnect everything and put it away in a cupboard when I had finished. Since then I have used quite a variety of objects to hold my equipment and serve as an operating position, including an old rolltop desk, a kitchen table, a garage workbench, basement storage shelves, and a bookcase. For the past year I have been using

Continued on page 262

W2NSD/1 NEVER SAY DIE

editorial by Wayne Green

from page 248

groups to cooperate toward getting it off the air. You can't tell me that an uncoordinated repeater can stick it out when several hundred local hams decide that it should not be on the air. There should be no problem at all working up teams of amateurs to drive the scoundrel off the band. Hundreds of tape-recorded messages played through the offending repeater demanding that it be taken off the air might encourage it to be shut down. Visits to the owner of the repeater by rather large groups of determined hams might also get the idea through.

There are a great many ways of tackling the situation, and the inability to cope with it is an admission that the repeater owner is smarter than your group. Let's use brains instead of trying to get the government into the act. Remember that once you get the FCC moving, you will have one hell of a job stopping them. The FCC invariably overreacts to things like this. It's the way government works. Don't mess with it.

If repeater councils feel they are not mentally equipped to cope with some of the local repeater owners, perhaps they should get together with other nearby councils and try to locate someone in the group with some ideas. There are always a lot of ways of tackling problems... if you have a creative thinker handy.

YOU MISSED BOXBOROUGH

Despite a heavy all-day rain (or perhaps because of it), exhibitors at the ARRL convention at Boxborough (Massachusetts) set all-time records for equipment sales. Many were delightedly reporting double and triple the sales of Dayton, previously the top hamfest for cash sales.

One reason for the tremendous sale of ham gear was the recent price increases. Dealers at the convention had bought at the old prices and were selling at discounts off the old prices, so hams found themselves in a wonderland of fantastic prices. They reacted by buying everything in sight. DSI was there with their new counters and sold out completely on Saturday. By Sunday

morning they had a new stock, flown in overnight.

The New England ARRL Convention is an odd one in many ways. For many years it was run at the old Swampscott Ocean House. Then one year the hotel burned to the ground just a month before the convention and the event had to be moved to Boston. This was not a popular move, considering Boston hotel and parking prices. They tried Cape Cod one year and found that Greater Boston hams were not about to drive that far for a convention. The new convention complex on Route 495 (the Boston outside perimeter road), the Sheraton hotel at Boxborough, is a fine location and met with ham approval. It is estimated that well over 5,000 turned out.

I say estimated because security is not lax at this show—it doesn't exist. If you want to buy a ticket and have a chance at the multitude of prizes, so be it. They had 3,500 tickets available and ran out of those early in the first day. Tickets were generally bought just by the ham of the family, with the rest tagging along at no charge.

Most of the planning for the show was done by Gene Hastings W1VRK, an old-timer at this event. Exhibitors had some gripes... such as paying \$300 for a booth with one table and one chair, extra chairs available for \$20 each from the show decorator... only to find themselves facing flea market-ers in the exhibit hall who had bought a table and two chairs for \$4. Even worse, some of the fleas hung up their business signs and went right into selling commercially.

The flea market, which was a wet mess on Saturday, perked up on Sunday, but to thinner crowds. It was well managed by Jack W1QXX, the keeper of the antennas and large power behind the yearly VHF contest effort from Pack Monadnock in New Hampshire. Jack will also be found wherever there is a ham auction, a tradition going back as far as I can remember... when there is an auction, Jack is the auctioneer. He takes these things seriously and got into a big battle with an itinerant badge maker who tried to set up in his flea market

in competition with the one who paid for a booth inside and had an exclusive agreement. This was finally settled when the inside badge maker ran completely out of badges. Only then would Jack let the flea market badger start grinding.

Despite a blanket prohibition of my being permitted to speak at ARRL conventions, Gene managed to get me on the program twice, once speaking about software for microcomputers and the other on the sore subject of WARC. I think he got the software talk through headquarters by not telling them I was going to do the talking. My name didn't appear on the program or on any posters in conjunction with that talk. I'll bet he had a battle with the other one. One year they wouldn't even let 73 buy a booth and exhibit at Boston!

Speaking of sore subjects, all of the dealers exhibiting at the show were absolutely furious about the HR special deal with the ARRL... apparently a sweetheart deal... where ARRL *Handbooks* were being sold across the counter for \$4.25! This is 85¢ less than wholesale, so dealers were left with piles of *Handbooks* which they couldn't sell. The book regularly sells for \$8.50, so HR was selling it at half price... wonder what they had to pay for it? Wonder what laws were broken with that secret deal?

Despite the few grumbles about the show, there is no doubt whatever that New England needs a yearly ham convention in the Greater Boston area. Finding the spot for it is the big problem. The Sheraton Boxborough was hopelessly overcrowded by the event. You couldn't get around on Saturday. The exhibit hall was filled with about 70 booths... perhaps 35 exhibitors. The restaurant couldn't cope with the people, not having brought in extra cooks or waitresses. They had lines an hour long and then ran out of food. Unfortunately, there are no fast food places within easy driving distance of the hotel.

On the good side, this Sheraton is one of the best of the chain. I've had such lousy rooms, service, and so many problems that I've been avoiding the Sheraton chain like the plague. I had breakfast there before the crowds arrived and their food is no better than elsewhere at Sheratons... very poor. But the decorations were gorgeous and they really tried hard to make sure that those with room reservations had rooms.

Perhaps if Gene would cut the banquet and use the banquet hall for more exhibits...? And please, some sort of

lounge for the exhibitors.

MORE TROUBLE BREWING

A newspaper clipping sent in by KA2CKV is enough to give us a bad case of hives. It has to do with a proposed city health code amendment which is in the works in New York City. This has to do with setting the levels for radio field strength for emitted radio waves.

If this beauty goes through, it will effectively throw most of the hams in New York off the air. Oh, hand transceivers might escape the impact, but most hams would have to have their antennas a minimum of 200 feet from anybody. In New York that kind of distance is pretty expensive to buy.

At least there is some fighting of the proposed amendment by TV broadcasters, since they would have to either drastically lower their transmitted power or else move their transmitters out of town. Either move would ruin television pictures for much of the city and be a godsend to cable television firms.

Until they outlaw irradiation by police radar units, who irradiate us with roughly 5,000 times more energy than is permitted to leak from microwave ovens, they should lay off amateurs. The problem comes from a worry about rf pollution. I love that use of the word "pollution," because it is ridiculous in this context—yet is a great emotional phrase for the uneducated. Who can be in favor of "pollution?"

The fact is that there have been no definitive tests as yet which indicate that radio waves cause harm. I've been around 'em for over 40 years now... but perhaps that would be a case to support strict control of radio transmissions. Perhaps I can point to my continual irradiation by signals from DX stations, repeaters, HTs, and such as a possible reason for the weird behavior of my children. We all need some excuse for that, right?

If New York gets this one through, will Los Angeles be far behind? Will Peterborough pass such a law and force me to move my antenna at least 200 feet from myself? There may be a big sale of 200-foot towers soon. Should we invest in a tower firm?

MORE ASSISTANCE

We are looking for a couple of hams who will, in exchange for a subscription to 73, forward mail to us. We have a mailing list we rent out in the computer field, and we need to know when mail is delivered to it, how long it takes for the mail to arrive, and if the use of our list was authorized. All our



assistants have to do is date the receipt of mail and forward it immediately to us for our records.

4U1ITU

While visiting the ITU back in June to check on the prospects for survival of amateur band allocations, I paid a visit to the ham station in the ITU building in Geneva.

Here I am, on the left, with my very good friend Gerard de Buren HB9AW, who is the chief operator at 4U1ITU. We're in front of the ITU building, with my little rented Fiat reflected in the door glass.

This is the new ITU building, just a short distance from the older one, where 4U1ITU is still set up. If the African vote bloc has too much influence at the WARC meeting next October, will it destroy the whole ITU body of agreements which have been built up over the last hundred years?

I thought, if I didn't show you this picture, you wouldn't believe my report that one of the two (only two these days) stations set up at 4U1ITU is an old Collins system. While I have nothing in the world against using one of those lovely old rigs, still . . . for a station that is supposed to be used as a demonstration to delegates from all of the countries of the world, shouldn't something more

technically modern be on display?

Just to the left of the Collins equipment is one of the new ARRL low-cost CW rigs for impoverished amateurs. This was designed as a solution to the problem of amateurs not being able to afford the average new sideband rig. While it is true that amateurs in many of the small countries are not able to afford a new Yaesu 901, the whole concept of individual communications is an anathema to the leaders of countries which are unstable, and that includes virtually every one of the 44-vote African bloc. These countries might be talked into the use of radio clubs, where operators could be supervised, but there is no way you are going to get very many individual amateur stations permitted. It is just far too dangerous because the stations could then easily be used for subversive communications. This is why the chaps at the ITU are laughing at the ARRL and their mini-rigs.

If you find yourself within driving distance of Geneva, stop in and say hello to all of the hams at the ITU . . . they are a great bunch and you'll enjoy the visit. Bring your license and get on the air from one of the smallest "countries" . . . 4U1ITU. Be sure to give my very best to Gerard.

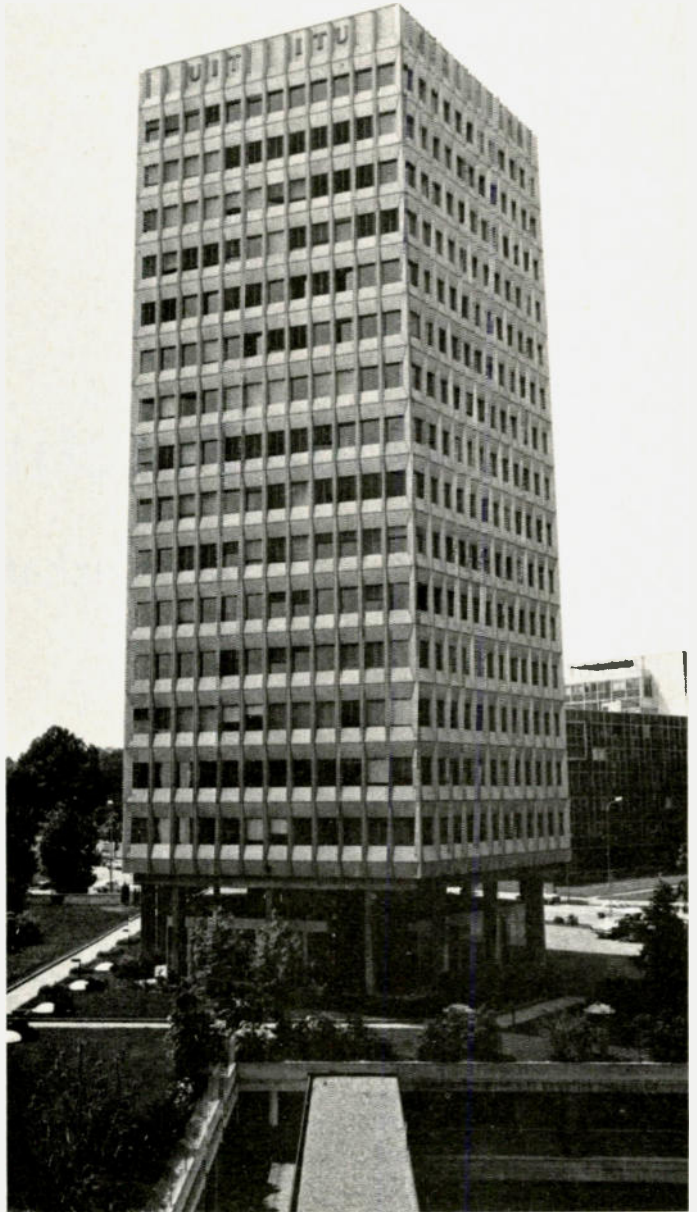

DXPEDITIONING HINT

For those of you who would like to get a little taste of what it's like to be on the other end of the pileups, take a good look at

the most interesting Eastern Airlines special fares. The chances are that you may be

Continued on page 277



Code-Practice Oscillators

— an exhaustive report

Hank Olson W6GXN
1751 Croner Ave.
Menlo Park CA 94025

From the earliest days of amateur radio, code-practice oscillators have been an integral part of the process of learning Morse code. To be sure, a great deal can be accomplished

by copying off the air in terms of receiving practice, but, for group instruction with a teacher or for individual keying practice, the code-practice oscillator is a necessity. In this article, I will take a look at the various forms of code-practice oscillators and suggest ways of improving them.

Perhaps the simplest

code-practice oscillator is an electromechanical buzzer and a battery. Such code-practice sets have been widely used, and some high-frequency buzzers for this purpose have a remarkably "pure" note.

Vacuum-tube oscillators came into use in the 1930s, and one very common circuit for a code-practice oscillator is shown in Fig. 1.¹

In earlier designs, a type-30 tube was usually employed. Note that the key and earphones are in the B+ lead.

A simplified vacuum-tube code-practice oscillator was also possible (one that did not need an audio transformer) which utilized the inductance of the earphones themselves, in a Colpitts circuit. This is shown in Fig. 2; the earphones and key are still in the B+ lead.

Since there are many forms of vacuum-tube oscillators possible (the tickler feedback and Colpitts versions are in Figs. 1 and 2), it is possible to find considerable variation in code-practice oscillator circuitry. However, generally, the oscillators all are simple tickler feedback, Colpitts, or Hartley oscillators which are started at each application of the keyed B+.

The neon-lamp relaxation oscillator was occasionally used as a code-practice oscillator, as shown in Fig. 3.² This unit

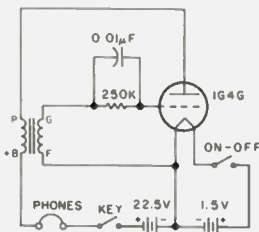

Fig. 1. Vacuum-tube code oscillator.

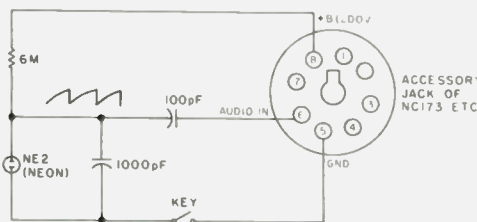

Fig. 3. Code-practice oscillator using neon-bulb relaxation oscillator.

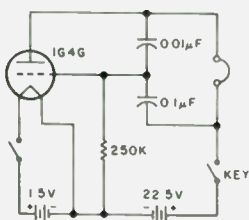

Fig. 2. Simplified vacuum-tube code oscillator.

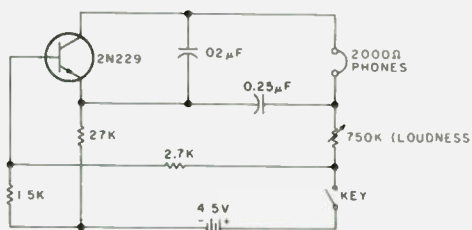

Fig. 4. Code-practice oscillator using early germanium NPN transistor.

SOME DRY INFORMATION ABOUT OUR ALL WEATHER ANTENNAS

Sooner or later almost all ordinary ham antennas are going to become victims of bad weather.

But Shakespeare's brand new line of two meter and HF antennas is anything but ordinary.

We're new to the ham market, but we've been making marine and military antennas for 26 years.

And those 26 years have taught us how to make a ham antenna that'll take just about anything Mother Nature can dish out.

Look at our 5705 omnidirectional VHF base antenna, for example.

Its radiating elements are non-ferrous brass and copper, the finest practical material available for conductivity and corrosion resistance. Surrounding the radiating elements and electrical components is a tough, flexible fiberglass shield. A shield that gives the antenna the strength to withstand winds in excess of 120 miles-per-hour.

The fiberglass keeps out rain, sleet and snow too. So the antenna's radiation pattern won't change, no matter how bad the weather.

Fiberglass protects radiating elements from rain and ice. Therefore no corrosion.

Fiberglass shield protects electrical components from corrosion caused by rain or ice.

Fiberglass gives added strength to the antenna. Prevents breakage in wind and sleet.

Fiberglass prevents radiation patterns from changing in wet weather.

The Model 5705

VHF Base Antenna

And you don't have to worry about radials breaking off, because the 5705 doesn't have any.

But it does have seven vertically polarized and phased 1/2 wave elements, stacked in colinear array and providing an impressive 10 dB gain.

And you can get optional style 5709 reflector that blocks out unwanted coverage and gives you an additional 2 dB gain in the opposite direction.

And here's another important piece of information: the 5705 is pre-tuned at our factory to operate in all environments. So it'll never have to be re-tuned.

Our full ham antenna line is featured in our new catalog: *The Complete Works of Shakespeare*. And

the catalog is yours. For free.

For additional information just write Shakespeare, Electronics and Fiberglass Division, Department C, Post Office Box 246, Columbia, South Carolina 29202.

Or call National Sales Manager John Hughes, (803) 779-5800 WA4EAU.

Shakespeare[®]

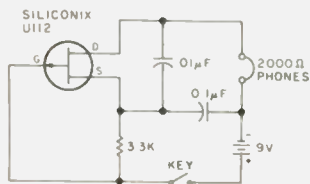

Fig. 5. Code-practice oscillator using early P-channel FET.

was designed to be plugged into the octal accessory jack of a National receiver, thereby utilizing the receiver's speaker, audio amplifiers, and power supply. The neon-lamp relaxation oscillator was the only form of tube-type RC oscillator commonly used as a code-practice oscillator. Unlike conventional oscillators (which produce a more or less sinusoidal output), the neon-bulb relaxation oscillator produces a sawtooth waveform.

When the first production (germanium) transistors became available at prices low enough to interest experimenters, they were immediately pressed into code-practice oscillator service. Fig. 4 shows a typical early transistor code oscillator using a germanium transistor.³ Note that this is very similar to Fig. 2, except that an NPN transistor replaces the tube and a lower plate (collector) voltage is used. The convenience of only one low-voltage battery to operate such a transistor code oscillator, and that at very low current drain, was a real boon to portability. The circuit would be substantially the same using a more modern silicon NPN transistor, such as a 2N3641. If a PNP transistor is used, the same circuit as in Fig. 4 can be built, but the battery polarity would be reversed.

As FETs became available, these were also used in code oscillators. Fig. 5 shows a simple code oscillator using one of the earliest available P-

channel junction FETs.⁴ The N-channel circuit would be the same, except with the battery terminals reversed. The FET code-practice oscillator is generally a bit simpler than an equivalent bipolar transistor circuit.

It must be made clear that in all the oscillators in Figs. 2, 4, and 5, the circuit requires the use of magnetic phones having an impedance of 2000 Ohms or higher. If low-impedance phones or piezoelectric (crystal) phones are used, the circuits do not have the required inductance to oscillate at the correct frequency (if at all).

The circuit of Fig. 3 used a neon tube as a negative-resistance element. In order to redesign the circuit for solid state, one could simply replace the NE2 with a four-layer diode having approximately a 50-volt breakdown voltage. Such diodes are made by ITT. The circuit would then be as shown in Fig. 6. Four-layer diodes are available in lower voltages, however, than neon bulbs, so a relaxation oscillator could be built using an even lower voltage, i.e., battery operated.

The circuit of Fig. 7 shows a unijunction transistor code oscillator, with an FET audio isolation source-follower after it to drive the phones and an NPN transistor as a keying device. With this circuit, you no longer have the supply current flowing through the key, and you finally have removed that same dc current from the phones. (Dc through the phones tends to eventually demagnetize the magnets in them.) The unijunction transistor oscillator, like the four-layer diode circuit, produces sawtooth waveforms.

Fig. 8 shows a "complementary" circuit for a simple code oscillator that uses an NPN (silicon) and a

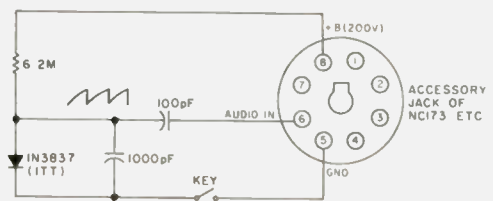

Fig. 6.

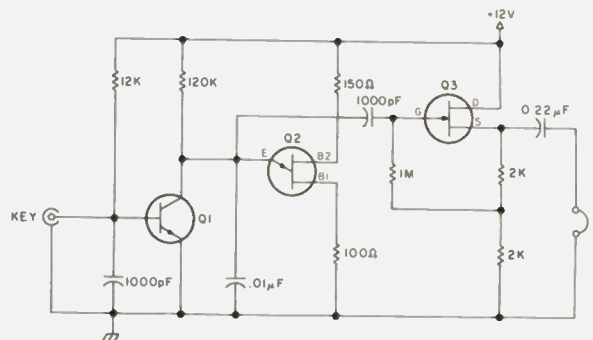

Fig. 7. Q1 = 2N3643; Q2 = 2N2646; Q3 = MPF102.

PNP (germanium) transistor which has been used extensively by those hams who swear by the *ARRL Handbook*.⁵ The circuit works well, driving an eight-Ohm speaker directly, but is somewhat sensitive to transistor substitutions.

Since we've used nearly every other active device as a code-practice oscillator, I feel that for completeness I should show one using an integrated circuit. The circuit of Fig. 9 uses an inexpensive and widely-available IC. The NE555V, as first introduced by Signetics, is now second sourced by nearly all linear IC manufacturers. This IC costs about 50 cents and is keyed, in this circuit, by a transistor costing about 30 cents; so the semiconductor cost is well below a dollar. The key is not in the +Vcc line, nor are the phones; and the code oscillator operates on a 6-volt battery such as a 4F lantern battery. The waveform output is essentially a square wave one.

Up to this point, I have concentrated on code-practice oscillators that have as their prime goals simplicity and the use of

low-priced components. This aim has apparently been in vogue because it was assumed that such oscillators are used only by beginners. However, there are many clubs with regular code classes conducted by expert CW operators, who no doubt despair at the sound of the average code-practice oscillator.

Morse code, as it comes out of the receiver, has a somewhat different quality to it than that from a code-practice oscillator. The receiver output is usually a near sine wave (providing the station being copied is "T9" and we have a good signal-to-noise ratio). The note sounds as if it simply "appears and disappears" rather than having the "crashing" quality of some

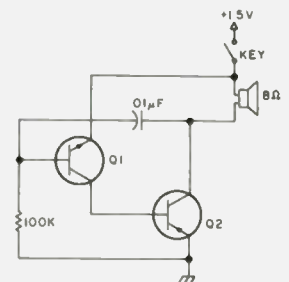

Fig. 8. Code oscillator using complementary-pair (PNP and NPN) transistors. Q1 = 2N2102; Q2 = 2N301.



INFLATION FIGHTER

AMATEUR RADIO'S BIGGEST MAGAZINE AT HALF PRICE!

We want you to enjoy amateur radio's biggest magazine for *only \$1 per copy*, but this is the *last time* you'll see 73 available for this price. Heck, 73 has gotten so fat, it costs \$1 per copy just to print and mail.

We're making this extraordinary offer on the world's biggest magazine of this kind to prove to you that 73 will put more fun into your hobby than anything else you can buy for under \$100.

MONEY-BACK GUARANTEE

If, after reading your first issue, or even your 11th, you don't agree that 73 is worth far, far more than \$1 an issue to you—simply cancel and receive a full refund on all remaining issues.

However, we think we'll have you for life. Because no matter what aspect of amateur radio you're interested in, or want to get interested in, 73 Magazine covers it more thoroughly and makes it more fun than any other publication.

Nearly 60 features each month fill you in on the latest techniques and equipment . . . expand your expertise . . . guide you into new areas that'll make amateur radio as exciting to you as the day you keyed your first transmission.

LAST-CHANCE OFFER

The cover price of 73 will be \$2.50 starting with the January issue, so this is the last time you'll see subscriptions for \$12, only \$1 per copy. Fill out the card attached on this page today and drop it in the mail (we'll pay the postage) and you'll receive your first, fat issue in four to six weeks.

73 magazine

Peterborough NH 03458

code-practice oscillators. In a search for a code-practice oscillator which has a more authentic on-the-air sound, the first requirement is having a sinusoidal waveform. There are a number of circuits for

generating sinusoidal waveforms; one such circuit is the Wien Bridge, used in most laboratory audio generators. The purer the sine wave, however, the longer these oscillators take to stabilize

when B+ is applied. In short, really pure sine-wave oscillators are not suitable for being keyed on and off.

One solution to the problem would be to allow a high-purity sine-wave oscillator to run continuously and then gate its output on and off. This has one problem: The key closure and opening times do not coincide with the zero-crossing times of the (asynchronous) sine wave. Such asynchronous gating of the sine wave causes transients that are very much like the "key clicks" of an improperly operating transmitter, so far as the listener is concerned.

It is possible to build a zero-crossing gate circuit

which delays turn-on and turn-off of the sine wave until that sine wave has reached a zero-crossing point. The penalty we must pay for the transient-free, pure-sine-wave gated audio pulse is delay. If the sine wave is 1000 Hz, the worst case would be slightly less than 1 ms delay at the start and 1 ms at the end of a keying pulse. Such a 1 ms delay would be almost totally undetectable to the ear.

A circuit, admittedly complex, which accomplishes the zero-crossing gating function is shown in Fig. 10. A Wien Bridge oscillator is used to generate a pure sine wave, and this is gated by a CD4016 analog gate. The CD4016 is a member of the RCA-CD4000 series of CMOS logic; it functions very well as an analog gate and is much less expensive than special ICs made for this purpose. The same sine wave is squared by a Schmitt trigger (LM311) to more sharply define the zero crossings. The output square wave of the Schmitt trigger is differentiated and the negative resultant spikes removed by a diode (D3). The positive spikes are inverted by the saturated amplifier, Q1, which makes them available at CMOS level to the logic ICs. The sequence of events in the logic is too tedious to go through here; you can go to reference 6 for details, if you're interested. The net effect is to delay the opening of gate U3, after application of a key pulse, until a negative-going zero crossing of the sine wave occurs. The gate is then held open until the key pulse ends, plus whatever time it takes until another negative-going zero crossing of the sine wave occurs. The logic uses the negative-going spikes from Q1 as information as to when the sine wave is mak-

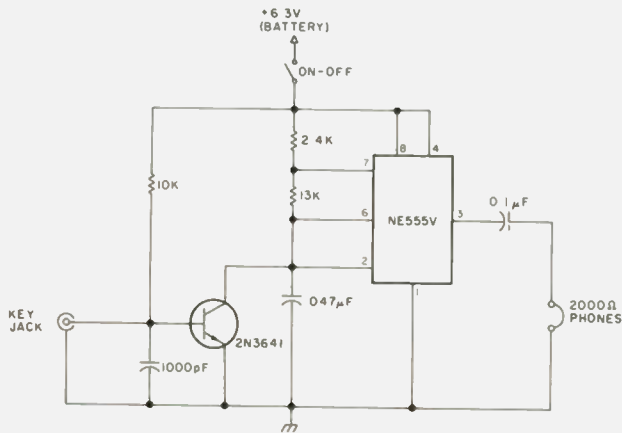

Fig. 9. Code oscillator using NE555V integrated circuit.

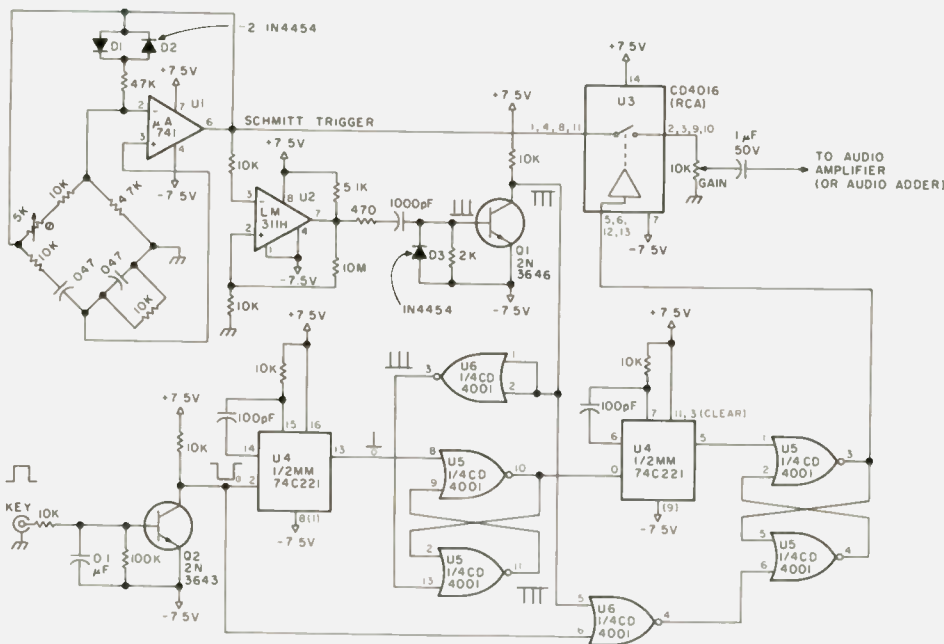

Fig. 10.

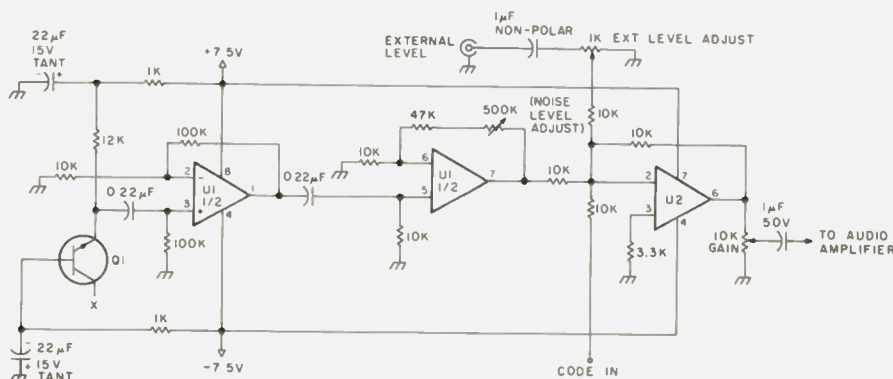

Fig. 11. U1 = LM458N; U2 = LM741CN; Q1 = 2N3641 (pick individual transistor for best noise output).

It's Thomas Communications For Top Quality Equipment and Service

FREE

- Call Toll-Free 1-800-243-7765
- Retail Price Catalog
- Monthly Used Equipment List



YAESU
FT-7



YAESU
FT-901



ICOM
IC-701



DRAKE
TR-7



KENWOOD
TS-820S



YAESU
FT-227R



TEN TEC
544



PANASONIC RECEIVER
RF 4800



KENWOOD
TS-700SP



KDK
2015R



DENTRON
MLA-2500B



WILSON
MARK IV

OVER 50 BRANDS IN STOCK

- KENWOOD • SWAN • KDK • DENTRON
- MOSLEY • WILSON • YAESU • DRAKE
- LARSEN • BENCHER • KLM • BEARCAT
- B & W • DATONG • ICOM • PANASONIC
- ARRL PUBLICATIONS • ALLIANCE • BIRD
- CUSHCRAFT • TRAC • MICROLOG • CDE
- HAM KEY • MFJ • DAYBURN INSULATORS
- DSI • SAXTON • TEN TEC • REGENCY
- HUSTLER • ASTATIC • PIPO • AMCOMM
- AMECO • CALL BOOK • FINCO • TEMPO

★ **OUR FINE REPUTATION SPEAKS FOR ITSELF** ★ **"YOU SHIP IT — WE FIX IT"**

★ **NEW AND USED EQUIPMENT**
"Get on our used equipment mailing list"

★ **TRADES WELCOME**
"The best allowances anywhere"
"We buy good used SSB gear"

★ **FREE CATALOG**
"Prices of all major manufacturers"

★ **SAME DAY U.P.S. SHIPPING**
"Just a phone call away"

★ **COMPLETE RADIO SERVICE SHOP**
• Fast Efficient Service • We Repair All Brands • All Work Guaranteed • Amateur Extra/First Class Licenses • Send Us Your Defective Equipment U.P.S. Collect • Free Shipping Both Ways If Work Is Done • Most Repairs Done & Shipped Within 7 Days

**Call or write for
your super quote today!**

Connecticut Residents Call:
203-667-0811

**95 Kitts Lane
Newington, Conn. 06111
"Near ARRL Headquarters"**



**THOMAS
COMMUNICATIONS**

T34

OPEN MON. - FRI. 10-6 • THURS. 10-8 P.M. • SAT. 10-4

EASY DIRECTIONS: Rt. 15 South — 2 blocks past McDonald's (Berlin Turnpike)

ing a negative-going zero crossing.

If you really want to offer code practice with as close as possible to off-the-air flavor, and yet have it under the control of your code class instructor, one additional complication may be added. A white-noise generator and operational adder can combine the code signal and the noise to produce any (adjustable) signal-to-noise ratio desired. In Fig. 11 is shown such a noise generator and operational adder. A back-biased emitter-base junction of a transistor is used to generate the noise as it goes into avalanche. Two operational amplifiers amplify this weak avalanche noise by a factor of up to 500. The third op amp is the operational adder, which has three combinational inputs: noise, code, and a third extra input. This third input could be used

to input background QRM from an actual HF receiver, if you really wanted realism. Note that each of the three inputs to the operational adder has its own level control, and the total combined signal level may be adjusted, also.

Fig. 12 shows a regulated power supply and audio output stage, suitable for Figs. 10 and 11. One of the

older IC audio amplifiers is used because it is easier to use in the low gain mode than some newer ones, which operate only in the fixed (high) gain mode. ■

References

1. Editors and Engineers, *Radio Handbook*, 7th edition, 1940, p. 15.
2. Lewis, A., "Hints and Kinks, Code Practice Oscillator,"

- QST*, March, 1950, p. 53.
3. Sylvania, *Performance Tested Transistor Circuits*, 1958, p. 35.
4. Flanagan, R., "Hints and Kinks, FET Code Practice Oscillator," *QST*, July, 1967, p. 49.
5. ARRL, *The Radio Amateur's Handbook*, 48th edition, 1971, p. 10.
6. Olson, H., "Tone-Burst Gate Minimizes Distortion," *Electronic Products*, March 19, 1973, p. 190.

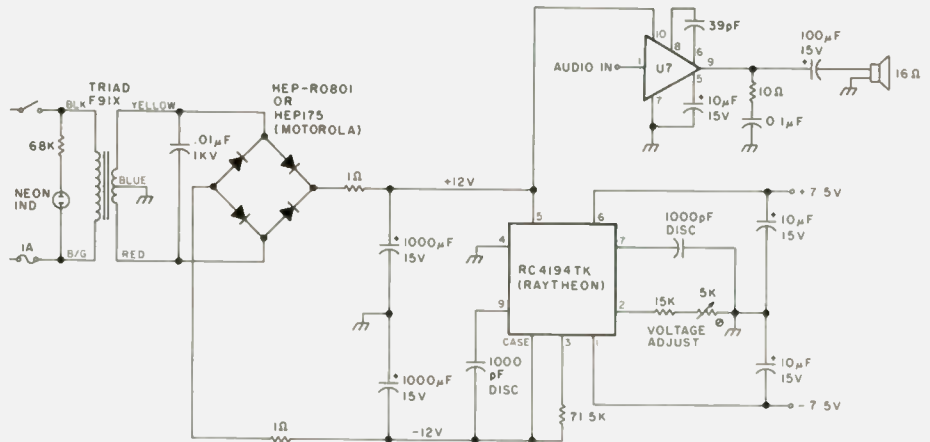

Fig. 12. Power supply and audio amp for zero-crossing code oscillator (use with Fig. 10 or 11). U7 = Motorola MC1454G, HEP593, HEPC6093G, MC1554G.

New Products

from page 253

an office conference table, perhaps the most practical and convenient of all the many items pressed into service over the years I have been an amateur. However, the conference table is now being relegated to more prosaic duty in my office-workroom. The reason for the table's retirement is my new S-F Radio Desk.

The S-F Radio Desk was clearly designed by an amateur for use by amateurs. It is a two-tiered affair with plenty of room for two HF transceivers and an amplifier, as well as my 2-meter rig, an antenna tuner, and a couple of other small accessories—without crowding or overloading. The rear of the bottom tier is angled so that equipment placed on it is tilted upward at the correct angle to provide comfortable viewing and ease of operation. Below the main desk surface is a convenient shelf for holding small accessories when not in use—logs, *Callbooks*, and all the other items that otherwise tend to clutter up the desktop.

Measuring 39 x 30 x 50 inch-

es, the Radio Desk is available in either teak or walnut finish, or unfinished birch veneer. Assembly is required. All hardware is supplied, and clear, easy-to-follow illustrated instructions make it simple to put together. The only unsupplied item I needed was a bit of Elmer's glue. Assembly went without a hitch and was completed by the time I had finished two cups of coffee. The finished desk is a mighty attractive addition to the shack and I wouldn't hesitate putting it in the living room for everyone to see.

If you could use an operating desk that will hold your equipment, improve your operating efficiency, and, at the same time, has sufficient eye appeal to satisfy the wife and rest of the family, you ought to be considering the S-F Radio Desk. The desk is priced at \$139.95 in teak or walnut finish, and \$124.95 in unfinished birch. Prices include shipping by UPS. S-F Amateur Radio Services, 4384 Keystone Avenue, Culver City CA 90230; (213) 837-4870. Reader Service

number S33.

Morgan W. Godwin W4WFL
Peterborough NH

NEW-TRONICS ENTERS 220-MHZ AMATEUR BAND WITH INTRODUCTION OF ALL-NEW 1 1/4-METER 7-DB-GAIN VERTICAL FIXED-STATION ANTENNA

The all-new Hustler 220-MHz vertical fixed-station amateur antenna, designated the Model G7-220, was recently introduced by New-Tronics Corpora-

tion of Brookpark, Ohio. The G7-220 marks New-Tronics' entry into the now-popular 220 MHz band and complements their existing base and mobile amateur antenna line. The superior 7-dB gain of the antenna, for both transmitting and receiving, makes it one of the most powerful omnidirectional 1 1/4 meter antennas available. The all-new rugged design of the Hustler G7-220 antenna keeps the signal radiation pattern at the lowest possible angle to the horizon, for maximum efficiency and longest range.

The Model G7-220 has an swr of 1.5:1 across its entire 5-MHz bandwidth, with swr at resonance of 1.2:1 at the antenna. The radiating elements of the Hustler G7-220 are dc-grounded for lightning protection, and the antenna has a 50-Ohm base impedance.

This new Hustler 220-MHz vertical antenna combines the latest antenna technology and the best available corrosion-resistant materials for extra-long life. Only Hustler uses all stainless steel hardware in amateur and professional products. Each component is precisely built for quick and easy assembly.

220 MHz
Vertical Antenna
Model G7-220



7 dB
Gain compared to 1/4 wave dipole

New-Tronics' new 220-MHz vertical Hustler antenna, the Model G7-220.

Continued on page 272

YOUR BEST BUYS IN KITS & FREQUENCY COUNTERS

6 GOOD REASONS FOR BUYING A HAL-TRONIX FREQUENCY COUNTER

(1) 100% COMPLETE KIT, (2) EASY ASSEMBLY, (3) COMPLETELY ENCLOSED IN METAL CABINET, (4) IC SOCKETS USED THROUGHOUT FOR EASY TTL REPLACEMENT (5) EASY ON YOUR POCKET BOOK, AND (6) NO EXPENSIVE CHIPS TO REPLACE (EXAMPLE—IF YOU LOSE A DECODER, LATCH OR DRIVE IN A HAL-TRONIX COUNTER, THE AVERAGE COST OF REPLACEMENT OF THE LOW-COST TTLS IS LESS THAN \$1.00 EXCLUDING THE PRE-SCALE CHIP. IN SOME OF THE NEWER COUNTERS NOW BEING MARKETED BY MY COMPETITION, THEY ARE USING THE EXOTIC SINGLE CHIP AND WOULD COST YOU CLOSE TO \$30.00 TO REPLACE). THIS IS SOMETHING YOU SHOULD CONSIDER.

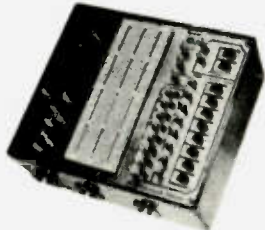

ANALOG-DIGILAB KIT \$139.50

DESIGNED BY HAL-TRONIX AND MIKE GOLDEN OF R.E.T.S. ELECTRONICS SCHOOL OF DETROIT. FOR RUGGED CLASSROOM USE.

FOR THE RADIO AMATEUR, STUDENT, EXPERIMENTER OR DESIGNER SPECIFICATIONS: OUTPUT VOLTAGES: +5V, +12V, -12V; USABLE CURRENT: 750mA; % Regulation at 500mA: 0.2%; Short-circuit limited at 1.0 amp; Thermal overload protected. Power requirements: 117VAC, 60HZ, 40 Watts. Function Generator: Frequency range: 1HZ to 100HZ in 5 bands. Amplitude adjustable from 0 to 10 VPP. DC offset adjustable from 0 to ± 10V. Waveforms: Sine, square, triangular and TTL Clock. TTL Clock 0 to +5V level, 200 ns rise and fall time. Frequency determined by Function Generator. Output impedance 1.2K ohm.

Most of all, it's easy to construct and service. PC boards are predrilled, plated thru and solder flowed. Over 1000 units sold to schools.



FROM HAL-TRONIX FIRST TIME OFFER

SIX-DIGIT ALARM CLOCK KIT for home, camper, RV, or field-day use. Operates on 12-volt AC or DC, and has its own 60-Hz time base on the board. Complete with all electronic components and two-piece, pre-drilled PC boards. Board size 4" x 3". Complete with speaker and switches. If operated on DC, there is nothing more to buy.

PRICED AT \$16.95
Twelve-volt AC line cord for those who wish to operate the clock from 110-volt AC. \$2.50

*Fits clock case advertised below.

TOUCH TONE DECODER KIT

HIGHLY STABLE DECODER KIT. COMES WITH 2 SIDED, PLATED THRU AND SOLDER FLOWED G-10 PC BOARD, 7-567's, 2-7402, AND ALL ELECTRONIC COMPONENTS. BOARD MEASURES 3 1/2 x 5 1/2 INCHES. HAS 12 LINES OUT. ONLY \$39.95

6-DIGIT CLOCK • 12/24 HOUR

COMPLETE KIT CONSISTING OF 2 PC G10 PRE-DRILLED PC BOARDS, 1 CLOCK CHIP, 6 FND 359 READOUTS, 13 TRANSISTORS, 3 CAPS, 9 RESISTORS, 5 DIODES, 3 PUSH-BUTTON SWITCHES, POWER TRANSFORMER AND INSTRUCTIONS. DON'T BE FOOLED BY PARTIAL KITS WHERE YOU HAVE TO BUY EVERYTHING EXTRA.

PRICED AT \$12.95

CLOCK CASE Available and will fit any one of the above clocks. Regular Price ... \$6.50 But Only \$4.50 when bought with clock

60-HZ TIME BASE CRYSTAL TIME BASE KIT. WILL ENABLE MOST ALL DIGITAL CLOCKS TO OPERATE FROM 12 VDC. LOW PROFILE UNIT, EASY 3-WIRE HOOKUP. ACC 2PPM, ADJUSTABLE. COST ONLY \$5.95 EACH OR 2 FOR \$10.00—OR ONLY \$4.50 WITH CLOCK PURCHASE.

10-MHz CRYSTALS HI-QUALITY CRYSTALS. DESIGNED FOR FREQUENCY CONTROL AND ELECTRONIC TIME PIECES. AGING FACTOR 5PPM. MEETS OR EXCEEDS MIL-C-3098 SPECS. MADE ESPECIALLY FOR HAL-TRONIX BY SENTRY. PRICE \$4.95 OR 2 FOR \$9.00



INTERSIL EVALUATION KIT

BUILD YOUR OWN D.V.M. or D.M.M. LOW COST DIGITAL PANEL METER DESIGN—KIT INCLUDES COMPLETE ASSEMBLY INSTRUCTIONS ALONG WITH A PREDRILLED P.C. BOARD, 4 LED READOUTS AND THE INTERSIL 7107 CHIP. ALONG WITH ALL REQUIRED ELECTRONIC PARTS TO COMPLETE KIT. ALL YOU NEED IS THE SUPPLY VOLTAGE. FEATURES FULL SCALE READING OF 200 MV OR 2.00V, HAS A CLOCK ON BOARD, WITH AUTO ZERO AND OVER RANGE FEATURES. \$19.95

ACCUKEYER (KIT) THIS ACCUKEYER IS A REVISED VERSION OF THE VERY POPULAR WB4VVF ACCUKEYER ORIGINALLY DESCRIBED BY JAMES GARRETT, IN QST MAGAZINE AND THE 1975 RADIO AMATEURS HANDBOOK. \$16.95

ACCUKEYER—MEMORY OPTION KIT THIS ACCUKEYER MEMORY KIT PROVIDES A SIMPLE, LOW COST METHOD OF ADDING MEMORY CAPABILITY TO THE WB4VVF ACCUKEYER. WHILE DESIGNED FOR DIRECT ATTACHMENT TO THE ABOVE ACCUKEYER, IT CAN ALSO BE ATTACHED TO ANY STANDARD ACCUKEYER BOARD WITH LITTLE DIFFICULTY. \$16.95

SHIPPING INFORMATION

ORDERS OVER \$15.00 WILL BE SHIPPED POSTPAID EXCEPT ON ITEMS WHERE ADDITIONAL CHARGES ARE REQUESTED. ON ORDERS LESS THAN \$15.00 PLEASE INCLUDE ADDITIONAL \$1.00 FOR HANDLING AND MAILING CHARGES. SEND SASE FOR FREE FLYER.

BY POPULAR DEMAND



— we are continuing to offer with any purchase of \$99 or more from ad or flyer, a Fairchild Clock Module FCS-8100A (suggested retail price of \$20).



look at these Summer Specials

COMPLETE KITS: CONSISTING OF EVERY ESSENTIAL PART NEEDED TO MAKE YOUR COUNTER COMPLETE. HAL-600A 7-DIGIT COUNTER WITH FREQUENCY RANGE OF ZERO TO 600 MHZ. FEATURES TWO INPUTS: ONE FOR LOW FREQUENCY AND ONE FOR HIGH FREQUENCY; AUTOMATIC ZERO SUPPRESSION. TIME BASE IS 1.0 SEC OR .1 SEC GATE WITH OPTIONAL 10 SEC GATE AVAILABLE. ACCURACY ± .001%, UTILIZES 10-MHZ CRYSTAL 5 PPM.

COMPLETE KIT ~~\$149~~ \$129

HAL-300A 7-DIGIT COUNTER WITH FREQUENCY RANGE OF ZERO TO 300 MHZ. FEATURES TWO INPUTS: ONE FOR LOW FREQUENCY AND ONE FOR HIGH FREQUENCY; AUTOMATIC ZERO SUPPRESSION. TIME BASE IS 1.0 SEC OR .1 SEC GATE WITH OPTIONAL 10 SEC GATE AVAILABLE. ACCURACY ± .001%. UTILIZES 10-MHZ CRYSTAL 5 PPM.

COMPLETE KIT ~~\$124~~ \$109

HAL-50A 8-DIGIT COUNTER WITH FREQUENCY RANGE OF ZERO TO 50 MHZ OR BETTER. AUTOMATIC DECIMAL POINT, ZERO SUPPRESSION UPON DEMAND. FEATURES TWO INPUTS: ONE FOR LOW FREQUENCY INPUT, AND ONE ON PANEL FOR USE WITH ANY INTERNALLY MOUNTED HAL-TRONIX PRE-SCALER FOR WHICH PROVISIONS HAVE ALREADY BEEN MADE. 1.0 SEC AND .1 SEC TIME GATES. ACCURACY ± .001%. UTILIZES 10-MHZ CRYSTAL 5 PPM.

COMPLETE KIT ~~\$124~~ \$109

ATTENTION RADIO CLUBS For club or group projects, request FREE information about our DISCOUNTS on any of the HAL-TRONIX kits. Discounts range from 10-25%, depending upon the quantity needed. We are experienced in supplying kits in volume quantities to schools, laboratories, clubs, and common-interest groups. Nobody beats HAL-TRONIX quality and price. Just try us and see for yourself.



FROM HAL-TRONIX

DELUXE 12-BUTTON TOUCHTONE ENCODER KIT utilizing the new ICM 7206 chip. Provides both VISUAL AND AUDIO indications! Comes with its own two-tone anodized aluminum cabinet. Measures only 2 3/4 x 3 3/4". Complete with Touch-Tone pad, board, crystal, chip and all necessary components to finish the kit.

PRICED AT \$29.95

For those who wish to mount the encoder in a hand-held unit, the PC board measures only 9/16" x 1 3/4". This partial kit with PC board, crystal, chip and components.

PRICED AT \$14.95

PRE-SCALER KITS

HAL 300 PRE \$19.95

(Pre-drilled G10 board and all components)

HAL 300 A/PRE \$24.95

(Same as above with preamp)

HAL 600 PRE \$34.95

(Pre-drilled G10 board and all components)

HAL 600 A/PRE \$39.95

(Same as above but with preamp)

SPECIAL OFFER—While they last

FND-70 Common cathode readouts direct replacement for the FND-359 same pin-out.

10 units (.40¢) — 10/ 4.00
100 units (.35¢) — 100/ 35.00
500 units (.30¢) — 500/150.00
1000 units (.25¢) — 1000/250.00



"HAL" HAROLD C. NOWLAND
WBZXH

HAL-TRONIX H24

P. O. BOX 1101
SOUTHGATE, MICH. 48195
PHONE (313) 285-1782

SF

S-f Amateur Radio Services

(213) 837-4870

4384 KEYSTONE AVE., CULVER CITY, CA. 90230

the W6TOG* ✓S33

RECEIVER MODIFICATION KITS

INCREASE SELECTIVITY • IMPROVE SENSITIVITY
LOWER INTERNAL NOISE
IMPROVE NOISE BLANKER OPERATION
COMBAT BLOCKING FROM LOCAL SIGNALS

TS-520 KIT	\$27.50	FT-101 SERIES KIT ...	\$32.50
TS-520S KIT	32.50	FR-101 SERIES KIT ...	34.50
TS-820 & 820S KIT ...	34.50	FT-301 SERIES KIT ...	34.50
R-599 A/D KIT	27.50	FT-901 SERIES KIT ...	34.50

EXPLICIT INSTRUCTIONS MAKE MODIFICATION A CINCH



IT'S MAGIC... IT'S "MAGICOM" PROCESSOR MODIFICATION KIT

IMPROVES AUDIO PUNCH
IMPROVES PROCESSED SPEECH QUALITY

Converts TS-820 / 820S speech processor from RF compressor to RF clipper \$27.50

RF speech processor for TS-520 / 520S \$42.50

The "MAGICOM" RF processor module provides up to 6dB increase in output with smooth, clean, non-distorted audio and more penetration for those pile-ups.

ENDORSED BY W6TOG AND BIG GUN DXers WORLD WIDE



the W6TOG*

INTERNAL ELECTRONIC KEYS

FOR ALL AMATEUR TRANSMITTERS OR TRANSCEIVERS USING GRID BLOCK KEYING

- No holes mounting with TS-820 Series
- Mounting options for TS-520, TS-520S, FT-101 Series, TR4 Series, T4X Series, T-599 Series and 32S Series.
- C-MOS DESIGN — Dot and dash memory — full iambic or manual operation.
- Simple installation \$49.50



THE S-F REJEKTOR FILTER

AN INTEGRATED CIRCUIT
ACTIVE BANDPASS FILTER
FOR PROCESSED RECEIVER AUDIO

- Separate active filter elements for CW and SSB audio output stage
- 8 ohm input and output impedance
- Headphone jack for convenience
- ON CW: from 500 hz to 100 hz, variable
- ON SSB: 2 Khz fixed bandwidth
- Rejects unwanted signal better than 60 dB
- Designed for today's transceivers or yesterday's older equipment \$49.50

* WELL KNOWN DXer WITH OVER 300 COUNTRIES CONFIRMED.

All prices postpaid - In Calif. add 6% sales tax - Mastercharge & Visa accepted

SATISFACTION GUARANTEED OR MONEY REFUNDED

ZZZ ELECTRONICS, INC.



Call Now For HAM Prices

We Sell & Service These Lines:

ICOM	Ameco
KLM	SAY Power Supplies
Dentron	B&W Switches
SWAN	Shore
KDK2015R	Integrated Electronics
TenTec	LARSEN
Wilson	ADI Auto Dialers
Telex	PanaVise
Hustler	Amphenol
Mosley	Aluma Towers
Cushcraft	And Many More

Special Prices On These Items Now:

ICOM 211	KLM 144-148-14
KDK 2015R	KLM 144-148-50
Ten Tec 570	RG8X COAX
Ten Tec 574	Dentron Big Dummy
Dentrol All Band	Dentron Jr. Monitor
Doublett	YAESU 7T101EE
SWAN TB4HA	ICOM 245SSB
SWAN TB3HA	SAY Elect. Power
Dentron MT2000A	Supplies
Dentron MT3000A	KLM 2-25B
ICOM 1C215	10' & 15' Roof Top
KLM 144-148-16	Tripods



We accept
MC & Visa & Interbank Cards
— will ship UPS C.O.D.
422 ARMOUR CIRCLE N E
ATLANTA GA 30324
(404) 876-0631
Come by or call
William/WA4SVY

TIMETRAC

By Comus

the microcomputer-controlled
appointment clock

NEW
First Time Offer

— NOT A KIT —
Regular Price \$79.95
Introductory Offer by
HAL-TRONIX
only \$69.95



FEATURES:

- Sleek modern styling to complement any home or office decor.
- Tells the time.
- Tells the date and year.
- Up-timer to 60 minutes, 59 seconds with pause.
- Alarm to ring at the same time everyday.
- Daily appointment sets appointments for the next 23 hours, 59 minutes.
- Future appointments up to one year.
- Dimmer switch for display.
- Memory will hold up to 30 appointments.
- Lithium power cell to retain memory during power outage.
- Appointments entered out of chronological order will be stored in chronological order.
- Colon flashes once each second.
- A.M./P.M. indicator.
- Plugs into any wall outlet.
- Easy to read vacuum fluorescent display.
- Extremely accurate quartz crystal clock.

EFFICIENT. REMARKABLE.

TimeTrac sold and distributed by HAL-TRONIX. Dealers welcome.

Send 15¢ stamp or S.A.S.E. for information and flyer on other HAL-TRONIX products. To order by phone: 1-313-285-1782.



"HAL" HAROLD C. NOWLAND
WBZXM

HAL-TRONIX ✓H24
P.O. Box 1101
Southgate, MI 48195

SHIPPING
INFORMATION:

ORDERS OVER \$15.00 WILL BE SHIPPED POSTPAID EXCEPT ON ITEMS WHERE ADDITIONAL CHARGES ARE REQUESTED. ON ORDERS LESS THAN \$15.00 PLEASE INCLUDE ADDITIONAL \$1.00 FOR HANDLING AND MAILING CHARGES.

RTTY made easy

WITH THE
NEW
TU-170
TERMINAL UNIT



Connect to your receiver speaker, transmitter microphone jack, and teletype machine and you're on the air. State of the art design features make the TU-170 ideal for HF and VHF autostat operation.

- Proved 170 Hz shift active filter demodulator
- Lighted tuning meter for easy tuning
- Current regulated loop keyer & power supply
- Autostat with threshold control and solid state relay
- Stable audio frequency shift oscillator produces phase coherent sine wave tones
- TTL compatible inputs and outputs for auxiliary equipment
- High level output for scope tuning

TU-170 Kit 149.95 TU-170 Wired 219.95

Flesher products . . . the critics choice!



✓F5
FLESHER CORP.



P.O. Box 976, Topeka, Kansas 66601 (913) 234-0198

N888 HAND-HELD HF/SSB

- 10 Watts PEP
- 2-9 MHz
- USB/LSB
- Rechargeable batteries
- Accessories

The N888 permits long range communications in difficult and adverse locations, thereby offering important communication advantages over AM and FM.

The smallest complete personal H.F. SSB communication system available.



NORTHERN RADIO COMPANY
COMMUNICATION PRODUCTS

14975 NORTHEAST 40TH, REDMOND, WASHINGTON 98052, USA
(206) 883-7700 TELEX 32-1160. CABLE ADDRESS: NORLECTRAD

✓N14



BARKER & WILLIAMSON, INC.

COAXIAL SWITCHES AND ACCESSORIES
for antenna selection and RF switching

Model	PRICE	Outputs	Remarks
375	18.95	6	PROTAX switch. Grounds all except selected output circuit.
376	18.95	5	PROTAX switch. Grounds all except selected output circuit. Sixth switch position grounds all outputs.
550A	14.00	5	
550A-2	12.50	2	
551A	17.50	2	Special 2 pole, 2 position switch used to switch any RF device in or out of series connection in a coaxial line. See figure (over).
556	.95	-	Bracket only, for wall mounting of radial connector switches.
590	17.95	5	
590G	17.95	5	Grounds all except selected output circuit.
592	16.50	2	
595	18.50	6	Grounds all except selected output circuit.

COAXIAL SWITCHES AND ACCESSORIES for antenna selection and RF switching. These high-quality switches have set the standard for the industry for years. Ceramic switches with silver alloy contacts and silver-plated conductors give unmatched performance and reliability from audio frequencies to 150 MHz. B&W coaxial switches are de-

signed for use with 52- to 75-ohm non-reactive loads, and are power rated at 1000 watts AM, 2000 watts SSB. Connectors are UHF type. Insertion loss is negligible, and VSWR is less than 1.2:1 up to 150 MHz. Crosstalk (measured at 30 MHz) is 45 dB between adjacent outlets and -60 dB between alternate outlets.



PA2501H Kit	2 mtr power amp—kit 1w in—25w out with solid state switching, case, connectors	64.95
PA4010H Kit	2 mtr power amp—10w in—40w out—relay switching	64.95
PA50/25 Kit	6 mtr power amp, 1w in, 25w out, less case, connectors & switching	54.95
PA144/15 Kit	2 mtr power amp—1w in—15w out—less case, connectors and switching	44.95
PA144/25 Kit	same as PA144/15 kit but 25w	54.95
PA220/15 Kit	similar to PA144/15 for 220 MHz	44.95
PA432/10 Kit	power amp—similar to PA144/15 except 10w and 432 MHz	54.95
PA140/10 W/T	10w in—140w out—2 mtr amp	219.95
PA140/30 W/T	30w in—140w out—2 mtr amp	189.95

POWER AMPLIFIERS



Model	BAND	Power Input	Power Output	Price
BLC 10/70	144 MHz	10W	70W	149.95
BLC 2/70	144 MHz	2W	70W	169.95
BLC 10/150	144 MHz	10W	150W	259.95
BLC 30/150	144 MHz	30W	150W	239.95
BLD 2/60	220 MHz	2W	60W	164.95
BLD 10/60	220 MHz	10W	60W	159.95
BLD 10/120	220 MHz	10W	120W	259.95
BLE 10/40	420 MHz	10W	40W	179.95
BLE 2/40	420 MHz	2W	40W	179.95
BLE 30/80	420 MHz	30W	80W	259.95
BLE 10/80	420 MHz	10W	80W	289.95

PS15C Kit	15 amp—12 volt regulated power supply w/case, w/fold-back current limiting and overvoltage protection	94.95
PS15C W/T	same as above—wired & tested	124.95
PS25M Kit	25 amp—12 volt regulated power supply w/case, w/fold-back current limiting and ovp, with meter	154.95
PS 25M W/T	same as above—wired & tested	179.95
O.V.P.	adds over voltage protection to your power supplies, 15 VDC max	12.95
PS3A Kit	12 volt—power supply regulator card with fold-back current limiting	10.95

POWER SUPPLIES



PS3012 W/T new commercial duty 30 amp 12 VDC regulated power supply w/case, w/fold-back current limiting and overvoltage protection 249.95

vhf engineering

The most convenient way to order! Just call our Credit Card Order Department 9AM-9PM at (617) 395-8280. Your order will be processed immediately—you'll be receiving it even more quickly than if you'd sent it by mail. Any way you look at it, our same-day service plus our special telephone credit card service equal the fastest way to shop by mail! (Sorry—we can't accept collect calls.) Helpful hint: To make your order as clear as possible, fill in all information on this order form, then read it when you call.



Name _____ Call _____

Address _____

City _____ State _____ Zip _____

Order: _____

_____ Check enclosed Visa Master Charge American Express _____

PRICES SUBJECT TO CHANGE WITHOUT NOTICE

Credit card # _____

Signature _____ Card expiration date _____

PLEASE — No Cash Or C.O.D.s!



Radio Electronics ✓ TS

209 Mystic Avenue
Medford MA 02155
(617) 395-8280

**Toll free:
(800) 225-4428**

OPEN DAILY 9-9
SATURDAY 9-6

Prices FOB Medford MA, MA residents add 5% sales tax.

Minimum \$3.00 for shipping & handling on ALL ORDERS.

MODEL	NET PRICE		
12V4	\$19.95	104R	\$49.95
102	\$24.95	108RA	\$79.95
107	\$28.95	108RM	\$99.95
103R	\$39.95	109R	\$149.95

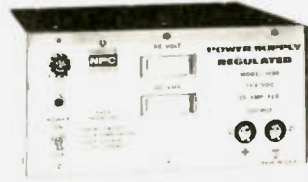

MODEL 108RM

NPC 12 Amp Regulated Power Supply Solid State 3 Way Protected Current Meter

This heavy duty unit quietly converts 115 volts AC to 13.6 volts DC ± 200 millivolts 8 amps continuous 12 amps max. All solid state. Features dual current overload and over-voltage protection. Ideally suited for operating mobile Ham radio 2 meter AM/FM SSB transceivers in your home or office. Can also be used to trickle charge 12 volt car batteries.

TYPICAL	MAXIMUM
Output Voltage	13.6 ± 2VDC
Line/Load Regulation	20 mV
Ripple/Noise	2 mV RMS
Transient Response	20 µSec
Current Continuous	8 Amp
Current Limit	12 Amp
Current Feedback	7.5 Amp
Overvoltage Protection	14.5 V
	15 V

Case 4½" (H) x 9" (W) x 8½" (D) Shipping Weight 15 lbs

MODEL 107

NPC 4 Amp Power Supply, 6 Amp Max. Solid State, Overload Protected

Functions silently in converting 115 volts AC to 12 volts DC. 4 amps continuous, 6 amps max. Enables anyone to enjoy CB radio, car B-track cartridge, cassette player or car radio in a home or office.

TYPICAL	MAXIMUM
Output Voltage (No Load)	12 V max.
Output Voltage (Full Load)	12 V min.
Filtering Capacitor	10,000 µF
Ripple (Full Load)	5 V RMS
Short Circuit Protection	Thermal Breaker

Case 3" (H) x 4½" (W) x 5½" (D) Shipping Weight 5 lbs

MODEL 103R

NPC 4 Amp Regulated Power Supply, Solid State, Dual Overload Protection.

Converts 115 volts AC to 13.6 volts DC ± 200 millivolts. Handles 2.5 amps continuous and 4 amps max. Ideally suited for applications where no hum and DC stability are important such as CB transmission, small Ham radio transmitter, and high quality eight-track car stereos. Can also be used to trickle-charge 12 volt car batteries.

TYPICAL	MAXIMUM
Output Voltage	13.6 ± 2VDC
Line/Load Regulation	20 mV
Ripple/Noise	2 mV RMS
Transient Response	20 µSec
Current Continuous	2.5 Amp
Current Limit	4 Amp
Current Feedback	1 Amp

Case 3" (H) x 4½" (W) x 5½" (D) Shipping Weight 4 lbs

MODEL 109R

NPC 25 Amp Regulated Power Supply 4 Way Protected Output Voltage and Current Meters

Extra heavy duty unit quietly converts 115 volts AC to 13.6 volts DC ± 200 millivolts 10 amps continuous 25 amps max. All solid state. Features dual current overload, overvoltage and thermal protection. Ideally suited for operating mobile Ham radio and linear amplifier in your home or office. Excellent bench power supply for testing and servicing of mobile communications equipment.

TYPICAL	MAXIMUM
Output Voltage	13.6 ± 2VDC
Line/Load Regulation	50 mV
Ripple/Noise	5 mV RMS
Transient Response	20 µSec
Current Continuous	10 Amp
Current Limit	25 Amp
Overvoltage Protection	14.5 V
Thermal Overload	160 F

Case 4½" (H) x 9" (W) x 8½" (D) Shipping Weight 15 lbs

MODEL 104R

NPC 6 Amp Power Supply Regulated Solid State Dual Overload Protection

Converts 115 volts AC to 13.6 volts DC ± 200 millivolts. Handles 4 amps continuous and 6 amps max. Ideally suited for applications where extreme DC stability is important, such as CB transmission, small Ham radio transmitter, and high quality eight-track car stereos. Can be used to trickle-charge 12 volt car batteries.

TYPICAL	MAXIMUM
Output Voltage	13.6 ± 2VDC
Line/Load Regulation	20 mV
Ripple/Noise	2 mV RMS
Transient Response	20 µSec
Current Continuous	4 Amp
Current Limit	6 Amp
Current Feedback	2 Amp

Case 3" (H) x 4½" (W) x 5½" (D) Shipping Weight 6 lbs

MODEL 12V4

NPC 1.75 Amp Power Supply 3 Amp Max.

Functions silently in converting 115 volts AC to 12 volts DC. Ideally suited for most applications including 8 track stereo, burglar alarm, car radio and cassette tape player within power rating.

TYPICAL	MAXIMUM
Continuous Current (Full Load)	1.75 Amp
Output Voltage (No Load)	12 V max
Output Voltage (Full Load)	12 V min
Filtering Capacitor	5,000 µF
Ripple (Full Load)	4 V RMS
Short Circuit Protection	Thermal Breaker

Case 3" (H) x 4½" (W) x 5½" (D) Shipping Weight 3 lbs

MODEL 102

NPC 2.5 Amp Power Supply 4 Amp Max. Solid State Overload Protected

Functions silently in converting 115 volts AC to 12 volts DC. 2.5 amps continuous, 4 amps max. Enables anyone to enjoy CB radio, car B-track cartridge, cassette tape player or car radio in a home or office.

TYPICAL	MAXIMUM
Continuous Current (Full Load)	2.5 Amp
Output Voltage (No Load)	12 V max
Output Voltage (Full Load)	12 V min
Filtering Capacitor	5,000 µF
Ripple (Full Load)	4 V RMS
Short Circuit Protection	Thermal Breaker

Case 3" (H) x 4½" (W) x 5½" (D) Shipping Weight 4 lbs



NEW
Jr. Monitor Antenna Tuner

- Continuous tuning 1.8—30 MHz
- Forward reading relative output power meter
- 300 watt power capability
- Built-in encapsulated balun
- Mobile mounting bracket

- Ceramic Rotary Switch 12-position
- Capacitor spacing 1000 volts
- Tapped toroid inductor
- Antenna inputs:
 - Coax unbalanced SO239
 - Random wire
 - Balanced feedline 75—660 Ohm
- 5½" w. x 2¾" h. x 6" d.
- All metal black wrinkle finish cabinet
- Weight: 2½ pounds
- Price: \$79.95

Denton

AUTOPATCH — Ready to go!

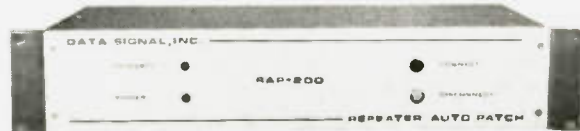

A Complete Autopatch facility that requires only a repeater and a telephone line. Features include single-digit access/disconnect, direct dialing from mobile or hand-held radios, adjustable amplifiers for transmitter and telephone audio, and tone-burst transponder for acknowledgement of patch disconnect.
RAP-200 P. C. Card
RAP-200R Rack Mount
\$199.50
\$249.50



- KLM RF Power Amplifiers**
- A simple, add-on-immediately Regulated Solid State Dual Overload Protection
 - Merely coax-connect amplifier between antenna and transceiver.
 - No tuning! Efficient strip-line broad band design.
 - Automatic! Internal RF-sensor-controlled relay connects amplifier whenever transmitter is switched on.
- Highest quality, American-made "brand" transistors are fully protected for VSWR, short and overload, reverse polarity. Highly effective heat sinking assures long life, reliable performance. Black anodized containers exclusive KLM extrusions, have seven, full length fins on both sides!
- Manual, remote-position switching is optional.
- Models for 6.2, 1¼ meters, 70CM amateur bands plus MARS coverage
 - Two types: Class C for FM/CW, Linear for SSB/AM/FM/CW.
 - Negligible insertion loss on receive.
 - American made by KLM.

New Model	List Price		
PA 2-25B	\$ 69.95	PA 4-70BC	189.95
PA 4-70BL	189.95	PA 15-60BC	164.95
PA 15-40BL	109.95	PA 45-120BC	209.95
PA 15-80BL	179.95	PA 4-40C	169.95
PA 15-160BL	259.95	PA 15-35CL	154.95
PA 45-140BL	219.95	PA 15-110CL	279.95

slinky

SLINKY! \$43.95 Kit A LOT of antenna in a LITTLE space New Slinky® dipole with helical loading radiates a good signal at 1/10 wavelength long!

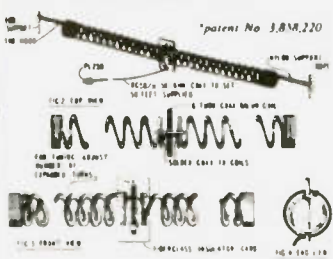

This electrically small 80/75, 40 & 20 meter antenna operates at any length from 24 to 70 ft. • no extra balun or transmatch needed • portable — erects & stores in minutes • small enough to fit in attic or apt. • full legal power • low SWR over complete 80/75, 40 & 20 meter bands • much lower atmospheric noise pick-up than a vertical & needs no radials • kit incl. a pr. of specially-made 4" dia. by 4" long coils, containing 335 ft. of radiating conductor, balun, 50 ft. RG58/U coax, PL259 connector, nylon rope & manual.

SOLAREX
SOLAR CELLS & SOLAR PANELS
in stock



Send for Catalog!

REPEATERS

RPT50 Kit	repeater—6 meter	499.95
RPT50	repeater—6 meter, wired & tested	799.95
RPT144 Kit	repeater—2 mtr—1Sw—complete (less crystals)	499.95
RPT220 Kit	repeater—220 MHz—1Sw—complete (less crystals)	499.95
RPT432 Kit	repeater—10 watt—432 MHz (less crystals)	\$79.95
RPT144 W/T	repeater—15 watt—2 mtr	799.95
RPT220 W/T	repeater—15 watt—220 MHz	799.95
RPT432 W/T	repeater—10 watt—432 MHz	849.95
DPLA50	6 mtr. close spaced duplexer	\$75.95
DPLA144	2 mtr, 600 KHz spaced duplexer, wired and tuned to frequency	379.95



DPLA220	220 MHz duplexer, wired and tuned to frequency	379.95
DPLA432	rack mount duplexer	319.95
DSC-U	double shielded duplexer cables with PL259 connectors (pr.)	25.00
DSC-N	same as above with type N connectors (pr.)	25.00

vhf engineering

ATB-34



4 ELEMENT BEAM

10-15-20 METERS

Cushcraft engineers have incorporated more than 30 years of design experience into the best 3 band HF beam available today. **ATB-34** has superb performance with three active elements on each band, the convenience of easy assembly and modest dimensions. Value through heavy duty all aluminum construction and a price complete with 1-1 balun.

SPECIFICATIONS			
FORWARD GAIN	EXCELLENT	LONGEST ELEMENT	32.8
F/B RATIO	30 dB	TURNING RADIUS	18.9
VSWR	1.5:1	WIND SFC	5.4 Sq Ft
POWER HANDLING	2000 WATTS PEP	WEIGHT	42 Lbs
BOOM LENGTH/DIA	18 x 2 1/8	WIND SURVIVAL	90 MPH

\$259.59

UPS SHIPPABLE complete

ENJOY A NEW WORLD OF DX COMMUNICATIONS WITH ATB-34

Hy-Gain REEL TAPE PORTABLE OIPOLE for 10 thru 80 Meters Model 18TD

The most portable high performance dipole ever...

The Model 18TD is unquestionably the most foolproof high performance portable doublet antenna system ever developed. It has proven invaluable in providing reliable communications in vital military and commercial applications throughout the world. Two stainless steel tapes, calibrated in meters, extend from either side of the main housing up to a total distance of 132 feet for 3.5 mc operation. 25 ft. lengths of polypropylene rope attached to each tape permits installation to poles, trees, buildings... whatever is available for forming a doublet antenna system. Integrated in the high impact housing is a frequency to length conversion chart calibrated to meter measurements on the tapes... makes installation foolproof. Feeds with 52 ohm coax. Delivers outstanding performance as a portable or permanent installation. Measures 10x5x2 inches retracted. Wt., 4.1 lbs. Order No. 228 Price: \$94.95

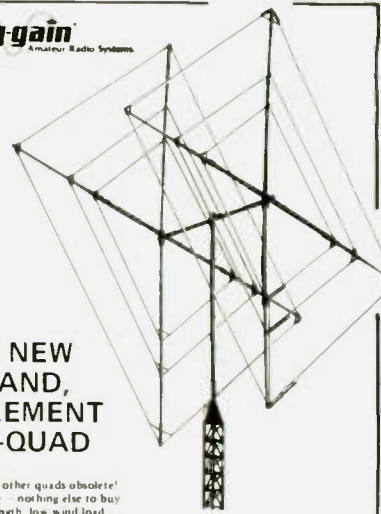

ALL NEW 3-BAND, 2 ELEMENT HY-QUAD

● Makes all other quads obsolete!
 ● Complete - nothing else to buy
 ● High strength, low wind load
 The Hy-Quad from Hy-Gain makes all other quads obsolete! Here's why. First, it's the only quad that is complete. There is nothing more to shop for or buy. Secondly, it is uniquely designed so that it overcomes all of the previously undesirable features inherent in quads. The all aluminum structure stays up! The angle feed line and diamond shape simplifies feed line routing. Hy-Gain's all new Hy-Quad will outdo all other quads because it's engineered to do just that. The Hy-Quad is new, it's superior, it's complete. It's the first quad to have everything... spreaders are broken up at strategic electrical points with Cycloc insulators / tri-band 2 element construction with individually resonated elements with no interaction / Hy-Quad requires only one feed line for all three bands / individually tuned gamma matches on each band with Hy-Gain exclusive vertex feed / full wave element loops require no tuning stubs, traps, loading coils or baluns / heavy duty mechanical construction of strong swaged aluminum tubing and die formed spreader-to-boom clamps / extra heavy duty universal boom to mast clamp that fits and mounts on any mast 1 1/4" to 2 1/2" in diameter / aluminum stranded wire. You can open and close the bands with this antenna. You'll experience the thrill of real DX.

Order No. 244 Price: \$219.95

SPECIFICATIONS

Overall length of spreaders	25.5'	Forward gain	8.5 db
Turning radius	13'6"	Input impedance	52 ohms
Weight	42 lbs	VSWR	1.2:1 or better at resonance on all bands
Boom diameter	2"	Power	Maximum legal
Boom length	8'	Front-to-back ratio	25-35 db
Mast diameter	1 1/4" to 2 1/2"	Surface area	6.4 sq ft
Wind survival	100 mph	Wind load at 100 mph	256.0 lbs
Surface area	6.4 sq ft	Polarization	Horizontal

HY-GAIN'S INCOMPARABLE HY-TOWER FOR 80 THRU 10 METERS



Model 18HT

- Outstanding Omni-Directional Performance
- Automatic Band Switching
- Installs on 4 sq. ft. of real estate
- Completely Self-Supporting

By any standard of measurement, the Hy-Tower is unquestionably the finest multi-band vertical antenna system on the market today. Virtually indestructible, the Model 18HT features automatic band selection on 80 thru 10 meters through the use of a unique stub decoupling system which effectively isolates various sections of the antenna so that an electrical 1/4 wavelength (or odd multiple of a 1/4 wavelength) exists on all bands. Fed with 52 ohm coax, it takes maximum legal power... delivers outstanding performance on all bands. With the addition of a base loading coil, it also delivers outstanding performance on 160 meters. Structurally, the Model 18HT is built to last a lifetime. Rugged hot-dipped galvanized 24 ft. tower requires no guyed supports. Top mast, which extends to a height of 50 Ft., is 6061ST6 tapered aluminum. All hardware is iridite treated to MIL specs. If you're looking for the epitome in vertical antenna systems, you'll want Hy-Tower, Shpg. Wt., 96.7 lbs. Order No. 182, Price: \$279.95. NEW Special hinged base assembly on Model 18HT allows complete assembly of antenna at ground level... permits easy raising and lowering of the antenna.

MULTI-BAND HY-Q TRAP DOUBLET'S Hy-Q Traps

- Install Horizontally or as Inverted V
- Super-Strength Aluminum Clad Wire
- Weatherproof Center and End Insulators

Installed horizontally or as an inverted V, Hy-Gain doublets with Hy-Q traps deliver true half wavelength performance on every design frequency. Matched traps, individually pretuned for each band feature large diameter coils that develop an exceptionally favorable L/C ratio and very high Q performance. Mechanically superior solid aluminum trap housings provide maximum protection and support to the loading coil. Fed with 52 ohm coax, Hy-Gain doublets employ super-strength aluminum clad single strand steel wire elements that defy deterioration from salt water and smoke... will not stretch... withstand hurricane-like winds. SWR less than 1.5:1 on all bands. Strong, lightweight, weatherproof center insulators are molded from high impact cyolac. Hardware is iridite treated to MIL specs. Heavily serrated 7-inch end insulators molded from high impact cyolac increase leakage path to approximately 12 inches.

MODEL 2BDQ for 40 and 80 meters. 100' 10 1/2" overall. Takes maximum legal power. Shpg. Wt., 7.5 lbs \$49.95 Order No. 380
 MODEL 5BDQ for 10, 15, 20, 40 and 80 meters. 94' overall. Takes maximum power. Shpg. Wt., 12.2 lbs. \$79.95 Order No. 383



Meet the SuperTuner

1KW Model \$129.50



The DenTron Super Tuner tunes everything from 160-10 meters. Whether you have balanced line, coax cable, random or long wire, the Super Tuner will match the antenna impedance to your transmitter. All DenTron tuners give you maximum power transfer from your transmitter to your antenna, and isn't that where it really counts?



- Model TA-33, 3 elements, 10.1 dB forward gain (over isotropic source) - \$264.00
- Model TA-33 Jr., 3 elements, 10.1 dB forward gain (over isotropic source) - \$197.00
- Model MPK-3, 7500 Watts AM/CW and 2000 Watts P.E.P. SSB - \$52.25
- Model TA-36, 6 elements - \$392.75
- AK-60 mast plate adapter - \$14.50
- Model CL-33, 3 elements - \$304.75
- Model CL-36, 6 elements - \$392.75
- Model CL-203, 3 elements - \$290.00
- Model TA-40 KR - 40 meter conversion kit - \$119.50

TELEX PROFESSIONAL HEADPHONES & HEADSETS

ROOM MIC HEADSETS

For the ultimate in communications convenience and efficiency, select a boom mic headset. Long-time favorites of professional communicators, boom mic headsets allow more freedom of movement while always keeping the mic properly positioned for fast, precise voice transmission. Boom microphones are completely adjustable to allow perfect positioning. And, boom mic headsets leave both hands free to perform other tasks.

All models are supplied with "close talking" microphones to limit ambient noise pick-up and provide superior intelligibility. Each model has a convenient "mute push to talk" switch, which can be wired for either push to talk relay control or mic circuit interrupt for voice operated transmitters. The switch may be used as a momentary push button or it can be locked in the down position. All models have tough, flexible 1/2 foot cords which are strapped and trimmed. Communication grey with black trim.

MODEL	C 610	SWL 610	C 1210	C 1320	CM 610	CM 1210	CM 1320	CM 1320S
Headphone Sensitivity Ref. 0007 Dynes/cm ² 1mW input 1kHz	103dB SPL +5dB	103dB SPL +5dB	103dB SPL +3dB	105dB SPL +5dB	103dB SPL +5dB	103dB SPL +3dB	105dB SPL +5dB	105dB SPL +5dB
Headphone Impedance	32 20 ohms	2000 ohms	32 20 ohms	32 20 ohms	32 20 ohms	32 20 ohms	32 20 ohms	32 20 ohms
Microphone Frequency Response				50 8000 Hz	50 8000 Hz	50 8000 Hz	50 8000 Hz	50 8000 Hz
Microphone Impedance				High	High	High	High	High
Microphone Sensitivity Below 1 volt/microbar at 1kHz				51dB +5dB	51dB +5dB	51dB +5dB	51dB +5dB	51dB +5dB
Price	\$10.45	\$12.25	\$29.70	\$41.80	\$47.20	\$62.75	\$75.25	\$59.95



Model C610 (SWL 610) Model C 1320 Model CM 610 Model C 1210
Model CM 1210 Model CM 1320 Model CM 1320S

the indispensable BIRD 43 THRU LINE WATTMETER



Power Range	Frequency Bands (MHz)				
	2-30	25-100	100-250	250-500	400-1000
5 watts	1A	1C	5D	5E	
10 watts	10A	10C	10D	10E	
25 watts	25A	25C	25D	25E	
50 watts	50A	50C	50D	50E	
100 watts	100A	100C	100D	100E	
250 watts	250A	250C	250D	250E	
500 watts	500A	500C	500D	500E	
1000 watts	1000A	1000C	1000D	1000E	
2500 watts	2500A	2500C	2500D	2500E	
5000 watts	5000A	5000C	5000D	5000E	

MODEL 43
 Elements (Table 1) 2-30 MHz \$125.00
 Elements (Table 1) 25-1000 MHz 45.00
 Carrying case for Model 43 & 6 elements 27.50
 Carrying case for 12 elements 17.00

READ RF WATTS DIRECTLY! (Specify Type N or SO239 connectors) 0.45 - 2300 MHz, 1-10,000 Watts ±5%, low insertion VSWR - 1.05. Unequaled economy and flexibility. Buy only the element(s) covering your present frequency and power needs, add extra ranges later if your requirements expand.

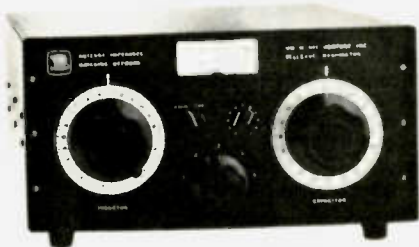

Model MB II \$285 (with Balun) \$315

MB II provides:
 * Constant SWR monitoring * Precision tuning of final amp * Harmonic suppression
 * Receiver input impedance-matching * Maximum power transfer to antenna * Continuous frequency coverage 16 to 30 MHz * Precision tuning of any wire 1/2 wavelength or longer, with SWR of 1:1

MB II features:
 * Finest quality, made-in-USA components * Large, precision, easy-to-read dials with 360° readout * Optional 3000 watt Balun for twin lead antennas

BOMAR

TWO METER CRYSTALS

Standard / Icom / Heathkit / Ken / Clegg / Regency / Wilson / VHF Eng. / Drake / Motorola HT 220 - and others! \$4.50.

LIFETIME GUARANTEE!
NOW ONLY \$8.00 A PAIR!

Why Waste Watts?

SWR - 1A \$29.95

SWAN ELECTRONICS

SWR-1 guards against power loss! If you're not pumping out all the power you're paying for, our little SWR-1 combination power meter and SWR bridge will tell you so. You read forward and reflected power simultaneously, up to 1000 watts RF and 1:1 to infinity VSWR at 3.5 to 150 MHz.

Got it all tuned up? Keep it that way with SWR-1. You can leave it right in your antenna circuit.

HF VERTICALS 10 through 80 METERS

EFFICIENT TOP RING
 FIBERGLASS TRAP FORMS
 ENAMELED WIRE COILS
 SOLID ALUMINUM CAPACITORS
 NO TUNING REQUIRED
 FULL COMPRESSION CLAMPS
 OMNIDIRECTIONAL COVERAGE
 REINFORCED BASE
 MAST OR GROUND MOUNTING
 PRE-MARKED SECTIONS
 EASY ASSEMBLY
 SUPERIOR QUALITY

3 BAND 20-15 TO 10 METERS MODEL ATV 3 \$49.95
 4 BAND 40-20 TO 10 METERS MODEL ATV 4 \$69.95
 5 BAND 80-20 TO 10 METERS MODEL ATV 5 \$109.95

DELUXE RECEIVER PREAMPLIFIERS

Ideal for Receivers - Converters
 High Gain - Low Noise

SPECIFICATIONS:
 Power: 6 VDC to 18 VDC (12 VDC recommended)
 Size: a. Single stage: 1" x 1 1/4" x 1/2"
 b. Double stage: 2" x 1 1/4" x 1/2"
 MOSFET: FT 0601, 500 MHz, dual-gate diode protected MOSFET

FEATURES:
 • Small size
 • Increases sensitivity of most receivers
 • Gold-plated copper shielding
 • Single or double stage models
 • Diode protected, dual-gated FETs

When ordering be sure to specify:
 1. frequency of operation
 2. single or double band stage
 3. kit or assembled version

FREQ. (MHz)	USE	STAGES	DELUXE PREAMPLIFIER GAIN dB	NF dB	WIRED
50 to 54	6 METER	SINGLE	25	2	\$15.50
		DOUBLE	48	2	\$28.50
108 to 144	VHF AIRCRAFT	SINGLE	20	2.5	\$14.50
		DOUBLE	40	2.5	\$26.50
135 to 139	SATELLITE	SINGLE	20	2.5	\$14.50
		DOUBLE	40	2.5	\$26.50
144 to 148	2 METER	SINGLE	20	2.5	\$14.50
		DOUBLE	40	2.5	\$26.50
146 to 174	HIGH BAND	SINGLE	20	2.5	\$14.50
		DOUBLE	40	2.5	\$26.50
220 to 225	1 1/4 METER	SINGLE	18	2.5	\$14.50
		DOUBLE	35	2.5	\$26.50
225 to 300	UHF AIRCRAFT	SINGLE	15	2.5	\$14.50
		DOUBLE	30	2.5	\$26.50

DATA SIGNAL, INC.

DRAKE TV FILTERS

High Pass Filters for TV sets provide more than 40 dB attenuation at 52 MHz and lower. Protect the TV set from amateur transmitters 6-160 meters.

Drake TV-75-HP \$13.25
 Model No. 1610. For 75 ohm TV coaxial cable; TV type connectors installed

LOW PASS FILTERS FOR TRANSMITTERS have two pi sections for sharp cut off below channel 2, and to attenuate transmitter harmonics falling in any TV channel and fm band. 52 ohm. SO-239 connectors built in.

Drake TV-300-HP \$10.60
 Model No. 1603. For 300 ohm twin lead

Drake TV-3300-LP Model 1608
 1000 watts max. below 30 MHz. Attenuation better than 80 dB above 41 MHz. Helps TV i-f interference, as well as TV front-end problems. \$26.60

Drake TV-5200-LP Model No. 1609. 200 watts to 52 MHz. Ideal for six meters. For operation below six meters, use TV-3300-LP or TV-42-LP. \$26.60

Drake TV-42-LP Model No. 1605 is a four section filter designed with 43.2 MHz cut-off and extremely high attenuation in all TV channels for transmitters operating at 30 MHz and lower. Rated 100 watts input. \$14.60

TUFTS RADIO CATALOG TUFTS RADIO

PCs Are Easy

—step-by-step details

The vast decrease in the cost of integrated circuits over the past five years has opened a totally new frontier for the electronic experimenter. Magazines, such as this one, offer a multitude of projects designed to whet the appetite of the most reluctant builder. These articles invariably offer schematic diagrams, parts lists, suppliers, and full or half-size printed circuit board layouts. Herein lies the crunch of the printed circuit board.

The avid experimenter, through frustration, usually ends up buying a commercially-made printed circuit board at a rather high price. This will obviously yield the desired result, a good-looking finished product. There is not, however, the self-satisfaction of having done it all by one's self.

An alternate and less acceptable method is to attempt to hard wire everything on the back of a piece of vectorboard. (Vectorboard is made of a

nonconductive material which has prepunched holes so that component leads may be passed through and soldered on the other side of the board.) I cannot think of any reason why the completed project should not work well, if reasonable care is taken in parts layout and soldering. Aesthetically, however, it leaves much to be desired.

Where do you go from here? There is only one obvious step, and that is to make your own.

Before I get into actual construction methods, perhaps I might discuss briefly just what is involved in making a printed circuit (PC) board.

The basic PC board is composed of a thin layer of copper coating on one or both sides of fiberglass or other nonconductive material. To obtain the desired circuit layout, it must be reproduced on the PC board using some type of "resist." (Resist is the coating which inhibits the etching process.) Once you have a perfect layout, the

unwanted copper between the traces must be removed. This process is called "etching." Ferric chloride solution is most commonly used and will remove the unwanted copper in short order. All that remains then is to clean up the board, drill a few holes, and solder on the components. Sound easy? It is. Well, almost that easy! There is still one big problem: How do you get the circuit onto the board before you etch it?

There are two answers to that question. The circuit layout can either be drawn onto the board or it can be done photographically. Both of these methods will be covered later in this article.

Procedure

To begin, there are four basic steps in the manufacture of circuit boards:

Step 1: Procure the blank circuit board.

Step 2: Reproduce the circuit board layout on the board with resist.

Step 3: Etch the PC

board.

Step 4: Clean and drill the board.

Now, let's deal with each step in turn and get down to the how-to-do-it stage. First, you must obtain a piece of blank circuit board of sufficient size for your project. Size is not as important as the thickness of both the copper and the insulating backing. Thin copper will etch off much faster, which is helpful, but it may not withstand as much heat during soldering. The thickness of the board must be considered when mounting heavy components such as transformers, etc. You do not want a warped board!

Having satisfied yourself as to the choice of board, the next step is to clean it before applying the resist. (I cannot emphasize enough that the board must be clean!) The surface should be scoured thoroughly using a steel wool soap pad. Absolutely all of the oxidation must be removed and the board left in a bright, shiny condition. After scouring, the board

must be rinsed thoroughly under hot tap water to remove any soap residue. Dry it with a clean, soft cloth, being careful not to touch the surface with your hands as this will leave an oily film which could affect the application of the resist.

Setting the clean board aside temporarily, you must decide which method to use in applying the resist. There are two choices available—the freehand and the photographic methods.

The freehand method requires that the connecting foils be drawn on the clean board by hand with a resist pen. Positioning your copy of the full-size layout on the blank circuit board and fastening it securely with Scotch™ tape, still being very careful not to touch the copper, take a sharp center punch or awl and gently, very gently, mark all of the holes by punching through the paper. When this has been done and the paper removed, a clear mark should be left where the components will eventually be positioned. From now on, the neatness of the board is determined by how carefully the marks are connected. The holes should not be drilled now since the etchant could undercut around them and ruin your efforts. For the very fine lines, a resist pen is recommended. This looks very much like an ordinary magic marker; however, the ink is resistant to ferric chloride solution. These pens are not really suitable for the larger areas for which resist is sold in bottles and applied with a brush. Every area of copper you wish to retain must be thoroughly coated with resist. It isn't necessary to use commercially-sold resist, since many pens of the waterproof-ink variety will work just as well, as will nail polish, for the larger areas.

At times, it gets difficult to draw fine lines and integrated circuit patterns which are very small and so often required. There are all types of decals, rubber stamps and drawing aids sold to help with this problem. For the larger and less complicated circuits, this method is best because it is quick and does not require a lot of equipment, just patience and a steady hand. The biggest drawback to this method must now be apparent.

What do you do, though, if a full-size layout is not available? A very complicated circuit can become a nightmare! Now is the time to investigate the photographic method.

Assuming that everyone at one time or another has seen a black and white negative, you should realize that it is really not black and white at all, but mostly made up of varying tones of grey. This is not good enough for these purposes. What you need is a full-size negative of only two tones, black and perfectly clear. This is accomplished by using lithographic film. Commercially, it is sold by Kodak (Kodalith) and Ilford (Ilfolith), both of which will serve your needs if the manufacturer's directions are carefully followed when using these films.

The first step in making a full-size working negative is to take a black and white picture of the circuit board in the magazine with a camera and close-up attachment. The layout must be kept perfectly flat and the camera level and parallel to it. Care in this part of the procedure will keep all of the lines in their proper perspective and to scale.

One magazine (that I know of) does not give a true black and white circuit layout. Instead, they use grey, and show the components overlaid in red ink. This does not pre-

sent much of a problem. Simply by placing a deep red filter over the camera lens, presto, the components disappear and the grey lines appear black. Because you need the small negative to make the big one, your film has to be processed. The next steps require the use of an enlarger and darkroom, so now is the time to enlist the aid of the local camera club if this equipment is not readily accessible.

You now progress into the darkroom where you'll be using the special "lith" film mentioned earlier. Lithographic film requires special safelights and developer, so following the manufacturer's directions is a must. Placing the negative into the enlarger, project the image onto the easel and focus it perfectly. You must project the image the exact size of the printed circuit board you desire, or none of the components will fit. This is quite easily accomplished. Simply place the full-size magazine layout, photographed earlier, under the enlarger and adjust the projected image until both are exactly the same size. If the layout was only half scale to begin with, you will have to measure the size of some known component and adjust the image to suit. The enlarger is switched off and the magazine layout is removed from under the enlarger and replaced with a piece of lithographic film. Exposure for the film may vary, but a figure of thirty seconds is a good starting point. The exposed film is placed in the developer for about one and a half minutes, stop bath for fifteen to thirty seconds, and then fixed according to the instructions. Before turning on the lights, you must put away the rest of the lith film. The wet full-size positive must now be washed and allowed to dry.

The next part of the process is relatively easy. After the full-size has dried, you can make the full-size negative that you were after in the first place. The positive is placed on top of a sheet of lith film (again in the darkroom) and a clean sheet of glass placed on top. The glass will keep everything flat, while you make a contact negative by exposing the film to light. A 60-Watt lamp held two feet above the film for 15 seconds is approximately the right amount of time. The film is processed as before, and, while it dries, carry on with the next step, the preparation of the circuit board.

In order to transfer the image of the full-size negative to the circuit board, you must first coat it with "etchant resist sensitizer." This type of resist, available in an aerosol spray can, when deposited on the circuit board, makes it sensitive to light much like a photographic paper, except in this case it is most sensitive to ultraviolet light. The spraying of the circuit board must be done in the darkroom under a safelight with adequate ventilation. Starting from the bottom, spray the board evenly, holding the can about 5 to 8 inches away. The resist looks like a thin lacquer with a purplish tint to it. The excess is allowed to run off by holding the circuit board vertically by the edges. Now put it away to dry overnight, somewhere where it will not be exposed to light.

The time has now arrived to expose the circuit board to ultraviolet (UV) light. Carefully, the full-size negative is placed over the treated circuit board in the darkroom and covered with the sheet of glass to hold it flat. In order to expose it to ultraviolet light, the board should be placed outside in the sun

about one and a half minutes or under a sun lamp. (I use a sun lamp about 18 inches above the board and expose for 1 minute.)

The PC board is brought back into the darkroom and developed in "photo-etching developer." This chemical dissolves the resist which was not exposed to UV light. After careful washing, the board is allowed to dry. (For safety's sake, read and follow all instructions on both the resist and developer containers because they are both highly toxic and volatile chemicals requiring a lot of ventilation.)

After taking one last look and possibly touching up an area or two with the resist pen, you now are ready to actually etch the circuit board using ferric chloride solution. (Take my word for it, ferric chloride solution is a highly cor-

rosive substance which will eat its way through the copper, the concrete floor, or, as I found out, the outside of my wife's washing machine. Wear gloves and eye protection, and follow the instructions to the letter!)

Having chosen a glass tray, not metal, of appropriate size, pour in the ferric chloride solution to a depth of about three quarters of an inch. The solution is used at room temperature and, again, inhalation of the fumes should be carefully avoided. The PC board is placed into the ferric chloride solution face up and agitated gently by raising and lowering the tray about one inch. The etching process will take about one half hour, so patience is the key word here.

When sufficient time has elapsed, the PC board is removed from the solution

and the etchant gently washed off under running water. By holding the board up to the light, you can see if all the unwanted copper has been removed. If not, replace the PC board in the etchant and continue agitation. The completely-etched board will have to be scoured with the soap pad again to remove all the resist. There are chemical removers, but this is the easiest way and makes the board easy to solder, too.

Steps 1, 2, and 3 were the hardest, and drilling the board is child's play in comparison. The only trick here is to use the correct size of drill bit (see the drill guide in Table 1) to fit the electronic components. A drill press is an asset,

although not a necessity; a little care will go a long way.

All of the items used in this article are available in most areas from the local electronics supplier. The resist, developer, and etchant will run about \$15.00, but that will do many, many PC boards. The lithographic film costs about \$30.00 for fifty 8" x 10" sheets. It is definitely more expensive to make the PC boards photographically, but the results certainly justify the expense if more than one board is going to be made.

Thus, with a little time and effort, home manufacture of printed circuit boards can be both relatively easy and definitely self-satisfying. ■

Number 65 drill	#20 AWG wire; Molex pin; ¼-Watt resistor
Number 60 drill	½-Watt resistor
Number 56 drill	1- or 2-Watt resistors; IC sockets

Table 1. Drill guide.

New Products

from page 262

The 122"-long vertical element and four 14 3/4"-long radials of the G7-220 are made from high-strength heat-treated aluminum. Each radial has a 3/16" o.d. The G7-220's N-type connector, used on all new Hustler amateur verticals, provides a tight all-weather seal and virtually perfect rf characteristics under all conditions.

The G7-220 weighs only 7 pounds, and is easily mounted on any capable vertical support of up to 1 3/4" o.d. The wind loading of the antenna is only 26 pounds at 100 mph velocities.

For further information on this or other Hustler products, write: Sales Department, New-Tronics Corporation, 15800 Commerce Park Drive, Brookpark OH 44142. Reader Service number N2.

BELDEN INTRODUCES TWO NEW LOW-NOISE COAXIAL CABLES

For high-impedance applications, including test leads and instrumentation, Belden Corporation's Electronic Division

has introduced two low-noise coaxial cables.

The two are a 174/U-type with 26-gauge stranded conductor (no. 9239), and a 59/U-type with a 22-gauge solid conductor (no. 9224). Construction details include bare copper-covered steel conductors, polyethylene insulation, and a conductive layer. Shielding for the 9224 is an 88%-coverage tinned copper braid; for the 9239, it's a bare copper braid with 93% coverage. Both utilize a black vinyl jacket with overall diameters of .101 inch (9239) and .242 inch (9224).

Electrical specifications: nominal capacitance—no. 9239, 39.3 pF/ft.; no. 9224, 21 pF/ft.

Both low-noise coaxial cables are available in 100-, 500-, and 1,000-ft. putups; no. 9224 also is available in Unreel®-packed 500- and 1,000-ft. lengths.

For additional information, write: Manager, Marketing Communications, Belden Corp., 2000 S. Batavia Ave., Geneva IL 60134. Reader Service number B41.

NEW DUAL OPERATIONAL AMPLIFIER FROM SIGNETICS OFFERS LOW NOISE AND WIDE BANDWIDTH

A dual low-noise general-purpose operational amplifier offering a wider bandwidth and improved output drive capability compared to standard op amps is now available from Signetics.

Designated the NE5533, the device is capable of driving 10 V (rms) into 600 Ohms directly and features a small-signal bandwidth of 10 MHz and power bandwidth of 200 kHz.

The 5533 is internally compensated for gain equal to or

higher than +3. Frequency response can be optimized with an external compensation capacitor for applications requiring it.

Other specifications of the 5533 include: dc voltage gain, 100,000; ac voltage gain, 6,000 at 10 kHz; and supply voltage range, ±3 to ±20 V. The 5533 comes in a standard 14-pin dual-in-line package.

For further information, contact: Guy Caputo, Industrial Marketing Manager, Signetics, 811 East Arques Avenue, PO Box 9052, Sunnyvale CA 94086; (408)-739-7700. Reader Service number S70.

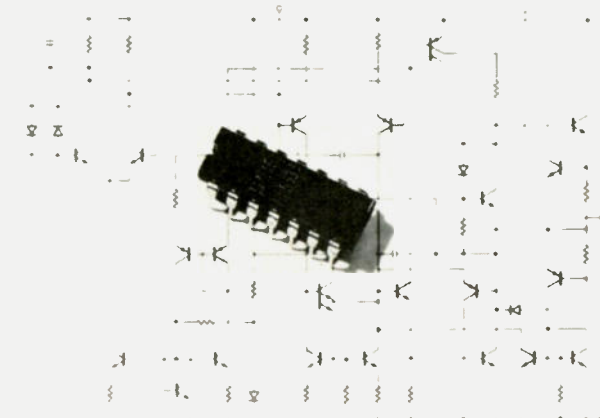

Signetics' new NE5533 dual op amp.

You're just a few digits away from name brand radio equipment - AT DISCOUNT PRICES!

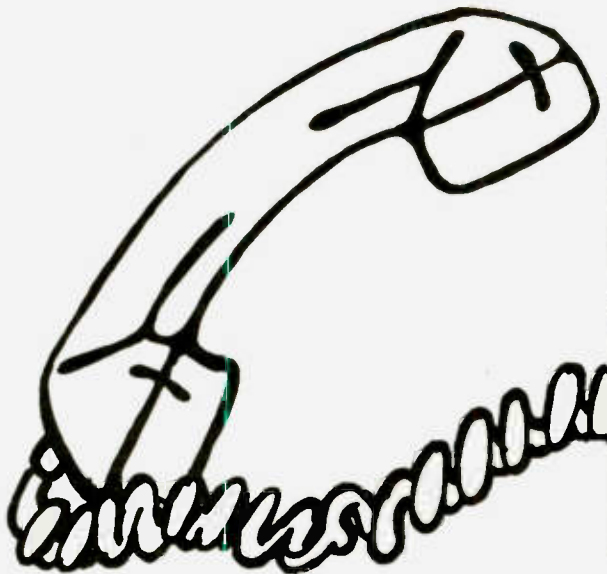

CALL TOLL FREE

1-800-228-4097
Communications Center

443 N 48th Street
Lincoln, Nebraska 68504
In Nebraska Call (402)466-8402

1-800-634-6227
**Communications Center
West**

1072 N. Rancho Drive
Las Vegas, Nevada 89106
In Nevada Call (702)647-3114

YAESU
KENWOOD
DRAKE
ICOM
STANDARD
EDGE COM
KDK

DENTRON
HY-GAIN
MOSLEY
CUSHCRAFT
WILSON
HUSTLER
LARSEN

TAYLOR
SWAN
TEMPO
TEN-TEC
MIDLAND
CDE
AUTEK

E.T.O. ALPHA
VHF ENGINEERING
BERK-TEK CABLE
CONSOLIDATED TOWER
SAY
SHURE
TELEX

plus many more

We carry all major lines of Antennas at Discount Prices

look

OUR NEW HOURS
at Lincoln store only

look

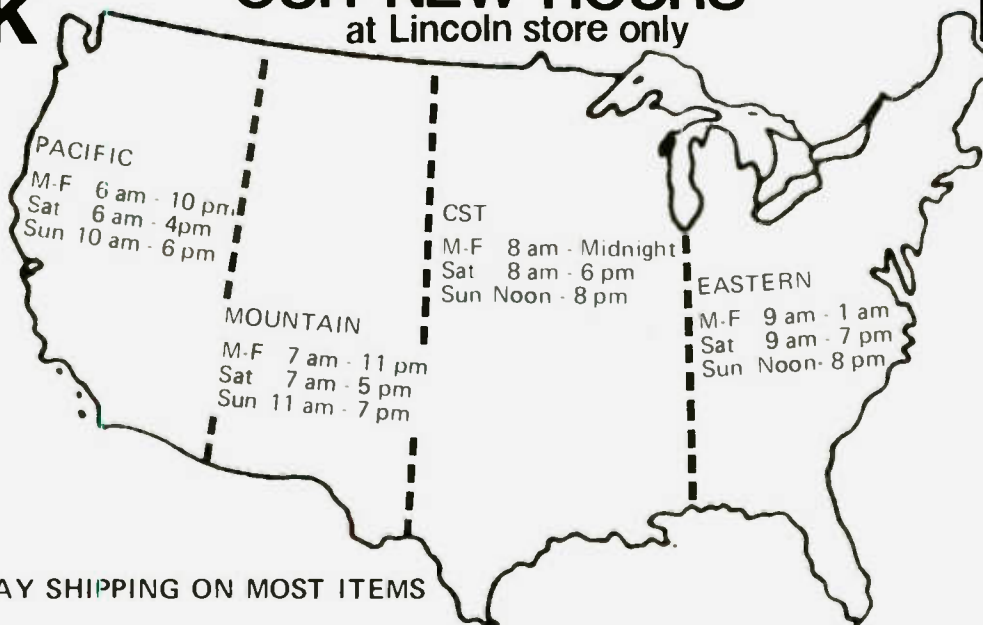

SAME DAY SHIPPING ON MOST ITEMS

1-800-228-4097

Communications Center

443 N. 48th, Lincoln, Nebraska 68504

In Nebraska Call (402)466-8402



The Games People Play

— why not hams?

Playing games on ham radio is nothing new. There is almost always someone on the air who will play, and the element of radio communication adds a new twist to any game. A good ham game could liven up dead bands, fill those extra hours, provide excellent opportunities for those who are not particularly given to rag chewing or new "mike shy" hams, give use to little-used 2 meter simplex channels, and possibly even make some new "wall-paper" available for award-conscious operators.

But good ham games have been few and far between. To be well used on the air, a game should fulfill all or most of the following requirements: The ideal ham game must 1) be easily played by two people, 2) be able to be played with only a paper and pencil as well as on commercial game boards,

3) have rules that are simple and can be easily given over the air to someone not at all familiar with the game, 4) be able to be played in a relatively short time, 5) have individual moves or plays that can be executed in a short time, and 6) be challenging and contain logically varying degrees of difficulty to ensure continued interest and allow advancement in playing skill.

After I found two games that met these requirements, a topical CQ of "CQ game, CQ for a game" brought hours of challenge and enjoyment. Why not give them a try yourself?

Game #1

This one is my favorite and, of the two, holds the most promise for a game that will be played on the air for years. Master Mind® by Invicta Blastics, Ltd., is a new game that has

won tremendous popularity throughout the world. There are even British National Master Mind Championships held yearly. It is said to be 80% logic and only 20% luck, is inexpensive to buy in its attractive game board form, can be played almost anywhere (even comes in a pocket-size board good for field days, etc.), and comes with instructions in ten languages.

Rather than give more details of the game, the following is offered as an explanation suitable for use on the air with a person who has no knowledge of the game. You may want to make a few changes, but I found this order to work well. These rules are designed for convenient use of the board by Invicta.

After calling "CQ game" and having secured a promise to at least give it a try, give the following instructions:

1. Secure a piece of

lined paper and a pencil or pen.

2. There are 6 colors. Write down "R" for red, "W" for white, "Bu" for blue, "G" for green, "Y" for yellow, and "Bk" for black.

3. Number down 10 lines, starting with 10 and ending with one.

4. Above these 10 lines, write a 4-color code of any combination of the 6 colors. For this first game, do not repeat a color; use four different colors.

5. Starting with line one, I will try to break the code. I will give you a 4-color code. Write it down. Then give me a rating of "Xs" and "Os." Write on your paper "X" = right color and right place; "O" = right color but wrong place.

If I have two reds, for example, but your code has one red, I get only one "X" or "O", depending on position. The order you give me the "Xs" or "Os" is not to show anything about the

order of the ones I have right.

6. I have up to ten tries to match your code. The winner is the one who breaks the code in the least amount of tries. Any questions? My try for line one is — — — —. What is my rating?

7. When he gives a rating, say "That means ..." and explain the rating to be sure he understands.

A condensed form of these rules for quick reference is found in Table 2. Both players should be keeping track of the entire game on a board or paper (the board is generally easier). After you break his code, make one for him, and the play goes on. You will find that it helps to "think out loud" over the air.

The sample game in Table 1 should help you to better understand the above instructions. Try to break the code on the next try. The answer is at the end of this article.

If your experience runs like mine, you'll find your opponent saying, "Once is not enough!", and the minutes will quickly and enjoyably pass by. Hopefully there will soon be many on the air who have played a few times. That's when the many variations keep the game going strong. First remove the restriction that all the colors must be different. You can make the code all one color if you want. Next you might want to change the number of possible com-

binations. For young children, you may want to make it three positions and only four colors. But you will most likely want to increase the number of possible combinations. The regular Master Mind game (the one just explained) has 1296 permutations, but, by allowing an empty space to be played as a color (designated with an "S" on the air), it increases the permutations to 2401. Those who expect to enjoy this game and want to further develop their skills may want to purchase the Super Master Mind version of the original (also by Invicta Blastics, Ltd.). It can be played as the version explained above, but allows for a game with 5 positions and eight colors (orange, "O", and brown, "Br", are added), allowing 12 tries to find the one of 32,768 (or if space is used, then one of 59,049) permutations in the code. (Note: The formula is: no. of permutations = CP^P , where C = no. of colors and P = no. of positions.) Other interesting variations, such as allowing the codemaker to make one incorrect rating during the game are offered in *Modern Board Games*, edited by David Pritchard and published by William Luscombe Publisher, Ltd., which should be available at your local library.

Developing strategies is an important part of the game and is necessary for the more advanced games. Also, the codemaker can learn to play more of an active role as he analyzes his opponent and tries to psyche him out with little

"extra comments." The history of the game and its tremendous popularity make interesting rag chewing. All this, plus discussion of tournaments and many more topics (with even a short chapter on computers that play Master Mind), can be found in *The Official Master Mind Handbook* by Leslie H. Ault, published by Signet. It's a must for the serious Master Mind.

For those who desire more practice, a computer pocket calculator-type game that will play against you is offered by Milton Bradley Co. under the name Comp IV™. You can play this with up to 5 positions and 10 choices. Cost is around \$25.00.

This game presents a golden opportunity. Why not have some awards for the Master Mind ham? How about WM-20—won Master Mind in 20 states—or, for real operators, WMAS—won Master Mind in all states? Perhaps a grueling challenge would be MDX-15—Master Mind played DX in 15 countries—or the ultimate: MDXCC! Well, anyway, it would be great to see some enterprising ham advertising saying "Send \$1.50 with a log to ..." for some sort of Master Mind or game award. Perhaps a common frequency could be chosen.

Who knows, maybe

there will even be some "Mind nets" and "tournaments in the air" and ... better get on to the next game.

Game #2

Here is another game that meets most or all of the requirements previously stated. Those who tire of Master Mind (devotees say that this is impossible) may find that this game offers the variety needed to spruce up their ham game venture. This game, which is also offered in plastic under various names (Tri-Tac-Toe at JC Penney for \$6.95), is a complex variation of tic-tac-toe I call Tri-Tac (for three-dimensional tic-tac-toe).

Following are two variations of the game, the second being the more difficult. The first game requires 3 in a row, the second requires 4 in a row. The rules are the same as in regular tic-tac-toe, except that those in a row can be on different levels. Letters and numbers provide easy coordinates for positioning "Xs" and "Os" over the air. In the examples given in Fig. 1, I use the letters a, b, c, and d to show winning combinations. Study them and try to imagine them stacked up in layers to form a cube.

For the first game, the person challenged goes first; thereafter, the winner goes first. The challenged calls coordinates to place

10
9
8
7
6
5
4 W R Bu G OO
3 R Bk G Bu OXX
2 Bu G Bk Y OOO
1 G W Y R OOX

Table 1. Sample Master Mind game.

1. Secure paper and pencil.
2. Colors = R, W, Bu, G, Y, Bk.
3. Number 10 lines.
4. Write down code.
5. Rate each try "X" or "O".
6. Review rating given.

Table 2. Master Mind instructions.



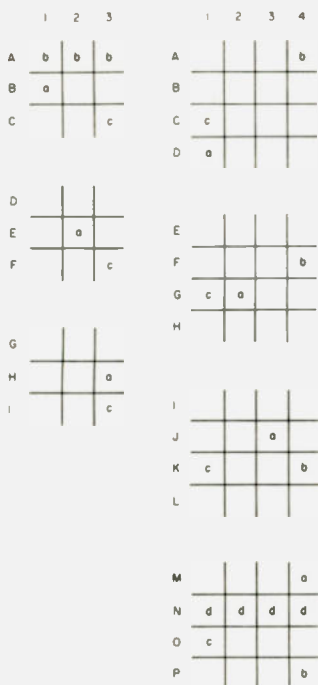

Fig. 1. Tri-Tac.

his "O", the challenger calls coordinates to place his "X", and so on, until one person gets his required number in a row and is thus

the winner.

You may want to write down a list of instructions to be given over the air for Tri-Tac, as was done for Master Mind.

Yet another variation that can be played on the four-grid version would be to give each player two markers—to one, "W" and "X", to the other, "Y" and "Z"—allowing for either to be played at any time. The first to get four of one of them in a row wins. Or try it as the first to get both of his markers four in row is the winner.

Again, some Tri-Tac enthusiast should offer a few awards as for Master Mind. Will you accept this challenge?

I hope you enjoy these ham games as much as I have. When playing, keep the individual plays short, repeat plays and instructions often, think out loud so as to occupy the fre-

quency, and watch that 10-minute timer for ID. Even if no one offers awards, you may want to keep a notebook of all your games, times, etc., for review and strategy development.

"Okay, my first try is W, Bu, Y, R. What's my rating?"

(By the way, the answer for the sample Master Mind is Y, Bk, G, R. It is not one of the most simple you will run into.)■

Editor's note:

I enjoy Master Mind enough so that Sherry and I take one along on trips and use it during plane rides to while away the time. Super Master Mind has eight colors of pegs and five holes, making it even more demanding than run-of-the-mill Master Mind.

Then you can play the same game with words. Think up a real stinky four-

letter word and use the same system for playing. This takes no equipment at all other than a pencil and pad. Sherry and I have played this while driving.

Card games have been difficult to play over the air... obviously. But, with the advent of microcomputers which can shuffle and deal cards for us, perhaps the day of the over-the-air gin rummy game is not that far off. If any group gets going with this and gets porky about their prowess at cribbage, I'll be on frequency to challenge.

Computers can throw dice for us, too, making backgammon possible. Please be sure to let 73 know if you get involved with this sort of mischief.

Oh, if you would like some rotten words for Word Master Mind, you might try: BUNK, PUMP, LULL, XRAY, JAZZ, FIZZ, FLOX, etc.—Wayne.

3 YEARS WARRANTY! EXACT Replacements for SYLVANIA

COMMUNICATIONS & TV
UNLIMITED

ECG Semiconductors

ECG#	ECG#	ECG#	ECG#	ECG#	ECG#
100	.94	163	8.10	220	1.90
101	.98	164	5.75	221	1.90
102	1.04	165	8.95	222	1.99
102A	.98	171	1.37	223	2.79
103	1.05	172A	.72	224	5.06
103A	1.11	175	1.62	225	4.34
104	1.20	176	2.06	226	1.67
105	2.60	177	.49	228	1.21
106	.80	179	5.69	229	1.06
107	.79	180	6.39	230	3.60
108	.89	181	5.40	231	4.40
121	2.38	182	3.35	232	.70
123	.79	183	3.63	233	.74
123A	.79	184	1.37	234	.72
124	1.53	185	1.70	235	3.83
126	1.16	186A	1.46	236	7.57
127	4.60	187A	1.46	237	5.07
128	1.37	188	1.59	238	8.95
129	1.56	189	1.59	239	3.02
130	1.95	190	1.85	241	1.71
131	1.98	191	2.07	242	1.90
132	1.01	192	.98	276	8.72
133	1.14	193	1.04	278	2.36
152	1.43	194	.82	279	5.85
153	1.85	195A	2.96	280	5.06
154	2.34	196	2.06	281	6.35
155	2.02	197	1.89	282	4.24
157	1.63	198	1.95	283	6.32
158	1.08	199	.59	284	7.35
159	.86	210	1.37	285	7.99
160	1.43	211	1.56	286	5.75
161	.98	218	3.08	287	.69
162	5.75	219	4.36	288	.74

- F-A-S-T Same Day Shipping-In Stock!
- FREE Freight on all prepaid orders
- EXCLUSIVE 3 YEAR CONDITIONAL WARRANTY!
- NO Min. Order-Quantity Discounts Available
- EXCLUSIVE INVENTORY ADJUSTMENT!
- Longer Hours Mon-Sat. 9a-10p, Sun 1-7p.
- Call Today—To place your order (518) 465-3367

Communications & T.V. Unlimited

17 Washington St., Rensselaer, N.Y. 12144
Exact Japanese Transistors & IC's Available
T.V.-C.B.-AMATEUR RADIO-STEREO-MONITORS-
ELECTRONIC PARTS ✓ C105

3/4 KILOWATT DC INPUT ALL MODE VHF AMPLIFIER

SPECIFICATIONS:

Frequency Range	: 144-148MHz; No Tuning
Power Output, Max.	: 350 to 400 Watts
Circuitry	: Fully Transistorized
Modes of Operation	: AM-FM-SSB-CW-RTTY
Duty Cycle	: Continuous Duty
Gain, Typical:	: 8 Watts Input 12 Watts Input 15 Watts Input
Primary Wiring	: Built-in AC Power Supply, 115/230 VAC
T/R Switching	: Built-in 1KW Coaxial T/R Relay
Spurious	: 60dB down all Harmonics 60dB down all Spurious
Power Output Select	: 10 Watts (LOW) or 350 Watts (HIGH)
Metering, Lighted	: Front Panel All Mode Set Indicator
Cooling	: Convection SSB and CW Model F136 or F235 required for continuous FM operation
Temperature Control	: Built-in Thermo-Switch for Fan Control
Auxiliary Output	: + 13 Volt at 3 Amperes on Rear Panel
Design Layout	: Hinged Amplifier and Heatsink Top Assembly for easy Accessibility and Service
Weight	: 52 pounds; 24 kilograms
Size (W x H x O)	: 17 x 8 x 13"; 432 x 203 x 330 mm
Mounting	: Bench Mounting, Rubber Bumpers Rack Mounting, 19" Adaptor Kit (OPTIONAL)
Connectors	: SD-238-UHF
USA Price	: \$895.00 FOB Factory



MODEL: V350

FOR BASE STATION & REPEATER USE



RF POWER LABS, INC. ✓ R27

11013-118th Place N.E. • Kirkland, Washington 98033 • Telephone: (206) 822-1251 • TELEX No. 32-1042



W2NSD/1 NEVER SAY DIE

editorial by Wayne Green

from page 255

able to take a simple business trip and, for less than the regular fare, fly anywhere in the Eastern system . . . and this includes such interesting DX hot spots as Saint Martin (which is two countries!), Martinique, Trinidad, and a lot of other great Caribbean islands.

Write ahead and get your license from the Department of Telecommunications. If you wait until you get there, you may find yourself up against several days of red tape, and be back home before the ticket comes through.

Here's the only border between the French side of Saint Martin and the Dutch side, Saint Maartens. It's just a marker alongside the road, and you have to keep your eyes open to see it.

You'll find that there are other demarcations between the two countries when you try to make a phone call from the Dutch side to the French. Good luck in dealing with the French operators . . . if they get off lunch break.

We could use a lot more activity in the islands, so check into the Eastern fares and see if you can't activate an island for a few days and find out why some hams get so addicted to DXpeditioning. With the current line of tiny rigs, you can carry one along, complete with antenna, right under the plane seat.

The Eastern fares have substantially changed the economies of the islands, so you'll want to be sure to reserve your seat well ahead of time and make sure that you have a



hotel reservation, complete with permission to use your ham rig and antenna. You'll want to save up some money, too, for the boom in Caribbean travel which has resulted from the Eastern fares has also jacked up the costs of hotels, food, etc.

AUGUST WINNER

"Ham Radio Is NOT A Rich

Man's Hobby"? Rick Ferranti WA6NCX/1, author of August's most popular article, will find himself in a slightly higher income bracket this year, thanks to the \$100 prize our readers voted him with their Reader Service card ballots. Rick, we suggest you drop the hobby or stop writing crackerjack articles for 73—or it will be a rich man's hobby for you.

Ham Help

I am a public school teacher at the Pine Point Experimental School on the White Earth Indian Reservation in Minnesota. The school is the main focus of the Pine Point community, and is involved with preschoolers through adults.

There is much interest on the part of the students and community in general in communications, and many students are excited about studying for their amateur radio licenses and starting a ham club. Interest was spurred by the CB club we started last spring, but the sunspot cycle put the lid on legal 11 meter communications during the school day. The motivation and built-in incentives in ham radio would serve an important function here, especially during the long and frigid winter.

In addition, the Tribal Council has been talking of a future Chippewa radio station to cover the reservation, and ham radio would be the seed from which engineers and technicians could grow.

If any individual, organization, or company could provide the school with working station or test equipment, learning aids, etc., new or used, donated or at low cost, please contact me at the school.

Walter Kimmel KB0CB
Pine Point Experimental
School
Ponsford MN 56575

I need a diagram or information on a 2 meter 1 W-in/10 W-out amplifier. The circuit board has #85-1661-091974-080674 printed on one side and the other side has #85-1661-1 plus 2 other numbers. A thick aluminum panel has #203-1466 stamped on it. It uses one 2N5589 and one 2N5590. It has a 4PDT, 12-volt relay built-in on the board. I am also missing coils L304 and L305. Can anyone help? I will pay you for whatever is needed to copy the info.

Jung Y. Lem KB6BO
5222 Coringa Dr.
Los Angeles CA 90042

I need a manual or schematic for a Swan 117B (117 V ac) power supply. Thanks.

B. Mongeau
2215 Marie Victorin
Sillery, Quebec
Canada G1T 1J6

I am in need of a schematic diagram for a Royal Canadian Navy transmitter-receiver, type FR-12-PH 05161-PH. The rating is 12 V dc 6 A cont., 11 A int., spec. is 122904, and it was manufactured in 1944 by the Canadian Marconi Company. Also, I would like the address of the Canadian Marconi Company in Canada, if at all possible.

Emil Schuchardt, Jr.
21 East Clark St.
Springfield OH 45506



OSCAR Orbits

The listed data tells you the time and place that OSCAR 7 and OSCAR 8 cross the equator in an ascending orbit for the first time each day. To calculate successive OSCAR 7 orbits, make a list of the first orbit number and the next twelve orbits for that day. List the time of the first orbit. Each successive orbit is 115 minutes later (two hours less five minutes). The chart gives the longitude of the day's first ascending (northbound) equatorial crossing. Add 29° for each succeeding orbit. When OSCAR is ascending on the other side of the world from you, it will descend over you. To find the equatorial descending longitude, subtract 166° from the ascending longitude. To find the time OSCAR 7 passes the North Pole, add 29 minutes to the time it passes the equator. You should be able to hear OSCAR 7 when it is within 45 degrees of you. The easiest way to determine if OSCAR is above the horizon (and thus within range) at your location is to take a globe and draw a circle with a radius of 2450 miles (4000 kilometers) from your QTH. If OSCAR passes above that circle, you should be able to hear it. If it passes right overhead, you should hear it for about 24 minutes total. OSCAR 7 will pass an imaginary line drawn from San Francisco to Norfolk about 12 minutes after passing the equator. Add about a minute for each 200 miles that you live north of this line. If OSCAR passes 15° east or west of you, add another minute; at 30°, three minutes; at 45°, ten minutes. Mode A: 145.85-.95 MHz uplink, 29.4-29.5 MHz downlink, beacon at 29.502 MHz. Mode B: 432.125-.175 MHz uplink, 145.975-.925 MHz downlink, beacon at 145.972 MHz.

OSCAR 8 calculations are similar to those for OSCAR 7, with some important exceptions. Instead of making 13 orbits each day, OSCAR 8 makes 14 orbits during each 24-hour period. The orbital period of OSCAR 8 is therefore somewhat shorter: 103 minutes.

To calculate successive OSCAR 8 orbits, make a list of the first orbit number (from the OSCAR 8 chart) and the next thirteen orbits for that day. List the time of the first orbit. Each successive orbit is then 103 minutes later. Due to incorrect tracking information obtained during the early days of OSCAR 8, the equator crossing times contained in most published charts are in error. To correct this error, multiply the orbit number by 0.00205 minutes and add

Oscar 7 Orbital Information				Oscar 8 Orbital Information			
Orbit	Date (Dec)	Time (GMT)	Longitude of Eq. Crossing °W	Orbit	Date (Dec)	Time (GMT)	Longitude of Eq. Crossing °W
18495 Bbn	1	0009:15	62.7	3771 Abn	1	0111:17	59.6
18508 Abn	2	0103:32	76.3	3785 Jbn	2	0116:28	60.9
18520 Bbn	3	0002:53	61.2	3799 Jbn	3	0121:39	62.2
18533 Bbn	4	0057:10	74.8	3813 Abn	4	0126:50	63.5
18546 Abn	5	0151:27	88.3	3827 Abn	5	0132:01	64.8
18558 Bbn	6	0050:48	73.2	3841 X	6	0137:12	66.1
18571 Bbn	7	0145:05	86.8	3855 Abn	7	0142:24	67.4
18583 Abn	8	0044:26	71.6	3868 Abn	8	0004:21	42.9
18596 Bbn	9	0138:43	85.2	3882 Jbn	9	0009:32	44.2
18608 Bbn	10	0038:04	70.1	3896 Jbn	10	0014:43	45.5
18621 Abn	11	0132:21	83.7	3910 Abn	11	0019:54	46.8
18633 Bbn	12	0031:42	68.5	3924 Abn	12	0025:05	48.2
18646 Bbn	13	0125:59	82.1	3938 X	13	0030:16	49.5
18658 Abn	14	0025:20	67.0	3952 Abn	14	0035:27	50.8
18671 Bbn	15	0119:37	80.5	3966 Abn	15	0040:38	52.1
18683 Bbn	16	0018:57	65.4	3980 Jbn	16	0045:49	53.4
18696 Abn	17	0113:15	79.0	3994 Jbn	17	0051:00	54.7
18708 Bbn	18	0012:35	63.8	4008 Abn	18	0056:11	56.0
18721 Bbn	19	0106:53	77.4	4022 Abn	19	0101:22	57.3
18733 Abn	20	0006:13	62.3	4036 X	20	0106:33	58.6
18746 Bbn	21	0100:31	75.9	4050 Abn	21	0111:44	59.9
18759 Bbn	22	0154:48	89.5	4064 Abn	22	0116:54	61.2
18771 Abn	23	0054:08	74.3	4078 Jbn	23	0122:05	62.6
18784 Bbn	24	0148:26	87.9	4092 Jbn	24	0127:16	63.9
18796 Bbn	25	0047:46	72.8	4106 Abn	25	0132:27	65.2
18809 Abn	26	0142:04	86.3	4120 Abn	26	0137:38	66.5
18821 Bbn	27	0041:24	71.2	4134 X	27	0142:49	67.8
18834 Bbn	28	0135:41	84.8	4147 Abn	28	0004:46	43.3
18846 Abn	29	0035:02	69.6	4161 Abn	29	0009:57	44.6
18859 Bbn	30	0129:19	83.2	4175 Jbn	30	0015:07	45.9
18871 Bbn	31	0028:40	68.1	4189 Jbn	31	0020:18	47.2

the result to the equator crossing time as printed in the chart. For example, the published time for orbit number 3352, the first equatorial crossing on November 1, 1978, is 0018:50 UTC. Thus, for orbit number 3352, the corrected equatorial crossing time would be:

$$\begin{aligned} \text{Corrected time} &= 0018:50 + (3352 \times 0.00205 \text{ minutes}) \\ &= 0018:50 + (6.8716 \text{ minutes}) \\ &= 0025:42.3 \end{aligned}$$

The longitude figures contained in the OSCAR 8 chart are virtually unaffected by this tracking error. The chart gives the longitude of the day's first ascending equatorial crossing. Add 26° for each succeeding orbit. To find the time OSCAR 8 passes the North Pole, add 26 minutes to the time it crosses the equator. OSCAR 8 will cross the imaginary San Francisco-to-Norfolk line about 11 minutes after crossing the equator. Mode A: 145.85-.95 MHz uplink, 29.4-29.5 MHz downlink, beacon at 29.40 MHz. Mode J: 145.90-146.00 MHz uplink, 435.20-435.10 MHz downlink, beacon at 435.090 MHz.



Canadian Amateur Radio Federation, Inc.

DOC PUBLISHES DETAILS OF NEW "NO-CODE" "DIGITAL" CERTIFICATE

Changes to the Radio Regulations, featuring the long-awaited details of the new "no-code" certificate known up to now as the "experimenter's" certificate and "packet radio," were made public on September 14, 1978. These changes came into effect September 30, 1978. Holders of the new ticket, now called the "Amateur Digital Radio Operator's Certificate," will be permitted operation on two meters and above using various modes of operation, including pulse modes. They may obtain an Advanced certificate after a year's operation and passing a 15-wpm code test. Advanced amateurs may use pulse modes after passing the relevant portion of the new exam. The new exams for all three classes of certificates will start November 15 of this year.

Packet radio will be permitted to all three classes in cer-

tain parts of the 220-MHz band. Along with other modes, it may be used from 220.1 to 220.5 MHz. An exclusive two megahertz slot for packet radio, only, is allowed from 221.0 to 223.0 MHz. There are no other changes in the 220 band which affect Amateur and Advanced Class operators. Another exclusive packet radio slot is from 433.0 to 434.0 MHz. Packet will also be permitted on 24.0 to 24.01 gigahertz. For identification purposes, packet headers will carry an ASCII mapping of the callsign. Secret codes and ciphers are not permitted. Modulation techniques and emissions for packet radio will be determined by experiments undertaken by amateurs themselves.

Pulse modes P0 and P1 are permitted on two meters between 145.5 MHz and 145.8 MHz, and P0, P1, P2, and P3 are allowed from 434.0 to 434.5 MHz, with P4, P5, and P9 being added in the 1215.0- to 1300-MHz slot and in bands

from 2300 MHz on up.

Further changes to the Regulations note that for all classes of certificates, exams will be held four times annually, normally in October, January, April, and July. Separate credits for code exams are good for one year. Multiple-choice questions will remain for the Regulations portion, with narrative-type questions for the theory.

Details of the new regula-

tions and the examination requirements for all three classes of certificates are contained in the new DOC bulletins, TRC 24, effective October 1, 1978, and TRC 25, effective September 30, 1978. These may be obtained from the Department of Communications Regional offices in Vancouver, Winnipeg, Toronto, Montreal, or Moncton, or from the Telecommunication Regulatory Service at DOC HQ, 300 Slater Street, Ottawa, Ontario K1A 0C8.

Corrections

Please pass this information on to the good people who were kind enough to read my article "Sleight of Hand" in the August, 1978, issue of 73.

The circuit shown in Fig. 5 on page 77 should not be used. This is due to the fact that as a greater load is placed upon the output, the impedances of the primary transformer windings begin to change every half-cycle. The impedance of one primary increases, while the other transformer primary impedance decreases. This gives rise to a sharp drop in output voltage as the load resistance

decreases.

My apologies to anyone who has tried to make this circuit work.

**Bob May K4SE
Jonesboro TN**

We have just received a belated correction to "The Beeper," (January, 1977) which should allow the unit to function as intended. It appears that a lone decimal point misplacement transformed C5 to 0.001 uF when it should have been 0.01 uF.

**Gene Smarte WB6TOV
News Editor**



THE FIRST CHOICE IN REPEATER CONTROL

The Power and Flexibility of Microprocessor Technology

AUTOPATCH, REVERSE PATCH, SMART ID, ACCESS CODE
MUTING, MORSE CODE ANNOUNCEMENTS, FLEXIBLE
FUNCTION TIMEOUT, COURTESY TONE, LINKING,
CONTROL OP. FUNCTIONS, TWELVE USER FUNCTIONS,
... AND MUCH MORE.

Call or write for specifications:

MICRO CONTROL SPECIALTIES (617) 372-3442

✓M69

23 ELM PARK GROVELAND, MA. 01834

CHICAGOLAND

See us for Integrated Circuits,
Transistors, Resistors, Capacitors,
Heat Sinks, Edge Connectors, Leds,
etc., etc.

Authorized Distributors For:
Continental Spec. (Breadboarding
Devices)

Datak Corp. (Photo Etch Supplies)
Vector Electronics (Perf Board)
OK Machine (Wire Wrap Supplies)
E-Z Hook (Test Clips and Jumpers)

Visit our Retail Store, Open Daily at 10:A.M.

MINI DIP SLIDE SWITCH

7 Switches — \$1.50
5/\$7.00



This offer good thru
12/31/78.

Reg. price — \$1.65 ea.

47.6 MFD-4500VDC CAPACITOR

Ideal for linear power
supplies. De rate to approx.
2750VDC for continuous duty.

Mfd: Cornell-Dubilier
Ship: Wt. 28 lbs.
Dim: 12½"H x 8"W x 4"D
\$30.00 ea. 2/\$55.00



HEAT SINKS

6030 B — Vertical Board
Mount For TO-220
Devices.
6/\$1.00



6010 B — For 14 &
16 Pin DIP IC's
10/\$1.00



All Merchandise New and 100% Guaranteed.
Please include shipping charges with your order.

R.W. ELECTRONICS, INC.

3203 North Western Avenue

Chicago, Illinois 60618

312-248-2480

✓R18

**AMATEUR
TELEVISION
ON
439.25 MHz**

**INTERESTED? ACTIVITY IS
INCREASING EVERY WHERE
YOU CAN GET ACTIVE IN YOUR
AREA WITH OUR PRODUCTS —**

**AM18 FSTV CONVERTER
complete \$150.00**

**AX10B FSTV TRANSMITTER
complete \$385.00**

**CALL 812-336-4775, OR WRITE US,
FOR COMPLETE DETAILS**

**APTRON
LABORATORIES**

PO BOX 323
BLOOMINGTON, INDIANA, 47401

✓A6

SCAN YOUR YAESU MEMORIZER



**NOW YOUR
RIG CAN SCAN**

- ★ COMPLETELY SCANS ALL 400 CHANNELS
- ★ TWO SCAN MODES PLUS CONTINUE
- ★ PROGRAMMABLE PAUSE AND LISTEN TIMEOUT
- ★ SEALED BRACKET ADAPTS TO EXISTING MOUNTS
- ★ STYLED TO COMPLEMENT THE MEMORIZER
- ★ EASY TO ASSEMBLE INSTRUCTIONS

Designed and engineered for the YAESU FT-227R, the scanner is ideal for locating occupied channels and local repeater frequencies, especially while traveling. Channel sampling occurs in the PAUSE mode with programmable monitoring time. In the LISTEN mode, the scanner locates and locks onto an occupied channel until the CONTINUE button is depressed at the channel remains unoccupied for the pre-programmed period. Complete scanner kit only \$23.99 plus \$1.00 shipping (AZ residents add 5% tax). Send your order to:

HOBBY SYSTEMS, 1642 N. OLEANDER, TEMPE, AZ 85281

✓H32

Jim DeNinno wants your name for his mailing list and is offering Three Super Specials to Get It

3.95 BUYS ALL OF THIS

Old & Rare Coins

1 Old Indian Head Cent
1 V Liberty Nickel
1 Buffalo Nickel
1 Large Cent eng
1 1943 WWII Cent
1 Cent 1920 or Older
1 Wooden Nickel
1 D Mint Cent 25 years
1 5 Cent 25 years
1 1968 5 Penny unc
1 1960 D Small Date

**OR 3.95 BUYS THESE TWO
RARE UNCIRCULATED COINS**

The mint made a mistake but we didn't!
Now is your chance to take advantage of their mistake

55
1955 5 Cents
Postman's Double Die
• PLUS •
1960
Small
Date

**OR 6.95 BUYS EVERYTHING
IN BOTH OF THE ABOVE SPECIALS**

With Every Offer you Receive
■ 1 Free Two \$ Bill
■ More Free Coins
■ Or Free Brachures

Add \$.25
for
Postage

JIM DeNINNO & CO. ✓D39

Suite 5, Pine Bldg. Viewmont Village, Scranton Pa 18508
717-961-0203

PASS FCC EXAMS

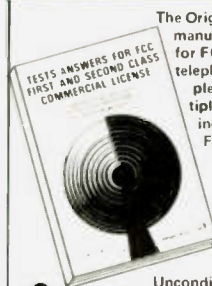

The Original FCC Tests-Answers Exam manual that prepares you at home for FCC First & Second class Radiotelephone licenses. You get the complete set of 15 newly revised multiple-choice examinations — covering all areas tested on the actual FCC exam. Also included — helpful study tips, short cuts, and "Self-Study Ability Test." These updated FCC Tests-Answers take the mystery out of preparing for current FCC exams. Practical proven Material. \$9.95 postpaid. Unconditional Moneyback Guarantee.

COMMAND PRODUCTIONS

RADIO ENGINEERING DIVISION ✓C106
P.O. BOX 26348-F SAN FRANCISCO, CA 94126
Please rush me Tests-Answers for FCC First and Second Class Commercial License. My \$9.95 is enclosed.

Name _____
Address _____
City _____ State _____ Zip _____

NEW

\$95 Stand Alone Video Terminal

αβΓδεθζηθρστυφχψωΩ0123°±÷×[]|←→↑↓
!"#\$%&'()*+,-./012456789:;<=>?
@ABCDEFGHIJKLMNPOQRSTUVWXYZ[\]^_
`abcdefghijklmnopqrstuvwxyz{|}~

SCT-100 FEATURES:

- 64 X 16 line format with 128 displayable characters
- Serial ASCII or BAUDOT with multiple Baud rates
- \$187 Assembled or \$157 Kit (Partial Kit \$95)
- Full cursor control with scrolling and paging
- On board power supply

Call or write today. MC/VISA accepted

XITEX CORP 13628 Neutron P. O. Box 402110
Dallas, Texas 75240 (214) 386-3859
X1
Overseas orders and dealers inquiries welcome

DISCOUNT SCANNERS

The Touch.™



\$ 255.00

Prepaid
USA

Regency

CHECK, M.O., MASTERCHARGE, VISA

BAY-COM ✓B32

196 FRONT STREET
SCITUATE MA 02066
617-545-9700

Other Regency models at
similar savings—send for list

Mass. residents please add 5% tax.



CONNECTOR ASSORTMENT

\$25.00 **\$23.50** each
Postpaid lots of three

Includes: 5- PL259, 5-SO239, 5-UG175, 5-UG176,
2- PL258, 1- DM, 1- M358, 2- M359, 1- UG255,
1- UG273, 2- PL259PO, 1- 1021-20, 1- Lightning
Arrestor.

Master Charge & Visa accepted / Send for Free Catalog

COAKIT ✓C21

P.O. Box 101-A Dumont, N. J. 07628
Circle C21 on Reader Service Card

PCP™ TYPE-A PATENT PENDING

PCP TYPE-A TRANSFER FILM lifts the ink DIRECTLY from printed paper!
(NO CHEMICALS or PHOTOGRAPHY required!)

Only additional materials required are: Sensitized boards, developer, & etchant!

**SEE POPULAR ELECTRONICS
FEB '78 ISSUE!**

FINALLY you can make HIGH QUALITY printed circuit boards directly from
magazine construction articles! Can also be used to make specialized
meter faces, front panel decals, component placement decals & others.

Small Pkg. 6pcs 4x6 \$5.49
Med. Pkg. 4pcs 6x9 \$6.95
Large Pkg. 3pcs 9x12 \$7.95

PCP PRINTED CIRCUIT PRODUCTS CO.
P.O. BOX 4834
P26 HELENA, MT 59601

Trans Com ✓T35

Tone Signaling Equipment

Featuring the **TG-1B Sub-Audible Tone Encoder**
Compatible with **P.L., CG** and other systems

Features:

- Low sine wave distortion of less than 1.5% THD
- Plug in tone element
- Excellent Temperature & frequency stability
- Low current draw using CMOS IC's
- Immunity to RF

Two year warranty

Priced at \$27.95
wired and tested
with tone element



Also Available

Touch tone encoders from \$29.95, touch tone decoders and
two tone sequential tone encoders and decoders.

Order from or for further information contact

Trans Com

P.O. Box 120, Addison, Illinois 60101 312-653-6724

REGULATED POWER SUPPLY

- Fully regulated, dual protected, 13.8 volts
- Illuminated on/off switch
- Hammertone metal case

3.3 Amp (30 Amp continuous) . \$119.95
20 Amp (16 amp. cont.) \$74.95
8 Amp (6 amp. cont.) \$39.95

TIMES CABLE

RG-8U - 100' multiples 18c/ft.
RG-213U - (Non-contaminating jacket)
- 100' multiples 22c/ft.
½" Aluminum Jacketed hardline - 75 ohm.
1000' rolls only 29c/ft.
PL259 connectors 25/50c ea.
or 100/45c ea. POSTPAID

UNIVERSAL TOWERS

SUPER DISCOUNTS —

S.A.S.E. for brochure and prices!

Send S.A.S.E. for additional information. Include shipping
charges with check or money order (Ohio
residents add 4 ½% sales tax)

JRS ELECTRONICS ✓J8

P.O. Box 1893—Cincinnati, Ohio 45201

ANTENNAS FOR ALL BANDS!



LOW COST - LIGHT - STRONG - NEAT - HIGH QUALITY
SINGLE BAND standard Transmitting or receiving Horizontal
ANTENNAS FOR AN AMATEUR BANDS, MARS, Short Wave,
Special Frequencies. POWER up to 2000 watts - all modes -
ALL MAKES - MODELS TRANSRECEIVERS! Wt. 3 lbs with
30 ft. 300 lb. test Dacron ends, 16 Ga Copperweld - Insulators.
Molded connector with lightning arrestor - 50 ft. FOAM RG58U
(RG8U at \$10.00 More) with PL259 Connector - COMPLETE-
LY ASSEMBLED - READY TO PUT UP AND USE! Set for
low end of band - adjustable to any exact freq. without tools or
cutting (Freq. chart furnished) Can be used on top of buildings-
in attics -- ANYWHERE for TRUE DI-POLE radiation - the
STANDARD OF ALL RADIO ANTENNAS! PORTABLE -
EASY TO MOVE and erect. Weatherproof - LONG LIFE!

80 meter - 125 ft. No. HD-80 10 meter - 16 ft. No. HD-10
40 meter - 85 ft. No. HD-40 6 meter - 9 ft. No. HD-6
20 meter - 33 ft. No. HD-20 Citizens B-17 ft. No. CB-40
15 meter - 22 ft. No. HD-15 49 meter 77 ft. No. HD-49

ANY MODEL No. \$19.95 (plus) \$2.00 postage in USA,
(Special Freq. \$3.00 more - advise exact freq. in MHz - 2 to
150) SEND FULL PRICE OR ORDER WITH VISA (Bank-
americard) MASTER CHARGE - AM EXP. Give No. and Ex.
Date. Ph 1-308-236-5333 9AM-6PM, weekdays. We ship
in 2-3 days. Order now and beat price increase - FREE
INFORMATION. WESTERN ELECTRONICS
Dept. A7-12 Kearney, Nebraska, 68847 ✓W18



ANTENNAS FOR ALL BANDS!

NEW
FROM XITEX

\$95 MORSE TRANSCIVER

SEND:

- 1 to 150 WPM (set from terminal)
- 32 character FIFO buffer with editing
- Auto Space on word boundaries
- Grid/Cathode key output
- LED Readout for WPM and Buffer space remaining

SERIAL INTERFACE:

- ASCII (110, 300, 600, 1200) or Baudot (45, 50, 57, 74) compatible
- Simplex Hi V Loop or T-L electrical interface
- Interfaces directly with the XITEX® SCT-100 Video Terminal Board; Teletypes® Models 15, 28, 33, etc.; or the equivalent



MRS-100 CONFIGURATIONS:

- \$95 Partial Kit (includes Microcomputer components and circuit boards; less box and analog components)
 - \$225 Complete Kit (includes box, power supply, and all other components)
 - \$295 Assembled and tested unit (as shown)
- Overseas Orders and dealer inquiries welcome

COPY:

- 1 to 150 WPM with Auto-Sync.
- Continuously computes and displays Copy WPM
- 80 HZ Bandpass filter
- Re-keyed Sidetone Osc. with on-board speaker
- Fully compensating to copy any 'fist style'

See your local dealer or contact XITEX® direct.

MC/Visa accepted

XITEX CORP.

13628 Neutron • P. O. Box 402110
Dallas, Texas 75240 • (214) 386-3859

Sere-Rose & Spencer Electronics ✓S39

1465 WELLS STATION ROAD
MEMPHIS, TENN. 38108
PH (901) 683-9125--685-8461

Authorized Dealer

**DRAKE—ICOM—KENWOOD
REGENCY—TEMPO—DENTRON**

CALL OR WRITE
FOR BEST DEAL

FLY YOUR RUBBER DUCKY !!

Get off the trunk lid and into the best location on the car... the center of the roof! Tests have proven that the low profile quarter-wave whip, or the rubber-ducky from a Handy-Talky, outperforms a 5/8 whip on the trunk. Take advantage of the super ground plane by converting to the FLYING-DUCKY magnetic mount. Although designed specifically for use with a H-T, it can be used with any mobile rig. Ten second installation.

FLYING-DUCKY magnetic mount consists of:

- Chrome-plated super magnet (holds 50 lbs.)
- Compatible coax plugs furnished to match rig requirements. Specify BNC, F type, PL259-SO239. For TNC Wilson type add \$3.
- Coax cable 105 in. long.

FLYING DUCKY MOUNT AND CABLE... \$13.95
QUARTER WAVE WHIP
(specify connector)..... \$ 5.95
RUBBER DUCKY to match
(specify connector)..... \$ 7.95

Face-Traps
✓P15

Box 234
Middlebury CT 06762
(203) 758-9228

CIRCUIT BOARDS

- REPEATER CONTROL
- COMPUTER PROJECTS
- SENSITIZED BLANKS
- NEGATIVES/POSITIVES
- PROTO-TYPE BOARDS
- PARTS KIT
- CUSTOM ETCH/DRILL
- RCA 1802 MP BOARDS
- CIRCUIT BOARD DESIGN
- PROGRAMMING PADS
- ART MASTER PREPARATIONS

We can supply many of the items you need to make a p-c board. Send SASE + 25 cents for catalog.

O.C. Stafford ✓S50

Electronic Service and Development
427 S. Benbow Rd.
Greensboro, NC 27401
919-274-9917 DAY/NITE
Serving Amateurs Around the World

PET® OWNERS Send-Receive RTTY & CW

M65 K
\$69.95
KIT



M65 A
\$99.95
WIRED

- Automatic send & receive: RTTY and CW
- Complete hardware and software package
- Connects to your PET User Port and the key/head-phone jacks of your rig
- Ten message memories—255 char each
- Keyboard buffer—allows typing ahead
- Uses built-in PLL or external TU
- Morse trainer—random 5 letter words
- Includes hardware, cassette & manual
- TRS-80 version available

Write or call for detailed brochure
California residents add 6% tax



✓M48
Microtronics



P.O. Box 747(S) • Keyes, CA 95328
(209)634-8888 • 667-2888

Write for CATALOG CRAMMED WITH GOV'T SURPLUS ELECTRONIC GEAR SEND 50¢ FOR HANDLING

- ARC-5 TRANSMITTER—with all tubes & crystal, brand new in original carton. \$12.95
- SCR-522 TRANSMITTER/RECEIVER—100-156 mc., crystal controlled on 4 channels, in excellent condition with all tubes (18). \$28.50
- LM FREQUENCY METER—frequency range 125-20,000KC, operates on 12 or 24 V dc with tubes, crystal & original calibration book, ex. cond., checked out. \$54.50
- AC POWER SUPPLY for above (original). \$22.50
- HEADSET, 2000 Ohms with 7' cord & PL-55 plug, new. \$3.95
- HEADSET, low impedance with chamois cushions, 4' cord & plug ex. cond. \$2.95
- RUGGED HEAVY DUTY CARBON HANDMIKE with cord & plug, new. \$1.88
- All types of transmitting, receiving & special purpose tubes available. We invite your inquiries.

Terms: F.O.B. NYC. 25% deposit with order, balance COD or remittance in full. Subject to prior sale and price change.

**G & G RADIO ELECTRONICS ✓G20
COMPANY** 45-47 Warren St. (2nd floor)
Ph. 212-267-4605 New York, N.Y. 10007

Key Electronics

GRI

Full ASCII Professional
Keyboard Kit, Model 756



- Full 128 Character ASCII • Tri-Mode MOS Encoding • MOS/DTL/TTL Compatible Output • Two-Key Rollover • Level and Pulse Strobe • Shift and Alpha Lock • Selectable Parity • Positive or Negative Logic • All New, OEM Grade Components • Gold Contact, Low Bounce Key Switches • Rugged G-10 Printed Circuit Board • Low Power Consumption ... and More

Model 756 Keyboard Kit \$64.95
Model 701 Plastic Enclosure \$14.95
Model 702 Steel Enclosure \$29.95

Send for catalogue of other NEW merchandise,
Semis, Sockets, ICs, Res., Caps, and MORE.

N.Y.S. Residents Add 4% Sales Tax

Send to: Key Electronics
P.O. Box 3506
Schenectady, NY 12303 ✓K14

MFJ INTRODUCES A NEW 24 HOUR DIGITAL CLOCK

with HUGE 1-5/8 inch digits that you can keep set to GMT. Alarm and snooze functions let you use it as an ID Timer. Assembled, too!



\$29⁹⁵

**BRAND
NEW**

MFJ Enterprises brings you a new 24 hour digital alarm clock with HUGE 1-5/8 inch orange 7 segment digits that you can see clear across the room.

This one is strictly for your ham shack, one that you can leave set to GMT. No more mental calculations to get GMT.

Use the alarm to remind you of a SKED or with the snooze function as an ID timer to buzz you in 8 minute intervals.

A constantly changing kaleidoscopic pattern indicates continuous operation.

Beige. 2-1/4 x 4-1/8 x 8-3/4 inches. UL listed. Requires 120VAC, 60Hz.

Order from MFJ and try it — no obligation. If not delighted, return it within 30 days for a re-

fund (less shipping). One year limited warranty by MFJ Enterprises.

To order, simply call us toll free 800-647-1800 and charge it on your VISA or Master Charge or mail us a check or money order for \$29.95 plus \$2.00 for shipping and handling.

Don't wait any longer to enjoy the convenience of a "Hams Only" clock. Order today.

MFJ ENTERPRISES, INC.

P. O. BOX 494 ✓ M52
MISSISSIPPI STATE, MS 39762
CALL TOLL FREE 800-647-1800
For technical information, order/repair status, in Miss., outside continental USA, call 601-323-5869.

The **ONLY** thing you need to know about

Quartz Crystals

is: **1-405-224-6780**

• Best delivery plus Emergency Service with Guaranteed Delivery

• Highest Quality with gold MIL-C-3098 Process

• Ask for Sentry Technology Manual

And, order Toll Free 1-800-654-8850



SENTRY

✓ S3 Crystal Park
Chickasha, Oklahoma
73018

G G.I.S.M.O. ✓ G22

2305 CHERRY ROAD ROCK HILL, S.C. 29730

Featuring



and now **too!**

IN ADDITION TO THE PRODUCTS LISTED ABOVE, WE ARE ALSO FACTORY AUTHORIZED DEALERS OR DISTRIBUTORS FOR B & W, BERK-TEK CABLES, BENCHER PADDLES, THE NEW AEA AUTO-DIALER AND MANY OTHER ACCESSORIES. OUR SERVICE SHOP, WITH TWO FULL-TIME FIRST PHONE TECHNICIANS, OFFERS EXPERT REPAIR ON ALL MAKES, AND FACTORY AUTHORIZED WARRANTY SERVICE ON SWAN AND YAESU PRODUCTS.

ORDER TOLL FREE!

73, THE GISMO GANG

800-845-6183

IN S.C. DIAL 803/366-7157

December Specials

HY-GAIN

TH6DX 6 element tribander	\$195 00
TH3RK 3 element tribander	158 50
TH3R Low Power Beam	104 00
1BAVT WB 10 NO Meter Vertical	70 00
Others—Write	

MOSLEY

TA 33 3 element tribander	\$169 95
TA 33R Low Power Beam	179 00
CL 33 3 element tribander	199 00
CL 36 6 element tribander	249 95
Others—Write	

CUSHCRAFT

ATB 34 4 element tribander	\$195 95
A147 11 11 el 2 M Beam	26 50
A147 22 22 el 2 M Beam	73 95
ARX 2 Ringo Ranger 2M	27 95

ROTORS

Ham III	\$117 00
T2X Tailwister	217 00
Alliance HD 73	99 00

WILSON

System One	\$209 00
System Two	167 00

SAXTON WIRE & CABLE

See Sept. Issue

COMMUNICATIONS C89 SERVICES



326A WEST MAIN STREET
PHILADELPHIA MS 39359
PHONE: 601-456-5345
HOURS: 9-5 Mon-Fri.

Send stamp for price list or \$1 check for full line catalog. \$1 refundable on first order. We ship only to 50 states. All shipping is FOB.

NEW ELECTRONIC PARTS

Brand name, first line components. Stocked in depth. 24 hour delivery. Low prices and money back guarantee on all products we carry.

STAMP BRINGS CATALOG

SPECIALS KEYBOARD ENCLOSURES

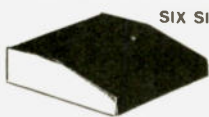

SIX SIZES	W	D	H	PRICE
14"	8.3"	3"		\$15.20
17"	8.3"	3"		18.35
20"	8.3"	3"		19.25
14"	11.3"	3"		16.50
17"	11.3"	3"		18.80
20"	11.3"	3"		20.75

Blue base, specify white or black top.

MAGNA-LITE JR

ONLY
\$5.79



IDEAL FOR

- Printed Master unit reading
- Electronics - Design, Production & Inspection
- Industrial - Engineers, Technicians, Draftsmen
- Laboratory & Research

RTTY

UT4 SPEED CVTR BOARD
KIT \$109.95
BOARD ALONE \$18.95
AUTO CW ID KIT \$37.90

VISA

SHIPPING
INCLUDED
IN PRICE

Daypro Electronics, Inc.

Formerly NuData Electronics - D35

3029 N. WILSHIRE LN., ARLINGTON HTS. ILL. 60004
PHONE 312-870 0555

NOW!

DIGITAL READOUT FOR YOUR YAESU FT-221/221R

YC-221 Digital Display. Only \$69.50 plus shipping. Kit for older FT-221s \$3.00 plus shipping. Built by Yaesu.

*California residents, add 6% sales tax to your order.

Send your check or
Money Order to:

**R. LEE TOWER
INTERNATIONAL**

13401 South Hoover Street
Gardena, CA 90247



**RTTY
made
easy**

TU 170 kit \$149.95
wired \$219.95

State of the art design features make the TU-170 ideal for HF and VHF autostart operation at an unchallenged price.

- SIZE 7 1/4" W x 3 1/4" H x 7 1/2" D
- Proved 170Hz shift 3 stage active filter demodulator
- Lighted tuning meter for easy tuning
- Current regulated loop keyer and power supply
- Autostart with threshold control and solid state relay
- Stable audio frequency shift oscillator, produces phase coherent sine wave tones
- TTL compatible inputs and outputs for auxiliary equipment
- High level output for scope tuning

FLESHER CORP.

P.O. Box 976

Topeka, Kansas 66601

(913) 234-0198 ✓ FS

VISA



How You Can Convert Your Rohn 25G Tower to a FOLD-OVER

**CHANGE, ADJUST OR JUST
PLAIN WORK ON YOUR
ANTENNA AND NEVER LEAVE
THE GROUND.**

If you have a Rohn 25G Tower, you can convert it to a Fold-over by simply using a conversion kit. Or, buy an inexpensive standard Rohn 25G tower now and convert to a Fold-over later.

Rohn Fold-overs allow you to work completely on the ground when installing or servicing antennas or rotors. This eliminates the fear of climbing and working at heights. Use the tower that reduces the need to climb. When you need to "get at" your antenna . . . just turn the handle and there it is. Rohn Fold-overs offer unbeatable utility.

Yes! You can convert to a Fold-over. Check with your distributor for a kit now and keep your feet on the ground.

AT ROHN YOU GET THE BEST

**Do not attempt to raise antenna or
antenna support near power lines—
You can be KILLED.**

Unarco-Rohn
Division of Unarco Industries, Inc.
P.O. Box 2000 Peoria, Illinois 61601

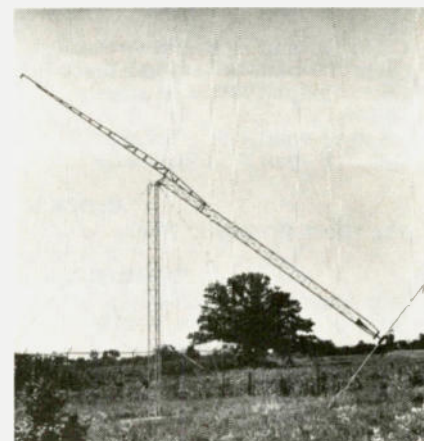
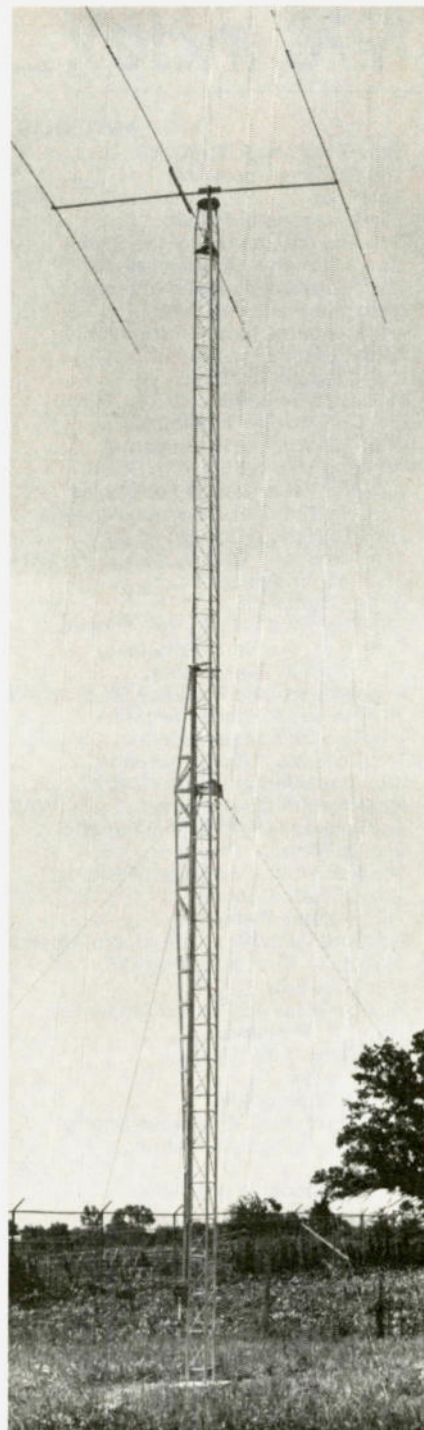

1978 Index

ANTENNAS

Tune Your Tower To 80/160.....	K9SOQ	118	Jan
The Extreme Basics of Antennas.....	K4SE/WA4DBG	116	Feb
The \$5 Magnetic Mount.....	WA2UMV	118	Feb
Keeping the Zap Out of the Shack.....	W7RG	130	Feb
Can A Miniature Antenna Work?.....	W6AQM	160	Feb
The Powerful Grounded Antenna.....	W0SII	26	Mar
Meet the Plastic Wonder.....	K0OXB/5	58	Mar
A 2m Antenna for the Perfectionist.....	WB2AWG	154	Mar
A Brass Horn For X-Band.....	W1SNN	164	Mar
Extended Double Zepp.....	W6TYH	34	Jun
New Dipole Feeder.....	AA6AX	38	Jun
The Cliff-Dweller's Delight.....	WA2UVC	40	Jun
Wait Till You Try 16 Elements!.....	WA8FCA	42	Jun
Working 15m With A 20m Beam.....	W8ZCQ	46	Jun
A Better Feedthrough For Cables.....	WA8FCA	50	Jun
Resurrecting The Beverage Antenna.....	W5USM	52	Jun
How To Hang A Longwire.....	W5GN	58	Jun
The "German" Quad.....	WD4CPK/DF3TJ	60	Jun
Mobile In Disguise.....	K9MLD	62	Jun
Better Than A Quad.....	WA4NWW	64	Jun
The Perverted Double Vee Antenna.....	W5VSR	66	Jun
Towering Low Band Antennas.....	K3OQF	74	Jun
The 80 Meter Pile Crusher.....	W2OZH	76	Jun
Phased Verticals For Easy DX.....	W1ZY/LA0BP	82	Jun
The Miserly Magnetic Antenna.....	W2AZD	86	Jun
The 75m DX Chaser Antenna.....	N4VD	88	Jun
The Invisible Allband Antenna.....	WA4FYZ	92	Jun
Who Says Verticals Don't Work?.....	W2LFLJ	96	Jun
New Use For CB Antennas.....	WA2KBZ/JY9KS	122	Jun
Confessions Of A Vertical Fanatic.....	KH6HDM	134	Jun
The 21-Element Brown Bomber.....	W9CGI	140	Jun
The Two Hour, Two Meter Beam.....	WB9TNW	154	Jun
The OSCAR Boppers.....	G3ZCZ/W3	160	Jun
The S-Meter Bender.....	W8HXR	170	Jun
Amazingly Simple Log Periodic Antenna.....	K1QAR	174	Jun
Disguised Birdhouse Vertical.....	K5LUW	178	Jun
Enjoy All Five Bands.....	W8FX/4	32	Jul
Novice Guide To Phased Antennas.....	W8HXR	48	Jul
The PVC Portable.....	WA6RJK	48	Aug
The Swiss Fork Special.....	Staff	90	Aug
The Sneaky J.....	W8FX/4	160	Aug
High Q Antennas.....	K4KI	68	Sep
The Ten Meter AM Antenna Special.....	W6RCL	146	Sep
Antenna Design: Something New!.....	W4FD, W4ATE	282	Oct
The Schizophrenic Triangle.....	WA4JTT	44	Dec

CALCULATORS

Negative Numbers On A \$9 Calculator.....	WB6IXT/7	32	Jan
The Experimenter's Dream Calculator.....	Reid	114	Apr

CB

The Ham CBER.....	WA4BBU	172	Jan
CB to 10—part VIII: the Publicom I.....	WB6LQE	98	Feb
From CB To Amateur Radio.....	WB4POH	114	Mar
How About SSB CB Conversions?.....	W4GBB	96	Jul
What? CB Repeaters?!......	WA4EOX	34	Aug
CB to 10—part IX: a pair of Radio Shack rigs.....	WB2UYI	78	Aug
CB to 10—part X: Realistic's Mini 23.....	K5LUW/K5SA	138	Sep
CB to 10—part XI: Hy-Gain's PLL rigs.....	WB5BSG	172	Sep
CB to 10—part XII: convert a Kraco PLL rig.....	W1PI	254	Oct
CB to 10—part XIII: the Lafayette Telsat.....	DF1SPW2	86	Nov
CB to 10—part XIV: a Realistic PLL.....	K0QLC	120	Nov
CB to 10—part XV: a Realistic HT.....	K5UKH	238	Nov

CLOCKS

The "Do It All" Digital Clock.....	K6UGT	176	Aug
------------------------------------	-------	-----	-----

COMMERCIAL GEAR

Reprogram Your IC-22S.....	W6UTE	54	Jan
Simple Scanner For the IC-22S.....	KH6EM	74	Jan
Improve the AX-190 Receiver.....	WA3TLD	106	Jan
I Love My GTX-1.....	WA4HVH	150	Jan
Heath HT Goodies.....	WA1ZS	180	Jan
Drake TR-4CW Review.....	K4TWJ	30	Feb
The Tempo 2020.....	WA2KOK	48	Feb

Put A Sony In Your Shack.....	Staff	102	Feb
Don't Miss the Excitement of QRP.....	K9SGZ	62	Mar
Wireless Monitoring For the Bionic Ham.....	W8FX/4	134	Mar
The Go Pro HT Mod.....	W8FX/4	152	Mar
Good Grief, Not the 22S Again?.....	WB2LEI	172	Mar
Improve Your HW-2021.....	K1WXX	130	Mar
The IG-102 Goes Transistor.....	Rossnick	120	May
No, Not Another 22S Mod?.....	VE2TM	158	May
Cushcraft Does It Again!.....	K1OPQ	166	Jun
Can A \$20 FM Rig Work?.....	WB4LJM, WA4WDL	52	Jul
Hiss Exterminator.....	K9POX	54	Jul
The FM Rebroadcaster.....	W8FX/4	72	Jul
22 Remote.....	W8FX/4	80	Jul
The IC-22S Scanner.....	W9LIJ	86	Jul
A Much Needed Micoder Power Supply.....	K3MPJ	90	Jul
Sometimes A Kit Is Best.....	W6SWZ	150	Jul
Rock Steady.....	WA5RON	60	Aug
Updating the Wilson 1402.....	WA9RAQ	114	Aug
HW-101 Owners, Check This!.....	HB9BLU	126	Aug
The Toggled 22.....	Fletcher	148	Aug
The End of Autopatch Embarrassment.....	W4CUG	168	Aug
Another IC-22S Scheme.....	WA1ZMQ	44	Sep
Improving the SWTPC UDI.....	K3MPJ	46	Sep
When In Doubt, Improvise!.....	W6LTV	72	Sep
The Case of the Missing Offset.....	K3JZD	118	Sep
What Do You Do With A Timekube?.....	Staff	122	Sep
Another Trick for the 22S.....	WB7SHW	164	Sep
Micoder™ Magic.....	K4BJF	214	Sep
Mighty Mods for the 820S.....	K4FK, WA4KIL	48	Oct
Improving Heath's HT.....	WA6TLK	54	Oct
Oddball Splits and the IC-22S.....	W6YUY	64	Oct
Triple Threat.....	K3CMY	130	Oct
Two Meter HT Survey.....	K5XY	142	Oct
Happiness Is A Smart Scanner.....	K8JS	250	Oct
Improved Scanner for the VHF/One Plus.....	W7AAY	262	Oct
Further Adventures of the IC-22S.....	W6WUT	274	Oct
The Multifunction Scan Can.....	W11BI, W1HZH	192	Nov
Happiness is a DMM Kit.....	W7AAY	208	Nov
Deep Dark Secrets of the TR-7500.....	WB9SEQ	212	Nov
Heath's GR-88 Gets Religion!.....	W2A0O	222	Nov
Wow! A Good Portable Receiver!.....	WA2EJT	130	Dec
The XITEX Video Terminal.....	AH6AQ	132	Dec
Light Up Your Life.....	WA4NUE	136	Dec
The 22S Goes Digital.....	KH6IEL	206	Dec

CONSTRUCTION

Forget Ohm's Law.....	Stanfield	46	Jan
Build A Deluxe QRP Transmatch.....	WB4VLQ	61	Jan
Dodge That Hurricane!.....	WB4IXK	62	Jan
New Life For Old Transformers.....	WA7NEV	70	Jan
Cool It!.....	K4KI	78	Jan
Build A Simple Capacitance Meter.....	W8DCC	164	Jan
PC Techniques.....	Staff	168	Jan
Inexpensive EKG Encoder.....	WA3AJR	20	Feb
Build A Better Phone Patch.....	Poirier	28	Feb
Build A 3-1/2 Digit DVM.....	WA5VQK/5	40	Feb
Tune-Up Aids For the Blind.....	WB1FFQ	64	Feb
Measure Periods With Your Counter.....	K6MWM	92	Feb
The Overkill Stall Warner.....	W9CGI	150	Feb
Flash Project For Camera Fiends.....	WA6UNK	140	Mar
The Solar-Powered Ham Station.....	W5VBO	146	Mar
A Cheapskate's Circuit Board.....	WA1BVD	168	Mar
Build This Digital Ball Game.....	N2RG	36	Apr
In Search Of The Ultimate.....	W6YUY	66	Apr
Super Deluxing the TR-33.....	WA6JFP	72	Apr
Hey, Old-Timers! The Breadboard Is Back!.....	WA7NEV	46	May
The COR Goes Solid State.....	WA6ILQ	162	May
Enjoy All Bands With A Remote Tuner.....	KL7AE	118	Jun
Counter Accuracy For Perfectionists.....	K0KDT/5	76	Jul
Graduate to a Better Operating Desk.....	WB6EKO	48	Sep
Relief for the Rockbound.....	WB2EQG	74	Sep
The ARC Tuner.....	K9QLL	128	Sep
Buddy, Ya Got A Match?.....	K4KI	152	Sep
"Stop Timeouts!" Revisited.....	WB3ELV	168	Sep
Add-A-Scanner.....	N2YK/WB2NYK	116	Nov
The Circuit Board Aquarium.....	WB9QZE	240	Nov
Build a Realistic S-Meter.....	DJ3NW	126	Dec
Build the Flexi-Filter.....	W3QVZ	222	Dec
The Klassic Kilowatt.....	K4TWJ	226	Dec
Code-Practice Oscillators.....	W6GXN	256	Dec
PCs Are Easy.....	VE3CGE	270	Dec

CONTROL

Simple Sequential Decoder.....	W7JSW	166	Jan
The World Of Tone Control.....	K3JE/2	82	Mar

Fake 'Em Out With Remote Control.....	W4VGZ	52	May	KIM-1 Can Do It!.....	W4CQI	68	Feb
The Miser's Delight Repeated Controller...	W2PMX	124	May	A Secret Weapon For Road Rallies.....	K9PTI	72	Feb
Give 'Em A Break.....	WB6JPI	62	Jul	Looking For A Micro?.....	O'Reilly	76	Feb
Should Repeaters Use Subaudible Tones?...	K9XI	102	Jul	Fiendish New QUBIC Program.....	Bishop	78	Feb
Power Line DX.....	N2CX	52	Aug	Put An ELF In Your Keyer.....	WB9MQY	82	Feb
Hung Up On Autopatch?.....	WA6THG	112	Aug	Try HCAI.....	Hughot	84	Feb
The Tiny Tone Repeater Saver.....	W4VGZ	132	Aug	Solve Those Parallel Problems.....	N3IE	88	Mar
T-R Exotica.....	W4VGZ	32	Sep	At Last! An RFI-free Computer.....	WB6JYK	92	Mar
The Autodialer Revisited.....	W7JSW	34	Sep	Another Approach To the ASCII/Baudot			
The Easiest Offset Ever.....	K4GOK	74	Nov	Headache.....	K4HBG	96	Mar
Automatic Repeater Offsets.....	N2YK/WB2NYK	82	Nov	Programming Coil Design.....	K7SBK	98	Mar
The 28¢ Touchtone™ Mod.....	W9CGI	56	Dec	Outstanding Computer Bargain			
SSTV Recorder Controller.....	K3JML	82	Dec	Exposed.....	WA6JSF	104	Mar

COUNTERS

VHF On Your Frequency Counter.....	WB0CLH	34	Oct
Good News!.....	Lassagne	44	Oct

CW

Brass Pounding Simplified.....	K6JM	58	Feb
Simple CW Interference "Filter".....	W8FX/4	132	Apr

DIGITAL

You, Too, Can Go Digital.....	K2RB	32	Mar
The Best Probe Yet?.....	WA6JMM/N6WA	134	Apr
A Darn Good IDer.....	K5OM	142	Jul
Time and Tide—Digitally.....	WA1TNG	156	Aug

GADGETS

The Trailer Light Solution.....	W1HCl	50	Feb
Custom-Made Thermistors.....	W7RXV	60	Feb
Super Siren.....	K3JE/2	96	Feb
New Protection For Your Car.....	WA4GIM	76	Mar
Kerchunk Counter.....	W6NUI	143	Mar
Shock the Car-Burglar.....	W1DIS	185	Mar
The Super Select-o-Ject.....	W8FX/4	116	May
De-Zap Strap.....	W6SWZ	156	May
The New, Improved Automatic Thermo-			
stat.....	W9YBU	60	Jul
It's Flora Clock!.....	W8FX/4	64	Jul
Computerized Capacity Meter.....	Eccleston	88	Jul
The Universal Notcher.....	W9CGI	98	Jul
Beat the Microphone Blahs.....	K1HQW/4	134	Jul
Roy Rogers Special: Triggered Sweep.....	Renaud	156	Jul
Watch the Wind!.....	WA4FWR/5	172	Jul
The Op Amp Beam Heading Indicator.....	K0BV	118	Aug
Watergate Special.....	HB9BLU	36	Sep
Be Mr. Clean!.....	WB4FXD	142	Sep
Maintain Control!.....	Stanfield	170	Sep
Active Voltage Divider.....	PY1AQL/CT1EM	174	Sep
Light Right?.....	Mills	204	Sep
Build A Better Beeper.....	W3QVX	122	Oct

HISTORY

How It Was.....	W6LM	152	Jan
The History of Ham Radio—part VI.....	W9CI	68	Oct
The History of Ham Radio—part VII.....	W9CI	90	Nov

HUMOR

I Need A Contact.....	WB2DYU/2	138	Mar
Murphy's Masterpiece.....	WA6PPZ	48	Nov

IC

Test Those ICs!.....	W7BBX/4	24	Jan
IC Timer Review.....	W3HB	40	Jan
The Op Amp Encyclopedia.....	K4IPV	166	Feb
How Do You Use ICs?—part			
IX.....	WA2SUT/NNN0ZVB	44	Apr
Is TTL Already Obsolete?.....	WB5IRY	120	Apr
Schottky: A New IC Generation.....	McClellan	158	Apr
The New Op Amps.....	WA0UVX	78	Jul
How Do You Use ICs?—part			
X.....	WA2SUT/NNN0ZVB	94	Sep
Build the IC Experimenter.....	Leonard	220	Sep
The Long-Term Effects of Working with			
ICs.....	WA2SUT/NNN0ZVB	182	Oct
Bargain Preamp.....	W5REZ	44	Nov
555 Basics—And More!.....	WB4CEO	60	Nov

I/O

To Err Is Human.....	WB2TOC	86	Jan
Practical Computer Projects.....	Mickle	92	Jan
You'll Like SOL!.....	WB6JYK	94	Jan
How To Keep Your Computer Happy.....	WD9DDV	98	Jan
The Bionic Clock!.....	W4CQI	102	Jan

Do Biorhythms Really Work?.....	W4KFT	110	Mar
Feeding A Hungry Microcomputer.....	W6GXN	76	Apr
The Exterminator.....	Lasher	84	Apr
At Last! A Use For Your Computer!.....	Stewart	88	Apr
Now Anyone Can Afford A Keyboard.....	Eaton	92	Apr
Godbout Strikes Again.....	WA7NEV	102	Apr
The Klingons Are Coming!.....	WB9LSS	104	Apr
Diary Of A Survivor.....	WA6PPZ	92	May
How Good Is the North Star Disk?.....	Bosen	100	May
Pseudorandomness Is Just Not Good			
Enough.....	WA1PTZ	103	May
Beethoven Need Not Fear.....	G8HBR	106	May
Hex Converter For True-Blue Octalists.....	Dolinear	110	May
The Cheaper Beeper.....	VE2BVV	111	May
Semi-Instant Program Loading.....	WB4GXE	112	May
Low-Cost Keyboard- II.....	Eaton	100	Jun
Computerized Loop Antenna Design.....	WB2IPD	108	Jun
Hey! Wait For Me!.....	WA3MWM	111	Jun
Morrow's Marvelous Monitor.....	Eigsti	114	Jun
RAMmed by Morrow.....	Hallen	110	Jul
Six Said His First Words Today!.....	WA3MWM	112	Jul
The 22S Programmer Program.....	W6OVP, K6MAR	114	Jul
The Occult Computer.....	WA6VIY	116	Jul
A Baudot Program For Your Micro.....	Fricke	118	Jul
The Calculating KIM-1.....	Lasher	100	Aug
A No-Cost Digital Clock.....	N8RK	106	Aug
The BASICS of L-Network Design.....	K7SBK	108	Aug
Nuclear Attack!.....	WA7WKA	100	Sep
Computerized QSO Records.....	WA7VZR	106	Sep
RAM Checkout's A Snap.....	WA7NEV	112	Sep
Interrupts Made Easy.....	WB6LOA	146	Oct
Use A Computer? Who, Me?.....	WB2HJD	154	Oct
Bird Watching in BASIC Land.....	K6EW	156	Oct
Computers and the Real World.....	W1FZA	161	Oct
World's Cheapest QSLs.....	WA7VZR	166	Oct
"Look What Followed Me Home!".....	Lilie	142	Nov
A Hex on Your 8223.....	Schneider	148	Nov
The Micro Maestro!.....	K6EW	150	Nov
SSTV Meets SWTPC: Part 1.....	K6AEP	168	Nov
Whither Microcomputers?.....	WB2HJD	148	Dec
SSTV Meets SWTPC: Part 2.....	K6AEP	152	Dec
A Multi-Memory Morse Machine.....	WA8TIW	160	Dec
"This is Your Computer Speaking".....	Sorrels	164	Dec
RTTY with the KIM.....	VE1AKL	170	Dec
DX Delight.....	WA4VQD, N3NN	174	Dec

KEYERS

Try A Sensor Keyer.....	WB4TED	184	Jan
The New, Improved "Best Keyer Yet".....	K4JEM	22	Mar
Novices, Paddle Your Way To			
Happiness.....	W0OGX	44	Mar
A Keyer? Who Needs Another Keyer?.....	W6APZ	24	May
The \$5 Memory Keyer.....	WA2EBY	100	Jul
The Heavyweight.....	K9MX	74	Aug
Sidetone Is A Must.....	VE3EKR	128	Aug
Custom-Make Your Key Paddle.....	W6JB	150	Aug
Build the Triple Threat Keyer.....	W8FX/4	144	Sep

MISC

The Unbeatable Base-Loaded Three-Element			
Rotary Vertical.....	W3KBM	22	Jan
Hooking the Kids.....	DiBlasi	114	Jan
Home Brew An Elephant!.....	WB6IQS	146	Jan
Grow A Giant Junk Box!.....	WB7CTH	158	Jan
Is It Glass ... Or Iron?.....	WA2SUT/NNN0ZVB	160	Jan
Raid!.....	W8JJO	88	Feb
See Q, See Q.....	VE3FLE	90	Feb
Coming of Age.....	VE3FLE	100	Feb
How To Compete With An HT.....	VE7AQS	110	Feb
S.A.S.E.....	W9CGI	112	Feb
A Ham's Life Cycle.....	VU2JS	114	Feb
How To Dissipate 200,000 Megawatts.....	W4NKV	158	Feb
The Great Cover-Up.....	W4FXE	78	Mar

Are You Afraid To Build?.....	W4RYO	156	Mar	Tracking the Wild Turkey.....	WA8BHR	64	Sep
Can A Diode Replace A Relay?.....	Staff	184	Mar	Meet Mr. Blizzard.....	K8YQH/AA8P	88	Sep
If You Want To Know Where You Are.....	Burhans	108	Mar	The Blizzard of '78.....	W8HXR	92	Sep
CW the Hard Way.....	Pelton	178	Apr	Two Meters At The Summit.....	W6FJT	224	Sep
Why Not Go First Class?.....	W9CGI	84	May	DXpeditioning.....	WA2VMS	26	Oct
Another Ten Minute Timer?.....	N9MX, K9MX	128	May	The Lady Saw Red.....	WB4ZVZ	184	Oct
If You Want To Know Where You Are.....	Burhans	146	May	Tweaking Your Linear.....	W5VSR	252	Oct
Scare the Hell Out Of Burglars.....	WA6WUI	160	May	Support Your Local Fire Chief.....	W1FYR	258	Oct
Happiness Is Being A Ham Manufacturer.....	W2NSD/1	30	Jun	Try FM On 29.6 MHz.....	WA7WYF	184	Nov
Creeping Crud Got Your Signal?.....	K4TJW	72	Jun	Automatic Autopatch.....	W6GJS	266	Nov
Modernize The Matchbox.....	W8FX/4	84	Jun	A DXer's Dream Vacation.....	WB6JPZ	30	Dec
The Towerless "Tower".....	K4FK, N4OG	146	Jun	POWER SUPPLIES			
Finding Radio Pests.....	WA1UUK	42	Jul	Power Supply Regulation.....	WA3TLD	140	Jan
Video Magic For Your Home.....	K4TJW	44	Jul	How To Cut Costs On Power Supplies.....	W9HDA	28	Mar
Instant Engraving.....	W7RXV	58	Jul	Surprisingly Low-Cost Lab Supply.....	W6GXN	132	Mar
J. B. Fields, Radioman.....	WB7SZC	74	Jul	Avoid An Overvoltage Catastrophe.....	W7RXV	176	Mar
Handling Ole George.....	K5GNZ	84	Jul	Coming In Out Of The Cold.....	W6GXN	154	Jul
Forbidden Contacts.....	Nobel	136	Jul	In the Eye of the Beholder.....	WB6JYK	64	Aug
Instant Paddle.....	W3IHA	170	Jul	Super Charger.....	WA7YGB	120	Aug
The War Against Rust.....	K8AO	176	Jul	Don't Let Your Battery Die.....	WB8TXG	151	Aug
Radio Row Revisited.....	W8JJO	26	Aug	Power Supply Magic.....	Burt	78	Sep
Shock!!.....	McAlister	44	Aug	Charge!.....	W4VGZ	201	Sep
Sleight of Hand.....	K4SE	76	Aug	The Frugal Alternative.....	W8FX/4	186	Oct
2001 - 3.....	WA5SNZ	94	Aug	A Perfect Power Supply?.....	WB3BUU/8/K8UR	268	Oct
Dispense It Right!.....	W4RYO	141	Aug	Build the Brute.....	N9KV	186	Nov
Ham Radio Is NOT A Rich Man's Hobby.....	WA6NCX/1	142	Aug	Four Terminals Are Better Than Three.....	W1SNN	226	Nov
Poor Man's Cruise Control.....	W9CGI	184	Aug	Fail-Safe.....	WA7DPX	250	Dec
Be Legal.....	AD4A/WA4MFY	40	Sep	RECEIVERS			
The SWL Bible.....	W2XQ	50	Sep	Old Receivers—A Hidden Gold Mine.....	W6GXN	36	Mar
Relax and Unwind.....	WA4TJJ	98	Sep	Build This Excitingly Simple Receiver.....	K4DHC	76	May
Home-Brew Circuit Boards.....	W9IWI	132	Sep	Build Your Own Digital Dial.....	W1OOP	66	Jul
Kerchunk... Kaboom!.....	N5KR	140	Sep	RTTY			
The KM1CC Story.....	WA1JWD	38	Oct	On Your Mark!.....	WA4KIL, K4FK	82	Aug
Reusing Coax Connectors.....	W0FEV	72	Oct	The UART Gear Shifter.....	KB8CE	38	Nov
Building From Magazine Articles.....	WA7NEV	74	Oct	Novel RTTY Autostart.....	K2OAW	68	Nov
Hello Hamdom!.....	WN3NNY	102	Oct	No More Excuses!.....	WB4MBL	124	Nov
More "Coming Of Age".....	VE3FLE	103	Oct	The TTY Lifesaver.....	Sergo	216	Nov
High Seas Adventure—Ham Style— part I.....	WA6FEI	112	Oct	Build the "Version Three".....	Colby	218	Nov
DMM Buyer's Guide.....	McClellan	126	Oct	Blockbuster RTTY Article!.....	W9IF	254	Nov
The Ultimate T-Hunt.....	WB6JPI	136	Oct	SATELLITE—OTHER THAN OSCAR			
It's A Ham's World.....	K2HTO	210	Oct	Weather Satellite Pix Printer.....	W3KH	82	Jan
Tuned Circuits In Your Junk Box.....	W3KBM	256	Oct	Toward A More Perfect Weather Picture.....	Cawthon	116	Apr
Electro Sculpture.....	VP2DN	32	Nov	Attention, Weather Watchers!.....	Cawthon	218	Oct
Silence Groaning Refrigerators.....	K4KI	42	Nov	Be A Weather Genius.....	WB8DQT	198	Nov
How About Some Ham Shack Safety?.....	W7FGD	52	Nov	Autophasing for WEFAX.....	Cawthon	96	Dec
Who Uses All Those Frequencies?.....	WB6JPI, WB6HDB	104	Nov	SSTV			
MDS: What Is It?.....	Edwards	106	Nov	What Are They Showing On SSTV?.....	K4TJW	24	Feb
The Junk Box Station.....	WA4DQN	126	Nov	What Happened To SSTV?.....	K4TJW	72	May
R-X Bridge + Calculator = Vswr.....	WB5ILK	130	Nov	SURPLUS			
High Seas Adventure—Ham Style— part II.....	WA6FEI	136	Nov	Space Age Junque III.....	W9CGI	170	Jan
Squelchifying Cheap Receivers.....	WA1PDY	182	Nov	Surplus Adventures.....	W9HDA	126	Feb
Vintage Receiver Mods.....	W2OLU	210	Nov	Be A Surplus Survivor.....	WB4APC	62	Sep
Using Bargain Muffin Fans.....	K4SE	276	Nov	Another Surplus Treasure.....	McClellan	96	Nov
Ham Help!.....	N4AL	286	Nov	Space Age Surplus.....	Endress, Endress	60	Dec
Close Encounters.....	K8NQN	36	Dec	TEST GEAR			
Receiver Diseases.....	K4IPV	90	Dec	Brew Up A Signal Generator.....	Staff	50	Jan
High Seas Adventure—Ham Style— part III.....	WA6FEI	142	Dec	Clean Up Your Act.....	Staff	136	Jan
The Packet Radio Revolution.....	VE2PY	192	Dec	Build This FM Signal Generator.....	W9HDA	154	Jan
WARC '79 Preview.....	WA9MZS	212	Dec	Pulses Galore!.....	Playcan	194	Jan
Ham Radio Goes To School.....	N2CF	230	Dec	Versatile Transistor Tester.....	WA5TFK	122	Feb
The Games People Play.....	WB3EUG	274	Dec	The Quicker, Slicker Transistor Checker.....	Sergo	31	Mar
An Improved HV Tube Socket.....	Miller	287	Dec	How Many pF Is That Capacitor, Really?.....	WA0ZCR	48	Mar
MOBILE/PORTABLE							
Hands-free Mobile Mike.....	W9KXJ	178	Jan	How Much Power Does It Draw?.....	Fowler	131	Mar
The Double Whammy Mobile Clarifier.....	K8JS	168	Apr	The Amazing Zener Sweeper.....	WB4YOD	178	Mar
The Amazing Mobile Life Preserver.....	W2EVM	51	Aug	Ecstasy in Multimeterland.....	WA4AIH	24	Apr
The Mobile Dream Machine.....	K9SQG/8	58	Sep	Use Noise To Tune Your Station.....	W6DOB	160	Apr
Mobile Security Blanket.....	WA1RTD	270	Oct	Now—A Digital Capacity Meter!.....	W3KBM	58	May
OPERATING							
Guilty? Or Not Guilty?.....	WA6HDK	69	Jan	Make Antenna Tuning A Joy.....	K5QY	134	May
Where, Oh Where.....	W2XQ	138	Jan	Home-Canned Dummy.....	WB2BWJ, WA2JZR	154	May
Shoestring Switching For CW.....	Baldwin	32	Feb	Reincarnating Old Test Equipment.....	W3KBM	40	Jul
Relaying For Fun And No Profit.....	N2RG	34	Feb	Your 'Scope Can Be Improved.....	N5KR	92	Jul
Repeater Procedure.....	WB4NAY	52	Feb	Pick A Frequency... Any Frequency.....	W8FX/4	146	Jul
QRP Hints.....	N2MW	54	Feb	In Search Of Stability.....	Burhans	80	Aug
How To Work Europe With An HT.....	WB9PYM	28	Aug	Build A TTY Tester.....	K7YZZ	198	Oct
Ruddy Good Show!.....	G3WDI	58	Aug	Interchangeable Test Leads.....	K3MPJ	249	Oct
The End of The Rat's Nest.....	WB9FRM	92	Aug	Build An Audible Transistor Tester.....	WB7NZG/DA1DB	291	Oct
Four-Wheel Frenzy!.....	K6WS	26	Sep				

The Chip Switch.....	WB2QEL	78	Nov	Tuned Feeders and Other Good Stuff.....	W0VM	118	Dec
Build An FM Tweaker.....	WA6THG/KH6JSA	100	Nov	Big Max Attacks.....	W2DU	182	Dec
FM Calibration on a Budget.....	W9HDA	108	Nov	The "Flim-Flam" Factor.....	WA2SUT/NNN0ZVB	216	Dec
Build the \$80 Wonder.....	W3HB	112	Nov	TOUCHTONE			
Build A Decent Dummy.....	K4IPV	244	Nov	Clean Up Your Touchtone™ Act.....	WA6THG	44	Feb
A Junk Box Load Simulator.....	W5JJ	252	Nov	Autopatch Digit Suppressor.....	K4FFW	124	Feb
An Experimenter's Delight.....	WA1WLW	288	Nov	Painless Touchtone™ Adjustment.....	W3HT	146	Feb
The Lunch Counter.....	WA4PIN	105	Dec	Is Your Repeater Up-To-Date?.....	W4VGZ	66	Mar
This Voltage Standard Is Precise!.....	WB6NTR	200	Dec	A Cheaper Chip.....	W7JSW	150	Mar
What's Your uF?.....	K5BTV	234	Dec	How To Thwart Ma's Dial System.....	Ring	164	Apr
THEORY				Quick Check For TT Pads.....	K3BPP	115	Aug
Think You Understand SSB?.....	W2FEZ	34	Jan	Total Control.....	WB2MPZ	60	Oct
Try The ID VIP Method.....	Hargett	58	Jan	Super Simple TT Generator.....	WA6AFX	78	Oct
Op Amp Insights.....	K4IPV	142	Jan	TRANSCEIVERS			
Transistor Primer.....	K1UZ	149	Jan	Tighten Up Your SB-102.....	W2PQG	53	Feb
Ham Shack Anthropometrics.....	W3ZVT	174	Jan	TS-700A Calibrator.....	K9POZ	128	Feb
Logical Logic.....	N6WA/WA6JMM	188	Jan	Exorcising Power Supply Demons.....	K4IPV	52	Mar
How To Use A Varactor.....	W6JB	182	Mar	Rejuvenate A Pawnee!.....	K4GRT, W4IEV	104	Oct
New Life For Your Old Dipper.....	W2CHO/K4EA	40	Apr	TRANSMITTERS			
How Sunspots Work.....	WA4FDE	136	Apr	Old Rigs Can Live Again!.....	K4IPV	40	Mar
Danger! Microwave Radiation.....	WB6JPI	170	Apr	You're Still Using Tubes?			
Official FCC RFI Report.....	FCC	30	May	Yecccch!.....	W6HPH/G5AWI	50	Apr
DMM Survival Course.....	McClellan	62	May	VHF			
Novice Guide To Phased Antennas.....	W8HXR	136	Jun	Try 220, You'll Like It!.....	K0OST	154	Feb
The End of Rf Feedback.....	K4TWJ	72	Aug	VHF Notch Filter.....	WA4WDL, WB4LJM	123	Jul
A WWV Primer.....	W8FX/4	84	Aug	Yes, You Can Build A Synthesizer!.....	K2DVQ	124	Jul
New Life For Double Sideband.....	K1IO	152	Aug	VHF Transverters and the FT-101.....	W6OJF	168	Jul
More CW Fun With Break-In Keying.....	WB0KTH	180	Aug	UHF			
DVM Scrapbook.....	McClellan	82	Sep	UHF Propagation.....	KL7IEP/1, W1KIQ	62	Feb
Gourmet Guide To Capacitors.....	W5JJ	126	Sep	1220 MHz—Use It Or Lose It!.....	K1CLL	72	Mar
Reveals Bias!.....	W5JJ	136	Sep	How To Succeed On 1296.....	W4UCH/2	32	Apr
Microstrip.....	N6TX	80	Oct	The Challenge Of 10.5 GHz.....	W1SNN/WR1AJE	60	Apr
Low-Pass Filter Primer.....	K2OAW	98	Oct	Can Hams Counter Police Radar?.....	WA4WDL	80	May
PLL Techniques.....	Earnshaw	188	Oct	Now Try 1296 MHz.....	WA4WDL, WB4LJM	158	Jun
The SUMSUE Method.....	K1RH	36	Nov	A Complete X-Band Transmitter.....	W1SNN	38	Aug
Head 'Em Off at the (High) Pass.....	WB6GNM	56	Nov	A New Type of 10 GHz Receiver.....	Kopeika, 4Z4TJ	222	Sep
Educate Yourself.....	WB1AHL	64	Nov	An X-Band Transceiver.....	W1SNN	64	Dec
One Meter—Many Jobs.....	Fletcher	102	Nov				
Who Needs Transistors?.....	W5JJ	250	Nov				
Loran-C as a Frequency Standard.....	WA4EID	278	Nov				
From CW to Computers.....	N6RY	48	Dec				

An Improved HV Tube Socket

— easy modification

Harry J. Miller
991 42nd St.
Sarasota FL 33580

pulse voltage on the plate pin of the socket. This may cause an arc to the adjacent cathode or filament pin.

Socket replacement, while proper, may take considerable time.

I suggest that a slot be cut with a keyhole saw between the pins which are defective. This air gap between the defective pins now provides better insulation than the original socket. ■

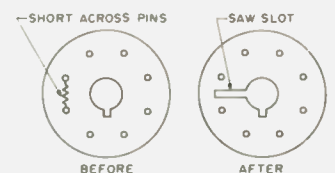

Fig. 1.

Vertical sweep amplifiers may have a high

QUALITY and SERVICE

SAME DAY SHIPMENT

TRANSISTORS, ETC.

type	case	IC	PD	MEP	each	ten
MPS410 NPN	T092	40V	1A	3W	50Hz	72¢
MPS452 PNP	T0202	40	1.5	1.0	150	53031
MPS456 PNP	"	60	1.0	5.0	50	"
MPS455 PNP	T092	60	5	5	50	708
2N2222 NPN	T092	30	8	5	250	736
2N2322 SCR	T0-5	25V	1	AMP	2ma gate I	"
2N2324 SCR	T0-5	150V	1	AMP	.02ma "	"
2N2325 SCR	T0-5	150	1	AMP	.2ma "	"
2N2907 PNP	T018	40	6	4	200	52
2N3440 NPN	T0-5	250	1.0	10.0	50	53021
2N3655 NPN	T0106	30	2	1	40	55
2N3639 PNP	T092	12	1	2	350	57
2N3640 PNP	T0106	15	2	2	400	57
2N3646 NPN	T0106	15	2	2	400	50
2N3704 NPN	T092	30	8	3	100	735
2N3903 NPN	T092	40	2	3	300	736
2N3904 NPN	T092	40	2	3	300	736
2N4248 PNP	T092	40	1	2	40	715
2N4250 PNP	T092	40	1	2	50	57
2N4400 NPN	T092	40	2	3	700	736
2N4437 NPN	T0106	30	5	2	250	736
2N5138 PNP	T0106	30	1	2	30	52
2N5172 NPN	T092	25	1	2	120	56
2N5210 NPN	T092	50	.05	3	80	728
2N5910 PNP	T0106	20	1	3	700	52
2N5954 NPN	T092	150	1	5	100	S0005
016P1 NPN	T098	12	(high gain)	10-pwr	DARL.	.20
040C1 NPN	T0220	30	5	6	DARLINGTON	.30
041D1 PNP	T0220	30	1.0	6	150	S3027
0448B PNP	T0220	60	10.0	50	50	"
RC105 PNP	T0220	60	5.0	70	PWR	DARLINGTON
MJE1091	T0220	60	5.0	70	PWR	DARLINGTON
MJE1100 NPN	T0220	60	5.0	70	PWR	DARLINGTON
TIP31A NPN	T0220	60	3.0	40W	"	"
2N6101 NPN	T0220	80	10.0	75	"	"
2N6304 H CHANNEL	FET	T0106	CASE	sim.	HEP802	.35
40327 NPN	T0-5	300	1.0	5W	"	40

* house number - we guarantee that the device sold is identical to the number specified. MEP numbers from MEP list.
 † leads are cut and formed for PC mount.

SPECIALS

WA776	programmable operation amplifier	\$1.00
F7068PC	Fairchild 5W audio pwr. amp.	"
ARM-1	14 pin DIP w/ integral heat sink	1.25
LM386	low voltage audio pwr. amp. (mini)	.40
MMS058	1024 bit static shift register (mini)	1.50
2504T	Sig. dyn. 1024 bit shift (T0-99)	.75
747	dual 741 operational amplifier DIP	.50
723	0-10V precision variable regulator DIP	.50
CD4011	CMOS gate	.19
CD4025	CMOS gate	.19
MC1303	stereo preamp (DIP)	1.00
LS1412	Lambda 12V 3A reg. (pulled out of computer board sockets) full spec. devices	3.95
7402	quad two input TTL NOR gate (DIP)	.12
7430	eight input NAND gate (DIP)	.13
7492	divide by twelve counter (DIP)	.30

TRANSISTOR BONANZA

\$6 per 100 - \$50 per 1000
 PRIME TO-18 PLASTIC TRANSISTORS FROM A FACTORY FIRST HOUSE. THESE ARE FIRST GRADE DEVICES WITH CUT AND FORMED LEADS AND HANDLED WITH A HOUSE NUMBER. THESE ARE NOT BARREL RECTIFIERS... PNP AND NPN AVAILABLE WE WILL SHIP 50/50 OR ANY MIX WITH 50¢ PRICE PER TYPE MINIMUM.

14 PIN GOLD PLATED WIRE WRAP 3 LEVEL SOCKETS

35¢ each
 25 for \$7.50
 100 for \$25

DIP TRIMMER

12 TURN 1/4" 1/2" 3/4" 5K or 200K units w/ DALE TEN FOR \$4

ZERO CROSSING SWITCH

A.C. powered 14 pin DIP IC used to trigger TRIAC devices... RCA CA3079

1/2 WATT RESISTORS

High quality, marked computer grade signal diodes. Leads trimmed for PCB mounting...

BISTABLE RELAY

SPD 6VDC 200 ohm coils 1 AMP, 20 watt PC contacts Long life (121049) oper. High speed (500 Hz) Hermetically sealed 1/8x3/8x3/4" \$2.95 ea

OPTO ISOLATOR

FCD820 6PIN DIP WILL DRIVE A TTL GATE WITH TEN MA LED CURRENT 69¢ ea ten \$6

Ge or Si SIGNAL DIODES

40 for \$2

POTTER BRUMFIELD

TYPE PSE RELAY 4PDT 3AMP 24VDC 650 ohm 120VAC 10.9mA please specify coil required \$1.60

VARO SEMICONDUCTOR

EPoxy BRIDGE RECTIFIERS 10 AMP 50V V1048 .90 ea. 10 for \$7.50 100-\$65

12 vdc REED RELAY

440 Ω coil .1" dpst n.o. PICTURE IS APPROXIMATION. RELAY HAS FOUR PINS ON ONE END AND TWO ON OTHER. PINS ARE SPACED .1" x 1". 1/22 CONTACTS.

DIODE ARRAY

10 IN914's 25¢ each 10 - \$2.25

special

20¢ ea. 10 - \$1.50 \$12.50/c CLAIREX

ELEC-TROL

79¢ ea. 10 - \$6

direct LINE (916) 334 2161 TOLL-FREE TELEPHONE SERVICE

24 HOURS A DAY \$15 minimum order
 7 DAYS A WEEK
 Dial: 800 423 2355 EXT 307
 PHONE ORDERS CAN ONLY BE CHARGED TO MASTER CHARGE OR VISA/BANK AMERICAN

BABYLON ELECTRONICS BOX 41778 4811 MYRTLE SACRAMENTO, CA 95841

CALL RUSH ELECTRONICS, INC. TOLL FREE

1-800-251-0264

TENN. RESIDENTS 1-615-764-0831

- AUTHORIZED DEALERS FOR**
- YAESU ROHN TOWERS
 - DENTRON LARSEN
 - CUSHCRAFT TURNER
 - WILSON CDE
 - HY-GAIN HUSTLER
 - CES KDK
 - BENCHER VIBROPLEX
 - ATRONICS ALLIANCE
 - TEMPO
- AND MORE...
 ALSO: THE APPLE II PERSONAL COMPUTER SYSTEM

CALL OR WRITE FOR THE BEST PRICES

ON AMATEUR EQUIPMENT

RUSH ELECTRONICS, INC.

NEW OUR CHRISTMAS SPECIAL

DENTRON SUPER TUNER PLUS
 Reg. 149.50 \$135.00

SUPER TUNER PLUS
 A full 1000 watts CW and 1200 watts SSB power handling capacity.

SOUTH'S FASTEST GROWING AMATEUR STORE
 1315 BLUFF CITY HWY. BRISTOL, TN 37620

TOWER/TUNER

RESONATES YOUR TOWER ON 40, 80 AND 160 !

NOW available for 160 meters



Now you can easily use your entire tower and present beam system as a complete low angle radiator on 40, 80 and 160 meters. It is common knowledge that a dipole or inverted-vee must be at least 1/2 wave length high (120 feet on 80 meters!) in order for it to be a low angle radiator. But your existing tower, if fed with the Stuart Electronics **TOWER TUNER**, can be made to be an optimum low angle radiator on 40, 80 and 160 meters. The Stuart **TOWER TUNER** can be installed and easily adjusted to a low swr on any tower no matter what the size or type. Tower can be grounded or not. Radials not necessary. No more haywire appearance of dipoles and I-V's. Even your wife will love it. The Stuart **TOWER TUNER** takes up virtually no extra space but greatly outperforms dipoles and I-V's at the same height plus it is easily adjustable from ground level. Start making better contacts on the 40, 80 and 160 meter bands with an antenna system that really gets out. The Stuart **TOWER TUNER** will handle 500 watts output.



We are so confident that you will like it that we offer a 30 day money back guarantee if you are in any way dissatisfied. Priced from \$129.95 includes shipping in continental United States.

STUART ELECTRONICS
 Dept. 9
 578 KENNEDY RD.
 AKRON, OHIO 44305
 (216) 798-9431

**SERVING
HAMS
BETTER!**

*North ... south ...
east ... west*

All leading brands ...
in-depth stocks ...
new/used gear.



Bob Ferrero, W6RJ/K6AHV, Jim Rafferty, N6RJ
other well known hams give you courteous,
personalized service

NOW...FREE PHONE!

**800
854-6046**

CALIF. CUSTOMERS PLEASE CALL OR VISIT STORES LISTED BELOW

**PLUS FREE SHIPMENT
ALL ITEMS U.P.S. (Brown).**

CALL US FOR SPECIAL PRICES ON:

- ALDA • ALLIANCE • ALPHA • AMECO • ATLAS • BIRD •
- CDE • COLLINS • CUSHCRAFT • CURTIS • DENTRON •
- DRAKE • EIMAC • HUSTLER • HY-GAIN • ICOM •
- KENWOOD • KLM • MFJ • MOSLEY • PALOMAR • ROHN •
- ROBOT • SHURE • SWAN • TELEX • TEMPO • TEN-TEC •
- TRISTAO • TELREX • TRI-EX • WILSON • YAESU • more.

KENWOOD!



DRAKE!



ICOM!



YAESU!



✓ H31

ANAHEIM, CA. 92801

2620 W. La Palma
(714) 761-3033, (213) 860-2040
1 mile east Knotts Berry Farm

SAN DIEGO, CA. 92123

5375 Kearny Villa Road
(714) 560-4900
Highway 163 & Clairemont Mesa Blvd

BURLINGAME, CA. 94010

999 Howard Avenue
(415) 342-5757
5 miles south on 101 from S F Airport

VAN NUYS, CA. 91401

6265 Sepulveda Blvd.
(213) 988-2212
San Diego Fwy at Victory Blvd



OVER THE COUNTER (Mon. thru Sat. 10 AM to 5:30 PM)

MAIL ORDER, Phone, Write.

electronic calculators

LIST	HAM NET	TEXAS INSTRUMENTS ELECTRONIC CALCULATORS
\$299.95	\$269.95	T.I.-59, 960 STEP PROGRAMMABLE SCIENTIFIC
124.95	112.45	T.I.-58, 480 STEP PROGRAMMABLE SCIENTIFIC
59.95	53.95	T.I.-57, 150 STEP PROGRAMMABLE SCIENTIFIC
49.95	44.95	T.I.-55, 32 STEP PROGRAMMABLE SCIENTIFIC
59.95	53.95	T.I. PROGRAMMER, CONVERTS DECIMAL/OCTAL/HEX
69.95	62.95	T.I. MBA, SUPER PROGRAMMED FINANCIAL
LIST	HEWLETT-PACKARD ELECTRONIC CALCULATORS	
\$750.00	\$675.00	H.P.-97, 224 STEP PROG SCIENTIFIC PRINT/VISUAL
450.00	405.00	H.P.-67, 224 STEP PROG SCIENTIFIC
275.00	247.50	H.P.-19C, 98 STEP PROG SCIENTIFIC PRINT/VISUAL
175.00	157.50	H.P.-29C, 98 STEP PROG SCIENTIFIC
175.00	157.50	H.P.-10 BASIC HAND HELD PRINTER VISUAL
325.00	292.50	H.P.-91, PREPROGRAMMED SCIENTIFIC PRINT/VISUAL
100.00	90.00	H.P.-33E, 49 STEP PROG SCIENTIFIC
80.00	72.00	H.P.-32E, PREPROGRAMMED SCIENTIFIC WITH STAT
60.00	54.00	H.P.-31E, PREPROGRAMMED SCIENTIFIC
495.00	445.50	H.P.-92, PREPROGRAMMED FINANCIAL PRINT/VISUAL
120.00	108.00	H.P.-38E STEP PROGRAMMABLE SUPER FINANCIAL
75.00	67.50	H.P.-37E, PREPROGRAMMED FINANCIAL

WE STOCK ALL HEWLETT-PACKARD CALCULATOR SOFTWARE AND ACCESSORIES

SEND ME THE CALCULATOR(S) INDICATED BELOW COMPLETE WITH INCLUDED ACCESSORIES INSTRUCTIONS AND MANUFACTURERS WARRANTY I UNDERSTAND THAT IF I AM NOT COMPLETELY SATISFIED I MAY RETURN IT WITHIN 10 DAYS FOR A COMPLETE REFUND (LESS SHIPPING)

MODEL(S) _____ QUANTITY _____ AMOUNT ENCLOSED \$ _____

WE HONOR _____ VISA _____ MASTERCHARGE _____ MONEY ORDERS _____ COD _____

ADD \$2.00 FOR POSTAGE AND HANDLING PLEASE ALLOW 10 DAYS FROM DATE OF RECEIPT OF ORDER FOR DELIVERY TEXAS RESIDENTS ADD 5% SALES TAX

CARD NUMBER _____ EXPIRATION DATE _____

FULL NAME _____ CALL _____

STREET _____ CITY _____ STATE _____ ZIP _____

MORE LITERATURE MODEL(S) _____

*****DEALER INQUIRIES INVITED*****

Hartwells ✓H26
Office World, Inc.

MAIL TO: 6810 LARKWOOD
HOUSTON, TEX 77074
ATTN: STEVE, WASOEN
PHONE: A.C. (713) 777-2673

2 METER CRYSTALS MANY IN STOCK

FOR THESE RADIOS ON
STANDARD ARRL REPEATER
FREQUENCIES

Clegg HT-146	Regency HR-212
Drake TR-22	Regency HR-2B
Drake TR-33 (rec only)	Regency HR-312
Drake TR-72	Regency HR-2MS
Genave	S.B.E.
Heathkit HW-201 (rec only)	Sonar 1802-3-4, 3601
Heathkit HW-202	Standard 146/826
Icom/VHF Eng	Standard Horizon
Ken/Wilson	Swan FM 2X
Lafayette HA-146	Tempo FMH
Midland 13-505	Trio/Kenwood
Regency HR-2	Trio/Kenwood TR2200
	Trio/Kenwood TR7200

\$3.95 EACH - IN QUANTITIES
OF 10 OR MORE, \$3.50 EACH

Certified check or money order only -

ROLIN DISTRIBUTORS ✓R15
P.O. Box 436
Dunellen NJ 08812
(201)469-1219

"THE PROFESSIONALS"

NEW MODEL CTR-2A • 500 MHz & 1 GHz **COUNTERS**

NEW
Period
Measurement

1 us to
1 sec.



NEW
Built-in
Pre-Amp

10 mv @
150 MHz

The New Model CTR-2A Series Counters are designed and built to the highest standards to fulfill the needs of commercial communications, engineering labs and serious experimenters. With an accuracy of + .00005% (oven option) the CTR-2A can handle the most critical measurements and is about half the cost of other commercial counters.

If you need a reliable counter at an affordable price, the CTR-2A is the answer.

- Built-in Pre-Amp 10 mv @ 150 MHz
- 8 Digit .3" LED Display
- High Stability TCXO Time Base
- Built-in VHF-UHF Prescaler
- Automatic Dp Placement
- TCXO Std. ± 2 ppm
- Period Measurement (Optional)
- Input Diode Protected
- 12V-DC Operation (Optional)
- Oven Controlled Crystal (Optional) ± .5 ppm
- Selectable Gate Times - .1 & 1 sec.

500 MHz Kit CTR-2A-500K	\$249.95
500 MHz Assembled CTR-2A-500A	349.95
1GHz Kit CTR-2A-1000K	399.95
1GHz Assembled CTR-2A-1000A	549.95

OPTIONS

02) Oven Crystal	\$49.95	05) 10 sec. Time Base	\$ 5.00
03) .43" LED	10.00	06) Period	15.00
04) 12 V-DC	10.00	07) Handle	10.00

DAVIS ✓D10



PROBES
Hi-Z
\$15.00
•
Low Pass
\$15.00

DAVIS ELECTRONICS 636 Sheridan Dr., Tonawanda, N.Y. 14150 716/874-5848

ALUMA TOWERS ✓A47

VERO BEACH, FLORIDA 32960

MFG'S OF
ALUMINUM TOWERS

- * TELESCOPING (Crank Up)
- * WALL MOUNTED
- * TILT-OVER
- * GUYED MODELS (to 100 Ft.)

Excellent for
Ham Communications.

HIGH QUALITY — LOW PRICES

MADE IN LONG-
LASTING
NO-RUST
ALUMINUM!

McCLARAN SALES TAKES IN
ANYTHING ON TRADE FOR NEW
ALUMA TOWERS.

NEED: Scanners, CB, 2 Meter, Marine,
Antiques, Coins,
Ham Gear.

We accept Master Charge & Visa Cards

FOR SALES & TRADES CONTACT
R.D. McCLARAN SALES

430 Franklyn at Beach
Indalantic, Florida 32903
(305) 723-4793

(Cut on dotted line and keep next to your radio equipment)

(Cut on dotted line and keep next to your radio equipment)

Call our toll-free number first

... and it's the last call you'll have to make!

(NO CHARGE TO CALLING PARTY)

1-800-325-3636

CALL FOR THE BEST PRICE AND FAST DELIVERY

ON THE FOLLOWING LINES:

ATLAS
COLLINS
DENTRON
DRAKE
HY GAIN

ICOM
INFO-TECH
KENWOOD
MOSLEY
STANDARD

SWAN
TEMPO
TEN-TEC
WILSON
YAESU

... AND MANY OTHERS.

HAM RADIO CENTER
8340-42 Olive Blvd. P.O. Box 28271 St. Louis, MO 63132

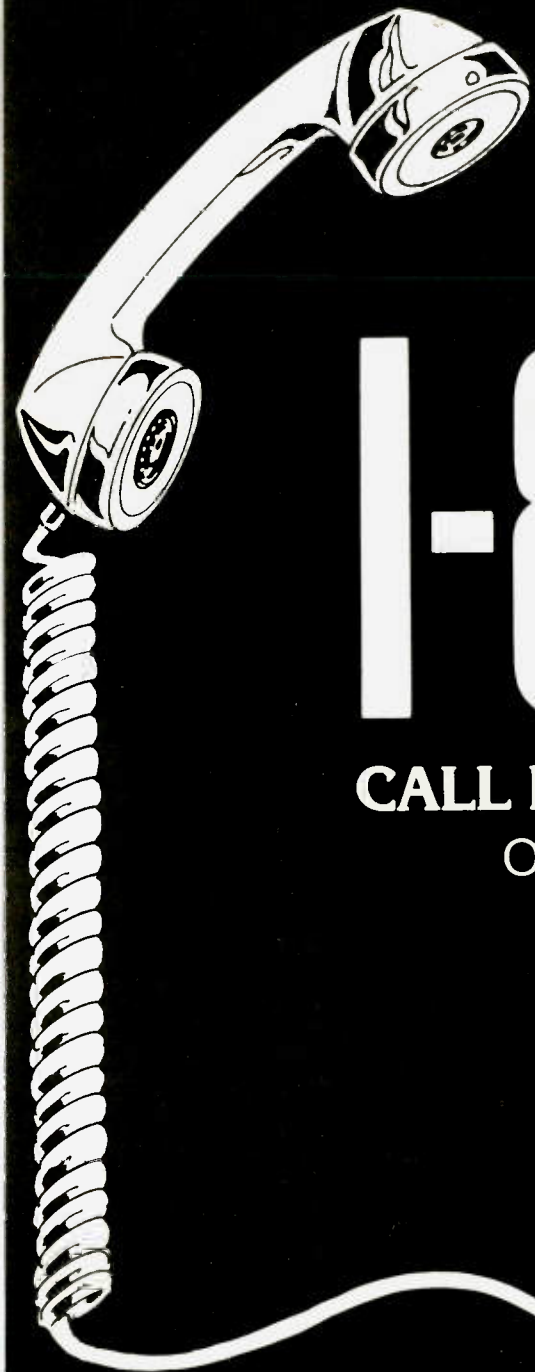

SPECIALS FROM MHz electronics

LASER TUBES

LASER TUBES

Hughes Electron Dynamics Division Model H.P. 3124 Plasma Laser Tube. 4mw min. Power output, .81mm. Beam Dia., 1960vdc ± 100vdc, 10KVdc starting voltage. With Data Sheet. **ONLY \$79.95**

BEACON TRANSMITTER

Microwave Associates Model MA-86C16. An all solid state high power fixed tuned C-band RF Generator. This unit is crystal controlled, and provides frequency stability in extreme environments. Designed for use in high performance aircraft and ground based beacon applications, this device can also be used as an up-converter pump for microwave communications relay.

Frequency Range	6.0 to 6.3 GHz
Power Output	1 Watt Min. 3 Watts Max.
Frequency Stability	± 1 x 10 ⁻⁶
Spurious Harmonics	-30dB
Input Voltage	24 to 32 Volts DC

ONLY \$99.95

HEWLETT PACKARD UHF, VHF, AND MICROWAVE SIGNAL GENERATORS AND SWEEPERS

MODEL 608D 10 to 420 MHz .1uv to .5v into 50 ohms ONLY \$399.99	MODEL 692D 2 to 4 GHz ONLY \$499.99	Model 612A 450 to 1230 MHz .1uv. to .5uv into 50 ohms ONLY \$499.99
MODEL 616B 1.8 to 4.2 GHz ONLY \$399.99	MODEL 618B 3.8 to 7.6 GHz ONLY \$499.99	

WHISPER FANS

This fan is super quiet, efficient cooling where low acoustical disturbance is a must. Size 4.68" x 4.68" x 1.50", impedance protected, 50/60 Hz 120 volts AC

ONLY \$9.95 or 2/\$18.00

MARCONI FM SIGNAL GENERATOR

Model TF1066B/1 10 to 470MHz FM or AM. Frequency Stability 0.0025%. Calibration Accuracy 1.0%. RF Output into 50 ohms 0.2uv to 200mv.

ONLY \$799.99

TRW BROADBAND AMPLIFIER MODEL CA615B

Frequency response 40 to 300 MHz
Gain—300 MHz 16dB MIN., 17.5dB MAX., 50 MHz 0 to -1dB from 300 MHz
Voltage—24 volts DC at 220ma MAX.

ONLY \$14.95

HEWLETT PACKARD/MOSELEY

Model 2D X Y Recorder 11" x 17" paper with slewing speed of 20"/sec. 16 DC Inputs ranges from 0.1 to 20v/Div. with Model 7502A line follower system control unit and a Type F-3B line follower.

ONLY \$329.95

LOW PROFILE IC SOCKETS

Qty.	1-10	11-50	51-100
8 Pin	\$ 20	\$ 18	\$ 16
14 Pin	17	15	13
16 Pin	19	17	.15
22 Pin	26	24	22
24 Pin	29	27	.25
28 Pin	34	32	.30
40 Pin	48	46	.44

MHZ ELECTRONIC KITS

Kit #1

Motorola CM14410CP CMOS Tone Generator. CMOS Tone Generator uses 1MHZ crystal to produce standard dual frequency dialing signal. Directly compatible with 12 key Chomeric Touch Tone Pads. Kit includes the following:

- 1 Motorola MC14410CP Chip
- 1 1 MHZ Crystal
- 1 PC Board

And all other parts for assembly. **NOW ONLY \$15.70**

Kit #2

Fairchild 95H90DC Prescaler 350 MHz. 95H90DC Prescaler divides by 10 to 350 MHz. This kit will take any 35MHz Counter to 350 MHz. Kit includes the following:

- 1 Fairchild 95H90DC Chip
- 1 2N5179 Transistor
- 2 UG-88/U BNC Connectors
- 1 PC Board

And all other parts for assembly. **NOW ONLY \$19.95**

CHRISTMAS SPECIAL DEDUCT 10% FROM TOTAL ORDER. GOOD UNTIL JANUARY 1st 1979!!!

Kit #3

Fairchild 11C90DC Prescaler 650MHz. 11C90DC Prescaler divides by 10/100 to F50 MHz. This counter will take any 65 MHz Counter to 650MHz, or with a 82S90 it will take a 6.5 MHz Counter to 650MHz. Kit includes the following:

- 1 Fairchild 11C90DC Chip
- 1 2N5179 Transistor
- 2 UG-88/U BNC Connectors
- 1 LM/MC7805 Voltage Regulator
- 1 50 volt 1Amp Bridge
- 1 LED Indicator
- 1 PC Board

And all other parts for assembly. **NOW ONLY \$29.95**

FAIRCHILD VHF AND UHF PRESCALER CHIPS

95H90DC	350MHz Prescaler Divide by 10/11	\$ 8.95
95H91DC	350MHz Prescaler Divide by 5/6	8.95
11C90DC	650MHz Prescaler Divide by 10/11	15.95
11C91DC	650MHz Prescaler Divide by 5/6	15.95
11C83DC	1GHZ Divide by 248/256 Prescaler	29.90
11C70DC	600MHz Flip/Flop with reset	12.30
11C58DC	ECL VCM	4.53
11C44DC	Phase Frequency Detector (MC4044P/L)	3.82
11C24DC	Dual TTL VCM (MC4024P/L)	3.82
11C06DC	UHF Prescaler 750MHz D Type Flip/Flop	12.30
11C05DC	1GHZ Counter Divide by 4	74.35
11C01FC	High Speed Dual 5-4 Input NO/NOR Gate	15.40

CRYSTAL FILTERS

Tyco 001-19880 same as 2194F

10.7MHz Narrow Band Crystal Filter. 3dB bandwidth 15khz minimum 20dB bandwidth 60khz minimum 40dB bandwidth 150khz minimum. Ultimate 50dB: Insertion loss 1.0dB Max. Ripple 1.0dB Max. Ct. 0 ± 5pF. Rt. 3600 ohms. **NOW ONLY \$5.95**

TUBES

2E26	\$ 5.00	4CX350A	\$ 32.25
3-500Z	74.50	4CX1500B	250.00
3-1000Z	185.00	572B	33.60
3B2B	5.00	811A	12.95
4-65A	54.50	589A	39.00
4-125A	68.75	6146A	5.25
4-250A	80.00	6146B	6.25
4-400A	81.50	6360	7.95
4-1000A	255.00	6907	35.00
4CX250B	24.95	6939	9.95
4CX250F	15.00	7360	10.60
4CX250G	15.00	8072	45.00
4CX250K	35.00	8295A/PL172	150.00
4CX250R	29.00	8950	5.95

MHz electronics

2111 W. Camelback Rd.
Phoenix, Arizona 85015
(602)242-3037



C.O.D.

M8

CRYSTALS

2.048KC	1.8575MC	2.207063MC	2.46125MC	2.737MC	2.987MC	3.23925MC	4.6895MC
16.00000	1.908125	2.208313	2.482	2.73975	2.9899	3.24	4.6965
37.35	1.925	2.209563	2.486	2.742125	3.001	3.24025	4.7
49.710	1.927	2.210812	2.5	2.7425	3.0235	3.2405	4.7175
70KC	1.932	2.210813	2.51375	2.744	3.045	3.241	4.7245
81.9	1.982	2.212063	2.531	2.7445	3.049	3.2425	4.7315
96	1.985	2.214562	2.604	2.74475	3.053	3.244	4.765
100	1.9942	2.214563	2.6245	2.746875	3.062	3.248875	4.89
225	1.995975	2.215625	2.618	2.751	3.067	3.24925	5.0000
250	1.964750	2.217938	2.62825	2.754	3.074	3.24975	5.348400
285.714	2.0000	2.21975	2.633125	2.75525	3.1125	3.2515	5.426636
500	2.0285	2.222125	2.639	2.762375	3.126	3.255	5.436636
576	2.05975	2.22325	2.65575	2.7735	3.137	3.256125	5.4990
720	2.125	2.22675	2.64325	2.776625	3.13975	3.258625	5.4675
1.008MC	2.126175	2.22875	2.646	2.78	3.1435	3.261	5.5065
1.2288	2.12795	2.23725	2.647	2.814	3.144	3.261125	5.515
1.229	2.1315	2.2395	2.650750	2.817	3.145	3.268625	5.5215
1.239	2.133275	2.24075	2.6545	2.8225	3.151	3.271125	5.544
1.248	2.13505	2.241	2.65825	2.835	3.1545	3.273625	5.5515
1.269	2.136825	2.246	2.660	2.854	3.158	3.276125	5.559
1.289	2.1425	2.2475	2.662	2.865	3.1585	3.3345	5.5665
1.297	2.144625	2.2925	2.66575	2.868	3.1615	3.4045	5.574
1.299	2.14675	2.2975	2.6695	2.8725	3.1625	3.4115	5.5815
1.309	2.148875	2.320	2.677	2.876875	3.166	3.4325	5.589
1.33245	2.151	2.326	2.68075	2.887	3.16975	3.4535	5.604
1.455	2.153125	2.32625	2.681	2.889	3.177	3.4675	5.619
1.689600	2.15375	2.32885	2.6845	2.894	3.181	3.4815	5.6115
1.7	2.155	2.3525	2.68825	2.910	3.1825	3.5	5.6265
1.76375	2.15525	2.35256	2.69575	2.920	3.18475	3.579545	5.6415
1.77125	2.157375	2.368	2.7	2.925450	3.1885	3.721666	5.6715
1.773125	2.1595	2.374	2.702	2.92545	3.2035	3.7735	5.675
1.78675	2.16375	2.375	2.704	2.931	3.20725	3.805	5.680
1.81875	2.165875	2.38725	2.71075	2.94375	3.2105	3.803	5.695
1.8275	2.170125	2.395	2.715	2.945	3.2165	3.901	5.7
1.845125	2.17255	2.396875	2.716	2.94675	3.2175	3.908	5.7105
1.84375	2.174375	2.42	2.723	2.952	3.2315	3.9168	5.733333
1.845625	2.1765	2.4375	2.730	2.966	2.23275	4.0000	6.08788
1.84575	2.17925	2.44275	2.7315	2.973	3.2365	4.011	6.110
1.846	2.18475	2.4495	2.73225	2.980	3.23775	4.126666	6.210
1.8425	2.18575	2.45	2.732625	2.981	3.2385	4.26	6.258333
1.84975	2.194125	2.4585	2.733	2.98325	3.238875	4.3	6.321458
6.424583MC	8.837MC	13.3045MC	32.2222MC	90.833MC			
5.425	8.8455	13.3145	33.0000	93.1346			
6.427083	8.854	13.3345	33.33333	93.535			
6.45	8.8625	13.3445	34.0000	93.9353			
6.47	8.871	13.3545	34.4	94.3			
6.471111	8.879500	14.315	34.4444	95			
6.510	8.888	15.016	34.44444	95.35			
6.537	8.905	15.036	35.0000	102			
6.567	8.9305	16.80417	35.25000	106.850			
6.582	8.939	16.99958	35.55555	123.5			
6.612	8.956	17.2800	36.0000	146.4			
6.6645	9.0265	17.8710	36.21750	146.64			
6.673	9.65	17.9065	36.6666	147.09			
6.693	9.7	17.9165	36.66666	165.5			
6.723	9.75	17.9265	36.66667	LATE ADD			
6.7305	9.8	17.9365	37.0000	ONS			
6.738	9.85	17.9465	38.0000				
6.75125	9.9	17.9665	38.77777	200KC			
6.753	9.95	17.975	38.77778	2.3MC			
6.7562	9.999	17.9935	38.88889	2.4			
6.7605	10.0000	19.100	39.0000	3.2			
6.7712	10.021	19.55416	39.160	3.64			
6.77625	10.20833	21.99965	40.0000	3.75			
6.880000	10.311	22.99966	48.97222	3.80			
6.910	10.5	23.25	49.95	5.456			
6.940	10.80375	23.575	50.14166	7.04			
7.35	11.1805	25.47667	53.45	7.15			
7.390	11.228	25.99961	54.95	7.26			
7.423	11.2375	26.66667	55.45	7.5			
7.443	11.2995	26.8965	57.45	11			
7.473	11.3565	26.958	58.45	22			
7.81	11.535	26.988	59.45	29			
8.00764	11.69626	27.77778	60.45	30			
8.00824	11.71	28.728	61.95	40			
8.075	12.80902	28.88889	72.855				
8.12	13.102	29.896	75				
8.15571	13.2155	30.0000	75.185				
8.364	13.2455	31.0000	82.75				
8.64	13.2745	31.11111	83				
8.820	13.2845	31.66667	84				
8.8285	13.2945	32.0000	85.833330				

ALL CRYSTALS \$4.95

SPECIALS FROM MHz electronics

RF TRANSISTORS

TYPE	PRICE	TYPE	PRICE
2N1561	\$15.00	2N5842	\$ 8.65
2N1562	15.00	2N5862	50.00
2N1692	15.00	2N5913	3.25
2N1693	15.00	2N5922	10.00
2N2857JAN	2.45	2N5942	46.00
2N2876	12.35	2N5943	1.75
2N2880	25.00	2N5944	7.50
2N2927	7.00	2N5945	10.90
2N2947	17.25	2N5946	13.20
2N2948	15.50	2N6080	5.45
2N2949	3.90	2N6081	8.60
2N2950	5.00	2N6082	9.90
2N3287	4.30	2N6083	11.80
2N3294	1.15	2N6084	13.20
2N3300	1.05	2N6094	5.75
2N3302	1.05	2N6095	10.35
2N3307	10.50	2N6096	19.35
2N3309	3.90	2N6097	28.00
2N3375/MM3375	7.00	2N6136	18.70
2N3553	1.45	2N6166	36.80
2N3818	6.00	2N6439	43.45
2N3866	1.09	MM1500	32.20
2N3866	2.70	MM1550	10.00
2N3866JANTX	4.43	MM1552	50.00
2N3924	3.20	MM1553	56.50
2N3925	6.00	MM1601	5.50
2N3927	11.50	MM1602/2N5842	7.50
2N3950	26.25	MM1607	8.65
2N3961	6.60	MM1620	17.50
2N4072	1.70	MM1661	15.00
2N4073	2.00	MM1669	17.50
2N4135	2.00	MM1943	3.00
2N4427	1.09	MM2605	3.00
2N4430	20.00	MM2608	5.00
2N4440	8.60	MM8002	2.05
2N4957	3.50	MM8006	2.15
2N4958	2.80	MRF304	43.45
2N4959	2.12	MRF502	49
2N4976	19.00	MRF504	6.95
2N5070	13.80	MRF509	4.90
2N5090	6.90	MRF511	8.60
2N5108	3.90	MRF901	3.00
2N5109	1.55	MRF5177	20.70
2N5160	3.34	MRF8004	1.44
2N5177	20.00	HEP76/S3014	4.95
2N5179	49	HEPS3002	11.30
2N5184	2.00	HEPS3003	29.88
2N5216	47.50	HEPS3005	9.95
2N5589	4.60	HEPS3006	19.90
2N5590	6.30	HEPS3007	24.95
2N5591	10.35	HEPS3010	11.34
2N5637	20.70	HEPS5026	2.56
2N5641	4.90	MMCM918	1.00
2N5643	14.38	MMT72	.61
2N5645	11.00	MMT74	.94
2N5764	27.00	MMT2857	1.43
		MMT3960A	\$ 6.25
		PT3539B	3.00
		PT4186B	3.00
		PT4571A	1.50
		PT4612	5.00
		PT4628	5.00
		PT4640	5.00
		PT8659	10.72
		PT9784	24.30
		PT9790	41.70
		PT9847	26.40
		SD1043	5.00
		SD1116	3.00
		SD1118	5.00
		SD1119	3.00
		40281	10.90
		40282	11.90
		40290	2.48
		TA7994	50.00

TUNNEL DIODES

TYPE	PRICE
TD261A	\$10.00
TD266A	10.00
1N2930	7.65
1N2939	7.65
1N4395	5.40

TERMS:

All CHECKS and MONEY ORDERS ARE IN US FUNDS!!!!
 ALL ORDERS SENT FIRST CLASS OR UPS
 Please include \$1.50 Minimum for postage.
 ALL PRICES ARE IN US DOLLARS.
 ALL PARTS PRIME/GUARANTEED

INTEGRATED CIRCUITS

MC1303L	\$ 2.00	M1460R	\$ 5.40
MC1461R	6.90	MC1463R	5.15
MC1469G	2.05	MC1469R	3.55
MC1550G	1.50	MC1560G	10.20
MC1560R	12.40	MC1563R	10.00
MC1568G	5.31	MC1568L	5.00
MC1569R	8.15	MC1590G	6.50
MC4024P	3.82	MC6800P	9.95
MC6820P	6.95	MC68B21P	12.00
2513	6.95	TR1602B	5.95
C2107B	6.95	TMS4060	6.95
2708T1	8.95	TMS4024	13.90



C.O.D.

2111 W. Camelback Rd.
 Phoenix, Arizona 85015
 (602)242-3037

MHz electronics

M8

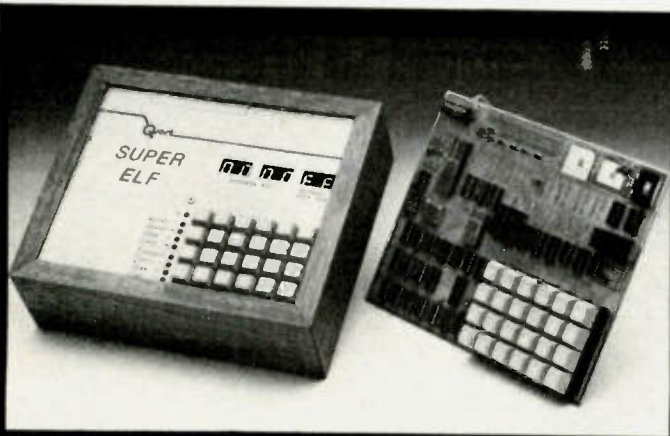

Same day shipment. First line parts only. Factory tested. Guaranteed money back. Quality IC's and other components at factory prices.

INTEGRATED CIRCUITS

7400TTL	LM3401-18	1.10	CD4511	94	8212	2.95
7400N	LM3401-24	1.10	CD4515	2.52	8214	2.95
7402N	LM3434	4.50	CD4516	1.10	8216	2.90
7404N	LM3437	1.15	CD4518	1.02	8224	2.90
7409N	LM3377	4.50	CD4520	1.02	8228	3.35
7410N	LM3379	5.00	CD4527	1.51	8231	6.50
7414N	LM3380N	1.00	CD4534	2.79	8233	9.25
7420N	LM3381	1.60	CD4553	5.75	8255	10.50
7422N	LM3382	1.35	CD4566	2.25	8257	19.00
7426N	LM3390H	4.00	CD4583	4.50	8259	94.50
7428N	LM3390N	2.80	CD4585	5.10	CDP1802CD	19.95
7445N	LM3723H-N	5.00	CD4192	3.00	CDP1802D	25.00
7447N	LM3738	6.7	74200	1.15	CDP1861	12.95
7448N	LM3741CH	35	74204	3.3	6820	3.95
7453N	LM3741N	25	74210	2.8	6850	12.95
7474N	LM3747N-N	62	74214	2.00	6500	12.50
7475N	LM3748N	35	74220	2.8		
7485N	LM3828N	82	74230	2.8		
7489N	LM3829	110	74234	1.95		
7490N	LM3305	1.27	74274	7.5		
7492N	LM3307	2.00	74276	1.40		
7493N	LM3310	2.75	74280	1.15		
7495N	LM3458	4.7	74283	1.40		
74107N	LM31812	1.75	742154	3.00		
74121N	LM31889	3.00	742175	1.35		
74125N	LM3190	1.75	742182	1.65		
74145N	LM32902	1.50	742221	1.44		
74154N	LM33900N	6.0	742305	3.00		
74155N	LM33901N	1.75	742306	1.75		
74156N	LM33902N	6.1	742394	1.50		
74157N	MCH458V	5.00	742392	5.50		
74158N	LM33903	2.80	742393	3.50		
74159N	NE5500N	65	742325	6.95		
74162N	NE555V	4.3	742326	6.95		
74163N	NE555	7.0	742327	6.95		
74174N	NE565A	1.00				
74175N	NE568V	5.00				
74176N	NE569	1.20				
74177N	NE570	5.00				
74178N	NE571B	6.00				
74179N	NE572	1.55				
74219N	680109	6.00				
74299N	681078	6.00				
74305N	78L05	7.00				
74306N	NE540C	2.80				
74307N	NE550N	65				
74308N	NE555V	4.3				
74309N	NE565A	7.0				
74310N	NE568V	5.00				
74311N	NE569	1.20				
74312N	NE570	5.00				
74313N	NE571B	6.00				
74314N	NE572	1.55				
74315N	NE573	6.00				
74316N	NE574	1.55				
74317N	NE575	6.00				
74318N	NE576	1.55				
74319N	NE577	6.00				
74320N	NE578	6.00				
74321N	NE579	1.55				
74322N	NE580	6.00				
74323N	NE581	1.55				
74324N	NE582	6.00				
74325N	NE583	1.55				
74326N	NE584	6.00				
74327N	NE585	1.55				
74328N	NE586	6.00				
74329N	NE587	1.55				
74330N	NE588	6.00				
74331N	NE589	1.55				
74332N	NE590	6.00				
74333N	NE591	1.55				
74334N	NE592	6.00				
74335N	NE593	1.55				
74336N	NE594	6.00				
74337N	NE595	1.55				
74338N	NE596	6.00				
74339N	NE597	1.55				
74340N	NE598	6.00				
74341N	NE599	1.55				
74342N	NE600	6.00				
74343N	NE601	1.55				
74344N	NE602	6.00				
74345N	NE603	1.55				
74346N	NE604	6.00				
74347N	NE605	1.55				
74348N	NE606	6.00				
74349N	NE607	1.55				
74350N	NE608	6.00				
74351N	NE609	1.55				
74352N	NE610	6.00				
74353N	NE611	1.55				
74354N	NE612	6.00				
74355N	NE613	1.55				
74356N	NE614	6.00				
74357N	NE615	1.55				
74358N	NE616	6.00				
74359N	NE617	1.55				
74360N	NE618	6.00				
74361N	NE619	1.55				
74362N	NE620	6.00				
74363N	NE621	1.55				
74364N	NE622	6.00				
74365N	NE623	1.55				
74366N	NE624	6.00				
74367N	NE625	1.55				
74368N	NE626	6.00				
74369N	NE627	1.55				
74370N	NE628	6.00				
74371N	NE629	1.55				
74372N	NE630	6.00				
74373N	NE631	1.55				
74374N	NE632	6.00				
74375N	NE633	1.55				
74376N	NE634	6.00				
74377N	NE635	1.55				
74378N	NE636	6.00				
74379N	NE637	1.55				
74380N	NE638	6.00				
74381N	NE639	1.55				
74382N	NE640	6.00				
74383N	NE641	1.55				
74384N	NE642	6.00				
74385N	NE643	1.55				
74386N	NE644	6.00				
74387N	NE645	1.55				
74388N	NE646	6.00				
74389N	NE647	1.55				
74390N	NE648	6.00				
74391N	NE649	1.55				
74392N	NE650	6.00				
74393N	NE651	1.55				
74394N	NE652	6.00				
74395N	NE653	1.55				
74396N	NE654	6.00				
74397N	NE655	1.55				
74398N	NE656	6.00				
74399N	NE657	1.55				
74400N	NE658	6.00				

QUEST Cosmac Super Elf Computer \$106.95

Compare features before you decide to buy any other computer. There is no other computer on the market today that has all the desirable benefits of the Super Elf for so little money. The Super Elf is a small single board computer that does many big things. It is an excellent computer for training and for learning programming with its machine language and yet it is easily expanded with additional memory, Tiny Basic, Ascii Keyboards, video character generation, etc.

The Super Elf includes a ROM monitor for program loading, editing and execution with SINGLE STEP for program debugging which is not included in others at the same price. With SINGLE STEP you can see the microprocessor chip operating with the unique QUEST address and data bus displays before, during and after executing instructions. Also, CPU mode and instruction cycle are shown on several LED indicator lamps.

An RCA 1861 video graphics chip allows you to connect to your own TV with an inexpensive video modulator to do graphics and games. There is a speaker system included for writing your own music or using many music programs already written. The speaker amplifier may also be used to drive relays for control purposes.

A 24 key HEX keyboard includes 16 HEX keys plus load, reset, run, input, memory protect, memory select, monitor select and single step.

Large, on board displays provide output and optional high and low address. There is a 44 pin standard connector for PC cards and a 50 pin connector for the Quest Super Expansion Board. Power supply and sockets for all IC's are included in the price plus a detailed 90 page instruction manual.

Many schools and universities are using the Super Elf as a course of study. OEM's use it for training and research and development.

Remember, other computers only offer Super Elf features at additional cost or not at all. Compare before you buy. Super Elf Kit \$106.95. High address option \$8.95, Low address option \$9.95. Custom Hardwood Cabinet with drilled and labelled front panel \$24.95. NiCad Battery Backup Kit \$4.95. All kits and options also come completely assembled and tested.

Questdata, a 12 page monthly software publication for 1802 computer users is available by subscription for \$12.00 per year.

Tiny Basic for ANY 1802 System Cassette \$10.00. On ROM Monitor \$38.00. Super Elf owners, 30% off. Object code listing or paper tape with manual \$5.50. Original ELF Kit \$14.95.

Other on board options include Parallel Input and Output Ports with full handsake. They allow easy connection of an ASCII keyboard to the input port. RS 232 and 20 mA Current Loop for teletype or other device are on board and if you need more memory there are two S-100 slots for static RAM or video boards. A Godbout 8K RAM board is available for \$127.95. Parallel I/O Ports \$9.95, RS 232 \$4.50, TTY 20 mA I/F \$1.95, S-100 \$4.50. A 50 pin connector set with ribbon cable is available at \$12.50 for easy connection between the Super Elf and the Super Expansion Board.

The Power Supply for the Super Expansion Board is a 5 amp supply with +8v ± 18v + 12v - 5v. Regulated voltages are +5v ± 12v \$29.95. Deluxe version includes the case at \$39.95.

Cassette Interface \$89.95 simply by calling them up. Improvements and revisions are easily done with the monitor. If you have the Super Expansion Board and Super Monitor the monitor is up and running at the push of a button.

Other on board options include Parallel Input and Output Ports with full handsake. They allow easy connection of an ASCII keyboard to the input port. RS 232 and 20 mA Current Loop for teletype or other device are on board and if you need more memory there are two S-100 slots for static RAM or video boards. A Godbout 8K RAM board is available for \$127.95. Parallel I/O Ports \$9.95, RS 232 \$4.50, TTY 20 mA I/F \$1.95, S-100 \$4.50. A 50 pin connector set with ribbon cable is available at \$12.50 for easy connection between the Super Elf and the Super Expansion Board.

The Power Supply for the Super Expansion Board is a 5 amp supply with +8v ± 18v + 12v - 5v. Regulated voltages are +5v ± 12v \$29.95. Deluxe version includes the case at \$39.95.

Linear
CA3045 90
CA3046 1.80
CA3081 3.00
CA3082 1.80
CA3089 2.95
CA3090 1.80
LM3035 87
LM3036 87
LM3037 1.02
LM3038 1.02
LM3039 1.15
LM3090 95
LM3091 95
LM3116 2.35
LM3117 1.90
LM3118 1.90
LM3119 1.90
LM3120 1.90
LM3121 1.90
LM3122 1.90
LM3123 1.90
LM3124 1.90
LM3125 1.90
LM3126 1.90
LM3127 1.90
LM3128 1.90
LM3129 1.90
LM3130 1.90
LM3131 1.90
LM3132 1.90
LM3133 1.90
LM3134 1.90
LM3135 1.90
LM3136 1.90
LM3137 1.90
LM3138 1.90
LM3139 1.90
LM3140 1.90
LM3141 1.90
LM3142 1.90
LM3143 1.90
LM3144 1.90
LM3145 1.90
LM3146 1.90
LM3147 1.90
LM3148 1.90
LM3149 1.90
LM3150 1.90
LM3151 1.90
LM3152 1.90
LM3153 1.90
LM3154 1.90
LM3155 1.90
LM3156 1.90
LM3157 1.90
LM3158 1.90
LM3159 1.90
LM3160 1.90
LM3161 1.90
LM3162 1.90
LM3163 1.90
LM3164 1.90
LM3165 1.90
LM3166 1.90
LM3167 1.90
LM3168 1.90
LM3169 1.90
LM3170 1.90
LM3171 1.90
LM3172 1.90
LM3173 1.90
LM3174 1.90
LM3175 1.90
LM3176 1.90
LM3177 1.90
LM3178 1.90
LM3179 1.90
LM3180 1.90
LM3181 1.90
LM3182 1.90
LM3183 1.90
LM3184 1.90
LM3185 1.90
LM3186 1.90
LM3187 1.90
LM3188 1.90
LM3189 1.90
LM3190 1.90
LM3191 1.90
LM3192 1.90
LM3193 1.90
LM3194 1.90
LM3195 1.90
LM3196 1.90
LM3197 1.90
LM3198 1.90
LM3199 1.90
LM3200 1.90
LM3201 1.90
LM3202 1.90
LM3203 1.90
LM3204 1.90
LM3205 1.90
LM3206 1.90
LM3207 1.90
LM3208 1.90
LM3209 1.90
LM3210 1.90
LM3211 1.90
LM3212 1.90
LM3213 1.90
LM3214 1.90
LM3215 1.90
LM3216 1.90
LM3217 1.90
LM3218 1.90
LM3219 1.90
LM3220 1.90
LM3221 1.90
LM3222 1.90
LM3223 1.90
LM3224 1.90
LM3225 1.90
LM3226 1.90
LM3227 1.90
LM3228 1.90
LM3229 1.90
LM3230 1.90
LM3231 1.90
LM3232 1.90
LM3233 1.90
LM3234 1.90
LM3235 1.90
LM3236 1.90
LM3237 1.90
LM3238 1.90
LM3239 1.90
LM3240 1.90
LM3241 1.90
LM3242 1.90
LM3243 1.90
LM3244 1.90
LM3245 1.90
LM3246 1.90
LM3247 1.90
LM3248 1.90
LM3249 1.90
LM3250 1.90
LM3251 1.90
LM3252 1.90
LM3253 1.90
LM3254 1.90
LM3255 1.90
LM3256 1.90
LM3257 1.90
LM3258 1.90
LM3259 1.90
LM3260 1.90
LM3261 1.90
LM3262 1.90
LM3263 1.90
LM3264 1.90
LM3265 1.90
LM3266 1.90
LM3267 1.90
LM3268 1.90
LM3269 1.90
LM3270 1.90
LM3271 1.90
LM3272 1.90
LM3273 1.90
LM3274 1.90
LM3275 1.90
LM3276 1.90
LM3277 1.90
LM3278 1.90
LM3279 1.90
LM3280 1.90
LM3281 1.90
LM3282 1.90
LM3283 1.90
LM3284 1.90
LM3285 1.90
LM3286 1.90
LM3287 1.90
LM3288 1.90
LM3289 1.90
LM3290 1.90
LM3291 1.90
LM3292 1.90
LM3293 1.90
LM3294 1.90
LM3295 1.90
LM3296 1.90
LM3297 1.90
LM3298 1.90
LM3299 1.90
LM3300 1.90
LM3301 1.90
LM3302 1.90
LM3303 1.90
LM3304 1.90
LM3305 1.90
LM3306 1.90
LM3307 1.90
LM3308 1.90
LM3309 1.90
LM3310 1.90
LM3311 1.90
LM3312 1.90
LM3313 1.90
LM3314 1.90
LM3315 1.90
LM3316 1.90
LM3317 1.90
LM3318 1.90
LM3319 1.90
LM3320 1.90
LM3321 1.90
LM3322 1.90
LM3323 1.90
LM3324 1.90
LM3325 1.90
LM3326 1.90
LM3327 1.90
LM3328 1.90
LM3329 1.90
LM3330 1.90
LM3331 1.90
LM3332 1.90
LM3333 1.90
LM3334 1.9



GALLIUM PHOSPHIDE L.E.D.
Provides Higher Intensity Than Regular LED's; T1-3/4 Dome (Red Diffused) AND Part #114R 1-99...22¢ 100+...20¢ We stock the full line of AND L.E.D.'s

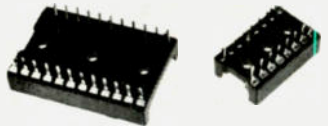

DIP SOCKET SPECIALS

16 Pin Low Profile Solder Tab	1-49	50+
18 Pin Standard Height Solder Tab	20¢	15¢
24 Pin Low Profile Solder Tab GOLD	25¢	20¢
	60¢	55¢

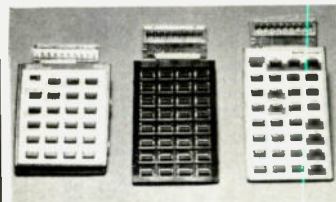

CALCULATOR GUTS Experimenter's delight. Each keyboard includes a monolithic calculator chip and a display. These are rejects. It might be something simple to repair or it could be very nasty. At this price, who cares! 9 volt. \$1.50 ea. \$33.00.



5 FUNCTION L.C.D. WATCHES FROM NATIONAL SEMICONDUCTOR

• Hours • Month • Seconds
• Minutes • Date

(Gold) Leatherette Band; (Chrome) Metal Band; (Gold) Metal Band; (Chrome) Leatherette Band. \$18.00 Each. Specify Model (Add \$1.00 For Metal Band) **A SPECIAL FACTORY PURCHASE!**



INSTRUMENT/CLOCK CASE KIT Perfect for your opto projects. Solid aluminum construction with real walnut sides. O.D. 5-3/8" by 5-3/8" by 2". \$6.95 ea.



EDGE CARD CONNECTOR
Cinch Jones 10/20 Pins .156 Spacing PC Mount 85¢

M-M Electronic Sales

A division of **united products Corporation**

Corp. Hdqts., 2322 1st Ave., Seattle, Wash. 98121 • (206) 682-5025



INSTRUMENT/CLOCK CASE KIT A real jewel for those smaller projects. Hinged top door allows you to hide your control area. O.D. 4 1/2" by 4" by 1 1/4". \$1.50 ea.

EUROPEAN 220V LINE CORD Building something for export? Then you might need this. 40¢ ea. 10/\$3.00.

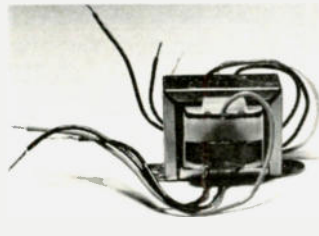

TRANSFORMER Pri. 110 VAC Sec. 11.2 and 5 VCT @ 1 amp. 95¢ ea.

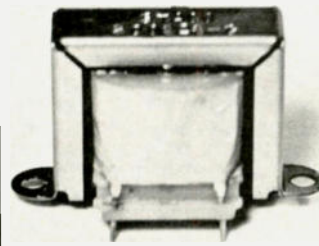

TRANSFORMER P-C mount. pri. 110 VAC Sec. 12:6 @ 1 amp. \$1.25 ea.



CLOCK DISPLAY NATIONAL SEMICONDUCTOR 6 digit multiplexed display. 1/2" characters. (Common anode) A real buy at just \$1.00 ea.



5 FUNCTION L.C.D. CAR CLOCK Wait no longer. We brought the price down on L.C.D.s. This is not a kit. It comes completely assembled, ready for you to easily install in the dash of your car, boat, or R.V. 5 functions, providing hours- minutes- seconds- month- and day. Power is provided from a simple pen light cell which will service for about 2 years. Night lighting is through connection to your existing dash lights. Time accuracy to 4 seconds per month. You won't need a magnifying glass to see the time, either. This beauty boasts a big 1/2" character display. Which, incidentally, has passed the temperature extremes encountered in an automobile. Battery not included. \$24.95

SPECTRA-STRIP Multi-color ribbon cable #22 stranded. 20 cond. 75¢ a foot ... 1-99; 50¢ ... 100+

36 PIN GOLD-PLATED HEADER Break off to desired length Has dip spacing. List price \$1.36 Your price 65¢.

PLASTIC PARTS BOX A nice little hinged-top box for storing all your small parts. O.d. 6 1/4" by 3 1/4" by 2". 75¢ ea. 10/\$5.00.

COMPUTER POWER SUPPLY TRANSFORMER PRI. 110/220 VAC; SEC. 12.1 V @ 9A, 44.0V @ 2.5A, 12.9V @ 2.0A, 12.9V @ 3.2A. Only \$14.95 ea.

EDGE METER 100-0-100 ua 1/2" by 1 1/8". Compare with other meters costing \$6.00. ONLY \$2.00 ea. Why pay more?

CALCULATOR BUBBLE DISPLAY BRAND NEW pocket calculator displays. Ranging from 6-9 digit. Your luck \$1.25 ea. 3/\$3.00

KEYBOARD HOBBY BAG Compare, then really save with our calculator hobby bag assortment. Each one contains 3 calculator keyboards. All this for only \$1.75.

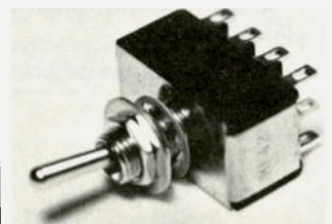

TOGGLE SWITCH J.B.T. #JMT 423, Subminiature 4 P.O.T. 5 amp. @ 125 VAC. LIST PRICE \$5.95. YOUR PRICE \$1.11 ea.

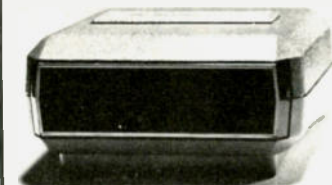

REPEAT OF A SELL-OUT A complete 12 hour digital clock. Some are manufacture line rejects, some are returns, and some are just scratched. Features: hours- minutes- alarm- snooze alarm. Parts value alone would equal \$20.00, you pay only \$6.00 ea.



DEFECTIVE CALCULATORS Well, some are and some are not. We can't afford the time to test them. \$2.50 ea. Batteries not included. 2/\$4.00

#30 KYNAR Bk., Brn., Red., Or., Yel., Grn., Blu., Vio., Gry., Wh. We will do our best to ship the color you specify. To ensure prompt delivery of your order we will substitute colors should we be temp. out, unless you specify otherwise. \$2.36 per hundred foot spool; \$14.16 per thousand foot spool; Multiples of 100' only.

Call us for quotes on larger quantities.

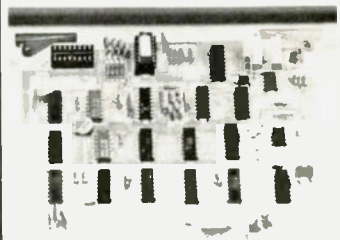

PARTS BOARDS A great way to buy parts on a budget. We guarantee your money's worth. ONLY \$1.00 ea.



CAPACITORS

Capacitance	Voltage	Style	Price
1000uf	25 VDC	P-C	25¢
220uf	25 VDC	P-C	25¢
2000uf	25 VDC	AXIAL	50¢
40/40	150 VDC	AXIAL	45¢
1uf	15 VDC	AXIAL	19¢
.018	100 V	MYLAR	25¢
.001	100 V	MICA	11¢
.01		DISC	7¢
.02		DISC	6¢
1		DISC	9¢

A CHRISTMAS BONUS Free with every \$50.00 purchase this month. One each National Semiconductor L.C.D. men's watch that you see advertised on this page. Hurry, this offer expires December 31.

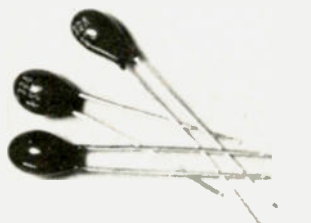

DIPPED TANTALUMS

Capacitance	Voltage	Tol. %	Price
1uf	50 V	20	28¢
2.2uf	50 V	20	42¢
4.7uf	50 V	20	62¢
22uf	20 V	20	51¢

We stock the full line of MICONICS dipped tantalums.

SELECTED VALUES

These items are chosen from our vast inventory of industrial quality components: Extruded heat sink 10 7/8" by 2 1/4" by 5/8" \$1.49
500 Ohm P-C mount trimmer 20¢
Line cord #18 ga 6' 25¢
74LS175 Quad D flip-flop. 50¢
S.P.D.T. sub-min slide switch. 40¢
S.P.S.T. P-C SWITCH 20¢
Extension speakers 18" cabinet (pair) \$19.00
ACID BRUSH 10¢
SMITH #8523 SPACER 5 by #8 hole. 5¢
2 cond. #24 spiral wrap shld. cable. 10¢

For Master Charge/Visa Orders Use Our TOLL FREE HOT LINE: 1-800-426-0634 for areas outside Washington (incl. Alaska & Hawaii)

O.E.M.'s WELCOME



Terms: All orders shipped promptly Minimum order \$5.00 Telephone orders accepted. All orders shipped UPS or PP Add 5% extra for shipping & handling Washington state residents add additional 5.4% sales tax Master Charge & Visa cards accepted. Money orders \$ your personal or company check are welcome. Funds made payable in U.S. currency only. No C.O.D. orders Your satisfaction is guaranteed on all merchandise purchased. All merchandise subject to prior sale. Open account to govt. agencies & publicly funded schools.

ATTN: PURCHASING AGENTS—Our surplus division is always looking for new sources of inventory. For a prompt reply, send samples, a list, or call us at (206) 682-5025

Store Hours M-F 9-6 • SAT 9-5

BULLET ELECTRONICS

✓ B8

P.O. BOX 19442E DALLAS, TEX. 75219

(214)823-3240

MINI GRANDFATHER CLOCK KIT

- Complete Electronics!
- Chimes the hour (ie: 3 times for 3 O'clock)
- Unique "swinging" LED pendulum
- Tick tock sound matches pendulum swing.
- Large 4 digit .5" LED readout
- All CMOS construction
- Complete electronics including transformer & speaker;

39.95

Reviewed
In April
1978 RADIO
ELECTRONICS

BEAUTIFUL SOLID WALNUT

Custom case for above kit. Over 9 1/2" tall. 19.95



POWER SUPPLY KIT PS-14

- Better than 200MV load and line regulation
- Foldback Current Limiting
- Short Circuit Protected
- Thermal Shutdown
- Adjustable Current Limiting
- Less than 1% ripple.
- 15 amps 11.5 to 14.5V
- All parts supplied including heavy duty transformer.
- Quality plated fiberglass PC board.

Less Case
meters & jacks
UPS SHIPPING
PAID!

REVIEWED IN 7/78 73 MAG.
15A CONT. 20A INT. 42.95

NEVER A SWEETER METER!

Beautiful American made panel meters are a snap to install. Huge 3 1/2" wide dials are easy to read. You would expect to pay more for each than we get for the pair! MATCHED SET 0-15VDC, 0-30ADC

12.95 *Set*

OVERVOLTAGE PROTECTION KIT 6.95

Provides cheap insurance for your expensive equipment. Trip voltage is adjustable from 3 to 30 volts. Overvoltage instantly fires a 25A SCR and shorts the output to protect equipment. Should be used on units that are fused. Directly compatible with the PS-12 and PS-14. All electronics supplied. Drilled and plated PC board. (Order OVP-1)

MK-05 MINI MOBILE CLOCK

The smallest and best priced mobile clock kit on the market. Designed to be a mobile clock from the ground up. There has been no compromise on quality.

- FEATURES
- Quartz crystal timebase
 - Toroid & zener noise & overvoltage protection
 - Magnified 15", 6 digit LED readout
 - Complete with presettable 24 hr. alarm
 - 9-14 VDC @ 40 to 50 ma
 - Readouts can be suppressed
 - EASY, QUICK ASSEMBLY
 - All components required included (you supply the speaker)
 - Top quality drilled and plated PC boards

12.95

Small enough to mount in the instrument panel!

New!

UNIVERSAL SOUND EFFECTS BOARD

HAVE YOU EVER WISHED YOU COULD DUPLICATE THE SOUND OF A STEAM TRAIN OR A PHASOR GUN? HOW ABOUT GUNSHOTS, WHISTLES, SIRENS, BARKING DOGS AND OTHER SOUND EFFECTS? NOW YOU CAN WITH OUR PROGRAMMABLE SOUND EFFECTS KIT. IT USES THE NEW 28 PIN T.I. SOUND SYNTHESIZER CHIP, SN76477 AND SUPPORT CIRCUITRY. 5 TO 12VDC IS REQUIRED TO GIVE APPROX. 1/4 WATT OF AUDIO OUTPUT. WE PROVIDE THE P.C. BOARD, PARTS AND INSTRUCTIONS ALONG WITH A CHART TO PROGRAM SOME COMMON SOUNDS. USE YOUR IMAGINATION TO CREATE ORIGINAL SOUND EFFECTS.

ORDER: SE-01 14.95 (Less Spkr.) 3/39.95

6 DIGIT ZULU CLOCK KIT

At last a clock for HAMS. Designed with large bright LED digits to enhance your shack. The unit is a pleasure to assemble and so easy on the budget! You get top quality parts and plated PC Boards. The unique design of the board set eliminates the headaches of running wires between clock and readout board. As a bonus the unit has a switchable timer that can be reset to zero without disturbing real time. Elapsed time in minutes and seconds up to 25 minutes. Six full sized FND510 readouts and colons making viewing easy from across the room. Does NOT use the old style 5314 chip. **DUE TO A SPECIAL PURCHASE WE HAVE A LIMITED QUANTITY.**

COMPLETE ZULU CLOCK KIT

Includes: All components, plated, drilled PC Boards, large easy to read instructions, and AC transformer. Clock board: 2 3/4" X 4 3/4". Readout Board: 1 1/2" X 4 3/4".

16.00
24 Hr. Format Only

Hand made solid hardwood case for the Zulu Clock. Includes ruby front filter and back panel.

6.95

MK-03A CLOCK/TIMER KIT

Features 24 hour Zulu time and up to 24 hours of elapsed time on the same set of six digit LED readouts. Totally independent operation of both functions. Clock has presettable alarm with 10 minute snooze. Timer has reset, hold, and count functions. Full noise and overvoltage protection. 24 hour only. Readouts has dimmer feature or they can be turned off without disturbing the clock or timer. Timebase included (.01% accuracy). Because of the many options and mounting considerations the case and switches are not included. Switches are standard types. Will fit inside standard aircraft instrument case.

9-14VDC 28.95

WARBLE ALARM Kit

A fun EASY kit to assemble that emits an ear piercing 10 watt dual tone scream. Resembles European siren sound. Great for alarms or toys. Operates from 5-12VDC at up to 1 amp (using 12VDC 8 ohm speaker). Over five thousand have been sold. All parts including PC board, less speaker.

2.50

ORDER WB-02

MOBILE CLOCK CALENDAR KIT

Seems like everybody sells digital clock kits, however we have the only low cost DIGITAL CLOCK / CALENDAR for Mobile operation. We provide quality plated through hole boards and step by step instructions, parts overlays and schematics. This clock has many features and we supply all the parts but a small speaker. Fantastic for car, boat or Van.

- Integral Timebase (.01% ACC)
- Large 4 DIGIT LED display with AM/PM indicators
- Flashing colon at 1HZ rate
- Special noise and overvoltage protection for mobile use
- Auxiliary output will drive relay or TRIAC to control external equipment

23.50 NO CASE
12 VAC XFMR for 110 VAC 1.50
24 Hour Format add 2.00

- ADD 5% FOR SHIPPING
- TX. RES. ADD 5% STATE SALES TAX
- FOREIGN ORDERS ADD 10% (20% AIRMAIL) U.S. FUNDS ONLY

- NO C.O.D.S
- SEND CHECK M.O. OR CHARGE CARD NO.
- PHONE ORDERS ACCEPTED ON VISA AND MASTERCARD ONLY

YOU'VE SEEN IT ON QUALITY STEREO GEAR

SUPER DEAL!



BLACK INSERT
BRUSHED CHROME

7/8" hole to hole

OPOT Toggle
ALCO CST-022
.3A @ 125V

.49

Diodes

1N4003	200V 1A	15/1.00
1N4006	800V 1A	12/1.00
1N270	Germanium Diode	8/1.00
1N38A	Germanium Diode	10/100
1N4148	Cut & Bent for PC Board Insertion	100/1.25

UNMARKED POWER DIODES with cathode bands. Guaranteed to be at least 400PIV @ 1A. 100% Good parts. Epoxy case.

25/1.00

NEW ITEMS:

MV1624 Varicap Diode 10pfd Nom. 2.1 Tuning Range **49c**

2N5583 High Freq. Amp 1 Watt @ 1.5 GHZ! TO-5 Case style. House # **50c**

MFC4000B 1/4 Watt Audio Amp 4 pin plastic pack **50c**

H110103 100V 3A SCR Ultra sensitive gate drives from TTL. TO-220 **55c**

H10355 50V 3A Triac Sensitive Gate TO-5 **40c**

FN0510 69c

COMMON ANODE READOUT CHARACTER LIMIT 24 PER CUSTOMER!

LED'S

JUMBO	RED	5/.89
	GREEN	4/.89
MEDIUM	RED	.15
	MINI	RED .10
	GREEN	.16
	YELLOW	.16

1 1/2" 10-30 ma

MC1351P FM-IF AMP AND DISCRIMINATOR

USED IN FM & TV SOUND CIRCUITS REQUIRES MINIMUM EXTERNAL COMPONENTS 14 PIN DIP DIRECT REPLACEMENT FOR HEPC 6060 ECG 748 AND MANY OTHERS HOUSE # **50c**

MC3301P HOUSE #

4 OP AMPS IN ONE PACKAGE USES SINGLE SUPPLY (4 to 28VDC) INTERNALLY COMPENSATED SIMILAR TO MC3401 BUT HIGHER GAIN **49c**

ALL COMPONENTS 100% GUARANTEED

CA3011	WIDEBAND IF AMP w/specs	50c
2N3569	NPN EPOXY 1W	6/1.00
741	OP AMP 8 PIN DIP	5/1.00
723	VOLTAGE REG 14 PIN DIP	50c
MPS8530	NPN HOUSE #	8/1.00
725	OP AMP LOW NOISE HOUSE #	99c
7815	15V 1A REGULATOR HOUSE #	69c
LM3407-12	12V 1A VOLT REG w/specs	75c
TC4430	QUAD OSCILLATOR 1/specs	69c
2N4343	P CHANNEL J FET	4/1.00
2N6111	PNP MED PWR 40W TO-220	3/1.00
2N6028	PROGRAMMABLE UNIJUNCTION w/specs	50c
TRIAC	200V 8A UNMARKED	3/1.00

MC1469R POSITIVE VOLTAGE REGULATOR

AMP COMPLETE SPECS AND APPLICATIONS SHOW HOW TO BUILD FIXED OR VARIABLE POWER SUPPLIES FROM 3 TO 30VDC DRIVE EXTERNAL SERIES PAIRS FOR CURRENT TO 20 AMPS!

1.25 EA.
10/10.00

HOUSE #

25A 100V SCR

1.95

Perfect for battery chargers, switching supplies, crowbars, etc.

739 FAIRCHILD

DUAL LOW NOISE AUDIO PRE-AMPLIFIER

89c 2/1.69

HOUSE # PNP POWER

TO-3

150 WATTS
80 VDC
10 AMPS

IDENTICAL TO 2N3790 **1.00**

MPP131 N-CHANNEL DUAL GATE MOSFET

50c

DESIGNED FOR AMPLIFIER AND MIXER APPLICATIONS TO 200 MHZ PLASTIC CASE UNITS ARE HOUSE NUMBERED WITH SPECS.

FANTASTIC SOUND EFFECTS CHIP

AVAILABLE ONLY FROM BULLETT

THIS 28 PIN MARVEL CONTAINS A LOW FREQUENCY OSCILLATOR VCO NOISE OSCILLATOR ONE SHOT MIXER AND ENVELOPE CONTROL WITH 8 PAGE MANUAL 5 to 9VDC **3.95**

EMITTER RESISTORS

HARD TO FIND VALUES!

.1 ohm @ 5W
.25 ohm @ 5W

YOUR CHOICE 7/1.00

HOUSE # LM3900 QUAD NORTON AMP

WE BOUGHT A LARGE QUANTITY OF THESE HOUSE NUMBERED PARTS AT A BARGAIN PRICE THAT ALLOWS US TO SELL THEM AT A LOW LOW **39c**

IL-1 OPTO ISOLATORS

BY LITRONIX 6 PIN DIP STANDARD PINOUT LED-TRANSISTOR COMBINATION **50c** WHILE THEY LAST!

WIREWRAP Wire

30 Gauge KYNAR Insulat.

500 FT

4.50

MJ900 - MJ1000

COMPLEMENTARY PNP NPN DARLINGTON POWER TRANSISTORS 8 AMPS! WE SUPPLY A SCHEMATIC TO BUILD A HIGH POWER (35W) LOW DISTORTION AUDIO AMP WITH ONLY ONE ADDITIONAL TRANSISTOR AND A DOZEN INEXPENSIVE COMPONENTS! TO-3 CASE STYLE BUY A PAIR FOR **\$3.00!**



CAPACITORS

SMALL SIZE!

2200 MFD @ 16 VDC RADIAL	3/1.00
500 MFD @ 35VDC	5/1.00 AXIAL
220 MFD @ 25VDC	7/1.00 AXIAL
1 MFD @ 20VDC DISC CERAMIC	15/1.00

D22 @ 100VDC Mylar	8/1.00
22 @ 50VDC Mylar	6/1.00
1.5mfd @ 400VDC Mylar	4/1.00
1mfd @ 35V Tant Axial	6/1.00
.47mfd @ 35V Tant Axial	6/1.00
2.2mfd @ 35V Tant Axial	5/1.00
22mfd @ 20V Dip Tant	4/1.00
33mfd @ 10V Dip Tant	4/1.00

ZENER GRAB BAG

A very nice assortment of 1/4, 1/2 & 1W zeners. Voltage ranges are from 2.7 to 30 VDC. Most have house # but we provide a cross over list to standard numbers. A great buy for any shop. **12 different types.**

69c

NO COD'S ADD 5% FOR SHIPPING ORDERS UNDER \$10.
SEND CHECK OR MONEY TEX RESIDENTS ADD 5% TAX ADD .75 for HANDLING
ORDER OR CHARGE CARD NO. FOREIGN ORDERS ADD 10%,
PHONE ORDERS ACCEPTED ON VISA & MC COPYRIGHT



FREQUENCY COUNTER KIT

Outstanding Performance

Incredible Price

\$89.95

CT-50

The CT-50 is a versatile and precision frequency counter which will measure frequencies to 60 MHz and up to 600 MHz with the CT-600 option. Large Scale Integration, CMOS circuitry and solid state display technology have enabled this counter to match performance found in units selling for over three times as much. Low power consumption (typically 300-400 ma) makes the CT-50 ideal for portable battery operation. Features of the CT-50 include: large 8 digit LED display, RF shielded all metal case, easy pushbutton operation, automatic decimal point, fully socketed IC chips and input protection to 50 volts to insure against accidental burnout or overload. And, the best feature of all is the easy assembly. Clear, step by step instructions guide you to a finished unit you can rely on.

Order your today!

CT-50, 60 MHz counter kit
 CT-50WT, 60 MHz counter, wired and tested
 CT-600, 600 MHz scaler option, add

\$89.95
\$59.95
29.95

CB-1, Color TV calibrator-stabilizer
 DP-1, DC probe, general purpose probe
 HP-1, High impedance probe, non-load

\$14.95
12.95
15.95

SPECIFICATIONS:

Frequency range: 6 Hz to 65 MHz, 600 MHz with CT-600
 Resolution: 10 Hz @ 0.1 sec gate, 1 Hz @ 1 sec gate
 Readout: 8 digit 0.4" high LED, direct readout in mHz
 Accuracy: adjustable to 0.5 ppm
 Stability: 2.0 ppm over 10° to 40° C, temperature compensated
 Input: BNC, 1 megohm/20 pF direct, 50 ohm with CT-600
 Overload: 50VAC maximum, all modes
 Sensitivity: less than 25 mV to 65 MHz, 50-150 mV to 600 MHz
 Power: 110 VAC 5 Watts or 12 VDC @ 400 ma
 Size: 6" x 4" x 2", high quality aluminum case, 2 lbs
 ICS: 13 units, all socketed

CAR CLOCK



The UN-KIT, only 5 solder connections

Here's a super looking rugged and accurate auto clock which is a snap to build and install. Clock movement is completely assembled—you only solder 3 wires and 2 switches. Takes about 15 minutes! Display is bright green with automatic brightness control photocell—assures you of a highly readable display day or night. Comes in a satin finish anodized aluminum case which can be attached 5 different ways using 2 sided tape. Choice of silver, black or gold case (specify)
 DC-3 kit, 12 hour format **\$22.95**
 DC-3 wired and tested **\$29.95**
 110V AC adapter **\$5.95**

Under dash car clock



12 24 hour clock in a beautiful plastic case features 6 jumbo RED LEDs, high accuracy (1 min mo), easy 3 wire hookup, display blanks with ignition, and super instructions. Optional dimmer automatically adjusts display to ambient light level
 DC-11 clock with mtg bracket **\$27.95**
 DM-1 dimmer adapter **2.50**

PRESCALER



Extend the range of your counter to 600 MHz works with any counter. Includes 2 transistor pre-amp to give super sens, typically 20 mV at 150 MHz. Specify +10 or -100 ratio
 PS-1B, 600 MHz prescaler **\$59.95**
 PS-1BK, 600 MHz prescaler kit **49.95**

OP-AMP SPECIAL

741 mini dip **12/\$2.00**
 B1-FET mini dip 741 type **10/\$2.00**

VIDEO TERMINAL

A completely self-contained, stand alone video terminal card. Requires only an ASCII keyboard and TV set to become a complete terminal unit. Two units available, common features are: single 5V supply, XTAL controlled sync and baud rates (to 9600), complete computer and keyboard control of cursor. Parity error control and display. Accepts and generates serial ASCII plus parallel keyboard input. The 3216 is 32 char, by 16 lines, 2 pages with memory dump feature. The 6416 is 64 char, by 16 lines, with scrolling, upper and lower case (optional) and has RS-232 and 20ma loop interfaces on board. Kits include sockets and complete documentation.
 RE 3216, terminal card **\$149.95**
 RE 6416, terminal card **189.95**
 Lower Case option, 6416 only **13.95**
 Power Supply Kit **14.95**
 Video/RF Modulator, VD-1 **6.95**
 Assembled, tested units, add **60.00**

CALENDAR ALARM CLOCK

The clock that's got it all. 6-5" LEDs. 12 24 hour snooze. 24 hour alarm. 4 year calendar, battery backup and lots more. The super 7001 chip is used. Size 5x4x2 inches. Complete kit, less case (not available) **\$34.95**
 DC-9

30 Watt 2 mtr PWR AMP

Simple Class C power amp features 8 times power gain. 1 W in for 8 out, 2 in for 15 out, 4 W in for 30 out. Max output of 35 W, incredible value, complete with all parts, less case and T-R relay.
 PA-1, 30 W pwr amp kit **\$22.95**
 TR-1, RF sensed T-R relay kit **6.95**

FM MINI MIKE KIT



A super high performance FM wireless mike kit! Transmits a stable signal up to 300 yards with exceptional audio quality by means of its built in electret mike. Kit includes case, mike, on-off switch, antenna, battery and super instructions. This is the finest unit available.

FM-3 kit **\$12.95**
 FM-3 wired and tested **16.95**



CLOCK KITS

our Best Seller
 your Best Deal

Try your hand at building the finest looking clock on the market. Its satin finish anodized aluminum case looks great anywhere, while six 4" LED digits provide a highly readable display. This is a complete kit, no extras needed, and it only takes 1-2 hours to assemble. Your choice of case colors: silver, gold, bronze, black, blue (specify)
 Clock kit, 12 24 hour, DC-5 **\$22.95**
 Clock with 10 min ID timer, 12 24 hour, DC-10 **27.95**
 Alarm clock, 12 hour only, DC-8 **24.95**
 12V DC car clock, DC-7 **27.95**
 For wired and tested clocks add \$10.00 to kit price

Ramsey's famous MINI-KITS

FM WIRELESS MIKE KIT

Transmits up to 300' to any FM broadcast radio, uses any type of mike. Runs on 3 to 9V. Type FM-2 has added sensitive mike preamp stage.
 FM-1 kit **\$2.95** FM-2 kit **\$4.95**

VIDEO MODULATOR KIT

Converts any TV to video monitor. Super stable, tunable over ch. 4-6. Runs on 5-15V, accepts std. video signal. Best unit on the market!
 Complete kit, VD-1 **\$6.95**

SUPER SLEUTH

A super sensitive amplifier which will pick up a pin drop at 15 feet! Greater for monitoring baby's room or as general purpose amplifier. Full 2 W rms output, runs on 6 to 15 volts, uses 8-45 ohm speaker.
 Complete kit, BN-9 **\$5.95**

tone DECODER

A complete tone decoder on a single PC board. Features 400-5000 Hz adjustable range via 20 turn pot. voltage regulation 567 IC. Useful for touch-tone decoding, tone burst detection, FSK, etc. Can also be used as a stable tone encoder. Runs on 5 to 12 volts.
 Complete kit, TD-1 **\$5.95**

POWER SUPPLY KIT

Complete triple regulated power supply provides variable 6 to 18 volts at 200 ma and +5V at 1 Amp. Excellent load regulation, good filtering and small size. Less transformers, requires 6.3V @ 1 A and 24 VCT.
 Complete kit, PS-3LT **\$6.95**

COLOR ORGAN/MUSIC LIGHTS

See music come alive! 3 different lights flicker with music. One light for lows, one for the mid-range and one for the highs. Each channel individually adjustable, and drives up to 300W. Great for parties, band music, nite clubs and more.
 Complete kit, ML-1 **\$7.95**

WHISPER LIGHT KIT

An interesting kit, small mike picks up sounds and converts them to light. The louder the sound, the brighter the light. Completely self-contained, includes mike, runs on 110VAC, controls up to 300 watts.
 Complete kit, WL-1 **\$6.95**

SIREN KIT

Produces upward and downward wail characteristic of a police siren. 5W peak audio output, runs on 3-15 volts, uses 3-45 ohm speaker.
 Complete kit, SM-3 **\$2.95**

LED BLINKY KIT

A great attention getter which alternately flashes 2 jumbo LEDs. Use for name badges, buttons, warning panel lights, anything! Runs on 3 to 15 volts.
 Complete kit, BL-1 **\$2.95**

Hard to find PARTS

LINEAR ICs	REGULATORS	TTL ICs
301 \$.35	78MG \$1.25	74500 35
324 1.50	723 .50	4011 20
380 1.25	309K .85	4013 35
380-8 .75	7805 .85	4046 1.85
555 .45	78L05 .25	4049 .60
556 .85	7905 1.25	4518 1.25
566 1.15	7812 .85	5369 1.75
567 1.25	7912 1.25	
1458 .50	7815 .85	
3900 .50		
CMOS ICs	TRANSISTORS	SOCKETS
4011 .20	2N3904 type 10/1.00	8 pin 10/2.00
4013 .35	2N3906 type 10/1.00	14 pin 10/2.00
4046 1.85	NPN 30W Pwr 3/1.00	16 pin 10/2.00
4049 .60	PNP 30W Pwr 3/1.00	24 pin 4/2.00
4518 1.25	2N3055 .60	28 pin 4/2.00
5369 1.75	UJT 2N2646 type 3/2.00	40 pin 3/2.00
	FET MPF102 type 3/2.00	
	UMF 2N5179 type 3/2.00	
	MRF-238 RF 11.95	
	LEDS	
	Jumbo red 8/1.00	
	Jumbo green 6/1.00	
	Jumbo yellow 6/1.00	
	Mini red 8/1.00	
	Micro red 8/1.00	
	BiPolar 75	
	FERRITE BEADS	
	With info, specs 15/1.00	
	6 hole balun 5/1.00	

ramsey electronics

BOX 4072, ROCHESTER, N.Y. 14610

PHONE ORDERS CALL
 (716) 271-6487



TERMS: Satisfaction guaranteed or money refunded. COD, add \$1.50. Minimum order, \$6.00. Orders under \$10.00, add \$3.75. Add 5% for postage, insurance, handling. Overseas, add 15%. NY residents, add 7% tax.

SSB TRANSMITTING CONVERTERS



FEATURES:

- Linear Converter for SSB, CW, FM, etc.
- A fraction of the price of other units
- 2W p.e.p. output with 1 MW of drive
- Use low power tap on exciter or attenuator pad
- Easy to align with built-in test points

Frequency Schemes Available:

MODEL	INPUT (MHz)	OUTPUT (MHz)
XV2-1	28-30	50-52
XV2-2	28-30	220-222
XV2-3	28-30	222-224
XV2-4	28-30	144-146
XV2-5	28-29	145-146
XV2-6	26-28	144-146

ONLY \$59.95!

VHF Linear PA's

- Use as Linear or Class C PA's
- For XV-2 Xmtg Converters, T50 Exciters, or any 2W Exciter

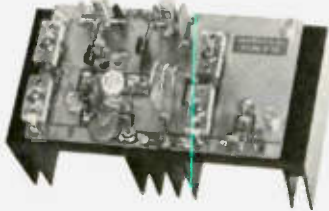

LPA 2-15 Kit \$59.95

- 15W out (linear) or 20W (class C)
- Solid State T/R Switching
- Models for 6M, 2M, or 220 MHz

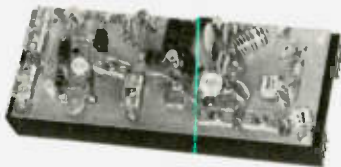

LPA 2-45 Kit \$109.95

- 45W out (linear) or 50W (class C)
 - Models for 6M or 2M
- LPA 8-45 Kit \$89.95
For 2M, 8-10W in, 45W out

T80 UHF POWER AMP

- Broadband PA
- No Tuning Required
- Class C PA
- 430-470 MHz
- 13-15W Out
- 200 mW Drive



Model T80-450
\$79.95
Wired & Tested

VHF RECEIVING CONVERTERS

LET YOU RECEIVE OSCAR AND OTHER EXCITING SIGNALS ON YOUR PRESENT HF RECEIVER!



MODEL	RF RANGE	I-F RANGE
C28	28-32MHz	144-148MHz
C50	50-52	28-30
C144	144-146	28-30
C145	145-147	28-30
C146	146-148	28-30
C110	Aircraft	26-30
C220	220-222	28-30
C222	222-224	28-30
Special	Inquire About Other Ranges	

ONLY \$34.95

UHF RECEIVING CONVERTERS



MODEL	RF RANGE	I-F RANGE
C432-2	432-434	28-30MHz
C432-4	432-436	144-146
C432-5	435-437	28-30
C432-7	427.25	61.25
C432-9	439.25	61.25
Special	Inquire About Other Ranges	

ONLY \$34.95

A9 Extruded Alum Case with BNC's for above Converters (Optional) ... \$12.95

VHF&UHF FM RECEIVERS

- NEW GENERATION RECEIVERS
- MORE SENSITIVE *MORE SELECTIVE (70 or 100 dB)
- COMMERCIAL GRADE DESIGN
- EASY TO ALIGN WITH BUILT-IN TEST CKTS
- LOWER OVERALL COST THAN EVER BEFORE



R70 6-channel VHF Receiver Kit for 2M, 6M, 10M, 220 MHz, or com'l bands..... \$69.95
Optional xtal filter for 100 dB adj chon 10.00



R90 UHF Receiver Kit for any 2 MHz segment of 380-520 MHz band..... \$89.95

FAMOUS HAMTRONICS PREAMPS

let you hear the weak ones!

Great for OSCAR, SSB, FM, ATV. Over 10,000 in use throughout the world on all types of receivers.

P9 Kit \$12.95
P14 Wired \$24.95



Specify Band When Ordering

- Deluxe vhf model for applications where space permits
- 1-1/2 x 3"
- Models avail to cover any 4 MHz band in the 26-230 MHz range
- 12 Vdc
- 2 stages
- Ideal for OSCAR
- 20 db gain
- Diode transient protection
- Easily tunable

P8 Kit \$10.95
P16 Wired \$21.95



Specify Band

- Miniature vhf model for tight spaces - size only 1/2x2-3/8
- Models avail to cover any 4 MHz band in the range 20-230 MHz
- 20 db gain
- 12V

P15 Kit \$18.95

P35 Wired \$34.95

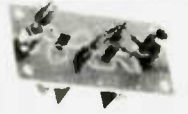

- Covers any 6 MHz band in UHF range of 380-520 MHz
- 20 db gain
- 2 stages
- Low noise

NEW FM/CW EXCITER KITS

BUILD UP YOUR OWN GEAR FOR MODULAR STATIONS, REPEATERS, & CONTROL LINKS

- Roted for Continuous Duty
- Professional Sounding Audio
- Built-in Testing Aids



T50 Six Channel, 2W Exciter for 2M, 6M, or 220 MHz (Specify bond)..... \$49.95

T50U Six Channel, 1W Exciter for 430-450 MHz uhf operation \$49.95

▶ Ask For Free Catalog ◀

IT'S EASY TO ORDER!

CALL OR WRITE NOW FOR FREE CATALOG OR TO PLACE ORDER!

PHONE 716-392-9430. (Electronic answering service eves & weekends)

Use credit card, c.o.d., check, m.o.

Add \$2.00 shipping & handling.

IN CANADA, order from Communications Plus, 3680 Cote Vertu; St-Laurent, Québec or phone 514-337-7255. Add 38% to cover duty, tax, and exchange.

Note New Address and Phone No.

hamtronics, inc.

65A MOUL RD · HILTON, NY 14468

--Dealer Inquiries Invited--

VARIABLE POWER SUPPLY KIT \$11⁹⁵

- Continuously Variable from 2V to over 15V
- Short-Circuit Proof
- Typical Regulation of 0.1%
- Electronic Current Limiting at 300mA
- Very Low Output Ripple
- Fiberglass PC Board Mounts All Components
- Assemble in about One Hour
- Makes a Great Bench or Lab Power Supply
- Includes All Components except Case and Meters

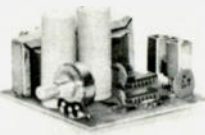

ADD \$1.25 FOR POSTAGE/HANDLING

SPECIALS—THIS MONTH ONLY

1N34A	Germanium Diode 80V 10mA	10/51	LM308H	Low Bias Current Op Amp—Super 700	\$0.94
1N270	Germanium Diode 80V 200mA	4/51	LM309K	5 Volt Regulator	T.O.3 .84
1N814	Silicon Diode 100V 10mA	25/51	LM317K	Adjustable Voltage Regulator	2.37V 3.50
1N6263	Hot Carrier Diode (HP2000, etc.)	\$1.80	LM380N	2 Watt Audio Power Amplifier	DIP .84
F7	Power Varactor 1-2W Dcr @ 432MHz		WE685A	Phase Locked Loop	DIP .84
	(Cases & Connects included with F7)	\$2.80			
	DIODE GRAB BAG—Mixed diodes, rectifiers, etc.	\$0.21	LM723CN	Precision Voltage Regulator	DIP 3/51
2N2906	NPN High-Speed Switch 75mA	4/51	LM747	Dual 741 Compensated Op Amp	DIP 2/51
2N918	UMF Transistor—Osc Amp up to 1 GHz	4/51	2182	1024-Bit Static RAM (1024 x 1)	DIP \$1.75
2N2909	P-Channel FET Amplifier 2500µmhos	\$1.80	2740E	FET-Input Op Amp—Like NE 538/A740	1.95
2N2920	NPN Dual Transistor 3mV Match β 225	2.95	CA3018A	4-Transistor Array/Darlington	.80
2N3004	NPN Amp/Switch β 100 40V 200mA	0/51	CA3028A	RF/IF Amplifier DC to 120MHz	1.45
2N4122	PNP RF Amplifier & Switch	3/51	CA3075E	FM IF Amp/Limiter/Detector	DIP 1.45
2N4888E	N-Channel Audio FET Super Low-Noise	2/51	RC4558	Dual High Gain Op Amp	mDIP 3/51
2N4908	150 Volt PNP Transistor for Relay	2/51	NE555V	Precision Fast Op Amp	mDIP 2/51
E112	N-Channel FET VHF RF Amp	3/51	9038	Dual Hi Gain Op Amp Comp.	mDIP 3/51
T574	N-Channel FET High-Speed Switch 60i	3/51		Function Generator/VCO with circuits	\$3.75

LP-10 LOGIC PROBE kit—TTL, CMOS, etc. Matched case included—1/2 hr. assembly \$7.85

SEND FOR ADVA'S NEW 1979 CATALOG
NEARLY 1000 SEMICONDUCTORS, KITS, CAPACITORS, ETC.—SEND 25¢ STAMP.

OTHER ADVA KITS:

LOGIC PROBE KIT—Use with CMOS, TTL, DTL, RTL, HTL, HNL and most MOS IC's. Built-in protection against polarity reversal and overvoltage. Draws only a few mA from circuit under test. Dual LED readout. Complete kit includes case and clip leads. **ONLY \$7.85**

FIXED REGULATED POWER SUPPLY KITS—Short-circuit proof with thermal current limiting. Compact size and typical regulation of 0.8% make these ideal for most electronic projects. Available for 5V @ 500mA, 6V @ 500mA, 9V @ 500mA, 12V @ 400mA, 15V @ 300mA. Specify voltage when ordering. **\$8.95 ea.**

These easy-to-assemble kits include all components, complete detailed instructions and plated freeform PCB boards. Power supply kits do not include case or meters. Add \$1.25 per kit for postage and handling.

1 MAIL NOW! FREE DATA SHEETS supplied with many items from this ad. FREE ON REQUEST—741 Op Amp with every order of 85 or more—748 Dual Op Amp or two E100 FET's with every order of \$10 or more, postmarked prior to 12/31/78. One free item per order. ORDER TODAY—All items subject to prior sale and prices subject to change without notice. All items are new surplus parts—100% functionally tested.

WRITE FOR FREE CATALOG \$7.95 offering over 700 semiconductors carried in stock. Send 25¢ stamp.

TERMS: Send check or money order (U.S. funds) with order. Add 5% postage for U.S. Canada and Mexico. \$1.00 handling charge on orders under \$10. Calif. residents add 8% sales tax. Foreign orders add 10% postage. COD orders add \$1.00 service charge.

MORE SPECIALS:

RC4195DN $\pm 15V$ @ 50mA VOLTAGE REGULATR IC. Very easy to use. Makes a neat Highly Regulated $\pm 15V$ Supply for DP AMP's, etc. Requires only unregulated DC (18-30V) and 2 bypass capacitors. **\$1.25**

RC4138 Quad 741 Low-Noise Op Amp mDIP **\$0.95**

LM1304 FM Multiplex Stereo Demodulator DIP **0.99**

LM2111 FM IF Subsystem (IF Amp, Det., Limiter) DIP **0.99**

1N6263 Hot Carrier Diode 0.4V @ 1mA 0.1ns DO-35 **1.00**

ZENERS—Specify Voltage 3.3, 3.9, 4.3, 5.1, 6.8, 8.2 400mW 4/\$1.00
9, 1, 10, 12, 15, 16, -18, 20, 22, 24, 27, or 33V ($\pm 10\%$) 1 Watt 3/\$1.00

- MONEY-BACK GUARANTEE
- ALL TESTED AND GUARANTEED

ADVA ELECTRONICS
BOX 4181 GB, WOODSIDE, CA 94062
Tel. (415) 328-1500

FREE IC or FET's WITH \$5 & \$10 ORDERS. 1 DATA SHEETS WITH MANY ITEMS.

DIODES	TRANSISTORS	TRANSISTORS	TRANSISTORS	LINEAR IC's
ZENERS & RECTIFIERS	2N706	2N4001	2N7063	LM309K-5
1N456 to 1N463	2N710	2N4002	2N7064	LM309K-5
1N465	2N722	2N4003	2N7065	LM309K-6
1N476 to 1N481	2N723	2N4004	2N7066	LM309K-7
1N482	2N724	2N4005	2N7067	LM309K-8
1N483	2N725	2N4006	2N7068	LM309K-9
1N484	2N726	2N4007	2N7069	LM309K-10
1N485	2N727	2N4008	2N7070	LM309K-11
1N486	2N728	2N4009	2N7071	LM309K-12
1N487	2N729	2N4010	2N7072	LM309K-13
1N488	2N730	2N4011	2N7073	LM309K-14
1N489	2N731	2N4012	2N7074	LM309K-15
1N490	2N732	2N4013	2N7075	LM309K-16
1N491	2N733	2N4014	2N7076	LM309K-17
1N492	2N734	2N4015	2N7077	LM309K-18
1N493	2N735	2N4016	2N7078	LM309K-19
1N494	2N736	2N4017	2N7079	LM309K-20
1N495	2N737	2N4018	2N7080	LM309K-21
1N496	2N738	2N4019	2N7081	LM309K-22
1N497	2N739	2N4020	2N7082	LM309K-23
1N498	2N740	2N4021	2N7083	LM309K-24
1N499	2N741	2N4022	2N7084	LM309K-25
1N500	2N742	2N4023	2N7085	LM309K-26
1N501	2N743	2N4024	2N7086	LM309K-27
1N502	2N744	2N4025	2N7087	LM309K-28
1N503	2N745	2N4026	2N7088	LM309K-29
1N504	2N746	2N4027	2N7089	LM309K-30
1N505	2N747	2N4028	2N7090	LM309K-31
1N506	2N748	2N4029	2N7091	LM309K-32
1N507	2N749	2N4030	2N7092	LM309K-33
1N508	2N750	2N4031	2N7093	LM309K-34
1N509	2N751	2N4032	2N7094	LM309K-35
1N510	2N752	2N4033	2N7095	LM309K-36
1N511	2N753	2N4034	2N7096	LM309K-37
1N512	2N754	2N4035	2N7097	LM309K-38
1N513	2N755	2N4036	2N7098	LM309K-39
1N514	2N756	2N4037	2N7099	LM309K-40
1N515	2N757	2N4038	2N7100	LM309K-41
1N516	2N758	2N4039	2N7101	LM309K-42
1N517	2N759	2N4040	2N7102	LM309K-43
1N518	2N760	2N4041	2N7103	LM309K-44
1N519	2N761	2N4042	2N7104	LM309K-45
1N520	2N762	2N4043	2N7105	LM309K-46
1N521	2N763	2N4044	2N7106	LM309K-47
1N522	2N764	2N4045	2N7107	LM309K-48
1N523	2N765	2N4046	2N7108	LM309K-49
1N524	2N766	2N4047	2N7109	LM309K-50
1N525	2N767	2N4048	2N7110	LM309K-51
1N526	2N768	2N4049	2N7111	LM309K-52
1N527	2N769	2N4050	2N7112	LM309K-53
1N528	2N770	2N4051	2N7113	LM309K-54
1N529	2N771	2N4052	2N7114	LM309K-55
1N530	2N772	2N4053	2N7115	LM309K-56
1N531	2N773	2N4054	2N7116	LM309K-57
1N532	2N774	2N4055	2N7117	LM309K-58
1N533	2N775	2N4056	2N7118	LM309K-59
1N534	2N776	2N4057	2N7119	LM309K-60
1N535	2N777	2N4058	2N7120	LM309K-61
1N536	2N778	2N4059	2N7121	LM309K-62
1N537	2N779	2N4060	2N7122	LM309K-63
1N538	2N780	2N4061	2N7123	LM309K-64
1N539	2N781	2N4062	2N7124	LM309K-65
1N540	2N782	2N4063	2N7125	LM309K-66
1N541	2N783	2N4064	2N7126	LM309K-67
1N542	2N784	2N4065	2N7127	LM309K-68
1N543	2N785	2N4066	2N7128	LM309K-69
1N544	2N786	2N4067	2N7129	LM309K-70
1N545	2N787	2N4068	2N7130	LM309K-71
1N546	2N788	2N4069	2N7131	LM309K-72
1N547	2N789	2N4070	2N7132	LM309K-73
1N548	2N790	2N4071	2N7133	LM309K-74
1N549	2N791	2N4072	2N7134	LM309K-75
1N550	2N792	2N4073	2N7135	LM309K-76
1N551	2N793	2N4074	2N7136	LM309K-77
1N552	2N794	2N4075	2N7137	LM309K-78
1N553	2N795	2N4076	2N7138	LM309K-79
1N554	2N796	2N4077	2N7139	LM309K-80
1N555	2N797	2N4078	2N7140	LM309K-81
1N556	2N798	2N4079	2N7141	LM309K-82
1N557	2N799	2N4080	2N7142	LM309K-83
1N558	2N800	2N4081	2N7143	LM309K-84
1N559	2N801	2N4082	2N7144	LM309K-85
1N560	2N802	2N4083	2N7145	LM309K-86
1N561	2N803	2N4084	2N7146	LM309K-87
1N562	2N804	2N4085	2N7147	LM309K-88
1N563	2N805	2N4086	2N7148	LM309K-89
1N564	2N806	2N4087	2N7149	LM309K-90
1N565	2N807	2N4088	2N7150	LM309K-91
1N566	2N808	2N4089	2N7151	LM309K-92
1N567	2N809	2N4090	2N7152	LM309K-93
1N568	2N810	2N4091	2N7153	LM309K-94
1N569	2N811	2N4092	2N7154	LM309K-95
1N570	2N812	2N4093	2N7155	LM309K-96
1N571	2N813	2N4094	2N7156	LM309K-97
1N572	2N814	2N4095	2N7157	LM309K-98
1N573	2N815	2N4096	2N7158	LM309K-99
1N574	2N816	2N4097	2N7159	LM309K-100
1N575	2N817	2N4098	2N7160	LM309K-101
1N576	2N818	2N4099	2N7161	LM309K-102
1N577	2N819	2N4100	2N7162	LM309K-103
1N578	2N820	2N4101	2N7163	LM309K-104
1N579	2N821	2N4102	2N7164	LM309K-105
1N580	2N822	2N4103	2N7165	LM309K-106
1N581	2N823	2N4104	2N7166	LM309K-107
1N582	2N824	2N4105	2N7167	LM309K-108
1N583	2N825	2N4106	2N7168	LM309K-109
1N584	2N826	2N4107	2N7169	LM309K-110
1N585	2N827	2N4108	2N7170	LM309K-111
1N586	2N828	2N4109	2N7171	LM309K-112
1N587	2N829	2N4110	2N7172	LM309K-113
1N588	2N830	2N4111	2N7173	LM309K-114
1N589	2N831	2N4112	2N7174	LM309K-115
1N590	2N832	2N4113	2N7175	LM309K-116
1N591	2N833	2N4114	2N7176	LM309K-117
1N592	2N834	2N4115	2N7177	LM309K-118
1N593	2N835	2N4116	2N7178	LM309K-119
1N594	2N836	2N4117	2N7179	LM309K-120
1N595	2N837	2N4118	2N7180	LM309K-121
1N596	2N838	2N4119	2N7181	LM309K-122
1N597	2N839	2N4120	2N7182	LM309K-123
1N598	2N840	2N4121	2N7183	LM309K-124
1N599	2N841	2N4122	2N7184	LM309K-125
1N600	2N842	2N4123	2N7185	LM309K-126
1N601	2N843	2N4124	2N7186	LM309K-127
1N602	2N844	2N4125	2N7187	LM309K-128
1N603	2N845	2N4126	2N7188	LM309K-129
1N604	2N846	2N4127	2N7189	LM309K-130
1N605	2N847	2N4128	2N7190	LM309K-131
1N606	2N848	2N4129	2N7191	LM309K-132
1N607	2N849	2N4130	2N7192	LM309K-133
1N608	2N850	2N4131	2N7193	LM309K-134
1N609	2N851	2N4132	2N7194	LM309K-135
1N610	2N852	2N4133	2N7195	LM309K-136
1N611	2N853	2N4134	2N7196	LM309K-137
1N612	2N854	2N4135		

**ALL
NEW**

Real-State-of-the-Art

TWO NEW AC•DC•BATTERY PORTABLE COUNTERS

OPTO-8000.1A 10Hz to 600 MHz — FREQUENCY COUNTER

- Precision TCXO time base 0.1 PPM Stability 17-40°C
- Super Sensitivity with preamps in both HI-Z & 50 Ohm inputs <10mV to 50MHz, 25 mV @ 150 MHz <50mV to 600MHz
- Auto Decimal Point • Aluminum Case • Socketed IC's
- Three position attenuator: X1, X10, X100 (avoids false counting)

#OPTO-8000.1A	Factory Assembled	\$329.95
#OPTO-8000.1AK	Kit Form	\$279.95
#NI-CAD-80	NI-CAD Battery Pack	\$ 19.95

OPTO-7000 10 Hz to 600 MHz MINIATURE COUNTER

- XTAL (TCXO) Time Base ±.08PPM/°C
- Aluminum Case • HI-Z & 50 Ohm inputs
- 1 Sec. & 1/10 Sec. Gate times • Auto Dec. Pt.
- Built-in Prescaler and Preamps Standard

#OPTO-7000	Factory Assembled - 1 Year-Guar ..	\$139.95
#OPTO-7000K	Kit Form	99.95
#AC-70	AC Power Pack	4.95
#NI-CAD-70	NI-CAD Battery Pack	19.95
#TCXO-70	Precision TCXO Time Base <0.1PPM, 17-40°C	79.95

ACCESSORIES

PROBES:

#P-100	50 Ohm, 1X	\$13.95
#P-101	Lo-Pass	16.95
#P-102	H1-Z, 2X	16.95
# AP- 8015	UHF Counter Preamp 20 MHz to 600 MHz 15-50 DB Gain (Not Shown) ..	\$49.95/Kit \$39.95

#D-450 Antenna

Rubber Duck RF Pick-up 450 MHz ... \$12.50

#D-146 Same as above

146.5MHz

#RA-BNC Right-Angle BNC Adapter for
above Antenna

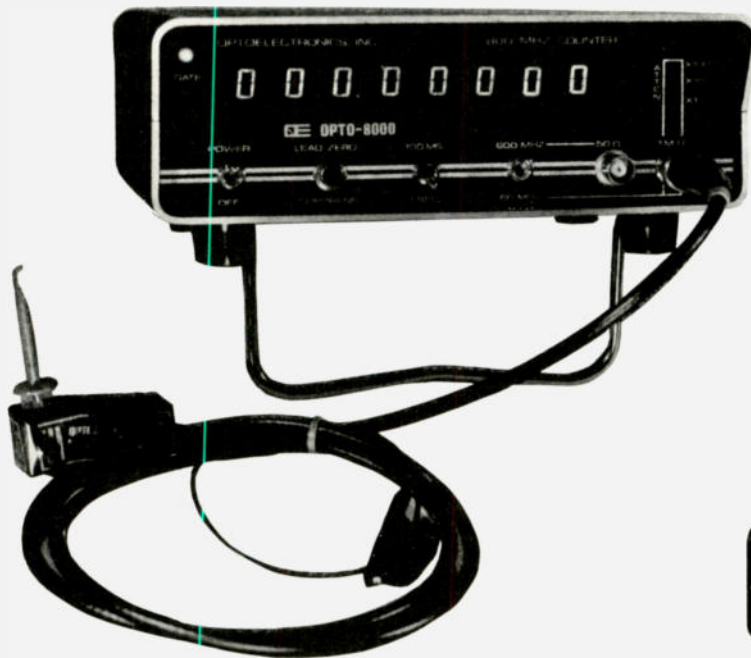

03

OPTOELECTRONICS, INC.

5821 NE 14 Avenue
Ft. Lauderdale, FL 33334
Phones: (305) 771-2050 771-2051

Phone orders accepted

ORDER FACTORY DIRECT — PHONE OR MAIL

TERMS: Orders to U.S. and Canada, add 5% to maximum of \$10.00 per order for shipping, handling and insurance. To all other countries, add 10% of total order. Florida residents add 4% state tax. C.O.D. fee: \$1.00. Personal checks must clear before merchandise is shipped.

New!

16K E-PROM CARD

IMAGINE HAVING 16K OF SOFTWARE ON LINE AT ALL TIME!

KIT FEATURES:

1. Double sided PC board with solder mask and silk screen and gold plated contact fingers.
2. Selectable wait states.
3. All address lines & data lines buffered!
4. All sockets included.
5. On card regulators.

KIT INCLUDES ALL PARTS AND SOCKETS (except 2708's). Add \$25. for assembled and tested.

S-100 (Imesai/Altair) Buss Compatible!

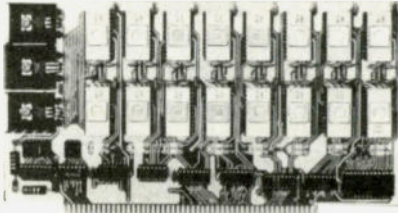

\$59.95 kit

SPECIAL OFFER:

Our 2708's (450NS) are \$8.95 when purchased with above kit.

NEW PRODUCTS FOR 1979

New Products are Scheduled for delivery during January 1979. Some may be available sooner. Call.

Z-80 CPU KIT \$129 For S-100 Buss. Features Jump on Reset capability. We feel this board has the most correct PSYNC signal for trouble free operation. Complete kit. More data on request. (for 4MHZ ADD \$10)	16K STATIC RAM KIT \$295 For SS-50 (S.W. TECH. 6800) Buss. Fully static uses 2114 RAM's. 450 N.S. At last, a quality RAM board for this popular Buss at an affordable price. Complete kit. Additional Data on request.	DUAL DENSITY FLOPPY DISC CONTROLLER For S-100 Buss. Reliability and Quality assured. Uses WD1791 Controller Chip. For 5 1/4 or 8 inch drives. Full IBM and S-100 compatible. Perfect for use with CP/M. Special P.L.L. design for maximum reliability. Assembled & Tested - \$219 Additional Data on Request.
--	--	--

CPM is a Trademark of Digital Research of California.

COMPUTER PARTS Z-80 - \$19.95 8080A - \$6.95 Z-80A - 24.95 8212 - 2.25	ALARM CLOCK CHIP N.S. MM5375AA Six Digits. With full Data. New! \$2.49 each	FULL WAVE BRIDGE 4 AMP. 200 PIV. 69¢ 10 FOR \$5.75	NOT ASSOCIATED WITH DIGITAL RESEARCH OF CALIFORNIA, THE SUPPLIERS OF CPM SOFTWARE.
---	--	---	--

MOTOROLA 7805R VOLTAGE REGULATOR Same as standard 7805 except 750 MA output. TO-220. 5VDC output. 44c each or 10 for \$3.95	450 NS! 2708 EPROMS Now full speed! Prime new units from a major U.S. Mfg. 450 N.S. Access time. 1K x 8. Equiv. to 4-1702 A's in one package. \$15.75 ea. \$9.95 4 FOR \$50.00 PRICE CUT
--	---

\$295.00 COMPLETE KIT

16K STATIC RAM KIT

ASSEMBLED & TESTED ADD \$30

OUR LATEST COMPUTER KIT!

FULLY S-100 COMPATIBLE!

FULLY STATIC, AT DYNAMIC PRICES!

WHY THE 2114 RAM CHIP?
 We feel the 2114 will be the next industry standard RAM chip (like the 2102 was). This means price, availability, and quality will all be good! Next, the 2114 is FULLY STATIC! We feel this is the ONLY way to go on the S-100 Buss! We've all heard the HORROR stories about some Dynamic Ram Boards having trouble with DMA and FLOPPY DISC DRIVES. Who needs these kinds of problems? And finally, even among other 4K Static RAM's the 2114 stands out! Not all 4K static Rams are created equal! Some of the other 4K's have clocked chip enable lines and various timing windows just as critical as Dynamic RAM's. Some of our competitor's 16K boards use these "tricky" devices. But not us! The 2114 is the ONLY logical choice for a trouble-free, straightforward design.

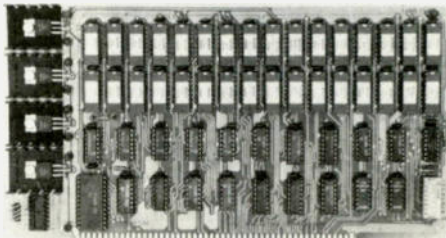

- KIT FEATURES**
1. Addressable as four separate 4K Blocks
 2. ON BOARD BANK SELECT circuitry (Cromemco Standard!) Allows up to 512K on line!
 3. Uses 2114 (450NS) 4K Static Rams
 4. ON BOARD SELECTABLE WAIT STATES
 5. Double sided PC Board, with solder mask and silk screened layout Gold plated contact fingers
 6. All address and data lines fully buffered
 7. Kit includes ALL parts and sockets
 8. PHANTOM is jumpered to PIN 67.
 9. LOW POWER under 2amps TYPICAL from the -8 Volt Buss
 10. Blank PC Board can be populated as any multiple of 4K

BLANK PC BOARD WITH DOCUMENTATION - \$33.00
 SUPPORT IC'S + CAPS - \$19.95
 LOW PROFILE SOCKET SET - \$12.00
 2114'S 4K RAM'S - 8 FOR \$69.95

(450 NS) SUPER SPECIAL: BUY 32 KI'S (512 KILOBYTES) (8-64K BANKS) for \$8,995.00

NATIONAL SEMICONDUCTOR JUMBO CLOCK MODULE

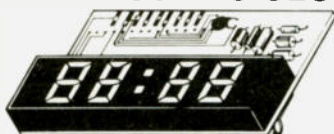

\$6.95

3 FOR \$13 (AC XFMR \$1.95)

- MA1008A BRAND NEW!**
- FEATURES**
- FOUR JUMBO 1/2 IN. LED DISPLAYS
 - 12 HR REAL TIME FORMAT
 - 24 HR ALARM SIGNAL OUTPUT
 - 50 OR 60 Hz OPERATION
 - LED BRIGHTNESS CONTROL
 - POWER FAILURE INDICATOR
 - SLEEP & SNOOZE TIMERS
 - DIRECT LED DRIVE (LOW RFI)
 - COMES WITH FULL DATA

SALE!
 1N4148 DIODES. SILICON.
 Same as 1N914. New, factory prime, Full Leads.
100 FOR \$2
1000 FOR \$17.50

New! REAL TIME Computer Clock Chip
 N.S. MM5313. Features BOTH 7 segment and BCD outputs. 28 Pin DIP. **\$4.95 with Data**

ASSEMBLED! NOT A KIT!

ZULU VERSION!
 We have a limited number of the 24 HR Real time version of this module in stock.
#MA10080 - \$9.95

PERFECT FOR USE WITH A TIMEBASE.

COMPARE AT UP TO TWICE OUR PRICE!

MANUFACTURER'S CLOSEOUT!

16K DYNAMIC RAM CHIP

16K X 1 Bits 16 Pin Package. Same as Mostek 4116-4 250 NS access 410 NS cycle time. Our best price yet for this state of the art RAM. 32K and 64K RAM boards using this chip are readily available. These are new, fully guaranteed devices by a major mfg. **VERY LIMITED STOCK!**

\$14.95 each 8 FOR \$89.95

Digital Research Corporation

(OF TEXAS)

P. O. BOX 401247 /GARLAND, TEXAS 75040/(214) 271-2461

TERMS: Add 30¢ postage, we pay balance. Orders under \$15 add 75¢ handling. No C.O.D. We accept Visa, MasterCard, and American Express cards. Tex. Res. add 5% Tax. Foreign orders (except Canada) add 20% P & H. 90 Day Money Back Guarantee on all items.

ROTRON FANS

#CT3A52 - CENTAUR. 4 3/4" SQUARE 220 VAC 60 HZ. WILL WORK ON 117 VAC REMOVED FROM NEW EQUIPMENT.

LIMITED STOCK

\$5.95 EACH

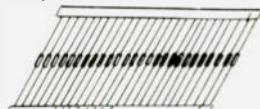

1N4148 DIODE SALE!

FULL LEADS! BRAND NEW!
COMPUTER MFG. SURPLUS

100 FOR \$2

1000 FOR \$17.50

FULL WAVE BRIDGE

25 amp
50 PIV

\$1.25



PRECISION OPTICS

31.5 POWER f:2.8
THREADED MOUNT

\$1.95 each

ORIG. COST \$16

These were used in MICRO-FILM equipment. Perfect for experiments.



PC BOARD EDGE CONNECTORS



75¢

36 Pin. Gold Plated. Solder Tail. .156 IN. Spacing. Double Rows of 18 Pins. For standard thickness (.062) PC Boards Major U.S. Mfg. **PRODUCTION QUANTITIES AVAILABLE.**

4 FOR \$2.50

MALLORY ELECTROLYTIC FILTER CAPACITOR



1500 MFD. 16 WVDC.
Radial Leads. Factory Fresh!

3 FOR \$1

10 FOR \$2.95

Perfect for Power Supplies!
Small Size: 1 1/4 x 3/8 Inches.

SUPER BRUTE RECTIFIER (limited stock)

160 Amps 100 PIV
Stud mount by Motorola
\$6.95 ea. or 4/\$25.

FERRITE BEADS

8 FOR \$1.00

3/8 inch long. For RF circuits. Make inductors or use for RFI suppression.



12VDC Relay by CDE.
SPDT. Coil is 280 ohm.
Small Size. **\$1.29**

DC PANEL METER

TOP QUALITY.
SMALL SIZE.
500 MA. F.S.

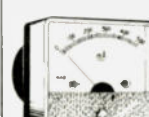

\$2.99

Z-80 PROGRAMMING MANUAL

By MOSTEK, or ZILOG. The most detailed explanation ever on the working of the Z-80 CPU CHIPS. At least one full page on each of the 158 Z-80 instructions. A MUST reference manual for any user of the Z-80. 300 pages. Just off the press.

\$12.95

IC SOCKETS

14 PINS LOW PROFILE — **6/\$1**
16 PINS LOW PROFILE — **5/\$1**
18 PINS LOW PROFILE — **4/\$1**
22 PINS LOW PROFILE — **3/\$1**
28 PINS LOW PROFILE — **3/\$1**

OPCOA LED READOUT
SLA-1. Common Anode.
.33 inch character size.
The original high efficiency LED display. 75¢ ea.

4 FOR \$2.50

WESTERN DIGITAL UART

TR1602A. PIN FOR PIN SUB FOR
AY5-1013 AND TMS6011.
FOR SERIAL I/O



\$2.99 EACH
SURPLUS SPECIAL

HEAVY DUTY DC MOTOR

1.5 to 3VDC. High Torque. Heavy duty magnet. Reversible. Do not confuse with cheap toy motors sold by others. High RPM.

75¢ EA.

3 FOR \$2



TIP-30 POWER TRANSISTOR

Prime new units. TO-220 Case. PNP silicon. VCEO-40 IC-1AMP. FT - 3 MHZ. 30 WATTS.

3 FOR \$1

SURPLUS SPECIAL!

COLOR BURST CRYSTAL

3.579545 MHZ. New Units.
Used in time bases, etc.

SUPER SALE!

99¢ EA.

ELECTROLYTIC CAP SPECIAL

Factory Fresh! Small Size.
100 MFD 16 WVDC



6 FOR \$1
30 FOR \$3.95

FAIRCHILD PNP "SUPER TRANSISTOR"
2N4402. TO-92 Plastic. Silicon PNP Driver. High Current. VCEO-40 HFE-50 to 150 at 150 MA. FT-150 MHZ. A super "BEEFED-UP" Version of the 2N3906.

8 FOR \$1

FAIRCHILD RED LED LAMPS

#FLV5057. Medium Size. Clear Case. RED EMITTING. These are not retested off-spec units as sold by some of our competition. These are factory prime, first quality, new units.



10 FOR \$1.19
50 FOR \$4.95

"WE BOUGHT 250,000 PCS."

✓ D20

VOLTAGE SUPPRESSORS

By Midwest. #67D5010. Silicon Carbide Varistors. These units grab voltage transients, spikes, surges, etc. For use on AC or DC in the range of 12 to 28 Volts. Small Size: .51 inch Disc with radial leads. For use across transformer secondaries, relays, etc. More rugged and reliable than silicon devices. Rated at 30 WATT-SEC. .25 WATT CONT. Perfect for use on AC operated clocks and instruments.

(THE GLITCH SWITCH)

SPECIAL PURCHASE: 3 FOR \$1

TERMS: Add 30¢ postage, we pay balance. Orders under \$15 add 75¢ handling. No C.O.D. We accept Visa, MasterCharge, and American Express cards. Tex. Res. add 5% Tax. Foreign orders (except Canada) add 20% P & H. 90 Day Money Back Guarantee on all items.

Digital Research Corporation

(OF TEXAS)

P. O. BOX 401247 • GARLAND, TEXAS 75040 • (214) 271-2461

Season's Greetings . . .

*and thank you . . .
for making this another extraordinary year!*

S-100 BUSS MEMORIES

**THE BIG ONE:
32K ECONORAM X™
unkit only \$599!**

Here is dense, low power **static** memory. Guaranteed 4 MHz operation. Configured as 3 individually addressable and protectable blocks (one 16K and two 8K). At last . . . you can fill your computer's memory without overstuffing your motherboard, or emptying your wallet.

MORE PRODUCTS . . .

**TRS-80 CONVERSION
KIT \$159**

Expand the TRS-80 mainframe from 4K to 16K, or use with the memory expansion module; our detailed instructions describe both conversion processes. **Includes all parts necessary for conversion, and is backed up by our standard 1 year limited warranty.** Also suitable for memory expansion in APPLE computers. 3 kits/\$450.

ECONORAMS COME IN THREE FORMS . . .

Most of our boards are available as "unkits" (sockets and bypass caps pre-soldered in place for easy assembly); **assembled and tested**; or qualified under our **Certified Systems Components (CSC)** program. CSC boards are burned in for 200 hours, serial numbered, and guaranteed to run at 4 MHz over the full temperature range. We exchange CSC boards if any defect occurs within 1 year of invoice date.

AND ALL OFFER THE FOLLOWING FEATURES:

Fully **static** design, buffered lines, tri-state outputs, dip switch address selection and deselection, write strobe selection switch for S-100 boards, complete socketing, guaranteed current and speed specs, a 1 year limited warranty, and more.

**8K ECONORAM II™
\$139 unkit, \$159 assm**

Our least costly way to add **static** memory to S-100 machines. Configured as two independent 4K blocks, with separate protect for each block and vector interrupt provision if you try to write in protected memory. Handles DMA. Less than 1500 mA current consumption.

16K ECONORAM IV™

\$279 unkit, \$314 assm, \$414 CSC

Static memory configured as 4 independent blocks (two 8K and two 4K). Write protect for each block; use with or without phantom line; provision for two qualifiers; runs DMS at 2 or 4 MHz; draws less than 2500 mA (1800 mA typical).

24K ECONORAM VII™

\$445 unkit, \$485 assm, \$605 CSC

Manual write protection for 4K blocks, use with or without phantom line, runs DMA at 2 or 4 MHz. Guaranteed under 2000 mA current (typically 1500 mA). Now you can have full static storage at less than the cost of dynamic equivalents.

**12K ECONORAM VI™
\$235 unkit, \$270 assm**

Same basic features as our S-100 memories, but designed specifically for the Heath H8. Configured as two blocks with switch selected protect. Also includes hardware and edge connector required to mate mechanically with the H8.

A SUPERB CLOCK: \$16.50!

We think the **MA1003 clock module** is the best clock module going . . . add three time-setting switches, a source of power, and you're up and running. Includes crystal controlled timebase for 12V DC operation — ideal for car, van, truck, boat, field day, or any other mobile application. Large (0.3") blue-green fluorescent readouts are visible under ambient light conditions that would wash out LEDs. Also, there are special options for car applications (for example, turning on headlights dims the display slightly for night viewing). All in all, whether you need one for yourself or want to present someone with a neat gift, this is an excellent choice. Includes applications data.

3 modules/\$46.

FREE FLYER: 40 pages packed with the latest in electronic goodies. Send us your name and address, we'll take care of the rest. For first class delivery enclose 41'.

GODBOUT

BILL GODBOUT ELECTRONICS
BOX 2355, OAKLAND AIRPORT, CA 94614

TERMS: Add \$1 handling to orders under \$15. Allow up 5% shipping (excess refunded). We prefer street address for UPS delivery. VISA®/Mastercharge® call our 24 hr. order desk at (415) 562-0636. CODs OK with street address. Californians add sales tax.

✓G4

Jameco ^{New} Kits

Regulated Power Supply



- Uses LM 309K
- Heat sink provided
- P.C. board construction
- Provides a solid 1 amp @ 5V
- Includes components, hardware and instructions
- Sizes: 3-1/2" x 5" x 2" high

JE200 \$14.95

Function Generator Kit



- Provides 3 basic waveforms: sine, triangle & square wave
- Frequency range from 1 Hz to 100 KHz
- Output amplitude from 0-volts to over 6 volts (peak to peak)
- Uses ± 12V supply or a ± 6V split supply
- Includes chip, P.C. board, components and instructions.

JE2206B \$19.95

Digital Stopwatch Kit



- Use Intersil 7205 Chip
- Plated thru double-sided P.C. Board
- LED display (red)
- Times to 59 min. 59.99 sec. with auto reset
- Quartz crystal controlled
- Three stopwatches in one: single event, split (cumulative) and taylor (sequential timing)
- Uses 3 penlite batteries
- Size: 4.5" x 2.15" x .90"

JE900 \$39.95

4-Digit Clock Kit



- Bright .357" ht. red display
- Sequential flashing colon
- 12 or 24 hour operation
- Extruded aluminum case (black)
- Pressure switches for hours, minutes and hold modes
- Includes all components, case and wall transformer
- Size: 3-1/4" x 1-3/4" x 1-1/4"

JE730 \$14.95

6-Digit Clock Kit



- Bright .300 ht. common cathode display
- Uses MM5314 clock chip
- Switches for hours, minutes and hold functions
- Hours easily viewable to 20 feet
- Simulated walnut case
- 115 VAC operation
- 12 or 24 hour operation
- Includes all components, case and wall transformer
- Size: 6-3/4" x 3-1/8" x 1-3/4"

JE701 \$19.95

Jumbo 6-Digit Clock Kit



- Four .630" ht. and two .300" ht. common anode displays
- Uses MM5314 clock chip
- Switches for hours, minutes and hold functions
- Hours easily viewable to 30 feet
- Simulated walnut case
- 115 VAC operation
- 12 or 24 hour operation
- Includes all components, case and wall transformer
- Size: 6-3/4" x 3-1/8" x 1-3/4"

JE747 \$29.95

MICROPROCESSOR COMPONENTS

8080/8086 SUPPORT DEVICES		MICROPROCESSOR MANUALS	
8080A	CPU	\$ 9.95	M 280 User Manual
8212	8-Bit Input/Output	3.25	M CDP1802 User Manual
8214	Priority Interrupt Control	5.95	M 2650 User Manual
8216	Bi-Directional Bus Driver	3.49	
8224	Clock Generator/Driver	3.99	
8226	Bus Driver	3.49	
8228	System Controller/Bus Driver	2513(2140)	Character Generator(lower case) \$9.99
8238	System Controller	5.95	Character Generator(upper case) 9.99
8251	Prog. Comm. I/O (USART)	2513(3021)	Character Generator 10.99
8253	Prog. Interval Timer	7.95	MM5250N 2048-Bit Read Only Memory 1.99
8255	Prog. Periph. I/O (PPI)	9.95	
8257	Prog. DMA Control	19.95	
8259	Prog. Interrupt Control	19.95	
5800/8000 SUPPORT DEVICES		ROM'S	
MC6800	MPU	1101	256X1 Static \$1.49
MC6802CP	MPU with Clock and Ram	2101(8101)	1024X1 Dynamic 9.99
MC6810API	128X8 Static Ram	2101(8101)	256X4 Static 2.39
MC6821	Periph. Inter. Adapt. (MC6820)	2102	1024X1 Static 1.75
MC6828	Priority Interrupt Controller	5.95	1024X1 Static 1.95
MC6830B	1024X8 Bit ROM (MC6830-B)	2111(8111)	256X4 Static 3.95
MC6850	Asynchronous Comm. Adapter	2112	256X4 Static MOS 4.95
MC6852	Synchronous Serial Data Adapt.	2114	1024X4 Static 450ns 10.95
MC6860	0-600 bps Digital MODEM	2114.3	1024X4 Static 300ns low power 10.95
MC6862	2400 bps Modem	5101	256X4 Static 7.95
MC6880A	Quad 3-State Buff. Triacs (MC6875)	5280(2107)	4096X1 Dynamic 4.95
		7489	16X4 Static 1.75
		745200	256X1 Static Tri-state 4.95
		93421	256X1 Static 2.95
		UP2414	4K Dynamic 16 pin 4.95
		(MM4227)	
		UPD416	16K Dynamic 16 pin 14.95
		(MM415)	
		TM54044	4K Static 14.95
		TM54045	1024X4 Static 14.95
		2117	16.384X1 Dynamic 9.95
		MM5262	2KX1 Dynamic 41.00
MICROPROCESSOR CHIPS—MISCELLANEOUS		PROM'S	
Z801780C1	CPU	1702A	2048 FAMOS \$5.95
Z80A1780-1	CPU	TM52516	16K EPROM(Inter 2716) 49.95
CDP1802	CPU	(2716)	*Requires single -5V power supply
8055	MPU	TM52532	4KX8 EPROM 89.95
8085	8-Bit MPU w/clock, RAM, I/O lines	2708	8K EPROM 10.95
PD805	CPU	2716 T1	16KX1 EPROM 29.95
TMS9900UL	16-Bit MPU w/hardware multiply & divide	5203	2048 FAMOS 14.95
		6301-1(7611)	1024 Tri-state Bipolar 3.49
		6330-1(7602)	256 Open C Bipolar 2.95
		82523	32X8 Open Collector 3.95
		825115	4096 Bipolar 19.95
		82S123	32X8 Tri-state 3.95
		74186	512 TTL Open Collector 9.95
		74188	256 TTL Open Collector 3.95
		74S287	1024 Static 2.95
SHIFT REGISTERS			
MM500H	Dual 25 Bit Dynamic	5.50	
MM503H	Quad 50 Bit Dynamic	5.50	
MM504H	Quad 16 Bit Static	5.50	
MM505H	Dual 100 Bit Static	5.50	
MM510H	Dual 64 Bit Accumulator	8.99	
MM5016H	500-512 Bit Dynamic	3.95	
2504T	1024 Dynamic	4.95	
2518	Hex 32 Bit Static	2.95	
2522	Dual 132 Bit Static	2.95	
2524	512 Static	9.99	
2525	1024 Dynamic	2.95	
2527	Dual 256 Bit Static	2.95	
2528	Dual 250 Static	4.00	
2529	Dual 140 Static	2.95	
2532	Quad 80 Bit Static	2.95	
2533	1024 Static	2.95	
3341	Fifo	6.95	
74LS670	4Kx Register File (Tri-State)	1.95	
UART'S			
A-Y 5-1013	30K BAUD	5.95	

The Sinclair PDM35. A personal digital multimeter for only \$59.95

Technical specification
 DC Volts (4 ranges): Range 1 mV to 100 V Accuracy of reading 0.1% ± 1 count Note: 100 V input impedance
 AC Volts (4 ranges): Range 1V to 500 V Accuracy of reading 1.0% ± 2 counts
 DC Current (4 ranges): Range 1 mA to 200 mA Accuracy of reading 1.0% ± 1 count Note: Max resolution 0.1 mA
 Resistance (5 ranges): Range 1 Ω to 20 MΩ Accuracy of reading 1.0% ± 1 count Note: Provides 4-function test ranges
 Dimensions: 6.5 x 3.5 x 1.5 in.
 Weight: 6 oz.
 Power supply: 9V battery or Sinclair M adapter (battery not included)
 Sockets: Standard 3 mm line resistor plugs
 Options: M adapter for 11.7 V NiCd power. De-luxe padded carrying case.

Now everyone can afford to own a digital multimeter

XMAS SPECIAL - Get your PDM-35 PLUS the 117 volt AC Adapter and Padded carrying case for only (Retail value \$73.85) \$64.50

BK PRECISION 3 1/2-Digit Portable DMM

- Overload Protection
- 7 High LED Display
- Battery or AC operation
- Auto Zeroing
- 1000 1/2% D 10m resolution
- Overrange reading
- 10 meg input impedance
- DC Accuracy 1% typical
- Ranges: DC Voltage 0-1000V AC Voltage 0-1000V
- Freq. Response 50-100 Hz
- DC AC Current 0-100mA
- Resizable 0-10 meg ohm
- Size 6.4 x 4.4 x 2

Model 2800 \$99.95

Comes with test leads, operating manual and spare fuse

100 MHz 8-Digit Counter

- 20 MHz 100 MHz Range
- 6 LED Display
- Crystal-controlled timebase
- Fully Automatic
- Portable — completely self contained
- Size — 1.75 x 7.38 x 5.63

MAX-100 \$134.95

ACCESSORIES FOR MAX 100:
 Mobile Charger/Eliminator \$39.95
 Charge/Eliminator Model 100 — CLA \$3.95
 Model 100 — CAI \$9.95

NEW ESE Mini-Max 6 Digit 50MHz Frequency Counter

- Guaranteed frequency range of 100 Hz to 50 MHz
- Full 6 digit display with anti-glare window
- Fully automatic range, polarity, slope, trigger, input level switching not required
- Lead-zero blanking—All zeros to the left of the first non-zero digit are blanked. Kilo Hertz and Mega Hertz decimal points automatically light up when the unit is turned on
- Built in input overvoltage protection.
- Use 9V Battery or 110/220V power.
- Complete with mini antenna
- Lightweight — Only 8oz

MINI-MAX \$89.95

Part No.	Description	Price
MM-A4	Antenna	\$ 3.95
MM-C5	Carrying case	5.95
MM-IPC	Input cable with clip leads	3.95
MM-AC2	110V adapter	9.95
MM-AC3	220V adapter	9.95

\$5.00 Minimum Order — U.S. Funds Only
 California Residents — Add 6% Sales Tax
 Spec Sheets — 25¢
 1979 Catalog Available—Send 41¢ stamp

NEW 1979 Catalog

Jameco ELECTRONICS

MAIL ORDER ELECTRONICS — WORLDWIDE
 1021 HOWARD AVENUE, SAN CARLOS, CA 94070

PHONE ORDERS WELCOME (415) 592-8097

Advertised Prices Good Thru December

The Incredible "Pennywhistle 103"

\$139.95 Kit Only

The Pennywhistle 103 is capable of recording data to and from audio tape without intricate speed requirements for the recorder and it is able to communicate directly with another modern terminal for telephone, teletype and communications. In addition, it is free of critical adjustments and is built with non-precision, readily available parts.

Data Transmission Method	Frequency Shift Keying full-duplex (half-duplex selectable)
Maximum Data Rate	300 Baud
Data Format	Asynchronous Serial (return to mark level required between each character)
Receive Channel Frequencies	2025 Hz for space 2225 Hz for mark
Transmit Channel Frequencies	Switch selectable Low (normal) — 1070 space 1270 mark High — 925 space 2225 mark
Receive Sensitivity	15 dbm nominal Adjustable from 6 dbm to -20 dbm
Transmit Level	15 dbm nominal Adjustable from 6 dbm to -20 dbm
Receive Frequency Tolerance	Frequency reference automatically adjusts to allow for operation between 1800 Hz and 2400 Hz
Digital Data Interface	RS-232C or 20 mA current loop (receiver is unpopulated and non-polar)
Power Requirements	120 VAC, single phase, 10 Watts
Physical	All components mount on a single 5 by 9 printed circuit board. All components included Frequency Counter and/or Oscilloscope as sign.

Requires a VOM, Audio Oscillator

TRS-80 16K Conversion Kit

Expand your 4K TRS-80 System to 16K. Kit comes complete with:

- 8 each UPD416 (16K Dynamic Rams)
- Documentation for conversion

TRS-16K \$115.00

Special Offer - Order both your TRS-16K and the Sup'R' MOD II Interface kit together (retail value \$144.95) for only \$139.95

COMPUTER CASSETTES

6 EACH 15 MINUTE HIGH QUALITY C-15 CASSETTES
 PLASTIC CASE INCLUDED
 12 CASSETTE CAPACITY
 ADDITIONAL CASSETTES AVAILABLE #C-15-52 \$0 ea

CAS-6 \$14.95

(Case and 6 Cassettes)

SUP 'R' MOD II

UHF Channel 33 TV Interface Unit Kit

- Wide Band B/W or Color System
- Converts TV to Video Display for home computers, CCTV camera, Apple II, works with Cromeco Dazler, SOL-20, IRS-80, Challenger etc.
- MOD II is pretuned to Channel 33 (UHF)
- Includes coaxial cable and antenna transformer

MOD II \$29.95 Kit

Custom Cables & Jumpers

DB 25 Series Cables

Part No.	Cable Length	Connectors	Price
DB25P-4P	4 Ft	2-DB25P	\$15.95 ea
DB25P-4S	4 Ft	1-DB25P 1-25S	\$16.95 ea
DB25S-4S	4 Ft	2-DB25S	\$17.95 ea

Dip Jumpers

Part No.	Length	Pin Configuration	Price
DJ14-1	1 ft	1-14 Pin	\$1.59 ea
DJ16-1	1 ft	1-16 Pin	1.79 ea
DJ24-1	1 ft	1-24 Pin	2.79 ea
DJ14-1-14	1 ft	2-14 Pin	3.19 ea
DJ16-1-16	1 ft	2-16 Pin	3.19 ea
DJ24-1-16	1 ft	2-24 Pin	4.95 ea

For Custom Cables & Jumpers, See JAMECO 1979 Catalog for Pricing

CONNECTORS

25 Pin-O Subminiature

DB25S(as pictured)	PLUG	\$2.95
DB25S	SOCKET	3.50
DB51226-1	Cable Cover for DB25 P or S	1.75

63-Key Unencoded Keyboard

This is a 63-key, terminal keyboard newly manufactured by a large computer manufacturer. It is unencoded with SPST keys, unattached to any kind of PC board. A very solid molded plastic 13 x 4" base suits most application. IN STOCK \$29.95/each

Hexadecimal Unencoded Keypad

19-key pad includes 1-10 keys, ABCDEF and 2 optional keys and a shift key

\$10.95/each

DIODES/ZENERS				SOCKETS/BRIDGES				TRANSISTORS, LEDS, etc.				
1N914	100v	10mA	.05	8-pin	pcb	.20	ww	.35	2N2222	NPN (2N2222 Plastic)	.10	.15
1N4005	600v	1A	.08	14-pin	pcb	.20	ww	.40	2N2907	PNP		.15
1N4007	1000v	1A	.15	16-pin	pcb	.20	ww	.40	2N3906	PNP (Plastic - Unmarked)		.10
1N4148	75v	10mA	.05	18-pin	pcb	.25	ww	.75	2N3904	NPN (Plastic - Unmarked)		.10
1N4733	5.1v	1 W Zener	.25	22-pin	pcb	.35	ww	.95	2N3054	NPN		.35
1N753A	6.2v	500 mW Zener	.25	24-pin	pcb	.35	ww	.95	2N3055	NPN 15A 60v		.50
1N758A	10v	"	.25	28-pin	pcb	.45	ww	1.25	T1P125	PNP Darlington		.95
1N759A	12v	"	.25	40-pin	pcb	.50	ww	1.25	LED Green, Red, Clear, Yellow			.15
1N5243	13v	"	.25	Molex pins .01	To-3 Sockets	.25			D.L.747	7 seg 5/8" High com-anode		1.95
1N5244B	14v	"	.25	2 Amp Bridge	100-prv	.95			MAN72	7 seg com-anode (Red)		1.25
1N5245B	15v	"	.25	25 Amp Bridge	200-prv	1.95			MAN3610	7 seg com-anode (Orange)		1.25
									MAN82A	7 seg com-anode (Yellow)		1.25
									MAN74A	7 seg com-cathode (Red)		1.50
									FND359	7 seg com-cathode (Red)		1.25

C MOS		- T T L -									
4000	.15	7400	.10	7473	.25	74176	.85	74H72	.35	74S133	.40
4001	.15	7401	.15	7474	.30	74180	.55	74H101	.75	74S140	.55
4002	.20	7402	.15	7475	.35	74181	2.25	74H103	.55	74S151	.30
4004	3.95	7403	.15	7476	.40	74182	.75	74H106	.95	74S153	.35
4006	.95	7404	.10	7480	.55	74190	1.25			74S157	.75
4007	.20	7405	.25	7481	.75	74191	.95	74L00	.25	74S158	.30
4008	.75	7406	.25	7483	.75	74192	.75	74L02	.20	74S194	1.05
4009	.35	7407	.55	7485	.55	74193	.85	74L03	.25	74S257 (8123)	1.05
4010	.35	7408	.15	7486	.25	74194	.95	74L04	.30		
4011	.20	7409	.15	7489	1.05	74195	.95	74L10	.20	74LS00	.20
4012	.20	7410	.15	7490	.45	74196	.95	74L20	.35	74LS01	.20
4013	.40	7411	.25	7491	.70	74197	.95	74L30	.45	74LS02	.20
4014	.75	7412	.25	7492	.45	74198	1.45	74L47	1.95	74LS04	.20
4015	.75	7413	.25	7493	.35	74221	1.00	74L51	.45	74LS05	.25
4016	.35	7414	.75	7494	.75	74367	.75	74L55	.65	74LS08	.25
4017	.75	7416	.25	7495	.60			74L72	.45	74LS09	.25
4018	.75	7417	.40	7496	.80	75108A	.35	74L73	.40	74LS10	.25
4019	.35	7420	.15	74100	1.15	75491	.50	74L74	.45	74LS11	.25
4020	.85	7426	.25	74107	.25	75492	.50	74L75	.55	74LS20	.20
4021	.75	7427	.25	74121	.35			74L93	.55	74LS21	.25
4022	.75	7430	.15	74122	.55			74L123	.85	74LS22	.25
4023	.20	7432	.20	74123	.35	74H00	.15			74LS32	.25
4024	.75	7437	.20	74125	.45	74H01	.20	74S00	.35	74LS37	.25
4025	.20	7438	.20	74126	.35	74H04	.20	74S02	.35	74LS38	.35
4026	1.95	7440	.20	74132	.75	74H05	.20	74S03	.25	74LS40	.30
4027	.35	7441	1.15	74141	.90	74H08	.35	74S04	.25	74LS42	.65
4028	.75	7442	.45	74150	.85	74H10	.35	74S05	.35	74LS51	.35
4030	.35	7443	.45	74151	.65	74H11	.25	74S08	.35	74LS74	.35
4033	1.50	7444	.45	74153	.75	74H15	.45	74S10	.35	74LS86	.35
4034	2.45	7445	.65	74154	.95	74H20	.25	74S11	.35	74LS90	.55
4035	.75	7446	.70	74156	.70	74H21	.25	74S20	.25	74LS93	.55
4040	.75	7447	.70	74157	.65	74H22	.40	74S40	.20	74LS107	.40
4041	.69	7448	.50	74161	.55	74H30	.20	74S50	.20	74LS123	1.00
4042	.65	7450	.25	74163	.85	74H40	.25	74S51	.25	74LS151	.75
4043	.50	7451	.25	74164	.60	74H50	.25	74S64	.15	74LS153	.75
4044	.65	7453	.20	74165	1.10	74H51	.25	74S74	.35	74LS157	.75
4046	1.25	7454	.25	74166	1.25	74H52	.15	74S112	.60	74LS164	1.00
4049	.45	7460	.40	74175	.80	74H53J	.25	74S114	.65	74LS193	.95
4050	.45	7470	.45			74H55	.20			74LS367	.75
4066	.55	7472	.40							74LS368	.65

9000 SERIES		MCT2		LINEARS, REGULATORS, etc.							
9301	.85	95H03	1.10	8038	3.95	LM320T5	1.65	LM340K15	1.25	LM723	.40
9309	.35	9601	.20	LM201	.75	LM320T12	1.65	LM340K18	1.25	LM725N	2.50
9322	.65	9602	.45	LM301	.45	LM320T15	1.65	LM340K24	1.25	LM739	1.50
				LM308 (Mini)	.95	LM324N	1.25	78L05	.75	LM741 (8-14)	.25
				LM309H	.65	LM339	.75	78L12	.75	LM747	1.10
				LM309K (340K-5)	.85	7805 (340T5)	.95	78L15	.75	LM1307	1.25
				LM310	.85	LM340T12	.95	78M05	.75	LM1458	.65
				LM311D (Mini)	.75	LM340T15	.95	LM373	2.95	LM3900	.50
				LM318 (Mini)	1.75	LM340T18	.95	LM380 (8-14 PIN)	.95	LM75451	.65
				LM320K 5(7905)	1.65	LM340T24	.95	LM709 (8, 14 PIN)	.25	NE555	.35
				LM320K12	1.65	LM340K12	1.25	LM711	.45	NE556	.85
										NE565	.95
										NE566	1.25
										NE567	.95

MICRO'S, RAMS, CPU'S, E-PROMS			
74S188	3.00	8214	8.95
1702A	4.50	8224	3.25
MM5314	3.00	8228	6.00
MM5316	3.50	8251	8.50
2102-1	1.45	8255	8.50
2102L-1	1.75	8T13	1.50
2114	9.50	8T23	1.50
TR1602B	3.95	8T24	2.00
TMS 4044	9.95	8T97	1.00
		2107B-4	4.95
8080	8.95	2708	9.50
8212	2.95	Z80 PIO	8.50

INTEGRATED CIRCUITS UNLIMITED ¹⁹

**7889 Clairemont Mesa Boulevard, San Diego, California 92111
(714) 278-4394 (Calif. Res.)**

All orders shipped prepaid	No minimum
Open accounts invited	COD orders accepted

Discounts available at OEM Quantities California Residents add 6% Sales Tax

All IC's Prime/Guaranteed. All orders shipped same day received.

24 Hour Toll Free Phone 1-800-854-2211	American Express / BankAmericard / Visa / MasterCard
---	---

SPECIAL DISCOUNTS

Total Order	Deduct
\$35 - \$99	10%
\$100 - \$300	15%
\$301 - \$1000	20%

STUDENTS & TEACHERS WITH YOUR ORDER, SEND PROOF OF YOUR PRESENT STATUS AND RECEIVE 5% OF YOUR ORDER AS A CREDIT CERTIFICATE YOU CAN USE ON YOUR NEXT ORDER.		FREE SOCKETS WITH PURCHASE OF ANY OF THESE I.C.'s.		8000 SYSTEM 8080A 5.95 8212 3.75 8214 8.95 8216 3.50 8224 4.80 8226 4.75 8228 7.25 8238 8.25 8251 9.45 8253 21.50 8255 10.75 8257 20.50 8259 20.50		CPU's cont. 8008 8.95 8035 19.95		PROC. LOGIC ARRAYS 825100 11.95 825101 11.95		S-100 MOTHER BOARD — 8 Slot Kit 69.00 S-100 32K STATIC MEMORY BOARD ALL BURNED IN AND TESTED 650ns 599.00 450ns 735.00 200ns 875.00 ultra low power S-100 EDGE CARO CONNECTORS MAXI KEYBOARD — 53 Keys 19.95 MAXI KEYBOARD — 74 Keys 33.95 KEYPAD — 16 key x y matrixed 1.95 KEYPAD — 20 key x y matrixed 2.95 WIRE WRAP POSTS 2 level 100/3.95 4 level 100/4.95 WIRE WRAP SOCKET PIN 100/7.95 TAPE READER — 12 level — includes both IR sources and pickups 29.00 MAKE YOUR OWN PAPER TAPE READER 109/5.00 REED RELAY — TTL compatible 1.89 SOLIO STATE RELAY — micro reed actuated for total isolation 3.95 CRYSTAL FILTERS — 455 Kc miniature single section 1.95 dual section 2.95							
CHRISTMAS SPECIAL OF 5% OFF EFFECTIVE ON ALL ORDERS MAILED BEFORE DECEMBER 25, 1978.				THE FIRST MEMORY SPECIAL YOU WON'T FORGET 2102-2 650ns 8/79 ⁹⁵ 32/37 ⁰⁰ 64/71 ⁰⁰ 128/135 ⁰⁰ 2102-4 450ns 8/10 ⁹⁵ 32/41 ⁰⁰ 64/78 ⁰⁰ 128/145 ⁰⁰ 2114D 450ns 8/79 ⁰⁰ 16/149 ⁰⁰ 32/274 ⁰⁰ 64/499 ⁰⁰				Z-80 SYSTEM 3880 22.50 3881 12.50 3882 12.50 3883 49.00 3884 73.00		OPTO ISOLATORS 1. MCT2 \$ 79 2. MOC1000 \$.89 3. 4N-26 \$.95 4. CL1422		6000 SYSTEM 6800 16.95 6810 7.20 6820 7.95 6821 8.50 6850 8.95 6852 11.95 6860 9.95 6862 13.75		PROCS 8223 2.95 8223 3.75 825126 5.95 825129 6.95 825131 7.25 6306-1 6.95 93427 5.95 03604 11.95 2616 50.00 1702A 4.95 2708 12.95 2716-5V 46.95		INTERFACE CHIPS DS0028 3.25 DS3608 3.85 DM8093 .95 DM8094 .95 DM8095 .95 DM8096 .95 DM8097 .95 DM8098 .95 DM8131 3.25 DM8202 1.45 DM8233 1.10 DM8234 1.10 DM8241 .45 DM8242 .45 DM8250 .90 DM8251 .90 DM8266 4.35 DM8267 1.35 DM8271 1.35 DM8544 3.30 DM8583 2.95 DM8584 2.60 DM8585 2.60 DM8586 4.75 DM8587 2.45 74273 2.60 74390 2.10 81LS95 1.95 81LS96 1.95 81LS97 1.95	
PRESCALER - 250 MHZ complete \$23 ⁹⁵ PRESCALER - 650 MHZ complete \$49 ⁹⁵ 11C90 - PRESCALER CHIP 650 mc \$19 ⁹⁵		CLAIREX PHOTO MODULE (USE AS VOLTAGE VARIABLE RESISTOR—40 MEG OHM TO 40 OHM—MILLION TO ONE RATIO—OR USE AS VERY HIGH VOLTAGE OPTO ISOLATOR) \$1 ⁹⁵		9900 SYSTEM 9900 66.00 9901 23.75 9902 19.50 9980 54.00 9981 54.00		REFLECTIVE PHOTO COUPLERS TIL-139 LED INTO PHOTO TRANSISTOR \$2 ⁹⁵ ROC100 INCANDESCENT INTO CDS CELL—20 MEG OHM OFF RESISTANCE \$1 ⁹⁵		1000 SYSTEM 1802 24.00 1821 19.50 1822 20.25 1824 13.50 1852 13.75 1856 11.75 1857 11.76 1861 20.00		CHARACTER GENERATORS 2513 LC 7.95 2513 UC 7.95 2516 7.95 5240 7.95 MM6571A 9.95		PHOTO DEVICES—DIODES, XSTR'S, DARLINGTONS 2N5771 1.25 FP1100A .79 M01 1.95 H-38 1.25 NND 250 1.95 LASCR 1.95 HIGH VOLTAGE TRANSISTORS 2SC1350 1100V 1400V/5A TO-3 7.95 BUY99B 1100V 800V/10A TO-3 5.95 954 500V/5A Plastic 4.95 957-4 20W 500V/1A Plastic 2.25 338-7 20W 350V/1A Plastic 1.50 HIGH VOLTAGE DIODES UNMARKED 1500V at 1 AMP 101/1.99 EG 250 2500V at 35 AMP .95 MV60EL 6000V at 25 ma 1.95 SUBMINIATURE 20,000V at 100 ma 2.95 CARBIDE DRILL BITS AND ROUTER BITS for P.C. board work — MIXED SIZES DRILL MIX — DRILLS 10/12.95 100/95.00 DRILL MIX — ROUTERS 10/15.95 100/125.00					
SOLID STATE RELAY • 400 V at 3 AMPS • TTL COMPATIBLE • MICRO REED ACTUATED TO MINIMIZE CHANCES OF AC POWER SPILLOVER INTO LOGIC CIRCUITS \$3 ⁹⁵		CHEAPER BY THE 100 LEADS (HP AXIAL RED) 100/8.95 LEADS (MINI-RED) 100/9.95 LEADS (JUMBO-RED) 100/13.95 LEADS (DUAL COLOR) 100/59.00 1N4001 (50V-1 AMP) 100/4.95 1N4148 (SWITCHING DIODE) 100/3.95 2N4303 (N-JFET) 100/21.95 2N3392 (PRIME-NPN LOW NOISE) 100/9.95		9980 SYSTEM 1802 24.00 1821 19.50 1822 20.25 1824 13.50 1852 13.75 1856 11.75 1857 11.76 1861 20.00		KEYBOARD ENCODER AYS-2376 14.95		UARTS AYS-1012 8.95 AYS-1013 8.95 TR-1602 9.95 LMS6011 8.95		UARTS AYS-1012 8.95 AYS-1013 8.95 TR-1602 9.95 LMS6011 8.95		UARTS AYS-1012 8.95 AYS-1013 8.95 TR-1602 9.95 LMS6011 8.95					
AUDIO POWER AMPS SINGLE TDA2020-20 Watt \$9.95 S11020H-20 Watt \$10.50 S11130H-30 Watt \$12.50 STK-50 .50 Watt \$18.95		STEREO STK433-5 Watts per channel \$6.95 STK435-7 Watts per channel \$9.95 STK437-10 Watts per channel \$11.95 STK439-15 Watts per channel \$13.95 STK441-20 Watts per channel \$16.95		CPUs 2650 19.95 2901 18.95 PACE 19.00 SC/MP 14.95		FIFO's 3341 7.95 1502E 10.95		REPAIR—WE WILL REPAIR ANY ORIGINAL TRS-80 MICROCOMPUTER OR ONE OF OUR MODIFICATIONS. ALL PARTS AND LABOR \$69⁹⁵									

RADIO SHACK® TRS-80™ COMPUTER SERVICE AND MODIFICATION

BE FIRST TO TURN YOUR TRS-80 INTO A SUPER MACHINE

1. Keyboard and Video Mod

ADD RAM FOR LOWER CASE CHARACTERS AND CLEAN UP HORIZONTAL SMEAR (SEND YOUR TRS-80 MICROCOMPUTER ONLY)
PARTS AND LABOR \$59⁰⁰

4. Clock Mod

INCREASE YOUR PROCESSING SPEED BY 30%. WITH THIS OPTION YOU CAN SWITCH-SELECT BETWEEN THE FASTER 2.66MHZ CLOCK RATE AND 1.77MHZ.
INSTALLATION, PARTS AND LABOR \$49⁰⁰

2. Install 16K Memory

JUST SEND US YOUR TRS-80 MICROCOMPUTER AND WE DO THE REST!
16K OF MEMORY AND LABOR \$18⁹⁵

5. Serial Printer Interface Mod

OPERATE CRYSTAL CONTROLLED TTY WITH LEVEL 1 OR 2. WE INSTALL SWITCH SELECTABLE BAUD RATES OF 75, 110, 137.5, 150, 300, 600, 1200, 2400, 4800, 9600 OR EXTERNAL EIA RS232 AND CURRENT LOOP OUTPUT.
PARTS AND LABOR \$119⁰⁰

3. Level 2 plus 1 Mod

WE INSTALL YOUR LEVEL 2 SO YOU KEEP LEVEL 1 AND CAN USE IT BY JUST FLIPPING A SWITCH. (SEND LEVEL 2 WITH YOUR TRS-80)
\$69⁹⁵

6. Mini Floppy Mod

YOU PROVIDE EXPANSION INTERFACE AND WE'LL INSTALL A PERTEC F D 200 MINI FLOPPY.
PARTS AND LABOR (PERTEC F D 200 MINI FLOPPY INCLUDED) FOR ONLY \$425⁰⁰

SPECIALS!! DO MORE THAN ONE MOD AND SAVE
 MODS 1, 2, 3, 4 AND 5 \$449⁰⁰
 MODS 1 AND 2 \$234⁰⁰
 MODS 2 AND 3 \$243⁰⁰
 16K MEMORY, PARTS AND INSTALLATION DATA \$159⁰⁰

SEND TRS-80 KEYBOARD ONLY!!

RETURN SHIPPING:
 FROM ENGLAND ADD \$30.00 FOR AIR, \$9.50 SURFACE MAIL
 FROM JAPAN ADD \$35.00 FOR AIR, \$8.50 SURFACE MAIL

REPAIR—WE WILL REPAIR ANY ORIGINAL TRS-80 MICROCOMPUTER OR ONE OF OUR MODIFICATIONS.
ALL PARTS AND LABOR \$69⁹⁵

NOTE: THIS IS AN INDEPENDENT SERVICE EFFORT NOT AFFILIATED WITH RADIO SHACK® OR TANDY CORPORATION.

ALL WORK GUARANTEED UNCONDITIONALLY FOR 1 YEAR
TERMS FOR TRS-80 WORK: WE ACCEPT ONLY TRS-80 MICROCOMPUTERS! SHIP YOUR TRS-80 MICROCOMPUTER TO US, INSURED AND SUITABLY PACKAGED AND WE WILL RETURN SAME FREIGHT COLLECT. ALL FACTORY SEALS MUST BE INTACT. ANY UNIT WHOSE SEALS HAVE BEEN TAMPERED WITH WILL BE SHIPPED BACK IMMEDIATELY. MODS 1, 2, 4 AND 5 SEND TRS-80 MICROCOMPUTER ONLY. MOD 3 SEND YOUR TRS-80 MICROCOMPUTER AND LEVEL 2. MOD 6 SEND TRS-80 AND EXPANSION INTERFACE. NORMAL TURN AROUND TIME IS UNDER 10 DAYS WITH CERTIFIED FUNDS

F. REICHERT SALES

✓R25

DROP INTO ONE OF OUR LOCATIONS

1110 E. GARVEY AVE.
 W. COVINA, CA 91790
 (213) 967-3846

- \$20 MINIMUM ORDER
- FREE UPS DELIVERY ON U.S. ORDERS ONLY—OR BY SURFACE MAIL IF SPECIFIED
- MONEY BACK GUARANTEE (MOS & LED DEVICES EXCLUDED)
- UNDER 8 HOUR PROCESSING ON MONEY ORDERS & CASHIER'S CHECK

- SORRY! NO COD'S, P.O.'S OR CREDIT CARDS
- CALIF. RES. ADD 6% SALES TAX
- CANADA, PUERTO RICO & U.S. POSSESSIONS ADD U.S. \$3.50. ALL OTHERS ADD U.S. \$7.00.
- U.S. FUNDS ONLY.

LOS ANGELES
 (213) 967-4611
LMN ELECTRONICS
 1042 E GARVEY AVE
 WEST COVINA, CA

PORTLAND
 (503) 646-4044
WIZARD OF PARTS
 8225 S.W. CIRRUS DR.
 BEAVERTON, OREGON

DENVER
 (303) 573-5214
ELECTRONIC LOLLIPOP
 5643 N. BROADWAY, DENVER
 (125 & 58th AVE.)

ASSOCIATED RADIO

8012 CONSER BOX 4327
OVERLAND PARK, KANSAS 66204

A50

913-381-5900



CALL US WITH YOUR REQUIREMENTS



OUR
32ND
YEAR

AMERICA'S #1 Real Amateur Radio Store

TRADE SELL BUY



**SEND \$1.00 FOR OUR CURRENT CATALOG OF
NEW AND RECONDITIONED EQUIPMENT.**

***ALSO WE PERIODICALLY PUBLISH A LIST OF
UNSERVICED EQUIPMENT AT GREAT SAVINGS.
A BONANZA FOR THE EXPERIENCED OPERATOR.
TO OBTAIN THE NEXT UNSERVICED BARGAIN LIST,
SEND A SELF ADDRESSED STAMPED ENVELOPE.**

POLY PAKS[®] P2 DISCOUNT ALLEY

WE'RE PUTTING "GREENBACKS" IN YOUR POCKET!

1 AMP REGULATED POWER SUPPLY KITS \$8.88

Easy to assemble! Uses LM340K positive voltage regulators. Reverse leads for negative supply! Buy 2 for a plus/minus supply! Complete kit, nothing else to buy! (Case not included) With step by step instructions. Wt. 4 lbs. Size 6 1/2 x 4 x 2 1/4"



Cat. No. Volts
 □ 3854 5
 □ 3857 12
 □ 3858 15
 □ 3859 18

NEW! DIGITAL CAPACITANCE METER KIT



5 Ranges! Measure any capacitor value from 100 pF to 10,000 uF! Five ranges: 0.1uF, 10uF, 100uF, 1000uF, 10,000uF. Also tests tubular capacitors. Directly reads all types of capacitors at the touch of a button. Easy to assemble! Complete kit, nothing else required. With step-by-step instructions. Size 6 1/2 x 2 1/4 x 5 1/4" deep, vinyl covered wooden cabinet. Wt. 2 lbs.
 Cat. No. 8238 Capacitance Meter Kit \$69.95
 Cat. No. 8239 Capacitance Meter Kit \$95

10% OFF

That's right! Take 10% discount off any item in this ad! Or, for any \$50 shipment, take 25% discount! POLY PAKS DISCOUNT ALLEY continues with the biggest discounts available anywhere!

3 AMP "TEFLON" RECTIFIERS

Order by Cat. No. 5278 and PIV

PIV	10 for Sale
25	10 for \$9.95
50	10 for \$10.99
100	10 for \$12.99
200	10 for \$14.99
400	10 for \$16.99
800	10 for \$18.99

MOTOR SPEED CONTROL "BASIC" KIT \$2.95



Controls up to 10 AMPs. 1000 watts! Works with noninductive type motors and incandescent light bulbs. Varies from 5% to 95% Wt. 10 lbs. Cat. No. 5227
 *Basic kits include all necessary electronic components, less PC board, case, line cord, transformer, or battery. Easy to breadboard with instructions.

IN4000 EPOXY RECTIFIERS

Cat. No.	Type	PIV	Sale
2377	1M4001	50	10 for .49
2378	1M4002	100	10 for .59
2379	1M4003	200	10 for .69
2380	1M4004	400	10 for .89
2381	1M4005	600	10 for 1.09
2382	1M4006	800	10 for 1.49

BLOCK FANS \$9.95



For cooling, flushing, heating and ventilating! Quiet & dependable. Lightweight, flame retardant. 3 blades or better (sorry no choosing). Removed from new equipment. Ship w/ 1 1/2 lbs. Cat. No. 92C31106
 *Famous USA Makers! • 4-11/16" sq. 1/4" deep.

30 WATT STEREO AMPLIFIER KIT \$24.95



Easy to build, assemble in minutes. Uses two 15 watt Hybrid Amplifier Modules with heat sinks included! Power output 2 x 16W RMS, both channels into 8 ohms from 40,000 Ohm. Total distortion less than 1%. Size: 5 1/2 x 2 3/4" Wt. 1 lb. Cat. No. 5408 Made For Fisher!

TRANSISTORS

TYPE	SALE	TYPE	SALE
5N7400	.12	5N7492	.39
5N7401	.12	5N7493	.43
5N7402	.12	5N7494	.49
5N7403	.12	5N7495	.38
5N7404	.12	5N7496	.12
5N7405	.12	5N7497	.12
5N7406	.12	5N7410	.70
5N7409	.20	5N74107	.25
5N7410	.12	5N74109	.20
5N7411	.19	5N74111	.25
5N7412	.12	5N74112	.25
5N7416	.25	5N74121	.20
5N7420	.12	5N74123	.39
5N7421	.12	5N74132	.69
5N7423	.12	5N74140	.39
5N7426	.12	5N74143	.59
5N7430	.14	5N74151	.55
5N7437	.12	5N74153	.49
5N7438	.14	5N74155	.49
5N7440	.12	5N74156	.29
5N7441	.49	5N74157	.55
5N7443	.29	5N74158	.49
5N7444	.12	5N74151	.59
5N7446	.65	5N74153	.69
5N7447	.65	5N74164	.39
5N7450	.12	5N74165	.69
5N7451	.12	5N74166	.99
5N7453	.12	5N74173	.99
5N7454	.12	5N74174	.79
5N7455	.12	5N74175	.69
5N7460	.19	5N74179	1.49
5N7464	.12	5N74179	1.49
5N7465	.12	5N74180	.39
5N7470	.12	5N74182	.29
5N7472	.12	5N74190	.79
5N7473	.29	5N74191	.99
5N7474	.29	5N74192	.69
5N7478	.19	5N74283	.69
5N7476	.35	5N74194	.69
5N7480	.12	5N74195	.19
5N7482	.12	5N74197	.69
5N7483	.59	5N74199	.79
5N7485	.69	5N74200	1.99
5N7486	.25	5N74251	.99
5N7488	.79	5N74284	2.49
5N7489	.19	5N74285	2.95
5N7490	.39	5N74298	.99
5N7491	.19		

FULL WAVE BRIDGE RECTIFIERS

PIV	2 AMP	5 AMP	10 AMP	25 AMP
50	.59	.88	1.29	1.59
100	.69	.99	1.49	1.79
200	.79	1.25	1.69	2.25
400	.89	1.50	1.89	2.75
600	.99	1.75	2.25	3.25
800	1.19	1.95	2.50	4.50

BARGAIN PRICED ONE-LINE SPECIALS

- ULTRASONIC TRANSDUCER, 42kHz, alarm, remote cont. (#5375) 1.49
- DYNAMIC MIKE, 500 ohm impedance, with stand (#5330) 1.95
- LED RAY DIODES, emits coherent beam, 9-W. (#3508) 2.00
- 12VDC BLOCK RELAY, 3A contacts, SPDT, 700 ohms (#4032) 1.00
- TUBULAR CAPACITORS, mostly marked, pop values (#5341) 15 for \$2.00
- LONG LEAD OISC CAPACITORS, pop values, upright, alt. (#2747) 100 for \$2.00
- MOLEX IC SOCKET PINS, cut to any length. (#3144) 200 for \$2.00
- AXIAL ELECTRO, ass'd values & capacitance. (#3277) 40 for 2.00
- LED DRIVER IC'S, untested, like 75491-2, 50%+ good. (#3360) 30 for \$2.00
- JUMBO RED LEDS, 100% prime, long leads. (#3368) 15 for \$2.00
- LINE CORDS, 18ga, 2 cond, with plug, 5 ft. (#3843) 8 for \$2.00
- HARDWARE SURPRISE! screws, nuts, washers, and more. (#3967) 500 pc for \$2.00
- 9 VOLT BATTERY SNAPS, like 75491-2, 50%+ good. (#354218) 70 for \$1.00
- COILS AND CHOKES, RF, AF, etc, peaking and more. (#354287) 30 for \$1.00
- RCA PLUGS & JACKS, for audio, RF, etc. (#358402) 15 for \$1.00
- SLIDE SWITCHES, pop types, from SPST up. (#1495) 20 for \$1.00
- 9 VOLT BATTERY SNAPS, like 75491-2, 50%+ good. (#354218) 70 for \$1.00
- 1N4148 SWITCHING DIODES, like 1N414, 100% prime. (#3000) 6 for \$1.00
- UTILITY AC OUTLET, rect mounting. (#3582) 6 for \$1.00
- 1 AMP CIRCUIT BREAKERS, glass, thermal, 1 3/8" x 3/8" x 1 1/2" (#3905) 2 for \$1.00
- CONVERTER SPECIALS, diodes, resistors, capacitors, etc. (#2736) 100 for 2.00
- VOLTAGE REGULATORS, hobby LM320, 340, TO-3 (#3330) 10 for 2.00
- PANEL SWITCHES, slides, rotaries, mod. etc. (#3268) 30 for 2.00
- RESISTOR SPECIAL, 1/4 to 1W, carbon, metal. (#3054) 200 for 2.00
- WIRE WOUND RESISTORS, 1/4, 1W, marked. (#3064) 100 for 2.00
- NATIONAL IC BONANZA, linear, 7400a ROMs (#2860) 100 for 2.00
- LM340T VOLTAGE REGULATORS, 5 to 24V, TO-220 (#2635) 18 for 2.00
- POLYETHYLENE CAPS, ass'd values, voltage, hi-Q (#2728) 100 for 2.00
- LED'S, untested, 2, 5, 6, 8, 10, 15, 20, 30, 40, 50, 60, 75, 100, 150, 200, 300, 400, 500, 600, 750, 1000, 1500, 2000, 3000, 4000, 5000, 6000, 7500, 10000, 15000, 20000, 30000, 40000, 50000, 60000, 75000, 100000, 150000, 200000, 300000, 400000, 500000, 600000, 750000, 1000000, 1500000, 2000000, 3000000, 4000000, 5000000, 6000000, 7500000, 10000000, 15000000, 20000000, 30000000, 40000000, 50000000, 60000000, 75000000, 100000000, 150000000, 200000000, 300000000, 400000000, 500000000, 600000000, 750000000, 1000000000, 1500000000, 2000000000, 3000000000, 4000000000, 5000000000, 6000000000, 7500000000, 10000000000, 15000000000, 20000000000, 30000000000, 40000000000, 50000000000, 60000000000, 75000000000, 100000000000, 150000000000, 200000000000, 300000000000, 400000000000, 500000000000, 600000000000, 750000000000, 1000000000000, 1500000000000, 2000000000000, 3000000000000, 4000000000000, 5000000000000, 6000000000000, 7500000000000, 10000000000000, 15000000000000, 20000000000000, 30000000000000, 40000000000000, 50000000000000, 60000000000000, 75000000000000, 100000000000000, 150000000000000, 200000000000000, 300000000000000, 400000000000000, 500000000000000, 600000000000000, 750000000000000, 1000000000000000, 1500000000000000, 2000000000000000, 3000000000000000, 4000000000000000, 5000000000000000, 6000000000000000, 7500000000000000, 10000000000000000, 15000000000000000, 20000000000000000, 30000000000000000, 40000000000000000, 50000000000000000, 60000000000000000, 75000000000000000, 100000000000000000, 150000000000000000, 200000000000000000, 300000000000000000, 400000000000000000, 500000000000000000, 600000000000000000, 750000000000000000, 1000000000000000000, 1500000000000000000, 2000000000000000000, 3000000000000000000, 4000000000000000000, 5000000000000000000, 6000000000000000000, 7500000000000000000, 10000000000000000000, 15000000000000000000, 20000000000000000000, 30000000000000000000, 40000000000000000000, 50000000000000000000, 60000000000000000000, 75000000000000000000, 100000000000000000000, 150000000000000000000, 200000000000000000000, 300000000000000000000, 400000000000000000000, 500000000000000000000, 600000000000000000000, 750000000000000000000, 1000000000000000000000, 1500000000000000000000, 2000000000000000000000, 3000000000000000000000, 4000000000000000000000, 5000000000000000000000, 6000000000000000000000, 7500000000000000000000, 10000000000000000000000, 15000000000000000000000, 20000000000000000000000, 30000000000000000000000, 40000000000000000000000, 50000000000000000000000, 60000000000000000000000, 75000000000000000000000, 100000000000000000000000, 150000000000000000000000, 200000000000000000000000, 300000000000000000000000, 400000000000000000000000, 500000000000000000000000, 600000000000000000000000, 750000000000000000000000, 1000000000000000000000000, 1500000000000000000000000, 2000000000000000000000000, 3000000000000000000000000, 4000000000000000000000000, 5000000000000000000000000, 6000000000000000000000000, 7500000000000000000000000, 10000000000000000000000000, 15000000000000000000000000, 20000000000000000000000000, 30000000000000000000000000, 40000000000000000000000000, 50000000000000000000000000, 60000000000000000000000000, 75000000000000000000000000, 100000000000000000000000000, 150000000000000000000000000, 200000000000000000000000000, 300000000000000000000000000, 400000000000000000000000000, 500000000000000000000000000, 600000000000000000000000000, 750000000000000000000000000, 1000000000000000000000000000, 1500000000000000000000000000, 2000000000000000000000000000, 3000000000000000000000000000, 4000000000000000000000000000, 5000000000000000000000000000, 6000000000000000000000000000, 7500000000000000000000000000, 10000000000000000000000000000, 15000000000000000000000000000, 20000000000000000000000000000, 30000000000000000000000000000, 40000000000000000000000000000, 50000000000000000000000000000, 60000000000000000000000000000, 75000000000000000000000000000, 100000000000000000000000000000, 150000000000000000000000000000, 200000000000000000000000000000, 300000000000000000000000000000, 400000000000000000000000000000, 500000000000000000000000000000, 600000000000000000000000000000, 750000000000000000000000000000, 1000000000000000000000000000000, 1500000000000000000000000000000, 2000000000000000000000000000000, 3000000000000000000000000000000, 4000000000000000000000000000000, 5000000000000000000000000000000, 6000000000000000000000000000000, 7500000000000000000000000000000, 10000000000000000000000000000000, 15000000000000000000000000000000, 20000000000000000000000000000000, 30000000000000000000000000000000, 40000000000000000000000000000000, 50000000000000000000000000000000, 60000000000000000000000000000000, 75000000000000000000000000000000, 100000000000000000000000000000000, 150000000000000000000000000000000, 200000000000000000000000000000000, 300000000000000000000000000000000, 400000000000000000000000000000000, 500000000000000000000000000000000, 600000000000000000000000000000000, 750000000000000000000000000000000, 1000000000000000000000000000000000, 1500000000000000000000000000000000, 2000000000000000000000000000000000, 3000000000000000000000000000000000, 4000000000000000000000000000000000, 5000000000000000000000000000000000, 6000000000000000000000000000000000, 7500000000000000000000000000000000, 10000000000000000000000000000000000, 15000000000000000000000000000000000, 20000000000000000000000000000000000, 30000000000000000000000000000000000, 40000000000000000000000000000000000, 50000000000000000000000000000000000, 60000000000000000000000000000000000, 75000000000000000000000000000000000, 100000000000000000000000000000000000, 150000000000000000000000000000000000, 200000000000000000000000000000000000, 300000000000000000000000000000000000, 400000000000000000000000000000000000, 500000000000000000000000000000000000, 600000000000000000000000000000000000, 750000000000000000000000000000000000, 1000000000000000000000000000000000000, 1500000000000000000000000000000000000, 2000000000000000000000000000000000000, 3000000000000000000000000000000000000, 4000000000000000000000000000000000000, 5000000000000000000000000000000000000, 6000000000000000000000000000000000000, 7500000000000000000000000000000000000, 10000000000000000000000000000000000000, 150000000000000000

7294 N.W. 54 STREET
MIAMI, FLORIDA 33166

SURPLUS ELECTRONICS CORP. ✓S43

PHONE: (305) 887-8228
TWX: 810-848-6085
WHOLESALE - RETAIL

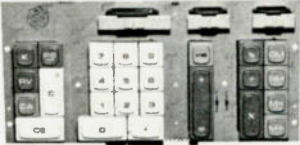
<p>PL 259's QUALITY AMERICAN MADE 10/\$5.00 100/\$35.00 50/\$40.00 1000/\$300.00</p>	<p>E. F. Johnson Desk Top Microphone Ceramic Element/High Imp \$20.00 ea While They Last</p>		<p>IC SOCKETS Cambion Gold Plated Wire Wrap 14 pin .35 ea 10/\$3.00 16 pin .38 ea 10/\$3.30</p>
<p>SURPRISE PACKAGE Resistors, Caps, Semis, Pots, Relays, etc. We guarantee it to be \$25.00 worth of material. Every package is different. \$5.00</p>	<p>TEXAS INSTRUMENT KEYBOARD \$1.95 ea., 5 for \$8.00 10 for \$13.95</p>  <p>Has 3 slide switches—28 different keys—keypads removable by removing 4 screws.</p>		<p>MODEN CABLE 50' cable contains 13 # 22 ga. wire DB-25p with DB-51226-1 cover on one end \$6.50 ea 10/\$50.00</p>
<p>White Porcelain Egg Insulator 1 1/2" x 1" 50¢ ea 3 for \$1.25</p>	<p>MINI TOGGLE SW C&H SPDT \$1.00 ea 6/\$5.00</p>	<p>12 Udc RELAY SPST 35 Amp Contacts Open Frame Rugged, great for mobile use \$4.50 ea 5/\$20.00</p>	<p>New Dry Nickel-Cadmium Battery 2 1/4" x 2 3/4" x 8 3/4" General Electric 12.0 Volts dc @ 4.0 Amp hrs. \$19.95 while they last.</p>
<p>Neon Panel Light 110 Vac Amber, w/ built in resistor & wire leads—3 for \$1.50</p>	<p>WIRE WOUND RESISTORS .1 Ohm—5 W .10 Ohm—10 W @ 15¢ each</p>		
<p>PANEL METERS 2 1/4" x 2 1/4" also 2 1/4" x 3" 10-0-10 dc Amps } \$4.00 ea 0-20 dc Volts } 25-0-25 dc Volts } 2 for \$7.00 0-25 dc Volts } 0-50 ac Volts } -Shunt Required-</p>	<p>CB SPECIAL Complete brand new printed circuit board assembly with all parts. Used in all Hygain 40 channel CB Transceivers. Fits many other manufactures units also. Board dimensions 6" x 6 1/2" 1-9—7.50 ea 10-50—6.50 ea 50-100—6.00 ea 100-up—5.50 ea</p>		<p>MUFFIN FANS 3 Blades, 110 Vac, 4 3/4" sq. Removed from equipment—Excellent condition—\$4.95</p> <p>"New" Muffin Fans 3 Blades-110 Vac, 4 3/4" sq. \$9.95</p>
<p>CMOS RCA CD 4012 AE Dual 4 in Nand Gate 6/\$1.00 100/\$10.00 50/\$6.00 1000/\$80.00</p>	<p>12 Vdc RELAY SPST Open Frame 5 Amp Contacts Mfg-Magnecraft \$1.50 ea 4/\$5.00</p>	<p>POLYFOAM COAX—50 OHM Equal to RG174 \$4.95/100' Low Loss Polyfoam Coax Cable</p>	<p>TRIMMER CAPS Small enough to fit in your watch— 3.5 to 20 pF 5 to 30 pF 7 to 40 pF \$.75 ea., 2 for \$1.25 5 for \$3.00</p>
<p>D Cell Nicad mfg. by G. E. 2.50 ea 1.2 volts 3.5 amp hrs. cat No. 41B004 AD08G5</p>	<p>Coax Connectors UG-273/U BNC-F/UHF-M 2.50 UG-255/U BNC-M/UHF-F 3.00 UG-146A/U N-M/UHF-F 4.50 UG-83B/U N-F/UHF-M 4.50 UG-175 RG-58 Adapt. .20 UG-176 RG-59 Adapt. .20</p>		<p>JOY STICK For TV games and hi fi with four, 100K pots 2 3/4" X 2 3/4" X 1" with 1" handle—\$3.95</p>
<p>Computer Grades 23,200 uf @ 50 Vdc 3.00 ea 3" diam x 4 1/2" high G. E.</p>	<p>New Boxer Fans 5 Blades 110V ac 4 3/4" —\$11.95</p>		
<p>GOLD PLATED CARD EDGE CONNECTORS</p>			
<p>Double Row/Wire Wrap .100 25 pins \$3.49 ea 10/\$30.00 30 pins \$3.96 ea 10/\$32.00 50 pins \$5.43 ea 10/\$45.00</p>	<p>Double Row/Solder Eyelet .156 6 pins \$1.10 ea 10/\$9.00 15 pins \$1.55 ea 10/\$12.50 22 pins \$2.08 ea 10/\$17.00 43 pins \$3.66 ea 10/\$30.00</p>		<p>22 pins/Double Row/Dipped Solder .156 \$2.08 ea 10/\$17.00</p> <p>22 pins/Double Row/Wire Wrap .156 \$2.44 ea 10/\$19.00</p>

TERMS: All material guaranteed • If for any reason you are not satisfied, our products may be returned within 10 days for a full refund (less shipping). Please add \$3 for shipping and handling on all orders. Additional 5% charge for shipping any item over 5 lbs. COD's accepted for orders totaling \$50.00 or more. All orders shipped UPS unless otherwise specified. Florida residents please add 4% sales tax. Minimum order \$15.00.

EQUIPMENT / COMPONENTS / WIRE & CABLE / ACCESSORIES

GET YOUR

NEW 1979

Published December 1st, 1978

RADIO AMATEUR CALLBOOKS

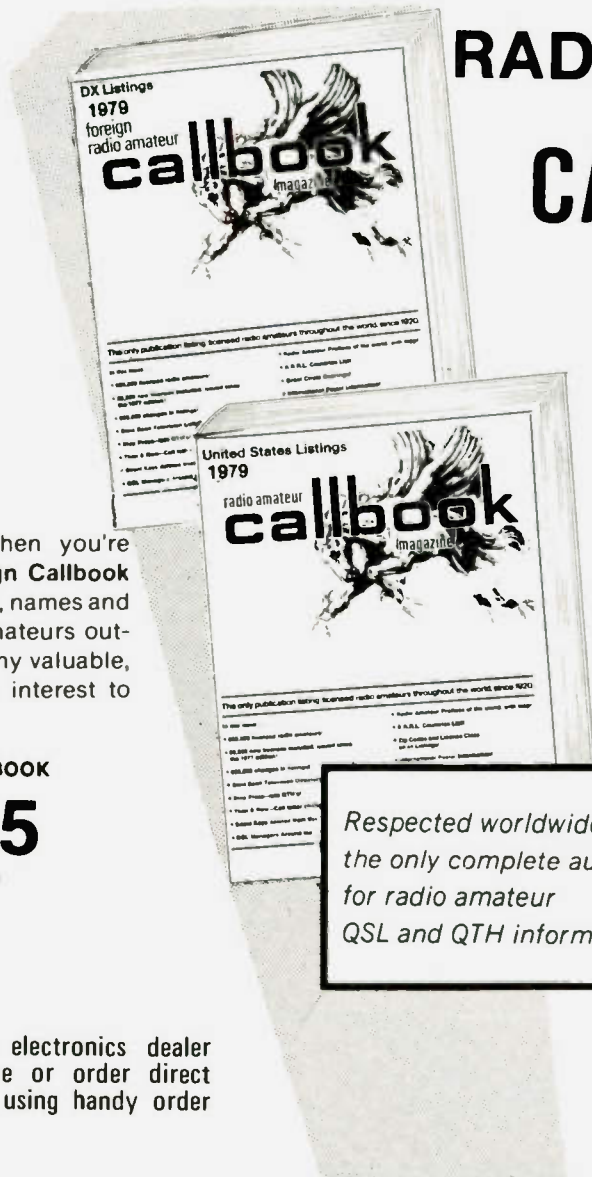

The **U.S. Callbook** has over 350,000 W & K listings. It lists calls, license classes, names and addresses plus the many valuable back-up charts and references you come to expect from the **Callbook**.

UNITED STATES CALLBOOK

\$15.95
PLUS SHIPPING

Specialize in DX? Then you're looking for the **Foreign Callbook** with over 280,000 calls, names and addresses of radio amateurs outside the USA plus many valuable, additional features of interest to the DX'er.

FOREIGN CALLBOOK

\$14.95

PLUS SHIPPING

Respected worldwide as the only complete authority for radio amateur QSL and QTH information.

See your favorite electronics dealer for the latest issue or order direct from the publisher using handy order form.

Payment in U.S. funds must be sent directly to publisher not through a bank.

**Radio
Amateur
callbook, INC.**

925 SHERWOOD DRIVE
LAKE BLUFF, ILLINOIS 60044

ORDER FORM

Item	Price Each	Shipping	Total Price
<input type="checkbox"/> U. S. CALLBOOK	\$15.95	\$1.75	\$17.70
<input type="checkbox"/> FOREIGN CALLBOOK	\$14.95	\$1.75	\$16.70

Illinois residents only add 5% sales tax _____

Name _____

Address _____

City _____

State _____ Zip _____

TOTAL _____

Charge my: Visa Card Master Charge

Card No. _____ Expiration Date _____

Dept. B

Signature _____



HOLIDAY SALE

HOLIDAY SALE

S.O.S.

"Save On Synthacoders"

NEW IMPROVED



Synthacoder 509

Provides full frequency coverage, 220-225 MHz, for your Midland 509, Cobra 200, or Clegg 76 transceiver. Provides simplex, repeater, and reverse modes on all frequencies. New improved interface circuit provides greater flexibility and RF immunity. FULLY ASSEMBLED & CALIBRATED

FREE Cushcraft Beam!

still only \$129**

Buy your Synthacoder 509 during our S.O.S. sale and receive a FREE Cushcraft BEAM ANTENNA



ATTENTION 22S OWNERS!

Save \$18.00

Regular 87.95
SOS 69.95



"The Original" Synthacoder 22, used by many hundreds of ICOM owners throughout the country for years! The ultimate in frequency control for the 22S. Full thumbwheel control in 15 KHz steps. You won't want to miss out on this SOS Super Saver!

SYNTHACODERS ARE AVAILABLE THRU YOUR LOCAL DEALER

We Are About To Announce Some New "SUPER PRODUCTS"

WATCH FOR OUR ADS

Engineering Specialties

P O Box 2233
1247 Commercial Avenue
Oxnard, California 93030
(805) 486-0817



Yes I want to take advantage of your SOS Super Saver!

- Please RUSH my Synthacoder 509 and FREE BEAM ANTENNA. Enclosed is my \$129.95 plus \$3.00 postage and handling.
 - Please RUSH my Synthacoder 22. Enclosed is my \$69.95 plus \$2.00 postage and handling.
- California residents add 6% sales tax.

\$ _____ Check Money Order Charge Card

Please charge my Master Charge BankAmericard/VISA

Credit Card # _____ Expiration date _____

Signature _____

Name _____ Call _____

Address _____

City _____ State _____ Zip _____

73-12



Does Your Unit Claim The New
Sub band 14.8, 14.9 MHz?
The FM2015R Does PLUS MARS-CAP!

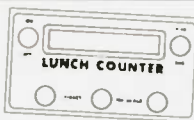

THE LUNCH COUNTER

Build a 600 MHz 6 Digit Frequency Counter. We supply 3 PC Boards, Silk Screened Front Panel and complete Instructions Only \$12.50

Chips used in Counter
11C90 Prescaler \$14.50
74C925 9.95
F9368 (2 used) ea 3.95

All Solid State CMOS PLL digital synthesized - No Crystals to Buy! 5KHz steps - 144 - 149 MHz-LED digital readout PLUS MARS-CAP *

• 5 MHz Band Coverage - 1000 Channels (instead of the usual 2MHz to 4MHz-400 to 800 Channels) • 4 CHANNEL RAM IC MEMORY WITH SCANNING • MULTIPLE FREQUENCY OFFSETS • ELECTRONIC AUTO TUNING - TRANSMIT AND RECEIVE • INTERNAL MULTIPURPOSE TONE OSCILLATOR • RIT • DISCRIMINATOR METER - 15 Watts Output - Unequaled Receiver Sensitivity and Selectivity - 15 POLE FILTER, MONOLITHIC CRYSTAL FILTER AND AUTOMATIC TUNE-O-RECEIVER FRONT END. COMPARE! • Superb Engineering and Superior Commercial Avionics Grade Quality and Construction Second to None at ANY PRICE.

PRICE
\$439.95



OVERVOLT 12

Crow Bar circuit protects Transceivers & Tape Decks from runaway power supply voltage that can zap expensive components. OV 12 causes fuse in Power Supply to blow if voltage exceeds preset level (approx. 16 to 18 volts). Rated at 25 Amperes. \$ 7.95

Model OV5. Protects 5 Volt circuits. Triggers at 7.5 Volts \$8.95
Other units available at 3.3 to 100 Trigger Voltages \$10.95 ea

AEC 1074 50W
@30 MHz \$21.15
AEC 1076 75W
@ 50 MHz \$24.00
both cases 500 4LFL

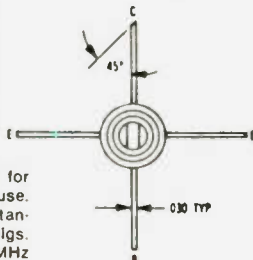

AEC 1158

Hard to find replacement for VHF Mobile & Marine use. Successfully used in Standard and other VHF Rigs. Rated 12 Watts at 200 MHz 12.5 Volts with 5.3 DB Gain. Heat Sink stud (8/32) isolated from leads. Only \$12.30

RF DEVICES

2N2876	18W	200 MHz	T060	\$12.35
2N3375	3.0W	400 MHz	T060	5.60
2N3553	2.5W	175 MHz	T039	1.40
2N3866	1.0W	400 MHz	T039	1.25
2N3926	7.0W	175 MHz	T060	6.30
2N4427	1.0W	175 MHz	T039	1.35
2N5589	3.0W	175 MHz	MT71	4.75
2N5590	10W	175 MHz	MT72	7.80
2N5591	25W	175 MHz	MT72	10.25
2N5913	1.75W	175 MHz	T039	1.70
2N6080	4.0W	175 MHz	MT72	5.40
2N6081	15W	175 MHz	MT72	8.45
2N6082	25W	175 MHz	MT72	10.95
2N6083	30W	175 MHz	MT72	12.30
2N6084	40W	175 MHz	MT72	16.30
2N6094	4.0W	175 MHz	X106 PNP	6.60
2N6095	15W	175 MHz	X106 PNP	8.50
2N6096	30W	175 MHz	X106 PNP	10.35
2N6097	40W	175 MHz	X106 PNP	20.00

ALDELCO KITS

DUAL DIGITAL 12/24 HOUR CLOCK KIT
NOW WITH A NEW WALNUT GRAIN WOOD CABINET



Features:

- 12 or 24 Hour Operation on either clock
- Each Clock separately controlled
- Freeze feature for time set
- Easy assembly for clock and cabinet

**BIG
0.5 LEDs**

MODEL ALD 5-W **ONLY \$49.95**

LEDS

Monsanto MAN 72 Red LED
Readout 300" High, Common Anode. ONLY \$.89

Monsanto MV5053 JUMBO LED
and Holder only 25
LED Holders10
Jumbo Red LED'S 8 for \$1.00
Jumbo Green, Orange or Yellow
LED'S 5 for \$1.00

FETS

40673	1.55
MPF102	.55
2N3819	.35
2N5457	.50
2N5458	.50
2N5459	.55
2N5485	.50

DARLINGTON

MPSA 13	.80
MPSA 14	.40
2N5306	.50
SCR	
C 106A	.55
C 106B	.65
C 122B	.85

— THE MIMIC —

PROGRAMMABLE IAMBIC MEMORY KEYS

- Four memory inputs, sixty letters each
- Five minutes of memory @ 10 wpm
- Operates on 110 V ac and 8-16 vdc
- Triggered clock for memory recording
- Built-in side tone monitor
- Speed control 5 to 40-plus wpm
- Two to three times the memory of nearest competitor



Comes in attractive light blue cabinet measuring 2 1/2" high x 4" wide x 5" deep.

KIT ONLY \$79.95
Kit with set of paddles \$104.95
Assembled unit 99.95
Paddles only 29.95

VOLTAGE REGULATORS

TO220 Package	
Positive \$1.00	Negative \$1.25
7805	7905
7806	7906
7808	7912
7812	7915
7815	7918

CLOCK CHIPS

5313	3.49
5314	3.49
5316	3.95
5375	3.95
CT7001	6.95

2200 MFD 16 volt
Radial Cap 3 for 89¢

ALARM CLOCK KIT

6 Big 0.5 LED Displays * On Board AC Transformer * 12 Hour Format with 24 Hour Alarm * Snooze Feature * Elapsed Timer. Timer feature makes this Popular in Broadcast Stations. It's a natural for cars, boats and campers when used with optional crystal time base. Fits our standard cabinet. \$19.95
Crystal time base when purchased with clock. \$2.95

12 or 24 HOUR DIGITAL CLOCK KIT

Uses 0.5 Display LED. 5314 Clock Chip. Freeze feature for accurate set, fits our standard cabinet. **ONLY \$18.95**

CLOCK CABINETS

Woodgrain or black leather ea. \$4.95

CRYSTAL TIME BASE KIT

Includes PC Board, Crystal, all parts and instructions. \$4.95

CLOCK FILTERS

Blue, Red, Green, Amber or Smoke \$.60

Blinky Flasher Kit

PC board, 555 & all parts works on 9 volts. Mouse button—\$1.00

DIGITAL MULTIMETER & THERMOMETER

3 1/2 Digit—5 ranges on each function AC/DC 2 Volts to 2000 Volts Current 2 Microamps to 2 Amps Resistance 2000 Ohms to 2 Megohms. Includes PC Board, ICL7107 Chip and all parts. Only \$49.95

LOGIC PROBE KIT

Measures Logic 1, Logic 0, and pulsing circuit conditions NOW reduced to \$9.95

SPECIALS

MC1458P	.29
555 Timer	3 for \$1.00
4011	.23

CRYSTAL SOCKETS

HOLDS 8 HC25U \$ 59
Single HC25U 29

144 MHz 10 Watts
RF Transistor
2N5590 \$5.50 ea.

NEW!

Tunable 420 MHz
Fast Scan TV
Converter



Receive Fast Scan Amateur TV in the 420 to 450 MHz Band with any TV set. Low noise, high gain rf Amp with Varactor tuned input and outputs. Built in AC supply. Comes in two tone walnut & beige cabinet measuring 1 7/8" x 4 1/4" x 4 1/8" Factory wired with 2 year guarantee. \$59.95

ADJUSTABLE POWER SUPPLY KITS

5-15 Volts 500 MA	\$6.95
12-28 Volts 500 MA	6.95

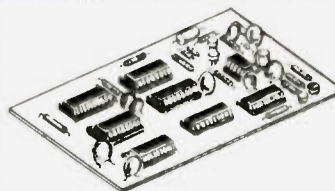

ACCUKEYER KIT

- Self Completing Dots & Dashes
- Provision for attachment of 256 or 512 Bit Memory for DX or Contest work
- Iambic Operation
- Single Dot & Dash Memories

Revised version of the Accukeyer featured in the ARRL Handbook. Has more logical IC Layout and ON Board sidetone Oscillator. Includes PC Board, TTL ICs, 555 Timer, IC Sockets, Switch, Speaker, Transistors, capacitors and resistors. Requires 5 VDC. **ONLY \$19.95**

ACCUKEYER MEMORY KIT



















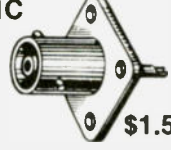

Simple low cost Memory Kit. Uses 2 programmable 1101 Memory chips. Provides 2 canned messages of 30 Characters each. Adaptable to Handbook and other Accukeyers. Includes PC board (same size as accukeyer board) and all parts. Requires 5 VDC. 9 VDC. **\$19.95**

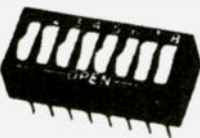
SEMICONDUCTORS SURPLUS

S63

2822 North 32nd Street/Unit -1 Phoenix, Arizona 85018 (602) 956-9423

We accept checks, MasterCard, and Visa

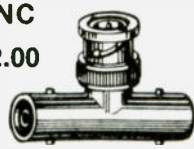
TYPE "N" FEMALE TO BNC MALE \$2.00 each  FRONT: BNC plug. REAR: Type "N" jack. DESCR.: Permits the use of a type "N" plug on equipment using a BNC jack. Std. Pkg. 1		LASCR Light activated SCR. 200 PRV at .3 amps. Extremely sensitive. 4 for \$1.00 		Pot Hex Nuts Standard size pot nut for all standard size bushings (3/8" dia.)  25 for \$1.00		Xenon Flash Tube, Xformer Flash tube with 4kv trigger transformer. Brand new. Great for photographic & strobe applications. 1-9/16 x 3/16 inch flash tube. 1/2" by 5/16" transformer. Price includes both. \$1.75 		MPF 112 IV channels FET VHF Amp. Mixer 2/\$1.00			
UHF  N \$1.50	optoelectronic coopters 4N26 2/\$1.00		BNC  D \$2.00	Green Neon Same as NE2 but glows GREEN. Operates on 120V. 6 for \$1.00 		SOLAR CELLS 2x2cm x 130 mA \$1.49 ea. 10/\$9.50				VOLTAGE REGULATORS 6 V. at 1 Amp 2/99¢ TO-220	
UHF  T \$2.00			BNC  M \$1.50	PHOTO TRANSISTORS similar to FPT 100 4/99¢	PHOTO DARLINGTONS MOTOROLA 4/99¢	VHF TUNING DIODE Cj typ. 30 pf Q 200 at 47 mc 2/99¢	1500V. 1 AMP RECTIFIERS 10/\$1.99	for that professional touch CARBIDE DRILL BITS for P.C. BOARD work HI-REL GOLD 10/\$1.25 100/\$9.50 1000/\$80 LIST PRICE 29¢ 		WIRE WRAP SOCKET PIN 1N914/N4148 Prime 30/\$1.00	
BNC  S 69¢	PRIME RED LED's Mini 10/79¢ Jumbo 10/99¢		ALPHA NUMERIC 5 x 7 DOT MATRIX TIL-305 same as MAN-2, DL 57 \$3.50	MOLEX PINS 200 EACH \$1.95 1000 EACH \$7.95	MALLORY SONALERT electronic signal Model SC828 H 8 TO 28 Volts \$5.50	NPN POWER TRANSISTORS 2N 5301 (30A) \$3.95 TO-3 200W 40V BUY69B 10A \$7.00 BUY69C 15A \$6.95 400V \$5.95		SUB MINIATURE CRYSTAL FILTER 455 KHz \$2.95		The right tool for the job Assortment will include sizes ranging from No. 55 thru No. 70. 5MIX/\$7.49 10MIX/\$12.49 100MIX/\$99.00	
BNC  A \$1.50	DIP SWITCHES  6- \$1.50 7- \$1.95 8- \$2.00		MJE3055 90 Watts 60VCE 10 Amps NPN 2/\$1.50		HEAT SINKS  TO-3 \$1.50  TO-5 30¢		ADAPTERS BNC FEMALE TO UHF MALE \$2.00 each FRONT: UHF plug REAR: BNC jack DESCR.: Permits the use of a BNC plug on equipment using a UHF jack. Std. Pkg. 1 				
BNC  P \$2.00	Muffins Fans  used \$5.00 new \$9.95		BNC FEMALE TO TYPE "N" MALE \$2.00 each FRONT: Type "N" plug. REAR: BNC jack DESCR.: Permits the use of a BNC plug on equipment using a Type "N" jack. Std. Pkg. 1 		CABLE REDUCING ADAPTER  50¢ each						
BNC  F \$1.75	LM301A 4/\$1.00 LM301N 5/\$1.00		BNC  E \$2.00								

SEMICONDUCTORS SURPLUS

S63

2822 North 32nd Street/Unit -1 Phoenix, Arizona 85018 (602) 956-9423

We accept checks, MasterCard, and Visa

LIQUID CRYSTAL WATCH DISPLAY

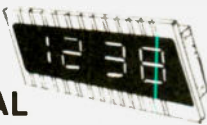

Brand new reflective type LCD watch readout made by Motorola. Actual size only .940" L x .540" H. Features high contrast ratio of 25:1 at 3.0V bias. LCD readouts require such low amounts of current that you can make the digits appear from static charges. Very unique and hard to find. Sorry, no socket available.

\$1 Each

Factory Box of 12 for \$10.00

MOTOROLA CRYSTAL 14.04 MHz OSCILLATOR \$1.98



Integrated circuit clock oscillator completely self-contained in a 14 pin package. Frequency stability $\pm .01$ percent, temperature range 0°C to 70°C, input requirement 5 V dc 10 percent. At 40 mA, output is a square wave, TTL compatible, with a rise and fall time of 10 nsec max. Size only .750" by .470" W by .375" H. Simple to use as it only requires 3 connections (+ GND and output). Great clock for CPUs, Timers, Time Bases, Frequency Counters, CVM, Clocks, etc. Brand new prime!

BURROUGHS PANAPLEX II 9 DIGIT DISPLAY



3 for \$1

Type BR12259 gas discharge 7 segment display. Requires 160 V dc. Right hand decimal on right of each digit. Bright and easy to read, has 1/8" thick glass over ceramic substrate. Used, excellent cond. No sockets available.

MINIATURE VACUUM RELAY JENNINGS



RF-2-B-26S
26.5V D.C. Coil
NEW \$15.99

BAG FULL OF HEAT SHRINK

89¢

NEW



Handy assortment of pre-cut pieces of high quality heat shrink tubing. Lengths vary from 1/2" long to 1 1/4" long and diameters vary from 1.8" up to 3/8". Very useful for almost all applications. Resealable bag contains at least 70 pieces. Buy several for your workbench or tool kit.

SEMICONDUCTOR MOUNTING HARDWARE ASSORTMENT

We purchased thousands of various semiconductor mounting hardware including insulating rings, rectifier solder lugs, spacers, nuts, etc.

\$1.00

100 pieces of semiconductor mounting hardware.



METAL CABINET

\$1.49

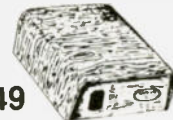

Small aluminum cabinet with wood grain vinyl covering. Has lettering on front panel and 5/8" hole cutout. Also has several other holes in case. Great for hundreds of small projects. Approx. size: 3-3/4" sq. x 1-7/8" W.

SEMICONDUCTOR INSULATOR MICA

Useful assortment of various mica insulators for most popular devices. Assortment of 10.

\$1.00

STUD RECTIFIER MOUNTING KIT

Prepackaged mntg kit for most stud mounting rectifiers & zener diodes.

3 for 49¢



3579.545 KHZ COLOR TV CRYSTALS

\$1.50



Prime crystals for use in color TV or with the National MM5369 to make a portable clock timebase.

NEONS

Useful neon tubes used to indicate when a photoflash capacitor has reached the proper voltage to flash strobe tubes. Assortment contains several different voltages.

20 for \$1



DC TO DC CONVERTER IC SC5889P

NEW



This Dc converter IC is designed to convert 5 V dc into 20 V dc to 40 V dc depending on zener chosen. Specifically useful for circuits where there is a voltage compatibility problem. Prime in minidip package with application schematic and spec \$1.00

SLIDE AND ROCKER SWITCH ASST



6 for \$1

QUENCH TUBES

Required in many electronic flash units to control light by absorbing energy that would normally go to the strobe tube. Brand new prime units

Type 1 3 for \$1.00
Type 2 4 for \$1.00

TO-5 HEAT SINKS

Black anodized aluminum solid fin type heat sinks for TO5 case devices. Very high quality. Well-made.

10 for \$1.00

SWITCH ASSORTMENT

Popular types—rotary, slide, push-button. All brand new.

6 for \$1

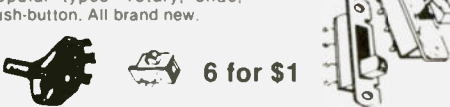

HIGH VOLTAGE ZENERS

All marked, voltages to 200 volts. Some PC leads.

10/\$1

GIANT SLIDE SWITCH ASSORTMENT



AT LEAST 5 DIFFERENT TYPES 20 for \$1

4KV TRIGGER COILS

Small ferrite core trigger coils required to "fire" all xenon flash tubes.

1. Submin 2/\$1.00
2. Std. 3/\$1.00
3. Encaps. 2/\$1.00

GREEN NEON LAMPS

Bright neon for 120 V ac—in- stead of the usual orange glow you get a bright green glow. Use with 39K resistor.

6 for \$1

RG174/0 50 Ohm Coaxial Cable
Precut 6 foot lengths of most popular mini cable.
6' length 25¢

Price per 10 lengths. \$1.75

.01 MFD 50 V Micro capacitor
Shown actual size

8 for \$1

9 DIGIT BOWMAR OPTOSTIK

Magnifier 10P, 9 digit display for calculators, etc. Size: 2-3/8" L x 3/4" W.

\$1

FND 10 FAIRCHILD

Miniature— .112" High digits. Common cathode. Prime.

75¢



DATA LITE 707

Common anode 7 segment LED readout. Driver 7446 or 7447

\$2.25



ITT 200V, 1 Amp SCR. Prime, in TO-18 metal case.

12/\$1.00



PHONE YOUR ORDER IN
602-956-9423
WE LIKE C.O.D.'s

GPSA-13 DARLINGTON TRANSISTOR
12 for \$1.00

.047 MFD Micro cap PC leads

10 for \$1

Radio Bookshop

license study guides & TAPES

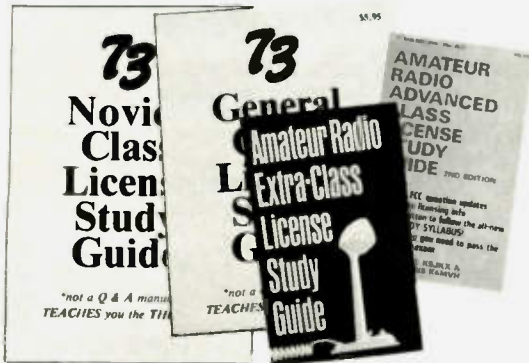

● **NOVICE STUDY GUIDE—SG7357**—Here is a completely new study guide and reference book for the potential ham. This is not a question/answer memorization course. Electronic and radio fundamentals are presented and explained in an easy-to-understand fashion, preparing the beginner for the Novice exam. Includes the latest FCC amateur regulations, as well as application forms. Easily the best path into the exciting world of ham radio! \$4.95.*

● **GENERAL CLASS STUDY GUIDE—SG7358**—A complete theory course for the prospective General or Technician. This reference explains transistor, amplifier, and general radio theory, while preparing the Novice for the "big" ticket. After getting your ticket, you'll use this guide again and again as an electronic reference source. Not a question/answer guide that becomes dated when the FCC updates the amateur exams. \$5.95.*

● **ADVANCED CLASS STUDY GUIDE—SG1081**—Ready to upgrade your license? To prevent retaking the FCC theory exam, you need the 73 Advanced theory guide. SSB, antenna theory, transmitters, and electronics measuring techniques are covered in detail in this easy-to-follow study guide. Special modes and techniques, such as RTTY, are also treated. An engineering degree is not necessary to master Advanced theory—try this book before visiting the examiner's office! \$5.95.*

● **EXTRA CLASS LICENSE STUDY GUIDE—SG1080**—Before going for your 1 x 2 call, it pays to be a master of the Extra class electronic theory. This study guide is the logical extension of the 73 theory course. All the theory necessary to pass the exam is presented. Antennas, transmission lines, swr are discussed, as well as noise, propagation, and specialized communication techniques. This book is not a classroom lecture or memorization guide, but rather a logical presentation of the material that must be understood before attempting the Extra exam. Save yourself a return trip to the FCC and try the 73 method first! \$5.95.*



NOVICE THEORY TAPES

Startling Learning Breakthrough



● **NOVICE THEORY TAPES—CT7300**—Startling Learning Breakthrough. You'll be astounded at how really simple the theory is when you hear it explained on these tapes. Three tapes of theory and one of questions and answers from the latest Novice exams give you the edge you need to breeze through your exam. 73 is interested in helping get more amateurs, so we're giving you the complete set of our tapes for the incredibly low price of **ONLY \$15.95.***

Scientists have proven that you learn faster by listening than by reading because you can play a cassette tape over and over in your spare time—even while you're driving! You get more and more info each time you hear it.

You can't progress without solid fundamentals. These four hour-long tapes give you all the basics you'll need to pass the Novice exam easily. You'll have an understanding of the basics which will be invaluable to you for the rest of your life! Can you afford to take your Novice exam without first listening to these tapes? Set of 4—\$15.95.*



SSTV

● **SLOW SCAN TELEVISION TAPE—CT7350**—Prize-winning programs from the 73 SSTV contest. Excellent for Demo! \$5.95.*

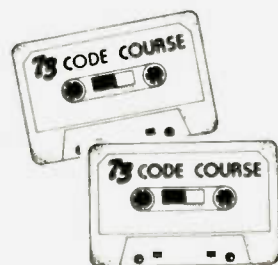

73 CODE SYSTEM TAPES

Any Four Tapes For \$15.95! *
\$4.95 Each! *

"GENESIS"

5 WPM—CT7305—This is the beginning tape for people who do not know the code at all. It takes them through the 26 letters, 10 numbers and necessary punctuation, complete with practice every step of the way using the newest blitz teaching techniques. It is almost miraculous! In one hour many people—including kids of ten—are able to master the code. The ease of learning gives confidence to beginners who might otherwise drop out.

"THE STICKLER"

6+ WPM—CT7306—This is the practice tape for the Novice and Technician licenses. It is made up of one solid hour of

code, sent at the official FCC standard (no other tape we've heard uses these standards, so many people flunk the code when they are suddenly—under pressure—faced with characters sent at 13 wpm and spaced for 5 wpm). This tape is not memorizable, unlike the zany 5 wpm tape, since the code groups are entirely random characters sent in groups of five.

"THE CANADIAN"

10+ WPM—CT7310—73 hasn't forgotten the Canadian hams—our 10 WPM tape prepares you to breeze through your country's licensing exams. Like the other code groups, the tape is not memorizable and, once mastered, provides a margin of safety in the actual text situation.

"BACK BREAKER"

13+ WPM—CT7313—Code groups again, at a brisk 13 per so you will be at ease when you sit down in front of the steely-eyed government inspector and he starts sending you plain language at only 13 per. You need this extra margin to overcome the panic which is universal in the test situations. When you've spent your money and time to take the test, you'll thank heavens you had this back-breaking tape.

"COURAGEOUS"

20+ WPM—CT7320—Code is what gets you when you go for the Extra class license. It is so embarrassing to panic out just because you didn't prepare yourself with this tape. Though this is only one word faster, the code groups are so difficult that you'll almost fall asleep copying the FCC stuff by comparison. Users report that they can't believe how easy 20 per really is with this fantastic one hour tape.

"OUTRAGEOUS"

25+ WPM—CT7325—This is the tape for that small group of overachieving hams who wouldn't be content to simply satisfy the code requirements of the Extra Class license. It's the toughest tape we've got and we keep a permanent file of hams who have mastered it. Let us know when you're up to speed and we'll inscribe your name in 73's CW "Hall of Fame."

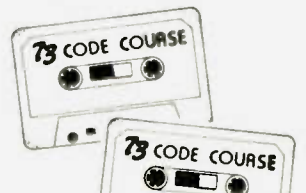

73 Radio Bookshop • Peterborough NH 03458. Be sure to include check or detailed credit card information.
* Add \$1.00 handling charge for orders under \$10.00. Note: Prices subject to change on books not published by 73 Magazine.

FOR CUSTOMER SERVICE CALL 603-924-6132

Radio Bookshop

73 TECHNICAL LIBRARY

● **BEHIND THE DIAL**—BK7307—By Bob Grove. Get more fun out of shortwave listening with this interesting guide to receivers, antennas, frequencies and interference. \$4.95.*

● **THE CHALLENGE OF 160**—BK7309—is the newest book in the 73 technical library, dedicated to 160 meter operating. Si Dunn provides all necessary information to get started on this unique band. The all-important antenna and ground systems are described in detail. The introduction contains interesting photos of Stew Perry's (the King of 160) shack. This reference is a must for new and experienced "Top Band" operators. Price: \$4.95.*

● **IC OP-AMP COOKBOOK**—BK1028—by Walter G. Jung. Covers not only the basic theory of the IC op amp in great detail, but also includes over 250 practical circuit applications, liberally illustrated. 592 pages, 5½ x 8½, softbound. \$12.95.*

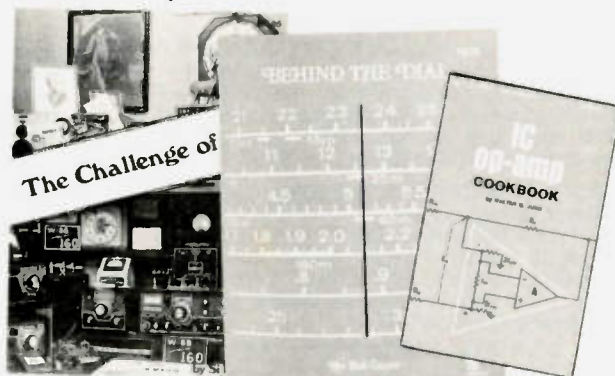

● **INTRODUCTION TO RTTY**—BK7380—A beginner's guide to radioteletype including teletypewriter fundamentals, signals, distortion and RTTY art. You can be a RTTY artist! A 73 publication. \$2.00.*

● **THE NEW RTTY HANDBOOK**—BK7347—is a new edition and the only up-to-date RTTY book available. The state of the art has been changing radically and has made all previous RTTY books obsolete. It has the latest circuits, great for the newcomer and expert alike. \$5.95.*

● **PROPAGATION WIZARD'S HANDBOOK**—BK7302—by J. H. Nelson. When sunspots riddled the worldwide communications networks of the 1940's, John Henry Nelson looked to the planets for an answer. The result was a theory of propagation forecasting based upon interplanetary alignment that made the author the most reliable forecaster in America today. The book provides an enlightened look at communications past, present, and future, as well as teaching the art of propagation forecasting. \$6.95.*

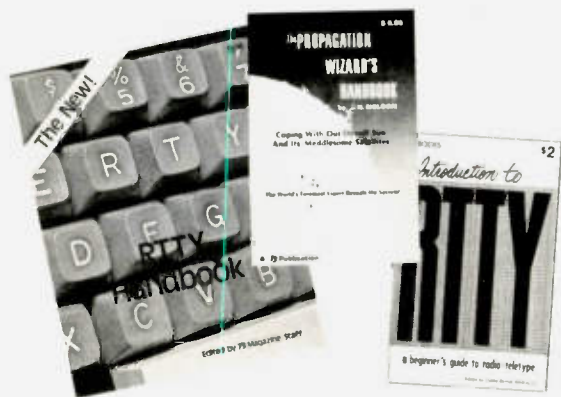

● **SSB . . . THE MISUNDERSTOOD MODE**—BK7351—by James B. Wilson. Single Sideband Transmission . . . thousands of us use it every day, yet it remains one of the least understood facets of amateur radio. J. B. Wilson presents several methods of sideband generation, amply illustrated with charts and schematics, which will enable the ambitious reader to construct his own sideband generator. A must for the technically-serious ham. \$5.50.*

● **SSTV HANDBOOK**—BK7354(hardcover), BK7355(softcover)—This excellent book tells all about it, from its history and basics to the present state-of-the-art techniques. Contains chapters on circuits, monitors, cameras, color SSTV, test equipment and much more. Hardbound \$7.00, softbound \$5.00.*

● **WEATHER SATELLITE HANDBOOK**—BK7370—Simple equipment and methods for getting good pictures from the weather satellite. Antennas, receivers, monitors, facsimile you can build, tracking, automatic control (you don't even have to be home). Dr. Taggart WB8DQT. \$4.95.*



ANTENNAS

● **73 DIPOLE AND LONG-WIRE ANTENNAS**—BK1016—by Edward M. Noll W3FQJ. This is the first collection of virtually every type of wire antenna used by amateurs. Includes dimensions, configurations, and detailed construction data for 73 different antenna types. Appendices describe the construction of noise bridges, line tuners, and data on measuring resonant frequency, velocity factor, and swr. \$5.50.*

● **73 VERTICAL, BEAM AND TRIANGLE ANTENNAS**—BK1069—by Edward M. Noll W3FQJ. Describes 73 different antennas for amateurs. Each design is the result of the author's own experiments covering the construction of noise bridges and antenna line tuners, as well as methods for measuring resonant frequency, velocity factor, and standing-wave ratios. 160 pages. \$5.50.*

● **VHF ANTENNA HANDBOOK**—BK7368—The NEW VHF Antenna Handbook details the theory, design and construction of hundreds of different VHF and UHF antennas . . . A practical book written for the average amateur who takes joy in building, not full of complex formulas for the design engineer. Packed with fabulous antenna projects you can build. \$4.95.*



73 Radio Bookshop • Peterborough NH 03458. Be sure to include check or detailed credit card information.

* Add \$1.00 handling charge for orders under \$10.00. Note: Prices subject to change on books not published by 73 Magazine.

FOR TOLL FREE ORDERING CALL 1-800-258-5473

Radio Bookshop

TEST EQUIPMENT

● **RF AND DIGITAL TEST EQUIPMENT YOU CAN BUILD**—BK1044—Rf burst, function, square wave generators, variable length pulse generators—100 kHz marker, i-f and rf sweep generators, audio osc, af/rf signal injector, 146 MHz synthesizer, digital readouts for counters, several counters, prescaler, microwave meter, etc. 252 pages. \$5.95.*

● **VOL. I COMPONENT TESTERS**—LB7359—... how to build transistor testers (8), diode testers (3), IC testers (3), voltmeters and VTVMs (9), ohmmeters (8 different kinds), inductance (3), capacity (9), Q measurement, crystal checking (6), temperature (2), aural meters for the blind (3) and all sorts of miscellaneous data on meters... using them, making them more versatile, making standards. Invaluable book. \$4.95.*

● **VOL. II AUDIO FREQUENCY TESTERS**—LB7360—... jam packed with all kinds of audio frequency test equipment. If you're into SSB, RTTY, SSTV, etc., this book is a must for you... a good book for hi-fi addicts and experimenters, too! \$4.95.*

● **VOL. III RADIO FREQUENCY TESTERS**—LB7361—Radio frequency waves, the common denominator of Amateur Radio. Such items as SWR, antenna impedance, line impedance, rf output and field strength; detailed instructions on testing these items includes sections on signal generators, crystal calibrators, grid dip oscillators, noise generators, dummy loads and much more. \$4.95.*

● **VOL. IV IC TEST EQUIPMENT**—LB7362—Become a troubleshooting wizard. All you need to know about pulse, audio and sync generators, frequency counters, digital component testers, logic probes and more! Plus a cumulative index for all four volumes of the 73 Test Equipment Library. \$4.95.*



THE WELL-EQUIPPED HAM SHACK



Style X



Style W

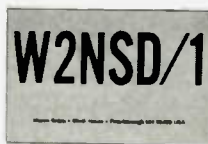

Style Y



● **NEW REPEATER ATLAS OF THE ENTIRE WORLD**—BK7345—150% as big as any list ever available—nearly 900 more repeaters listed. New improved maps show the locations by frequency of every repeater in the States. Only \$1.95.*

● **QSL CARDS**—73 turns out a fantastic series of QSL cards at about half the cost of having them done elsewhere because they are run as a fill-in between printing books and other items in the 73 Print Shop. 250 Style W—QW0250—for \$8.95*; 500 Style W—QW0500—for \$13.95*; 250 Style X—QX0250—for \$8.95*; 500 Style X—QX0500—for \$13.95*; 250 Style Y—QY0250—for \$8.95*; 500 Style Y—QY0500—for \$13.95.*

● **73 MAGAZINE BINDERS**—Preserve and protect your collection for your lifetime! There's no excuse for lost issues when you have these handsome red binders with gold lettering. Order 1—BN1001—for \$6.50*; 2 or more—BN1002—for \$6.00 each.*

● **BACK ISSUES**—Complete your collection—many are prime collectibles now, classics in the field! A full collection is an invaluable compendium of radio and electronics knowledge! \$2.00 each*, or 5 for \$5.00.*

● **LIBRARY SHELF BOXES**—These sturdy white, corrugated, dirt-resistant boxes each hold a full year of 73 or Kilobaud. With your order, request self-sticking labels for any of the following: 73, Kilobaud, CQ, QST, Ham Radio, Personal Computing, Radio Electronics, Interface Age, and Byte. Order 1—BX1000—for \$2.00*; order 2-7—BX1001—for \$1.50 each*; order 8 or more—BX1002—for \$1.25 each*.



73 Radio Bookshop • Peterborough NH 03458. Be sure to include check or detailed credit card information.
* Add \$1.00 handling charge for orders under \$10.00. Note: Prices subject to change on books not published by 73 Magazine.

FOR CUSTOMER SERVICE CALL 603-924-6132

Radio Bookshop

● **SSB... THE MISUNDERSTOOD MODE** —BK7351—by James B. Wilson. Single Sideband Transmission... thousands of us use it every day, yet, it remains one of the least understood facets of amateur radio. J. B. Wilson presents several methods of sideband generation, amply illustrated with charts and schematics, which will enable the ambitious reader to construct his own sideband generator. A must for the technically-serious ham. \$5.50.*

● **PROPAGATION WIZARD'S HANDBOOK** —BK7302—by J. H. Nelson. When sunspots riddled the worldwide communications networks of the 1940's, John Henry Nelson looked to the planets for an answer. The result was a theory of propagation forecasting based upon interplanetary alignment that made the author the most reliable forecaster in America today. The book provides an enlightened look at communications past, present, and future, as well as teaching the art of propagation forecasting. 6.95.*

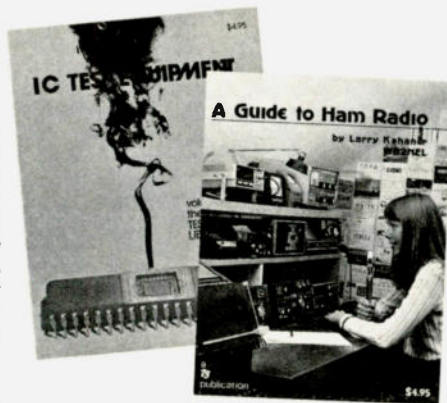

● **A GUIDE TO HAM RADIO**—BK7321—by Larry Kahaner WB2NEL. What's Amateur Radio all about? You can learn the basics of this fascinating hobby with this excellent beginner's guide. It answers the most frequently asked questions in an easy-going manner, and it shows the best way to go about getting an FCC license. A Guide to Ham Radio is an ideal introduction to a hobby enjoyed by people around the world. \$4.95.*

● **VOLUME IV—IC TEST EQUIPMENT**—LB7362—it's easy and fun to build your own test equipment with ICs! Here in this fourth volume of the 73 TEST EQUIPMENT LIBRARY are 42 home construction projects for building test equipment to work with your ham station and in servicing digital equipment. Counters, scalars, frequency standards, synthesizers, logic probes... JUST ABOUT EVERYTHING you need and can build with ICs. \$4.95.*



73 Radio Bookshop • Peterborough NH 03458. Be sure to include check or detailed credit card information.

* Add \$1.00 handling charge for orders under \$10.00. Note: Prices subject to change on books not published by 73 Magazine.

THE 73 Radio Bookshop ORDER FORM

Qty.	Cat.#	Description	Unit Price	Total

Add \$1 shipping & handling for orders under \$10:

Merchandise total:

SUBSCRIBE!

- 73 One year—73: \$18* 3 years—73: \$45*
 Kilobaud One year—KB: \$18* 3 years—Kilobaud: \$45*
 Life Sub (73/KB) \$195** New Sub Renewal Subscription total: _____

*U.S. & Canada only

**U.S. only

Enclosed _____ Check Money order

Bill my: Visa Master Charge American Express

Credit card # _____ Expiration date _____

Signature _____

Name _____

Address _____

City _____ State _____ Zip _____

Total subscription &/or merchandise:

73
magazine
peterborough nh 03458

For Toll Free Ordering : (800) 258-5473

(coupon expires in 60 days)

S12A

FOR TOLL FREE ORDERING CALL 1-800-258-5473

**21,560
pages.**



**That's the size of the world's
most comprehensive guide to
the subject of ham radio:
18 years of 73 Magazine.**

The back issues of 73 are a gold mine of interesting articles. Unlike the other magazines, which fill their pages with activity reports, there's little to go stale in 73. You'll find pioneering articles on SSTV, FM, repeaters, ICs, and computers. Even the editorials are fun as Wayne Green's dire predictions, like the debacle of incentive licensing, have come to pass.

Clip the coupon below and send for 73's new back issue catalogue. Treat yourself (or a friendly ham) to some fun, and a fantastic bargain to boot.

YES! Rush me 73's FREE Back Issue Catalogue!

Name _____

Address _____

City _____ State _____ Zip _____

s12

73 magazine
PETERBOROUGH NH 03458

IS HARD COPY STORAGE A PROBLEM?

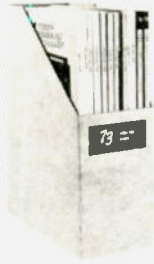

73, as thick as it is, is more like a floppy when it comes to standing on the bookshelf. Try the 73 Library Shelf Boxes, . . . sturdy corrugated white dirt resistant cardboard boxes which will keep them from flopping around. We have self-sticking labels for the boxes, too, not only for 73, but also for *Kilobaud* . . . and for *CQ*, *QST*, *Ham Radio*, *Personal Computing*, *Radio Electronics*, *Interface Age*, and *Byte*. Ask for whatever stickers you want with your box order. They hold a full year of 73 . . . or *Kilobaud*. Your magazine library is your prime reference, keep it handy and keep it neat with these strong library shelf boxes . . . One box is \$2.00, 2 boxes are \$3.00 and eight boxes are \$10.00. Be sure to specify which labels we should send. Have your credit card handy and call our toll-free order number 800-258-5473, or use the order card in the back of the magazine and mail to:



MOVING?

Let us know 8 weeks in advance so that you won't miss a single issue of 73 Magazine. Attach old label where indicated and print new address in space provided. Also include your mailing label whenever you write concerning your subscription. It helps us serve you promptly. Write to:



- Address change only
- Extend subscription
- Enter new subscription
- 1 year \$15.00
- Payment enclosed (1 extra BONUS issue)
- Bill me later

If you have no label handy, print OLD address here.

AFFIX LABEL

Name _____ Call _____

Address _____

City _____ State _____ Zip _____

print NEW address here:

Name _____ Call _____

Address _____

City _____ State _____ Zip _____

propagation

by
J. H. Nelson

EASTERN UNITED STATES TO:

GMT:	00	02	04	06	08	10	12	14	16	18	20	22
ALASKA	14	7A	7	7	7	7	7	7	14A	14A	21A	21
ARGENTINA	14	7A	7	7	7	7	14	21	21A	21A	21A	21
AUSTRALIA	21	14	7B	7B	7	7	7B	14	14A	21	21	21A
CANAL ZONE	14	7A	7	7	7	7	14	21	21A	21A	21A	21
ENGLAND	7	7	7	7	7	7B	14	21A	21A	14	7B	7
HAWAII	21	14	7B	7	7	7	7	7B	14	21	21A	21A
INDIA	7	7	7B	7B	7B	7B	14	14A	14	7B	7B	7
JAPAN	14A	14	7B	7B	7	7	7	7	7B	7B	7B	14
MEXICO	14	7A	7	7	7	7	7	14	21	21A	21A	21
PHILIPPINES	14	14B	7B	7B	7B	7B	7	7	7B	7B	7B	14
PUERTO RICO	14	7	7	7	7	7	14	21	21A	21A	21	14
SOUTH AFRICA	14B	7B	7	7	7B	14	21	21A	21A	21A	21	14
U. S. S. R.	7	7	7	7	7	7B	14	21	14	7B	7B	7
WEST COAST	21	14	7	7	7	7	7	14	21	21A	21A	21

CENTRAL UNITED STATES TO:

ALASKA	21	14	7	7	7	7	7	14	14A	21	21A	
ARGENTINA	14A	14	7	7	7	7	14	21	21	21A	21A	21A
AUSTRALIA	21A	14	7B	7B	7	7	7B	7B	14A	21	21	21
CANAL ZONE	21	14	7	7	7	7	14	21	21A	21A	21A	21A
ENGLAND	7	7	7	7	7	7	7B	14A	21A	14	7B	7B
HAWAII	21	14	7B	7	7	7	7	14	21	21A	21A	
INDIA	7	7	7B	7B	7B	7B	7B	14	14	7B	7B	7B
JAPAN	21	14	7B	7B	7	7	7	7	7	7B	7B	14
MEXICO	14	7A	7	7	7	7	7	14	21	21	21	21
PHILIPPINES	21	14	7B	7B	7B	7B	7	7	7	7B	7B	14
PUERTO RICO	14	7A	7	7	7	7	14	21	21A	21A	21A	21
SOUTH AFRICA	14	7B	7	7	7B	7B	14	21	21A	21A	21	21
U. S. S. R.	7	7	7	7	7	7B	7B	14A	14	7B	7B	7B

WESTERN UNITED STATES TO:

ALASKA	21	14	7	3A	3A	7	7	3A	7	14	21	21A
ARGENTINA	21	14	14	7	7	7	7B	14	21	21	21A	21A
AUSTRALIA	21A	21	14	7B	7	7	7B	7B	14	21	21	21A
CANAL ZONE	21	14	7	7	7	7	7	14	21A	21A	21A	21A
ENGLAND	7B	7	7	7	7	7	7B	14	21	14	7B	7B
HAWAII	21A	21	14	7	7	7	7	14	21	21A	21A	21
INDIA	14	14	7B	7B	7B	7B	7B	7	7	7B	7B	7B
JAPAN	21A	14	7B	7B	7	7	7	7	7	7B	14	14A
MEXICO	21	14	7	7	7	7	7	14	21	21A	21A	21
PHILIPPINES	21A	21	14B	7B	7B	7B	7B	7	7	7	7B	14A
PUERTO RICO	21	14	7	7	7	7	7	14	21A	21A	21A	21
SOUTH AFRICA	14	14B	7	7	7B	7B	14	21	21A	21A	21	21
U. S. S. R.	7B	7	7	7	7	7B	7B	7B	14	14B	7B	7B
EAST COAST	21	14	7	7	7	7	7	14	21	21A	21A	21

- A = Next higher frequency may also be useful
- B = Difficult circuit this period
- F = Fair
- G = Good
- P = Poor
- SF = Chance of solar flares

december

sun	mon	tue	wed	thu	fri	sat
☉ ☽ ☿ ♃					1 G	2 G
3 G	4 G	5 F	6 F	7 G	8 G	9 P/SF
10 P/SF	11 F	12 G	13 G	14 G/SF	15 G/SF	16 P/SF
17 P	18 G	19 G	20 G	21 G	22 G	23 G
24 31 G/G	25 G	26 F	27 G	28 G	29 G	30 F

READER SERVICE

A46 ABC Communications..... 247	D35 Daytapro Electronics, Inc..... 283	L9 Long's Electronics..... 194-199	S4 Slep Electronics Co..... 178
A1 Adirondack Radio Supply..... 78	D39 Jim DeNinno & Co..... 279	L17 Lunar Electronics..... 80	S8 Spectrum Com..... 110, 111
A24 Adva Electronics..... 300	D15 DenTron..... 5	M35 Madison Electronics Supply..... 139	S10 SST Electronics..... 87, 88, 89
A60 AED Electronics..... 77	D29 Dielectric..... 211	M38 Maggiore Electronic Lab..... 229	S50 O. C. Stafford Electronics..... 281
A2 Aidelco..... 313	D20 Digital Research Corp..... 302, 303	M71 Matric..... 54	S18 Standard Communications..... 190
A47 Aluma Tower Company..... 290	D23 Dovetron..... 77	M52 MFJ Enterprises..... 45, 103, 282	S38 Stuart Electronics..... 288
A40 Amateur Radio Supply of Nash- ville, Inc..... 213	D11 R. L. Drake Company..... 94, 95	M8 MHZ Electronics..... 292, 293	S43 Surplus Electronics..... 310
A51 Amateur Radio of Rochester..... 163	D25 DSI Instruments..... 21, 220, 221	M69 Micro Control Specialties..... 279	* Ten-Tec..... 135
A26 Amidon Associates..... 113	E1 ECM Corporation..... 75, 79	M48 Microtronics..... 19, 281	T34 Thomas Communications..... 261
A70 AMP Special Industries..... 204	E19 Edgecom..... 35	M62 Mid Com Electronics, Inc./Edge- com..... 63	T48 Tower Electronics Corp..... 113
* Amsat..... 229	E12 Engineering Specialties..... 312	M41 Midland International..... 233	T44 Tower Electronics Corp./Edge- com..... 43
A6 Apron Laboratories..... 279	F5 Flesher Corporation..... 265, 283	N2 New-Tronics..... 141	T18 Trac Electronics, Inc..... 79
A50 Associated Radio..... 308	G12 Germantown Amateur Supply..... 171	N14 Northern Radio..... 265	T35 Trans Com..... 280
A64 Aureus Elec., Inc./Edgecom..... 71	G20 G & G Radio Electronics Co..... 281	O5 OK Machine & Tool..... 171, 173	T3 Tufts Radio Elec..... 232, 266-269
B1 Babylon Electronics..... 288	G22 G.I.S.M.O..... 282	O3 Optoelectronics, Inc..... 301	T45 Tufts Radio Electronics/Edge- com..... 59
B23 Barker-Williamson..... 191	G23 Globalman Products..... 211	P15 Pace-Traps..... 281	U2 Unarco-Rohn..... 283
B32 Bay-Com..... 280	G4 Godbout Electronics..... 304	P30 Palomar Electronics..... 138	U8 United Products..... 295
B41 Belden..... 272	* HAL Communications Corp..... 78	* Palomar Engineers..... 19	U6 Universal Amateur Radio Service, Inc..... 79
B29 Britt's 2-Way Radio..... 178	H24 Hal-Tronix..... 263, 265	P41 P.C. Electronics..... 75	V1 Vanguard Labs..... 75
B8 Bullet Electronics..... 296, 297	H2 Ham Radio Center..... 215, 291	P2 Poly Paks..... 309	V5 VHF Engineering..... 27
B30 Burghardt Amateur Center..... 225	H31 Ham Radio Outlet..... 289	P26 Printed Circuit Products..... 280	V18 VHF Engineering/Edgecom..... 55
C88 C & A Electronic Enterprises..... 205	H16 Hamtronics, NY..... 299	P21 Priority One..... 151, 153	W15 Wacom..... 78
C3 Clegg..... 125, 179	H8 Hamtronics, PA..... 236-245	Q3 Quest Electronics..... 294	W17 Westcom Engineering..... 42, 140
C21 Coakit..... 280	H26 Hartwell's Office World..... 290	R1 Radio Amateur Callbook, Inc..... 311	W18 Western Electronics..... 79, 280
C95 Cohoon Amateur Supply/Edge- com..... 47	H30 Heuer Time & Electronics..... 158	* Radio World..... 75	W2 Wilson Electronics..... 3
C75 Comm Center, Laurel..... 232	H3 Henry Radio..... CII, 117	R10 Rainbow Industries..... 77	X1 Xitex..... 280, 281
C106 Command Productions..... 279	H4 Hy-Gain Electronics..... 45	R8 Ramsey Electronics..... 29, 298	Y1 Yaesu Electronics Corp..... CIII
C105 Communications & TV Unltd..... 276	I1 ICOM..... 17	R25 F. Reichert & Sales..... 307	Z1 ZZZ Electronics, Inc..... 264
C58 Communications Ctr, NE..... 249, 273	I32 Instant Software..... 180, 181	R27 RF Power Labs, Inc..... 276	From 73..... Pages 77, 259, 316-322
C96 Communications Center, NE/ Edgecom..... 69	I9 Integrated Circuits, Unltd..... 306	* R. Lee Tower International..... 283	
C5 Communications Electronics..... 159	I27 IRL..... 23	R15 Rolin Distributors..... 290	
C89 Communications Services..... 282	J1 Jameco Electronics..... 305	R21 Rush Electronics..... 288	
C6 Communications Specialists 24, 25	J2 Jan Crystals..... 140	R18 R. W. Electronics, Inc..... 279	
C90 Curtis Electro Devices..... 140	J8 JRS Electronics..... 75, 280	S63 Semiconductors Surplus 314, 315	
* Dade County Hamfest..... 190	K13 Kantronics..... 163	S3 Sentry..... 78, 282	
Peter W. Dahl Company..... 171	* Kilobaud..... 169	S39 Sere-Rose & Spencer Elec..... 281	
D10 Davis Electronics..... 290	* Kenwood..... CIV, 6-13	S33 S-F Amateur Radio Services 75, 264	
	K14 Key Electronics..... 281	S58 Shakespeare..... 257	
	L18 Lafayette..... 22	S70 Signetics..... 272	

*Reader Service inquiries not honored.
Please contact advertiser directly.

BOOKS, ETC.

BK1016 73 DIPOLE & LONG WIRE ANTENNAS..... \$ 5.50	QW0500 QSL CARDS—STYLE W—500..... \$13.95
ST0000 73 BACK ISSUE..... \$ 3.00	QX0250 QSL CARDS—STYLE X—250..... \$ 8.95
ST2500 73 BACK ISSUES—25 OUR CHOICE..... \$10.00	QX0500 QSL CARDS—STYLE X—500..... \$13.95
ST0500 73 BACK ISSUES—5 YOUR CHOICE..... \$ 5.00	QY0250 QSL CARDS—STYLE Y—250..... \$ 8.95
ST1000 73 BACK ISSUES—10 YOUR CHOICE..... \$12.00	QY0500 QSL CARDS—STYLE Y—500..... \$13.95
ST2501 73 BACK ISSUES—25 YOUR CHOICE..... \$20.00	BK7345 REPEATER ATLAS..... \$ 1.95
BK7307 BEHIND THE DIAL..... \$ 4.95	BK1044 RF DIGITAL TEST EQUIPMENT..... \$ 5.95
BN1001 BINDER—73—1..... \$ 6.50	BK7347 RTTY HANDBOOK..... \$ 5.95
BN1002 BINDER—73—2&UP..... \$ 6.00	BX1000 SHELF BOX—1..... \$ 2.00
BK7309 CHALLENGE OF 160..... \$ 4.95	BX1001 SHELF BOX—2..... \$ 1.50
CT7305 CODE TAPE—5 WPM..... \$ 4.95	BX1002 SHELF BOX—8 UP..... \$ 1.25
CT7306 CODE TAPE—6 WPM..... \$ 4.95	BK7351 SSB THE MISUNDERSTOOD MODE..... \$ 5.50
CT7310 CODE TAPE—10 WPM..... \$ 4.95	BK7354 SSTV HANDBOOK (HARDCOVER)..... \$ 7.00
CT7313 CODE TAPE—13 WPM..... \$ 4.95	BK7355 SSTV HANDBOOK (SOFTCOVER)..... \$ 5.00
CT7320 CODE TAPE—20 WPM..... \$ 4.95	CT7350 SSTV TAPE..... \$ 5.95
CT7325 CODE TAPE—25 WPM..... \$ 4.95	SG1081 STUDY GUIDE—ADVANCED CLASS..... \$ 5.95
CT7399 CODE TAPE—LEARN MORSE CODE..... \$ 4.95	SG1080 STUDY GUIDE—EXTRA CLASS..... \$ 5.95
CT7394 CODE TAPES (ANY FOUR ABOVE)..... \$15.95	SG7358 STUDY GUIDE—GENERAL CLASS..... \$ 5.95
BK7321 GUIDE TO HAM RADIO..... \$ 4.95	SG7357 STUDY GUIDE—NOVICE CLASS..... \$ 4.95
BK7325 HOW TO BUILD A MICROCOMPUTER..... \$ 9.95	LB7359 TEST EQUIP LIB V1—COMP TESTERS..... \$ 4.95
BK1028 IC OP AMP COOKBOOK..... \$12.95	LB7360 TEST EQUIP LIB V2—AUDIO TESTERS..... \$ 4.95
BK7380 INTRO TO RTTY..... \$ 2.00	LB7361 TEST EQUIP LIB V3—RADIO EQUIP..... \$ 4.95
CT7300 NOVICE THEORY TAPES..... \$15.95	LB7362 TEST EQUIP LIB V4—IC TEST EQUIP..... \$ 4.95
BK1100 PRACTICAL TEST INSTRUMENTS..... \$ 4.95	BK1069 VERTICAL BEAM & TRIANGLE ANTNS..... \$ 5.50
BK7302 PROPAGATION WIZARD'S HANDBOOK..... \$ 6.95	BK7368 VHF ANTENNA HANDBOOK..... \$ 4.95
QW0250 QSL CARDS—STYLE W—250..... \$ 8.95	BK7370 WEATHER SATELLITE HANDBOOK..... \$ 4.95

READER SERVICE

To receive more information from any of the advertisers in this issue of 73, postage paid return cards are provided here for your convenience.

If you wish to hear from one or several advertisers, refer to the ad itself. You will find numbers near the logo of each advertiser. Each represents the advertiser's individual Reader Service number. Circle the corresponding numbers on one of the cards on this page, include your name and address & zip and drop in a mailbox. In four to six weeks you'll hear from the advertiser directly.



INSTANT INFORMATION CARD

If you're in a real

hurry to hear from one of our advertisers (some of us just can't wait), we have included an **Instant Information Card** for your use. Simply include your name and full address on the request card. Fill out the front of the card with the specific advertiser's name and address, include a stamp, and drop it in the mail. You should receive information within two to three weeks.

READER SERVICE REPLY CARD

Return this card to receive full information on the many products advertised in this issue. Limit: 25 requests. Subscriber Newsstand. This card is valid until February 30, 1979.

A1	A60	C6	C106	D39	H2	I9	M8	N14	R1	S8	T3	V1
A2	A64	C21	D6	E1	H3	I27	M35	O3	R8	S10	T18	V5
A6	B1	C58	D10	E12	H4	I32	M36	O5	R10	S18	T34	V18
A24	B8	C75	D11	E19	H8	J1	M41	P2	R15	S33	T35	W2
A26	B23	C88	D15	F5	H16	J2	M48	P15	R18	S38	T44	W15
A40	B29	C89	D20	G4	H24	J8	M52	P21	R21	S39	T45	W17
A46	B30	C90	D23	G12	H26	K13	M62	P26	R25	S43	T48	W18
A47	B32	C95	D25	G20	H31	K14	M69	P30	R27	S50	U2	X1
A50	C3	C96	D29	G22	H32	L9	M71	P41	S3	S58	U6	Y1
A51	C5	C105	D35	G23	I1	L17	N2	Q3	S4	S63	U8	Z1



kilobaud

This month's **ARTICLE WINNER** (title page number): _____

Name _____

Address _____

City _____ State _____ Zip _____

73/12/78



Place Stamp Here

instant information

Advertiser _____

Street or box number _____

City _____

State _____

Zip _____

READER SERVICE REPLY CARD

Return this card to receive full information on the many products advertised in this issue. Limit: 25 requests. Subscriber Newsstand. This card is valid until February 30, 1979.

A1	A60	C6	C106	D39	H2	I9	M8	N14	R1	S8	T3	V1
A2	A64	C21	D6	E1	H3	I27	M35	O3	R8	S10	T18	V5
A6	B1	C58	D10	E12	H4	I32	M36	O5	R10	S18	T34	V18
A24	B8	C75	D11	E19	H8	J1	M41	P2	R15	S33	T35	W2
A26	B23	C88	D15	F5	H16	J2	M48	P15	R18	S38	T44	W15
A40	B29	C89	D20	G4	H24	J8	M52	P21	R21	S39	T45	W17
A46	B30	C90	D23	G12	H26	K13	M62	P26	R25	S43	T48	W18
A47	B32	C95	D25	G20	H31	K14	M69	P30	R27	S50	U2	X1
A50	C3	C96	D29	G22	H32	L9	M71	P41	S3	S58	U6	Y1
A51	C5	C105	D35	G23	I1	L17	N2	Q3	S4	S63	U8	Z1



kilobaud

This month's **ARTICLE WINNER** (title page number): _____

Name _____

Address _____

City _____ State _____ Zip _____

73/12/78

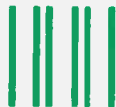

NO POSTAGE
NECESSARY
IF MAILED
IN THE
UNITED STATES

BUSINESS REPLY MAIL
FIRST CLASS PERMIT NO 17 PETERBOROUGH NH 03458

POSTAGE WILL BE PAID BY ADDRESSEE

73 magazine
Peterborough NH 03458



Att: Reader Service

73 instant information

Please rush information on your products or services to the following address:

Your name

Number and street

City

State

Zip Code

Information requested from the December Issue of 73.

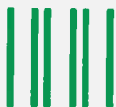

NO POSTAGE
NECESSARY
IF MAILED
IN THE
UNITED STATES

BUSINESS REPLY MAIL
FIRST CLASS PERMIT NO 17 PETERBOROUGH NH 03458

POSTAGE WILL BE PAID BY ADDRESSEE

73 magazine
Peterborough NH 03458



Att: Reader Service



THE CHRISTMAS GIFT OF A LIFETIME!

YAESU ANNOUNCES THEIR SENSATIONAL COMPUTER AGE
CPU-2500R/K 2-METER 25 WATT TRANSCEIVER



Again, Yaesu, THE RADIO, takes a giant step forward with their computer age 4-bit Central Processor Unit controlling the Phase Locked Loop. It allows selection of 800 PLL channels with touch button station selection built into the optional keyboard mike . . . **PLUS** automatic scan, up or down across the entire 2 meter band . . . **PLUS** four memory channels . . . **PLUS** optional tone squelch encoding . . . **PLUS** tone burst . . . **PLUS** high SWR and reverse voltage polarity protection . . . **PLUS** 3/25 watts of power . . . **PLUS** fixed ± 600 KHz offsets . . . **PLUS** programmable offsets . . . **PLUS** tone pad microphone option . . . **PLUS** bright 3/8" LED six digit frequency display and another LED for memory display . . . and much more.

The CPU-2500R/K is a space age radio for discriminating amateurs utilizing the latest solid state techniques and it's on your dealer's shelf today!

Price And Specifications Subject To
Change Without Notice or Obligation



YAESU
The radio.

YAESU ELECTRONICS CORP., 15954 Downey Ave., Paramount, CA 90723 • (213) 633-4007
YAESU ELECTRONICS Eastern Service Ctr., 9812 Princeton-Glendale Rd., Cincinnati, OH 45246

arma
radio electronics association

THE ALL NEW

TR-7600



EVERY FEATURE YOU COULD POSSIBLY WANT IN A 2-METER FM RIG IS AVAILABLE NOW IN THE KENWOOD TR-7600

...THE RADIO THAT REMEMBERS

The new TR-7600 gives you...

- Full 4-MHz coverage (144.000-147.995 MHz) on 2 meters • 800 channels • Dual concentric knobs for fast frequency change (100-kHz and 10-kHz steps)
- 5-kHz offset switch • MHz selector switch...for desired band (144, 145, 146, or 147 MHz) • Mode switch

for operating simplex or for switching the transmit frequency up or down 600 kHz for repeater operation... or for switching the transmitter to the frequency you have stored in the TR-7600's memory (while the receiver remains on the frequency you have selected with the dual knobs) • Memory channel...with simplex or repeater (plus or minus 600 kHz transmitter offset) operation.

The optional RM-76 Microprocessor Control Unit provides more operating features to the TR-7600 2-meter FM transceiver than found in any other rig! With the Microprocessor Control Unit attached to your TR-7600, you can...

- Select any 2-meter frequency • Store frequencies in six memories • Scan all memory channels • Auto-

Actual Size



RM-76
Microprocessor
Control Unit

atically scan up all frequencies in 5-kHz steps • Manually scan up or down in 5-kHz steps • Set lower and upper scan frequency limits • Reset scan to 144 MHz • Stop scan (with HOLD button) • Cancel scan (for transmitting) • Automatically stop scan on first busy or open channel •

Subject to FCC approval