

TRROUBLE SHOOTER

COLOR TV

For Service Technicians

INDEX TO COLOR TELE-VUE TROUBLE SHOOTER

INSTRUCTIONS FOR USING

In troubleshooting a color receiver, it is best to determine if the trouble is present only on a color program, or if it is present on both color and black and white. For example, if there is lack of height,

then this will be present regardless of the program present. However, if blue is missing on a color program, and yet the raster is normal for a black and white show, then this trouble would be per-

taining to color only. The following index is in two parts, the first being devoted to color troubles, and the second to troubles common to all programs.

INDEX TO CHARTS 1-20 COLOR SECTION

CHART NO. SYMPTOM

1. No color on color program
2. No red present on color program
3. No blue present on color program
4. No green present on color program
5. 60cps hum bar present
6. Color missing on one channel
7. Weak colors
8. Loss of color sync
9. Color present in black and white pictures
10. Too much red in color program

CHART NO. SYMPTOM

11. Too much blue
12. Too much green
13. Incorrect colors
14. Colors fading
15. Blooming and out of focus
16. H.V. arcing
17. Colored snow in B & W
18. Colors too vivid
19. Convergence adjustment
20. Purity adjustment

NOTE: Although the above symptoms occur for color, charts numbers 9, 15, 16, will also show on a black and white program, however, because they are normally present only in color receivers, the author has included them in the above index.

INDEX TO CHARTS 21-40 BLACK AND WHITE SECTION

CHART NO. SYMPTOM

21. Snowy pix
22. Weak pix
23. No pix or sound
24. No pix
25. Loss of sync
26. No vertical sweep
27. Not enough height
28. Vertical off frequency
29. No vertical sync
30. Poor vertical linearity

In the second index, it may at first appear that the troubles are similar to those found only in a black and white receiver. However, due to the circuitry of a color receiver, even the normal pat-

tern of a black and white receiver is changed somewhat. This is why special attention is given to these troubles.

CHART NO. SYMPTOM

31. Vertical foldover
32. Loss of horizontal sync
33. Horizontal off frequency
34. Not enough width
35. Postage stamp raster
36. No raster, sound ok
37. No raster or sound
38. Low brightness
39. Distorted sound
40. No sound, pix ok.

THE PRACTICAL APPROACH TO COLOR TELEVISION THEORY

INTRODUCTION

The color receiver is more complex to troubleshoot than black and white, because of the additional circuits that are used. However, the principles that are used for black and white troubleshooting, can also be applied to color. Once again the picture tube can be used to isolate the cause of trouble to a particular section. This is possible because if the trouble is in the color program only, then our attention is focused on that part of the receiver. Whereas, if color and black and white are affected, then we would check the circuits that are common to both. For all of their complexity, color receivers have stood up well, and many of the repairs do not go beyond tube replacement. However, as time goes by, the receiver is more susceptible to breakdown, and it was found that repairs go beyond the simple tube replacement. It is the purpose of the Color Tele-Vue Troubleshooter, to explain the steps that must be taken if it is necessary to go into the circuitry of the color receiver. You will find that even the black and white section of the color receiver is different than that found in the normal television set. For example, take the signal that goes to the CRT. In the simple black and white receiver the signal is amplified by the video amplifiers, and passed to the picture tube grid or cathode. In a color receiver, the black and white picture is formed by signals that go to THREE grids of the picture tube. This means that the picture consists of three parts all working together to form the black and white picture. It is for these reasons that the Color Tele-Vue Troubleshooter is broken down into two parts. Part 1 deals with the troubles that would affect only the color program such as, no color, poor color, wrong color, etc. Part 2 deals with the troubles that will affect both the color AND the black and white picture.

REVIEW OF COLOR TELEVISION

Color television began to make its appearance in the United States around the early 1950's. The system that was used at that time required a rotating disc, consisting of three colors, to be placed in front of the screen of a regular black and white receiver that had had its vertical and horizontal sweep circuits changed slightly to coincide with the synchronization of the rotating disc. As the picture was viewed through the rotating disc, color in the picture would occur. This early system had its drawbacks in the mechanical workings of the disc, and in the fact that it was not a compatible system. This

meant that every person desiring the color effect, would have to take his set to the shop and have it changed over so that with the flip of a switch, it could be synchronized with the rotating disc. Toward the mid fifties, another system was introduced that did not require any mechanical devices, and was completely compatible, that is, a color program could be received on any set but would only appear as color to those who had a color receiver. This is the system we have today, and, I am sure you will agree it produces a wonderful color picture. The first problem to overcome, was to be able to fit the color information into the black and white carrier, so that it could be transmitted along with the black and white. This problem was solved by producing a color subcarrier at approximately 3.58 mc above the station carrier for black and white, and clustering all of the color information around the subcarrier. See Fig. 1. Due to its frequency of 3.58 mc, all information that modulated it would just happen to fall into the empty spaces that exist around the black and white information. It was found that three colors were enough to represent almost all of the colors in the color spectrum, those chosen were green, red and blue.

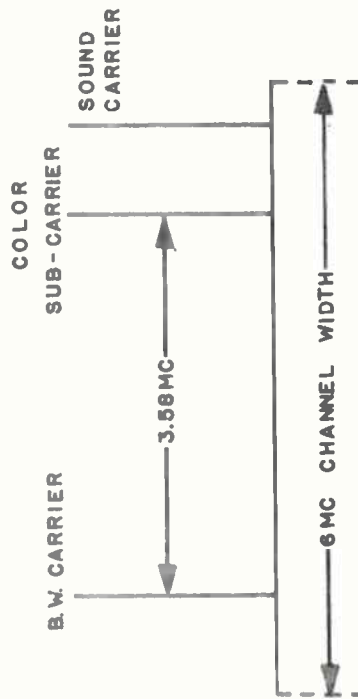

FIG. 1

THE COLOR TRANSMITTER

At the studio, see Fig. 2, reflected light from the scene is passed through red, green and blue filters. Only the red in the scene can pass through the red filter, only the green from the scene can pass through the green filter, and only the blue in the scene can pass through the blue filter. This breaks the picture up into three signals, each

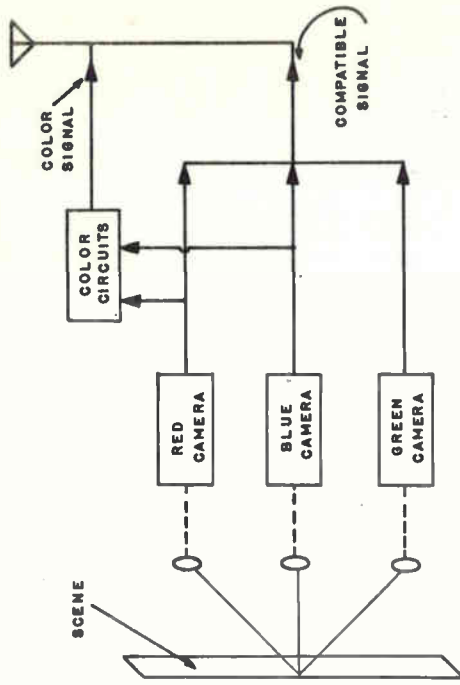

FIG. 2

one representing a certain color in the scene. The light that passed through each of the filters is now focused into the camera for that particular color. This means that three cameras are required. The output from the red and blue cameras are the signals that modulate the color subcarrier, but the green camera output is combined with the red and blue to provide a picture that contains all of the information in the scene, and is the signal that makes it possible for a black and white receiver to produce a black and white picture on a color show. In a color receiver, in order to obtain the green for the green part of the picture, the red and blue signals that are transmitted separately, are now combined with the total signal in such a way that they cancel the red and blue in the total picture, and leave green. Therefore, the green is obtained in the receiver, and no special modulation of the green on the color subcarrier is required. One additional feature of the transmitter for color, is that the color subcarrier at 3.58 tends to introduce too much interference in the signal, and is suppressed at the transmitter. Since the color subcarrier is not transmitted, it now becomes necessary to provide a 3.58 mc signal in the color receiver. In order to synchronize the 3.58 mc signal in the color receiver, with the 3.58 mc signal that is suppressed at the transmitter, a special synchronizing burst of the original subcarrier is allowed to be sent along with all of the information. Fig. 3. This small burst of the signal rides on top of the horizontal blanking pulse, just after the horizontal sync pulse. It is this, and this alone, that synchronizes the color receiver with the color transmitter.

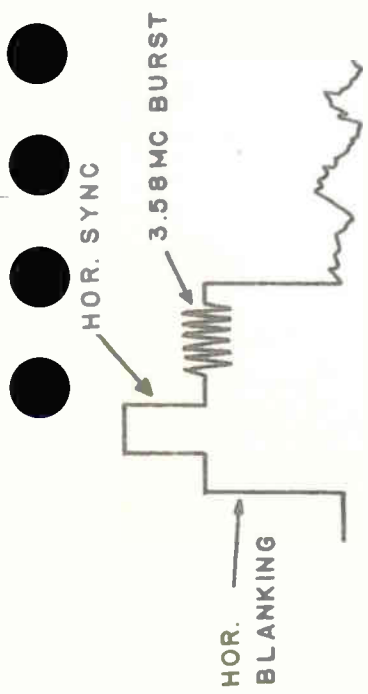

FIG. 3

THE COLOR RECEIVER

The front end, video I.F.s, and detector are similar in the black and white and color receivers, the differences being after the detector. Refer to Fig. 4. The composite video signal at the detector is amplified by a video amplifier that has many outputs, one of these outputs goes to a special unit that is called a delay line. It is the purpose of this delay line to actually delay the signal going to the MATRIX network. In the matrix the signals are combined to produce the green, or cancel out certain signals so that only blue or red or green are left, if the scene happens to be just one color.

Another output of the video amplifier goes to a circuit called the BANDPASS AMPLIFIER. This circuit allows a band of frequencies to pass that contain all of the red and blue color information. You will recall that the color information is clustered around a sub carrier that is positioned 3.58 mc away from the video carrier. Therefore, the bandpass amplifier passes those frequencies around 3.58mc, in fact it passes from 2 mc to 4 mc. Once past the bandpass amplifier, the color signal must be demodulated, and in fact goes to a demodulator. Also being applied to the demodulator, is the local oscillator signal at 3.58 mc. This signal is synchronized by the burst of 3.58 mc sent on top of the horizontal blanking pulse. This burst of 3.58 mc is separated by the action of the BURST KEYSER and amplified by the BURST AMPLIFIER. Once separated, it is applied through an automatic phase control system similar to the a/c in black and white television, to the local 3.58 mc oscillator.

The combined signals at the red and blue demodulators, produce demodulation, and the output from the demodulators is a signal that represents color sections of the total scene. It is at this time that the red and blue signals combine with the composite signal, called the Y signal, to produce the desired color signal as well as the signal to the matrix. Finally, the signals

are amplified in separate amplifiers, and fed to their respective guns in the CRT. Most sets employ a circuit called the COLOR KILLER. This circuit cuts off the bandpass amplifier if there is no 3.58 mc burst present on top of the horizontal blanking. Therefore, if there is no color program on the air, the burst will be missing, and the bandpass amplifier is cut off. This prevents any signal from passing into the color demodulators, and in turn allows no signal from the 3.58 mc local oscillator to pass. As a result, there can be no interference on the screen from the color circuits, if there is a black and white picture on the screen.

Because of the three guns that are used in the color CRT, there is a problem of getting all the beams to hit the screen at the correct point. This is referred to as "converging the beams." You see, the screen consists of three color phosphors, one of each gun, each color is separated from the next by a very small amount and the electron beam for the red must hit the red phosphor, and so on. Since the screen is fairly large, it has a curved surface, and the beams must follow the curve if they are to do their job correctly. Therefore, an additional boost must be given all beams, so that they will converge at the outer edges of the screen. A special circuit is used to shape the vertical and horizontal waveforms so that they can be applied to the convergence magnets located around the neck of the picture tube. This circuit is called the convergence circuit, and it has many adjustments. One of the problems that faces the technician working on a color receiver, is the convergence adjustments that must be made. This is done during the initial set up procedure,

and if done incorrectly, will cause color to be seen around the edges on a black and white program.

TROUBLESHOOTING PROCEDURE FOR THE COLOR RECEIVER

The best way to troubleshoot the color receiver, is to understand the various color sections of the receiver, then determine what troubles they can cause in the picture. Let us take a look at the color sections.

1. Luminance channel
2. Color sync and a/c
3. Band pass amp and color killer
4. Demodulators and amplifiers
5. Matrix
6. Tri color CRT
7. Convergence

LUMINANCE CHANNEL

The luminance channel is that part of the color receiver that carries the composite video signal containing all information. It is sometimes referred to as the Y channel, and it begins after the video detector, and continues up to the matrix. Troubles can be isolated to the Luminance channel if we cannot pick up a black and white program, and a color show does not produce the correct colors. This symptom occurs because on a black and white show, the color sections of the receiver are cut off by the color killer, therefore, only the luminance section is supposed to operate. However, on a color show, the luminance and color sections operate, and if the luminance circuit is not functioning, then the colors will be incorrect. An

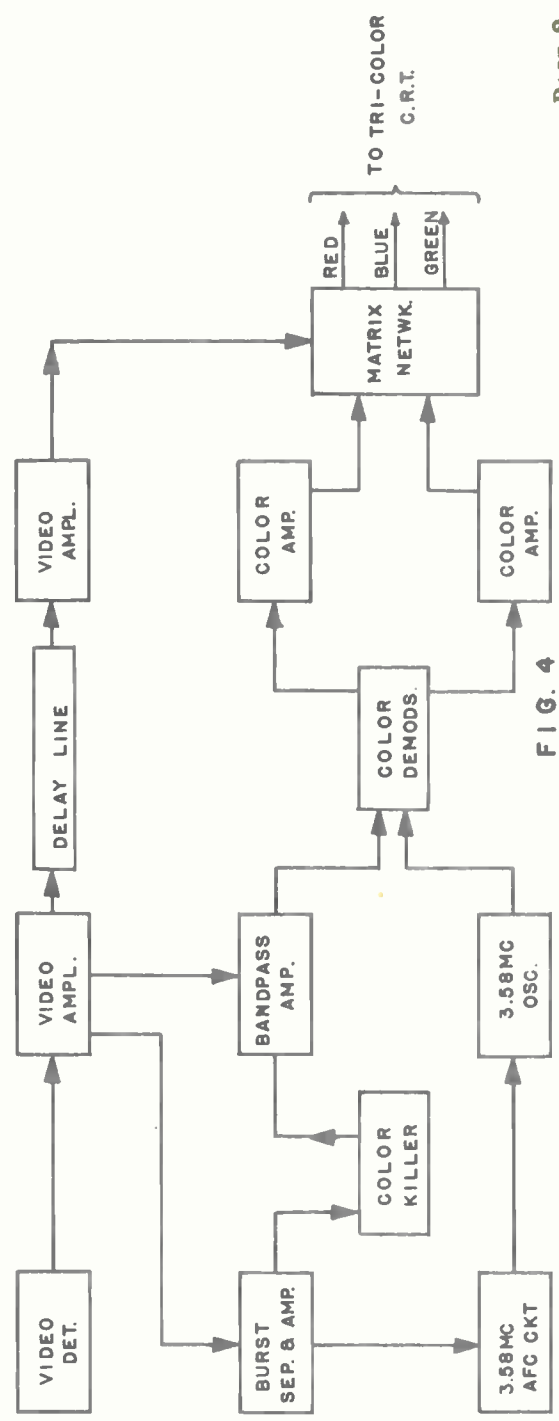

FIG. 4

oscilloscope can be used in much the same manner as in a black and white receiver for troubleshooting the Luminance channel.

COLOR SYNC AND A.F.C.

This section of the color receiver, synchronizes and produces the 3.58 mc signal that is used for the demodulation of the color information that passes the bandpass amplifier. If the 3.58 mc signal is not present, then there will be no color present on a color program. Black and white reception will be normal. With the complete loss of color, our attention is drawn to this circuit that must operate in order for the color to be present.

If the color is present, but is changing hue, and sometimes color bars drift across the screen, then the color sync circuit is at fault. This circuit is very similar to the afc networks found in the conventional black and white receivers, in fact troubleshooting procedures are the same.

BANDPASS AMPLIFIER AND COLOR KILLER

The bandpass amplifier must pass the band of frequencies that contain all of the color information. This covers a band from about 2 mc to 4 mc. If loss of color is noted on a color program, and the 3.58 mc oscillator has been checked, and found to be working, then an oscilloscope can be used to check the input and output of the bandpass amplifier. If there is no output, then either the amplifier circuit itself is defective, or the color killer is keeping the bandpass amplifier cut off. This can be easily checked by measuring the bias of the tube, if it is sufficient to cut off the amplifier, then the color killer circuit should be checked. The color killer circuit is itself controlled by the afc circuit that works on the 3.58 mc burst sent from the transmitter. If the burst is present, then the output of the afc controls the bias on the color killer and prevents it in turn from cutting off the bandpass amp. If there is no 3.58 mc burst, then color killer conducts and cuts off the bandpass amp.

DEMODULATORS AND AMPLIFIERS

With the signal from the bandpass amplifier, and the local 3.58 mc signal being applied to the demodulators, demodulation occurs and the output is a color signal, one representing the red, and the other representing the blue. These outputs are amplified to obtain the correct amounts of gain, and are now ready to go to the matrix. If one or the other demodulator is not working, then there will be an absence of color signal for that particular demodulator. This will produce color on a color program, but the color will be incorrect, and a definite absence of the red

or blue will be noted. Black and white operation will be normal, but colors will not be right. Once again the scope can be used to check for the output signals from each of the demodulators. If the demodulators are working, then the scope can follow the signal through the amplifiers until the loss of signal is noted.

MATRIX

All of the signals are combined in the matrix network and the resultant color signals are produced. Here is where green is obtained, and for that matter, any combination of red, green, and blue. Actually, the matrix consists of a number of resistors that have a common load resistor. Each signal is channeled into one of the resistors, and the resultant signal is present across the common resistor. Once this signal is obtained, it is passed to an amplifier that is sometimes called an "adder", and finally to the color gun of the CRT. All color receivers use a DC restorer, this will be found in each grid circuit of the CRT. Troubles in the matrix will show up on both a color show, and a black and white. For example, if one of the matrix networks is not working correctly, then the black and white program will have some color present. However, the raster, if observed on an off channel, will be normal black and white unless the DC restorers are upsetting the bias on the CRT. On a color show, the color will be incorrect. This may be best noted if the normal flesh tone of the people is not obtainable.

TRI COLOR CRT

The picture tube for a color receiver, consists of a three gun structure that provides three electron beams. Each beam is supposed to hit its respective color phosphor on the screen. The screen itself contains hundreds of thousands of phosphor dots for each of the colors, namely red, green, and blue. When all of the red dots are hit, and the others are not, then the screen will be all red, the same goes for the blue and the green. If all of the color dots are struck with their correct beams, the screen appears as white. This is an optical illusion, because if you were to take a magnifying glass and watch any part of the screen, you would notice that there is no white, only red, green, and blue. Troubles in the CRT will affect the raster whether it is on or off a channel. If, for example, the green gun is not working, then there will be no green in a color program, which will be quite obvious, as on a black and white program you will be seeing a magenta or reddish blue picture. Even off channel the raster will be magenta. Adjustment of the green gun of the CRT will not change the tint in the raster, and this will indicate that some trouble exists in the CRT.

CONVERGENCE

Special attention is given to this section of the color receiver even though it is part of the adjustment of the CRT. The problem is to make sure that each of the color gun electron beams hits its correct color phosphor. If the blue beam were to hit the red phosphor dots, then incorrect color would occur, and even a raster will have color tinges. In order to make sure that the beams do their job, special circuits produce waveshapes that influence the electron beam for each color as it sweeps across the screen. This must include up and down movement as well as sideward motion. This part of the color receiver is the convergence section, and if convergence is poor, then color will be noticed at points on the screen.

The most affected by poor convergence are the outer edges. Look at these on a black and white show. If severe color tinging is occurring, then check the convergence of the set. Even the best receivers have some color showing at the extreme edges, however, a small amount can be tolerated because at normal viewing distance it is not apparent.

This completes our discussion of the color receiver. Always read over the troubleshooting digest found in every chart, before you begin the repair. You will find this an aid in understanding the condition itself.

1 Adjust fine tuning control. This setting is very critical.

2

2 Replace the 3.58 mc osc tube, and any tubes that are associated with 3.58 mc osc.

3

3 Replace the bandpass amplifier and color killer.

4

4 Disable color killer circuit. If separate tube is used remove it.

5

5 If color signal now on screen check color killer circuit voltages.

6

6 If no color when killer disabled, check video with scope at bandpass amp.

7

7 If no video at plate of bandpass amp, check voltages and resistance of circuit.

IF COLOR IS MISSING ON ALL CHANNELS THAT ARE PRODUCING A COLOR PROGRAM, THEN TROUBLE IN THE COLOR SECTION SHOULD BE SUSPECTED. IF COLOR IS MISSING ON ONLY ONE CHANNEL THOUGH, THEN CHECK COLOR CHART NO. 6. THIS TROUBLE IS CAUSED BY EITHER THE COLOR KILLER CIRCUIT OR SOME DEFECT IN THE DEMODULATOR SYSTEM, OR THE BANDPASS AMPLIFIER.



NO COLOR SYMPTOM

WITH A BLACK AND WHITE SIGNAL ON A COLOR CHANNEL IT WOULD APPEAR AS THOUGH THE COLOR KILLER IS PREVENTING THE COLOR CIRCUITS FROM RECEIVING THE SIGNAL TO THE CRT, OR THAT THE DEMODULATORS ARE NOT PRODUCING THE OUTPUT THAT WOULD CAUSE THE COLOR SYSTEM TO WORK. WITH THIS TROUBLE, ALL OF THE DEMODULATORS ARE OUT OF OPERATION. ANOTHER POSSIBILITY IS THAT THE BANDPASS AMPLIFIER IS NOT WORKING, WHICH WOULD PREVENT ANY COLOR FROM GETTING TO THE CRT.

8 If video is present at output of bandpass amp, then trouble is in 3.58 mc osc.

9

9 Use scope to see if 3.58 mc osc is working. If not check voltages.

10

10 If osc okay, follow 3.58 mc signal with scope.

11

11 Be sure to use a color scope in order to see 3.58 mc signal.

12

12 Trouble must be between 3.58 mc osc and demod's.

13

13 Some color sets require color burst to start 3.58mc osc.

14

14 In this case be sure burst amp is passing burst to 3.58 mc osc.

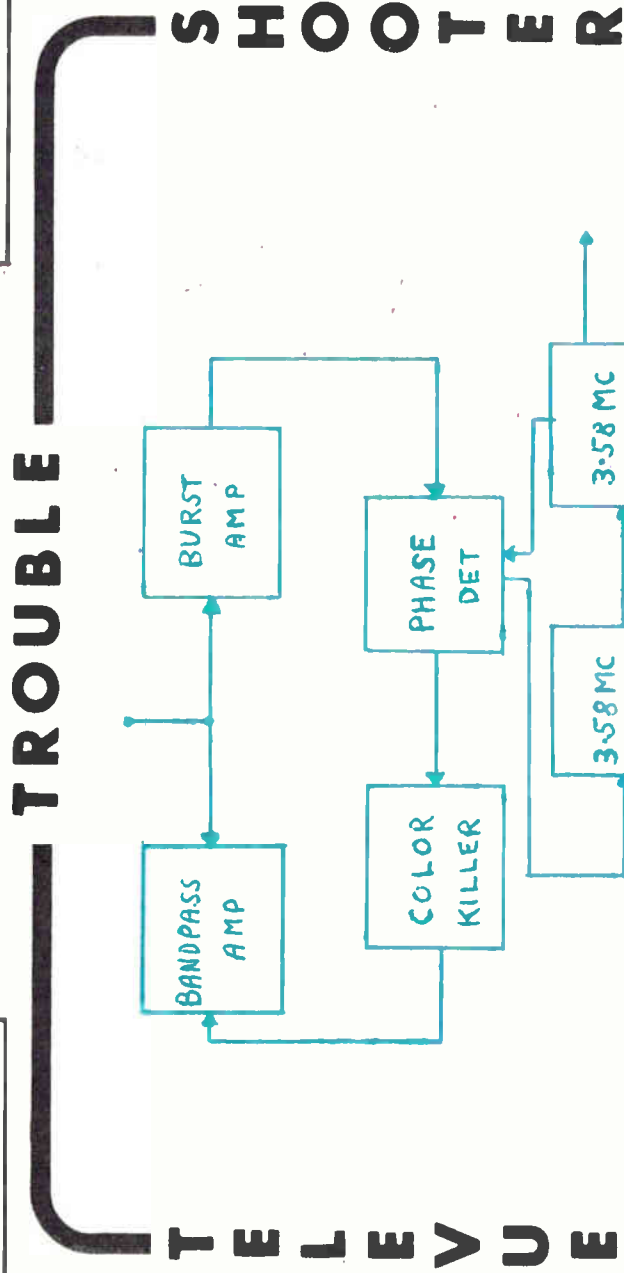

DIGEST (A)

1

First determine if red gun is bad.

2

Adjust green and blue screen controls off until red left.

3

If screen is red then red gun okay.

4

If screen is black then red gun is bad.

5

Check the filaments for an open. If open, try soldering filament pins.

6

Check cathode, grid, and screen, for an open or short.

7

If all voltages are normal, and filaments light, replace CRT.



DIGEST (B)

8

If red gun ok then red signal not getting to CRT.

9

If an I and Q set, check red adder and red output tubes.

10

If R-Y, B-Y set check R-Y demodulator and amplifier tubes.

11

Use scope to follow red signal from demodulators.

12

Move scope from grid to plate of each tube in red circuit.

13

At point where signal is lost take I- and R checks.

14

Trouble must be in red signal circuit.

THE COMBINATION OF RED, BLUE AND GREEN SIGNALS FORM THE BLACK AND WHITE PORTION OF THE PICTURE. IF ANY ONE OF THESE SIGNALS IS MISSING, CORRECT COLOR RENDITION WILL NOT BE OBTAINED. IF THE COLOR GUN IS DEFECTIVE THEN NOT ONLY WILL THE COLOR BE AFFECTED, BUT THE BLACK AND WHITE SIGNAL ALSO. IF THE COLOR SIGNAL ONLY IS MISSING, THEN BLACK AND WHITE OPERATION WILL BE UNAFFECTED.

NO RED IN PICTURE

SYMPTOM

TROUBLE

TELEVISION

SHOOTER

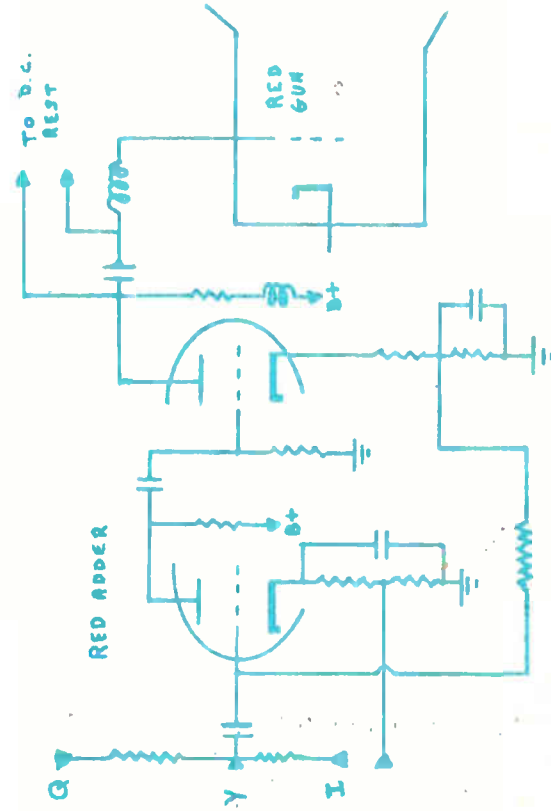

1 First determine if the blue gun is operating.

2

Adjust the red and green screen controls until only blue left.

3

If screen is all blue then blue gun OK.

4

If screen is black then blue gun is inoperative.

5

Check the filaments for an open. If open try soldering filament pins.

6

Check cathode, grid, and screen, for an open or a short.

7

If all voltages are normal, and filaments light, replace CRT.

LOSS OF BLUE IN THE COLOR SIGNAL CAN BE CAUSED BY TROUBLES SIMILAR TO THAT FOUND IN LOSS OF RED OR GREEN COLOR. THAT IS A DEFECT IN THE BLUE GUN OF THE CRT OR POSSIBLY SOME TROUBLE IN THE BLUE SIGNAL CIRCUIT. ONCE AGAIN A BLACK AND WHITE RASTER WILL NOT BE POSSIBLE IF THE TROUBLE IS IN THE BLUE GUN.



NO BLUE IN PICTURE

SYMPTOM

IT IS THE COMBINATION OF ALL THREE GUNS OF THE CRT THAT PRODUCE A BLACK AND WHITE RASTER. IF THE BLUE SCREEN IS INOPERATIVE THEN A BLACK AND WHITE RASTER WILL NOT BE OBTAINED. IF THE TROUBLE IS IN THE BLUE SIGNAL CIRCUIT THEN A NORMAL RASTER WILL BE POSSIBLE. LOSS OF THE BLUE SIGNAL CAN BE FOUND BY USE OF THE SCOPE.

8 If blue gun is ok then blue signal not getting to CRT.

9

In an I and Q set, check blue adder and amp tubes.

10

If R-Y, B-Y set, check demodulator and amp tubes.

11

Use scope to follow signal through blue circuits.

12

Start at the demodulators and move from grid to plate.

13

At point where loss of signal is found take E and R checks.

14

Trouble must be in the blue signal circuit if CRT is okay.

TELEVISION TROUBLE SHOOTER

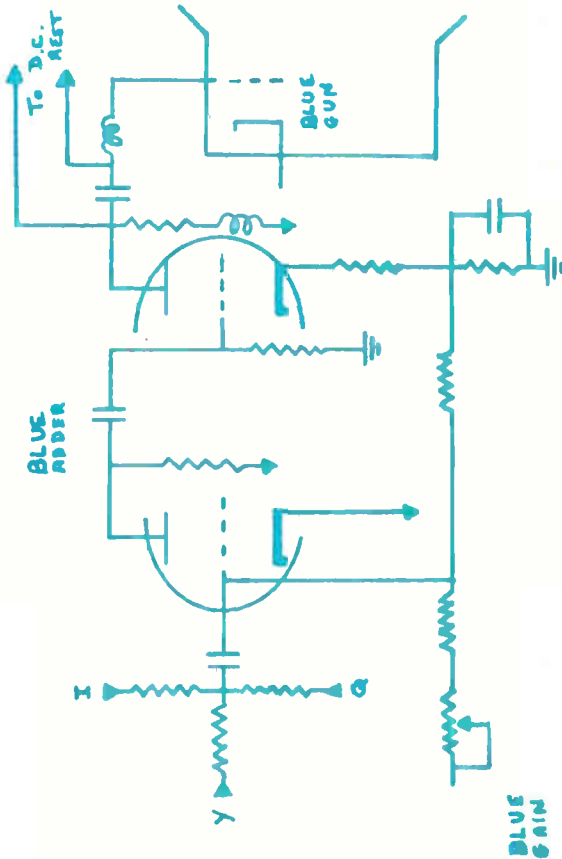

DIGEST (A)

1

2

3

4

5

6

7

LOSS OF GREEN IN THE PICTURE CAN BE CAUSED BY TROUBLES IN THE GREEN GUN OF THE CRT OR BY A TROUBLE IN THE GREEN SIGNAL CIRCUIT. SIMILAR TROUBLES CAN OCCUR FOR THE RED AND BLUE SYSTEMS TOO. IF THE GREEN GUN OF THE CRT IS BAD THEN A NORMAL BLACK AND WHITE RASTER WILL NOT BE POSSIBLE. IF THE GREEN SIGNAL CIRCUITS ARE DEFECTIVE THEN THE BLACK AND WHITE RASTER WILL BE NORMAL BUT COLOR OPERATION WILL BE AFFECTED.

DIGEST (B)

8

9

10

11

12

13

14

ALL THREE ELECTRON BEAMS ARE NECESSARY IN ORDER TO PRODUCE A BLACK AND WHITE RASTER. IF ANY OF THE THREE GUNS ARE NOT OPERATING THEN A NORMAL BLACK AND WHITE RASTER WILL NOT BE POSSIBLE. WITH THIS TROUBLE IF A NORMAL RASTER IS OBTAINED THEN THE TROUBLE MUST BE IN THE GREEN SIGNAL CIRCUITS.



NO GREEN IN PICTURE

• SYMPTOM •

TROUBLE

SHOOTER

TELEVIEW

1 With this symptom on the screen it is a bad tube.

2

Locate the section with the bad tube as follows.

3

If bars are black, or gray and white on raster, check video amp.

4

If bars come only with pix, check I.F.R.F. or det tubes.

5

If bars are colored on B & W picture, check demods and color amps.

6

The above will appear as color even on raster only.

7

If bars appear only on a color show, check band-pass amp.



60 CYCLE HUM BAR SYMPTOM

A HEATER TO CATHODE SHORT OR LEAK IN ANY OF THE TUBES OF COLOR CIRCUITS WILL PRODUCE A 60 CYCLE HUMBAR THAT WILL APPEAR ON THE SCREEN. THE REASON FOR THIS IS THAT THE 60 CYCLE LEAKAGE TO THE CATHODE PRODUCES A VARYING VOLTAGE AT THE CATHODE WHICH WILL MIX WITH THE SIGNAL THAT THE TUBE IS PASSING.

8 After determining bad section replace tubes.

9

If in doubt about bad section do as follows.

10

Replace all I.F., R.F., det, video, and color tubes.

11

Trouble might also be the CRT.

12

If you suspect CRT check from filaments to cathode for leakage.

13

14

TELEVISION TROUBLE SHOOTER

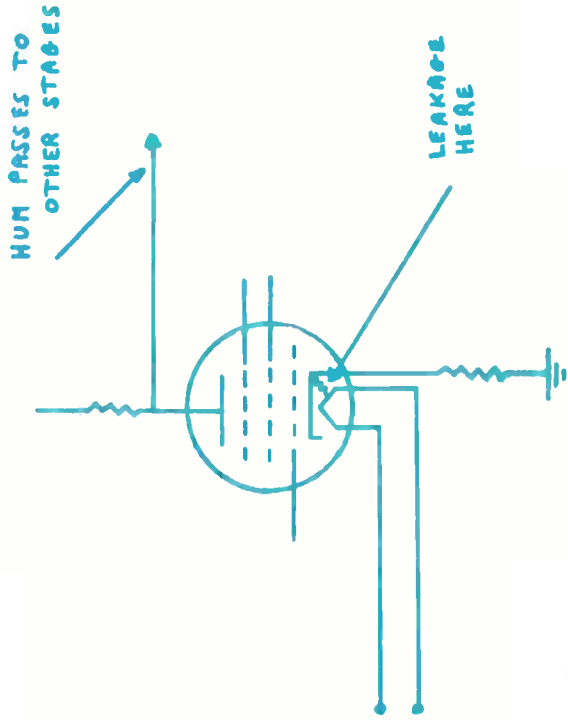

DIGEST (A)

1

Check other channels to be sure that reception is ok.

2

If only one channel has no color when it should check below.

3

Check lead in wire to set. May be broken

4

Check orientation of antenna. This is critical.

5

Do this by moving antenna slowly and check channel.

6

If antenna doesn't help, check local oscillator.

7

Replace oscillator tube.

IF A COLOR RECEIVER IS PRODUCING A COLOR PROGRAM ON ALL COLOR CHANNELS EXCEPT ONE, IT INDICATES THAT THE ENTIRE COLOR SECTION IS IN WORKING CONDITION BUT THAT THE COLOR FOR THE PARTICULAR CHANNEL IN QUESTION IS NOT GETTING TO THE COLOR SECTION OF THE COLOR RECEIVER.



NO COLOR ON ONE CHANNEL

SYMPTOM

TROUBLE

TELEVIEW

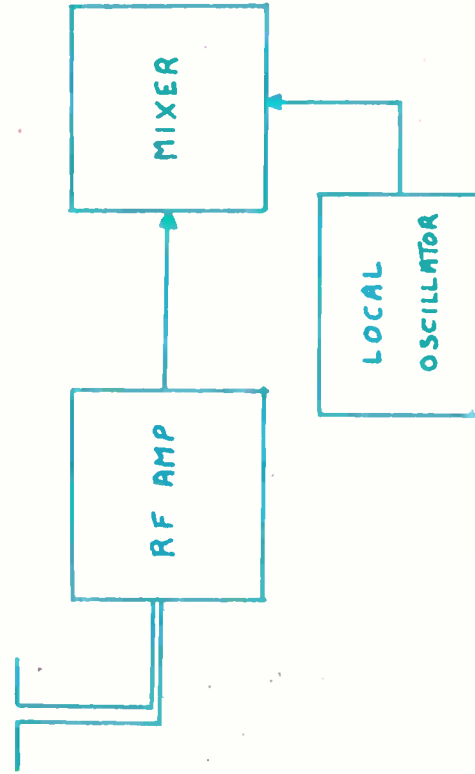

SHOOTER

DIGEST (B)

THIS CONDITION MUST BE DUE TO SOME TROUBLE IN THE FRONT END OR IN THE ANTENNA ITSELF. THE CORRECT LOCATION OF THE ANTENNA IS VERY IMPORTANT IN COLOR RECEIVERS AND SHOULD BE CHECKED IF THIS TROUBLE OCCURS. MOST LIKELY HOWEVER THE FRONT END OF THE COLOR SET IS OUT OF ALIGNMENT RESULTING IN THE 3.58mc SIGNAL NOT PASSING TO THE I.F.s.

8

Adjust local oscillator screw of bad channel.

9

If standard coil tuner, replace channel strip.

10

On additive type tuner, align front end.

11

Use manufacturers notes on front end alignment.

12

If all of the above fails to help, replace antenna.

13

[Empty box]

14

[Empty box]

1 Replace the following tubes.

2 RF, IF, Video amp. Bandpass amp, Demodulators, Demod Amps.

3 Connect signal generator or color bar generator to grid of 1st video amp.

4 Observe output of video amp on scope. Should be larger than input.

5 If stage not amplifying, take E and R measurements.

6 If Video amp normal, check bandpass amp output on scope.

7 If output poor, check E and R of this stage. Check bias from color killer.

WITH WEAK COLORS ON ALL CHANNELS THAT ARE PRODUCING A COLOR SIGNAL, THE TROUBLE MAY BE IN THE COLOR CHANNEL OF THE RECEIVER, OR LOW AMPLIFICATION IN THE RF OR IF AMPLIFIERS. A WEAK BLACK AND WHITE PICTURE ALONG WITH THIS TROUBLE WOULD INDICATE POOR AMPLIFICATION COMMON TO BOTH COLOR AND BLACK AND WHITE.
NOTE: IF SIGNAL GEN IS USED IN CHECK 3, A SIGNAL AROUND 3.5 MC SHOULD BE USED.



WEAK COLOR

SYMPTOM

IF THE COLOR SUBCARRIER SIGNAL IS NOT AMPLIFIED MUCH BY THE RF AND IF AMPLIFIERS, THEN THE COLOR SECTION OF THE RECEIVER WILL NOT PRODUCE THE CORRECT AMPLITUDE SIGNAL FOR STRONG COLOR REPRODUCTION. ANOTHER POSSIBLE CAUSE IS THE POOR OPERATION OF THE FIRST VIDEO AMPLIFIER, BANDPASS AMPLIFIER, COLOR DEMODULATORS OR DEMOD AMPLIFIERS.

8 If bandpass amp okay, check operation of demodulators.

9 With normal operation of demods, check demod amplifiers.

10 The above checks should show an increase through each stage.

11 If all the above check okay, then check alignment of IF and RF.

12 Use manufacturers note for alignment check.

13 If alignment okay, try antenna adjustment.

14

TROUBLE

TELEVISION

SHOOTER

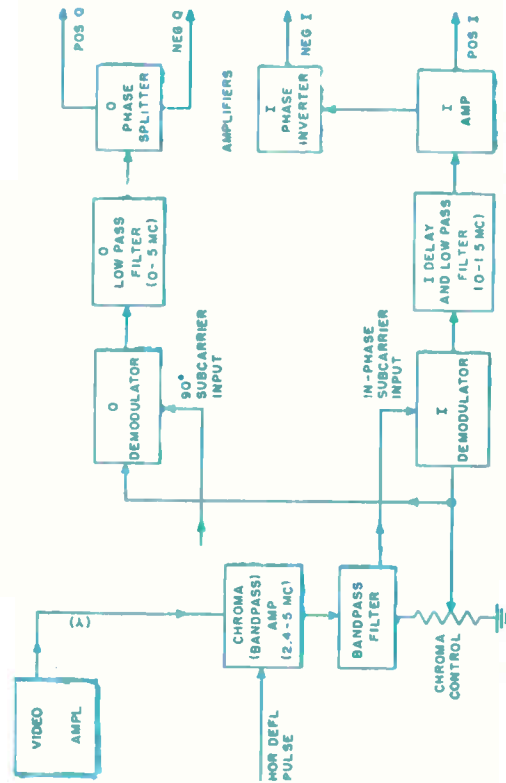

DIGEST (A)

1

Reject the following tubes.

2

Burst gate and amp. AFC tube. Reactance tube 3.58 mc osc.

3

Adjust the 3.58 mc frequency control.

4

If pix locks in for a moment, trouble in AFC system.

5

If pix will not lock in, trouble in 3.58 mc osc.

6

If AFC defective, check for color burst input from burst amp.

7

If no output from color burst, check burst gate and amplifier.

DIGEST (B)

8

If burst is present, check afc circuit and reactance circuit.

9

Output of afc should vary as 3.58 mc osc control is adjusted.

10

If trouble in 3.58 mc osc, check voltage applied to tube.

11

Take resistance checks of 3.58 mc osc.

12

If all appear normal, replace capacitors in osc circuit.

13

If none of the above help, replace osc transformer or 3.58 mc crystal.

14



NO COLOR SYNC

SYMPTOM

TROUBLE

SHOOTER

TELEVIEW

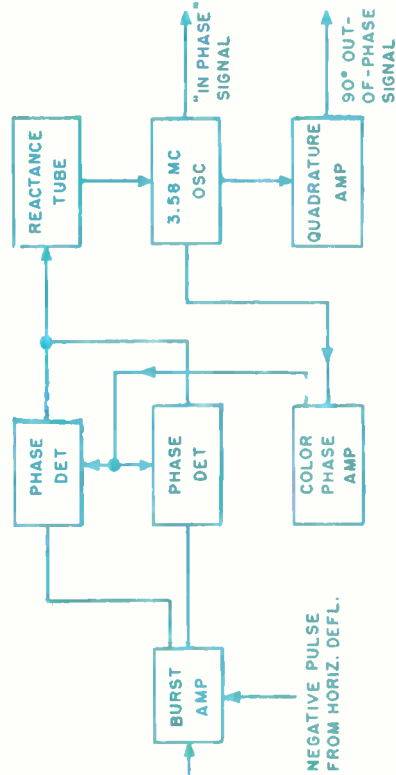

1 If poor convergence is noted, follow the procedure below.

2 Connect a dot generator to the color receiver.

3 Obtain a uniform pattern of dots on screen.

4 Adjust the static convergence controls.

5 These controls adjust the center dots.

6 Make adjustments until center dots appear as single dots.

7 Locate the dynamic vertical adjustment controls.

IF SOME COLOR IS NOTICED ON A BLACK AND WHITE PROGRAM THE CHANCES ARE THAT THE RECEIVER IS OUT OF CONVERGENCE. THIS CAN BE CAUSED BY ANY OF THE CONVERGENCE ADJUSTMENTS, OR BY A DEFECTIVE CRT. HOWEVER MOST OF THE CRTs ARE CAREFULLY CHECKED AT THE FACTORY AND WE MUST ASSUME THAT IT IS THE CONVERGENCE THAT IS AT FAULT.



COLOR IN B & W PIX

• SYMPTOM •

IN ORDER FOR THE CONVERGENCE TO BE CORRECT, IT IS NECESSARY TO HAVE ALL OF THE THREE BEAMS OF THE CRT MEET AT THE SAME POINT ALL OVER THE FACE OF THE CRT. IN ORDER TO CONVERGE THESE THREE BEAMS IT IS NECESSARY TO USE A DOT GENERATOR OR A CROSS HATCH GENERATOR. IN ALL CASES OF CONVERGENCE IT IS RECOMMENDED THAT MANUFACTURERS SPECIFICATIONS BE FOLLOWED.

8 Adjust these controls until the vertical dots at top and bottom are one.

9 Locate the horizontal dynamic controls.

10 Adjust these until dots on either side are one.

11 The dynamic controls affect the static convergence.

12 Recheck and adjust static controls if necessary.

13 Be sure that purity adjustments are okay before converging.

14 If convergence notes are available for set, use them.

TROUBLE

SHOOTER

TELEVIEW

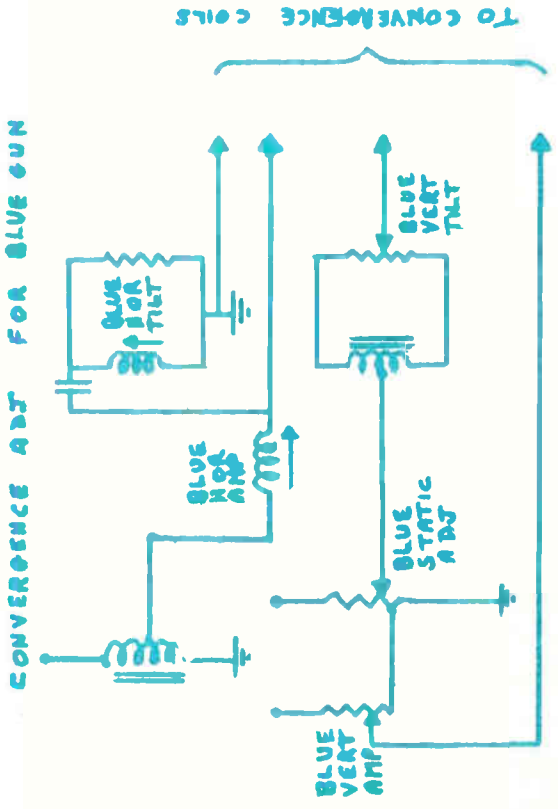

1

Switch to an odd channel and observe raster.

2

If raster has red tint, adjust red screen for B & W raster.

3

If black and white raster unobtainable, check guns of CRT.

4

If raster had red tint but now is B & W, set will operate normally.

5

If raster was normal, trouble must be in red signal circuit.

6

Replace all tubes in red signal circuit.

7

In I and Q sets, replace red adder and red DC restorer.

DIGEST (A)

IF TOO MUCH RED IS NOTICED IN THE PICTURE IT IS A GOOD IDEA TO CHECK FOR A NORMAL BLACK AND WHITE RASTER FIRST. IF THE RASTER HAS A REDDISH TINT TO IT THEN THE TROUBLE IS IN THE CRT ADJUSTMENTS. IF THE RASTER APPEARS NORMAL THEN THE TROUBLE MUST BE IN THE RED COLOR SIGNAL CIRCUITS.



TOO MUCH RED

SYMPTOM

DIGEST (B)

IN ORDER TO OBTAIN A BLACK AND WHITE RASTER ON A COLOR RECEIVER, THE THREE GUNS OF THE CRT MUST STRIKE THE COLORED PHOSPHOR SCREEN WITH JUST THE CORRECT AMOUNT OF FORCE TO PRODUCE WHITE. IF THE RED ELECTRON BEAM IS STRIKING WITH MORE FORCE THAN THE OTHER TWO, THE SCREEN WILL HAVE A RED TINT. AT THE SAME TIME, IF THE RED COLOR SIGNAL IS LARGER THAN IT SHOULD BE, THERE WILL BE TOO MUCH RED IN SIGNAL.

8

In R-Y, B-Y sets replace demods and amplifiers.

9

If tubes okay, take voltage checks of red stages.

10

Check for possible decrease in plate load resistors.

11

Follow signal through red color stages with scope.

12

Look for excessive gain in any of the red stages.

13

The red color stage does not have a red gain control.

14

TROUBLE

SHOOTER

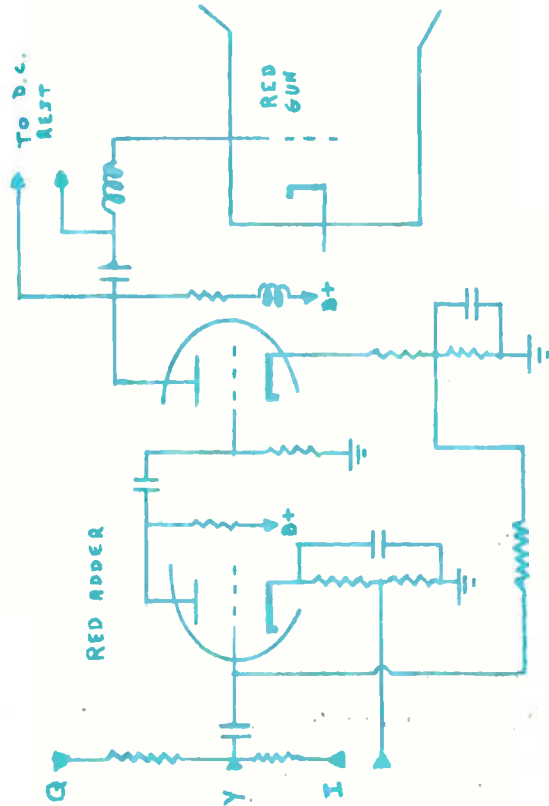

TELEVIEW

1 Switch to an off channel and observe raster.

2 If raster is bluish, adjust blue gun of CRT, for B & W Raster.

3 If B & W raster is unobtainable, check guns of CRT.

4 If a B & W raster is obtained now after adjusting, check picture.

5 If color now normal, set ok.

6 If B & W raster was normal, trouble must be in blue circuit.

7 Replace all tubes in blue signal circuit.

WITH THIS PARTICULAR TROUBLE, THE BLUE CIRCUITS ARE NOT OPERATING CORRECTLY. THIS COULD BE DUE TO THE GUN OF THE CRT, OR THE BLUE SIGNAL CIRCUITS. IN ORDER TO DETERMINE WHICH SECTION IS AT FAULT, CHECK FOR A GOOD BLACK AND WHITE RASTER. IF THE RASTER HAS A BLuish TINT TO IT, THEN ONLY CRT ADJUSTMENTS ARE NECESSARY.



TOO MUCH BLUE

• SYMPTOM •

WHEN ALL THREE BEAMS OF THE CRT ARE ADJUSTED CORRECTLY, THEY STRIKE THEIR RESPECTIVE PHOSPHOR DOTS WITH JUST THE RIGHT INTENSITY TO PRODUCE A BLACK AND WHITE RASTER. IF THE BLUE GUN CIRCUIT IS MISADJUSTED, THE BLUE PHOSPHOR WILL GLOW BRIGHTER THAN THE RED OR GREEN AND AN INCORRECT HUE WILL BE PRESENT. IF THE BLUE SIGNAL IS TOO STRONG, THE SAME CONDITION WILL RESULT.

8 In I and Y sets, replace adder, output, and restorer tubes.

9 In R-Y, B-Y sets, replace demodulators and amps.

10 Adjust the blue gain control for normal blue on color show.

11 If gain control has little or no effect, take voltage checks.

12 Check for a decrease in plate load resistors.

13 Use scope to follow blue signal to CRT.

14 Look for too much gain in blue signal.

TELEVISION TROUBLE SHOOTER

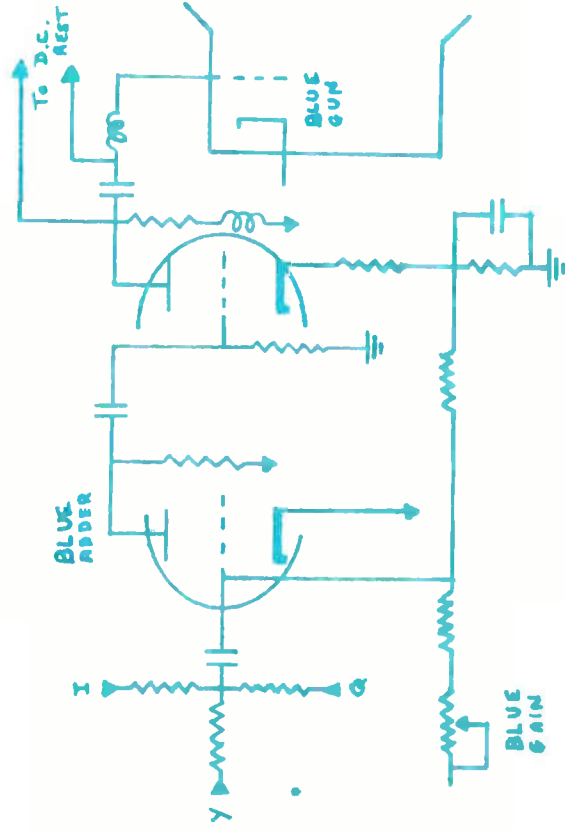

THIS TROUBLE IS THE SAME AS TOO MUCH BLUE. THE CAUSE MUST BE EITHER IN THE GREEN GUN OF THE CRT, OR IN THE GREEN SIGNAL PATH. IN ORDER TO CHECK TO SEE IF THE TROUBLE IS IN THE GREEN GUN OF THE CRT, IT IS ONLY NECESSARY TO CHECK THE RASTER ON AN OFF CHANNEL. IF THE RASTER APPEARS AS A NORMAL, BLACK AND WHITE ONE, THEN IT MUST BE THE GREEN SIGNAL CIRCUIT THAT IS AT FAULT.

1 Switch to an off channel and observe raster.

2 Raster should be B & W. If it has a green tint, adjust green gun.

3 If adjustments bring raster to B & W, then set is now ok.

4 If raster cannot be adjusted to B & W, check all guns of CRT.

5 If raster was a normal B & W, then trouble in green circuit.

6 Replace all tubes in green signal circuit.

7 In I and Q sets, check adder, output, and restorer tubes.



TOO MUCH GREEN
● SYMPTOM ●

WITH A NORMAL BLACK AND WHITE RASTER ON THE SCREEN IT MEANS THAT ALL THREE COLOR BEAMS ARE STRIKING THE PHOSPHOR WITH THE CORRECT AMOUNT OF INTENSITY AND THAT THIS TROUBLE OF TOO MUCH GREEN IN THE COLOR PICTURE IS DUE TO THE GREEN SIGNAL BEING TOO STRONG. THIS CAN BE DUE TO MISADJUSTMENT OF THE GREEN GAIN CONTROL, OR SOME TROUBLE IN THE GREEN CIRCUITS.

8 In R-Y and B-Y sets, check demods and amps.

9 If tubes okay trouble in circuit. Adjust green gain.

10 Gain should be adjusted on a color show for normal color picture.

11 Check voltages in green signal circuit.

12 Take resistance checks in green circuits. Check plate load resistors.

13 Use scope to follow signal from demods to CRT.

14 Watch for excessive gain of signal.

TROUBLE SHOOTER

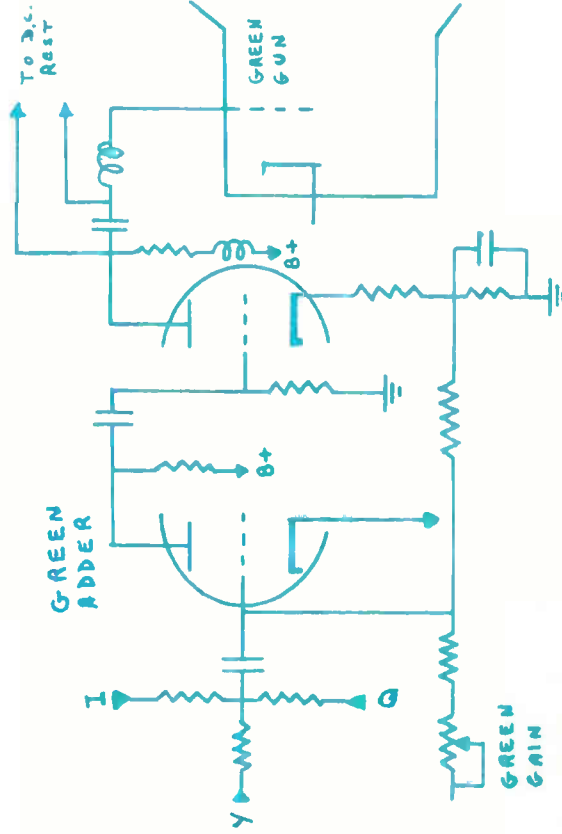

1

If flesh tones are not present, adjust fine tuning.

2

If this does not help, adjust hue control.

3

Hue control should be at its center when flesh tones present.

4

If hue control set to one side for flesh tones, adjust 3.58mc osc.

5

When adjusting 3.58mc osc, follow manufacturers instructions for set.

6

If hue control does not bring in correct color, check color CKT.

7

Replace all color tubes and readjust controls as above.

8

9

WHEN OBSERVING A COLOR PROGRAM ONE OF THE BEST WAYS TO TELL IF THE CORRECT COLORS ARE PRESENT IS TO OBSERVE THE FLESH TONES IN THE PICTURE. IF THESE ARE NOT CORRECT THEN THE SET IS NOT ADJUSTED FOR CORRECT COLOR REPRODUCTION. ONE OF THE FIRST THINGS TO DO IS TO MAKE THE ADJUSTMENTS THAT WILL CHANGE THE COLORS.



INCORRECT COLORS

• SYMPTOM •

8

Check output of demods with scope.

9

If color show not on the air, use color bar gen.

10

If output of demods appears normal, follow signal to next tube.

11

If output of demods is missing, check 3.58mc osc circuit.

12

In I and Q sets, check adders and adder amps.

13

In R-Y, B-Y sets check R-Y, B-Y, and G-Y amps.

14

Use color bar gen to check for correct operation of color ckts.

TELEVISION TROUBLE SHOOTER

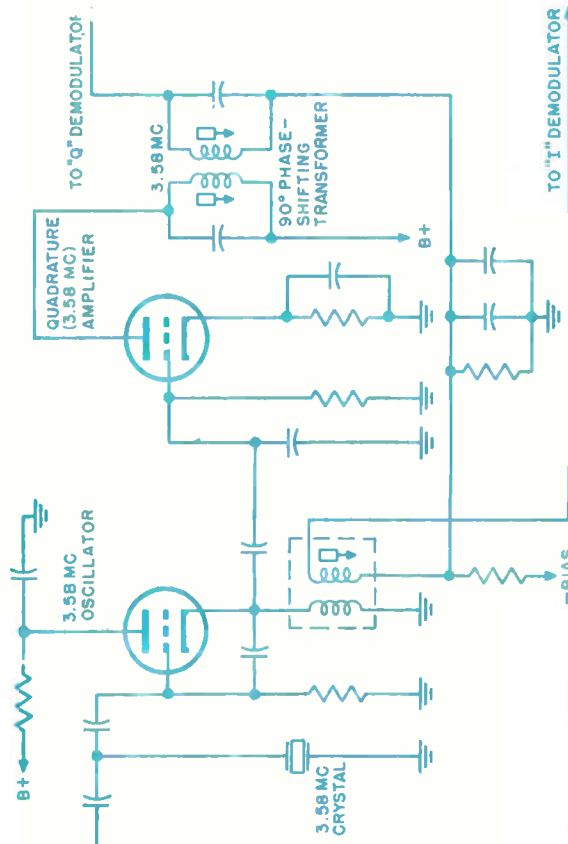

If picture remains on screen, and only colors fade, check color tubes.

If complete pix fades check RF, IF, Det, and video amp tubes.

If detector is a crystal, replace it.

If only color fades check output of demods with scope.

If output of demods comes and goes, check demod and 3.58mc osc circuits.

Use soldering iron held close to components to bring on defect.

If output of demods remains stable, follow signal to next tube.

Use same method as in demods to check for defective part.

Follow signal from tube to tube on scope until output comes and goes.

Once isolated to defective stage, use hot iron method.

If complete pix fades, check output of det with scope.

If output changes, check RF, IF, and det stages for bad part.

If det output constant, follow signal through video amps.

When defective stage found, use hot iron method.



COLOR FADING

SYMPTOM

WHEN THE FILAMENTS OF A VACUUM TUBE ARE OPEN, SOMETIMES THE TWO ENDS TOUCH AND ONLY OPEN AGAIN AFTER THEY HEAT UP. SUCH A CONDITION COULD BE TAKING PLACE WITH THIS TROUBLE. VERY OFTEN TOO, A CAPACITOR WILL CHANGE VALUE AFTER IT HAS BEEN HEATED FOR SOME TIME. OF COURSE IT IS ALSO POSSIBLE THAT ANY PART CAN BECOME INTERMITTENT.

TROUBLE

TELEVISION

SHOOTER

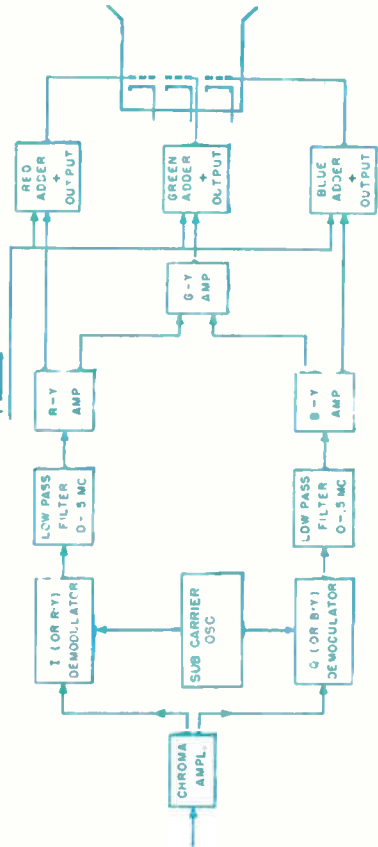

1

Some blooming is normal if contrast or brightness adj. too far.

2

If blooming present with slight adj. of control, replace HV regulator tube.

3

Check HV with HV probe, move controls as you check HV.

4

If HV increases as controls varied, check regulator circuit.

5

May have poor connection on cap lead to HV regulator.

6

Some sets have HV regulation adjustment. Check for this.

7

If HV measured low, trouble in HV circuit and not regulator.

GES (A)

THIS TROUBLE IS USUALLY ASSOCIATED WITH THE HIGH VOLTAGE SECTION OF THE RECEIVER. IN COLOR TELEVISION SETS, THE HIGH VOLTAGE IS REGULATED SO AS TO PROVIDE A CONSTANT VALUE OF VOLTAGE TO THE COLOR CRT. IF THE REGULATION IS NOT WORKING, THEN BLOOMING, POOR FOCUS, AND WRONG COLORS WILL ALL BE PRESENT WHEN THE CONTRAST AND BRIGHTNESS CONTROLS ARE ADJUSTED.



BLOOMING AND POOR FOCUS
• SYMPTOM •

dic (B)

WHEN THE CONTRAST OR BRIGHTNESS CONTROL ARE ADJUSTED, THE BEAM CURRENT OF THE CRT IS VARIED. WITH HIGH VOLTAGE REGULATION HOWEVER, THESE CURRENT VARIATIONS DO NOT CHANGE THE HIGH VOLTAGE UNLESS THESE CONTROLS ARE ADJUSTED TOO FAR. THEN EVEN WITH THE REGULATION SOME BLOOMING AND POOR FOCUS WILL RESULT. WITHOUT THE REGULATION EVEN THE SLIGHTEST ADJUSTMENT OF THESE CONTROLS WILL UPSET THE PICTURE.

8

Replace all tubes in HV section. Also, low voltage rectifier.

9

Change HV rectifier, horizontal output, and horizontal osc.

10

If none of above help, check for correct peak to peak at hor. output

11

If normal here, check any resistors in HV rect circuit.

12

Replace HV capacitors. If doubler used check for doubling action

13

If all appear normal, replace horizontal output trans.

14

TROUBLE

TELEVISION

SHOOTER

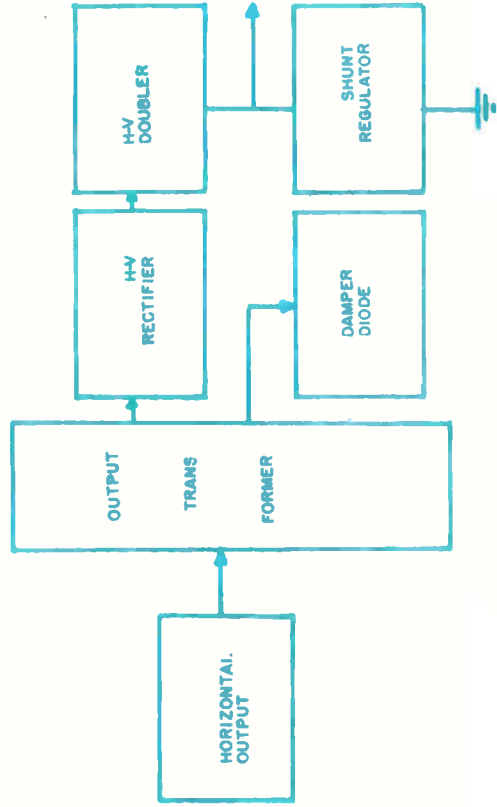

1

Replace the HV rectifier, HV regulator, and focus tubes.

2

Check for correct lead dress on flyback and CRT lead.

3

Lead to CRT may be making poor contact.

4

Check adjustment of HV control. Be sure it is set correctly.

5

Clean all dust and dirt from HV rectifier socket and flyback.

6

If resistors are used in lead to CRT, check them for open.

7

Check filter capacitor at HV rectifier base for defect.

DIGEST (A)

IN COLOR TELEVISION RECEIVERS THE HIGH VOLTAGE IS MORE ADAPT TO ARC OVER THAN IN BLACK AND WHITE RECEIVERS. THIS IS DUE TO THE AMOUNT OF HIGH VOLTAGE USED IN COLOR SETS. THE LOWEST AMOUNT THAT HAS BEEN USED IN SOME OF THE EARLY 15" SETS WAS AROUND 21KV. TODAY 21" COLOR RECEIVERS ARE USING 25KV.



HV ARCING

SYMPTOM

DIGEST (B)

WITH A LARGE AMOUNT OF HIGH VOLTAGE, THE ARCING CAN BE TAKING PLACE IN THE FLYBACK TRANSFORMER, OR IN THE HIGH VOLTAGE LEAD TO THE CRT. IF THE ARC IS IN THE FLYBACK IT WILL USUALLY SOUND LIKE SIZZLING BECAUSE IT IS A.C. IF THE ARC IS IN THE HIGH VOLTAGE LEAD TO THE CRT IT WILL PROBABLY SOUND LIKE A POPPING BECAUSE IT IS D.C.

8

Remove HV rectifier. If arcing continues, check flyback.

9

If arcing stops, check HV rectifier socket and lead to CRT.

10

Arcing may be occurring in yoke.

11

Switch set on in a dark room and see if you can find arc.

12

If in flyback, try HV insulating spray.

13

14

TELEVISION TROUBLE SHOOTER

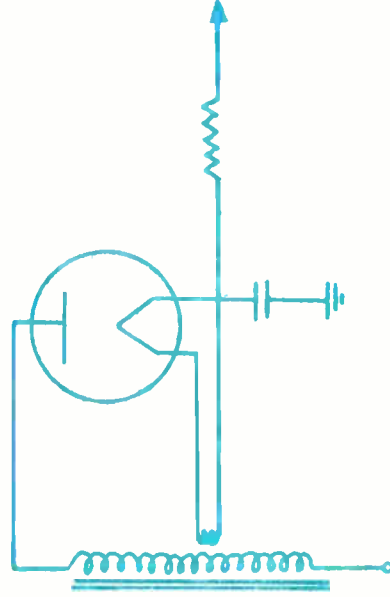

1

Check the adjustment of the killer control.

2

This control should remove colored snow on B & W program.

3

If it has no effect then replace killer tube.

4

Measure the voltage applied to killer control. Check for correct voltage.

5

Check cathode circuit of killer for an open.

6

Check plate circuit of killer for correct voltage.

7

Some killer circuits use pulse from horizontal output Xfmr.

DIGEST (A)

WHEN A BLACK AND WHITE PICTURE IS BEING TRANSMITTED THERE IS NO COLOR BURST ON THE BACK PORCH OF THE HORIZONTAL SYNC PULSE. WITH THIS PULSE MISSING, THE 3.58MC OSCILLATOR WILL NOT BE WORKING AND AS A RESULT THE COLOR KILLER CIRCUIT WILL CUT OFF THE BANDPASS AMPLIFIER. IF SOME TROUBLE DEVELOPES IN THE KILLER CIRCUIT, THEN COLOR INTERFERENCE WILL APPEAR DURING A BLACK AND WHITE SHOW.



COLOR SNOW IN B & W

SYMPTOM

DIGEST (B)

A KILLER ADJUSTMENT CONTROLS THE BIAS OF THE KILLER TUBE. THIS SHOULD BE SET SO THAT ON A BLACK AND WHITE SHOW, THERE IS NO COLOR COMING OUT OF THE COLOR CIRCUITS. IF THIS CONTROL IS SET WRONG OR IF THE KILLER CIRCUIT IS NOT WORKING, CORRECTLY, THEN SOME SIGNAL FROM THE COLOR CIRCUITS WILL BE APPLIED TO THE CRT ON A BLACK AND WHITE PROGRAM.

8

In these type of circuits, check at plate with scope.

9

Should have a horizontal positive pulse at plate.

10

May have open plate resistor in killer stage.

11

Trouble is that killer is not conducting on a B & W program.

12

13

14

TROUBLE

SHOOTER

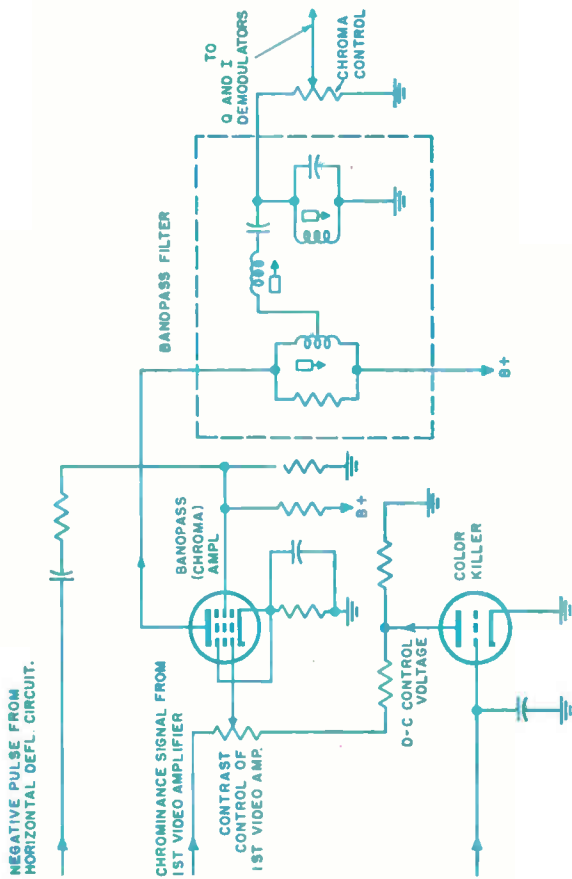

DIGEST (A)

1

If colors too vivid, check adjustment of color control.

2

Set this with minimum light falling on face of CRT.

3

If adjustment fails, to remedy trouble, replace bandpass amp tube.

4

Use scope at grid and plate of bandpass amp while adjusting color control.

5

If amplitude of signal does not change, check control circuit.

6

When using scope be sure that it is a wide band type for color TV.

7

If control does vary amplitude of signal, then check bias of band pass amp.



COLORS TOO VIVID
SYMPTOM

DIGEST (B)

THE POSITION OF THE COLOR CONTROL IN THE CIRCUIT WILL VARY SLIGHTLY FROM SET TO SET. HOWEVER THE FUNCTION OF THIS CONTROL IS THE SAME REGARDLESS. IF THIS IS SET TOO FAR THEN WE WILL HAVE TOO MUCH COLOR. IF THE SIGNAL GETTING TO THE DEMODULATORS IS TOO LARGE IT WILL ALSO CAUSE THIS SYMPTOM.

8

Control should vary bias of bandpass amp tube.

9

May have defective capacitor in bias for grid.

10

Some sets have control just before demodulators.

11

In this is the case, check control for open.

12

With this trouble, signal going to the demodulators is too large.

13

14

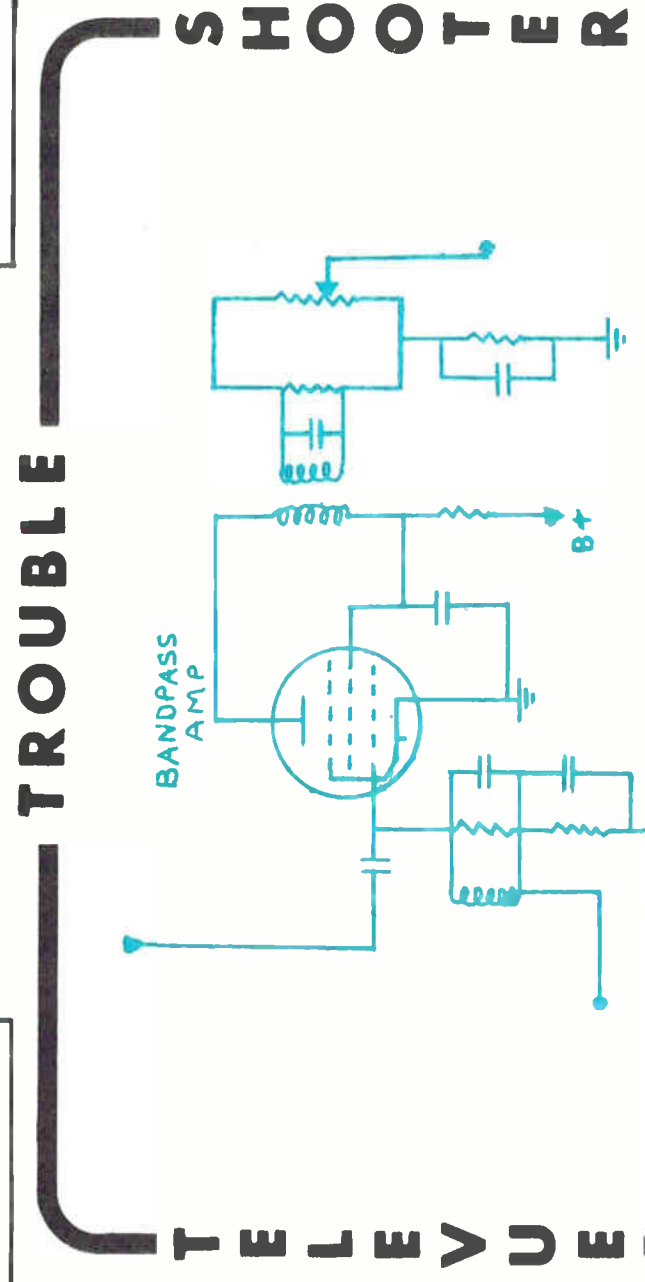

1 Tune in a channel and adjust controls for good picture.

2

Adjust purity if necessary as indicated on purity chart.

3

Connect dot or crosshatch generator to color set and obtain pattern.

4

Check convergence at center of screen, use magnifying glass if necessary.

5

Adjust static convergence controls to obtain convergence in center.

6

Adjust green and red vertical tilt and amplitude controls by observing one vertical line.

7

Converge vertical line with above controls and static controls.

WHEN THE COLOR PICTURE TUBE IS PRODUCING A BLACK AND WHITE PICTURE IT ACTUALLY IS PRESENTING THREE COLORED RASTERS THAT APPEAR AS ONE. THE SCREEN OF THE PICTURE TUBE IS COVERED WITH THOUSANDS OF COLOR PHOSPHOR DOTS THAT GLOW WHEN HIT BY AN ELECTRON BEAM. WHEN THE THREE COLORS ARE STUCK WITH ELECTRONS, THEY ARE SO CLOSE TOGETHER THAT IT APPEARS AS ONE COLOR, WHITE.

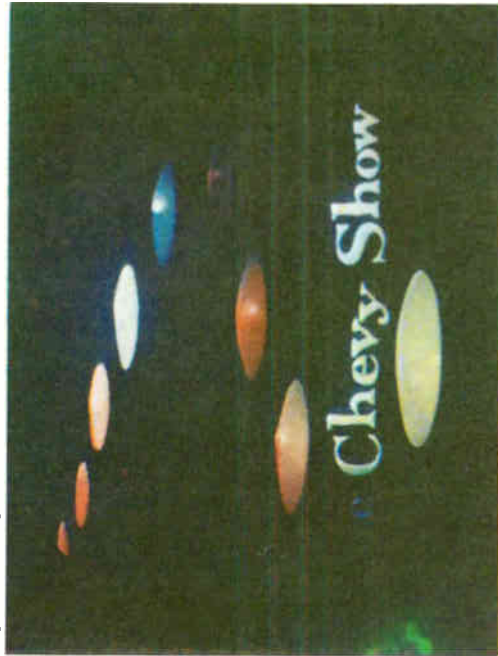

CONVERGENCE

• SYMPTOM •

THE PROBLEM OF CONVERGENCE, IS TO GET THE ELECTRON BEAM TO STRIKE THE CORRECT COLOR PHOSPHOR ALL OVER THE SCREEN. SINCE THERE ARE THREE BEAMS THE PROBLEM IS THREE FOLD. HOWEVER BY USING THE CORRECT WAVE-SHAPE TO DEFLECT THE BEAM, IT IS POSSIBLE TO OBTAIN GOOD RENDITION ALL OVER THE SCREEN. THE ORDER OF CONVERGENCE AS GIVEN BY THE MANUFACTURER SHOULD BE FOLLOWED IF DATA IS AVAILABLE.

8 Now adjust blue vertical tilt and amp for convergence of center section.

9

Adjust horizontal red and green tilt and amp while looking at center hor. line.

10

Adjust above until red, green, and blue are parallel.

11

Now adjust static controls to converge bars to one line.

12

These horizontal adjustments are to converge the vertical along horizontal center.

13

Final adjustment is blue tilt and amp. Set these by observing center hor. line.

14

It may be necessary to repeat some of the above for correct adj.

TROUBLE

SHOOTER

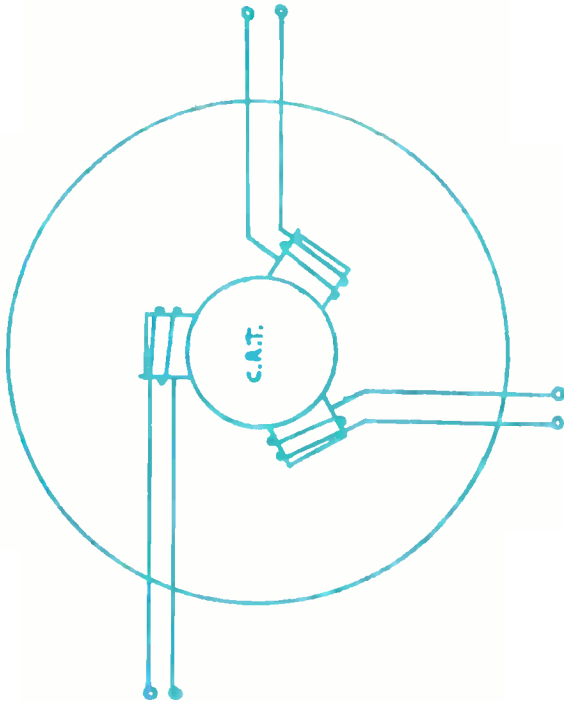

DIGEST (A)

1

Demagnetize the CRT by use of a degaussing coil as follows.

2

Move all rim magnets out, plug in coil and bring slowly toward screen.

3

Start about 6ft away. When at screen move around edges for about 1/2 min.

4

Use dot pen to adjust static convergence in center of CRT.

5

Turn down the contrast control, color or hue control and blue and green screen control.

6

Adjust the brightness control for clear red screen.

7

Loosen yoke, and center purity magnets over gap in gun structure.

DIGEST (B)

8

Move yoke back as far as it will go. Center of CRT should be red.

9

If center is not red, rotate purity magnets until red is in center.

10

Move yoke forward until as much of screen as possible is red.

11

Readjust purity magnets to get screen all red.

12

Continue to adjust yoke and purity magnets for good red.

13

If edges show some in purity, adjust rim magnets at impure point.

14

Check green and blue screen for purity. If necessary repeat above.

IN SETTING UP A COLOR SET FOR PURITY, THE BLACK AND WHITE ADJUSTMENTS MUST BE MADE FIRST. THIS INCLUDES WIDTH, HEIGHT, LINEARITY, HORIZONTAL AND VERTICAL ADJ. ETC. AFTER THIS HAS BEEN CHECKED, AND ITS A GOOD IDEA TO DO THIS ON A TEST PATTERN, YOU ARE THEN READY TO ADJUST PURITY. THE STEPS THAT SHOULD BE FOLLOWED MAY HAVE TO BE REPEATED UNTIL A PURE PATTERN IS OBTAINED.



PURITY ADJUSTMENTS

• SYMPTOM •

TROUBLE

SHOOTER

TELEVIEW

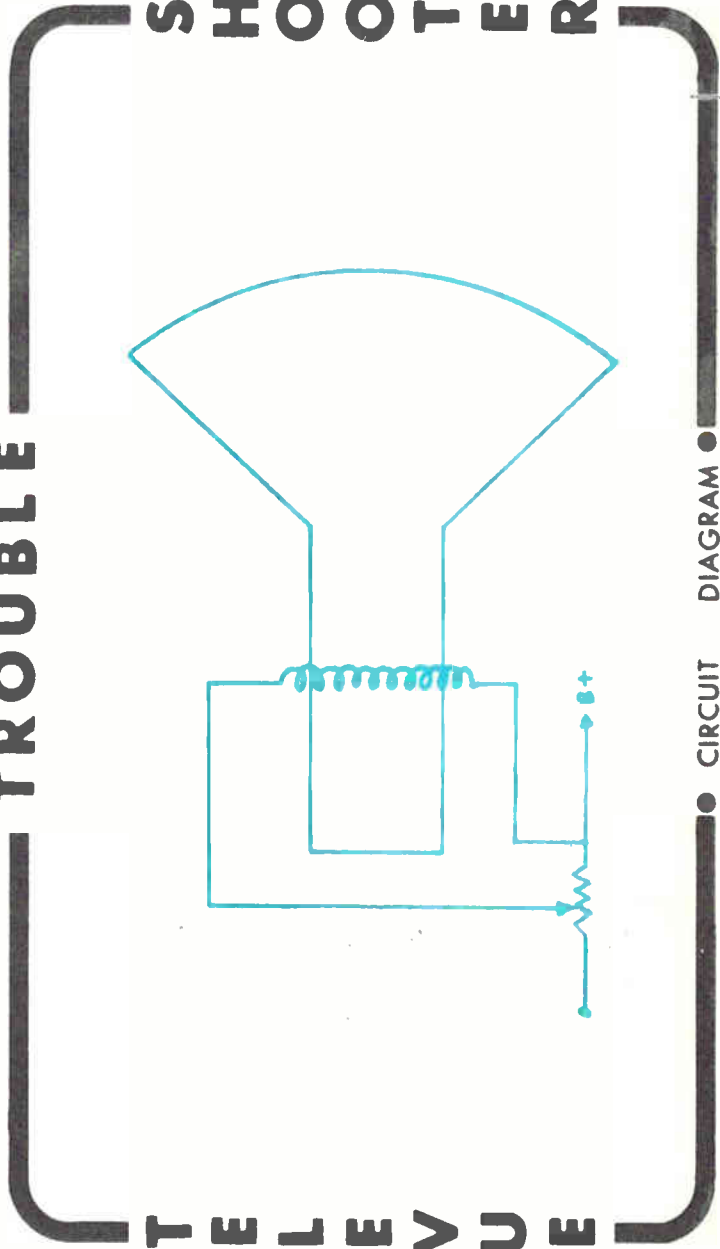

1 Check antenna system, and antenna lead in for open.

2

Be sure antenna is oriented to transmitter point.

3

Replace RF amplifier tube.

4

Check for correct voltage at plate and screen of RF amp.

5

If voltage at plate missing, check B plus lead to tuner.

6

If B plus going into tuner, check for open in line to RF plate.

7

Common trouble is resistor below RF amp Plate coil.

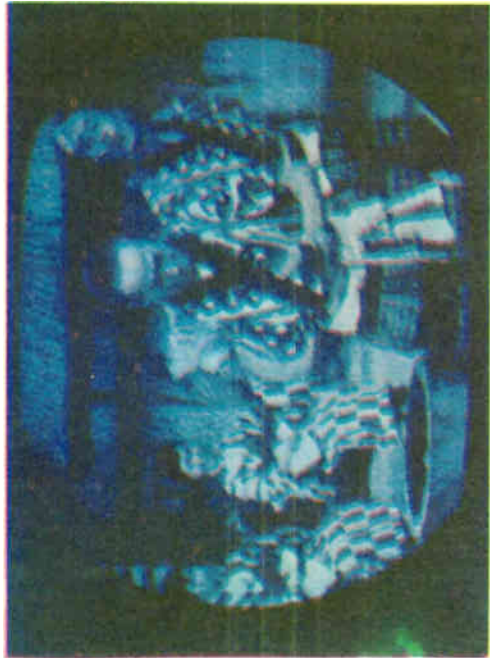

SNOWY PICTURE

SYMPTOM

THE SIGNAL MUST BE AMPLIFIED BY THE RF AMPLIFIER IN ORDER THAT THE NOISE PRODUCED BY THE SET ITSELF BE OF LOW AMPLITUDE COMPARED TO THE SIGNAL. IF THE RF CIRCUIT IS INOPERATIVE, THE NOISE WILL BE ALMOST AS LARGE AS THE SIGNAL AND SNOW WILL APPEAR ON THE SCREEN. IN COLOR RECEIVERS THIS WILL MEAN THAT THE 3.58 MC BURST WILL BE TOO LOW TO ACTIVATE THE COLOR SYNC CIRCUITS.

8 This resistor often opens.

9

Check tuner contacts to RF amplifier. May have open contact.

10

If tuner is very dirty it can cause this trouble.

11

Clean tuner. Use some recommended cleaner.

12

If RF amplifier has correct voltages, check antenna input coil for open.

13

14

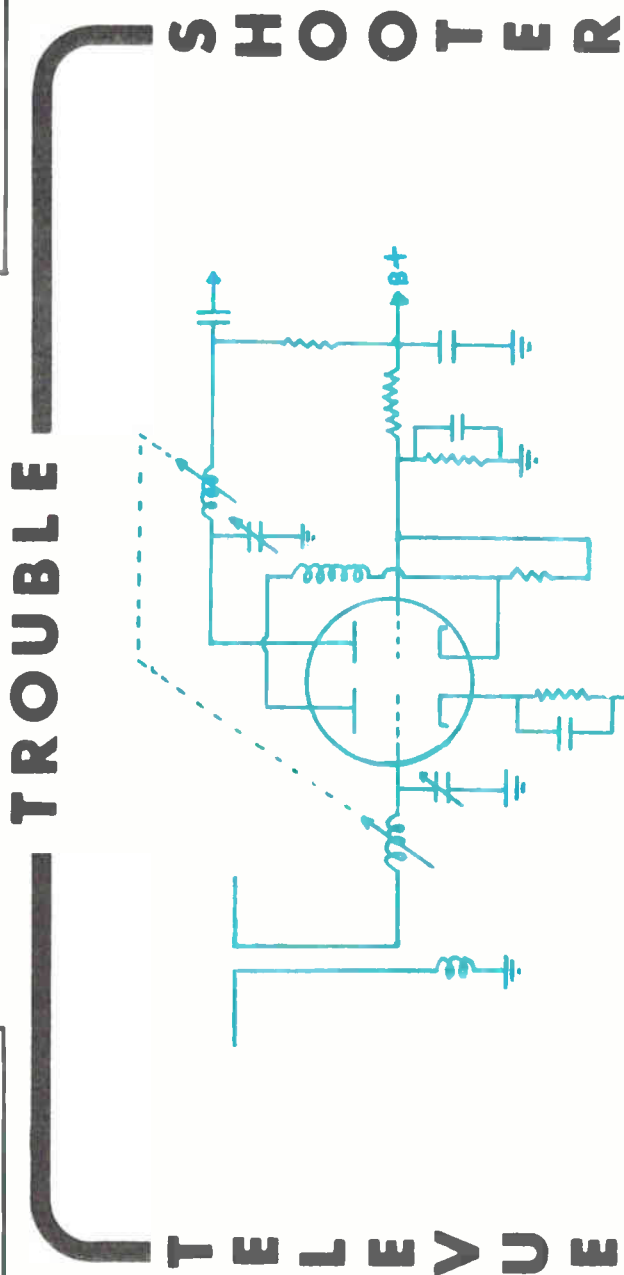

1

Replace the tuner, IF detector, video amp, and adder tubes.

2

Check the output of the video detector with scope.

3

If below normal, use generator to locate defective stage.

4

Connect gen to last IF grid, feed in mod signal around IF.

5

If clear black bars seen on screen, move gen back to next IF grid.

6

Continue moving gen back one stage at a time to grid of tubes.

7

At point where black bars are weak, trouble-shoot that stage.

DIGEST (A)

POOR AMPLIFICATION OF THE SIGNAL IN THE TUNER, IFS, OR VIDEO AMPLIFIERS WILL PRODUCE A WEAK SIGNAL AT THE GRIDS OF THE PICTURE TUBE. HOWEVER IT SHOULD ALSO BE KEPT IN MIND THAT IN SOME COLOR RECEIVERS, THE BLACK AND WHITE SIGNAL MAY HAVE TO ALSO BE AMPLIFIED BY THE COLOR ADDERS, AND THEREFORE THEY CAN BE THE CAUSE OF A WEAK PICTURE, TOO.

DIGEST (B)

THIS TROUBLE MUST BE IN THE SIGNAL CIRCUITS SINCE IT IS THE SIGNAL ITSELF THAT IS WEAK. OF GREAT HELP IN SOLVING THIS TROUBLE IS A SIGNAL GENERATOR THAT CAN PRODUCE A SIGNAL AT THE IF OF THE SET. IF THE SOUND APPEARS TO BE NORMAL, THEN OUR TROUBLE IS PROBABLY AFTER VIDEO DETECTOR. IF THE SOUND IS NOT PRESENT, THEN THE TROUBLE IS PROBABLY BEFORE THE VIDEO DETECTOR.

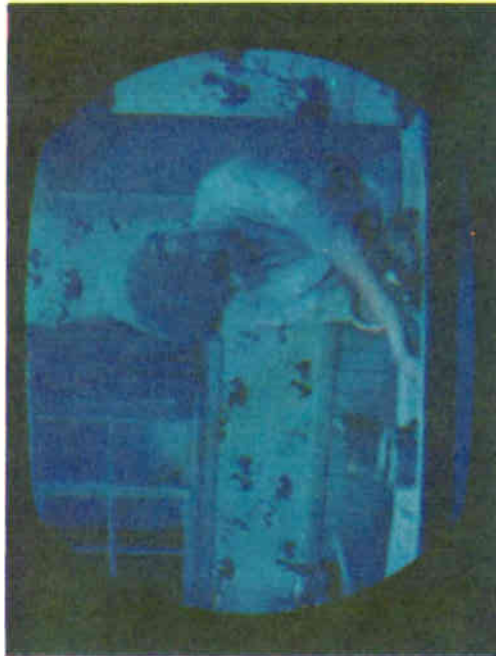

WEAK PICTURE SYMPTOM

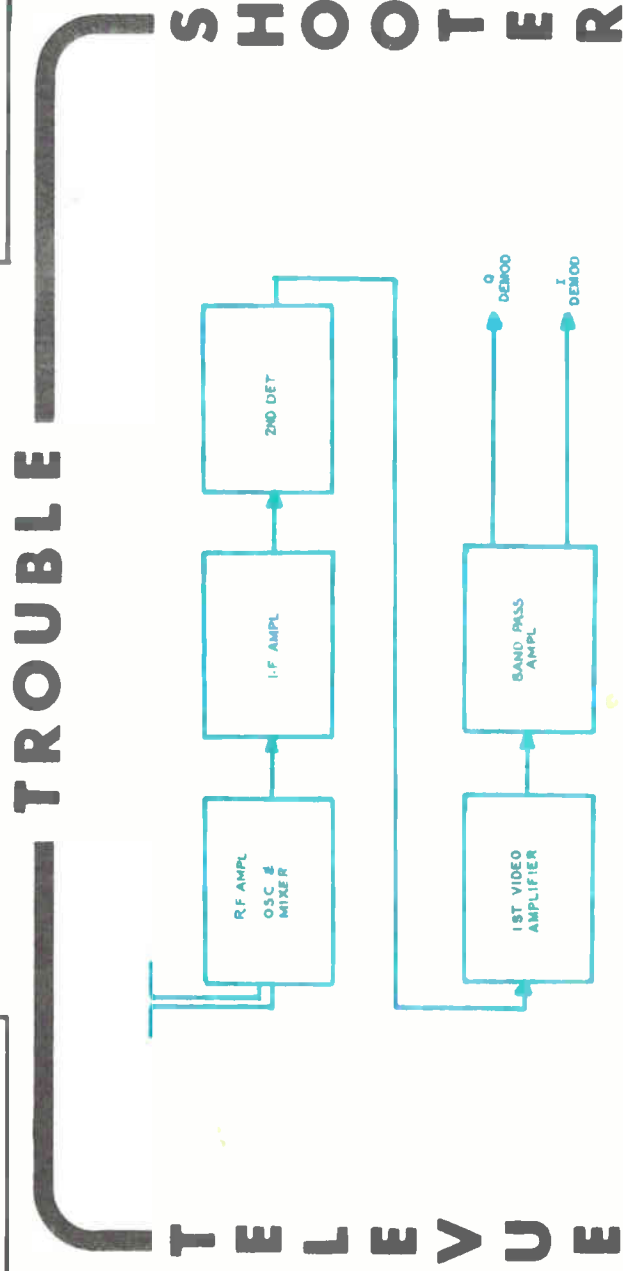

8

Take E and R measurements of defective stage.

9

If grid voltage very negative, check agc circuit.

10

If output of detector normal, follow signal through video amps.

11

If adder stage used, follow signal through adder circuit.

12

At point where signal is not being amp, take E and R checks.

13

[Empty box]

14

[Empty box]

1
Replace the front end and video IF tubes.

2

Connect sig gen at mod IF to grid of tube just before sound take off.

3

If stage is working, should see black bars on screen.

4

If no black bars, take voltage and resistance checks of that stage.

5

If black bars are seen, move gen back to grid of next IF.

6

If no black bars at this point, then trouble is in this stage.

7

Take voltage and resistance checks of this stage.

IF THE RASTER IS PRESENT, BUT THERE IS NO PICTURE OR SOUND, THEN THE MOST LIKELY CAUSE OF THE TROUBLE IS THE FRONT END OF THE RECEIVER, OR THE IF STAGES. THE REASON FOR THIS IS THAT THE SOUND IN A COLOR RECEIVER IS TAKEN OFF JUST BEFORE THE VIDEO DETECTOR AND APPLIED TO THE SOUND CIRCUITS. SO IF THE TROUBLE IS COMMON TO BOTH PIX AND SOUND, THEN IT MUST BE BEFORE SOUND TAKE OFF POINT.

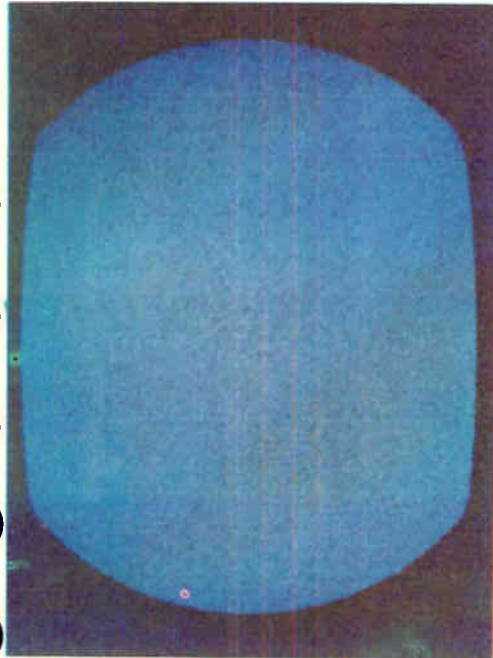

NO PICTURE OR SOUND

SYMPTOM

THE FRONT END AND IF STAGES OF A COLOR RECEIVER CAN BE CHECKED BY THE USE OF A SIGNAL GENERATOR IF THE TROUBLE IS MORE THAN JUST TUBES. BY FEEDING IN A SIGNAL TO THESE STAGES, YOU CAN SEE IF THE SIGNAL IS PASSING OR NOT BY LOOKING FOR BARS ON THE SCREEN AS THE GENERATOR IS APPLIED TO EACH STAGE.

8
If black bars are present on screen, move gen back to grid of next IF.

9

Continue to move gen back from grid to grid, until mixer grid.

10

If black bars are seen when gen at mixer, check local oscillator.

11

Best method for this is to check for neg volts at osc grid.

12

If no neg volts, then osc stage defective.

13

If neg volts present at osc grid, then trouble must be in RF stage.

14

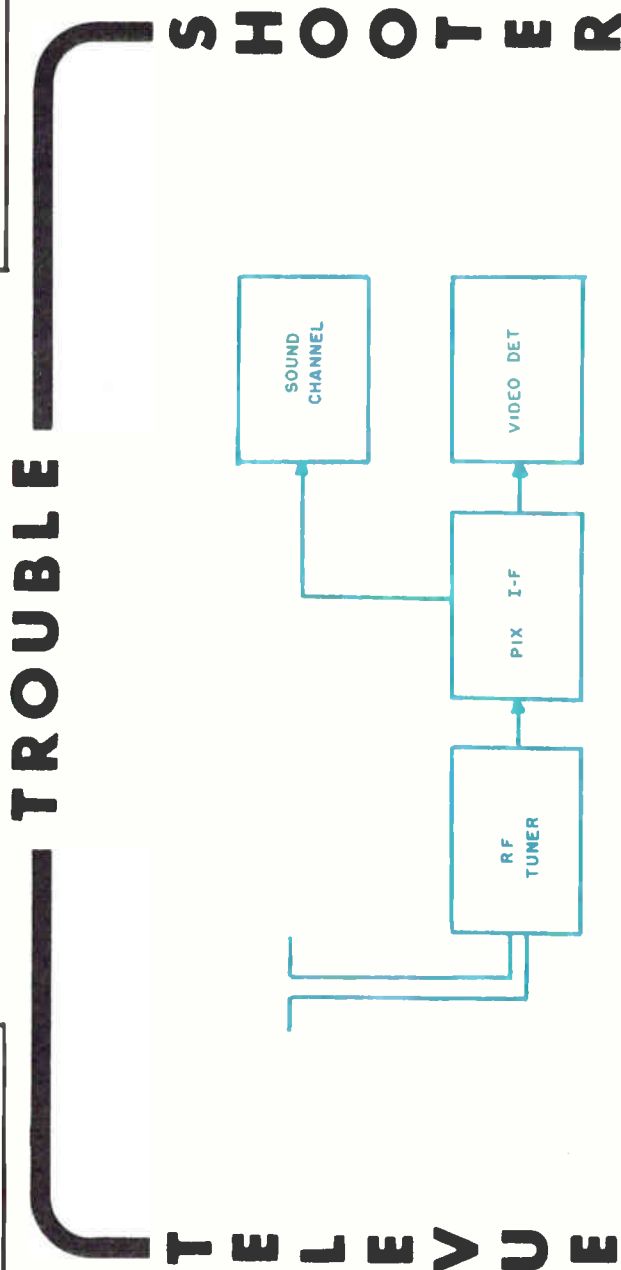

DIGEST (A)

1

Replace the front end, video IF, detector, and 1st video amp.

2

Check the output of the video detector with scope.

3

If signal present, follow signal to input and output of 1st vid amp.

4

If no output, take voltage and resistance checks of amp.

5

If output signal present, follow signal until break located.

6

Must be at some point from 1st video to junction of color and Y paths.

7

If no output at video detector, use signal gen as follows.

IF THERE IS NO PICTURE ON THE SCREEN, BUT THE RASTER APPEARS NORMAL, IT MEANS THAT ALL THREE GUNS OF THE COLOR CRT ARE WORKING NORMALLY, BUT THAT NO SIGNAL IS REACHING THE COLOR CIRCUITS, OR THE Y CHANNEL. IN THIS CASE THE TROUBLE MUST BE IN THE SIGNAL CIRCUITS PRIOR TO THE TAKE-OFF FOR THE Y CHANNEL AND COLOR CIRCUIT.

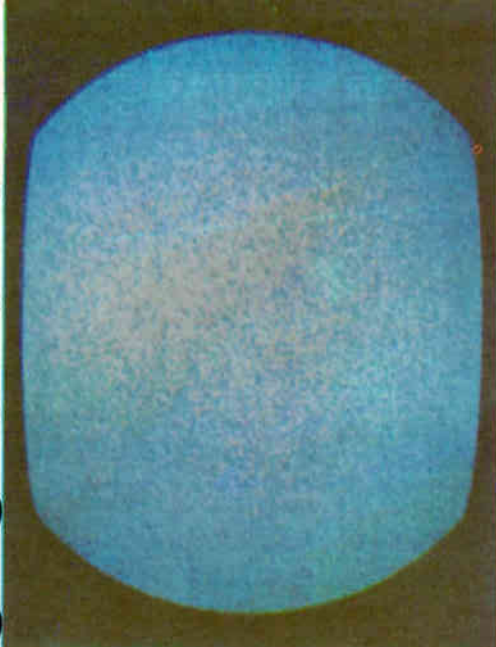

NO PICTURE SYMPTOM

DIGEST (B)

SINCE THE SIGNAL MUST PASS THE 1ST VIDEO AMPLIFIER BEFORE IT IS SPLIT TO THE COLOR AND Y CHANNEL, IT IS POSSIBLE TO USE THE OSCILLOSCOPE TO CHECK FOR THE SIGNAL AT THE OUTPUT OF THE VIDEO DETECTOR. IF NO SIGNAL IS PRESENT AT THIS POINT, THEN THE TROUBLE IS BEFORE THE DETECTOR STAGE. IF THE SIGNAL IS PRESENT AT THE DETECTOR, THEN THE TROUBLE MUST BE IN THE 1ST VIDEO AMP.

8

Connect gen to grid of last IF with modulated IF input.

9

Look for black bars on CRT. If none, troubleshoot last IF.

10

If black bars present, move gen to grid of next IF.

11

If no bars here, troubleshoot that stage. If bars show, move back.

12

Continue this until bars missing, then troubleshoot that stage.

13

To check osc, measure osc grid voltage. Should be negative volts.

14

If zero or positive, then troubleshoot oscillator circuit.

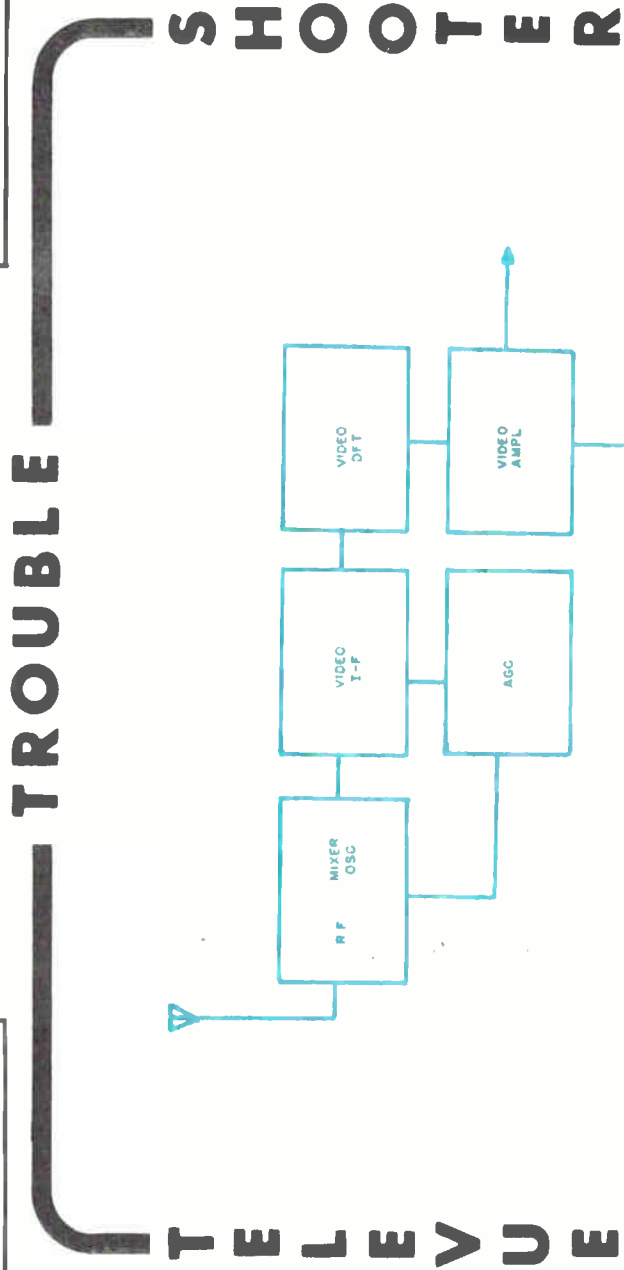

1

Adjust the vertical and horizontal hold controls.

2

If pix stays momentarily and then drifts off sync, trouble in sync circuits.

3

Replace the sync separator, amplifier, and clipper tubes if used.

4

Check for signal at input to first sync tube.

5

If no signal at this point, check for an open coupling cap to sync tube.

6

If signal at first sync, follow with scope through sync tubes.

7

If signal lost at any point, look for an open coupling cap.

8

IF THE PICTURE IS ROLLING VERTICALLY AND HORIZONTALLY, AND THE HOLD CONTROLS WILL NOT LOCK THE PICTURE IN SYNC IN EITHER DIRECTION, THEN WE HAVE LOSS OF SYNC. IF A COLOR PROGRAM IS ON THE AIR, THEN WE WILL SEE COLOR BARS. IF PIX IS ON, THEN WE WILL SEE ONLY BLACK AND WHITE BARS.



LOSS OF SYNC

SYMPTOM

9

IF THE SYNC SEPARATOR CIRCUITS ARE NOT WORKING, THEN THE SIGNAL THAT SHOULD SYNC THE PICTURE WILL BE MISSING. THIS WILL CAUSE THE VERTICAL AND HORIZONTAL OSCILLATORS TO BE FREE RUNNING, AND THEY WILL DRIFT OFF OF FREQUENCY. THE HOLD CONTROLS WILL BE ABLE TO BRING THE PIX BACK INTO SYNC FOR A MOMENT, BUT THEN IT WILL START TO DRIFT AGAIN.

If no signal at plate of one of the sync tubes, take voltage checks.

10

Do not be concerned if signal is poor, this trouble is complete loss of signal.

11

Take resistance checks of stage that has loss of signal.

12

Using the scope should isolate the stage that is not passing the signal.

13

14

15

TROUBLE

SHOOTER

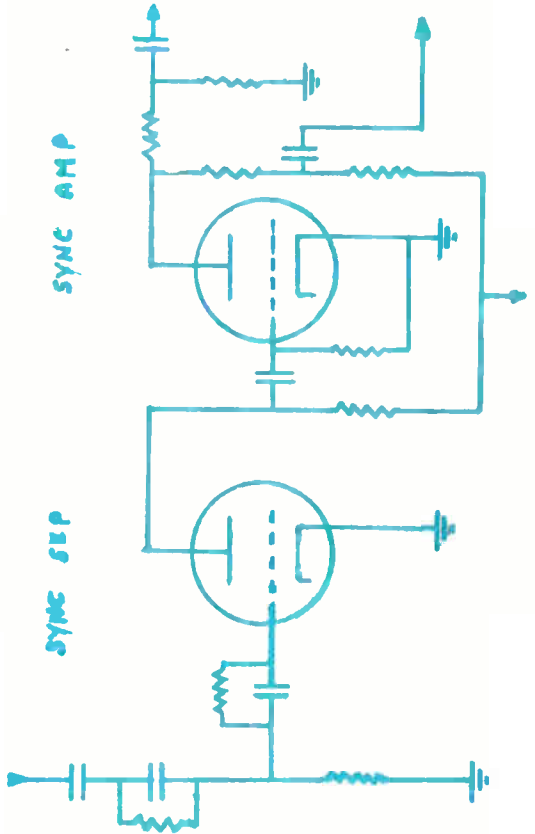

DIGEST (A)

1

Remove the vertical osc and output tubes.

2

Place scope at grid of vertical output tube.

3

If no signal at this point check osc circuit.

4

May have open plate circuit or grid circuit in osc.

5

If signal is present at grid of output tube, put scope at plate.

6

If no signal at plate, check for open circuit in plate and cathode.

7

May have open in B plus line to tube plate.

DIGEST (B)

8

Plate line goes to the convergence circuits.

9

Check for open resistor in convergence circuit.

10

Blue, Red, and Green tilt controls are in this line.

11

If signal present at plate, check secondary of output Xfmr for open.

12

If Xfmr okay, check vertical yoke for open.

13

If yoke is plug in type, check plug connection.

14

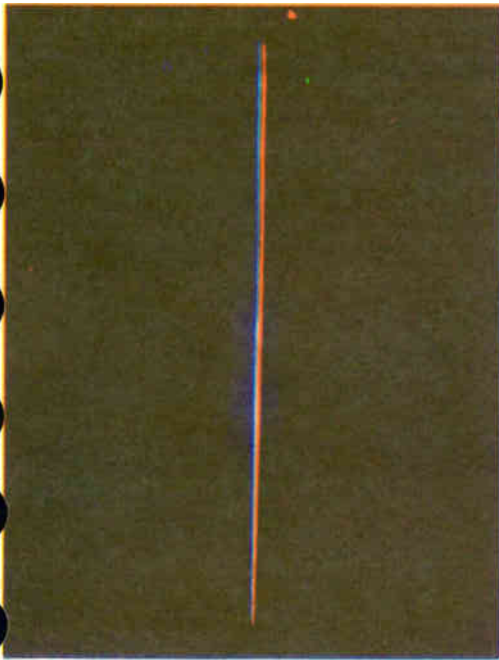

NO VERTICAL SWEEP

SYMPTOM

TROUBLE

SHOOTER

TELEVIEW

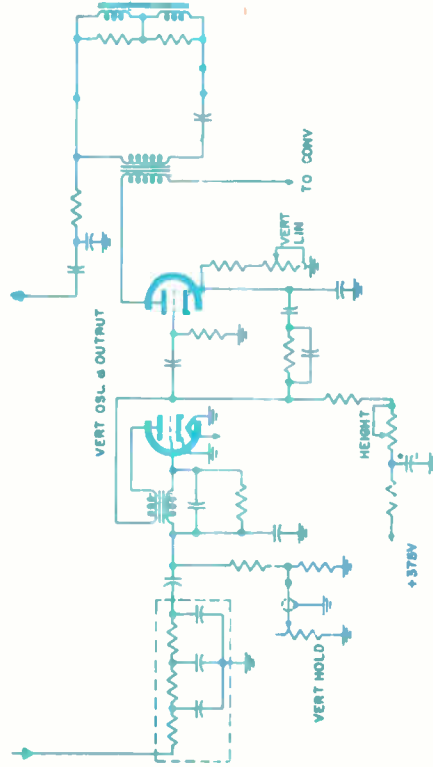

1 Replace the vertical osc and output tubes.

2 Check the signal at the input and output of vertical output tube.

3 Should have large amplification of signal.

4 If poor amp noticed, check for signal on cathode and screen grid.

5 Should be a small parabolic. If sawtooth, check bypass cap.

6 If correct signal on cathode and screen, check resistors.

7 May have increase in cathode resistor or screen resistor.

IF THE VERTICAL CONTROLS WILL NOT ADJUST THE PICTURE TO ITS FULL HEIGHT, THEN SOME TROUBLE EXISTS IN THE VERTICAL SWEEP CIRCUIT. THIS CAN BE CAUSED BY TUBES, OR CHANGE IN VALUE OF SOME PART. THE OSCILLOSCOPE CAN BE USED TO SEE IF THE TUBE CIRCUITS ARE AMPLIFYING, OR IF SOME OF THE BYPASS CAPACITORS ARE OPEN.



NOT ENOUGH HEIGHT

SYMPTOM

WHEN THE SIGNAL TO THE VERTICAL YOKE IS NOT LARGE ENOUGH, THEN THE ELECTRON BEAM WILL NOT BE SWEEPED ALL THE WAY FROM THE TOP TO THE BOTTOM OF THE RASTER. IN SETTING UP A COLOR TELEVISION RECEIVER, THE HEIGHT, AND VERTICAL LINEARITY CONTROLS, AND THE WIDTH SHOULD BE ADJUSTED FIRST. IN OTHER WORDS, A GOOD BLACK AND WHITE PICTURE SHOULD BE OBTAINED BEFORE ANY COLOR ADJUSTMENTS ARE MADE.

8 Check for correct plate voltage. If low, check plate circuit.

9 Plate line goes to vertical convergence controls.

10 Check vertical convergence circuit for change in resistance.

11 If input to output tube seems small, check osc circuit.

12 If output of vertical output tube okay, check output Xfmr.

13 If Xfmr checks normal, check vertical yoke.

14

TELEVISION TROUBLE SHOOTER

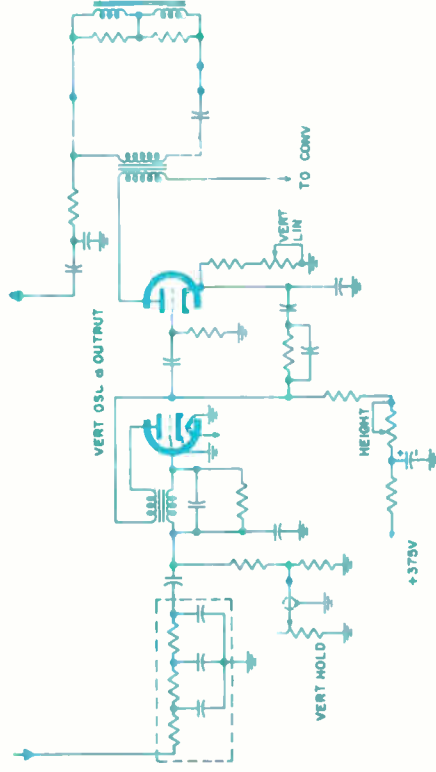

DIGEST (A)

1

If hold control will not lock in one pix, replace vert osc tube.

2

Remove set and check value of hold control.

3

If hold control normal, check resistor in series with hold control.

4

If this checks normal, replace coupling capacitor at grid of osc.

5

If set still off frequency, replace osc transformer.

6

If a blocking oscillator is not used, check all grid resistors.

7

Check all resistors in plate circuits.

DIGEST (B)

8

Replace all capacitors at grid of osc tube.

9

Replace all capacitors at plates of oscillator tube.

10

Continue to check parts in oscillator circuits.

11

Trouble must be in the oscillator circuit.

12

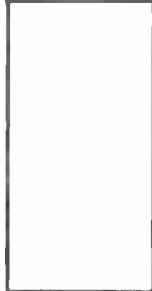

13

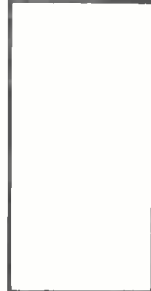

14



VERTICAL OFF FREQUENCY

SYMPTOM

THE VERTICAL CIRCUIT IN A COLOR TELEVISION SET IS SIMILAR TO THE VERTICAL CIRCUIT OF A TV. ONE OF THE DIFFERENCES IS THAT IN THE OUTPUT OF VERTICAL SWEEP OF COLOR SET, SOME OF THE SIGNAL IS APPLIED TO THE CONVERGENCE CIRCUITS. HOWEVER, THE VERTICAL OSCILLATOR IS THE SAME FOR BOTH TYPE SETS. IF THE OSCILLATOR IS OFF FREQUENCY, THE TROUBLE WILL BE LIMITED TO THE OSCILLATOR CIRCUIT.

IF ANY OF THE COMPONENTS OF THE OSCILLATOR CHANGE VALUE, THE HOLD CONTROL CAN BE ADJUSTED TO COMPENSATE FOR THESE CHANGES. HOWEVER, SHOULD THESE CHANGES CONTINUE, THE HOLD WILL NOT BE ABLE TO BRING THE PICTURE IN TO THE CORRECT FREQUENCY. THIS TYPE OF TROUBLE IS CAUSED BY THE OSCILLATOR CIRCUIT AND TROUBLE SHOOTING SHOULD BE RESTRICTED TO THIS STAGE.

TROUBLE

TELEVIEW

SHOOTER

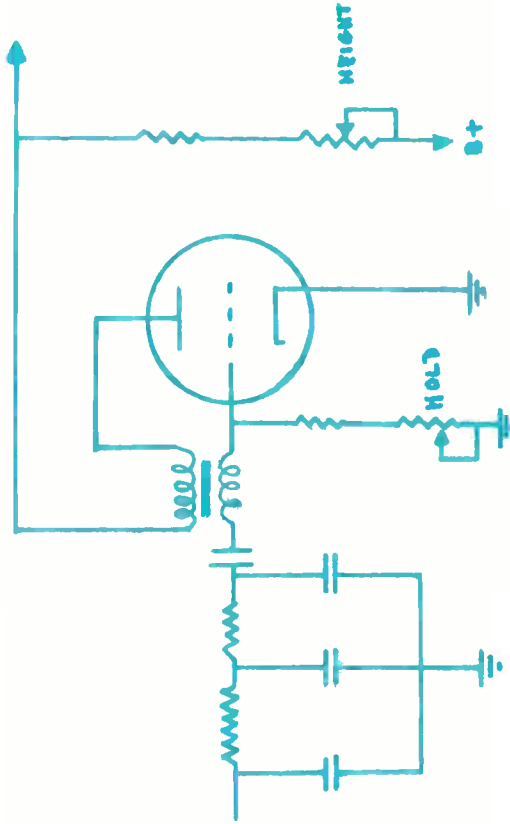

1 Check to see if a separate tube is used for vertical sync.

2

If one is used replace it. Also replace sync tubes.

3

In a circuit that uses a vert sync tube, check plate voltage.

4

If voltage present, check for open cap to grid of tube.

5

Use scope to check for output signal. If none present, check input.

6

If output present, check for shorted integrator capacitor.

7

If a printed circuit is used, replace it.

WITH LOSS OF VERTICAL SYNC, THE HORIZONTAL SYNC WILL BE NORMAL. THE VERTICAL HOLD CONTROL WILL BE ABLE TO MOMENTARILY HOLD THE PICTURE ON THE SCREEN, BUT IT WILL NOT REMAIN FOR LONG IF THE HOLD CONTROL IS RELEASED. THE COLOR WILL ROLL AS THE PICTURE ROLLS. THIS TROUBLE IS USUALLY A SIMPLE ONE AS IT MUST BE OCCURRING FROM SOME POINT BETWEEN THE SYNC TAKE OFF AND THE GRID CIRCUIT OF THE VERTICAL OSC.

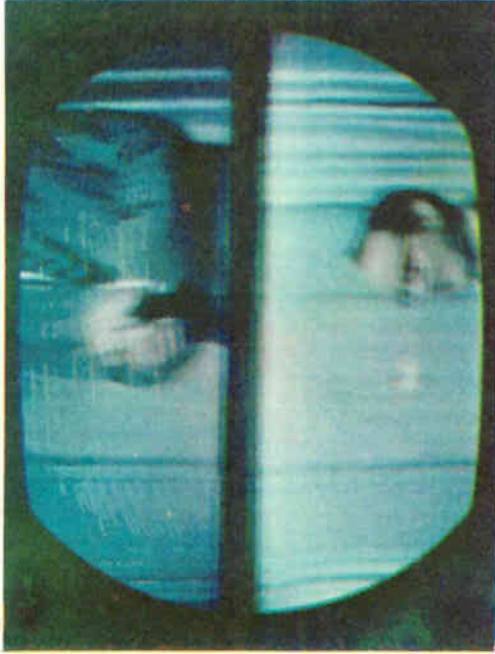

LOSS OF VERTICAL SYNC

SYMPTOM

IF ONLY THE VERTICAL CIRCUIT IS AFFECTED THEN OUR TROUBLE MUST BE LIMITED TO A SMALL SECTION OF THE RECEIVER. IN SOME COLOR SETS, A SEPARATE TUBE IS USED TO SEPARATE THE VERTICAL SYNC PULSES FROM THE VIDEO INFORMATION. IF THIS IS THE CASE THEN THIS SECTION MUST BE CHECKED FOR THE CAUSE OF THIS TROUBLE.

8 If the vertical circuit does not use a vert sync tube, check below.

9

Turn down brightness control and remove vert osc.

10

Check for signal at grid of osc, if small or not present, check integrator.

11

May have shorted capacitor or open resistor.

12

If integrator printed circuit, replace entire circuit.

13

If horizontal is poor on hold, then check for trouble in sync circuit.

14

TELEVISION TROUBLE SHOOTER

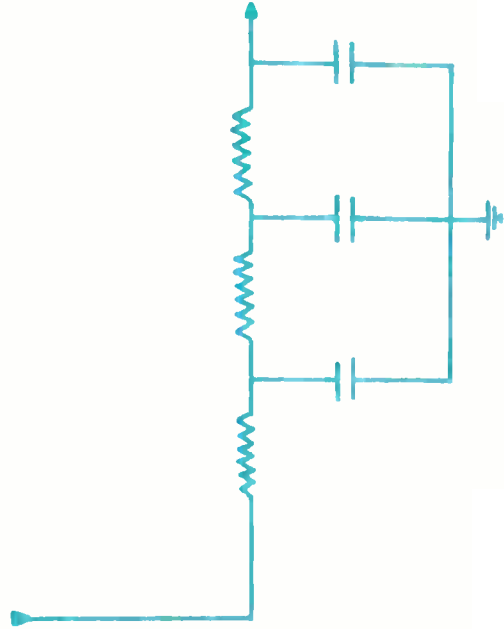

1

Adjust the height and linearity controls.

2

Replace the vertical oscillator and output tubes.

3

Place scope at grid of vertical output tube.

4

If sawtooth normal at this point, trouble must be in output stage.

5

If signal poor at grid of output, check oscillator circuit.

6

Trouble probably in sweep capacitor changing value.

7

With normal signal at grid of output, take E and R checks of output tube.

DIGEST (A)

IF THE VERTICAL LINEARITY CANNOT BE ADJUSTED, OR IF IT WAS SET CORRECTLY, BUT HAS GONE OUT OF ADJUSTMENT, BE SURE TO FIND THE CAUSE OF THE TROUBLE BEFORE MAKING ANY COLOR ADJUSTMENTS THAT MAY SEEM TO BE NECESSARY. THE TROUBLE ITSELF IS IN THE VERTICAL SWEEP CIRCUIT, AND PROBABLY IN THE VERTICAL OUTPUT STAGE.



DIGEST (B)

WHEN INITIALLY SETTING UP A COLOR SET, THE BLACK AND WHITE ADJUSTMENTS MUST BE MADE BEFORE THE COLOR ADJUSTMENTS, OTHERWISE THE CONVERGENCE WILL BE UPSET AFTER IT HAS BEEN ADJUSTED. PART OF THE BLACK AND WHITE SET UP PROCEDURE IS THE VERTICAL LINEARITY. IF THIS IS OUT, THE OSCILLOSCOPE CAN BE USED TO SEE IF THE INPUT TO THE VERTICAL OUTPUT TUBE IS CORRECT. THIS HELPS IN LOCALIZING THE TROUBLE.

POOR VERTICAL LINEARITY

SYMPTOM

TROUBLE

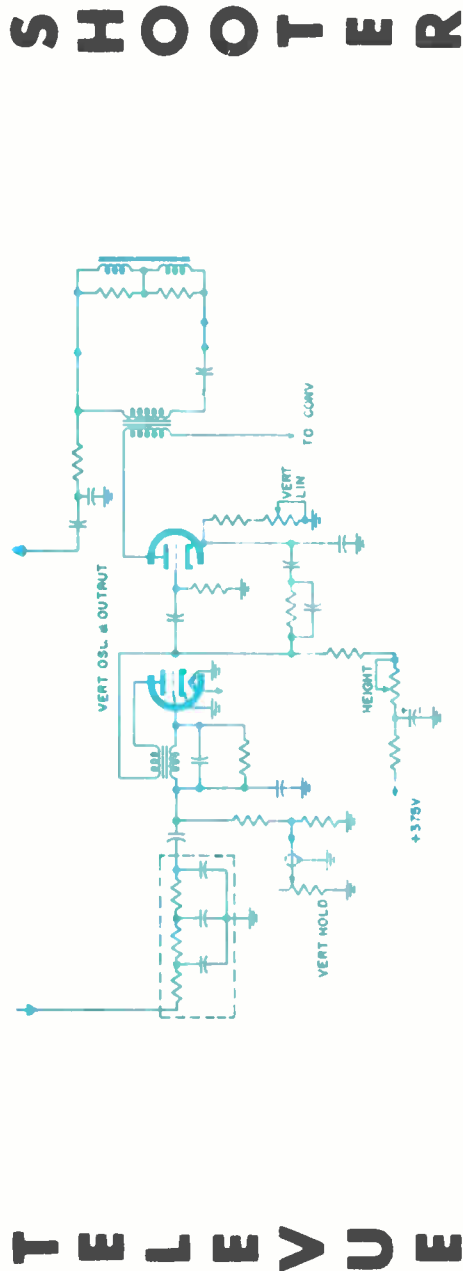

8

Cathode circuit of output may have shorted capacitor.

9

Check for open capacitor in plate circuit below output transformer.

10

If all parts are okay, replace output transformer.

11

If trouble still present, replace yoke.

12

After vertical linearity trouble is cleared, check convergence.

13

Reconverge if necessary.

14

1 Adjust setting of height and vert. linearity controls.

2 If they do not help, return to original setting.

3 Replace the vertical osc and output tubes.

4 Check input to vert output tube with scope.

5 If sawtooth is flat at top, trouble is in vertical oscillator.

6 Replace coupling capacitor and sawtooth charging capacitor.

7 If trouble still present, check peaking resistor.

IF THE PICTURE HAS VERTICAL FOLDOVER AT THE BOTTOM OF THE SCREEN, IT COULD BE BECAUSE OF MISADJUSTMENT OF THE VERTICAL HEIGHT OR LINEARITY CONTROL. HOWEVER BEFORE TOUCHING THESE CONTROLS IT IS ALWAYS A GOOD IDEA TO CHECK THEIR SETTING AND MARK IT WITH A PENCIL. OTHERWISE, IF THE TROUBLE IS FOUND TO BE A TUBE ETC. IT MIGHT CAUSE MISCONVERGENCE AND RESULT IN COMPLETE RECONVERGENCE.



VERTICAL FOLDOVER

• SYMPTOM •

WHEN THE SAWTOOTH APPLIED TO THE DEFLECTION COILS IS NOT LINEAR, THE SCANNING BEAM MIGHT COVER THE SAME LINES AGAIN AND AGAIN. THIS TROUBLE, FOLDOVER, IS CAUSED BY POOR LINEARITY, AND AN OSCILLOSCOPE CAN HELP PINPOINT THE DEFECTIVE STAGE. IF THE FOLDOVER IS AT THE TOP OF THE SCREEN, THEN THE TROUBLE IS MOST LIKELY IN THE OUTPUT TRANSFORMER OR VERTICAL YOKE.

8 If signal at grid of output normal, trouble is in output stage.

9 Check cathode resistors, and bypass capacitor for short.

10 Check screen grid resistor and any res in plate line for change.

11 If filter cap is in plate line, check for open.

12 If foldover at top, check damping resistors across yoke.

13 Replace output transformer.

14 Replace yoke

TROUBLE

SHOOTER

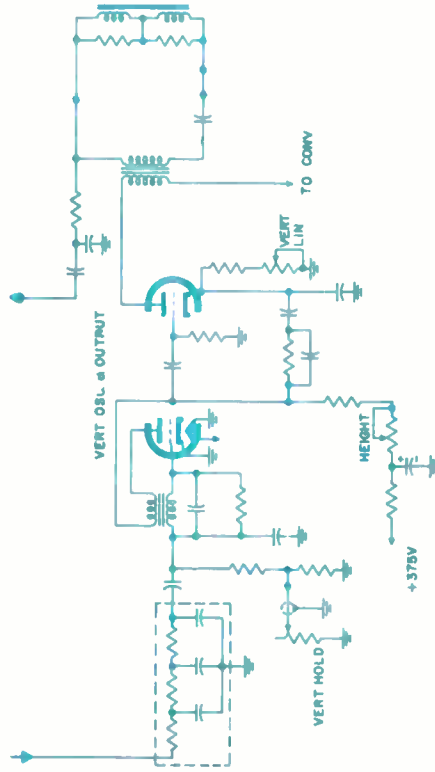

DIGEST (A)

1

As long as the horizontal hold control is set, the picture will lock.

2

If pix is present for a moment but goes off, trouble is in afc.

3

If pix will not appear even for a moment, trouble is in hor osc.

4

If trouble in horizontal oscillator, check chart for off freq. trouble.

5

With afc trouble, replace any tube in afc circuit.

6

Use scope to check for correct wave shapes at afc tube.

7

If wave shapes missing, check for open or short.

WITH LOSS OF HORIZONTAL SYNC THE BARS ACROSS THE SCREEN WILL HAVE COLOR PRESENT IF A COLOR PROGRAM IS ON THE AIR, OR BLACK AND WHITE BARS IF NO COLOR PROGRAM IS PRESENT. THIS TROUBLE IS CAUSED BY THE AFC NETWORK FEEDING THE CORRECTION VOLTAGE TO THE HORIZONTAL OSCILLATOR. IF THE VERTICAL CIRCUIT IS STABLE, THEN THE TROUBLE MUST BE THE AFC.



LOSS OF HORIZONTAL SYNC

SYMPTOM

TROUBLE

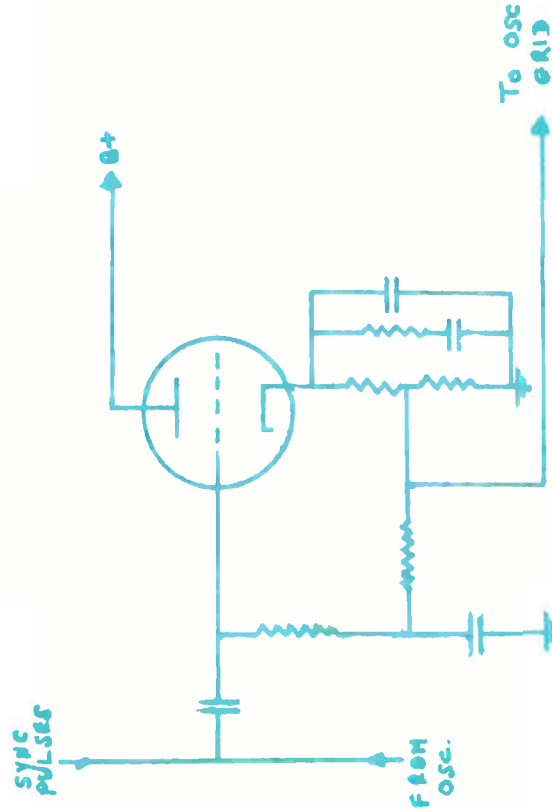

DIAGRAM

DIGEST (B)

8

If all waves normal, take voltage checks of all afc tubes.

9

Check for correct sync pulses feeding afc circuit.

10

If all voltages check okay, take resistance check of afc.

11

Replace all capacitors in afc circuit.

12

Some receivers use crystals as afc diodes. If so, replace.

13

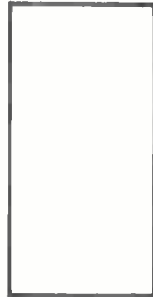

14

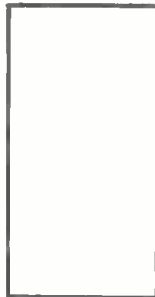

IN ORDER FOR THE HORIZONTAL OSCILLATOR TO REMAIN STABLE, IT IS NECESSARY TO HAVE A SPECIAL AFC CIRCUIT IN ORDER TO CORRECT FOR THE NORMAL DRIFT IN THE OSCILLATOR. IF THIS CIRCUIT IS NOT WORKING CORRECTLY THEN THE HORIZONTAL OSCILLATOR WILL GO OFF FREQUENCY.

SHOOTER

TELEVIEW

1

Adjust the hold, frequency and lock controls.

2

If picture appears for a moment, trouble in afc circuit.

3

If picture will not come in with controls, trouble in hor osc circuit.

4

Replace Hor oscillator and any afc tubes.

5

After replacing tubes, try controls again.

6

Check all voltages at plate, grid, and cathode of oscillator.

7

If plate voltage low, check B plus circuit feeding plate.

8

WHEN THE PICTURE IS OUT OF HORIZONTAL FREQUENCY, THE CONTROLS THAT WILL BRING THE PICTURE BACK ARE THE HORIZONTAL HOLD, FREQUENCY, AND LOCK CONTROLS. IF ADJUSTMENTS OF THESE CONTROLS DO NOT BRING THE PICTURE INTO SYNCHRONIZATION, THEN IT IS NECESSARY TO CHECK INTO THE HOR OSCIL LATOR CIRCUIT.



OFF HORIZONTAL FREQUENCY

SYMPTOM

9

WITH THE TROUBLE ON THE SCREEN, AND A COLOR PROGRAM ON THE AIR, COLOR BARS WILL BE SEEN ON THE SCREEN. IF A BLACK AND WHITE PROGRAM IS ON THE AIR, THEN ONLY BLACK AND WHITE BARS WILL BE SEEN. THIS TROUBLE IS IN THE HORIZONTAL OSCILLATOR CIRCUIT, AND CAN BE CAUSED BY ANY PART ASSOCIATED WITH THE OSC.

8

Check all resistors in osc circuit.

9

Look for a change in value of grid resistors.

10

Replace all capacitors in osc circuit, especially grid capacitor.

11

If all parts of the osc check normal, bridge filter cap in B plus.

12

If trouble still present replace hor osc transformer.

13



14



TELEVISION TROUBLE SHOOTER

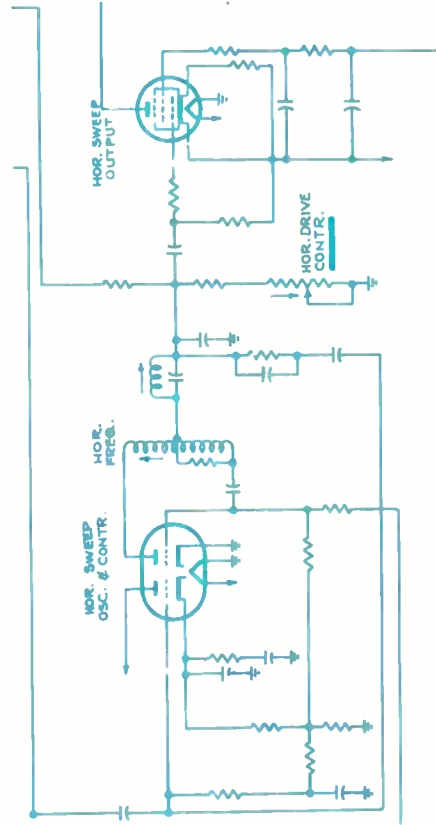

DIGEST (A)



DIGEST (B)

IF THE PICTURE DOES NOT COVER THE SCREEN IT MAY CAUSE COLORS TO BE SEEN ALL OVER THE SCREEN AROUND THE OUTLINES OF THE PICTURE. THIS IS DUE TO THE MISCONVERSION THAT COULD OCCUR AS A RESULT OF NOT ENOUGH WIDTH. UNDER NO CIRCUMSTANCES TRY TO ADJUST THE CONVERGENCE, BECAUSE IF YOU DO, AND THEN CURE THE WIDTH YOU WILL HAVE TO CONVERGE ALL OVER AGAIN.

NOT ENOUGH WIDTH

SYMPTOM

TROUBLE

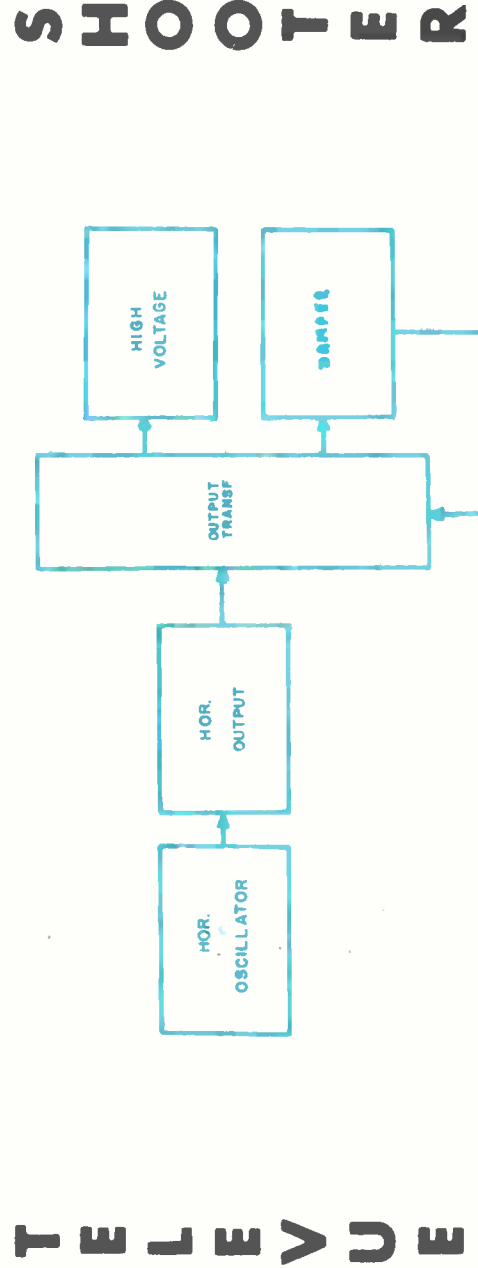

1 Adjust the width and horizontal drive controls.

2 Replace the Hor osc, output, damper, and HV rectifier tubes.

3 Check HV and try to adjust to correct amount.

4 Check the low voltage. If lower than normal, check rectifier circuit.

5 Measure peak to peak with scope at hor output grid.

6 If low at grid, check oscillator circuit for low output.

7 If normal at grid of output, take E and R measurements of output stage.

ALL OF THE BLACK AND WHITE ADJUSTMENTS MUST BE MADE FIRST BEFORE ANY COLOR ADJUSTMENTS CAN BE MADE, OTHERWISE AFTER COLOR ADJUSTMENTS ARE MADE YOU WILL THROW THEM OUT AGAIN BY CHANGING THE WIDTH OR HEIGHT. WITH WIDTH PROBLEMS FIND THE TROUBLE FIRST BY CHANGING THE TUBES AND RUNNING THE NORMAL CHECKS FOR POOR WIDTH. AFTER THE TROUBLE IS FOUND, CHECK THE COLOR ADJUSTMENTS.

8

Check damper circuit for correct boost voltage.

9

If boost voltage low, check damper circuit.

10

Remember that boost may be low due to poor signal from output.

11

If damper and output stage appear okay, replace flyback.

12

If flyback okay, replace yoke.

13

Check convergence and adjust if necessary.

14

1 If tubes are used as rectifiers, replace.

2 If seleniums are used, measure output of seleniums.

3 Output voltage for color sets is around 375vdc.

4 If output low, substitute filter capacitor.

5 Check filter choke for increase.

6 Measure voltage across negative part of power supply.

7 If large neg voltage, check for change in resistors in power supply.

WITH THIS TYPE OF TROUBLE, THE B PLUS CIRCUIT SHOULD BE SUSPECTED. IT SUPPLIES ALL OF THE VOLTAGES FOR THE OPERATION OF THE VERTICAL AND HORIZONTAL SWEEP CIRCUITS. IN SOME RECEIVERS THE DAMPER CIRCUIT NOT ONLY SUPPLIES THE HORIZONTAL CIRCUITS, BUT ALSO THE VERTICAL OUTPUT STAGE. IN THESE TYPE OF SETS, THE DAMPER CIRCUIT COULD ALSO CAUSE NOT ENOUGH WIDTH OR HEIGHT.

NOT ENOUGH WIDTH OR HEIGHT SYMPTOM

WITH LOW B PLUS APPLIED TO THE SWEEP OSCILLATORS, THE SAWTOOTH THAT IS DEVELOPED BY THESE CIRCUITS, WILL NOT HAVE SUFFICIENT AMPLITUDE AS A RESULT OF THIS THE SAW TOOTH CURRENT IN THE VERTICAL AND HORIZONTAL DEFLECTION COILS WILL NOT BE ENOUGH TO CAUSE THE ELECTRON SCANNING BEAM TO COVER THE RASTER. CONVERGENCE MAY BE OUT OF ADJUSTMENT WITH THIS TROUBLE. DO NOT ATTEMPT TO CONVERGE UNTIL TROUBLE FOUND.

8 If output of power supply is normal, check damper.

9 If output of damper low, replace the following tubes.

10 Hor osc and output, and damper tube.

11 Check capacitors in cathode of damper.

12 If trouble still present check chart for not enough width.

13 May have a defective yoke. Try replacement.

14

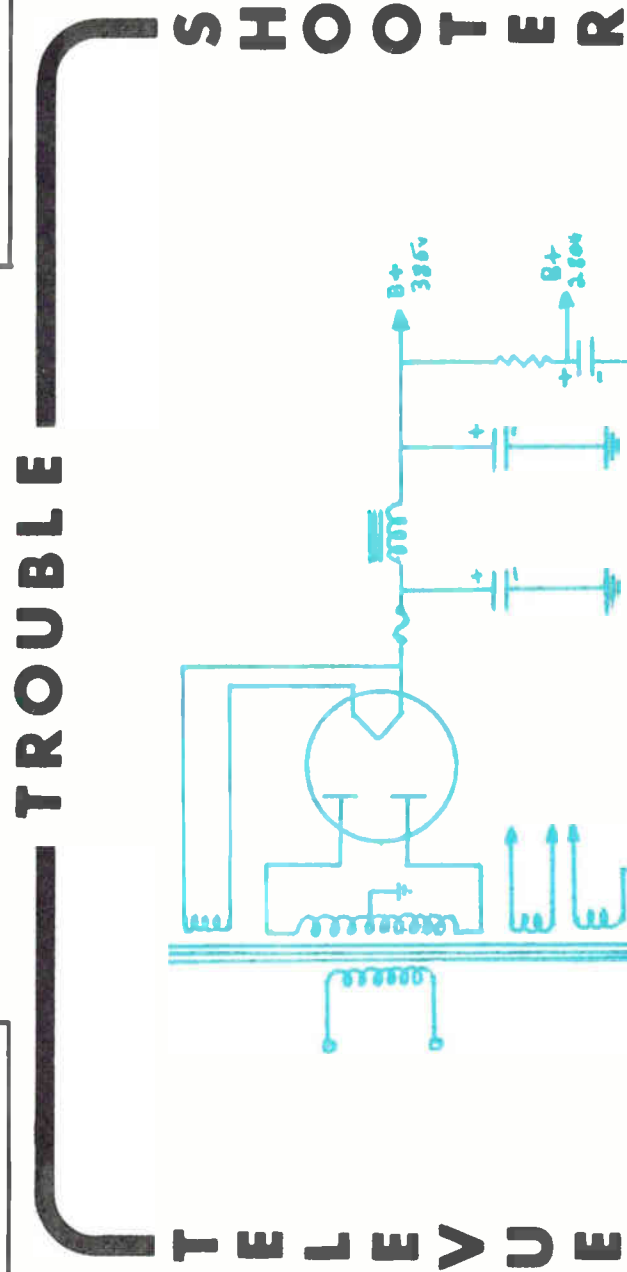

DIGEST (A)

1

Check to see if the filaments of the CRT are lit.

2

If not lit, check wiring to filament and filament itself for an open.

3

If filament open, try to solder filament pins since open may be there.

4

If CRT filaments lit, measure HV with high voltage prob.

5

If high voltage normal, check voltages applied to CRT screens and cathodes.

6

If no high voltage, replace HV rect, damper, hor osc, and hor output tubes.

7

Check for sawtooth at input to hor output tube.

DIGEST (B)

8

If no signal at grid, troubleshoot hor osc circuit.

9

With signal at grid, check for arc at plate of output tube.

10

With no arc at plate, troubleshoot output stage.

11

Check flyback transformer for open. May also have short in circuit using flyback.

12

Disconnect all circuits tied to flyback. Check damper circuit for short.

13

If arc at output plate, may have trouble in HV rect or regulator.

14

Check HV filter capacitors for short, or resistor in series with HV for open.

IN THE COLOR CRT THERE ARE THREE GUNS THAT SUPPLY THREE SEPARATE ELECTRON BEAMS TO THE PHOSPHOR SCREEN. IF ANY ONE OF THESE BEAMS WERE DEFECTIVE, THE OTHER TWO WOULD STILL PROVIDE A RASTER. WITH NO RASTER AT ALL EITHER THE FILAMENTS OF THE CRT ARE OPEN, OR THERE IS NO HIGH VOLTAGE FOR THE CRT. THE HIGH VOLTAGE FOR THE COLOR CRT IS AROUND 21,000 VOLTS.

NO RASTER, SOUND OKAY.

SYMPTOM

TROUBLE

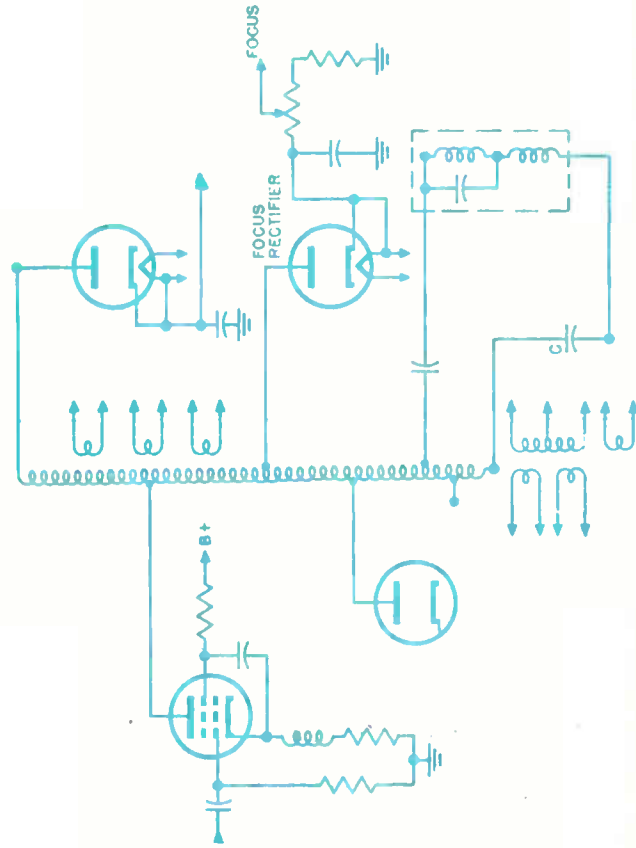

SHOOTER

TELEVISION

1 Turn set on and check to see if tubes are lit.

2

If none of the tubes light, check the following.

3

Blown fuse, break in ac line cord, or a defective on off switch.

4

If all appear normal, check primary of power transformer for open.

5

If fuse is blown, try replacement. If it blows, there is short in power supply.

6

If tubes light, replace rectifier tube.

7

Watch rectifier closely as you switch set on. If tube arcs, there is short in B plus.

IF THERE IS NO SOUND AND THERE IS NO RASTER, THE TROUBLE MUST BE EITHER IN THE POWER SUPPLY CIRCUIT, OR IN THE AC LINE INPUT TO THE POWER SUPPLY. IN ANY CASE IT IS EASY TO LOCALIZE TO ONE OR THE OTHER. BE SURE THAT THE ON OFF SWITCH IS IN THE ON POSITION.

NO RASTER OR SOUND

SYMPTOM

IF THE AC LINE INTO THE POWER SUPPLY IS BROKEN, NONE OF THE TUBES WILL BE LIT AND THERE WILL BE NO AC POWER TO THE SET. IF THE TUBES ARE LIT THEN THE AC LINE MUST BE INTACT, AND THE TROUBLE WOULD THEN BE IN THE POWER SUPPLY ITSELF. WE ARE SPEAKING OF THE LOW VOLTAGE POWER SUPPLY SINCE, IF THE HIGH VOLTAGE SUPPLY ONLY WERE BAD, WE WOULD STILL HAVE SOUND.

8 Remove rectifier tube and check ohms from cathode to ground.

9

If below 20k there is short in B plus line.

10

Check input and output filter capacitors for short.

11

Follow B plus line from cathode of rectifier with ohm meter.

12

Disconnect lead from B plus line checking for short to clear.

13

If short clears as you remove a lead, check lead circuit for short.

14

TROUBLE SHOOTER

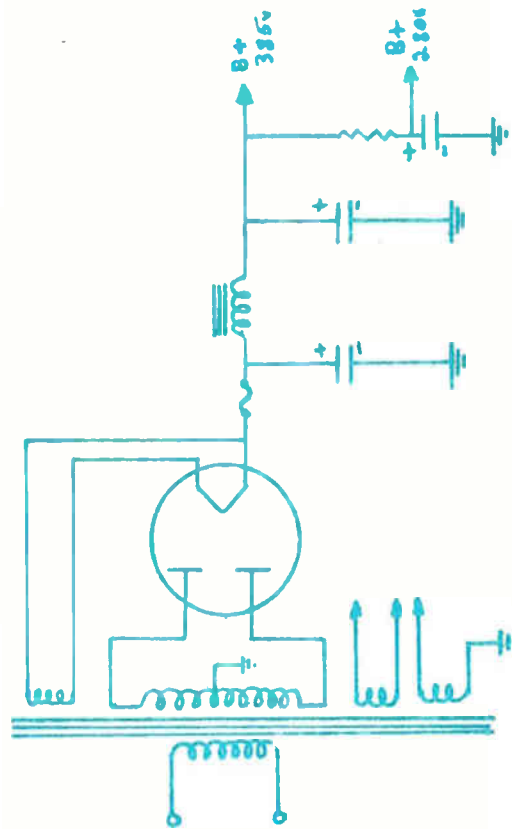

1

Be sure that set is being operated in a dark room.

2

Too much light falling on the screen will make pix washed out.

3

Check high voltage for correct amount.

4

If high voltage is low, try to adjust to normal.

5

If HV still low, replace all tubes in HV and horizontal circuits.

6

Check for sufficient signal at input of horizontal output tube.

7

If low input, check horizontal oscillator circuit.

DIGEST (A)

WHEN THE BRIGHTNESS CONTROL IS ADJUSTED THE PICTURE SHOULD GET BRIGHTER TO A POINT WHERE IT IS TOO BRIGHT. WITH THIS TROUBLE OF LOW BRIGHTNESS, ADVANCING THE CONTROL WILL NOT INCREASE THE SCREEN BRIGHTNESS ENOUGH. IN BLACK AND WHITE PICTURE TUBES, THIS WOULD OFTEN MEAN THAT THE PICTURE TUBE MIGHT BE GETTING WEAK, BUT IN A COLOR RECEIVER, THE PICTURE TUBE CONTAINS THREE GUNS AND IT IS MOST UNLIKELY THAT ALL THREE WILL GO BAD AT THE SAME TIME.



LOW BRIGHTNESS

SYMPTOM

TROUBLE

TELEVISION

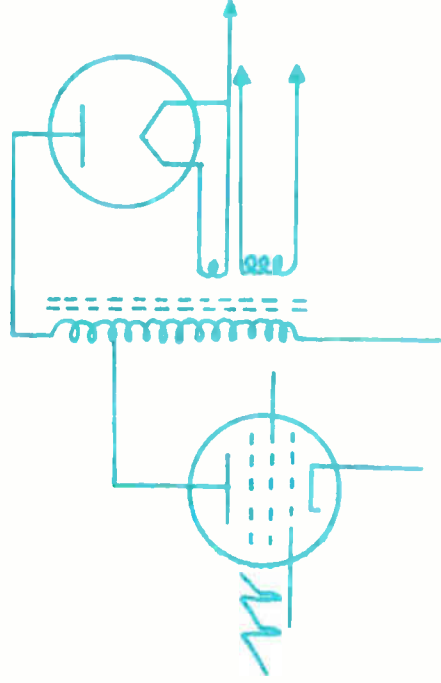

NTR L WHITTIER, CALIF. U.S.A.

CIRCUIT

DIAGRAM

DIGEST (B)

THERE ARE TWO POSSIBLE CAUSES OF THIS TYPE OF TROUBLE. ONE IS THE HIGH VOLTAGE SYSTEM THAT MIGHT NOT BE PRODUCING ENOUGH HIGH VOLTAGE, AND THE OTHER POSSIBILITY IS THAT THE BRIGHTNESS CONTROL CIRCUIT IS DEFECTIVE. THIS CIRCUIT IS COMMON TO ALL GUNS OF THE PICTURE TUBE, AND IF IT IS NOT FUNCTIONING CORRECTLY THEN ALL GUNS WILL BE AFFECTED.

8

If input to output tube good, check chart on blooming.

9

With normal HV, trouble is in CRT.

10

Check voltages applied to base of CRT.

11

B plus may be low. If so, check power supply.

12

If voltage to all cathodes of CRT is low, check brightness circuit.

13

Look for an increase in voltage divider resistors in brightness circuit.

14

1

Replace all sound tubes.

2

Check the bias on the audio output tube.

3

Coupling capacitor to grid may be leaking.

4

Be sure that the speaker voice coil is not rubbing.

5

To check this push gently on cone at various points.

6

Check voltages at 1st audio amplifier.

7

This tube operates with small bias, around 1v.

8 (A)

WHEN THE SOUND IS DISTORTED, THE TROUBLE IS LIMITED TO THE SOUND CIRCUIT OF THE COLOR RECEIVER. THE TROUBLESHOOTING PROCEDURE TO FOLLOW IS THE SAME AS FOR DISTORTED SOUND IN ANY FM SYSTEM. OF COURSE A CLOSE CHECK SHOULD BE MADE TO BE SURE THAT THE PICTURE IS OF GOOD QUALITY. OTHERWISE THE AGC MIGHT BE AT FAULT.



DISTORTED SOUND

SYMPTOM

8 (B)

IT IS ALWAYS A GOOD IDEA TO TRY AND ISOLATE THE CAUSE OF THIS TROUBLE TO EITHER THE AUDIO CIRCUITS OR THE RF CIRCUIT. IN MOST CASES A CHANGE IN BIAS IN THE AUDIO OUTPUT STAGE IS THE LIKELIEST CAUSE, ALTHOUGH ALIGNMENT COULD ALSO CAUSE THIS TROUBLE.

8

If audio stage appears normal check alignment.

9

Connect gen to grid of last IF tube.

10

Feed in 4.5mc with 1mc sweep. Set marker at 4.5 mc.

11

Place scope at high side of volume control.

12

Should observe "S" curve with marker at center.

13

If marker off center, adjust detector, xfmr until marker at center.

14

TELEVISION TROUBLE SHOOTER

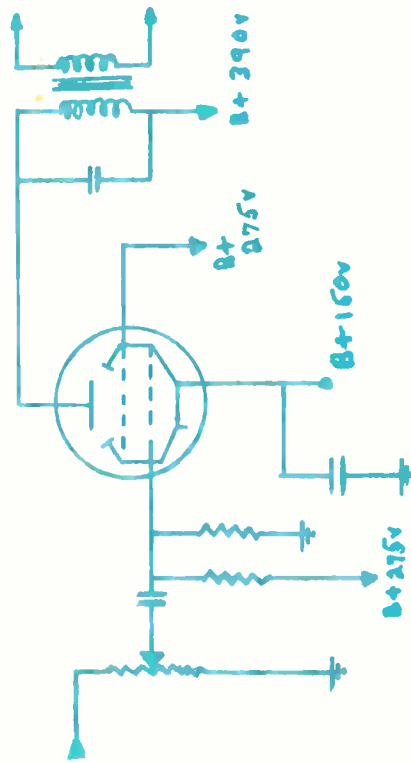

DIGEST (A)

1

Replace all sound tubes.

2

Place finger at center tap of volume control, with control at max.

3

A buzz should be heard in the speaker. If no buzz, trouble in audio.

4

Feed signal into audio output grid. If no tone, troubleshoot output stage.

5

If tone at output grid, troubleshoot first audio amp.

6

If a buzz is heard at volume control, entire audio okay.

7

Connect gen at grid of last IF tube. Feed in 4.5 mc signal.



WITH NO SOUND, AND A GOOD PICTURE, THE TROUBLE IS LIMITED TO THE SOUND SYSTEM FROM THE SOUND TAKE OFF POINT TO THE LOUDSPEAKER. METHODS SIMILAR TO TROUBLESHOOTING A RADIO CAN BE USED HERE TO FIND THE DEFECTIVE STAGE. CHECK AUDIO STAGES FIRST, AND THEN WORK BACK TO THE IF STAGES.

NO SOUND. PIX OK.

SYMPTOM

DIGEST (B)

8

Vary frequency of gen slightly above and below 4.5mc. A tone should be heard.

9

If no tone when doing this, troubleshoot detector stage.

10

Remember, FM detectors do not require Bplus. They operate on signal.

11

If a tone is heard at grid of last IF, move gen back one stage.

12

Continue to move gen back until point of no tone, then troubleshoot.

13

14

