

Color Television

Home Study Course

RCA Institutes, Inc.

A SERVICE OF RADIO CORPORATION OF AMERICA

© RCA INSTITUTES, INC. 1962
1966 PRINTING

ALL RIGHTS RESERVED
TRADEMARK'S ® REGISTERED
MARCA(S) REGISTRADA(S)

8001



COLOR TELEVISION COURSE

PRINCIPLES OF COLOR TELEVISION

- 1. An Elementary Color Television System**
- 2. Light and Color**
- 3. The Color TV Signal**
- 4. Principles of Two-Phase Modulation**
- 5. Development of the Color TV Transmission Standards**
- 6. Recovering the Chrominance Signals at the Receiver**
- 7. An Over-All View of the System**
- 8. Supplementary Information**



RCA INSTITUTES, INC.

A SERVICE OF RADIO CORPORATION OF AMERICA

HOME STUDY SCHOOL

350 West 4th Street, New York, N.Y. 10014



INTRODUCTION

A startling demonstration of the impact of Color Television can be performed by turning down the color control on a receiver during a color telecast. Blue skies, sparkling green waters, red lips, and eye-catching costumes all assume disappointing and monotonous shades of gray.

In addition to its appeal in entertainment and advertising, the full-color picture conveys more information about the objects being televised. This greatly improves the value of television in many medical, industrial, and military applications.

In this first lesson you will find out how colored images are transformed into electrical signals, how the properties of human color vision are utilized in obtaining optimum fidelity with a minimum of transmitted information, and how the added information for color is squeezed into the standard television channel.

The first few lessons of the course deal mostly with theory — the hows and whys. However, we do not wish to burden the practicing technician with more theory than he needs. For those students who wish to dig deeper into the subject matter presented in the first lesson, we have added a supplement at the end of the lesson. This section is put at your disposal so that you may enhance your understanding of some of the basic concepts of color TV transmission, and become more knowledgeable about the over-all color TV system. The examination does not

cover the material presented in the supplement. Skip this section now if you like. You may want to return to it after you have mastered the practical matters of receiver servicing.

1-1. AN ELEMENTARY COLOR TELEVISION SYSTEM

If you will recall some grade school experiences with paints and crayons, you will remember that almost every color can be produced by mixing proper amounts of three primary colors. An elementary color TV system based on this principle is shown in Fig. 1-1. The scene to be televised is split into its primary components by means of color-selective filters placed in front of the cameras. A red filter is placed in front of one of the cameras so that the red light is admitted to the camera. The camera "sees" only the brightness variations of the red components of the scene. All other colors are rejected by this camera. Similarly, a green filter on another camera makes that camera responsive only to the green components of the scene. The remaining camera is likewise arranged to be responsive only to blue light. Thus three signals are produced, each proportional to the amounts of red, green and blue light in the scene to be transmitted.

The student may object to this choice of primary colors, as we all remember that red, yellow, and blue are the familiar primaries when mixing paints. However, the mixing of *light sources* is quite a different process

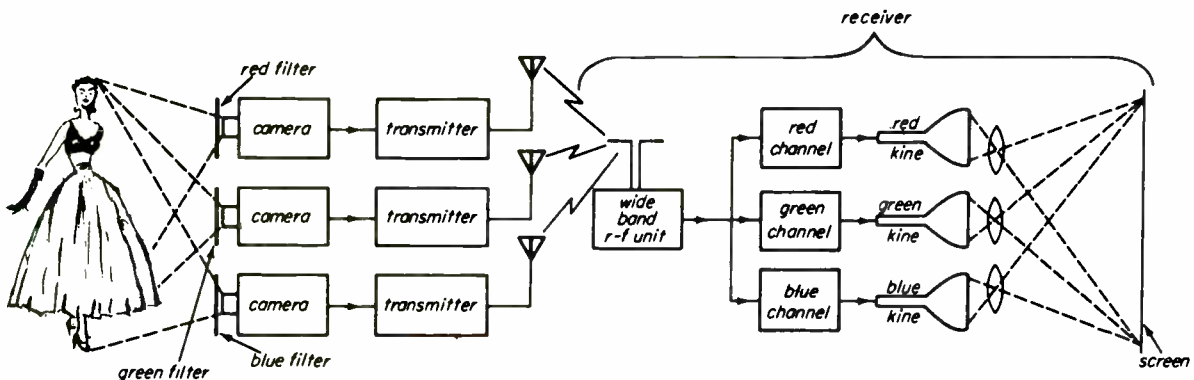

Fig. 1-1. An elementary color TV system could be made using three conventional black-and-white channels. Full-color information is conveyed in terms of three primary colors.

from the mixing of reflective pigments, as we shall see.

Each of the camera signals is used to modulate a separate television transmitter. In this simple example, the transmitters radiate different carrier frequencies.

At the receiver, each of the three modulated carriers is amplified and routed to separate amplifying sections by frequency-selective circuits. The detected video signals in each section are reproductions of the red, green, and blue brightness variations of the original scene. The red video signal is fed to a kinescope having a red phosphor. Similarly the blue and green signals are applied to kinescopes whose phosphors emit blue and green light respectively. An optical system of mirrors or prisms may be used to superimpose or *register* the images so that they are projected exactly on top of each other. The images are added together by the eye and a full-color picture is seen. (The modern color TV receiver employs a single tri-color picture tube to do the job described here in terms of three separate picture tubes.)

The system just described consists of three separate television channels. The transmission and reception of color is accomplished by adding filters in front of the cameras and colored phosphors to the kinescopes. This system can produce high-quality color pictures, yet requires no special color circuits. *However, despite its simplicity and good color fidelity, such a system could not be used for television broadcasting.* The simple system does not meet certain requirements that must be imposed on a broadcasting system. These requirements are so important that the color television system has been built to satisfy each of them. Let us examine these requirements in detail.

Bandwidth. The system of Fig. 1-1 requires three complete TV channels, occupying a total spectrum space of about 12 mc. The great demand for television channels makes this disadvantage serious enough to disqualify this simple system. An acceptable system must occupy no more spectrum space than the standard TV broadcast channel.

Compatibility. Another important requirement is that existing black-and-white receivers be able to reproduce black-and-white pictures when tuned to a color telecast. This requirement is called the *compatibility* of the system. It is important because of the large number of black-and-white receivers in use. Reception of color TV pictures by black-and-white receivers is possible if: the scanning frequencies and modulation standards are the same for both systems; a monochrome, or black-and-white, signal can be obtained from the color signal; and the color information in the transmitted signal does not degrade the quality of the black-and-white picture. Compatibility also requires that color TV receivers produce acceptable black-and-white pictures when receiving a black-and-white telecast. This is sometimes called *reverse compatibility*.

The transmission of all the information needed for color television within the 6-mc bandwidth of a standard TV channel, in such a way as to be compatible and produce high-quality color pictures, is a considerable achievement. To fill these requirements advantage is taken of certain characteristics of human vision, principles of light and color, and recently developed electronic techniques. The following sections will deal with these topics in detail. You will see how the elementary system of Fig. 1-1 is made to meet the aforementioned requirements, yielding a color TV system that is compatible, fits into the standard 6-mc channel, and produces high-quality color pictures.

1-2. LIGHT AND COLOR

Nature of Light. Radiant energy from a certain portion of the electromagnetic spectrum appears in the form of light. The band of frequencies in the electromagnetic spectrum that produces a visual sensation is shown in Fig. 1-2. It lies between 385×10^6 and 790×10^6 megacycles. We may consider our eyes to be receivers that tune to this band of frequencies.

The wavelengths of visible light are extremely short, and special units have been assigned to describe them conveniently. The units are the millimicron ($m\mu$), which is a

millionth of a millimeter, and the angstrom unit (A), which is a ten-millionth of a millimeter.

Light from the sun at noon on a clear day may be defined as *white light*. In order to investigate the composition of white light, an arrangement like that shown in Plate 1 can be used. In a darkened room, white light is projected through a narrow slit. A glass prism and a screen are arranged so that the light passes through the prism and falls upon the screen. A brilliant display of colors can be observed on the screen. The prism separates the white light into its component colors and produces a *visible spectrum* on the screen. Hundreds of different colors, blending imperceptibly into each other, may be distinguished, but they may be roughly grouped into six principal colors. The names of the principal colors, or *hues*, and their approximate locations in the frequency spectrum are shown in the expanded section of the visible spectrum shown in Fig. 1-2.

The prism in Plate 1 splits white light into its component parts. We may extend this demonstration by arranging another prism to catch the dispersed beam. When

the proper angle is found, the spectral colors can be made to fall in register on a screen and white light results. Thus white light is composed of all the spectral colors, and if the spectral colors are added together, white light results.

Light from different parts of the visible spectrum produces the sensation we call color. For example, light restricted to a band of wavelengths near 500 millimicrons appears to us as green light. Sunlight is white, but objects illuminated with sunlight appear colored because the objects do not reflect all wavelengths equally. Grass is green because it absorbs a large part of the visible spectrum and reflects that part of the spectrum near 500 millimicrons.

Describing Colors. To reproduce colors, we must find out what minimum amount of information is required to describe a color accurately. Three pieces of information are required. These are hue, saturation, and brightness. What are usually spoken of as "colors" are more scientifically referred to as *hues*. Thus red, green, yellow, and blue are different hues. Hue is determined by the energy distribution of the color over the

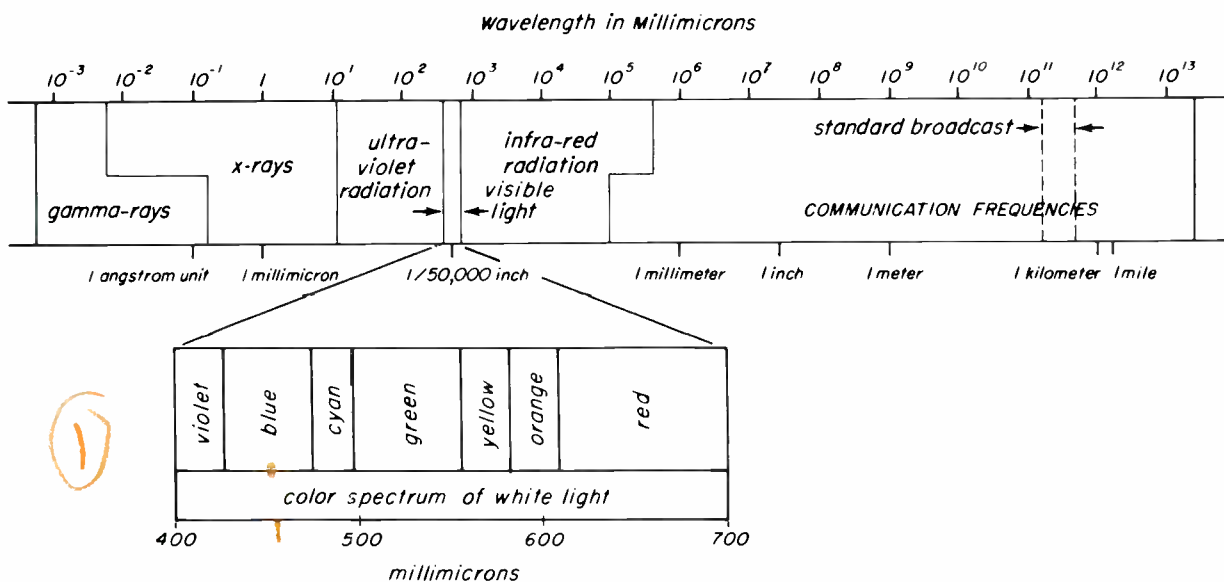

Fig. 1-2. A portion of the electromagnetic spectrum produces the visual sensation we call light. Our eyes can identify radiations from different parts of the visible spectrum by characteristic hues or colors.

2

visible spectrum. The wavelength at which the energy is concentrated is called the dominant wavelength, and the hue is usually that of the dominant wavelength. The vividness of a hue is termed its saturation. Thus pink, pale red, and deep red are different degrees of saturation of the same hue. Deep vivid colors are said to be highly saturated. The various shades of gray produce no color sensation, and therefore have zero saturation. Colors of low saturation, such as pink, may be considered as being diluted with white light, while highly saturated colors are free from dilution by white light. The brightness of a color refers to its lightness or darkness. In order to completely describe a color in terms of its visual sensation, it is necessary to describe its brightness, hue, and saturation. The student should note that from this point on, the word color is used in its precise sense: to talk about a certain color its hue, saturation, and brightness must be known. The hue and saturation components are known as the chromaticity information.

Primary Colors and Color Mixtures. It was shown in previous paragraphs that addition of all the spectral colors produces white light. However, it has been found that white or any other color can be produced by a mixture of only three colors. These three colors are called the primary colors. Any three colors can be used as primary colors, provided that no two when mixed together produce the third. Theoretically, any color may be produced by a mixture of certain amounts of any three primaries. For color television the commonly used primaries are red, blue, and green because they can most conveniently be combined to produce a great number of other colors. White light can be produced by adding certain definite amounts of red, blue, and green, and almost any color may be produced by adding red, blue, and green in different proportions.

The principles of adding colors can be seen with an arrangement like that shown in Plate 2. Three projectors, each with a white light source, are arranged to project overlapping beams of light. A red filter is placed in front of one of the projectors, a green filter in front of another, and a blue filter in front of the third. A filter passes

only light of the same color as the filter. Thus, the first projector projects a beam of red light, the second a beam of green light, and the third a beam of blue light. Where the three beams overlap, white is produced. Where the red and blue beams overlap, a purplish hue called magenta is produced. (It is interesting to note that magenta does not appear in the spectrum of white light, but may be produced by the addition of red and blue light.) Where the red and green beams overlap, yellow is produced; and where the blue and green beams overlap, a bluish green called cyan is produced. By varying the relative amounts of red and green, various hues ranging from orange to yellowish green can be produced. By varying the relative amounts of blue and green, various hues ranging from a bluish green to a greenish blue can be produced, and various shades of purple can be produced by varying the relative amounts of red and blue. Thus, almost any color can be produced by adding appropriate amounts of red, blue, and green light. Since we are dealing with the addition of lights of different wavelengths, red, green, and blue are called additive primaries.

A convenient unit for measuring the amount of light from the primary sources is called a primary unit. If the amount of light from each of the projectors shown in Plate 2 is adjusted until a standard white is produced, then the amount of colored light from each projector is defined as one primary unit of that color. Equal amounts of red, blue, and green (in terms of their primary units) produce gray or white. White and grays are achromatic, or without color. Whether white or gray is produced by the mixture of red, blue, and green is determined by the brightness of the primaries in the mixture. Bright red, bright blue, and bright green combined in the proper proportions produce white, while dull red, dull blue, and dull green combined in the proper proportions produce some shade of gray.

It is important for the technician to become familiar with the mixing of primary colors to produce white, as adjustments of this kind are needed in the receiver. When the proper amounts of red, green, and blue light are added, almost any desired "white" may be produced. If the light output of one

of the projectors mentioned in connection with Plate 2 is too strong, the resulting white appears predominantly red, blue, or green. Insufficient output from one of the primary-color projectors results in a predominant hue determined by the remaining primary hues. For example, lack of blue results in a white that contains too much red and green, and appears as a yellowish white. Lack of red results in a pale bluish-green or cyan hue, and lack of green produces a white that looks pale purple.

Subtractive Processes. The color of an object as perceived by the eye depends upon the light reflected by that object to the eye. This in turn depends upon the nature of the reflecting surface and the quality of the light falling upon the surface. In daylight, a white object appears white because it reflects all the light falling upon it back to the eye. A red object appears red because it absorbs all the light except red, which it reflects back to the eye. A yellow object appears yellow because it absorbs only blue light, and reflects the remaining light back to the eye. The light reaching the eye produces the visual sensation of yellow light. Colored objects are, therefore, seen by a subtractive process, in which the color of the object depends upon what is absorbed from the white light falling upon the object.

If white light is passed through a yellow filter, the blue component of the white light is absorbed; therefore, yellow may be thought of as "minus blue." If a white light is passed through a cyan filter, the blue and green components of white light are transmitted but the red component is absorbed; thus cyan may be thought of as "minus red." In the same manner, magenta may be thought of as "minus green." By varying the amount of red, blue, and green light removed from white light (by passing it through cyan, magenta, and yellow filters) any color may be reproduced. Therefore, cyan, magenta, and yellow are called the subtractive primaries. For example, red may be produced by passing white light through a magenta and yellow filter. The magenta filter absorbs green, the yellow filter absorbs blue; only red is transmitted. If white light is passed through all three subtractive filters, a neutral gray or black results. All colored

objects, color slides and movies, and paintings are seen by this subtractive process.

The student may remember from his drawing or art studies that blue and yellow make green, which seems to contradict the statement made previously that red and green make yellow. However, the mixing of the colored *light sources*, as in the overlapping projectors described earlier, or in color television, is an additive color process. It is *not* the same as the subtractive color process by which pigments produce color in paintings. The colors used by artists as basic colors are not exactly red, blue, and yellow, but the bluish red called magenta, the greenish blue called cyan, and yellow; in other words, the subtractive primaries. When cyan and yellow pigments are mixed together on a surface, green is produced in this manner: white light falls on the surface, and the cyan or "minus red" absorbs red light, leaving blue and green light. However, the yellow pigment is intermixed with the cyan. The yellow, which is "minus blue," absorbs blue light. This leaves only the green light, which is not absorbed but returned to the eye.

Illuminants. The color of an object as seen by the eye is dependent not only on the reflecting characteristics of the surface, but also upon the nature of the light falling on the object. The well-known practice of examining garments or matching materials in both daylight and artificial light is based on this fact. For example, a blue material might appear black in artificial light that contains very little blue. Conversely, a yellow material might appear greenish under a light that has very little red, such as that from a mercury-vapor lamp. The make-up of some common light sources is shown in in Fig. 1-3. The energy from the incandescent lamp is mostly concentrated toward the red end of the spectrum, whereas light from the sky is concentrated toward the blue end of the spectrum. Despite this variance in light sources, everyday experience shows that a white shirt or white paper is "seen" as white under artificial tungsten light, which is quite yellow, and also under fluorescent lamps, which are quite blue. This is because of the color adaptation properties of the eye, which tend to compensate for the differences

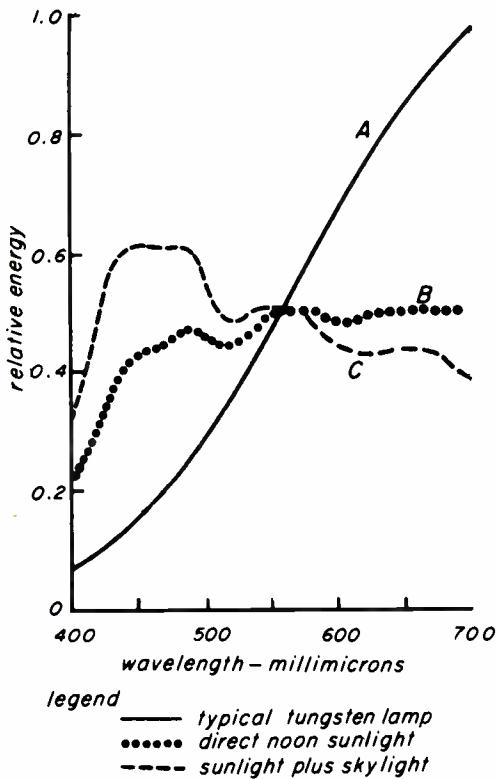

Fig. 1-3. These curves are like response curves, showing relative energy versus wavelength for three common sources of light.

in illumination, and because of our psychological acceptance that the shirt or paper is white. However, for truly accurate color matching, the exact nature of the light should be specified.

Specification of White Light. The specification of any one light source as white light poses a difficult choice. A color which contains an equal amount of radiant energy over the entire visible spectrum, so that it would be represented by a straight horizontal line in Fig. 1-3, is termed an equal-energy white. An equal-energy light source is very convenient for use in calculations, but it cannot be produced easily. Several practical light standards have been established by the International Commission on Illumination. They are made by known light sources and accurate filters, and are defined as Illuminants A, B, and C. Illuminant A is typical of tungsten lamps, Illuminant B is typical of direct noon sunlight, and Illuminant C is typical of average daylight, which is combined sunlight and skylight, as distinguished from direct noon sunlight. These are identified by the corresponding letters in Fig. 1-3.

Characteristics of Human Vision. The response of the human eye is not uniform within the visible spectrum. A sort of response curve showing the eye's response in terms of the brightness sensation versus wavelength is shown in Fig. 1-4. Note that the eye is most sensitive, or "peaks," in the green-yellow region of the curve, near 550 millimicrons. Thus, if we observe several light sources that emit equal amounts of light of different hues, the green light sources appear brightest.

The black-and-white television system responds only to brightness variations, so that the black-and-white cameras should produce the same brightness variations as the human eye. For this reason the photosensitive surface of the black-and-white camera tube is selected to have a response curve like that shown in Fig. 1-4. Greens, blues, reds, and all other hues then produce the same brightness variations as the human eye. Figure 1-5 shows how a black-and-white TV system would reproduce the color picture in Plate 2. The relative positions of the colors are the same. Note that the green area appears much brighter than the red and blue areas.

Compatibility requires that a black-and-white or monochrome signal be obtained from the color signal. A monochrome signal may be obtained from the outputs of the color cameras in Fig. 1-1 by adding the outputs of the three cameras in the proper proportions.

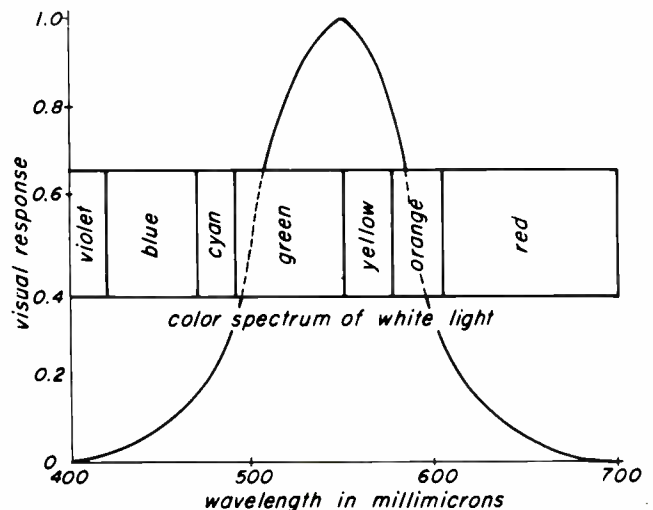

Fig. 1-4. Our eyes are not equally sensitive throughout the visible spectrum. Maximum response occurs in the green-yellow portion of the spectrum.

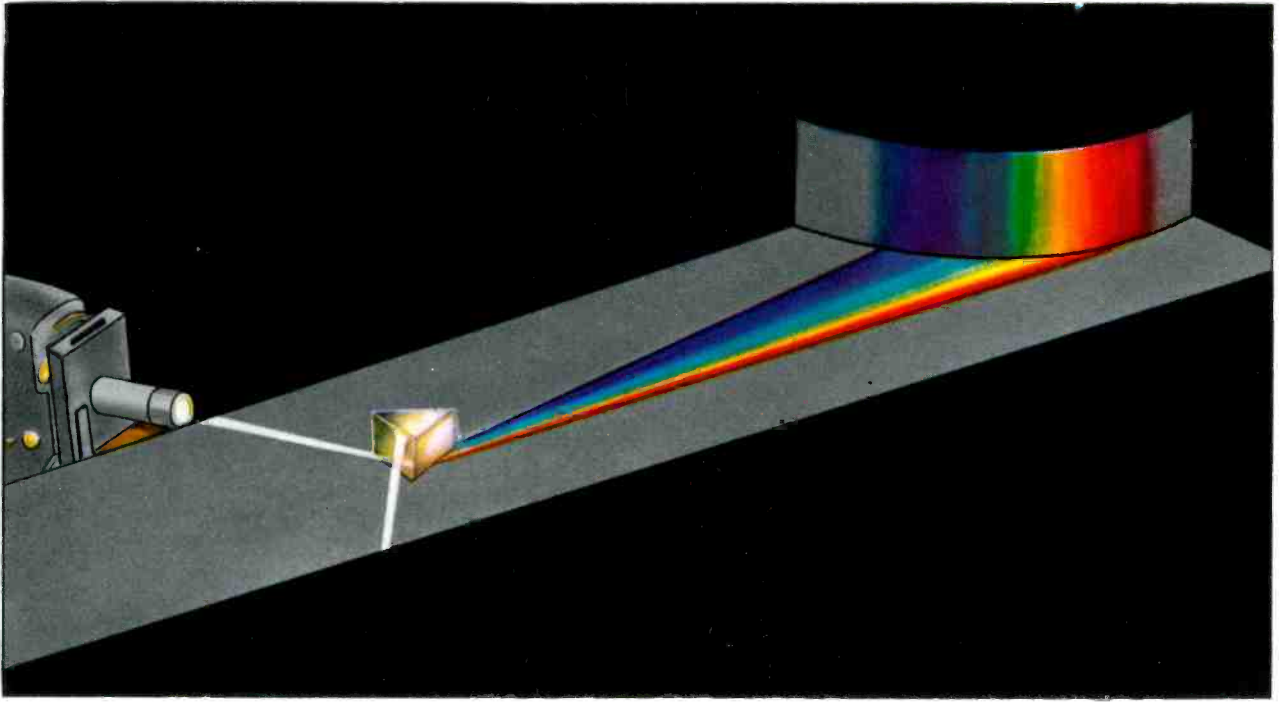

Plate 1

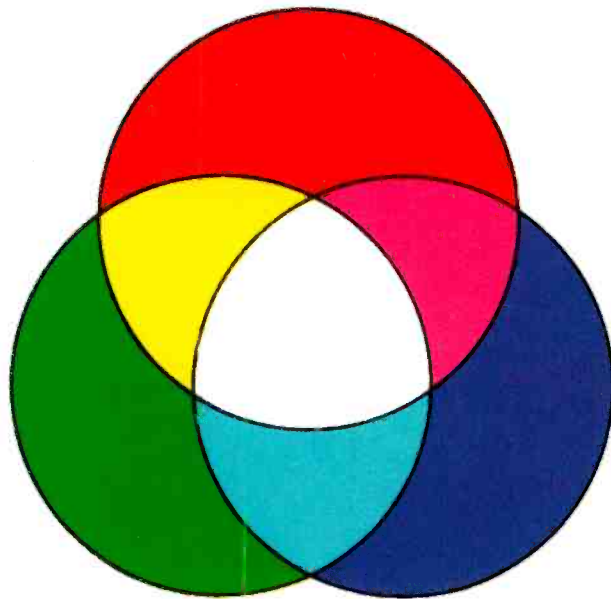

Plate 2

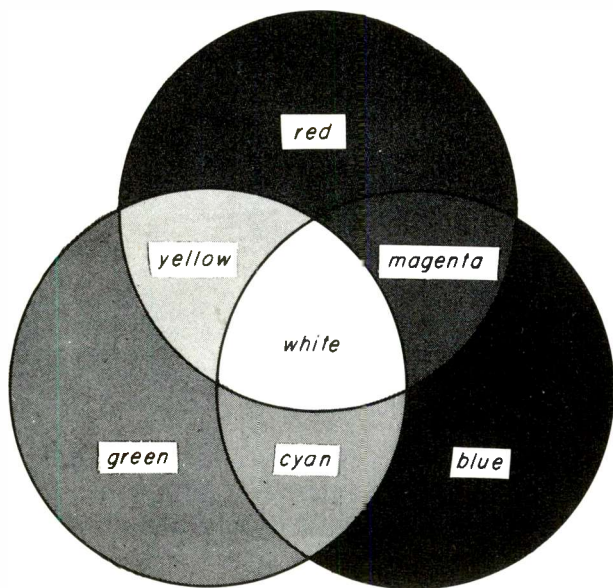

Fig. 1-5. A black-and-white reproduction of Plate 2 looks like this. Notice that the green area appears brighter than the blue and red areas.

To duplicate the brightness sensations of human vision, a larger proportion of the green signal appears in the monochrome signal. Based on experimental findings using the selected red, green, and blue primaries, a correct monochrome picture is produced by adding together 30 percent of the red camera output, 59 percent of the green camera output, and 11 percent of the blue camera output. The sum of these signals is called the brightness or luminance signal and is designated by the letter *Y*. The *Y* signal is similar to the signal produced by a standard black-and-white camera.

$$Y = 30\% \text{ red} + 59\% \text{ green} + 11\% \text{ blue}$$

Visual Acuity. In our study of monochrome television, we found that the illusion of a complete picture can be produced by taking advantage of certain characteristics of vision. For example, the rapidly moving spot of light on the TV screen produces the illusion of a picture through the characteristic known as *persistence of vision*. In color TV, the amount of information required to transmit a full-color picture is minimized by taking advantage of the way in which the human eye resolves small details in the picture. The ability to see fine detail is called *visual acuity*. The subject of visual acuity is important in television because it determines

the amount of information that the system must handle. If certain details in the picture are so small, or so close together, that they cannot be resolved by the eye, the system need not reproduce them. Thus there is little advantage in extending the video passband in our TV system beyond 4mc, as it would be difficult for us to see an improvement.

Figure 1-6 provides an interesting demonstration of the way in which pattern arrangement affects acuity. Prop up this book and walk backward slowly until the lines in the left-hand illustration become just barely distinguishable. Then focus your eyes on the illustration at the right, and you will see that the vertical lines can still be seen quite clearly. This fact, that a 45-degree pattern is less noticeable than a vertical or horizontal one, is made use of in the halftone process by which pictures are reproduced for printing. The halftone screen used to divide the picture into dots for reproduction is so placed that the dot pattern is at a 45-degree angle to the edge of the page, making it less visible to the eye. The application of this principle to color television is that any dot pattern appearing in the construction of the picture on the color kinescope will be less visible if it occurs at a 45-degree angle to the vertical. As we shall see later, the interference pattern caused by the color signal is also arranged to produce a 45° pattern in order to minimize its visibility.

Our visual acuity for differences in chromaticity is decidedly different from our visual acuity for differences in brightness. Our ability to resolve differences in hue in small details in the picture is far poorer than our ability to see differences in black and white and shades of gray. In addition, when the eye cannot resolve small adjacent colored areas separately, it sees a new color formed by the mixture of the individual colored

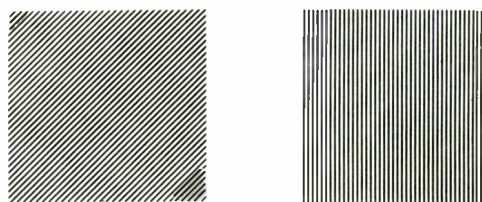

Fig. 1-6. Visual acuity depends somewhat upon pattern arrangement. The slanted lines at left are more difficult to resolve at a distance.

zones. For example, consider three small luminous colored dots arranged as in Fig. 1-7: one blue, one red, and the third green. If the dots are too small to be resolved individually, the eye sees a mixture of the three colors.

The apparent lack of visual acuity for hue and saturation reduces greatly the amount of information required to provide the illusion of a high-definition color picture. Since we cannot see hues in very small areas of the picture, it is not necessary to reproduce colors in small areas. Color information can then be restricted to a relatively narrow band of frequencies. The wide-band brightness, or monochrome, signal can provide the brightness variation in small areas that our eyes can detect.

In addition, our poorer visual acuity to hue and saturation makes the tricolor kinescope possible. In this picture tube, the light from very tiny red, green, and blue phosphor dots are mixed by our eyes to produce white. By proportioning the light output of the red, green, or blue phosphor dots, a very wide range of hues can be reproduced.

Another aspect of color vision is that the apparent color of an area is influenced by its size. It is interesting to consider one of the tests that have been made to show the effect of size on apparent color. A small patch was cut out of a colored sheet, and observers were asked to match this small patch. The majority of observers found that the patch did not visually match the original sheet from which it was cut as well as it appeared to match other sheets of different hue and saturation! It was found that any small colored patch, regardless of its actual chromaticity, could be visually matched by

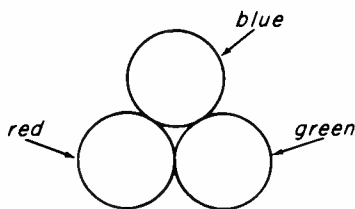

Fig. 1-7. If this pattern of colored light is moved away from the observer the individual dots merge to appear as white light.

some mixture of orange and cyan. This means that the chromaticity of all of these small patches appeared to the observers as mixtures of orange and cyan. This is very important. It shows that small-area color vision is two-color vision, and that the chromaticity of any such small area may be completely described by specifying the amount of orange or cyan required to match it. It also indicates that the greatest portion of the channel bandwidth used for color television transmission should be allotted to these two colors.

Requirements of the Color TV Signal.

The data given in the preceding sections on the nature of color vision enable us to determine the amount of information that must be contained in the color television signal. We will now summarize the most important features of color vision, and state how they are applied to the color TV system.

1. As the size of the viewed object is decreased, or its distance from the eye is increased, until it occupies a very small part of the field of vision, the eye becomes progressively color blind.
2. Objects that occupy a very small part of the field of vision (and objects of very low brightness) produce no color sensation — only a brightness sensation. Thus they appear colorless. Therefore no color information need be transmitted or received for these small objects. The absence of color detail corresponding to video frequencies above about 1.5 mc cannot be detected by the eye.
3. Objects that occupy an intermediate part of the field of view, corresponding to video frequencies from about 0.5 mc to 1.5 mc, are seen by two-color vision; that is, they may be matched or reproduced by a mixture of only two primaries. Thus, only two-color information need be transmitted or received for these objects. The two primaries are orange and cyan. A colored area in the size range described above is always seen as some mixture of orange and cyan, regardless of its actual color. Thus, for such colored areas, only orange and cyan information need be transmitted, since some mixture of orange and cyan will visually match the color.

4. Large areas, corresponding to video frequencies up to about 0.5 mc, are seen by three-color vision, and therefore three-color information is needed for these areas.

It should be noted that these limitations of color information do not mean that the picture quality has been reduced. It means only that the information the eye cannot use has been eliminated from the color signal.

From the information that has been given regarding relative visual acuity for various colors, we can also summarize the following:

It would be wasteful to allot equal space in the channel spectrum to all colors. Since the smaller details of an image are seen as mixtures of orange and cyan, the greatest portion of the channel spectrum space available for color information is allotted to colors that are orange, cyan, or mixtures of orange and cyan. Such colors are allotted about 1.5 mc of spectrum space. Colors other than orange-cyan combinations are allotted only about 0.5 mc of spectrum space.

1-3. THE COLOR TV SIGNAL

In order to provide compatibility, the complete color signal must contain a black-and-white signal in the conventional form. In other words, existing black-and-white receivers must be able to reproduce monochrome pictures with no changes required in

their circuitry. For this purpose, the complete color signal contains a monochrome or Y signal. The additional information required for color is added in such a way that black-and-white receivers ignore the chromaticity information. Color receivers are designed to detect the chromaticity information and reconstruct the original primary-color signals.

The Color Camera. The colored scene is analyzed by the tri-color camera; in this camera, the televised scene is separated into three primary-color pictures by the use of *dichroic mirrors*. A dichroic mirror has the property of reflecting a selected color and passing all other colors. A simplified sketch of the optical system used in the RCA three-tube color television camera is shown in Fig. 1-8. Note that two dichroic mirrors are used: one reflecting blue light and passing red and green, the other reflecting red light and passing green. Thus, the green component of the light from the scene passes unreflected to the green camera tube, the red component of the light is reflected upward to the red camera tube, and the blue component is reflected downward to the blue camera tube. Additional filters (*B*, *E*, and *F*) are placed in front of the image orthicons to give the camera the desired spectral response. In this manner the red, green, and blue light components from the televised scene are focused on the faces of the corresponding image-orthicon camera tubes, which transform these light energies into

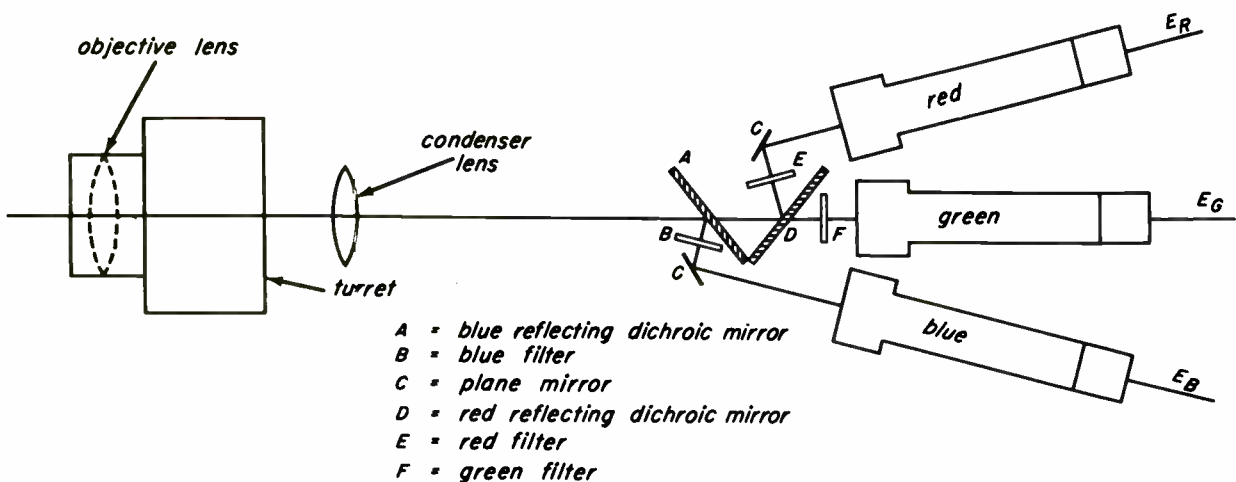

Fig. 1-8. Basic arrangement of the tricolor camera. Dichroic mirrors split incoming light into primary-color components.

electrical impulses representing the intensities of the three primary colors. The voltage outputs of the three image orthicons are adjusted so that they are equal when a white or neutral scene is scanned.

Generating the Y Signal. The Y or monochrome signal is obtained by adding certain definite proportions of the red, green, and blue signals to produce a composite monochrome signal.

The monochrome, or Y signal, conveys brightness information only. As was shown earlier, the visual sensation of brightness is not uniform throughout the visible spectrum, but peaks near the green-yellow hue. To produce a Y signal whose voltage response is similar to the human brightness sensation, we must construct a composite signal using 30% of the red signal, 59% of the green signal and 11% of the blue signal. A simple circuit for obtaining the Y signal is shown in Fig. 1-9. The output voltage of each of the three cameras is adjusted to provide one unit. The red signal is applied to a linear potentiometer whose arm is set to pick off 30% of the red signal E_R . Similarly the

green and blue signals are applied to potentiometers that are set to provide 59% of the green signal E_G , and 11% of the blue signal E_B , respectively. The output of the circuit is the sum of the voltages found at the taps on the potentiometers. Thus:

$$E_Y = 0.30E_R + 0.59E_G + 0.11E_B$$

In actual practice the job of dividing the input signals in their proper proportions is not accomplished by potentiometers, but by voltage dividers formed of accurate, fixed resistors.

Consider the Y signal that will be generated by the circuit of Fig. 1-9 when the scene to be viewed is the color-bar pattern shown in Fig. 1-10a. All the colors are fully saturated. When the white bar is scanned, each camera tube produces an output proportional to one primary unit. With a reference white background the camera outputs are adjusted to some reference level – say 1 volt. The resistor network in Fig. 1-9 provides an output consisting of 0.30 volt of the E_R signal, 0.59 volt of the E_G signal,

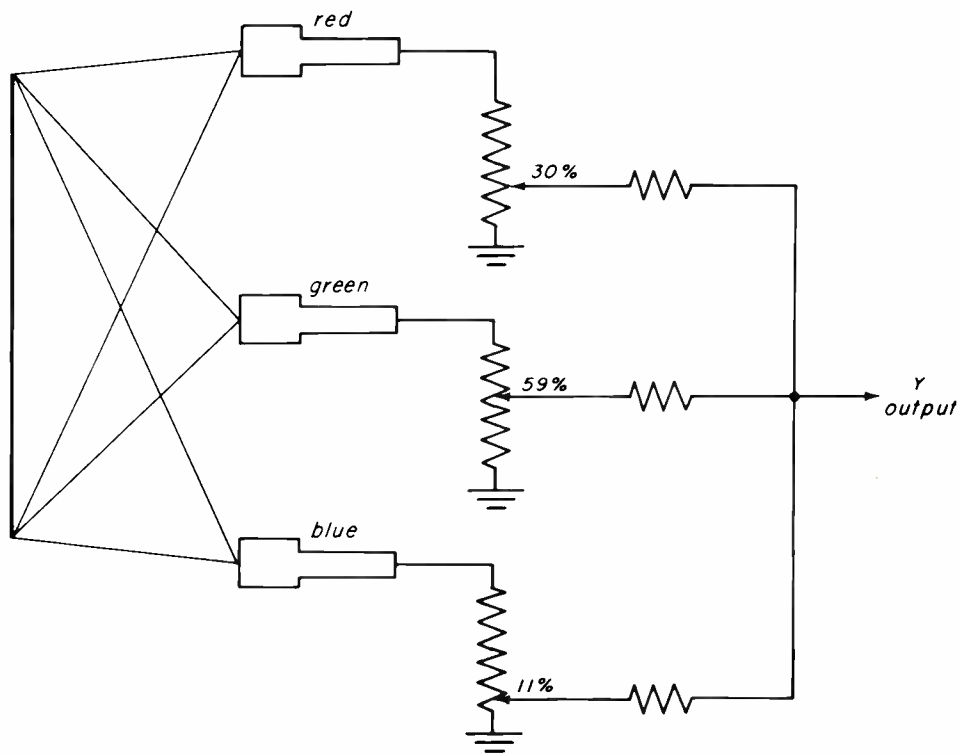

Fig. 1-9. The brightness or Y signal is obtained by adding the proper proportions of the primary-color signals.

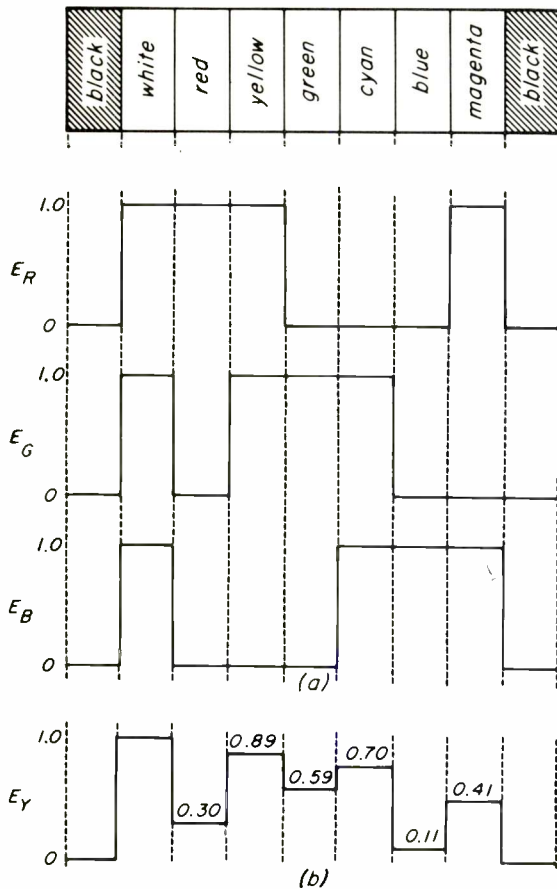

Fig. 1-10. (a) A color-bar pattern of saturated colors plus white, and the camera waveforms that result when the pattern is scanned: (b) the Y signal produced by the network of Fig. 1-9.

and 0.11 volt of the E_B signal. These fractions add to 1 volt for the white bar as in *b* of the figure.

When the red bar is scanned, the red camera tube continues to provide full output; the green and blue camera tubes receive no light, hence the E_G and E_B outputs are zero. The Y signal is then 30% of the E_R signal or 0.30 volt.

As the scanning beam passes the yellow bar there is an output from both the red and green camera tubes. Red and green in equal primary units produce yellow. Thus, the red and green camera tubes produce 1 volt each during the scanning of the yellow bar. The blue output is zero. The Y signal is now $0.3E_R + 0.59E_G$ or 0.89 volt.

We may continue analyzing the Y output at each bar in the same fashion to reconstruct the complete Y signal for one line as

shown in *b* of the figure. To illustrate one more case, the cyan bar is:

$$0.59E_G + 0.11E_B = 0.70 \text{ volt}$$

Looking at the waveform for the Y signal, we see that yellow and cyan produce the brightest sensations. If you check back to Fig. 1-5, you will see that the yellow and cyan zones in the projector pattern are the lightest zones.

The Y signal (including sync and blanking pulses) will provide a correct monochrome picture in a standard black-and-white receiver.

Adding the Chromaticity Information. We must now consider the problem of deriving a chromaticity signal that can be sent to the receiver separately. Black-and-white receivers will ignore this added information, but color receivers will be capable of detecting the color signal and combining the chromaticity signal with the Y signal to reconstruct the original red, green and blue signals. Since the Y signal conveys brightness information, the chromaticity signal, or signals, will convey hue and saturation information.

Chromaticity signals may be generated by subtracting the Y signal from the red, green, and blue signals. This yields a new set of signals, called the color difference signals, which are designated as $R-Y$, $B-Y$, and $G-Y$. These new signals are transmitted separately, and are added to the Y signal at the receiver to reproduce the original R, G, and B signals.

A simplified setup, showing how the color difference signals may be generated at the transmitter and recombined at the receiver, appears in Fig. 1-11.

At the left of the figure we see the network of resistors used to generate the Y signal from the red, green, and blue signals. The Y signal is transmitted to the receiver through a separate coaxial cable. (We shall use cables to simplify our early discussions. Later we shall deal with actual multiplexing techniques used to broadcast the signals.) The Y signal could be applied to a standard

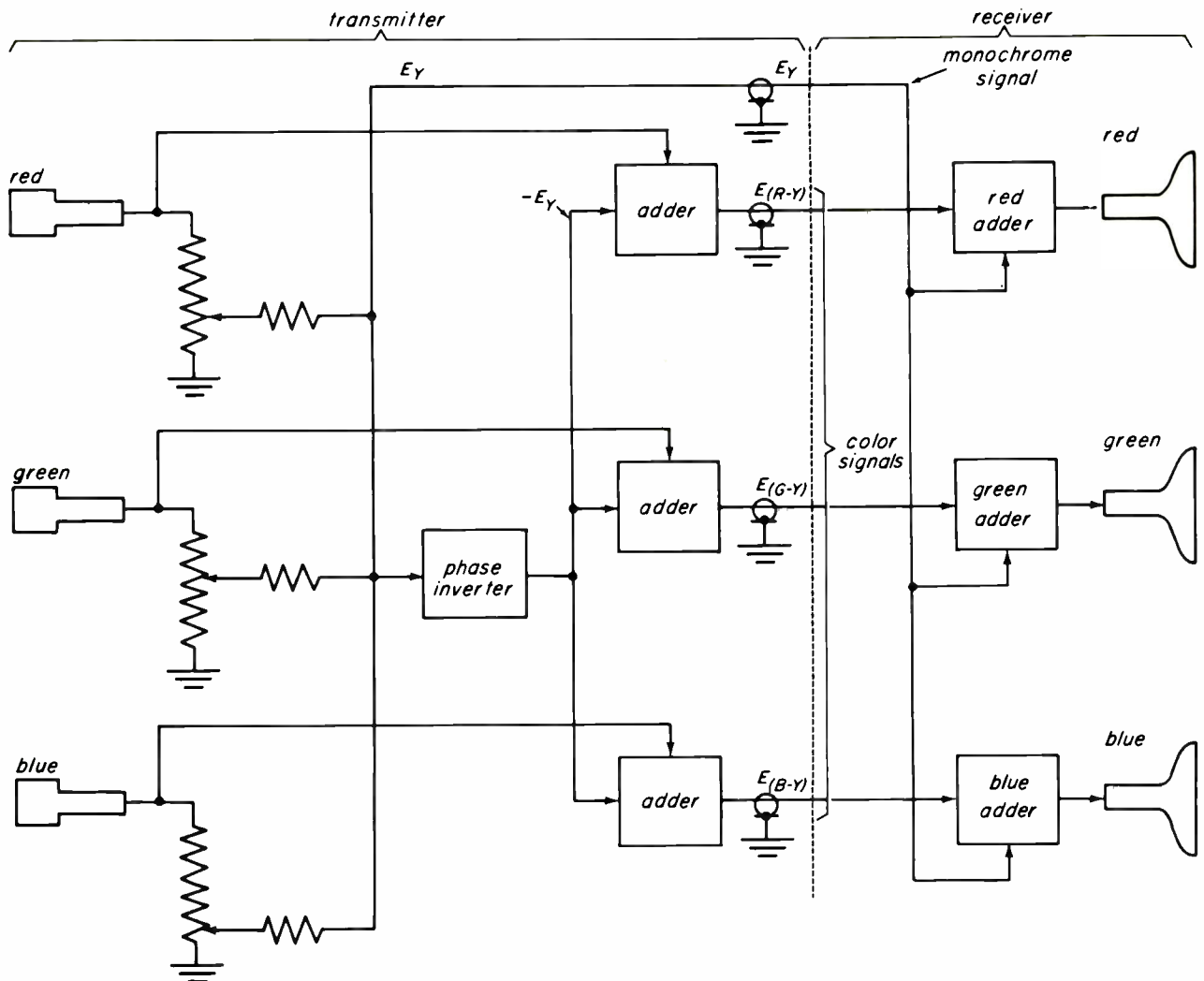

Fig. 1-11. A color TV system using four cables (four signal paths) to convey brightness and chrominance information.

black-and-white receiver to produce a correct monochrome picture.

At the transmitter, the Y signal is inverted in a phase inverter stage to produce a $-Y$ signal. The $-Y$ signal is distributed to three adder stages where the $-Y$ signal is added to the red, green and blue signals. By adding a $-E_Y$ signal to E_R , we are subtracting the Y signal, and the result is a new signal $E_R - E_Y$, or $E_{(R-Y)}$. The remaining adders produce $E_{(G-Y)}$ and $E_{(B-Y)}$ in the same fashion.

At the receiver, the E_Y voltage and the $E_{(R-Y)}$ voltage are added in another adder stage. The result is:

$$E_Y + E_{(R-Y)} = E_Y + E_R - E_Y = E_R$$

Thus, the red signal, a reproduction of the signal produced by the red camera tube, is applied to the red kinescope. Similarly, reproductions of the outputs of the green and blue camera tubes appear at the inputs to the green and blue kinescopes.

Let us follow the signals generated by the simple color-bar pattern through the system shown in Fig. 1-11. Consider the white bar. As shown in Fig. 1-12, each camera is producing a one-volt video signal. One volt appears at the output of the Y network (refer to Fig. 1-10). The Y signal is inverted (-1 volt) and added to the red, green, and

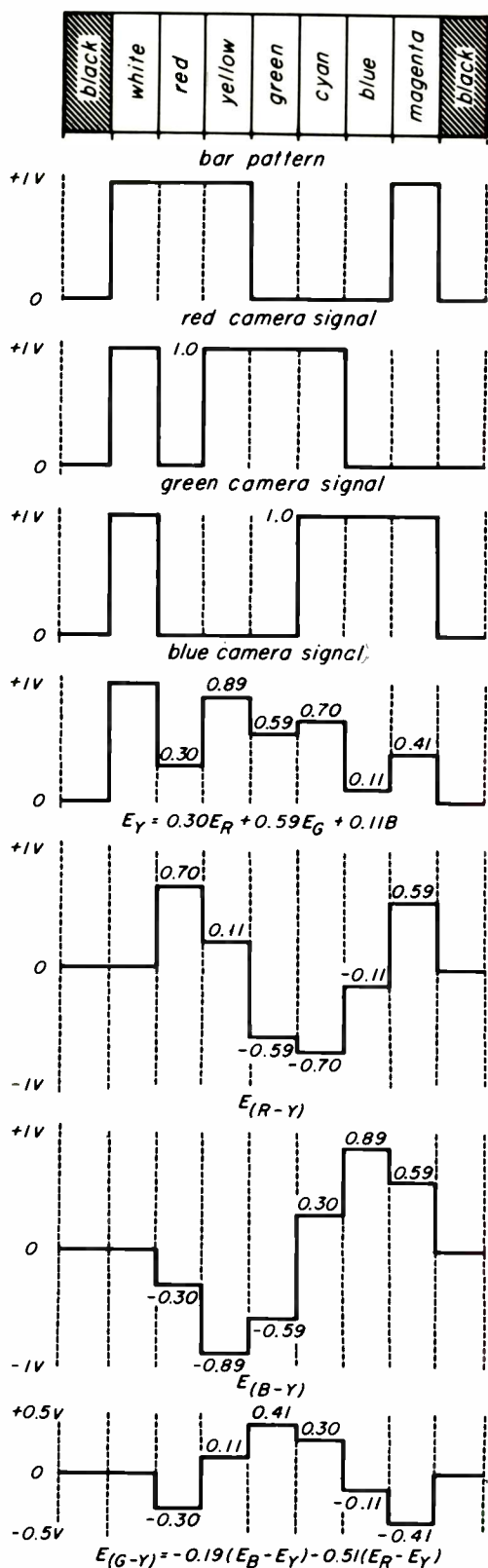

Fig. 1-12. Waveforms of the primary-color signals, the brightness signal, and the color-difference signals. The primary signals may be reconstructed by adding the brightness signal to each of the color-difference signals.

blue signals in the respective adder stages. Now each of the camera-tube signals is +1 volt when the white bar is being scanned. Thus, the $E_{(R-Y)}$ signal is equal to +1 volt plus (-1 volt) or zero. Similarly, the $E_{(G-Y)}$ and $E_{(B-Y)}$ signals are zero. Thus, there is no chromaticity information during white portions of the picture. In other words there is no color information being sent when the camera sees black-and-white or monochrome information.

Now let us turn our attention to the red bar. The red camera tube produces +1 volt and the blue and green camera tubes produce no output. The E_Y signal is +0.3 volt. The $E_{(R-Y)}$ signal is 1 volt - 0.3 volt or 0.7 volt. The $E_{(G-Y)}$ signal is 0 - 0.3 volt or -0.3 volt. Likewise the $E_{(B-Y)}$ signal is 0 - 0.3 volt or -0.3 volt. These signals travel through the cables to the adders in the receiver. At the red adder the E_Y signal, 0.3 volt, is added to the $E_{(R-Y)}$ signal, plus 0.7 volt, to provide the red signal of +1 volt. Thus, the red signal is reconstructed properly. At the green adder, the E_Y signal, 0.3 volt, is added to the $E_{(G-Y)}$ signal, -0.3 volt, and the output is canceled to zero. The output of the blue adder is zero for the same reason. Thus, when the red bar is scanned, the red kinescope provides an output, but the blue and green kinescopes are blanked. This provides the same results as the elementary system shown in Fig. 1-1, but we have shown how the Y and chromaticity signals can be separated and transmitted as separate signals. Figure 1-12 shows how each of the color bars is handled by the system. You are urged to follow the signals corresponding to each color bar through the system. Follow the same reasoning as was shown for the white and red bars. At the transmitter the signals are processed by following Fig. 1-12 from the top down. We may reconstruct the signals at the receiver by reversing the process; add the color difference signals to the Y signal to produce the red, green, and blue signals at the top.

Just for practice let us analyze the cyan bar in the test pattern. When cyan is scanned, the red output is zero but the blue and green camera tubes produce 1 volt each. The E_Y signal is 0.7 volt. The $E_{(R-Y)}$ signal is 0 - 0.7 or -0.7 volt. The $E_{(G-Y)}$ signal is

1 - 0.7 or 0.3 volt. The $E_{(B-Y)}$ signal is also 1 - 0.7 or 0.3 volt. At the red adder in the receiver the E_Y signal, 0.7 volt, plus the $E_{(R-Y)}$ signal, -0.7 volt, add to produce zero output. The red kinescope is cut off (blanking level). The green adder receives the E_Y signal of 0.7 volt plus the $E_{(G-Y)}$ signal of 0.3 volt, producing 1 volt at the output of the green adder. The output of the blue adder is also 0.7 volt (E_Y) plus 0.3 volt $E_{(B-Y)}$ or one volt.

We may express the color difference signals in terms of the three primaries by working out the required subtraction. That is, we may subtract the equivalent of E_Y or $0.30E_R + 0.59E_G + 0.11E_B$, from the E_R , E_G , and E_B signals:

$$\begin{aligned} E_{(R-Y)} &= E_R - (0.30E_R + 0.59E_G + 0.11E_B) \\ &= 0.70E_R - 0.59E_G - 0.11E_B \end{aligned}$$

$$\begin{aligned} E_{(B-Y)} &= E_B - (0.30E_R + 0.59E_G + 0.11E_B) \\ &= -0.30E_R - 0.59E_G + 0.89E_B \end{aligned}$$

$$\begin{aligned} E_{(G-Y)} &= E_G - (0.30E_R + 0.59E_G + 0.11E_B) \\ &= -0.30E_R + 0.41E_G - 0.11E_B \end{aligned}$$

It is important to note that the colors in the bar pattern represent fully saturated colors. There is no white in any of the colored bars to contaminate or "water-down" the colors. Under these conditions the red bar produces maximum drive to the red kinescope, and the green and blue kinescopes are cut off. When less saturated, or pale colors, are transmitted, the drive to one kinescope may predominate, but the other kinescopes are not driven to cutoff.

Two Chrominance Signals. The simple system of Fig. 1-11 actually transmits more information than is needed by the receiver. We have developed a system of four signals to convey the information originally provided by only three camera-tube signals. All of the original information is contained in the Y signal and two of the color-difference signals. It is possible to reconstruct the third color-difference at the receiver. This means that one of the connecting cables in Fig. 1-11, and the corresponding signal, are not necessary.

One way to set up a three-cable system is shown in Fig. 1-13. The transmitter is the same as in Fig. 1-11 and is not repeated here. Only the E_Y , $E_{(R-Y)}$ and $E_{(B-Y)}$ signals are sent to the receiver. At the receiver the $E_{(G-Y)}$ signal is developed by combining the $E_{(R-Y)}$ and $E_{(B-Y)}$ signals. The proper proportions are shown in the following formula:

$$E_{(G-Y)} = -0.51E_{(R-Y)} - 0.19E_{(B-Y)}$$

For those students interested in more detailed information, we have provided a derivation of this formula in the Appendix.

To handle the operations indicated by the formula for $E_{(G-Y)}$, both the $E_{(R-Y)}$ and the $E_{(B-Y)}$ signals are inverted by phase-inverting amplifiers. This provides negative $E_{(R-Y)}$ and $E_{(B-Y)}$ signals. Voltage dividers attenuate these signals to 0.51 for $E_{(R-Y)}$ and 0.19 for $E_{(B-Y)}$. The $E_{(G-Y)}$ signal that results is applied to the green adder as was shown in Fig. 1-11.

We have now shown how a compatible, full-color TV system may be set up by transmitting a Y or monochrome signal plus two chrominance signals. The system we have shown has used cables as the transmitting medium. We now show how to break into the system at the cables and insert the r-f transmitting system. The goal is the same: transmission of a Y signal plus two chrominance signals. The Y signal is transmitted so that existing monochrome receivers can reproduce the black and white picture. The two chrominance signals are used to modulate another carrier. This new carrier is called a subcarrier, and is placed near the high-frequency end of the video passband. In the next section, you will see how the chrominance signals are used to modulate the subcarrier, and how they are separated and recovered at the receiver.

1-4. PRINCIPLES OF TWO-PHASE MODULATION

Two-Phase Modulation. We have learned that the color information may be conveyed by two chrominance signals and a luminance (black-and-white) signal. All this information must be transmitted within a 6-mc channel, the same bandwidth allocated for black-and-white transmission. A technique has been developed that permits the transmission of an additional carrier, called a subcarrier, within the same spectrum space occupied by the luminance channel. The two chrominance signals are transmitted on this single subcarrier. This requires the combination of the two chrominance signals to form a single chrominance signal.

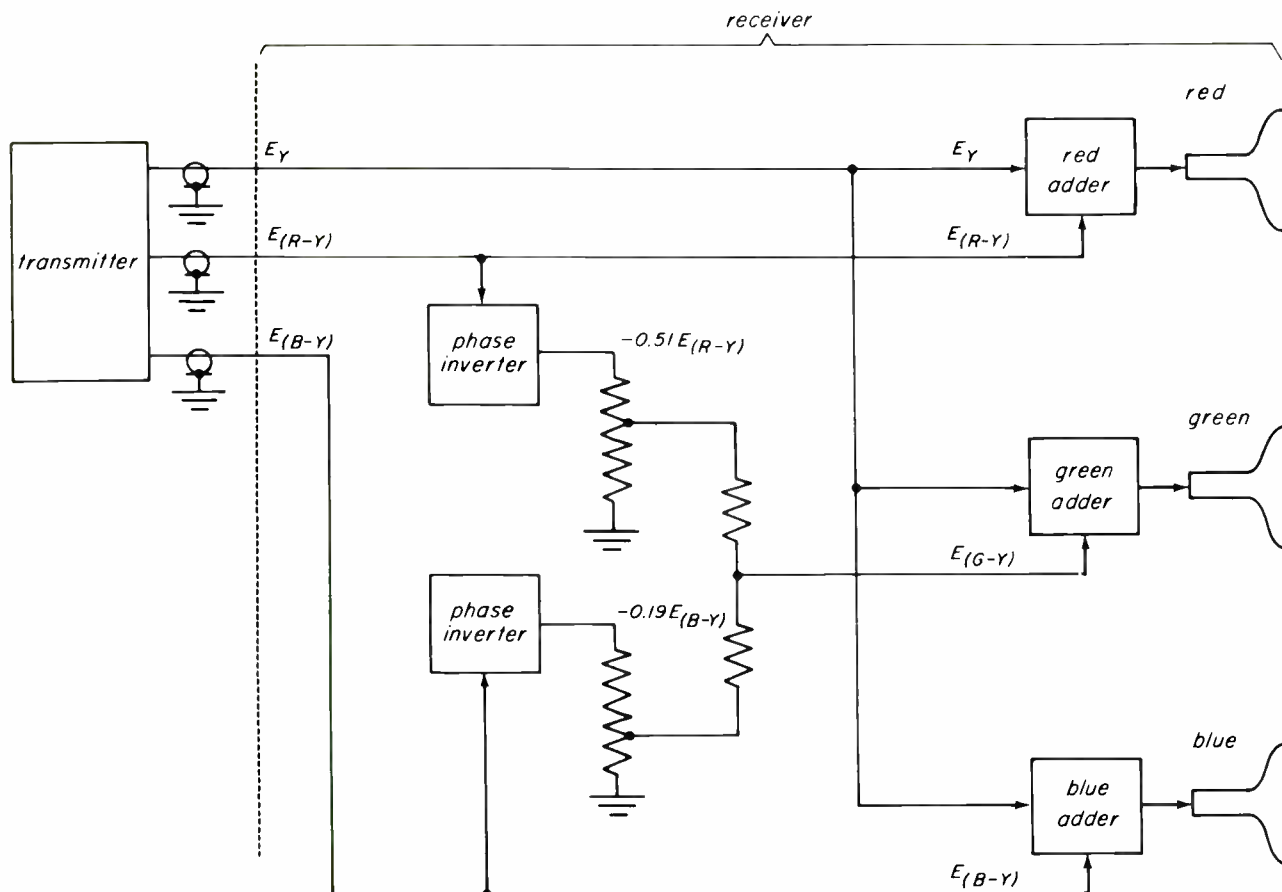

Fig. 1-13. Full-color information can be conveyed using only two color-difference signals. Here $E_{(G-Y)}$ is reproduced at the receiver by combining the proper proportions of $E_{(R-Y)}$ and $E_{(B-Y)}$.

To combine the two chrominance signals into one signal, use is made of a technique known as *two-phase modulation*. In ordinary amplitude modulation, the instantaneous amplitude of the modulated carrier varies, but its phase remains constant.¹ Only one discrete signal may be sent on a modulated carrier in this manner. In two-phase modulation, two carriers, of the same frequency but 90 degrees apart in phase, are each independently modulated by one of the two chrominance signals. The two carriers are then added, and produce a single carrier, the instantaneous amplitude and phase of which both vary. Two discrete signals may be sent on a modulated carrier in this manner. The two discrete signals may be independently recovered by proper detection techniques.

Figure 1-14 illustrates the two-phase modulation technique. The frequency of the

carrier used for transmitting the color information is approximately 3.58 mc (for reasons that will be given later). It is transmitted within the 6-mc spectrum of the TV station, and is called the *color subcarrier*. This 3.58-mc subcarrier is applied directly to the *A* modulator, and through a 90-degree phase shifting device (such as a tuned transformer) to the *B* modulator. As shown, one chrominance signal is fed into the *A* modulator and the other chrominance signal is fed into the *B* modulator. Briefly, each modulator consists of two tubes operating with opposite-polarity inputs and a common output. This type of operation cancels the individual chrominance signal and subcarrier components that feed the modulators, so that the only signals appearing in the common

¹Vectors and amplitude modulation are discussed at length in the supplement.

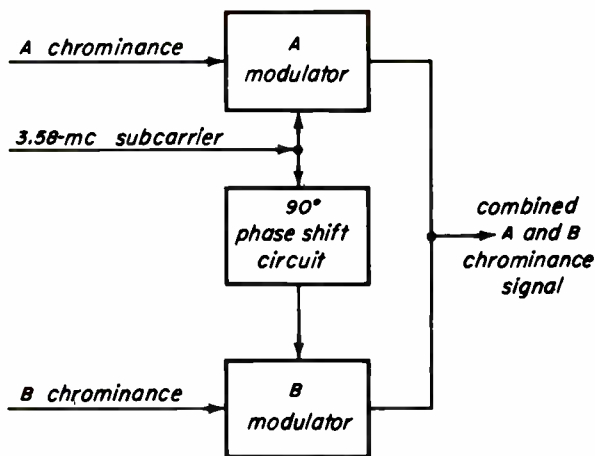

Fig. 1-14. The two-phase modulation technique permits the transmission of two chrominance signals on a single carrier frequency.

plate or output circuit are the sideband signals.

A vectorial representation of the two-phase modulation technique is shown in Fig. 1-15. The resultant of the sidebands, which always falls in phase with the carrier, represents the output of the modulator at any instant. Figure 1-15a shows the output of modulators A and B. It should be noted that the sideband resultants are in quadrature or 90 degrees out of phase. This 90-degree phase displacement of the two modulator outputs is maintained by the 90-degree phase relationship of the 3.58-mc subcarrier which feeds the A and B modulators. As shown in Fig. 1-14, the outputs of the modulators are added. In Fig. 1-15a, the outputs of the A and B modulators are shown in quadrature, producing a resultant R_1 . The resultant may vary in both amplitude and phase, in accordance with the chrominance information input to the modulators. The output from each modulator varies in amplitude only, in accordance with the chrominance information being supplied to it. However, because the two separate outputs are 90 degrees out of phase, the vector sum of the two can vary in both phase and amplitude. The instantaneous amplitude of the vector conveys information as to saturation and the instantaneous phase conveys information as to hue. For example, if the modulation output of A remains constant while the modulation output of B increases

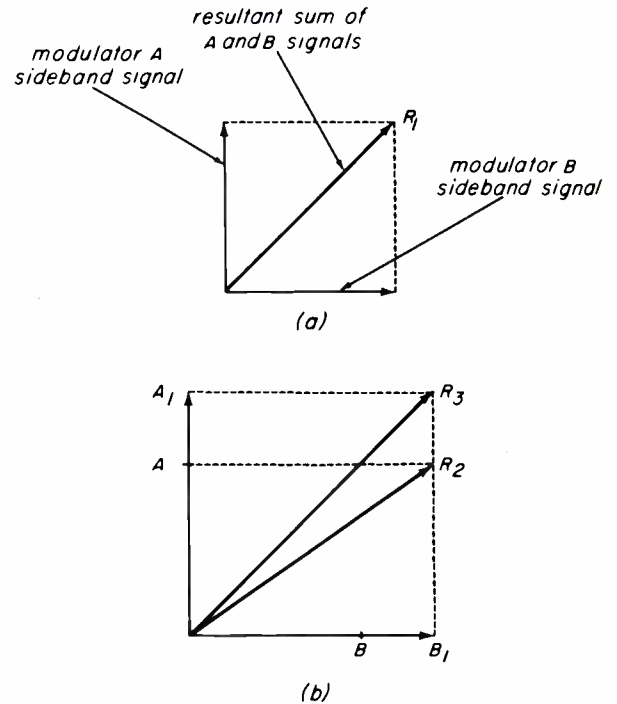

Fig. 1-15. A vector representation of two-phase modulation. The transmitted signal is the final resultant. It is found by adding the resultant outputs of the two modulators.

to B_1 , the phase and magnitude of the resultant change to R_2 . See Fig. 1-15b. If the modulation of A and B are both increased by equal amounts to A_1 and B_1 , the resultant R_3 is of the same phase as R_1 but greater in magnitude. The chrominance signals into modulators A and B are the signals transmitted to reproduce a particular hue and saturation. The hue is represented by the phase, and the saturation by the amplitude, of the resultant. If a different hue is to be transmitted, a different combination of chrominance signals is fed to the modulators. Resultant R_2 shows a new hue obtained by changing the chrominance signal into modulator B. The amplitude change of R_2 is so small that it can be neglected. The important change is the change in phase. If the hue represented by R_1 is to be transmitted but a greater saturation is desired, the chrominance information feeding the modulators is of the same relative phase but greater in amplitude. A phase change, which would indicate a change of hue, does not occur. This is shown by vector R_3 . Thus, we see that the chromaticity information of the scene is carried

by the output of the two modulators, and that the phase of this resultant represents hue while the magnitude represents saturation. This combined chrominance information, represented by a vector that varies in phase and amplitude, is all that is required, in addition to the luminance signal, to reproduce faithfully a color picture, since a color picture is a function of hue, saturation, and brightness.

Figure 1-16 illustrates the over-all process. The luminance or brightness information is amplified by a Y amplifier and fed to the input of a modulator. The two chrominance signals, A and B, are fed to their respective modulators and the outputs added to give a resultant signal A and B. This combined chrominance signal is then added to the luminance signal Y, forming modulation information labeled (A, B, and Y). This information is used to amplitude-modulate the transmitter.

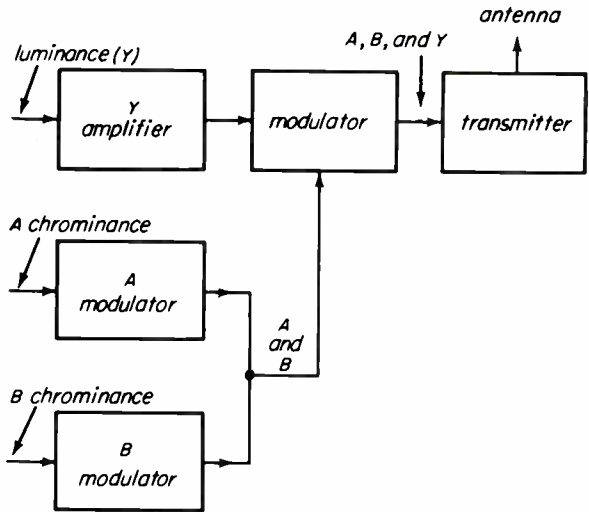

Fig. 1-16. The composite color signal is formed by adding the resultant subcarrier signal to the Y, or brightness, signal before the video transmitter's modulator.

Synchronous Detection. Recovering the chrominance information at the receiver involves the application of a process termed *synchronous detection*. In synchronous detection, two separate detectors or demodulators recover the separate chrominance information, just as two modulators combine the information at the transmitter. The 3.58-mc subcarrier, which was suppressed during transmission, must be reinserted to recover the chrominance information. The

basis of synchronous detection is the phase relationship of the reinserted 3.58-mc subcarrier. Figure 1-17a illustrates the basic principles of the synchronous detection process. Let us assume that the original chrominance information is represented by A and B in Fig. 1-17a. These are added to form the combined chrominance signal R, which is transmitted. At the receiver the combined chrominance information is fed to two demodulators, labeled A and B in Fig. 1-17b. The 3.58-mc subcarrier is also fed to the demodulators, with the same phase relationship that existed at the transmitter. Figure 1-17b shows that when the subcarrier

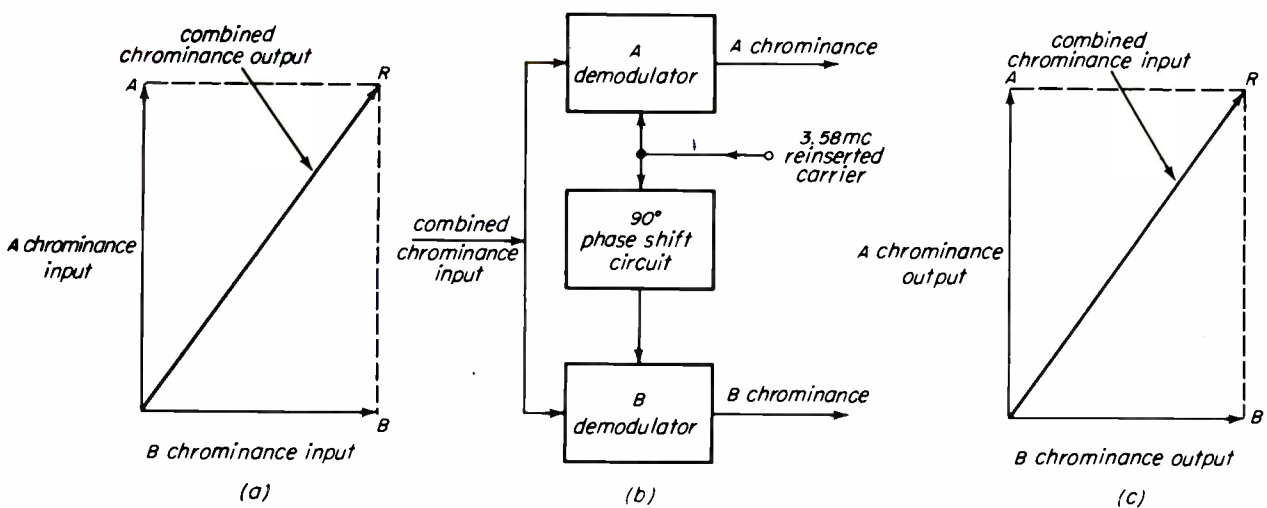

Figure 17. At the receiver, the single subcarrier signal is resolved into its quadrature components to reproduce the two transmitted chrominance signals.

is reinserted in the same phase as the *A* signal, the original *A* chrominance signal is obtained in the output of the *A* demodulator. When the subcarrier is reinserted in quadrature, or in phase with the *B* signal, the original *B* chrominance signal is obtained in the output of the *B* demodulator. Actually, the synchronous detectors are sensitive to that part of the resultant signal that is in phase, or 180° out of phase, with the reinserted carrier signal. In this way, resultant *R* representing the combined chrominance signal is merely resolved into its *A* and *B* components, as shown in Fig. 1-17c.

Synchronous detection plays a very important part in color television. A more detailed discussion will be presented in a later lesson.

Hue and Phase. Let us put the two modulators together and see what sort of signals result from the color-bar pattern we used earlier. Assume that a 0° phase, 3.58-mc signal is applied to the *B* - *Y* modulator and a 3.58-mc signal shifted 90° is applied to the *R* - *Y* modulator. The output is the sum of the modulator outputs. Note that in the Color

TV system, the phase of $-E_{(B-Y)}$ is taken as the reference phase, or 0°. All phase angles are measured in a clockwise direction from the reference phase.

As shown in Fig. 1-18, when the red bar is scanned the $E_{(B-Y)}$ signal is -0.30, and the *B* - *Y* modulator produces an output proportional to 0.3 volt at a phase angle of 0°. The $E_{(R-Y)}$ signal is +0.70, and the *R* - *Y* modulator produces an output proportional to 0.7 volt at a phase angle of 90°. These two signals are added vectorially to produce the signal marked *red* in the vector diagram. Similarly, we may lay out the yellow vector by taking $-0.89E_{(B-Y)}$ and $+0.11E_{(R-Y)}$. The vectors representing the remaining hues are drawn in a similar manner.

Notice that each hue can be represented by an output vector of a particular phase. At the receiver, the two chrominance signals are reproduced by resolving the signal vector into its $E_{(B-Y)}$ and $E_{(R-Y)}$ components.

Due to our inability to see color in small areas of the picture, the video bandwidth of

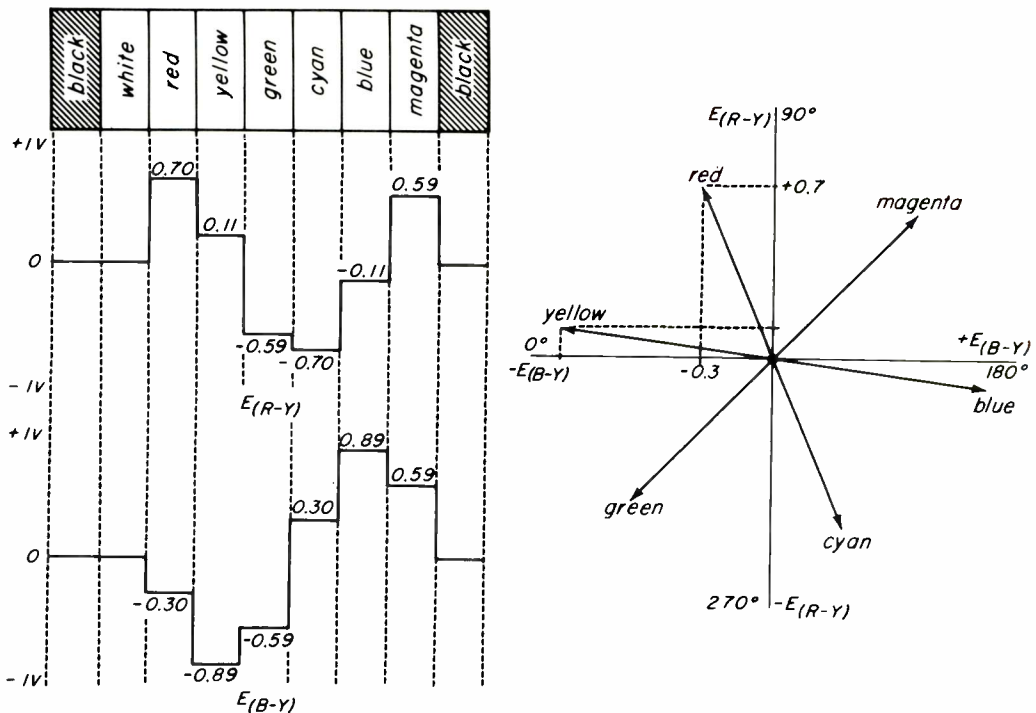

Fig. 1-18. Vectors representing the major hues may be constructed by laying out the appropriate quantities of $E_{(R-Y)}$ and $E_{(B-Y)}$ on the modulation axes.

the chrominance signals is limited to a narrow band of frequencies. The 3.58-mc sidebands are thus clustered in a narrow band that centers at 3.58 mc. This makes it possible to separate the chrominance signal from the Y signal at the receiver by means of frequency-selective circuits. We shall look at the bandwidth requirements more closely later in this lesson.

Practical Considerations. If we look at the output of the modulators with an oscilloscope we will see a waveform like the one shown in Fig. 1-19a. The amplitude of each group of 3.58-mc signals corresponds to the length of the vectors in Fig. 1-18. This signal is added to the Y signal shown at b, and the composite is applied to the modulators at the TV transmitter. The composite signal (Y plus the 3.58-mc chrominance signal) is shown in c of Fig. 1-19. Note that the total signal excursion exceeds the white level in the positive direction, and the sync-tip level in the negative direction. Such a signal would overmodulate the transmitter and result in the cutting off or compression of the chrominance signals, notably the yellow and cyan signals. To remedy this situation, the amplitude of the 3.58-mc chrominance signal is reduced. The reduction in signal amplitude is accomplished ahead of the B-Y and R-Y modulators. Optimum operation is obtained by reducing the R-Y signal by a factor of 0.877 and the B-Y signal by a factor of 0.493. The method used in determining the multipliers for adjusting the $E_{(R-Y)}$ and $E_{(B-Y)}$ signals is shown in the Appendix. The chrominance signals are restored to their original amplitudes at the receiver by proper adjustment of the E_{R-Y} and $E_{(B-Y)}$ amplifiers. The composite signal appears as shown in a of Fig. 1-20 when the proper corrections are made. The chrominance signal still exceeds the peak-white signal by 33% (yellow and cyan), but this much overshoot can be tolerated without picture degradation.

A modified vector diagram, showing the locations of various hues after the $E_{(B-Y)}$ and $E_{(R-Y)}$ signals have been corrected, appears in b of Fig. 1-20.

Reproducing Chrominance Signals at the Receiver. The manner in which the receiver

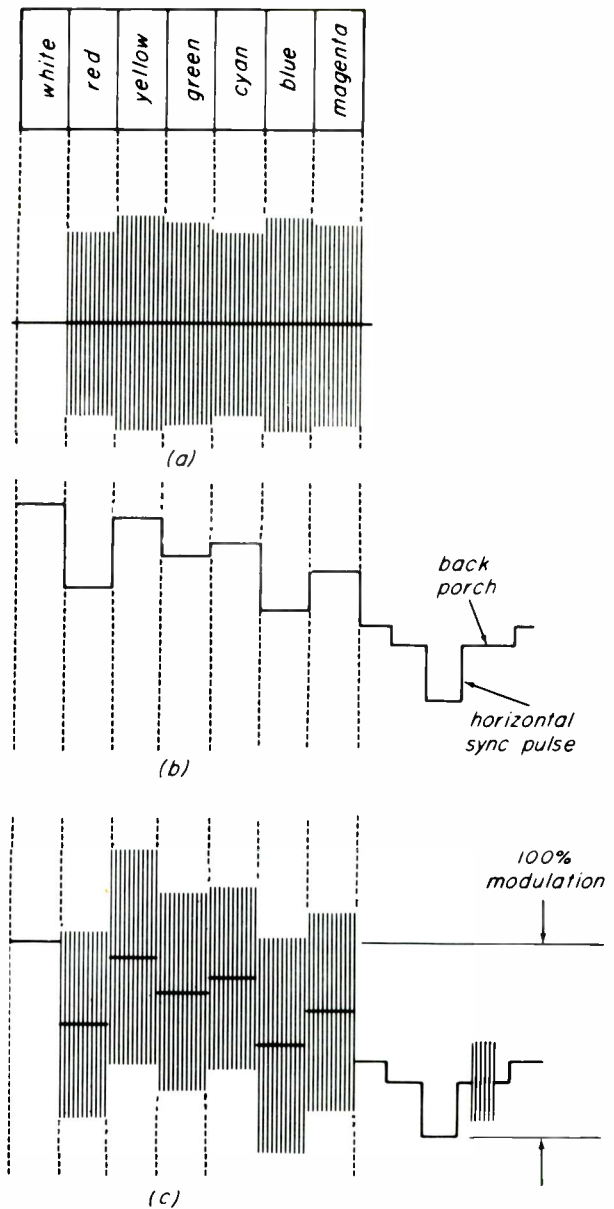

Fig. 1-19. Adding the unmodified 3.58-mc chrominance signal to the Y signal results in a composite signal that exceeds the amplitude limits that determine 100% modulation of the transmitter.

reconstructs the chrominance signals from the composite video signal is shown in Fig. 1-21. The composite video signal, including the 3.58-mc chrominance signal, is applied to a conventional video amplifier and a bandpass amplifier. The bandpass amplifier rejects the low-frequency video components and passes the narrow band of frequencies that contains the 3.58-mc sideband signals.

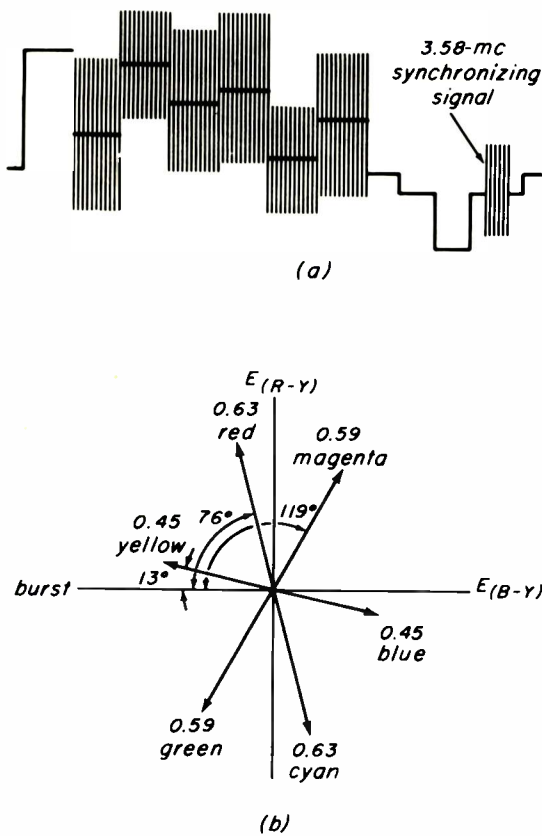

Fig. 1-20. The composite color signal when the chrominance signals have been attenuated to prevent overmodulation of the transmitter. An overshoot of 33% is tolerated.

Signals at the output of the bandpass amplifier are routed to the synchronous demodulators. Here the sideband signals are compared with a reinserted 3.58-mc carrier. This carrier signal is generated in the receiver. The carrier signal applied to the A demodulator has the same relative phase as the 3.58-mc carrier signal applied to the $E_{(B-Y)}$ modulator at the transmitter. The A demodulator resolves the chrominance signal into components that are at 0° or 180° relative phase. Thus it produces $\pm E_{(B-Y)}$ signals. Similarly, the B detector resolves the sideband signal into its 90° and 270° components and produces $\pm E_{(R-Y)}$ signals. The E_Y signal and the two chrominance signals are routed to the adder stages as was explained with reference to Fig. 1-13.

Color Synchronization. In order to function properly, the demodulators must be supplied with 3.58-mc carrier signals that are locked in frequency and in phase with

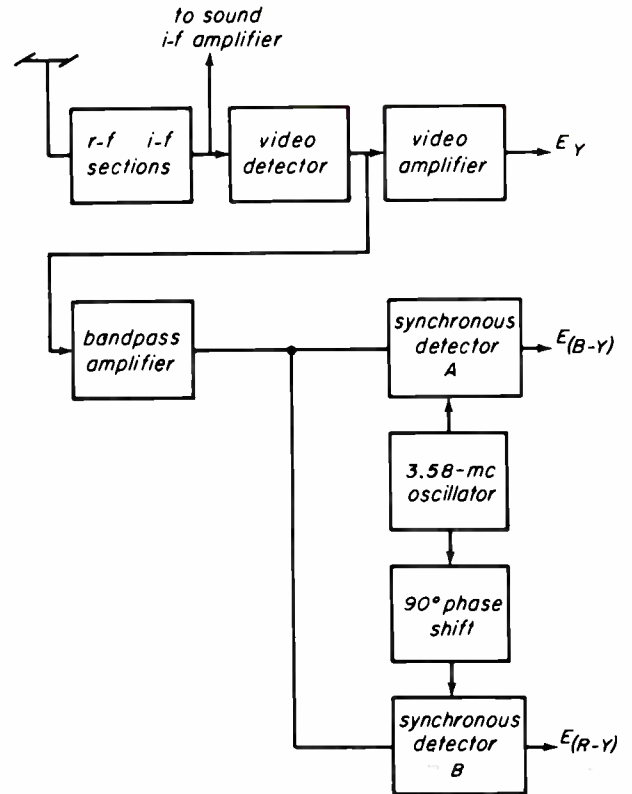

Fig. 1-21. Block diagram showing the route of the 3.58-mc chrominance signal in the receiver.

the carrier signals applied to the modulators at the transmitter. A local 3.58-mc oscillator supplies these signals in the receiver. This oscillator is made to operate at the correct frequency and phase by means of a synchronizing signal sent out by the transmitter. The synchronizing signal consists of a short burst of 3.58-mc signal. It is transmitted during the horizontal blanking interval, and follows the horizontal sync pulse, as shown in Fig. 1-22. The phase of this burst signal is taken as the reference phase for the system. It is chosen to have the same relative phase as the $-E_{(B-Y)}$ signal, as shown in Fig. 1-20b.

The route of the burst signal in the receiver is shown in Fig. 1-23. The composite video signal, including chrominance and burst signals, is applied to a burst amplifier. This amplifier, tuned to 3.58 mc, is normally nonconducting. A keying pulse, obtained from the horizontal deflection circuits, and delayed to be coincident in time with the burst signal, drives the amplifier into conduction. Thus the amplifier ignores most of

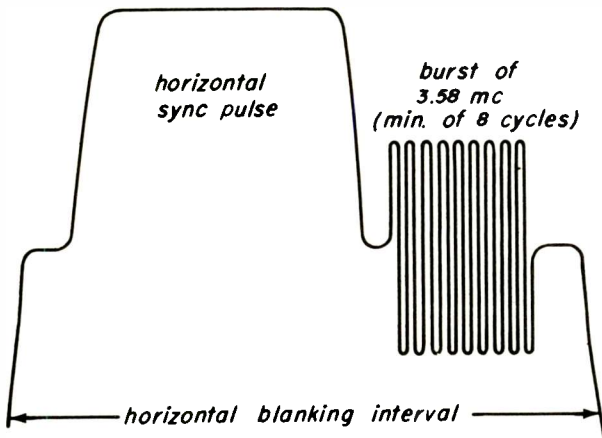

Fig. 1-22. A synchronizing signal, consisting of about 8 cycles of the subcarrier signal at the reference phase, is transmitted in short bursts following every horizontal sync pulse.

the composite video signal, but amplifies the burst signal. The separated and amplified burst signal is applied to a phase discriminator, where it is compared with the signal from the local 3.58-mc oscillator. The phase discriminator produces a d-c correction voltage when the phase of the local signal is in error. This function is somewhat similar to the sync discriminators used in horizontal AFC systems. The correction voltage acts to correct the phase of the oscillator through a reactance-tube circuit. These circuits will be examined in detail in later lessons.

1-5. DEVELOPMENT OF THE COLOR TV TRANSMISSION STANDARDS

In this section we shall examine the color transmission standards as they are used today. We shall see what factors determine the choice of subcarrier frequency, and how spectrum space is used to best advantage.

Selecting the Subcarrier Frequency. The two-phase chrominance signal must be added to the Y signal in such a way that black-and-white pictures, as well as color pictures, are not degraded. The presence of any high-frequency signal will produce an interference pattern in the picture. To make this pattern less noticeable, the subcarrier frequency should be as high as possible. However, enough space must be set aside to allow double-sideband transmission of the chrominance signal. If the requirements of our visual acuity are such that satisfactory pictures are obtained when colors are accurately reproduced by chrominance signals that extend to 0.5 mc, the carrier may be placed 0.5 mc below the high-frequency end of the video band (4.2 mc). This places the subcarrier frequency at about 3.7 mc. If the subcarrier is placed nearer to the high-frequency end of the video band, less space is provided for color sideband information and color definition is sacrificed. Moving the subcarrier frequency further away from

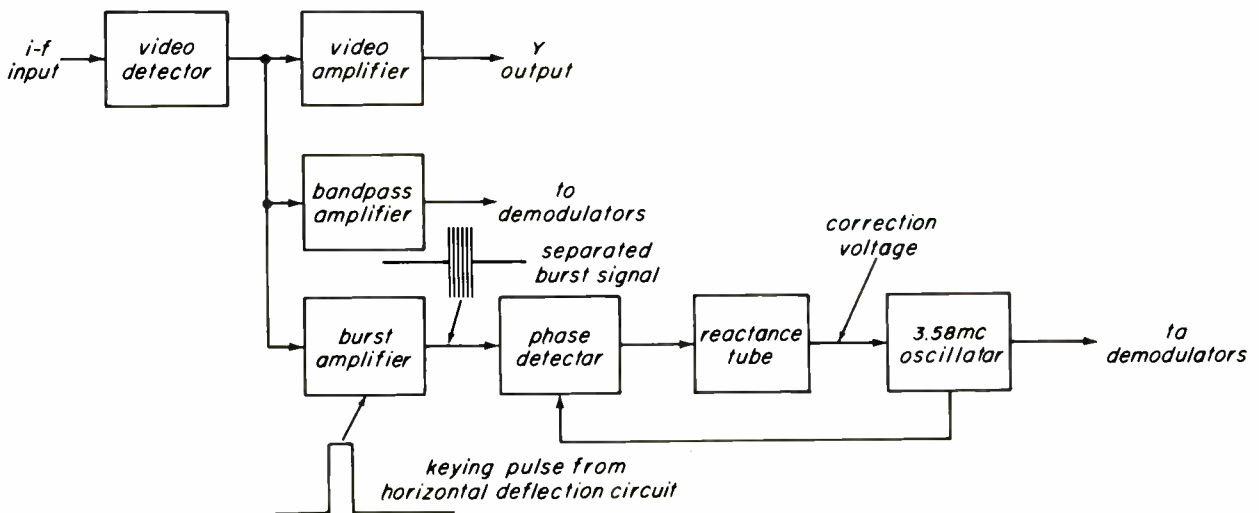

Fig. 1-23. The color subcarrier synchronizing system resembles horizontal AFC systems. The oscillator signal is compared with the burst signal and an error in phase produces a d-c correction voltage that forces the oscillator to operate at the correct phase.

19 the high-frequency end allows greater color definition, but makes the interference pattern more noticeable. Extensive field tests were performed to find the optimum subcarrier frequency. As a result of these tests the subcarrier was chosen to be approximately 3.58 mc.

Frequency Interlace. The foregoing discussion tells about the general location of the subcarrier frequency in the video passband. Another consideration determines its precise frequency. By selecting the exact subcarrier frequency to be harmonically related to the scanning frequency, it is possible to make the beat pattern on the television screen a pattern of fine lines that cross the horizontal at an angle of 45° . As mentioned earlier in the lesson, this pattern has minimum visibility. The result of this consideration is a subcarrier frequency of 3.579545 mc. Since the harmonic relation between the subcarrier and the scanning frequency (called frequency interlace) is maintained at the transmitter, the receiver technician need not concern himself with it. A more detailed discussion appears in the supplement.

Bandwidth Limitations. The choice of 3.58 mc as a subcarrier frequency is the result of balancing the desire for reduced dot structure against the desire to transmit color signals in the range of detail where the eye can make use of the information. With this subcarrier frequency, assuming that the receiver passes frequencies up to 4.2 mc, there is 0.6 mc between the subcarrier and the end of the passband. This chrominance sideband limitation is shown in Fig. 1-24. Double-sideband transmission of the two chrominance signals $E_{(R-Y)}$ and $E_{(B-Y)}$ is thus limited to 0.6 mc in frequency. Most modern receivers reproduce two chrominance signals whose video bandwidths extend from zero to 600 kc. In this region both upper and lower sidebands remain intact. Note that if the bandwidth of the chrominance signals is extended, the upper sideband signals will be attenuated. There is only about 600 kc of spectrum space between the color subcarrier frequency and the high-frequency end of the video passband. However, the lower sideband (below 3.58 mc) is not affected. Whenever one of the sidebands of an amplitude-

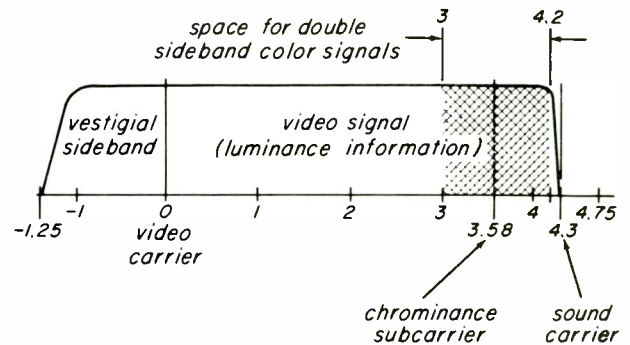

Fig. 1-24. The location of the subcarrier frequency in the video passband.

modulated signal is attenuated or removed, the phase of the resultant signal is altered. Since the phase of the 3.58-mc chrominance signal conveys hue information, an error in phase results in an error in hue. The results of this distortion are small errors in hue in relatively small areas of the picture, or at the edges of colored objects. In large areas of the picture, representing video information between zero and 600 kc, both chrominance sidebands are passed by the system and no phase or hue error exists.

I and Q Signals. When the transmission standards for color TV were being developed, a way was found to extend the bandwidth of the chrominance channel to about 1.5 mc while minimizing the effects of the form of phase distortion mentioned in the previous paragraph. The solution to the problem lies in the way in which human visual acuity varies with hue and saturation.

Let us review the important characteristics of visual acuity. If we were to arrange a test pattern of vertical colored lines and we placed the pattern at a distance such that the lines represent television video information above about 1.5 mc, we would not be able to discern hue or saturation at all, but only variations in brightness. In other words, the lines would appear black and white. As we move the pattern closer we would be able to discern color. But at the distance where the lines represent television video information in the range of frequencies between 600 kc and 1.5 mc we see all colors as different degrees of saturation of orange or cyan. Essentially our eyes

see only two hues in these intermediate picture areas. If the pattern is moved still closer, to represent video signals below 600 kc, we can then see all hues and degrees of saturation. Since there is no need to transmit more information than we can see, no color information need be transmitted above 1.5 mc. Between 600 kc and 1.5 mc, information can be based on a two-hue (orange and cyan) system. In the range of frequencies below 600 kc, three primary colors are required.

Now let us see how the limitations in visual acuity can be applied to the transmission system to provide maximum color definition with minimum phase error. First of all let's locate the hues orange and cyan on our vector diagram. Refer to the corrected vector diagram of Fig. 1-25. As shown earlier, any hue can be represented by a vector of a particular phase in this diagram, and any vector may be resolved into components of the $E_{(R-Y)}$ and $E_{(B-Y)}$ signals. Suppose that we take approximately $0.7E_{(R-Y)}$ and $-0.3E_{(B-Y)}$ and draw the resultant vector as in Fig. 1-26. The resultant falls about halfway between red and yellow, and the extension falls about halfway between blue and green, or cyan. In other words, this is the orange-cyan line, and a voltage with this phase angle will produce mixture colors of orange and cyan on the kinescope.

By taking the correct proportions of $E_{(R-Y)}$ and $E_{(B-Y)}$ it is possible to generate a new signal corresponding to orange and cyan.

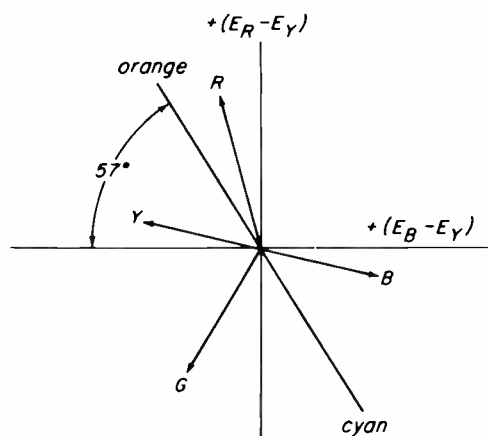

Fig. 1-26. The hues orange and cyan are found on a single line on the vector diagram.

This new signal, called the I signal, is used to modulate one of the balanced modulators in the transmitter, resulting in a new modulation axis called the E_I axis. It is located on the vector diagram shown in Fig. 1-27. Another axis, rotated 90° from the E_I axis and called the E_Q axis, can similarly be developed by taking the correct proportions of the $E_{(R-Y)}$ and $E_{(B-Y)}$ signals. Along this axis lies the Q signal. Experimentation has shown that the best color reproduction is obtained when the proportions of $E_{(R-Y)}$ and $E_{(B-Y)}$ are such as to rotate the axes 57 degrees. This has become one of the color signal standards, and is shown in Fig. 1-27.

Rotating the modulation axes does not alter the system basically. The phase of the locally-generated subcarrier oscillator in the receiver may be rotated 57° so that the demodulators produce an E_I and E_Q signal in the receiver. By reversing the process whereby the E_I and E_Q signals were produced in the transmitter, it is possible to reconstruct the $E_{(R-Y)}$ and $E_{(B-Y)}$ signals. The advantage of the new axes comes about as the result of limiting the bandwidth of the E_Q signals at the transmitter and at the receiver to about 600 kc. A wider bandwidth, 1.5 mc, is allotted to the E_I signals. This means that between 0 and 600 kc, both E_I and E_Q signals are being transmitted. In this range of frequencies all hues can be reproduced by the receiver. Between 600 kc and 1.5 mc only the E_I chrominance signal is transmitted and the receiver shows all hues as either orange or cyan.

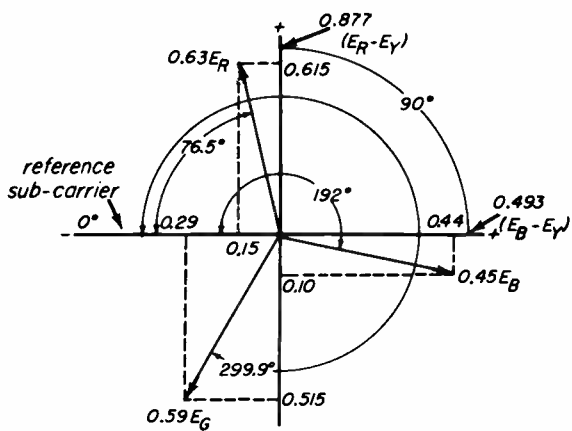

Fig. 1-25. Vector diagram based on the $E_{(R-Y)}$ and $E_{(B-Y)}$ quadrature axes.

18

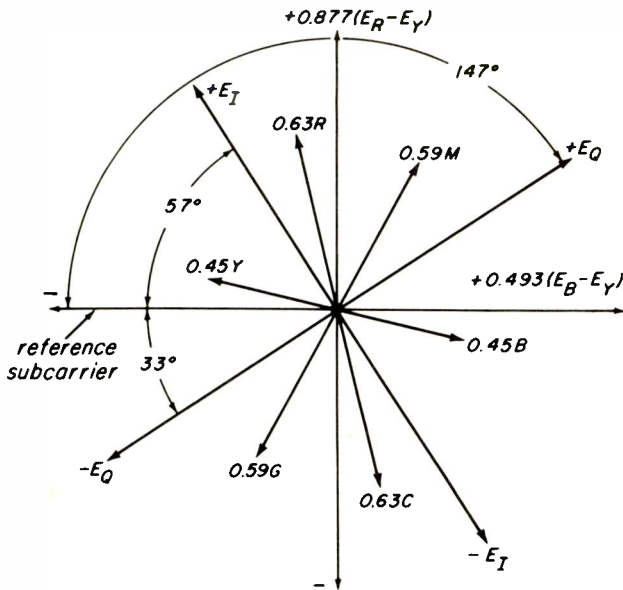

Fig. 1-27. The E_I axis is on the orange-cyan line in the vector diagram. The E_Q axis is perpendicular to the E_I axis and crosses the yellow-green and magenta areas.

The effects of phase errors, in the frequency range between 600 kc and 1.5 mc, are not seen because the E_I demodulator in the receiver "sees" all phases as either orange or cyan. The E_Q demodulator is effectively out of the system in this frequency range due to a low-pass filter in its output circuit.

Although the I - Q system provides for a maximum color definition of about 1.5 mc, few receivers have been built to reproduce I and Q signals. Practical experience, gained since the color TV standards have been established, have shown that good color pictures can be obtained with less than 1.5 mc of color definition. Furthermore, the effects of small amounts of phase error due to upper-sideband distortion do not degrade picture quality to a measurable degree. In addition, the I and Q system presents several problems in receiver design. Time and phase delays must be carefully matched between the I and Q circuits, and the special filters introduce ringing effects. These factors tend to offset the effects of a slight improvement in color definition. However, the I and Q signals are provided in the transmitted signal, for anyone who wants to make use of them. Receivers can be designed to reproduce any pair of color-difference signals from the transmitted

3.58-mc chrominance signals, as we shall see.

Development of the Composite Signal at the Transmitter. By applying some simple trigonometry to the vector diagram of Fig. 1-27, we may resolve the E_I and E_Q vectors into components of the $E_{(R-Y)}$ and $E_{(B-Y)}$ signals. However the color-difference signals are obtained from the R , G , and B signals at the output of the camera. It is simply another step in algebra to obtain formulas for E_I and E_Q directly from the E_R , E_G , and E_B signals. These derivations appear in the Appendix.

The diagram of Fig. 1-28 shows how the E_Y , E_I , and E_Q signals are obtained in the transmitter. The network of resistors and phase inverters used to proportion the amounts of E_R , E_G , and E_B signals is called the *matrix section*. Phase inverters are used to provide negative quantities where required.

A delay network is shown in the E_Y channel. The delay is necessary to make the E_Y signal correspond in time with the E_Q signal. The E_Q signal undergoes a natural time delay as the result of the narrow-band filter in the E_Q channel. We shall explain the need for delays more fully in a later lesson.

In the E_I channel, positive quantities of E_G and E_B are combined with a negative quantity of E_R to produce a *negative* E_I signal (refer to Appendix). A phase inverter in the E_I channel then produces the $+E_I$ signal. The E_I channel contains a low-pass filter in the filter section to restrict the bandwidth of the E_I channel to 1.5 mc. As in the Y channel, a delay network also delays the E_I signal so that it is coincident in time with the E_Q signal.

A low-pass filter in the E_Q channel restricts the signal fed to the E_Q modulator to 600 kc. Figure 1-29 shows the bandpass of the E_Y , E_I , and E_Q channels. Note that the upper portion of the E_I channel is attenuated by the over-all response of three video systems (0 - 4.2 mc).

The E_I and E_Q signals are fed to two doubly-balanced modulators. Subcarrier

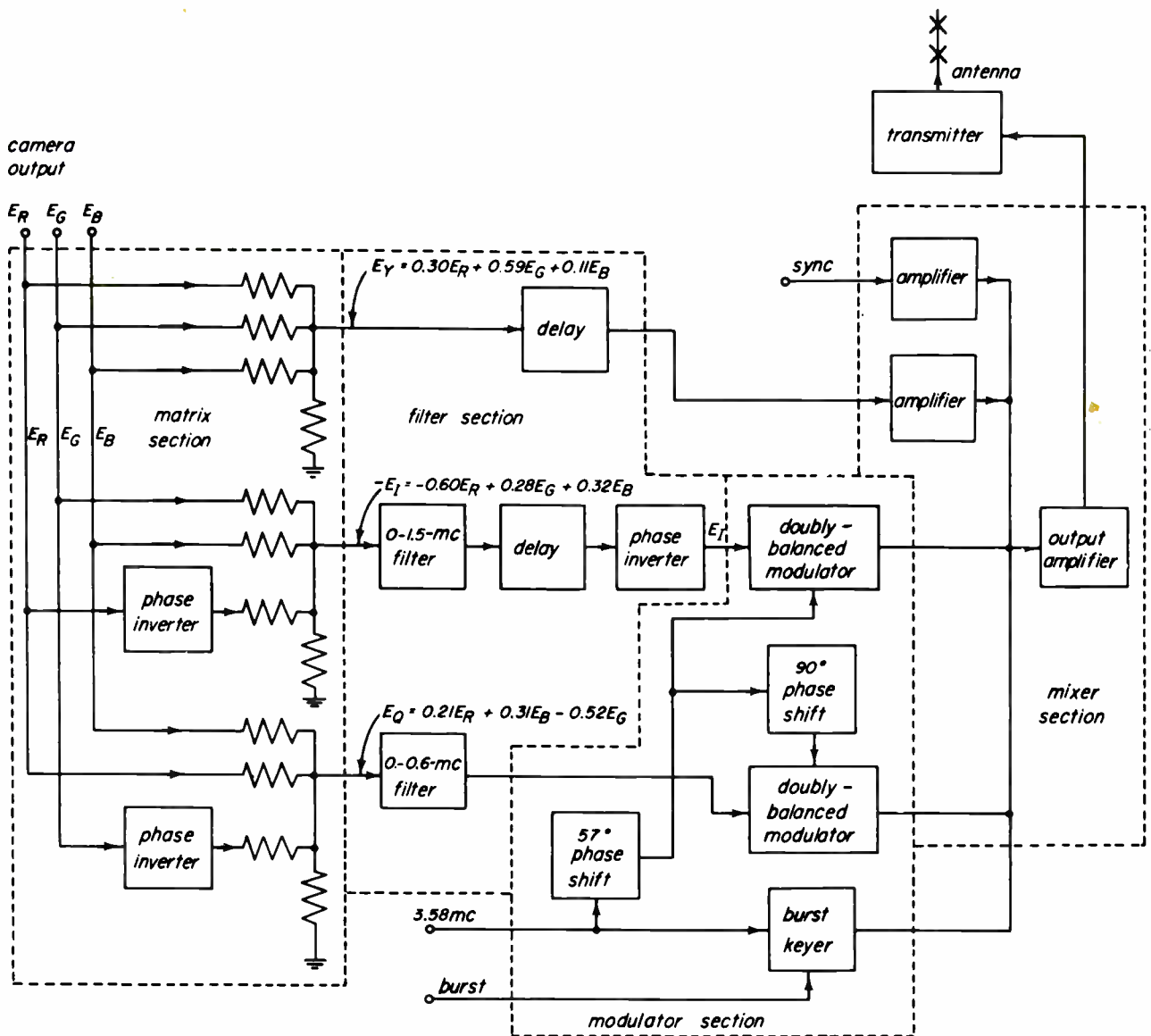

Fig. 1-28. A simplified block diagram of a color TV transmitter.

signal for the E_I modulator is obtained from the reference 3.58-mc signal via a 57° phase-shifting network. This adjusts the phase of the E_I axis properly. An additional 90° phase-shifting network adjusts the phase of the subcarrier signal applied to the E_Q modulator. The outputs of the modulators are added together and sent to the mixer section where the E_Y and chrominance signals combine to form the composite signal. Sync and burst signals are added in the mixer section. Burst signals, consisting of about 8 cycles of the reference signal, are obtained from the burst keyer stage. The bursts are timed to follow the horizontal sync pulse.

1-6. RECOVERING THE CHROMINANCE SIGNALS AT THE RECEIVER

Recovery of the chrominance signals at the receiver is substantially similar to the process outlined earlier for $E_{(R-Y)}$ and $E_{(B-Y)}$ operation. Let us review the process as it applies to the E_I and E_Q signals.

The chrominance signal, containing the E_I and E_Q signals in the form of sidebands of the subcarrier signal, is separated from the brightness signal by means of a band-pass amplifier. At this point the chrominance signal consists of sidebands of

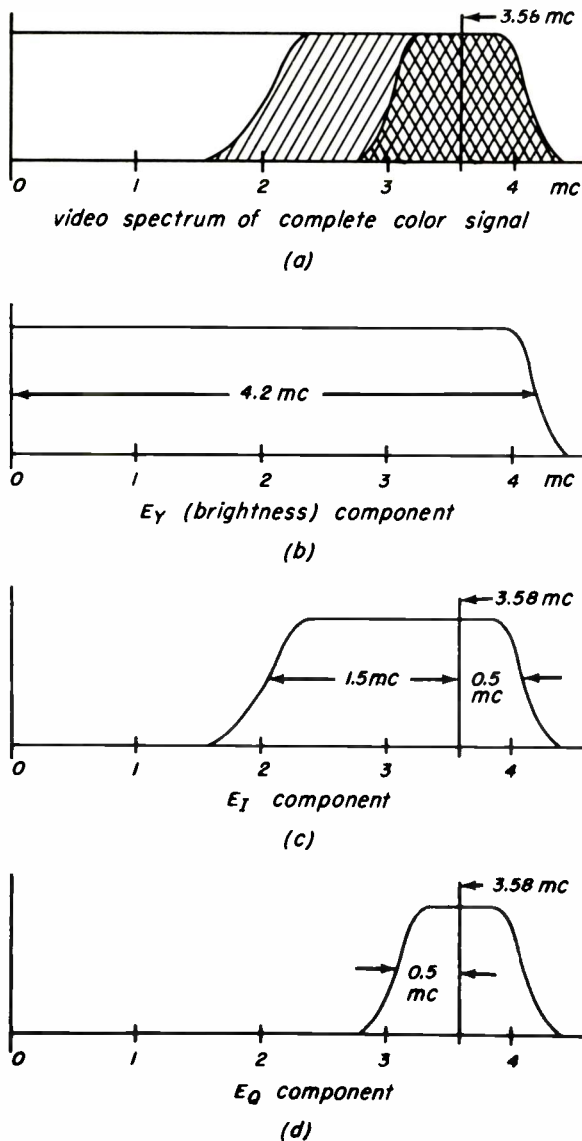

Fig. 1-29. Response curves show the location of the frequency bands that contain the E_Y , E_I , and E_Q signals.

3.58 mc, whose resultant varies in phase and amplitude. The next job is that of separating the two chrominance components. The chrominance subcarrier was suppressed at the transmitter. In order to recover the original modulation, it is necessary to reinsert the subcarrier at the receiver. By reinserting two subcarriers, the two chrominance components can be recovered separately. Demodulation of the chrominance signals takes place in two synchronous detectors, shown in simplified form in Fig. 1-30. Each detector requires a reinserted subcarrier, both of the same frequency. These reinserted subcarriers must be in synchronism

with the original subcarriers at the transmitter modulator. A burst signal having the same phase as that of the master oscillator in the transmitter is transmitted during horizontal blanking intervals. This burst signal is used in the receiver to keep its local 3.58-mc oscillator in frequency and phase lock with the subcarrier oscillator in the transmitter.

System Flexibility. Examinations of any of the vector diagrams, such as that of Fig. 1-27, will show that the E_I axis is separated by 57 degrees from the burst or phase reference. Thus, if we delay the phase of the local oscillator in the receiver by 57 degrees, the phase of the reinserted carrier applied to one of the demodulators is the same as that of the E_I signal, and the I chrominance information is obtained at the output of this demodulator. Since the reinserted carrier applied to the other demodulator is separated in phase by 90 degrees, the output of this demodulator is the Q chrominance information. If the 57° delay is eliminated, the phase of the reinserted carriers applied to the demodulators will be in phase with $E_{(R-Y)}$ and $E_{(B-Y)}$, and the output of the two demodulators will be the $E_{(R-Y)}$ and $E_{(B-Y)}$ chrominance signals.

Consider, for example, the chrominance voltage produced when red is scanned. As we have seen previously, a red scene produces a chrominance voltage of 0.63 amplitude at a phase angle of 76.5 degrees with respect to burst. The red voltage vector is shown in Fig. 1-31a. This amplitude and phase angle is the same whether E_I and E_Q or $E_{(R-Y)}$ and $E_{(B-Y)}$ axes are being considered. However, we can produce this red voltage vector with either $0.62E_{(R-Y)}$ and $-0.15E_{(B-Y)}$ as shown in Fig. 1-31 or with $0.60E_I$ and $0.21E_Q$, as shown in Fig. 1-31c. So far as the receiver is concerned, the red signal arrives as a single voltage of 0.63 amplitude at an angle of 76.5 degrees, as in a of the figure. At the receiver we can separate this into $E_{(R-Y)}$ and $E_{(B-Y)}$, or E_I and E_Q , whichever we desire. If the reinserted carrier applied to the receiver demodulators is in phase with E_I and E_Q , then I and Q chrominance information is obtained at the output of the demodulators. If the reinserted carrier applied to the receiver has

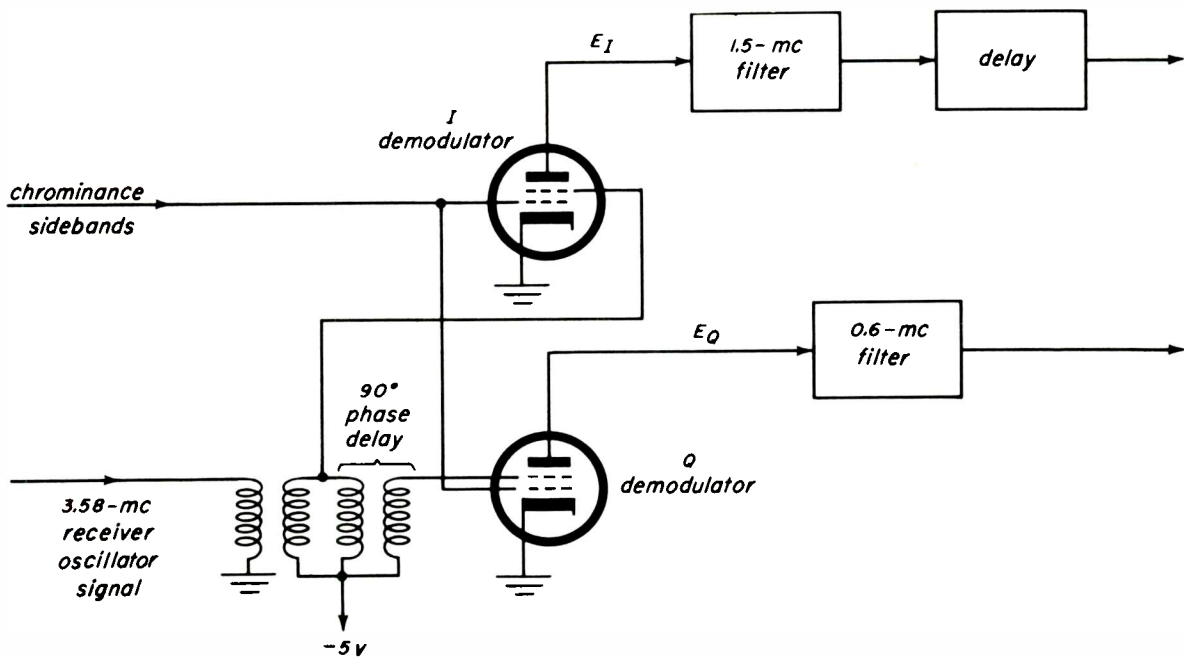

Fig. 1-30. At the receiver, the 3.58-mc chrominance signal is resolved into its E_I and E_Q components by a pair of synchronous detectors.

the phase of $E_{(R-Y)}$ and $E_{(B-Y)}$, then $E_{(R-Y)}$ and $E_{(B-Y)}$ chrominance is obtained at the output of the demodulators. Some economy in receiver design can be achieved by demodulating $E_{(R-Y)}$ and $E_{(B-Y)}$ instead of E_I and E_Q . Matrixing is simplified, since the E_Y signal can be applied to the cathodes of the color kinescope and the $E_{(R-Y)}$, $E_{(G-Y)}$, and $E_{(B-Y)}$ signals to the red, green, and blue grids respectively. The $E_{(B-Y)}$ and $E_{(R-Y)}$ signals can be matrixed to produce $E_{(G-Y)}$,

as discussed earlier in this lesson. In this way, matrixing takes place in the kinescope itself, saving the cost of an external matrix, which is necessary in the case of E_I and E_Q demodulation.

In addition to demodulation on the $E_I - E_Q$ axes and the $E_{(R-Y)} - E_{(B-Y)}$ axes, it is possible to demodulate the signal by choosing any set of axes that we wish. As long as the signals produced by the demodulators

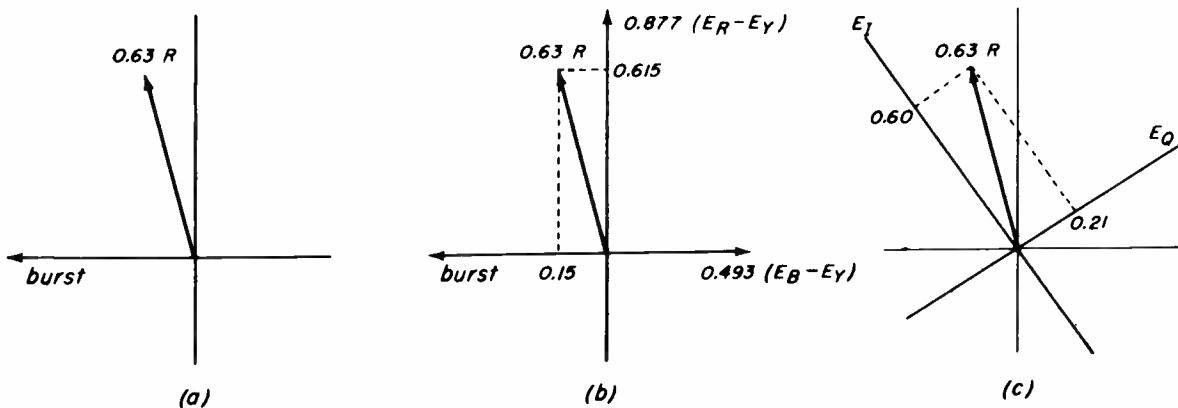

Fig. 1-31. (a) A red signal is represented by a 3.58-mc signal having this phase relation; (b) this vector may be resolved in the receiver into its $E_{(R-Y)}$ and $E_{(B-Y)}$ components; (c) the same red signal may be resolved into its E_I and E_Q components by proper adjustment of the phase of the 3.58-mc signal applied to the demodulators.

are added in the correct proportions to develop color-difference signals, any set of demodulation axes may be chosen. In many RCA receivers a set of axes called the X and Z axes are chosen, as shown in Fig. 1-32. Note that these axes are not perpendicular to one another. The merits of this demodulation system will be shown in a later lesson.

The system also makes it possible to build a low-cost color receiver based upon two-color primaries. By employing a single demodulator, arranged to demodulate on the E_I axis, a receiver can be made to display a color picture in terms of black and white and various saturations of orange and cyan.

Regardless of which pair of chrominance signals are produced by the demodulator section, the color difference signals $E_{(R-Y)}$, $E_{(B-Y)}$, and $E_{(G-Y)}$ must be the final products of the chrominance section of the receiver. Matrix units, which are networks designed to combine the chrominance signals in the correct proportions, are used to produce the color difference signals. We will show representative receiver demodulator-matrix systems in a later lesson.

1-7. AN OVER-ALL VIEW OF THE SYSTEM

The major features of the color television process will now be reviewed with the aid of the block diagrams of Figs. 1-33 and 1-34.

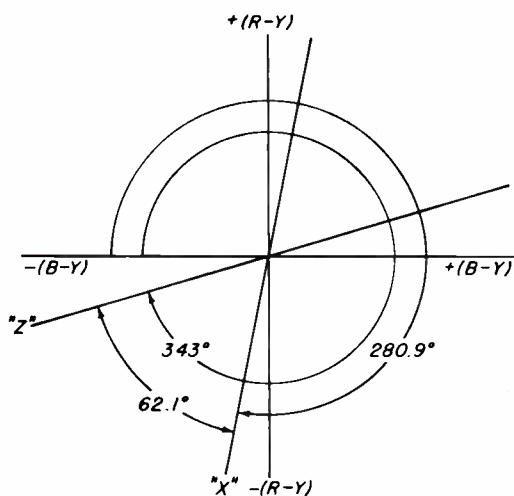

Fig. 1-32. Many late-model color receivers use the "X" and "Z" demodulation axes shown here.

At the Transmitter. The scene to be televised is analyzed in terms of its red, blue, and green components by the color television camera. The output of the camera consists of three voltages, proportional to the amounts of red, blue, and green in the scene. These three voltages are applied to the transmitter matrix, where E_Y , E_I , and E_Q signals are formed. The E_Y signal contains video frequencies from approximately 0-4 mc, and carries the brightness and fine-detail information regarding the scene. The E_I signal contains video frequencies from approximately 0-1.5 mc, and carries information regarding the orange-cyan content of the scene. The E_Q signal contains video frequencies from approximately 0-0.5 mc, and carries information regarding the magenta-green content of the scene. The E_Q signal is limited in bandwidth to prevent distortion that would result from cutting off the upper sideband. When both the E_I and E_Q signals are present, all colors are accurately reproduced. When only the E_I signal is present (corresponding to frequencies in the video range of 0.5 mc to 1.5 mc) only the hues of orange and cyan are reproduced. However, this results in good color reproduction for areas corresponding to this frequency range. The E_I and E_Q signals are applied to two doubly balanced modulators, in which the carrier is suppressed and a single chrominance signal that contains the E_I and E_Q information is formed. This single chrominance signal is combined with the E_Y signal and applied to a transmitter to be broadcast. A sync signal, made up of about 8 cycles of the color subcarrier frequency, is transmitted during the blanking intervals for phase control in the receiver. In addition, the normal black-and-white synchronizing signals are transmitted.

At the Receiver. The signal arriving at the receiver is the complete color signal, consisting of the luminance or E_Y signal, the combined chrominance signal, and sync signals. The luminance, chrominance and burst signals are channeled to their respective sections of the receiver. The E_Y signal is handled as in black-and-white receivers. It is detected, amplified, and applied to the matrix, as shown. A delay line is inserted to compensate for the delay introduced in the chrominance channels by the

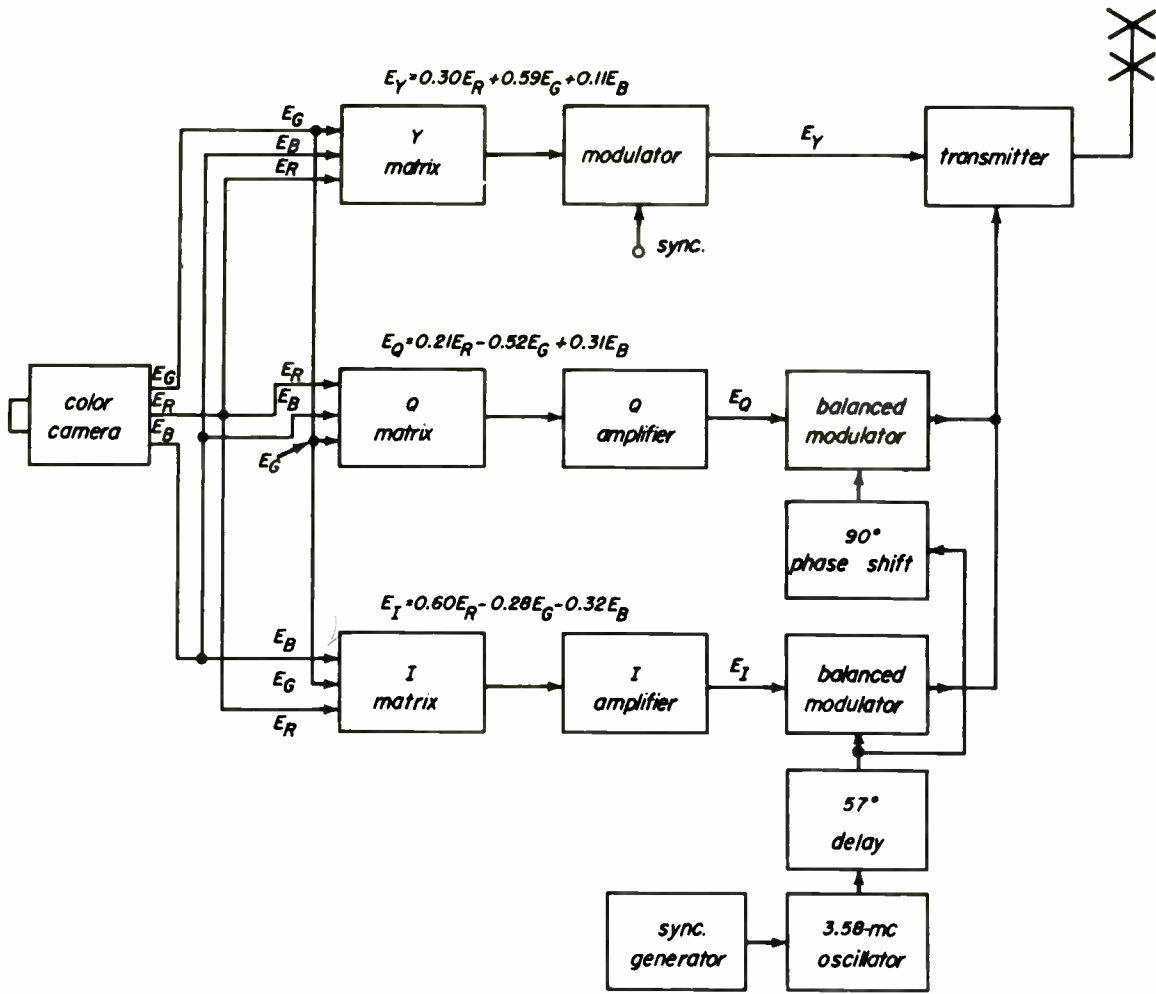

Fig. 1-33. Basic block diagram of the color transmitter.

bandpass filters. The chrominance signal is applied through the bandpass amplifier to both demodulators. The demodulators are also supplied with 3.58-mc CW signals obtained from a local oscillator. The phase of the oscillator is controlled by the burst signals and is adjusted to correspond with a particular set of demodulation axes.

The phase of the signals applied to the demodulators may be adjusted in the receiver to obtain chrominance signals in terms of any sets of axes. The chrominance signals so obtained may be $E_{(R-Y)}$ and $E_{(B-Y)}$ or some other set of chrominance signals. The matrix is designed to combine the correct amounts of the chrominance signals and the E_Y signal to reproduce the correct amounts of E_R , E_G and E_B for application to the color picture tube. Part of the job of the matrix,

that of adding the luminance and color-difference signals, may be performed in the color picture tube.

1-8 SUPPLEMENTARY INFORMATION

A deeper understanding of the principles of two-phase modulation can be obtained by reviewing the basic principles of modulation and demodulation.

A Brief Review of Vectors.¹ One of the most useful applications of vectors is in representing sine waves. This eliminates

¹The term "phasor" is used in some modern texts instead of vectors when dealing with electrical quantities; however, we will use *vector* throughout.

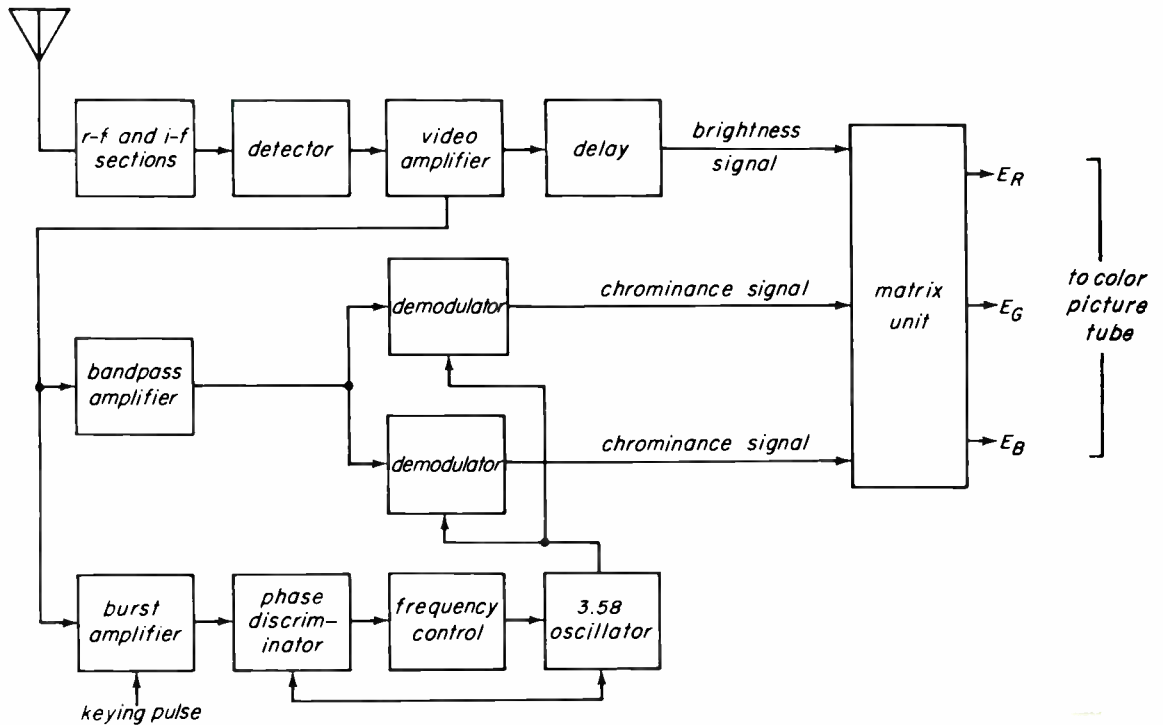

Fig. 1-34. Basic block diagram of the color receiver.

drawing complete sine waves, and simplifies the analysis of circuit operation. To represent a sine wave of either voltage or current, a vector is drawn, its length proportional to the peak value of the sine wave. If the vector is rotated around its origin, the projection of the end of the vector will trace out a sine wave. Figure 1-35 shows how the sine wave traced out by the projection of the end of the

revolving vector may be plotted. In the illustration, the vector is assumed to be starting at position P. It is conventional to think of the vector as rotating in a counterclockwise direction. The frequency of the sine wave generated depends upon the speed at which the vector rotates; the vector generates one sine-wave cycle with each revolution.

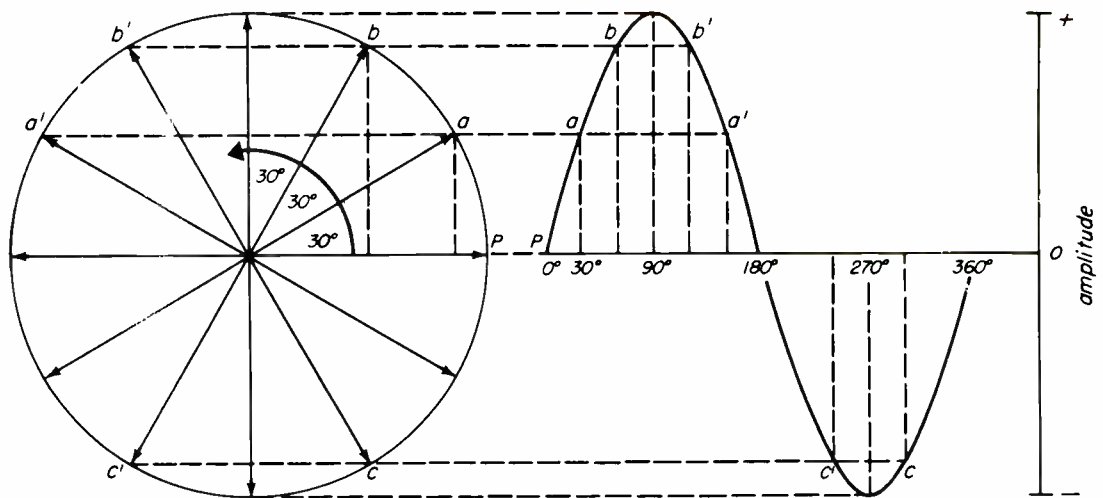

Fig. 1-35. The sine wave may be constructed graphically by plotting the projections of a rotating vector whose length is determined by the peak value of the wave.

Now suppose that two sine waves, A and B , 90 degrees apart, are to be added. This is done as shown in Fig. 1-36. To do this it is necessary to add them point by point, using sufficient points to plot an accurate curve. For example, at instant t_1 the instantaneous amplitude a_1 is added to the instantaneous amplitude b_1 to obtain the instantaneous amplitude c_1 . If this is done for a sufficient number of points to obtain an accurate curve, the sine wave C is obtained. By examination of the figure we can see that adding the two equal sine waves 90 degrees out of phase results in a sine wave that has 1.4 times the height of either, and this resultant sine wave lags A by 45 degrees.

It is possible to obtain the same result with much less work by using the principles of vectors. This method is shown in Fig. 1-37. A vector A , whose length is proportional to the peak value of sine wave A , is drawn. A vector B is drawn from the same point, its length proportional to the peak value of sine wave B . Since the two sine waves are 90 degrees out of phase, the

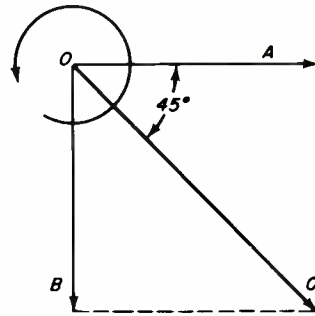

Fig. 1-37. Vector addition as it is applied to the problem of Fig. 1-36.

vectors are drawn 90 degrees apart. As stated previously, the vectors are considered to rotate in the counter-clockwise direction. Therefore B is drawn as shown to indicate that it lags A by 90 degrees. If these two vectors are added using the parallelogram method, the resultant C is obtained, which is equivalent to sine wave C . Measurement shows that C is 1.4 times the length of A or B . Keeping in mind that the vector diagram is really rotating at the sine-wave frequency, measurement with a protractor shows that C lags A by 45 degrees. Thus, we have added the two sine waves more conveniently. In addition, it is easier to see what has happened by examining the vector diagram.

We may reverse the procedure discussed in Fig. 1-37 by starting with the resultant vector and resolving it into its 0° and -90° components. To do this we extend perpendiculars from the tip of the resultant vector to the horizontal and vertical axes. The process is quite important in color television so let us look at another example.

The vector OR in Fig. 1-38 is to be resolved into two components that are 90° apart. These components lie on the OA , OB axes. By extending perpendiculars from the point of OR to the OA and OB axes we can resolve the vector into the components OA_1 , and OB_1 . In other words, the vector OR can be produced by adding two voltages at 0° and $+90^\circ$ whose peak values are OA_1 and OB_1 respectively. The axes OA and OB are 90° apart and are said to be in *quadrature*.

It is possible to resolve the vector OR into any set of components we choose. For

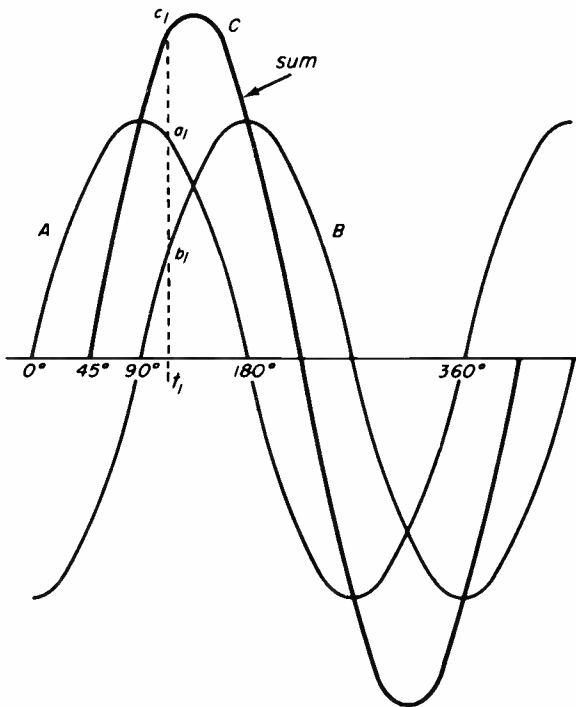

Fig. 1-36. The graphical addition of two sine waves that are 90° apart in phase.

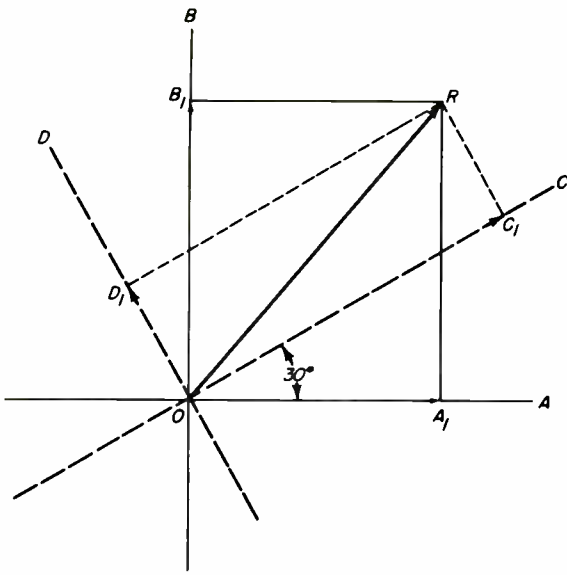

Fig. 1-38. In this example, a single vector, OR , is shown to be the sum of two quadrature components OA_1 and OB_1 . It can also be represented by another pair of quadrature components OC_1 and OD_1 .

example, we may resolve OR into components of another set of axes. Figure 1-38 shows another set of axes, in quadrature with each other, but rotated 30° with respect to OA . In terms of components of these new axes, the vector OR can be resolved into the voltage components OC_1 and OD_1 .

Analysis of Amplitude Modulation. A sine wave can be represented by a rotating vector. Each complete revolution of the vector corresponds to one complete sine wave. However, during amplitude modulation, the peak amplitude of the sine-wave carrier varies according to the modulation being impressed on the carrier. Therefore, no single vector could represent what is occurring, since the amplitude of the rotating vector would have to vary at every instant in accordance with the modulating waveform. However, we will show how the instantaneous change in amplitude of the carrier may be shown by a vector diagram without the need for drawing a vector of different length at every instant.

When a carrier is modulated by an audio tone, for example, additional signals are produced in the output of the transmitter. These new frequencies are called sideband signals, or simply sidebands; they are equal to the sum of the carrier frequency and the modulating frequency and the difference between the carrier frequency and the modulating frequency. For example, if the carrier is 800 kc and the modulation frequency 2 kc, the two sideband signals are 802 kc and 798 kc. Figure 1-39 shows a vectorial presentation of the 800-kc carrier and the sidebands

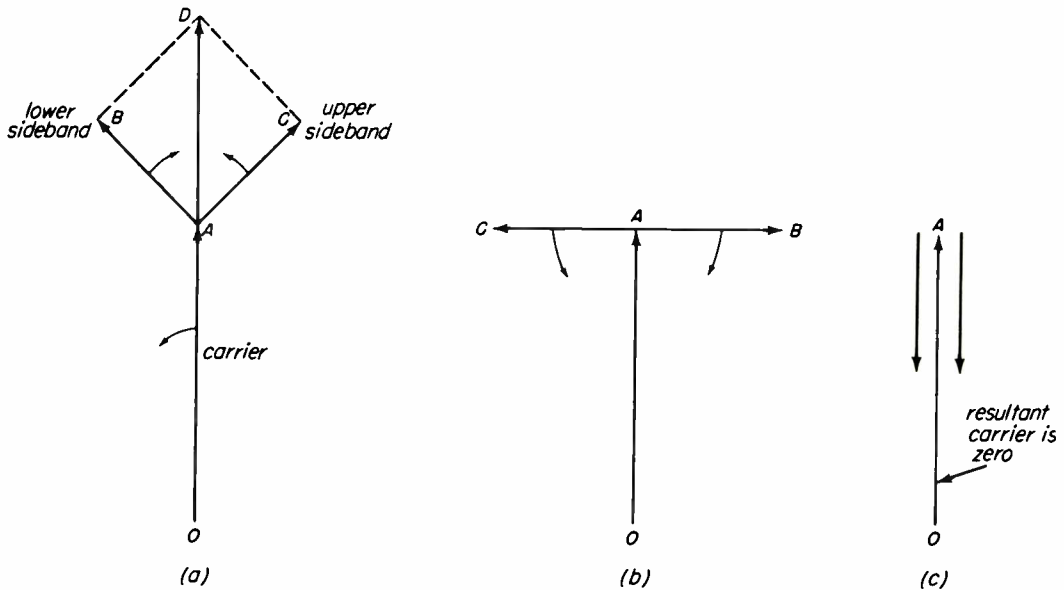

Fig. 1-39. An illustration of amplitude modulation using vectors to represent the carrier and sideband signals.

produced by modulation. The carrier is represented by vector OA ; vectors AB and AC represent the lower and upper sideband respectively. One hundred percent modulation is assumed, so that each sideband vector is one-half the length of the carrier vector. The entire diagram is rotating about the point O at the carrier frequency. However, it is convenient to consider the carrier vector OA as standing still, since we know that the rotating carrier vector produces a sine wave of fixed amplitude. Now the upper sideband AC rotates about the point A in the counterclockwise direction, since its frequency is higher than the carrier vector. The lower sideband AB rotates around the point A in the clockwise direction, since its frequency is lower than the carrier frequency.

An analogy may help to make this clear. Consider three trains side by side on parallel tracks, one train traveling at 49 miles per hour, the center train traveling at 50 miles per hour, and the train on the other side traveling at 51 miles per hour. To an observer in the center train, the first train will appear to be traveling *backward* at one mile per hour, while he is standing still,

and the third train will appear to be traveling *forward* at one mile per hour.

Returning to the rotating sideband vectors, the resultant of the sidebands adds vectorially to the carrier at every instant to produce a modulated wave. The frequency difference between the sidebands and the carrier is always equal; consequently the speed of rotation of the sideband vectors is equal but opposite in direction when compared with the carrier. Therefore, the resultant of the sidebands is always in phase with the carrier. Figure 1-39a shows the sideband resultant AD adding to the carrier. Figure 1-39b shows the sidebands cancelling one another, since they are 180 degrees out of phase. The carrier amplitude at this instant is the same as that of the unmodulated carrier. Figure 1-39c shows that the carrier amplitude is zero, because the vector sum of the two in-phase sidebands and the carrier cancel. Let us now consider the effect on the carrier of a full cycle of sine-wave modulation. Referring to Fig. 1-40, we find:

Position 1: the sidebands cancel and the carrier is unchanged.

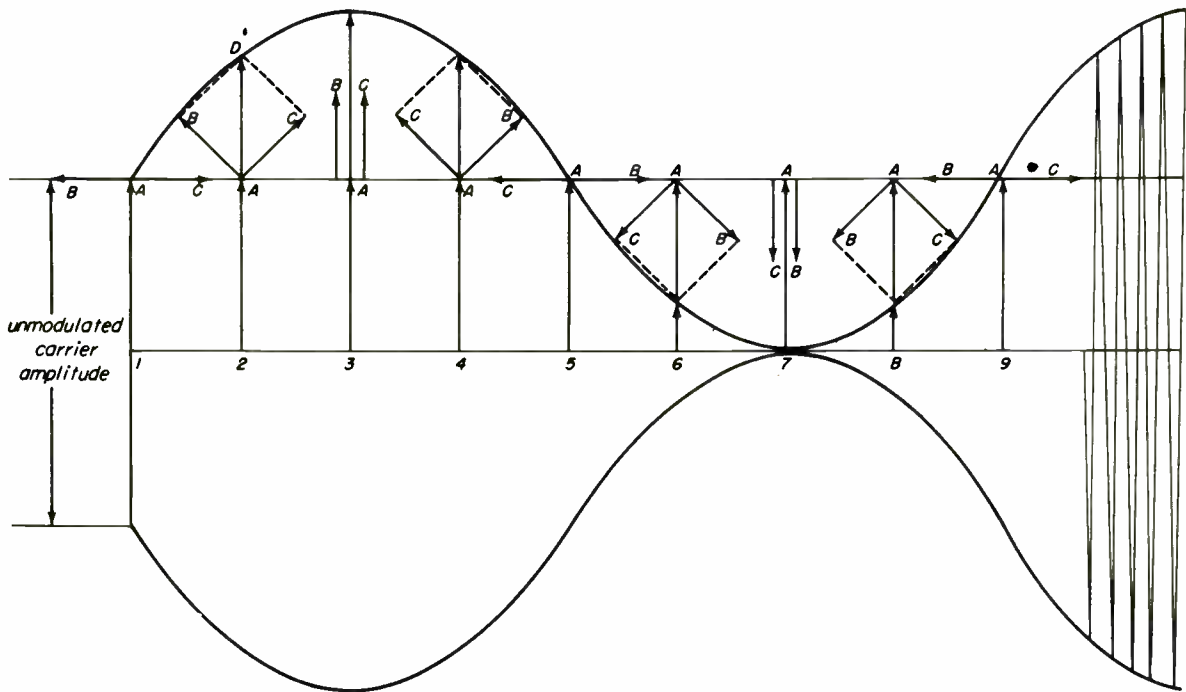

Fig. 1-40. Vector analysis of an amplitude-modulated wave for one complete cycle of the modulating signal.

Position 2: the resultant of the sidebands adds to the carrier to produce some intermediate point of the modulated envelope.

Position 3: the sidebands are in phase and add to produce maximum envelope amplitude.

Position 4: the sidebands again add to the envelope amplitude as in Position 2, but, due to the rotation of the sideband vectors, they have exchanged positions.

Position 5: the sidebands again cancel so that the carrier amplitude is not changed at this point.

Position 6: the sidebands subtract from the carrier to produce some intermediate point of the modulated envelope.

Position 7: the sidebands are again in phase, but this time their resultant is 180 degrees out of phase with the carrier and produces the trough or complete cancellation of the carrier necessary for 100-percent modulation.

Position 8: the sidebands again subtract from the carrier as in Position 6.

Position 9: the sidebands have completed one cycle of rotation and are in the same relative phase as in Position 1.

Note that at all times the *resultant sideband signal*, formed by the addition of the upper and lower sideband vectors, is in phase or 180° out of phase with the carrier signal. Thus we may treat the *resultant sideband signal* by itself as a signal that may be in phase, or 180° out of phase, with the carrier. This is important in color TV since the chrominance sideband signals are transmitted separately and the carrier signal is reinserted at the receiver.

Balanced Modulators. Figure 1-41 shows the basic balanced modulator. Two of these circuits are used in the production of the transmitted subcarrier chrominance signal. The balanced modulators suppress the carrier signal so that there is no 3.58-mc information being sent out when the two chrominance signals are zero. In other words

there is no 3.58-mc information when the camera is scanning white or any shade of gray, including black.

Notice that both input signals are applied in push-pull form, but the output signals from both tubes are taken across a common load impedance. When the chrominance input signal is zero, both modulator tubes conduct equally. The 3.58-mc signals at the plate, being equal in amplitude but opposite in phase, cancel to zero. Thus, there is no 3.58-mc output from either modulator when both $E_{(R-Y)}$ and $E_{(B-Y)}$ are zero.

Now consider the modulator when a simple square wave is applied at the chrominance-signal input terminals. During the first half cycle, the grid of V_1 is driven more negative and the grid of V_2 is driven less negative. Conduction in the modulator tubes is then unbalanced and a net output signal appears. The phase of the output signal is determined by the tube that produces the greatest output. Since V_2 conducts more heavily, and there is a phase inversion between suppressor grid and plate, the phase of the output signal is 0°. During the next half cycle, conditions reverse and the phase of the output signal is 180°.

Since the carrier is suppressed, the output of the doubly balanced modulator contains only the upper and lower sidebands produced by the modulation process. The sum of the two sidebands at any instant is the output signal of the doubly balanced modulator. The amplitude of the output signal varies with the amplitude of the video (chrominance) signal. For example, if the video signal is low in amplitude, the outputs of the two modulators are not so widely separated in amplitude, and the output signal is small. If the video signal is high in amplitude, the amplitude difference of the modulators is greater, thereby producing a greater output. In a doubly balanced modulator, then, the subcarrier frequency is suppressed; the output is composed of sidebands of subcarrier frequency only. The instantaneous amplitude of the modulator output depends upon the amplitude of the video color signal input at any instant, and the instantaneous phase of the output depends upon the instantaneous polarity of the video input.

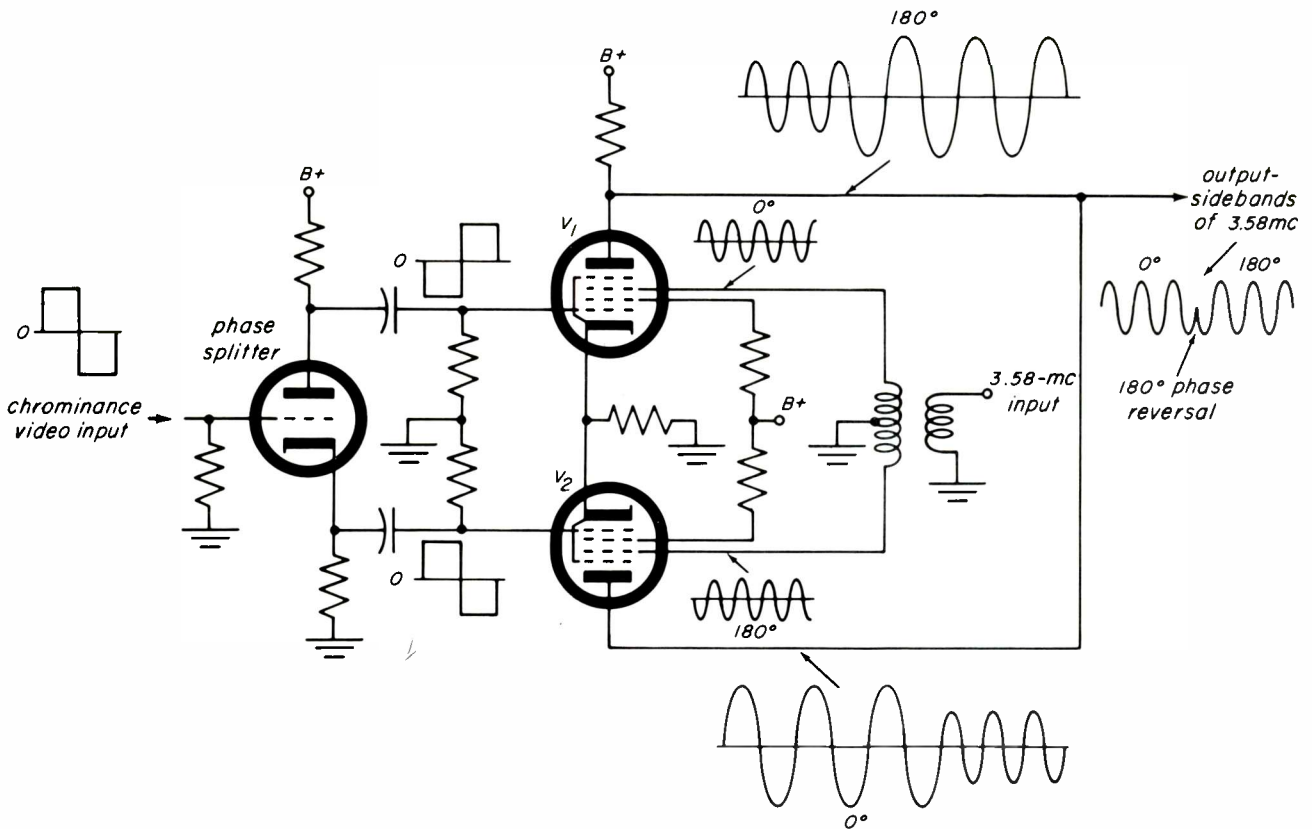

Fig. 1-41. The basic balanced modulator. The 3.58-mc output is cancelled to zero when there is no video output.

Phase Distortion Due to Upper Sideband Attenuation. Whenever one of the sidebands of a double-sideband signal is attenuated, the phase of the resultant signal is altered. This causes errors in hue and saturation in that part of the video passband where upper sideband attenuation is likely to occur. The following is an explanation of how the phase distortion comes about.

The output of one doubly balanced modulator in the transmitter consists of a pair of sidebands as shown in Fig. 1-42a. These rotate around the point O to produce a resultant vector, the amplitude of which varies from OA , through zero, to OB . However, the phase of the resultant never changes; as long as both sidebands are present the resultant always falls along the dotted line in the figure. The actual chrominance signal is the vector sum of the outputs of two

doubly balanced modulators, 90 degrees out of phase with each other.

To see the effects of the attenuation of the upper sideband, let us suppose that at one particular instant the phase of the chrominance signal being transmitted is 90° or $+E_{(R-Y)}$. In that case there should be a positive output from the $E_{(R-Y)}$ demodulator in the receiver, but the $E_{(B-Y)}$ output at the receiver should be zero. This would produce reddish-magenta color on the screen of the receiver. Now suppose that the upper sideband of the 3.58-mc chrominance signal becomes attenuated due to the fall-off in i-f response at the high end of the video band. We must redraw the vectors representing the sidebands as in b of Fig. 1-42. Note that the resultant vector is no longer in phase with $E_{(R-Y)}$ but has been rotated to some new phase angle. Since the resultant is no

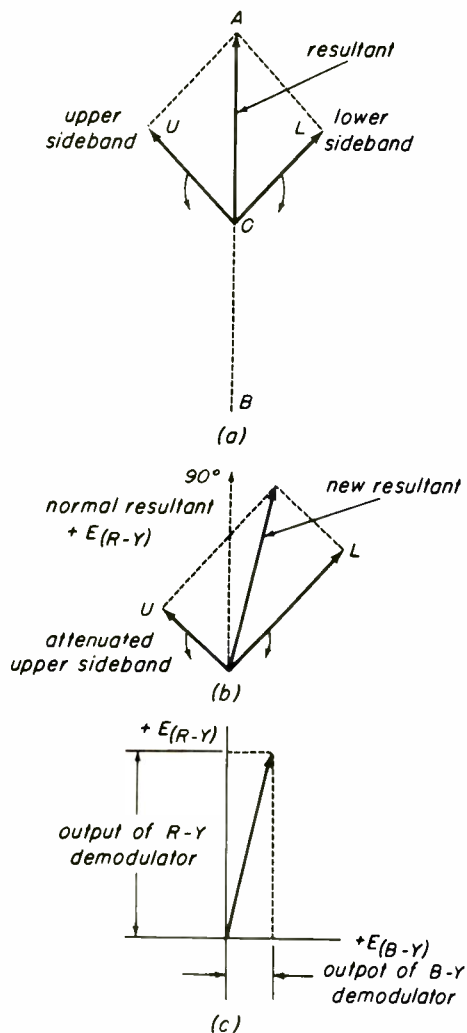

Fig. 1-42. (a) When both upper and lower sidebands are intact the phase of the resultant signal does not vary. (b) Attenuation of one of the sideband signals causes a shift in phase of the resultant. (c) A phase error results in crosstalk between the two chrominance channels.

longer in phase with $E_{(B-Y)}$, the $E_{(R-Y)}$ demodulator output in the receiver will be reduced somewhat. In addition, as shown in Fig. 1-42c, the $E_{(B-Y)}$ demodulator will resolve a component of the resultant vector and provide an output. The result of the phase error caused by sideband limiting is incorrect hue. Put another way, the isolation between $E_{(R-Y)}$ and $E_{(B-Y)}$ channels is lost since a pure $E_{(R-Y)}$ signal has caused an output in the $E_{(B-Y)}$ channel. The loss of isolation between the two chrominance channels is sometimes referred to as crosstalk or

quadrature distortion. We have taken the simple example where the phase of the transmitted signal is 90° . However, crosstalk, and incorrect hue, occurs at any transmitted phase angle if one of the sideband signals becomes attenuated.

The result of crosstalk in the picture is incorrect color in small areas of the picture and at the vertical edges of colored objects. Chromaticity information in these areas of the picture represents signals in the range of frequencies above 600 kc. In relatively large areas, representing low-frequency chromaticity signals, both sidebands remain intact and colors are reproduced correctly. Faulty i-f alignment may cause this trouble.

Frequency Interlace. The subcarrier frequency is synchronized with the horizontal-line frequency in a way that minimizes the visibility of the beat pattern on the picture tube. Visual cancellation of the beat pattern takes place when the bright spots caused by positive excursions of the subcarrier signal are interleaved on alternate scanning lines, as shown in Fig. 1-43. At a we see sections of the waveforms for two consecutive horizontal lines. In the top line, the subcarrier signal starts on a positive half cycle. On the next line (one frame later), the subcarrier signal begins with a negative half cycle. The beat pattern appears as in b of the figure. If we pick any small area in the picture, we might see a bright spot on one line, but the next line (one frame later) will display a darkened spot. Persistence of vision causes an averaging of the visual sensation, and we see an average light level. The average light level is determined by the amplitude of the Y signal upon which the subcarrier signal rides. In addition, the lines of the beat pattern are at a 45° angle with the horizontal. As was shown earlier in this lesson, visual acuity is poorest when fine lines are set at a 45° angle with the horizontal.

The visual cancellation shown in Fig. 1-43 occurs when the subcarrier frequency is made an odd multiple of one-half the horizontal-line frequency. Alternate scanning lines then present the pattern shown in Fig. 1-43b, because the time interval that elapses between the instants that any spot

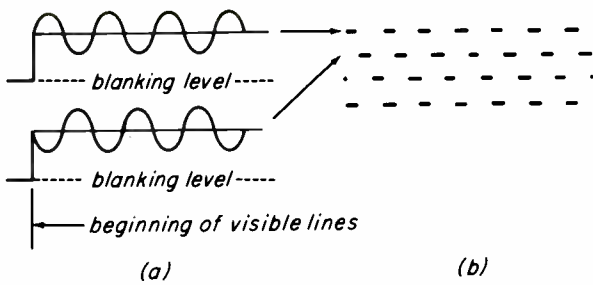

Fig. 1-43. (a) The subcarrier-signal is synchronized with the scanning rate so that peaks and valleys are lined up on adjacent scanning lines; (b) the dot pattern resulting from the frequency interlace technique.

cycles *plus one half cycle*. Thus at any particular spot, successive scans cause a reversal in the instantaneous polarity of the subcarrier signal. To meet the requirements of this technique, called *frequency interlacing*, the subcarrier frequency is set at exactly 3.579545 mc. A small change in the horizontal-line frequency, to 15,734.264 cps, is also required, as well as a small change in the frame frequency to 59.94 cps. The new line and frame frequencies fall within the scanning tolerances for the present black-and-white system.

The exact determination of the subcarrier frequency is shown in more detail in the Appendix.

is scanned on alternate frames allows the completion of an even number of subcarrier



NOTES

APPENDIX

1. OBTAINING $(E_G - E_Y)$ FROM $(E_R - E_Y)$ AND $(E_B - E_Y)$

$$E_Y = 0.30E_R + 0.59E_G + 0.11E_B$$

Transposing: $0.59E_G = E_Y - 0.30E_R - 0.11E_B$

Subtracting $0.59E_Y$ from both sides: $0.59E_G - 0.59E_Y = E_Y - 0.30E_R - 0.11E_B - 0.59E_Y$
 $= 0.41E_Y - 0.30E_R - 0.11E_B$

Rearranging terms: $0.59E_G - 0.59E_Y = -0.30E_R + 0.30E_Y - 0.11E_B + 0.11E_Y$

Factoring: $0.59(E_G - E_Y) = -0.30(E_R - E_Y) - 0.11(E_B - E_Y)$

Dividing through by 0.59: $(E_G - E_Y) = -\frac{0.30}{0.59}(E_R - E_Y) - \frac{0.11}{0.59}(E_B - E_Y)$

$$(E_G - E_Y) = -0.51(E_R - E_Y) - 0.19(E_B - E_Y)$$

2. DETERMINING THE COLOR SUBCARRIER FREQUENCY

In order to obtain interlacing, the color subcarrier frequency must be such that during the time of one horizontal line there is some whole number of subcarrier cycles plus one half-cycle, as shown in Fig. 1.

Let H = horizontal frequency

S = subcarrier frequency

n = number of subcarrier cycles

Then $\frac{1}{H}$ = time duration of one horizontal line

$\frac{1}{S}$ = time duration of one subcarrier cycle

$\frac{n}{S}$ = time duration of n subcarrier cycles

$\frac{1}{2S}$ = time duration of one half subcarrier cycle

Therefore $\frac{n}{S} + \frac{1}{2S} = \frac{1}{H}$

Adding fractions: $\frac{2n+1}{2S} = \frac{1}{H}$

Solving for S : $S = \frac{H}{2}(2n+1)$

Examining this equation, we can see that whether n is odd or even, $(2n+1)$ is odd.

Let $(2n+1)$ be called N . Thus, the subcarrier frequency must be some odd multiple N of one-half the line frequency for interlacing.

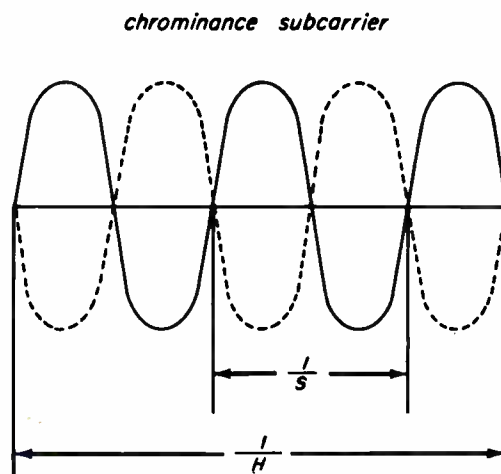

Fig. 1.

From other considerations previously given, we know that the subcarrier frequency should be in the neighborhood of 3.58 mc.

Dividing 3.58 by 7.875 kc gives N as approximately 455.

Since N must be a whole odd number, let us define N as 455 exactly, and

$$S = 455 \times \frac{H}{2} \quad (1)$$

Also, the difference beat between S and the 4.5-mc sound carrier must also be a whole odd multiple of $H/2$, so that the beat between the sound carrier and the color subcarrier will interlace.

The difference between 3.58 mc and 4.5 mc is approximately $117 \times (H/2)$. If we use exactly $117 \times (H/2)$, the beat between them will be an exact odd multiple of $H/2$, as required for interlacing. The relationships are shown in Fig. 2. The separation between sound carrier and picture carrier, in terms of $H/2$, is $572 \times (H/2)$, and in terms of frequency is 4.5 mc.

We can now write the equations:

$$572 \times \frac{H}{2} = 4.5 \text{ mc} \quad (2)$$

$$\frac{H}{2} = \frac{4.5 \text{ mc}}{572} \quad (3)$$

$$H = 4.5 \text{ mc} \times \frac{2}{572}$$

$$H = 15.734 \text{ kc/sec}$$

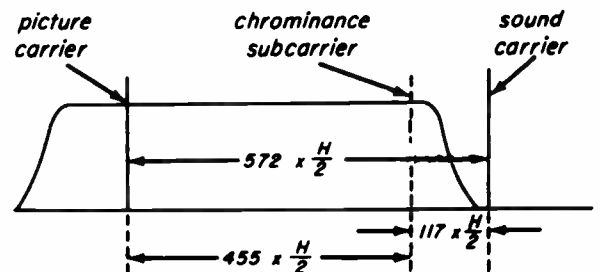

Fig. 2.

Substituting the value of $H/2$ from equation (3) in equation (1) we have:

$$S = \frac{H}{2} \times \frac{455}{1} = 4.5 \times \frac{455}{572} = 3.579545 \text{ mc}$$

Since 525-line interlaced scanning is to be maintained, the vertical frequency is

$$\frac{2}{525} \times H = 59.94 \text{ cycles/sec.}$$

3. OBTAINING THE MULTIPLIERS FOR ADJUSTING $(E_R - E_Y)$ AND $(E_B - E_Y)$

Let h be the multiplier for $(E_R - E_Y)$

k be the multiplier for $(E_B - E_Y)$

The E_Y value for red = 0.30

blue = 0.11

green = 0.59

The sum of E_Y and the combined chrominance signal must not cause overshoot greater than 33 percent. To limit either positive or negative overshoot to 0.33, from Fig. 3. we find that the maximum values allowable for the combined chrominance (chroma) signals are:

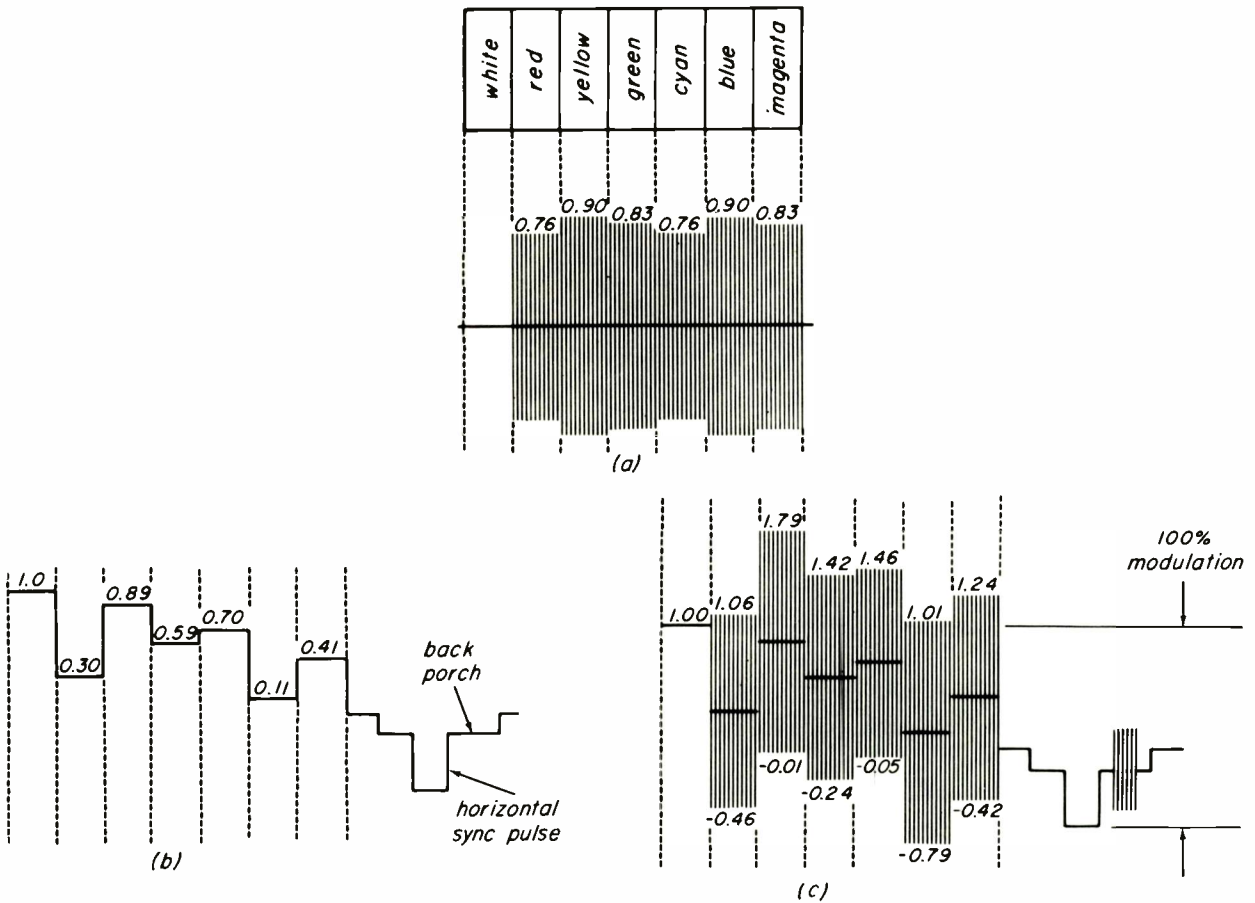

Fig. 3.

Red scene: $0.30E_Y + \text{chroma} = -0.33$; maximum allowable chroma for red = -0.63
 Blue scene: $0.11E_Y + \text{chroma} = -0.33$; maximum allowable chroma for blue = -0.44
 Green scene: $0.59E_Y + \text{chroma} = 1.33$; maximum allowable chroma for green = 0.74

The red and blue scenes are the limiting cases.

For a red scene, $(E_R - E_Y) = 0.70$, $(E_B - E_Y) = -0.30$, and the combined chrominance signal is the vector sum of these. But the maximum allowable chrominance value for a red scene is 0.63 . Thus:

$$\sqrt{[h(E_R - E_Y)]^2 + [k(E_B - E_Y)]^2} = \text{chroma signal}, \sqrt{(0.7h)^2 + (0.3k)^2} = 0.63 \quad (1)$$

For a blue scene, $(E_R - E_Y) = -0.11$, $(E_B - E_Y) = +0.89$,

and
$$\sqrt{(0.11h)^2 + (0.89k)^2} = 0.44 \quad (2)$$

Solving simultaneous equations (1) and (2) gives: $h = 0.877$, $k = 0.493$.

Therefore, the adjustment is as follows:

$$0.877(E_R - E_Y) \text{ and } 0.493(E_B - E_Y)$$

These are sometimes expressed in reciprocal form, thus:

$$\frac{(E_R - E_Y)}{1.14} \text{ and } \frac{(E_B - E_Y)}{2.07}$$

The adjusted signal is shown in Fig. 4.

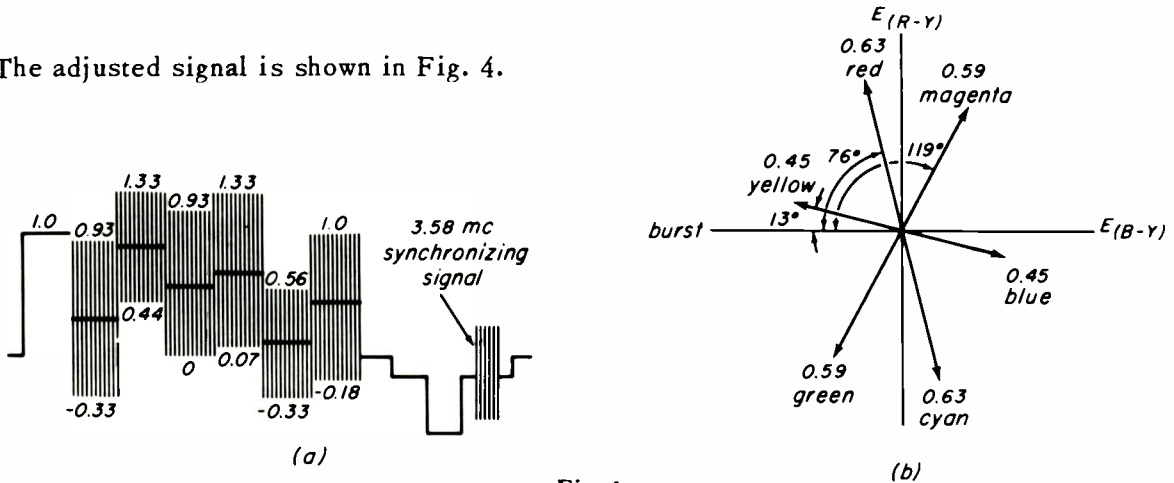

Fig. 4.

4. OBTAINING THE E_I AND E_Q VALUES FROM $(E_B - E_Y)$ AND $(E_R - E_Y)$, GIVEN THAT THE I AND Q AXES ARE ROTATED 57° FROM THE $(E_B - E_Y)$ AND $(E_R - E_Y)$ AXES

Assume some color indicated by point P , and draw diagram as shown in Fig. 5.

The $(E_R - E_Y)$ component of P is $OB = AP = 0.877(E_R - E_Y)$

The $(E_B - E_Y)$ component of P is $OA = BP = 0.493(E_B - E_Y)$

The E_I component of P is $OC = DP$

The E_Q component of P is OD

$$E_I = DP = PF \cos 33^\circ; PF = AP - AF = AP - OA \tan 33^\circ$$

$$DP = (AP - OA \tan 33^\circ) \cos 33^\circ$$

$$= AP \cos 33^\circ - OA \sin 33^\circ$$

$$= 0.877(E_R - E_Y) \cos 33^\circ - 0.493(E_B - E_Y) \sin 33^\circ$$

$$= 0.74(E_R - E_Y) - 0.27(E_B - E_Y)$$

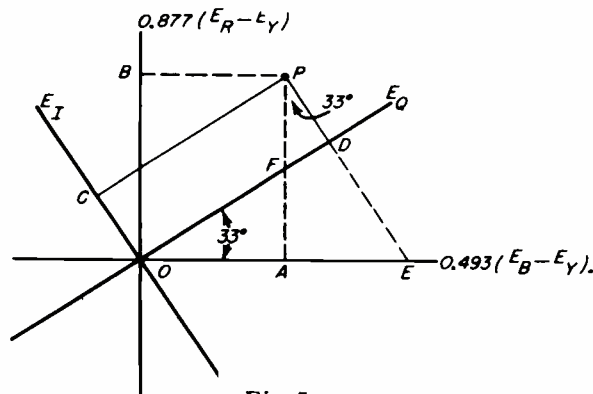

Fig. 5.

$$\begin{aligned}
 E_Q &= OD = OE \cos 33^\circ; \quad OE = OA + AE; \quad AE = AP \tan 33^\circ \\
 &= (OA + AP \tan 33^\circ) \cos 33^\circ \\
 &= 0.493(E_B - E_Y) \cos 33^\circ + 0.877(E_R - E_Y) \sin 33^\circ \\
 &= 0.48(E_R - E_Y) + 0.41(E_B - E_Y)
 \end{aligned}$$

Similar analysis will give $(E_R - E_Y)$ and $(E_B - E_Y)$ in terms of E_I and E_Q .

$$0.877(E_R - E_Y) = E_I \cos 33^\circ + E_Q \sin 33^\circ; \quad (E_R - E_Y) = 0.96E_I + 0.62E_Q$$

$$0.493(E_B - E_Y) = -E_I \sin 33^\circ + E_Q \cos 33^\circ; \quad (E_B - E_Y) = -1.01E_I + 1.70E_Q$$

5. FORMULAS USED IN COLOR TELEVISION

$$E_Y = 0.30E_R + 0.59E_G + 0.11E_B$$

$$(E_R - E_Y) = 0.70E_R - 0.59E_G - 0.11E_B$$

$$(E_B - E_Y) = -0.30E_R - 0.59E_G + 0.89E_B$$

$$\begin{aligned}
 (E_G - E_Y) &= -0.30E_R + 0.41E_G - 0.11E_B \\
 &= -0.51(E_R - E_Y) - 0.19(E_B - E_Y)
 \end{aligned}$$

$$\begin{aligned}
 \text{Adjusted } (E_R - E_Y) &= 0.877(E_R - E_Y) \\
 &= 0.615E_R - 0.515E_G - 0.10E_B
 \end{aligned}$$

$$\begin{aligned}
 \text{Adjusted } (E_B - E_Y) &= 0.493(E_B - E_Y) \\
 &= -0.15E_R - 0.29E_G + 0.44E_B
 \end{aligned}$$

$$\begin{aligned}
 E_I &= 0.877(E_R - E_Y) \cos 33^\circ - 0.493(E_B - E_Y) \sin 33^\circ \\
 &= 0.74(E_R - E_Y) - 0.27(E_B - E_Y) \\
 &= 0.60E_R - 0.28E_G - 0.32E_B
 \end{aligned}$$

$$\begin{aligned}
 E_Q &= 0.877(E_R - E_Y) \sin 33^\circ + 0.493(E_B - E_Y) \cos 33^\circ \\
 &= 0.48(E_R - E_Y) - 0.41(E_B - E_Y) \\
 &= 0.21E_R - 0.52E_G + 0.31E_B
 \end{aligned}$$

$$0.877(E_R - E_Y) = E_I \cos 33^\circ + E_Q \sin 33^\circ; \quad (E_R - E_Y) = 0.96E_I + 0.62E_Q$$

$$0.493(E_B - E_Y) = -E_I \sin 33^\circ + E_Q \cos 33^\circ; \quad (E_B - E_Y) = -1.10E_I + 1.70E_Q$$

$$(E_G - E_Y) = -0.28E_I - 0.64E_Q$$



NOTES

COLOR TELEVISION COURSE

COLOR PICTURE TUBES

- 1. Means of Displaying Color TV Pictures**
- 2. RCA Shadow-Mask Color Picture Tube**
- 3. Electron Guns**
- 4. Purity**
- 5. Convergence**
- 6. Focus**
- 7. Associated Picture Tube Components**
- 8. Color Picture Tube Circuit Requirements**
- 9. Color Picture Tube Handling and Safety**



RCA INSTITUTES, Inc.

A SERVICE OF RADIO CORPORATION OF AMERICA

HOME STUDY SCHOOL

350 West 4th Street, New York, N.Y. 10014

INTRODUCTION

The color picture tube provides the output of the color TV system. Here three electrical signals, representing the telecast scene in terms of the selected primary colors, are turned into the full-color image.

2-1. MEANS OF DISPLAYING COLOR TV PICTURES

The display device to be used with the color TV system must meet several basic requirements. First of all it should be *compatible*. For the display device, *compatibility* requires that it reproduce full color pictures and standard monochrome pictures with acceptable picture quality. The *color range* should be large enough to reproduce three-color pictures, of the order of quality that we accept in high-quality color films. In addition, the color display device should be comparable to modern black-and-white picture tubes in terms of picture size, contrast, and brightness.

Methods of Combining Colored Images. The basic job of the color display device is to *combine* the separate images in each of the primary colors, so that the eye sees a mixture of the primary colors. Some of the early systems use an optical arrangement to

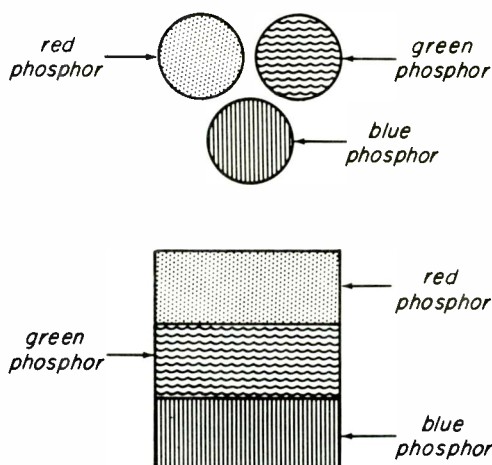

Fig. 2-2. Colored images may be combined by breaking the images up into many tiny groups of phosphors that cannot be resolved individually by eye.

superimpose the images displayed by three separate picture tubes. Refer to Fig. 2-1. The phosphors of the picture tubes are chosen so that each kinescope displays one of the primary colors – red, blue, and green. In an alternate arrangement, black-and-white kinescopes are employed with red, green, and blue filters. The images are projected on a common screen, and care is taken to make the images fall in *register*, or exactly on top of one another. The eye adds these images, and sees the mixture of the three colors at each point on the screen. Projection systems of this type are now used in theaters. Other optical systems, employing dichroic mirrors similar to the mirrors used in the camera, were used in early developmental receivers. Optical systems are too large and bulky to be used in home instruments. In addition, great care must be taken in the deflection systems of the three kinescopes to ensure identical picture size and linearity in each tube.

Another way to combine images is to construct the image from adjacent colored elements so small that they cannot be resolved as individual colored elements. The elements may be arranged in triangular groups of phosphor dots, or in the form of thin strips of phosphor. The basic arrangements of individual groups of phosphors may appear as in Fig. 2-2. Again the eye will add the three colors, and a sensation corresponding

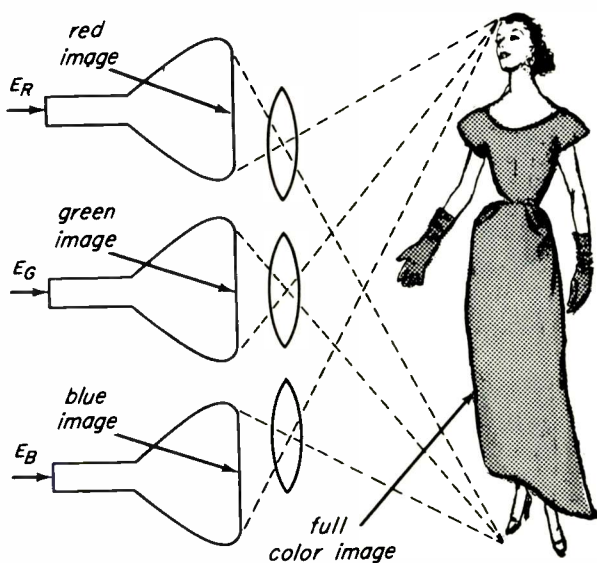

Fig. 2-1. An optical system to combine primary-color images.

to the mixture color of the three phosphors will be obtained. The basic principle is the same for either arrangement. During the scanning of the raster, the red phosphors are excited in those areas of the image corresponding to the red portions of the original scene, the green phosphors are excited in those areas corresponding to the green portions of the scene, and the blue phosphors are excited in those areas corresponding to the blue portions of the scene. In those areas of the image that correspond to a yellow portion of the scene, both the red and green phosphors are excited. The phosphor strips or dots should be so small that the eye cannot perceive them separately, and sees instead the mixture color of the two, or yellow. Similarly, the red and blue phosphors are excited to reproduce the magenta portions of the image, and the green and blue phosphors to reproduce the cyan portions. White or gray areas are produced by correctly exciting all three phosphor areas. This method of combining colors is employed in the shadow-mask picture tube.

Methods of Presentation. The color information may be presented to the eye in either a simultaneous or a sequential manner. If the primary-color components of the scene are presented to the eye at the same time, in such a way that they are effectively superimposed, the eye and brain will mix the colors, and a sensation corresponding to the mixture color will be obtained.

If the primary-color components of the scene are presented to the eye one after the other, rapidly enough for persistence of vision to be effective, the eye and brain will still mix the three primary colors and a sensation corresponding to the mixture color will be obtained. For instance, the sensation of yellow can be produced by exciting the red and green phosphors at the same time, so that red and green light are presented simultaneously to the eye, or by exciting the red and green phosphors one after the other, so that the red and green light are presented to the eye in rapid sequence.

An early color TV system was based on the sequential system. Primary-color images were transmitted sequentially on sequential



Fig. 2-3. A 21-inch color picture tube.

vertical fields. A mechanical system, using a rotating wheel of color filters in front of a black-and-white picture tube, placed the proper filter in front of the screen at the proper time. For example, when the red field was scanned, the red filter was placed before the kinescope. When the green field was scanned, the green filter came into place, and so on. A synchronizing system kept the color wheel of the receiver rotating in synchronism with a similar wheel in front of the camera. A major drawback of this system was that flicker became objectionable unless the field rate was speeded up. Therefore, the system did not use the standard scanning rates, and was incompatible. Another problem was that colors would appear to break up with rapid movement. If a man ran rapidly across the viewed screen, he might appear as a series of red, green, and blue figures instead of one continuously moving colored image.

Present-Day Color Picture Tubes. Present-day technology has provided the industry with direct-view color picture tubes. Several types of single-gun tubes have been proposed and developed in laboratories, but none have so far met the test of production. This leaves, then, the three-gun shadow-mask color picture tube that has been in production since 1953 and, with improvements, is still in use

today. Figure 2-3 shows a photograph of an RCA 21-inch color picture tube.

2-2. RCA SHADOW-MASK COLOR PICTURE TUBE

Shadow-Mask Principle. The shadow-mask principle can be understood quite easily with the aid of the simple setup shown in Fig. 2-4. Here a single light source is placed above a shadow mask, which is simply a perforated plate or sieve. Light passes through the holes in the sieve and causes a polka-dot pattern to appear on a flat screen placed below the sieve. If we mark the spots on the screen, paint them red, and then reassemble the light source, sieve, and screen in their original positions, only the red spots will be illuminated by the light source. If the light source is now moved to the side a sufficient distance, the light rays will pass through the sieve at a different angle and

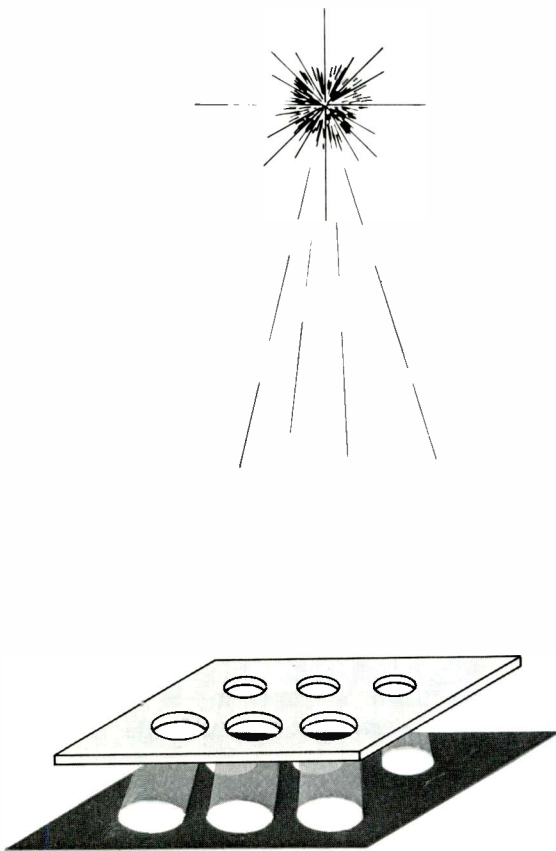

Fig. 2-4. A simple illustration of the shadow-mask principle.

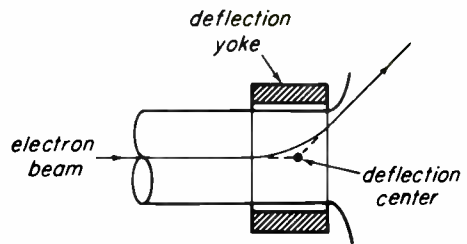

Fig. 2-5. The deflection center is the spot inside the deflection yoke from which electrons appear to emerge.

will miss the red spots altogether. The new illuminated areas could be painted green. Now we could have two light sources – one controlling only red output on the screen, the other only green. This experiment can be verified quite easily using a flashlight, a sieve (or perforated shield), and a sheet of paper. A third light source, at a new lateral position, can be added to illuminate a new set of blue spots. The result will be a screen covered with trios of small red, blue, and green spots. The light falling on any of the three primary colors can be altered by controlling the light output of the light source associated with a particular primary color.

In the shadow-mask picture tube, the light sources are, of course, replaced by sources of electrons. Just as light emanates from a point in our simplified setup, electrons appear to be sprayed out from a point inside the deflection yoke, as shown in Fig. 2-5. The point from which electrons appear to be

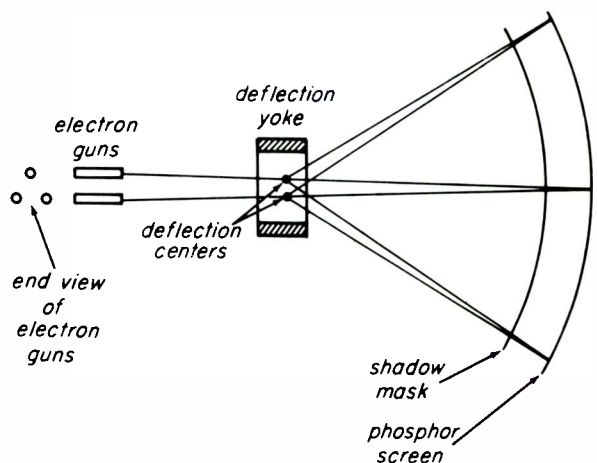

Fig. 2-6. Sideview shows the locations of the deflection centers for two electron beams in relation to the shadow mask and the phosphor screen.

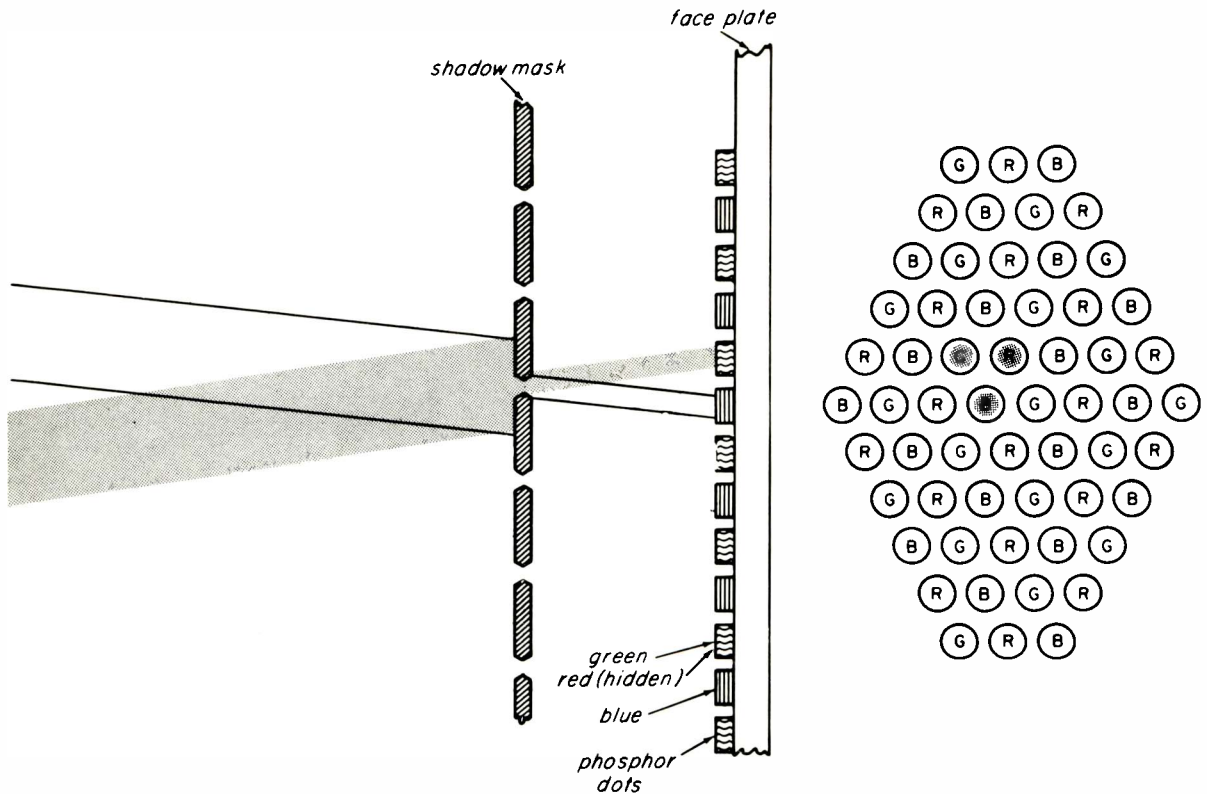

Fig. 2-7. These enlarged side and front views of the shadow mask and phosphor screen show two electron beams striking the shadow mask at the correct angles. The unshadowed portions of the beams strike the center of the correct phosphor dots. One beam, from the green gun, is hidden behind the beam from the red gun in the view. For simplicity, the individual beams are shown striking the area surrounding a single hole in the shadow mask. Actually, each beam has a larger diameter, and strikes an area on the shadow mask that includes about three holes.

3 deflected is called the deflection center. In the color kinescope, the deflection center corresponds roughly to the point light source used in our analogy. To serve as three controllable sources of electrons, three electron guns are placed in the neck of the tube, as shown in Fig. 2-6. They are grouped in a circle, 120° apart, around the long axis of the tube. The three guns are angled slightly so that the three electron beams will naturally come together, or converge, at the face of the tube. The electron beams from these guns are shadowed through holes in a shadow mask. See the enlarged side view of a small section of the shadow mask and phosphor screen in Fig. 2-7. Since this figure shows a side view, only two electron beams are visible, one of the two electron beams at the bottom being hidden by the other. Note that the electron beam is larger than the holes in the shadow mask. The figure clearly shows

that the angle of approach of the electron beam to the shadow mask allows the unshadowed portions of the electron beam to strike only the phosphor dots. The unshadowed portions of the electron beams from the green and blue guns strike only their associated phosphor dots. One of the three guns produces one color, the second gun produces the second color, and the third gun produces the third color. Grid Number 1 of each of those guns is capable of controlling the intensity of its associated color as required by a color television system. Figure 2-8 shows the basic arrangement of the electron guns, the shadow mask, and the phosphor screen.

Shadow Mask Construction. The shadow mask itself is made from a flat sheet of steel. The surface of this sheet is coated with light-sensitive material that hardens

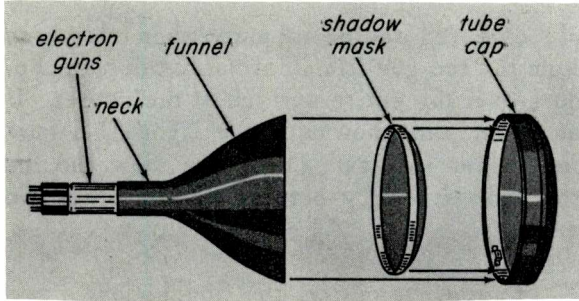

Fig. 2-8. Exploded view showing the relative placement of the major parts of the color picture tube.

when exposed to light. This coated steel sheet is exposed to light through a master dot pattern that permits light to strike it in all areas except where the holes are to be located. Unexposed material is then washed off the sheet, leaving the steel sheet bare of material at the places where the holes are to be made. The sheet is next dipped into an acid bath; where the sensitizing material has been washed away, the acid eats through the metal and produces the holes. By this method, approximately 330,000 holes are produced in the flat sheet. The perforated flat steel sheet is then formed under pressure into a spherical shape, and a steel frame is attached to it to complete the shadow-mask assembly.

Phosphor Screen. The phosphor screen is made by distributing red phosphor with an added sensitizing binder on the inside surface of a tube cap. A shadow mask is placed in position in the tube cap. Figure 2-8 shows how the shadow mask and tube cap are assembled. A point source of light is placed at the position where the red electron beam would pass through the deflection center of the deflection yoke. The material that has been deposited on the tube cap is then exposed to light from the point source passing through the shadow-mask holes. The shadow mask is then removed and the unexposed phosphor material is washed away, leaving the red phosphor dots. The process is repeated using the same shadow mask as before, but with green phosphor. The light source is moved to a position where the green beam would pass through the deflection center. The same process is again repeated for blue phosphor, with a light position corresponding to the blue beam

location at the deflection center. By this method, approximately 1,000,000 phosphor dots are located precisely on the face of the color picture tube.

Color Picture Tube Assembly. The shadow mask is now laid aside and the tube cap is baked. After the baking operation, only pure phosphor remains. The tube cap is then flashed with a thin film of aluminum over the backside of the phosphor dots. The shadow mask used for exposure of the phosphor dots is next placed in position in the tube cap, and the tube cap is sealed to the tube funnel by means of a special glass sealant, called frit cement, in a high-temperature oven. Finally, the three-electron gun assembly is sealed into the neck of the tube, and the air is evacuated from the tube.

2-3. ELECTRON GUNS

The elements of the electron gun are the heater, the cathode, grid 1, grid 2, grid 3, and grid 4, as shown in Fig. 2-9. The heater is a coiled wire inserted into, but insulated from, the cathode. When current is passed through the heater, the cathode is heated to a temperature that allows it to emit electrons. Grid 1, located immediately following the cathode and very close to it, is used to control the flow of electrons from the cathode. This grid usually consists of a small disk with a tiny hole, or aperture, located in

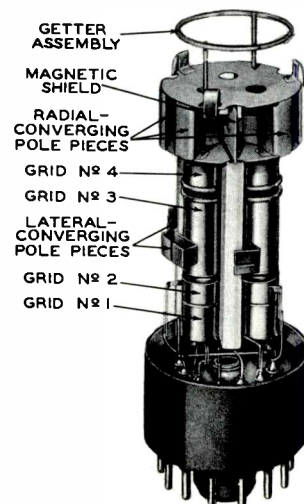

Fig. 2-9. The electron-gun assembly for a color picture tube.

its center. Grid 2 is of similar construction but is used to control the cutoff characteristics of the electron gun. This element is called the accelerating electrode or screen. Grid 3, called the focus grid, is usually a long cylinder rather than a disk like the previous two grids. It generally has one form or other of the blue-lateral convergence pole pieces attached to it. The function of this element is to focus the electron beam to a point at the picture tube screen. Grid 4, also cylindrical in shape, is called the *ultor*. It is operated at a high voltage to enable it to speed the electrons to the picture tube screen. The radial convergence assemblies, which will be discussed shortly, are attached to grid 4.

ple, the red raster is pure when electrons from the red gun illuminate only red phosphor dots over the entire surface of the screen. If no other phosphor dots are lighted, a pure red raster results. (You may view the red raster by itself by biasing off the other two guns.)

For perfect purity, the nonshadowed portions of each electron beam must strike the associated phosphor dots squarely in the centers. This is illustrated in Fig. 2-10.

If a large error exists in the angle of approach to the shadow mask, the electron beams may strike the wrong phosphor dots, as shown in Fig. 2-11. In this case, individual color rasters, called *fields*, would be contaminated with the wrong colors. A red field may show a yellow area, for example, if both red and green phosphor dots are struck. When color contamination shows up on one or more of the individual primary-color fields, the condition is referred to as a *purity* problem.

4

2-4. PURITY

The rasters produced by the red, green, and blue electron guns are said to be *pure* when electrons from each gun strike only their associated phosphor dots. For exam-

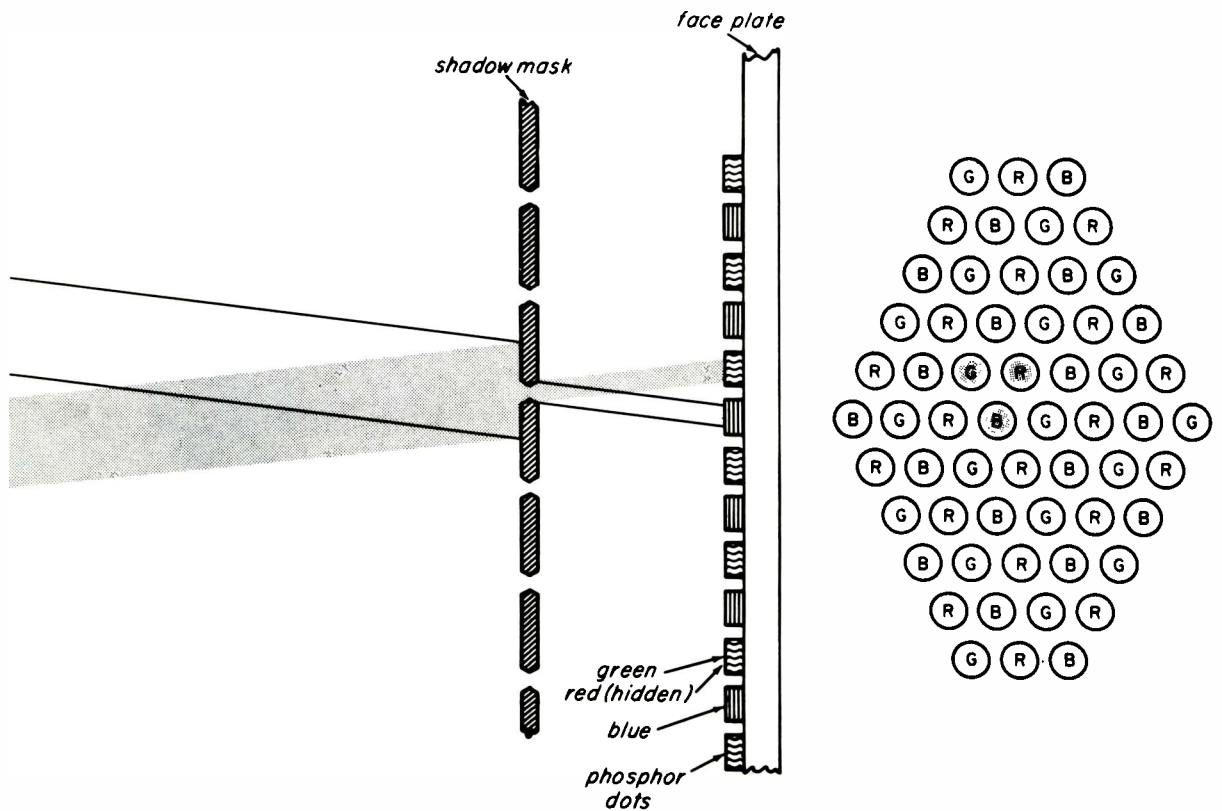

Fig. 2-10. Correct purity is obtained when the unshadowed portions of the electron beams strike the correct phosphor dots squarely in their centers.

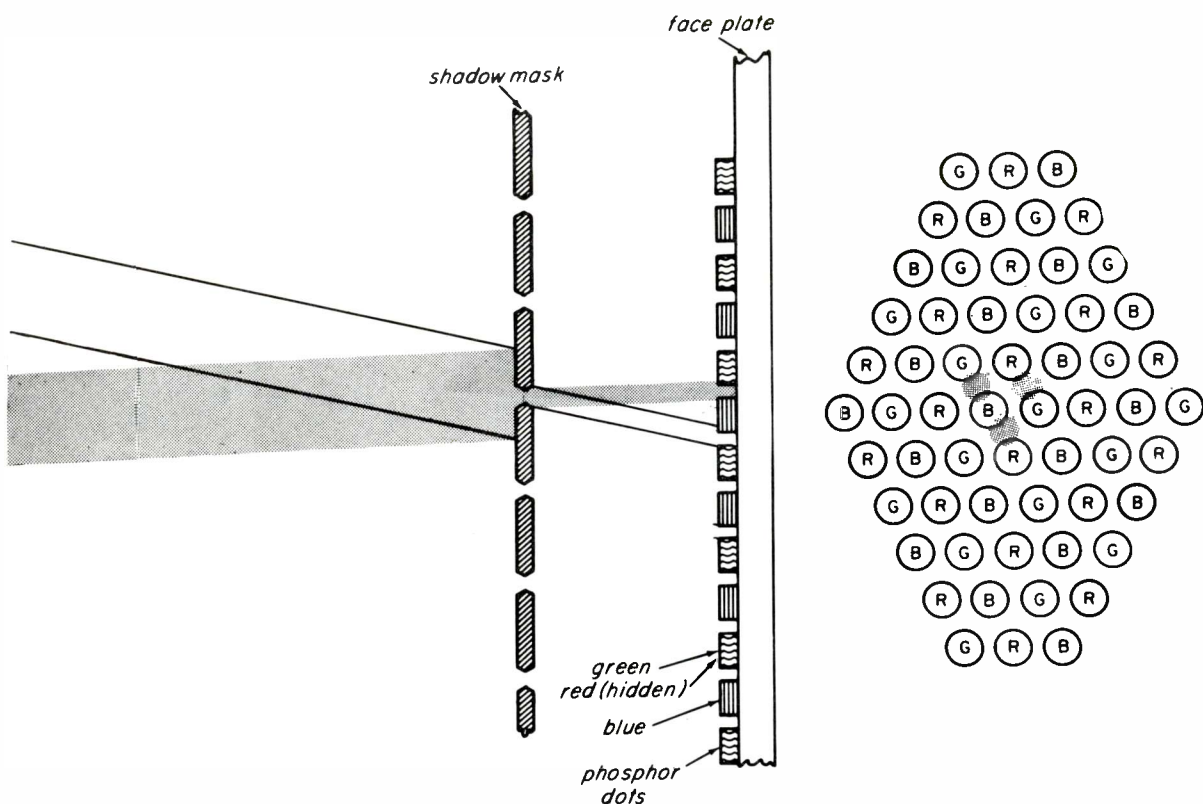

Fig. 2-11. An example of poor purity. The electron beams approach the shadow mask at the wrong angles. Unshadowed beams miss their assigned phosphor dots and strike others as well.

A smaller error in beam landing also introduces a problem with raster uniformity. Figure 2-12 shows the effects of a smaller beam-landing error. In this case, the correct phosphors are struck, but the beam landing is considerably off center. In areas where this condition exists, the total light output is diminished. Loss of light output for a particular color may go unnoticed when the primary-color fields are viewed individually, but when the three fields are illuminated to make white, a definite color is seen. For example, if some part of the red raster lacks red light output, that area of the white raster will have insufficient red to make white and will appear cyan. This problem, while resulting in a nonuniform white raster, is not usually referred to as a purity problem. The red raster would appear a pure red in this case, but the area in question would appear darker, or "dirty looking," due to the lack of light output.

Factors that Affect Purity. As shown in Figs. 2-11 and 2-12, purity problems are caused by improper landing of the unshadowed portions of the electron beams. This in turn is caused by improper angle-of-approach of the electron beams. Therefore, the attainment of good purity is related to the positioning of the deflection centers for the electron beams at the precise locations of the light sources used when the phosphor screen was exposed. (Refer back to the discussion of phosphor screen fabrication.) To locate the deflection centers properly, the electron guns must be aimed with precision and the deflection yoke must be placed at one particular spot. Figure 2-6 shows the effects of beam aiming and deflection yoke position on the location of the deflection centers. Various factors, such as the effects of stray magnetic fields and slight errors in electron-gun alignment, can cause displacement of the deflection centers.

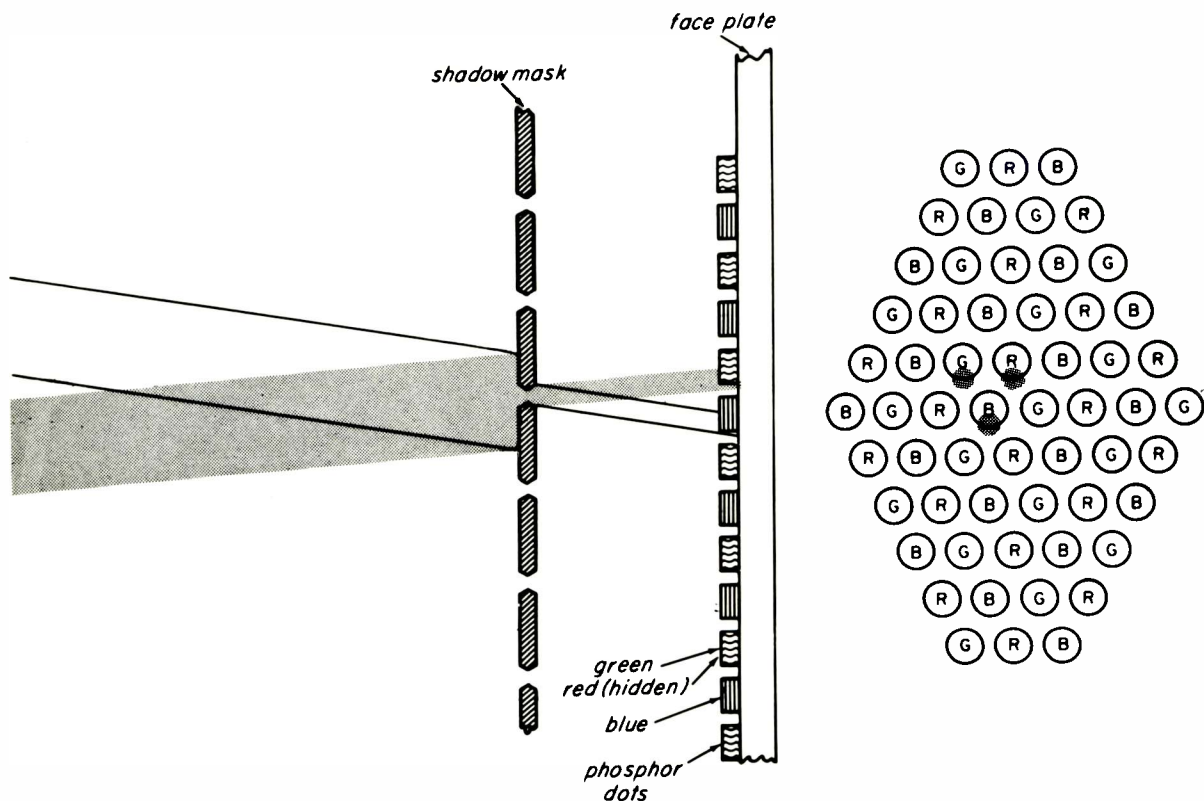

Fig. 2-12. A small error in the angle of approach of the electron beams causes this condition. The unshadowed beams do not land on the centers of the phosphor dots, resulting in reduced light output.

Adjustments are provided to allow corrections in electron-beam aiming and yoke positioning. These adjustments are called purity adjustments.

Yoke Position. The position of the deflection yoke along the axis of the tube has a great effect upon beam landing at the edges of the screen, but practically no effect on it at the center of the screen. A somewhat simplified and exaggerated demonstration of this fact is shown in Fig. 2-13. In *a* of the figure, the yoke is placed properly to cause the unshadowed electron beams to strike the centers of the phosphor dots. The yoke is moved back towards the electron gun in *b* of the figure. Note that the unshadowed beams are approaching the parallel condition and are missing the phosphor dots at the top and bottom of the screen. However, the beams that pass through the center of the shadow mask continue to strike the phosphor dots in the center. It is important to remember that yoke position does not affect beam landing in the center of the screen. The effects of

yoke position on beam landing, as viewed from the front of the screen, are shown in Fig. 2-14. Moving the yoke back towards the guns causes the beam landings at the edge of the screen to move towards the center of the screen. Moving the yoke too far forward causes the edge beam landings to move outward. Note: Beam landings on individual phosphor dots, as indicated in Fig. 2-14, cannot be observed with the naked eye. A low-power microscope can be used for this purpose. However, microscopes invert the image so that the beam landings appear to move in opposite directions. In other words, when observed through a microscope, the beam landings at the screen edges appear to move outward from the center as the yoke is moved back towards the electron guns.

Neck Purity Magnet. A device, similar to the magnetic centering devices employed on monochrome kinescopes, is used to adjust purity and beam landing at the center of the screen. This magnetic device is commonly

mounted on the neck of the color picture tube. It is adjusted to center the beam landings on the phosphor dots in the middle of the screen, where the yoke has no effect. How the neck-purity magnet does its job can be visualized by referring to Fig. 2-15. The neck-purity magnet enables all three beams to be bent slightly before they enter the yoke. This permits precise adjustment of the angle at which the beams approach the shadow mask in the center of the screen, and hence allows control of center-beam landing. When center-beam landing and yoke position are properly adjusted, the deflection centers are in the correct positions.

The neck-purity magnet must be variable in magnetic strength, and capable of being rotated about the neck of the tube so that its direction of field can be changed. It must also be possible to reduce its field strength to a negligible value, in case little or no

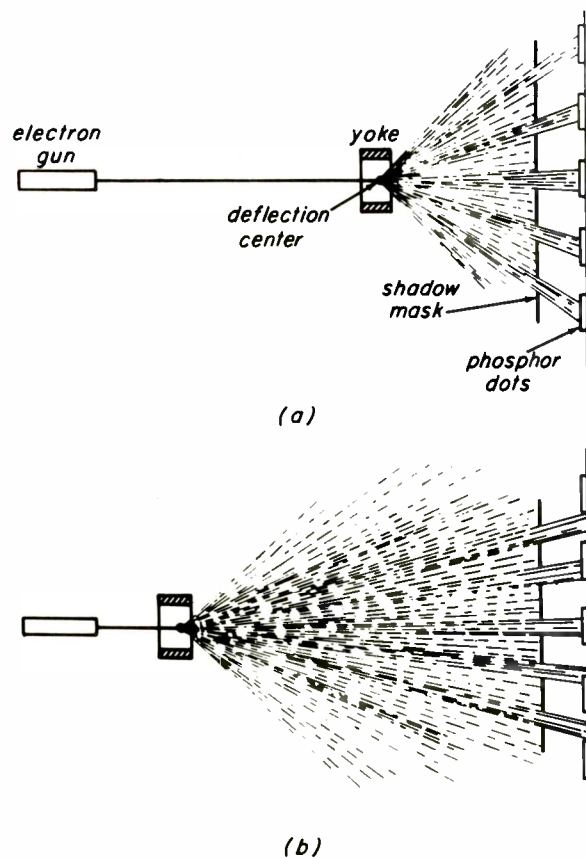

Fig. 2-13. This simplified drawing shows what happens to the electron-beam landing when the yoke is moved back towards the electron guns. Note that beam landing does not change in the center of the screen.

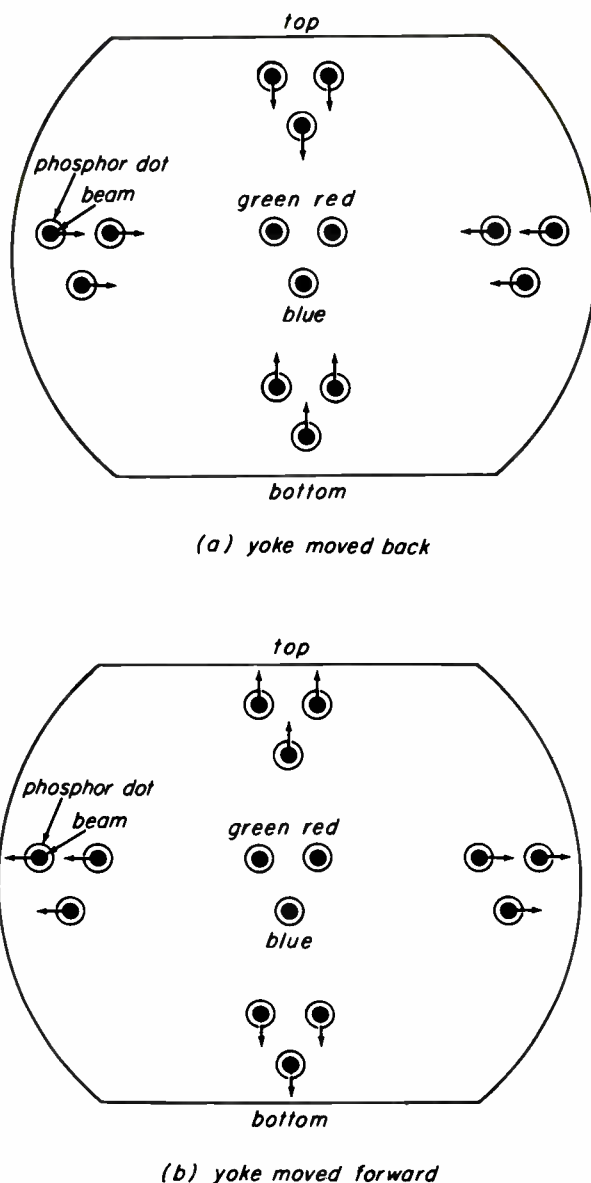

Fig. 2-14. The displacement of electron beams landing at the edges of the screen as the yoke position is changed.

correction is needed. It is essential that the field across the neck of the tube be uniform so that all three beams are affected equally. The neck-purity magnet has one major drawback; adjustments change static and dynamic convergence. We shall look into these effects later.

Post-Deflection Purity Device. The corrections accomplished by the neck-purity magnet may be obtained by mounting a similar, but much larger, magnet between the yoke and the shadow mask. This device,

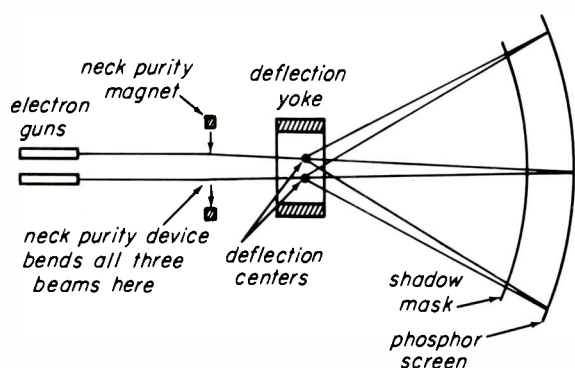

Fig. 2-15. The neck-purity magnet is used to position the three electron beams so that they pass through the proper deflection centers.

mounted on the bell of the picture tube, is called a post-deflection purity magnet. It is more costly than the neck-purity magnet because of its size and the difficulty of obtaining uniform fields over a larger diameter. However, post-deflection purity magnets allow purity adjustments to be made without altering convergence. This feature becomes more important as tubes with larger deflection angles are developed.

Causes of Purity Faults. Although misalignment of the electron-gun assembly can be a cause of improper beam landing, the most usual cause of improper beam landing is the effects of external magnetic fields. External magnetic fields, such as the earth's field and stray magnetic fields, can cause an error in beam landing. They may also cause the steel of the chassis and mounting assemblies in the receiver to become permanently magnetized. The latter results in a "built-in" magnetic field, which can be removed by following the degaussing operations to be described.

Earth's Magnetic Fields. The earth's magnetic fields have an effect on the landing of the electron beams. One component of the earth's magnetic field is perpendicular to the surface of the earth. The strength of this component is essentially constant over the entire United States, and a fixed correction can be built into the color picture tube to compensate for this field. The component of the earth's magnetic field that acts in a horizontal direction might be called the compass field. As might be expected, this

field causes a change in the landing of the electron beam when the picture tube (and the receiver) are rotated in a horizontal plane. This change can be corrected with the neck or post-deflection purity magnet. A partial correction can usually be made by eliminating the magnetism that has been induced by the compass field into the steel of the picture tube, the chassis, or the steel supporting members. This is accomplished by degaussing the picture tube and its mounting assembly. Degaussing is a process of applying a strong alternating-current field by means of a coil, and slowly removing that field. The field may be reduced to zero slowly by moving the coil away from the vicinity of the picture tube, as by walking several yards from the set with the energized coil in hand. Experience has shown that degaussing corrects about half of the beam-landing error that results from rotating the picture tube in a horizontal plane.

Degaussing actually provides a "built-in" correction for the purity error caused by the earth's field. When the degaussing coil is moved away from the steel components in or near the picture tube, the tiny magnetic elements in the steel tend to align themselves with the earth's field. In this way, the steel members become magnetized so that the north poles of the local magnets point towards the south pole of the earth's field. However, the field of these local "built-in" magnets opposes the earth's field and cancels, partially, the effect of the earth's field.

Stray Magnetic Fields. There are other sources of magnetic fields that can cause purity problems. For example, the framework of a steel building may become magnetized or may alter the local direction of the earth's magnetic field. Certain types of d-c electrical machinery may cause strong local fields. Lightning striking a nearby power line may result in a strong local field that magnetizes the steel in the receiver. The effects of a child playing with a toy magnet near the receiver can cause a change in beam landing. Some of these conditions can be completely corrected by degaussing. Others might require a change in the purity adjustments.

Edge Correction Magnets. In some early receivers small permanent magnets were placed around the edge of the picture tube to correct local beam-landing errors that occurred near the edges of the screen. For tubes where the beam landing at the edges is poor after all regular purity adjustments have been made, this correction method is very difficult. Often, the magnets cannot be oriented in the proper directions to give the correction desired. This type of correction is no longer used due to improvements in color picture tube design.

2.5. CONVERGENCE

The shadow-mask principle permits three primary-color rasters to be traced out on a common phosphor screen. An important requirement is that the three rasters register or converge on the screen. When properly registered, a single white raster is displayed,

with no color fringing at the edges. Normally the edges of the rasters are not visible because picture size is adjusted for some degree of overscan. Thus, misconvergence cannot be detected on a blank raster. But when a picture is displayed, misconvergence becomes visible in all the details of the picture. To take a simple example, suppose a small one-inch white square on a black background is transmitted. This white square is simply a small section of the complete raster. If the rasters are misconverged (do not fall exactly on top of one another) the displacement will be seen at the edges of the square as colored fringes. When making convergence adjustments, patterns of dots or crossed lines are used to make the state of convergence visible at all points on the screen. Convergence is obtained by making the beams from the three guns converge, or cross, at the same spot in the plane of the shadow mask. This converged condition must be maintained over the entire area of the raster.

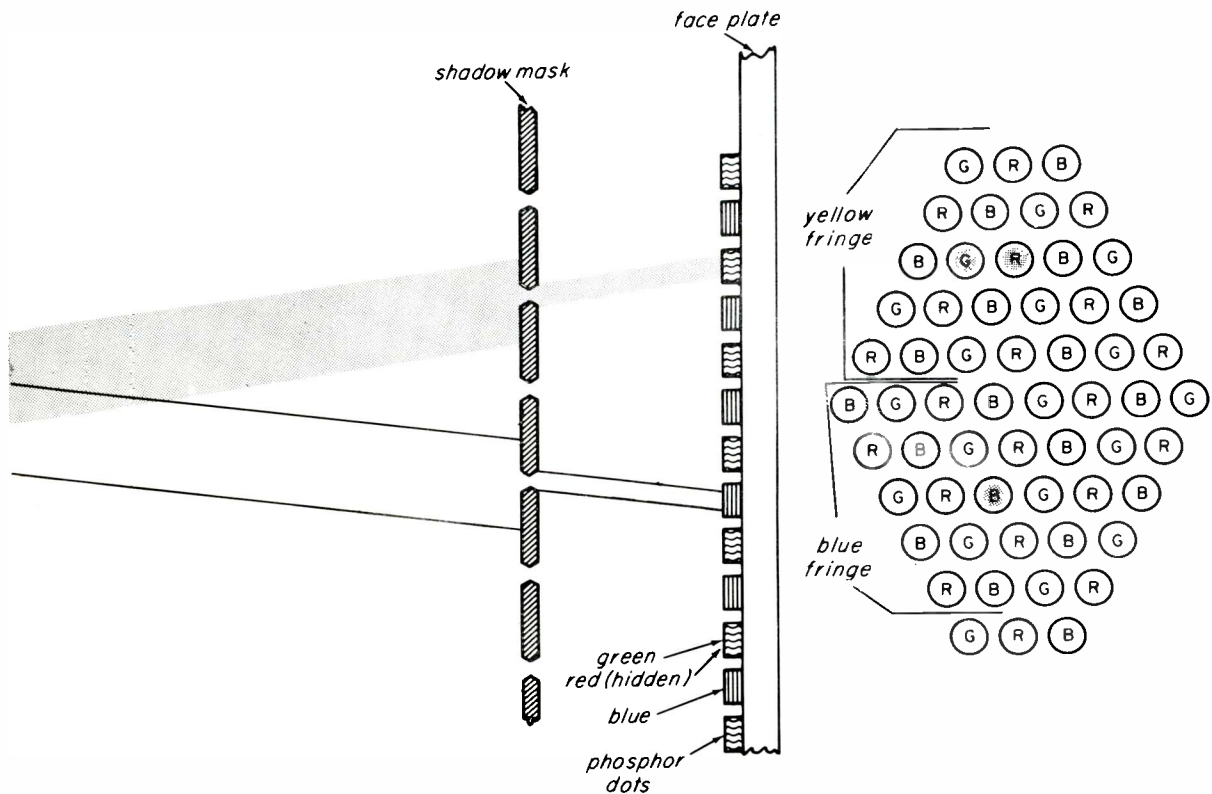

Fig. 2-16. An example of misconvergence. Beam landing and purity are correct, but the beams do not cross at the shadow mask. In this case a white picture element displays a blue fringe at bottom and a yellow fringe at the top.

Proper convergence is illustrated in Fig. 2-10. In this drawing the beam landing is correct and the three beams cross or meet right at the shadow mask. Since all three phosphors are lighted in the same small area, the spot appears white (when viewed from normal viewing distances).

An example of misconvergence is shown in Fig. 2-16. Note that the beam landing is still correct, but the beams no longer converge at the shadow mask. In this particular instance, the beams have crossed behind the shadow mask, to the left of the illustration, and are diverged again as they enter the shadow mask.

The blue gun is uppermost in the electron-gun assembly; hence, the beams must have crossed for the blue beam to be below the others as shown. Since the blue beam strikes the phosphors below the red-green group, a white spot would show a blue fringe on the bottom and a yellow fringe (red plus green light) at the top.

If convergence is changed drastically, the beam landing, or purity, will be affected. The reason is that the effective location of the electron-gun or guns is altered slightly. This changes the location of the electron centers and the angles at which the electron beams pass through the shadow mask on their way to the phosphor screen. However, a large change in convergence is required to cause a noticeable change in beam landing. Thus, the effect of convergence adjustments on purity is secondary.

Electron-Gun Convergence Assembly. The electron guns are not parallel to one another, but are aimed so that the three beams converge at the center of the shadow mask. However, some means must be provided to aim the beams electronically, since misalignment may occur for various reasons. In addition, extra correction is required for the screen edges, as we shall see. This aiming arrangement is provided magnetically by a convergence assembly that mounts on the neck of the tube, over grid 4. Unlike the neck-purity magnet, which moves all three beams at once, the convergence assembly permits each electron beam to be aimed individually.

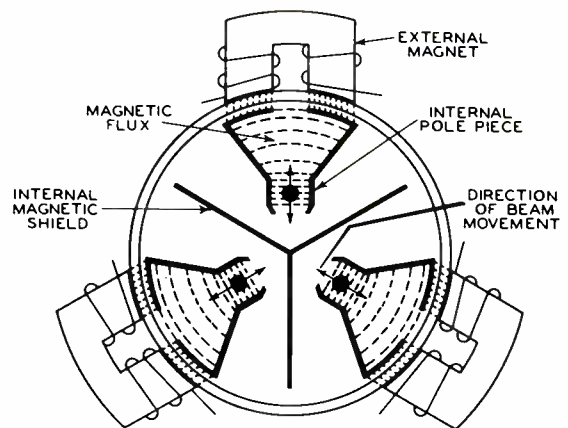

Fig. 2-17. A cross section of the picture-tube neck at the convergence-cage assembly shows the internal radial pole pieces and the external convergence magnets.

Figure 2-17 shows a cross section of the neck of the picture tube at the place where the convergence assembly is mounted. Three electromagnets are mounted around the neck of the tube. The fields from these magnets are collected and concentrated by internal pole pieces that are mounted on the grid 4 cylinders (refer back to Fig. 2-9). Electron beams cross the fields of the magnets and internal pole pieces as they emerge from grid 4. Since electrons are deflected at right angles to the magnetic field, they move as indicated by the arrows in Fig. 2-17.

A Y-shaped shield is positioned as shown to keep the magnetic fields for the separate guns from interacting.

Center Convergence. The electron beams are converged in the center of the screen by means of static magnetic fields applied to the pole pieces. These fields may also be obtained by passing a controllable direct current through the windings of each of the external pole pieces. However, d-c current sources are subject to fluctuations due to line-voltage changes, component aging, and other factors. Unless special, well-regulated power supplies are employed, d-c electromagnets lack the necessary stability.

Several ways of using permanent magnets have been devised. At one time a small rotatable permanent magnet was mounted in

the top-center of the external pole-piece core. Modern receivers use a small permanent magnet located at the end of a plastic tube. This tube is mounted in a holder attached to the external pole-piece assembly, and can be slid in or out from the neck of the tube. In addition to their permanent magnets for static convergence, all external pole pieces have coils wound upon them for edge-convergence correction.

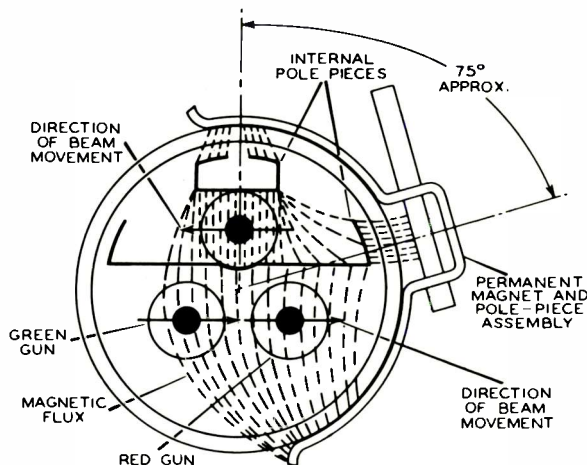

Fig. 2-19. A blue-lateral convergence assembly.

The action of the static convergence magnets is shown in Fig. 2-18a, which illustrates how the beams appear to move when viewed from the screen of the picture tube. Note that if the electron beams land at the corners of an equilateral triangle, as shown in a of the figure, the adjustments permit the three beams to converge at the point P. However, if one or more of the beams is out of position, the static convergence adjustments alone cannot secure convergence. In b of Fig. 2-18, a possible convergence condition is shown. Note that the adjustments allow the red and green beams to come together at point P, but the blue adjustment

cannot bring the blue beam to this point. However, if the blue beam could be moved sideways, or laterally, convergence could be obtained. If the blue beam could be moved laterally, convergence could be achieved for any starting position. For this reason, an additional magnetic device is added to the picture tube to permit lateral adjustment of the blue beam.

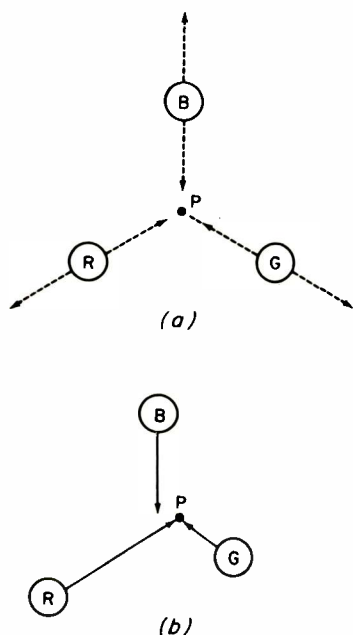

Fig. 2-18. (a) This view of the screen of the picture tube shows how the static convergence adjustments cause the electron beams to move. Convergence is obtained at point P. (b) Slight beam misalignment may cause this condition, where the three beams cannot be made to converge at a single point. Convergence can be achieved by moving the blue beam laterally.

Blue-Lateral Magnets. The blue-lateral magnet assembly mounts on the neck of the tube between the kinescope socket and the convergence assembly. Refer back to Fig. 2-9 to see the location of the internal pole pieces for the lateral convergence assembly. Figure 2-19 shows a cross section of the tube neck where the blue lateral magnet is mounted. The effect of the internal pole pieces is to distribute the magnetic field as shown. The magnetic lines of force are vertical where they cross all three beams, but the field crossing the blue beam is opposite in direction to the field crossing the red and green beams. This causes the red and green beams to move left if the magnet is poled to move the blue beam to the right, and vice versa. By moving the red and green beams in the opposite direction from that of the blue beam, less magnetic field strength is required to properly position the blue beam. It is desirable to accomplish convergence with as little magnetic field strength as possible, because strong magnetic fields tend to defocus the beam.

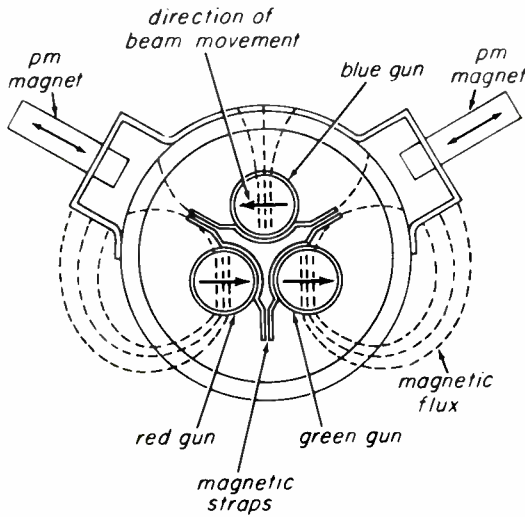

Fig. 2-20. This blue-lateral convergence assembly employs two magnets.

Figure 2-20 shows another blue-lateral positioning arrangement. This assembly does not employ special internal pole pieces, but uses the straps that connect the grid 3 cylinders. Two magnets are used, as shown, to obtain the desired positioning action. This type of blue-lateral arrangement is less common than the type shown in Fig. 2-19.

Figure 2-21 shows the over-all effects of the static-convergence and blue-lateral adjustments.

Screen-Edge Convergence. The static convergence adjustments permit the three electron beams to converge at the center of the screen. However, unless special corrections are made, the edges of the raster will remain out of convergence. The need for these corrections is caused by several factors. First, the deflection center is not the geometrical center for the radius of curvature of the tube face. If it were, all points on the screen would be equidistant from the deflection center, and beam convergence at the center of the screen would result in beam convergence at almost all points on the raster. But because of the large radius of curvature of the screen, the distance from the deflection center to the edges of the screen is greater than the distance from the deflection center to the center of the screen. This means that if

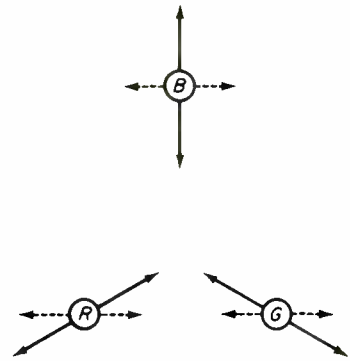

Fig. 2-21. Diagram showing the direction of movement of each color spot on the screen of the picture tube produced by the associated static convergence fields. Solid lines show action of radial convergence fields. Dashed lines show effects of the blue-lateral convergence adjustment - the direction of movement of the red and green spot is opposite to that of the blue spot.

the beams are converged at the center of the screen, the point of convergence will fall short of the screen at the edges. Figure 2-22 shows a simplified view of this condition. Since the beams cross at a point before reaching the screen, they are spread out again or overconverged as they strike the screen. This causes the positions of the spots of light on the screen to be opposite to the way in which the guns are positioned in the neck of the tube. The blue beam is low, the green beam is to the left and the red beam is to the right. Figure

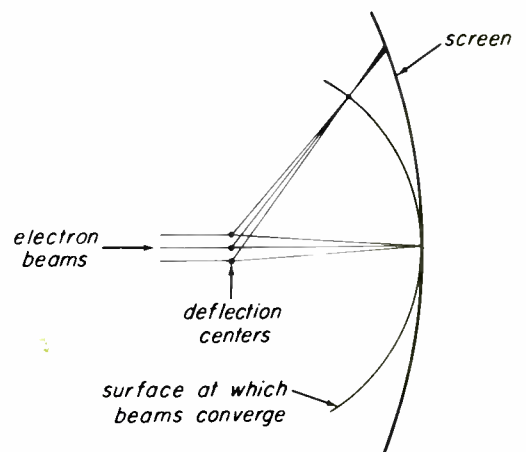

Fig. 2-22. Dynamic convergence correction is needed because the distance from the deflection centers to the screen is greater at the edges of the raster than at the center.

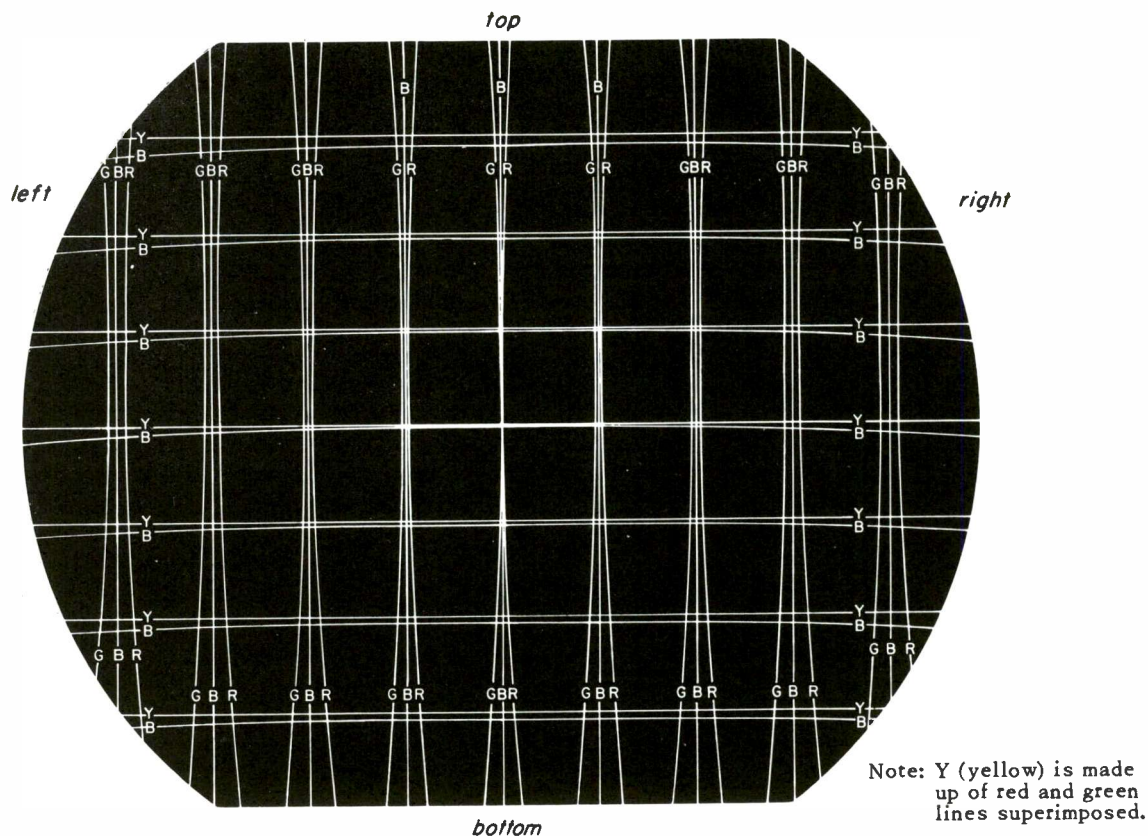

Fig. 2-23. The appearance of a crosshatch pattern on the screen when the center is properly converged, but no dynamic convergence corrections are applied.

2-23 shows how a crosshatch pattern of white lines appears on the screen when the center is converged, but when no corrections are applied to converge the edges.

Another factor affecting edge convergence is the triple-gun arrangement. In the foregoing explanation it was stated that the three beams would converge at *almost* all points in the raster if the distance from the deflection center to the screen were equal over the entire raster. The word *almost* is used because perfect convergence actually could not be obtained in this way. Remember that the three beams are at different locations in the deflection center, due to the electron-gun spacing. Thus, the beam on the right of the tube's axis must travel further when deflected to the left side of the screen than when deflected to the right side.

A third factor affecting edge convergence is that the deflection fields produced by the yoke are not perfectly uniform, particularly

those at the front, or screen side, of the yoke. The result of this nonuniformity is that the deflection center in the yoke moves from the desired fixed location when the beam is deflected. The greater the degree of deflection, the more the deflection center is shifted. This, in turn, changes the effective distance to the face of screen at the screen edges. If the three beams could somehow be superimposed as they passed through the yoke, the field nonuniformity would not cause a convergence error, as each beam would be affected in the same way. Thus, this type of error is minimized by bringing the electron beams as close together as possible as they pass through the yoke. It is very important to reduce the spacing between electron beams in kinescopes built to operate with larger deflection angles.

Dynamic Convergence. To correct convergence at the edges of the raster it is necessary to alter the magnetic convergence

fields when the electron beams are deflected away from center screen. The fields are altered so that the beams straighten out slightly at the limits of deflection, and converge at the shadow mask at the screen edges. To do this job, it is necessary to alter the convergence fields in step with the deflection signals. This a-c correction of the convergence fields is called *dynamic convergence*.

Waveforms Required for Convergence. A correcting magnetic field is supplied to the three guns at the vertical and horizontal scan rates. The fields are obtained by passing currents, obtained from the deflection circuits, through windings on the external convergence pole pieces. Proper correction requires little change in the center of the scan but maximum change as the deflected beam reaches the ends of the scan. A parabola-shaped waveform, synchronized

with the scanning signal, provides this form of correction. In addition, some means must be provided to alter somewhat the shape of the parabola waveform. This alteration is needed to correct for the misconvergence that occurs because of the spacing between the deflection centers for the three beams and because of other factors. A sawtooth waveform is added to the parabolic waveform to obtain the desired change in waveshape. Figure 2-24 shows the parabolic and sawtooth waveforms, and the resultant waveform when they are combined. The sawtooth waveform is referred to as the "tilt" waveform. To illustrate the need for tilt correction, consider the electron beam for the blue gun. This beam is above the central axis of the tube as it passes through the yoke. It therefore travels further when deflected to the bottom of the picture than when it is deflected to the top of the picture. Thus, the field of the convergence magnet must be a little stronger near the end of the vertical scan (bottom of picture) than it is at the beginning of the vertical scan.

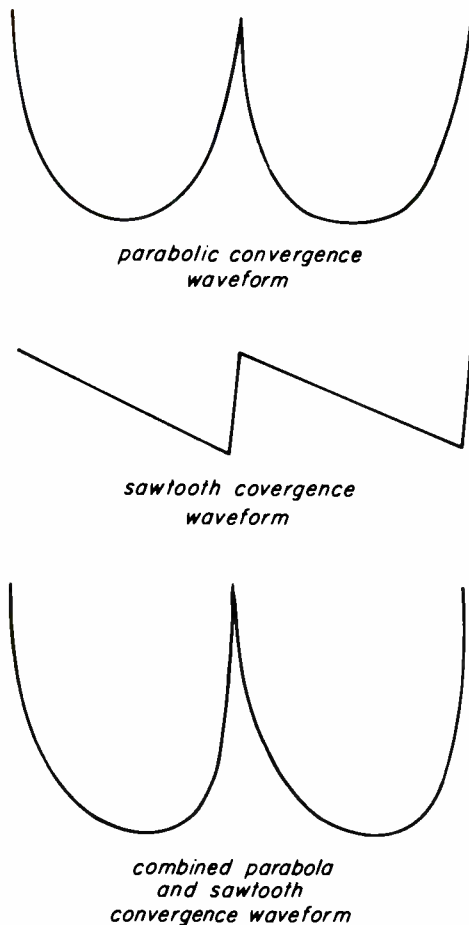

Fig. 2-24. Dynamic convergence waveforms.

The horizontal and vertical waveforms are similar, and may be applied to the same coil on the external pole piece for each gun. From a circuit standpoint, however, it is more convenient in some cases to apply the vertical waveform to one coil and the horizontal waveform to another coil on the same pole-piece assembly. This arrangement isolates the vertical and horizontal dynamic convergence circuits from each other.

Controls are provided in the receiver to allow the amplitude of the horizontal and vertical parabolic waveforms, and the tilt components, to be adjusted separately for each gun. This means that there are twelve dynamic convergence controls.

When receiver dynamic convergence is being observed or checked, only vertical and horizontal lines passing through the center of the screen need be considered. Convergence in the corners will be satisfactory when the centerlines are dynamically converged. The extent to which convergence is achieved in the corners depends a great deal upon the quality of the deflection yoke.

2-6. FOCUS

To focus an electron beam is to cause the beam to be compressed into as small a spot as possible at the picture tube face. On the color picture tube, focus is achieved electrostatically for each electron beam. An electrostatic lens in each gun focuses each individual beam on the phosphor screen. At proper focus, the diameter of each beam is such that each beam will pass through approximately three holes in the shadow mask. In the case of a white element, the red, green, and blue beams light approximately nine phosphor dots. Under conditions of high video drive, where very bright picture elements are being scanned, spot size becomes somewhat larger.

Focus adjustments do not change purity or convergence. The focus adjustment alters only the diameter of the beams. Beam positions are not changed by the focus adjustment; hence, convergence and purity are not altered. It is possible, in rare cases, to see a slight convergence change when focus is adjusted. This is caused by an electron gun that is not perfectly aligned.

Focus Voltage. In the color picture tube, there are three focus electrodes, one for each gun. See Fig. 2-9. These three electrodes are connected electrically, so that only one focus voltage is required for all three guns. In tubes of modern design, the voltage required for best focus is between 16.8% and 20% of the ultor voltage. If the ultor voltage is 25 kv (kilovolts), then the maximum required focus voltage is 20% of 25 kv, or 5 kv. A focus adjustment must be provided to handle the 16.8%-20% design range. If the ultor voltage changes in the receiver for any reason, the focus voltage must track. For instance, in the example given above, where the receiver produced a 25 kv ultor voltage with a focus voltage of 5 kv, if the ultor voltage dropped for some reason to 20 kv, the focus voltage would still have to be 20% of the ultor voltage, or 4 kv, without any focus adjustment. The focus supply does not have to deliver any current to the focus electrodes, as they draw no current.

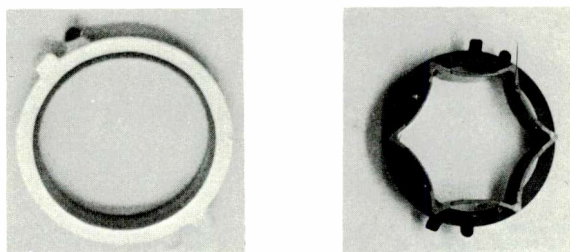

Fig. 2-25. Two types of neck-purity magnets.

2-7. ASSOCIATED PICTURE TUBE COMPONENTS

Purity Magnets. Purity magnets can take either of two forms. One type, called a neck-purity magnet, is small in diameter and is positioned on the neck of the tube. Figure 2-25 shows typical neck-purity devices. The other type, known as a post-deflection purity device, is shown in Fig. 2-26. It is much larger in diameter and is placed around the picture-tube funnel between the deflection yoke and the picture tube face. Both devices consist of two circular permanent magnets that can be rotated with respect to each other or rotated simultaneously. The individual magnets are poled to produce a field that crosses the axis of the tube at right angles, as shown in Fig. 2-27a. When the magnets are placed so that their poles oppose each other, the fields cancel. If the

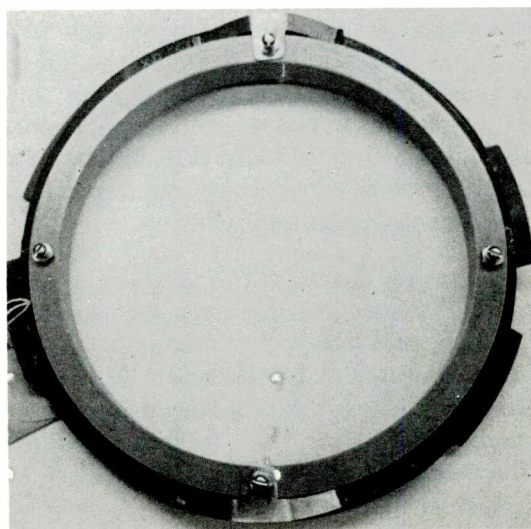

Fig. 2-26. A post-deflection purity device consists of ring magnets mounted in a holder.

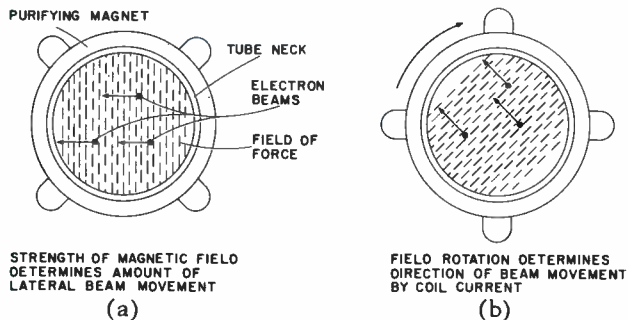

Fig. 2-27. Effects of the neck-purity magnet.

poles are placed together, the fields add. Thus, rotating one magnet with respect to the other will adjust the magnetic field to any strength from essentially zero to some maximum value. If the two magnets are rotated simultaneously, the direction of the magnetic field can be changed through a full 360 degrees, as shown in Fig. 2-27b.

The magnetic flux lines produced by these magnets must be uniform near the center of the device. This is the area where the electron beams pass through the magnetic field. It is very important that each beam be acted upon equally by the magnetic field. These purity devices will not produce a perfectly uniform magnetic field over the entire inside area of the device but, if they succeed in producing a uniform field at the area through which the electron beams pass, their design is adequate. Of the two types of purity magnets, the neck-purity device is the easier to manufacture with a uniform magnetic field, because the area through which the beams pass in the neck of the tube is much smaller than the area through which they pass where the post-deflection purity magnet is mounted. For this reason, neck purity devices have been most commonly used in commercial receivers.

Deflection Yoke. The deflection yoke, used to deflect the electron beams at the horizontal and vertical scanning rates, consists of two pairs of coils and a ferrite core. Ferrite is a magnetic material capable of conducting magnetic flux. A typical color TV deflection yoke is shown in Fig. 2-28.

An undeflected converged beam trio will land approximately in the center of the picture tube screen. Two coils, placed on the

yoke core at its top and bottom, are connected in series, and a current is passed through them. This current produces magnetic lines of flux running vertically from the top coil to the bottom coil. The action of the vertical magnetic flux lines is to deflect the beams in a horizontal direction. When a sawtooth of current is passed through this pair of coils, the beam will be deflected from left to right across the tube as required for television scanning. Another pair of coils is placed at the left and the right side of the yoke core. These two coils are also connected in series, and the magnetic lines of flux that they produce lie in a horizontal

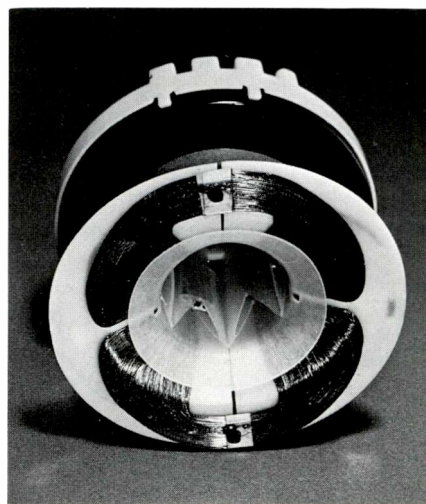

(a) Front view

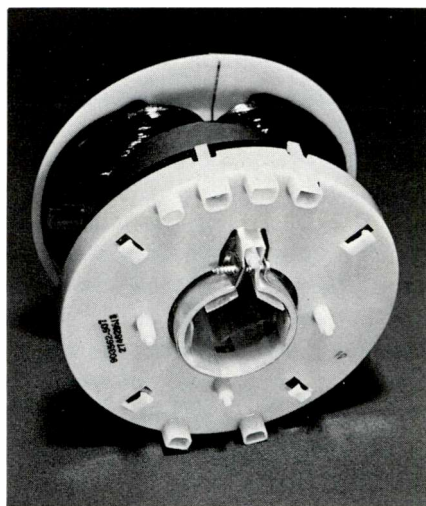

(b) Rear view

Fig. 2-28. A 70° deflection yoke for a color picture tube.

direction. This flux will cause the beams to be deflected in the vertical direction. When a sawtooth of current is passed through these two coils, vertical deflection is produced as required by the television system. When both pairs of coils are energized by their proper current waveforms, the television raster is produced.

The design of the yoke and its coils is such that most of the flux is produced at approximately halfway between the front and the back of the yoke, near the deflection center. Unfortunately, the ends of the coils also produce magnetic fields. These fields produce an additional deflection to that produced at the deflection center. The magnetic fields at the deflection center are quite uniform while those at the ends of the yoke are, to some extent, nonuniform. The beams at the back of the yoke are still close to the center of the neck and are not greatly influenced by the nonuniform fields. At the front of the yoke, the beams have been deflected by the main deflection center and are no longer located close to the center of the neck at the extremes of scanning. In these areas, the nonuniform front field of the yoke causes a condition called pincushion distortion in addition to convergence errors. The larger the deflection angle, the greater these errors will be. A raster that is pincushioned has the appearance of an old-fashioned pincushion, as shown in Fig. 2-29.

Convergence Assembly. The radial convergence pole-piece exciters employ U-shaped ferrite cores, shown in Fig. 2-30. Wrapped on each leg of the ferrite core are the dynamic

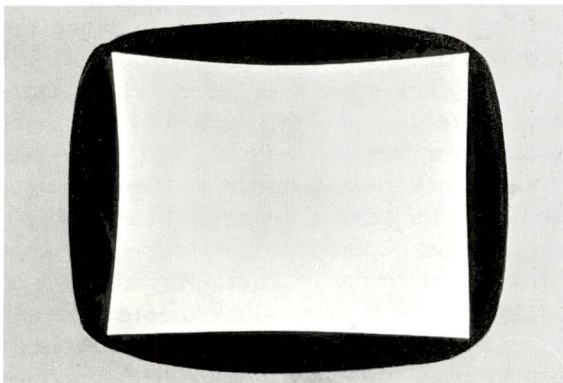

Fig. 2-29. Pincushion distortion as it appears on the screen of a black-and-white receiver.

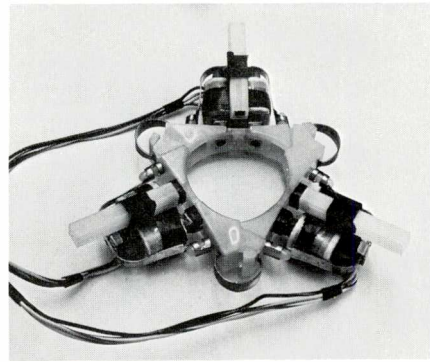

Fig. 2-30. Radial convergence pole piece excitor assembly.

convergence coils. The open end of the ferrite core is placed as close to the neck of the picture tube as possible. Usually, a thin layer of plastic protects the neck from being scratched by the ferrite. Three of these assemblies are placed in a holder around the neck of the picture tube so that the magnetic poles are directly over the internal pole pieces. If a permanent-magnet convergence device is used, it is located either as a part of the external pole-piece exciters, or in conjunction with it. In one system using PM magnets, a small, rotatable magnet is placed at the top of the U-shaped ferrite core. Figure 2-31 shows how the small magnet is arranged. Note that the poles are at the sides, and not at the ends, of the small magnet. Maximum field strength occurs when the small magnets are turned to the positions shown in the drawing. When the magnet is turned 90° (so that the poles of the magnet in the top pole-piece assembly

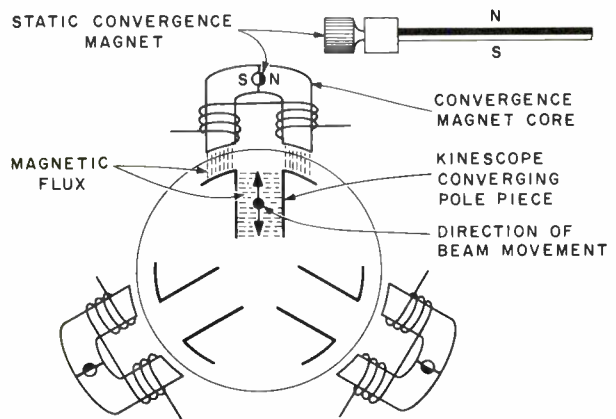

Fig. 2-31. A static convergence adjustment using rod-shaped permanent magnets.

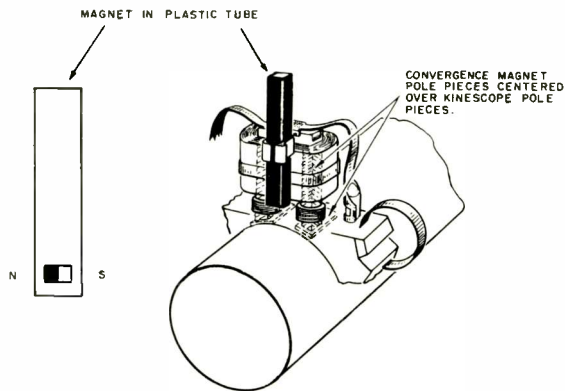

Fig. 2-32. This convergence assembly uses a small permanent magnet mounted in a plastic tube. The magnet is held against the rear surface of the external pole piece by a small clip.

face up and down) the magnetic field strength in the gap is almost zero.

In a later system, the magnet is placed outside the external pole-piece assembly. See Fig. 2-32. The small magnet is placed in a plastic tube that can be slid in or out perpendicularly from the neck of the tube. The holder for this plastic tube is usually clamped onto the ferrite core. The strength of the magnetic flux into the internal pole pieces is controlled by the in or out adjustment of the plastic tube containing the magnet. If the direction of the flux needs to be changed, the plastic tube is pulled out of the holder and rotated 180° (not end for end).

Blue Lateral Convergence. The blue lateral convergence assembly usually consists of a magnetic strap mounted on the neck of the picture tube. See Fig. 2-33. It will approximately span the 120 degrees between two electron guns. Mounted in this strap is a small rotatable permanent magnet, or a small bar permanent magnet, sometimes

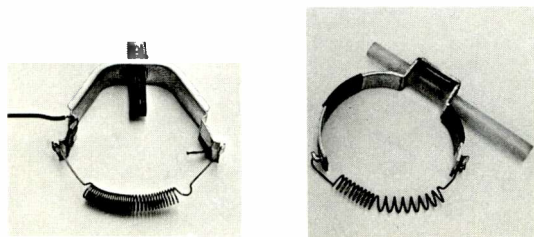

Fig. 2-33. Two types of blue-lateral convergence magnets for 70° picture tubes.

referred to as a push magnet, that can be moved in or out from the neck of the tube. When the picture tube has a large angle of deflection and is therefore made with small-diameter neck, two push magnets are usually required, as shown in Fig. 2-34. For this blue lateral device, the magnetic strap usually is nearer 240° in length, and the magnets are placed symmetrically 120° apart. This places the magnets approximately half-way between the blue and the green gun, and half-way between the blue and the red gun. In some cases it may be desirable to apply a dynamic blue lateral correction. For this purpose, coils are wound around the position through which the permanent magnets are adjusted. A horizontal scan sawtooth of current, similar to but smaller than that used for horizontal deflection, is passed through the coil or coils. Usually, the amount of current used is a fixed value, because the correction required is primarily determined by the deflection yoke characteristics.

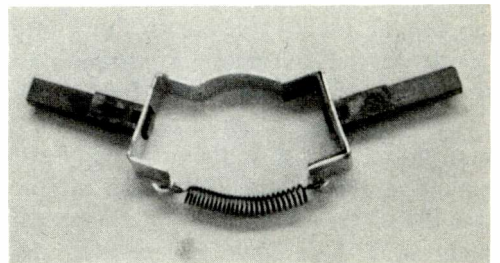

Fig. 2-34. Small-neck blue-lateral convergence magnet for use on picture tubes with a large deflection angle.

Magnetic Shielding. Magnetic shielding can be achieved in many ways. One of the simplest ways of shielding is to place the color picture tube in a metal cabinet; the metal cabinet serves as an excellent magnetic shield. Another type of magnetic shield is a formed piece of thin steel that extends back from the face of the tube over the funnel for several inches. When a shield of this type is used, it also serves to support the tube in the cabinet. Another form of shield is a large, flat sheet of steel placed back from the front of the tube, with a large hole in it to clear the funnel of the picture tube. A "wrap-around" chassis also will serve as a magnetic shield.

The magnetic shield reduces the effect of the earth's magnetic fields. This lessens the amount of purity-magnet correction required for proper beam landing. It also makes the receiver less sensitive to changes in beam landing when it is rotated in the earth's magnetic fields. Some form of shielding is needed in order to achieve the full benefits of degaussing. Degaussing is necessary to remove any residual magnetic fields that might have been induced into the picture tube or any other steel parts adjacent to it. Degaussing will correct approximately 50% of the beam-landing error caused by rotating the picture tube in the earth's magnetic field. This correction feature cannot be adequately utilized without some form of magnetic shielding.

2.8. COLOR PICTURE TUBE CIRCUIT REQUIREMENTS

At this point, let us see what the color picture tube needs in terms of operating conditions such as high voltage, focus voltage, deflection, centering, and so on. In later lessons we shall study the circuits that supply the operating voltages and currents.

High Voltage. The color kinescope demands greater power from the high-voltage power supply than does a black-and-white kinescope. A large part of the energy in the three electron beams is absorbed by the shadow mask; only the remaining portion reaches the screen and produces visible light. Hence, for a light output comparable to that produced by black-and-white kinescopes, higher accelerating voltages must be used. Accelerating potentials range between 20 and 25 kv.

Current demands on the high-voltage supply are also greater, since three electron guns are involved. The total ultor current includes the current collected by the shadow mask, and is in the range of 1000 microamperes, or 1 milliamperes.

Besides supplying greater power, the high-voltage supply in the color receiver must be well regulated. This means that high voltage must not change appreciably when beam current (brightness) is varied. A

change in high voltage results in a change in convergence. Remember that the effect of the convergence magnets is determined by the strength of the magnetic field and the speed at which the electrons are traveling. If the accelerating voltage increases, for example, the bending action of the convergence magnets is diminished and convergence changes. All color receivers employ an electronic voltage regulator in the high-voltage supply. In modern receivers the high-voltage supply is adjusted to 24 kv when beam current is zero (black picture). Regulation is considered adequate if raising the total beam current to 1000 μ a results in a drop in high voltage of no more than 1 kv.

Focus Voltage. Focus voltage requirements were discussed earlier in the lesson. Focus voltage is approximately 20% of the ultor voltage. The focus-voltage supply must have an adjustable output.

Deflection. The horizontal and vertical deflection circuits in the color receiver are basically the same as those found in black-and-white receivers. The strength of the deflecting fields must be somewhat greater, since higher accelerating voltages are employed. In addition, the diameter of the neck of the picture tube is large, and hence the gap in the magnetic circuit between pairs of deflecting coils is greater. The deflection circuits are also required to supply power to the convergence circuits.

Pincushion Correction. Pincushion distortion is not a problem in picture tubes with deflection angles of 70°. However, the distortion is easily visible when tubes with larger deflection angles are used. Correction is achieved in black-and-white receivers by embedding magnets in the circumference of

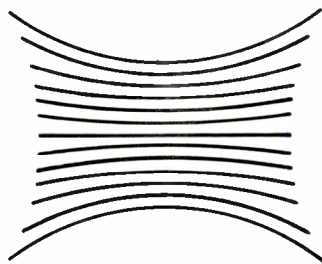

Fig. 2-35. An exaggerated drawing showing how the raster lines are bent due to pincushion distortion.

the forward edge of the deflection yoke assembly. This type of correction cannot be applied in color receivers, since the magnets would upset convergence and purity. Instead, pincushion correction is obtained by modulating the horizontal deflection signal with a signal obtained from the vertical deflection circuit, and vice versa. Look at the simplified illustration of pincushion distortion in Fig. 2-35. Note that the raster sides could be made straight if horizontal deflection is made greater in the vertical center and is reduced at the top and bottom. This can be achieved by applying a parabola-shaped waveform, obtained from the vertical deflection circuits, to the screen grid of the horizontal output tube. The polarity of the parabolic waveform is chosen so that the gain of the horizontal output stage is reduced at the top and bottom of the picture, but is increased at the time that the vertical scan is at midposition.

The top and bottom edges of the raster can be corrected by altering vertical deflection at the horizontal rate. Consider the top of the picture, at the start of the vertical scan. A parabolic waveform, at the horizontal frequency, is added to the vertical deflection current. The polarity of the parabola is chosen so that total vertical deflection is reduced somewhat at the beginning and end of the horizontal scan, but is increased at the mid-point of the horizontal scan. This acts to straighten the raster lines at the top of the raster. As the vertical scan progresses downwards, less and less pincushion correction is needed. At the center of the vertical scan, the raster lines are normally straight, and no pincushion correction is needed. Correction must increase again as the vertical scan passes the center point. However, the polarity of the deflection current changes at the center of the scan, so that the polarity of the parabolic waveform must also change. At the bottom of the raster, maximum correction is needed again, and the amplitude of the horizontal parabola must reach a maximum. The resultant vertical-deflection current waveform looks something like the waveform shown in Fig. 2-36. Time and amplitude scales have been deliberately altered in this figure to show the nature of the waveshape.

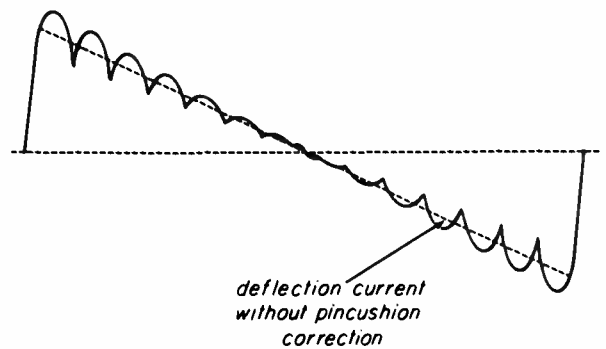

Fig. 2-36. Vertical deflection current waveforms showing the addition of a horizontal-rate parabola to correct for pincushion distortion.

Dynamic Convergence. The fields of the convergence magnets must be altered at the horizontal and vertical scanning rates to correct the misconvergence that occurs at the screen edges. The waveform needed in both cases is a parabola. Parabolic waveforms are derived from the vertical and horizontal deflection signals by means of waveshaping networks. The amplitude of both the horizontal and vertical parabolic waveforms applied to each convergence magnet can be adjusted independently. This means that there are three vertical-amplitude and three horizontal-amplitude controls. In addition, provision is made to alter the shape of each parabolic waveform by adding a sawtooth component. The controls that permit adjustment of the sawtooth component are called *tilt* controls. These controls are arranged to allow the polarity of the tilt waveform, as well as its amplitude, to be changed. The effect of changing the polarity of the tilt component is shown in Fig. 2-37. There are three vertical-tilt and three horizontal-tilt controls; in all, twelve controls are used.

In late-model receivers, the controls are arranged to provide easier adjustment. Here, a single control adjusts the amplitudes of the vertical parabolic waveforms that are applied to both the red and green convergence magnets. Another control adjusts the *differential* between the amplitudes of the parabolic waveforms applied to the red and green magnets. Turning the differential control causes the amplitude of the signal applied to the green magnet to increase and

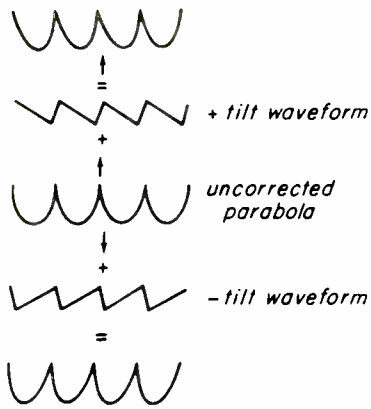

Fig. 2-37. Dynamic convergence waveforms, showing the effects of adding tilt waveforms of opposite polarities.

... signal applied to the red magnet to decrease, or vice versa. A similar amplitude differential control arrangement is used in the red-green tilt circuits, and in the red-green horizontal-amplitude and horizontal-centering circuits. Although adjustment procedures differ, the number of controls is the same - twelve.

The circuits and their adjustment procedures are described fully in later lessons.

A form of misconvergence occurs due to magnetic coupling between the horizontal-deflection windings of the yoke and the convergence assembly. (The rear of the deflection yoke is quite close to the convergence assembly.) Figure 2-38a shows how the vertical magnetic field of the horizontal deflection windings crosses the internal pieces of the convergence assembly. Note that the field is vertical where it crosses the blue beam so that any deflection of the blue beam remains in the horizontal direction. The field is collected and dispersed by the red and green internal pole pieces, however, and the red and green beams are caused to move in the directions indicated by the arrows. This action imparts vertical as well as a horizontal displacement. On one side of the raster the direction of the deflection field moves the red beam upwards and the green beam downwards. At center scan the deflection field is zero and the beams are not affected. On the other side of the raster the direction of the deflection field reverses so that the red and green beams are moved in the opposite directions.

The result is a misconvergence between red and green beams as shown in *b* of Fig. 2-38. This convergence error is eliminated by applying the correct amount of tilt correction to the red and green dynamic convergence waveforms. The amount of error is predictable, and fixed proportions of red and green tilt are applied by the dynamic convergence circuits.

Centering. The magnetic centering devices that are mounted on the neck of the kinescope in nearly all late-model black-and-white receivers cannot be used in color receivers. Such devices would interact with purity adjustments and might upset convergence. Centering is accomplished in the color receiver by adjusting the d-c component of current flowing in the vertical and horizontal windings of the deflection yoke. The centering controls are very similar to the potentiometer-type centering controls that were employed in the earliest black-and-white receivers.

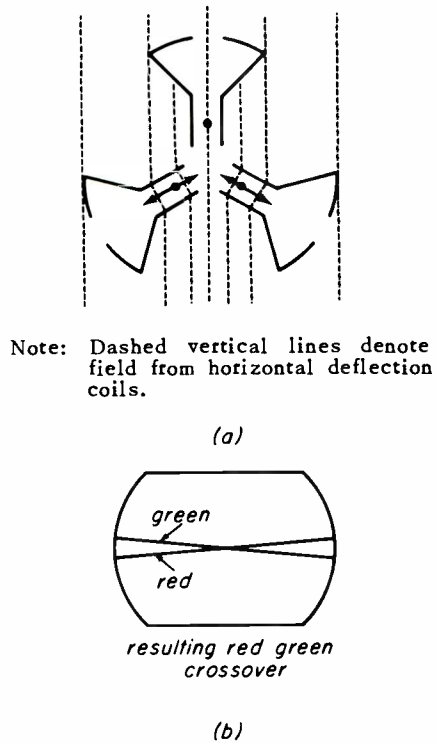

Note: Dashed vertical lines denote field from horizontal deflection coils.

Fig. 2-38. Magnetic coupling between the horizontal deflection windings of the yoke and the radial convergence assemblies causes the red and green beams to be out of convergence at the screen edges.

Video Drive Considerations. In a comparison of the video drive requirements of the black-and-white kinescope with those of the color kinescope, the first general observation is that larger driving voltages are required for the color kinescopes. The reason is that part of the total video energy in the electron beams is dissipated in the shadow mask and does not produce useful light output.

Another major factor is the way in which the color video signals are applied. In very early color receivers, the video signals applied to the color picture tube were the reconstructed E_R , E_B , and E_G signals. The process of adding the luminance signal, E_Y , to the color difference signals, $E_{(R-Y)}$, $E_{(G-Y)}$, and $E_{(B-Y)}$, was accomplished in special adder stages. The adder stages supplied reconstructed color signals to the color picture tube. This system was discarded because of its cost and the drift problems associated with the large number of stages employed. Today, the luminance signals are added to the color-difference signals in the picture tube itself. In this method, the luminance signal is applied to all three electron-gun cathodes in parallel, and the separate $E_{(R-Y)}$, $E_{(G-Y)}$, and $E_{(B-Y)}$ signals are applied to the appropriate control grids. The reconstructed color signals appear only in the electron-beam currents for each electron gun.

It is possible to obtain the same mixing action in the picture tube by applying the color difference signals to the cathodes and the luminance signals to the grids. However, fewer stages are needed in the chrominance circuits if the color-difference signals are applied to the picture-tube grids. The reason for this is as follows. The chrominance signals are contained in a narrow band of frequencies (0-600 kc in most receivers). This narrow bandwidth makes possible large voltage gains in single stages. Remember that gain is sacrificed in monochrome video stages to secure more bandwidth. The necessary voltage gain can be obtained in the stages that couple the color demodulators to the picture tube if these stages can employ large load resistances. Amplifiers with large load resistances can be used to drive the grids of the picture tube, but they cannot be used to drive the cath-

odes. In cathode drive systems, the output impedance of the video output stage forms the cathode impedance for the picture tube. A large unbypassed impedance in the picture tube cathode circuit introduces degeneration in the same way as it does in any ordinary triode. Thus, the color difference signals are handled by high-gain stages that are coupled to the grids of the picture tube. The luminance signal is applied to the cathodes, and is supplied by a driver stage designed to have a low output impedance.

Both luminance and chrominance amplifiers are direct-coupled to the color picture tube. The d-c component of the composite video signals must be preserved in the color receiver in order to reproduce colors correctly. We shall examine the need for direct coupling, or d-c restoration, in later lessons.

Color Balance. As was explained in the earlier lesson, specific ratios of light radiations of the red, blue, and green phosphors are required to produce the desired white. If a satisfactory gray scale is to be obtained, these ratios must be maintained at all light levels. For any particular picture tube the ratios of electron gun current must remain constant or *track* for all settings of the brightness control, and for all monochrome video signal levels. The ratios vary somewhat among picture tubes due to variations in the efficiency of the phosphors.

The system used to maintain color balance in modern color receivers permits simplified tracking adjustments. Provision is made to adjust the three guns to cut off at the same bias voltage. Figure 2-39 shows a simplified schematic diagram of the kinescope cathode circuits. The potentiometers, R_4 and R_5 , permit level adjustment of the video signals applied to the blue and green electron guns. The full output of the video amplifier is applied to the red gun. Most color picture tubes require greatest video drive to the red gun. Provision is made, in the receiver, to interchange the red cathode lead with either the blue or green cathode leads in case the blue or green guns should require maximum drive. A service switch is provided to permit cutoff adjustments. It functions as follows. In the *service* position, the video drive to all three guns is

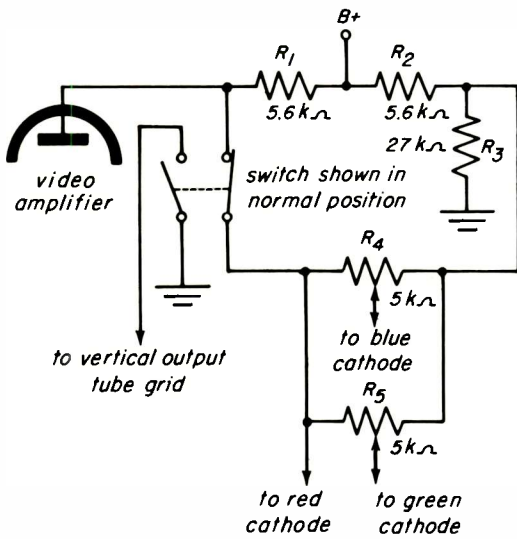

R_1 is plate resistor which is shunted by R_2 , R_4 , R_5 in normal operation
 R_3 establishes equal voltage on cathodes for adjusting cut-off when the switch is in the service position

Fig. 2-39. The coupling circuit between the plate of the luminance video amplifier and the cathodes of the picture tube.

removed, and all cathodes are placed at the same d-c potential. No current flows through R_4 and R_5 , so there is no voltage drop across the controls when the switch is in the service position. A fixed cathode voltage on all three guns establishes equal bias voltages for the three guns. An individual grid 2 (screen) control is provided for each of the guns. The grid 2 controls are adjusted to turn off the electron beams for all three guns. To make this point of cutoff easier to see, a second section of the service switch shorts the grid of the vertical-output stage to ground. This reduces the raster to a single horizontal line, which remains visible when beam current is very close to cutoff. Cutoff adjustments are made with the switch in the *service* position. The grid 2 controls are adjusted to produce a neutral gray line. The switch is then thrown to the *normal* position and the drive controls R_4 and R_5 are adjusted to produce the proper black-and-white picture. This completes the color balance, or tracking, adjustments. This system works well because all three electron guns are cut off at the same level of

video drive. A picture element that is a very dark gray is very close to this equal cutoff position, and will not contain any coloration. The drive characteristics of each of the electron guns are nearly identical when all guns cut off at the same bias. Drive adjustments are made to compensate for differences in light output of each of the primary-color phosphors. Once the drive ratios are set, they will remain constant, from low light to high light. In addition, color balance does not change as the brightness control is turned. The brightness control is in the grid circuit of the direct-coupled video amplifier, so it controls picture tube bias by controlling the plate voltage of the video amplifier. A change in plate voltage appears at the cathodes of the color picture tube through the drive-control system that includes R_4 and R_5 .

In older receivers, color balance is more difficult to set up. Video signal levels are applied in fixed monochrome drive ratios. The video drive is preset to three predetermined levels by means of fixed resistors. Color balance adjustments are made by individual grid 2 (screen) controls, and individual bias controls, called *background* controls. The procedure for adjusting color balance in a receiver using fixed monochrome drive ratios is as follows. The individual background controls are adjusted for maximum bias. The grid 2 (screen) controls are preset to the near maximum voltage position as recommended in the service notes of the receiver. The brightness control is turned down until the picture is very dark. Grid 2 controls are then adjusted to give a neutral black-and-white picture. The brightness control is then turned up until the picture is fairly bright. Background (bias) controls are next adjusted to obtain neutral white highlights. These adjustments interact with the low-light adjustment, however, so that the brightness control must be turned down again and the grid 2 controls reset. Experienced technicians learn to overcompensate the control settings so that a minimum of back-and-forth adjustment is required.

An understanding of the action of the grid 2 and background controls may be gained by referring to Fig. 2-40. The curves

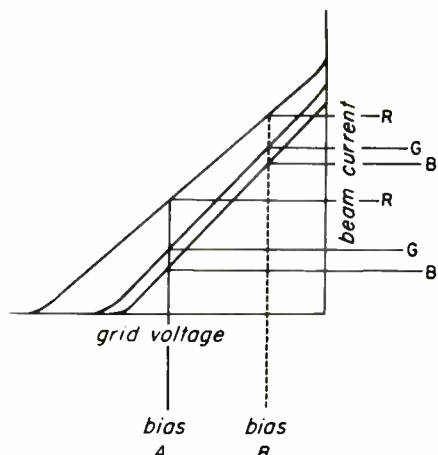

Fig. 2-40. Static characteristic curves for the three electron guns show the need for color balance controls.

represent the grid voltage-beam current characteristics for each gun. For simplicity, we shall neglect video drives, and just see what happens when the master bias, or brightness control, is varied. At a low setting (high bias) of the brightness control, as shown by bias *A*, the grid 2 controls are adjusted to give a neutral gray. The beam currents for the red, green, and blue guns are as shown. Note that this particular ratio of beam currents does not cause all the guns to cut off at the same grid voltage. In addition the slopes of the characteristic curves differ somewhat. As the brightness control is turned up, the master bias advances to position *B* in the drawing. Note that the ratio of beam currents is different at this bias. Green and blue beam currents have increased more than the red beam current. This condition can be offset by applying *additional* bias to the blue and green guns individually. When the grid 2 and background controls have been adjusted properly, the ratios of beam currents remain nearly constant over the range of the brightness control. Similarly, beam current ratios remain constant over the range of video signal levels.

2-9. COLOR PICTURE TUBE HANDLING AND SAFETY

The color picture tube is a large bulb that is completely evacuated of air. The

atmospheric pressure pushing in on the device is tremendous, and would cause all parts of the tube to be pushed towards the center and then out from the tube if a fracture of the glass occurred. The pieces of glass would be thrown from the tube at a high speed. When this happens, the tube is said to implode. Consumers are protected from an implosion of the tube in their color receiver by a large plate of safety glass in front of the picture tube and by the natural protection of the television cabinet. Modern tubes have the safety glass sealed directly to the face plate of the tube. This method of providing a safe tube when mounted offers many advantages besides safety to the consumer. The picture tube can be placed further forward in the cabinet for wider viewing angles, the contrast of the picture is improved, and the consumer can clean the front of the picture tube without having to remove any parts. The tube is somewhat safer to handle, but it still can implode under impact.

Installation Methods. A 70° color picture tube with the integral safety plate weighs 43 pounds. This is a considerable weight to handle, and care must be taken not to strike the tube on any object while removing it from the television receiver or installing a new one in the receiver. The neck of the picture tube is particularly vulnerable to damage if struck against some object in the receiver. One of the easiest ways to install the color picture tube is to place a television receiver face down on a pad and lower the picture tube into its mount by grasping the bulb at the face-plate area. See Fig. 2-41. Most mounting systems will allow the picture tube to rest on the mount without any holding devices when the receiver is in this position. The retaining device can then be either loosened or tightened as required without having to hold the picture tube in place. Some mounting methods allow the picture tube to be installed while the cabinet is in the upright position; however, it is still easier to install the picture tube with the receiver positioned face down.

Safety. When a color picture tube requires handling, safety should be considered at all times. The best safety measure is to handle the picture tube with *extreme* care. The tube



may result in an electric shock. The shock itself may not be dangerous, but the reaction to the shock may cause the person to drop the picture tube, resulting in an implosion. It is good practice to ground the ultor button to the external coating to remove the electric charge, and then keep fingers away from the ultor button. Fingers should also be kept away from the clear glass area around the ultor button, as dirt and salt left from the fingers sometimes produce a conductive path for the discharge of high voltage. During humid weather, arcs from the ultor button to the outside coating may result.



It is a remote possibility that an implosion can occur for no apparent reason. This being true, shatter-proof safety goggles are mandatory at all times when handling the picture tube. See Fig. 2-42. It is recommended that long-sleeve shirts, or other protective clothing, be worn. Other people not properly protected should be kept away from the area when a tube is being handled.

Fig. 2-41. Correct way to handle the color picture tube when installing it or removing it from the color receiver.

should never be struck against any object, and anything that might scratch the tube in handling should be avoided. A scratch in the seal area of the picture tube is particularly dangerous.

It should be remembered that the inside and outside coatings of a color picture tube form a capacitor capable of storing a considerable electric charge. Contacting the ultor button after the tube has been operated

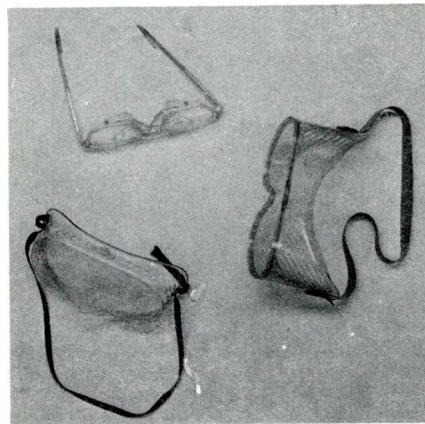
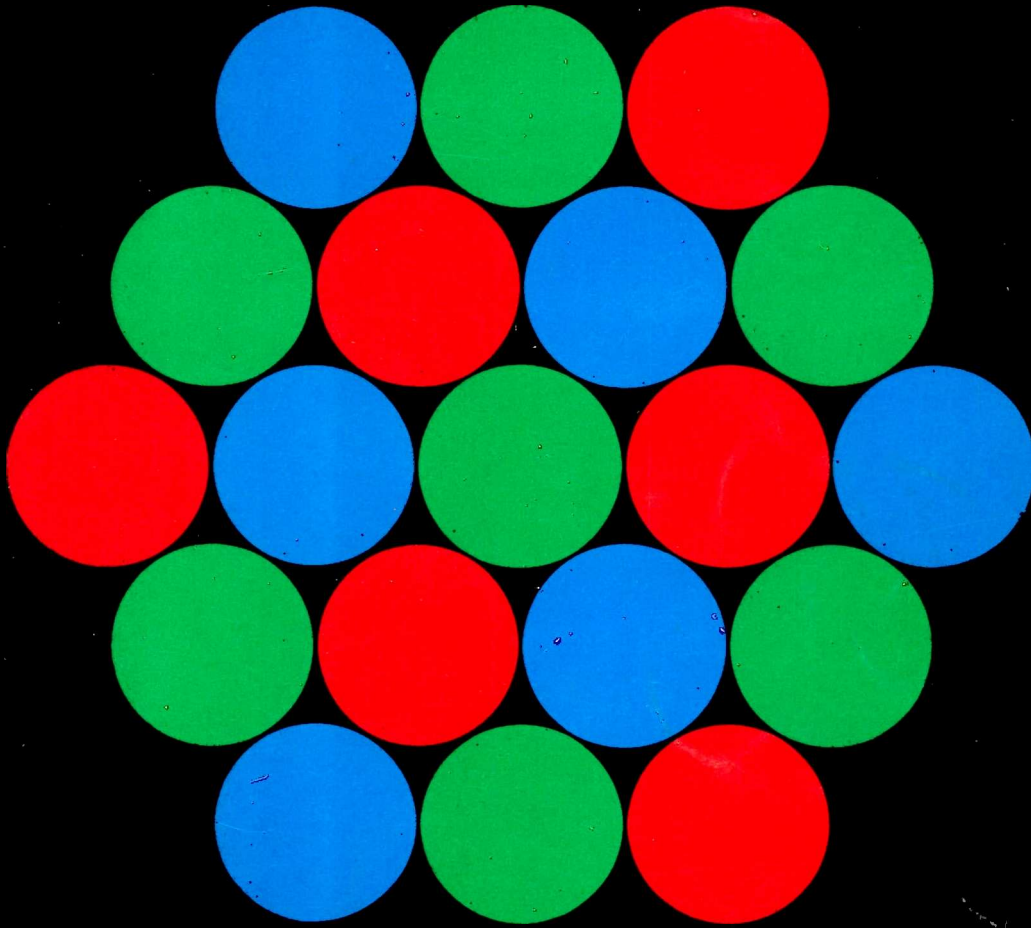

Fig. 2-42. Shatterproof safety goggles.



NOTES



Color Television

Home Study Course

RCA Institutes, Inc.

A SERVICE OF RADIO CORPORATION OF AMERICA

© RCA INSTITUTES, INC. 1962
1966 PRINTING

ALL RIGHTS RESERVED
TRADEMARK(S) ® REGISTERED
MARCA(S) REGISTRADA(S)

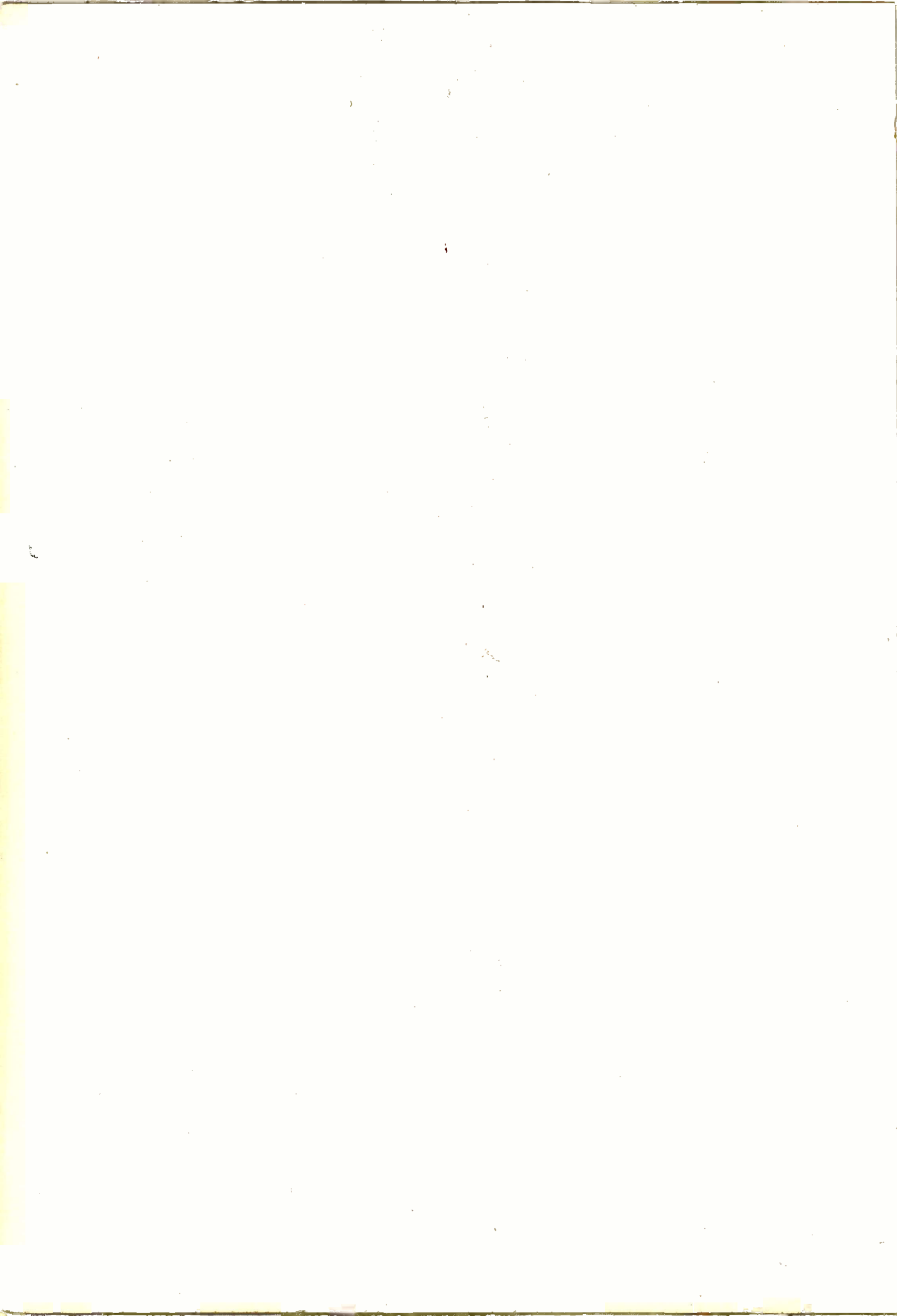

COLOR TELEVISION COURSE

BASIC RECEIVER FUNCTIONS

1. Review of the Color TV system
2. Black-and-White Reception on the Color TV Receiver
3. Chrominance Circuits
4. Color Synchronization



RCA INSTITUTES, Inc.

A SERVICE OF RADIO CORPORATION OF AMERICA

HOME STUDY SCHOOL

350 West 4th Street, New York, N.Y. 10014

INTRODUCTION

In this lesson we shall examine the ways in which the color TV receiver processes the r-f signal to reproduce black-and-white or colored images. Two basic functions are involved; we must study both. First, we will learn how the receiver reproduces monochrome pictures on the tricolor kinescope. Secondly, we will see how the chrominance signals are sorted out in the receiver, and how they are added to the brightness, or luminance, signal to reproduce the three primary-color signals.

3-1. REVIEW OF THE COLOR TV SYSTEM

At this point, it is worthwhile to review the basic characteristics of the over-all system. Let us briefly trace the picture from the color camera to the kinescope.

The color camera is shown at the left in Fig. 3-1. A selective filter arrangement is placed in front of the camera tubes, so that only red light is admitted to one camera tube, only green light to another, and only blue light to the third. Thus, the output of the color camera consists of three voltages which correspond to the amounts of red, green, and blue in each element of the scene being scanned. These three voltages, called E_R , E_G , and E_B , are applied to a resistive mixer in the transmitter called the matrix. By taking certain proportions of each of these voltages, the matrix produces the luminance or brightness signal (E_Y), and the two chrominance signals. The two chrominance signals, called E_I and E_Q , are applied to two balanced modulators, and each modulates a 3.58-mc subcarrier. The subcarriers supplied to the two modulators are suppressed, and the output of each modulator consists only of the sidebands produced by modulation. These two output signals, which are ninety degrees out of phase, are added to produce a single signal whose instantaneous phase and amplitude vary in accordance with the hue and saturation of the color being scanned at each instant. The E_Y signal and this combined chrominance signal are added and applied to the transmitter,

along with the normal black-and-white synchronizing signals and the 3.58-mc color burst.

At the receiver, the luminance signal is detected and amplified as in black-and-white receivers. The combined chrominance signal is separated from the luminance signal by a bandpass filter, and applied to the demodulators or synchronous detectors. Also applied to the demodulators are two locally generated carriers, supplied by the 3.58-mc oscillator in the receiver. The color burst signal, in conjunction with an automatic phase-control circuit, maintains this oscillator in frequency and phase-lock with the 3.58-mc signal source at the transmitter.

The output of each demodulator depends upon the amplitude of the 3.58-mc chrominance signal, and also upon the instantaneous phase of the chrominance signal as compared to the phase of the locally supplied 3.58-mc CW signal. In this way, each demodulator responds to that component of the chrominance signal that is in phase, or 180° out of phase, with the locally generated 3.58-mc carrier. The phase of the carrier signals may be adjusted in the receiver to make them coincide with the phase angles of the E_I and E_Q signals. The demodulators will then reproduce the E_I and E_Q chrominance signals. The phase of the locally-generated carrier signals may also be adjusted to demodulate the chrominance signal on any desired pair of phase axes. Color difference signals, $E_{(R-Y)}$ and $E_{(B-Y)}$, may be demodulated directly. However, the demodulators may be adjusted to resolve the 3.58-mc chrominance signal into components that lie along any pair of phase axes, as long as the demodulated signals are added together in the correct proportions to reconstruct the color difference signals $E_{(R-Y)}$, $E_{(B-Y)}$, and $E_{(G-Y)}$. We shall look into these processes in detail in this lesson.

The matrix section in Fig. 3-1 is a group of adder stages. Here, the chrominance signals are added together in the correct proportions to produce the color-difference signals. In receivers that demodulate $E_{(R-Y)}$ and $E_{(B-Y)}$ directly, the matrix section is employed to obtain $E_{(G-Y)}$ by adding negative quantities

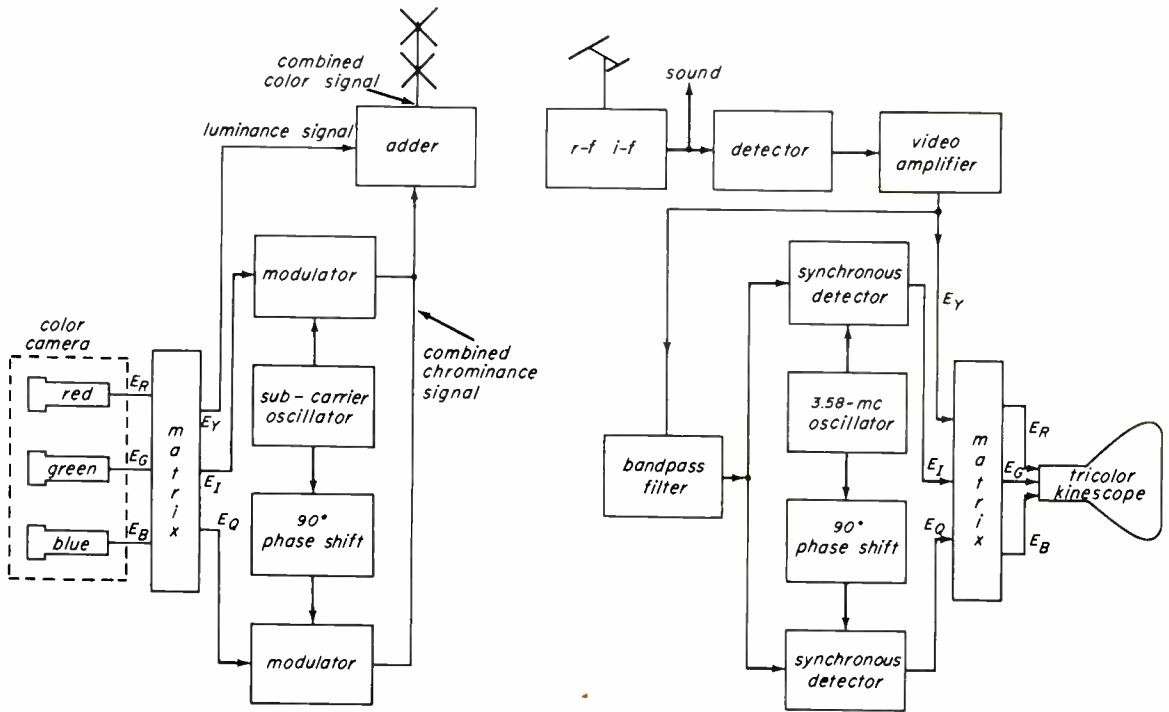

Fig. 3-1. A block diagram of the over-all color TV system.

of $E_{(R-Y)}$ and $E_{(B-Y)}$. From a previous lesson we learned:

$$E_{(G-Y)} = -0.51 E_{(R-Y)} - 0.19 E_{(B-Y)}$$

The matrix section may be used to add the color-difference signals to the luminance signals so as to produce the final product — the red, green, and blue video signals. However, in most cases, this addition is performed in the kinescope itself.

Chrominance Signals. The position of the color subcarrier in the video passband is shown in Fig. 3-2. The subcarrier is placed about 0.5 mc below the high-frequency end of the passband, and is synchronized with the horizontal scanning frequency to operate at an odd multiple of one half the scanning frequency. This system, called frequency interlace, allows the color sideband signals to be transmitted inside the normal video passband with minimum interference between the monochrome and color signals. The interference takes the form of a barely perceptible beat pattern in the picture.

Modulation of the subcarrier with chrominance signals results in sidebands extending on either side of the carrier, as in any amplitude modulation process. However, as can be seen from Fig. 3-2, only about 0.5 mc of spectrum space is available for the upper sidebands. Thus, when the subcarrier is modulated by chrominance signals whose frequencies exceed 0.5 mc, the upper sideband will be cut off. Now, it is an important fact that when one of the sidebands is missing in two-phase modulation, the phase of the resultant of the sideband signals changes. This phase error introduces erroneous signals at the output of the demodulators and results in a loss of isolation,

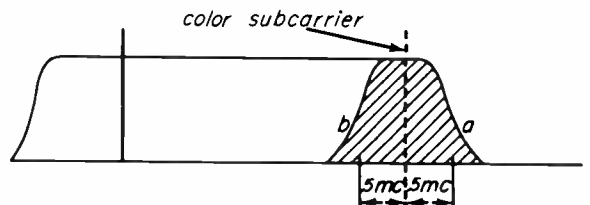

Fig. 3-2. The color subcarrier is placed near the high end of the video passband. There is sufficient spectrum space for approximately 500 to 600 kc of double-sideband chrominance information.

or crosstalk, between the two chrominance channels. Let us assume, for instance, that the subcarrier shown in Fig. 3-2 is being modulated by video signals from 0 to 0.5 mc, so that sidebands extending 0.5 mc on either side of the subcarrier are formed. In the frequency range from *a* to *b*, both chrominance signals are present with both sidebands. No phase distortion occurs in this frequency range. If we now increase the modulating frequencies so that they range from 0 to 1.5 mc, sidebands extending 1.5 mc on either side of the subcarrier are formed, as shown in Fig. 3-3. In the region from *b* to *c*, both chrominance signals are present but the corresponding upper sideband has been cut off, as shown by the dashed line. Phase distortion will occur in this frequency range, resulting in incorrect reproduction of colors in the frequency range from *b* to *c*.

The phase error is prevented by limiting the bandwidth of one of the chrominance signals to about 0.5 mc, as shown in Fig. 3-4. The signal chosen to have the wider sideband is the *I* signal; the one chosen to have the narrower bandwidth is the *Q* signal. The *I* signal alone is transmitted in the frequency range from *b* to *c*. But one chrominance signal cannot reproduce the original colors exactly. The *I* signal, therefore, is made up of the correct proportions of E_R , E_G , and E_B so that when it is transmitted alone, in the frequency range of about 0.5 mc to 1.5 mc, the colors it reproduces for the small areas corresponding to that frequency range come closest to satisfying the eye. In other words, the *I* signal is so constituted that, by itself, it reproduces all colors as mixtures of orange and cyan, which is how the eye tends to see such small colored areas.

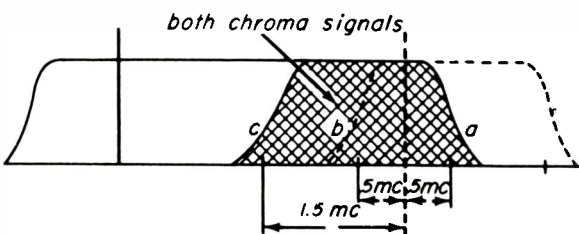

Fig. 3-3. By using part of the lower sideband of the 3.58-mc carrier, we can extend the color bandwidth to about 1.5 mc.

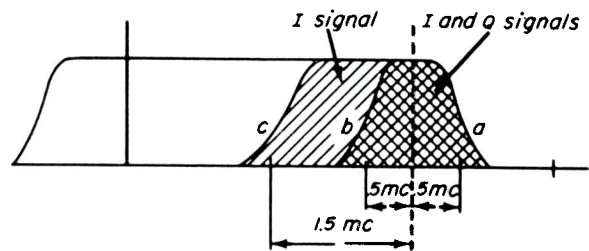

Fig. 3-4. This response curve shows how the chrominance signals are distributed in the video passband. The *Q* signal is a full double-sideband signal extending 500 kc above and below the color subcarrier. The *I* signal has both sidebands intact in this range, but retains only the lower sideband between 500 kc and 1.5 mc.

3-2. BLACK-AND-WHITE RECEPTION ON THE COLOR TV RECEIVER

Figure 3-5 shows the basic block diagram of a color receiver. The black blocks represent the stages that either process the color signal or supply the needs of the color kinescope. As you can see, the color TV receiver appears basically the same as the familiar monochrome receiver, if we simply disregard the stages that are added for color. Let us briefly review the functions of the monochrome stages of the color receiver, and see what changes or special considerations must be made.

The Tuner. The tuner in the color receiver is no different essentially from the familiar tuners found in black-and-white receivers. However, the requirements of an r-f unit for color are more exacting than for black-and-white receivers. Each channel position must present a flat response to the incoming signal, so that the chrominance subcarrier is not attenuated. Gain and signal-to-noise ratio are just as important to the color receiver as they are to monochrome receivers. Some r-f units employ a carrier-shift feature for weak signals, so that as the signal strength decreases the response of the r-f unit shifts toward the picture carrier, and picture sensitivity is increased. This feature is not desirable for color, however, since emphasis of the picture carrier would mean de-emphasis of frequencies near the sound carrier. The chro-

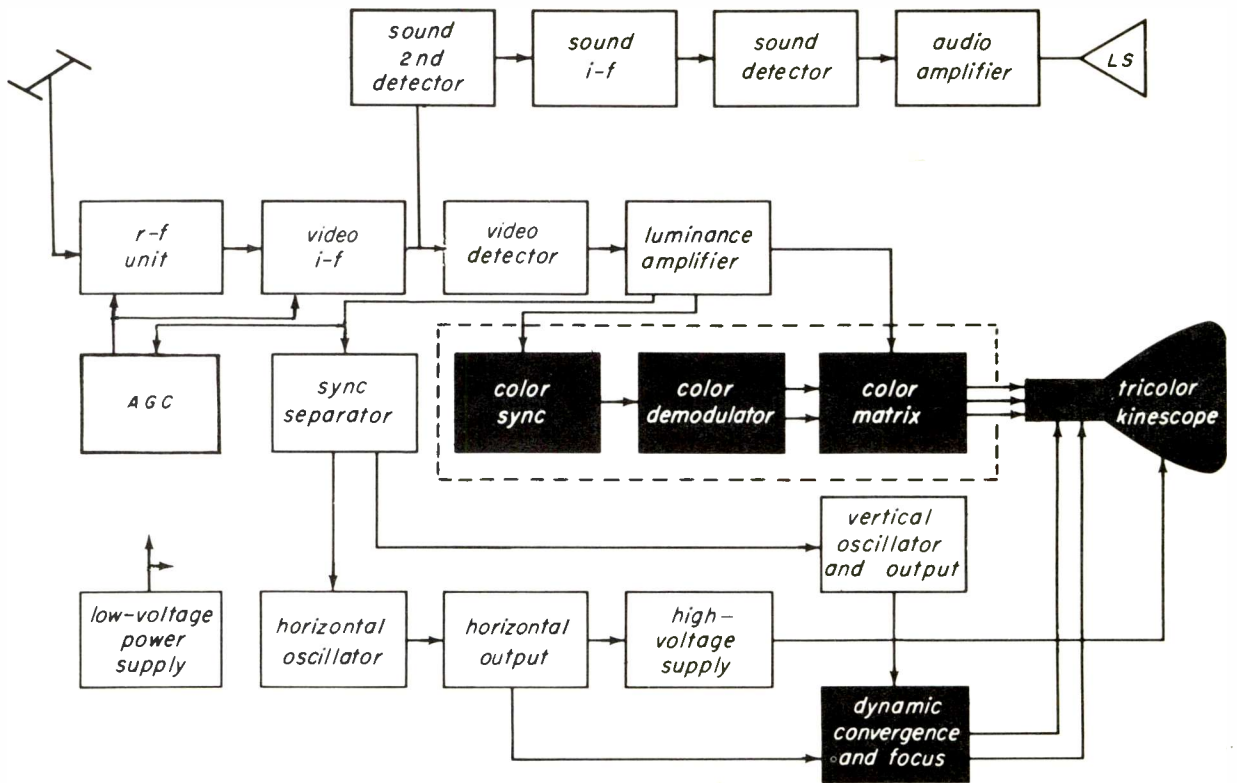

Fig. 3-5. The basic block diagram of a color TV receiver is very similar to that of a black-and-white receiver. The additional stages needed for color are shown in black.

minance subcarrier would thus also be de-emphasized on weak signals, where attenuation could not be tolerated.

Another important factor in the selection of a tuner for color is its ability to handle strong signals without overload and cross-modulation. Crossmodulation in an early stage of the receiver can produce a low-frequency beat signal from the mixing of the sound i-f and chrominance signals. Once this beat signal were formed it would be impossible to remove it in later stages. We will look more closely at the sound-chrominance beat problem in the next few paragraphs.

Video I-F Section. Figure 3-6 shows the basic block diagram of the video i-f section of a color receiver. Again the basic arrangement is similar to that of monochrome receivers, but the requirements are more stringent. Bandpass, flatness of response, and gain are very important.

When studying black-and-white receivers, we learned that the precise placement of the video carrier on the i-f response curve is very important, in order to compensate for the effects of vestigial sideband transmission. In the color receiver we have two carriers to place accurately, one at the low end and another at the high end of the video

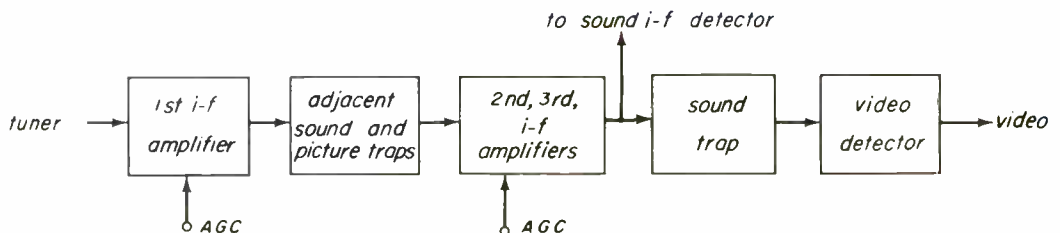

Fig. 3-6. The i-f section of a color receiver, shown in this block diagram, differs from that of a black-and-white receiver only in the way in which the sound r-f signal is routed.

passband. A flat response must be maintained in the region of the color subcarrier frequency to ensure that the chrominance sidebands receive uniform amplification. Refer to Fig. 3-7. Some early color receivers employ more i-f stages than are found in the black-and-white receiver, in order to meet the special gain and bandwidth requirements. These i-f stages, in addition to maintaining a flat response to the high-frequency end of the video passband, must also greatly attenuate the sound carrier. Note the steepness of the curve near the sound i.f. This means that very efficient traps and precise alignment techniques must be employed.

Another approach to i-f amplification is to design the i-f section to have a response curve shaped as shown in Fig. 3-8a. The 3.58-mc subcarrier frequency, which occurs at 42.17 mc in the video i-f range, is placed at the 50% point on the slope of the curve. So that the correct relative amplitudes of the upper and lower sideband signals may be restored, one of the stages that handles the separated chrominance signal is designed to provide a sloped response. The slope is reversed, as shown in b of the figure, to complement the shape of the i-f curve. Note that the upper sideband receives greater amplification, offsetting the attenuation of the upper sideband in the i-f section. This system is similar to the receiver's system for correction of vestigial-sideband transmission. The resultant over-all response for the chrominance signals is shown in c of the figure. Uniform response is provided for

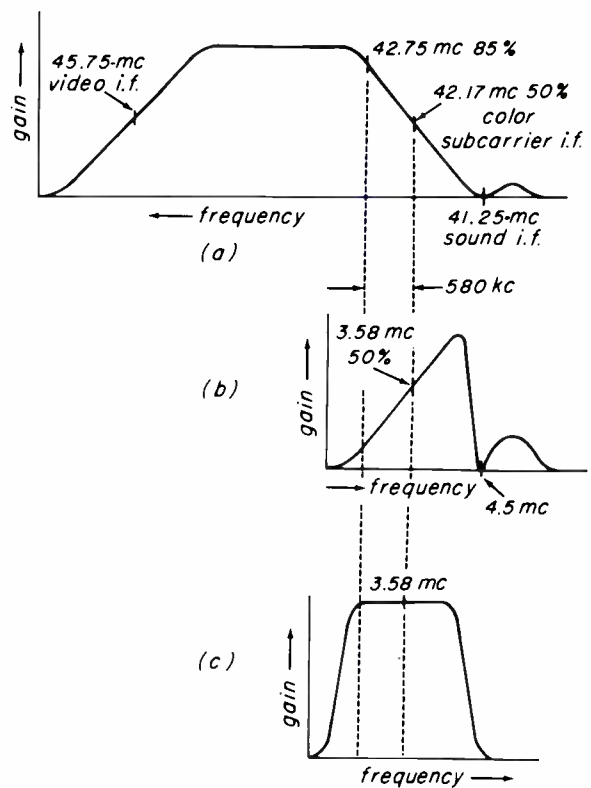

Fig. 3-8. (a) Most modern receivers use this type of i-f response curve; (b) the response of the bandpass amplifier is adjusted to compensate for the distortion introduced by the i-f amplifier; (c) the resultant over-all response to the chrominance signals.

both sidebands to about 600 kc. (This system is not used in receivers designed to demodulate the E_I and E_Q signals.) The i-f response curve shown in Fig. 3-8a can be obtained with the same number of tubes found in the i-f section of black-and-white receivers.

Intercarrier Operation. In color receivers, specialized circuits are needed to employ the intercarrier principle. Note, in Fig. 3-6, that the sound i-f signal is extracted from video i-f section ahead of the video detector. This is the only difference between the block diagrams of black-and-white and color receivers. The sound i-f signal must not reach the video detector because a beat signal is produced between the sound i-f signal and the color subcarrier i-f signal. The beat frequency between the 3.58-mc and 4.5-mc signals is approximately 920 kc.

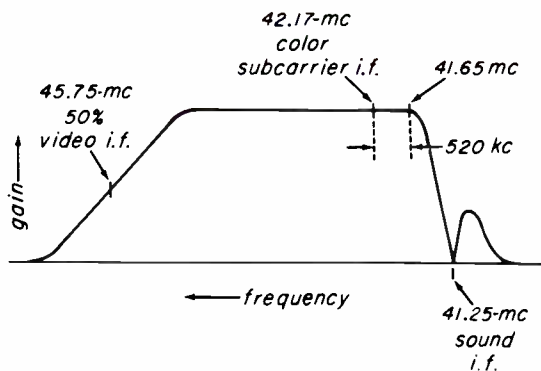

Fig. 3-7. The r-f response curve of a color receiver designed to demodulate I and Q signals.

A 920-kc trap cannot be inserted in the video circuit, since there is also important video formation at this frequency. Yet the beat between the chrominance subcarrier and the sound i.f. must not be allowed to appear on the kinescope. If the sound i-f signal were suppressed before it reached the video detector, this beat would be minimized. However, the sound carrier cannot be suppressed before the video detector since the intercarrier sound principle depends on the 4.5-mc beat produced between picture i.f. and sound i.f. Most color receivers handle this problem as follows. At the plate of the final i-f amplifier the signal (both sound and picture) is split. One leg supplies signal to the picture video detector, while the other leg supplies signal to a separate sound i-f detector (either a crystal diode or an electron tube). The separate sound i-f detector beats the sound and picture i-f signals together to produce a 4.5-mc second sound i.f. that carries the audio intelligence. The output of the leg of the final i-f amplifier that feeds the picture video detector goes through a series of traps and filters that eliminate the sound i-f signal before it arrives at the video detector. It might be well to note that the elimination of the 920-kc beat in the picture is dependent to a great extent on the fine-tuning adjustment, since the sound trap operates in the i-f amplifier. The fine-tuning control adjusts the relationship of the picture and sound i-f carriers with regard to the response, by changing the i-f frequency produced. This varies picture definition and sound i-f attenuation, but in an intercarrier sound system the sound i.f. at the output of the sound detector is always 4.5 mc. Thus, fine tuning has little effect upon sound. The most noticeable effect of the fine-tuning control is a variation in the visibility of the color-beat signal. The beat looks like FM interference, and appears only on color telecasts in those parts of the picture that contain highly saturated colors. The 3.58-mc

chrominance signals are absent when black-and-white objects are scanned, and are lower in amplitude when pale or unsaturated colors are scanned. When the fine-tuning control is set correctly, the sound intermediate frequency coincides with the trap frequencies, and the beat disappears. Color receivers are always tuned for minimum sound-beat interference.

After the 4.5-mc sound i-f signal is produced in the separate sound detector, it is amplified by a 4.5-mc i-f amplifier stage before being applied to the FM detector. Refer to Fig. 3-9. The sound signal at this point is similar to that found in black-and-white receivers, and any of the various methods of detection and audio amplification may be used.

Video Amplifiers. The composite video signal is developed at the output of the video detector and applied to the first video amplifier. The composite signal, at this point, contains the luminance signal, the sync and blanking pulses, the 3.58-mc chrominance signals, and the burst, or color-synchronization signals. The first video amplifier provides part of the total amplification needed to obtain sufficient video drive for the kinescope. In addition, it is the feedpoint for the sync, AGC, chrominance, and burst circuits. Refer to Fig. 3-10.

Note that the composite video signal takes four paths upon leaving the first video amplifier. It is applied to a second video amplifier for further amplification of the luminance signal; to the bandpass amplifier for extraction of the 3.58-mc chrominance signals; to the burst amplifier for the separation of the 3.58-mc synchronizing signal; and to the sync separators and AGC detector for the recovery of the synchronizing pulses, and the development of an AGC bias.

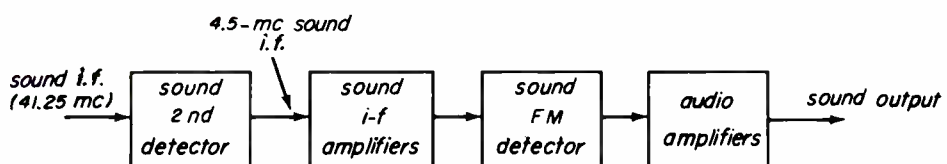

Fig. 3-9. Block diagram of the sound system.

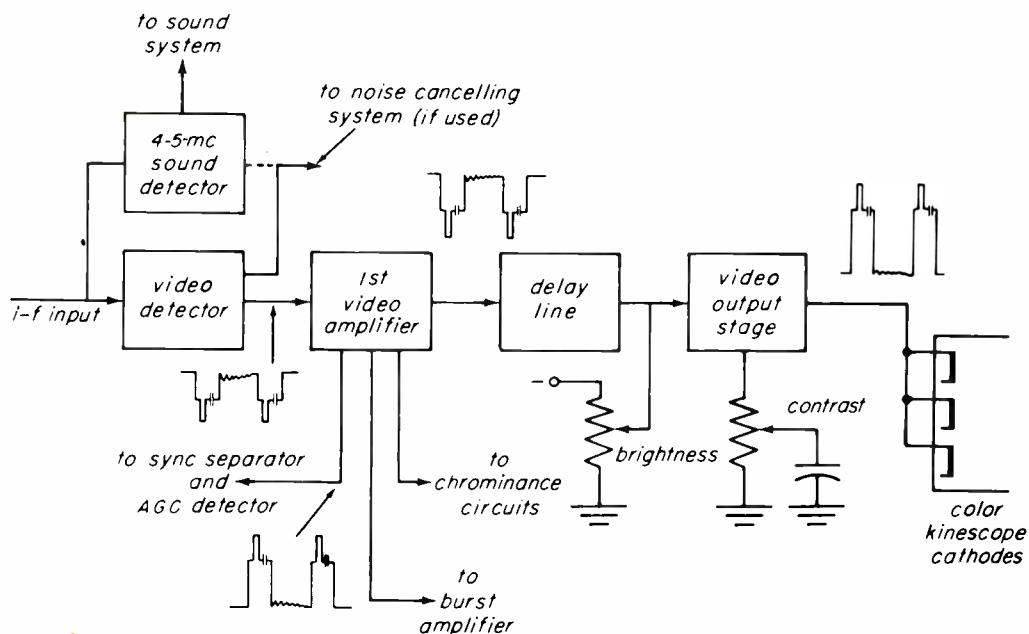

Fig. 3-10. Block diagram of the luminance video stages shows the location of the luminance delay line.

The contrast control is not incorporated into the first video amplifier, because it is important that the feeds to the sync, AGC, and burst circuits have a nearly constant amplitude. A video amplifier with fixed gain, and a highly efficient AGC system, ensure constant-amplitude input signals to the scanning and color synchronization circuits.

As is the case in all TV receivers, the video detector is arranged to provide an output signal in which sync and blanking pulses extend in the negative direction. This affords some reduction in impulse-noise interference, as noise pulses will act to drive the first video amplifier into cutoff. The signal at the plate of the first video amplifier has its sync and blanking pulses extending in the positive direction. In those receivers that employ noise cancellation circuits to protect the sync circuits, a signal containing noise pulses is obtained from some point preceding the first video amplifier. Feed for the noise cancelling circuits is obtained from the video detector, or from the 4.5-mc sound detector.

The Luminance Delay. A delay line, which is a coaxial cable especially constructed to give it the properties of a long

piece of transmission line, is placed in the signal path between the first and second video amplifiers. The delay line has uniform amplitude characteristics throughout the video range of frequencies, but delays the total signal in time by a fraction of a microsecond. The time delay is needed because the chrominance signal undergoes a time delay in passing through the narrow-band chrominance circuits. Both the chrominance signal and the luminance signal must arrive at the color kinescope in their original time relations if the colors are to "fit" properly into the black-and-white picture. An error in the relative time delays will cause the color information to be displaced to the left or right of the monochrome picture.

The reason for the natural delay in the narrow-band chrominance circuits can be understood by the following simplified analogy. Figure 3-11 shows a source of rectangular pulses feeding two parallel branches, one containing a wide-band resistive network, the other a simple RC low-pass filter. The output of the resistive divider is an undistorted replica of the input signal. The capacitor in the low-pass filter takes time to charge to the applied voltage, so that the leading edge of the pulse at B follows the familiar exponential charge curve. At the

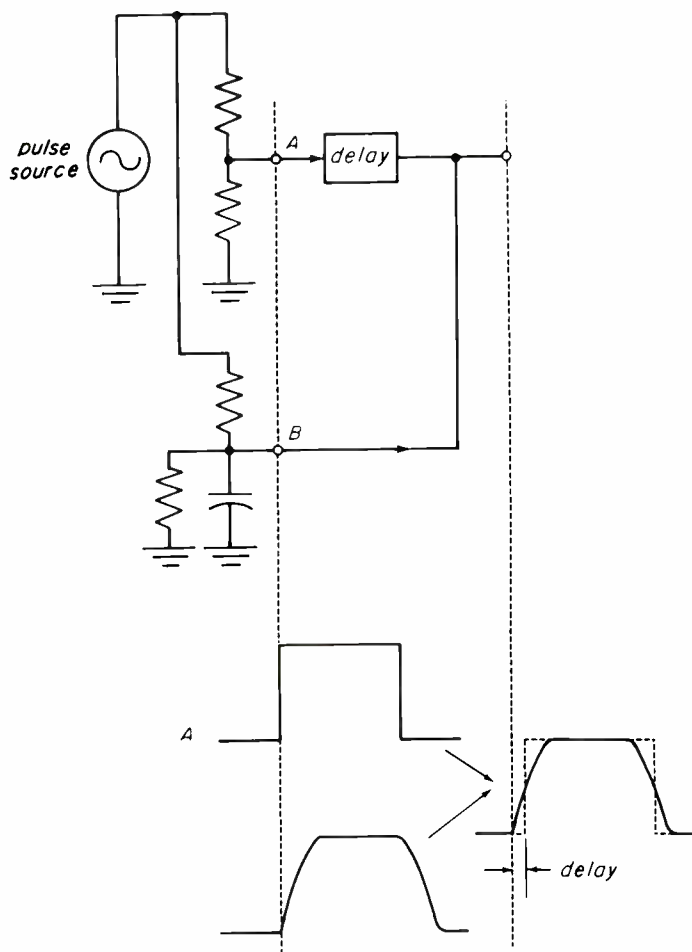

Fig. 3-11. A simplified illustration of the need for the luminance delay line. The time delay line is inserted in the upper circuit to match the natural delay introduced by the low-pass filter of the lower circuit.

termination of the input pulse the output at *A* falls to zero. But the capacitor in the low-pass filter takes some time to discharge, as shown. Note that both leading and trailing edges of the output at *B* are delayed. A delay line inserted into the output of the *A* circuit makes the centers of both output pulses coincident in time. The rectangular pulse, which represents luminance information, preserves the fast leading and trailing edges needed to produce good resolution. The signal from the low-pass filter, which represents chrominance information, cannot resolve sharp edges, but injects color into the larger areas of the picture.

The delay cable has an impedance of roughly 1500 ohms, and is fed from a low-impedance point in the cathode circuit of the

first video amplifier. In some cases, an additional driver stage is used to drive the delay line. In all cases, the polarity of the signal at the input to the delay line is the same as that of the detector - sync and blanking pulses extend in the negative direction. The video output stage inverts the signal, so that the output signal applied to the kinescope cathodes has its sync pulses extending in the positive direction. The delay line must be terminated properly at the input to the video output stage, to prevent ringing and line reflections in the monochrome picture.

The D-C Component. Loss of the d-c component of the video signal may go unnoticed in black-and-white receivers, especially if retrace blanking is applied to the kinescopes. In a color receiver, however, loss of the d-c component can cause incorrect colors. This can be explained as follows. Consider the color kinescope grid signals needed to produce the simple picture of a white vertical bar on a red field. The correct waveforms are shown at the top of Fig. 3-12. Note that the red signal is "on" between blanking pulses, but the blue and green signals remain at the blanking level, except when the white bar is scanned. (For simplicity, let us assume that all three input signals to the kinescope are equal in amplitude.) If the d-c component of the signal is lost, by passing the signals through an a-c coupled stage, the resultant signals average themselves about zero. These are shown at the bottom of Fig. 3-12, where the grid signals are averaged above and below the kinescope bias voltage. Comparing the height of the signals above and below the bias voltage, we see that the red signal does not extend as far in the positive direction as do the green and blue signals. As a result, the white bar lacks red, and appears cyan. During the remainder of the picture the blue and green grids do not swing sufficiently negative to reach cutoff. The red field is then diluted with blue and green and appears pink.

To preserve the d-c component of the video signal, direct coupling is employed in

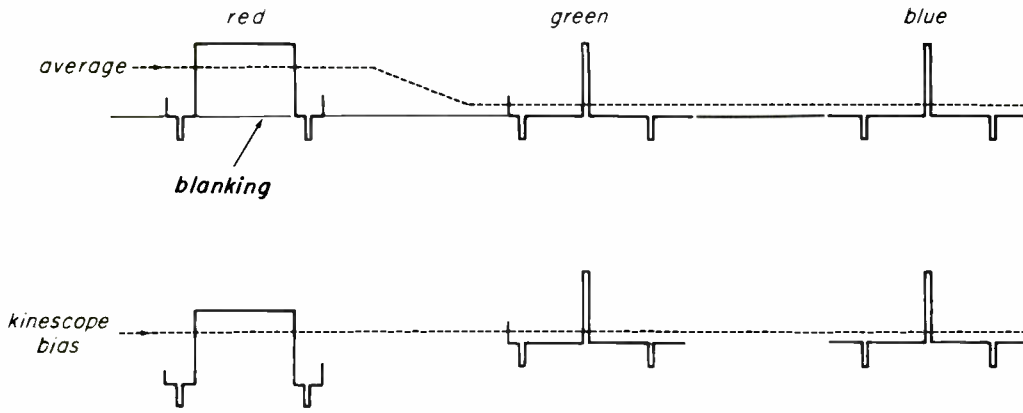

Fig. 3-12. Loss of the d-c component in the three color signals results in incorrect color reproduction.

all video stages, and between the color demodulators and the kinescope. As an alternative to direct coupling, d-c restorer circuits are employed at the kinescope control elements.

Contrast and Brightness Controls. The block diagram of Fig. 3-10 shows both the contrast and brightness controls associated with the video output stage. The brightness control is a master bias control for all three guns of the kinescope. It may be placed in the grid or cathode circuits of the kinescope. However, if the video output stage is direct-coupled to the kinescope, the brightness control may be a bias control in grid circuit of the video output stage. Increasing the

grid bias on the video output stage causes the plate voltage to swing in a positive direction. This makes all the cathodes of the kinescope swing towards cutoff. In short, the bias on the video output stage is transferred directly to the three kinescope guns. Placing the brightness control in the grid circuit of the video amplifier effectively makes the master bias control operate through the coupling circuits to the cathodes of the picture tube. Thus, any color-balance corrections applied to the video signals in the coupling system are applied to the bias voltages as well.

The contrast control usually applies variable degenerative feedback to the output

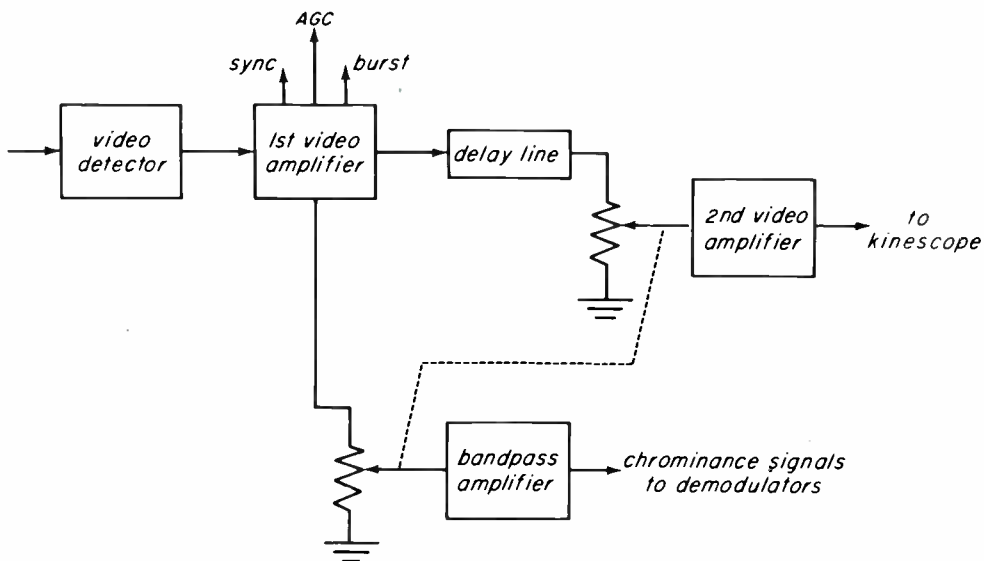

Fig. 3-13. Ganged contrast controls have been used to make the gains of the luminance and chrominance sections "track".

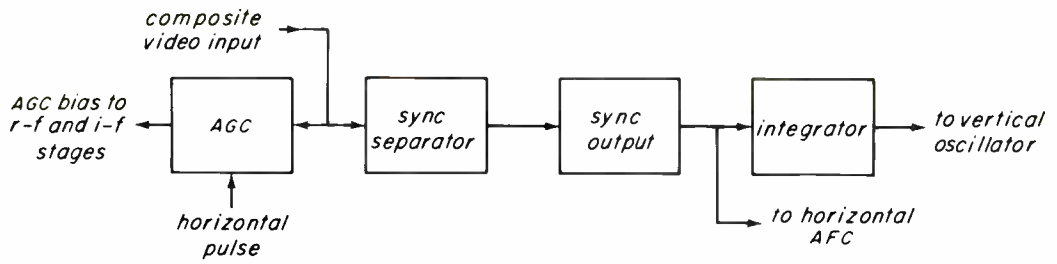

Fig. 3-14. Basic block diagram of the sync and AGC sections of the receiver.

stage to control stage gain. The range of the control is limited to about 3:1. Note that a change in luminance signal level upsets the proper addition of luminance in chrominance signals. Thus, a change in contrast requires a change in the setting of the color saturation control. For this reason, the contrast control is grouped with those viewer controls that do not need frequent adjustment. An alternative setup for the contrast control is shown in Fig. 3-13. Here, ganged controls allow the amplitudes of the luminance and chrominance signals to be altered simultaneously.

Sync and AGC. The sync separator and AGC circuits in a color receiver perform the same functions as in black-and-white receivers, and the requirements are approximately the same. These circuits are shown in Fig. 3-14. The AGC circuit develops a bias proportional to the height of the sync pulses received, for controlling the gain of the receiver. Keyed AGC circuits are usually employed, since they provide better noise immunity. Whether a telecast be in color or black-and-white, deflection circuits require clean, constant-amplitude sync for all usable signal input levels.

Vertical Deflection. This section of the receiver has the same function as in black-and-white receivers, and its design is not greatly different. As shown in Fig. 3-15, a sync pulse from the vertical integrating network in the sync section keeps the vertical oscillator operating at the vertical scanning rate. The output of the oscillator is amplified by a power amplifier and applied to the vertical deflection coils on the kinescope. The vertical power output stage also provides feedback for the oscillator section. A pulse, taken from the vertical output stage, may be applied to the kinescope for retrace-blanking purposes. In color receivers the vertical output stage provides the source of vertical-scanning signals for the dynamic convergence circuits.

Horizontal Deflection and High Voltage. Basically, the horizontal section is similar to the horizontal deflection section in a monochrome receiver. However, the electrical demands on this section in terms of power, additional pulse outputs, and high voltage, are greater. The basic circuit consists of a sawtooth generator or oscillator controlled by an AFC system. An AFC system compares the frequency of the oscillator

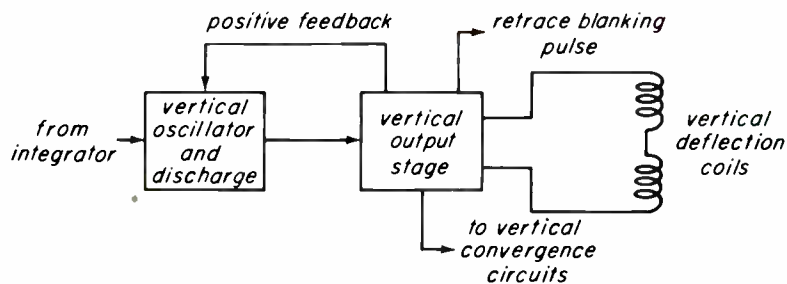

Fig. 3-15. Block diagram of the vertical deflection circuit shows the source of the vertical dynamic convergence signals.

with the frequency of the separated sync pulses, and applies a corrective d-c voltage to the oscillator when a frequency error exists. The sawtooth output of the oscillator drives the horizontal output stage, a conventional flyback circuit employing a damper tube. Deflection current for the horizontal deflection coils, as well as the retrace or flyback pulse used to generate high voltage, is obtained from the flyback circuit. Refer to Fig. 3-16.

High-voltage pulses from the flyback circuit are applied to high-voltage and focus-voltage half-wave rectifiers. Color kinescopes require a greater high voltage (ultor voltage) than do monochrome kinescopes - 18 to 25 kv. In addition, the high-voltage supply must meet the beam-current demands provided by three kinescope guns instead of one.

Properly regulated high voltage is important in color receivers, since proper focus and convergence depend upon fixed, stable

accelerating voltages. The high-voltage supply therefore contains a regulating system to maintain a steady high voltage despite variations in kinescope-beam loading. High voltage is controlled by means of a shunt regulator. The shunt regulator is effectively in parallel with the load formed by the kinescope. It acts to maintain the total load current on the high-voltage supply nearly constant. A simplified version of the shunt regulator appears in Fig. 3-17. A special triode is in parallel with the kinescope. Part of the high-voltage supply is tapped off and applied to the grid of the triode. A voltage divider holds the cathode at some reference voltage. If high voltage increases, due to a drop in kinescope beam current perhaps, the tapped-down voltage at the grid of the regulator likewise increases. This causes increased conduction of the regulator, and the total current load on the supply remains nearly constant.

In addition to the high-voltage demands, a number of other voltages and signals must

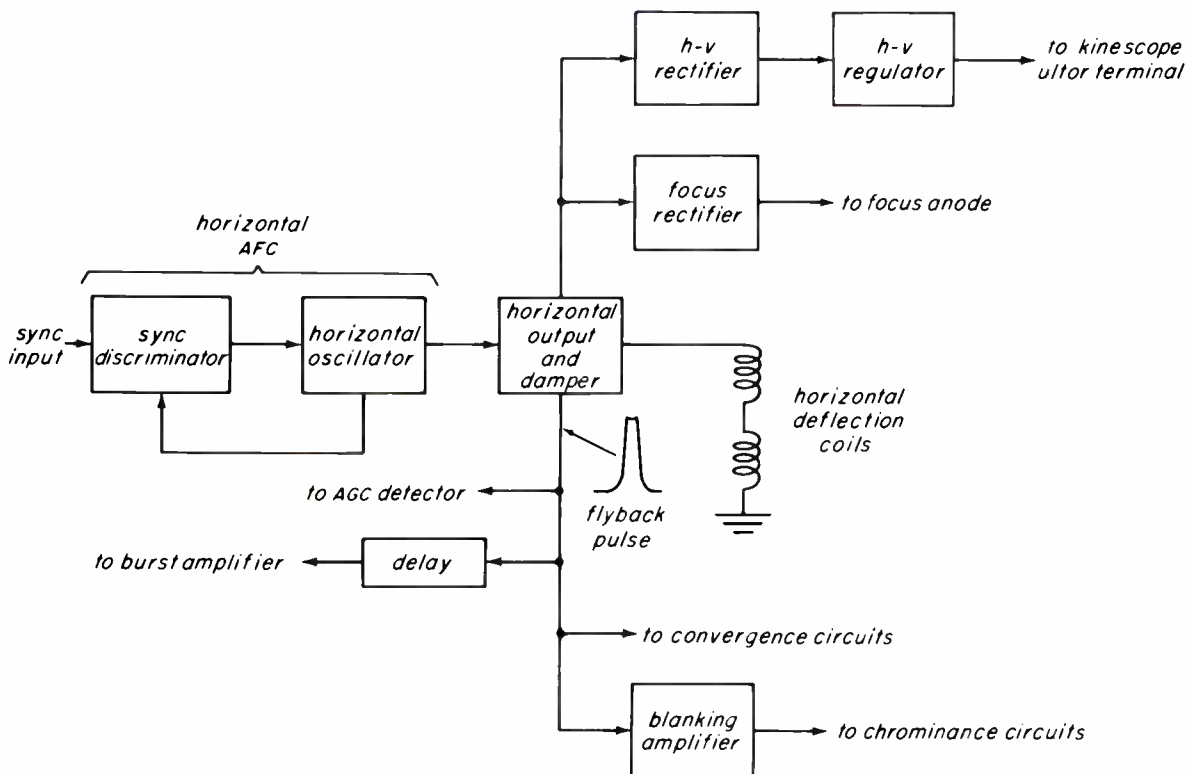

Fig. 3-16. Block diagram of the horizontal deflection and high-voltage sections of the receiver.

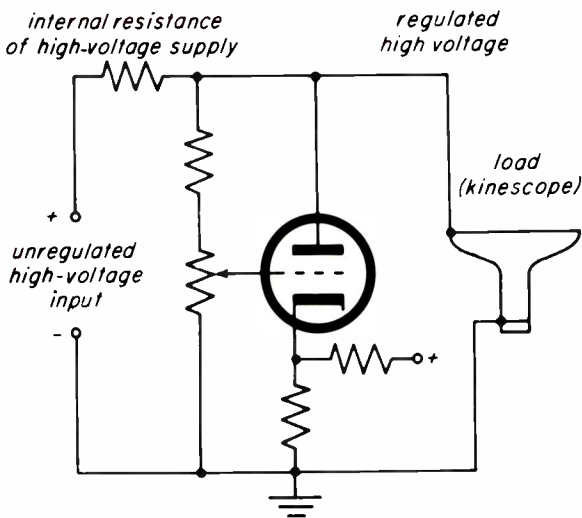

Fig. 3-17. The high-voltage shunt regulator acts to keep a constant load on the high-voltage supply.

be supplied by the horizontal deflection circuit. These include focus voltage for the kinescope and B+ boost voltage for the kinescope and deflection circuits. Flyback pulses are routed to the keyed AGC system, and a delayed flyback pulse is used as a keying pulse for the burst amplifier. Flyback pulses are also used for blanking purposes in the chrominance circuits, as will be explained later. Finally, a pulsed waveform is fed to the convergence circuits where the horizontal convergence waveforms are developed. A blanking amplifier is sometimes used to isolate some of these pulse loads from the flyback circuit.

Centering. The picture centering devices commonly found in late-model monochrome receivers cannot be used in color TV receivers. This type of permanent-magnet centering device would upset the fields of the purity magnet or the convergence-magnet assemblies. Centering systems are similar to those found in very early black-and-white sets. A controllable and reversible d-c current is passed through both sets of coils in the deflection yoke. An alternative system use special permanent magnets that are located inside the deflection yoke. To illustrate the centering systems in use, consider the vertical output circuit shown in Fig. 3-18a. The circuit is redrawn and simplified in b of the figure. Note that the centering control,

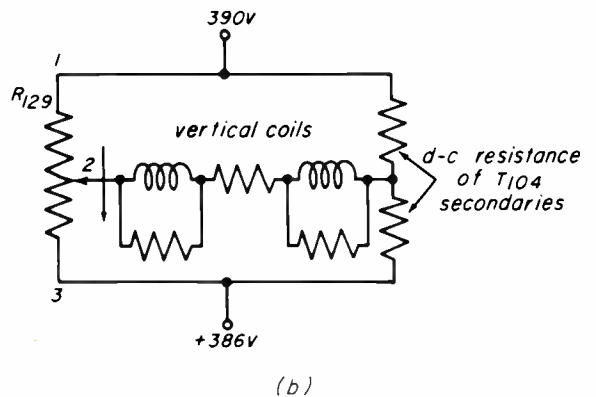
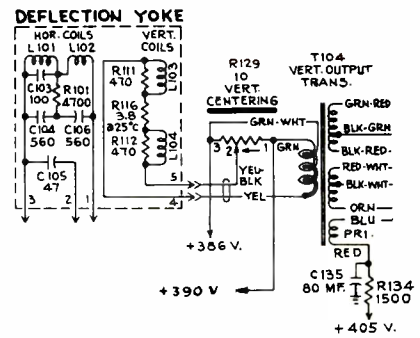

Fig. 3-18. (a) A section of a schematic diagram showing the vertical centering control; (b) a simplified diagram of the centering control showing the d-c bridge circuit.

R_{129} , forms one side of a bridge circuit connected between +390 volts and +386 volts. The other side of the bridge is formed by the d-c resistance of the bifilar secondary windings of the vertical output transformer. When the control is set at midposition, the bridge is balanced and no d-c current flows in the deflection coils. Current is made to flow in either direction through the coils by moving the arm of the control away from center. A bifilar winding is used in the transformer so that the transformer fields resulting from the d-c centering current cancel; core saturation is therefore minimized.

Convergence Signals. For a satisfactory black-and-white picture on the color receiver, the three primary-color rasters must be registered, or converged, on the screen of the picture tube. As we learned in an earlier lesson, the magnetic convergence fields for the three guns must be corrected at the edges. When proper correction is made, the spherical

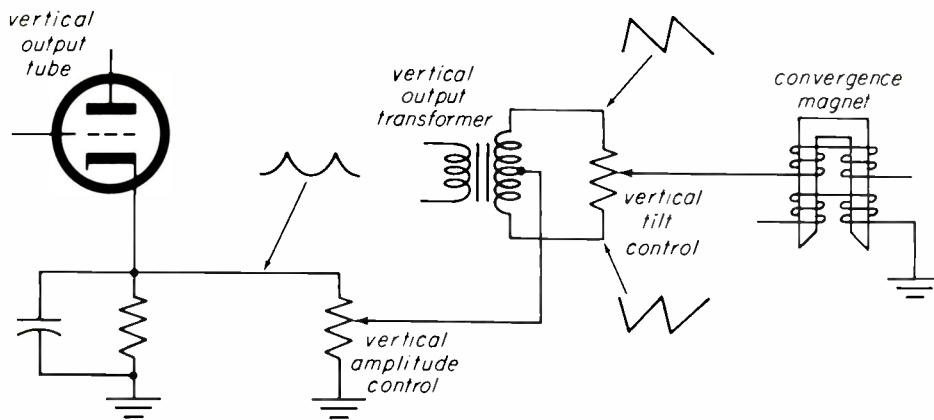

Fig. 3-19. A simplified diagram of the vertical dynamic convergence circuit for one of the three convergence magnets.

surface at which the three kinescope beams converge coincides with the shadow mask. Correction is achieved by varying the strength of the convergence magnets in step with the deflection signals. The current needed in the convergence magnets must be parabola-shaped; it is obtained from the deflection circuits.

A simplified diagram of the vertical dynamic convergence circuit for one gun is shown in Fig. 3-19. A parabola-shaped waveform, synchronized with the vertical scan frequency, is obtained from the cathode of the vertical-output tube. This waveform is the result of the integration of the sawtooth waveform at the cathode by the cathode bypass capacitor. The amplitude of the vertical parabolic waveform is adjusted with a vertical-amplitude potentiometer. A correction waveform, called *vertical tilt*, is added to the parabolic waveform. The distortion added by the tilt waveform corrects for natural irregularities that arise in the convergence system. The tilt waveform is a vertical sawtooth obtained from a winding on the vertical output transformer. When the vertical tilt control is at midposition the sawtooth component provided by the transformer is zero. In that case, the undistorted parabola is applied to the convergence magnet. Moving the tilt control towards or away from the midposition adds a sawtooth component of either polarity to the parabolic waveform. The effects of adding the tilt waveform are shown in Fig. 3-20.

Three circuits of the type shown in Fig. 3-19 are needed, one for each gun. Thus, there are six adjustments to be made for vertical convergence. In later receivers the adjustments for the red and green guns have been coordinated to simplify their operation. The details of these systems and of their adjustments will be given in later lessons.

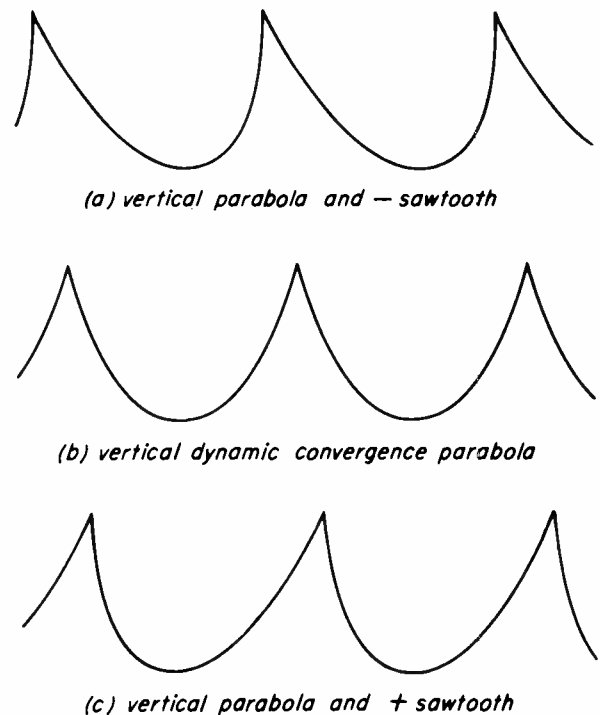

Fig. 3-20. Vertical dynamic current waveforms showing the effects of adding the tilt sawtooth.

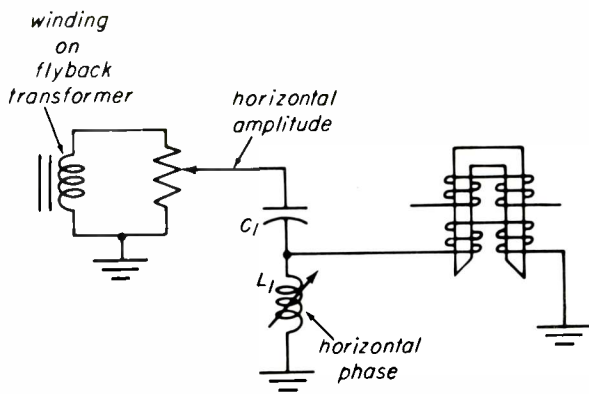

Fig. 3-21. An early system used to develop the horizontal dynamic convergence current.

An early method used to obtain a parabola at the horizontal scanning frequency is shown simplified in Fig. 3-21. A pulsed waveform, taken from a winding on the flyback transformer, is tapped down by the horizontal amplitude control and applied to a resonant circuit consisting of C_1 and L_1 . Due to the action of the resonant circuit, a sine wave of voltage is developed across L_1 and applied to the horizontal winding on the convergence magnet. Although the waveform is not parabolic in shape, the portion of the sine wave that is used during the active scan (between blanking pulses) is similar

enough to the parabolic curve to give satisfactory results. Corrections in waveshape are made by positioning the tuning slug in L_1 , which adjusts the phase of the waveform.

Later color receivers use the horizontal convergence waveshaping system shown in Fig. 3-22. A pulsed waveform, obtained from a winding in the flyback transformer, is applied through C_c to the waveshaping network. The coupling capacitance, C_c , is a large capacitor and acts like a short circuit to the input signal. The coil, L_1 , presents a large impedance compared to that of the remainder of the circuit to the right of L_1 . Therefore, the total current flowing in the circuit is determined to a great extent upon L_1 .

When a rectangular waveform of voltage is applied to an inductive circuit, the current waveform is that of a sawtooth. The total current flowing to the right of the coil has the waveshape designated i_T in the diagram. For a study of the effects of the remainder of the network, it is convenient to think in terms of current rather than of voltage. To the right of the coil, we see three parallel branches. The current flowing in all of the branches must add up to the total current i_T . Therefore, if we find the currents flowing

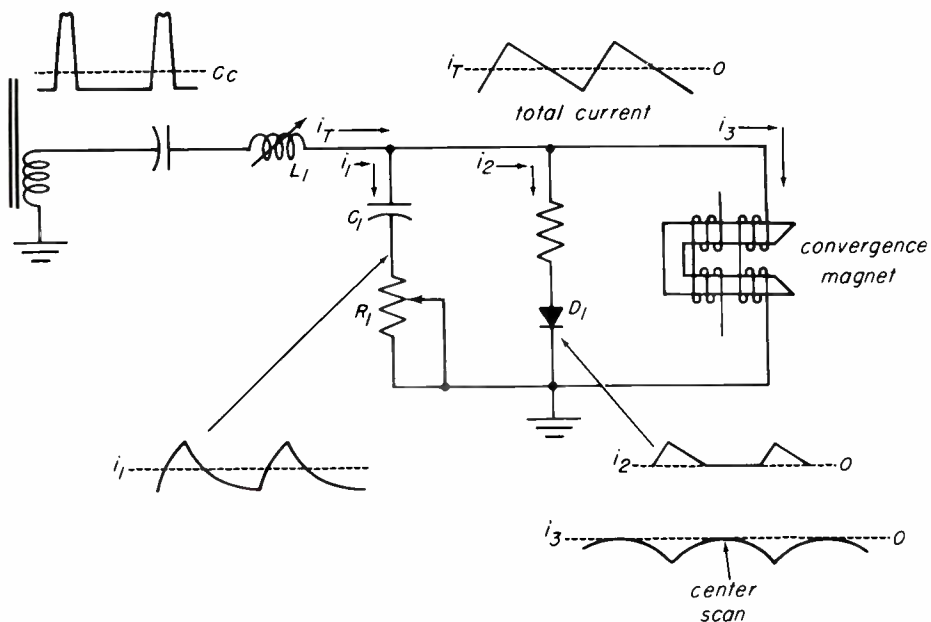

Fig. 3-22. A system used in late-model color receivers to produce the horizontal dynamic convergence waveform.

in branches 1 and 2, we may subtract these currents from i_T to find the current flowing in the convergence coil. The current in branch 1 has the waveshape designated i_1 , since the capacitor integrates the sawtooth waveform. Rheostat R_1 controls the amplitude of the current flowing in branch 1. The diode rectifies the sawtooth waveform, and conducts only when the input waveform is positive with respect to zero. To find the resultant current, i_3 , we must invert the current waveforms i_1 and i_2 and add them to i_T . This performs the necessary subtraction. The resultant convergence waveform is a parabola, as shown by i_3 . Note that the current waveform is entirely negative, and approaches zero at center scan. This is an advantage, since the dynamic waveform does not alter convergence in the center of the picture. As a result, the static convergence adjustments do not interact with the horizontal dynamic adjustments. In addition, R_1 has most effect upon the left side of the picture and very little effect upon the right. This greatly simplifies adjustments as L_1 , the total amplitude control, is adjusted to converge the right side of the picture, and R_1 is then adjusted to converge the left side of the picture. As in the vertical dynamic system, a separate network of the type shown in

Fig. 3-22 is employed for each of the three convergence magnets.

Static convergence is achieved by means of small permanent magnets attached to the convergence magnets. In some receivers, static convergence is achieved by passing a controllable direct current through the windings of the convergence magnet. Permanent magnets have the advantage that the strength of the field does not change with line-voltage changes or other factors that affect d-c currents in the receiver.

3-3. CHROMINANCE CIRCUITS

An over-all block diagram of the chrominance circuits appears in Fig. 3-23. In this section the sidebands of the 3.58-mc subcarrier are extracted from the composite video signal and are processed to produce the color-difference signals $E_{(R-Y)}$, $E_{(B-Y)}$ and $E_{(G-Y)}$. Chrominance information, in the form of 3.58-mc sidebands, is extracted from the output of the first video amplifier. The bandpass amplifier amplifies the sideband signals inside the chrominance band and rejects the remainder of the video signal.

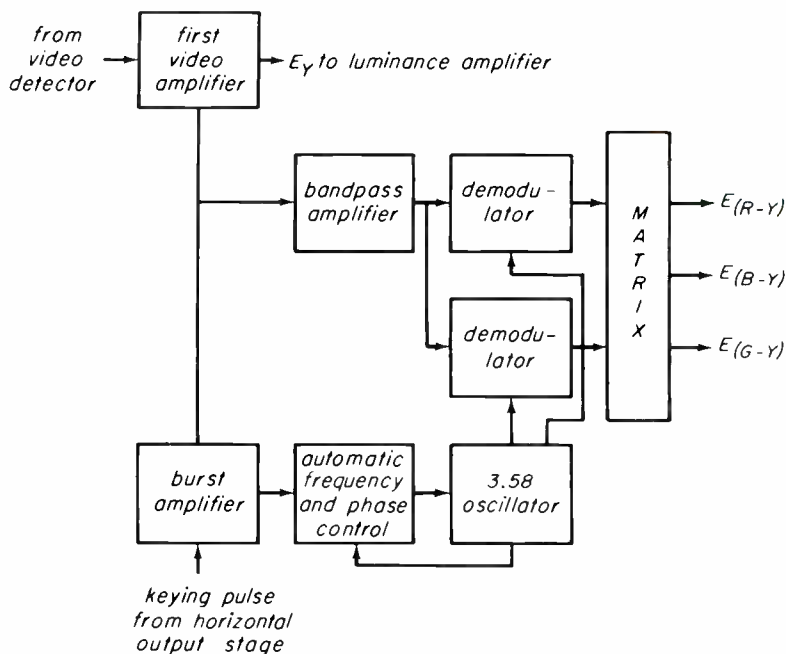

Fig. 3-23. Basic block diagram of the chrominance section of a color TV receiver.

The bandpass amplifier supplies 3.58-mc chrominance signals to the inputs of both demodulators. Reference carriers are reinserted in the demodulators, and detection takes place. The demodulators produce two chrominance signals in the form of video signals. Several pairs of chrominance signals may be obtained, depending upon the phase relation of the reinserted carriers as compared with the reference phase (burst). The detected signals are routed to a matrix section that combines the chrominance signals to produce the color-difference signals. They are then applied to kinescope grids.

The color synchronization section, shown in the lower part of Fig. 3-23, supplies the reinserted carriers for the demodulators. It consists of a local subcarrier oscillator that is kept in phase lock with the reference or burst signal by an automatic frequency and phase control (AFPC) system. We shall now look into these blocks in greater detail.

The Bandpass Amplifier. This stage is very much like a wideband i-f amplifier stage whose center frequency is 3.58 mc. Both input and output circuits are tuned, however, and special coupling circuits are employed to secure wide bandwidth (usually 1.2 mc) at the relative low center frequency of 3.58 mc. In those receivers that place the color subcarrier on the slope of the i-f response curve, the input tuned circuit of the bandpass amplifier is designed to restore uniform amplification of the color sideband signals. In such cases, the input tuned circuit has a response curve like that shown in Fig. 3-8b. The output tuned circuit provides uniform amplification over the range of sideband signals. In most receivers this band is symmetrical about 3.58 mc, and extends 600 kc above and below this center. In those receivers that demodulate the E_r and E_o signals, the response of the bandpass amplifier is not symmetrical, but extends 600 kc above 3.58 mc and 1.5 mc below 3.58 kc.

The color saturation control, sometimes called the chroma control, controls the gain of the bandpass amplifier. See Fig. 3-24. This is a viewer's control, and it adjusts the saturation of color in the picture. When the control is set fully counterclockwise,

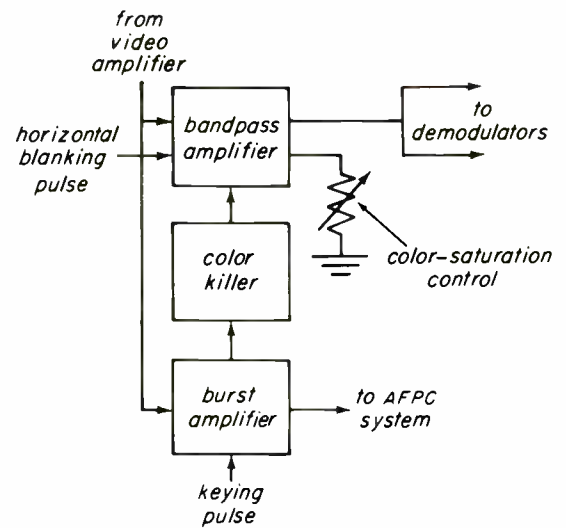

Fig. 3-24. The bandpass amplifier and its associated circuits and controls.

the bandpass amplifier is cut off, no chrominance signals are produced, and a black-and-white picture results. Advancing the control increases the gain of the amplifier, and increases the amplitude of the color-difference signals that are added to the luminance signal. Actually, this control has only one correct setting, but it allows the viewer to compensate for slight errors in antenna response, or errors in the response of the r-f and i-f amplifiers. In some receivers an automatic saturation control system is employed (ACC for automatic color control). This is a sort of AGC system for the bandpass amplifier. It regulates the gain of the bandpass amplifier, using the amplitude of the burst signal as a reference. If color saturation is low, perhaps as the result of poor antenna response, burst is also low in amplitude, and the ACC bias voltage is reduced. This allows the bandpass amplifier to operate at greater gain, and color saturation increases.

In most receivers, the bandpass amplifier is biased off when monochrome telecasts are being received. Cutoff bias for this purpose is obtained from the color-killer stage. This stage senses the absence or presence of burst signals in the burst amplifier, and supplies cutoff bias to the bandpass amplifier when burst is absent. It is necessary to disable the bandpass amplifier during

19

monochrome telecasts so that the color circuits will not sample the monochrome information and random noise that exists at the high end of the video passband. The result of this sampling is colored noise (snow) on very weak signals, or color in areas of the picture where 3.5-mc information is displayed. The latter can be seen as color in narrow vertical stripes, such as the vertical wedge in test patterns and the fabric patterns in the clothing of performers.

A blanking pulse is applied to the bandpass amplifier to cut it off during the transmission of the burst signal. This is necessary to prevent an output from the demodulators during the horizontal blanking period. An output at that time would produce color during retrace, and might also upset the operation of d-c restorers at the chrominance output circuits.

Demodulators. The signal passed by the bandpass amplifier is the vector sum of two 3.58-mc chrominance signals that are in phase quadrature. The chrominance signals must now be recovered separately. This job is accomplished by two phase-sensitive detectors known as synchronous detectors, or demodulators.

The demodulators are similar to the basic amplitude-modulation detectors. In the familiar AM detector, a modulation envelope is rectified to produce an output proportional to the amplitude variations of the modulation envelope. These variations in amplitude are formed by the addition of the carrier signal and those components of the sideband signals that are in phase, or 180° out of phase, with the carrier signal. The major difference between the familiar AM detectors and the chrominance demodulators is that the carrier signal is injected from a local source, and does not accompany the received signal.

A basic demodulator circuit is shown in Fig. 3-25. The chrominance signal, consisting of sidebands of the subcarrier signal, is applied to the control grid. The 3.58-mc subcarrier signal, obtained from the color synchronization section in the receiver, is applied to a high- μ suppressor grid.

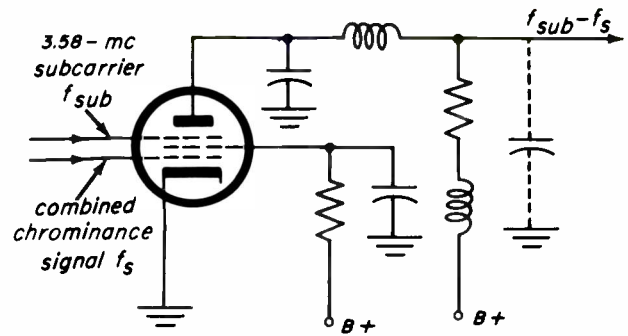

Fig. 3-25. A basic synchronous detector or demodulator.

The action of the synchronous detector may be explained with the aid of the simplified waveform drawings of Fig. 3-26. The 3.58-mc subcarrier is supplied to the suppressor grid and may be considered, for the sake of simplicity, as gating the tube into conduction on the positive half-cycles, and out of conduction on the negative half-cycles. The gating action of the 3.58-mc subcarrier signal on the suppressor grid with no other signal applied may be seen in Fig. 3-26a. The plate current consists of half-cycle pulses, whose average value is indicated on the diagram. This average plate current may be called the no-signal average plate current. We can now examine the action when the combined chrominance signal is applied to the control grid. The result, when the signal on the control grid is in phase with the suppressor signal, is shown in Fig. 3-26b; the result when the two signals are ninety degrees out of phase is shown in Fig. 3-26c.

A study of the in-phase condition shows that the control grid is now more positive whenever the tube is gated into conduction, and, as a result, the pulses of plate current are of greater amplitude. Thus, the average plate current is increased, as shown, and an output corresponding to the amplitude of the control-grid signal is obtained. If the signal on the control grid is 180° degrees out of phase with the suppressor signal, the control grid is more negative whenever the tube is gated into conduction, and the pulses of plate current are now of smaller amplitude. The average plate current is now less than the average plate current for the no-signal condition. An output of opposite polarity is therefore obtained.

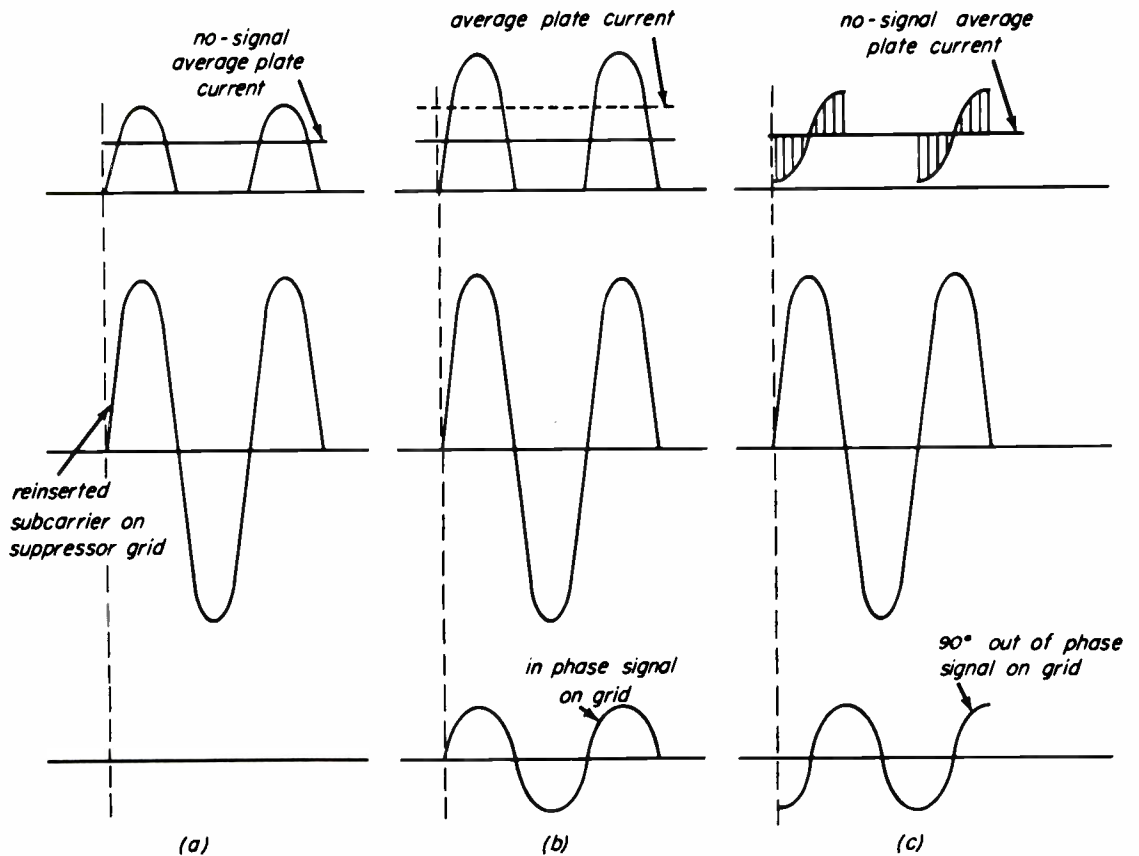

Fig. 3-26. Waveforms showing the output current of the demodulator when: (a) no chrominance signal is applied; (b) chrominance and CW signals are in phase; (c) chrominance and CW signals are 90° out of phase.

A study of the 90-degree out-of-phase condition illustrated in Fig. 3-26c shows that, during the half cycle when the tube is conducting, the signal on the control grid is both negative and positive. This causes an approximately equal decrease and increase in plate current, and the average change in plate current over the entire cycle is therefore zero. Thus, it can be seen that when the signal on the control grid is 90 degrees out of phase with the suppressor signal there is no change in plate current, and consequently no output in the plate circuit.

The output current of the demodulators, then, varies from a maximum when the two signals are in phase, as shown in Fig. 3-26b, to the no-signal average value when the two signals are in quadrature, as shown in Fig. 3-26c, and to a minimum when they are 180 degrees out of phase. This is summarized in Fig. 3-27, which shows the output voltage

at all phase angles from zero to 360 degrees. Note that the output of the detector may be negative or positive, depending upon the phase angle between the two signals.

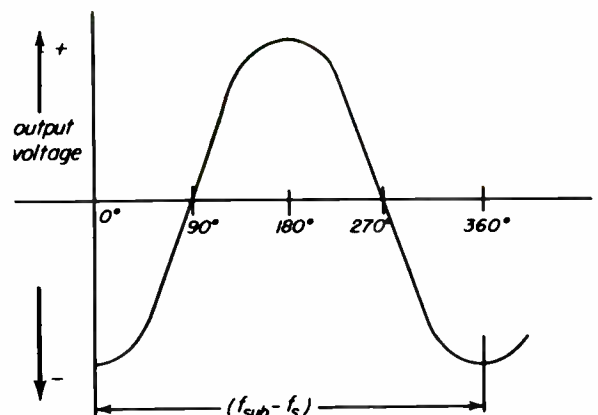

Fig. 3-27. Graph of output voltage versus phase difference between chrominance and CW signals applied to a demodulator. Amplitudes are considered constant.

Demodulation Axes. At the transmitter, each of the two chrominance signals is applied to a separate balanced modulator. The two balanced modulators are supplied with subcarrier signals that are in phase quadrature. If the burst signal is considered as a reference, the signal applied to the E_I demodulator is 57° from it (measured clockwise), and the signal applied to the E_Q axis is rotated in phase an additional 90° , making it 147° from the reference. A vector diagram showing the locations of the E_I and E_Q axes appears in Fig. 3-28. The composite chrominance signal is the sum of the outputs of both modulators; the transmitted signal may assume any phase angle, depending upon the relative amplitudes of E_I and E_Q . These, in turn, depend upon the color that is being scanned at any particular instant.

The demodulators in the receiver may be adjusted to detect the E_I and E_Q signals directly. This is accomplished by arranging the phase of the reinserted subcarrier signals supplied to the demodulators to be at 57° and 147° with respect to the reference (burst) signal. By altering the phase of the subcarrier signals in the receiver, to 0° and 90° , it is possible to directly recover the color difference signals $E_{(R-Y)}$ and $E_{(B-Y)}$. Other

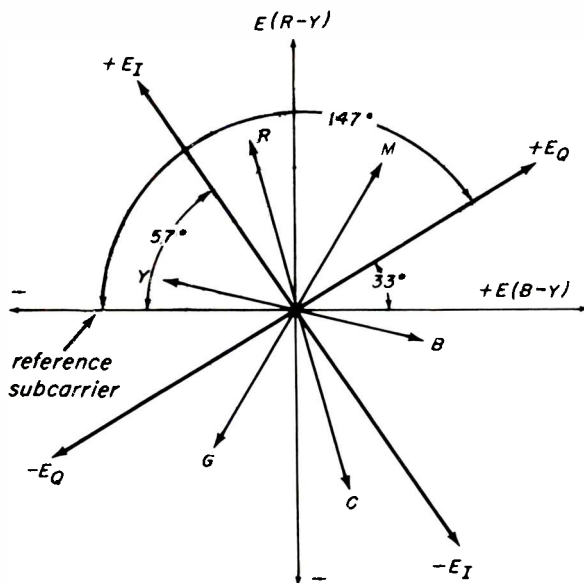

Fig. 3-28. Vector diagram showing phase references for the major hues and the I and Q axes. The reference subcarrier (burst signal) is in phase with the $-E_{(B-Y)}$ signal.

pairs of demodulation axes may be chosen, as we shall see.

It should be mentioned, at this point, that most late-model receivers are designed to demodulate the color difference signals directly, or to produce some other pair of chrominance signals from which the color-difference signals can be obtained. Demodulation of the I and Q signals was accomplished in very early color receivers. Extensive field tests have shown that over-all picture quality is about the same in receivers that demodulate I and Q and those that demodulate the color-difference signals. Although the I - Q system provides an improvement in color definition, it introduces problems with time-delay matching, critical alignment, and other factors that might tend to degrade picture quality.

I and Q Demodulation. Demodulation of the E_I and E_Q signals permits maximum color definition with a minimum of crosstalk between the chrominance signals. The crosstalk shows up as incorrect hue in the small areas of the picture. It occurs at modulating frequencies above 500 kc, where upper sideband attenuation causes the phase of the resultant chrominance signal to be in error.

A block diagram of the I and Q demodulation section of a color receiver appears in Fig. 3-29. The output of the demodulators contains color video signals whose instantaneous frequency is the difference between the frequencies of reinserted subcarrier and the input signal. A low-pass filter is employed at the output of the demodulators to remove the 3.58-mc component, and allow the color video signals to pass.

The low-pass filter in the output of the E_Q demodulator removes all signals above 500 kc, as shown by the response curve in Fig. 3-30a. Because of band limiting in the Q channel, any signals above 500 kc that may be detected by the E_Q demodulator are rejected by the filter.

A low-pass filter in the output of the E_I demodulator cuts off above 1.5 mc as shown in Fig. 3-30b. It should be noted, however, that a uniform video response does not result in uniform output between 0 and 1.5 mc.

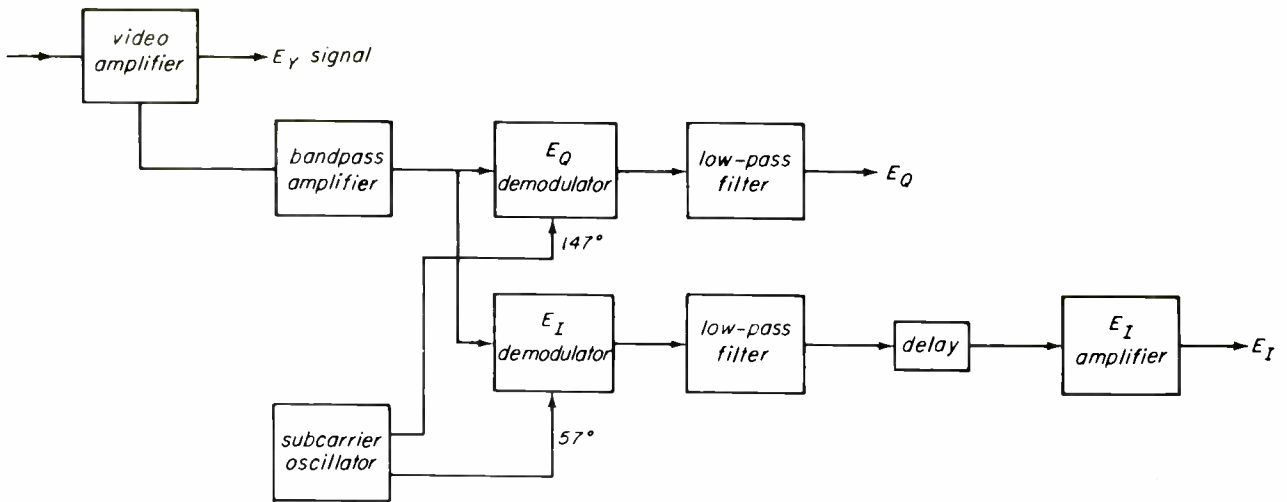

Fig. 3-29. Block diagram of the chrominance section of a receiver using the I and the Q demodulation axes.

The reason is that the E_I signal is carried by two sidebands in the frequency range between 0 and 500 kc, but only one sideband, the lower, carries E_I modulation signals between 500 kc and 1.5 mc. To restore uniform output throughout the E_I band, additional amplification may be given to that part of the lower sideband between 500 kc and 1.5 mc. This compensation may be performed in the bandpass amplifier or in the E_I amplifier. A bandpass amplifier response, designed to compensate for the loss of the upper sideband, appears in Fig. 3-31.

A delay line, or delay network, is shown in the I channel of Fig. 3-29. This delay is needed to match the over-all time delay of the E_I signal to the naturally-longer time delay of the E_Q signal. An amplifier stage is needed in the I channel, since this amplifier channel has a wider bandwidth.

Matrixing. A matrix is a mixing circuit that combines the outputs of the demodulators in the correct polarities and proportions to produce the color difference signals. In one early-model receiver, a matrix was used to mix the E_Y , E_I , and E_Q signals to produce the color signals E_R , E_G , and E_B directly. The matrix in this receiver produces the color signals by performing the additions noted in the following formulas:

$$E_R = 0.96 E_I + 0.62 E_Q + E_Y$$

$$E_G = -0.28 E_I - 0.64 E_Q + E_Y$$

$$E_B = -1.11 E_I + 1.70 E_Q + E_Y$$

The operations indicated in these formulas reverse the process at the transmitter, where E_Y , E_I , and E_Q are obtained from E_R , E_G , and E_B . Note that negative quantities of E_I and E_Q are needed. The basic matrix system is shown in Fig. 3-32. Phase inverter stages provide the negative quantities of E_I and E_Q ; the resistive dividers proportion the signals properly. In addition, the resistors restore the color-difference signals

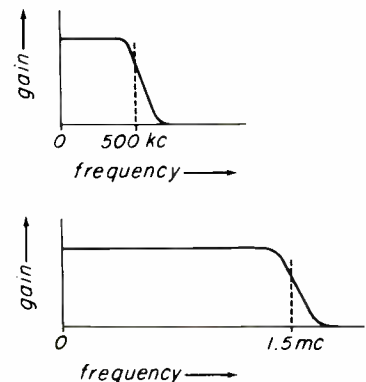

Fig. 3-30. Low-pass filters limit the response of the E_Q and E_I channels to 0.5 mc and 1.5 mc, respectively.

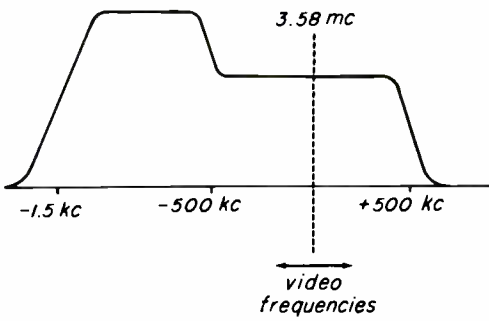

Fig. 3-31. Response curve of a bandpass amplifier used to compensate for the loss of part of the upper sideband of the chrominance signal.

to the proper relative amplitudes. Recall that the chrominance signals are attenuated at the transmitter to prevent overmodulation of the transmitter by the chrominance signals. The E_R , E_G , and E_B signals produced by this matrix are amplified further, and applied to individual d-c restorer circuits before being applied to the grids of the color picture tube.

R-Y, B-Y Demodulators. By shifting the phase of the CW signals applied to the demodulators shown in Fig. 3-29, it is possible to make them detect the $E_{(R-Y)}$ and $E_{(B-Y)}$ signals directly. Referring to Fig. 3-28, you can see that a shift of 33° clockwise will make the $E_{(R-Y)}$ demodulator respond to the $E_{(R-Y)}$ signals. A block diagram of the chrominance section of a receiver designed to demodulate $E_{(R-Y)}$ and $E_{(B-Y)}$ is shown in Fig.

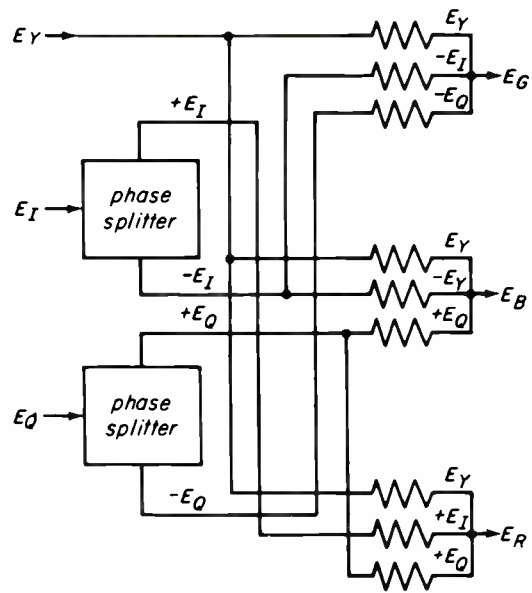

Fig. 3-32. The matrix system used in a receiver designed to demodulate the I and Q chrominance signals.

3-33. Identical low-pass filters are employed in the outputs of both demodulators. These filters are designed to pass video signals of from 0 to 600 kc or slightly higher. Phase distortion that occurs at modulating frequencies above 600 kc is therefore band-limited in both channels (at some sacrifice in color resolution). Since both chrominance channels have identical bandwidths, the time delays are equal. No time delay matching is needed in the chrominance channels; only the E_Y time delay system is

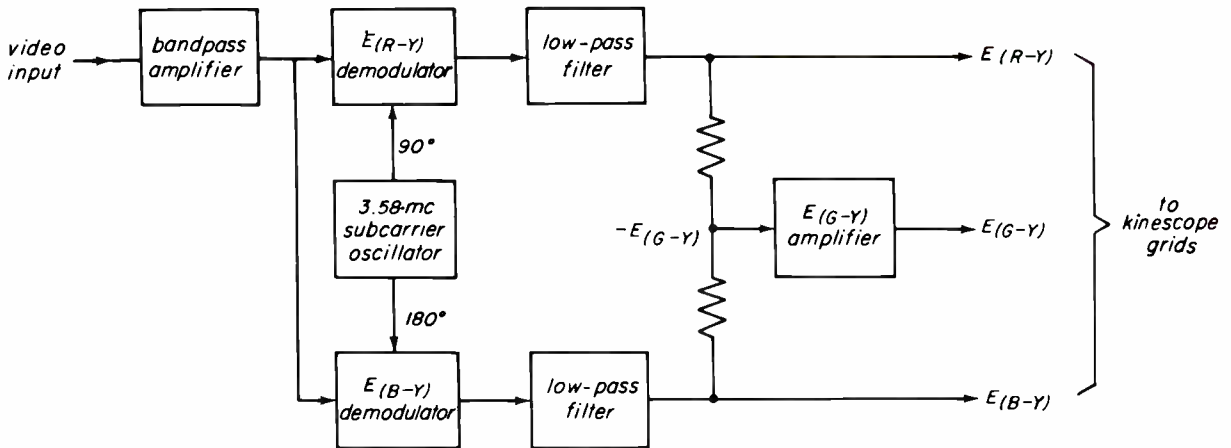

Fig. 3-33. Block diagram of the chrominance section of a receiver designed to demodulate the $E_{(R-Y)}$ and $E_{(G-Y)}$ signals directly.

needed. In addition, no complex compensation need be made in the chrominance channel for the single-sideband condition that occurs at chrominance frequencies between 500 kc and 1.5 mc.

Matrixing. Since $E_{(R-Y)}$ and $E_{(B-Y)}$ are demodulated directly, it remains only to reclaim the $E_{(G-Y)}$ signals. As shown in an earlier lesson, the $E_{(G-Y)}$ signal is related to the remaining color difference signals by:

$$E_{(G-Y)} = -0.51 E_{(R-Y)} - 0.19 E_{(B-Y)}$$

The matrix unit that performs the operations indicated in the formula is shown in Fig. 3-33. The resistors attenuate the $E_{(R-Y)}$ and $E_{(B-Y)}$ signals to 51% and 19% respectively. This results in a *negative* $E_{(G-Y)}$ signal. An amplifier inverts the $-E_{(G-Y)}$ signal to produce a positive $E_{(G-Y)}$ signal. Color-difference signals are applied to the grids of the kinescope. The Y signal is applied to all three cathodes. Addition takes place in the electron stream yielding red, green, and blue beam currents for the corresponding guns.

R-Y, G-Y Demodulation. Several early-model RCA receivers were designed with high-level demodulators. These are triode demodulators that are capable of producing video output signals large enough to drive the grids of the kinescope directly. In such cases there is an advantage in demodulating the $E_{(R-Y)}$ and $E_{(G-Y)}$ signals directly. Since the demodulators drive the kinescope grids

directly, the relative amplitudes of the chrominance signals are adjusted by adjusting the amplitude of the CW signals applied to the demodulators. If $E_{(B-Y)}$ were demodulated, it would require the largest CW input. Recall that the $E_{(B-Y)}$ signal is attenuated by the larger factor at the transmitter in order to prevent overmodulation. Therefore, the $E_{(B-Y)}$ demodulator would have to operate at greater gain in order to restore the $E_{(B-Y)}$ signal to its proper relative amplitude. With $E_{(R-Y)}$ and $E_{(G-Y)}$ demodulated, less CW drive is required for the demodulators, and a separate amplifier may be used to amplify the $E_{(B-Y)}$ signal.

A block diagram of the R-Y, G-Y system appears in Fig. 3-34. The CW signals supplied by the local subcarrier oscillator are arranged to be on the R-Y and G-Y axis, at 90° and 304° measured clockwise from burst. Note that these demodulators are not operated in quadrature.

The $E_{(B-Y)}$ signal may be obtained from the $E_{(R-Y)}$ and $E_{(G-Y)}$ signals by adding these chrominance signals in the following proportions:

$$E_{(B-Y)} = -2.73 E_{(R-Y)} - 5.36 E_{(G-Y)}$$

The matrix unit shown in Fig. 3-34 proportions the $E_{(R-Y)}$ and $E_{(G-Y)}$ signals properly to produce a negative $E_{(B-Y)}$ signal. The amplifier inverts the signal and brings it up to

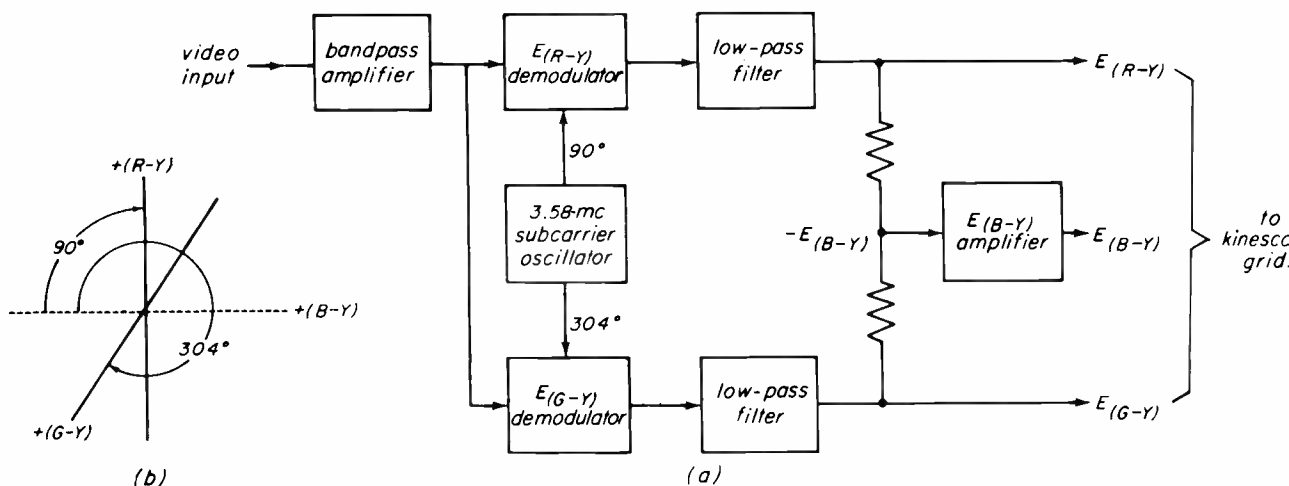

Fig. 3-34. Block diagram of the chrominance section of a receiver built to demodulate the $E_{(R-Y)}$ and $E_{(G-Y)}$ signals directly.

the proper level to drive the blue kinescope grid. In receivers using this system, the luminance signals and the color-difference signals are added in the kinescope.

X and Z Demodulators. The demodulation axes used in many RCA color receivers are chosen to suit the needs of a special demodulator-adder system. The heart of the system is the unique three-tube adder, whose simplified schematic diagram appears in Fig. 3-35a. It consists of three amplifiers with a common cathode resistor. Feeds from the demodulators are applied to the grids of two of the tubes; the grid of the third tube is grounded. Part of the signal applied to the R-Y amplifier appears across

the common cathode resistor and is effectively applied to the cathodes of the G-Y and B-Y amplifiers. Similarly, part of the signal applied to the grid of the B-Y amplifier appears at the cathodes of the G-Y and R-Y amplifiers. The signal voltage that appears between grid and cathode of any of the adder tubes is the input signal voltage minus the voltage that appears across the common cathode.

The demodulation axes are arranged as shown in Fig. 3-35b. Note that the +Z axis lies between the -(B-Y) and the +(G-Y) axes. Thus, the output of the Z demodulator contains -(B-Y) component and a +(G-Y) component. The X axis lies between +(G-Y)

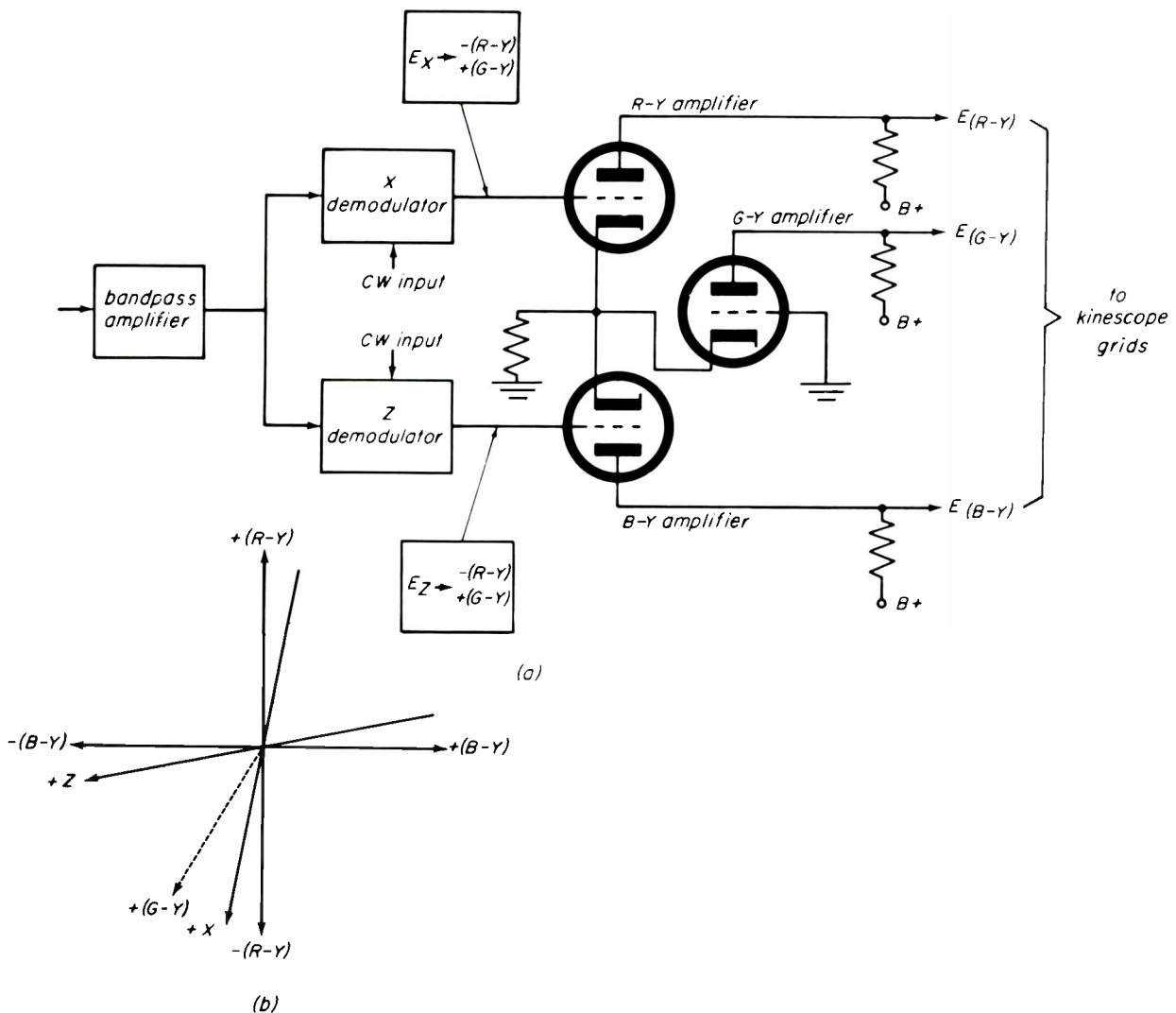

Fig. 3-35. Late-model RCA receivers are designed to demodulate two sets of chrominance signals designated X and Z. This system uses a special three-tube adder circuit.

and $-(R-Y)$ axes, and so the X demodulator output contains $+(G-Y)$ and $-(R-Y)$ information. Both X and Z signals are added across the common cathode resistor in the adder circuit. The demodulation axes are so chosen that a $+(G-Y)$ signal is developed across the cathode resistor. Since the grid of the $G-Y$ adder is grounded, and no phase shift takes place between cathode and plate, a positive $G-Y$ signal appears at the plate.

Now consider the $B-Y$ amplifier. A signal containing $-(B-Y)$ and $+(G-Y)$ components is applied at the input, and a $+(G-Y)$ component is developed at the cathode. To find the grid-to-cathode signal, we must subtract the cathode signal from the input signal. The $(G-Y)$ components cancel and a $-(B-Y)$ component remains. Since this signal is applied at the grid, a $+(B-Y)$ signal is developed at the plate of the $B-Y$ amplifier. A similar action takes place in the $R-Y$ amplifier. The $(G-Y)$ components cancel, leaving a $-(R-Y)$ signal at the grid of this stage. The phase inversion that occurs between grid and plate voltage produces a $+(R-Y)$ output.

Several factors are involved in the choice of demodulation axes for the X and Z system. The phase angles are chosen so that the gains of the demodulators are nearly equal and the gains of the three adders are also equal. In addition, the basic system provides color difference signals of the correct relative amplitudes to meet the drive requirements of the picture tube. A derivation of the phase angles used for the demodulation axes of one form of the X and Z system appears in the Appendix.

The X and Z demodulation system has several advantages. The three adder stages have equal gains, and identical components in the plate, grid and cathode circuits. This renders the entire system relatively insensitive to changes due to component aging. Another advantage is that the CW feeds to both demodulators are equal in amplitude, so that setup adjustments are relatively easy, and consist of phase adjustments and one balancing adjustment. A third advantage is that the adder system lends itself well to a particular form of d-c restoration, called

keyed d-c restoration (to be discussed shortly). This system employs a 15.75-kc keying pulse to develop the d-c components of the chrominance signals. In ordinary adder stages identical keying pulses must be fed to each individual adder stage. In the special adder circuit, employed with the X and Z system, only a single pulse feed is required; the keying pulses are applied to all three adders through the common cathode circuit.

D-C Restoration in the Chrominance Circuits. It was pointed out earlier in this lesson that the d-c component of the color signals must be preserved if correct color reproduction is to be obtained. Since most receivers perform the addition of luminance and chrominance signals in the picture tube, the d-c component must be maintained in both the luminance and chrominance channels. Direct coupling is employed in the luminance circuits of most color receivers; the video circuits between the video detector and the picture tube are d-c coupled. In some color receivers d-c coupling is employed in the chrominance circuits as well. These receivers are made with "high-level" demodulators, the outputs of which have sufficient amplitude to drive the picture tube directly. In this system, direct coupling is used between the high-level demodulator and the grids of the picture tube.

D-c coupling introduces drift problems, if one or more amplifier stages separate the demodulator from the picture tube. Drift problems are more serious in the chrominance amplifiers, since there are three separate stages, and unequal drift may upset color balance. For this reason, receivers using low-level demodulators use d-c restorers to reclaim the d-c component of the chrominance signals.

The type of d-c restorer circuits used in some early-model black-and-white receivers cannot be used in the chrominance circuits of the color receiver. These simple diode circuits restore the d-c component of the video signal by clamping the sync-tip level at zero or some bias level for the picture tube. There is no such reference signal in

the output signals of the chrominance demodulators. During the sync and blanking periods there is no chrominance information and the demodulator outputs are zero. It is this zero level that is used as the signal reference in restoring the d-c component of the signal. The following discussion shows what happens when the d-c component is lost, and how the d-c component is reclaimed.

Figure 3-36 shows how the output of an $E_{(R-Y)}$ demodulator appears when a predominantly red pattern is being transmitted. Note that the output of the demodulator is zero at the time the horizontal blanking pulse is being transmitted. When this type of signal is applied through a coupling capacitor to the next stage, the d-c component is lost.

The coupling capacitor charges to the average d-c voltage and retains that charge. Fluctuations in d-c level take place at a slow rate compared to the RC time constant of the coupling capacitor-grid resistor circuit, so that the charge on the capacitor remains equal to the d-c level. The average

of the a-c signal, developed across the grid resistor, is zero, since the area of the video signal above zero is equal to the area of the signal below zero. Note that, in resolving itself about zero, the signal interval that represents zero at the input to the coupling capacitor may have a negative or positive value at the output of the coupling capacitor. This condition may be corrected by making sure that the charge on the coupling capacitor remains fixed, and is not influenced by the average value of the input signal. (If a battery were used to couple the signal the d-c component would be preserved.) The charge on the coupling capacitor is "set" by applying a negative pulse to the cathode of the adder amplifier during the horizontal blanking period. This pulse makes the grid positive with respect to cathode, and grid current is drawn charging the coupling capacitor. Note that the pulse is applied during blanking, when the output of the demodulator is zero. Thus, the charge on the capacitor is determined only by the amplitude of the pulse waveform. The capacitor discharges between the set pulses, establishing a bias voltage for the adder stage. This bias volt-

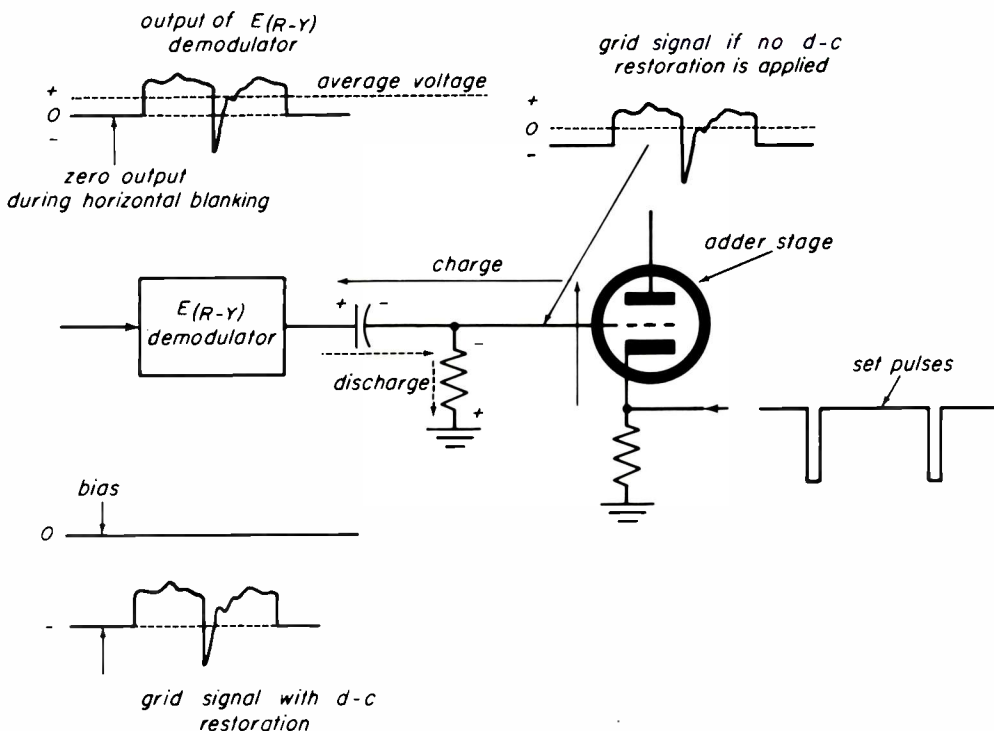

Fig. 3-36. An illustration of the effects of loss of the d-c component in one of the chrominance signals. The set pulses applied to the cathode of the tube make the tube act as a keyed d-c restorer.

age has a fixed value determined by the amplitude of the set pulse. At the grid of the adder-amplifier, the signal fluctuations simply add to or subtract from the bias voltage, and zero output from the demodulator corresponds to the bias voltage at the grid of the adder.

In the X and Z system, the set pulse used for d-c restorer action is applied to the common cathode terminal of the three adders. This establishes the bias for all three adders. Set pulses are obtained from the horizontal deflection circuits.

3-4. COLOR SYNCHRONIZATION

The chrominance demodulators, discussed in the previous section, produce a pair of chrominance video signals by a detection process whereby the information carried in the 3.58-mc sidebands is combined with a pair of "reinserted" carrier signals. These CW carrier signals are developed by an oscillator circuit in the receiver. An automatic frequency and phase control system keeps the local subcarrier oscillator operating at the correct frequency and at the correct phase with respect to the reference phase signal sent out by the transmitter.

Figure 3-37 shows the basic block diagram of the color synchronization system, known as the automatic frequency and phase control system (AFPC). Basically, the AFPC system operates like the horizontal

AFPC system, which controls the frequency of the horizontal-deflection oscillator in the receiver. A sample of the 3.58-mc signal developed by the oscillator is fed back to a phase discriminator. Here, the locally generated signal is compared with the separated burst signal. An error in phase causes the discriminator to produce a d-c correction voltage whose polarity is determined by the direction of error, and whose amplitude is determined by the amount of phase error.

The d-c correction voltage produced by the discriminator is applied to a reactance-tube circuit. Here, the d-c correction voltage effectively changes the reactance that shunts the frequency-determining network of the oscillator. Oscillator phase then changes in the direction that acts to reduce the correction voltage to zero.

The reference signal for the discriminator is supplied by the burst amplifier. Burst signals are separated from the remainder of the video signal by the burst amplifier. Separation is accomplished by gating or keying the burst amplifier into operation only during the time intervals that the burst signals are being received.

The Subcarrier Oscillator. The source of the 3.58-mc CW signals in the receiver is a precision oscillator. It must supply signals at the correct subcarrier frequency, and with practically zero error in phase. For this reason, the local subcarrier oscillator is a crystal-controlled oscillator. Although the

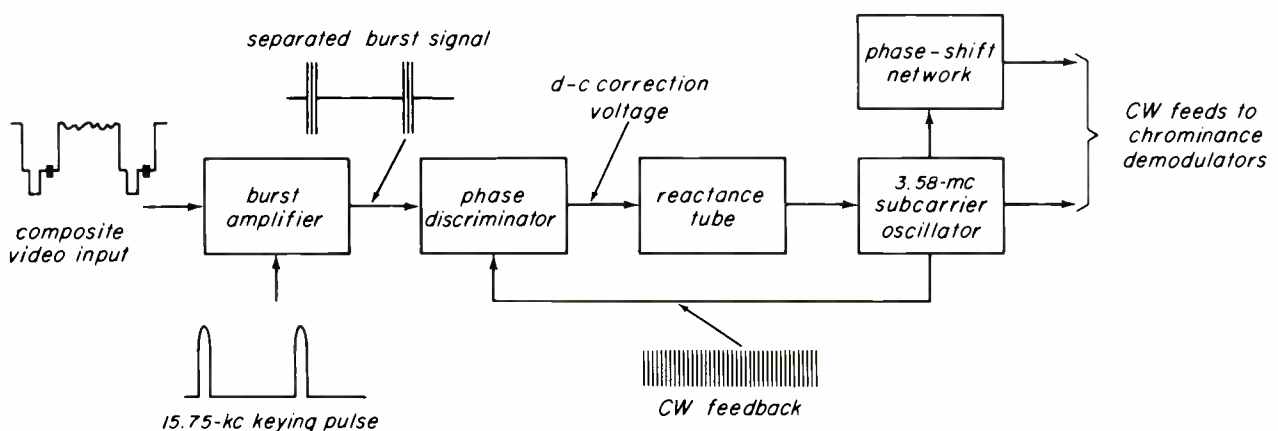

Fig. 3-37. Basic block diagram of the AFPC system for automatic control of phase and frequency of the local subcarrier oscillator.

crystal maintains extremely good frequency stability, it is possible to tune the oscillator over a narrow range of frequencies by placing a variable reactance in shunt with the oscillator. It is useful to think of the crystal as a very high- Q tank circuit.

The CW feed to one of the demodulators is usually obtained directly from the oscillator circuit, as shown in Fig. 3-37. This means that the oscillator must operate in phase (or 180° out of phase) with one of the selected axes of demodulation. In many cases the axis of demodulation does not have the same phase reference as the burst signal. For example, when the demodulation axes are the I and Q or the X and Z axes, the oscillator does not operate in phase with the $-(B-Y)$ burst signal. This means that there is usually some fixed phase difference between the burst signal and the local oscillator signal. In practice, the correct oscillator phase is set up by looking at the reproduced colors. When they are correct the oscillator is operating at the correct phase. The AFPC system acts to maintain the fixed phase delay that is set up between oscillator phase and burst phase when color adjustments are made.

The feed to the remaining chrominance demodulator is applied to a phase shifting network to establish the phase difference between the two demodulation axes.

The Reactance Tube. The reactance tube and its load circuit are effectively in parallel

with the frequency determining components of the oscillator. Refer to Fig. 3-38. The tube functions as a variable reactance whose value is determined by the d-c bias applied to the grid. One form of reactance tube functions in the following way: Capacitor C_p is a small capacitance and R_g is a very low-value resistor. Since C_p is so small, the effect of C_p and R_g across the tank circuit is negligible. Capacitors C_c and C_d are large capacitors and have a negligible impedance at 3.58 mc. Thus, the tube is effectively in shunt with the oscillator tank circuit, and the bottom of the grid resistor is at a-c ground potential. The function of C_p and R_g is to introduce the oscillator signal into the grid circuit of the reactance tube. Since the impedance of C_p is large compared to the resistance of R_g , the circuit is predominantly capacitive, and current leads the oscillator voltage by about 90° . The voltage drop across R_g is in phase with this current, and therefore the grid voltage also leads the oscillator voltage by 90° . Since plate current is in phase with grid voltage, the tube supplies a current that leads the oscillator tank voltage by 90° . In other words, the tube acts like a capacitance. If the gain of the tube increases, more capacitive current flows, and the tube produces the same effect as a larger capacitance. Conversely, a reduction in tube gain has the effect of reducing the capacitance across the tank circuit. In this way it is possible, by controlling grid bias, to tune the oscillator.

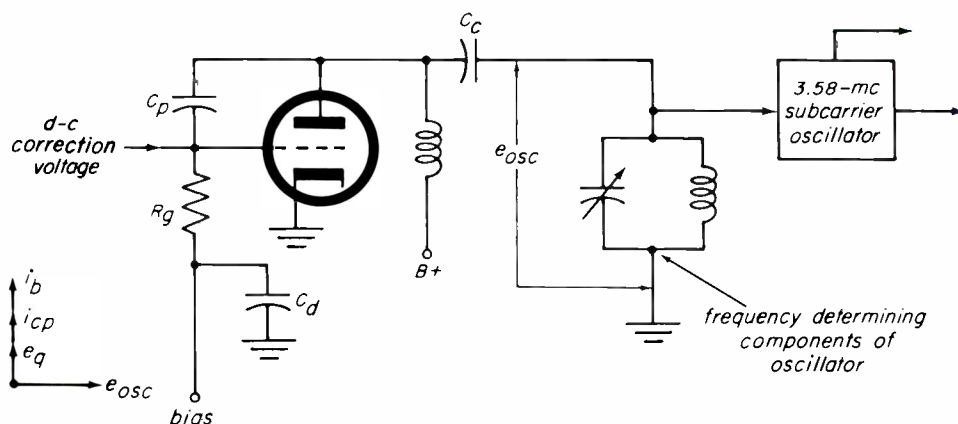

Fig. 3-38. Simplified diagram of a reactance-tube circuit.

The Phase Discriminator. A simplified schematic diagram of a phase discriminator appears in Fig. 3-39. The burst signal is coupled into the circuit by means of a center-tapped transformer. The secondary winding, therefore, feeds equal and opposite polarity burst signals to each diode. At the same time, a 3.58-mc CW signal from the subcarrier oscillator is fed to both diodes. Thus, the net voltage applied to each diode is the sum of the burst voltage and the 3.58-mc oscillator voltage. Referring to the vector diagram of Fig. 3-40a, it can be seen that only when the burst signal and the oscillator signal are 90° apart (in quadrature) will the total voltage across each diode be equal. If the oscillator signal should shift phase in either direction, it will approach an in-phase condition with the burst signal applied to one of the diodes. This unbalances the voltage drop across the diodes, and one of the diodes will conduct more heavily. Thus, the rest condition (when no correction voltage is produced) occurs when the applied burst signals and the subcarrier oscillator signal are 90° apart in phase.

The diodes are rectifiers that conduct when the instantaneous sum of burst and CW signals causes their plates to become positive with respect to their cathodes. Diode V_1 conducts, charging C_1 . At the end of each conduction interval, C_1 discharges

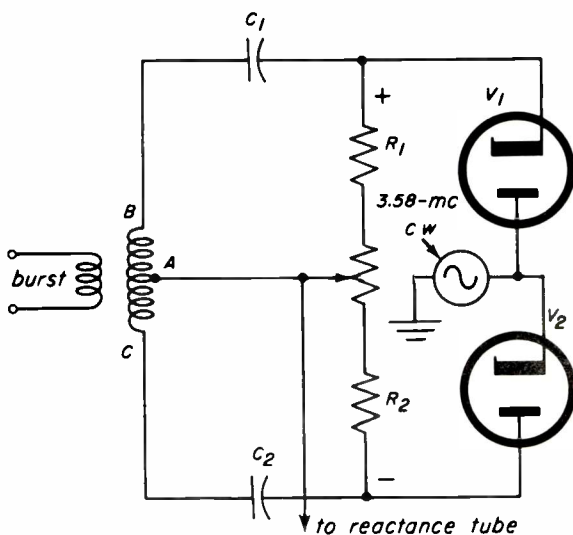

Fig. 3-39. Simplified diagram of a phase discriminator circuit.

slowly through R_1 , causing a voltage drop with polarity as indicated on the diagram. Similarly, the conduction of V_2 causes a d-c voltage drop to appear across R_2 as shown. When the total a-c drives to both diodes are equal, both diodes conduct equally, and the d-c voltage drop across R_1 equals the d-c voltage drop across R_2 . The output voltage, which is the sum of the voltages developed across R_1 and R_2 , is zero.

Now consider the operation of the phase discriminator if the oscillator should shift in phase. Look at b of Fig. 3-40. In this case, the oscillator signal is shown shifted away from the quadrature condition with the burst signal. The oscillator signal is closer, in phase, to the phase of the burst signal applied to V_1 . Therefore, the total a-c voltage across V_1 becomes greater. The voltage applied to V_2 decreases. As a result, the d-c voltages across R_1 and R_2 are no longer equal, and a net negative voltage appears at the output terminal. The diodes are connected in such a way that the polarity of the correction voltage shifts the oscillator phase back towards the quadrature condition shown in Fig. 3-40a.

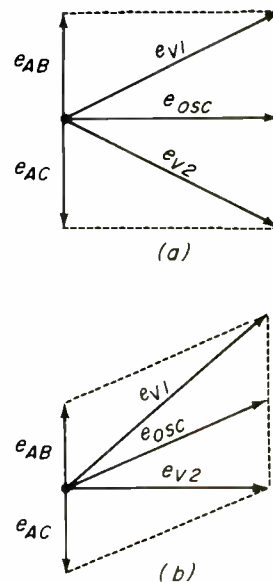

Fig. 3-40. Vector diagrams show the a-c voltages across the diodes of the phase discriminator for the quadrature phase and phase error conditions.

Burst Amplifier. Reference burst signals are separated from the composite video signal in this amplifier, and are amplified to the level required by the phase discriminator. The amplifier is similar in many ways to a narrow-band i-f amplifier designed to operate at 3.58 mc. Single-tuned coupling circuits are employed to maintain a narrow bandwidth. The burst signals are separated from the composite video amplifier by the burst amplifier being keyed into operation during the times that the burst signals occur in the composite signal. The amplifier is held cut off for the remainder of the time.

Figure 3-41 shows a simplified schematic diagram of a burst amplifier (also called a burst keyer). This particular amplifier uses a triode in a grounded-grid arrangement. Composite video signals are applied to the cathode from a low-impedance source. (In the receiver that uses this circuit, the burst signals are obtained from the output circuit of the bandpass amplifier. Thus, the Y component of the video signal is absent, and 3.58-mc information predominates.) A 470- $\mu\mu\text{f}$ capacitor in the grid circuit of the burst amplifier places the grid at ground potential for 3.58-mc signals. Since the grid is effectively grounded, it acts like a shield between cathode and plate, and the triode amplifier requires no neutralization.

Keying pulses are applied to the grid of the tube. A positive pulse, whose leading

edge is timed to be coincident with the leading edge of the horizontal sync pulse, is obtained from a winding on the horizontal-output transformer. The pulse is coupled through the RC network, as shown, and drives the tube into conduction. Grid current is drawn on the peaks of the keying pulses, charging the coupling capacitor C_c . Between keying pulses, C_c discharges through R_g , developing a large bias for the stage. Due to the large time constant of the R_g-C_c network, the capacitor loses very little charge between successive pulses. Thus, the bias remains high, and the tube comes into conduction only during the peaks of the applied keying pulse. The keying pulse is somewhat rounded so that the peaks of the signal are delayed with respect to the leading edges. Hence, the peaks arrive somewhat later than the horizontal sync pulses and are coincident with the burst pulses.

Hue or Tint Controls. One of the viewers' controls on a color receiver is labelled *hue* or *tint*. This control is located in the color synchronization circuit. Its function is to shift the phase of the 3.58-mc oscillator in the receiver so that the demodulation axes occur at the proper phase angles. This can be accomplished by controlling the phase of the CW feed to the phase discriminator. Hue control can also be obtained by controlling the phase of the separated burst signal in the burst amplifier. Refer to Fig. 3-42a. In this case, the plate tank coil of the burst

20

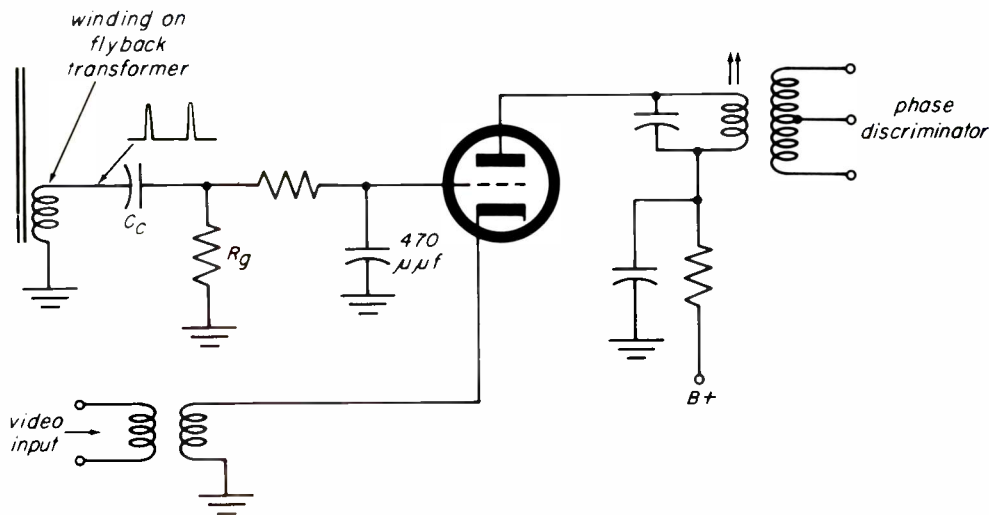

Fig. 3-41. A burst keyer stage. Keying pulses are applied to the grid, which is effectively grounded for the high-frequency burst signals.

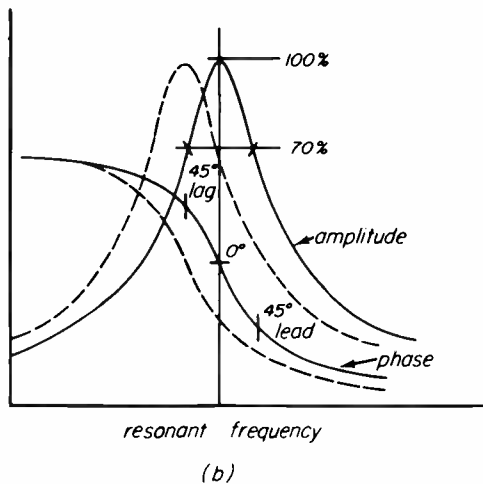
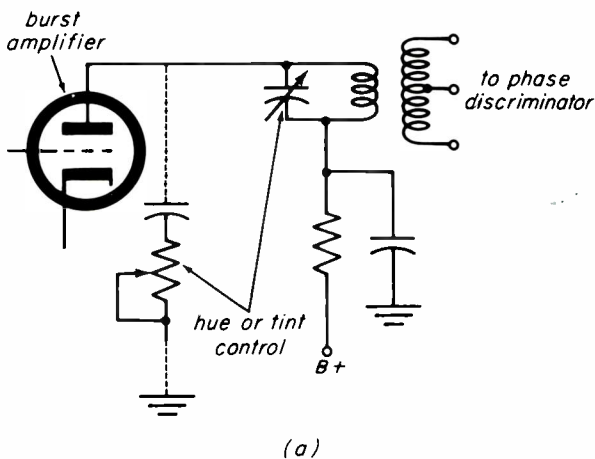

Fig. 3-42. (a) Possible hue or tint controls in the burst amplifier; (b) a graph of phase and amplitude response as the burst amplifier is tuned through the subcarrier frequency.

amplifier is tunable. If the plate tank is tuned to 3.58-mc, the phase shift in the amplifier is zero (or 180°). The phase of the burst signal may be advanced or retarded by resonating the plate tank on either side of 3.58 mc. Figure 3-42b shows the selectivity curve and phase characteristics of a parallel-tuned circuit, such as is found in the plate circuit of the burst amplifier. Tuning may be accomplished by a variable capacitor in shunt with the plate tank, or by means of a variable resistor in series with the tuning capacitance.

To properly adjust the hue control, the viewer looks at the end product — the picture. He sets this control for proper flesh tones (neither too yellowish nor too pink). When

proper flesh tones are obtained, the demodulation axes are proper, and the phase shift between the 3.58-mc oscillator and the transmitted burst signal is approximately correct. With color test equipment, the phase of the 3.58-mc oscillator may be adjusted precisely, as will be shown in later lessons.

3-5. COLOR KILLER

The job of the color killer is to shut down the chrominance section of the receiver during monochrome telecasts. If the chrominance sections are permitted to operate, the energy in the video signal near 3.58 mc is processed by the chrominance circuits. The result is extraneous color signals, which show up as rainbows and colored patches in the black-and-white picture. Color is usually seen in the garments (especially neckties) and hair of performers, wherever groups of fine vertical or near-vertical lines represent video information near 3.6 mc. No definite color is produced because there is no coherent relationship between this 3.6-mc information and the 3.58-mc oscillator. (However, the color produced is often predominantly magenta.) This production of color in the monochrome picture is particularly troublesome when weak, snowy pictures are received. There is a good deal of energy in random noise signals, in the 3.6-mc region. These noise signals are demodulated in the chrominance section, and appear as colored snow (sometimes called confetti) on the screen. Since the bandwidth of the chrominance sections is quite narrow, the colored snow appears as longer dashes than black-and-white snow.

The color killer produces a bias voltage that cuts off the bandpass amplifier during monochrome telecasts; it removes this bias when color telecasts are received. To do this job, the killer circuit must be able to sense the presence or absence of color signals.

The presence of separated burst signals in the AFPC section of the receiver provides the necessary indication that color telecasts are being received. Refer to Fig. 3-39. It was shown earlier that the output voltage applied to the reactance tube is zero when

the 3.58-mc oscillator is operating at the proper phase and frequency. This is so because the voltages developed across R_1 and R_2 are equal but opposite in polarity. However, the voltage developed across either load resistor is maximum when burst signals are received. When burst is absent, the d-c voltage developed across either resistor falls to the value determined by the amplitude of the 3.58-mc oscillator signal alone. Many early killer circuits use the voltage developed across one of the load resistors of the phase discriminator. An example appears in Fig. 3-43. In this system, negative pulses from the horizontal-deflection circuits are applied to the grid of the killer stage. When no burst signals are received, the negative grid bias (developed by the phase discriminator) is low, and the killer stage amplifies the pulses. Positive pulses at the plate of the color killer are applied to

the grid return of the bandpass amplifier. These positive pulses cause grid current to be drawn in the bandpass amplifier tube. The time constant of the coupling circuit is quite long, so that the grid-leak bias developed holds the bandpass amplifier cut off between pulses. When color telecasts are received, the presence of burst signals in the phase discriminator causes a large negative bias to be developed at the grid of the color killer. With the killer cut off, positive pulses are no longer coupled to the bandpass amplifier, and the source of grid leak bias is removed.

Noise-Immune Killer. Early killer circuits do not work well when very weak signals are received. In such cases, large pulses of noise signals are passed by the burst amplifier, and the noise signal itself may cause the killer circuit to be biased to cutoff.

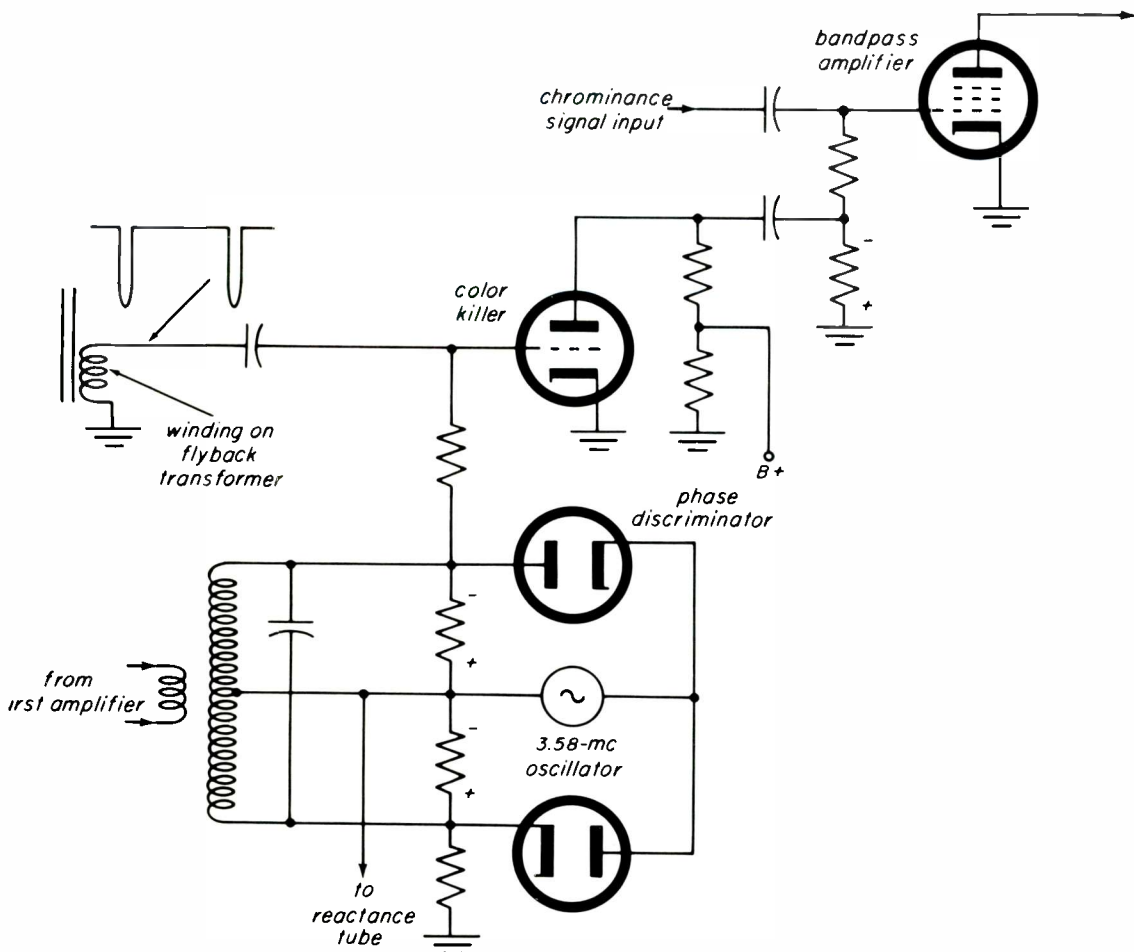

Fig. 3-43. A simplified diagram of the color killer system.

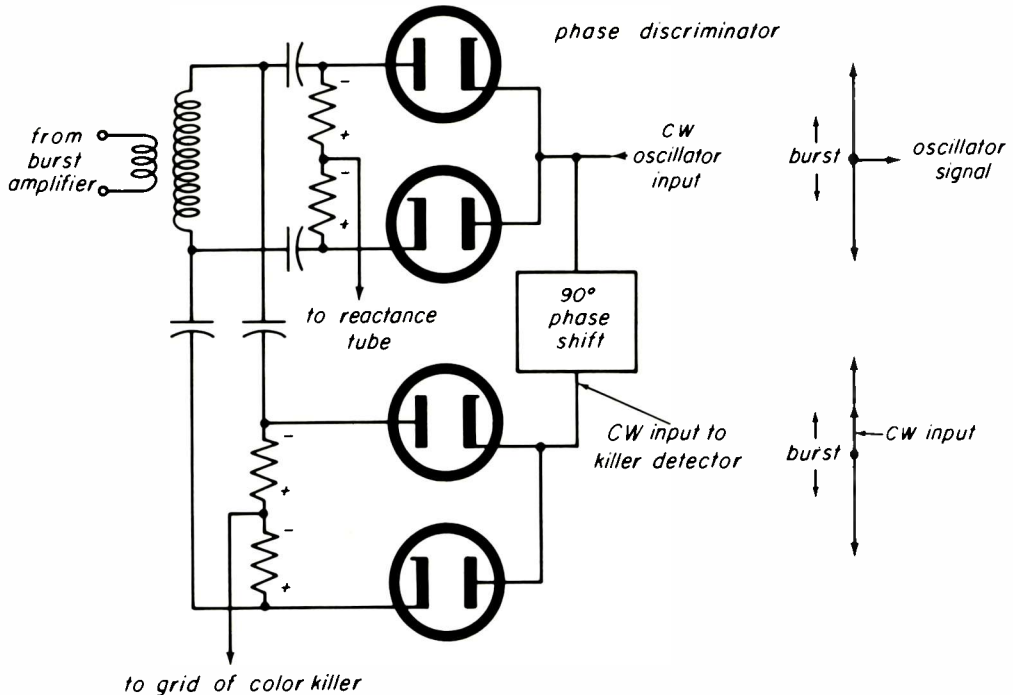

Fig. 3-44. A newer color killer system using a separate killer detector. This system works well when very weak signals are received.

Modern killer circuits are designed to discriminate between noise and burst signals. Figure 3-44 shows the system employed in late-model RCA receivers. A separate *killer detector* circuit is employed to provide bias for the color killer. This killer detector is just like the phase discriminator in the AFPC system, except that the phase of the CW input is shifted approximately 90° from that of the 3.58-mc oscillator. Thus, when the oscillator is operating at the proper frequency and phase, the signals applied to the killer detector have the phase relations shown in the lower vector diagram of Fig. 3-44. Since the burst signal applied to one of the diodes is *in phase* with the CW signal, maximum bias is developed at the output. When the oscillator is not operating at the proper frequency and phase, the voltages developed across the two load resistors are equal and the killer-detector output is zero. Thus, the killer detector not only detects the presence of burst, but also determines whether or not the AFPC system is operating correctly. Since the AFPC system cannot operate correctly when only noise signals are passed by the burst amplifier, the killer system ignores the effects of noise on weak signals.

Blanking. It is important that burst signals be prevented from reaching the inputs to the chrominance demodulators. If burst signals are permitted to get to the grids of the demodulators, the demodulators will produce color "burst" signals at their outputs. The amplitudes of these signals are determined by the phase of the CW signals applied to the demodulators. These demodulated burst signals result in color that appears on the screen during horizontal retrace. In late-model receivers, the presence of demodulated burst signals upsets the operation of the keyed d-c restorers. Recall that the adders are "keyed" during the flyback interval, when burst signals are being received. To prevent the effects of demodulated burst signals, the bandpass amplifier is cut off during the horizontal blanking interval. This is accomplished by a blanking pulse obtained from the horizontal deflection circuit. (In the circuit shown in Fig. 3-43, blanking pulses are applied to a second bandpass amplifier.) In many receivers an additional *blanker* stage is added to the receiver to supply some of the circuits that use horizontal pulses. The blanker acts as a buffer stage to prevent excessive loading of the horizontal deflection circuits.

APPENDIX

1. DEVELOPMENT OF X AND Z DEMODULATION AXES

The following is a derivation of the phase angles of the demodulation axes employed in a particular model RCA receiver.

In these receivers the luminance signal is fed unequally to the three cathodes of the kinescope to compensate for differences in phosphor efficiencies. The luminance signal is applied to the cathodes in the following ratios: 1.25 for the red cathode, 1.0 for the green cathode, and 0.75 for the blue cathode. The peak-to-peak amplitudes of the luminance signal are approximately 125 volts at the red cathode, 100 volts at the green cathode, and 75 volts at the blue cathode.

The color-difference signals must be corrected correspondingly, so it is necessary to apply $+1.25 (R-Y)$ to the red grid, $+1.0 (G-Y)$ to the green grid, and $+0.75 (B-Y)$ to the blue grid. Refer to Fig. 1.

All three of the matrix amplifiers have equal gain, so the ratio of input-signal

amplitudes should be the same as the ratio of the output-signal amplitudes, but of opposite polarity because of the phase inversion in the amplifiers. The ratio of grid-cathode signals therefore should be -1.25 for $R-Y$, -0.75 for $B-Y$, and $+1.0$ for $G-Y$ across the cathode resistor.

"X" therefore must equal $-1.25(R-Y) + (G-Y)$

Substituting $-0.51 (R-Y)$ and $-0.19 (B-Y)$ for $(G-Y)$

$$"X" = -1.25 (R-Y) + [-0.51(R-Y) - 0.19 (B-Y)]$$

$$"X" = -1.76 (R-Y) - 0.19 (B-Y)$$

The transmitted signal is composed of $0.493 (B-Y)$ and $0.877 (R-Y)$. These reductions are required to prevent chrominance over-shoots in the composite signal. The above formula for "X" must be multiplied by the reciprocal of these reductions. Therefore:

$$"X" = -1.76(R-Y) \frac{1}{0.877} - 0.19(B-Y) \frac{1}{0.493}$$

$$"X" = -2.01 (R-Y) - 0.386 (B-Y)$$

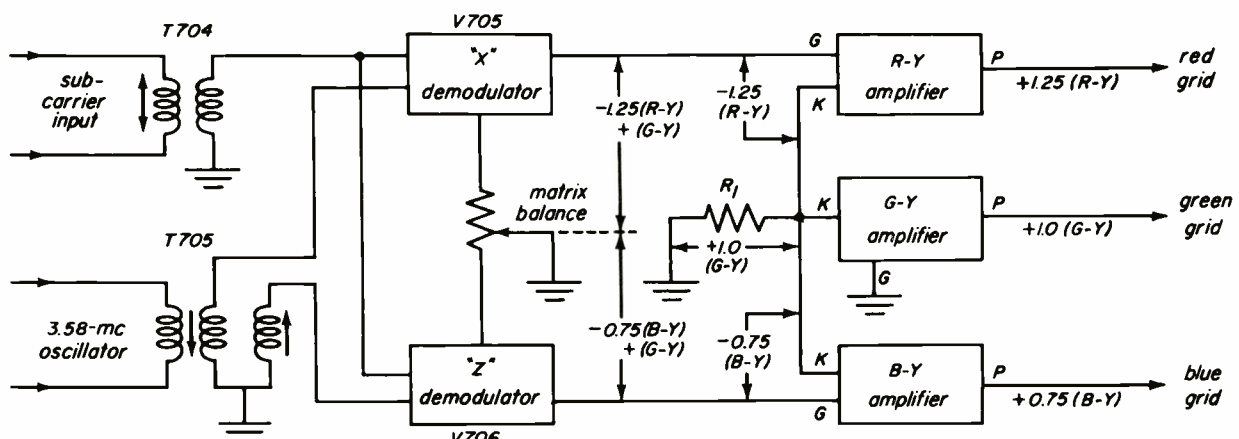

Fig. 1

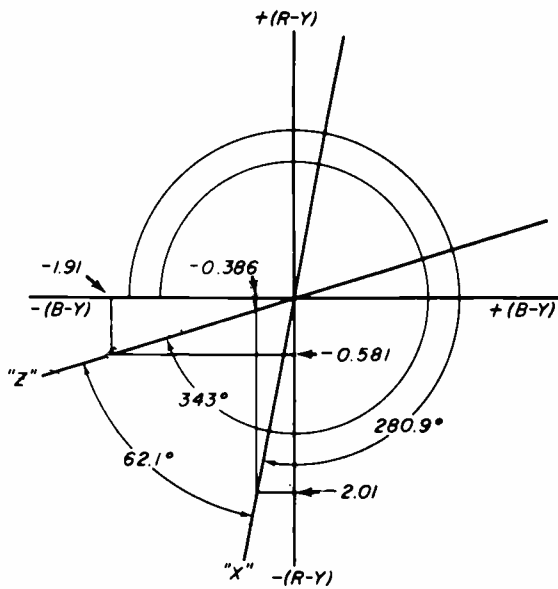

Fig. 2

From Fig. 2 it can be seen that the phase angle of "X" clockwise from burst is 280.9°.

The phase angle of "Z" is similarly calculated:

$$"Z" = -0.75 (B-Y) + (G-Y)$$

$$"Z" = -0.75 (B-Y) + [-0.51(R-Y) - 0.19 (B-Y)]$$

$$"Z" = -0.94 (B-Y) - 0.51 (R-Y)$$

$$"Z" = -0.94 (B-Y) \frac{1}{0.493}$$

$$-0.51 (R-Y) \frac{1}{0.877}$$

$$"Z" = -1.91 (B-Y) - 0.581 (R-Y)$$

From Fig. 2 it can be seen that the phase angle of "Z" clockwise from burst is 343°. It can also be seen that the "X" and "Z" axes are separated by 62.1° in phase.



COLOR TELEVISION COURSE

SETUP AND ADJUSTMENTS

1. **General Setup and Adjustment Considerations**
2. **Comparison of Adjustments Required on a Black-and-White Set and a Color Set**
3. **Test Equipment Requirements**
4. **Setup Sequence**
5. **Purity**
6. **Convergence**
7. **Black-and-White Tracking**
8. **Phase and Matrix**



RCA INSTITUTES, INC.

A SERVICE OF RADIO CORPORATION OF AMERICA

HOME STUDY SCHOOL

350 West 4th Street, New York, N.Y. 10014

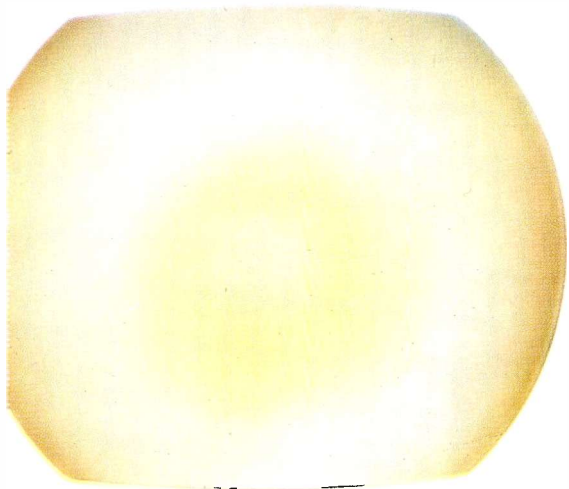

Plate 1. An example of poor purity.

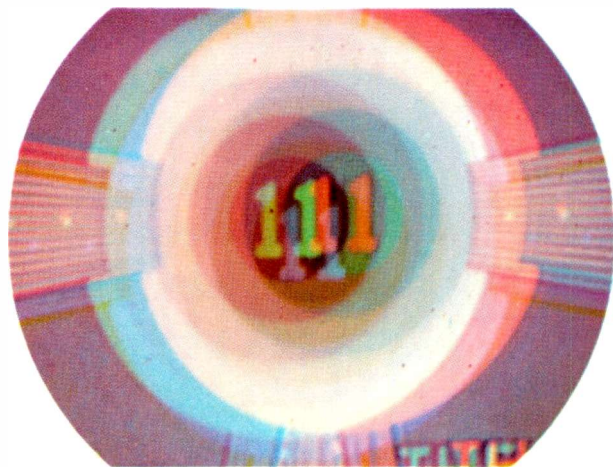

Plate 2. An example of poor convergence. This case is somewhat exaggerated. To produce this condition, the static convergence magnets were pushed all the way in towards the picture tube.

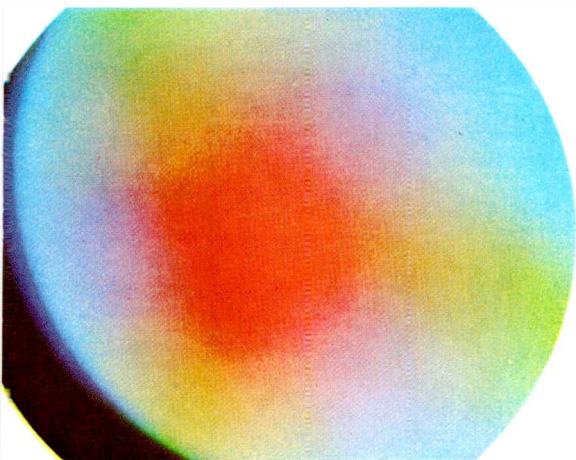

Plate 3. The purity magnet is adjusted to center the red area when the yoke is pulled all the way back towards the socket of the picture tube.



Plate 4. Appearance of the transmitted color stripe.

INTRODUCTION

Since the introduction of color television several years ago, a steady progression of new color sets has been developed and released yearly to the public. Each one of these has incorporated improvements in circuitry and design. The color receivers being produced today incorporate all of these improvements. In no single section of the receiver have these advancements been more dramatic than in those areas related to the setup and adjustment of the receiver.

Setting up the original 15-inch color set involved a continuous series of adjustments and readjustments. In contrast, recent receivers can be set up by following a relatively simple and clean-cut procedure. Setting up and adjusting today's receiver takes only a fraction of the time that was previously required, and the final results obtained are superior to those of the past.

While the circuitry has been improved and the setup and adjustments simplified, one basic factor remains unchanged. To make even the simple adjustments required on today's set, a technician must have a full understanding of the setup procedures involved. This lesson will therefore cover all steps involved in setting up and adjusting the current color receiver. In addition, a portion of the lesson will be devoted to a review of the setup procedures used on earlier models.

As each step of the procedure is discussed, the lesson will first explain why the step is required. The action of the circuit or components used in the step will then be reviewed. Finally, the procedure to be used in properly adjusting the particular section of the receiver will be presented. In this manner, the lesson will give the student an understanding of how to adjust a color set, plus an insight into the theory of what he is doing.

4-1. GENERAL SETUP AND ADJUSTMENT CONSIDERATIONS

When Does a Color Set Need to Be Set Up or Adjusted? If you have been led to believe

that a color set is an unstable device constantly in need of readjustment, you have been misinformed. The fact of the matter is that a color set will normally require setup or adjustment only as a result of one of the following four conditions.

1. *On Installation:* A new receiver will require some setup and adjustment.
2. *When the Set Is Relocated:* When a receiver is moved to a new location, a re-adjustment will be required.
3. *Aging:* When the operating characteristics of different receiver components change as a result of the normal aging process, a compensating adjustment may be necessary.
4. *Kinescope Replacement:* Changing a picture tube is the remaining occasion when the color receiver will have to be set up and adjusted.

How Extensive Are the Adjustments Required in Each of These Cases?

1. The initial setup of today's receiver has been simplified by the combination of improved design, and careful attention to the final setup each receiver is given at the end of the production line. It is not unusual, for example, to unpack a receiver and produce a good quality picture after only degaussing and making center convergence adjustments.
2. Modern receivers usually require only a degaussing and minor center convergence adjustments after they have been moved to a new location.
3. The amount of readjustment required as a result of aging has been greatly reduced. The readjustments that are still required to correct the effects of aging are usually of a minor nature.
4. A picture tube replacement is the one instance where a complete setup and adjustment of the set is always required.

4.2. COMPARISON OF ADJUSTMENTS REQUIRED ON A BLACK-AND-WHITE SET AND A COLOR SET

A number of the adjustments made when setting up a black-and-white set are also made when setting up a color receiver. For example, height, width, focus, vertical linearity, and AGC are all adjustments that are common to both types of receivers. These adjustments are made on a color set in much the same way that they are made on a black-and-white receiver. There are two exceptions to this rule; they will be discussed in detail later in the lesson.

In addition to the standard adjustments listed above, there are a number of different adjustments that are found only in color receivers. These can be broken down into four main categories:

1. Purity
2. Convergence
3. Black-and-white tracking (Color Balance)
4. Color phase and matrix

Identifying the Different Color Misadjustments. While purity, convergence, and black-and-white tracking are commonly referred to as color adjustments, they are adjustments that are made to obtain a good quality black-and-white picture on the color receiver. In making these adjustments, the student must first learn to distinguish the particular irregularity that is introduced in the picture when each of the three is misadjusted.

Purity Misadjustment. A purity problem is indicated by a raster which is not uniform in color over the entire face of the picture tube. Plate 1 illustrates one type of purity problem. The areas of impurity in this case lie in the center and at the sides of the raster. Purity errors can, however, occur at any point on the face of the tube. While a blank raster provides the best means of evaluating purity, the same nonuniformity would be apparent with a picture added to the raster. The purity errors shown in Plate

1 are primarily yellow; however, purity misadjustments can appear as any primary or complementary color. Good purity exists when the raster is uniform in color over the entire face of the tube.

Convergence Misadjustment. Misconvergence can be identified by the presence of color fringing around the edges of the video information of a scene. Plate 2 illustrates an extreme case of misconvergence. In this instance, the separate pictures produced by each of the three electron guns can be individually identified. When these three pictures are made to overlap each other perfectly, and a black-and-white picture free of color fringing is produced, the picture is properly converged. In Plate 2 all three colors are misconverged. However, it is possible to have a misconvergence condition where the pictures produced by two of the electron beams converge properly and only the third beam fails to converge. In this situation, a picture whose color is the complementary sum of the two converged beams will be produced. For example, where green and red beams are converged, a yellow picture is produced. Fringing the picture formed by the converged beams will be the picture produced by the third electron beam (blue in this example).

Just as in the case of purity, convergence misadjustments can occur at any point on the screen. In addition, different combinations of convergence errors can occur simultaneously at different points on the picture tube. For example, it is possible to have a slight red fringing at the center of the screen, at the same time that there is pronounced green fringing in one corner of the screen. Purity errors can be seen whether video information is present or not, as in the blank raster of Plate 1. A convergence error, however, can be seen only when some detail of the video signal falls in the area where misconvergence exists.

Black-and-White Tracking Misadjustment. A black-and-white tracking error exists when the over-all black-and-white picture has a predominant tint and is not a true black-and-white picture. The predominant tint may be any one of the primary colors or any complementary combination of these.

Occasionally, a technician with little color TV experience may have some difficulty in distinguishing between a black-and-white tracking problem and a purity problem. If the tinted area is irregular in shape and occupies only a portion of the screen, it is a purity problem. On the other hand, if the entire screen is uniformly tinted, a tracking adjustment is required.

4.3. TEST EQUIPMENT REQUIREMENTS

Having learned to identify the different misadjustments which are found in a color set, the next consideration is the test equipment that is required to correct these errors.

Degaussing Coil. When setting up purity, the path of travel of the three electron beams is adjusted to obtain a condition where each beam strikes only its respective phosphor dot. Any magnetic fields present on the metal elements of the kinescope will tend to bend these beams from their normal path and cause them to strike incorrect dots. To avoid this, one of the early steps in the purity procedure calls for the kinescope to be demagnetized.

A degaussing coil (see Fig. 4-1) is used for this purpose. The degaussing coil consists of many turns of wire, the two ends of which are terminated in a standard a-c plug. When connected to a 120-volt outlet, an a-c current flows in the coil. This constantly

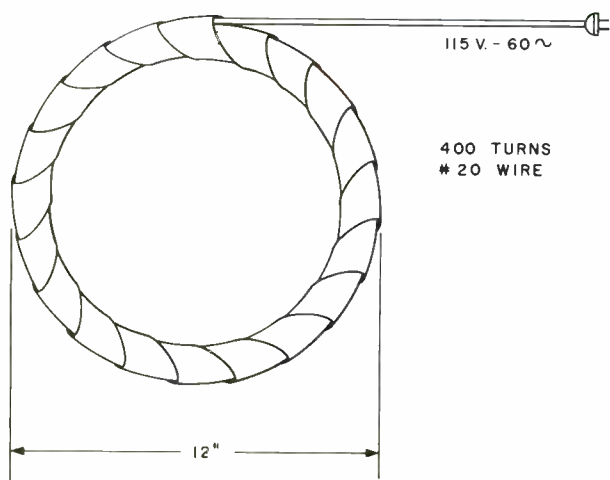

Fig. 4-1. Degaussing Coil.

reversing current creates a regularly expanding and contracting magnetic field around the coil. When a varying field of this nature is placed adjacent to a magnetized object, it tends to reorient the field found on the object. By gradually reducing the strength of the field the original magnetism is neutralized. Degaussing coils are available through your local parts distributors or may be constructed to the specifications given in Fig. 4-1.

Microscope. An additional piece of equipment used when adjusting purity is the microscope. See Fig. 4-2. By greatly enlarging a small area of the screen, the microscope shows the actual landing point of each of the electron beams. This establishes the direction and amount that the electron beams must be moved, to get each beam landing directly on the center of its respective dot.

The degaussing coil is an *essential* piece of test equipment. The microscope, on the other hand, can be classified as an optional item, since good purity can be obtained without it in most cases.

Crosshatch/Dot Generator. From our previous discussion, you will recall that convergence errors can be seen only when detailed video information is present in the misconverged area. Therefore, to adjust convergence, a stationary picture which provides video detail over the entire screen is required. The signals received from a TV station are unsuitable for this purpose since this type of video material is constantly moving. In addition, there are often areas in a televised screen in which no detail appears.



Fig. 4-2. Microscope used to check beam landing on the phosphor dots.

The signals required for adjusting convergence are normally obtained from a dot/crosshatch generator. The two common patterns produced by this type of generator are illustrated in Fig. 4-3 and Fig. 4-4. The RCA WR-64A, shown in Fig. 4-5, is a good example of the current trend in dot/crosshatch generator design. This unit is particularly versatile in that it provides a color-bar presentation in addition to the dot and crosshatch patterns.

How It Works. To provide a stable crosshatch pattern such as that shown in Fig. 4-4, four separate signals must be produced by the generator.

Signal	Function
900 cps	Produces the horizontal bars of the crosshatch pattern.
189 kc	Produces the vertical bars of the crosshatch pattern.
15,750 cps	Locks the pattern in sync horizontally.
60 cps	Locks the pattern in sync vertically.

The WR-64A derives all four of these signals from a master 189-kc oscillator. The four signals are combined in a mixer stage to produce a composite video signal. An r-f oscillator, adjusted to operate on the video-carrier frequency of Channel 3, is modulated by the composite video signal. Another 4.5-mc oscillator beats with the

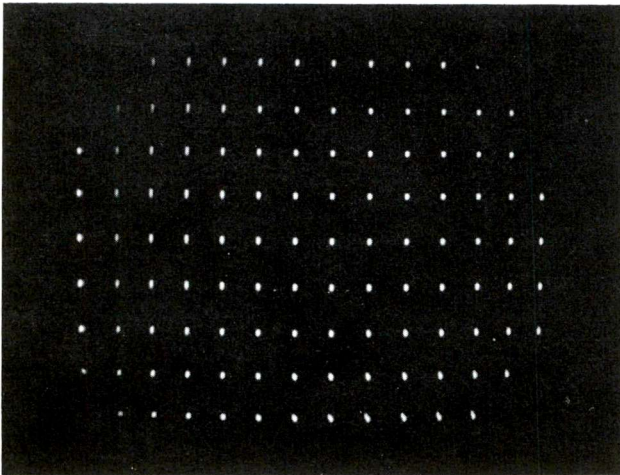

Fig. 4-3. Dot pattern used for convergence adjustments.

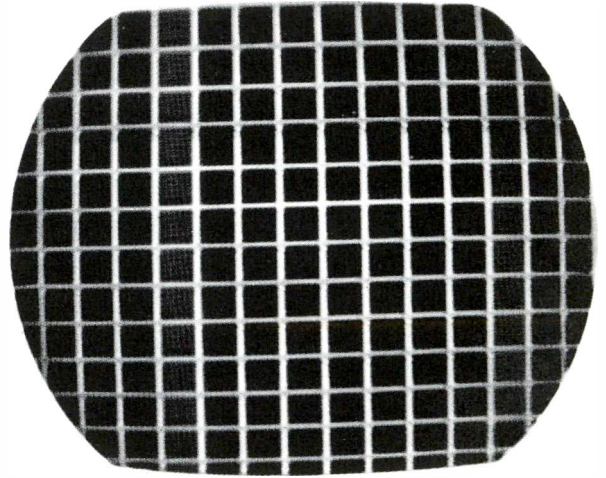

Fig. 4-4. Crosshatch pattern used for convergence adjustments.

Channel 3 oscillator to produce a sound-carrier signal. The latter is used in adjusting fine tuning in the receiver. Thus, the WR-64A is a miniature transmitter. It provides a video carrier signal that carries the full information needed by the receiver to produce the dot or crosshatch pattern. No external sync signals are needed. The only connections required are those between the r-f output jack on the generator and the antenna terminals of the receiver. A full description of the operation of the WR-64A appears in a later lesson.



Fig. 4-5. The WR-64B color-bar dot/crosshatch generator. This late model incorporates a built-in grid shunt switch and an improved sound-carrier signal.

Operating the Generator. To use the WR-64A, the output cable is connected directly to the antenna terminals of the receiver. The channel selector on the receiver should be set to Channel 3. (The WR-64A is shipped pretuned to Channel 3.) Select the desired pattern on the generator's function switch and the unit is ready for operation.

When using the generator in areas where there is a station on Channel 3, the antenna lead-in must be disconnected from the set, or the output of the generator must be shifted to Channel 4. Failure to comply with one of these last steps will produce an unstable pattern which will tear and roll. This lack of stability is the result of the receiver's deflection oscillators trying to lock up on two separate sets of vertical and horizontal sync pulses. One set of pulses are those produced by the generator and the other are those produced by the TV station on Channel 3. While these two pairs of sync pulses are close in frequency, they are not identical and the slight difference produces the rolling pattern.

Other Models. Earlier dot/crosshatch models used two separate oscillators to produce the vertical and horizontal bars. The output of each oscillator was shaped and fed to a mixer, as in the WR-64A. In many of these early units, the output of the mixer could be fed to either an r-f modulator or a video amplifier. These units could therefore provide either an r-f or video output signal. When used in the video position, the generator's output cable should be connected to the common cathode of the color picture tube. If additional video gain is needed (pattern does not override the video signal from the station), the cable may be connected through a socket adaptor to the control grid of the second video amplifier in the receiver.

Since no sync pulses are developed in this type of generator, an external sync signal must be fed to the generator to lock up the two bar oscillators. The required sync signals are obtained from the color receiver. The set is tuned to an active channel and the hold controls (vertical and horizontal) are adjusted to obtain a synchronized picture. A separate lead is then run from the horizontal and vertical output stages in the

receiver to the inputs of the two bar oscillators in the generator. The pulses obtained in this manner serve to synchronize the generator pattern.

To Summarize. When using a generator which produces vertical and horizontal sync pulses, the antenna lead-in must be disconnected or the generator must be used on an inactive channel to prevent jitter. When using a generator which does not produce a sync signal, the receiver must be tuned to an active channel. Sync pulses must then be coupled from the two deflection output stages of the receiver to the generator to synchronize the bar oscillators.

Picture Tube Grid Shunt Switch. At different points during the setup procedure, it is desirable to temporarily bias off one or two of the electron guns. The kinescope-grid shunt switch provides a means of doing this without disturbing any of the receiver's screen or background controls, thereby avoiding the need for readjusting these controls. A diagram of the unit is shown in Fig. 4-6. In use, the alligator clips are connected to the individual control grids of the color kinescope. As each switch is closed, a portion of the voltage present on the individual control grid is shunted to ground. The change in control grid voltage is sufficient to drive the individual gun to cutoff. The kinescope-grid shunt switch is also available from your local parts distributor.

Mirror and Stand. Since many adjustments on a color receiver are made from the rear of the receiver, a mirror and stand will prove to be a valuable aid to the technician. Refer to Fig. 4-7.

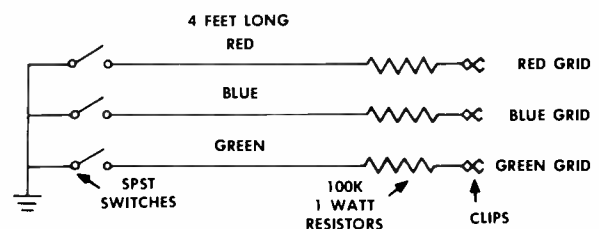

Fig. 4-6. Kinescope-grid shunt switch allows individual fields to be viewed without upsetting setup adjustments.

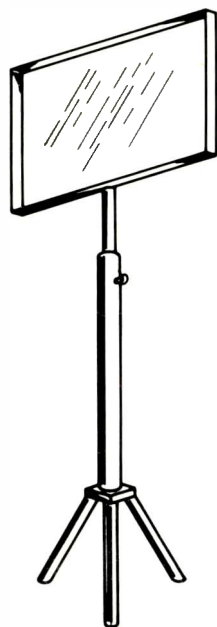

Fig. 4-7. A mirror and stand is useful in making purity and static convergence adjustments.

4.4. SETUP SEQUENCE

The key to successfully setting up and adjusting a color receiver lies in following a definite setup sequence. This is nothing more than a specific series of steps by which each section of the color set is checked and adjusted where necessary. The recommended sequence is listed below:

1. Standard adjustments (height, width, AGC, etc.)
2. Purity
3. Center convergence
4. Vertical dynamic convergence
5. Horizontal dynamic convergence
6. Black-and-white tracking
7. Phase and matrix adjustments

The technician who does not follow a planned setup sequence can ultimately set up a color receiver. However, in haphazardly jumping from one control to another, he will waste valuable time. In addition, experience has shown that he will seldom achieve a top-quality end result.

What Is Normal? Before proceeding with a discussion of the individual steps listed in the setup sequence, let's consider this question of "what is normal?"

There are sections of a color receiver where letter-perfect performance cannot be achieved. For example, a very small amount of misconvergence at the extreme sides of a color receiver can often be considered normal. How, then, can an inexperienced technician establish whether the amount of horizontal misconvergence he finds on a given receiver is normal or requires adjustment? The solution to this problem lies in practical experience. The student must first familiarize himself with the correct setup techniques for each section of the receiver. He should then go through the entire setup procedure on each of the initial sets he comes in contact with. As a result of the experience gained in this manner, he will ultimately learn to distinguish between what is normal and what should be adjusted.

Preliminary Steps. When setting up a color receiver, the set should be facing in the direction it will face in its final operating position. This is important since the earth's magnetic field, like any other external magnetic field, can influence the purity of the picture. The effect of the earth's field, however, can be minimized by degaussing the set.

During the degaussing process, a number of the tiny magnetic elements in the metal elements of the kinescope are aligned with the earth's magnetic field. The combined magnetic field produced by these particles produces a weak local field whose direction is opposite to the earth's field and provides the partial compensation needed to counteract the earth's field. However, rotating the receiver after it has been degaussed changes the relationship between the two fields. As a result, the compensating field is no longer effective and purity may be thrown off. To gain access to the rear controls the set should, therefore, be pulled directly forward from its normal operating position, rather than swiveled around from this position. After the adjustments have been completed, the unit should be moved straight back to its original position. In this manner the change

in the relationship of the two fields is held to a minimum.

Position of the Kinescope Assemblies.

Throughout the setup procedure, adjustments are made on a number of different magnetic assemblies located on the neck of the kinescope. To achieve the desired results from these adjustments, these assemblies must be properly positioned with relation to a series of pole pieces found inside the kinescope. These pole pieces are a part of the three-gun assembly, and serve to concentrate and contain the fields of the individual magnets. See Fig. 4-8. Figures 4-9 and 4-10 illustrate the correct position for each assembly. The student should make it a practice to check the position of these assemblies whenever setting up or adjusting a color receiver.

Standard Adjustments.

Another preliminary consideration is the standard black-and-white adjustments such as vertical height and linearity, width, focus, centering, AGC, etc. It should be noted that there is some degree of interaction between certain of these adjustments and the color adjustments. For example, the vertical and horizontal output stages develop the waveshapes that are used by the dynamic convergence circuits

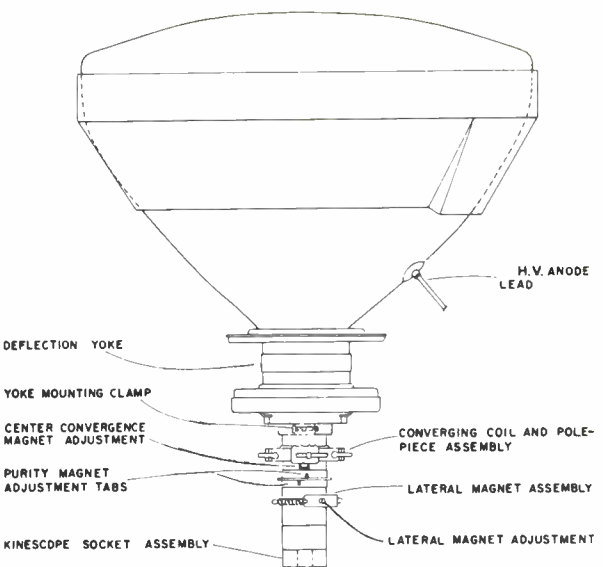

Fig. 4-9. Positions of magnetic assemblies on the color kinescope.

to provide edge convergence. If width or vertical linearity is changed after dynamic convergence has been adjusted, a change in edge convergence will be noted. For this reason, these standard black-and-white adjustments should be made prior to doing convergence or purity adjustments. For the same reason, the width and vertical size controls are adjusted to provide an overscan of one-half inch on all sides of the picture. This overscan makes the occasional changes in drive that occur in the two output stages, and the accompanying change in convergence, less apparent to the viewer.

Color receivers also include a control for adjusting high voltage. Since the correct

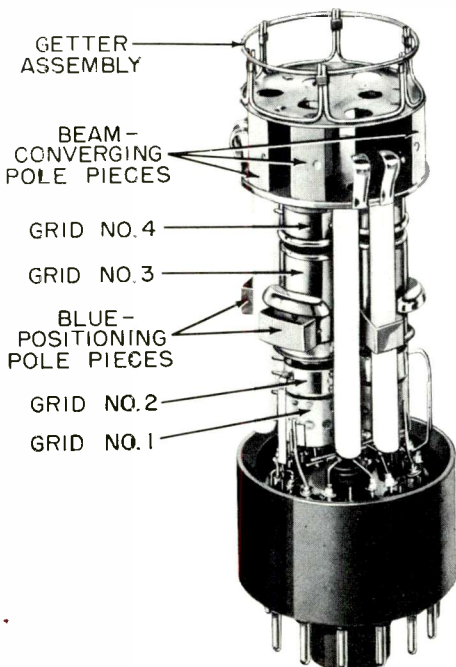

Fig. 4-8. Electron gun assembly.

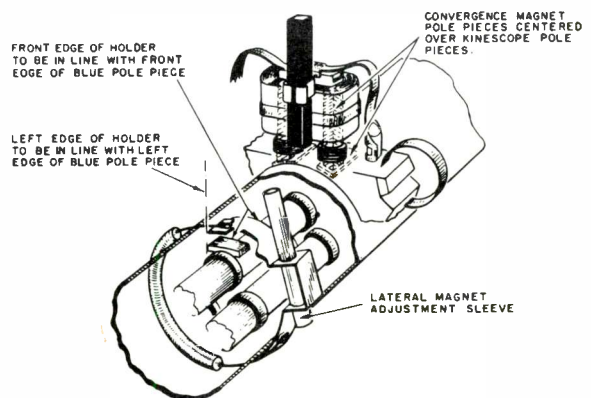

Fig. 4-10. Cutaway view of part of the neck of the picture tube shows the blue lateral magnet and the blue convergence magnet assembly.

high voltage might be different from one model to another, the service data should be checked to determine the correct voltage for the set being adjusted.

The remaining "standard adjustments" are all made in the conventional manner.

4.5. PURITY

The purity adjustments provide a means of compensating for any misalignment that may exist between the position of the three electron beams and the centers of deflection in the fields of the yoke. The student might find it helpful at this point to review the color kinescope construction details given in an earlier lesson. Recall that a photographic process is used to position the primary-color phosphor dots on the screen. The proper positions for the dots associated with each primary color are found by exposing the screen to light passing through the shadow mask. The sources of light are accurately placed at three different positions to locate the red, green, and blue phosphor dots. For purity in the completed kinescope, the path taken by electrons in traveling from the three electron guns to the phosphor screen must coincide with the paths taken by the light beams when the dots were being applied. By passing through the shadow mask at the same angle as the light beams, the individual electron beams will strike only their respective phosphor dots, and good color purity will be obtained. To establish the correct paths, the electron beams must be aimed accurately, and the deflection yoke must be positioned precisely.

Need for Adjusting the Electron Beams.

The three electron guns are aimed so that their beams pass through the shadow mask at the correct angles at the center of the screen. (The position of the deflection yoke has no effect here.) However, the degree of precision required in aiming the guns mechanically is too great to be obtained in mass production. In addition, slight variations between yokes would require slight repositioning of the three-gun assembly. What is needed, then, is a means of readjusting the position of the three-gun assembly after the kinescope has been installed in the

set. Obviously, the three guns cannot be physically repositioned once the kinescope has been sealed. However, the three beams produced by these guns can be repositioned through the use of another external magnetic field. The source of this field is the purity magnet.

Purity Magnet. This magnet consists of two permanently magnetized rings, mounted in an assembly which permits independent rotation of each ring. Refer to Fig. 4-11. Each ring has two tabs mounted on it; these provide a means of rotating the individual rings and serve to identify the north and south poles of each ring. Changing the spacing between the tabs of the two rings changes the polar relationship of the two fields. This in turn changes the strength of the combined field produced by both rings. Rotating the entire purity magnet changes the direction of the combined magnetic field. This action is illustrated in Fig. 4-11. From this it can be seen that the purity magnet simultaneously positions all three electron beams.

Setup Sequence for Purity. The following procedure may be used on all 21-inch color receivers.

1. Degauss the Set. Plug the degaussing coil into a 120-volt a-c outlet. Holding the coil parallel to the face of the tube, slowly move the coil around the entire front of the screen. Gradually back away from the set; when at least six feet away, disconnect the line cord.

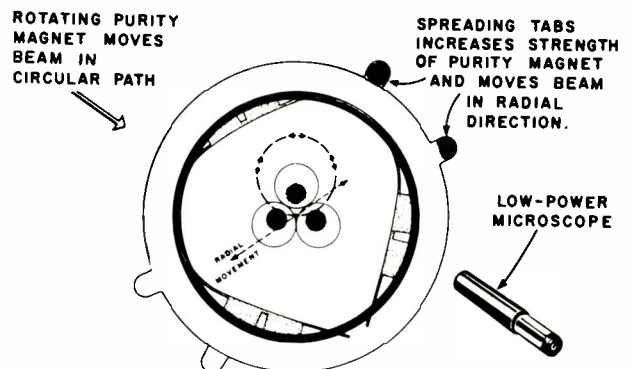

Fig. 4-11. Action of the purity magnet.

2. *Adjust Center Convergence.* Center convergence should be adjusted next. Follow the procedure outlined in the next section of this lesson. To understand the need for this step, consider the following: The path of the three electron beams is influenced by both the purity magnet and the convergence magnets. Some degree of interaction is therefore inevitable between these two magnets. If center convergence is badly misadjusted, it may be impossible to obtain good purity by adjusting the purity magnet. For this reason, center convergence is adjusted as a preliminary step to adjusting purity. Center convergence may again require readjustment after purity has been adjusted.

3. *Bias Off the Green and Blue Guns.* Using the kinescope-grid shunt switch, cut off the blue and green guns. The purity adjustment is simplified by first biasing off two of the guns and making the adjustment with only one gun active. Normally, when good purity is obtained on the raster produced by this gun, it will simultaneously be good on the other two rasters.

Traditionally, the red raster has been used in setting up purity. Red was chosen because the red phosphor material used in early kinescopes had a lower light efficiency than the blue or green phosphors. This meant that a greater red beam current was required to obtain the same light output produced by the green and blue phosphors. Should this high-current red beam fall on either blue or green dots, it would light them vividly, making the purity error they represent readily apparent on the red raster. A change in the red phosphor material used in recent color kinescopes (21FBP22 and 21FJP22) has improved the efficiency of the red dots. However, red is still commonly used as the raster for setting up purity.

Many technicians find video information on the screen annoying when adjusting purity; a blank raster can be obtained conveniently by pulling out the plug-in cable that links the r-f unit to the picture i-f stages.

4. *Adjusting the Yoke and Purity Magnet.* Overlap the two red tabs of the purity magnet. See Fig. 4-11. Loosen the screw on

the yoke clamp and slide the yoke back until it almost touches the convergence coil and pole piece assembly. Refer to Fig. 4-9.

Adjust the purity magnet to obtain a uniform red area in the center of the screen, as shown in Plate 3.

Slide the yoke forward slowly until a position is found where the greatest area of the screen is a uniform red. It is possible to go too far forward, in which case the red area will begin to decrease in size again. In this case, the yoke should be slid back to the point where the greatest red area is obtained.

Readjust the purity magnet to obtain a solid red raster. Occasionally, it may be necessary to reset the yoke once more at this point.

Before tightening the yoke clamp down in its final position, check to see that the picture is not tilted. This can be done by throwing the normal/service switch (back panel of set) to the service position. This temporarily disables the vertical deflection circuit and produces a single horizontal line across the screen. This line can be used to check for picture tilt. After the yoke is tightened in its final position, return the normal/service switch to the "normal" position; switch the blue and green guns back on, and plug the cable back into the r-f unit.

Older Receivers. On early receivers, a group of "edge purity magnets" were mounted around the outer circumference of the kinescope. Figures 4-12 and 4-13 illustrate two such assemblies. On models equipped with these magnets, purity is set up following the procedure just outlined. As a final step, these edge magnets are adjusted to eliminate any edge impurity that exists after the yoke and purity magnets have been adjusted.

The edge magnet which lies closest to the impure area is adjusted in the case of the assembly shown in Fig. 4-12. The adjustment is made by rotating the knob provided. By turning the knob one way and then the other, the magnet will be positioned closer to or further from the kinescope. In

this manner, the strength of the magnetic field at the edge of the kinescope is varied. In addition, the polarity of magnet is continually reversed by this same rotation. The adjustment then provides a means of varying the strength and direction of the magnetic field. Starting in the extreme counterclockwise position, the knob is rotated in a clockwise direction until good purity is obtained in the affected edge area. Before degaussing a receiver equipped with this type of edge magnets, each knob should be turned fully counterclockwise. This positions the magnets in a housing which prevents the degaussing coil from partially demagnetizing them.

Hairpin Version. This later version of the edge magnet looks like a pair of oversized hairpins. Holders are located at different points on a mounting ring which surrounds the bell of the kinescope. Refer to Fig. 4-13. Unlike the previous assembly, these magnets are not fixed in one position around the kinescope. These magnets can be moved from holder to holder. With this

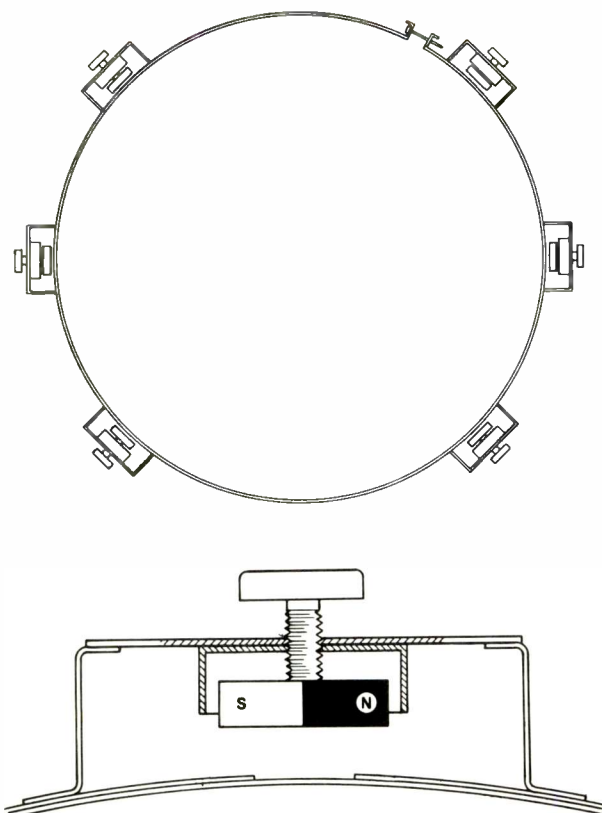

Fig. 4-12. Edge magnet assembly (older type).

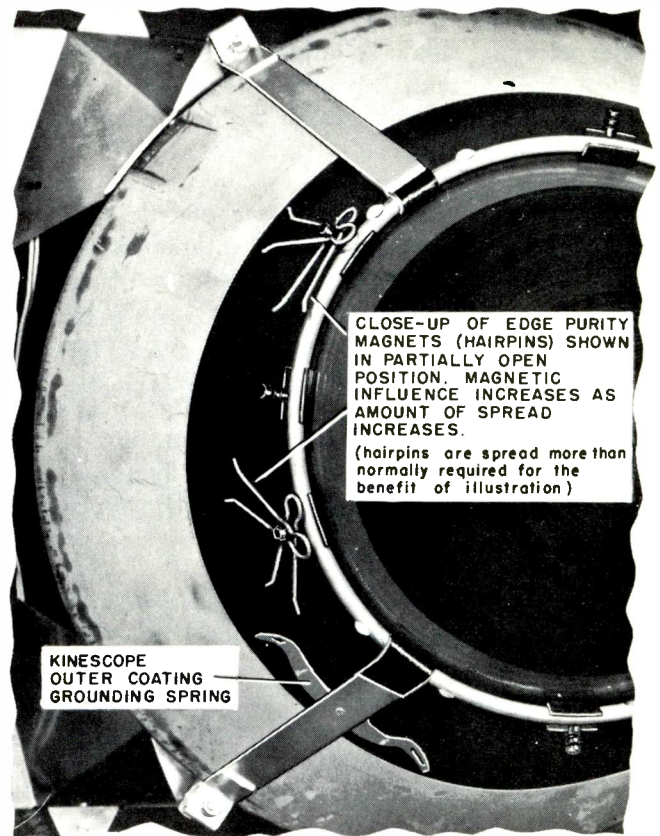

Fig. 4-13. Edge magnet assembly (newer type).

flexibility, the magnets can be mounted on the holder directly adjacent to the area of impurity, thereby localizing the edge magnet's action to the area of impurity. The strength of the field produced by these magnets is varied by changing the spacing between the individual magnets. The direction of the field is varied by rotating both magnets simultaneously.

4-6. CONVERGENCE

Each of the three electron guns produces one complete picture. The black-and-white (or color) picture seen on the screen of a color set is actually these three separate pictures combined to produce one composite picture. When these three pictures are perfectly superimposed, one on top of the other, the picture is completely free of color fringing.

The three pictures appear superimposed to the human eye when the electron beams from the three guns converge at the shadow

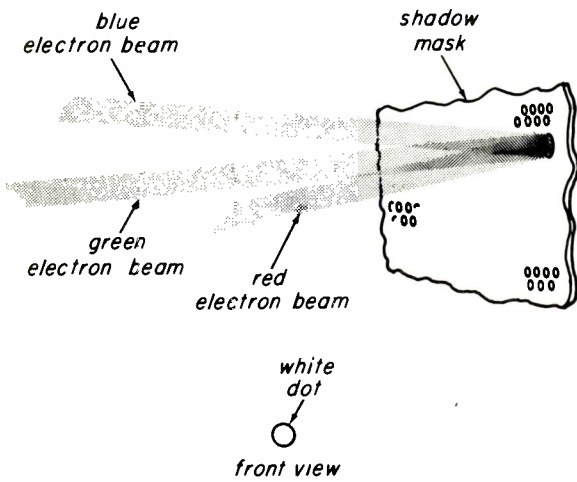

Fig. 4-14. Proper convergence is obtained when all three electron beams meet or converge at the shadow mask.

mask, enter the same group of holes in the mask, and light the common dot trios that lie behind that particular group of holes. This condition is illustrated in Fig. 4-14.

The dots in a common dot trio are positioned so closely together that the eye does not see them as individual dots. What it does see is the composite sum of the three. When misconvergence exists, the dots in different trios are lighted as in Fig. 4-15. Because of the increased spacing between dots, the eye no longer sees the composite

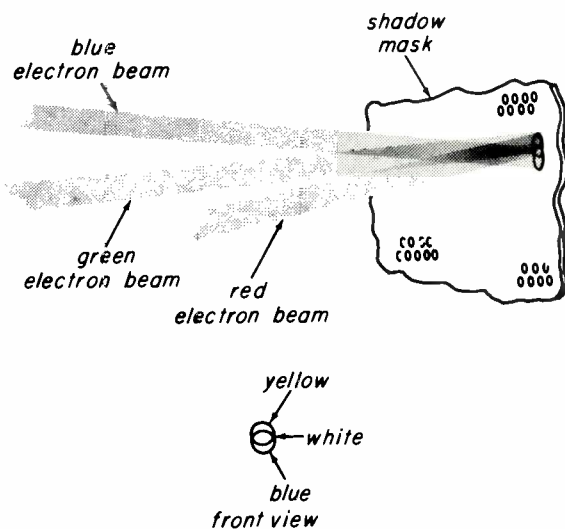

Fig. 4-15. Misconvergence occurs when the beams do not converge at the shadow mask. In this case the blue beam is low. White areas on the screen have a blue fringe at the bottom and a yellow fringe at the top.

sum of the three dots. Instead, it now sees the separate picture produced by the misconverged dot pattern. In the case of Fig. 4-15, the blue beam has not converged with red and green; it has entered another group of holes in the shadow mask and has lighted the blue dots of other trios. This condition would produce a yellow picture (red + green) which would be fringed by the misconverged blue picture.

Center Convergence. In an effort to obtain convergence at the center of the picture, the three electron guns are tilted toward the central axis of the picture tube, as shown in Fig. 4-16. Mass production techniques, however, cannot produce a three-gun assembly in which each gun is so precisely tilted that the three beams automatically converge. Once again, as in the case of purity, a means of readjusting the path of the electron beams is required. In this case, separate PM magnets are used, so that each beam can be independently adjusted to obtain the desired center convergence.

Center Convergence Magnets. The position of the three center convergence magnets is shown in Fig. 4-17. The small permanent magnets are mounted in plastic sleeves and are adjusted by sliding the sleeves up and down in their holders. This varies the strength of the magnetic field applied to the individual internal pole pieces, which in turn, changes the path of the electron beam. Figure 4-10 shows a more detailed view of one of the plastic sleeves and its holder.

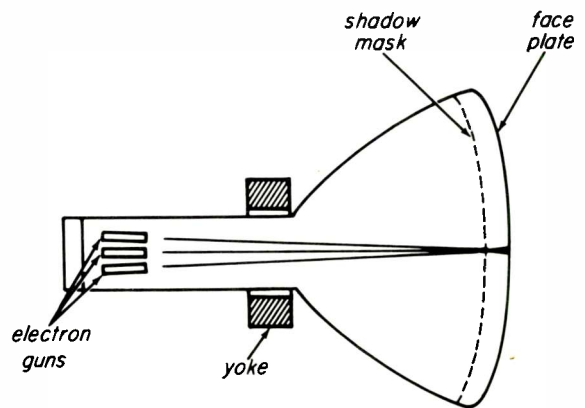

Fig. 4-16. A simplified illustration of static convergence.

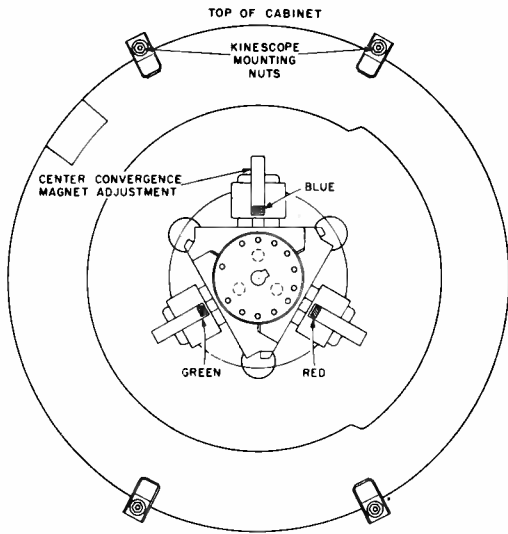

Fig. 4-17. Positions of static convergence magnets.

The results of adjusting these magnets can best be seen by displaying a dot pattern on the screen. As each individual sleeve is adjusted, the corresponding dots will travel either forward or backward along the individual paths indicated in Fig. 4-18. The red and green dots can always be made to overlap or converge (producing a yellow dot) because of their diagonal paths of travel. The blue dot will occasionally land to the left or right of this pair, as in Fig. 4-19. To correct this situation, a fourth magnet, the blue lateral magnet, was added. Refer to Fig. 4-10. This magnet provides a means of moving the blue dot laterally to the left or right. The lateral magnet, shown in Fig. 4-10, is adjusted by rotating the sleeve in

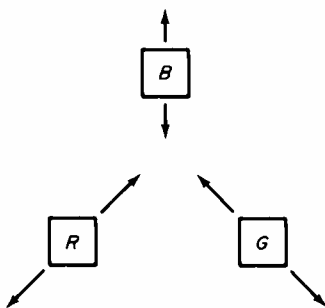

Fig. 4-18. Paths of travel of individual dots. Note: The pattern may also appear inverted (overconverged), with the blue dot at the bottom, the green dot to the left and the red dot to the right. In either case the paths of travel remain the same.

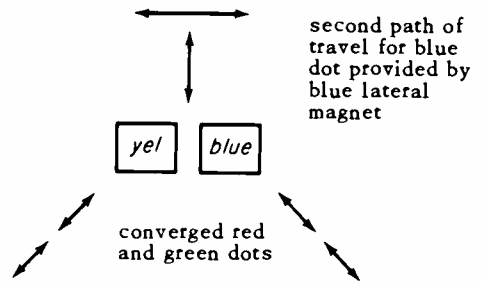

Fig. 4-19. Action of the blue-lateral magnet.

its holder. A later version consists of a small bar magnet which is adjusted by sliding it in and out of a holder.

Adjusting the center convergence and lateral magnets will move all of the dots on the screen. However, when doing center convergence, attention should be focused on the center dot in the pattern.

Setup Sequence for Center Convergence.

1. *Obtain a Dot Pattern.* Connect dot/crosshatch generator and obtain a dot pattern on the screen.

2. *Bias Off the Blue Gun.* Using kinescope-grid shunt box, bias off the blue gun. The student will find it easier to converge the red and green dots if the blue dots are absent.

3. *Converge Red and Green Dots.* Adjust the red and green center convergence magnets until the *centermost* red and green dots overlap (converge). In making this adjustment, keep the path of travel of each beam in mind. Position either one of the dots in the *anticipated path of travel of the other.* Advance the remaining dot until it converges with the first. Reposition each dot slightly until a perfect yellow dot is obtained.

4. *Switch On the Blue Gun.* Using the blue center convergence magnet and the blue lateral magnet, overlap the center blue dot with the yellow dot obtained in Step 3.

Adjusting the blue lateral magnet may change the position of the red and green dots slightly. If this occurs, repeat Steps 2 through 4 until a white dot free of color

fringing is obtained in the center of the screen.

Occasionally, one of the dots will not move far enough along its normal path of travel to converge with the others. To extend the range of travel, pull the plastic sleeve completely out of its holder, rotate the sleeve 180° (turn the sleeve on its long axis, not end over end) and reinsert it in the holder. This reverses the polarity of the magnet and provides the required additional travel.

CAUTION: The plastic sleeve can be reinserted in the holder after it has been rotated only 90°. However, with the magnet in this plane, the dot movement will be limited and it will not move along its normal path of travel.

Earlier Models. The center convergence magnets on earlier models differ somewhat in appearance and method of adjustment. However, the same basic setup sequence applies in all cases.

Need for Edge Convergence. The center convergence magnets provide a means of converging the three electron beams in the center area of the screen. However, as the yoke deflects the beams from this area, another convergence problem is introduced. This is illustrated in Fig. 4-20. The distance between the centers of deflection and the point of convergence remains the same, as the yoke deflects the beams from the center to the top of the screen. However,

the distance between the center of deflection and the shadow mask are not the same in these two areas. As a result, the three beams converge in front of the shadow mask at the top of the screen, resulting in mis-convergence in this area. This same basic problem exists at the bottom and at both sides of the picture.

Making the radius of the shadow mask and face plate equal to the radius of the converged beams would appear to be a quick answer to the problem. However, to keep the curvature of the face plate practical from a viewing standpoint would mean lengthening the tube considerably.

Edge Convergence Magnets. The solution to the problem lies in providing a means of momentarily changing the point of convergence while the three beams are being deflected through the edge areas of the picture.

A permanent magnet is unsuitable for this correction application since it produces a constant field. What is required in this instance is a magnet which will produce a field only when the three beams are at the extreme edges of the picture. The answer lies in the use of an electromagnet which is fed a parabola of current similar to that shown in Fig. 4-21. You will recall that an electromagnet produces a field only when current is present in the coil. In addition, the strength of the field produced is directly proportional to the amplitude of the current present. Referring to Fig. 4-21, it can be seen that field developed by the parabola of

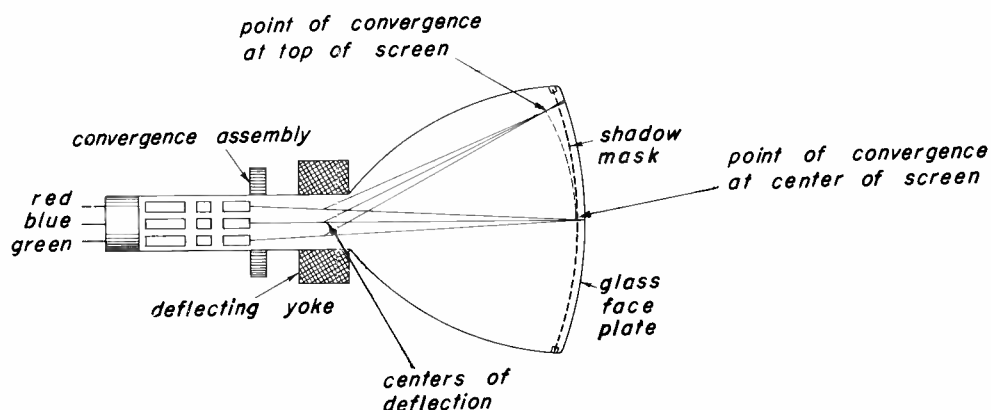

Fig. 4-20. An illustration of the need for dynamic convergence.

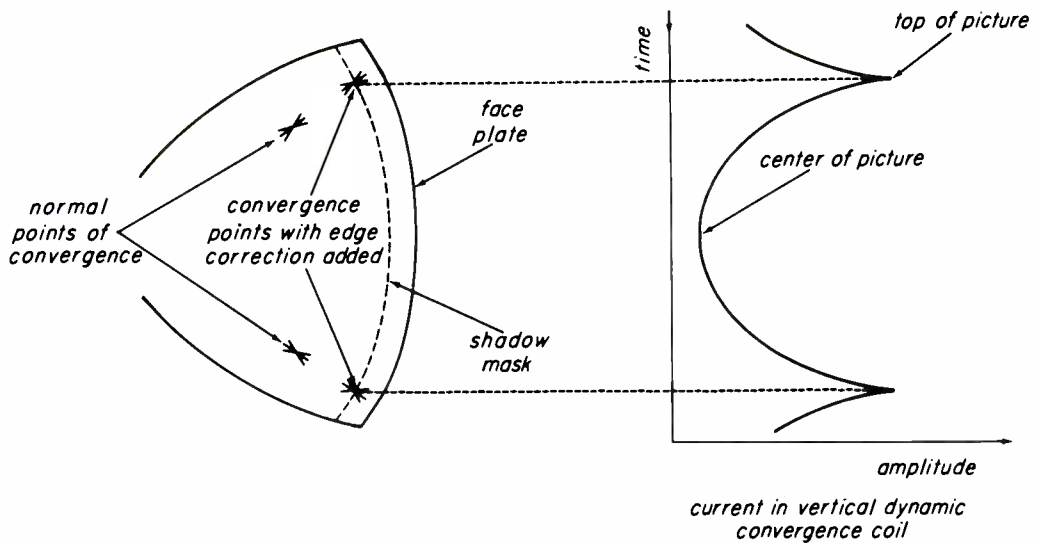

Fig. 4-21. This drawing shows how the parabolic waveform corrects convergence at the screen edges.

current will be negligible in the center of the picture. However, it will build to an appreciable level at the top and bottom of the picture. The lack of an electromagnet field at the center of the picture is no problem since convergence in this area is established by the center convergence magnets.

Since all three beams must be reconverged as the sweep reaches the top and bottom of the picture, a separate electromagnet is required for each gun. These electromagnets are commonly referred to as the convergence coils. The position of these coils is illustrated in Fig. 4-9 and Fig. 4-17. A more detailed view of one assembly can be seen in Fig. 4-10.

The peaks of the parabola shown in Fig. 4-21 should occur in step with vertical deflection if they are to provide the desired correction at the right time. For this reason, the vertical output stage is used as the source of the parabola of current. Signals taken from the cathode of the vertical output stage and the vertical output transformer are combined and shaped to produce the required parabola.

Since both the amplitude and time of the current peaks are critical, separate controls are provided to permit each characteristic to be adjusted. A pair of these controls is provided for each of the three convergence

coils. They are known as the vertical amplitude and vertical tilt controls. It is these controls which are adjusted when vertical edge convergence is set up.

Vertical edge convergence is sometimes referred to as vertical dynamic convergence, since the correction field involved is constantly changing or in motion. The fixed center convergence, on the other hand, is occasionally referred to as static convergence.

Setup Sequence for Vertical Dynamic Convergence.

1. *Connect Dot/Crosshatch Generator.* Obtain dot pattern, check center convergence, readjust if necessary. Switch generator to crosshatch pattern.

2. *Move Dynamic Convergence Board to Adjustment Position.* The dynamic convergence controls are mounted on a separate printed board which is connected to the receiver through two long extension leads. Under normal operating conditions, the board is mounted inside the cabinet, and is thereby hidden from the customer's view. When dynamic convergence adjustments are to be made, the board is moved to a pair of screws provided on the top rear rail of the cabinet. This arrangement permits the technician to make the dynamic convergence

adjustments while standing in front of the receiver.

3. *Bias Off Blue Gun.* Using the kinescope-grid shunt switch, cut off the blue gun. The dynamic convergence control panel includes a total of twelve controls. The six on the left side (see Fig. 4-22) are used when adjusting vertical dynamic convergence. The top four of these are all designated as R-G controls. These controls simultaneously converge red and green at specific points on the screen. The adjustment of these controls is simplified by first biasing off the blue gun.

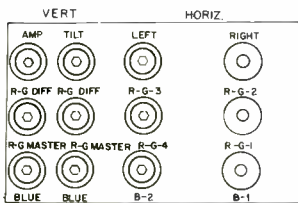

Fig. 4-22. Dynamic convergence control board.

4. *Adjust R-G Master Tilt.* Adjust control to obtain best convergence between red and green along the upper portion of the center-most vertical line. (Figure 4-23 should be referred to throughout this entire sequence.)

5. *Adjust R-G Master Amplitude.* Adjust the control to obtain best convergence between red and green along the lower portion

of the centermost vertical line. A certain amount of interaction exists between the two controls. However, the action of each is clean and decisive and the desired results can be obtained within a few minutes.

6. *Adjust R-G Differential Tilt.* Adjust the control to obtain best convergence between red and green on the upper horizontal lines in the center area of the picture.

7. *Adjust R-G Differential Amplitude.* This control should be adjusted to obtain best convergence between red and green on the lower horizontal lines, in the center area of the picture. Here again, the interaction between controls may be noted. In addition, some degree of interaction between the differential and master controls will also be encountered. But, again the decisive action of the individual controls makes short work of the entire process. Should center convergence be off at this point, readjust the red and green center convergence controls. This will throw vertical dynamics off slightly and Steps 4 through 7 should be repeated as required.

8. *Reactivate the Blue Gun.* Open the switch on the kinescope-grid shunt box.

9. *Adjust the Vertical Blue Amplitude Control.* Advance the control clockwise until a displacement between the blue and yellow horizontal lines at the top and bottom

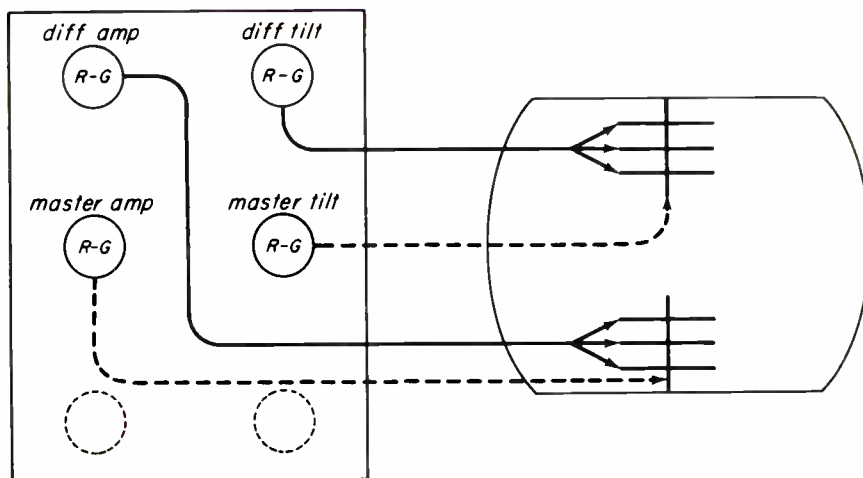

Fig. 4-23. Red and green vertical dynamic convergence. Look at vertical lines when adjusting master amplitude and tilt. Look at horizontal lines when adjusting differential amplitude and tilt.

of the center area of the picture is seen. See Fig. 4-24a.

10. *Adjust the Vertical Blue Tilt Control.* Set the control to equalize the amount of displacement between the blue and yellow horizontal lines at the top and bottom of the picture. See Fig. 4-24b.

11. *Readjust the Vertical Blue Amplitude Control.* Turn control in a counterclockwise direction until the blue and yellow horizontal lines converge at the top and bottom of the picture. Occasionally, either the top or bottom may converge first. In this case, divide the remaining displacement equally between the top and bottom horizontal lines by adjusting the vertical blue tilt control. Next, reduce the blue amplitude control in a counterclockwise direction until both areas converge.

The procedure used to set up vertical dynamic convergence on the newer receivers is very easy to execute and results in optimum convergence with a minimum of backtracking. But let us spend a few minutes in considering what happens during setup, so that we may see a little more about what we are doing.

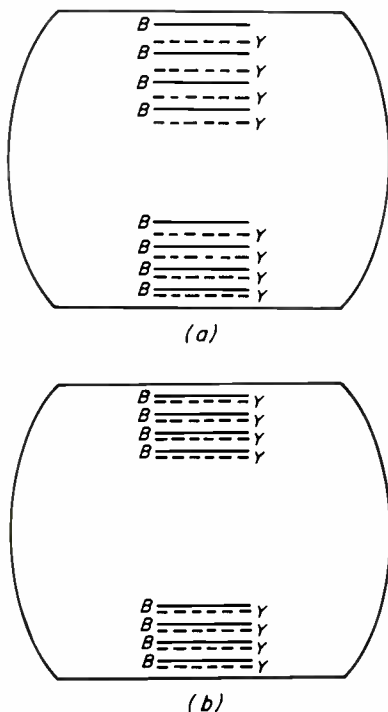

Fig. 4-24. Blue vertical dynamic convergence.

Note: A crosshatch pattern is used when setting up convergence. For this reason, vertical and horizontal lines are shown in the drawings of Fig. 4-25. However, a dot pattern is more helpful in explaining what happens to the lines during the convergence procedure. Thus, the drawings in Fig. 4-25 call attention to a particular spot on each line. Remember that these spots are not visible when viewing the actual crosshatch pattern. They can be made visible, of course, by removing the crosshatch pattern and substituting a dot pattern.

The *R-G* master amplitude control adjusts the amplitude of the parabolic current waveforms in both the red and green convergence magnets. When this control is turned, the red and green spots at the top and bottom of the screen move as shown in Fig. 4-25a. Since the control currents are equal, the spots move in equal increments. Although the beams move towards convergence at both the top and bottom of the screen, we focus our attention at the bottom when adjusting master *R-G* amplitude. The master tilt control is used to trim-up convergence at the top. Tilt correction is needed at the top of the picture because the red and green guns are mounted below the center-axis of the neck of the picture tube. Thus, the red and green beams travel further when deflected towards the top of the screen. The tilt component of the convergence waveform acts to increase the convergence currents in the red and green electromagnets when the vertical scan is near the top of the picture.

When either the master *R-G* amplitude or tilt controls are turned, the red and green spots move equal distances from their starting points. When adjusting these controls, we converge the beams on a vertical line. Figure 4-25b shows how the red and green spots can be moved from two typical starting positions to converge on a vertical line. But notice that, in this case, one spot is above the other. These two spots may be made to converge perfectly in this case if the red spot is made to move further in its original direction of movement and the green spot is made to back up an equal amount. When this is done, the spots will converge on point *P* in Fig. 4-25c. The differential tilt controls make this sort of adjustment possible. When

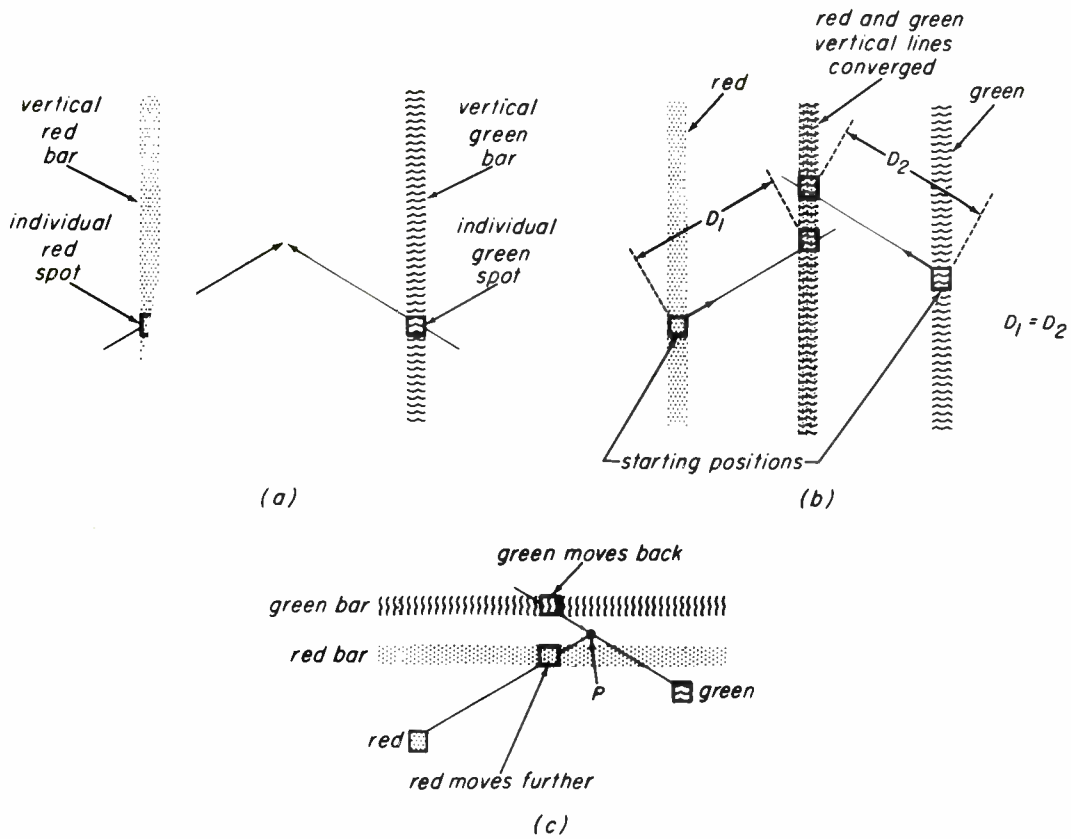

Fig. 4-25. An illustration of the action of the red-green vertical dynamic controls.

the differential amplitude control is turned one way, the convergence current for the red electron gun increases, while the convergence current for the green beam decreases. Reversing the rotation reverses this action. When making differential adjustments, we can tell when the beams are converged by looking at the horizontal lines at the top-center and bottom-center of the picture. Here again differential amplitude is adjusted to obtain convergence at the bottom; differential tilt is used to obtain convergence at the top.

The blue dynamic convergence controls are quite simple as they are operated independently.

Older Receivers. Red and green vertical convergence controls on the older receivers are not interrelated as they are on the newer sets. As shown in Fig. 4-26, there were separate vertical amplitude and tilt controls for both red and green. To adjust these controls, a slightly different technique is used. In adjusting vertical convergence

on these receivers, the centermost vertical blue line is used as a reference and red and green are adjusted to match blue.

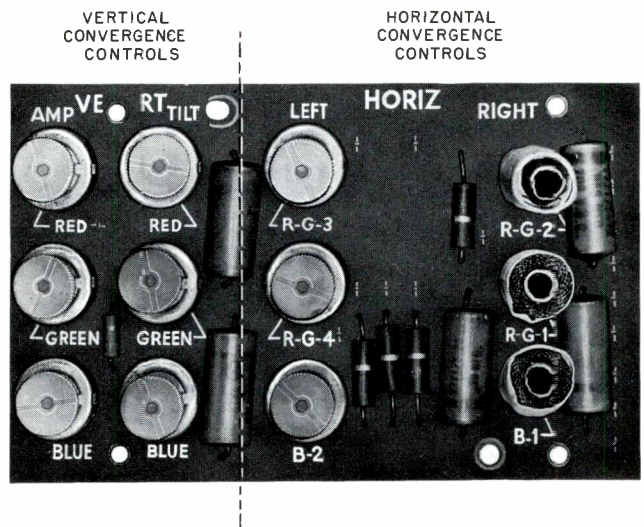

Fig. 4-26. Dynamic convergence board used in older color receivers.

Setup Sequence for Vertical Dynamic Convergence (Older Models).

1. *Connect Dot/Crosshatch Generator.* Obtain dot pattern and adjust center convergence; switch to crosshatch pattern.

2. *Short Out Red Gun.* Using kinescope-grid shunt switch, bias off the red gun.

3. *Adjust Vertical Green Amplitude Control.* Advance control fully clockwise. This will introduce a displacement between green and blue at the top and bottom of the center vertical line.

4. *Adjust Vertical Green Tilt Control.* Adjust control to equalize the amount of displacement between green and blue at the top and bottom of the center vertical line.

5. *Adjust Vertical Green Amplitude Control.* Turn control counterclockwise until green and blue converge at either the top or bottom of the picture. (Occasionally they will converge at both the top and bottom at this point; in which case the adjustment is complete.)

6. *Readjust Vertical Green Tilt Control.* Reset control to equalize remaining displacement between the top and bottom of center vertical line.

7. *Adjust Vertical Green Amplitude.* Continue turning counterclockwise until green and blue converge at the top and bottom of center vertical line.

8. *Reactivate Red Gun and Bias Off Green Gun.*

9. *Red Vertical Dynamic Convergence.* Repeat Steps 3 through 7, substituting the appropriate red control for the green control adjusted in each step. This setup sequence for red and green may be used on any early model color receiver.

10. *Blue Vertical Dynamic Convergence.* The procedure previously described for blue vertical dynamic convergence is also used on the older models.

The action of the vertical dynamic controls on the older receivers can be summarized as follows: The tilt controls are adjusted to equalize the displacement of lines at the top and bottom in the center area of the screen. The amplitude controls are then adjusted to eliminate this displacement.

Horizontal Dynamic Convergence. Once vertical edge convergence has been properly adjusted, the next major step in the setup sequence is horizontal dynamic convergence. Figure 4-20 illustrates the misconvergence which was introduced when the three electron beams were deflected from the center to the top of the screen. A similar convergence error develops when the beams are deflected from the center to the sides of the picture tube. As mentioned previously, a separate horizontal coil is incorporated in each of the three dynamic convergence coils, to provide a means of correcting this problem. As in the case of the vertical dynamic circuits, a group of controls are provided for adjusting the amplitude and timing (tilt) of the individual parabolic waveforms in these coils.

The six controls on the right side of the convergence control board (see Fig. 4-22) are used when adjusting horizontal dynamic convergence. The three along the extreme right edge are coils; they are adjusted by tuning the slug within each coil. A hexagon-shaped "neut stick" is required for this purpose. These coils have most effect upon the horizontal dynamic convergence at the right side of the screen. The remaining three controls are the conventional variable potentiometers; they are adjusted to obtain horizontal dynamic convergence along the left side of the screen.

Setup Sequence for Horizontal Dynamic Convergence.

1. *Switch Generator to Dot Pattern.* Check center convergence; readjust if necessary. Switch generator to crosshatch pattern.

2. *Bias Off Blue Gun.* Using the kinescope-grid shunt switch, cut off the blue gun. As in the case of vertical dynamic convergence, the top four controls (see Fig. 4-22) are combined red and green controls.

Their adjustment converges red and green simultaneously at specific points on the screen. Here again, the adjustment of these controls is simplified by first removing blue.

3. *Adjust R-G₁*. This coil should be adjusted to obtain the best convergence between red and green along the *vertical lines* at the *right side* of the screen. (Refer to Fig. 4-27 throughout this sequence.)

4. *Adjust R-G₂*. Adjust this coil to obtain the best convergence between red and green on the *horizontal lines* which lie at the *right side* of the screen.

5. *Adjust R-G₃*. Set this control to obtain best convergence between red and green along the *vertical lines* on the *left side* of the screen.

6. *Adjust R-G₄*. This control should be adjusted to obtain the best convergence between red and green on the *horizontal lines* found at the *left side* of the screen.

As in the case of vertical dynamics, some degree of interaction exists between the four horizontal dynamic controls. However, here again, the easily identified and decisive action of each control makes short work of the entire sequence.

7. *Reactivate the Blue Gun*. Open the switch on the kinescope-grid shunt box.

8. *Adjust B₁*. Set this control to the point where the blue *horizontal lines* on the

right side of the picture converge with the yellow horizontal lines (converged red-green lines) in this area.

9. *Adjust B₂*. Adjust this control to obtain the best convergence between the blue and yellow horizontal lines on the *left side* of the picture.

10. *Final Over-All Convergence Check*. Check and readjust if necessary, center, vertical, and horizontal convergence.

Earlier Receivers. The horizontal sequence just outlined is applicable to all receivers produced by RCA from 1956 to date. Prior to that, a different technique was employed. As shown in Fig. 4-28, separate red and green horizontal amplitude and tilt (phase) controls were used on these early receivers. This meant that red and green horizontal-dynamic controls were each adjusted separately.

Setup Sequence for Horizontal Dynamic Convergence (Older Models). Space does not permit a detailed setup sequence on each of the early models. Instead, we will briefly outline the basic technique which should be used on these early models.

1. *Set Dot/Crosshatch Generator for Dot Pattern*. Adjust center convergence and switch generator to crosshatch pattern. Bias off green and red guns.

2. *Blue Horizontal Amplitude and Tilt Adjustment*. Alternately adjust the blue

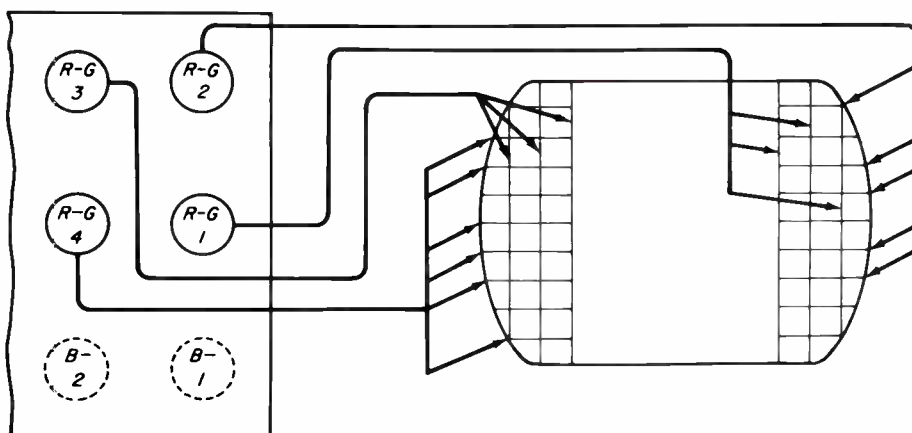

Fig. 4-27. Horizontal dynamic convergence adjustments.

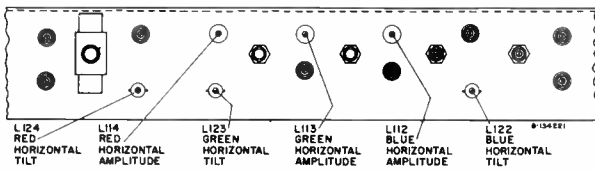

Fig. 4-28. Horizontal dynamic controls (early receiver).

horizontal amplitude and tilt controls until a straight *horizontal* blue line is obtained in the center of the picture. See Fig. 4-29.

Since the vertical blue bars are not affected by the horizontal dynamic convergence fields, they are used as a reference for red and green adjustments. First the green and then the red vertical bars are matched to this reference.

3. *Green Horizontal Amplitude and Tilt Adjustments*. Reactivate the green gun and adjust green center convergence to displace the center green vertical bar to the left of the center blue vertical bar. (Hold displacement to a minimum.)

Alternately adjust the green horizontal amplitude and tilt controls to obtain a uniform displacement across the screen between the green and blue vertical bars. The green

bars should be to the left of the blue bars in every case. Readjust green center convergence.

4. *Red Horizontal Amplitude and Tilt Adjustments*. Bias off the green gun and reactivate the red gun. The red horizontal dynamic adjustments duplicate the procedure given in Step 3. The one exception being that the center red vertical line is displaced to the right of the center vertical blue line.

Note: When adjusting red and green horizontal dynamics, concentrate on the vertical lines in the area that extends about one inch above and below the center horizontal bar. Remember that convergence along the top and bottom of these vertical lines is a function of vertical-dynamic adjustments.

5. *Readjust Horizontal Blue Controls*. Reset blue horizontal amplitude and tilt to obtain the best convergence between blue and yellow on the centermost horizontal line.

4-7. BLACK-AND-WHITE TRACKING

The red, green, and blue phosphors used in the color kinescope are not equally efficient. This means that different values of beam current will be required to produce an

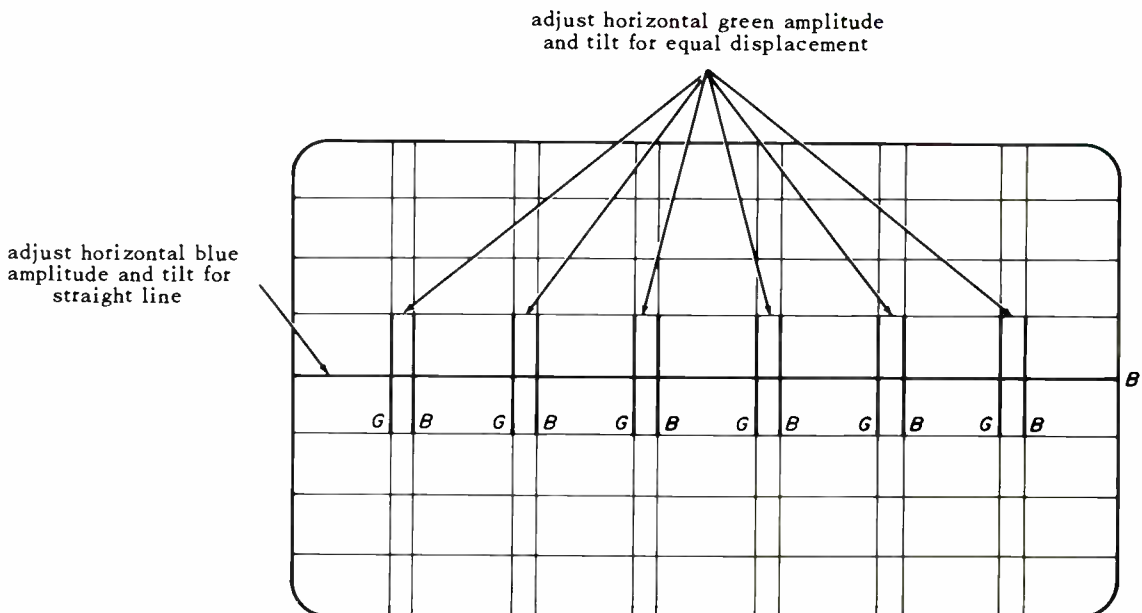

Fig. 4-29. Horizontal dynamic convergence adjustments for older receivers.

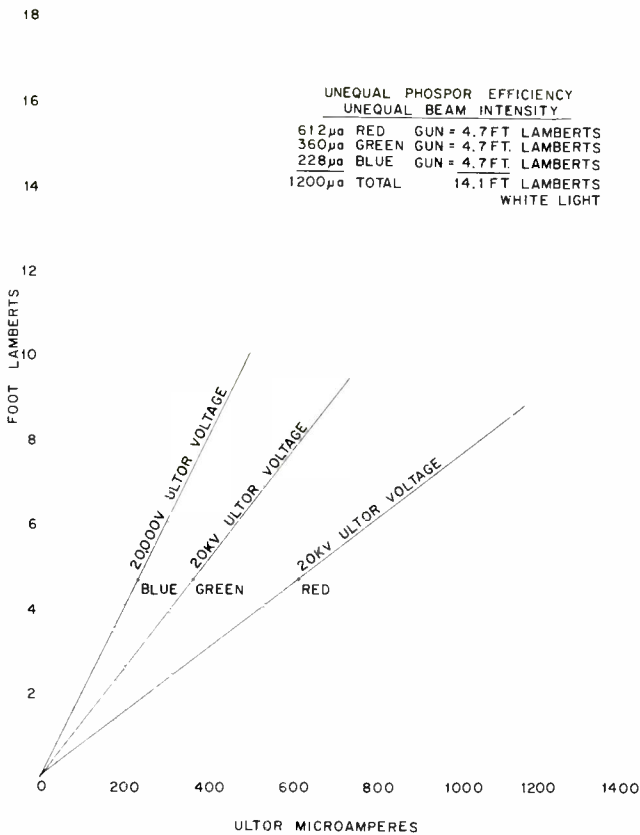

Fig. 4-30. Light output versus beam current (older 21-inch kinescope).

equal light output from each of the three phosphors. Figure 4-30 illustrates this action. (Foot Lamberts are the units of measure of the brightness of a light source.) It can be seen that to produce white light (assuming equal light outputs for simplicity), the red beam current must be 612 μ a, the green current must be 360 μ a, and the blue current must be 228 μ a. Notice also that as the light decreases from white, to gray, to black (0 Lamberts) this same ratio of beam currents must be maintained.

Tracking Controls. Different beam currents values are established by varying the screen and bias voltages on each of the guns. Two variables are required in order to maintain the proper beam current ratio as the kinescope is varied through the gray scale from white to black.

Black-and-White Tracking Circuit. Figure 4-31 is a simplified version of the current kinescope circuitry used to obtain black-and-white tracking. The brightness control in this arrangement varies the d-c bias on the third video amplifier which produces a change in the average B+ on the plate of this stage. Since this stage is directly coupled to the kinescope cathodes, a corresponding change in cathode voltage occurs. This in turn

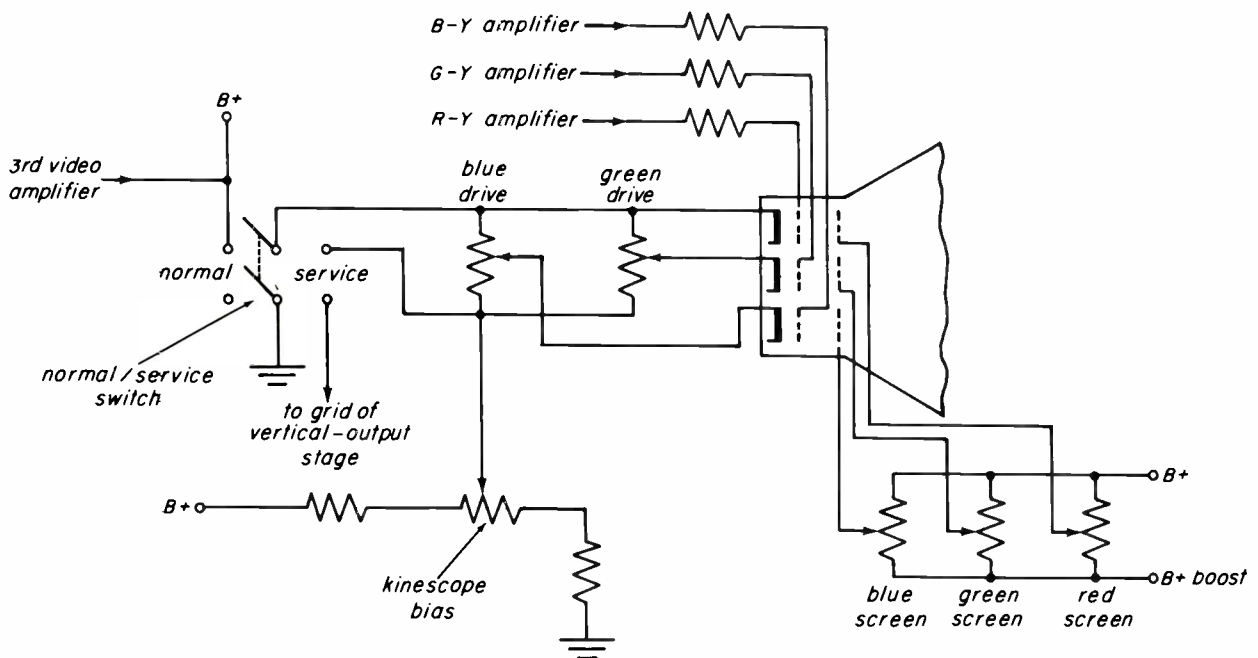

Fig. 4-31. Detail of the tracking controls in late-model receivers.

varies the bias on the kinescope producing the desired change in brightness.

3 Normal/Service Switch. This switch is used when adjusting the screen controls. When thrown to the service position, the grid of the vertical output stage is grounded. This temporarily disables vertical deflection and leaves a thin horizontal line across the screen. The sharp contrast of the thin white line against the totally black background provides the ideal means of adjusting the screen controls. Also in this position, video is removed from the kinescope cathode, the two drive controls are shunted, and the cathodes are at equal potentials. This removes the influence of the brightness, contrast, and drive controls while the screens are being adjusted. A black-and-white program, which displays the full range of contrast from highlights to lowlights, should be used when setting up tracking.

Setup Sequence for Black-and-White Tracking.

1. *Screen Controls.* Initially turn all screen controls (see Fig. 4-32) fully counterclockwise.

2. *Kinescope Bias.* This control should also be turned fully counterclockwise initially.

3. *Normal/Service Switch.* Set switch to service position.

4. *Screen Controls.* Advance each control (in any sequence) until a horizontal line, which corresponds in color to the screen control being adjusted, becomes barely visible on the screen.

Should no line appear after a given screen control has been advanced fully clockwise, leave the control set fully clockwise and adjust the *kinescope bias control* until a dim horizontal line appears. Any screen controls that had been set up prior to adjusting the kinescope bias control will have to be re-adjusted so that they will cause the line to be barely lighted at the new bias setting.

5. *Normal/Service Switch.* Return switch to normal position.

6. *Drive Controls.* With the *contrast* and *brightness* controls set to produce normal contrast and brightness, adjust the blue and green drive controls to obtain a black-and-white picture.

7. *Check Brightness Range.* Check the picture at all brightness levels for proper tracking. If the screens were accurately adjusted in Step 4, no further adjustment will be required. The key to properly adjusting the screen controls lies in getting each line to just barely light. This makes the three guns cut off at the same cathode-grid potential.

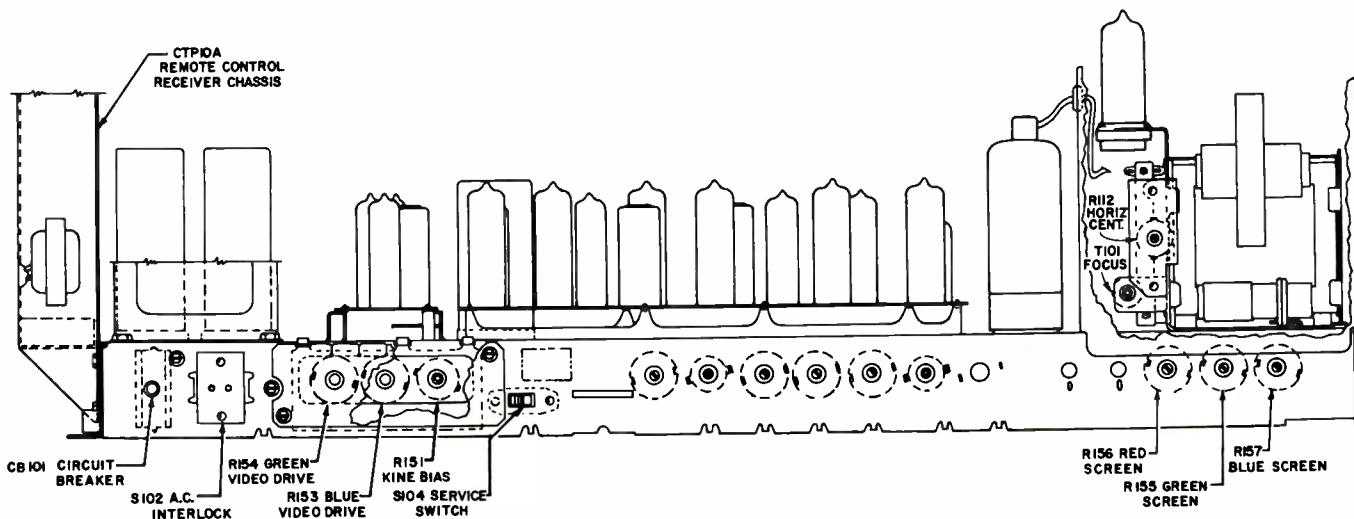

Fig. 4-32. Location of black-and-white setup adjustments on the RCA CTC-12 receiver.

Previous Models. Figure 4-33 illustrates the kinescope circuitry on an earlier model receiver. Three screen controls are provided as in the previous case. However, the bias on the individual guns is varied in this instance by changing the control grid voltage.

Setup Sequence for Black-and-White Tracking. (Older Receivers).

1. *Preliminary Steps.* Turn screen controls fully clockwise and background controls fully counterclockwise. Set contrast and brightness controls to obtain a picture that is somewhat darker than the normal brightness level.

2. *Background Controls.* Adjust the three background controls to produce white in the highlight areas (brightest parts) of the picture.

3. *Screen Controls.* To obtain optimum performance one, or possibly two, of the screen controls should be left at its maximum (fully clockwise) setting. To establish which screen is to be left at maximum, proceed as follows:

a. Reduce brightness control to obtain a dim picture.

b. Determine the *predominant* color in the *lowlight* (darker) area of the picture.

c. If it is cyan, leave the red screen at maximum. If it is magenta, leave the green

at maximum. If it is yellow, leave the blue screen at maximum.

d. If the predominant lowlight color is one of the three primary colors, slowly reduce the corresponding screen control; the lowlight area will either become gray or one of the complementary colors listed in Step c. If the lowlight areas become gray the screens are properly adjusted, and both of the remaining screens are left at maximum. If the lowlights become one of the complementary (cyan, magenta, or yellow) colors, the screen listed for that particular color in Step c should be left at maximum.

15

The remaining two screens are then combined with the screen control set at maximum to obtain gray in the lowlight areas.

4. *Readjust Background Controls.* Increase brightness setting and readjust background controls for white in the highlight areas.

5. *Check Brightness Range.* Check tracking at all brightness settings. If readjustment is required, adjust the screen controls to obtain gray in the lowlight areas of the picture and the background controls to obtain white in the highlight areas. Do not change the setting of the screen control that has been set at maximum.

7

4-8. PHASE AND MATRIX

When purity, convergence and tracking have been properly adjusted, a good black-and-white picture will be obtained. Following this, the color operation of the receiver should be checked and adjusted where necessary. A color program, of course, provides an ideal signal for checking the color performance of a receiver. However, there are occasions when a color show will not be on the air. A number of TV stations across the country attempt to solve this problem by transmitting a color stripe along with their daytime black-and-white shows. The stripe provides a means of checking color performance, without interfering with normal black-and-white reception. The correct use of the color stripe will be covered later in this section. Where neither a program nor a

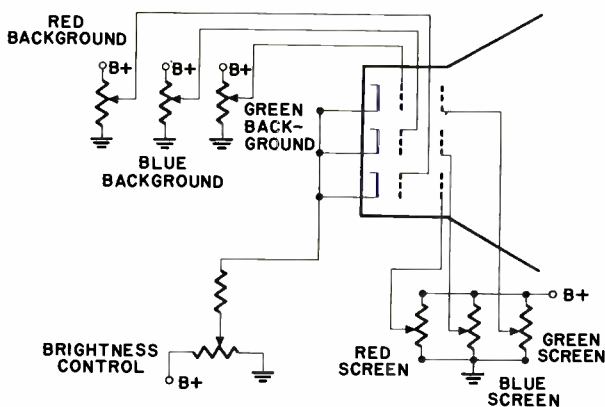

Fig. 4-33. Kinescope circuitry used in older color receivers.

color stripe is available, a color bar generator will be needed to check color performance. As a signal source, the color bar generator has the advantage of always being able to produce the required color signal. In addition, it represents the ideal signal for correcting any misadjustments that may be encountered.

Color Bar Generator. Earlier in the lesson, we mentioned that the WR-64A could provide a color bar pattern in addition to the normal dot and crosshatch patterns. Color bars are generated, in the WR-64A, through the use of an offset subcarrier technique. You will recall that different colors (hues) are produced in a color receiver by shifting the phase of the incoming subcarrier with relation to the phase of the local 3.58-mc oscillator. If the relative phase of the incoming subcarrier is shifted from 0° through 360° the hue will vary from yellow to orange, red magenta, blue, cyan, and green. The frequency of the subcarrier oscillator in the WR-64A is reduced or offset by 15,750 cycles below the normal subcarrier frequency of 3,579,545 cps. The offset subcarrier and the signal from the receiver's local 3.58-mc oscillator are applied to each of the color demodulators. The difference in frequency between these two (15,750 cycles) is equal to the horizontal scanning rate. Therefore, the relative phase difference between the two signals will change by one complete cycle (0° to 360°) during each horizontal scanning period.

This difference of one cycle or 360° produces a rainbow of colors across the face of the screen. In this application, the AFPC circuit in the receiver locks up on the average phase of subcarrier during the burst-sync gate time interval.

A rainbow pattern can be used to check for the presence of color and to demonstrate color operation to a customer. However, this type of presentation does not identify the specific phase angle of the different colors. As a result, it cannot be used for checking the phase and matrix of a color set. The WR-64A, however, generates a color bar pattern rather than a rainbow pattern. The bars are produced by feeding the offset subcarrier to a keyer stage which keys or gates the

subcarrier on and off at a 189-kc rate. This produces 12 separate color bars ($180 \text{ kc} \div 15,750 \text{ cps} = 12$) accurately spaced at 30° phase intervals. The output of the keyer is fed to the mixer and from there to the modulator.

One of the 12 bars produced is cancelled by the horizontal sync pulse. The bar following it occurs during horizontal retrace time and is therefore not seen on the screen. This stripe serves as the burst signal for the color bar pattern. The remaining 10 bars appear on the screen in the color and sequence shown in Fig. 4-34. From this figure, it can be seen that a signal is provided at each of the major demodulator axes.

Using the Color Bar Generator. To obtain a color bar pattern with the WR-64A:

1. Connect the output cable to the antenna terminals of the receiver (disconnect the antenna line).
2. Set pattern selector switch to COLOR BARS.
3. Set the CHROMA control to 100% (this control varies the amplitude of the subcarrier — the normal setting is 100%).
4. Turn the function switch to the PATTERN PLUS SOUND position. (The 4.5-mc sound beat is added in this position.)
5. Tune the receiver to Channel 3 (unless generator has been returned to Channel 4).
6. A bar pattern should appear on the screen. Adjust the fine tuning control on the receiver fully clockwise; this will introduce a sound carrier beat in the bars. Retune fine tuning counterclockwise to the point where the sound beat is at a minimum. At the correct tuning point, a small amount of beat will still be present. This step is extremely important since, if the fine tuning is misadjusted, there may be no color or incorrect color. (The function switch may now be switched to the PATTERN position to eliminate the slight beat that remains.)

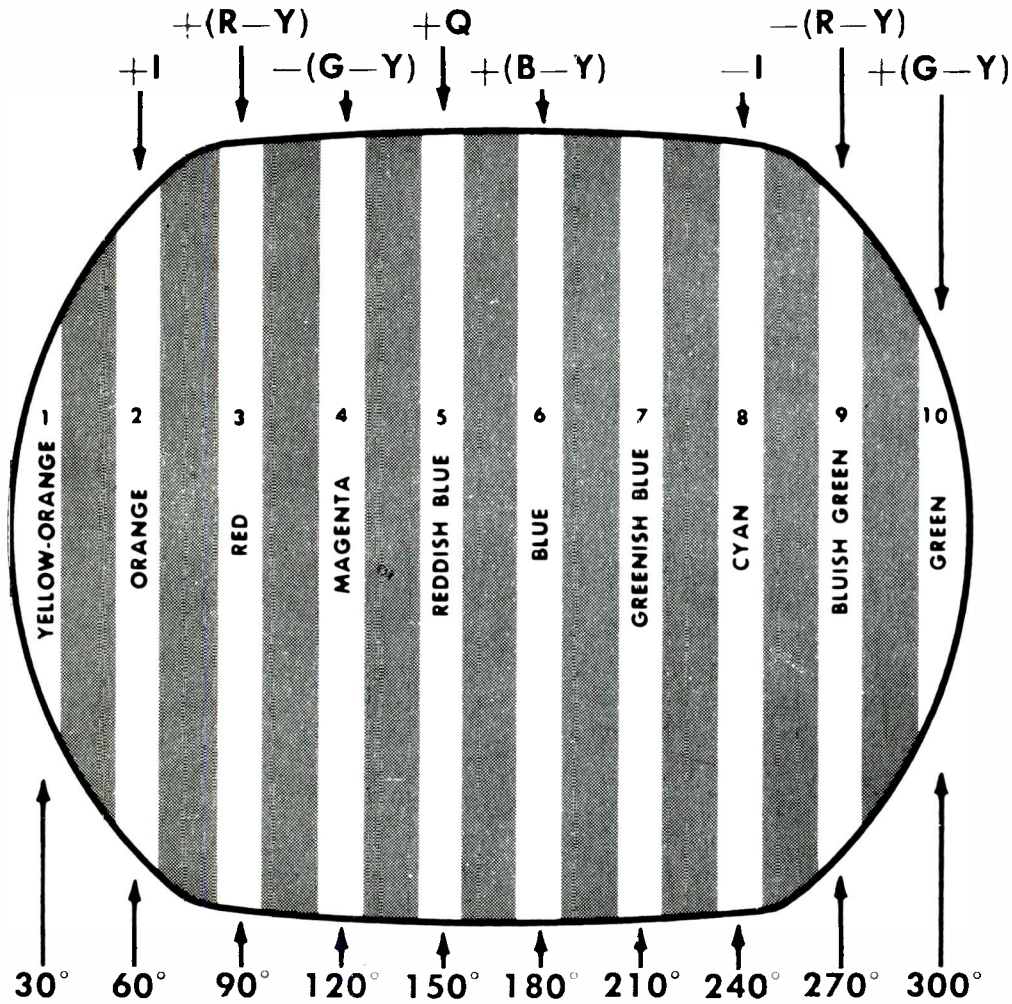

Fig. 4-34. Color-bar pattern produced by the WR-64A generator.

7. Adjust the TINT (hue) control on the receiver to the center of its mechanical range.

8. Adjust the receiver's COLOR (chroma or color saturation) control, to obtain a low level of color in the bars.

If the phase and matrix of the receiver are properly adjusted, a color pattern which corresponds to Fig. 4-34 should now appear on the screen. If the color relationship of the bars differs from that shown in this figure, the phase of the receiver may require adjustment.

Checking Phase. An exact evaluation of the phase characteristics of the set can be obtained by connecting an oscilloscope to the individual kinescope control grids.

(Test points are usually provided for this purpose.) The waveforms illustrated in Fig. 4-35 should be obtained at the appropriate kinescope grids. In the case of the blue grid, the sixth bar should be at maximum amplitude while the third and ninth bars should be at zero level. To understand this amplitude relation, refer back to Fig. 4-34. The sixth bar represents the $B-Y$ signal and will therefore be the bar with the greatest amplitude at the blue grid. $R-Y$, on the other hand, being 90° out of phase with $B-Y$, will produce a minimum amplitude signal at the blue grid. Referring again to Fig. 4-34, it can be seen that the third and ninth bars represent the $R-Y$ signal. A similar relationship between the phase and amplitude of the bars exists at the red and green grids.

Checking Phase with the Kinescope Switch. While an oscilloscope represents

20

the ideal means of checking the phase of a color receiver, it is a piece of test equipment which is seldom brought into the home. The kinescope-grid shunt switch provides an alternate method of checking receiver phase in the home. For example, to check the phase of the blue grid, obtain a normal color bar pattern and using the kinescope-grid shunt switch, bias off the red and green guns. This will produce a series of ten blue bars which vary in brightness. Those bars which are above the zero axis in the blue grid waveform (Fig. 4-35) will appear brighter than the background (background being the area between color bars), while those bars that fall below the axis will appear darker than the background. Bars that fall at the zero axis in Fig. 4-35 will blend with the background. If the receiver phase is properly adjusted, the third and ninth bars should blend with the background, when checking the blue grid. The phase at the red grid can be checked by reactivating the red gun and biasing off the blue gun with the kinescope-grid shunt switch. In this case, the sixth bar should blend with the background. The green grid may be checked in turn using this same technique.

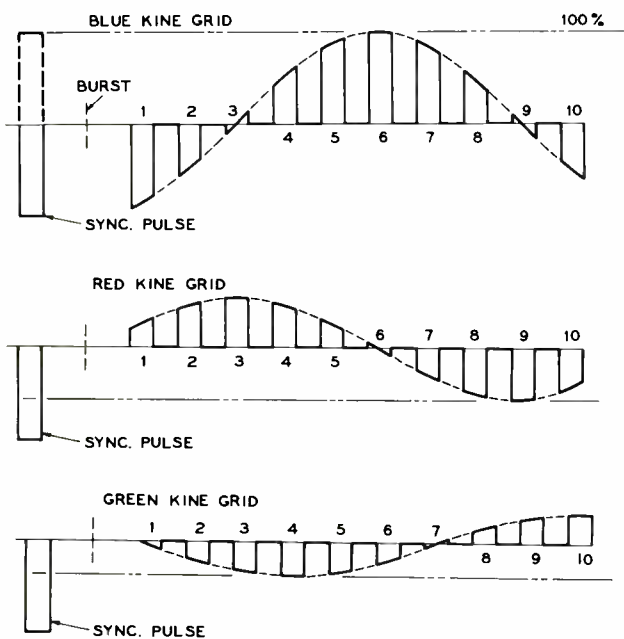

Fig. 4-35. Waveforms produced by the WR-64A at the grids of the kinescope of a receiver that has been adjusted properly. These are ideal waveforms. Actual oscillograms appear more like clipped sine waves due to the narrow bandwidth of the color circuits.

Adjusting Phase. If the phase relationship illustrated in Fig. 4-35 does not exist when the tint (hue) control is near the center of its mechanical range, the phase of the receiver will require adjustment. This portion of the setup procedure varies considerably from model to model. The procedure used on the CTC-12 will be reviewed here as an example. Each receiver's Service Data should be referred to for the correct phase sequence on all other models.

Sequence for Adjusting Phase (CTC-12).

1. Obtain normal color bar pattern.
2. Using kinescope-grid shunt switch, bias off blue and green guns.
3. With the tint (hue) control at the center of its range, adjust the Burst-Phase Transformer T_{702} .
4. Rotate the tint control from one extreme to the other. At one end the seventh bar should be the same brightness as the background. At the other end, the fifth bar should be the same brightness as the background. Continue to adjust T_{702} until the above condition is obtained.

By adjusting the burst-phase transformer, the phase of the 3.58-mc local oscillator is being adjusted indirectly so that proper phase exists at the center of the tint controls mechanical range. On older receivers, the phase relationship between the two CW signals being fed to the demodulators was adjusted next. However, on recent receivers, this phase relationship is fixed and does not require adjustment.

Matrix. Notice that the maximum amplitude of the bar signals present on the three grids is not the same. Refer to Fig. 4-35. The blue grid has the greatest amplitude, the red grid is next and the green grid has the least amplitude. These variations in amplitude come about in the following way. As you learned in earlier lessons, the chrominance signals are reduced in amplitude at the transmitter so that the transmitter will not be overmodulated by the peak chrominance signals. The $B-Y$ signal receives more

attenuation than the $R-Y$ signal. At the receiver, the original amplitude relations are restored. Thus the $B-Y$ signal receives more amplification in the receiver than does the $R-Y$ signal. Now there is no chrominance-signal attenuation in the color bar generator. Thus, the $B-Y$ signal at the output of the receiver is larger than the $R-Y$ signal. In the very early receivers, provision was made for adjusting the amplitude ratio between the individual guns. These were known as matrix adjustments. In subsequent receivers, a fixed matrix is employed and no matrix adjustments are required.

Alternate Color Check. The transmitted color stripe provides an alternate method of checking the color performance of the receiver. When used properly, it can establish:

- a. If the set is making color.
- b. If color sync section is operating properly.
- c. If color phase is approximately correct.

The stripe consists of two pulses of 3.58-mc information which appear just before and after the horizontal blanking pulse. See Fig. 4-36. When the horizontal phase has been adjusted, the left bar will function as the burst signal and the right bar will appear in color on the screen.

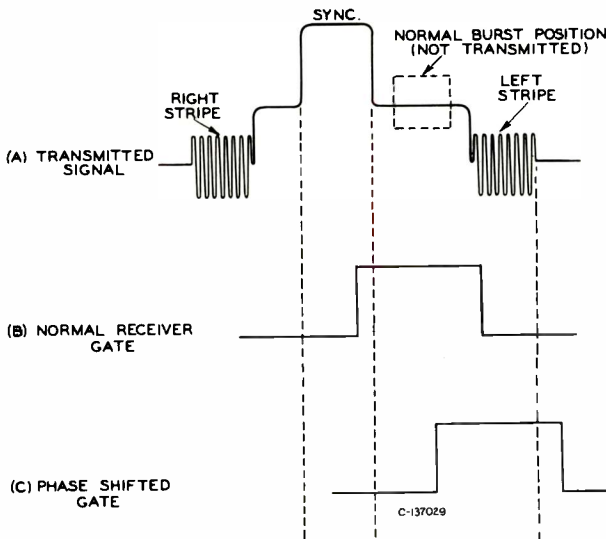

Fig. 4-36. Location of the color stripe signals in the composite video signal.

Normally, no color appears on the screen since the bandpass amplifier is biased to cutoff by the action of the color killer. The gating pulse shown in Fig. 4-36b regularly pulses the burst amplifier stage into conduction. If burst is present at this time, a bias will be developed which will cut the killer off and in turn activate the bandpass amplifier.

If the receiver gate shown in Fig. 4-36b can be shifted to the position shown in Fig. 4-36c, the left stripe will function as the burst signal. The desired phase shift can best be obtained by temporarily connecting a 0.005- μ f capacitor between the plate of the sync amplifier (or sync separator) stage and ground. The capacitor distorts the normal sync pulse, as shown in Fig. 4-37d. This produces a shift in the phase of the horizontal output transformer pulse, as shown at e. Since the horizontal output pulse triggers the gate pulse, this in turn will also be shifted as shown in f. With the killer deactivated, a color stripe should appear at the right edge of the picture. Refer to Plate 4.

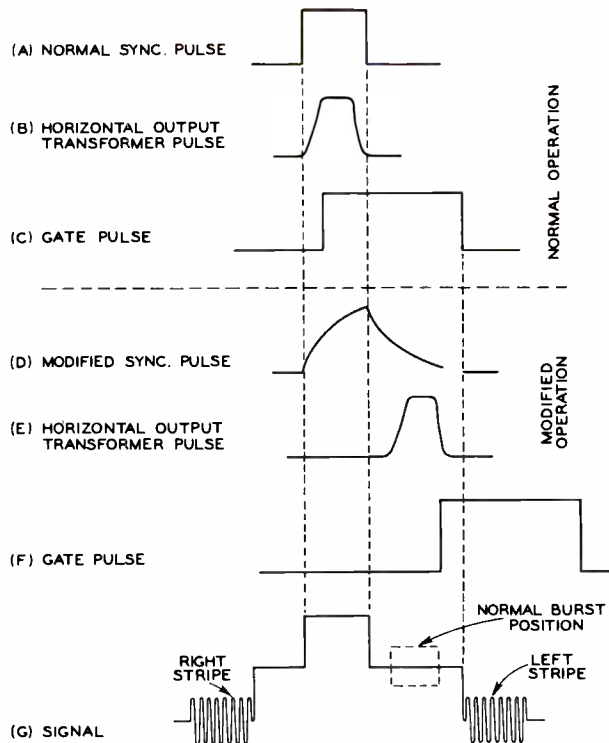

Fig. 4-37. Action of the phase shifting capacitor installed in the sync circuits to make the color stripe visible.

Sequence for Checking Color, Using the Transmitted Stripe.

1. Tune in the channel transmitting the stripe and carefully adjust fine tuning.

2. Connect the 0.005- μ f capacitor from the plate of the sync amplifier (or sync separator) to ground. Slight readjustment of the horizontal hold control may be required at this point to stabilize the picture.

3. Position the tint control to the center of its range.

10
4. Advance the color control until color just appears in the stripe. A normal receiver should produce a solid yellow-green stripe at this point.

2
No color would indicate failure of a color stage. A barber-pole effect would indicate a color sync problem. If yellow green cannot be obtained at or near the center of the range of the tint control, a phase problem is indicated.

Note: While the color stripe can be used to check color phase, a color bar generator is required to adjust phase accurately.

Using a Program to Check Color. When a color program is in progress, it may be

used to check color operation. The following sequence should be followed in this case:

1. Tune in the channel broadcasting the color show and adjust fine tuning carefully for minimum sound beat.

2. Set brightness and contrast controls for a normal black-and-white picture (chroma control should be fully counterclockwise in this step).

3. Adjust chroma control until color saturation appears normal (neither too vivid, nor too pale).

4. Adjust hue control to obtain normal flesh tones.

Failure to produce color would again indicate a problem in the color circuits. Diagonal color stripes in place of a solid color picture indicates a color sync problem. Inability to make flesh tones at or near the center of the tint control indicates a need for adjusting phase.

Instructing the Customer. The sequence of steps listed in the previous paragraphs should be followed when instructing the customer. Be sure to spend adequate time in properly instructing the customer.



NOTES

NOTES

study group 3
lessons 5 & 6

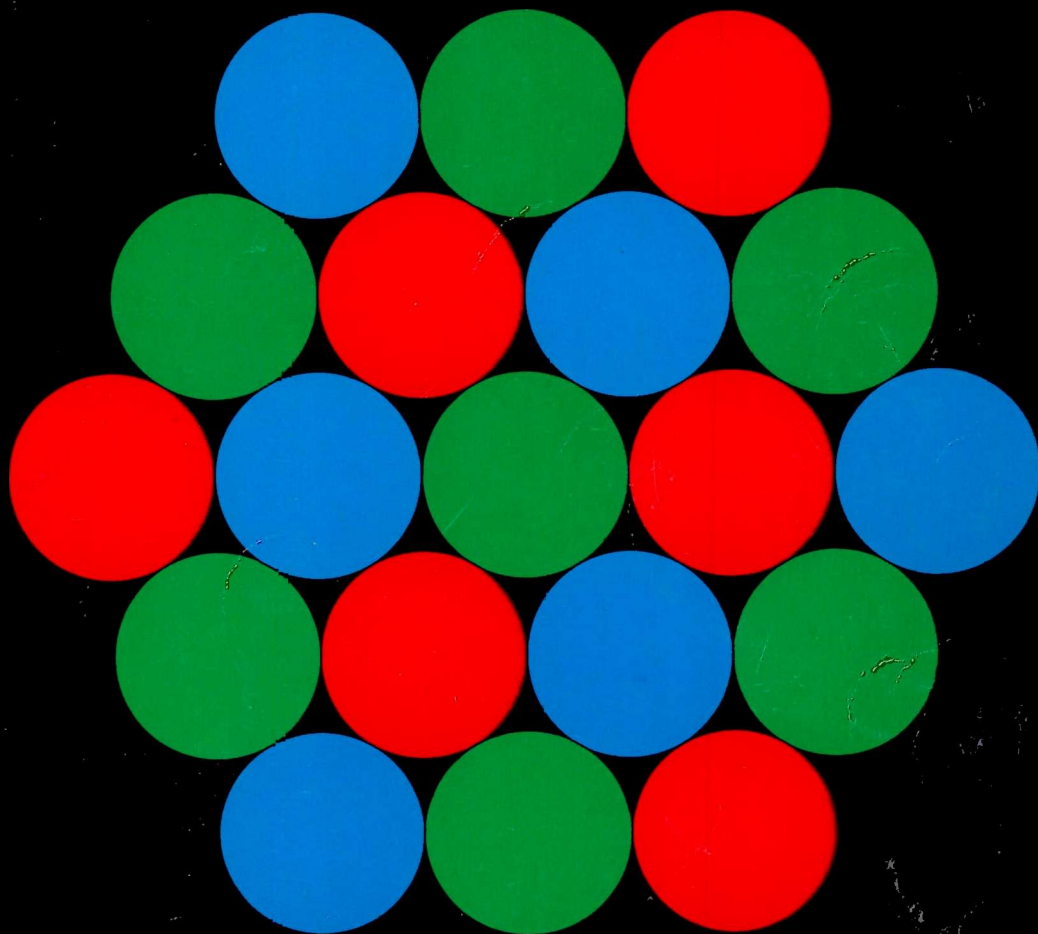

Color Television
Home Study Course
RCA Institutes, Inc.

A SERVICE OF RADIO CORPORATION OF AMERICA

© RCA Institutes, Inc. 1963
All Rights Reserved
Printed in U.S.A.

COLOR TELEVISION COURSE

LESSON 5

MODERN RECEIVER CIRCUITRY

- 5-1. Tuners and Antennas
- 5-2. I-F Amplifiers
- 5-3. Sync and AGC
- 5-4. Deflection and High Voltage
- 5-5. Convergence Circuits
- 5-6. Chrominance Section
- 5-7. Demodulators
- 5-8. Color Synchronization Circuits
- 5-9. Color Killer
- 5-10. Color Video Output Circuits
- 5-11. Luminance Amplifiers
- 5-12. Remote Control
- 5-13. Servicing Features



RCA INSTITUTES, INC.

A SERVICE OF RADIO CORPORATION OF AMERICA

HOME STUDY SCHOOL

350 West 4th Street, New York 14, N.Y.

INTRODUCTION

The development of commercial color television in the early nineteen fifties required the creation of a considerable number of new engineering concepts, components, and circuits. New words came into being, and some older but not generally familiar scientific terms had to be used to define and describe certain parts of the system. In the years since the introduction of color television, considerable engineering work has been done resulting in color receivers having very high performance characteristics. It is the purpose of this lesson to familiarize the student with recent receiver designs so that he will know what is presently being done. In addition, the lesson will provide a working knowledge of why and how certain things are done so that you will be in a better position to understand future developments.

The Color Signal. Before beginning the technical description of the receiver, a brief review of the transmitted color signal is in order. Four basic signals are combined to form the transmitted signal. These are: (1) the chrominance signal, which is the color video signals modulated on a 3.58-megacycle subcarrier; (2) the color sync signal, or "burst," which consists of about eight cycles of the color subcarrier and occurs immediately after the horizontal sync pulse; (3) the horizontal and vertical deflection sync pulses; and (4) the luminance signal, which is made up of certain fixed proportions of the red, blue, and green camera signals, but is generally similar to the video signal of the black-and-white transmissions.

The phase of the color video subcarrier relative to that of the burst determines the hue of the transmitted color (whether it's orange or green or purple), whereas its amplitude is indicative of the saturation of the color (whether it is vivid red or pale pink). Consequently, absence of the color video subcarrier indicates that only shades of gray are being transmitted.

General Receiver Considerations. The color receiver is capable of reproducing black-and-white as well as color signal pictures. Consequently, in addition to the

specialized color signal processing circuits, the receiver contains many sections related to those of a black-and-white receiver. Since it may be helpful to those students who are already familiar with black-and-white receivers to divide the receiver into these two parts, the over-all block diagram shown in Fig. 5-1 has those blocks which have a black-and-white function drawn shaded. However, we must be careful to realize that although the shaded blocks are related to the black-and-white receiver functions, the actual circuits are somewhat different for reasons which will be brought out later in the lesson.

Block Diagram Description. In order to permit a broad view of the over-all operation of a color receiver, let us follow the signal path indicated on the block diagram of Fig. 5-1.

R-f signals are picked up at the antenna, amplified, and converted to i-f signals in the tuner. The i-f signals are amplified further in the i-f amplifier. Separate sound and video detectors are used at the i-f output. The output of the video detector is applied to a three-stage video amplifier whose output, the luminance signal, is applied to the cathodes of the color kinescope.

The first video amplifier, in addition to providing luminance signal drive to the second video amplifier, provides signal to the sync separator and noise-inverter-AGC system. The outputs of these blocks provide noise-immune AGC control of the tuner and i-f amplifier, and sync signals to lock in the horizontal and vertical deflection systems. Another output from the first video amplifier is passed through the bandpass amplifier which selects and amplifies the chrominance signal in the vicinity of 3.58 mc. This signal is then passed on to the demodulators which extract the color video information and apply it to the R-Y and B-Y amplifiers. Portions of the R-Y and B-Y signals are added together to form G-Y in a matrix at the input of the G-Y amplifier. The three color video signals are key-clamped to restore their d-c components by means of a pulse from the blanker and are applied to the control grids of the color kinescope.

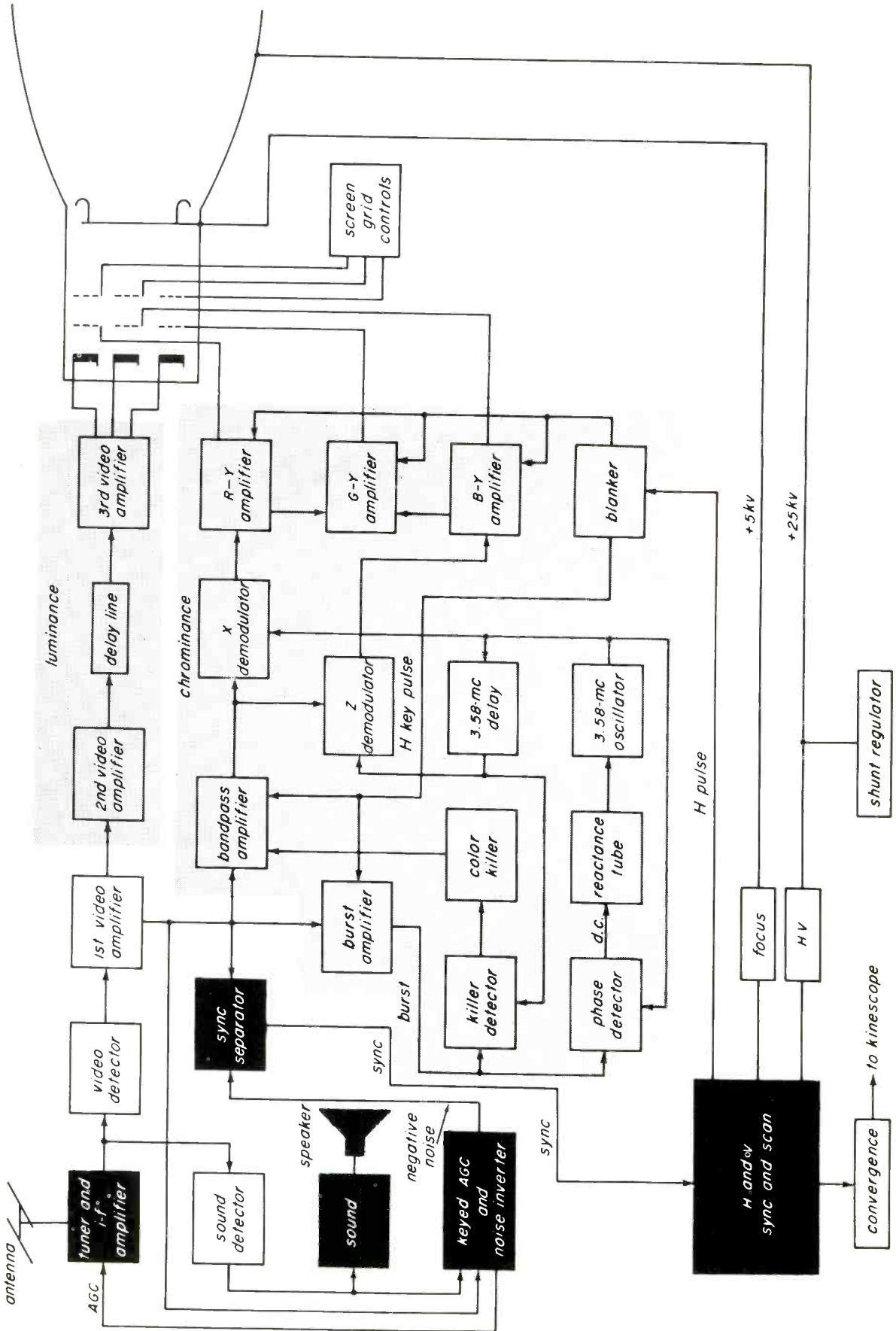

Fig. 5-1. Block diagram of the color receiver showing all major interconnections between color circuits.

Since a part of the color video information is transmitted as the phase of the chrominance signal, the demodulators must be provided with phase reference carriers in addition to the chrominance signal. The reference carriers are generated in a 3.58-mc oscillator that is synchronized in the following way: The same chrominance signal that is applied to the bandpass amplifier is applied to the burst amplifier. This amplifier is normally cut off, but is pulsed on for the short burst interval immediately following each horizontal sync pulse. Any burst signal present is amplified and applied to the phase detector which compares the phase of the transmitted burst with that of a locally-generated reference carrier. If these phases are not at the correct phase difference, a d-c "error" voltage is generated by the phase detector. The error voltage is applied as a correction voltage to the reactance tube. The reactance tube tunes the oscillator.

A separate phase detector is used to determine the presence or absence of burst, and its output is used to operate the color killer. It provides a noise-immune color killer signal. In the absence of burst, which indicates absence of color signals, the killer is turned on and it cuts off the bandpass amplifier, thereby preventing colored noise from getting to the kinescope.

The sound, horizontal and vertical circuits drive their respective output devices as in black-and-white receivers. Convergence waveforms, required to keep the three beams of the color kinescope converged at the screen edges, are obtained from the horizontal and vertical circuits. They are applied to the convergence yoke which is mounted behind the main deflection yoke on the neck of the kinescope. A separate focus rectifier is provided. A shunt regulator is used in the kinescope high-voltage or ultor supply to maintain a constant high voltage.

The block diagram shown in Fig. 5-1 is that of the RCA CTC-12 color receiver. Since much of the material covered in this lesson is based on this receiver, a complete schematic is included at the end of this lesson. If, in the following sections, specific reference is not made to some other figure, the student may assume that the complete

schematic diagram of the CTC-12 is being discussed.

5-1. TUNERS AND ANTENNAS

Antenna Requirements. As was pointed out in the introduction, the color signal is transmitted as modulation of a 3.58-mc sub-carrier. Consequently, to achieve good color reception it is very important that the frequency response of the antenna-tuner system be flat across the channel bandwidth and not vary from channel to channel. Antennas which may be satisfactory for black-and-white viewing may not be adequate for color. In particular, some antennas of the Yagi types may not give satisfactory results, and built-in or "rabbit ear" types are definitely troublesome. Depending upon location, good quality conical or in-line types can generally be used with good results. Careful aiming of the antenna is necessary since ghosts and reflections may have the same effect as a poor frequency response. Whenever distribution systems or TV boosters are used it is important that they too have adequate bandwidth.

Another type of problem may occur if the receiver is installed in an area which is very close to a transmitter. If the signal is strong enough to overdrive the r-f amplifier, a phenomenon called cross-modulation takes place in addition to the clipping of signal. The usual consequence of cross-modulation is flat looking pictures and the appearance of a 920-kc beat signal in the picture which is the result of the inter-modulation of the 3.58-mc color signal and the 4.5-mc sound

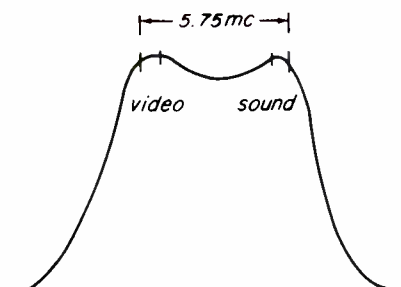

maximum tilt between video and sound carriers - 30%
maximum difference between peak and valley - 30%

Fig. 5-2. Tolerances on the response curve of a tuner employed in a color receiver.

signal. When the beat signal results from cross-modulation in an early stage, it cannot be tuned out by adjusting the fine-tuning control. This problem can usually be solved by placing a resistive attenuator between the receiver antenna terminals and the lead-in wires.

Tuners. The two tuner types which are most common in black-and-white receivers,

the turret and the switch types are also used in color receivers. They are generally similar to black-and-white designs but in general are subject to more careful alignment and inspection for the reasons given in the discussion on antennas. Figure 5-2 shows the r-f response required of the tuner. In the RCA CTC-12 tuner, shown in Fig. 5-3, antenna signals are passed through a balun transformer T_1 which converts the signal

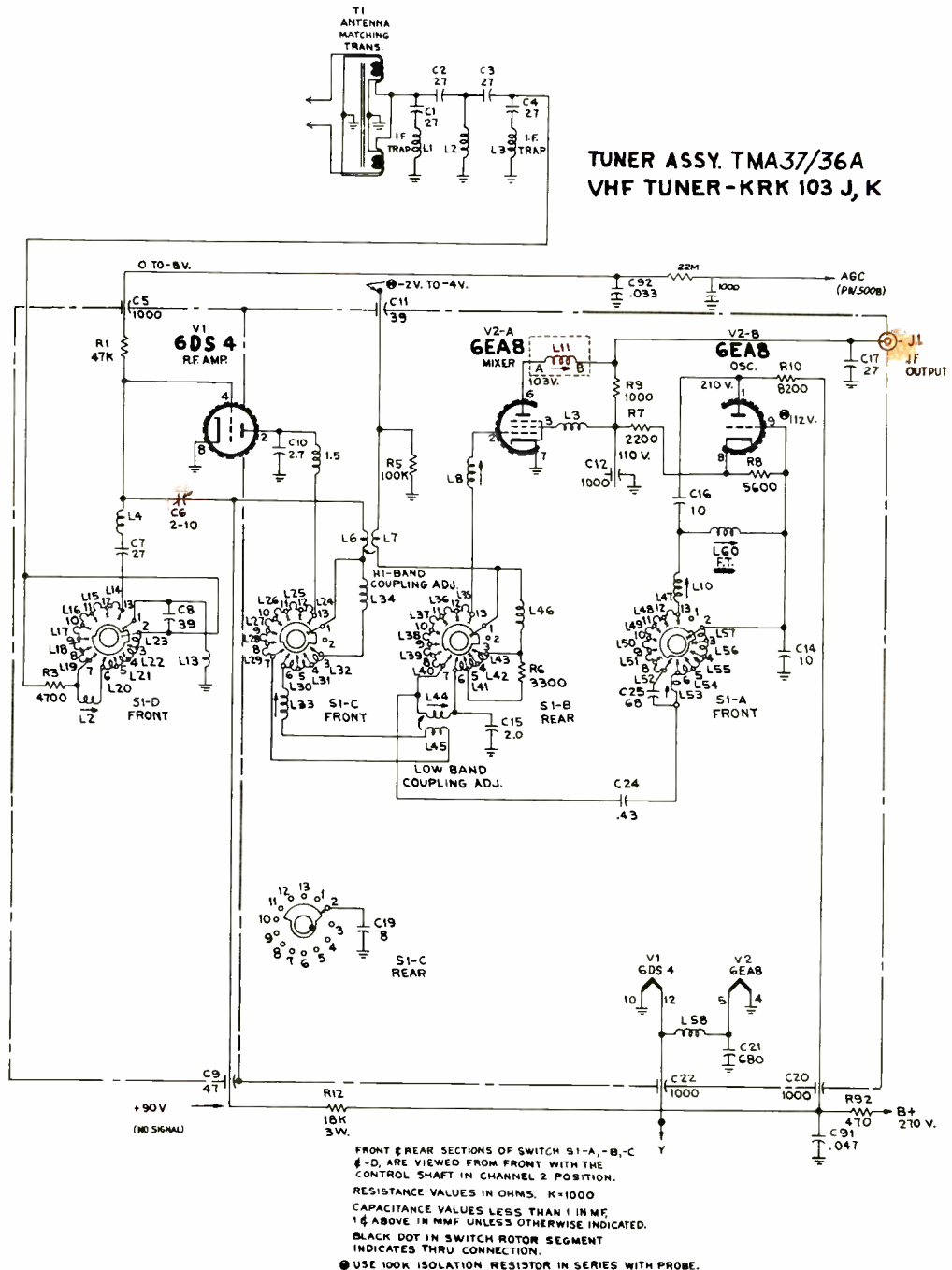

Fig. 5-3. Schematic diagram of the KRK-103JK VHF tuner used in RCA color receiver.

from the push-pull form in the antenna system to the single ended form at the receiver input. The signal then passes through a high-pass filter which is arranged to have extra attenuation at the i-f frequencies, and is applied to the antenna tuning circuit S_{1-D} . This switch is arranged to provide a tapped-capacitor pi network for the low VHF channels and a tapped inductor for the high VHF channels. The signal then passes through a double-tuned, over-coupled interstage network using the coils on S_{1-C} and S_{1-B} with the low and high band couplings substantially independent of each other. A triode r-f amplifier V_1 is used. It is a nuvistor type tube and is neutralized by means of C_6 . V_{2-B} is arranged as a Colpitts oscillator. Oscillator injection to the mixer, V_{2-A} , takes place by a combination of C_{24} and the interelectrode capacitance of V_2 . The i-f output is taken from the plate of the mixer, in which L_{11} is tuned to the i-f frequency with C_{17} and the capacitance of the output cable. The oscillator is designed to be stable and is compensated to provide essentially drift-free operation.

5-2. I-F AMPLIFIERS

A variety of i-f amplifier designs have been used in the design of color receivers. However, the trend in recent years has been to use designs which are basically similar to those of black-and-white receivers. However, the design provides a slightly greater bandwidth, and more trapping of undesired interfering signals. Typical of recent design practice is the i-f amplifier used in RCA CTC-12. Refer to Fig. 5-4.

I-f signals from the mixer plate are passed through the link cable to the i-f board, PW 300. After passing through coupling capacitor, C_{301} , the signals enter the first picture i-f grid transformer T_{301} , which is tuned near the center of the i-f passband at 44 mc. Very heavy attenuation of the adjacent-channel sound signal, which appears at 47.25 mc, is achieved in T_{301} . The trap is quite complex and a rigorous analysis is not warranted for our purposes. It is sufficient for us to observe that the circuit does not

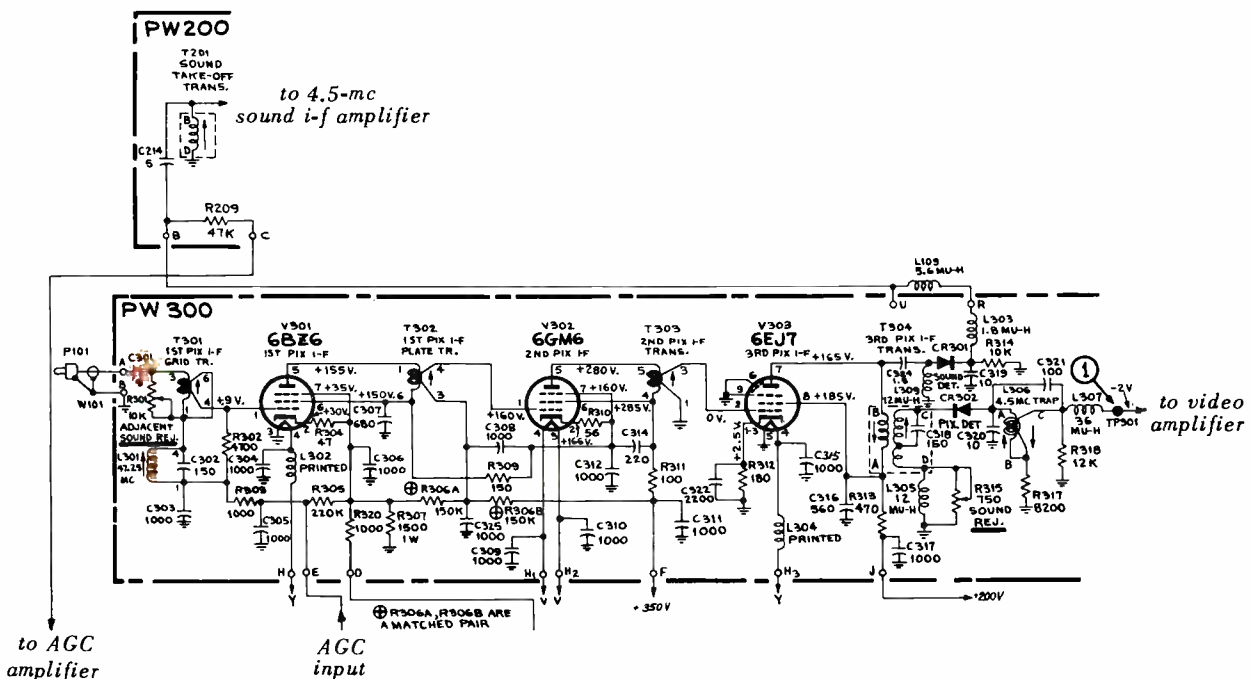

Fig. 5-4. Video i-f amplifier and detector section of the RCA CTC-12 receiver.

employ conventional shunt- or series-connected traps. Instead the circuit effectively develops two 47.25-mc signals of opposite phase in the feed to V_{301} . The control, R_{301} , is adjusted to produce almost complete cancellation of the signal. Coil L_{301} is adjusted to set the frequency at which cancellation occurs to 47.25 mc, the adjacent-channel sound frequency.

Coupling between the first and second i-f amplifiers is conventional. The plate transformer, T_{302} , is tuned to the i-f picture carrier frequency of 45.75 mc. T_{303} , which couples the second and third i-f amplifier, is tuned just above the i-f color-carrier frequency at 42.5 mc. The last i-f transformer is T_{304} . It is double tuned, with a center frequency near the middle of the i-f band. Sound i-f signals are taken from the plate of the 3rd picture i-f amplifier, V_{303} , and are coupled through C_{324} into the diode CR_{301} . Here the sound inter-carrier at 4.5 mc is detected. This 4.5-mc signal, developed across C_{319} and R_{314} , is passed through i-f filters L_{303} and L_{109} into the sound board PW 200. The sound system, consisting of a pentode amplifier, a locked-oscillator quadrature-grid sound demodulator and power output stage, is sufficiently similar to that of RCA black-and-white receivers to make additional description unnecessary.

Other signals, in addition to 4.5-mc sound signal, are taken from CR_{301} . The d-c and lower video-frequency components are preserved in the diode load circuit. They are filtered and applied through R_{209} as the main input signal to the grid of the keyed AGC amplifier V_{503A} .

Since sound is taken off in a separate detector, the sound attenuation at i.f. and 4.5-mc in the video detector circuit, CR_{302} , may be made very much greater than that used in black-and-white receivers. The trap circuits in the video detector are also complex. In addition to the conventional low-pass filter, C_{320} , a special notch filter made up of the added components C_{321} , L_{306} , and R_{317} provides sharp attenuation of the 4.5-mc signal. This filter functions by effectively providing two paths to the grid of the video amplifier at 4.5 mc. One path inverts the polarity of the signal so that complete

cancellation occurs at the output of the filter.

The sound signal is further rejected in the video detector by minimizing the amount of 41.25-mc signal that is applied across CR_{301} . This is accomplished by means of the tapped secondary winding on T_{304} . By simultaneously adjusting the tuned portion of the secondary of L_{304} and the resistance R_{315} , the total 41.25-mc voltage developed across the diode detector can be reduced to a very low value.

Figure 5-5 shows the over-all r-f, i-f response. The picture carrier, at 45.75 mc, and the color carrier, at 42.17 mc, are aligned at the 50% response points on the curve. The top of the response is substantially flat from 45 mc to 42.75 mc.

If you trace the path for d-c current through the first and second i-f stages, you will find that the first two stages are in series across a high-voltage tap on the power supply. This has been standard practice in RCA black-and-white receivers for some time. In this system, AGC voltage applied to the grid of the first stage is direct coupled to the cathode of the second stage. Thus, both stages are controlled by AGC. The series arrangement allows the AGC controlled i-f stages to be fed from a high-voltage tap on the power supply. Improved power-supply regulation is obtained because there are no large voltage-dropping resistors between the output side of the rectifiers and the varying load represented by the AGC controlled i-f stages.

In early color receivers, an attempt was made to maintain the i-f passband flat to beyond the color subcarrier at 42.17 mc. It was found, however, that several factors

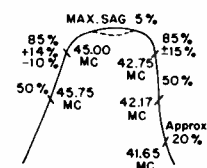

Fig. 5-5. Over-all r-f/i-f response curve of the RCA CTC-12.

combined to make this appear to be a less attractive solution to the problem than the one just described. These factors include the loss in i-f gain due to the increased bandwidth, more unsymmetrical color transients due to upper sideband distortion, and greater difficulty in removing 3.58-mc dots from the luminance signal.

5-3. SYNC AND AGC

The basic functions of sync separation and AGC in a color receiver are generally similar to those of black-and-white receivers. However, since color receivers are high-quality products, additional care is taken in their design. To this end, noise immunity provisions have been incorporated in most chassis to maintain excellent vertical and horizontal sync despite high noise levels. Two systems will be described in this lesson.

RCA CTC-12. This circuit is closely related to the fairly common pentode keyed AGC amplifier and triode sync separator of

black-and-white practice. The AGC portion is shown in simplified form in Fig. 5-6a. To obtain an understanding of this circuit, imagine first that R_3 is shorted so that the screen grid is connected directly to $B+$, and that C_3 is open and R_4 shorted so that the suppressor is tied directly to the cathode. The cathode is held at a fixed potential since it is tied to a low-impedance source of positive voltage from the R_5 - R_6 bleeder. Composite video signals, with sync extending in the positive direction, are d-c coupled to the control grid. Horizontal frequency pulses, obtained from the high-voltage transformer, are applied to the plate through a coupling capacitor C_1 . If the tube is cut off, C_1 does not take an average charge. If there is conduction in the tube, electrons will pile up on the plate side of C_1 whenever the pulse is present. The electron pile-up is proportional to the tube conduction and results in an average negative voltage at the plate. Since the tube is a pentode, any variations which might occur in the plate pulse amplitude do not affect plate current. Thus, the average negative voltage is a function only

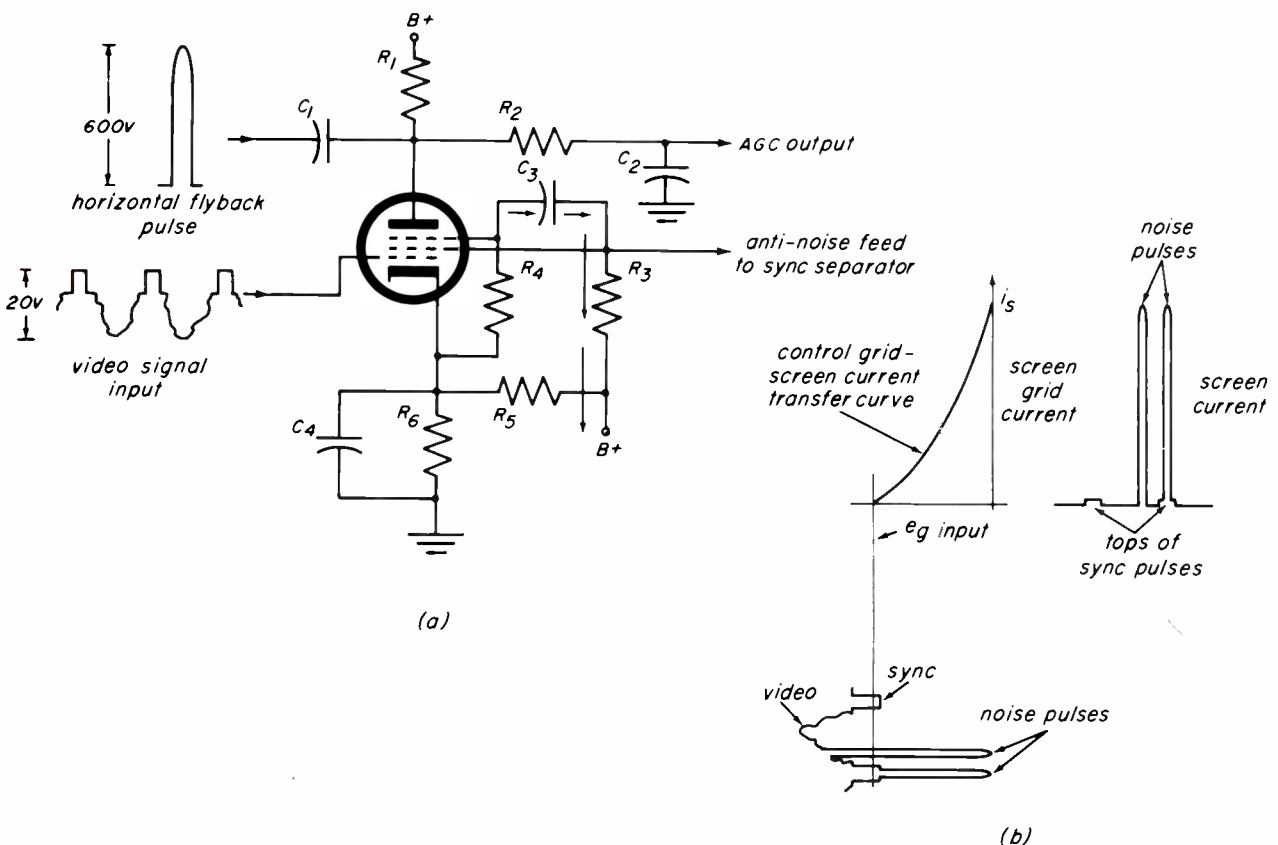

Fig. 5-6. Operation of the noise-protected AGC detector in the RCA CTC-12.

of the d-c level of the sync tips on the grid relative to cathode potential. The average negative plate voltage is filtered, and then used to supply the AGC control voltage for the r-f and i-f amplifiers. With typical r-f, i-f amplifiers the AGC will keep the sync tips constant at a level which is a little lower than the d-c voltage level at the cathode for antenna signal variations from about 7 microvolts to about 1 volt.

If impulse noise pulses should be added on top of the signal as shown in Fig. 5-6b, pulses occurring on top of sync cause a large plate current to flow which makes an abnormally large AGC voltage. This in turn reduces the receiver gain and washes out the picture. This undesirable condition is commonly called "setting-up" of the AGC system. To prevent this, the full circuit as it is shown in Fig. 5-6a is used. The tube used is a pentode with an active suppressor grid. Part of the cathode current flows to the screen and part to the plate, the division being a function of the suppressor grid voltage. With a noise-free input signal, sync tips cause a small amount of screen current to flow as shown, developing a small negative voltage pulse on the screen. This small pulse doesn't interfere with the AGC detection going on in the plate circuit. However, if a noise pulse comes in on top of sync, cathode current and hence screen current become large, causing a large current pulse on the screen as shown in Fig. 5-6b. The resulting negative voltage pulse is fed to the suppressor grid through C_3 . A large negative voltage on the suppressor grid prevents plate current from flowing, and the AGC system effectively ignores large noise pulses. In addition, negative noise pulses from the screen may be fed over to the sync separator input to cancel the positive noise on the signal feed to that tube. In this manner, the sync separator, as well as the AGC system, is protected.

In the RCA CTC-12, the cathodes of AGC and sync separator tubes (V_{503}) are tied together internally and are returned to ground through R_{130} , the AGC control. This relatively low impedance resistor has a positive voltage across it since it is tied through terminal G on PW 700 to the plate of the 2nd video amplifier V_{304B} . Sync-positive video

signals from the grid of the second video amplifier are applied to the control grid of the AGC tube V_{503A} . Noise signals, developed across R_{534} and R_{535} in the screen, are coupled to the suppressor grid by means of C_{528} , thereby protecting the AGC plate circuit. The AGC plate pulse is obtained from a capacitive divider, C_{113} and C_{114} , that is returned to the high voltage transformer. The d-c voltage developed in the plate is filtered and fed to the r-f and i-f amplifiers by means of the other components in the plate circuit. Negative noise pulses to protect the sync separator are coupled to the top of C_{527} from the screen through R_{533} . The sync separator is a more or less conventional triode type with a double time-constant RC network in its grid current to further improve its noise immunity. This RC network contains C_{526} , R_{532} , C_{527} and R_{542} . The sync separator's grid resistor, R_{542} , is returned to the cathode of the first picture i-f stage. The purpose of this connection is to improve sync separator action when weak signals are received. Under weak signal conditions the cathode voltage of the AGC-controlled i-f stage increases, reducing the bias on the sync separator. The output of the sync separator is fed to the horizontal phase detector, SR_{501} , and also to the vertical-scan input integration network consisting of network $R_{504}-C_{504}$.

The circuit used in the Zenith 29JC20 color receiver is substantially the same as that used in Zenith black-and-white receivers. A simplified version is shown in Fig. 5-7. The tube used has a simple cathode, control grid, and screen grid. It has, however, two plates and two active suppressor grids as is indicated in Fig. 5-7. Large amplitude a-c coupled (sync-positive) signals are applied to the right-hand suppressor, and separated sync is developed in its associated plate in a manner similar to that of the triode sync separator. D-c coupled sync-positive signals are applied to the left-hand suppressor and AGC voltage is developed in the pulsed left-hand plate circuit. The cathode is held at some positive potential. Noise immunity is obtained by applying video signals (and noise) in which sync extends in the negative direction to the common control grid. These signals are applied from a high impedance source

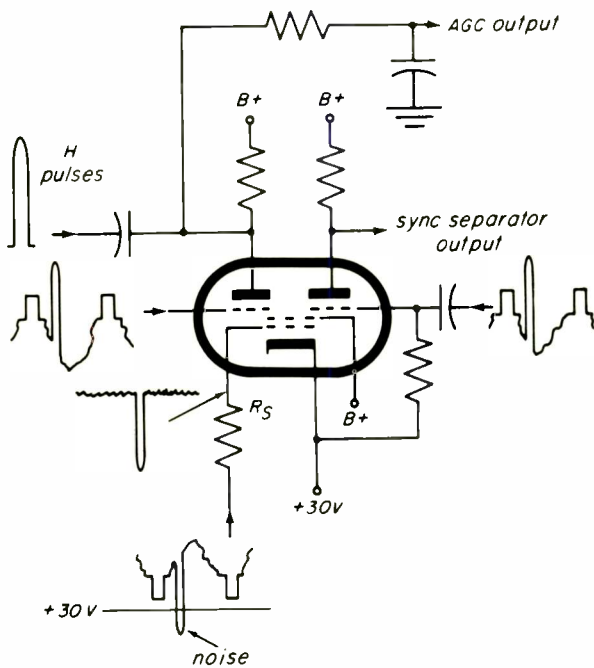

Fig. 5-7. AGC/sync separator operation in the Zenith 29JC20 color receiver.

that is returned to a d-c potential which is positive with respect to the cathode. As a result, grid current is drawn and very little of the applied voltage is dropped across the grid-to-cathode impedance. Large negative noise pulses, however, can overcome the positive bias and cut the tube off so that no cathode current flows. Thus, noise pulses shut down the AGC detection and sync separation processes.

5.4. DEFLECTION AND HIGH VOLTAGE

In general, the circuits for both horizontal and vertical deflection in color receivers are quite similar to their black-and-white counterparts. Balanced-diode horizontal AFC combined with some form of sine-wave stabilized multivibrators are used to develop the horizontal scan, and a sync-triggered multivibrator is used to generate vertical scan signals. The principal point of departure is the power required in the deflection and high voltage circuits, which is considerably higher in color than in black-and-white receivers. The reasons for the increased power are the larger kinescope neck diameter and the higher high voltage. In addition, about 25 watts of high-voltage power must

be taken from the horizontal system to light up the kinescope instead of the four or five watts used in black-and-white sets. The high voltage supply in the color receiver must also be regulated and must supply a separate focus voltage.

Regulated HV. Excellent high-voltage regulation is an important necessity in color TV receivers. It is needed to provide constant picture size and convergence in spite of variations in average scene brightness. The dotted curve in Fig. 5-8a shows the regulation characteristic of the high-voltage power supply with the regulator tube itself disconnected. When 1 ma of kinescope current flows, the voltage is 25 kv, but if a dark scene is transmitted, such that the kinescope current falls to near zero, the high voltage rises to about 35 kv. In order

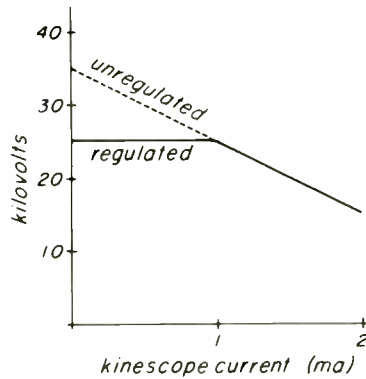

(a)

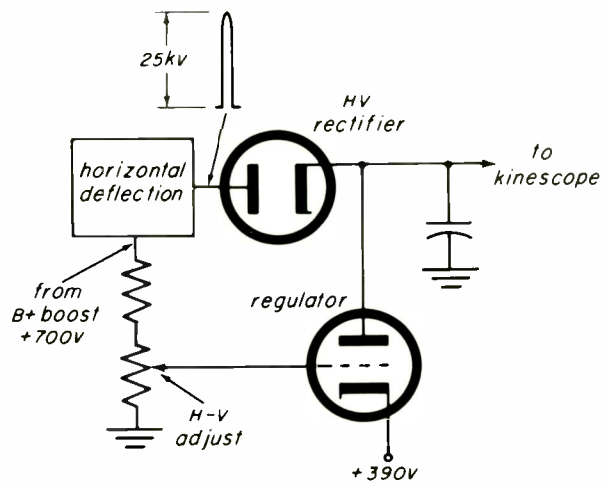

(b)

Fig. 5-8. Regulation graph and simplified schematic diagram of a typical high-voltage shunt regulator.

to prevent this rise, a regulator tube is placed in shunt with the kinescope high-voltage electrode as shown in Fig. 5-8b. It functions to maintain a constant total load current on the power supply regardless of variations in kinescope ultor current. This happens in the following way: the cathode of the regulator is tied to the fixed +390-volt power supply tap, and its plate is tied to the ultor supply. The grid is connected to an adjustable bleeder on the B+ boost supply. B+ boost varies in proportion to the amount of current drawn from the high-voltage supply. Consequently, with a change in scene that makes the kinescope draw more current, B+ boost voltage falls, driving the grid of the regulator in the negative direction, and thereby reducing the regulator current. If the scene changes so as to reduce kinescope current, B+ boost rises, thereby increasing the regulator current. Thus, the total current remains the same. The final regulation curve is shown as the solid line curve of Fig. 5-8a. If the kinescope draws more than 1 ma, the regulator is cut off and can no longer maintain a constant high voltage. At this point the picture "blooms."

In the RCA CTC-12 a specially designed high-voltage regulator tube, 6BK4, is used for the shunt regulator. Resistors R_{106A} and R_{106B} , and R_{105} , an adjustable resistor used to set the operating level of high voltage, form the bleeder from boost B+ to ground. The cathode return to the +390-volt line is made through a test jumper and the secondary of the vertical output transformer, T_{104} . The test jumper may be opened and a milliammeter inserted to measure the regulator tube current, which should be about 1 ma when the kinescope screen is black.

Focus. Variable focus voltage is usually obtained from a separate high-voltage rectifier that is connected to a suitable tap on the high-voltage transformer. The required d-c voltage is about 5000 volts, and it must be adjustable. In the Zenith 29JC20 a tuned circuit is placed between the tap and the plate of the rectifier to provide the adjustment. The tuned circuit develops a sine wave of a few thousand volts across it and by varying the tuning, by means of the slug in the coil, the phase of this sine wave can be shifted so that more or less rectified

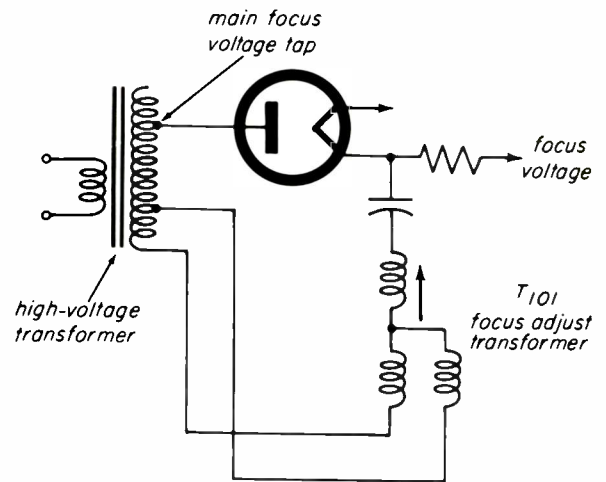

Fig. 5-9. A simplified diagram of the focus-adjust transformer.

output is available. In older RCA receivers, adjustment was made by means of potentiometers in either the pulse feed or the d-c output. On RCA receivers, models CTC-11 and 12, a circuit has been used which can apply either a positive or negative pulse of variable amplitude to the cathode of the focus rectifier. Refer to Fig. 5-9. This pulse voltage either aids or opposes the main pulse applied to the plate. In the CTC-12, focus adjust transformer T_{101} is used. The three windings are interconnected in such a way as to make the pulses across the total winding either add to, or subtract from, the main pulse from the focus tap, as determined by the position of the slug. About 1000 volts of variation is available.

5.5. CONVERGENCE CIRCUITS

The horizontal and vertical deflection circuits supply the current waveforms needed for edge convergence. Composite waveforms, consisting of parabolic and sawtooth components, must be supplied to the windings on the convergence pole pieces.

The circuits that supply the vertical dynamic convergence currents for the CTC-12 are redrawn in Fig. 5-10. The circuit has three inputs: a parabolic waveform is obtained from the cathode of the vertical output tube. Sawtooth waveforms, to add the tilt component, are obtained from two separate secondary windings on T_{104} , the vertical

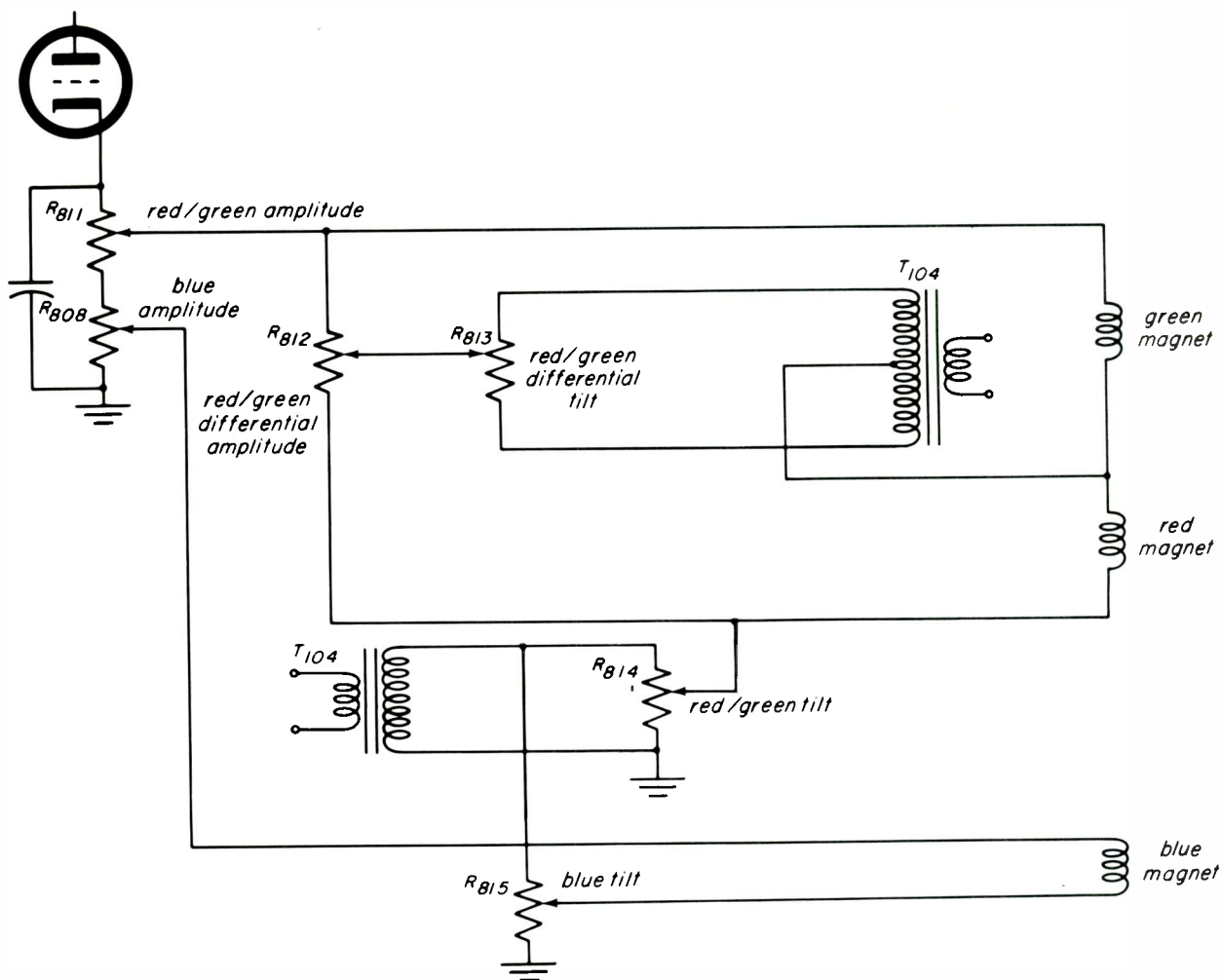

Fig. 5-10. Simplified schematic diagram of the vertical-dynamic convergence system in the RCA CTC-12 receiver.

output transformer. We have drawn T_{104} as two transformers in Fig. 5-10 to avoid complicating the drawing. Only the windings on T_{104} that are involved with convergence are shown.

The blue convergence circuit is straightforward. A vertical parabolic waveform is tapped off at R_{808} , the blue amplitude control, and applied to the vertical winding on the blue pole piece. The bottom of this coil is returned to ground through the blue tilt control, R_{815} . Thus the current in the windings of the blue magnet is determined by the sum of the voltages picked off by the blue amplitude and blue tilt controls.

The vertical red/green convergence circuits are somewhat more complicated. The

master red/green amplitude control, R_{811} , supplies the total parabolic waveform input. Thus, current is applied to the red and green windings in series. A parallel path for the parabolic feed is provided by R_{812} . Let us assume for the moment that controls R_{812} and R_{813} are set at midposition, and that R_{814} is at the ground end of its travel. In that case we have a simple balanced bridge circuit consisting of the red/green coils on one side and R_{812} on the other. The bridge is balanced when R_{812} is at midposition and no current flows between the arm of R_{812} and the junction of the red/green coils. Thus, R_{811} controls the amplitude of the parabolic waveform in both the red and the green coils, and equal currents flow in these coils. By advancing R_{814} , the sawtooth component of current is added to both the red and the

green coils. Thus, R_{811} controls the parabolic component, and R_{814} controls the tilt component in both coils. Now consider the red/green differential controls R_{812} and R_{813} . Note that R_{813} and the tapped winding of T_{104} form another bridge circuit. If R_{813} is set at midposition this bridge is balanced and there is no difference of potential between the arm of R_{813} and the tap on the secondary winding of T_{104} . Since there is no voltage drop between these points, we may consider them shorted for now. This effectively places the short between the arm of R_{812} and the junction of the red/green coils. Now we may see the action of R_{812} by itself. If R_{812} is turned away from its midposition the bridge circuit consisting of R_{812} and the red/green coils becomes unbalanced. If the arm of R_{812} is moved all the way to the top, the green coil becomes shorted and maximum current flows through the red coil. Similarly if the arm of R_{812} is moved below the midposition current increases in the green coil as the current in the red coil decreases. Thus, adjustment of the red/green differential amplitude control causes current to increase in one coil while current decreases by an equal amount in the other coil. (Refer to the setup and adjustment lesson for the effects of these controls on the picture-tube screen.)

Finally, consider the red/green differential tilt control, R_{813} . Moving the arm of R_{813} from the midposition unbalances the bridge consisting of R_{813} and the tapped secondary of T_{104} . Sawtooth current then flows from the top of the transformer. The direction of current flow depends upon the direction in which the shaft of R_{813} is turned. But this sawtooth component of current flows in the junction of the red/green coils. The sawtooth current divides in the red/green coils and flows back to the transformer through R_{812} and R_{813} . When R_{813} is turned in one direction, sawtooth current flows up in the red coil and down in the green coil. Turning R_{813} in the opposite direction has the opposite effect. This means that the differential red/green tilt component of sawtooth current aids the red/green tilt component in one coil and opposes it in the other coil. Thus, the total tilt or sawtooth component in the red coil can be made to increase while the green coil decreases by the same amount.

Reverse rotation of R_{813} reverses these conditions.

Amplitude and differential control of parabolic and sawtooth currents in the red/green magnets makes the job of adjusting convergence easier. In older receivers, the circuits provide individual control of parabolic and tilt components. In these sets, the convergence job could be done in the same way that it is now, but the technician must learn to manipulate the red and green controls simultaneously.

The horizontal dynamic convergence circuits used in the CTC-II and 12 are shown redrawn in Fig. 5-11. Here again the blue convergence circuit is simple and straightforward. A positive pulse, obtained from the high-voltage transformer, is applied to the blue amplitude coil through a coupling capacitor. The impedance of T_{801} is large compared to the impedance represented by the blue magnet and the shunt components including the blue tilt control and the diode. This makes the circuit appear predominantly inductive and a sawtooth of current is developed. The amplitude of the sawtooth is controlled by means of the slug in T_{801} . The current flowing in the blue magnet's winding is this sawtooth minus the currents that flow in the two shunt paths provided by the diode circuit and the blue tilt control. (Refer to the discussion of the basic circuit in an earlier lesson.)

As in the vertical circuits amplitude and differential controls are used to control the red/green correction currents. The master amplitude control is L_{801} . It controls the total current flowing in both red and green coils. Coil L_{802} provides the differential adjustment. The position of the core determines the impedance in series with the red and green coils. When the core is centered in L_{802} the currents in the red and green magnets are equal. When the core is moved away from midposition, the current in one side of L_{802} increases while the current in the other side of L_{802} decreases by the same amount. The amplitude controls are labelled R in the receiver since master and differential amplitude are adjusted to converge the right side of the picture. When the right side of the picture has been converged, the tilt

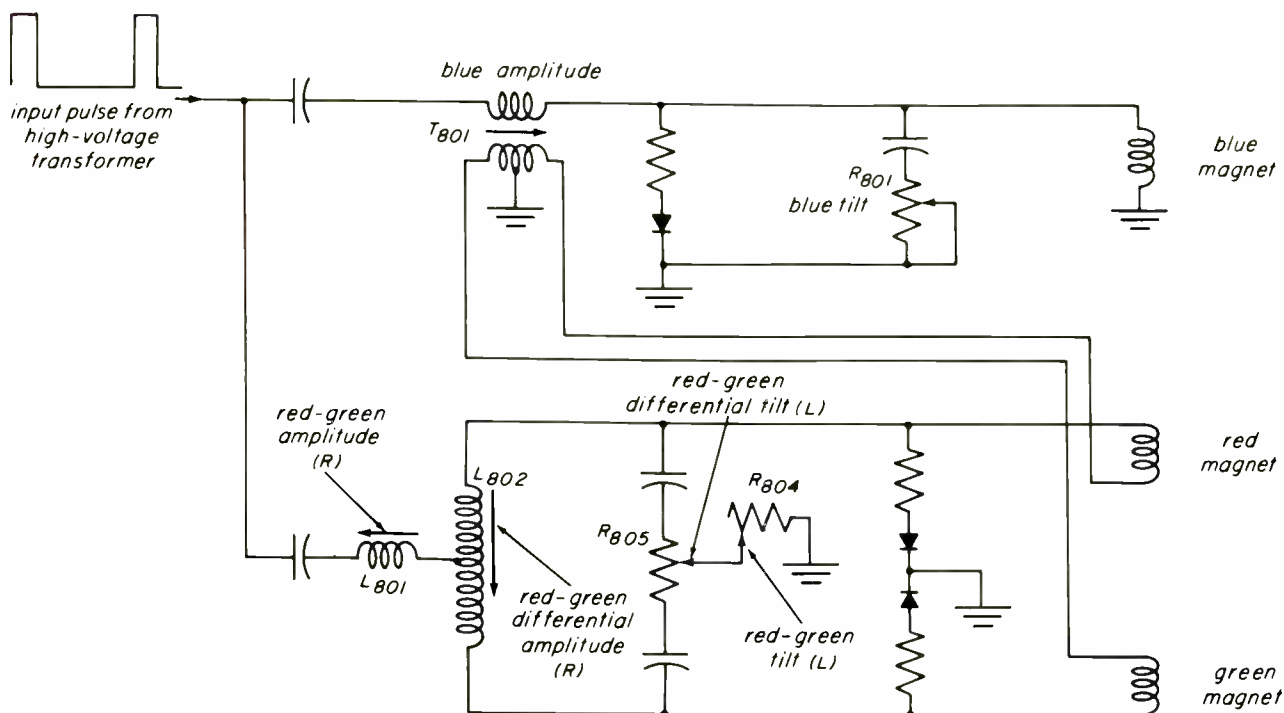

Fig. 5-11. Simplified schematic diagram of the horizontal-dynamic convergence system in the RCA CTC-12 receiver.

controls, marked L , are adjusted to converge the left side of the picture. Control R_{804} adjusts the peak amplitude of the current waveform applied to the red and green magnets at the beginning of the horizontal scan (left side of picture). These currents are equal when R_{805} is set at midposition. After the arm of R_{805} is moved away from midposition the peak current that flows during the early part of the horizontal trace increases in one of the magnets and decreases in the other. Thus, R_{805} provides the differential red/green adjustment for the left side of the screen.

One item remains to be explained in Fig. 5-11. Note that the red and green coils are returned to ground through a centertapped secondary winding on T_{801} . This system couples an additional sawtooth component into the red and green coils. Since a centertapped winding is employed, the additional sawtooth components are opposite in phase in the red and green coils. The purpose of the extra correction is to correct for the red-green tilt that results from coupling between the deflection yoke and the convergence pole pieces. Refer to the picture-tube lesson for a description of this cause of red-green tilt.

5.6. CHROMINANCE SECTION

Earlier discussions have shown the basic function of the stages in the chrominance section. At this point we will examine these functions as they apply to actual, late-model circuits.

Bandpass Amplifier. The basic job of the bandpass amplifier is to separate the 3.58-mc chrominance signal from the composite video signal, and amplify it to the level needed by the color demodulators. Figure 5-12 shows the bandpass amplifier, V_{701A} , for the RCA CTC-12.

Signals from the plate of the first video amplifier are taken and passed through the i-f trap L_{110} , the coupling capacitor C_{132} and impressed across the chroma transformer L_{701} . The transformer is tuned to resonance with stray capacitance at a frequency of about 4 mc. This resonant peak, in combination with the high-frequency roll-off of the i-f response, produces the swept frequency curve shown in Fig. 5-13a at the grid of the bandpass amplifier. Resistor R_{752} helps to damp L_{701} to provide the proper Q and bandwidth.

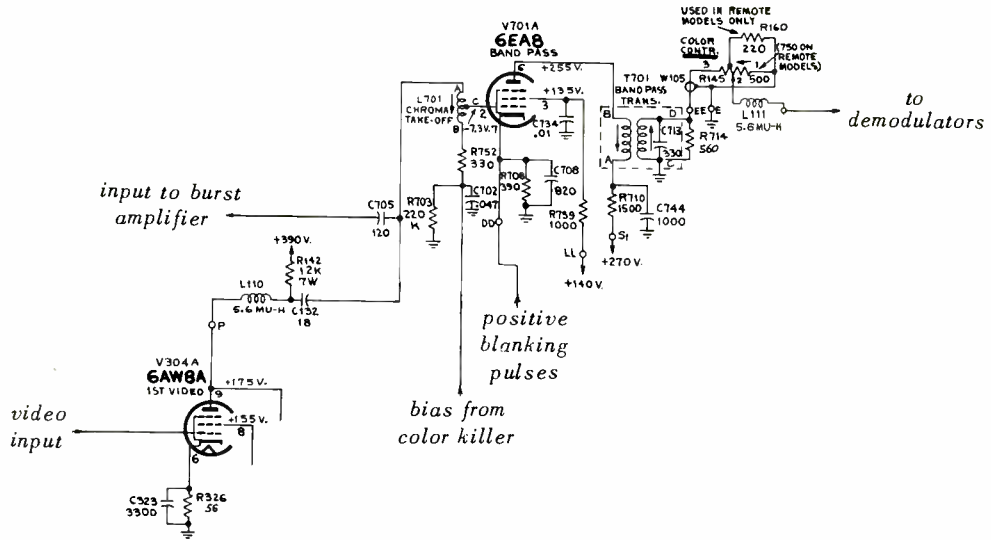

Fig. 5-12. The bandpass amplifier.

The bandpass transformer, T_{701} , in the plate circuit of V_{701A} , is double tuned and is designed to be overcoupled. Its response is shown in Fig. 5-13b. The over-all flat response (antenna to secondary of T_{701}) is shown in Fig. 5-13c. The signal from the secondary of T_{701} consists principally of 3.58-mc-sideband signals. They are passed through the color control R_{145} , to the control grids of the demodulators V_{704} and V_{709} . Control R_{145} is a front-panel control used by the viewer to adjust the saturation (or intensity) of colors in the picture. In this circuit it is a simple variable voltage divider, which works like the familiar volume control.

Two additional functions are performed in V_{701A} . The first is to prevent the burst from getting to the demodulators. This is necessary in order to prevent the appearance of the detected burst on the kinescope during horizontal retrace. By blanking the bandpass amplifier, a clean interval is provided during which the clamping of the chrominance output amplifier may take place. This is tied in with d-c restoration and will be discussed later. Burst blanking is accomplished by pulsing the cathode of V_{701A} with a positive pulse that cuts off the amplifier during the burst interval. Pulses are shaped horizontal-flyback pulses provided by the blanker stage.

The second additional function of the bandpass amplifier is to provide a place in the receiver circuitry where the color section may be "killed" during black-and-white reception. To accomplish this, a d-c voltage from the plate of V_{701B} , the killer stage, is applied to the control grid of the bandpass amplifier through the bottom of L_{701} . This voltage is designed to provide proper operating control-grid bias for the bandpass amplifier during normal color reception but is highly negative and beyond cutoff when black-and-white signals are received.

5-7. DEMODULATORS

Demodulators have been described by a variety of names, such as sampler, decoder,

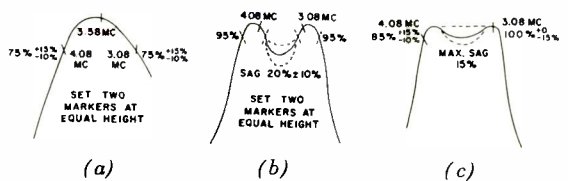

Fig. 5-13. (a) Response of the input circuit of the bandpass amplifier; (b) response of the output circuit of the bandpass amplifier; (c) over-all r-f, i-f, bandpass response.

synchronous detector, etc. The reason for the many names is that there are many ways of picturing what it is these circuits do, as well as the way in which they do it. Since the color information we are seeking is contained in the amplitude and phase of the 3.58-mc signal, we must do more to get this information than simply detect the 3.58-mc signal in the familiar way. We must find something related to the phase of the signal. One way to learn about demodulators is to consider them as two separate and independent "detectors", which in effect look at, or "sample", the modulated 3.58-mc signal at slightly different times. Consider each demodulator as a sort of quick-acting voltmeter that measures the amplitude of the chrominance signal once during each complete sub-carrier cycle. The exact time at which the signal is sampled is determined by the phase of the 3.58-mc CW signal that is supplied by the local 3.58-mc oscillator. Since there are two demodulators, the signal is sampled at two time intervals. The time difference between these samples is stated in terms of the phase difference between the CW signals applied to the demodulators. This difference is usually between 70° and 110° , or about 0.07 microseconds. Figure 5-14a shows the

outputs when we instantaneously sample a 3.58-mc wave with two samplers separated by about 90° . Figure 5-14b shows the average values of the pulsed outputs that result when the pulses are passed through a low-pass filter. Each independent demodulator can put out positive or negative signals depending on the phase (hue) of the input 3.58-mc signal. It can be seen that the output of sampler 2 is positive and that of sampler 1 is negative with the particular phase of input wave shown in Fig. 5-14a. When the phase of the input signal changes relative to the sampler phases, the amplitudes and polarities of the samples will change.

Visualize the 3.58-mc chrominance signal as starting with the phase shown in Fig. 5-15a. At the instant that sampler 1 examines

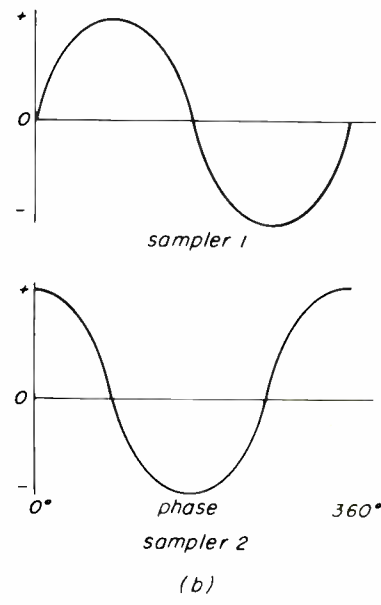
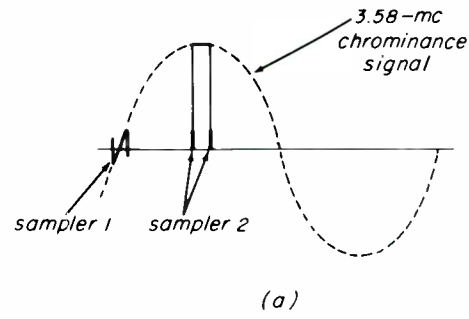
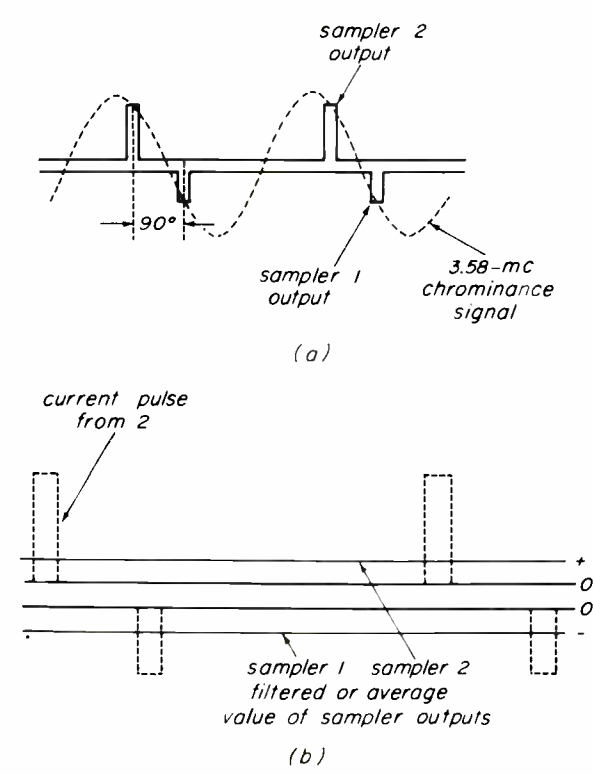

Fig. 5-15. (a) Phase relation between two sampling pulses at one particular phase of input chrominance signal; (b) d-c outputs of the two samplers as the phase of the chrominance signal is shifted through 360° .

Fig. 5-14. Action of a narrow-pulse sampler.

the chrominance signal the chrominance signal is zero. Sampler 2 looks at the signal 90° later and finds a positive signal with maximum amplitude. Now suppose we vary the phase of the chrominance signal while the phase of the samplers with respect to burst is held constant. Visualize chrominance signal of Fig. 5-15a as moving to the left one complete cycle. As the wave progresses the output of sampler 1 will increase, while the output of sampler 2 will diminish. A graph showing output versus phase may be plotted, as shown in Fig. 5-15b. If only the amplitude of the input signal changes indicating a change in color intensity, the output level of both "samplers" will change in direct proportion. In other words, if we inspect the two signals that come out of the two "samplers" we can tell exactly what phase (hue) was transmitted and what intensity (related to saturation) the hue had. Fortunately, it is rather a simple procedure to convert from these signals to the color

signals needed to drive the color kinescope. It is accomplished in the matrix which is the subject of a following section.

"Samplers" to accomplish the phase sensitive detection can be built in a variety of ways. Usually the "sampling" pulse is not the sharp square pulse shown in Fig. 5-14a, but rather approximates a square pulse by means of a narrow flow angle from the top of a 3.58-mc sine-wave reference signal.

Triode Demodulators. In RCA receivers CTC-7 through CTC-11 demodulation based upon the principle discussed in the previous paragraph was used. A typical circuit from the CTC-9A receiver is shown, somewhat simplified, in Fig. 5-16a. The 3.58-mc chrominance signal is applied to the grids of the two triode demodulators. The cathodes of the demodulators are driven with 3.58-mc carrier signals separated in phase by about

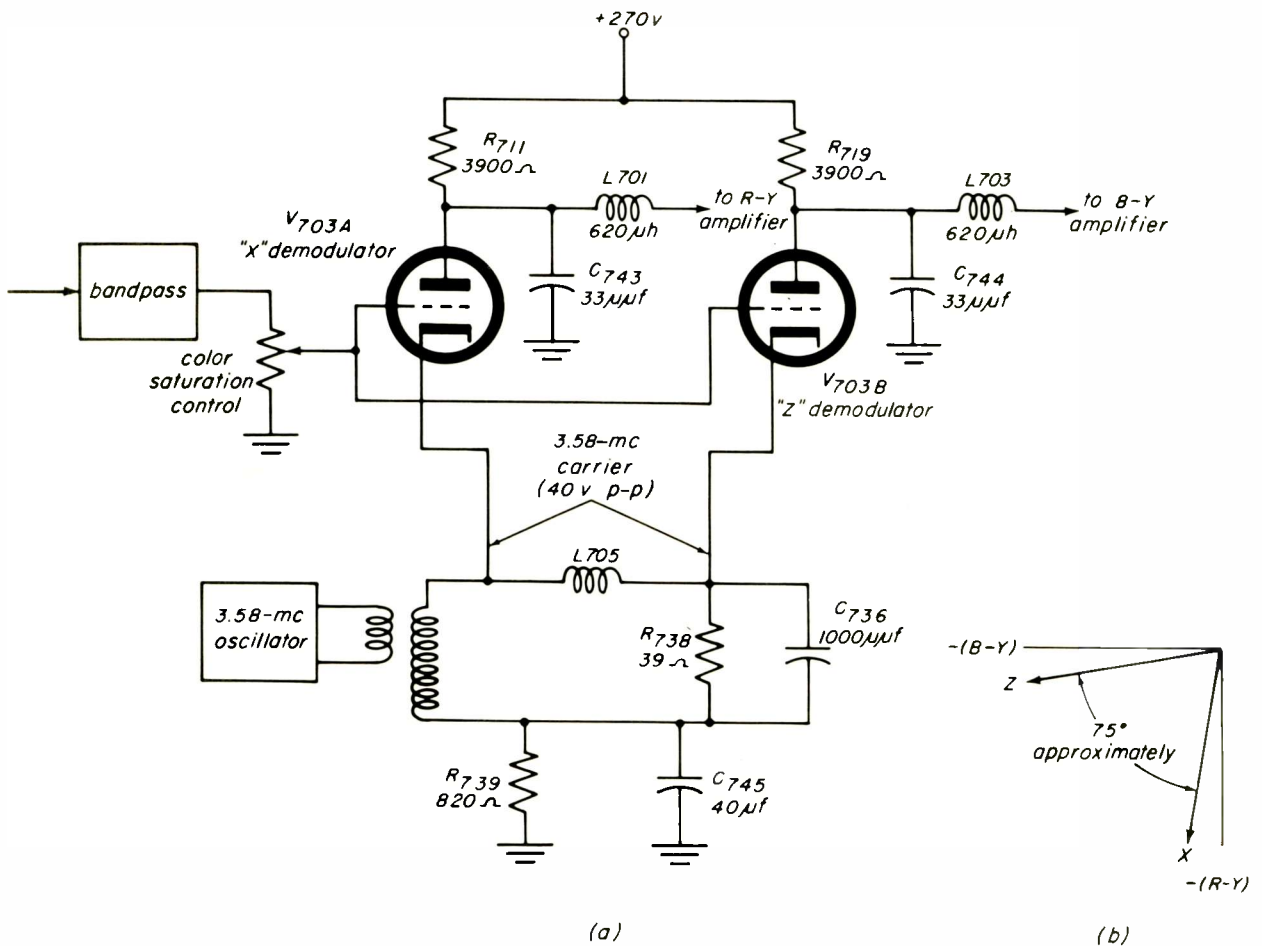
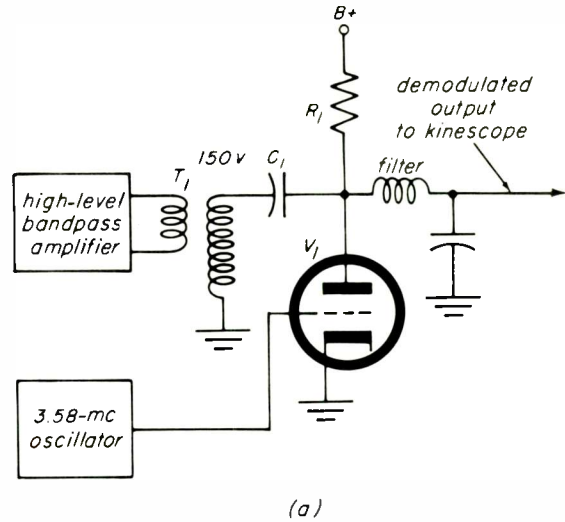

Fig. 5-16. Triode demodulators using a common cathode impedance.

75°. The carrier level into the cathodes is high so that the triodes conduct heavily during the tip of the negative going peak. The plate current of each triode is therefore a narrow pulse whose amplitude is determined by the phase and amplitude of the chrominance signal, in much the same way as the "samplers" of the preceding paragraph. In the CTC-9A the high-frequency components of the current pulse are filtered in C_{743} , L_{701} (X demodulator) and C_{744} , L_{703} (Z demodulator) leaving the average component of the pulse, which contains the color video information. The network drawn below the demodulators determines the 75° phase difference between the 3.58-mc CW feeds to the cathodes.



Another form of narrow conduction angle "sampler-type" of color demodulator is shown in Fig. 5-17a. It was used in an early RCA color receiver model 21CT662 as well as in receivers of other manufacturers based on that design. In the circuit, 3.58-mc chrominance signals from the coupling transformer T_1 are impressed upon the plate of the triode through coupling capacitor C_1 . Reference carrier signals from the 3.58-mc oscillator are applied to the control grid. The carrier signal power is relatively high and its source impedance is low so that the control grid is driven strongly into the positive grid region of its control characteristic for a relatively short period at the positive peak of the reference carrier. When there are no chrominance signals applied, V_1 conducts in short bursts and an average of about +25 volts is developed at the plate.

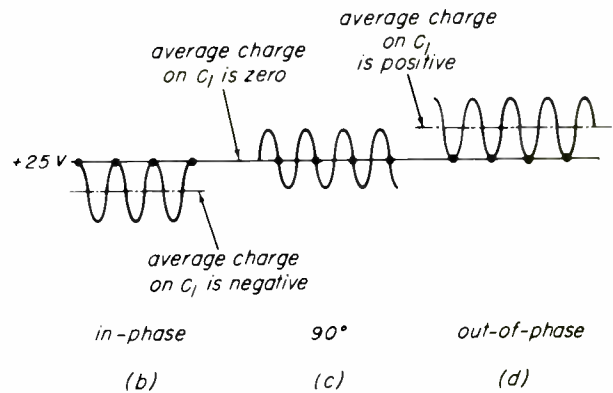

Fig. 5-17. Operation of a high-level triode demodulator.

Figure 5-17b shows the situation when a chrominance signal that is in phase with the oscillator signal is applied. The dots on the waveform indicate the intervals during which the tube is conducting heavily. At the instant that the tube fires, the chrominance signal is at its positive peak. Since the tube effectively grounds the plate side of C_1 , C_1 first discharges and then charges rapidly to the positive peak voltage. At the end of the conducting interval C_1 is left with a negative charge on the plate side that is equal to the positive peak value of the chrominance signal. The a-c chrominance signal adds to the voltage across the capacitor resulting in the situation shown in b of

Fig. 5-17. Note that the part of the signal that occurs during the conducting interval is clamped to the normal plate voltage for V_1 .

The quadrature condition is shown in c of the figure. In this case the tube "fires" as the chrominance waveform goes through zero. The situation is the same as if there were no chrominance signal at all, and the charge on the capacitor is not altered. Thus, zero on the chrominance signal is clamped at +25 volts. When the chrominance signal is out of phase with the CW signal, the tube fires at the negative peak of the input signal. In this case the capacitor does not discharge completely during the firing interval, but retains a charge equal to the peak voltage of the chrominance signal. This charge is positive on the plate side of C_1 and results in a positive swing in average plate current. As the waveforms show, the part of the input

10
 waveform that occurs when the tube conducts is effectively clamped to +25 volts. A low-pass filter to the right of V_1 filters out the 3.58-mc component, leaving the video signal indicated by the dashed lines in Fig. 5-17b, c, and d. It may be noted that the circuit has unity gain, because the triode acts as a switch that is turned on only for short periods during which its plate resistance is very low. Furthermore, reasonable variations in tube characteristics or carrier-drive levels do not substantially affect the performance of the circuit. As a result, this circuit is used as a high-level demodulator, handling a 3.58-mc chrominance signal of such level that it is high enough, after demodulation, to provide direct drive to the kinescope with good a-c and d-c stability.

Pentode Demodulators. In RCA receivers CT-100 and CTC-12 pentode demodulators are used. In the earlier CT-100, tube type 6BY6 is used, while in the CTC-12 the 6GY6 is used. However, the circuits and functions are generally the same. The principal difference between the triode sampler demodulators and the pentodes is that in the former the tube is driven into a nonlinear, narrow angle switching mode in order to provide demodulation, while in the latter the tube characteristics themselves provide the demodulation mechanism.

In the pentode demodulator tubes, the grid no. 3, or suppressor, is designed to be active so that it can control plate current. Its action is not quite the same as that of the control grid. The control grid voltage determines the number of electrons leaving the cathode, whereas the suppressor determines the percentage of these electrons that will strike the plate, as against the percentage that will end up on the screen grid. In a well designed pentode demodulator tube, the suppressor only affects the division of cathode current between plate and screen, but not the actual amount of cathode current, while the control grid affects the actual amount, but not the division of, cathode current. Consequently, if we look at the plate current it is the product of the signals on the control grid and suppressor. For example, if the phase of the signal on the suppressor is positive at the same time the signal phase on the control grid is positive

the plate current will increase, causing a negative going average voltage across the plate load. On the other hand, if the control grid is positive when the suppressor is negative most of the current goes to the screen grid so that plate current decreases and the output voltage swings positive. The average output voltage, available when the plate signal is passed through a low-pass filter, is the color video signal. The screen supply is usually obtained from a well regulated voltage source to prevent signal current variations from affecting its potential, which if permitted would interfere with normal operation of the tube.

In the CTC-12, 3.58-mc chrominance signals are taken from the front-panel color control, passed through i-f trap L_{111} and applied to the control grids of the demodulators V_{704} and V_{709} . Refer to Fig. 5-18, Cathode resistors R_{749} and R_{762} serve two functions. First they improve the linearity of the control grid characteristic. Second, since the resistors are of unequal size, they make the output of the X demodulator smaller than that of the Z demodulator. This is necessary so as to provide proper relative signal amplitudes for the matrix operation.

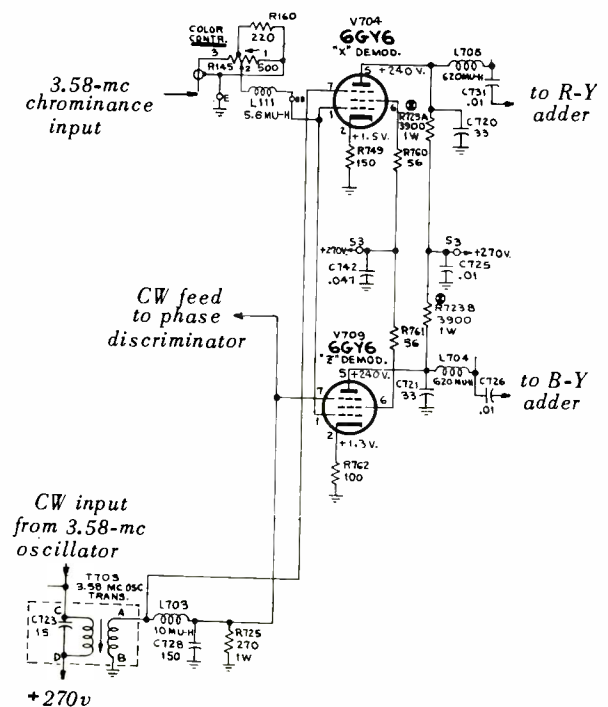

Fig. 5-18. The X and Z demodulators of the RCA CTC-12 receiver.

The screen grids are returned to B_+ through the small parasitic suppressors R_{760} and R_{761} . The suppressor grids are driven by two CW signals, approximately 75° apart, of reference carrier from the 3.58-mc oscillator circuit. High-amplitude carrier signals are applied to the suppressor grids. The purpose is not to provide a narrow sampling pulse as was the case with the triode demodulators, but rather to be sure that at the positive peak of the carrier all available cathode current flows to the plate. Similarly, at the negative peak all cathode current flows to the screen. This mode of operation improves stability since any variation in the carrier level produces only minor changes in output. The desired low-pass filtering of the X demodulator output is provided by the combination of C_{720} , L_{705} and the input capacitance of the R-Y amplifier, V_{706A} . Related components exist in the output circuit of the Z demodulator. The demodulator plate loads are limited to 3900Ω primarily by the need for a bandwidth of about 500 kc. These resistors must be small to attain this bandwidth since they are shunted by the large input capacitances of the triode adder stages.

Beam-Deflection Demodulators. In the Zenith color receivers using the 29JC20-type chassis, the demodulation is accomplished by means of two 6JH8 beam-deflection tubes. The 6JH8 is constructed with a cathode, control grid, and screen grid which perform more or less in conventional fashion. However, the electrons, which in conventional pentodes move toward the plate in a cloud, are directed and focussed into a beam. After passing the screen grid, the beam may be deflected by a pair of deflector electrodes in such a way as to cause the beam to land on one or the other of the two plates.

Chrominance signals are applied to the control grids of the demodulators V_{14} and V_{15} through transformer L_{27} . Refer to Fig. 5-19. The signal to the R-Y demodulator V_{15} is taken from a tap at reduced level to provide proper levels for the subsequent matrix operation. Horizontal blanking is also applied to the control grids by means of a positive pulse. This pulse appears negative at the plates to blank the kinescope grids during retrace. Control-grid linearity is aided by means of cathode resistors R_{115}

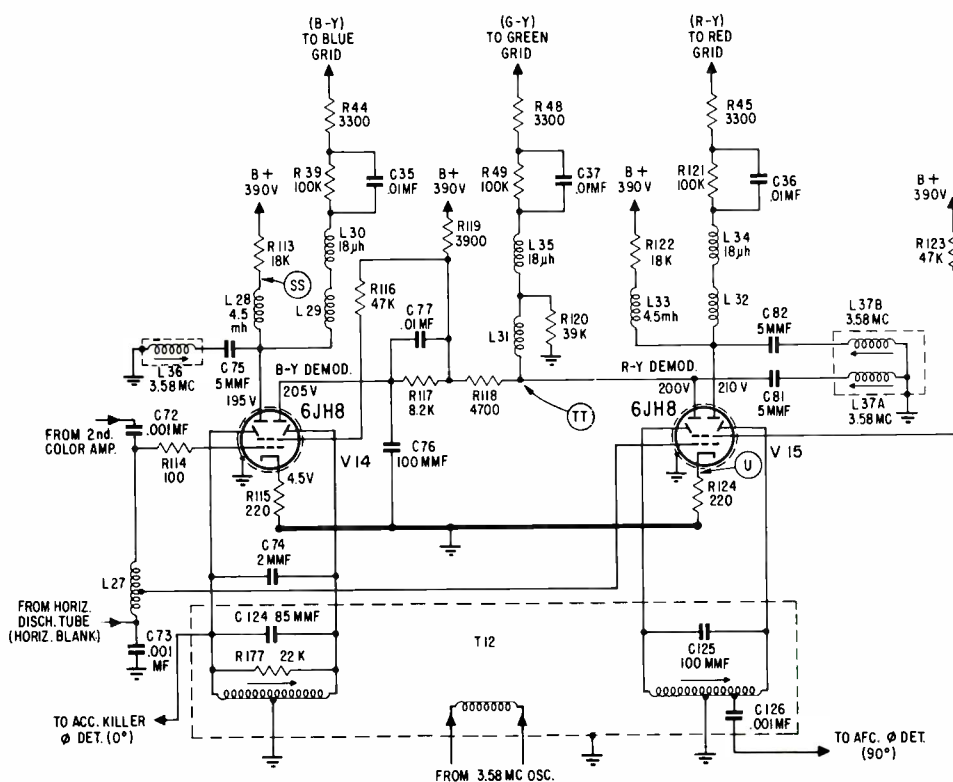

Fig. 5-19. Beam deflection demodulators employed in the Zenith 29JC20 receiver.

(Courtesy Zenith Radio Corporation.)

and R_{124} . The deflectors are driven push-pull by means of the balanced outputs of the 3.58-mc oscillator transformer T_{12} . When the input chrominance signal is in phase with the 3.58-mc carrier on say the left-hand deflector of V_{14} , the average current to the left plate will increase, with a corresponding negative-going change in plate voltage. If the signals are out of phase the left-hand plate average voltage rises. Once again this change in average voltage is the demodulated color video signal. Since the switching action caused by the deflectors is between the plates only, the output current of the right plate is equal in amplitude, but opposite in polarity, to that of the left plate. Thus, both plus and minus $B-Y$ signals are available from the two plates of V_{14} . The left-hand plate (pin 9) is connected to the control grid of the blue gun of the kinescope through a low-pass filter consisting of $C_{75}-L_{36}$ (3.58-mc trap), L_{28} , L_{29} , L_{30} and stray capacitances. Related components exist in the other kinescope grid drive circuits.

The relative angle of the 3.58-mc carriers in the two demodulators is 90° , and the input levels are chosen to provide $B-Y$ color video at pin 9 of V_{14} and $R-Y$ color video at pin 9 of V_{14} . In order to obtain proper $G-Y$ signal the minus $R-Y$ and minus $B-Y$ signals, available at pins 8 of V_{14} and V_{15} , are added across R_{120} . Filtering and d-c level setting are accomplished in a manner generally similar to that of the $B-Y$ and $R-Y$ outputs.

5-8. COLOR SYNCHRONIZATION CIRCUITS

The basic block diagram of the automatic phase control type of color sync circuit is shown in Fig. 5-20. It is generally similar to that of the horizontal AFC circuits and performs for color sync the same functions that the horizontal AFC system does for horizontal deflection system. Broadly speaking, the synchronizing burst is separated from the rest of the signal and applied to a phase comparator, or detector, which compares the phase of 3.58-mc carrier that is generated in the receiver with that of the separated burst signal. If there is an error

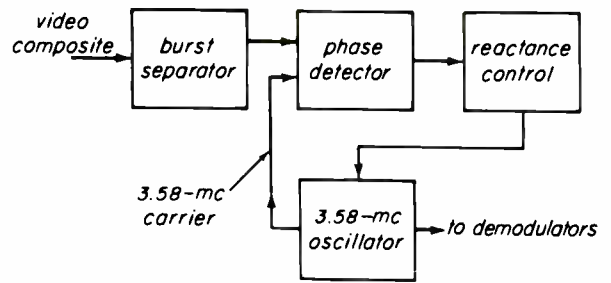

Fig. 5-20. Block diagram of the basic AFPC system.

in phase between the two, a d-c error voltage is generated by the phase detector. This error voltage is applied to a reactance tube which corrects the phase of the oscillator. Although the detailed description that follows is concerned with the RCA CTC-12 receiver, all receivers using AFPC color sync use generally similar circuits.

Burst Separator. The burst separator does the same operation for the color synchronizing burst that the sync separator does for deflection sync signals. Burst always occurs right after the horizontal sync pulse. In order to separate it from the rest of the signal, the composite signal is applied to a gating tube. This tube is normally cut off but is gated on during burst time. In the CTC-12, the function is performed by V_{702} . Refer to Fig. 5-21. A signal, which is principally the 3.58-mc chrominance signal including the burst, is taken from the top of the chroma take-off transformer L_{701} , passed through C_{705} , and applied to the control grid of V_{702} . In addition, the gating pulse, taken from a winding on the high-voltage transformer, T_{102} , is passed through R_{709} , and applied to the control grid. R_{705} , from the control grid to ground, completes the circuit. As a result, a 60-volt positive pulse is applied to the control grid with the burst from the 3.58-mc chrominance signal riding on top of it. The cathode of V_{702} has a large bypassed resistor (R_{706} , C_{706}) as a ground return. Since the cathode resistor is large, the tube is nearly at cutoff when there are no signals applied. The positive grid pulses drive the tube heavily into conduction. During these conduction intervals C_{706} charges through the tube towards B+. At the end of the conducting interval, C_{706} is left with a

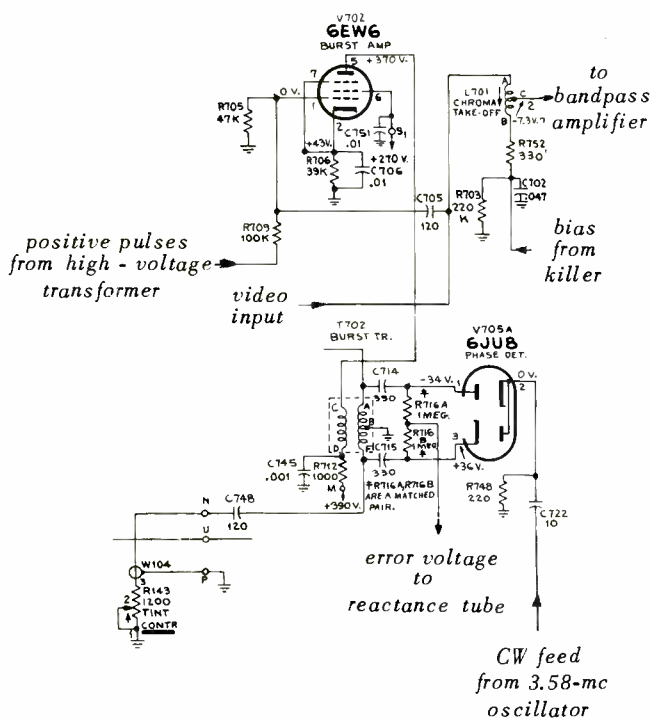

Fig. 5-21. Burst amplifier and phase detector of the CTC-12 chassis.

large charge and begins to discharge through the large cathode resistor. The voltage developed across the cathode resistance by the discharge of C_{706} holds the burst amplifier cut off until the next positive pulse arrives at the grid. As a result conduction in V_{702} can take place only at the peak of the pulse, when the burst appears. Amplified and separated burst is taken from the plate of V_{702} and applied to the primary of the burst transformer T_{702} .

Phase Detector. The phase detector, shown in Fig. 5-21, is basically similar to the simple phase detector shown in an earlier lesson. The secondary of T_{702} is balanced with its center tap grounded. The burst signal is transformer-coupled into the phase detector circuit by T_{702} . Burst signals of one polarity are applied through C_{714} to the plate of the upper diode of the phase detector V_{705A} . An inverted burst signal is passed through C_{715} to the cathode of the lower diode of V_{705A} . The remaining plate and cathode are tied together and returned to ground through the 220- Ω resistor R_{748} . Also applied to R_{748} (and to the remaining

cathode and plate) is the 3.58-mc carrier signal from the local 3.58-mc oscillator. To complete the description, resistors R_{716A} and R_{716B} are tied from plate to cathode on the burst-input side of the phase detector diodes. These resistors are a matched pair so that at their junction the voltage that is present is the precise sum of the rectified voltages at the plate (pin 1) and the cathode (pin 3). An understanding of the operation may be aided by reference to the vector diagram Fig. 5-22. The phases of the push-pull burst signals are shown in Fig. 5-22a. Let us assume the peak amplitude to be 30 volts as shown. Now if there were no oscillator signal on pin 2, rectification of the burst by itself would cause d-c voltages of +30 at the cathode (pin 3), -30 at the plate (pin 1), and 0 at the junction of R_{716A} and R_{716B} . Now let a 3.58-mc oscillator signal be applied to pin 2. Assume that the oscillator is locked-in in frequency, phased at 90° , and at a peak level of 10 volts as shown in Fig. 5-22b. The voltage available for rectification in the upper diode is the vector sum of the burst at 30 volts and the carrier at 10 volts. By the geometric laws of triangles

$$\sqrt{(30)^2 + (10)^2} = 32 \text{ volts.}$$

The lower diode will rectify +32 volts, and the junction point of R_{716A} and R_{716B} will remain at zero. But suppose now that the oscillator frequency tried to change a little; the frequency lock-in would still remain but the phase of the oscillator might try to change to that shown in Fig. 5-22c. Now the resultant, which is the signal available for rectification on the upper diode, is say -35

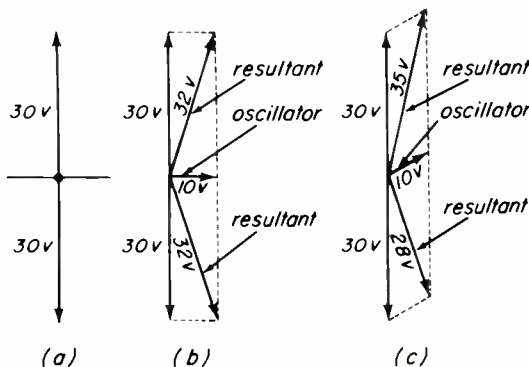

Fig. 5-22. Phase relations between CW and burst signals in the phase detector.

volts while that on the lower diode is only +28 volts. As a result a negative voltage appears at the junction of R_{716A} and R_{716B} . This negative error signal is filtered and applied to the grid of the reactance control tube.

In the discussion of Fig. 5-13 at the beginning of this section it was pointed out that when the error signal is applied to the grid of the reactance control tube it changes the frequency of the oscillator to bring it more nearly to the correct phase. Consequently, when the d-c error signal appears, it causes the oscillator to shift back in frequency toward the frequency that results in zero error signal.

In practical circuits the AFPC system can't bring about a perfect phase correction, but the resultant error may be reduced to only a tenth of a volt or so, indicating a very small sustaining phase error.

The hue or tint control affects the tuning of the secondary of T_{702} , and so alters the phase of the burst signals applied to the phase detector. Tuning is accomplished by C_{748} and the series rheostat R_{143} . Altering the resistance of R_{143} effectively controls the amount of capacitance across one half of the secondary of T_{702} .

Reactance Control Tube. V_{703A} is the reactance control tube of the AFPC system shown in Fig. 5-23. It operates in the following way. C_{717} and L_{702} form a part of the resonant circuit that determines the exact oscillator frequency. A variation of capacitance across C_{717} will therefore change the

oscillator frequency. The plate of V_{703A} is across C_{717} , and connected from the plate to the grid is a small ($4 \mu\text{f}$) capacitor C_{709} . The grid return for a-c signals is through the $1500\text{-}\Omega$ resistor R_{746} . The impedance of the small capacitor is high compared to 1500Ω so that the voltage coupled from the plate will have a leading phase shift of about $+90^\circ$ as it is applied to the grid. Plate current, which is in phase with grid voltage, is therefore advanced 90° with respect to the plate voltage. Thus the tube supplies a leading current and acts like a capacitor. Furthermore, since the plate current is controlled by the a-c grid bias, the effective size of the "capacitor" can be made to change as desired. Resistor R_{711} , which is bypassed by C_{710} , in conjunction with R_{713} form a bleeder bias circuit that maintains the correct "rest" or no-signal bias for the reactance tube. The network of C_{703} , R_{707} , and C_{707} form a low-pass filter and anti-hunt network for the d-c correction voltage that is applied to the grid.

3.58-mc Oscillator. In the oscillator used in the CTC-12 (V_{703B}) the screen grid acts as the oscillator plate. Refer to Fig. 5-23. A large load resistor, R_{721} , is used ($47,000\text{-}\Omega$) so that the a-c screen current is forced to flow into the pi-network consisting of C_{724} , the 3.58-mc crystal, and the combination of C_{717} , L_{702} , and the plate of the reactance control tube. There is a 180° phase shift across the crystal due to its effective pi-configuration, as is required to produce oscillations. The phase-shifted signal is applied to the control grid through the grid-leak network of C_{718} and R_{719} . Output is taken from the plate of V_{703B} through

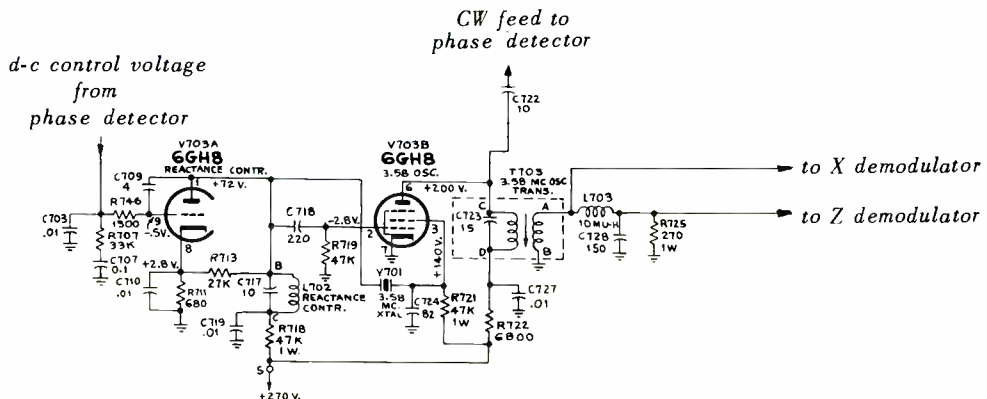

Fig. 5-23. Oscillator and control circuit in the AFPC section of the CTC-12 chassis.

the 3.58-mc oscillator transformer, T_{703} . A small portion of the plate output is fed to the phase detector, V_{705A} , through the small, 10- μf capacitor C_{722} . The 3.58-mc reference carrier drive for the X-demodulator is taken directly from the secondary of T_{703} . The drive for the Z-demodulator is first phase-delayed in the L_{703} , C_{728} , R_{725} network, which phase-shifts it by about 70° , and then is applied to the suppressor grid of the Z-demodulator.

5-9. COLOR KILLER

There are two basic demands made on the color killer: First, during black-and-white reception, it must prevent high-frequency noise or signal components from passing through the color demodulator chain. If this is not done, noise components in the vicinity of 3.58-mc will be "demodulated" and appear as low-frequency blobs of colored noise during weak-signal black-and-white reception. In addition, during strong-signal black-and-white reception, fine black-and-white detail will be "demodulated" and show up as color rainbows which degrade the appearance of the fine detail and edges. The second consideration is that during

weak-signal color reception, the color chain must not be disabled until all vestiges of the burst have disappeared well into the noise. In that case the color circuits continue to function when weak color signals are received. The key to both demands, therefore, is the ability of the color killer to differentiate between burst signals and noise. To provide noise immunity, a synchronous killer detector is used in receivers such as the RCA CTC-12 and the Zenith 29JC20. Broadly speaking, the killer-detector circuit closely resembles that of the phase detector described in the preceding section. The single exception is that the phase of the internal 3.58-mc that is compared with the burst signal is in phase with the burst signal rather than 90° out of phase. To provide the in-phase 3.58-mc signal a connection is made to the feed point that drives the Z-demodulator. Refer to Fig. 5-24. This signal then passes through C_{735} and is developed across R_{757} to be applied to pin 8 of V_{705B} , the killer detector. Burst is taken, in push-pull form, from T_{702} and applied through coupling capacitors C_{740} and C_{741} to the cathode and plate of V_{705B} . The output is taken from the junction of a matched pair of resistors R_{705A} and R_{705B} . The amplitudes and relative polarities of the burst

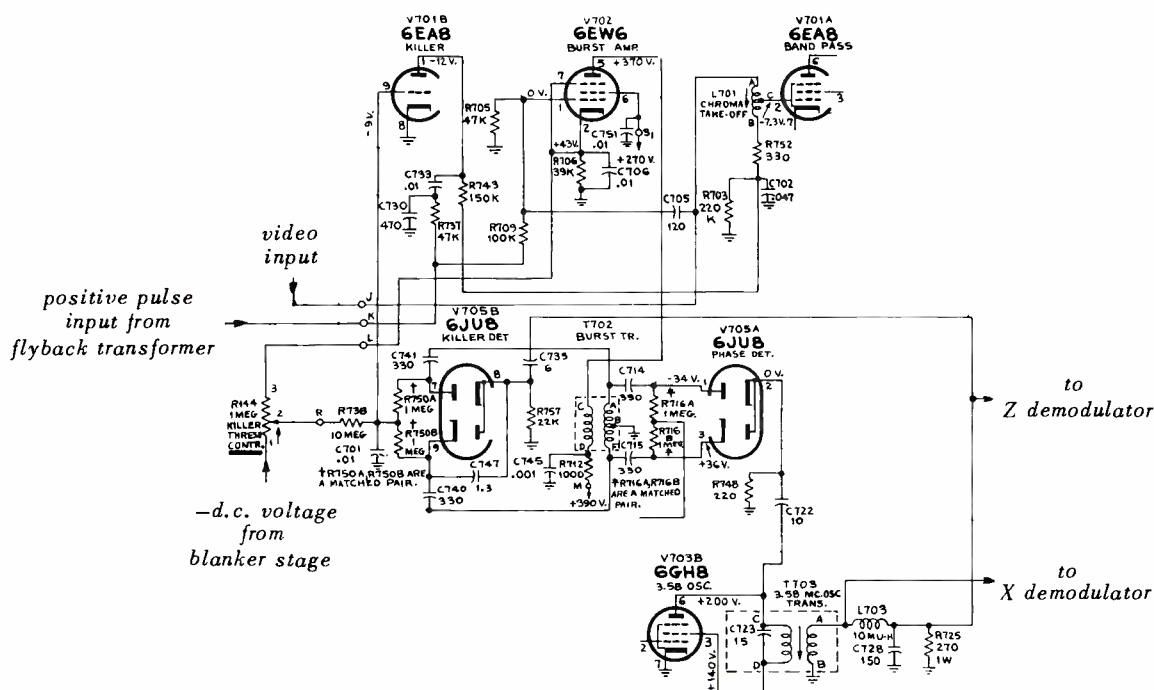

Fig. 5-24. Partial schematic diagram showing the circuits of the phase detector, the killer detector, the color killer, and the blanker.

signal and 3.58-mc CW signal are designed to provide a high negative output voltage when normal burst is present. To understand this refer to the vector diagrams of Fig. 5-25. As shown in *a* of the figure, the signal obtained from the CW oscillator (when the AFPC system is working correctly) is in phase with the burst signal applied to the diodes. The resultant signals that are applied to the killer-detector diodes are shown in *b* of the figure. This causes unequal conduction of the diodes, and the circuit connections are such that a negative voltage appears at the junction of R_{705A} and R_{705B} . When burst is absent, or if the oscillator signal is out of lock, the average voltages applied to the killer diodes are equal, and the d-c output of the circuit is zero.

The d-c output voltage of the killer detector is filtered by C_{701} and passes to the grid of V_{701B} , which is the killer tube. The d-c return for the grid of V_{701B} is made through a large resistance, R_{738} , to the arm of the killer threshold control, R_{144} . This potentiometer has a positive d-c voltage, obtained from the cathode of the burst amplifier, connected to one end, and a negative d-c voltage, obtained from the grid of the blanker tube, at the other. The arm of the potentiometer can therefore be varied from plus to minus d-c volts. The arm of the potentiometer is factory set at a voltage which permits the killer tube to conduct when the burst signal becomes smaller than some predetermined level, or disappears entirely.

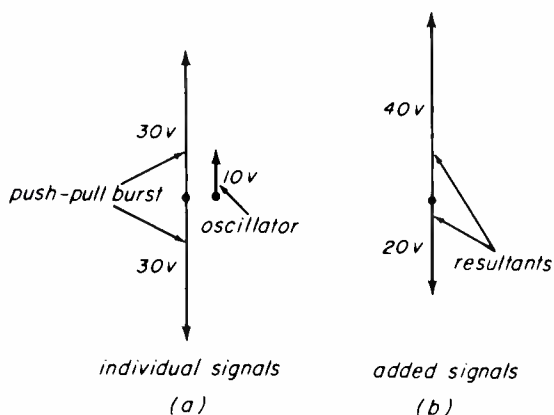

Fig. 5-25. Phase relations in the killer detector circuit when the AFPC system is working normally.

Noise immunity is obtained because burst, if it is present, makes a negative d-c output as long as the color sync circuit is working. On the other hand, random noise signals will be either out-of-phase causing a positive output, or in-phase causing a negative output. Consequently, noise averages to zero when integrated over a long time period by the output-filter capacitor C_{701} .

The killer itself, V_{701B} , is operated in a manner similar to that of keyed AGC amplifier circuits. Its only plate voltage is a positive horizontal-frequency pulse, which is obtained from a tap on the high-voltage transformer. These pulses are shaped in passing through R_{737} and C_{730} , and are applied to the plate of V_{701B} through capacitor C_{733} . If normal burst is present, the grid of the killer tube is negative beyond cutoff so that no plate current can flow, and no d-c voltage is developed at the plate. However, in the absence of burst, the bias on the killer is reduced enough to permit plate current to flow during the peak of the plate-voltage pulse. The resulting plate-current pulse causes electrons to pile up on the plate side of C_{733} resulting in an average negative voltage at that point. This negative d-c voltage is filtered in R_{743} , C_{702} , and R_{703} , and applied to the grid of the bandpass amplifier. The bandpass amplifier is cut off by the bias supplied by the killer.

5-10. COLOR VIDEO OUTPUT CIRCUITS

Requirements. There are four basic requirements for the color video output circuits. **First**, in receivers using kinescope adding, the chrominance circuits must be capable of delivering over 180 volts p-p of color video signals without undue distortion. **Second**, the d-c component of the signal must be substantially maintained. **Third**, d-c drift, such as may occur during warm-up, must not cause an objectionable shift in kinescope white balance. **Fourth**, they must provide the matrix operation to produce the final R-Y, B-Y, and G-Y color video signals needed to drive the kinescope.

Output Level. The 180-volt p-p output level comes about as follows. See Fig.

5-26. The kinescope typically requires 100 volts of black-to-white drive for the blue gun. If a high intensity blue signal is transmitted, the blue component of the luminance signal is about 10% of the white level or about 10 volts. The luminance signals applied to the three gun cathodes are approximately equal. In order to bring the blue gun up to full drive (100 volts) the chrominance video signal must provide an additional 90 volts to the grid. See Fig. 5-26a. On the other hand, if the transmitted signal is an intense yellow, the luminance signal is about 90% of the white level or about 90 volts. In order to make a saturated yellow, the red and green guns should have maximum drive and the blue gun should be cut off. However, since the 90-volt luminance signal is applied about equally to the three cathodes, there is a 90-volt drive on the blue cathode. Therefore, it is up to the $B-Y$ chrominance video signal to provide a -90 volt signal to the grid, so that there is zero signal voltage between grid and cathode. Since both saturated blue and yellow signals may be transmitted, the $B-Y$ color video amplifier must be able to deliver at least ± 90 volts, or 180 volts p-p. This is a minimum figure. Due to differences in drive characteristics between the kinescope cathode and grid circuits, the chrominance video signal must be somewhat larger.

Matrix Operation. All modern receivers use two demodulators that provide only two of the three required chrominance video signals. The third signal is usually $G-Y$ and it is made by combining proper amounts and polarities of $B-Y$ and $R-Y$ signals. The amounts of $R-Y$ and $B-Y$ required are obtained from the equation

$$E_{(G-Y)} = -0.51 E_{(R-Y)} - 0.19 E_{(B-Y)}$$

Therefore, if we take 51% of a negative $E_{(R-Y)}$ signal and 19% of a negative $E_{(B-Y)}$ signal and add them we get $E_{(G-Y)}$. Actually, we could demodulate any two outputs and get the third by means of a matrix but $G-Y$ is usually chosen to be produced by the matrix because it is the smallest of the three chrominance signals and is therefore easiest to construct.

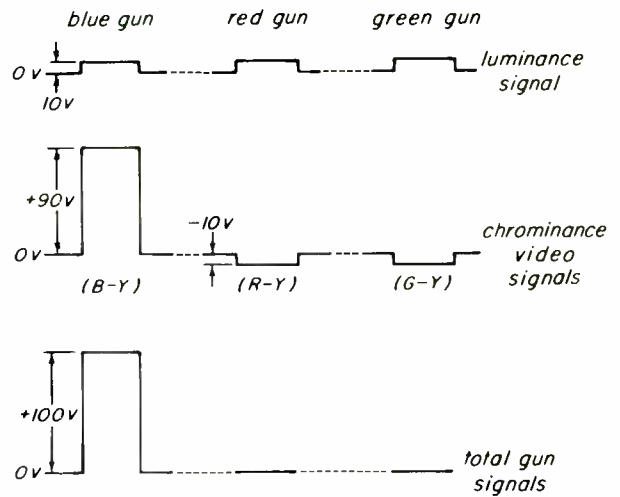

(a) blue signal transmission

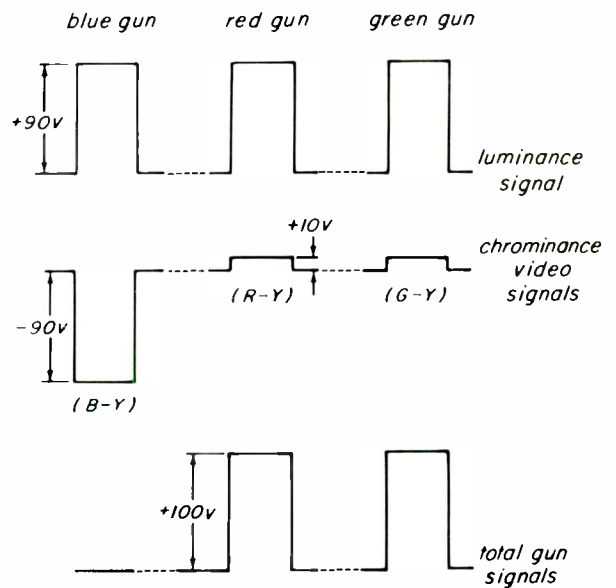

(b) yellow signal transmission

Fig. 5-26. Signal construction at the kinescope inputs for a fully saturated blue and yellow signal.

Output System Approaches. There are three general approaches to the color video output circuit: (1) Demodulation may be done at high level and the resulting color video signals may be fed directly to the kinescope grids. This was done in the early RCA 660 color receivers and in more recent Zenith 29JC20 type receivers. (2) Demodulation may be done at a relatively low level. The

resulting color video signals are amplified to a level required to drive kinescope grids. RCA receivers CTC-7 through CTC-12 employ this system. (3) The demodulation may be done at low level, with the luminance signal added to each of the three demodulated color video signals in special adder stages. In this case complete, red, blue, and green color signals are applied to the kinescope grids. This is done in the early RCA CT-100 color receiver.

High Level Demodulation. The operation of the Zenith type demodulators has been discussed in Section 5-8. Matrixing is obtained by adding the proper amounts of $-(B-Y)$ and $-(R-Y)$ available at the second plates of the demodulators. In the demodulators of the early RCA 660 receivers matrixing is obtained in a generally similar manner by taking two demodulators like the ones shown in Fig. 5-17 and returning their cathodes to ground through a common resistor. The $G-Y$ signal is taken from the top of the resistor. The reason this works is that since there is $+(R-Y)$ and $+(B-Y)$ at the respective plates, the cathode circuits have some proportions of $-(R-Y)$ and $-(B-Y)$ developed in them. Consequently, by selecting proper input levels and circuit components a $+(G-Y)$ signal is obtained. Although proper $R-Y$, $B-Y$, and $G-Y$ signals are obtained at their respective output points the relative phase between the carriers on the grids of the demodulators cannot be 90° . The reason is that once the cathodes are tied together, and a portion of the demodulated signal from the $R-Y$ demodulator appears in the common cathode, this $R-Y$ signal, in effect, drives the cathode of the $B-Y$ demodulator so that a $-(R-Y)$ signal appears in the $+(B-Y)$ output. This "crosstalk" is balanced out by setting the phase of the carrier which drives the $B-Y$ demodulator at an angle which produces not only $+(B-Y)$ in its output but also just enough $+(R-Y)$ to cancel the "crosstalking" $-(R-Y)$. A similar cancelling operation is performed in the $R-Y$ demodulator. The resulting demodulator carrier phases are therefore less than 90° apart as shown in Fig. 5-27. This same reasoning may be applied to the X and Z demodulation system employed in current RCA models.

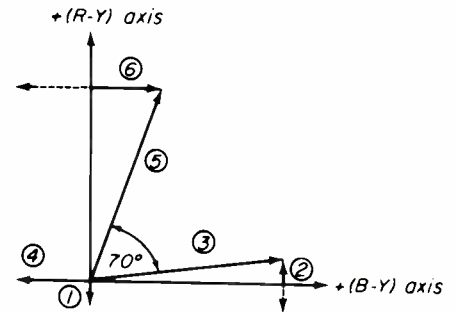

1. Common cathode crosstalk due to $R-Y$ signals appearing in $B-Y$ plate circuit.
2. $+(R-Y)$ from $B-Y$ demodulator to cancel crosstalk.
3. Corrected $B-Y$ demodulation axis.
4. Common cathode crosstalk due to $B-Y$ signals appearing in $R-Y$ plate circuit.
5. Corrected $R-Y$ demodulation axis.
6. $+(B-Y)$ from $R-Y$ demodulator to cancel crosstalk.

The circled numbers show the order in which the construction is made to find corrected $B-Y$ axis.

Fig. 5-27. Construction of the demodulation axes when there is crosstalk in the demodulators, or in the adder amplifiers.

Amplified Low Level Demodulation. In the RCA CTC-12, the general situation in regard to demodulator angles described in the previous paragraph also exists even though the matrix operation is performed in the output amplifiers (adders). Refer to Fig. 5-28. Color video signals from the X demodulator are filtered in C_{720} , L_{705} , and are applied to the grid of V_{706A} , the $R-Y$ amplifier. A similar circuit exists in the Z demodulator $B-Y$ amplifier chain. No direct demodulator signal is applied to the grid of the $G-Y$ amplifier V_{707A} . However, the cathodes of the three output amplifiers are tied together and returned to ground through the common resistor R_{728} . As a result the $G-Y$ amplifier is cathode driven by a portion of the signals in the $R-Y$ and $B-Y$ amplifiers. These signals not only produce the $G-Y$ signal at the plate of V_{707A} but also cause the kind of crosstalk described previously. Consequently, the demodulator angles were set closer than 90° apart, at phases which could cancel this "crosstalk". This is why the demodulators are called X and Z instead of

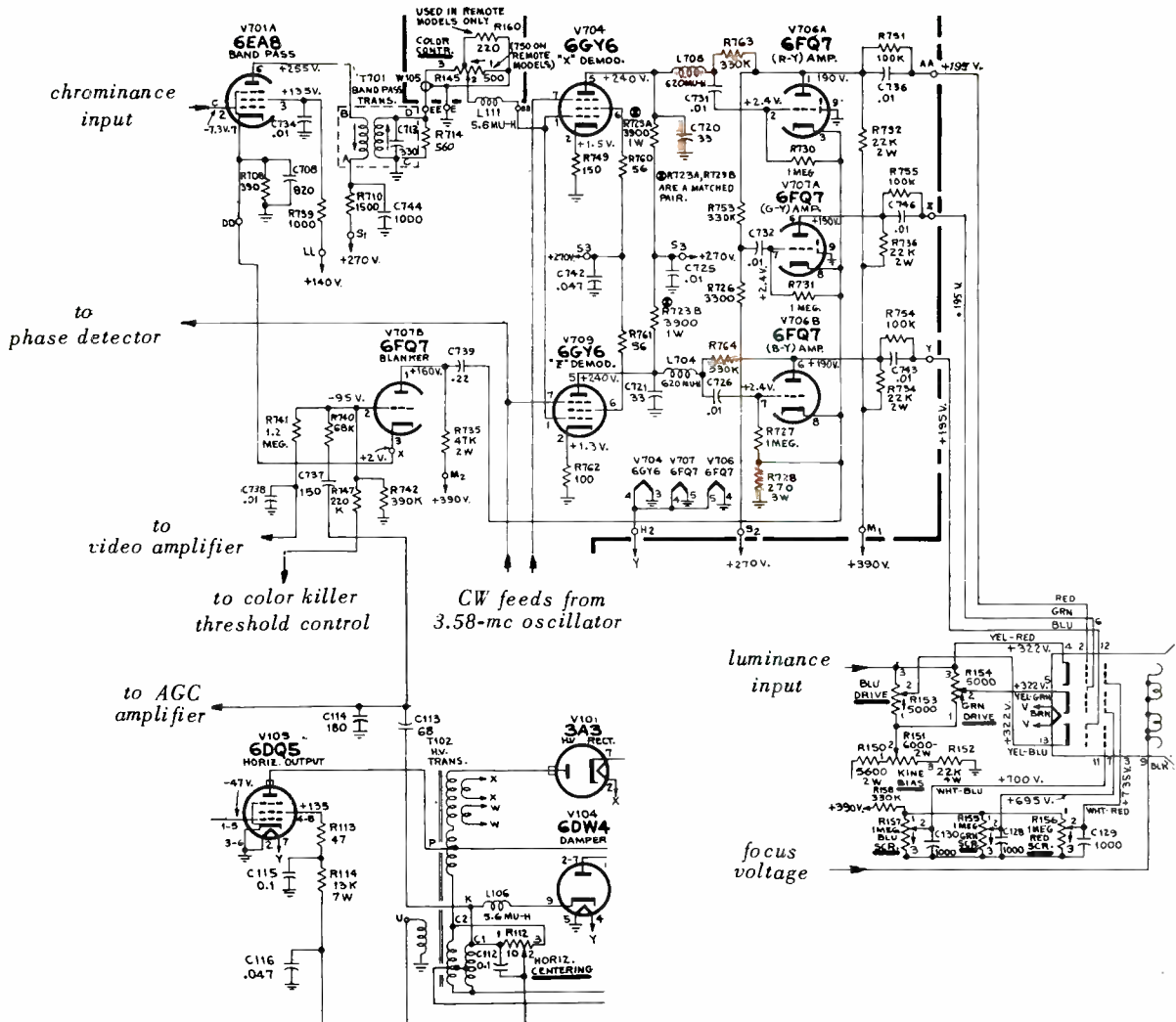

Fig. 5-28. Partial schematic diagram showing the chrominance circuits of the CTC-12 chassis.

R-Y and B-Y. Resistors R_{763} and R_{764} are used mainly to apply negative plate-to-grid feedback to the R-Y and B-Y output amplifiers. This feedback increases the stability and bandwidth of the circuits. Resistors R_{753} and R_{726} were included to provide substantially the same function for the G-Y amplifier. The plates of the output amplifier are actually 100% direct coupled to their respective kinescope grids. The parallel RC networks $R_{751}-C_{736}$, $R_{755}-C_{746}$, and $R_{754}-C_{743}$ are included to protect the circuits should a kinescope short develop. This may occur inadvertently during servicing if one of the kinescope grids should be shorted to ground. Since there is no return to the kinescope grids other than these RC pairs, they do not affect normal operation.

One of the most interesting features of this circuit is the way in which the d-c component is handled. The pentode demodulators, although quite stable for a-c gain, are not sufficiently stable for d-c drift to be direct coupled to the kinescope through the output amplifiers. Therefore they are a-c coupled to the output amplifiers by means of RC circuits. For example, C_{731} couples signals from the X demodulator to the R-Y amplifier grid. In order to restore the d-c component, the cathode of the output amplifier is driven by a negative pulse derived from the high-voltage transformer and applied to the cathodes through the blanker stage. This causes the grid to draw a short peak of current which clamps the grid voltage to the cathode voltage. The clamping

18
 action insures that there will be a constant fixed voltage or bias between grid and cathode which depends only on the blanking-pulse level and not on the color signal. It is re-established during every horizontal blanking period so that the d-c component is 100% restored. Since the action depends upon the instantaneous value of the signal during the blanking period, it is important that the burst signal be completely removed from the signals applied to the demodulators. This is done, as previously mentioned, in the bandpass amplifier. Clamping action in the output amplifier is very stable for the following reason: the principal cause of d-c drift in a triode is the development of ohmic resistance either in the cathode material or in the physical contact between the cathode material and the metal sleeve upon which the cathode material is deposited. When a tube is new this ohmic resistance is low, less than a few ohms. As the tube ages the cathode is "poisoned" slowly by various chemical processes which go on inside the cathode material and the resistance starts to increase, and may reach several hundred ohms. This is what generally causes older tubes to be "weak". Their emission capability is not really reduced, but rather it is as though a large resistor were placed between cathode and ground within the tube. As a result, the internal cathode voltage rises so that the bias is much too high and if a fixed bias is used, the plate current is greatly reduced. Since the internal resistance is the result of a complex chemical balance, it will vary as a function of temperature, plate current, heater volts, etc. However, when bias is obtained by pulse clamping, the bias is established with respect to the actual *internal* cathode voltage since the cathode will conduct to the grid only when the *internal* cathode voltage is driven negative with respect to the grid regardless of the absolute voltage involved. Consequently, the true bias is constant and the plate current is stable despite aging effects.

Blanker. The negative clamping pulses required to set the d-c color video output amplifiers are obtained from the plate of V_{707B} , the blanker. See Fig. 5-28. The pulses are developed across R_{735} and fed to the common cathode resistor of the output

amplifiers through the coupling capacitor C_{739} . The grid drive is a 600-volt positive pulse obtained from the capacitive voltage divider, C_{113} and C_{114} , on the high-voltage transformer T_{102} . This pulse is fed to the grid through C_{737} and R_{740} , which in conjunction with grid conduction of the blanker shape the top of the pulse. The flat portion between blanker is biased beyond cutoff during that period. Note that the blanker and the bandpass amplifier share a common cathode resistor, R_{708} . Thus, the positive pulses appearing in the cathode circuit (when the blanker conducts) are applied directly to the bandpass amplifier. This provides the blanking action that is required for the bandpass amplifier during the burst interval. Negative d-c voltage for use in the color killer and 3rd video amplifier are taken from the grid circuit of the blanker. About -95 volts is developed by grid-current action.

Luminance Adder Operation. In an early color receiver, the RCA CT-100, the complete red, green, and blue color signals were produced in separate adder stages. Before getting into the discussion of the output circuits, however, there is another point of interest which must be mentioned. In this receiver, see Fig. 5-29, demodulation takes place along the *I* and *Q* axes. As you may recall from earlier lessons, the designers of the color TV system made certain special provisions for *I* and *Q* operation. Based upon a number of viewer tests it was found that the eye is more sensitive to color detail along the orange-cyan axis (the *I* axis) than along the green-magenta or *Q* axis. Because of the difference in eye sensitivity it was decided to transmit *I*-axis colors in a wide band of about 1.5 mc. The *Q*-axis colors are transmitted in a narrow band, about 0.5 mc wide. A receiver properly designed to use these signals may have, in theory at least, some advantages in terms of the sharpness of the edges of colored objects. Certain practical difficulties with *I*, *Q* operation have thus far limited the popularity of this system in receiver design. One of these is the need for time-delay equalizations between the *I* and *Q* signals. Another is the fact that the simple matrix systems which are used in modern receivers do not work out so conveniently with *I*-*Q* systems. In the CT-100 these problems were overcome by

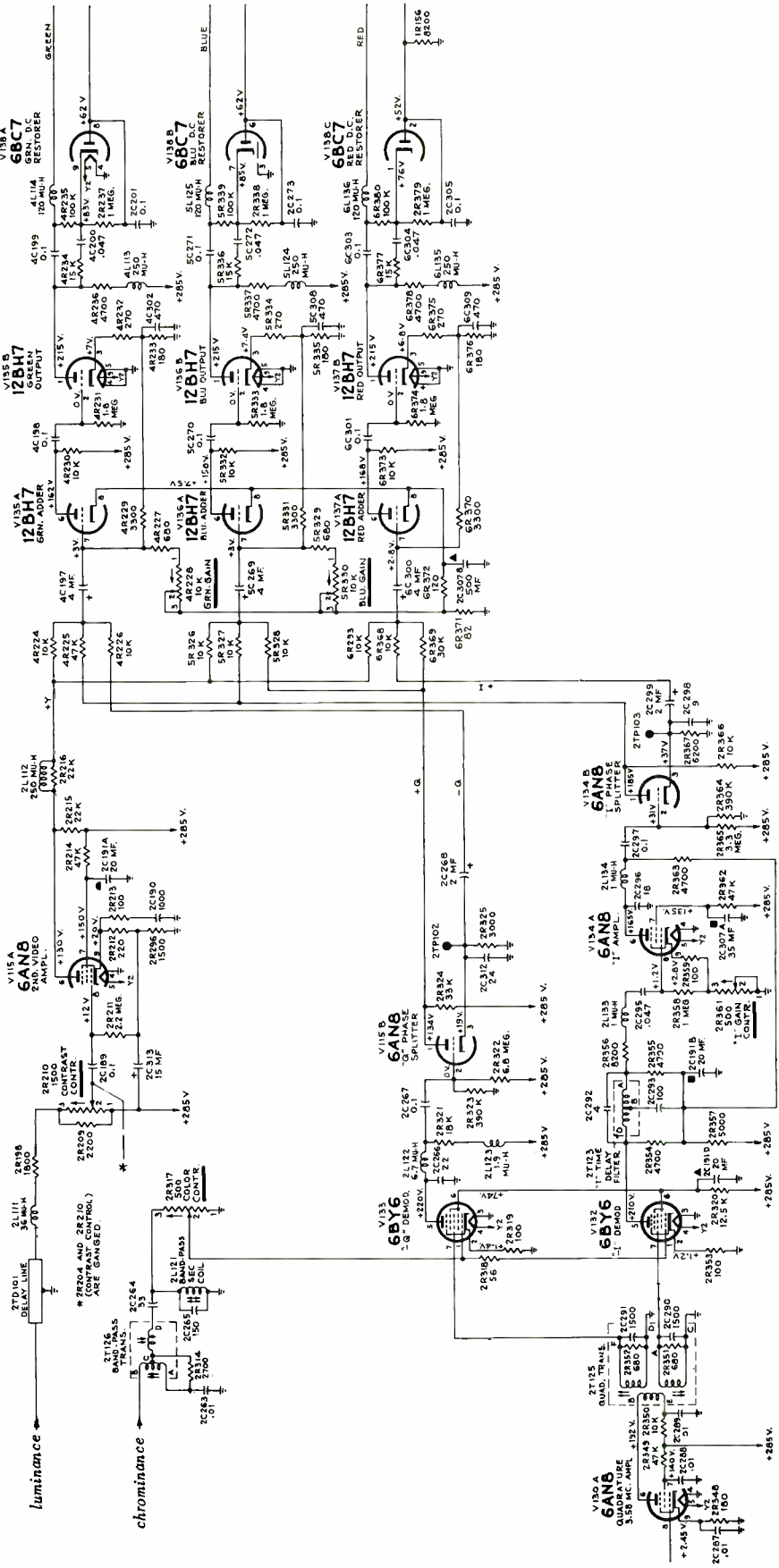

Fig. 5-29. Chrominance circuits of the RCA CT-100 chassis. This early receiver was designed to demodulate I and Q signals.

means of a special I -channel time-delay (filter $2T_{123}$) and the use of triode phase splitters to obtain $+Q$, $-Q$, and $+I$, $-I$ signals. A resistance adder including a connection to the Y (or luminance signal) was used, as shown in Fig. 5-29, to obtain green, blue, and red signals at the grids of the green, blue, and red adders respectively. These tubes formed the first half of a feedback pair which, with the respective output amplifiers, provided the video drive required by the kinescope. Feedback is provided from the cathode of the output tube to the grid of the adder stage. The green amplifier feedback is accomplished by means of resistor $4R_{229}$. The signal is a-c coupled through the output amplifier. The d-c component is reinserted by means of a d-c restorer diode. A problem comes up in the use of d-c restorers in TV in that they are easily upset by noise, with resulting black-outs and heavy streaks in the picture. In an attempt to improve the noise immunity of d-c restorers, a relatively narrow band of frequencies was applied to the restorers. In the green channel, for example, resistor $4R_{324}$ and capacitor $4C_{200}$ supply signals to the green d-c restorer. The higher-frequency components were passed around the restorers (through capacitor $4C_{199}$ and across resistor $4R_{235}$ on the way to the grid of the green gun).

5-11. LUMINANCE AMPLIFIERS

Many types of luminance amplifiers have appeared in commercial color receivers. One of the reasons for this variety in design is the development through the years of improved components and vacuum tubes. Another is the large number of functions which must be performed in the luminance amplifier in addition to simply amplifying the luminance signal. These include:

1. Provisions for brightness and contrast controls.
2. Passage of the luminance-signal d-c component.
3. Proper number of stages so that a sync-negative signal at the detector is amplified and applied to the kinescope cathodes with sync extending in the positive direction.

4. Take-off points, at proper impedance levels and polarities, for the 3.58-mc chrominance signal, burst, sync, and AGC (as well as the sound i-f signal in some designs.)

5. Time-delay, so that luminance and demodulated chrominance signals arrive at the kinescope at the same time.

6. Kinescope drive and white-balance controls.

Time-Delay Equalization. Of all the above requirements probably the least obvious is the need for time-delay equalization. The need is based on the fact that when luminance and color video signals are added together to form the drives for the electron guns we are dealing with signals which have passed through circuits having different bandwidths. Figure 5-30a shows what happens to a video signal when it goes through a narrow-band circuit. Delay of square waves is usually measured from the center of the rise as shown in the figure. It is not necessary to start with a sharp step to get the time delay; any signal which passes through the narrow-band circuit will be delayed by substantially the same amount.

Consider the construction of a yellow bar. Luminance and color video signals are added at the blue gun as shown in the figure. Since the bandwidth of the chrominance signal is only about 500-kc, the drive to the blue gun would appear as in Fig. 5-30b. On the kinescope, the yellow bar would have a broad, bright, blue left edge and a fuzzy, black, right edge. However, if we delay the luminance signal in a wideband delay line, to match the time delay of the $B-Y$ signal, the wave of Fig. 5-30c results. The "transients" are still there but they are balanced between left and right edges and are of shorter duration, resulting in a sharper color picture.

The delay line itself consists of a solenoid-wound coil with a grounded strip of copper running along its length. The strip provides a distributed capacitance to the distributed-inductance coil. A coil about 6 inches long is sufficient to provide the required delay of something less than a microsecond.

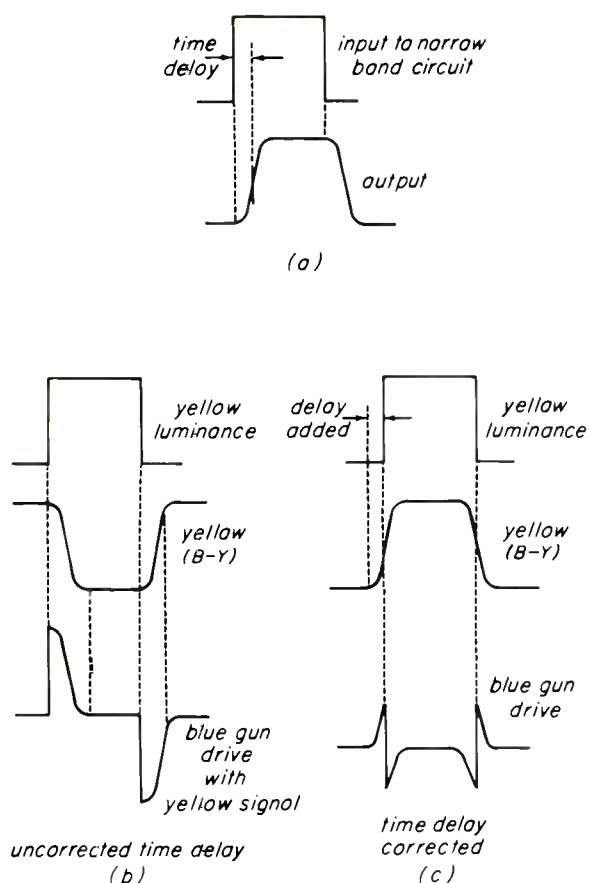

Fig. 5-30. An illustration of the need for the luminance-channel time delay.

RCA CTC-12 Luminance Channel. Refer to Fig. 5-31. In this circuit, detected video signals are applied to the control grid of the first video amplifier V_{304A} . Sync extends in the negative direction at this point. Bias for V_{304A} is provided by R_{326} . The bypass capacitor, C_{323} , is chosen to be $3300 \mu\text{f}$, a value which peaks the luminance signal in the 1- to 2-mc region. The screen grid return is made through a small isolating resistor, R_{325} , to the junction of R_{129} , which is tied to the screen $B+$ supply, and R_{535} , which is a part of the screen load of the keyed AGC noise-inverter circuit. The common tie point between the two screens helps the AGC operation under conditions that may occur when switching between strong- and weak-signal channels.

Four outputs are taken from the plate of V_{304A} . The first, through L_{110} , provides signals for the chrominance and burst portions of the receiver. The second, through R_{329} ,

provides drive to the sync separator, V_{503B} . The third, through terminal T on PW 300, provides an additional noise signal for use by the noise inverter V_{503A} . The fourth supplies the drive to the second video amplifier V_{304B} . The second video amplifier operates in an unconventional manner. Since its cathode is grounded, and its grid is more or less direct coupled (through R_{330} in parallel with C_{326}) to the positive voltage at the plate of V_{304A} , the control grid is always positive with respect to the cathode. The principal effect that positive grid action has is to make the tube present a rather low input and output impedance. As such this stage provides a low source impedance to match the input characteristics of the delay line. The plate output is developed across the load resistor R_{132} and is passed through TD_{101} which is the luminance delay line. The delay line is terminated in the network R_{745} , R_{733} , and L_{708} which matches the delay-line impedance, thereby removing reflections and providing a substantially flat video frequency response.

The a-c components of the signal are passed through C_{729} , then through L_{709} and R_{759} , which provide some video peaking, and finally reach the grid of the third video amplifier, V_{708} . After leaving the delay line, the low-frequency and d-c signal components are passed through R_{729} and into one end of the front-panel brightness control. The other end of the brightness control is returned to the negative d-c voltage available at the grid of the blanker, V_{707B} . Consequently, the low-frequency, d-c signal components are translated downward from the positive potential at the plate of V_{304B} in the negative direction across the brightness control. The arm of this control feeds the low-frequency, d-c signal components, to which a negative bias has been added, to the control grid of V_{708} . Because of the high resistance of the source of negative voltage (1.2 megohms R_{741}) only a small portion of the d-c component of the luminance signal is lost in the brightness control circuit. The cathode circuit of V_{708} provides mid-and-high frequency boost by means of R_{720} , C_{750} , C_{716} , and C_{125} . Contrast control is also provided in this circuit by R_{141} , which forms the d-c return for the cathode. An electrolytic bypass capacitor is connected to the arm of

R_{141} . When the arm is at the top, R_{141} is bypassed and causes no degeneration. As the arm is slid down toward ground, an increasing amount of R_{141} becomes unbypassed and the resulting degeneration reduces the gain of the stage. It may be noted that when the arm is at the top, all cathode video peaking is shorted so the over-all video response narrows. This effect was designed into the receiver. Normally the only time the gain control has to be adjusted to maximum is when weak and noisy signals are received. Under these conditions, reduced high-frequency response provides a somewhat clearer picture. On the other hand when strong clean signals are received, the contrast control will be turned back and the video signal will be somewhat peaked for greater sharpness.

A vertical blanking signal is added to the luminance output signal at the plate of V_{708} . Blanking pulses are taken from the plate of the vertical output tube. The deflection signal then passes through a network consisting of R_{518} , C_{711} and R_{702} on the way to the plate. The network has a time constant which is a little too short to pass the 60-cycle sawtooth part of the wave. Thus, the sawtooth component is removed, leaving only the positive retrace pulse which blanks the kinescope during vertical retrace.

The luminance output signal is applied through C_{127} and R_{146} , which provide additional peaking to the peaking transformer

T_{106} . A simplified schematic diagram of the output circuit is shown in Fig. 5-32. From it we can see that the peaking circuitry is similar to the more common series-shunt peaking circuit. The principal difference in the CTC-12 circuit is the magnetic coupling between the series and shunt coils. Since the effective coupling is a function of frequency and can be controlled, the designer has one more factor to take advantage of, and can provide a more efficient peaking circuit in the same sense that a shunt peaking circuit becomes more efficient when a series coil is added. Drive to the cathode of the red gun is taken directly from the output of the peaking circuit, whereas the blue and green cathode drive signals are taken at reduced level from the arms of the blue drive (R_{153}) and green drive (R_{154}) potentiometers. The control labeled *Kine Bias* on the complete schematic diagram is a service adjustment which can vary the d-c potential of all the kinescope cathodes simultaneously and is used to optimize the operating range of the front-panel brightness control.

Zenith 29JC20 Luminance Amplifier. In this receiver (see Fig. 5-33) the output of the video detector is developed across R_{20} and the shunt peaking coil L_{12} . The signal is further peaked by L_{11} - R_{21} and applied to the grid of V_{6A} , which functions as the first luminance amplifier. This tube is used as a cathode follower, with R_{29} serving as the main cathode load. R_{27} and C_{30} , connected

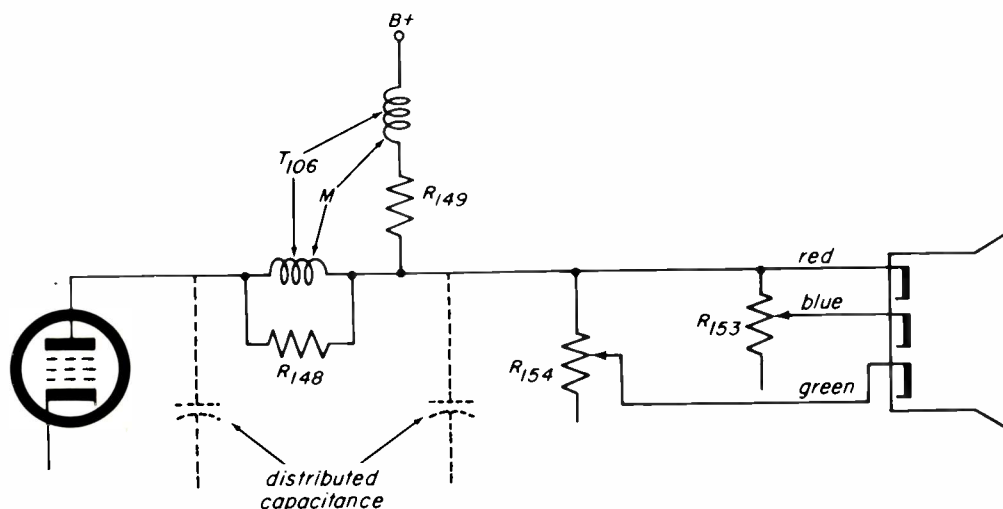

Fig. 5-32. A simplified drawing of the coupling circuit between the third video amplifier and the kinescope.

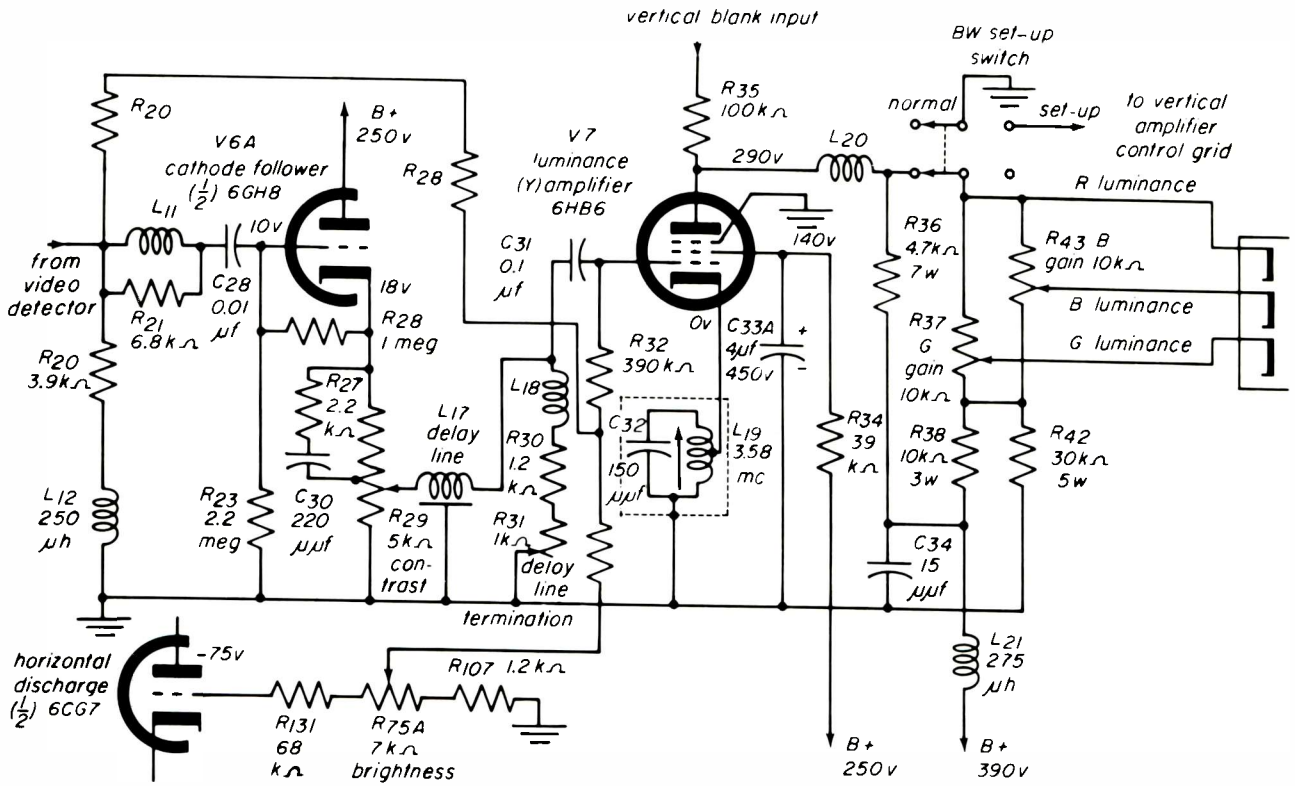

Fig. 5-33. A partial schematic diagram of the luminance section of the Zenith 29JC20 receiver.

from the cathode to a tap on R_{29} , are used to correct the video response. R_{29} is a potentiometer used as the front-panel contrast control. Video signals taken from the arm of R_{29} are passed through the luminance delay line L_{17} to the terminating network L_{18} , R_{30} , and R_{31} . R_{31} is adjusted to provide proper termination. The output of the delay line is then a-c coupled through C_{31} to the grid of the Y amplifier, V_7 . Only the a-c component is passed through the cathode follower circuits and fed directly to the grid of the Y amplifier, V_7 . The grid return for V_7 is through R_{28} and R_{20} to the load circuit of the video detector. Thus, the d-c voltage developed at the detector is shunted around V_6 to the grid of V_7 . In this way the total signal on the grid of the Y amplifier contains both the a-c and d-c components. The grid return of V_7 is also made through R_{32} to the arm of R_{75A} , which is the front-panel brightness control. One end of the brightness control is returned to ground through R_{107} ; the other end is tied through R_{131} to a negative 75-volt point at the grid of the horizontal output tube. Consequently,

by adjusting the brightness control, the grid bias on V_7 can be varied from about -1 to -8 volts to produce the desired brightness range. Vertical blanking is applied from the plate of the vertical output tube through R_{35} to the plate of the Y amplifier, V_7 . The luminance signal at the plate passes through series peaking coil, L_{20} , into the main load resistor R_{36} and the shunt peaking coil L_{21} . The drive to the red gun cathode is taken directly from L_{20} , while the drive to the blue and green gun cathodes is taken from the service-adjustable controls R_{43} and R_{37} . These controls are used in setting up the white balance of the kinescope. A parallel resonant 3.58-mc trap in the cathode of the Y amplifier introduces degeneration at 3.58 mc and minimizes the dot pattern in the picture.

It may be of interest to note that in the Zenith receiver both sound and sync are obtained from a separate second detector and amplified in a common tube. Chrominance signals are taken from the top of the video detector load, R_{20} , by means of a small

capacitor which passes the 3.58-mc signals on to the color circuits.

Bootstrap 1st Video Amplifier. In RCA receivers CTC-6 to CTC-11, an unusual type of amplifier is used as the first video amplifier. A simplified version of the circuit is shown in Fig. 5-34a. It is called a "bootstrap" or "cathode loaded" amplifier. Although it superficially resembles a cathode follower, and its output has the same polarity as its input, it behaves quite differently in all other respects. Its output impedance is substantially equal to the cathode load resistor. In addition, the stage provides voltage gain. To understand the circuit, consider the triode amplifier of Fig. 5-34b. Notice that there is no ground return shown. If the cathode is grounded we have a normal amplifier. However, we can always ground

any point we care to. If, in Fig. 5-34b, we interchange the battery and load resistor, and put the circuit ground between them, we have the bootstrap circuit shown in Fig. 5-22c. The important thing to notice is that the input signal remains applied between grid and cathode (not between grid and ground or the circuit would be a cathode follower). A circuit arranged like this can have the same gain as the plate loaded circuit of Fig. 5-34b. For most video applications it is not a very convenient arrangement, but in circuits where the source of input signals can be floated between grid and cathode it is not too difficult to use. The simplified circuit of Fig. 5-34a shows how it can be done when the input signals are obtained from a detector. In this case the detected signal is developed across R_d with the whole detector circuit connected between the grid and cathode of the amplifier. In the circuit used in the RCA CTC-9A (see Fig. 5-35), the detector circuit consists basically of the third pix i-f transformer T_{304} , the crystal pix detector, CR_{302} , the detector capacitor, C_{317} , and detector load which is the parallel combination of R_{313} and R_{314} . L_{309} and C_{324} keep i-f signals out of the video amplifier, and the 41.25-mc and the 4.5-mc traps attenuate sound i-f and inter-carrier signals severely. The top of the detector load is coupled to the grid through the peaking circuit $L_{307}-R_{318}$. The bottom of the detector load connects to the bottom of a small cathode bias resistor R_{405} and its peaking capacitor C_{402} . R_{406} and L_{401} form the cathode load to which the luminance delay line is connected. The circuit has a gain of about three. Signals for the sync separator, chrominance channels, etc. are taken from the plate circuit.

5-12. REMOTE CONTROL

Remote control of color television receivers is related to that of black-and-white to the extent that an ultrasonic transmission is generally used to control the receiver. Color, as usual, presents some additional complications primarily because it is generally felt that it is desirable to remote control the color functions (hue and saturation) as well as channel, volume, and off-on controls. Remote control receiver, CTP10A,

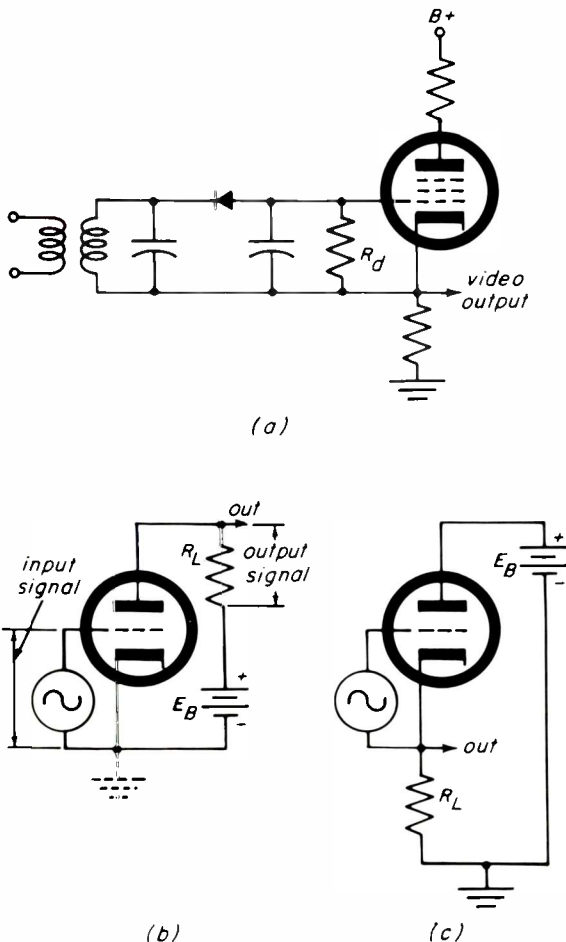

Fig. 5-34. A simplified approach to bootstrap amplifiers.

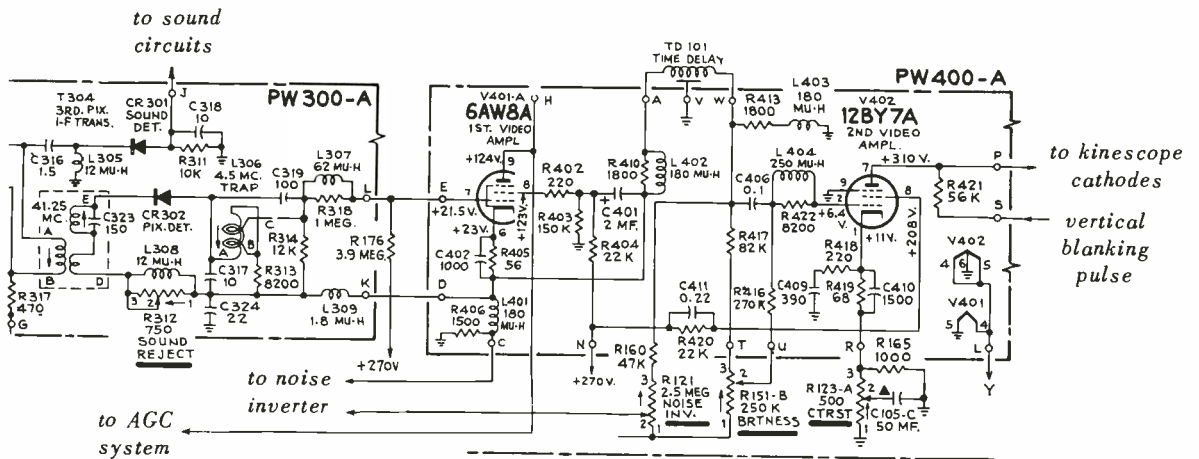

Fig. 5-35. The first video amplifier in the RCA CTC-9 chassis is a bootstrap amplifier.

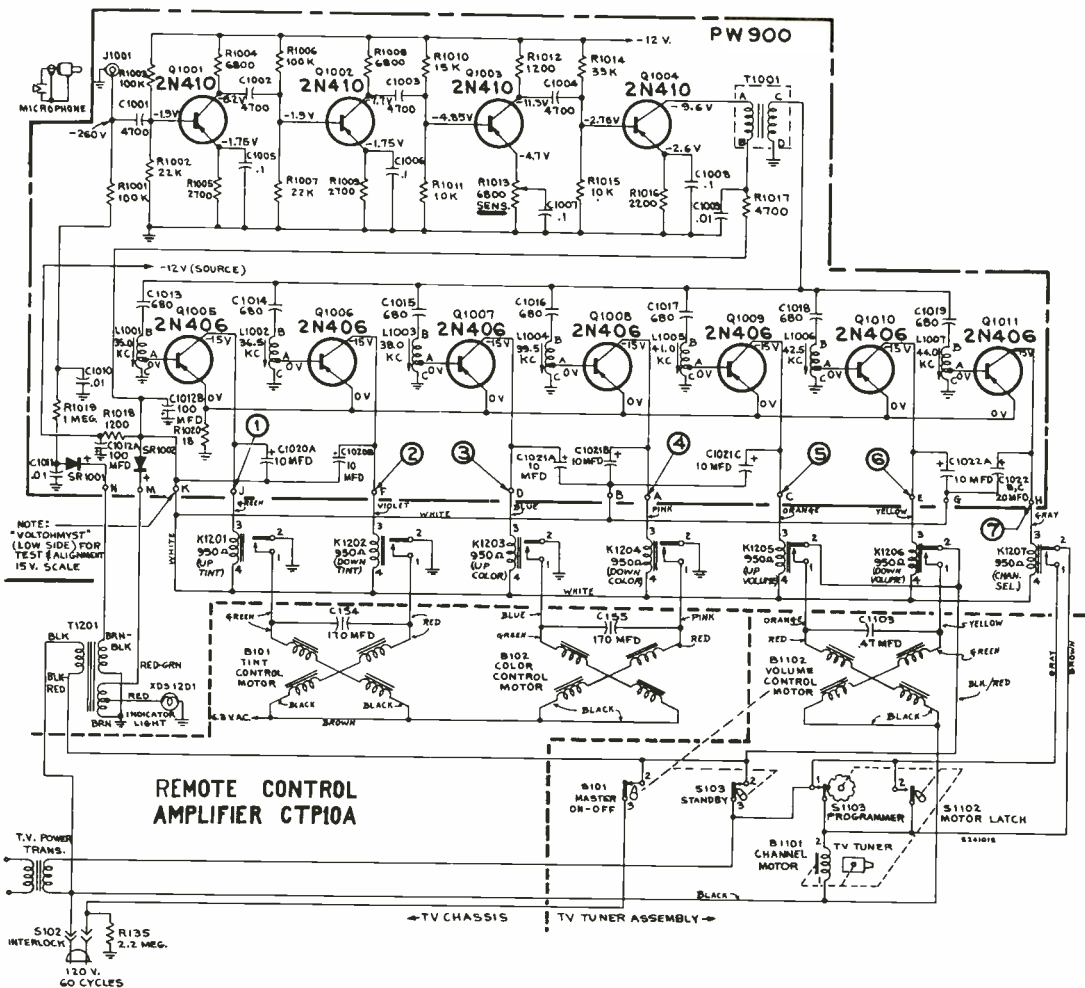

Fig. 5-36. Remote control receiver used with RCA color receivers.

is used in the RCA CTC-12. Figure 5-36 shows the schematic diagram. The sonic band employed covers the frequency range of 35 kc to 44 kc. The transmitter used by the viewer consists of an oscillator which drives a small loudspeaker. Depression of one of the control buttons on the transmitter sets the oscillator at a predetermined frequency in the band. For instance, depression of the Tint-Up button sets the oscillator at 17.5 kc. This signal is doubled by the special nonpolarized speaker and is radiated at 35 kc. The sonic signal is picked up by a microphone connected to T_{1001} on the receiver chassis. The signal is then amplified in a four-stage transistor amplifier whose output appears in the transformer T_{1001} . The secondary of T_{1001} drives seven series-tuned circuits, each tuned to a specific frequency to provide a particular function. The 35.0-kc signal is selected by the $C_{1013} - L_{1001}$ circuit and causes conduction of the transistor Q_{1005} . This operation actuates relay K_{1201} which starts the tint-control motor moving in the direction to increase tint. The motor continues turning until the viewer releases the button on the transmitter. The other operations are done in a similar manner. Two "off" positions are made available: In the first "Standby" function, the color receiver is turned off but the remote control receiver is left on, so that the receiver can be turned on again from the remote control transmitter. In the "Master-off" position the remote unit is also switched off and the receiver has to be turned on manually.

5-13. SERVICING FEATURES

Detailed servicing information may be obtained in the form of Service Notes from the manufacturer of the particular receiver of interest. For example, "Color Television Service Data - File: 1962 No. T6" published by RCA Sales Corporation covers the CTC-12 chassis in considerable depth. However, some of the more important points are worth pointing out in this lesson.

First, there are a variety of test points and interconnection points printed on the circuit diagram* with either a letter (A, B, C,

U, etc.) or a test point (TP 501, etc.) designation. These same designations are also printed on the printed wiring boards used in the construction of the receiver. The receiver schematic diagram included with this lesson has on it oscillograms of the wave shapes of the signals which exist at several key points in the circuit. For instance, at TP-301 there should be a 3-volt sync-negative video signal as indicated by the balloon 1. Normal d-c voltages are also indicated on the schematic for a variety of points. It is a good exercise for the student to try to figure out why the voltages are what they are.

Control Location. On the CTC-12 all controls are on separate shafts. All viewer controls are brought out to the front, and with very few exceptions all service controls are readily accessible from the back of the set. Figure 5-37 shows the locations of all controls and in addition the location of the major receiver components.

Tuner and Chassis Removal. The following procedure, taken from the service data for the CTC-12, illustrates a typical chassis removal job.

Recommended tools: Screwdriver (4" to 6" shank), 1/4" and 5/16" socket head wrench or nut driver, 5/16" "off-set" socket head.

1. Pull all the front-panel knobs.
2. Disconnect the antenna.
3. Remove the back and disconnect the antenna terminal board from the cabinet.
4. Remove the four 5/16" hex-head bolts securing the chassis to the cabinet shelf.
5. Disconnect the speaker output cable at the speaker terminal board.
6. Disconnect the convergence yoke plug located forward of the high-voltage cage.
7. Disconnect all deflection leads at the yoke.
8. Disconnect the picture tube socket.

* See end of book

adapted to the requirements of other receivers.

Chassis Service Position. Since the tubes and controls are for the most part readily accessible without removing the chassis, routine servicing does not involve any complication. In the event, however, that it is necessary to operate the receiver

out of the cabinet, the first step is to follow the steps in the preceding paragraphs. Use of a work bench or table is desirable. After removal, the chassis is placed behind the cabinet. It is made to stand on edge, as shown in Fig. 5-37, with the high-voltage cage at the bottom and the tubes pointing toward the cabinet. In this position the sets of leads to the kinescope socket, yoke, high-voltage terminal, etc. can be connected.



NOTES

NOTES

NOTES

COLOR TELEVISION COURSE

LESSON 6

RECEIVER ALIGNMENT

- 6-1. Preliminary Considerations
- 6-2. Equipment Requirements
- 6-3. Review of Basic Operations
- 6-4. Tuner Alignment
- 6-5. Sound I-F Section Alignment
- 6-6. Video I-F Amplifier Alignment
- 6-7. Bandpass Amplifier Alignment
- 6-8. AFPC Alignment
- 6-9. Horizontal Deflection Alignment
- 6-10. Remote-Control System Alignment



RCA INSTITUTES, INC.

A SERVICE OF RADIO CORPORATION OF AMERICA

HOME STUDY SCHOOL

350 West 4th Street, New York 14, N.Y.



INTRODUCTION

The word *alignment*, as applied to TV servicing, refers to the general process of adjusting the tuned circuits of the receiver so that the over-all frequency response of the receiver meets original factory specifications. Normally, the service technician does little alignment except for the familiar oscillator-tracking adjustments in the tuner. Other tuned circuits, such as are found in the i-f and video stages, usually do not drift from their original settings. However, occasions do arise when it becomes necessary to perform extensive alignment checks and adjustments. For example, the video i-f section may require alignment following the replacement of defective components in that unit. Alignment checks can actually save time when it becomes necessary to evaluate the performance of major sections of the receiver to localize the cause of a "tough" trouble.

Hence, although extensive alignment jobs are rarely necessary, the professional service technician should be ready for them when the need arises. The purpose of this lesson is to present the principles of color receiver alignment, and to help the beginner avoid some of the common mistakes that cause misleading indications and waste time.

6-1. PRELIMINARY CONSIDERATIONS

What Circuits Require Alignment? As in the black-and-white receiver, the circuits that handle the r-f and i-f signals may require alignment. The sections involved are the tuner, the video (picture) i-f amplifier, and the 4.5-mc intercarrier-sound i-f amplifier. It is rarely necessary to check the response of the video amplifier in the monochrome receiver. However, the response of the video amplifier in the color receiver is quite critical and rather elaborate traps are used in the video circuits to eliminate the 4.5-mc signal. Trap adjustment in the video sections is an important part of the alignment procedure.

The bandpass amplifier is very similar to a broadband i-f amplifier. The alignment

adjustments that apply to this stage are like the adjustments made in the video i-f amplifiers.

Alignment of the color synchronization section (the AFPC section) is somewhat like alignment of the sound section. The AFPC section contains a narrow-band amplifier, the burst amplifier, and a phase discriminator. In addition, the local 3.58-mc oscillator must be adjusted so that it runs at the correct frequency and is locked-in by the AFPC system. Adjustments to do this job are similar to the adjustments made in the AFC systems that control the horizontal deflection oscillator.

Another portion requiring adjustment includes the high-voltage and horizontal-output section. This workhorse of the color receiver must be adjusted for optimum performance to ensure that the system meets the power and voltage demands of the color kinescope, while not exceeding the power ratings of the horizontal output tube. These adjustments are not exactly alignment adjustments, since there are no tuning operations. However, horizontal deflection circuit adjustments fall under the general heading of "bench" or "shop" adjustments, and so they will be covered in this lesson.

Finally, alignment of the tuned circuits in the remote-control system may be required. Remote-control systems in color receivers are designed to handle a larger number of control functions (usually eight) than black-and-white receivers, and so use a larger number of ultrasonic control frequencies.

When Is Alignment Necessary? Improvements in receiver design and tube tolerances have minimized the possibility of drift in tuned circuits due to tube replacement or component aging. Alignment may be needed in case of actual component failure, or following extensive repairs in the tuned circuits. An i-f coil that has been smashed, when handling the chassis on the bench or in the truck, is a painful example of this situation. But perhaps the most important use of alignment procedures is in making alignment checks to judge the performance

of particular sections of the set. Troubles that elude ordinary troubleshooting techniques can often be localized by making sure that the tuner, i-f sections, and video amplifiers are working properly. Alignment checks allow the technician to check these sections individually.

What Can Be Done in the Home? Most alignment jobs are "bench" jobs. However many touch-up jobs can be performed in the home with a minimum of test equipment.

Tuner tracking adjustments, intercarrier-sound section alignment, AFPC alignment, and some of the adjustments made in the horizontal output/high-voltage section can be done in the home.

6-2. EQUIPMENT REQUIREMENTS

The basic tools for alignment work are the oscilloscope, the sweep generator, the marker generator, and the VTVM. An additional major piece of equipment for color work is the dot/color-bar generator. In addition to these major test equipments, a number of accessories, such as various pads, bias supplies, detector probes, and other items are necessary. The following paragraphs discuss each item in detail. One item that cannot be overlooked is the manufacturer's *service notes* or *service manual* for the particular receiver being serviced. While many jobs can be done without the service manual, alignment work requires knowledge of the specifications for each particular receiver model. For this reason no general discussion of alignment can give the technician all he needs to do the job. This lesson is a general guide and supplement to the procedures detailed in the service notes, but the lesson cannot substitute for them.

Oscilloscope. For alignment work, the basic requirement of the oscilloscope is high-deflection sensitivity. A high-gain CRO is needed to amplify and display the low-voltage signals that provide the response curves for VHF and UHF tuners. A deflection sensitivity of 18 rms millivolts per inch is usually adequate.

While wide bandwidth is helpful for general troubleshooting in color receivers, it is not required for alignment purposes. Nearly all sweep generators operate at a sweep repetition rate of 60 cps. This means that the detected video signals picked up by the oscilloscope vary in amplitude at a 60-cps rate. The oscilloscope need only pass a narrow band of frequencies from about 10 cps to 600 cps to display the response curve correctly.

A very useful feature of some oscilloscopes designed for TV work is a provision for internal 60-cps horizontal deflection. This feature makes it unnecessary to make wire connections between the sweep generator and the oscilloscope in order to get horizontal deflection. Since nearly all sweep generators employ a 60-cps sine-wave modulating signal, the horizontal deflection signal required for the oscilloscope is a 60-cps sine-wave and can be obtained directly from the power line. A *phase control* is included on oscilloscopes that contain this feature, so that the phase of the 60-cps signal fed to the horizontal deflection plates may be controlled. By controlling the phase of the deflection signal, it is possible to make the beginning of a horizontal scan on the oscilloscope start out at the same instant that the frequency-modulated sweep starts in the sweep generator. (We will show later how to make this phase adjustment.) Sixty-cycle sine-wave deflection is obtained on oscilloscopes equipped with this feature by turning the horizontal deflection function switch to the *line position*.

Oscilloscopes like the RCA WO-78A, and the RCA WO-91A shown in Fig. 6-1, are well suited for alignment work.

Sweep Generator. A sweep generator is a signal generator whose output frequency moves across a selected range of frequencies. In most service sweep generators the sweep action is repeated sixty times per second. During one cycle the generator sweeps up and down over the selected frequency range. Usually the return sweep is blanked by disabling the oscillator for one half cycle. This prevents a double response

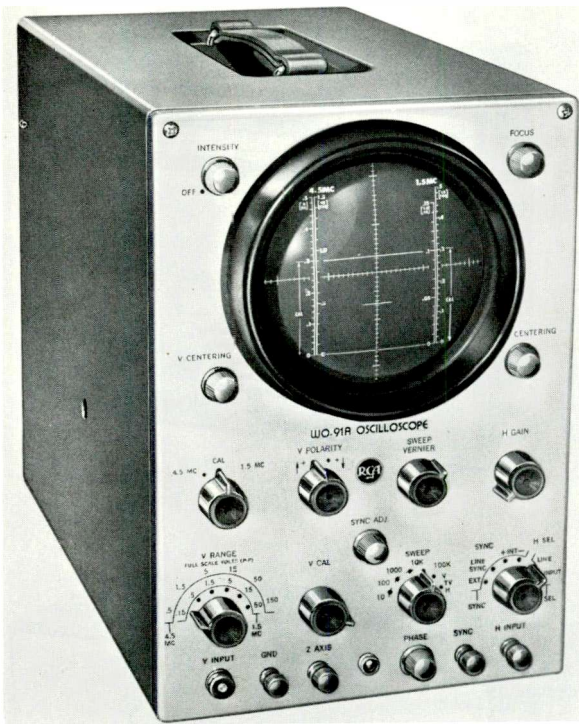

Fig. 6-1. The RCA WO-91A oscilloscope.

curve, and provides a horizontal zero reference or base line for the response curve.

The primary requirement of a sweep generator is that its output voltage remain constant at all frequencies in the selected sweep range. Increases and dips in generator output at various frequencies produce misleading humps and valleys in the response curve of the device being tested.

For color television work the sweep generator should have a continuously variable sweep range, or sweep width, of 0 to 12 mc. The frequency range of the instrument should be such that this 0-12-mc range can be tuned from zero frequency for video work to about 50 mc for i-f alignment. In addition, all 12 VHF channels should be covered by the sweep generator.

The sweep generator should be equipped with a "flat" output attenuator. This means that uniform output voltage is maintained in the sweep range for all settings of the output attenuator.

The RCA WR-69A, shown in Fig. 6-2, meets all the requirements for color align-

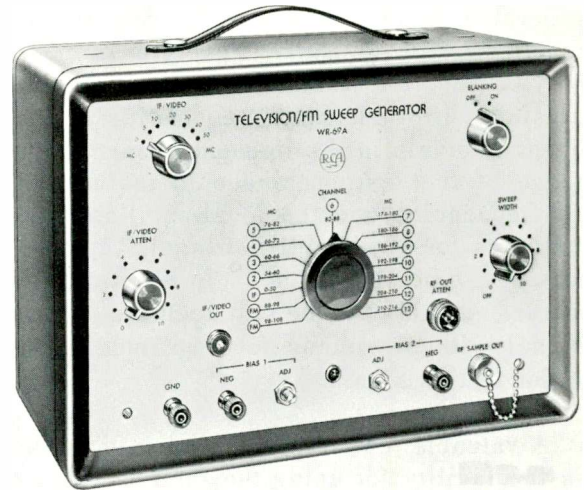

Fig. 6-2. The RCA WR-69A sweep generator.

ment work. As an added feature, it provides two continuously variable bias voltages, thus eliminating the need for separate battery or rectifier bias supplies.

Marker Generator. The marker generator, or calibrator, is simply a precision signal generator. It is used to place reference frequency markers or "pips" on the response curve. It is also employed in peak alignment of the video and sound i-f amplifier. In peak alignment, the marker generator supplies an input signal to the amplifier under test, and a VTVM is used to indicate detected output. The marker generator is tuned to the designated frequency for a particular coil (or trap) and the coil (or trap) is tuned for maximum (or minimum) output. Peak alignment is frequently used when a complete alignment job is to be done. Peak alignment is very useful when the receiver is completely out of alignment.

A separate marker generator is more advantageous than the marker generators that are built into some sweep generators. A separate marker generator allows the sweep and marker inputs to be fed to different circuits. For example, when aligning the i-f amplifier, it is sometimes better to feed the sweep generator r-f output to the antenna terminals, but feed i-f marker signals into the i-f amplifier. This allows the i-f response curve to be marked at i-f frequencies regardless of the channel to which the sweep

generator and tuner are set. The primary requirement of the marker generator is accuracy. Superior marker generators provide crystal-controlled check frequencies at frequent intervals in the frequency range. The range of the instrument should include the i-f frequencies and the local-oscillator frequencies for all the VHF channels (approximately 30 mc to 260 mc). In addition, the marker should provide an accurate 4.5-mc signal with provisions for amplitude modulation of this signal.

A valuable feature of the marker generator is the facility for using the instrument as a heterodyne frequency meter. This requires a built-in detector, audio amplifier, and speaker. To use the heterodyne frequency meter, the signal whose frequency is to be determined is applied to an r-f input terminal on the instrument. The variable oscillator of the marker is tuned to produce an audible zero beat, indicating that the marker oscillator and unknown signal are on the same frequency. The marker dial is read to determine this frequency. The heterodyne system is extremely useful in making local-oscillator adjustments in the tuner.

All the features discussed in the preceding paragraphs are found in the RCA WR-99A shown in Fig. 6-3a. This generator provides crystal check points at 10-mc and 1-mc check intervals throughout the range of the instrument.

UHF Sweep and Marker Generators. When alignment includes UHF work, additional sweep generators and marker generators are required. The requirements are the same except that the frequency range of these instruments should include from 470 mc to 890 mc. The RCA WR-86A UHF sweep generator is shown in Fig. 6-3b.

Special Color Equipment. A dot-cross-hatch/color-bar generator is mentioned here although it is properly classified as setup rather than alignment equipment. The color bar generator is employed in alignment of the AFPC system. This piece of equipment will be covered in detail in a later lesson.



(a)



(b)

Fig. 6-3. RCA VHF and UHF marker generators.

Video Marker Box. When aligning color receivers, it is sometimes necessary to place frequency marks in the video passband. Marker generators are unsuitable for this purpose. An absorption-type marker, like the RCA WR-295B shown in Fig. 6-4, is used in the video range. It is placed in series with the output cable of the sweep generator and provides frequency marks by making holes or "suck-out" points at specified fixed frequencies in the video range.

Bias Supplies. The r-f and i-f sections of the receiver are aligned with fixed bias voltages; the AGC system is effectively disabled. The bias supply should supply three continuously-variable d-c voltages. The



Fig. 6-4. The RCA WR-295C absorption-type video marker.

voltage range at each tap should be at least 0-15 volts. These supplies may be constructed by the technician from "junkbox parts." A schematic diagram of a simple battery-powered supply is shown in Fig. 6-5. Some sweep generators (such as the WR-69A) provide variable bias voltages. Manufactured bias supplies are also available. Examples are the RCA WG-307B shown in Fig. 6-6, and the Sencore Model BE3.

R-F Modulator. The r-f modulator is a piece of alignment equipment that is not usually associated with black-and-white alignment work. It is used with the VSM (video sweep modulation) system employed to check the over-all r-f, i-f, and video response of color receivers. We will discuss this piece of equipment when the VSM system is shown later in this lesson. Figure 6-7 shows the RCA WG-304B r-f modulator used in the VSM system.

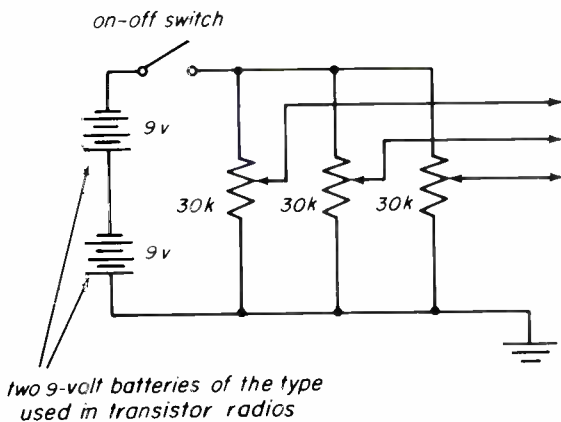

two 9-volt batteries of the type used in transistor radios

Fig. 6-5. A battery-powered bias supply.

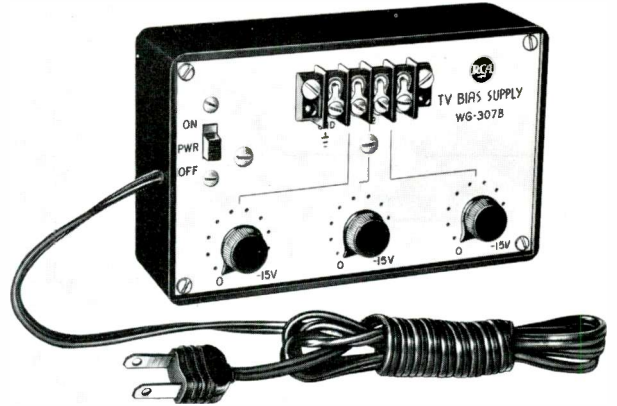

Fig. 6-6. Commercial bias supply, RCA WG-307B.

Other Accessories. There are several other items to be discussed, such as matching pads, detectors, load blocks, etc. Most of these items are put together by the technician when they are needed. We will show the necessary accessories as they come up in the alignment procedures that are outlined in the remainder of this lesson.

6.3. REVIEW OF BASIC OPERATIONS

Before we look into the alignment operations performed on color receivers, let's review briefly some of the basic practical considerations for any alignment job. As a practical example, we shall look into the test equipment connections and control settings that are made in sweep aligning a video i-f amplifier. Throughout the discussion, refer to Fig. 6-8.



Fig. 6-7. The RCA-3044 r-f modulator.

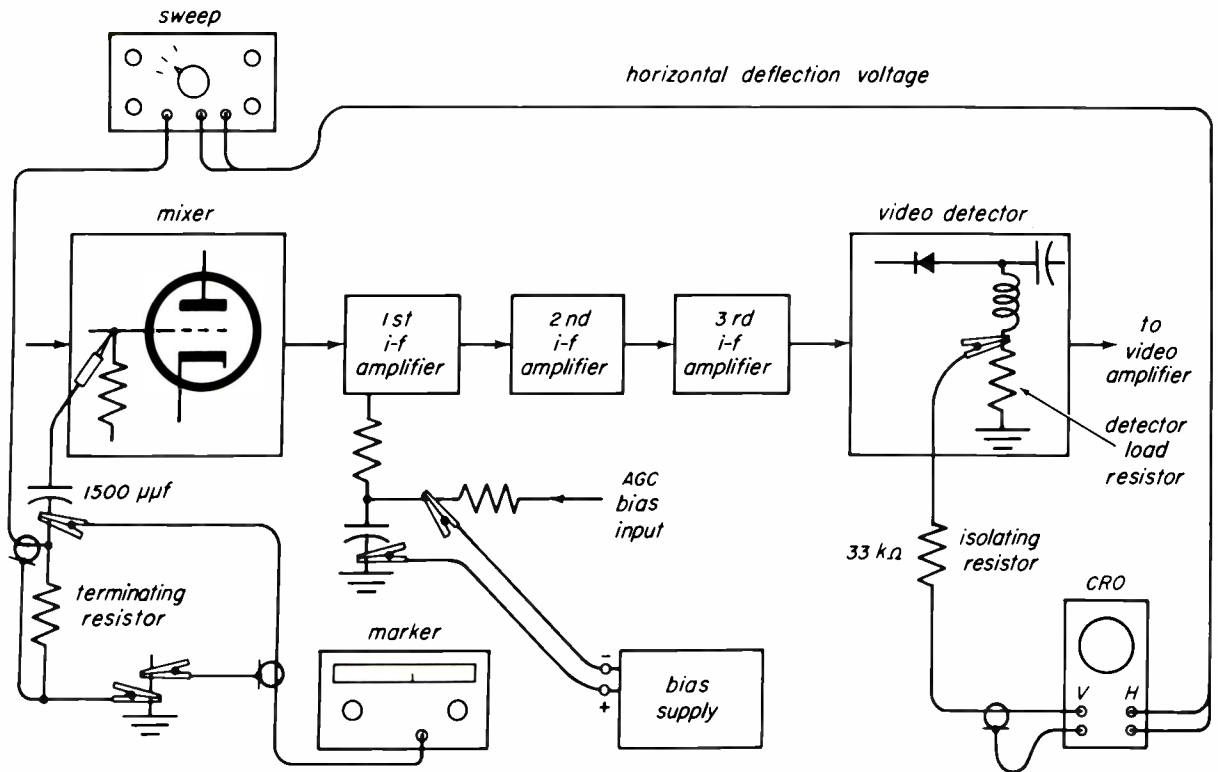

Fig. 6-8. Connections made to sweep-align the video i-f amplifier.

Oscilloscope Connections. In sweep-alignment of a video i-f amplifier, the signal being applied to the r-f amplifier varies between about 41 and 47 mc. The oscilloscope must be connected to the output of the detector in order to display the over-all i-f amplifier response. Here the output voltage is a d-c voltage whose amplitude is determined by the gain of the i-f amplifier at every point in the frequency range being swept. Since the sweep generator covers the sweep range at the rate of 60 cps, the detected signal applied to the oscilloscope is a 60-cps signal. Hence the oscilloscope can be, and indeed should be, a narrow-band oscilloscope.

The oscilloscope is connected to the detector load resistor as shown in Fig. 6-8. Avoid connections to the output side of a coupling capacitor, as the capacitor may introduce some phase shift in the low-frequency (60-cps) signal. Connection is made to the "cold" side of the peaking coil, since we are interested in the low-frequency components of the signal. It is not desirable to have high-frequency (i-f) signals applied to

the oscilloscope leads, as radiation of the i-f signal may occur, and lead to regeneration problems. The isolating resistor further isolates the oscilloscope leads, and forms a simple low-pass filter with the cable capacitance of the oscilloscope. It is useful to restrict oscilloscope bandwidth in this manner, as frequency markers appear narrower and more distinct on the response curve. Remember that the marker pip is actually the zero beat between the marker frequency and the sweep frequency. By restricting oscilloscope bandwidth we see only the low-frequency beat signals that surround the zero-beat point. If a wide-bandwidth oscilloscope is used, the marker pips may spread out over a large part of the response curve as in Fig. 6-9a. In some cases a 0.01-µf capacitor is added across the CRO's terminals to reduce frequency response. This results in a clean, narrow marker pip, as shown in Fig. 6-9b.

Horizontal deflection required for the oscilloscope is the modulating signal applied to the FM modulator in the sweep generator. It is a 60-cps sine wave. Unless

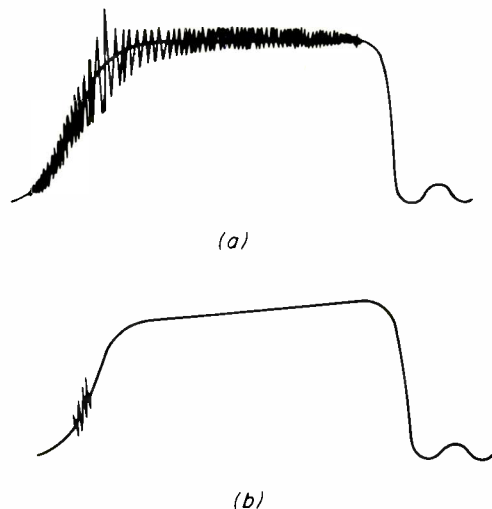

Fig. 6-9. (a) Appearance of the marker pip on a wideband oscilloscope; (b) appearance of the marker pip on a narrow-band oscilloscope.

the CRO is equipped for internal 60-cps deflection, with control of phase, the deflection signal is obtained from the sweep generator. This signal is applied to the horizontal input terminals of the CRO. The sweep selector switch in the CRO is set to the amplifier position, in which the internal time-base generator for the CRO is disabled. If the CRO is equipped with a variable-phase 60-cps deflection signal, the sweep selector is simply set to the *line* position. Phase adjustments will be reviewed shortly.

It is a good idea to calibrate the oscilloscope to read peak-to-peak voltage when doing an alignment job. By monitoring the output voltage from the amplifier under test, it is possible to avoid overload problems. For example, in aligning an i-f amplifier we can be sure that we are not overloading the amplifier if the peak-to-peak output voltage is kept below about 0.5 volts. Service notes often dictate the maximum output voltage for this reason. Overload is one of the most common mistakes made by inexperienced technicians in doing alignment work. We will show other ways to avoid overload later.

Bias. Check the service notes for proper bias connections and the recommended bias voltage. Bias connections are usually made to the decoupling networks that apply AGC bias to the controlled stages, as in Fig. 6-8. Often, when aligning the i-f amplifier, the

r-f amplifier is biased off. This prevents antenna signals from interfering with the alignment job.

Sweep Generator Connections. There are several factors to be considered in connecting the sweep generator to the amplifier. First of all, the cable in the sweep generator must be terminated properly. If not, the cable will introduce reactive effects of its own and make the alignment curve *meaningless*. Secondly, the output impedance of the sweep generator should not swamp out any of the tuned circuits that make up the response curve we wish to see. For example, we cannot connect the sweep generator to the grid of the first i-f amplifier in Fig. 6-8. In that case the terminating resistor on the sweep generator's cable would short out the tuned circuit in the grid of that stage. Since the coupling circuit between the mixer and the first i-f amplifier forms part of the overall i-f amplifier, the sweep generator must be connected to a point ahead of the mixer. In most cases connections are made directly to the mixer grid. A blocking capacitor is used in series with the sweep cable, so that the terminating resistor does not alter the bias on the mixer stage. Some, but not all, mixer test points are used for the injection of alignment signals. Usually the test points provided for the measurement of injection voltage have a series isolating resistor and are not suitable as points at which to connect the sweep generator. The service notes usually tell of the best and most convenient point to connect the sweep generator.

In setting the controls for the sweep generator, start with the output attenuator set for minimum output. Adjust the frequency control to place the center frequency in the range desired. Set the sweep-width control to cover the range of frequencies desired. For example, in sweeping the i-f amplifier, set the main frequency control, or controls, to a center frequency of 44 mc and the sweep-width control to sweep a range of approximately 6 mc. The generator then provides a sweep output of 44 mc \pm 3 mc, or from 41 to 47 mc.

Advance the output attenuator of sweep generator until a response c

obtained. If the oscilloscope has not been calibrated, set the CRO for maximum vertical gain. Phase adjustments are made at this point.

Phase Adjustments. The phase control adjusts the phase of the horizontal deflection signal in the oscilloscope so that the frequency sweep and the horizontal scan start at the same instant. To make this adjustment the *blanking* switch on the sweep generator is switched to the *blanking-off* position. Then you should see two response curves, one as the frequency sweeps up the band, the other as it sweeps down, as in Fig. 6-10a.

The phase control on the unit supplying the deflection signal is then adjusted to superimpose the two response curves as shown in Fig. 6-10b. When this adjustment is completed, the start and finish of the frequency sweep coincide with the start and finish of the horizontal scan on the CRO. The blanking switch on the sweep generator is then switched to the *blanking-on* position. This causes the sweep oscillator to be cut off during one half of the 60-cycle modulating signal. Hence, there is no output from the sweep generator during this interval, the return frequency sweep is blanked out, and only one response curve is displayed. The return trace that occurs during the time that the sweep oscillator is blanked provides a zero base line for the response curve, as shown in Fig. 6-10c.

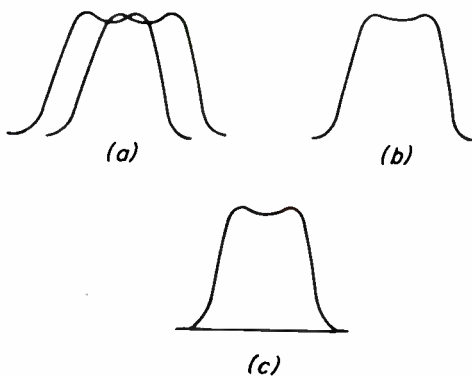

Fig. 6-10. Phase adjustments; (a) incorrect phase adjustment, blanking off; (b) correct phase adjustment, blanking off; (c) blanking on.

Check Sweep Width. A frequent cause of a misleading response curve is a misadjusted sweep-width control. You should learn to recognize the symptoms that result from a misadjusted sweep-width control. Remember that the horizontal deflection signal supplied to the CRO is *not* affected by the sweep-width control. It controls only the width of the band of frequencies being swept. Consider the response curve of Fig. 6-11a; in this case the sweep width is sufficient to sweep over the entire i-f passband. If the sweep width is reduced to 1 mc, only a small portion of the passband close to the generator center frequency will be swept. Since the response curve is flat in this region the detected output voltage stays constant. The response curve appears as shown in b of the figure. If sweep width is adjusted to cover a wider bandwidth than needed, the entire response curve occupies only a fraction of the total horizontal scan, as in c of Fig. 6-11.

Check for Overload. To make sure that the response curve is not distorted due to overload somewhere in the i-f amplifier, the following check may be made. Set CRO gain (vertical amplifier) to maximum. Set the attenuator on the sweep generator to provide minimum output. Then, increase the sweep generator's output slowly until a response curve is observed. Continue to increase the

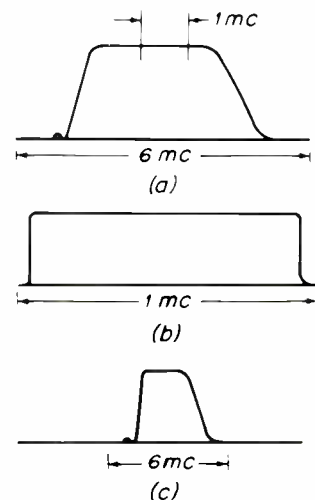

Fig. 6-11. Sweep-width control settings: (a) correct sweep width for i-f response curve; (b) sweep width too narrow; (c) sweep width too wide.

output slowly until the curve changes shape; it may square off at the top. This indicates overload. Note the vertical amplitude of the curve at the point where the first sign of overload can be seen. Reduce the output of the generator until the curve is at least one half the size at which overload was seen and work at this level. Note: excessive noise ("grass"), or tilt of the base line that results from too much hum pickup, may indicate excessive CRO gain. Reduce the gain of the CRO and repeat the sweep attenuator adjustments outlined in the preceding discussion.

Putting In Frequency Markers. Frequency markers are inserted into the response curve by coupling the marker generator to the amplifier under test. Coupling should be as loose as possible to prevent detuning of the i-f circuits and distortion of the response curve. To avoid trouble, set up the sweep generator and CRO to produce the response curve before the marker generator is coupled into the system. In this way we can see if coupling of the marker alters the shape of the curve. If it does, some other coupling means must be found.

In some cases the sweep and marker generator may be coupled to a common point in the circuit. In these cases adequate coupling may be obtained by clipping the "hot" lead of the marker generator's cable around the insulated part of the hot or ground lead of the sweep generator cable, as shown in Fig. 6-12. When checking the over-all response of the tuner i-f system, the sweep generator is connected to the antenna terminals, but the marker generator still supplies i-f marker signals to the i-f amplifier. To ensure loose coupling, the hot lead of the marker generator may be connected to a grounded pin on the tube socket of the first i-f amplifier, or to the insulated body of a grid resistor, or to a ground lance near the first i-f stage. Some experimentation is needed to find a point that provides a visible marker pip but does not cause the shape of the response curve to be altered.

Demodulator Probes. In some cases it is necessary to check or adjust the sweep

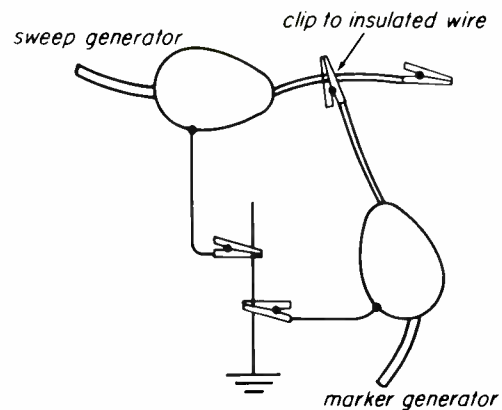

Fig. 6-12. A method of coupling the marker generator into the circuit.

alignment of one or two stages by themselves. For example, it is sometimes required to sweep align the coupling system between the mixer and the first video i-f stage. To do this, the detector must be moved up to the first i-f stage. A demodulator probe is a sort of portable detector that allows us to insert the detector wherever we wish. If we wish to check the coupling system between the mixer and the first i-f stage, the sweep generator is connected to the grid of the mixer (the same input terminals as are used when sweeping the entire i-f amplifier). To avoid loading the coupling circuit with the detector probe, the detector is placed in the plate circuit of the first i-f stage, as in Fig. 6-13. A low-value resistor (180 to 300 ohms) is placed across the tuned circuit in the plate of the first i-f amplifier. The loading effect of the small resistor eliminates the selectivity of the tuned plate circuit, and makes the first i-f stage act like a wideband buffer amplifier. The plate circuit of the second i-f stage may be loaded in a similar manner to prevent any feedback effects. This system is used in alignment of late-model RCA receivers. Special "i-f load blocks" consisting of a detector and i-f loading resistors are used, as we shall see.

Disabling Horizontal Deflection Circuits.

The horizontal deflection system often interferes with the sweep alignment job, as large-amplitude flyback pulses are picked up on CRO leads and in the circuits under test.

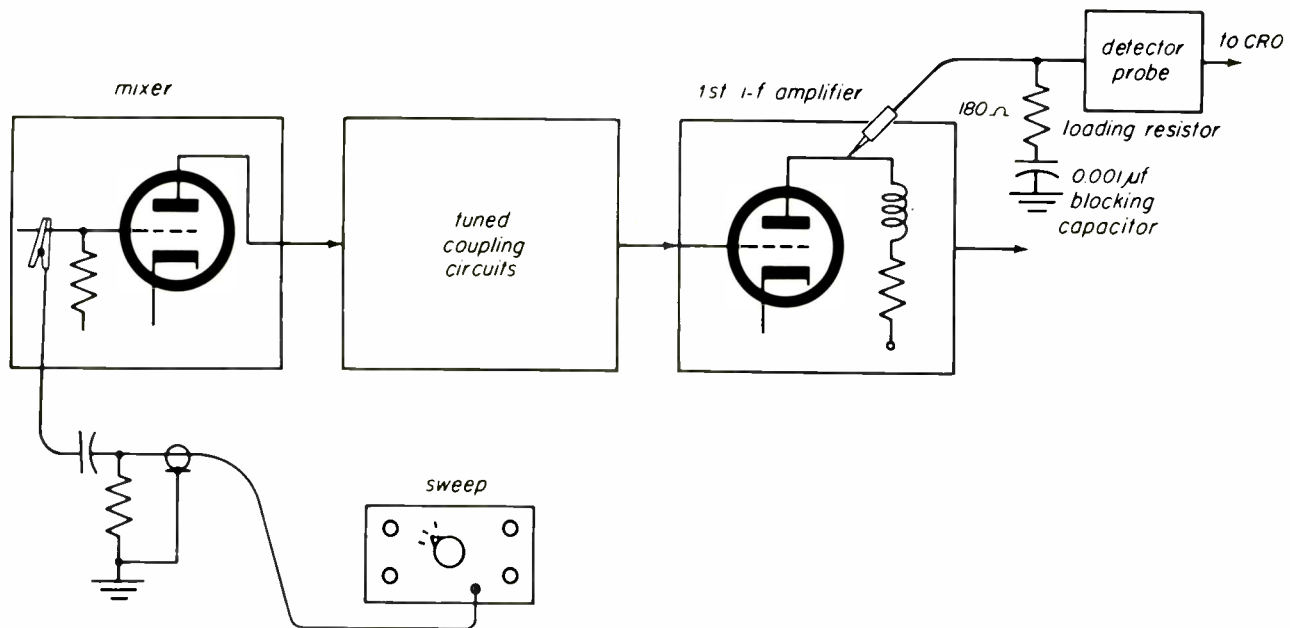

Fig. 6-13. Use of loading resistors and detectors to check the response of the coupling circuit between the mixer and the first i-f stage.

The result is a row of tightly packed spikes that ride on the response curve. These spikes make it difficult to see the response curve, and they may obscure the marker pips. For this reason, technicians make a practice of disabling the horizontal deflection system. Removing the horizontal output tube or opening the cathode circuit of the horizontal output tube is the usual way. However, disabling the horizontal output tube takes away a very large part of the total load on the power supply (200 ma or so) and all supply voltages become abnormally high. To prevent this a dummy load resistor is installed to take the place of the horizontal output stage. In late-model RCA receivers, a 2000-ohm, 100-watt resistor is connected between the +386-volt buss and ground.

6-4. TUNER ALIGNMENT

The discussions that follow are based on the alignment procedures for the RCA CTC-11 receiver. A complete schematic diagram of this receiver appears at the end of this lesson. Although this discussion is in terms of a specific receiver, the general principles apply to all receivers.

Figure 6-14 shows the setups used to sweep align the VHF tuner. The procedures are summarized in tabular form in Fig. 6-15.

The Setup. For sweep alignment of the r-f amplifier and the coupling circuits to the grid of the mixer, the sweep generator is connected to the antenna terminals, the r-f bias is set at -2.5 volts and the CRO input is connected to the plate of the mixer through I_1 . A detected response curve appears at I_1 because the mixer acts like a grid-leak detector.

A pad is shown between the cable of the sweep generator and the antenna terminals of the tuner. The purpose of this pad is to terminate the sweep generator's cable properly and provide a balanced 300-ohm source for the tuner. Three such pads are shown in Fig. 6-16. Choose the pad that matches the termination requirements of your sweep generator.

Step 1 (Fig. 6-15) is a preliminary adjustment to tune the r-f plate and mixer-grid coupling circuit approximately. The instructions direct you to "knife" the coupling coils (L_5 and L_8 on the KRK98) to produce

KRK98 AND KRK99 VHF TUNER SERIES R-F ALIGNMENT

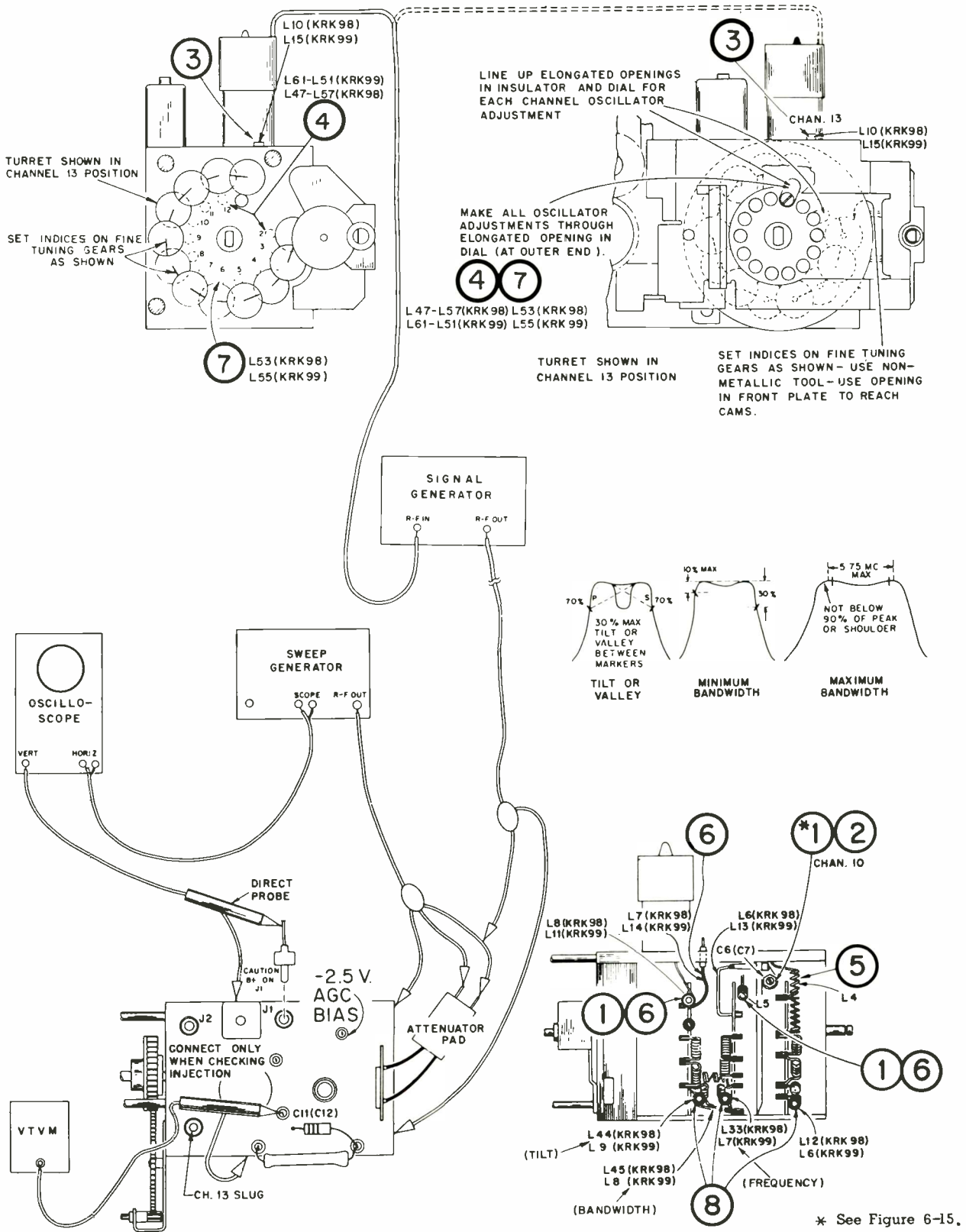

Fig. 6-14. Alignment equipment setup and response curves for tuner alignment.

KRK98 AND KRK99 VHF TUNER SERIES R-F ALIGNMENT

TEST EQUIPMENT CONNECTIONS:

- BIAS SUPPLY**Apply —2.5 volts to AGC terminal on tuner. Ground positive lead to tuner case.
- OSCILLOSCOPE**Connect to J1 as shown in Figure 25 using direct probe. Set scope for 1½ to 2 v. peak to peak.
- SWEEP GENERATOR**Connect to antenna terminals through pad shown in Figure 6-16.
- SIGNAL GENERATOR**Couple R-F output cable loosely to sweep cable to provide markers. Insert insulated wire into top of Osc./Mixer tube shield. Connect other end to "R-F-IN" terminals of generator.
- VACUUM TUBE VOLTMETER** Connect to mixer grid at C11 (KRK98) or C12 (KRK99) as shown in Fig. 6-14. (Note:—Connect only when checking injection.—Do not have connected during adjustment.)

ALIGNMENT PROCEDURE

See "General Alignment Instructions" Before Attempting Alignment

STEP	SWEEP GENERATOR	SIGNAL GENERATOR	ADJUST		REMARKS	
			KRK98	KRK99		
Tuner shield must be in place with access shutter removed. Set channel selector at channel being aligned.						
1	Preset R-F Plate & Mixer Grid on Chan. 10	Chan. 10	193.25 mc. 197.75 mc.	L5 (Knife) L8 & *C6	L5 (Knife) L11 & *C7	Refer to Fig. 6-14 for adjustment locations and responses. Adjust for approx. correct waveshape as shown in Figure 6-14. * [If spiked response or oscillation is obtained, adjust C6 (C7) for minimum response and repeat adjustment of L5 & L8 (L11).—Do not adjust bandwidth].
Change the bias at the AGC terminal to approx. —12 volts.						
2	Adjust neutralization on Chan. 10	Chan. 10 (Maximum Output)	---	C6	C7	Adjust C6 (C7) for minimum response.
Return bias at the AGC terminal to —2.5 volts. Set indices on fine tuning gears as shown in Figure 6-14.						
3	Adjust osc. Chan. 13	---	257 mc.	L10	L15	Adjust for audible beat with Sig. Gen.
4	Check, and if necessary, adjust osc. Chan. 12 downward to Chan. 2	---	Osc. Freq. for Chan. involved	L47 to L57	L61 to L51	Adjust for audible beat with Sig. Gen. from Chan. 12 down to Chan. 2.
5	Dress R-F Amp. Grid. Input Coil	Chan. 12	205.25 209.75	L4	L4	Dress position of L4 for maximum amplitude at center of response.
6	Adjust R-F Plate, Mixer Grid & Bandwidth on Chan. 12	Chan. 12	205.25 209.75	L5, L8 & L7	L5, L11 & L14	Adjust L5 (Freq.) and L8 (L11) (Tilt) for response shown in Figure 6-14. Dress L7 (L14) with respect to L6 (L13) for bandwidth.
Check tracking and response on all channels from 13 to 7; if necessary, knife R-F plate and mixer-grid loops on channels 10, 9, 8 and 7 for flat response. Turn off generators, check osc. injection (—2.0 to —5.0 volts) on meter. See note above under VTVM. Replace V2 if outside limits and repeat steps 1 to 6.						
7	Adjust osc. Chan. 6	---	129 mc.	L53	L55	Adjust for audible beat with Sig. Gen.
8	Adjust Ant., R-F Plate, Mixer Grid & Bandwidth coils Chan. 6	Chan. 6	83.25 mc. 87.75 mc.	L12, L33, L44 & L45	L6, L7, L9 & L8	Adjust L12 (L6) (Ampl.), L33 (L7) (Freq.), L44 (L9) (Tilt), and L45 with respect to L44 (or L8 with respect to L9) (bandwidth), for response in Figure 25. Check for injection within limits.

Fig. 6-15. Summary of the tuner r-f alignment procedure.

the response shown in Fig. 6-14. Knifing means adjustment by spreading or compressing the turns of the coils.

Step 2 is the neutralization adjustment. To do this job the r-f stage is biased beyond cutoff. Any signals that pass through the

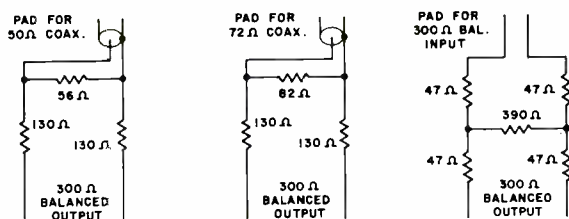

Fig. 6-16. Pads for terminating various types of sweep generator output cables.

stage then couple through the separate paths of the grid-to-plate capacitance and the neutralizing capacitance. The neutralizing capacitor is adjusted for minimum output (zero response) on the oscilloscope. By balancing these two "feedthrough" paths, the "feedback" paths, formed by the grid-to-plate and neutralizing capacitances during normal operation, are also balanced.

Steps 3 and 4 are made to preset the local oscillator to the proper frequency on each channel. To do this job, a heterodyne frequency meter is employed. A sample of the local oscillator signal is applied to the r-f input terminals on the marker generator, and the marker generator is tuned to the local oscillator frequency for the selected channel. With the fine-tuning control set at midposition, the appropriate local-oscillator tracking adjustment is made until an audible zero beat is heard in the speaker of the marker generator. If the marker generator does not have provisions for use as a frequency meter, the setup shown in Fig. 6-17 may be used instead. In this case the oscillator sample and the output of the marker generator are developed across an external detector and the CRO is used as an indicator.

In all switch-type tuners (not turret-type) tracking adjustments always begin with the highest channel (Channel 13). Adjust each channel in reverse order, making the last adjustment on Channel 2.

Step 5 adjusts the grid circuit of the r-f amplifier. This circuit tunes quite broadly and is set for maximum output in the center of the response.

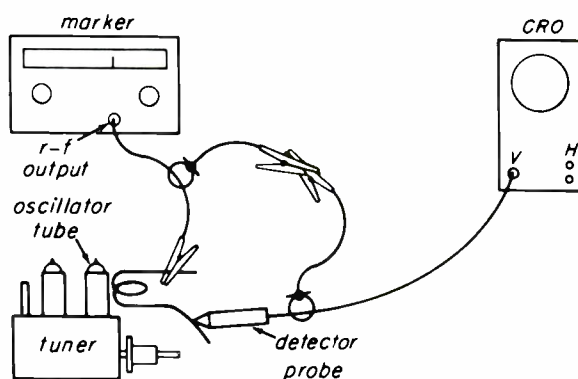

Fig. 6-17. Method of presetting local oscillator when heterodyne frequency meter is not available. With the marker generator adjusted to the proper oscillator frequency, the oscillator is adjusted for zero-beat response indication on the oscilloscope.

Step 6 trims up the coupling circuit between the r-f amplifier and the mixer on the high VHF band. Coils L_5 and L_6 tune the double-tuned circuit, and are adjusted to obtain flatness across the top of the response curve. In dressing L_7 with respect to L_6 , the coupling between these coils is varied. This adjustment sets over-all bandwidth.

At this point, a check of the amount of injection voltage is made. Refer to the VTVM connections shown in the lower left of Fig. 6-14. If the injection voltage is not as called for in Fig. 6-15, follow the procedure given in this table. Steps 7 and 8 are similar to Steps 5 and 6, but they are made in the low VHF band (Channel 6).

6.5. SOUND I-F SECTION ALIGNMENT

Alignment of the sound section involves tuning of the 4.5-mc i-f amplifier and the sound detector. In addition, the 4.5-mc traps in the video amplifier are adjusted at this time. We shall refer to the typical alignment job shown in Fig. 6-18.

The first few steps deal with aligning the circuits that supply 4.5-mc signals to the sound detector. Study the test equipment

SOUND I-F, SOUND DEMODULATOR AND 4.5 MC TRAP ALIGNMENT

TEST EQUIPMENT CONNECTIONS:

- GENERAL** Connect a 330 ohm resistor in series with a 2 mfd. capacitor from pin 5 of V201 to ground. Connect the Sound Detector Test Block Fig. 6-21 as shown below to pin 1 of V202. Ground terminal "D" of T203 with a short jumper. Use a "live" signal from local TV station for signal source.
- BIAS SUPPLY** Connect a -15 volt bias source to the AGC terminal on the tuner.
- VACUUM TUBE VOLTMETER** Connect to the output of the Video Detector Test Block Fig. 6-20 as shown connected below.

ALIGNMENT PROCEDURE			
See "General Alignment Instructions" Before Attempting Alignment			
STEP	ADJUST	REMARKS	
1	Adjust Sound Take-Off. Trans. T201	T201	Adjust T201 for maximum DC on meter. Set R-F bias at tuner AGC terminal to produce 0.5 volt on meter when finally peaked. (Core set on peak at top end of coil.) Note: If R-F bias does not reduce voltage to 0.5 volt on meter because of a strong signal, bias the I-F section of the receiver by grounding terminal "C" of PW300.
Remove the video detector test block, 2 mfd. capacitor, and the 330 ohm load at pin 5 of V201. Connect the meter to the output of the sound detector test block as shown below.			
2	Adjust Driver Transformer Primary and Secondary	T202 (top & bottom)	Adjust T202 top & bottom for maximum deflection on meter. Adjust R-F AGC bias to produce 1.0 volt on meter when finally peaked. Peak cores at open end of coils. (I-F bias may be required as explained in step 1 if 1.0 volt cannot be obtained with R-F bias adjustment.)
Repeat steps 1 and 2 if necessary to obtain maximum indication on the meter, maintaining 0.5 volt in step 1 and 1.0 volt in step 2.			
3	Disconnect the sound detector test block and the jumper from terminal "D" of T203. Turn the R-F bias supply for 0 volts at the tuner AGC terminal. Adjust the volume control for normal volume level. Turn the core of T203 flush with top of coil form. Remove ground from terminal "C" of PW300 if used in step 1 or 2.		
4	Adjust Sound Demodulator Transformer	Listening to the audio output, adjust T203 clockwise to a peak. Continue clockwise to a second louder peak and adjust T203 for a maximum on this second peak. Decrease the signal input by increasing the R-F AGC bias (and I-F bias by shorting terminal "C" of PW300 to ground if necessary) until signal distorts. Adjust T202 (top) for clear signal without distortion. Continue reducing signal input and adjusting of T202 (top) until a very sharp point is obtained where the signal is clear, with distortion occurring as T202 (top) is adjusted the slightest amount in either direction. (Note: In extremely strong signal areas, the R-F and I-F bias may not produce a weak enough signal to make the signal distort. If so, further reduction of the signal can be obtained by loosely coupling the antenna to the receiver or by use of an attenuator pad in the antenna lead.)	
Remove the R-F bias supply and the jumper grounding terminal "C" of PW300. Set the fine tuning to produce a 4.5 mc. beat on the kinescope.			
5	Adjust 4.5 mc. Trap	L306	Adjust L306 for minimum 4.5 mc. indication on the kinescope.

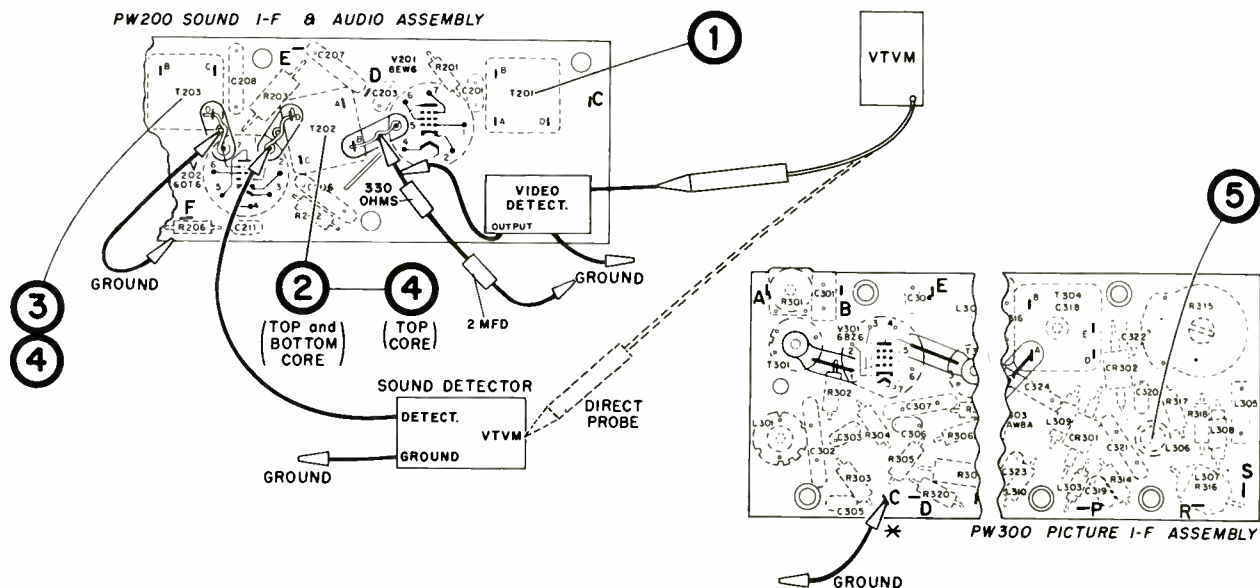

Fig. 6-18. Summary of procedure, and equipment connections for alignment of the sound i-f amplifiers, sound demodulator, and 4.5-mc video trap.

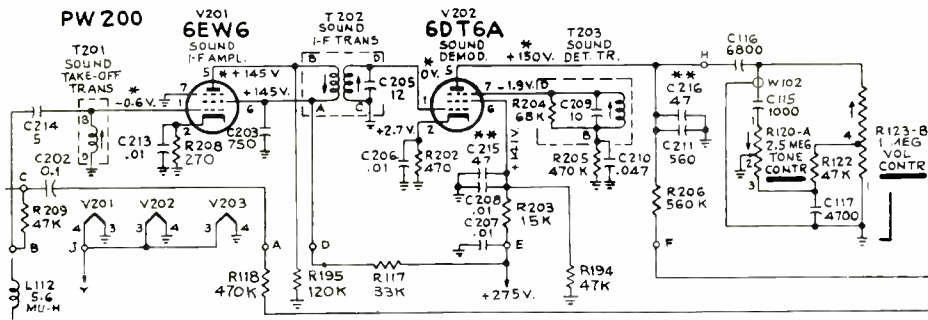

Fig. 6-19. Partial schematic diagram of the sound section.

connections (Fig. 6-18) and refer to the partial schematic diagram of the sound section in Fig. 6-19. The connections accomplish the following. The plate circuit of the 4.5-mc i-f amplifier is loaded and so operates as a wideband amplifier. A diode detector, the "video" detector shown in Fig. 6-20, is placed across the loaded plate impedance of the i-f amplifier, and the LOQD detector is prevented from oscillating by grounding the quadrature coil. Now, you are ready to tune the sound take-off coil, T_{201} . A "station" signal is used for the signal source. The set is switched to a local station and the bias on the tuner is reduced until a reading appears on the VTVM (Step 1). Bias is set to produce a reading of 0.5 volts. T_{201} is then tuned for a peak meter reading.

The load and detector are then removed from the plate circuit of the i-f amplifier, restoring normal amplifier operation. The high-impedance sound detector shown in Fig. 6-21 remains connected to the grid of the sound detector, however. This provides an indication for tuning the primary and secondary of the plate transformer T_{202} (Step 2). Step 2 completes alignment of the 4.5-mc i-f stage. Step 3 is a presetting adjustment. Step 4 adjusts the quadrature coil, T_{203} , on the LOQD sound detector. This detector operates in a locked-oscillator mode when weak signals are received. The signal is therefore attenuated and the adjustment of T_{202} is "rocked" to find the spot where the oscillator continues to "sync" with the weak sound signal. This completes the alignment of the sound system. The remaining step, Step 5, sets the 4.5-mc trap in the video detector circuit. This is accomplished by

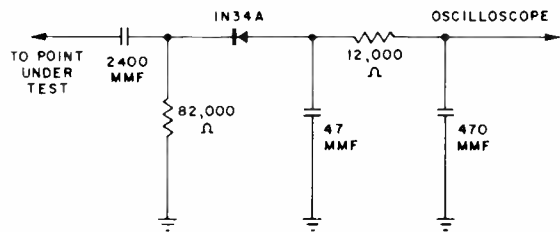

Fig. 6-20. The "video" detector test block contains loading resistors and a detector diode. It is used for adjustment of the 4.5-mc sound circuits and 4.5-mc video trap.

detuning the fine-tuning control until a 4.5-mc sound beat is observed on the kinescope. (On color telecasts the 4.5-mc beat produces a strong 920-kc beat in the color picture.) The 4.5-mc sound trap is then tuned for minimum beat interference in the picture.

6-6. VIDEO I-F AMPLIFIER ALIGNMENT

There are two ways of aligning the video or picture i-f stages - peak alignment and sweep alignment. Peak alignment is a simple procedure using a signal (marker) generator as the signal source; a VTVM is connected

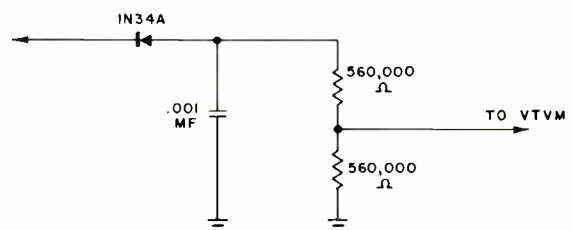

Fig. 6-21. The sound detector used in sound section alignment.

TEST EQUIPMENT CONNECTIONS:

- GENERAL** Ground terminal "C" of PW400 with a short jumper. Set channel selector to channel 3. Picture I-F shield must be in place. Disable the horizontal sweep section of the receiver (see page 11, "General Alignment Instructions").
- BIAS SUPPLY** Short terminal "C" of PW300 to ground. Apply -15 volts R-F AGC bias to the AGC terminal on the tuner. Apply -15 volts to pin 2 of V707 Blanker.
- SIGNAL GENERATOR** Connect in series with matching pad, to mixer grid as shown below.
- VACUUM TUBE VOLTMETER** Connect in series with 10,000 ohms to 2nd Detector output at terminal "D" of PW400. Use direct probe.

ALIGNMENT PROCEDURE				
See "General Alignment Instructions" Before Attempting Alignment				
STEP		SIGNAL GENERATOR	ADJUST	REMARKS
1	Peak 3rd pix. I-F transformer	43.8 mc.	T304 (bottom)	Peak T304 (bottom), T303, and T302 at their respective frequencies for maximum deflection on meter. Avoid excessive signal input. Use peak with core nearest printed board end of coil. Repeat steps 1, 2, and 3 maintaining signal generator output for -1.5 volts on meter.
2	Peak 2nd pix. I-F transformer	42.5 mc.	T303	
3	Peak 1st pix. I-F plate transformer	45.75 mc.	T302	
4	Peak 1st pix. I-F grid transformer	44.0 mc.	T301	Peak T301 and L11 (L17) at 44.0 mc. Use -1.5 v. on meter when peaked. Peak T301 with core at board end of coil. Peak L11 (L17) with core at top of coil.
5	Peak mixer plate coil	44.0 mc.	L11 (KRK98) L17 (KRK99)	
6	Adjust 3rd pix. I-F sound trap	41.25 mc.	T304 (top)	Adjust T304 (top) and R315 simultaneously for minimum deflection on meter. Reduce I-F bias as necessary for sufficient indication. Adjust L301 & R301 for minimum deflection on meter. Keep cores of T304 and L301 at coil end away from board.
7	Adjust sound rejection control	41.25 mc.	R315	
8	Adjust 47.25 mc. traps	47.25 mc.	L301 & R301	

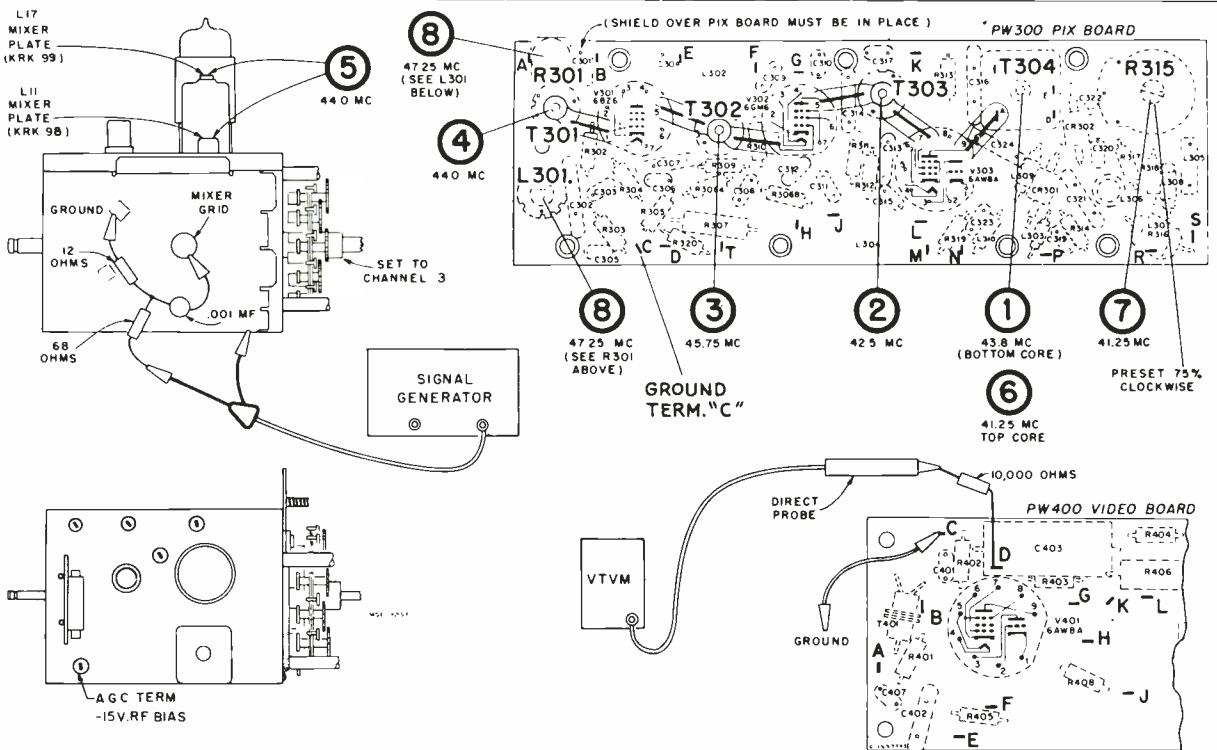

Fig. 6-22. Peak alignment procedure for the picture i-f section.

across the video detector load resistor as an output indicator. Each tuned circuit is simply tuned for maximum output at the detector, with the signal generator set to the tuned circuit's designated resonant frequency. The traps are tuned in similar fashion to produce minimum output on the meter.

Peak alignment does not show the results of the alignment job. It only allows the coils to be tuned to their correct frequencies. A weak stage or incorrect tank-circuit loading cannot be detected by this method. Peak alignment is usually done when the set is so far out of alignment that sweep alignment should not be attempted directly.

The picture i-f alignment instructions from the CTC-11 Service Notes are shown in Fig. 6-22. The input signal is applied to the grid of the mixer through a special matching pad. This pad terminates the generator output properly and swamps out the tuned circuits of the mixer grid. The VTVM is connected across the video detector load resistor. The tuner r-f stage is biased off to prevent extraneous input signals, and the i-f amplifier operates at maximum gain by grounding the AGC input to the i-f stages at terminal C of PW300. Note the instructions regarding core positions. These must be observed when aligning transformers with two cores in order to prevent interaction.

Sweep alignment of the video i-f amplifier is accomplished in three major operations: (1) the coupling circuit between the mixer and the first i-f amplifier is aligned by itself; (2) the remainder of the i-f stages is aligned by sweeping the over-all i-f section; (3) an over-all check is made by applying the sweep signal to the antenna terminals and checking the over-all r-f/i-f response. Refer to the instructions in Fig. 6-23 and the drawings in Fig. 6-24.

Steps 1-4 show how to align the double-tuned coupling circuit between the mixer and the first i-f stage. To check this circuit by itself, the first i-f stage is changed into a broad-band amplifier by the i-f load block and detector. The sweep generator is

set to sweep the i-f range and is connected through the special matching pad to the mixer grid. The CRO is connected to the output of the video detector (refer to Fig. 6-20 for the video detector and load block diagram). Marker generator signals are loosely coupled into the mixer circuit by clipping the "hot" terminal of the marker generator to the insulated body of the 12-ohm resistor in the input matching pad. Response curve "A" in Fig. 6-24 is obtained by adjusting L_{11} or L_{17} on the tuner (mixer plate), and the grid coil of the first i-f amplifier, T_{301} . The adjacent-channel-sound trap, L_{301} and R_{301} , is adjusted for minimum output at 47.25 mc in Step 3. To properly tune this trap, the i-f stage is first made to operate at maximum gain by removing i-f bias.

To align the remaining i-f stages, the r-f detector load block is removed and the CRO is connected through a 10,000-ohm isolating resistor to the "hot" side of the video detector load at point D in the PW400 video board. Steps 5 through 8 are then followed to obtain the over-all response curve shown at "B" of Fig. 6-24. Note that the color subcarrier, at an intermediate frequency of 42.17 mc, is set at the 50% point on the slope of the curve.

The remaining steps of the video i-f alignment procedure allow an over-all r-f/i-f check. The CRO remains connected to the output of the video detector, but the sweep generator connections are transferred to the antenna terminals. The feed signal at the antenna terminals must be in push-pull form, so the special pads shown in Fig. 6-16 must be used. Remember to reduce the bias applied to the tuner. The sweep generator, and the tuner's channel selector, are adjusted to sweep each of the 12 VHF channels in turn. Any fault, such as a tilt in the over-all response curve, that appears on every channel indicates a fault in i-f alignment. If only one or two channels display a faulty alignment curve, the tuner alignment should be checked.

The over-all check is a good troubleshooting aid. A weak stage will show up as insufficient response at the frequency to

SWEEP ALIGNMENT OF PICTURE I-F

TEST EQUIPMENT CONNECTIONS:

- GENERAL** The shields over PW300, picture I-F board, must be in place during alignment. Disable the horizontal sweep section of the receiver (see page 11, "General Alignment Instructions"). Ground terminal "C" of PW400.
- BIAS SUPPLY** Ground terminal "C" of PW300. Apply -15 volts to the tuner AGC terminal. Apply -15 volts to pin 2 of V707 Blanker.
- OSCILLOSCOPE** Connect to pin 5 of V301 using I-F Test Block shown in Figure 21. Load the plate of the 2nd picture I-F, pin 5 of V302, by connecting to "LOAD" of I-F Test Block.
- SWEEP GENERATOR** Connect in series with matching pad, shown in Figure 19, to strap on tuner wafer switch section (S1B) at mixer grid.
- SIGNAL GENERATOR** Couple loosely to sweep generator output cable to provide markers.
- VACUUM TUBE VOLTMETER** Connect to AGC terminal on the tuner.

ALIGNMENT PROCEDURE

See "General Alignment Instructions" Before Attempting Alignment

STEP	SWEEP GENERATOR	SIGNAL GENERATOR	ADJUST	REMARKS
Set channel selector to channel 3				
1	Adjust mixer plate trans. 40-50 mc. (I-F)	42.17 mc. 45.75 mc.	L11 (KRK98) L17 (KRK99)	Sweep set for 0.1 v. P-P on scope. Adjust for max. gain and response "A" in Fig. 6-24. Reduce I-F bias, if necessary, by connecting a 6800 ohm resistor from terminal "D" of PW300 to ground.
2	Adjust 1st pix. I-F grid transformer 40-50 mc. (I-F)	42.17 mc. 45.75 mc.	T301	
3	Check 47.25 mc. I-F input trap 40-50 mc. (I-F)	47.25 mc.	L301 & R301	
4	Recheck adjustment of L11 or L17 and T301 for correct response as shown in "A" of Fig. 6-24. Repeat steps 1, 2, and 3 if necessary. Remove short between "C" and "D" of PW300.			
Remove the I-F test block from the 1st picture I-F plate and the load from the 2nd picture I-F plate. Calibrate the oscilloscope for 3 volts P-P and connect to PW400 at terminal "D" in series with a 10,000 ohm resistor. Remove 6800 ohm resistor at terminal "D" of PW300 if used in steps 1 and 2.				
5	Align 3rd pix. I-F transformer 40-50 mc. (I-F)	41.65 mc. 42.17 mc. 42.75 mc. 45.00 mc. 45.75 mc.	T304 (bottom)	Align T304 (tilts curve), T303 (affects 42.17 mc. side) and T302 (affects 45.75 mc. side) alternately to obtain the response shown in "B" of Fig. 6-24. Use 3 volts P-P on scope.
6	Align 2nd pix. I-F transformer 40-50 mc. (I-F)		T303	
7	Align 1st pix. I-F transformer 40-50 mc. (I-F)		T302	
8	Check 41.25 mc. attenuation at 3rd pix. I-F 40-50 mc. (I-F)	41.25 mc.	T304 (top) & R315	
Adjust for minimum at 41.25 mc. along with response "B".				
Connect VHF sweep generator to the VHF antenna terminals using pad shown in Fig. 6-16. Decrease the R-F AGC bias to -3 volts. (See Figure 30.)				
9	Check R-F/I-F overall on VHF Chans. 13 to 2	Channels 13 to 2 Pix. and Sound Markers	T304 (bottom)	Retouch slightly, if necessary, to correct for any overall tilt. Maintain response "B".
NOTE:—In step 9 above, if only one or two channels are out of limits the tuner R-F alignment should be checked. However, any tilt consistent to all channels may be corrected by I-F retouch. If any major adjustment is required, be certain to repeat step 8.				
UHF/VHF MODELS ONLY				
Connect the UHF sweep generator to the UHF antenna terminals as shown in Fig. 6-24.				
10	Check R-F/I-F overall on UHF	Tune entire UHF range	Channel Markers L16 & L10 on tuner	Retouch slightly to correct any overall tilt. Do not retouch I-F adjustments on UHF check of overall.

Fig. 6-23. Summary of instructions for sweep alignment of picture i-f section.

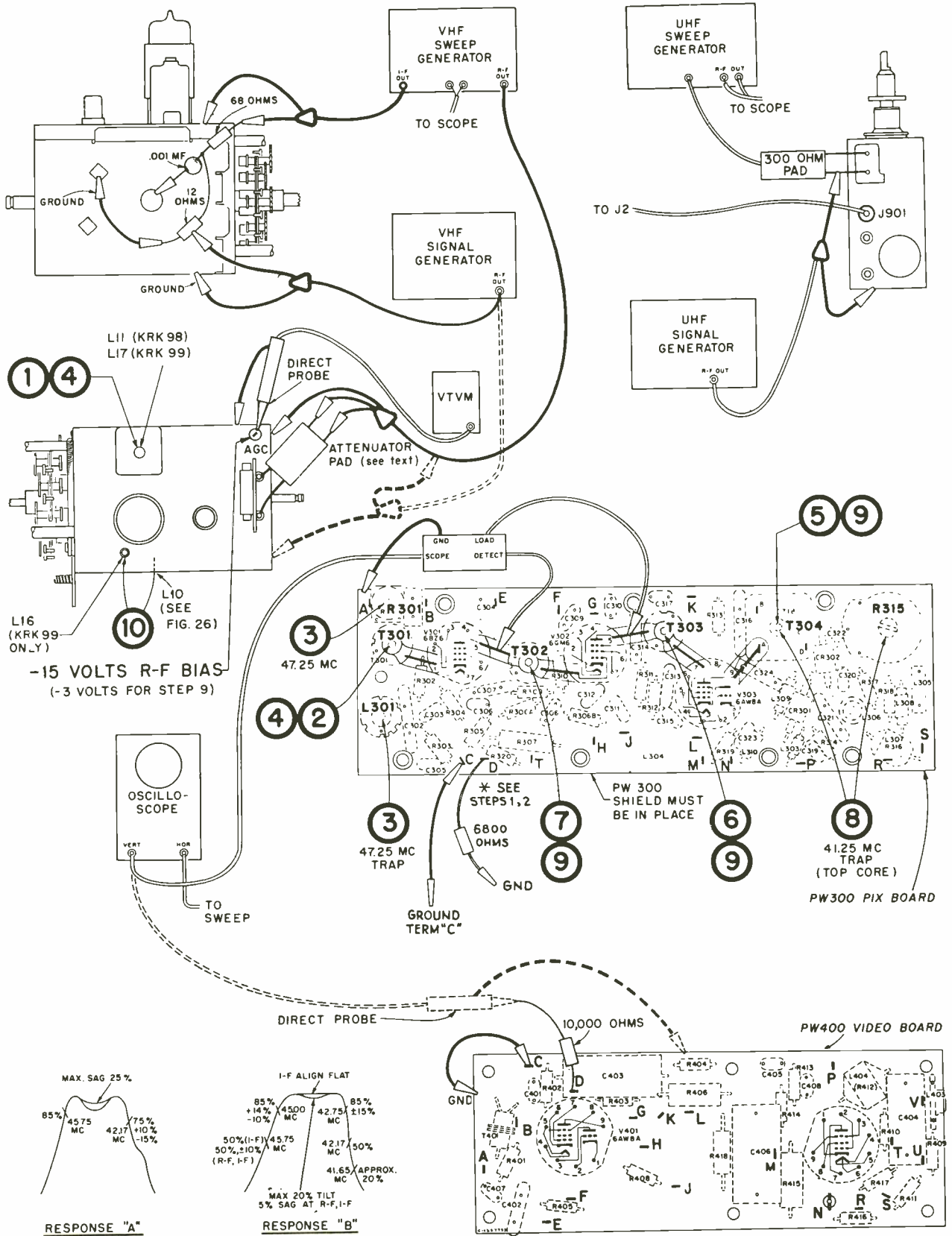

Fig. 6-24. Alignment equipment setup and response curves for sweep alignment of picture i-f section.

which the stage should be tuned. An i-f coil that tunes very broadly (several turns are required before there is a very small change in response) indicates a tuned circuit that is loaded excessively. A shorted (damaged) coil or a wiring short might be the cause. An open decoupling capacitor can also cause a stage to tune broadly.

6-7. BANDPASS AMPLIFIER ALIGNMENT

The bandpass amplifier is the only amplifier circuit that requires sweep alignment in the modern color receiver. Because the response of this amplifier works in conjunction with the response of the video i-f amplifier to produce a flat response for 3.58-mc sidebands, a new alignment system is needed. This system, called video-sweep-modulation, or VSM, may be unfamiliar to the veteran technician.

Video Sweep Modulation. The procedure for aligning the bandpass amplifier in the RCA CTC-11 is shown in Fig. 6-25. Step 1 shows how to align the circuit that couple the separated chrominance signals to the demodulators. The sweep generator is connected to the grid of the bandpass amplifier through the absorption-type video marker box (RCA WG-295C). The sweep is set to cover the video range of 3 to 5 mc (2-mc sweep width at a 4-mc center frequency). To detect this signal, and provide the response curve, the video detector of Fig. 6-20 is connected to the grid of the demodulator. Bias connections are made to disable the color killer. In Step 1, the transformer T_{701} , which couples signals to the demodulators, is aligned to produce the double-tuned response curve shown at "A" of Fig. 6-25.

Steps 2 and 3 show how to adjust the tuned circuit in the grid circuit of the bandpass amplifier. Since the response of this circuit complements the slope of the r-f response curve near the color subcarrier frequency, some means of checking the over-all i-f and video response is needed. The setup for the VSM system is shown at the lower right of Fig. 6-25. The system functions as follows. The sweep generator is adjusted to sweep the video range of 0 to 5 mc. This

signal is applied to an r-f modulator where it is impressed on the i-f signal at 45.75 mc. One of the sidebands produced by the modulator then sweeps from 45.75 mc to 40.75 mc (the i-f range). This signal passes through the i-f amplifier to the detector. The detector recovers the original modulation (0-5 mc). This video-sweep signal passes through the video system to the bandpass amplifier. At the output of the bandpass amplifier, another detector rectifies the 0-5 mc signal, producing a d-c voltage whose amplitude varies at the sweep rate of 60 cps. This 60-cps signal provides the over-all response curve. Note the difference between this system and the familiar i-f sweep alignment system. In the latter, the video i-f range is swept from 40 to 45 mc at a 60-cps rate but the output of the video detector is only a d-c signal whose amplitude varies at 60 cps - no video signal is produced.

In Step 2 of Fig. 6-25 the plate circuit of the bandpass amplifier is loaded with a 330-ohm resistor to broaden the output response. This allows you to see the effect of the input tuned circuit by itself. The input coil, L_{701} , is tuned to produce the response at "B". Step 3 provides the over-all check. The load is removed from the plate of the bandpass amplifier, and you see the over-all r-f/i-f/bandpass response.

Note that several circuits must be biased correctly for proper alignment. The killer and blanker stages must be biased off to allow the bandpass amplifier to operate properly. The r-f amplifier must be biased properly and the input signal must be set to produce a normal detected voltage at the output of the video detector.

6-8. AFPC ALIGNMENT

Alignment of the AFPC system is not unlike alignment of the horizontal AFC systems that employ diode sync discriminators. Test equipment requirements include a color bar generator, an oscilloscope, and a VTVM. An adequate job can be done with just a VTVM when a color telecast is being received.

TEST EQUIPMENT CONNECTIONS:

- GENERAL** Ground terminal "C" of PW400 with a short jumper. Disable the horizontal sweep section of the receiver (see page 11, "General Alignment Instructions").
- BIAS SUPPLY** Apply -6 volts bias to terminal "F" of PW400. Apply -15 volts on pin 2 of V707 Blanker. Ground terminal "C" of PW300 (see Figure 30). Apply -15 volts bias to tuner AGC terminal.
- OSCILLOSCOPE** Connect to Demodulator grids using Video Detector Test Block Figure 6-20.
- R-F MODULATOR** Connect as shown below for steps 2 and 3.
- SWEEP GENERATOR** Connect as shown below for steps 2 and 3.
- SIGNAL GENERATOR** Connect in series with Absorption Marker Box and .1 mfd. capacitor to pin 1 of V701. Set generator for video sweep.
- VACUUM TUBE VOLTMETER** Connect through 10,000 ohm resistor to terminal "D" of PW400, ground lead to terminal "C".

ALIGNMENT PROCEDURE

See "General Alignment Instructions" Before Attempting Alignment

STEP	SWEEP GENERATOR	SIGNAL GENERATOR	ADJUST	REMARKS
1	3-5 mc. sweep width at 3.58 mc. center freq.	—	T701 (top & bottom cores)	Adjust T701 (top & bottom cores) for response "A" shown below. Maintain equal marker height.
Turn brightness and contrast controls fully counterclockwise. Connect a 330 ohm resistor and a 4 mfd capacitor in series from the plate of 1st Bandpass Amplifier to ground, pin 5 of V701 (see below). Move the Video Detector Test Block to pin 5 of V701. Connect the sweep generator, signal generator, marker box and R-F modulator to the mixer grid, using input pad shown in Fig 6-16; refer to drawing below for proper connection. Adjust sweep outputs for 1.5 volts DC at picture 2nd detector (terminal "D" of PW400). Then remove jumper at terminal "C" of PW400.				
2	0-5 mc (I-F)	45.75 mc	L701	Adjust L701 for response shown in "B" below. Adjust with core at chassis end of coil.)
Remove the 330 ohm resistor and the 4 mfd. capacitor from pin 5 of V701. Move the Video Sweep Detector Test Block and oscilloscope back to the Demodulator grids, pins 2 & 7 of V704.				
3	0-5 mc (I-F)	45.75 mc	T701 (top core)	Check for response "C" below. If necessary retouch T701 (top) for flat response.

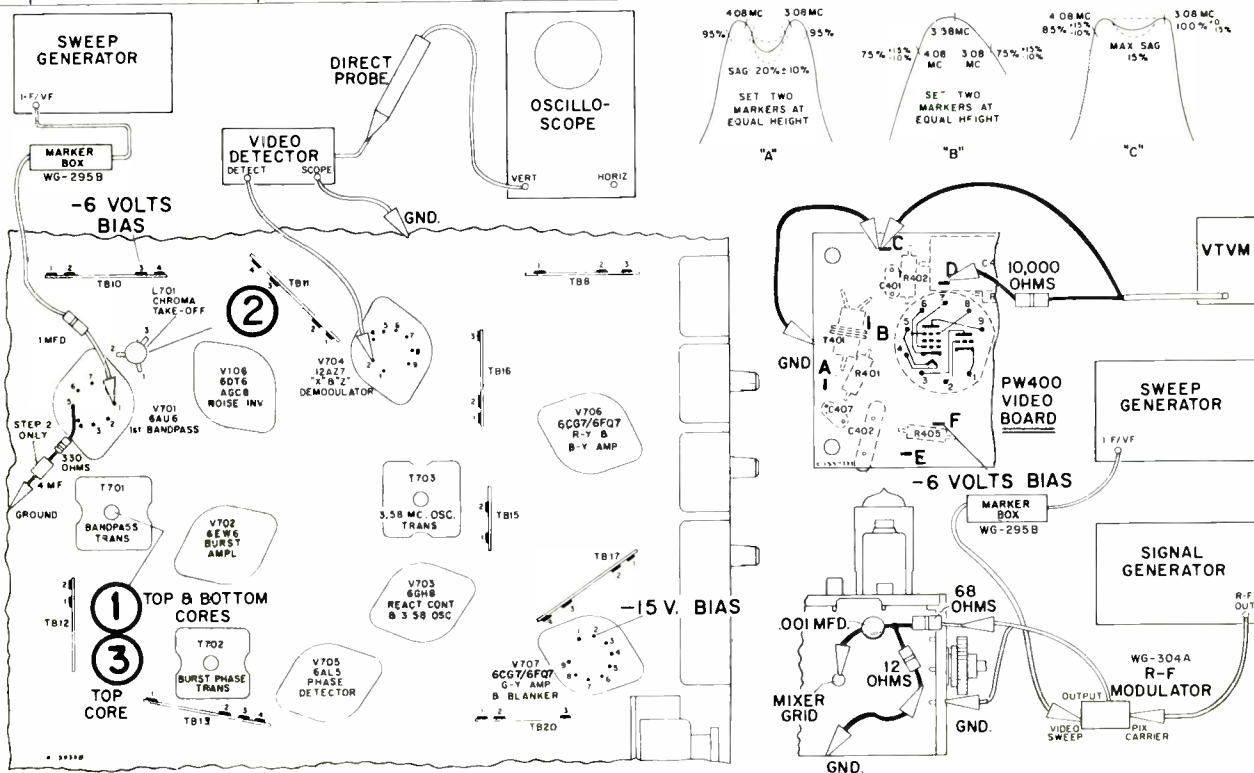

Fig. 6-25. Test equipment setup and instructions for chroma bandpass alignment.

TEST EQUIPMENT CONNECTIONS:

- GENERAL** Set the tint control to the center of its range and turn killer threshold control R159 fully counter-clockwise. Be certain the horizontal deflection circuits are operating and the AGC control is set properly (see "AGC Adjustment", page 4).
- COLOR BAR GENERATOR** Connect to receiver antenna terminals. Adjust receiver for normal color reception.
- OSCILLOSCOPE** Connect as prescribed.
- VACUUM TUBE VOLTMETER** Connect in series with a 470,000 ohm resistor to pin 1 of Phase Detector V705.

ALIGNMENT PROCEDURE

STEP	ADJUST	REMARKS
Short pin 1 of V702 to ground with a very short jumper.		
1	T703 (bottom)	Adjust T703 (bottom) for maximum DC reading on the VTVM. If the 3.58 mc. oscillator is not running, no reading will be obtained. If necessary, adjust the reactance tube plate coil L702 to start the oscillator. <u>After adjustment is made, remove short from pin 1 of V702.</u>
2	T702	Adjust T702 for maximum DC reading on the VTVM. Make sure the 3.58 mc. oscillator is running and locked in.
Ground the reactance tube input. This can easily be done by grounding the brown wire (TP701) protruding through the chassis in the chroma section (see Fig. 6-25, top view). Remove the VTVM from Phase Detector V705.		
3	L702	Observe the kinescope and adjust L702 for zero beat (Color bars stand still on screen or drift slowly).
Remove the short grounding the reactance tube input at TP701. Repeat step 3 using low level color signal. Adjust for zero beat and best hold.		
4	T702	Connect the oscilloscope to R-Y output at terminal 1 of TB8 (see Fig. 6-27, top view) and observe the bar pattern. Check that tint control (when rotated from one extreme to the other) provides for a minimum of + and - 30 degrees from nominal phase. Refer to Figure below left. If necessary, adjust T702 to achieve this condition.
After completion of demodulator phase adjustment, return the tint control to approximately mid-range (nominal phase position). The 6th bar (R-Y waveform) should be cancelled as shown at "A" below left.		
DEMODULATOR PHASE CHECKS: Check the three color outputs at the kinescope grids (Fig. 6-27 for proper matrixing. The waveforms and amplitudes should conform to those shown below at the right. a. Check R-Y waveform at terminal 1 of terminal board TB8. b. Check G-Y waveform at terminal 3 of terminal board TB20. c. Check B-Y waveform at terminal 3 of terminal board TB17 (phase should be correct within $\pm 1/2$ bar).		
5	R159B	Adjust with strong black and white signal. Adjust R159B so that color just disappears from the picture on kinescope. Check with color signal to assure setting is not killing on color.

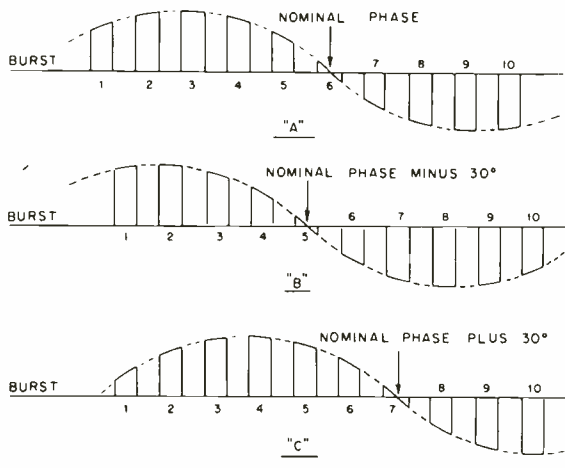

Waveforms at "R-Y" Output

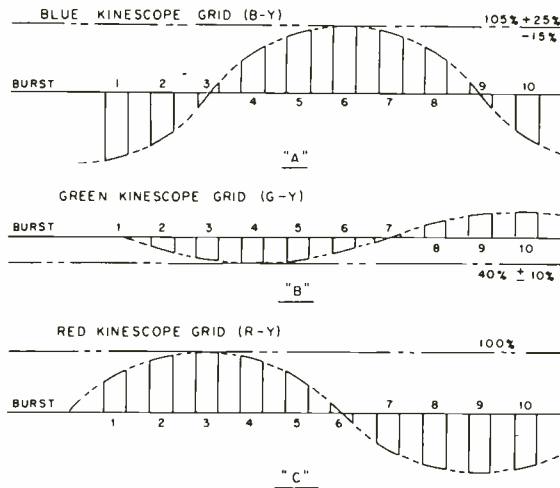

Waveforms at Kinescope Grids

Fig. 6-26. Summary of shop procedure for color AFPC alignment.

Read the alignment instructions given in Fig. 6-26 and Fig. 6-27 carefully. In general, the procedure is as follows. The first job is to secure maximum CW and burst drive to the phase detector. The VTVM is effectively connected across one of the two load resistors of the phase detector. The voltage read at this point is proportional to the amplitude of the CW and burst signals applied to the detector. In Step 1, the burst amplifier grid is shorted to ground, so that the only input to the phase detector is that provided by the 3.58-mc oscillator. The transformer in the plate circuit of the electron-coupled oscillator is tuned for maximum reading on the meter. To tune the burst amplifier (Step 2) the short is removed from the grid of the burst amplifier and T_{702} is tuned for maximum. T_{702} is in the plate circuit of the burst amplifier.

Following Step 2, maximum amplitude CW and burst signals are applied to the phase detector. The adjustments performed in the next few steps set the correct operating frequency and phase.

In Step 3, the grid of reactance tube is grounded. This simulates zero error voltage. In this case, the oscillator should be normally operating at the correct frequency and phase. To tune the oscillator, L_{702} (the reactance tube's output tank) is tuned to produce a "zero beat". This means that the colors on the screen should drift slowly through the correct values. If the oscillator is off frequency, the colors in the color bars will be divided vertically and will appear to change. They look somewhat like multi-colored "barber poles". As the correct frequency is approached, the number of vertical bands of color in the color bars diminish. At zero beat the bars are uniform in color throughout their length, but change color slowly. Step 3 completes the frequency-control part of the job. Step 4 adjusts the phase of the subcarrier oscillator to the correct value relative to the transmitted burst signal. To do this the tint or hue control is centered, and the phase detector transformer is tuned. Proper phase is indicated by observing the waveform at the R-Y output. Phase is adjusted until the sixth bar goes through zero, as shown at the bottom left of Fig.

6-26. Step 5 sets the threshold for the color killer.

Figure 6-28 shows the "field" procedure for aligning the AFPC system in the CTC-11. The basic procedure is the same as the "shop" procedure shown earlier.

6.9. HORIZONTAL DEFLECTION ALIGNMENT

The horizontal deflection circuit supplies 15.75-kc deflection power, regulated high voltage, B+ boost voltage, and convergence currents. To ensure proper high voltage and maximum life of the horizontal output tube, the following adjustments should be followed. Figure 6-29 summarizes the procedure and shows the setup.

The first two steps set up the horizontal oscillator. Step 1 shows how to adjust the sine-wave coil. The waveform shown at the upper right in the figure depicts the correct setting of the sine-wave stabilizer coil. This waveform is obtained at terminal G of PW600. The sine-wave stabilizer coil, which is the hold control in this case, is adjusted so that the positive peaks of the waveform are at the same voltage level. Next (Step 2) the frequency of the blocking oscillator is adjusted to the correct frequency. The short to ground at TB-11-1 effectively reduces the AFC correction voltage to zero. The oscillator is made to "free-run" at the correct frequency by tuning L_{601} until a single up-right picture just floats from side to side across the screen.

Next, the horizontal efficiency is adjusted (Step 3). The total cathode current of the horizontal output tube is monitored, and the horizontal efficiency coil is adjusted to produce a minimum of cathode current. The horizontal efficiency control is essentially similar to the familiar horizontal linearity adjustment.

In Step 4, the high voltage applied to the kinescope is adjusted to the recommended 24 kv. This adjustment is made with brightness set to minimum, in which case the shunt regulator tube should be drawing almost

To check the color demodulator phasing adjustment in the field, connect a color bar generator (WR-61A or WR-64A) to the antenna terminals of the receiver and adjust for a normal color bar pattern on the screen of the color picture tube. Then proceed as follows:

STEP	REMARKS
1	Set the tint control to the center of its range, and turn the killer control fully counterclockwise. Shunt the green and blue kinescope grids to ground through 100,000 ohm resistors at TB17-3 and TB20-3, (refer to Fig 6 27 for tube and TB locations.)
2	Observe the bar pattern on the kinescope. With the tint control at the center of its range, adjust T702 so that the sixth bar is about the same brightness as the background.
3	Rotate the tint control from one extreme to the other. At one extreme the fifth bar should become about the same brightness as the background. At the other extreme the seventh bar should be about the same brightness as the background. Repeat the adjustment of T702 until the above conditions are obtained at or near the extremes of the tint control range. After adjustment return the tint control to the mid-position where the sixth bar is the same brightness as the background. (Note:—this adjustment is identical to step 4 in Fig 6 26; however, the kinescope bar pattern is used instead of using the oscilloscope bar pattern.)
4	Move the 100,000 ohm shunt on the blue kinescope grid and observe the bar pattern on the kinescope for correct B-Y output, (third and ninth bars at same brightness level as the background).
5	Move the shunt on the green kinescope grid to the blue kinescope grid at TB17-3 and check for correct G-Y output. The first and seventh bars should be the same brightness level as the background. Readjust the killer control, using a strong black and white signal, so that color disappears from the picture on the kinescope. Check on color signal to assure setting is not killing on color.

Whenever V703 (the reactance control /3.58 MC. CW. oscillator tube) is replaced, the color AFPC adjustments should be checked. A simple field expedient for making these adjustments is outlined below.

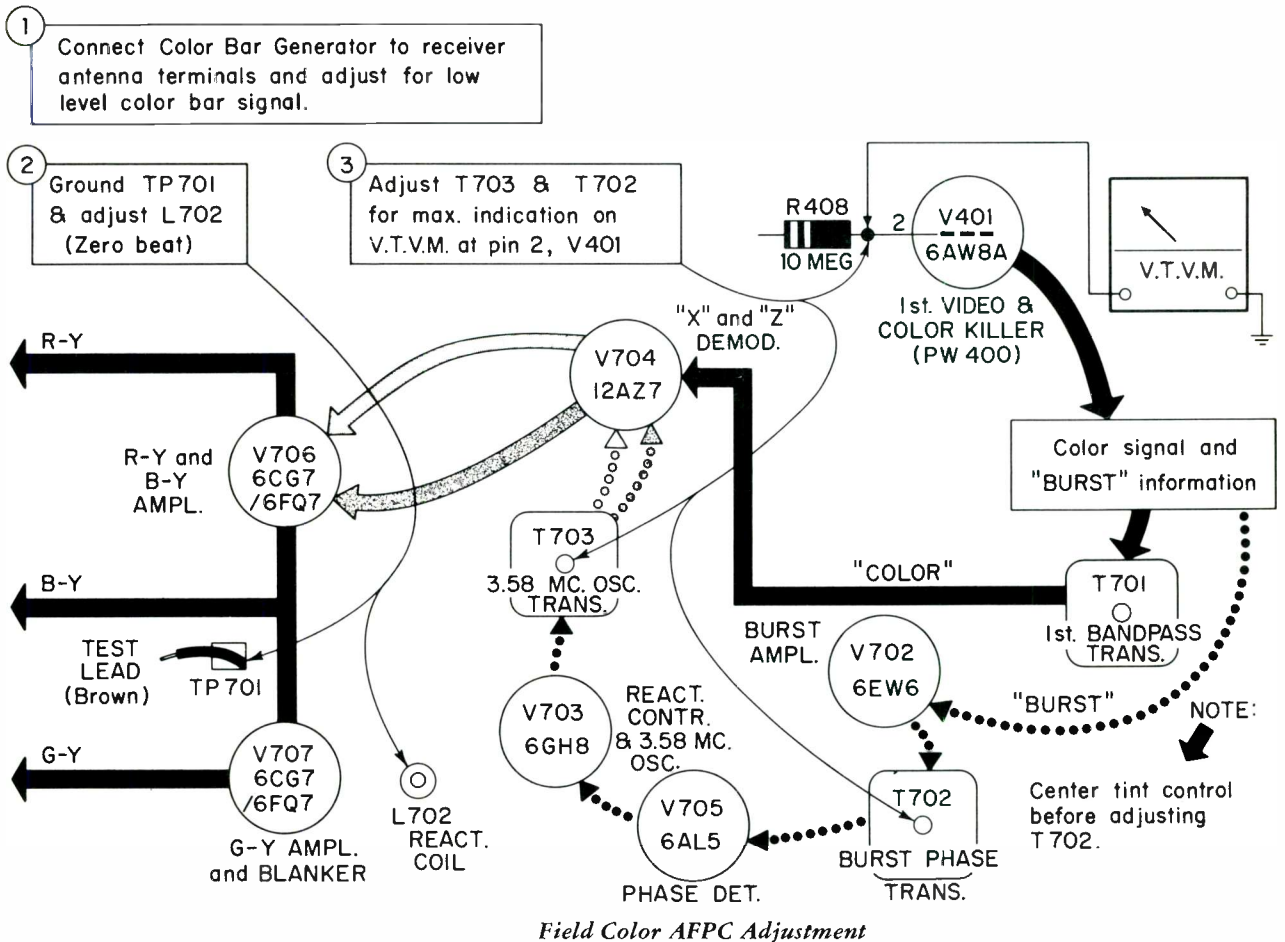

Fig. 6-28. Procedure and test equipment procedure for field alignment of color AFPC section.

TEST EQUIPMENT CONNECTIONS:

- GENERAL** Tune receiver to signal and synchronize the picture.
- MILLIAMMETER** Open the jumper and insert a 0-500 ma. meter between pin 3 (cathode) of V105 (Horizontal Output) and ground. Bypass meter with .47 mfd. capacitor.
- MICROAMMETER** Connect 0-1500 μ a. meter in series with cathode lead of V102 Shunt Regulator by opening jumper between terminals 2 & 3 on terminal board TB27 as shown below.
- OSCILLOSCOPE** Connect to terminal "G" of PW600 using low capacity probe.
- VACUUM TUBE VOLTMETER** Connect to H.V. anode lead through H.V. probe at kinescope.

ALIGNMENT PROCEDURE			
	STEP	ADJUST	REMARKS
1	Adjust horiz. sine wave	L108	Adjust L108 for correct wave shape shown below, keeping picture in sync with horizontal frequency coil L601.
2	Adjust horiz. frequency	L601	Short terminal 1 of TB11 to ground (see below). Adjust L601 to put horizontal oscillator on frequency (picture will slowly drift). Do not adjust L108. Remove short on TB11.
3	Adjust horizontal efficiency	L106	Adjust L106 (horizontal efficiency coil) for minimum current on milliammeter. Current should not exceed 200 ma.
4	Adjust high voltage	R104	Adjust for 24KV. with R104. Check current on microammeter. Current must not be less than 850 μ a. with minimum brightness. If below 850 μ a., turn L106 $\frac{1}{2}$ turn clockwise, while checking to see that horizontal output tube current does not exceed 200 ma.
5	Recheck of horizontal efficiency setting	L106	If foldover occurs after adjustment of R104, readjust L106 (horizontal efficiency coil) clockwise to eliminate the foldover. Be sure that current on milliammeter does not exceed 200 ma. Readjust focus, height, and vertical linearity controls for proper focus and vertical size.

Be certain to replace jumpers when milliammeters are removed.

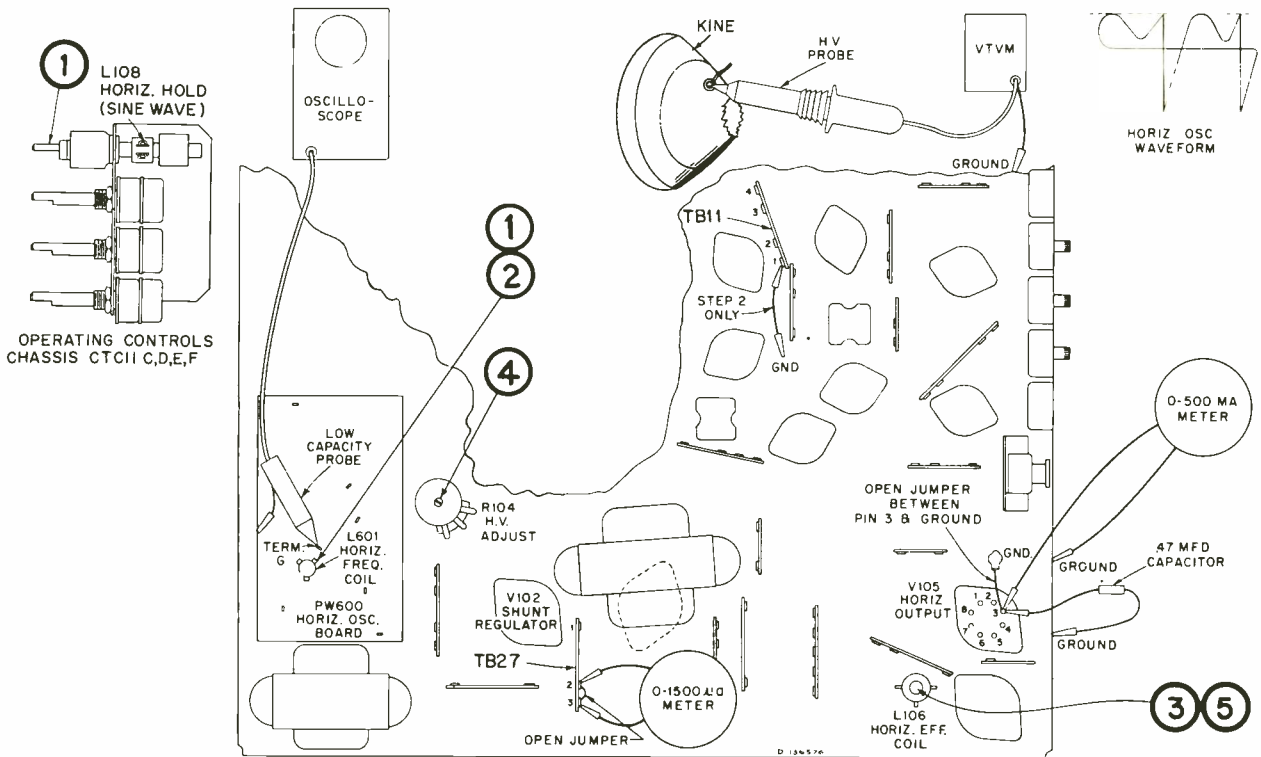

Fig. 6-29. Procedure and test equipment setup for horizontal deflection alignment.

TEST EQUIPMENT CONNECTIONS:

- GENERAL** The illustration below and the CTP10A circuit schematic diagram Fig. 6-31. indicates adjustment points 1 through 7 and the corresponding frequency and function to be adjusted. Depress the appropriate transmitter function button as shown below and hold depressed while peaking each coil (L1001 to L1007).
- SIGNAL SOURCE** A CRK5A transmitter checked for accuracy by the beat frequency method shown in Fig. 6-32, or checked with a CTP10A receiver known to be in correct adjustment, may be used as a signal standard.
- TRANSMITTER** The transmitter distance selected should provide a maximum v.t.v.m. reading of approximately —7 volts peak. Or, a strip of tape may be placed over all or part of the transmitter transducer and adjusted to provide the correct attenuation.
- VACUUM TUBE VOLTMETER** .. Adjust the v.t.v.m. on the —15 volt d.c. scale, and connect the ground lead to terminal K (noted below). The meter probe is then connected progressively through Steps 1 to 7 in the course of the alignment as indicated below.

ALIGNMENT PROCEDURE					
STEP	TRANSMITTER OUTPUT FREQUENCY	TRANSMITTER FUNCTION BUTTON	V.T.V.M. CONNECTION	ADJUST FOR MAXIMUM	
1	Adjust up tint	35.0 kc.	Depress and hold button 1	K to J TP1	L1001
2	Adjust down tint	36.5 kc.	Depress and hold button 2	K to F TP2	L1002
3	Adjust up color	38.0 kc.	Depress and hold button 3	K to D TP3	L1003
4	Adjust down color	39.5 kc.	Depress and hold button 4	K to A TP4	L1004
5	Adjust up volume	41.0 kc.	Depress and hold button 5	K to C TP5	L1005
6	Adjust down volume	42.5 kc.	Depress and hold button 6	K to E TP6	L1006
7	Adjust channel selector	44.0 kc.	Depress and hold button 7	K to H TP7	L1007

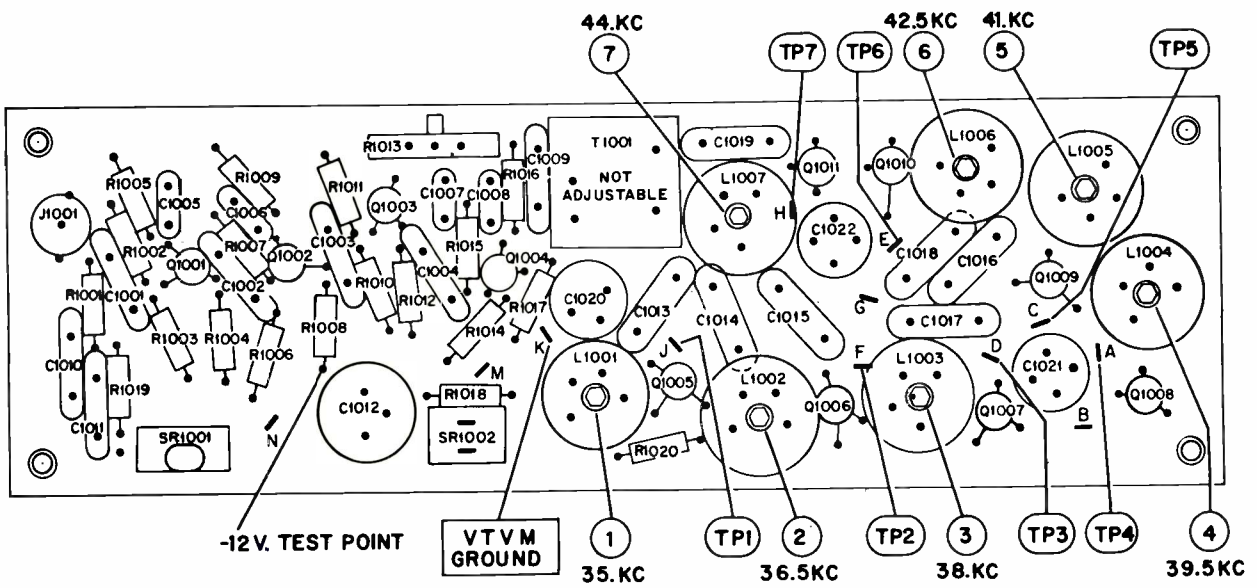

Fig. 6-30. Alignment procedure for the CTP10A remote control receiver.

all of the current obtained from the high-voltage supply. If the shunt regulator is not drawing sufficient current (at least 850 μ a or 0.85 ma), the horizontal efficiency coil is reset slightly (Step 4). A final check is made in Step 5 to make sure that there is no foldover, and that the horizontal output tube is not drawing excessive cathode current. A cathode current exceeding 200 ma indicates a potential danger to the useful life of the horizontal output tube.

for remote control equipment in black-and-white systems. The major difference is that there are more functions, and hence more channels and more tuned circuits to be adjusted.

Receiver alignment techniques for the all-transistorized CTP10A remote-control receiver are shown in Fig. 6-30. A schematic diagram of this unit appears in Fig. 6-31.

6-10. REMOTE-CONTROL SYSTEM ALIGNMENT

Alignment of remote-control receivers and transmitters for color receivers is basically the same as the alignment procedures used

The signal source for alignment of the receiver is the transmitter. The transmitter should be checked for frequency accuracy against a "standard" transmitter before the receiver is aligned. "Standard" transmitters, in this sense, are transmitters that are known to be good — those that work with a number

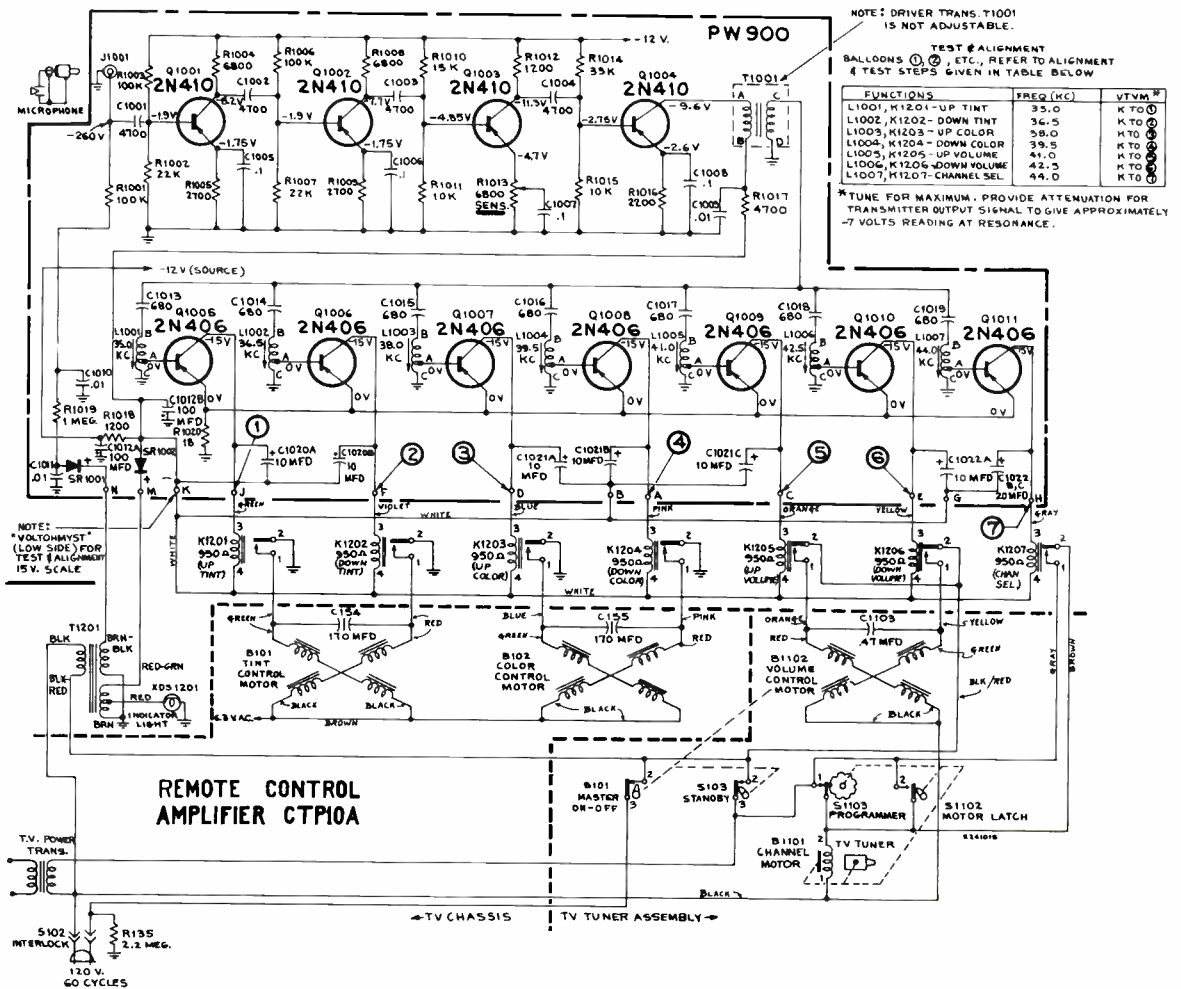

Fig. 6-31. Schematic diagram of the CTP10A remote control receiver.

TEST EQUIPMENT CONNECTIONS:

- GENERAL When depressing function buttons, depress fully and hold depressed as adjustment is made. CAUTION: Do not change any adjustments of the TRANSMITTER STANDARD.
- SIGNAL SOURCE A separate CRK5A transmitter, checked for accuracy and proper operation, is recommended as a signal standard to be used in aligning the transmitter. (Transmitters used as standards should be checked frequently against a crystal standard or several receivers known to be operating properly.)
- TRANSMITTER STANDARD ... Remove the complete back cover from the transmitter. Loosely couple the transmitter to the Horizontal Input of the oscilloscope. To do this, place the probe of the oscilloscope approximately one inch in front of the transducer opening at the end of the transmitter. Ground the oscilloscope to the negative terminal of the battery.
- TRANSMITTER BEING ALIGNED Remove the complete cover from the transmitter. Loosely couple the transmitter to the Vertical Input of the oscilloscope. Place the probe of the oscilloscope approximately one inch in front of the transducer opening at the end of the transmitter. Keep the transmitter being aligned about two feet from the transmitter standard. Ground the oscilloscope to the negative terminal of the battery.
- OSCILLOSCOPE Connect as shown below.

ALIGNMENT PROCEDURE				
STEP	ADJUST	TRANSMITTER FREQUENCY (BOTH UNITS)	TRANSMITTER FUNCTION (BOTH UNITS)	ADJUST FOR ZERO BEAT (Circular "Scope" Trace)
1	Up tint	17.50 kc. (35 kc. output)	Depress right hand tint button	Adjust T2001
2	Down tint	18.25 kc. (36.50 kc. output)	Depress left hand tint button	Adjust C2003
3	Up color	19.0 kc. (38 kc. output)	Depress right hand color button	Adjust C2009
4	Down color	19.75 kc. (39.50 kc. output)	Depress left hand color button	Adjust C2006
5	Up volume	20.50 kc. (41.0 kc. output)	Depress right hand volume button	Adjust C2013
6	Down volume	21.25 kc. (42.50 kc. output)	Depress left hand volume button	Adjust C2010
7	Channel selector	22.0 kc. (44.0 kc. output)	Depress channel button	Adjust C2014

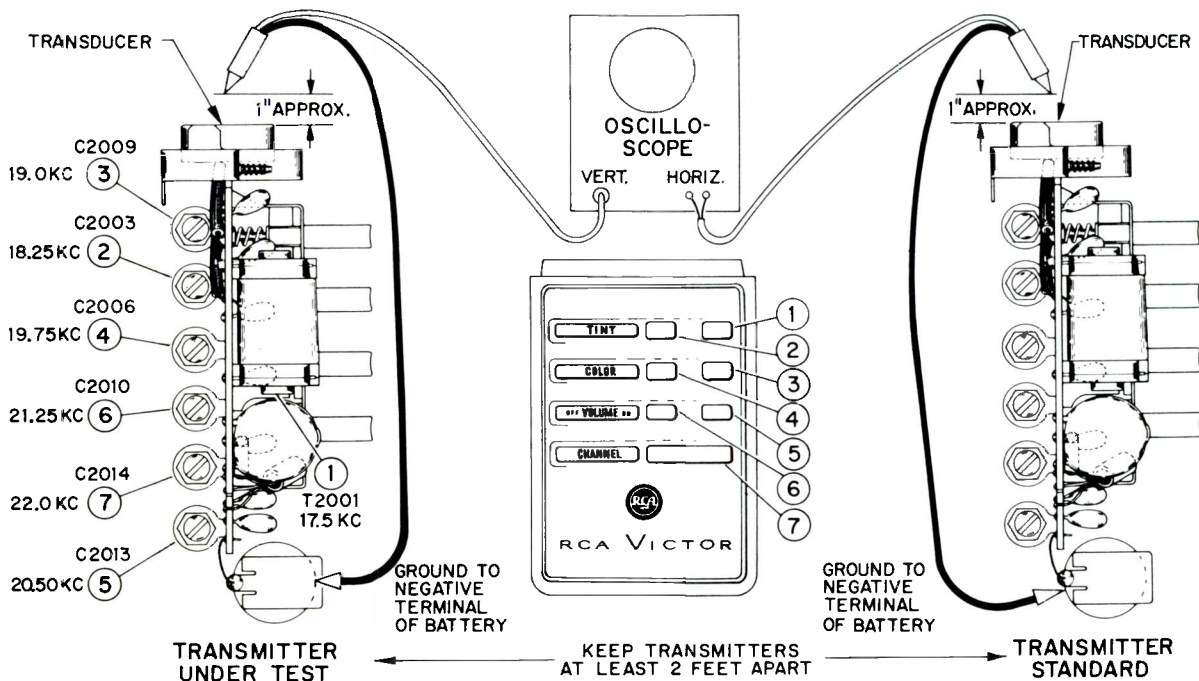

Fig. 6-32. Test equipment setup and alignment procedure for the CRK5A remote control transmitter.

of receivers, or transmitters whose frequencies have been checked against an accurate frequency source.

To tune the receiver, simply depress one of the function buttons on the transmitter and tune the associated frequency-selective coil in the receiver to produce maximum d-c voltage across the associated relay coil. Each function is checked in turn as shown in Fig. 6-30.

Transmitter alignment is illustrated in Fig. 6-32. Two transmitters are employed, one being the "shop standard". Signals from the "standard" are coupled to the horizontal amplifier of the oscilloscope (set horizontal selector to amplifier X1 position) as shown. A small electrical signal is picked up by placing the direct probe of the CRO near the ultrasonic transducer. In a like manner, the transmitter under test is connected to the vertical input terminals of the CRO. Asso-

ciated function buttons are depressed and held down on *both* units. The transmitter under test is adjusted to give a zero beat indication on the oscilloscope screen. Note this "zero beat" indication is actually a Lissajous pattern. When two signals are exactly at the same phase and frequency, the pattern is a straight line at 45° from the horizontal. At a 90° phase difference, the pattern becomes a circle (if amplitudes are equal). Thus as zero beat is approached, the pattern slows down and slowly revolves, oscillating between a line and a circle. At intermediate phases the pattern becomes elliptical. When the two signals are not close in frequency, the pattern becomes a square or rectangle with sharp edges but a blurred interior. If a stationary pattern is obtained, then one frequency is an even multiple of the other. Such patterns may appear as a figure eight or some other pattern with multiple loops.



EXAMINATION

Instructions:—PRINT your name, address, and student number assigned to you below.

Name Edwin R. Nichols Date 6-27-70
 Street Address RT. 2 Box 351A Student Number _____
 City Manassas Zone 22110 State Va.

Answer all of the questions in each lesson. Send your *answer sheets* to RCA INSTITUTES, INC., Home Study School, 350 West 4th Street, New York 14, N. Y. Use the self-addressed return envelope that is enclosed. To avoid delays, *be sure to use enough postage.*

Percentage Grade: _____ %
 Graded by: _____

Each question in this examination is a statement that requires completion. Four possible answers, each of which is lettered, are provided to complete each statement. Select the correct answer. In the answer column at the right of the page, draw a line through the letter that corresponds to the letter of the answer you have chosen. For example:

Two multiplied by five equals: (a) two; (b) seven; (c) ten; (d) fourteen. a b ~~c~~ d

1. A primary requirement of the sweep generator is that: (a) the horizontal deflection voltage be a linear sawtooth; (b) it should have a built-in marker generator; (c) its output voltage be constant over the sweep-frequency range; (d) its output voltage should exceed 100 volts.
2. An essential requirement of an oscilloscope used in alignment work is: (a) high deflection sensitivity; (b) calibration facilities; (c) wide bandwidth; (d) z-axis modulation.
3. In the VSM alignment system, the sweep generator is adjusted to sweep the: (a) r-f range; (b) i-f range; (c) audio range; (d) video range.
4. To make sure that injection of the marker signal does not alter the response curve when sweeping the video i-f circuit: (a) couple the marker to the grid of the video amplifier; (b) obtain the response curve first and then inject the marker signal; (c) connect the marker cable directly to the cable of the sweep generator; (d) mark the curve at video frequencies.
5. In order to prevent overload of the i-f amplifier during sweep alignment: (a) turn the sweep output to maximum; (b) turn the vertical gain of the oscilloscope to minimum; (c) monitor the d-c voltage at the video detector and keep the output below about 0.5 volt; (d) keep the detected video voltage below 50 volts.
6. When tracking the local oscillator in a switch type (incremental-inductance type) tuner: (a) tune the highest channel first; (b) tune the lowest channel first; (c) tune any channel in any order; (d) tune the even-numbered channels first.

a b ~~c~~ d
~~a~~ b ~~c~~ d
 a b c ~~d~~
 a ~~b~~ c d
 a ~~b~~ c d
~~a~~ b c d

7. When making the neutralizing adjustment in a tuner that employs a neutralized-triode r-f amplifier; (a) the r-f stage is biased at about -3 volts; (b) the r-f stage is cut off; (c) tune for maximum output on the CRO; (d) tune for a flat response curve on the CRO.
8. When aligning the video i-f section, the sweep generator is connected to the: (a) grid of the r-f amplifier; (b) grid of the mixer; (c) grid of the first i-f amplifier; (d) input of the video detector.
9. To prevent interference on the sweep-response curve, the horizontal deflection circuit is usually disabled by: (a) removing the damper tube; (b) removing the horizontal oscillator tube; (c) installing a resistor to keep a normal load on the power supply; (d) removing the rectifier tube.
10. The video i-f detector shown in Fig. 6-20: (a) takes the place of the video detector; (b) is used to measure oscillator injection voltage; (c) is used in peak alignment only; (d) is used to check the response of one or two stages individually.
11. The sweep generator is not used in: (a) tuner alignment; (b) VSM alignment; (c) peak alignment of the video i-f stages; (d) sweep alignment of the video i-f section.
12. The signal source used in alignment of the remote control receiver is: (a) the remote control transmitter; (b) an accurate marker generator; (c) the sweep generator; (d) a dog whistle.
13. When setting up the horizontal deflection circuit in a color receiver, the horizontal efficiency control is adjusted for: (a) maximum high voltage; (b) minimum cathode current in the high voltage regulator; (c) minimum cathode current in the horizontal output tube; (d) best horizontal linearity.
14. The sweep generator must provide a balanced or push-pull output when it is to be connected to the: (a) mixer grid; (b) r-f modulator; (c) tuner antenna terminals; (d) band-pass amplifier.
15. When the sweep response curve is a straight line about 1 inch above the base line, and you are sure that the amplifiers are not overloaded, the most likely cause is: (a) insufficient marker amplitude; (b) sweep width set too wide; (c) sweep width set too narrow; (d) CRO gain too high.
16. An essential function of the pads connected to the output of the sweep generator's cable is that they: (a) attenuate the signal; (b) promote radiation; (c) terminate the cable in its characteristic impedance; (d) prevent overload.
17. In the AFPC alignment procedure the purpose of grounding the grid of the reactance tube is to: (a) disable the color killer; (b) simulate a zero error voltage; (c) short the burst signal; (d) permit phase adjustments.
18. When aligning the bandpass amplifier the: (a) burst amplifier must be disabled; (b) killer must be biased off; (c) 3.58-mc oscillator must be stopped; (d) bandpass amplifier must be neutralized.
19. Killer threshold adjustments are made: (a) at any time during alignment of the AFPC system; (b) after alignment of the AFPC system has been completed; (c) to make sure that the bandpass amplifier operates when very weak black-and-white signals are received; (d) to make sure that the bandpass amplifier is cut off during color telecasts.
20. To check maximum burst and CW input to the phase detector, measure the d-c voltage between ground and the: (a) CW feed point to the phase detector; (b) cathode terminal of the phase detector on the burst-input side; (c) grid of the reactance tube; (d) grid of the 3.58-mc oscillator.

a b c da b c da b c da b c da b c da b c da b c da b c da b c da b c da b c da b c da b c da b c d

NOTES

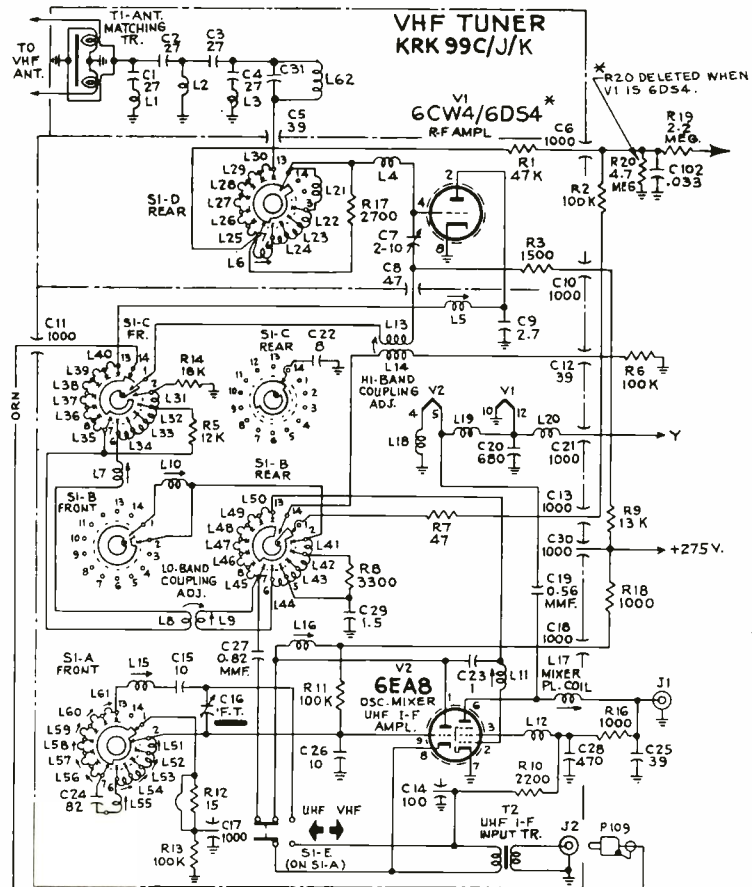

FRONT AND REAR SECTIONS OF S1A-B-C-D VIEWED FROM FRONT WITH CONTROL SHAFT IN CHANNEL NO. 1 POSITION.

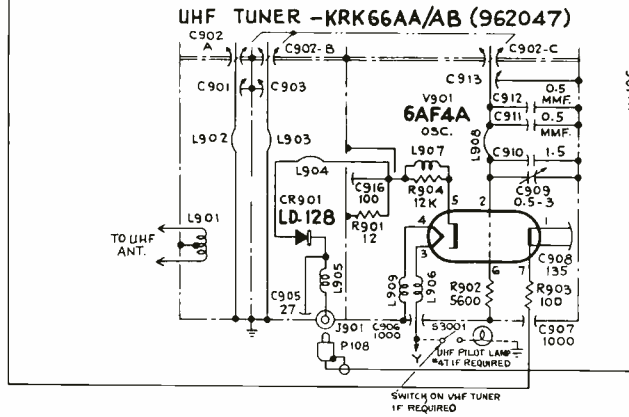

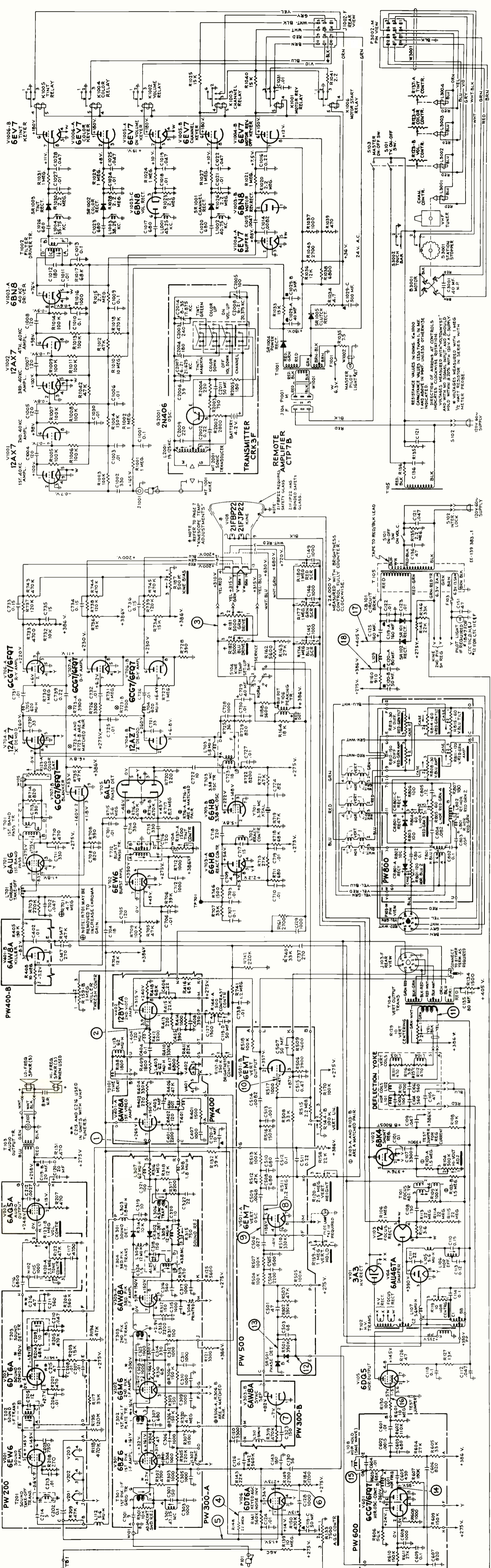

Black and White Circuitry Waveforms

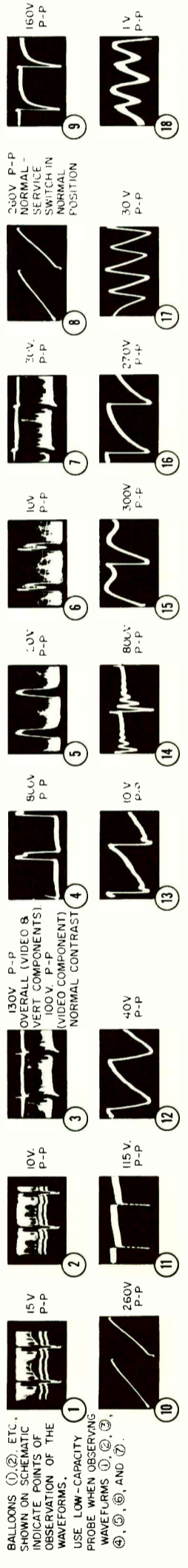

Complete schematic diagram of the CTC-11 chassis.

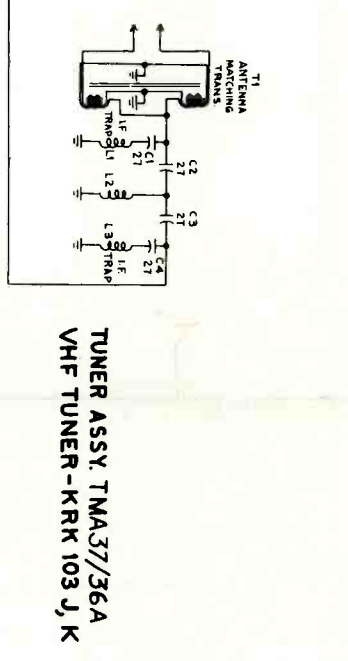

TUNER ASSY. TMA37/36A
VHF TUNER - KRK 103 J, K

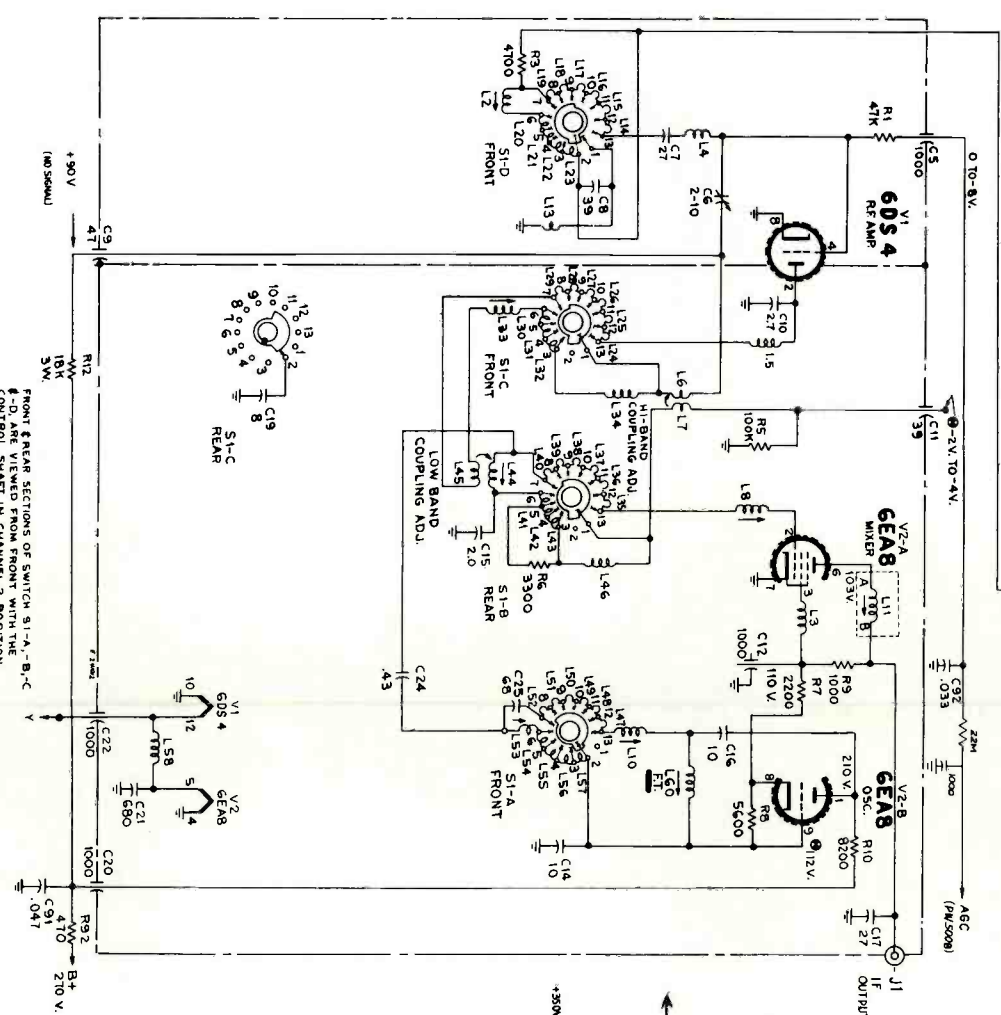

FROM 8-PIN STRIP OR QUINCY 81-A, B, C
 6D84 VIEWED FROM FRONT WITH THE
 CONTROL SHAFT IN CHANNEL 2 POSITION.
 RESISTANCE VALUES IN OHMS, K-1000
 CAPACITANCE VALUES IN P.F., μF, μMFD
 1. RESISTANCE VALUES LESS THAN 1 IN MS.
 INDICATE THAT THE RESISTOR IS DISCRETE.
 BLACK DOT IN SWITCH ROOM SEGMENT
 INDICATES THRU CONNECTION.
 ● USE 100K ISOLATION RESISTOR IN SERIES WITH PROBE.

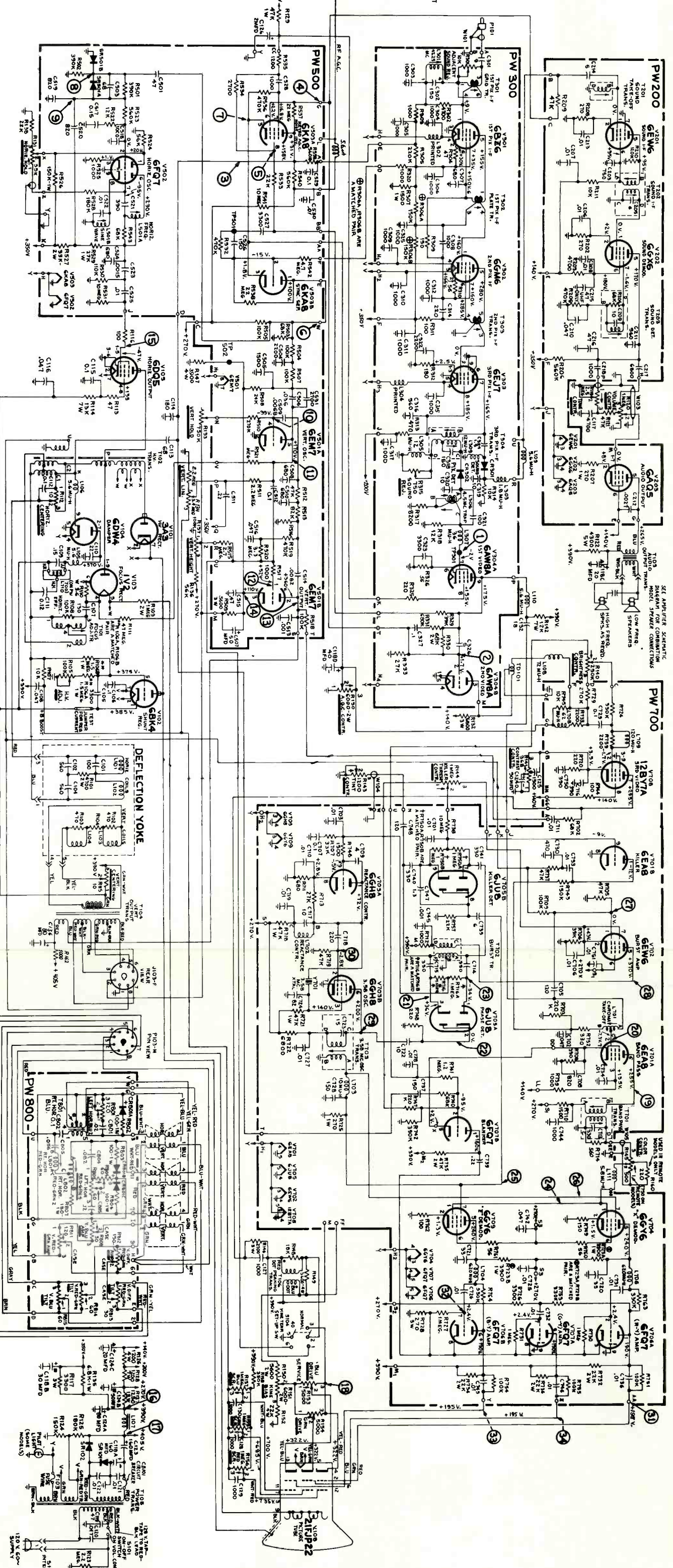

- BALLOONS ①, ②, ETC.
 SHOWN ON SCHEMATIC
 INDICATE POINTS OF
 OBSERVATION OF THE
 WAVEFORMS.
- USE LOW-CAPACITY
 PROBE WHEN OBSERVING
 WAVEFORMS ①, ②, ③,
 ④, ⑤, ⑥, ⑦, ⑧, ⑨,
 ⑩, ⑪, ⑫, ⑬, ⑭,
 ⑮, ⑯, ⑰, ⑱, ⑲, ⑳, ㉑, ㉒, ㉓, ㉔, ㉕, ㉖, ㉗, ㉘, ㉙, ㉚, ㉛, ㉜, ㉝, ㉞, ㉟, ㊱, ㊲, ㊳, ㊴, ㊵, ㊶, ㊷, ㊸, ㊹, ㊺, ㊻, ㊼, ㊽, ㊾, ㊿, 1, 2, 3, 4, 5, 6, 7, 8, 9, 10, 11, 12, 13, 14, 15, 16, 17, 18, 19, 20, 21, 22, 23, 24, 25, 26, 27, 28, 29, 30, 31, 32, 33, 34, 35, 36, 37, 38, 39, 40, 41, 42, 43, 44, 45, 46, 47, 48, 49, 50, 51, 52, 53, 54, 55, 56, 57, 58, 59, 60, 61, 62, 63, 64, 65, 66, 67, 68, 69, 70, 71, 72, 73, 74, 75, 76, 77, 78, 79, 80, 81, 82, 83, 84, 85, 86, 87, 88, 89, 90, 91, 92, 93, 94, 95, 96, 97, 98, 99, 100.
- ① 3V P-P
 - ② 2V P-P
 - ③ 600V P-P
 - ④ 20V P-P
 - ⑤ 11V P-P
 - ⑥ 30V P-P
 - ⑦ 1V P-P
 - ⑧ 15V P-P
 - ⑨ 30V P-P
 - ⑩ 108V P-P
 - ⑪ 145V P-P
 - ⑫ 186V P-P
 - ⑬ 195V P-P
 - ⑭ 740V P-P
 - ⑮ 12V P-P
 - ⑯ 210V P-P
 - ⑰ 1V P-P
 - ⑱ 15V P-P
 - ⑲ 30V P-P
 - ㉑ 283V P-P

Complete schematic diagram of the
 RCA CTC-12 receiver.

study group 4
lessons 7 & 8

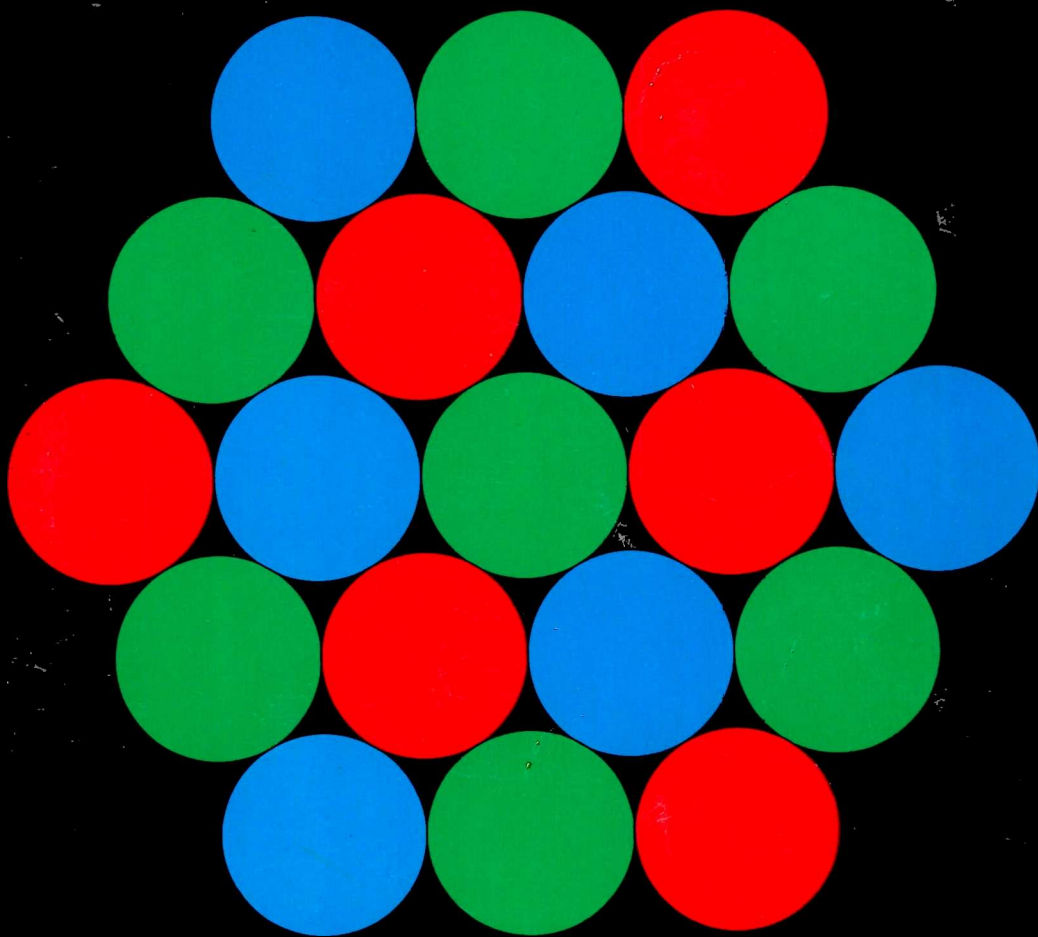

Color Television
Home Study Course

RCA Institutes, Inc.

A SERVICE OF RADIO CORPORATION OF AMERICA

© RCA Institutes, Inc. 1963
All Rights Reserved
Printed in U.S.A.

COLOR TELEVISION COURSE

LESSON 7

TROUBLESHOOTING TECHNIQUES

- 7-1. Isolating Monochrome and Color Troubles
- 7-2. Troubles in the Monochrome Sections
- 7-3. Color in the Monochrome Picture
- 7-4. Loss of Color
- 7-5. Loss of Color Sync
- 7-6. Incorrect Color Reproduction
- 7-7. Interference Effects



RCA INSTITUTES, INC.

A SERVICE OF RADIO CORPORATION OF AMERICA

HOME STUDY SCHOOL

350 West 4th Street, New York 14, N.Y.

INTRODUCTION

In this lesson, you will study the service techniques used in servicing color television receivers. Our primary objective is to show you how to interpret trouble symptoms, and make tests, in order to localize the causes of trouble. Where applicable, we will examine actual field problems, and show the service methods used as well as a step-by-step diagnosis. In addition, the lesson will suggest some service hints and short cuts to localize the faulty stage and the defective parts.

7-1. ISOLATING MONOCHROME AND COLOR TROUBLES

General Approach to Color Receiver Servicing. Servicing procedures for color television are basically the same as those used on all other electronic equipment. The serviceman must, through analyzing the apparent symptoms, isolate the problem first to a section, then to a stage, and ultimately to the particular parts involved.

When servicing the color receiver, the technician should first divide the problem into one of three general categories; the monochrome picture, receiver setup, and the color portion of the picture. A brief review of the color signal development will help to show how this can be done. In most modern receivers, the chrominance signal is demodulated on the *R-Y* and *B-Y* axes or the somewhat similar *X* and *Z* axes. These systems permit simplified matrixing circuits. The *Y*, or monochrome, portion of a color signal is coupled directly into the cathodes of the picture tube. The color-difference signals *R-Y*, *B-Y*, and *G-Y* are coupled to their respective control grids. The combination of the two voltages at the picture tube produce the color picture. Correct color reproduction requires undistorted chrominance and luminance signals. Any defect that alters the color balance of the black-and-white picture will affect color reproduction as well. A good monochrome picture is therefore a prerequisite for good color production. The technician must recognize

defects caused by a poor setup of the receiver, such as impurity, misconvergence, and poor gray-scale tracking. When a properly setup receiver is producing a good monochrome picture, you may assume any defects in color reproduction are due to faults in the chrominance section of the receiver. Figure 7-1 shows a color receiver in a block diagram form. This diagram is useful as a troubleshooting aid because it shows the paths of the following signals:

1. Monochrome (*Y*) signal.
2. Chrominance signal (color information).
3. Burst signal (color synchronization signal).

This block diagram will be referred to throughout the lesson.

Identifying Problems in Monochrome or Color Circuits. Tune the receiver to a channel transmitting a monochrome picture and observe the over-all quality of the picture. Particular attention should be paid to the items sometimes overlooked on a black-and-white receiver. Some of these items are frequency response, obvious alignment problems, focus, and the physical size of the picture (height, width, and linearity). Certain defects which can be tolerated in black-and-white receivers may cause severe color deterioration in color receivers. Problems such as no picture, no sound, no sync etc., should be handled in the same manner as in black-and-white receivers. A detailed explanation of the entire monochrome section will be covered later in the lesson.

Receiver setup is important, and to a great extent determines the final viewing quality of the monochrome picture. The technician must be able to distinguish between a *maladjusted* and a *malfunctioning* receiver. The setup must provide the following:

1. *Good purity.* Red, green, and blue rasters should be free of any color contamination. Good individual fields are required to produce a clean white raster.

horizontally and vertically. Weak color sync is indicated when the fine-tuning setting is critical in obtaining color sync.

Antenna Effects on the Chrominance Signal. The prime consideration in selecting an antenna to be used with a color receiver is frequency response. The antenna should provide uniform frequency response on the channel(s) broadcasting color signals, as shown in Fig. 7-2a. All local conditions should be considered in selecting an antenna. In areas where multipath reception is a problem, or weak-signal conditions exist, the gain and directional qualities of the antenna should be considered when making your selection. There are several types of antennas available that have been specifically designed for use with color receivers.

With the exception of obviously defective antenna installations, such as loose or broken transmission lines, missing antenna elements, and so forth, most existing antenna installations that produce good black-and-white pictures will provide satisfactory results on a color receiver. However, there is a tendency on the part of the serviceman

when first exposed to color work, to evaluate the antenna performance by the monochrome picture, and assume equally good results for color. This assumption is wrong, and may cause extra hours of work. It is possible for a particular antenna installation to produce a good black-and-white picture without producing acceptable color. If the frequency response of the antenna system is severely tilted toward the color subcarrier side, as shown in Fig. 7-2b, a weak or no-color condition may exist. Since the color subcarrier is in close proximity to the sound carrier, a severe tilt toward the sound-carrier side would indicate possible color deterioration.

When color is absent or weak and the antenna system is suspected, the following procedure may help determine the cause.

1. Adjust the killer threshold control to the minimum position. This will cut off the color-killer circuits and allow the bandpass amplifier to conduct at all times.

2. Substitute the existing antenna system with an indoor V-type antenna, reception conditions permitting. As an alternate, disconnect one lead of the antenna transmission line at the receiver antenna terminals.

A substantial increase in the chrominance level as the result of one of the above steps would indicate a problem within the antenna system.

Many faults in the antenna system may affect color reception. Among them are:

1. Improper attenuation pads. Proper value "H" (300-ohm line) or "T" (coaxial cable) type pads should be used.

2. Poorly designed multiple coupling devices that do not provide suitable frequency response and sufficient isolation between receivers.

3. Lightning arrestors that have become corroded may cause a "suck out" on a color channel.

4. Poorly aligned master-antenna distribution amplifiers.

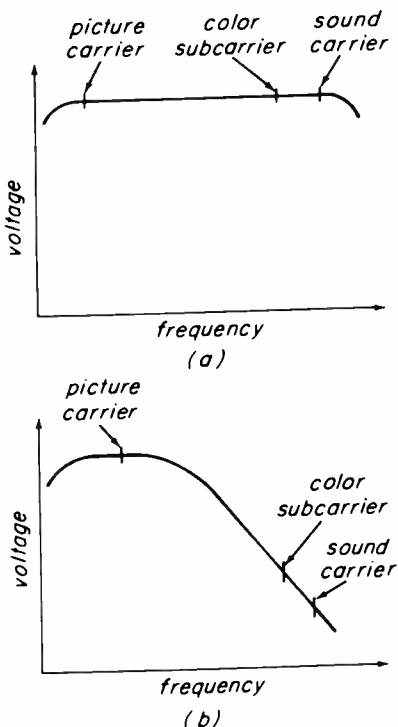

Fig. 7-2. Antenna frequency response curves (one channel).

5. Overdriven master-antenna distribution amplifiers. If these amplifiers are driven into nonlinear operation by a strong signal, it may not be possible to tune out the 920-kc sound-beat with the fine tuning control.

6. Incorrect antenna orientation, particularly in locations where more than one station broadcasts color.

7. Stubs or "gimmick" r-f traps.

8. Improper termination of the lead-in. When coaxial cable is used, proper balun or matching transformers should be installed.

7.2. TROUBLES IN THE MONOCHROME SECTIONS

R-F/I-F Troubles. The r-f units used in the color receivers are essentially the same as those used in black-and-white receivers. However, due to the more complex nature of the composite color signal, the r-f unit in a color receiver must adhere to closer operating tolerances. Care has to be taken to achieve the wideband performance and uniformly flat frequency response needed on channels receiving color signals. Low-noise triodes are responsible for the improved fringe-area performance of modern TV receivers. To perform correctly, however, most triode amplifiers must be neutralized. We may be accustomed to thinking of the neutralizing as a means of preventing the r-f stage from breaking into

oscillation. Actually, **neutralization** does more than that. The triode amplifier exhibits a large input capacitance due to the effects of the feedback signal that is coupled from the plate circuit to the grid circuit via the grid-plate capacitance. Not only is the input capacitance larger than we might expect, but it is also dependent upon stage gain, since the amplitude of the feedback signal depends upon gain. This is called the **Miller effect**. Neutralization effectively cancels the feedback signal, and the effects that feedback produce. If an r-f stage is not neutralized properly, the effects of the feedback may cause oscillation or regeneration, but detuning of the stage and severe distortion of the r-f response curve can surely be expected. For these reasons **neutralization** should be checked and adjusted when the tuner is suspected of being the cause of a color problem on one particular channel. Refer to the alignment lesson for a typical neutralizing adjustment. Figure 7-3 shows a simplified schematic diagram of the cascode r-f amplifier used in an early-model color receiver. The components of the neutralizing circuit are shown in the grid circuit of V_1 . The second stage is a grounded-grid r-f amplifier and does not require neutralization. Late-model RCA tuners employ the nuvistor tube in a neutralized triode circuit. A simplified diagram of the neutralization circuit for the nuvistor-equipped tuners appears in Fig. 7-4. Note that the normal feedback circuit and the neutralizing feedback circuit form two arms of a bridge circuit.

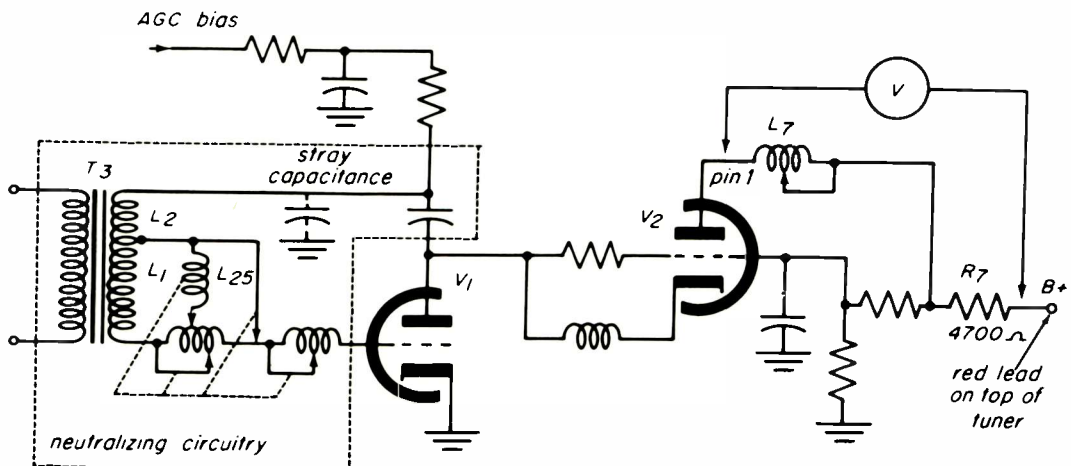

Fig. 7-3. Cascode r-f amplifier stages used in the RCA CTC-7 chassis.

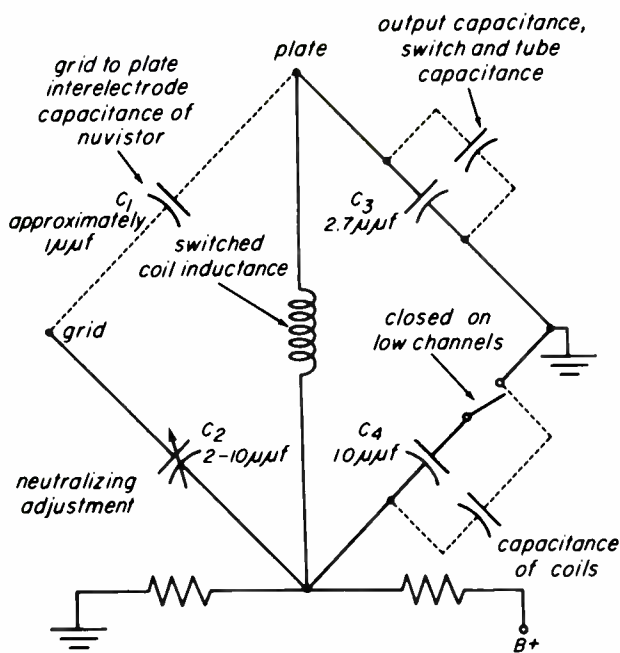

Fig. 7-4. Simplified nuvistor r-f circuit resembles a balanced bridge.

When the bridge is balanced, the stage is neutralized properly.

Neutralization should be checked following repair work on the r-f amplifier. Normally, neutralization need not be checked following replacement of the r-f amplifier tube. This is particularly true in tuners employing nuvistor triodes since interelectrode capacitance and other characteristics vary very little between nuvistor tubes of the same type.

Uniform frequency response of the r-f amplifier, as shown in Fig. 7-5a, is essential for the color receiver. Since it is possible for a tilt, as shown in Fig. 7-5b, to be compensated for in the i-f section of the receiver, the r-f amplifier stage should be aligned separately. It is necessary that all channels on which color is transmitted be examined and aligned in the same manner.

The most common trouble encountered in the r-f amplifier is loss of gain. This trouble is characterized by snow in the monochrome picture. Color program symptoms would not be important since correct service procedure would not allow you to ignore the

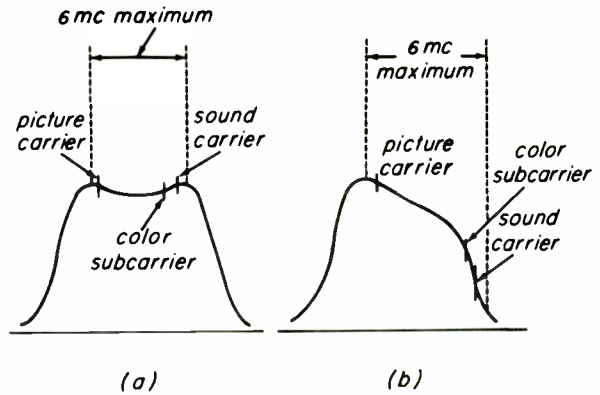

Fig. 7-5. R-f amplifier response curves.

defective black-and-white picture. Frequent causes of loss of gain are a defective r-f tube or intermittent contacts on the r-f portion of the selector switch. A common cause of low gain in one early color receiver is an open R_7 , shown in Fig. 7-3. Failure of R_7 results from an internal short in the r-f amplifier tube. This causes the resistor to overheat and change value. The value of R_7 may be easily determined by removing the r-f tube from the tuner and connecting an ohmmeter from pin 1 to the B+ (red) lead on the top of the tuner. The low resistance of L_7 may be disregarded and the meter should read 4700 ohms.

The r-f oscillator and mixer stages are often in series or "stacked" across the B+ supply voltage. It should be remembered, when servicing this type of circuit, that failure in one stage will materially affect the voltages applied to the other. As an example, if T_2 in Fig. 7-6 opens, no voltage will be present at the plate of V_4 , or at the cathode and grid of V_3 , and B+ will be present on the plate of V_3 . A low voltage will be read at these points (the plate of V_4 , and the cathode and grid of V_3) due to the internal resistance of the meter completing a circuit to ground.

Operation of the r-f oscillator may be checked by measuring oscillator injection voltage at the mixer grid. A requirement of the r-f unit that takes on additional importance in a color receiver is that of a drift-free oscillator. Since the proper setting of

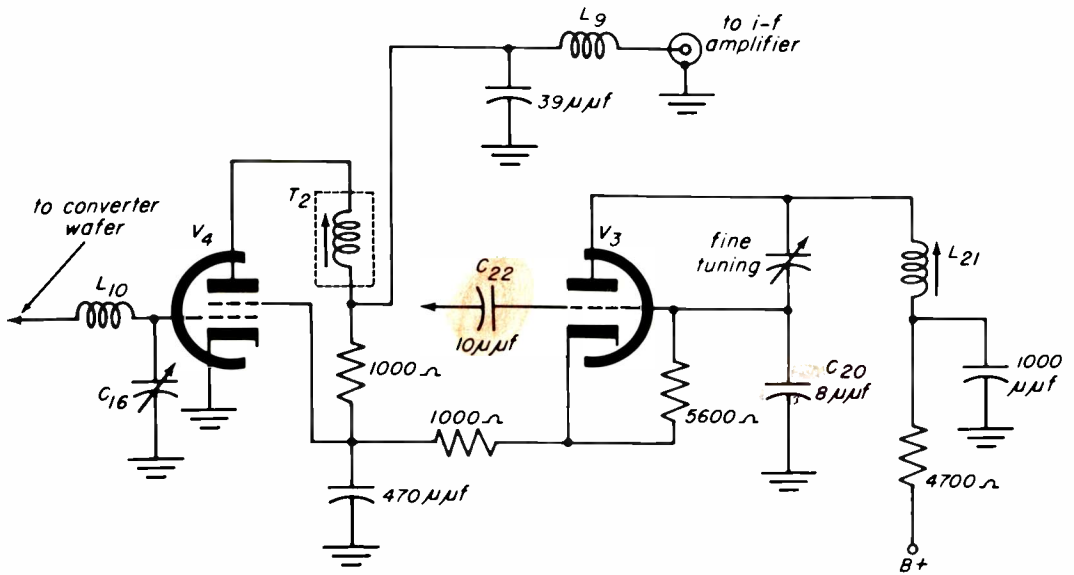

Fig. 7-6. Stacked oscillator and mixer stages used in the RCA CTC-7 chassis.

the oscillator (fine tuning control) is essential to produce color, a drifting oscillator may result in intermittent loss of color or the appearance of the 920-kc sound beat in the picture. Common causes of this problem are:

1. Dirty or intermittent contacts on the oscillator or mixer wafers.
2. Defective capacitors (C_{20} and C_{22} , in Fig. 7-6).

I-F Section. In addition to the normal requirements, the i-f section in a color receiver must provide a picture-to-sound-carrier ratio of 2000:1. This high ratio is necessary to avoid a 920-kc beat in the picture. The 4.5-mc sound intercarrier is produced by a separate sound detector in the output circuit in the last i-f stage. An additional trap is inserted in the video detector circuit to remove any 41.25-mc signal components. Figure 7-7 illustrates the over-all picture i-f response. The picture carrier is at 45.75 mc, color subcarrier is at 42.17 mc, and the sound carrier is at 41.25 mc. The technician should become familiar with the alignment procedures of the color receivers. He will find it a valuable aid in troubleshooting receivers whose performance is marginal.

With the exception of the items explained in the previous paragraph, the i-f section is a conventional three-stage stagger-tuned i-f strip, of the type used in many black-and-white receivers. Therefore, normal servicing methods apply.

Video Amplifier Troubles. The video amplifier performs three functions: It provides distribution for the chrominance, AGC and sync signals. It supplies sufficient video drive to the kinescope, and it introduces proper time delay in the luminance channel. Figure 7-8 illustrates signal distribution of video amplifiers.

The term "time delay" may at first seem unfamiliar to the TV serviceman. However, the technician has worked with it in various forms. For example, a TV signal passes through coaxial cable at $0.66 \times 186,000$ miles

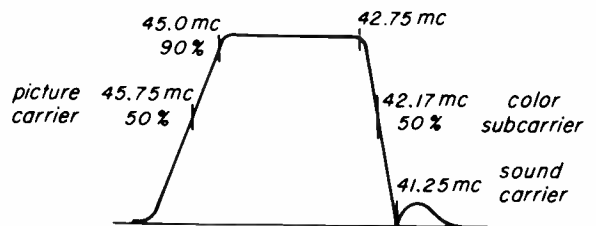

Fig. 7-7. Over-all picture i-f response.

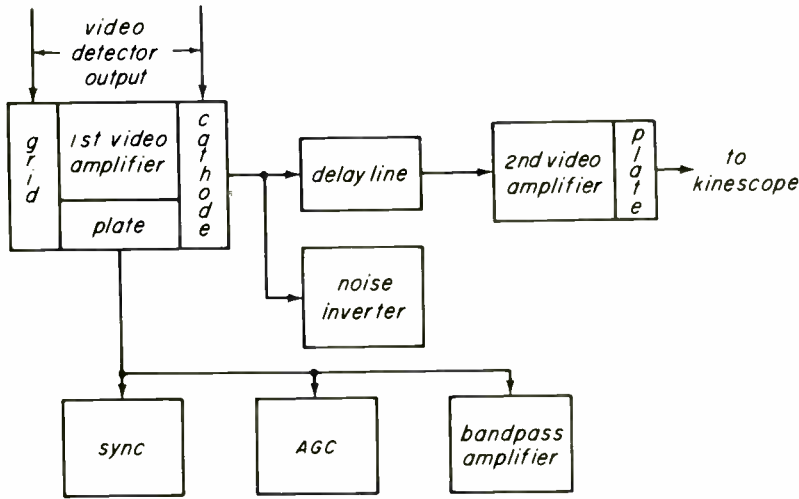

Fig. 7-8. Block diagram showing signal distribution from the video amplifier.

per second (speed of light). (0.66 is the velocity factor for RG-59U coaxial cable.) Therefore, the signal in a coaxial cable has a "time delay" when compared to a signal traveling in free space. In strong-signal areas this condition becomes a problem, known as "direct pickup". The television set receives two signals: one signal from the antenna through the coaxial cable; the second signal is picked up directly at the receiver or on the cable. Since the signal from the antenna, through the cable, is generally strongest, the weaker direct-pickup signal results in a leading reflection (ghost), as shown in Fig. 7-9a. The separation or "time delay" of the two signals depends on the length of the coaxial cable.

When the luminance and chrominance signals arrive at the kinescope simultaneously,

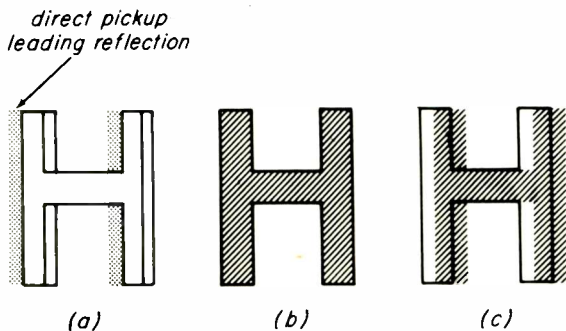

Fig. 7-9. Incorrect time delays cause color misregistration.

the color information is correctly "superimposed" on the luminance signal as shown in Fig. 7-9b. However, let's assume that no time delay has been introduced into the video amplifier. The luminance information would then arrive at the kinescope ahead of the chrominance signal. The chrominance signal would be displaced to the right of the luminance signal, as shown in Fig. 7-9c.

The time delay of a fraction of a microsecond is achieved by inserting a delay line, as shown in Fig. 7-10, between the first and second video amplifier stages. As shown in Fig. 7-11, the delay line consists of a wire wound on a core with an insulated shield surrounding the coil. This simulates a long piece of coaxial cable which has a characteristic impedance of about 1200 ohms. The design of the video amplifier matches this impedance at both ends of the delay line.

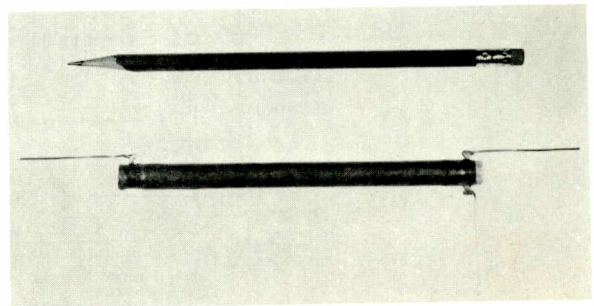

Fig. 7-10. Photograph of the delay line used in the CTC-7 chassis.

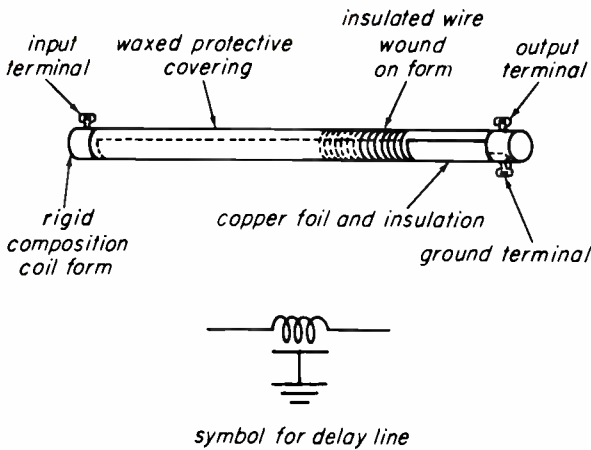

Fig. 7-11. Construction details of a delay line.

Due to the rugged construction of the delay line, and the low operating voltage, the delay line seldom fails under normal operating conditions. Failure of a delay line would normally be an open condition, and in most instances is caused by rough handling. The symptoms are loss of video, and low or no brightness (this would depend on the setting of the screen controls). The d-c resistance of the delay line is approximately 200 ohms. Care should be taken when measuring the resistance of the delay line in the circuit, for there is a "sneak path" shunting the delay line of approximately 3000 ohms, as shown in Fig. 7-12. It is possible, however, for the line to become partially shorted. The symptom of this condition is video ringing with the appearance of multiple,

closely-spaced ghosts. Substitution of a new delay line would be the most conclusive check if a problem of this type is suspected.

Currently, there are two basic types of video amplifier circuits in general use. One employs two stages of amplification; the latest version utilizes three stages. The following is a brief discussion of the two stage video amplifier. As illustrated in Fig. 7-12, the chrominance, sync, and AGC signals are distributed in the plate circuit of the first video amplifier. The Y or luminance signal is coupled to the second video amplifier through the delay line. The luminance signal is amplified by the second video amplifier and coupled directly to the cathodes of the kinescope. The brightness and contrast controls are both located in the second video amplifier circuit. The brightness control varies the bias on the control grid, thereby varying the plate voltage of the stage. This in turn varies the cathode voltages of the kinescope. Contrast variation is obtained by controlling the amount of cathode-circuit degeneration.

Figure 7-13 shows a diagram of the three-stage video amplifier. All outputs are taken from the plate circuit of the first stage. This provides full tube gain for the video information as well as the sync, chrominance and AGC signals. Since the video information is taken off at the plate of the first video amplifier, the video signal is inverted in phase.

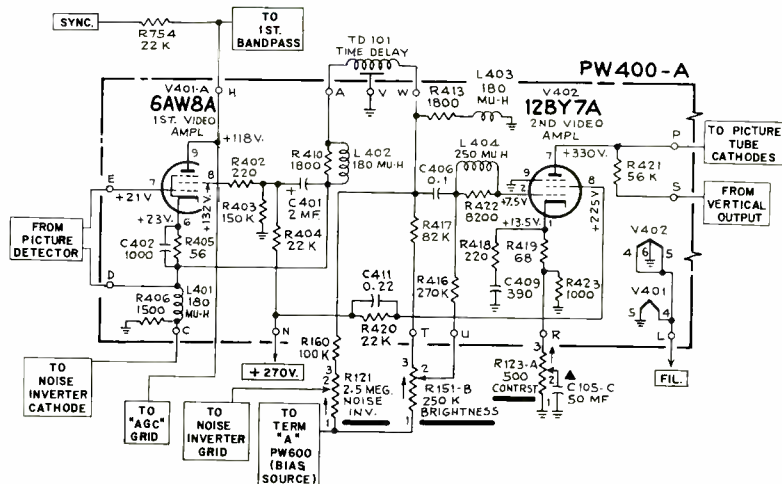

Fig. 7-12. Two-stage video amplifier circuit showing signal distribution.

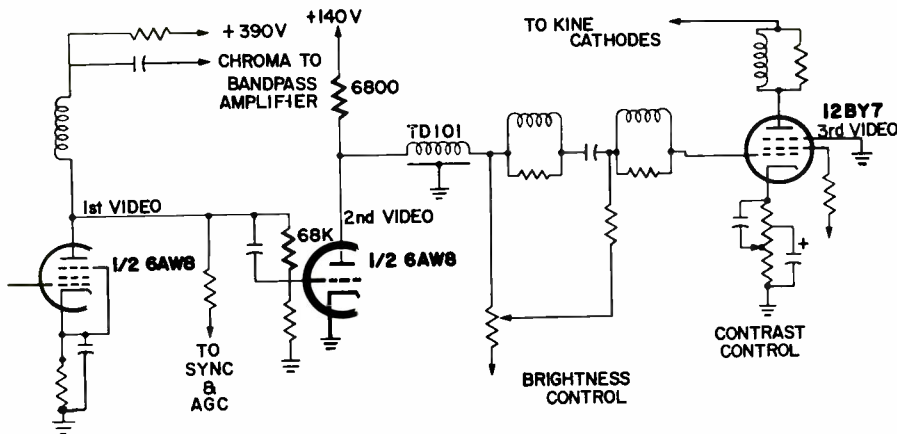

Fig. 7-13. Three-stage video amplifier used in the RCA CTC-12.

The second video amplifier shifts the phase an additional 180° , thereby providing the proper polarity of the video signal at the grid of the output stage. Low d-c voltage on the plate of the second stage permits direct coupling, through the delay line, to the grid of the third stage. The low impedance in the plate circuit of the second stage provides good matching to the delay line. The third (output) video amplifier is quite similar in design and operation to the second (output) stage used in the two-stage video amplifier circuit. Since the video section of the color receiver employs two or three direct-coupled stages, some troubles arise that produce unfamiliar symptoms. The following example of a typical service call illustrates some of the problems and their solutions. The RCA CTC-10 chassis is used for this discussion; a fold-out schematic diagram appears at the end of this lesson.

Customer description of trouble:

1. No picture for the first 20 minutes.
2. Sound is good.
3. Poor color when the set is operating.

Since the customer has established a time-related trouble, the technician should organize his approach before the receiver is turned on. While there is no choice on *this* service call, the technician should remember a good

monochrome picture is a prerequisite, before evaluating the chrominance performance.

To help identify the cause of a no-raster condition on a color receiver, the serviceman should train himself to *listen* for the high voltage (approximately 24 kv) to "hit" the kinescope. This is identified by a low crackling sound, caused by ionization of the air immediately surrounding the picture tube. This will establish, without measurements, whether the problem is one of no high voltage, or kinescope cutoff. On this service call we hear the high voltage come up. At this point the technician finds the no picture complaint is actually a no-raster (brightness) kinescope-cutoff problem. Therefore, the second step would be to measure the kinescope bias on one gun. It is not necessary to measure bias on all three guns, for if one gun is operating we would see a red, green or blue raster. We find approximately 185 volts bias on the gun(s). The 21CYP22 kinescope will cut off with approximately 130 volts of bias (the control grid being 130 volts negative with respect to the cathode). By measuring the kinescope cathode and grid potentials, with respect to ground, we find that the cathode is at the B+ voltage. By examining the schematic diagram you can see that cathode voltage is determined by the amount of conduction of the video output stage. Therefore, if the tube (12BY7) is not conducting (filament open, no emission), B+ voltage would appear on the plate of the

NO RASTOR

video amplifier as well as on the cathode(s) of the kinescope. This can be checked quickly by removing the video amplifier from the receiver and noting the change, if any, in the cathode voltage. No change in the cathode voltage indicates a nonconducting video output stage. However, a defective tube is not the cause of our problem. We must now find what is causing the video output stage to be cut off. A voltage check of the video output stage reveals a higher than normal negative voltage on the control grid, sufficient to cut off the stage. By examining the schematic diagram of the stage, we find that the amount of negative d-c voltage on the grid is determined by the brightness control. The B-minus supply to the brightness control is obtained by filtering the grid-leak bias on the blanker tube. This bias is developed from high-voltage pulses applied to the grid of the blanker tube. To maintain the proper voltage required, two neon bulbs (NE-2 lamps) are employed as voltage regulators. See the simplified diagram in Fig. 7-14. The bias developed at the grid of the blanker tube approaches -220 volts with the neon lamp disconnected. Therefore, there is sufficient voltage to fire the lamps (firing voltage for

two lamps in series is about -160 volts) and the lamps are normally lighted. In the receiver we are servicing, the lamps do not light. An "open" neon lamp may be the cause of our no raster condition. Note: The neon bulbs are in series. Therefore, when one bulb is open, neither one will fire.

A quick check of the bulbs can be made by shorting out the bulbs one at a time. When you short out the open neon lamp the remaining lamp should fire, and the set should produce a raster.

Having located and corrected the cause of the no raster condition (one neon lamp open), we may now evaluate the color performance. We find the "poor color" complaint is insufficient level of color, with the color saturation control in the maximum position. After eliminating tubes as a cause of the low color gain, a voltage check reveals a slightly higher than normal negative potential on the grid of the first bandpass amplifier. In tracing the grid circuitry, we find it couples through a 3.3-megohm resistor, back to the neon bulbs. By measuring the voltage across the neon bulbs, we find the voltage higher than normal. We may assume,

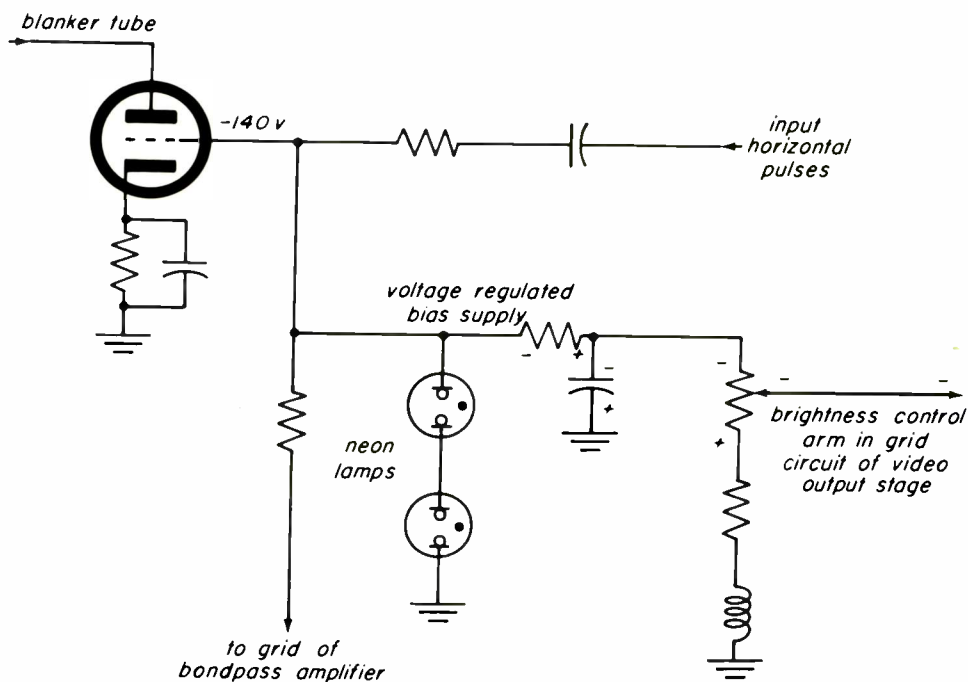

Fig. 7-14. Simplified brightness control circuit, RCA CTC-10.

and in this instance be right, that the neon bulb we did not change is firing at too high a voltage, causing the low color problem. The normal voltage across each lamp is 70 volts. This condition produces no noticeable effect on the monochrome picture, since a slightly higher setting of the brightness control would overcome the small increase in voltage.

Synchronization Troubles. The synchronization circuits in color receivers and black-and-white receivers perform the same functions. Most color receivers use a noise cancellation circuit in conjunction with the sync stages to maintain good synchronization despite impulse-noise interference.

Since the sync circuits for color receivers are basically no different from the sync circuits in high-quality black-and-white receivers, the same troubleshooting procedures apply. However, let us review some of the basic concepts of troubleshooting sync systems.

Loss of sync is evidenced by vertical and/or horizontal movement of the picture. The first step in localizing the trouble is to see if the fault lies in the deflection oscillators or the sync separation circuits. If, by manipulating the hold controls, a single upright picture can be produced, the deflection oscillators are capable of operating at the correct frequencies and the trouble is loss of sync somewhere between the antenna and the sync circuits. Hold controls that require critical adjustment to maintain a steady picture indicate weak sync. Erratic pulling or tearing of the picture points to intermittent loss of sync or some extraneous signal getting through the sync separators to the deflection oscillators.

If the deflection oscillators can operate at the correct frequencies (if a single, upright picture can be obtained, even momentarily), the next step is to localize the loss or attenuation of sync pulses to the video or sync sections. Since the tip of sync represents maximum modulation at the transmitter, sync pulses are at the peaks of the signals in the r-f and i-f stages. If an i-f

stage is overdriven (driven to cutoff or to the point where grid current is drawn) the sync signal will be attenuated. We can check to see if the sync signals are surviving the trip through the r-f/i-f/video sections by rolling the picture to stop a vertical blanking bar at midscreen and advancing the brightness control, as shown in Fig. 7-15a. If the hammerhead pattern, representing vertical sync and equalizing pulses, is blacker than the blanking bar, then the sync signals are not being clipped in the i-f or video sections. A severely clipped sync signal in the video i-f section results in the solid dark blanking bar shown in Fig. 7-15b with little or no evidence of the vertical sync signals.

If sync appears normal in the check mentioned in the previous paragraph, the trouble is isolated to some point between

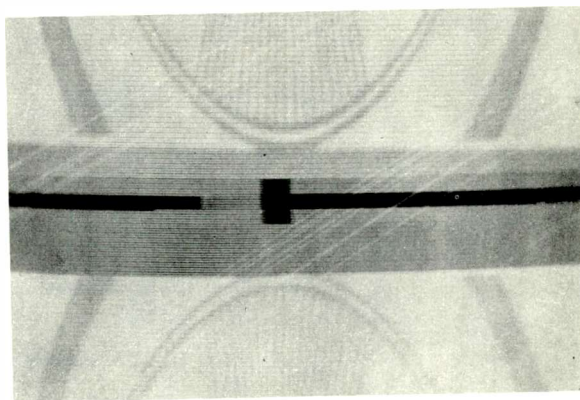

(a)

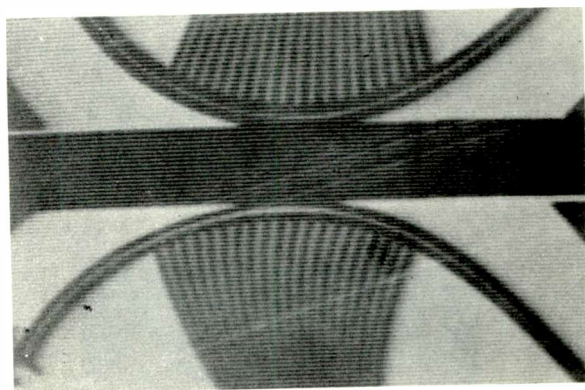

(b)

Fig. 7-15. (a) Correct sync indicated on the kinescope; (b) sync deterioration due to clipping in the i-f or video circuits.

the video amplifier and the deflection oscillators. It is a good idea to check AGC and noise threshold adjustments before proceeding.

The sync-handling circuits may be checked by making voltage and resistance checks. If these fail to reveal any malfunction, the technician should trace signals through the sync section with an oscilloscope. Most manufacturers show waveforms of the signals at various key points in the sync system.

Note: To view the sync pulse at the input to either deflection oscillator, it is necessary to disable the oscillator. Normally the sync pulse is quite small compared to the deflection signal at the input to either the vertical oscillator or the horizontal AFC system.

Deflection Troubles. In addition to the normal requirements of a black-and-white receiver, the deflection circuits of a color receiver must provide the following:

1. Vertical convergence voltage
2. Horizontal convergence voltage
3. Pulse signals for the burst amplifier
4. Pulse signals for the blanking amplifier
5. Regulated high voltage (24,000 volts)
6. Pulse signals for the color killer
7. Electrostatic focus voltage.

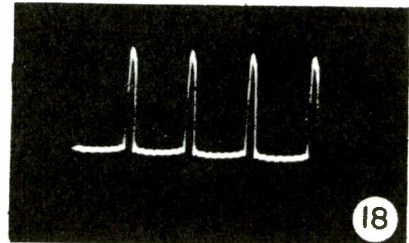
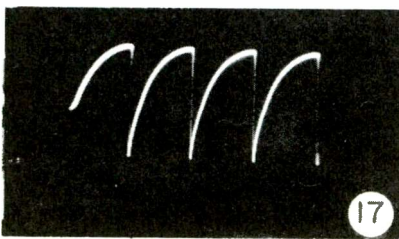
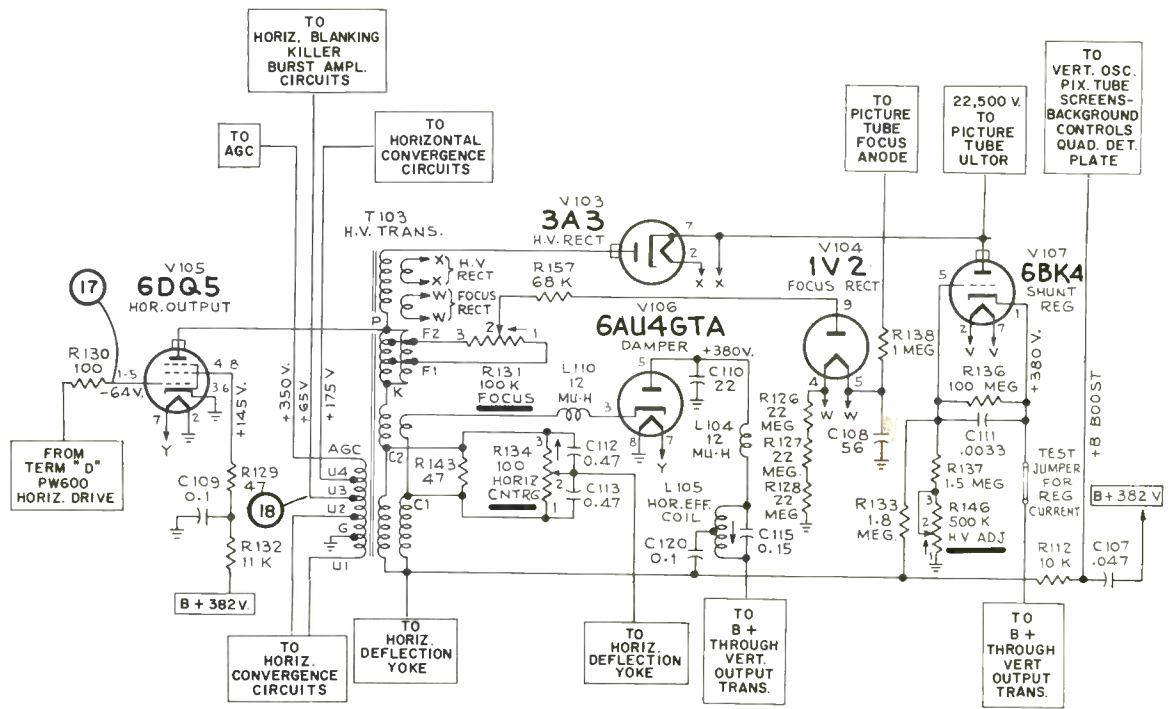
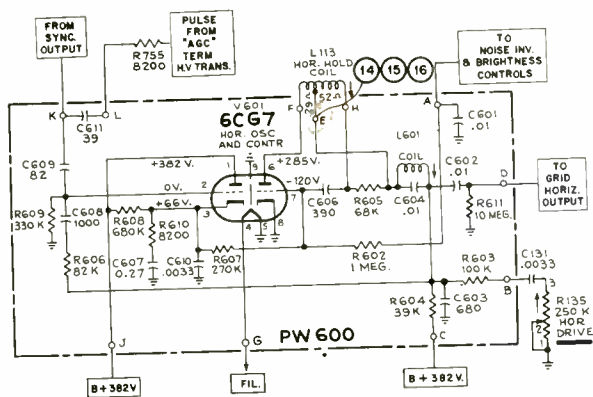

Fig. 7-16. RCA CTC-7 horizontal output and high-voltage circuits.

Figure 7-16 illustrates the signal distribution of the horizontal sweep circuit in the RCA CTC-7 color chassis.

The horizontal oscillator circuit, shown in Fig. 7-17, is a modified version of the RCA synchroguide design. The stability and good noise immunity of this circuit make it an excellent choice for a color receiver.



(a)

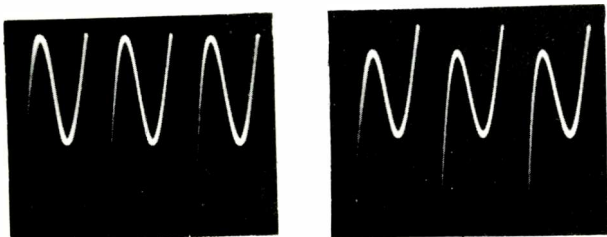

(b)

(c)

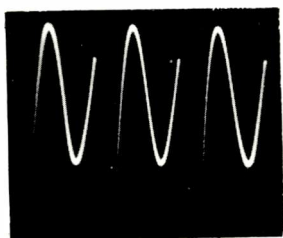

(d)

Fig. 7-17. (a) Horizontal oscillator circuit of the CTC-7 chassis; (b) correct waveform showing proper adjustment of the sine-wave coil; (c) incorrect waveform; (d) incorrect waveform.

The problems generally encountered in the horizontal oscillator circuit fall into one of three categories:

1. Stabilizing (sine-wave) coil misalignment causing the picture to "break up" into parasitic oscillation. Parasitic oscillation, in this case, shows up as a rhythmic blocking of the horizontal oscillator. The picture appears out of sync horizontally, the raster is ragged, and there is a rhythmic collapse of horizontal deflection. This condition is often accompanied by a chirping sound.
2. Insufficient range on the horizontal hold control (customer adjustment).
3. Lack of drive to the horizontal output stage.

A misadjusted sine-wave (stabilizing) coil results in a time-related (intermittent) type of complaint. Familiarization with the symptoms will enable you to recognize the problem with ease. The customer often complains that the picture breaks up into jagged lines after the set is on for a while. The "while" can be anywhere from 10 minutes to 2 hours. Alignment of the sine-wave coil may be checked by one of the following methods:

1. Shop procedure. Attach scope lead through a low capacitance probe, to terminal "E" of PW-600, as in Fig. 7-17a. Adjust L_{601} for waveform shown in Fig. 7-17b. Figures 7-17c and 7-17d illustrate incorrect alignment of L_{601} .

2. Field procedure. Adjust the horizontal hold control (frequency coil) to move the picture to the right, until the picture loses sync and the lines slant toward the upper right hand corner of the kinescope. The sine-wave coil is correctly adjusted when you are able to obtain three and one-half bars before the oscillator "breaks up" into parasitics. However, if you go directly from a synchronized picture into parasitics or you get less or more than three and one-half bars before going into parasitics, a misadjusted sine-wave coil is indicated. Adjust the sine-wave coil until

the correct condition is observed. The procedures explained in the foregoing paragraphs refer to the RCA CTC-4, -5, -5N, -7, and -9 chassis. Since the procedure may vary on other receivers, the service notes should be consulted. Some newer receivers use the sine-wave coil as a horizontal hold control.

While the particular causes of insufficient range on the horizontal hold control are varied, it is generally caused by a malfunctioning oscillator control stage. For example: if R_{607} , shown in Fig. 7-17a, were to increase in value to 300 k Ω , the range of the hold control narrows and the picture locks only at one extreme end of the controls range.

Lack of drive to the horizontal output tube causes the plates of the tube to glow red. Oscillator operation may be checked by measuring the grid voltage. A high negative voltage reading at the grid indicates that the stage is oscillating. We can check to see if the deflection signal is being coupled to the horizontal output tube by checking the grid bias on that tube. This tube uses grid-leak bias, and a reading of about -60 volts indicates proper drive to the horizontal output tube. A low negative, or slightly positive reading, indicates leakage in the coupling capacitor, C_{602} , shown in Fig. 7-17a.

The horizontal output and high-voltage circuits used in the RCA CTC-7 chassis are shown in Fig. 7-16.

The shunt regulator maintains the high voltage at a constant potential under varying load conditions. Regulation is accomplished by using the voltage difference between B+ (as cathode voltage) and B+ boost (as grid voltage) as bias on the 6BK4. As the high voltage increases, the B+ boost voltage increases. As a result, the bias on the 6BK4 decreases, causing the stage to conduct more heavily, thereby lowering the high voltage. The high-voltage adjustment (in the grid circuit) establishes the bias and operating range on the 6BK4.

When troubleshooting the high-voltage circuits, extreme caution should be used.

The loss of high-voltage regulation would produce one or both of the following symptoms:

1. Excessive change in the height and width of the picture while varying the brightness control.
2. Corona discharge or arcing due to excessive high voltage. With no regulation the high voltage will increase to approximately 27,000 volts (with the kinescope cut off). Arcing becomes more pronounced when humidity is high.

Failure of the 6BK4 (no emission), or an off-value resistor in the grid circuit of this tube, are the main causes of no regulation. A tube element short, cathode to heater or grid to cathode, or a shorted C_{111} (refer to Fig. 7-8) results in blooming and low high-voltage.

Regulator cathode current can be checked to identify faults in the regulation system. A low current reading indicates poor or no regulation. Excessive current causes over-regulation, resulting in low high-voltage. Consult the service notes for correct regulator current and recommended high voltage. The correct values for the CTC-7 chassis, shown in Fig. 7-16, are 800 microamperes of 6BK4 cathode current at 22.5 kv. Figure 7-18 shows the component locations of the horizontal output and high-voltage stages on the CTC-7 chassis.

A separate multitap winding on the high-voltage transformer provides the waveforms required for horizontal convergence, AGC, color-killer, horizontal blanking, and burst amplifier circuits. If these circuits malfunction, the waveforms on the transformer taps should be checked.

Focus voltage is obtained by rectifying and filtering a pulse from the horizontal output transformer. The focus control varies the amplitude of the pulse. Since the focus anode in the picture tube also functions as

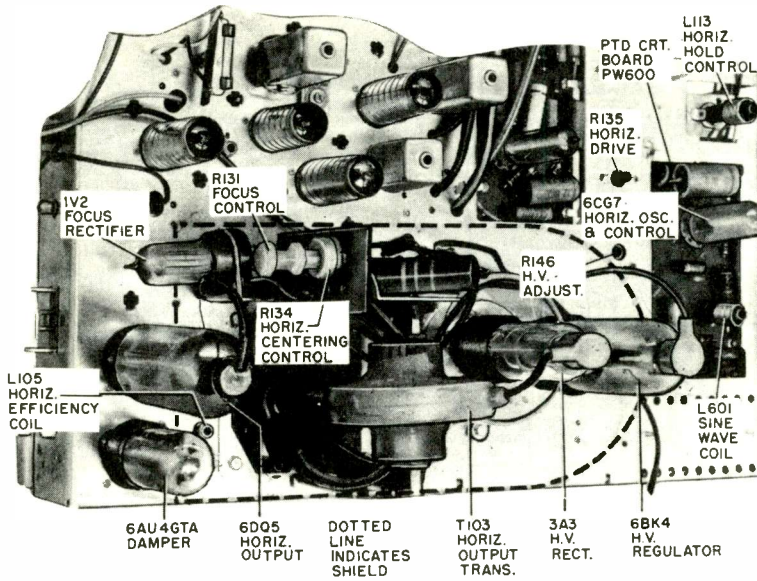

Fig. 7-18. High-voltage compartment with cover removed.

an accelerating anode, loss of the focus voltage results in a no-raster condition.

Some receivers use a potentiometer to control focus. Due to the high potentials involved, there is a tendency for the control to become pitted. A pitted control can cause a poor, intermittent, or varying focus condition. A severely pitted focus control may result in a no brightness problem. Repeated failure of the focus control indicates an intermittent short, causing excessive current to flow in the focus control. If this condition exists, C_{108} should be checked. Refer to Fig. 7-16. Note: Immediate replacement of a pitted focus control is recommended. Conventional cleaning and lubrication methods do not effect lasting repairs in this case.

RCA chassis(s) CTC-10, -11, and -12 use a newer type of focus circuit. Refer to Fig. 7-19. This circuit employs the use of a coil to control the focusing voltage. Variation of the focus voltage is obtained by adding to or subtracting from the amplitude of the pulses that charge C_1 . Heater voltage is supplied by a winding on the high-voltage transformer. Since this circuit absorbs very little power, focus control failures are practically eliminated.

Vertical Deflection. Most RCA color receivers use a two stage vertical blocking

oscillator circuit. Refer to Fig. 7-20. This type of circuitry is used in many black-and-white receivers and can be easily identified by the absence of a vertical oscillator transformer. The service methods used are exactly the same as those employed in black-and-white receivers.

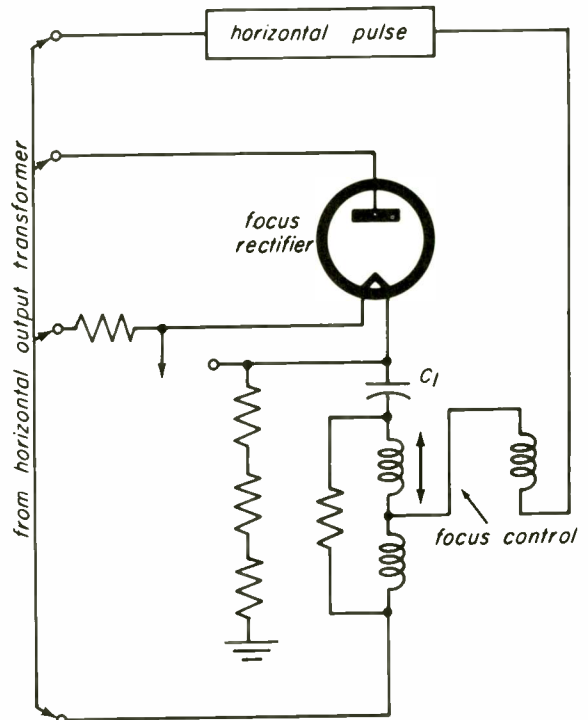
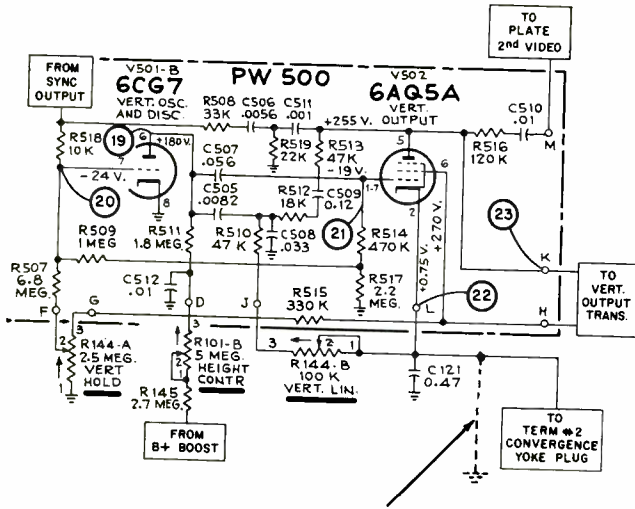

Fig. 7-19. CTC-10 focus circuit.



Short this point to ground when servicing chassis without convergence yoke attached.

Fig. 7-20. Vertical deflection circuit for the CTC-7 chassis.

In a color receiver, the vertical circuit must provide vertical convergence waveforms. The waveforms are obtained from separate windings on the output transformer and from the cathode circuit of the output stage. These waveforms are coupled through an octal socket to the convergence assembly. When servicing the receiver without the convergence assembly plugged in, pins one and two on the socket must be shorted. This will complete the cathode circuit to ground, allowing proper vertical deflection. We will discuss convergence problems later in the lesson.

AGC Troubles. The AGC circuit for the CTC-7 chassis is shown in Fig. 7-21. The operation of the AGC circuit is quite similar to the keyed AGC circuits of black-and-white receivers. A large positive pulse (400 volts p-p), from the horizontal output transformer, is applied to the plate of the AGC tube. When the pulse is present at the plate, the positive sync tips that appear at the grid will cause the stage to conduct. This produces a rectified negative voltage at the plate. The negative voltage is then filtered and used as bias on the i-f and r-f stages, thereby controlling the gain of the stages. The AGC control establishes the signal level at which the AGC amplifier will operate.

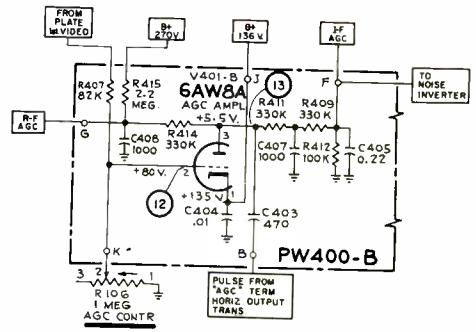

Fig. 7-21. Diagram of the AGC circuit used in the CTC-7 chassis illustrates signal distribution.

The amount of bias on the r-f and i-f stages will vary in direct proportion to the amplitude of the sync pulse. As the sync level increases, the bias on the controlled r-f and i-f stages increases, thereby lowering the gain of the r-f and i-f amplifiers. When the sync level decreases, the AGC amplifier conducts less, the bias on the controlled stages decreases, and the gain of the stages increases. The over-all action of the AGC system is to maintain a constant level of video signals at the output of the video detector. This level is set by the AGC control.

Problems encountered in the AGC circuit generally fall into one of four categories:

1. No picture or sound. This is caused by excessive bias on the controlled r-f/i-f stages.
2. Weak picture. This is caused by higher than normal bias on either the r-f or i-f stages, lowering the gain of these stages.
3. Overloaded picture with a loud buzz in the sound. This is caused by insufficient bias on the controlled r-f and i-f stages.
4. "Venetian blind" effect, multiple horizontal strips superimposed on the picture or bending of the picture may be caused by insufficient filtering on the AGC bias line. The horizontal lines are produced by oscillation in the AGC system.

Since it is possible for a defect in the r-f, i-f or video circuits to give the "wrong

information" to the AGC amplifier, we must eliminate these stages as trouble sources when servicing an AGC problem. This can be accomplished by substituting an external bias supply in place of the AGC-developed bias. Figure 7-22 shows the application of external bias to the r-f/i-f stages. The bias controls are adjusted to produce a normal picture. If the picture does not change as the bias controls are turned, we should check the voltages at the grids of the r-f and i-f stages to make sure that the bias distribution lines are not shorted. Inability to produce a normal picture by using external bias indicates that the AGC problem is actually a malfunctioning r-f, i-f or video amplifier section. The next step is to establish the presence and proper amplitude of the horizontal pulse at the plate of the AGC tube. The amplitude of the pulse must be within 10% of its stated value to obtain proper operation of the AGC circuit. If a horizontal sweep problem exists in conjunction with an AGC defect, the sweep trouble should be repaired first. The sweep problem may cause the AGC pulse to be of insufficient amplitude. A check of the operating voltages and bias (setting of the AGC control) on the AGC stage should indicate the existence and

location of a fault in this stage. If inadequate filtering of the r-f/i-f bias line is suspected, the bias-line filter capacitors should be checked by substitution.

A malfunctioning AGC circuit, or an improperly adjusted AGC control, could cause color deterioration.

7-3. COLOR IN THE MONOCHROME PICTURE

In this section we will discuss the troubles that cause color contamination of the black-and-white picture. Since the consumer will probably watch as much black-and-white as he will color programs, a good setup becomes extremely important. In addition, any color contamination of the black-and-white picture will also be present when reproducing a color program. Therefore, a poor black-and-white setup usually results in a service call. A thorough and complete understanding of the fundamentals involved in setting up a color receiver is required when attempting to service a color receiver. (The complete setup procedure is covered in Lesson 4).

Purity and Shading. Purity, stated very simply, is achieved when all the electrons from the red, green and blue guns "hit" only their respective phosphors (red gun to red phosphor, etc.). Pure single fields are combined in proper proportion to produce a clean white raster, free from color contamination. Final purity evaluation should be made under normal viewing conditions.

While purity is mainly an initial setup function, the serviceman must be thoroughly familiar with the causes of poor or changing purity. Purity adjustments (purity magnet and deflection yoke) once properly adjusted, are rarely the cause of a subsequent purity problem. The build-up of a magnetic field on the metal shadow (aperture) mask, or a strong varying external magnetic field, are the general causes of purity problems.

A low-power microscope is helpful in analyzing purity problems. By seeing where the beam lands in individual phosphor dots, we can differentiate between a misadjusted purity magnet or a misadjusted deflection

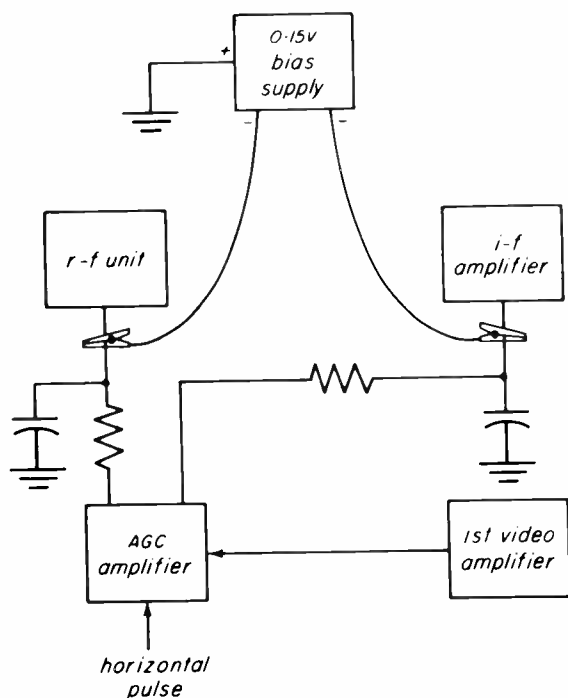

Fig. 7-22. AGC block diagram showing external bias supply being used.

yoke. To check the adjustment of the purity magnet, examine the beam landing in the center of the screen. To check for proper yoke adjustment, check beam landing at the screen edges. For example, if the beam landings are centered on the phosphor dots in the middle of the screen, but fall on the outside edges of the dots at the edges, the purity magnet needs no adjustment, but the yoke is positioned too close to the screen. Note, the microscope will show the beam landings at the edges to be on the inside (towards center screen) edges of the dots in this case, as the microscope *inverts* the image. Figure 7-23 reviews the action of the purity magnet and the deflection yoke

on beam landing as viewed with a microscope.

If the technician does not have a microscope, the most direct way to attack a purity problem is to perform the routine purity adjustments. These are quite simple and can be done quickly. If the normal purity setup procedure does not produce good purity, the problem may be due to one of the following causes:

1. Insufficient degaussing of the kinescope, particularly if the kinescope is a metal type or the cabinet is made of steel.

2. A large convergence error may make purity difficult, or in some receivers, impossible to obtain. Both dynamic and center convergence should be fairly close before final purity adjustments are made. Since the purity magnet will also affect center convergence, several readjustments of the center convergence may be required while making purity. If a *closely spaced* dot pattern is used, it is possible to be one dot off. Checking center convergence on a normal black-and-white picture would reveal this condition.

3. If the receiver has edge magnets, they should be set to their minimum-effect positions. Hairpin-type magnets should be superimposed on each other, and rim magnets should be withdrawn into their magnetic shields while preliminary purity adjustments are made.

4. Misalignment of electron gun(s) can cause trouble. Generally this defect results in two good single fields while the third (bent gun) field will not make acceptable purity.

5. A buckled shadow mask or a loose phosphor backing plate will result in the inability to produce even a pure single field. This type of defect will produce large blotches of color in the raster. Poor purity, due to the items mentioned in 4 and 5, is rare.

6. Color contamination sometimes occurs in the white raster even though the individual fields appear pure. Some of the causes are discussed in the following paragraphs.

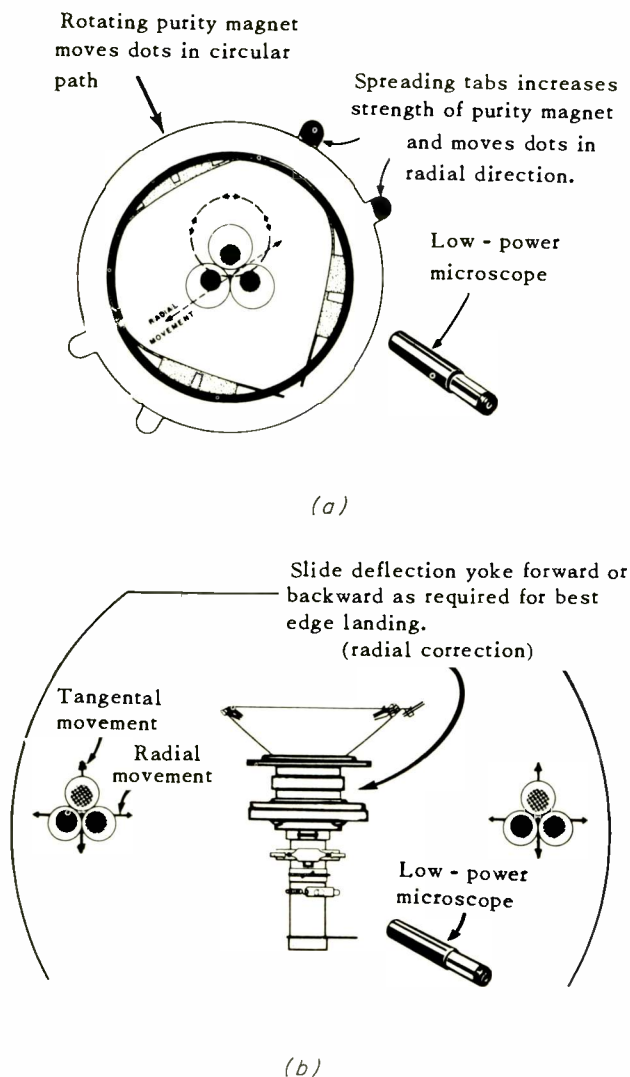

Fig. 7-23. (a) Center landing adjustments for optimum purity, using purity magnet; (b) edge landing adjustments for optimum purity, using deflection yoke.

A small error in beam landing might cause contamination in the white raster. This might occur if beam landing error is such that the beam misses part of its designated phosphor dot, but the error is not large enough for the beam to strike the wrong phosphor dot. Individual fields then display no impurity but certain areas produce insufficient light output. This condition is most obvious on a white raster. For example, if one area of the raster lacks blue light, that area will appear yellow when the remainder of the raster is white. Although the individual fields appear pure in this case, the standard purity adjustments should be repeated to correct the condition. A low-power microscope might be of help in examining beam landing.

Another cause of color contamination in the white raster is shading caused by extraneous signals that find their way into one or more of the chrominance channels. An example of this type of condition occurs when C₇₁₁, of Fig. 7-24 opens. C₇₁₁ is in the plate circuit of the (R-Y) amplifier. In the absence of signals, the waveform of the red gun contains negative pulses that occur during the horizontal blanking interval. These are caused by the "set" pulses applied at the amplifier cathodes. When C₇₁₁ opens, the frequency response of the coupling circuit changes and the waveform is integrated to appear like a sawtooth. This signal causes the grid signal to swing in the positive direction during the early part of the trace. The result is red shading at the left side of the picture. This condition may be observed by biasing off the blue and green guns and reducing brightness until the red field is dimly lighted. The left side of the raster then appears definitely brighter than the right side. A similar condition may occur in the green or blue fields if C₇₁₄ or C₇₂₄ should open.

Convergence Troubles. Convergence faults show up as color fringing of the objects being televised. Location of the color "hangout" tells us which convergence function is defective or in need of adjustment. For example, a misconverged center area of the kinescope indicates a problem in the static convergence system, while misconverged outer areas indicate a dynamic cir-

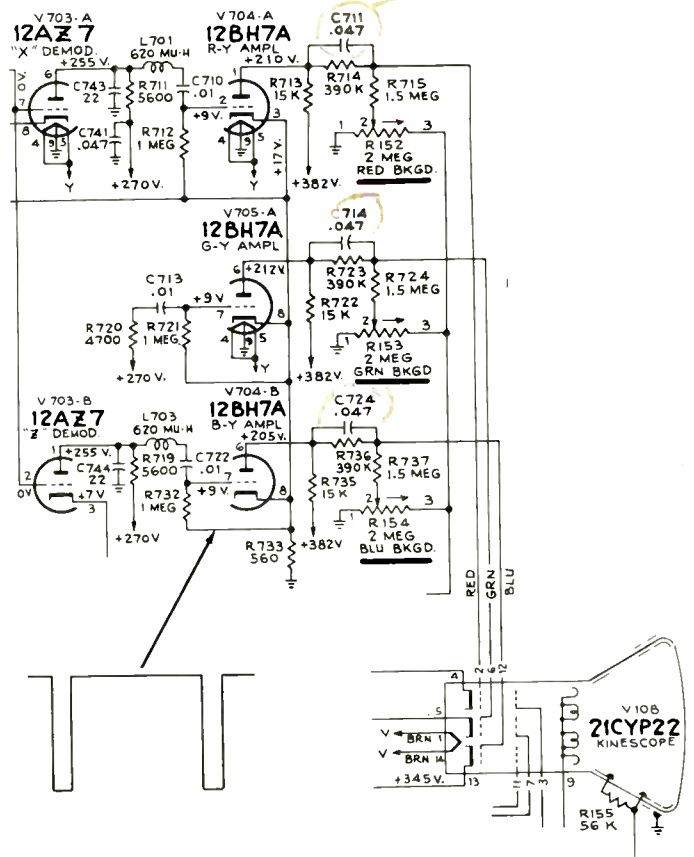

Fig. 7-24. Demodulator-matrix sections of the RCA CTC-7 chassis.

cuitry problem. A dynamic convergence problem can almost be pin-pointed by observing the exact locations of the errors and the colors involved. The serviceman must be able to distinguish between a receiver needing adjustment and one with a defect in the convergence circuitry. In addition, he must be able to recognize acceptable convergence. Convergence is accomplished when all three electron beams enter the same group of holes in the shadow mask, over the entire area of the kinescope.

Convergence in the center of the screen is obtained through the use of PM magnets, or by controlled d-c currents on the convergence electromagnets. Figure 7-25 shows the PM-type center-convergence and lateral beam positioning (blue-lateral) controls found in some older receivers. In this method of obtaining center convergence, a small PM magnet is installed in a nylon sleeve. The sleeve is mounted in a holder which is attached to the external pole pieces of the

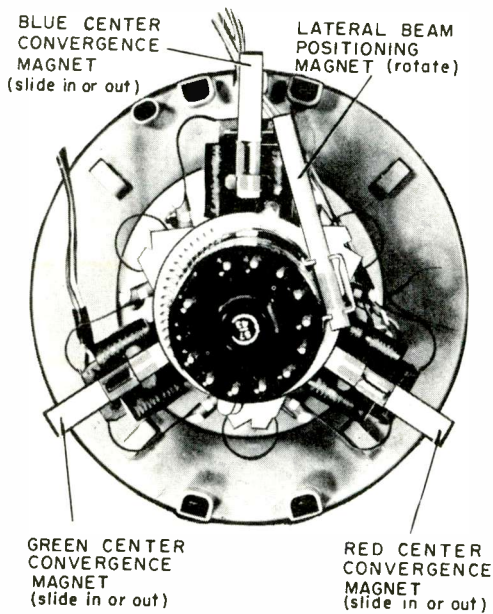

Fig. 7-25. Center convergence adjustments.

convergence coils. Convergence is obtained by varying the physical proximity of the magnet to the electron gun. Lateral beam movement is achieved by rotating the magnet within the holder of the lateral beam-positioning assembly.

The normal amount of beam movement with the PM-type adjustments is approximately 1-1/2 to 3/4 inches. Insufficient beam movement can be caused by a physical restriction, limiting the travel of the sleeve. The direction of beam movement can be changed by rotating the sleeve 180° in the holder. The sleeve is nearly square. Therefore, it is possible to mount it in the holder in one of four positions, only two of which are correct positions. If (by mistake) the sleeve is rotated a quarter turn from a correct position, the range will be limited. In addition, the path of beam movement will be abnormal. Rotating the sleeve 90° will re-establish correct operation in this case. If rotating the sleeve produces little or no change, the magnet itself may not be mounted correctly in the sleeve. See Fig. 7-26. Insufficient range, or incorrect direction of beam movement, of the blue beam during lateral magnet adjustments, can result from improper positioning of the lateral beam-positioning magnet assembly. Refer to the service notes for the correct position of the

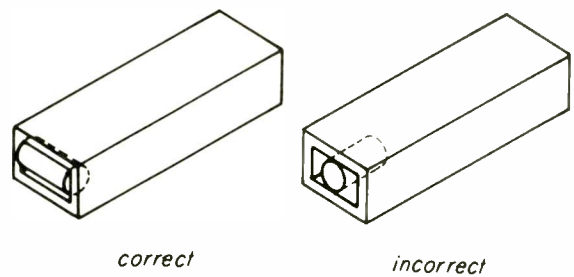

Fig. 7-26. PM magnet in the nylon mounting sleeve.

lateral beam positioning assembly. In some late-model receivers, the center convergence magnet sleeve has an I-shaped form, and the holder configuration is such that the sleeve can be inserted in only the correct positions.

Figure 7-27 shows a simplified diagram of the convergence circuits of an older receiver. This receiver employs electromagnetic center convergence. Static adjustments are controlled by the d-c convergence control in the cathode circuit of the horizontal output tube. Normal over-all beam movement with this type circuitry is approximately 1 to 1-1/2 inches. Since the d-c convergence voltage is obtained from the cathode circuit of the horizontal output tube, a cause of insufficient static convergence range might be low conduction of the horizontal output tube. If the electromagnetic blue-lateral magnet becomes defective in these early receivers, it can be replaced with a PM-type.

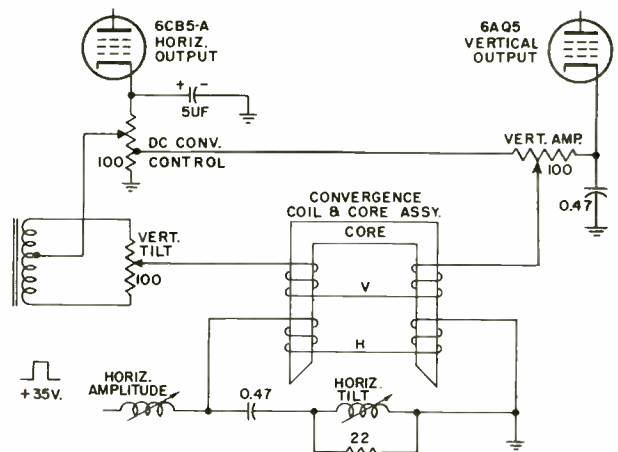

Fig. 7-27. Simplified diagram of the CTC-5 chassis convergence circuits. The receiver uses electromagnetic center convergence.

Problems in the dynamic convergence circuitry appear as color (fringing) in a monochrome picture, in areas other than the center of the screen. The technician should first attempt to eliminate the misconvergence by adjustment of the dynamic controls. If the fringing is the result of a defect rather than misadjustment, you will be unable to correct the misconvergence. However, you will then know which controls have little or no effect. By analyzing the effect of the controls involved, and the color of the fringes, the defect can be localized to the horizontal or vertical circuitry. If the defect affects convergence of all three colors in the vertical or horizontal areas, the controlling waveform (vertical or horizontal) circuit should be examined. Misconvergence of both the vertical and horizontal areas indicates a common failure, such as an open ground return. Figure 7-28 illustrates the relationship of the controls of the newer receivers to the areas of the screen they affect.

Some of the controls shown in Fig. 7-28 are marked R-G; this means that the control affects red and green simultaneously.

This type of control circuitry greatly simplifies the dynamic convergence setup procedure and is employed in the RCA CTC-10, -11, and -12 chassis. RCA chassis CTC-7 and CTC-9 use independent controls for vertical dynamic convergence and combined R-G controls for horizontal convergence. Figure 7-29 shows a simplified convergence circuit with waveforms, for the CTC-7 chassis. Waveform checks made with an oscilloscope help to quickly locate any problem in the convergence circuits. However, many component failures in the convergence circuitry can be located by simple resistance checks. In some cases a problem of limited range or improper action of a dynamic convergence control is caused by improper positioning of the deflection yoke.

Black-and-White Setup. A requirement of the color receiver is that it maintain a neutral gray-scale monochrome picture, with no color predominating, through the useful range of the brightness control. Since the color phosphors do not have equal light output for a given beam intensity, separate controls for each electron gun are used to obtain the correct color balance. These controls set the beam intensity required for each gun, to produce an acceptable white. The sulphide phosphors used in the 21FBP22 and 21FJP22 kinescopes, have more uniform phosphor efficiency in addition to greater light output. Therefore, the black-and-white setup of receivers using the newer kinescopes is simplified.

Complete black-and-white tracking procedures are covered in Lesson 4. The color serviceman will find that a thorough knowledge of the tracking procedures will aid in troubleshooting tracking errors. Many times reference is made to the term "useful range of brightness control." By this we mean the range from cutoff of the kinescope (no brightness) to the point when the picture blooms. Incorrect adjustment of the screen controls may result in excessive blooming (high setting) as well as the inability to cut off the picture tube. Low screen settings result in insufficient brightness. If either

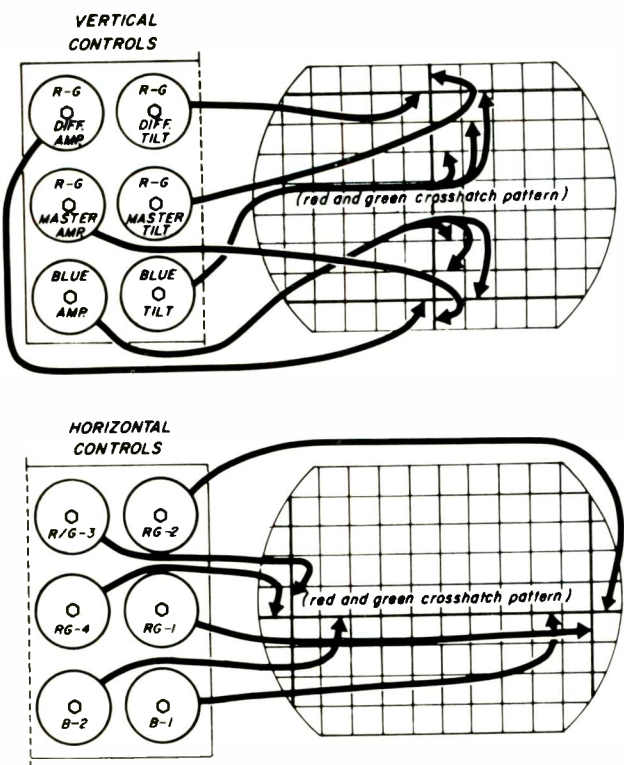

Fig. 7-28. Locations of areas affected by each of the dynamic convergence controls.

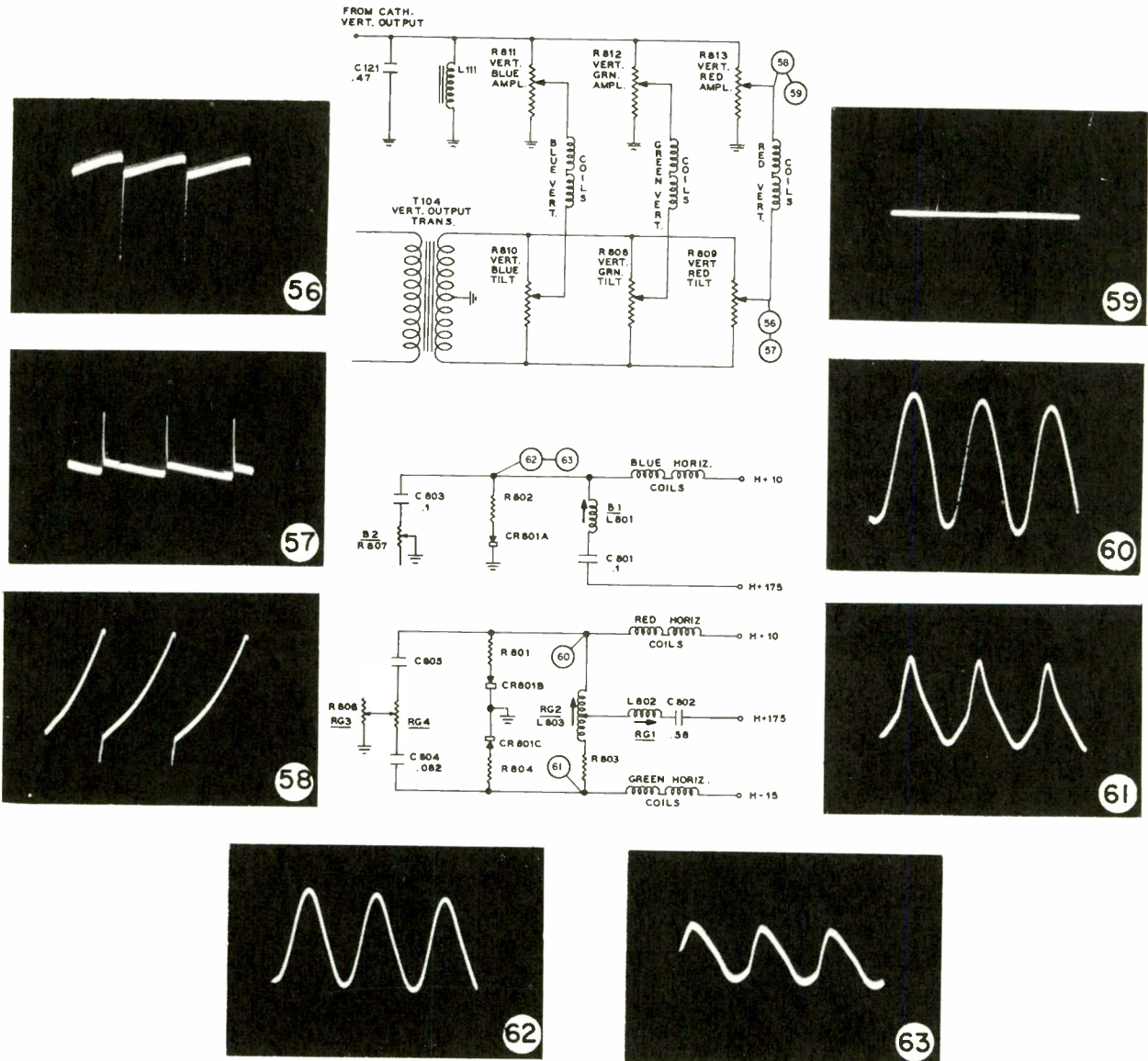

Fig. 7-29. Simplified CTC-7 dynamic convergence circuitry with waveforms.

of the above conditions exists, the technician should retrack the receiver, compensating (increase or decrease the screen settings) for the original condition. The screen controls set the cutoff level for their respective guns. The background controls, in older receivers, maintain color balance through the useful range of the brightness control. Screen controls should be adjusted while observing low lights (low brightness condition) and the background controls with highlights (high brightness condition). When tracking the receiver the technician should attempt to "match," within reason, the white light produced by black-and-white picture tubes. The

correct white for the color picture tube is specified as approximately 9300° Kelvin. This means that the light produced by the kinescope should match the light produced by a "black body" when heated to a temperature of 9300° on the Kelvin scale. As yet, there is no standard that the TV technician can use to reproduce this specified "white." The technician should try to match the light produced by modern black-and-white kinescopes. You may, of course, be required to yield to the customer's view of the proper "white." Remember, however, that correct color reproduction depends upon a correct monochrome picture.

Substantial variations in the hue of the monochrome picture should be interpreted as an indication of a defect. Measurement of kinescope socket voltages will indicate the source of trouble. Small variations are generally due to tube aging in the (R-Y), (B-Y), and (G-Y) amplifiers, or in the kinescope. Small changes due to aging should be compensated for by retracking the receiver. Figure 7-30 reviews the tracking adjustments for the RCA CTC-11 chassis. Troubles that cause large variation in black-and-white tracking are covered in the following paragraphs.

Kinescope Failures. The monochrome picture in a color receiver consists of three individual rasters: red, green, and blue. Therefore, the color kinescope is actually the equivalent of three picture tubes in one, consisting of three separate electron gun assemblies and three separate, but superimposed, screens. The technician can observe each screen, one at a time without disturbing the tracking adjustments, by shunting the control grids of the unwanted guns to ground through 100 k-ohm one-watt resistors. This increases the bias sufficiently to cut off the guns and allow evaluation of each "kinescope" separately. At first the technician may feel that problems in the tricolor kinescope might result in unusual symptoms. However, the serviceman will find that color kinescope failures are caused by the same type of defects as are found in the black-and-white picture tubes.

Color kinescope failures can generally be placed into one of three categories:

1. *Tracking or color-balance.* This type of problem usually indicates a single gun failure.

2. *Brightness problems.* A low or no-brightness problem occurs when all three guns are affected equally. Therefore, a voltage check at the common elements of the kinescope, such as the ultor, focus grids, and cathodes should reveal the defect. The guns cut off with approximately -70 to -100 volts of bias. At maximum brightness the bias decreases to almost zero.

3. *Phosphor screen and shadow mask defects.* These generally result in the inability to obtain good purity. A blocked aperture in the shadow mask will cause a phosphor trio to be extinguished.

Color kinescope problems can be localized by considering the following facts:

1. The brightness control varies the cathode potential on all three electron guns simultaneously. Therefore, if a single gun does not react to brightness control variations, the gun or its remaining circuitry is defective.

2. A white screen is produced by combining the three primary colors, red, green, and blue. The complementary colors, magenta, cyan, and yellow, are produced when a primary color is deficient. For example:

White minus red = cyan (blue and green)

White minus blue = yellow (red and green)

White minus green = magenta (red and blue)

Therefore, the color that is missing identifies the defective nonconducting gun or the defective circuitry involved. When one of the primary colors predominates, excessive conduction (low or no bias due to leakage between grid and cathode) of the corresponding electron gun is indicated.

The following is a discussion of some common color kinescope failures and the methods used to locate the defects. In this discussion we will assume that a single defect exists, and prior to the defect, a normal black-and-white picture existed.

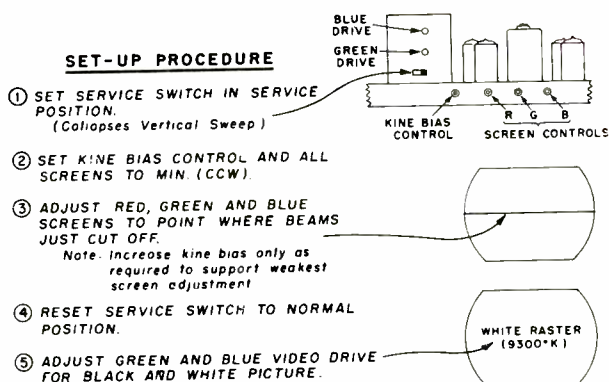

Fig. 7-30. CTC-11 tracking procedure.

Problem 1. Grid-to-cathode low-resistance leakage in the red gun. Leakage between the control grid and cathode reduces the bias voltage on the (red) electron gun. Therefore, the red gun will conduct heavily and the screen will be predominantly red. The brightness control will not cut off the red gun; however, the blue and green guns will cut off. Since the symptoms indicate a failure in the red gun (red screen and no red cut off) the bias voltage should be checked. Connect a voltmeter, as shown in Fig. 7-31, and note the voltage. Pull off the kinescope socket. If the voltage reading increases, the kinescope is defective.

Problem 2. Low emission in the green gun. The screen will be magenta, indicating a lack of green. In addition, the screen will not track properly through the range of the brightness control. These symptoms are most evident when the receiver is first turned on.

Cut off the red and blue guns using the 100 k-ohm resistors. Observe the green picture (video present) and rotate the brightness control. If the kinescope is defective, a "silvery" effect will be apparent at maximum brightness. This condition is caused by saturation of the electron gun during bright signal excursions. The cause of trouble in this case is loss of emission in the green gun.

Kinescope socket color coding is illustrated in Fig. 7-32 as an aid to identifying electrode connections.

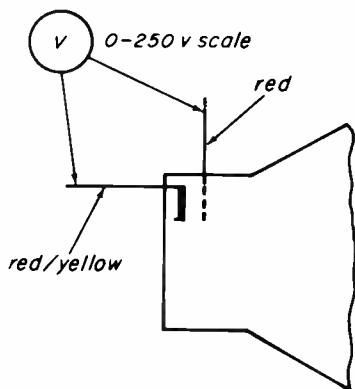

Fig. 7-31. Measuring kinescope bias.

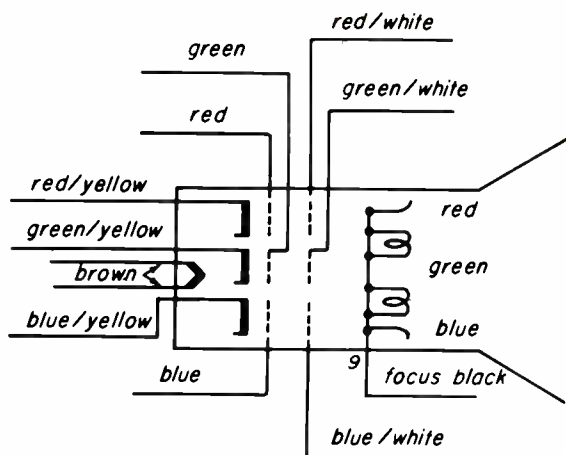

Fig. 7-32. Color code used on the kinescope leads.

Tracking Variations. All color-balance drift problems result in a change in voltage readings at one of the kinescope elements. In addition, the loss or predomination of a primary color identifies the problem gun. By properly analyzing the color change, and the voltages on the gun involved, the technician can locate the defective circuit. For example, suppose there is excessive red in the monochrome picture. Since it is more likely a single defect exists, we will assume the problem is in the red gun. Excessive red could be caused by a simultaneous decrease in both blue and green. However, this suggests two troubles at the same time, an unlikely condition. A voltage check reveals low bias on the red gun. By measuring the voltages on the grid and cathode with respect to ground, we find the grid voltage to be high. We now know our problem is in the (R-Y) amplifier or red kinescope-grid circuitry. See Fig. 7-33. Excessive voltage at the plate of the (R-Y) amplifier indicates a nonconducting stage. Therefore, the excessive red condition may be the result of a defective (R-Y) amplifier tube.

Consider a yellow monochrome picture. The yellow screen indicates that the red and green circuits are functioning properly. Therefore, the problem is localized to the blue circuitry. A higher than normal bias on the blue gun is the cause of low blue-beam intensity. A check of the kinescope blue control grid voltage with respect to ground

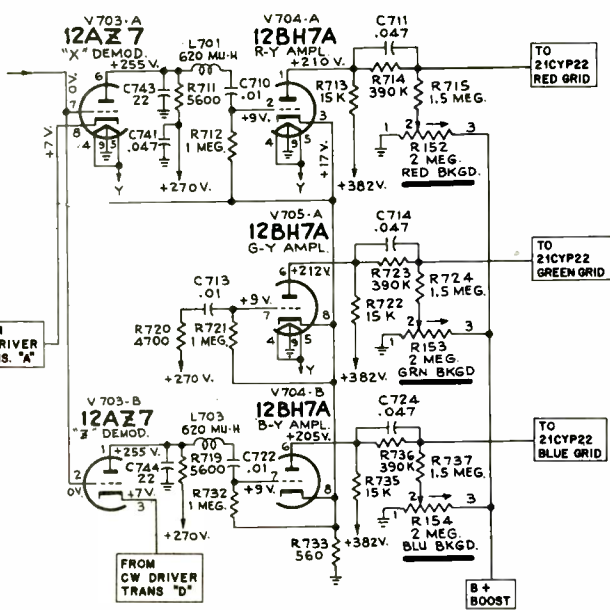

Fig. 7-33. Demodulator and matrix section of the CTC-7 chassis.

reveals a low voltage. A voltage check of the (B-Y) amplifier reveals low plate voltage, due to excessive positive voltage on the control grid. The cause might be a leaky coupling capacitor or a shorted tube. To check, measure the voltage between the grid, pin 7 of the socket V_{704B} , and ground. Refer to Fig. 7-33. If this voltage swings more positive when V_{704} is removed from its socket, the coupling capacitor C_{722} is probably leaky. A resistance measurement of C_{722} shows a high resistance leakage of approximately one megohm. However, if the coupling capacitor C_{722} were shorted (low or no resistance) the symptoms would be considerably different. The picture would "bloom out" almost immediately after receiver warm-up. This would be due to excessive positive voltage on all three control grids of the kinescope. When C_{722} shorts, a high positive voltage is applied to the grid of the (B-Y) amplifier. This causes excessive current drain through the stage. As a result, R_{733} , the common cathode resistor for the (R-Y), (B-Y) and (G-Y) amplifiers, will burn open. Since the tubes become cut off, B+ voltage is applied to the kinescope control grids. A shorted C_{722} also causes excessive current to flow through R_{719} , the plate load resistor of the Z demodulator. This causes the resistor to overheat and change value.

In each of the previous problems, proper color reproduction is impossible. However, since each problem has a distinct effect on the monochrome picture, we consider them black-and-white defects.

Intermittent or varying color balance problems can be located by the methods outlined in the previous paragraphs. The loss or excess of a primary color on a monochrome picture identifies the defective gun, and voltage checks will localize the problem to the grid, cathode, or screen circuits. Non-uniform warm-up of the guns results in color balance variations. A minimum of 3 to 5 minutes should be allowed for warm-up before evaluating or adjusting black-and-white tracking.

Killer-Circuit Troubles. A defective killer circuit can produce undesirable effects in the monochrome picture. If the killer stage is held at cutoff continuously, by misadjustment of the killer threshold control or as a result of a defect in the killer circuit, noise and spurious signals will be amplified by the chrominance circuits and appear at the kinescope grids. The amount of colored noise appearing in the monochrome picture depends on the setting of the color saturation control. If adjustment of the killer threshold control cannot remove the color noise, a defect in the killer circuit is indicated. Operation of the killer circuit will be discussed later in this lesson.

7-4. LOSS OF COLOR

The preceding sections of this lesson discussed the problems which may be encountered in obtaining a good monochrome picture. The following sections cover chrominance problems and the servicing approach that applies.

When servicing the color sections of the receiver, the technician will find a color-bar generator is an indispensable tool. Therefore, we will assume in the following sections that a color-bar generator is available to the technician. The color circuits of the receiver can be divided into three separate categories for the purpose of localizing color troubles. They are:

1. *Chrominance circuits.* This section determines the level of all colors simultaneously. Problems in this section will result in weak or no color.

2. *Color synchronization.* The sync section maintains stable color. Loss of color sync results in colored objects that change color and are divided vertically into multicolored bands. The bars produced by the color-bar generator resemble multicolored barber poles.

3. *Demodulator matrix.* This section "mixes" the reference 3.58-mc signal and the chrominance information to produce the three color difference signals. Problems in this section can cause improper hues, weak or missing single colors.

Causes of Absent or Weak Color. When a weak color or no-color condition exists, the serviceman must localize the area of the defect to the antenna system, monochrome circuits (r-f, i-f, picture detector video amplifier) or the chrominance section of the receiver. The following procedure will aid in locating the defective area:

1. Adjust color saturation control to its maximum position.
2. Adjust the killer threshold control to bias off the killer stage (maximum CCW rotation on most receivers).
3. Rotate the fine tuning control through its entire range. The range of the control should include the ability to move the sound i-f carrier up into the video response. This is evidenced by the appearance of the 920-kc beat.

Under the above conditions, the presence of heavy colored snow, on an unused channel, shows that the bandpass amplifier is passing color. Therefore, the problem may exist in the r-f, i-f, picture detector, or first video amplifier stages. If no colored snow can be obtained, the defect is in the chrominance circuitry. Since it is possible that the antenna system may cause weak or no color, a color-bar generator should be used to establish or eliminate the receiver as the cause of the problem.

Let us assume that colored snow cannot be produced in the test mentioned in the previous paragraph. The chrominance circuits are then at fault and a defect may be in the color bandpass amplifier, burst keyer, color killer, phase detector, or the 3.58-mc oscillator circuit. The chrominance signal actually passes through only the bandpass amplifier(s). However, the bandpass amplifier(s) will only conduct when the killer circuit is cut off. The killer circuit is held in cutoff by a burst signal that must pass through the burst keyer and phase detector stages. Therefore, a defect in these stages may result in color deterioration. These stages may be eliminated as a cause of low or no color by shorting the killer bias line to ground. If normal color operation is restored, the problem is localized to the killer or its associated circuitry. Loss of the local 3.58-mc reference oscillator will cause the demodulators to be inoperative. Therefore, no color reproduction would be possible. Figure 7-34 traces the chrominance signal through the color circuits of the RCA CTC-7 chassis.

The bandpass stages are similar in operation to a standard video amplifier. However, the bandwidth of the bandpass amplifier(s) is only about 1 mc, and the response of the amplifier(s) is adjustable. The response of the bandpass amplifier(s) must complement the i-f response curve and result in a uniform over-all response on each side of 3.58 mc. See Fig. 7-35. Problems such as color smear, single color misregistration, and phase errors that cannot be corrected with an AFPC alignment may be caused by poor bandpass alignment. Most problems in the bandpass amplifiers are caused by defective tubes or component failures that can be located by voltage and resistance measurements.

If the "colored-snow" test, mentioned earlier in this section, indicates trouble in the r-f, i-f or video sections, visual or sweep alignment provides the most accurate means of evaluating the performance of the sections. The over-all response may be used to see if there is a drop in response in that region of the receiver response that carries the chrominance signal. By examining the response

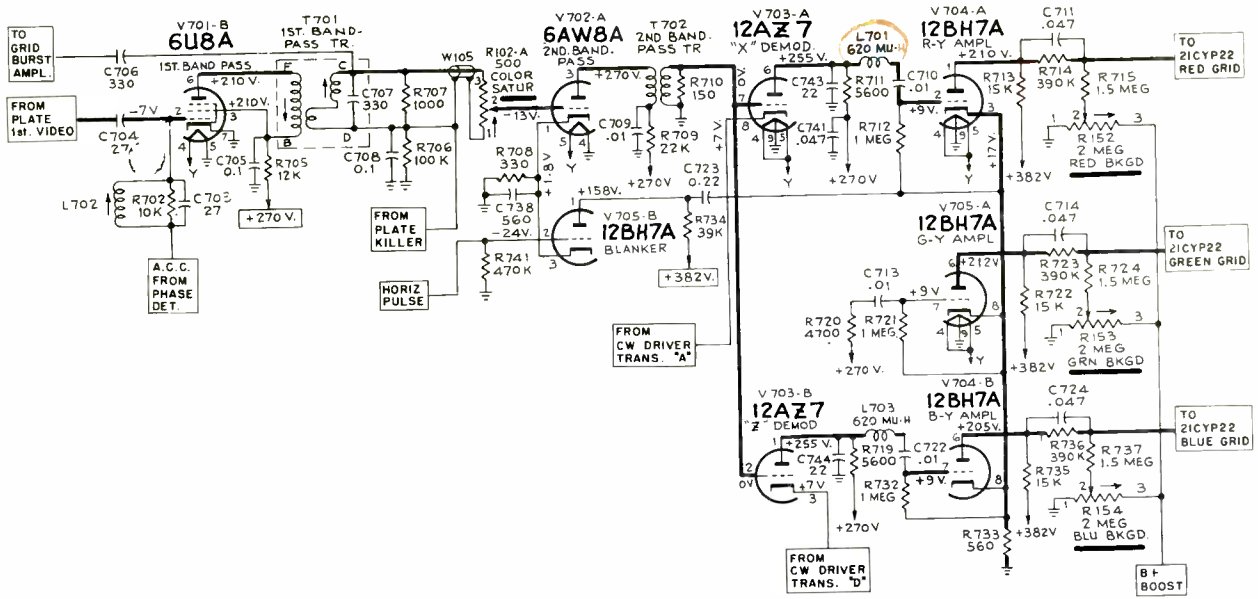

Fig. 7-34. Chrominance signals traced through the CTC-7 color circuits.

of the tuner, mixer/i-f coupling, and i-f amplifiers separately, the defective section may be pinpointed.

Performance of the video bandpass circuits may also be examined visually by using sweep alignment methods. Problems such as color smear and certain phase problems might require sweep alignment checks to be made. The serviceman would do well to thoroughly familiarize himself with alignment procedures on a normal operating receiver.

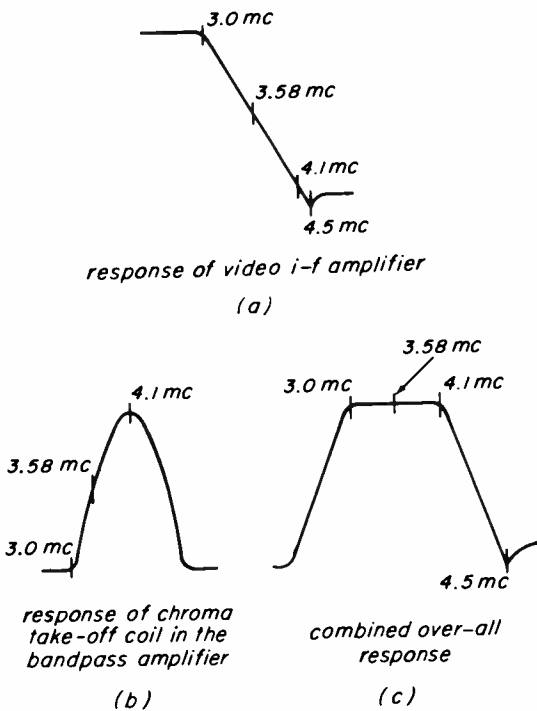

Fig. 7-35. The response curve of the bandpass amplifier corrects the i-f response curve to give the over-all chrominance response curve shown at c.

Tracing the Color Signal. A controlled source of color signal (color-bar generator) allows the technician to signal trace the color circuits. Figure 7-36 shows the bandpass circuits including waveforms of the RCA CTC-7 chassis. There are two methods of signal tracing the color circuits; both employ the use of a color-bar generator as the signal source. A VTVM used in conjunction with an r-f detector probe may be used to signal trace in the field. To obtain an accurate voltage indication of the color signal, the technician must take two readings. The first is made with the generator on, and the second with the generator off. The difference between the two readings indicates the amount of color signal present at the point of measurement. The shop method utilizes a wideband (4.5-mc) oscilloscope with a low-capacitance probe. This method allows the technician to check the gain of each stage, by comparing the peak-to-peak

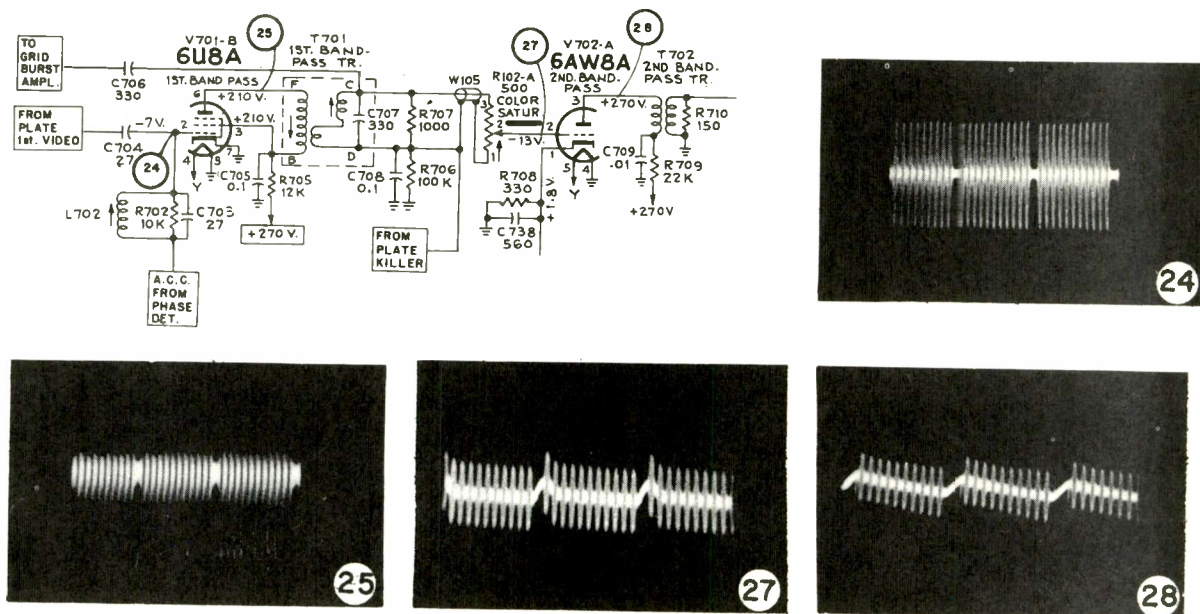

Fig. 7-36. Waveforms in the bandpass amplifier stages.

voltage of the waveform at the input and the output of each stage. Figures 7-37a to d show typical waveforms produced by a color bar signal at several points between the picture detector and the kinescope grids.

The technician should try to gain some experience in the use of the oscilloscope by tracing the color signals through receivers that are known to be operating normally. Some precautions must be observed. A low-capacitance probe must be used with the oscilloscope to prevent detuning of the chrominance circuits when the probe is connected. However, even low capacitance probes may affect some circuits. For example, if the probe is connected to the 3.58-mc oscillator at certain critical points, the oscillator may become detuned, and may stop oscillating.

Many stations that broadcast color programs transmit a color stripe during black-and-white telecasts. The stripe enables the serviceman to determine if the antenna system and receiver r-f unit are passing color on the particular station.

The two vertical stripes of color sub-carrier signal (both have the same phase) are added to a standard black-and-white signal at the transmitter. The stripes are

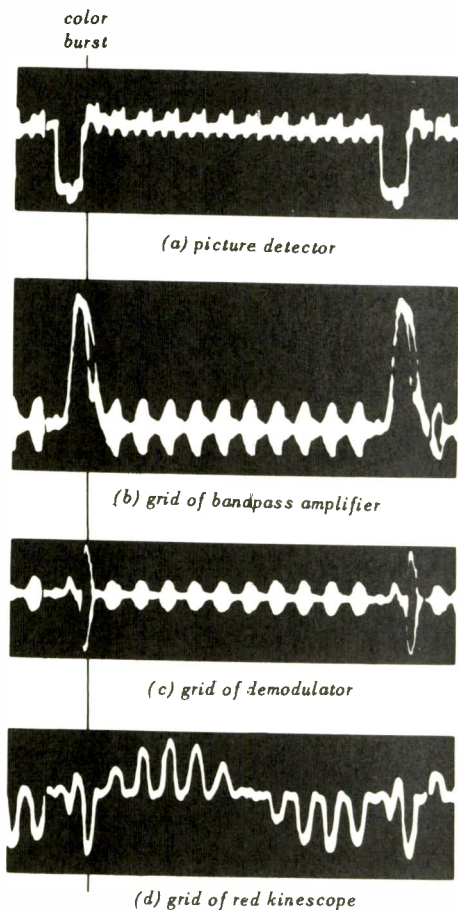

Fig. 7-37. Typical color-receiver waveforms observed between the picture detector and the kinescope grid.

positioned immediately preceding and following horizontal blanking as shown in Fig. 7-38. A properly adjusted color receiver will not produce color in the stripe areas, since the normal burst signal is not transmitted. Therefore, the killer stage will bias off the bandpass amplifier. However, the sync pulse may be modified to shift the phase of the gate pulse sufficiently to accept the left stripe as a burst signal. In that case, the right stripe will be handled by the receiver as though it were a chrominance signal.

There are two methods that may be used to observe the color stripe:

1. Quick check.

a. Adjust fine tuning on the channel to be checked.

b. Adjust killer threshold control maximum CCW (cut off the killer stage).

c. Set the color control at maximum, and the hue control to the center of its range. The stripe should be visible, but without sync ("barber-pole" effect).

d. Adjust horizontal hold control to produce two and one-half steady bars slanted from bottom left towards upper right of screen (out of horizontal sync condition). The stripe should now appear as a solid colored bar that responds to the color and hue controls.

2. Standard procedure.

a. Same as Step a in the quick check.

b. Connect a 0.005- μ f capacitor from the sync amplifier output to chassis.

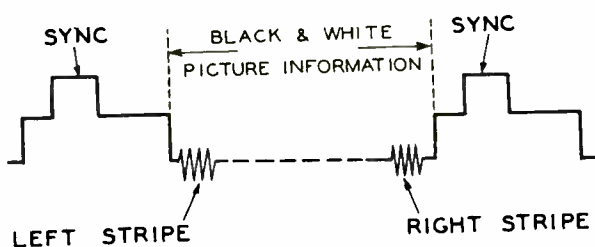

Fig. 7-38. Positions of the color stripe signals in the composite video signal.

c. Adjust horizontal hold control to maintain horizontal sync. The stripe may now be observed.

Using either of these procedures, with the receiver adjusted correctly (fine tuning, color control almost maximum, hue control set at midrange) the stripe should appear greenish-yellow. If there is no color or the wrong hue appears, the receiver should be checked with a color-bar generator. If a receiver operates normally with the color-bar generator, but does not produce the colored stripe, a defect in the antenna system is indicated.

A condition might arise, in areas where color is transmitted on several channels, in which color may be normal on one channel, but weak or absent on another. This condition suggests a faulty antenna system or misalignment of the r-f sections of the tuner. Before service work is attempted on the sections, the killer threshold control should be adjusted using the channel that produces insufficient color. It is possible that the threshold control has been set too high and the killer cuts off only on very strong burst signals.

7-5. LOSS OF COLOR SYNC

The burst signal in addition to "unlocking" the bandpass amplifier, accomplishes color synchronization. The burst signal consists of 8 cycles of 3.58-mc signal that is transmitted on the back porch of the horizontal blanking pulse as shown in Fig. -39. This signal is a sampling (minimum of 8 cycles) of the color subcarrier used at the transmitter. Burst is used in the receiver to lock the local 3.58-mc reference oscillator, in both frequency and phase, to the station color subcarrier. Since the color information is a "separate" signal, loss of color sync will not affect the monochrome picture. An out of color sync condition is shown in Plate 2. Note the "barber-pole" effect. The methods used in servicing the color sync circuits are similar to those employed in troubleshooting horizontal sync problems.

Causes of Sync Trouble. Figure 7-40 illustrates, in block diagram form, a typical color synchronization circuit. A malfunction

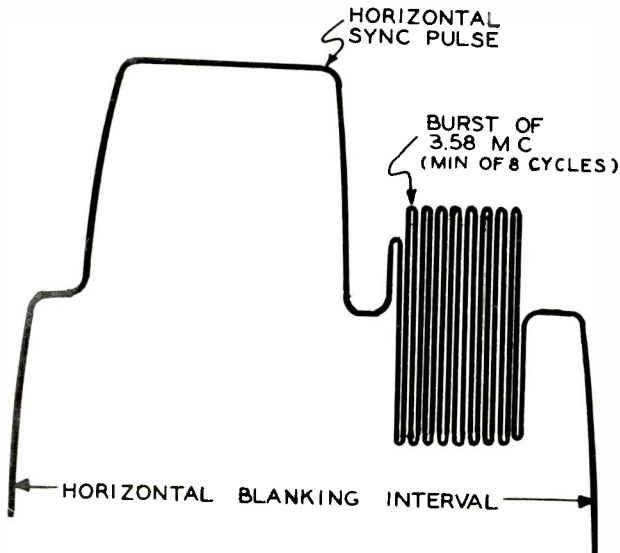

Fig. 7-39. Position of burst signal in the composite video signal.

in any of these circuits may cause a color sync problem. However, with proper operation of the color killer, the loss of burst in the burst amplifier or phase detector results in complete loss of color. Therefore, it is important to remember that killer bias voltage must be removed (killer control maximum CCW or in older receivers the killer bias voltage shorted out) before servicing the color circuitry. Otherwise, we may spend time troubleshooting the wrong section.

The burst amplifier, which is normally cut off, is keyed into conduction only during burst time, by a delayed pulse from the high-voltage transformer. Thus, only the burst signals are amplified by this stage. Loss

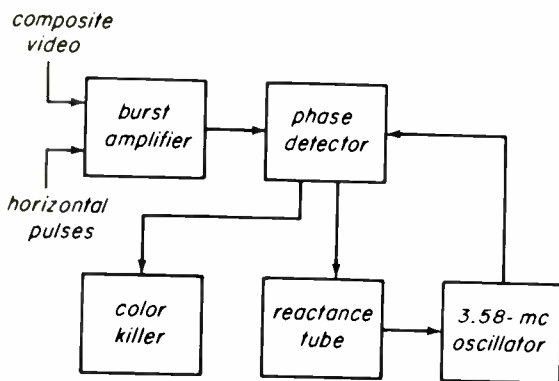

Fig. 7-40. Block diagram of the color sync circuits.

of the keying pulse results in no burst amplification. Loss of gain in the burst amplifier causes unstable color sync, while no amplification causes the complete loss of color sync. Alignment of the burst phase transformer, located in the plate circuit of the burst amplifier, is part of the AFPC alignment and will be discussed in the following sections.

The phase detector compares the incoming burst phase to the output of the local 3.58-mc oscillator. If an error exists in phase or frequency of the local 3.58-mc oscillator, the phase detector develops a correction voltage that is applied to the reactance tube control grid. When both the incoming burst and local 3.58-mc oscillator are of the same phase, no correction voltage is developed. The phase detector stage forms a bridge circuit, as shown in the simplified diagram of Fig. 7-41. Failure of either diode in the bridge circuit will render the detector inoperative. The resistors R_1 and R_2 are a matched pair. A variance in value in either resistor unbalances the bridge and causes a constant, erroneous correction voltage. The presence of such a voltage at the reactance grid results in unstable or complete loss of color sync, depending on the amount of change in resistance.

The reactance stage functions as a variable capacitor shunted across the 3.58-mc oscillator crystal. The amount of capacitance varies as the bias on the stage varied, thereby changing the frequency of the 3.58-mc oscillator. Component values are so chosen that with no correction voltage on the grid, the stage is in the center of its frequency range. A defective reactance circuit results in no control of the 3.58-mc oscillator.

The 3.58-mc oscillator is a crystal-controlled, free-running oscillator. At this point it should be remembered that no output from the oscillator causes complete loss of color. If the oscillator is operating at the wrong frequency, beyond the correcting range of the reactance and phase detector circuits, color synchronization is impossible. We can estimate how far the oscillator is off frequency in the same way as we judge the

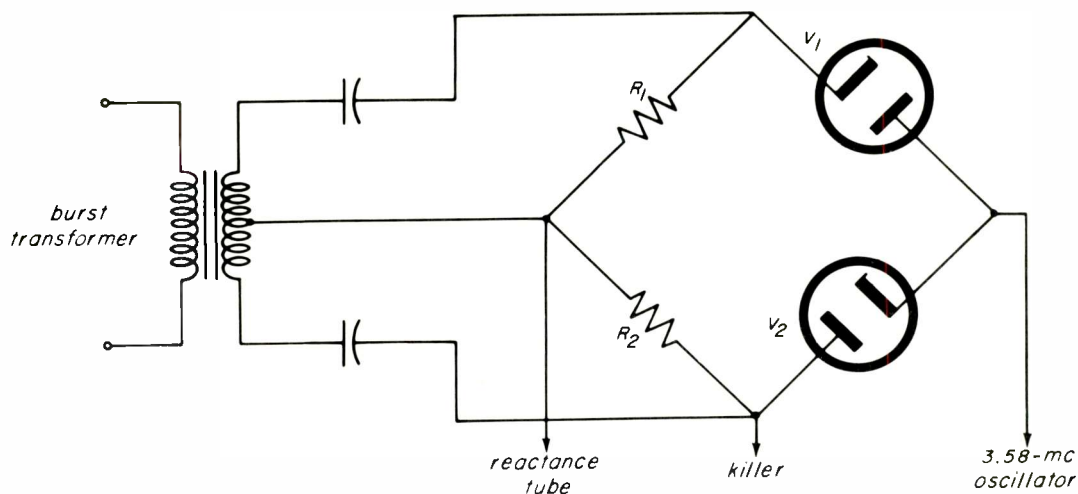

Fig. 7-41. Simplified color phase-detector circuit.

frequency error of the horizontal oscillator. If the 3.58-mc oscillator is very close to the correct frequency the entire picture changes color slowly. As the error increases the colors break up into horizontal bands (the barber-pole effect). Large frequency errors result in a greater number of narrower horizontal bands.

Localizing Problems in the AFPC Circuits. Figure 7-42 shows a schematic diagram of the AFPC circuits used in the RCA CTC-11 chassis. Problems in the AFPC circuitry can be localized by signal tracing, using a color-bar generator and a wideband oscilloscope. Typical waveforms for the AFPC circuits are shown in the figure. These waveforms allow us to check for the presence of CW and burst signals at key points in the circuit.

While signal tracing is very helpful in establishing the cause of trouble in the AFPC circuits, perhaps the most powerful troubleshooting tool is the proper use of the AFPC alignment procedure. By following the alignment steps, we can check the operation of each circuit and combination of circuits as they are made to work together. Inoperative circuits that fail to respond to alignment are quickly localized. In the following paragraphs we will illustrate the use of the alignment procedure as a troubleshooting aid.

A color-bar generator is used as a color signal source because it provides a stable signal of known characteristics and constant output. We shall use the AFPC system of the RCA CTC-11 in our example. Refer to Fig. 7-42.

AFPC Alignment. Attach color-bar generator (r-f output) to the antenna terminals. Set the hue control in the center of its range. Set the color control at maximum, and turn the killer threshold control fully CCW. Turn the channel selector to Channel 3, and adjust the fine tuning control for minimum sound beat, using sound-carrier output from generator. There are three adjustments in the AFPC alignment of this chassis. They are:

1. 3.58-mc oscillator transformer, T_{703}
2. Burst-phase transformer, T_{702}
3. Reactance coil, L_{702}

Step 1 Connect the probe of a VTVM (positive d-c volts) through a 470 k-ohm resistor to pin 1 of phase detector V_{705} . Adjust T_{703} , 3.58-mc oscillator transformer, for maximum output, as indicated by a peak reading on the meter. Since we want to read only the oscillator output, we will remove the burst signal by shorting the burst amplifier grid to ground. The 3.58-mc output can be measured at pin 1 of the phase detector. Low or

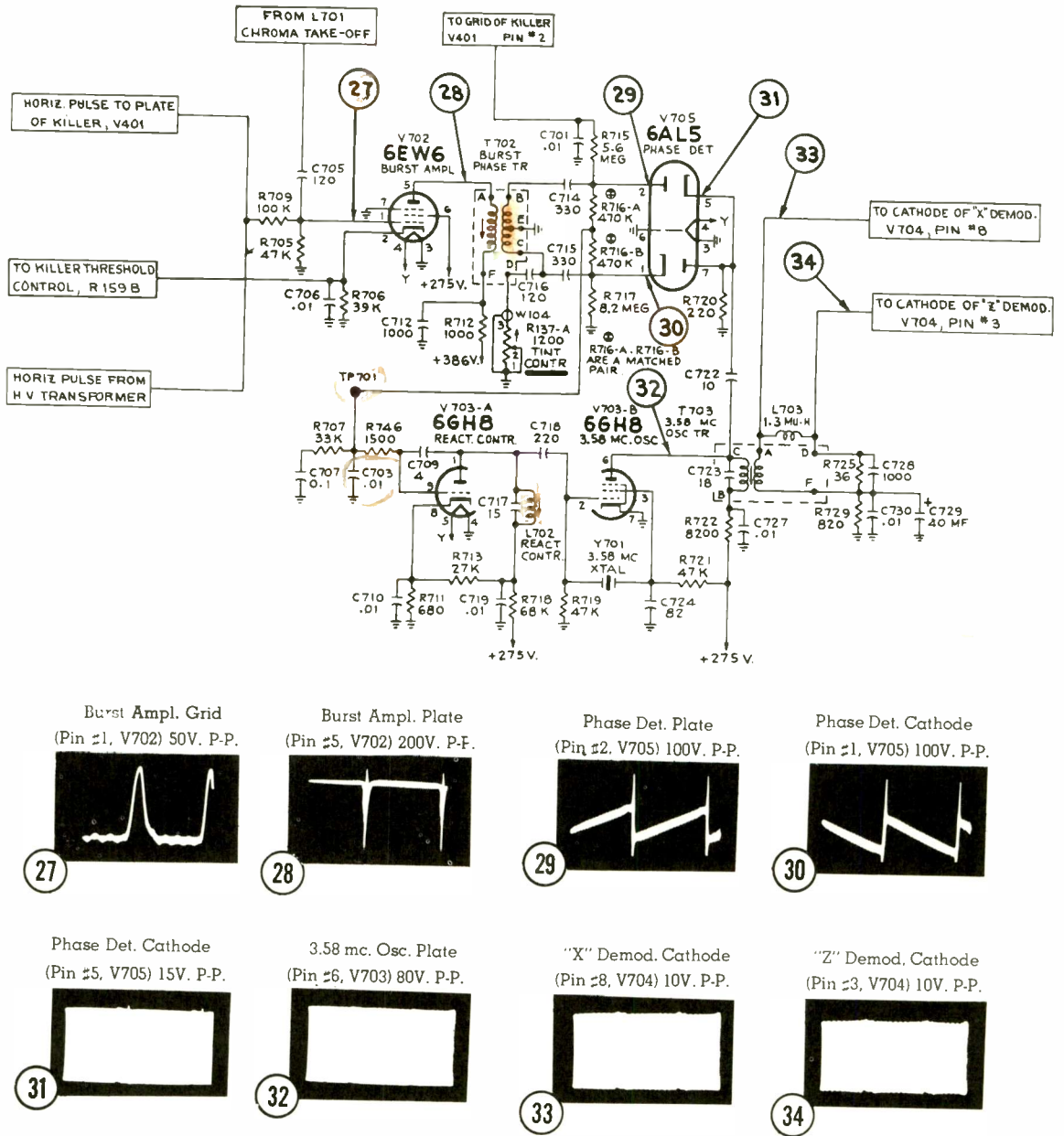

Fig. 7-42. Color sync circuits in the RCA CTC-11 chassis.

no reading at this point indicates a defective oscillator or phase detector. When normal oscillator drive is applied to the phase detector, about +45 volts is developed at pin 1 of V_{705} (about -45 volts is developed at pin 2). If no voltage is developed, loss of oscillator drive may be the cause. We can check to see if the oscillator is operating by measuring grid bias at the oscillator. The voltage at pin 2 of V_{703B} is normally about -6 volts.

Step 2. Remove the short from the burst amplifier. Adjust T_{702} for maximum voltage

at pin 1 of the phase detector. An increase in the meter reading when we remove the short on the burst amplifier grid, tells us that the burst amplifier is operating. Failure to obtain an increase in the voltage reading when the short is removed, or no voltage variation when adjusting T_{702} , indicates a defect in the burst amplifier. Check for the presence of horizontal pulses at pin 1 of V_{702} .

Step 3. Ground TP_{701} and adjust L_{702} for free-running color sync (zero beat), the color

bars should show solid colors (no barber-pole effect) that change slowly. When we ground TP_{701} , the correction voltage from the phase detector is removed and zero correction voltage is simulated. The ability to zero beat the color bars shows that the 3.58-mc oscillator is capable of operating at the correct frequency when there is no correction voltage. If color sync is lost when the short is removed from TP_{701} , a defect in the phase detector circuit is indicated. For example, severe imbalance in the phase detector results in a steady, false correction voltage. This false correction voltage acts to shift the frequency of the oscillator away from the near zero-beat condition that is set up in Step 3. To check for imbalance of the phase detector, measure the correction voltage at TP_{701} , with the grid of the burst amplifier shorted to ground. This voltage should be zero. If it is not, there is some fault that has caused the detector to become unbalanced. An open secondary winding on T_{702} , a defective diode, or a change in one of the detector's load resistors might be the cause.

With minor variations (consult the service data for the particular chassis involved) the above procedures can be used on the RCA CTC-7, -9, -10, and -12 chassis. The basic considerations can be applied to all color receivers.

Field Checks. Two of the three AFPC alignment steps can be done quickly and accurately in the field, when observing a color telecast.

Step 1. Tune burst phase transformer, T_{702} .

a. Set hue control in the center of its range.

b. Adjust T_{702} for proper flesh tones.

The burst phase transformer requires adjustment when the hue control produces flesh tones only at one end of its range, or the hue control has insufficient range.

Step 2. Tune reactance coil, L_{702} .

a. Short TP_{701} to ground (some receivers provide top-of-the-chassis access to TP_{701} , see service data).

b. Adjust L_{702} (reactance coil) for color zero beat. Zero beat is obtained when a colored object is of a solid hue and slowly changes through red, green, and blue.

The stability of color sync may be determined by observing the effect and range of the reactance coil (remove short from TP_{701}). On a normal operating receiver, the range of the reactance coil is approximately 3 to 6 turns. This is the number of turns required to lose color sync on each side of the correct (zero beat) setting. If color sync is weak, the range will be reduced to 2 or 3 turns. Each time a reactance/oscillator tube is replaced the reactance coil should be adjusted for zero beat (Step 2).

7-6. INCORRECT COLOR REPRODUCTION

Color reproduction involves hue, saturation and brightness. A defect that upsets any of these values results in improper color reproduction. In the previous section of this lesson we determined that a good monochrome picture is required before attempting to evaluate or service the chrominance sections of the receiver. Good monochrome reception tells us that the brightness (Y) signal is normal. In a color telecast the luminance channel supplies the (Y) brightness component. Correct hue and saturation characteristics are determined in the chrominance sections of the receiver.

Color hue is the result of the phase relationship between the reference oscillator and the chrominance signals. When all hues are present but are in the wrong places (pink or green flesh tones), the phase relationship between burst and the 3.58-mc oscillator is incorrect. This type of problem is generally caused by a defect or misalignment in the AFPC circuits.

Saturation problems will be observed as weak or no color, too much color or no control of color. When the symptoms affect all

colors (assuming the r-f, i-f, and first video stages are functioning properly) simultaneously, the bandpass amplifier should be checked first. Incorrect killer or AGC bias voltages also affect saturation. The blanking amplifier, burst amplifier, color killer and phase detector are the circuits that are most likely to be at fault when there is insufficient color.

Problems that occur in the demodulator circuits and adder-amplifiers (R-Y, B-Y, G-Y amplifiers) usually affect only one color. Some types of failures in these circuits change the black-and-white color temperature and are therefore serviced as a monochrome defect. However, it is possible that a slight tracking change may take place and be mistaken as some form of drift such as tube aging. However, retracking the black-and-white picture will not restore correct color reproduction. In these instances, analyzing a pattern produced by a color-bar generator will reveal the cause of color error.

Use of the Color-Bar Pattern. The color-bar pattern shown in Fig. 7-43 is produced by the RCA WR-64A generator. The pattern consists of ten color bars of different hues accurately spaced at 30° color-phase intervals. Figure 7-44 illustrates the idealized waveforms produced at the kinescope grids

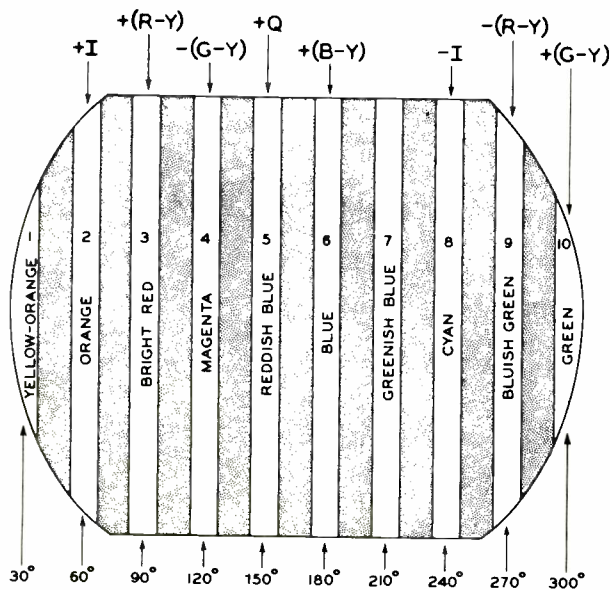

Fig. 7-43. Normal color-bar pattern phase relationship.

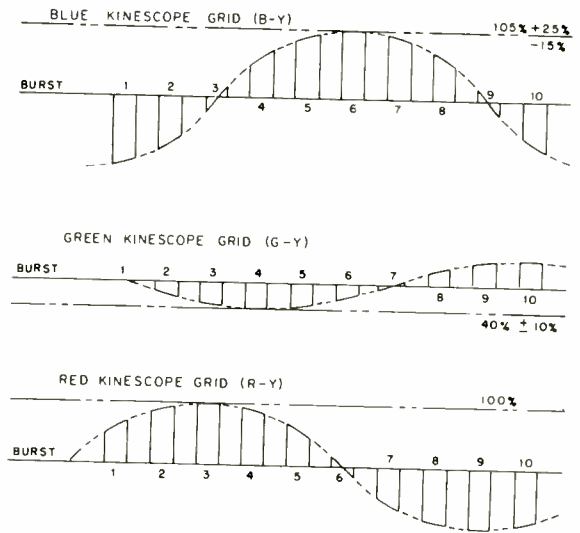

Fig. 7-44. Waveforms at the kinescope grids when the signal source is a color-bar generator.

by a color-bar generator. By analyzing the waveforms in Fig. 7-44, it is easy to understand how the various hues are produced. The fourth bar has approximately equal parts of red and blue and therefore appears magenta. The eighth bar contains both green and blue output, and appears cyan. The appearance of normal color bars is shown in Plate 1.

When using the color generator, be sure the saturation control of the receiver is not set too high. An extreme setting of the control causes distortion of the color bars.

Troubles that affect hues are usually caused by incorrect phasing of the color demodulators or malfunctioning R-Y, B-Y or G-Y amplifiers. Since the generator supplies a known output (the hue of each bar), any variance in the pattern identifies the problem circuit. Additional uses of the color-bar generator are discussed in the following sections.

Color Demodulator Troubles. For proper color demodulation, two input signals are required. These are:

1. A constant amplitude of properly-phased 3.58-mc CW signal.
2. Amplified chrominance sideband signals.

Presence of both of the above signals may be established by examining the input waveforms with an oscilloscope or with a VTVM equipped with an r-f probe. Absence of the 3.58-mc CW signal indicates failure of the 3.58-mc oscillator stage. In some receivers, loss of the oscillator signal causes a severe change in black-and-white tracking in addition to loss of color reproduction (the color bar pattern appears to have ten bars of the same magenta hue). Loss of the color video signal at the grid of the demodulators results in no color reproduction. Figure 7-45 illustrates in simplified form the demodulators and their input waveforms (signal source is a color-bar generator). Most late model receivers use low-level demodulation and demodulate on the X and Z phase axes.

In newer RCA receivers (CTC-10 and later) only one phase adjustment is made. The burst transformer is adjusted to produce the correct phase indications at the kinescope. Figure 7-46 shows how correct phase is indicated by either waveform observation or observation of the kinescope screen with

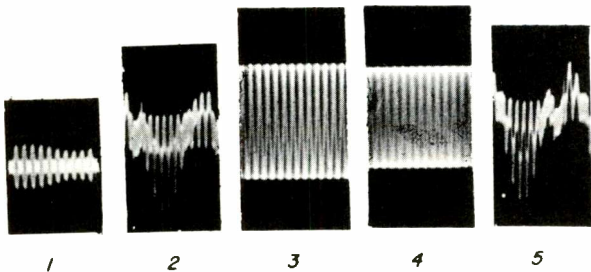
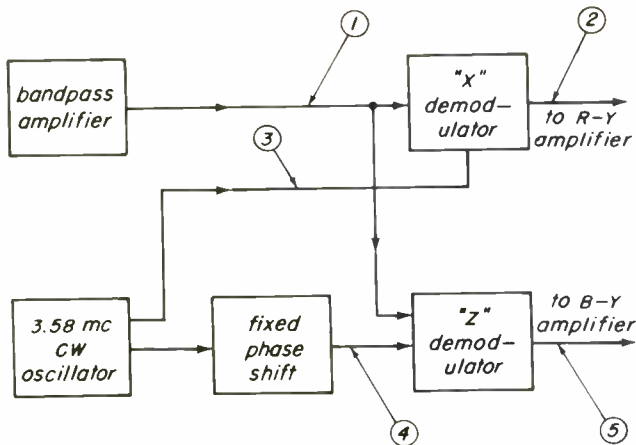
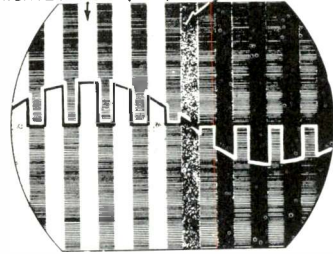

Fig. 7-45. Waveforms at key points in the chrominance circuits.

6th. BAR BLENDS WITH RED BACKGROUND. BRIGHTEST RED (R-Y)



COLOR BAR PATTERN (BLUE AND GREEN BARS REMOVED)

3rd. & 9th. BARS BLEND WITH BLUE BACKGROUND. BRIGHTEST BLUE (B-Y)

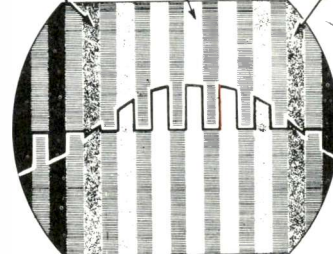

COLOR BAR PATTERN (RED AND GREEN BARS REMOVED)

1st. & 7th. BARS BLEND WITH GREEN BACKGROUND. BRIGHTEST GREEN (G-Y)

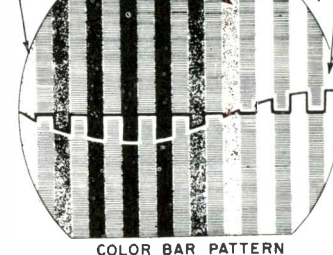

COLOR BAR PATTERN (RED AND BLUE BARS REMOVED)

Fig. 7-46. Correct phase, as observed at the kinescope grids and on the screen of the picture tube.

selected guns biased off. In these receivers a fixed phase-shifting network is used to establish the phase difference between the two demodulation axes. No adjustment is required. Burst phase is tuned to produce a correct output from the X demodulator. Refer to Fig. 7-45. If the Z demodulator output is incorrect after the phase adjustment has been made, a fault exists in the fixed phase-shift network.

In earlier receivers, the phase difference between demodulation axes is adjustable. In that case burst phase is adjusted to obtain the correct output signal from the demodulator that is fed directly from the CW oscillator. The phase-shift network is then adjusted to secure the proper output from the

remaining demodulator. Service notes should be consulted for the proper waveforms.

Matrix Troubles. A schematic diagram of the demodulator and matrix, or adder, amplifiers of the CTC-11 chassis, including typical waveforms, is shown in Fig. 7-47. Defects such as defective coupling capacitors in the matrix amplifiers generally result in a change in black-and-white tracking. Careful examination of the color-bar pattern in addition to the information obtained by analyzing the tracking drift (look for excess or lack of a primary color) will enable the technician to locate the defective stage. Correct gain of the matrix amplifiers is essential for good color fidelity. Proper matrix operation may be checked by comparing the peak amplitudes of the color-bar waveforms at the kinescope grids. Figure 7-48 shows the correct relative amplitude of the three-color difference signals for the RCA CTC-11 chassis. To make the check, monitor the R-Y signal on the oscilloscope, and set the oscilloscope gain controls so that the waveform fills some reference deflection (10 divisions). Use this deflection to represent 100%, and compare the amplitudes of the B-Y and G-Y with the reference. For example, if R-Y is set to yield 10 units of deflection, the G-Y signal should fill about 4 units. Note, do not look at the sync pulse when making these checks.

Refer only to the peak-to-peak voltage of the color-bar portions of the waveform. Check the service notes on each particular receiver for the correct relative values of R-Y, B-Y, and G-Y.

Plates 4, 5, and 6 illustrate the effects on a color bar pattern when $E_{(G-Y)}$, $E_{(B-Y)}$, or $E_{(R-Y)}$ is missing.

Localizing Hum Troubles. Hum produced by heater to cathode leakage in the demodulator and matrix amplifiers causes 60-cycle hum in both monochrome and color pictures. The defective stage can be easily located by alternately biasing off the kinescope control grids. When the defective stage (red, green or blue) is biased off, most of the hum will disappear. Hum originating in the band-pass amplifiers appears only in color pictures, and disappears when the color control is turned to minimum position.

Blanker Troubles. The blanker stage V_{707B} , shown in Fig. 7-47, has two functions:

1. It cuts off the bandpass amplifier during horizontal retrace time. This is done to prevent burst signals from being demodulated and appearing on the kinescope as a yellow stripe on the left side of the screen. Note, the burst take-off is usually in the grid

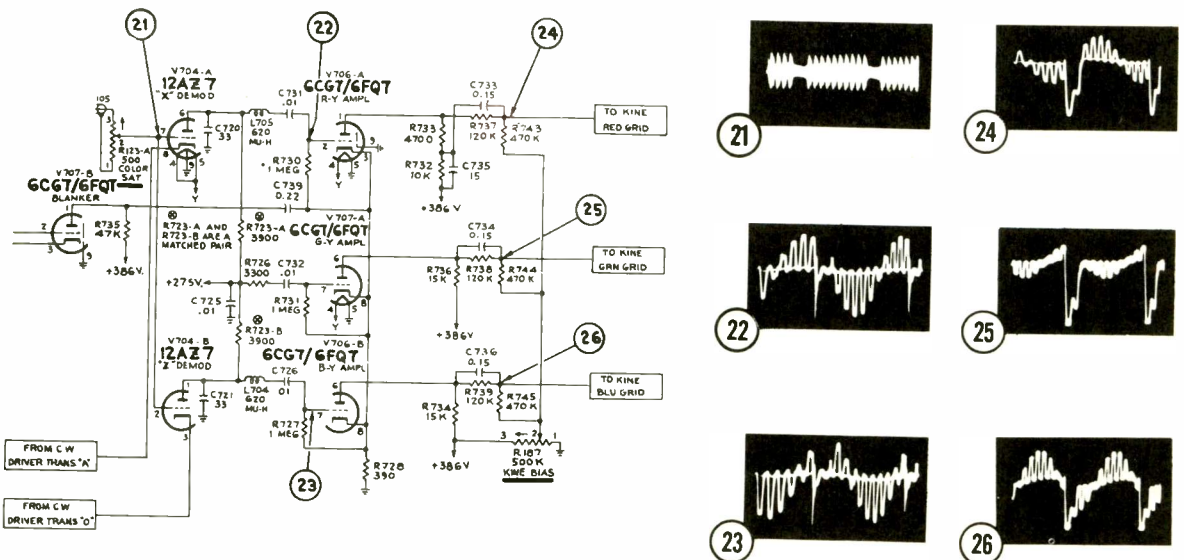

Fig. 7-47. Waveforms in the CTC-11 demodulator and matrix circuits.

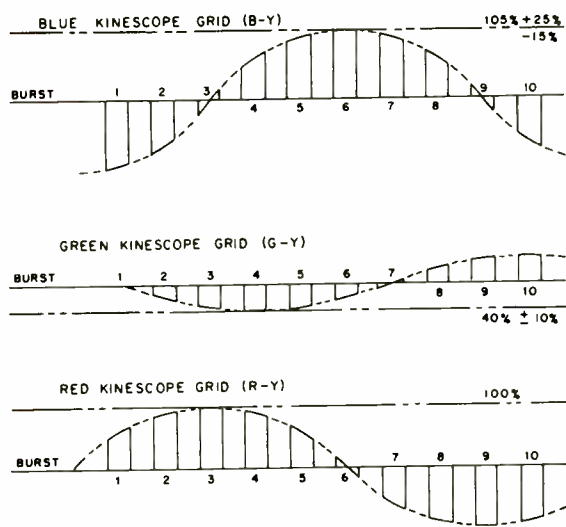

Fig. 7-48. In comparing signal amplitudes at the kinescope grids, the R-Y signal is used as the reference.

circuit. In some receivers the burst take-off is in the plate of the first bandpass amplifier. In this case the second bandpass amplifier is blanked.

2. The blanker applies the set pulse that restores the d-c component of the signal at the input to the adder amplifiers. This is accomplished by applying a negative pulse to the common cathode circuit of the adder amplifiers, causing the plate voltage of the stages to be lowered. Since the stages are d-c coupled to the kinescope grids, the bias on each gun is increased resulting in kinescope cutoff.

Symptoms produced by failure of the blanker stage vary from model to model. The following list of symptoms will aid in recognizing blanker troubles.

1. Retrace line visible on the top 1/3 of picture.
2. Yellow stripe on left side of picture.
3. Insufficient or no control of color.
4. Insufficient or no brightness (depends on tracking setup).

Hue Control (Phase-Shift) Troubles. Limited or excessive range of the hue control

indicates misalignment of the AFPC circuits. Most receivers require a minimum of ± 30 degrees phase shift from the nominal phase position. This amounts to an over-all control range of 60 degrees. While a maximum shift is seldom specified, an over-all shift of more than 90 degrees is considered excessive. Excessive hue-control range is also indicated when adjustment of the fine tuning or chroma controls cause a change in phase (hue).

The amount of phase shift may be determined by observing the color-bar pattern and rotating the hue control. We know that each successive bar-position represents a phase variation of 30 degrees. Therefore, if we count the number of bar positions through which a particular hue moves, we can calculate the phase shift in degrees (a two bar movement $2 \times 30^\circ = 60^\circ$). For example, a normal receiver produces a magenta hue in the fourth bar position (hue control in center of its range). If we turn the hue control fully clockwise, the magenta hue should be in the fifth bar position. This represents a $+30$ degree phase shift. Setting the hue control maximum CCW should put the magenta hue in the third bar position, representing a -30 degree shift from normal (hue control mid-range) phase. By placing an oscilloscope on the R-Y output (kinescope red grid) you can "see" the phase shift, as shown in Fig. 7-49.

Field Checks. It is unlikely that the serviceman will carry both a color-bar generator and an oscilloscope on a house call. However, accurate phase adjustments and rough matrix checks can be made by using the color-bar generator and the patterns it produces on the kinescope. A working knowledge of the color-bar signals is needed; refer to Fig. 7-43 and Fig. 7-48. The following points should be kept in mind when looking at the complete color-bar pattern on the screen.

1. $E_{(B-Y)}$ has maximum amplitude. The sixth bar produces the brightest blue.
2. $E_{(R-Y)}$ has the second highest amplitude. The third bar produces maximum red.
3. $E_{(G-Y)}$ has the lowest amplitude. The tenth bar produces maximum green.

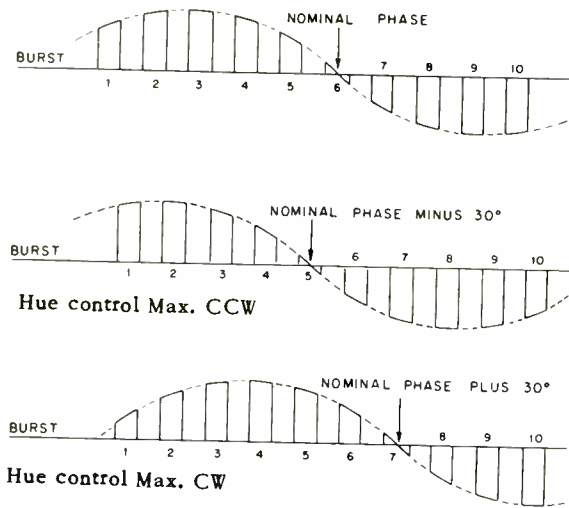

Fig. 7-49. Effect of hue control at red kinescope grid.

To adjust phase, turn the hue control to put the brightest blue bar in the sixth position. A rough check of the matrix section can be made by turning down the brightness and color-saturation controls simultaneously. The green bars should cut off first, the red bars second, and the blue bars should be the last to be extinguished.

More accurate phase adjustments can be made by viewing individual red, green, or blue fields. Master phase is usually adjusted by viewing the field associated with the demodulator that receives its drive directly from the 3.58-mc oscillator. For example, in the RCA CTC-10, -11, and -12, the 3.58-mc oscillator feeds the X demodulator which produces the R-Y signal. To check phase on these receivers, we bias off the blue and green guns, and view the red field alone. Phase is adjusted to make the third bar (see Fig. 7-48) brightest. Since maximum brightness may be difficult to determine accurately, some other parts of the signal may be used as a reference. For example, the center of the sixth bar goes through the zero-signal level. Therefore, the center of the sixth bar should produce the same brightness as the spaces between the bars when phase is set correctly. Another alternative is to adjust phase until the fifth and seventh bars produce equal brightness. In older receivers, the phase-shift network that drives the remaining demodulator is adjusted next. The electron gun associated

with this demodulation is then actuated and the phase-shift network is adjusted for the proper indication. (Service notes must be consulted to see which color is associated with each of the demodulators.)

7-7. INTERFERENCE EFFECTS

Steps are taken in the design of the color receiver to ensure that the additional color circuitry does not introduce interference effects. In addition, the extra care that goes into the design and manufacture of color receivers renders them less likely to be troubled with the familiar forms of interference. However, the technician should be familiar with the symptoms encountered as a result of the color circuitry.

Cochannel Effects. Cochannel interference appears when two stations operating on the same carrier frequency are received simultaneously. The interference appears as horizontal bars (Venetian blind effect) covering the entire screen. During a color telecast, the bars are rainbow colored. Re-orientating the antenna may reduce the interfering signal amplitude.

920-Kc Beat. This interference is the result of the color subcarrier beating with the sound carrier ($42.17 \text{ mc} - 41.25 \text{ mc} = 920 \text{ kc}$) ($4.50 \text{ mc} - 3.58 \text{ mc} = 920 \text{ kc}$). The 920-kc beat can be easily recognized. It appears only during a color telecast and resembles a coarse 4.5-mc beat pattern. The beat appears strongest in those areas that represent highly saturated colors. In a normal operating receiver, the 920-kc beat is eliminated by correct adjustment of the fine tuning control. If the beat cannot be removed by adjusting the fine tuning control, the receiver alignment should be carefully checked. Late-model receivers virtually eliminate the beat problem by separating sound in the plate circuit of the third picture i-f amplifier and inserting a highly effective 41.25-mc trap in the picture detector circuit.

Interference sometimes produces colored bands or streaks in the picture. This can happen if the beat signal produced by the interfering signal is close to the color subcarrier frequency. Color is produced in this

case because the receiver processes the beat signal as though it were a color signal. The symptoms are multicolored bars or rainbows. They might appear in either a color or a black-and-white telecast. Color may be produced because the killer can mistake the interfering beat signal for the burst signal. Remember that interfering beat signals are present during the blanking intervals as well as during the visible parts of the picture. Thus they are present when the burst amplifier is keyed into operation. In some cases the interfering signal may lock-up the 3.58-mc oscillator. This can come about if the beat frequency is some multiple of 15,750 cps above or below the subcarrier frequency. The symptoms are vertical, stationary, rainbow patterns. The color-bar generator is an

example of the results of this form of interference. Here, the chrominance signal is supplied by a crystal oscillator that operates 15,750 cps below the color subcarrier frequency. The result is a beat signal that completes one complete cycle in the time taken by one complete horizontal scan.

When interference is encountered the following items should be checked:

1. Missing or loose shields
2. Tube shields not grounded
3. Improperly grounded r-f/i-f link cable
4. Poor ground returns in the i-f stages.



NOTES



Plate 1. Normal picture.



Plate 2. Loss of color sync.

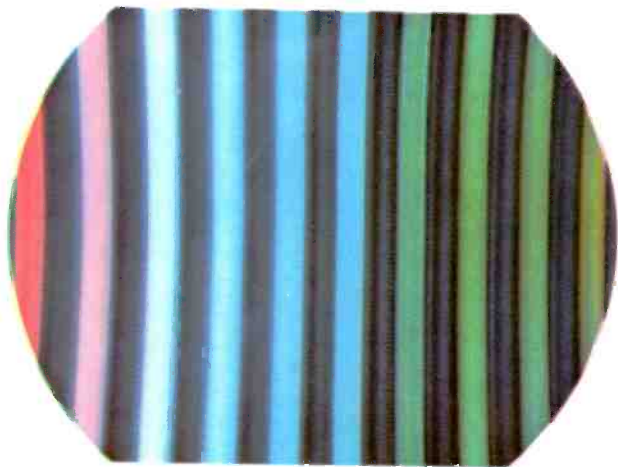

Plate 3. Incorrect hue control adjustment.

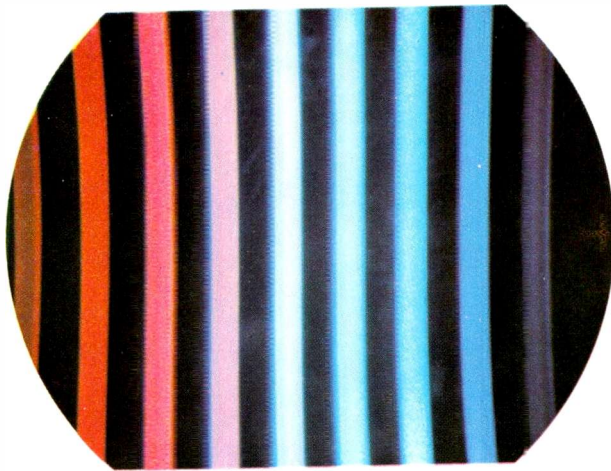

Plate 4. Green missing.



Plate 5. Blue missing.

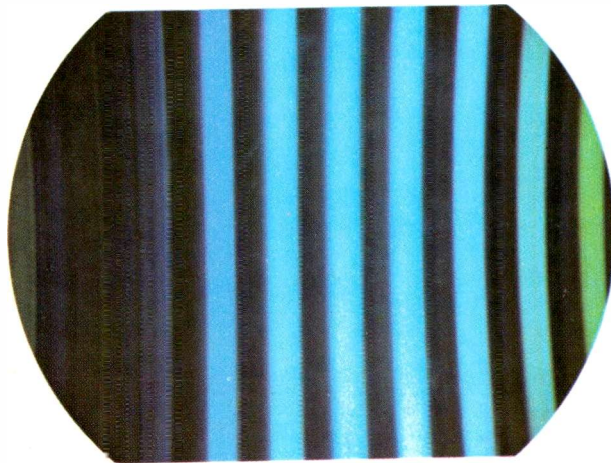

Plate 6. Red missing.

EXAMINATION

Instructions:—*PRINT your name, address, and student number assigned to you below.*

Name _____ Date _____
 Street Address _____ Student Number _____
 City _____ Zone _____ State _____

Answer all of the questions in each lesson. Send your *answer sheets* to RCA INSTITUTES, INC., Home Study School, 350 West 4th Street, New York 14, N. Y. Use the self-addressed return envelope that is enclosed. To avoid delays, *be sure to use enough postage.*

Percentage Grade:	%
Graded by:	

Each question in this examination is a statement that requires completion. Four possible answers, each of which is lettered, are provided to complete each statement. Select the correct answer. In the answer column at the right of the page, draw a line through the letter that corresponds to the letter of the answer you have chosen. For example:

Two multiplied by five equals: (a) two; (b) seven; (c) ten; (d) fourteen. a b ~~c~~ d

1. In an area having two operating color channels, the technician finds one channel producing satisfactory color signals while the second station produces no color. A probable cause is: (a) a cut off killer circuit; (b) a defect in the antenna system; (c) an inoperative bandpass amplifier stage; (d) misalignment of the AFPC circuits.

a ~~b~~ c d

2. In appraising the performance of a color receiver, the technician should first: (a) align the AFPC circuits; (b) adjust the killer threshold control; (c) check the monochrome picture; (d) replace the local 3.58-mc oscillator tube.

a b ~~c~~ d

3. A loss of focus voltage at the kinescope results in: (a) improper picture focus; (b) poor color reproduction; (c) no brightness; (d) poor monochrome picture and distorted sound.

a b ~~c~~ d

4. The second video amplifier (refer to Fig. 7-12) has an open filament. This would result in: (a) limited range of the brightness control; (b) no brightness; (c) brightness but no picture; (d) excessive brightness (blooming) and no monochrome picture.

a ~~b~~ c d

5. If correct center convergence cannot be obtained (receiver uses PM centering magnets) the technician should check for: (a) bent electron gun; (b) an open dynamic convergence coil; (c) improper placement of the center convergence magnets or incorrect placement of the magnets in their holders; (d) a defective purity magnet.

a b ~~c~~ d

6. The symptoms produced by a cathode to grid short (one gun only) in the kinescope are: (a) loss of a primary color and a lack of contrast in the monochrome picture; (b) excessive primary color and limited effect of the brightness control on the affected primary color; (c) a normal monochrome picture but the brightness control has no effect; (d) poor purity, focus, and center convergence.

a ~~b~~ c d

Cut out page along wavy line.

7. An open delay line results in: (a) no picture but normal brightness; (b) poor high-frequency video response and excessive brightness; (c) normal monochrome picture but no color reproduction; (d) no picture and low or no brightness.
8. Low emission in the red electron gun produces the following symptoms: (a) no noticeable effect on black-and-white reception but a lack of red in flesh tones; (b) a cyan monochrome picture and improper color reproduction; (c) a magenta monochrome picture and normal color reproduction; (d) excessive red in both monochrome and color picture.
9. Misadjustment of the killer threshold control may cause: (a) weak or no color; (b) weak color sync; (c) limited hue-control range; (d) improper flesh tones.
10. Using a color-bar generator as a signal source, failure of the 3.58-mc oscillator would be indicated when: (a) $B-Y$ is shifted 90° from its proper phase; (b) a "barber-pole" effect is apparent; (c) there is no color reproduction and all bars have the same magenta hue; (d) the color control affects brightness.
11. Limited range of the hue control indicates: (a) incorrect AFPC alignment; (b) defective delay line; (c) inoperative 3.58-mc oscillator; (d) incorrect $r-f/i-f$ alignment.
12. An inoperative color-killer stage may cause: (a) random color noise in the monochrome picture; (b) improper hues; (c) color misregistration; (d) loss of color sync.
13. Color problems that produce symptoms affecting a single color, are generally caused by: (a) a failure in the burst amplifier; (b) a loss of gain in the bandpass circuits; (c) a defect in the demodulator or matrix amplifier circuits; (d) a failure in the power supply.
14. A defect in the matrix amplifiers will generally affect: (a) only the color pictures; (b) both color and monochrome pictures; (c) only the monochrome picture; (d) only color phase.
15. If L_{701} , in Fig. 7-34, opens, the following indication would be present at the kinescope (using a color-bar generator as a signal source): (a) no red bars and the green bars would have insufficient amplitude; (b) $R-Y$ phase would be incorrect and all other bars normal; (c) all bars would be cyan; (d) the bar pattern would be normal but color sync would be unstable.
16. If capacitor C_{703} (grid circuit of the reactance tube) in Fig. 7-42 shorts, the result would be: (a) no color; (b) no color sync, but L_{702} tunes normally; (c) poor range of the tint control; (d) no color sync and no effect from L_{702} .
17. If V_{703A} in Fig. 7-42 has leakage between pins 8 and 9 the symptoms will be: (a) loss of 3.58-mc output; (b) severe black-and-white tracking change; (c) improper flesh tones; (d) unstable or no color sync.
18. Refer to Fig. 7-42. The ability to produce free running color sync (zero beat) by adjusting L_{702} with TP-701 shorted to ground indicates: (a) the reactance tube and 3.58-mc oscillator stages are functioning properly; (b) the burst amplifier is defective; (c) the reactance and 3.58-mc oscillator stage are malfunctioning; (d) a defective demodulator stage.
19. Considering that a zero beat can be obtained in Question 18, and the frequency of the 3.58-mc oscillator changes considerably when the short is removed from TP-701, the stage that is probably defective is the: (a) reactance stage; (b) bandpass amplifier; (c) 3.58-mc oscillator circuit; (d) phase detector circuit.
20. The presence of a 920-kc interference pattern (present only during color reproduction) indicates: (a) a defective 3.58-mc oscillator; (b) misalignment of the chrominance circuits; (c) misalignment of the $r-f/i-f$ circuits; (d) incorrect adjustment of the killer threshold control.

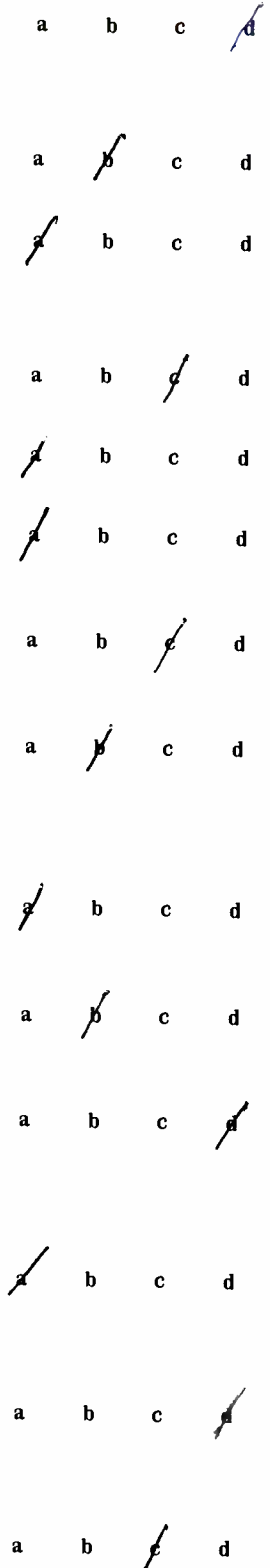

COLOR TELEVISION COURSE

LESSON 8

TEST EQUIPMENT

- 8-1. The Bench Setup
- 8-2. Test Equipment Used in Color TV Servicing
- 8-3. Dot/Crosshatch Generators
- 8-4. Producing Color Test Signals
- 8-5. Accessories



RCA INSTITUTES, INC.
A SERVICE OF RADIO CORPORATION OF AMERICA
HOME STUDY SCHOOL
350 West 4th Street, New York 14, N.Y.

INTRODUCTION

The production, installation, and servicing of color television receivers has created a need for new test equipment and has imposed stricter requirements on existing equipment.

Essentially, two new pieces of test equipment are required for checking and servicing color television receivers: a color-bar and a dot/crosshatch generator. A color-bar generator is used for checking the operation of the chrominance circuits and for troubleshooting and adjusting the matrix and demodulator circuits. The dot/crosshatch generator is used for making convergence adjustments. As an added convenience, a color test jig (color kinescope), a grid shunt switch and extension cables should be considered when planning a bench setup for color. In addition, a degaussing coil is required for installation. Since a color test jig, which consists of a color picture tube and associated components mounted in a cabinet, is not a permanent part of the bench setup, but used as the occasion demands, additional space on the bench need be provided only for the color-bar and the dot/crosshatch generators. Several accessories such as a TV bias supply, high-voltage probe, crystal diode probe, and marker adder will also prove valuable for servicing both color and black-and-white receivers.

8-1. THE BENCH SETUP

The inclusion of color test instruments will not require any major changes in the layout of an efficient black-and-white bench setup. Most of the leading manufacturers of color test equipment are incorporating both the dot/crosshatch and color-bar features in one unit, thus further reducing the bench space requirements. An efficient bench setup for black-and-white receivers will easily accommodate the additional space requirements of color servicing.

With the addition of a color-bar generator and a dot/crosshatch generator, the same type of test equipment required for the proper maintenance of black-and-white receivers can be used in the installation and servicing

of color television receivers. These include a sweep generator, an oscilloscope, a marker generator, and a VTVM.

It is not practical to recommend a specific bench setup which will be useful in every operation. Each shop installation has special requirements based on the type of operation and the available space. There are, however, several points which may help in the design of a work area. Where space permits, each technician should have his own bench space, his own set of basic hand tools, and have, if possible, his own vacuum tube voltmeter and oscilloscope. Other equipment such as a sweep generator, marker generator, dot/crosshatch/color-bar generator, can be placed at one location which is reserved for alignment work, or can be placed on a table with casters to permit moving it to the desired location. All instruments should be positioned so that the operating controls are within easy reach and all leads should be identified.

Parts storage is most useful when it is in a central area. The proper organization of the inventory, with specific locations assigned to each type of component, is extremely important. Proper organization of parts permits a running inventory, provides a means of maintaining only those parts which are used most often, and saves time.

8-2. TEST EQUIPMENT USED IN COLOR TV SERVICING

Need for a Dot/Crosshatch Generator. The dot/crosshatch generator is an essential instrument for checking and adjusting convergence in color receivers. In addition, this instrument is useful for checking horizontal and vertical linearity and overscan in both color and black-and-white receivers.

The purpose of convergence is to produce a picture with the least amount of color fringing over the entire area of a color picture tube. Convergence is attained when the three electron beams land or register directly at the same spot on the shadow mask. This convergence condition must also be maintained as the three beams are scanned across

the shadow mask. Static and dynamic adjustment controls are provided in color receivers for positioning the beams so they converge at the shadow mask and register on the appropriate phosphor dots.

In a color receiver, color fringing may be observed in either the color or black-and-white picture. However, to determine whether a receiver is properly converged the technician merely has to look for objectionable color fringing in a black-and-white picture from a normal viewing distance. It is, in fact, more difficult to see misregistration on a color picture. An experienced technician may make rough adjustments of static convergence by observing the effects at the center of a black-and-white picture, but it is impracticable if not impossible to adjust dynamic convergence without aid of a suitable dot/crosshatch generator. Either dot or crosshatch function may be used to make convergence adjustments. Detailed convergence adjustments procedures are given in the manufacturer's service notes for each receiver model. Because receivers may differ, the specific instructions supplied by the manufacturer should be followed. After gaining sufficient experience it will be possible for the technician to analyze misconvergence on a dot or crosshatch pattern and then make only those adjustments which are necessary, instead of repeating the entire convergence procedure.

The dot/crosshatch generator is also an excellent instrument for checking vertical and horizontal-scanning linearity and overscan of both color and black-and-white receivers. In addition, the over-all quality of the receiver alignment may be appraised by an observation of the leading and trailing edge of the dot. The horizontal-bar pattern is used for checking vertical linearity and the vertical-bar pattern is used for checking horizontal linearity. Of course, the crosshatch pattern permits display of both the horizontal and vertical bars simultaneously. The technician familiar with linearity problems in black-and-white receivers will readily appreciate this convenient method for making proper linearity adjustments. The crosshatch pattern also provides a convenient method for adjusting receiver overscan to insure that the proper portion of the raster

is extended beyond the edge of the receiver mask. Service notes for color receivers usually specify the recommended amount of overscan on the picture tube.

Requirements of a Dot/Crosshatch Generator. The previous section pointed out the need for a dot/crosshatch generator. But to be a useful tool, the instrument should provide those features which will permit the technician to obtain convergence and adjust linearity and overscan in a minimum of time.

Dot/crosshatch generators produce a white dot pattern on a solid black background and a series of vertical or horizontal bars, which can be combined to form a crosshatch pattern. There are two basic types of instruments for producing these patterns. One generates a video signal; the other generates an r-f signal. While both types of generators are useful for making adjustments for convergence and linearity, each has its particular merits.

Some video-signal dot generators are designed to produce high-level signals, others produce low-level signals. A high-level video signal generator, such as the RCA WR-46A, may be connected directly to the picture tube. A low-level video signal generator is usually connected to the input of the first video stage. Some generators that are designed to inject video signals into the color receiver must be supplied with sync signals. Sync pulses are needed to synchronize the oscillators in the dot/crosshatch generators that develop the vertical and horizontal bars. To synchronize these oscillators, the receiver is first adjusted to produce a normal picture using signals from a TV station. Sync signals are then coupled from the receiver to the dot/crosshatch generator. This is accomplished quite easily. Horizontal sync signals are obtained by clipping the horizontal-sync lead of the generator to the insulated "hot" lead of the horizontal deflection coils. Enough flyback pulse is coupled in this manner to synchronize the vertical-bar oscillator in the generator. Vertical sync, for the horizontal-bar oscillator, may be obtained from the 60-cps power line, or it may be obtained by connecting the vertical sync lead to the "hot" lead of the vertical deflection coils. Note

that both the receiver and the dot/cross-hatch generator are synchronized by sync signals from the TV station. Video signals from the generator are simply made to take the place of the normal station video in order to produce the dot or crosshatch pattern on the screen.

The r-f type of dot generator is connected directly to the antenna input terminals and does not require an external source for synchronization. This type of generator is convenient to use because all the required signals are generated by the instrument and no connections are required to the receiver other than r-f connections to the receiver's antenna terminals. The use of an r-f signal also offers a convenient method for appraising the over-all r-f/i-f response of the receiver, as will be shown.

The patterns produced by the dot/cross-hatch generator should have sharp edges. In other words, there should be an abrupt transition from the black to the white level and vice versa. Sharp edges are achieved when the signal pulses which form the dots and vertical bars have a fast rise and fall time. In addition, it is essential that generator-pulse signals maintain constant amplitude and have excellent frequency stability. In order to meet these requirements, r-f signal type instruments, such as the RCA WR-64A, use crystal-controlled oscillator circuits and wideband pulse circuits. When a generator of this type is used, any loss of sharpness at the edge of the dot or vertical bar may be attributed to misalignment or insufficient gain in the r-f or i-f circuits of the receiver.

The instrument should provide vertical and horizontal bars of equal brightness when displayed on a picture tube. The pulses forming the vertical and horizontal bars are employed to modulate the r-f carrier applied to the receiver. The vertical bars represent the high-frequency video information, while the horizontal bars represent low-frequency video information. The over-all response of the receiver, which is dependent upon the tuning, and response of the r-f, i-f, and video amplifiers, will also determine the relative amplitude of the horizontal and vertical pulses. If the low- and high-frequency

pulses from the generator are unequal in amplitude, we can expect the vertical and horizontal bars to show brightness differences on the picture tube. A receiver that is operating correctly produces vertical and horizontal bars of equal brightness.

It is important that the dot/crosshatch generator maintain precise horizontal and vertical sync frequencies. Small errors in sync frequencies may go unnoticed as the receiver circuits may maintain a synchronized condition and produce a stable pattern. However, dynamic convergence adjustments made when the deflection circuits are operating at the wrong frequency will not produce the proper dynamic corrections when the receiver is restored to normal operation using the sync signals of a TV station.

The modern receiver with its high-sensitivity and high-gain stages may pick up transmitted signals even though the antenna leads are removed from the input. Such signals can mask or beat with the instrument signals and make receiver adjustments difficult. The generator should have provisions for tuning the r-f circuits to more than a single channel. This feature permits the adjustment of the generator to a channel frequency which is not in use in the particular area.

The Color-Bar Generator. The color-bar generator is used for checking, adjusting, and troubleshooting color receivers. In the absence of a transmitted color program, this instrument is needed during installation to check the operation of the receiver on color signals. (However, some TV stations transmit a stripe signal which may be used for checking color reception.) A color-bar generator is a necessity for phase and matrix adjustments, and for troubleshooting, because it is a readily available means of producing a color pattern of known characteristics. The experienced technician can get a great deal of information about troubles from the appearance of the transmitted telecast, but the most direct approach, and one that can be used in every case, is tracing the signal produced by a color generator. Specific information on troubleshooting can be found in Lesson 7.

Types of Color-Pattern Generators. There are three basic types of color-pattern generators currently available: the gated rainbow type, the display rainbow type, and the saturated signal, or NTSC type. The method used to produce color in each type of generator will be discussed in the section describing commercial equipment.

The gated rainbow generator produces 10 usable color bars of different hues. These bars correspond to specific demodulator phase angles which can be readily identified. The signals generated by this type of instrument cover the complete range of phase angles required for adjusting and troubleshooting any color receiver. Gated rainbow generators are crystal controlled and usually incorporate a means of producing horizontal sync pulses and an unmodulated r-f sound carrier. The precise gating of the generator's output signal make it possible to adjust demodulator phasing without the use of an oscilloscope. This feature makes the gated rainbow generator particularly useful in the field as well as in the shop.

The display rainbow color generator produces approximately the same range of hues as the gated rainbow generator but no provision is made for separating the colors into bars. The colors produced by this type of generator blend into each other; consequently, there is no readily available reference point for locating a specific phase angle. The subcarrier signal from the generator is usually crystal controlled, depending on the design of the instrument. While the display color generator is useful in determining if the color circuits are operating, it is more restricted as an alignment and troubleshooting instrument, than the gated type. An oscilloscope is required for demodulator adjustments.

The saturated signal produced by the NTSC type of generator produces a color-bar pattern of saturated primary and complementary colors. Depending on the design of the instrument, these colors can appear as a pattern of bars (green, yellow, red, magenta, white, cyan, and blue), or single colors may be displayed one at a time. In addition, subcarrier signals without brightness pedestals may be available for some or all of the

demodulation angles such as $R-Y$, $B-Y$, $G-Y$, I and Q . This type of instrument is crystal controlled.

While the saturated signal may be used for adjustments and troubleshooting, there is no adjustment in the receiver which requires the use of this type of signal. The "color" control and the contrast control in the color television receiver are used to set the relative level of the chroma and luminance signals. Because these controls are "set" by the customer, there is no need to use saturated signals in the adjustment of the color receiver. As a matter of fact, there is no point in the modern color receiver, where both the luminance and demodulated chroma signal may be simultaneously observed with an oscilloscope. These signals pass through completely separate channels to the picture tube.

Color-Bar Generator Requirements. The chrominance stages of the receiver require precise alignment to assure a good color picture because they contain phase sensing circuits. Therefore, it is important that the color subcarrier oscillator of the generator be crystal controlled. The generator should also produce an unmodulated r-f sound carrier which is needed for adjusting the fine tuning control of the receiver before alignment or troubleshooting is attempted. This signal too should have crystal accuracy.

R-f signal output is convenient for making field adjustments because the signal can be applied directly to the antenna input of the receiver. In addition, the use of an r-f signal permits the observation of the effects that the tuner, i-f stages, and chrominance stages have on the signal. Video output from the color-pattern generator allows the technician to apply signal directly to a video stage, and offers a means of isolating a trouble to the video stages or to the r-f or i-f stages. The same technique may also be used with a generator which produces only r-f output. In this case an oscilloscope can be used to check for the presence of the signal at the output of the video detector. If the proper signal is present, the r-f and i-f stages can be eliminated as a source of trouble.

To simplify field adjustments, and to reduce the number of pieces of equipment to be taken into the customer's home, the generator should produce a color subcarrier which provides the type of signal required for checking and adjusting demodulator phasing without the use of an oscilloscope.

The instrument should also provide horizontal sync. In a color-bar generator using the offset-signal method (rainbow and gated rainbow generators), the sync signal must be locked to the correct submultiple of the bar frequency. It is not necessary to provide vertical sync, since the color pattern appears as vertical bars. Any slight residual-hum pattern that may appear on the screen can be kept from rolling by adjusting the vertical-hold control on the receiver.

The instrument should incorporate a control which can be used to vary the amplitude of the color sync burst signal. This feature permits one to check on the sensitivity of the color sync system in the receiver. For greatest flexibility this control should have a range which can produce a change in the amplitude of the color sync burst both above and below the normal level. This range is helpful in cases where the response of the r-f or i-f amplifier stages may be low, or when the color sync action is not normal.

Other desirable features which might be included in a color-bar generator include: provision for checking nonlinear amplifier characteristics in the receiver; and a means of checking to see if the luminance and chrominance time delays are matched. Correct delays are indicated when the color bars "fit" or coincide with the monochrome pips on the screen of the picture tube,

The test equipments described in this lesson are representative of the types of instruments that are commercially available. Each instrument was selected to illustrate a different method of producing the signals used for adjusting and troubleshooting color television receivers. Some manufacturers make a variety of color-pattern generators; some have instruments which are available in kit form. Kits provide a means of acquiring equipment at low cost, but they should not be attempted unless the builder has had

some kit construction experience. A wide-band oscilloscope is usually required for alignment of the kit.

As is the case in the selection of any test instruments, check those features which are meaningful for practical servicing. It doesn't make much sense to pay for a feature that will not be used frequently. If possible, try to use the equipment before making your final selection. To obtain maximum usefulness from an instrument, read the instruction booklet and follow the operating procedure given by the manufacturer.

8-3. DOT/CROSSHATCH GENERATORS

The RCA WR-64A, Color-Bar/Dot/Cross-hatch Generator. This instrument, shown in Fig. 8-1, provides all the test facilities required for adjusting convergence circuits in color television receivers and for making linearity and overscan adjustments in black-and-white and color receivers. Color-bar signals produced by the instrument provide the type of display that allows troubleshooting and adjustments of color-phasing circuits without the use of an oscilloscope. The color-bar function will be discussed in a later discussion on color-bar generators.

The dot function provides approximately 150 white dots on a black background. These



Fig. 8-1. RCA WR-64A Color-Bar/Dot/Cross-hatch Generator.

dots are formed at the intersections of ten vertical and fifteen horizontal lines, which can also be used to display the crosshatch pattern. Both the dot and crosshatch patterns may be used for convergence adjustments. Because the number of lines in the pattern is fixed, the unit provides a means for adjusting the amount of receiver overscan.

R-f output of this instrument is set at Channel 3 (61.25 mc), but can be adjusted to Channel 4 (67.25 mc). The picture carrier has a maximum output voltage of 0.05 volts. The output impedance of the instrument is 300 ohms balanced.

Horizontal and vertical synchronizing pulses, as well as the signals for vertical and horizontal lines, are produced from a master crystal-controlled oscillator whose output frequency is divided down by block-oscillator stages.

Circuit Description of the Dot/Crosshatch Function. To produce the dot and crosshatch patterns, the WR-64A generates four separate crystal-controlled pulse signals having frequencies of 189 kc, 15.75 kc, 900 cps, and 60 cps. These pulses are applied to the r-f carrier (Channel 3 or 4), which is also generated by the instrument, and applied to a balanced 300-ohm output cable. The four signals have the following functions: the ten vertical lines are produced by the 189-kc signals, the fifteen horizontal bars are produced by the 900-cps signals, and sync is provided by the 15.75-kc and 60-cps signals.

For the following circuit description of the WR-64A refer to the block diagram shown in Fig. 8-2, and to the schematic diagram shown in Fig. 8-3.

The crosshatch pattern displayed on the picture tube, plus the vertical and horizontal

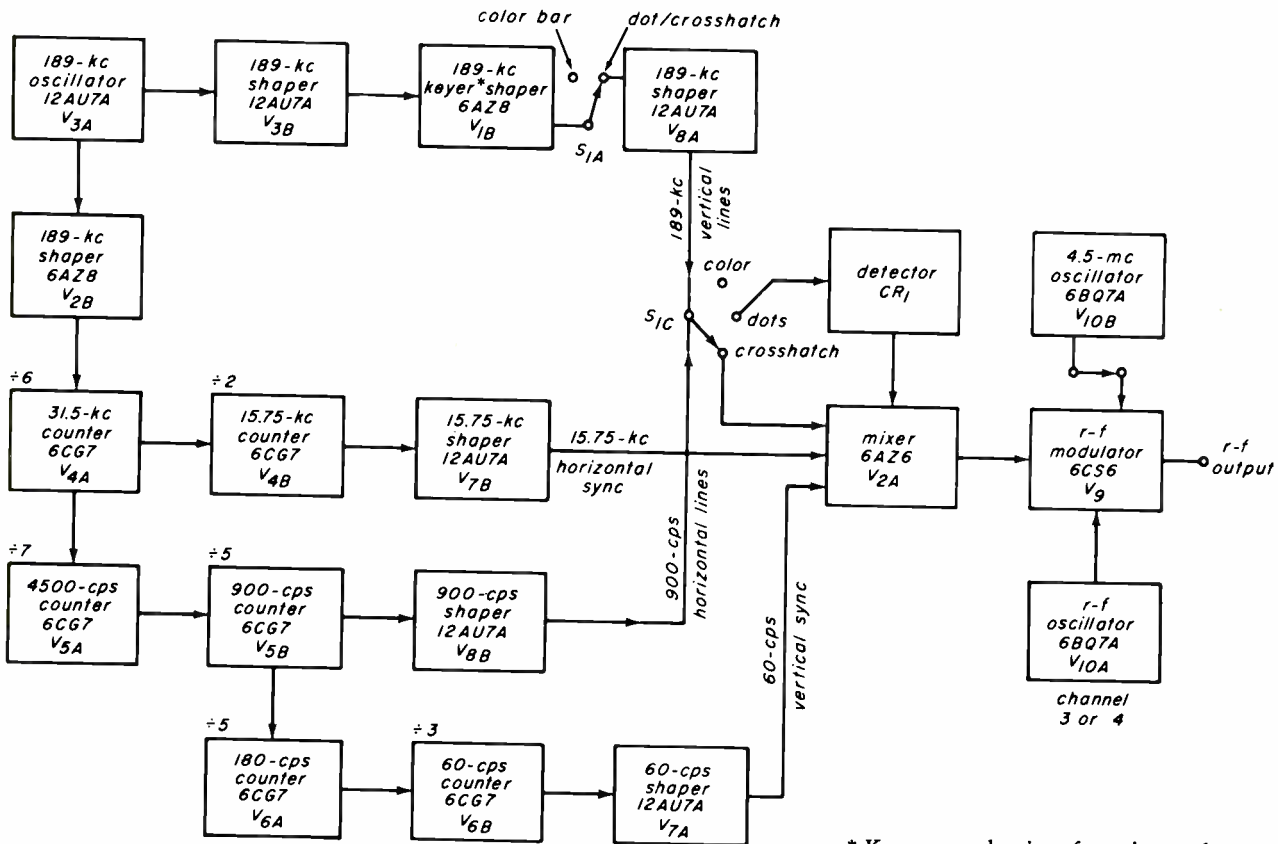

* Keyer - color-bar function only.

Fig. 8-2. Partial block diagram showing the circuits that develop the dot/crosshatch signal in the RCA WR-64A generator.

DOT/CROSSHATCH GENERATORS

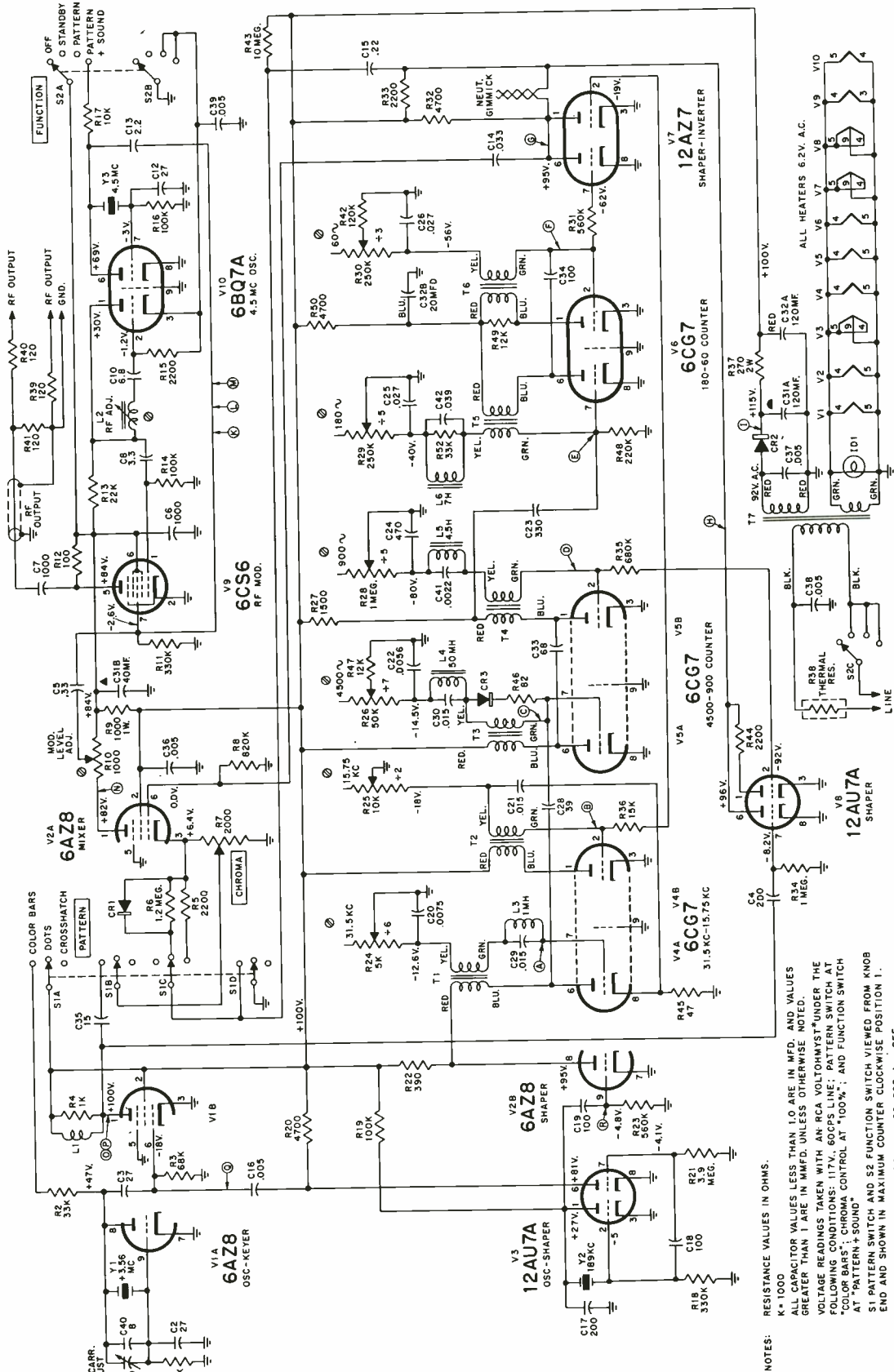

NOTES:

RESISTANCE VALUES IN OHMS.

K = 1,000
 M = 1,000,000
 CAPACITOR VALUES LESS THAN 1.0 ARE IN MFD. AND VALUES GREATER THAN 1 ARE IN MFD. UNLESS OTHERWISE NOTED.

VOLTAGE READINGS TAKEN WITH AN RCA VOLTOHMYST* UNDER THE FOLLOWING CONDITIONS: 117V, 60 CPS LINE; PATTERN SWITCH AT "COLOR BARS"; CHROMA CONTROL AT "100%"; AND FUNCTION SWITCH AT "PATTERN + SOUND".

S1 PATTERN SWITCH AND S2 FUNCTION SWITCH VIEWED FROM KNOB END AND SHOWN IN MAXIMUM COUNTER CLOCKWISE POSITION 1.

S1 POS. 1 - COLOR BARS
 POS. 2 - DOTS
 POS. 3 - CROSSHATCH
 POS. 4 - PATTERN + SOUND

S2 POS. 1 - OFF
 POS. 2 - STANDBY
 POS. 3 - PATTERN
 POS. 4 - PATTERN + SOUND

Fig. 8-3. Schematic diagram of the RCA WR-64A generator.

synchronizing pulses, are all derived from the 189-kc crystal-controlled master oscillator, V_{3A} .

Vertical Line Signal. The 189-kc signal is used to generate pulses that produce 10 vertical lines on the kinescope screen. Actually, 12 pulses are produced during a complete horizontal period ($189\text{ kc}/12 = 15.75\text{ kc}$). However, two of the pulses occur during horizontal retrace and are not visible. The sine-wave signal generated by the 189-kc oscillator is coupled directly to a shaper tube, V_{3B} . The signal is amplified, shaped and applied to a keyer and shaper stage, V_{1B} . The 189-kc signal is further shaped and the resultant pulses are applied to another shaper tube, V_{8A} . Output pulses at the plate of V_{1B} are shown in Fig. 8-4a with the switch, S_{1A} , in the "DOT" position. The action of the shapers is to square and differentiate

the sine-wave signal producing the narrow spikes shown in Fig. 8-4a. (V_{1B} also applies 189-kc keying pulses to the color-bar sub-carrier signal. This function, however, will be described in greater detail in the section on color-bar generators.) The output of V_{8A} contains the signal information that produces the vertical lines.

Horizontal Line Signal. The signals producing the horizontal lines also originate from the 189-kc master oscillator, V_{3A} . The 189-kc sine-wave produced by this stage is applied to the grid of V_{2B} . The signal is shaped into pulses in V_{2B} and is coupled into the plate circuit of a blocking-oscillator stage, V_{4A} .

This oscillator is adjusted to free run at a frequency somewhat lower than 31.5 kc.

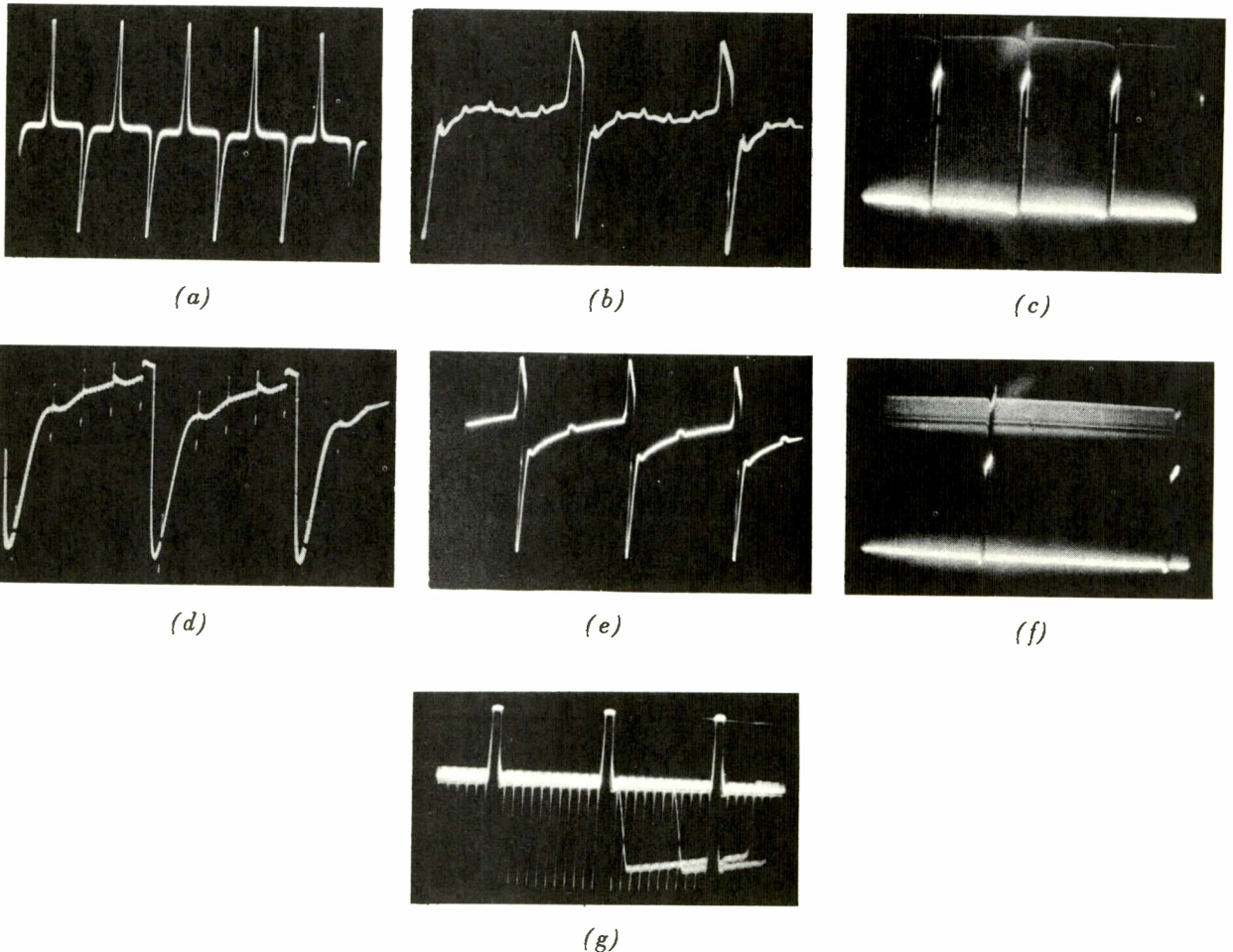

Fig. 8-4. Key waveforms in the generation of the dot/crosshatch signal.

The short conducting interval of the blocking oscillator may be initiated by one of the 189-kc pulses. Following each conducting interval the oscillator holds itself cut off for a period of time. Just before conduction would resume due to the decay of grid leak bias, the sixth 189-kc pulse triggers the conduction interval again. Thus the blocking oscillator fires on every sixth pulse, and the signal is divided down six times to a frequency of 31.5 kc. A potentiometer is included in this stage, and in all the subsequent blocking-oscillator stages, for adjusting the RC circuits. These are adjusted to set up the correct free-running frequencies. The resulting waveform (Fig. 8-4b) shows 5 pips, which are pulses of the 189-kc signal, plus the sixth peak pulse (31.5-kc) by which the circuit is triggered. The 31.5-kc pulse is applied to another blocking oscillator stage, V_{5A} , where frequency is divided down seven times to provide an output frequency of 4500 cps. The 4500-cps signal is coupled to a final blocking oscillator stage, V_{5B} , and divided down five times to the frequency of 900 cps. This signal provides the horizontal lines in the pattern. The resultant 900-cps pulse is transformer coupled to a shaper stage, V_{8B} . Since the plates of the horizontal and vertical line stages (V_{8A} and V_{8B}) are tied together, a composite 189-kc and 900-cps video waveform is produced. This composite signal is found at the common terminal of the PATTERN selector switch, S_{1C} . The resultant wave is shown in Fig. 8-4c.

The composite horizontal and vertical line signal, which now contains all the information to produce a crosshatch pattern, can be switched by the PATTERN selector to generate either the crosshatch or the dot pattern. In the CROSSHATCH position of the switch, the signal is applied directly to the cathode of mixer stage, V_{2A} . The vertical and horizontal line signals at the cathode of V_{2A} are negative-going pulses. These are amplified and appear as negative pulses at the plate. From the plate of V_{2A} , the negative pulses are fed to the suppressor grid of the modulator tube, V_9 . Negative pulses at the modulator yield downward modulation (white) of the carrier signal. Thus a white crosshatch pattern is produced on a black background.

When the PATTERN selector is switched to the DOT position, the composite pulse signal is applied through a diode, CR_1 , to the cathode of the mixer stage. The diode acts as a peak detector due to the long time constant circuit formed by C_{15} and R_6 . The diode conducts only on the very peaks of the composite signals. These peaks occur when the 189-kc pulses and the 900 cps pulses are coincident in time. Thus a negative pulse is coupled to the cathode of V_{2A} only when the vertical and horizontal lines intersect. The result is the white dot pattern. The pattern produced by this procedure is a series of rectangular dots arranged in vertical and horizontal rows.

Vertical Sync Signal. Like all the pulse signals in the generator, the vertical sync signal is obtained from the 189-kc master oscillator. The signal path from the master oscillator follows the same route as was described earlier in conjunction with the 900-cps signal. A sample of the 900-cps signal is taken at the output of V_{5B} , the 900-cps counter, and routed to an additional pair of frequency dividers. Capacitor C_{23} couples the 900-cps signal to the grid of V_{6A} . Here the 900-cps waveform is divided down five times to a subharmonic frequency of 180 cps. The resultant output is applied to another blocking oscillator, V_{6B} , where the 180-cps is divided down three more times to its final vertical sync frequency of 60 cps. The signal is then applied to a final shaper stage, V_{7A} , and from there applied to the control grid of the mixer stage, V_{2A} .

Horizontal Sync Signal. The horizontal sync signal is also derived from the 189-kc master oscillator. A sample of the 31.5-kc signal is taken from the cathode circuit of blocking oscillator V_{4A} and applied to another blocking oscillator stage, V_{4B} . The 31.5-kc pulse is divided down two times to its final horizontal sync frequency of 15.75-kc. See Fig. 8-4e. The 15.75-kc signal is coupled to a shaper stage, V_{7B} . The output of V_{7B} (horizontal sync) and the output of V_{7A} (vertical sync) are coupled in the common plate circuit to produce a composite synchronizing signal. The resultant waveform, which contains the 60-cps and 15.75-kc sync signals (Fig. 8-4f), is applied to the

control grid of the mixer stage, V_{2A} . In the mixer stage the composite sync signal combines with the dot or crosshatch signal depending on the setting of PATTERN selector switch, S_{1C} . Note that the sync signals are applied to the grid of the mixer stage, while the video signal (vertical and horizontal lines) is applied to the cathode. Thus sync and video pulses are opposite in polarity at the output. The output of the mixer is applied to the suppressor grid of the r-f modulator stage, V_9 . Figure 8-4g shows the output signal of the mixer stage, when the PATTERN selector is in the CROSSHATCH position.

An r-f picture-carrier signal, which can be tuned to 61.25 mc (Channel 3) or to 67.25 mc (Channel 4), is generated by the oscillator stage, V_{10A} . This signal is coupled to the control grid of the modulator, V_9 , where it is then modulated by the incoming crosshatch and sync signals. The resultant modulated r-f output signal is applied to the balanced 300-ohm output cable. This signal now contains all the information required to display a synchronized dot or crosshatch pattern on the picture tube.

The WR-64A also has provisions for generating an unmodulated sound-carrier signal. This signal permits accurate adjustment of the fine-tuning control on the receiver. The 4.5-mc is generated by a crystal-controlled oscillator stage, V_{10B} , and is applied to the grid of the modulator tube, V_9 , when the FUNCTION selector switch, S_2 , is in the PATTERN and SOUND position. The 4.5-mc carrier combines with the picture carrier at V_9 and produces a beat frequency of 65.75 mc or 71.75 mc depending on whether r-f oscillator is tuned to Channel 3 or Channel 4.

Operation of the RCA Dot/Crosshatch Generator. The operation of this generator is simple and straightforward. The following setup procedure describes the connection of the instrument to the TV receiver, and the method for obtaining the dot or crosshatch pattern on the picture tube.

Disconnect the antenna leads from the television receiver, and attach the two output leads of the generator to the television antenna input terminals. The two leads are

identified by the red-rubber insulators. Connect the ground lead of the output cable, which is identified by the black rubber insulator, to the chassis of the receiver.

Set the FUNCTION switch of the generator to the "STANDBY" position. In this position the picture-carrier oscillator, V_{10A} , is inoperative. Allow a few minutes for the generator to warm up before switching to the other positions.

Turn on the television receiver and set the channel selector to Channel 3. If the local station is transmitting on Channel 3 and interfering with the generator signal, it may be necessary to set the r-f oscillator of the WR-64A to Channel 4.

To obtain a crosshatch pattern set the FUNCTION switch to the PATTERN or the PATTERN and SOUND position and set the PATTERN selector switch to the CROSSHATCH position. A crosshatch pattern will appear on the picture tube.

To obtain a dot pattern, set the FUNCTION switch to the PATTERN position and set the PATTERN selector switch to the DOT position. A dot pattern should appear on the picture tube.

When using the dot or crosshatch pattern to make convergence, size, or linearity adjustments, adjust the brightness control on the receiver to maintain a sharp pattern. Excessive brightness may cause blooming with subsequent defocusing of the pattern. It may be necessary to switch the FUNCTION selector from the PATTERN and SOUND to the PATTERN position to eliminate all traces of sound beat in the pattern. Use the PATTERN and SOUND position to adjust fine tuning. When fine tuning is set for minimum beat in the picture, turn the FUNCTION switch to the PATTERN position. If the receiver is operating properly, vertical and horizontal lines in the crosshatch pattern should have equal brightness.

B and K Color Analyst Model 850. The B and K Color Analyst, which is shown in Fig. 8-5, produces a dot, crosshatch, vertical-line, or horizontal-line pattern. These patterns can be used for static and dynamic

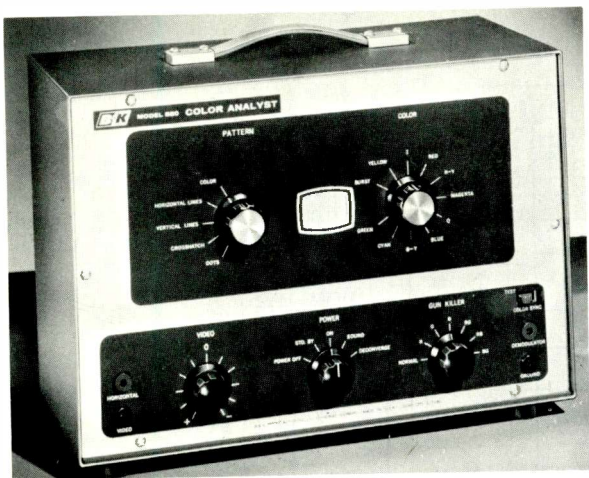

Fig. 8-5. B and K Model 850 Color Analyst. (Reproduced by permission of B and K Manufacturing Company, Division of Dynascan Corporation.)

convergence adjustments, linearity and overscan adjustments. The instrument also produces a saturated color signal which results in eleven colors, displayed one at a time as determined by the settings of the function switches. A dial, which is mechanically coupled to the selector switches, shows the pattern generated by the instrument in the small window in the center of the front panel. The color-pattern functions of this instrument will be discussed in the section on color-pattern generators.

The Model 850 produces a pattern of approximately 140 dots which are formed at the intersection of 10 vertical and 14 horizontal lines. In a properly converged receiver, they appear as white rectangular dots on a dark background. The instrument has an r-f output which is tuned to Channels 3, 4, or 5 by means of a switch on the chassis of the instrument. A low-level, low-impedance video signal is also available from a jack on the front panel. This signal cannot be used for making demodulator adjustments because it may not produce the correct hue and may contain a beat pattern. The video output signal is used only to check if a particular stage passes a signal.

A crystal-controlled oscillator keys multivibrator and blocking oscillator circuits to produce the vertical and horizontal lines as well as the horizontal and vertical sync pulses. Another crystal-controlled oscillator

produces a sound-carrier signal. The Model 850 includes a gun-killer circuit which permits one or more of the guns in the picture tube to be turned off, and a *deconvergence* assembly which can be used when making dynamic convergence adjustments to separate the dot or line pattern into its red, blue, and green components.

Circuit Description. A schematic diagram of the B and K Model 850 is shown in Fig. 8-6. The block diagram in Fig. 8-7 shows the stages of the Model 850 which are used to produce the dot, crosshatch, vertical-line, horizontal-line, and sync signals. A 189-kc crystal controlled oscillator stage, V_{1A} , keys a multivibrator stage, V_2 , which is triggered on every sixth pulse. The 31.5-kc output signal of the multivibrator is fed to a transistor shaper stage and also synchronizes a blocking oscillator stage, V_{3A} , which divides down seven times to produce a 4.5-kc signal. This 4.5-kc signal is counted down five times in the 900-cps blocking oscillator, V_{3B} . Two additional blocking oscillator circuits V_{4A} , V_{4B} produce a 300-cps signal and a 60-cps signal by means of a count down of 3 and 5.

In addition to synchronizing the 31.5-kc multivibrator, the 189-kc signal is fed to a transistorized Schmitt trigger circuit, Q_1 , Q_2 , which shapes the sinewave to produce 189-kc pulses. The Schmitt trigger is a monostable multivibrator circuit that changes state when the input signal rises above a predetermined amplitude. In this circuit the multivibrator triggers on the peaks of the applied 189-kc signal, producing narrow steep-sided output pulses. These pulses are used to form the vertical lines. The 31.5-kc output of the multivibrator, which is fed to the transistor shaper circuit, Q_7 , is divided down by two and is used to synchronize a 15,750-cps blocking oscillator, V_{1B} .

The outputs of the 15,750-cps blocking oscillator and the 60-cps blocking oscillator are fed to separate shaper circuits. The output of the 15,750-cps shaper circuit, Q_6 , is used as a horizontal synchronizing pulse, and the output of the 60-cps shaper circuit, Q_5 , is used as a vertical synchronizing pulse.

The signal from the 900-cps blocking oscillator is shaped by a transistor stage,

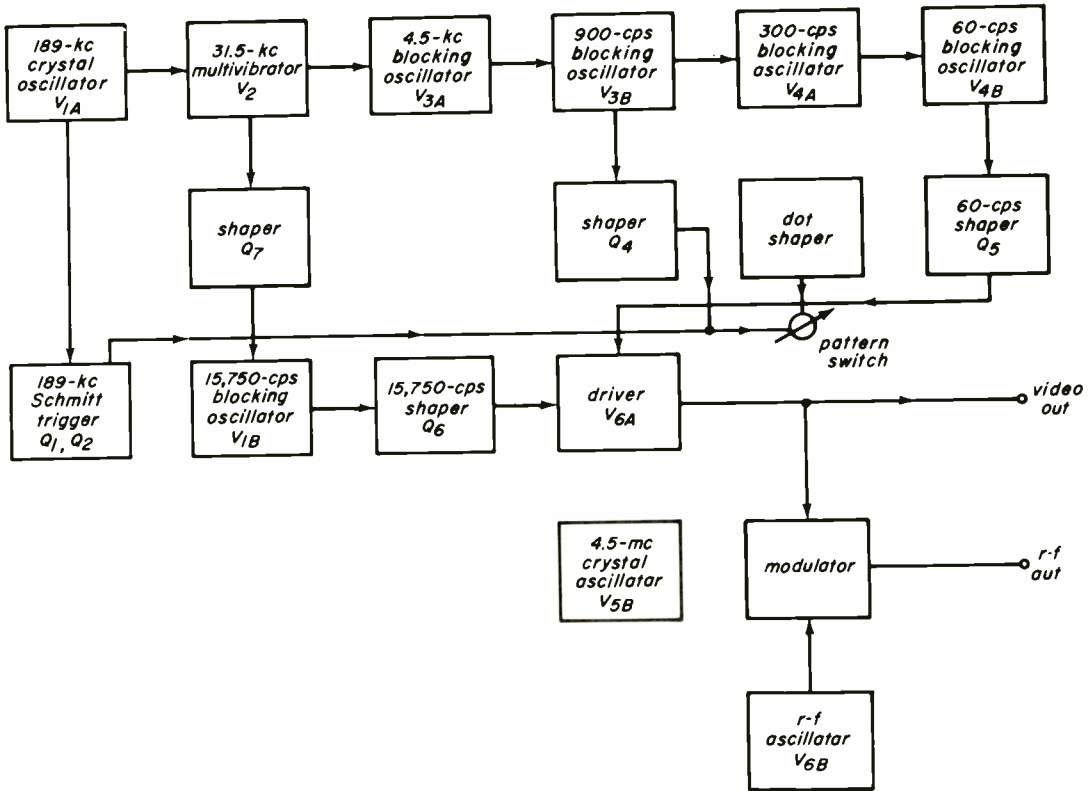

Fig. 8-7. Partial block diagram showing the circuits that generate the dot/crosshatch signal in the B and K Model 850 Color Analyst.

Q₄, and is used to form the horizontal line pattern. When the 900-cps pulses are mixed with the signals from the 189-kc Schmitt trigger circuit, a crosshatch pattern is produced. These same signals are fed to a dot shaping circuit to produce the dot pattern.

The desired signal is selected with the pattern switch, and fed to a driver stage, V_{6A}. A 4.5-mc signal from a crystal-controlled oscillator, V_{5B}, is also fed to the driver stage. No coupling circuit is shown from the 4.5-mc oscillator to the driver in the schematic diagram. Sufficient signal is coupled through adjacent leads to make additional coupling unnecessary. The output of the driver is fed to a jack on the front panel as a low-level video signal, and is also fed to a modulation stage. Modulation is achieved by adding the video and r-f signals across the diode D₃. In the modulator, an r-f carrier signal produced by an electron coupled oscillator, V_{6B}, is combined with the video information. The modulated r-f output of the generator is connected directly to the antenna terminals. The generator can be

used with either balanced or unbalanced antenna inputs.

Setup of the B and K Model 850. Before applying power to either the receiver or the generator, remove the antenna lead-in from the antenna terminals on the receiver and connect the r-f output leads of the generator to the terminals. Remove the socket from the base of the picture tube and push the socket of the gun-killer assembly onto the base of the picture tube. This assembly is equipped with a female 14-pin socket on one end, and a male 14-pin plug, like that of the kinescope base, on the other end. Next, replace the receiver's kinescope socket on the plug of the gun-killer assembly, as shown in Fig. 8-8. Connect the ground lead of the gun-killer assembly to the chassis. With the gun-killer assembly in place, it is possible to cut off selected electron guns by means of the GUN-KILLER switch on the front panel of the generator. This allows convenient purity and demodulator-phase checks to be made.

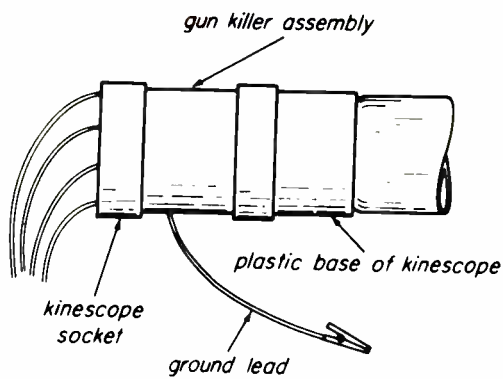

Fig. 8-8. The Gun Killer assembly of the B and K Color Analyst fits between the base of the color kinescope and the kinescope socket.

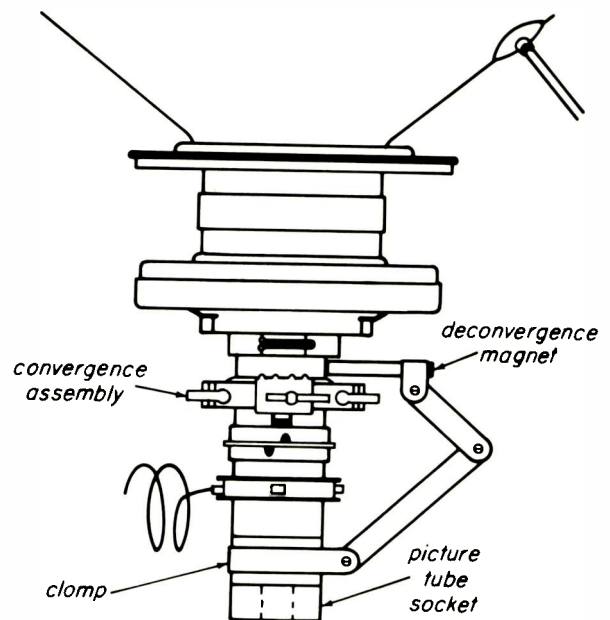

Fig. 8-9. Positioning the Deconvergence assembly of the B and K Color Analyst on the picture tube.

A unique feature of the Model 850 is a deconvergence assembly, which is also positioned on the neck of the picture tube. This unit consists of a swivel arm whose base clamps to the base of the picture tube. At the end of the adjustable arm is an electromagnet. To position the deconvergence assembly, snap the C-shaped clamp over the plastic base of the picture tube, and adjust the swivel arm to place the probe (electromagnet) against the neck of the picture tube between the deflection yoke and the convergence assembly. The probe is placed against the neck, between the blue and red electron guns. See Fig. 8-9. By energizing the deconvergence probe (switching the POWER switch to the DECONVERGENCE position), static convergence is upset and the lines of the crosshatch pattern diverge. If you check back to the lesson covering setup adjustments, you will find that there are instances during dynamic convergence adjustments when it is necessary to alter static convergence in order to observe parallelism or spacing between lines of different color. This is particularly necessary when adjusting older color receivers. The deconvergence assembly permits us to alter static convergence without disturbing the normal static adjustments in the receiver.

Convergence Adjustments. Set the POWER switch to the "On" position; the PATTERN switch to "Dots" position; and the GUN-KILLER switch to "Normal" position. Turn the receiver on and tune it to

the channel that the generator r-f carrier is set to. Set the receiver contrast control to maximum and the brightness control to the position at which the dots can just be seen. A brightness control setting which is too high may cause the dot pattern to "bloom", thereby increasing the size of the dot. If possible, make all adjustments in a darkened room. Follow the color TV receiver manufacturers' instructions for making static and dynamic convergence adjustments. The deconvergence assembly may be used to separate the dot or line pattern, if desired.

Hickok Color-Bar/Dot/Crosshatch Generator, Model 660. The Hickok Model 660, shown in Fig. 8-10, produces a dot and crosshatch pattern which can be used for static and dynamic convergence adjustments. The instrument also produces a color display of the "rainbow" type. Both the dot and crosshatch and the color output are available as either r-f or video signals. The color function of this instrument is described in the section on color signal generators.

This instrument produces approximately 300 white dots which are formed at the intersections of 20 vertical and 15 horizontal lines. The r-f output frequency is adjustable

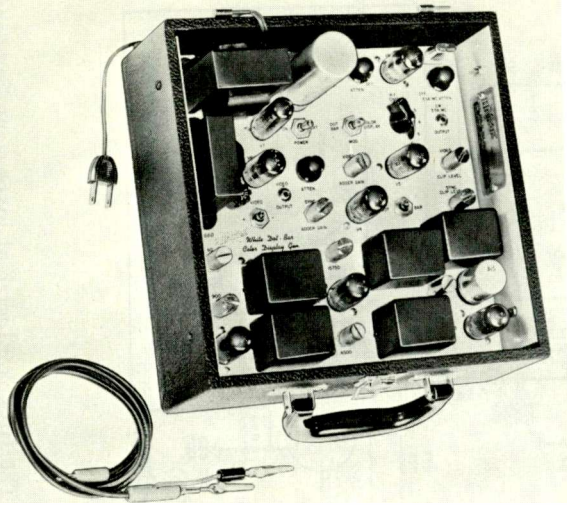

Fig. 8-10. Hickok Model 660 White Dot-Bar, Color Display Generator. (Courtesy The Hickok Electrical Instrument Company.)

from Channel 2 through 6, by means of a selector switch. Video output is adjustable from 0 to 3 volts peak-to-peak and either a positive- or negative-going signal is available.

Horizontal and vertical synchronizing pulses are produced by dividing the frequency of the signal from a crystal-controlled oscillator. Sync pulses are applied to the composite signal only in the white dot or crosshatch mode.

Circuit Description. A schematic diagram of the Hickok Model 660 is shown in Fig. 8-11. The block diagram, Fig. 8-12, shows the stages which are used to produce the dot/crosshatch patterns. A crystal-controlled oscillator, V_{1A} , with an output frequency of 315 kc, is coupled to a blocking oscillator, V_{1B} , which divides the input frequency by 10 to produce two outputs at 31.5 kc. A low-impedance output from the cathode of V_{1B} feeds 31.5-kc pulses to the cathode of V_{2A} , another blocking oscillator, which counts down two times to produce a 15,750-kc signal. The output from the plate of V_{1B} is fed to a blocking oscillator stage, V_{2B} , which counts down seven times to produce a 4500-cps output. This output signal is further divided by 5 in V_{3A} . The 900-cps signal from V_{3A} is fed to V_{3B} which counts down fifteen times to produce a 60-cps signal, which is fed to V_{5A} , the sync-gate tube.

A portion of the 15,750-cps output signal from V_{2A} , and the 900-cps output signal from V_{3A} , are fed to a shaper V_8 . The 15,750-cps signal, shaped by V_8 , is fed to the sync gate tube, V_{5A} , where it is mixed with the 60-cps signal from V_{3B} to produce the synchronizing signals. The crosshatch pattern is developed in V_{4A} , the video gate tube. Positive 315-kc pulses are applied to the grid of V_{4A} to produce vertical lines. The horizontal lines of the pattern are made by 900-cps pulses applied to the screen of V_{4A} . In the BAR position of the DOT-BAR switch, the drive signals applied to V_{4A} are arranged so that both 900-cps and 315-kc pulses drive the tube into conduction. Thus the output contains the signals that produce the horizontal and vertical lines of the crosshatch pattern. When the DOT-BAR switch is placed in the DOT position, V_{4A} conducts only when both the 900-cps pulses and the 315-kc pulses are simultaneously present at the screen and control grid. Thus output pulses occur at the intersection of the vertical and horizontal lines, and the dot pattern is produced.

Output signals from V_{4A} and V_{5A} are combined in the adder stage to produce the composite video signal. The adder stage consists of V_{4B} and V_{5B} with their plates tied together. Composite video information is then applied to the phase splitter stage, V_{6A} , which has cathode and plate resistors having the same value. Output is taken from either the cathode or the plate by means of the video polarity switch. A cathode follower stage, V_{6B} , provides a low-impedance output for the video output cable. The low-impedance output signal from V_{6A} can also be used to modulate the r-f oscillator signal generated by V_{7B} . The relative signal levels are set to produce a 60-percent modulated signal, which can be applied directly to the antenna terminals of the receiver.

Setup of the Model 660 for Convergence Adjustments. To inject video signals into the grid of the first video amplifier of the receiver, the setup is as follows. Set the POWER switch to the "ON" position. Allow 15 minutes for warmup to assure stable operation. Rotate the R-F ATTEN control maximum counterclockwise to the "OFF" position. Set the VIDEO POLARITY switch to

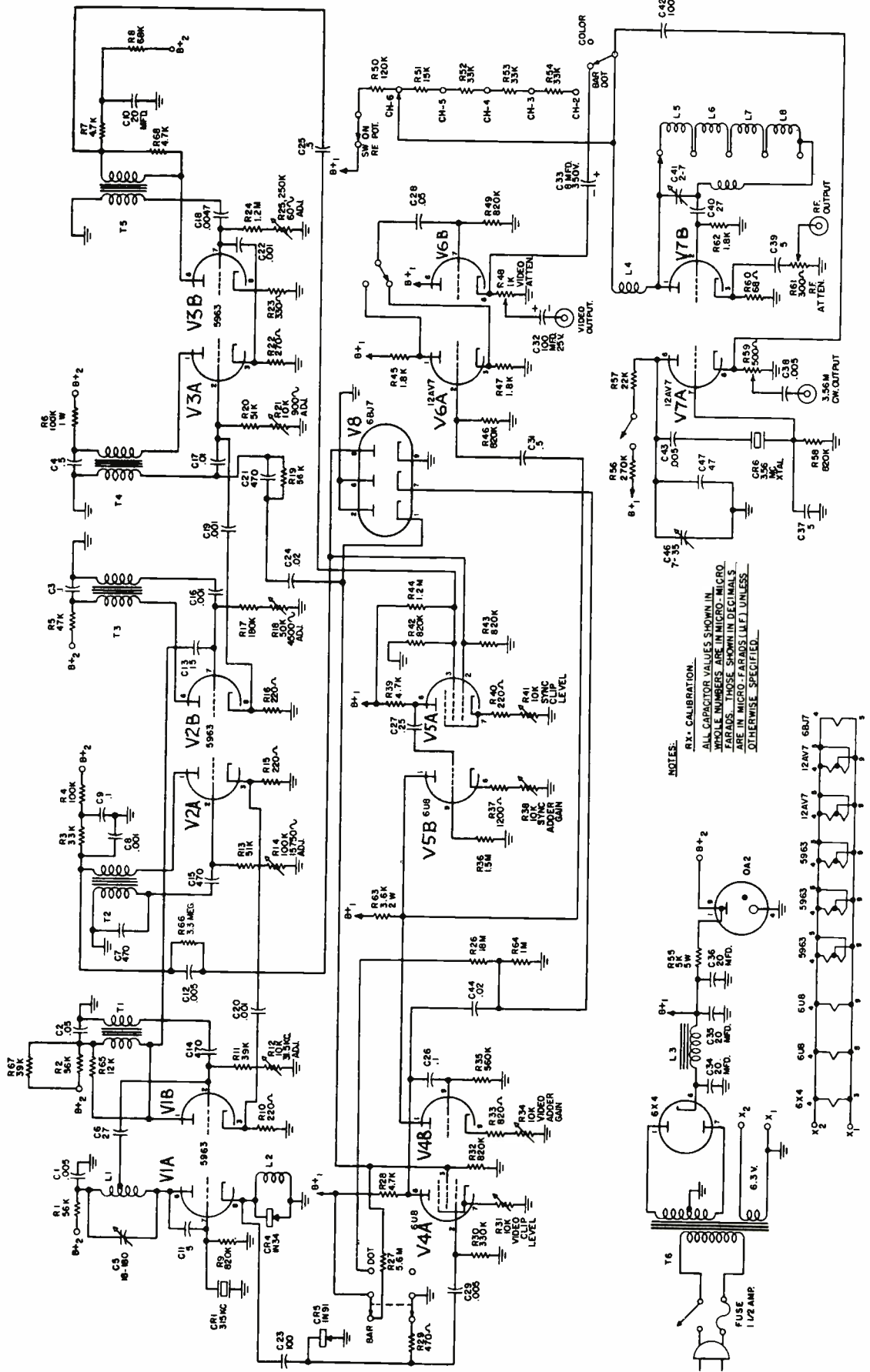

Fig. 8-11. Schematic diagram of the Hickok Model 660, White Dot-Bar, Color Display Generator. (Courtesy The Hickok Electrical Instrument Company)

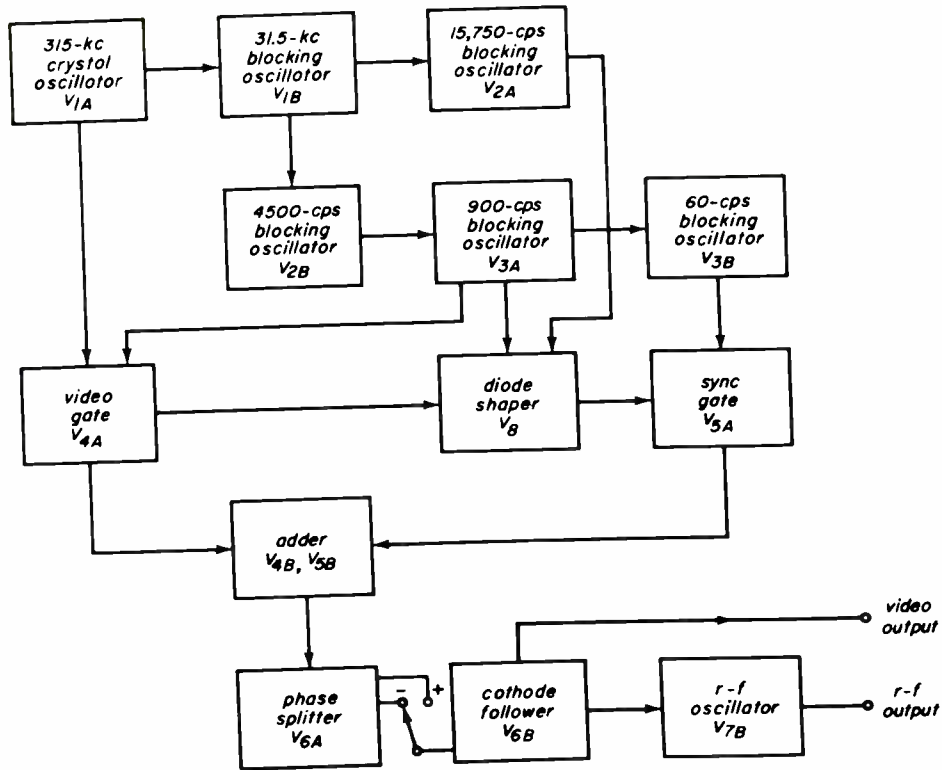

Fig. 8-12. Block diagram showing the circuits that develop the dot/crosshatch signals in the Hickok Model 660 generator.

“+” or “-” (usually a negative going voltage is required) and the BAR-DOT switch to the desired function. Turn the 3.56-mc ATTEN control to the “OFF” position. Connect the output cable to the video-output connector, clip the ground lead to the chassis of the receiver, and clip the “hot” lead to the grid of the first video amplifier. Set the VIDEO ATTEN control to produce a video signal of the desired level.

To obtain r-f output with the dot or crosshatch pattern, set the switches and controls as outlined above, except that the R-F CHANNEL SELECTOR is set to the desired channel, and the R-F ATTEN control is set to its maximum clockwise position. Set the VIDEO POLARITY switch to “+” and connect the output cable to the R-F OUTPUT CONNECTOR and the antenna input to the receiver.

8-4. PRODUCING COLOR TEST SIGNALS

The transmitted signal of a color telecast contains information which results in a color

picture on the picture tube of a properly adjusted color television receiver. The voltages, which actually produce the color are, of course, the demodulator output voltages. If a color signal generator is to be useful for checking color circuits, the generator must have the same effect on the demodulator circuits as the transmitted signal. To produce various hues, there must be a variable phase difference (phase angle) between the transmitted 3.58-mc color subcarrier and the 3.58-mc local oscillator which is used as a reference. Hue depends on the phase relationship between these signals, and a given phase angle will always produce the same color each time it is sensed by the demodulator. The colors produced by specific phase angles are shown in Fig. 8-13. If a signal has a phase angle of 90 degrees, bright red is produced. A phase angle of 180 degrees produces blue; a phase angle of 300 degrees produces green, and so on. Intermediate phase angles produce colors which are a mixture of these colors. Thus, a color-signal generator produces a color pattern by supplying a signal which has a variable phase difference with respect to the receiver's local oscillator.

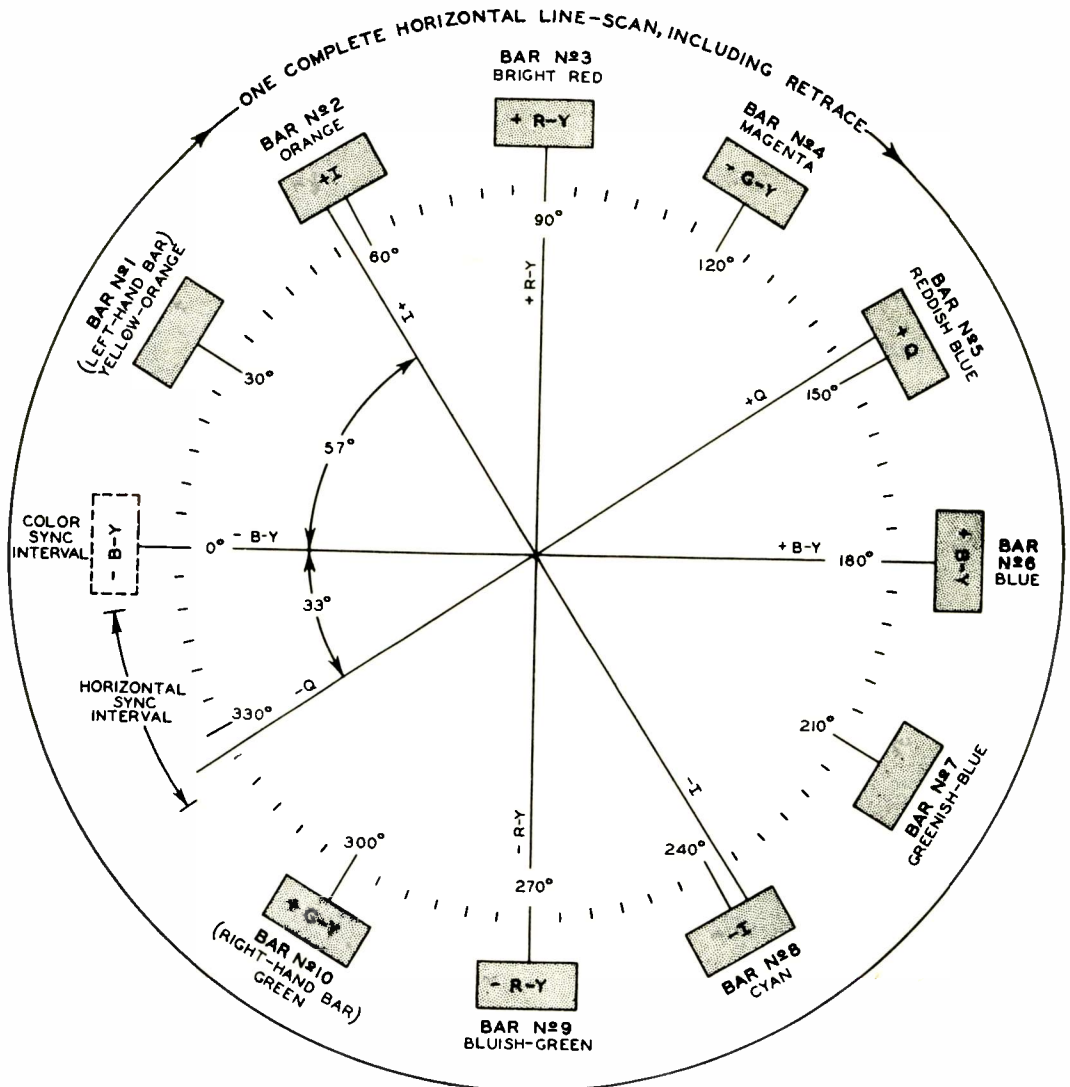

Fig. 8-13. Vector diagram showing the hues represented at 30° phase increments between 0 and 360°

There are two commonly used methods of producing the required phase shift, and both are used in commercially available instruments. One method introduces a phase difference, with respect to a 3.58-mc reference oscillator, by means of delay lines; the other by the use of a frequency difference between the signal supplied by the generator and the 3.58-mc reference oscillator in the receiver. This latter method is called the offset-carrier method.

Delay-Line Method. Delay lines can be made of lengths of coaxial cable or lumped constants arranged to simulate a transmission line. Their purpose is to introduce a

time delay between two points in a circuit. In color signal generators that use delay lines for producing the color signal, a specific delay is introduced to a 3.579545-mc signal which is generated by a crystal-controlled oscillator in the generator. The delay is measured with reference to the subcarrier signal generated in the receiver, and the colors produced are dependent upon the change in phase produced by the delay lines. Delays are usually defined in terms of phase angles from 0 to 360 degrees. No delay results in a phase angle of zero degrees. A signal that starts after the reference signal has completed one quarter of a cycle is said to have a 90-degree phase angle.

The delayed signal is usually gated and is combined with synchronizing pulses to form a composite signal which can be used as a video signal. Brightness signals may also be added to the composite signal for each of the hues generated. This composite signal can be used to modulate an r-f signal to provide output which can be applied directly to the antenna terminals of the receiver. A reference burst signal must be provided in the composite signal to control the phase of the receiver's subcarrier oscillator.

A simplified representation of the delay-line method is given in Fig. 8-14. The duration of a single cycle of subcarrier signal is about 0.28 microseconds. If the signal is delayed by one-twelfth of that interval, or about 0.023 microseconds, the signal will be phase-shifted by about 30 degrees. Thus, if each of the delay-line sections shown in the figure introduces a delay of about 0.023 microseconds, the signal will be shifted from the initial burst signal in 30-degree steps and a signal representing one of the several hues will be present at each position.

Offset-Carrier Method. This system provides a subcarrier signal whose phase shifts continuously with respect to the reference carrier signal. When the relative phase of

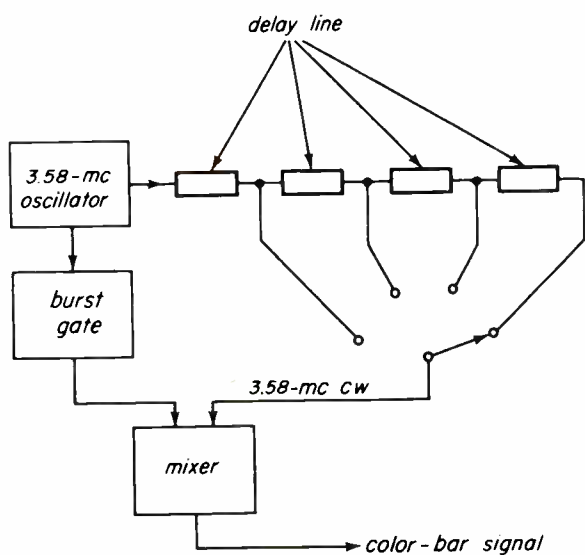

Fig. 8-14. A simple way of developing signals with a calibrated phase shift through the use of delay lines.

the subcarrier signal shifts through 360 degrees, hue changes through yellow, orange, red, magenta, blue, cyan, green, and all intermediate hues. If this 360° phase shift can be accomplished in the time taken for one horizontal scan, and can be repeated on each horizontal scan, a complete vertical rainbow pattern is produced on the screen. Hues will be arranged in vertical bands that blend into one another. (A small portion of the spectrum is lost during horizontal retrace.)

The offset carrier principle accomplishes the 360° phase shift during the horizontal scan period by making the frequency of the subcarrier signal higher or lower than the reference subcarrier frequency by the horizontal-line frequency (15.75 kc). By making the beat or difference frequency 15.75-kc, the difference signal completes one cycle or 360 degrees in one horizontal line. The demodulators in the receiver sense the new subcarrier signal as one that is shifted through 360 degrees with respect to the reference oscillator during each horizontal scan. The result is a continuous rainbow or spectrum of colors across the screen, except for the small portion lost during horizontal retrace. Each hue appears as a vertical band of color which gradually blends into the next hue.

The frequency of the color signal generator subcarrier may be offset either above or below the reference oscillator in the receiver. If it is 15,750 cps lower than the reference oscillator, the colors start with orange on the left (facing the screen) and gradually change to green at the right. If the generator subcarrier frequency is 15,750 cps higher than the reference oscillator, the colors are reversed on the screen. In commercially available equipment the offset carrier is usually lower in frequency.

The offset signal can be combined with horizontal synchronizing pulses to provide a composite video signal. The offset signal or the composite signal can also be used to modulate an r-f carrier at a desired television frequency to provide a signal which can be fed directly to the antenna terminals of the receiver. If sync pulses are not provided by the generator, they must be obtained from

the receiver. The AFPC circuit in the receiver locks on the average phase of the offset carrier during the burst-sync gate period.

A continuous color spectrum has little value for practical adjustment of color circuits in the field. A more practical type of display is one which provides reference points in the form of readily identifiable phase angles. These phase angles should include the I and Q signals as well as the $R-Y$, $B-Y$, and $G-Y$ signals.

To provide these reference points, the gated-rainbow or color-bar generator incorporates a keying signal which gates the 3.563795-mc subcarrier signal on and off to produce distinct color bars. The keying rate is determined by the number of bars required. Because the major reference phase angles are separated by multiples of 30 degrees (see Fig. 8-13), a logical choice is to provide a bar for each 30-degree phase angle. (Note that the axes of the I and Q signals are actually either 33 degrees or 57 degrees from the $R-Y$ and $B-Y$ axes. This 3-degree difference can be ignored because a slight adjustment of the hue control can compensate for it.) This results in 12 bars which can be identified by color, each color representing a 30-degree change in phase angle from the preceding color.

To provide 12 bars in a system that uses a 15,750-cps horizontal line frequency, the gating frequency must be 189 kc ($12 \times 15,750$ kc). Only ten bars actually appear on the kinescope screen, as shown in Fig. 8-15. One bar is removed for the horizontal-sync pulse. The other bar, that follows immediately after horizontal sync, serves as the color-sync burst. Since the color-sync burst occurs during horizontal retrace time this bar does not appear on the screen. The relationship of the color bars to the color vector diagrams is shown in Fig. 8-13.

RCA WR-64A (Color Bar Function). The WR-64A generates a pattern of 10 color bars of different hues which are simultaneously displayed on the picture tube. These bars are spaced at 30-degree phase angles, and include all the phase angles required for color-TV servicing. The hues produced are shown in Fig. 8-15. The color signal is

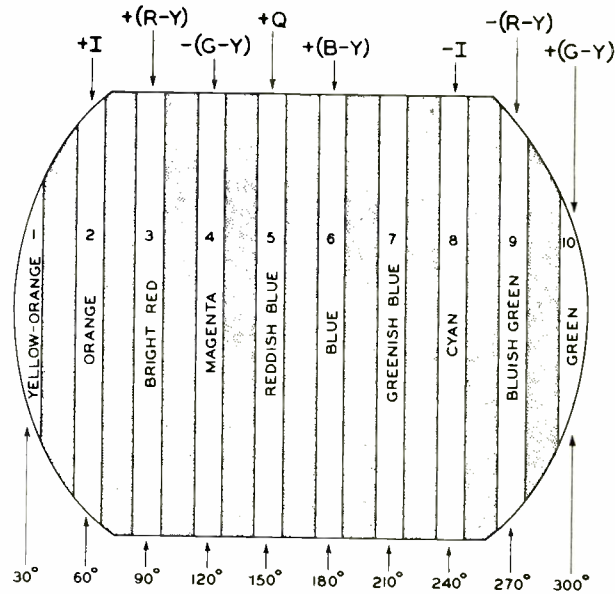

Fig. 8-15. Color bar pattern produced by a keyed "rainbow" generator such as the RCA WR-64A.

generated by the gated-offset-carrier method, from a crystal-controlled oscillator operating at 3.563795 mc. Narrow "brightness" pulses are added at the edges of each color bar to check color "fit" or relative time delays of the brightness and color signal. The instrument also incorporates a 4.5-mc crystal-controlled oscillator which is used as an unmodulated sound carrier signal. This signal is used in setting the fine-tuning control in the receiver. A CHROMA control, which is continuously variable from 0 to 200 per cent, is also included. This control alters the amplitude of the subcarrier (and burst) signals, and is used to check the color "sync lock" action of the receiver.

Circuit Description of the RCA Color Bar Generator WR-64A. A block diagram of the color-bar function is shown in Fig. 8-16, and a complete schematic diagram of the circuit is shown in Fig. 8-3.

A crystal-controlled oscillator, V_{1A} , operating at precisely 3.563795 mc, provides the color-subcarrier signal. The sinewave generated by V_{1A} is applied to a shaper and keyer stage, V_{1B} .

At the same time a 189-kc gating signal is generated by the crystal-controlled oscillator, V_{3A} , and applied to a shaper stage,

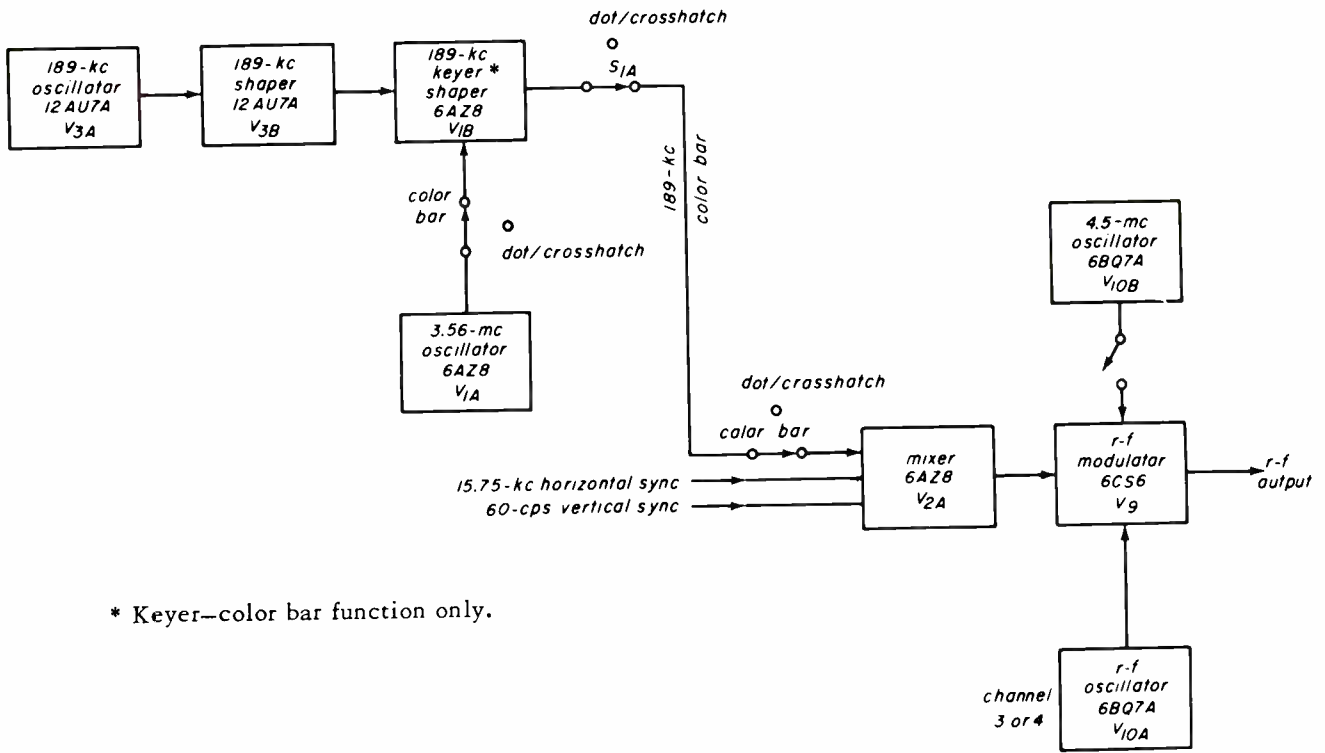

* Keyer—color bar function only.

Fig. 8-16. Partial block diagram showing the circuits that produce the color-bar signal in the RCA WR-64A generator.

V_{3B} . The 189-kc sinewave output is modified by the shaper stage to form gating pulses. The pulse and subcarrier signals are combined at the grid of V_{1B} . The resultant grid waveform, illustrated in Fig. 8-17a causes the tube to conduct during the positive portions of the envelope. Output appears in the form of bursts of subcarrier signal. The waveform in Fig. 8-17b shows the 3.563795-mc subcarrier signal bursts spaced or gated at a 189-kc rate. This signal is coupled through switch S_{1B} to the mixer tube, V_{2A} . In addition, narrow pulses or "pips" of brightness signal are inserted at the start and finish of each color burst signal. These brightness-signal pulses produce the jagged effect in the color-bar traces shown in Fig. 8-17b.

In the mixer tube, V_{2A} , the gated subcarrier signal is combined with the incoming 15.75-kc horizontal sync signal. The combined signal, illustrated in Fig. 8-17c, shows eleven subcarrier bursts and one 15.75-kc horizontal sync pulse for each horizontal

scanning line. An expanded view of this waveform is shown in Fig. 8-17d. The subcarrier bursts represent the color bars which will be displayed. Although twelve color-bar signals are produced in one complete horizontal scanning line (189 kc/15.75 kc = 12), only ten bars are actually displayed on the picture tube. One of the bars is blanked in the WR-64A by the horizontal sync pulse and the other bar serves as a color sync-burst signal.

Composite Color-Bar Signal Produced by WR-64A. The composite signal, shown in Fig. 8-17c, is applied to the modulator stage, V_9 , to modulate the picture-carrier signal. The r-f picture-carrier signal, which can be tuned to 61.25 mc (Channel 3) or to 67.25 mc (Channel 4), is generated by the oscillator stage, V_{10A} . The sinewave output from the oscillator is fed to the modulator stage, V_9 , and is amplitude modulated by the composite subcarrier signal. Combined output signal from the modulator is applied to the balanced 300-ohm output cable.

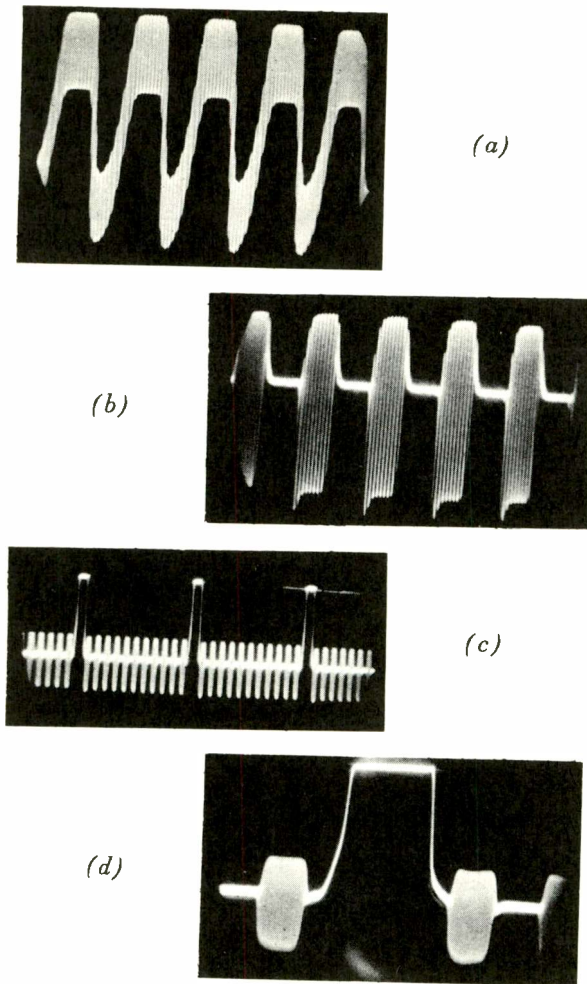

Fig. 8-17. Color-bar waveforms in the RCA WR-64A generator.

When the WR-64A FUNCTION switch is in the PATTERN and SOUND position, an unmodulated sound-carrier signal is generated by the 4.5-mc crystal-controlled oscillator, V_{10B} . The 4.5-mc output combines with picture carrier signal at the modulator to produce a beat frequency of 65.75 mc or 71.75 mc, depending on whether the r-f oscillator is tuned to Channel 3 or Channel 4. The resultant sound carrier signal permits adjustment of the fine-tuning control in the receiver. Fine tuning is adjusted for minimum sound-beat interference in the pattern.

Operation of the RCA Color Bar Generator.

The following setup procedure describes the connection of the instrument to the TV receiver, and the recommended method for obtaining the color-bar pattern on the picture-tube screen.

Disconnect the antenna leads from the receiver input terminals. Connect the two generator output leads to the receiver input terminals. The output leads are identified by the red-rubber insulators. Connect the ground lead, which is identified by the black-rubber insulator, to the receiver chassis.

Switch on the receiver and turn the station selector to Channel 3. In areas where Channel 3 is an operating channel, use Channel 4 and readjust the r-f frequency of the generator.

Set the FUNCTION switch of the generator to the STANDBY position. Allow a few minutes for the generator to warm up and turn the FUNCTION control to the "PATTERN and SOUND" position, the PATTERN control to the COLOR BARS position, and the CHROMA control to 100%.

Turn the fine-tuning control of the receiver slightly in the direction that causes the generator sound carrier to start blanking out the picture. Then turn the control in the opposite direction to a point where the sound interference just disappears or at a point where sound interference is at a minimum.

The technician should observe the effects that are produced in the color-bar pattern by adjustment of the receiver fine-tuning control. In conventional black-and-white receivers, the adjustment of the fine-tuning control is not too critical. In color receivers, however, it is essential that the bandpass characteristic of the receiver be properly adjusted to permit good color reception. Rotate the fine-tuning control from one side to the other and observe that incorrect settings cause the following:

- a. Sound interference, with partial or complete blanking of the picture.
- b. Color contamination, or shift in hue of the color bars.
- c. Color misregistration, or shift of position of the colors away from their correct position in the bar pattern.

At the correct tuning point sound interference is at a minimum, hues are correct,

and color and monochrome delays are matched. Thus it is important that the fine-tuning control be set correctly before making adjustments in the color circuits.

If the bars do not show color, advance the receiver color-saturation control (usually designated *color*) until the colors appear. If the receiver is in operating condition, with the proper width adjustment, ten bars will be seen on the picture tube. Adjust the *tint* or *hue* control of the receiver until the eighth bar is cyan. Refer to Fig. 8-15 for the proper color sequence. Incorrect adjustment of the control in one direction causes the eighth bar to be predominantly blue, while an incorrect adjustment in the opposite direction causes the bar to be predominantly green.

The locking action of the color AFPC section of the receiver may be checked by means of the generator's CHROMA control. Since the 100% position of the CHROMA control represents normal color-sync burst amplitude, variation of the control will indicate how well the color sync lock is holding as the burst amplitude is reduced. Turning the CHROMA control down should cause the colors to become pale and finally disappear. The rate at which the colors fade will depend upon the model under test. Most receivers will hold color lock throughout the entire color range. Some sets may lose color sync just before the colors fade. Loss of sync is indicated by diagonal running of the colors. This condition still indicates normal operation of the color sync circuits. If, however, a slight reduction of subcarrier amplitude causes the color to fall out of sync, insufficient locking action is indicated.

Turning the CHROMA control beyond the 100% position, so that color subcarrier burst amplitude is increased, provides a convenient means for checking the response of the r-f, i-f, and bandpass amplifiers or improper sync lock-action. If a higher setting of the CHROMA control is needed to produce saturated, locked colors, loss of response is indicated in the receiver.

Brightness pulses are inserted at the start and finish of each of the color bars to check the "fit" or delay matching of the

luminance (brightness) with the chrominance (color) signals. These pulses are seen as vertical dark and light lines at the edges of each of the color bars. In order to have perfect fit the brightness signals must arrive at the picture tube at the same instant as the corresponding color signals. Any deviation from this timing will cause the brightness display to shift to the left or the right of the color bars.

Deviations in the timing of the signals may be caused by misalignment or trouble in the r-f/i-f amplifiers, bandpass filters, demodulator output filter, or a faulty delay line in the luminance channel. Thus the brightness signals are useful in revealing these faults.

Adjustment Procedures Using the WR-64A.

The following adjustment procedures, using the RCA color receiver CTC-12, gives a practical example of the steps required for aligning the color circuits.

Checking the Phasing of the CTC-12 without an Oscilloscope. Turn on the WR-64A and allow several minutes warm-up time. Connect the generator output cable to the antenna input terminals of the receiver.

Tune the receiver to an open channel (3 or 4) and adjust for a normal color-bar pattern on the screen of the color picture tube. Adjust the fine-tuning control unit until the least amount of sound interference appears in the pattern of the picture tube.

Set the *tint* control to the center of its range, and turn the killer threshold control completely counterclockwise.

Shunt the green and blue picture tube grids to ground through 100,000-ohm resistors.

Note: The following adjustments may be simplified by the use of a grid shunt switch (Gun Killer). This device is shown in Fig. 8-18.

The center of the sixth bar should have about the same brightness level as the background (spaces between the bars). If the

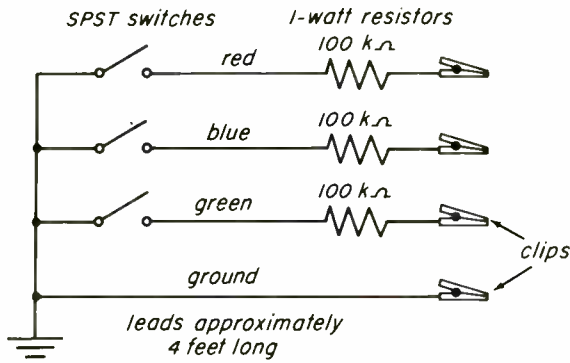

Fig. 8-18. Kinescope-grid shunt switch used to cut off selected guns in the color picture tube.

brightness level is not the same, adjust the burst phase transformer to obtain correct phasing (same brightness level as the background). Rotate the tint control from one extreme to the other. At one end the fifth bar should change to about the same brightness as the background. At the other end of the control's range the seventh bar should change to about the same brightness as the background. This indicates a control range of $\pm 30^\circ$. After readjustment, return the tint control to the midposition (to where the sixth bar is the same brightness as the background).

Remove the shunt from the blue grid. The sixth bar should show the proper blue color. Shunt the red grid with a 100,000-ohm resistor. The centers of the third and ninth color bar should have the same brightness level as the background. Note: In some older color-receiver models it may be necessary to adjust the 3.58-mc oscillator transformer, as well as the phase transformer, to obtain correct phasing.

Remove the shunt from the green grid and connect to the blue grid. The centers of the first and seventh color bars should have the same brightness level as the background.

Using the WR-64A with an Oscilloscope. An oscilloscope provides a very helpful indication of the proper phase adjustments of the receiver. In addition, observation of the waveforms at the kinescope grids gives us a way of checking the matrix or adder stages in the receiver. Modern receivers,

with very stable matrix circuits, do not require matrix adjustments. However, circuit faults such as off-value resistors can cause matrix errors, and the technician needs a way of checking the matrix job.

To use the oscilloscope in phase and matrix checks, set up the color-bar generator and the receiver as outlined in the previous section. Connect the oscilloscope to the blue kinescope grid, and sync the oscilloscope to view two horizontal lines (time base at 7875 cps). Adjust the horizontal gain and centering of the oscilloscope so that a horizontal sync pulse appears near each end of the horizontal trace. The waveform should appear as shown for B-Y in Fig. 8-19. Study the waveforms for the three grid waveforms in Fig. 8-19. Note that the blue bar has maximum positive amplitude (excursion in the white direction) at the blue kinescope grid. The red and green bars likewise reach maximum amplitude at the red and green grids respectively. If the sixth (blue) bar is not at maximum amplitude at the blue grid, then the phase (burst transformer) should be adjusted until it does.

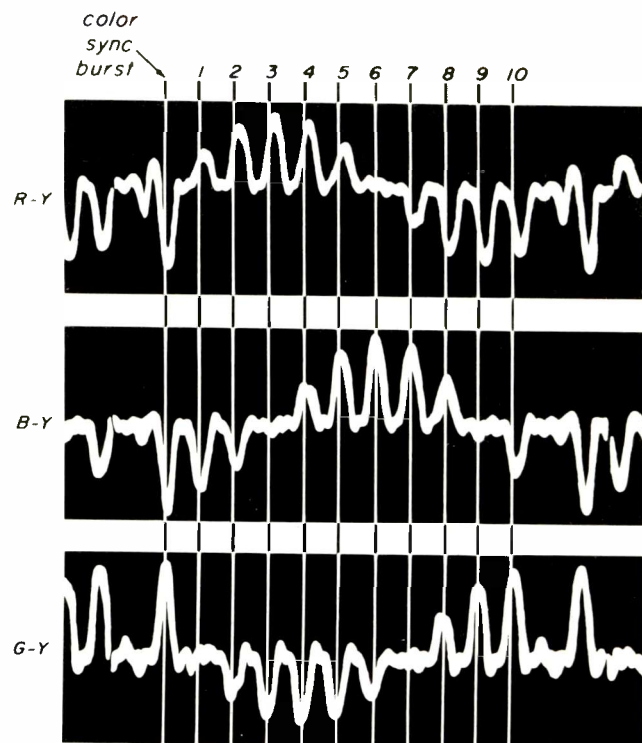

Fig. 8-19. Oscilloscope waveforms showing the normal color-bar signals at the red, green, and blue kinescope grids.

Matrix checks are made in late-model receivers by comparing the relative amplitudes of the three kinescope grid signals. Figure 8-20 shows how the relative amplitude of the $R-Y$, $B-Y$, and $G-Y$ signals compares in a properly-operating CTC-12 receiver. To make the check, monitor the red-grid waveform and set the vertical gain of the oscilloscope to produce some reference deflection such as 1 inch for the positive peak excursion. Consider this reference to be 100% and check the positive peak amplitudes of the remaining grid signals. The blue signal should have a positive peak signal of 1.05 inches, and the green-grid signal should have a negative peak signal of 0.4 inches.

At the end of phase and matrix checks, set the generator to STANDBY and disconnect the cable from the antenna terminals of the receiver. With a snowy raster, readjust the killer-threshold control in the receiver until the colored snow just disappears. Recheck using the color-bar generator to make sure that the color killer works properly on a color signal.

B and K Model 850 (Color Function). The Model 850 produces eleven colors which are displayed on the picture tube one at a time. The colors, selected by means of a COLOR switch, are burst, yellow, I , red, $R-Y$, magenta, Q , $B-Y$, blue, cyan, and green. Bars are produced by saturated signals developed from a crystal-controlled oscillator feeding a

delay line. Selecting a particular color results in the color being displayed over most of the area of the screen. A vertical bar, near the center of the screen, is blanked out to provide a reference level for phase adjustments.

A block diagram of the stages used to generate the color signals is shown in Fig. 8-21. A 3.579545-mc electron-coupled crystal oscillator feeds the burst signal to the driver stage. The oscillator output signal also feeds into a delay line composed of coils and capacitors. Specific inductance and capacitance values in the delay line are switched into the circuit by the COLOR control to produce the phase shift required for the desired color. This phase-shifted 3.579545-mc signal is the chroma signal. The output of the delay line feeds a transistor shaping circuit (Q_3 , Q_7) which is keyed by the 31.5-kc multivibrator. Keying the chroma signal blanks out the center portion of the oscillator output waveform to produce a pattern which can be used for making color-phasing adjustments without an oscilloscope. The output of the shaper circuit is fed to the driver stage, V_{6A} ; and the resulting signal from the driver is used to modulate the r-f carrier. A 4.5-mc unmodulated sound carrier can also be switched into the driver stage to produce the sound-beat pattern required for setting the fine-tuning control of the receiver before demodulator adjustments are made.

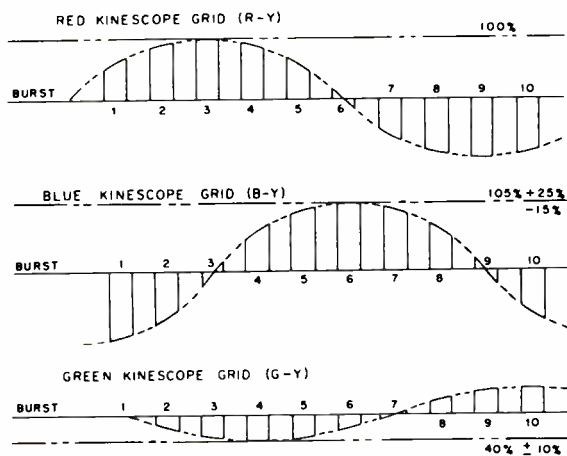

Fig. 8-20. Idealized kinescope grid waveforms showing the relative amplitudes of the $E_{(R-Y)}$, $E_{(B-Y)}$, and $E_{(G-Y)}$ signals.

Phase checks can be made in the following way. First, set up the generator and the receiver to display the $R-Y$ signal. Make the necessary fine tuning and chroma adjustments. Then bias off the red and green guns. The $B-Y$ signal should be zero when only an $R-Y$ signal is being transmitted. Phase controls are therefore adjusted to make the $B-Y$ signal go to zero (the color area of the picture should have the same brightness as the blanked bar in the center screen). A similar check may be made at the red grid by setting the generator to produce the $B-Y$ signal.

Hickok Model 660 (Color Function). The Model 660 produces a color display by means of the offset-carrier method. However, the signal is not gated and as a result the colors are not separated into a bar pattern. The

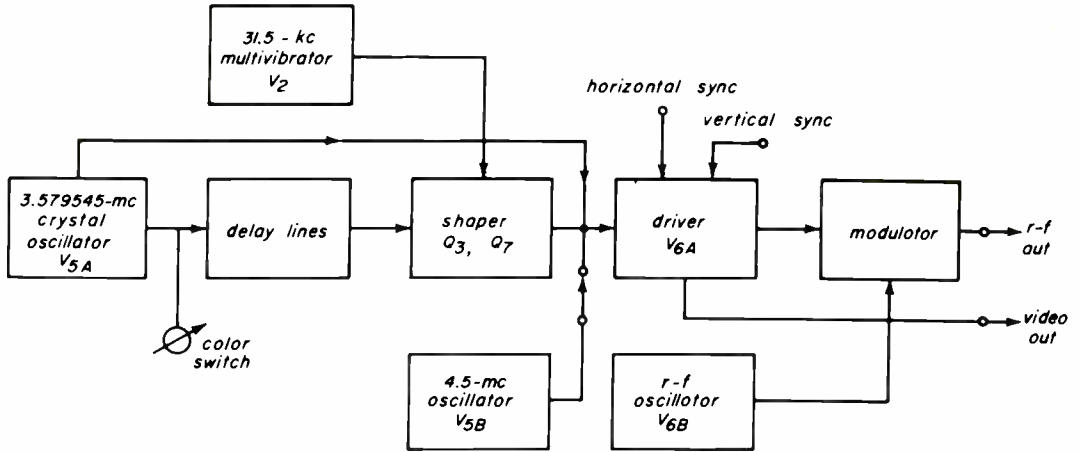

Fig. 8-21. Partial block diagram of the B and K Model 850 Color Analyst showing the color display circuits.

colors, starting with red-orange at the left side of the picture tube, gradually blend into red, blue, and green at the right side of the tube. Rapid troubleshooting checks and approximate phase checks can be made by observing the screen. An oscilloscope is required for demodulator alignment.

A block diagram of the stages in the Hickok Model 660, used to generate the color signal, is shown in Fig. 8-22. The color section of the Model 660 is a crystal-controlled r-f oscillator tube, V_{7A} , operating at 3.563795-mc. Direct output, which can be used as a video signal, is taken from the cathode of the oscillator through the 3.56-mc output connector. The 3.56-mc signal is also applied to the plate of the r-f oscillator tube, V_{7B} , where the 3.56-mc signal modulates the r-f carrier. Modulated r-f output is taken from the r-f output connector in the cathode circuit of V_{7B} .

No synchronizing voltages are produced when the Model 660 is used to generate a color signal. To obtain proper synchronization it is necessary to display the dot or crosshatch pattern at the same time.

8-5. ACCESSORIES

Accessories refer to a device used with other equipment to simplify servicing or to add a function to an existing piece of equipment. This section describes some of these service aids and test equipment.

Degaussing Coil. A degaussing coil is required when installing a color TV receiver and when readjusting purity. This device is a simple coil of wire which creates a magnetic field when a-c line voltage is applied across it. It is used to demagnetize the metal parts and hardware of the receiver, and to "set in" a permanent field to compensate for the earth's field.

The RCA 205W1, shown in Fig. 8-23, is representative of commercial degaussing coils which may be purchased. It is also possible to make a degaussing coil by winding approximately 400 turns of insulated number 20 wire to form a ring 12 inches in diameter. Connect line cord (at least 10 feet long) to the ends of the wire and wrap the coil with insulating tape.

To use the coil, plug the line cord into a 120-volt a-c line and slowly move the coil

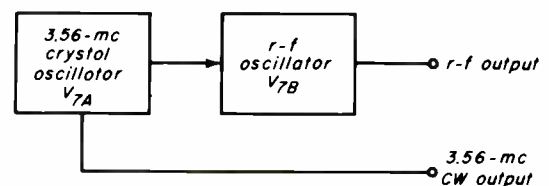

Fig. 8-22. Partial block diagram of the Hickok Model 660 White Dot-Bar, Color Display Generator showing the stages that generate the rainbow pattern.



Fig. 8-23. Degaussing coil, RCA 205W1.

over the entire area of the picture tube faceplate and the top and sides of the cabinet. Withdraw the coil very slowly to a distance of eight to ten feet before disconnecting the coil. Moving the coil away gradually reduces the magnetic effect and prevents remagnetization by the collapsing force field when the coil is disconnected from the a-c line.

Color Test Jig. A color test jig is used as a substitute for the receiver's picture tube, and enables a technician to service color television receivers more quickly and efficiently.

A complete unit, such as the RCA test jig, consists of a cabinet to house a color picture tube, and all necessary mounting hardware, components, and cables for providing a color picture when connected to a color chassis.

The color test jig is an extremely useful accessory for testing, servicing, and adjusting the color receiver. The jig eliminates the need to completely disassemble the receiver or to carry the entire receiver and cabinet to the shop. Thus, the color test jig enables one man to do a job that would ordinarily require two men. Since only the chassis is transported, there is no possibility of damage to the cabinet and picture tube when taking the receiver to the shop. The jig also eliminates the need to reconverge the set completely when the chassis is remounted into the cabinet. Purity and static convergence adjustments need not be disturbed, and dynamic convergence adjustments need not

be altered unless there is a trouble in the convergence circuitry. Some minor touch-up adjustments may be needed when the chassis is reinstalled in the receiver's cabinet.

Figure 8-24 shows the RCA Color Test Jig. It uses a 21-inch picture tube, and contains the convergence and purity assemblies as well as the necessary connecting cables.

Low-Power Microscope. A microscope or suitable magnifying glass of approximately 12-power will prove helpful in making convergence and purity adjustments. A microscope enables the technician to view the phosphor dots on the face of the color picture tube.

When the separate red, blue, and green fields appear to be pure over the entire area of the screen, but impurities show up in the white raster, it is advisable to check beam landing with the microscope.

The microscope can be used to see if one of the color components needs to be shifted up, down, or sideways to obtain the best landing of the three electron beams in the center of their associated phosphor dot. Inspection of the dots will aid the technician in understanding how incorrect landing of the beams produces poor purity.

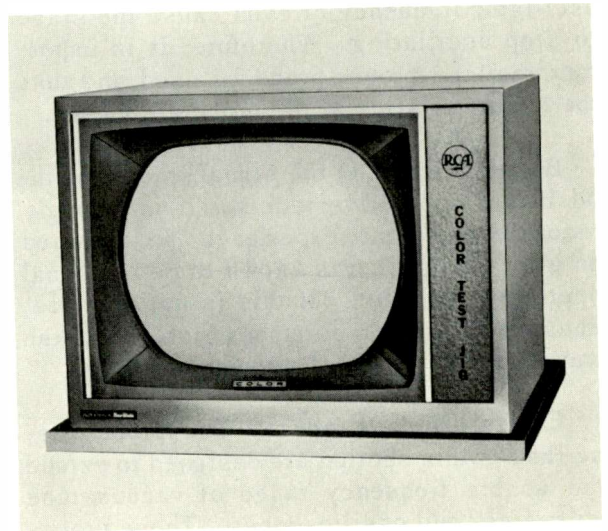

Fig. 8-24. RCA Color Test Jig.

Signal Tracing Accessories. Analysis of the picture on the screen and tube substitution are the first steps which should be taken to localize a defect in a color television receiver. If this does not correct the trouble, then voltage and resistance measurements, and a check of the components should be made. If routine troubleshooting procedures do not reveal the source of the trouble, the signal-tracing method may help to localize a fault in the signal path.

It is not practical to attempt signal tracing using a transmitted color signal because of the constantly changing characteristics of the signal. A signal of known characteristics such as is generated by a color-bar generator must be used. Of course, a wideband oscilloscope capable of handling the signals involved must also be used.

Signal tracing with the proper equipment will show the effect of the various stages on the signal. Loss of the signal, weak, or distorted signals are all symptomatic of problems in the stages in which they occur.

When the signal-tracing method is used, it must be remembered that both the oscilloscope and the probes can alter the characteristics of the signal. Even a low-capacitance probe can detune a circuit to the point where the signal level is appreciably reduced. In some cases, direct connection to the 3.58-mc oscillator stage can change the oscillator frequency or even cause the stage to stop oscillating. Therefore, it is important that the proper probe be used and that the characteristics of the probe are known.

Before attempting the signal-tracing method in an inoperative receiver it is strongly recommended that experience be obtained on a receiver which is known to be in normal operating condition. If this is not feasible, obtain a schematic diagram which shows the waveforms at pertinent circuit points.

Crystal-Diode Probes. The probes described in this section are designed to extend the usable frequency range of vacuum-tube voltmeters and oscilloscopes. These probes are of the "slip on" type and are used with the regular probe and cable assembly supplied with the RCA VoltOhmyst® and with RCA



Fig. 8-25. Crystal diode probe for use with a VTVM, RCA WG 301A.

oscilloscopes. They are representative of the types of probes available from most manufacturers either as complete units or "slip on" accessories.

The WG-301A, crystal diode probe, which is illustrated in Fig. 8-25, is a "slip on" accessory which fits the RCA WG-299 series probe and cable supplied with a VoltOhmyst such as the RCA WV-98C and the WV-87A. The crystal-diode probe is used with a VTVM to measure the rms value of sine-wave voltages at frequencies up to 250 mc.

The WG-301A probe contains a crystal diode, which functions as a half-wave rectifier, and an r-f filter. A schematic diagram of the probe is shown in Fig. 8-26. The output of this probe is a d-c voltage which is proportional to the peak value of the sinusoidal input voltage. The rms value of the voltage is read on the d-c scales of the voltmeter. The peak value may be found by multiplying the reading by 1.41. Voltages up to 20 volts rms (28 volts peak) can be measured in the presence of d-c voltages up to 250 volts. The probe has an essentially flat characteristic, ± 0.75 db, over the range of frequencies from 50 kc to 250 kc.

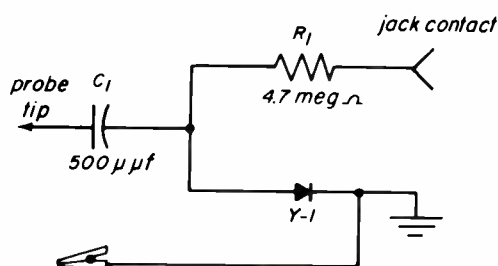

Fig. 8-26. Schematic diagram of the WG 301A.

The time constant of C_1 and R_1 is chosen so that the probe acts as a peak detector. Since this peak detector draws current only during the positive peaks of the input signal, the probe draws very little current from the circuit under test and does not load the circuit excessively. The resistance of R_1 is selected so that R_1 acts with the input resistance of the VTVM to provide a *rms* reading. For this reason, the probe resistance must be tailored to fit a particular value of VTVM input resistance, and all probes will not function properly with all VTVMs.

The WG-302A, r-f/i-f signal tracing probe, which is illustrated in Fig. 8-27, is designated to be used in conjunction with an oscilloscope to observe the response characteristics of individual amplifier stages. It is used in conjunction with the WG-300 series direct/low capacitance probes supplied with oscilloscopes such as the RCA WO-91A.

The WG-302A consists of a half-wave crystal rectifier and an r-f filter, as shown in Fig. 8-28. The time constant of the filter is such that, when used with a modulated high-frequency signal, it separates the low-frequency modulating signal from the high-frequency modulating signal from the high-frequency modulating signal from the high-frequency modulating signal. The signal waveform is centered vertically on the zero axis of the screen when an RC coupled oscilloscope is used. When a direct-coupled oscilloscope is used, the waveform is displaced vertically by a distance which is proportional to the d.c. developed from the rectified carrier.

The input capacitance of the WG-302A is less than $3.75 \mu\mu\text{f}$, which permits the use of the probe in most circuits without a serious detuning effect. The probe extends the useful response of the oscilloscope to 50 mc,



Fig. 8-27. Demodulator probe for use with an oscilloscope, RCA WG 302A.

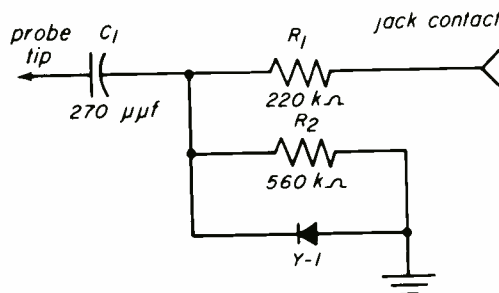

Fig. 8-28. Schematic diagram of the WG 302A.

which covers the i-f and video frequency range of the receiver. A short ground lead may be attached to extend the range to 250 mc for signal tracing in the tuner. Voltages up to 20 rms volts (28 volts peak) can be measured in the presence of d-c voltages up to 250 volts. The demodulation frequency range is 30 to 2000 cps which makes the probe especially useful, when used with a sweep generator, in obtaining an over-all bandpass characteristic of a stage. The WG-302A has a relatively flat characteristic, ± 1 db over the range of 100 kc to 250 mc.

Kinescope Grid Shunt (Gun Killer). The RCA 226X1 Convergence Grid Shunt or similar device is a convenient accessory aid for performing convergence, color phasing, and purity adjustments. The Grid Shunt Switch Box permits the technician to disable one or more guns of the picture tube by shunting the control grid circuit of each gun, through 100,000-ohm resistors, to ground. By shunting the grid of one of the electron guns to ground, we alter the bias to cut off the gun. The 100,000 ohm resistors reduce the positive voltage at the grid by a factor of 2 (approximately), while the cathode voltage remains at a high positive value. The effect is a large increase in grid to cathode bias voltage. Large value resistors are needed for this purpose to prevent excessive d-c loading of the grid-driving circuitry. The use of the grid shunt switch has been described in previous lessons.

If such an accessory is not readily available, then construct the simple circuit shown in Fig. 8-18. However, when constructing the grid shunt, connect the 100,000-ohm resistors close to the clip ends of the leads to minimize the effects of stray pickup in the leads.

Kinescope Testers. There are several types of testers available for checking color picture tubes. Some of these are a part of a shop-type receiving tube tester, others are separate instruments. However, at the present time, there is no commercially available picture tube tester which checks *all* of the characteristics which should be known about the color picture tube.

This does not mean that the technician should not use these testers. It does mean that the readings obtained from a CRT tester will have to be analyzed carefully before a decision, that the color picture tube is defective, is reached. In receivers where the color picture tube is thought to be defective, a substitution check using the color test jig is recommended.

Extension Cables. Extension cables can greatly simplify bench servicing of color receivers. They allow the picture tube and its associated components to be connected while the chassis is outside the cabinet. Extension cables, terminated with the proper connectors, can be placed in series with the interconnecting cables used in the receiver to extend their length. This permits observation of the picture while servicing or making bench adjustments.

A set of extension cables should provide additional working lengths for the following leads:

1. High-voltage lead – 50-kv insulation, special connectors.

2. Deflection yoke leads – special plugs and sockets.

3. Kinescope socket leads – 14-pin plug and socket.

Extension cables should be about four feet long.

In some older receivers an additional cable is needed to connect the chassis to the convergence assembly on the kinescope. In a few of the RCA CTC-5 chassis, a two-pin plug and socket is needed for the EM blue-lateral magnet. In later RCA models (CTC-7 through CTC-12) the convergence assembly, including the convergence control board, connects to the main chassis by means of an octal plug and socket. In most cases an extender cable is not needed for the convergence assembly, as the convergence control board can be removed from its mounting and positioned so that there is plenty of slack in the leads.

When using these cables, some detuning may occur due to the introduction of inductance or capacitance in the circuit. This detuning effect may be minimized by keeping the leads separated to reduce interaction between the wires in the cable. Touch-up adjustments may be required when the chassis is replaced in the cabinet. It may be necessary to obtain or construct several sets of cables to cover all receiver models. Table 8-1 lists the extension cables used with RCA chassis CTC-4 through CTC-12. The numbers in the table are RCA part numbers.

TABLE 8-1
RCA EXTENSION CABLES

Extension Cable	RCA CHASSIS NUMBER						
	CTC-4 (600 Series)	CTC-5 (700 Series)	CTC-7	CTC-9	CTC-10	CTC-11	CTC-12
Kinescope Socket	220X1	220X1	220X1	220X1	220X1	220X1	220X1
High-Voltage Lead	223X1	225X1	225X1	225X1	225X1	—	—
Deflection Yoke	221X1	221X1	228X1	228X1	228X1	228X1	228X1
Convergence Assembly	222X1	224X1	221X1	221X1	221X1	221X1	221X1

High-Voltage Probes. Normal changes in the value of high voltage have a relatively minor effect in black-and-white receivers, but similar changes cannot be tolerated in color receivers because of the resultant adverse effect on purity, convergence, high-light and low-light tracking, etc. Consequently, the high voltage in color receivers is regulated in order to maintain a specified constant value. On initial installation, and on subsequent service calls, the technician should measure the high voltage accurately and adjust for correct regulation before adjusting purity, convergence, etc.

The high-voltage in color receivers ranges from 20 to 30 kv. Hence, it is necessary to use a voltmeter and a high-voltage probe capable of accurately measuring d-c voltages up to 50,000 volts. The RCA high-voltage probe, shown in Fig. 8-29, is an example of the type of probe that is needed. The probe should be designed with an ample safety factor for the technician, because the high-

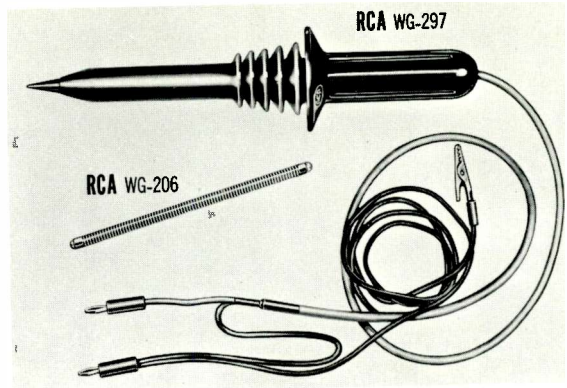

Fig. 8-29. High-voltage probe, RCA WG-297.

voltage supplies in color receivers are capable of storing a greater charge than those in black-and-white receivers. Desirable safety features include a long, low-loss leakage path, a grounded arc-over protection baffle, an anti-corona tip, completely insulated grip, and a separate ground lead.



NOTES

NOTES

NOTES

1

Developments in Color TV

Servicing the New Color Sets

RCA

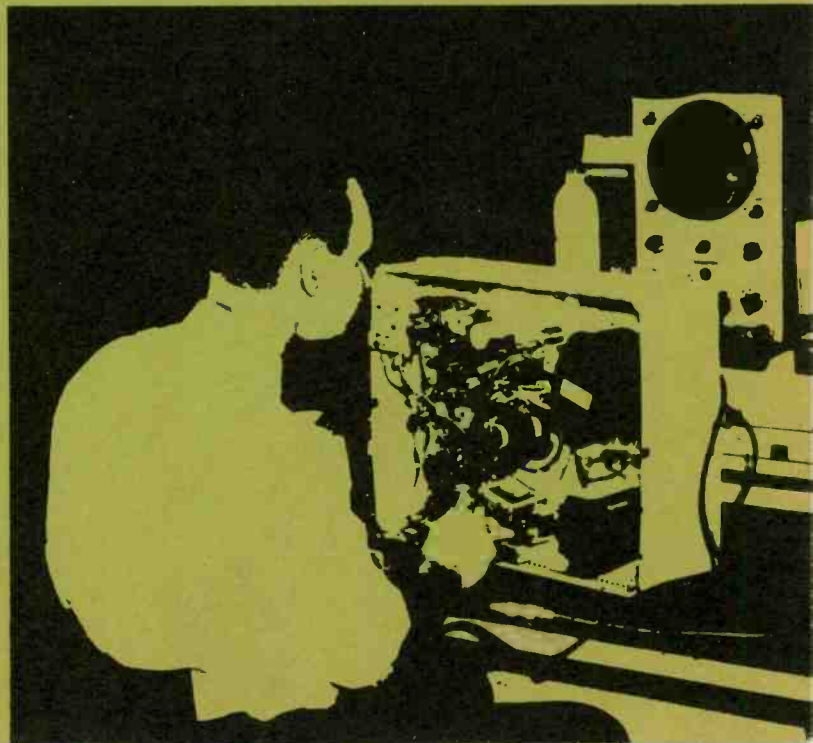
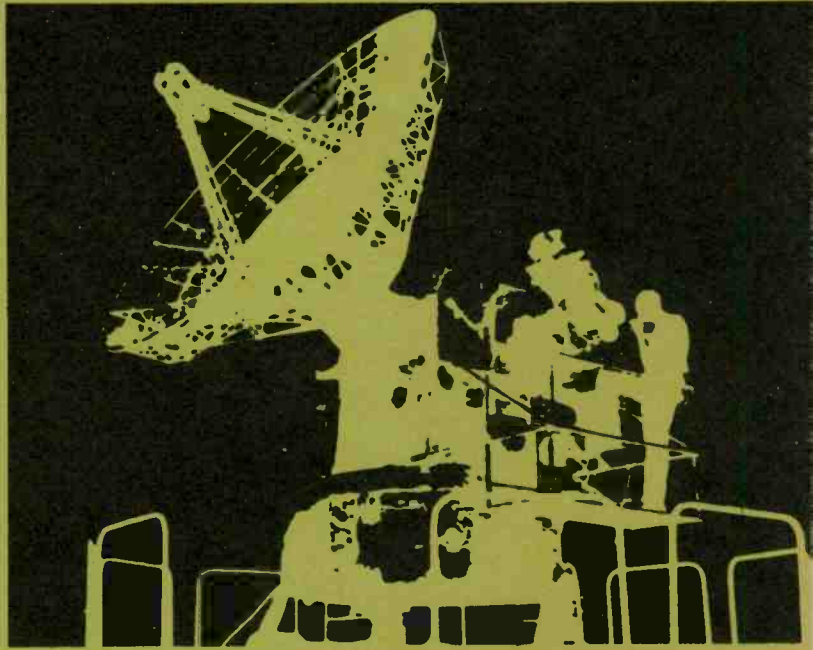

RCA Institutes

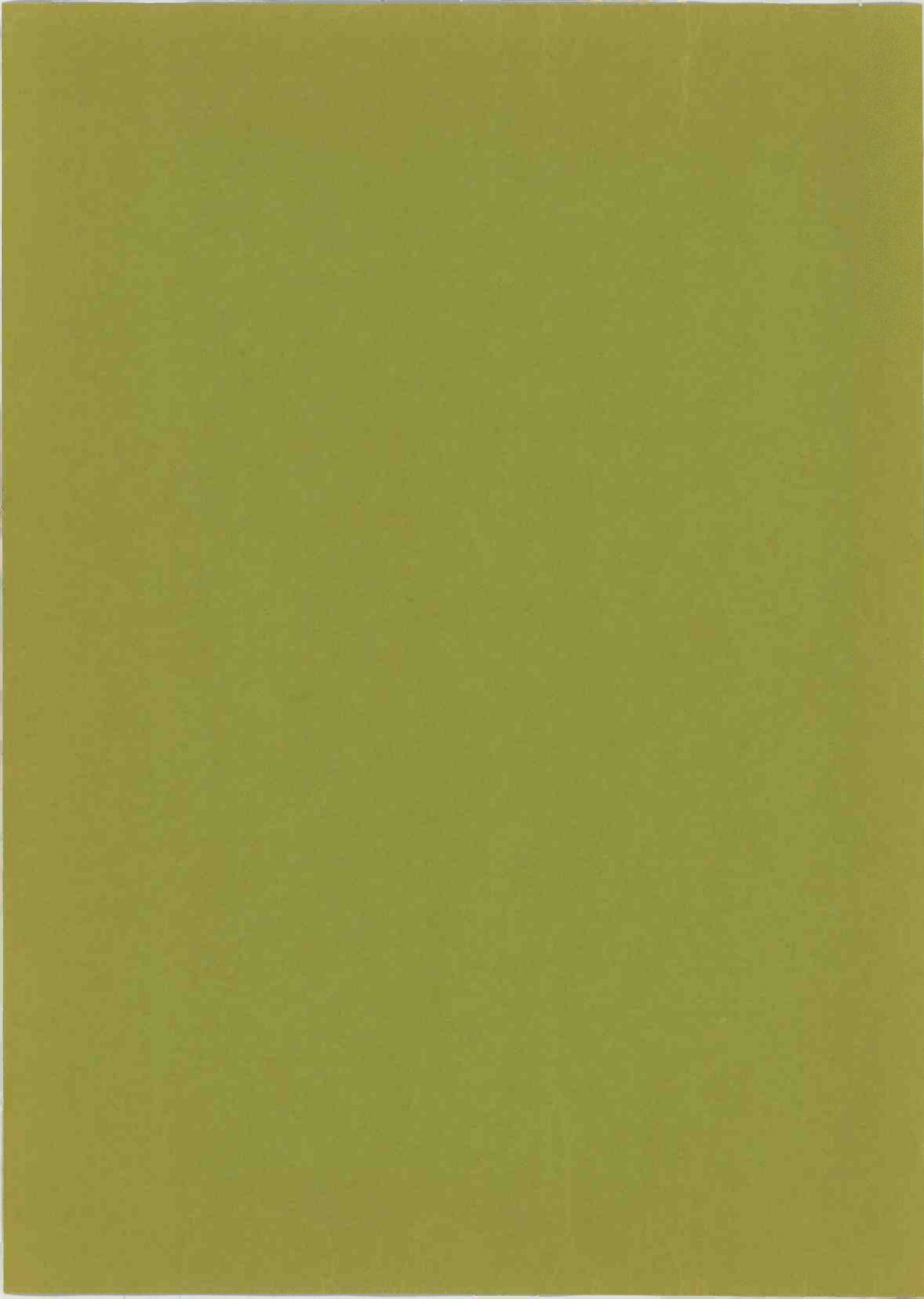

COLOR TELEVISION

Developments in Color TV

1. Rectangular Picture Tubes
2. Anti-Pincushion Systems
3. Built-In Degaussing Systems
4. Small-Screen Color Sets
5. Recent Color Picture-Tube Developments
6. Color AFPC Systems
7. Color-Demodulator Circuits
8. Foreign Color Systems

RCA Institutes, Inc.

Home Study School

320 West 31st Street | New York, NY 10001

© RCA Institutes, Inc. 1967 All Rights Reserved 1969 Printing

INTRODUCTION

This lesson covers technical developments in color television which have evolved since rectangular color picture tubes were introduced. It also covers recent color picture tube developments and examines foreign color systems.

9-1. RECTANGULAR PICTURE TUBE

Rectangular picture tubes have become popular because more of the tube's face plate is utilized as the viewing screen. Television receiver and cabinet size can be reduced without making the picture smaller. However, distortion resulting because of the change in configuration from a round picture tube to a rectangular one has added to circuit complexity and design problems.

Tube Size. Modern rectangular picture tubes are shorter than earlier round picture tubes and require wider-angle beam deflection. Rectangular picture tubes are now available in sizes from 11 to 25 inches (diagonal screen dimension). The neck of a 21-inch round tube is 2 inches, compared to $1\frac{1}{8}$ -inches for a 25-inch rectangular tube. Figure 9-1 shows a rectangular tube alongside a round tube to illustrate the contrast in dimensions.

Beam Deflection. Because of the shorter length of rectangular picture tubes, the beam-deflection

angle of most types is 90° , except for 11-inch rectangular tubes whose required beam-deflection angle is 70° .

Brilliance. The brilliance (particularly red) of color picture tubes has been greatly increased through the use of rare-earth phosphors and the use of cover plates, bonded to the tube screen, which have a higher light transmission factor.

Electron Guns. To provide 90° beam deflection in rectangular picture tubes with smaller diameter necks, the guns are placed closer together than in 70° -deflection round tubes. This requires more careful gun alignment and tighter tolerances. In most picture tubes the guns are arranged so that the beams strike the phosphor dots in a triangular configuration. In a recently developed 11-inch tube, the guns are aligned horizontally and the beams hit the screen in a horizontal configuration.

Shadow Masks. The shadow mask of a rectangular picture tube is printed on the glass face plate which has to be specially treated to avoid distortions which could occur during manufacture. The phosphor screen of the shadow-mask picture tube is covered with about one million phosphor dots, arranged in tiny trios of the three primary colors. Between the electron guns and the phosphor screen is a shadow mask, a sort of sieve containing about one-third of a million holes—one



(a) a rectangular picture tube



(b) a round picture tube

Fig. 9-1. A modern and an early picture tube.

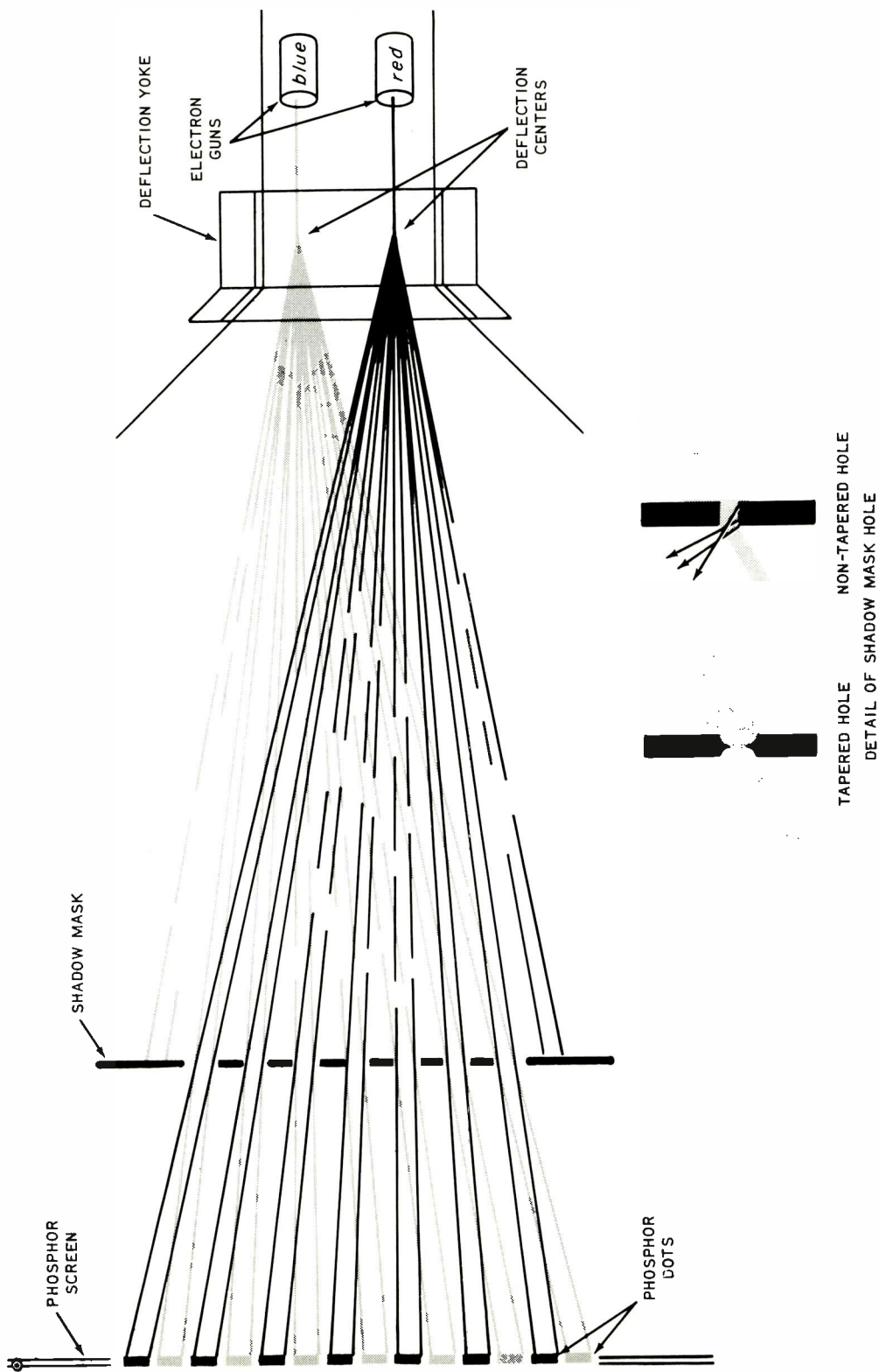

Fig. 9-2. A simplified illustration of the shadow-mask principle. The detail shows how the holes in the mask are tapered to reduce the spray of electrons that would occur if cylindrical holes were used.

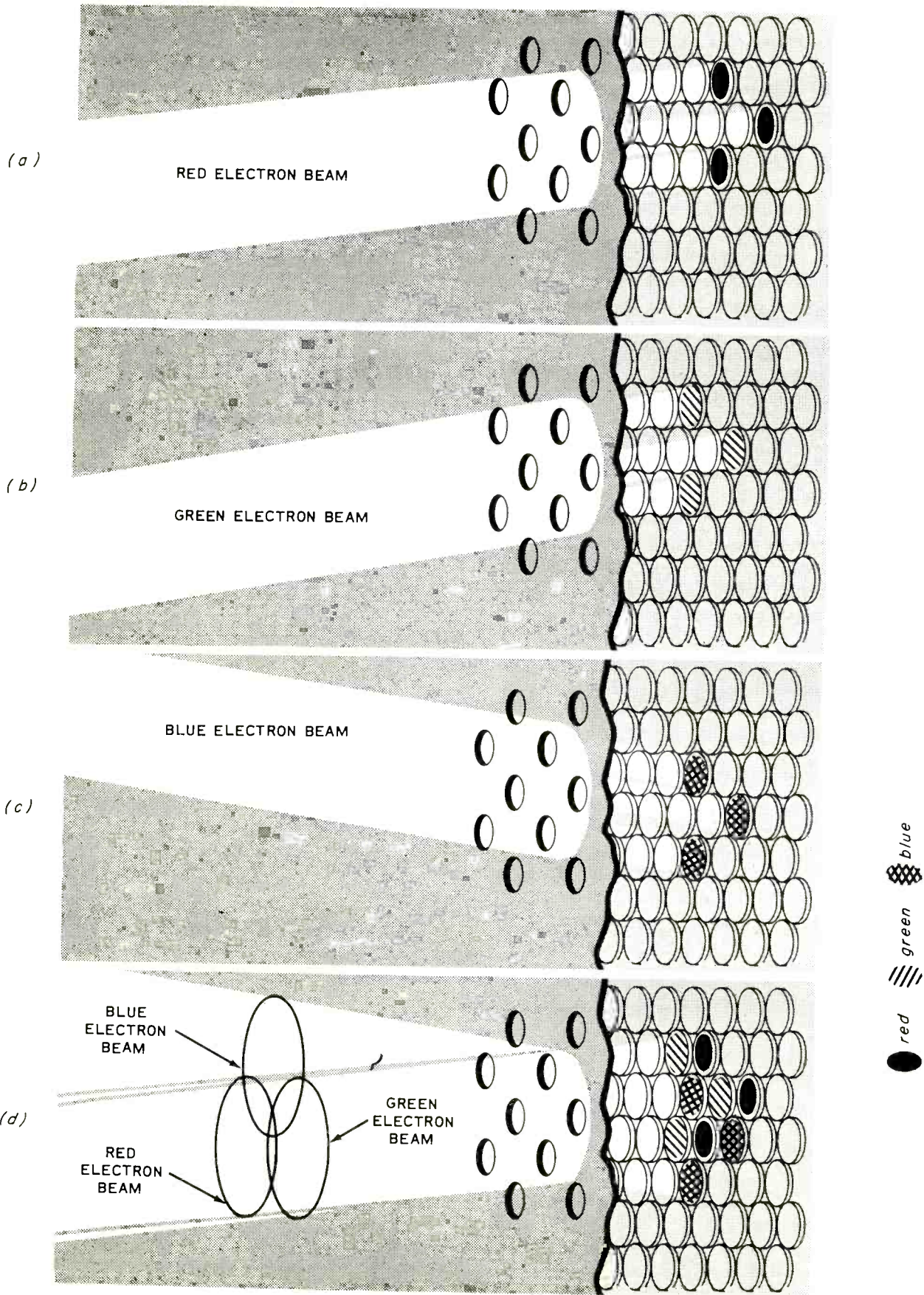

Fig. 9-3. A closeup view of the phosphor screen and shadow mask, showing how electron beams strike selected phosphors.

for each phosphor-dot trio. The mechanical arrangement of the phosphor screen, the shadow mask, and the sources of electrons permit electrons from a particular electron gun to strike phosphor dots of one particular color only when the picture tube is adjusted correctly. Each gun, and its group of associated primary-color phosphor dots, operates independently.

Figure 9-2 illustrates the shadow-mask principle. To simplify the idea, using this two-dimensional drawing, a hypothetical color picture tube using only two guns and two groups of phosphors is shown. Electrons proceed down the neck of the tube in a beam until they enter the field of the deflection yoke. Here the beams are deflected to the left or right, and up or down as required for scanning. As a result of deflection, electrons seem to originate from a point source inside the field of the yoke. This point source of electrons is called a deflection center. Consider the deflection center for the blue electron beam. Electrons that emerge from this spot hit either the sieve-like shadow mask, or pass through the holes and strike blue phosphor dots. Electrons traveling in straight lines from the "blue" deflection center cannot hit red phosphor dots. You can verify this by laying a straight edge on the diagram so that it pivots on the blue deflection center. Regardless of the deflection angle, any beams that pass through the holes in the shadow mask strike only blue phosphor dots. Red may be checked in the same way.

The detail in Fig. 9-2 shows that the edges of the holes in the shadow mask are tapered. Note how this arrangement cuts down the spray of secondary-emission electrons that would result if the holes were cylindrical. Such spray would cause all nearby phosphors to be lighted. Tapered holes also help to preserve the circular shape of the electron beam near the edges of the screen.

To maintain purity over the entire face of the screen, the deflection centers must be accurately placed inside the neck of the tube. If you pick some other point in Fig. 9-2 for a deflection center you will find that electrons emerging from this new point strike both red and blue phosphor dots at some point on the screen. The result is impurity—that is, contamination from an unwanted primary hue.

Figure 9-3 shows an enlarged view of a small section of the shadow mask and phosphor screen.

Note that the electron beam is larger in diameter than the holes in the shadow mask. In fact, the beam usually straddles three holes, as shown. Since the beams approach the mask from three separated deflection centers, they approach at different angles and strike only the designated phosphor dots.

Circuit Requirements. Some picture tubes now employ a low-voltage, electrostatic focus lens instead of a high-voltage electron-tube focus gun. This does away with the requirement for a separate high-voltage source for the optical-focusing system.

9-2. ANTI-PINCUSHION SYSTEMS

When a rectangular picture tube is used, the "pincushioning" effect prevails and must be corrected. Figure 9-4 illustrates top-bottom and side pincushioning. The raster is stretched out at all four corners.

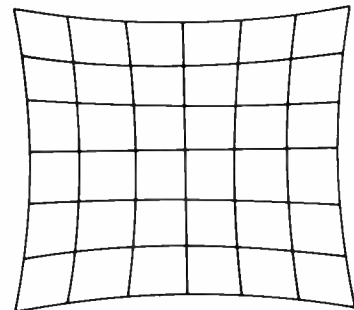

Fig. 9-4. Top-bottom and side pincushioning.

Top and bottom pincushioning, illustrated in Fig. 9-5, can be corrected by adding vertical-sweep amplitude to the vertical-deflection circuits at the top and bottom of the raster. Side pincushioning,

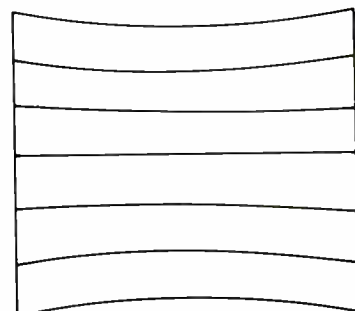

Fig. 9-5. Top-bottom pincushioning.

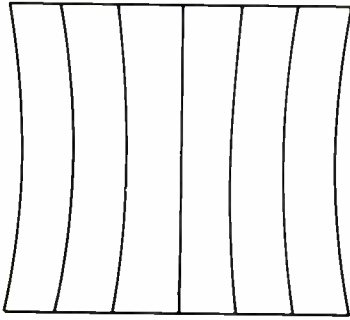

Fig. 9-6. Side pincushioning.

illustrated in Fig. 9-6, can be corrected by reducing the horizontal-deflection width at the top and bottom of the vertical-scanning line.

Top-Bottom Pincushion Correction. Figure 9-7 is a simplified circuit of the top and bottom pincushioning correction system used in the Heath Model GR-295 receiver. To the vertical deflection-yoke circuits are added a pincushion phase-adjusting coil (L) and a saturable reactor (T). The sawtooth vertical-deflection current, fed through the control windings of the saturable reactor, controls the reluctance of the cores on which the load coils are wound. The change in core reluctance alters the inductance of the load coils.

As the vertical-sawtooth current passes through the control coils, the inductance of the load coils alternately increases. These alternating inductance changes induce horizontal pulses into the

control coils. Phase coil L and capacitor C filter these pulses into sine waves which are added to the sawtooth current in the control windings. The vertical deflection is thus increased at the top and bottom of the raster, and its amplitude can be controlled with variable resistance R .

Side-Pincushion Correction. By subtracting from the horizontal deflection at the top and bottom of the vertical-scanning line, side pincushioning can be corrected. A simplified circuit used for this purpose in a Heath receiver is shown in Fig. 9-8. The control winding of saturable reactor T is biased by a low, positive d-c voltage to establish a reference level of inductance. The horizontal-sweep current passes through the two load windings of the saturable reactor and through width coil L . The vertical pulses from the cathode of the vertical-output tube are fed to the control winding. The pulses change the reluctance of the reactor cores, altering the inductance of the load windings. Each vertical pulse passing through the control winding reduces the amplitude of the horizontal sweep. This reduces the horizontal-deflection width and offsets the side-pincushioning effect.

RCA Pincushion Control. Figure 9-9 is a simplified diagram of the top-bottom pincushion correction circuit used in the RCA Victor CTC19 series receivers. This diagram includes the thermistor in the vertical-deflection circuits which damps out oscillations and anti-ringing in RC networks, and voltage-dependent damping resistor

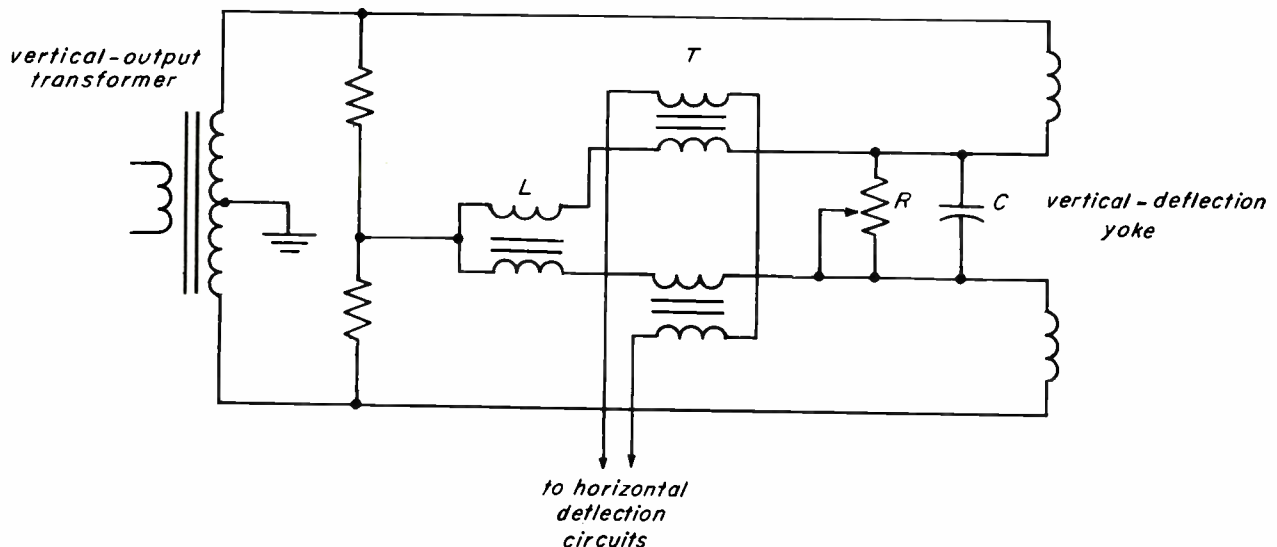

Fig. 9-7. Top and bottom pincushioning correction.

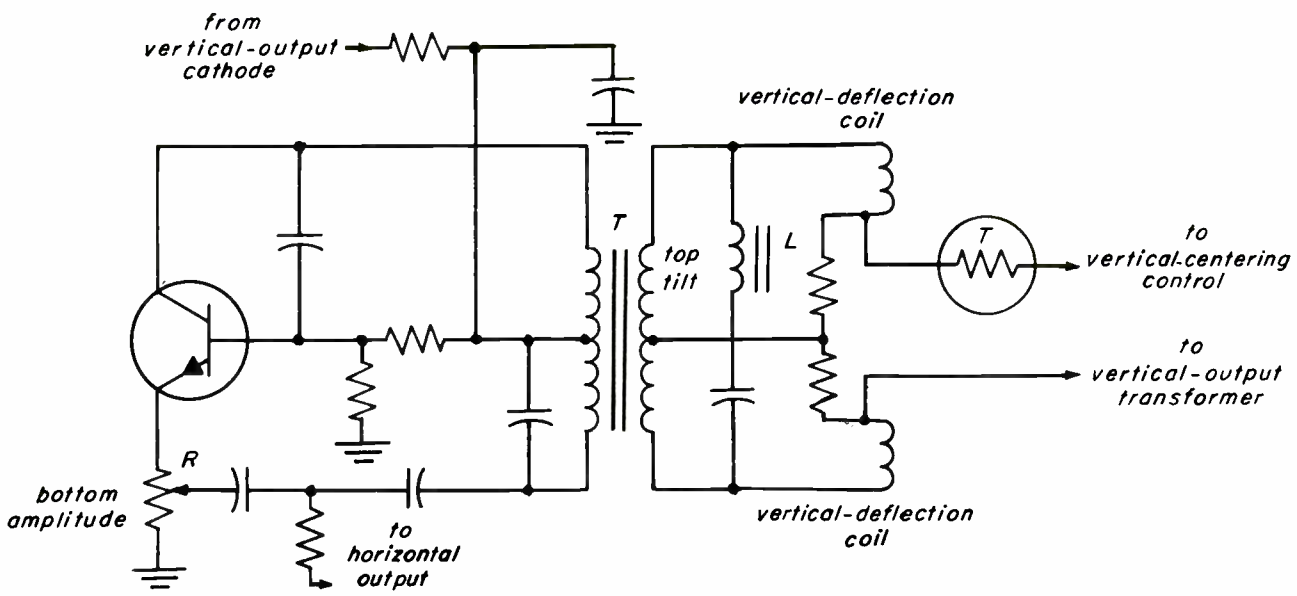

Fig. 9-10. Motorola dynamic pincushion-correction circuit (transistorized).

in the horizontal-deflection circuits. It operates on the same principle as the circuit shown previously in Fig. 9-7.

Motorola Pincushion Corrector. Top and bottom pincushion correction is achieved in some Motorola receivers with a simple transistor-controlled saturable reactor (T) as shown in the simplified diagram, Fig. 9-10. Bottom-amplitude adjustment is afforded by potentiometer R. Top

tilt is adjusted by changing the inductance of coil L. A vertical pulse from the cathode of the vertical output changes the conductivity of the transistor by altering its bias. This changes the value of the current flowing through the control winding of the saturable reactor which changes the reluctance of the core and, in turn, the inductance of the load winding.

Another similar Motorola pincushion correction circuit is shown in Fig. 9-11. Here, vertical pulses

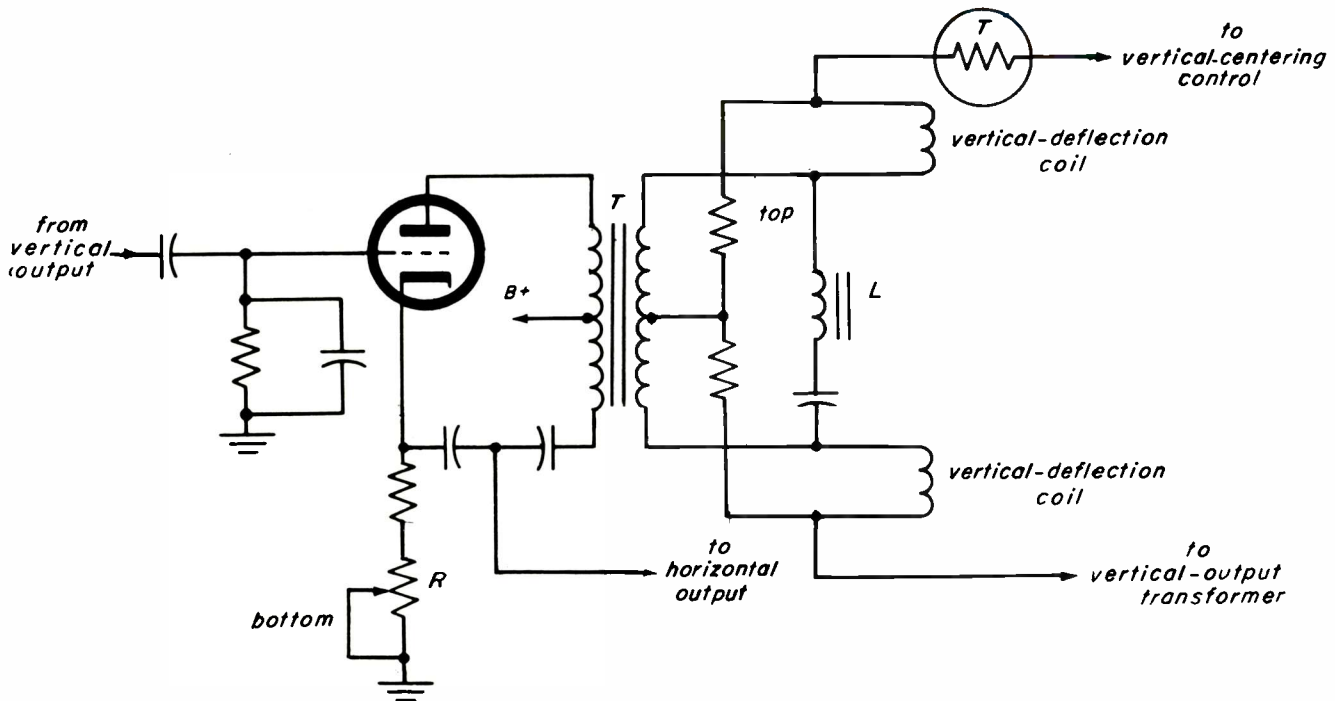

Fig. 9-11. Motorola dynamic pincushion-correction circuit (vacuum tube).

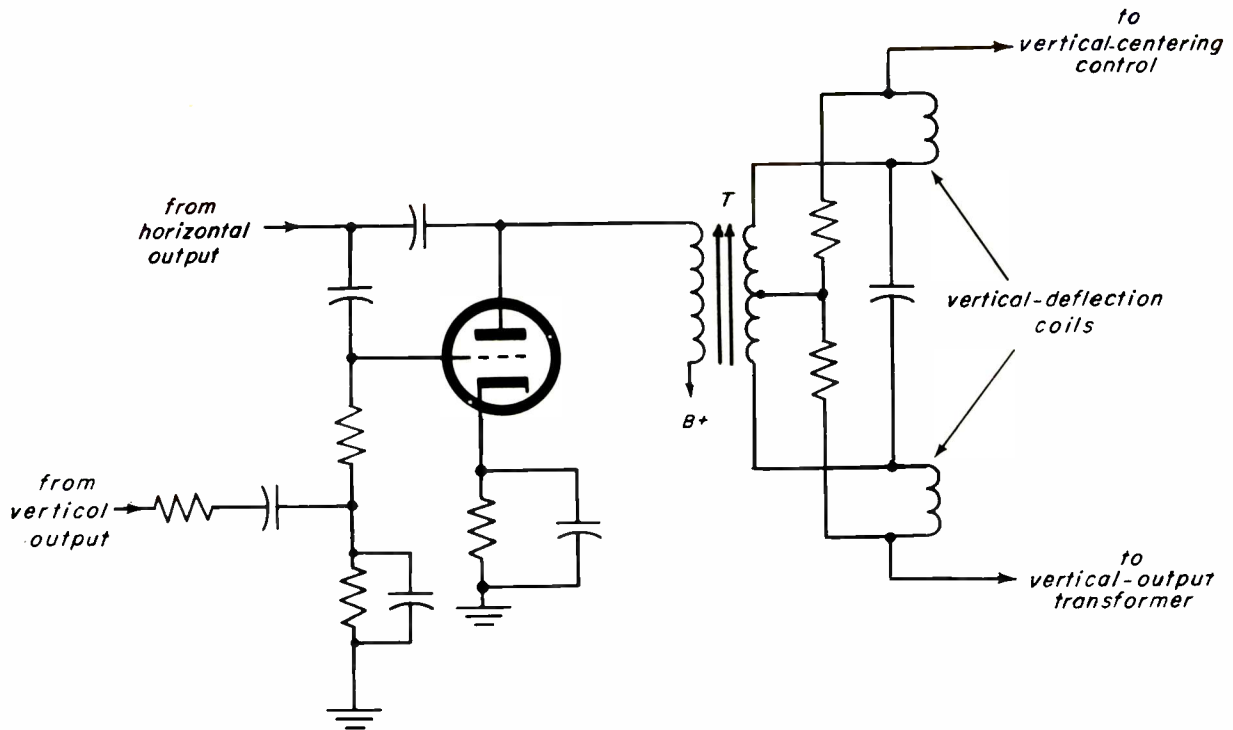

Fig. 9-12. Zenith pincushion-correction circuit.

are fed to the grid of a tube. Resulting plate-current changes alter the current flow through the control winding of saturable reactor T . The changes in load-coil inductance cause an increase in vertical deflection so as to correct for top-bottom pincushioning.

Zenith Pincushion Corrector. Figure 9-12 is a simplified diagram of a Zenith top and bottom pincushion-correction circuit. Vertical- and horizontal-output pulses are fed to the grid of the tube. Resulting changes in plate current alter the inductance of the load winding of transformer T to correct for top and bottom pincushioning, adjustable by tuning transformer T .

9-3. BUILT-IN DEGAUSSING SYSTEMS

Many color television receivers have built-in degaussing systems consisting of coils or wire placed around the picture tube. The manner in which the degaussing coils are installed in the Heath Model GR-180 is illustrated in Fig. 9-13.

Even if a receiver has a built-in degaussing system, the picture tube should be degaussed

with an external degaussing coil at the time of installation. The purpose of a built-in degaussing system is to correct magnetic effects periodically.

Shields. Magnetic shields are ordinarily provided around the sides, top and bottom of the picture tube, as shown in Fig. 9-14, to isolate the tube from external magnetic fields.

Manual Systems. A manual, built-in degaussing system enables the user to degauss the picture tube by simply pressing a button. A schematic of such a system is given in Fig. 9-15. The switch is shown in the normal position. When the receiver is operating, capacitor C charges through resistor R . The voltage source is 1060-volts d.c. When the switch is placed in the degauss position, the source voltage is cut off and the capacitor discharges through the degaussing coils. Relatively high current flows through the coils and a magnetic field is developed around them momentarily.

Automatic Systems. Most built-in degaussing systems operate automatically. When the receiver is turned on, current flows through the degaussing coils for a short period of time. Most automatic-degaussing systems are similar.

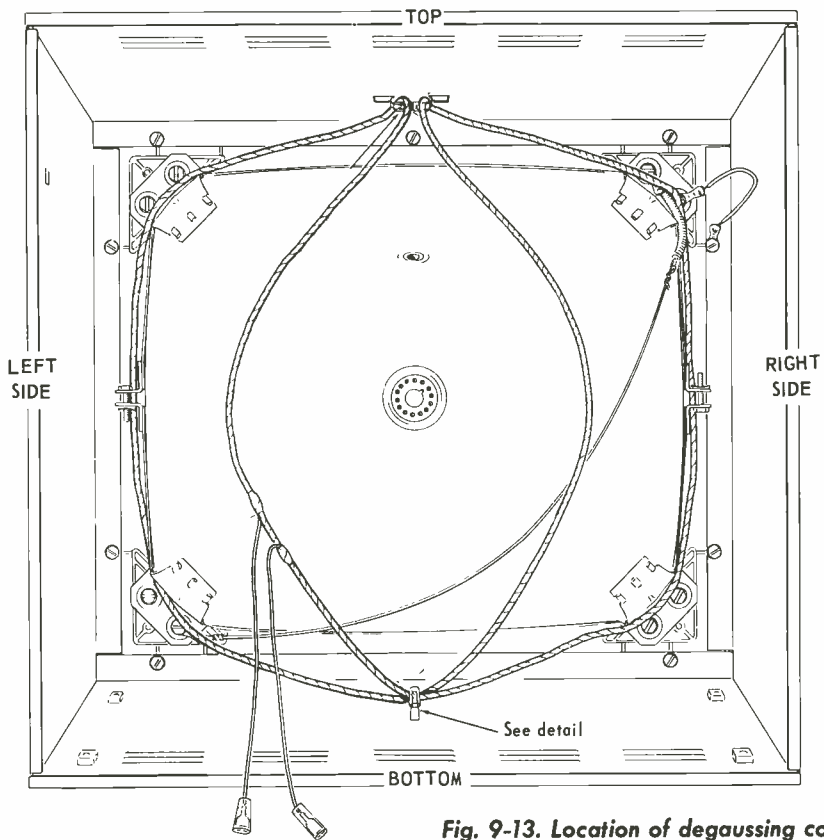

Fig. 9-13. Location of degaussing coil.

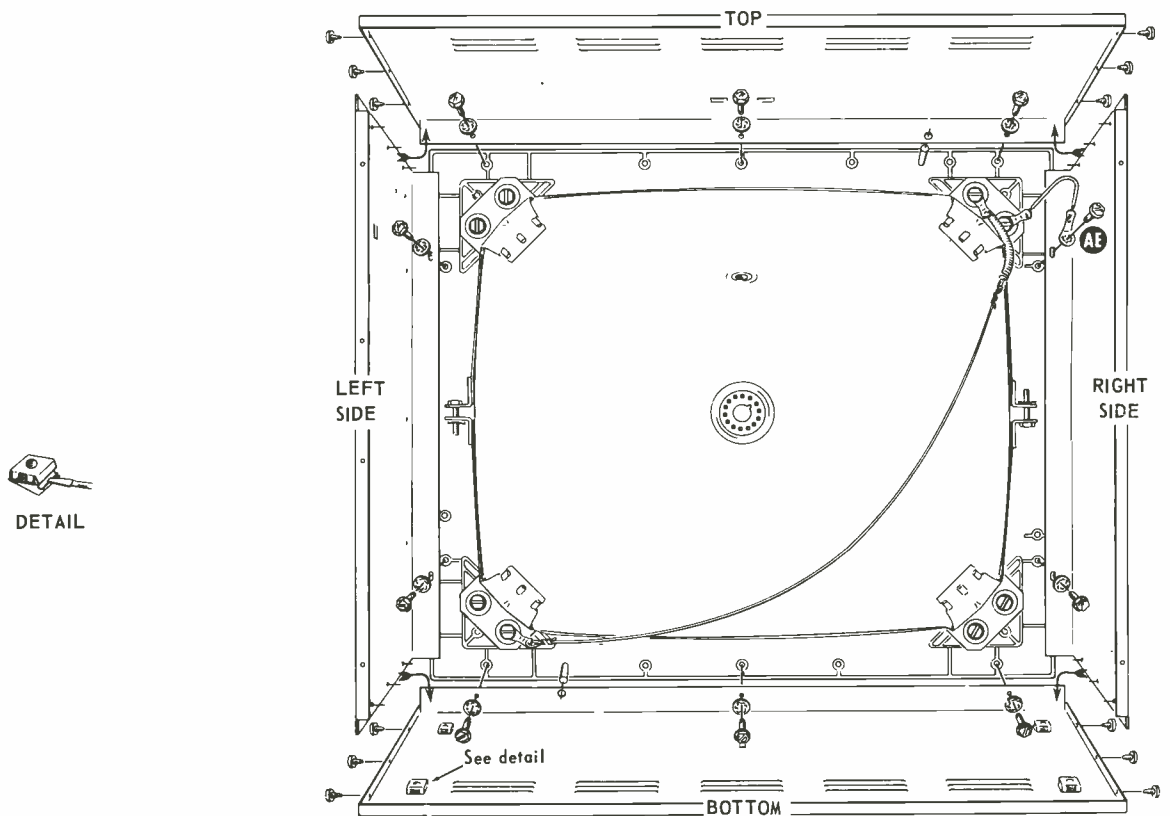

Fig. 9-14. Locations of picture-tube shields.

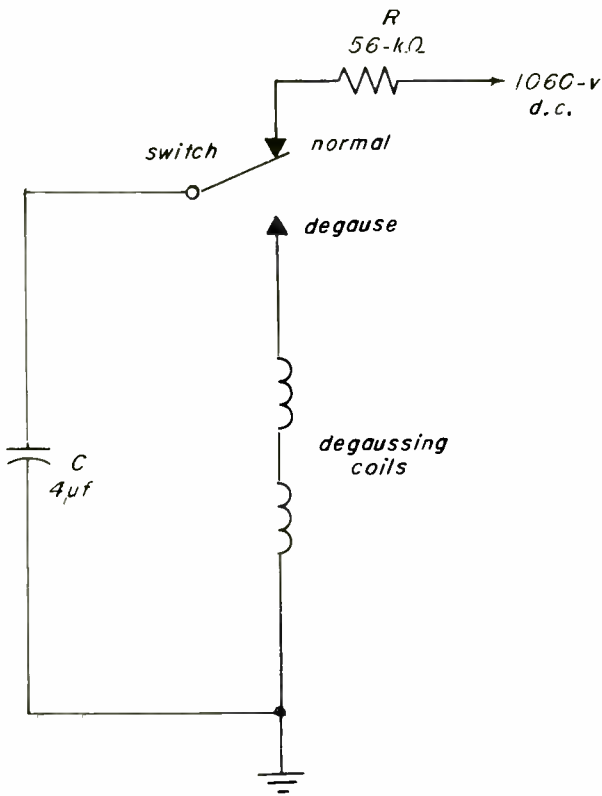

Fig. 9-15. Manual degaussing system used in some Motorola receivers.

Figure 9-16 shows the circuit used in some RCA and Philco receivers. Current flows through the degaussing coil when the receiver is first turned on since the thermistor is cold and its resistance is high. The resistance of the varistor (voltage-dependent resistor) is low since there is a relatively high voltage across it. As the thermistor temperature rises due to self-heating, its resistance lowers and the voltage drop across the

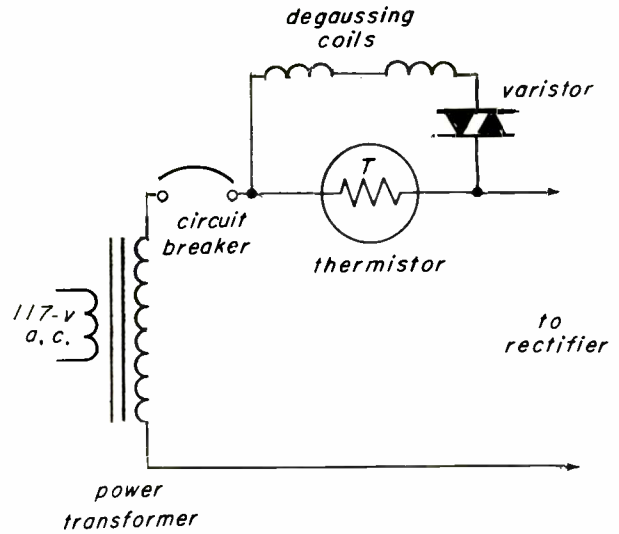

Fig. 9-16. Automatic degaussing system.

degaussing coil and the varistor reduces. This causes the resistance of the varistor to rise. Thus, the current through the coil is reduced to a very low level because of the low shunt resistance of the thermistor and the high series resistance of the varistor.

A thermal switch is used in some Motorola receivers to control automatic degaussing, as Fig. 9-17 indicates. When the receiver is turned on, the contacts of the thermal switch are open and current flows through the degaussing coils. As the heater of the thermal switch warms up, the contacts close, shorting out the degaussing coils.

A thermal switch is also used in some Admiral receivers. Here, as shown in Fig. 9-18, the degaussing current is obtained by connecting the

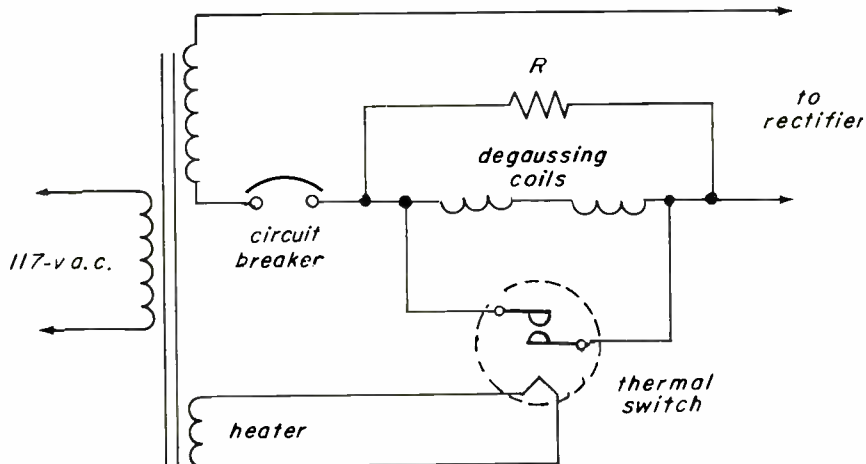

Fig. 9-17. Thermal switch degaussing control.

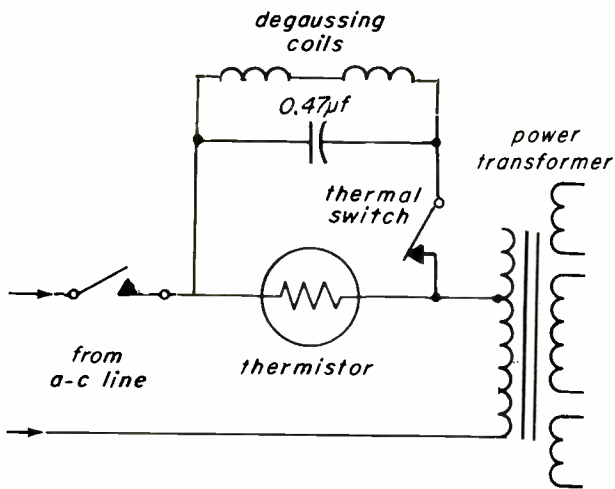

Fig. 9-18. Thermal switch and thermistor control.

coils in series with the a-c line side of the power transformer instead of the high-voltage secondary as shown in the two previous examples. At first, the thermistor resistance is high and the thermal-switch contacts are closed. When the thermistor warms up, its resistance decreases and reduces the level of current flowing through the coils. When the thermal-switch temperature rises adequately, its contacts open and cut off current flow through the coils.

It should be noted that in all of the automatically-controlled degaussing systems, a.c. flows

through the coils. In the manual system shown earlier in Fig. 9-15, d.c. is applied to the coil from the charged capacitor, but the direction of current flow reverses and oscillates for a brief period as the coil and capacitor alternately discharge into each other.

In most automatic systems, the degaussing action will not take place if the receiver is turned on shortly after it has been shut off. Time is required for the thermistor and/or thermal switch to cool to their normal standby temperature.

9-4. SMALL-SCREEN COLOR SETS

More and more small-screen color television receivers can be expected to be placed on the market as the demand for portable and auxiliary color receivers in homes increases.

General Electric Porta-Color. This compact, portable color receiver employs the 11SP22 11-inch rectangular picture tube in which the three electron guns are in line horizontally. Their electron beams strike the phosphor dots in a horizontal configuration instead of triangularly, as previously shown in Fig. 9-3. Two of the beams are aligned with respect to the center beam (green) which serves as a reference. Convergence coils and magnets are required for only two of the electron beams, as Fig. 9-19 illustrates. As with

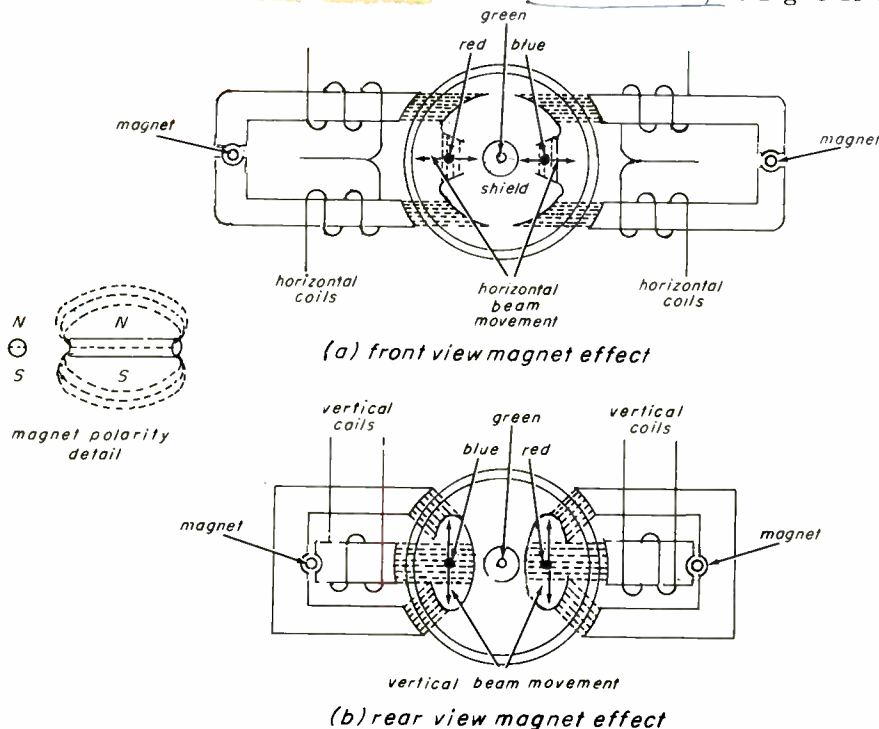

Fig. 9-19. Convergence system for in-line tube.

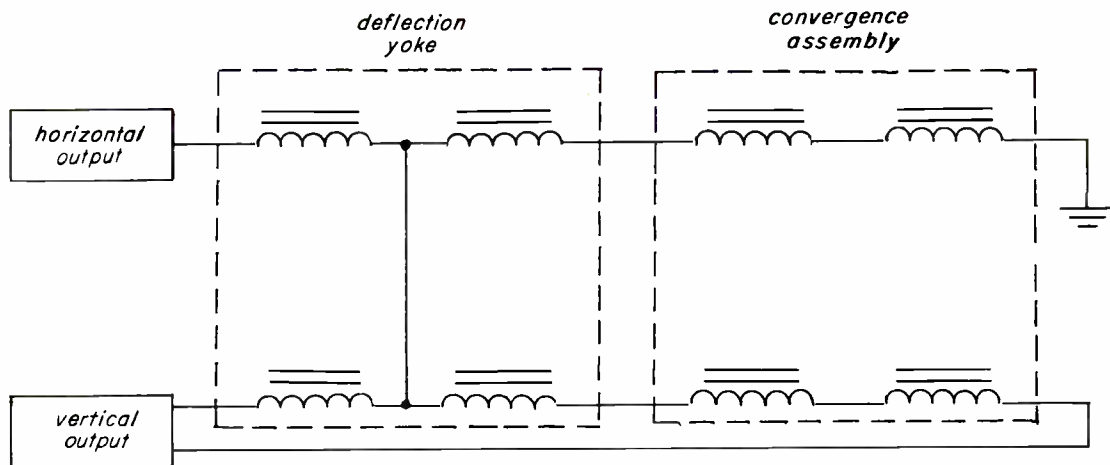

Fig. 9-20. Basic deflection and convergence circuit used in GE Porta-Color receiver.

other picture tubes, a purity magnet assembly is provided, but its adjustment is not as critical. Wave-shaping circuits and adjustments for vertical- and horizontal-convergence amplitude and tilt are not required. It is necessary only to set the magnets for best attainable convergence. The deflection yoke and convergence coils are connected in series as shown in Fig. 9-20.

This receiver employs only 13 tubes, one transistor and 13 diodes plus the picture tube. Fig. 9-21 is a block diagram of the receiver. The AFPC system is unique, as Fig. 9-22 reveals. When a 3.58-mc burst is received, the crystal and its associated resonant circuit "rings," oscillating at this frequency with amplitude decaying exponentially. However, the oscillations do not cease since they are re-started by the next 3.58-mc burst.

The video circuit is given in Fig. 9-23. The output of the i-f amplifier is fed through transformer T_1 and a 45.25-mc trap to video detector CR_1 . A 4.5-mc trap (T_2) attenuates the 4.5-mc i-f beat frequency, preventing it from affecting the video circuits.

The output of the i-f amplifier is also fed through C_1 to another detector (CR_2) which extracts the 4.5-mc difference beat frequency of the picture and sound intermediate frequencies and feeds this FM signal to the 4.5-mc sound i-f amplifier.

The receiver's power supply is quite simple, as Fig. 9-24 illustrates. No power transformer is

used, but there is a filament transformer for the picture tube. Its primary is connected in series with the heaters of the other tubes. A basic half-wave rectifier (CR_1) and an RC filter provide +135 volts; +280 volts is provided by a voltage-doubler rectifier (CR_2, CR_3) which employs an LC ripple filter.

Yaou Colonel[®]. This compact, Japanese-made, portable color television receiver employs a 9-inch Colometron[®] picture tube which has a 7½-inch screen. The picture tube is described in the next section of this lesson. Solid state circuitry is used throughout in this receiver with the exception of the picture tube and high-voltage rectifiers. Figure 9-25 is a simplified block diagram of the receiver circuitry with the tuner, i-f amplifier and video detector not shown.

The luminance signal (E_Y) at the output of the first-video amplifier is fed through a delay line, as in conventional receivers, to a 3.58-mc notch filter and another video-amplifier stage to the single cathode of the Colometron[®] picture tube. The chroma signal is fed to the bandpass amplifier and the color demodulator which differs greatly from those used in conventional receivers.

The big difference between this receiver and conventional receivers is that it employs a single-gun color picture tube. Thus, only one color demodulator (detector) is required, not two or three as in receivers employing a three-gun picture tube. Figure 9-26 is a schematic of the color demodulator which employs a single transistor. The 3.58-mc signal fed to it through T_2 is shifted in phase 120°

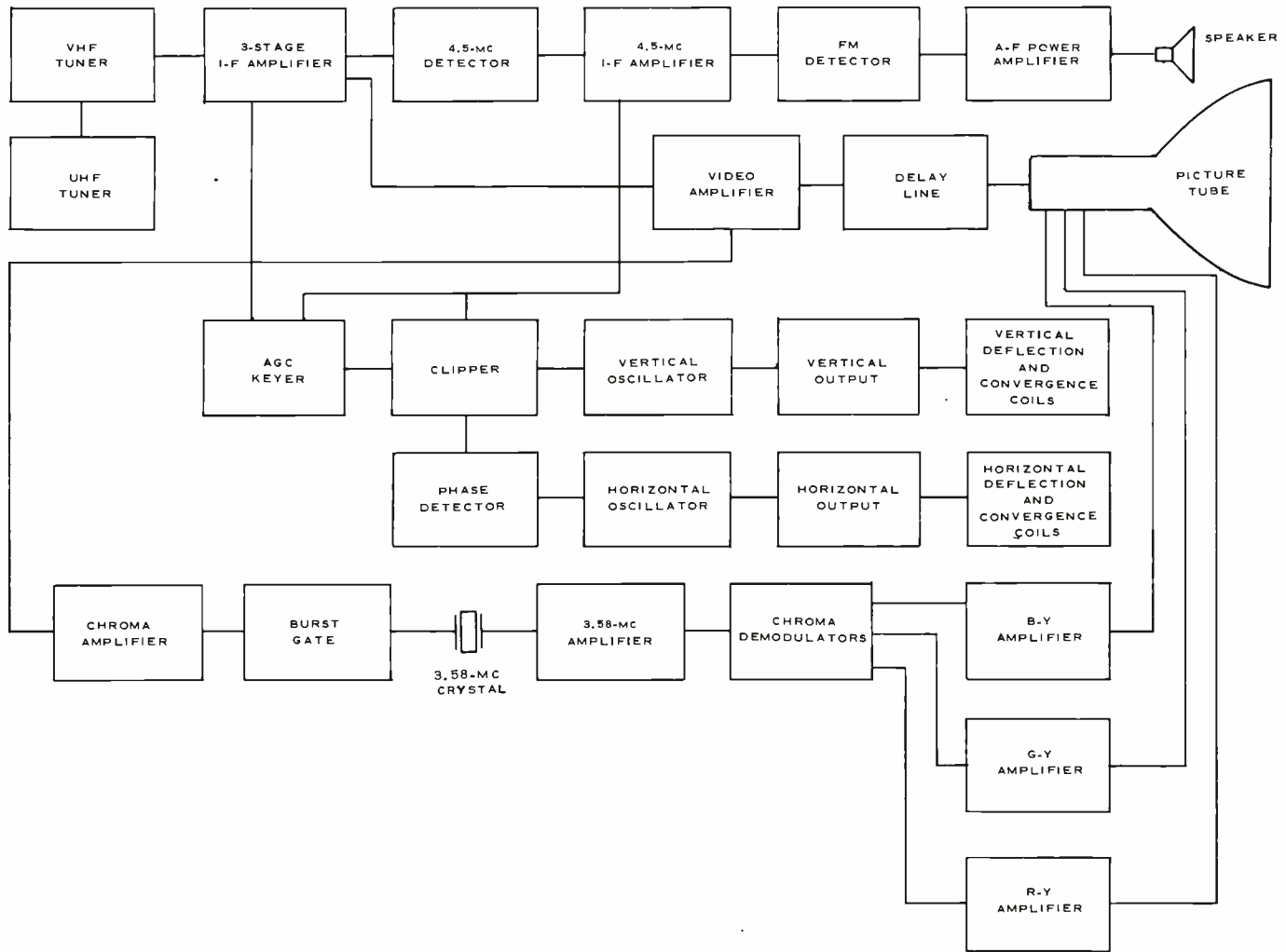

Fig. 9-21. Block diagram of GE Porta-Color.

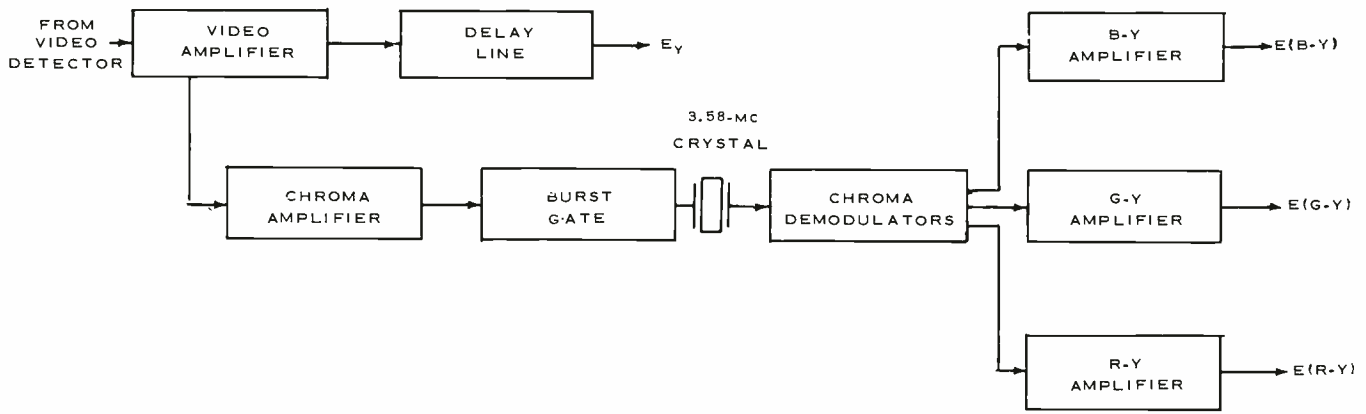

Fig. 9-22. Block diagram of chrominance section of GE Porta-Color.

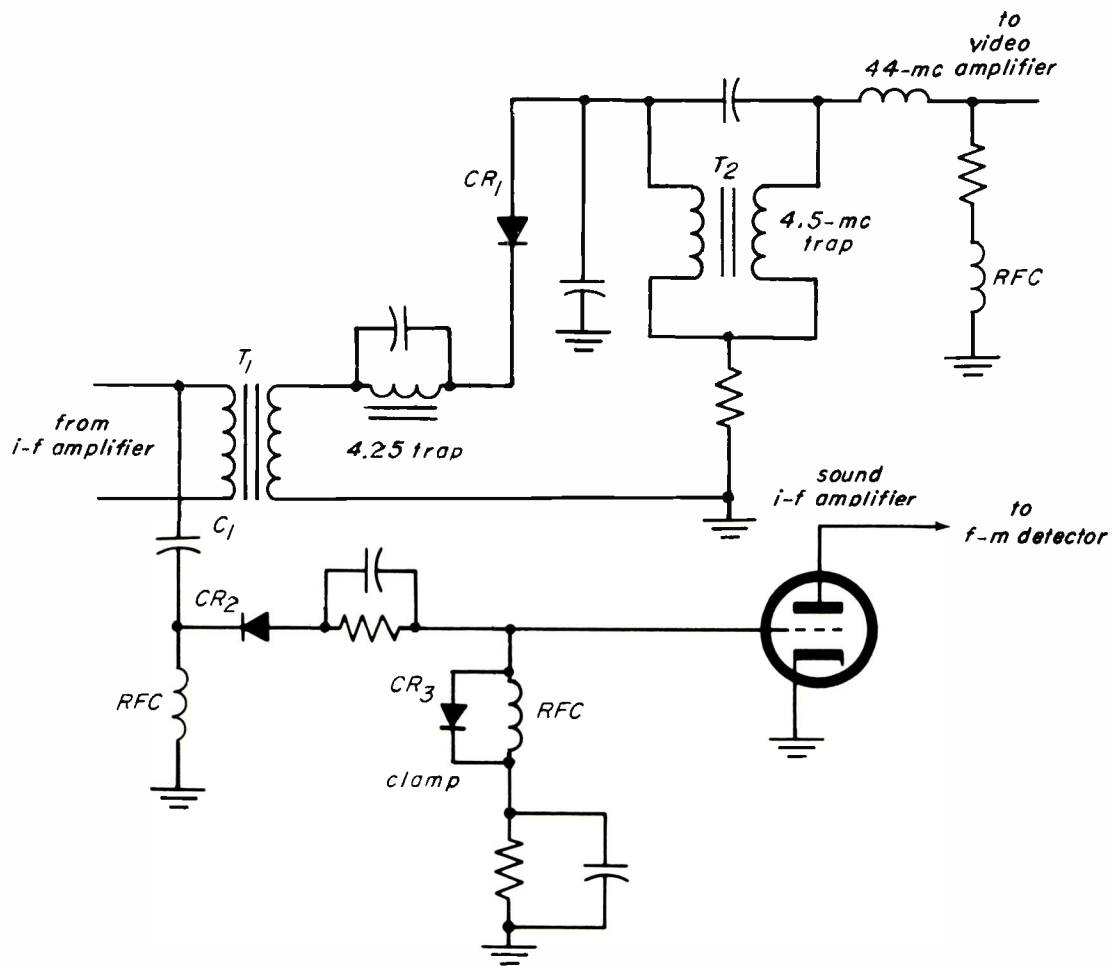

Fig. 9-23. Video detector and sound i-f extractor.

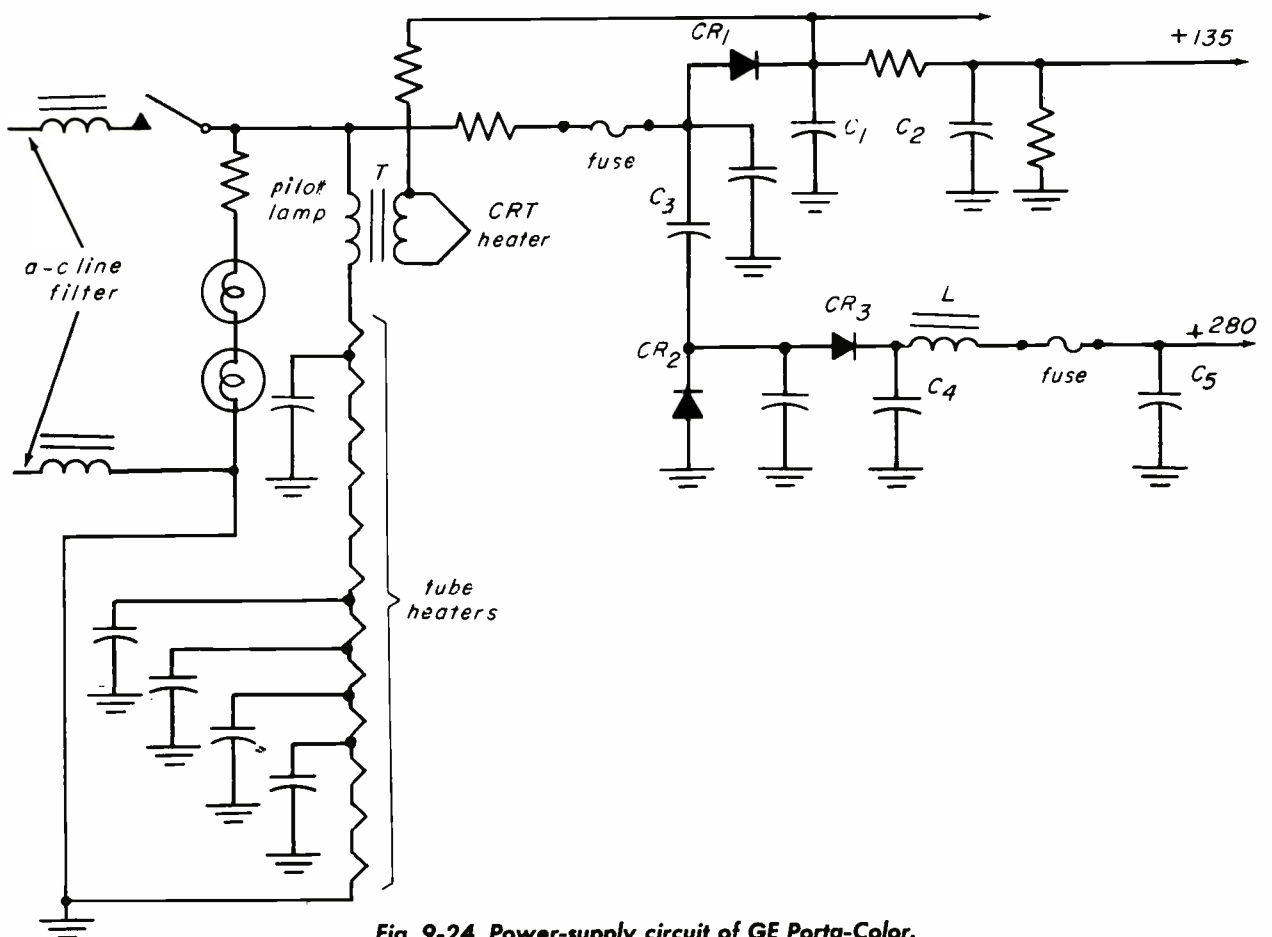

Fig. 9-24. Power-supply circuit of GE Porta-Color.

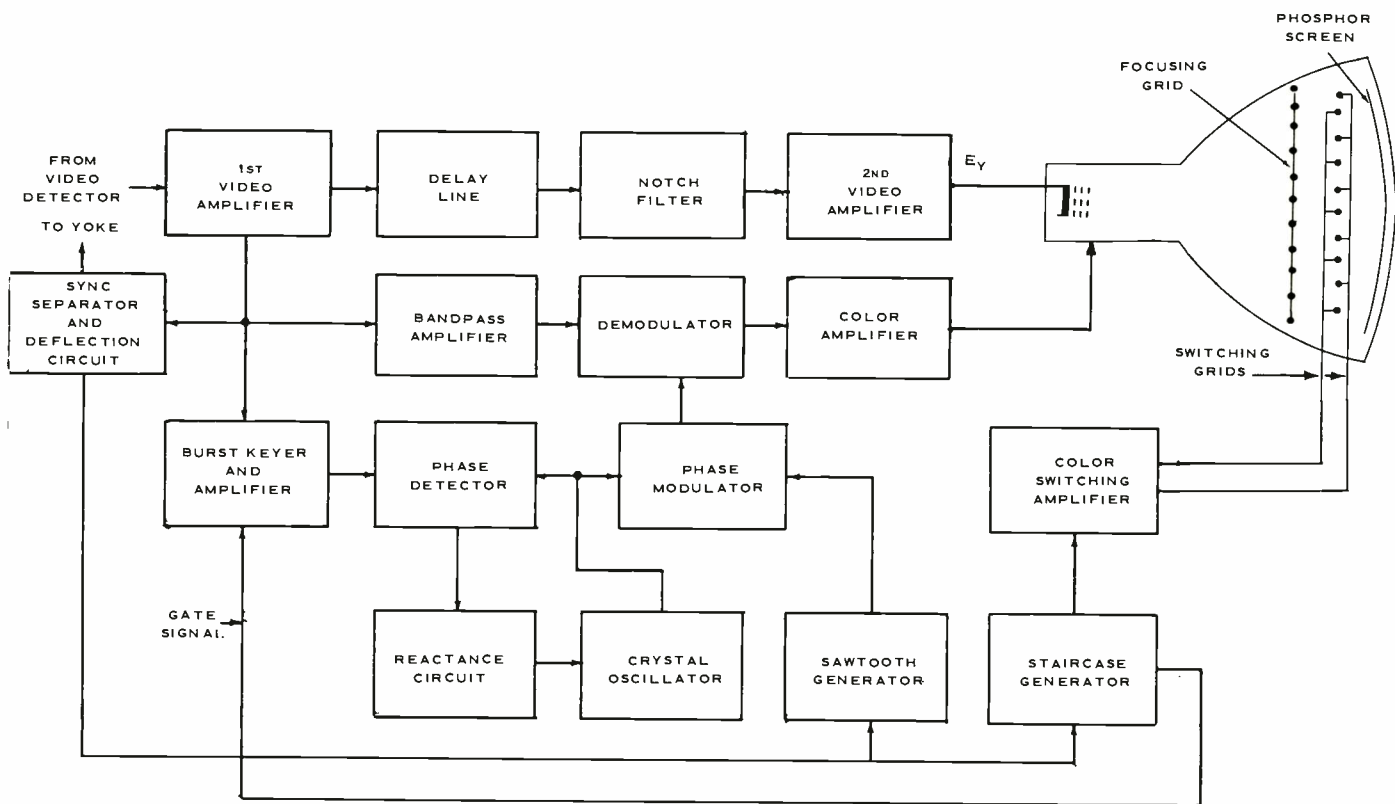

Fig. 9-25. Block diagram of Colornet[®] video circuitry.

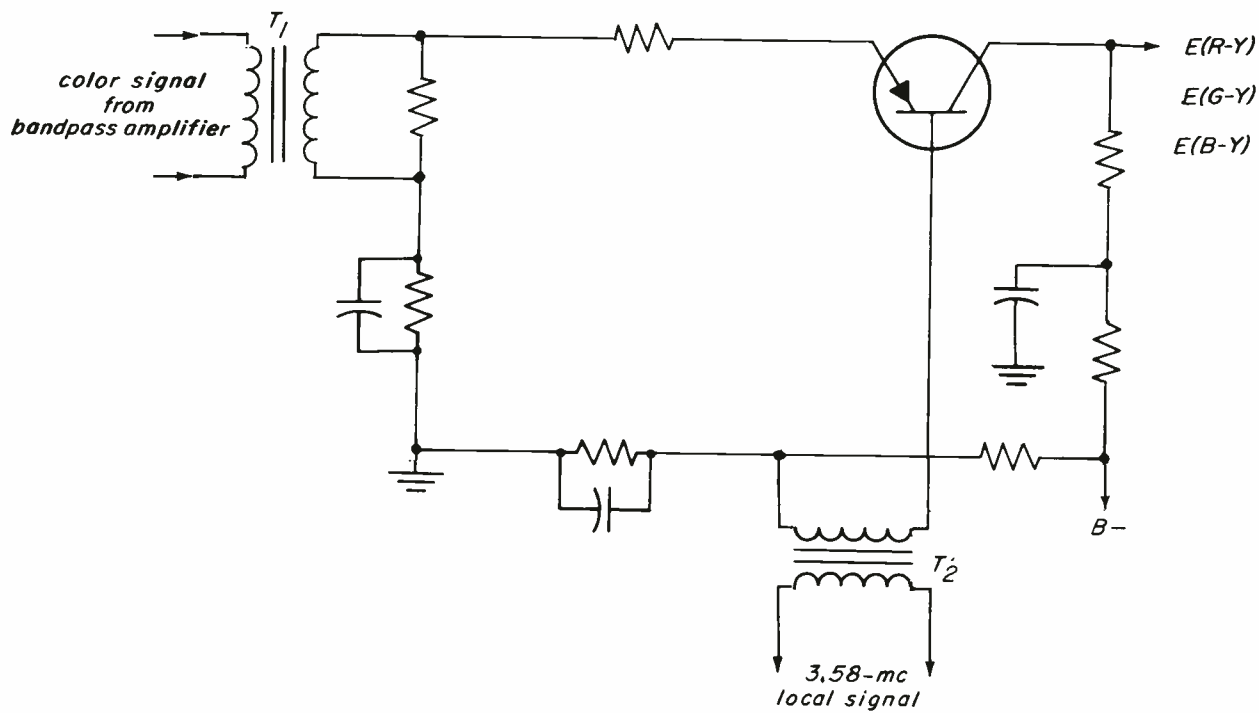

Fig. 9-26. Color demodulator of Colornet[®] receiver.

by the gated phase modulator in the AFPC circuitry before every horizontal-line scan. The 3.58-mc signal gates the transistor in and out of conduction. The chroma signal is fed to the transistor through T_1 and is essentially in series with the 3.58-mc signal. The $E_{(R-Y)}$, $E_{(G-Y)}$ and $E_{(B-Y)}$ signals are demodulated sequentially and, after amplification, are fed to the single control grid of the picture tube.

The operation of the receiver can be better understood after studying the next section which describes the functioning of the Colormetron[®] picture tube.

9-5. RECENT COLOR PICTURE TUBE DEVELOPMENTS

Considerable effort is being made to develop new color picture tubes which will reduce the cost of color-television receivers. In the future, television screens will undoubtedly be flat like a picture frame. At present, all of the television screens which are in relatively advanced stage of development are some form of cathode-ray tube (kinescope).

Chromatron[®]. The so-called Lawrence tube employs only a single gun instead of the three guns used in a conventional color picture tube. It was used in experimental color television receivers as early as 1956. While such receivers required fewer components than those employing a three-gun picture tube, the Chromatron itself was more expensive to manufacture at that time. Interest in the Chromatron has been revived and some Japanese (including Sony) and American manufacturers have obtained licenses to produce Chromatron[®] color picture tubes.

In the Chromatron[®], the single gun can employ electro-magnetic focusing and a conventional deflection yoke can be used. Instead of converging three electron beams on red, green and blue phosphor dots through tiny holes in a shadow mask, as in conventional color picture tubes, a single electron beam is switched by color selection grids just behind the screen.

Thin strips of red, green and blue phosphor are applied horizontally to the metallized rear surface of the tube's face plate. Parallel to the red and blue phosphor strips, as shown in Fig. 9-27, there are two sets of color selection grids about a half-inch behind the face plate. The electron beam

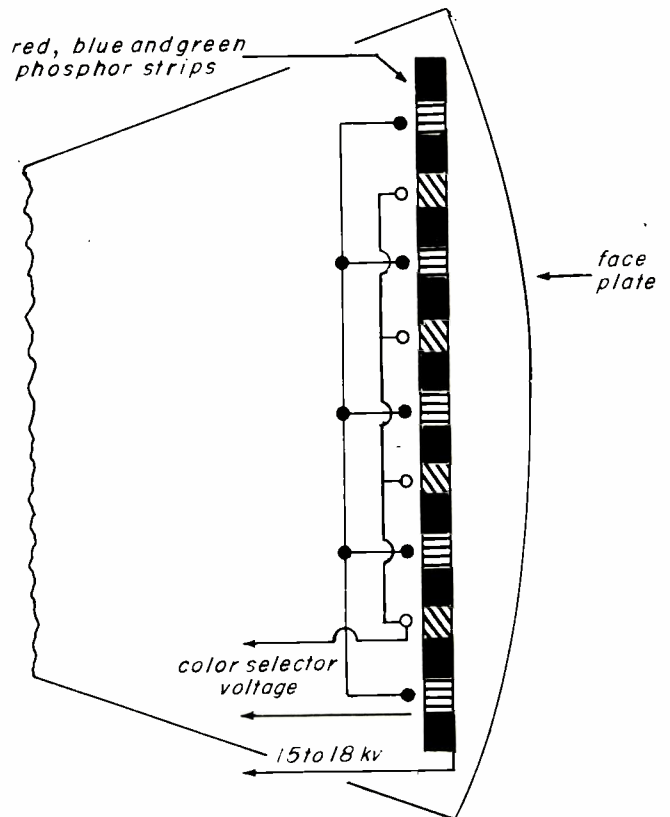

Fig. 9-27. Cross-section of Chromatron[®].

normally passes between the grids and strikes a green phosphor strip. The beam is shifted to either the red or blue phosphor strip by applying a voltage of appropriate polarity to the grids.

When a 3.58-mc sine wave voltage is applied to the red and blue beam-switching grids, the electron beam is deflected up and down from the green phosphor strips alternately striking the strips of red and blue phosphor. In a television receiver, the beam is also swept horizontally and color information is fed to the Chromatron's control grid.

The potential of the 3.58-mc beam switching signal is in the vicinity of 4500 volts. To the aluminized backing of the phosphor strips, a d-c potential between 15,000 and 18,000 volts is applied. This polarizing voltage has no effect on the electron beam until after the beam has passed through the deflection grids. An array of electronic lenses is formed between the grid wires and the phosphor strips which provides post-deflection focusing.

In short, then, the Chromatron is a single-gun color picture tube employing beam switching and

post-deflection focusing. Its use in television receivers has been retarded by the cost of providing the deflection grids and by the interference-producing radiation of the high-voltage 3.58-mc beam-switching signal.

Colornetron.[®] This tube is similar to the Chromatron[®] in that it employs a single electron gun and two sets of beam-switching grids near the phosphor-coated screen. Like the Chromatron,[®] the Colornetron[®] scans narrow strips of red, green and blue phosphors horizontally. Directly behind the beam-switching grids is the focusing grid, as Fig. 9-28 illustrates.

When no potential exists on the beam-switching grids, the electron beam strikes the blue phosphor strips. One of the sets of beam-switching grids diverts the beam to the red phosphor strips, the other to the green. The blue, red, and green signals are fed sequentially to the control grid. And, in the same sequence, the beam-switching grids are polarized so that only the correct phosphor strips are illuminated.

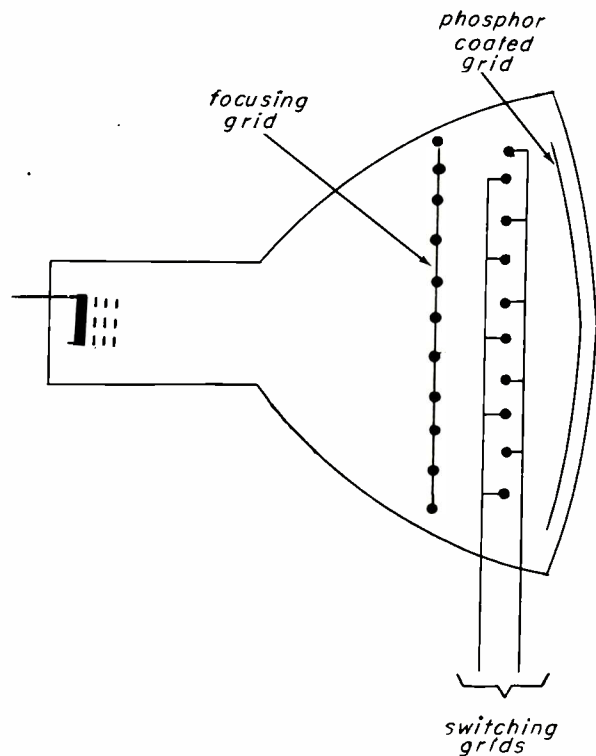

Fig. 9-28. Cross section of Colornetron tube.

9-6. COLOR AFPC SYSTEMS

The color-synchronization system is known as the automatic-frequency and phase-control system (AFPC) in which the local 3.58-mc signal is generated and phase-corrected by the transmitted burst signal. As previously shown in Fig. 3-37 in Lesson 3, and explained in that lesson, the burst signals are separated from the remainder of the video signal in the burst amplifier (also known as a burst gate or burst keyer). This stage is gated by 15.75-ke pulses from a winding of the flyback transformer. Thus it operates only during the time interval that burst signals are being received.

Conventional AFPC System. Many color television receivers employ very similar subcarrier generators of which Fig. 9-29 is an example. Here pentode V_2 functions as an electron-coupled crystal-controlled Pierce oscillator and r-f amplifier. The frequency of oscillation is determined by the crystal and can be adjusted over a limited range by tuning coil L_1 . The frequency and phase of the oscillator signal with respect to the burst signal is automatically controlled by reactance tube V_1 which is essentially the same as an FM reactance modulator. Its reactance, shunted across C_1 - L_1 is varied by the d-c voltage applied to its grid through R_1 from the phase detector

(not shown). Hence, the frequency and phase relationship of the 3.58-mc subcarrier generator (V_2) is controlled by the color bursts.

Two 3.58-mc outputs are provided, which are out of phase with each other. This phase difference is provided by a phase-shift network at the output of the oscillator.

Motorola Color-Burst Amplifier. A similar subcarrier generator circuit is used by Motorola. But, the burst gate and burst-amplifier circuits are unique, as Fig. 9-30 illustrates. Here, V_1 is the burst amplifier. Most of the time it is biased to cut off by cathode bias and fixed bias provided by R_1 and R_2 . Note that the cathode, grids and plate are all positive with respect to ground, but the control grid is negative with respect to the cathode. The burst gate tube (V_2) is cathode biased by R_4 to limit maximum plate current. Its grid is normally at a potential of -140 volts and the tube is therefore cut off. This tube functions as a variable cathode resistor for V_1 .

When a positive pulse (350-volts pp) is applied to the grid of V_2 , its plate current rises sharply and its plate resistance drops, lowering the bias

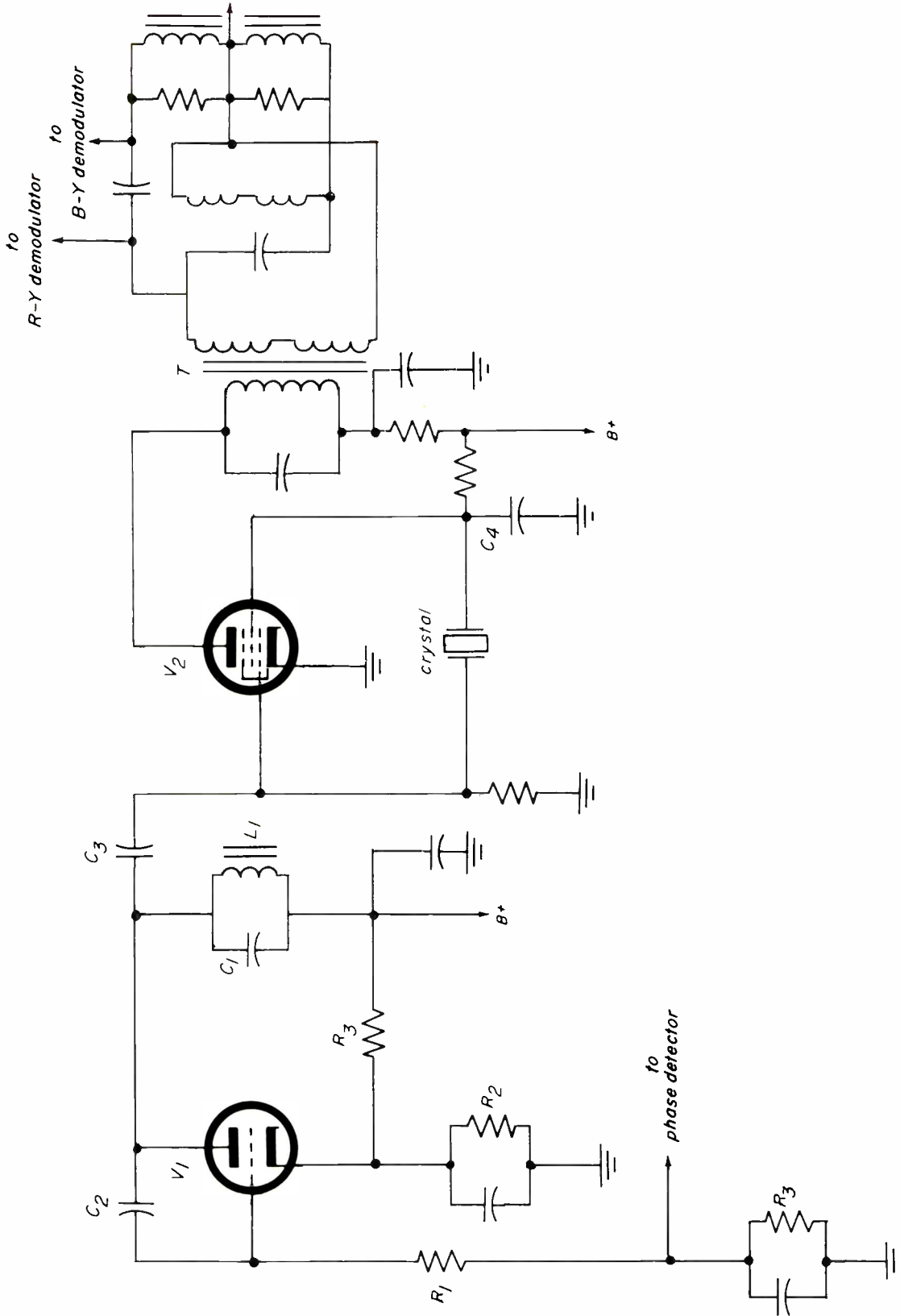

Fig. 9-29. Conventional subcarrier generator.

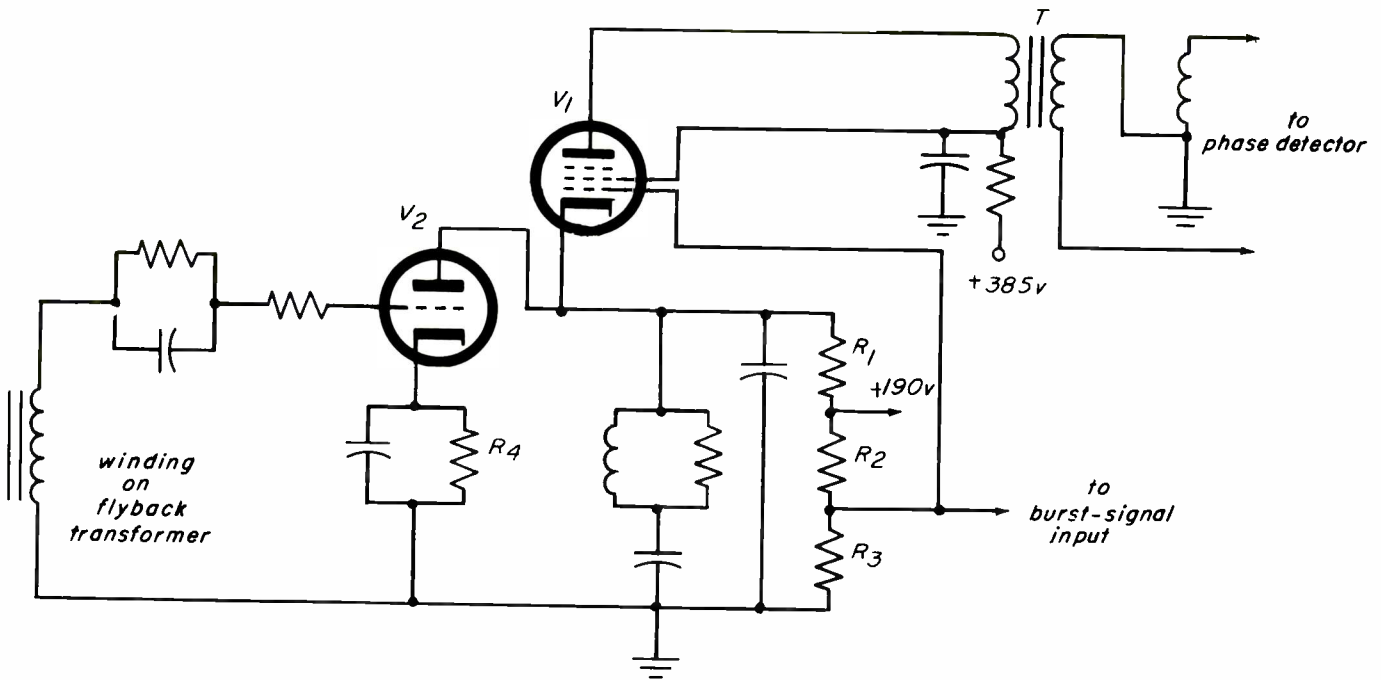

Fig. 9-30. Motorola colorburst amplifier.

on V_1 , allowing it to conduct. Thus, when conducting, and a color burst signal is applied to the control grid of V_1 , the color burst signal will be amplified and developed across the primary of T which is tuned to 3.58-mc. Its bifilar-wound secondaries feed the phase detector which controls the subcarrier generator frequency and phase.

RCA Victor AFPC System. In the RCA Victor CTC19 series receivers, one tube functions as the gated color-burst amplifier. The 15.75-kc pulses from the flyback transformer (positive) and the color-burst signal are both fed to the control grid of V_1 . The amplified 3.58-mc color bursts are fed through T_1 to a 3.58-mc crystal whose resonance can be trimmed with capacitor C_1 . (See Fig. 9-31.)

Tube V_2 functions as an oscillator-amplifier. Oscillation is established by a parallel-resonant circuit (L_1-C_2) in the screen circuit. Its frequency, however, is determined by the 3.58-mc crystal in the grid circuit. And, its frequency and phase relationship are controlled by the periodic 3.58-mc color bursts.

General Electric Color-Sync Generator. An oscillator, in the usual sense, is not employed in the General Electric CB series receivers. The output of the burst gate, as shown in Fig. 9-32, is fed through T which shock excites a 3.58-mc

crystal, causing it to "ring" at its resonant frequency. While the oscillations thus produced decay at an exponential rate, they do not die out since the crystal is re-excited by each color burst. Variable inductor L permits adjustment of the crystal's resonant frequency.

The varactor diode (voltage-sensitive capacitor) also has an effect on frequency and phase. The d-c voltage for biasing the capacitor is obtained from the voltage divider consisting of R_1 , R_2 and R_3 . Tint is controlled by adjusting R_3 (a potentiometer) which controls the bias on the varactor whose resultant capacitance affects the frequency and phase of the 3.58-mc CW signal amplified by the tube.

9-7. COLOR DEMODULATOR CIRCUITS

The function of the color demodulator system, as was previously examined in Lesson 3, is to extract the $B-Y$, $G-Y$ and $R-Y$, color difference signals from the composite chrominance (chroma) signal. The signal, fed through the bandpass amplifier is the vector sum of two 3.58-mc chrominance signals that are in phase quadrature. The color-demodulator system recovers these two signals separately yielding the $E_{(B-Y)}$ and $E_{(R-Y)}$ signals directly, and deriving the $E_{(G-Y)}$ signal by

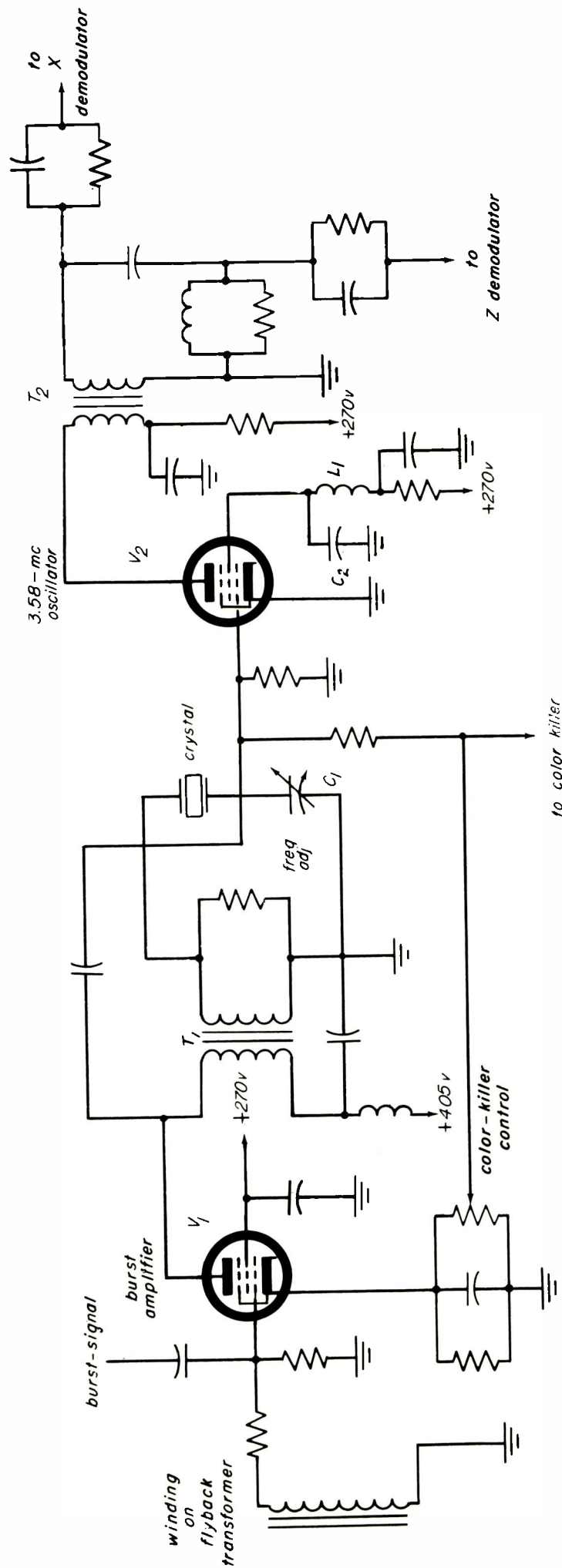

Fig. 9-31. AFPC system of RCA Victor CTC19 series.

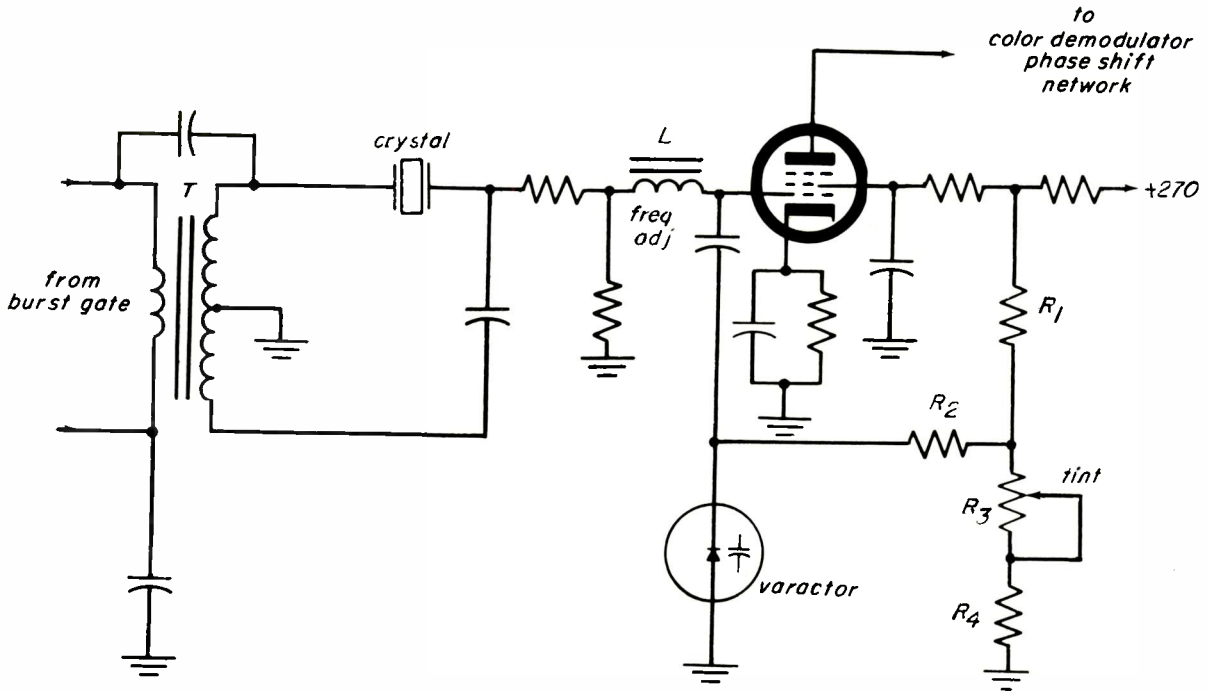

Fig. 9-32. General Electric subcarrier generator.

matrixing. Modern color receivers employ either *R-Y*, *B-Y* demodulator system or an *X* and *Z* demodulator system.

RCA Chroma Demodulator. Figure 9-33 is a block diagram of the color-demodulator system used in RCA Victor CTC19 color receivers. The chroma signal is extracted at the first video-amplifier stage and passed through a bandpass amplifier whose frequency response is limited to

pass only the color information contained in the sidebands of the chroma signal. The amplified chroma signal is fed simultaneously (in phase) to the *X* and *Z* demodulators. Two signals, approximately 62° apart in phase, are fed to the *X* and *Z* demodulators from the receiver's 3.58-mc oscillator. The *X* and *Z* demodulator outputs are fed to a matrix which yields the color-difference signals which are then amplified and fed to the grids of the color picture tube.

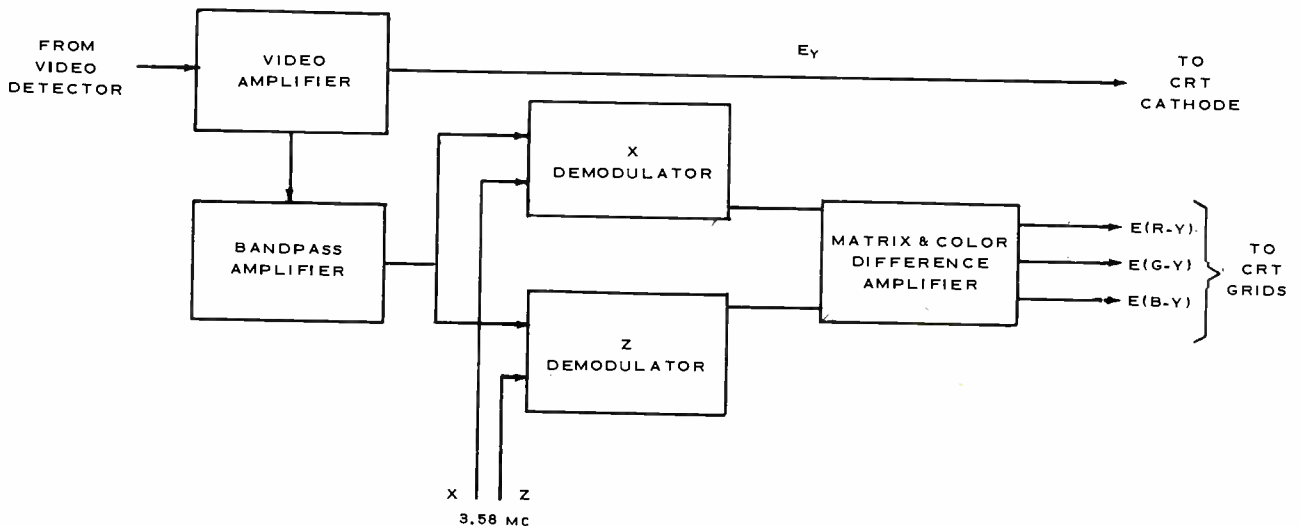

Fig. 9-33. Block diagram of RCA-type color demodulator.

The chroma signal is fed through color control R_3 to the screen grids of the X (V_1) and Z (V_2) demodulators as Fig. 9-34 indicates. Since the screens are not bypassed to ground, they function as control grids and are positively biased with respect to the cathodes. The chroma signal thus modulates the electron stream of both tubes.

Potentiometer R_3 performs two functions. It permits adjustment of the level of the chroma-input signal and it also sets the screen-grid bias level. It is part of a voltage divider consisting of R_1 and R_2 and itself. The actual d-c voltage on the screen grids is less than 2 volts. The low screen voltage limits plate current to a very low level.

The signal from the 3.58-mc oscillator is fed through transformer T to the control grids of the tubes. To provide approximately 62° of phase difference, the control grid of V_1 is fed through a phase-shift network consisting of C_1 , L_1 and R_4 .

The 3.58-mc signal gates the tubes. Thus, the chroma signal is sampled at the 3.58-mc rate, and

the signal at the plates will consist of short pulses. Since the control grids of the demodulators are not fed in phase, their output pulses will not be in phase.

The output of each demodulator is fed through an integrator (C_2 and L_2 for V_1 , C_3 and L_3 for V_2) to provide a smooth video signal, and which also functions as a 3.58-mc rejection filter.

The output of the X demodulator is fed through an RC network to the grid of V_1 , the R-Y amplifier, as shown in Fig. 9-35, and through another RC network to the grid of V_2 , the G-Y amplifier. The output of the Z modulator is fed through an RC network to the grid of V_3 , the B-Y amplifier. The cathodes of all three tubes are paralleled and share a common cathode resistor.

The R-Y amplifier (V_1) receives a $-X$ (negative) signal at its grid, and the B-Y amplifier (V_3) receives a $-Z$ signal at its grid. Because the cathodes of these tubes are connected together, a small amount of the X signal is injected into the cathode of V_1 . These cathode-injected voltages

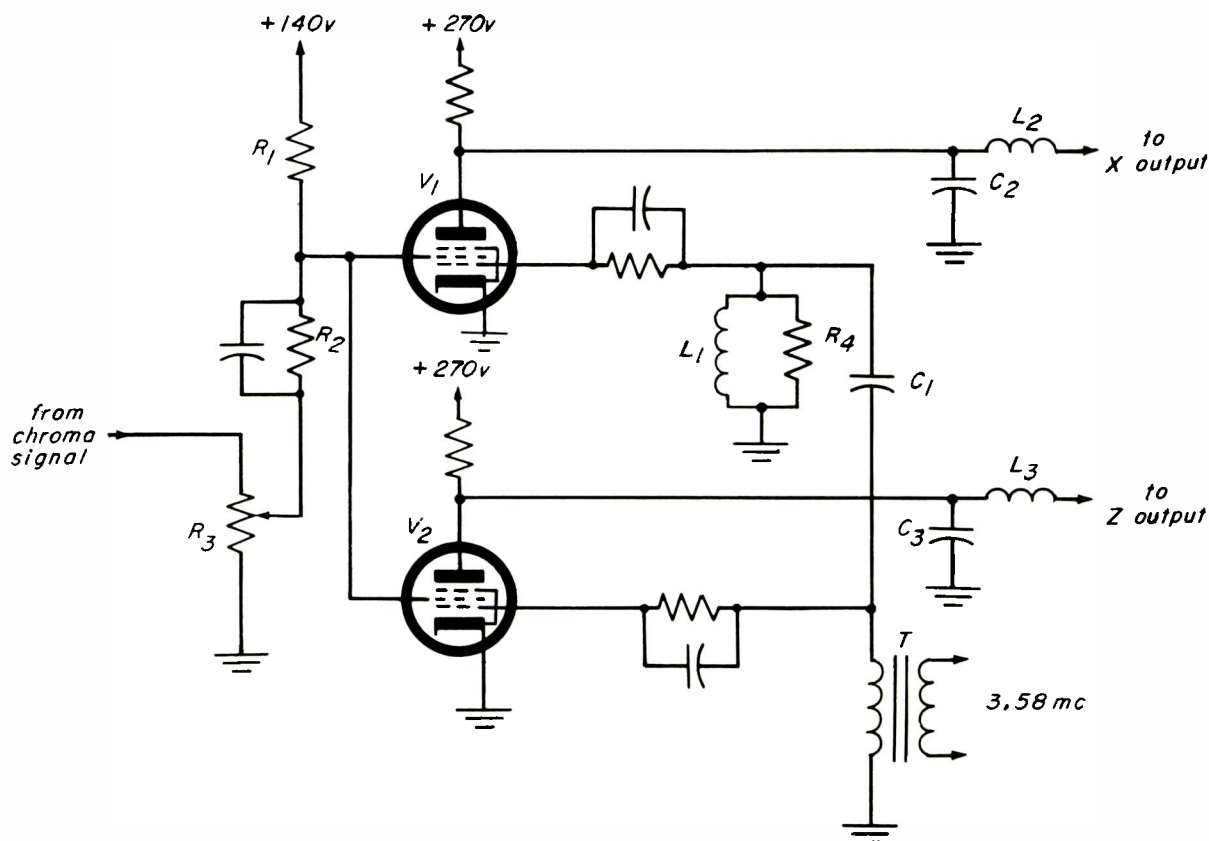

Fig. 9-34. Simplified schematic of X and Y demodulator.

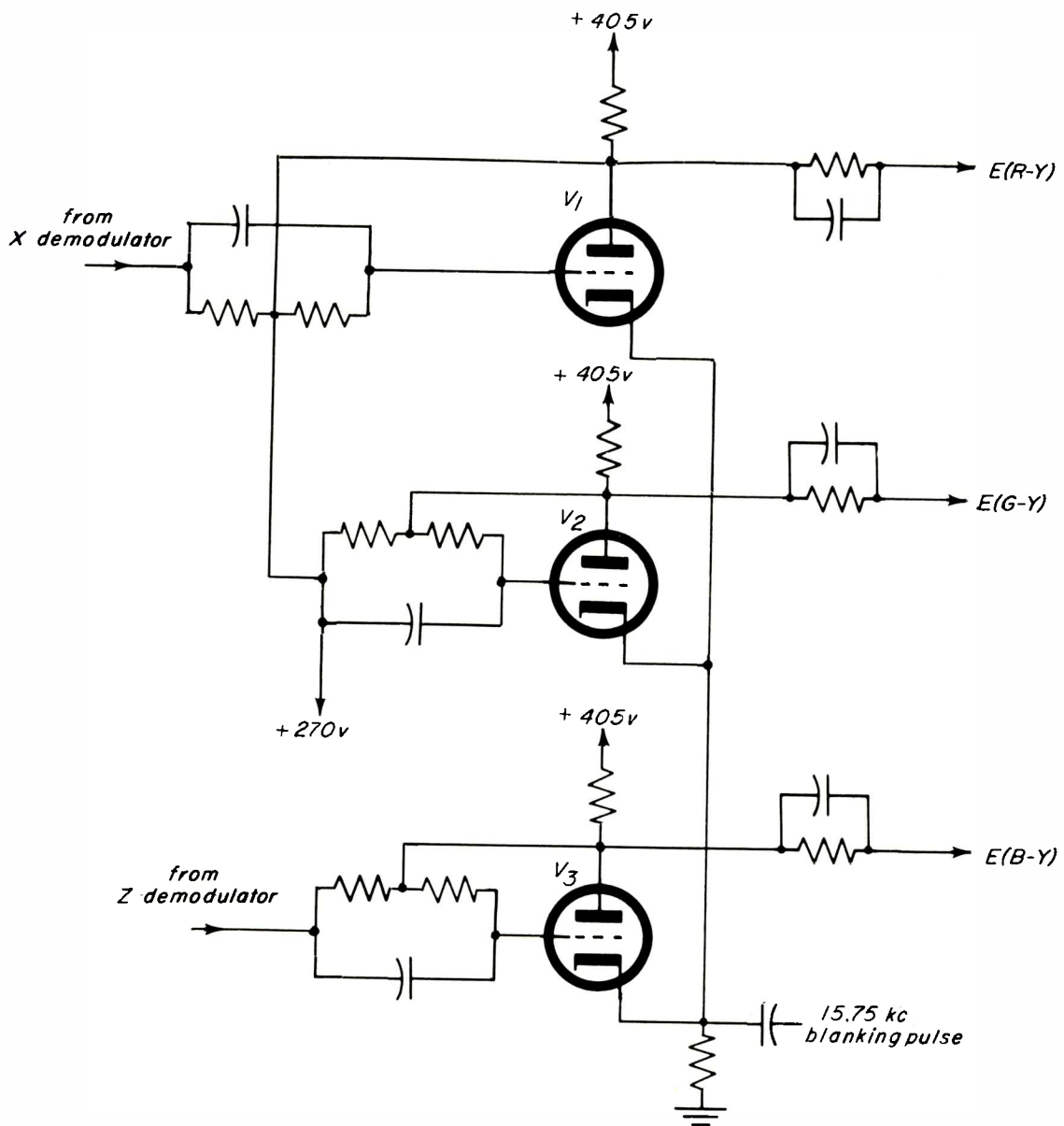

Fig. 9-35. Simplified schematic of matrix and color difference amplifiers.

are subtracted from the total cathode-to-grid voltages of these tubes. The X and Z signals are also injected into the cathode of V_2 . Since its output requires more X signal than Z signal, $R-Y$ signal is also fed to its grid from the output of the tube V_1 , as the diagram indicates. As a result of this matrixing, the $R-Y$, $G-Y$ and $B-Y$ signals are separated and are fed to their respective picture tube grids.

Motorola Color Demodulator. Figure 9-36 is a simplified schematic of the color demodulator used in the Motorola TS-917 series receivers. Two

triode-connected pentodes are used. The chroma signal is fed directly to the control grids. The 3.58-mc color-sync signals are fed to the cathodes through R_1 and R_2 . Ground return for the cathodes is through R_4 , which provides bias for both tubes. As far as the 3.58-mc color-sync signal is concerned, the tubes function as grounded-grid amplifiers, gated by the color-sync signals. The time of gating of the two tubes is staggered by the phase shift network L , C_1 and R_3 . Thus, the gating action allows the chroma signal to be separated into X and Z signals which are subsequently matrixed into $R-Y$, $G-Y$ and $B-Y$ signals.

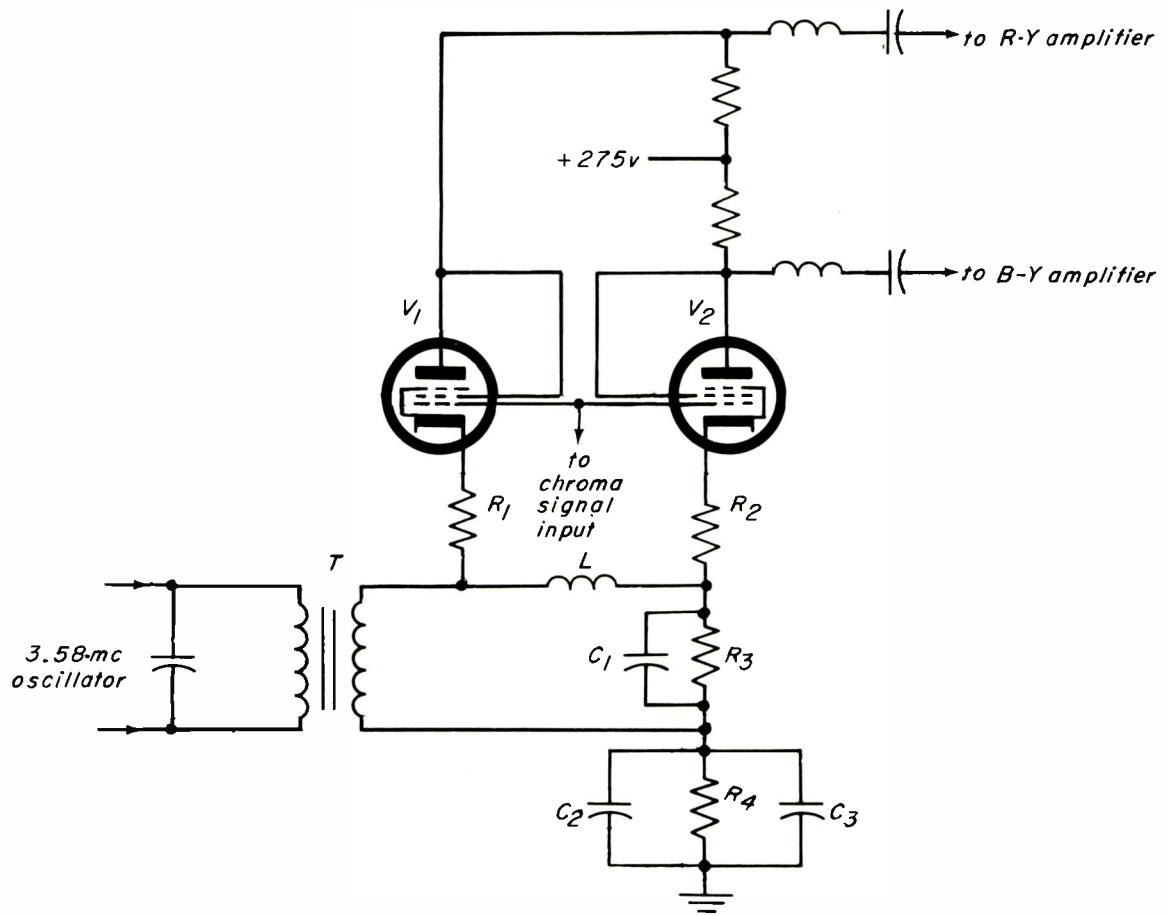

Fig. 9-36. Motorola-type color demodulator.

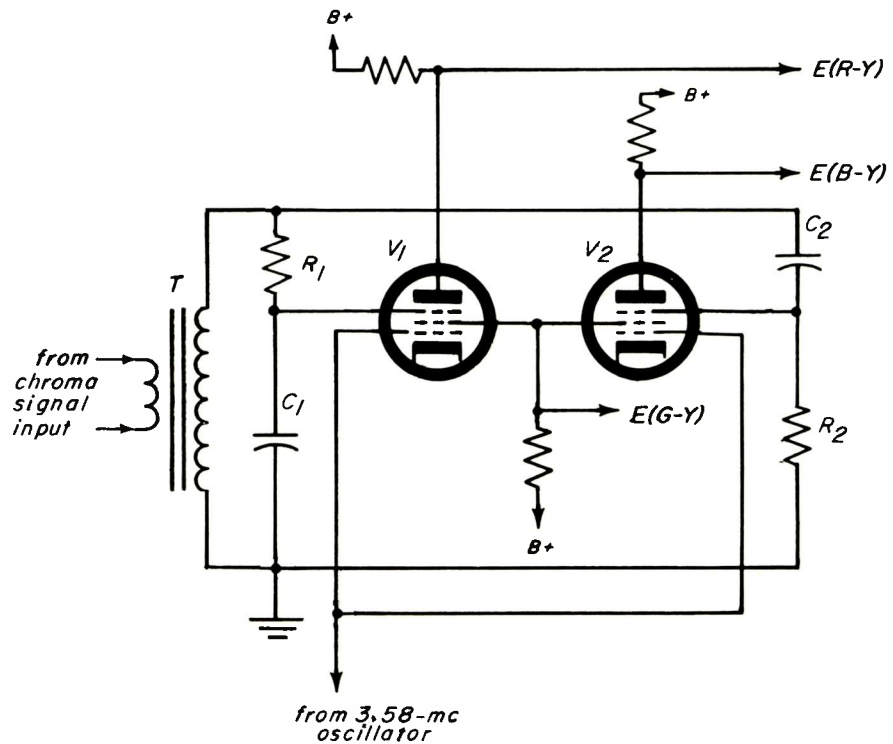

Fig. 9-37. Motorola single-step color demodulator.

A unique color demodulator is used in the Motorola TS-914 series receiver. Only a single dual-pentode tube is used (shown here in Fig. 9-37 as two tubes, V_1 and V_2). The chroma signal is fed through two phase-shift networks, R_1, C_1 and R_2, C_2 , the former providing 45° of lag and the latter 45° of lead. The 3.58-mc locally-generated CW signal is fed to the control grids in parallel. But, the chroma signals are applied to the suppressor grids 90° out of phase with each other. The $E_{(R-Y)}$ and $E_{(B-Y)}$ signals are obtained directly from the plates of V_1 and V_2 . The $E_{(G-Y)}$ signal is obtained from the paralleled screen grids of the two tubes.

Sheet-Beam Demodulator. Only two tubes are required in a color demodulator employing sheet-beam tubes. Figure 9-38 illustrates how a sheet-beam tube functions. With positive voltage applied to the two signal plates (tube terminals 8 and 9) and the screen (terminal 3), as well as to one of the control plates (terminal 1), as shown, milliammeter M_1 will indicate flow of plate current. The current level can be adjusted with R_1 which enables varying control grid (terminal 6) voltage.

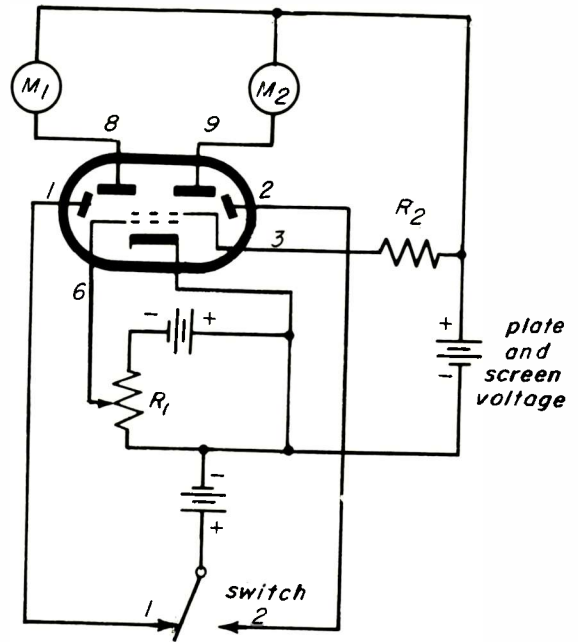

Fig. 9-38. Sheet-beam tube.

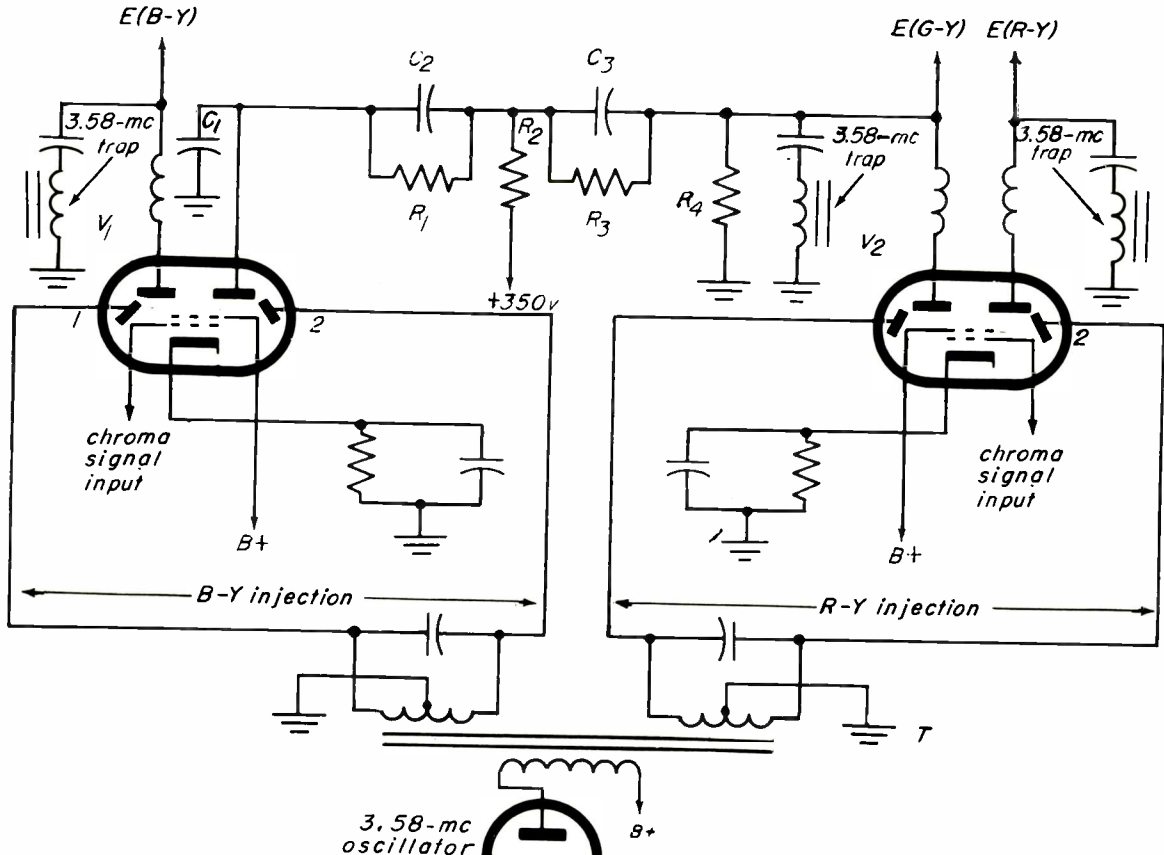

Fig. 9-39. Sheet-beam modulator.

If switch S is thrown to the 2 position the other control plate (terminal 2) will be at a positive potential. The electron beam will deflect from the left control plate to the right control plate. Milliammeter M_2 will now indicate plate current flow. Thus, the tube can function as an electronic SPDT switch.

In a sheet-beam color demodulator, an a-c signal is applied to the control plates to alternately switch the electron beam from one signal plate to the other. In a color demodulator, the 3.58-mc CW signal is fed from a secondary winding of transformer T to the control plates of V_1 in push-pull fashion, as Fig. 9-39 shows. So are the control plates of V_2 . But, the signals applied to the tubes are 90° out of phase with each other.

The signals fed to the control plates of V_1 represent $B-Y$ information, since V_1 is the $B-Y$ demodulator, and those fed to the control plates of V_2 represent $R-Y$ information, V_2 being the $R-Y$ demodulator. When the signals at the $B-Y$ plate of V_1 and the $R-Y$ plate of V_2 are positive going, the signals at the other two plates are negative going. The signals at these latter two plates are combined through an RC network ($C_1, C_2, C_3, R_1, R_2, R_3, R_4$) to form the $G-Y$ signal. In this simplified diagram the compensating networks leading to the picture-tube grids are not shown.

Admiral Color Demodulator. Only one tube is required in the color demodulator used in some Admiral receivers, shown in Fig. 9-40. A special

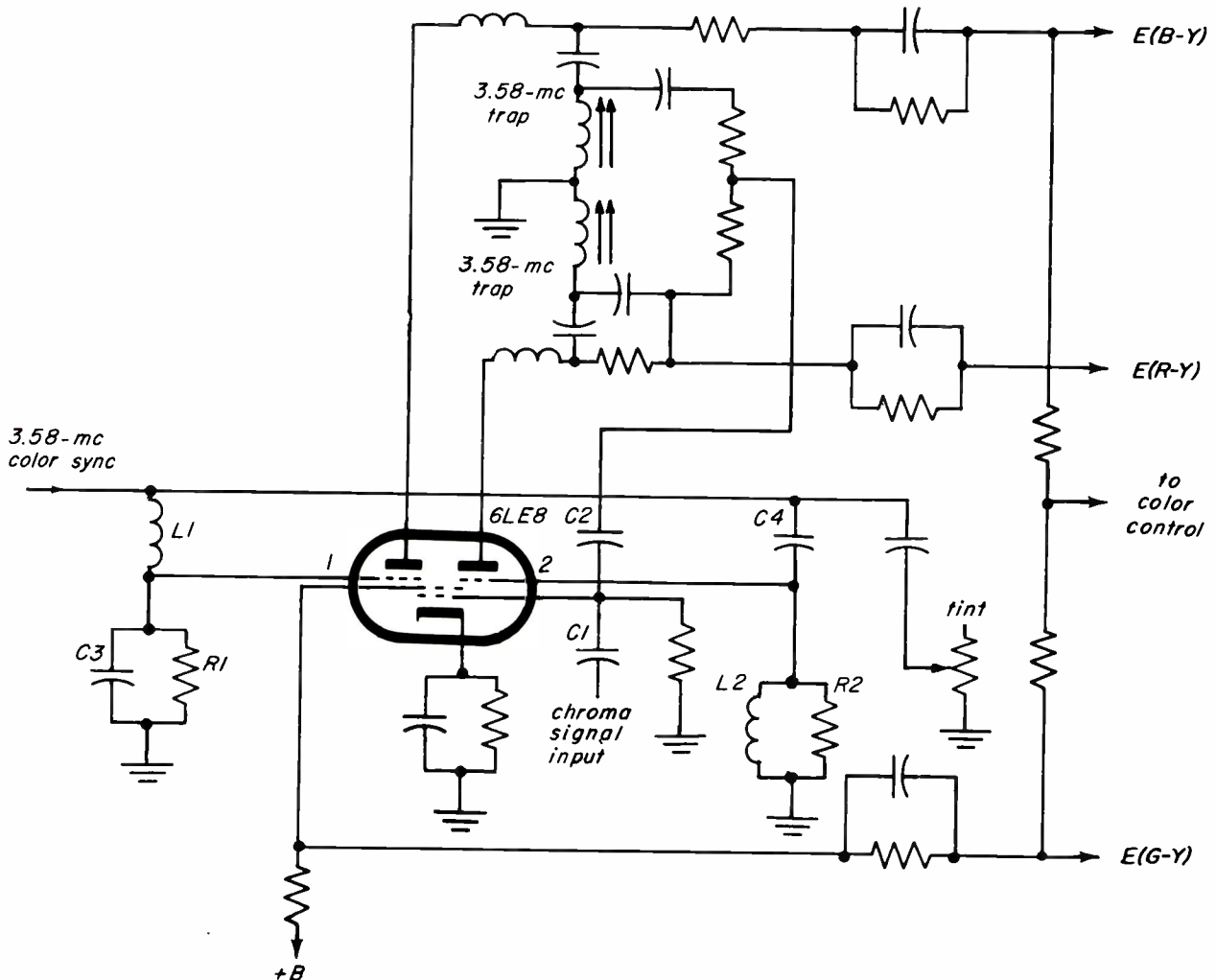

Fig. 9-40. Admiral color demodulator.

type tube (6LE8) is used. The chroma signal is fed into the control grid (common to both plates) through C_1 . Feedback from the plate circuits is obtained through C_2 .

The 3.58-mc color-sync signal is fed to the suppressor grids (1 and 2), the required phase shift being provided by L_1 , C_3 , R_1 , C_4 , L_2 and R_2 . The $E_{(B-Y)}$ and $E_{(R-Y)}$ signals are obtained from the tube's plates. The $E_{(G-Y)}$ signal is obtained from the screen grid which is common to both plates and the control grid.

Solid-State Demodulator. The General Electric CB series receivers employ a balanced-diode synchronous demodulator. Three identical detectors are employed. Figure 9-41 is a simplified schematic of one detector section. The 3.58-mc CW signal is applied to the diodes through transformer T . When the cathode of diode CR_1 is positive, the anode of CR_2 is negative and the diodes won't conduct since they are reverse-biased. The chroma signal across L can't reach the grid of amplifier V . But, when the cathode of CR_1 is made negative and the anode of CR_2 is made positive during the other half-cycles of the CW signal, the diodes conduct. The chroma signal now gets through to the grid of the amplifier. So does the 3.58-mc CW signal, but its amplitude

depends upon the setting of potentiometer R which is used for controlling color balance.

The full demodulator circuit is shown in Fig. 9-42. The required phase relationships of the subcarrier signals fed to the three detectors are arranged through the combinations of coils with T_1 and T_2 . Potentiometers in all three detector circuits permit individual adjustment of blue, green and red balance.

9-8. FOREIGN COLOR SYSTEMS

If all nations employed identical television systems, world-wide network broadcasting would be more feasible. As it is now, there are seven different sets of standards for black and white television and seven different color-television systems.

Most of the color systems described in the following paragraphs are *proposed* systems. They are not yet in use, and therefore subject to refinement or outright change.

SECAM. There are now four versions of SECAM (sequence and memory) systems which were developed by French engineers seeking to improve on the American NTSC system which

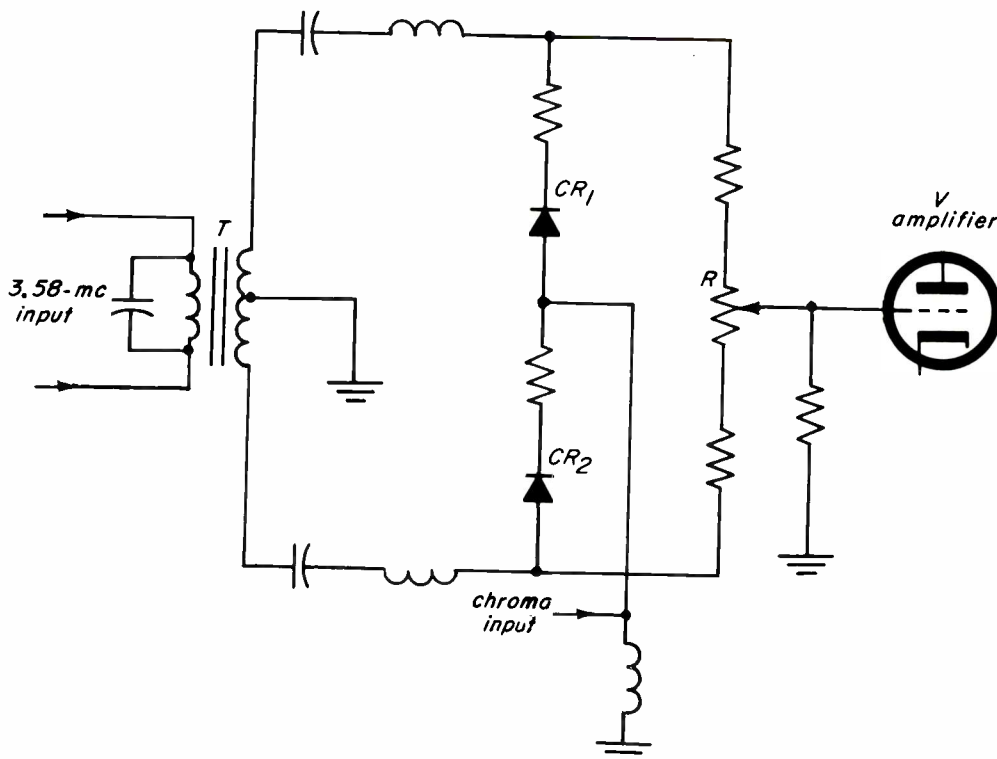

Fig. 9-41. Solid-state balanced demodulator.

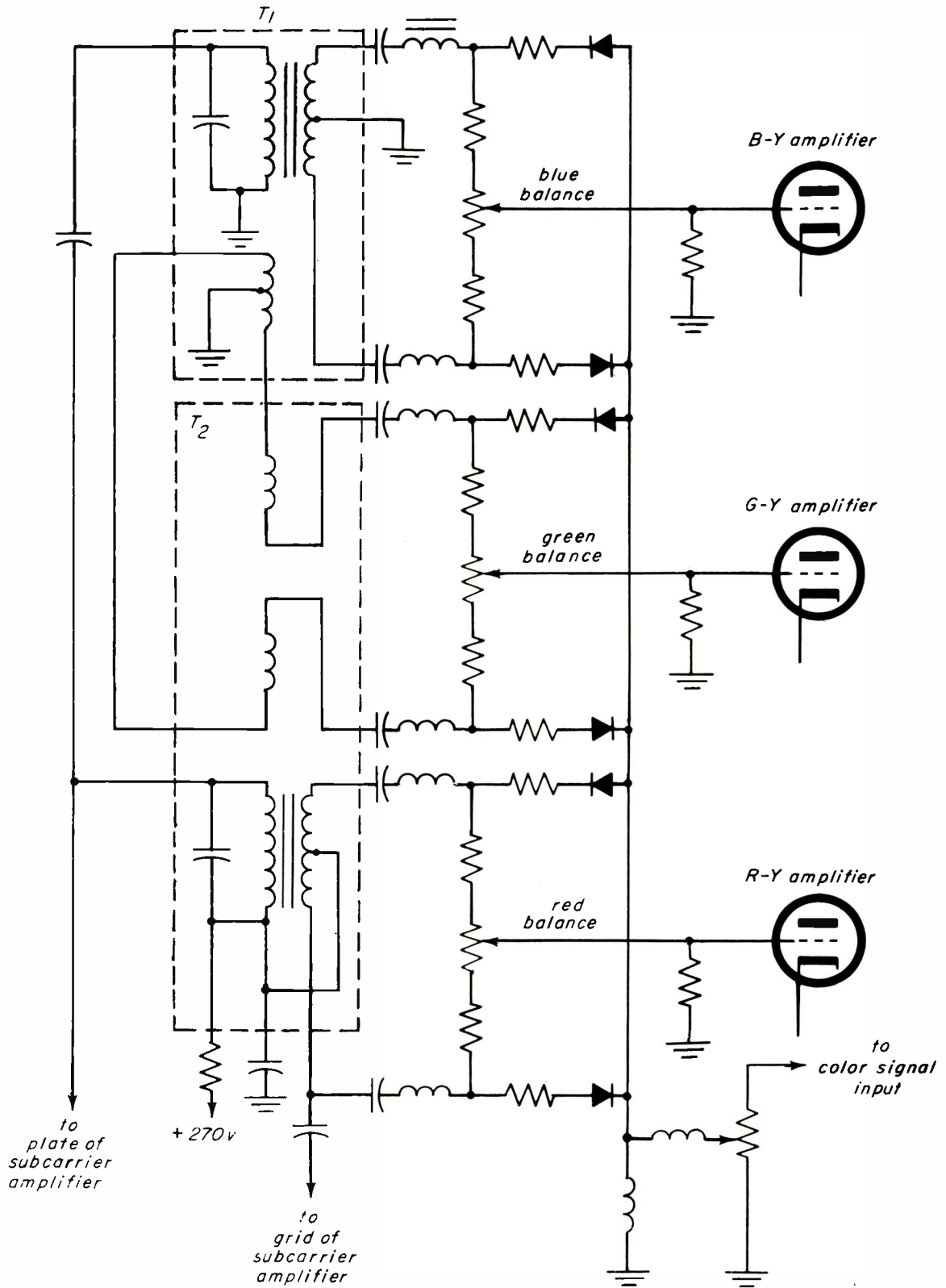

Fig. 9-42. General Electric color demodulator.

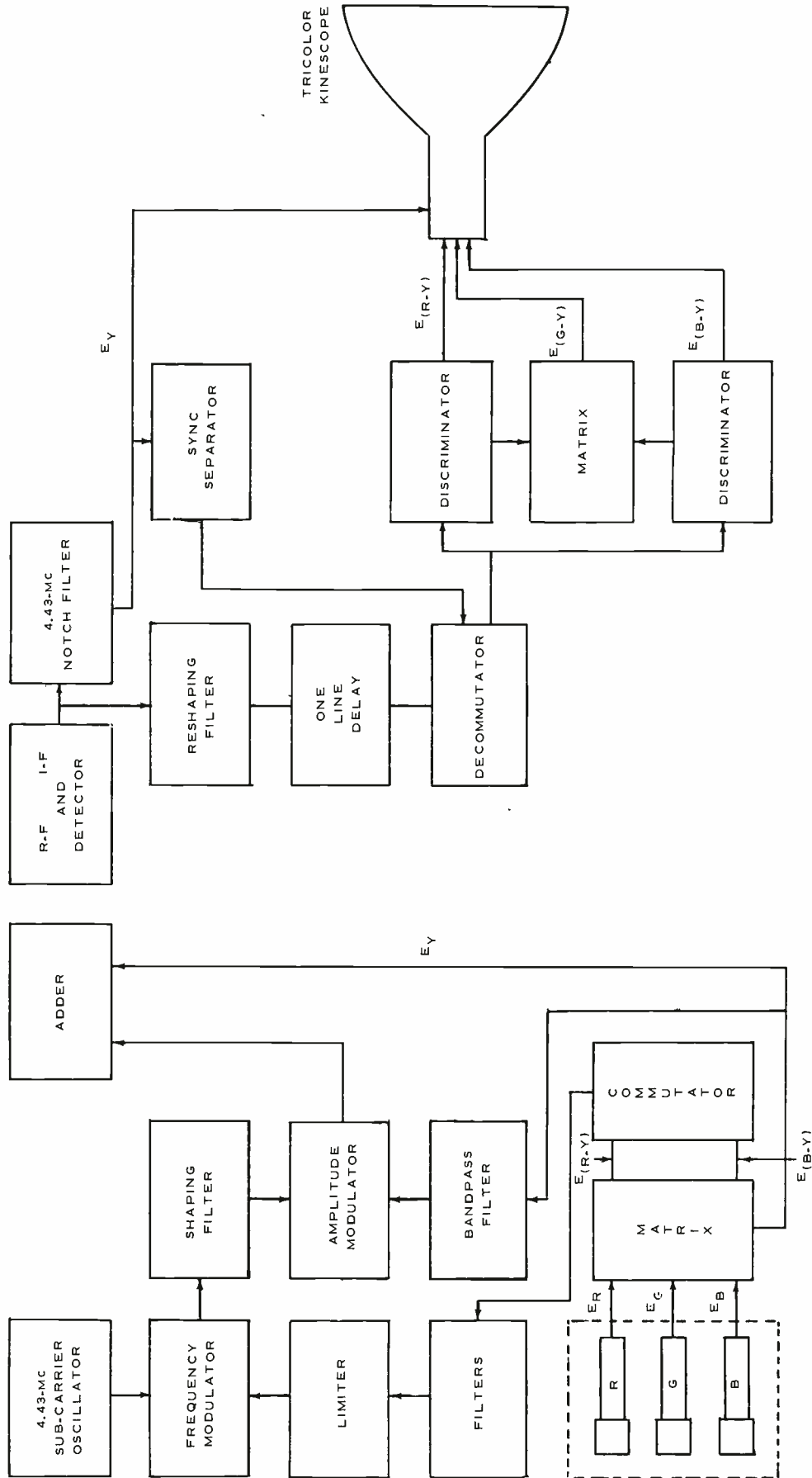

Fig. 9-43. A block diagram of overall SECAM system.

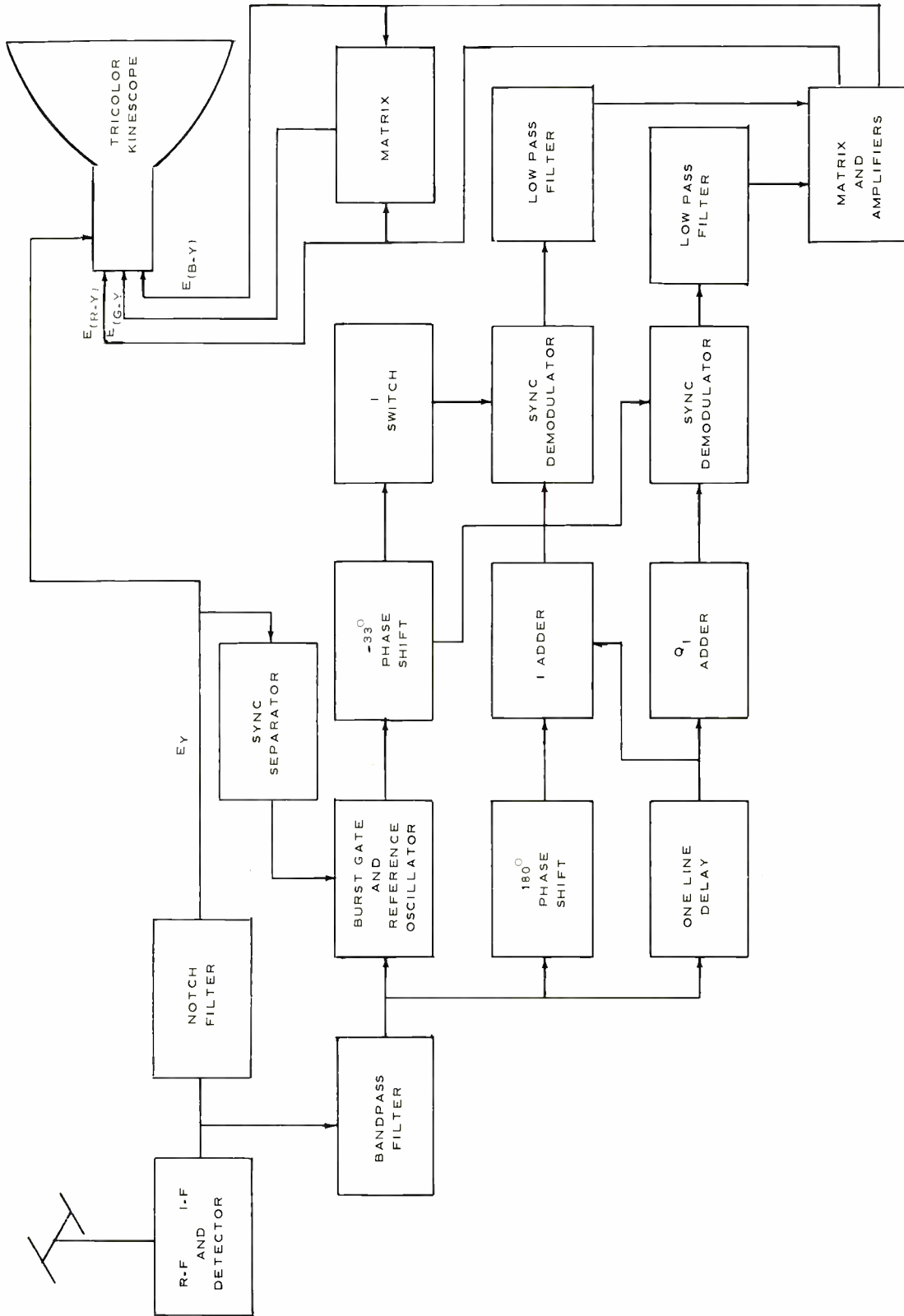

Fig. 9-44. A block diagram of a de luxe PAL receiver.

requires more sophisticated transmission facilities than SECAM. It is less sensitive to phase distortion and is not subject to crosstalk between two simultaneously transmitted color signals required in the NTSC system.

In SECAM, a continuous FM color subcarrier is used and only one color is transmitted at a time during each horizontal scan. A one-line delay network is required and at the receiver a switching circuit is needed for deriving the color difference signals.

Figure 9-43 is a simplified overall block diagram of the SECAM system. The color signals from the camera are fed into a matrix to derive $E_{(R-Y)}$ and $E_{(B-Y)}$ signals. These are fed into an electronic switch (commutator) which selects the signals alternately. The selected signal is fed through low pass and pre-emphasis filters and an amplitude limiter to a frequency modulator. The 4.43-mc subcarrier is frequency modulated by the color signals with maximum frequency deviation limited to ± 700 kc. When no color signals are present (black and white being transmitted), the subcarrier frequency holds still at 4.43 mc. The subcarrier is transmitted at all times, not in bursts and during color transmission only as in the NTSC system.

Since only $E_{(R-Y)}$ or $E_{(B-Y)}$ is being transmitted during any one horizontal-line scan, the one not being transmitted is stored for transmission during the next horizontal-line scan. Since both signals must be available simultaneously at the receiver, it contains a memory device. This is why the name SECAM—sequence and memory.

The frequency-modulated signal bearing the color information is fed through an inverse bell-shaping filter to an amplitude modulator and then to an adder where the luminance signal (E_Y) is inserted.

At the receiver, the E_Y signal is fed to the picture-tube cathodes through a notch filter which eliminates the 4.43-mc frequency-modulated signal. Instead, the 4.43-mc signal is fed through a bell-shaping filter (re-inverts inverse bell shaping at the transmitter) to the memory system. It consists of a one-line delay and an electronic switch (decommutator) which is controlled by the horizontal-sync pulses.

The memory system feeds the composite color signal to a pair of FM discriminators. Their demodulated outputs are fed through de-emphasis filters to the red and blue grids of the picture tube. The $E_{(R-Y)}$ and $E_{(B-Y)}$ signals are also fed to a matrix which extracts and feeds the $E_{(G-Y)}$ signal to the green grid.

SECAM was selected for use in several countries because the signals can tolerate the phase distortion introduced by microwave and coaxial-cable transmission systems whose standards are inferior to those available in the United States.

PAL. In the "phase alternation line" (PAL) color system, devised by West German engineers, the E_I and E_Q color signals are transmitted in phase quadrature. However, the phase at the subcarrier in the I modulator in the transmitter and in the receiver is reversed 180° for every line. Its transmission quality is said to be excellent and much more free of ghosts than the American NTSC system. But, the cost of receivers for PAL is higher than for NTSC receivers. Figure 9-44 is a block diagram of a deluxe PAL receiver which is more complex than an American receiver. The simple PAL receiver is almost identical to an American receiver.

ART. This is a British system (additional reference transmission) in which a reference signal is provided for decoding the quadrature-modulated color subcarrier during the entire active part of the line-scanning interval, and for correcting subcarrier amplitude distortion. ART is similar to NTSC in many respects and may be used with PAL.

NIR. Russian and French engineers developed this system which is sometimes called SEQUAM or SECAM IV. It is said unofficially to employ substantially conventional NTSC $R-Y$ and $B-Y$ color difference signals. Hue is transmitted as phase modulation on the subcarrier. Saturation is a function of the ratio of the square of the subcarrier amplitude to the E_Y signal (luminance) amplitude. No color-reference burst signal is required. One set of lines provides chroma information only. Alternate lines provide the subcarrier reference. Their positions are reversed during the following field. The receiver employs an electronic switch, one of whose inputs is delayed one horizontal line. The chroma information is available during one switch position, and the reference information during the other.

NOTES

EXAMINATION

DEVELOPMENTS IN COLOR TV

Instructions:—*PRINT your name, address, and student number assigned to you below.*

Date _____

Student Number _____

Date you mailed last examination _____
(mo.) (yr.)

Name _____

Street Address _____

City _____ State _____

Zip No. _____

Please!

_____ correct out of 20 = _____ %
Graded by _____

80-68

1. The following color picture tubes have a single electron gun: (a) Chromatron[®] and Colornetron[®]; (b) shadow mask; (c) Colornetron[®] and shadow mask; (d) tri-color kinescope.

a b c d

2. Side pincushioning is corrected by: (a) reducing the horizontal deflection at the top and bottom of the vertical-scanning line; (b) reducing the vertical-gain; (c) expanding the horizontal deflection; (d) increasing the sync-pulse voltage.

a b c d

3. In an automatic-degaussing system, current flows through the degaussing coils: (a) continuously; (b) when the receiver is turned off; (c) when the receiver is turned on; (d) when degaussing is automatically called for.

a b c d

4. The SECAM system was selected for use in some countries because: (a) it is compatible with the NTSC system; (b) it permits use of relatively poor quality transmission links; (c) receiver cost is lower than for NTSC standards; (d) it is free of ghosts.

a b c d

5. When a receiver has an automatic-degaussing system: (a) manual degaussing is never required; (b) the receiver should be degaussed manually when first installed and whenever moved; (c) manual degaussing should be performed monthly; (d) manual degaussing should be performed only when the receiver is moved.

a b c d

6. The 4.5-mc sound carrier is extracted: (a) at the video detector; (b) at the color-burst gate; (c) at the output of the first-video amplifier; (d) at the tuner.

a b c d

7. A receiver employing a Colornetron[®] picture tube employs: (a) three color demodulators; (b) two color demodulators; (c) one color demodulator; (d) no color demodulators.

a b c d

8. A sheet-beam tube has: (a) two grids and two signal plates; (b) three grids; (c) four grids; (d) two signal plates only.

a b c d

9. The 3.58-mc subcarrier is transmitted: (a) continuously; (b) 60 times per second; (c) following every horizontal-sync pulse; (d) at random.

a b c d

10. A varactor diode is: (a) a voltage-sensitive resistor; (b) a voltage-sensitive capacitor; (c) a temperature-sensitive inductance; (d) a temperature-sensitive capacitor.

a b c d

12-70

11. The color brightness of picture tubes has been improved by use of: (a) higher voltages; (b) more selective bandpass amplifiers; (c) new phosphors; (d) pincushion correctors.
12. In a crystal-ringing circuit: (a) the 3.58-mc oscillator runs continuously; (b) the crystal is shock-excited; (c) the crystal functions as a notch filter; (d) the oscillations do not decay.
13. The resistance of a voltage dependent resistor (varistor): (a) rises with voltage; (b) reduces with voltage; (c) remains constant; (d) drops to zero when voltage is applied.
14. The resistance of a thermistor: (a) rises with voltage; (b) rises with temperature; (c) reduces with temperature; (d) is not affected by temperature.
15. The Chromatron[®] color picture tube employs: (a) color phosphor strips and beam-deflection grids; (b) color dots; (c) beam-deflection grids, and color dots; (d) three electron guns.
16. The frequency of oscillation of the color-sync generator is controlled by: (a) the video-carrier frequency; (b) the set owner; (c) burst signals from the transmitter; (d) the fine-tuning control.
17. In a solid-state synchronous color demodulator, the diodes: (a) conduct continuously; (b) are gated by the locally generated 3.58-cm signal; (c) are gated by the chroma signal; (d) conduct alternately.
18. In an in-line color picture tube the electron guns are: (a) positioned triangularly; (b) positioned side by side; (c) positioned one above another; (d) pointed in three different directions.
19. Rectangular picture tubes are popular because: (a) more of the tube's face is utilized by the picture; (b) they are longer than round tubes; (c) they require less beam deflection; (d) circuit requirements are simpler.
20. When a rectangular picture tube is used, the following are required: (a) wider beam deflection; (b) automatic degaussing; (c) pincushion correction; (d) a power transformer.

- | | | | |
|--------------|--------------|--------------|--------------|
| a | b | c | d |
| a | b | c | d |
| a | b | c | d |
| a | b | c | d |
| a | b | c | d |
| a | b | c | d |
| a | b | c | d |
| a | b | c | d |
| a | b | c | d |



COLOR TELEVISION

Servicing the New Color Sets

1. Purity Adjustments
2. Convergence Adjustments
3. White-Balance Adjustments
4. Adjusting the new AFPC Circuits
5. High-Voltage Adjustments
6. Pincushion Adjustments
7. Antenna Requirements
8. Test Equipment Improvements

RCA Institutes, Inc.

Home Study School

320 West 31st Street | New York, NY 10001

© RCA Institutes, Inc. 1967 All Rights Reserved 1969 Printing

INTRODUCTION

Since the rectangular color picture tube was introduced, circuit changes have been made and new servicing techniques are required. Setup procedures, however, are essentially the same as covered in Lesson 4.

10-1. PURITY ADJUSTMENTS

When only the red gun of the picture tube is turned on, nothing but red should appear on the screen. The red gun lights only the red phosphor dots. When only the blue gun is turned on, only blue should be seen. And, when only the green gun is turned on, only green is seen. This is "purity." But, if the red gun is aimed wrong so that it illuminates other than red phosphor dots, we have "impurity."

Purity-Adjustment Procedure. Before purity adjustments can be made, the receiver should be degaussed and should be operated with full brightness (without bloom) for 5 to 20 minutes, and center convergence must be correct. If purity adjustments are made during minimum operating-temperature conditions, the yoke should be set as close to the rear edge of adjustment as is consistent with good purity. If the receiver is hot (2 to 3 hours operating time) the yoke should be placed as far forward as consistent with good purity.

The receiver should always be facing either to the north or to the south when setting purity adjustments.

Purity adjustments are most accurate while observing one color only (preferably red). Disable the blue and green guns by jumpering their grids to ground through a 100,000-ohm resistor. Isolating resistors are provided on the chroma board of some receivers for this purpose. Alternately, the blue and green guns can be disabled by turning down their respective drive controls.

Loosen the deflection-yoke clamp and slide the yoke back against the convergence-magnet assembly (see Fig. 10-1). Adjust for a uniform red area in the center of the screen by spreading or rotating the purity magnet assembly located on the picture tube neck.

Spreading the tabs increases the magnet strength and moves the beams in a radial direction. Rotating the purity magnet moves the beams in a circular path. A low power microscope can be used to check for optimum beam-landing adjustment.

After center purity has been attained, slide the yoke toward the picture-tube bell while observing the entire screen. Position the yoke for best overall red screen. Tighten the yoke clamp.

NOTE: If purity rings are used to obtain best over-all red screen with the yoke forward, recheck beam landing.

Reactivate the blue and green guns and observe all three beams. If the screen is not a uniform

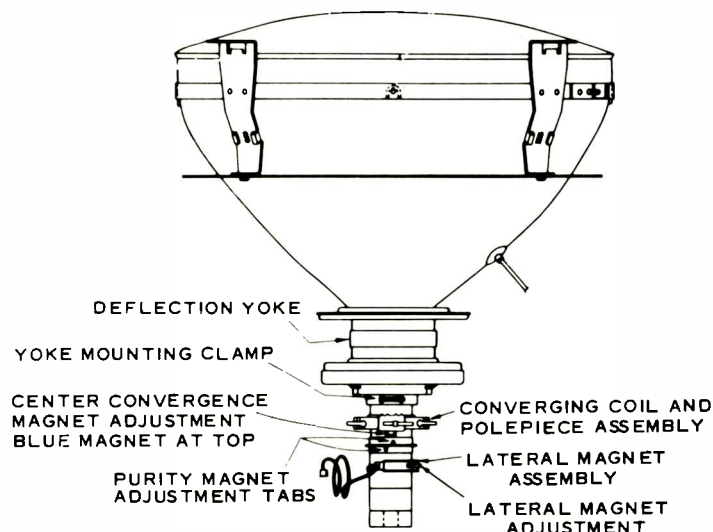

Fig. 10-1. Picture-tube assembly.

white, readjust center convergence and repeat the purity adjustment.

NOTE: The above is generally applicable, but check the applicable service manual to determine if the manufacturer recommends different procedures.

Some manufacturers recommend that in a receiver employing a rectangular tube with post-deflection purity, the picture tube be degaussed manually after obtaining center purity (before adjusting the yoke for full screen illumination). If the red cloud changes position after degaussing, readjust the purity-magnet rings and degauss again until further degaussing does not affect the position of the red cloud. Then, adjust the yoke for full-screen red illumination.

Degaussing. A receiver should be degaussed manually (see Lesson 4) when it is first installed or moved to a new location, even if it has an automatic-degaussing system. Thereafter, if the receiver is not moved, manual degaussing should not be required unless the automatic-degaussing system fails. The degaussing system could fail to operate if one of the coils opens or the voltage-dependent resistor is defective. The degaussing system could fail to turn itself off, as it should, if the thermistor opens or the thermal switch is defective (when one is used).

Color-Temperature Adjustments. The following procedures are applicable to some receivers, including current RCA models. Turn screen controls to minimum. Place kinescope bias switch in the high-bias position. Turn brightness and contrast controls to approximate mid-range. Position NORMAL-SERVICE switch to SERVICE position. Advance screen controls to just light each

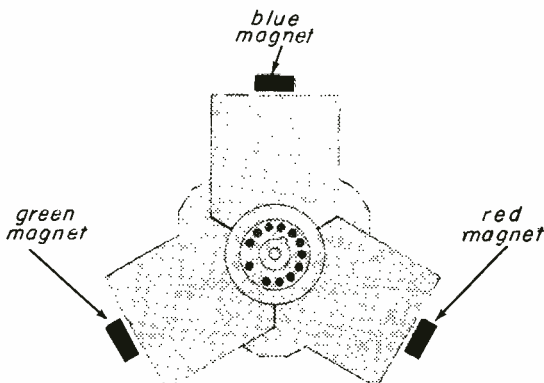

Fig. 10-2. Static-convergence magnets.

gun (a horizontal line). When one or more guns do not produce a light, move kinescope bias switch to the next highest bias position. Readjust all three guns to just produce a horizontal line. Change NORMAL-SERVICE switch to NORMAL position. Adjust brightness throughout the usable brightness range. No further adjustments are required if screen controls were set accurately. Accuracy of the screen setting is very important.

10-2. CONVERGENCE ADJUSTMENTS

Convergence involves both static and dynamic phenomena. The receiver should be first adjusted for static convergence and then for dynamic convergence as explained previously in Lesson 4.

Static Convergence. In addition to the procedures described in Lesson 4, the student should be familiar with adjustment of the newer static-convergence assemblies. For example, the procedures below are recommended by Sylvania for its DO3 series receivers.

Adjust the receiver for a normal black and white receiver. The receiver should be in the position in which it will be operated. Degauss and adjust purity if required. Connect the r-f output of a dot/cross-hatch generator to the antenna terminals of the receiver. Adjust red, green and blue magnets, shown in Fig. 10-2, and the blue lateral magnet, shown in Figs. 10-3 and 10-4, to

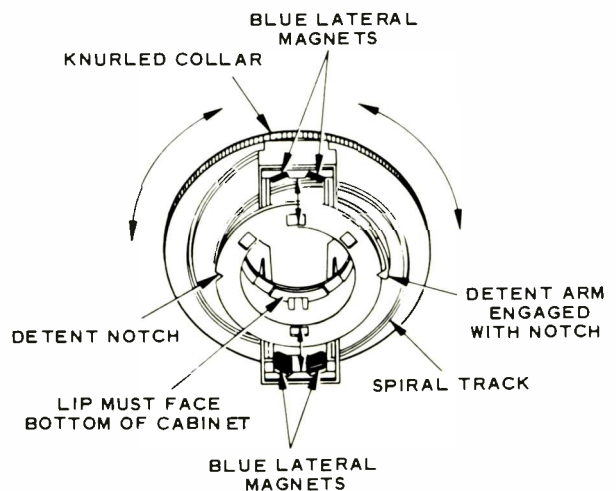

COURTESY OF SEARS, ROEBUCK AND CO.

Fig. 10-3. Blue lateral magnet.

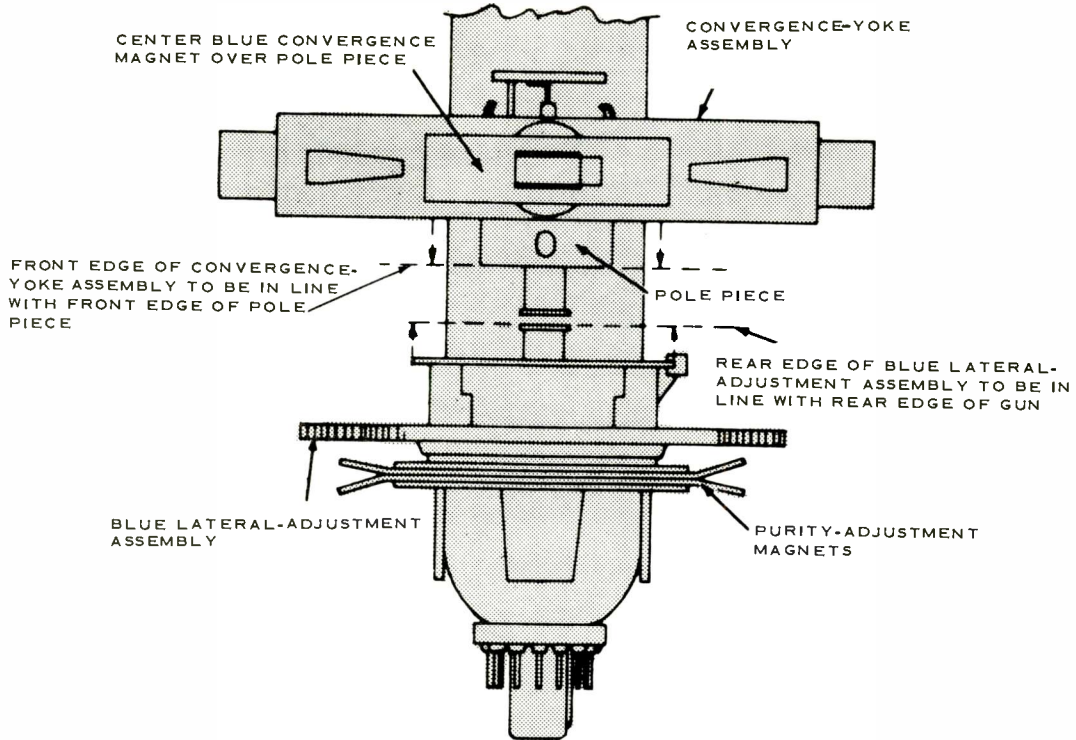

Fig. 10-4. Blue lateral magnet is directly forward of purity-adjustment magnets.

attain convergence of dots in the center of the picture-tube screen. The direction of movement of the dots using these magnets is illustrated in Fig. 10-5. Lateral movement of the blue dot is accomplished by rotation of the blue lateral-magnet adjustment. To increase the range of adjustment, the magnets may be reversed (top to bottom) by rotating the magnet-adjustment disc until magnets are rotated 180° from their original position.

Dynamic Convergence. Again, the procedures recommended by the receiver manufacturer should be followed. Below are the procedures for adjusting dynamic convergence in current RCA receivers.

Feed a cross-hatch signal (r-f) from a color-signal generator directly to the receiver's VHF input terminals. Adjust the top and bottom vertical-convergence controls (*R811* and *R814* in Fig. 10-6) for convergence of the red-green vertical center line. Readjust static-center convergence if necessary. Then adjust the bottom-horizontal convergence control (*R812*) to converge the bottom red and green horizontal lines at the center vertical line of the screen. Adjust the top horizontal-convergence control (*R813*) to converge the top

red and green horizontal lines at the center vertical line of the screen.

Adjust the left blue horizontal line controls (*R801* and *T801* in Fig. 10-7) to obtain a straight horizontal blue line. Then, adjust the bottom (*R808*) and top (*R815*) blue horizontal lines controls for uniform displacement of blue horizontal lines along the center vertical lines.

Converge the blue horizontal lines with the red and green horizontal lines by adjusting the blue

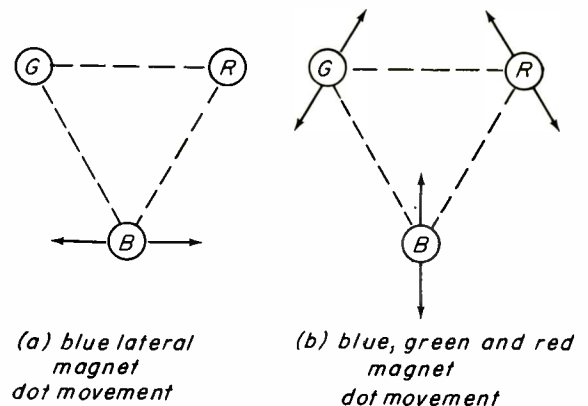

Fig. 10-5. Movement of dots.

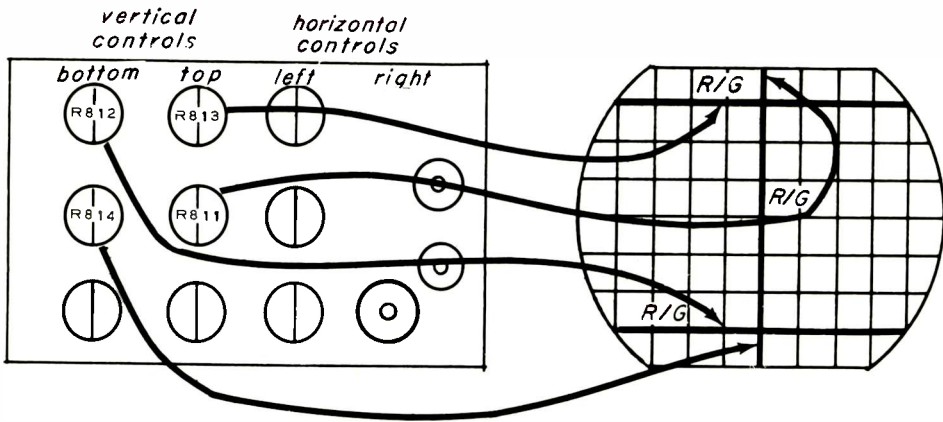

Fig. 10-6. Effect of R811, R812, R813 and R814 adjustment.

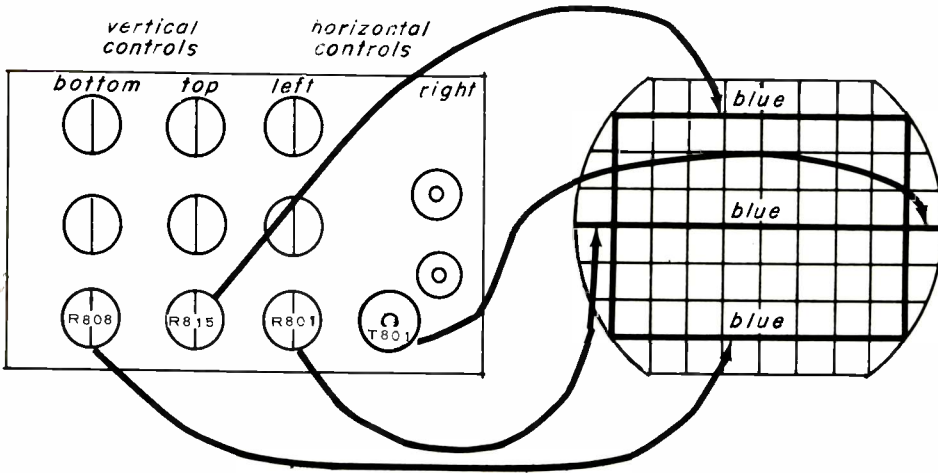

Fig. 10-7. Effect of R801, T801, R808 and R815 adjustment.

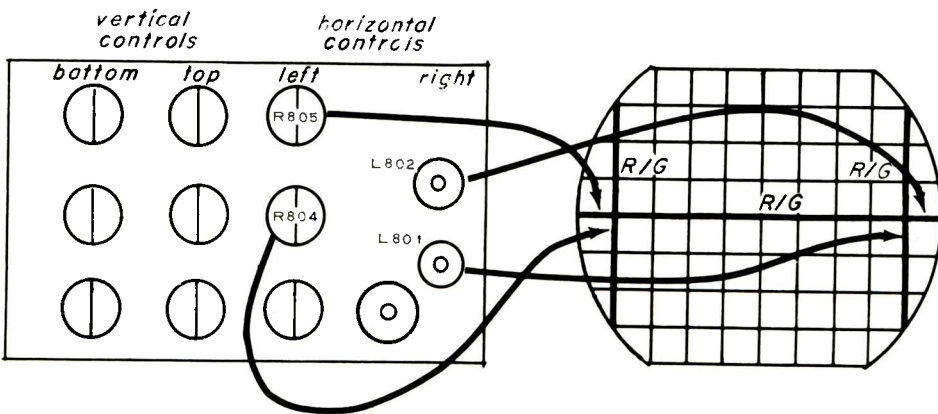

Fig. 10-8. Effect of L801, R804, L802 and R805 adjustment.

convergence magnet. Also adjust the red and green magnets and readjust *R801*, *T801*, *R808* and *R815*, if necessary.

Alternately adjust the right (*L801*) and left (*R804*) vertical-lines controls, shown in Fig. 10-8, to obtain convergence of the red and green vertical lines. Then adjust the right (*L802*) and left (*R805*) horizontal-line controls for convergence of the red/green horizontal center line. Repeat adjustments if necessary and recheck purity and color temperature.

Blue-Shaping Coil. The blue horizontal-shaping coil is factory adjusted and normally does not require readjustment. Misadjustment of this coil will cause poor horizontal blue convergence and possible failure of one or more of the horizontal-convergence components. This control is located on the convergence-board assembly in some receivers. To adjust the coil, connect an oscilloscope between the "hot" end of the coil (the end not connected to the left blue horizontal-line potentiometer) and ground. Adjust the coil until the harmonic bump is converged at the 50% point (about 40 volts peak-to-peak) on the sine-wave slope as indicated in Fig. 10-9.

Wide Blue-Field Adjustment. This adjustment is also preset at the factory. If adjustment is required because the blue field over-scans the red and green, loosen the yoke thumbscrews and then tighten the wide blue-field screw to reduce the width of the blue field.

General Electric In-Line Tube. In receivers employing this tube (see Lesson 9) there are no adjustments for vertical and horizontal convergence and tilt. It is only necessary to set the magnet on each of the horizontal and vertical coils for best convergence.

10-3. WHITE-BALANCE ADJUSTMENTS

Black-and-white tracking adjustment procedures vary among different makes of receivers but the principles are the same. The picture-tube screen-grid controls, the blue and green gain controls, the picture-tube (CRT) bias control, the brightness and contrast controls are used for making white-balance adjustments. The procedures suggested for Zenith receivers, for example, are as follows.

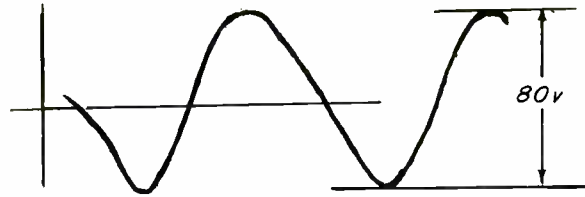

Fig. 10-9. Blue horizontal-shaping signal waveform.

Tune in a black and white picture that displays an adequate range of light levels, light and grey objects, dark objects, etc. Set the brightness and contrast controls for a normal picture. Set the CRT bias and the three screen adjustments to minimum (fully counter-clockwise). Set the BW switch to setup position. In this position the vertical sweep is removed to facilitate adjustments. Advance each screen control to produce a white horizontal line of medium brightness through the center of the screen.

In some instances, the red, green and blue lines may not completely overlap to form a white line due to the removal of the vertical sweep and necessary vertical-convergence waveforms. In such cases, adjust the three screen controls for red, green and blue lines of approximately equal intensity.

If one or more of the screen adjustments fail to produce a line, leave that particular screen adjustment at maximum. Advance the CRT bias setting to produce a line of medium brightness for that particular screen adjustment. Adjust the remaining screen controls for a white line, or lines of approximately equal intensity.

Return the BW switch to "Normal" position and alternately adjust the blue and green gain controls to produce a normal black and white picture. Check overall black and white tracking throughout the normal brightness and contrast range.

10-4. ADJUSTING THE NEW AFPC CIRCUITS

While the basic functions of AFPC circuits remain the same, some of the newer receivers employ circuits that differ from those used in earlier receivers. Lesson 4 explains how conventional AFPC circuits are aligned. Here, the procedures for adjusting some of the new circuits are described.

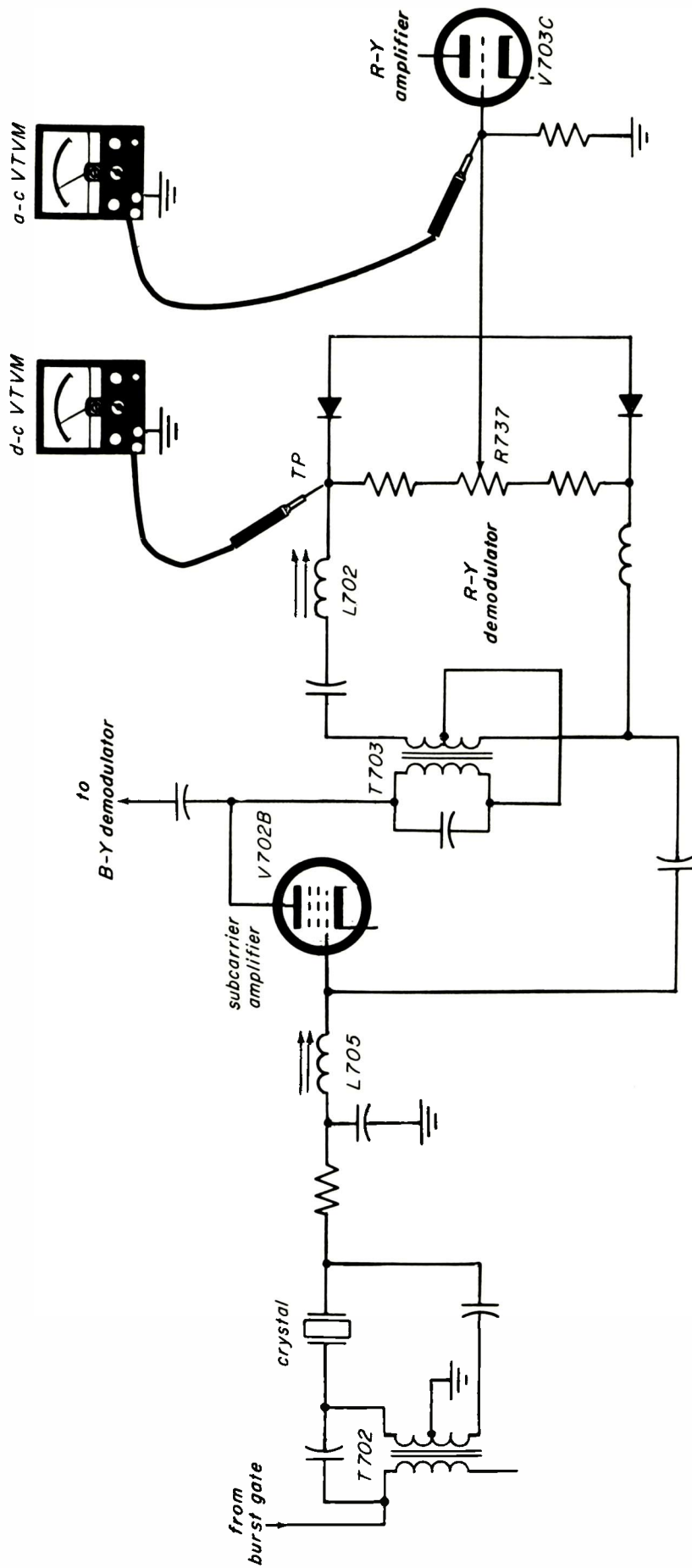

Fig. 10-10. Partial schematic of crystal ring-type AFPC circuit.

Crystal Ringing Circuits. As discussed in Lesson 9, some General Electric receivers do not employ a conventional 3.58-mc oscillator but instead employ a crystal ringing circuit to provide the color-sync signal. To adjust this type of circuit, connect a color-bar generator to the receiver's VHF antenna terminals and adjust the receiver for normal color reception. Connect a d-c VTVM to the test point (TP) in the R-Y demodulator as shown in Fig. 10-10 (TP701 in HB series receivers).

Set the red, blue and green balance controls to their center position and the chroma gain control for zero output. Adjust the core of the crystal-filter transformer (T702) for maximum VTVM reading, followed by adjustment of the crystal tuning coil (L705), also for maximum d-c voltage reading. The objective is to develop maximum 3.58-mc signal output, measured as a d-c voltage at TP. Then tune T703 the R-Y demodulator input transformer and T704 the B-Y demodulator input transformer (not shown in diagram), also for maximum d-c voltage indication. Repeat above adjustments.

Connect an a-c VTVM to the grid of the R-Y amplifier (V703C) and adjust L702 and R737 alternately for minimum a-c voltage indication. With the a-c VTVM connected to the grid of the B-Y amplifier (not shown) perform the same adjustments in the B-Y demodulator circuit, also for lowest a-c voltage indication. Now, with the a-c VTVM connected to the grid of the G-Y amplifier (not shown) adjust the equivalent components in the G-Y demodulator circuit, again for minimum a-c voltage.

Connect a d-c VTVM to the grid of the R-Y amplifier (V703C) and adjust R737 for zero volts. Do the same at the B-Y demodulator and amplifier, and then the G-Y demodulator and amplifier, while measuring d-c voltage at their respective amplifier grids.

With the chroma gain control still set for zero output, adjust the fine tuning from crystallization to smear. This must not cause a shift in the grey scale. If it does, repeat the demodulator d-c balance adjustments described above. Then, advance the chroma gain control to obtain a normal color picture. When adjusting the fine-tuning control from crystallization to smear, there must not be a shift in color highlights. If there is, repeat the demodulator a-c balance adjustments as above.

When the tint control is set at the center of its range, correct flesh tones should be produced with the red bar turning slightly magenta at one end of the control and the blue bar turning slightly magenta at the other. If the control range is off center, adjust the core of T703.

Sheet-Beam Demodulators. To align AFPC circuits employing sheet-beam demodulators, the following procedures should be followed. Apply a gated rainbow signal to the receiver's VHF input terminals from a color-bar generator. If the receiver has a color switch, put it in the ON position. Ground the output of the first color amplifier (test point K in Fig. 10-11) and the d-c output of the phase detector (test point W in Fig. 10-12). Adjust the reactance-oscillator coil (L36) for zero beat as viewed on the picture-tube screen. Zero beat is indicated by minimum movement of color bars through the picture.

Ground the output of the video detector (test point C1 in Fig. 10-13) and connect a d-c VTVM to one leg of the phase detector (test point V in Fig. 10-12 shown previously) through a 4.7-megohm resistor. Adjust the R-Y slug of the injection transformer (T12) for maximum d-c voltage indication. Then, adjust the B-Y slug, for minimum voltage indication.

Remove the grounds from the three test points (C1, K, W). Apply a gated rainbow test signal to the antenna terminals. Set the color level and hue controls to their mid-position. Connect an oscilloscope to the grid of the red picture-tube

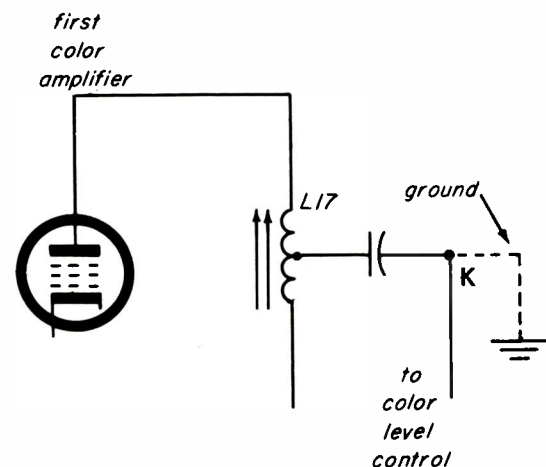

Fig. 10-11. Color amplifier grounding point.

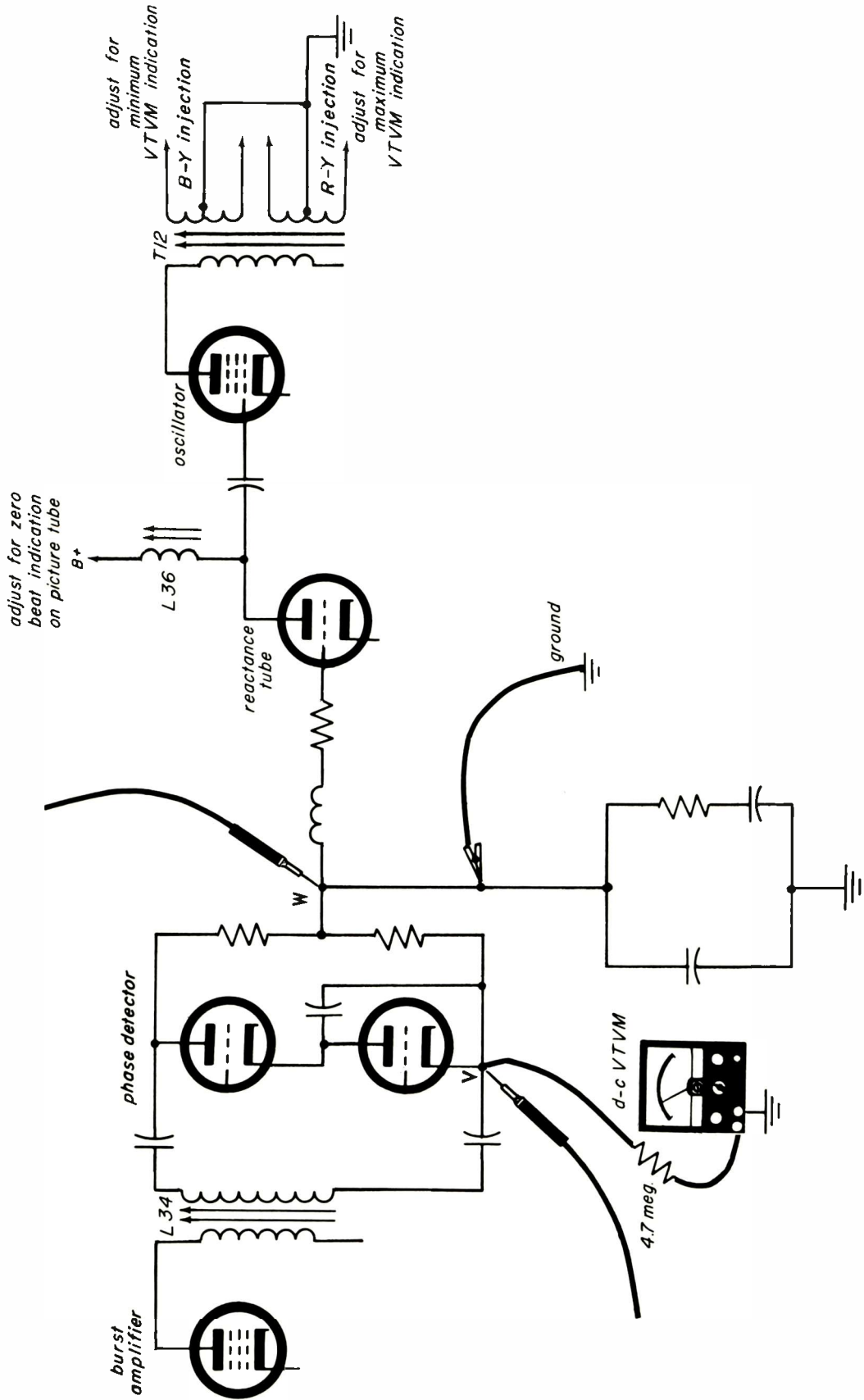

Fig. 10-12. Partial circuit of AFC for sheet-beam demodulators.

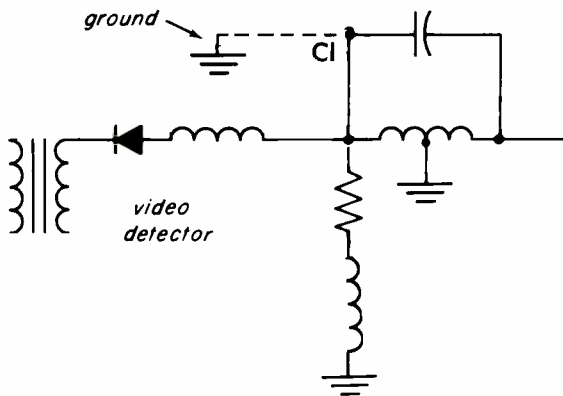

Fig. 10-13. Video detector grounding point.

gun (test point *R* in Fig. 10-14) and adjust the burst-amplifier plate coil (*L34* in Fig. 10-12) to obtain the pattern shown in Fig. 10-15a. Move the oscilloscope lead to the grid of the blue electron gun (test point *S* in Fig. 10-14) and slightly re-adjust the *B-Y* slug of the injection transformer (*T12* in Fig. 10-12) to obtain the pattern shown in Fig. 10-15b, if necessary.

Motorola Type. The following procedures are recommended for Motorola receivers employing a 6LE8 tube as a color demodulator. Connect a color-bar generator to the receiver antenna terminals and adjust the fine-tuning control for the best picture. Set color intensity control to minimum and the color killer to maximum. Connect

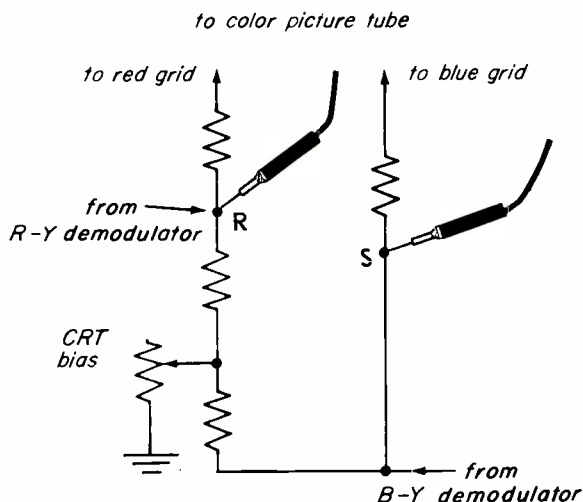
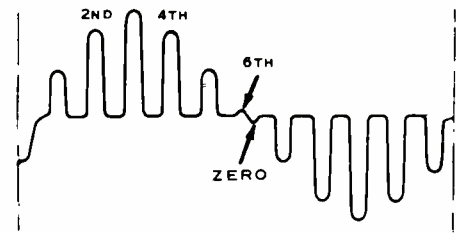
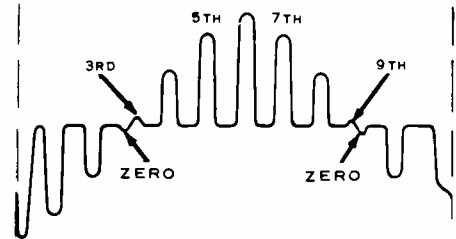

Fig. 10-14. Oscilloscope connection points.



(a) test point *R* (*R-Y*)



(b) test point *S* (*B-Y*)

Fig. 10-15. Color test patterns.

a d-c VTVM to one plate of the color-demodulator tube (pin 1 of *V17*) through a detector as shown in Fig. 10-16. Ground the cathode of the tube (pin 3) to the chassis with a short clip lead. Adjust screen trap *L907* for minimum d-c voltage indication. Then remove the ground (clip lead) from the cathode.

Now, connect the VTVM through a 5.6-megohm resistor to the control grid (pin 9) of the 6LE8 tube and to the junction of *L904* and *R919* (negative lead) as shown in Fig. 10-17. Ground the junction of the crystal and the color-sync filter (*T902*) with a short clip lead. Also ground the cathode of the color sync and gate tube (not shown). Adjust *L904* for maximum meter indication.

Remove the ground from the crystal and adjust the core of the color-sync filter (*T902*) for -3 volts d-c meter reading. Advance the color-intensity control until a trace of color is visible on the picture tube screen. Then, adjust *L904* until the color is in sync. Readjust *T902* to obtain a -3 volts d-c meter reading. Alternately adjust *L904* and *T902* to keep color in sync and -3 volts meter reading. Now, remove the ground from the cathode of the color sync and gate tube (*V18A*).

Disconnect the VTVM and connect it to test point *B* on the color-sync interstage transformer

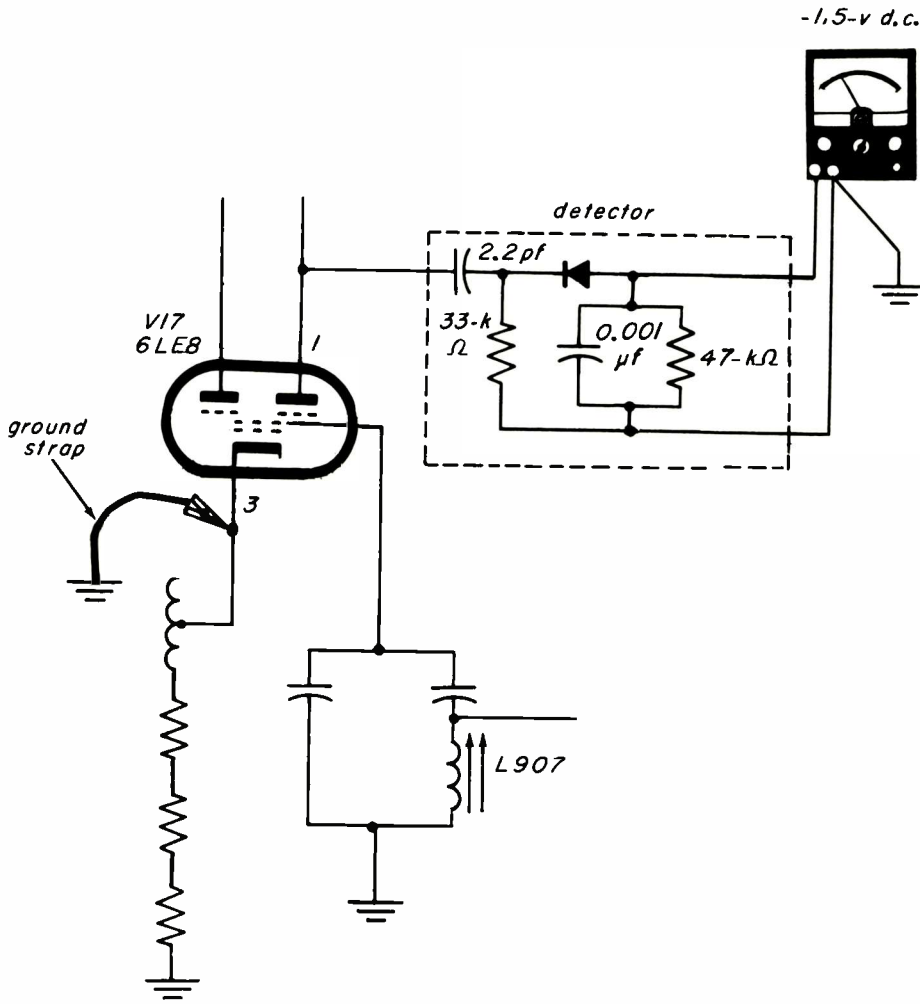

Fig. 10-16. Setup for adjusting screen trap.

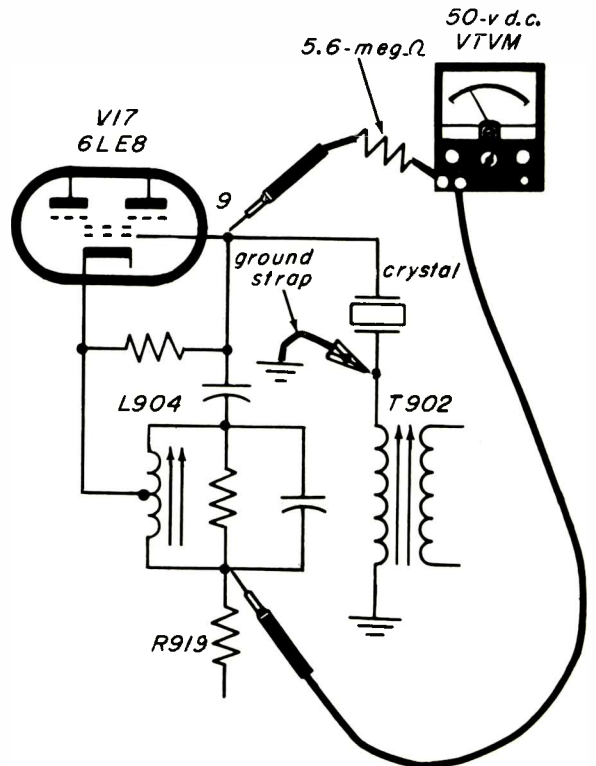

Fig. 10-17. Setup for adjusting color-oscillator and color-sync filter.

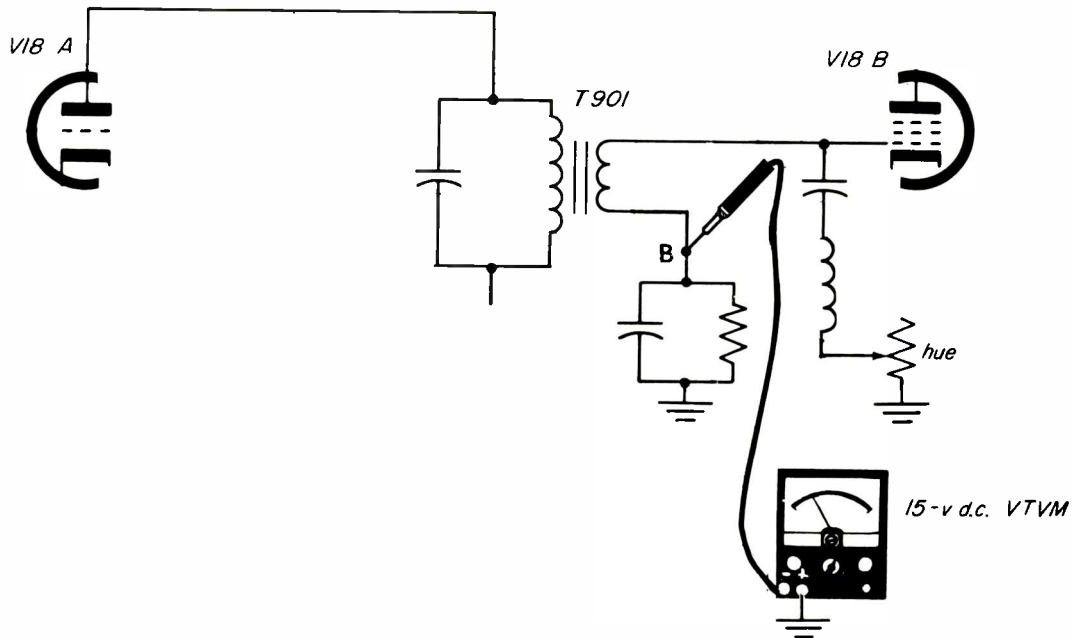

Fig. 10-18. Setup for adjusting hue centering.

(*T901*) and ground as shown in Fig. 10-18. Set color intensity control to minimum. Adjust the core of *T901* and rotate the hue control through its entire range. When *T901* is correctly adjusted, the VTVM indication should be equal at the minimum and maximum extremes of the hue control. Then turn up the color-intensity control and mechanically center the tint control. The magenta bar should go from blue to magenta to red. If flesh tones are not obtained with the hue control centered, readjust *T901*.

10-5. HIGH-VOLTAGE ADJUSTMENTS

In the newer receivers, from 20,000 to more than 25,000 volts are required for the color picture tube. This high voltage must be regulated in order

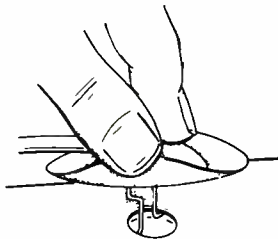

Fig. 10-19. High-voltage meter is connected to second anode of picture tube.

to maintain picture size, focus, linearity and convergence. Means are provided for high voltage-level adjustment. The procedures for making these adjustments varies among receiver makes and models, depending upon the type of regulator circuit used.

Admiral G12 Series. To make the high-voltage adjustments in these receivers, a 0-1.5 d-c voltmeter, with an internal resistance of not less than 20,000 ohms is required. Also, a 0-500 d-c milliammeter and a 0-30,000 d-c voltmeter are required.

With the receiver turned OFF, the focus control at mid-range and the high-voltage control at two-thirds of counter-clockwise rotation, connect the high-voltage meter to the second anode of the picture tube. See Fig. 10-19. Connect the 0-1.5 volts d-c meter across the 1000-ohm shunt-regulator tube's cathode resistor as shown in Fig. 10-20. Disconnect the lead from the cathode of the horizontal-output tube, as shown in Fig. 10-21, and connect the 0 to 500 d-c milliammeter between the cathode and the horizontal-bias control *R*. Make sure capacitor *C* is left in the circuit.

Turn the receiver on and allow it to warm up for at least five minutes. Tune in the weakest available station and adjust for a normal picture. Ground both the pulse input-control grid and the

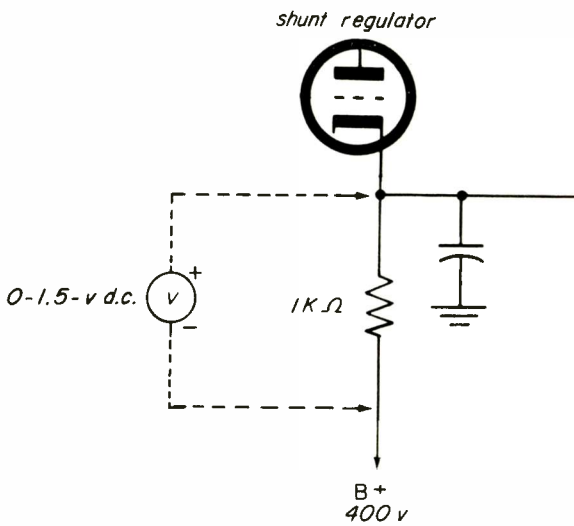

Fig. 10-20. Connections to shunt regulator.

horizontal-stabilization coil of the horizontal oscillator through clip leads. See Fig. 10-22.

Adjust the horizontal-hold control to sync the picture which will wave back and forth slightly. Now, remove the ground from the horizontal-stabilization coil, and adjust this coil to synchronize the picture horizontally. Remove the ground from the grid of the horizontal-oscillator tube. The picture should lock in.

With the brightness and contrast controls set at minimum, adjust the horizontal-efficiency coil

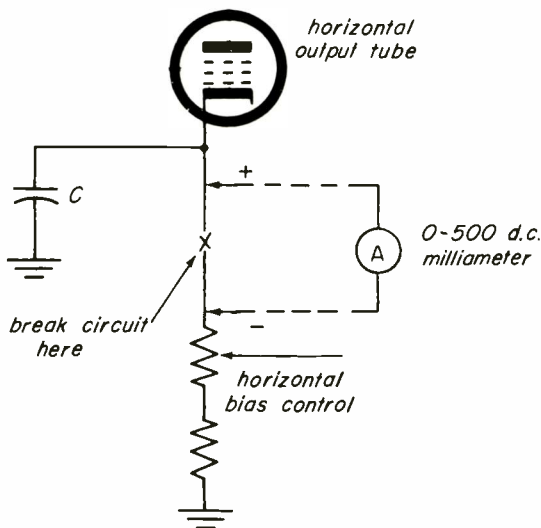

Fig. 10-21. Connections for measuring horizontal output-tube cathode current.

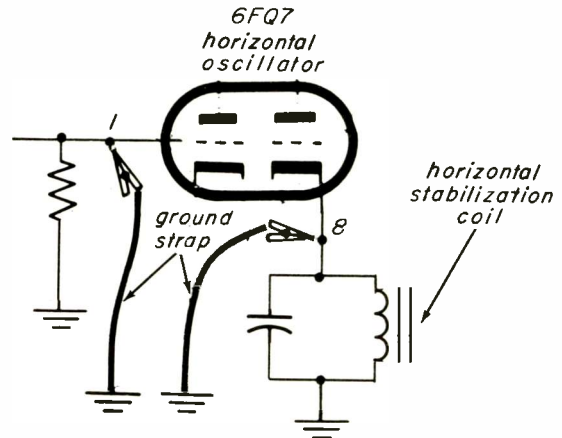

Fig. 10-22. Grounding points in horizontal oscillator circuit.

(in damper plate circuit) to obtain maximum indication on the 0-1.5 volt d-c meter. Adjust the high voltage control to get a reading of 25,000 volts on the high-voltage meter connected to the second anode of the picture tube. The milliammeter should not indicate more than 235 milliamperes and the 0-1.5 d-c voltmeter should indicate at least 0.75 volt. Disconnect the meters and reconnect the horizontal-bias control to the cathode of the horizontal-output tube.

RCA CTC19 Series. Using a similar set-up, the high-voltage control should be set to apply 24,000 volts to the second anode of the picture tube with the brightness control turned off. The 0-1.5 d-c voltmeter should indicate not less than 0.9 volt and the milliammeter should not indicate more than 195 milliamperes.

Compensation for Line Voltage. Zenith recommends that the high voltage be set according to a-c line voltage as follows: 20,900 volts for 100-volt line voltage; 22,200 for 105; 23,200 for 110; 24,400 for 115; 25,000 for 120; 25,600 for 125; 26,500 for 130; and 27,100 volts for 135 volts a-c line voltage.

10-6. PINCUSHION ADJUSTMENTS

Pincushioning-correction circuits are required in color receivers employing rectangular picture tubes. Most receivers employ pincushion-correction circuits similar to those employed by RCA.

RCA CTC19 Series. The top and bottom pincushion adjustment has been set at the factory. If

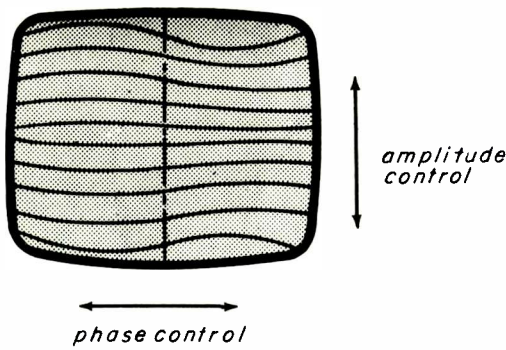

Fig. 10-23. Improperly adjusted top-bottom pincushion correction.

subsequent adjustment is required, feed a cross-hatch pattern into the receiver antenna terminals. Turn the top-bottom pincushion-amplitude control fully clockwise. Then adjust the top-bottom pincushion phase coil to move the curvature to the center of the screen. Readjust the amplitude control for straight horizontal lines. Fig. 10-23 shows the effect of extreme misadjustment of the phase coil.

Dynamic-Pincushion Correction. Some receivers employ a tube or transistor in the pincushion-correction circuit. A tunable transformer is usually provided whose core can be adjusted to provide top-bottom pincushion correction. With a cross-hatch pattern on the screen, adjust the transformer until the top and bottom of the pattern are straight.

10-7. ANTENNA REQUIREMENTS

Satisfactory color television reception requires an antenna system which delivers adequately strong signals (1000 microvolts) at the receiver

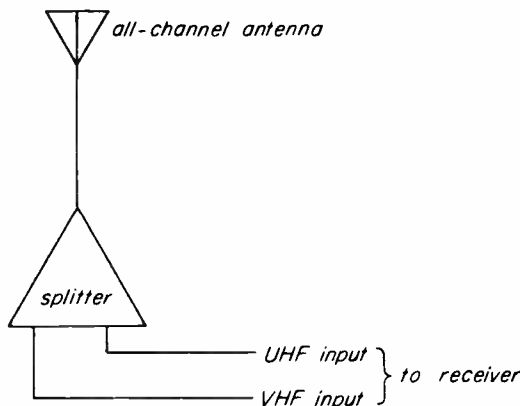

Fig. 10-24. Single antenna for VHF and UHF.

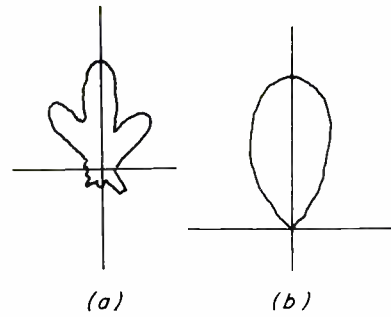

Fig. 10-25. Antenna directivity patterns.

antenna terminals, and the antenna should have sufficient directivity to minimize ghosts.

All-Channel Antennas. New antennas have been developed specifically for color reception. Some are suitable for reception of all VHF (2—13) and UHF (14—83) television channels plus the 88—108 mc FM broadcast band. These include so-called “log periodic” types. Only a single transmission line is required. But, at the receiver, a UHF/VHF “splitter” is required, as shown in Fig. 10-24, to feed signals into the separate VHF and UHF receiver antenna terminals.

The polar patterns of two types of all-channel antennas are shown in Fig. 10-25. The pattern in Fig. 25a is that of a typical “V”-type antenna. Note that it has side lobes and can receive signals from the rear. The pattern in Fig. 25b is that of a log-periodic type which has no side lobes and does not receive signals from the rear. This, of course, is an ideal pattern but is not fully attainable since no antenna has an infinite front-to-back ratio.

When the signals do not all come from the same direction or when ghosts affect some channels, an all-channel can be installed on a rotator and oriented for best reception on each channel.

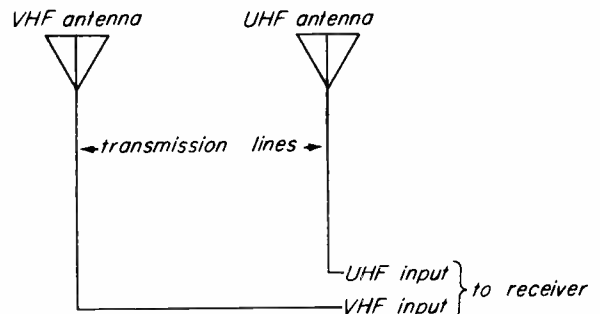

Fig. 10-26. Separate VHF and UHF antenna systems.

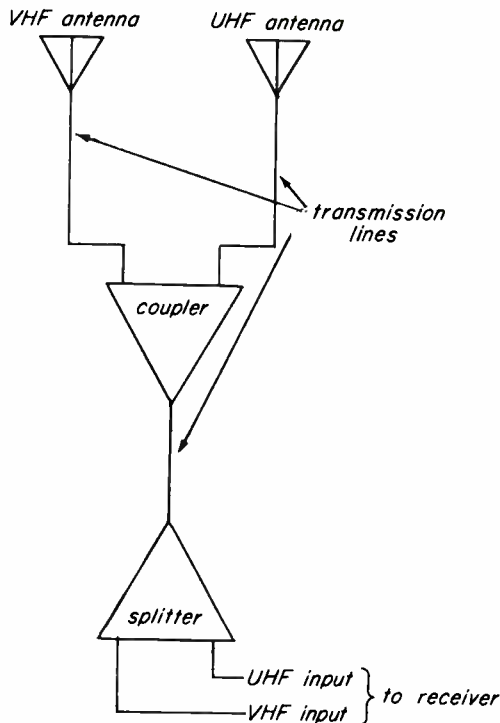

Fig. 10-27. Single transmission line for two antennas.

Separate Antennas. For optimum reception in some locations, two or more antennas can be used. For example, one antenna can be used for VHF band reception and another for UHF band reception, as shown in Fig. 10-26. Here, each antenna has its own transmission line. However, one transmission line can be used by using a *splitter/coupler* at each end of the transmission line as shown in Fig. 10-27. The *splitter/couplers* may be identical. They join the signals at the antenna end of the transmission line and separate them at the other end. Also, they provide isolation between the antennas and the receiver inputs.

In some cases, a single-channel and a broadband antenna are used, coupled in the same manner as above. The single-channel antenna may be a Yagi array pointed at a specific station or reflecting surface, whereas the broadband antenna may be pointed in the direction of the other stations to be received. Figure 10-28 is a schematic diagram of an antenna coupler used in such an antenna system. In this case, the coupler circuit shown is for use with 75-ohm coaxial-cable transmission lines which will be discussed later.

Transmission Lines. Before color television, most television antenna systems employed 300-ohm twin-lead as the transmission line. Most

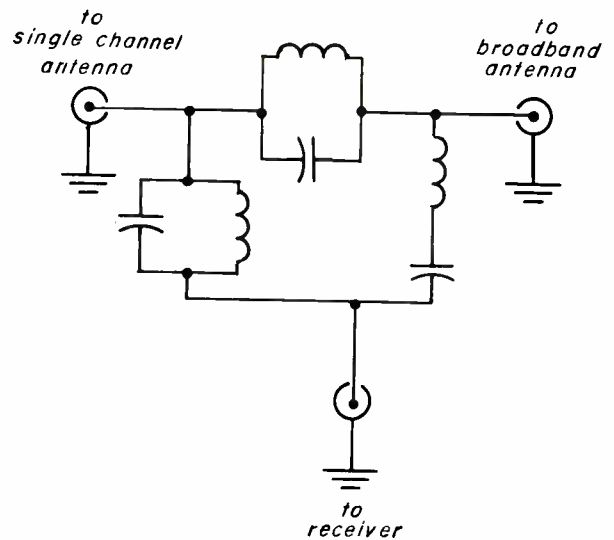

Fig. 10-28. Single-channel and broadband-antenna coupler.

antennas have a 300-ohm output impedance (generator) and most receivers have a 300-ohm input impedance (load). Maximum electrical energy is transferred when the generator and load impedances are equal and when interconnected through a transmission line whose surge impedance is the same. Under unattainable ideal conditions, all of the energy would be transferred from the antenna to the receiver, and the transmission line itself would not pick up any signals. Ideal conditions can be approached, but not realized.

The input and output impedances of the antenna and receiver are not always exactly 300 ohms at all frequencies. When the impedances are not matched standing waves appear on the transmission line, their magnitude being referenced to VSWR (voltage standing-wave ratio). When the VSWR is high, less energy is transferred from the antenna to the receiver. Ghosts appear on the TV screen because of changes in phase relationships and because the transmission line is now capable of picking up signals. These signals are not in phase with the signals picked up by the antenna.

There are also other transmission losses due to the series resistance of the twin-lead wires and the shunt-leakage resistance of the insulation between the wires. Additional losses occur when the twin-lead is wet. Transmission loss (attenuation) increases with frequency.

Shielded Twin-Lead. Ordinary, unshielded twin-lead is still very popular because of its relatively low attenuation. It is nearly always used

as a "balanced" line. The potential of each wire is the same with respect to ground.

An improved type of twin-lead is now available which has a braided copper shield over the two internal leads. The shield and the two inner leads are insulated from each other. The shield provides protection from pick-up signals and noise. Figure 10-29 shows the three popular types of television antenna transmission line.

Coaxial Cable. Now very popular is coaxial cable as an antenna transmission line (see Fig. 10-29c). It consists of a wire (center conductor) surrounded by insulating material (dielectric) over which a metallic shield is placed (copper braid or solid aluminum). This is covered with an outer, insulating protective jacket.

Coaxial cable is an "unbalanced" line since the shield is usually grounded. In TV work, coaxial cable with a surge impedance of approximately 75 ohms is used. There are many types of 75-ohm coaxial cable, including the popular RG-59/U and RG-11/U types and lower-loss types such as "balloon" cable and cables employing foamed insulation.

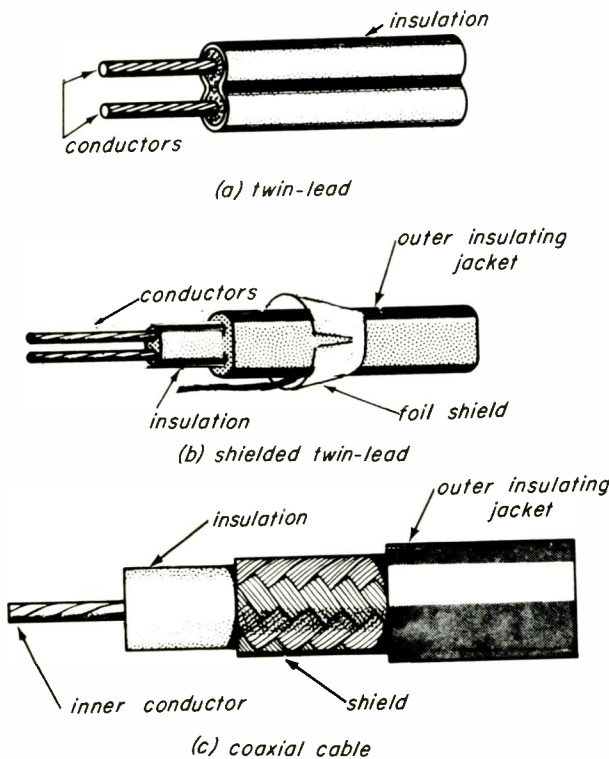

Fig. 10-29. Antenna transmission lines.

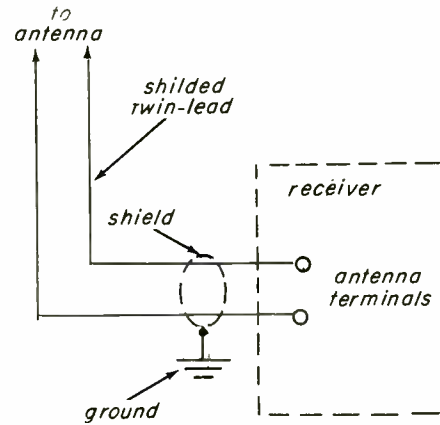

Fig. 10-30. Connections for shielded twin-lead.

Comparison of Transmission Lines. In areas where signals are strong, coaxial cable or shielded twin-lead afford maximum protection against signal pickup by the transmission line. In deep fringe areas, tests indicate that shielded twin-lead was best, coaxial cable was excellent and ordinary twin-lead was satisfactory.

Antenna Connections. In most cases, twin-lead is used, one end connected to the antenna terminals, the other to the 300-ohm receiver antenna terminals. When shielded twin-lead is used, the inner wires are connected to the 300-ohm receiver antenna terminals and the shield is grounded, as shown in Fig. 10-30. The shield may

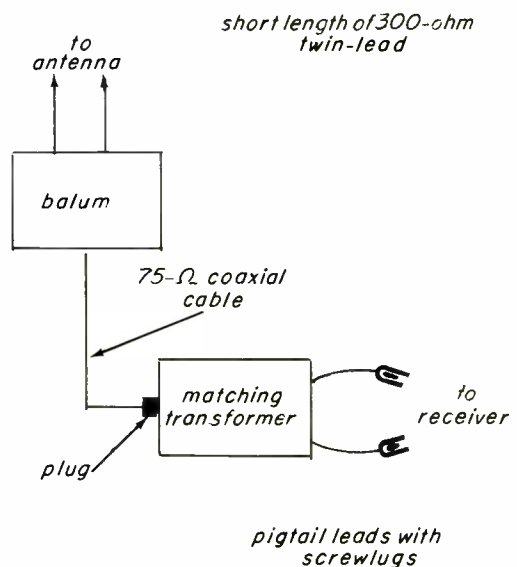

Fig. 10-31. 75-ohm antenna transmission line.

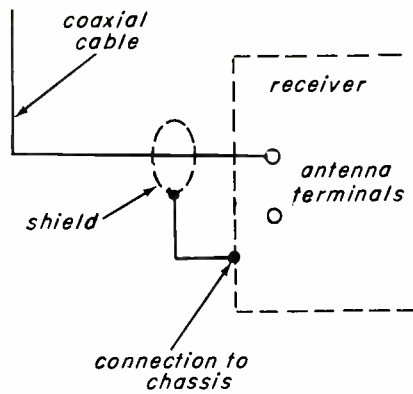

Fig. 10-32. Direct connections of coaxial cable to receiver.

one of the 300-ohm antenna terminals and the receiver chassis, as shown in Fig. 10-32.

WARNING

Never connect the coaxial cable shield to the chassis if the chassis is "hot" with respect to ground.

Receiver Input Circuits. Most receivers have two pairs of antenna terminals, one for VHF and one for UHF, and both for connection to a 300-ohm line or matching transformer. Figure 10-33 shows a typical VHF input circuit in which *T1* is a balun (converts from balanced circuit to unbalanced circuit) and *FL1* is a high-pass filter. A

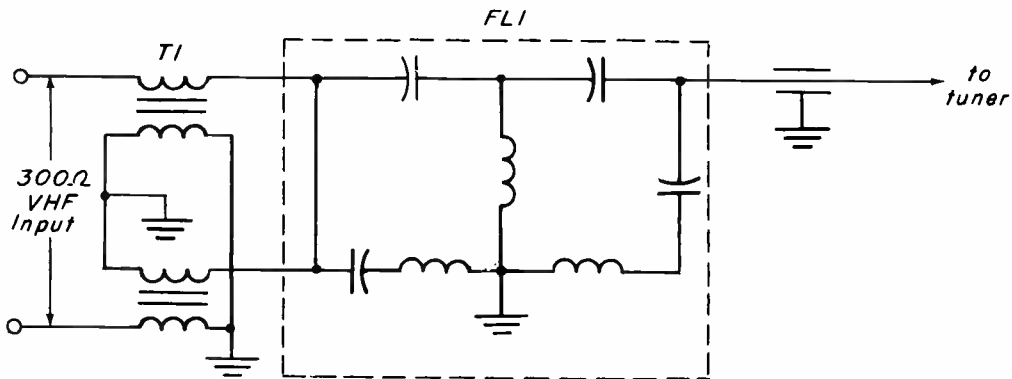

Fig. 10-33. Typical VHF input circuit.

be grounded to the receiver chassis but only if the receiver employs a power transformer and the chassis is not "hot" with respect to ground.

When coaxial cable is used with a 300-ohm antenna, a "balun" (300- to 75-ohm matching transformer) is required near the antenna. A 75- to 300-ohm matching transformer is also required at the receiver antenna terminals, as shown in Fig. 10-31.

Some antennas have a 75-ohm output impedance. No balun is required at the antenna. A matching transformer is required at the receiver end of the coaxial cable, as shown previously in Fig. 10-31, if connection is to be made to the receiver's 300-ohm input terminals. The coaxial cable may be connected directly to the receiver if it has a 75-ohm antenna-input connector, or to

typical UHF input circuit is shown in Fig. 10-34. The signal developed across coil *L* is inductively coupled to the tuner input circuit. Resistor *R* (half-megohm or more) provides a static discharge path to ground.

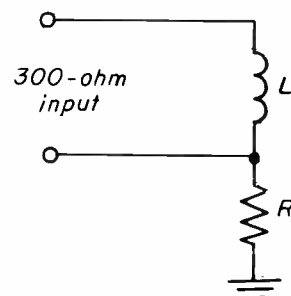

Fig. 10-34. Typical UHF input circuit.

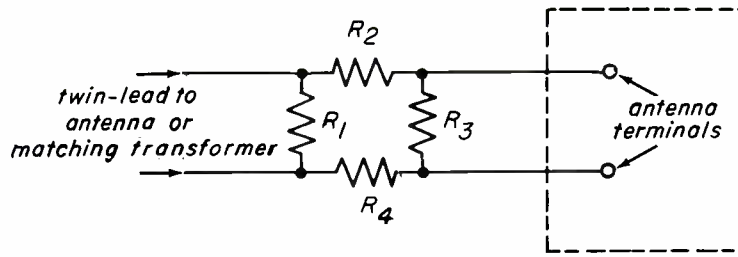

Fig. 10-35. Attenuator pad.

Signal Attenuators. In some locations, the signals may be **too strong** for color reception. The signal level can be reduced by installing an **attenuator pad**, as shown in Fig. 10-35. To attenuate the signal 6 db (halving the voltage) R_1 and R_3 should be 910 ohms each and R_2 and R_4 should be 110 ohms each. For 12-db attenuation, use 510-ohm resistors for R_1 and R_3 and 270-ohm resistors for R_2 and R_4 . And, for 18-db attenuation, R_1 and R_3 should have a value of 390 ohms and R_2 and R_4 values should be 560 ohms. The resistors may be ordinary, fractional-watt carbon-composition types.

Signal Boosters. In **weak signal** areas, a signal booster (pre-amplifier) may be required. It may be installed near the antenna, as shown in Fig. 10-36. Power for the amplifier is fed through the transmission line (twin-lead or coaxial cable) as simplified schematic (Fig. 10-37 illustrates. Low-voltage a.c. is fed through the transmission line to a rectifier in the booster assembly. Its d-c output powers the amplifier. Chokes L_1 and L_2 isolated

the power transformer (T) from the line for r-f. Capacitors C_1 and C_2 allow the r-f signal to pass to the receiver but, because of their high reactance at 60 cycles, they block passage of a-c into the receiver. At the pre-amplifier, L_3 and L_4 prevent the rectifier from shunting the r-f and C_3 and C_4 allow passage of r-f.

When it is necessary to **boost only one channel**, a single-channel pre-amplifier can be used as shown in Fig. 10-38. The signals from the broadband antenna are coupled with the signals from the pre-amplifier and are fed down the same transmission line.

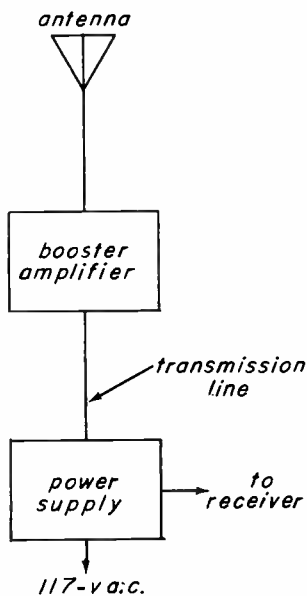

Fig. 10-36. Mast-mounted pre-amplifier.

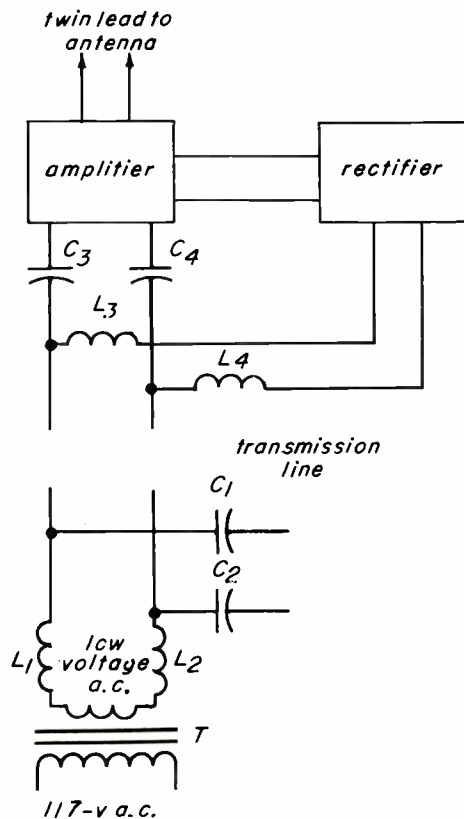

Fig. 10-37. Power-supply system for mast-mounted pre-amplifier.

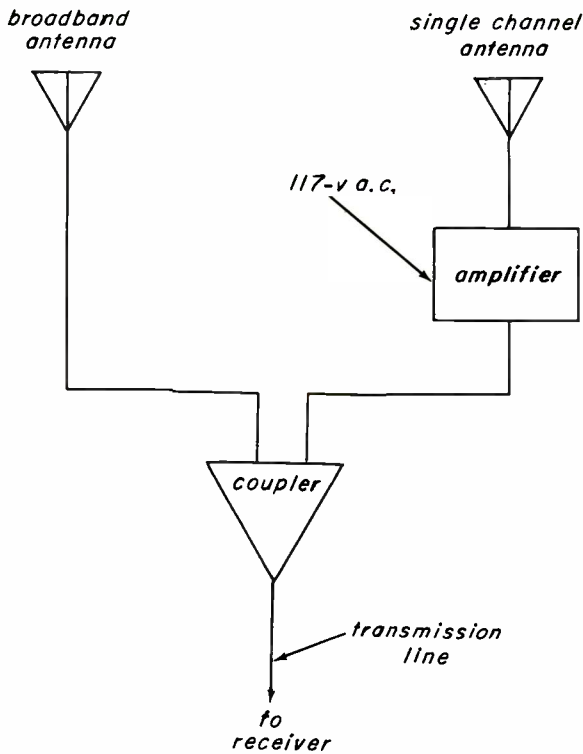

Fig. 10-38. Booster for a single channel.

When all-VHF channels need boosting, the pre-amplifier can be installed at the receiver instead of near the antenna. Various types are available with output terminals for feeding from one to several receivers. Figure 10-39 shows a typical TV signal booster.

RCA Nuvistor® TV Booster. This amplifier employs two RCA 6CW4 Nuvistor triodes to provide approximately 13 db of gain on Channels



COURTESY OF RCA ELECTRONIC COMPONENTS AND DEVICES

Fig. 10-39. RCA Nuvistor® TV booster.

2 through 6 and approximately 11 db of gain in Channels 7 through 13. Both input and output impedances are 300 ohms. Screw terminals are provided. When used with a 75-ohm coaxial cable, a 75 to 300 ohm matching transformer is required as shown in Fig. 10-40. From one to six additional receivers can be fed by the amplifier through suitable couplers, as shown in Fig. 10-41. The amplifier operates from a 117-volt a-c source and consumes approximately 5 watts of power.

MATV Systems. Most large apartment buildings, hotels and motels have master antenna television (MATV) systems. All television receivers in such a building share the same antenna system. There may be only one antenna, or two or more antennas, depending upon local reception conditions. The output of the antenna system is fed into a coaxial-cable distribution system whose feeder cables are tapped at each receiver location, as illustrated in Fig. 10-42.

At a receiver location, the tap (usually a wall plate) may be designed to connect to 300-ohm twin-lead or to 75-ohm coaxial cable. In the former

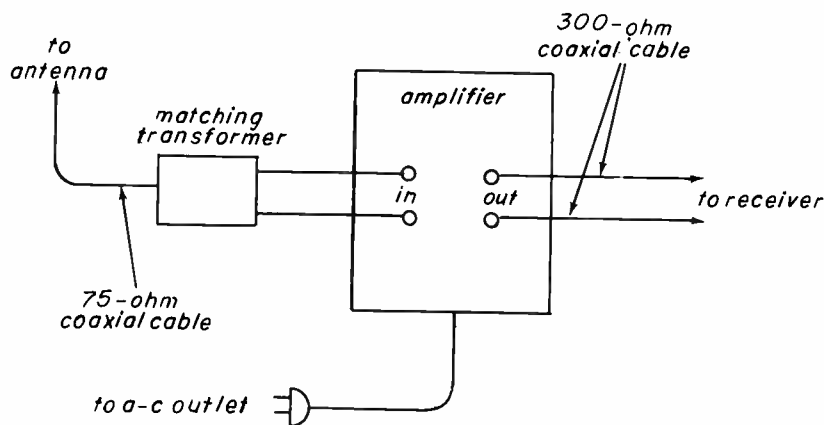

Fig. 10-40. TV booster used with 75-ohm cable.

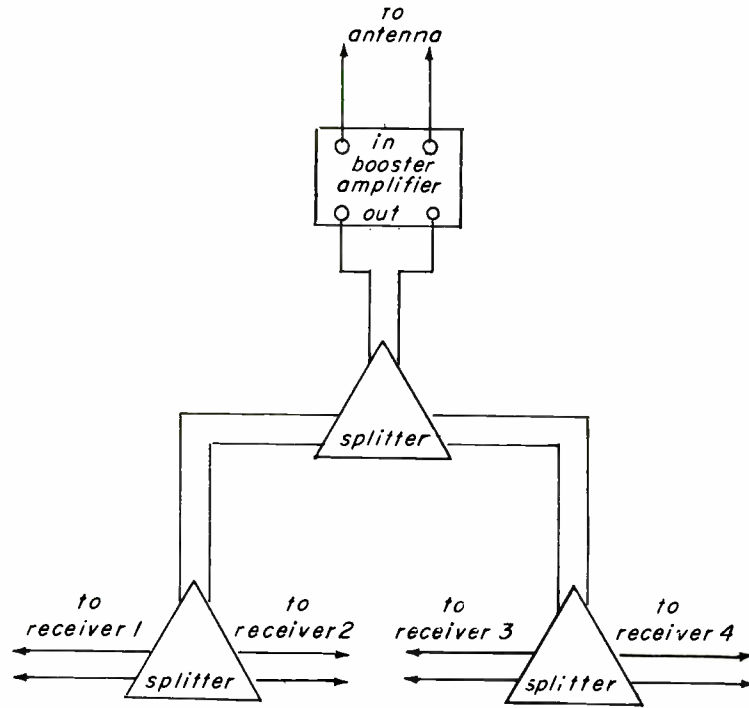

Fig. 10-41. Feeding four receivers from one booster.

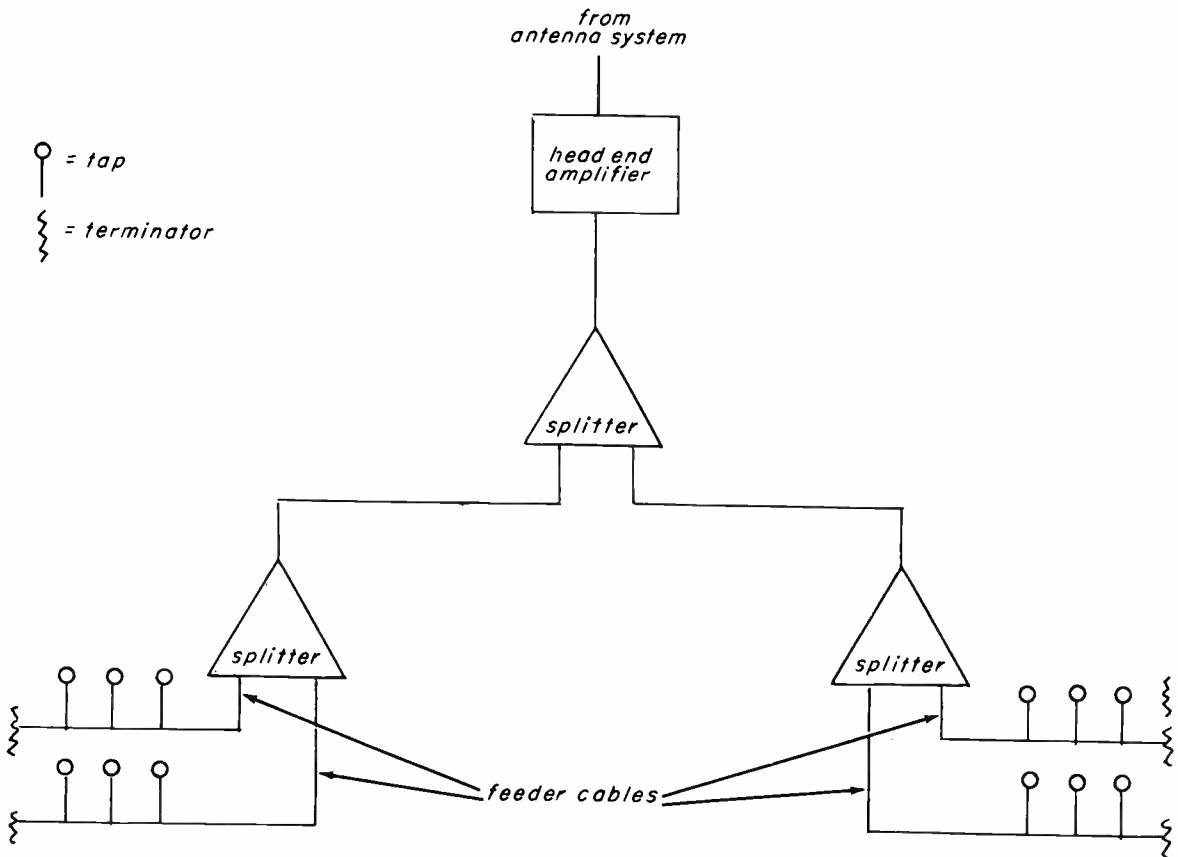

Fig. 10-42. Simple MATV system.

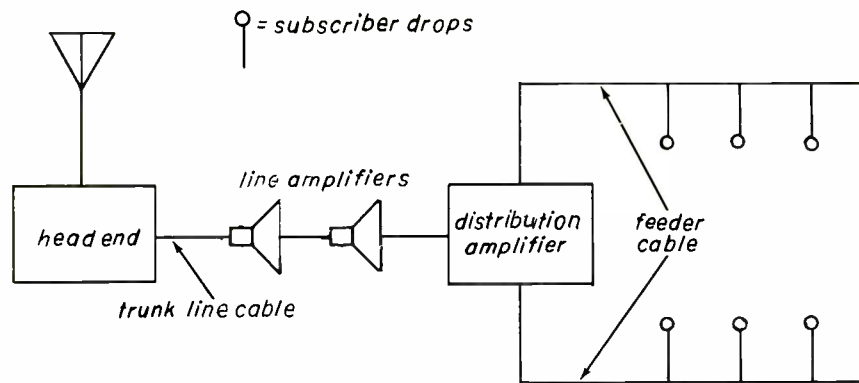

Fig. 10-43. Simplified block diagram of a CATV system.

case, 300-ohm twin-lead is used to connect the receiver to the tap. In the latter case, 75-ohm coaxial cable is used in conjunction with a 75- to 300-ohm matching transformer, unless the receiver has a 75-ohm antenna connector.

Nearly all existing MATV systems provide only VHF television and FM radio broadcast signals at a minimum level of 1000 microvolts. Reception of UHF television stations is not provided for except in some cases where a UHF-to-VHF translator is installed at the master antenna head-end location. A UHF channel is translated to a VHF channel for transmission through the cable system. This enables reception of a UHF station on an otherwise vacant VHF channel.

When color reception is poor because the MATV system is poorly designed or improperly adjusted, nothing can be done at the receiver to correct the problem. A complaint should be made to the building management.

CATV Systems. In many areas, television programs are fed to receivers through a CATV (community antenna television) system. Often, no antenna is provided at the receiver. The television signals are picked up by a distant antenna system, amplified and distributed throughout a community via a coaxial-cable network, as illustrated in Fig. 10-43.

The signals are fed to a receiver by tapping a distribution cable. The cable leading to the house is known as a "subscriber drop". At the receiver location, the signals are available at a 75-ohm or 300-ohm tap-off (often a wall plate). If it is a 75-ohm tap, 75-ohm coaxial cable is used in conjunction with a 75- to 300-ohm matching transformer

for making the connection to the receiver. If it is a 300-ohm tap, 300-ohm twin-lead is used and the transformer is not required.

As in MATV systems, reception of UHF television stations is not direct. The UHF channels are translated at the CATV system head end to unused VHF channel slots and are transmitted as VHF signals through the cable network.

A television receiver can be connected to both a CATV (or MATV) system and one or more external antennas. When fed by a CATV (or MATV) system, the cable is fed to the receiver's VHF antenna terminals. For direct reception of UHF stations, an external UHF antenna can be connected to the receiver's UHF antenna terminals, as shown in Fig. 10-44. An external VHF

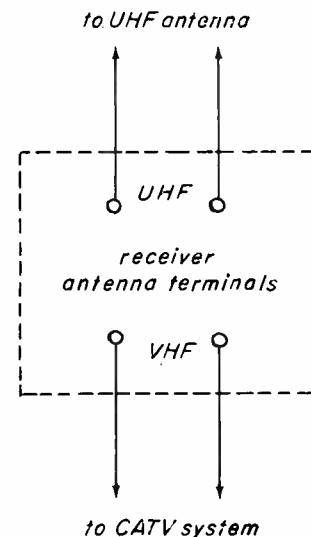

Fig. 10-44. Receiver connections for CATV and external UHF antenna.

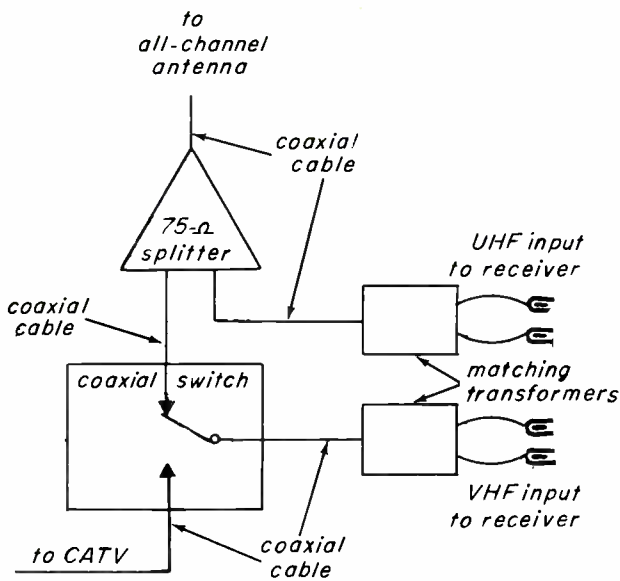

Fig. 10-45. Set-up for optional CATV or direct reception.

antenna can be connected to the receiver's VHF antenna terminals through a coaxial switch, as shown in simplified block diagram Fig. 10-45. The user can thus select direct reception or signals from the CATV (or MATV) system.

Interference from Radio Communications Transmitters. Severe interference to television reception can be caused by nearby radio transmitters. Citizens band (CB) transmitters, including base stations, mobile units and walkie-talkies, which operate in the 27-mc band, can cause interference to reception of TV Channel 2 in particular. This is true because the second harmonic of a 27-mc band signal is in the 54-mc space in the VHF band.

Other land-mobile stations operating near the upper end of the 25-50-mc land-mobile band, and amateur radio stations operating in the 50-54-mc (6-meter) band, can also cause interference to television reception. The interference is sometimes caused by the transmitter carrier, not a harmonic. If the carrier is strong enough, it can desensitize a nearby television receiver whose front-end selectivity is inadequate.

Interference from transmitters operating at frequencies below Channel 2 can often be eliminated or reduced by installing a high-pass filter at the television receiver terminals as shown in Fig. 10-46. Filters of this type are available in various makes at radio-parts distributors.

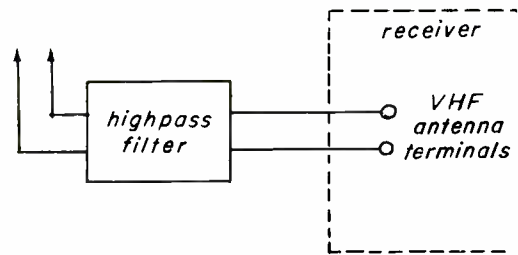

Fig. 10-46. Filter for reducing interference from HF and VHF transmitters.

If the location of the interfering transmitter is known, its owner should be persuaded to install a low-pass filter between the transmitter and its antenna, connected as shown in Fig. 10-47. If the owner of the transmitter will not cooperate, a complaint can be made to the nearest field office of the Federal Communications Commission.

This kind of interference can be minimized by installing the television antenna as far as possible, and higher or lower than the transmitter's antenna. A coaxial-cable transmission line, or shielded twin-lead, should be used for the television receiver.

10-8. TEST EQUIPMENT IMPROVEMENTS

Considerable new test equipment is now available for color-television servicing. These instruments include new color signal generators, improved oscilloscopes, test jigs and probes.

RCA Color TV Test Jig. This test jig, which resembles a table model receiver in appearance (see Fig. 10-48), contains a color picture tube, deflection yoke, convergence yoke and convergence magnets. It makes it possible to service TV

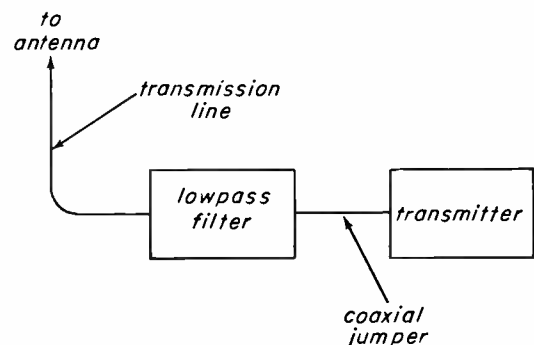

Fig. 10-47. Transmitter harmonic attenuator.

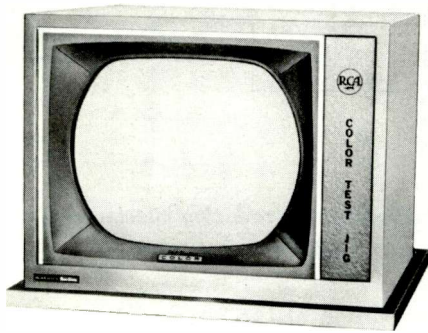

Fig. 10-48. Color television test jig

chassis in the shop without having to bring in the picture tube or entire receiver, including its cabinet. Various extension cables are available for connecting the test jig to different types of receiver chassis.

Alignment Probes. A line of RCA test probes has been developed to make servicing easier. The 8B105 video-detector test block is used during chroma-bandpass alignment and chroma-circuit troubleshooting. Its circuit is given in Fig. 10-49. The probe is applied to the circuit under test and its output is fed to an oscilloscope. This probe can also be used with a VTVM for adjusting the sound take-off transformer.

The 8B106 i-f test block is used for connecting a load to the plate of the second i-f amplifier and as a detector at the plate of the first i-f amplifier when adjusting or checking out the over-coupled i-f link circuit. Figure 10-50 is a schematic diagram of this probe.

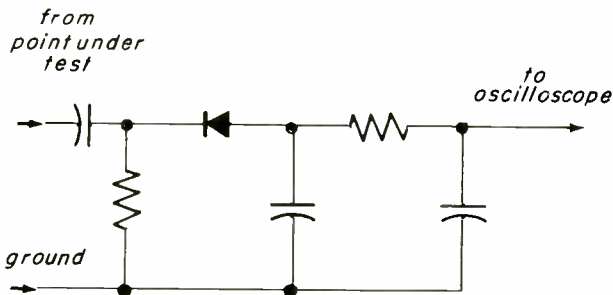

Fig. 10-49. Video detector test block.

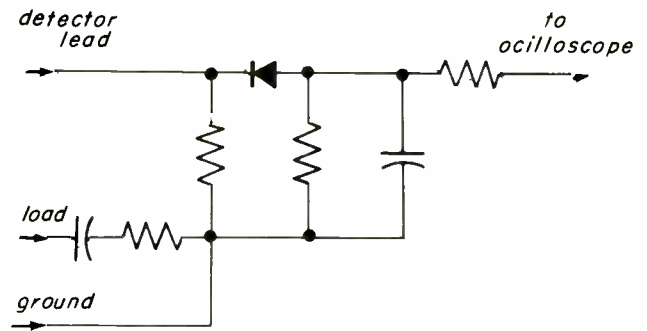

Fig. 10-50. I-f test block.

The 8B107 sound-detector test block is used during peak alignment of the sound take-off transformer and the audio-driver transformer. The probe, whose schematic is given in Fig. 10-51, functions as a detector for a VTVM.

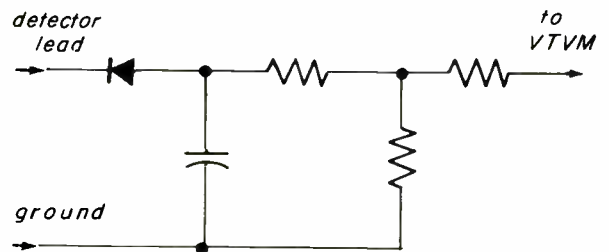

Fig. 10-51. Sound detector test block.

The 8B108 mixer grid-matching pad is used to couple the outputs of sweep and signal generators to the mixer grid during picture i-f and link alignment and trap adjustments. (See Fig. 10-52.)

The 8B109 tuner i-f input head is a matching pad used for coupling a sweep generator to the i-f input jack when adjusting the 40-mc input coil on VHF tuners used as UHF i-f amplifiers. (See Fig. 10-53.)

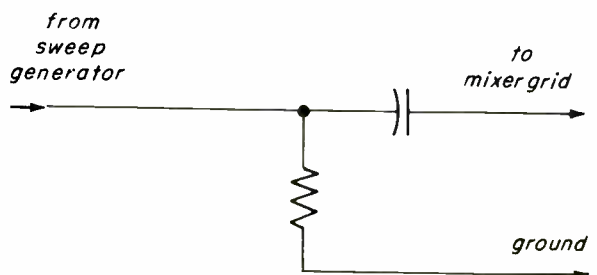

Fig. 10-52. Mixer grid matching pad.

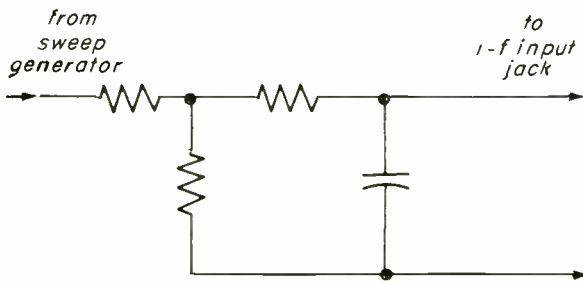

Fig. 10-53. Tuner i-f input head.

Oscilloscopes. For successful color servicing, a wide-band oscilloscope with vertical response from d.c. to at least 4 mc is required. Triggered sweep oscilloscopes are now being used by some technicians. Some are also using what is known as a Vectorscope® which gives a vectorial presentation of the color signal.

Color-Signal Generators. The RCA WR-64A color-bar generator has been superseded by the newer WR-64B color bar/dot/crosshatch generator, combining in one unit the test facilities needed for adjusting the color-phasing, matrixing, linearity and convergence circuits of color-television receivers.

In the color-bar position, the unit provides ten bars simultaneously, including *R-Y*, *B-Y*, *G-Y*, *I* and *Q* signals, spaced at 30-degree phase intervals. When operated in this position, the generator may be used to check the phase and matrix of a receiver and to perform automatic-frequency and phase alignment. In addition, it provides a constantly-available color signal ideally suited for use in servicing color receivers.

In the dot position, the unit provides a stable dot pattern, enabling proper convergence adjustment of the receiver. In addition, correct interpretation of the preshoot and overshoot areas (small black edging preceding and following each dot) will enable an appraisal of the overall quality of the receiver alignment.

The crosshatch function of the WR-64B produces a sharp, well-defined crosshatch pattern, as Fig. 10-54 illustrates. This function of the generator may be used for adjusting the vertical and horizontal linearity in both black-and-white and color receivers, and as an alternate signal for

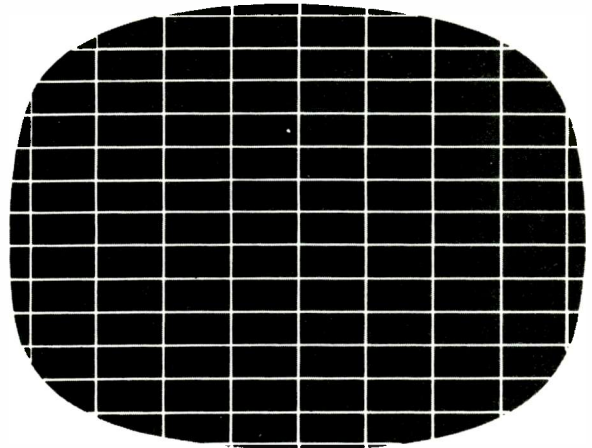

Fig. 10-54. Crosshatch pattern showing fixed number of horizontal and vertical bars.

adjusting convergence. Since the crosshatch pattern consists of a fixed number of bars, this function also provides a convenient check of the receiver overscan.

Three slide switches are provided on the front panel for shorting out the control grids of the color picture tube. This enables the red, blue, or green color guns to be "killed", as required in convergence and purity adjustments. Leads are located on the back of the instrument for connection to the control grids of the color picture-tube socket.

The WR-64B provides crystal-controlled r-f output on Channel 3 or 4. The r-f output cable is connected directly to the antenna input terminals on the receiver.

The WR-64B utilizes the "offset-subcarrier" principle to generate the color bars. The frequency of the subcarrier is offset 15,750 cycles below the normal frequency of 3,579.545 kc. The frequency of the offset subcarrier is therefore 3,563.795 kc. This signal is fed into the receiver, together with horizontal sync pulses of 15,750 cycles.

The 3,563.795 kc offset-subcarrier signal and the signal from the 3,579.545-kc oscillator in the receiver are applied to each of the color demodulators. The difference in frequency between these two signals is then 15,750 cycles, or one cycle difference for each complete horizontal-scanning period. Hence the relative phase between the two signals changes through one complete cycle, from

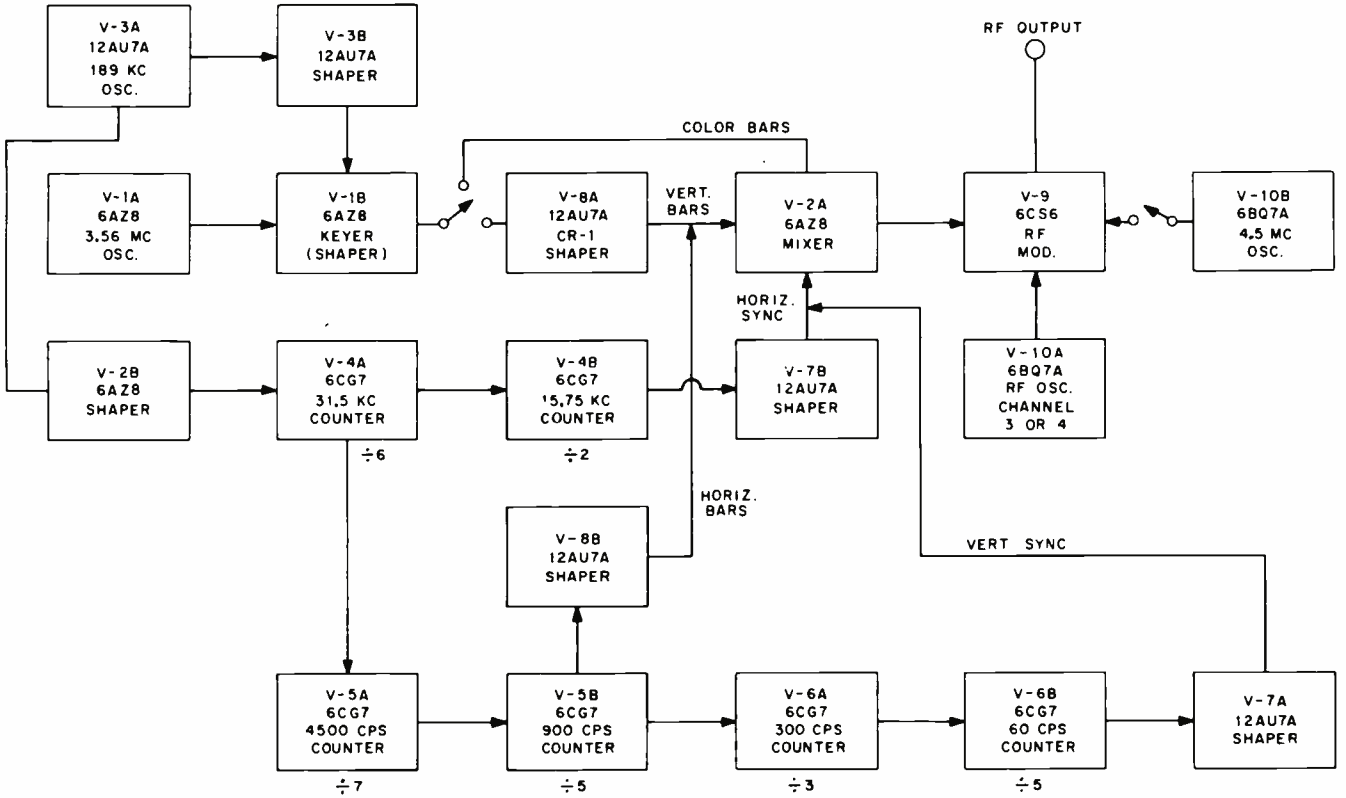

Fig. 10-55. Block diagram of WR-648.

Function of Controls

GRID-SHORTING OR "GUN KILLER" SWITCHES

For use in convergence and purity adjustments to short out the red, blue, or green gun of the color picture tube. Clip-Leads extending from back of case must be connected to the control grids of the color tube. Set these switches to the "OFF" position to short out the grids of the color tube, and to the "ON" position for normal operation.

FUNCTION—Turns off all power when set to "OFF" position. In "STANDBY" position, the picture-carrier

oscillator is inoperative. In "PATTERN" position, power is supplied to all circuits except the sound-carrier oscillator. In "PATTERN + SOUND" position power is also supplied to the sound-carrier oscillator, thereby adding an unmodulated sound carrier signal to the generator output. The "PATTERN + SOUND" function of the WR-64B is for use in obtaining proper fine-tuning adjustment of the color receiver when using the color bar pattern.

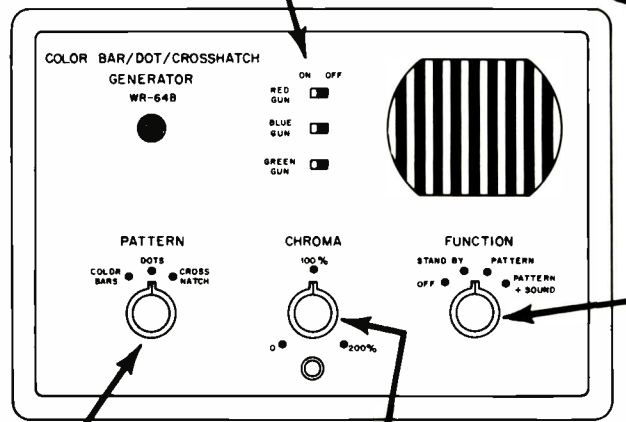

PATTERN—Selects COLOR BAR, DOT, or CROSS-HATCH pattern.

CHROMA — Varies the subcarrier amplitude continuously from 0% to 200%, with 100% output being the normal position.

NOTE: When the FUNCTION switch is set to the "PATTERN" position, noise, hiss, or sound from a TV station may be heard from the speaker. When the switch is set to "PATTERN + SOUND", the receiver is quieted by the action of the unmodulated CW sound carrier from the WR-64B.

Fig. 10-56. Typical color bar/dot/crosshatch generator.

0° to 360° , in each complete horizontal-scanning period. Consequently each demodulator produces a sine-wave output of one cycle in each complete horizontal-scanning period. The sine-wave output signal has maximum positive amplitude at 90° in the *R-Y* demodulator, at 180° in a *B-Y* demodulator, and at approximately 300° in a *G-Y* demodulator. These three output signals produce a "rainbow" on the picture tube, with maximum red intensity toward the left, maximum blue intensity near the center, and maximum green

intensity at the right.

The offset-subcarrier in the WR-64B is gated to produce ten color-bar signals which are accurately spaced at 30° phase intervals. Narrow brightness pulses are added at the edges of each color bar to aid in checking the "fit" or registration of the brightness and color signals. Fig. 10-55 is a block diagram of the instrument and Figure 10-56 shows the operating controls.



NOTES

EXAMINATION

SERVICING THE NEW COLOR SETS

Instructions:—*PRINT your name, address, and student number assigned to you below.*

Date _____

Student Number _____

Date you mailed
last examination _____
(mo.) (yr.)

Name _____

Street Address _____

City _____ State _____

Zip No. _____

Please!

_____ correct out of 20 = _____ %
Graded by _____

80-69

1. Purity adjustments should be made: (a) before degaussing; (b) with a station tuned in; (c) after degaussing; (d) with all electron guns turned on. a b ~~c~~ d
2. If the thermistor in an automatic degaussing system opens up: (a) the degaussing coils will burn out; (b) degaussing current flows at all times when the receiver is turned on; (c) no degaussing current will flow; (d) the receiver can't be turned on. a b ~~c~~ d
3. The setting of the picture-tube screen controls affects the: (a) focus; (b) blooming; (c) color temperature; (d) convergence. a b ~~c~~ d
4. Static convergence is adjusted with; (a) magnets, (b) the yoke; (c) potentiometers; (d) variable inductors. ~~a~~ b c d
5. When making dynamic-convergence adjustments, the instrument required is a: (a) sweep generator; (b) oscilloscope; (c) dot generator; (d) crosshatch generator. a b c ~~d~~
6. The instrument required when adjusting the blue horizontal-shaping coil is: (a) an oscilloscope; (b) a VTVM; (c) a sweep generator; (d) a dot/bar generator. ~~a~~ b c d
7. To obtain white balance, adjust the: (a) phase detector; (b) picture-tube screens; (c) high voltage; (d) crystal oscillator. a ~~b~~ c d
8. To connect one antenna transmission line to both the VHF and UHF receiver inputs: (a) use a balun; (b) parallel the inputs; (c) use an attenuator pad; (d) use a splitter/coupler. a b c ~~d~~
9. An antenna with a high front-to-back ratio is: (a) bidirectional; (b) tends to reject signals from the rear; (c) omnidirectional; (d) unsuitable for color. a ~~b~~ c d
10. High VSWR is caused by: (a) impedance mismatch; (b) electrical interference; (c) excessively strong signals; (d) pickup of signals by the transmission line. a b c ~~d~~
11. Shielded twin-lead is: (a) an unbalanced line; (b) not suitable for color reception; (c) is a 75-ohm line; (d) is a 300-ohm balanced line. a b c ~~d~~

12. Connecting the shield of a coaxial cable to the receiver chassis: (a) is always safe; (b) is never safe; (c) is dangerous if the receiver chassis is not at ground potential; (d) causes high VSWR.
13. A balun is a: (a) signal splitter; (b) harmonic filter; (c) matching transformer; (d) signal booster.
14. To reduce excessive signal strength on all channels: (a) install a balun at the antenna; (b) realign the tuner; (c) install an attenuator pad at the receiver input; (d) use twin-lead instead of coaxial cable.
15. The function of a splitter/coupler is to: (a) isolate inputs and outputs; (b) convert from a balanced line to an unbalanced line; (c) eliminate ghosts; (d) boost the signal.
16. For adjusting AFPC, use of the following instrument is essential: (a) sweep generator; (b) VTVM; (c) white-noise generator; (d) VOM.
17. The high-voltage adjustment should be made: (a) when the receiver is first turned on; (b) with brilliance and contrast controls at maximum; (c) after the receiver has warmed up; (d) while watching the screen for maximum green.
18. Top and bottom pincushioning correction adjustments should be made: (a) while observing horizontal lines; (b) when using a dot pattern; (c) whenever the receiver is moved; (d) when using a sweep generator.
19. To be suitable for color servicing, an oscilloscope: (a) must have triggered sweep; (b) should have vertical-frequency response from d.c. to at least 4 mc; (c) can be used only in conjunction with a sweep generator; (d) must present a vector pattern.
20. When making purity adjustments: (a) two of the picture-tube grids must be grounded; (b) all of the screens must be grounded; (c) the horizontal sweep must be off; (d) a crosshatch generator is required.

a	b	c	d
a	b	c	d
a	b	c	d
a	b	c	d
a	b	c	d
a	b	c	d
a	b	c	d
a	b	c	d
a	b	c	d



NOTES

NOTES

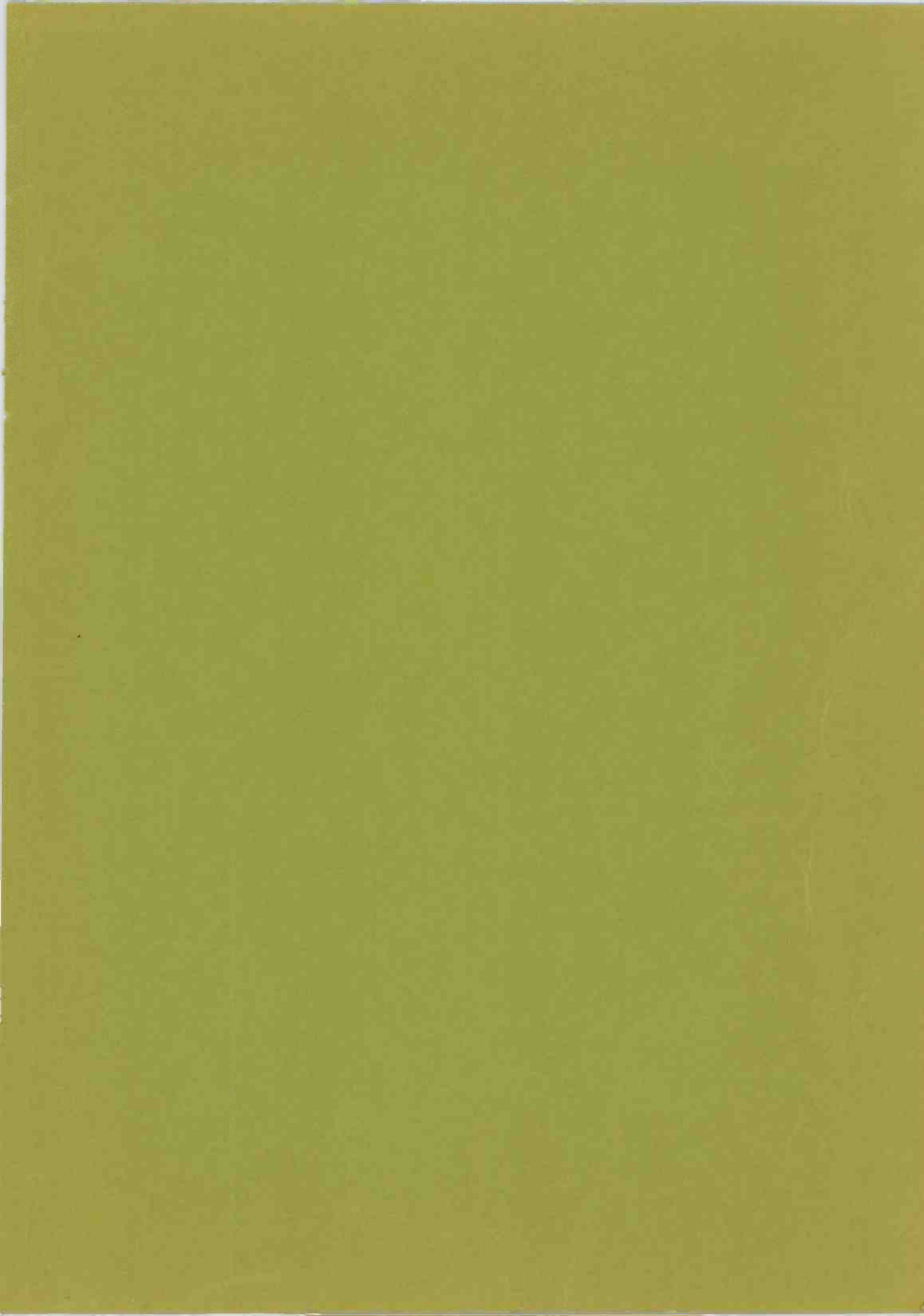

RCA