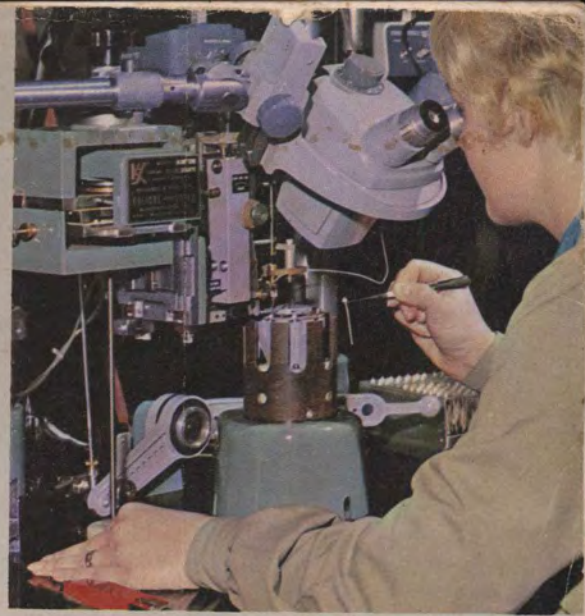


# BASIC RADIO COURSE

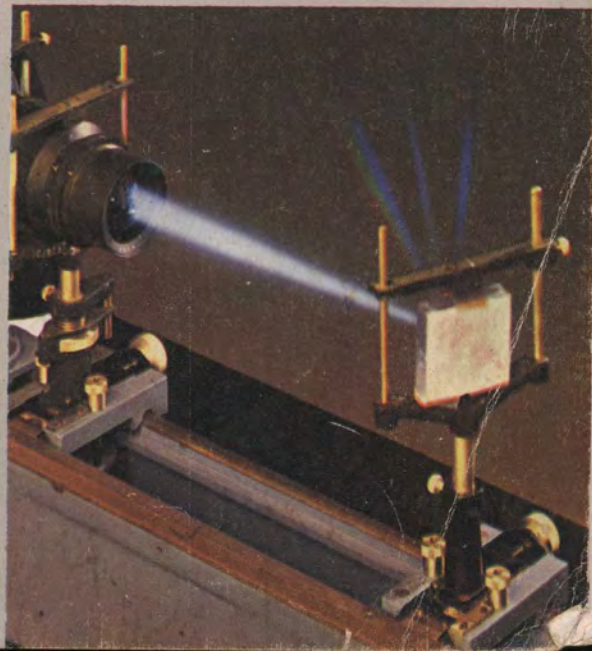
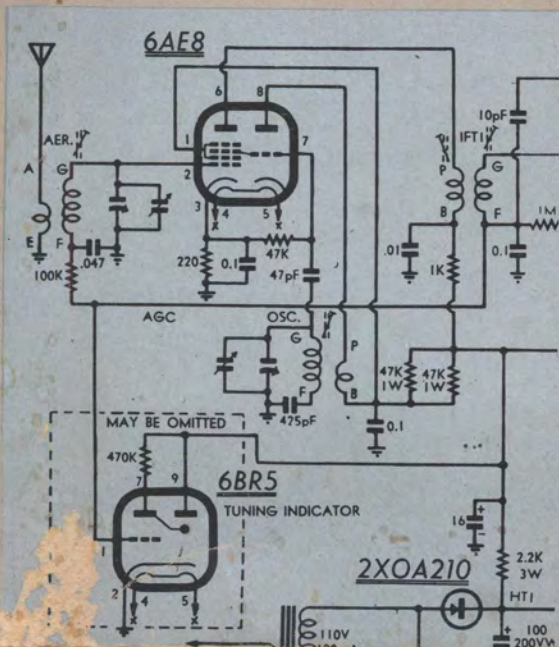
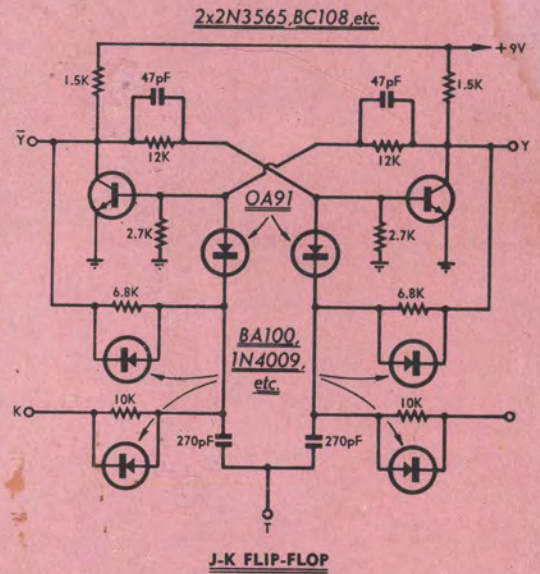


Prepared and published by  
**ELECTRONICS AUSTRALIA**  
Incorp. "Radio, Television & Hobbies"

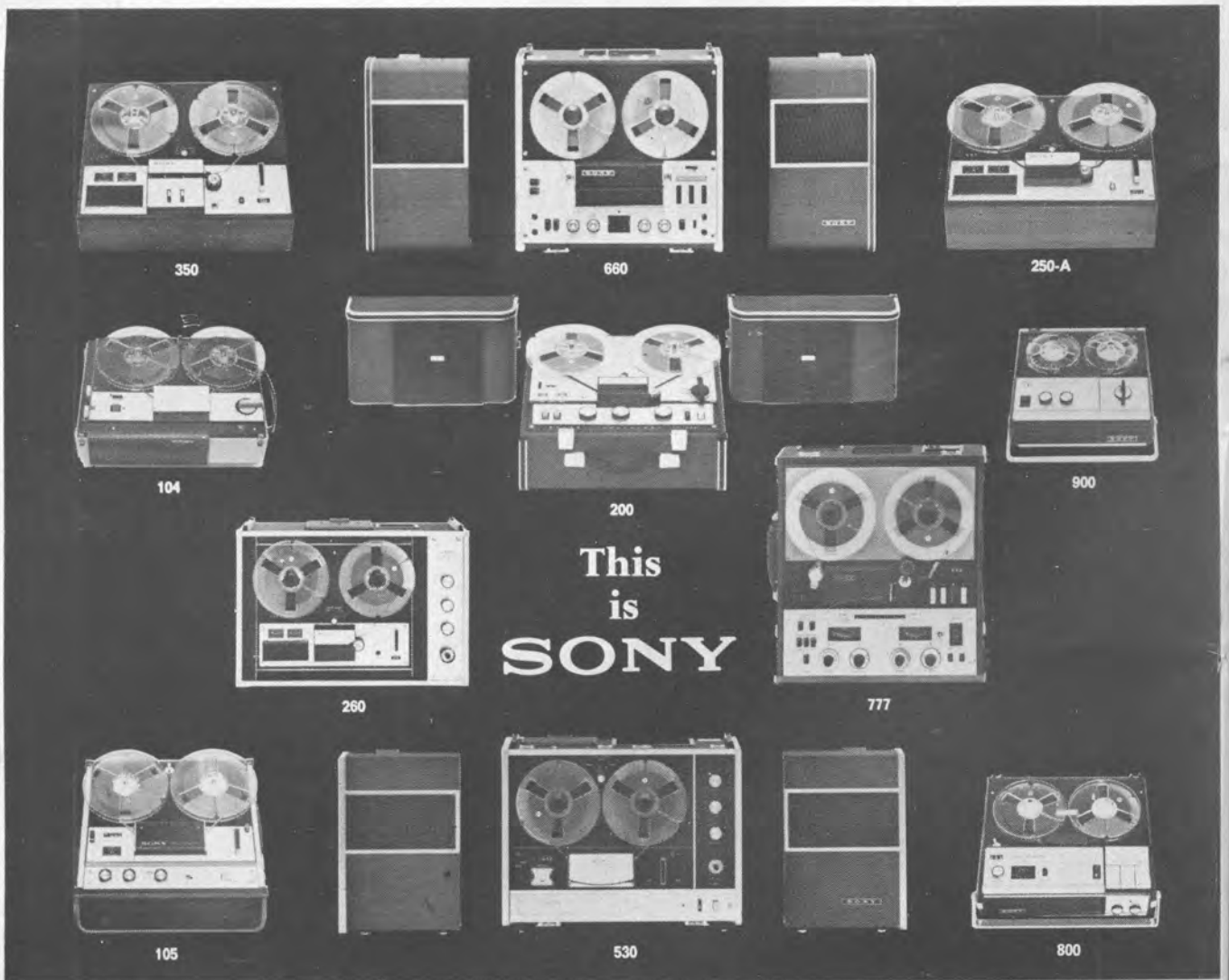
AN  
EASY-TO-READ  
INTRODUCTION  
TO RADIO  
AND  
ELECTRONICS



1967



**\$1.50**



# The Best-Selling Tape Recorders in the World

**Best-Looking, Best-Performing, Best-Value, Too!**

In the spring of 1950, SONY released the first tape recorder in Japan, under the trade name "Tapecorder." Today, its line embraces a wide selection of models available in Australia—ranging from popular home-use monaural and high-quality stereophonic to the professional equipment for the broadcasting industry. SONY tape recorders are now sold in countries all over the world.

It was back in 1949 that a group of SONY physicists, chemists, metallurgists and engineers developed the magnetic recording tape and, simultaneously, the tape recorder, and finally succeeded to put on the market the first recording tape—the "SONI-tape," as well as the "Tapecorder."

SONY kept moving forward, pioneering in the field of tape recording, until SONY stood out as a leading manufacturer of integrated production of tape recorders, with achievements like these:

**FIRST IN JAPAN:**

Magnetic Recording Tape .....	In 1949
Tape Recorder .....	In 1950
Transistor .....	In 1954
All-transistor Radio .....	In 1955

**FIRST IN THE WORLD:**

Pocketable Transistor Radio .....	In 1957
Two-band Transistor Radio .....	In 1957
Transistor FM Radio .....	In 1958
Esaki Tunnel Diode .....	In 1959
All-transistor TV .....	In 1959
Transistor Video Tape Recorder .....	In 1960
Chromatron Colour TV .....	In 1963
Home-use Video Tape Recorder .....	In 1964
Line-sequential Colour Tape Recording System .....	In 1964
Transistor Microphones .....	In 1965
Home-use Colour Video Tape Recorder .....	In 1966

# SONY®

PRODUCTS ARE DISTRIBUTED IN AUSTRALIA BY  
**JACOBY, MITCHELL & CO. P/L.**

469-475 KENT STREET, SYDNEY. TEL.: 26-2651

SONY TAPE RECORDERS RANGE FROM 29 GNS. TO £400

# *Basic Radio Course*

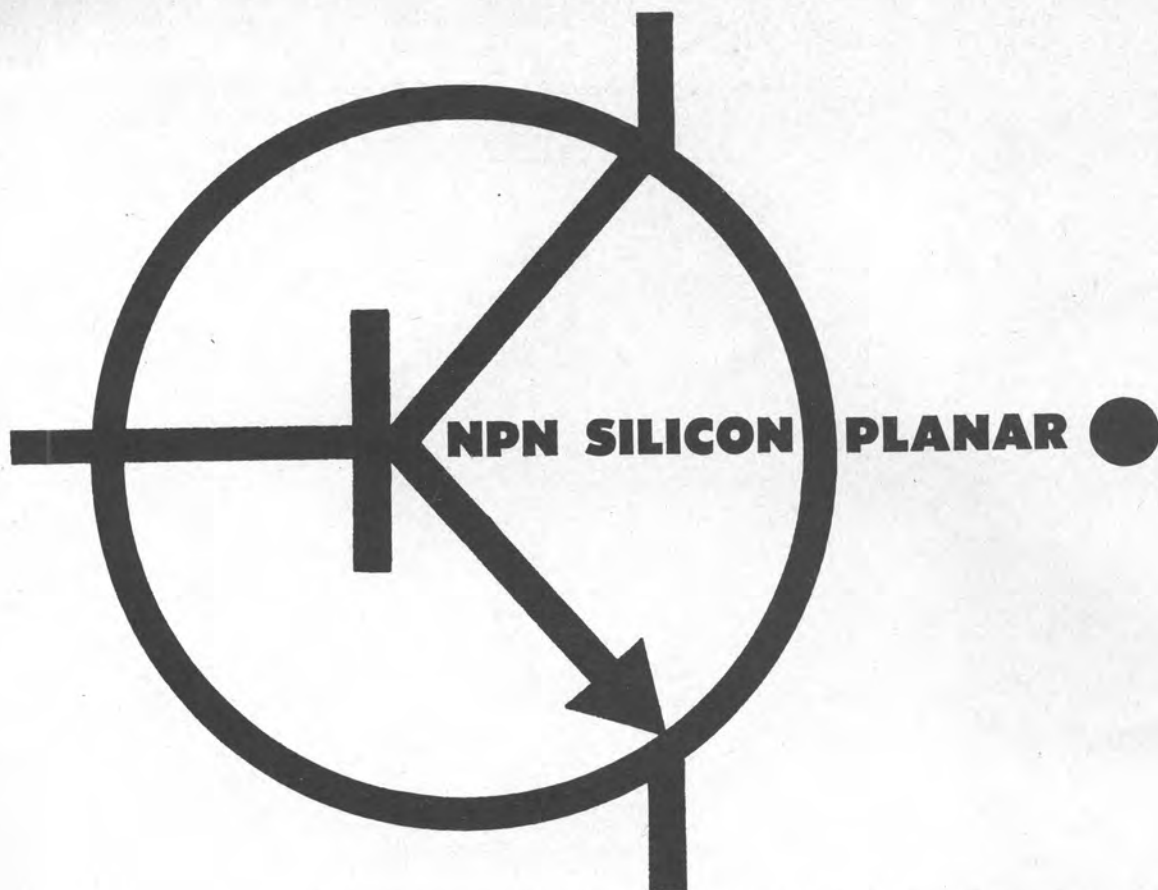
AN INTRODUCTION TO ELECTRONICS

Second Edition 1967

Produced by "ELECTRONICS Australia"

Printed and published by Sungravure Pty. Limited, of Jones Street, Broadway,  
at Morley Avenue, Rosebery.

The material in this book is copyright and the contents may not be reproduced in whole or in part  
without written permission from the Editor of "ELECTRONICS Australia."



Everything about the Anodeon transistor is right—quality, characteristics and ratings in particular. These Australian-made, hermetically sealed metal TO-1 case transistors are designed for longer life under severe conditions in all low to medium power consumer, industrial and professional applications. Don't say "Transistor" without saying Anodeon first!

TYPE	BVCBO Volts	BVCEO Volts	BVEBO Volts	IC Max. mA	PC Max. mW	fT. MHz	hFE @ 2mA		NF @ 1MHz		PRICES \$	
							Min.	Max.	db Typ.	db Max.	PER HUNDRED 1.99	100-499
<b>AT310</b> G.P. Audio	45	30	5	30	200	230	40	—	—	—	\$75.00	\$43.50
<b>AT311</b> Conv. i.f. amp.	45	30	5	30	200	230	40	160	—	—	\$75.00	\$44.95
<b>AT312</b> Conv. i.f. amp.	45	30	5	30	200	230	100	400	—	—	\$77.50	\$44.95
<b>AT313</b> Lo. noise r.f.	35	20	5	30	200	230	20	180	4	5.5	\$80.00	\$46.40
<b>AT314</b> G.P. Audio	35	20	5	30	200	230	40	—	—	—	\$72.50	\$42.05
<b>AT315</b> Conv. i.f. amp.	35	20	5	30	200	230	40	160	—	—	\$75.00	\$43.50
<b>AT316</b> Conv. i.f. amp.	35	20	5	30	200	230	100	400	—	—	\$75.00	\$43.50

Full data from

**ANODEON SALES DIVISION**

Electronic City, 443 Concord Rd., Rhodes, N.S.W.



SYDNEY 73-0211  
MELBOURNE 69-0300  
ADELAIDE 23-4022

DIVISION OF ELECTRONICS INDUSTRIES LIMITED

IN an era when the key word is "electronics," it may seem strange to be publishing a book under the title "Basic Radio Course." We do so quite deliberately, however, firstly because "radio" is still accepted as a collective term and secondly because the course itself is so well established under that name.

It was written, in the first instance, by Neville Williams, present Editor of "ELECTRONICS Australia" and presented as a series of self-contained articles in the journal, then under its old name: "Radio, Television and Hobbies." The material was subsequently revised and up-dated by Jamieson Rowe (Technical Editor) and by other members of the editorial staff, and re-run as the "Basic Radio Course" between August 1963 and November 1965.

The course gained recommendation as standard reading for radio clubs and tutorial groups throughout Australasia and continued requests for copies of it soon exhausted stocks of the relevant back numbers. This present reprint brings all the material together between two covers and constitutes a technically sound, easy-to-read introduction to the entrancing science of radio. But, having used the word "radio" for its past associations, let's try to get used to the more appropriate and embracing term "electronics."

In fact, this course will give you a basic insight into electronics — the most rapidly expanding branch of science in this modern age. Electronics includes radio, television and sound reproduction — the activities which nurtured it. It provides the key to communication, navigation and control of "earth-bound" vehicles and missiles, and those which now head outwards into space; electronics is responsible for the computers which are taking over the storage and processing of data, ranging from the humble electric light account to the most complicated mathematical procedures; it is providing the technologies to revolutionise manufacture, measurement and research, from inanimate machines and products to the diagnosis and treatment of human sickness.

In more and more fields of endeavour, the person who can think in terms of electronics has a tremendous advantage over those who can't. Young people with an interest in electronics, perhaps generated by a hobby activity, have their foot on the first rung of a ladder which can lead to successful and rewarding careers in various branches of this rapidly expanding science.

This basic course will serve as an introduction to electronics — we trust an effective one. When you have assimilated the information it contains, you will be in a good position to enlarge upon it by studying other more comprehensive textbooks and by embarking upon more advanced constructional projects, with the help of magazines such as "ELECTRONICS Australia."

## Index

CHAPTER 1	Basic Theory — The Electron — Volts, Amps and Ohms .....	6	CHAPTER 13	Power Supply Filters — Bias Supply — Portable Receivers .....	66
CHAPTER 2	Primary and Secondary Cells — Batteries .....	10	CHAPTER 14	Alignment — Why It Is Necessary — Techniques .....	72
CHAPTER 3	Magnetism — DC and AC — Inductance .....	14	CHAPTER 15	Alignment (cont.) — AVC and AGC — Instability—Instruments for Alignment .....	75
CHAPTER 4	Capacitance and Capacitors ..	18	CHAPTER 16	Test and Measuring Instruments — Meters, Oscilloscopes, Bridges	80
CHAPTER 5	Resistance and Ohm's Law — Reactance—Resonance — Tuned Circuits .....	23	CHAPTER 17	Audio Techniques — Microphones —Recording—Audio Amplifiers Loudspeakers — Stereo .....	85
CHAPTER 6	The Valve — Amplification ....	27	CHAPTER 18	Electronic Servicing — Servicing Equipment .....	95
CHAPTER 7	Semiconductors .....	33	CHAPTER 19	Amateur Radio — Licences — Clubs — Examinations .....	100
CHAPTER 8	Transmission Theory — RF Carrier —Modulation .....	38	CHAPTER 20	Electronics in Industry .....	105
CHAPTER 9	Reception — Tuning — Demodulation—A Simple Receiver ....	44	CHAPTER 21	Practical Set Construction ....	110
CHAPTER 10	Reception (cont.) —RF and Audio Amplification — Detectors — Reaction — Overload and Gain Control .....	50	CHAPTER 22	Practical Set Construction (cont.) — A Simple Regenerative Receiver .....	114
CHAPTER 11	RF Amplification—Neutralisation the Superheterodyne .....	55	CHAPTER 23	Magnetic Recording — History— Principles—Bias—Erasure .....	120
CHAPTER 12	Power Supplies and Rectifiers ..	60	CHAPTER 24	Magnetic Recording (cont.) — Modern Tape Recorders .....	124

## Soldering Irons

### SCOPE



#### DELUXE

Only 6 seconds INITIAL heat-up time from cold, then temperature control at your fingertips with EXCLUSIVE "Switching." Heat only where, when, and as much as needed.



#### MINISCOPE

EASIER ACCESS to confined areas. New, unbreakable slotted NYLON centre-piece allows adjustment to switch lever travel.



#### NATIONAL TRANSFORMER

The only transformer approved for Scope Products, is fitted with 6 ft. of 3-core flex and 3-pin mains plug. Manufactured by National Transformers Pty. Ltd. KINGSGROVE.

Australian & Overseas Agents:  
Wm. J. McLELLAN & CO. PTY. LTD.  
The Crescent, Kingsgrove.

natronic

National

### NATIONAL TRANSFORMERS PTY. LTD.

... manufacturers of a large range of Transformers and Iron-Cored Components, to the highest specifications, for defence, communications and modern industry.



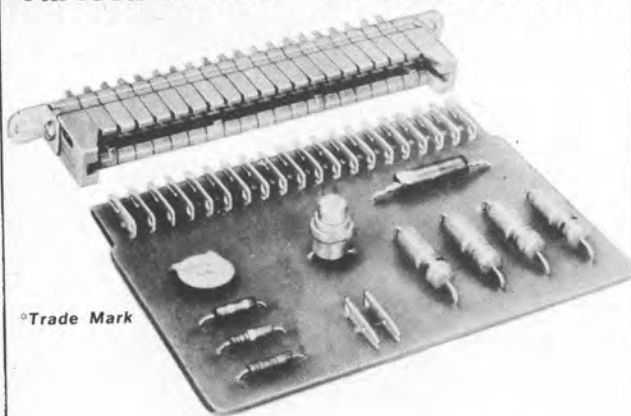
NATIONAL TRANSFORMERS PTY. LIMITED  
The Crescent, Kingsgrove, N.S.W.  
Telephone 50.0111

# International Resistance Holdings Ltd.

## ELECTRONIC COMPONENTS DIVISIONS

### Connectors

#### Varicon Printed Circuit Connectors



Trade Mark

#### The VARICON® Connector System

America's most reliable, versatile connector system, composed of only four basic parts, making it possible to assemble any size connector with almost any number of contacts.



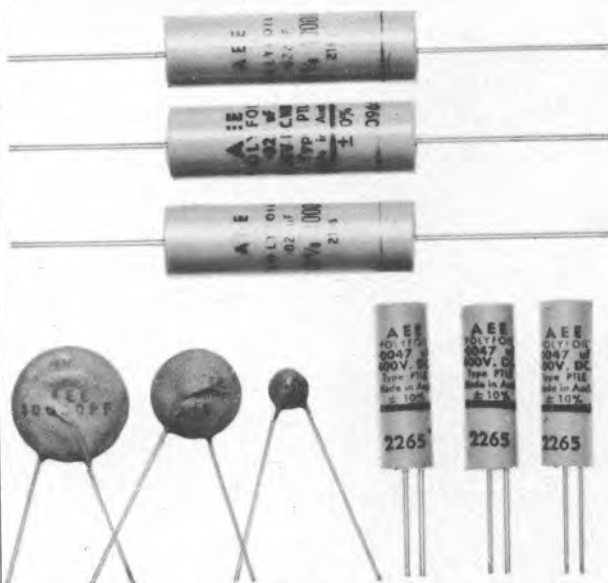
Patented fork-like contact, identical for male and female connectors; provides "spring" contact wiping action; remains positive under all operative conditions.



Illustrated cross-section of pair of mated contacts shows how additional contact area provides for high voltage and current capacity; positive contact at all times. Send for catalogue.

**ELCO** (AUSTRALASIA) PTY. LTD.  
THE CRESCENT, KINGSGROVE, N.S.W.

### Capacitors



Capacitors for TV, radio and electronics in a variety of dielectrics—metallised paper—metallised polyester—polyester film—paper and foil—disc and tubular ceramic. C.R. units for relay contact protection—industrial and fluorescent power factor correction.

A.E.E. CAPACITORS PTY. LTD.  
202 BELL STREET, PRESTON  
VICTORIA. 44-0491

**AEE**

# Resistors

 <p>Miniature insulated carbon composition 1/4 to 2 watts Bulletin BT62A</p>	 <p>Miniature insulated wire wound 1/2 and 1 watt Bulletin BW62A</p>	 <p>Miniature insulated R.F. chokes Bulletin H</p>	 <p>Deposited carbon High stability 1/8 to 2 watts Bulletins DM and DC</p>	 <p>Variable carbon and wire wound Bulletins CTS and 2W</p>	 <p>Evaporated metal film 1/4 and 1 watt Bulletin CC</p>
 <p>Vitreous coated Wire wound 1.5 to 14 watts. Bulletin RWV.621A</p>	 <p>Tubular, fixed and adjustable Wire wound 3 to 200 watts with "Pyrosil" coating. Bulletin PRS.62A</p>	 <p>High voltage and High frequency Resistors up to 100 kV, 90 watts. Lead, lug and ferrule types. Bulletin MPMV62A</p>	 <p>Ceramic case Wire wound Fireproof inorganic construction 5 to 15 watts. Bulletin PW.2</p>	 <p>Glass insulated Wire wound Silicone impregnated glass fibre core 6-9 watts per inch. Reference: Type AW</p>	
 <p>Power Film High Reliability Mechanically rugged 4 to 7 watts. Bulletin PF64AE-1</p>	 <p>Sliders Wire wound 50 to 200 watts. Bulletin SLS.62A</p>	 <p>Flat Wire wound with "Pyrosil" coating 20 to 75 watts. Bulletin FRW(a)</p>	 <p>Variable Wire wound 2 to 100 watts. Bulletin PRA65A</p>		

## International Resistance Holdings Ltd.

ELECTRONIC COMPONENTS DIVISIONS

### Sockets, Terminal Strips and Switches



The most complete range of resistors, sockets, plugs, terminal strips and switches available in Australia from

For complete information on these and other products manufactured by the Electronic Components Divisions of International Resistance Holdings Ltd., please write or mail coupon.



#### INTERSTATE ENQUIRIES

- A.E.E. Capacitors Pty. Ltd.  
202 Bell Street, Preston, Vic.
- I. W. Holman & Co.  
249 James Street, Perth
- Collett & Cant Pty. Ltd.  
103 Halifax Street, Adelaide
- W. P. Martin Pty. Ltd.  
202 Argyle Street, Hobart
- K. H. Dore & Sons  
505-507 Boundary Street  
Brisbane
- David J. Reid (N.Z.) Ltd.  
3-5 Auburn Street  
Takapuna, Auckland
- ALSO Townsville and Rockhampton.

International Resistance Holdings Ltd.  
The Crescent, KINGSGROVE  
N.S.W.

C  
O  
U  
P  
O  
N

SCOPE  ELCO  A.E.E.  IRC  TELETRON  NATRONIC   
Please forward literature of product marked

Name \_\_\_\_\_

Address \_\_\_\_\_

My usual supplier is \_\_\_\_\_



BRC/2



# CHAPTER 1: Electrons, protons and electric charge. Atoms, molecules and ions. Electric current and pressure. The Ampere and the Volt. Conductors, semiconductors and insulators. The Ohm. Fixed resistors, wire-wound and carbon. Variable resistors, rheostats and potentiometers.

ALL good stories of our childhood began, it seems, with the phrase, "Once upon a time." In like manner, most elementary radio textbooks begin with a discussion of the electron theory—and surely that is the logical place to make a start.

One can never hope to understand the principles of modern radio and electronic apparatus, without a working knowledge of electrons and their behaviour.

Once having grasped the idea of electrons in motion, the question of electrical current ceases to be a mystery. You will see immediately the significance of terms like conductor, insulator, resistor and so on.

Let's start then with a little bit of chemistry or physics—call it what you like.

Scientists tell us that all matter, whether it be solid, liquid or gas, is composed basically of minute electric charges, of which there are two main varieties.

One of these is the ELECTRON, which may be defined as the smallest existent quantity of negative electricity. Its opposite number of the more massive PROTON, which is an electric charge of the same magnitude, but of opposite or positive sign.

## ELECTRIC CHARGES

Just what electrons and protons and other uncharged components of atoms actually are need not concern us here. For our purposes they may be thought of simply as electric charges, using this term as a convenient name.

Electrons and protons do not "normally" exist alone, but are usually associated with one another in groups. Each group is thought to resemble in certain ways the planetary system of which our world forms a part.

If it were possible to peer into these sub-microscopic realms, we would behold a host of miniature "planetary systems." In each, we would see a proton, or a group of protons and other particles forming a nucleus, and whirling around them, a number of single electrons.

In actual fact, each tiny "planetary system" constitutes an atom of a particular substance. And, from our chemistry, we know that an atom is the smallest particle of any substance obtainable by chemical separation, or capable of entering into chemical combination. One hundred million of them, arranged end to end, would just about equal in length three words of this type. Although no one has ever seen a

single atom, or the electric charges which compose them, scientists have been able, by roundabout means, to deduce quite a lot of information about them.

They know, for example, that the simplest of the lot is the hydrogen atom, which has a single proton as a nucleus, with a single electron spinning around it. A helium atom has two protons with two planetary electrons. An atom of lithium has three protons in the nucleus, two electrons whirling on an inner orbit and a single electron on an outer orbit.

Every atom is electrically balanced in its normal state. The three examples just quoted contained respectively one, two and three positive and negative charges each.

This state of affairs is maintained in even the very complicated atomic struc-

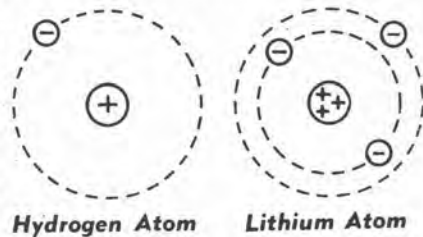


Figure 1: Atoms consist basically of one or more electrons revolving around a positively charged nucleus. Some atoms have a quite complex nucleus and numerous planetary electrons in a variety of orbits.

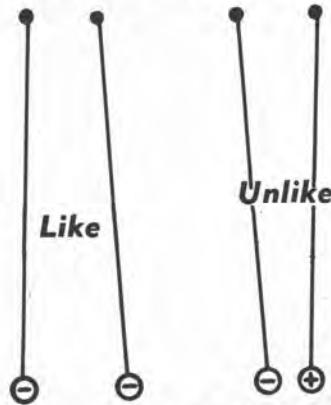


Figure 2: The classic rule that "like charges repel, unlike charges attract one another" can be illustrated by the behaviour of charged pith balls, hung side by side on fine, silk or nylon threads.

tures. An atom of copper, for example has 64 protons and 35 electrons grouped in the central nucleus; but the excess positive charge here is exactly balanced by the 29 electrons which revolve on various orbits around the nucleus.

It is important to note that the electrons and protons comprising the various atoms remain simply electric charges. An electron associated with a hydrogen atom is identical to one in a copper atom, even though it may be placed differently in the structure.

The particular combination of protons and electrons determines to what chemical element the atom belongs. The number of natural chemical elements is believed to total 95, which means that there are 95 different atomic structures.

Theoretically, at least, some atoms can exist in the solitary state and exhibit all the chemical properties of the element in bulk; typical are the atoms of the rare gases helium and neon. Such atoms may also be referred to as MOLECULES.

In the case of other elements, the atoms, for chemical purposes, are normally found in groups of two or more, and these atomic groups are also known as molecules.

A third variety of molecules is that belonging to a chemical compound, in which unlike atoms are found in combination.

In short, molecule can be defined as "The smallest portion to which any given substance can theoretically be divided, without altering its chemical properties."

## ELEMENTS & COMPOUNDS

The chemical compounds in existence are without number but they are all produced by varied combination of the 95-odd basic elements; they are built from the 95-odd atomic "bricks."

It is hard to realise that the most uninteresting, the most inert substance one can imagine is composed of countless atoms, with their numerous swiftly moving electrons. Indeed, the speed with which each individual electron revolves in its orbit is enormous, despite the fantastically small circumference of even the largest atom.

But there are other matters of more immediate interest to the reader of this article. The outer electrons in many types of atom are rather wayward in certain conditions and it is not uncommon for them to wander rather aimlessly into the structure of an adjacent atom.

This leaves the original atom short of an electron so that, for a very brief interval, it may have an excess positive charge. In other words, the loss of an electron has upset its electrical balance.

Atoms in this state are known as IONS. They are said to be positive



ions if they have lost an electron, and negative ions if they have perchance acquired an extra electron.

The electrons which are wandering free of attachment to an atom may also be called negative ions. The word ion is, in fact, often simply used to signify a charged particle.

A fundamental principle of electricity is that like charges repel and unlike charges attract. (See figure 2). The operation of this principle soon corrects the state of unbalance created by a meandering electron. The positively charged atom (ion) immediately attracts an electron from elsewhere. While the negative ion quickly disposes of one surplus electron.

Naturally, nearby atoms are disturbed in the process, so that there may be a continuous and random movement of electrons within the confines of the particular piece of material.

This movement can often be greatly accentuated by the application of heat and the agitation can actually become so violent that some electrons momentarily jump off into space.

Such movement is purely random in character and the average movement of electrons in one direction is exactly balanced by electron movement in the opposite direction.

However, it is possible to alter this state of affairs so that there is a defined movement of electrons in a certain direction through the substance. Any such clearly defined electron movement in a given direction through a substance is known as an **ELECTRIC CURRENT**.

All readers will have handled an electric battery at some time or other, in one of its many forms. This general subject will be treated in detail in a later article; it is sufficient to state just here that a battery is a device which, by electro-chemical action, can produce a surfeit of free electrons (as negative ions) at one terminal and positive ions at the other.

Between its terminals is built up an electric pressure which, in electrical parlance, is known as an electro-motive force (EMF) or, more simply, a potential.

These terms actually have definite and slightly different meanings, but for our purposes they may be regarded as identical.

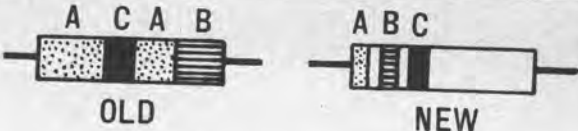
**ELECTRON MOVEMENT**

In figure 3, we see a piece of copper wire connected between the terminals of an electric battery. We can expect the positive terminal to exercise a strong attraction for the outer electrons in the nearest atoms. This, indeed, is the case and a definite movement of electrons becomes evident in the direction of the positive battery terminal.

At the other end of the wire, the negative battery terminal is quite ready to part with some of its excess electrons, and these go to replace those lost to the positive terminal. The potential or EMF of the battery thus initiates an electric current through the copper wire, there being a net electron flow from the negative to the positive terminal.

Unfortunately, in making this statement, we run up against an apparent contradiction. The early pioneers knew nothing of electrons, although they could observe the effects of electric current and potential. So charges were labelled "positive" and "negative" for identification, after which they reasoned that current must flow from positive to negative.

Unfortunately they were wrong and we can do no better than brand their ruling as the "conventional" direction of flow. But, for our own clarity of thought, let us remember that true electric current is a movement of electrons,



A—Color for 1st significant figure.  
B—Color for 2nd significant figure.  
C—Color for No. of noughts.

COLOR	SIGNIFICANT FIGURE	No. OF NOUGHTS
Black	0	—
Brown	1	1
Red	2	2
Orange	3	3
Yellow	4	4
Green	5	5
Blue	6	6
Violet	7	7
Grey	8	8
White	9	9

**EXAMPLES**

47000 ohms Yellow-4 Violet-7 Orange-000  
1000 " Brown-1 Black-0 Red-00  
68 " Blue-6 Grey-8 Black —

*Rather than mark on the body of a resistor its value in ohms, it is common practice to indicate the value by means of a colour code. The chart on the right should enable you to read the values of most resistors without undue difficulty. After a little use, resistors can be recognised spontaneously, without consciously working out colors. In any case, there would be no room on the smallest resistors, now in use, to print the value in figures.*

and that is always from negative to positive.

Electrons are far too minute to be useful as a measure of current flow, and the standard unit is the AMPERE, generally abbreviated to the AMP.

The ampere has a physical definition, the exact nature of which concerns standards laboratories throughout the world. Our requirement is merely to record the ampere as the basic unit for current measurement.

For purposes requiring a smaller unit than the ampere, we have:

- 1 milliamperes equals .001 amp.
  - 1 microampere equals .000001 amp.
  - Conversely:
  - 1 amp equals 1,000 milliamperes.
  - 1 amp equals 1,000,000 microamperes.
- These relationships should be mem-

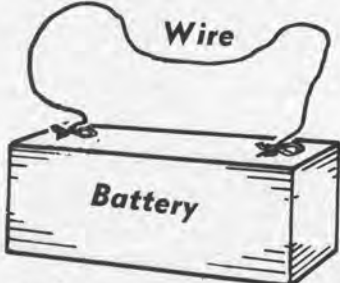


Figure 3: When an external agency causes electrons to move predominantly in one direction in a conductor, the phenomenon is described as a flow of electric current.

orised as you will find yourself coming up against them all the time in radio and electrical theory.

The accepted unit of electro-motive force (EMF) or potential is the VOLT. A battery may typically be defined as having an EMF between its terminals of, say, 1.5 volts. Alternatively we may state that its VOLTAGE is 1.5, or any other figure which might apply.

Larger and smaller terms for defining voltage are:

- 1 kilovolt equals 1,000 volts.
- 1 millivolt equals .001 volt.
- 1 microvolt equals .000001 volt.
- Alternatively:
- 1 volt equals .001 kilovolt.
- 1 volt equals 1,000 millivolts.
- 1 volt equals 1,000,000 microvolts.

Coming back to figure 3, we must not imagine that the path of any individual electron through the copper wire is unimpeded, like a meteor through outer space.

It leaves the negative terminal and collides with the first atom in its path. It may take its place in the planetary system of that atom, while the electron it displaced moves off toward the positive battery terminal. An instant later it may itself be displaced, allowing it to move on again. So the current may consist of many small inter-atom "jumps" by many different electrons.

By its very structure the copper offers some resistance to the passage of the current, because of electron-atom collisions, etc.

For all that, the current passes easily enough, so that copper is one of the

substances classified as a CONDUCTOR of electricity. Into this general classification fall the various metals, carbon and certain other substances and liquids. Some offer more resistance to current flow than others, but all are conductors.

Current can flow through them, or from one to another if two or more conductors are brought into direct physical contact.

In another group are a large number of substances in which there is very little transfer of electrons from atom to atom, unless a very large external electric pressure is applied. Such substances, which under normal conditions conduct to a negligible degree only, are called INSULATORS.



Some substances are very useful in this respect, maintaining their insulating properties despite heat and high electric pressures. Others can withstand only moderate heat or applied electric pressure before they conduct appreciably, and may "break down" and char, due to permanent structural damage.

In a later chapter we will deal with a third group of substances which are midway between conductors and insulators and which may be used in special ways. These are called SEMICONDUCTORS but, apart from mentioning their existence, we will not deal with them any further at present.

Typical insulating materials are ebonite, mica, shellac, silk, oil, and dry hair, and most modern plastics.

Insulating materials are used to support, isolate or contain conductors which are part of an electric circuit. Because no appreciable current can flow through the insulating materials, their presence does not—or should not—affect the operation of the circuit.

### CONDUCTORS & INSULATORS

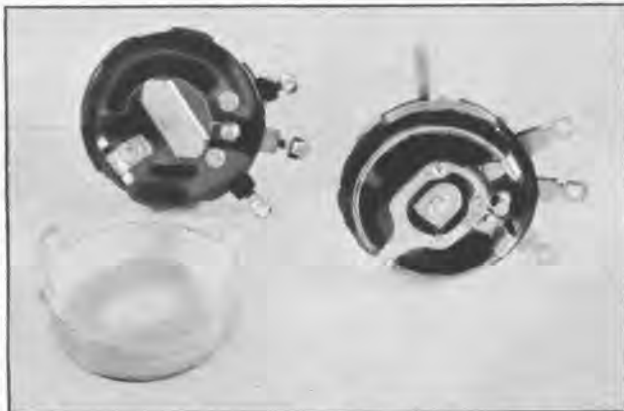
A good illustration of conductors and insulators in combination is seen in the plug and socket arrangement in figure 4. When the two units are fitted together, current can flow via each individual metallic pin and its metallic contact. The surrounding bakelite provides the necessary mechanical support, but does not allow appreciable electron transfer between individual pins.

As we shall see in later chapters, there is a very definite place in electrical circuits for substances which can be classed as neither good conductors nor good insulators; in other words, for substances which offer considerable resistance to the passage of current through them.

The connection of a copper wire between the terminals of a battery, as in figure 3, would result in a heavy flow of current, sufficient probably to discharge the battery.

A longer connecting wire would tend to reduce the current by reason of the

Shown at the right are disassembled views of two types of potentiometer. The one at the left has a carbon strip element, a type commonly used in receivers as a volume control. The second has a wire-wound resistance element, commonly used for resistance values of 10,000 ohms and less.



Typical resistors used in present-day electronic equipment. The large resistor at the rear is a wire-wound type rated to dissipate up to 20 watts of heat energy. The smaller ones in front are much lower wattage carbon-element types.

longer path the current would have to traverse. Substitution of a finer gauge wire would have the same effect, since much reduced cross-sectional area is available for the electron movement.

By substituting an iron wire for the copper, still greater resistance would be evident, with a consequent reduction in current flow.

In other words, by deliberately introducing resistance into a circuit, it is possible to limit or control the current flowing, exactly as a tap controls the flow of gas in your domestic range.

Actually, there are other uses for this

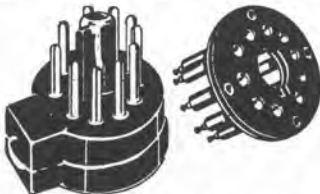


Figure 4: Electrons can move along conductors but not through insulating materials. Each, therefore, has an important part to play in electrical apparatus. Illustrated above is a plug and socket.

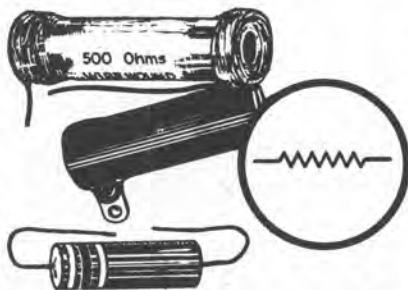


Figure 5: A group of resistors, each offering a specific degree of opposition or resistance to the flow of electric current. The appropriate symbol is shown in the circle.

property of resistance in an electrical circuit, but the above remarks will be sufficient for the time being.

The basic unit of resistance is the OHM, which is that amount of resistance which will limit the current through a circuit to one amp, when the applied EMF is one volt. For very high values of resistance it is more convenient to speak in terms of KILOHMS and MEGOHMS, the symbols for which are K and M.

1 Kilohm equals 1,000 Ohms.

1 Megohm equals 1,000,000 Ohms.

1 Megohm equals 1,000 Kilohms.

Resistance values up to 9,900 ohms are generally expressed directly in ohms, but between 10,000 and 990,000 ohms they are commonly expressed in Kilohms, and above 1,000,000 ohms in Megohms. It is obviously easier to say and write 120K and 12M, for instance, than 120,000 ohms and 12,000,000 ohms, although the two ways of showing the figures concerned mean the same thing.

### PRACTICAL MATERIALS

Coming to the practical side of the matter, many substances exhibit sufficient opposition to the passage of an electric current to suggest their use in a circuit as a resistance element. However, their physical adaptability is also an important consideration.

Certain metals and alloys, for example, exhibit quite high resistance, compared to copper, and lend themselves for the purpose. Carbon, too, is the basis for some resistance elements.

To facilitate the inclusion of a specific amount of resistance in an electrical circuit, component manufacturers produce small units known as RESISTORS. For resistance values up to a few thousand ohms, these units consist generally of a length of so-called "resistance" wire, wound spirally on a tube of cardboard, glass, porcelain or other suitable insulating material.

The wire is joined to a terminal at either end, or to a lug or bare copper lead, to facilitate soldered connections. The resistor is then coated with lacquer or enamel to protect and locate the individual turns of wire, and it is finally branded with its nominal resistance value in ohms.

The actual resistance depends on the nature and the gauge of the wire used, and on the length of wire wound around the tube or FORMER. Resistors made up after this fashion are known as WIRE-WOUND types.

For resistance values above a few thousand ohms, the wire-wound type presents manufacturing difficulties, owing to the fine gauge and the nature of the wire which would have to be used, and also the bulk of the finished component.

As a result, an alternative type of resistor is generally used. Finely divided carbon or similar granules are mixed with a non-conducting binding material and moulded into small rods. The proportion of carbon and binder and the physical dimensions govern the ultimate resistance of the small rod. This basic element may be moulded into a bakelite tube for further protection or simply coated with lacquer or enamel.

Some carbon resistors are made by spraying a carbon compound on to the surface of an insulating rod, the nature and thickness of the coating determining the resistance of the layer.

Two copper "pigtailed" for soldering complete the assembly of these so-called CARBON RESISTORS. Like the wire-wound types, they may be branded directly with their nominal resistance value or distinguished by means of a colour code.

The standard RMA (Radio Manufacturers' Association) colour code is included for reference. It will be seen that the colour of the body, the colour of the end and of the band (or dot), all have a special significance.

As the colour code table shows, the coding system used nowadays differs slightly from that used in the early days of radio. The significance of the colours has not changed, however, only the way in which the coloured bands are arranged on the resistors themselves.

When current flows through a resistor, the erratic movement of the electrons and the resulting electron friction absorb energy from the source of current, which is made evident in the resistor as heat.

Without being more precise just here, the heat generated can be expressed in WATTS. The amount of heat which any resistor can DISSIPATE is closely related to its physical size and to the ability of the associated insulating materials to withstand the effects of increased temperature.

### TYPICAL RATINGS

Resistors commonly used in radio work, and illustrated in figure 5, range from one half to two inches long and carry dissipation ratings of from .25 to 20 watts. Larger resistors are available for special purposes.

The association of resistance and heat is best illustrated by certain common household electrical appliances.

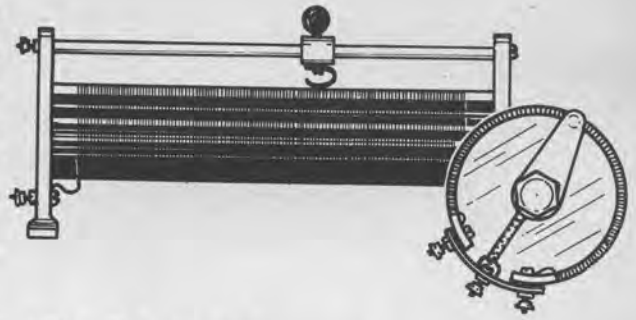
In the ordinary electric light globe, the filament is, in reality, a small but carefully designed resistance element. When connected to the specified EMF or voltage, a current flows which is of sufficient magnitude to raise the temperature to a white heat: the exclusion of oxygen from the glass envelope prevents the filament from disintegrating chemically.

In the electric radiator or toaster, the resistance element is more bulky and is designed to dissipate from 500 to 1,500 watts, glowing at red heat in the process. This red hot glow supplies the desired warmth.

In figure 5 you will note a circle containing the first of many rather mysterious symbols. The zig-zag line is actually the schematic symbol for a resistance.

When electrical or radio engineers are depicting an electrical circuit, solid lines represent wires or connecting links. This is simple enough, but it would be a nuisance to have to sketch a resistance in detail whenever one had to be

**Figure 6:** The term "variable resistor" normally denotes a unit having a fixed resistance element, with a moving contact arranged so that it can make connection at any point along its surface.



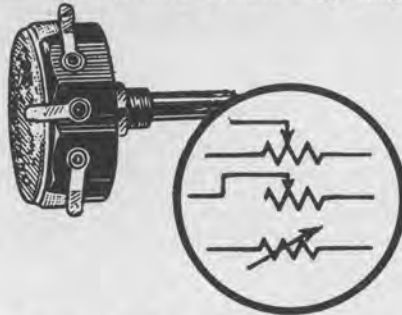
shown in a particular portion of a circuit.

Engineers use these symbols to simplify both the drawing and the reading of schematic circuit diagrams. The subject will be explained later in more detail; just remember that a zig-zag line in a circuit normally represents a resistor.

One more point, and your reading of chapter 1 will be complete.

There are various applications where it is necessary to vary the amount of resistance in circuit; this brings us to the term VARIABLE RESISTOR.

The most elementary form of variable resistor is a wire-wound type with a small guide rail mounted above it; the guide rail carries a spring contact which presses down on the coil of resistance wire. One terminal or lug is connected to one end of the wire and the other to the adjustable contact. By simply



**Figure 7:** In radio parlance, the term "potentiometer" usually denotes variable resistor with a connection to each end of the resistance element and to a moving connector. It is represented by the top symbol in the group, the other two inferring that only two connections are necessary—to one end and the tapping.

moving the contact along the guide rail, the whole or part of the resistor is effective between the terminals. (See figure 6.)

As an alternative, a simple clip may be fixed around the resistance element, so arranged that it can be moved along as required, then tightened to make contact with the wire.

Where ease of adjustment is important, it is possible to have the resistance wire wound on a flat insulating strip, bent into about a three-quarter circle. A spindle is located at the centre point of the arc carrying a radius arm. As the spindle is rotated, this radius arm moves over the resistance element, making contact, as it passes, with each individual turn.

One terminal connects to one end of the resistance element and the other terminal to the contact arm. Any value from zero to maximum resistance may be effective between the terminals, depending on the setting of the contact

arm.

In the earliest controls of this type, the wire-wound resistance element was left exposed, but present practice is to house it in a moulded bakelite case for appearance and protection.

For resistance values in excess of a few thousand ohms, the resistance element is usually a carbon mixture, moulded into the required shape.

Some of the earliest variable carbon resistors merely contained loose carbon and mica granules, or carbon impregnated discs, which were pressed together by the action of a screw; this decreased the resistance as required.

The appropriate schematic symbol for a variable resistor is the central one in figure 7. It depicts quite clearly the resistance element, with its end connection and the moving contact.

The bottom symbol also depicts a simple variable resistor, but it is less precise, in that it does not differentiate between the moving and fixed contacts, nor does it show the unused portion of the resistance element. Variable resistors having just the two connections, are commonly known as RHEOSTATS.

Modern practice is to provide a variable resistor with three connections, one to each end of the resistance element and one to the moving contact. Such a unit is generally referred to as a POTENTIOMETER and all three connections are normally employed in modern circuit practice.

In cases where only two of the three connections are used—one moving and one fixed—the unit is said to be employed as a rheostat. The appropriate symbol for a potentiometer is the top one in figure 7. It shows quite clearly the two end connections and the moving contact.

## For Cycles Read "Hertz"

In common with many of the world's leading technical journals, "ELECTRONICS Australia" now uses the basic term "Hertz" (abbreviated to "Hz") instead of the time-honoured term "cycles per second" (abbreviated to cps) used throughout this basic radio course.

Also adopted at the same time were the compounds and abbreviations KHz or kilohertz (in place of kilocycles per second) and MHz or megahertz (instead of megacycles per second).

"Hertz" has been used for many years in continental Europe to honour the German physicist Hertz. At one time radio waves were called "Hertzian waves," since it was Hertz who did so much to verify their existence.

Recently the term was adopted by the American Bureau of Standards and by the European CCIR organisation as the basic term for frequency measurement. In the interests of standardisation, "ELECTRONICS Australia" decided to follow suit.



## CHAPTER 2: Primary cells. Their chemistry, construction and life — series and parallel connections — layer-built batteries. Secondary batteries or accumulators. The hydrometer.

A BATTERY may be defined as a device which, by chemical action, produces a surfeit of free electrons at one terminal and a large number of positive ions at the other. The first terminal is negative; the second is said to have a positive charge, because it is deficient in free electrons.

When the two terminals are joined by an external conducting path, the electron pressure or EMF of the battery causes a movement of electrons along this path. In other words, the battery initiates the flow of an electric current through the external conductor.

To be precise, a single electrochemical unit should be referred to as a CELL; an inter-connected group of cells makes up a battery.

Investigators have produced quite a variety of electric cells and a lot of space could be devoted to a discussion of their chemical action and their characteristics. However, for the purpose of this article, it seems more appropriate to devote the necessary mental energy to a study of the types normally used with radio apparatus.

The first crude cell was made in 1789, sufficient to establish the electro-chemical principle.

The first really practical cell was produced by Georges Le Clanche in 1868. Le Clanche cells utilised a carbon rod for the positive electrode and a piece of zinc for the negative pole; the carbon is surrounded in a porous container by powdered manganese dioxide and the whole lot located in glass jar containing a solution of sal-ammoniac (ammonium chloride).

### WET AND DRY

The Le Clanche cell in this form, though an entirely practical arrangement, suffers from the disadvantage of having a liquid electrolyte, subject to spilling and "creeping."

The problem was largely overcome when, in 1888, a "dry" cell was produced by Dr Gassner, utilising the basic Le Clanche principle but in a more convenient form.

The modern "dry" cell is essentially similar to that produced by Gassner. The glass jar is eliminated and the negative zinc electrode becomes the container for the chemicals. The positive carbon electrode is retained, as is the manganese dioxide, but the sal-ammoniac is thickened to a non-spillable paste. A coat of wax over the top serves to seal the whole unit.

Such a cell is not truly dry and, indeed, could not be so. However, the cell may be used in any position without danger of the electrolyte spilling or doing damage to other apparatus.

Although dry cells have changed little in appearance for many years, various chemical refinements have trebled and even quadrupled their service life.

When first manufactured, the cell builds up a certain potential across its terminals and, thereafter, the chemical action becomes very slight. However, there is always a slow chemical action going on and a drying out process, so that a cell will not remain fresh indefinitely.

After a few months, its terminal voltage begins to diminish and the amount of electrical energy it can supply becomes very limited.

The ability of a cell to remain "fresh" for a long period of idleness after manufacture is expressed in terms of its SHELF LIFE. Generally speaking, large cells have a much longer shelf life than small ones.

The main factor controlling shelf life is the purity of the materials employed, particularly the zinc. If these were all 100 per cent pure, most of the shelf life problems would be solved. Unfortunately, this level of purity is impractical on a commercial basis and the battery manufacturer has to be content with something less than this.

However, against this background battery manufacturers have improved battery shelf life significantly over the years. In addition, they can design a battery to have either a long shelf life—at the expense of some other characteristic — or minimum shelf life where other characteristics are more

important and can be improved by so doing.

important and can be improved by so doing.

Again, for any one design, the temperature at which the battery is stored will have a significant effect on shelf life. High temperatures shorten it, low temperatures prolong it, so that it is customary to keep batteries in cold storage where the type of battery, kind of usage, and climatic conditions would otherwise create problems.

When, in actual service, a conducting path is provided between the terminals there is an evident electron movement from negative to positive along the path, which tends to relieve the electron pressure within the cell. However, the cell automatically tries to maintain the initial potential between its terminals, so the flow of electric current is invariably accompanied by increased chemical activity.

The zinc of the container combines with the ammonium chloride to produce hydrogen and a basic chlorine compound containing both zinc and ammonia. This latter compound is responsible for the whitish crystals which are often in evidence in and around a run-down cell.

The hydrogen makes its way toward the carbon rod, tending to surround it with a film of hydrogen. The gaseous layer could ultimately interrupt the

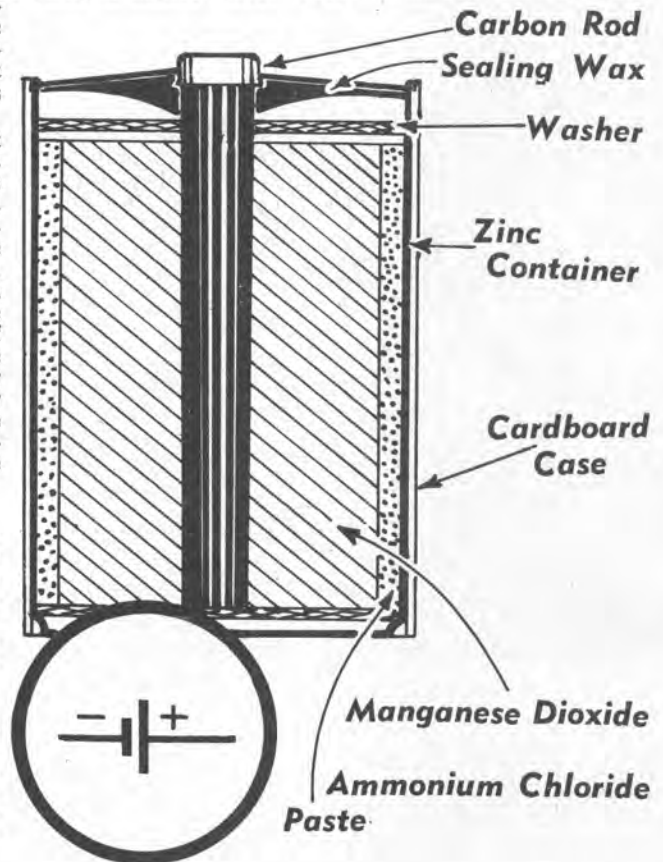


Figure 1. Cutaway view of the "dry" Le Clanche cell, showing details of contents. Note the paste form of the ammonium chloride electrolyte, which permits the so-called "dry" construction. Voltage of the cell is approximately 1.5, regardless of size.

chemical action but this so-called POLARISATION of the cell is prevented by the manganese dioxide which has already been mentioned as surrounding the carbon. The manganese dioxide oxidises the hydrogen to form water and manganic oxide.

An accepted explanation of the electro-chemical action is that zinc is deprived of zinc ions (not atoms) so that the zinc is left with an accumulation of free electrons. Further, that hydrogen ions move toward the carbon rod, so that it exhibits a positive charge and the zinc a negative charge.

All dry cells of this description have an initial EMF of 1.5 volts or thereabouts between their terminals, irrespective of their physical size. However, large cells have a much longer shelf life than small cells, and, in service, can supply much heavier currents without running down.

### OPTIMUM SIZE

Because of this, some care should be exercised in selecting the best size cell for a particular application. In general, larger cells are more economical than smaller ones, even though the latter have the advantage of low initial cost and, possibly, greater convenience.

On the other hand, it is unwise to use a cell which is so large, relative to the current drain, that its theoretical discharge life far exceeds its shelf life. There is, therefore, an optimum size for any application.

The larger a cell, the greater is the surface area over which chemical activity can be evident. Therefore, such a cell is better able to maintain its electron pressure — or EMF — when called upon to deliver relatively high current.

The loss of EMF due to output current may be regarded very conveniently as an apparent INTERNAL RESISTANCE of the cell itself. This internal resistance is small with large cells, and increases as the size of the cell is diminished.

The largest dry cell in common usage measures about 6in in height and 2in in diameter, and has a shelf life of two or three years—sometimes much longer. It is designed for a normal intermittent load of between 200 and 300 milliamps and is frequently used in telephone circuits.

### TYPICAL CURRENTS

The cells used in the larger type of "radio B battery," used in the valve-type portable radios of a few years back, were designed to handle normal loads up to only 15 milliamps or so, but gave a useful life on intermittent service of 500 to 700 hours.

The cells in the "energiser" type of batteries used in transistor equipment are designed along somewhat different lines to the usual type of cell, to suit them to the type of loading conditions imposed by transistor circuitry. When used with a piece of equipment which draws the current values for which they are intended, such batteries have about the same useful life as the "B" batteries mentioned above.

Small single cells of the "penlight" variety will deliver only 8 or 10 milliamps comfortably and would give only a small fraction of their service life if asked to supply such currents for any length of time.

A sectional drawing of a typical dry

cell is shown in figure 1, together with another of the schematic symbols dear to the hearts of radio and electrical engineers.

As you can see, a single cell is represented by two parallel strokes of unequal length, occurring in a solid line. As a rule, the longer stroke signifies the positive side of the cell, but it is occasionally found the other way round.

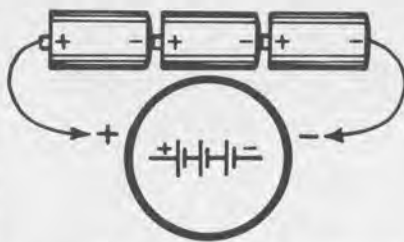


Figure 2. Simple series connection of cells, as in a torch. Total voltage will equal single cell voltage (1.5) times the number of cells.

To be on the safe side, most circuit draughtsmen clearly mark the polarity with a plus and a minus sign, as shown.

For many purposes the E.M.F. or voltage available from a single dry cell is often inadequate and a higher voltage is obtained by connecting two or more cells in SERIES. That is to say, they are linked together with the positive terminal of one cell going to the negative terminal of the next, and so on.

Any number of cells may be connected in this way, and the two terminals left over are the positive and negative connections to the bank of cells—or the battery, as it is generally called.

The most familiar illustration of this principle is that afforded by the ordinary two or three-cell torch.

In ordinary torch cells the tip of the positive carbon rod protrudes through the wax and is fitted with a brass contact cap. The negative connection is actually the bottom of the zinc can.

When the cells are pushed into the torch case they are automatically connected in series and the resultant E.M.F. is equal to the sum of their individual voltages. For two cells it is approximately 3.0 volts, for three cells about 4.5 volts, and so on.

The connection is illustrated graphically and schematically in figure 2.

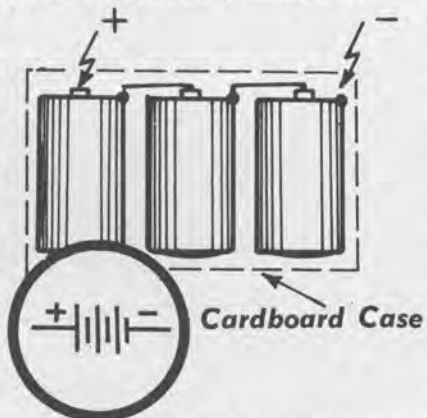


Figure 3. Another form of series connection, this time using soldered connections between cells. The form used by manufacturers to combine a number of cells into a battery.

For the sake of convenience, battery manufacturers often assemble a number of cells in a single package or carton, connecting the cells together internally and bringing out just the one negative and the one positive lead. The actual voltage depends mainly on the number of cells contained.

In figure 3, three cells are shown connected in this way, with the appropriate schematic symbol beneath.

The traditional radio B-battery, as indicated in figure 4, contained a total of 30 cells, delivering an E.M.F. of 45 volts between the negative and positive terminals. Batteries delivering even higher voltages were quite common a few years ago, many being fitted with socket connections instead of clips, as shown.

The method of representing such batteries schematically is worth noting. There is an obvious objection to drawing 30 or more individual cells, so that circuit draughtsmen normally show a couple of cells at each end, with a dashed line between them and a figure

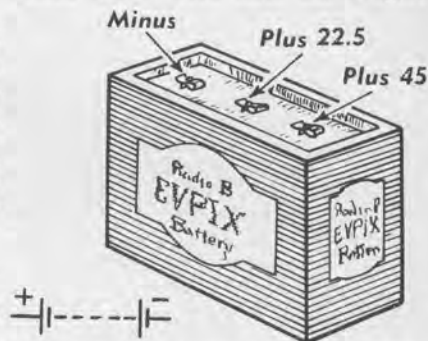


Figure 4. Typical battery (radio "B" battery). Tapping allows intermediate voltage. Note symbol.



Figure 5. Parallel connection of cells. Voltage remains the same as for one cell but combination has lower internal resistance. It can therefore deliver greater current without serious loss of voltage.

signifying the voltage of the battery, or even of a group of batteries.

For certain applications, voltages may be required intermediate between the negative and the full positive E.M.F. Standard procedure, in this case, is to provide the battery with one or more intermediate terminals, connected to the appropriate point in the series network of cells.

In the radio B-battery illustrated a lead is brought out from a point halfway along the series network of cells, giving a voltage 22.5 volts positive with respect to the negative terminal.

Some special-purpose radio batteries have intermediate tapings brought out from each cell in the network, or from each second or third cell.

It is well to note in passing that two or more cells may alternatively be connected in PARALLEL, the positive and negative terminals being joined together as shown in figure 5.

With this arrangement, the E.M.F. between the terminals remains at 1.5 volts (approx.), but the load current is shared between the total number of cells.

Because each cell is then called upon to deliver only one half, one third, one quarter, etc., of the total load, the bank of cells can handle a proportionately higher current than any one of the cells singly.

A similar current capacity, with possibly longer shelf life, could be obtained from a single very large cell, but the parallel arrangement is sometimes used for convenience or expedience.

One of the later forms of dry battery is the LAYER BUILT type. The complete battery is made up of units (they are not strictly cells) consisting of a sheet of zinc faced with carbon, a separator impregnated with ammonium chloride, and a flat cake of manganese

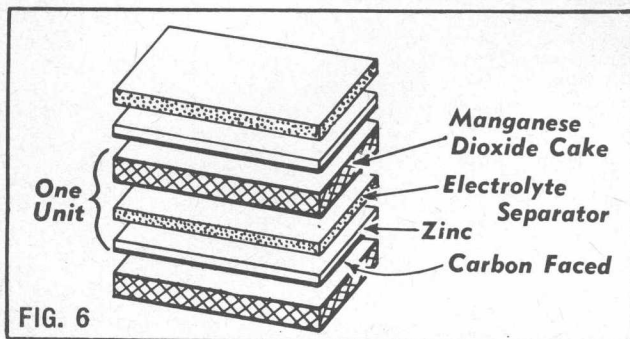
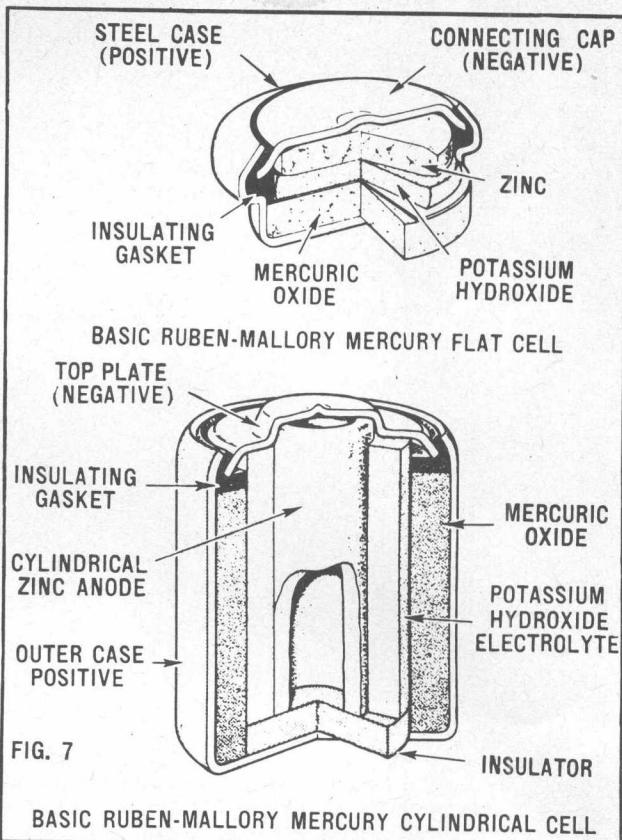


Figure 7. The mercury cell, showing two forms of construction, the flat and cylindrical. Note the "inside out" construction, with the positive outer case.



Figure 6. Construction of the "Layer Built" battery. This form saves considerable space and weight.



dioxide (figure 6). Although these are all the components of a complete cell, they are not in the right order to make it work. Each unit requires the carbon electrode from the next one, while supplying this electrode for the previous unit.

The direct contact between units eliminates interconnecting wires and there is none of the waste space occasioned by the former practice of assembling round cells in rectangular cardboard separators. Chemically, however, the cells are identical.

**THE ALKALINE CELL.** A modified version of the Le Clanche cell, utilizing an alkaline electrolyte instead of the acidic ammonium chloride, gives a better high rate performance and can be more readily manufactured in smaller sizes.

The smaller sizes are generally for low current drain applications only, although an "inside out" construction (i.e., with the positive plate connected to the outer case) has been designed, with potassium hydroxide as the electrolyte, for higher current drains.

### ADVANTAGES

The energy volume ratio of alkaline manganese cells is higher than the acidic Le Clanche cell and they have a longer shelf life. They may well eventually replace the Le Clanche for general commercial use but, at present, are slightly more costly to produce.

Another type of primary cell is the so-called "mercury" cell, which has been used for some years now in hearing-aids and other continuous-use devices, and is finding use in some of the newer transistor equipment (figure 7).

The mercury cell uses zinc as the negative electrode, as before, but the positive electrode is of mercury. Mercuric oxide is used both as a source of the mercury and as a depolariser. The electrolyte is a strong solution of potassium hydroxide and zinc oxide in water.

Mercury cells are commonly made "inside out"—that is, with the negative (zinc) electrode brought to the top as a cap. This enables a steel case to be used, both to connect to the positive mercury electrode and to act as a container.

They may also be made in the "flat" variety, for stacking in series piles to produce voltages higher than that of a single cell. The voltage of a single mercury cell is approximately 1.35 volts, slightly lower than the Le Clanche type, but the internal resistance is generally very low in comparison, and mercury cells have a very high capacity. This makes them more suited to applications where the battery cannot be replaced very often, and to circuits which draw high currents for short periods.

In all the cells we have described so far, the electro-chemical action necessarily ceases when the chemicals have been used up, and the cells are then of no further use.

These so-called **PRIMARY CELLS** are distinguished from **SECONDARY CELLS** by the fact that the latter can be made to deliver current afresh by a process called **RECHARGING**.

The most common type of secondary cell or battery is the lead-acid accumulator used in motor vehicles and as "A" batteries in the earliest battery radio sets.

In the lead-acid accumulator, two sets of lead plates are immersed in a mixture of sulphuric acid and water. The plates are connected to an external E.M.F. in such a way that a current of up to several amperes flows through the acid via the plates.

The flow of current causes the acid-water mixture to be decomposed, releasing atoms of hydrogen and oxygen at the respective plates. The hydrogen mostly escapes, but the oxygen liberated at the positive plate combines with the plate to form the dark brown peroxide of lead.

When the charging has proceeded for

an adequate length of time, the battery may be removed from the charging circuit.

If a conductor is then connected between the two plates, a current is found to flow, and, as it does so, a chemical change becomes evident in both plates. The positive plate, coated with lead peroxide begins to take a coating of greyish lead sulphate, and much the same thing happens to the lead negative plate.

The "sulphate" molecule comes from

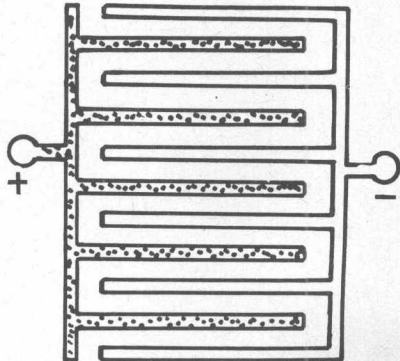


Figure 8. Basic construction of the lead-acid accumulator, showing alternate placing of the positive and negative lead plates.

the acid, which is therefore progressively weakened as the discharge continues.

When next the cell is charged, the lead sulphate on the negative plate is reduced to pure spongy lead, and the coating on the positive plate reverts to the dark coloured lead peroxide. At the same time, the strength of the acid is built up again, so that the cell is ready once more for a period of discharge.

This charge and discharge cycle can be repeated hundreds of times until, after a period of perhaps several years,

the active electrodes begin to disintegrate.

The chemistry and construction of a lead-acid accumulator are rather more complicated than the foregoing simplified statements may have implied. To ensure that the plates are utilised most efficiently, they are usually ribbed to present the greatest possible surface area to the electrolyte.

During manufacture, a special reverse charging procedure may be used to transform the surface of the negative plate into a spongy lead mass. Alternatively, the crevices in the plate may be filled with red-lead paste, which is readily reduced during charge to a spongy mass of pure metal.

## SEVERAL PLATES

To increase the current handling capacity of each cell, it is usual to use a number of interconnected negative and positive plates in a grid formation. (See figure 8.)

To allow them to be packed close together, yet without danger of shorting, they are usually separated by thin layers of wood or other selected insulating material.

The whole assembly has to be suspended clear of the bottom of the case, so that conductive particles which may become detached from the plates will not collect on the bottom and ultimately cause a short-circuit and a discharge path within the accumulator itself.

The E.M.F. of a lead-acid secondary cell is normally reckoned at 2.0 volts, irrespective of its size. The actual current handling capacity is governed largely by the number, the size, the spacing and the nature of the plates.

For voltages greater than 2.0, it is usual to mount several cells, side by side, in the one large subdivided container. The cells are sealed across the top to prevent spilling of the acid and then connected permanently in a series arrangement, as already described for dry cells.

For radio work, accumulators delivering 2, 4 or 6 volts are usual, and either 6 or 12 volts for motor vehicles. These voltages require the use of 1, 2, 3, or 6 cells respectively.

Because the strength of the acid is affected by the chemical condition of the plates, it may be taken as a good guide as to whether the cell is fully charged or otherwise.

## SPECIFIC GRAVITY

In new cells for car or radio use, it is usually arranged that the SPECIFIC GRAVITY of the acid be about 1.25, when fully charged (often quoted as 1.250), 1.18 when half-charged and 1.11 when discharged.

(Specific gravity has effectively the same meaning as "density compared with that of water, which is taken as 1.0.")

Where cells are intended for industrial or home lighting purposes, acid of somewhat lower specific gravity is often specified in the interests of long service life.

To measure the specific gravity, a device known as a **HYDROMETER** is used. This is rather like an oversize syringe with a small glass float in the barrel.

The acid is drawn up into the barrel and specific gravity is indicated by the depth to which the float submerges in the acid. The upper section of the float is usually calibrated directly in terms of

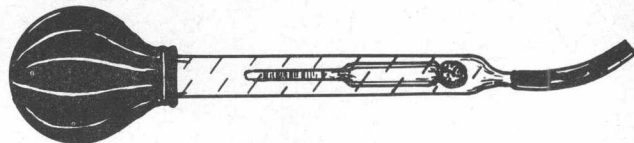
specific gravity, with "Full" and "Discharged" zones indicated for general guidance.

The EMF of a fully charged cell is often as high as 2.2 volts to begin with but rapidly drops on load to almost exactly 2.0 volts. There it remains for a long period, falling to 1.8 volts at very low charge.

Generally speaking an accumulator should not be used when the voltage per cell is less than 1.8, or when the specific gravity is less than about 1.110 (1.11, strictly). Failure to observe this requirement may result in permanent damage to the plates.

The current capacity of an accumulator is summed up in its AMPERE-HOUR rating, which gives a rough idea of the number of hours it will continue

**Figure 9. The hydrometer, as used for testing the condition of lead-acid cells.**



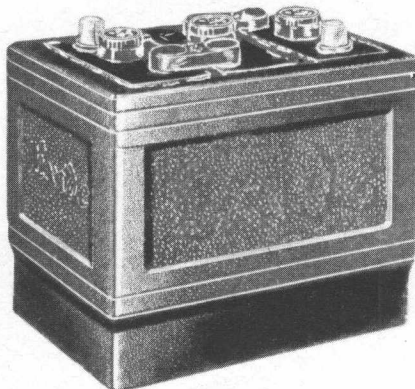
to deliver a specified amount of current after a full charge.

The rate at which an accumulator is discharged does not appear to be important as far as the life of the battery is concerned. It has even been claimed that an accumulator can be short-circuited without damage to the plates or the active materials.

The same is not true of charging, though this is frequently the subject of debate. In general, however, the charging rate should never be such that it causes excessive temperature rise or gassing. High temperatures may distort the plates and cause loss of active material, while excessive gassing also tends to dislodge active material.

The maximum safe charging rate is not constant over the charging cycle. When a battery is in a discharged condition it can safely be charged at a high rate, since most of the charging energy is employed in producing chemical change and very little is wasted in generating heat or gas. As the charge progresses there is an increasing tendency to generate heat and gas, and the charge rate should be decreased, or "tapered," to keep these within safe limits.

In a modern motor car the charging system is designed to behave in exactly this manner. If the battery is well discharged the system will charge it, initially, at a very high rate, up to 50 amps in a six-volt system. As the charge progresses, the rate decreases until, at full charge, it may be no more than 1 amp. Fast chargers used in service



**Figure 10. A typical three cell, six volt, lead-acid accumulator.**

stations are—or should be—designed to observe the same precautions.

When not in actual use an accumulator will gradually discharge through its own internal losses, the effect increasing as the battery ages. To offset this and prevent sulphation of the plates, an idle battery should be given a small charge every couple of weeks and its condition checked periodically with a hydrometer.

When the electrolyte evaporates sufficiently to uncover the tops of the plates, it should be brought back to normal level by the addition of pure distilled water.

As well as the lead-acid accumulator, there are a number of other secondary cells used for special applications. One

of these is the Nickel-Iron (Ni-Fe) cell, sometimes called the Edison cell, after Thomas Edison, who is credited with its invention.

The cell is a complex structure, the positive electrodes being rows of perforated nickled-steel tubes filled with alternate layers of nickel hydroxide and thin flakes of pure nickel. The negative electrode is a grid made from nickeled sheet steel containing pockets filled with iron oxide. The electrolyte is a 21 per cent solution of potassium hydroxide in distilled water, plus a small percentage of lithium hydrate.

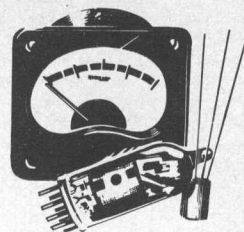
The voltage of this cell is 1.37 when fully charged, dropping to 1 volt when discharged. A greater number of cells are therefore required for a given battery voltage. The specific gravity of the cell does not vary appreciably from charge to discharged conditions, and the voltage is usually taken as a guide to the condition of charge.

This cell is a good deal more costly than the lead-acid type, but offers a number of advantages in certain applications, particularly for electric traction vehicles and similar heavy-duty service. It is a very robust cell, not easily damaged by other than optimum charging conditions—even including accidental reverse charge—which would quickly ruin a lead-acid cell. Its working life may be 20 years or longer.

A more recently developed secondary cell is the nickel cadmium type. Although initially dearer than the lead-acid cell, it has many advantages which make it attractive for modern, compact, electronic equipment.

Among its advantages are a very favourable power to weight ratio, a chemical cycle which permits complete sealing of the cell—thus minimising damage to associated equipment due to corrosive fumes—and a better tolerance to "neglect" than the lead-acid type. As a result, it is finding increasing use in portable equipment, such as electronic photo-flash units, hand held transceivers, portable transistor radios, etc.

Another application is in self-contained electric appliances. Electric shavers and electric drills are two examples of this, in which these cells make possible a compact, convenient device which can be used anywhere, independently of power lines, or where the use of high-voltage equipment may be dangerous.



## CHAPTER 3: Magnetic fields. Coils with air and iron cores. Inductance and mutual induction. Direct and alternating current. The alternator. The Sine wave and its properties. Inductive reactance and phase angle. Practical inductors.

AT some time or other, most of us have toyed with a horse-shoe magnet and noted the mysterious attraction it has for iron and steel.

We know how a magnetised steel needle will align itself with the earth's magnetic field — a phenomenon which is the basis of the magnetic compass. The following discussion involves this same rather mysterious force.

If a pocket compass is held close to a wire carrying heavy direct current, the pointer is found to be deflected from its normal due-north setting. Very

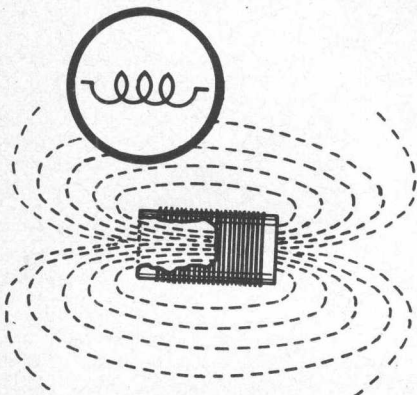


Figure 1. Showing how a magnetic field encircles a coil carrying current. In the circle is the schematic symbol for a coil (inductor).

obviously, the wire must be surrounded by a magnetic field which interacts with that of the earth and thus affects the compass needle.

The exact nature of the magnetic field is a matter of much debate, but it is convenient to think of it as so many lines of force. The stronger the current, the stronger the magnetic field and the more numerous the lines of force.

Alternatively, we may say that the magnetic FLUX DENSITY is greater. The direction in which the force operates is defined by identifying its poles in terms of north and south, based on their reaction to the earth's magnetic field.

In actual fact, the magnetic field surrounding a single conductor is not very great, but it becomes much more evident if the wire is wound up into the form of a coil. The magnetic field assumes the shape indicated in figure 1, the lines of force all passing through the centre and completing their circuit

via the much greater space outside the coil.

It is obvious enough that the magnetic concentration must be much greater within the coil than in any other region.

It is actually possible to state the direction of the lines of force surrounding a conductor or a coil, but there seems little point in the beginner committing this to memory just here. But note the schematic symbol for a coil, shown within the circle in figure 1.

Because of its magnetic properties, the inclusion of a CORE of iron within the coil can greatly increase the magnetic flux density for a given current through the coil.

To be a little more technical, we may say that the iron core has greater PERMEABILITY to the magnetic flux than air; the term "permeability" may

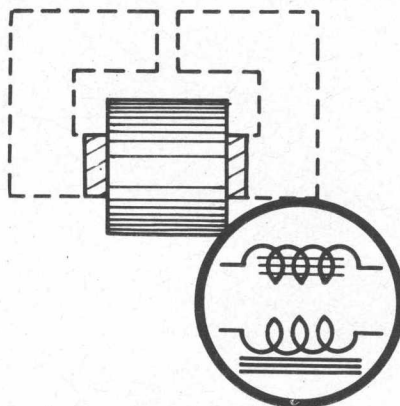


Figure 2. The inductance and magnetic properties of a coil are vitally affected by placing a soft iron core in and around the coil. Note the modified symbol.

be roughly defined as the flux multiplying property of a substance.

According to particular requirements the iron core may be a simple iron rod, a bundle of iron wires, or a stack of iron strips. It may be of either round or rectangular cross-section, the latter being the most common in practice.

If the iron core is straight, as actually shown in figure 2, it assumes the characteristics of a bar magnet in the presence of a steady current through the coil.

In other words, it has a north and

south pole, will attract iron objects and will align itself with the earth's magnetic field if there is no mechanical hinderance. (Note should be taken of the schematic symbols for air and iron-cored coils; in the latter case the core is shown either within or alongside the coil symbol, according to the whim of the circuit draughtsman.)

With a soft iron core, the magnetic effect is entirely dependent on the strength and the direction of the current through the coil. If the direction of the current is reversed, then the magnetic poles are interchanged. If the current is interrupted altogether, nothing but a slight residual magnetic effect remains.

Magnetic effects in a core due to current through the associated coil are very widely utilised in a variety of radio apparatus, as we shall see in later chapters.

However, it is interesting to note that steel and certain alloys will retain their magnetic property even after the energising current is switched off. In other words, they become permanent magnets.

Where the iron core is continued around the side of the coil (shown dotted in figure 2), the lines of force tend, for the most part, to follow the easier path through the iron, and the magnetic flux in the free air surrounding the coil is correspondingly reduced.

If a small gap is left in the IRON CIRCUIT, a very great magnetic concentration is evident across it, and this fact is also utilised in numerous electro-mechanical devices.

The important points to grasp in all this are (1) That a magnetic field is evident round a conductor carrying an electric current, and (2) That this magnetic field can be controlled to serve particular purposes.

That can be regarded as step number one in our thinking. Now to go on:

Assume that we have a battery and a switch so arranged that we can direct

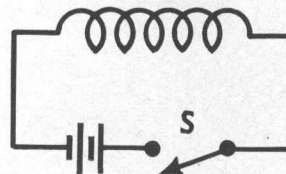


Figure 3. Schematic diagram showing how a current can be directed through an inductor.

an electric current at will through a coil. Refer to figure 3 which, by the way, is the first wholly schematic drawing we have used.

When the switch is closed, the current builds up at a limited rate to an ultimate value determined largely by the potential of the battery and the resistance of the coil. With a very large iron-cored coil, the building up of the



current is slow enough to be seen on an ordinary milliamp meter.

The effect cannot be duplicated with a purely resistive circuit, where the current always comes immediately to its ultimate value.

Very obviously, the coil must offer some initial and temporary opposition to the flow of current by a property quite distinct from the resistance of the wire.

To cut a rather long story short, the opposition is produced in the process of building up the magnetic field around the coil.

The very action of building up the field produces in every turn of the coil what is known as a counter EMF—an induced voltage, which is in opposition to that from the battery. This counter EMF is evident only while the magnetic effect is in the process of building up, but it exercises a definite retarding effect on the action.

Once the current has reached its ultimate value—as determined by the battery voltage and the resistance of the coil—the magnetic field remains stationary and constant while ever the switch remains closed.

When the switch is opened, one might expect the EMF to disappear from across the terminals of the coil, but, for sheer stubbornness, the magnetic field must rival the classic mule.

The opening of the switch is the signal for the magnetic field to begin collapsing, which is to be expected, but in the very process of doing so an EMF is generated in the coil. The EMF is of such a polarity that it would tend to maintain the current initiated by the battery, were the circuit still complete.

The induced EMF across the terminals of the coil may even cause a spark as the switch contacts begin to separate.

This magnetic effect is just as much a property of the coil as its resistance. It is defined as **INDUCTANCE**, and is measured in units known as **HENRIES**.

A coil is said to have an inductance of one Henry if one volt is induced across its terminals when the current through the coil is changing at the rate of one ampere per second.

Smaller units of inductance are the **MILLIHENRY** (equal to one-thousandth part of a Henry) and the **MICROHENRY** (equal to one-millionth part of a Henry).

## INDUCTOR & INDUCTANCE

In the form of a general statement, it may be said that a circuit or coil possessing inductance—often referred to as an **INDUCTOR**—tends to oppose any change in the amount of direct current flowing through it.

If there is zero initial current, then the coil offers temporary opposition to the building up of a current in either direction. If there is an initial steady current, then the coil opposes any tendency for it to increase or diminish.

Read those last two statements again. They are very important.

An interesting phenomenon can be demonstrated by mounting two coils in close proximity, so that the magnetic flux from one coil can intersect the turns of the other.

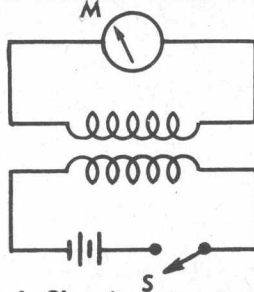
Assume, as in figure 4, that one coil can be connected through a switch to a battery and that a sensitive indicating meter is connected across the terminals of the other coil.

On closing the switch, the meter

pointer will be found to move slightly—say to the right—and then return to its normal position. If the switch is now opened, the pointer will show a slight movement to the left, demonstrating that, somehow or other, an EMF has been induced in the second coil.

The explanation is found in a general law that an EMF is always induced in a conductor, which is cut by moving lines of force, or, yet again, in a conductor which itself moves through a stationary magnetic field.

In the illustration of figure 4, the closing of switch "S" causes a magnetic

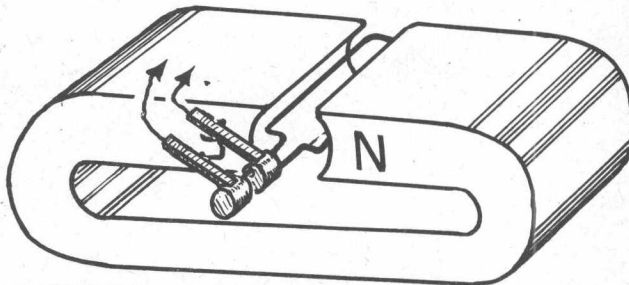


**Figure 4.** Changing currents through the lower coil produce corresponding EMF's in the upper coil by mutual induction. Back EMF's will also be produced in the lower coil itself, due to its self inductance.

field to build up around the lower coil, and, for a brief interval, lines of force are evident moving outwards from the coil. These moving lines cut through the turns of the upper coil and induce in it a voltage, which is made evident by the meter "M."

Once the magnetic field has become stationary, no further voltage is induced until such time that the circuit is broken and the field begins to collapse. The reverse movement of the lines of force

**Figure 5.** In its simplest form, the AC generator or "alternator" is a loop of wire revolving between the poles of a permanent magnet. The ends of the loop are connected to the "slip-rings."



then causes an induced EMF of opposite polarity.

A similar effect could be produced by passing a powerful bar magnet rapidly through the centre of a coil, or by sliding the coil to and fro over a stationary magnet.

While ever the magnet and coil were in close proximity and there was movement of the coil relative to the magnetic poles, small voltages would be evident between the terminals of the coil.

An interesting condition arises if the switch "S" in figure 4 is opened and closed rapidly for a sustained period of time. Under these conditions, the magnetic field around the two coils would be maintained in continual movement, building up one instant, collapsing the next.

The result would be a current through the upper coil, which is continually changing its polarity. At one instant, electrons would be moving from right to left; next instant from left to right, and so on.

Let us assume, for argument's sake,

that the two coils are quite large and intimately coupled together, and that heavy currents are caused to flow through them; further, that the meter M is replaced by a small torch globe.

Each time the switch is opened or closed, we can expect the induced current to cause a momentary glow in the lamp, so that it flickers off and on at a rapid rate.

Carrying our assumption a little further, let us step up the rate of opening and closing the switch to such an extent that the individual surges of current through the lamp can no longer be discerned, and it appears to glow steadily.

We then have a state of affairs where useful work is being done, not by a steady direct current from a battery, but by an ever-changing current produced by the relative movement of a conductor and a magnetic field.

## ALTERNATING CURRENT

The electron movement which produces the heat phenomena is no longer a steady flow of electrons through a conductor, but an oscillatory or to-and-fro motion.

In this simple way, then, we have been introduced to **ALTERNATING CURRENT**, which is of tremendous importance in the field of radio and electricity.

Before pursuing the subject further, it is as well to be quite sure of the difference between **DIRECT** and **ALTERNATING** current.

In the first case, electron movement is always in the one direction. It may be large or small, or subject to continuous variation but, so long as it remains uni-directional, it is referred to as a direct current, or **DC**.

An alternating current is one in which the actual direction of electron movement is changing continually or in periodic fashion.

The amplitude of the electron movement may, of course, be large or small at any particular instant, depending on the circumstances which initiate it.

An alternating current cannot be produced directly by electro-chemical action, as in a battery, but is always generated by relative movement of a conductor and a magnetic field.

An elementary type of AC generator (note the abbreviation) is illustrated in figure 5.

Imagine that a loop of wire is mounted so that it can rotate between the poles of a permanent magnet; further, that the two ends are brought out to mutually insulated copper bobbins, which make rubbing contact with a pair of metal or carbon rods known as **BRUSHES**.

The magnetic field surrounding the loop of wire will be evident as lines of force joining opposite points on the faces of the two magnet poles.

When the loop commences to rotate, the movement relative to the lines of

force will immediately initiate a flow of current through the wire.

Thus, as the left-hand side of the loop (as illustrated) moves upwards with respect to the South pole of the magnet, there will be a movement of electrons along the wire.

At the same instant, the other wire is moving downwards with respect to the North pole, so that the electron movement in this half is in the same general direction around the loop. As a result, an electron pressure—an EMF—becomes evident between the ends of the loop and is thence transferred to the two brushes.

At the instant when the plane of the loop is exactly parallel with the lines of force—that is, in the horizontal position—the loop cuts through the flux at the highest rate, so that the generated voltage reaches a peak value.

As the loop continues to rotate, the relative movement becomes less, so that the generated voltage is also reduced.

At the instant when the loop is in an exactly vertical plane, the wire is moving parallel to the lines of force and no voltage whatever is generated. Beyond this point, the loop again approaches the horizontal position, so that the voltage or EMF rises once more.

### REVERSED POLARITY

However, the electron movement through the loop is now found to be in the reverse direction; or we may choose to say that electrons are accumulated at the alternate brush. Whichever way we look at it, the simple result is that the voltage between the brushes is reversed in polarity.

Following the movement further, the current reaches a peak in this direction, then falls away to zero, immediately building up again with the original polarity. This process goes on just as long as the loop continues to rotate.

The matter can be made clearer with the aid of a simple graph.

Assume that we can observe the instantaneous value of voltage or current generated over a brief period of time, and that values of voltage (or current) are plotted against corresponding time intervals. On joining the plotted points we would have a curve similar to that shown in figure 6.

Assuming a zero reference line, the voltage would rise smoothly to a peak value, then diminish and pass through zero to an equal peak negative value; then back to zero again and so on, "ad infinitum." The plane of the loop, relating back to figure 5, is suggested by the small rectangles beneath the curve.

A practical AC generator (alternator) is actually a far more elaborate device than figure 5 might lead one to believe, but the operating principles are the same.

In every country of the world, great AC generators are ceaselessly producing current for factories, homes, street lights and a dozen other purposes. Rotating machines of rather different type are employed to generate direct current for similar purposes, but AC has proved easier to handle and distribute on a large scale; just why does not concern us here.

Direct current finds its greatest application these days for trains, trams and other forms of electric traction, and a DC installation on a small scale is found in every automobile and aeroplane—in fact, anywhere a battery and generator are in direct association.

It is just as well at this stage, to

memorise certain common terms which have to do with alternating current.

A wave pattern such as is shown in figure 6 is referred to as a SINE WAVE, because it has a definite relationship to the sine of an angle—something familiar to all who have studied trigonometry.

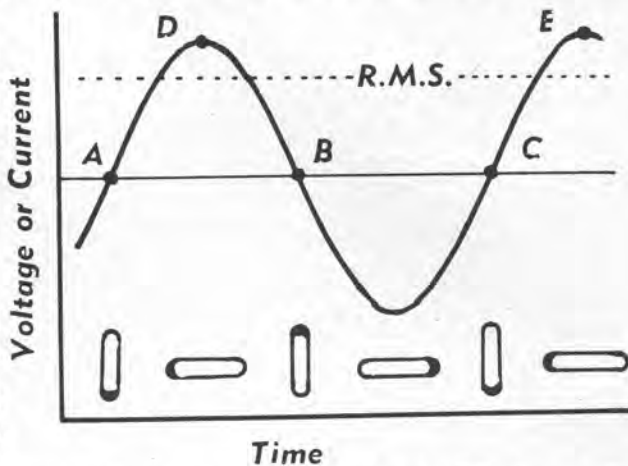
We will not interrupt your train of thought by enlarging on the matter, but remember that a SINE WAVE represents alternating current or voltage in its purest form. If irregular peaks, dips or

peak value; in other words, it is a little under three-quarters of the peak value of the wave.

Unless otherwise stated, figures of AC voltage or current are always assumed to refer to the RMS value. Therefore, the application of an alternating potential of 6.0 volts RMS to the filament of a lamp will cause it to glow with exactly the same brilliance as 6.0 volts DC, as from an electric battery or DC generator.

To express the magnitude of an alternating voltage or current, we use the

Figure 6. Illustrating a single sine wave and its characteristics. The small diagrams below the curve represent the position of the loop in Fig. 5 at various times during the cycle.



bumps appear in a wave pattern, it is no longer a pure sine wave.

The maximum value attained by the voltage or current in either direction is known as PEAK value. However, this peak value is a purely instantaneous one and, at all other times, the current or voltage is of lesser magnitude.

The peak value, therefore, can scarcely be regarded as a fair indication of the ability of the current to produce secondary effects, such as lighting the filament of a lamp or raising to red heat the element of a household radiator.

The ability of an alternating current to do useful work, in this sense of the term, is expressed by what is known as the RMS value of the current (or voltage).

This RMS (or root-mean-square) value has a definite mathematical basis and, for a sine wave, it is equal to .707 times the

same quantities as for DC: Amps, milliamps, microamps; volts, millivolts, microvolts.

It is necessary to bear in mind, however, that the stated RMS quantity summarises the heating or energy value of the alternating wave over a period of time. The value of the current or voltage at any particular instant may be greater or less than this, depending on which particular portion of the wave train we happen to pick.

Referring again to figure 6, the space between points A and C is known as one complete CYCLE. From point D to E is also one cycle, since they are exactly equivalent points on the curve and represent one complete rotation of the simple alternator.

### PARTS OF A CYCLE

By the same reasoning, from A to B, and from B to C is exactly one half cycle, representing half the time interval of a complete cycle and a half rotation of the alternator loop. From A to D and from D to B are each one quarter-cycle.

Of vital importance is the FREQUENCY of an alternating current or voltage, which is the number of complete cycles occurring in one second of time.

In the simple alternator of figure 5, the frequency is obviously dependent on the speed with which the loop is rotated, or the number of revolutions per second.

The frequency of the alternating current power mains is not standardised throughout the world but it is usually either 40, 50 or 60 cycles per second, depending on the particular country or area in question.

In most cases, the adopted frequency is maintained very accurately by the electricity supply authorities, who maintain a constant check against observatory time signals. The widely used synchronous clocks depend for their accuracy on the frequency of the power mains.

The vista of frequency is almost unlimited, as we shall see later in our



A typical radio type tuning coil, shown withdrawn from and alongside its aluminium shield can. This one has three separate windings, with iron-dust core "slugs" which are adjusted in position by means of the brass screws seen protruding from the top and bottom of the coil former.

discussions of sound waves and radio broadcasting. So while you are busy forming a mental picture of an alternating wave, leave room for an enormous range of frequencies and for the peculiar ways the higher frequency voltages are liable to behave.

The final step in this chapter is to correlate the earlier discussion on inductance and our more recent discovery of alternating currents.

Remember that a coil of wire exhibits an initial and temporary opposition to the passage of an electric current but, once this current is maintained for a brief period of time, the coil offers just the same opposition to any tendency for the current to increase or decrease. The property is referred to as the inductance of the coil.

It is, therefore, not difficult to imagine just how an inductance reacts to the passage of an alternating current, which is continuously changing in value and direction.

Obviously, the coil is going to offer a continuous opposition, quite distinct from that due to the DC resistance of the wire.

Furthermore, since the opposition involves the building up and collapsing of a magnetic field, it is fairly obvious that the opposition will increase in proportion to the speed with which the current tries to build and collapse the field; that is, with rising frequency.

### COIL REACTANCE

The opposition offered by a coil (i.e., by an inductance) to the passage of current is referred to as its **REACTANCE**. Like resistance, it is measured in ohms, but, as we have seen, its value for a given coil is directly related to the frequency of the current or voltage concerned.

Thus, a given coil may have a reactance of 1000 ohms at one frequency and 2000 ohms at twice that frequency. In this respect, it differs from pure DC resistance which is a fixed and definite quantity for DC or for AC of any frequency.

Inductive reactance differs from pure resistance in another vital aspect in the opposition it offers to the flow of an electric current.

When a voltage is applied across a resistance, the flow of current commences instantaneously and ceases immediately the voltage is removed.

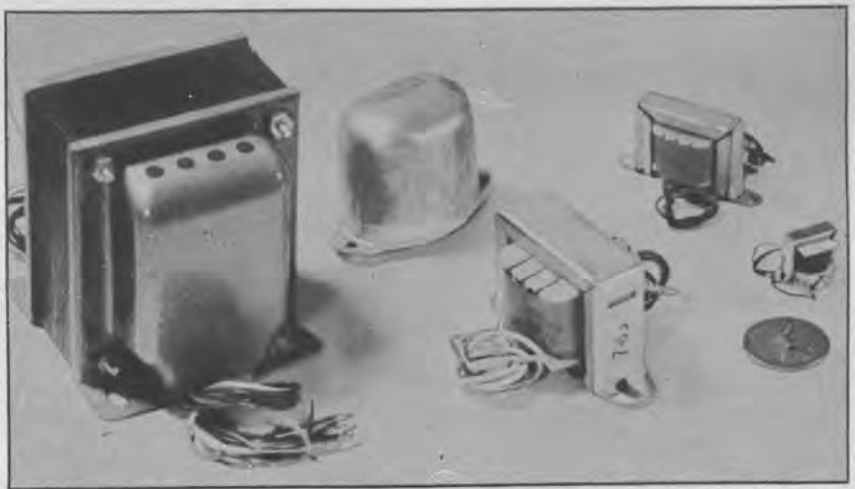
Thus, when the voltage applied is alternating, the current reaches its peak value at the same instant as the voltage peak, and goes through the same variation in value.

In the case of an inductance, the current builds up more gradually, taking a definite time to reach a peak value.

Thus, when the applied voltage is alternating, the current does not reach its peak value until a measurable time after the voltage peak. It goes through the same cycle of alterations, but the peak and minimum values are attained somewhat later than the corresponding voltage variations.

The current is said to be **OUT-OF-PHASE** with the voltage, **LAGGING** behind it by a definite amount. Alternatively, it may be said that the voltage **LEADS** the current.

With a purely inductive circuit, the difference in phase amounts to a complete quarter-cycle.



A group of iron-cored transformers used in electronic and radio equipment. All have windings mounted on iron cores, some being sealed in pitch inside metal cans to protect them from moisture and damage. Others are impregnated with varnish for similar reasons and clamped in open frames. A penny at bottom right indicates comparative size.

Inductance plays a vital role in all radio circuits. The simplest cases are coils having from half a dozen to a hundred turns of wire wound in a single layer on a plastic, cardboard or wooden spool.

In other coils, the turns are wound one over the other in a compact "pie." Sometimes a powdered iron core is in-

cluded within the spool or former to increase the efficiency of the coil.

More elaborate forms of inductance are the iron-cored **FILTER CHOKES** and **TRANSFORMERS**, which are essentially an elaboration of figure 2. The part all these components play in a radio circuit will become apparent as these studies progress.





*The Transformer People!*

**SUPPLIERS OF A COMPLETE RANGE OF**

- **AUDIO**
- **POWER**
- **STEP-DOWN**
- **TRANSISTOR**

**TRANSFORMERS**

*for your every need!*

We at A. & R. are proud of our claim to be the "beginner's friend" — for we, like you, also had our beginnings. Right from the start we learned that to keep selling Transformers, our product had to be dependable. The widespread popularity of A. & R. Transformers today indicates we have far exceeded that aim. We don't say they'll work miracles for you — or correct elementary mistakes. We do say they'll do the job they're designed to do . . . and do it better for longer!

**FOR FULL DETAILS OF THE COMPLETE A & R RANGE SEE THE 1966 A & R STOCK TRANSFORMER CATALOGUE — CONTACT YOUR LOCAL STOCKIST for your copy—it's free for the asking!**

**A & R TRANSFORMERS PTY. LTD.**

46 Lexton Road, Box Hill, Vic. Phone 89 0238



## CHAPTER 4: Capacitance effects and Capacitors.

Displacement current, storage of energy. Capacitance defined.

Mica capacitors. Paper and plastic tubular capacitors.

Ceramic dielectric capacitors. Electrolytic capacitors. Variable capacitors and trimmers. Padder capacitors.

**T**O understand just what capacitance is it is necessary to recall certain earlier discussion of conductors and insulators.

It was pointed out that an atom consists of a positive nucleus, around which revolve one or more planetary electrons.

The outer planetary electrons are not always intimately bound to the nucleus and, in so-called conductors, an externally applied E.M.F. can cause a definite drift of electrons from one atom to the next along the length of the material.

The electron movement is always toward the positive pole of the applied E.M.F., in accordance with the general law that unlike charges attract, like charges repel.

In a vacuum where there are no atoms present, this migration of electrons obviously cannot occur, while in materials known as insulators it is difficult to initiate because the electrons are strongly bound to their parent atoms. However, the application of an E.M.F. to a vacuum or an insulator does produce an interesting effect.

Consider figure 1, where two plates of a metal conductor are placed near and parallel to one another and connected to the opposite terminals of a battery.

Because of the chemical reaction within it, the battery tends to remove electrons from atoms of Plate A and transfer them to plate B, making plate A positively charged with respect to B. A current thus tends to flow, despite the gap in the circuit.

As a consequence of this current, however, a state of tension is produced in the gap between the plates which tends to resist the electron flow. This state of tension is called an **ELECTRIC FIELD**, and it eventually sets up a voltage across the gap which opposes the E.M.F. of the battery and causes the current to cease.

In other words, even though the gap between the plates does not conduct a current, it permits a current to flow for a brief period in the rest of the circuit, and also produces a voltage across the gap.

This effect is known as **CAPACITANCE**, and a component which exploits the capacitive effect is known as a **CAPACITOR**. The word **CONDENSER** is an older term for such devices.

The initial current which flows in the connecting wires when E.M.F. is connected to a capacitor is known as a **DISPLACEMENT** current, to distinguish it from normal conduction current. Its size depends on the capacitance of the capacitor which, in turn, depends upon

the dimensions of the plates, the spacing between them and any insulating material (**DIELECTRIC**) which may be introduced between them—but more about this later on.

Practical capacitors have plates made from metal sheet, foil or coating, while between them may be a vacuum or a dielectric material such as air, waxed paper, mica, plastic, ceramic or a metallic oxide.

If a capacitor is connected to an E.M.F., as we have seen, a displacement current flows for a brief interval of time and an electric field is set up in the space between the plates or electrodes.

If the capacitor is now disconnected from the battery the electric field remains. Referring to figure 1 again, plate

A remains positively charged with respect to plate B, having less electrons than normal, while B has more than normal. As far as the gap is concerned, nothing has altered with the removal of the battery, so that the gap maintains a voltage difference equal to the battery voltage.

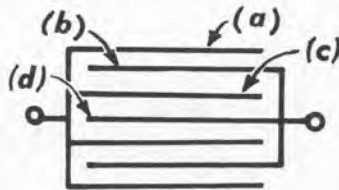
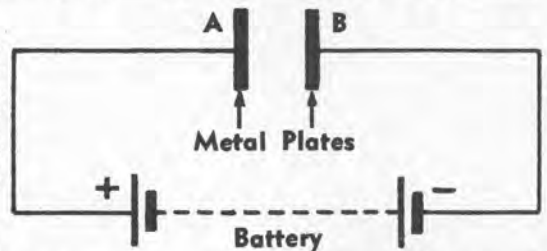
A capacitor in this condition is said to be **CHARGED**. There is a voltage across it and an electric field between the electrodes.

However, if the two charged capacitor plates are joined by a conductive path by touching their wires together, the excess electrons on plate B will move along the conductor to plate A and correct the state of unbalance.

The electric field across the gap will collapse and the voltage will disappear. The capacitor is then said to have been **DISCHARGED** by this second flow of displacement current.

Obviously, then, a capacitor has the ability to store electrical energy, as it will retain a voltage across its terminals

**Figure 1: Showing a basic capacitor connected to a battery. The battery sets up a potential difference between the plates, which results in the formation of an electric field in the space between.**



**Figure 2: Many capacitors have the plates arranged sandwich-fashion, as shown. They may be separated by air, or by a solid insulating material as the dielectric.**



**Typical mica capacitors, in which thin metal plates, often of shim brass, are separated by mica sheet, and moulded inside a bakelite casing.**

and can supply a current if connected to a conducting circuit.

If a capacitor is connected across a source of fixed voltage, the displacement current flows for only a brief interval of time and then ceases. However, if the applied voltage is continuously varied at a given rate over a definite interval of time, the displacement current through the circuit is found to vary in sympathy with it.

This must obviously be so, for a gradual increase or decrease in the applied voltage will cause an increase or decrease in the electron displacement, and therefore result in a continuing flow of displacement current.

On this statement is based the means adopted to define the capacitance of any given condenser—or capacitor.

When a change of one volt per second across a capacitor produces a displacement current of one ampere, it is said to have a capacitance of one **FARAD**.

Just as resistance is measured in ohms, and inductance is measured in henries, so is capacitance measured in farads.

In actual practice the farad is too large a unit for ordinary radio and electrical work, and the unit most commonly used is the **MICROFARAD**, which is one-millionth of a farad.

Typical capacitors employed in radio receivers range from something like 200 microfarads down to .00005 microfarads,

although still larger and smaller units are not uncommon.

To save unwieldy decimals, small capacitance values are sometimes written in millionths of a microfarad, namely in MICROMICROFARADS. Thus, .0001 microfarad becomes 100 micromicrofarads. The value .00002 microfarad is written as 20 micromicrofarads.

To simplify expression, various abbreviations for the word microfarad are commonly employed.

One is the purely Anglicised abbreviation "mfd."

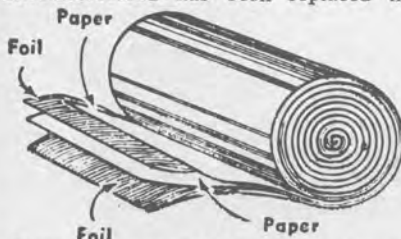
Another follows technical practice in using the Greek letter mu ( $\mu$ ) to mean one-millionth, this being coupled to a capital F for Farad, giving the term  $\mu\text{F}$ .

Typesetting difficulties may cause the English letter u to substitute for the Greek  $\mu$ , giving the symbol "uF."

Actually there should be little difficulty, knowing this, in recognising any of the ordinary abbreviations.

By the same token, micromicrofarad is frequently abbreviated to "mmfd" or "uuF."

During the war and since, the term micromicrofarad has been replaced in



**Figure 3:** In paper tubular capacitors, two lengths of metal foil, constituting the electrodes, are separated by layers of paper as the dielectric. The whole is tightly rolled and protected by an outer casing.

most quarters by "picofarad," which is abbreviated to "pF."

Thus mmfd, uuF or pF all signify the same unit of capacitance—one-millionth of a microfarad.

The capacitance of a condenser—or capacitor—depends on several factors, as we suggested before.

First is the total area by which the plates or elements actually overlap; capacitance increases directly with area.

Secondly, capacitance varies inversely as the distance between the plates; the smaller the separation the greater is the capacitance.

The material occupying the space between the plates also has a marked effect on capacitance. A vacuum is the reference standard, but the insertion of air, mica, plastic, ceramic, glass, waxed paper etc., increases the capacitance substantially.

The ability of an insulator to multiply the capacitive effect between capacitor plates of given area and spacing is expressed by its DIELECTRIC CONSTANT. Thus, if the space between two electrodes is occupied by an insulator having a dielectric constant of 5, the capacitance between the electrodes would be five times as great as if the intervening space was occupied only by a vacuum.

We have assumed, thus far, that only two plates are involved, whereas any number of plates may be arranged sandwich fashion, as illustrated in figure 2.

There is a capacitive effect between plate a and plate b, between plate b and plate c, between c and d, and so on,



A typical group of modern tubular paper capacitors. These are widely used in electronic equipment though, for critical applications, designers may prefer capacitors having a plastic dielectric.



Plastic tubular capacitors vary in their specifications, according to the choice of dielectric material. The types pictured above can be used where the application calls for accuracy and stability of capacitance value.



In a "metallised paper" tubular capacitor, the metal foils are replaced by a continuous metallic film deposited directly on the surface of the paper dielectric.



Tubular capacitors, too large for convenient "pigtail" mounting, are often housed in round or rectangular metal cans. These should not be confused with "electrolytic" capacitors.



the total capacitance of the unit is the sum of all the above.

In actual practice, only low capacitance or ceramic capacitors employ two simple flat plates. Most others employ a multiplicity of plates, or some other arrangement which will give the required capacitance in a physically compact and convenient form.

In producing a component with any given figure of capacitance, it is necessary to consider the amount of space which the complete unit will occupy, the mechanical rigidity of the structure and also the voltage which can be impressed across it without danger of breakdown.

If the spacing between the plates is too small, or the dielectric material unsuitable, the stress set up may be so great as to disrupt altogether the structure of the dielectric. This would allow a flow of current and consequent charring, rendering the capacitor un-serviceable.

In the past, capacitors rated up to about .001 uF (1000 pF) were usually of the so-called mica type. Small strips of thin metal were sandwiched between pieces of mica insulation, alternate metal strips being joined together at the ends, similar to figure 2.

The whole assembly was held together with a metal clamp, or sealed with wax into a ceramic case. Many manufacturers moulded the completed assembly into a bakelite case.

Connection to the two sets of plates was provided by terminals or short copper wire leads commonly called "pig-tails."

Different values of capacitance were obtained by varying the size and number of the plates, and the thickness of the insulation between them.

Mica capacitors are still used nowadays, to a limited extent, but plastic and ceramic dielectric units are often preferred in many of the applications where the mica type were formerly used. We will discuss the plastic and ceramic capacitors a little later on.

Ordinary mica capacitors are comparable in size to a postage stamp and up to  $\frac{1}{16}$  in thick. They will operate safely with applied voltages up to about 500, and their capacitance value is usually stamped directly on the case. Some brands, however, employ a colour code to distinguish one capacitance from another.

For capacitance values above about .01 uF, the bulk of a mica assembly

begins to multiply unduly and a more convenient and economical form of capacitor is usually employed; this is the paper or plastic tubular type.

Two thin metal ribbons (usually aluminium) are rolled tightly together with a special impregnated paper or plastic film separating them. The two strips of foil serve the same purpose as the metal plates previously assumed, while the impregnated paper or plastic film is the dielectric.

The capacitor is usually wound with the respective foils overlapping the paper at each end. The overlapping portion of the foil is pushed into a compact mass and maintained in contact with a pigtail for connection to the external circuit.

Squeezing together the ends of each foil ensures a short path between the pigtail and all portions of the metal foil. If connection were made only to one end, each foil would resemble a flat coil and exhibit an undesired inductance, as well as the required capacitive effect.

The ultimate capacitance depends on the length of the foils, the distance by which they overlap and the characteristics of the paper or plastic dielectric.

Tubular capacitors are generally sealed with a special wax or plastic material into round bakelite tubes, or coated directly with plastic. In size they may be up to two inches or so long and one inch in diameter.

## CAPACITANCE VALUE

They are stamped or printed with their nominal capacitance value and also the maximum DC voltage which they will withstand across their terminals. Most ordinary tubular capacitors are rated to operate with a maximum voltage of about 400 DC but ratings as low as 100 or as high as 2,000 volts are not uncommon.

They are made up in a variety of values between 100 pF and 2 uF, the particular value being marked on the case.

In recent years, a particular type of paper capacitor has been introduced, known as "metallised paper."

In these, there are no separate metal foils, as illustrated in figure 3. Instead, a continuous metallic layer is deposited on one side of each of the two paper strips, forming the dielectric. When the strips are rolled together, the metallic films act as the two electrodes, being separated by the intervening layers of paper.

The main advantage of the process lies in the reduction which it makes possible in the size of a capacitor of given capacitance value and voltage rating.

Paper capacitors of capacitance larger than 0.5 uF are almost invariably sealed into rectangular metal cans intended for bolting to a chassis. These can-type paper capacitors are not uncommon in values up to about 4 uF, a limit set, as much as anything, by physical bulk.

The can type of construction is actually used on occasions for smaller capacitance values than 0.5 uF and, in some cases, several distinct units are mounted for convenience in the one can, and provided with separate leads or terminals.

Plastic dielectric capacitors are of similar construction to paper types but, as the name suggests, they employ a thin plastic film as the dielectric mate-

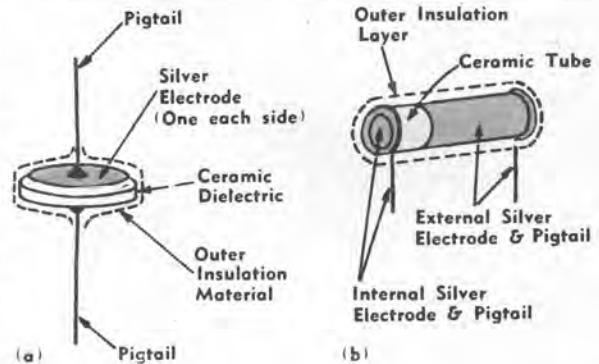
rial. They are often given names like "polyester" or "polystyrene," to signify the particular type of plastic film actually used.

Plastic dielectric capacitors are made in approximately the same values as paper types. However, they tend to be somewhat more stable and reliable than paper types, owing to the chemical characteristics and moisture-resistance

of the plastic dielectric. For a given value of capacitance and a given voltage rating, plastic capacitors also tend to be somewhat smaller than equivalent paper capacitors. They are usually somewhat dearer, however.

Ceramic dielectric capacitors are different again in construction from paper and plastic or mica capacitors. This is due to two factors. One is that fired

**Figure 4: Illustrating the construction of ceramic type capacitors. In ceramic capacitors, quite high values of capacitance are obtainable between relatively small metallic surfaces because the ceramic can be manufactured with an extremely high dielectric constant.**



**Typical ceramic capacitors including multiple tube types in which two or three separate metallised segments on the outside of the tube exhibit capacitance to a common metallic layer on the inside. With multiple capacitors, the common electrode is normally intended for connection to chassis or "earth."**



**Figure 5: Sketched at right is one of the old can-type "wet" electrolytic capacitors, in which the centre connection normally goes to the positive side of the circuit. At lower left is a conventional tubular type, with the positive end marked on the outer sleeve. Sometimes a plus sign is used, or the end is coloured red.**

ceramic material of the type used by these capacitors as the dielectric is rather brittle, and cannot be stressed, or made in the form of a thin film to be rolled up with the metal foil electrodes.

The other factor is that the ceramic material can be made with an extremely high dielectric constant, which means that, in any case, it is not necessary to adopt the multi-plate or rolled-electrode type of construction, in order to produce high values of capacitance. A flat ceramic disc with silver electrodes fired on to each side, or a hollow tube with a deposited silver surface inside and out is usually sufficient. (See figures 4a and 4b.)

By using the same basic construction and varying both the size and the dielectric constant of the ceramic, capacitors ranging from 1pF up to 1uF may be produced, in voltage ratings of from 1 to 20,000 volts. The smallest ceramic capacitors are about 3/16in in diameter and 1/32in thick, while the largest may be more than an inch in diameter and 1/2in thick.

The high-capitance types use a ceramic material which has a very high dielectric constant (around 6000). Two different types of high capacity ceramic capacitor are commonly available, being known as "HI-K" and "ultra-cap" units. The latter are a comparatively recent development and are mainly suitable for circuit applications where the voltages are below 25 volts. They offer a high capacitance in a very compact form.

Due to the effects of heat upon both the physical dimensions and the characteristics of the dielectric material, most capacitors exhibit a capacitance change with changes in temperature. The amount of capacitance change which occurs for a change in temperature of one degree C expressed as a fraction of the nominal value of the capacitor is called the TEMPERATURE COEFFICIENT of capacitance.

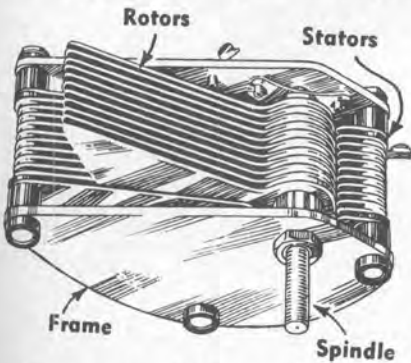
The temperature coefficient of mica, paper and plastic capacitors cannot be manipulated to any great extent and is usually kept as small as possible during manufacture. With ceramic capacitors, at least in the smaller values, it is possible to produce almost any desired value

of temperature coefficient — over a fairly wide range of both positive (capacitance increases with temperature) and negative (capacitance decreases with temperature) values.

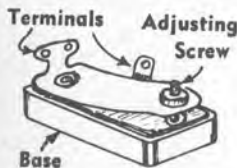
This makes ceramic capacitors extremely useful in many types of circuit where temperature variations in other components would otherwise cause the circuit to change its function with temperature. By using a ceramic capacitor which has the opposite kind of temperature coefficient, it is possible to arrange for a degree of cancellation so that the circuit as a whole is less affected by temperature variations.

Besides being classified in terms of capacitance and voltage rating, therefore, ceramic capacitors are also classified in terms of the value and polarity (positive or negative) of their temperature. Types having a positive tempera-

**A group of modern electrolytic capacitors, ranging typically from 16uF (lower right) to 100uF at the top and capable of operating at 200 volts or more. Transistor circuits, now so popular, call for electrolytic capacitors, much smaller in size but requiring to operate at lower voltages — typically up to about 20.**



**Figure 6: A variable capacitor, rather old in style, but typical of many which are quite suitable for use in simple receivers using crystal detectors, or one or two valves or transistors.**



**Figure 7: A semi-variable capacitor in which the capacitance is altered by adjusting a screw controlling the position and pressure of a springy metal leaf.**

ture coefficient are commonly given a type number having as a prefix the letter "P", while the letter "N" is used to signify a negative coefficient. If the construction and ceramic material have been arranged to give a zero temperature coefficient (no variation with temperature) the capacitor is usually marked "NPO".

The ceramic used for the high value capacitors — "HI-K" types — is less suitable for this form of manipulation and normally has quite a high temperature coefficient. This fact, coupled with a natural tendency for individual units to vary considerably from the nominal value — usually upwards —, means that these are unsuitable for use in any circuit where the value of capacitance is critical. However, in circuits which are not critical, they are extremely useful.

Modern circuit practice often calls for capacitors having very high values — up to 100 microfarads or more — and capable of operating with applied voltages to 500 or 600 DC.

To produce rolled paper, plastic film, or ceramic capacitors to this specification would be a costly job, besides which the finished article would be very bulky indeed.

The difficulty has been overcome by the development of the so-called ELECTROLYTIC capacitor, which makes use of the fact that aluminium and some other metals form extremely thin layers of an insulating oxide, when immersed in certain electrolytes.

An electrolytic capacitor, in its simplest form, consists of shaped aluminium plate immersed in a liquid electrolyte, itself a conductor of electricity.

During the process of manufacture, the capacitor is connected to a source of direct current and FORMED. In other words, the aforementioned layer of oxide is caused to form on the aluminium electrode by electro-chemical action.

Once the forming process is complete, the capacitor ceases to pass appreciable current, since the oxide coating forms an insulating layer between the aluminium electrode and the electrolyte in which it is immersed. The aluminium is, therefore, one electrode, the electrolyte the other, and the oxide coating is the dielectric.

The thickness of the coating and the voltage which the capacitor will withstand is determined by the method of manufacture.

Since the dielectric is produced and maintained by electro-chemical action, it

is necessary to use an electrolytic capacitor with the electrolyte connected to the negative side of the voltage source, and the aluminium electrode to the positive side.

Ordinary types must not be used in reverse polarity, or connected to a purely A.C. circuit.

The oxide coating is actually a less efficient insulator than, say, ceramic or paper, so that a certain small leakage current has usually to be tolerated. The coating and the electrolyte are also likely to deteriorate after a few years' service, necessitating replacement.

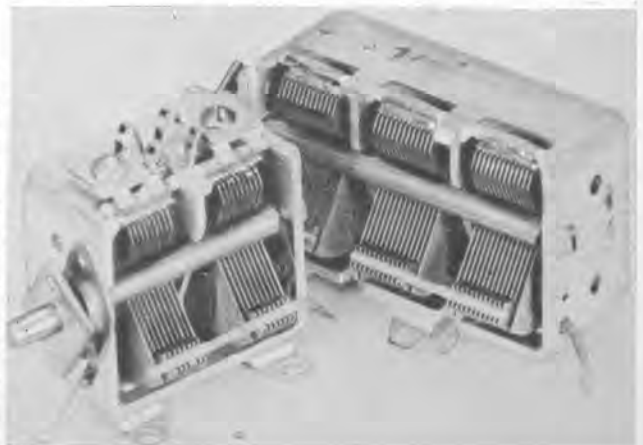
For all their disadvantages, electrolytic capacitors are widely used, because they make possible large capacitance values with economy in both space and cost.

In old-style can-type electrolytic capacitors, the electrolyte was contained as a liquid within a sealed metal can — usually aluminium; this can provided electrical connection to the electrolyte. The positive aluminium electrode was supported centrally within it, being roughened, fluted, crimped or otherwise treated to present the maximum possible surface area to the electrolyte.

Can-type electrolytics have now given place almost completely to tubular types, employing an aluminium foil rolled with an absorbent material soaked in electrolyte.

These "dry" electrolytic capacitors often resemble the larger paper tubular types, although others are assembled within small cans for mounting on the

**Typical 2-gang and 3-gang capacitors as used in the tuning circuits of domestic radio receivers. This particular 2-gang has small semi-variable "trimmer" capacitors built on to it for supplementary adjustment of the tuning circuits. In principle, they are similar to the unit shown in figure 7.**





## PRINTED CIRCUITS MAKE THE JOB EASIER!

If you design your own circuits . . . or if you are making an "Electronics Australia" design . . . printed circuits from Precision Windings can speed the task and enable you to complete your project more effectively. Many standard "Electronics Australia" circuit boards are kept in stock and are available for immediate delivery at low cost. Special circuit boards made from artwork supplied are delivered in seven days. Send a stamped, addressed 9 x 4 envelope for Precision Winding FREE folder . . . "Artwork for Printed Circuits." This provides you with all the necessary information to assist you to prepare your own personally designed circuit boards. Artwork aids in the form of solder lands, black crepe tapes, clear film and transfer letters are also available from Precision Windings at modest cost. Ask for a PW price list!

### AND FOR INDUSTRY . . .

Many leading designers and engineers in Australian industry are finding new uses for printed circuits . . . PW's process enables economical production of one or a thousand printed circuits. And there are many other advantages.

Build for the future today . . . with PW circuit boards!



52 Cambro Road, Clayton, Victoria.  
Tel. 54-7370

chassis. Electrolytic capacitors are distinguished usually by the description on the container, by the comparatively high capacitance rating and by the "plus" and "minus" markings at either end.

An almost universal feature in the tuning portion of radio receivers and other pieces of electronic equipment is one or more variable capacitors (or variable condensers) whose capacitance value is capable of easy adjustment.

The most common type employs a number of fixed and a number of moving vanes which mesh with one another to a greater or lesser extent.

The fixed vanes, which are rigidly mounted on a supporting framework, are referred to as the STATOR plates. The moving vanes, locked on a revolving shaft, are known as the ROTORS.

A variable capacitor must be well constructed mechanically, so that the two sets of plates will not foul one another at any position.

The plates of variable capacitors are shaped in various ways to obtain a specific relationship between capacitance and the number of degrees through which the control shaft is rotated. One purpose of this is to spread the stations more evenly across the tuning dial of a completed radio receiver.

Variable capacitors may be made singly, but two, three or four units are often mounted within the one framework and on the one shaft, so that they operate together. Multiple units coupled together in this way are commonly



At the top is a ceramic trimmer in which capacitance between the outer metal layer and the screw increases as the latter is turned into the tube. Below it is a typical "trimmer" capacitor, as illustrated in figure 7.

called GANG CAPACITORS or GANG CONDENSERS.

Ganged capacitors commonly used in the tuning circuits of radio receivers have a maximum capacitance of about .0004 uF (400pF) but only about .00002uF (20pF) in the fully open or minimum position.

This capacitance is achieved with anything from 17 to 23 plates in all, the ultimate capacitance depending on the number of plates, the area enmeshed and the spacing between them.

Smaller variable capacitors of the same general pattern are used for special purposes. Some employ a smaller number of conventional-sized plates; others use a large number of small plates,



Concentric air trimmer capacitors shown fully out (minimum capacitance) at the top and fully in (maximum capacitance) at the bottom.

comparable in size to a penny, cut across the centre.

Some circuit applications call for capacitors which are capable of only occasional adjustment within certain limits. Various described as SEMI-VARIABLE or SEMI-FIXED capacitors, the most common are the mica compression type, the air-concentric type, and the ceramic type.

The mica compression type incorporate two or more metal leaves, insulated with mica and normally held apart by spring tension. Adjustment of a screw forces the leaves closer together, increasing the capacitance. These TRIMMER or PADDER capacitors are comparable in size to a postage stamp, and about one quarter-inch thick. They are widely used to effect adjustments made necessary by the use of ganged tuning capacitors.

For critical purposes, mica compression capacitors are not above reproach, which is why the various other types of trimmer capacitor have been devised.

The air-concentric type uses air as the dielectric, as the name would imply, and has two sets of concentric metal tubes—one set of which may be moved along a threaded shaft so that its tubes enmesh with, but do not touch, the other set.

Ceramic trimmers are made in a number of different forms, but the most popular consists of a hollow, internally threaded ceramic tube which has a metallic electrode fired onto the outside and a screw which is threaded into the tube. Adjusting the length of screw inside the tube varies the capacitance between it and the outer electrode.

Other ceramic trimmers have a fixed inner electrode and an outer electrode which is in the form of a spiral of wire. Portion of the wire spiral may be unwound to vary the capacitance. This type is mainly used in circuits where the trimmer value is only required to be adjusted once, and then left.

## USE A HEAT SINK

When soldering transistors and diodes, care should be taken to prevent heat damage to the semiconductor elements. Attention to the following points will prevent this: Do not shorten the leads any further than necessary; don't hold the soldering iron to the lead for longer than a few seconds; use a "heat sink" to absorb heat from the soldering iron, close to the body of the transistor. A pair of thin-nosed pliers can be used, but a crocodile clip with strips of brass soldered to the teeth to ensure good thermal contact is preferable and leaves both hands free for working.





## CHAPTER 5: Simple connections, complete and open circuits. The effect of resistance; Ohm's Law; resistors in series and parallel. Inductors and inductive reactance, and series and parallel combinations of inductors; capacitors and capacitive reactance, capacitors in series and parallel. Impedance. Resonance in parallel and series circuits containing inductance and capacitance; variable tuned circuits.

THE word "circuit" is quite broad in meaning, so that it is perhaps better that we try to explain and illustrate its meaning by example rather than try to define it. An electrical circuit is possibly best regarded as a combination of conductors and components intended to control the movement of electrons in a specific manner; or alternatively to cause a electric current to perform some desired task.

The concept of controlling the movement of electrons is fundamental.

When a house is in the process of building, the plumber installs a water circuit, which carries the water from the street mains to certain parts of the house.

The pipes are made large enough to carry the expected flow of water, and appliances are designed on the assumption of a certain maximum expected water pressure. The taps at the end of each run provide a means of controlling the quantity and duration of flow.

An electrical circuit is designed just as deliberately. There are conductors to lead electrons along certain paths and insulators to prevent them flowing in other directions. Resistance, inductance and capacitance all have a definite part to play in controlling and utilising electron flow.

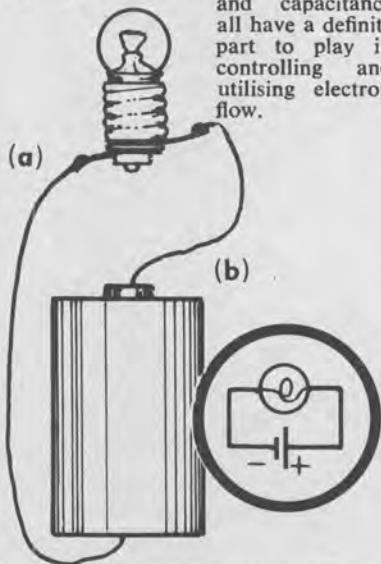


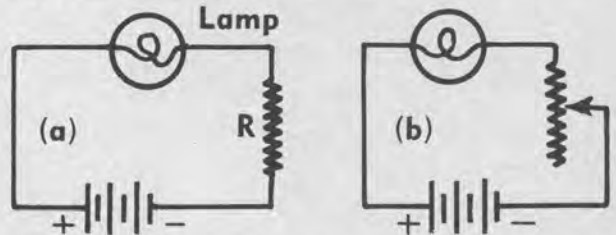
Figure 1: An example of an elementary "circuit," involving a torch globe, a socket and a cell capable of supplying direct current. Inset in circle is the equivalent circuit diagram.

The natural urge at this stage is to present a series of mathematical formulae setting out in precise fashion the function of these circuit properties.

However, not everybody is equally at home in the realm of mathematics and our aim is rather to impart a clear mental picture of conditions in various electrical circuits, deriving the few basic formulae in as natural a fashion as possible.

Consider the simple circuit arrangement of figure 1, in which a small torch globe is connected by means of wires

*Introducing resistance into the circuit of figure 1 will reduce the amount of current which can flow in the circuit and therefore through the lamp. In (a) the resistance is of fixed value; in (b) it is variable.*



and a socket to a dry cell. The connections are illustrated pictorially and by means of a schematic circuit.

Remember that there is a surplus of free electrons at the negative terminal of the battery and positive ions at the positive terminal. Immediately the connections are made, as shown in figure 1, electrons move along the wire "a" to the connection shown beneath the lamp socket.

An insulating washer separates this bottom connection from the rest of the socket, so that there can be no direct movement of electrons across it. Instead, they move along the centre pin of the socket, which is bearing against a metal blob in the base of the lamp.

Because there is still no alternative path, the electrons move along the leads within the globe, through the fine metal filament, thence to the metal shell forming the base of the lamp.

This latter is in contact with the metal shell of the socket, so that the electrons pass on to this shell, thence to the terminal, the wire "b" and back to the positive terminal of the battery.

This forms a complete electric circuit, which is often described as being CONTINUOUS.

Provided the lamp is of suitable pattern the flow of electric current as described will cause the lamp filament to glow—the normal purpose of such a

circuit. However, various circumstances could prevent this desirable state of affairs from being realised.

For example, the washer in the base of the socket could conceivably split sufficiently to allow the two portions of the socket to touch one another directly; the electrons, instead of flowing through the lamp, would then take the easier path across the socket and the unwanted result would be described in technical parlance as a SHORT-CIRCUIT.

If one of the leads were to be snipped through, or the lamp partially unscrewed from its socket, the electron path would be interrupted and the globe filament would again fail to glow. This circumstance is described aptly by the term OPEN CIRCUIT.

The switch on an electric torch, or on the wall of your home, is simply a device which makes and breaks the electrical circuit between the globe and the source of power. When moved to the "off"

position, it opens the circuit; in the "on" position it closes the circuit.

It provides a simple illustration of how electron flow can be controlled at will.

Going a step further, consider the schematic diagram of figure 2, which shows a lamp and a resistor connected in SERIES.

The word "series" is important because it indicates that the components to which it refers are connected end-to-end, electrons moving first through one, then the other.

The complementary term "connected in parallel" indicates that the particular components referred to are connected side-by-side in the circuit, so that the electron flow divides between them.

As might be expected, a SERIES-PARALLEL circuit is one in which the individual circuit components are connected, some in parallel and some in series. However, we are tending to get ahead of ourselves.

Coming back to figure 2a, there will obviously be a movement of electrons from the negative terminal of the battery, through resistor R, through the lamp, and thence back to the positive battery terminal.

We have already learned that a resistor, by its very nature, offers a definite opposition to the passage of an electric current.

The circuit may be compared in some respects to a ferry boat turnstile. On one side there is a crowd jostling to get

through, while a thin file issues from the other side. So it is with a resistor—an accumulation of electrons on one side and fewer on the other. Look again at that last sentence.

What we really have is a potential difference—or a voltage drop—across the resistor. The larger the electron flow or the higher the resistance value, the greater is the voltage drop across the resistor.

This observation is of fundamental importance, and deserves plenty of attention.

The exact mathematical relationship between current, resistance and voltage is set out in what is known as Ohm's Law:

$$E \text{ equals } I \times R \dots \dots (1)$$

where E is in volts, I is in amps and R is in ohms.

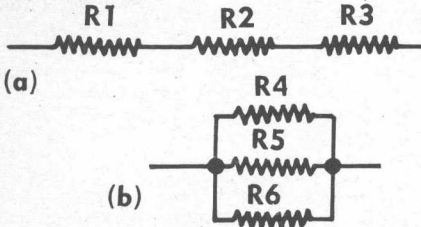


Figure 3. Introducing two important terms in circuit parlance, the three resistors in (a) are said to be connected in **SERIES**. In (b) they are in **PARALLEL**.

Explained in so many words, the formula simply means that the potential difference developed across a resistor is equal to the product of the current flowing through it (expressed in amps) and the resistance (expressed in ohms).

Thus, a current of 0.5 amp., flowing through a resistor of 6 ohms, would develop a voltage drop of 3 volts across the resistor.

Try it out for yourself with the formula!

By a simple mathematical "wangle," formula (1) can be transposed into a second form:

$$I \text{ equals } E/R \dots \dots (2)$$

Thus, if the voltage across a resistor of stated value is known accurately, formula (2) makes it possible to calculate the amount of current which is flowing through it.

For example, if a potential difference of, say, 12 volts exists across the terminals of a 4 ohm resistor, the current flowing through it would necessarily be 3 amperes.

Further transposition of formula (1) gives:

$$R \text{ equals } E/I \dots \dots (3)$$

If the voltage across a resistor is known, and the current flowing through it, it therefore is possible to calculate also the value of the resistor.

To elaborate further on these important and basic formulas would take up more space than is available, but the foregoing should give some idea of the essential relationship which exists between voltage, current and resistance.

It is important to note that all three formulas apply equally, whether one is concerned with direct or alternating current and potentials.

In figure 2a, the voltage across the lamp filament must inevitably be less than that of the battery by the voltage drop across the series resistor.

If the value of the resistor is small—just a few ohms—the lamp filament may still glow, but with reduced brilliance.

With higher values of "R", the current flowing may be so limited that the filament will fail to glow at all, unless the battery terminal voltage is greatly increased.

By having a variable resistor in place of "R" (figure 2b), it is possible to exercise control over the current flowing through the circuit and the voltage which is actually effective across the lamp. In many cars, such an arrangement allows the driver to adjust the brightness of the panel lamps. This is just one simple illustration of the actual effect of resistance in an electrical circuit. But let's take in a few more facts about resistors in a circuit.

In figure 3a, three separate resistors are shown connected in series—that is, connected end to end. The total resistance of the combination is simply the sum of their individual values.

Thus, if R1 is 1 megohm, R2 is .05 megohm and R3 is 7,000 ohms, the total resistance of the combination would be 1,057,000 ohms or 1.057 megohms. Call to mind our explanation of the terms ohm and megohm and check back on our addition.

In figure 3b, three resistors are shown connected in parallel—that is, side by

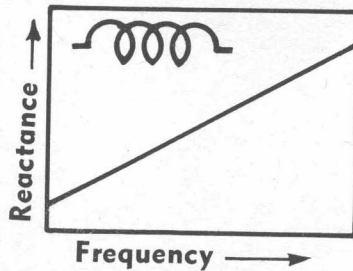


Figure 4: An inductor (or coil) will carry direct current and presents to it a certain amount of resistance, often referred to as its "DC resistance." However, it presents what is called "inductive reactance" to alternating current, reactance increasing as the frequency rises.

side in an electrical sense. If the three occur in this fashion in an electrical circuit, they provide three suitable paths for the current.

For a given electrical pressure (i.e. applied voltage), more electrons can move through the combination than could move through, say, just R5 on its own; in other words, the **PARALLEL RESISTANCE** of the combination is less than that of any individual resistor in it.

The general mathematical expression is:

$$\frac{1}{R_t} = \frac{1}{R_1} + \frac{1}{R_2} + \frac{1}{R_3} \dots \text{etc.} \dots (4)$$

in which  $R_t$  is the paralleled resistance of the combination, R1, R2, R4, R5, etc., are individual resistors and all values are expressed in the same unit of resistance, be it ohms, kilohms or megohms.

Whether you can apply this formula immediately will depend on your familiarity with algebra. If your recollection of algebra is not too good, simply remember the general statement just ahead of the formula.

But let us move on.

As explained in a previous chapter, the passage of an electric current through a conductor is attended by considerable atomic agitation and a certain amount of the electrical energy is dissi-

pated in the conductor as heat. An extreme illustration is seen in the filament of an electric lamp, where the heat generated is so great as to cause the filament wire to glow brightly. The same heating effect is evident in resistors.

The electrical energy dissipated in a resistor is expressed in **WATTS**, being equal to the product of the voltage across the resistor and the current through it in amperes. That is,

$$W = E \times I \dots \dots (5)$$

The above formula can be transposed in various ways and combined with the Ohm's law expressions given earlier, but it is not our intention here to pursue mathematical investigations.

Just remember that there is a definite limit to the current or voltage which any given resistor or combination of resistors can handle. For this reason, radio circuit designers often specify the minimum wattage rating required for certain resistors, as well as the resistance value.

If the constructor is careless enough to use too small a unit, the resultant heating effect may easily cause it to char and fail in service. So much, then, for resistors.

Because of their special characteristics, inductance coils—**INDUCTORS**, to be more correct—find frequent application in circuits involving alternating currents.

If necessary, they will carry direct current but offer marked opposition to the flow of AC; this much we have already seen.

The opposition to alternating current, that is the reactance of an inductor, is expressed by the formula:

$$X_L = 2\pi fL \dots \dots (6)$$

In which reactance is in ohms, pi is equal to 3.1416, f is the frequency of the current in cycles per second, and L is the inductance in henries.

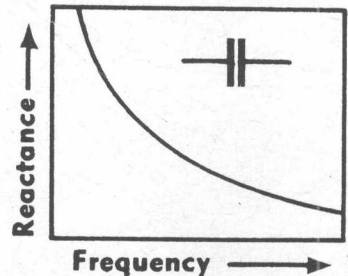


Figure 5: A capacitor is virtually an "open circuit" as far as direct current is concerned but it will conduct alternating current. It offers "capacitive reactance" to the passage of AC, the reactance becoming smaller as the frequency of the alternating current rises.

Without worrying too much about the formula, one point is obvious, namely that the reactance of any given inductor varies with frequency. The higher the frequency of a current, the greater the opposition a given inductor offers to its passage.

Plotted graphically, the result is as shown in figure 4.

Imagine an inductor connected into a complex circuit arrangement requiring it to carry a direct current and two alternating currents of different frequency. The inductor would offer little opposition to the direct, but definite and

different degrees of opposition to the two alternating currents.

This discriminating effect of an inductor is very widely utilised in radio circuits, as we shall come to appreciate later.

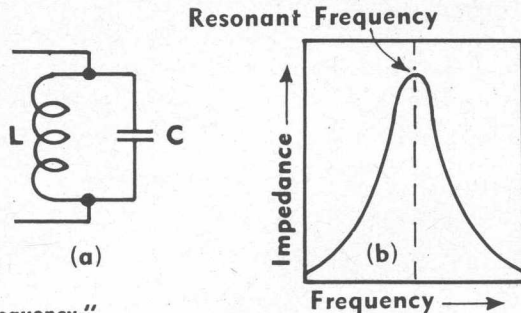
If two or more inductors are connected in series, the total inductance value is equal to the sum of their individual inductances, providing there is

capacitors in series, we revert again to the familiar reciprocal expression:

$$\frac{1}{C_t} = \frac{1}{C_1} + \frac{1}{C_2} + \frac{1}{C_3} \dots \text{etc.} \dots (10)$$

These expressions may be rather baffling to some, but don't worry overmuch about that. The whole purpose in

**Figure 6: Vital to the operation of all radio and television receivers is the parallel tuned circuit—an inductor and capacitor connected in parallel as at (a). Curve (b) shows how the impedance of the combination rises in the vicinity of a particular frequency, known as the "resonant frequency."**



no magnetic coupling between them; this is exactly the same as with resistors.

In like manner also, the inductance value of a number of parallel-connected non-coupled inductors is less than that of any one of them and the expression is similar to formula (4):

$$\frac{1}{L_t} = \frac{1}{L_1} + \frac{1}{L_2} + \frac{1}{L_3} \dots \text{etc.} \dots (7)$$

Condensers — or may we call them capacitors—are almost an opposite in their characteristics to inductors.

Since the component parts of a capacitor are necessarily insulated from one another, a capacitor cannot carry direct current. However, because of the phenomenon of electron displacement, it will carry alternating current, although offering some opposition to its passage.

This opposition, known as capacitive reactance, is expressed in ohms and is given by the formula:

$$X_C = \frac{1}{2\pi f C} \dots \dots (8)$$

In which pi is equal to 3.1416, f is the frequency in cycles per second, and C is the capacitance in farads.

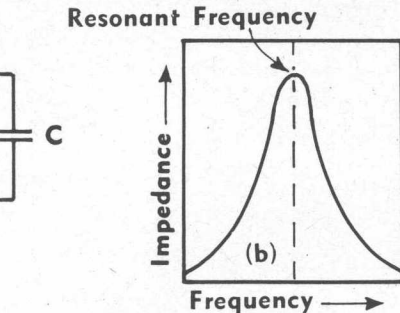
It is interesting to note that the reactance of a capacitor also is dependent on the frequency of the current flowing, but the relationship is just the reverse of that which characterises an inductor. With a capacitor, the higher the frequency of the current in the circuit, the lower is the opposition offered by the capacitor to its passage (Figure 5).

A capacitor in an electrical circuit thus offers no path for the flow of direct current, but allows alternating current to flow through it with an ease depending on its own capacitance value, and the frequency of the current. Here is yet another discriminating effect, which is widely utilised in radio receiver and electronic apparatus design.

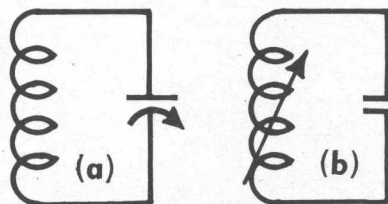
When capacitors are connected in parallel, the total capacitance is equal to the sum of their individual capacitance values. That is:

$$C_t = C_1 + C_2 + C_3 \dots \text{etc.} \dots (9)$$

This is just the opposite effect to that stated for resistors and inductors. For

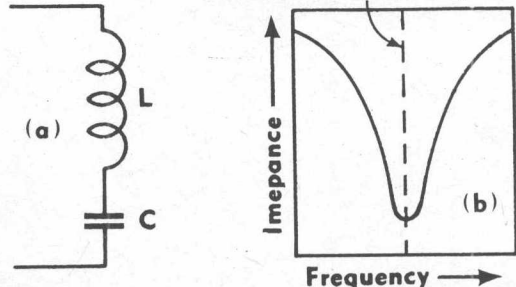


**Figure 7: Energy fed into a tuned circuit tends to produce an oscillatory voltage, as described in the text. The oscillation takes place at the resonant frequency of the tuned circuit.**



**Figure 8: The resonant frequency of a tuned circuit can be changed by varying either the value of the capacitance (a) or the value of inductance (b). Such circuits provide the basis on which a radio receiver can "tune in" individual radio stations.**

**Figure 9: A series tuned circuit (a) and the way in which its impedance varies with frequency, to a minimum value at resonance. Circuits of this type are frequently used to absorb energy at particular frequencies, being then known as "trap" circuits.**



this chapter is to give a general picture of how components behave and why they are used, rather than to get down to a precise mathematical basis.

Circuit requirements often call for a combination of resistance and inductance, either in parallel or in series. The opposition to such a combination to the flow of alternating current is neither wholly resistive nor wholly inductive and is expressed instead as an IMPEDANCE of so many ohms.

The same word "impedance" also applies in circuits involving a combination of resistance and capacitance.

Examination of the word impedance from a mathematical viewpoint is rather too involved for inclusion in this chapter, but the student is well advised to follow up the subject in other texts which choose to cover it in detail. But remember the term and remember also the effect of resistance inductance and capacitance in an electrical circuit.

- Resistance is a definite property, independent of frequency.
- Inductive reactance depends on, and increases with frequency.
- Capacitive reactance depends on, but varies inversely with frequency.
- Inductors will carry direct current, but capacitors will not do so.
- Circuits combining the above properties offer impedance to the flow of alternating current, the impedance depending on the frequency and the quantities involved.

At this juncture, it is necessary to mention a matter of vital importance, namely the combination of an inductor (or coil) and a capacitor (or condenser).

We have seen that the reactance of a coil increases with frequency and that the reactance of a capacitor decreases with frequency.

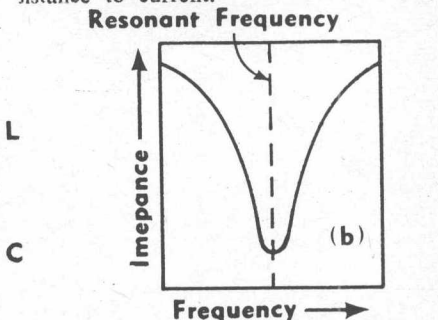
Referring then to figure 6a it is obvious that, for any given value of inductance and capacitance, there must be a particular frequency at which the reactance values of the two are equal.

The frequency at which this occurs is commonly known as the RESONANT FREQUENCY and the coil and capacitor are said to be TUNED to this frequency.

Because the two components are connected side by side (in the electrical sense), the combination is referred to as a PARALLEL TUNED circuit.

In previous chapters we have learned something of phase; that the current through an inductor lags behind the voltage but leads the voltage in the case of a capacitor.

At the resonant point of a tuned circuit such as that of figure 6a the currents through the two components — which are opposite in phase, one lagging the voltage by one-quarter of a cycle, the other leading by the same amount—are equal in amplitude. They accordingly cancel each other, so that the circuit offers an infinitely high resistance to current.



The above assumes that the components are lossless or perfect — the coil having no resistance, and the capacitor no dielectric loss. In practice, however, this will not be true, so that at resonance the parallel tuned circuit will have a large but finite resistance.

Note that the word used is RESISTANCE, for at resonance the inductive and capacitive reactance cancel each other, and the impedance of the combination becomes simply a resistance.

Because the reactive currents cancel

**20,000 ohms per volt**  
**Diode protected**  
**Famous "University"**  
**Full range multimeter**  
**Full size 4 3/16" x 6"**  
**(including test leads)**



**\$14.50 plus 12½% sales tax**  
 Packing and freight \$1.00

**UNIVERSITY GRAHAM**  
**INSTRUMENTS PTY. LTD.**

**106 Belmore Rd. Riverwood. N.S.W.**  
**38 Milton Pde. Malvern. Vic.**

Available through all wholesale & Retail outlets.

**REPRESENTATIVES**

W.A.: Atkins (W.A.) Ltd,  
 894 Hay Street, Perth W.A.  
 S.A.: George Procter  
 52 Gawler Place Adelaide S.A.  
 VIC.: Eastern Instrument Service Ltd.  
 38 Milton Parade, Malvern. S.E.4

QLD.: Keith Percy & Co. Pty. Ltd.  
 Box 1478V, G.P.O. Brisbane, Qld.  
 TAS.: W.P. Martin and Company  
 188 Collins Street, Hobart  
 and  
 134 Cambridge Street, Launceston  
 EA5

at resonance, any current which still flows is in phase with the applied voltage, since the circuit behaves as a pure resistance. For this reason resonance is usually defined as that frequency at which the phase shift of the circuit is zero.

The resonance of a parallel tuned circuit may therefore be thought of in terms of two connected but different effects. One, the cancellation of reactances to leave simply an effective resistance (in other words, zero phase shift), and the other a rise and peak (or near-peak) in impedance to current.

The relationship between circuit impedance and frequency is suggested by figure 6b.

At its resonant frequency, a tuned circuit has an OSCILLATORY quality. Assume, in figure 6a, that the capacitor is disconnected, charged from a battery, instantly connected again to the coil.

The charge across the capacitor would immediately commence to leak away, initiating a current through the inductor; in so doing, it would build up a magnetic field around it. Immediately the charge disappears, the initial current would cease, causing the magnetic field to collapse.

Even as it collapses, however, the magnetic field maintains the current flow to the point where the capacitor becomes charged again in the opposite polarity. Then the capacitor would begin to discharge in the opposite direction and the whole action would be repeated again and again.

In practice, some of the energy is lost in each ALTERNATION, and the oscillatory action ultimately comes to an end. The result, illustrated in figure 7, is known as a damped train of waves. It is important to note that the natural period of oscillation of a tuned circuit corresponds to the resonant frequency—or that frequency where the reactance of inductor and capacitor are equal.

From an inductor and capacitor of fixed value there can obviously be only one definite and fixed resonant frequency. However, as we shall see later, radio design frequently calls for tuned circuits whose resonant frequency is capable of adjustment within certain limits.

In practice, this is achieved by varying either the capacitance of the condenser or the inductance of the coil. Of the two methods, the former is the more usual (figure 8a), and it is for just this purpose that the variable condenser, illustrated in the last chapter, is employed.

Variation of inductance is less common, but can be achieved by altering the physical relationship between two halves of a coil, or by inserting or withdrawing a metal core through the centre of the coil former, thus acting directly on the magnetic circuit.

It is worth noting, in passing, that a resonant effect is also apparent between an inductor and capacitor connected in series. (9a). The reactance of such a combination reaches a minimum value at resonance, as is illustrated in figure 9b. In later chapters, we shall see just how these various combinations of resistance, inductance and capacitance are employed in actual receiver circuits.



## CHAPTER 6: Electron emission, filaments and cathodes.

The plate or anode. The diode valve and rectification. The triode valve and amplification. The screen-grid or tetrode valve. Pentode and beam-power valves. Development of the various valve types, including multiple types in a single envelope.

WE have already seen that all matter, whether in solid, liquid or gaseous form, is made up of innumerable atoms. Further, that these atoms are composed of protons and electrons in a constant state of motion.

In materials known as conductors, some of the outer planetary electrons can migrate from one atom to the next in more or less random fashion. We launch into our discussion of valves from this point.

This random movement of electrons can be accelerated by increasing the temperature of the conductor—usually one

positive charge, so that it acquires a marked attraction for the minute negative particles. They shoot out from the surface of the heated conductor, then fall back again.

The net result is that the heated body is surrounded by a cloud of free electrons, like steam above the surface of boiling water. These free electrons can nevertheless be attracted from the immediate vicinity of the parent body by the simple expedient of placing a positively charged metal plate elsewhere within the evacuated space.

Evidence of this so-called "electron emission" was first noted by Thomas Edison in about 1880. Edison discovered that an electric current could be made to pass the ostensibly empty space between the heated filament of an electric lamp and another metallic conductor contained within the same glass envelope.

The effect was duly noted but was unexplained until about 1899, when the electron theory was first propounded.

When the reason for the current was appreciated, and something of its characteristics investigated, its application to the new science of wireless communica-

tion was envisaged. Electron emission ceased to be a mere incidental effect and became a phenomenon to be controlled and utilised.

The essential features of a radio valve are, therefore, a heated electrode to supply free electrons, and one or more additional electrodes to control and utilise their movement—the whole mounted within an evacuated envelope.

The electrode supplying the electrons is commonly referred to as the CATHODE and is usually heated by the passage of an electric current, in precisely the same manner as the filament of an electric light globe. The shell enclosing the evacuated space may either be of metal or glass, the latter being the more common.

Before going on to investigate just how the emitted electrons are controlled and utilised, it is as well to become familiar with the emitting electrode—the cathode.

For many years, the cathode was a tungsten or similar wire, heated by the passage of an electric current; because of its similarity to the element in a light globe, this type of cathode was—and is—commonly referred to as a FILAMENT.

Since the heating current is directly utilised to raise the temperature of the emitting surface, the filament is called, in technical language, a DIRECTLY HEATED CATHODE.

In the early valves, the filaments were generally of pure tungsten, which emitted a goodly supply of electrons when

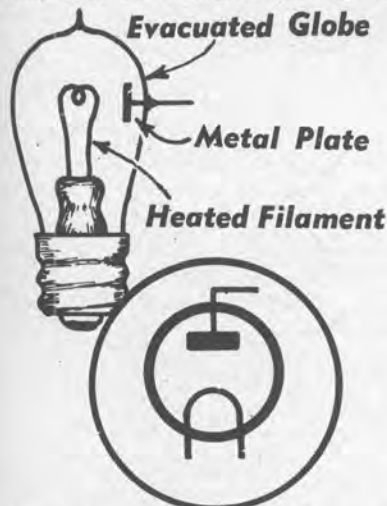


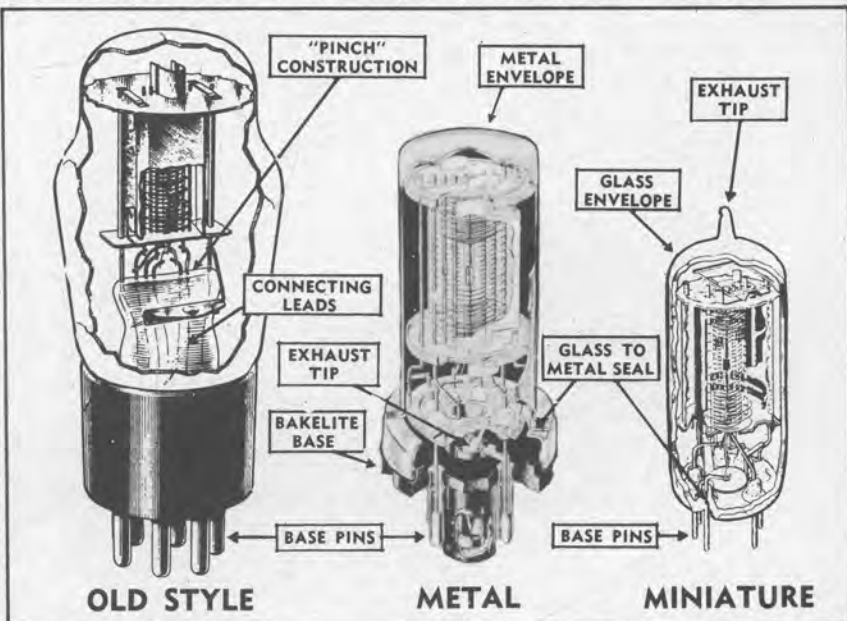
Figure 1. An elementary form of diode rectifier and (in circle) the schematic symbol for a diode. The arc at the bottom represent the cathode; the rectangle at top the anode (or plate).

or other of the metals or a metallic compound.

As the temperature is gradually raised, the velocity of electron movement increases and a condition may ultimately be reached where some of the planetary electrons acquire sufficient velocity to break beyond the confines of the conductor. However, because of the attraction of the parent body and the outside blanket of air, the electrons so EMITTED return immediately to the parent body.

Conditions are different when the emitting agent is contained within an evacuated space.

With no gas molecules to bar the way, the electrons emitted from a heated conductor can move an appreciable distance from it. In the normal way, the loss of electrons leaves the parent body with a



At the left is an old-style valve, with the electrodes supported on an internal glass "stem" and long leads running down inside the stem to the base pins. In modern miniature glass valves, the stem and the long leads are virtually eliminated, reducing inductive and capacitive effects. The structure of metal-envelope valves is illustrated in the centre; very few of these are being produced today, most receiving and equipment valves being of the miniature all-glass construction, as at right.

heated to a brilliant white heat. Subsequent experiment showed that similar emission could be obtained, with greater economy in heating power, by impregnating the tungsten with thorium and operating the filament at a bright gold colour.

Constant research has produced the modern OXIDE-COATED filament, which gives a copious supply of electrons

ensure constant emission throughout the AC cycle. An indirectly heated cathode is illustrated in figure 2b.

The fact that the emitting surface is isolated electrically from the heater also confers other advantages which are much appreciated by the designers of radio receiver circuits.

Many thousands of different valve types have been sold within the short

Coming back to the original line of thought, let us assume that we have a metal plate mounted within the evacuated envelope and in proximity to the heated cathode. This second electrode can quite correctly be referred to as an ANODE or a PLATE.

If it is connected externally to the cathode, a few high velocity electrons may strike it and return ultimately to cathode via the external connecting circuit. However, the vast majority of the emitted electrons remain in the immediate vicinity of the cathode, forming what is known as a SPACE CHARGE.

Think of this space charge as a restless cloud of negative electrons — and therefore a negative charge.

If a battery is connected between cathode and plate in such a way that the plate is negative with respect to cathode, it naturally tends to repel any electron

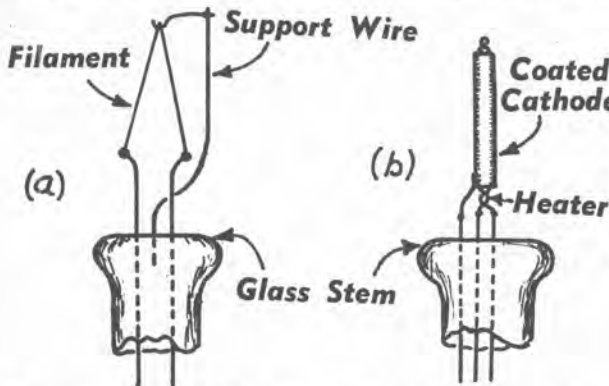


Figure 2. A directly heated filament is illustrated on the left and, on the right, an indirectly heated cathode. Most valves, these days, use indirectly heated cathodes.

at a temperature sufficient only to heat the filament wire to a dull red colour.

The current utilised to heat the filament, in a sense represents a waste of power, since it does not contribute further to the basic function of the valve; thus, for most purposes, there is every reason to reduce it to an absolute minimum.

Filament-type (or directly-heated) cathodes have chiefly been used in valves intended for battery-operated equipment, their particular advantage being economy of filament heating power. (It should be noted, in passing, that transistors are rapidly displacing valves nowadays in battery operated equipment).

The battery used to supply the filament is commonly referred to as the "A" battery. A typical filament is illustrated in figure 2a.

Although this type of valve was used in the early days of radio, there was a definite need for a valve that could be operated from a low voltage AC supply, as provided by a simple step down transformer. Conventional directly heated valves could not be used in this way because the AC introduced severe hum into the output circuit. This was due both to the heating and cooling of the filament during the AC cycle, and the change in polarity across the filament, which formed part of the signal circuit.

One approach to this problem was to use a very heavy filament, so that it would store considerable heat, and to make the signal connection to an electrical centre tap of the filament. This idea was only partly successful. It was satisfactory for the last stage (output valve) of a receiver, but introduced far too much hum if used in earlier stages. Such valves are still used to a limited extent in this and similar applications, such as high power stages of transmitters.

However, the real breakthrough came with the development of the INDIRECTLY HEATED CATHODE. In this the cathode is a nickel sleeve coated with electron emitting oxides. Inside the sleeve is a filament or HEATER, insulated from it electrically, but able to heat the cathode indirectly by conduction. Since the filament no longer forms part of the signal circuit, it can be operated from AC without introducing hum, while the cathode stores enough heat to

Figure 3. The characteristic curve for a diode. Plate current flows only when the plate is positive with respect to cathode. Curves are used freely in valve literature to show the characteristics of individual types.

history of electronics, and there is a wide variation in the voltage at which their filaments or heaters are intended to operate.

In battery valves, the filaments have variously been rated to operate at 1.4, 2.0, 4.0, or 6.0 volts, according to the particular type. Mains-type valves have heaters rated to operate at various potentials from 1.6 to over 100 volts.

When installing a valve in a receiver, this matter has to be kept in mind, as the application of an excessive voltage to a filament or heater may completely ruin a valve.

which happens to approach it. Remember our earlier axiom — like charges repel.

Reversing the polarity of the battery so that the plate is made positive, has just the opposite effect, the plate tending to attract electrons to itself; the higher the applied plate voltage, the greater the attraction, and therefore the greater the electron flow across the space between cathode and plate.

A point is ultimately reached where the plate attracts every electron the cathode is capable of emitting, and when this stage is reached, the valve is said to have reached SATURATION.

The whole relationship is most easily

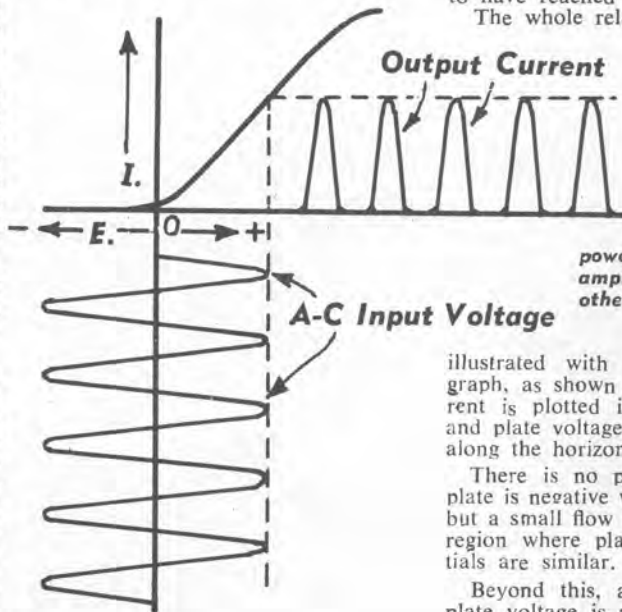


Figure 4. Illustrating the rectifying action of a diode. Only the positive half-cycles produce an output current. Negative half-cycles are suppressed. Valve-type power rectifiers are used in amplifiers, receivers and other pieces of electronic equipment.

illustrated with the aid of a simple graph, as shown in figure 3. Plate current is plotted in a vertical direction, and plate voltage, positive and negative, along the horizontal axis.

There is no plate current while the plate is negative with respect to cathode, but a small flow becomes evident in the region where plate and cathode potentials are similar.

Beyond this, an increase in positive plate voltage is accompanied by an in-

crease in plate current until ultimately the region of saturation is reached.

A valve having only a plate and a cathode — either directly or indirectly heated — is commonly known as a DIODE.

Just what happens when an alternating voltage is applied to a diode is illustrated in figure 4. The voltage/current curve has been redrawn and the quantities are designated by the common abbreviations "E" (for voltage) and "I" (for current).

The added curve at the bottom suggests the application of an alternating voltage which swings the plate alternately positive and negative. The diode passes current only on the positive swings, the negative swings having no effect.

## RECTIFICATION

The ability of a diode to suppress the negative peaks of an alternating input wave is an extremely valuable feature, the process being described as RECTIFICATION.

Diode valves, with heavy cathodes and large plates, are widely used to convert alternating current to direct current in power supplies for electronic equipment, large and small.

Other diode valves, small enough to conceal in the palm of the hand, play a vital part in radio receivers in making the signals from a broadcast station audible in the loudspeaker. The whole subject of rectification is a big one, but no more can be said of it just now.

Diode valves of various patterns were used quite extensively in the early days of radio, but, in 1907, Dr Lee De Forest patented a type of valve rather like previous diodes in construction, but with a third electrode interposed between the cathode and the plate.

Commonly called the CONTROL GRID (or simply the grid), this third electrode proved to have a pronounced effect on the number of electrons passing from cathode to the positive plate.

De Forest's valve, known as a TRIODE, is illustrated pictorially and schematically in figure 5.

The grid usually resembles in form a short length of open mesh helical spring, provided with one or more side rods for support.

## VOLTAGES ON THE GRID

If the grid is unconnected, the electrons pass through its meshes from cathode to plate in the manner already described for a diode. However, if the grid is made slightly negative with respect to cathode, it exercises a repulsive effect on electrons moving outwards from the cathode, and some of them are turned back.

If the grid is made progressively more negative, the repulsive effect becomes stronger and a condition can ultimately be reached where the electron current to the plate is cut off altogether.

On the other hand, making the grid positive with respect to cathode has an accelerating effect on the electron movement, so that the plate current is made higher than would normally be the case.

In fact, the positively-charged grid is likely to attract a certain number of electrons itself, giving rise to grid current. This is a condition which is generally avoided. Instead, the valve is designed to operate normally with a certain initial negative voltage, known as a BIAS.

Making the grid more or less negative

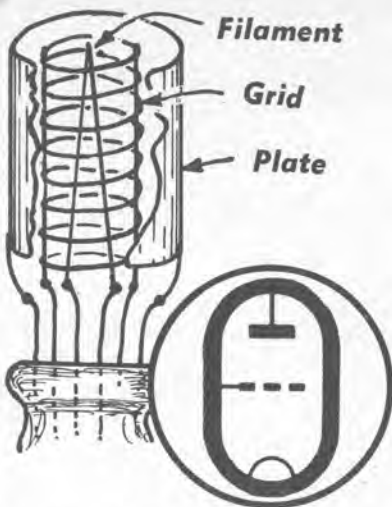


Figure 5. The arrangement of electrodes within a simple triode. The schematic symbol for a triode is shown in the circle.

than this initial bias voltage decreases or increases the plate current with respect to its initial value.

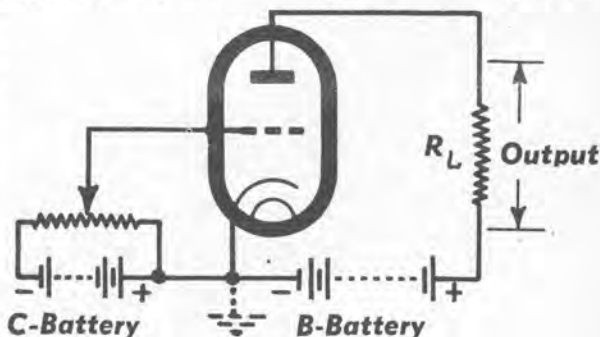
The degree of control which the grid exercises over the plate current depends very largely on the physical construction of the valve. However, De Forest's triode demonstrated conclusively that a small voltage applied to the grid could exercise control over a plate circuit in which comparatively large currents were flowing.

In modern triode valves to quite ordinary pattern, a change of 1.0 volt on the grid can effect a change of 10 or more milliamps in the plate current. Here is a chance to recall and apply Ohm's Law, as mentioned in an earlier chapter.

In figure 6, the plate of a triode is shown connected through a PLATE LOAD resistor to the positive terminal of a battery. This is commonly referred to as the "B" or high tension supply battery.

The grid, on the other hand, returns to an adjustable resistor across a "C" or bias battery. No heater supply is shown,

Figure 6. With the aid of this diagram and a simple Ohm's Law calculation, the amplifying property of a triode is demonstrated. The plate load is shown as a resistor, but it may be any device offering a substantial impedance to the flow of alternating current at the signal frequencies.



it being taken for granted that this requirement is attended to as a matter of course. Note that both batteries are connected, at one end, to the cathode of the valve.

In equipment operating from the power mains, the various batteries are supplanted by electronic power supply equipment, but the traditional terms "A," "B" and "C" supply are still often used to distinguish filament (or heater), high tension, and grid voltages respectively.

Assume that the grid bias of the valve is set at -4.00 volts, and that it is draw-

ing a plate current of 3 milliamps through the load resistor, equal to 50,000 Ohms. The voltage developed across resistor RL by this current would be:

$$E = I \times R \\ .003 \times 50,000 \\ 150 \text{ volts.}$$

If the grid bias voltage is now increased to -5.0 volts, we may find that the plate current has decreased by, say, 1.0 milliamp, so that the voltage drop across resistor RL becomes:

$$E = .002 \times 50,000 \\ 100 \text{ volts.}$$

In other words, a change of 1 volt on the grid has effected a change of 50 volts on the plate potential.

## AMPLIFICATION

It follows that, if an alternating voltage of 1.0 volt were applied to the grid, an alternating voltage of no less than 50 volts would appear in the plate circuit. Thus, the triode, with its associated components and power supply, is capable of AMPLIFYING a signal.

Not all triodes can achieve an amplification of 50 times, as our illustration might suggest, but the importance of this development is not hard to imagine. Diode valves could only alter the nature of an incoming radio signal; the triode could do this, if necessary, and amplify it as well!

This fact was of tremendous importance in the development of early radio receivers. Signals from radio stations too weak to be discerned with equipment using a simple diode valve were amplified to complete audibility with triodes.

Nowadays, one-valve sets using a single triode valve can receive stations from all over the world under favourable conditions.

Valve manufacturers have provided us with special high amplification triodes, and with others intended to deliver enough power to operate a loudspeaker. There are also general purpose triodes—valves intended for a variety of applications.

With the rapid advance in radio knowledge, it soon became evident that, notwithstanding all its advantages, the

triode had definite limitations. And, as valve designers sought to overcome these limitations and to keep step with progress in circuit design, there came into being one new class of valve after another.

Nor has the process finished even now. However, whereas attention at first was on new electronic principles, it is now more along the lines of achieving the most favourable physical and electrical characteristics.

The chief single difficulty with the triode was the considerable capacitance between the plate and control grid. A

little thought will show that a condenser effect must surely exist, because the grid and plate are both fairly large physically; they are mounted quite close together and insulated the one from the other.

In some circuit applications this grid-plate capacitance effect did not matter, but in others it caused a lot of trouble and seriously limited the usefulness of the valve.

If we can venture a little ahead of ourselves it may be said that the grid-

**Figure 7. The basic circuit connection for a screen-grid valve, represented schematically, and showing typical operating voltages for the grid, screen and plate.**

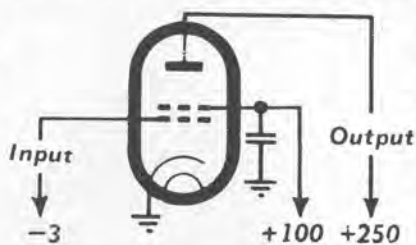


plate capacitance caused instability and oscillation in radio frequency amplifier stages.

The ultimate answer to this problem was the introduction of another grid between the control grid and plate. The resulting four-electrode valve became known popularly as a "screen-grid" valve or "tetrode."

Valve designers arranged that this extra grid should be operated at a positive potential sometimes equal to, sometimes less than that applied to the plate. A bypass capacitor was—and is—connected between this SCREEN-GRID and cathode (or earth), the capacitor value being chosen so that its reactance is low at the signal frequencies at which amplification is required. Thus while the screen grid is positively charged with respect to the cathode for DC purposes, it is virtually at cathode potential as far as the AC signals are concerned. (See figure 7.)

### REDUCED CAPACITANCE

It thus acts as an electrostatic shield between grid and plate, and reduces the capacitance effect between them to a very small figure. Whereas the capacitance averages 8 pF. in a triode, the grid-plate capacitance with screen grid or tetrode valve is seldom more than 0.01 pF.

Further, to reduce the grid-plate capacitance it became common practice to provide a connection for one or the other in the form of a cap on the top of the glass envelope, instead of connecting it to the usual base pin. American practice was to connect the grid to the top cap, while in Europe the plate was often brought out on top.

The reduced grid-plate capacitance, together with other characteristics peculiar to the screen-grid construction, allowed much higher amplification to be achieved in radio frequency amplifier stages without danger of instability.

Stability was further improved by installing a metal screen to enclose the valve, or alternatively spraying the envelope with a metallic coating which could be connected via a base pin to cathode or to the chassis.

In modern miniature valves, careful design and small size has largely obviated the need for top-cap connections and metal shield cans. Plate and grid connections are brought out to pins on opposite sides of the base socket and shields are built into the basic electrode structure.

The screen grid was found to have interesting effects on the electrical char-

acteristics, quite apart from the reduction in grid-plate capacitance.

Being operated at a substantial positive potential with respect to cathode, it tends to attract electrons from the latter in just the same way as the plate. Thus, some electrons are collected by the posi-

tive screen, but the majority simply pass through its open mesh and proceed outward to the plate.

However, the screen assumes a marked control over the plate current and, speaking generally, we may say that the plate current in a screen grid valve depends very largely on the applied screen voltage, and to a lesser extent on the plate voltage.

This is reflected in the changed values of plate resistance, amplification factor, and transconductance, all of which are important and basic valve characteristics.

Instead of being a few thousand ohms, the plate resistance is more like 0.5 to 1.0 megohm; amplification factor increases from 10 or 20 times to a figure of several hundred; transconductance is not greatly affected.

The first and best known screen grid valve in this country was the old type 24A, and it is interesting to compare characteristics and curves for this valve, if you can still locate them, with those of the type 27 triode of the same general period.

Although the screen grid represented a distinct advance, it introduced certain difficulties, chief of which was the so-called SECONDARY EMISSION effect. When moving electrons strike the plate of a valve at high velocity, they tend to penetrate its molecular structure and dislodge other electrons, which are thus literally "bounced" off into space.

Because this action is an incidental effect of main electron stream from the cathode, it is described by the general term of secondary emission. The effect is evident in triode valves, but it does not lead to ill-effects because the second-

ary electrons are immediately attracted back to the positively charged plate.

In a screen-grid valve, however, the positively charged screen tends to attract some of the secondary electrons so that an electron flow is evident in the reverse direction between plate and screen.

It is most noticeable when the screen voltage is equal to or greater than the plate voltage. This can occur easily in normal operation, when the control grid receives a positive-going signal impulse and the instantaneous plate voltage is reduced sharply.

Hence, secondary emission, by producing undesirable effects in the plate current, limits the amount of plate current swing and offsets partially the advantages of the screen-grid structure for some circuit applications.

The ultimate solution to the secondary emission problem was offered by the addition of yet another grid — this time located between screen and plate. The resultant five electrode valve came to be known as a PENTODE or PENTHODE. The SUPPRESSOR grid is usually a very open spiral and is generally connected internally or externally to the cathode.

### SUPPRESSOR ACTION

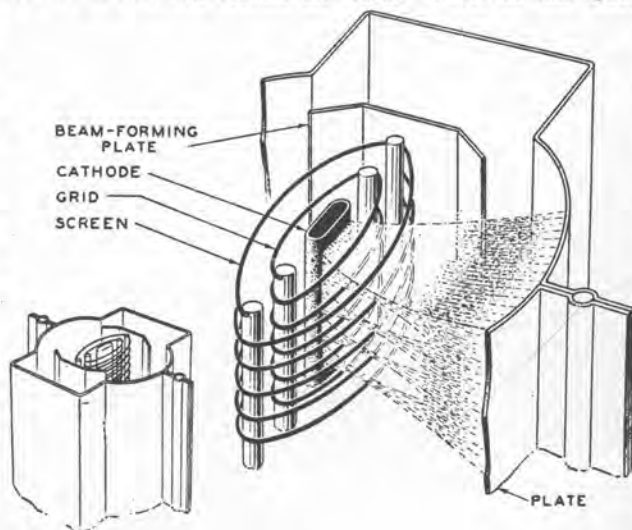
Being negative with respect to both plate and screen, it tends to reduce the velocity of electrons approaching the plate in the normal manner, and diverts back to the plate the slow-moving electrons produced by secondary emission.

Pentode valves are widely used nowadays in all classes of service. For radio frequency amplification they have superseded the screen-grid type, typical modern RF pentodes being the 6BA6, 6BH5 and 1T4. Other pentodes have been designed especially for audio voltage amplification (types like the Z729 and EF86) and audio power amplification (types 6F6-G, 3S4, 6M5, etc.).

The modern beam power valve makes use of a different principle to suppress secondary emission. There are the four major electrodes—cathode, grid, screen and plate, but they are so shaped that secondary emission from the plate is prevented without an actual suppressor grid.

Because of the way the electrodes are spaced, electrons travelling to the plate slow down to a low comparative velocity in a certain region between screen and plate. In this region the electrons form a dense cloud—a space charge. The effect of this space charge is to repel secondary electrons emitted from the plate and thus cause them to return to the plate.

Two additional electrodes known as beam forming plates, which are connected intern-



**Figure 8. The electrode structure of a typical beam power valve, showing how the secondary emission is suppressed. (Diagram by courtesy of R. C. A., America.)**



ally to the cathode, are so placed as to concentrate the electrons emitted to two beams, on opposite sides of the oval cathode.

Another feature common to beam power valves has the effect of reducing greatly the screen current. The helical coils of the screen and the grid are wound so that each turn of the screen is shaded from the cathode by a turn of the control grid. This alignment of the screen and grid causes electrons to travel in sheets between the turns of the screen so that comparatively few of them flow to the screen.

The ultimate effect of forming the electron stream into horizontal and vertical beams, together with the reduction of screen current and other refinements, results in beam power valves being very efficient in operation. Typical beam power valves are the 6V6-GT, 6AQ5, and the transmitting type, 807.

It is possible to make quite a long story about valve design and development, for the evolution of the pentode structure has not by any means satisfied all requirements. Special circuit arrangements have brought the need for pentodes with a wide variety of characteristics. For example, SUPER-CONTROL or VARIABLE-MU pentodes have been evolved to permit smooth control to be achieved over the gain of a receiver.

#### MULTIPLE VALVES

Furthermore, numerous valves have been developed and released which contain in the one envelope two or more distinct electrode structures. Most rectifier valves contain two diode structures but twin triodes and triode-pentodes are quite common. Some valves contain two diodes and a triode or pentode unit in the one envelope, while the battery-type 1D8-GT contained no less than a diode, a triode, and an audio power pentode—all within its small glass bulb.

Yet another distinctive class of valve is that intended for use as a frequency changer in superheterodyne receivers. This special subject has yet to be explained, but it is sufficient to say here that valves with no less than five grids—hence called PENTAGRID CONVERTERS—are in common use.

Other valves intended for the same purpose have a triode and another complex structure in the one envelope, the two being independent or interconnected, according to the particular design.

Physically, there is a like variety in design. Envelopes may be of either glass or metal, and fitted with bases having anything from 3 to 9 or more pins. Some glass envelopes are sprayed with a metallic coating, and overall size ranges from 6 to 7 inches in height to less than an inch for special types. The beginner can do no more than keep a very open mind on the whole subject, becoming acquainted with the characteristics of particular types, as they are met with in practice.

There is, unfortunately, little standardisation in the manner in which valves are depicted schematically. Generally, however, the filament is shown as an arc at the bottom of a large circle representing the envelope.

A larger arc or a straight line in proximity to the filament indicates the presence of a cathode sleeve.

A solid or open rectangle at the top of the circle depicts the plate, while the various grids are shown by dotted or

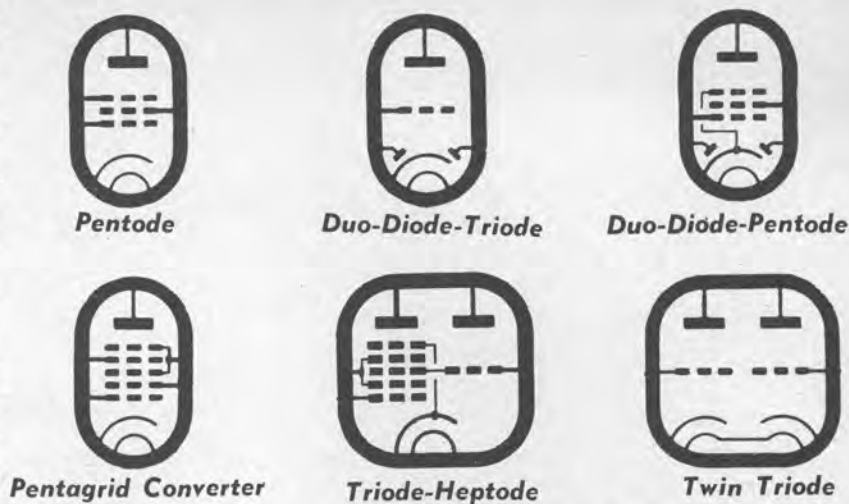


Figure 9. Schematic symbols for a variety of typical valve types.

zig zag lines between cathode and plate, generally in the same progressive order as they are found in the actual valve.

Typical valve symbols are shown in figure 9, but only familiarity will enable the student to interpret all circuits without hesitation, because of small departures from the usual practice.

Physical and electrical details of the

various valves are given in valve data charts released by most valve manufacturers. The various type numbers are listed in alphabetical or numerical order followed by details as to type, dimensions, base connections and electrical characteristics. It is a good idea to obtain one of these charts and spend an hour or so studying its columns.

## Wireless Institute of Australia

The wireless institute of Australia is an association of Radio Amateurs, bonded for the promotion of interest in amateur radio communication and experimentation, for the advancement of radio art and public service, and for the representation of the radio amateur in regulatory matters.

Each state division provides a variety of activities, including training courses for prospective amateurs, and for the younger member Youth Radio Clubs and Short Wave Listener Groups give instruction and assistance to the beginner.

Inquiries regarding membership are requested—it is not essential that you hold a station licence.

**SEND** for application form and **FREE** copy of our brochure "How to Become a Radio Amateur".

A sample copy of the institute journal "Amateur Radio" will be sent. To "bona fide" enquires **FREE**.

#### PUBLICATIONS FOR RADIO AMATEURS

Be informed of latest techniques and amateur constructional articles from U.S.A. and the U.K. Subscribe through the Institute to one or more of these publications.

"QST" Associate membership \$5.40 p.a.

"RSGB" Bulletin—Includes membership \$5.95 p.a.

The bulletin is only sent to members. Send for application form for membership of **RSGB**.

"CQ" \$5.25 p.a.  
"73" \$3.50 p.a.

Address all enquires to **FEDERAL EXECUTIVE**  
c/- **BOX 36. P.O. EAST MELBOURNE.**

# MULLARD TECHNICAL PUBLICATIONS

A comprehensive and varied selection of technical publications for reference and educational purposes has been prepared by Mullard engineers to assist technicians, servicemen, junior engineers, students and teachers of electronics.

These publications are available from Mullard offices throughout the Commonwealth or from all leading booksellers. The Mullard Representative in your State will be happy to assist you.

Classification	Title	Price \$	Postage \$
Valve Amplifiers	Circuits for Audio Amplifiers	1.25	0.13
	Stereo Sound Systems	0.62	0.07
Educational	Demonstrations & Experiments in Electronics	1.25	0.10
	A Programmed Book on Semiconductor Devices	1.05	0.07
	Simple Explanation of Semiconductor Devices	0.52	0.04
	Simple Transistor Measurements	0.35	0.04
	Simple Oscilloscope Measurements	0.50	0.04
	Simple Valve Measurements	0.40	0.04
	Class Instructional Work Sheets (Set of four)	0.25	Free
	Principles of Electrostatics	0.40	Free
	Principles of X-rays	0.40	Free
	Enlarged Data Sheets (10 Valve, 2 Transistor, Set of 12.)	0.25	Free
Reference	Great Circle Map of World	1.00	0.20*
	List of the Elements (per 100)	0.50	Free
	Reference Manual of Transistor Circuits	1.50	0.13
	Transistor Radio Servicing Course	1.00	0.13
	Transistor Radios — Circuitry & Servicing	0.52	0.07
	Valve, Tube & Semiconductor Guide	1.50	0.13
	Vinkor Manual	0.52	Free
	Heatsink Manual	0.25	Free
	Transistor Interchangeability List	0.25	Free
	Voltage Regulator (Zener) Diodes	0.85	0.07
Cadmium Sulphide Photoconductive Cells	0.25	Free	

\*Includes packaging

*Mullard Outlook (six copies per annum) is available on subscription basis of \$1.80 per annum, post free. You are invited to contact our Sydney Office for your subscription form.*



## Mullard-Australia Pty. Ltd.

- 35-43 Clarence Street, SYDNEY, N.S.W. Phone 29 2006
- 123-129 Victoria Parade, COLLINGWOOD, N.5, Vic. Phone 41 6644
- 33 Bowen Street, BRISBANE, Qld. Phone 2 8746
- 266-270 Sturt Street, ADELAIDE, S.A. Phone 51 6341
- 579 Murray Street, PERTH, W.A. Phone 21 2561



## CHAPTER 7: Semiconductor materials, germanium and silicon.

"Doping" semiconductors with impurities. "P" and "N"

type semiconductors. The junction diode and its properties.

The junction transistor and its operation.

Leakage currents, gain factors and other types of transistor.

**I**N the first chapter, we learned of the atomic theory of the structure of matter, and how the atoms of the various chemical elements are composed of differing numbers of electrons, protons and other particles. We saw that all atoms consist of a central nucleus of protons and other particles, around which "orbit" a number of electrons—like a miniature planetary system.

The orbiting electrons of every atom are imagined as being grouped in "shells" or "rings." In atoms of a particular element, the number of electrons in the outermost shell of each atom is of particular interest, since it determines many aspects of the behaviour of the



A physicist in the laboratories of Delco Radio inspects the growth of a large crystal of germanium which will be used to make many thousands of transistors. Germanium and silicon are the heart of most transistors and semiconductor diodes.

element, both chemically and electrically. It provides the basis, in fact, for the whole discussion which follows.

Considering solid materials in general, an element will allow current to flow through it in the form of a passage of electrons if it has a small number of loosely-bound electrons in its outer shell.

Elements which exhibit this characteristic are those which we have already defined in chapter 1 as "conductors."

If, on the other hand, an element has an outer shell containing a number of electrons either near or equal to the normal maximum number (usually eight), it is harder to produce a current of electrons through the material. Such elements are the "insulators," another term introduced in chapter 1.

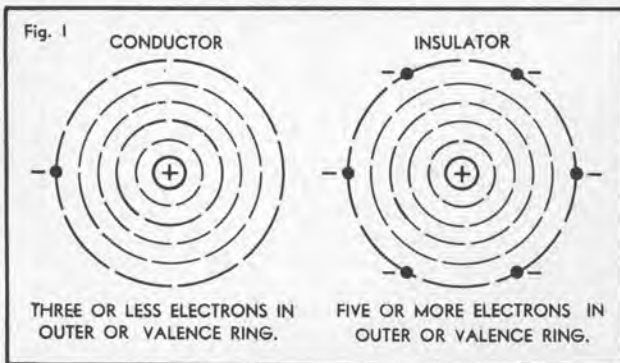
The disinclination of insulators to

support current flow may be pictured as being due to an increase in the "binding" of the outer electrons when there are close to the optimum number of them in the outer shell. The more there are, the more force must be exerted, in the form of an applied EMF, before they can be persuaded to move.

It so happens, however, that certain elements, such as germanium and silicon, exhibit electrical properties approximately midway between conductors and insulators, as well as behaving in other interesting ways.

These elements, as one might perhaps expect, have four electrons in their outer shell. They are called **SEMICONDUCTORS**, a name which includes not only elements but also certain chemical compounds having a similar electrical behaviour.

Resorting to diagrams, figure 1 represents the atoms of a conductor and an insulator, while figure 2 represents the atom of the semiconductor germanium. These diagrams should not be considered as "pictures" of atoms, but simply as a convenient way of depicting them.



To be somewhat more accurate, the planetary electrons should be depicted as orbiting in a variety of planes around the central nucleus.

In a lump of a substance, the atoms or molecules of the element or compound comprising it tend to be cohesive rather than to drift apart. There are a number of different ways in which they may be "bound together" but the type of bond which concerns us here is that which occurs in the semiconductors. This type of bond is called "covalent bonding" and is represented diagrammatically in figure 3.

Here the dotted circles represent the outer or "valence" shells of each of nine atoms of germanium (the inner shells of each are omitted for clarity). Note that each atom shares each of its four valence electrons with the four

neighbouring atoms. Thus any two adjacent atoms are effectively "sharing a pair" of electrons and each atom, in one sense, has eight electrons in its valence shell. This produces a stable bond and a disinclination to pass current.

Germanium atoms, arranged as in figure 3, in a typical pure crystal, are said to be in a "lattice," as the diagram would suggest.

As already mentioned, pure germanium having this lattice structure has a rather poor conductivity (high resist-

**Don't be discouraged if this chapter is heavy going, because the fundamentals of semiconductors, diodes and transistors are concepts which often prove difficult to grasp even for those with considerable experience with electronics.**

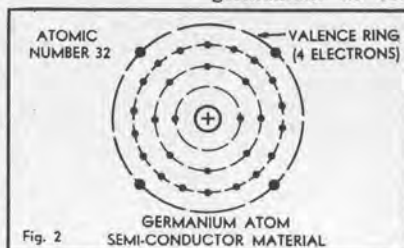
**Try to persevere with the ideas involved, however, for you will find that your effort will be well spent when we go a little further. But don't think future chapters will be as hard as this one—they're not! Next month we start on the basic ideas behind radio transmission and reception, so stay with us.**

ance), as all the outer shell electrons are employed in the lattice bonding and are fairly strongly bound.

If heat is applied, the added energy causes the atoms and electrons to become energetic, so that a certain number of electrons are freed and made available for current flow. At low temperatures, however, the conductivity is poor.

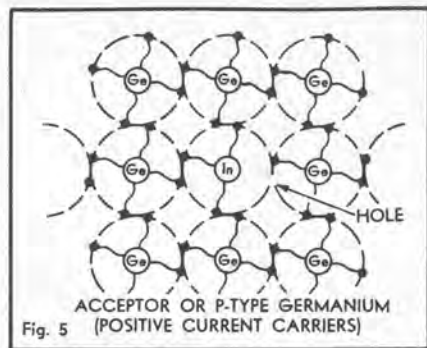
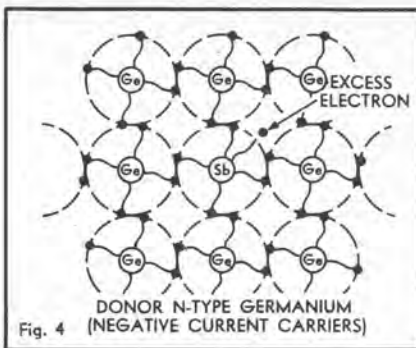
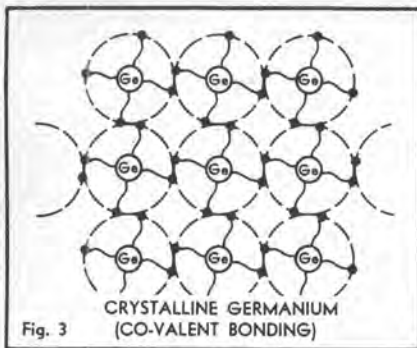
Pure germanium is known as an **INTRINSIC** semiconductor, because of this behaviour.

If small amounts of other elements are added to the germanium as con-



trolled impurities, the conductivity at normal temperatures may be greatly increased. This may occur in one of two ways, by adding one of two types of impurity element. This process is known as "doping" the semiconductor.

For instance, if a small amount of an element having not four, but five electrons in its outer shell (such as phos-



phorus, arsenic, or antimony) is added, conditions such as that shown in figure 4 may arise.

The impurity atom joins in the lattice structure and forms four covalent bonds with the surrounding atoms, but is still left with a "spare" electron. Thus this type of impurity is called "donor" impurity, as its addition results in there being free electrons available for current conduction through the crystal lattice.

Germanium crystal with a small amount of donor impurity is called N-TYPE germanium, the "N" suggesting additional negative charges. Semiconductor materials in general having donor impurity are known as n-type semiconductor.

The other type of impurity which may be added is one which has only three electrons in its outer shell, such as boron, aluminium, gallium or indium. When small quantities of any such element are added to the germanium, conditions such as those shown in figure 5 appear in the lattice.

Here again the impurity atom joins in the lattice structure, but in this case it is only able to enter into covalent bonding with three of the surrounding atoms. There is no fourth electron to share with the remaining atom, so a defect in the form of an electron vacancy or HOLE is set up.

It happens that such holes are able to "travel" through the lattice from atom to atom, in much the same way as the free electrons do in the n-type material. Thus, under the influence of thermal (heat) energy or light energy or the electric field of an applied EMF, they move around the lattice and effectively constitute a current of positive charges.

The type of impurity which produces holes in the lattice is termed an "acceptor" impurity for, when the hole moves away from the impurity atom, the atom is regarded as having "accepted" a fourth valency electron from the atom which then has the hole.

A semiconductor material which has been doped with an acceptor impurity is termed P-TYPE, to distinguish it from n-type material by indicating that the conduction is by holes rather than electrons. While hole movement is in fact movement in the opposite direction of an electron or electrons, the hole proves to be a convenient and simple way of imagining the different types of conduction in n-type and p-type materials.

It is interesting to note that the impurity atoms scattered through the parent material occupy normal positions in the lattice structure, just as if they were atoms on the parent material (i.e., atoms of germanium). However, the fact that the valence bond system associates each with one outer electron too few, or one too many, means that the orbiting elec-

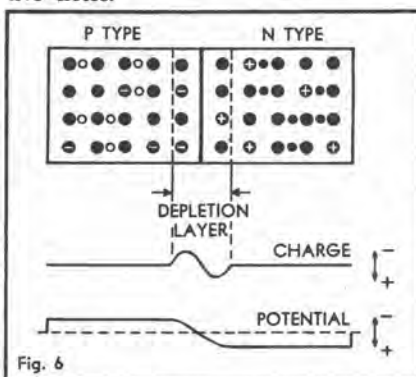
trons do not exactly balance the charge of the nucleus.

Thus, although the impurity atoms occupy normal positions in the lattice, they are actually atoms with an electrical charge—IONISED atoms, in other words, or simply IONS.

Atoms of a donor impurity, having now one less than their normal outer electrons, become positive ions.

Atoms of an acceptor impurity, on the other hand, having one more than their proper number of outer electrons, become negative ions.

Thus the two types of impurity semiconductor should be visualised as (1) n-type, having fixed POSITIVELY charged donor ions in the lattice and a normally equal number of "free" (for current conduction) negative electrons, and (2) p-type, having fixed NEGATIVELY charged acceptor ions in the lattice and a normally equal number of free positive holes.



The presence of impurity ions in the lattice structure of, say, germanium, with the attendant free electrons or holes, greatly modifies its conductivity.

Now let us see what happens when a crystal is arranged so that an area of p-type and an area of n-type are next to one another. Such a state of affairs is shown in figure 6, which is a diagram representing what we can now call a P-N JUNCTION—simply a junction between a p-type and an n-type lattice. As we shall see, such a junction behaves in a very similar way to the thermionic diode valve which we examined in the last chapter, and thus is used as the basis of the JUNCTION DIODE.

At normal temperatures, due to thermal energy, the current carriers—electrons in the n-type, holes in the p-type—wander freely throughout the lattice. Some may wander across the junction in the course of their travels.

If a current carrier from one side wanders across the junction, there is a good chance that it will meet a carrier of the other type, each neutralising the other.

For instance, if a conduction electron from the n-type side wanders into the

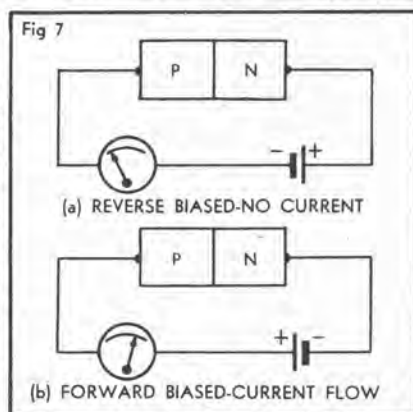
p-type, it may easily meet a hole and "fill" it, the lattice in that immediate region reverting to normal. Similarly, when a hole appears in the n-type region, there is a very good chance that it will meet a conduction electron and the two will cancel one another as before.

Due to this action, at normal temperatures there is a section of the crystal surrounding the junction which has virtually no carriers. This is called the DEPLETION LAYER, signifying that it is effectively a "no-man's land" as far as free current carriers are concerned.

In the p-type section of the depletion layer there are no free holes present, and there is thus a net negative charge—due to the fixed acceptor impurity ions. Similarly, the depletion layer in the n-type region acquires a net positive charge, due to the fixed donor impurity ions and the lack of free electrons.

As the small graph in figure 6 labelled "charge" shows, this means that the section of the crystal occupied by the depletion layer differs from the rest of the crystal in having nett charge "humps," one each side of the junction. There is a negative charge "hump" on the p-type side, and a positive charge "hump" on the n-type side (this is shown as a "dip" because it is of the opposite polarity).

Because of this setting-up of opposite charge concentrations, each side of the junction, the p-type and n-type sections are effectively shifted in potential with respect to one another. For instance, the p-type region is effectively negatively-charged with respect to the n-type, because electrons in the n-type are prevented from passing to the p-type region



due to the "hump" of negative charge on the far side of the depletion layer. (Remember, like charges repel one another.)

The same is true of holes in the p-type region, which are discouraged from passing to the n-type region by the nett positive charge n-type part of the depletion layer.

As the second curve of figure 6 shows, we can represent the potential difference which is set up by the depletion layer by showing a gradient in the depletion region, with the p-type negative with respect to the n-type. Or the n-type positive with respect to the p-type, whichever you prefer (see footnote).

Looking at this potential diagram one can see the potential "hill" that carriers have to surmount to cross the depletion layer and reach the other region. Right-

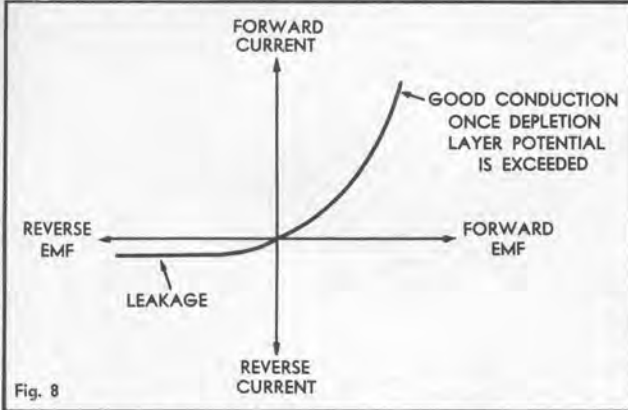


Fig. 8

way-up, the hill for electrons may be seen, travelling from right to left; inverting the page will show the hill seen by the holes.

Since the depletion layer is brought about by holes and electrons crossing the junction, and since their ability to do so is derived largely from thermal energy, it follows that the width of the depletion layer and the potential difference between the two regions of the crystal is partly a function of temperature.

With us so far?

If you're not too sure, re-read some of the previous material for, as the old saying goes, "Here's where the story REALLY starts!"

If we now try to pass a current through a germanium junction diode or "crystal" having a p-n junction, by applying an EMF across its ends, we find that interesting things happen. And it all depends upon the way we connect our EMF, for different things happen for each connection.

If we connect an EMF so that its positive polarity connects to the n-type region and its negative polarity to the p-type region, as in figure 7(a), we are simply increasing the potential difference which the depletion layer has already set up between the two regions. What happens is that we simply increase the width of the depletion layer (and its potential difference gradient) by causing more carriers in the crystal structure to cancel.

After a very brief and tiny flow of these carriers no current flows apart from a leakage current which is due to various lattice imperfections and effects which need not worry us just at present. The initial flow amounts to a capacitive charge current, just as if the junction was a capacitor—which, in fact, it is.

In this condition, which is called REVERSE BIASING, the junction may thus be regarded as an open circuit. Or more exactly, as a low value capacitor with a small leakage current.

If on the other hand we connect an EMF to the crystal so that its positive and negative polarities connect to the p-type and n-type regions respectively, as in figure 7 (b), the situation is quite

different. In this case the external EMF opposes that set up by the depletion layer rather than assists it.

If the external EMF is greater than that of the depletion layer (which is in practice only a few hundred millivolts) there will thus be a net EMF acting in the direction of the external EMF and the potential "hills" of the junction will be compensated by larger "downhill" sections. Current is thus able to flow, electrons and holes within the crystal and electrons alone in the external circuit.

A junction in this condition is said to be FORWARD BIASED. Forward biasing thus results in high conductivity (low resistance) and easy current flow. Figure 8 shows a typical current-voltage curve for a semiconductor junction—note the low current with reverse biasing (due to leakage) and the sharp rise

appropriate time to produce the required p-type and n-type regions. Although some diodes are actually made in this way, most of the commonly available units are made somewhat differently.

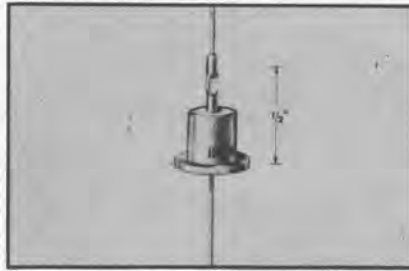
In figure 9 is shown a diagram of the construction of a typical small germanium junction diode. Metal-cased silicon diodes of the high-voltage variety are constructed along similar lines, although the junction is arranged so that the depletion layer can withstand quite high levels of reverse bias.

During construction the piece of n-type germanium is soldered to the cathode lead, and the fine wire "cat's whisker" contact welded to the anode lead so that it is in contact with the surface of the germanium. When assembly is complete, a short but heavy pulse of current is fed through the device, whereupon a small amount of the wire material melts and dissolves in the germanium near the contact.

The composition of the wire and the techniques used are such that this produces a very small area of p-type germanium in the immediate vicinity of the wire contact, to which the wire is firmly welded. Thus a p-n junction is formed which is small in area—and thus low in capacitance, which is desirable for many applications—yet quite robust.

Higher power silicon diodes are generally made in a similar way, except that a flat metal contact spring may be used, together with a pellet of p-type impurity which is diffused-welded to the larger n-type cathode wafer in the same way as above.

Having discussed the junction diode we can now progress to the junction transistor. This is simply the junction diode carried one step further—a semiconductor crystal having not one but



Above is a silicon power diode of the type used in many radio and television sets. It will rectify currents of up to half an ampere, at pressures up to 400 volts. At right is a diagram showing the construction of a small germanium junction diode of the type used in "crystal" sets and radios as a detector.

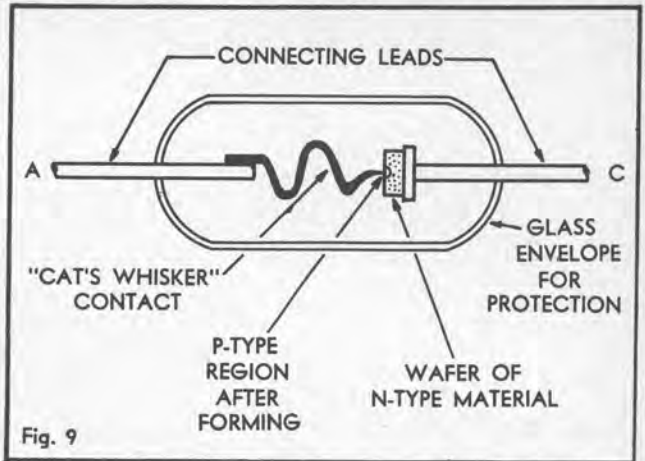


Fig. 9

in current with forward biasing as the depletion layer potential is exceeded.

As this curve shows, the semiconductor junction is thus very similar to the diode valve which we examined last month—it is effectively a "one-way" path for conduction.

Sealed in a small glass shell for moisture protection and fitted with two connection leads, it is the familiar junction diode which is used in "crystal" sets, in radio and TV receivers for detection and other jobs, and in power supplies for rectifying AC into DC. We will see some of these uses in later chapters.

Figure 6 showed the p-type and n-type regions as they might be if the crystal was "grown" as one lump, with the correct impurities added at the

two p-n junctions. They are near one another and, as we shall see, they interact in a way which makes the transistor able to amplify small signals. The junction transistor is thus the semiconductor version of the triode valve, in the same way that the junction diode is the version of the diode valve.

There are two different types of junction transistor, as there are two different ways in which one can arrange two p-n junctions to be side by side. One type is the common PNP type, where, as the symbols suggest, the two junctions have a common n-type region and separate p-type regions; the other is the less common NPN type, where the two junctions share a common p-type region.

Both types are quite practical and, in fact, they are often used side by side in

circuits—one type being best suited for some jobs, the other type for different jobs.

Figure 10 shows a diagram of an elementary PNP transistor. The common n-type region in the centre is thin, and is called the BASE region. The left-hand p-type region which is called the EMITTER is normally forward-biased with respect to the base by means of the battery E1, so that the base-emitter junction conducts freely.

The right-hand p-type region, termed the COLLECTOR, is biased in the opposite direction by battery E2, so that the base-collector junction is reverse-biased and would normally be considered to be a high resistance. However things are not the same as they would be with single junction.

As we mentioned before, the base region is made quite thin. It is also made weakly n-type by only doping it with small quantities of donor impurity, whereas the emitter region is made quite strongly p-type by strongly doping it with acceptor impurity.

This "differential" doping has one major effect: it makes holes play the major part in the current conduction of the emitter-base junction. In other words, most of the current passed is in the form of holes passing from emitter to base rather than in the form of electrons passing in the reverse direction.

### THIN BASE

Because the base is thin, the base region part of the reverse-biased collector-base junction depletion layer extends almost to the emitter-base junction. This would not normally have much effect on the base, as the normal base carriers are electrons and would not be inclined to "climb" the potential "hill" to the negatively-charged collector, but it has quite an effect on the holes which reach the base from the emitter region.

To these, the "hill" is not an uphill grade but an inviting downward slope. Thus, unless they are met and cancelled by one of the free electrons in the base as soon as they arrive, there is a good chance that they will "roll down" the potential hill into the collector region.

Confused? Then consider it from another viewpoint. The base-collector junction is reverse-biased, meaning that carriers would normally not pass from one side to the other because of the fixed-ion concentrations and potential "hill" of the junction depletion layer. But the "hill" is only an upward grade for the particular carriers normally present on each side.

### "WRONG" CARRIERS

What the emitter-base junction does, because of its forward bias, is to INJECT the "wrong sort" of carriers into the base-collector region. Not the usual electrons, which see an upward grade to the collector region, but holes — which see the potential gradient as a downward grade, and may therefore pass straight through.

The holes "haven't been told" that the collector junction is meant to be an open circuit, as it were, and they accordingly have no objection to crossing over!

Not all of the holes which cross the emitter-base junction pass through into the collector. A few are cancelled by electrons before they can do so, and the base region accordingly receives a corresponding number of electrons from the external base connection — in other

words, a small amount of the original emitter current flows "out" via the base lead, but most of it passes through to the collector.

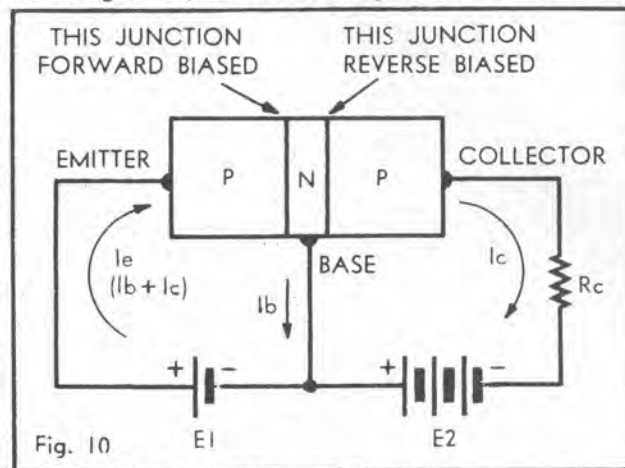
The currents in the transistor can be visualised in terms of the base lead current  $I_b$  and the collector lead current  $I_c$ . In figure 10,  $I_b$  can be imagined

pressing the gain of a transistor, but many need not concern us here. For the present, it is probably sufficient to know that there are two common terms used, both being current gain ratios.

The first is ALPHA ( $\alpha$ ), which is basically the ratio of collector and emitter currents,  $I_c/I_e$ . Since  $I_c$  is always smaller than  $I_e$ , Alpha is always smaller than one, being nearer to one for high gain transistors than it is for low gain transistors.

The other current gain ratio is BETA ( $\beta$ ) which is basically the ratio of collector and base currents,  $I_c/I_b$ . Beta is almost always more than one and, in high gain transistors, can be as high as three or four hundred.

Since Alpha and Beta are simply different ways of con-



as flowing in the small left-hand circuit loop, while  $I_c$  flows around the large outside loop.  $I_e$  may be considered as simply the sum of the two, as they both flow through the emitter lead.

Due to the action of the transistor, there will be a definite ratio between  $I_b$  and  $I_c$ , the collector current normally being many times  $I_b$ . If we change  $I_b$  by a small amount thereby modifying the base-emitter depletion layer,  $I_c$  will be found to change by a proportional and much greater amount.

In other words, the transistor will amplify small current changes. If we superimpose a small signal on the base current  $I_b$ , a larger replica of the signal will appear in the collector current  $I_c$ . If we include a resistor  $R_c$  in series with the collector, it will develop a voltage drop which will be proportional to the current changes, to produce an amplified output voltage.

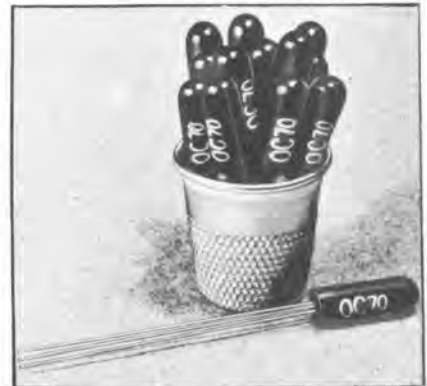
Like the triode valve, then, the transistor can amplify tiny signals so that they may be used to perform such tasks as operate earphones, loudspeakers, television picture tubes and so on. It is thus a very useful device in many fields of electronics — particularly as it does not need to be supplied with heater current as does the triode valve.

Before we end this discussion of the transistor, there are one or two points which we should look at. The first is the matter of the amount of amplification obtained.

It should be fairly obvious from the foregoing discussion of the operation of the transistor that the amplification will be governed by the number of holes which pass straight through the base from emitter to collector. The fewer the number of holes which are intercepted by electrons to produce  $I_b$ , the higher will be the gain.

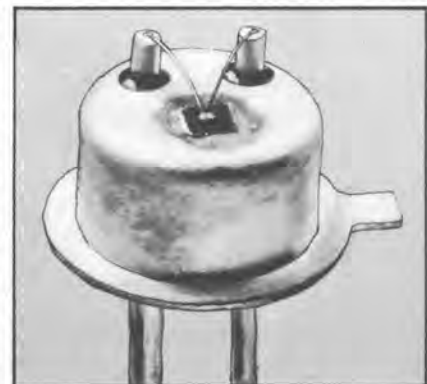
In manufacturing the transistor the gain can thus be manipulated by two methods: (1) making the doping ratio between the emitter and the base high so that the current is mostly holes going from emitter to base, and (2) making the base thin so that there is less opportunity for the holes to meet electrons before crossing to the collector. There are also a number of other techniques which need not concern us at present.

There are a number of ways of ex-



A dozen low-power transistors can easily fit into a thimble. These are not sub-miniature types as used in hearing aids, but normal general-purpose types.

considering the same effect in the transistor, they are related to one another; knowing one permits the other to be calculated. Beta is given by Alpha divided by (one minus Alpha); by turning the expression around, Alpha equals Beta divided by (one plus Beta).



A photograph showing the construction of a typical high-frequency transistor. This type is called a "mesa" because the base wafer is etched away and resembles a mesa plateau.

It should be realised that due to thermal energy at normal ambient temperatures, some electrons and holes are generated in small quantities in all types of semi-conductor—intrinsic, n-type and p-type. Thus, in the transistor, EVEN WHEN AN EXTERNAL INPUT CURRENT IS NOT APPLIED, there are small currents flowing because thermally generated carriers "of the wrong sort" are present in small numbers and are able to cross the various junctions.

For instance, due to heat energy, there will be some holes present in the base region even in the absence of holes being injected from the emitter, and these will be able to "roll down the hill" into the collector.

These thermally generated "minority carriers," as they are called, are the reason for small LEAKAGE currents which are observed to flow in the transistor even when no input is applied. As the number of minority carriers generated depends upon the temperature, the leakage currents are likewise proportional to temperature, both externally applied and internally generated. This is one of the things which tends to complicate transistor circuits.

Although, in discussion of the operation of the transistor we examined only the PNP type, the operation of the NPN type is very similar, except that all operating potentials are reversed. The NPN type, by the way, use electrons as the principal conduction carriers rather than holes.

Besides the simple PNP and NPN types there are also many others, developed for various purposes. Special types such as the tetrode, "mesa,"

"drift," "micro-alloy diffused," and many others, are used for amplification at very high frequencies and for other special jobs. However, all are based on the type which is shown in figure 10, except some few special types which are strictly not transistors at all but are so called for the sake of simplicity.

A final word: Although the transistor is the semi-conductor equivalent of the triode valve there is one vital difference.

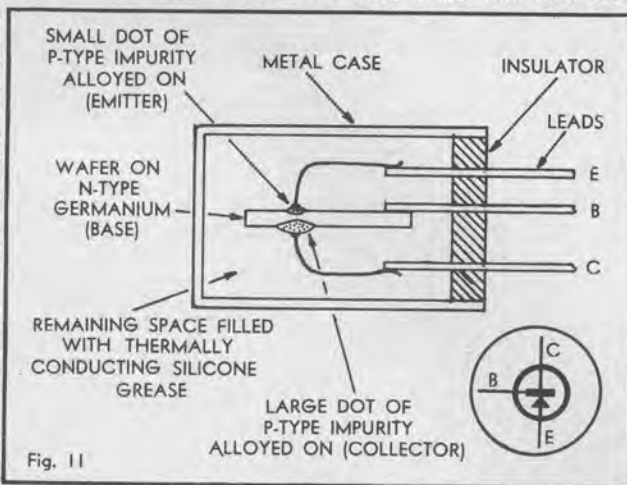


Fig. 11

A diagram showing the construction of a low-power transistor. This transistor is not made with the junctions "grown" side-by-side as in Fig. 10, but has the emitter and collector sections formed by alloying on "dots" of impurity. The collector dot is larger as it has to dissipate more heat, being a higher resistance. The silicone grease helps conduct heat to the case, for cooling.

The valve controls output current with input voltage (grid bias), and has a very high resistance input—it draws a microscopic input current, if any at all. On the other hand, the transistor controls output current with input CURRENT and may present quite a low input resistance.

By suitable circuit arrangements it is possible to make the transistor present the input circuit with quite a high resistance, but never as high as that presented by a valve, because the transistor works by input current and must draw a certain amount before it can work.

Because greater radiation energy is given to the carriers near the exposed junction, the depletion layer which is set up has a greater voltage than that at the connections, which are "dark" and at ambient temperature only. Thus there is a nett voltage produced, which can be used to operate small radio receivers or other devices.

## FOOTNOTE:

From the discussion of the "depletion" layer in the above article, it might seem that one could measure the voltage set up across a semiconductor junction (due to the cancellation of holes and electrons) by means of a sensitive voltmeter. One might expect to find a small voltage across a germanium diode when it was connected to a vacuum-tube voltmeter, for instance.

This is not the case, however, because as soon as an external measuring circuit is connected to the diode ANOTHER depletion "layer" forms. It forms in two parts, at the ends of the crystal where the wires connect—the external circuit simply acts like another junction, and cancellation occurs as before. Thus there is no nett voltage in the circuit, and the meter will show nothing.

While we cannot measure the depletion layer voltage of a normal diode, we can measure a voltage across a special type of diode known as a "solar cell." In this type of diode, the "main" p-n junction is made so that it can be exposed to light or heat radiation while the rest of the diode remains unexposed.

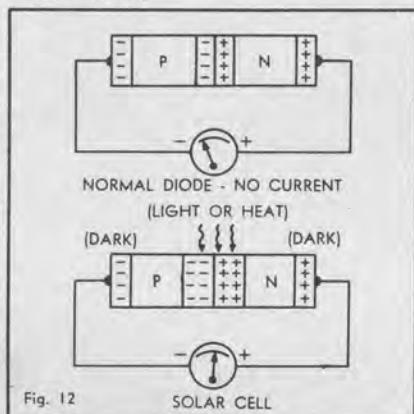


Fig. 12

# RADIO ENTHUSIASTS

Learn  
amateur radio  
in your spare time.

If you are interested in Amateur Radio, then you'll enjoy studying Stott's outstanding Home Study Radio Courses. You receive the expert guidance of a highly qualified radio engineer right through your practical, easy-to-follow lessons. Whatever your interest there's a Stott Radio Course for you.

## Radio For Amateurs:

If you are interested in building radio receivers, then Stott's famous Amateur Radio Course will suit you. This course is completely up to date and incorporates the latest advances in the application of electronics to the design, construction and operation of modern radio receiving apparatus.

## Amateur Operators' Certificate Course:

If your interest lies in broadcasting then you will enjoy Stott's course for Amateur Radio Operators. This completely new course has been specially designed to cover all the requirements of the Amateur Operator's Certificate of Proficiency Examinations. Write, telephone or call for full information on Stott's Radio Courses.

# Stotts

TECHNICAL CORRESPONDENCE COLLEGE

159 Flinders Lane, Melbourne: 383  
George Street, Sydney: 290 Adelaide  
Street, Brisbane: 45 Gilles Street,  
Adelaide: 1130 Hay Street, Perth.

Post this coupon:

TO STOTT'S: Please send me, free and without obligation, full particulars of your Courses in Radio for Amateurs.

NAME \_\_\_\_\_

ADDRESS \_\_\_\_\_

ST62



## CHAPTER 8: Electromagnetic radiation. Radio waves.

Escape of energy as electromagnetic waves from charging and discharging reactance. The transmitting aerial.

The use of a high-frequency carrier. Frequency and Wavelength.

Generating the RF carrier. The RF oscillator. Quartz crystal oscillators. The RF amplifier. Keyed CW transmitters. AM and FM transmission. The AM transmitter.

**I**N the first seven chapters, we have been introduced to the basic components or "building blocks" of electronics—resistors, capacitors, inductors, valves, transistors, and so on. We have also seen something of the various ways in which these components may be connected together to make elementary circuits.

It is important that one has a firm grasp of these matters before one attempts to delve into the more practical aspects of electronics. However, there are no doubt many readers who have so far been thinking along the lines—"All these

—step out into the sunlight, and you have proof that energy is traversing the 93 million or so miles between the sun and you. It warms your body, it can stimulate the retina of your eye, it can be used to evaporate water, and so on.

Radio waves are simply another sort of electromagnetic radiation, along with light and heat. We shall see in a moment how these three forms differ from one another; first we must learn just what electromagnetic radiation really is. To explain this fully we would need to delve into lots of mathematics, but we're deliberately going to simplify the story so that you will be able to form a mental picture of just what is going on.

In an earlier chapter, we saw that the application of a voltage

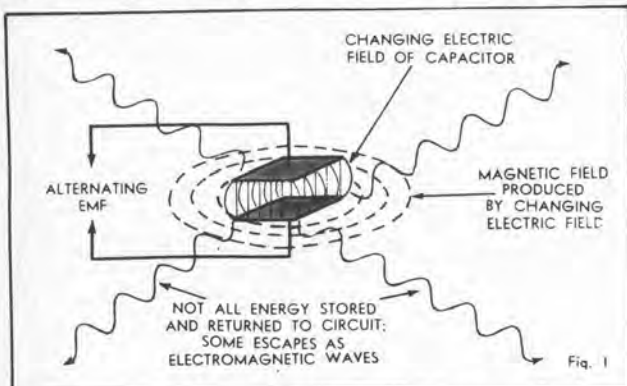
said could be returned to the circuit when the field was allowed to collapse.

Now, in implying that ALL the energy stored in electric and magnetic fields could be returned to the circuit, we were simplifying the situation slightly. We did it to emphasise the difference between the basic energy STORAGE behaviour of reactance (capacitance and inductance), as opposed to the energy DISSIPATION (conversion to heat) behaviour of resistance.

In actual fact, however, NOT QUITE ALL the energy stored in an electric or magnetic field is returned to the circuit. Some is lost—it escapes, and flows or RADIATES away from the capacitor or inductor like the ripples from the surface of a pond disturbed by a stone. It can be picked up at a distant spot, by a suitable detecting device.

It happens that the form in which it radiates is the same in both cases—it doesn't escape from the capacitor as electric field alone, nor from the inductor as magnetic field alone. In both cases, the energy radiated as COMBINED electric and magnetic fields—hence the name, "electromagnetic" radiation.

The reason why the energy radiated is in the form of a combined field is that a changing field of either type is always accompanied by the other type. One can't have a changing electric field without a magnetic field along with it,



**Figure 1.** When a capacitor is connected to an alternating EMF, the alternating electric field produced is accompanied by a similarly alternating magnetic field.

Not all the energy stored in the capacitor is returned to the circuit, some escaping and being radiated as radio waves.

components may be very interesting, but how are they used to send messages and music—or even pictures—to a distant place, without any physical connection?"

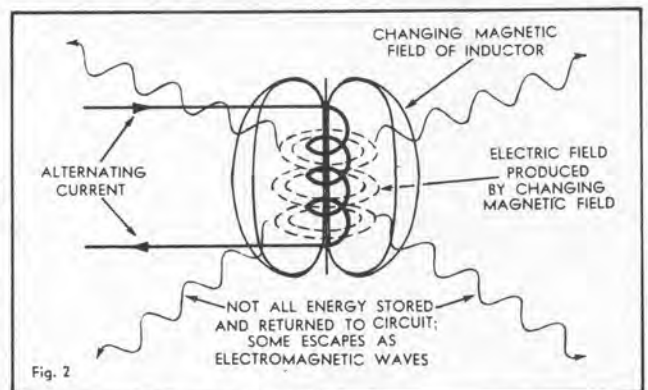
With this chapter we begin to answer such questions, for we are now in a position to start examining how electronic components may be put together to transmit intelligence (whether it be messages, music, or pictures) from one point to another—without wires. In other words, we are now going to look at the basic principles of radio transmission and reception.

The whole of radio depends upon the fact that a certain form of energy, called "electromagnetic radiation," can travel from one place to another practically instantaneously, and EVEN THROUGH A VACUUM or the near-vacuum of outer space.

You are already familiar with at least two types of electromagnetic radiation—light and heat. You are also aware that these two forms of energy radiation can travel through the near-vacuum of space

or EMF to a capacitor caused the capacitor to "charge up." We saw that this was a process whereby the space between the two capacitor plates became "strained" or in a state of tension. We called this state of tension an electric field, and we said that it was stored energy which could be returned to the circuit when the capacitor was discharged.

In another chapter, we saw that passing a current through an inductor sets up a magnetic field around the inductor. The magnetic field, like an electric field, is a state of tension in space, but it is a different type of tension. It represents another sort of stored energy, which we



**Figure 2.** As with a capacitor, so too with an inductor. The alternating magnetic field is accompanied by an electric field, and radiation of energy again takes place.

nor can there be a changing magnetic field without an electric field.

Let's just summarise these ideas about electromagnetic radiation before we go any further: the total energy "stored" in a capacitor or in an inductor, in their respective types of field, can never be fully returned to the circuit, because some of it escapes or "radiates" away. It escapes as a combined electromagnetic field, which is produced during the charging and discharging processes when the fields are changing (building up or collapsing) because whenever one type of field changes it produces the other type.

When the field of a capacitor or of



an inductor is built up or allowed to collapse, then, a small "wave" of electromagnetic energy radiates away in all directions. But if we apply an alternating EMF to the capacitor or inductor, a continuous series of electromagnetic waves will be produced. The continuous buildup-decay-reversal nature of the field in the capacitor or inductor will produce electromagnetic energy which will radiate away in waves having the same frequency as that of the alternating EMF.

What we know as RADIO WAVES are electromagnetic waves produced by currents so that they have a frequency of from about 10,000 cycles per second (EXTRA LONG WAVES) to about 100,000,000,000 cycles per second (MICROWAVES).

Incidentally, when discussing the fre-

Light waves are so short that their wavelength is measured in Angstrom units (ten-thousand-millionths of a metre).

But let us return to radio waves and their generation. When people first observed that energy was radiated from a changing electric or magnetic field, and saw that it could be picked up at a distant spot, they started thinking.

Surely, they reasoned, this effect could be used to transmit intelligence from one point to another. And thus was born the idea of using radio waves as a means of communication.

Experiments showed that radio waves could be radiated in more efficient ways than from a simple capacitor or inductor. There have thus been developed various types of special radiating devices, which you will be familiar with as AERIALS.

magnetic waves with frequencies as low as those we can hear (between about 30 cycles and 16 Kc/s). Transmitting aerials miles in length are needed if practical amounts of energy are to be radiated. There are also other difficulties associated with the transmission of such low frequencies, but these need not concern us here.

It so happens that higher frequency waves are easier to radiate. Efficient aerials may be made in convenient sizes, which will radiate suitable amounts of energy if high frequencies are used.

In practice, then, we do not radiate voice-frequency radio waves. We radiate at considerably higher frequencies, called RADIO FREQUENCIES (RF), by supplying the aerial with alternating current generated by an RF OSCILLATOR and amplified by an RF AMPLIFIER. These may use valves or transistors, as we shall see a little later on.

The broadcast radio stations radiate waves with frequencies in the range 550 Kc/s-1500 Kc/s. Long distance communication stations operate from about 2 Mc/s to 30 Mc/s, in what is called the "short wave" or high-frequency (HF) band. Television stations transmit waves at frequencies between about 50 Mc/s and 250 Mc/s (the VHF band), and so on.

Radiating at radio frequencies is desirable from the ease-of-transmission-of-energy point of view, then, but it complicates the procedure of sending messages. Unfortunately, human beings can neither talk nor hear at radio frequencies!

Means must, therefore, be used whereby our RF waves can be used as a vehicle or CARRIER for the information to be transmitted. This is called MODULATING the RF carrier.

The simplest way of doing this, and the way that was first used, is to arrange that the alternating RF currents fed to

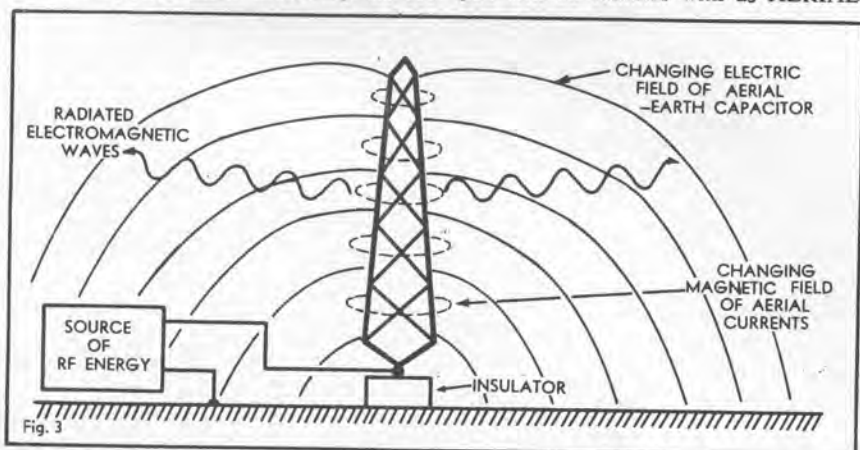


Fig. 3

**Figure 3.** The transmitting radiator or "aerial" is a device specially designed to radiate energy. The aerial system shown here can be seen to combine the features of a capacitor and an inductor. Varying potentials between the aerial and the earth create a varying electric field, while currents in the aerial itself create a varying magnetic field.

quency of radio waves or of the currents which produce them, the simple unit of "cycles per second" often becomes unwieldy. Things are simplified by using the KILOCYCLE/sec, which is 1,000 cycles/sec, the MEGACYCLE/sec, which is 1,000,000 cycles/sec, and the GIGACYCLE/sec (formerly called the KILO-MEGACYCLE/sec), which is 1,000 Megacycles/sec.

Often the ending "per second" (/sec) is written p.s. or even left off completely.

The radio frequency spectrum thus extends from about 10 Kilocycles/sec (10 Kc/s) to about 100 Gigacycles/sec (10 Gc/s, or, as formerly written, 10 K-Mc/s). The alternative descriptions in terms of wavelength (long-, short-, medium-, micro-waves, etc.) are less often used, but describe the length of one cycle of the electromagnetic waves concerned.

Wavelengths are inversely proportional to frequency, which means that the higher the frequency, the shorter the wavelength, and vice-versa. Wavelength is measured in METRES, and the length of a wave in metres is given by its frequency in Megacycles/sec (Mc/s) divided into 300. Waves of a frequency of 100 Mc/s thus have a length of 3 metres, and so on.

We said before that light and heat were electromagnetic radiation but that they differed from radio waves in some way. In fact, they differ in terms of frequency. Heat radiation is in effect super-high-frequency radio waves or "extra-short" microwaves, while light radiation is a higher frequency again.

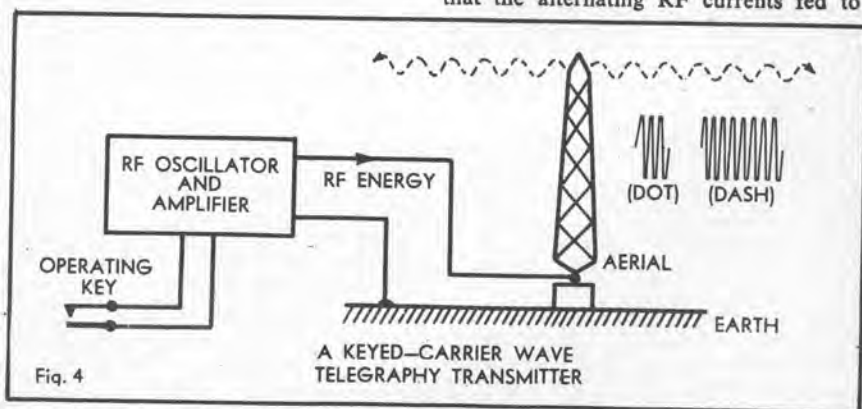


Fig. 4

**Figure 4.** A keyed-carrier wave transmitter is a system whereby messages can be radiated in the form of long or short "bursts" of RF waves. A key switches the RF oscillator and amplifier sections on and off according to the "dots" and "dashes" of the morse code.

A properly designed aerial stores very little energy fed into it—it lets most of it escape, as radiation.

At this stage, it might be thought that to transmit messages by radio, one need simply speak into a microphone, amplify the resulting voice-frequency voltages with a valve or transistor amplifier, and feed the amplifier to an aerial. Then, it might be reasoned, one would only need another aerial and an earphone to receive the message at a distant spot.

Now while messages can be and have been sent in this way, it proves quite difficult to satisfactorily transmit electro-

the transmitting aerial are turned on in bursts or PULSES. The pulses are arranged to be either long or short in duration, and various combinations of long and short bursts made to correspond to letters of the alphabet and numerals.

This type of transmission is known as KEYED CARRIER WAVE transmission, or just "carrier wave" (CW) transmission. And the code used to pulse the carrier wave in short ("dots") and long ("dashes") bursts is, of course, the familiar "MORSE" CODE.

With CW transmission the operator is provided with a KEY, which is a switch connected to the transmitter. The key is

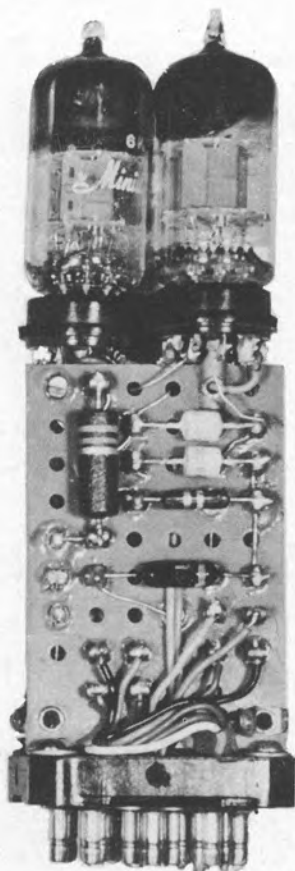
# MATRIX BOARD

Module Construction

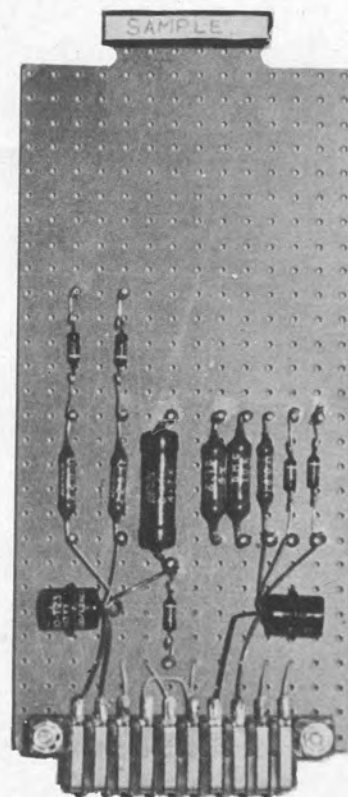
CHOOSE A SPACING TO SUIT YOUR REQUIREMENT

*Available in a large range of sizes*

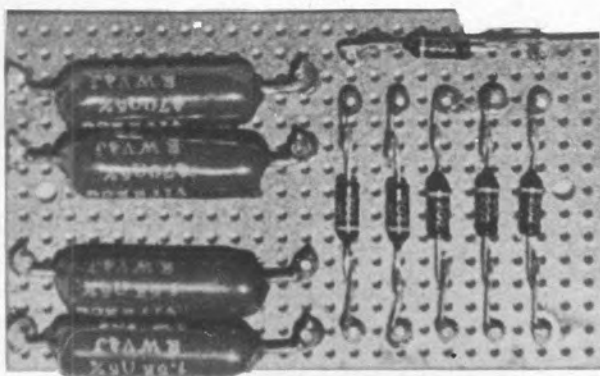
VERSATILE — COMPACT



.25 inch  
HOLE SPACING



.2 inch  
HOLE SPACING



.1 inch  
HOLE SPACING

*Obtain your supply from all leading Radio Parts Suppliers*



**ZEPHYR PRODUCTS PTY, LTD.**

70 BATESFORD ROAD, CHADSTONE, VICTORIA

arranged so that in its rest position the RF oscillator and RF amplifier send no energy to the aerial. When the key is pressed down, however, the oscillator and amplifier are turned "on," and by pressing the key briefly or for slightly longer the operator can send short or long bursts of RF energy to the aerial—to be radiated as dots and dashes.

A long burst followed by three short bursts means "B," for instance, while a short burst followed by a long means "A." Each letter of the alphabet and numeral is represented by a particular combination of short and long bursts.

One way of describing keyed carrier wave transmission is to say that the carrier is **AMPLITUDE MODULATED**. This is because the code information is carried by the waves as differences in their strength or "amplitude." The strength is zero between dots and dashes, while the full carrier strength is present while they are being transmitted.

Keyed carrier wave transmission is quite satisfactory as a means of transmitting simple messages, but it obviously lacks something where speech, music or pictures are concerned. Who would be able to recognise their favourite piece of music translated into dots and dashes?

Fortunately, there are other ways of

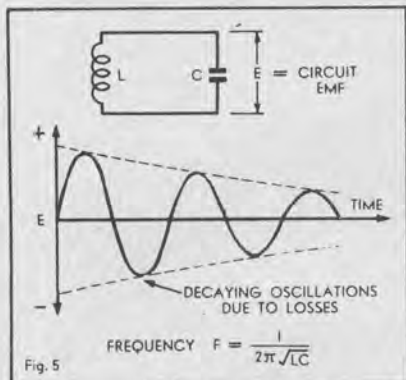


Figure 5. A parallel-tuned circuit will produce an oscillatory EMF if it is fed with energy. The EMF decays due to circuit losses unless energy is continually supplied.

modulating the RF carrier in order to send information, besides the simple on-off amplitude modulation of keyed CW transmission. Although there are quite a large number of alternative modulation systems, we will confine ourselves here to the discussion of only one — that used by all the "radio" broadcasting stations.

The broadcasting stations, like keyed CW stations, amplitude modulate (AM) the RF carrier. However, rather than switch the carrier through only two steps of amplitude (off and on), they vary its amplitude continuously. In this way, the continuous variations of the human voice or music can be transmitted faithfully, as similar variations in the strength of the radiated waves.

In the remainder of this chapter, we will see how this is done. Following chapters will be devoted to the operation of the receiving end of the system, to show how the receiver is able to recover the original transmitted voice or music from the amplitude modulated waves.

Before we examine how the signals to be transmitted are made to amplitude modulate the RF carrier, we should have a look at the way in which the

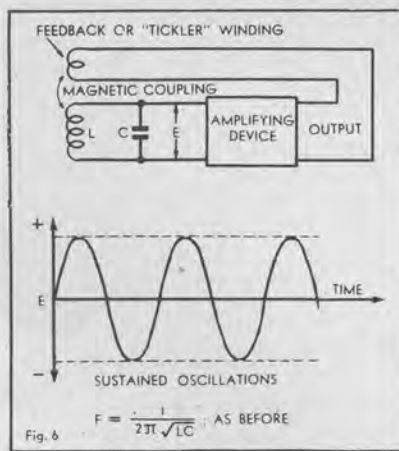


Figure 6. By using an amplifier device such as a valve or transistor to feed amplified oscillations back to the tuned circuit, it can be made to oscillate continuously. The combination of tuned circuit and amplifying device is called an **OSCILLATOR**.

RF carrier is generated in the first place. In other words, we should look at the RF oscillator, which perhaps can be regarded as the "heart" of any radio transmitter.

You may remember that in chapter 5 of this course, we saw that a capacitor and an inductor can be connected in parallel to form a parallel tuned circuit. We saw that when such a tuned circuit is fed with a short burst of energy, it tends to oscillate, producing a decaying or "damped" alternating voltage.

The frequency at which the circuit oscillates, which is the frequency of the alternating voltage, is determined by the resonant frequency of the tuned circuit. This in turn depends upon the values of the capacitor and the inductor, as one might expect.

In fact, the frequency of the voltage produced is given by

$$F = \frac{1}{2\pi\sqrt{LC}}$$

where  $F$  is the frequency in cycles/sec,  $\pi$  is 3.1416,  $L$  is the coil inductance in Henries, and  $C$  is the capacitor value in Farads.

A tuned circuit can thus be used to

generate an alternating EMF of any desired frequency, by suitable choice of the inductor (coil) and capacitor. So if we want to generate an RF carrier of a certain frequency, we can select a capacitor and coil to resonate at this frequency.

But a tuned circuit alone is not sufficient, for it has coil resistance and other losses which make the alternating voltage decay and die away. To produce a continuous, steady supply of alternating EMF at our carrier frequency, we must arrange for the tuned circuit to be continually fed with energy, to overcome its losses and keep it oscillating.

Here is where valves or transistors or other amplifying devices enter the picture, for by means of a valve or transistor we can keep the tuned circuit oscillating steadily.

By the way, note that wording carefully. It is always the **TUNED CIRCUIT** which oscillates, **NOT** the valve or transistor. The amplifying device simply keeps the tuned circuit going.

Figure 6 gives the basic operation of a simple tuned circuit oscillator. The amplifying device is connected so that it picks up the oscillatory voltage  $E$  appearing across the tuned circuit. The output of the amplifying device is then connected to a **FEEDBACK** or "tickler" winding which is placed close to the inductor of the tuned circuit.

The feedback winding is arranged so that it can magnetically induce voltages into  $L$  which **RE-ENFORCE** the voltage  $E$ , when fed with an amplified version of  $E$  by the amplifying device. In this way, the tuned circuit is fed with energy which keeps it oscillating steadily.

The amplifying device may be a valve, a transistor, or anything else capable of doing the same job. Figure 7 shows simplified circuits for tuned oscillators using a valve and a transistor.

In the valve circuit, the tuned circuit voltage is fed to the input of the valve, which passes the corresponding amplified plate current oscillations through the feedback winding to supply energy back to the tuned winding.

The transistor circuit does the same thing in a different way. It connects the tuned circuit in the collector (output) circuit of the transistor, and uses a small feedback winding to supply the input circuit of the transistor. Thus small oscillatory voltages induced in the feedback winding are amplified by the tran-

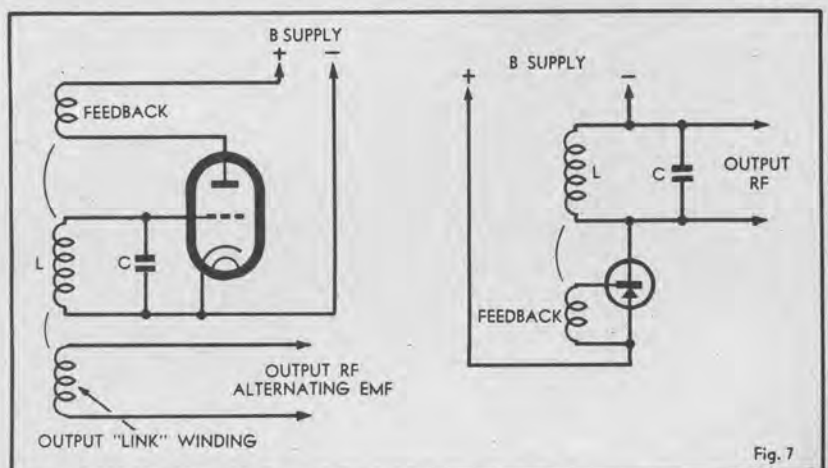


Figure 7. Examples of tuned oscillators. At left is an oscillator using a triode valve, while the oscillator at right uses a PNP transistor. Note that the feedback and output coupling circuits may be different from those shown.

sistor and fed directly to the tuned circuit.

In all oscillator circuits of this type, the amplifying device not only supplies the tuned circuit with enough energy to overcome losses and keep it oscillating. It supplies MORE than enough, so that a small amount of the oscillatory energy of the tuned circuit can be picked off for external purposes—in our case, for amplification and supply to the transmitting aerial.

This OUTPUT of the oscillator can be obtained in a number of different ways. A third winding may be used, magnetically coupled to the tuned and feedback windings, to produce an induced EMF, as shown in the valve circuit. Or a connection may be made directly across the tuned circuit, as shown in the transistor circuit. Or various other methods may be used, depending on the sort of oscillator actually used and the amplifier circuit which is to be connected to the output.

### L-C CIRCUITS

In our discussion of oscillators so far, we have been talking in terms of L-C parallel tuned circuits. However, oscillators using such tuned circuits tend to waver or "drift" in frequency. Only to a small degree, if the circuit is well designed, but enough to make them unsuitable as a source of RF carrier energy in a broadcast transmitter—for transmitters must radiate on a fixed frequency, or one would never quite know where to find them on the receiver dial!

Actual radio transmitters do not use L-C tuned circuits in the RF oscillator, for this reason. They use instead a carefully prepared wafer of quartz crystal, which has the property of resonating mechanically when an EMF is applied to opposite sides of the wafer. When it is made to oscillate, it does so with very much less frequency drift than a normal tuned circuit, particularly if it is kept at a constant temperature in a thermostatically controlled oven.

The frequency of such CRYSTAL-CONTROLLED RF oscillators is set by the dimensions and preparation of the quartz crystal. To change the frequency, the crystal must either be replaced by

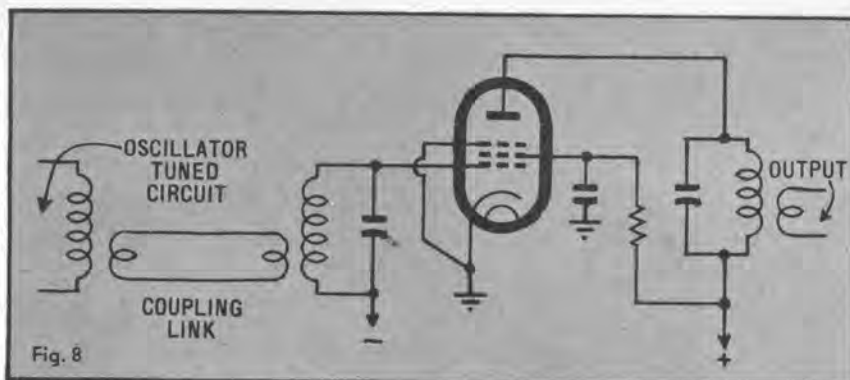
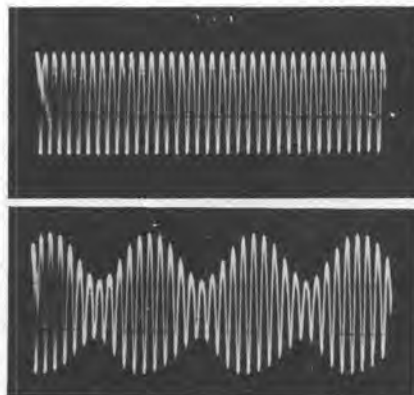


Fig. 8

Figure 8. An RF amplifier stage using a pentode valve. Transistors may also be used. If the RF oscillator uses a quartz crystal rather than an L-C tuned circuit, a different type of input coupling would be used.



Two photographs taken from the screen of an oscilloscope, an instrument used for visually observing electrical currents and EMF's. The upper pattern shows a high-frequency alternating EMF like that generated by an RF oscillator, while the lower pattern shows how the high-frequency carrier may be modulated in amplitude by a signal of lower frequency. Counting the number of small cycles per large cycle will show that in this case the carrier frequency is ten times that of the modulating signal.

another, or taken out and altered in size.

So much, then, for the source of the RF carrier energy in our transmitter. But the output of the oscillator is seldom strong enough to be fed direct to the transmitting aerial. Usually, it must first be amplified by one or more valve or transistor stages in the RF amplifier, as we mentioned before.

An RF amplifier using a pentode valve is shown in Figure 8. It has a tuned circuit in both the grid and plate circuits, and both tuned circuits are made to a multiple of the oscillator frequency. Other types of RF amplifier stage called "multipliers" have the plate circuit tuned to a multiple of the oscillator frequency, and the stage is arranged to multiply the frequency. This is used where the required carrier frequency cannot conveniently be generated directly by the oscillator.

For instance, multiplier-type RF amplifiers must be used with crystal-type RF oscillators if very high carrier frequencies are required, as it is impractical to make quartz crystals to oscillate at very high frequencies.

Link windings couple the tuned circuit of the RF oscillator to the input of the amplifier, in this case. If the RF oscillator used a crystal rather than an L-C tuned circuit, one of the other types of coupling would be used.

Negative bias is applied to the grid of the valve to ensure that it operates at a convenient point and amplifies efficiently. The amplified RF carrier which appears in the plate tuned circuit (the "TANK" circuit) is coupled to the next stage—or to the aerial if this is the last stage—via another coupling loop.

### CARRIER STRENGTH

We have now seen something of those parts of a radio transmitter responsible for the generation of the RF carrier energy. By adding a keyed-carrier or CW transmitter, but let us progress a little further and see how the carrier may be varied in strength so that it can be used to transmit voices, music, or even pictures. In other words, let us see how continuous amplitude modulation is performed.

The strength of the RF carrier fed to the aerial depends on a number of things, but one of these is the plate supply voltage of the final RF amplifier stage. The output is, in fact, proportional to the plate voltage, with a circuit like that of Fig. 8.

Because of this, to vary the strength

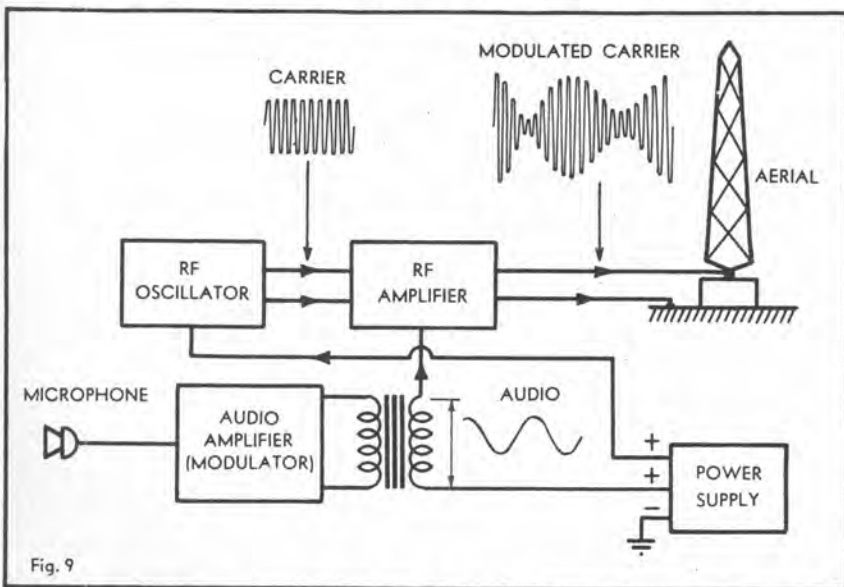


Fig. 9

Figure 9. The block diagram of an AM transmitter. The signals from the microphone are amplified and then superimposed upon the plate voltage of the final RF amplifier, which varies the strength of the RF carrier fed to the aerial and radiated.

of the RF carrier—to amplitude modulate it—all that need be done is superimpose the audio (sound) frequency signals on the plate supply voltage. In this way the audio signals add to and subtract from the plate voltage, and vary the strength of the RF carrier in sympathy with the sound waves reaching the microphone.

There are other ways of modulating the carrier, but they all produce the same effect and need not concern us here. The basic idea of a PLATE-MODULATED AM TRANSMITTER is shown in Figure 9.

There is an RF oscillator and an RF amplifier, as with the CW transmitter, in order to generate the RF radiation energy. However, added to this section is the microphone, an audio amplifier (the MODULATOR) and a transformer used to superimpose the amplified audio frequency signals on to the plate voltage of the RF amplifier.



Figure 10. The final RF amplifier stage in a radio transmitter has to handle quite a lot of power, and the valve or transistor used must be arranged accordingly. The valve shown here is a type used in medium-power transmitters, and is air-cooled. In the higher-power transmitters large water-cooled valves are used.

The audio amplifier may use either valves or transistors, and builds up the strength of the tiny voice-frequency voltages generated by the microphone. The output of the audio amplifier is fed to one winding of the MODULATION TRANSFORMER.

The other winding of the transformer is connected in series with the plate circuit of the final RF amplifier, so that the amplifier receives its plate current through the transformer winding. In this way, the amplified audio voltages induced in this winding of the transformer add to or subtract from the supply voltage, and can vary the strength of the carrier fed to the aerial.

The small waveform sketch shows what the modulated carrier would look like if we could see it. In fact, we can see it if we use an instrument called an oscilloscope, as the two photographs show.

Instead of the microphone, we can use a gramophone pickup, a tape recorder, and so on. In television transmission, we would use cameras, film scanning machines and picture (video) tape recorders instead.

And with the description of a basic AM transmitter, we must end this chapter. Now that we are reasonably familiar with the nature of radio waves and the way in which information can be transmitted, we are ready to look at the way in which the radiated radio waves are used. In the next chapter, then, we will start at the "other end" of the radio system—the receiver.



## AMATEUR ASTRONOMERS SUPPLY CO.

11a Clarke St.,  
Crow's Nest,  
Sydney.

Phone: 43-4360.

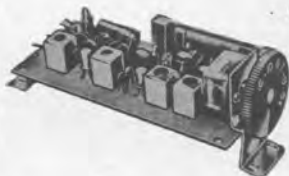
FREE CATALOGUE: ● Build-it-yourself kits  
● Telescopes ● Optical Parts ● Binoculars  
● Books ● Star and Lunar Atlases.

LATEST SELECTIONS—LOWEST PRICES

# LAFAYETTE

## Miniature Transistor Amplifiers and Tuners

SUPER VALUES for Experimenters and Hobbyists



99-9040  
\$11.75

### 3-TRANSISTOR SUBMINIATURE AM BROADCAST TUNER

A sensitive superhet circuit covers 540-1600KC. Features 3 IF transformers and ferrite antenna. Add audio amplifier and have highly efficient receiver.

99-9040 NEW LOW PRICE! \$11.75.

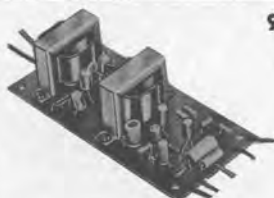


99-9037  
\$9.75

### 5-TRANSISTOR PUSH-PULL AMPLIFIER OUTPUT 360 MW

Three stages of audio drive a push-pull output stage designed to deliver 360 MW to speakers with a voice-coil impedance of 8-11 ohms. Size 3-15/16" x 1-15/16" x 11/16"

99-9037 NEW LOW PRICE! \$9.75



99-9038  
\$9.75

### 1-WATT 4-TRANSISTOR PUSH-PULL AUDIO AMPLIFIER

A more powerful miniature amplifier with many direct audio frequency applications. Push-pull circuit is very sensitive and has 1 watt output. Size 4-7/8" x 1-1/2" x 2/4."

99-9038 NEW LOW PRICE! \$9.75



99-9042  
\$6.95

### 4-TRANSISTOR SUBMINIATURE PUSH-PULL AMPLIFIER 100 MW

Tiny in size it can be mounted inside other equipment. Two audio stages are followed by a push-pull output stage designed to deliver 100MW into 8-11 ohms. Size 3" x 1-9/16" x 11/16."

99-9042 NEW LOW PRICE! \$6.95



BK-24  
\$2.50  
Post Paid

### An Exclusive Lafayette Publication

#### TRANSISTORISED MINIATURE AMPLIFIER AND TUNER APPLICATIONS

96 Pages of interesting applications for the LAFAYETTE transistorised miniature amplifiers and tuners. An excellent source of information for equipment builders and experimenters.

BK-24 Post Paid. \$2.50

COMPONENTS In addition to the exclusive LAFAYETTE products we are importers and distributors, of HITACHI electron tubes and carry large stocks of electronic components. Let us know your requirements.

# LAFAYETTE ELECTRONICS

Division of Electron Tube Distributors Pty. Ltd.

VICTORIAN SALES CENTRE AND HEAD OFFICE,  
15A WELLINGTON STREET,  
WINDSOR, S.1, VICTORIA  
51-6362



## CHAPTER 9: Revision of basic transmitting principles.

The use of capacitors and inductors in various forms as receiving aerial systems. Tuning, or the selection of signals from the desired transmitter by means of a parallel tuned circuit. Demodulation or detection. The diode detector. The simplest radio receiver. Earphones and their operation.

**I**N the last chapter of this course, we described the process of radio transmission; how telegraph code, speech and music can be carried by radio waves over great distances. In this chapter, we see what happens at the "other end." We find out how the radio waves are intercepted and the required signal selected and changed back into the information being transmitted.

When we talked of radio waves in the last chapter, we said that they were waves of energy in the form of an oscillating electromagnetic field. Energy in this form radiates from any oscillating electric or magnetic field.

It therefore radiates to a certain extent from any capacitor or inductor in a circuit carrying alternating currents and EMFs, but it radiates most profusely from devices which are specially designed for the purpose. These **RADIATORS** or **AERIALS** combine in various proportions the characteristics of a capacitor and an inductor, and when properly designed will radiate as radio waves most of the electrical energy fed to them.

Now it so happens that the process is reversible. If capacitors, inductors or aerial systems combining capacitive and inductive elements are placed in the path of radio waves, energy will be extracted from the electromagnetic field to appear as induced alternating EMFs or currents in the circuit. And, if the RF carrier voltage fed to the original transmitting aerial system was amplitude modulated, the voltages or currents induced at the receiving end will similarly be varying in amplitude.

Figure 1 illustrates some of the ways in which energy may be extracted from the transmitted waves to obtain induced EMFs.

A capacitor **C** (right) placed in the path of the waves interacts with the "oscillating electric field" aspect of the electromagnetic waves, and generates an EMF, as shown. In a very similar fashion, an EMF will be generated by the "capacitor" formed by a suspended wire **A** and the earth beneath it.

The latter example is the familiar "inverted L" aerial, which often becomes a simple "length of wire strung around the picture rail" when the transmitter is not too far away. The connection to the earth side of the "capacitor" may not be an actual physical one, but may be made via inter-winding capacitance in the mains transformer and thence to earth via the power mains system.

Another version (not shown) of the capacitor aerial is seen on cars, where the insulated whip forms the "suspended

wire" side of the capacitor and the car body itself forms the other side.

If we place an inductor **L** in the path of the radio waves, it will interact with the "oscillating magnetic field" aspect of the electromagnetic waves, and will also produce an EMF. Examples of this type of receiving aerial are the "loop" coils used in older-style portable sets and the ferrite-rod aerials used in modern portables.

There are many more types of receiving aerial, such as the folded dipole shown in Figure 1 as **D**. This is used in many aerials of the higher frequency type, and will be familiar to many as part of their TV antenna. The dipole combines capacitor and inductor action, in such a way that it responds mainly to waves of only one frequency. Aerials of this type are said to be **RESONANT**.

In general, we can say that any capacitor or inductor or device which combines the two types of reactance will produce an EMF when placed in the path of electromagnetic waves; the more the capacitor or inductor is "pulled apart" to embrace more of the waves, or the higher and longer the wire in an "inverted L" aerial, the better, while the greater the area of a loop aerial coil the better. And so on . . .

So far, we have "intercepted" the radio waves streaming from the transmitter

and used an aerial to extract a small amount of energy from them and produce an EMF.

The next step is fairly obvious when we consider that most aerials will produce EMFs corresponding to ALL the waves which stream past them. Before much more can be done, therefore, it is necessary to select the desired signal from the jumble. This is usually done by means of a parallel tuned circuit.

As we saw in the last chapter, a parallel tuned circuit will oscillate when it is excited into doing so by energy arriving as an alternating EMF corresponding to its resonant frequency. The resonant frequency is governed, you may remember, by the size of the capacitor and of the inductor.

It is most important that the rate of alternation of the incoming energy corresponds to the resonant frequency of the tuned circuit, to keep it oscillating. If it is not of the same frequency, it will not have a sustaining effect and the tuned circuit will not keep oscillating. It will be like trying to make a playground swing oscillate by giving it pushes at a rate faster or slower than that dictated by its size and weight; the energy will be almost completely wasted, for a swing will only oscillate at its natural frequency.

To select a particular radio signal from the jumble of EMFs supplied by the aerial system, then, the aerial signals are fed to a parallel tuned circuit. The capacitor and inductor of the tuned circuit are arranged to be resonant at the desired frequency, so that the only aerial EMFs which can cause it to oscillate are those of the signal concerned. (It is very unlikely that the aerial will receive signals from two transmitters having the

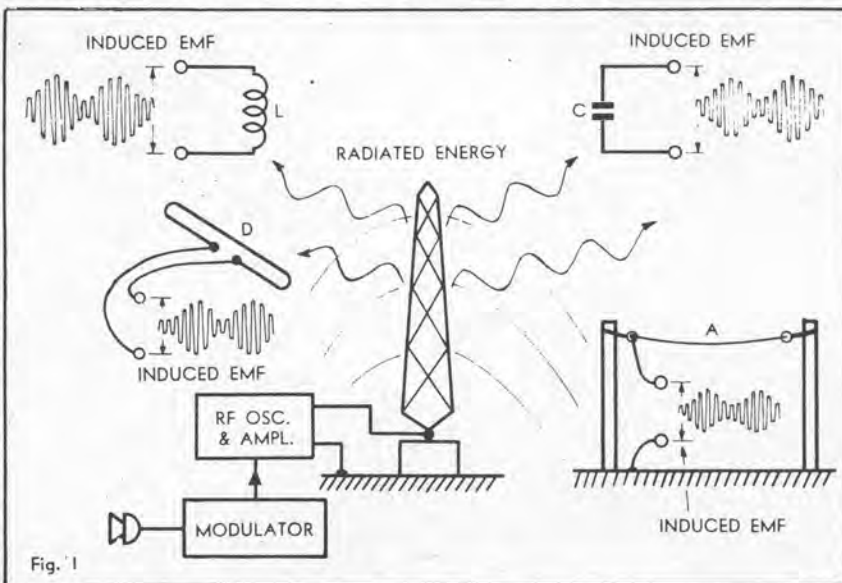


Fig. 1

Figure 1: Illustrating some of the ways in which a small amount of the energy in radio waves may be extracted to produce an EMF. Devices which do this are known as receiving aerial systems.

same carrier frequency, because regulations ensure that such stations are long distances from one another.)

If it is desired to receive signals from a number of transmitting stations, the tuned circuit is arranged to have its resonant frequency adjustable over the band of frequencies concerned. This can be done by making either the capacitor or the inductor a variable unit.

The control knob fitted to the variable component in the tuned circuit is the "tuning" knob familiar to all who have operated a radio receiver.

There are a number of ways in which the aerial EMFs may be fed to the tuned circuit. Two such methods are shown in Figure 2. In one case (a) the EMFs

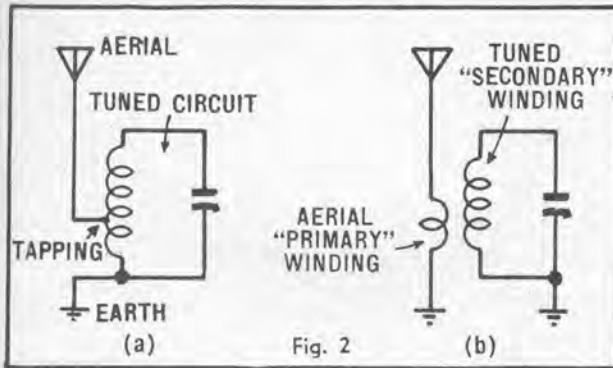


Figure 2: Two ways of feeding the induced aerial-earth EMFs to the parallel tuned circuit. The tuned circuit is arranged to resonate at the frequency of the desired signals, by which means other signals are rejected.

appearing between the aerial and earth are directly connected to part of the inductor; in the other case (b) they are connected to the small primary winding which is magnetically coupled to the inductor.

In neither case is the aerial-earth circuit connected directly across the tuned circuit. Among other reasons, this is because the aerial-earth capacitance would tend to upset the tuned circuit if it were connected directly across it. The same aerial "capacitor" would also tend to re-radiate some of the oscillatory energy as soon as the tuned circuit started to oscillate — remember, a capacitor connected across an alternating EMF will radiate!

We have now obtained across the tuned circuit of our receiver a tiny replica of the modulated RF carrier voltage which was fed to the transmitting aerial system of the station in which we are interested. The selective action of the tuned circuit has effectively discarded all the unwanted EMFs fed to it from the aerial circuit, to leave only the desired signal. The task is now to turn this tiny modulated RF carrier voltage back into the original speech and music.

There would be no point in feeding the signal from the tuned circuit directly to an earphone or to a loudspeaker, because these devices would not be able to vibrate mechanically at radio frequencies. And even if they could do so, the air would not transmit the vibrations more than a tiny fraction of an inch. Furthermore, we wouldn't be able to hear the "sound" anyway, as our ears do not respond to such high frequencies.

Before we can feed our signals to an earphone or loudspeaker for conversion into sound waves, we must separate the

modulating information (the speech and music) from its "transport" — the RF carrier. This process is known as DEMODULATION or DETECTION.

The first of these terms is perhaps to be preferred, because it indicates that the process is the opposite of the modulation which occurs at the transmitter. The second term is quite commonly used, however, being a heritage from the pioneering days of radio.

There are a number of ways in which an amplitude modulated RF carrier may be demodulated, but the simplest is the DIODE DETECTOR, which takes advantage of the "on-way" conduction behaviour of any one of the various types of diode. Thermionic diode valves, germanium or silicon

semiconductor diodes, or even a "cats-whisker" wire touching a suitable spot on a crystal of galena — all will serve as a diode detector.

Detector action is quite complex, unfortunately, even in the simple diode detector. However, we can form a simplified understanding of the way in which they work by reference to the waveforms of Figure 3.

The waveforms in (a) should be familiar, as it is a replica of the modulated RF carrier voltage fed to the transmitting aerial system; it is the signal developed across our receiver tuned circuit.

What the detector does is to let only part of this signal through, as shown in (b). The "one-way" action of the diode is used to allow only half of the RF oscillations to pass through — only the upper half-cycles of carrier, in the waveforms shown.

The resistor marked "load" represents in simplified form the effect of an earphone or loudspeaker were it connected across the output of the detector.

### HALF-CYCLE PULSES

As may be seen, the output of the diode detector consists of half-cycle RF pulses which are all of the same polarity and which vary in amplitude with the modulating information.

Were we to feed these pulses directly to an earphone or loudspeaker — and assuming them to be strong enough — we would hear faintly the original sound. We would hear the sound, not because the earphone or loudspeaker would be vibrating at the high frequency of the pulses, but because it would tend to regard them as "instalments" or a succession of "little pushes," which tend to displace the diaphragm.

In other words, it would be responding to the AVERAGE VALUE of the pulses. As the pulses are modulated, their average effect on the diaphragm will be similarly modulated and thus the earphone or speaker would produce faint sounds.

Before we go any further, make sure that you can see why an earphone or speaker would respond — even if faintly — to the waveform of Fig. 3(b), when it would not do so to the "whole"

## BY WAY OF ILLUSTRATION

A TRANSMITTING aerial can be likened to a huge tuned circuit surrounded, in operation, by alternating electric and magnetic fields. These fields may extend for hundreds, even thousands of miles.

Many find this difficult to comprehend, because electrical energy is so intangible, particularly when there are no wire circuits to carry it. However, one doesn't need to search very far to find illustrations of how electrical energy can bridge empty space.

Everyone is familiar, for example, with the trick of rubbing an ebonite or plastic rule against dry cloth and seeing it attract small scraps of paper.

A lecturer might explain the effect as due to the attraction between two bodies carrying an unlike electrical charge. This would be true, but for our present purpose, it illustrates graphically the fact that an electrical charge can exert an influence THROUGH SPACE, even though it may only be over a few inches in this particular case.

Again, there is the familiar case of a permanent magnet and the way in which it can attract to itself small iron and steel objects. Just what the force of magnetism is puzzles even the scientists, but there is no denying its effect.

Nor is the effect of a magnet measurable only in inches. Bring a magnet within many feet of a compass and the needle will deviate perceptibly from its normal reading, depending on the way in which the magnet poles happen to lie in respect to the earth's magnetic field.

Of course, a permanent magnet has a steady unidirectional field, but we can easily change that. If the magnet is rotated in the appropriate fashion, its field will rotate—or alternate—also and the compass needle will swing to and fro. Or we could gain the same effect by substituting an electromagnet and passing through it a slowly alternating current. The compass needle would again swing to and fro.

But here is the point of the illustration: There is no tangible connection between magnet and compass, just a magnetic field ACTING THROUGH SPACE. One could very rightly regard the magnet and its manipulations as a transmitter of energy and the compass needle as a receiver, reacting to its influence.

And remember, it would act just the same if magnet and compass were both in a vacuum. Air is not necessary to sustain electrical phenomena.

Now substitute for the magnet, in your thinking, a transmitting aerial which can produce a much more powerful electromagnet field, alternating or varying at a frequency determined by the transmitter.

Substitute for the compass needle a receiver, which is much more sensitive to such variations, and you have the picture. The same kind of forces which you can so easily demonstrate over a distance of inches or feet are shown to operate over vastly greater distances, given the right kind of apparatus.

# ELECTRONIC DEVELOPMENTS PTY. LTD.

## KITSETS - -

AMPLIFIERS	INSTRUMENTS	CONVERTERS	RECEIVERS
Guitar Stereo Monaural P. A. Units	C.R.O.'s V.T.V.M.'s Millivolt Meter Tacho's	S/W A.C. 50 & 144 MC/s S/W Battery Xtal Locked	Transistor Valve A.C. Valve Battery Amateur R.X.

### ALL COMPONENTS AVAILABLE SEPARATELY

#### FOR MULLARD, E. A. & PHILIPS PROJECTS

METALWORK—PRINTED WIRING BOARDS—SWITCHES — POTENTIOMETERS—  
VALVES — DIODES — PLUGS — SCR'S — PANELS — WINDING WIRE — BEZELS  
TRANSISTORS — SOCKETS — TERMINALS — TRANSFORMERS — CONDENSERS  
— METERS — HIGH STAB RESISTORS — INSTRUMENT CASES—VERNIERS—HEAT  
SINKS—SHEET TUBE AND ANGLE ALUMINIUM.

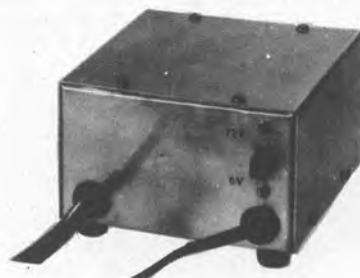
WRITE OR CALL FOR QUOTES  
ON ANY COMPONENTS OR KIT



Playmaster 113



1966 VTVM



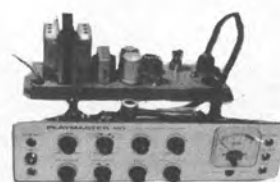
Battery Charger



Mullard 3—3



103 Guitar Amplifier



110 Tape Amplifier

# ELECTRONIC DEVELOPMENTS PTY. LTD.

Phones 63-3596  
63-5973

232 FLINDERS LANE  
MELBOURNE . . . . VICTORIA

Phones 63-3596  
63-5973



tuned circuit output shown in (a). The reason is simply because the complete waveform has an average effect of zero; there are as many negative pulses as there are positive.

It is only by either removing one or the other set of half-cycle pulses, or by somehow "up-ending" them so that they add to the first set, that there is a net effective voltage to which the earphone or loudspeaker can respond. The diode detector uses the "remove one set" method, which is called HALF-WAVE detection. Most detectors use this method, but one or two use the "up-end one set" method, which is known as FULL-WAVE detection.

By using a diode detector to "chop off" one side of our tuned circuit EMF, we can feed the result to an earphone or loudspeaker with the possibility of being rewarded with faint sounds. Just how faint they will be will depend upon our aerial system and the distance from the transmitter, because these factors will control the strength of our aerial and tuned circuit EMFs.

In some cases, we can improve the efficiency of this "simplest" radio receiver by adding another capacitor.

Figure 3 (c) shows where this additional capacitor is connected — right across the load. If the capacitor is arranged to be a suitable value, it can help in the pulse averaging operation carried out by our earphones or loudspeaker. It does this by charging up during each tiny radio frequency pulse and supplying its stored energy to the earphone or loudspeaker until the next pulse arrives.

### EXTRA CAPACITOR

In other words, the added capacitor "smoothes" out the pulses into a direct voltage which varies only with the modulation. This is illustrated by the waveform in Fig. 3 (c).

The circuit above this waveform represents what may be regarded as the "simplest practical radio receiver," and is, in fact, the basis of the "crystal" set which we will discuss in a moment. It involves no amplification of the received signals, but is simply a means whereby a small amount of energy may be drawn from the electromagnetic waves from a radio transmitter and turned into the sound which has been superimposed on it.

In the more elaborate receivers which we will be discussing in following chapters, the signals are amplified to make them more powerful and better able to operate a loudspeaker or earphone under poor signal conditions. In most types of receiver, the signals are amplified both before and after they are demodulated in the detector.

For the remainder of this chapter, however, let us see how a typical "crystal" set carries out the tasks which we have been discussing. Incidentally, the term "crystal" is still used for sets of this type, even though the old galena crystal-and-cat's-whisker-wire detector is rarely ever used nowadays. As long as the set does not amplify the signal, it is usually called a "crystal set" despite the fact that it might use a diode valve or a germanium diode.

The circuit for a simple receiver of this type is shown in Figure 4. As you can see, there is not really much difference between this circuit and that of Fig. 3 (c). The earphones are shown connected to the output of the germanium

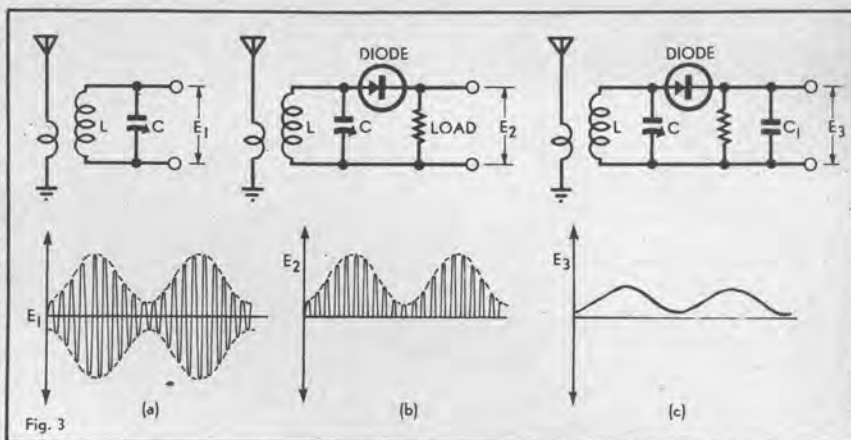


Figure 3: Steps in the demodulation or detection of the modulated RF carrier EMFs present across the tuned circuit. A diode and an additional capacitor are used to remove carrier oscillations and leave the modulation information.

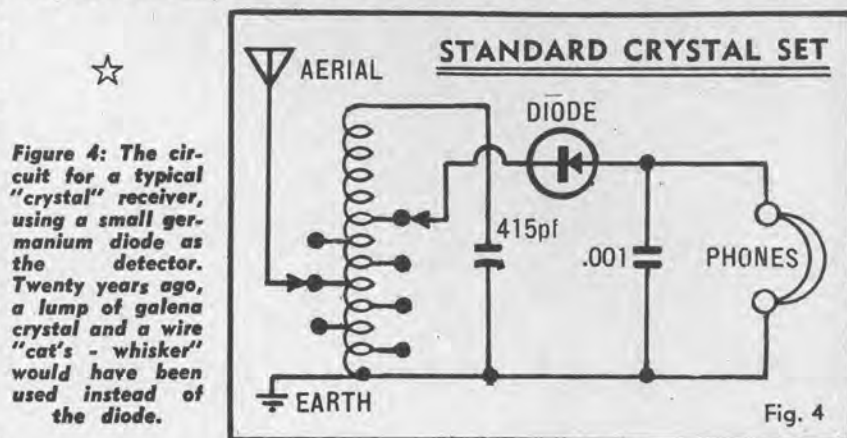


Figure 4: The circuit for a typical "crystal" receiver, using a small germanium diode as the detector. Twenty years ago, a lump of galena crystal and a wire "cat's - whisker" would have been used instead of the diode.

ium diode, and the small smoothing capacitor is connected across the phones to ensure proper detection efficiency.

The EMFs induced in the aerial-earth capacitor system by the radio waves are magnetically coupled to the inductor L of the tuned circuit as before, and the capacitor C is variable so that the tuned circuit may be adjusted to resonate at any frequency within the broadcast band (550 to 1600 Kc/s).

A point of difference is that the detector diode connects to a tap on the inductor, so that the diode and earphone circuit are connected across only a small portion of the tuned circuit rather than right across it.

This is done because practical earphones load the tuned circuit too much if they are connected in series with

the diode across the whole inductor. As this prevents the tuned circuit from properly rejecting all the unwanted signals — upsets its SELECTIVITY — the detector and earphone circuit are connected across only part of the inductor.

How far the detector is tapped down the coil depends also upon the strength of the available signals, and hence upon the distance from the transmitter. This is because tapping down the inductor reduces the proportion of tuned circuit voltage fed to the detector and earphone, and reduces the loudness of the sound heard.

The position of the tap is therefore a compromise between good sensitivity and good selectivity. The higher the tap is moved up the inductor the greater will be the volume, but the poorer the selectivity; conversely, lowering the tap will generally lower the volume but give better rejection of unwanted stations.

There is only one component in Fig. 4 which we have not as yet said much about — the earphones. Most readers will be aware that these somehow convert a varying voltage into sounds, but some may not be familiar with their construction or operation. It might be as well if we spent a few moments clarifying these matters, particularly as we will be meeting with earphones again in later chapters.

Figure 5 shows the basic construction of an earphone of the type used in most "headsets" and in many telephone handsets. The plastic or metal cap and housing are shown dotted as these simply support and protect the actual working parts.

Basically the earphone consists of a permanent magnet which attracts a thin

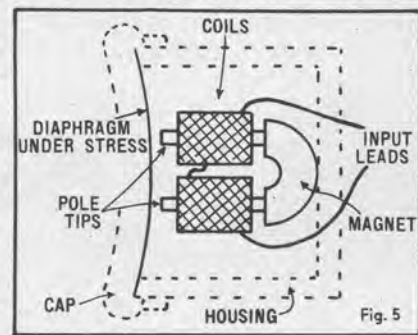


Figure 5: The construction of a typical earphone. When a varying or alternating current passes through the coils, the thin metal diaphragm is caused to vibrate and generate sound waves.

# now another new model



model A-10/P with  
in-built signal in-  
jector.  
sensitivity 30000  
ohm/volt d.c.,  
10000 ohm/volt  
a.c. \$54.00

## in the tested range of **PEAK MULTIMETERS**

			
CT-500/P \$17.00	200H \$11.95	370J/P \$22.00	M-650/P \$21.00
			
HT-100/P \$31.50	370W/P \$46.00	F-66/P \$28.50	F-75JH/P \$22.95

all PEAK multimeters are guaranteed for three months against faulty materials or workmanship. available from all leading electrical retailers.

adelaide  
hobart  
perth

brisbane  
melbourne  
sydney

sole  
australian  
agents

**H. ROWE**  
& CO. PTY. LTD.

# A TYPICAL CRYSTAL SET

"stalloy" metal diaphragm via two soft iron pole-pieces. The diaphragm is stressed inward due to the attraction and thus assumes a slight concave shape under normal conditions. The housing and cap are arranged so that the diaphragm almost touches the tips of the pole-pieces, but never quite does so.

A coil of fine wire is wound on each pole-piece, and the coils are connected in series so that when a current is passed through them they both have the same effect upon the magnetic field produced by the magnet.

When a current is passed through them in one direction, their magnetic fields add to that of the magnet and attract the diaphragm still further. Conversely, when a current is passed through them in the opposite direction their magnetic fields tend to cancel the magnet field and the attraction is reduced.

If a varying or alternating EMF is applied to the coils, a correspondingly varying or alternating current will flow through them. This will cause the diaphragm to move in sympathy with the variations or alternations in the EMF, as its attraction will vary with the current variations.

And when the diaphragm vibrates in sympathy with the voice—or music—frequency variations in the applied EMF, it sets up sound waves in the air. If the applied EMF is the output of our detector diode, the sound will be a reproduction of the sounds which were picked up by the microphone at the transmitter.

As we shall see in later chapters, earphones and their "big brothers" the loudspeakers are an important part of every radio receiver. Without them to reconvert the electrical signals back into sound waves, radio would scarcely be practical.

Readers who are following the Basic Radio Course may care to construct a "crystal" set to give themselves practical instruction supplementing this month's chapter. Below are condensed details of our "Standard Crystal Set" originally published in November 1957, which would be ideal for experiment. The circuit of this receiver is given in Figure 4 of the theory article.

**T**HE construction and wiring of the receiver should be fairly obvious from the photographs and wiring diagram. The components are mounted on a piece of plywood some 6½ in x 5 in, to which is nailed a wooden front panel approximately 8 in x 6 in.

Two terminals on the front panel are used to allow the aerial and earth lead-in wires to be connected easily. The aerial should be as long and as high as is practical, and should preferably be a length of 7 x 0.022 in copper "earth" wire. It must be insulated from its supports, and this may be done with "egg" type insulators of plastic or porcelain.

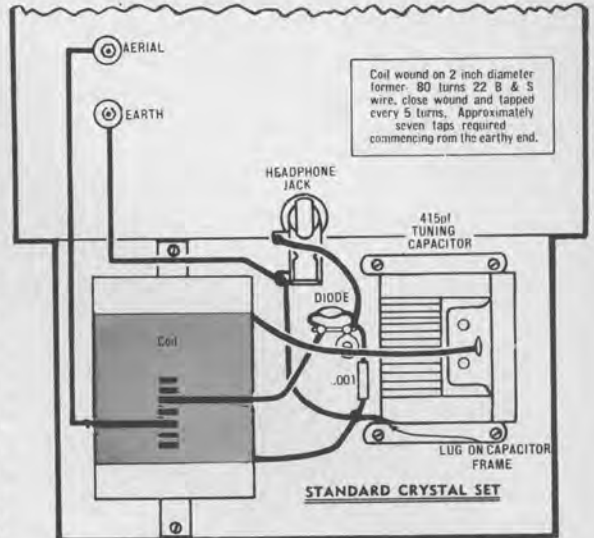
The earth may be connected to the house water-pipe near where it leaves the ground, or if this is not practical, it may be a connection to a yard or so of galvanised pipe driven into fairly damp ground. Don't connect to a gas pipe, though, for this is frowned upon by the authorities.

The tuning capacitor need not be a new one. A tuning gang salvaged from an old radio set may be pressed into service providing it is still working satisfactorily. Make sure that none of the moving plates touch the fixed plates, and connect to only one set of fixed plates if the unit happens to be a multi-section or "gang" capacitor.

The shaft of the capacitor is taken through a hole in the front panel and fitted with a large knob, as can be seen in the photograph. A dial scale pasted on the front panel can then be marked with the station names when the set is completed.

The table in the wiring diagram gives coil winding details for those who would like to wind their own. The former may be of plain or waxed cardboard, or even of wood. To make the taps, wind the appropriate turns over a piece of match-stick. The raised wire at each tap can then be scraped free of enamel and soldered to when required.

If desired, of course, a commercial coil may be used in place of the home-wound one. The most suitable type would be a high-gain transistor aerial coil, such as that used for our "Three Band Transistor Eight" receiver. Connect aerial, earth, and the two sets of capacitor plates to the coil exactly as originally intended, using the "base"



Using this wiring diagram and the circuit shown in the theory article, it should be a simple matter to build up the receiver even if you have never wired up a circuit before.

tapping for the detector in the crystal set.

The germanium diode may be almost any of the common types, such as the 0A91, 0A90, 0A85, 0A81, 0A80, 0A79, 0A5, GEX35, GEX34 or GEX33. If readers have an old "cats-whisker" detector they could try it, but results generally will not be as good as with one of the modern diodes.

For this particular application, it does not matter which way round the diode is connected into the circuit.

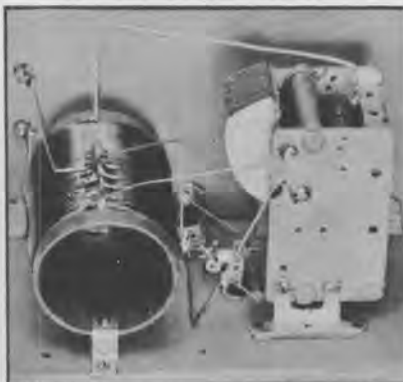
The 0.001µF capacitor may or may not have much effect, depending upon the type of earphones used. Since it will only cost a few pence, it may as well be put in.

Low impedance earphones are not suitable for this type of receiver. For best results, use high impedance 1000-4000 ohm units. Crystal earpieces are in general rather too insensitive, despite their high impedance, although they may prove satisfactory in strong signal areas.

The earphones are connected to a jackplug, which plugs into a jack mounted on the front panel of the set.

There is no need for an on-off switch, for there is nothing to turn on and off. Simply connect up the aerial and earth, plug in the earphones, and you should be able to tune in to one or more stations, provided you are not further from them than about 15-20 miles.

How many stations you will actually be able to receive without mutual interference will depend on relative strengths at the listening site, some sites being much more favourable for crystal sets than others.



Above is a front view of the receiver, and below a rear view showing the wiring. The diode is supported by a small 2-lug tagstrip, and the coil fastened to the baseboard via two small aluminium brackets.

## CHAPTER 10: Limitations of a crystal set.

Amplified crystal sets and audio stages. Diode and triode detectors using valves and transistors. Grid-leak and base-leak detection. Reaction or regeneration.

Two-stage receivers with transformer or resistance-capacitance coupling. Three-stage receivers. Power output stages.

Overload and gain or volume control.

**H**AVING used the crystal receiver to learn some of the basic facts about radio reception, we are now in a position to discuss simple valve and transistor receivers. The emphasis in the discussion will be on the operating principles of the various types of receiver rather than on their construction, but circuits will be provided with component values for the benefit of those who would like to experiment.

As we saw in the last chapter, a crystal set is a very useful and interesting device. It is simple to make, it costs nothing to operate and it demonstrates, in a practical way, many important radio principles.

For all that, however, a crystal set has very serious limitations. The only energy available to it is the radio frequency energy picked up by the aerial and earth system from the desired transmitter. This is selected, demodulated and made available to the earphones as an audible signal.

As the distance between receiver and transmitter is increased, the energy available becomes less and less until, at a distance which may be as little as 25 miles, the signal becomes inaudible. Only in very exceptional circumstances are the signals from a crystal set ever strong enough to operate a loudspeaker.

Yet another serious problem is that of poor selectivity, a crystal set often being unable to separate the wanted signal clearly from other strong signals in the receiving area.

In the face of such limitations, it is not surprising that engineers, very early, sought to improve the performance of crystal receivers or, alternatively, to supplant them altogether. Nor is it surprising that they have been relegated, in this modern age, to the role of a "beginner's set."

As you have probably guessed, the answer was found in a device we have already discussed—the thermionic valve. If you've forgotten this earlier discussion, we suggest you turn back to chapter 6, in the January, 1964, issue.

Strangely enough, the very first valve receivers were no more ambitious in their performance than crystal sets—in fact, there were plenty of early radio operators of the day who claimed that they were not as good.

These early valve receivers were just like crystal sets, in fact, except that they used a diode rectifier in place of the metallic crystal detector.

As we explained in the earlier article, diodes exhibit the same rectifying properties as a crystal, being able to pass current only in one direction. They make signals audible in the phones by the

same process as explained last month for a crystal set.

The main advantage of the valve or thermionic diode was that it needed no critical adjustment. This advantage was very real in a day when the surface of crystal diodes had to be probed with

control plate current (see earlier article) flowing from a B-battery. The resultant and larger plate current excursions, dependent on the grid signal, produced much louder signals in the phones.

Figure 1 shows a type of receiver which was quite popular in its day—the combination of what is virtually a crystal or diode receiver and a triode amplifier stage. This type of receiver is often built, even nowadays, as a beginner's project.

The incoming signal is selected by the tuning circuit and applied to the detector. This latter may be either semiconductor diode or a thermionic diode, which suppresses half the incoming carrier and

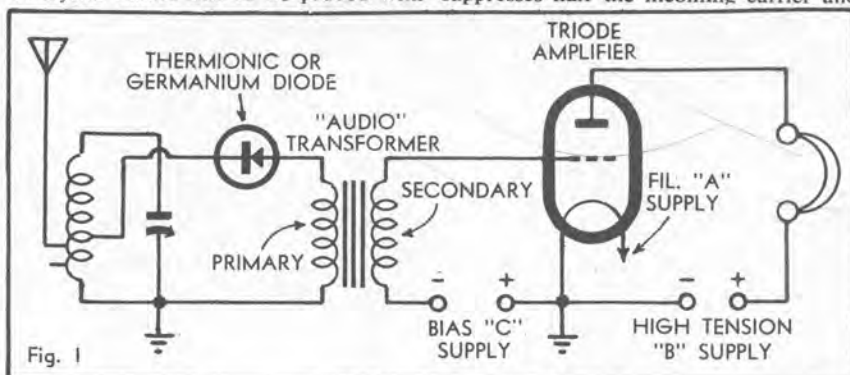


Figure 1. A simple receiver which uses a triode valve to amplify the demodulated signals produced by a diode detector. The diode may be either a thermionic (valve) type or a semiconductor type.

the "catswhisker" contact to discover a sensitive spot.

Against this, of course, the diode valve needed a filament battery, which was something of a nuisance. Hence the arguments of the day as to which was the better proposition.

The development of the triode valve settled such arguments, because it brought with it the ability to amplify the incoming signals. Instead of being utilised to operate the phones directly, the signals were applied to the grid to

delivers to its output circuit what we described, last month, as a series of unidirectional pulses proportional in strength at each instant to the modulated carrier.

Instead of being passed directly through the phones, to produce an audible sound, these pulses are passed through the primary winding of an audio transformer. Perhaps we should pause here to explain these terms, at least in brief.

The word "audio" comes from the

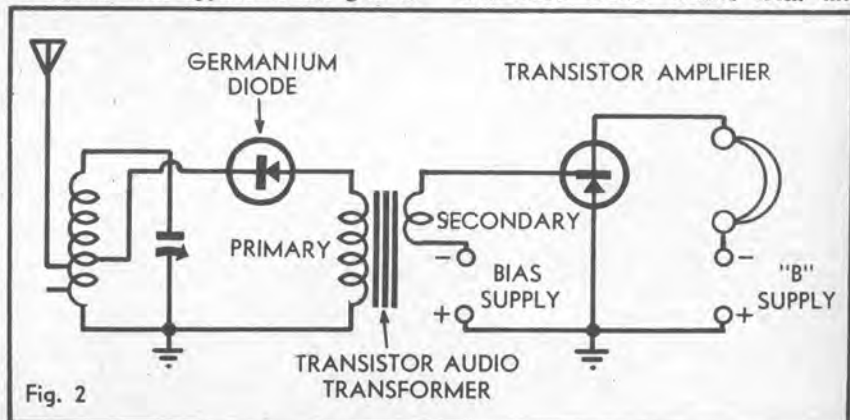


Figure 2. The transistor counterpart of the receiver shown in Fig. 1. Here a transistor is used in place of the triode valve, and a step-down audio transformer used to match it to the detector circuit. The transistor needs only two battery supplies, having no filament.

Latin verb "to hear" and is used in radio to describe any circuit or component which handles signals at a frequency within or adjacent to the range of sound frequencies. Thus an audio amplifier stage is one which amplifies signals at audio frequencies.

By the same token, an audio transformer is one which is designed to handle, or transfer, or couple signals at audio frequencies.

The principles of transformers generally have been discussed in an earlier chapter and obviously cannot be repeated here. An audio transformer is usually wound on a core made up from iron

to merge into a pattern, which follows the rise and fall of the incoming carrier with modulation.

The changing magnetic field, due to current through the primary winding, induces current in the secondary winding and a corresponding signal voltage between its two ends.

These two ends are connected respectively to the grid and filament circuit of a triode amplifier valve and the audio voltage between them therefore constitutes a grid signal controlling the flow of electrons through the valve from filament to plate.

For the reasons explained in chapter 6, a bias voltage is normally provided to keep the grid slightly negative with respect to filament, the optimum bias depending on the type of valve and its other operating conditions. When the incoming signal carries the grid more negative than the standing bias, current

gives a step-down voltage ratio, it actually gives a step-up CURRENT ratio, and this suits the transistor perfectly. It also "matches" correctly the relatively high-resistance detector circuit in the primary and the low resistance transistor input circuit connected to the secondary.

A simple receiver along the lines of figures 1 and 2 is capable of substantially better performance than an ordinary crystal set. Sound volume from nearby stations is increased. Range is effectively improved because signals which might otherwise be inaudible are amplified to listenable strength.

Even the effective selectivity can be improved because amplification from the audio stage allows the tappings on the coil to be moved closer to the earthed end, than would otherwise be the case. Selectivity is improved as a result.

Still further improvement would be possible by providing two or even three audio stages after the crystal detector. In practice, however, this is seldom done because better overall performance can be obtained by following different circuit principles, at least for simple beginner's type receivers.

What is involved, primarily, is the elimination of the crystal or diode detector and the substitution of a triode or transistor or one of the other multi-element valves already discussed.

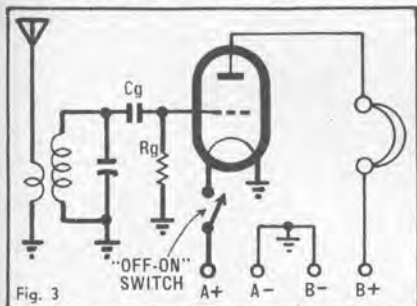
Figure 3 shows the basic circuit for a triode detector. Its operation must be considered in two distinct steps.

Within the valve, the grid and filament constitute what is virtually a diode rectifier, even though the grid is a spiral of wire, intended to serve another function altogether. If the grid, at any instant, should become positive with respect to filament, electrons will flow to it, just as if it were a plate. The flow will cease immediately the grid becomes negative again.

### THROUGH CAPACITOR

Now in figure 3, the input signal selected by the tuned circuit is fed to the grid through a capacitor, shown as Cg. This kind of notation is often used, by the way, to facilitate discussion of electrical circuits. "Cg" is simply an abbreviation for "Capacitor, grid." In a typical detector circuit, its value would be from about 100 to 270pF.

Since there is no standing bias on the grid, it will be carried positive during each alternate half cycle of the input signal. Electrons will flow from filament to grid, thence back to earth



**Figs. 3 and 4. Circuits in which the triode valve or transistor is made to perform both the detection and amplification operations.**

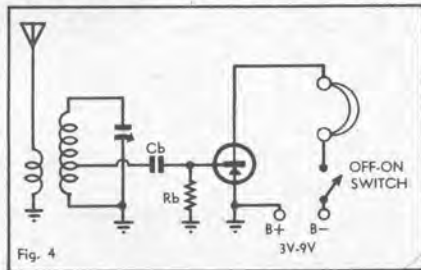


Fig. 4

laminations. It normally has two windings, and each may comprise many thousands of turns of fine wire.

The input signal is fed to the winding normally referred to as the primary, while signal is taken for the following circuit from the secondary.

It is possible to secure a step-up in signal voltage from a transformer by winding more turns on the secondary than on the primary. Old-style transformers, which often come into the hands of experimenters, typically have a step-up ratio of 1 to 3 or 1 to 5 from the primary winding to the total secondary winding.

Now back to figure 1.

The signal currents from the diode detector flow through the primary winding of the transformer. Now the transformer is no more able to respond to individual uni-directional carrier pulses than the earphones referred to in the last chapter.

However, the current through the primary winding, and therefore the magnetic field it produces in the core, tends

through the valve is reduced. Conversely, when the signal makes the grid less negative, current through the valve is increased.

This ever-changing current, flowing from the High Tension or B-battery through the phones in sympathy with the grid signal, produces much more output from the phones than could the current pulses available from the detector.

Figure 2 shows a receiver which is the transistor counterpart of that in Figure 1. A PNP transistor is used in place of the triode valve, and is supplied with base bias voltage and collector supply voltage with the polarities shown. The audio transformer used with the transistor usually has a step-down primary-secondary turns ratio rather than a step-up ratio, because as we saw in chapter 5 transistors have a relatively low input resistance and are current amplifiers rather than voltage amplifiers.

While fewer turns in the secondary of the transformer than in the primary

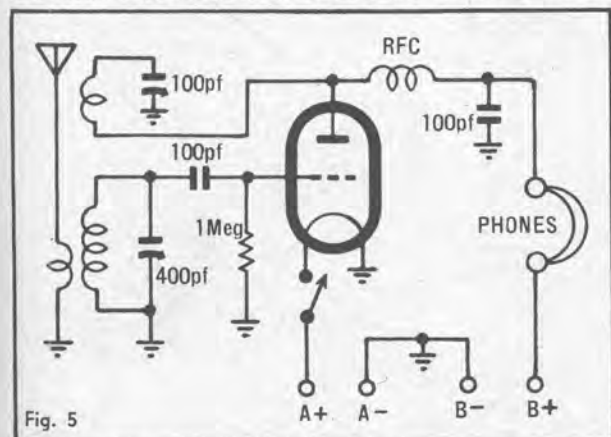


Fig. 5

**Figure 5. By using a third winding to feed back some of the RF present at the triode plate and reinforce the signals in the tuned winding, the gain and selectivity of the receiver can be improved considerably.**

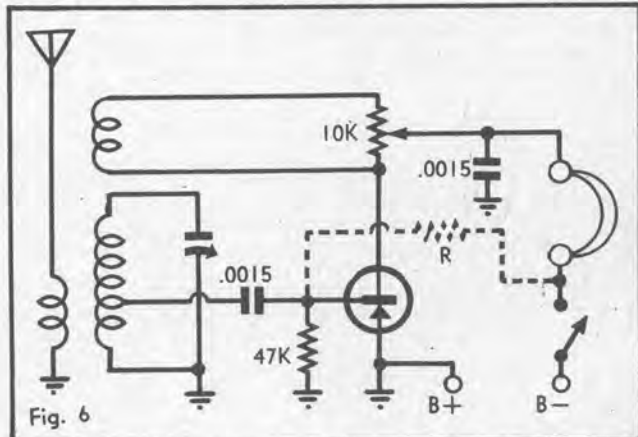


Fig. 6

**Figure 6. Regeneration feedback can similarly be applied to the transistor receiver to improve its gain and selectivity. Due to the lower impedance levels involved, a different method of feedback control is used.**

through the grid return resistor  $R_g$ . This latter may typically have a value of between 270K and 2.7 megohms.

Now whenever current flows through a resistor, a voltage drop must appear across the resistor. This much will be evident from our earlier study of Ohm's Law. Since the voltage is caused by electrons (or negative charges) flowing to the grid, the voltage at the grid will obviously be negative with respect to earth.

This negative voltage is also present across the capacitor  $C_g$ , which has one end connected to grid and the other to earth, through the coil. By normal storage action, the capacitor therefore tends to acquire a charge, which is proportional to the voltage developed across  $R_g$ .

Without going into a lot of detail, it should be fairly obvious that a large input signal to the grid will cause heavier bursts of grid current to flow during the positive half cycles. As a result, considerable voltage will appear across  $R_g$  as a charge stored by  $C_g$ .

With a small (or weak) input signal, the bursts of grid current will be of a lesser order, there will be less current through  $R_g$  and a smaller voltage across it and across  $C_g$ .

And here is a vital point. When the input signal varies in strength, with modulation, then obviously the voltage across  $R_g$  and  $C_g$  will vary in sympathy, increasing as the carrier amplitude rises, decreasing as it falls.

In other words, across those two components and therefore at the grid, a voltage is present which is negative in polarity and which varies in proportion to carrier amplitude. Thus, in its grid circuit, the triode provides a complete detecting action, changing the modulated RF input signal into a negative bias varying in sympathy with the original audio signal.

This is the first half of the total action in the valve and involves those sections of figure 3 which are drawn in heavy outline. The second half involves the normal amplifying action of the triode. The varying negative voltage on the grid causes a corresponding variation in plate current through the phones, producing an amplified version of the original audio signal.

From the foregoing it will be obvious that operation of the detector depends on the presence of a grid capacitor and grid resistor (often called the "grid leak") and the absence of any initial bias, it is usual to operate a "grid detector" with only a moderate plate voltage — 20 to 50 volts — so that it will not draw too much plate current with no input signal.

Figure 4 shows the transistor counterpart of the valve circuit. Here  $C_b$  and  $R_b$  are the equivalents of  $C_g$  and  $R_g$ , and function in a very similar fashion. The only difference is that the base circuit is a much lower resistance circuit than the grid circuit of a valve, making it necessary to tap the circuit connection down the tuned circuit. The values of  $C_b$  and  $R_b$  are similarly different from those in the valve case, typical values being 0.0015uF and 47K.

The transistor circuit uses only one battery, you will notice, and is therefore somewhat more economical than the valve version. As there is no filament circuit the "off-on" switch is placed in series with the collector battery.

For all its technical interest, however, a grid or base detector as shown in

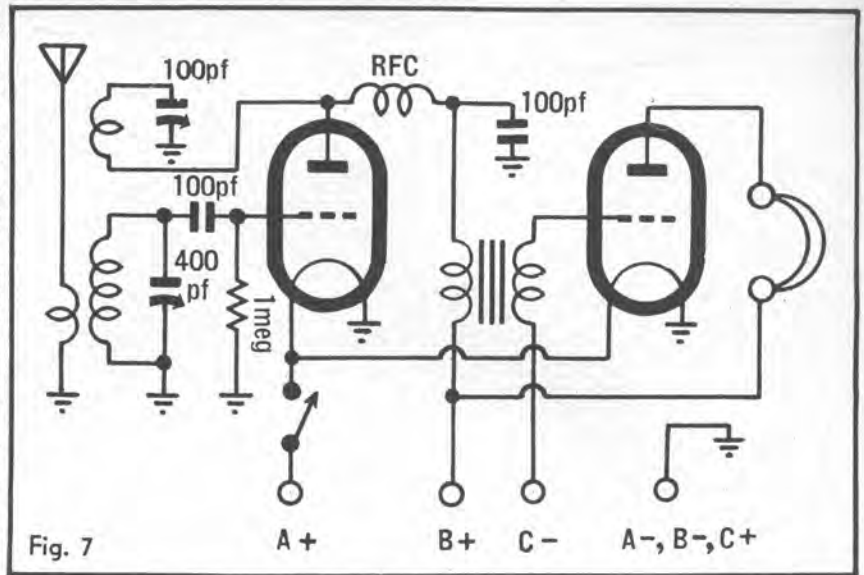


Fig. 7

Figure 7. Adding a further stage of audio amplification can increase the gain of the regenerative one-valve set still further, giving louder reception and making it less critical in operation. Audio transformer coupling between the stages is shown here.

figures 3 and 4 cannot boast any special order of performance. It is not markedly different, in fact, from the arrangement in figures 1 and 2 and the best that can be said is that it eliminates the need for a separate detector, the triode or transistor acting both as detector and amplifier.

That is not the end of the story, however. An addition to the circuit can make an enormous difference to the whole performance. It involves the use of reaction or regeneration or positive feedback, terms which all mean much the same thing.

Figure 5 shows a triode detector incorporating what is probably the best-known reaction circuit. Typical component values have been added for the sake of completeness.

It must be emphasised that this is not by any means the only possible arrangement for a one-valve receiver using reaction. It is a popular and typical arrangement but it would be possible to

produce a quite imposing article on the many circuits which have been evolved during the last 30 or 40 years around regenerative detectors.

The tuning, detection and amplifying action are basically the same as for figure 3. However, advantage is taken of the fact that, over and above the detected audio voltage, there is present on the grid of a detector some of the original RF input signal. This is amplified and the signal at the plate contains the audio component, which operates the phones, plus an amplified RF signal.

When reaction is employed, this amplified RF signal is coupled back into the tuning coil in such a way that it adds to the signal energy already present. This involves placing a reaction winding close to the tuned winding and so arranging the connections to it that the signals tend to add rather than to cancel.

Assume, for example, that there is a positive signal pulse at the grid, at a

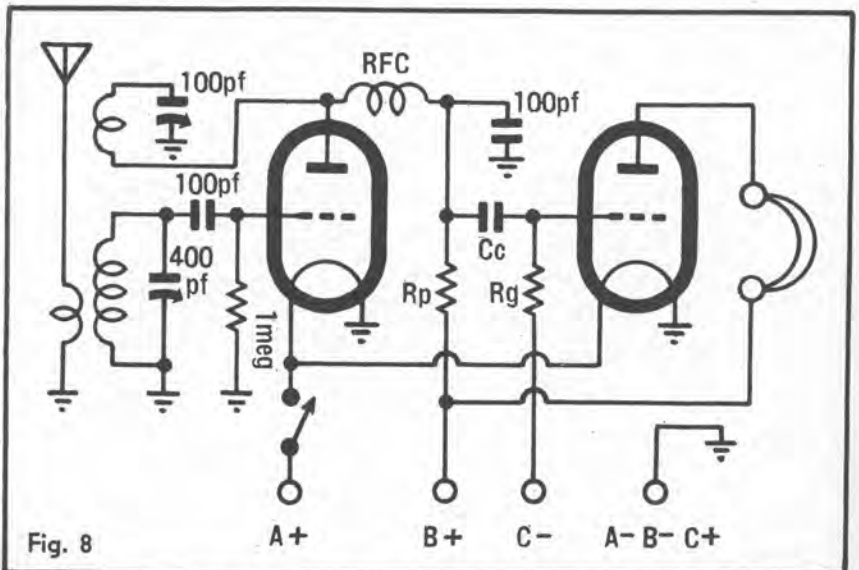


Fig. 8

Figure 8. The only difference between this circuit and that of Fig. 7 is that resistance-capacitance coupling is used between the first and second stages. This both improves the listening quality and reduces the cost.

particular instant. This increases the plate current and causes a negative pulse at the plate. By impressing this pulse across the reaction winding and suitably arranging the connections, its phase can be reversed and coupled into the tuned winding as a positive signal.

This augments the original signal and produces a far greater total effect on the plate current than would the original signal alone.

The effect of feedback, therefore, is to make every positive signal excursion much more pronounced than it would normally be and every negative excursion likewise. The changes in signal level due to modulation are made much more evident and therefore the audio signal delivered to the phones is greatly increased.

The letters "RFC," in the circuit, stand for "radio frequency choke." This component, which is usually a honeycomb-wound coil, is inserted between the plate and the phones to ensure that RF energy at the plate is not bypassed to earth by capacitance of the phone cords. The RF is therefore retained for use by the reaction circuit.

At the same time, RF energy is undesirable in the phone cords, because it can radiate into space and back into the aerial tuning circuit, causing the reaction adjustment to be upset by random movement of the phone cords or even by the person wearing the phones.

The radio frequency choke (inductor) is intended to prevent this trouble, its effect being augmented by the 100pF capacitor shown in the circuit. This bypasses any RF energy to earth which may still be present but it does not bypass the audio components, which have a much lower frequency than the RF carrier.

Exactly the same feedback procedure may be performed on the transistor circuit, as figure 6 shows. The regeneration effect is the same and the performance is considerably improved.

For a regenerative detector to operate correctly, it is most important that the amount of feedback be properly adjusted. If there is insufficient feedback, only limited benefit is obtained from the scheme. If there is too much feedback, the detector will oscillate of its own accord and begin to act as a generator of RF energy, exactly as described in the chapter on radio transmitters. (See figure 7, Chapter 8.)

To give the necessary control over reaction, it is customary with valve circuits to connect a small variable capacitor in series with the reaction winding. When this is fully meshed, maximum feedback current can flow from plate, through the reaction winding to earth. As the capacitor plates are opened, the impedance of the circuit rises and less feedback energy can flow through the coil.

To adjust the reaction in transistor circuits it is more convenient to place a potentiometer across the feedback winding as shown in figure 6, because of the lower circuit impedances. With the slider of the potentiometer at the collector end no voltage is developed across the potentiometer and coil, while a controlled amount of voltage drop may be produced by moving the slider toward the other end to pass current through an increasing amount of the potentiometer and feedback coil.

The capacitor bypassing the slider of

the potentiometer to earth ensures that all the RF energy appearing at the transistor collector is connected across the potentiometer and coil, none being passed through to the earphones to be wasted. As with the valve circuit the capacitor is arranged so that it bypasses only the RF, allowing the audio signals to proceed.

In transistor circuits of this type it is fairly common to wire a high-value bias resistor (about 2.2 Megohms) between the base and the negative pole of the battery. This is shown dotted in Figure 6 as "R," and is done to improve the performance by allowing the transistor to amplify the detected signals at its base more efficiently.

When the reaction control of the circuits in figures 5 and 6 is set so that the detector is just below the point of active oscillation, the gain and selectivity

earlier chapter on valves, we may say that it has to be provided with a plate voltage and grid bias to suit the particular type of valve.

The amplified signals appearing in its plate circuit are then applied to the phones. Because of the extra amplification or GAIN, weak signals can be heard with less effort. Furthermore, the reaction control may not have to be set so critically to obtain adequate sound level, making operation and adjustment of the receiver that much easier.

The use of audio inter-stage transformers was commonplace many years ago, mainly because of the step-up they could give in the signal voltage. This supplemented, very usefully, the rather limited gain that was available from early valves.

As a component, however, audio transformers have always been rather

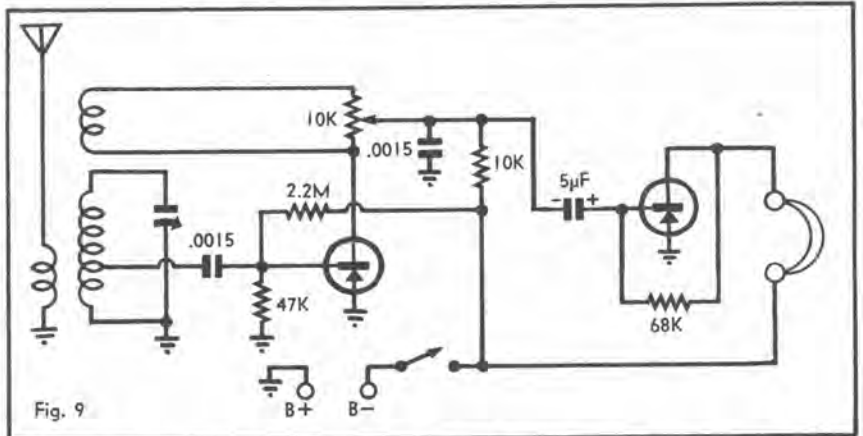


Fig. 9

Figure 9. A transistor receiver which is the counterpart of the valve circuit shown in Fig. 8. Only one supply battery is required, whereas the valve circuit requires three different supplies. The transistor biasing system is explained in the text.

of the detector and its tuning circuit is increased enormously. Used with an efficient aerial and earth, a one-valve or one-transistor reaction set can receive signals under favourable conditions from transmitters thousands of miles away.

From the foregoing description, it might possibly be assumed that a one-valve set is all that should ever be necessary to receive radio signals but such is not the case.

Compared with a crystal receiver, a one-valve set has an enormous advantage in terms of sensitivity and selectivity — terms which relate to its ability to pick up a wanted signal and separate it from other signals. For all that, however, its performance is still capable of substantial improvement.

For example, the signals heard in the phones from a distant station may be quite weak, requiring a good deal of concentration to follow them. The usefulness of the set can be increased greatly by adding an audio amplifier stage after the triode detector, exactly as already described in figures 1 and 2 for a crystal set.

This gives the basic circuit shown in figure 7, if valves are used.

The first valve is used as a regenerative detector but, instead of its output being fed directly to the phones, it is passed through an audio transformer and fed to the grid and cathode of a second valve, acting as an audio amplifier.

It must amplify the signal without distortion and, referring back to the

bulky and expensive, prone to breakdown and liable to introduce distortion of one type or another. As a result, the growing tendency through the years has been to avoid them and to develop valves which are able to give adequate stage gain without the assistance of a transformer.

Figure 8 is similar to figure 7 except that resistance-capacitance coupling is used between the detector and audio amplifier stage. Some discussion relevant to the operation of this circuit appeared in Chapter 6 of this series, to do with valves.

A resistor, normally referred to as the PLATE LOAD resistor, is connected between plate and B-plus. With no input signal, a certain plate current flows through the resistor and produces a voltage drop across it. The plate, therefore, assumes an initial potential with respect to earth, often equal to about half the B-plus supply voltage.

The following grid is returned through a resistor R<sub>g</sub> to the bias source. Since there is no current flowing through this resistor, there is no voltage drop across it and the grid has the same initial potential as the bias source.

Between plate and grid is a COUPLING CAPACITOR (C<sub>c</sub>). Since one end is connected to plate (a positive point) and the other end to grid (a negative point), the capacitor will acquire an initial charge equal to the difference between the two points.

The capacitor is always made large

enough in value in respect to the two resistors so that it cannot alter its charge appreciably at an audio rate.

Now, when an audio component at the grid swings the plate current up and down, the voltage drop across the plate load resistor varies. As a result, the plate voltage itself varies at an audio rate.

Since the capacitor cannot alter its charge at an audio rate, it simply transfers the VARIATIONS in plate voltage to the following grid, the variations appearing at the grid and across the grid resistor as an alternating audio signal. The signal is then amplified by the second valve in the ordinary way.

In other words, the coupling capacitor transfers the signal from plate to grid, but prevents the positive DC voltage on the plate from cancelling or upsetting the negative DC bias voltage on the grid.

Much more could be said about resistance-capacitance coupling, but the foregoing should convey the general principles involved.

Just as the addition of one audio stage to a detector makes for a more sensitive and versatile receiver, so can further improvement be obtained by using two audio stages, with either transformer or resistance-capacitance coupling. In point of fact, many domestic receivers in the early days of radio were designed around a detector and two audio stages.

In such a case the amplification can be of such an order that the use of a speaker can be considered, rather than headphones. The convenience of a speaker is obvious but it does need to produce a great deal more sound output than phones, if it is to be heard properly.

This raises a special difficulty. If a speaker has to produce a lot more sound output or ACOUSTIC POWER, it has to be supplied with a lot more AUDIO POWER in the form of electrical energy.

## CURRENT CHANGE

If we can cut a lot of corners to make the point clear, we can say that most speakers and, of course, earphones operate by virtue of a changing flow of current through their windings. Therefore a lot of acoustic output requiring a lot of audio electrical power can also be thought of as requiring a large change of current flowing through the windings.

Now if a valve is to amplify without distortion, its plate current cannot swing beyond the limits of zero to twice the standing plate current. Therefore, if the last valve in a receiver is intended to draw only 1 milliamp of standing plate current, the maximum plate current change it can effect through phones or speaker is plus and minus 1 milliamp—that is, from zero to 2 milliamps.

Such a change might be plenty for phones but it certainly would not be enough to produce much output from an ordinary speaker. To operate a speaker, therefore, it is necessary to use in the last stage of a receiver a valve which can draw a higher standing plate current. With a signal, the plate current can then swing through wider limits.

In point of fact, valve manufacturers have provided set designers with a whole variety of POWER OUTPUT or POWER AMPLIFIER valves, expressly designed for use in the final stages of receivers and amplifiers. They draw more plate current, of necessity, than

other comparable amplifier valves, and usually have a heavier filament or heater, to provide a more copious supply of electrons.

Throughout the discussion, also, we have assumed the use of triode valves. In actual fact, tetrode or pentode valves are frequently used as detectors or audio amplifiers, often giving higher gain or more efficient operation in particular circuits than comparable triodes.

Just as further audio stages can be added to the one-valve reaction set, they can be added to a one-transistor reaction set. Figure 9 shows a two-transistor set formed by adding an audio stage to the circuit of Figure 6. Resistance-capacitance coupling is used just as in the valve circuit of Figure 8, the earphones

A certain amount of gain or volume control effect can be obtained by varying the setting of the reaction control. The more nearly this control approaches the position for oscillation, the louder will the signals become, and vice versa.

The big difficulty with this method is that the setting of the reaction control also affects selectivity and it may easily happen that a position which gives adequate signal level may not give enough selectivity to select the wanted from the unwanted signals.

Ideally, the reaction control should be operable for best detector performance, with an entirely separate control for gain.

Over the years, many methods of gain control have been devised, including in

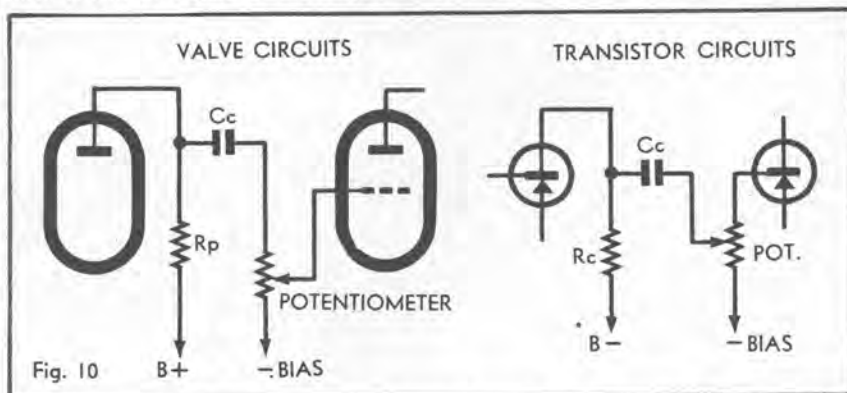


Figure 10. Volume or gain controls in valve and transistor circuits. It should be stressed that these are only two of the ways in which the gain of the receiver or amplifier may be controlled. Many other ways are possible and are often used.

being replaced in the collector circuit of the first transistor by a 10K resistor.

The bias for the audio amplifier transistor is provided by a resistor connecting the base directly to the collector, rather than from the base to the negative pole of the battery. This is done because it gives the transistor a measure of protection from a condition known as THERMAL RUNAWAY. There are other methods of providing such thermal stabilisation, but we shall not be able to discuss them here for lack of space.

It is beyond the province of this chapter to discuss the many possible circuit arrangements of either valve or transistor designs, and, from the beginner's point of view, individual designs have to be accepted and constructed on their merits. As knowledge increases, the general ideas conveyed by this article will gradually be supplemented by other knowledge.

It should be mentioned also that the provision of high gain or amplification in a receiver can introduce the problem of OVERLOAD. The word is almost self-explanatory.

On weak signals, the amplification available in a receiver may be just enough to raise their level sufficiently to operate the phones or loudspeaker.

If the same amplification is applied to signals which are already fairly strong, they will be amplified so much in, say, the first stage that they are too great for the second stage to handle. As a result, the stage overloads and produces a very distorted output signal—sounding rough and harsh to the ears.

To avoid this difficulty, it is often necessary to include in a receiver some means of varying the amplification. To use another phrase, some method of VOLUME CONTROL or GAIN CONTROL must be included.

valve circuits the variation in filament voltage with a rheostat, variation in plate voltage or grid bias or variation of screen voltage in a pentode or tetrode. All of these schemes are open to criticism because, in reducing gain, they also limit the valve's ability to handle strong signals, thereby introducing distortion in many cases.

Nowadays, the method adopted almost universally in audio circuits uses a potentiometer (see chapter 1). The relevant circuits are shown in figure 10.

In the valve version, instead of the signal voltage being applied directly from one plate to the following grid, it is coupled through a capacitor to one end of a potentiometer. The following grid connects to the moving tapping.

When the potentiometer is set so that the tapping is at the end connecting to the coupling capacitor, all the available signal passes to grid. With the tapping right down at the other end, the grid receives its normal bias but NO signal.

At intermediate positions, the grid receives more or less of the signal for further amplification. Thus, moving the tapping by means of the control shaft and knob varies the volume of sound heard in the phones or speaker.

In the transistor version, the same general principle of operation holds, but the potentiometer is wired in the reverse direction because this is found to give a smoother control. The action is still the same, however, and the signal level is adjustable while the bias on the transistor remains constant.

In designing a receiver, it is normal to place the control ahead of the first point of the circuit, which is likely to be overloaded. In simple receivers of the type which we have discussed so far, this would normally be between the detector stage and the first audio stage.





## CHAPTER II: Limitations of simple receivers.

The RF amplifier stage, its operation and use.

Neutralisation and unilateralisation. Gain control of TRF receivers.

The Superheterodyne principle, its operation and advantages.

Autodyne converters and modifications to the basic superheterodyne receiver.

WHILE a beginner may concentrate initially on building small regenerative receivers of the type discussed in the last chapter, he must inevitably wonder about the design of larger receivers. In this chapter, we explain the basic idea behind two well-known types of receiver, the "TRF" and the "superheterodyne."

In an article of feasible length, it is not possible to discuss individual circuits in detail—the how and why of every resistor and capacitor. The reader will have achieved something, however, if he can understand the general idea behind these circuits, particularly the superheterodyne.

Having grasped the basic idea, it should be possible to enlarge upon it later by studying the circuit and design information on actual receivers which are described from time to time in these pages.

The TRF and, later, the modern superheterodyne receiver, came as a natural development from the desire to produce receivers which were more sensitive, more selective and more suitable for use by non-technical members of an ordinary household.

Their story is really a continuation of the story told in the last chapter about small receivers and it must inevitably read like a piece of radio history.

As we pointed out in the last chapter, a receiver having a regenerative detector followed by two audio stages is capable of receiving a great many stations, both on the broadcast and short-wave bands.

By using a power valve or transistor in the final stage, such a set can operate a loudspeaker at good volume on the stronger stations and, in the early days

of radio broadcasting, many domestic receivers were of this general type.

For domestic use, however, such receivers have certain basic limitations.

In the first place, performance depends very largely on proper use of the reaction (regeneration) control. If it is too far advanced, the set oscillates, producing whistles in its own loudspeaker and in neighbouring receivers tuned to the same station.

If the reaction control is not sufficiently advanced, perhaps to limit volume, selectivity is likely to suffer to the point where two or more signals are heard together.

### HARD TO USE

While this is no special problem to anyone who understands what the controls are for and how they are supposed to be adjusted, it did prove an embarrassment in the early days for non-technical members of the household. Some less critical arrangement was obviously desirable for general use.

Another difficulty with simple regenerative sets lies in the fact that there is a practical limit to the amount of amplification one can provide after a detector. Thus, while one or two audio stages can usefully increase gain and even selectivity (the latter by roundabout means), anything more than this can lead to difficulty.

Slight vibration in the detector valve, causing slight changes in plate current, can be amplified by subsequent stages to produce what are known as MICROPHONIC effects. Tapping the valve, or even normal vibration, may produce thumps and ringing noises from the loudspeaker.

Then again, noise due to electron flow

in the detector itself can be amplified to the point where it produces a continuous background hiss. And in mains-operated receivers, very slight 50-cycle or 100-cycle voltages, coupled into the detector circuit from heater and power supply, can produce an audible hum from the loudspeaker.

Last, but not least, slight variations in high-tension supply voltage, caused by plate current variations in the output valve, can be fed back as a spurious signal to the plate of the detector. If regenerative, this feedback can cause an effect called MOTOR-BOATING, evident as a regular pop-pop-pop noise from the speaker.

While all these problems can be minimised by careful design, they do set a limit beyond which the detector-plus-audio idea becomes rather impractical.

This limit was reached very early in the history of broadcasting, and designers had to find other means of improving the performance of their receivers. Since additional stages could not be added after the detector, the only alternative was to add stages AHEAD of the detector and to amplify the incoming signal at its own frequency.

Such stages were known as RADIO-FREQUENCY AMPLIFIER stages or simply RF stages.

Now an ordinary valve will not amplify radio frequency signals very effectively if merely coupled to the following stage by a resistance-capacitance network or by some kind of audio transformer.

It will give a great deal more amplification if coupled to the following stage by means of a circuit tuned to the incoming signal frequency.

Figure 1 shows the essential details of a TUNED RF AMPLIFIER.

The incoming signal is fed through a tuned circuit to the grid of the RF amplifier valve. This first coil, connected to the aerial, is normally referred to as an AERIAL COIL. It is connected directly to the grid of the valve, without any capacitor or resistor, because the valve is intended to operate as an amplifier, not as a detector.

For the same reason, it is provided

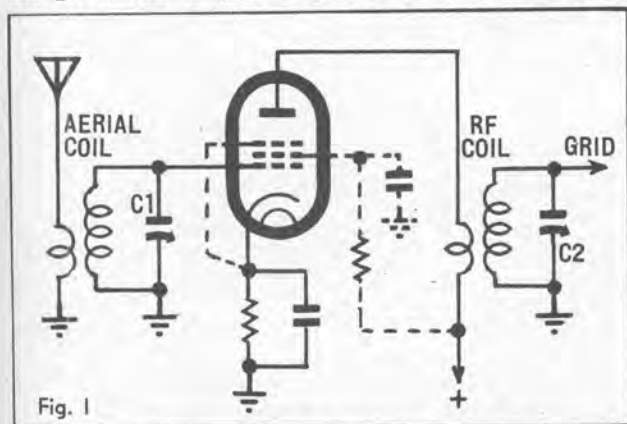


Fig. 1

Figure 1: The circuit of an RF amplifier stage using a triode valve. The connections for a pentode are shown dotted. Input and output are both tuned.

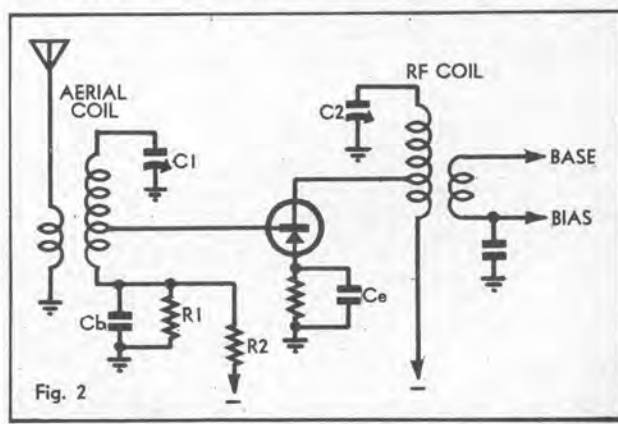


Fig. 2

Figure 2: The transistor equivalent to the circuit of Fig. 1. The transistor requires a base bias voltage divider and has a slightly rearranged output circuit.

with the cathode (or grid) bias necessary to ensure operation as a class A amplifier.

Signal output current from the plate circuit flows through the primary winding of a second coil assembly, and is coupled into a tuned secondary winding, the two windings forming what is commonly referred to as an RF COIL or RF TRANSFORMER.

The two secondary windings, with their associated capacitors, must be capable of tuning over the entire broadcast band. To receive any given station, both tuned circuits should be set to the frequency of that station.

Under these conditions, the signal from the desired station is selected and passed to the RF amplifier grid, in preference to other signals which may be present. It is amplified by the RF amplifier valve and passed through the second tuned circuit, which also favours the desired signal and tends to reject signals on other frequencies.

In other words, the use of a tuned RF stage not only provides amplification, but it also increases selectivity. This was—and is—a most important point.

An RF amplifier stage employing a transistor is very similar to the valve type, as may be seen from the circuit of figure 2. The differences between this circuit and that of figure 1 are due to the rather lower impedances of the transistor, making it necessary to tap the base and collector across only part of their respective coils, and to reverse the role of the two RF coil windings. There is also the need to supply the base of the transistor with forward bias from the resistive voltage divider comprising R1 and R2. Cb and Ce are bypass capacitors, effectively earthing the lower end of the coil and the emitter as far as the radio frequency signals are concerned.

Since an RF amplifier stage feeds into a circuit tuned to the signal frequency, this is the only frequency which it can amplify properly. Because there is no load resistor in the plate or collector circuit and no audio transformer, it cannot amplify or pass on signals within the audio range. Therefore, it is not nearly as susceptible as an audio stage to hum, hiss, microphony or motor-boating. This, too, is important.

Many early receivers used one triode RF amplifier stage, a regenerative detector and two audio stages. There were the first "TRF" receivers, the letters indicating the use of a tuned radio frequency amplifier stage.

Such receivers were generally better than earlier types without the RF stage. They had better gain and selectivity and therefore relied too a lesser extent on critical setting of the reaction control. And because there was an amplifier stage between the detector and the aerial, the reaction setting was not affected so much by the type of aerial in use.

For all that, the basic problem remained that there was still a reaction control to set, and attempts were made to produce receivers with two RF amplifier stages ahead of the detector, but with no reaction.

Here designers came up against the full measure of a problem which was mentioned in Chapter 6 of this series. They found that, because plate and grid in a triode were side by side, there was considerable capacitance between them and energy was being fed back from plate to grid as a result.

In detector or audio service it did not

matter a great deal, but in RF stages, with both grid and plate circuits tuned to the one frequency, the feedback tended to cause oscillation. One low-gain triode RF stage was practicable (even if barely so) but two such stages were almost unmanageable.

A temporary answer to the problem was found in the so-called "Neurodyne" principle, which enjoyed some popularity in the late twenties. The basic idea is shown in Figure 3(a).

The primary winding of the RF coil was centre-tapped so that a signal voltage appeared at the lower end similar to but out-of-phase with the signal voltage at the plate end. A small variable capacitor was connected from the lower end of the primary to grid and adjusted to have the same value as the grid-plate capacitance of the valve.

Being connected in this fashion, this so-called NEUTRALISING capacitor fed back to the grid a signal equal to and out-of-phase with that fed back from the plate, so that the two cancelled out. As a result, the tendency to oscillation was overcome and two triode RF amplifier stages became practical.

The early "Neurodyne" receivers were, therefore, a special type of TRF receiver, employing the principle of neutralisation.

In point of fact, neutralised TRF receivers did not enjoy a lengthy period of popularity because valve designers came to light with the screen-grid principle. Applied in RF tetrodes and pentode valves, it almost eliminated grid-plate capacitance, and therefore, eliminated the major source of instability in RF stages.

As a result, it became possible to achieve high figures of stage gain, and, further, to use two high-gain stages in sequence. Nor was there any great trouble with instability. By shielding the valves and coils and adopting a layout which kept input and output leads reasonably apart, such a set could remain completely stable, even under full gain conditions.

With such gain available and the selectivity afforded by three tuned circuits, reaction became unnecessary, and the familiar reaction control therefore largely disappeared from sets of the day.

By carefully matching tuning coils and adding TRIMMER capacitors across each tuned circuit, designers were able to gang together the three tuning capacitors and operate them from a single tuning dial. This done, domestic receivers became really simple to operate for the first time—one dial to select the station and one knob to control the volume.

TRF receivers reached their heyday about 1930 and their general design fol-

lowed the pattern shown in the block schematic diagram of figure 4.

Before we discuss this diagram, however, it should be noted that the principle of neutralisation has been given a new and important application of late—in transistor receiver RF (and as we shall see, IF) amplifier stages. It has proved worthwhile to use neutralisation in many transistor tuned amplifier stages, because the transistor is very similar to the triode valve in that it has collector-base feedback capacitance.

As may be seen in figure 3(b), the neutralisation system used with many transistor amplifiers is very similar to that used with triode valves. The only difference is that quite often it is possible

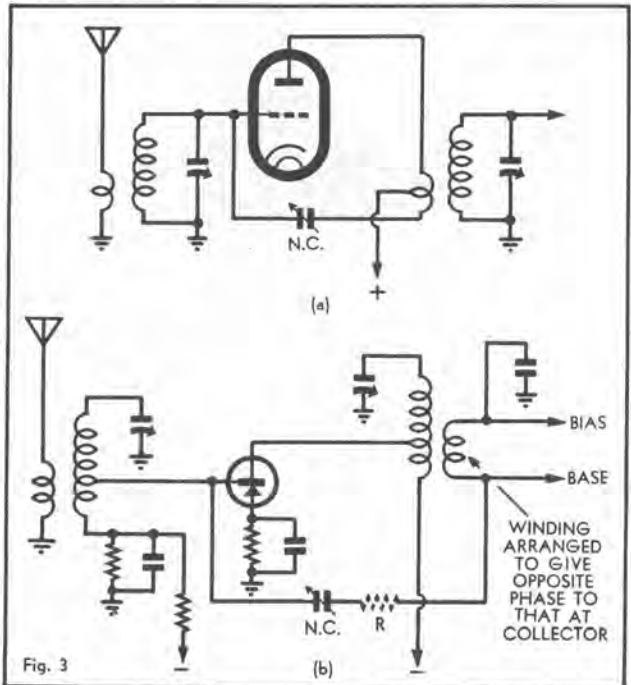


Figure 3: The application of neutralisation feedback to valve and transistor RF amplifiers. The neutralisation feedback cancels the internal feedback of the triode and transistor, to give stable and improved amplification.

to arrange that the RF transformer secondary winding provides a suitable out-of-phase voltage to which the neutralisation capacitor NC can be connected. This makes it unnecessary to add special windings or extensions to windings.

In addition to capacitance, transistors also have a collector-base feedback RESISTANCE which can upset the amplification of a tuned amplifier. However, it is possible effectively to cancel this resistance along with the feedback capacitance by wiring a resistor R (shown dotted) of suitable value in series with the neutralising capacitor. This more elaborate form of neutralising is called UNILATERALISATION. As it often gives only a marginal improvement over ordinary neutralisation, unilateralisation is often not attempted in receivers, unless the best performance is required irrespective of complication.

Let us now return to the block diagram of early valve TRF receivers shown in figure 4.

The incoming signal was fed by the aerial to the first RF amplifier stage, then passed to the second RF amplifier stage and thence to the detector. This was followed by a single audio stage,

but, using a sensitive pentode valve, which gave high amplification as well as ample power output to operate a loud-speaker.

Power to operate all these stages came, in mains receivers, anyway, from a power supply built on to the same chassis. This included a power transformer, a rectifier, a filter choke of some description and two or more filter capacitors.

The volume control in such receivers usually took the form of a potentiometer connected at one end to the two RF amplifier cathodes, and at the other

niques, the superhet receiver quickly established itself in popular favour, and has remained in undisputed leadership ever since.

But how does the superhet work? At this point, we can drop the semi-historical sort of discussion and settle down to some straight theory. This is appropriate, because the superhet principle does not yet belong to history. Practically every modern broadcast, communication and television receiver uses the principle, including those using transistors.

As the name suggests, the superheterodyne receiver utilises a method of hetero-

quency components in the output, due to the presence or generation of harmonics, but we can afford to neglect these as being incidental to the main effect.

As we already know, stations on the broadcast band transmit on allotted frequencies between the limits of 550 and 1,600 Kc/s. To tune and amplify them on a TRF receiver involves the use of a ganged capacitor tuning two or three matched coils.

There are difficulties in the way of tuning more than about three coils in this way, so that the performance of a TRF receiver is largely limited by the selectivity and gain which can be achieved with three variable tuned circuits.

But, in the superheterodyne, the designers utilise the heterodyne principle to change the frequency of any and every desired incoming signal to a new, pre-arranged and fixed frequency. This is passed to and amplified in a section of the receiver, which can employ a greater number of fixed tuned circuits.

The new frequency is usually lower than the signal frequency but still well above the audio spectrum, which is perhaps the reason why it is commonly referred to as the "Intermediate" frequency — shortened to "IF."

The particular intermediate frequency is selected by the designer to suit his requirements. If high gain and extreme selectivity is the object, he may choose an intermediate frequency of about 200 Kc/s. But, with such a low frequency, great care has to be exercised to avoid receiving the same signal at two points on the dial — called "two-spotting" — owing to unwanted heterodyne effects.

An intermediate frequency of more like 2,000 Kc/s minimises double-spotting, but requires greater attention to the design of the tuned circuits, if gain and selectivity are not to be sacrificed.

**A compromise figure, which is widely employed in this country, is**

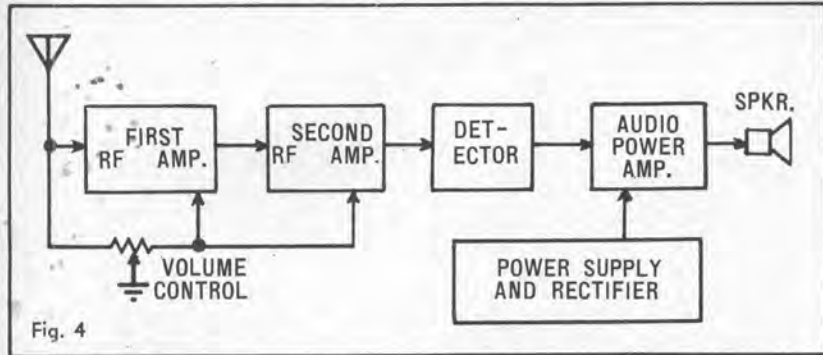


Fig. 4

**Figure 4: The block diagram of an early TRF receiver using valves and two RF amplifier stages. The volume control alters the bias on the RF stages and also acts as a variable shunt across the aerial circuit.**

to the aerial terminal. The adjustable tapping went to earth.

With the moving arm towards the cathode end, the RF amplifier valves operated with minimum bias and maximum gain, while the amount of resistance between aerial, and earth was too high to make any real difference to its efficiency. Adjusting the control the other way applied high bias to the RF amplifier cathode and reduced the stage gain; at the same time it shunted the aerial to ground and therefore reduced the signal input.

It might be thought that the evolution of this standard kind of TRF receiver would have largely halted receiver development in that it provided good gain and selectivity with plenty of acoustic output and simplicity of operation.

But it didn't.

About the same time, many new stations were coming on the air, crowding the broadcast band and ever increasing the demand for selectivity. The limitations of the simple TRF soon became apparent, particularly for the more difficult reception areas.

To add yet another RF stage or yet another tuning circuit gave only limited improvement at the cost of much greater complexity and with the attendant risk of instability. What was more there didn't seem to be any obvious way of making tuned circuits much more efficient. To resort again to reaction as an aid to selectivity was unthinkable to a commercial designer.

As a result, they began to look for other basic methods of receiver design, and the one which seemed to hold the greatest promise was the superheterodyne principle. This was not new, having been employed, in a limited way, for many years. But with new valves and new methods it might be capable of transformation from a very cumbersome system to something much more manageable. This, indeed, proved to be the case.

Designed around the better valves available, and using modern circuit tech-

nying or beating two signals together. Let's explain this.

It has been found that, when two signals are fed into a non-linear circuit, they combine to produce signal voltages at frequencies additional to and distinct from either of the original input frequencies. Further, that these new frequencies are equal to the sum and the difference of the original frequencies.

Consider, for example, two frequencies which we shall designate as  $f_1$  and  $f_2$ .

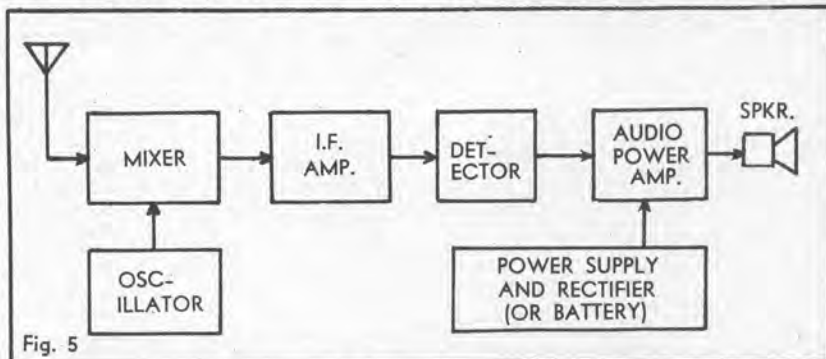


Fig. 5

**Figure 5: The block diagram of a superheterodyne receiver. Most modern receivers, both valve and transistorised, are of this type. The more sensitive designs have an RF stage between the aerial and the mixer to improve the sensitivity, selectivity and noise performance.**

If fed into a non-linear amplifying stage, it would be possible to detect output voltages, as expected, having the original frequencies  $f_1$  and  $f_2$ . But, in addition, we would find that output voltages were present at frequencies equal to  $f_1$ -plus- $f_2$ , and  $f_1$ -minus- $f_2$  (assuming  $f_1$  to be the higher numerical value).

Taking an actual case, we may feed signal voltages at, say, 2,000 and 1,500 Kilocycles into a non-linear stage. Both original signal frequencies would be present in the output, plus additional frequencies of 3,500 Kc/s (2,000 plus 1,500) and 500 Kc/s (2,000 minus 1,500).

In actual fact, there may be other fre-

**an intermediate frequency of 455 Kc/s or thereabouts.**

Assume that a desired signal is on 1,000 Kc/s. The first obvious requirement then, is for the tuned aerial input circuit to be resonated to this figure. This is accomplished by tuning the aerial input coil with a variable capacitor, exactly as in an ordinary TRF receiver.

The desired 1,000 Kc/s signal is then fed into the "mixer" or "frequency changer" valve. In the output, remember, one desires a frequency equal to the selected intermediate frequency, which one may assume to be 455 Kc/s.

Essential for the frequency change is



# The place of 1000 (and 1) PARTS



Everything you need for use in  
**RADIO, TELEVISION**  
and other Electronic devices.



## BACKED BY REALLY PROMPT AND HELPFUL SERVICE

Hobbyists and beginners especially  
catered for at attractive prices.



## call at our SPACIOUS SHOWROOMS

for expert personal advice and  
service. FREE PARKING. If unable  
to call or phone, avail yourself of  
our fast, reliable mail order service.



Watch for our ads. in "Electronics"  
and "Amateur Radio" each month  
for

## SPECIAL BARGAINS

and details of the latest compon-  
ents as they become available.

**WARBURTON  
FRANKI** INDUSTRIES  
(Melb.) Pty. Ltd.  
**RADIO PARTS DIVISION**  
220 Park St., Sth. Melb., Vic.  
69 0151 (Ex. 64, 22 or 21)  
**OPEN SAT. MORNINGS**

an oscillator valve, which delivers a locally generated signal voltage to the mixer stage. To obtain the desired result, the oscillator would be tuned to 1,455 Kc/s — a frequency higher than the incoming signal frequency by just 455 Kc/s.

At the output of the mixer stage, one would expect frequency components of 1,000, 1,455, 2,455 and 455 Kc/s. But the mixer valve plate invariably feeds directly into a tuned circuit, which would be resonated permanently at 455 Kc/s. This one frequency is, therefore, selected and passed on, while the first three mentioned above, together with all other incidental harmonic frequencies, are suppressed.

If the desired signal were on 1,020 Kc/s, then it would be necessary to increase the local oscillator frequency by another 20 Kc/s to ensure the output at 455 Kc/s.

Thus, in a simple superhet, there are two variable tuned circuits. One gives initial selection at the signal frequency, and the other adjusts the local oscillator frequency to a figure which differs from the signal frequency by the selected intermediate frequency.

In the earliest "superhets" the aerial and oscillator circuits were controlled by separate capacitors and tuning dials. But, in all modern sets, the coils are accurately adjusted and the oscillator tuned circuit provided with a "padder" capacitance, so that they maintain the required frequency difference automatically.

Alternatively, a ganged capacitor having specially-shaped and smaller rotor plates on the oscillator section is used. Such a capacitor is called a "padderless" gang, as the padder capacitor is no longer required.

With either method, turning the one dial selects the desired input signal and maintains the required frequency difference between the signal and oscillator tuning circuits.

The new intermediate frequency generated at 455 Kc/s from the broadcast carrier retains the original modulation, so that it can be amplified and passed on to the detector in the usual way.

It is here that the advantage of the superheterodyne principle becomes evident. Since each selected signal is automatically transformed to a constant frequency (which we have assumed to be 455 Kc/s), the IF amplifier channel may be provided with any desired number of circuits, permanently tuned to the selected intermediate frequency.

Coupling coils between valves may have both primary and secondary tuned, instead of the secondaries only, as in ordinary TRF practice. No variable tuning gang is necessary for this purpose, and the coils may be designed for compactness and efficiency, and thoroughly shielded for stability.

Intermediate frequency (IF) tuning circuits are frequently resonated by means of small compression type mica trimmers, adjusted with a screwdriver. Alternative and common practice nowadays is to have a fixed mica or ceramic tuning capacitor and to vary the inductance of the coil by a small adjustable iron core.

Most ordinary superhets employ one stage of IF amplification, involving two double-tuned IF transformers — and, therefore, four tuned circuits. Larger sets may use two IF amplifier valves or transistors with three IF transformers, and, therefore, six tuned circuits.

These tuned circuits in the IF channel

are fully effective in discriminating against unwanted signals.

For example the desired signal may be on 1,000 Kc/s with an adjacent and interfering signal of 1,010 Kc/s. The single tuned circuit ahead of the mixer valve could not discriminate effectively against a signal only 10 Kc/s removed from the desired one, so that a substantial 1,010 Kc/s signal may reach the input of the mixer valve.

In the output of the latter, there would, therefore, be the desired heterodyne frequency of 455 Kc/s, plus another heterodyne produced by the unwanted carrier at 445 Kc/s. But, with four or more circuits to negotiate, all tuned to 455 Kc/s, the signal on 445 Kc/s would have little chance of reaching the detector at troublesome level.

Thus, even though the average domestic superhet uses only a two-gang tuning capacitor, there are actually five tuned circuits to discriminate against unwanted signals — as against two tuned circuits provided by a two-gang capacitor in the TRF arrangement.

The double-tuned IF transformers provide higher gain and efficiency into the bargain, and their isolation from one another adds greatly to the flexibility of the individual circuits.

Another reason for improved selectivity in the superhet is the basic fact that the frequency is changed to a lower value. As shown in the example above, the difference in frequency between the wanted and unwanted station—10 Kc/s in this case—is retained when the frequency is changed. However, relative to 455 Kc/s, 10 Kc/s is a greater change, in terms of percentage, than is the same change relative to 1000 Kc/s.

Thus, assuming tuned circuits of equivalent "Q", the one at 455 Kc/s will be better able to reject the unwanted signal than the one at 1000 Kc/s. It will also be understood why some circuits use even lower frequencies, 175 Kc/s and even 50 Kc/s being employed where very high selectivity is required.

The output from the IF amplifier stage ultimately feeds into a detector, which may be any one of several varieties. The output and power supply arrangements are exactly as for a TRF receiver.

Figure 5 shows the sequence of stages in a typical superhet in block schematic form. The aerial input signal is fed to the mixer or frequency changing stage, where it is mixed with a signal generated by the in-built oscillator.

The resultant or intermediate frequency is then amplified in the IF stage and passed on to the detector, where the audio component is extracted. This is amplified in the audio stage and applied to the loudspeaker.

At first, the functions of mixer and oscillator were entirely separate, as indicated in Figure 4.

The oscillator, generally a triode, occupied an appropriate position on the chassis, with its associated components.

In the absence of other specialised types, the mixer valve was a triode and later a tetrode or pentode, when these became available.

The mixer was normally operated under very high bias conditions, as employed for a detector. Hence, the mixer valve in these early superhets, was commonly referred to as the "first detector." The normal detector for demodulation naturally gained the title of "second-detector."

In the inevitable trend to simplification, it was found possible to obviate the

separate oscillator valve, and the first detector was made simultaneously to fulfil the function of oscillator by connecting it to the oscillator tuned circuit.

This arrangement, employing generally the 57 or 6C6 pentode, was widely used around 1932. Known as the "autodyne" circuit, it proved quite efficient and adequate until the demand for dual-wave sets emphasised its non-suitability for such receivers.

Ultimately, the trend to superhet. circuits, the popularity of dual-wave receivers and adoption of automatic volume control, led to the evolution of special valves for use as frequency changers.

These vary a good deal in structure from one type to the next, but normally have a triode oscillator and a screen-grid mixer section within the one envelope. For all intents and purposes, they are treated as a single valve.

With the advent of transistors, the autodyne principle has been revived with the first transistor acting as both local oscillator and mixer.

It is also commonplace in valve circuits to have one or two diode elements, serving as detector, in the same envelope as the IF amplifier or audio power valve.

Because of such economies and other circuit developments, it is now possible to make perfectly serviceable domestic superhet. receivers incorporating only four valves in all: Frequency-changer, IF amplifier and detector, output valve, rectifier.

Receivers intended for specialised communication work invariably use the superhet principle, because of the high gain and high selectivity which it offers.

In such case, economy is of only secondary importance and it is commonplace to use two or even three intermediate frequency stages. These can be arranged to give high overall gain and the high selectivity necessary to separate weak individual signals coming from distant transmitters.

Many such receivers, in fact, use what is known as a "crystal filter" in the IF amplifier to achieve extreme degrees of selectivity. The heart of the circuit is a quartz crystal ground to resonate mechanically at the intermediate frequency.

The provision of this and other facilities at the fixed intermediate frequency is something which could not reasonably be duplicated in any TRF design.

At the same time, most high performance superhet receivers do use at least one RF amplifier stage ahead of the frequency changer.

An RF stage ahead of a superhet circuit makes a minor contribution to gain and selectivity and also helps exclude from the frequency changer strong signals at frequencies remote from the desired station. In special circumstances such signals may cause spurious beats with harmonics of the local oscillator and penetrate the IF channel.

The main advantage of an RF stage however, is that it has a lower inherent noise level than a frequency changer. By amplifying the incoming signal somewhat before its frequency is changed, a more favourable signal-to-noise ratio can be obtained.

Modern television receivers also use the superhet principle. The problem in this case is not to get extreme selectivity but a specific amount of selectivity—no more and no less. To meet this requirement in the variable tuned circuits of a TRF would be very difficult but in the IF channel of a superhet it can be provided without any special difficulty.

# MULTIMETER TESTERS

## MODEL RH-50

Modern Design, 33 Micro Amp Meter.  
30,000 Ohms per Volt D.C.  
13,000 Ohms per Volt A.C.  
1 p.c. Multipliers and Shunts used.  
Printed circuit.  
Clear Scale, rugged moulded case.

### SPECIFICATIONS:

DC Voltages: 0-0.3-1.2-3-12-30-120-300-600-1,200 V at 30,000 Ohms per volt.  
AC Voltages: 0-3-12-30-120-300-600-1,200 V at 13,000 Ohms per volt.  
DC Current: 0-.06-6-60-600 mA, 0-12 A.  
Resistance: 0-60K-6M-60M (350, 35K, 350K at mid-scale).  
Decibels: minus 20 to plus 57 dB (0 db equals 1 mW, 600 ohms).  
Audio Out: Capacitor in series with AC volt ranges.  
Short Test: Internal buzzer.  
Accessory: 1 pr. heavy test leads.



Price \$31 (£15/10/-)

Postage 50c to \$1 extra.

Batteries: 1 (1.5V), 1 (15V).  
Sizes: 3 5-16" x 6 5-16" x 2 3/4"  
Weight: 1.4lb approx.

## MODEL RH-5

- \* High sensitivity-20,000 Ohms/V DC, 10,000 Ohms/V AC.
- \* 3in Meter.
- \* Handy pocketable size.

### SPECIFICATIONS:

DC Voltages: 0-10-50-250-500-1000 V (20,000 Ohms/V).  
AC Voltages: 0-10-50-250-500-1000 V (10,000 Ohms/V).  
DC Current: 0-50uA, 0-5-50-500mA.  
Resistance: 0-10K, 0-100K, 0-1Meg, 0-10Meg. (62 Ohms, 620 Ohms, 6.2K, at centre scale).  
Capacitance: 0.0001uF-0.005uF, 0.05uF-1uF.  
Decibels: minus 20db to plus 36db in 2 ranges.  
Dimensions: (3 1/2" x 5 1/2" x 1 3/4").  
Weight: 15oz approx.  
Complete with internal battery, testing leads with prods.



Price \$18 (£9/-/-)

Postage 50c to \$1 extra.



## SCOOP PURCHASE

6 Transistor de luxe model Radio made by International. Complete with leather carrying bag and earphone, etc. Size 4 1/2in x 2 1/2in.

**\$21 reduced from \$31.50**

Plus postage and packing 75c.

**Now! TV Antenna that combines versatility with practical electronic design**

The DX "SX-1 SILVER RIBBON" is absolutely phenomenal . . . the most sensitive, selective tuning mechanism ever devised for an indoor antenna.

**only \$6.50**

Posted 25c extra.



• Rejects Noise and Ghost

• Sharp Focus Reception

# RADIO HOUSE PTY. LTD. PHONE 26-2817

306-308 PITT ST., SYDNEY. Also at 760 George St. and 6 Royal Arcade



## CHAPTER 12: Valve equipment power supplies. Problems in using AC to heat valves. The indirectly heated valve and its use. The full-wave rectifier, using thermionic and semi-conductor diodes. Voltage doubler and half-wave rectifiers. Transistor equipment power supplies and the bridge rectifier.

FOR the sake of simplicity, most of the circuit discussion to date in this course has assumed the provision of suitable filament, bias and high tension voltages, without much emphasis on how such voltages are obtained. In this chapter, we explain how supply voltages are derived from the AC power mains in an ordinary domestic receiver.

In the early days of radio, receivers were invariably supplied from batteries. It was commonplace to use either an accumulator for the filament supply or a number of heavy-duty dry cells capable of supplying the requisite and often considerable filament current.

The grid bias voltages were taken from a special bias battery, not intended to deliver significant current, but with tappings at each cell junction to give voltages in 1½-volt steps to 4½ volts or 9 volts—to quote what were common figures.

For the high tension supply, radio "B-batteries" were used. These were large and rather expensive banks of dry cells, usually made up in 45-volt blocks and tapped at 22½ volts. Two such B-batteries in series could supply 90 volts, while three in series were commonly employed to give 135 volts. How cumbersome and expensive batteries were tends to be forgotten in these days of transistor receivers.

While the early sets were simple enough from the designers' point of view, the need to provide, attach, and conserve batteries was a constant worry to radio set users and it was natural that efforts should be made to cut the operating costs, at least.

As a result, various gadgets appeared aimed at supplementing or replacing the expensive batteries.

Numerous chargers or "trickle chargers" were put on the market for radio accumulators. The chargers might deliver currents up to 3-odd amperes and would top up a discharged battery in a day or so. Trickle chargers were designed to be left on more or less continuously, keeping the battery full at all times and saving the hitherto regular trip to the local garage for a battery re-charge.

So-called "B-Battery Eliminators" were released to replace the high-tension batteries altogether. These incorporated transformer, rectifier and filter system, rather like a modern AC power supply. Various resistors and tapping points were included so that they could supply the requisite intermediate voltages at the order of current drain commonly encountered in battery sets of the day.

Some B-battery eliminators also included auxiliary circuits to provide negative bias voltages, although the cost of a bias battery was never a major item.

These various units enjoyed a limited degree of popularity, but the obvious objection of having gadgets and accumulators attached to the family radio provided strong incentive to produce receivers which could simply be plugged into the power point and operated therefrom just like any other electrical appliance.

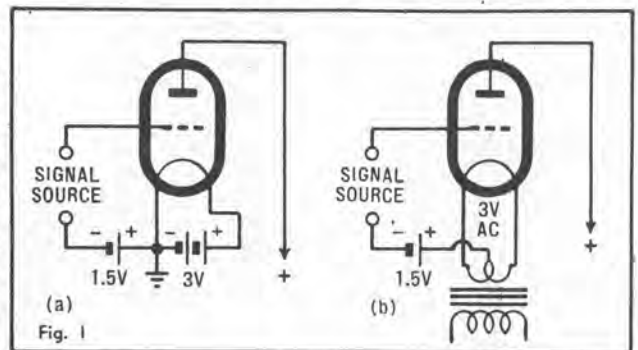
Initially, the main difficulty was that of providing filament supply. For reasons we shall see a little later, AC from the power mains could not readily be changed to DC at the voltage and current needed to operate a number of parallel-connected filaments.

There were—and still are—two basic objections to applying AC to valve filaments.

The first and obvious one stems from the fact that the plate current of a (directly heated) valve is controlled substantially by the voltage present between grid and filament, this voltage being the sum of:

(1) The voltage along the filament itself;

Figure 1: In a "battery" valve, potentials are normally reckoned in respect to the negative filament pin as in (a). Early attempts to use directly heated valves with AC on the filament involved the use of a centre-tapped filament circuit as in (b).



(2) The deliberately applied negative bias, and

(3) The input signal voltage.

Consider the basic circuit shown in figure 1a. Following common practice, the negative end of the filament is earthed, forming the reference point from which other voltages applied to the valve are reckoned. Thus, nominally, the valve would be operating with a negative grid bias of 1.5 volts.

In point of fact, however, this figure of bias only applies between the grid and the negative end of the filament. As far as the other end of the filament is concerned, the bias is really 4½ volts, being the difference between minus 1.5 and plus 3.0 volts.

The average or mean bias effective at the centre of the filament must obviously be the sum of the applied bias plus half the filament voltage — in this case a total of 3 volts — and the plate current assumes a certain value as a result.

If the filament battery were to be

reversed, so that the negative end of the filament and the positive side of the battery were earthed, the effective bias between grid and the earthed end of the filament would still be minus 1.5 volts. However, the grid would be 1.5 volts POSITIVE with respect to the other end of the filament and the average or mean bias from grid to the centre of the filament would be zero

As a result, plate current would be greater than with the normal battery connection.

It follows that if the effective bias and, with it, the plate current, changes when the filament battery is reversed then application of an alternating potential to the filament would cause the plate current to vary at 50 cps. This alternating plate current would be heard in the output of the receiver as an intolerable hum, over and above the desired signal.

The effect could be cancelled partially by supplying the filament from a source of alternating voltage with its centre tapping point earthed, as in figure 1b. In this way the average potential of the filament with respect to grid would remain constant and the effect of either end of the filament swinging negative would be cancelled by the other end swinging simultaneously positive.

Unfortunately, the problem does not end with an effort to balance the fila-

ment circuit. During each cycle the voltage applied to the filament rises to a peak value in one direction, falls to zero, swings to a peak in the opposite direction and then falls again to zero.

As a result, the filament temperature varies in a cyclic fashion and with it, the supply of electrons. This tends to produce hum in the output quite independently of any interaction between grid bias and AC on the filament, as already explained.

Despite these very serious problems, the first all mains-operated receivers did use directly heated valves in most sockets.

The valves were not ordinary battery types, however, but had special low-voltage high-current filaments which were massive enough to maintain a fairly even temperature, notwithstanding the AC supply.

The designers did not rely on a centre-tapped transformer winding, either, but earthed the filament wiring through an

adjustable "centre-tapping" resistor which was set in each receiver to give the lowest possible order of hum.

But, for all these precautions, early mains-operated receivers were distinguished by their very high hum level.

A satisfactory solution to the problem only came with the introduction of valves having "indirectly heated" cathodes. Figure 2, reprinted from the earlier chapter on valves, illustrates the difference between such valves and earlier types having directly heated filaments.

In the case of indirectly heated valves electrons are emitted from the surface of a metal tube, which is coated with suitable emissive oxide. This is commonly referred to as the "cathode."

Inside the tube, but insulated from it electrically, is a "heater" element, the sole purpose of which is to raise the temperature of the cathode tube or sleeve to a red heat, so that it will emit electrons freely from its surface. The heater element plays no other part in the functioning of the valve.

This being the case, it can be fed from either an AC or a DC source and does not affect bias or signal voltage, which is purely a matter of the relative voltage between the grid and the cathode sleeve. What is more, the mass of the heater and cathode assembly is such that its temperature does not vary to any noticeable extent over the AC input cycle. The two major sources of hum are therefore obviated.

With the development and release of valves having indirectly heated cathodes the major problem with all-mains operation disappeared and numerous receivers were released using them. It was still necessary to produce from the mains a pure DC supply for the valve plates and screens, but, as we shall see, this was not—and is not—a major problem.

Figure 3 shows a typical valve rectifier power supply circuit, whose operation we can proceed to discuss.

The heart of the supply is the power transformer, which is shown diagrammatically as a number of windings adjacent to an iron core.

The incoming power lead is connected across the PRIMARY winding, which will normally be rated to receive an input of 240 volts AC. It must be AC. A power transformer MUST NOT BE CONNECTED across DC mains. If it is, it is almost certain to blow the fuses or burn itself or do both!

The reason for this is not hard to discover in that a transformer relies for its operation on a constantly changing magnetic field.

As the alternating current from the power mains flows to and fro through the primary winding, it causes a strong magnetic field in the iron core to build up and collapse in cyclic fashion.

The moving lines of force thus created induce current and voltage in the various SECONDARY windings, obeying the laws of magnetism explained in an earlier chapter.

The alternating voltage developed across each secondary winding is almost exactly proportional to the ratio of turns between the primary and the secondary winding in question.

Thus, if there are 1,200 turns on the primary winding, a secondary winding also having 1,200 turns would deliver the same 240 volts as fed into the primary—because the turns ratio would be 1:1.

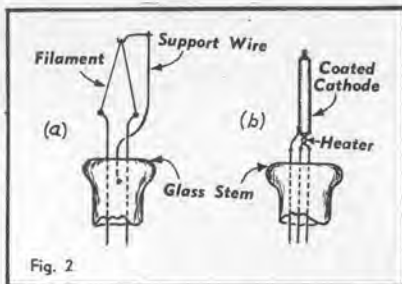


Figure 2: Illustrating the difference between a directly heated filament (a) and an indirectly heated cathode (b). AC can be applied to the heater in (b) without producing hum or otherwise affecting the operation of the valve.

On the other hand, if a 6.3 volt winding is required to operate a number of valves with 6.3 volt heaters, then this heater winding would need to have 1,200 times 6.3/240, or approximately 32 turns.

In the above illustration we suggested 1,200 turns for a 240-volt winding on the assumption that the transformer might be wound on the basis of five turns for every volt of input or output. This is a likely enough figure, but, in practical transformers, the turns-per-volt figure may vary considerably from one type to another, according to the size of the core, the grade of the iron used and the ideas of the designer.

The thickness of the wire used on each winding depends on the current which it has to handle or deliver. In the case of a heater winding, which may be required to deliver several amperes, relatively thick wire has to be used and it is commonplace to see heater windings

deliver 6.3 volts at two amperes. One intended for use in a television receiver may have two or three windings to supply the larger number of valves involved.

In the circuit of Figure 3 we have shown two heater (or filament) windings, one to supply the rectifier and the other to supply the heaters of all other valves in the receiver. The latter is marked "6.3V" because most valves intended for mains operation have a 6.3-volt heater.

The winding is also shown as having a centre-tap connection, earthed to the chassis. This earth connection has nothing to do with the basic functioning of the associated valves since, as we pointed out earlier, the heater's only role is to raise the temperature of the cathode sleeve so that emission can take place.

Heater wiring is usually earthed for two reasons:

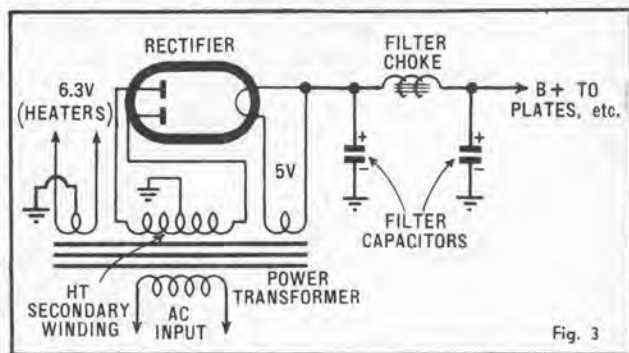
Firstly, the heater winding is very close, inside the transformer, to other windings producing high alternating voltages. Because there is some capacitance between them, some of the high voltage energy can be coupled capacitively to the heater winding and to the wiring connected to it.

This doesn't interfere in any way with the basic operation of the heater circuit but the high ripple voltage present on the heater wiring throughout the chassis can couple into grid circuits and produce an objectionable hum or buzz in the output.

A second reason is that wiring running from one stage to another throughout a high-gain receiver can transfer signals by stray coupling and produce troublesome regeneration.

Earthing the heater wiring largely obviates both effects.

Figure 3: A typical power supply circuit using a thermionic (i.e. valve) rectifier, as used in most receivers and amplifiers still in use. Supplies using semiconductor rectifiers are now gradually taking over.



using 16-gauge enamelled wire or thicker.

It is important to realise that the gauge of wire used in a transformer winding determines only the amount of load current it can handle, without overheating, IF REQUIRED TO DO SO. Thus a winding rated to deliver, say, three amperes, can deliver up to three amperes without tending to overheat, according to the number of valves which may be connected to it. If only one valve were connected to the particular winding, the current drawn from it would probably be less than one amp.

Typical radio type power transformers may have one or two, or even three, heater windings, to give the amount of voltage and current likely to be required in the particular sets for which they are intended.

A small transformer, intended for use in a four-valve mantel set, may only have a single heater winding rated to

Although we have shown a centre-tap earth return, this is not strictly necessary except, perhaps, in equipment having very high audio gain. In many cases it is sufficient to earth one side only of the heater wiring.

It should be emphasised that there can be no question of applying an alternating potential to the plates, screens or grids of amplifying valves, since the alternation would be construed as a low frequency signal and heard in the output as a hum, blanketing any other signal which might be present.

For these electrodes, AC from the mains must be rectified and filtered till it becomes virtually pure DC. This involves, normally, a high tension secondary winding on the power transformer, a rectifier valve, a filter choke and two or more filter capacitors.

As might be expected, the high tension winding involves many turns of fairly fine wire, so that a considerable

voltage is developed between its outer ends. Since the voltage across it is alternating, each end swings alternately positive and negative with respect to the other.

In valve rectifier circuits such as that shown, the high tension secondary winding has a centre-tap which is returned to chassis (shown as earth) so that half the total secondary voltage appears between earth and the respective ends. When one end of the winding swings positive with respect to earth the other end simultaneously swings negative by an equal amount.

As with the heater windings, the rating of the high tension secondary, in terms of voltage and current, varies with the size of transformer and the receiver which it is to supply. A small transformer, to supply a small mantel receiver, might typically have a HT secondary rating of 150 volts either side of the centre tapping, at a nominal current rating of 30 milliamps — this figure referring to the permissible DC load current.

A large transformer, intended to supply a large receiver, or amplifier, might have a voltage rating per side of up to 400 and a nominal DC load current of up to 250 or even 300 milliamps.

The two ends of the HT secondary winding are connected to two plates in a rectifier valve, as depicted. This valve is virtually two diode elements in the one envelope, the plate and filament structure being expressly designed to carry a considerable amount of current.

A valve of this type, intended for use in a power supply and having two separate anodes or plates, is commonly referred to as a FULL-WAVE RECTIFIER.

The filament of the rectifier is fed from a separate winding on the transformer, which is typically rated to deliver five volts at two or three amperes. It is quite usual for rectifier valves to consume considerable heater or filament power, the cathode or filament being designed to provide copious electron emission and thus allow the valve to pass heavy current without danger of early failure in service.

To follow the action of the rectifier, consider the instant when a positive voltage has appeared on the left-hand half of the H.T. secondary and therefore on the upper rectifier plate, as drawn.

Since the plate is positive, electrons will tend to flow to it from the heated filament. We can consider the result in a couple of ways, both of which lead to the same conclusion:

(1) In losing electrons, which are essentially negative charges, the filament of the rectifier must itself become positive.

(2) When conduction takes place through the rectifier, the impedance of the filament-to-plate path in the valve must decrease. The filament must, therefore, approach the plate potential, and, since this is temporarily positive, the filament must tend also to become positive.

Whichever way one cares to look at it, the result is the same—a positive potential on the plate and conduction through the valve produces a positive voltage at the filament.

When the same plate swings negative, during the next half-cycle, there is no conduction through the valve and, therefore, no tendency for the filament to develop a simultaneous negative potential.

On the contrary, as the first plate swings negative, the second plate simultaneously becomes positive and conduction takes place between filament and this second plate. Once again, therefore, the filament tends to be carried positive.

In other words, during successive half cycles, when each plate in turn swings positive, current flow through one half of the rectifier or the other tends to carry the filament positive also. Since there are 100 half cycles per second, with 50-cycle power mains, 100 positive pulses are apparent at the rectifier filament per second.

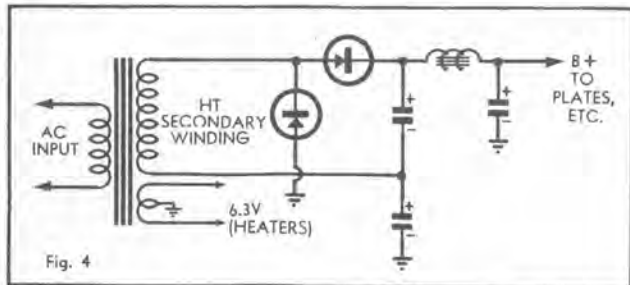
The 50-cycle alternating voltage at the rectifier plates is thus changed to pulsat-

life, and are more reliable in service. At the present time, their only disadvantage is that they are more expensive than valves where low-power rectifiers are required.

Two semiconductor diodes can be used in a full-wave rectifier circuit similar to that shown using a valve in figure 3, the only difference being that the diodes do not require a 5V filament wiring on the transformer. They are simply wired with their cathode connections tied together as the output connection leading to the filter circuit and the load circuit, and each anode connecting to one end of the transformer HT secondary winding.

This type of rectifier circuit is not often used where semiconductor diodes

**Figure 4: Most power supplies using semiconductor rectifiers utilise the full-wave voltage-doubling circuit, as shown here. It suits the rectifiers better, as well as being more compact and economical.**



ing DC at the rectifier filament, positive with respect to chassis and having a heavy ripple content of 100 cycles per second.

This positive voltage is generated at the rectifier filament quite independently of the five-volts AC coming from the transformer winding to heat the filament. This latter voltage, applied across the rectifier filament, raises it to operating temperature. When the positive voltage is generated, it carries the filament as well as the transformer winding feeding it, to a high positive potential in respect to chassis.

Obviously enough, since the rectifier filament winding is expected to be at a positive potential with respect to chassis, it must not be earthed.

Instead a wire connected to one wire of the filament or its supply winding becomes the source of the positive potential which must ultimately be fed to the plates and screens of the amplifying valves in the receiver.

However, the plates and screens must be fed with substantially pure DC, not a voltage which has a very high ripple content. To get rid of the ripple, it is necessary to use what is known as a FILTER system involving, usually, a filter choke and a number of filter capacitors. These are shown in figure 3, but an explanation of their operation must wait till another issue.

There are rectifier circuits other than the full-wave valve rectifier type shown in figure 3, and the remainder of this chapter will be taken up in examining some of the more commonly-used of these other types.

Readers may recall from the earlier chapter on semiconductors that a semiconductor diode behaves almost identically with a valve or thermionic diode. In view of this, it should not be very surprising to learn that semiconductor diodes can be used in rectifier circuits in place of diode valves.

In point of fact, they are somewhat better suited to this task than valves, as they require no heating power and also tend to conduct more easily during the part of the cycle when they are called upon to do so. They also have a longer

are employed, however, because it requires the diodes to have a high PEAK INVERSE VOLTAGE RATING. The peak inverse voltage is the reverse-bias voltage which appears across each diode when it is "off" and the other is conducting.

With the full-wave rectifier circuit, the reverse-bias impressed upon the diodes when they are non-conducting is actually 2.828 times the half-secondary RMS alternating voltage, and this requires the use of costly diodes having a very high peak inverse voltage rating.

Because of this, it is more usual to employ what is called the full-wave VOLTAGE DOUBLER rectifier circuit whenever moderate to high voltages and currents must be rectified by semiconductor diodes. Figure 4 shows a circuit of this type.

A single untapped secondary HT winding is used on the power transformer, and the winding is arranged to produce an alternating voltage of only HALF (approx.) the required DC output voltage. It should be noted, in passing, that this makes the power transformer somewhat simpler than in the full-wave circuit, and consequently somewhat less bulky and costly to produce.

Two semiconductor diodes are used as before, but this time they are connected in a different fashion. The first filter capacitor also undergoes a change, becoming two separate units which fill a more complex role than did the single unit of figure 3.

Neither end of the transformer HT secondary winding is earthed. Instead, one end goes to the junction of the two series-connected filter capacitors, while the other end goes to the two diodes. One diode has its cathode connecting to the winding and its anode earthed, while the other has its anode connecting to the winding and its cathode connecting to the top of the uppermost filter capacitor and the DC output circuit.

The operation is as follows: For the half-cycles when the top of the HT winding is negative and the bottom positive, the "series" (upper) diode is reverse-biased and non-conductive. The "shunt" (lower) diode is forward-biased, how-



ever, being connected to the winding via the LOWER filter capacitor.

It therefore conducts, and in doing so it charges the lower capacitor to the PEAK value of the alternating voltage appearing across the winding. The capacitor voltage is as shown, with its earthed end negative with respect to the top end.

During the other half-cycle of the

fication and, as the diode has to have a peak inverse voltage rating of approximately 2.828 times the DC output (which is approx. equal to the RMS voltage of the H.T. secondary) it is really only practical for low voltages as well.

The half-wave rectifier circuit delivers only one pulse of DC for each AC input cycle, so that its DC output ripple is of 50 cycles per second. This makes

and higher current) to deliver the same power.

This means that power supplies for transistor circuits must be rather different from those used to supply valve circuits. They must be able to deliver fairly high current, but only at a low voltage.

Figure 6 shows one type of transistor power supply. The power transformer has only one secondary winding, an untapped low voltage winding. This is connected to a bridge rectifier circuit using four silicon diodes or a selenium "stack" (as used in battery charger rectifiers) and thence to a very high value filter capacitor and a further regulator and filter circuit using a transistor.

The bridge rectifier is full-wave, in that it operates on both half-cycles of the AC wave. It differs from the full-wave circuit of figure 3 in that it does not require a tapped supply winding, and it differs from the doubler in that it does not supply a DC output voltage twice that of the RMS input voltage.

In the bridge circuit, two diodes conduct during each half-cycle. When end A of the transformer winding is positive, diodes D1 and D4 conduct, and when end B of the winding is positive diodes D2 and D3 conduct.

The load, in whatever form it takes, is effectively connected between points X and Y. When A is positive electrons flow from B, via D4, THE LOAD FROM Y to X, and D1 to A. When A is negative, flow is from A, via D2, THE LOAD FROM Y to X, and D3 to B.

The peak reverse voltage across the

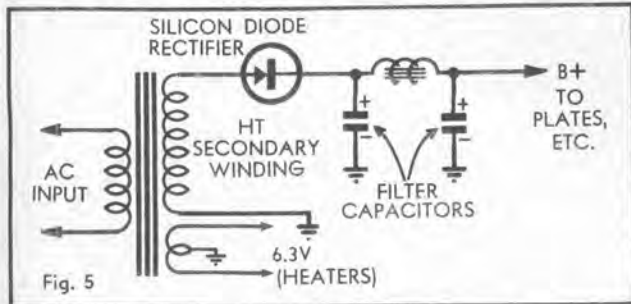


Figure 5: Where only very low current drain is involved, a half-wave rectifier system may be employed. If the voltage required is too high for a semiconductor rectifier, a valve rectifier can be substituted.

AC wave, when the top of the HT winding is positive with respect to the bottom, the "shunt" diode is reverse-biased and non-conductive, while the "series" diode conducts. This time the upper capacitor is charged to the peak value of the AC secondary voltage, as it completes the circuit back to the lower end of the winding. The voltage across it has a polarity as shown.

As may be seen, the two capacitor voltages add together, and the total pulsating DC voltage available for filtering is TWICE the peak value of the HT winding RMS voltage. Under load this voltage drops toward twice the RMS voltage.

The most important thing to realise about the voltage doubler circuit is that for a given and required DC output voltage, each diode has to deal with only HALF the voltage it would meet in a conventional full-wave circuit. Thus the doubler circuit allows the use of relatively inexpensive semiconductor diodes having but a moderate peak inverse voltage rating.

The voltage doubler circuit is finding almost universal acceptance in television receiver power supplies and in many other places where high current is required at a fairly high voltage. Silicon diodes are used almost universally in this circuit, as they are most easily arranged to have the required peak inverse voltage and forward conduction current ratings.

In power supplies where the voltage and current demands are very slight, it is possible to use a single diode valve or a single semiconductor diode in what is called a HALF-WAVE rectifier circuit. Such a circuit using a semiconductor diode is illustrated in figure 5.

A single untapped HT secondary winding is used as with the doubler, but this time it needs to provide an RMS voltage approximately equal to the required DC output voltage. One end of the winding is earthed and the other connects to the first filter capacitor via the diode.

The circuit is in effect half the full-wave circuit, and the diode only conducts on every alternate half-cycle when the top of the HT secondary is positive. The half-cycles when the winding voltage is reversed are not used.

The half-wave circuit is thus rather inefficient, as it only uses half the energy available from the transformer. It is thus only suitable for low current recti-

filtering somewhat more difficult compared to the 100-cycle ripple produced by the full-wave and doubler circuits, as we shall see in a later chapter.

So far in this chapter, we have thought mainly in terms of valve-equipment type mains power supplies — that is, power supplies required for the operation of valve receivers and equipment from the mains. Before we leave the subject of power supplies, however, we should glance at the type of power supply required to operate transistor equipment from the mains.

As we saw in an earlier chapter, transistors are low-voltage devices compared

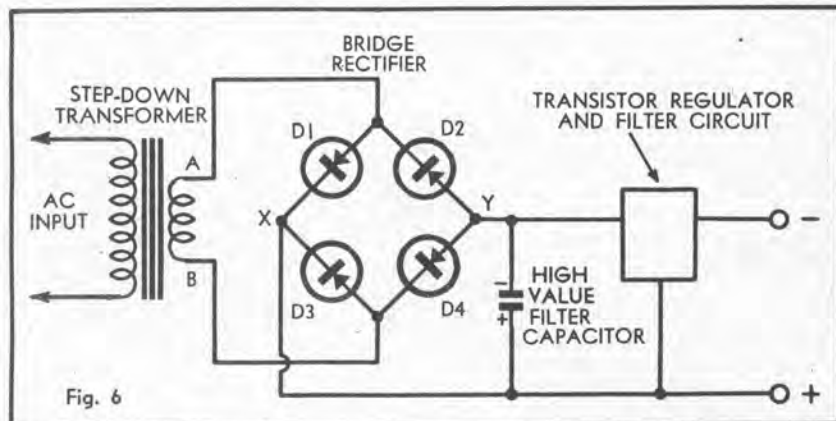


Figure 6: Fully transistorised equipment normally needs a much lower supply voltage than valves but at much higher current. This typical transistor power supply shows a bridge rectifier system, a high value filter capacitor and a supplementary transistorised regulator and filter circuit.

with valves. They operate with supply voltages of from 3 to about 40 volts, whereas valves normally use considerably higher voltages.

Where transistor circuits are required to deliver appreciable amounts of power — for example, in the case of transistorised audio amplifiers — they must accordingly be supplied with higher currents than valve circuits of equivalent performance. This is simply because to deliver power, they must be supplied with power, and power is effectively the voltage multiplied by the current.

Valves operate at a high voltage, and can thus supply and can be supplied with power at a moderate current (high voltage and low current); transistors with their lower voltage operation must be supplied with higher current (low voltage

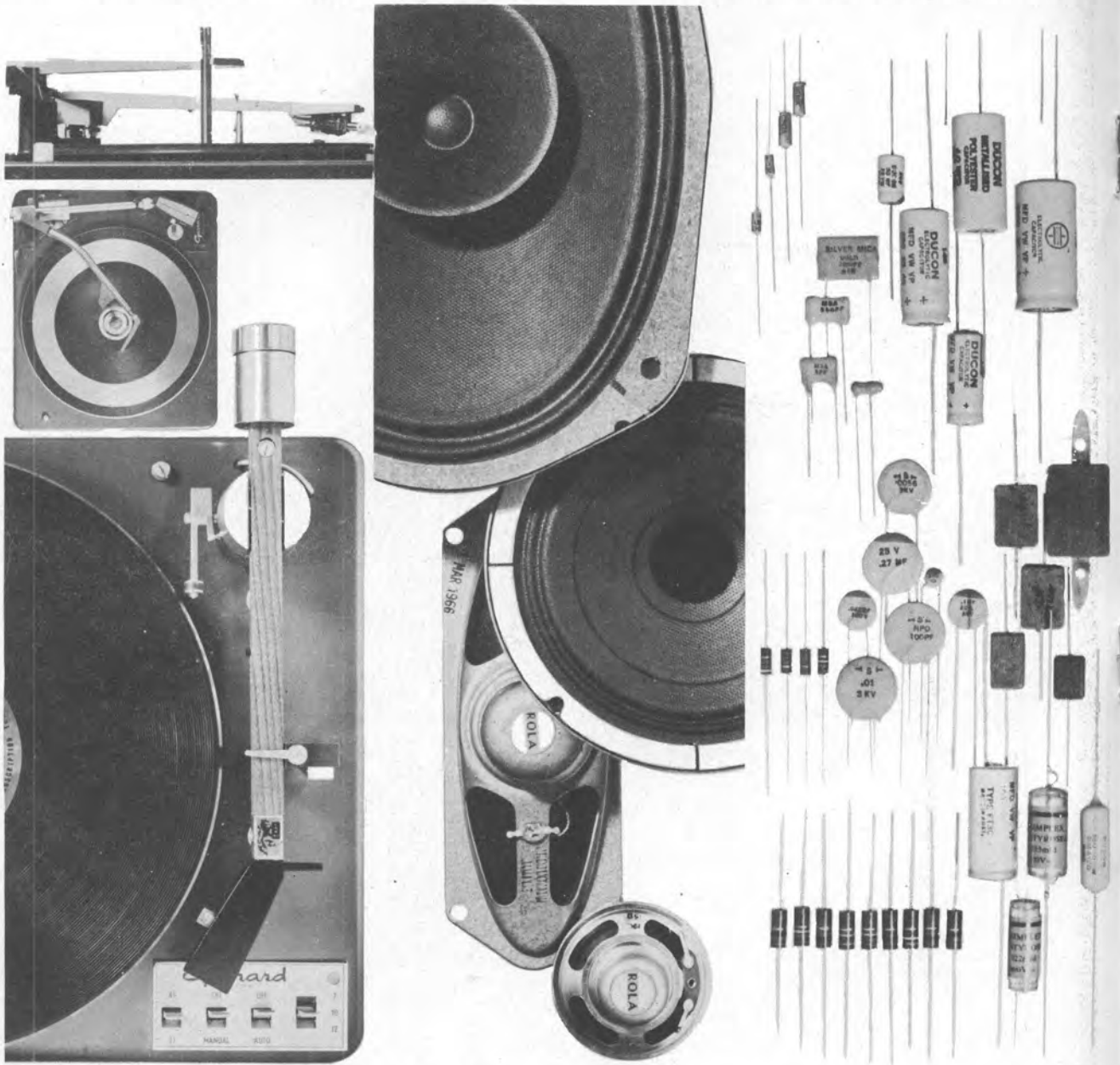
and higher current) to deliver the same power. This means that power supplies for transistor circuits must be rather different from those used to supply valve circuits. They must be able to deliver fairly high current, but only at a low voltage.

The low-voltage, high current requirement of transistor power supplies makes filtering the AC ripple from the DC output a difficult task. A very large first filter capacitor is required (some supplies use 5000 uF or higher), and as we have shown a transistor regulator and filter circuit must often be used for additional filtering and to maintain the output voltage constant under load.

As we mentioned earlier, however, the subject of filtering and regulation must wait until a later chapter.

# PLESSEY CO

The most comprehensive component range for



PLESSEY COMPONENTS, one of the five Plessey manufacturing groups in Australia, offers a complete range of electronic components and sound reproduction equipment for industrial, professional and entertainment applications.

Wherever there is a requirement for a reliable electronic component, electrical equipment or a quality record changer, names such as Ducon, Rola and Garrard spring automatically to mind — all three companies are divisions of Plessey Components.



## Plessey Components Group

Ducon & Garrard Divisions Box 2 PO Villawood NSW Sydney 72 0133  
Rola Division The Boulevard Richmond E1 Vic Melbourne 42 3921

# COMPONENTS

## Radio, Television and Industrial applications

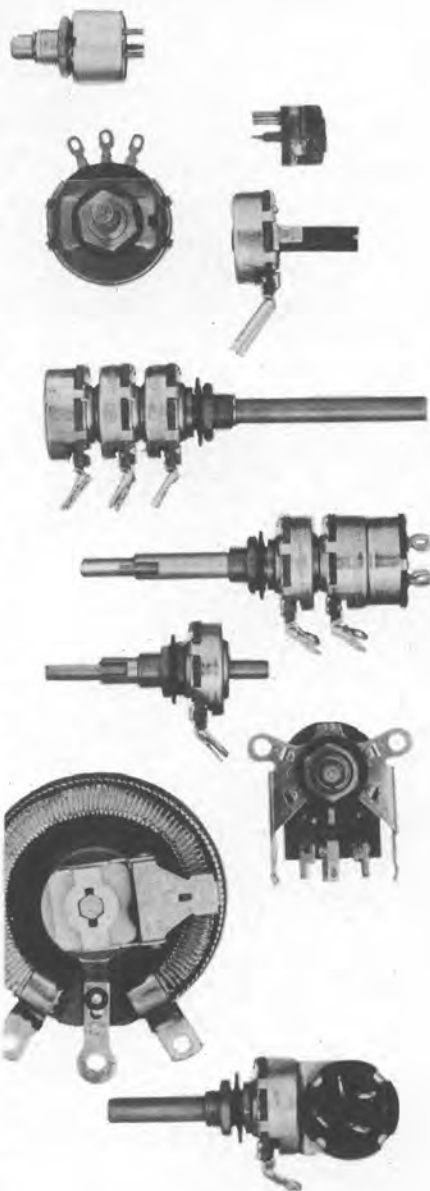
### Garrard Division

Record Changers unsurpassed for sound reproduction and elegant styling . . . offering greater listening enjoyment from any selection of the wide variety available.

The complete Garrard range of sound reproduction equipment features the following: Wired for stereo — all available cartridges can be fitted. Fully-automatic playing of intermixed 12", 10", 7" records of the same type and speed. Dynamically balanced motor ensures highest lasting performance with minimum wow, flutter and rumble. All major bearings self-lubricating for maximum service with least maintenance. All automatic models can be operated manually or automatically with readily accessible controls. Special short record spindle available for manual playing of single records if desired. Positive selection of all speeds.

### Rola and Ducon Divisions

Wide range high-fidelity speakers . . . unsurpassed in clarity, performance, transient response and musical quality. Magnetic tape equipment for broadcast use: Studio consoles, transportable recorders, high speed tape copiers, automatic tape programming systems. Magnetic drum announcement equipment: Multi-channel, variable message length and short duration announcement units, broadcast turntables, specialised electronic devices. Loudspeakers: Circular, elliptical and wide range alnico and ferrite magnet models for all applications. TV components: Deflection yokes, fly-back and vertical output transformers. Output transformers: Isocore (shielded), open and encapsulated types, electro-mechanical sub-assemblies for specialised applications. Encapsulated wound components: Solenoid coils and special assemblies. Magnet winding wire in gauges from 10-44 B. & S. Standard enamelled, special enamelled and fabric covered. Alnico and barium ferrite magnets of various shapes and sizes for a wide range of applications. Electronic components for audio and visual perfection . . . reliability and efficiency assured by manufacturing experience: Ceramic dielectric capacitors, ceramic components and valve sockets, cold cathode, neon and number tubes, dry reed relay inserts, electrolytic capacitors, ferrite products in-



Some indication of the extent and diversity of the Plessey product range can be gauged from the abridged list shown above and opposite.



cluding rods, slabs, yokes and cores, infra-red detectors and solar cells, metallised ceramics, mica products, memory systems, mica dielectric capacitors, printed circuit switches and connectors, paper dielectric capacitors, potentiometers, power rheostats, plastic film dielectric capacitors, pickup cartridges, relays, rotary solenoids, resistors — carbon, wire-wound and metal film, switches — pushbutton and rotary, solid state circuits, sub-miniature valves, semiconductor devices, transformers and transducers, tantalum capacitors, connectors.



# CHAPTER 13: Power Supply Filtering using inductors and capacitors.

- Provisions made for the supply of grid bias to valves. Cathode bias and back-bias.
- Valve type portable receivers and series-string filament wiring.
- Dynamic filtering and regulation using transistors.

**I**N the last chapter of this course, we introduced the topic of mains power supplies with a discussion of the various transformer and rectifier combinations used to change the mains AC into pulsating unidirectional form. In this chapter we will continue the discussion by examining the ways in which the pulsating DC produced by rectifier circuits is smoothed of its pulsations or ripples and thereby made suitable for supplying the operating potentials and currents of valves and transistors.

The first and major part of the discussion will be concerned with the type of filtering circuitry used in power supplies associated with valve equipment, because it is this type of power supply which will be met by the newcomer to electronics in all his initial contact with mains-operated equipment. As yet, mains-powered transistor equipment is relatively rare, although transistors are being introduced to the field all the time.

Before actually discussing filter circuits at length, some additional points can well be made in relation to the power transformer and rectifier combinations discussed in the last chapter.

In figure 3, last month, we showed a rectifier with its filament circuit operated from a separate 5-volt winding on the transformer. This scheme has been used ever since the inception of domestic all-mains receivers and is still widely used, particularly in larger receivers and amplifiers requiring a substantial HT voltage and current.

However, in recent years, valve manufacturers have produced a number of rectifiers for small receivers which do not require a separate heater winding. Typical of these are the 6X5-GT, 6X4 and 6V4.

All these rectifiers have a 6.3-volt heater but an indirectly heated cathode, with more than the usual insulation between them. In use, the heater is fed from the same heater winding as the other valves, the high tension point now being the rectifier cathode.

The revised circuit arrangement is shown in figure 1. It is noteworthy that the rectifier heater is earthed and the cathode at the full high tension voltage—hence the need for adequate insulation between them within the valve.

There are two advantages in the scheme, both important in small receivers. In the first place, the fact that only one heater winding is needed simplifies the transformer design, making it somewhat smaller and cheaper to produce. Secondly, the heat dissipation from small indirectly heated rectifiers is less than half that from the older 5-volt types, as less power is required to obtain adequate emission from the cathode material used. This simplifies the ventilation problem in a small cabinet.

One small point in figure 1 warrants special mention, namely the dotted line drawn between the primary winding and the core and shown as earthed.

This dotted line represents a so-called ELECTROSTATIC shield, a thin layer

of copper shim wound over the primary but with its ends insulated one from the other, so that it will not form a shorted turn. Its purpose is to minimise radiation of RF energy, either noise interference or signal, from the power mains into other wiring and thence into the signal circuits of the receiver.

The desirability of eliminating noise interference from the receiver is obvious.

Signal which enters the receiver by the power mains can be modulated by the 50-cycle supply frequency to produce a hum which is only heard when a station is tuned in. The inclusion of an electrostatic shield in the transformer may or may not eliminate the effect but it is a worthwhile precautionary measure.

As a result, transformers normally include an electrostatic shield and a wire is provided, often a cotton-covered stranded lead, to allow it to be earthed. The shield does not always appear in schematic circuits but one should seek it out as a matter of course and connect the appropriate lead to chassis.

As already explained, the input to the rectifier from the power transformer is an alternating voltage, which may be illustrated as per the diagram in figure 2a.

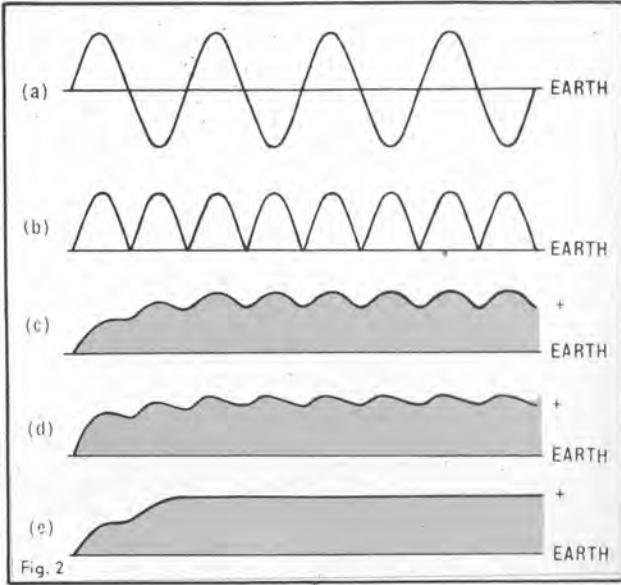
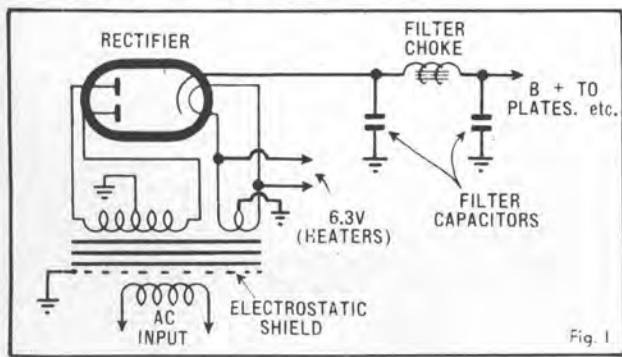
After passing through the rectifier valve, the alternating voltage emerges as a series of positive-going pulses, shown in figure 2b. This is commonly described as PULSATING DC and, because of its nature, is quite unsuitable for application to the plates and screens of amplifying valves. The effect of feeding such a supply to a receiver or amplifier would be to produce a hum level differing only in degree from what would result with AC on the plates.

An essential part of an AC power supply is therefore the filter system, which serves to smooth out these unidirectional pulses to pure DC.

The properties of inductance and

**Figure 2: Voltage waveforms associated with rectification and filtering circuits. Filtering is necessary to produce smooth DC from the pulsating rectifier output.**

**Figure 1: A typical full-wave rectifier circuit, using an indirectly-heated rectifier valve. Only one heater winding is needed, reducing the complexity and cost of the transformer.**



capacitance are both commonly put to use in such filter systems.

The inductor consists normally of a large number of turns of wire wound within laminated iron core, much like that used for small power or output transformers. Known as a FILTER CHOKE, it must be capable of carrying the amount of current involved in the particular supply and, with this current flowing, must have an inductance usually of several Henries.

In some older-type receivers a filter choke, as such, was not used. Instead, the current from the power supply was passed through a winding around the pole piece of the dynamic speaker. This gave the requisite inductive effect for filtering, and the magnetic field created by the current served at the same time to energise the speaker's magnet system. The so-called "field" winding on the loud-speaker therefore served a double purpose.

Earlier in the series, we learned that an inductor tends to resist any change in the amount of CURRENT flowing through it.

If the current increases above average, part of the energy involved is diverted into creating a stronger magnetic field around the winding. If the current decreases, the magnetic field is reduced and returns some of its energy to the winding as current flow.

As a result of this action, current flowing through a filter choke loses a good deal of its ripple content and becomes more nearly pure DC, as shown in figure 2c.

As indicated earlier, capacitance is also involved in a filter system, its effect being more or less complementary to that of inductance.

A capacitor tends to oppose any change in the POTENTIAL or VOLTAGE across it.

If the voltage rises above an average value, some of the energy involved is diverted into the capacitor as an extra charge. If the voltage then subsequently falls, the charge is released, tending to maintain the original potential.

When one or more capacitors is connected between the B-plus supply line and earth, as in figure 1, they naturally tend to oppose or absorb the change in potential due to ripple from the rectifier. They charge on "peaks" and release energy subsequently to fill the "troughs." Diagrammatically, the effect is as illustrated in figure 2d.

### VIRTUALLY PURE DC

Given sufficient filtering effect, the ripple content can be completely eliminated, for all practical purposes, and the output from the supply becomes virtually pure DC. (See figure 2e.)

Filter systems vary a good deal in actual detail. Over the past years, most receivers have used a filter system basically like that illustrated in figure 1—a filter capacitor followed by a filter choke or a field coil, with a second filter capacitor on the output side supplying the load circuit.

This is known as a Condenser Input or Capacitor Input filter, because the rectifier feeds directly into a capacitor. In the less common arrangement, where the rectifier feeds directly into an inductor, the filter is described as a Choke Input filter.

Filter capacitors normally need to have a large value of capacitance, certainly not less than eight microfarads

each. To obtain this capacitance in small space and with adequate working voltage, not forgetting price either, they are invariably electrolytic types, as described earlier in the series.

The main point to remember about electrolytics is that they must be connected the right way round, with their positive terminal connected to the positive side of the circuit.

In recent years, much higher values of filter capacitance have become practical and, as a result, chokes having much lower inductances will suffice for the same degree of filtering. In point of fact, many small receivers these days do not use a choke at all, relying only on large capacitors to give an adequate storage and filtering effect.

In such receivers, the output from the rectifier feeds directly to a large capacitor, usually about 24 microfarads and then to the plate circuit of the output valve. The ripple may not be entirely eliminated but, because there is no amplification following the output plate, the ripple content is not sufficient to produce an audible hum in the speaker.

The screen of the output valve, together with other stages in the receiver, is normally fed through a resistor of a few hundred to a few thousand ohms, depending on requirements, the further supply point being bypassed with another large capacitor.

The technique of supplying portions of the receiver through resistors, bypassed to earth at the further end, is commonly referred to as Decoupling.

The size and value of the components used in a power supply depend very

largely on the amount of voltage and current required by the receiver it needs to supply.

A small set may require something like 150-200 volts at 30-50 milliamps. A medium-sized console or radiogram receiver may require 250-300 volts at 80-100 milliamps. A very large receiver or amplifier may require 300 volts at 100 milliamps or more, while a television set may require up to 300 volts at nearly 300 milliamps.

### POWER SUPPLY DESIGN

We cannot hope to study here in detail the design techniques for power supplies, but a simple explanation of the procedure may cast sufficient light on the subject for present purposes.

The receiver designer first calculates the total voltage and current which will be required to operate the projected receiver. There is more to this than just adding up the nominal figures of current drain for the valves concerned. Depending on operating conditions, the valves may draw varying amounts of current, so that fairly careful study of characteristics is necessary to predict voltage and current accurately.

Knowing the current and the likely DC resistance of the filter choke, the designer can work out the voltage drop in the filter and add this to the high tension requirements to obtain the voltage necessary from the rectifier.

The rectifier valve must be a type capable of delivering the required current and, by reference to manufacturers' curves, the designer can ascertain the alternating voltage which needs to be applied to the rectifier plates to give the

## BUILD — EXPERIMENT — EXPLORE WITH TRANSISTORISED KITS or PARTS AND INSTRUCTION SHEETS

NEW RELEASE

**60** SIMPLE  
ELECTRONIC  
PROJECTS  
YOU CAN  
BUILD NOW!



6 Transistor Pocket Radio Kit Set.  
Complete to Last Nut and Bolt —  
With Full Directions for Assembly.  
£9/10/ . . . \$19.00.

MAKE—A 2 Transistor Radio, A Motor Speed Control Unit, A Screaming Siren, Infra-Red Burglar Alarm, Electronic Thermometer, Headphone Amplifier, Short Wave Receiver, Short Wave Converter, or any one of 60 Exciting, easy-to-build projects, with full Instructions.

FULL RANGE OF PARTS STOCKED — RESISTORS, ELECTROLYTIC CONDENSERS, ETC.

### TRANSISTORS AND DIODES AT SPECIAL PRICES

BC107	11	0	AF114	10	0	AF117	9	6	AC126	9	0	2N301	£1	5	0
BC108	10	6	AF115	10	0	OC44	10	0	AC127	11	0	OC74		3	0
BC109	14	0	AF116	9	6	OC45	10	0	AC132	10	6	AA119		3	0

SEND STAMPED, ADDRESSED ENVELOPE FOR LIST OF PROJECTS— PLUS FREE CIRCUITS OF 10 MINIATURE AND SUB-MINIATURE 1, 2 AND 3 TRANSISTOR MATCH BOX SIZE, AND WRIST RADIOS; also AMPLIFIERS.

**S. E. WILLIS TRADING CO.**

38 RIVERSDALE ROAD, CAMBERWELL, VIC.

82-5787

required DC output voltage at the expected current drain.

The power transformer HT secondary ratings can then be nominated as so many volts either side of the centre tap, at a load current of so many milliamps.

This, in turn, dictates the gauge of wire on the secondary and the likely bulk of the winding. Allowing for this, for the power load it represents and for the filament windings already discussed, the size of the transformer core can be determined. Naturally, the greater the output required in volts and milliamps, the larger must the transformer be.

If the designer elects to use, instead, the now-popular voltage doubler circuit (figure 4, July issue), it becomes a matter of choosing suitable semiconductor type of rectifiers and working out the necessary transformer specifications.

No reference has been made thus far to obtaining negative volts from an AC power supply, to meet the possible need for negative grid bias in the receiver.

In point of fact, the need for a negative grid bias voltage is not so urgent in a mains-operated receiver as in a battery-powered set.

The reason is simply that most, if not all, of the valves have indirectly heated cathodes and bias can be obtained very easily by connecting a resistor between cathode and earth, as shown in figure 3.

Electron current flowing through the valve from cathode to screen and plate has to pass through the cathode resistor  $R_c$ . In doing so, it creates a voltage drop across the resistor, the cathode end becoming positive with respect to earth.

### CATHODE POSITIVE

If the grid circuit is returned to earth, the cathode must obviously be positive with respect to grid by the voltage developed across the resistor  $R_c$ . Alternatively, it can be said that the grid is negative with respect to cathode by the same amount, so that, effectively, the grid has a negative bias.

The voltage drop across  $R_c$  can be calculated readily by Ohm's Law, and is simply the product of  $R_c$  in ohms and the total plate and screen current in amps. Alternatively, knowing the plate and screen current and what the bias voltage should be, the optimum value of cathode resistor can be calculated readily.

Because the plate and screen current vary at signal frequency, the voltage developed across  $R_c$  varies in sympathy tending, as it happens, to cancel partially the effect of the signal on the grid.

This is normally not desirable, and, to prevent it, it is usual to connect a capacitor shown as  $C_c$  across the bias resistor, sufficiently large to prevent a change in cathode voltage at the signal frequencies concerned. In other words, it exercises an energy storage effect.

The method known as CATHODE BIAS or SELF BIAS, is widely used in mains-operated equipment and, if applied to all stages, obviates the need for a source of negative voltage from the power supply.

However, there are occasions where cathode bias is not convenient or where it involves more components than might strictly be necessary. In such cases the circuit arrangements shown in figure 4 can be adopted.

Instead of the transformer HT centre-tap being returned directly to earth, as

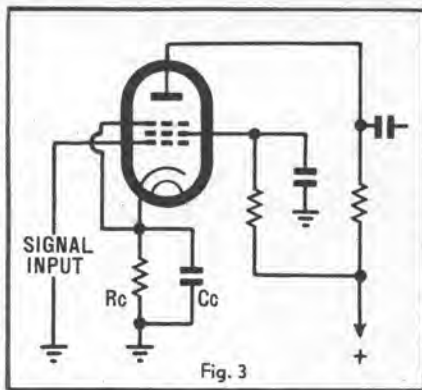


Figure 3: A pentode voltage amplifier stage, illustrating the technique of "cathode biasing." Resistor  $R_c$  and its bypass  $C_c$  produce a steady voltage difference between the cathode and the grid.

in the circuits previously discussed, it is returned to earth through a resistor. Current flowing from the power supply to the external circuits has to pass through this resistor, and, in so doing, develops a voltage drop across it.

The polarity of the current flow is such that the end of the resistor connecting to centre tap becomes negative with respect to earth. The actual voltage developed is calculable by Ohm's Law and is dependent on the value of the resistor and the TOTAL current drain from the power supply.

Knowing the bias requirements in a set and the total current drain, it is a simple matter to calculate a value for the resistor  $R_b$ . If two or more bias

voltages are required, resistors can be connected in series to give the required total value, with appropriate tapings.

The general circuit arrangement is normally referred to as a BACK-BIAS system.

It should be noted that the first electrolytic filter capacitor does not return to earth in a back-bias system, but to the transformer centre-tap. There is a definite reason for this. If it were to return to earth, the charging current from the rectifier into the capacitor would flow through the resistor  $R_b$  and develop across it a very high ripple voltage which may be injected into a grid circuit, to appear as hum.

Connecting the capacitor as shown puts it right across the output of the transformer-rectifier combination and avoids most of the difficulty.

Where ripple in the bias system must be kept to an absolute minimum, a capacitor may be connected across  $R_b$  or, alternatively, additional filtering or decoupling may be inserted in the lead carrying the bias voltage to the relevant grid circuits.

One other point needs to be made about the final filter capacitor in an AC power supply system. It provides valuable filtering, as already explained, but this is not its only role. Have a look at figure 5.

It shows the plate output circuit of the final stage and the lead coming to it from the filter choke. In the presence of grid signal, the plate current of the output valve will vary and develop a voltage across ANY impedance in the plate circuit.

Without the filter capacitor, shown

Figure 4: The bias technique known as "back-bias." A small resistor placed in the negative output of the power supply provides negative bias voltage.

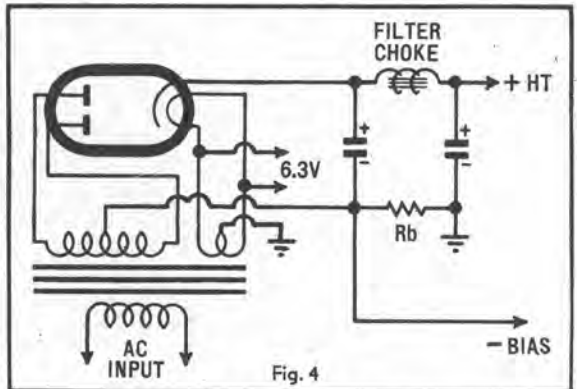
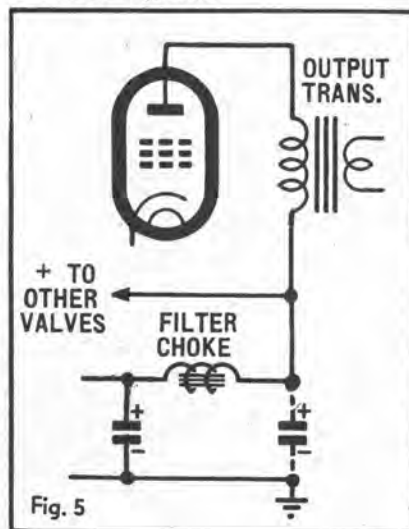


Figure 5: A diagram illustrating the job done by the final filter capacitor.



dotted, the valve would develop a voltage across the output transformer and also across the filter choke. In other words, some of the energy intended for the loudspeaker would be wasted quite uselessly in energising the magnetic circuit of the filter choke.

What is no less serious, the signal voltage developed across the filter choke would be superimposed on the B-plus line feeding other valves in the receiver. This could lead to quite serious effects, notably audio oscillation.

With a filter capacitor in circuit having a large enough value, the storage effect is sufficient to prevent the B-plus line from varying its potential at the signal frequency. As a result, all the available energy from the output valve is concentrated into the output transformer and very little of it finds its way to previous stages.

In the face of the foregoing explanation of AC power supplies and the

need for filtering and indirect heating, the reader may well ask how so many of the battery portables, in vogue a few years ago, could operate from the mains, still using battery valves throughout. Nor were there any hum problems. Why could not the same have been achieved with early battery sets and early directly heated valves?

The answer to this question lies in the fact that modern battery valves use filaments having a very low battery drain, a typical figure being 50 milliamps.

In the portables concerned, the valve filaments were connected in SERIES, instead of in parallel, so that their total supply requirement was something like 9 volts at 50 milliamps. Now, 50 milliamps is well within the current rating of an ordinary valve rectifier, and presents no difficulty in terms of filtering, using standard filter chokes and capacitors.

## LIMITED PERFORMANCE

These portables, therefore, included a power supply capable of delivering about 90 volts DC — sufficient for the plate supply—at about 65 milliamps, representing the total high tension and filament current. The 90 volts was fed to the B-plus line, while a large dropping resistor reduced it to 9 volts for the filament circuit.

Successful application of the method was therefore, largely due to the availability of suitable valves coupled with the demand for sets capable of operating from both batteries and power mains.

While undoubtedly convenient, such receivers were nevertheless limited in ultimate performance by the modest design of the battery valves, while reliability was not as good, either, as that of valves having robust cathode structures and intended for prolonged operation from the power mains.

The use of a series filament network also poses some tricky problems of circuit arrangement, since the different potentials between each filament and earth effectively represent an initial bias in relation to the grid circuit. But we are getting into deep waters.

In any case, valve type battery portables are now a thing of the past, having been superseded completely by all-transistor portables. For the most part, the battery requirements of the all-transistor portables are so modest that there is little incentive to arrange for alternative mains operation.

However, transistors are finding increased application in equipment other than portable receivers and there is an increasing interest in the problems of filtering in power supplies intended for use with transistorised equipment.

As we mentioned in the last chapter, the low-voltage high-current requirements of transistor circuitry make it hard to obtain adequate filtering with the usual capacitor-inductor combinations, even when capacitors of values up to 5000uF are used. Maintaining the supply output voltage constant as current is drawn by the load also becomes a problem.

To overcome the filtering problem, a system of "active" or DYNAMIC filtering has been evolved, using a transistor to give what we might think of as "amplified" smoothing of the power supply output. The transistor may also be arranged to improve the constancy of the supply output voltage as the load

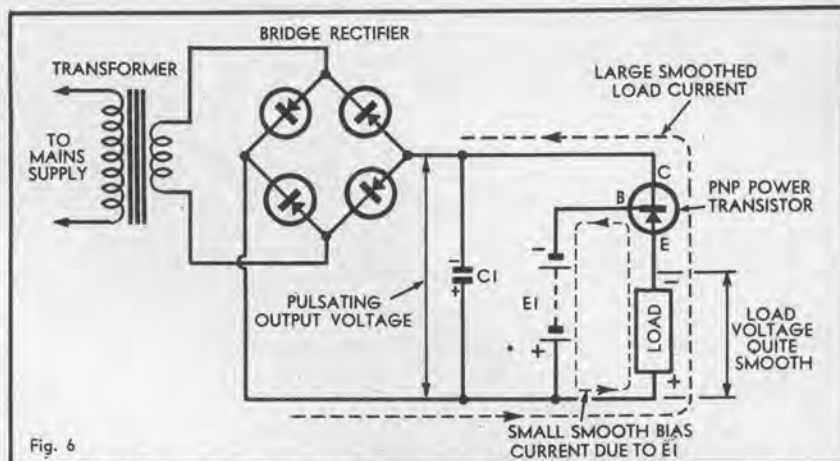


Figure 6: The basic operation of the dynamic filter and regulator. A power transistor maintains a near-replica of the reference voltage across the load connected in series with its emitter, and can be used as either a filter or a regulator, or both.

draws current—in other words, to REGULATE the output voltage.

Transistor filtering and regulation relies upon the fact that the transistor is a current amplifier. It is capable of controlling large currents when supplied with small input or "bias" currents, as we saw in chapter seven of this course.

The general principle of transistor filtering and regulation is that the transistor is made to control the relatively large current drawn by the load circuit by supplying its control electrode—the base—with a smoothed and/or regulated source of bias current. As this REFERENCE source is required to supply only the small control current of the transistor, it is a relatively easy matter to provide it with filtering and regulation.

Figure 6 may help in understanding the principles involved. A PNP power transistor is connected in series with the power supply and the load, so that the load current has to flow through the collector-emitter circuit of the transistor.

Because the load is in the emitter lead of the transistor, any load current which flows sets up a voltage drop and tends to make the emitter negative with respect to the base; the load is virtually a "cathode bias" resistor. In other words, load voltage tends to CANCEL the forward-biasing effect of the reference source (represented by E1).

## FORWARD BIASED

You don't see why? Well, to be forward biased, the transistor has to have its base negative with respect to its emitter—or looking at it the other way around, its emitter positive with respect to its base. The reference source, because it aims at making the base negative with respect to the rest of the circuit, thus encourages the transistor to conduct, but any voltage developed across the load tends to cancel the efforts of E1 by making the emitter negative as well. The base-emitter forward bias is thus reduced.

We thus have a rather interesting state of affairs. The reference source, represented by E1, provides a forward bias for the transistor. This allows the transistor to conduct and collector-emitter current flows—through the load. But this produces a voltage drop across the load, which tends to cancel the for-

ward bias and STOP the transistor from conducting.

Obviously, the transistor can't conduct to a degree where the load voltage drop equals the reference source voltage, for if it did, it would have no forward bias! What it does do is adjust its conduction so that the load current which flows produces a load voltage which is smaller than E1 by a voltage just able to produce a base-emitter bias current corresponding to the load current.

## TO EQUILIBRIUM

Sound like a vicious circle? It is, in the sense that the circuit just can't help but adjust itself to this position of equilibrium. The load current can't fall below the correct figure, or the load voltage will fall and the transistor will receive more forward bias, to make it conduct more; conversely, if the current exceeds the correct figure, the load voltage will rise and tend to cut off the transistor and reduce the current.

For any value of E1, the transistor will adjust the load current so that the load voltage stays at a certain critical value below E1. If we keep E1 constant and alter the load resistance, it will adjust the current to maintain this critical voltage. Keeping the load resistance constant and altering the reference voltage will result in the transistor adjusting the load current up and down, to make the load voltage "follow" the variations in E1.

The higher the gain of the transistor, the smaller the bias voltage which it will require for any given load current. And since the transistor bias voltage is the difference between E1 and the load voltage, this means that for a very high gain transistor the equilibrium load voltage will be only slightly smaller than E1. A "perfect" transistor with infinite gain would result in the two voltages always being equal, as it wouldn't require any forward bias.

Because the transistor in this connection causes the load voltage to "follow" the reference voltage, the connection is commonly called the "emitter follower" mode.

The feature of the emitter follower mode of connection which is of particular importance from the viewpoint of dynamic filtering and regulation, is that the load voltage is more or less independent of the transistor collector volt-

## "M" SERIES PRECISION SOLDERING & DE-SOLDERING TOOLS

*"The soldered joint is the link between components in the most scientifically designed and developed apparatus the world has ever known. One faulty joint can upset the functioning of the apparatus."*

*"The first important decision in Radio or Electronics is the careful selection of a Precision Soldering Tool."*



**M20 1 OZ. 1/8" DIA. TIP:**

FOUR "TRICLAD" TIP SIZES

MICRO MINIATURE ELECTRONICS  
6 volt, 12 volt, 24 volt, 32 volt, AC/DC



**M64 3½ OZS. 3/16" DIA. TIP:**

FOUR "TRICLAD" TIP SIZES

RADIO AND TV ASSEMBLY AND  
SERVICING  
230-250 volt and all lower voltage  
ranges AC/DC



**M207 4 OZS. 1/4" DIA. TIP:**

TWELVE "TRICLAD" TIP SIZES

RADIO AND TV SOLDERING AND DE-  
SOLDERING  
230-250 volt and all lower voltage  
ranges AC/DC

PRECISION MADE  
THOROUGHLY TESTED  
ACCURATELY CALIBRATED  
EASILY APPLIED  
EFFICIENT AND RELIABLE  
CORRECT TIP TEMPERATURE  
RIGHT TIP SIZE AND SHAPE  
LIGHT WEIGHT  
FINE BALANCE  
FINGERTIP GRIP  
SLIM BARREL  
CONSTANT OPERATION  
MAINS VOLTAGE APPROVED  
AVAILABLE ALL VOLT RANGES  
NO TRANSFORMER NECESSARY  
STANDARD IN R.A.N.  
STANDARD IN ARMY  
STANDARD IN R.A.A.F.  
STANDARD IN P.M.G.  
STANDARD IN COMPUTER FIRMS  
STANDARD IN SPACE TRACKING  
AUSTRALIAN MADE  
SERVICE IN ALL STATES  
QUALITY GUARANTEED

# ADCOLA

Available from all Principal Radio and Electrical Components Suppliers.  
Further information is available from:

N.S.W. H. Rowe & Co. Pty. Ltd., 512 Punchbowl Road, Lakemba. Tel.: 75-0681

S.A. F. R. Mayfield Pty. Ltd., 11 Halifax Street, Adelaide. Tel.: 8-4131

Qld. T. H. Martin Pty. Ltd., 56-74 Edward Street, Brisbane. Tel.: 2-0555

W.A. C. L. Sedunary & Co., 126 Brown Street, East Perth. Tel.: 23-2551

Tas. H. Rowe & Co. Pty. Ltd., 231 Liverpool Street, Hobart. Tel.: 34-3860

**ADCOLA PRODUCTS PTY. LIMITED, 12 CHURCHILL STREET, MONT ALBERT,  
MELBOURNE. Tel.: 88-4351**



age. As long as there is sufficient collector supply voltage to supply the requirements of the transistor and load, any pulsations or variations present in the collector supply voltage have no effect upon the load current and voltage.

If the collector supply voltage rises, for instance, any tendency for the load current and voltage to rise results in a decrease in the bias of the transistor and its conduction is reduced to restore the current to its correct value. Similarly, if the collector voltage falls, any tendency for the load current and voltage to fall results in an increase in transistor bias and a consequent increase in transistor conduction to restore the load current value.

Obviously, the transistor acts like a filtering and regulation circuit, which prevents variations or pulsations in the rectifier output voltage from reaching the load. Providing the transistor is kept operating within its limits and the supply voltage remains sufficient to supply the needs of the transistor and the load, the only thing which controls the load voltage is the reference source.

Batteries can be used as reference voltage sources, as shown in figure 6 but, in fact, they are rarely employed. It is more usual to arrange for the reference source to be supplied from the rectifier output, via suitable filtering and/or regulation circuits. These may often be rather simple circuits, as they handle only the small bias current of the transistor.

Figure 7 (a) shows the basic circuit for the transistor dynamic filter. The reference voltage is derived from the pulsating rectifier output via the appropriate series resistor R and is smoothed of ripple by the capacitor C. The transistor then acts to approximate this smoothed reference voltage across the load.

### CAPACITANCE "AMPLIFIED"

Often this filtering action is pictured by considering the transistor to have "amplified" the filter capacitor C to a value given by the product of C and the transistor current gain. Thus, it is said to act as a "filter capacitance multiplier."

For example, if C has a value of 500uF and the transistor has a gain of 100, the effective filtering is considered to be equivalent to a capacitor of 50,000uF shunted directly across the load.

While this comparison is fairly accurate as far as the filtering is concerned, it is not accurate as far as the source impedance seen by the load is concerned. This point is a little too involved for our purposes at present, but it should be remembered that the concept of capacitance multiplication is rather limited in its application.

Figure 7 (b) shows the basic circuit for a transistor load voltage regulator. Again the reference voltage is derived from the pulsating rectifier output, but this time a zener diode is connected from the transistor base to the positive side of the supply.

The zener diode is a special sort of semi-conductor diode which can be arranged to have a constant voltage drop over a wide range in current. Thus, it represents a constant reference voltage for the transistor and the transistor, accordingly, acts to keep the load voltage similarly constant. The output voltage in 6 (b) is not particularly free from

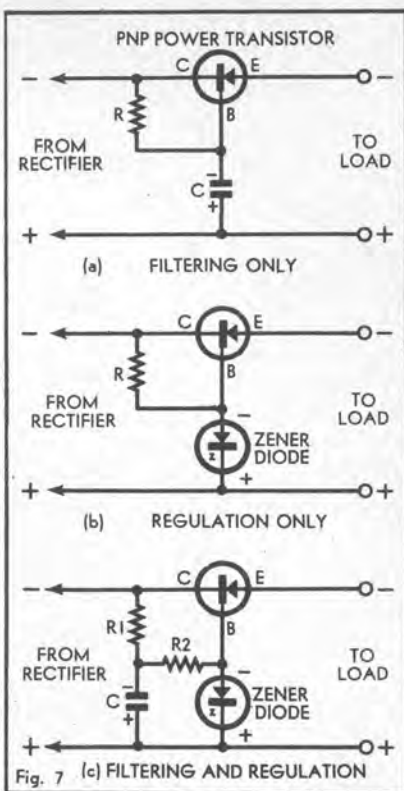


Figure 7: In more detail, the types of circuit used for dynamic filtering, regulation, and a combination of the two.

ripple but is fairly constant, despite changes in load current and rectifier output voltage.

If both regulation and filtering are desired, as they often are in practice, a circuit such as that shown in figure 7 (c) can be used. Here the transistor-zener diode biasing resistor R is split into two sections, and a filter capacitor C connected so that it filters the bias supply. This means that the final reference voltage developed across the zener diode is filtered as well as regulated, and the transistor is made to act upon the load voltage similarly to smooth and regulate it.

In closing the discussion of power

supplies, filtering and voltage regulation, it should be mentioned that, although the principles of dynamic filtering and regulation have been explained by reference to transistors, the same principles apply to valves. Dynamic filtering is not often employed in valve circuits—principally because it is fairly easy to achieve adequate filtering using normal inductor-capacitor filters—but valve-type voltage regulators are quite often used in test equipment and other equipment requiring well-regulated supply voltages.

## BLACK LIGHT

**SPECIAL** New Black Light (Ultra Violet) Kit . . . Explore The Unseen World Around Us . . . Many Practical Uses For The Science Minded And Hobbyist.

Kit contains large 24" x 1 1/8" UV Tube, 24" white enamel housing with sockets, Transformer and Instant Starter, 3-core Safety Lead and Plug, Reflector, plus full instructions and suggestions.

Complete Kit **ONLY \$17.75** post paid. Includes **FREE** Strip Phosphor Tape for simple experiments.

Be prepared for the Computerised Future, learn how the giant electronic brains operate . . . with DIGI-COMP.



New working model Digital Computer. Easy to assemble from rigid plastic parts . . . Teaches Computer fundamentals, adds, subtracts, multiplies, complements, shifts, carries, memorises, compares, sequences . . . Kit includes step-by-step assembly diagrams plus 28-page manual covering operation, computer language (binary system), programming, problems and experiments . . . Complete at

**ONLY \$10.95** post paid. Also 50-page Programming Book for further experiments . . . \$1.95 post paid.

**SEND TODAY! SEND TODAY!**

**"NEW ERA" Dept. EL8**

P.O. Box A 274

SYDNEY SOUTH, N.S.W.

# ATTENTION

ANNOUNCING OUR INSTRUMENTS PARTS DIVISION

- KNOBS
- METERS
- SWITCHES
- TERMINALS
- INDICATORS
- METER SHUNTS
- 1% H/S RESISTORS
- POTENTIOMETERS

WRITE FOR OUR ECONOMICAL PRICE LIST  
**FERRIER ELECTRICAL INSTRUMENTS**  
 45 ALBANY ST. CROWS NEST. 43 5596



## CHAPTER 14: The concept of alignment; why it is necessary to align receivers. General techniques used in alignment, and tools required. Preliminary notes on practical alignment.

THE inclusion of a chapter on alignment may seem rather out of keeping with earlier and more elementary material, or the absence from the course of actual receiver constructional data.

In point of fact, however, it is reasonable to assume that many readers will have tried their hand at building one or more of the receivers described elsewhere in the magazine and may by now be facing up to this very subject.

Such being the case, it seems appropriate to do three things:

(a) Explain what is behind this matter of alignment and why it is necessary at all;

(b) Discuss some of the side-issues as, for example, dial setting, alignment tools and so on.

(c) Give an alignment procedure for both TRF and superhet receivers.

Even if the reader does not happen to have a receiver on the table, awaiting attention, the information should be useful and will be available against the day when it may be required.

Forty years ago, the word alignment was virtually unknown.

For the most part, each tuning circuit in receivers of the day was brought out to a separate tuning dial and tuning involved turning each dial to the appropriate setting for the particular station.

### STATION CARDS

In fact, a standard accessory at the time was a card listing local stations, with two or three spaces alongside each, in which the set owner could insert the dial readings for optimum reception.

As time went by, designers sought to simplify matters by making all the tuning coils and capacitors as nearly identical as possible, so that the dial settings would correspond fairly closely. Thus, the owner could remember if he wished that a certain station came in with all the dials set to about 70, another station with the dials about 55 and so on.

From here, it was an obvious step to take even greater care with the tuning circuits and arrange them so that they could all be adjusted simultaneously by rotating a single tuning knob. At first, the individual tuning capacitors were linked behind the panel with gears or belts. Later they were combined into the one assembly as a two, or three or even four-gang capacitor. Thus "single-dial tuning" became the vogue.

Single-dial tuning has been with us ever since and is obviously a very convenient feature. However, several tuning circuits will not remain exactly in step—or TRACK—accurately just because they are superficially alike. Special provision has to be made to ensure that the ganged tuning circuits all resonate

to the correct frequency at each and every setting of the tuning dial.

By very carefully maintaining the number of turns on the coils during manufacture and by matching the tuning gang sections, fairly good tracking can be obtained, as a matter of course, near the low frequency end of the range: that is, with the tuning capacitor plates well into mesh.

However, at the other end of the band, with the capacitor plates well out of mesh, the exact tuning of the circuits is affected, as much as anything, by STRAY capacitance—that to do with the valves, the position of the connecting leads and so on.

Variation in this stray capacitance between one tuning circuit and another leads to tracking error at the higher frequencies, and therefore loss of efficiency.

To overcome this problem, it has become accepted practice to connect small trimmer capacitors in parallel with each tuned circuit. They are commonly adjustable between about 10 and 30pF. Sometimes they are separate components; sometimes included as part of the ganged capacitor.

Normal intention is for the trimmers to be set at about half capacitance, the tuning coils and the gang itself then being designed to cover the requisite band of frequencies—from about 1,700 to 535KC for the ordinary medium-wave broadcast band.

If the stray capacitance across one or



**A typical 2-gang variable capacitor. Despite care in the manufacture of such units and the coils that go with them, minor inaccuracies and stray capacitance effects make it necessary to align or "peak" tuned circuits which operate from a common control. Hence this article on alignment.**

more of the tuned circuits happens to be a little high, then the relevant trimmer or trimmers are unscrewed a little. Conversely, if the strays happen to be low, the trimmer can be screwed in a fraction to increase the amount of capacitance to the anticipated figure.

Provided that the coils and gang sections are accurately manufactured, the tuning circuits thus aligned at the high frequency end of the band, remain reasonably in step over the whole tuning range.

In more recent years, a further technique has been evolved which leaves even less to chance at the low frequency end of the tuning range. This involves the provision of an adjustable iron dust slug inside each tuning coil. Moving the core in or out of the winding changes the inductance by quite a large percentage.

Thus, in modern receivers, very accurate alignment can be achieved by adjusting the coil cores for exact inductance balance at the LOW FREQUENCY end of the band and the trimmers for capacitance balance at the HIGH FREQUENCY end of the band.

Note that the cores and trimmers perform different functions and they should always be adjusted to fulfil those basic functions. The fact that tuning circuits include variable iron cores therefore does not obviate the need for trimmers.

There is another facet to this matter of alignment which must be mentioned.

Originally, receivers used tuning dials simply numbered 0-100, leaving the set owner to memorise the tuning position for each station. Provided the receiver tuned over the necessary frequency band, the exact position of the stations within that band did not matter a great deal.

Thus trimmers could be set for proper tracking, without special reference to the dial reading. The only point which needed to be watched was that the trimmers were not all screwed in so far that they restricted coverage of the receiver at the extreme high frequency end of the band.

It is not necessary to refer to cores in this context because uncalibrated dials went out of vogue long before adjustable cores came in.

Their use is covered however, later in the article.

More recently and, in fact, for many years, station call-signs have been marked directly on the dial scale. This means that the trimmer and core settings and the position of the pointer relative to the tuning gang shaft must be determined for accurate indication of the incoming station as well as for accurate alignment.

It involves also, one other important point. There is some variation from one type of ganged capacitor to the other in the maximum and minimum capacitance figures and the shape of the moving plates. This affects the distri-

bution of stations across the dial scale.

In an existing receiver, it can usually be assumed that the dial has been calibrated to match the particular ganged capacitor and correct alignment should therefore bring the stations in on their calibrated positions.

In a home-constructed set, however, there is a chance that a dial might be used having a glass or other scale calibrated for some gang capacitor other than the one used. In this case, no amount of manipulation of the cores and trimmers may succeed in getting ALL the stations to come in at the right positions on the dial.

In assembling components, constructors should therefore see to it that the dial glass or scale is for the type of gang capacitor selected.

In the case of a superhet receiver, there is more to alignment than merely getting two or three tuned circuits to track, one with the other. This much will be evident from our explanation in chapter 11, of the superheterodyne principle.

Alignment involves getting all the IF transformer windings resonated to the appropriate frequency, usually 455KC. It then involves getting the oscillator circuit to track with the aerial and possibly RF circuit, the requirement, in this case, being that the oscillator tune at all times 455KC higher than the signal frequency.

This sounds a rather formidable task but the desired result can be achieved by following a fairly simple routine, which will be described later.

## WHY IT IS NECESSARY

By now, the reader should have a fairly clear idea as to what alignment is all about. It should be equally clear that a receiver which has not been aligned cannot operate efficiently, because its various tuning circuits will be a long way out of step.

So much for section (a)—why alignment is necessary. Now for a few of the side-issues.

In a factory, receivers are aligned with the aid of a signal generator and an output meter and there is no doubt that the most accurate job can be done in the shortest time with their aid.

Since this is essentially an article for beginners, however, we do not plan to say overmuch about alignment procedures using such instruments.

The average home constructor is likely to have to rely on broadcast stations for a source of signal and to rely on his ears to indicate whether an adjustment has brought about an increase or a decrease in sound volume. Nevertheless, providing care is taken, quite good alignment is possible by these means.

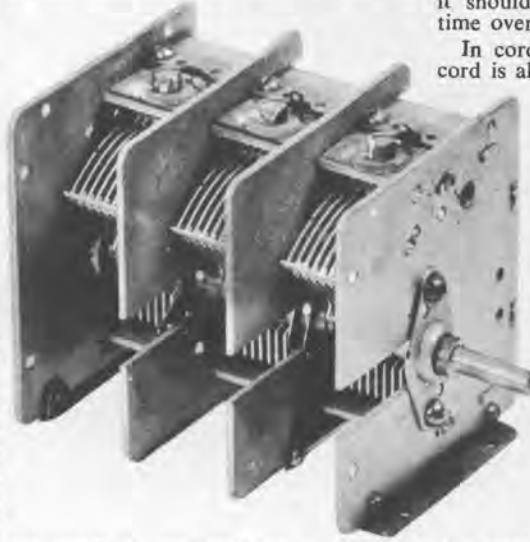
If the alignment is to proceed smoothly, a few preliminary points must be checked. Firstly, there is the action of the dial mechanism and the setting of the pointer relative to the dial scale and tuning gang plates.

If the receiver has a simple Q-100 dial scale with no station call sign marked, it is only necessary to see that the dial drives the tuning gang smoothly between the full-in and full-out positions and that the pointer travels over the scale with any overlap about equal at the two ends.

The pointer travel can be corrected in some dials by loosening a screw or slipping the drive cord through a loop. In others, it involves loosening the grub-screws locking the dial to the gang shaft and retightening the screws with the two in different relative positions.

With dials having the station calls marked on them, the position is rather more confused. Because the capacitor plates are specially shaped, precise tracking can only be expected if the pointer and its travel is locked to the gang shaft in one specific position—that for which the dial was originally calibrated.

With the two in the wrong relative positions, stations may be brought to correct calibration at the two ends of



Some tuning capacitors, such as this typical 3-gang, have the alignment trimmers in-built. In this case a trimmer can be seen above each of the separate sections, controlled by a hexagonal screwhead. The whitish marks are the residue of a sealing compound which had been used to prevent the screws from turning after adjustment — as well as to discourage unauthorised tampering.

the bands by manipulation of the cores and trimmers, but those near the centre may be displaced slightly one way or the other.

Some dials—but not many—have a “dial set” line marked just beyond one end of the scale. The intention is that the dial shall be locked to the gang shaft with the pointer set to this reference line and the gang plates either full in or full out, depending on which end of the scale is involved.

Where there is no “dial set” line, the pointer can only be locked in a likely position and the alignment procedure followed out. If the stations can duly be made to fall in the calibrated positions, the pointer can be left set; if not, the pointer may have to be reset slightly one way or the other in relation to the gang shaft and the alignment procedure repeated, noting whether the new position has improved matters or otherwise.

Alignment instructions often suggest that the pointer should be set initially for “equal overlap” at the two ends of the scale. In our own experience, however, we have often found that the following procedure gives an optimum pointer setting at first trial:

Measure the distance between the 550 KC calibration point and the 600KC



Trimmer capacitors come in all shapes and sizes, those pictured above being on a clear polystyrene base and measuring about  $\frac{1}{2}$  inch across. As the screw is turned clockwise, it forces the top, springy plate down, increasing capacitance to the fixed plate beneath.

point. Divide the distance by two and set the pointer on the low frequency side of the 550KC calibration point by this amount. Lock the dial drum with the capacitor plates fully in. The lower limit of the band will thus be about 530KC.

Before going further, make sure that the dial will rotate the capacitor between the limits of its travel without obstruction, or straining the cord in a cord-drive type. If there is any such trouble, it should be corrected before spending time over the alignment.

In cord-drive dials, the tension of the cord is also important. If it is too loose,

the cord will slip. If too tight, it may bind and ultimately break. In general, it is best to have the cord twisted twice around the control knob shaft, with the tension no higher than necessary to ensure positive drive.

Depending on the receiver, a special alignment tool may or may not be required.

Many trimmers are adjustable with an ordinary small metal screwdriver. As a rule, they are connected into circuit so that the screwhead makes contact with that trimmer plate which returns to earth or to the “earthy” side of the circuit. If touching the trimmer with a metal screwdriver alters the signal level, the chances are that it has been installed the wrong way round.

## WATCH THE HT

The trimmers in many early type IF transformers are likewise adjustable with a small metal screwdriver. Fingers should be kept off the shaft, however, and the blade kept clear of the metal can, because the trimmers on the plate side often connect internally to the B-plus circuit.

Iron cores are often adjustable also with a plain metal screwdriver, notably cores which are attached to threaded brass rods protruding from top and/or bottom of the shield cans. In some cases, where the threaded rods are not earthed, touching them with a metal object will affect the behaviour of the coil, making it difficult to pick the proper peak position.

To overcome this difficulty, a type of alignment tool has been available for many years having a very small metal screwdriver tip embedded in a moulded handle.

Alternatively, if the cores are not too stiff in their action, a suitable non-metallic screwdriver can be made by sharpening a piece of ebonite rod to a wedge point, or an ordinary plastic knitting needle.

In recent years alignment “screw-drivers” have been made available of

nylon or similar material and these are also very handy for adjusting cores which have a screwdriver slot moulded directly into their ends.

A still further type of alignment tool has a hexagonal end meant to engage a similar hole in moulded cores of a somewhat different type.

Irrespective of the core style and tool, however, it is wise to keep in mind that core adjustment systems are seldom very robust. If a slug has become jammed, don't try to force it. It may shatter, or become detached from its brass shank (if any) or the whole coil former may be twisted from its mountings inside the can. If you come up against a jammed slug, the best plan is to leave it until advice can be sought from someone who has had experience with such problems.

## TRF ALIGNMENT

So much for what we referred to earlier as the "side-issues." Now for the actual alignment procedure, which must needs be subdivided into "TRF" and "Superhet."

TRF receivers are fairly rare, these days, but there may be enough of them in the hands of home constructors to warrant at least brief mention.

In old-style TRF sets, of the type current about 1930, the only adjustment normally provided is to the three trimmer capacitors, usually mounted as part of the main tuning gang. There are no variable cores and no station-calibrated dials.

The procedure, in such cases, is simply to examine and check the action of the dial and travel of the gang, for reasons already explained.

The receiver should then be tuned to a station near the high frequency end of the band, at somewhere about 1300KC. Keeping the volume low, each of the three trimmers should be adjusted in turn to achieve any possible increase in receiver gain, and therefore volume.

In some cases, the effectiveness of adjustments can be better judged by aligning the receiver with a smaller than normal length of aerial or doing the alignment on a weak but steady distant station, rather than on a strong local one. Especially is this true of receivers fitted with an automatic volume control system, although this is quite uncommon in TRF receivers.

## TRY AGAIN

If one of the trimmers should have to be screwed hard down, without passing through a peak, the remaining two should be unscrewed by a turn or so, the dial reset as necessary and the "difficult" one re-peaked. Alternatively, should one or more trimmers not peak, even when screwed full out, the remaining trimmers should be screwed in and the dial reset as necessary until all trimmers peak satisfactorily.

In a few cases the dial may be calibrated in terms of frequency or station call signs. In such a receiver, the first step is to tune a station near the low frequency end of the band (about 600KC) and set the pointer to indicate the station correctly.

The receiver should then be tuned to a station around 1300KC and the trimmers peaked as just described. Now observe the accuracy or otherwise of the station indication.

If the station is being received on the high frequency side of its calibrated



**Typical alignment tools used for adjusting radio and television receivers. They are normally non-metallic, or use a minimum of metal, in order to minimise any effect on the circuit being adjusted by proximity of the tool.**

position—that is with the gang plates too far open—it may be moved towards its calibrated position by re-peaking all trimmers in a further-out position.

Conversely, screwing all trimmers further in and re-peaking will move a station towards the high frequency end of the scale.

If a TRF receiver has variable cores as well as trimmers, the procedure is first to set the dial to the "pointer set" line or for equal overlap or to indicate an approximate 530KC as the lowest frequency (see earlier paragraphs).

Having set the dial pointer, tune a station in the vicinity of 600KC and peak the cores for highest sensitivity and output.

Now check the accuracy or otherwise of the station indication. If the station is coming in at too high a frequency, on the dial scale, unscrew all the cores a turn or so, move the dial towards its calibrated position and re-peak. Repeat the procedure until the dial pointer is indicating the particular station accurately. Make sure that all cores are peaked.

If, of course, the station appears at too low a frequency on the dial scale, all cores have to be re-peaked further in.

Having obtained correct calibration at the low frequency end of the scale, tune to a high frequency station, again about 1300KC. Peak the trimmers and check calibration at this end of the scale.

As before, if adjustment is necessary, screwing all trimmers in and re-peaking will move the incoming stations towards the high frequency end of the scale. Unscrewing the trimmers and re-peaking will have the opposite effect.

Having peaked the trimmers, tune the low frequency station in again and re-check the cores. Then go back and check the trimmers on the high frequency station.

In describing this and the preceding operations, we have assumed what might be called a "static" approach, each step towards correct peaking and calibration being quite distinct.

An experienced serviceman is likely to adopt a much more sweeping approach to alignment with a TRF receiver. He may select a strong signal at the low frequency end of the band, then turn up the gain and/or screw the cores rather wildly—anything to hear the signal even weakly with the dial pointing to the calibrated position. The cores are then peaked for maximum output without touching the dial further.

As a final step, he may then tune the set to an adjacent weaker signal and give the cores a final touch-up.

Likewise for the trimmers at the high frequency end of the band.

Another time-saving serviceman's trick

is that of rocking the dial while aligning the cores or trimmers.

The dial is simply rocked back and forth over the reference station and note taken of its general strength and peak position. The cores or trimmers are then progressively screwed in or out as required, the dial being rocked meanwhile, until maximum response and correct calibration is obtained.

But whatever the method remember that, in all this, there is a "golden rule" of alignment about cores and trimmers:

**Adjust the cores only on low frequency signals. Adjust the trimmers only on high-frequency signals.**

To back-track somewhat, we mentioned earlier the possibility of aligning a receiver with the aid of a SIGNAL GENERATOR and an OUTPUT METER, instruments which are commonly used for the purpose in radio laboratories, factories and service organisations.

## BRIEF EXPLANATION

We shall have more to say about these instruments in the next chapter but, in brief, a signal generator is an instrument designed to produce a radio frequency signal at any desired frequency, adjustable in strength and modulated by, usually, a 400-cycle tone. Cheaper forms of signal generators are often referred to as MODULATED OSCILLATORS.

For alignment, the receiver is tuned to a signal from such an instrument and, since its strength can be adjusted and the modulation is a constant tone, the effect of any adjustments can be noted very readily. Also, since the dial is normally calibrated directly in Kilocycles, it is easy to verify the exact frequency coverage of a receiver and to provide a signal for alignment at any particular frequency required. In aligning a TRF receiver with a signal generator, the procedure is exactly the same as when using stations, as set out.

An output meter is any form of meter which can be made to give a reading proportional to the strength of signal being fed to the loudspeaker. Since a meter can indicate variations in signal level much more accurately than the ear can judge them, it makes for higher precision.

More often than not, the output meter facility is part of the ordinary radio MULTIMETER, with which radiomen also measure the variety of voltages and currents throughout a radio receiver, in the course of testing.

This is part one of the alignment story. In the next chapter, we will have something to say about aligning superheterodynes, also the possible effect of instability.



## CHAPTER 15: Alignment, continued.

Automatic Volume Control or Automatic Gain Control and its effect upon alignment.

The effect of receiver instability. Aligning the IF stages of a superhet.

Aligning the aerial and oscillator circuits. Shortwave alignment.

The service oscillator and output meter alignment technique.

NOT long after the general adoption of the superhet principal, designers began to adopt also the technique of Automatic Volume Control, abbreviated commonly to "AVC." The general principal involved has since been extended to television receivers and other equipment concerned with the reception of signals other than those from the "entertainment" radio stations, and a more appropriate modern name for the technique is Automatic Gain Control — "AGC" for short.

Most of the old-style TRF receivers, which would have been covered in the last chapter employed ordinary manual gain control. In such receivers the gain is directly and only dependent on the setting of the volume control potentiometer, this latter usually serving to vary the cathode bias on one or more early stages.

Any adjustment during alignment, which changes the gain of the receiver, increases or decreases the volume of the signal by an equivalent amount, and the effect of any such adjustment can therefore be discerned readily.

In an ordinary broadcast receiver the AGC circuit is usually fairly simple. Negative voltage, developed by the detector across its load resistor, is fed back as a bias voltage to the grids of one or more valves in the tuning section — RF amplifier, converter or IF amplifier.

On weak input signals, very little bias is developed by the detector or fed back to the controlled grids, so that the early stages operate at almost full gain.

With stronger input signals, however, the detector develops a greater negative voltage and this, fed back to the controlled grids, reduces quite drastically the gain or amplification of the relevant valves.

As a result of this quite automatic action, the receiver operates at full gain for weak signals but at much reduced gain for stronger signals. "Blasting" and overload effects are largely eliminated, together with at least some of the fading experienced when listening to distant signals.

A volume control still needs to be provided, of course, but it normally operates in the audio system. It allows listening volume to be set to the required level and adjustment to be made for any residual difference between weak and strong signals, not fully compensated by the AGC system.

AGC can be used with either a TRF or a superhet circuit and has much to recommend it from the user's point of

view. However, it does complicate alignment somewhat and for a fairly obvious reason.

With the receiver tuned to any given input signal, the AGC voltage attains a level depending on the strength of that signal and the gain of the receiver.

Now, if adjustment of a trimmer should increase the effectiveness of a tuned circuit, the resulting increased signal at the detector will produce more negative AGC voltage. This will decrease the gain of the valves, making the effect of the trimmer adjustment much less apparent than it would otherwise be.

Conversely, an adjustment which reduces the effectiveness of a tuned circuit will also reduce the AGC voltage and allow the valve gain to rise in consequence.

In other words, an AGC circuit in a receiver tends to mask the effect of any adjustments, and quite substantial changes in the efficiency of a tuned circuit through peaking might make only a slight audible difference in the loudspeaker output.

The best way to counter this masking effect is to align such a receiver on very weak signals, as from distant transmitters. Unfortunately, during evening

hours, when most homebuilders would want to work on a receiver, there is often a hopeless confusion of weak signals between the strong locals, most of them subject to fading effects which can be most misleading.

If the constructor has to rely on stations for alignment, the best plan is to carry out a rough alignment procedure on local stations to make the dial track correctly, leaving fine adjustment of the trimmers, etc., to some daylight period when it should be possible to pick up a couple of weak but steady signals at the respective ends of the band.

Out of all this comes another golden rule of alignment.

**Peak all receiver circuits as far as possible on weak input signals, advancing the volume control, if necessary, to make them audible.**

So much for AGC action and its complicating effect on alignment. Now for a few words on INSTABILITY.

In a well-designed receiver it is possible to peak all adjustments for optimum performance, without any complication arising. Each adjustment merely increases the gain and sensitivity till it reaches the maximum of which the set is capable.

In some cases, however, poor design, wrong choice of components, wrong placement or long active leads may allow an excessive amount of signal from one or more stages to couple into an earlier point in the circuit, producing a feedback or regenerative effect.

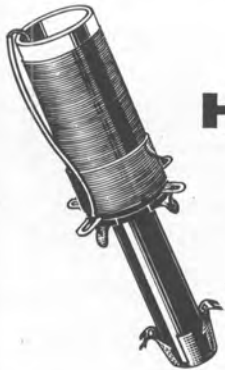
As the gain is increased by progressive adjustment, the receiver may suddenly become unstable or "burst into

*Aligning a dual-wave superhet receiver. The tuning coils in this case are mounted in a dual-wave coil "bracket" and the trimmers for the respective aerial, RF and oscillator coils are mounted on top of the chassis. Note the alignment tool, a commercial type with a body moulded in plastic and two metal tips, one like a screwdriver, the other slotted to suit miniature tuning coils and transformers.*



# \*AEGIS

## TESTED RADIO TV AND HIGH-FIDELITY PARTS



### AERIAL, R.F. and OSCILLATOR TUNING COILS

We manufacture and stock a complete range for the broadcast and shortwave bands (from 550 KHz to 30 MHz).



### I.F. TRANSFORMERS WITH B.F.O. COILS TO SUIT

All popular frequencies available.

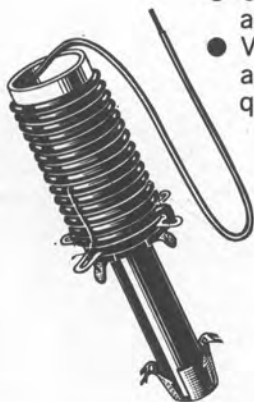
### HEAVY GAUGE HONEYCOMB TYPE INDUCTANCES

Supplied in the range 0.5H to 10.0H, for use in loudspeaker cross-over networks and other heavy duty low resistance applications.



### OTHER POPULAR AEGIS LINES

- R.F. and Video Peaking Chokes
- Feed-through and stand-off ceramic insulators
- Radio, T.V. and Instrument Knobs
- Noise reducing Aerial Systems and Mains Filters
- Complete range of coil formers, tuning cores, etc. available for the man who winds his own coils.
- Vinkor type inductors to standard Mullard designs — also to special order. Write with details for quote.



WRITE FOR CATALOGUE PRICE LIST!



\* Available from all good  
radio parts stores



Aegis Manufacturing Co. Pty. Ltd.  
347 Darebin Rd., Thornbury, N.17  
Telephone 49-1017

oscillation," to use another very common phrase.

Oscillation in a large receiver sounds much the same as oscillation in a small regenerative receiver, except that it is produced deliberately in the latter case and controlled by the "reaction" knob.

Instead of the station signals being heard clearly, each one is accompanied or even blotted out by a loud whistle which varies in pitch as the set is tuned across the carrier.

Many superhets produce faint whistles on odd stations, particularly when operating near powerful transmitters. They are fairly distinct, however, from the strong whistles on every station produced by instability. And while a set is unstable, complete alignment is impossible.

The cure for instability in most cases involves elimination of the cause—improved design if the circuit is of doubt-



On the left, and withdrawn from the shield can is a typical 455KC IF transformer. The alignment slugs, in this instance, are threaded and screwed directly into the central former. At right is a conventional tuning coil.

ful origin, use of the proper components or rearrangement of the wiring and layout.

Needless to say, this is good argument for care in the first place, when building a receiver, whether it be a TRF or superheterodyne.

Unfortunately, it is not always possible, merely by looking at a receiver, to pick out and correct the cause of an unstable condition. There is also the chance that it may be due to two or more unrelated causes, such that correcting either one separately seems not to have improved the situation.

A common test-bench procedure, when faced with an unstable receiver, is to stabilise it by wiring a potentiometer (say, 10,000 ohms) as a variable resistor in the cathode return circuit of the IF amplifier stage. As the total resistance in the cathode circuit is increased, a setting will usually be reached where the receiver is stable, even though the gain is poor.

It can be roughly aligned, when thus stabilised, after which the effect can be tried of rearranging various suspect leads, etc. Any rearrangement which allows the added cathode resistor to be reduced before the onset of oscillation will have been a step in the right direction.

## ALIGNING TELEVISION RECEIVERS

THE alignment of television receivers involves special techniques and special equipment and IN NO CIRCUMSTANCES should beginners tamper with TV tuners or IF systems.

Unlike the tuned circuits in broadcast receivers, those in a television receiver are not peaked for maximum gain. They have to be adjusted to pass a band of frequencies, from 5 to 6 megacycles wide, over which the audio and video signals from a television station are distributed. If the tuned circuits in a TV receiver were simply peaked in the normal way, the receiver might well become unstable. In any case it would produce only a poor picture, with no

sound, or sound with little or no picture.

Even the sound channel in a television receiver is "special," involving a frequency modulated signal, as distinct from amplitude modulation, used by ordinary broadcast stations.

Alignment of picture IF channels in a television receiver is normally performed with the aid of a "sweep and marker" signal generator and a cathode-ray oscilloscope.

The alignment problems inside a television tuner are even more complicated than for the IF systems, such that tuner alignment is rarely attempted other than at the factory or at special tuner service depots.

Again . . . don't tamper with TV alignment adjustments.

The aim is to find and correct all possible sources of feedback causing instability, such that the receiver can be operated at full gain, with no limiting resistance in circuit.

So much then for instability or oscillation.

The basic principles of a superhet receiver have been explained in an earlier chapter and do not require further elaboration here.

It is sufficient to recall that the incoming signals are passed through a conventional aerial (and possibly RF) coil, then heterodyned with a signal from a local oscillator stage to produce a resultant known as the intermediate frequency.

Matters are arranged so that each incoming signal, as it is tuned, is changed to the one intermediate frequency—usually 455 KC. All transformers in the IF amplifier section therefore need to be peaked to this figure.

Fortunately, the task of aligning a superhet receiver is not as difficult as it might appear at first encounter and a home constructor can do a passable job of alignment without instruments and without help, provided a certain routine is followed.

Here it is, as set out in a special article published on the subject some time ago:—

Connect the set to an aerial and earth, preferably the ones with which it is to be used; connect the speaker and switch the power on. Tuning across the band, you will probably be able to hear quite a few stations, if the set is otherwise in order.

Try to find a weak but steady station near the low frequency end of the band.

Tune the receiver as accurately as possible to the station you choose. The best way to do this, or in fact to make any of the adjustments about to be described, is to rock the setting backwards and forwards over the correct point gradually converging on it.

You can now adjust the IF transformer cores or trimmers as the case may be (most modern IF transformers have core adjustments) for maximum sound output from the speaker.

It is possible that what was previously a weak signal now becomes a strong signal as the sensitivity of the receiver rises. This being the case, do the best you can on the original station, and then tune accurately to a weaker adjacent station and go over the procedure again.

The IF windings do not usually need to be peaked in any special order but be sure not to miss any. There may be a slight amount of interaction between the adjustments, so it is a good idea to

## asdic STEREO HI-FI

ASTOR THEATRE BUILDING

166D GLEBE POINT RD., GLEBE Phone: 68-1453

Specialising in quality Cabinets to any design . . . Complete Systems including Radford, Quad and Fisher . . . Installations in the home. All good brands supplied and guaranteed.

**ENGINEERING: H. BEN WILSON, S.M.I.R.E.E., M.S.I.T.A.**

Phone 68-4283. Authorised Service Centre for:—

Quad, Goodmans, Ferrograph, Rogers, Roland, Trio, Beocord, B and O, Labcraft, Radford, K.E.F., Wharfedale.

**BRISBANE AGENCIES HI-FI STEVE ECKLUND — Prop.**

76 WICKHAM ST., VALLEY, QLD. Phone L-6931

Specialised installations for homes, halls and institutions. Cabinets to any design. Complete System including Radford, Quad, Fisher and all good brands Agents for ADC Labcraft, J.H., Radford, K.E.F., Roland. All work guaranteed. No job too small or too large in Hi-Fi. Qualified engineers for all major service.

go over the IF adjustments a second time.

When you have finished with the IF transformers they should be fairly close to the nominal frequency. This is 455 KC for most receivers nowadays, but occasionally you will strike a receiver with a different arrangement.

For this method of alignment it doesn't matter and, further, even if you do finish up a few KC off the specified frequency, it will not be serious. The main thing is that all IF circuits be accurately aligned to the one frequency.

Having satisfactorily completed the alignment of the IF amplifier it remains to adjust the aerial and oscillator circuits. If your receiver has an RF amplifier stage, the adjustments for the RF coil are exactly the same as for the aerial coil.

With most modern receivers the adjustments consist of trimmers and variable slugs associated with both aerial and oscillator coils, and the padder or tracking capacitor is a fixed mica type.

You may be called upon to realign an older receiver with coils or fixed inductance and variable padder, so we will describe the procedure later.

In the case of the variable slugs, tune to a station which you can easily identify toward the low frequency end of the band and adjust the oscillator coil slug until the station coincides with its position as marked on the dial.

Then tune to a station toward the high frequency end of the band and adjust the trimmer associated with the oscillator section to bring this station to its correct position on the dial.

Repeat the above adjustments a couple of times because each adjustment does have some effect on the other.

### STATIONS SHOULD TRACK

If everything is in order, i.e. the dial and tuning capacitor correctly matched, all stations should now coincide with their marked positions on the dial.

Should the AGC system tend to make the strong local stations appear broad it would be in order to remove the aerial or operate the set with a short length of wire while making the adjustments to the station positions.

Finally, the aerial coil slug and the aerial trimmer should be adjusted to obtain the strongest signals. The slug adjustment should be made with the receiver tuned toward the LOW frequency end of the band and the trimmer adjustment toward the HIGH frequency end.

The aerial circuit should preferably be adjusted with the aerial with which the receiver is to be used connected, and it is a good idea to go over it several times to make sure that you get the best results.

By this time the set will probably be very sensitive, and you may not be able to find exactly the sort of signal you require. In this case it is quite in order to tune the set off a station and adjust for the greater noise output.

The procedure is a little different if

you are called upon to realign an older receiver which is fitted with a variable padder capacitor. The inductance of both aerial and oscillator coils will most probably be fixed.

The first thing to do after adjusting the IF transformers is to tune to a weak but steady station toward the low frequency end of the band and then find the setting of the padder capacitor which



*A typical signal generator, providing signals at any frequency between 150KC and 30MC. Panel controls allow the strength of signal to be varied over a wide range, also the depth of modulation.*

gives the loudest signal. Unfortunately, every time you shift the padder, the position of the station alters.

The job is made easier if you hold the alignment tool in one hand and the tuning knob in the other so that you can rock the tuning capacitor backwards and forwards over the station while the padder is being adjusted. Set the padder for the greatest level of sound output, irrespective of how it affects the position of the station on the dial.

The grub screw securing the dial drum to the capacitor shaft should then be loosened and the pointer made to coincide with the station's position on the dial.

At the high frequency end of the band, the two trimmer capacitors are adjusted as before, the oscillator trimmer being used to control the calibration and the aerial trimmer to give the best sensitivity.

### EFFECT OF AERIAL

Modern aerial coils are designed so that the alignment is little affected by the aerial be it long or short, but some of the earlier aerial coils may not be above reproach in this respect. In any case we suggest that you do the final adjustment of the aerial trimmer with the aerial connected.

It may be worth mentioning in passing, that some broadcast band superhet receivers have no padder capacitor, either fixed or variable. The necessary tracking between the aerial and oscillator tuned circuits is ensured by having dissimilar sections in the tuning capacitor. The aerial (and possibly RF) tuning section is normal but the oscillator section plates are smaller and differently contoured.

The alignment procedure is exactly as

set out for the fixed padder type of receiver.

To this point we have spoken only of the broadcast band. The procedure for the shortwave band or shortwave bands is essentially the same, but there is the added difficulty that it is often hard to find and identify a suitable station for alignment.

Conditions vary a great deal, and sometimes change within a matter of minutes. Therefore, do not be discouraged if first results are not very satisfactory. Of course, the aerial is more important than in the case of the broadcast band, because you frequently wish to listen to very weak signals.

However, shortwave stations are heard strongly in Australia, and even a poor aerial will often receive them at considerable strength.

Another problem is that most conventional dual-wave receivers will "double spot" on strong signals. Double spotting is due to the fact that the local oscillator can produce the required 455KC beat when it is in either of two conditions—455KC higher OR lower than the wanted frequency. Thus, a second spot is always twice the IF (910KC in this case) away from the correct dial setting.

While the simple aerial tuned circuit will easily reject the second spot on the broadcast band, it is inadequate on the short-wave bands, and a strong signal will inevitably be found at two points on the dial. For alignment purposes, and assuming normal circuitry, the setting having the higher frequency of the two is the correct one.

As a first step, we suggest that you leave the shortwave oscillator coil slug at its original factory setting. The aerial slug (and RF slug, if fitted) should then be adjusted for the loudest signal, or background noise, at the low frequency end of the range. Now set the trimmer capacitor across the oscillator section to about the middle of its range, and with the set tuned to the high frequency end

## RADIO BOOKS

HUNDREDS OF TITLES . . . ALL THE LATEST AVAILABLE . . . CALL AND INSPECT, OR WRITE GIVING YOUR REQUIREMENTS.

<b>THE RADIO AMATEURS HANDBOOK</b>	
A.R.R.L. U.S.A. . . . .	\$6.20
R.S.G.B. Brit. . . . .	\$6.10
<b>GENERAL ELECTRIC TRANSISTOR MANUAL</b> . . . . .	\$3.85
<b>BASIC ELECTRONICS</b>	
In six parts. A complete basic course. Each . . . . .	\$2.20
Or complete set . . . . .	\$10.50
<b>BASIC RADIO</b>	
In six parts. Complete basic course	\$17.70
<b>FOUNDATIONS OF WIRELESS</b>	
Scroggie . . . . .	\$3.90
<b>RADIO HANDBOOK</b>	
Editors And Engineers . . . . .	\$12.00
<b>RADIOTRON DESIGNERS HANDBOOK</b>	
Langford-Smith . . . . .	\$8.00
<b>ELECTRONIC AND RADIO ENGINEERING—Terman</b> . . . . .	\$9.00

## TECHNICAL BOOK COMPANY

289-299 Swanston Street,  
Melbourne, C.I.  
Telephone 32-3951



of the band, adjust the aerial trimmer for greatest output on noise or a signal.

The calibration can be checked later by noting the positions of stations of known frequency.

Toward the low end of the band use the oscillator slug for adjustment and toward the high end of the band the oscillator trimmer, always bringing the aerial circuit into line after an alteration has been made.

**This use of the slugs for low frequency adjustment and the trimmers for high frequency adjustment is a rule you should apply when lining up any of the RF circuits.**

An excellent frequency check with an extremely high order of accuracy is the American station WWV. It transmits on a number of frequencies, but those most likely to be heard in Australia at good strength are 5MC, 10MC and 15MC or 60 metres, 30 metres and 20 metres respectively.

The signals can easily be identified by the 440 and 4,000 cycle tones which are superimposed on the RF carrier and the fact that the tones are interrupted by a one-second pulse. The pulse is omitted on the fifty-ninth second of every minute and there are other interruptions at regular intervals for call sign announcement and other purposes.

Carefully carry out the procedure we have described and there is every chance that your set will perform very much better as a result of your efforts.

If suitable test instruments are available, of course, a more precise job can be made of the alignment. As we said earlier, we are not so much concerned in this chapter with readers who are sufficiently advanced to own or have access to test instruments, but a brief explanation may help the beginner understand what it is all about.

The best instrument for alignment is a modulated oscillator or the more elaborate instrument which usually goes under the name of a signal generator. These instruments can produce radio frequency signals anywhere in the spectrum required for alignment and the strength of the signals can be controlled by turning a knob on the front panel.

The signal is modulated usually by a 400-cycle tone, so that when reproduced by the receiver a single whistling note is heard from the loudspeaker. With a signal thus available at any desired frequency, at any desired strength and producing a constant output tone, alignment is much simplified.

#### OUTPUT METER

Almost invariably the "output" range of a standard multimeter is used in conjunction with an alignment oscillator. The leads from the multimeter are clipped across the voice coil wires or between the output valve plate and either B-plus or earth.

By suitably adjusting the meter range it is possible to have the meter read proportional to the strength of the tone issuing from the speaker. The effect of adjustments can thus be noted on the meter, the indication being quite clear on changes in level too slight for the ear to notice.

The alignment procedure for a TRF using these instruments is very simple.

The oscillator is set to produce a signal at about 600KC and the signal tuned in on the receiver. If there are adjustable cores in the coils these can be

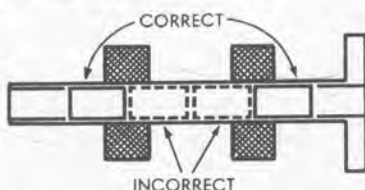
varied for maximum response and at the same time screwed generally inwards or generally outwards to make the receiver dial pointer correspond with any calibrations on the scale.

If the frequency calibration of the oscillator is accurate the receiver dial can be set against it, but it is often just as easy to swing to the nearest local station and adjust the calibration, reverting to the oscillator signal for final peaking.

If the receiver is an old style, with no cores to adjust, calibration can be corrected only by re-setting the dial pointer. Having thus attended to the low frequency end of the band the oscillator

### IF TRANSFORMERS

**A**N important point needs to be watched when aligning the IF transformers in a superhet receiver. In many IF transformers the adjustable slugs can be screwed right through each winding, so that two peaks can be found, one with the core passing from the end of the former into the coil, and another with the slug passing beyond the coil towards the centre of the former and the adjacent winding.



Unless there are specific instructions to the contrary the core should always be peaked in the outer position, that is, furthest away from the centre of the former and the adjacent winding.

Peaking one or both cores to the inner position can upset the coupling and the shape of the IF selectivity curve and may increase gain sufficiently in some cases to promote instability and oscillation of the type already discussed.

can be reset to the 1,200 to 1,300KC region, the signal level reduced to the minimum usable figure and trimmers peaked for maximum response.

At the same time, if need be, the trimmers can be worked generally inward or outward to make the dial read correctly.

When aligning a superhet with instruments the first step is to set the modulated oscillator to 455KC (or other desired intermediate frequency) and by feeding the signal through from the converter grid, peak all IF transformer windings for maximum response.

Having aligned the IF transformers, the procedure for the tuning circuits is exactly the same as it is when using only station signals. The important difference is that the readily controllable signal from the oscillator, together with an output meter, allows the job to be done with greater precision.

In this and previous chapters we have mentioned various test instruments, such as the multimeter, the oscilloscope and the service oscillator. In chapter 16 we will take a closer look at test instruments, discussing their operation and use.

## Save More at Australia's Greatest Hi-Fi Centre!

Learning about electronics can be great fun . . . the satisfaction gained from constructing an amplifier or tuner . . . or for that matter any other equipment . . . is quite an experience! But in common with other hobbies, there's a snag . . . buying all the components you need can be quite expensive. This is where Encel Electronics can help you . . . make your money go further!

When you want a turntable, a pick-up and cartridge, speakers, a tape recorder or a tape deck . . . in fact anything at all . . . write to or call at your nearest Encel Stereo Centre. Encel prices are the LOWEST IN AUSTRALIA . . . all equipment is BRAND NEW and FULLY GUARANTEED. Many items are exclusive to Encel Electronics and are not available elsewhere — for Encel Electronics are Australian Distributors for over twenty world famous manufacturers of quality electronics components.

Thousands of satisfied customers endorse Encel sales policy. Join them . . . you'll save more at Australia's Greatest Hi-Fi Centre!

## ENCEL ELECTRONICS PTY. LTD.

#### Head Office:

431 Bridge Rd., Richmond,  
Victoria. Tel. 42-3762.

#### City Store:

18 Bourke St., Melbourne.  
Tel. 32-2672.

#### N.S.W.:

257 Clarence St., Sydney. Tel.  
29-4563, 29-4564.



## CHAPTER 16: Test and measuring instruments. The moving-coil meter and its use in measuring voltage, current and resistance. The multimeter or VOM and the vacuum-tube voltmeter or VTVM. The cathode-ray oscilloscope or CRO. Oscillators and signal generators. Measuring bridges; the common R-C bridge. A brief idea of the many less common instruments.

**I**N many of the preceding chapters of this course we have had occasion to mention a number of test and measuring instruments, such as the multimeter, the oscilloscope and the signal generator. It would therefore seem wise at this stage to spend a little time looking at the various measuring instruments used in radio and in other fields of electronics, to give the reader some idea of their operation and use.

A basic component in many measuring instruments is the moving-coil meter. This is a device which has an indicating pointer so arranged that, when a current is passed through the meter, the pointer moves along a scale by an amount which is directly proportional to the amount of current flowing.

Figure 1 gives the general idea, and may be used to explain how the moving-coil meter works. The heart of the meter is a rectangular coil of fine insulated wire, pivoted at opposite ends on jewelled bearings so that it can rotate.

This is fitted with two pole-pieces which concentrate its magnetic field through the movable coil. There is also a cylindrical soft iron core arranged to be within the coil, but not to rotate. It is fixed, and serves to ensure that, no matter where the coil is, it always moves perpendicular to the magnetic field. This must be done if an evenly-spaced or "linear" scale is required.

In an early chapter, you may recall, we saw that a current flowing in a coil of wire produces a magnetic field; this is precisely what happens when current flows through the meter coil. Two magnetic fields are thus present around the coil—that due to the permanent magnet, and that produced by the current being passed through the coil.

The two fields interact, and the coil experiences a turning force or TORQUE; it therefore tends to rotate and, in so doing, to move the pointer needle along the indicating scale. When it does this, the spiral springs begin to have an effect;

coil rotation compresses one spring and expands the other, so that both springs tend to resist such movement. The further the coil rotates, the greater the force of "resistance" produced by the springs, which are all the time trying to RESTORE the coil to its original position. Hence we say that the springs provide "restoring torque" as well as providing flexible connections to the coil.

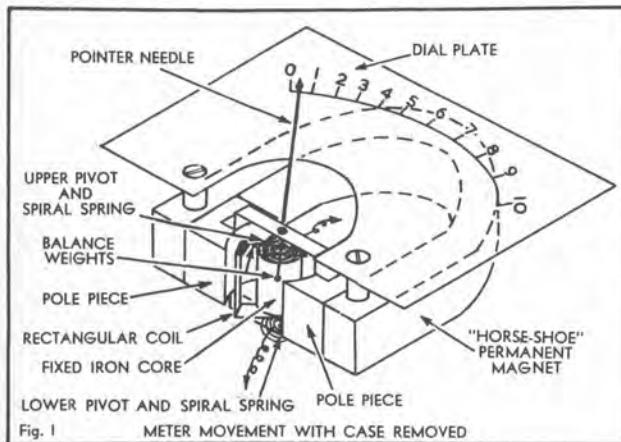
The springs are thus fundamental to the operation of the meter. Because of their "proportional-to-angle-turned" restoring force, the coil and pointer are brought to rest at a point where the pointer needle indicates a value directly proportional to the actual current flowing.

If a strong current flows through the coil, its forward torque will be large and the coil will be able to rotate through quite a large angle before the restoring torque of the springs is able to counteract the current torque and bring it to a halt. On the other hand, a small current will only produce a small forward torque and the coil will only be able to move through a small angle before the springs are able to stop it.

For every value of coil current there will be a corresponding coil and pointer position, providing that the meter is not "overloaded" by passing through it a current greater than it is designed to handle.

The moving-coil meter can be used to measure very small orders of current. It can also be used to measure larger currents, as well as voltage and resistance, as we shall explain.

In passing, however, it should be noted that there are other types of basic meter movement beside the moving-coil type. These types are not as common as the moving-coil meter and, for this reason,



**Fig. 1: Showing the essential parts of a moving-coil meter movement. Current enters and leaves the pivoted coil via the fine spiral springs.**

Current is fed through the coil via two delicate spiral springs, one at each pivot. The springs also supply what is known as the "restoring torque," which will be explained in a moment.

Attached to the coil is a long but extremely light and delicate pointer, along with a set of three short arms and small weights. These are used to counter-balance the pointer so that the whole rotating assembly remains balanced, irrespective of the position in which the meter is mounted. The pointer moves over a dial plate having a measuring scale printed upon it.

Behind the dial plate is a strong "horse-shoe" shaped permanent magnet;

**A modern protected multimeter, having more than thirty ranges of voltage, current and resistance measurement. The power cord is only used on the very highest resistance measuring range, batteries being used for all of the commonly-used resistance ranges.**



they need not concern us here. It is sufficient merely to mention that they exist.

When we discussed Ohm's Law in chapter 5, we saw that resistances in parallel share any current which may be flowing. In fact, the proportion of the total current which flows through each of a number of resistances in parallel is inversely—and exactly—proportional to their resistance. The lowest resistance will take most of the current, while the highest resistance will take least current, and so on.

Because of this fact, a moving-coil meter may be arranged to measure large currents. Its coil has a certain value of resistance and, by placing in parallel with it a smaller resistance called a SHUNT, the meter coil will receive only a known minor part of the current.

A typical meter movement giving full-scale deflection of the pointer needle with only 1 milliamp through its coil can thus be arranged to read as a 1

plier of 99,900 ohms in series with the meter to convert it into a 0-100 volt-meter.

In practice, if subtracting the meter resistance only affects the multiplier resistor value by the small amount shown above, it would be neglected. An accurate 100K resistor would be quite close enough as the multiplier.

In these circumstances, 100 volts applied to the combination would make the meter read full scale. With 50 volts applied it would read half-scale and with

by the user, depending on the measuring job to hand.

The multimeter is one of the most useful instruments in electronics. A modern instrument of the type shown in the photograph provides some thirty different measuring ranges, covering voltages (AC and DC) from a fraction of a volt to many thousands of volts; currents from microamps to amps; resistance from a fraction of an ohm to many megohms. It also provides built-in protection for the meter, to guard against damage due to improper setting of the controls.

Because the moving-coil meter is essentially a current reading device, the multimeter always draws a small current when being used to measure voltage. With modern, sensitive meter movements this metering current may be as low as 10 or 20 microamps for full-scale deflection, but even this current can load some circuits unduly and produce reading errors.

### VALVE VOLTMETER

It is principally because of the loading imposed by the moving-coil multimeter that the VACUUM-TUBE VOLTMETER or VTVM has been developed for work in high resistance circuits. Other names used for the VTVM are the "Valve Voltmeter" and the "Electronic Test Meter." The last name is regarded by some as being the most appropriate, as most VTVMs provide other ranges besides those for voltage measurement.

The VTVM uses valves — usually triodes—to increase the sensitivity of the basic moving-coil meter. And since valves do not draw input current, the VTVM may be arranged to have a very high input resistance so that it does not seriously load the circuit being tested. Typical VTVMs used in radio and TV service work have an input resistance of 10 or 11 megohms, while special types may have an input resistance of hundreds of megohms.

The principal disadvantage of the VTVM is that it needs power to supply its valves. This means that it is not quite as versatile as the multimeter, even though it may be provided with resistance and current ranges along with the basic voltage ranges. Small VTVMs



A typical VTVM, intended for use on the workbench of the laboratory or service shop. It is just as simple to operate as the multimeter, and is often used in place of the latter for voltage and resistance measurement.

amp meter, by wiring it in parallel with a shunt which takes 999/1000ths of the current flowing through the two. The shunt would simply have a resistance of 1/999 that of the meter coil so that, when 1 amp flows through the two, the shunt takes 999 milliamps and the meter receives its correct 1 milliamp.

If the total current should be less than 1 amp, the meter will read the same proportion of 1 milliamp. Thus 1/2-amp of total current would read half-scale on the meter.

When we discussed Ohm's Law we also saw that, when a voltage is applied to a resistance, a current flows which is proportional to the applied voltage and inversely proportional to the resistance. It is this fact which permits us to use the moving-coil meter to measure voltage.

### MEASURING VOLTAGE

All we have to do is connect the meter coil in the series with a resistor, which is called the MULTIPLIER. The multiplier is made to have a resistance which, when added to that of the meter coil, will draw the full-scale meter current when the intended full-scale voltage is applied to the two.

An example should make this clear: Suppose we have a 1-milliamp meter and we want to use it to read from 0 to 100 volts. All we need do is work out from Ohm's Law the resistance which draws 1 milliamp when 100 volts is applied, which works out to be 100K (100 divided by 1/1000, giving 100,000). To find the multiplier resistor value, we simply subtract the resistance of the meter coil from this figure. Thus, if the meter coil has a resistance of 100 ohms (a typical figure) we will need a multi-

plier of 99,900 ohms in series with the meter to convert it into a 0-100 volt-meter.

Different voltage ranges may be provided simply by selecting different values of multiplier resistance.

There are a number of different arrangements whereby the moving-coil meter may be used to measure resistance. The resistance-measuring circuit most often used is basically little more than a battery wired in series with the meter.

When an unknown resistance is connected into the circuit between the appropriate terminals, it completes the circuit and a current flows through the meter. The amount of current (and hence the meter reading) will depend upon the value of the resistance. Small resistors will produce a large current, and large resistors a small current; thus the scale of the meter can be marked in terms of resistance.

The moving-coil meter may also be used to measure AC, with the aid of a small rectifier circuit to change the AC into DC. Multiplier resistors may be added to the meter-rectifier combination to measure alternating voltage, while a small transformer is used to allow the combination to be used to measure heavy alternating currents.

The common MULTIMETER or VOM (short for Volt-Ohm-Milliammeter) is simply a meter movement fitted into a case along with a variety of current shunts, multiplier resistors and resistance measuring circuits, to enable it to be used to perform a wide variety of measuring tasks.

It is usually provided with switches to select the various shunts or multipliers, etc. Alternatively it may have a series of pin-jacks or terminals to which the test leads may be connected

### KEEP UP-TO-DATE . . .

. . . with events in the world of electronics by taking a regular copy of "ELECTRONICS Australia." Each issue contains feature articles covering just about every aspect of electronics, whether it concerns space research or deep sea fishing, or any of hundreds of other activities in which electronics play a major part.

In addition, each issue carries practical construction projects, scientific and industrial news, a large audio section with reviews of latest records, notes for the amateur and short wave listener, and trade reviews of a wide range of products.

Place your order now with your newsgagent for a regular copy of "ELECTRONICS Australia" or take out a subscription and have your copies mailed to you each month.

like that shown in the photograph are quite portable, but they must still be plugged into the power mains or powered by a fairly bulky battery pack.

Recently, transistorised voltmeters or TVMs have been developed to answer the need for a portable, very high input resistance meter. These are still rather expensive compared with many simple VTVMs, however, and tend to be rather lower in temperature stability.

Multimeters and VTVMs permit the measurement of voltages, currents and resistances in circuits, but they do not allow us to see the ways in which currents or voltages may be changing — unless the changes are taking place very slowly. The CATHODE-RAY OSCILLOSCOPE (or CRO) is an instrument which allows both fast and slow changes to be seen. It may also be arranged to measure voltages and frequencies.

The heart of the CRO is the cathode-ray tube, which is a small-scale version of the picture tube used in television receivers. In addition to the size difference, the cathode-ray tube used in most oscilloscopes uses what is termed



*This modern oscilloscope is quite small, but it permits both voltage and time measurements to be made, besides providing the user with a "picture" of circuit operation. Although it may seem to have a lot of controls, it is relatively simple to operate as many of the controls are used only occasionally.*

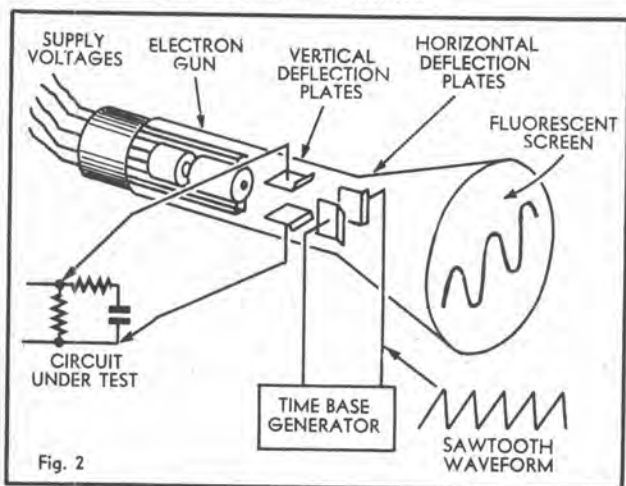


Fig. 2

*Fig. 2: This sketch should help in understanding how the cathode-ray oscilloscope works. The pattern which appears on the screen is virtually a graph of circuit voltage plotted against time.*

electrostatic deflection rather than the magnetic deflection used by television picture tubes, and has no "yoke" mounted on its neck.

Figure 2 should help in understanding how the cathode-ray oscilloscope works. The tube consists of three main parts—a group of electrodes called the "electron gun," two pairs of flat plates called the deflection plates, and a fluorescent screen.

It is the screen which is visible at the front of the oscilloscope, and it is on the screen that a "picture" of circuit voltage or current changes appears. Repeating changes, like those of alternating voltages and currents, produce a fixed wave-like pattern on the screen—hence the use of the term "waveform" to describe the screen patterns and the circuit variations which they represent.

The purpose of the electron gun is to produce a fine stream of electrons aimed at the fluorescent screen. The gun has a heated cathode similar to that in a normal valve, and a system of cylindrical and disc electrodes used to control and guide the electrons into a narrow beam.

If the deflection plates were not there, or if they were not connected to anything, the electron beam from the gun would strike the centre of the fluorescent screen and cause the phosphor powder at that spot to glow. All that would be visible would be a small bright dot at the centre of the screen.

Consider what happens to the beam

The two deflection plates are in effect a parallel-plate capacitor, and the voltage difference between them will set up an electric field in the space between them—through which the electron beam is travelling. As the voltage of the circuit varies, the electron beam will therefore find itself in a varying electric field.

Electrons, it will be recalled, are negatively charged, and the electrons of the beam will thus tend to be moved or deflected by the electric field toward the more positive plate. The beam is travelling quite fast, so the electrons will not actually be able to reach the more positive plate, but the beam will be bent in the direction of the plate and the electrons will hit the fluorescent screen at a new spot somewhat removed from the centre of the screen. The exact distance moved will depend upon the voltage applied to the two plates.

As the voltage of the circuit varies, the bending of the beam will also vary and the glowing spot on the screen will move up and down in sympathy. Whenever the top plate is more positive than the lower plate, the beam will bend upward and the spot will move up. Conversely, when the lower plate is more positive than the upper plate, the beam will be deflected downward and the spot will move below the centre of the screen.

The amount of beam deflection produced at any instant will be proportional to the circuit voltage present at

that instant, and so the distance moved by the spot on the screen will be directly proportional to the circuit voltage applied at all times. If too much voltage is applied to the plates, the beam will be deflected right into the glass neck of the tube, and the spot will disappear off the top or bottom of the screen.

So far, the cathode-ray tube is simply acting like a meter with an electron-beam indicator needle. But here is where the second set of plates come in—those marked "horizontal deflection." These are very similar to the first set, but are closer to the screen (for mainly physical reasons) and are turned sideways so that any voltages applied to them will tend to move the beam and spot horizontally.

## TIMEBASE

A circuit called the TIMEBASE GENERATOR applies to this second set of plates, a voltage which changes linearly (smoothly) for a certain period then drops back to its initial value, then changes linearly again, and so on. The waveform of this voltage is thus shaped like the teeth of a rip-saw, and is accordingly called a SAWTOOTH sweeping voltage.

The effect of this sweeping voltage is to move the beam and spot smoothly across the screen from the one side to the other, then quickly back again, then smoothly across again, and so on. The speed at which this occurs can be adjusted over a wide range by controls in the timebase generator circuit.

By this horizontal movement of the beam and spot, the timebase waveform "spreads out" the up-and-down spot motion produced by the signal so that it can be seen. In effect, the cathode-ray tube plots a graph of the test



**A very compact modulated RF oscillator, intended for the testing and alignment of radio receivers. It is transistorised and operates from a small internal battery.**

voltage compared with time; the time represented by one sweep of the timebase waveform can be worked out or measured.

The cathode-ray oscilloscope thus allows us not only to see the circuit voltages changing, but to measure by how much they change—by the height of the pattern—and how long they take in changing—by a knowledge of the period of time represented by one sweep of the timebase waveform. It is thus an extremely useful instrument.

A modern oscilloscope like that shown in the photograph includes an amplifier (called the "Y" or "vertical" amplifier) to enable very small circuit voltages to be made large enough to produce a visible deflection of the spot. The amplifier has a switch to allow the selection of various amounts of amplification, and the switch is marked directly in terms of the amount of input voltage which is represented by 1 centimetre of vertical spot deflection. Voltages can thus be measured quite easily.

The speed of the timebase generator is adjustable by means of other switches, and these again are marked directly in terms of the period of time (in seconds, milliseconds or microseconds) represented by 1 centimetre of screen width. Time duration and frequency can thus be measured quite easily.

In passing, it should be noted that some oscilloscopes, notably the older types and the simpler modern types, do not have such "calibrated" vertical amplifier and timebase controls. They often have just a variable gain control on the vertical amplifier and have timebase controls either unmarked or marked in terms of the approximate timebase sweeping frequency (in cycles per second). Such instruments are intended mainly for "looking" at circuit goings-on, and are not really suitable for making measurements.

Most oscilloscopes have knobs to control the brightness and focus of the spot, and to set the spot to the centre of the screen when voltages having a large steady component are being measured. These latter are called the "shift" controls.

Oscilloscopes are also fitted with circuits to enable the timebase to be locked or "synchronised" with the voltage under inspection so that the screen pattern is held steady. Depending upon the exact type of circuit used, the controls associated with this feature may be marked "synch." or "triggering" or "locking" adjustments.

In some of the preceding chapters, we have referred to sources of RF alternating voltage, called variously MODULATED RF OSCILLATORS or RF SIGNAL GENERATORS depending upon their degree of refinement. It was explained that such devices are basically valve or transistor type oscillators, provided with a tuning capacitor and various coils to set the desired frequency band.

They usually include provision for modulating the RF voltage with a fixed audio tone (usually 400 or 1,000 cps), and with a reliable control over the amount of output voltage delivered—the

photograph will deliver audio signals from 18 cps to 500KC, covering the audio spectrum, supersonic frequencies and right up to the lower end of the RF broadcast band. It can provide either normal sinewaves (smooth alternations) or SQUARE WAVES, which are very useful in testing audio amplifiers and other equipment.

Like an RF signal generator, it has a meter to monitor the output voltage, and attenuator controls to enable the output to be set to any voltage between about 1 millivolt and 11 volts.

There are many occasions when resistors, capacitors and inductors must be accurately measured to determine their value of resistance or reactance. While



**An audio generator which will deliver either sine or square waves of any frequency between 18cps (sub-audio) and 500KC. The output meter and attenuator controls allow the output to be set to any voltage between a fraction of a millivolt and 11 volts.**

ATTENUATOR. In laboratory parlance, the name "Signal Generator" is usually reserved for instruments which have a meter to monitor the output voltage and the degree of modulation present, and an output voltage attenuator capable of setting the output to a known level between a fraction of a microvolt and a few volts.

In chapter 15 there appeared a picture of a reasonably elaborate instrument of the signal generator variety. The instrument shown in the photograph in this chapter is somewhat simpler, being a modulated oscillator intended for general radio testing and alignment. It is transistorised, covers three frequency bands and is quite small and portable.

Just as there is a need for instruments able to supply RF voltage, there is a similar need for instruments able to supply low- and audio-frequency alternating voltages. Such instruments are known as AUDIO OSCILLATORS or AUDIO GENERATORS, the latter being the counterpart of the RF signal generator in terms of accuracy and refinement. One type of audio oscillator is called a BEAT-FREQUENCY OSCILLATOR or BFO because it generates the audio frequencies by heterodyning or beating together two RF voltages.

The audio signal generator shown in

a reasonably accurate measurement can be made using various circuits of the multimeter or VTVM, it is usually necessary to employ what is known as a MEASURING BRIDGE in order to make really accurate measurements.

Basically, a measuring bridge is a device which balances the unknown resistor, capacitor or inductor against a known or STANDARD unit, to give

## Talking about test instruments . . .

. . . reminds us that we talk about new instruments and quite a few other new products each month in the Trade Review pages of "ELECTRONICS Australia." Keep up-to-date with new developments in the electronics field in Australia and abroad by reading "ELECTRONICS Australia" each month. Better still . . . place a standing order with your newsagent, or take out a subscription and have copies mailed to you. For details of subscription rates, write to the Circulation Manager, ELECTRONICS Australia, Box 2728, G.P.O., Sydney.

# SAFETY FIRST

Never underestimate the danger of an electric shock. No one is immune to the danger.

To be sure, plenty of people have received electric shocks and lived to tell the tale. They are the lucky ones.

Many have been less fortunate. Carelessness or ignorance has cost them their lives.

The moral is simple: Don't rely on luck; don't be careless; don't tolerate ignorance — your own or anybody else's!

Electric shock can affect the human body in various ways: It can burn; it can cause violent muscular reaction; it can cause loss of muscular control; it can interrupt the natural pumping action of the heart.

This last is probably the most insidious and it can result from a shock through the heart region amounting only to milliamps of current. Because this is so, electric shocks are most dangerous when the current passes between the two hands or arms, or between an arm and an opposite leg.

Here are some safety rules, commonly observed by people who have to deal with electrical, radio or other electronic equipment:

- When modifying or repairing equipment, always withdraw the plug from the power point. The "off-on" switch on the wall or on the equipment itself may conceivably break the neutral rather than the active power lead and leave mains wiring in the equipment still "live."

- If you cannot avoid working on equipment when it is actually switched on, first make sure that it is supported firmly in a position which will afford the necessary access. Never put yourself into the situation where you might have to support (or grab at) the chassis with one hand while you have the other hand near active circuits.

- When working on "live" equipment good safety-first habits are to keep the unoccupied hand by your side, or in a pocket, to squat on a wooden stool or chair, with feet on the rungs or on rubber or a dry carpet. Hazardous situations include standing on damp earth or damp concrete, as in so many garage-workshops, or letting parts of the body rest against conduit or other metalwork.

- Make sure that all test leads and prods are adequately insulated and use tools with insulated handles. But do not rely on this; if there is any risk of shock, switch the equipment off and, if advisable, remove the power plug before changing the position of a test lead or making some extensive adjustment.

- Don't be led into carelessness by an experienced technician who appears to take liberties with live equipment. Because of his experience and knowledge of the equipment, he may be taking a lot more care than you give him credit for.

- See to it that you, and the members of any electronics club with which you are associated, know how to act in the event of someone receiving an electric shock. (Inquire of ambulance services electricity undertakings, industrial authorities.)

Radio, as a hobby, has a record in Australia of being particularly accident free. Let's keep it that way!

an indication of the relative value of the unknown component. This type of measurement is accurate because the bridge simply performs a comparison between the unknown unit and a highly accurate standard unit; it does not rely upon the voltage of an internal battery or the accuracy of a meter. If a meter is used in the bridge, it is simply used as a balance indicator and not used as a measuring device.

For the measurement of inductance a rather elaborate bridge is required, whereas

**A typical R-C measuring bridge, having an electron-ray tube or "magic eye" as its balance indicator. The dial gives the value of an unknown component as a ratio of the internal standard resistor or capacitor selected.**

quite a simple bridge can measure resistance and capacitance fairly accurately.

For this reason most of the simpler measuring bridges are called R-C BRIDGES to signify that they are really only suitable for measuring resistance and capacitance.

The R-C bridge shown in the photograph has inbuilt standard resistors and capacitors for six comparison ranges, with a pair of terminals provided so that additional standard resistors or capacitors may be connected if desired. The comparison is carried out at a frequency of 50cps, and a special valve known as a "magic eye" or ELECTRON-RAY INDICATOR indicates a balance by means of two overlapping fan-shaped glowing segments on a fluorescent screen.

The bridge is adjusted for a balance by means of the large dial knob, which effectively "tries out" various ratios between the unknown and standard components. When it finds the ratio which produces a balance, as indicated by the electron-ray tube, the dial reading gives the value of the unknown component relative to the standard. If it reads "0.5" when the standard is 100pF, for instance, the unknown capacitance is 50pF. If it reads "3.4" with the same standard, the unknown would be 340pF.

The instruments which we have looked at so far are perhaps the most common types which are met in electronics. Before we leave this topic, however, it might be worthwhile briefly mentioning a few of the many not-so-common instruments.

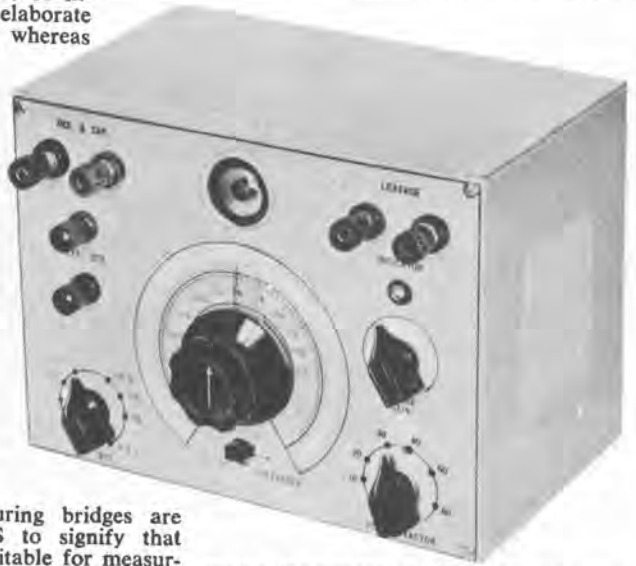
The SWEEP AND MARKER generator is an instrument used in the alignment of TV receivers and similar applications. It is in effect two RF oscillators or signal generators in one. The sweep section generates an RF signal which is swept back and forth in frequency, and may be used in conjunction with a CRO to show how tuned circuits and amplifiers behave over the band of frequencies being swept. The marker is a fairly normal RF oscillator used to identify or "mark" the various frequencies being swept through.

VALVE TESTERS and TRANSISTOR TESTERS are instruments used to check valves and transistors for proper

operation. Simple types may only indicate the difference between useless or very poor units and those which should operate more or less normally.

The more elaborate instruments place the valve or transistor being tested under its correct operating conditions and measure just how well it performs as compared with an equivalent new component.

DISTORTION METERS are audio



testing instruments which may measure one or more of a number of different types of signal distortion. They are often combined in the one case with an instrument called a MILLIVOLTMETER — which, as the name suggests, measures very small alternating voltages. The millivoltmeter is very useful for measuring the performance of microphones and gramophone pick-ups, as it can measure their output voltage directly.

GRID-DIP OSCILLATORS or GDO's are small RF oscillators which have externally mounted resonance coils and a meter which indicates their strength of oscillation. They are used to determine the tuning frequency of resonant circuits in receivers and other equipment. When the coil of the GDO is brought near the coil of the unknown tuned circuit, the frequency of the GDO is varied until the meter indicates that the test circuit is absorbing some of the oscillation energy — this shows as a "dip" in the meter reading. The GDO dial then indicates the frequency of the unknown circuit.

Incidentally, the term "grid-dip oscillator" is inappropriate when applied to the transistorised instrument and it would be better if the term were simply shortened to "dip oscillator."

The SIGNAL TRACER is effectively a sensitive radio receiver fitted with a switch which permits signals to be fed into it at any of the various points along the signal path. It is used to follow the path of radio signals through a receiver under test, in order to find out speedily the section of the receiver which is faulty.

Although we may seem to have looked at quite a number of test and measuring instruments in this chapter, there are a great many more that we have not been able to mention. All sorts of test and measuring instruments have been developed in order to make the job of the electronics worker a little easier, faster and surer.



**CHAPTER 17:** Subjects yet to be covered. The importance of audio techniques. Microphones. Distortion in audio reproduction. Magnetic recording — principles, equalisation, fidelity and distortion, noise, wow and flutter. Disc recording and playback principles. Piezo-electric and magnetic pickups. Audio amplifiers and their main characteristics. Loudspeakers. Stereo reproduction. The significance of the term "hi-fi."

**I**N this and the following three or four chapters of our Basic Radio Course, we seek to present to readers a broad picture of various important aspects of electronics. Included will be chapters on audio, television, servicing, amateur radio and industrial electronics.

Each of these subjects could easily occupy a complete course in its own right and there can be no thought of an adequate technical coverage in a number of single chapters.

What we will try to do is to answer an imaginary question along the lines... what is this all about? Each chapter will aim to "orientate" the reader in relation to the particular subject and put him in a more favourable position to delve deeper by other reading.

This particular instalment is devoted to the subject of audio and sound reproduction, one of the major subdivisions of the electronic art.

#### WIDE FIELD

A very large proportion of the industry is directly involved in producing "audio" components of one type or another or in using them professionally. A large proportion of workers in the electronic field have high fidelity sound reproduction as their prime hobby. Perhaps a still larger number have developed an interest in—and a working knowledge of—"hi-fi," even though they are not engaged in the industry.

It may be helpful, at the outset, to take a quick look at familiar and everyday uses of audio techniques and components.

The most prolific use of audio components is found in ordinary radio receivers. Readers could well refer back to chapter 10 of this course (May, 1964) for fundamental concepts and to the following issue for reference to more complex types of receiver.

Basically, a radio receiver makes available at its detector a small audio signal, which is a close replica of the speech and music signal being radiated by the broadcasting station. Apart from "crystal" sets and such like, all radio receivers use one or more audio amplifier stages to build up the signal to a level where it can adequately operate a loudspeaker.

Much the same thing happens in a television set, the two applications adding up to literally millions of audio amplifiers in this country alone.

Added to these are all the record playing equipments and the tape recorders currently in use, hardly less familiar than radio receivers and every one involving an audio amplifier... in fact two, where a stereo system is involved.

Then there are public address amplifiers for reinforcing speech, amplifiers for theatre sound, amplifiers to do with electronic organs and other musical instruments, amplifiers in paging and intercommunication systems, and so on into a variety of less obvious applications.

Little wonder that engineers can specialise at length in audio techniques and components, without any fear of exhausting the subject.

A discussion of audio techniques, at least for our present purpose, can logically begin with a look at the sources from which enthusiasts may derive signals for amplifying equipment. These would include, most commonly, radio and TV receiver detectors, as already mentioned, magnetic tape and tape heads, and gramophone records and pickups.

The microphone must qualify as the most fundamental of signal sources, because it performs the primary task of changing sound from a pattern of pressure waves in the air to an equivalent pattern of electrical signals. The original sound may be voice, music,

*Figure 1: A typical medium quality microphone made by AKG. It is suitable for high quality home recording, high quality public address and non-critical use in broadcast and TV studios.*



noise, or any combination of the three; anything, in fact, which we can hear and which we may wish to amplify or record.

An ideal microphone would be capable of changing any audible sound pressure wave into an exactly equivalent electrical signal without DISTORTION, a collective term indicating any departure from perfect reproduction.

It would exhibit no FREQUENCY DISTORTION; in other words, it would handle all sound with equal efficiency, irrespective of the frequency or pitch of

the sound. If its signal output voltage were plotted against frequency, the resulting graph or curve would be flat.

An ideal microphone would not exhibit any HARMONIC DISTORTION; in other words, it would not add to the electrical output signal extra frequencies or harmonics which were not present in the original sound. Conversely, it would not suppress any of the natural harmonics in the original sound.

Again, an ideal microphone would not introduce any INTERMODULATION effects. This means that it would not produce extra and spurious output signals as a result of heterodyning or mixing of original signals. To quote a simple example, there would be no tendency for two tones (say 500cps and 700cps) fed to the microphone to heterodyne (or intermodulate) to produce extra spurious signals at 200cps (700 - 500) or at 1,200cps (700 + 500).

Perhaps it would be a good plan to re-read these last three paragraphs and look again at the terms which have been put in capital letters. While we have chosen to introduce them in connection with microphones, they have an application to all audio components. Frequency distortion, harmonic distortion and intermodulation effects are terms which you will strike over and over again in audio literature — and which you will certainly strike again in this chapter.

Not surprisingly, there is no such thing as an ideal or perfect microphone, although good quality studio type microphones are commendably free from these failings. The same cannot be said for the class of microphones more commonly handled by audio hobbyists, however, or

those used for utility public address systems.

A hobbyist or small-scale P.A. operator might class a microphone in the £10 to £25 group as "good," and it is so to the extent that it can give acceptable results on speech, singing and non-critical instrumental groups. However, to varying degrees, microphones in this group do evidence some distortion — using the word collectively — which is responsible for the reproduced sound being not quite natural.

In the still cheaper grades of microphone — and this includes practically all those supplied with domestic tape recorders and so on — distortion is plainly evident, particularly frequency distortion in the way of a strong prominence in the middle of the range (say about 3,000cps), with diminished re-

sponse in the upper register and at the bass end. That is why speech and music recorded through such microphones commonly has an unnatural or "metallic" quality.

Microphones use a variety of basic principles to convert sound pressure waves to electrical signals.

Studio quality microphones are commonly of the "condenser," "ribbon" or "dynamic" type. Among medium quality microphones, one finds an occasional ribbon type, a preponderance of dynamic types and a few "crystal" (or piezo-electric) units. In the inexpensive class one finds a fair number of dynamics but a preponderance of crystal types.

At this stage, these must remain mere terms, although some clue as to their meaning may be picked from later references.

The electrical signal available from most microphones is quite small, being commonly very much smaller than that available from the detector of a radio or television receiver. This being so, an amplifier used with a microphone must have a higher amplification or GAIN than one intended to operate only from a radio detector.

But enough about microphones. Let us move on.

If sound is to be recorded for future replay, it is most commonly done, these days, first of all on magnetic tape equipment. The tape itself, on which the recording is impressed, is a ribbon of thin plastic, normally 1/4-inch wide, coated on one side with a thin layer of finely divided and magnetically sensitive particles.

A tape recording system provides the necessary spooling and traverse mechanism to pull the tape at an even speed past the magnetic head assembly. Most readers will be sufficiently familiar with tape recorders not to require any elaboration of these remarks.

## ERASE AND BIAS

Internally, a tape recorder normally contains an erase OSCILLATOR. This is a normal oscillator circuit (see chapter 8, March, 1964) but arranged to provide output in the supersonic region, usually between about 40KC and 100KC.

During the recording process, a large proportion of this supersonic energy is fed to an ERASE head, being the first head over which the tape rides as it is drawn from the feed spool to the take-up spool. The signal in the erase head creates a powerful, supersonic magnetic field which is intended to erase or cancel any signal that may be on the track on which the new recording is to be made.

A small proportion of the erase signal is taken also to the RECORD head, where it is combined with the audio signal to be recorded. Most likely this latter will have come from a microphone and will have passed through a number of amplifier stages to bring it to a level where it can produce adequate signal current through the windings of the record head.

The reason for feeding some of the erase signal energy to the record head involves some rather obscure theory to do with magnetic recording and is beyond the scope of this article to cover.

We will have to be content with the statement that magnetic recording depends for its efficiency on the presence of a fairly critical amount of supersonic signal in the record head, along with the signal to be recorded. Though it is usually taken from the erase oscillator, it is referred to, in relation to the record head, as the high frequency BIAS voltage.

The audio signal and bias voltage fed to the record head produce a magnetic field evident across a tiny gap in the exposed face of the head. As the tape

**Figure 2: A typical tape recorder and playback unit, actually a Ferroglyph, mid-way in price and performance between fully professional studio equipment and the less pretentious units commonly bought for home use.**



is drawn across this gap, the particles are magnetised according to the field which is present at the particular instant. This they retain so that, in effect, the tape can be regarded as being coated with an extremely large number of separate magnets of particle size, each one magnetised in a particular way, according to the original signal which produced it.

To play back the tape, the erase (or bias) oscillator is switched off, the tape is rewound and then drawn across the head assembly again, at the same speed as it was recorded. The tiny magnetised particles, drawn across the

heads, now induce a signal current in the windings of the heads, more or less equivalent to the signal originally recorded. When the induced current is amplified and fed through a loudspeaker, the original sound is re-created.

In simple recorders, the same head is commonly used for record and playback, being switched from one function to the other by operation of the controls and, in particular, the "record-playback" switch. In more complex equipment, separate record and playback heads are used, allowing the designer to suit the characteristics of the individual heads more specifically to the job they have to do.

Either way, however, the signal recovered from a magnetic replay head is quite small, being comparable to that produced by a microphone. As with a microphone, quite a high order of amplification is required from the amplifier itself, to bring the signal to a level adequate to operate a loudspeaker.

And here we must introduce another consideration, which will have implications wider than in tape recorders alone... that of EQUALISATION.

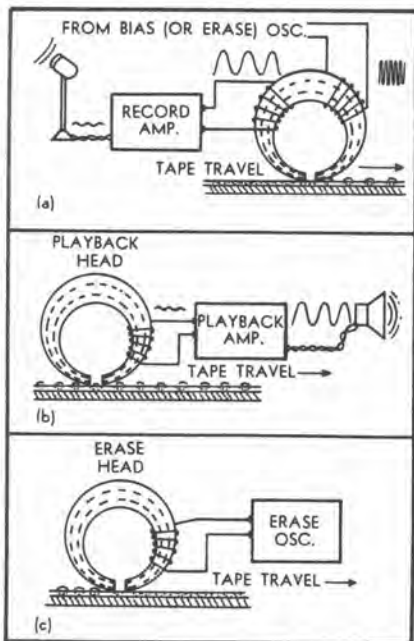
## FREQUENCY DISCRIMINATION

The natural characteristics of a magnetic recording system is that it tends to record and replay most efficiently frequencies in the middle of the audio range — say between about 1000cps and 3000cps, lower frequencies and higher frequencies being very much reduced or ATTENUATED by comparison.

The amount of high frequency attenuation varies, in turn, with the speed of travel of the tape. At slower tape speeds, say 3 1/2 inches per second and below, the attenuation is much more serious than at higher tape speeds, say 7 1/2 inches per second and above.

To counteract this peculiarity, steps must be taken to BOOST the bass response and the treble response during recording and/or playback so that their level, as finally heard, is equivalent to that of the middle frequencies. The process of equalising the performance of the system at all frequencies is commonly referred to as EQUALISATION.

Here again, having mentioned the word and the concept, it is necessary to leave the reader to follow it up



**Figure 3: These diagrams illustrate, in elementary fashion, (a) the tape recording process, (b) tape playback and (c) signal erasure when the recording is no longer required or when a new recording is to be made on the same tape.**



independently, as opportunity occurs. It must be sufficient to take note of magnetic tape and tape heads as a signal source and to register that they involve the need for (a) high amplification and (b) suitable equalisation.

As with microphones, so it is with tape recording and playback equipment in the matter of performance.

The best studio and commercial tape recording equipment is very good in terms of equality or FIDELITY, exhibiting a minimum amount of intermodulation distortion, harmonic distortion and frequency distortion. In view of what we have just said about equalisation, this last remark implies that the equalisation in the internal circuitry of a good quality tape system exactly balances its inherent losses at bass and treble, so that the final response curve is exactly equalised, or is FLAT.

With less costly and elaborate tape equipment, and because of resultant design compromises, the overall fidelity may not be as good, the output containing a higher content of intermodulation, harmonic and frequency distortion. In fact, with very cheap tape equipment, the overall distortion content can be quite high, to the point where it can seriously compromise listening enjoyment.

Tape equipment can also suffer from certain other important limitations on its performance.

One of these is BACKGROUND NOISE, usually evident as a soft hiss heard behind the recorded sound. Some of this hiss can come from the recording amplifier, and some from the playback amplifier, being an indirect result of having to amplify signals of such a small original magnitude.

## TAPE NOISE

Noise can also be introduced as a result of random passage of the tiny tape particles past the gap in the replay head. A tape can be "noisy" if the magnetic particles are too coarse or too irregular in their distribution, or if the tape has not been properly erased prior to recording.

Noise will also be more evident if the laminations in the replay head are partially magnetised rather than being magnetically neutral.

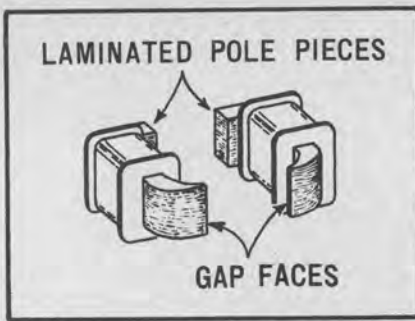
Unfortunately, while background noise is most common in inexpensive equipment, it is noted all too frequently in tapes made at professional level on professional machines.

Other important limitations on the performance of tape equipment take the form of WOW and FLUTTER. Both are mechanical in origin.

Tape equipment is said to exhibit "wow" if there is a slow, periodic variation in tape speed (a retition rate of say not more than once per second) causing a variation in the pitch of the recorded sound. Such wow is usually caused by some eccentricity in the drive system, a bearing which tends to bind or a spool clutch mechanism which causes a varying load on the drive motor(s).

Flutter is a much more rapid speed variation caused notably by unbalance or eccentricity in the motor and spindle which actually pulls the tape past the head.

In most modern recorders, domestic as well as professional, the wow and flutter content are held to within accept-



**Figure 4: Illustrating the construction of a magnetic head. The field tends to concentrate along the gap faces, which are separated, typically, by .001in or less.**



**Figure 5: The head assembly from a Collaro tape deck. At left is the erase head and, at right, a head which is used alternatively for recording and replay. Note the separate pole faces for multiple track recording.**

able limits but, in some of the very cheap battery portable equipment currently being offered, wow is so bad that the equipment is quite unusable on music.

Perhaps brief mention is warranted, just here, of the varying track arrangements used in tape equipment. Normal recording tape is  $\frac{1}{4}$ -inch wide and earliest practice was to record right across the full width of the tape. This is still done in professional recordings.

Subsequently, it became the practice to record two tracks on the tape, side by side, each somewhat less than half the width of the tape. HALF-TRACK recording allows twice the playing time from a given reel of tape at any given speed.

Nowadays, QUARTER-TRACK recording is quite commonplace.



**Figure 6: Taken from our files and somewhat dated, this picture nevertheless epitomises the care which goes into the preparation of a master recording. Here a B.B.C. engineer examines a test track with the aid of a permanent microscope and inspection light.**



The use of narrower tracks does involve some loss in overall performance, but quarter-track recording can still give acceptable results for domestic applications.

While tape recording and replay equipment is currently in very wide use, the most popular medium for recorded sound entertainment remains the disc; the descriptive words "phonograph" or "gramophone" have become almost redundant in modern usage except perhaps for the contractions "gram" or "gramo."

At a manufacturing level, discs have the basic appeal of ease and economy of mass production, to the extent that there is no embarrassment at all if a "hit" disc sells a million copies in a relatively short period. At the user level, discs are easy to handle, easy to code in terms of artists and selections, lend themselves to attractive packaging and can produce sound quality which is adequate for present-day requirements.

On a disc, the recording is retained as tiny deviations in a spiral track. In a sense, the track can be regarded as a mechanical graph or plot of signal waveform against time.

An original or master disc recording is made on a RECORDING LATHE, which carries a recording head slowly across the surface of the disc, from outside to inside, as the disc rotates at predetermined speed beneath it. The resulting spiral track is cut by a specially shaped diamond stylus protruding beneath the recording head.

A coil and magnet system within the head, fed from an external amplifier, drives the stylus, so that it vibrates laterally, and sometimes vertically as well, in sympathy with the audio signal which is to be recorded. As a result, the spiral track deviates in accordance with the actual pattern of audio waveforms which has been fed to the stylus.

By a process involving spraying and electroplating, the original recorded track can be transferred to metal STAMPERS or DIES and used to stamp out any required number of copies of the master disc for distribution to the public. For all practical purposes, the disc which you

buy carries a track identical to the one cut in the original master.

To reproduce the recorded sound, the disc is replayed — nowadays — with a PICKUP. This has fine stylus which traces the spiral groove as the disc rotates. The tiny waveform serrations in the groove impart a corresponding motion to the stylus which actuates a mechanism inside the pickup head capable of generating a corresponding electrical signal.

This is built up in an amplifier to a level where it can operate a loudspeaker, in the usual way.

The disc technique has undergone drastic revision within the living memory of many readers.

Originally, disc recording and playback was an entirely mechanical process, involving no electrical amplification whatever. The sound to be recorded was collected in a large horn and conducted through tubing to a diaphragm attached to the recording stylus, so that the sound waves actuated the stylus directly.

For playback, the disc was tracked by a steel needle attached directly to a diaphragm. This vibrated and created air waves which were conducted into the listening room by tubing and a flared horn.

Because the system relied on the direct transfer of mechanical energy throughout, its specifications needed to be "robust" so that heavy diaphragms, steel needles, relatively large grooves and coarse-grained record materials were accepted without too much question. This was the era of the early 78 r.p.m. discs.

## ELECTRICAL RECORDING

Later, the techniques of using electrical cutting equipment and then electrical reproducing equipment removed many of the limitations of the mechanical system. More types of sound could be successfully recorded, the frequency response of the system could be widened and flattened, harmonic distortion reduced, with a reduction also in the noise content contributed by the coarse grained disc materials.

However, while enormous advances were made along these lines, the traditional standards of groove dimension and record speed were retained up till the end of World War II.

At this juncture sound engineers began to accept the fact that the old standards were needlessly cumbersome in a situation where disc recording no longer relied on the direct transfer of mechanical energy from cutting to reproducing stylus. In other than retarded countries, electrical amplification was universal in record playing equipment.

Groove dimensions could be drastically reduced, record speed likewise, non-abrasive disc materials and gem styli could minimise noise and wear problems, and playing time could be dramatically increased.

Vital to the latter point was the fact that, meanwhile, magnetic recording had been developed to the point where original recordings could be assembled on a tape, mistakes could be edited out and the whole thing checked and timed. Then the material could be transferred to a master disc, without fear of the effort being ruined by an inadvertent error on the part of a performer.

So after the war came the era of "fine groove" or microgroove discs, in-

tended to be played with sapphire or diamond styli, contoured to a spherical-shaped tip of radius .001in.

Two major standards emerged — 7-inch diameter discs turning at 45 r.p.m. and 12-inch diameter discs turning at 33 r.p.m.

Nowadays, 7-inch discs are issued as "singles" (single play) or as "EP's" (extra play). The "singles" carry one item per side, while the "EP's" carry two items per side.

The 12-inch discs are used for major musical works, with a playing time of 20-30 minutes per side, or for popular recitals with, usually, five tracks per side.

The quality of reproduction from current fine groove (or

**Figure 7 (right) shows a B & O magnetic pickup which has had fairly wide use in Australia. It plays microgroove records only — not 78's. Figure 8 (below) shows an Acos turnover crystal cartridge. This has two styli, one for fine groove (33 and 45 rpm) records and the other for 78 rpm records. The appropriate stylus is presented to the record surface by turning the cartridge over with the knob protruding from the front.**



long playing or LP) discs varies widely.

In the popular "hit parade" field, quality is made secondary to immediacy of issue and, often, the overall distortion is tolerated only because they are played on nondescript equipment by a non-critical audience.

For the average long playing disc much higher standards of reproduction are sought and maintained, while there is a high proportion of modern discs which qualify — by current standards — in the "excellent" to "superb" class. As often as not, the ultimate quality of such discs is limited, not by their own inherent characteristics, but by the original recording situation and the original tape equipment.

They compare very favourably with mass-produced pre-recorded tapes.

As with magnetic recording, problems of equalisation occur also with disc recording, though for different reasons.

In the case of disc recording, there is a tendency for low frequency audio waveforms to produce excessive deviation, leading to a danger of waveforms on one section of the track breaking through into waveforms on adjacent tracks.

At the other extreme, waveforms corresponding to high audio frequencies tend to diminish in physical dimensions

to scarcely perceptible serrations in the sides of the groove.

To minimise these problems, and by common agreement, recording companies now manipulate the frequency response of their recording systems to restrict (a) the natural increase in waveform magnitude with decreasing frequency and (b) the natural decrease in magnitude with increasing frequency.

The amount of such restriction is stated in the so-called RIAA recording standard and its effect is to produce something much closer to a CON-



STANT AMPLITUDE recording characteristic.

If one were to feed into such a system a tone of constant loudness but gliding in frequency from very deep bass to very high treble, the resulting waves recorded on the disc, while varying in length along the groove, would not exhibit too great a variation in side-to-side deviation.

Putting this another way, it can be said that present-day practice is to attenuate the bass and boost the treble, while recording a disc, in order to achieve a more convenient recording characteristic.

**This has to be taken into consideration for playback, where bass needs to be boosted and treble needs to be attenuated for the final sound, as heard, to be level, or equalised.**

For replaying records, two classes of pickup are now widely used.

## CRYSTAL PICKUPS

By far the most numerous is the so-called "crystal" pickup or, to give it its proper name, the "piezo-electric" pickup.

In this type of pickup the stylus is attached, directly or through a tiny lever system, to a slab of material exhibiting the piezo-electric effect. Such materials produce an electrical potential between certain faces when they are subjected to physical stress.

In a piezo-electric pickup, movement of the stylus stresses the material, producing a signal voltage between two of its faces, directly related to the movements of the stylus and the deviations of the recorded groove. The signal voltage developed by the piezo-electric element is picked up by metal foils cemented to the relevant faces and made accessible by attached wires.

When this signal is passed through an amplifier to a loudspeaker, it produces a sound similar to the sound originally recorded.

Two important characteristics of piezo-electric pickups account for their very wide use.

The first is that they tend inherently to boost the bass response and to attenuate the treble, in playing a record. By a certain amount of manipulation in their design, it is possible to make this inherent characteristic just about balance out the reverse characteristic

used for recording. As a result, they need no special provision for equalisation in the amplifier system.

The second factor is that their signal output voltage is fairly high, so that it can be fed into the same general class of amplifier as might be used, for example, to follow the detector of a radio or television receiver. This makes it very simple to produce combination radio-receivers and record players, because the same amplifier and loudspeaker system can be switched to serve either function.

Two types of piezo-electric pickup are in common use. In the original and still popular CRYSTAL pickup, the piezo-electric element is a slab of rochelle salt. In practice, it suffers the major disadvantage of being liable to deterioration under conditions of high temperature and high humidity, a certain number of failures occurring on this account.

### CERAMIC PICKUPS

The second type is the so-called CERAMIC pickup (or cartridge) where the piezo-electric element is a piece of specially manufactured ceramic. Pickups of this type are not affected by temperature and humidity and are gaining favour on that account. They deliver a somewhat lower signal output voltage than a normal crystal type, but it is usually sufficient still to avoid the necessity for special amplifier circuitry.

As distinct from piezo-electric pickups the other major class is the MAGNETIC pickup. These pickups all involve coils of wire and a magnetic field provided by a tiny, in-built permanent magnet. Their mechanisms vary widely in detail, but they all rely on the stylus effecting a change in the relative position of turns of wire and magnetic lines of force. As a result of this relative movement, signal current is induced in the coil (or coils) being brought out through leads for subsequent amplification.

A great deal of effort has been directed to refining the design of magnetic pickups to achieve the highest possible order of fidelity, along with low-tracking weight, in the interests of minimum record wear. The refinement has involved not only the signal generating system—or cartridge—but the pickup arm and the bearing system on which it moves.

This effort has resulted in a range of magnetic pickups being available throughout the world, with extremely good performance characteristics—but quite highly priced in comparison with the more common piezo-electric types.

Magnetic pickups, as a class, deliver a relatively low level of output signal, approximating that from a microphone or magnetic replay head. Unlike piezo-electric pickups, they provide no inherent correction for the original recording characteristics so that the amplifier into which they operate must provide high gain and full frequency compensation as well. The need for a special amplifier involves extra complication and further cost.

Now for a brief look at the subject of amplifiers.

Because this is so large and the space available is so restricted, it may be helpful to cover some of the necessary ground, glossary style, listing and explaining terms which occur very frequently in discussions about amplifiers.

**POWER OUTPUT:** This is the amount

of audio power which an amplifier, without producing serious distortion, can deliver to a loudspeaker. Australian practice has been to express this power in watts RMS, although the practice has grown up in America of expressing it in peak watts or peak music power, allowing advertisers to quote a figure which looks bigger on paper. In transistor portable receivers, the available audio power lies in the range 0.1 to 0.4 watt RMS. In mains powered domestic radio and television receivers, from 2 to 6 watts of power is usually available, while specialised "hi-fi" amplifier equipments range between about 6 and 30 watts RMS.

**GAIN or AMPLIFICATION:** This refers to the amount of amplification which is available in

*Figure 9: Designed by our technical staff for home construction, this 107*

*Playmaster tuner-amplifier is a commonsense compromise between ordinary radiogram standards and the somewhat exotic systems used by no-compromise hi-fi enthusiasts. It provides for stereophonic reproduction.*



in an audio amplifier system and is really a measure of the magnitude of signal which has to be fed into it to obtain its maximum power output. From what has been said in earlier pages, it will be apparent that an amplifier which has to work from a microphone or magnetic pickup will need more gain or amplification than one which has to work from a crystal pickup or radio tuner.

**FIDELITY or QUALITY:** These are comprehensive terms which describe the correspondence between the reproduced and the original signal. A good amplifier is one which is characterised by high-quality reproduction or HIGH FIDELITY. Using negative rather than positive terms, it could be said that such an amplifier will introduce a minimum of distortion.

**DISTORTION:** This term has already been explained. As with microphones and pickups, an amplifier can introduce frequency distortion, harmonic distortion and intermodulation distortion.

**INSTABILITY:** An amplifier can oscillate, either due to an internal design fault or because of incorrectly made connections. The oscillation may occur at an audible frequency and be heard as a "popping" noise, a growl or a whistle, depending on its pitch. Alternatively, it may occur at a supersonic frequency and, while it will not then be directly audible, it will generally affect the performance of the amplifier in other respects, often causing a severe reduction in power output.

**HUM:** Hum is a fairly familiar problem in amplifiers operating from the power mains, being evident as a consistent low-pitched humming sound. It is due to energy from the AC power mains reaching the amplifier circuitry through lack of filtering in the power supply, through poor design in other respects, a faulty component or by unsuit-

able arrangement of the signal input leads.

**NOISE:** As distinct from hum, an amplifier may produce a certain amount of noise, most evident when the volume control is turned towards maximum. Most amplifiers produce some noise, evident as a gentle hissing or rustling sound, but it can reach objectionable proportions as a result of poor design or a faulty component.

By far the largest number of audio amplifiers in common use are those which serve as the audio systems of

ordinary radio and television receivers. Their power output, as already indicated, is modest, being no greater than necessary—or convenient—for the particular class of use.

Their gain, or amplification, is also modest, since they need operate only from the comparatively substantial signal available from the detector.

The order of fidelity required might typically warrant such descriptions as "fair only" for small transistor receivers or "reasonably good" in the case of domestic radio and television receivers. Listeners usually accept the sound from radio and TV receivers without much question, provided it is not positively "unpleasant" or "harsh"—which is as good as saying that the distortion level may be high but not intolerable.

In terms of facilities, the minimum requirement is a VOLUME CONTROL, being normally a potentiometer which affords control over the amount of signal passing through the amplifier and therefore the loudness of the sound, as ultimately heard from the loudspeaker.

A large number of receivers also have a TONE CONTROL which usually takes the form of a potentiometer, so arranged in the circuit, that its operation allows the treble response to be reduced at will.

It might be considered that use of a tone control in this way is a form of deliberate frequency distortion and this may well be true. However, many listeners seem to like the "mellow" kind of sound which results from attenuating the higher frequencies and provision of a control for this purpose is, at one time, a concession and a sales feature.

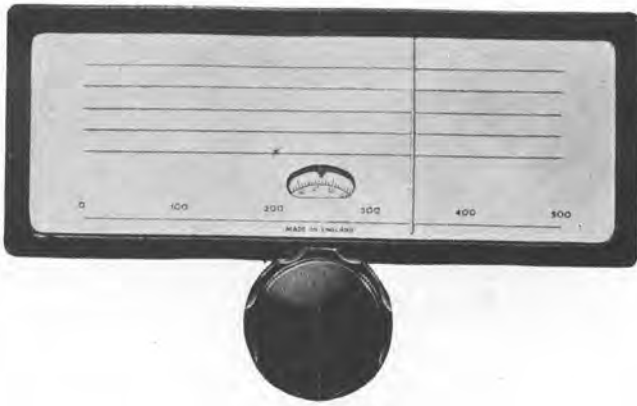
Where a receiver is to be used as part of a "radiogram," with the combined facility of playing records, there follows the implication that the user may be rather more critical than usual, and more demanding in terms of fidelity.

There is a tendency, therefore, for the amplifiers in radiograms to be designed to marginally higher standards and, in some cases, to provide separate knobs for controlling independently the level of bass and treble.

While these controls can conceivably be used to improve the sound from a record which exhibits questionable bass-to-treble balance, they are more frequently used to modify the sound to the

# EDDYSTONE RADIO

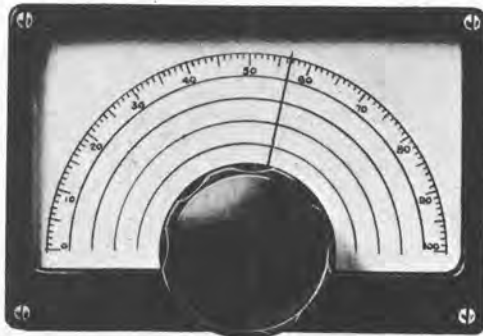
DRIVES AND DIALS



**Geared Slow-motion Drive Assembly Cat. No. 898.** A high grade assembly designed for instrument applications. The movement is gear-driven and flywheel loaded, giving a smooth, positive drive, with a reduction ratio of 110 to 1.

The pointer has a horizontal travel of 7 inches. A circular vernier scale, marked over 100 divisions, rotates five times for one traverse of the pointer, and, read with the "100" scale on the dial, provides a total of 500 divisions.

A diecast escutcheon, finished glossy black, is supplied and the assembly is complete with perspex window, knob, fixing screws, and mounting template. Overall external dimensions are 9 $\frac{1}{8}$ " (23.34 cms.) by 5 $\frac{3}{4}$ " (14.6 cms.). Weight is approximately 1 lb. 14 ozs. (.85 kilogrammes).



**Full Vision Dial Cat. No. 598.** The epicyclic, ball-bearing drive mechanism is of improved design and has a reduction ratio of approximately 10 to 1. The movement is smooth and free from backlash. The dial escutcheon measures 6" long by 4 $\frac{1}{8}$ " wide plus a  $\frac{1}{8}$ " lip. The scale is marked 0-100 over 180°, and is 5" across. A large fluted instrument knob is fitted. Ripple black finish.

AVAILABLE  
FROM  
ANY RADIO  
DISTRIBUTOR



VICTORIA: 8 Bromham Place, Richmond.

Tel. No. 42-1614

N.S.W.: 64 Alfred Street, Milson's Point.

Tel. No. 929-8066

QLD.: L. E. BOUGHEN AND CO., 95 Central Avenue, Sherwood. Tel. No. 79-2207

W.A.: H. J. McQUILLAN PTY. LTD., 1017 Welling Street, Perth. Tel. No. 21-4821

ASK FOR  
EDDYSTONE  
COMPONENT  
CATALOGUE

way the listener happens to prefer it. Over and above the large number of people who own and use radiograms on a fairly routine or casual basis, there are many with a lively interest in reproduced sound and these fill the ranks of the so-called high fidelity enthusiasts. We shall have something to say later about the whole subject of high fidelity and this will involve further reference to amplifiers, as well as to all other units in the reproducing chain.

However, it is appropriate to note here that high fidelity enthusiasts, as a class, tend to purchase or build amplifiers with facilities and performance figures well ahead of the amplifiers used in ordinary radiograms.

Very frequently, they include an extra amplifier stage, referred to as a PRE-AMPLIFIER, to enable them to operate from the low level signal produced by a magnetic pickup. This provides the extra amplification necessary, as well as the requisite frequency compensation or equalisation.

Then, too, the amplifiers often incorporate a special tone control stage providing facilities for treble boost or treble

## DON'T MISS OUT

Make certain of your monthly copy of **ELECTRONICS** Australia and avoid disappointment by placing an order with your newsagent, or take out a subscription and have your copies mailed each month. Subscription rates for anywhere in the world will be supplied on request by the Subscription Manager, **ELECTRONICS** Australia Box 2728, G.P.O., Sydney.

cut, and bass boost or bass cut. With these controls, the listener can vary the balance of the sound reproduced to suit his own tastes, whatever these may be.

As already mentioned, the power output available from special quality amplifiers is usually quite high, in the range of say 6 to 30 watts.

Precautions are taken also to ensure a low order of harmonic intermodulation distortion from the amplifier. This is secured automatically, in part, by providing for high power output so that, in practice, the amplifier is always operated well below its maximum capacity. In addition, however, the circuit and components are selected with greater emphasis on performance and less on cost and complexity.

Considerable attention is paid also to filtering and to other points in the design which might affect the inherent hum level. Because the loudspeaker systems used in a high fidelity installation are likely to be very efficient at 50 and 100 cps., the two main hum frequencies with 50 cps. power mains, an amplifier hum level which might be unnoticed in a fairly nondescript receiver or record player, may be quite objectionable in a premium quality installation.

As far as actual design is concerned, quality amplifiers vary widely, both in physical appearance and electrical circuitry. However, while many claims and counter-claims are made, it is not difficult to produce these days, either valve or transistor type amplifiers which have excellent characteristics and which add very little to the total distortion of a reproducing system.

At this point, lack of space compels us to hold over the rest of this chapter until next issue. Next month, we shall be talking about loudspeakers and baffle systems, hi-fi reproduction and stereo-phonics systems.



## CHAPTER 17 — Continued

FROM amplifiers, we pass to a brief discussion of loudspeakers. Since at least 1930, the vast majority of loudspeakers used for sound reproduction have been of the so-called DYNAMIC type, making use of the moving coil principle of operation.

In this type of loudspeaker, a small solenoid coil, wound usually on a paper former, is attached to the apex of a cone. (See figure 10.) The cone is suspended within the frame of the loudspeaker by a corrugated ring or a "spider" around the apex, and a corrugated cloth or ring around the periphery. So suspended, it is able to move back and forth, although it always tends to return to an intermediate or rest position.

The moving coil or VOICE COIL attached to the apex of the cone is arranged to be inside a magnet structure which envelopes it in a strong magnetic field. (Figure 11.) Initially, the coil structure is not affected by this field because it is made of copper wire and wound on a paper former — both non-magnetic substances.

However, if audio current from the amplifier is passed through the voice coil, the current sets up a magnetic field which interacts with the fixed magnetic field, causing the coil to move rapidly back and forth with the alterations of the audio current. In fact, it behaves as an elementary type of motor.

### AIR WAVES

As the coil vibrates back and forth, it imparts the same motion to the cone, setting up air waves which recreate the original sound.

During the 1930s the vast majority of dynamic (i.e. moving coil) loudspeakers used an electromagnet system to provide the fixed magnetic field, because this was the most convenient and effective way at the time. Surrounding the voice coil was a structure of soft iron enclosing a quite large coil containing, usually, many hundreds or even many thousands of turns of copper wire.

Current was passed through this so-called FIELD coil, sometimes from a separate DC power supply and sometimes by wiring the field coil directly across the high tension supply in the associated receiver or amplifier. A third and popular arrangement was to wire the field coil in series with the power supply, so that it functioned also as a filter choke.

The DC resistance was an important characteristic of a field coil, since it had to suit the voltage and current available from any particular power supply, receiver or amplifier.

The DC resistance of loudspeaker field coils ranged, commonly, from about 700 ohms to about 7000 ohms. Values from 700 to 2500 ohms were most frequently involved in the "filter" connection, while

those above 2500 ohms were frequently connected directly across HT supply circuits.

The actual wattage dissipated in the fields, being also a measure of the strength of the magnetic field produced, ranged from 3 or 4 watts in very small loudspeakers to about 25 watts in very large ones.

During World War II a great deal of research went into the production of permanent magnets and, as a result, it became possible to produce permanent magnets for loudspeakers which could provide the same field density — or greater — than from electromagnets, much more easily and cheaply than before.

As a result, field coil type or ELECTRODYNAMIC loudspeakers gave place almost entirely to loudspeakers using permanent magnet fields. These may be described in full as "permanent magnet dynamic loudspeakers," being more frequently contracted to "permags." In fact, this type of loudspeaker is now so universal that a permanent magnet field is taken for granted, electrodynamic units being found only in old equipment.

A second major factor to do with dynamic loudspeakers is the resistance or impedance of the voice coil. This coil has to be relatively small and light, to be able to vibrate at audio frequencies. Up till quite recently, it has been taken for granted that the coil will necessarily have too low a resistance or impedance to make much use of the audio energy available to it from an amplifier.

As a result, it has been standard practice to provide a coupling transformer — or OUTPUT transformer — between the amplifier and loudspeaker. The transformer is given a turns ratio such

that it can MATCH the output load requirements of the amplifier to the resistance or impedance of the loudspeaker voice coil. The output transformer is sometimes fitted into the amplifier, sometimes attached to the loudspeaker frame, as in figure 13.

In considering a loudspeaker, therefore, certain vital specifications are involved — the voice coil impedance of the particular loudspeaker, the load requirements of the amplifier to which it is to be connected, the provision of an output transformer which can "match" the two and the physical size and position of the output transformer.

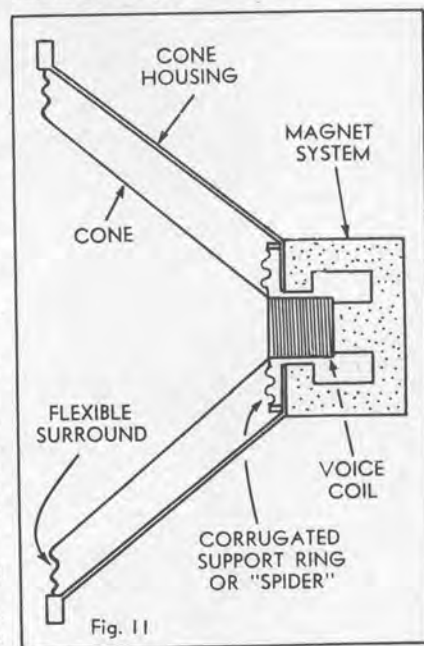


Figure 11: A dynamic (i.e. moving coil) loudspeaker, sketched in cross-section. Note the flexible support around the edge and the apex of the cone. The magnetic field surrounding the voice coil can be provided either by an electromagnet or a permanent magnet.



Figure 10: Rear view of a typical loudspeaker cone, with the voice coil cemented to its apex. Special flexible leads connect the voice coil to lugs or terminals mounted on the cone housing.

Earlier, we hinted at exceptions to the normal procedure of using an output transformer between amplifier and loudspeaker.

The exceptions fall into two general classes. The first involves a few specially designed valve amplifiers capable of feeding directly a few equally special loudspeakers having voice coil impedance of between about 400 and 800 ohms.

The second includes some transistor amplifiers capable of operating directly into voice coils of more usual values — between about 4 and 30 ohms.

As most readers will probably know already, loudspeakers vary in size from the very tiny units used in transistor

portable receivers to very large units, 12 to 18 inches in diameter, used in home hi-fi systems, electronic musical instruments, public address, theatre systems and so on.

Very tiny loudspeakers are broadly capable of doing no more than producing the limited kind of sound heard from baby transistor receivers. The potential quality rises with cone size but, from nominal 6-inch loudspeakers upwards, other characteristics, as well as mere size influence the ultimate quality of sound.

If advertisements are to be believed, there are no poor loudspeakers in this class, only good through to superb! In fact, however, quality of reproduction varies enormously and the newcomer, surveying the scene, must rely partly on independent recommendations and the general principle that quality follows price, at least in a measure.

Perhaps it should be mentioned that the majority of loudspeakers are designed for and used as full-range units; that is to say, they are fed with the full range of frequencies available from the amplifier and reproduce those frequencies to the extent of their ability to do so. Not unexpectedly, some loudspeakers are much better than others in this respect.

## FREQUENCY BANDS

Where extra cost can be tolerated, there is some advantage in splitting up the frequency range so that all the lower frequencies are handled by one speaker (say below 3,000cps) while the higher frequencies are handled by another. Or, again, three speakers may be used as a group with one handling frequencies below say 400cps, another frequencies between 400cps and 5,000cps and a third handling frequencies above 5,000cps.

Where this is done, it is usual to select loudspeakers designed to handle the appropriate range of frequencies.

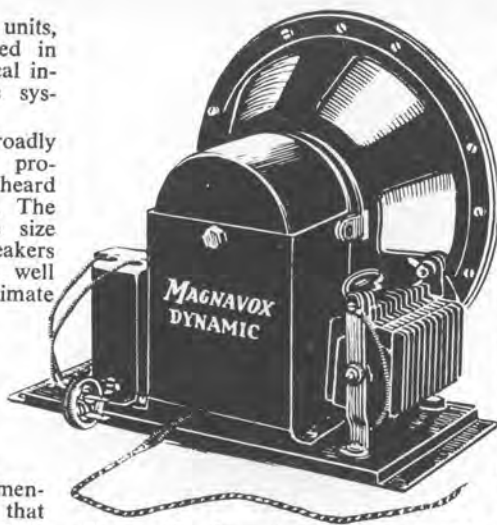
Those designed to handle only the lower frequencies are commonly referred to as "WOOFERS," while high frequency loudspeakers have acquired the name "TWEETERS." Where a MID-RANGE loudspeaker is used, it is commonly a general-purpose type, but fed only with the middle frequencies.

To divide up the signal in terms of frequency, so that it can be diverted to this loudspeaker or to that, FREQUENCY DIVIDER NETWORKS are commonly employed, involving one or more inductors and one or more capacitors interconnected with the loudspeakers. As an illustration of the use of divider networks, reference can be made to last month's article on the "Playmaster Bookshelf Loudspeaker Unit."

For proper results, a moving coil loudspeaker must be provided with some form of BAFFLE system.

When the loudspeaker cone vibrates at an audio rate, it alternatively compresses and rarifies the air adjacent to its surface, creating sound waves. These move away from the cone at the normal

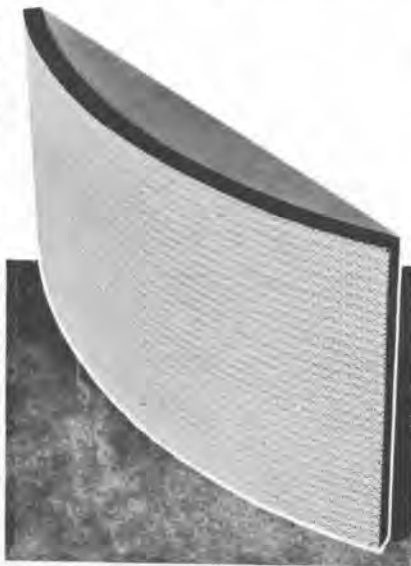
**Figure 14: An electrostatic loudspeaker. The diaphragm occupies practically the whole area behind the grille. Electrostatic tweeters are only a few inches across but dimensions of a full-range type are more likely to approximate 24 inches.**



**Figure 12: Reproduced from an old magazine, this drawing shows an early dynamic loudspeaker, with attached mains transformer and dry rectifier to energise its field coil.**



**Figure 13: A post-war 6-inch permag. loudspeaker. Magnets can now be made smaller for the same field strength, the latest being the so-called "ceramic" magnets. The loudspeaker illustrated carries its own matching transformer, presenting a load, in this case, of 7000 ohms.**



speed of sound—approximately 1,100 feet per second.

At frequencies above a few hundred cycles per second, the sound waves radiate fairly efficiently into the surrounding area, more or less as a broad beam of sound diverging from the surface of the cone. Sound is actually produced from both surfaces of the cone—front and rear—but that from the rear is liable to be obstructed by the body of the loudspeaker and whatever supports it.

However, toward the lower end of the frequency spectrum, there is an increasing tendency for air, compressed as the cone moves in either direction, simply to flow around to the other side of the cone, where there is a zone of rarefaction. Thus, instead of the loudspeaker radiating low frequency sound into the surrounding area, it tends simply to "pump" air back and forth around the periphery of the cone.

As far as the listener is concerned, the loudspeaker becomes less and less efficient as the frequency is lowered and the reproduction therefore appears to be lacking in bass.

To overcome the effect, it is necessary to limit the flow of air around the periphery of the cone and thus ensure that the low frequency pressure waves are propagated into the listening area.

The most elementary baffling method is to mount the loudspeaker over a hole cut in a flat board. The larger the board the better, since it then provides more complete isolation between the front and rear of the cone. If the loudspeaker should be mounted in a dividing wall between two rooms, the isolation may then be virtually complete.

Because neither flat baffle boards nor holes cut in a wall are a very practical solution to the problem, it is much more usual, for domestic situations, to have the loudspeaker of a radio/TV receiver or radiogram mounted in the front face of an ordinary radio or TV cabinet.

## SIZE IMPORTANT

A large cabinet provides a fair degree of baffling and ensures reasonable bass response but, as the cabinet is shrunk towards "mantel" or "portable" size, bass response tends to shrink with it. The extreme is seen in the present crop of personal portable transistor sets where the combination of a tiny loudspeaker and very little effective baffling results in reproduction which is completely lacking in bass.

While the vast majority of loudspeakers are nevertheless mounted in radio and TV cabinets of one kind or another, those interested in better quality reproduction have put an enormous amount of effort into devising baffle systems—some to give optimum bass response, irrespective of size and price, right through to the other extreme, where the prime objective is small size with bass response preserved as far as possible.

Baffle systems other than mere radio cabinets are usually dignified with the name ENCLOSURE. Loudspeaker enclosures are designed and built to a variety of patterns and given a variety of names, which we can hardly pause to list here. However, those interested can pick up some useful background from the article in last month's issue, as already mentioned, on the Playmaster Bookshelf Loudspeaker.

The discussion on loudspeakers has been confined to dynamic types and their

baffle requirements for the reason that they are, far and away, the most widely used. It must suffice merely to mention other types which the reader may encounter:

**HORN LOUDSPEAKERS.** Commonly used for outdoor public address work, these have a compact moving coil driver unit feeding into the small end of a metal horn. Speakers of this type are substantially weatherproof, highly directional and efficient over the range of "speech" frequencies, being therefore well suited to public address applications. However, restricted frequency range severely limits their usefulness for reproducing music.

**ELECTROSTATIC LOUDSPEAKERS.** These have a very thin metallic membrane adjacent to, but separated from, a metallic back plate. When audio voltages are fed between membrane and back plate, the membrane vibrates and creates sound waves. The device may be likened to a capacitor having one plate flexible enough to vibrate in the presence of applied signal voltage. Small electrostatic loudspeakers have been used frequently as "tweeters" but full-range electrostatic loudspeakers are available. The latter are highly regarded for their performance but have not, as yet, posed any significant challenge to the conventional dynamic type.

**RIBBON LOUDSPEAKERS.** These are the converse of the ribbon microphone. In the loudspeaker, a thin non-magnetic metal ribbon, usually about 3 in by 1 in, is suspended in an intense magnetic field. When signal current is passed through the ribbon, it vibrates and sets up sound waves. Ribbon loudspeakers are suitable only as tweeters and, while capable of excellent results, are expensive and rather easily damaged.

## STEREO REPRODUCTION

To this point in the chapter, it has been assumed that the total original sound is transcribed into a simple equivalent signal voltage for recording, transmission, amplification and reproduction. In short, we have assumed a "single-channel" system.

Up to a few years ago, in fact, it was scarcely necessary to consider anything else, for records, radio stations, television stations and sound motion pictures all provided single-channel sound, as a matter of course and necessity.

Sound, so reproduced, contains considerable "information" about the loudness and frequency content of the original, but no information about direction. Thus, while an orchestra may be heard as a whole, it is not possible to nominate, from the reproduced sound, the relative positions of the various instruments or instrumental groups.

This remains true, whether the original sound is picked up by one microphone or by several. Information relative to direction is lost immediately the total signal is combined into a single amplifier or recording or transmission channel.

Once "directional" information has been sacrificed there is no way in which it can genuinely be recovered. At best, it can only be subsequently contrived or faked.

However, for casual listening from radio or records, the loss of directive information does not currently seem to matter a great deal, the sound as often as not providing a mere background to other activities.

For television, single-channel sound

also appears to be adequate, because the picture, to which the sound normally relates, is itself quite small or "localised."

Films viewed in the theatre raise rather interesting questions. On the one hand it can be argued that the eye is the dominant organ and that the ear finds no difficulty in relating sound from a central loudspeaker system to action anywhere on the screen. On the other hand, motion picture interests have considered it worth their while to provide multi-channel sound to go with their wide-screen film presentations.

For readers of this course, the



**Figure 15:** Larger-than-life picture of a magnetic stereo cartridge, with its four output lugs, one pair for each signal channel. The stylus will move both laterally and vertically, though it is not wise to try to verify this by pushing at it with a fingernail. Excessive pressure may well damage the stylus suspension.

question is likely to be of greatest importance in relation to high quality reproduction of music—for music lovers—in the home.

It is certainly true that, over the years, single-channel sound has provided a great deal of pleasure to music lovers, be it at popular or classical level. This is, in no small measure, due to the knowledge and techniques of studio and recording engineers in being able to position instruments and microphones to obtain optimum balance and definition with a single-channel.

However, there is little doubt that loss of directive information is a serious one for the music lover. In a way, it can be likened to the loss of definition which results from deafness in one ear.

(Try listening for a particular sound in a noisy room, with one ear blocked off, and the reader will gain some appreciation of what it means).

## FAKE SPREAD

Enthusiasts have tried, in a variety of ways, to counter loss of directive information from single-channel sound, with a view to producing more "natural" sound. Some have favoured multiple loudspeakers or woofer/tweeter combinations with the individual units widely separated. Others have mounted speakers at oblique angles to bounce the sound from adjacent walls. Some have even preferred listening to sound from adjacent rooms, the actual source of the sound being thereby rendered less apparent.

At best, however, such measures are a palliative and no real substitute for the directive quality missing from the reproduced sound.

Audio engineers have known for 30

or more years that directive qualities could be preserved in various ways. Perhaps the most obvious way is to arrange a number of microphones in front of the orchestra, or other sound source, conveying their individual signals to as many loudspeakers placed similarly in front of the audience.

The loudspeakers virtually reconstitute the "spread" of the original sound and the listener has little difficulty in locating and concentrating attention upon individual instruments or groups.

The real problem has been to take practical advantage of this knowledge.

In terms of radio transmission, there has been no easy way to superimpose multiple signals on the one station carrier, while it has been equally impractical to allot more than one transmitter to each program—to say nothing of the need for more than one receiver in every listening room.

Similarly, there seemed no easy way to record multiple signals on the one track of a disc record—or at least not without introducing serious attendant problems.

## MAGNETIC TAPE

Magnetic tape-recording offered the first promise of a breakthrough, because there was no particular difficulty about recording a number of tracks side by side on a tape or a magnetically coated film, each track representing the signal for an individual microphone/loudspeaker link. This is the course which has been followed by the movie industry.

Despite the promise of tape, however, multiple-signal recording and playback found wide domestic application only with the successful development of discs carrying more than the conventional one signal. This development stemmed from the combination of an idea put forward by Blumlein in the early thirties, with the new microgroove techniques, and the further realisation that very convincing signal "spread" could be achieved with just two channels—left and right.

Twin-signal recordings, designed to feed loudspeakers placed one to the left and one to the right of the listener, have come to be known as STEREOPHONIC recordings, commonly abbreviated to the single word STEREO.

Stereo disc records and stereo disc record players—or STEREOGRAMS—are now commonplace, if not standard, in Australian homes.

Conventional disc recordings, carrying only the one signal, have come to be known as MONOPHONIC or simply Mono records. The term MONAURAL should be avoided in this context, since it really means "one ear."

Just as there are mono and stereo disc recordings and playing equipment, so there are mono and stereo tape recordings and players.

To all appearances, a stereo disc record looks the same as a mono record but there is a vital difference in the way in which the groove is inscribed.

In a conventional mono record, as described in the first part of this chapter, the groove deviates laterally and causes the pick-up to generate a signal when its stylus is vibrated from side to side.

For a stereo record, a special cutting head is used in which the stylus tip is driven obliquely and independently by "left" and "right" signals, fed to different driving coils. The left channel signal tends to drive the stylus tip in one direction, at 45 degrees to the surface of the record, while the right channel tends

to drive the stylus at 45 degrees in the other direction.

It is not too far from the truth to say that the left and right-hand signals appear as separate indentations on opposite walls of the V-shaped groove.

However, because the recorded signals tend to drive the cutting stylus up and down, as well as from side to side, the groove in a stereo recording varies both laterally and in depth. This is a most important point to keep in mind.

In a stereo pickup, the stylus is so mounted that it can move vertically, horizontally and obliquely to follow the groove. The generating system inside the cartridge, be it magnetic or piezo electric, is arranged to deliver two distinct output signals, corresponding to respective 45-degree movements of the stylus tip and to the original "left" and "right" channel information.

The two signals so produced are taken through two amplifiers to separate loudspeakers placed, preferably, several feet apart. To listeners seated in front of the loudspeakers, the sound appears to be spread out in a much more natural fashion than is possible from a mono system.

It is generally agreed that, for ordinary domestic listening, the loudspeakers should be about ten feet apart, while the optimum listening position is equidistant from the speakers and at a point where one is about 30 degrees to the right and the other about 30 degrees to the left.

## STEREO TECHNIQUES

Perhaps it should be mentioned that producers of stereo records follow various techniques to secure the effect they want.

Classical orchestral records are generally recorded in such a way as to produce an even spread of the orchestra across the intervening space between the loudspeakers. Some popular music is recorded this way also.

However, plenty of popular music is arranged to emphasise channel separation, so that a lead sound may issue from one speaker, and the accompaniment from the other.

It is also possible to manipulate a recording so that a soloist appears to be located close-up, midway between the loudspeakers, while the accompaniment is widely spread.

Stereo records should only be played with stereo pickups, since these can be expected to have the necessary lateral and vertical COMPLIANCE (i.e. the ability to move in a lateral or vertical direction) to follow the modulation in the stereo groove.

While a mono pickup may seem to play a stereo record and produce from it an acceptable mono signal, there is a strong chance that it will damage the groove in so doing.

However, while a mono pickup should not be used with anything but mono records, a stereo pickup can be used freely with either stereo or mono records. The vast majority of stereo cartridges are fitted with styli having a tip radius of .0006in; this is a compromise dimension capable of tracing modern stereo records as well as the older mono 33 and 45rpm discs, in which groove dimensions were not always so rigidly maintained.

Incidentally, the term "microgroove" applies equally to mono and stereo 33 and 45rpm discs, since the groove dimensions are similar and quite distinct

from the old wide groove standards used for 78rpm records.

To round off this chapter, it may be appropriate to examine the term HIGH FIDELITY, which is so much used, these days.

Originally, it was used within the audio industry and by audio enthusiasts, do describe components and systems which could provide a higher standard of reproduction than they currently accepted as "standard."

Thus, in purchasing a "high fidelity" pickup, amplifier or loudspeaker, one could reasonably expect to receive a better unit than the ordinary and cheaper item not so marked.

Infringements of this general idea certainly occurred from time to time but the industry and enthusiasts generally found it convenient to sustain it.

Naturally, the term, being a relative one, reflected the rising standards of reproduction through the years. Products that might reasonably have been regarded as "high fidelity" at a particular time would be no better than was commonplace a few years later, but this was only to be expected.

In the 1950 era, following the introduction of magnetic recording and microgroove discs, standards of musical reproduction in the home rose sharply and this seemed to provide the signal for all and sundry to attach the words "High Fidelity" to their products, relative quality notwithstanding.

To be sure, quite ordinary equipment of the post-1950 era could sound as well as earlier high fidelity equipment but the term rapidly lost its potential meaning for the public. It now appears on a large proportion of tape and record players offered for sale, and even on records of very dubious quality re-recorded from the 1930 era!

However, while the term has been rendered valueless, as far as the public is concerned, it is still used within the industry and amongst audio enthusiasts in its genuine and original sense — to describe equipment capable of better than average performance by reason of extended frequency response, minimal distortion and adequate power handling capacity. It will probably continue to be so used.

### What is the connection between high fidelity and stereophonic reproduction?

This question is not as strange as it may seem, because the terms are often confused or regarded as alternatives.

Basically, a stereophonic or multi-channel system represents another step towards more adequate sound reproduction, because it reproduces "information" which a single channel system cannot present.

Just as it is possible to have a good, bad or indifferent mono system, so is it possible to have a stereo system which is good, bad or indifferent in terms of response, distortion and power output.

### What is better ... a high fidelity mono system or an ordinary stereo system?

This question can only be answered on a personal basis but neither answer is very satisfying because both fall short of current concepts and standards. The logical objective is a system combining both stereo and high quality.

Nor is this quite as frustrating as might at first appear because, with rising equipment standards, quite ordinary stereo components compare favourably with high fidelity mono components of a past era. This observation extends even to loudspeakers, where intensive effort has produced economical, high-performance systems like the R. TV & H. "Playmaster Bookshelf" unit described in the last issue of this journal.

Based on the foregoing, it is possible to make some observations about high fidelity systems, using the word in its traditional sense and related to present standards.

**SYSTEM:** Stereo as a basic requirement.

**SIGNAL SOURCE:** Modern records or tapes, selected preferably for their quality, on the basis of published reviews.

**PICKUPS:** High quality magnetic for preference, otherwise a crystal or ceramic which, according to reviews and reputation, has better than average characteristics.

**TURNTABLE, ARM:** Ideally premium-quality components but otherwise ordinary good quality unit. Avoid "bargain" record changers, in fact any but the highest quality varieties unless there is a specific need for a changer.

**AMPLIFIER:** Twin channel, with a minimum power output of 4 watts RMS per channel. Input facilities to suit the type of pickup selected, separate bass and treble controls for preference. Better than average quality output transformers should be included (or transformerless circuitry) plus negative feedback and other design precautions to ensure minimum distortion.

**LOUDSPEAKERS:** Select highest quality types practicable according to recommendations and reviews. They should be placed about 10 feet apart in the ordinary home situation; closer spacing seriously deteriorates stereo effect.

**BAFFLE:** Essential for adequate bass response. Be guided by recommendations. Small random boxes and small open-backed cabinets are quite inadequate.

## Selectronic Components

ELECTRONIC ENGINEERS  
COIL WINDING SPECIALISTS

MANUFACTURERS AND DISTRIBUTORS OF ELECTRONIC COMPONENTS

### ASK YOUR PARTS SUPPLIER FOR:

- Aerial, R.F., Oscillator B/C & S/W
- IF Transformers
- TV Coils & Transformers
- RF Chokes, Video peaking chokes
- Unwound coil Assemblies, bases, cans
- Formers, P/C lug assemblies

- CHANNELLOCK TOOLS
- Tape recorder coils
- Electronic organ coils
- Coil lacquer, core lock, contact lube.

P.O. BOX 103, BORONIA VIC.

phone (72) 9 2233





## CHAPTER 18: Electronic servicing. Servicing as a career.

Training to be a serviceman. "Trades" courses, private study, private colleges. Avoiding the "dead end" job. Practical experience and putting training to work. Servicing in practice.

Diagnosis. Customer relations. Typical equipment. The Multimeter. Sensitivity and loading problems. The VTVM etc.

The service oscillator. The sweep generator. The cathode ray oscilloscope. The audio generator. Valve and transistor testers. Service data.

**S**ERVICING is a vitally important part of the whole electronics industry and, today, this embraces a much wider field than that of radio and television sets. Electronics, in one form or another, has invaded almost every phase of our modern life and, wherever there is a piece of electronic equipment, there is a need for someone with skill and knowledge to maintain it in proper working order.

This fact holds a promise not only of a continuity of service work, but of increasing scope.

But what is a radio—or should we say an electronic—serviceman? How does he acquire this status? What are his qualifications? How does he go about his job? What equipment does he use? These, and similar questions, are invariably asked by members of the rising generation who are seriously considering a career in electronics, and to whom servicing may have an appeal.

It is the purpose of this chapter to try to answer these questions, at least in a general way. Fairly obviously, we cannot tell you how-to-be-a-serviceman-in-one-easy-lesson; no one can hope to do that. But we can provide some useful background, which will better enable the reader to appreciate what is involved if he elects to choose such a calling.

### WISE CHOICE

For those who are seeking something other than the routine of factory mass production but who feel that, for various reasons, they cannot advance to engineering level, servicing could be a wise choice.

In spite of all the attempts to make it otherwise, a good serviceman still has to think and, if he has any liking for his job at all, there is little chance that he will stagnate technically. On the contrary, the rapid growth of electronics provides a continual challenge to move beyond the routine to more specialised—and more remunerative—fields.

How does one become a serviceman? At present, there are few, if any, hard and fast rules but, these days, anyone who shows an aptitude for the job should have little difficulty in finding employment which will provide the necessary practical training. At the same time, the would-be serviceman must be prepared to study diligently if he is really to get anywhere.

What are his qualifications?

Again, there are few hard and fast

rules, a fact which many people deplore, believing that a certain minimum standard of proficiency should be demanded before a person is allowed to offer his services to the public. Be that as it may, the truth is that, in this country, there is very little to stop almost anyone calling himself a radio/TV serviceman.

Whether he can maintain such a front is quite another matter, involving honesty, personality, business ability—and technical knowledge.

However, for his own benefit and that of future customers, the aspiring serviceman should consider nothing less than a thorough basic training at around trade-course level, plus as much practical experience as he can get. There

### THE SERVICEMAN

This chapter of the Basic Radio Course has been written, logically enough, by the The Serviceman, author of a regular monthly article in "ELECTRONICS Australia." If you want to follow this series, place an order for "ELECTRONICS Australia" with your newsagent now.

is little doubt that a good serviceman is a balanced combination of basic training and practical experience, with each aspect as important as the other.

In line with this, the would-be serviceman should have aimed, as a minimum requirement, at passing the examination at the end of three or four years of secondary school, which normally qualifies for a tertiary "trades" course, apprenticeship and so on.

The difficulty then arises as to where to go from here. For most other trades, there is an established pattern of apprenticeship and training but, because of its relatively short history, the "tradesman" pattern in the electronics industry is still very much in the formative stage.

Nevertheless, at many centres where tertiary education is available, students should be able to find courses offering a substantial content of electrical and electronic fundamentals. They may not be aimed at producing certificated electronic servicemen and they may, in fact, produce a trade qualification of a quite different type. But such qualification will be no load to carry and it will provide a very useful practical and theoretical basis from which a career in servicing can be developed.

Vocational guidance officers should be able to assist in choosing the best course at the various centres.

By and large, "trade" courses are not so onerous as to prevent the willing student from supplementing the official syllabus with parallel reading and some kind of parallel practical work.

The latter is most important if the student is to develop any tie-up between theory and practical equipment.

### PARRALLEL STUDY

Do-it-yourself projects, such as described in this journal, are one way of gaining additional experience. Linking up with a local radio club or an amateur operator are other possibilities. Occasionally, local radio dealers will offer spare-time bench work to trainees, working under supervision.

If circumstances are such as to make it impossible for a trainee to attend a Government-sponsored college, training at a private institution can be considered, with a preference to those which offer practical sessions in addition to lectures and/or correspondence.

In fact, there is something to be said for doing a private servicing course, more or less in parallel with a trades course, where the latter is only obliquely related to electronic servicing.

The vital point is for the intending serviceman to be committed to some definite course of study, involving fundamentals, which will impose upon him obligation and discipline. "Private study" can lapse all too easily, added to which the student has nothing tangible to display for his efforts, when later applying for a position.

Strangely enough, and despite all this, there are still people who believe that basic principles, or "theory" as they are inclined to disparagingly call it, is unimportant to a "practical" serviceman. In fact, the "valve jockey" so often encountered in the TV servicing field, relies for his existence on this kind of thinking.

### "DEAD END" JOBS

While service organisations can make a case for "valve jockeys" on economic grounds, this approach could pose a serious hazard for the younger would-be serviceman. While there is no valid objection to anyone starting as a "valve jockey," such a position can easily turn out to be a "dead end" job, unless the individual is encouraged to educate himself out of it.

In five years time he will still be a "valve jockey" — a somewhat more experienced one perhaps — but still working by rote to a monotonous formula, with all his advancement (if any) behind him, and in a job which, for him, holds no future.

Summing all this up, we might say that training should involve all the elementary basic theory — the nature of resistance, inductance and capacitance;

the behaviour of tuned circuits, RC networks, etc.; the operation valves and transistors and so on. On top of this should come the more practical training; how the basic theory applies to the practical circuits of radio and TV receivers or, in short, how they work.

Thus a serviceman should be able to explain, at a fair technical level, just how any section of a receiver works. And, arising out of this, he should be able to make a reasonable estimation of what would happen if a particular component failed in a particular manner. In short, he should begin to anticipate faults as his training progresses.

The other aspect of this training is practical field experience; an excellent teacher for those equipped — by study — to learn. This is where the student learns the things not found in the ordinary text book: That Blank and Co.'s model X123 TV set used a batch of vertical oscillator transformers that were unusually prone to breakdown; that poor sensitivity in a certain radio receiver is almost always due to faulty resonating capacitors in the IF transformers; or that hot humid weather and broken down crystal pickups go together.

Similarly, it does not take the astute person long to realise that most sets have weaknesses which are peculiar to them by reason either of the circuit they employ or the components they use. Knowledge of this kind helps enormously in rapid diagnosis and repair of the more routine faults.

This last statement may suggest that such an approach to diagnosis is no more than an extension of the valve jockey idea; that one simply learns what are the most likely faults in each make of set, and equips oneself to treat the set on this basis.

But there is a vital difference. The valve jockey type is "through," once he has exhausted his fund of experience. Unless he can fluke a cure on a costly trial-and-error basis, he has nothing to fall back on. He must either waste still more time or seek assistance.

## TRAINING COUNTS

The well-trained man, on the other hand, expects that he might have to search for the fault. To be sure, he will first investigate the most likely possibility, based on experience; to do otherwise would be foolish. But when he draws a blank, in terms of expected faults, that is when he really starts to work.

Knowing how this part of the set should function, he combines his basic training, his experience with voltages or waveforms normally found in this part of the circuit, and his ability to make and interpret measurements, to go over the section systematically until, inevitably, he is rewarded.

This then becomes experience on which he can draw, next time, to do a quicker job. In short, the trained man constantly adds to his own experience. The valve jockey can do so only on a very limited basis, with the additional hazard that his "knowledge" will be tainted with a good many wrong ideas.

So it is that practical experience helps to consolidate the basic training, so that the student not only learns but understands. And when he understands he is well on the way to becoming a good serviceman and a good technician, with a latent ability to tackle other tasks.

How does a serviceman go about his job?

Whether he realises it or not, every serviceman attacks each job in three stages: First he notes the symptoms; from these he diagnoses the fault; then he effects the necessary repair.

Even the valve jockey works this way. In his case, however, the symptoms noted will normally be confined to the most obvious ones, the diagnosis to nominating the section of the set at fault, and the repair to replacing the appropriate valve or valves. If this fails, he may well have to seek assistance from someone more experienced.

**This brings us to the first require-**



"He says he was trying to pull a car radio." (PF Reporter.)

ment of good servicing—the ability quickly and accurately to diagnose a fault.

Perhaps this may appear to be stating the obvious, but it is not always fully appreciated that diagnosis is usually the most difficult part of the job. Almost anyone who is handy with pliers, screwdriver and soldering iron can replace a faulty component once it is nominated, but it often takes real skill to nominate it.

The need to do the job in a reasonable time is fairly obvious; time is money in business and anyone who consistently takes longer than necessary to locate a fault will soon price himself out of the market — or starve!

Accuracy is equally important. A false diagnosis means wasted time and, while even the most experienced will go off on a false trail sometimes, the person who consistently needs several bites at the one problem will prove as costly as anyone who is too slow for any other reason.

But even more important is the question of customer satisfaction. Wrong diagnosis can involve the customer in unnecessary expense or, possibly worse, result in a fault seeming to be fixed when it is not, with consequent customer inconvenience and dissatisfaction. The latter occurs most frequently when the fault is of an intermittent or nebulous nature.

What makes a good diagnostician?

There are many things. Fairly obviously he needs adequate training, adequate experience, and adequate testing facilities. But most of all he needs an inquiring mind and an ability to reason things out for himself; an ability — and a willingness — to collate all the signs, symptoms, and history of a fault and then, from basic principles and

experience, to nominate its most likely cause.

This implies, in turn, that he has the ability to collect all these data, and this is also part of his training. Keen observation plays a large part, but he must also learn how to ask questions in a pleasant and tactful manner, and without risk of antagonising the customer.

Most "signs" can be taken in at a glance, almost automatically. They are all the things we observe about a set, other than its actual performance; whether it has suffered physical damage, whether it appears to have been tampered with, the type of aerial it uses, the presence of appliances which might cause interference, and so on.

Symptoms refer to the set's actual performance. The more accurately the serviceman observes them, the better his chances of a good diagnosis. More important, however, is the desirability of having the customer demonstrate the symptom about which he is complaining. If every serviceman made this a rule, there would be fewer cases of customers being charged for something about which they didn't complain, while the "important" fault remains uncorrected.

In practice, history is all that you can encourage a customer to tell you about the set in general, and the fault in particular. Most of it will be valueless prattle, but it is surprising how often they let drop a vital clue. And if it is one that draws attention to an obscure or intermittent fault, then it may well mean the difference between holding and losing a customer.

What equipment does a serviceman need?

As with the other aspects of servicing, there are no hard and fast rules as to what constitutes the ideal combination of test instruments. At the one extreme we have the type who used to boast — mostly before the days of TV — that he could service any set with a screwdriver. To him, the need to use even a multimeter was a sure sign of incompetence!

At the other extreme we have the type who buys—or wishes he could buy—every piece of test equipment in the catalogue. He firmly believes that if he can only acquire enough pieces of equipment he will become a top-notch

## IF WRITING—

As a result of reading this book, you may wish to write to either the advertisers or the editorial staff. If so, please note the following points carefully:

PRINT your name AND address clearly. Include the STATE and, if applicable, the COUNTRY.

When forwarding money, take all possible precautions to ensure that this is negotiable only by the person or firm for whom it is intended. Postal orders should be filled in with the name of the person or firm.

Cheques should be crossed and marked "NOT NEGOTIABLE." Where the exact charges may be in doubt, due to such variables as postage, freight, etc., cheques may be left open, but should be clearly endorsed "NOT OVER \$—," the figure usually being the next highest even amount above the anticipated price.

serviceman, lack of training and/or experience notwithstanding.

Fairly obviously, the ideal lies somewhere in between. Too little equipment makes for inefficiency and probably leads to secondary faults, and faults in the making, being overlooked.

For example: It may not be difficult for an experienced person, working on a conventional radio set, to diagnose that the reason the set failed is because the output valve has packed up. So, all that is necessary to get the set going again is to replace the output valve.

But how is he to know, without the aid of some equipment, that the HT voltage is significantly below par, probably because the rectifier is on the way out too? Detection of such a condition is something the customer has a right to expect, otherwise he is likely to find himself involved in the inconvenience and expense of another service call in only a few months' time. Such a situation does not enhance the serviceman's image in the customer's eyes.

## CAPITAL OUTLAY

At the other end of the scale, the "buy everything" type ignores two vitally important fundamental facts: that equipment alone never made a serviceman and that, in the hard world of business, every piece of equipment in the workshop will have to pay for itself in a reasonable time.

In short, what the individual finally buys in the way of test equipment will be a compromise between what he would like and what his business can afford—the latter based not so much on available cash, but on what the equipment will earn for the business.

All this simply means that some pieces of equipment are essential, some are highly desirable but not essential, and some virtual luxuries. But just where the line of demarcation occurs is a matter for individual decision. About all this article can do is discuss the more usual items in the approximate order that a serviceman might consider them.

In so doing, we would remind readers that a previous chapter (16) discussed test and measuring instruments in their own right. As such, it was able to cover many of the finer points of design which we cannot hope to cover in this chapter. It is suggested that the reader refer to this chapter for detailed explanations of the operation of measuring instruments.

## THE MULTIMETER

One piece of equipment, the worth of which no one is likely to question, is the multimeter. This is an essential item, used for tracking down a large percentage of routine faults. About the only decision needing to be made is the type to purchase.

A popular version in bygone years was based on a 0-1mA meter movement and provided 12 basic ranges; four DC voltage, four DC current, and four resistance. In addition, a rectifier provided AC voltage ranges, and an "output" version of the latter was normally provided.

Such a meter was—and still is in some cases—the favourite instrument of the serviceman. It is compact, relatively rugged, works independently of the power mains, and will cope adequately with the majority of voltage measurements in a radio and TV set. Even when something better is acquired, it still comes in for a lot of routine work.

Nevertheless, it does have limitations. When used as a voltmeter it has a sensitivity of only 1,000 ohms per volt and this can lead to serious measuring errors in certain parts of a circuit.

The sensitivity of a meter is a measure of the degree to which it loads the circuit under test or, looking at it another way, the amount of power it must take from the circuit in order to move the pointer. Whether the circuit can supply this power, without seriously altering its operating conditions, is the point to be determined when considering the suitability, or otherwise, of the meter.

The "ohms per volt" refers to the resistance of the meter—as seen by the circuit under test—relative to the full scale value of the voltage range selected. For example: In the case of a 1,000 ohms per volt meter the 10V range would have a resistance of 10,000 ohms (10K), the 50V range 50K, and so on.

This is a very practical way to express sensitivity, because it is usually fairly easy to assess the resistance of the voltage supply being measured. Provided this is significantly lower than the selected meter range, the error introduced by the meter's presence will not be serious. However, when it approaches or exceeds the meter resistance, the error will be gross.

## EXAMPLES

Typical examples are the screen and plate circuits of an ordinary resistance coupled audio stage, say a pentode with a 0.25M plate load resistor and a 1.5M screen dropping resistor. Here, the plate voltage supply has a resistance of at least 0.25M and the screen voltage supply at least 1.5M. To these could be added the resistance of the main HT supply, but this is normally small enough to be neglected.

If we attempt to measure the plate voltage, using, say, the 250V range of the meter, we find that the supply resistance of 0.25M is the same as that of the meter, and the latter will create considerable error. If we drop to the 50V range, which is not unreasonable, the meter resistance is only one fifth that of the supply resistance, and the meter reading becomes quite meaningless. It need hardly be stressed that the position is just so many times worse in the case of the screen voltage.

In practice, most servicemen overcome this problem, to a degree, by familiarising themselves with typical readings made in these circumstances, error notwithstanding. These then become the voltages one expects to read at these points if all was well. The fact the readings themselves are wrong matters little.

The AGC voltage is another having a very high resistance source, but it is also one which can reveal a lot about a set's behaviour if we can measure it accurately. Unfortunately, it is not possible to read this with even an allowable error, using the conventional 1,000 ohm per volt meter.

This limitation of the simple multimeter has been emphasised for two reasons: to provide a logical background against which the advantages of more elaborate instruments can be considered, and to introduce the idea that the presence of any test instrument—multimeter, CRO, generator, tracer etc.—can, in certain circumstances, upset the behaviour of the circuit under test. An important lesson a serviceman has to learn is to recognise such a possibility and

## MASTER ELECTRICS for METERS



KYORITSU K140 VOLT-OHM  
MILLIAMMETER

### SPECIFICATIONS

- DC Voltage
  - Range: 0-5000V (in 8 ranges)
 

0-0.25V	0-50V
0-1V	0-250V
0-2.5V	0-1000V
0-10V	0-5000V
  - Input Resistance: 20,000 ohms/V
  - Loading effect upon circuit being tested: 50μA, each range
  - Accuracy: better than ± 3% full scale
- AC Voltage
  - Range: 0-5000V (in 6 ranges)
 

0-2.5V	0-250V
0-10V	0-1000V
0-50V	0-5000V
  - Input Resistance: 5000 ohms/V
  - Loading effect upon circuit being tested: 200μA, each range
  - Accuracy: better than ± 4% full scale
- DC Current
  - Range: 0-10A (in 6 ranges)
 

0-50μA	0-100mA
0-1mA	0-500mA
0-10mA	0-10A
  - Drop in Voltage between Terminals: 0.25V
  - Accuracy: better than ± 3% full scale
- Resistance
  - Range: 0-20M ohms (in 3 ranges)
 

Full Scale At Centre Current @ 0 ohm	
Rx1 0-2K ohms	12 ohms 12mA
Rx100 0-200K ohms	1200 ohms 1.2mA
Rx10K 0-20M ohms	120K ohms 0.006mA
  - Accuracy: better than ± 3% scale length
  - Power Source: for Rx1 and Rx100 UM-1 (1½V RCA VS036); for Rx10K UM-1 and 4 pcs. of UM-3 (RCA VS034) connected in series, 7.5V in total
- Decibel:
  - Range: -20 to +50 dB
 

2.5V	-20 to +10
10V	-8 to +22
50V	+6 to +36
250V	+20 to +50
  - Standard Level: 0 dB = 1mW, 600-ohm Load
- Frequency Response:
  - Range: 10 cps to 100KC (for 2.5V, 10V and 50V)
  - Error: ± 0.5 dB

Price \$48.35

MASTER ELECTRICS PTY. LTD.  
a wholly owned subsidiary of  
Motor Spares Limited

547 Elizabeth Street, Melbourne.

Branches: Albury, Ararat, Bairnsdale, Ballarat, Benalla, Bendigo, Box Hill, Cheltenham, Clifton Hill, Colac, Dandenong, Echuca, Essendon, Footscray, Frankston, Geelong, Glenroy, Halvern, Hilldura, Sale, St. Arnaud, Dads Auto, Shepparton, Wagg, Wangaratta, Warragul.

take precautions against it. This includes selecting test instruments which are least likely to create such problems.

But to return to the multimeter. There are two broad approaches to improved sensitivity, (1) substitute a more sensitive meter movement or (2) interpose a valve or valves between the meter and the input to the instrument and use the amplification so provided to improve the sensitivity.

In the first case we may typically substitute a 100 $\mu$ A (0.1mA) or 50 $\mu$ A (.05mA) for the previous 1mA movement, giving an increase in sensitivity of 10 or 20 times respectively. (10,000 or 20,000 ohms per volt.) Either represents a very significant improvement and will cope with most measuring problems without significant error.

A further worthwhile improvement is the extension of the ohms ranges by a factor of 10 (or 20) times. Thus, where a 1mA meter will normally be limited to reading about 1M maximum resistance with a convenient size battery, a 100 $\mu$ A movement will extend this to 10M.

While such instruments were relatively expensive in the past, the position is a good deal better today. As a result they are a popular choice, either in place of or, better still, in addition to the 1,000 ohm per volt variety.

Increasing use of transistors, incidentally, has introduced another factor into the formulation of an "ideal" multimeter. Whereas valves involve voltages widely spread up to 300 or more, transistor circuits seldom operate above about 15 volts. The voltages at various points in the circuit may be quite low and, for easy testing of transistor equipment, it is an advantage if a multimeter has ranges of the order of 0-1.5V and/or 0-3V, instead of earlier practice of 0-10V as the most sensitive range.

A valuable addition to any multimeter, high sensitivity or not, is a system of protective diodes. Properly fitted, as a part of the overall instrument design, they make a meter virtually "bash proof," thus eliminating costly repairs and loss of use of an instrument.

## THE VTVM

Approach No. 2, the use of valve amplification, gives us what we call the VTVM—the "vacuum tube" or "valve" voltmeter. The VTVM normally has a constant input resistance of around 11M, regardless of the voltage range selected. This means that its sensitivity is about on a par with a 10,000 ohms per volt meter on the upper ranges (1,000V) but is many times better in the lower ranges. This makes it particularly suitable for checking the low voltage, high resistance AGC circuits.

The VTVM is a naturally protected meter, by reason of the valve operating conditions and it is also capable of measuring a very wide range of resistance values.

Its main disadvantage is the need for a power point to operate it. While not a serious problem in the workshop, it makes it less suitable for field work than the high sensitivity self-contained multimeter.

A second point is that the majority of VTVM's include only voltage and resistance ranges, with no provision for measuring current. If this has been the result of regarding them as a supplementary instrument to a regular multimeter, it has also confirmed them in this role.

Here again, transistors are likely to make their presence felt. With special transistors now becoming available, it is possible to build transistorised voltmeters having the same general performance as a valve voltmeter but without the need to connect it to a power point.

While the ability to measure voltage, resistance and, occasionally, current, will enable a serviceman to track down a good many faults, not all faults manifest themselves as a significant change in one of these characteristics. Many are a good deal more subtle and need other equipment to help track them down.



"Well don't just stand there saying 'short circuit!—lengthen it!'"

In radio servicing, the service oscillator or signal generator is one of the most used items, next to the multimeter. Although primarily intended as a means of alignment, it plays a much wider role in practice.

A good generator will deliver a signal suitable for feeding into any part of the receiver, from the speaker to the aerial terminal, at audio, intermediate, or radio frequencies, and at a known level. Using these facilities, an experienced serviceman can quickly isolate a faulty stage, whether it be completely dead or simply below standard.

Many radio servicemen use the generator as the first line of attack, using it to pinpoint the faulty stage. Then they may test the appropriate valve—often by substitution and using the generator signal as a basis for comparison—and, if this does not completely cure the trouble, attack the stage with the multimeter.

Thus the signal generator provides a quick means of isolating a faulty stage, will show up poor performance due to other causes, makes a top-notch valve tester in conjunction with a stock of known good valves, and finally provides the means to put the set into top working order. On a value for money basis it is well worth while.

In the TV field, the equivalent is the sweep generator, used in conjunction with a CRO. However, it is seldom used as an aid to diagnosis—except, perchance, when the fault lies in the tuner of IF strip—and is usually reserved for its intended role, that of alignment. This is something that the average TV serviceman avoids as far as possible; it normally involves returning the set to the service bench, and can be tricky and time consuming.

As a rule, the faulty section of a TV set is usually fairly evident from the set's behaviour, enabling the serviceman to start with the faulty area already well

defined. However, a sweep signal source may sometimes be useful when tracking down some of the more obscure faults.

Mention of the sweep generator leads naturally to its companion instrument the CRO—or cathode-ray oscilloscope. For TV servicing this is an essential item, not only as a companion to the sweep generator, but also as a test instrument in its own right. A glance at the waveforms on any manufacturer's service diagram will explain this latter point. These represent correct operating conditions and any significant departure from them generally indicates a fault.

Ideally, a CRO should be capable of displaying accurate waveforms up to about 5MC, the video bandwidth of our TV system. However, such an instrument may be too costly for the average serviceman, and some compromise is generally necessary. About the lowest figure which should be considered would be 100KC, with something around 1 to 2MC being a good deal better if it can be managed.

At one time the CRO was regarded as being of little value for radio servicing, and it is true that the average radio set seldom needs its help. However, the rapid growth of high-quality audio systems has changed the picture markedly, and anyone who hopes to service this kind of equipment will find it essential. Remember, however, that it needs some form of audio generator as a companion instrument, and one suitable for the job might cost nearly as much as the CRO.

Another service instrument is the valve tester, plus—or possibly combined with—a transistor tester. As its name implies, the valve tester provides a means of checking a valve's performance without the need to operate it in its normally associated circuit. The accuracy with which it does this varies according to the cost—and complexity—of the tester.

The simplest tester, and the type which is usually favoured by servicemen, is the emission tester. This normally provides two main tests, a shorts test to establish that there are no shorts between elements, and the emission test proper.

The shorts test usually employs a neon lamp as the indicator, with an appropriate voltage supply and the necessary switching to enable the test voltage to be applied between every element and every other element. As well as a legitimate test for the valve, it is necessary to avoid possible damage to the tester during the emission test.

The emission test, in simple terms, is a measure of the number of electrons being released by the cathode and, by means of a simple "GOOD-BAD" scale, indicates whether this is more or less than sufficient for the valve's operational requirements.

This is not a complete test, because there are several other factors which could prevent a valve from functioning correctly. On the other hand, it is the most logical single test because emission is the one characteristic of a valve which must ultimately fail.

Thus, when an emission tester says "Bad" there is little doubt that it is telling the truth. However, when it says "Good" there may still be a doubt in a small percentage of cases.

The more elaborate instruments test the valve's mutual conductance, by applying suitable voltages to all elements and testing the valve under conditions

very closely related to those it will experience in a set. It is thus a much more valid test, but suffers from the disadvantage that the tester is normally a good deal more expensive, and sometimes quite complex to set up.

### SUBSTITUTION TEST

Because of all these facts, most servicemen prefer, whenever possible, to test a valve by substituting a known good one in the receiver socket, and judging the results on performance. Performed intelligently, such a test is normally quicker and more accurate. Furthermore, since servicemen normally carry a stock of likely valves when on outside service, such valves provide a means of testing without the need to carry a bulky instrument.

This does not mean that a valve tester is redundant. One occasionally strikes an odd valve type, not available from the shelf. Then the tester can be very handy in helping to decide whether the valve is at fault and, thus, whether a new one should be ordered or not.

Again, there are occasions when the set may be in such a bad condition, due to other faults, that it is not immediately available as a test bed in which to check its own valves. In such cases it is often more convenient to be able to test the valves independently, particularly if the customer wants to know what is involved before committing himself to an expensive reconditioning job.

Very often it is the customers who use the valve tester most. Many people like to be able to test their valves when their set fails, rather than call in a serviceman right away. They reason that any valves which are faulty should be replaced anyway, and that it is time enough to call for a serviceman when this fails to cure the trouble.

While some servicemen may feel that this cuts across their own interest, others feel that it is good public relations. If a customer wants his valves tested it is usually because a set has failed. If the test reveals a dud valve he will buy a new one, on which the serviceman makes his usual profit. If it does not reveal a dud, the serviceman has a ready-made opportunity to offer his services. The same applies if a faulty valve is replaced but does not cure the fault.

Some of the above comments also apply to transistor testing, particularly those applying to the substitution test which, again is generally preferred. However, there is virtually no demand from customers to test transistors, since they normally have neither the knowledge or the means to remove these from a set.

No discussion on a serviceman's needs would be complete without mention of data sheets and service manuals. Service data, usually in booklet form, are normally made available in the first instance by the set manufacturer. However, they may be reprinted by independent organisations (by arrangement with the manufacturers) and offered as bound books or in loose-leaf form in suitable binders. In the latter case there may be an arrangement whereby the purchaser is entitled to additional or corrected pages as they are printed, to keep his file up to date.

In the days before TV there did not appear to be a great need for such data. Sets had become pretty well standardised around a four- or five-valve chassis,

using circuits which differed only in minor details. Most servicemen soon found their way around a new model, and knew pretty well what to expect in the way of voltages, etc., from past experience.

Nevertheless, those who studied these booklets generally picked up a point or two which saved valuable time later on. Often, this was nothing more than the best way to remove the chassis, how to string the dial, or details about the mechanics of the record changer, if one was used.

Similarly, some car radios were a good deal easier to handle if one was forewarned about some of the mechanical problems. And, where time is money, one should not be too proud to note what the maker has to say about a new model. Once the lesson has been learned, it will seldom be necessary to refer to the manual again. Nevertheless, it is useful to have on hand, particularly if it is a set which is not encountered very often.

With the advent of TV the need for such data became intensified. The simplest TV set is many times more complex than the most complex radio set, plus the fact that it was a brand new field for most. Even for those who had studied hard, it was impossible to keep all the data, for all the makes of set, in one's head.

At least until most newcomers got the feel of TV, the circuits, waveforms, voltage tables, etc., supplied a very real need. Also, as with the radio sets, the

mechanical data were often just as valuable as the purely electronic ones.

As might be expected, this need has slackened to some extent, due to greater familiarity with TV in general, and the committing of much such information to memory. Nevertheless, there is still a very real place in the scheme of things for the manufacturer's service manual.

A good serviceman would be wise to make sure that he acquires such a manual for every new set which appears, and keeps it handy the first couple of times he handles such a set. He may seldom need it for routine faults after that, but it can be mighty handy when a real "stinker" comes along.

Those servicemen who followed this rule when TV commenced, have a very good reason to be glad they did so. Many of the firms which mushroomed in the initial boom have long since passed from the scene, leaving a legacy of receivers for which no one is responsible except the serviceman. When substitute parts have to be provided, the data in the service manual can be very useful.

Another point worth remembering is that very few new sets are released on the market without some modifications becoming necessary after they are in the field. These may be minor, but they can often waste a lot of time if the serviceman is unfamiliar with them. The serviceman should therefore make sure that he is in a position to be advised of all such matters as soon as they are released.

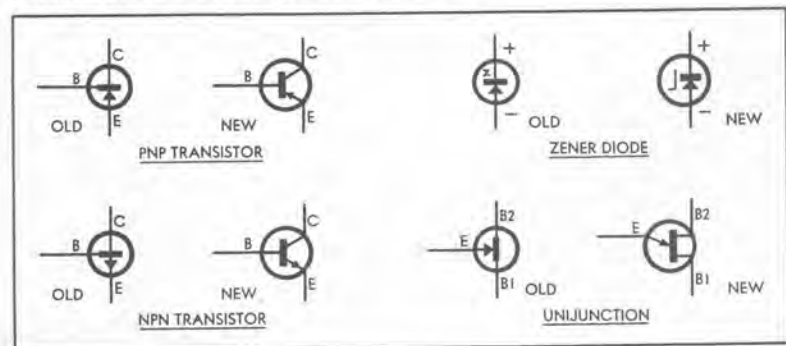
## ... about the transistor symbols

When the chapters of this book were published originally in the magazine (then "Radio, Television and Hobbies"), the semiconductor symbols in current use were those which at that time seemed likely to become international standards. Since then these symbols have fallen into disuse, and in May, 1966, "ELECTRONICS Australia" changed over to the symbols now used by a majority of journals and manufacturers.

In presenting the chapters in book form, mechanical problems have dictated that the original symbols be retained. However, in order to prevent reader confusion we present below side-by-side comparison of the new and old versions of the symbols for the most commonly encountered semiconductor devices.

For further information regarding the new symbols, readers should refer to the small article in the May 1966 issue of "ELECTRONICS Australia." In addition readers who encounter difficulty with circuit symbols as a whole might find it worthwhile to refer to the article "Radio Symbols and Circuits" published in the October, 1962, issue of "Radio, Television and Hobbies."

It may also be noted that since the original publication of the Basic Radio Course, a number of new semiconductor devices have come into use. For information regarding the operation of many of these devices, interested readers may refer to the current series of small articles entitled "Keeping Up With Semiconductors," which commenced in the August, 1966, issue of "ELECTRONICS Australia."





## CHAPTER 19: Amateur radio. History of the hobby.

What makes an amateur and what are his activities.

What are the licensing requirements.

Amateur radio clubs. Studying for the examination.

Sitting for the examination.

**T**HERE are, in the world today, some 400,000 people to whom amateur radio represents the most satisfying, most exciting of all hobbies. To these people this scientific hobby provides a means of gaining personal skill in the art of electronics and, at the same time, an opportunity to communicate with their fellow enthusiasts over their own private short-wave radio.

In this section of our course we will endeavour to give the reader some idea of just what amateur radio is and does, and discuss ways and means of obtaining the licence to operate an amateur station.

The history of amateur radio goes back a long way. In fact, Guglielmo Marconi, who astounded the world with his first experiments showing that messages could be sent between distant points without wires, liked to style himself as the first radio amateur.

Amateur radio really began, however, when private citizens saw in this new marvel a means of personal communication with others and set about learning enough of the art to construct a home-made station.

### HISTORY

The equipment of these early stations consisted of spark transmitters and simple crystal or coherer detector receivers. In those days the range of the highest powered transmitters, under the most favourable conditions, was very small, and stations were so few and far between that they frequently took, as a call sign, the name of the town or area in which they were located.

Interest in the new art grew rapidly, however, and soon there were large numbers of private and commercial stations competing for "air" space. At this stage the need for some form of control became obvious and in 1904-5 various "Wireless Telegraphy" acts were passed giving the Governments licensing control over stations and the right to allocate call signs and frequencies of operation.

Australian amateurs were given three letter call-signs prefixed by the letter X and quite a number were active in these early days. In 1910 the Wireless Institute of N.S.W. (now the Wireless Institute of Australia) was formed and it is interesting to note that this was the world's first formation of an amateur institute. Great Britain followed with the London Wireless Institute in 1913 (changed to the Radio Society of Great Britain in 1922) and American amateurs formed the American Radio Relay League in 1914.

The war of 1914-1918 brought a temporary halt to amateur activities as such, but a majority of amateurs joined the

armed forces and gave valuable service as instructors and operators. Radio was, in fact, regarded as a "secret weapon" in this war in much the same manner as radar was in the early years of World War II.

At the conclusion of World War I, radio amateurs were, quite naturally, eager to return to their hobby but Governments, notably those of America, were loath to relinquish the supreme control over all communications which they exercised in wartime. It was only the determined fight put up by amateur institutes established before the war which eventually caused the Governments to relent and allow the resumption of amateur radio activities.

From the very start, however, post-war amateur radio took on new aspects. The pressures of wartime had stimulated technical developments and there were new types of equipment available. Licensing regulations restricted amateurs to wavelengths of 200 metres and below in the mistaken belief that they would "never get out of their own backyard" on these frequencies.

Amateurs, however, adapted the newly discovered "valve" to these frequencies and they were soon covering many times the distances covered with their pre-war, lower frequency spark equipment. Contacts over 1,000, 1,500 and then 2,000 miles were made, and amateurs began

to dream of trans-Atlantic and trans-Pacific contacts.

In December, 1921, the ARRL sent a prominent amateur to Europe with the best receiving equipment then available. Tests were run on the 200 metre band and 30 American amateur stations were heard. The news greatly excited the amateur world and the following year further trans-Atlantic tests were carried out. This time no less than 315 American calls were logged by European amateurs and, what was more, one French and two British stations were heard in America. None of these tests, unfortunately, were heard in Australia.

Technically it might have been possible to span the Atlantic with a two-way contact at this time and on 200 metres but, for one reason or another, this was not achieved and amateurs began to look for another answer to their problem.

Further increases in power were out of the question since most were already at the legal limit of 1,000 watts. Better receivers didn't seem to be the answer since they already had the super-heterodyne and it didn't seem possible to make any great advances in that direction. It was at this stage that they began to wonder about the wavelengths BELOW 200 metres. Engineers had said these were useless but maybe they were wrong.

Experiments were begun on 130 and then 90 metres and it was noted that, as the wavelength decreased, the results were better. On April 22, 1923, the first signals of an American amateur station were heard in Australia. The Pacific had been spanned, one way to be sure, but it was a good start.

Finally, in November, 1923, the first



No two amateur stations are ever exactly alike but the station of G3DO, D. A. G. Edwards of Birmingham, England, is typical of many. Note the classic collection of "QSL" (confirmation) cards pinned to the walls with some encroaching on the ceiling space!

(Time allowed — 2½ hours)

NOTE: SEVEN questions only to be attempted. Credit will not be given for more than SEVEN answers. All questions carry equal marks.

1. (a) Draw a circuit diagram of a triode Class C modulated R.F. amplifier and its associated modulator. Power supply need not be shown. Explain how modulation of the carrier may be achieved.  
(b) Explain, step by step, how you would neutralise a single ended triode R.F. amplifier. Why is neutralisation necessary?
2. (a) With the aid of a suitable sketch, describe the construction and principle of operation of a moving coil (dynamic) type microphone.  
(b) Discuss the relative merits of moving coil and carbon type microphones as regards fidelity and sensitivity.
3. (a) With the aid of sketches, explain how and why the construction of an audio frequency transformer differs from that of a radio frequency transformer.  
(b) What effect does the primary/secondary turns ratio of an iron cored transformer have on the secondary:—  
(i) voltage, (ii) current and (iii) impedance?
4. (a) Draw a circuit diagram of a heterodyne frequency meter suitable for use in an amateur station and explain its theory of operation.  
(b) Explain fully how you would make a frequency measurement with the equipment described in (a).
5. (a) What is meant by the term "Dielectric Constant" in relation to a condenser?  
(b) Three condensers of 2, 3 and 6 microfarads respectively are connected in series. Calculate the total capacity of the group.  
(c) Discuss briefly the losses which may occur in a condenser.
6. (a) Explain fully the theory of grid leak bias.  
(b) Is it desirable to include some additional form of bias in a R.F. amplifier when grid leak bias is employed? Explain.
7. (a) Explain the theory of operation of a thermionic valve as a generator of oscillations.  
(b) Discuss the factors which affect the frequency stability of an oscillator of the self excited type.
8. (a) With the aid of a diagram describe a means of loading a whip aerial for a mobile transmitter.  
(b) Describe any advantages to be gained by centre loading such a whip aerial.
9. (a) What are the advantages to be gained by including a radio frequency amplifier before the mixer stage in a superheterodyne receiver?  
(b) What type of tube (triode, tetrode, pentode, etc.) would you select for the R.F. stage of a 3.5 Mc/s receiver? Give reasons for your choice.

two-way amateur communication across the Atlantic became a reality when two stations in America worked one in France for several hours, all three stations using a wavelength of 110 metres. Other stations dropped to 100 metres and found that they, too, could easily work two-way across the Atlantic.

The exciting possibilities of this discovery did not go unnoticed and soon hundreds of commercial companies were rushing stations into the 100 metre band. Chaos threatened for a while but finally the first of a series of radio conferences partitioned off various bands of frequencies for the various services clamouring for space.

Although thought, at this time, was mainly centred around 100 metres the various amateur organisations at these conferences came to the conclusion that the surface had probably only been scratched and, quite wisely, petitioned for frequencies not only at 80 metres but also at 40, 20, 10 and even down to 5 metres.

Many amateurs promptly moved to 40 metres and the band responded by enabling two-way trans-Pacific communications between America and Australia, New Zealand and South Africa. A second jump to 20 metres brought about another dream of amateur radio, daylight two-way communication over long distances.

## BROADCAST PROGRAMS

In many countries, and particularly in Australia, amateurs were the first to set up stations broadcasting program material of a type similar to that transmitted by the "broadcast band" stations we know today. The interest aroused by this amateur program material encouraged many people to either purchase or build suitable receivers and, eventually, commercial broadcasting with paid advertising became a reality.

In this, as in many other countries, the earliest commercial broadcasting set-ups developed from amateur stations but, upon doing so, they became legally divorced from the "amateur service" and came under separate licensing. Amateurs, in Australia at least, continued to broadcast musical programs until just before World War II, but they did so purely for experimental purposes and without pecuniary interest.

In the 20s and 30s, amateur radio expanded rapidly, both in technical advances and the numbers licensed to operate stations, until World War II once again brought a temporary halt to activities.

In this war some 25,000 amateurs used their skill and knowledge in the armed forces and many, on both sides, paid the supreme sacrifice in the defence of their countries.

After the war amateur radio took up where it had left off, at least initially. However, wartime pressures had produced dramatic technical advances in communications equipment and much of this equipment, now declared surplus by the various armed forces, was made available to amateur operators. Then, too, the ranks of amateur radio enthusiasts were swelled by many who had received training in communications during the war and decided to continue their interest in the art.

The technical advances in amateur equipment since World War II would make a complete article on its own but, suffice to say, the equipment used by a typical modern station would have been only a "wild dream" to a prewar

amateur. Amateurs have even produced their own satellites and, by the time this article appears, it is anticipated that a satellite capable of relaying signals in the 144MC band will be in orbit.

So far we have given a very brief history of amateur growth and, in doing so, we may have given some idea of what an amateur is and does. Perhaps, however, we should elaborate a little on this point.

The Australian P.M.G. "Handbook for Operators Of Radio Stations in the Amateur Service" provides these definitions:

**"Amateur Service" means a service of self-training, intercommunication and technical investigations carried on by amateurs, that is, by duly authorised persons interested in radio technique solely with a personal aim and without pecuniary interest.**

**"Amateur Station" means a station licensed in the Amateur Service, and used, without pecuniary interest, for the purpose of investigation or research into, or instruction in radio transmission and reception.**

From this we can see that an amateur is a person who is (a) interested in electronics with an emphasis on the transmission and reception of signals by "wireless" and, (b) owns and operates a private station for the purpose of communicating with fellow amateurs and, in doing so, furthering his knowledge of the art.

This is not to say that all amateurs are cast in the same mould, for indeed

they obtain pleasure from their chosen hobby in many and diverse ways.

Some are mainly interested in the technical aspects of their equipment and spend many hours constructing various pieces of "gear" and trying out new ideas. These amateurs might spend very little time on the air, only coming on when they have a new piece of gear to try.

Other amateurs find that, once having set up a station, their greatest interest is in operating it. They may be of a gregarious nature and enjoy long conversations (called "rag chews" in amateur parlance) with fellow amateurs on subjects of mutual interest.

Still other amateurs find pleasure in "DX'ing" (long distance working) with a view to contacting as many amateurs in as many countries as possible. Special awards are available for this and, to obtain these awards and as a confirmation of their contacts, these amateurs like to exchange "QSL" cards. An illustration of a typical QSL card sent by an overseas amateur to the author is included in this article.

Then, too, these amateurs variously interested in experimenting, operating and DX'ing can often be subdivided according to favourite bands of operation and the different modes of transmission they employ.

Some operate on one or all of the HF bands (3.5 to 28MC) while others prefer to confine their operating to the VHF bands above 52MC. A very limited band of enthusiasts confine their

activities to operation on microwave frequencies.

Amateurs are known to employ all available modes of transmission but the most popular are AM (amplitude modulation), SSB (single sideband), CW (continuous wave), RTTY (radio teletype), FM (frequency modulation) and TV (television), probably in that order, although SSB is rapidly growing in popularity and may soon become the method used by most.

Some amateurs have elaborate stations with maximum power transmitters on all bands employing several different modes of transmission and feeding into complex aerial arrays. Others are satisfied with the simplest bare minimum of equipment which, quite typically, might be stowed in a bedroom cupboard when not in use. Fortunately, for the latter amateur, the pleasure to be derived from the hobby is NOT directly proportional to the quantity and quality of the equipment owned.

Amateurs are a fraternal lot; their common interest makes them "brothers under the skin." When visiting strange towns an amateur often looks up friends with whom he has become acquainted over the air and, even if he knows no amateurs in a given vicinity, his amateur call makes him more than welcome.

Amateur radio clubs have been formed all over the world and most feature meetings with both elementary and advanced technical talks, study lessons and code classes, social contacts, and "eats."

In this country the Wireless Institute of Australia has branches in each State and are affiliated with most of the country radio clubs and the school radio clubs. The WIA keeps its members in touch with current affairs by the publication of a monthly journal and each division publishes its own monthly bulletin.

Each State has its own official station (N.S.W.—VK2WI, Vic.—VK3WI etc.) and these broadcast news to members each Sunday morning. Many of these stations are also available to intending members wishing to gain practical experience in the operation of transmitters, and most broadcast slow code transmissions on several nights of the week for those studying for the amateur licence.

The aims and objects of the WIA are to encourage and assist all persons interested in any or all aspects of amateur radio and allied techniques. Membership is divided into two grades:

Grade "A" ("Full Members")—Those who have obtained their Amateur Operators' Certificate of Proficiency or the Limited Amateur Operators' Certificate of Proficiency, and

Grade "B" ("Associate Members")—Those studying for their Certificates or who are interested in some aspect of radio science.

Honorary life membership has been bestowed on those who have rendered valuable assistance to a division or to radio science.

Apart from being a fine hobby there is always the possibility that amateur radio will lead to a lifetime career in electronics. Operators with amateur experience are several steps ahead when it comes to the operation of commercial stations because they have developed a "feel" for radio equipment.

Many of today's research scientists and engineers, men with full professional standing, can trace their careers back to an early interest in amateur radio.

# Maritim

# Mobile

S. S. AMES VICTORY

# W 2 I E V

Maritime Mobile QTH. Lat. 21 N Long. 147 W

Station VK2BK	Date 3/20/62	Time 0732GMT	RST 5 9	Band 14.1C SSB
Rcvr. NC 303	Trans. HT 32A		Ant. 21 ft Multiband Vertical	
At Sea Home QTH	124 Romain Ave.			
Pse QSL Txn	Pompton Lakes, N. J.		73, De Forest O. Romain	

WSOWC PRESS

*This "QSL" card from an American Maritime Mobile station is typical of these exchanged by amateurs all over the world. Note particularly the sender's christian name (bottom right hand corner of card). Rather appropriate for an amateur isn't it!*

Some of these men, while radio amateurs, made major contributions to the art, and there is no doubt that they, and a coming generation of amateurs, are continuing to make such contributions.

Most would-be amateurs know that they are required to sit for an examination before obtaining a transmitting licence, but not all of them realise just why this is necessary and how they can best prepare themselves for their test.

Radio communication is now essential to the navigation of thousands of ships and aircraft, not to mention international message handling and mobile communications circuits.

Co-ordination between nations on the use of the radio spectrum is therefore necessary so that there will be little mutual interference. Ships and aircraft moving between countries should also be able to communicate with control stations, weather stations, etc., with as little trouble as possible.

The way in which the frequency spectrum is split up between all these essential services, plus the amateur requirements, is decided at an international telecommunications convention at which are represented the governments of all the major countries of the world. The major amateur bodies are also invited to send representatives to these conferences with an aim to protecting their interests.

The authority which carries out the decisions of these conferences in Australia is the Postmaster-General's Department through its various Radio Branches. The department carries out in detail the local rules and administration of all radio stations in this country.

Matters such as the frequency or range of frequencies in which individual stations may operate, the allowable power level and, more to the point of this article, the minimum knowledge and skill required of the operator in order that he may operate his station efficiently and without interference to others, are decided by this authority, which acts within the framework of international agreement.

The required minimum standard is established by the Amateur Operators Certificate of Proficiency (AOCP) which is issued after the applicant has passed the appropriate P.M.G. examination.

Having obtained the certificate, it is

largely a matter of routine for the individual to obtain a station licence and be allotted a call-sign. The latter will be prefixed "VK" to indicate an Australian station, a following number to indicate the State and a final combination of two or three letters for individual identification. If you live in New South Wales you could be VK2XYZ or if in Queensland VK4XYZ.

The qualifications required to obtain the AOCP are set out in publications available from the P.M.G. radio branches.

They are:—

(1) An elementary knowledge of wireless telegraphy and wireless telephony and electrical principles.

(2) A knowledge of such of the radio communication regulations for the time being in force under the telecommunication convention and related to the operation of amateur stations.

(3) Ability to send correctly and to receive correctly by ear in Morse code, a test in plain language, including figures, at a speed of 14 words per minute.

The examination to prove these qualifications is in three sections as follows:

**SECTION K. (REGULATIONS).** A half-hour written examination consisting of one paper containing questions based on the "Handbook for Operators of Amateur Wireless Stations" issued by the P.M.G.

**SECTION L. (TELEGRAPHY).** (a) One Morse test covering the correct transmissions of text in plain language—including figures—at a speed of fourteen (14) words per minute. Sending test 2½ minutes.

(b) One Morse test covering the correct reception by ear of text in plain language—including figures—at a speed of fourteen (14) words per minute. Receiving test 5 minutes.

In both the above tests the text averages five characters to a word, each figure counting as two characters.

**SECTION M. (THEORY).** A two-and-a-half-hour written examination of one paper containing questions based on the theory of wireless telegraphy and wireless telephony as applied to amateur transmitting and receiving systems, and the elementary theory and practical applications of the principles of electricity and magnetism.

In order to gain a pass the candidate



must obtain at least 70 per cent of the total marks allotted in each section.

There is also a Limited AOCPC certificate which does not require the candidate to have passed the telegraphy tests. (Section L.)

The limitation is that transmissions must be confined to the amateur bands at 52MC and higher.

This certificate will be of interest to many who can reach the necessary standard in radio theory but who may not have the time necessary to reach the necessary standard in Morse. An unrestricted licence can always be obtained at a later date simply by passing the Morse tests.

Four examinations are held each year on the second Tuesday in January, April, July and October in the capital city of each State and also at Newcastle, Armidale, Wagga Wagga, Townsville, Rockhampton and Bendigo. When a candidate nominates the place at which he would like to take the examination, full particulars of the local arrangements are forwarded to him.

There is also provision for people living in areas away from the cities. A candidate living more than 50 miles from the nearest Radio Branch office can, provided the facilities are available, arrange to take the examination under the supervision of the Postmaster at the official post-office nearest to his home.

### EXAMINATION

Applications to sit for the examination must be made on a printed form obtainable from The Controller, Radio Branch, Fourth Floor, ICI House, 1 Nicholson Street, Melbourne, Victoria. The completed application form should also be returned to this address and must reach Melbourne on or before the 22nd day of the month before that set down for the examination.

Applications to sit for the examination will be accepted only from people 15 years of age or over and an official copy of the applicant's birth certificate plus an entrance fee of £1 must be forwarded with the completed form.

Once having passed the examination the AOCPC may be applied for and will be issued without charge when the following particulars are forwarded to the department:

Height, Colour of Eyes, Colour of Hair, Complexion and any special peculiarities. At the same time a recent head-and-shoulders photograph about 3in by 2in is required and this photograph should be autographed on the front.

Those who pass the examination before their sixteenth birthday will be required to wait until that date before the certificate is issued.

The bare outline of the requirements does not provide a very good idea of how to commence studying for the examination. One method adopted by many is to obtain copies of the previous AOCPC examination papers, free of cost, from Radio Branch offices. From the same source, at a cost of 3/, may be obtained the "Handbook for Operators of Amateur Wireless Stations" which is essential for section K (Regulations) of the examination.

To give some idea of a typical paper we publish, in this article, the theory section of the October, 1964, examination.

For the theory section of the examination the P.M.G. recommend the following textbooks: The "Radio Amateurs Handbook" (ARRL), "Radio Handbook"

by Editors and Engineers Ltd., "The Amateur Radio Handbook" (RSGB). For electrical theory they recommend "Essentials of Electricity for Radio and Television" by Slurzburg and Osterheld.

Unless you have plenty of money to spend we recommend you start with either the RSGB or the ARRL Handbooks and consider the other books as extras later on if you need them.

There is also a great deal of literature available from the valve companies at little or no cost. A typical example of this is the RCA Receiving Tube Manual which has comprehensive chapters on valve fundamentals, applications and practical circuits in addition to data on

the majority of receiving valves in use today. It is worth while having a valve data book, at least, available so that you can check theoretical points with practical valves and circuits.

The program of study you set yourself will depend on how much previous knowledge you have of the subject. There are courses leading to the amateur certificate at some of the radio colleges where you will cover the entire program in a set time. Provision is also made for regular Morse instruction so that you can progress to the required 14 wpm in both receiving and sending.

The WIA also run a complete course lasting 12 months and this may be taken

MYER'S

LONSDALE STREET

SWANSTON ST.

ELIZABETH ST.

DOWN-TOWN CAR PARK

PATRICK ST.

LT. LONSDALE ST. ← ONE WAY

208

**MAGRATH'S**  
THE CENTRE FOR YOUR  
ELECTRONIC HOBBIES NEEDS

Magrath's provide the components for projects sponsored by "Electronics Australia", Mullard "Outlook", Phillips "Miniwatt Digest", "Radiotronics", etc.

For the beginner Magrath's suggest the following items for setting up an adequate work bench —

- Soldering Irons. Both mains operated and low voltages through transformers.
- Wire strippers and cutters
- Multimeters, etc.
- Chassis Punch Kits
- Bench metal folding machine (to enable the bending of metals for all standard chassis, brackets, etc.)

*Magrath's means everything for the Electronic Hobbyist!*

**J. H. MAGRATH & Co. Pty. Ltd.**  
208 LIT. LONSDALE ST.  
(Straight through from Myers)  
Phone 32 3731

# RADIO HOUSE PTY. LTD.



## K. G. K. INTERCOM STAND PHONES.

**\$9.75 pair.**

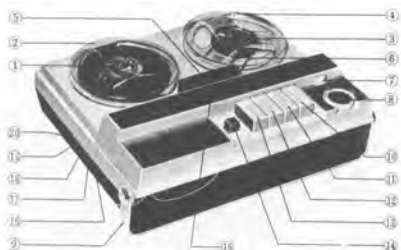
Complete with wire and batteries and instructions for installation.



## FEATURES OF THE BLACKWELL 2-STATION TRANSISTOR INTERCOM

1. Designed to stand in vertical position for convenience in handling and ease of operation.
2. Provides simultaneous conversation between any two parties.
3. The tone is clear and distortion free, assuring natural voice reproduction.
4. Installation consists of simply plugging in sockets of lead wires and adding 2 type "C" batteries for each unit.
5. Circuit is ingeniously designed to assure maximum efficiency and economy. Battery current is not drawn when intercom is not in use.

**\$23.75 pair complete**



## PORTABLE "ELECTRA" TAPE RECORDER.

Model TC 655.

**\$64.00 complete**

Battery operated (four UMI batteries) optional extra. 240 V. mains adaptor available.

- |                        |                                 |                              |                                   |
|------------------------|---------------------------------|------------------------------|-----------------------------------|
| 1. Supply reel shaft.  | 7. Zero set control knob.       | 12. Forward button.          | 17. Earphone Jack (EAR).          |
| 2. Supply reel.        | 8. Volume control knob.         | 13. Rewind button.           | 18. Auxiliary Input Jack (AUX.).  |
| 3. Take up reel shaft. | 9. Handle.                      | 14. Record button.           | 19. Microphone Jack (MIC.).       |
| 4. Take-up reel        | 10. Stop button.                | 15. Level meter.             | 20. Remote control Jack (R.E.M.). |
| 5. Head cover.         | 11. Fast forward button (F.F.). | 16. Foot switch Jack (F.S.). |                                   |
| 6. Recording tape.     |                                 |                              |                                   |



## PORTABLE TRANSISTOR TAPE RECORDER.

"Sunace" PD 401

**\$21.00 (£10/10/-)**

Postage 75c (7/6)

Complete with Mike, Battery and Tape.

either by correspondence or with practical lectures given twice weekly. The cost is quite nominal and Morse code practise is included.

By following a recognised course the student can be sure that nothing is left out and it should ensure that he does progress from week to week. There is a tendency when studying privately to imagine a thing is understood when, in fact, he has only a sketchy outline. Some students become disheartened when working alone for long periods, and it does help to have sympathetic assistance from a qualified tutor or an interested amateur.

You can become proficient at Morse by working on your own and listening to some of the WIA and other slow Morse transmissions. It is even possible to buy recordings of slow Morse for practice. There is every advantage, however, in having assistance from someone who is already proficient, particularly in the matter of sending, because you can easily develop bad habits which are hard to eliminate on your own. Wait until you have had a few weeks receiving practice before attempting to send.

## MORSE PRACTICE

Always see that you have practice in receiving Morse a little too fast for perfect copy. This is essential if you are to pick up speed. You should aim for a standard several words ahead of the required 14 words per minute, for under the stress of examinations even the best do not show their full capabilities.

If you can locate and make friends with a nearby amateur he will almost certainly help you by sending to you on the key. Use a standard PMG key, if possible, because you are sure to be examined on this type.

When sitting for the theory paper, take time out to read each question carefully and then make sure that your answer gives ALL the information the paper requests. In the typical paper we have published all 9 of the questions consist of either 2 or 3 parts and many of these parts could again be sub-divided into 2 parts.

For example; question 1 (a) asks the applicant to draw the circuit of a Class C modulated RF amplifier with its associated modulator AND explain how modulation of the carrier may be achieved. If you were to draw a perfect circuit diagram for the transmitter but omitted to explain how modulation was accomplished you could easily fail in the question.

At the same time do NOT offer information which is not specifically asked for in the question. To do so is not only time wasting but if, in offering additional information, you should make several bad errors your examiner may take it into account when marking the paper. Keep your answers brief and to the point—the examiner is not interested in your abilities as a marathon writer—only in your knowledge of the questions.

When you feel you may be ready to sit for the examination do not hesitate to do so. Even if you should fail you can sit again in three months' time and, in fact as many times as you like. Remember that the examiner is not interested in your proving yourself a genius at radio, he just wants to be sure you can build a transmitter and place it on the air without interference to others. When you have passed you will find that the pleasures of amateur radio as a hobby will make it all worth while.

# RADIO HOUSE PTY. LTD.

PHONE  
26-2817

306-308 PITT ST., SYDNEY. Also at 760 George St. and 6 Royal Arcade.



## CHAPTER 20: Industrial electronics defined.

Examples of electronics in industry. Job opportunities in industrial electronics. Photoelectric systems and devices. Induction heating. Dielectric heating. Microwave cooking. Timing sports events. Pressure transducers. Strain gauges. Other electronic gauges.

**A**N article on industrial electronics might logically begin by defining its subject; one might ask "what is industrial electronics, as distinct from other kinds of electronics, and what does the classification include?"

The first part of this question is not easy to answer, for it requires that we draw a hard line between one branch of electronics and all the others.

At one stage, industrial electronics was simply defined as "that field dealing with the noncommunication use of electronics." Nowadays, however, two-way radio and closed circuit TV have become generally accepted in industrial applications, thus making inappropriate this early definition.

Similarly, industrial electronics is once regarded as the area of applied electronics dealing primarily with the control of motors, generators, and other "heavy" equipment. Today, however, the field includes a multitude of applications involving sensitive, high precision instruments for measurement and control.

### DEFINITIONS

In actual fact, the boundaries of industrial electronics cannot be precisely defined but we can give a general definition by saying that "any electronic devices which comprise a regular part of industrial processes can be considered as constituting industrial electronics."

Industrial electronics therefore includes: (1) those applications where electronics is a major ingredient in the process; (2) those in which electronic devices serve to control a process by measurement and feedback techniques; and (3) where electronics is involved primarily in recording data about the process.

In this last paragraph we have automatically started answering the second half of our question, namely "What is included?"

We have mentioned processes in industry where electronics is an essential, functional part of the program. Some excellent examples of this are dielectric heating (heat applied to insulating materials), induction heating (heat applied to conducting materials) and microwave cooking or curing, which is related to both but mostly to the former.

Also in this category would be any process using electrolysis to separate constituents of a solution, plating done by purely electronic means without the conventional plating "bath" and, as another extreme, a printing process called xerography in which the letters

are deposited on the paper electronically by charged particles on a surface.

In the field of control we find industrial electronics employed in such diverse tasks as directing the operations of a large oil refinery, through to the simple photoelectric safety control on a punchpress which protects the operator's hands from the crushing force of the machine.

In the measurement field we find many industrial processes guided in accordance with precise data obtained electronically from transducers which measure pressure, position, density, speed, weight, temperature, size, humidity, radiation, flow, vibration and strain.

In this category we find equipment to detect pinholes in large sheets of steel, or very tiny particles of metal in boxes of baby food; counters which count every jelly bean sealed in a colourfully printed cellophane wrapper; automatic testers which accept or reject vacuum tubes, transistors, capacitors and resistors according to predetermined tolerances; radiation detectors which automatically warn of danger when the radioactivity level in a process becomes unsafe and, on the other hand, gauges for registering the level of liquid in tanks which use radioactivity as their active element.

In the examples given in the previous paragraph, measurements may well be tied in with a control system but there are other situations in which industrial electronic instruments are used pure-

*Industrial electronics plays its part in a delicate assembly operation in a controlled environment room. An industrial TV camera watches the assembly through the eyepiece of a microscope, the magnified picture being portrayed on the screen of a television monitor receiver. High accuracy can be realised with a minimum of eye fatigue. (Photo by courtesy of IBM Aust. Pty. Ltd.)*



ly for measurement and recording. Typical of these are the electronic recorders which keep a precise count of the gallons of oil in a refinery, the quarts of milk processed in dairy machines, the sensitive gauges which measure the exact amount of flour in tall storage bins, and countless other such functions.

Finally, there is a large group of electronics equipment used in industry for communication of all kinds, often in conjunction with equipment in the categories just mentioned.

For example, we may mention such applications as industrial closed circuit TV systems, which permit one man in an operating position to keep careful watch, simultaneously, over many gauges widely separated in a factory; telemetering systems which convey data over considerable distances for control, co-ordination and recording purposes; and the familiar industrial public address and music systems, special intercoms and portable, pocket-sized communicators for large warehouses.

Other examples in the communications category include alarm systems of all types and proportions, and for all kinds of purposes, from keeping out intruders to warning of fire, flooding, overheating and the presence of dangerous gases.

Industrial electronics, viewed in all its facets, is truly an enormous and rapidly expanding field, with plenty of job opportunities, particularly for those who will take the trouble to learn the basic fundamentals of the field.

Because industrial electronic equipment most frequently forms only part of a factory plant, it is not uncommon to find that personnel responsible for the maintenance of the mechanical or electrical portions of the plant will frequent-

ly be given the added responsibility of servicing the industrial electronic equipment.

Where the equipment is basically simple, these men might have little difficulty in maintaining it in operation but, for more complicated equipment, such as an induction heating plant, a specialised knowledge is required.

In such a case there would be no substitute for a formal training in industrial electronics to be added to their existing knowledge. Probably the best way to obtain this knowledge would be through the special courses in industrial electronics offered by technical colleges or a recognised correspondence school. Employers will often sponsor this extra training in one way or another.

On the other hand those who are about to embark on a career and feel that electronics might be a suitable field might give a thought to entering the world of industrial electronics. This can be a very rewarding field, both financially and in job interest, and there is no doubt of the job opportunities for suitably trained men.

Vocational guidance officers in the major training centres should be able to offer guidance in regard to job opportunities and courses available.

Although it is not possible, in an article of this nature, to give even brief details of all the equipment which might logically be classified as "industrial electronics" we can, nevertheless, outline certain typical equipment. By doing so we may perhaps aid our reader in gaining a better understanding of the field.

One of the common applications of industrial electronics is the photoelectric control of equipment. These devices can be simple or complex, depending on need, but industry will generally choose only those circuits which have very high reliability and which, for preference, will "fail safe" if they have to fail. A man's life or limb may well depend on their proper functioning.

An example of this is in the aforementioned punch-press safety control. One method of protecting a press operator is to use a mechanical safety guard which must be raised to insert parts in the press and then lowered (excluding the operator's limbs from the working area) before the press can be actuated. The guard mechanically operates a switch which is usually wired in series with the foot-pedal control of the press.

Raising and lowering this guard takes time and effort on the operator's part and the system is often subject to abuse. Operators on bonus rates frequently "jam" the safety switch so that the press can be operated with the guard up, thus increasing their operating speed and, of course, their bonus rates.

### PHOTOELECTRIC CONTROL

Industrial electronics can replace this cumbersome mechanical guard with a protective system based on the photoemissive or photoconductive cell.

The photoemissive cell consists of a glass envelope, vacuum or gas filled, and containing a cathode and an anode. The cathode is constructed from a material, usually caesium sulphide, which emits electrons when a light beam impinges on it, and these electrons are attracted to the high positive voltage applied to the anode.

Most PE cells will not pass sufficient current to operate a relay directly so that, in practice, they are used to vary the bias on the grid of a thyratron valve which, in turn, is used to operate a control relay.

The photoconductive cells are made from certain semiconductor materials which drastically change their resistance when the element is exposed to light.

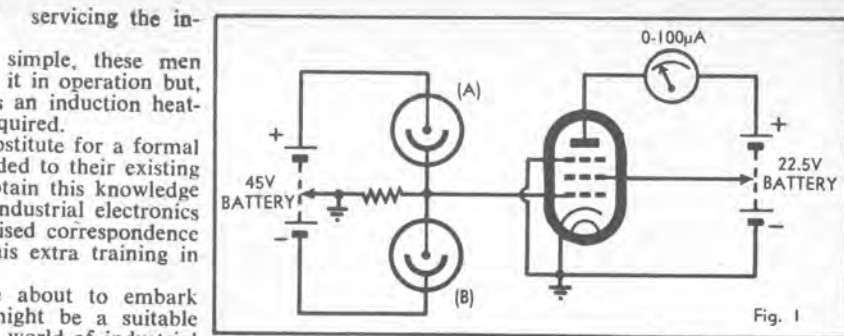


Fig. 1

Figure 1: The brightness of two surfaces can be compared, using a circuit arrangement such as this. In practice, the system might be powered from the mains rather than from batteries, while modern semiconductor counterparts might be preferred to the photoelectric cells and valve, as depicted.

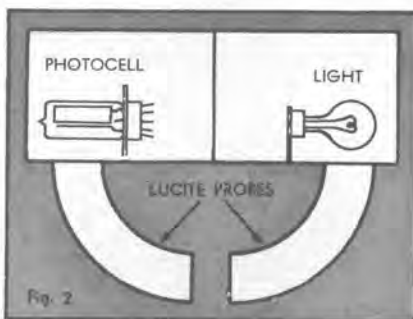


Fig. 2

Figure 2: Another example of photoelectric techniques. A device, as illustrated above, can be used to limit the quantity of liquid or granular solid in a container, by reacting to the amount of light passing between the ends of the lucite rods.

Typical materials used are germanium, silicon and cadmium sulphide. The latter has the widest range since it can respond to a wide range of radiation, from infrared up to X-rays. Some of these cells will pass sufficient current to permit direct operation of a relay but, in industrial electronics, they are mostly used to operate a control valve (or transistor) and a relay in the manner of the PE cell.

### "FOOLPROOF" SYSTEM

To provide a safety guard, the cell would be fed from a multiple path light beam so arranged that, while ever a solid object (e.g. the operator's arm) is interrupting the beam, the safety relay, and therefore the press, could not be actuated.

This system is acceptable to operators because it removes the cumbersome, mechanical safety guard and is particularly acceptable by management because it is virtually foolproof. In use, it allows a press to be run at a faster rate, thus increasing its output.

By way of example, a time study of a typical press operation showed that by removing the mechanical safety guard and substituting an electronic guard the output of the press was increased by over 20,000 parts per year, representing that number of extra operations.

Then, too, photoelectric systems are often used to guard the press itself against injury.

In many fast press operations there is an ever present risk of a part sticking on the die so that the next part is placed over the top of it and the press comes down on two parts. When this happens the die may be shattered or, even worse, the whole frame of the press may be fractured.

To guard against this a photoelectric

cell and light beam may be placed so that as each finished part leaves the die and drops into the work bin it breaks the beam and "re-arms" the press ready to punch the next part.

It can readily be appreciated that there are many other applications for photoelectric control of the type just mentioned in industrial processes, not forgetting the "blood brother" of this control which is often encountered as a door warning in shops, restaurants, garages, etc. Similarly, phototubes operated by daylight are used to turn on, automatically, plant and road lighting.

An interesting and unusual use of photoelectric circuits is in the comparison of brightness of reflectance of colours. The circuit of figure 1 is typical of those used for this purpose.

With this circuit objects of the same brightness are placed in front of each of the photocells and the earth point

## WHY NOT JOIN THE YOUTH RADIO SCHEME?

The Wireless Institute of Australia, which looks after the interests of amateur radio in Australia, conducts, as one of its educational agencies, a Youth Radio Scheme to encourage young Australians to follow radio as a hobby and to provide background for those who might ultimately enter the electronics industry after leaving school.

The activities of the Y.R.S. are based on radio clubs in schools, colleges and youth organisations. Member may obtain certificates at various grades of proficiency as evidence of their progress. Enthusiasts who do not find it possible to join a club can still participate in Y.R.S. activities through a postal group scheme.

Further information about the scheme can be obtained from the Supervisor, Youth Radio Scheme, Wireless Institute of Australia, at the following addresses: Wireless Institute Centre, Crow's Nest, N.S.W.

Box 36, P.O., East Melbourne, C2, Vic.  
Box 638-J, G.P.O., Brisbane, Qld.  
Box 1234-K, G.P.O., Adelaide S.A.  
Box 1002, G.P.O., Perth, W.A.  
Box 851-J, G.P.O., Hobart, Tasmania.

on the 45-volt battery is adjusted so that the meter reads centre zero. If we now place a standard object in front of photocell (a) and a test object in front of photocell (b), the meter will give us a reading of brightness difference between the two objects.

If need be, optical filters can be added to make the system selective in regard to colour values.

Further, the meter can be replaced with sensitive relays which are wired to operate other circuits when actuated by plus or minus differences in brightness level. The system can thus be used to accept or reject products by matching them with a standard.

A common application of this is the inspection of fruit for colour, and if colour or ripeness is an indication of grade, the fruit may be sorted into categories by two or more circuits, functioning in sequence.

Another interesting application of photocells is in flame-failure safeguards on furnaces. For this purpose the photocell (usually water jacketed to prevent overheating of the unit) looks through

from the lamp able to reach the photocell only by passing through the two lucite probes and across the gap between them.

In use, this unit is mounted on a bin wall at the level to be sensed and connected to a relay which is actuated when the level in the bin reaches or exceeds this level. Relay action can be used to provide a visual indication or to initiate either a filling or emptying operation, depending on whether the unit is mounted at the minimum or maximum level.

In cases where photoelectric control with a light beam is required over greater distances, use is often made of "modulated" light.

This is achieved by chopping the beam at a rate of several hundred times per second with a motor driven disc having a series of equally spaced holes in

Note particularly the utter simplicity of this circuit including the lack of filtering or smoothing on the DC plate supply. In communications we could not tolerate 50 cycle modulation of the generated RF, but in heating, it is of no concern. This latter accounts, by the way, for the raw sounding signal these plants will produce in your broadcast or shortwave receiver if you are unlucky enough to suffer interference from such a source.

In an induction heater the work coil, or in some cases the final tank coil of

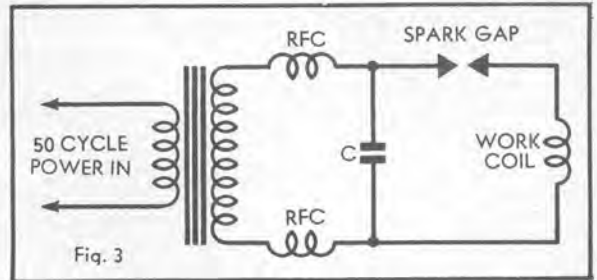


Fig. 3

Figure 3: An early type of RF induction heater, derived from spark transmitter techniques. The "work coil" must be made physically large enough to contain the item to be heated, while the RF power level at which the device operates must be sufficient to raise it to the desired temperature.

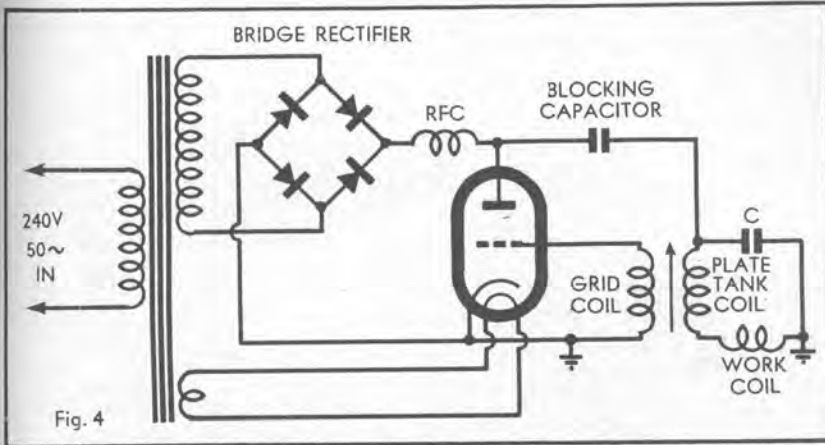


Fig. 4

Figure 4: Modern induction heaters are more akin to valve type transmitters, except that they are often supplied from AC or rectified AC, as shown, the heavy mains modulation being of no special consequence.

a hole in the furnace wall. In the event of flame loss, the circuitry operated by the photocell shuts off the fuel supply to the furnace to prevent a dangerous accumulation of unignited fuel.

The design of these units is rather cunning in that they will respond only to the flickering light of the flame and will ignore non-flickering light such as is produced by radiant parts in the furnace or the furnace walls themselves.

In most of these devices the circuitry contains a further safeguard in the form of a time delay mechanism which will not allow the fuel to be turned back on until a period of time has passed, sufficient to purge the combustion chamber of all unburnt gases. Most systems feature a warning light and bell which operate in the event of a flame failure.

Before passing on to other types of industrial electronic equipment, we might mention one further common usage of photoelectric cells. This application is in level of liquids or small solids in bins, vats, etc. The diagram of figure 2 will serve to illustrate the principle of this application.

This diagram shows a photocell and a lamp in a small box, separated from each other by a compartment down the middle of the box, and with the light

it. The photocell is fed into an amplifier with tuned circuits which will only respond to the frequency of the chopped or "modulated" light. This system also has the advantage of being relatively insensitive to daylight illumination and other extraneous light.

Induction heating is now well established as a modern industrial electronics process, but it is interesting to find that it was known in the early 1800s and was an established process shortly after the turn of this century. In other words, this kind of industrial electronics has been with us for several decades.

The earliest of these induction heaters used a circuit similar to that shown in figure 3. It consists of a power transformer, a spark gap and a tuned circuit, of which the "work coil" forms the inductor. This type of unit produces short bursts of high frequency damped oscillations and generators of this type have been made to supply up to several hundred kilowatts of RF energy.

Many of these old spark type industrial electronic heaters are still in use, but modern heaters make use of thermionic valves, usually in a simple tuned-plate-tuned-grid oscillator circuit with the work coil being part of the plate tank coil. The basic circuit of such a generator is shown in figure 4.

the RF amplifier, is made large enough to surround the part to be treated. When a metal part is placed in this coil it is subjected to intense, changing magnetic fields and these produce circulating or "eddy" currents within the metal, the metal becoming hot in the process.

At lower frequencies this heating is substantially uniform throughout the conductor but, as the frequency is increased, the material tends to heat more rapidly on the outside than on the inside.

This effect can be used to control the depth of induction heating and, in fact, with the right kind of equipment, it is possible to do what could never be done with a flame applied to the surface of a metal object — that is to accurately control the depth of surface hardening.

By specially shaping the work coil in an induction heater, it is possible to heat a piece of work to many different temperatures over and inside its mass simultaneously. It is not difficult to see the obvious advantages of this.

Also induction heating at higher frequencies, since it does not depend on natural magnetic properties in the metal itself, can be applied to any metal and, in fact, to any conductor. Thus glass, which is normally considered an insulator, becomes conducting when heated to 600 degrees F and may then be further heated by induction methods.

An induction heater is so rapid in operation that the equipment is readily adapted to conveyer-belt operation and, because of the uniform heating capabilities and the fact that induction heating is virtually pushbutton control, high-quality results can be obtained by relatively unskilled operators.

Closely allied to induction heating, but with significant differences, is dielectric heating.

In induction heating the part to be heated is placed within the turns of a

work coil which is coupled to the plate tank of the power oscillator. Induction heating works by inducing eddy currents within the part under treatment so the part must be an electrical conductor, e.g. metals.

Dielectric heating, on the other hand, is used to treat non-conducting materials or, in other words, substances normally regarded as electrical insulators. With dielectric heating the capacitor in parallel with the plate tank coil of the power oscillator is made large enough so that the part to be treated may be placed within its plates.

When a nonconductor is placed in a powerful dielectric field (as exists between the capacitor plates in an industrial heater) the electrons of the material are alternately attracted and repelled by the changing flux of the field and this produces a distortion of the orbital paths of the electrons around their parent nuclei.

## DIELECTRIC HEATING

There is a considerable mechanical energy involved in this distortion of the electron path and this mechanical energy is converted to heat energy.

This, somewhat simplified is the principle of dielectric heating. Because the heating originates at the atomic level it is uniform without the material and, depending on the strength of the field, can be extremely rapid. It follows also that, the more often we distort the electron orbit, the greater will be the amount of heat generated; thus frequency is important.

As a matter of fact, dielectric heating is ineffectual at low frequencies and very high frequencies must be used. There is a practical limit to the frequencies used for dielectric heating, but the limit is imposed by the equipment, not by the principle. This kind of RF will cook any material which is non-conducting, even hot dogs and steak, but since steak is not entirely non-conducting some other principles are involved and this will be discussed later when we get around to microwave cooking.

## ALTERS CONSIDERABLY

Dielectric heaters are mostly operated in the 27MC region, a band specially set aside for their use. Since the material being heated forms part of the dielectric of the tuning capacitor of the generator and the dielectric constant of the material alters as the material heats, it stands to reason that the frequency of the generator will alter, sometimes quite considerably.

In some of the better type, modern industrial heaters the frequency of operation is controlled by a crystal oscillator which drives the final power amplifier that is actually doing the heating job. The source of those raw sounding signals which often drift across the higher communications frequencies can usually be traced to a dielectric heater which is not crystal controlled.

Dielectric generators come in all shapes and sizes, from small machines used to seal plastic bags through to "king size" equipment designed for laminating sheets of wood or plastic. The development of this heating process is more recent than induction heating and more and more uses are being found for it every day.

One of the most recent developments in industrial heating is microwave or "radar" cooking and, included in this



*A modern microwave heating oven by Raytheon, marketed in Australia by Hawker de Havilland Pty. Ltd. It can raise pre-cooked, frozen foods to serving temperature in about 20 seconds, without causing the loss of texture and flavour familiar with other methods.*



*Electronics in sport. At the Crystal Palace Recreation Centre in England, electronic equipment starts and times races to split-second accuracy and stops a swimmer who fails to touch on a turn.*

article, is a photograph of a "Radarange" which is now available in this country. Housewives may be interested to learn that a domestic version of this range will soon be available at a price which will, reputedly, be competitive with contemporary ovens of more conventional heating methods.

A microwave cooker usually consists of a magnetron which develops considerable RF power at approximately 2,400MC and this is fed into an oven through a waveguide which has a rotating vane in front of it. The rotating vane ensures that the microwave energy is evenly distributed throughout the oven.

The cooking potential of microwaves was accidentally discovered by Dr P. L. Spencer, of the American Raytheon Company. While testing some magnetrons for radar applications, Dr

Spencer felt a chocolate melt in his pocket and was prompted to investigate.

It was discovered that microwaves striking objects reacted in three ways. Metal objects gave almost total reflection of the microwaves, and this is the principle on which radar equipment is based. Good insulators, such as ceramic, glass, paper, etc., were "neutral" with the microwaves passing right through them without effect. Food and substances containing moisture absorbed the microwave energy and became hot, rapidly, uniformly, and in very much the same manner as a dielectric heater effects non-conducting materials.

There is, at the moment, some lack of agreement on the exact manner in which microwaves heat foodstuffs. Some authorities claim that it is a combination of induction and dielectric heating, with the induction process working on those portions of the food which are conductors and the dielectric method heating those portions of the food, such as fats, which are insulators.

Other authorities feel that some sort of "resonance" in the foodstuffs may be the factor responsible for the heating but, for ourselves, we are inclined to believe that it is dielectric heating with the big difference in dielectric constants (at the frequency involved) between the food and the plate on which it is placed

being responsible for the food heating and the plate remaining cool in the oven.

Whatever the cause, however, it is obvious that microwave cooking is here to stay and that it must eventually produce some big changes in professional and domestic kitchens. And, more to the point of this article, it is obvious that this rapidly growing field must produce demands for technicians who can understand and service the new equipment.

Although a microwave oven can cook a complete meal in less than 20 seconds, its greatest application is not the actual cooking, but in the "reconstituting" of food cooked by conventional means. Numerous studies have been conducted on such things as moisture, palatability, vitamin content and loss from evaporation and drippings and all indicate that,

apart from the speed of the cooking time, the conventional method is still the best way to cook food.

In a restaurant or hospital, however, food may be prepared (by conventional means) during slack or off-peak periods and then frozen and stored until there is a demand for it. It can then be reheated in seconds by the microwave oven and with no loss of food value or flavour.

Such an operation spreads the work load over the whole day. This results in a more efficient use of labour, and the more rapid service permits a quicker turnover of customers.

A rather off-beat example of the new fields which industrial electronics are invading is shown in our illustration of a new automatic starting and timing mechanism for competitive swimming events.

## SPORTS TIMING

This equipment is installed at the racing pool of the new Crystal Palace National Recreation Centre in London. Timing is initiated at the instant an audible signal is given from inside the starting blocks so that swimmers receive the signal simultaneously. At the same time the starting block is made to vibrate so that even the time delay of the sound reaching the competitors' ears is eliminated.

Rubber enclosed pads on the waterline at both ends of the pool contain contacts to register that the swimmer has reached one end or the other, and signals from these pads can be interlocked with the starting blocks for relay races.

The timing equipment in this setup is based around a 1MC crystal standard and this is coupled to automatic readout equipment which gives times, order of finish and any disqualifications. In the event of a disqualification a signal is automatically given to recall the swimmers and drop the disqualification rope into the pool.

Much of industrial electronics is associated with the measurements of physical phenomena occurring during the operation of an industrial process. Factors such as heat, pressure, vibration, strain, etc., must be converted from a physical factor into an electrical signal and, to accomplish this, a device known as a "transducer" is used.

Although these devices range from simple to highly sophisticated types, they all operate on well known physical principles. To conclude this section of our

## TELEVISION

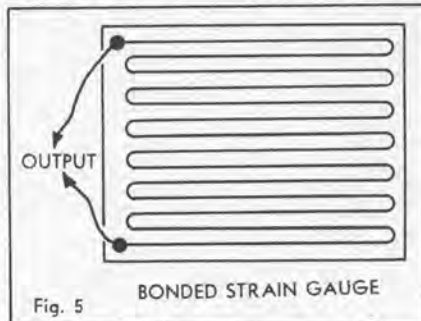
A notable omission from this course is a section on television. It had been our intention to publish special chapters on the subject in the original series, but circumstances conspired to make it impractical. We may be able to compensate by publishing companion material at a future date in "ELECTRONICS Australia" but felt that it would be unrealistic to hold up this present printing until it could be written and prepared. In the meantime, there should be plenty to occupy your attention in the material which is presented!

course we might examine a few typical transducers with a view to finding out how they work and how they are used.

Many industrial processes use pressure in some phase, whether this is liquid, gas, steam or simply air. Probably the earliest forms of pressure transducers are based on the simple Bourdon tube (a spirally wound tube which tries to unwind itself when we increase the pressure inside it) and the familiar aneroid barometer, which is a simple chamber having one wall in the form of a bellows which expands outwards when the pressure in the chamber increases.

In their simplest form these devices might mechanically operate a pointer which directly reads pressure but if the pointer is replaced with a potentiometer having a DC voltage applied to the ends, the wiping arm of the potentiometer will give a varying DC potential proportional to the motions of the chamber or tube.

This DC potential may be used to operate a moving coil or digital voltmeter for direct readout of pressure. The



Our illustration shows the basically simple form a "bonded" strain gauge might take. In many applications, these gauges are often considered expendable.

advantage of this type of transducer over the purely mechanical form of instrument is that its output, being in the form of an electrical signal, may be conveniently monitored at a point remote from the transducer.

It has the additional advantage that its electrical output may be used to operate, usually through a valve amplifier, relays which control the industrial processes associated with the pressure being monitored.

Another very common form of pressure transducer makes use of rochelle salts or ceramic crystals. These materials exhibit "piezoelectric" properties, that is to say, they will produce electrical signals when acted upon by a mechanical force and, conversely, they will be mechanically deformed when subjected to an electrical signal. It is the former property which is used in the case of a pressure transducer.

Piezoelectric transducers usually consist of a small chamber with a diaphragm at one end which is mechanically fixed to the crystal, the crystal itself being fixed to the walls of the chamber. For use in instrumentation circuits ceramic materials, such as barium titanate, are generally preferred to the natural crystalline substances because they are not as susceptible to changes in temperature and humidity. They offer high output, excellent frequency response, practically no phase shift, and small

compact construction.

In industry there are many instances where a measure of the thickening, bending or twisting of a metal bar may be required. A typical example of this would be the testing of an aircraft frame where the whole structure would be subjected to stresses, perhaps far in excess of those it might normally encounter, and a measure of the strain at various positions on the frame would be required.

For this purpose a "bonded strain gauge" of the type illustrated in figure 5 would be used. Of all the transducers used in industry, this is probably the simplest and yet it is most effective in terms of what it can reveal.

It consists, essentially, of some extremely fine wire which is formed into a "grid" shape and then cemented to a thin piece of insulating material. In use, this whole unit is cemented to the structural member on which it is desired to measure strain.

When the member to which the gauge is attached deforms even slightly, the wire in the grid will be slightly elongated and, if we add together all the bits of lengthening of all the sections in the grid, it amounts to quite a substantial total lengthening of the wire in the grid.

Since the resistance of the wire is proportional to its length and to its cross section, a slight elongation of the member can change the resistance of such a fine wire by quite a measurable amount.

## STRAIN GAUGES

Strain gauges of this type are usually placed in one leg of a bridge circuit which is fed with audio voltage so that the signal output is easy to separate from the noise and amplify in a tuned amplifier.

In a typical airframe testing several hundred of these gauges might be cemented to strategic points on the frame and their output recorded on suitable instruments as the frame undergoes stress testing.

Transducers that employ a change in capacitance to indicate some mechanical function are commonly employed in industrial instrumentation.

A typical example of this is in the measurement of deviations from true centre (runout) on the shaft of a rotating device. For this purpose a small metal plate would be placed near the rotating shaft and the plate and shaft connected as a capacitor across the coil in an oscillator set to run at around 15MC.

Any deviation in the spacing between plate and shaft would result in a change of the oscillator frequency and, with the use of a suitable demodulator circuit, this FM signal can be converted into an analog output voltage.

Probes of this type can indicate differences of a few microinches and, since they have excellent frequency response, they are most useful in dynamic tests of the type mentioned. They can also be used, with suitable modifications of the probe, in static tests, usually in the form of an "electronic micrometer."

There are, it will be realised, many other forms of transducers used in industrial electronics which space will not permit us to list. For those with a further interest in the subject, we would suggest obtaining one of the better books on the subject or perhaps a course at one of the technical colleges or recognised correspondence schools.



## CHAPTER 21: Practical set construction.

Simple regenerative circuits. Salvaging parts from old sets.  
Types of power transformer. Resistors to control HT voltage. Alternate valve types.  
Sockets, pin connections and other valve data.  
Valve data books. Old type loudspeakers and modern substitutes. Physical layout and critical leads.  
Points about regeneration. Adjusting the coils. Coil details.

5BC3, 5AS4A, 5W4GT, 5X4G, 5Y4G.  
The first of the sets we present is "Monty," an interesting little receiver which appeared in the July 1945 issue of the magazine. "Monty" used a 6J8G valve which, at the time the article was written, was about the only triode/pentode available on the market. Today, there are a number of triode/pentodes available, many of which would probably work in this circuit with only minor changes.

AS a change from the broader discussions which have characterised the last few chapters of this course, this chapter is devoted to essentially practical things. It is particularly aimed at our younger readers who, while keen to put theory into practice and build something for themselves, are often embarrassed by the cost of new components, and must make do with what they can acquire from discarded radios, from "an older friend's junk box, or the disposals market.

We have therefore gathered together a selection of circuits from past issues which, either by design or by reason of the period from which they come, use those components most likely to be found on present day discarded chassis. With a little ingenuity, most of the major components may be used, and only a few shillings need be spent, mainly on minor components.

With simple receivers the most popular circuit arrangement is the regenerative detector (see Chapter 10) and, in this respect, all the circuits featured are

basically similar. This simplifies coil details since a single set of data can be used for all the receivers. At the end of this article will be found coil winding details for coverage from the broadcast band through to 30MC with the receivers described.

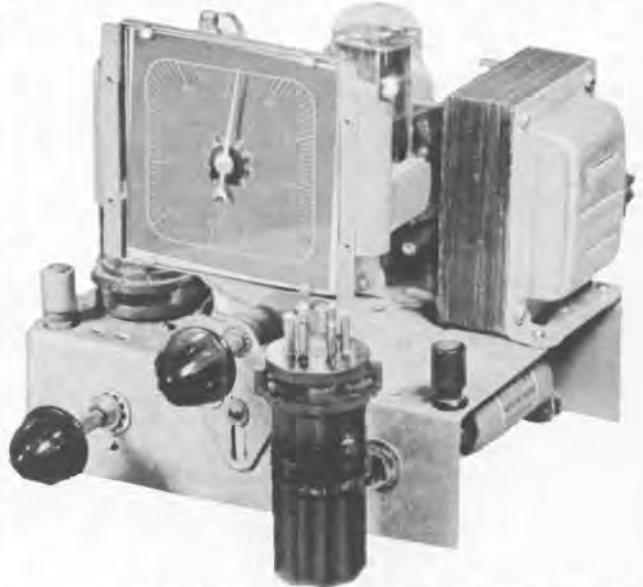
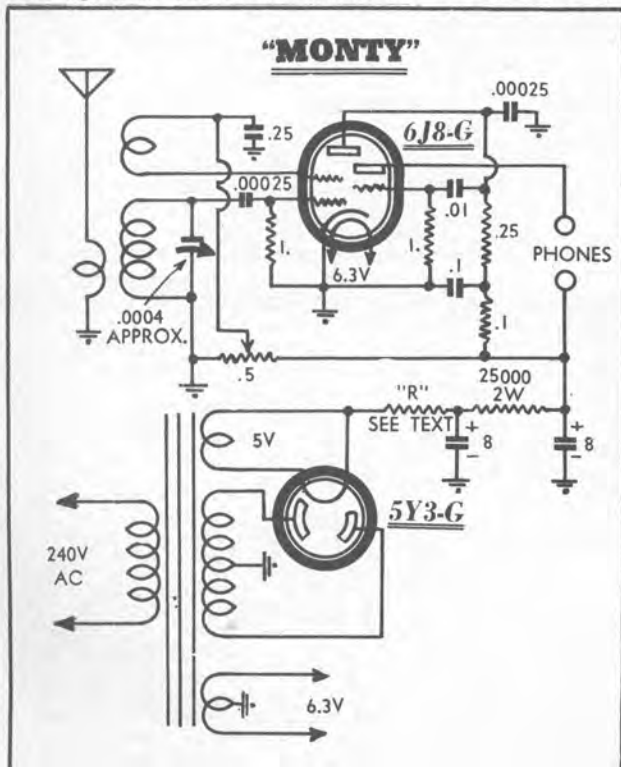
In preparing this article we are mindful of the fact that some of the power transformers shown deliver considerably less voltage than most of those used on full size receivers. To overcome this difficulty, we have included details which will allow the receivers described to use the transformers salvaged from discarded broadcast sets.

In many receivers the transformer used has only one filament winding and is used with 6X5GT and 6X4 type rectifiers. If your transformer has two or more filament windings then one can be used to power the filament of the rectifier, independently of the other valves in the receiver. In this case any of the following valves could be used as a rectifier: 80, 5Y3GT, 5Z4G, 5U4G, 5V4G, 5R4GY, 5AZ4, 5T4, 5DJ4,

Many of the disposals stores have available, at a very reasonable price, valves of the "loctal" base series. The type numbers of these valves mostly begin with the figure 7 and valve socket to suit them can often be obtained, also at a very reasonable price. The type 7J7 or 7S7 can be directly substituted for the 6J8G in our "Monty" receiver circuit.

In this respect it will be appreciated that the use of substitute valves, even where recommended for the circuit, usually presents the problem of pin numbers and socket connections. Since it is impossible for us to list all the possible variations on this theme, the reader will have to exercise a little initiative, and track down this information for himself.

In fact, we imagine most followers of the course will, by now, have acquired some valve data books or sheets (Chapter 6). If not, then this is as good a time as any to start. Such information is normally available from local valve manufacturers either gratis or for a nominal charge. However, some of the more comprehensive books, both local



Our original version of this set. While a logical arrangement with new components, it need not be followed if salvaged components can be used.

This circuit uses a 6J8 triode-pentode valve, with the pentode as the detector and the triode as an audio amplifier. It is about as simple a set as can be envisaged.



and imported, are a little more expensive, costing perhaps £1 or more. Considering the information they contain, and the value to the user for many years to come, they are well worth the cost. Two typical volumes are the "RCA Receiving Tube Manual" and "Minivox Technical Data." (See also page 71 September 1964 issue.)

Finally the matter of the power transformer. As shown, this circuit was designed for a transformer of around 150 to 200 volts (per side) but can be used with a larger transformer if a suitable resistor ("R") is included in the filter circuit. For a 250V transformer, "R" should be 2000 ohms, 1W. For 325V; 12,000 ohms, 2W. For 385V; 25,000 ohms 2W. The current drain in this case is so small that any transformer should be adequate.

## THE "MINIVOX"

Another very popular little receiver was the "Minivox" which we featured in the December 1947 issue. This receiver uses 3 valves, including the rectifier, and will give quite respectable loudspeaker volume, particularly when used on the broadcast band for local station reception.

The 6V6GT power output valve in this circuit could be replaced with the octal types 7A5, 7B5 and 7C5 and the 6SJ7GT with types 7V7, 7W7, 7L7, 7G7 and 7C7. Modern small 7 and 9 pin valves can of course be used and for this circuit we suggest a 6AU6 to replace the 6SJ7GT and a 6M5 or 6AQ5 for the 6V6GT. The 6M5 will need a cathode bias resistor of about half that needed for the other types.

If a 385V transformer is to be used a 10K-5 watt resistor should be used as in the previous circuit. A 325V transformer would need a 7.5K-5 watt resistor, and for a 250 or 225V transformer it would only be necessary to change the value of the cathode resistor on the 6V6GT to 470 ohms—all other values remaining the same.

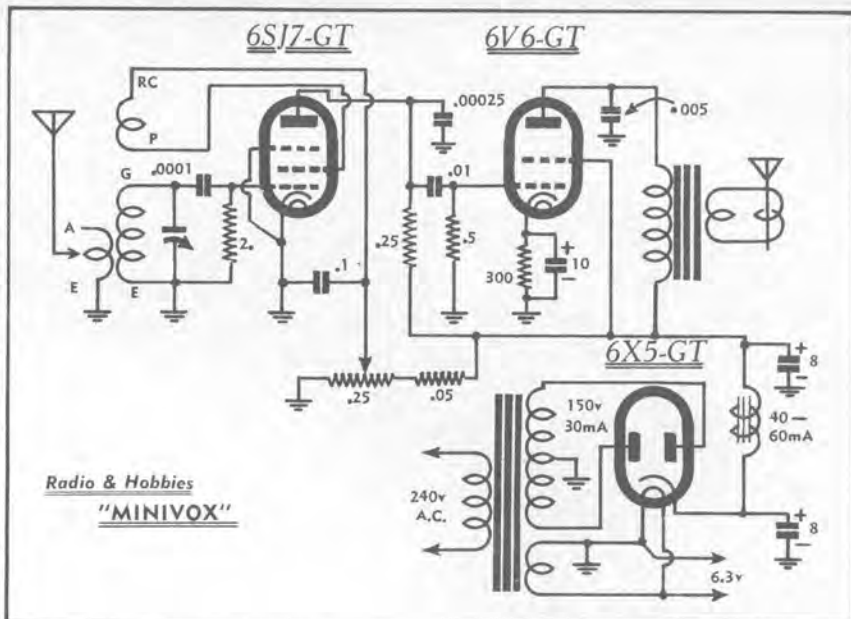
In the May 1950 issue we published our "50-Three," a small receiver which is, basically, no different from the "Minivox" except that it used the type EF50 valve. This valve is a very high gain pentode and was used by the hundreds of thousands in services equipment during the last war. We understand that these valves are still available at about eight for £1, so there is good reason to consider this particular circuit.

## POWER OUTPUT

Although it was never designed to operate as a power output valve, the EF50 gives a good account of itself in this position and will provide good speaker volume on reasonable signal levels. The 20,000/3.5 ohm speaker transformer might be a little hard to obtain these days, but transformers having a lower impedance ratio could be used with some loss of volume.

If the "50-Three" is used with a 385V transformer a 12K-5 watt dropping resistor should be used. For a 325V transformer use an 8K-5 watt resistor and for a 250V transformer use 4.7K at 3 watts.

The circuit of this receiver, in common with many others in the article, was published before "preferred values" of resistors and capacitors were established. It will, therefore, not be possible



*This set uses a conventional power output valve and so is quite capable of operating a loudspeaker in reasonable signal strength areas.*

to purchase many of the values shown on the diagrams and in this case the nearest preferred value should be used.

In the circuit of the "50-Three," for instance, a ".05" resistor (.05M or 50K—which ever way you like to look at it) would be replaced with a 47K resistor—this being the nearest, preferred value. Similarly, the .005uF capacitors would be replaced with .0047uF units, again the nearest preferred value.

The next circuit we present is that of "Little Jim," a small receiver with quite a history and a name which will bring a smile of recognition to the face of many an "old timer." There are, today, many professional radio technicians who first "cut their teeth" on the "Little Jim" circuit.

This receiver was originally featured in the very first issue of "Radio and Hobbies" (April, 1939) and such was its popularity, that it was revised, revamped and refeatured in many succeeding issues. The version we present in this article appeared in the May 1953 issue and was the last published version.

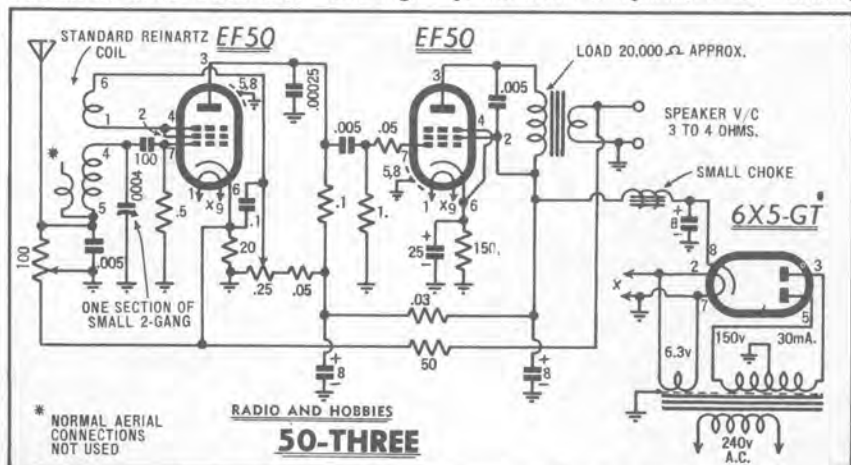
The receiver uses a twin triode valve in a regenerative detector—audio amplifier configuration and will give a good account of itself when used with high

impedance earphones. The major difference between this circuit and the three so far shown is that it uses capacitive control of regeneration in lieu of the variable resistors used in the other circuits.

If desired, disposal valves such as the 6SN7GT and 6SL7GT could be used in lieu of the 12AT7. For use with a 385V transformer the series resistor would be 25K at 2 watts and for transformers of 325, 250 and 225V the resistor would be 18K, 10K and 8K respectively. These latter resistors should have a rating of 1 watt.

The last of the circuits we present is the "Basic Three" which was featured, originally, in our November, 1958 issue. This receiver was deliberately designed to make use of any "junk box" parts which might happen to be lying around or, alternatively, it could be put together from parts salvaged from an old broadcast receiver.

The rectifier valve in this circuit can be any one of the following: 80, 5Y3 (GT), 5Z3, 5U4-G, 83V, 5V4-G and 5R4-G. The rectifiers just listed are the ones most likely to be obtained from an old style receiver. All are intended to operate from a separate 5 volt winding



*This set will also operate a loudspeaker, although the rather unconventional use of the EF50 as a power valve will limit the available power.*

on the transformer with the HT taken from one filament pin.

If you should happen to have on hand one of the more modern miniature rectifiers, such as the 6X4, 6V4, etc., they could be used provided the transformer has a 6.3 volt winding. This can supply one of the above mentioned rectifiers as well as the other valves, the HT being taken, in this case, from the rectifier's cathode pin.

### RECTIFIER SOCKET

The rectifier socket, if salvaged from an old set, will most likely be of the wafer type and must be thoroughly cleaned before using. If there are any signs of breakdown or charring between the pins, the socket should be discarded. Cleanliness is important for the rectifier socket because it is subject to a considerable voltage and, together with the speaker socket, would be the first to break down if the insulation is impaired by charring or excessive dirt and soldering flux.

If the power transformer has a 2.5 volt filament winding on it (and many of the older types have only this voltage for filament windings) then type 59 or 2A5 valves could be used as power amplifiers. If the type 59 valve is used its third grid should be connected to the cathode.

If the transformer has a 6.3 volt winding then types 6F6, 6K6 and 6V6 could be used in the putput socket. All of the above valves will work in the circuit as is and require the speaker transformer to have a primary impedance of 5,000 to 7,000 ohms.

The loudspeaker shown on the circuit diagram is, incidentally, of the "electrodynamic" type, since this is the type most likely to be found on an old radio set. If the speaker you have on hand happens to be of the "permanent magnet" type it may be used by substituting a filter choke and resistor, in series, in place of the field coil. The choke should be rated at at least 50mA and from 10 to 30H, and the resistor should be of a value to make the total value (choke plus resistor) to 2,500 ohms.

Many of the older receivers used European output valves, notably the types EL3NG, EL33, EL33A and EL33B. These valves can be used provided the transformer has a 6.3 volt filament winding but the cathode resistor would need to be changed from the 470 ohms shown on our circuit to 150 ohms. Also these valves are sometimes prone to parasitic oscillation and may require the addition of a 10K resistor between their grid and the moving arm of the volume control.

A large number of valve types can be used in the detector socket of the receiver. Among the better known types are the 24A, 78, 58, 6C6, 6D6, EF39, 6U7, 77, 6K7, 6SK7, 6S7, 6J7, and 6SJ7.

As with the output valve, they must be of a type requiring the same filament voltage as is available on the transformer and, of course, you will have to provide the right type of socket and appropriate connections to it.

All the circuits we have described call for a single section ("gang") tuning capacitor, and these are sometimes available quite cheaply from disposals and other sources. However, most old radio sets are fitted with a two gang capacitor, and there is no reason why these should not be used if they are on hand. Assuming that they are working correctly, it is simply a matter of ignoring one section.

The physical form which sets of this kind are likely to take will vary a great deal, depending on the whims of the builder, and the size and shape of the chassis, dial, power transformer, etc., which happen to be available.

Fortunately, most of the wiring in such simple sets is not unduly critical. The exception is the tuned circuit, and the leads to and between the tuning capacitor and coil should be kept as short as possible. This is most important at the higher frequencies.

The success of these simple sets is dependent almost entirely on the correct functioning and adjustment of the regenerative circuit. If the set does not regenerate it will have poor sensitivity and

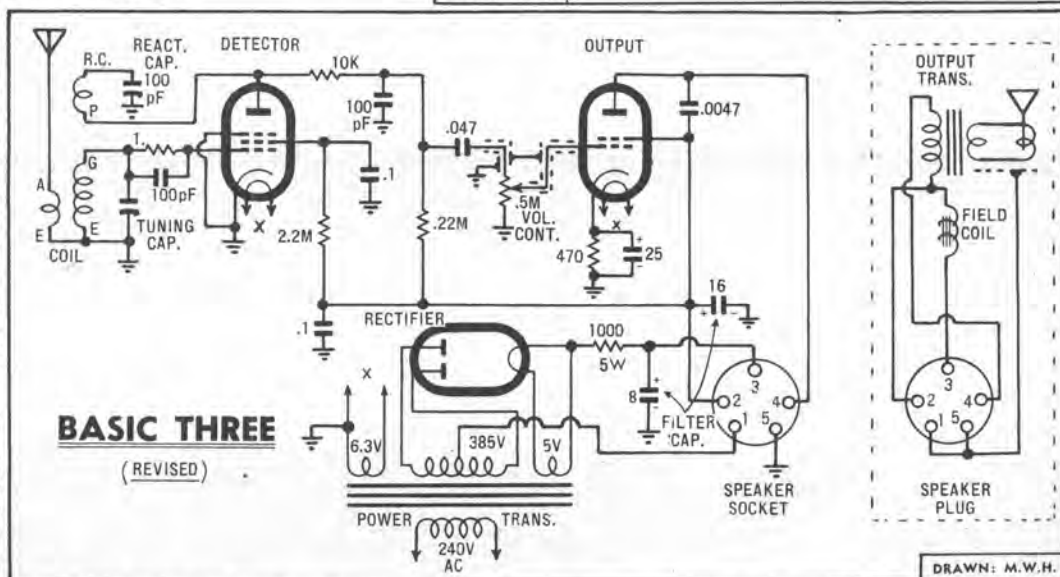
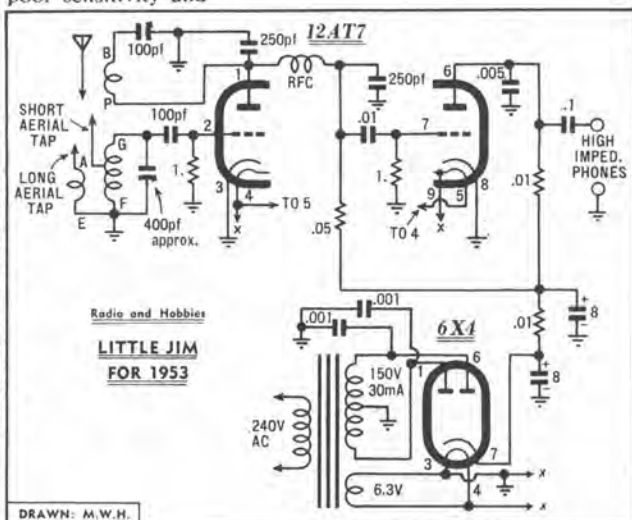
may appear not to be working if there are no strong signals around. It will also lack selectivity and, where there are strong signals present, these will swamp any weaker ones.

The regeneration must also be smooth so that it can be accurately set for best results. A set should "slide" into regeneration, never "plop" or "jump" in. It should also come out of regeneration at the same setting of the control at which it went in.

The regeneration winding on the coil has a great deal to do with this behaviour. If connected the wrong way round, the set will not regenerate at all. If too close to the secondary winding, or too large, regeneration will be fierce and difficult to control. If too far away, or too small, regeneration may not occur over part or all of the band.

Where a pentode detector valve is used, and the screen voltage is varied to control regeneration, there is a danger that the coupling between the regeneration and secondary windings may be too tight, making it necessary to reduce the screen voltage to a very low value in order to control the regeneration. This results in poor performance from the valve. If this is suspected, the coupling should be slackened until it is only just sufficient to ensure reliable operation over the band.

*Another simple set, intended for earphone operation. The twin triode is unlikely to be found in a discarded set, but should be available cheaply through disposals. The rather unusual heater connections for the 12AT7 are to operate from 6.3 volts.*



*Another design for loudspeaker operation. This set was specifically designed to use parts salvaged from an old receiver, and will work with a wide variety of valves.*

# Coil Details for Small Receivers

**DURING** past years, hundreds of small sets have been described in technical magazines for home construction and there has been a wide variation in the design of appropriate tuning coils.

The accompanying data will be found suitable for nearly all small regenerative receivers, with or without an R-F stage. Formers should be of the usual 1½ in diameter, either ribbed or plain.

Exact coil requirements for any individual set are affected by associated components and reception conditions generally, so that a little experimenting will often result in vastly improved performance.

Thus, if a receiver proves in practice to be too unselective try the effect of reducing the number of turns on the primary winding and/or increasing the spacing between primary and secondary. This improves the selectivity at the expense of the gain. Increasing the number of turns and/or the coupling has the opposite effect.

With regard to the reaction winding: If the receiver fails to oscillate toward the low frequency end of the band, it may be necessary to increase the number of turns on the reaction winding and/or to move it closer to the secondary. If the reaction cannot be controlled properly, it may be necessary to remove turns and/or move the winding away from the secondary. If the reaction does not work at all, try reversing the connections to the reaction winding.

For reasonable coverage of the broadcast band, a tuning capacitor with a maximum capacitance of from 350 to 400pF (.0004uF) is required. The use of a smaller tuning capacitor would necessitate additional sets of coils, or, alternatively, switching in a capacitor in parallel with the tuning capacitor to cover the low frequency end of each band.

Thus when using a .00025uF capacitor, the high frequency portion of each band may be covered in the normal manner. To cover the low frequency portion, switch a mica capacitor of .0001 or .00015uF directly in parallel with the tuning capacitor.

The coil details given in the table are

designed for use with a tuning capacitor with a maximum capacitance in vicinity of 400pF. The overlap is sufficient to allow for considerable variation in maximum and minimum capacitance.

All coils are wound on 1½ in diameter formers, which is the most usual size for plug-in coils. For the sake of economy, only three popular SWG gauge enamelled wires are specified. Wires of slightly different gauge and/or with different insulation could be used, but due allowance would have to be made for the different space occupied by the coils and the resultant effect upon the inductance.

It is helpful to refer to wire tables, as given in the "Radiotron Designer's Handbook" and similar texts. Thus, 32 SWG gauge enamel will be found to occupy similar winding space to 29 or 30 B & S gauge enamel, or to 32 B & S gauge DSC, and so on. Wire requiring greater winding space may make the broadcast coil too long to fit on to the former.

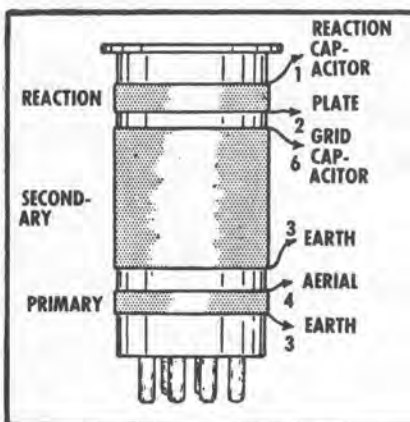
The broadcast reaction winding must use fine wire to allow the required number of turns in the small space at the grid end of the secondary.

Wire gauges for the other bands are less critical, since winding space is not a problem. However, the specification should be followed as closely as possible.

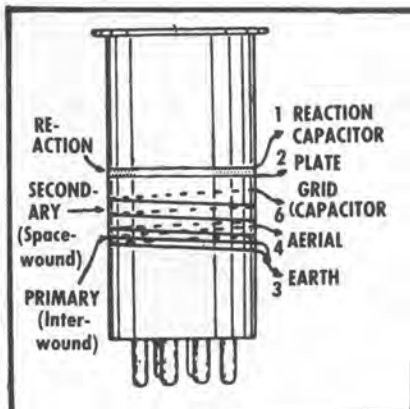
Unless otherwise stated all coils are normally wound in the same direction. The normal connections are as follows: Top of reaction winding to the "earthy" side of the circuit, bottom toward the plate or screen. Top of the secondary winding toward the grid, bottom to earth; top of the primary winding to the aerial or to plate, as the case may be, bottom to earth or to B plus.

For simple receivers having no RF stage the coil will consist of an aerial primary winding, secondary winding, and reaction winding. The arrangement of the windings on the former is shown in the accompanying diagrams, the one on the right applying to most of the lower frequency band coils and that on the left showing the general style for the higher frequency bands where space winding and interwound winding is used.

In the case of a set using an R.F. stage there will be some re-arrangement of the various windings. The aerial coil will now consist of two windings only, one wound to the "aerial primary" specification and the other to the "secondary" details. The RF coil will have three windings, wound according to the



The general style of winding for the low frequency close wound coils.



The general style of winding for high frequency coils, showing spaced winding and interwound primary.

RF primary," "secondary," and "reaction" data.

In order to ensure perfect tracking between the two stages each coil should have exactly the same inductance and any stray capacitance in either circuit will need to be balanced out by means of trimmer capacitors. Failure to match the two coils will cause poor tracking — and poor performance — at the low frequency end of the band and render it difficult or impossible to peak the trimmers at the high frequency end. Stray capacitance, if not corrected by means of trimmers, will cause poor tracking at the high frequency end of the band. (Continued on page 119).

BAND (With Trimmer)	BAND (Without Trimmer)	AERIAL PRIMARY	RF PRIMARY	SECONDARY	REACTION
1620KC to 550KC (Broadcast Band)	2MC to 570KC (Broadcast Band)	15T. 32 SWG Enam. Spaced 3/16in from earthed end of sec- ondary.	Increase to 25 turns	100T. 32 SWG Enam. Close wound	40 - 60T. 40 SWG Enam. Spaced 1/8in. from grid end of sec- ondary.
79 to 256 metres 3.85 to 1.7MC	64 to 255 metres 4.7 to 1.18MC	11T. 32 SWG Enam. Spaced 1/8in from earthed end of sec- ondary.	Increase to 15 turns	38T. 25 SWG Enam. Close wound	20 - 35T. 32 SWG Enam. Spaced 1/8in. from grid end of sec- ondary.
32 to 108 metres 9.3 to 2.8MC	26.7 to 103 metres 11.2 to 2.9MC	5T. 32 SWG Enam. Spaced 1/16in from earthed end of sec- ondary.	Increase to 8 turns	13T. 25 SWG Enam. Spaced to occupy 1/2in.	9 - 15T. 32 SWG Enam. Spaced 1/8in. from grid end of sec- ondary.
11 to 37 metres 27 to 8MC	10 to 36.6 metres 30 to 8.2MC	1T. 32 SWG Enam. Interwound from earthed end of sec- ondary.	Increase to 3 turns	4T. 25 SWG Enam. Spaced to occupy 1/2in.	4 - 6T. 32 SWG Enam. Spaced 1/8in. from grid end of sec- ondary.



## CHAPTER 22: Following last month's chapter on practical set construction, we are presenting a similar chapter this month. However, whereas last month's circuits were intended for use with components salvaged from old sets, this month's project is a new design using all new parts.

FROM the earliest days of radio, the majority of enthusiasts seem to have "cut their technical teeth" on small regenerative receivers, progressing later to bigger things. The transistor receiver described here is in true tradition, as far as general form is concerned, but the transistors and their associated circuitry can provide an effective introduction to modern techniques.

Strictly speaking, the term "regenerative" receiver can be regarded as applicable to any receiver employing the principal of regeneration (or positive feedback) anywhere in its circuitry.

However, as you will have come to appreciate, if you have followed our Basic Radio Course, it is usually taken to describe a receiver in which the detector, for maximum gain and selectivity, relies on the use of regeneration, reaction, or positive feedback. In this context, all three terms mean much the same thing.

The simplest regenerative receiver would be one using only a detector feeding, probably, a pair of headphones. Larger regenerative sets incorporate one or more stages of audio amplification after the detector and/or, less frequently, a stage of RF amplification ahead of the detector. (If further explanation is required, we would refer you, once again, to Chapter 10 of the Basic Radio Course.)

Over the years, we have described many regenerative receivers in this journal, details of some being available still through the Information Service.

Of these, circuits using battery-powered valves can be regarded as truly obsolete. Battery-type valves were never distinguished for reliability, performance or economy so that, by and large, even if you have some of these valves on hand, it is probably cheaper not to use them!

The money you might spend on batteries to power them would be better put towards buying transistors.

Regenerative receivers using mains-operated valves are in a different class, if only because they can often be built with a minimum of outlay, and with good experience, using parts salvaged from discarded receivers. That is why we presented a selection of such circuits last month.

For those who may prefer to use new parts, it is very hard to go past the kind of transistor receiver described here, with the distinct advantage that no high voltages are present, to make contact with, accidentally.

Unfortunately, we cannot pretend that building a receiver like this, using all new parts, is a very economical proposition. If the purpose is primarily to acquire a receiver to "follow the hits," it is hard to compete with the cheaper transistor sets which are so plentiful just now on the local market.

But a manufactured receiver will leave its owner as ignorant as ever of technicalities and there is much to be said for building up a small regenerative receiver, with a view to gaining experience, particularly if savings can be effec-

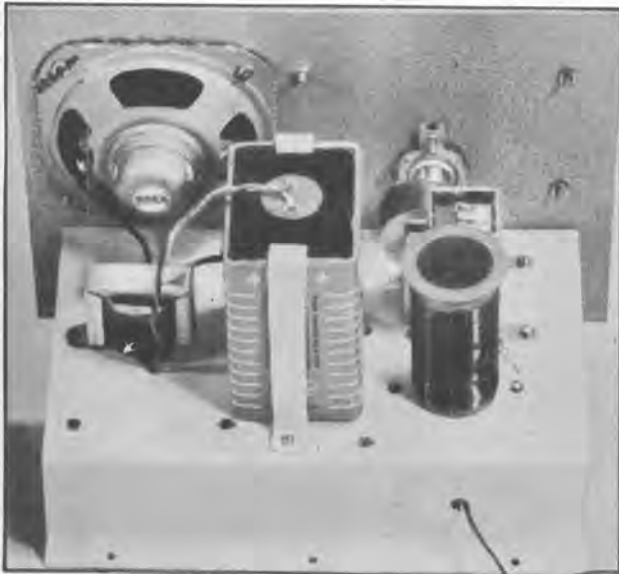
ted by judicious buying from surplus sources.

From a home-built receiver, many prospective constructors may be quite satisfied with broadcast station reception only. However, others may fancy the prospect of listening to conversations between Amateur Radio operators and tuning to overseas short-wave stations. To cater for both tastes we have made provision for plugging in different coils. If broadcast reception only is required, one coil only need be wound. Should the short-wave urge develop at a later date, additional coils may be provided.

The coil data supplied allows the receiver to tune radio signals between 500KC and 20MC. The broadcast coil gives sufficient tuning range to cover the University of N.S.W. broadcasts on 1750KC, a feature that will have some appeal for N.S.W. readers. The coils have been designed to give a small overlap in the tuning ranges, so that no portion between the abovementioned limits will be omitted.

While some may require this receiver to operate as a "mantel" set with loudspeakers, others may prefer to use headphones. Provision is made, by the use of a suitable phone jack, to cut out the speaker when earphones are plugged in. This allows the set to be operated at any time of the day or night, without disturbing other occupants of the house. Although the power output is in the vicinity of 45 milliwatts only, this can represent quite a lot of noise in a quiet situation.

Referring to the circuit diagram it will be noticed that three transistors in all are used. The first transistor is a 2N372, 2N370 or 2N371, all of which are designed for high frequency applications. This class of transistor is commonly referred to as a "drift" transistor and its use allows the detector circuit to operate efficiently to the top of the frequency range selected for our re-



Above: Front view of the complete receiver. Output may be directed to either the internal speaker or a pair of headphones. Frequency range is from 550KC to 20MC.

Left: Rear view of the receiver, showing general layout. Note the Planetary drive in front of the turning capacitor.

ceiver. An alternative detector transistor suggested in our circuit diagram is a diffused alloy transistor, AF115N, with similar properties to the drift transistor.

The circuit which selects the frequency to which the receiver is tuned comprises the plug-in coil and a variable capacitor of approximately 10-415pF. The signal from the aerial is injected into the tuned circuit via a tap on the coil in the three lower bands and separate primary winding on the highest frequency coil.

This represents a slight departure in method from that suggested for the circuits last month, but there is no special significance in this. Separate primary windings and tapings on the tuned secondary are both legitimate methods of introducing signals from the aerial.

Next comes the tuned circuit itself. To obtain maximum transfer of energy from one circuit to another it is necessary to consider their relative impedance levels. The tuned circuit exhibits a high impedance between the two ends of the coil, whereas the transistor detector has a relatively low impedance input. To obtain a good impedance match it is necessary to connect the coupling capacitor from the base of the transistor to a tap on the coil, as shown.

The base and emitter circuit of a transistor, considered alone, is not unlike a simple "crystal" diode, with its property of passing current more readily in one direction than the other. In effect, the incoming signal is rectified or "detected" by the diode action of the base-emitter junction.

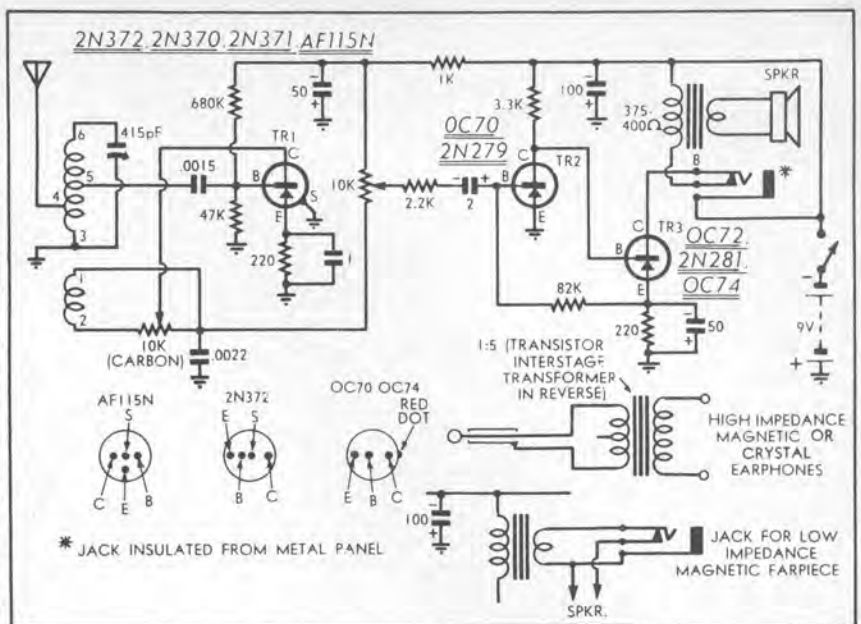
The signal currents, which are "detected" in the emitter-base circuit, also exercises an effect upon the current flowing between emitter and collector. Here amplification is evident, small signal current changes in the emitter-base circuit causing much larger current changes in the emitter-collector circuit.

This means that if we were to place a suitable headphone circuit in the return from the collector we would be able to listen to the program of the station to which the tuned circuit is set. Since the signals are amplified as well as detected, the output would exceed that obtained from a normal crystal set.

This arrangement, while practical, leaves something to be desired in terms both of gain and selectivity. Fortunately, there is a simple solution. The detector transistor, being a high-frequency drift transistor, is capable of amplifying the original RF signals quite efficiently and these appear also at the collector. This amplified RF may be used in a regeneration circuit to increase the selectivity and sensitivity of the detector circuit by a large degree.

To achieve regeneration it is necessary to couple the amplified RF back into the tuned circuit in the correct phase so that it will assist the original signal. In our circuit we achieve this feedback through a winding coupled closely to the original tuned circuit. This winding forms part of the collector circuit of the detector transistor.

A potentiometer is used in the feedback circuit to give the correct amount of regeneration. If too much feedback is used the circuit will become unstable and it is necessary to set this control very carefully for the best results. The setting will vary for different sections of the tuning range and from band to band.



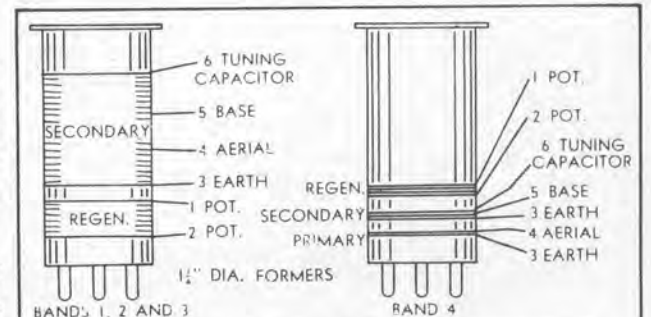
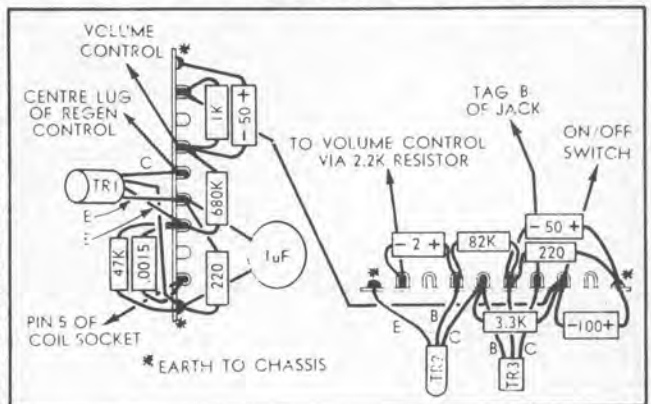
The circuit features a form of direct coupling between the audio and output stage. This also provides thermal stability for the output stage, under high ambient temperature conditions. Note also the alternative headphone output circuits.

However, our coils are designed so that sufficient regeneration can be achieved on all bands.

The audio section of the receiver consists of two transistors directly coupled. This particular circuit saves a number of components by using a simplified thermal stabilisation circuit. With this circuit the audio output will drop if the transistors are subjected to a high ambient temperature. However, this fall in output is brought about by a reduction of current flow in the output transistor circuit and the system thus "fails safe," causing no damage to the transistors.

For the second transistor in our receiver we selected an OC70 or 2N279 transistor. This transistor may be used in combination with either an OC72, 2N281 or

OC74 in the output stage. While the OC72 is not a current type we feel that there may be quite a few of these transistors in the hands of our readers. For anyone who happens to have available a TS1 and a 2N185 these may be used instead of the 2N279 and 2N281 respectively with one minor alteration. This involves replacing the 82K resistor in our circuit with a 68K resistor.



Above: Wiring diagram showing how most of the components are mounted on two tagstrips. Compare this with the photo on page 41.

Right: Coil winding data showing number of turns and method of winding for each band. These data may be modified slightly, on an experimental basis, for best results in each case.

BAND	PRIMARY	SECONDARY	TAPS	REGENERATION
BC	—	110.5	10,20,30,50	30
2-5MC	—	25.5	3,6,9,12	8
4-12MC	—	10.5	1,2,3,5	4
9-20MC	2	3.5	1.5	4

BC COIL WOUND WITH 31SWG ENAMELLED WIRE. ALL OTHERS 24SWG. NOTE THAT BAND 4 COIL HAS AN ADDITIONAL WINDING. ALL COILS ARE CLOSEWOUND IN THE SAME DIRECTION WITH WINDINGS SPACED 1/8".



# MASTER ELECTRONIC FUNDAMENTALS in all three phases . . .

**THEORY:** Electronic theory is gained through articles described in our magazine "Transistor Kits" (20 cents), devoted entirely to transistor circuit theory, repairs, ideas and projects. Radios, switches, amplifiers, relays, logic circuits and power supplies are all featured; Also available, for your help, are programmed courses in three separate volumes on 1, 2 and 3 transistor modules (\$2.00 each). These contain full explanations and practical descriptions of circuit theory and practical construction. And for wider knowledge, two authoritative books from RCA's "Home Study Course"— Basic Electronics (\$15.00) and Fundamentals of Transistors (\$11.30).

**PRACTICE:** This is obtained from our monthly magazine "Transistor Kits" (20 cents) which contains projects ranging from the most elementary to advanced stages.

**MATHEMATICS:** Easily mastered with the aid of our "Electronic Maths Course Based on the Slide Rule," freeing you from time consuming calculations and enabling quicker project assembly.

**KEEP UP-TO-THE-MINUTE IN ELECTRONICS:** From the magazine you learn about new transistors and how to use them as soon as they are released. Take the insulated gate transistor, also called "MOSFET," "IG FET" and "MOST"— this device not only has an input impedance much higher than most valves, but is also voltage controlled, has high current gain and very small size. You can buy one now for only \$3.50 and in two years' time they are expected to be as common as the PNP transistor and perhaps even as cheap. Learn about them now, study how to use them in high impedance pre-amplifiers and electronic voltmeters, compare them with valve circuits, see the similarity between illustrations (i) and (ii) and why this type of transistor behaves so like a valve. Learn practical handling too . . .

- Earth your soldering iron and choose a constant heat type.

- Avoid touching the gate with fingers or ungrounded tools.

- Keep all four leads shorted with the substrate by wrapping with fine wire until soldered into place — then remove wire.

**FREE OFFER:** Receive absolutely free "Transistor Kits Pocket Electronics Data Guide"— a helpful pocket size electronics encyclopaedia with every returned coupon (below).

**FREE OFFER:** Receive absolutely free "Transistor Kits Pocket Electronics Data Guide" — a helpful pocket size electronics encyclopaedia, with every order.

**PLEASE WRITE:**

**TRANSISTOR KITS** (Educational Division), 69a Church Street, Brighton, Victoria. Tel. 92 3158 for the FREE pocket "Electronics Data Guide" which includes ● Schematic Symbols ● Colour Code ● Quantity and Unit Abbreviations ● Ohms' Laws ● Kirchhoff's Laws ● Transistor Formulas and . . . "Transistor Kits" magazine (20 cents each), "Basic Electronics" RCA Institute's Autotext (\$11.00), "Fundamentals of Transistors" RCA Service Company (\$15.00); also Details of the "Electronic Maths Course," based on the slide rule.

The following manuals at \$2.00 each. Price includes FREE printed circuit board.

- One transistor modules. ● Two transistor modules. ● Three transistor modules. ● Personal 6 transistor superhet; OR ● All four manuals for \$7.75. And send Cheque/Money Order for the publications you would like.

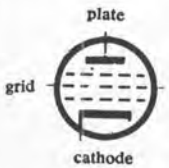


illustration (i)

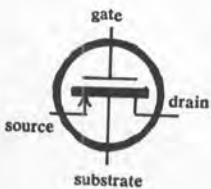


illustration (ii)

## CLIP OUT COUPON

Transistor Kits (Educational Division),  
69A Church Street, Brighton, Victoria. PHONE 92-3158.

Please send me FREE the pocket "Electronics Data Guide" and . . .

- "Transistor Kits" magazine (20c each.)
- "Basic Electronics" RCA Institute's Autotext (\$11.00)
- "Fundamentals of Transistors" RCA Service Company (\$15.00) also
- Details of the "Electronics Maths Course, based on the slide rule.

The following manuals at \$2.00 each. Price includes FREE printed circuit board.

- One transistor modules
- Two transistor modules
- Three transistor modules
- Personal 6 transistor superhet OR
- All four manuals for \$7.75.

NAME .....

ADDRESS ..... STATE .....

Cheque/Money Order for \$..... enclosed.

3320

The output transistor is run in class-A, which means that there is a steady drain on the battery. In larger transistor radios, use is made of push-pull class-B stages which only draw heavy current during audio peaks, resting the battery in between. The total current drain of this receiver is approximately 16.5mA with a 9-volt battery. This is not an excessive figure but, as is usual, best economy will be obtained by using larger rather than smaller batteries.

The relatively low output impedance of the class-A power amplifier is ideally suited to low-impedance head phones, of DC resistance of about 200 ohms, and our prototype has the headphone jack arranged to suit. However, for those readers who prefer to use high-impedance phones or a very low impedance magnetic plug-in earphone, conversion details of the output circuit are given.

To obtain reasonable results with high impedance, about 2,000 ohms, headphones it is necessary to use a step-up transformer of approximately 5:1. A suitable transformer is a transistor driver stage transformer used in reverse.

Very low impedance magnetic earphones, such as those used with portable transistor receivers, require a different approach again. The jack in this case should be wired into the secondary circuit of the output transformer, thus achieving a reasonable impedance match between the output collector and the low-impedance earpiece.

Coming now to the physical side, the receiver panel and chassis were designed to allow the unit either to be screwed on a plywood base or fitted into a wooden box. The box would require a lift-up lid for coil changing, unless one band of frequencies only is used. The use of a metal front panel minimises the possibility of hand capacitance effects on the tuning of the receiver.

#### PRE-WIRED TAGSTRIPS

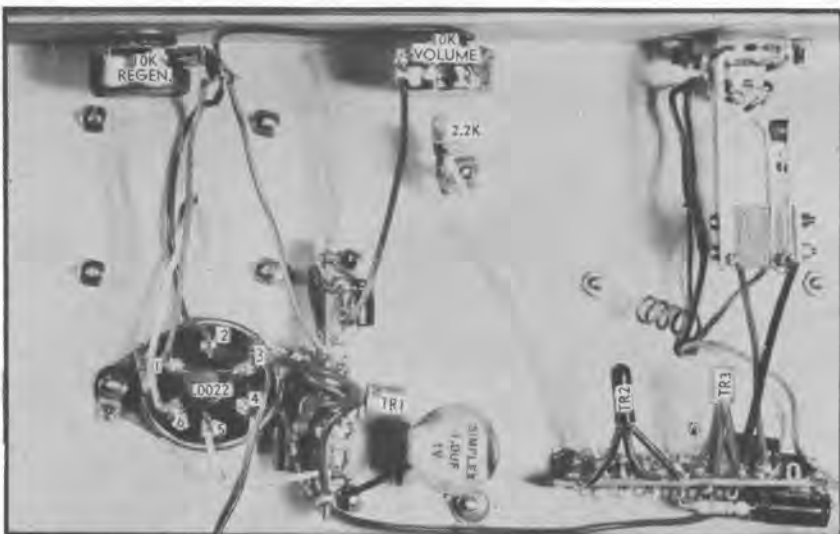
To simplify construction the receiver has been divided into three major sections. Two of these are tagstrips which are pre-wired before mounting on the chassis. The third section is composed of front panel and chassis, together with the larger components.

The first tagstrip is pre-wired with all the detector stage components and, after it is fastened to the chassis, requires only four wires for connection to other sections of the receiver. The second tagstrip with most of the audio components, similarly has only four wires to connect to components mounted on the chassis.

By pre-wiring these tagstrips to the drawings supplied, the construction of the receiver becomes simple enough for the youngest and most inexperienced of our readers.

Bending the chassis should present little worry and may be tackled by using two pieces of angle iron in a vyece, tapping the section to be bent with a block of wood and a hammer. Sometimes the bend can be made easier by scoring the aluminium on the side which will become the inside of the bend.

After manufacturing the panel and chassis, the larger components should be mounted, ensuring that the dial and tuning capacitor are in exact alignment. Before mounting the tuning capacitor solder a lead of wire to the fixed plates



This underchassis view should be studied in conjunction with the wiring diagram on page 39. Note the coil socket orientation and that pins 1 and 6 are the two larger ones.

and pass it through a hole in the chassis ready for wiring.

The smaller components may now be wired to the two tagstrips, carefully following the wiring diagram supplied. The audio tagstrip is then mounted on the chassis with the OC70, 2N279, etc., pointing towards the centre of the chassis.

The detector tagstrip is mounted with the 1K resistor closest to the front panel.

Commence the wiring by connecting the output leads of the speaker transformer to the speaker. Next the wire from the tuning capacitor fixed plates

should be soldered to pin 6 of the coil socket. Pins 1 and 2 of the coil socket can now be wired to opposite ends of the regeneration control and pin 1 connected to pin 3 via a .0022uF ceramic capacitor. If the regeneration control is required to increase regeneration with clockwise rotation, the accepted standard, then pin 1 of the coil socket should be connected to the left hand lug (rear view) of the control and pin 2 to the right hand lug.

Pin 3 of the coil socket is connected to a solder lug underneath the socket

## LEARN THE EASY WAY

with printed circuit kits from

# R.C.S.

The best and fastest way to learn about radio is with R.C.S. do-it-yourself kits. You'll enjoy the achievement of building yourself a transistor personal portable or amplifier and you'll be learning at the same time. Complete kits of parts and easy-to-follow instructions ensure that you just can't go wrong!

Call personally or use our special mail order service. And if you need any advice, just ask the experts at R.C.S., they'll be pleased to help.

For full details of kits available write for blueprint data sheets and see our advertisement each month in "Electronics" for the latest releases.



#### PERSONAL TRANSISTOR

1 transistor, 1 diode. Do-it-yourself kit No. 582, \$5. Postage 10c.

#### 2 TRANSISTOR PORTABLE

Range 30 miles, 200 with short aerial and earth. Ear-piece only, no speaker. Do-it-yourself kit No. 566C, \$9.00. Postage 20c.



Send cheque, or money order to:

## R.C.S. RADIO PTY. LTD.

651 FOREST ROAD, BEXLEY, N.S.W. 58-3491, 58-5385.

# HAM

# RADIO SUPPLIERS

5A MELVILLE STREET, HAWTHORN, VICTORIA.

PHONE: 86-6465

BULK DISPOSAL STORE, 8 PARK STREET, GLEN FERRIE, VIC. 81-1935.

## FERROCART POCKET MULTIMETER

Model PT34



300 uA movement.  
AC and DC voltages:  
0-10, 0-50, 0-250,  
0-500, 0-1,000c.  
Current ranges (mA)  
0-1, 0-100, 0-500 mA.  
Ohms range: 0-100,000

Size 3 3/4 x 2 1/2 x 1 1/4 inches.

Price 57/6. \$5.75

inc. tax  
Complete with leads.

## MULTIMETER MODEL 200H

20,000 ohms per V. d.c. 10,000 ohms per V. a.c.



Specifications:  
DC volts: 0-5,  
25, 50, 250,  
500, 2,500.  
AC volts: 0-10,  
50, 100, 500,  
1,000.  
DC current:  
0-50 uA.; 25,  
250 mA.  
Resistance: 0-60  
K ohms: 0-6  
meg.  
Capacity: 0.01-  
0.3 uF. (at  
AC 5V);  
0.0001 - 0.01  
uF. (at AC  
250V).  
Decibel: Minus  
20 db, plus  
22 db.

Output range: 0-10, 50, 100, 500, 1,000.  
Battery used: UM3 1.5s, 1-piece. Dimensions:  
3 1/4 x 4 1/2 x 1 1/8 in.

Complete with internal battery, testing-leads and prods.

Price \$11.25 inc. tax

## LSG 11 SIGNAL GENERATOR



120 Kc.-390 Mc.

Freq. range (six bands): 120 Kc to 130 Mc on fundamentals; 120 to 390 Mc. on harmonics. Mod. freq. 400 and 1,000 c.p.s. Tubes: 12BH7, 6AR5. Rectifier: Half wave selenium. Provision for crystal oscillator (xtal not supplied). 1 to 15 Mc. 100, 117 or 230v. A.C. input, 50/60 c.p.s. Size: 7 1/2 x 10 3/4 x 4 1/2 in. Weight: 6lb.

Price £15/5/- (\$30.50)

inc. tax

## MULTIMETER

Model CT-630



30,000 ohm/volt  
DC  
15,000 ohm/volt  
AC

DC Volts: 0.3, 0-15,  
0-60, 0-300, 0-600,  
0-1200.

AC Volts: 0-6, 0-30,  
0-120, 0-600,  
0-1200.

DC A.mperes: 0-0.03, 0-3, 0-30, 0-300mA.  
Ohms: 0-16K, 0-160K, 0-1.6M, 0-16M, (10, 100,  
10K, 100K at centre scale)

Decibels: Minus 20 to plus 46dB.  
Dimension: 90 x 132 x 36mm.  
Net weight: 380g.

Price: £9/5/- (\$18.50)

## SINCLAIR Z-12 INTEGRATED HIGH FIDELITY PRE-AMPLIFIER AND 12 WATT AMPLIFIER

PRICE £9/15/ (\$19.50)

inc. tax

POWER SUPPLY for Z-12: 6, 9, 12, 15 volts at 1 amp,

PRICE £7/17/6 (\$15.75)

inc. tax



### SPECIFICATIONS:

No. of transistors: 8.  
Overall size: 3in. x 1.8in. x 1.3in.  
Weight: 3oz.  
Output power into 3 ohm load:  
5 watts RMS continuous with 12-volt supply.  
8 watts RMS continuous with 15-volt supply.  
13 watts RMS continuous with 18-volt supply.  
Output power into 1.5 ohm load:  
10 watts RMS continuous with 12-volt supply.  
16 watts music power with 15V. supply.  
Power response: 1.5dB below 1KC at 20KC and 65 cps.  
Frequency response: 15 c/s to 50KC plus or minus 1dB.  
Input sensitivity: 2mV into 2Kohm.  
Quiescent consumption: 12-volt supply—15mA.  
Signal to noise ratio: Better than 60mA.  
Total distortion: Less than one per cent.

## SWR METERS Model KSW-10



### SPECIFICATIONS:

Standing Wave Ratio: 1:1 to 1:10.  
Accuracies: Plus or minus 3% scale length.  
Impedance: 52 ohms and 75 ohms.  
Meter: 0-100 DC microamperes.

PRICE £9/10/- \$19 inc. Tax.



## 3 WATT 4 TRANSISTOR AMPLIFIER.

Circuit: 4 Transistor Push Pull. Output Power: 2 Watt, 10 p.c. U.D. 3 Watts Maximum. Gain: 10 mv for 2 watt output at 1 Kc. Output Impedance: 8 ohms and 16 ohms. Frequency Response: 150—10,000 c/s. Current Consumption: 12 mA at no Signal. 500 mA for maximum power.  
Dimensions: 3in x 2in x 1in.

PRICE \$9.75 (£4.17.6d.)

inc. tax

## WANTED TO BUY

COMMUNICATION RECEIVERS, TRANSMITTERS, TEST EQUIPMENT, AMPLIFIERS, TRANSISTOR RADIOS, TAPE RECORDERS, SPEAKERS, TRANSFORMERS, ETC.



## STEREO AMPLIFIER

10 WATTS

Manufactured to give stereo amplification over a wide frequency range, the Stereo Amplifier uses the new 6GW8 Audio Tubes to attain its fine performance. It has stereo inputs and outputs to suit most requirements. We can also supply any auxiliary equipment that may be required.

### SPECIFICATIONS

MAX. OUTPUT POWER: 10 Watts, 5 Watts per channel.  
FREQUENCY RESPONSE: 50 to 15,000 c.p.s. plus minus 1 db.  
HARMONIC DISTORTION: Less than 2 per cent at normal levels.  
CROSSTALK AT 1 KC: Better than 40 db.  
HUM AND NOISE: 40 db. below rated output.  
INPUT (FOR FULL OUTPUT):  
Phono CER: 0.22V., 100,000 Ohm.  
Phono x-tal: 0.24 V., 50,000 Ohm.  
Aux.: 0.15V., 150,000 Ohm.

OUTPUT IMPEDANCE: 4, 8 and 16 Ohm. (Each channel).

SELECT SWITCH:  
1. Phono Stereo.  
2. Aux. Stereo.  
3. Phono—Mono.  
4. Aux. Mono.

Price: £19/- (\$38.00)

inc. tax

### VOLUME CONTROL:

Channel 1 with Power Switch and Channel 2.

### TO NE CONTROL:

More than 14 db. at 10,000 c.p.s.  
More than 11 db. at 100 c.p.s.

VACUUM TUBE: 2-6GW8, 1-6CA4.

POWER SUPPLY: 240V, 50 c/s, A.C.

OVERALL DIMENSIONS: 11in x 6 1/2in x 4 1/2in.

NETT WEIGHT: 10lb.

## MULTITESTER MODEL OL-64



DC volt: 0-0.3 1 10 50 250 500 1,000 5,000V (20,000 ohms/V)

AC volt: 0-10 50 250 1,000V (8,000 ohms/V)

DC Current: 0-0.03 1 50 500mA 10A

Resistance: 0-5K 500K 5M 50M

Capacitance: 250 pF-0.02 uF

Inductance: 0-5,000 henries

Decibels: minus 20 to plus 22 plus 20 to plus 36dB (Reference: 0 dB equals 0.755 volt equals 1mW in 600 ohms).

Load Current: 0-0.06 0.6 60mA

Dimensions: 5.91 x 4.17 x 1.97 inch.

Weight: 650 grams

Batteries: UM-3 1.5v x 2 BL-015 22.5v x 1.

Price: £9/17/6 (\$19.75)



## TRANSISTOR SIGNAL INJECTOR—\$5.25

inc. tax



mounting screw. A wire is extended out through a hole at the back of the chassis from pin 3 and 4 of the socket being the earth and aerial connections respectively. The remaining pin 5 is connected to lug 9 of the detector tagstrip.

Pin 2 of the detector tagstrip is wired to pin 3 of the audio tagstrip to supply battery voltage to the detector circuit. Lug 4 of the detector tagstrip is joined to the left hand lug, rear view, of the volume control while lug 5 of the detector tagstrip is joined to the centre lug of the regeneration control. This completes the wiring of the detector circuit.

A two terminal tagstrip is mounted by the screw holding the battery retaining clip close to the volume control. A 2.2K resistor joins the insulated lug of the tagstrip to the centre lug of the volume control. The remaining lug on the volume control is wired to one side of the regeneration control. This must be the side that is wired to pin 1 of the coil socket.

From the vacant end of the 2.2K resistor a connection is made to lug 9 of the audio tagstrip. Lug 3 of the audio tagstrip goes to one side of the on/off switch, the other side of which is connected to the negative lead from the 9-volt battery.

The wiring of the output transistor collector circuit will depend on the type of earphones to be used. The various configurations are shown on the main circuit diagram and are relatively simple to follow. The positive lead from

the coil pins specified. In general we found that the first tap appears best for the aerial and the third or fourth tap for the base.

In general, moving either the aerial or base connection away from the

### ART CUSHEN WRITES FOR "ELECTRONICS Australia"

World famous short-wave correspondent Art Cushen writes exclusively for "ELECTRONICS Australia." Mr Cushen's contribution appears monthly, under the title "Listening Around the World." In addition, a complete list of MW and SW broadcast stations and television stations operating in Australia and New Zealand appears each January.

earthed end of the coil will increase the strength of the signals, but impair the selectivity. The best compromise has to be struck for each individual location and for each aerial installation.

When the receiver is fully wired and re-checked for mistakes plug in the broadcast coil and switch on. With the volume control advanced and the regeneration control turned off, try tuning for a local station. If you live in a city area it is quite likely that several will be heard and possibly interfering with each other. Advancing the regeneration control will increase the volume of the

## COIL DETAILS . . .

(Continued from page 113).

The presence of the trimmers across the coils will restrict the tuning range slightly and alter the coverage, so we have shown the coverage to be expected both with and without trimmers. Naturally there is no point in using trimmers where only a single stage is employed.

The coil former shown in the diagram is fitted with six pins which are designed to suit a standard six pin valve socket. This allows the required band to be selected by simply plugging in the appropriate coils. It is not particularly important what arrangement of pins is used for the various connections, providing they are the same for all the coils and the sockets are wired to correspond.

Where it is desired to provide one band only, such as the broadcast band, there is no need to use the plug-in type of formers and less expensive types, intended to be permanently mounted, may be used.

For reception much above 30Mc simple receivers are not very efficient and a somewhat different approach is required. The coil data also becomes more critical and dependent on the circuit wiring and layout.

## PARTS LIST

- 1 3in loudspeaker.
  - 1 Speaker transformer (400 ohms primary, secondary to suit loudspeaker).
  - 1 Tuning capacitor, 10-415pF.
  - 1 Dial with vernier drive.
  - 1 6-pin socket.
  - 1 9-volt battery, 276P or similar.
  - 1 Plug for above battery.
  - 1 Phone jack.
  - 1 Slide type on/off switch.
  - 2 10K carbon potentiometers.
  - 2 10-lug tagstrips, both end lugs with mounting feet.
  - 1 2-lug tagstrip.
  - 4 6-pin plug-in coil formers, 1½ diameter.
- SEMI-CONDUCTORS**
- 1 2N372 transistor, or equivalent.

- 1 OC70 transistor, or equivalent.
  - 1 OC72 transistor, or equivalent.
- RESISTORS (all half watt)**
- 2 220 ohm.
  - 1 1K.                   1 47K.
  - 1 2.2K.                1 82K.
  - 1 3.3K.                1 680K.

### CAPACITORS

- 1 .0015uF, ceramic, low voltage.
- 1 .0022uF, ceramic, low voltage.
- 1 1uF, ceramic, low voltage.
- 1 2uF 12VW electrolytic.
- 2 50uF 12VW electrolytic.
- 1 100uF 12VW electrolytic.

### MISCELLANEOUS

Metal for chassis and panel, plywood, spaghetti, hookup wire, screws, nuts, resin-cored solder, expanded aluminium grill, etc.

the battery is connected to the chassis completing the wiring of the receiver.

Take care that the polarity of the battery is not reversed, otherwise the transistors will be destroyed.

While any orientation of the coil socket will work, for best layout of the wiring it is suggested that pins 1 and 6 should face the end of the chassis. The data for winding all the coils is given in the accompanying diagram. Note that the coil for band 4 has an additional winding. This winding is necessary to couple the aerial efficiently on this range as it would be difficult to tap the tuned winding with its small number of turns as we have done on the other coils.

It will be noticed in the first three coils that there are more taps than can be used. One of these taps is for the aerial and another for the transistor base connection. When first trying the coils, connections to these taps should be varied for best results and this combination permanently wired to

receiver and will also increase the selectivity to allow the separation of the stations. The volume can be adjusted separately by means of the volume control potentiometer.

As the regeneration control is advanced a stage will be reached where there is a distinct whistle as you tune over a station. This indicates that too much regeneration is being used and the control should be turned back slightly. A little practice will soon accustom the beginner to the tricks of regeneration. At this stage various combinations of the coil taps may be tried to achieve the best results.

The other coils may now be tried and their taps also adjusted. Remember this is a small receiver and does require an efficient aerial and earth system. The earth may be run from a nearby water tap or a reasonably large piece of metal buried in the ground. An aerial wire of at least 30 feet in length well elevated is desirable.

"INNERBOND" (Regd.)

## BONDED ACETATE FIBRES

For packing in

### SPEAKER ENCLOSURES

A new resilient Bonded Wadding made from ultra fine Cellulose Acetate Fibres that gives high efficiency for Sound Absorption.

"INNERBOND" is light, clean dust free and easy to handle. Because all the fibres are bonded "INNERBOND" will hang as a "curtain" and will not fracture or break down due to vibration.

"INNERBOND" is odourless, highly resistant to attack by bacteria or fungus and is vermin repellent: "INNERBOND" at 16oz sq. yd. has a nominal thickness of 1" and at this density is recommended as a packing in Speaker Enclosures for Sound Absorption.

### STOCKISTS

SYDNEY—Arrow Electronics Pty. Ltd., 432 Kent St.; Broadway Electronics Pty. Ltd., Broadway and City Rd.

MELBOURNE—J. H. Magrath and Co. Pty. Ltd., 208 Little Lonsdale St.

BRISBANE—A. E. Harrold Pty. Ltd., 123 Charlotte St.

ADELAIDE—Duncan Agencies, 57 Woodville Rd., Woodville; General Accessories, 81 Flinders St.

PERTH—General Accessories, 46 Milligan St.

If unobtainable

For 1 sq. yd. as above send \$2.00

For 2 sq. yds. as above send \$3.75

For 4 sq. yds. as above send \$6.50

Postage paid in Australia and Territories.

to the manufacturers

## WONDER WOOL PTY. LIMITED.

87 James Street, Leichhardt, N.S.W.

BOX 548 — G.P.O., SYDNEY.

Phone: 56-2780.



## CHAPTER 23: Magnetic recording. Historical.

Poulsen's early wire recorders. Stille's wire and tape recorders. Wartime developments. Principles of operation. Magnetic characteristics. Distortion and need for bias. DC bias. AC bias. Erasure. Wire and tape compared. Modern equipment.

ONE of the spectacular advances in electronics following the last war was the development of the tape recorder; a development which found ready acceptance by radio stations, artists, dramatic schools and clubs, and a host of others who had a special need for a simple sound recording system.

Their reaction was understandable. Most previous recording systems had called for extremely complex equipment, considerable skill to operate it, and expensive and lengthy after processes before the results could be heard. The acetate disc was a step in the right direction, but was still relatively expensive and inflexible.

The tape recorder, on the other hand, seemed to overcome all these problems in one sweep. It was relatively inexpensive to buy, simple to operate, required no processing and, above all, permitted erasure of mistakes and re-recording to correct them. This latter feature not only avoided waste of recording material, but also the precious time and effort put into what had already been recorded.

The development of the transistor and its application to the tape recorder permitted the latter to be developed to the point where it is compact enough, and priced low enough, to appeal directly to the individual. Even without any special requirement, the ability to make personal recordings appeals in much the same way as does the ability to make personal pictures with a camera. In fact, personal recorders are currently enjoying a popularity approaching that of the camera.

Where did it all start?

If we endeavour to trace the definite beginning of magnetic recording we find that, although credit for building the first magnetic recorder belongs to Valdemar Poulsen, there are indications that others had thought of the idea before Poulsen.

One of several references to magnetic sound recording may be found in "The Electrical World" of September, 1888. An article in this issue by Oberlin Smith tells of his developing "a successful machine for spinning metallic dust into a cotton cord on which sound might then be recorded." Like so many other experimenters, however, Smith did not press on with his invention and it was left to Poulsen, in 1898, to produce the first actual working model for a magnetic recording machine.

Poulsen's early recorder consisted of a drum on which was wound steel wire a few millimetres thick. As the wire unwound from the drum it passed in contact with a magnetic "head" com-

prising two soft iron laminations in a coil. Magnetic impulses were transferred to the wire by the head laminations pressing against opposite sides of the wire.

The head was arranged to move along a path parallel with the drum, and the wire, being wound in spiral form on the drum, was used to propel the head.

There being no electronic means of amplification available at the time, the coil of the magnetic head was connected to a carbon microphone and a battery during recording and to a set of headphones for the playback. From the mechanical point of view the "Telegra-



A 1930 magnetic recorder using steel tape. Developed by Dr Karl Stille it is similar to those used by the B.B.C. A modern tape recorder is shown for comparison.

phone," as Poulsen called his invention, was similar to Edison's phonograph, although it operated on much more advanced principles of recording and reproduction.

Although Poulsen's invention enjoyed some popularity at the turn of the century, it never made any inroads into the domestic market because it required headphones for listening, whereas the gramophone, although of inferior sound quality, was a "loudspeaking" device. The gramophone was also a much cheaper device to produce and this has always been an influencing factor on the domestic market.

In addition, gramophone records, at least in disc form, were ideally suited to mass duplication by pressing, thus further reducing costs. Even today, this factor remains a major one in favour of the gramophone record as a medium for mass program distribution.

Poulsen's company eventually went bankrupt and magnetic recording was forgotten until 1919, when the recently invented valve led to a revival of interest. At this time Dr Karl Stille tried

to adapt the "talking wire," as he called it, into a sound carrier for motion pictures. Experience showed, however, that photographic film recording was not only better in quality but also easier to use for the purpose; and the "talking wire" once more passed into obscurity, at least as far as a popular or domestic market was concerned.

Magnetic recording continued to be developed by some companies, and was used extensively by the B.B.C., using steel tape as the recording medium. At the outbreak of World War II it was pressed into service by the armed forces as a means of recording high speed code transmissions for later replay at a slower speed.

During this period some very compact wire recorders were developed and used by the Allies. The Germans, in their turn, had developed a recorder using a plastic based, metallic oxide coated tape, very similar to that used in present day machines. Magnetic recording really "arrived" after the war and the art continued to develop to the high standards achieved today.

In order to understand just how magnetic recording works we will need to enlarge on some of the basic fundamentals of magnetism covered in Chapter Three of our course.

In this chapter we found that certain materials, namely iron and similar alloys and compounds, have the ability to concentrate magnetism within themselves. These ferrous materials are termed "ferromagnetic" and they are said to have high "permeability," permeability being the ratio of magnetic flux density produced in a material to the magnetic flux density that would be produced in air by the same magnetising force.

If we take a sample of unmagnetised iron and subject it to a magnetising force, we will find that the amount of magnetism induced in the iron will rise slowly at first, then more rapidly, and then again slowly until the iron will



A commercial wire recorder marketed about 1948. Wire recorders were not developed much beyond this stage.

absorb no more magnetism, this latter state being known as the SATURATION point of the material. This process is shown graphically in figure 1.

Here we start at point "A", which represents zero magnetising force and zero induced magnetism, and apply a steadily increasing magnetising force along the "H" (Magnetising Force) axis, to the right of point "A." As we do, the induced magnetism which results is plotted along the "B" (Induced Magnetism) axis, giving rise to the curve "A"- "C"- "D"- "E".

From this graph we can see that only the middle section of our curve shows a reasonably linear relationship between magnetising force and induced magnetism, the sections from A to C and D to E being distinctly non-linear.

When the magnetising force is removed from the iron the induced magnetism in the material does not disappear entirely but, following a path other than that of its original magnetisation curve, it falls to a value which is a proportion of the original value. This is shown by the curve E to E', and the magnetism remaining in the iron is known as its "remanent" magnetism.

If we consider any value of induced magnetism along the curve A to E we will find that it will fall to a remanent value along a path which may be regarded as "parallel" to E-E'. Thus induced values C X D and E will produce remanent values C' X' D' and E' along the B axis. It is important to note that remanent values resulting from any induced values between C and D will be linearly spaced along the B axis, while those resulting from values from A to C and D to E will be non-linearly spaced.

The curve shown as A to E might typically be that created in our piece of iron by the "north" pole of a bar magnet or by current through a coil in a specific direction. If we had used the "south" pole, or caused the current to flow in the opposite direction, we would have created the curve A-J in the bottom left of the drawing. Note that the two curves, although of opposite polarity, are mirror images and both show the same degree of non-linearity at the beginning and end of their trace.

But note that the iron would only have followed the curve A-J had it been initially in the unmagnetised state. If we had simply applied our reverse magnetising force after first taking the iron up to E and then down to E', the curve followed would have been as shown by the dashed line. The induced magnetism would have gone directly from E' to J, as shown, and on removal of the reverse magnetising force it would have dropped to J'.

If we again applied a magnetising force, this time in the initial direction, the induced magnetism would pass from J' to E, and so on. Unless we demagnetise the iron, it will not return to the zero point A but simply swing around the "loop" EE'JJ', shown dashed. Such a loop is called a HYSTERESIS LOOP, and it will have a shape depending upon the type of magnetic material concerned.

In the first and simplest form of magnetic recorder produced by Poulsen, the recording head was fed with an AC signal at audio frequencies. This is shown in figure 2, where the head signal is shown as "Input Waveform" and can be visualised as swinging the magnetising force alternately left and right along

the H axis. From this we can plot points of induced magnetism along the B-H curve, from these plotting remanence points along the B axis resulting from them, and, finally, extend these points to the right and use them to create a graph of the waveform which has been recorded.

As can be seen, this is badly distorted. The distortion comes from two sources, the non-linearity represented by G-A-C, which is called "crossover" dis-

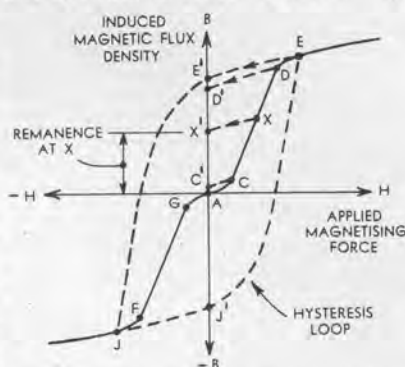


Figure 1: The curve of induced flux (B) plotted against applied magnetic force (H) for a magnetic material, showing initial and repeated magnetisation. (The BH curve).

ortion, and that represented by D-E and F-J, which is called overload distortion, or saturation.

Overload distortion may be avoided by restricting the level of signal recorded, and this precaution must still be observed in modern recording systems; but there is no such simple solution for the crossover distortion problem, and this is the real limitation of such simple recording systems.

In an effort to overcome this distortion Poulsen introduced a simple form

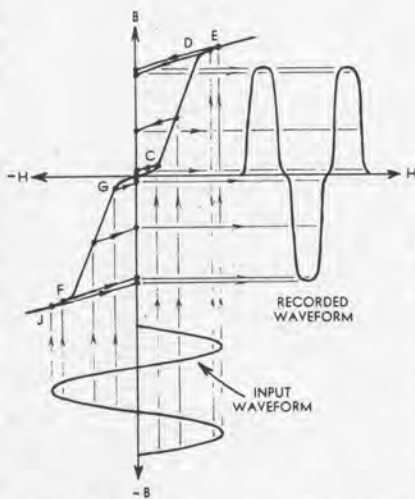


Figure 2: What happens if one attempts to record an audio signal without any form of bias. The non-linearity of the B-H curve causes distortion at both the zero-crossings and peaks of the signal.

of biasing, known as "DC biasing." He achieved this by applying a voltage of fixed polarity to the recording head so that, without an input signal, a magnetising force approximately midway between points C and D was applied to

the wire (figure 3). When an input waveform was applied along with the bias voltage it would cause the magnetising force, and therefore the induced magnetism, to swing from the centre point of the curve up toward D or down to C, depending on the polarity and amplitude of the signal. Subsequently the remanent magnetism would range between C' and D'.

The important thing about the introduction of "bias" was the fact that it allowed magnetism to be induced in the wire over the substantially linear portion of the curve. The distortion introduced by the previous method was therefore reduced to a minimum.

The use of DC bias in this fashion allows quite faithful recordings to be made, and many early tape and wire recorders used this system. It is still used to the present day in battery-operated recorders of the cheaper variety.

The main disadvantage of DC biasing is that recordings made in this way are noisy; they have a very poor signal-to-noise ratio. The noise level is high because the steady bias remanence recorded on the tape along with the signal tends (for complex reasons) to accentuate noise due to the unevenness and granularity of

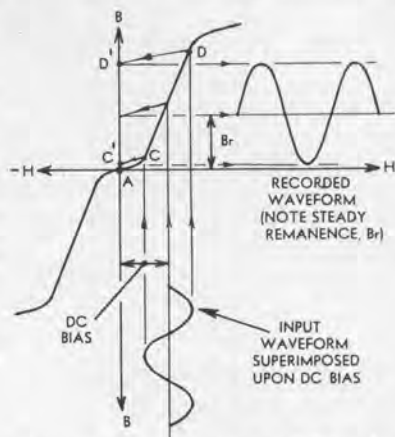


Figure 3: The principle of DC biasing. The DC bias is arranged to give an "operating point" halfway along one of the linear sections of the B-H curve, giving distortionless (but noisy) recording.

the magnetic coating of the tape. Also the signal level is lower than one would like, because DC biasing uses the linear section of only one side of the B-H curve; the other section is virtually wasted.

The system of biasing which is used in all modern recorders (except the cheaper battery machines) produces recordings having a considerably better signal-to-noise ratio than DC biasing, by using as bias an AC signal of super-sonic frequency. Let us now see how this SUPERSONIC BIAS system works.

Let us first consider no-signal conditions—the case where we have no audio recording signal. Under these conditions the recording head of a recorder using super-sonic bias has applied to it a current alternating at a super-sonic frequency—usually from 40 to 100KC.

The effect of this current is to produce in the head gap and the tape passing over it a magnetic field reversing at the same extremely rapid rate. The amplitude of the bias current is arranged so that the peak value of the magnetic flux density experienced by the tape immediately

over the gap is halfway up the linear section of its B-H curve, in each direction.

This procedure results in the state of affairs suggested by figure 4. As the tape approaches the recording head gap, and enters the field, it is swung through a number of rapid flux alternations, passing through a series of expanding hysteresis loops (not shown) until it is swung through the loop MNOP directly over the gap. M and O are points halfway up the linear portion of the B-H curve of the tape oxide in each direction.

When the tape moves away from the head gap, it is swung through a further series of alternations, but this time they are decreasing in amplitude. Thus, as figure 4 shows the tape passes through a series of decreasing hysteresis loops. It ends up at a point which is virtually at the intersection of the B and H axes—i.e., with zero remanence.

In other words, the net effect of the high frequency bias signal itself is virtually zero. Now let us consider what happens when we superimpose upon the bias signal our audio recording signal. Figure 5 should help in understanding this.

At the bottom of the diagram is shown the audio signal superimposed upon the supersonic bias signal. Above this is shown the hysteresis loop corresponding to zero signal amplitude, marked A (solid line); the loop corresponding to the time BB', when the audio is at maximum amplitude in one direction, marked B (dashed line); and the loop corresponding to the time CC', when the audio is at maximum amplitude in the other direction, marked C (dotted line).

Note that the loops shown correspond to the tape directly over the recording head gap. In each case there will be an expanding and contracting series of loops as the tape approaches and moves away from the gap. These have been omitted to preserve clarity.

As may be seen the effect of the audio signal is to "wobble" the hysteresis loop of the bias either side of zero, and providing the amplitude of the audio signal is kept below the level where the tips of the loops reach the saturation "knee" of the curve in either direction, this wobbling will be quite linear. The movement of the loop will follow faithfully the audio signal waveform.

Because the movement of the loop is linear, the net remanence produced by the loop will also be linear. Thus, although the AC bias alternations themselves produce no recording, the tape is left with a recording of the audio signal which is a faithful replica of the original. The recording represents the net remanence of the linearly wobbled loop.

The effect of supersonic AC bias is thus to make the effective B-H curve of the tape oxide material quite linear around the zero-remnance point. This is suggested by the small diagram at the right of figure 5, which shows the actual B-H curve and the effective curve produced by using supersonic bias.

Before a recording is made, of course, the tape must be wiped clean or ERASED of any previous recording. This can be done by either passing the tape close to a permanent magnet or electro-magnet, or by passing it over the gap of a head similar to the recording head but fed purely with a supersonic alternating current.

With the first of these methods, called "DC" or "permanent magnet" erasure,

the tape oxide is taken into saturation in one direction (i.e., past E or J); when it leaves the erasing field it simply drops back to either E' or J'. This leaves it with a steady remanence only — although on replay the tape will sound very noisy for the same reasons which make DC biasing noisy.

The second method is the one used in most modern recorders, and is the logical method of erasure where supersonic biasing is used. As we saw from figure 4, a head fed solely with supersonic AC simply forces the magnetic oxide through a series of expanding and then contracting hysteresis loops, leaving it finally at A with zero remanence (or close to it). A supersonic erase head

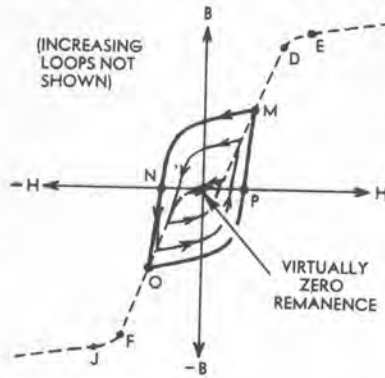


Figure 4: The effect of supersonic AC bias alone. As it passes the recording head gap, the oxide is swept through first an increasing series and then a decreasing series of hysteresis loops.

thus erases by taking the oxide through a series of loops until it saturates in both directions, and then back through another series of loops to zero. As with supersonic bias, this gives a very low noise level, and supersonic erase gives a very "clean" tape for new recordings.

Having thus explained the manner in which a magnetic recording is induced in a wire or a metallic oxide coated plastic tape, we might now investigate some of the properties of the actual recording material.

In the earliest recorders produced by Poulsen and others, the recording material was either a steel wire or tape of

approximately 1/16in thickness. In order to obtain a reasonable frequency response with the fairly wide head gaps then used, this wire was transported past the head at the relatively high speed of 80 inches per second.

It takes little imagination to see that this thick wire posed difficulties in mechanical handling and, even when large spools were used, yielded very short playing times. Recording wire was eventually refined, however, to a thread of 0.003in diameter, made from stainless steel and able to withstand a pull of approximately three pounds.

In the later stages of development, recording wire was considered, in many respects, to be superior to oxide coated tapes of the type used today. The wire then developed would stretch less than tape, was relatively immune to the effects of extreme temperatures and humidity, and was much more compact, for a given playing time, than any of the plastic tapes then produced.

It has been said, in fact, that wire would be an almost perfect recording medium were it not for three inherent faults. First, since it is round, it tends to twist and therefore the parts in contact with the recording head may be twisted around when the wire is played back. The result is a deterioration, often quite severe, in the quality of the reproduced sound.

Secondly, one recorded layer in intimate contact with another causes magnetic "print through" and this leads to echoes and a much higher background noise level than that of tape. The third fault is that wire cannot be as easily edited as tape, since good knot-tying in thin wire requires more dexterity than many people possess.

The development of metallic oxide coated paper and plastic tapes occurred at around the same period in the history of magnetic recording, but the paper tapes soon fell from favour because of various inherent faults which they possessed.

The unwanted sound, or noise, that any coated tape produces is caused mainly by two factors (a) the lack of uniformity in the size and distribution of the tiny needle-shaped particles of ferric oxide in the coating, and (b) the roughness of the surface of the base material.

Since even the finest grade of paper

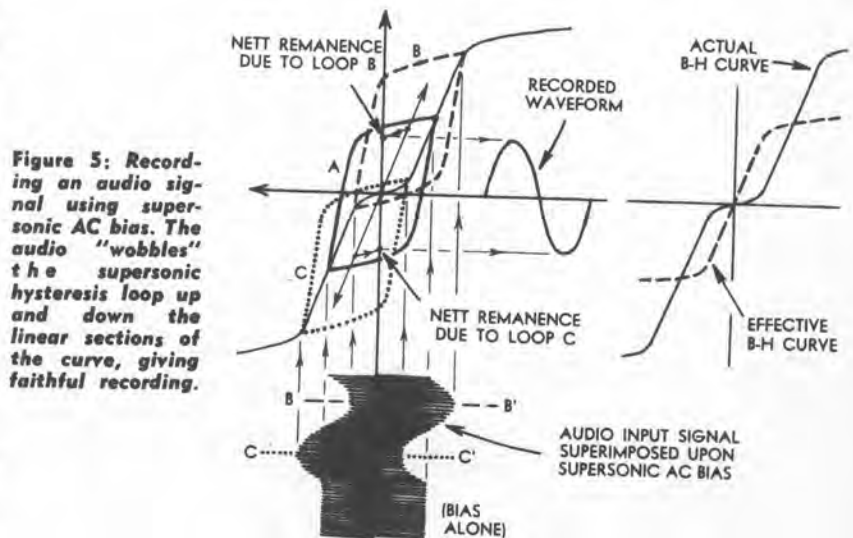


Figure 5: Recording an audio signal using supersonic AC bias. The audio "wobbles" the supersonic hysteresis loop up and down the linear sections of the curve, giving faithful recording.

has a noticeable "grain," it would, when coated with a magnetic oxide, have "hills" and "valleys" in its thickness and these irregularities will produce noise in spite of the fact that the outer surface of the oxide coating may, to all intents and purposes, appear to be perfectly smooth.

Paper-backed tape was, to be sure, quite a deal cheaper than the plastic tapes and it did have good dimensional stability but the disadvantage already mentioned plus the fact that it tore easily and deteriorated rapidly under adverse (very humid) storage conditions soon precipitated its downfall in favour of the plastic tapes used almost exclusively for magnetic recording today.

When plastic tapes were first developed, they were of two basic types—homogenous and coated. The homogenous tape, as the name implied, consisted of a plastic material with ferric oxide particles dispersed evenly throughout the body of the material.

This tape never really achieved any popularity because not enough oxide to permit good quality recording could be mixed with the plastic without excessively weakening the material.

The first really successful tape was the "coated" variety, originally developed in Germany by Fritz Pfelemer. This tape consisted of a cellulose acetate base to which a thin coating of ferrous oxide was glued. At a later stage, but still in the years prior to World War II, polyvinyl chloride (PVC) was used as a tape base. This material was extremely pliant but had the disadvantage of stretching rather badly in use.

When first developed the coated tapes were inferior in performance to the steel tapes then in use, though much cheaper. Even at the outbreak of World War II very little had been heard about them, and the Allies continued to develop and use fine steel wire.

It was only after the war, when the Allies overran Germany, that it was discovered that the German scientists had developed tape and tape recording to a very high standard; a standard which put it far ahead of wire techniques of the day.

Today the wire recorder has virtually passed into history, tape having proved superior in all important respects. Extended playing time in particular, once a feature in favour of wire, has been markedly improved in recent years.

Thus, where as some early tape machines ran at tape speeds as high as 30 inches per second, many modern machines run as low as 15/16ips and still offer a quality of reproduction perfectly adequate for many applications.

At the same time, the development of thinner tapes, such as "double play" and "triple play,"

and the technique of putting two ("half") tracks or four ("quarter") tracks on the one tape have also contributed.

As a result many hours of recording can now be packed onto quite small reels of tape. For example, a five-inch reel will hold 1,200 feet of double play tape which, if used with a half track head at 15/16ips, will provide four hours playing time in each direction, or a total of eight hours. And this is without considering quarter track recording and/or triple play tape.

Today, tape is the recording medium in a wide range of applications. It is used as the "master" for gramophone records, for motion picture recording, for recording sound in broadcast studios, and sound and video in TV studios.

Tape recording is also used in a wide range of other applications, from computers to office dictaphones. Portable tape recorders are used extensively as "talking note books" by students, by reporters, by storemen for taking stock, by engineers checking large works, etc.

Typical of these is the situation illustrated in the photograph. Here an engineer for the British Railways is shown using a miniature tape recorder—small enough to hold in the hand—to record comments as he examines the overhead wiring on a new electrification scheme.

Previously, this was a two-man job; the engineer, and a clerk to take down his comments. And, since such inspections must normally be made during slack periods, they usually involved weekend work—at penalty rates.

Also, wet weather and damp locations, such as tunnels, made note taking a difficult job, adding further to the time needed for a complete inspection.

Now, with a portable tape recorder the engineer can do the whole job himself, even in wet weather. For such adverse conditions, the recorder can be carried in the pocket and used with a remote control microphone.

Our next chapter will have more to say about modern tape recorders. □



*This pocket tape recorder, made by Fi-Cord of Switzerland, is typical of the present state of the art. Because of the convenience they afford, these devices are finding wide acceptance in industry, education and commerce.*



**Do-It-Yourself**

## PRINTED CIRCUIT MATERIALS

Copper clad XXXP grade panels in handy sizes:

6" x 3"—34c    6" x 6"—60c  
 12" x 3"—60c    9" x 6"—84c  
 12" x 12"—\$2.25

KIT OF FERRIC CHLORIDE ETCHING CHEMICALS

Bituminous Paint, Resin and Instructions 75c (sufficient to process up to 1 sq. ft.) All prices include Sales Tax and are post-free within Australia.

FROM RADIO SUPPLY STORES EVERYWHERE

Distributed by:

**WATKIN WYNNE PTY. LTD.**  
 32 FALCON STREET, CROW'S NEST,  
 N.S.W. — 43-1912. 43-2107.

## ALWAYS RELY ON R.D.S.

For All Supplies of  
**RADIO PARTS and ACCESSORIES**

## METERS A SPECIALITY

**R** RECORD PLAYERS  
**R** RECORD CHANGERS  
**D** AMPLIFIERS  
**S** STEREO EQUIPMENT  
**S** TV PARTS & TV AERIALS

H200 20,000 ohm per volt  
 multimeter.  
 £5.12.6 net or \$11.25

CT500 20,000 ohm per volt  
 multimeter lar scale  
 £6.9.4 net or \$12.93

The Independent Wholesaler  
**RADIO DESPATCH SERVICE**  
 Radio and Electrical Distributors  
 Cnr. George and Harris Streets,  
 Railway Square

**869 GEORGE STREET, SYDNEY**

Telephone 211-0816, 211-0191

Open Saturday mornings



## CHAPTER 24: Modern tape recorders, their construction and operation. Drive systems. Single and three motor decks. Types of motor. Operating speeds. Magnetic heads. Two- and three-head recorders. Pressure pads and alternatives. Azimuth adjustment. Recording and replay equalisation. Recording level indicators. Bias and erase oscillators. Recording interlocks. Stereo recording and replay.

tions. Tape EDITING is rendered impossible.

But, quite apart from the problem of editing, there is a more serious problem: Tape slippage and uneven winding in the take-up spool cause the tape movement to be jerky and variable rather than smooth and steady. This causes unpleasant intermittent variations in the pitch of the record—the so-called WOW and FLUTTER, referred to in an earlier chapter.

Because of the severe limitations of the simple drive system, recorders intended for serious recording employ a more refined system known as CAPSTAN DRIVE. In this system the tape is drawn past the heads, not by tension



*A modern high-quality tape recorder, suitable for either domestic recording or commercial dictation.*

from the take-up spool, but by being friction-driven by a smooth, constantly rotating spindle called the capstan.

The diagram shown in figure 1 should help in visualising the essentials of capstan drive. The diagram represents a deck of the type used in many modern domestic machines, employing only one drive motor.

By means of either a pulley and belt system, as shown, or a friction-drive system employing a rubber intermediate wheel, the motor drives at constant speed a spindle carrying a heavy flywheel. The inertia of the flywheel is used to ensure that the spindle rotates extremely smoothly despite possible variations in either the speed of the motor or the loading imposed by the tape.

The top of the spindle forms the capstan. The tape is pressed against the capstan by a sprung rubber PINCH WHEEL, and thus the tape is driven at a constant, steady rate. The take-up spool is driven by a slipping clutch arrangement whereby it does not control tape speed but simply winds up the tape fed to it by the capstan.

When rapid forward motion of the tape is required, in order to select a required section of the tape, the usual procedure is to move the pinch wheel away from the capstan and alter the takeup spool clutch so that it no longer slips. For reverse motion of the tape to REWIND, drive is transferred to

IN the last chapter of this course we discussed the history of magnetic recording, the theory behind it and the structure of recording tape. Using this material and that of previous chapters as background we can now proceed to a more detailed discussion of the construction and operation of a modern tape recorder.

Although to the casual observer a tape recorder may seem to be a single unit, it is most conveniently considered as having two distinct parts: The part concerned with physical or mechanical handling of the tape itself, called the "transport" or DECK, and the part concerned with processing the electrical signals being recorded and played back—the "electronics." Let us first look at the construction and operation of the tape deck—the mechanics.

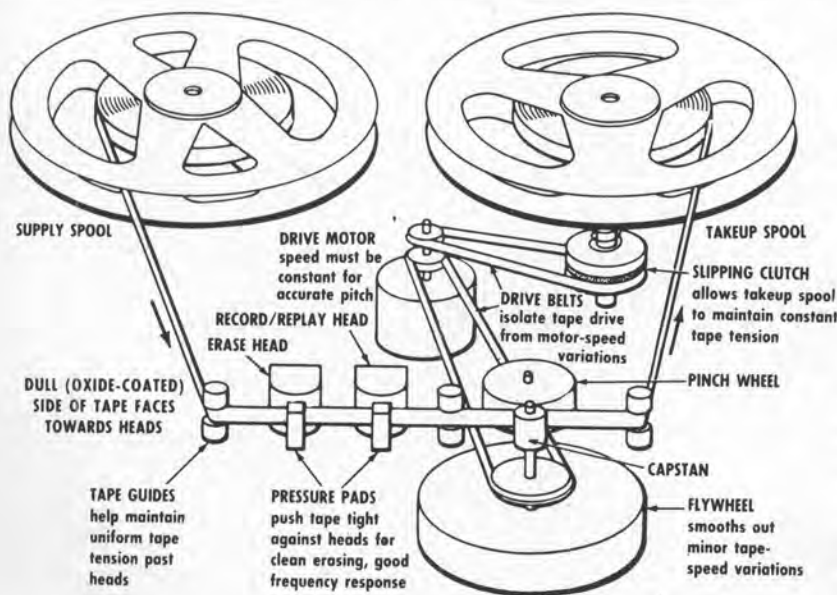
The principal function of the tape deck is to move the tape smoothly and steadily past the magnetic heads during recording, erasure and replay. Modern decks also allow rapid forward and reverse movement of the tape to permit the easy selection of a particular section of tape and to provide for rewinding the tape after recording or replay.

It is possible to perform these func-

tions in an elementary fashion by simply connecting an electric motor or motors to the spindles used to support and pivot the spools of tape—energising the TAKE-UP spool spindle for forward motion of the tape, or the SUPPLY spool spindle for reverse motion. This system has in fact been used in the past and is still used in many of the very cheap types of battery-powered transistorised recorder.

However, this simple drive system has a serious disadvantage. The speed of the tape past the magnetic heads is not constant. Because the tape motion is simply due to the tape being wound on to the take-up spool, the steady rotation of the spool causes a progressive speeding up of the tape as the amount of tape wound on the spool increases.

As a result, it becomes impossible to cut a recorded tape and transpose a section of the recording to another position in the sequence; doing so would mean that the transposed section would be replayed at a different speed to that at which it had been recorded, and the pitch of the sounds would either rise or drop. Even cutting out an undesired section of the recording would disturb the replay speed of the remaining sec-



*Figure 1: The main parts of a single-motor tape deck, as used in many domestic recorders. The text explains its operation.*

the supply spool, again with the pinch wheel moved away from the capstan.

While a single-motor drive system of the type just described is capable of excellent performance, it often necessitates a complex system of pulleys, levers, intermediate shafts and wheels in order to permit the single motor to perform all the required functions. Because of this, some designers adopt an alternative course, using three separate motors. This often permits considerable simplification of the deck mechanism, and it also allows the use in each position of the type of motor best suited for the task. The disadvantage is that the use of three motors proves rather costly.

The diagram of figure 2 shows the essentials of three-motor drive. One motor is used to drive the capstan, and the other two the spools.

It should perhaps be mentioned here that there are other types of drive system besides those shown in figures 1 and 2. There are also drives using two motors, or multiple capstans with sprung loops of tape, or combinations of all these; however, discussion of these systems is beyond the scope of the present course. The two systems illustrated are the most popular drive methods and will serve to illustrate the broad principles.

### MOTOR TYPE

Whichever drive system is used, the type of motor or motors used is quite important, as the speed regulation and general performance of the motors determines to a very large extent the quality of the recording. As the tape speed in a capstan-drive system is directly controlled by the capstan speed, the motor responsible for capstan drive is of prime importance in this regard.

The majority of modern tape decks are intended to operate from AC; the choice of motor types is thus between commutator-type motors of the series, parallel or compound type, induction motors and synchronous-induction.

Commutator-type motors are rarely used because of their poor load-speed and voltage-speed regulation. Four-pole, and occasionally two-pole, induction motors are used in decks of the less pretentious domestic variety and for spool drive in professional machines, because of their controllable regulation, reliability and modest cost. For spool drive it is usual to give the motors a poorly regulated or "torque" characteristic, either by running them via a series resistance or by using a high resistance rotor cage.

Synchronous-induction motors are used in the highest quality machines, particularly for capstan drive. In some cases the motor drives the capstan and flywheel via a flexible coupling, as shown in figure 2; in others, via a rubber intermediate wheel. Some further cases employ a motor having an external rotor which acts as the flywheel, and use the motor spindle itself as the capstan.

Battery-operated recorders usually employ small commutator-type motors, either fitted with a centrifugal governor or connected into an electronic speed regulation circuit. The more elaborate professional instruments may alternatively employ a three-phase synchronous-induction motor driven by a transistorised oscillator system.

Most modern recorders operate at a number of speeds. The faster speeds are used where high quality recording is essential, while the slower speeds are used where either tape economy or the need to make a long continuous recording are more important than quality. Standard operating speeds are 15 inches per second (mainly used for professional recording), 7½ips, 3½ips, 1-7/8ips and 15/16ips.

Regardless of the number of motors used to power a deck or the drive system used, some sort of braking system must be employed to bring the spools to a halt smoothly and without tape spillage when it is desired to stop. Either mechanical or electrical braking may be used, electrical braking being performed by applying DC to the spooling motors to convert them into eddy-current brakes.

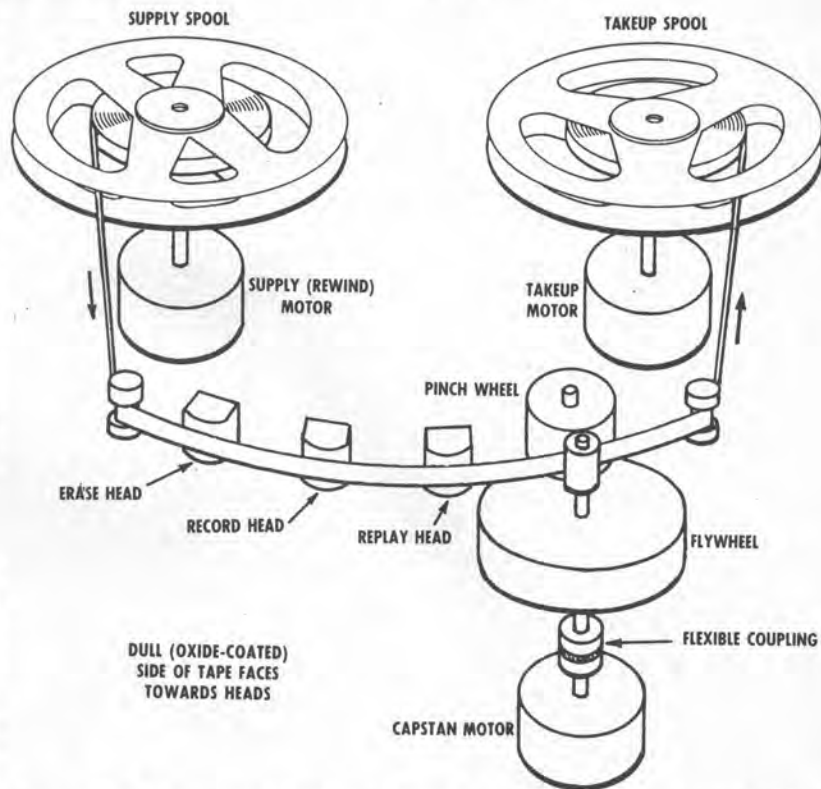


Figure 2: A three-motor deck, as used in the better-quality tape machines. The use of three separate drive motors tends to make the deck simpler mechanically, but increases cost.

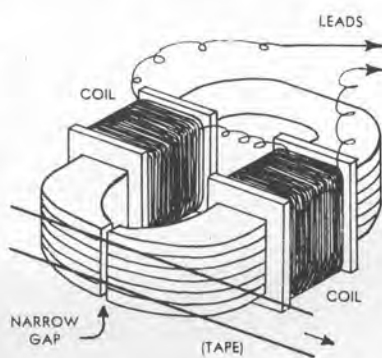


Figure 3: The basic construction of a magnetic head.

Where a pulley-and-belt or intermediate wheel capstan drive system is used it is common to provide the various speeds by arranging a stepped-diameter motor pulley to provide different drive ratios. In recorders where the capstan is directly driven either the motor is arranged to run at different speeds using electrical pole-changing, or interchangeable capstan bushes are provided, each of a different diameter and providing a different tape speed from the fixed motor speed.

Light braking is also applied to the supply spool spindle during normal recording and replay, to keep the tape under tension and prevent free-wheeling.

Having looked at drive systems let us now turn to the magnetic heads. As we have seen from previous chapters these are small electro-magnets, having a narrow "air-gap" over which passes the magnetic oxide coating of the tape. The basic construction of a tape head is shown in figure 3.

The "closed-C" configuration of a magnetic head arises from the need to achieve an efficient magnetic coupling with the tape oxide, and also from the desirability of scanning at any one moment a relatively small section of the oxide — the latter for reasons which will be made clear shortly. A bar magnet construction would be capable of only loose coupling with the oxide, and it would also tend to couple with a fairly long section at any one time; apart from this it would tend to be disturbed by ambient magnetic fields because of the "open" nature of the magnetic path.

The width of the gap in figure 3 is greatly exaggerated for clarity. The gap of practical heads is often barely visible, if at all. It should also be noted that although the gap is often called an "air-gap," an open gap is rarely used as this

would tend to clog up with dirt and oxide particles. Usually the gap consists of a shim of non-magnetic material such as beryllium copper alloy, selected for its wear resistance.

As indicated in figure 3 the core of a magnetic head is often made from thin laminations of a magnetically "soft" material such as mu-metal. Laminations are used for the same reason that they are used in power transformers — to reduce eddy-current losses. Another way of reducing such losses is to use a core made from a ferrite material, although to date such cores have been used only in erase heads because the provision of an extremely narrow gap proves to be rather difficult.

There are three separate functions performed by the heads—erasure, recording and replay. The three functions may or may not be carried out by three separate heads, as we shall see a little later on; for the present, however, we shall look a little closer at the functions and the type of heads best suited to perform them.

In the last chapter we saw that super-sonic AC erasure involves taking the magnetic oxide particles through an expanding series of hysteresis loops to saturation in both directions, and then back down through a series of contracting loops until they have effectively zero remanence.

For efficient erasure, then, the oxide must (a) be taken to saturation in passing the erase head gap, and (b) stay long enough in the field of the gap to be cycled through a fairly large number of loops. These requirements are best met in practice by keeping the frequency of the erasing head signal below about 80KC (above this becomes too hard to develop enough magnetic induction), and by making the gap of the head relatively wide — at least .001in. and sometimes as large as .02in. Note the term "relatively wide:" the erase head gap is still quite small, although it is many times larger than the gaps used for recording and replay.

The requirements for a recording head are somewhat similar to but slightly different from those for an erase head. Although a record head must be able to produce a fairly high flux density throughout the tape oxide, for which purpose alone a fairly wide gap is desirable, less power is conveniently available for the purpose than for erasure. This usually means that a gap used only for recording should be somewhat narrower than for erasure, a typical recording head having a gap of approximately .0005in.

The requirements for a replay head are different again from those for either an erase or record head. The main difference is that the width of the gap for replay must be as small as possible in order to obtain acceptable high frequency response.

The reason for this is as follows: For a constant tape speed, the length of tape occupied by a full cycle of a recorded signal is inversely proportional to the

signal frequency; a cycle of low-frequency signal will occupy a relatively long section of tape, while that of a high-frequency signal will occupy a short section. The actual length will be given by the tape speed in ips divided by the frequency in cps: thus at 7ips one cycle of 100cps tone will occupy .075in while that of a 10KC tone will occupy only .00075in. Lower tape speeds will give correspondingly shorter recorded cycles.

Now to reproduce a recorded signal of a given frequency the gap of the replay head must be somewhat narrower than the length of tape occupied by the

otherwise be. However, this tends to produce a fairly bulky head and one which tends to be sensitive to stray hum fields from motors and transformers.

The alternative professional practice is to use a replay head having only a few turns of wire, connected to a shielded step-up transformer. The output of the transformer may be little more than that delivered by a high impedance replay head but, because the head itself has only a few turns of wire, it may be made quite small physically and the overall sensitivity to external hum fields is reduced, despite the fact that the induced hum is stepped up with the signal. This approach is rather more costly than that using a high-impedance head, as shielded step-up transformers are quite expensive items.

As may be seen from the foregoing, the optimum requirements for heads to perform the functions of erasure, recording and replay are somewhat different. Because of this, the highest quality recorders use three separate heads, each one of the appropriate construction. This also offers other advantages—one is that it is possible to monitor a recording being made by replaying it, at the same time, with the separate replay head.

However, because magnetic heads are rather expensive to produce, designers of domestic recorders usually effect a worthwhile compromise between performance and cost by combining the recording and replay functions in a single head. Thus the majority of domestic recorders have only two heads, an erase head and a record-play or "R/P" head. The R/P head is designed with a gap narrow enough to give acceptable frequency response on replay, yet wide enough to make it possible to achieve the required flux densities in the tape oxide during record, using moderate power levels.

An essential of the tape recording process is that the tape oxide makes an intimate and reliable contact with the head gaps. If this is not obtained, the recording quality suffers greatly, with very poor signal-to-noise ratio and serious loss of high frequencies. For example, a separation between oxide and gap of only .00025in on replay will reduce the output at 7KC to approximately one-quarter of its full value at 7.5ips.

The most usual method of ensuring adequate contact is by using so-called PRESSURE PADS, as shown in figure 1. These are spring-loaded levers having small felt pads, being arranged to press the tape against the heads during recording and replay.

Although pressure pads ensure that the oxide and head gap remain in reliable contact, they can produce excessive wear of the heads. This arises from the difficulty of adjusting the springs on the pads so that the pressure is no more than is absolutely necessary.

Because of this, some designers elect not to use pads, arranging instead that the desired contact is achieved by mounting the heads so that the tape is pulled past them in a hyperbolic curve. Providing the tape is kept under tension, the inward pull of the tape itself provides sufficient contact pressure.

Apart from oxide-gap contact, there is another factor which in practice proves to have an important bearing on the quality of recording and reproduction. This is the angle between the long dimension of the head gap and the direction of tape travel, called the AZIMUTH.

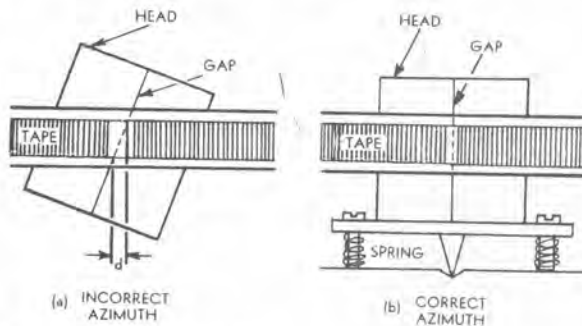


Figure 4: Illustrating the meaning of head azimuth, its effect and adjustment. Correct azimuth is essential for high-quality reproduction.

recorded cycle, because the head can only sense changes in the magnetic field induced in the gap as a whole. If the width of the gap is comparable with the length of the recorded cycles the gap will at any instant scan a large portion of the recorded cycle, and will respond only to the average effect of the portion.

Thus at that frequency where the gap width is exactly equal to the length of a recorded cycle the replay head will have zero output because at every instant the gap will scan a complete cycle of the recorded signal—and the average value of a complete cycle is zero.

From this it can be seen that a replay head with a gap of .00075in would be able to reproduce easily a 100cps signal recorded at 7ips, but would be useless for reproducing 10KC at the same speed. In fact, its response would probably be unacceptable even at 7KC; to reproduce signals up to 10KC adequately it would be necessary to reduce the gap to approximately .0003in. The use of lower tape speeds makes it desirable to use an even smaller gap, say .00015in or better.

## IMPEDANCE

Whereas heads intended solely for erasure or recording may be made in almost any convenient impedance, as dictated by such factors as the number of permissible turns on the coils, available drive current, and so on, the impedance of a replay head is dictated by signal-to-noise considerations. There are two alternatives, one usually adopted in the more modest recorder and the other in professional matches.

The designer of the domestic recorder usually elects to use a high impedance head having many turns of very fine wire. In this way he produces a relatively large head output (but still only a few millivolts) which makes amplifier noise less of a problem than it might



To see why this is important, consider the case where the head used to make a particular recording has its gap perpendicular to the direction of tape travel. If we use the same head for replay, all will be well; similarly if we use another head for replay we will obtain high-quality reproduction **providing** the gap of the second head is also perpendicular to the direction of tape travel.

However if we attempt to replay the tape using a head with its gap at another angle, as shown in figure 4 (a), reproduction will be very poor — particularly at high frequencies. This is because different sections of the head gap will scan different parts of the recording; the effect will be very similar to that

not always there is a wheel or button to enable the counter to be reset to zero.

Let us now turn to the electronics section of a tape recorder. This comprises two main sections: the amplifiers and the bias/erase oscillator. There is also a power supply to operate these sections, but this will not be considered here.

Amplification must be performed within a tape recorder during both recording and replay. During recording it is required to boost the small signals from a microphone or gramophone pick-up to the point where they have sufficient amplitude to operate the recording head; during replay it is required to boost the tiny output of the replay head

to the point where it can operate a loud-speaker.

In elaborate recorders, these functions are performed by two separate amplifiers as in figure 5 (a); this is in fact desirable where three heads are used. However in most domestic recorders economy dictates that a single amplifier is used for both functions. The input and output of the amplifier are switched to the appropriate points, as shown in figure 5 (b).

With either system it is necessary to employ frequency correction or **EQUALISATION** along with amplification during both recording and replay. This is necessary in order to compensate for various losses in the recording and replay processes and arrive at a system which produces a replay signal which is a faithful copy of the signal originally recorded.

Losses occur in the recording head and recording process which degrade the high frequencies more than the low frequencies. For this reason it is usual to apply a certain amount of treble boost or **PRE-EMPHASIS** to the signal during recording.

During replay, both bass and treble boost must be applied to produce properly balanced reproduction. Bass boost is necessary because the output from a replay head is fundamentally proportional to rate of change of recorded flux density and, accordingly, rises with frequency; treble boost must be applied because of head losses and falling response as the gap width approaches the length of a recorded cycle at high frequencies.

Strictly, both recording and replay equalisation must be changed for each

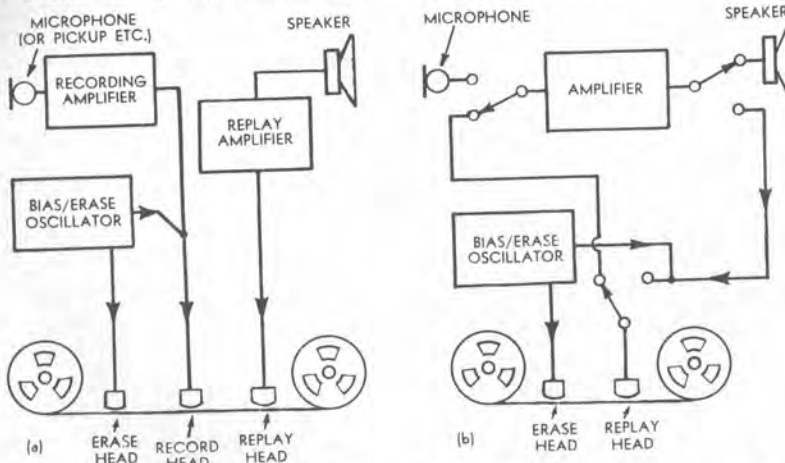


Figure 5: Block diagrams illustrating the operation of two-head and three-head recorders. Domestic recorders are usually of the two-head variety.

which would be obtained with a head gap as wide as the scanned section of tape "d."

For optimum recording quality, then, it is essential that the recording and replay head gaps are both at the same angle relative to the direction of tape travel. In practice this means that all heads of all recorders are adjusted to have a standard azimuth, in order that a tape recorded on any machine may be replayed on any other machine. The standard azimuth is 90 degrees to the direction of tape travel.

The standard way of providing for azimuth adjustment is to use a head mounting like that shown in figure 4 (b). The head is supported on a knife-edge sitting in a groove. It is tilted and clamped at the appropriate angle by means of the small screws and springs. Azimuth adjustment is often omitted on erase heads as these are not as critical as record and replay heads; a fixed mounting is found sufficiently accurate.

Before we pass to the electronics side of tape recorders one or two small points about decks may be mentioned.

Often decks are fitted with an "instant stop" or **PAUSE** control, to permit the tape to be stopped for a short period without turning off the power to the motors. Typical pause controls simply lift the pinch wheel away from the tape and capstan; they may or may not allow for latching the pinch wheel in the retracted position for extended pauses.

Many tape decks have a tape position indicating device consisting of a series of counter wheels or a geared dial operated by a belt and pulley system from one of the spool spindles. Usually but

**MODULATOR & POWER SUPPLY**  
**(ALL-BAND TRANSFORMER)**

DEAR STUDENT,  
We would like to help you!  
During your studies you will carry out the practical construction of radio and electronic apparatus.  
We are suppliers of components for projects such as yours and will welcome you and your problems any time.  
With 20 years experience in the radio and electronic merchandising field we can assist you to buy the right component for the right job.  
And don't forget! We can sell you the components you want at the right price too!  
Feel free to call, write or phone us any time. You will be welcome.  
Yours Sincerely,  
**WILLIAM WILLIS & CO. PTY. LTD.**  
430 Elizabeth Street,  
Melbourne. C.I. Phone 34-6539

operating speed and, in the more elaborate recorders, this is done. However, it may not be done in recorders of the cheaper variety, the designer saving on switch wafers and components by adopting values of equalisation which give satisfactory—though not necessarily optimum—operation at a number of speeds.

Apart from the need for providing and switching equalisation circuitry and the need for switching amplifier inputs and outputs for recording and replay, tape recorder amplifiers employ fairly standard circuitry. However, special care must usually be taken with the input or

head. In fact, unless the erase head is well designed it is difficult to achieve satisfactory erasure above about 50-60KC.

The conflict between bias and erase frequency requirements usually results in a compromise, as both are usually generated by the one oscillator and must accordingly be the same frequency. In recorders of the cheaper variety the compromise frequency is often around 50KC, while in semi-professional recorders it may be 80KC or even 100KC where a high-quality erase head is used.

In the most elaborate recorders, where

The button may work a mechanical lock or stop via levers, or it may be a switch which completes the circuit to a relay.

In some professional machines there is no interlock of this type, but a switch at the back of the machine which can only be turned using a removable key. This makes the recorder quite "safe" where non-technical operators must use the machine to replay valuable tapes.

To conclude this chapter we should perhaps mention stereo tape recorders, which permit simultaneous recording and replay of the two channels of a conventional stereo signal.

In essence a stereo tape recorder is simply two recorders in one, recording and replaying adjacent tracks on a single ribbon of tape. However, in practice, a stereo tape recorder tends to be a fairly complex piece of equipment.

Part of the reason for this is that stereo involves additional controls, over and above those for two mono recorders—such as balance controls and channel reversing facilities. Also it is usual for the designer of a stereo tape recorder to provide for mono recording and replay on either of the two tracks separately, and this involves extra switching. Again the designer may include more extensive input signal mixing facilities than in common mono recorders, as mixing is more essential in producing a worthwhile stereo recording.

One of the main reasons for the current popularity of stereo tape recorders is the growing number of pre-recorded stereo tapes available, competing with the microgroove disc as a medium of home entertainment. Although stereo tapes tend to be less convenient, somewhat noisier and rather more costly than discs, they offer extended frequency response and improved channel separation.

To replay pre-recorded stereo tapes it is not necessary to have a complete stereo recorder, however. Thus many audio enthusiasts elect to take simpler and less costly alternatives, such as a "replay only" tape deck-and-replay pre-amp combination connected to their existing stereo system, or a recorder having only mono recording facilities combined with facilities for stereo replay.

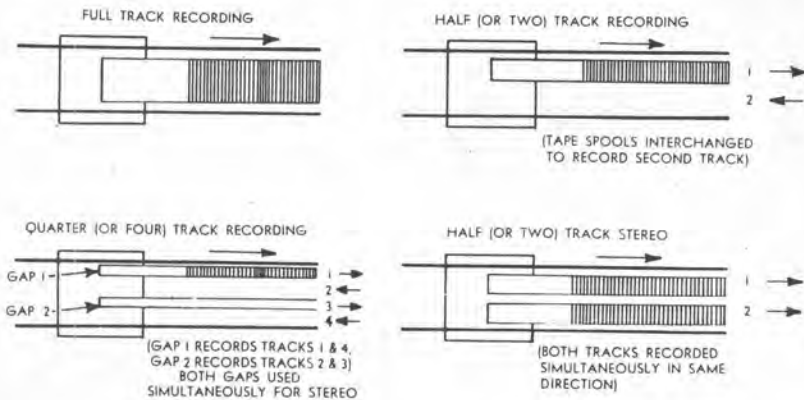


Figure 6: The various track systems in common use. These were discussed in chapter 17, of December, 1964.

preamplifier stages to keep hum and noise to an acceptably low level.

During recording it is important that the recording level be kept high enough to obtain a sufficiently large signal-to-noise ratio yet below the point where tape or head saturation cause distortion. A recording level monitor is therefore provided.

In domestic recorders of the simpler variety this may simply be a neon lamp or pair of neons arranged to glow at appropriate signal levels. Some recorders use "magic eye" indicator tubes for the same purpose, while professional recorders usually provide a moving coil meter whose needle moves proportionally to either the peak or average value of the recording signal.

In most recorders supersonic bias and erase voltages are generated by a valve or transistor oscillator circuit. The oscillator is usually arranged to feed supersonic signals directly to the erase head, but indirectly to the recording head by way of a variable control. This allows the user to find the optimum value of bias for the particular tape used.

During the recording process there is a tendency for the supersonic bias and the high frequencies in the recording signal to beat or heterodyne together to produce distortion and "chirps." Because of this tendency, the bias frequency is made as high as possible so that any beats produced will tend to be supersonic and inaudible. A bias frequency of at least 80 to 100KC is usually considered necessary to reduce this effect to a satisfactory minimum.

This often raises problems where the erase function is concerned, as it is hard to achieve efficient erasure at such high frequencies due to losses in the erase

cost is no object, two separate oscillators may be used. The erase oscillator delivers a signal of 50-70KC, for optimum erasure, while the bias oscillator delivers some 100-120KC for low recording distortion.

Most recorders feature a mechanical or electrical "interlock" system associated with the "recording" control or the switch controlling power to the bias and erase oscillator. The interlock is simply to prevent the operator turning the recording and erasure circuitry on accidentally, which might ruin a treasured recording.

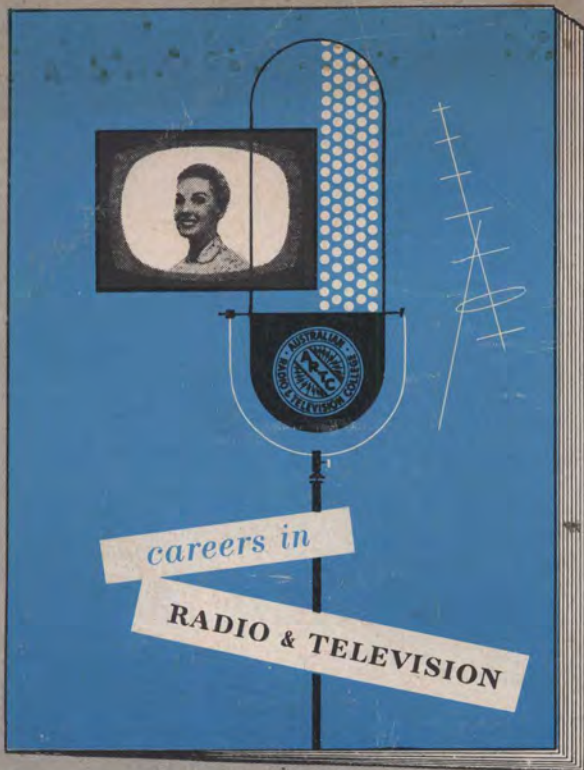
A typical interlock involves a button which must be pressed down before the main control can be turned to "record."

# POSITRONICS

Positronics specialises in the "moving parts" of electronic equipment. In even the simplest equipment, the controls must be smooth and as reliable as the circuitry they are used with. Careful attention to design and strict quality control during manufacture makes our mechanical components the finest available. Inquire about our special design service.

POSITRONICS, 12 MUNRO AVENUE, CHELTENHAM, VICTORIA.  
TELEPHONE 93 1134

## MECHANICAL COMPONENTS



# THIS FREE BOOK

## COULD BE THE TURNING POINT

## IN YOUR CAREER

### ASK YOURSELF THESE 3 QUESTIONS

1. Am I in a dead-end job?
2. Can I use my spare time to get ahead?
3. Am I capable of earning more money?

If the answer is yes, there is room for you in radio-television. Does your job really offer security — worthwhile prospects? If not, now is the time to do something about it. Send the coupon below for the free booklet "Careers in Radio and Television" which shows you just how A.R.T.C. training can help you to a bright future with good prospects.

### TRAIN AT HOME OR AT THE COLLEGE

With A.R.T.C. you can obtain the training you need at the benches and lecture halls of Australian Radio and Television College or in your own home by correspondence . . . you can be taught every important aspect of radio-television, details of the fundamental principles of Electronics.

### GET INTO ONE OF THESE PROFITABLE CAREERS IN RADIO/TELEVISION

There is a profitable career for you in the many phases of radio-television including manufacturing, radio servicing, television servicing, research, sales, broadcasting and television executive, armed forces. A.R.T.C. can help you gain one of these much-sought-after positions, but remember, it is only the trained men who succeed and A.R.T.C. can give you the complete training which is necessary for success in Electronics.

### Make Spare-Time Money

If you wish, you can make your spare time earn money for you by training at home and many students make extra money after only the first few weeks. However, if it is not convenient for you to train at home, then you may use the modern A.R.T.C. workshops. The course is intensely practical and individual. Safeguard your future . . . mail the coupon today.

### A.R.T.C. CAN TRAIN YOU AS IT HAS THOUS- ANDS OF OTHERS!

Thousands of ambitious men have realised the benefits offered by A.R.T.C. training and are now making money in radio. You can join the ranks of the skilled men. . . and it costs only pence a day.

### MAIL COUPON NOW

You are invited to mail the coupon below which can be your first step towards securing a job or business of your own with good prospects, security and big money. A.R.T.C. will mail to you, by return, at no obligation to you, the big free booklet "Careers in Radio and Television." This booklet will show you definite steps you can take for a better job . . . how you can succeed in life. Post the coupon, phone or call NOW.

## AUSTRALIAN RADIO AND TELEVISION COLLEGE PTY. LTD.

E. S. & A. BANK BUILDING,

Cnr. Broadway and City Road, Sydney.  
(Opp. Grace Bros.) Phone 211-4244 (3 lines.)



## AUSTRALIAN RADIO & TELEVISION COLLEGE PTY. LTD.,

206 Broadway, Sydney, N.S.W.

Dear Sir,

Please send me, without obligation, your free booklet "Careers in Radio and Television."

NAME .....

ADDRESS .....