



SYLVANIA NEWS

JANUARY, 1949

Copyright 1949
Sylvania Electric Products Inc.

EMPORIUM, PENNA.

R. A. PENFIELD, *Editor*

VOL. 16, NO. 1



DC Voltage Multiplier For Sylvania Polymer

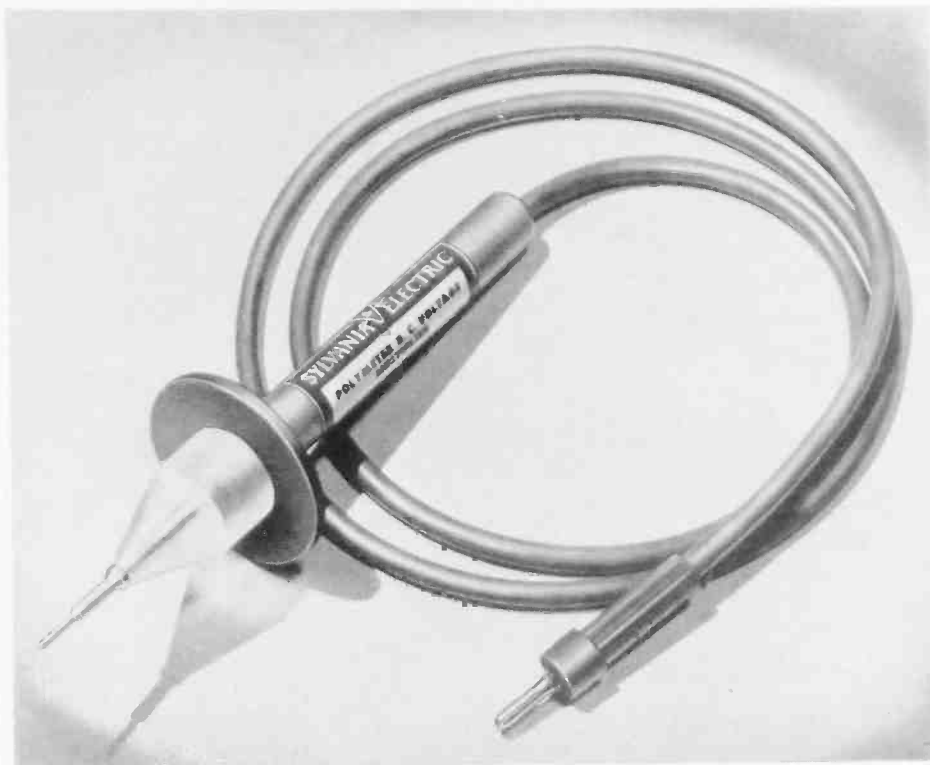

Compact dc voltage multiplier consists of a 48" plug-in flexible lead tested for 22,000 volt breakdown; nickel-plated brass contact pin mounted in tapered polystyrene rod 13/4" long, a removable bakelite safety flange 2" in diameter; and varnished bakelite handle, 4 1/4" long, enclosing dropping resistor tested at 30,000 volts.

A new dc voltage multiplier for the Sylvania Polymer, which extends dc voltage measurements to 10,000 volts, has been announced by Sylvania.

The new multiplier extends the applications of the Polymer, Sylvania's multi-purpose vacuum tube voltmeter, to television high voltage supplies, transmitter plate circuits, experimental power supplies, industrial electronic equipment, electronic flash tube circuits, and many other high voltage dc circuits.

When used in place of the standard Polymer low-voltage probe, it multiplies each of the present dc voltage ranges by a factor of 10. In such applications, for example, the 1,000 volt dc range setting will read 10,000 volts dc full scale. The 300 volt dc range setting will read 3,000 volts dc full scale. This unit is calibrated especially for use with the Sylvania Polymer.

Price of the voltage multiplier is \$9.95. It is available now from your Sylvania Distributor.

Predictions—1949

"One of the brightest spots in the 1949 picture is the television market," according to Don G. Mitchell, president of Sylvania. "In 1947 the industry produced 180,000 sets. In 1948, production will top 800,000. The latest estimated 1949 production is 2,000,000 sets.

"We are on the threshold of a multi-billion dollar business that soon will be among the largest of consumer markets.

"Sylvania has embarked on a program of expansion for television viewing tube production. Last summer we purchased a plant in Ottawa, Ohio and we have just purchased a larger plant at Seneca Falls, N. Y., to meet increased demand for picture tubes.

"So far the television tube market has been almost entirely for new receiving sets but a large replacement market is beginning to appear. This may mean that within a couple of years the replacement market will be greater than the entire output of viewing tubes in 1948.

"We are a major factor in germanium crystal diode production but it will be several months before commercial production of germanium triodes at competitive prices can be announced."

Trademarks are a guide to people on how they should spend their dollars; they let them know whether they are getting their money's worth for the things they buy to eat, to live with, to wear.

A. O. Buckingham

ON THE COVER

Compact and lighter than a pocket camera this new citizen's radio station was developed by the Citizens Radio Corporation, Cleveland, Ohio for person-to-person communication. Equipment may be carried anywhere. Receiver and transmitter shown includes microphone, antenna and four Sylvania subminiature tubes for oscillator and super regenerative receiver. See page G-3 for complete story.

New Factory To Increase CR Tube Output

Further expansion of Sylvania's television picture tube production has been announced by J. C. Farley, general manager of the Radio Tube Division. The company has purchased a new plant in Seneca Falls, N. Y. for the production of television picture tubes.

The plant, formerly occupied by the Rumsey Pump Co., will provide 98,000 square feet of space. Operations will begin immediately and it is expected that 350 to 400 people will eventually be employed.

The decision by Sylvania's management to open a television picture tube plant in Seneca Falls is consistent with our decentralization policy. Seneca Falls has a population of 8,500 and is 40 miles west of Syracuse.

The opening of the new plant provides the third Sylvania television picture tube plant. Others are located at Emporium, Pa. and Ottawa, Ohio. The latter began production this fall.

SYLVANIA NEWS

MERCHANDISING SECTION

JANUARY, 1949

Copyright 1949
Sylvania Electric Products Inc.

EMPORIUM, PENNA.

VOL. 16, NO. 1

Want To Service 5 Million Radio Sets?

Sylvania ads like this appear monthly in five leading magazines. They tell the radio listener to take his radio to the man displaying the RADIO SERVICE decal for service. This is just one part of the Sylvania Coordinated Advertising Campaign.

←

advertising; newspaper ad mats for local newspaper advertising and radio spot announcements for use over your local broadcast station. All of this is topped with national advertising which ties-in closely with the material furnished for local use.

All of the material, in the form of a new campaign for every month, is available to service dealers at extremely low cost. The only charge for the material is the postage on the postal cards which the dealer mails to his prospects every month. This money is what Sylvania pays to the government for the stamped postal cards. All of the other material in the program is furnished to the dealer free of charge.

For additional economy to the dealer, the campaign is furnished in a kit which contains complete material for three months. By receiving the material in such a form the dealer can use the material to plan his window displays and advertising over a longer period. The postal cards can be addressed more easily because the dealer can address the entire mailings at one writing, or he can distribute the job over a long period of time.

Complete material for the months of February, March and April is now available to service dealers. For a pictorial review of how the campaign works and what the kit contains for each month see pages M-2 and M-3 of this issue of THE NEWS. The material may be ordered from your Sylvania distributor or a card or letter to the Advertising Department, Sylvania Electric Products Inc., Emporium, Pa. will bring you complete details along with an order form.



"It sounded flat, so he's been trying to pump up the tubes!"

RADIO SERVICE
SYLVANIA RADIO TUBES
Authorized Dealer

SIGN OF
DEPENDABLE
RADIO SERVICE

Don't give your radio the air just because it's lost its bounce—call up the nearest serviceman who displays the Sylvania sign. You can depend on him to pump new life into your tired set! With Sylvania test equipment your serviceman will root out hidden faults. With Sylvania radio tubes he'll make your set sound as good as the day you bought it. For dependable radio service, look for the Sylvania sign!

SYLVANIA RADIO TUBES
PRODUCT OF SYLVANIA ELECTRIC PRODUCTS INC.



One of the most striking facts revealed in the latest radio set ownership survey by the Broadcast Measurement Bureau is that 5,177,100 radios in the U. S. are not in operating condition. Not only does this reveal the large volume of potential business waiting for service dealers, but it also shows that a great promotional effort on the part of the dealer will show results.

From the facts we know the business is there, but getting your share of that business is the big problem. Especially designed

to help you effectively obtain this business is the Sylvania co-ordinated advertising campaign. This campaign is a complete promotion for each month of the year. Its use helps you keep pounding away at your prospects month after month. It is tailored to meet the advertising problems of the service dealer.

The material furnished to the dealer in this campaign consists of every known type of advertising. There are direct mail postal cards; big colorful window displays and window streamers for point of sale

HERE'S YOUR COORDINATED ADVERTISING CAMPAIGN FOR FEBRUARY, MARCH, APRIL

This Is How It Works To Increase Your Service Business

1

"It's the Birdcallers' Convention, and I can't turn this off!"

RADIO SERVICE
SYLVANIA RADIO TUBES Authorized Dealer

Is your radio getting out of hand? Is it giving you the bird instead of your favorite station? Don't despair—turn your set over to the serviceman who displays the Sylvania sign. He has accurate Sylvania test equipment to hunt out trouble. He has the skill to put your set in top-notch shape. He'll use those wonderful Sylvania radio tubes to give you better-than-ever reception. No wonder so many people look to the Sylvania sign as the guide to dependable radio service!

SYLVANIA RADIO TUBES
PRODUCT OF SYLVANIA ELECTRIC PRODUCTS INC.

Each month your prospects see ads like this in Life, Collier's, Post, Look and Radio And Television Best.

2

"It's the Birdcallers' Convention, and I can't turn it off!"

When your radio gives you the bird instead of Bach, call our service department. We're expert radio technicians. Our quick service and low prices will please you too.

CALL US FOR EXPERT RADIO SERVICE

WE ARE AN AUTHORIZED DEALER FOR SYLVANIA RADIO TUBES

RADIO SERVICE
SYLVANIA RADIO TUBES Authorized Dealer

Every month he receives a colorful postal card in the mail. This card has your name, address, phone number printed on it.

3

"It's the Birdcallers' Convention and I can't turn it off!"

We repair any make or model radio...

RADIO SERVICE
WE USE AND RECOMMEND SYLVANIA TUBES

If your radio gives you the bird instead of Bach, call our service department. We're experts in any radio trouble. We'll give you a complete check-up and repair your radio promptly and efficiently. You'll like our low prices, too.

FIRM NAME
STREET ADDRESS
AND TELEPHONE NUMBER

"It's the Birdcallers' Convention and I can't turn it off!"

We repair any make or model radio....

RADIO SERVICE
WE USE AND RECOMMEND SYLVANIA TUBES

If your radio gives you the bird instead of Bach, call our expert service department. We're experts in any radio trouble. We'll give you a complete check-up and repair your radio promptly and efficiently. You'll like our low prices, too.

FIRM NAME
STREET ADDRESS
AND TELEPHONE NUMBER

Each month he sees your ad in your local newspaper. The ads feature your name and address and the RADIO SERVICE decal.

4

Spot Radio Announcement

MARCH 1949

FOR SYLVANIA RADIO SERVICE DEALERS

RADIO SERVICE

He hears your spot announcement over your local radio station.

5

"It's the Birdcallers' Convention and I can't turn this off!"

When your radio gives you the bird instead of your favorite station...

Call us

RADIO SERVICE
WE USE AND RECOMMEND SYLVANIA RADIO TUBES

He sees this full color window display in your window. Each month there is a new display for your use.

6

"It's the Birdcallers' Convention, and I can't turn this off!"

When your radio needs fixing—call our expert service department

RADIO SERVICE
WE USE AND RECOMMEND SYLVANIA RADIO TUBES

He sees this colorful window streamer in your shop window. There is a different streamer each month of the year.

7

RADIO SERVICE

SYLVANIA RADIO TUBES Authorized Dealer

He sees the colorful RADIO SERVICE decal your window, door, truck, recognizes you as the serviceman talked about in this advertising.

Advertising Department

WRITE TODAY
SYLVANIA ELE

SYLVANIA NEWS

TECHNICAL SECTION

JANUARY 1949

Copyright 1949,
Sylvania Electric Products Inc.

EMPORIUM, PENNA.

A. V. BALDWIN
Technical Editor

VOL. 16, NO. 1

TELEVISION

VIDEO DETECTION AND A. G. C.

By Wilfred B. Whalley

This month we are printing the sixth and seventh of the series of articles on Television by Sylvania Engineers.

Video Detector

Following the Picture IF amplifier described in the December issue, and which increased the signal voltage over its pass band $f_1 - f_c - f_2$, (where f_c is the equivalent carrier frequency of the Picture IF, usually 25.75 mc.) is the video detector, sometimes called the video demodulator. Its function is to reproduce from the IF signal, the video signal originally developed by the camera in the television station, in the same manner that

Wilfrid B. Whalley received the degree of B.A.Sc., with honors from the University of Toronto in 1932, was on the staff of the Department of Electrical Engineering for the next four years and received the M.A.Sc. degree in 1935. In 1936 he was development engineer at the Radio Valve Company in Toronto. From 1937 to 1940 he was with RCA Manufacturing Company in Harrison and in 1940 transferred to war work on radar systems and cathode ray tubes in Canada. In 1943 Mr. Whalley returned to Radio Corporation of America doing research on radar and television transmitting tubes and circuits at the RCA Laboratories Division. In 1947 he was appointed Assistant Professor of Engineering Physics at Cornell University. At present, Mr. Whalley is at the Research Laboratories of Sylvania Electric Products Inc., New York. He is a Member of Sigma Xi, American Association of University Professors and Associate Member of the Institute of Radio Engineers.

GOOD NEWS
Type 6A5G Back Again

Experimenters and custom set builders will be pleased to hear that the Type 6A5G discontinued early in the war by order of the W.P.B. is now being made available. Many servicemen have written in complaining that they were unable to make as hum-free an amplifier with the available substitute tube.

the second detector in the usual radio receiver reproduces the sound frequency signal originally developed in the broadcast studio microphone.

The video detector rectifies the intermediate frequency signal converting the voltage envelope of IF into a "pulsating" DC signal having, in present television receivers, a frequency range from 60 cycles to 4 mc.

It may be pointed out that a television receiver could be constructed having a first detector (directly after the antenna tuning network) and followed by a multi-stage video amplifier. However, aside from adjacent channel selectivity difficulties in the detector input circuit, there would be a practical limit to the maximum gain, determined by the video amplifier

stability; hence, the reason for the usual procedure of r-f amplification followed by the converter, then the IF amplifier (which has the greatest gain in the receiver), video detector and a moderate gain video amplifier.

The video detector can be any one of the usual radio receiver types, such as; half-wave or full-wave diode, plate circuit, grid leak, or infinite impedance type. For simplicity the diode detector is used almost exclusively. Some diode circuits in general use are shown in Figures 1 and 2. Both of these are half-wave rectifiers.

As the IF voltage envelope varies in magnitude due to its contained video modulation, the rectified voltage from the detector also varies in magnitude being a maximum during the synchronizing pulse interval and a minimum at the time when the signal corresponds to maximum white in the picture. A previous article has explained the modulation pattern. Figure 3 illustrates the choice of positive or negative polarity, positive sync with cathode output, negative sync with anode output.

Since the video detector output covers the whole video frequency range from 60 cycles to 4 mc., the coupling circuit to the receiver video amplifier should be designed to pass this frequency range with-

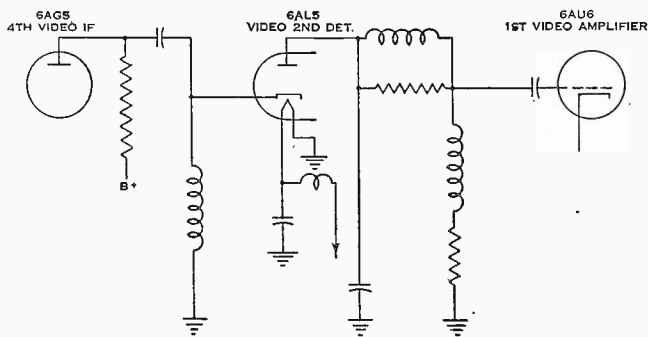

FIGURE 1
DIODE VIDEO DETECTOR OF A TYPICAL RECEIVER

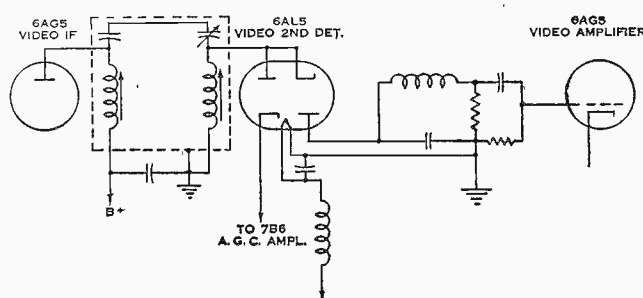
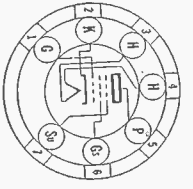

FIGURE 2
ANOTHER VIDEO DETECTOR



7CM-O-7

Sylvania Type 6BJ6 REMOTE CUT-OFF PENTODE

PHYSICAL SPECIFICATIONS

Base..... Small-Burton Miniature 7-Pin
 Bulb..... 15 1/2
 Maximum Overall Length..... 2 1/8"
 Maximum Seated Height..... 1 3/8"
 Mounting Position..... Any

RATINGS

Heater Voltage AC or DC..... 6.3 Volts
 Heater Current..... 150 Ma.
 Maximum Plate Voltage..... 300 Volts
 Maximum Screen Voltage..... 125 Volts
 Maximum Screen Supply Voltage..... 300 Volts
 Maximum Plate Dissipation..... 30 Watts
 Maximum Screen Dissipation..... 0.6 Watt
 Maximum Control Grid Voltage..... 50 Volts
 Negative bias..... 0 Volts
 Positive bias..... 0 Volts
 Maximum Peak Heater-Cathode Voltage..... 90 Volts
 Direct Inter-electrode Capacitances*
 Grid to Plate..... 0.0035 μ mf. Max.
 Input..... 4.5 μ mf.
 Output..... 5.5 μ mf.
 *Without external shield

TYPICAL OPERATION

Class A1	
Heater Voltage.....	6.3 Volts
Heater Current.....	150 Ma.
Plate Voltage.....	250 Volts
Screen Voltage.....	100 Volts
Control Grid Voltage.....	-1 Volt
Suppressor.....	Connected to cathode at socket
Control Grid Bias (Approx.) for 13 μ mhos Transconductance.....	-20 Volts
Plate Current.....	9.0 Ma.
Screen Current.....	3.3 Ma.
Transconductance.....	3850 μ mhos
Plate Resistance (Approx.).....	1.3 Megohms

APPLICATION

Sylvania Type 6BJ6 is a remote cut-off pentode of miniature construction designed for use in sets requiring 150 Ma. heater current. It is similar in application to Sylvania Type 6BA6.

SYLVANIA RADIO TUBES

Issued as a supplement to the manual in Sylvania News for January 1949

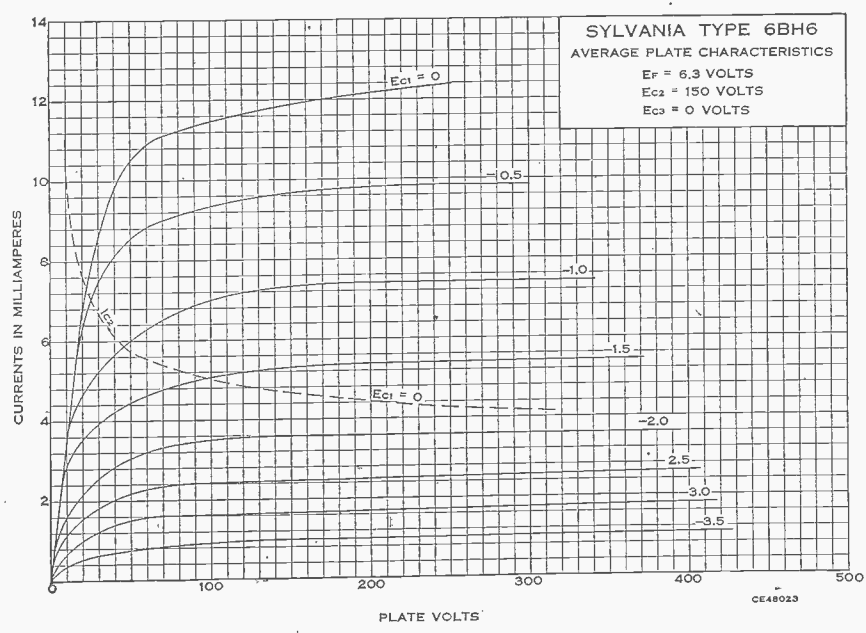
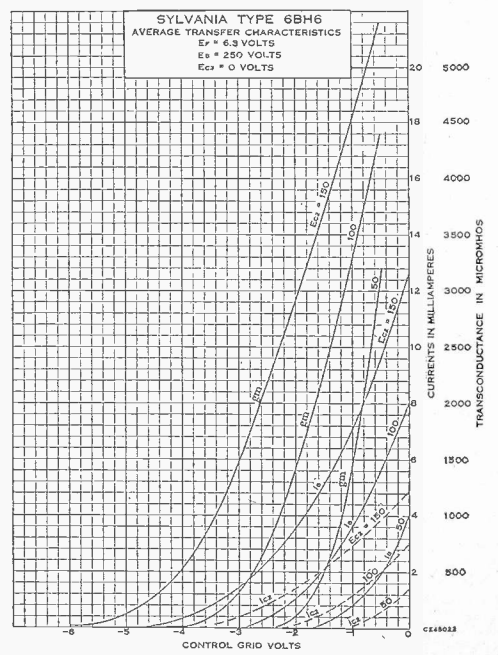

SYLVANIA RADIO TUBES

INTERCARRIER METHOD OF SOUND RECEPTION

An interesting method of sound reception in television receiver operation was proposed some years ago by Messrs. L. W. Parker and R. B. Dome. The particular purpose of this system was to reduce the number of components and tubes in the IF amplifiers, by making use of the modulated 4.5 megacycle beat signal which is present at the output of the video detector of any television receiver. This modulated 4.5 megacycle signal is produced by the simultaneous rectification of the AM modulated picture IF carrier and of the frequency modulated sound IF. (In a typical receiver the picture IF equivalent carrier frequency is 25.75 megacycles and the sound IF equivalent carrier frequency is 21.25 megacycles.) As is well known, the spacing between a television sound transmitter RF carrier frequency and the associated picture transmitter carrier frequency is set at 4.5 megacycles.

The amplitude of the 4.5 megacycle signal at the output of the video amplifier of a television receiver, depends upon the frequency response characteristic of the picture (or video) IF amplifier and of the video amplifier, being small when good quality bandpass filter circuits are used, large in amplitude when staggered-tuned IF amplifiers with inadequate sound rejection filters are used. In the intercarrier type of receiver, the frequency response of the IF amplifier is controlled to give a reasonable gain at the sound IF frequency usually between 30 and 40 db. below that of the gain at the picture IF frequencies.

Figure 1 shows the basic layout

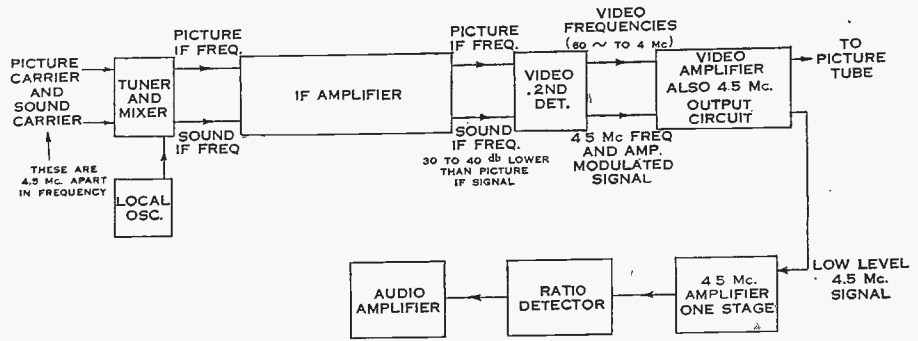

FIGURE 1
BLOCK DIAGRAM OF INTERCARRIER SYSTEM

of an intercarrier receiver. The sound and picture RF frequencies, after passing through the tuner, are converted to suitable frequencies for the IF amplifier by the mixer and local oscillator. The IF output signals (those of the picture frequencies having been amplified 30 to 40 db more than those of the sound frequencies) are rectified in the second detector giving (a) the usual video frequencies from 60 cycles to 4 megacycles, (b) a low level 4.5 megacycle amplitude-and-frequency-modulated beat signal, (c) signals whose frequencies are the sum of the two IF frequencies and their side-bands. Both (a) and (b) are amplified by the video amplifier, but (c) does not pass through. At the output of the video amplifier a suitable coupling circuit abstracts the 4.5 megacycle signal which then passes through a single stage 4.5 megacycle amplifier into a ratio detector and to the audio amplifier.

The ratio type of detector is preferred since it will operate satisfactorily with a weaker signal than

will the usual type of FM discriminator. Figure 2 shows the voltage frequency characteristic of a typical picture IF amplifier and, as mentioned in the December issue of SYLVANIA NEWS, the slope of the response curve on the high frequency side is designed to suit the single side-band operation of the television picture transmitter and give optimum overall receiver operation. In an intercarrier receiver using an IF amplifier of the same basic design, it is necessary that the sound IF frequency response be not too small, otherwise the 4.5 megacycle signal level from the video amplifier will be too

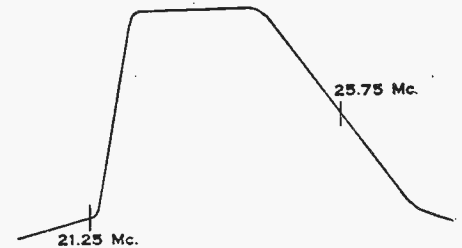

FIGURE 2
TYPICAL IF RESPONSE
(Continued on page T-4)

MULTIPLIER PROBE FOR POLYMER GOES TO 10,000 VOLTS

Sylvania has just announced a multiplier probe for use with Polymer Type 134 and 134Z. This will be particularly interesting to those now servicing television receivers because it increases the DC ranges to 3000 and 10,000 volts.

From the illustration on another page (G-2) you can see that it is carefully designed to reduce the possibility of leakage or shock to the user. Notice that the nose is made of polystyrene and that the lead wire is tested for break-

down at 22,000 volts. Instead of painting the handle, a moisture-resisting varnish is used to minimize the deleterious effect of perspiration.

Although its use in television servicing equipment will be the largest field, the Polymer with this multiplier will be useful also with any other equipment operating at high voltages, such as amateur transmitters, industrial electronic equipment, electronic photoflash equipment, etc.

When used on television high voltage supplies of very low current capacity, such as the high frequency oscillator type, the small voltmeter current can be compensated for by turning the picture intensity to its lowest position. The reading obtained this way will be very close to the actual operating voltage.

Since the resistor in the probe is adjusted for use with Sylvania Polymers, it will not read correctly with other makes of instruments.

INTERCARRIER METHOD OF SOUND RECEPTION *(Cont'd)*

small for the single stage amplifier. Also, the local oscillator in the receiver must always be higher in frequency than the received signal RF frequency.

A cheaper IF amplifier may be made by employing a symmetrical frequency response; this is illustrated in Figure 3. One disadvantage is that the overall receiver bandwidth will be much less than 4 megacycles;

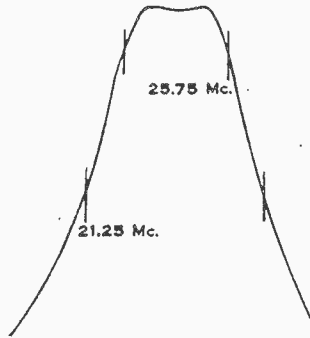

FIGURE 3
TYPICAL SYMMETRICAL
IF RESPONSE CURVE

however, the local oscillator may be operated on the higher channels at a frequency lower than the received carrier signal, making the highest required frequency of the local oscillator, for channel 13, equal to 190 megacycles.

Operating tests and measurements have already indicated that the stability requirements of the local oscillator in an intercarrier receiver are less stringent than in a conventional two IF amplifier receiver. A change in frequency of the local oscillator moves the frequency of both the picture and sound intermediate frequencies by the same number of cycles, leaving the difference frequency of 4.5 megacycles unaffected. For the same reason, microphonic and hum modulation of the local oscillator has much less effect upon operation than in a conventional receiver and tuning of the receiver is less critical.

A necessary condition for satis-

factory sound reception, is that the television picture transmitter radiate some carrier power at all times, requiring that the whitest part of the transmitted scene correspond to a power level of not less than 1% of the power during the synchronizing pulse interval (to not less than 10% in terms of voltage). Cessation of the picture carrier will immediately cause the 4.5 megacycle beat frequency to disappear giving no sound output from the receiver. If the power level of the picture transmitter drops below the 1% peak power point, the amplitude of the 4.5 megacycle beat frequency will drop giving sufficient additional amplitude modulation to show up in the audio amplifier and speaker. This would manifest itself as 60 cycle hum superimposed upon the sound.

Next month's article will deal with Sync. Separators and Sweep Circuits.

SERVICE HINTS

Emerson Model FU-428: The complaint on this receiver indicated that it would become inoperative in the evenings when the line voltage decreased. With tubes found good on the tube tester, checking voltages indicated that with the line voltage at 117 v AC, each 1.4 volt section of filament had a voltage drop of 1.1 v and under these conditions, according to RMA Standards, should be at a nominal value of 1.3 volts. The schematic diagram showed that the filaments of the 1.4 volt tubes were in series and in the cathode circuit of the beam power amplifier section of the 117P7GT doubling as a cathode resistor. Installing a 117N7GT in the 117P7GT socket (no rewiring necessary) brought the voltage drop across the 1.4 volt tubes up to specifications and the variation of the AC line voltage did not make the receiver inoperative at any time.—Seymour Sinuk, New York 60, N. Y.

EDITOR'S NOTE: This seems like an acceptable substitution in many respects but it means operating the Type 117N7GT into a 3000 ohm load instead of the rated 4000 ohms. Perhaps a new Type 117P7GT would work equally well.

Brush Soundmirror Model BK-401: On rewind, the supply reel (left hand reel, usually plastic) goes very fast, usually so fast that when the stop button is pushed the reel takes so long to stop that the tape is torn in the process. To save a lot of checking, start the rewind slowly, then before it gets up to speed, push stop button. If the reel stops normally in that fashion then the button, switching mechanism and DC supply are all normal. The only way to control the complaint is to remove the left hand supply motor carefully. Below the spindle will be found a felt brake operating against the brass spindle. Using an Allen wrench loosen the spindle, then slide spindle down so it makes greater contact against felt friction brake. Now replace the whole mechanism. The supply reel will no longer be able to get up to uncontrollable speed.—David Gnessin, Columbus, Ohio.

* * *

Hum in Philco Model 48-300: An annoying hum at low volume which first appears to be a filter condenser can be silenced by shielding the Type 1U5 tube.—Elmer DeLorm, No. Tonowanda, N. Y.

RCA V-215, Audio Distortion: Removing either of the 6F6 output tubes improved tone, also improved when 6SQ7 phase inverter was removed. The trouble was caused by one-half of the audio output transformer having high resistance. Checking voltages at tube sockets with the set operating will not indicate this defect, as the added resistance causes very little voltage drop, so a static test with an ohmmeter is necessary.—Harold Fread, Irvington, N. J.

VIDEO DETECTION AND AGC

(Continued)

trol voltage to the RF and IF tubes.

It should be noted that the circuit of Figure 5 operates to maintain a constant IF output voltage, which may not correspond to the black level of the signal since the synchronizing pulse amplitude may not be constant from station to station.

FEBRUARY

"It does that on every high note!"

RADIO SERVICE
SYLVANIA RADIO TUBES
Authorized Dealer

SIGN OF
DEPENDABLE
RADIO SERVICE

Does your radio hit the ceiling instead of high "C"? Has your loudspeaker turned into a loud squeaker? Then turn your set over to the radio serviceman who displays the Sylvania sign. He'll search out troubles quickly, accurately with his Sylvania test equipment. And he'll assure you the clear-toned reception you want with dependable Sylvania radio tubes. Remember, there are no finer radio tubes made!

SYLVANIA RADIO TUBES
PRODUCT OF SYLVANIA ELECTRIC PRODUCTS INC.

This ad appears in Look, February 15, Post, February 19, Radio Best, March.

"It does that on every high note!"

WHEN YOUR RADIO NEEDS FIXING...

WE USE AND RECOMMEND SYLVANIA RADIO TUBES

Build a window display around this full color card in February.

Use these spot radio announcements over your local station during Feb.

"It does that on every high note!"

Expert radio repair - economical prices

RADIO SERVICE
SYLVANIA RADIO TUBES
Authorized Dealer

WE REPAIR ANY MAKE OR MODEL RADIO...

IF YOUR RADIO GIVES YOU THE BIRD INSTEAD OF YOUR FAVORITE STATION... WE REPAIR IT! We have the skill and experience to make repairs quickly, surely. And he has those dependable Sylvania radio tubes to give you A-1 reception. No doubt about it—you'll get the best in radio service when you stop at the Sylvania sign!

FIRM NAME
STREET ADDRESS
CITY AND TELEPHONE NUMBER

Run these ad mats in your local paper during February. Available in 1 and 2 column sizes.

Spot Radio Announcements

FEBRUARY 1949

FOR SYLVANIA RADIO SERVICE DEALERS

"It does that on every high note!"

If your radio makes high "C" sound like "B" Flat better give us a call. Our expert technicians will make it work like new in no time. Our low prices and prompt service are hard to beat.

CALL US FOR EXPERT RADIO SERVICE

WE ARE AN AUTHORIZED DEALER FOR SYLVANIA RADIO TUBES

RADIO SERVICE
SYLVANIA RADIO TUBES
Authorized Dealer

Mail this handsome postal card during February. You pay only the postage on the card.

"It does that on every high note!"

When your radio gives you trouble—try our expert service... You'll like our LOW PRICES too!

WE USE AND RECOMMEND SYLVANIA RADIO TUBES

Attach this colorful window streamer to your window in February. Use it during the entire month.

MARCH

"It's the Birdcallers' Convention, and I can't turn this off!"

RADIO SERVICE
SYLVANIA RADIO TUBES
Authorized Dealer

SIGN OF
DEPENDABLE
RADIO SERVICE

Is your radio getting out of hand? Is it giving you the bird instead of your favorite station? Don't despair—turn your set over to the serviceman who displays the Sylvania sign. He has accurate Sylvania test equipment to hunt out trouble. He has the skill to put your set in top-notch shape. He'll use those wonderful Sylvania radio tubes to give you better-than-ever reception. No wonder so many people look to the Sylvania sign as the guide to dependable radio service!

SYLVANIA RADIO TUBES
PRODUCT OF SYLVANIA ELECTRIC PRODUCTS INC.

This ad appears in Life, March 7, Collier's, March 26, Radio Best, April.

"It's the Birdcallers' Convention and I can't turn this off!"

When your radio gives you the bird instead of your favorite station...

Call us

WE USE AND RECOMMEND SYLVANIA RADIO TUBES

Use this big window display in your window during March.

Use these spot radio announcements over your local station during March.

"It's the Birdcallers' Convention and I can't turn it off!"

We repair any make or model radio...

RADIO SERVICE
SYLVANIA RADIO TUBES
Authorized Dealer

WE REPAIR ANY MAKE OR MODEL RADIO...

IF YOUR RADIO GIVES YOU THE BIRD INSTEAD OF YOUR FAVORITE STATION... WE REPAIR IT! We have the skill and experience to make repairs quickly, surely. And he has those dependable Sylvania radio tubes to give you A-1 reception. No doubt about it—you'll get the best in radio service when you stop at the Sylvania sign!

FIRM NAME
STREET ADDRESS
CITY AND TELEPHONE NUMBER

Use this new set of ad mats in your local paper during March. They tie-in with the other material.

Spot Radio Announcements

MARCH 1949

FOR SYLVANIA RADIO SERVICE DEALERS

"It's the Birdcallers' Convention, and I can't turn it off!"

When your radio gives you the bird instead of that call you service department. We're expert radio technicians. Our quick service and low prices will please you too.

CALL US FOR EXPERT RADIO SERVICE

WE ARE AN AUTHORIZED DEALER FOR SYLVANIA RADIO TUBES

RADIO SERVICE
SYLVANIA RADIO TUBES
Authorized Dealer

Mail this colorful government postal card during March. Imprinted with your name, address, phone.

"It's the Birdcallers' Convention, and I can't turn this off!"

When your radio needs fixing—call our expert service department

WE USE AND RECOMMEND SYLVANIA RADIO TUBES

This three-color window streamer is for use during March. Leave it on your window all month.

APRIL

"The reception's been a bit foggy lately!"

RADIO SERVICE
SYLVANIA RADIO TUBES
Authorized Dealer

SIGN OF
DEPENDABLE
RADIO SERVICE

Is your radio in a haze? Is it on the blink instead of on the beam? Then let the serviceman who displays the Sylvania sign clear it up for you. He has accurate Sylvania test equipment to search out toughest troubles. He has the skill and experience to make repairs quickly, surely. And he has those dependable Sylvania radio tubes to give you A-1 reception. No doubt about it—you'll get the best in radio service when you stop at the Sylvania sign!

SYLVANIA RADIO TUBES
PRODUCT OF SYLVANIA ELECTRIC PRODUCTS INC.

This ad appears in Post, April 9, Look, April 26, Radio Best, May.

"The reception's been a bit foggy lately!"

WHEN YOUR RADIO NEEDS REPAIR...

Call us

WE USE AND RECOMMEND SYLVANIA RADIO TUBES

Big, bright window display, will attract prospects during April.

These spot radio announcements help you tie-in with the campaign during April.

"The reception's been a bit foggy lately!"

See us first with your radio problems

RADIO SERVICE
SYLVANIA RADIO TUBES
Authorized Dealer

WE REPAIR ALL TYPES AND BRANDS OF RADIOS...

IF YOUR RECEPTION IS A BIT FOGGY LATELY... WE REPAIR IT! We have the skill and experience to make repairs quickly, surely. And he has those dependable Sylvania radio tubes to give you A-1 reception. No doubt about it—you'll get the best in radio service when you stop at the Sylvania sign!

FIRM NAME
STREET ADDRESS
CITY AND TELEPHONE NUMBER

These ad mats for April help identify you with the campaign. Use them in your local paper.

Spot Radio Announcements

APRIL 1949

FOR SYLVANIA RADIO SERVICE DEALERS

"The reception's been a bit foggy lately!"

If your radio reception is lost in a fog, let us put it on the beam. With the best in test equipment, we're equipped to do a good job quickly and inexpensively.

CALL US FOR EXPERT RADIO SERVICE

WE ARE AN AUTHORIZED DEALER FOR SYLVANIA RADIO TUBES

RADIO SERVICE
SYLVANIA RADIO TUBES
Authorized Dealer

Mail this colorful postal card to your prospects during April. You pay only the one cent postage.

"The reception's been a bit foggy lately!"

WE REPAIR ALL TYPES AND BRANDS OF RADIOS...

WE USE AND RECOMMEND SYLVANIA RADIO TUBES

Use this eye-catching window streamer in your window during April. Leave it there all month.

FOR MORE INFORMATION

SYLVANIA ELECTRIC PRODUCTS INC.

Emporium, Penna.

Field Service Stations For Sylvania Instruments

Sylvania has established a nation wide network of Authorized Test Equipment Service Stations for the convenience of service dealers who require repair and recalibration to their Sylvania Test Equipment. These service stations are equipped to handle all difficulties encountered in the operation of Sylvania test instruments.

In accordance with our standard RMA warranty, all equipment sent to these service stations should be carefully packed to avoid damage in transit. Shipment to the station must be prepaid. The service station will carefully check the instrument and return it to you prepaid. Your instrument should be accompanied by a letter describing the trouble and listing the purchase date.

No charge will be made for service if the instrument is in warranty, if the instrument is out of warranty, charges will be made by the service station direct to the instrument owner.

Through the establishment of these service station Sylvania hopes to contribute to continued good customer relations. Listed below is

Modernize Your Tester

Those dealers who want to keep their Sylvania Tube Testers up-to-date, can now purchase the nine pin socket kit which can easily be installed in their present tube tester. This kit contains all of the necessary wires, already color coded, the nine pin socket and full instructions for installing.

All early models of the Sylvania tube testers are equipped with a dummy socket for the addition of new sockets as new tube types are developed. The nine pin socket kit is available from Sylvania distributor, or one of the conveniently located Authorized Sylvania Service Stations. The price of the kit is 75c. All orders should be placed with your distributor or your nearest Service Station. Do not order the kit from the Sylvania factory.

a list of the Authorized Sylvania Service Stations.

East Coast States

Home Radio Service, Inc.
253 East 72nd. Street
New York 21, N. Y.

Radio Television Company
723 Ponce de Leon Ave., N. E.
Atlanta, Georgia

Central States

Master Electric Service Co.
835 W. Washington Blvd.
Chicago 7, Ill.

Mr. Francis T. Wright
6606 Snider Plaza
Dallas 5, Texas

West Coast States

Howell's Electric Supply
522 Union Street
Seattle 1, Washington
Service Radio Wholesale
1357 Post Street
San Francisco 9, Calif.

Ionic Equipment Company
1705 North Kenmore
Los Angeles 27, Calif.

Canada

Bayly Engineering, Ltd.
112 Simcoe Street, North
Oshawa, Ontario, Canada

IDEA DEPARTMENT

For New Business

Here is an idea which will help servicemen interested in helping their business. It was contributed by Ralph G. Chasse, Lawrence, Mass.

"Once a week we have a drawing and award the winner a Sylvania Radio Tube. Names and addresses of the winners are found, at random, in our city directory. On the right is a copy of the postal card certificate which is mailed to the winner.

"This particular scheme has been successfully employed by us for nearly eight months. We have found it very helpful in acquiring new radio customers. The cost of the program is low compared with the results it brings. If your business is slow, we honestly suggest that you give our scheme a try."

This idea helps to promote good will and draws customers into your shop automatically.

CERTIFICATE OF AWARD

Congratulations Dear Winner,

You have been chosen as being this week's winner of a SYLVANIA RADIO TUBE. You may call at your convenience for your award or if you prefer, you may reserve this certificate until such time that you have radio trouble. We shall be pleased to install, free of charge, the Sylvania Radio Tube in your radio whenever you so desire.

VETERAN RADIO SERVICE

GUARANTEED REPAIRS ON ALL MAKES
671 Center St. Tel. 33967 Lawrence, Mass.

Ralph G. Chasse

Send Us Your Idea

We need your idea! For each idea published in the NEWS, Sylvania sends the writer a certificate worth \$5.00 in merchandising aids. Ideas concerned with better merchandising and more shop efficiency are considered for this department. Technical Ideas and hints appear in the Technical Section. Send yours today to The Editor, SYLVANIA NEWS, 500 Fifth Ave., New York 18, N. Y.

Customer Reminder

Customer reminders are always good when it comes to getting radio repair business. J. T. Cookson, Puxico, Mo. sent us this one.

"This little sticker is put on the back of radios I repair. I also send them out in my mailings. I do some

Stick Me Up Somewhere
for Future Reference—

For Radio Repair Service
J. T. COOKSON "IDEAL"
RADIO SERVICE and SALES

repairs for other dealers and use the same stickers on these sets. This gives me the future business of most of my set owners.

"I sure like Sylvania tubes and wish our supply company handled them. I now have to order them from St. Louis."

A sample of the sticker used by Mr. Cookson is shown above.

Tiny Transceiver For Citizens Radio

The first portable radio transceivers for public use between homes, automobiles, offices, plants, farms and many other person-to-person radio-telephone applications are now in pilot plant production according to Al Gross of the Citizens Radio Corporation which has received the first F.C.C. type approval for equipment to be used on the 465 megacycle band allocated for civilian use.

The equipment, according to Gross, is one fourth the size of the famous wartime walkie-talkie, and is the result of more than two years of research and engineering in which many new techniques, including subminiature tubes and the use of silver-on-ceramic circuits, have been perfected for practical push-button, person-to-person radio communication for public use.

Experimental units, he said, have been given exhaustive field tests between auto and home; home and office; boats and shore; planes and ground; and person to person on city streets. He predicted that this

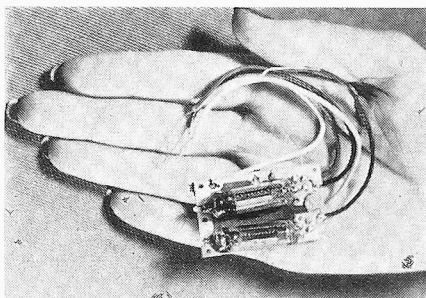

Receiver audio section of new transceiver developed by the Citizens Radio Corporation of Cleveland, Ohio embodies new silver-on-ceramic circuit techniques. This audio section (shown above) uses two Type 1V5 Sylvania subminiature tubes.

revolutionary type of personal two-way radio will soon become a standard means of eye-witness reporting of sports and spot-news events to radio and television audiences and newspapers.

The transceiver, two of which are required for person-to-person contact, is housed in a tiny case measuring only 6" x 2 $\frac{7}{8}$ " x 1 $\frac{1}{4}$ " topped by a small folding antenna. This pocket-sized radio station includes all necessary equipment except a tiny headphone and

batteries. These are carried in a separate case about the size of a miniature camera.

Development of the Citizens Radio, Gross said, was made possible largely through the availability of subminiature tubes manufactured by Sylvania and the cooperation of Sylvania's advanced development laboratories. He admitted, however, that many practical problems,



Party line can now take to the air with this new citizen's radio station which includes complete high frequency receiver and transmitter. The equipment, weighs only 11 ounces; Has a range of several miles.

without which, FCC type approval CR-401 could not have been obtained, were solved in the laboratories of the Citizens Radio Corporation.

He described the model 100-B Citizens Radio as a transceiver for Class B stations only; operating at 465 mc., tolerance 0.4; input 3 watts; emission A-3 with 30% maximum modulation. The transmitting section uses a Sylvania 6K4 subminiature oscillator and the receiver is super-regenerative using three Sylvania 1V5 subminiature tubes. The transceiver weighs only 11 ounces including antenna total station equipment. Including batteries the transceiver weighs only two-and-one-half pounds.

More information about Citizens Radio transceivers can be obtained by writing directly to Citizens Radio Corporation, 1865-71 Prospect Avenue, Cleveland Ohio.

Sylvania Appoints



EDWARD P. ATCHERLEY

The appointment of Edward P. Atcherley as Northwest division manager of renewal tube sales for Sylvania has been announced today by H. H. Ranier, manager of distributor tube sales. Atcherley will take charge of sales of renewal radio and television tubes, test equipment and electronic products to Sylvania distributors in Montana, Idaho, Oregon and Washington.

He attended the University of Pennsylvania and was formerly associated with the Tide Water Oil Company, Shell Oil Company, R. M. Hollingshead Corporation and The Paraffine Companies. He will make his headquarters at 941 White Henry Stuart Building, Seattle, Washington.

Coaxial Link Opens

Another history making event in the life of television took place on January 11 when the first coaxial link between eastern and mid-western cities was opened.

The coaxial cable link makes available television network programs on stations in New York, Philadelphia, Schenectady, Washington, Baltimore, Richmond and Boston in the eastern group and in Pittsburgh, Chicago, St. Louis, Milwaukee, Toledo, Detroit, Cleveland and Buffalo in the midwest.

Since this is the one connecting link between east and midwest, its facilities will be used jointly by the five operating television networks for relaying programs between cities.

Specialty Opens New Branch

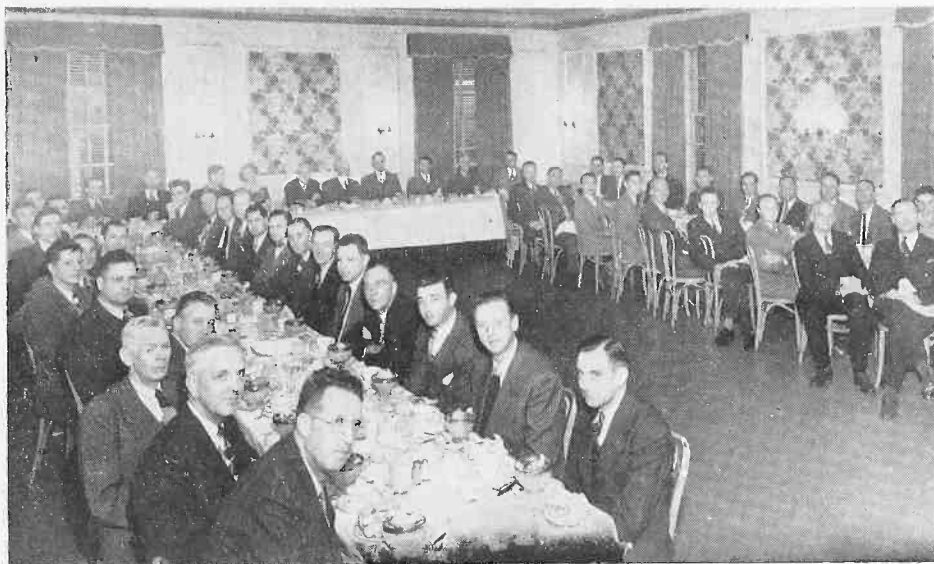

Specialty Distributing Co. staff met for a two day conference in Atlanta, Ga. just before the close of the year to discuss plans for 1949. President F. A. Morris announced the opening of a new branch of the firm in Albany, Ga.

Herman Eidson will be the manager of the new store which will be located at 104 Pine Street in Albany. Specialty now has branches in Macon, Savannah and Chattanooga in addition to their main store in Atlanta.

FACTS & FIGURES

Station Statistics

Two new television stations have begun operation within the past month. This brings the total number of TV stations now operating to 50. FCC records show that 725 FM stations are now in operation. Of this number, 27 are non-commercial educational stations.

November Set Production

Spurred on by pre-Christmas buying, television set manufacturers increased production in November by 28% to reach a new peak of 122,304 TV receivers for the month. This brings the number of sets manufactured in 1948 to more than 700,000 receivers.

FM-AM radio receiver production remained at a high level during November although the total of 166,701 sets was slightly under the figure for October. AM sets manufactured by RMA member-companies during November numbered 827,122.

Ban on Auto TV

When the Connecticut state legislature meets in January a representative will introduce a bill to prohibit the installation of a television receiver in either an automobile or a locomotive. The bill will provide a penalty of \$1000 fine for offenders.

Radio Sets in Use

Broadcast Measurement Bureau reports that 74 million radio sets are in working order in the U. S. The report also shows that 40.9% of all radio families have more than one home set. Auto sets in use were pegged at more than 10 million.

SYLVANIA NEWS

SYLVANIA ELECTRIC PRODUCTS INC.
P. O. BOX 431
EMPORIUM, PENNA.

Sec. 562, P. L. & R.
U. S. POSTAGE
PAID
Permit No. 1
Emporium, Pa.

RETURN POSTAGE GUARANTEED

For:

J. A. Renville
163 Main St.
Luzerne, Pa.

A

POSTMASTER: If addressee has moved, notify sender on Form 3547, postage for which is guaranteed. When Form 3547 is sent abandon this mailing. Return only if no correct address is available.

Vol. 16, No. 1

JANUARY, 1949

Published By
SYLVANIA ELECTRIC PRODUCTS INC.
Manufacturers of Sylvania Radio Tubes and Electronic Devices, Sylvania Incandescent Lamp Bulbs, Fluorescent Lamps and Equipment

In This Issue

NEWS
DC VOLTAGE MULTIPLIER
FOR SYLVANIA POLYMER

MERCHANDISING
WANT TO SERVICE FIVE
MILLION RADIO SETS?

TECHNICAL
TELEVISION VIDEO
DETECTION AND A.G.C.

SYLVANIA NEWS

TECHNICAL SECTION

FEBRUARY 1949

Copyright 1949,
Sylvania Electric Products Inc.
The information in Sylvania News is furnished without assuming any obligations

EMPORIUM, PENNA.

A. V. BALDWIN
Technical Editor

VOL. 16, NO. 2

CHECKING TELEVISION WAVEFORMS WITH A C R O

By SAMUEL MARSHALL*

This month we are interrupting our Television series to bring you an outstanding article on the use of an Oscilloscope for servicing Television receivers. This article is reprinted from "Radio Service Dealer" for January by permission of the author.

In making these tests it is best to tune in a station broadcasting a test pattern, as this lends itself to easy interpretation. Set the receiver on its side or back so that all the test points may be conveniently reached. No tests are recommended on the high voltage section and care should be taken to avoid contact with that circuit.

Initial Test Point

The most convenient initial point of measurement is the output of the second detector. The reason for this choice is that the signal voltage at this point is 1 or 2 volts, and lends itself to good observations on an oscilloscope. Remember that we are primarily concerned with measuring and observing the video picture signal and the synch pulses, and that these are first observable in their demodulated forms at the output of the second detector.

Figure 1 at the top right illustrates a combined video signal and vertical synch pulse obtained at the detector output. The sweep frequency of the CRO has been set at 30 cycles in order to permit two of these pulses to appear on the screen. The partial circuit diagram on the left illustrates the test points for this test. This corresponds to point E on the block diagram. The complete front view of the cathode ray oscilloscope with all its settings, and the waveform appearing on the screen is at the right of Figure 1.

To make this test a connection is made

*Samuel L. Marshall, Managing Editor of Radio Service Dealer, has taken courses in Electrical Engineering at Brooklyn Polytechnic Institute and New York University. He has been a radio service technician since 1923. In 1937 Mr. Marshall joined the George Westinghouse Vocational High School in Brooklyn, New York, where he is engaged as a TV instructor. In 1945 he wrote "Elements of Practical Radio Mechanics", a book which is used as a standard text in many schools throughout the country. First and foremost is his interest in advancing the cause and status of the radio serviceman. At present he is Chairman of the Board of Directors of the Associated Radio-Television Servicemen of New York, and is currently arranging a TV Lecture Course for the New York Empire State Federation of Electronic Technicians Associations.

between the detector output and the vertical input connection on the CRO. Another connection is then made between the ground connections of the receiver and the oscilloscope. The detector output connection may be taken off at either side of the coupling condenser, C, whichever is most convenient. The receiver output is adjusted to its optimum level, thereby requiring a minimum setting of the vertical gain control on the scope. This will result in more accurate and satisfactory patterns.

Notice the amplitude A of the combined synch pulse and signal as compared with the signal amplitude itself shown as B. The middle line at B, represents the blanking level, and the height above this level—in the slide this occurs below the blanking level because of the reversed phase of the pattern—is the region called "blacker-than-black."

The blanking level should be 75% of the total height, A, according to FCC standards.

Shown in the lower right hand side of this illustration are the horizontal synch pulses and the associated picture signal. The same test point is used. However, the sweep frequency of the CRO is now adjusted to one-half the incoming horizontal synch pulse frequency. This is 15,750 divided by 2, or 7,875 cycles

Figure 2 shows the vertical and horizontal pulses at the output of the first video amplifier. Notice that the phase has been reversed 180° which is characteristic of vacuum tube action. The amplitude of the signal at this point is about 16 volts. Varying the gain of the receiver by means of the contrast control will produce corresponding variations in the height of the pattern.

(Continued on next page)

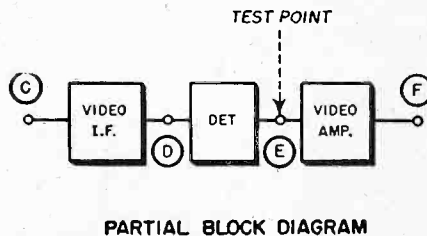
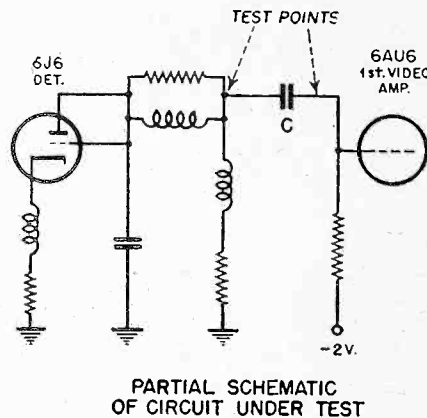
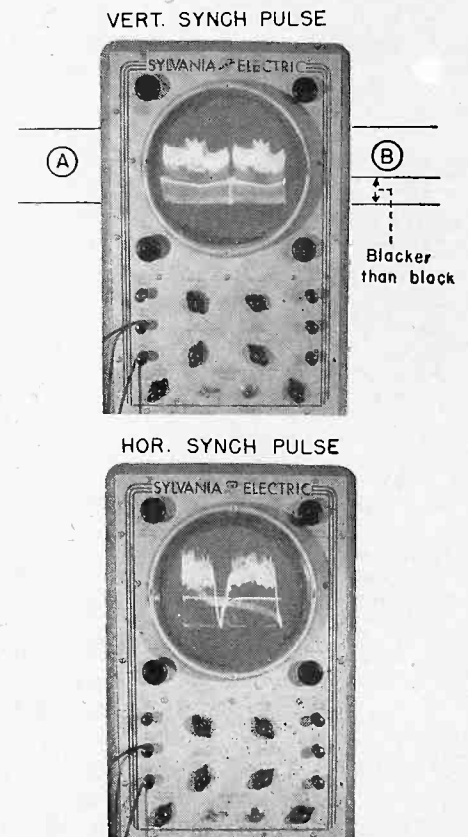

Figure 1
Waveforms horizontal and vertical obtained at detector output.



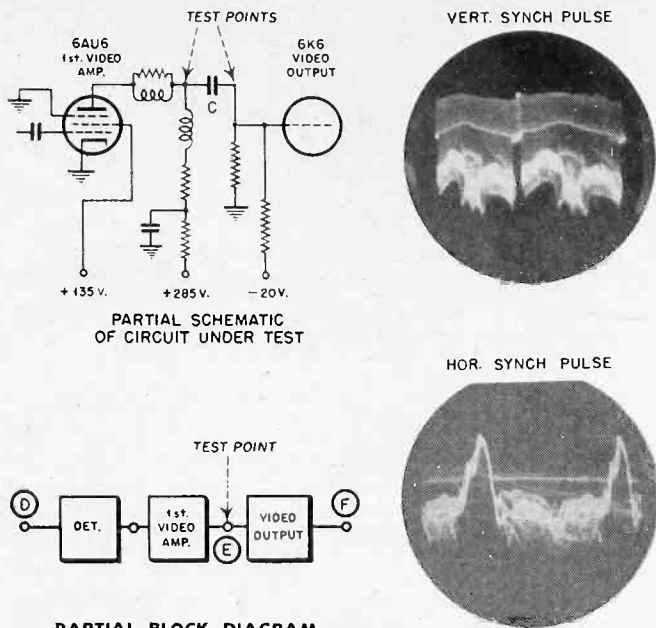

Figure 2
Horizontal and vertical pulses obtained at 1st video amplifier.

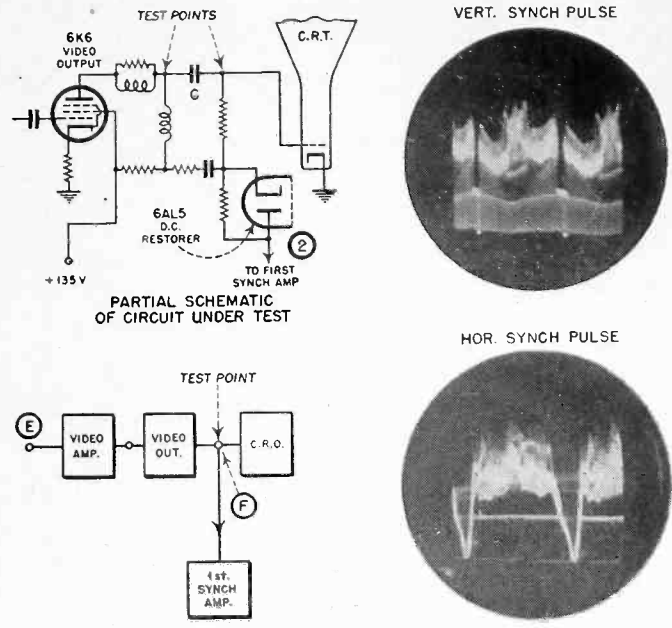

Figure 3
Horizontal and vertical pulses obtained at video output tube.

As in the previous test, the sweep of the CRO is adjusted to portray two pulses. The test point may be made on either side of the coupling condenser, C, shown in the partial schematic at the left of the slide. The probe connection of the scope may be brought to the plate side of the coupling condenser if an isolating condenser is located in series with the vertical input terminal; and it usually is.

Proceeding now to the output of the final video stage, as shown in Figure 3, we notice that the phase for both horizontal and vertical plates is again reversed, and that the amplitudes of the signal are considerably increased. In this case it is 45 volts. This output is fed directly into the grid of the first sync amplifier, and as previously pointed out, represents a positive picture phase.

Sync Circuit Section

A portion of the video signal is taken off the d-c restorer at the 6AL5 plate connection No. 2. The signal at this point, containing both video and sync components, with the video somewhat reduced, is fed into the first sync amplifier at a negative sync phase, or what amounts to the same thing, a positive picture phase.

This is shown in Figure 4. The operating characteristics of this circuit result in a reduction of pulses due to noise and other interfering signals. The amplitude of the signal at the grid of the first sync amplifier is about one-fourth that of the output at the plate of the final video amplifier. This is due to the signal being taken off a point on a voltage divider connected across this circuit.

Figure 5 shows the horizontal and vertical pulses as they appear at the grid of the sync clipper or separator. Notice that the amplitude at this point is 60 volts, and that the signal still contains considerable picture components. Also, the signal now has a negative picture phase, or a positive sync phase.

We now shift our take-off point to the output circuit of this tube, as shown in Figure 6. Observe that the picture signal has now been completely eliminated, and that only the sync pulses remain. The amplitude of these pulses at this point is 80 volts, and the sync phase is now negative.

The action in this circuit that produces this clipping of the picture signal results from the following:

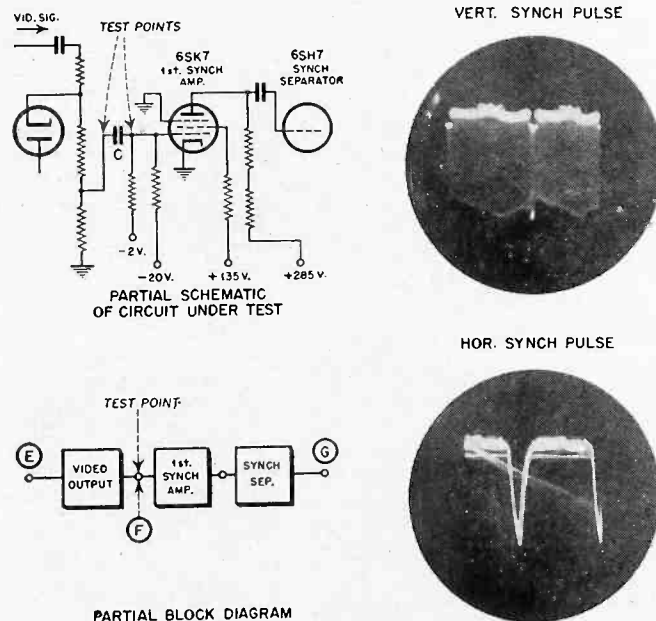

Figure 4
Pulses obtained at 1st sync amplifier on either side of C.

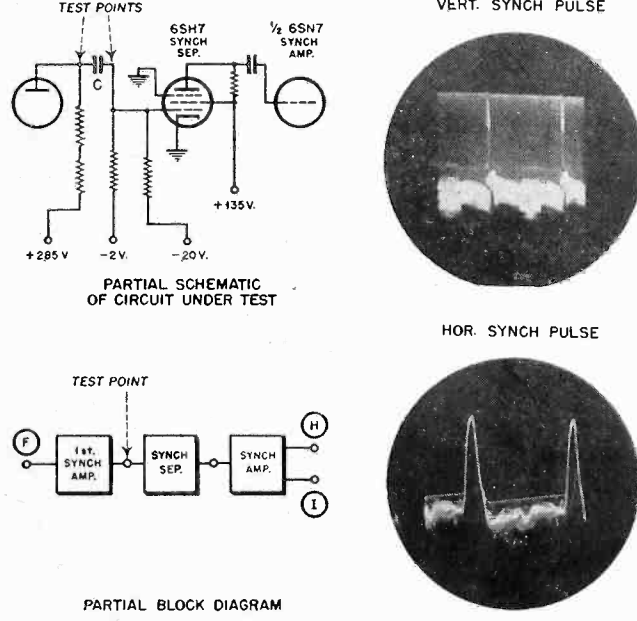

Figure 5
Pulses obtained at input of 6SH7 sync separator. Note waveforms.

1. The picture signal at the grid of the tube has a negative polarity.

2. The operating voltages on the tube are such that all negative portions of the signal are cut off.

Since the polarity of the video or picture portion of the signal is negative, and since all negative portions of the signal are clipped off, only the synch pulses remain.

The next test point is the plate of the third synch amplifier. The polarity of the synch signal at the grid of this tube is now negative. At the plate it becomes positive. The complete change taking place in the synch signal polarity in the three stages of the synch amplifiers is shown in Figure 7. Here we see a negative synch pulse entering the grid of the first synch amplifier, and, after going through three complete 180° phase reversals, emerging from the last stage with a positive polarity.

This last synch tube, which is one half of a duo-triode, operates at low enough potentials so that an 80 volt signal applied to the grid drives the tube beyond cut-off passing only the peaks of the signal. This results in an additional clipping action, thereby further reducing noise and other interfering pulses.

Integrating Circuit

The amplitude at the output of this tube, which is shown as point 1 in Figure 8 is 30 volts. The synch pulse phase is positive, and we are now in a position to inject this signal into the horizontal and vertical blocking oscillators for purposes of triggering them to the exact frequency of the incoming station pulses.

The signal at the output of the final synch amplifier contains both the horizontal and vertical pulses which we must separate from each other. This is done by the integrating and differentiating networks. These are shown in Figure 8 as combination R-C filter circuits. The integrating circuit shown at the top left consists of a number of resistors and capacitors connected in such a manner as

to short out the horizontal pulses and build up the amplitude of the vertical pulses. Notice the shunt capacitors, C₁, C₂, and C₃. These condensers in addition to building up the amplitude of the vertical synch signal during successive pulses of the serrated vertical synch pulse, short out the higher frequency horizontal pulses, leaving only the vertical pulse to reach the grid of the 6J5 vertical oscillator.

Proceeding now to the differentiating circuit, the 100 uuf condenser connecting the output of the third synch amplifier to the input of the horizontal oscillator presents a high reactance to the low frequency vertical pulses as compared to high frequency horizontal pulses, so that the signal permitted to pass thru this condenser contains only the horizontal pulses.

If we apply the test probe of the CRO to point 1, both the vertical and the horizontal pulses appear. At point 2 only the vertical pulses appear, and at point 3 only the horizontal pulses appear.

We are now ready to trace the vertical pulses as they proceed from the output of the 6J5 oscillator to the input of the vertical deflecting coils. The lower left-hand portion of Figure 9 is devoted to the block diagram of this portion of the circuit.

The upper left-hand portion of the figure is confined to a simplified partial schematic of this circuit. The four test points shown in the partial schematic by identical numbers. Thus:

No. 1 is the input of the vertical oscillator.

No. 2 is the output of the vertical oscillator, the amplitude of which is about 120 volts. The signal is acted upon by the discharge or peaking circuit. The object of this circuit is to obtain a wave at the output of the oscillator which insures the presence of a sawtooth current wave in the vertical deflecting coils. But, more on that shortly.

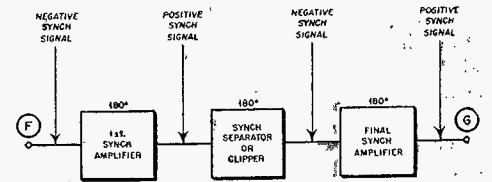

SYNCH SIGNAL PHASE REVERSALS IN SYNCH AMPLIFIER SECTION

Figure 7
Signal phase is reversed 180° as it passes through each tube.

No. 3 is the output of the vertical deflecting coils. The potential at this point is about 65 volts.

No. 4 is the input to the vertical output tube, which is about 450 volts.

The corresponding waveforms for test points 1, 2, 3, and 4 are shown at the right of the screen.

No. 1 proceeding from top to bottom indicates the sharp steep discharge, and slow saw-tooth charge portions of the wave which are characteristic of the blocking oscillator.

No. 2 indicates the effect of the peaking, or discharge circuit on this waveform. Variations of this waveform may be produced by varying the vertical amplitude control. This is an excellent check on the operation of this circuit.

No. 3 indicates the waveform of the pulse at the plate of the vertical output tube, or the 6K6. Notice how high the pulse voltage is for the retrace portion. This is necessary to insure a high retrace current rate on the vertical deflecting coils during the retrace period.

Peaking

The formula relating to voltage, inductance, and the rate of change of current in coil can be given in two forms:

$$e = L \times \text{Rate of change of current}$$

$$\text{Rate of change of current} = e/L$$

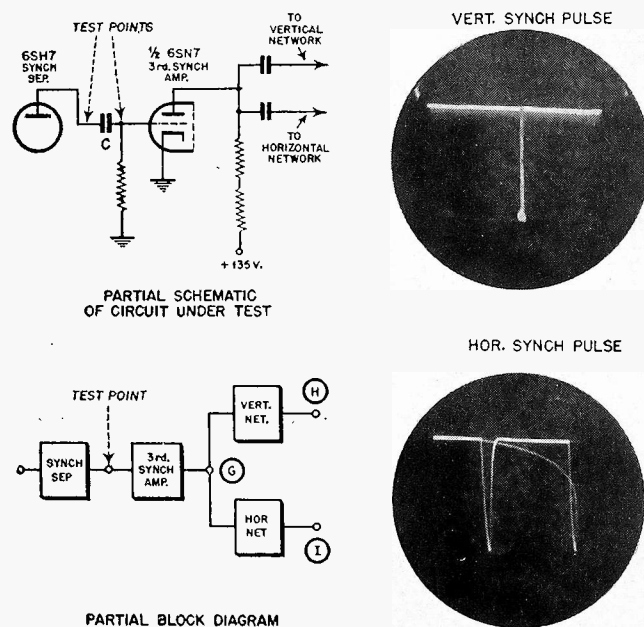

Figure 6

Horizontal and vertical pulses obtained at 3rd synch amp. input.

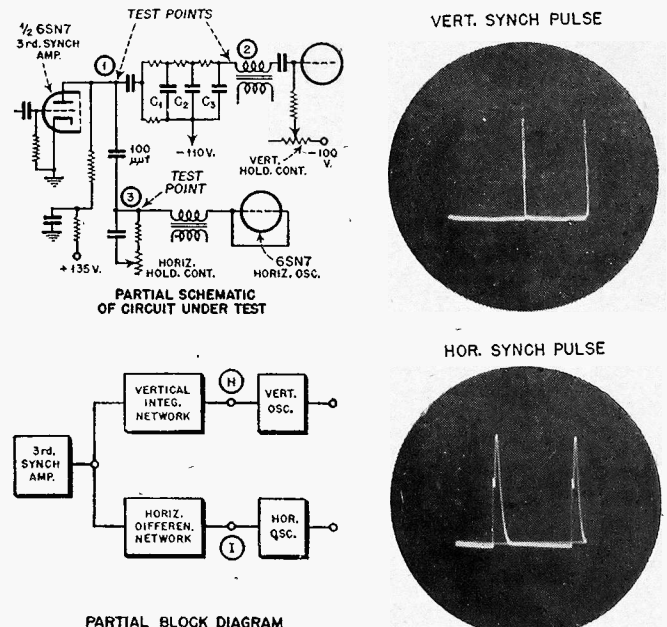

Figure 8

Waveforms obtained at horizontal and vertical separation points.

During the retrace period the frequency is much higher than the 60 cycle frequency of the trace period. As a result, the reactance set up by the inductance in the coil is much higher than before. This affects the current considerably. From the formula shown above, in order to get a high and fast discharge of current during the retrace period the voltage amplitude must be high and its waveform steep.

Returning again to Figure 9, and examining waveform No. 4 once again, we notice that the trace portion of the voltage curve is somewhat of a sawtooth. This is due to the fact that during the retrace period, the inductance of the vertical deflecting coil is negligible as compared to its resistance. In a resistance, if we want a saw-tooth current we must have a saw-tooth voltage. This explains why, in the composite wave, the waveform of the retrace is a sharp high amplitude pulse, and the waveform of the trace is a low amplitude saw-tooth.

Horizontal Circuit

We can now proceed to the horizontal oscillator and the circuits devoted to the development of the horizontal sweep. Figure 10 illustrates the partial schematic of this portion of the circuit in the upper left portion of the screen. Below it is the block diagram showing the test points numbered to correspond to the same points in the schematic above. These test points are as follows:

No. 1 is the input of the horizontal oscillator.

No. 2 is the output of the horizontal oscillator, at about 120 volts.

No. 3 is the output of the horizontal discharge circuit, at about 45 volts.

No. 4 is the output of the horizontal output tube, at about 4,000 volts. The utmost caution should be used when measuring high voltages of this nature.

No. 5 is the output of the horizontal output transformer, which is about 800 volts, and represents the voltage waveform appearing across the horizontal deflecting coils. Notice the flattop characteristic of this waveform. It will be recalled that in order to obtain a saw-tooth current wave in a circuit which is predominantly inductive, a flattop voltage wave is required. When measuring these high voltages a high voltage test probe should be used, and a capacitance voltage divider should be employed for the CRO to prevent damage to its input circuit.

Space does not permit further analysis of the many fine points each of the circuits abound in. Television technicians have a powerful tool in this waveform analysis, for in reality it is dynamic analysis applied to the video and synch portions of the television receiver. Acquainting himself with its techniques the TV technician will add to his stock-in-trade a very powerful ally in helping him lick those "difficult" TV service problems.

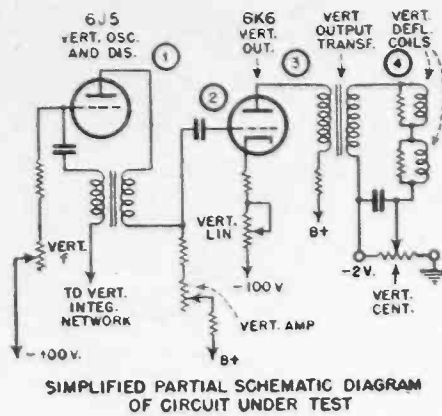

SIMPLIFIED PARTIAL SCHEMATIC DIAGRAM OF CIRCUIT UNDER TEST

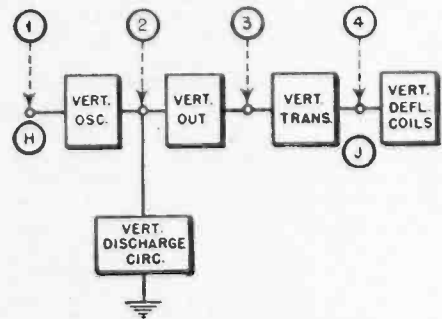

PARTIAL BLOCK DIAGRAM

Figure 9—Waveforms obtained at various test points in vertical circuit.



INPUT VERT. OSC.

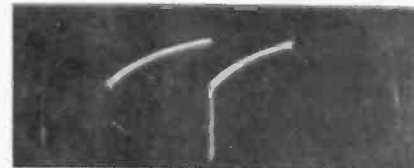

OUTPUT VERT. OSC.

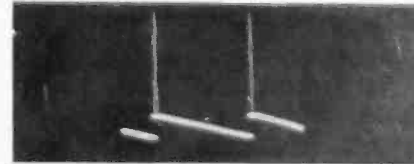

OUTPUT VERT. OUTPUT TUBE

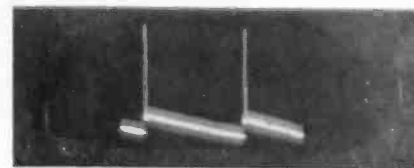

INPUT VERT. COILS

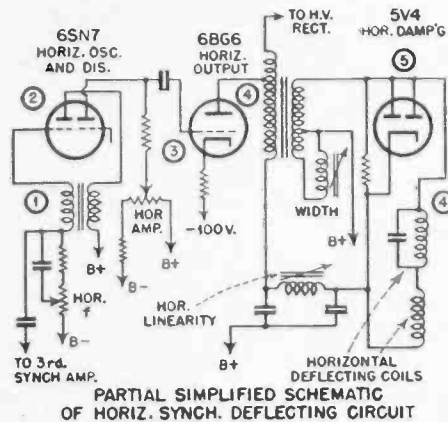

PARTIAL SIMPLIFIED SCHEMATIC OF HORIZ. SYNCH. DEFLECTING CIRCUIT

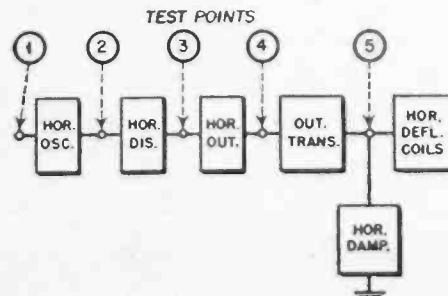

BLOCK DIAGRAM OF PARTIAL HORIZ. SYNCH. DEFLECTING CIRCUIT

Figure 10—Waveforms obtained at various points in horizontal sweep circuit.

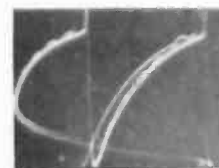

INPUT HOR. OSC.



OUTPUT HOR. OSC.

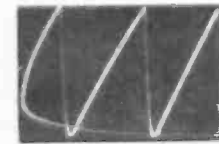

OUTPUT HOR. DISCHARGE

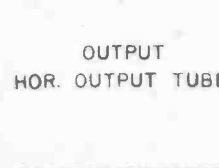

OUTPUT HOR. OUTPUT TUBE

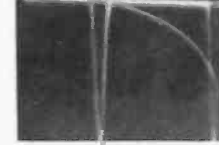

OUTPUT HOR. OUTPUT TRANS.

SYLVANIA NEWS

TECHNICAL SECTION

MARCH 1949

Copyright 1949
Sylvania Electric Products Inc.
The information in Sylvania News is furnished without assuming any obligations

EMPORIUM, PENNA.

A. V. BALDWIN
Technical Editor

VOL. 16, NO. 3

TELEVISION

SYNC STRIPPERS AND SEPARATORS

BY H. C. PLEAK*

This is the eighth of a series of articles on Television by Sylvania Engineers.

Previous articles of this series in the SYLVANIA NEWS have traced the television signal through the video detector. At this point we have a constant demodulated video signal available for our use. This signal, a portion of which is shown in Figure 1, contains the electrical information to be translated by the synchronizing, sweep, and video amplifier sections into visual information and presented on the screen of the picture tube. It is called a composite video signal.

The first article of this series outlined briefly the functions of the various sections. Figure 2 presents a more detailed block diagram of the sync, sweep, and video amplifier sections. This article will deal only with the sync stripper, the sync amplifier, and the vertical and horizontal sync separators.

Referring to Figure 1, the synchronizing information lies on top of the blanking signal, or pedestal, and is in the appropriately termed "blacker than black" region. This terminology arises from the fact that the blanking amplitude fixes the black level, hence the sync pulses, being of greater amplitude, are actually "blacker than black" and will be incapable of modulating the picture tube.

*H. C. Pleak received the degree of Bachelor of Science in Electrical Engineering from Iowa State College in 1942. He joined Sylvania after graduation, starting in the Engineering Test Department. He worked four years in the Equipment Design and Measurements Section of the Commercial Engineering Department, and also spent one year doing quality control work. Mr. Pleak is now working on television tube applications and circuits in the Commercial Engineering Department at Emporium.

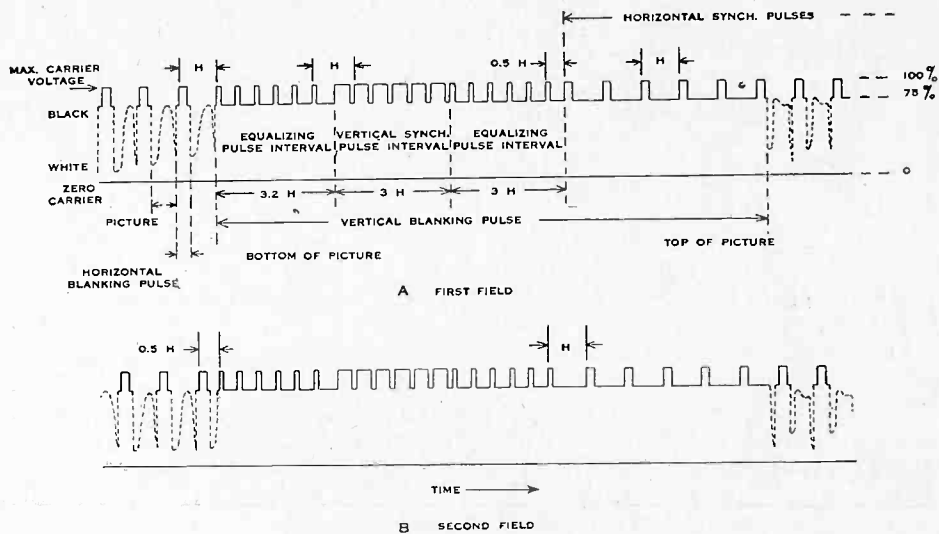

STANDARD TELEVISION SYNCHRONIZING WAVE SHAPE
FIGURE 1

There are 3 types of pulses contributing to the synchronization of a television receiver. We will review these pulses and their uses briefly. First is the horizontal pulse, occurring 15,750 times per second, whose duration is approximately 4.8 microseconds, and whose spacing is 63.5 microseconds from leading edge to leading edge. Second is the vertical pulse which occurs 60 times per second with a duration of 3 times the horizontal spacing, or 190.5 microseconds. This pulse is notched, or serrated, with 5 narrow pulses occurring at a rate of 31,500 pulses per second, and is called a serrated vertical pulse. The pulses are spaced 16,666.66 microseconds from leading edge to leading edge. The horizontal sync pulse is used to trigger the horizontal sweep oscillator, the vertical sync pulse to trigger the vertical sweep oscillator, and the equalizing pulse to maintain interlace and trigger the horizontal sweep oscillator

(Continued on next page)

TUBE COMPLEMENT CHART FOR TELEVISION RECEIVERS

To help you stock the right tube types for use as television set replacements, Sylvania has made available a Tube Complement Chart for Television Receivers. This lists in convenient form the tubes required by each of 111 different receivers by 44 different television set manufacturers. By comparing this chart with local sales of television sets you can make a fair estimate of the types you should carry in stock.

This chart is folded to fit a standard 8½ x 11" binder and has each tube type listed in a separate column. To obtain your free copy, write to Sylvania Electric Products Inc., Advertising Department, Emporium, Penna.

Binders With Complete File of Technical Information Vol. 1 \$1.00-Vol. 2 \$1.00-Vol. 3 \$1.00

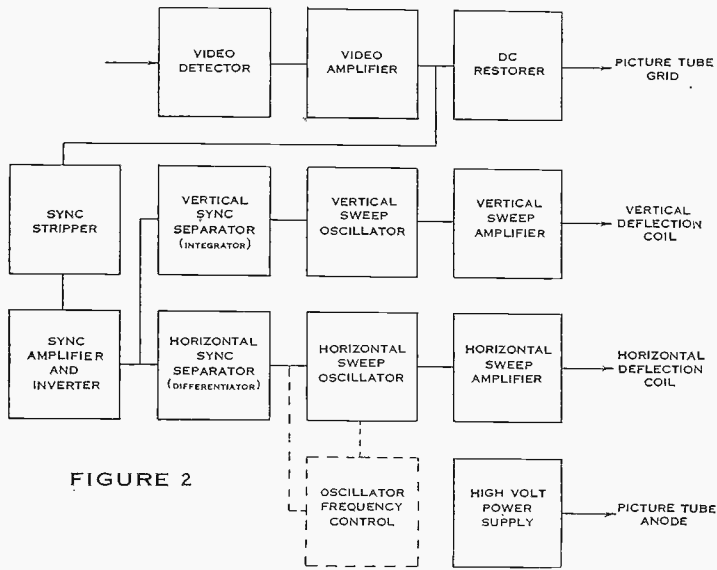

FIGURE 2

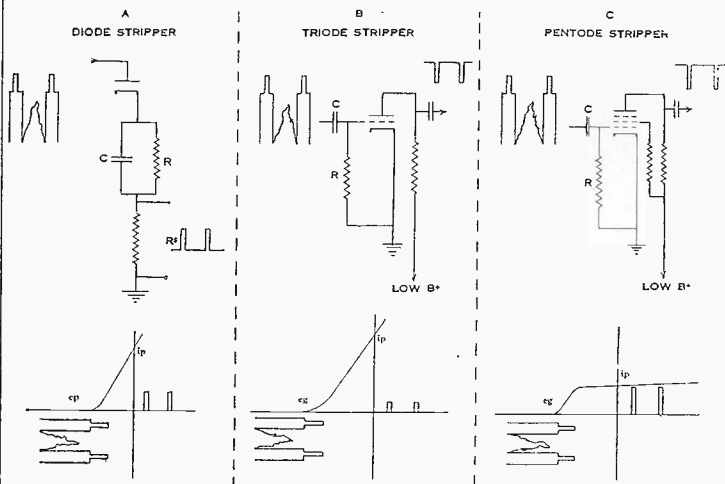

FIGURE 3

during the vertical blanking interval.

Before these signals can be used for synchronizing purposes, they must be stripped from the remainder of the video and blanking information, which would otherwise interfere with the sync circuits. This may be performed in several ways. Let us assume that we have a source of positive going composite video signal. Figure 3 illustrates some of the possible methods of stripping the sync from the remainder of the composite signal. In Figure 3A a diode is used for stripping, in a form of detector. The time constant of R and C is made sufficiently large that only the sync pulses cause diode current. The direct current develops sufficient bias voltage across R to prevent stripping of any blanking or video information from the composite signal. The pulse current flows through R, and the stripped pulse voltage may be taken off across this resistor. This stripper should be driven from a constant source, as any change in input calls for a change in the voltage across C and the long time constant of RC may cause loss of the sync pulse until the clipping level adjusts to the proper value.

Figure 3B illustrates a common form of triode pulse stripper. The triode is operated at very low plate voltage and the grid resistance made very large, 1 to 10 megohms. The bias is determined by the signal and only the sync tips cause plate current to flow. These current pulses appear across the load resistor and the resulting voltage

is of inverted polarity. This signal is further clipped, amplified, and inverted in a following amplifier stage to obtain the same polarity as was assumed; i.e., positive going pulses.

Figure 3C illustrates a pentode stripper circuit. This, too, is operated with bias from grid rectification, or signal bias, and extremely low plate voltage. The low plate voltage is obtained from a bleeder circuit in the low voltage power supply of the receiver. The pentode stripper has the advantage of good clipping over a wider range of signal amplitudes, yielding essentially constant output over the range. This is due to the fact that with the plate voltage held constant, the output is the result of grid voltage variations between cut-off and the positive grid voltage at which limiting occurs.

The composite signal furnished to the stripper may be obtained from the video detector, or at any stage of the video amplifier. It is usually obtained, in present-day sets, from the output of the video amplifier, as a high amplitude signal with a better signal-to-noise ratio is available at this point. Although reduction of contrast (or video gain) will reduce video intelligence, and sync, when it is derived from this point, the stripper should operate satisfactorily to or past the point at which picture intelligence vanishes, since usable sync is not then necessary. Most present-day receivers furnish sufficiently good sync signals if the contrast control is adjusted for proper picture presentation.

We have now stripped the sync signals, horizontal, vertical, and equalizing, from the remainder of the composite video signal. It now remains to separate the sync signals from each other. The only differences between the vertical and horizontal sync signals are in their durations and frequencies, the amplitudes being constant. This separation is handled by resistance-capacitance (RC) filter circuits. One with a short time constant, called a differentiator, passes only narrow pulses. Another, called an integrator, has a long time constant and reacts only to much longer duration pulses.

Figure 4 shows a typical differentiator circuit. Its time constant is short in comparison with the duration of the pulse applied. At the instant the pulse, E_p , is applied the voltage across R rises quickly to the pulse amplitude by virtue of the condenser charging current. The condenser charges rapidly, due to the short time constant, to the maximum applied pulse voltage, at which time the condenser current flow rapidly stops and the voltage

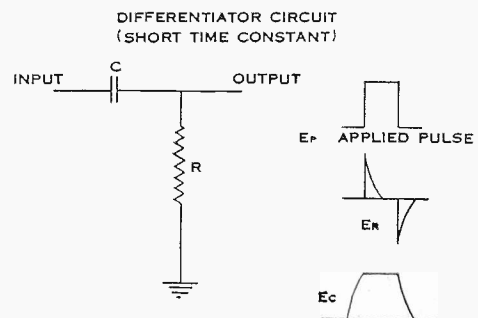

FIGURE 4

across R drops to zero. This condition of maximum voltage across C and zero voltage across R will exist for the duration of the pulse. Immediately upon cessation of the pulse, the condenser discharges, the discharge current appearing across R as a negative spike and as the condenser current approaches zero, the voltage across R approaches zero from the negative direction.

The differentiator circuit then yields two spikes, one positive, resulting from the first or leading edge of the pulse, and the other negative, resulting from the terminating edge of the pulse. The second, or terminating negative spike, is incidental to this circuit and not used in the synchronizing section. All synchronizing circuits are operated from the leading edge pulse. The negative trailing edge pulse may be clipped and discarded. The differentiator circuit then is sensitive only to leading and trailing edge, or high frequency, components of the sync signal.

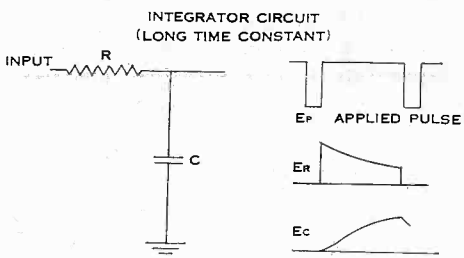

FIGURE 5

The serrated vertical pulse is nearly forty times the duration of the horizontal pulse. The serrations are at twice line (horizontal) frequency and their leading edges affect the differentiator circuit, yielding a leading edge spike to sync the horizontal oscillator during the vertical sync pulse interval.

A method must be found to make these long serrated pulses a usable sync signal. A low pass filter circuit, an integrator, is used for this purpose. The time constant of this circuit is very long compared with the duration of the vertical serrated pulse. Figure 5 shows an example with the associated voltage waves.

When the pulse, E_p , is impressed on this circuit the voltage across R rises immediately to the maximum pulse amplitude, while the voltage across the condenser rises very slowly during the entire duration

of the pulse. The discharge occurs almost as slowly. The short duration almost horizontal and equalizing pulses have little effect upon this circuit. However, this small effect might cause critical timing difference on the vertical oscillator, and practical integrator circuits in television sets usually have a minimum of 3 sections. Figure 6 demonstrates the wave forms found in a 3-section integrator. Notice that a considerable amplitude of horizontal pulse appears on the output of the first section, but this is reduced to a completely negligible amount after the last section, while at the same time the leading edge has been cleared of the horizontal and equalizing pulse hash.

Figure 7 illustrates the reaction of both differentiator and integrator circuits to the three types of synchronizing pulses. The integrator reaction to the vertical serrated pulse is that of a single section rather than a multiple section. Notice that although the integrator circuit discharges slightly during the serration and changes slightly during horizontal and equalizing pulses, the total effect is negligible, due to the much higher charge applied by the longer vertical pulse.

The operation of the sync amplifier stage has been treated lightly as this is a conventional amplifier used for increasing the stripped pulse amplitude, inverting the polarity, or both.

Since proper presentation of the picture is the final step in a television

WAVE FORMS OF A TYPICAL INTEGRATOR

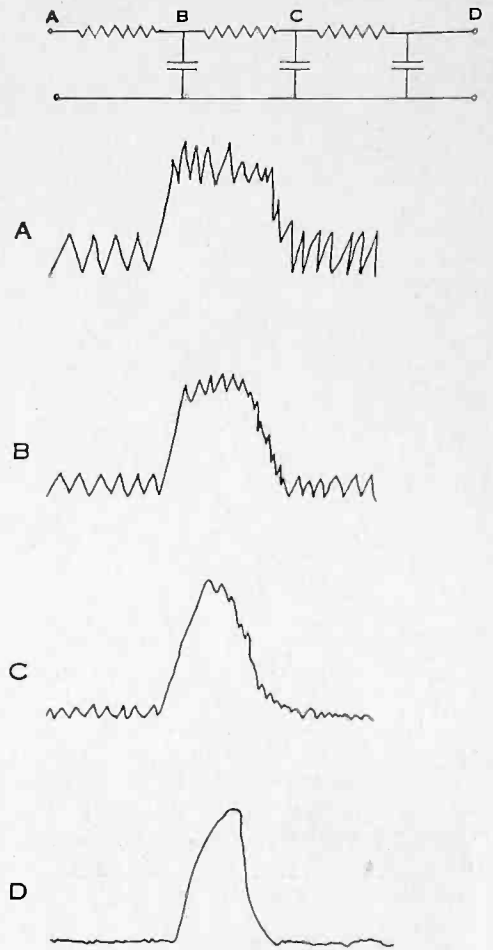

FIGURE 6

receiver, proper operation of the sweep circuits is essential. As these circuits embody some of the more unusual features, they will be covered in a separate article.

DIFFERENTIATOR AND INTEGRATOR WAVE FORMS FOR THE VARIOUS SYNC PULSES

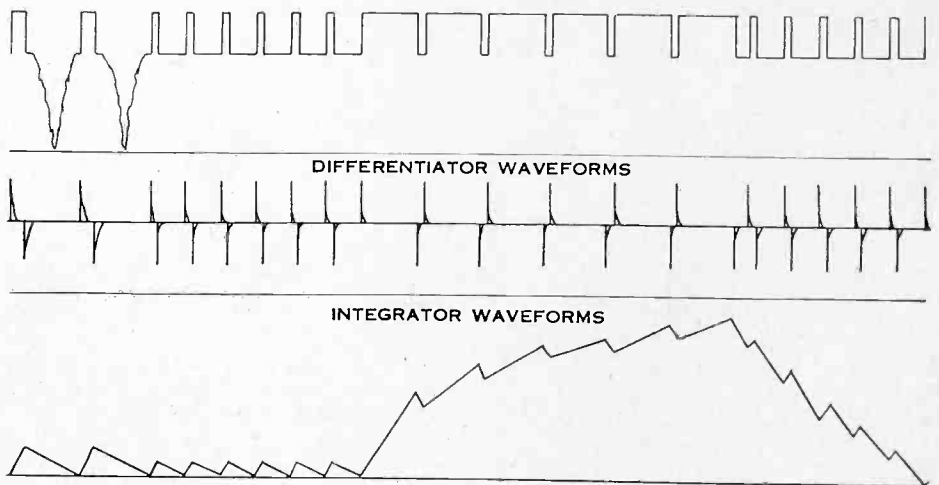
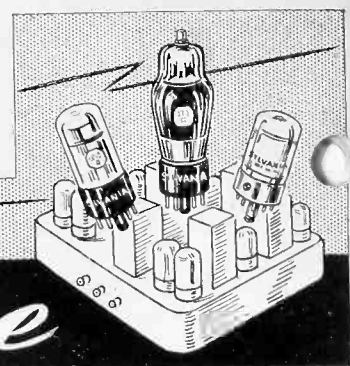

FIGURE 7

THE information presented in the Sylvania Service Exchange is contributed by servicemen as the result of practical experience. It is very carefully considered before being accepted, and we believe it to be correct and authentic. However, we assume no responsibility for results. Please do not send routine or generally known information. Each hint accepted entitles the writer to his choice of one Sylvania receiving tube. Please specify tube choice when submitting hints.



THE Service Exchange

Preventing Oscillator Trouble in Battery Portables: To prevent unwarranted complaints soon after a set has been serviced, the minimum effective filament operating voltage should be determined. This is done by making up a separate extension cable for the A-plus line. A 10 ohm rheostat is inserted in the lead and the resistance increased until the tube ceases to oscillate. If it refuses to oscillate at any voltage above 1.1, it should be replaced, as it will not get all of the usable power out of a set of batteries. In making this test, a good voltmeter should be connected directly across the filament terminals at tube socket. A high resistance or vacuum tube voltmeter connected to the stator of the oscillator tuning condenser will indicate the instant that oscillator fails.—Alvin Sydnor, Chester, Pa.

* * *

Improved Tinning for Soldering Iron: As soon as you buy a new soldering iron (or clean the one you already have) remove the tip, heat it with a torch to the temperature required for melting silver solder. Flux it if necessary, then allow the silver solder to flow all over the soldering tip, practically plating it. When the tip is cool insert it in the soldering iron. Now you have a tip which will always stay bright, never need tinning, fluxing or filing. The silver solder will stay on because the normal operating temperatures of the soldering iron will not approach silver solder melting point.—David Gnessin, Columbus 1, Ohio.

* * *

Type 50Z7GT Substitution: I had an old model Zenith radio which had a burned out 50Z7GT tube and none of the radio parts stores in my home town had this tube and said they could not get it. I found that a Sylvania Type 50Y6GT tube works OK for a substitute.—Ray Duncan, Manchester, Alabama.

EDITOR'S NOTE: This seems to be a fair substitution for an unobtainable type, but of course the panel lamp will not work.

Intermittent Operation of Zenith Portables: Zenith portable AC-DC battery radios such as Model 5AO-1. Intermittent operation on AC current is caused by a defective metal cased voltage dropping resistor (in most of these sets it is stamped Muter), the resistance of which increases slightly at the contacts and causes the oscillator in the set to quit working because of a reduced filament voltage. Moving these terminals with a prod or squeezing the metal shell at the point where the terminals emerge from the case will frequently restore operation momentarily, indicating the replacement necessary.—Donald Slattery, Chadron, Nebraska.

* * *

Brush Soundmirror Model BK-401: On recording, the tape operates too fast. This can be traced to slippage around the cork layer about the control capstan. Through misuse or greasy hands a layer of oil forms on the cork surface, permitting the capstan to act as lubricated bearing, rather than control capstan. Under these conditions the speed is controlled entirely by the take-up reel, a condition which will permit the tape to go through so fast it will tear. The remedy is to scrub the cork capstan with carbon-tetrachloride, using a stiff brush. (Also remind the operator that record and forward buttons must be pushed simultaneously, then locked in down position before start button is pushed to start recording.)—David Gnessin, Columbus, Ohio.

* * *

Car Radio Interference: If it is established by removal of the aerial lead from the car radio aerial connection that the interference is coming in on the aerial lead, then this trick often will completely stop the noise, and it is to install a separate wire wound suppressor (distributor type) at the coil end of the wire which comes from the distributor. This leaves two suppressors in this same lead, but I have found that this is only effective when installed at the distributor end. This is not effective in every

case but is very helpful in many, and especially where the ignition coils are mounted on the fire wall of the cars. Being a wire wound suppressor it will have no effect on the car's gasoline mileage.—Donald Slattery, Chadron, Nebraska.

* * *

Servicing AC-DC Radios: The sketch below illustrates an idea that I have used for some time in servicing AC-DC radios. For alignment it serves as an isolation transformer, eliminating hum, shorts through signal generator, etc. With its variable output of 95 to 135 volts it shows up defective oscillators, condensers, etc. Parts can be found in the average junk box, or even if purchased will result in a substantial saving over the cost of a straight isolation transformer alone. I have it mounted permanently under the bench with line cord and male plug

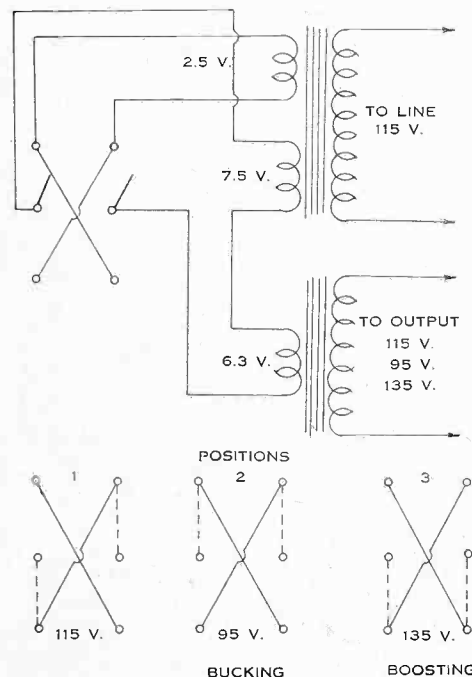

on input and female plug on the output for plugging in radio. With the transformers I am using I get good voltage regulation at 50 watts, which is more than ample for most AC-DC sets. Huskier filament transformers would, of course, give greater watts output.—Vincent E. Viall, Malone, N. Y.

SYLVANIA NEWS

TECHNICAL SECTION

APRIL 1949

Copyright 1949
Sylvania Electric Products Inc.
The information in Sylvania News is furnished without assuming any obligations

EMPORIUM, PENNA.

A. V. BALDWIN
Technical Editor

VOL. 16, NO. 4

TELEVISION TUBES ARE NOT DANGEROUS IF PROPERLY HANDLED

This month we are interrupting the technical articles on Television to bring you two general articles which will be important to those now engaged in Television service.

Most servicemen have heard of cases where use of a radio in a bathroom or other damp location has caused fatal shock to some careless or uninformed user. Fear of this has never caused any servicemen to go out of the servicing business because they understand the dangers and take the proper precautions. The need for similar information on Television and Television tubes is generally recognized in the industry, and the RMA, of which Mr. M. F. Balcom of Sylvania is President, has in fact appointed a committee to determine the best method of getting this information to all servicemen.

Television is new with its own peculiar dangers, and we believe that servicemen will appreciate an honest statement of those dangers and a review of the precautions they should take to work safely. You should consider also that you are to some extent responsible for injury resulting from your failure to advise a customer of the possible dangers. One of the best ways of driving this point home without frightening him is by your own use of all safety precautions when working on a set in his presence.

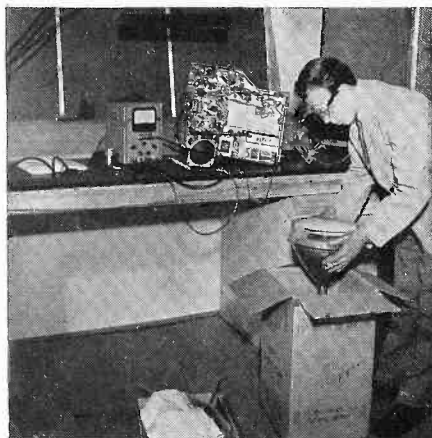

**THIS IS THE SAFE WAY TO
UNPACK A TUBE.**

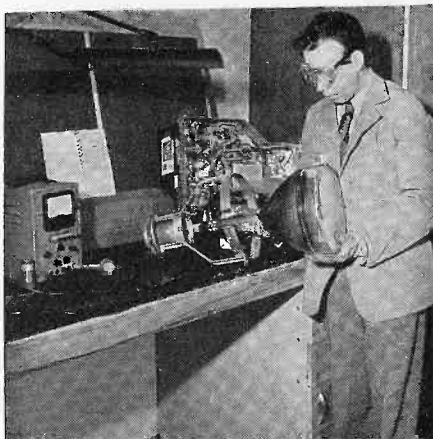

**THE SAFE WAY TO INSERT A
TUBE IN THE SET. NOTE THE
GOGGLES AND GLOVES.**

The greatest possibilities of injury are through breakage of the picture tube or high voltage shock. In consideration of breakage, we must constantly remind ourselves we are handling glass. Glass in almost any form—such as a window pane, electric light bulb or bottle—can give a serious cut on accidental breakage. Picture tubes should always be handled carefully, more carefully than one would handle a window pane or sheet of glass, for we must remember that the tube, being exhausted, is under pressure from the atmosphere and any mishandling may cause the tube to break or “implode.” This may cause sharp particles of glass to be scattered with considerable force. Regarding electric shock, we must also remember that television sets operate at higher voltages and differ in some respects from common radio sets. We are listing the suggested precautions:

To prevent injury from picture tube breakage:

(1) While handling picture tubes we recommend wearing safety goggles and gloves for protection in case a tube should implode.

- (2) The proper method of removing 5" or larger tubes from the carton is as follows: Lift the tube by the sides, face upward. When inserting horizontally into a socket, grip the neck for guidance only, support most of the weight at the big end.
- (3) When not installed, keep any tubes in the shipping cartons with the covers closed. They may easily roll off a table and, when exposed, the glass may get scratched causing a break then or later. For the same reason never place tubes face downward unless on a surface protected by felt or similar material.
- (4) If a tube does break and you get a small cut, wash it carefully to be sure all dirt and small particles are removed. While the materials used for coating Sylvania picture tubes are not considered poisonous, one should bear in mind the possibility of an unusual personal sensitivity or allergy.
- (5) If you wish to use a display of picture tubes in your window, worn-out tubes may be made relatively safe as follows:
 - a. Place the tube in the carton, base up, with enough soft packing material under the face to let the base protrude above the folded-in flaps.
 - b. Drill a hole about $\frac{1}{4}$ " diameter in the end of the locating lug. If desired, the whole lug may be broken off with a sharp blow.
 - c. With a metal rod like a nail set or small file, break the exhaust tip allowing air to enter. If only the point is broken off and the air is allowed to enter slowly, the inrush of air which would blow off the screen coating will be avoided. In tubes using a metal exhaust tip,

(Continued on next page)

TELEVISION TUBES ARE NOT DANGEROUS IF PROPERLY HANDLED *(Cont'd)*

a small three-cornered file will make the small hole required. The bright getter deposit on the neck should change color almost immediately, but to be sure the tube is safe, break the tip completely later on.

Tubes treated this way will be as safe to handle as a fish bowl or other glassware of equal weight. It cannot implode but still should be handled as described in (2).



A FIRST STEP IN MAKING A WORN-OUT TUBE SAFE.

- (6) Use discretion in the breaking up or disposal of picture tubes. Even when put out for the rubbish collector be sure they are broken to avoid their coming into the possession of children, or for that matter, curious adults who may suffer injuries in case of breakage. Keep in mind that you may incur a legal liability if you fail to eliminate the hazard by proper and complete disposal of worn out tubes.
- (7) A quick easy method of disposal is to seal the tube into the carton and then drive a heavy tool, such as a wrecking bar through the side or bulb end of the case.

No Danger from Packed Tubes

The possibility of injury to people handling, or mishandling, packed tubes has been investigated by the Association of American Railroads as well as by tube manufacturers. It has been found that if a packed tube is dropped far enough to break the tube it generally cracks where the neck joins the large part of the

bulb. When a piece of metal is forced through the carton into the tube, the bulb is pierced but not shattered. A tube sealed in its proper carton should not be dangerous to anyone.

To avoid electrical shock:

- (1) Do not bypass any safety interlock switches, and when working on equipment see that such switches are in order. Your relatives may be sorry if one sticks.
- (2) Check the condition of the insulation on the wire in the high voltage circuits. If necessary to change wiring, use insulation rated for the voltage supplied.
- (3) Keep one hand in your pocket and be sure you are standing on dry wood, a rubber mat or linoleum when "looking" for trouble in a television circuit.
- (4) Take the extra minute required to make changes the safe way.
- (5) Discharge the high voltage condenser after turning the power off and before working on the circuit. The bleeder resistor may be open.
- (6) Some large cathode ray tubes, Type 10BP4 for example, have both internal and external coatings on the bulb which form a condenser like the old Leyden Jars. If the tube is



TREAT HIGH VOLTAGES WITH RESPECT. SAFE WAY OF READING HIGH VOLTAGES WITH A SYLVANIA POLYMER.

removed without discharging this condenser, even a slight unexpected shock from it might cause you to drop the tube.

- (7) It is usual to think of the cathode circuit as harmless (it is in radio) but that is not so in television. Keep the ground lead of the voltmeter on chassis ground and if necessary to read high negative voltages in sets in which the anode is ground, use the meter polarity reversing switch to avoid having the meter case above ground or requiring high voltage insulation for both leads.



THE WRONG WAY! DOESN'T IT MAKE YOU SHUDDER?

TELEVISION TUBES ARE NOT DANGEROUS IF PROPERLY HANDLED *(Cont'd)*

- (8) It is no more dangerous to put up a television antenna than those used for AM reception, but don't let your inexperienced help forget to keep clear of the power lines.
- (9) Be careful!
- (10) Don't work on television servicing when tired or sleepy.

When high voltage tubes are operated in the set enclosures provided by the manufacturer a safety face plate prevents injury to the user. Other safety devices such as interlocks are also provided. When under repair on the service bench, however, these sometimes cannot be used and may introduce the possibility of injury from X-rays produced by operation of certain tubes at high voltages. The possibility seems to be remote in the case of direct view tubes up to the 12" size when not operated at grossly excessive voltages but as larger sizes or projection types become more popular the danger should be considered. At the present time the Type 1B3GT rectifier tube, required in many television sets when used near its maximum voltage rating, can produce weak X-rays.

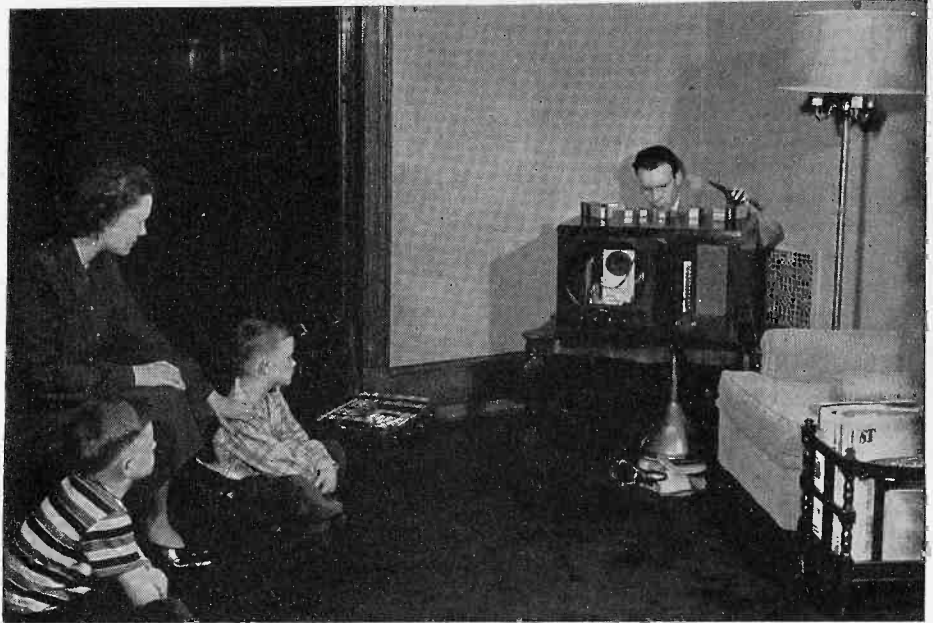

IF YOU MUST CHANGE TUBES IN THE HOME, DO IT THIS WAY.

Other common rectifiers such as the 8013A, as well as other tubes with thin walls, when operated at voltages over 15,000 may give off X radiation. The hazard from such tubes is probably slight, but some protection may be advisable, if exposure for extended periods is necessary.

Since this whole subject is quite new we will be watching for other suggestions which will help you to work safely. We will also try to keep you up to date with any changes made necessary by new types or changes in operating conditions.

PICTURE TUBE DAMAGE

RESULTING FROM INCORRECT ION TRAP MAGNET ADJUSTMENT

This article is a reprint of material supplied to all the engineers on the Sylvania mailing list. Since it is of great importance to television servicemen, it is reprinted here in full.

Of major importance in the installation of a television set is the proper adjustment of the ion trap magnet on the neck of the cathode ray picture tube. Improper positioning of the magnet may result in circular areas of discoloration developing on the face of the bulb, thus injuring the picture screen, even though the

ions developed in the cathode section of the tube have been properly "trapped." When the magnet is not in the correct position, the electron beam, instead of going through the aperture in the anode top disk, bombards the edge of the hole. The heat thus produced vaporizes the metal of the disk (as shown in the illustration) releasing gases which have a harmful effect on the operation of the tube. Some of this vaporized material may be deposited on the screen

of the tube causing darkened areas.

To insure long life and satisfactory operation of the picture tube, the ion trap magnet should be adjusted immediately when the tube is installed in the set and, as a precaution, should be checked when the set is moved to a new location. If a permanent magnet type is used, the magnet should be placed on the neck of the tube in the direction indicated by the marking on the magnet (usually an arrow which points toward the picture screen), so that the stronger magnet of the double magnet type is at the base end of the tube. This stronger magnet in the case of the double magnet type (or the only magnet in the case of the single magnet type) should be positioned over the internal pole pieces which are mounted on the gun structure. With the tube operating and with the brightness

(Continued on page T-16)

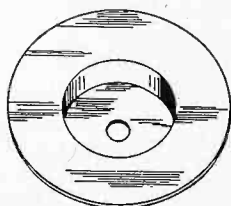

**NORMAL ANODE TOP DISC
ION TRAP MAGNET
CORRECTLY ALIGNED**

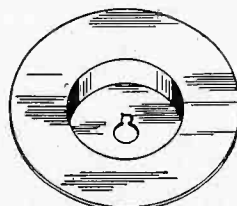

**DAMAGED ANODE TOP DISC
ION TRAP MAGNET
INCORRECTLY ALIGNED**

PICTURE TUBE DAMAGE *(Cont'd)*

control adjusted for low intensity, the magnet should be moved a short distance forward and backward, at the same time rotating it to obtain the brightest raster. If, in obtaining the brightest raster, the ion trap magnet has to be moved more than $\frac{1}{4}$ inch from the internal pole pieces or if it is pushed against the focus coil, the magnet is probably weak and a new magnet should be tried. As a final check, the ion trap magnet should again be adjusted for maximum raster brilliance, this time with the brightness control set to obtain a raster of slightly above average brilliance and with the focus adjusted for a clear line structure to simulate actual operating conditions with a picture.

Never move the ion trap magnet to remove a shadow from the raster if by so doing the intensity of the raster is decreased. In such a case the shadow should have been eliminated by moving the focus or deflecting coils. The ion trap magnet should always be in the position to give maximum raster brilliance.

If the electromagnetic type ion trap magnet is used, it should be placed on the neck of the tube with the larger magnet over the internal pole pieces and nearest the base,

and adjustment for brightest raster is obtained by rotating the magnet and adjusting the current through it. The effect of current variation is the same as longitudinal movement of the permanent magnet type. The longitudinal position of the permanent magnet type or the current applied to the electromagnetic type is dependent upon the voltage applied to the tube and may vary for the same type of tube from one receiver to another.

(CAUTION: If a raster is not obtained in a few seconds using the above procedure, turn the set off and check to make sure that the ion trap magnet is positioned according to the manufacturer's instructions or markings. If the desired results cannot be obtained, it is suggested that a new magnet be tried.)

If the picture tube has just been installed or the set has been moved, it is imperative that the brightness control be kept low until after the initial adjustment of the magnet and also that adjustment of the magnet be made immediately when the set is turned on. It is important that the intensity of the beam be low when the set starts operating, if the magnet has not yet been adjusted, because tubes have been

ruined in 15 seconds of operation due to the ion trap magnet being out of adjustment and the intensity being set too high. By keeping the intensity low, the beam current is low enough so that the electron beam is not likely to damage the anode top disk before the magnet is adjusted. The amount of damage that is done to the tube is a function also of the voltage applied to the tube; therefore, tube types which operate at high voltages may be ruined more easily than those operated at lower voltages.

In order to assure that the magnet will stay in place after it has been adjusted, care should be taken that the magnet fits the neck of the tube securely. If it is at all loose, a small piece of rubber placed under the clamps or a piece of friction tape wound around the clamps should prevent the magnet from slipping.

The procedure for aligning the ion trap magnet should not be omitted just because the set seems to be operating satisfactorily—it is not always safe to assume that the magnet is still in adjustment if the set has been transported. Even with the magnet poorly aligned a good picture can be obtained, but within a short time circular darkened areas will appear on the screen.

SERVICE HINTS

Silvertone 6421 Chassis 101.571: A troublesome case of hum with distortion and weak reception was found to be caused by the 120 and 45 ohm candohm line resistor being partially shorted to the chassis.—Edgar O'Rourke, Bear Lake, Mich.
* * *

Hum and Distortion in Philco 46-1201 Revised: Check 80 ohm candohm filament dropping resistor which shorts out to chassis. Since this is not common ground, all voltages will still check OK.—R. W. Smith, Brooklyn, N. Y.
* * *

EDITOR'S NOTE: *These two hints are very similar and show that a common cause of hum and distortion on any AC-DC set can be due to a partially shorted condition between chassis and ground. This can be considered general enough so that other hints showing a similar condition in other models would not help other servicemen enough to justify our printing them.*

Intermittent Oscillation in 1948 Ford Zenith Radios, Model 7R887, Chassis 7E22: Some 1948 Ford Zenith car radios and Zenith cabinet radios, particularly Model 7R887, Chassis 7E22, are troubled with intermittent oscillation which will cease with the slightest circuit disturbance and may not reoccur for days, hence is difficult to locate. In checking these sets through I found that a paper by-pass condenser which ordinarily bypasses the electrolytic filter condenser for radio frequency currents has been omitted. Installation of a .1 mfd. condenser from the ground to the B plus supply for the intermediate frequency and radio frequency stages will invariably clear this trouble up.—Donald Slattery Chadron, Nebraska.

Brush Soundmirror Model BK-401: On recording, the tape operates too fast. This can be traced to slippage around the cork layer about the control capstan. Through misuse or greasy hands a layer of oil forms on the cork surface, permitting the capstan to act as lubricated bearing, rather than control capstan. Under these conditions the speed is controlled entirely by the take-up reel, a condition which will permit the tape to go through so fast it will tear. The remedy is to scrub the cork capstan with carbon-tetrachloride, using a stiff brush. (Also remind the operator that record and forward buttons must be pushed simultaneously, then locked in down position before start button is pushed to start recording.)—David Gnessin, Columbus, Ohio.

SYLVANIA NEWS

TECHNICAL SECTION

MAY 1949

Copyright 1949
Sylvania Electric Products Inc.

EMPORIUM, PENNA.

A. V. BALDWIN
Technical Editor

VOL. 16, NO. 5

NEW SYLVANIA POLYMER

Multi-purpose Vacuum Tube Voltmeter Designed for Television, FM, AM and Electronic Circuits

by Ralph R. Shields*

Sylvania announces a new electronic volt-ohm-current meter for AM, FM, and TV servicing, and for general use with electronic circuits, retaining the essential features of its predecessor, the widely used Sylvania Polymer Type 134Z. The new Polymer, known as Type 221, carries forward the tradition started by preceding Polymeters in presenting the most appealing features which can be incorporated into a multi-purpose instrument. No features not genuinely useful in modern service problems are to be found in the Type 221.

Inspection of the Type 221 Polymer now being displayed by Sylvania distributors will show that it reads a-c and d-c voltages to 1000 volts; r-f voltages to 300; d-c current to 10 amperes; and resistance to 1,000,000,000 ohms (1000 megohms). As in previous Polymeters, accuracy is retained which permits use of the instrument without concern for error. Also as in previous Polymeters, the instrument has the rare feature of furnishing RF voltage readings at frequencies up to 300 megacycles for those whose work includes tests within this frequency spectrum.

Several notable improvements are apparent in the Polymer Type 221. Improved cabinet design results from use of rounded corners and better proportioning. There are fewer test leads—less to store—less to wear out—less to handle—but no reduction in the number of tests that can be made. The ohms, milliamperes, and a-c volts inputs are combined into one panel connector. Panel connectors are improved in that except for the RF probe, standard microphone connectors are used for all leads. This means more positive contact and no accidentally pulled-out leads. The a-c voltage range operating as a true vacuum tube voltmeter has been extended to 1000 volts.

With the increased emphasis modern trends are placing on measurements in the frequency spectrum up to 300 megacycles, several notable improvements have been made in the RF probe. The Polymer probe now has an alligator clip fixed to its barrel so that the probe may be attached to the chassis of a receiver under test. In addition, a flexible probe tip extension is provided for connecting to



**SYLVANIA
TYPE 221
POLYMER**

TABLE I

Input Resistance	- 17 Megohms	
Input Capacitance AF	- 40 μ f. (with shielded lead 194 μ f.)	
RF	- 3 μ f.	
Frequency Range	- 20 to 300 Mc.	
AC and DC Voltage Ranges		
0 - 3 Volts	0 - 100 Volts	
0 - 10 "	0 - 300 "	
0 - 30 "	0 - 1000 "	
R. F. Voltage Range with Probe		
0 - 3 Volts	0 - 100 Volts	
0 - 10 "	0 - 300 "	
0 - 30 "		
Ohmmeter Ranges		
0 - 1000 Ohms	0 - 1.0 Meg.	
0 - 10,000 Ohms	0 - 10 Meg.	
0 - 100,000 Ohms	0 - 1000 Meg.	
Current Ranges		
0 - 3 Ma.	0 - 300 Ma.	
0 - 10 "	0 - 1000 "	
0 - 30 "		
0 - 100 "	0 - 10 Amps	

the probe tip. This feature is a real convenience at the frequencies usually encountered in service procedures. Above about 30 megacycles it is recommended that this flexible tip be removed so accuracy will not be affected by the impedance of the extension at these higher frequencies.

During a-c and audio frequency measurements the effect of stray a-c fields inducing a voltage in the test lead is eliminated by the use of a shielded lead. Thus, the meter indication is the voltage at the test point of the circuit, and is neither added to nor subtracted from by stray voltages induced in series along the test lead. For some special audio frequency work an unshielded a-c lead may be used, reducing the shunt input capacitance from 194 mmf to the low value of 40 mmf on the AF ranges.

The Type 221 Polymer provides for RF measurements (from 10,000 cycles to 300 megacycles) with a shunting input capacitance of only 3 mmf. This extremely low input capacitance, comparable to that found in laboratory test equipment, is doing more than any other single feature to recommend the Polymer to forward-looking technicians and engineers.

Features retained in the new Type 221 Polymer include the use of two standard leak-proof flashlight batteries in the ohmmeter circuit. With a retail price of 10 cents each, and available everywhere, the battery replacement problem found with many instruments is reduced to the vanishing point. At the same time, no resistive circuit under test is ever subjected to more than the 3 volts furnished by these batteries.

(Continued on page T 20)

*Ralph R. Shields is a graduate Radio Engineer who has had 10 years experience solving servicemen's problems. During the war he was with the Signal Corps Laboratories and specialized in interference elimination. Since joining Sylvania he has engaged in a study of how Television is affecting the radio serviceman.

Section Vol. 1 \$1.00—Vol. 2 \$1.00—Vol. 3 \$1.00
Binders With Complete File of Technical

TELEVISION SWEEP CIRCUITS

H. C. Pleak*

This is the eighth of a series of articles on Television by Sylvania Engineers.

In Article 2 (September 1948 issue) of this television series was presented a brief description of the essentials of the video system. Since a knowledge of the overall principles of the video system will aid in the understanding of the sweep system operation, it is suggested that this portion of Article 2 be re-read before reading this article.

It is the function of the sweep circuit to control the movement of the spot of light on the picture tube screen. In the United States the FCC has standardized on a 525 line interlaced scanning system. Figure 1 is an exaggerated view of the operation of interlacing. The spot starts at the upper left hand corner of the raster and only one half the lines are scanned at one time, the 1st, 3rd, 5th, and so on. The beam is blanked out, returned to the top of the raster, and sweeps lines 2, 4, 6, 8, etc. Figure 1b illustrates the vertical retrace to move the beam from the bottom of the raster to the top so that active sweeps may start again. Each set of horizontal lines is called a field, and two complete fields are called a frame. The vertical sweep frequency has been chosen as 60 cps as this coincides with standard power line frequency. Since the vertical sweep operates twice for each frame, the frame repetition rate is 30 cps. There are 525 lines in a frame and 30 frames per second, and, therefore, the horizontal sweeps must operate at a repetition rate of 15,750 cps.

Methods of Deflection

There are two widely used methods of deflecting electron beams in television picture tubes, electromagnetic and electrostatic. Generally speaking, magnetic deflection is used for direct view tubes of 10 inches or greater face diameter, and electrostatic deflection is used for tubes under 10 inches in diameter. With magnetic deflection, the electron beam is deflected by action of a magnetic field produced by current through 2 pairs of coils placed around the neck of the tube. With electrostatic deflection, the electron beam is deflected by a voltage applied between two pairs of deflecting plates mounted on the electron gun in the tube. Magnetic deflection requires higher power while electrostatic deflection requires little power but considerable voltage. The circuits used to drive either the deflection coils or deflection plates are very different and will be discussed separately.

Regardless of the deflection method, the spot must be moved across and down the screen at a constant velocity. If the velocity is not constant, the picture becomes distorted over a section of the raster; that is, crowded (decrease in velocity) or

*H. C. Pleak received the degree of Bachelor of Science in Electrical Engineering from Iowa State College in 1942. He joined Sylvania after graduation, starting in the Engineering Test Department. He worked four years in the Equipment Design and Measurements Section of the Commercial Engineering Department, and also spent one year doing quality control work. Mr. Pleak is now working on television tube applications and circuits in the Commercial Engineering Department at Emporium.

INTERLACED SCANNING

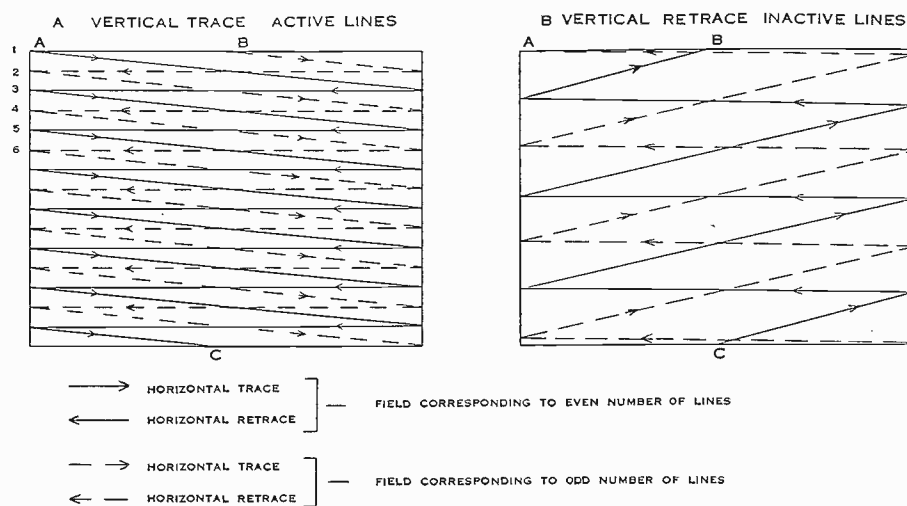

FIGURE 1

stretched (increase in velocity). Distortion of the raster caused by sweep circuits is termed non-linearity and may be caused by either the horizontal or vertical or both sweep circuits. The ideal sweep wave shape is a sawtooth with extremely short retrace interval compared to the sawtooth or trace time. In magnetic deflection a current sawtooth is required, and in electrostatic deflection a voltage sawtooth is necessary.

Oscillators and Sawtooth Generators

Several types of oscillators are in general use, including the blocking oscillator, the multivibrator and a multitude of variations on the basic circuits of both. Since the sawtooth generator is generally considered a portion of the oscillator circuit the two will be discussed together.

Figure 2 illustrates a typical blocking oscillator and sawtooth generator whose operation is as follows: When B voltage is applied, current through the plate winding of T_1 induces a positive voltage on the grid of tube A, rapidly causing plate current saturation. C_1 is charged negatively towards the grid by the flow of grid current through R_1 . Steady current through the transformer inductance means no induced voltage on the grid so that the grid goes negative from the charge on C_1 . The current to the plate decreases, causing a negative voltage to be induced at the grid, driving the tube rapidly to cut-off. The grid voltage is held below cut-off until the charge on C_1 leaks off through R_1 . During the cut-off period of tube A, condenser C_2 charges through R_2 from the B supply voltage. Tube B is driven into rapid conduction by the positive pulse from T_1 and discharges C_2 . The required sawtooth of voltage is developed across C_2 . The free-running frequency of the oscillator is determined by C_1 and R_1 in conjunction with a given transformer. For television use the grid is held negative for a long period in comparison with the positive, or conduction period. If a positive pulse from another source could be superimposed on the grid a short

interval previous to the natural positive pulse, the entire sequence would be started sooner. If a series of equally-spaced positive pulses (sync) were applied, the oscillator would "lock in" at the sync frequency. The oscillator must be operating at slightly lower frequency than the sync for proper locking.

The multivibrator is essentially a two stage amplifier with the output coupled to the input. A typical circuit of the multivibrator is shown in Figure 3. Let us assume the grid of tube A is less negative than that of tube B, at the moment B voltage is applied. Plate current commences to flow in A, reducing the voltage at its plate. C_1 attempts to change its voltage to the lower value, causing the grid of B to become more negative. This decreases the plate current through B, increasing the voltage on C_2 , and on the grid of A, resulting in a cumulative increase of plate current through A and decrease through B. Tube B is held inoperative until C_1 discharges through A and R_{g2} . When C_1 discharges to cut-off, B commences passing plate current, driving the grid of A more negative, resulting in A being driven to cut-off and B passing current. C_2 discharges through B and R_{g1} , and the cycle then repeats. During the non-conducting interval of B, condenser C_d is charged through R_2 from the B voltage. When B conducts, C_d discharges giving the required sawtooth of voltage.

If, in the circuit of Figure 3, C_2 is omitted, the two cathodes are connected together and tied to ground through a common resistor, the arrangement is called a cathode-coupled multivibrator. Coupling is through C_1 and the common cathode resistor, and operation is similar to that of Figure 3. Multivibrators may be synchronized by positive pulses applied to either grid.

All the oscillator circuits discussed depend upon individual sync pulses for correct synchronization. If an incoming noise impulse, such as that from automobile ignition, should obliterate several

TELEVISION SWEEP CIRCUITS (Continued)

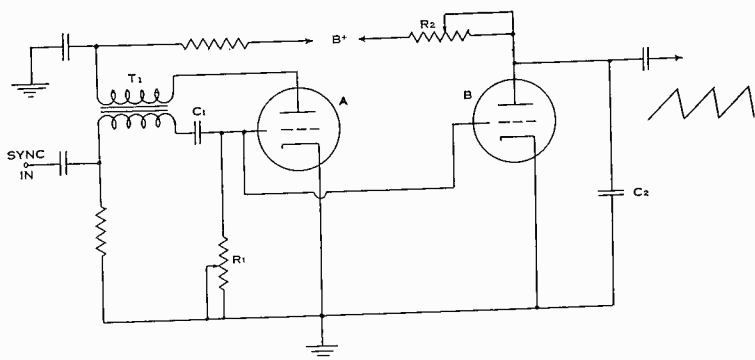

TYPICAL BLOCKING OSCILLATOR AND SAWTOOTH GENERATOR
FIGURE 2

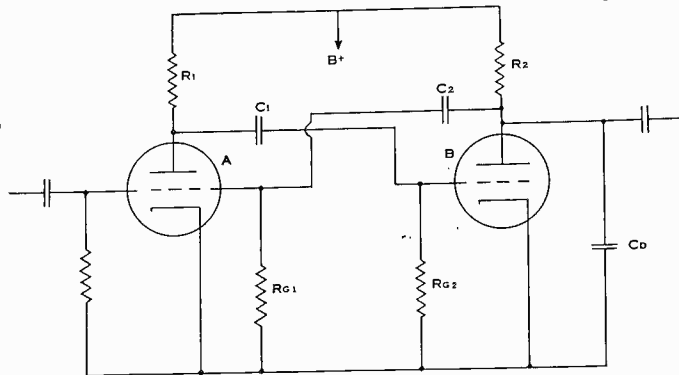

TYPICAL MULTIVIBRATOR CIRCUIT

FIGURE 3

horizontal sync pulses, then the sync would lose control and the oscillator would "drop out of sync" for some portion of the noise interval. To overcome this type of interference several circuits have been evolved. They operate by averaging the sync pulses to control the oscillator, so that loss of several sync pulses due to noise has a very small effect on the oscillator frequency. A typical example is illustrated in Figure 4.

The operational analysis of the circuit illustrated in Figure 4 is comparatively complex, but basically the operation is thus: Tube B is a blocking oscillator whose frequency may be changed over a limited range by small changes in bias. If this variation in bias can be made automatic, so that the oscillator frequency will be increased if too low, or decreased if too high, then a form of AFC (automatic frequency control) will be obtained. Tube A is the control tube of this circuit. Bias is obtained across R_1 , R_2 , R_3 , and C_1 and applied to tube B through R_4 . The bias is controlled by the average plate current of tube A, which in turn is controlled by a complex wave shape on its grid. The grid wave shape is obtained from three sources, two in-phase components and one variable-phase component. When all three components are in the proper relationship, the frequency of the oscillator is correct. Variations of phase produce an increase or decrease in plate current in tube A and subsequent bias change on

tube B. Circuits in the cathode of tube A perform the functions of averaging plate current pulses and allowing passage of sync pulse peaks. The sawtooth output is obtained across C_d which is charged through R_c and discharged through tube B during its conduction period.

The above circuit operates to maintain synchronism by averaging sync pulses so that noise bursts do not affect it as seriously as a normal blocking tube oscillator.

Deflection Amplifiers

Considering first the electrostatic system of deflection, we must obtain opposite polarities of sawtooth voltage upon the two horizontal and the two vertical deflection plates. Looking at the face of the tube, if the left hand deflection plate has a negative-going sawtooth and the right hand plate a positive-going sawtooth, the spot will move to the right. Similarly, if the top deflection plate has a negative-going sawtooth voltage on it, and the bottom plate a positively-going sawtooth, then the spot will move down. To obtain these opposite polarity sawtooths we need a phase inverting output circuit. A skeletonized deflection system is illustrated in Figure 5. The vertical deflection plates are nearer the face of the tube and require a larger amplitude of sawtooth voltage for deflection. For this reason, their B voltage is usually obtained across a resistor near the bottom of the high voltage bleeder string. The plate loads for the horizontal deflection circuit may be either chokes or resistors, and the normal B supply is usually used.

Magnetic deflection utilizes deflection coils placed on the neck of the tube, one pair of coils for the horizontal deflection and one pair for the vertical deflection. The magnetic field formed by current sawtooths through the pairs of deflection coils cause the deflection of the electron beam.

Since these coils are both inductive and resistive, the pure sawtooth of voltage must be changed slightly to cause a sawtooth of current to flow. Figure 6 illustrates a magnetic horizontal amplifier circuit. R_p added in series with C_d forms a peaking circuit, adding controllable amplitude of negative peaking to the sawtooth. This negative peaking added to the sawtooth is necessary to cause a sawtooth of current through the deflection coils.

Tube A, Figure 6, is a beam power tube capable of handling high peak currents and with insulation for high peak plate voltages. Tube B is a damper tube to damp out shock-excited oscillations in the secondary circuit; tube C is a high voltage rectifier.

The basic circuit operation is as follows: As the sawtooth of voltage applied to the grid of A increases in the positive direction, cut-off is passed and A passes increasing plate current. This current flow induces voltage in the output transformer secondary, causing a portion of current sawtooth

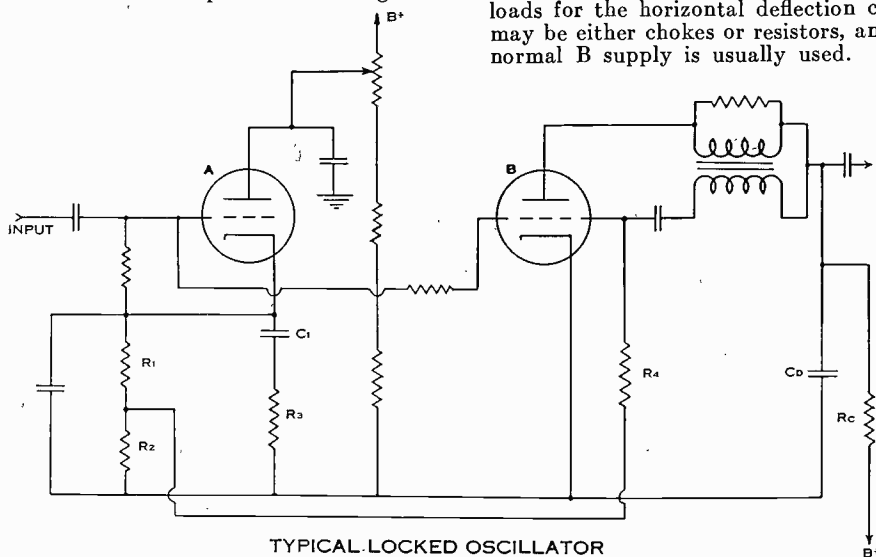

TYPICAL LOCKED OSCILLATOR
FIGURE 4

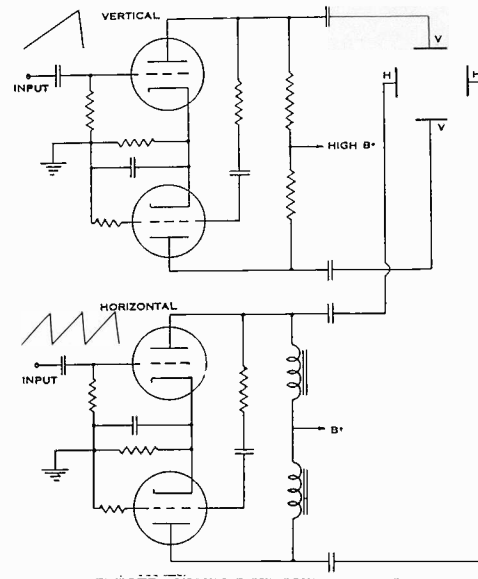

ELECTROSTATIC DEFLECTION SYSTEM
FIGURE 5

TELEVISION SWEEP CIRCUITS (Continued)

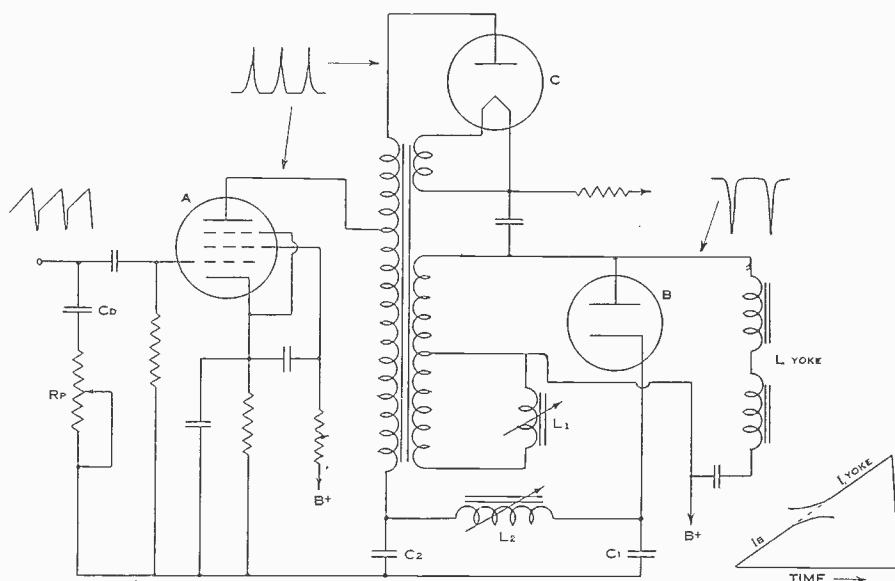

HORIZONTAL AMPLIFIER CIRCUIT FOR MAGNETIC DEFLECTION

FIGURE 6

to flow through the deflection coils L_y . When the driving voltage sawtooth reaches its peak, the tube is driven rapidly to cut-off, current flow ceases. The secondary is shocked into oscillation at its resonant frequency (designed for 70 kc or higher) and one half cycle of this oscillation, the negative swing, is allowed. The oscillation is halted by the damper tube conduction load on the system, but the one-half cycle of oscillation has reversed the current flow in the deflection coils and returned the spot to the left hand side of the screen (retrace). The energy stored in the yoke inductance is allowed to discharge toward zero through the damper tube. As it approaches zero,

tube A again starts conducting, causing a repetition of the above cycle. The sketch of the idealized yoke current wave forms in Figure 6 indicates how the yoke sawtooth is made up of both currents.

The high negative pulse appearing at the plate of the damper tube, when transferred to the primary of the transformer, is positive. The amplitude is further increased by an autotransformer winding and the pulse is rectified by tube C, where the approximately 9 kilovolts is filtered by a small condenser-resistor filter and fed to the second anode of the picture tube.

Since the damper tube, B, rectifies the shock-excited oscillation, this voltage

appears across C_1 and C_2 , and is added to the B supply voltage, yielding additional plate voltage for tube A. Condensers C_1 and C_2 partially discharge during conduction through A, causing an approximate sine wave to appear across L_2 . By changing the inductance of L_2 , by means of a slug, a small degree of linearity adjustment is available.

The slug tuned inductance L_1 is a shunt across a small percent of the secondary. By appropriate slug adjustments, the current through the transformer secondary and deflection coils may be varied, controlling the raster width.

The vertical deflection circuit is similar to the horizontal in operation. However, the lower frequency at which it operates allows considerable simplification. The output tube, which can be a small triode, drives the deflection coils through a transformer of more standard design. No damper tube is necessary as the inductive reactance of the vertical deflection coils is much lower. A low value of resistance across each deflection coil effectively loads the circuit and prevents oscillation.

The charging rate of a resistor-condenser combination is not constant, but flattens off as the condenser becomes charged. This would cause crowding of the raster if not corrected. Use is made of the curvature of the plate current-plate voltage characteristics of triodes to overcome the flattening caused by non-linear condenser charging. The amount of curvature of the triode plate characteristic may be controlled by bias changes, which may be obtained by a rheostat in the cathode circuit. The plate characteristic curvature is opposite to the non-linearity caused by the condenser, effectively causing a linear sawtooth to be formed.

SYLVANIA TYPE 221 POLYMER (Continued)

Also retained in the Type 221 is the value proven heater voltage divider adjustment used to balance the separate sections of the duo-diode employed as a rectifier in the a-c voltage measuring circuit. To the user, this means stable zeroing of all a-c ranges once the instrument is zeroed for any one range. In addition, natural tube aging may be compensated for by this control. This feature is a happy combination of tube and circuit engineering seldom found in this type instrument.

The new Polymer also retains enough range of adjustment in its zero control to permit "zero center" operation for discriminator alignment, or any application where it is convenient to read plus or minus d-c voltages without using the polarity reversal switch. High voltage probes for reading the high anode voltages found in TV sets are available as accessories.

The name, Polymer, of course means a many-purpose, many-range meter. It is a vacuum-tube instrument in the true sense of the term on all resistance ranges,

dc, ac (audio), and ac (r-f) voltages. Whereas ordinary meters, no matter how sensitive, depend on energy supplied by the circuit under test to move the meter hand, this type of instrument depends on the circuit under test only for a control voltage. Meter hand deflection is accomplished by energy supplied from the power line through the power supply circuits within the instrument. In this manner, the Polymer very nearly approaches the ideal condition of reading voltages present in a circuit as though no instrument is connected. The degree to which a vacuum tube voltmeter succeeds in acting as though "it wasn't there" is a direct measure of its success.

The general appearance of the new Type 221 Polymer with its leads is shown in Figure 1 of this article, along with a table showing range and input impedance specifications. It is interesting to note from the tabulated data that with a constant input resistance of 17 megohms for all d-c voltage measurements, the loading of a circuit being tested is always

exactly the same no matter what range is used. On the often critical low (3-volt) range the circuit under test sees a meter load of 17,000,000 ohms as compared with the only 75,000 ohms meter load attainable by using even the most sensitive non-vacuum-tube instruments. This is an improvement of some 227 times. On the often-used range covering voltages in the vicinity of 150 to 250 volts, this 17,000,000 ohm input resistance is $2\frac{1}{2}$ times that attainable using the most sensitive non-vacuum tube meters. Considering all factors including stability, comparison of the loading effect of various available vacuum tube voltmeters will show the Polymer as a well designed instrument.

Servicemen, technicians and engineers looking for a modern, volt-ohm-current measuring instrument with good "work-horse" features and no unnecessary frills, are invited to see the Type 221 Polymer at their Sylvania distributor. A descriptive folder describing all features of the instrument may be had by writing to the Advertising Department of Sylvania Electric Products Inc., Emporium, Pa.

SYLVANIA NEWS

TECHNICAL SECTION

JUNE, JULY 1949

Copyright 1949
Sylvania Electric Products Inc.
The information in Sylvania News is furnished without assuming any obligations

EMPORIUM, PENNA.

A. V. BALDWIN
Technical Editor

VOL. 16, NO. 6

VIDEO AMPLIFIERS and D. C. RESTORERS

H. C. PLEAK*

This is the tenth of a series of articles on Television by Sylvania Engineers.

In a television receiver, the video amplifier serves as the means for amplifying the demodulated picture signal from the video detector to an amplitude sufficient for modulating the picture tube grid. Primarily, a voltage gain is needed, and peak to peak signals of 120 volts may be necessary for driving the picture tube. A television picture tube may be driven by the grid or by the cathode requiring negative and positive going signals, respectively. Either polarity of signal is available at the detector and either 1, 2, or 3 video amplifier stages may be utilized, depending upon the amplitude of output voltage required, and the method (either cathode or grid) of driving the picture tube. In an audio amplifier, a frequency response of 60 cps. to 12 KC is considered very good, but video amplifiers must pass frequencies from 30 cps. to 4.5 MC with linear phase shift.

DC restoration is the name given

*H. C. Pleak received the degree of Bachelor of Science in Electrical Engineering from Iowa State College in 1942. He joined Sylvania after graduation, starting in the Engineering Test Department. He worked four years in the Equipment Design and Measurements Section of the Commercial Engineering Department, and also spent one year doing quality control work. Mr. Pleak is now working on television tube applications and circuits in the Commercial Engineering Department at Emporium.

to a method of automatically setting the background or brightness level of any given scene by means of so called restorer circuits. This will be explained in more detail later on.

Video Amplifiers

The basic circuit for video amplifiers is an R-C coupled amplifier as shown in Figure 1. For the range of audio frequencies the above amplifier would be satisfactory. The gain will fall off at both the low and high frequencies and the phase shift will not be proportional to the frequency.

Investigation of the circuit at low frequencies shows that the reactance of the coupling condenser C_c will increase, so that less voltage appears at the grid of tube B across R_c . If high frequencies are considered, the shunt capacitance C_t , consisting of the output capacitance of tube A, the input capacitance of tube B, and the stray wiring capacitances, becomes important. This shunt capacitance effectively lowers the plate load impedance of tube A causing it to appear as a resistance paralleled by a capacitance, reducing the output voltage to tube B.

Low Frequency Compensation

In order to compensate for the

loss in low frequency response, a decoupling network is inserted between B plus and the plate load circuit, as illustrated in Figure 2. As previously explained, the value of the coupling capacitance C_c is the primary cause of reduction of low frequency response. Theoretically the value of this condenser might be increased to compensate for this reduction, but practically this is impossible, since the size of the condenser would cause an increase in shunt capacitance high enough to be intolerable for good high frequency response. The network consisting of R_d - C_d is inserted to accomplish the same result.

In addition to furnishing decoupling between the plate and screen, the resistor R_d and condenser C_d tend to increase the load impedance at low frequencies. If the effective load impedance can be increased at low frequencies, then the low frequency response will be increased. Referring to Figure 2, as the frequency is reduced, the reactance of coupling condenser C_c increases. The plate load impedance of tube A then appears as R_b plus the combination of R_d paralleled by C_d . Experimentation has shown that best results will be obtained if $C_d R_d$

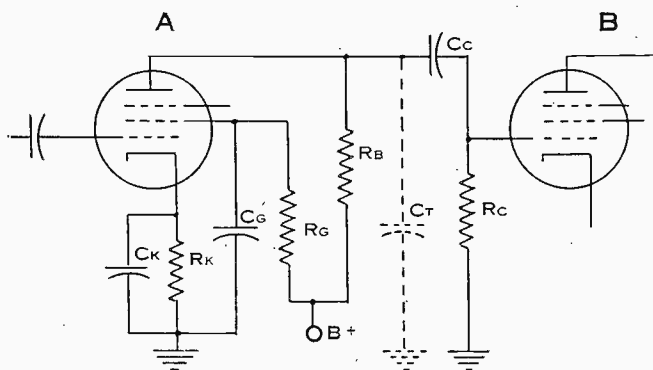

FIGURE 1
TYPICAL UNCOMPENSATED AMPLIFIER

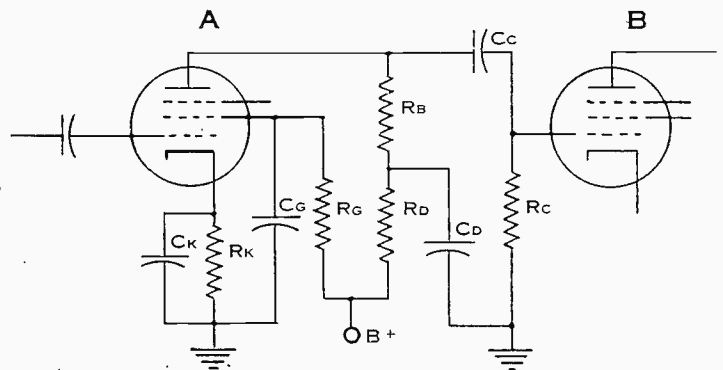

FIGURE 2
AMPLIFIER
WITH LOW FREQUENCY COMPENSATION

VIDEO AMPLIFIERS and D. C. RESTORERS (Cont'd.)

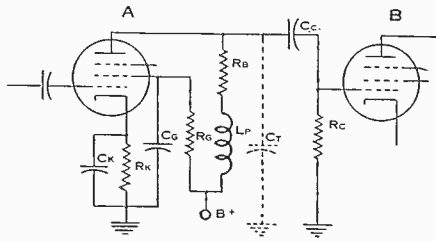

FIGURE 3
AMPLIFIER WITH HIGH FREQUENCY SHUNT COMPENSATION

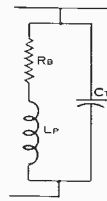

FIGURE 4
EQUIVALENT SHUNT PEAKING CIRCUIT

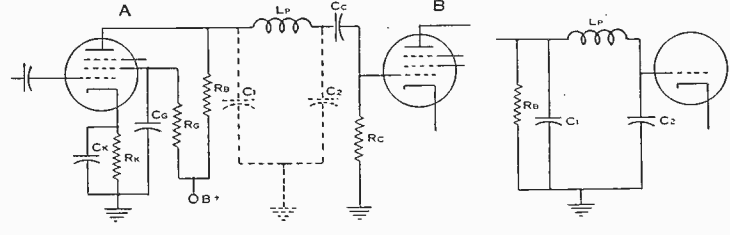

FIGURE 5
A SERIES PEAKING HIGH FREQUENCY COMPENSATION

B EQUIVALENT SERIES PEAKING CIRCUIT

equals $R_b C_c$. This network also corrects phase shift caused by coupling condenser C_c . The resistance-capacitor cathode bias combination, $R_k C_k$ is also a cause of phase shift, and, if the cathode is grounded and bias obtained by another method, this cause of phase shift may be removed. The phase shift may also be made inconsequential by making the time constant of $R_k C_k$ equal to $C_d R_d$.

High Frequency Compensation

Figure 3 illustrates a typical RC coupled amplifier with high frequency shunt compensation. It can be shown that serious loss of high frequency response is due to the shunt capacitance C_t , made up of input, output, and stray wiring capacitances. For instance, a shunt capacitance of only 10 mmf has a reactance at 4.5 mc of approximately 3600 ohms. Since, at high frequencies, this shunt capacitance effectively parallels the load impedance R_b , which may be the same order of magnitude, the output voltage will be reduced by about 30%. By utilizing tubes having very low input and output capacitances, and by reducing stray wiring capacitances by good layout and design, a minimum C_t will be reached. Analysis of the circuit of Figure 3 shows that the equivalent high frequency load is as illustrated in Figure 4. Coil L_p is a "peaking" coil inserted in series with the load resistor. By proper

choice of values, the reactance of the coil L_p increases with a frequency increase causing the load to become the impedance R_b plus X_{Lp} in parallel with the shunt capacitive reactance X_{Ct} , thus, the peaking coil effectively peaks the high frequencies. It is known as shunt compensation because the peaking coil is in shunt with the capacity C_t .

Another type of high frequency compensation, called series peaking is illustrated in Figure 5. This type of peaking isolates and divides the input, output, and shunt capacitances of the circuit. By this means the value of load resistance, R_b , is determined by C_1 , which is considerably smaller than C_t since C_1 is comprised of only the output capacitance of tube A and stray capacitances up to L_p .

Variations of the series peaking circuit call for moving L_p to the plate side of the load resistor R_b , or to move L_p to the grid side of the coupling condenser C_c . These variations are used to adjust for input and output capacitance differences. Generally, the peaking coil L_p is so placed that the lowest capacitance, C_1 , is in shunt with the plate load, R_b .

In operation the series peaking circuit operates somewhat differently than the shunt peaking circuit. Referring to Figure 5, it will be recognized that at high frequencies coupling condenser C_c

is effectively a short circuit, and that grid resistor R_c is very large in comparison with R_b , so that these may be neglected resulting in the simplified circuit of Figure 5B. If the circuit consisting of L_p and C_2 is disconnected from C_1 and R_b in Figure 5, then the shunt capacitance C_1 appears across load resistor R_b , reducing the effective voltage across this load at high frequencies. If L_p and C_2 are now connected to C_1 and R_b , a voltage divider is formed in which the voltage across C_2 (or on the grid of tube B) is maintained constant by series resonance in the combination of $L_p C_2$, increasing the high frequency response.

Usually the high frequency response of the amplifier is overcompensated in order to increase the bandwidth sufficiently. Figure 6 illustrates a typical amplifier response curve with both high and low frequency compensation, with the normal uncompensated response. Gain of the mid frequencies is plotted as unity for simplicity. Both series and shunt high frequency peaking may be employed in a video amplifier in conjunction with low frequency compensation.

DC Restorers

Before we undertake analysis of the operation of DC restorer circuits we should understand why they are desirable. In Figure 7 are illustrated two video signals representing two separate horizontal

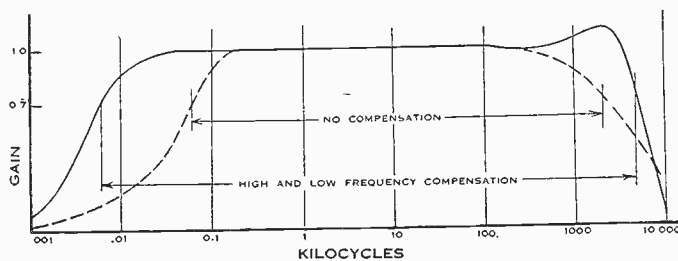

FIGURE 6
TYPICAL AMPLIFIER RESPONSE CURVES

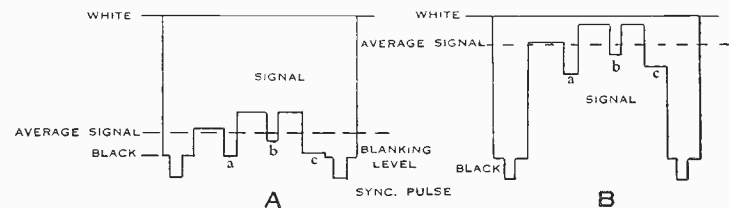

FIGURE 7
IDENTICAL SIGNALS WITH DIFFERENT BRIGHTNESS LEVELS.

VIDEO AMPLIFIERS & D. C. RESTORERS (Cont'd.)

lines. The camera signal in A contains the same amount of detail as in B, but the average brightness of B is higher than that of A due to the signal being near the white level. If, in Figure 7B, we moved the average brightness level, shown by the dotted line, to the same point as in A the two signals would be identical. The average of the picture signal determines the average brightness and is called the DC component, while the signal variations are called the AC component.

When the video signal is passed through coupling or blocking condensers, such as those present in a video amplifier, the DC component is lost and the entire signal is averaged around the AC axis. This means that the blanking and sync pulses will not be lined up, due to varying amounts of video information, synchronism and blanking will tend to be lost, and background lighting will become darker.

To overcome these defects a circuit, known as a DC restorer, is utilized. This circuit usually automatically selects either the

blanking pedestal or sync pulse level for use as a reference axis.

A simple DC restorer circuit is illustrated in Figure 8. The action of the circuit is as follows: With a positive going signal on the plate of the video output amplifier, tube A, the cathode of diode D becomes positive and passes no current. When the output signal swings negative, the cathode of the diode D become negative and current flows through Rd, causing the cathode of D to become positive, charging the condenser C1. The positive voltage, determined by the signal, is applied through resistor R1 to the grid of the picture tube. This positive voltage is added to the grid across the resistance Rk, and since it is proportional to the signal, the sync tips will be aligned and the DC component, or average brightness, automatically restored to the picture. In order that the average brightness will not change so rapidly as to affect the eyes, the time constant C1Rd is made many times longer than the duration of one horizontal line, say 500 times or one frame. In this manner scene

lighting will be truthfully reproduced and extremely rapid changes making up the detail of the picture will be faithfully reproduced.

A Germanium diode Type 1N34 may be used in the same circuit.

In Figure 9, another type of restorer, known as the grid leak restorer, is illustrated. Here the grid cathode circuit of the video amplifier output tube is utilized as a diode, and plate is directly coupled to the picture tube grid so that the DC component will not be lost through a coupling condenser. The essentials of operation are very similar to those of the diode type of restorer. As the positive peaks of the signal and sync tips pass through Cc, the grid, operating at zero bias, is driven positive and grid current flows in such a direction as to make the grid more negative, but again proportional to the impressed signal amplitudes. The time constant of the RgCc combination is made sufficiently long so that Cc does not appreciably discharge between line sync pulses, but sufficiently small to handle scene changes.

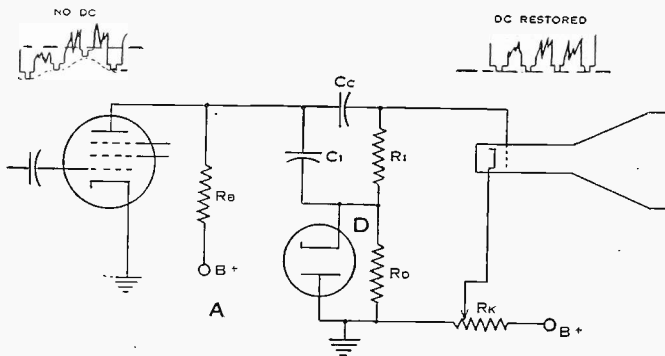

FIGURE 8
DIODE DC RESTORER CIRCUIT

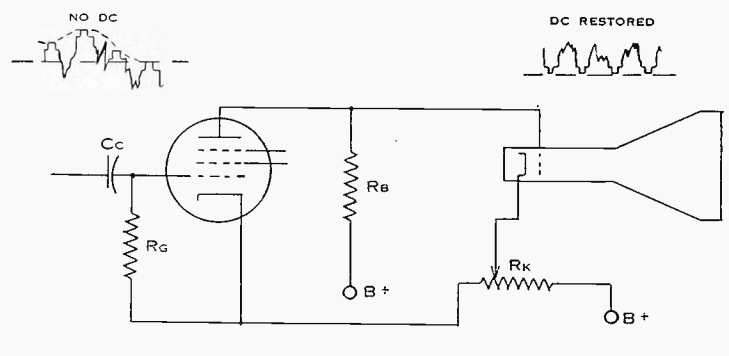

FIGURE 9
TYPICAL GRID LEAK DC RESTORER CIRCUIT

SERVICE HINTS

Whistle in Emerson Model 517: A number of people have brought the Emerson Model 517 to me, and all of them complain of the same trouble. A loud whistle keeps developing as soon as a certain volume level is reached. This whistle is especially loud on the higher audio frequencies. The trouble can easily be cured by placing a 100 mmfd condenser across the volume control. Most sets on the market seem to have that condenser already in place; however, the Emerson Model 517 does not.—H. C. Loewy, Hoboken, N. J.

Zenith Ford Model 6MF080: Symptoms: Playing good, but suddenly began blowing fuses (naturally no play at all then.) Short traced to Delayed Mute Switch, S5 on schematic. The 6 volt contact had slipped slightly, allowing contact to frame to be made through rivet holding the assembly. If this condition is met in sets of this series, much time can be saved by unsoldering yellow wire to switch and checking contact to ground with low range ohmmeter. Remedy: Adjust contact to proper position and tighten rivets.—John L. Cooper, Purvis, Mississippi.

NOTICE

Latest Revisions And Additions To Tube Checker Settings

The list on the next page includes all changes and additions available to June 1949 which are not given on the "C" chart for Sylvania Type 139-140 tube checkers. The chart number is shown in the lower left hand corner as PC No. 15845C.

Keep This Near
Your Tube Checker

TYPE	A	B	C	D	E	F	G	TEST
OZ4.....	.75	0	—	0	1	—	19	Y
					3	—	19	Y
1A1/5E1...	.75	0	—	0	0	—	—	Fil.*
1B1.....	.75	0	—	0	0	—	—	Fil.*
1B4/P.....	2	0	—	0	1	039	16	V
1C1.....	.75	0	—	0	0	—	—	Fil.*
1D1.....	.75	0	—	0	0	—	—	Fil.*
1E1.....	.75	0	—	0	0	—	—	Fil.*
1F1.....	.75	0	—	0	0	—	—	Fil.*
1G1.....	.75	0	—	0	0	—	—	Fil.*
1J1.....	.75	0	—	0	0	—	—	Fil.*
1K1.....	.75	0	—	0	0	—	—	Fil.*
1LH4.....	1.4	0	—	0	1	6	64	T
1R1G.....	.75	0	—	0	0	—	—	Fil.*
1R5.....	1.4	3	5	4	1	016	41	V
					0	8	13	V
1S1G.....	.75	0	—	0	0	—	—	Fil.*
1SA6.....	1.4	0	—	0	6	36	50	T
1T1G.....	.75	0	—	0	0	—	—	Fil.*
1U4.....	1.4	2	45	4	1	016	20	V
1W1.....	.75	0	3	5	0	—	—	Fil.*
1X1.....	.75	0	—	0	0	—	—	Fil.*
1Y1.....	.75	0	—	0	0	—	—	Fil.*
1Z1.....	.75	0	—	0	0	—	—	Fil.*
2.....	6.3	0	—	0	0	—	—	Fil.*
2C45.....	7.5	0	—	0	1	3	21	W
2C51/396A	6.3	0	—	0	7	6	36	U
					3	7	36	U
2E24.....	6.3	0	3567	0	8	024	25	Y
3.....	117	0	—	0	0	—	—	Fil.*
3A5.....	2.5	2	4	4	1	1	58	U
			4	4	5	5	58	U
3D24.....	6.3	0	156	0	8	48	18	W
3LF4.....	2.5	0	7	0	1	036	36	U
3V4.....	2.5	2	5	4	1	016	45	U
4.....	117	0	—	0	0	—	—	Fil.*
4A1.....	3.3	0	—	0	0	—	—	Fil.*
4A6G.....	2.0	6	—	0	1	3	19	V
					5	4	19	V
5.....	117	0	—	0	0	—	—	Fil.*
6.....	.75	0	—	0	0	—	—	Fil.*
6A7.....	6.3	0	—	0	1	039	66	W
					3	036	18	V
6A8.....	6.3	0	—	0	1	039	76	W
					5	036	23	V
6AG5.....	6.3	0	4	0	4	36	30	V
6AH6.....	6.3	0	—	0	4	36	39	W
6AN5.....	6.3	0	—	0	4	3	39	U
6AQ7.....	6.3	0	—	1	3	3	70	W
					1	—	55	T
					4	—	55	T
6AR5.....	6.3	0	—	0	4	36	25	W
6AS5.....	6.3	0	5	0	3	26	25	Y
6AV6.....	6.3	0	—	0	3	3	55	T
					5	—	60	T
					4	—	60	T
6BA7.....	6.3	0	—	0	4	027	59	T
					1	3	39	U
6BE6.....	6.3	0	—	0	4	46	85	W
					5	3	35	U
6BF6.....	6.3	0	—	0	3	3	53	W
					4	—	55	T
					5	—	55	T
6BH6.....	6.3	0	—	0	4	36	50	U
6BJ6.....	6.3	0	—	0	4	36	29	W
6F5G.....	6.3	0	—	0	2	9	55	T

TYPE	A	B	C	D	E	F	G	TEST
6SB7Y.....	6.3	0	—	0	1	037	49	T
					2	4	22	X
6SV7.....	6.3	0	—	1	5	380	73	U
					3	—	54	T
7.....	117	0	—	0	0	—	—	Fil.*
7AD7.....	6.3	0	—	0	1	036	45	Y
7F8.....	6.3	1	7	1	2	8	43	U
					5	1	43	U
7G7.....	6.3	0	—	0	1	03	60	W
8.....	117	0	—	0	0	—	—	Fil.*
9.....	50	0	—	0	0	—	—	Fil.*
12AT6.....	12.6	0	—	0	3	3	52	T
					4	—	55	T
					5	—	51	T
12AT7.....	12.6	0	5	0	3	7	40	U
					1	3	40	U
12AV6.....	12.6	0	—	0	3	3	47	T
					4	—	55	T
					5	—	55	T
12AW6.....	12.6	0	—	0	4	36	52	V
12AX7.....	12.6	0	5	0	3	7	50	T
					1	3	50	T
12BA7.....	12.6	0	—	0	4	26	54	T
					1	3	34	U
12BD6.....	12.6	0	—	0	4	36	41	X
12BE6.....	12.6	0	—	0	4	46	85	W
					5	3	35	U
12BF6.....	12.6	0	—	0	3	3	56	W
					4	—	55	T
					5	—	55	T
12S8GT.....	12.6	0	78	1	5	9	50	T
					4	—	55	T
					2	—	55	T
					1	—	55	T
14Q7.....	12.6	0	—	0	1	036	96	W
					2	4	40	U
14X7.....	12.6	0	—	0	1	3	51	T
					4	—	55	T
					5	—	55	T
19J6.....	12.6	0	—	0	1	5	50	T
					2	6	50	T
19T8.....	12.6	0	—	0	4	9	54	T
					3	—	52	T
					2	—	52	T
					1	—	52	T
35C5.....	35	0	5	0	3	26	16	W
			2	—	3	56	16	W
46A1.....	35	0	—	0	0	—	—	Fil.*
46B1.....	35	0	—	0	0	—	—	Fil.*
50C5.....	50	0	5	0	3	26	18	Y
			2	—	3	56	18	Y
50Y7.....	50	0	6	0	1	—	19	Y
					3	—	19	Y
262B.....	10	0	—	0	1	9	55	T
274A.....	5	0	—	0	1	—	22	Y
					2	—	22	Y
300B.....	5	0	—	0	1	3	24	Y
310B.....	10	0	—	0	1	039	53	X
802.....	6.3	0	—	0	8	034	63	Y
807.....	6.3	0	—	0	8	023	30	Y
841.....	7.5	0	—	0	1	3	61	W
1280.....	12.6	0	—	0	1	036	61	T
5516.....	6.3	0	3567	0	8	024	28	Y
FM1000....	6.3	0	—	0	4	6	62	T
					3	056	52	T
VT-52.....	7.5	0	—	0	1	3	21	W

*NOTE:—This ballast test shows hot continuity only.

SYLVANIA NEWS

TECHNICAL SECTION

AUGUST 1949

Copyright 1949
Sylvania Electric Products Inc.

EMPORIUM, PENNA.

A. V. BALDWIN
Technical Editor

VOL. 16, NO. 7

The information in Sylvania News is furnished without assuming any obligations

1949

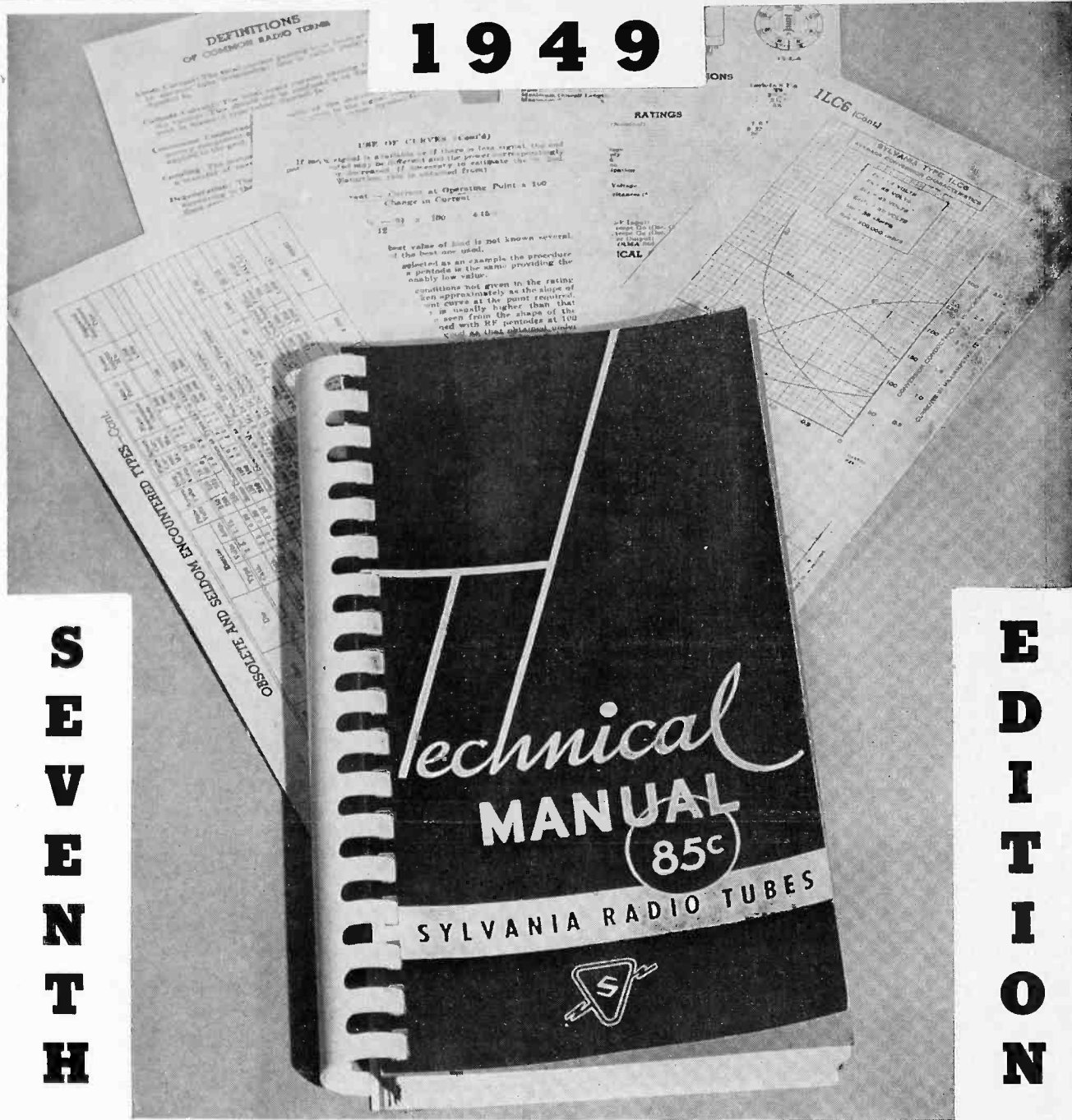

**S
E
V
E
N
T
H**

**E
D
I
T
I
O
N**

By the time you receive this issue of "Sylvania News" the new seventh edition of the Sylvania Technical Manual will be ready for distribution. All the good features of the previous edition have been continued, and in addition the more important cathode ray tubes are included.

In order to provide data and

curves for all the new tubes which have been announced recently, the number of pages has been increased to 418, and the total number of basic tube types is now 637 — 92 more than the previous edition. Resistance coupled data is now given for 16 tube characteristics and the usefulness of the tables has been increased by listing all the types for

which the data may be used on the same page.

The popular plastic binding is being used again and in a month or so we hope to continue the loose leaf supplements supplied with "Sylvania News."

Get yours from your dealer or order from the Advertising Department. No price increase, still 85¢.

Section Vol. 1 \$1.00—Vol. 2 \$1.00—Vol. 3 \$1.00

Binders With Complete File of Technical

NEW SYLVANIA TYPE 216 AM—FM SIGNAL GENERATOR

By CLARENCE L. SIMPSON

Sylvania engineers have developed a quality FM-AM Signal Generator which has long been needed by all progressive radio service technicians. The new instrument now available at Sylvania distributors is enclosed in a steel cabinet with baked pearl-gray crackle finish. The panel has green lettering and trim with contrasting black plastic control knobs, continuing the style of previous Sylvania test equipment. The accompanying picture, Figure 1, displays the modern styling, which will give your service shop an up-to-date appearance.

Principle

The general design principles followed in developing this instrument are those found most successful in obtaining maximum utility by service technicians. By mixing the output of a stable fixed oscillator with an accurately calibrated variable oscillator, a steady, powerful signal is obtained having frequency coverage from 80 kc to 120 mc with no skips and without resorting to the use of harmonics.

The use of the mixer principle contributes to the stability and accuracy of the FM Signal Generator. This is because frequency deviation when produced by a reactance tube is proportional to the carrier frequency. Therefore, if the carrier is varied, the deviation varies with the carrier frequency. This would be the case if the variable oscillator in the signal generator were frequency modulated. This is undesirable for an FM signal source. However, if a fixed oscillator is frequency modulated, the deviation will be constant and the various output frequencies required may be obtained by mixing the output of the frequency modulated fixed oscillator and the variable oscillator. The result of this beat frequency design is an FM signal source of constant deviation even when the output frequency is varied. Additional stability is obtained by

Clarence L. Simpson is known to many readers of SYLVANIA NEWS for the technical help on Television he has given at Sylvania Service Meetings. His experience during the war as radio and radar instructor and development engineer for the U. S. Air Force, and later as instructor in Television at the United Television Laboratory gives him a thorough knowledge of the subject.



this method for it is extremely difficult to keep a single oscillator sufficiently stable at the high frequencies required for FM. A more accurate and stable FM signal will result from the mixing of two low frequency oscillators such as used in the Sylvania Type 216 Signal Generator. An additional feature contributing to the fine stability of the instrument is a regulated high voltage power supply. This holds the frequency stability to a tolerance comparable to battery operated equipment.

The accompanying functional block diagram, Figure 2, shows the major operating sections of the instrument. The following paragraphs describe the technical features and advantages of this instrument.

Technical Features

The basic section is the calibrated variable oscillator which operates between the frequencies of 80 kc and 60 mc, and a fixed oscillator which functions as either a 1 mc or a 60 mc source, or as a 1 mc crystal oscillator to be described later. For CW operation from 80 kc to 60 mc, the variable oscillator alone feeds

through the mixer section which acts in this case merely as a buffer between the signal source and the output system. Amplitude modulation over the same frequency range is accomplished by introducing an internal or external audio modulating voltage at the suppressor grid of the mixer tube. Internal amplitude modulation is variable between 0 and 100%. For FM and for CW frequencies above 60 mc, one or the other of the fixed oscillators is mixed with the variable oscillator signal to produce the desired output up to 120 mc. The commonly used combination output frequencies are shown in direct reading red figures on the tuning dial.

Output

At this point it may be interesting to note that high voltage signal level is a feature of this new instrument. The high voltage output jack is connected ahead of the attenuator and therefore is not affected by it but it does operate the constant level output meter. This output will on some bands be as much as 1.5 volts RF. All are as high as one full volt except band "G" which provides .8 volts RF at

SYLVANIA TYPE 216 SIGNAL GENERATOR

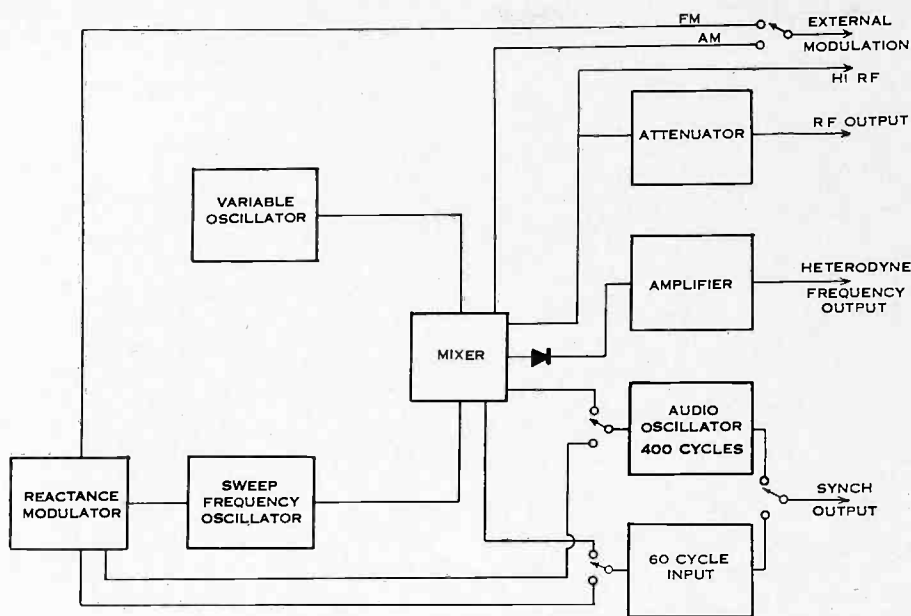

FIGURE 2

the 500 ohm impedance "Hi RF jack." This feature is advantageous when servicing very badly aligned sets or those tampered with by novices. For aligning normal sets, the output is delivered through an attenuator with seven steps plus a variable adjustment. The maximum output through coaxial cable is at least 25,000 microvolts on all bands. An RF meter is provided to give the user an indication of a constant reference level output. This is very useful in testing receiver stage-to-stage gain. The instrument is equipped with a 50 ohm output cable terminated in its characteristic impedance which means it is non-resonant and its radiation is negligible.

FM Operation

For FM operation the fixed oscillator is frequency modulated by

the conventional reactance tube principle similar to that found in radio sets featuring automatic frequency control (AFC). An internal 400 cycle oscillator may be used either for AM or FM modulation as desired. Oscilloscope synchronizing voltage of approximately 1.3 volts is made available from this source at the panel "AF Out (Sync)" terminal.

When the signal generator is adjusted to produce wide band FM (+350 kc deviation), the variable oscillator and the 60 mc fixed oscillator are operating and the latter is frequency modulated at 60 cycles by the reactance tube. In this case, the 60 cycle voltage controlling the reactance tube comes from the power lines and is at the same time available at the "AF Out (Sync)" terminal on the panel. By

using the internal 400 cycle signal, +75 kc frequency modulated output may be obtained. This 400 cycle voltage is from the audio oscillator previously described. For an example of wide band FM, consider the case when the dial of the instrument is set to 100 mc (red figures). The variable oscillator will be operating at 40 mc (black figures), the frequency modulated fixed oscillator will be at 60 mc, and the output of the mixer section will contain the sum of these two frequencies or 100 mc. The amount of FM sweep depends on the amount of modulating voltage applied to the reactance tube controlled by adjusting the modulation control on the panel. External sine-wave modulating voltages from 50 to 1200 cycles may be used, as well as sawtooth modulating voltages. Approximately 1 mc sweep may be obtained by use of higher voltage external modulation sources. Modulating voltages exceeding 50 volts should not be applied.

With the Sylvania FM-AM Signal Generator, visual alignment of AM radio is easily accomplished through the use of an oscilloscope such as Sylvania Oscilloscopes Types 131 or 132. In this case, the 1 mc fixed oscillator signal with ± 15 kc deviation is mixed with the variable oscillator signal instead of using the 60 mc fixed oscillator as previously described for wide band FM. The variable oscillator will operate between the frequencies of 80 kc and 60 mc; therefore, narrow band FM up to 61 mc center frequency is available from the mixer section. The frequency modulating voltage for narrow band FM is 60 cycles and

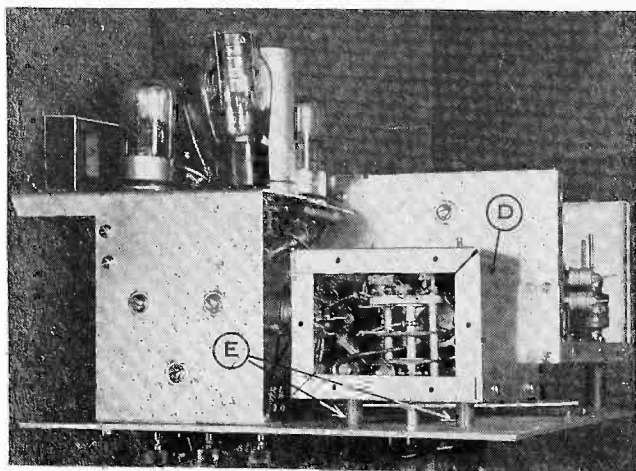

FIGURE 2

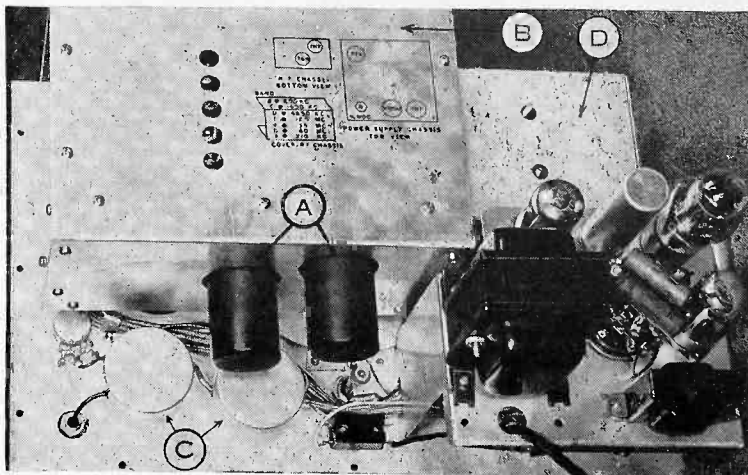

FIGURE 3

SYLVANIA AM—FM SIGNAL GENERATOR

is, of course, available at panel terminals for oscilloscope synchronizing purposes. External modulation as explained for wide band FM may also be used for this type of operation.

The panel modulation control is used to adjust percent of modulation for AM and the sweep width of FM. Therefore, for CW operation of the instrument at any frequency between 80 kc and 120 mc, it is necessary only to set the instrument controls to produce the desired frequency and turn the modulation control to zero. The result is a powerful, accurately calibrated, wide range CW signal generator. Although the primary purpose of the variable audio signal voltage is for oscilloscope synchronizing purposes, it may be found useful for checking audio sections of receivers or public address systems.

Necessity for Complete Shielding

Formerly servicemen have had to contend with leaky signal generators. Possibly nothing disgusts a technician more than to discover, after desperately trying to tune in a weak station, that his leaky signal generator was "on" and tuned to the IF frequency or the same frequency he was trying to tune in on the receiver. In this case, the signal generator was possible radiating a stronger signal than the station was delivering at that location. This becomes particularly serious and less easily solved when servicing FM sets because some FM alignment techniques call for use of a signal with no audio modulation. The confused technician hears no signal from the set he is servicing and therefore is not aware of the nature of his trouble. Even more disconcerting than the foregoing is the interference caused by a leaky signal generator being operated by another serviceman in the same shop. Everytime the other man makes certain adjustments to the leaky instrument, it will produce a "blurb" of noise in all receivers near it. In the design of the new FM-AM signal generator, Sylvania engineers have reduced leakage to the barest minimum by multiple shielding and filtered lines.

The accompanying Figure 3 shows how extensively and carefully shielding has been carried out in the Sylvania Type 216 Signal Generator. The two black cans marked A are

shields for the variable oscillator and buffer tubes. These shields do not contact the variable oscillator coil shield marked B but extend through to the chassis of the oscillator itself. This in effect is a separate unit with a separate shield. The other two round cans marked C are the fine and coarse attenuators. These controls are shielded by seamless metal cans with snug fitting lids. The other unit of major concern in shielding is marked D and contains the frequency modulator and fixed oscillator coils with their associated components. All high level RF energy is confined by a completely closed shield as shown in Figure 4. The parts marked E are high frequency insulators and isolate the RF units from the panel. The panel and outside case form the second complete shield for the instrument. The two shields are bonded at only one point, thus preventing RF eddy currents common to both inner and outer shields.

As an example of dual shielding, let us assume that we have an oscillator coil producing a signal of 10 volts at a distance of a few inches. Let us say that after shielding the coil, the signal at the same point is reduced to 100 microvolts, giving an attenuation factor of 100,000. If we place around the first shield an additional shield as in the case of this instrument, we find that for each 10 volts at the oscillator coil there will be only .001 (one-thousandth) of a microvolt radiated beyond the second shield. The most sensitive receivers require at least one microvolt to cause interference. The foregoing example is entirely arbitrary and used only as a simple example to illustrate the general effect of double shielding. In addition to double shielding, further effort has been made to reduce radiation and leakage to a minimum. The jacks for "RF OUT," "RF IN" and "XTAL OUT" as shown in Figure 1 have been mounted in the inside RF compartment in order to allow only one connection between the inner and outer shields. These jacks are accessible to test prods inserted through small holes in the panel. In addition, the variable oscillator shaft, (a possible source of radiation), does not protrude through the panel but is extended with a fiber rod to make contact with the tuning dial. The instrument is equipped

with a coaxial output cable terminated in its characteristic impedance which means it will be non-resonant and will have negligible radiation from that source. Other precautions of less dramatic interest have been taken in the design of this new instrument to present the service technician with a signal generator of both minimum leakage and spurious radiation.

Other Features

The signal generator contains two Sylvania Germanium Type 1N34 crystal rectifiers, one for the constant reference level meter and the other for the audio amplifier used in the heterodyne detector circuit.

The heterodyne detector feature can be used to advantage in checking unknown frequencies. When an unknown frequency of at least 0.1 volt is introduced at the "RF IN" jack, it appears at the plate of the mixer tube. The beat note, between the signal generator output and the unknown signal, can be heard in headphones plugged into the panel jack provided for this purpose, and the frequency of the unknown determined by tuning for zero beat.

Provision is made in the instrument for installing a 1 mc crystal to be used as a standard for calibration or as a frequency standard. This circuit is that used for the 1 mc fixed oscillator previously mentioned. The output for this oscillator is at the panel jack "XTAL OUT." Although the instrument is calibrated to $\frac{1}{2}$ of 1% at the calibration points on each band, the operator may desire crystal check points on the dial of the instrument, or the 1 mc crystal signal may be used to assist in checking unknown frequencies with the heterodyne detector described immediately above.

In addition to the salient features herein described, the Sylvania FM-AM Signal Generator has the various standard features such as vernier dial, microphone type output jack, as well as sufficient harmonic power to be useful at frequencies as high as 240 mc if needed. Considering the many special features of the new instrument as well as the highly refined standard items, the service technician should be pleased with the performance of the latest addition to the Sylvania test equipment line.

TELEVISION HIGH-VOLTAGE SUPPLIES

By H. C. PLEAK*

This is the eleventh of a series of articles on Television by Sylvania Engineers.

Television applications have resulted in the design and use of some rather special circuits for the generation of high voltages. Since television applications require currents under 1 Ma. at voltages ranging from 6 KV to 30 KV, a power line frequency supply is generally considered unnecessarily heavy and expensive. In addition power line frequency supplies necessitate bulky filtering systems with some shock hazard due to the necessarily large filter capacitors.

In general use in the television field today are 3 separate systems of generating the high voltages for accelerating the electron beam in a picture tube. These types are: (a) Flyback; (b) Radio Frequency; and (c) Pulse Type. Each of the above circuits will be discussed separately since they differ in regard economy, current drain, size, interference, and efficiency.

The Flyback Type Supply

This type of supply is found only in receivers utilizing magnetic deflection. The flyback voltage pulse occurring during the return trace or dark screen interval is rectified and filtered for use as the anode voltage. It requires fewer additional parts and no additional source of power. Since it operates during a blanked interval, there is little interference visible on the face of the picture tube.

Figure 1 illustrates a typical flyback high voltage supply. The circuit components of the high voltage section consist mainly of transformer windings L_1 , L_2 , and L_4 ,

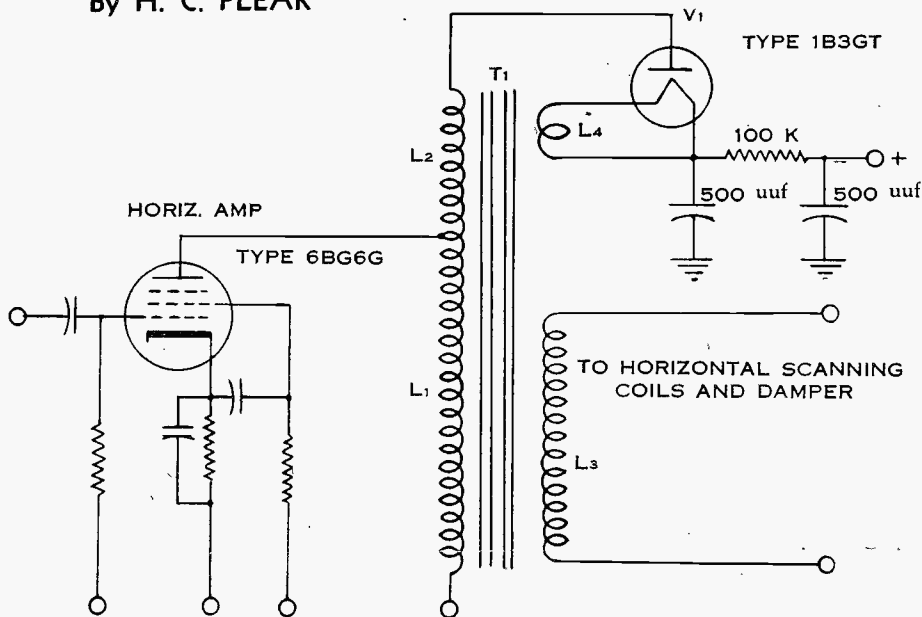

FIGURE 1
BASIC CIRCUIT FOR FLY BACK
HIGH VOLTAGE SUPPLY

rectifier V_1 and filter components C_1 , C_2 , and R . A sharp negative pulse occurring because of the rapid collapse of the driving sawtooth appears across L_3 . This becomes transformed to a positive pulse across winding L_1 , appearing at the plate of the horizontal amplifier with a peak of 4.5 to 6 Kv. Winding L_2 serves as an auto transformer stepping up the 4.5 Kv. to approximately 9 Kv. The pulse is rectified by V_1 . This tube has a 1.25 volt, 200 Ma. filament (1B3GT) so that a two turn well insulated winding on the transformer serves as the filament voltage supply with the entire tube operated above ground. The 500 μ f condenser C_1 serves as the input filter condenser of the filter section made up of C_1 , R , and C_2 . R may be from 100 K to 1 megohm and C_2 is usually the picture tube anode capacity, formed between the inner and outer conductive coatings of many glass picture tubes.

Since the frequency of the flyback supply is 15,750 c.p.s., no elaborate filter is necessary. C_1 is large enough to furnish peak current demands, but the regulation and capacity remain low enough that heavy currents cannot be drawn.

Voltage Doubling

In some types of receivers using larger picture tubes, a higher anode voltage is sometimes required than is available from the flyback supply. This voltage may be obtained from doubler and tripler circuits such as those illustrated in Figure 2.

In flyback circuits, the pulse voltage to be rectified is not usually of symmetrical form, requiring slightly different multiplier circuit designs.

In the doubler circuit of Figure 2A the pulse input appears across V_1 and C_1 where C_1 is charged to nearly the peak to peak pulse voltage. Condenser C_2 is charged through R_1 to the same value as C_1

*H. C. Pleak received the degree of Bachelor of Science in Electrical Engineering from Iowa State College in 1942. He joined Sylvania after graduation, starting in the Engineering Test Department. He worked four years in the Equipment Design and Measurements Section of the Commercial Engineering Department, and also spent one year doing quality control work. Mr. Pleak is now working on television tube applications and circuits in the Commercial Engineering Department at Emporium.

HIGH-VOLTAGE POWER SUPPLIES FOR TELEVISION

where its charge adds in series with the applied pulse voltage and the sum is rectified by V_2 , charging C_3 . Nearly twice the pulse input voltage appears at the cathode of V_2 .

Figure 2B illustrates a typical tripler circuit wherein both positive and negative swings of the input wave are utilized in developing the high voltage. In operation, as the plate of V_1 is swung positive, V_1 conducts charging C_1 . On the negative swing V_1 is non-conducting and C_2 is charged through V_2 by the amount of the charge on C_1 plus the negative peak. On the next positive swing V_3 conducts, charging C_3 by the amount of the charge on C_2 plus the peak positive swing, while at the same time C_1 is again charged to its original value. If the rectified voltage resulting from V_1 is E , then at this time there will appear at the output terminal a voltage of $3E$ resulting from E across C_1 in series with $2E$ across C_3 . This type of multiplier circuit may be found with radio frequency and some pulse type supplies. It should be observed that condensers C_2 and C_3 in the tripler circuit of Figure 2A must be capable of 2 times the peak positive swing, while C_1 needs only to be rated at the peak positive swing.

In Figure 2C is illustrated a slightly different tripler circuit design which will be found associated with flyback power supplies. Its operation is as follows: As the positive pulse appears at the plate of V_1 , it is rectified, charging C_1 to nearly peak pulse amplitude. During interval between pulses, C_1 discharges through R_1 charging C_2 , which discharges through V_2 , charging C_3 , which discharges through R_2 , charging C_4 , which finally discharges through V_3 , and charges C_5 . After the first pulse all condensers are charged to approximately the same value. After a sufficient number of pulses have been applied, all condensers will be charged to approximately the peak value of the applied pulse voltage. The polarity of these charges are such that the voltages across C_1 , C_3 , and C_5 are additive so that a voltage of approximately $3E$ appears at the high voltage terminal. This multiplier has the advantage of requiring condensers of lower voltage rating than the circuit of Figure 2A.

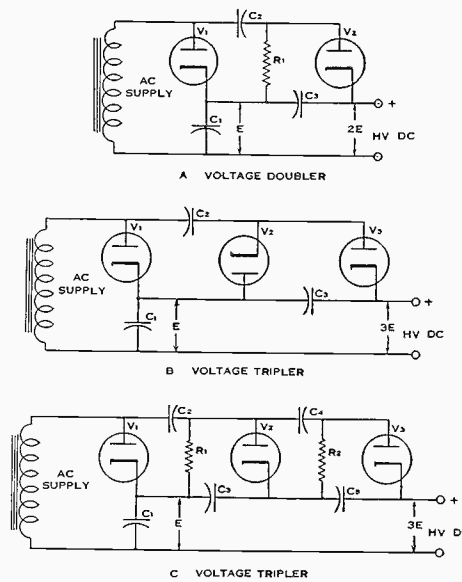

FIGURE 2
VOLTAGE MULTIPLIER CIRCUITS

Radio Frequency High Voltage Supplies

A typical R.F. power supply circuit is illustrated in Figure 3. This circuit usually utilized a small beam power tube as a Class C oscillator whose output is tightly coupled to a high voltage winding. The plate is tuned to the resonant frequency of this winding across which appears the high voltage rectifier and stray wiring capacitances. A well insulated 2 to 4 turn winding is usually included to operate the high voltage rectifier filament, since the Type

1B3GT, usually used, requires only one quarter watt of filament power.

R.F. power supplies may be built to supply voltages in excess of 50 Kv, with fair regulation. Since they operate in the range of 50 to 500 Kc, filtering requires only small capacity high voltage condensers. The chief disadvantage is the strong R.F. field, which sometimes causes beats in the sound and video sections of receivers. Complete shielding and good supply lead filtering is necessary. The circuit of Figure 2B would be used for multiplication since both positive and negative swings would be utilized. Additional windings may be found on the coil form for the purpose of obtaining extra filament voltages or intermediate B+ voltages of low current drain.

Pulse Type High Voltage Supply

The pulse type high voltage supply is not found so often as the previous two types. It is also capable of producing high voltage independent of the deflection circuits, which makes it useful in sets employing electrostatic deflection. A simple pulse type high voltage supply is illustrated in Figure 4.

The operation of this is similar to the magnetic scanner circuit without scanning coil windings. The blocking oscillator circuit is so arranged that a sync pulse derived from the

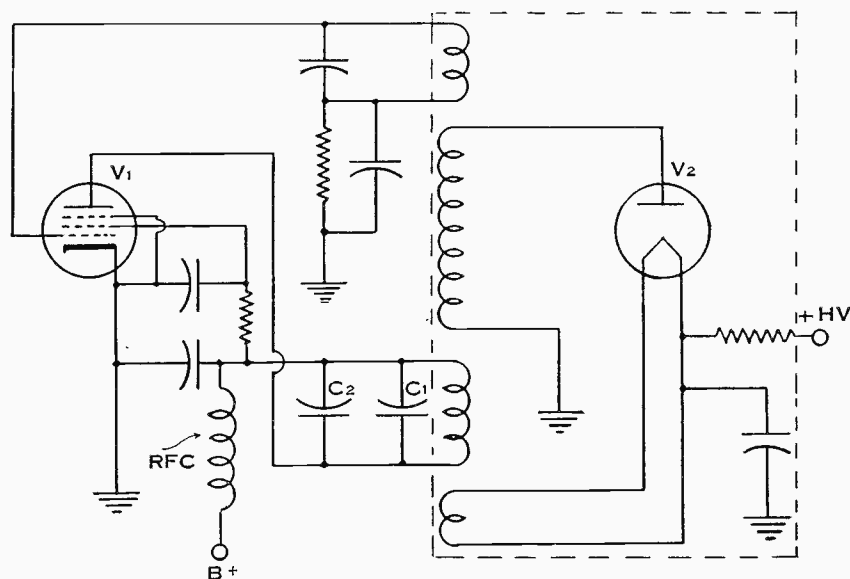

FIGURE 3
TYPICAL RF TYPE
HIGH VOLTAGE SUPPLY

HIGH-VOLTAGE POWER SUPPLIES FOR TELEVISION

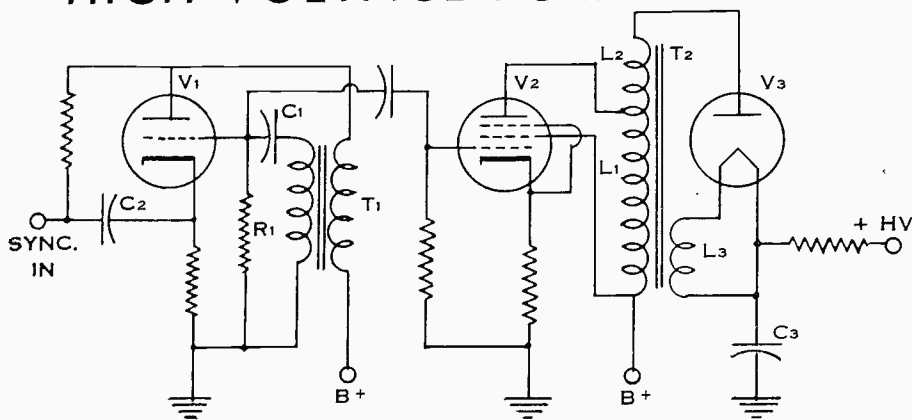

FIGURE 4
TYPICAL PULSE TYPE
HIGH VOLTAGE SUPPLY

horizontal scanning circuit is necessary to cause triggering of the oscillator. This prevents high voltages being present on the picture tube with no scanning, thus preventing screen burns. Ordinarily T2 is a special transformer and tube V2 is a Type 6BG6G or similar tube with sufficient insulation to withstand high positive peak plate voltages. No damping is utilized other than that furnished by the amplifier tube (V2) itself. The multiplier circuit of Figure 2B would be utilized in this application. Since this supply operates during the blanked out retrace interval, no interference should be expected.

TELEVISION ANTENNAS

A BOOK REVIEW

TELEVISION ANTENNAS
By Donald A. Nelson
Published by Howard W. Sams Co., Inc.

This is a very informative book on antennas used in television, written from a practical viewpoint, and should be of help to all those engaged in antenna installation. The material is presented in five chapters. The first deals with Antenna Principles and gives a brief explanation of the fundamental theory, followed by a description of the various types of antennas currently used and their characteristics, and an introduction to impedance matching and trans-

mission lines. Antenna Construction lists the tools required to fabricate an antenna and describes the most popular types together with complete tables of dimensions, spacings, etc. The third chapter is a reference table of Commercial Antennas giving manufacture, model and description with a brief discussion of representative types.

Antenna Installation is the title of chapter four. A rather complete description of the various types of wall and roof structures, which may be encountered is presented, together with much practical information on mounting methods,

masts, guys, etc. The last chapter deals with trouble shooting, the elimination of ghosts, interference, etc.

The book as a whole is well presented with many good illustrations. Some reference to FM antennas would have been a useful addition. The text on the H and stacked broadside arrays seems somewhat confused in that it suggests that the impedance matching properties so readily obtained with antennas spaced a half wave are obtained with quarter wave spacing.

W. P. Mueller

SYLVANIA SERVICE MEETINGS

Television and the Service Man

Most of our steady readers know about the service meetings conducted by engineers from the factory and sponsored by the Sylvania distributors around the country. They were introduced to Sylvania News readers in the August issue.

These distributors generally notify the dealers and servicemen on their mailing list but you might be missed. Please notify your Sylvania distributor that you wish to attend so he will have room for you. Sylvania News is printed too far ahead for us to give a complete list of meetings but the list below may help some of you.

Date	Sponsored By	Location	Speaker
9-20	Radio Equipment Co. 2822 Farnam St. Omaha, Nebraska	Hotel Rome Omaha, Nebraska	Clarence L. Simpson
	Carlson, Hatton & Hay, Inc. 96 East Tenth Ave. Eugene, Oregon	Osborne Hotel Eugene, Oregon	Ralph R. Shields
9-21	Duke's Radio Co. 209 6th St. Sioux City, Iowa	209 6th St. Sioux City, Iowa	Clarence L. Simpson
	Verl G. Walker Co. 205 West Jackson Medford, Oregon	Medford Hotel Medford, Oregon	Ralph R. Shields
9-23	Radio Trade Supply Co. 1224 Grand Avenue Des Moines, Iowa	Junior Ballroom Savery Hotel Des Moines, Iowa	Clarence L. Simpson
	Gifford-Brown, Inc. 1216 Grand Ave. Des Moines, Iowa		
9-28	Kopke Electronics Co. 119 Peasley St. Boise, Idaho	Hotel Boise Boise, Idaho	Ralph R. Shields

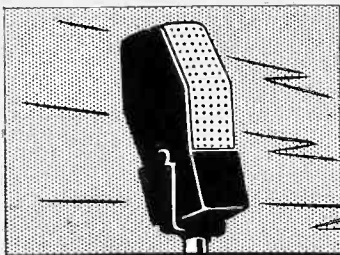

THE information presented in the Sylvania Service Exchange is contributed by servicemen as the result of practical experience. It is very carefully considered before being accepted, and we believe it to be correct and authentic. However, we assume no responsibility for results. Please do not send routine or generally known information. Each hint accepted entitles the writer to his choice of one Sylvania receiving tube. Please specify tube choice when submitting hints.

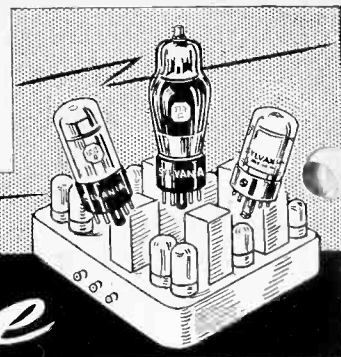

THE *Service Exchange*

Aid For Adding Manual Sheets: In regard to using the loose-leaf Manual sheet insertion tool described in the October 1947 issue of SYLVANIA NEWS, I find that using 2 speaker shims to hold the sheets together when the comb is pulled out speeds the reassembly of same by keeping the freed sheet's comb slots aligned. As I have showed this idea to three other repairmen who spoke of the difficulty to keep the sheets aligned I thought perhaps it should be passed along to the trade.—W. A. Richards, Norwich, N. Y.

* * *

Distortion in RCA 66BX Portable: When this set has low volume and great distortion with no appreciable plate voltage on the Type 1S5 first audio tube, the 220,000 ohm plate load resistor would be suspected first. This is not the trouble in this case because the circuit is unusual. In addition to the usual .02 ufd. bypass condenser on the screen there is a .01 ufd. bypass across the 4.7

meg screen dropping resistor. This condenser is the cause of the trouble, as a very little leakage reduces the effective value of the 4.7 meg resistor to the point where the screen grid draws too great a proportion of the current with resulting poor operation. I replace both bypass condensers when repairing these sets.—Paul F. Wing, Independence, Ohio.

* * *

Type 50Z7GT Substitution: I had an old model Zenith radio which had a burned out 50Z7GT tube and none of the radio parts stores in my home town had this tube and said they could not get it. I found that a Sylvania Type 50Y6GT tube works OK for a substitute.—Ray Duncan, Manchester, Alabama.

EDITOR'S NOTE: This seems to be a fair substitution for an unobtainable type, but of course the panel lamp will not work.

* * *

Substitute For Type 1N6: Since the Type 1N6 was only used in a relatively few sets it is not always available from suppliers. I find

that it is easy to use a Sylvania Type 1N34 in place of the diode and a Type 1A5 in place of the output pentode section. The socket connections do not need to be changed except for the diode lead which goes to the crystal and the other end of the crystal to ground. Lazelle Clark, Newton, Mississippi.

EDITOR'S NOTE: The end of the Type 1N34 marked - goes to ground.

* * *

Reducing Frequency Drift in Admiral Model 8C14: Frequency drift of Admiral radio-phono combination Model 8C14 is due to the fact that the broadcast trimmer of the oscillator section of the gang C5d is very tight. In order to make this trimmer less sensitive to temperature change, place a 5 of 10 mmfd. mica or ceramic condenser across it. Turn the gang condenser all the way out and repeat the trimmer at 1620 kc. This will eliminate frequency drift during warm-up period.—W. J. Fair, Cave Springs, Arkansas.

SYLVANIA CAPACITANCE BRIDGE

The illustration shows a piece of Sylvania test equipment we don't expect to sell to radio servicemen. This is the Sylvania Type 125 capacitance bridge, which we make to sell to laboratories such as those used by universities for research, Bureau of Standards and other radio tube manufacturers.

We mention it here as another example of the type of equipment turned out by the Sylvania WilliamSPORT Factory, which also makes the Sylvania oscilloscopes, polymeters, signal generators and tube checkers with which readers of Sylvania News are already familiar.

This bridge is used in our own laboratories for measurement of interelectrode capacitances on tubes. It is very versatile, however, having five multiplier ranges with which any capacity from .0001 to 100 micro-microfarads may be read. The frequency of the oscillator used is 465 kc and the circuit permits

the balancing out of the out-of-phase component due to resistive leakage.

This item currently sells for

\$2875.00 complete with power supply but without adapters, which explains why we said we don't expect to sell it to service technicians.



SYLVANIA NEWS

OCTOBER 1949

Copyright 1949,
Sylvania Electric Products Inc.

VOL. 16, NO. 9

TECHNICAL
SECTION

The information in Sylvania News is furnished without assuming any obligations

Technical Editor A. V. BALDWIN

TELEVISION INTERFERENCE *

by HERBERT B. MICHAELSON*
Photographs by John Schinkel†

Television interference which affects the quality of the received picture is particularly annoying because the eye tires more quickly than the ear. Because remedies differ for the various types of interference, the serviceman must first identify the source of the unwanted signal. Unfortunately, since several kinds of interference give identical patterns and since these patterns also vary considerably with signal strength, the appearance of the disturbed image will sometimes be unreliable as a criterion for identifying the source and finding a suitable remedy. In many cases, however, there is a characteristic pattern.

*H. B. Michaelson has been employed in the Editorial and Information Section at the Sylvania Product Development Laboratories at Kew Gardens, New York, since 1946 as a technical writer. He prepares literature surveys on topics related to electron tube development projects, including editorial research on thermionic emission and semi-conductors.

†Photographs in this article, taken by John Schinkel, were made through the cooperation of W. B. Whalley and Carmine Masucci at the Sylvania Physics Laboratory, Bayside, N. Y., who also gave valuable assistance in the preparation of this article.

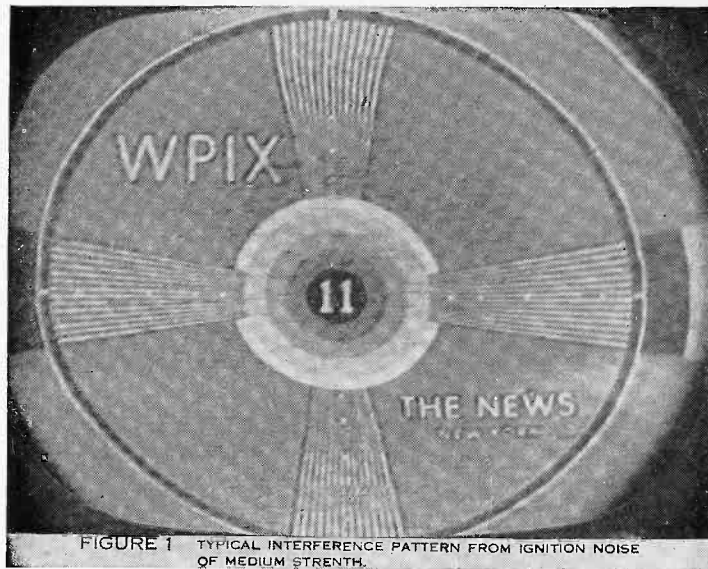

FIGURE 1 TYPICAL INTERFERENCE PATTERN FROM IGNITION NOISE OF MEDIUM STRENGTH.

Typical Interference Patterns

One of the most common of these is short white and black streaks across the picture, as shown in Figure 1, caused by poorly suppressed spark-plug impulses from passing automobiles, airplanes, or from nearby fixed engines. Strong interference from automotive ignition sources will cause torn scanning lines or may even throw

the picture out of synchronization. Another characteristic pattern is that caused by diathermy or industrial r-f induction heating apparatus. Here, in Figure 2, the wavy lines may be confined to a dark bar across the picture or may instead cover the entire screen. Weak interference of this type may merely result in a light, wavy distortion of the picture as in Figure 3.

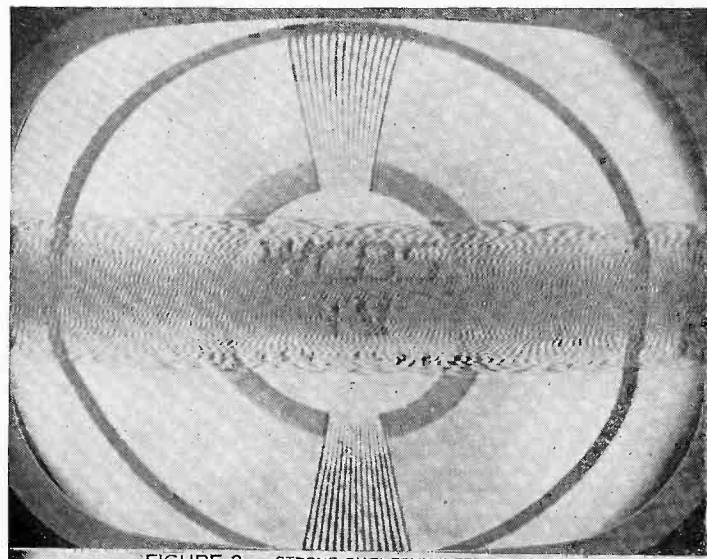

FIGURE 2 STRONG DIATHERMY INTERFERENCE

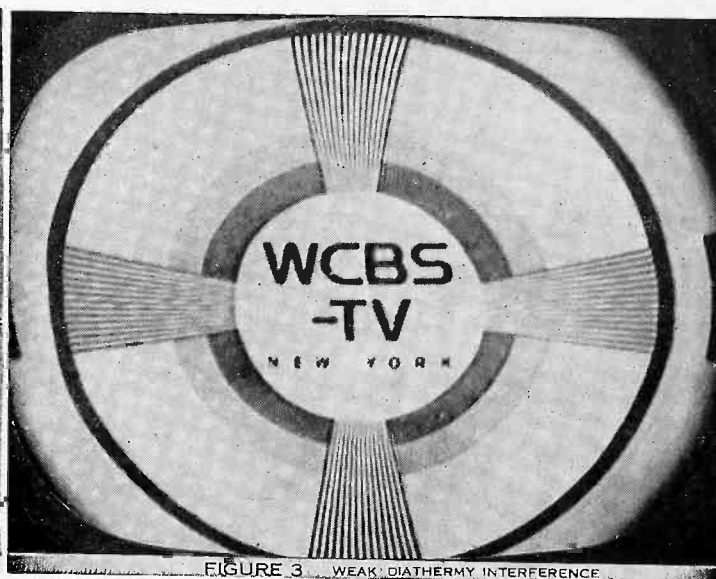

FIGURE 3 WEAK DIATHERMY INTERFERENCE

Vol. 1 \$1.00 — Vol. 2 \$1.00 — Vol. 3 \$1.00
Binders With Complete File of Technical Section:

TELEVISION INTERFERENCE (Contd.)

Evidence of radiation from a nearby receiver tuned to a lower channel can appear in several forms. If the offending receiver is not too close, the effect may be one of diagonal lines, as illustrated in Figure 4. Medium-strength radiations can cause reduced picture contrast, and strong radiations can turn the picture to a negative, as in Figure 5. Another source of interfering radiations is from nearby short-wave AM transmitters. Here again a weak signal is indicated by stationary cross-hatching, as shown in Figure 4. A strong signal heavily modulated by a 120-cycle hum results in stationary black bars across the picture, as in Figure 6. An FM transmission is characterized by broadly curved lines across the screen or by an overall herringbone pattern.

Ghosts

Another type of interference is that arising from wave reflections of the TV signal. "Ghosts" are the result either of out-of-phase waves reflected by buildings or of a mismatch in the antenna system. When a plane passes through areas where its reflected waves are alternately in and out of phase with the direct signal at the receiver the result is a rapid fading or "fluttering" of the picture. A similar kind of interference occurs where the receiver is not sufficiently selective to reject a strong signal in an adjacent channel and the two images are received simultaneously.

TVI from Electrical Equipment

Electrical motors in household

appliances are also a source of disturbance. If sufficiently strong, radiations from these sources cause severe distortion or even loss of synchronization as illustrated in Figure 7. Other miscellaneous radiations that cause trouble emanate from lightning, trolley wires, neon signs, dynamos, power lines, x-ray machines, and practically any other electrical device which will generate r-f waves.

Differences in Receivers

Some receivers are less susceptible to interference than others because of certain features of circuit design. The most important of these is probably the receiver front end. The use of one or more tuned circuits in the r-f stage will aid considerably in obtaining better image rejection at frequencies remote from the TV channel. The additional gain at signal frequency improves the signal-to-noise ratio and thus contributes to the elimination of miscellaneous interference patterns. The use of at least one tuned r-f stage also reduces local oscillator radiation which would interfere with reception by nearby receivers. The output curve of the i-f amplifier should have steep sides to give adequate adjacent-channel selectivity. Automatic gain control is another desirable feature in that it helps to minimize fluctuations in signal level caused by reflected waves from passing airplanes. Adequate shielding, including a bottom pan on the receiver chassis, is also an aid in preventing pickup of unwanted radiations at i-f, sync

pulse, or power-line frequencies. Most receivers have a by-pass condenser at each side of the power line input to reduce r-f coming into the set from the power line. None of these design features, however, give adequate protection against strong interfering radiations, especially those of a broad-band nature, and a brief account will be given here of clarifying reception by means other than the alteration of the receiver circuit design.

Procedure

The general appearance of the interfering patterns on the screen will give some hint of the source. A logical first step is to disconnect the antenna. If the interference still persists it is being picked up either by exposed receiver wiring or from the power-line input. Turning off nearby electrical appliances may identify the source of the trouble immediately. An r-f line filter in series with the power cord at the receiver or at the electrical apparatus in question will usually reduce this kind of interference to an appreciable extent. For small motors an 0.01 mfd. condenser connected across the terminals is often all that is needed. The frame of electrical apparatus and of switch boxes housing arcing contacts should in addition be well grounded. Further suggestions for electrical appliance interference are given in Table 1.

When the interfering signal is picked up by the antenna, a re-orientation or relocation of the antenna will sometimes be sufficient.

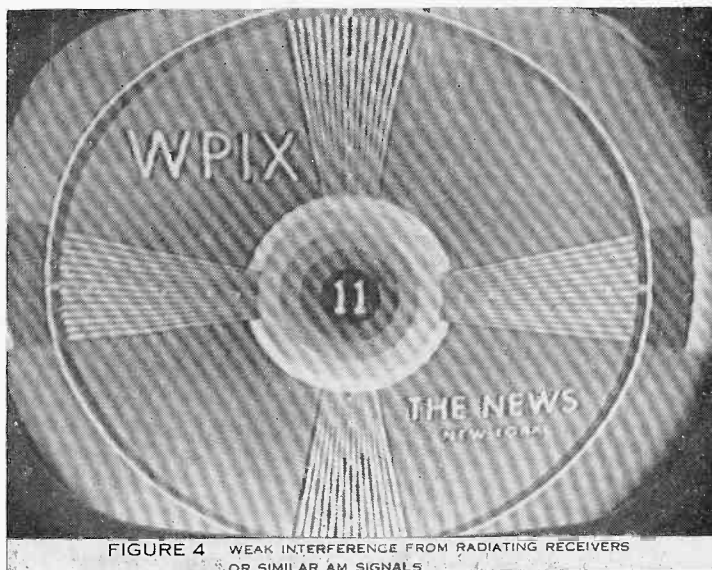

FIGURE 4 WEAK INTERFERENCE FROM RADIATING RECEIVERS OR SIMILAR AM SIGNALS

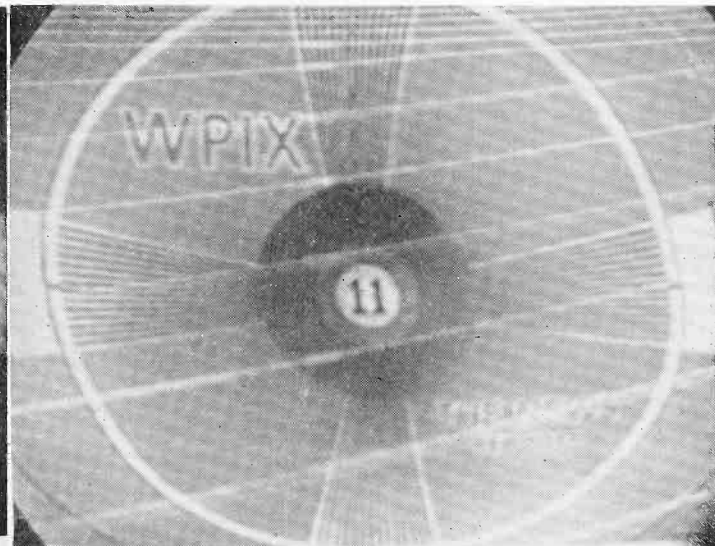

FIGURE 5 STRONG INTERFERENCE FROM AM SIGNALS

TELEVISION INTERFERENCE (Contd.)

If the source of radiation is sufficiently far away and in a direction other than that of the stations to be received, highly directional arrays or a metal shield properly placed will be effective. Occasionally noise will be picked up by a 300-ohm line instead of the antenna. In locations where the line passes through a "noisy" area it can be transposed by twisting or replaced by a shielded cable.

Amateur Interference

Among the sources of interference are amateur a-m radio stations. If the signal is much lower in frequency than that of the TV station, it may be passing through an untuned or broadly tuned r-f section to the i-f stages. A high-pass filter with a cut-off at 45 mc (Figure 8A) or a parallel-tuned wave trap (Figure 8B) in the antenna lead will some-

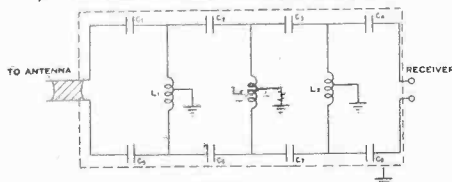

FIGURE 8A
HIGH-PASS FILTER FOR 300 OHM LINE FOR
ELIMINATING SIGNALS LOWER THAN 45 MC

TABLE OF VALUES

- L1 = 0.5 μ h
- L2 = 0.5 μ h
- L3 = 0.5 μ h
- C1 = 24 mmfd
- C2 = 12 mmfd
- C3 = 12 mmfd
- C4 = 24 mmfd
- C5 = 24 mmfd
- C6 = 12 mmfd
- C7 = 12 mmfd
- C8 = 24 mmfd

times eliminate this type of interference. More often the unwanted signal is a harmonic which happens to fall somewhere in the TV channel. This kind of interference from amateur stations is usually best eliminated at the source. Efficient

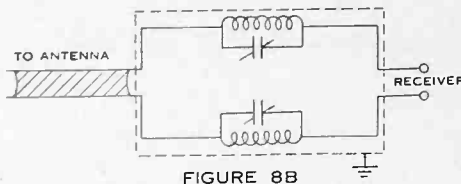

FIGURE 8B
PARALLEL-TUNED WAVE TRAP IN ANTENNA
TUNE TO FUNDAMENTAL OF INTERFERING STATION

shielding of the r-f circuits at the transmitter, filtered leads, improved key-click filters, and r-f power line filters are essential. In addition, a slight change in fundamental frequency will often reduce interference in neighboring TV sets except those

very close to the transmitter. A temporary solution is time-sharing, where the amateur stays off the air during hours of television programming, until the cause can be located and corrected.

FM Interference

Transmissions from FM stations can be rejected at the antenna posts of the receiver by an open stub made of a length of 300-ohm line tuned to a quarter wavelength of the station frequency. The exact length in feet

(Continued on next page)

TABLE I
Methods of
Eliminating Interference

Source	Method
Amateur radio stations.....	a,b,c,d,e,f,g
Commercial, police, and other short-wave transmissions....	a,b,f,g
FM, AM and other UHF stations.....	f,g,h
Ghosts.....	f,g,i,j
Airplane-reflected waves.....	k
Receiver radiation.....	f,g,l,m
Image interference.....	n
Spark-plug radiation.....	f,g,i,n,o,p
Diathermy, X-ray, induction heaters.....	b,g,n,q,r,s
Heavy motors and generators....	f,g,s
Household appliances.....	r,s,t
Power lines and trolley wires....	f,g,p,u
Flashing incandescent signs....	f,g,r,s,v
Neon Signs.....	f,g,r,v,w
a — parallel-tuned wave traps in receiver antenna lead	
b — high-pass filter in receiver antenna lead	
c — r-f filter in input power line and thorough shielding of r-f section at amateur transmitter	
d — wave traps in AM transmitter antenna, final, buffer, and/or oscillator stages	
e — slight change in AM transmitter fundamental frequency	
f — reorient or relocate receiver antenna	
g — use highly directional receiving antenna	
h — open stub wavetraps	
i — shield antenna from interference source	
j — check antenna system for mismatch	
k — automatic gain control	
l — install bottom pan on receiver chassis	
m — add r-f stage to offending receiver to isolate oscillator if receiver does not have one	
n — add tuned r-f booster for better selectivity	
o — for fixed engines, add distributor suppressors; ground sparkplugs shield to engine block	
p — transpose 300-ohm line or replace with shielded cable	
q — screen entire room housing apparatus	
r — r-f filter in receiver power-line input	
s — r-f filter at power line input of equipment; ground frame	
t — 0.01 capacitor across power input terminals of equipment	
u — elevate antenna	
v — ground shield on switch box housing the arcing contacts	
w — use commercial neon noise suppressors in power input to sign	

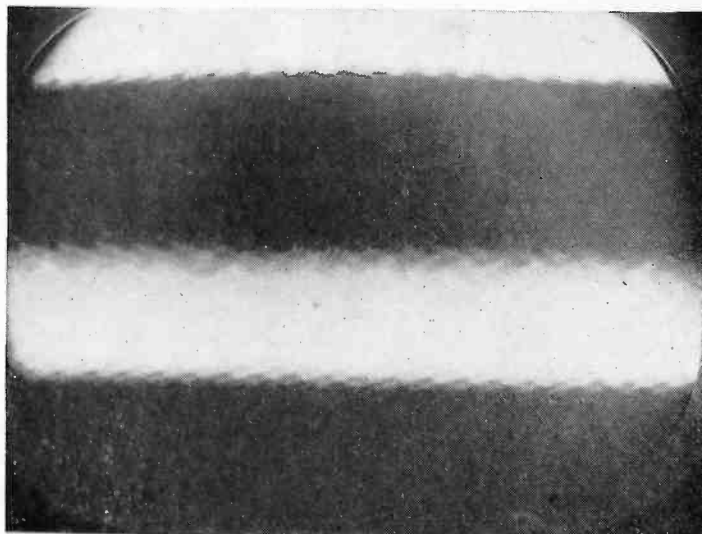

FIGURE 6 STRONG INTERFERING SIGNAL HEAVILY MODULATED BY 120 CYCLES

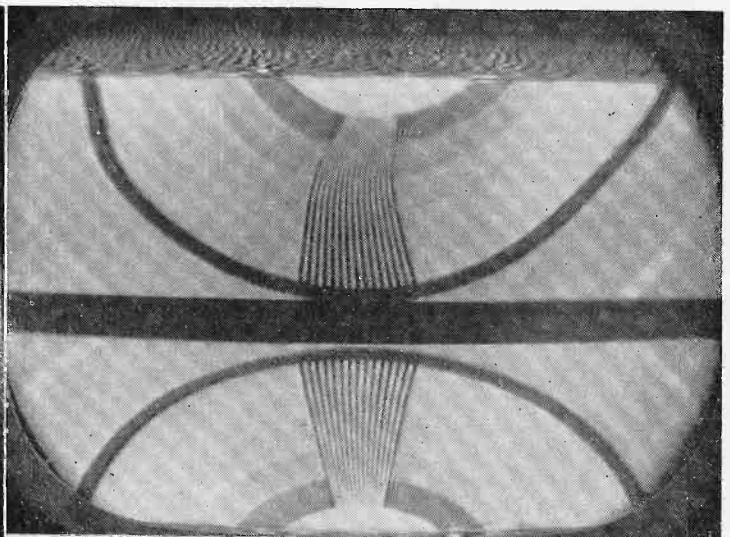

FIGURE 7 LOSS OF SYNCHRONIZATION DUE TO STRONG INTERFERENCE. SOURCE SHOWN BY TYPICAL DIATHERMY PATTERN AT TOP

TELEVISION INTERFERENCE (Contd.)

of the stub, shown in Figure 9, can be found by dividing the frequency of the station into 246, as in the following example: For an interfering FM station operating at 92.1 mc

$$\text{a stub of } \frac{246}{92.1} = 2.67 \text{ ft. or } 32.04 \text{ inches}$$

would be required. The correct tuning may also be determined experimentally if the interfering frequency is unknown, by using a longer or shorter open stub, wrapping loosely a piece of tin foil over the insulation near the end and sliding it along the stub until

the interference is eliminated.

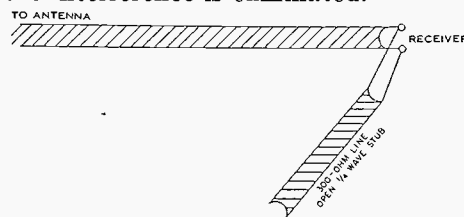

FIGURE 9
QUARTER-WAVE OPEN STUB MADE OF LENGTH OF
300 OHM LINE FOR USE AS A WAVE TRAP

Fringe Areas

Where the receiver is located in a "fringe" reception area and the unwanted radiation differs from the

TV frequency, the whole problem becomes one of improving the signal-to-noise ratio and increasing sensitivity and selectivity. If a highly directive receiving antenna does not give the desired result, a remedy may be the addition of a booster amplifier. A list of suggested remedies for various types of interference is given in Table 1, which will serve not as a "cure-all" but as a general guide. Each location has a different set of reception conditions and every television service technician will, with experience, learn the answer to the local problems.

SYLVANIA SERVICE MEETINGS

Television and the Service Man

Most of our steady readers know about the service meetings conducted by engineers from the factory and sponsored by the Sylvania distributors around the country. Mr. Shields and Mr. Simpson were introduced to Sylvania News readers in the August issue.

These distributors generally notify the dealers and servicemen on their mailing list but you might be missed. Please notify your Sylvania distributor that you wish to attend so he will have room for you. Sylvania News is printed too far ahead for us to give a complete list of meetings but the list below may help some of you.

USING ELECTRONIC EQUIPMENT

We believe Service Technicians should be reminded that most precision electronic instruments such as vacuum tube voltmeters, signal generators, etc., should be allowed to warm up for at least half an hour and preferably one hour before being used for accurate work. The reason, of course, is the slight change in characteristics of many of the parts with temperature. When adjusted at the factory they are allowed to become stable before calibrating and the factory guaranteed accuracy can only be obtained when operated in a similar manner. Fortunately, tube checkers do not require this precaution.

DATE	SPONSORED BY	LOCATION	SPEAKER
10/21	DeJarnatt Wholesale Radio Parts 515 North Hunter Street Stockton, California	Hotel Stockton White Room Stockton, California	Clarence L. Simpson
10/24	Bluff City Distributing Company 905 Union Avenue Memphis, Tennessee	Claridge Hotel Rose Room Memphis, Tennessee	Ralph R. Shields
10/25	C. C. Brown Company 61 Ninth Street San Francisco, California W. D. Brill Company 198 Tenth Street Oakland 7, California	Whitcomb Hotel San Francisco, Calif.	Clarence L. Simpson
10/25	Randolph & Cole, Inc. 1516 Church Street Nashville, Tennessee	Noel Hotel Assembly Room Nashville, Tennessee	Ralph R. Shields
10/26	Chemcity Radio & Electric Company Roden Electrical Supply Company Both of Knoxville, Tennessee	Farragut Hotel Parlor "C" Knoxville, Tennessee	Ralph R. Shields
10/27	Curle Radio Supply & Sound Service 825 Cherry Street Chattanooga, Tennessee Specialty Distributing Company 709 Chestnut Street Chattanooga, Tennessee	Read House Chestnut Room Chattanooga, Tennessee	Ralph R. Shields
10/28	Standard Supply Company 531 South State Street Salt Lake City, Utah	Standard Supply Co. 531 South State Street Salt Lake City, Utah	Clarence L. Simpson
10/28	James W. Clary Company Auto Service Company Reid Distributing Company All of Birmingham, Alabama	Redmont Hotel Quarterback Room Birmingham, Alabama	Ralph R. Shields
10/31	Teague Hardware Company Nolin-McInnis, Inc. Both of Montgomery, Alabama	Whitley Hotel Civic Room Montgomery, Alabama	Ralph R. Shields
11/1	Nelson Radio & Supply Company 263-71 St. Louis Street	Admiral Sommes Hotel Main Ball Room Mobile, Alabama	Ralph R. Shields
11/2	Southern Distributors, Inc. 330 W. Capitol Street Jackson, Mississippi	Heidelberg Hotel Silver Room Jackson, Mississippi	Ralph R. Shields
11/3	Central Radio Supply Company 509 Monroe Street Alexandria, Louisiana	Alexandria Community Center Alexandria, Louisiana	Ralph R. Shields
11/4	William B. Allen Supply Company Crescent Radio & Supply, Inc. Radio Parts, Inc. Bell Radio Supply Shuler Supply Company All of New Orleans, Louisiana	Jung Hotel Jung Roof New Orleans, Louisiana	Ralph R. Shields

The information in Sylvania News is furnished without assuming any obligations

Technical Editor A. V. BALDWIN

THE ION TRAP MAGNET AND ITS ADJUSTMENT

by WALTER W. HENSLER†

This is the thirteenth of the series of articles on television

One Television service operation, which has become so routine that it has fallen into the careless class, is that of ion trap magnet adjustment. The adjustment, through practice, has become comparatively simple and it is performed without thinking what is actually being done. Because of this, there may be a tendency to be less critical of the setting. As will be pointed out, the presence of a raster does not necessarily indicate the correct ion trap magnet setting. Operation of the receiver with the magnet misadjusted may result in permanent picture tube damage. Adjustment should, therefore, be made immediately after the receiver is warmed up as the tube may be damaged in the matter of seconds. The adjustment should be checked everytime the instrument is moved in case vibration may have changed the setting.

The first type of ion trap magnet generally employed in television receivers was the electro-magnetic unit having two windings arranged to provide two fields of opposite polarity. Gradual simplification in design and manufacture have led to almost complete supersedence of the electro-magnetic unit, by structures employing permanent magnets in varying arrangements. Hence, the following discussion deals only with adjustment of PM types.

EARLY TYPES

The first types of ion traps using permanent magnets were made so that their field duplicated those of the electro-magnet type, thus having two fields of opposite polarity, with one much stronger than the other.

†Walter W. (Bill) Hensler comes from Kokomo, Indiana and was first employed by Kingston Radio Corporation and Delco Radio Division there. During the war he served as an electronic technician in the Navy. After the war he joined the Howard W. Sams organization where he is now Chief Television Engineer.

Ion trap magnet "H", in Figure 1, is representative of such types. Two rings are mounted on a sleeve, with their gaps opposite each other, to obtain opposite fields. This ion trap magnet will work at only one setting, and, with its markings, can be preset very closely to its correct setting before the receiver is turned on.

In recent months, however, many companies have taken up the manufacture of ion trap magnets. Many of these are of new design and require special technique in their adjustment. This is especially true of the units having single magnets with a single pair of poles.

In order to understand why special technique is required for this type unit, let us review the theory

of the operation of the ion trap. What we refer to as the ion trap magnet in this article is commonly called the ion trap. The complete ion trap includes the magnet and the parts inside the picture tube with which it works. It is the purpose of the ion trap magnet to bend the electron beam back on its correct path; hence, it is sometimes called "beam bender magnet."

OPERATION

Figure 2 is a cutaway view of a typical electron gun assembly of a picture tube. The heavy dotted line, through the center of the gun, represents the approximate path of the electron beam. The course by which the beam deviates from a straight line has been exaggerated slightly in order to show more

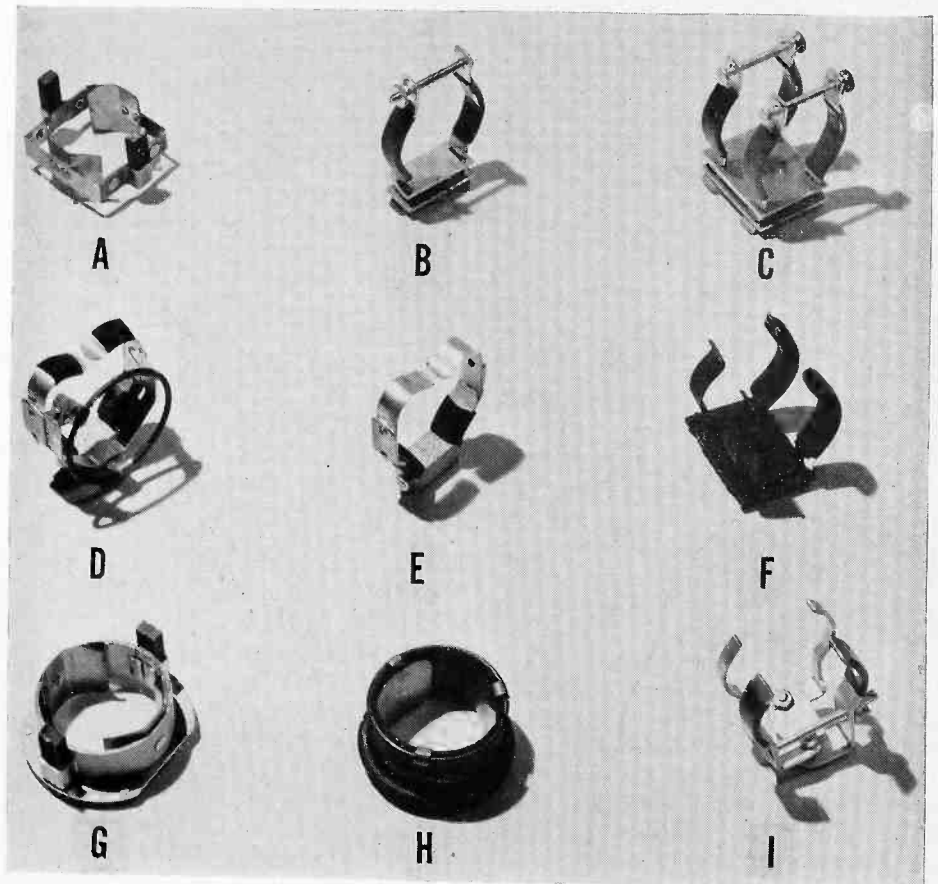

FIGURE 1—TYPES OF ION TRAP MAGNETS

Binders With Complete File of Technical Section: Vol. 1 \$1.00 — Vol. 2 \$1.00 — Vol. 3 \$1.00

THE ION TRAP MAGNET AND ITS ADJUSTMENT

clearly the effect of the fields on the beam. Also, the diagonal slot which generates the electrostatic field has been widened to show the field and its effect on the beam.

The pole pieces, commonly called "flags," which are placed at the rear of the accelerating anode are the only parts of the entire gun assembly which are of magnetic material. When the ion trap magnet is correctly adjusted, these "flags" will act as poles and will have a concentrated field existing between them. This is extremely important to the operation of the electron gun. Referring again to Figure 2, an "X" has been shown

beam will be deflected upward and, upon leaving the field, will be back on its path through the center of the gun, which is the ideal condition. Another theory on the operation of the unit is to assume that a magnetic field is generated by the ion trap magnet of just the correct strength to overcome the electrostatic field. This will permit the electron beam to continue in a straight line through the gun structure. Actually, this is the same theory as above, except for the fact that the beam being deflected twice is not taken into account.

EFFECT OF MISADJUSTMENT

The question now arises. If the

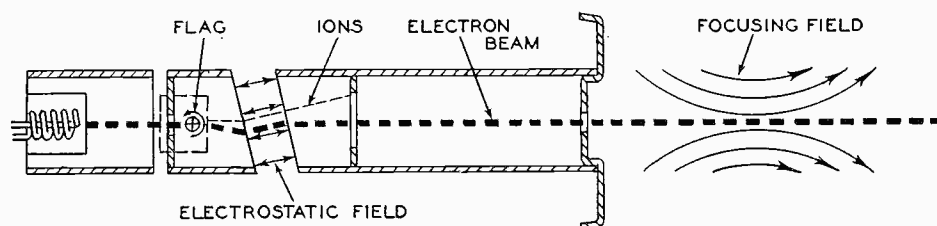

FIGURE 2—BEAM PATH WITH MAGNET CORRECTLY ALIGNED

at the center of the "flag." This is intended to represent the tail end of the arrow which means the magnetic field extends into the paper. In order to achieve this condition, the ion trap magnet is adjusted so that the "flag" on the back side of the gun assumes the polarity of the South pole.

As the electron beam moving to the right crosses this concentrated field, the beam is deflected downward, as is shown in Figure 2. The ions, however, which are also present in the beam, are not materially affected by the magnetic field, and continue on their course. As both the electron and ion beam enter the electrostatic field, they are deflected upward by the strong field. This field is generated because of the great potential difference between the two anodes, the first anode being at approximately 250 volts, while the second is at the high voltage potential of 9000 volts, or higher. The ions, after being deflected sharply upward, strike the second anode and are removed from the beam. Thus, it can be seen that the true ion trap is in the picture tube itself. It can be seen that if the electron beam strikes this field at just the right angle, the

ion trap is built into the tube itself, how can the misadjustment of the external ion trap magnet cause damage to the tube? Referring again to Figure 2, it can be seen that the electron beam would not be centered in the hole in the end of the gun structure if the ion trap magnet setting were not correct. By the time the electrons reach this point, they have been accelerated to a very high rate of speed. If they strike the edge of this hole, the bombardment will actually tear away the edge of the hole, and the particles of metal will be hurled toward the screen of the tube and may cause a darkened area in its center. Even though the darkened area is not present, any change in the shape of the hole in the end of the gun structure will result in a change in the smallest spot which can be focused on the screen. If the receiver is turned on with the ion trap magnet misadjusted, and the brightness control advanced, this hole may be enlarged in a matter of seconds, and the focusing ability of the tube will be permanently impaired. This is especially true where very high accelerating voltages are used. The ion trap

magnet should always be set to its approximate setting and the brightness control turned down before the receiver is turned on. The actual adjustment of the unit will be discussed later.

SINGLE MAGNET TYPE

As was previously mentioned, the adjustment of the single magnet type requires special care. With most of these units, a raster can be obtained at two points on the neck of the tube. Only one of these settings is correct. Usually, one setting is brighter than the other, but unless special care is taken, it is quite easy to arrive at the wrong setting. Ion trap magnets "B", and "E", of Figure 1, are representative of this type. The correct setting is obtained with these units when the field between the poles causes the beam to be deflected to enter the electrostatic field at exactly the correct angle. When this is done, the beam is again restored to its original path and will pass through the hole at the end of the gun assembly. In every case, this type ion trap magnet is either directly over the "flags" or behind them; that is, nearer the base of the tube. It is possible to obtain a raster with the ion trap magnet set in front of the "flags," but, as pointed out, this is an incorrect setting.

Figure 3 shows how a raster is obtained at this wrong setting. The three X's are at the point where the ion trap magnet is set, and, again, the "X" represents the direction of the magnetic lines extending into the paper. Note that the lines of force are in the same direction as before, and that the beam will be deflected in the same direction. In other words, this setting is obtained by moving the ion trap magnet forward on the neck without turning it. Even though the ion trap magnet has been moved forward, part of its field extends back as far as the "flags," and, as a result, there will be a certain field existing between them. This field, however, is very weak and will have very little effect on the beam as it passes through it. In other words, the beam will continue in nearly a straight path until it enters the electrostatic field where it will be deflected upward. Normally,

THE ION TRAP MAGNET AND ITS ADJUSTMENT

this beam would strike the second anode and would be lost. In this case, however, the beam is entering a strong magnetic field existing between the poles of the ion trap magnet, and the beam will be deflected downward. As can be seen, there may be a setting of the

One magnet is much larger and stronger than the other and is placed nearer the base of the tube and over the "flags." All three of these units have arrows on their frame, which aid in setting them. The arrow should point forward and toward the high-voltage connector.

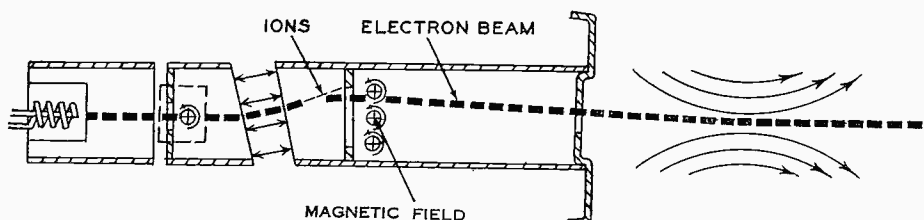

FIGURE 3—BEAM PATH WITH MAGNET TOO FAR FORWARD

ion trap magnet where the field is at the correct point to bend the beam downward just before it strikes the second anode. It is at this point that the incorrect setting of the ion trap magnet is obtained. Note that the electron beam passes through the hole in the second anode at an angle, and it is very probable that some electrons will always strike the edge of the hole at this setting. Also, there is a possibility that some of the electrons were removed from the beam when they were very close to the second anode. This accounts for the slightly dimmer raster, which is usually obtained when the ion trap magnet is at this point. This setting can easily be avoided if care is taken to insure that the single magnet type of ion trap magnet is never moved in front of the "flags." A raster cannot be obtained with the dual magnet type if the entire unit is moved in front of the "flags," since the two fields are such that the beam is deflected into the second anode and is lost.

ADJUSTMENT PROCEDURE

So much for incorrect settings. Let's talk about methods of obtaining the correct setting. Referring again to Figure 1, it can be seen that types A, G, and H are of the two-magnet type. Types A and G have two bar magnets which are held parallel to the neck of the tube. In each case the magnets are held in place by a frame, and since this frame offers a path for lines of force, this represents the weaker of the two fields. Type H has two ring magnets which encircle the neck of the tube.

Types A and G are placed so the tail ends of the bar magnets are over the "flags." Before the receiver is turned on, the unit should be positioned at this point. After the set has warmed up, slowly advance the brightness control and a raster will usually be seen. While viewing the raster, slide the unit forward and backward with a turning motion. If the raster brightens, decrease the setting of the brightness control and again move the ion trap magnet, as before, to obtain the point where the most brightness can be obtained. Never misadjust the ion trap magnet to obtain a full raster. If part of the raster is cut off, the focus coil or deflection yoke is not properly positioned and proper adjustment should be made, on these components.

Types C and D are also dual magnet types but do not have arrows to indicate their correct setting. In the case of type C, the outline of a picture tube is printed on the bottom of the magnet. The unit is placed on the neck of the tube so that the outline of the tube points in the same direction as the tube itself. The two poles nearer the face of the tube on this unit have blue sleeving, while the rear ones are black. The rear poles should be placed over the "flags" with the magnets on the opposite side from the high-voltage connector. Type D has one bar magnet and one ring magnet, and should be positioned so that the ring magnet is nearer the face of the tube with the rear poles over the "flags." This unit is also positioned so that the bar magnet is opposite the

high-voltage connector.

Type F is very similar in construction to type C, but, instead of having an outline of a tube, it has an arrow stamped on the bottom of the magnet. The arrow points toward the face of the tube. This unit is also placed so that the magnet is opposite the high-voltage connector. Note that the arrow is 180° off from the setting of types A, G and H.

Type I is unique in design in that two fields of opposite polarity are obtained with but a single bar magnet. The magnet is held parallel to the neck of the tube and, instead of being polarized lengthwise, it is polarized crosswise. By forming the pole pieces so that one set of diagonal poles is on one side of the magnet and the other pair of poles is on the other side, fields of opposite polarity are obtained. This unit is positioned so that the larger poles are near the base of the tube and over the "flags," with the magnet on the opposite side of the high-voltage connector.

In almost every case, the above-mentioned double magnet types of ion trap can be pre-positioned so that a raster can be obtained to make final adjustment.

In the case of types B and E, this does not apply. No markings are present on the unit as to which way it should be slipped over the neck of the tube; the fact is, it may be mounted either way. The best course to follow on one of these units is to slip it over the base of the tube just onto the glass neck. Turn the unit so the magnet is opposite the high-voltage connector. Turn on the receiver and advance the brightness control to slightly over half way. If a raster is present, move the ion trap magnet forward with a slight turning motion, at the same time reducing the setting of the brightness control. If a raster is not obtained, turn the brightness down and rotate the ion trap magnet 180° around the neck of the tube and, again, increase the brightness control to slightly over half way, or until the raster is visible. If a raster is not obtained at either of the settings, move the ion trap magnet forward, about a half inch, and, again, try for a raster at both settings. If it is necessary to move an ion trap

(Continued on next page)

REVISIONS AND ADDITIONS TO TUBE CHECKER CHART

TYPE	NEW SETTINGS					F	G	TEST	TYPE	NEW SETTINGS					F	G	TEST
	A	B	C	D	E					A	B	C	D	E			
1R5	1.4	2	45	4	1	016	28	V	6BQ6GT	6.3	0	5	0	8	034	21	Y
1Z2	1.4	2	12456	6	8	..	24	V	6W4	6.3	0	57	1	3	..	15	X
2E30	6.3	0	4	..	4	36	32	Y	7X6	6.3	0	..	0	2	..	18	Y
3D24	6.3	0	147	1	8	56	47	X			0	..	0	5	..	18	Y
3V4	2.5	2	45	4	1	016	45	U	12AL5	12.6	0	..	0	1	..	52	T
6A8	6.3	0	..	0	1	039	76	W			0	..	0	3	..	52	T
					5	034	23	V	12BE6	12.6	0	..	0	5	3	27	X
6AN5	6.3	0	2	..	4	36	22	X			0	..	0	4	64	18	V
6AV6	6.3	0	..	0	3	3	60	X	19BG6G	12.6	0	..	0	8	47	27	Y
				0	4	..	55	T	25W4	25	0	57	1	3	..	16	X
				0	5	..	55	T	50Y7	50	0	6	..	1	..	19	Y
6BC5	6.3	0	..	0	4	36	70	T					3	..	19	Y	
6BD5	6.3	0	..	0	3	57	25	Y									

USE OF TYPES 6AG5 & 6BC5 IN TELEVISION SETS

When television set production really got going about a year ago one of the best tubes for use in the IF video amplifier was the Type 6AG5. Many set manufacturers used this type but found that they were unable to obtain the required sensitivity with regular tubes. To overcome this, the highest mutual tubes of this type were provided for use in these positions. In some later production the special tubes were marked 6AG5/S.

We wish to point out to all engaged in television service work that there is now a new tube, Sylvania Type 6BC5, which is

identical with Type 6AG5 except for the higher mutual conductance desired by some set manufacturers. This may help out in many cases where replacement of the Type 6AG5 has left the customer dissatisfied with the sensitivity obtained. One tube only in the usual three-stage amplifier may not produce a noticeable change, but when all are regular tubes the loss in gain may be considerable.

Users of Sylvania tube checkers (and perhaps of other makes) may have noticed that some Type 6AG5's "hit the peg" on the tester meter.

These are the high mutual conductance tubes. Don't blame the tester, set these aside for television replacements if you have no Type 6BC5's and question any 6AG5's in television sets which test on the lower half of the good part of the scale. These may prove weak in fringe areas but perfectly OK in most sets.

This new tube is recommended only for use in the video IF of older sets or new sets designed for it. Use in other stages may disturb the band pass characteristic or cause regeneration.

REVISED CHART NOW AVAILABLE

The Sylvania Receiving Tube Characteristics Chart has recently been revised. This time a number of changes have been made which make it more useful to radio and television technicians. In addition to including about 100 recently announced types, a section on Sylvania Germanium Crystals has been added.

A major change is the complete

rearrangement of the types and base diagrams so that the base diagram for any desired type can always be in view at the same time as the ratings. No need to look for it in the back of the booklet now.

You may obtain your copy free from your Sylvania distributor or by sending your request to the Advertising Department in Emporium.

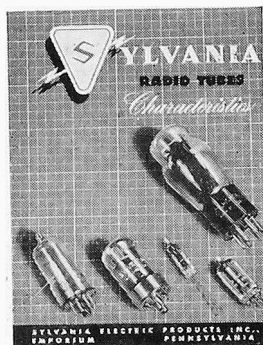

THE ION TRAP MAGNET AND ITS ADJUSTMENT (cont'd.)

magnet of this type completely over the "flags," it may be too weak for correct operation. In this case, try another ion trap magnet of known merit. If a much brighter raster is obtained with the good unit, the weak unit should be discarded. It will usually be found that the single magnet will be well behind the "flags" when properly adjusted.

In some cases, the dual-magnet type has been known to come apart. Should this happen, it can be put back together properly by using

a ten cent store variety compass to check to see that the fields are opposite. This compass can also be used to determine the polarity of the field on a unit where the markings have been removed. By placing the compass near the stronger field, identify the pole to which the South indicator points. This pole is the one which is placed on the right side of the neck of the tube while holding the tube with the face away from you and the high-voltage connector up. This is true of all tubes having the

diagonal electrostatic field built in the gun, but does not apply to tubes employing bent gun assemblies.

Although there are many other ion trap magnet than the ones pictured in Figure 1, these were selected as they were representative of units of their type. Too much care cannot be taken in making the ion trap magnet adjustment. Remember that the picture tube is still the most expensive part of the television receiver. Take a little extra time and check the ion trap setting carefully.

SYLVANIA NEWS

TECHNICAL SECTION

DECEMBER 1949

Copyright 1949,
Sylvania Electric Products Inc.

VOL. 16, NO. 11

The information in Sylvania News is furnished without assuming any obligations

Technical Editor A. V. BALDWIN

TELEVISION RECEPTION IN A FRINGE AREA

By William P. Mueller*

Photographs by Mary Jane Danko, Henry Hagman and H. C. Pleak

This is the fourteenth of a series of articles on Television by Sylvania Engineers.

Previous issues of Sylvania News have contained articles on the subject of television and how it works. Another interesting problem is television reception at long distances or "fringe area" reception. This is a fascinating field for the experimenter who is not too easily discouraged or disappointed, and has the drive to put a lot of work into the undertaking. The reception of a picture, "snowy" though it may be, provides a thrill reminiscent of the early days of broadcasting, and though it might not be up to the standards deemed necessary for entertainment, any picture is infinitely superior to none at all. If one is patient and persevering, he may occasionally or eventually be

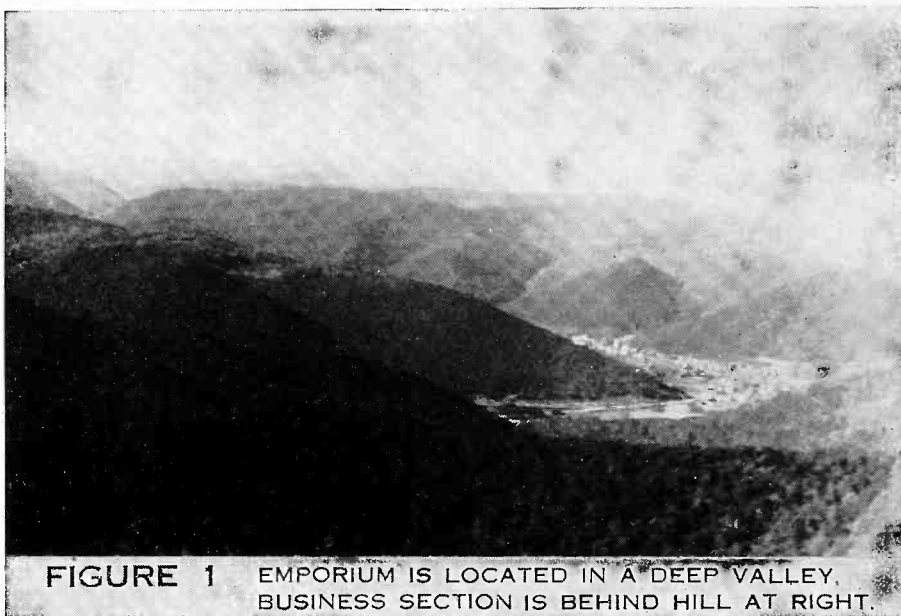

FIGURE 1 EMPORIUM IS LOCATED IN A DEEP VALLEY, BUSINESS SECTION IS BEHIND HILL AT RIGHT.

*W. P. Mueller received the degree of B.S.E.E. in 1932 from the Ohio State University. He joined Sylvania in 1933, starting in the Engineering Test Department at Emporium. In 1934 he worked in the Transmitting Tube Department at Clifton, New Jersey, and returned to Emporium the following year where he specialized in tube application problems at VHF as a member of the Tube Application Department. Mr. Mueller served as Supervisor of Engineering at the Industrial Apparatus Plant of Sylvania at Williamsport, Pennsylvania from 1944 to 1946. Since then he has devoted his time to tube application problems in the FM and TV services as a member of the Commercial Engineering Department at Emporium.

rewarded by pictures surprisingly good, and the equal of those received by the lucky people who live within the service area of the TV station.

The location of Emporium at a distance of 90, 100, 120 and 125 miles, respectively, from the nearest TV stations puts it definitely in the

"fringe area" or perhaps more accurately beyond the fringe. The surrounding terrain which consists of hills that rise 500 to 1,000 feet above the town on all sides make reception virtually impossible. The rugged terrain surrounding Emporium is shown in Figure 1

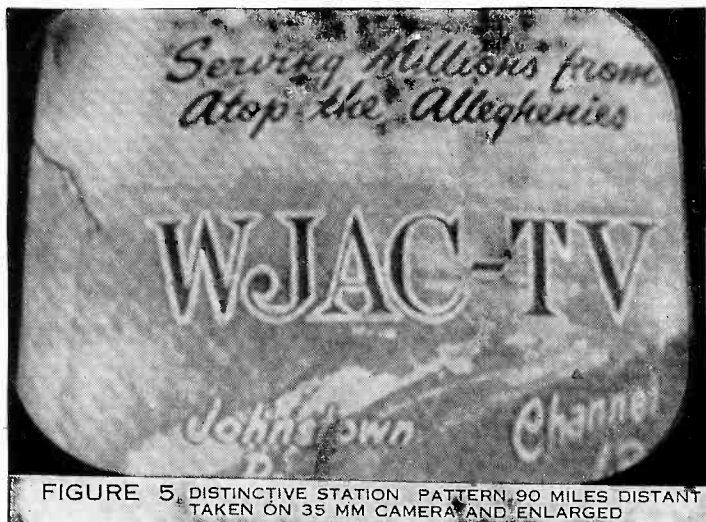

FIGURE 5, DISTINCTIVE STATION PATTERN, 90 MILES DISTANT TAKEN ON 35 MM CAMERA AND ENLARGED

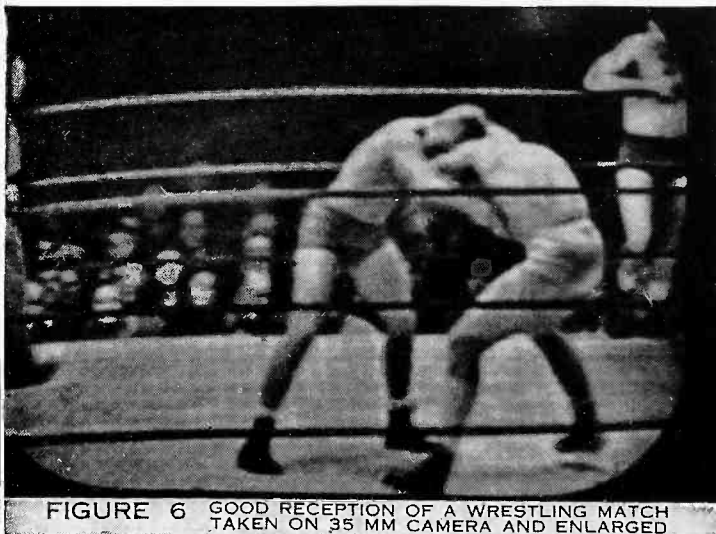

FIGURE 6 GOOD RECEPTION OF A WRESTLING MATCH TAKEN ON 35 MM CAMERA AND ENLARGED

Binders With Complete File of Technical Section: Vol. 1 \$1.00 — Vol. 2 \$1.00 — Vol. 3 \$1.00

TELEVISION RECEPTION IN A FRINGE AREA Continued

which was taken from an airplane. Extended tests were first made within the town, however, to confirm the absence of TV signals except on very rare occasions under freak atmospheric conditions.

The next logical step was to look for signals on the tops of the surrounding hills. A signal strength meter which could be operated from a storage battery, and a simple dipole antenna provided the minimum equipment necessary. Since the roads usually do not go to the summit of the hills, it was often necessary to carry the equipment on foot through the underbrush. This was a bit rugged at times! Signals were obtained on field strength measuring equipment from the two then available stations on several of the higher spots, but at a level so low as to be very discouraging most of the time. At night the signal level seemed to come up a bit, however, so that it was finally decided to try for a picture.

Equipment Used

A vibrator type inverter was obtained on the surplus market, rated at 12 V DC input for 115 V AC output at 150 watts. This was capable of operating a small 7" portable TV set and a low noise booster. The antennas were home built Yagis selected to provide good gain with a minimum size and weight, and constructed so that they could be easily taken apart and carried in a car. Permission was obtained from the District Forester to conduct the initial experiments at the Whittimore Hill Fire Tower which provided a site reached by car with a 48 foot tower at an elevation of 2,000 feet above sea level. Fair reception was obtained with this equipment from both Pittsburgh and Buffalo, the signals varying from complete fadeouts to excellent pictures at times. This amount of equipment represents the minimum necessary to receive pictures in remote locations, and requires no changes to be made in the wiring of the TV receiver. Since the inverter was somewhat overloaded, the booster amplifier was later operated directly from batteries. The wave shape of the inverter was largely square wave and at a frequency slightly different from 60 cycles. This gave somewhat of

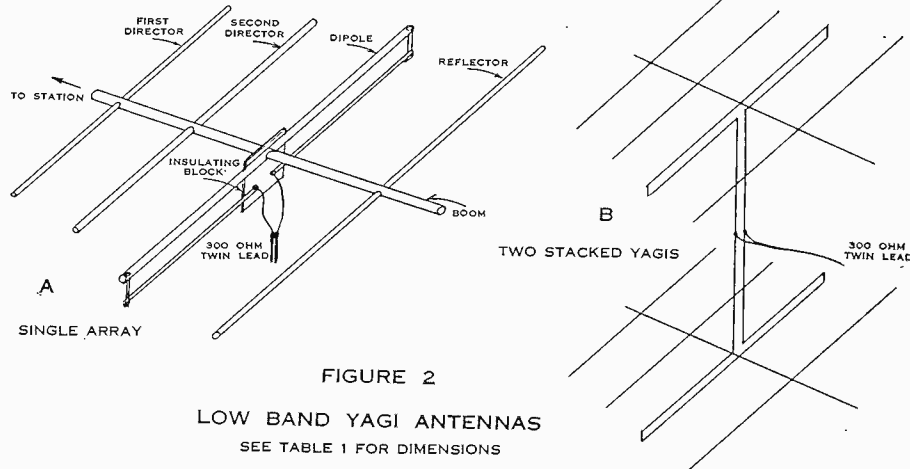

FIGURE 2
LOW BAND YAGI ANTENNAS
SEE TABLE 1 FOR DIMENSIONS

TABLE I
DESIGN OF YAGI ANTENNA
FIGURES GIVEN FOR A CHANNEL 4 ANTENNA

Channel 4 66-72 Mc
 $\lambda = \frac{300}{66} = 4.55 \text{ meters}$
 $\lambda = \frac{455}{2.54} = 179 \text{ inches}$

Material: Aluminum Tubing—3SH14 Grade or Harder

Formula	Length Inches	Name of Part	Diameter Inches
.415 λ	74½	First Director	3/8
.43 λ	77	Second Director	3/8
.45 λ + 1"	81.5	Dipole*	1
.45 λ + 1"	81.5	Dipole* (3/4" between open ends of dipole)	1/4
.49 λ	87¾	Reflector	3/8
.35 λ + 6"	69	Boom (6" added to length for mounting) (May also be supported at center of boom by mast)	3/4
.1 λ	17¾	Spacing between directors and dipole	
.15 λ	26¾	Spacing between reflector and dipole	

*NOTE 1—1 inch was added to length to allow pieces to be joined together at points ½" from ends. Dipole elements spaced 1¼ center to center to step up impedance to 300 ohms.
 *NOTE 2—To stack two antennas vertically, make the dipole of ¾ and 3/8 diameter tubing and space 1¾" center to center. See Figure 2.

a wiggle to the picture received, which was not too objectionable, and even enhanced the picture for certain subject matter. The only precautions taken to eliminate hash from the vibrator were to enclose it in the metal trunk of a car and operate the TV set with about 30 feet of connecting cable. A 500 watt gasoline engine driven generator was acquired later so that two sets could be operated at the same time.

Antennas

No article on fringe reception is complete without a lengthy description of the antennas. As stated previously, portability was an important factor in influencing the design of our first antenna. The Pennsylvania Department of Forests and Waters later granted us permission to mount the antenna

temporarily on the tower for a two-month period. The design features of the four element Yagis are shown in Figure 2 and the formula used in determining the dimensions is shown in Table 1. Preliminary measurements indicated that the antenna should be cut for the low frequency end of the band to center its maximum gain at the frequency of the video carrier. The impedance of the antenna using an ordinary folded dipole as the driven element is roughly 100 ohms. By using conductors of different size in the folded dipole it is possible to step this up to 300 ohms or some other desired value. By stepping up the impedance to 150 ohms, two arrays can be conveniently stacked and matched using ordinary 300 ohm twin lead to interconnect the arrays.

TELEVISION RECEPTION IN A FRINGE AREA *Continued*

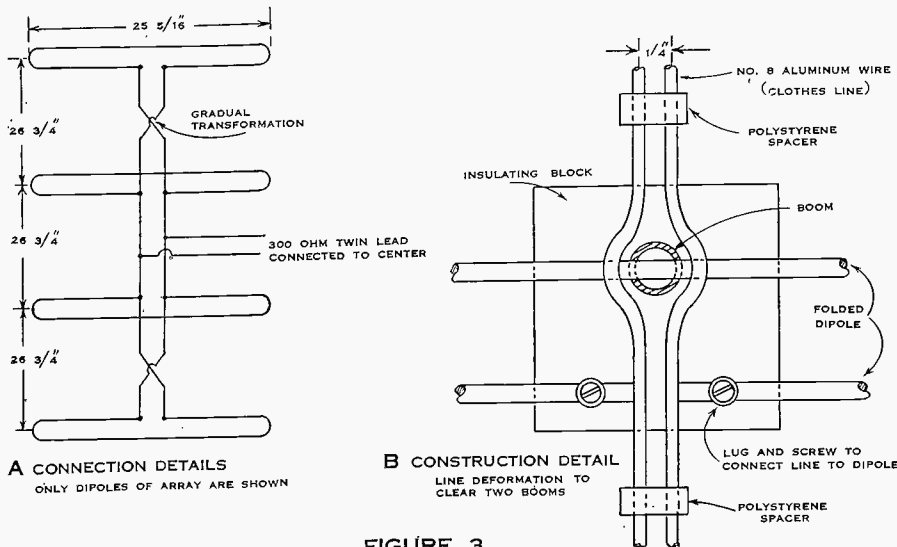

FIGURE 3
FOUR STACKED YAGI ANTENNA

TABLE II
DESIGN OF FOUR STACKED YAGI ANTENNA
FIGURES GIVEN FOR A CHANNEL 13 ANTENNA

Channel 13 210-216 Mc
 $\lambda = \frac{300}{210} = 1.43$ meters
 $\lambda = 56.2$ inches
 Material: Aluminum Tubing—3SH14 Grade and #8 Aluminum Wire (clothes line)

Formula	Cut Length Inches	Diameter	Number Required	Name of Part
.415 λ	23 1/4	#8	4	First Director
.43 λ	24 1/4	#8	4	Second Director
2 x .45 $\lambda + 1/2''$	51 1/8	#8	4	Folded Dipole. Space 3/4''. Bend ends on 3/4'' diameter. Leave 1/2'' spacing between open ends at feed point. Flatten ends and drill for 4-36 screw to fasten to feed line. Overall formed length is 25 5/16''.
.49 λ	27 3/4	#8	4	Reflector
.1 λ	5 5/8			Spacing between directors and between director and dipole.
.15 λ	8 1/2			Spacing between reflector and dipole.
.475 λ	26 3/4	3/8''	4	Vertical stacking distance
.35 $\lambda + 6''$	25 3/4			Boom: All booms fastened to mast at end beyond reflector.
3 x .475 $\lambda + 12''$		3/4'' Min.	1	Top mast section to which booms are mounted. 92 1/2'' minimum length.

*NOTE: See Figure 3 for details of matching the antenna to transmission line.

Since the antennas are quite sharp frequency-wise a separate antenna was used for each channel. Four four-element yagis were stacked on channel 13. Ordinary folded dipoles (conductors of equal size) were used in this array and the impedance of the line connecting the various bays was made of such a value as to properly match the antenna to the conventional 300 ohm twin lead. Details of the channel 13 antenna are shown in Table 2 and Figure 3. The fire tower with the TV antennas attached is shown in the photograph of Figure 4.

In the early experiments home-built single-channel boosters designed for the best noise factor possible were used. There are now several commercial boosters available whose performance is adequate and these were later used because of their added convenience in being tunable over all channels. Yagi antennas are also now available from several manufacturers.

Results Achieved

The signals were monitored throughout the summer months mostly at night. Stations in Pittsburgh, Buffalo, Rochester and Johnstown, Pa., on channels 3, 4, 6 and 13 have been consistently received. At times during the summer, more distant stations were also received, sometimes with resulting co-channel interference apparent on the "near-by" stations. The signals of the three lower channel stations have in general been quite poor during daylight, usually improving with darkness. Occasionally excellent signals have been observed from Buffalo, free of "snow" and excellent in detail. A more con-

(Continued next page)

REVISED TELEVISION CHART NOW AVAILABLE

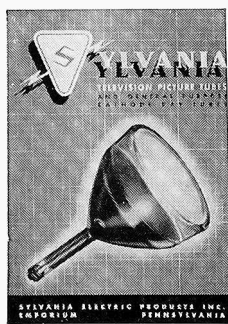

the new Sylvania Cathode Ray Tube Characteristics Chart which has just been published. Besides giving complete technical data for over 120 different electrostatic and magnetic cathode ray tubes with their respective basing diagrams, this booklet contains helpful information on the cathode ray tube nomenclature being used today. By referring to this subject in the chart, the type of screen required for any use may be determined.

Another section of the book lists thirty-seven different television

picture tubes and the possible substitutions for each type. Any small adjustments necessary to replace the type in question are clearly noted for each tube.

Finally, this book gives instructions for the proper way to handle cathode ray tubes when removing or replacing them in a receiving set in order to avoid danger of implosion.

Servicemen may receive free copies of this booklet by writing to Sylvania Electric Products Inc., Advertising Dept., Emporium, Pa.

"Packed with information" is the only expression to use in describing

TELEVISION RECEPTION IN FRINGE AREA *Continued*

sistent signal free of fading and of the same strength day or night has been received from the closest station, only 90 miles, in Johnstown, Pa., on channel 13. The station identification pattern is shown in Figure 5, as photographed directly from the picture tube of the receiver. In Figure 6 is shown a scene from a wrestling match. This match originated in Chicago, was sent over coaxial cable to Pittsburgh, put on the air by WDTV in Pittsburgh, picked up and retransmitted by WJAC-TV in Johnstown, and finally received at the Whittimore Hill receiving location, 90 miles from Johnstown and photographed directly from the screen of the receiver. These pictures are typical of the signal usually received from Johnstown. Those from the other stations were on the average worse, but on several nights they have been even better. Man made noise is nonexistent at the isolated receiving location used.



FIGURE 4 THE FIRE TOWER SHOWING ANTENNA ARRAYS

The work described herein was done by the members of the TV application group of the Commercial Engineering Department. If you

live a long way from the TV stations, but have a hill handy, it might be

worthwhile to go hunting for a picture some night. It's fun!

TYPE 1B3GT IN EARLY TELEVISION SETS

Mr. E. J. Haase, Renewal Sales Manager of the Sylvania Western Division, has called our attention to the fact that some early television receivers such as the Philco type

1275 use pin No. 3 on the type 1B3GT socket as a tie point. With most recent tubes of many manufacturers this pin is internally connected and their insertion in this

set renders the set inoperative.

We suggest that servicemen encountering such sets remove this tie point to avoid possible trouble.

TECHNICAL SECTION INDEX

JANUARY 1949 TO DECEMBER 1949

This annual index is prepared for the use of those servicemen who keep their copies for reference.

Bound volumes of all previous issues are available for \$1.00 each as follows:

- Vol. 1 Technical Sections
1935 to 1940 inclusive*
- Vol. 2 Technical Sections
1941 to 1945 inclusive*
- Vol. 3 Technical Sections
1946 to date (loose-leaf)*

ARTICLES

Television Series (continued from 1948)

	Vol.	No.
Checking Television Waveforms with a CRO.....	16 -	2
High Voltage Supplies.....	16 -	8
Intercarrier Method of Sound Reception.....	16 -	1
Interference.....	16 -	9
Ion Trap Magnet and Its Adjustment, The.....	16 -	10
Reception in a Fringe Area.....	16 -	11
Sweep Circuits.....	16 -	5
Sync Strippers and Separators.....	16 -	3
Video Amplifiers and D. C. Restorers.....	16 -	6
Video Detection and AGC.....	16 -	1
Picture Tube Damage From Incorrect Ion Trap Magnet Adjustment.....	16 -	4
Television Antennas — A Book		

Review.....	16 -	8
Television Servicing, Use of Sylvania Type 132 Scope in.....	16 -	2
Television Tubes Are Not Dangerous if Properly Handled.....	16 -	4
Use of Types 6AG5 and 6BC5 in Television Sets.....	16 -	10
SERVICE HINTS		
Admiral Model 8C14, Reducing Frequency Drift in.....	16 -	8
Brush Soundmirror Model BK401.....	16 -	1
	16 -	3
	16 -	4
Emerson Model 517, Whistle in.....	16 -	6
Emerson Model FU-428.....	16 -	1
Ford Zenith Model 6MF080.....	16 -	6
Ford Zenith Model 7R887 Chassis 7E22, Intermittent Oscillation in.....	16 -	4
Oscillator Trouble in Battery Portables, Preventing.....	16 -	3
Philco 4601201 Revised, Hum and Distortion in.....	16 -	4
Philco Model 48-300, Hum in.....	16 -	1
RCA 66BX Portable, Distortion in.....	16 -	8
RCA V-215 Audio Distortion.....	16 -	1
Silvertone 6421 Chassis 101.571.....	16 -	4
Zenith Portables, Intermittent Operation of.....	16 -	3
SERVICE HINTS (Miscellaneous)		
Aid for Adding Manual Sheets.....	16 -	8
Car Radio Interference.....	16 -	3
Electronic Equipment, Using.....	16 -	9

Improved Method of Tinning Soldering Iron.....	16 -	3
Servicing AC-DC Radios.....	16 -	3

SYLVANIA TEST EQUIPMENT

Capacitance Bridge, Sylvania.....	16 -	8
Polymeter, New Sylvania Type 221.....	16 -	5
Polymeter Probe for 10,000 Volts D.C.....	16 -	1
Signal Generator, New Sylvania Type 216 AM-FM.....	16 -	7
Sylvania Technical Manual, New.....	16 -	7
Television Servicing, Use of Sylvania Type 132 Scope in.....	16 -	2
Tube Checker Settings, Additions to..	16 -	6
	16 -	10

TUBE DATA

Type 6BF6.....	February Insert
Type 6BC6G.....	February Insert
Type 6BH6.....	January Insert
Type 6BJ6.....	January Insert
Type 7AD7.....	March Insert
Type 7AH7.....	April Insert
Type 7AJ7.....	April Insert

TUBE NOTES AND SUBSTITUTIONS

Type 1B3GT in Early Television Sets	16 -	11
Type 6A5G Is Back Again.....	16 -	1
Substitutes for Type 1N6.....	16 -	8
Substitutes for Type 50Z7GT.....	16 -	3
Use of Types 6AG5 and 6BC5 In Television Sets.....	16 -	10