

25¢

# 28 Uses for JUNCTION TRANSISTORS

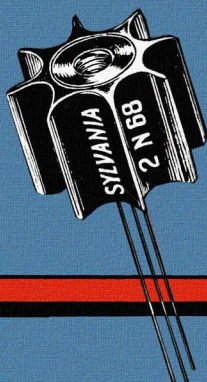

*A* MANUAL  
OF PRACTICAL  
APPLICATIONS



SYLVANIA ELECTRIC PRODUCTS INC.

# 28 USES FOR JUNCTION TRANSISTORS

*A Manual of Practical Applications*



**SYLVANIA ELECTRIC PRODUCTS INC.  
1740 BROADWAY • NEW YORK 19, N. Y.**

*Copyright, 1955*

**SYLVANIA ELECTRIC PRODUCTS INC.**

**FIRST EDITION**

**FIRST PRINTING**

## **PREFACE**

This brief manual of practical transistor circuits has been prepared from laboratory data accumulated from tests of many devices. While the booklet is addressed primarily to experimenters and electronic hobbyists, we believe that engineers and technicians will find material of interest on its pages.

Theory has been held to a minimum. In Chapter 1, only a brief presentation of essential junction transistor theory is given. The reason for this is obvious: Considerable theoretical discussion is to be found in print elsewhere. A short list of such references appears at the end of the first chapter.

In presenting this booklet which will join our family of publications on the practical applications of crystal diodes, we hope to satisfy the need, voiced by innumerable technicians and hobbyists, for practical circuits with which they may get their hands in transistor work.

No license is to be implied with respect to any inventions described herein, and no responsibility is assumed for the application or interpretation of the information contained herein, or for any infringement of patent or other rights of third parties which may result from the use of that information.

*Sylvania Electric Products Inc.*

# CONTENTS

## **CHAPTER 1. Elementary Transistor Theory.**

1.1 Advantages of the Transistor. 1.2 Construction of Junction Transistor. 1.3 Junction Transistor Action. 1.4 Transistor Circuit Configurations. 1.5 Transistor Parameters. 1.6 Collector D-C Characteristic Curves. 1.7 Preliminary Notes on Practical Circuits.

## **CHAPTER 2. Transistorized Amplifiers.**

2.1 Simple Audio Preamplifier. 2.2 Single-Stage Preamplifier with Emitter Degeneration. 2.3 Common-Collector Amplifier. 2.4 Transistor Dynamic Microphone. 2.5 Cascade RC-Coupled Audio Amplifier. 2.6 Hearing Aid. 2.7 Direct-Coupled NPN-PNP Amplifier. 2.8 Single-Ended Pushpull Amplifier using Complementary Symmetry. 2.9 Phase Inverter. 2.10 Medium-Power, Class-A Loudspeaker Amplifier. 2.11 Class-A Audio Power Amplifier. 2.12 Five-Watt Audio Amplifier.

## **CHAPTER 3. Transistorized Oscillators.**

3.1 Single-Frequency Sine-Wave Oscillator. 3.2 Self-Excited 100-KC Oscillator. 3.3 100-KC Crystal Oscillator. 3.4 Code-Practice Oscillator. 3.5 Multivibrator.

## **CHAPTER 4. Transistorized Control Devices.**

4.1 Sensitive D-C Relay. 4.2 Sensitive R-F Relay. 4.3 Photo Timer. 4.4 Photoelectric Counter.

## **CHAPTER 5. Transistorized Instruments.**

5.1 Simple D-C Microammeter. 5.2 D-C Microammeter with Zero-Set Circuit. 5.3 Electronic D-C Voltmeter. 5.4 Sensitive Light Meter with Rugged Indicator. 5.5 Bridge Null Detector (Peaked 1000-Cycle Amplifier). 5.6 Keying Monitor. 5.7 Field Strength Meter.

## **LIST OF ILLUSTRATIONS**

### **FIGURE**

- 1-1. Junction Transistor Forms and Symbols.
- 1-2. Typical Junction Transistors.
- 1-3. Transistor Bias and Signal Connections.
- 1-4. Circuit to Demonstrate High Base-Collector Current Amplification.
- 1-5. Transistor Configurations.
- 1-6. Collector DC Characteristic Curves.
  
- 2-1. Simple Preamplifier.
- 2-2. Single-Stage Preamplifier with Emitter Degeneration.
- 2-3. Common-Collector Amplifier.
- 2-4. Transistor Dynamic Microphone.
- 2-5. Cascade RC-Coupled Audio Amplifier.
- 2-6. Hearing Aid.
- 2-7. Direct-Coupled NPN-PNP Amplifier.
- 2-8. Single-Ended Pushpull Amplifier using Complementary Symmetry.
- 2-9. Phase Inverter.
- 2-10. Medium-Power, Class-A Loudspeaker Amplifier.
- 2-11. Class-A Audio Power Amplifier.
- 2-12. Five-Watt Audio Amplifier.
  
- 3-1. Single-Frequency Sine-Wave Oscillator.
- 3-2. Self-Excited 100-KC Oscillator.
- 3-3. 100-KC Crystal Oscillator.
- 3-4. Code-Practice Oscillator.
- 3-5. Multivibrator.
  
- 4-1. Sensitive DC Relay.
- 4-2. Sensitive RF Relay.
- 4-3. Photo Timer.
- 4-4. Photoelectric Counter.
  
- 5-1. Simple DC Microammeter.
- 5-2. DC Microammeter with Zero-Set Circuit.
- 5-3. Electronic DC Voltmeter.
- 5-4. Sensitive Light Meter with Rugged Indicator.
- 5-5. Bridge Null Detector (Peaked 1000-Cycle Amplifier).
- 5-6. CW Keying Monitor.
- 5-7. Field Strength Meter.

# CHAPTER 1

## Elementary Transistor Theory

### 1.1 Advantages of the Transistor.

The transistor performs many of the functions formerly possible only with vacuum tubes. As an amplifying device, the transistor is smaller than the tube, has no filament, and can be operated in any position. It also is non-microphonic, mechanically rugged, and makes more efficient use of its d-c power supply than the tube does. Transistors can oscillate with only a few microwatts of d-c input power.

Point-contact and junction type transistors currently are being manufactured. Each has particular special areas of application, although either type can be used in many applications. This booklet is concerned only with the applications of junction transistors.

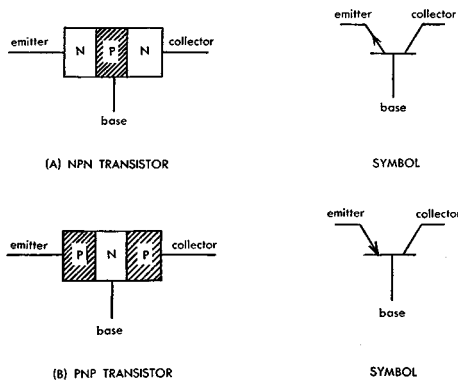

FIGURE 1-1—Junction Transistor Forms and Symbols.

## 1.2 Construction of Junction Transistor.

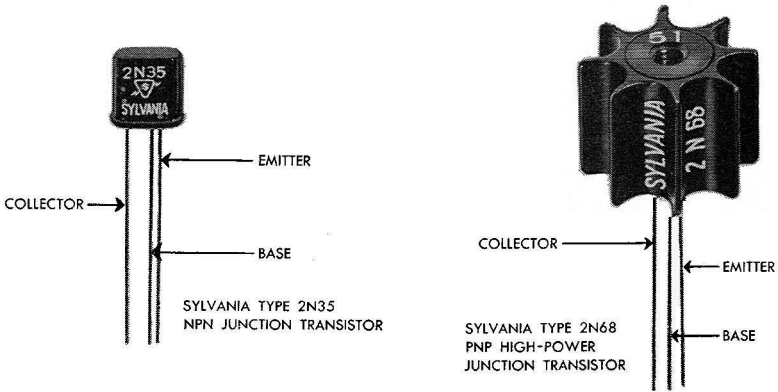

FIGURE 1-2—Typical Junction Transistors

Experimental transistors have been made from several semiconductor materials, but most commercial units presently are made from germanium. Sylvania was one of the pioneers in the use of germanium in the crystal diode, predecessor of the transistor.

The heart of the junction-type transistor is a thin wafer of highly-refined germanium into which three distinct conduction regions have been created by introducing controlled amounts of certain chemical impurities. A wire lead is attached to each of these regions.

These regions are designated as *N-type* germanium when the added impurity is a material rich in electrons, and *P-type* when the material is deficient in electrons—or, to another way of saying, rich in *holes*. Electric conduction through an N-type semiconductor is by means of electrons, and through a P-type semiconductor by means of holes. Holes travel through the material somewhat more slowly than electrons.

The arrangement of the conduction layers in the germanium wafer is shown in Figure 1-1. In this illustration, the P and N regions have been magnified for the sake of clarity, but in reality they are quite thin. Figure 1-1 (A) shows the cross section and circuit symbol of the NPN type of junction transistor, while Figure 1-1 (B) shows the PNP type. In each type, one outer layer is termed the *emitter* electrode, the center layer the *base*, and the other outer layer the *collector*. Emitter, base, and collector correspond roughly to cathode, grid, and plate of a triode tube.



To complete the transistor, the processed 3-region germanium wafer is hermetically-sealed in a suitable casing and its three pigtail leads brought out through an insulating header for circuit connections. Sylvania Types 2N34 and 2N68 are PNP transistors. Sylvania Type 2N35 is an NPN transistor. Figure 1-2 shows two typical Sylvania units.

### 1.3 Junction Transistor Action.

The N-P and P-N junctions processed into the germanium (see Figure 1-1) form equivalent crystal diodes. When a d-c voltage is applied to either junction in such a way that the N region is made negative and the P region positive, a high forward current flows. Conversely, when the N region is positive and the P region negative, a low reverse current flows. Thus, the junction exhibits the properties of high forward current, low reverse current, and rectification which characterize the crystal diode.

*Electrodes.* In a transistor, the emitter electrode is so called because this electrode, when d-c-biased for forward current flow, effectively injects or emits current carriers (electrons or holes) into the center base region of the germanium wafer. The collector receives its name from the fact that this electrode, when d-c-biased for reverse current flow, apparently collects these carriers which then increase the reverse current. In the NPN transistor, the injected carriers are electrons from the N-type emitter layer; in the PNP type, they are holes from the P-type emitter layer.

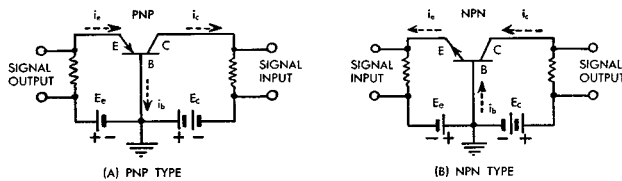

FIGURE 1-3—Transistor Bias and Signal Connections.

*DC Biasing.* Figure 1-3 shows how the transistor is connected to sources of emitter and collector d-c bias voltage, and the points at which signals might be fed in and taken out. Figure 1-3 (A) shows connections for the PNP transistor; Figure 1-3 (B) for the NPN type.

In each case, the emitter supply ( $E_E$ ) biases the emitter junction in the forward (low-resistance, high-current) direction, and the collector supply ( $E_C$ ) biases the collector junction in the reverse (high-resistance, low-current) direction. Because of the difference in emitter and collector resistance,  $E_C$  can be much higher than  $E_E$ . A steady value of emitter current ( $I_E$ ) flows through the emitter junction. The corresponding steady value of collector current ( $I_C$ ) is proportional to the emitter current. When the emitter voltage is reduced to zero, while maintaining the collector voltage, a small static value of collector current (*cutoff* or *leakage* current,  $I_{CO}$ ) flows through the high resistance of the collector junction.

*Operation, Current Gain (Alpha).* In the PNP transistor, the emitter injects positive holes. These carriers travel through the base region where a few are neutralized by the electrons in the N-type germanium found there. But the base is very thin, so most of the holes survive to reach the collector junction where they are attracted by the strong negative field due to the high collector voltage. They succeed in increasing the collector current from the low  $I_{CO}$  value to a higher level. If all of the holes injected by the emitter managed to reach the collector, the final collector current would equal the emitter current and the transistor would be considered to have an emitter-collector current gain ( $\alpha$ , alpha) of 1. However, some holes do recombine with electrons in the base region and thus can contribute nothing to the increase in collector current. In practice, therefore, alpha for a junction transistor approaches unity but usually does not reach this value. Practical values range from 0.80 to 0.999 in commercial junction transistors. Alpha is comparable to the amplification,  $\mu$ , of a vacuum tube.

The NPN junction transistor operates in the same manner, except that the injected carriers are electrons which pass through a P-type (hole-rich) base region toward a *positively*-charged collector.

The forward resistance of the emitter junction is designated  $R_E$ , the reverse resistance of the collector  $R_C$ , the emitter voltage drop  $V_E$ , and the collector voltage drop  $V_C$ . Base current,  $I_B$ , is very small compared to either  $I_C$  or  $I_E$  because of the few carriers available for this current flow. From the current and voltage relationships, the emitter and base resistances are seen to be low in value and the collector resistance high.

*Voltage and Power Amplification.* Although the foregoing explana-

tion shows the transistor essentially to be a current-operated device, the transistor can display voltage and power amplification as well. In Figure 1-3, an input signal is applied in series with the d-c emitter bias,  $E_E$ . Signal-voltage fluctuations cause corresponding fluctuations in emitter current,  $I_E$ , and in turn in collector current,  $I_C$ . Although the current gain is slightly less than 1 in this case, the collector resistance circuit level, as previously explained, is higher than the emitter circuit resistance level, and the output-signal voltage therefore is larger than the input-signal voltage. Power amplification also results because of this resistance ratio. The magnitude of voltage and power amplification depends upon various other parameters which must be taken into consideration in accurate calculations. These parameters include load resistance and generator resistance.

*Base-Collector Current Amplification (Beta).* In Figure 1-3, the base is the transistor electrode common to both input and output circuits. In this arrangement, the current amplification factor, *alpha*, is the ratio of a collector current change to the emitter current change and must be less than unity. A different situation results when the emitter is made the common electrode, as in Figure 1-4.

In this arrangement, a small current ( $I_B$ ) flows into the base and produces a large change in collector current ( $I_C$ ). In practice,  $I_B$  is in microamperes and  $I_C$  in milliamperes. This base-collector current amplification, which is many times the alpha value for the same transistor, is designated  $\beta$  (beta) and is related to alpha in the following respect:  $\beta = a / (1-a)$ .

A PNP transistor is shown in Figure 1-4, but an NPN type may be used with the same results if the battery polarities are reversed.

## 1.4 Transistor Circuit Configurations.

Depending upon which of its terminals are used for input and output, a transistor may be connected into its circuit in any one of three ways. These configurations, illustrated in Figure 1-5, are termed common-base, common-emitter, and common-collector.

The common-base roughly is equivalent to the grounded-grid vacuum-tube amplifier, the common-emitter to the grounded-cathode, and the common-collector to the cathode follower. The common-base will be recognized as the type of circuit shown

earlier in Figure 1-3, and the common-emitter in Figure 1-4. While NPN transistors are shown in Figure 1-5, PNP units can be used by reversing the battery connections.

The common-emitter is the only transistor configuration producing a phase reversal between output and input signals. In the common-base and common-collector circuits, output is in phase with input.

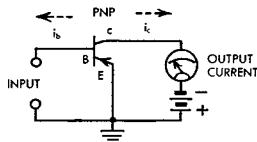

**FIGURE 1-4—Circuit to Demonstrate High Base-Collector Current Amplification.**

The frequency response and current gain of the common emitter and common collector circuits are essentially the same. This frequency response is lower than that of the common base circuit, whereas the current gain is greater than that of the common base circuit.

The common-base circuit has the lowest input impedance and the highest output impedance. The common-collector circuit has high input and low output impedances. Moderate input and output impedances are provided by common emitter circuits.

The configuration employed depends upon requirements. The common-emitter, for example, while having an input impedance of the order of 1000 ohms, provides the highest voltage gain and power gain. The common-collector, on the other hand, provides much higher input impedance but, like the cathode follower tube amplifier, will not afford a voltage gain in excess of 1.

## **1.5 Transistor Parameters.**

Input and output impedances of the three configurations vary with junction transistor types and to a slight extent between individual units of the same type. However, representative values of input and load resistances are: 60 and 100,000 ohms respectively for the common-base; 600 and 20,000 ohms, common-emitter; and 0.5 megohm and 20,000 ohms, common-collector.

Unlike the vacuum tube, the transistor does not possess

isolated input and output circuits. The output impedance, for example, depends upon the value of input impedance, and vice versa, and is affected also by the impedance of the generator (signal source). This interdependence of transistor parameters necessitates a different approach to circuit design than that employed with tubes.

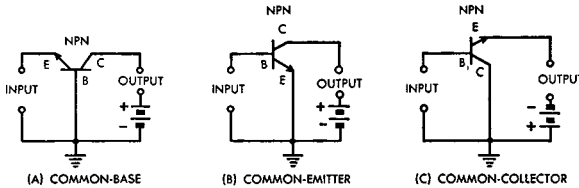

FIGURE 1-5—Transistor Configurations.

The principal parameters of the junction transistor are: emitter-collector current amplification factor ( $\alpha$ ), base-collector current amplification factor ( $\beta$ ), base resistance ( $R_B$ ), collector resistance ( $R_C$ ), emitter resistance ( $R_E$ ), base voltage ( $V_B$ ), collector voltage ( $V_C$ ), emitter voltage ( $V_E$ ), base current ( $I_B$ ), collector current ( $I_C$ ), emitter current ( $I_E$ ), collector power ( $P_C$ ), and emitter power ( $P_E$ ). The external circuit into which the transistor operates can contain base resistance ( $R_B$ ), collector resistance ( $R_C$ ), and emitter resistance ( $R_E$ ). It also includes one or more bias supply voltages: base voltage ( $V_B$  or  $E_B$ ), collector voltage ( $V_C$  or  $E_C$ ), or emitter voltage ( $V_E$  or  $E_E$ ).

## 1.6 Collector DC Characteristic Curves.

Junction transistor operation may be expressed with the aid of static EI curves similar to tube curves. These curves may be used with superimposed load lines in the conventional manner in the graphic design of transistor circuits. The basic difference between tube curves and transistor curves is the use of *current* as the independent variable when plotting transistor curves.

While various sets of transistor d-c curves may be plotted, most important perhaps is the collector voltage-vs-collector current set. These curves, similar to the plate current-vs-plate voltage tube curves, are illustrated by Figure 1-6.

Figure 1-6 (A) is a family of collector curves corresponding to various values of constant emitter current (common-base circuit).

Figure 1-6 (B) shows collector curves for various values of constant base current (common-emitter circuit). In each case, the curves are seen to resemble the constant current curves of a pentode tube. Note, however, that the common-base collector curves are the

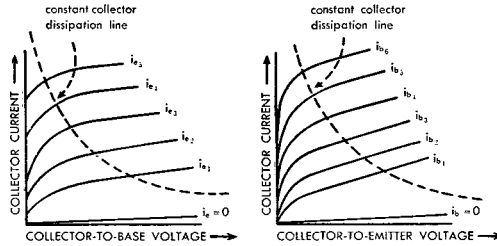

FIGURE 1-6—Collector D-C Characteristic Curves.

more evenly-spaced of the two and also are flatter. This accounts for the more linear operation of common-base circuits.

The dotted line crossing the curves is a plot of constant collector dissipation ( $V_C I_C$ ). When this curve is drawn to correspond to the maximum allowable collector dissipation for a given transistor, it serves as a safety guide, all design values being chosen to the left of this curve.

## 1.7 Preliminary Notes on Practical Circuits

Batteries are shown as d-c power sources in the transistor circuits in the following chapters. The first reason for this is simplicity—it is easy to draw a battery. The second and most important reason is that batteries often will be preferred to a-c-operated power supplies in these circuits. The low current drain of transistors makes battery operation, frequently desired in electronic equipment, much more economical than in equivalent vacuum-tube circuits. Because a battery is shown in a circuit, however, does not preclude use of an a-c-operated supply if the latter is more suitable in a particular application.

The circuit constants shown are those which have been found to be optimum. Operating data are typical and have been obtained in laboratory tests of the circuits. Constants may be varied to some extent in one direction or the other to compensate for unavoidable small variations in individual transistors.

Sylvania Type 2N35 NPN transistors are shown in most of the circuits. Sylvania Type 2N34 PNP transistors also may be employed, provided the batteries are reversed. In the case of d-c amplifier devices, the input-signal polarity and the current-meter terminals also must be reversed when changing from NPN to PNP transistors.

Frequency response may be altered somewhat by changing the values of circuit constants, especially the coupling capacitances.

In all circuits, resistance values are in ohms, capacitances in microfarads, and all resistors are of  $\frac{1}{2}$  watt power rating except where noted otherwise.

## REFERENCES

For more detailed explanations of the behavior of transistors and transistor circuits, the reader is referred to the following books.

### Advanced

William Shockley, *Electrons and Holes in Semiconductors*, D. Van Nostrand & Co., Inc. (New York, 1950).

### Engineering

Richard F. Shea, *Principles of Transistor Circuits*, John Wiley & Sons, Inc. (New York, 1953).

Richard F. Shea, *Transistor Audio Amplifiers*, John Wiley & Sons, Inc. (New York, 1955).

### Intermediate

Leonard M. Krugman, *Fundamentals of Transistors*, John F. Rider Publisher, Inc. (New York, 1954).

### Elementary

Rufus P. Turner, *Transistors, Theory and Practice*, Gernsback Publications, Inc. (New York, 1954).

# CHAPTER 2

## Transistorized Amplifiers

### 2.1 Simple Audio Preamplifier.

Figure 2-1 shows the circuit of a 1-stage, common-emitter, RC-coupled audio-frequency preamplifier. This amplifier can be built small enough for inclusion, complete with battery, in the handle or case of a dynamic microphone, giving the latter an a-f output voltage comparable to that of a carbon microphone. It may be mounted also in other instruments in which preamplification is required. A typical application is as a millivoltmeter probe for a conventional a-c vacuum-tube voltmeter.

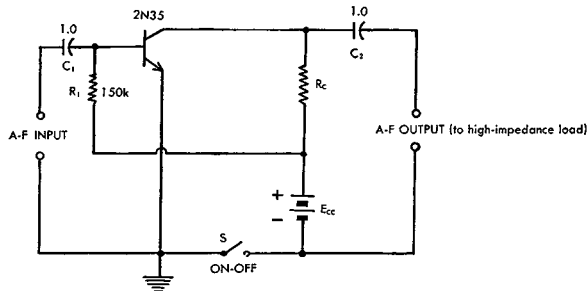

FIGURE 2-1—Simple Preamplifier.

The preamplifier is built into a Millen No. 74001 octal-based shield can. The transistor, capacitors C<sub>1</sub> and C<sub>2</sub>, and resistors R<sub>1</sub> and R<sub>C</sub> are mounted on a small bakelite card by passing their pigtail leads through holes in the card. The tiny 1-microfarad capacitors are Sangamo Type EHT tantalum electrolytic units. All wiring is done on the back of the card. Switch S has been



eliminated from this assembly, since the input, output, and battery connections are brought to the base pins of the plug-in can.

This preamplifier is designed to operate into a high-impedance load, such as the grid input circuit of a speech amplifier or modulator or an a-c vacuum-tube voltmeter.

Most transistors have been found to operate satisfactorily with a base bias resistor  $R_1$  of 150,000 ohms. However, some adjustment of this value might yield higher voltage gain, lower distortion, or reduced noise output. The correct resistance for a particular transistor will limit the d-c base current to 40 microamperes.

Battery Voltage (E <sub>cc</sub> )	Current Drain (d-c $\mu$ a)	Collector Resistor (ohms)	Input Impedance (ohms)	Input* Voltage (rms volts)	Output Voltage (rms volts)	Voltage Gain
1.5 v	100	6,500	625	0.005	0.16	32
3.0	200	7,500	350	0.011	0.60	54.6
4.5	225	6,500	500	0.0285	1.20	42.2
6.0	225	10,000	400	0.019	1.50	79
22.5	100	100,000	450	0.013	4.80	369

\*Maximum value before output distortion.

TABLE 2-A. Preamplifier Performance Data.

Table 2-A shows operating characteristics of the preamplifier for various battery voltages (E<sub>cc</sub>). These data were taken with a 1000-cycle signal generator having an output impedance of 600 ohms. Table 2-B shows voltage-gain frequency response of the preamplifier.

FREQUENCY (CPS)	50	100	1000	5000	10,000	50,000
RESPONSE (% of Maximum Voltage Output)	97.5	98	100	97.5	87	36.6

TABLE 2-B. Preamplifier Frequency Response. (Corresponding to the 6-volt Operating Conditions in Table 2-A).

## 2.2 Single-Stage Preampifier with Emitter Degeneration.

The addition of an emitter series resistor in the common-emitter circuit introduces degeneration. An effect of this degeneration is to increase the input resistance of the amplifier. This action is highly desirable, since the input impedance of transistors normally is low. (Note column 4, Table 2-A).

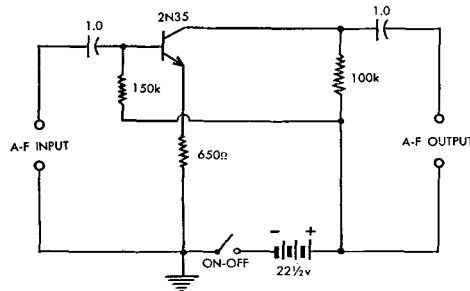

FIGURE 2-2—Single-Stage Preamplifier with Emitter Degeneration.

Figure 2-2 shows the addition of an emitter series resistor to the simple preamplifier previously described. The other circuit constants are the same shown in Table 2-A for maximum voltage gain (369). The emitter resistor was adjusted experimentally for a measured voltage gain of 100 at 1000 cycles. The signal generator output impedance was 600 ohms.

For the emitter resistor value of 650 ohms, the measured input impedance at 1000 cycles was 30,000 ohms, compared with 1500 ohms without degeneration. The maximum rms input signal voltage before output distortion was 35 millivolts, and the corresponding maximum rms output signal voltage 3.5 v. The new input impedance is almost 20 times that of the simple amplifier without degeneration, and the voltage gain of 100 is adequate for many applications. Table 2-C shows frequency response of the stage.

FREQUENCY (CPS)	50	100	1000	5000	10,000	50,000
RESPONSE (% of Maximum Voltage Output)	99	100	100	94.7	85.5	27

TABLE 2-C. Frequency Response of Degenerated Preamplifier.

## 2.3 Common-Collector Amplifier.

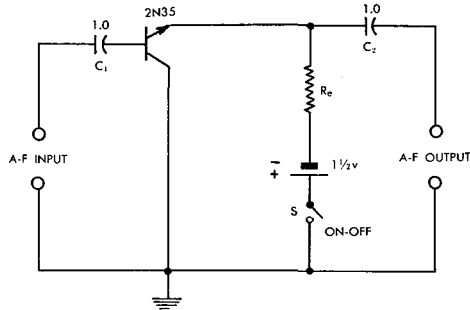

FIGURE 2-3—Common-Collector Amplifier.

The normally high input impedance of the common-collector circuit suits this transistor configuration to numerous applications, such as input and interstage coupling, in which this feature is the prime requisite. Like the vacuum-tube cathode follower, the common-collector also has low output impedance, less-than-unity voltage gain, and no phase reversal. The common-collector provides a small power gain, usually of the order of 16 db.

Figure 2-3 shows one version of the common-collector amplifier. The "floating base" arrangement (no fixed base d-c bias) and low collector voltage have been adopted to insure high input impedance.

Supply Voltage (d-c v)	Current Drain (d-c $\mu$ a)	Emitter Resistor, $R_e$ (ohms)	Input Impedance (ohms)	Input* Voltage (rms volts)	Output Voltage (rms volts)	Voltage Gain
1.5	40	50,000	100,000	0.40	0.38	0.95
1.5	42	25,000	100,000	0.42	0.40	0.952
1.5	90	10,000	100,000	0.41	0.38	0.928
1.5	120	1,000	40,000	0.10	0.071	0.71
1.5	125	500	22,000	0.052	0.027	0.52

\*Maximum value before output distortion.

TABLE 2-D. Common-Collector Performance Data.

Table 2-D gives operating characteristics of this circuit. From these data, it may be seen how input impedance and voltage gain

of the common-collector amplifier vary with output impedance. Table 2-E shows frequency response of the common-collector.

FREQUENCY (CPS)	50	100	1000	5000	10,000	50,000
RESPONSE (% of Maximum Voltage Output)	100	100	97.5	97.5	97.5	87.2

TABLE 2-E. Frequency Response of Common-Collector.

## 2.4 Transistor Dynamic Microphone.

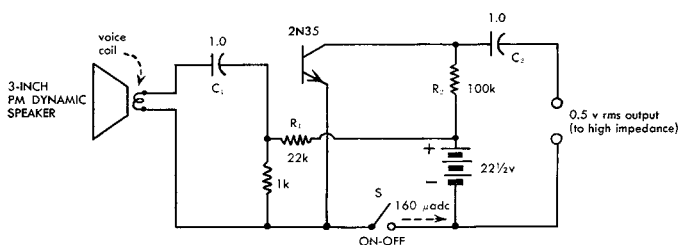

FIGURE 2-4—Transistor Dynamic Microphone.

An unused permanent-magnet dynamic loudspeaker conveniently may be converted into a high-output dynamic microphone by adding to it a 1-stage transistor amplifier. The low input impedance of the normal transistor amplifier is compatible with the low impedance of the speaker. A 3-inch speaker affords the smallest size, but a larger one will give the best tone quality. Such a microphone may be used directly or as the basis of a simple intercom system.

Figure 2-4 shows the simple circuit of the microphone. In this arrangement, the base resistor,  $R_1$ , should be adjusted for a d-c base current of 40 microamperes. The median value of  $R_1$  has been found to be 22K ohms. Output of the circuit is 0.5 volt rms for close talking into a 3-inch, 3.2-ohm speaker.

The unit was built into a 7" x 5" x 3" aluminum box, but could be made much smaller if required. In fact, the entire amplifier and battery might be mounted on a plate attached to the back of the loudspeaker. A small 22½- or 30-volt hearing aid battery is adequate for power supply.

## 2.5 Cascade R-C-Coupled Audio Amplifier.

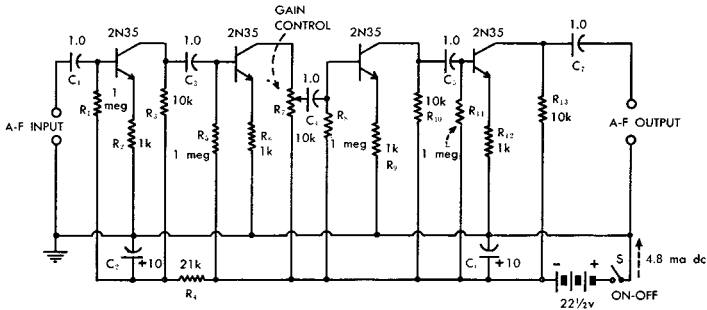

FIGURE 2-5—Cascade R-C-Coupled Audio Amplifier.

In order to secure higher voltage gain, resistance-capacitance-coupled transistor amplifier stages may be cascaded in the same manner as tube stages. Because of the impedance mismatch between transistor stages cascaded in this way, however, there is some loss of gain and this necessitates more stages for a given gain than in tube practice. The additional advantages of small size, low d-c requirements, and long life in the transistor amplifier often nullify this disadvantage.

Figure 2-5 shows a 4-stage amplifier suitable for general-purpose applications. With the gain control set at maximum, this amplifier has an over-all voltage gain of 2500 when operating into a high-impedance load. Degeneration, provided by the 1000-ohm emitter series resistors, provides an input impedance of 40,000 ohms at 1000 cycles, increases stability, and enables transistors to be replaced with others of the same type without seriously degrading amplifier performance because of slight differences in their characteristics. The maximum rms input signal voltage before output distortion is 0.8 millivolt, and the corresponding maximum rms output is 2 volts. Noise level, with the input terminals short-circuited and with the gain control set at maximum, is 10 millivolts without a special selection of transistors for low noise properties. Total current drain is 4.8 ma dc. Signal measurements were made at 1000 cycles with a 600-ohm generator. In the circuit, capacitor  $C_2$  and resistor  $R_4$  form an anti-motorboating filter.

With 2000-ohm magnetic headphones substituted for the output collector resistor,  $R_{13}$ , the total current drain increases to

6 ma dc. At half-gain setting of the gain control,  $R_7$ , 7.5 v rms are developed across the headphones with 3 mv rms input to the amplifier at 1000 cycles. The residual noise under these conditions is 20 mv.

Table 2-F shows frequency response of the amplifier operated into a 0.5-megohm load impedance.

FREQUENCY (CPS)	50	100	500	1000	2000	5000	10,000	20,000
RESPONSE (% of Maximum Voltage Output)	100	100	100	100	91	79	45.4	18.2

TABLE 2-F. Frequency Response of Cascaded RC Amplifier.

## 2.6 Hearing Aid.

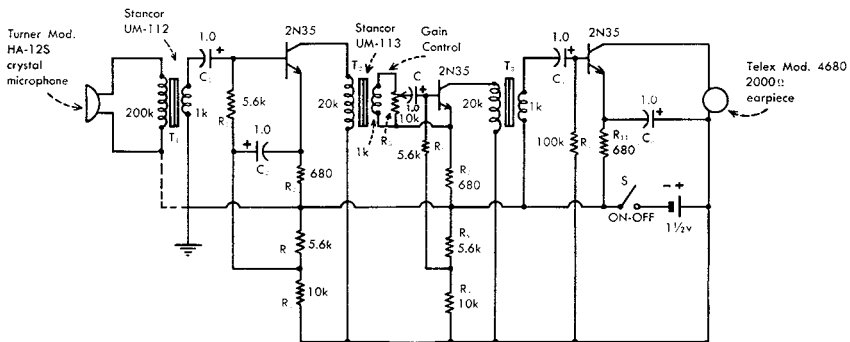

FIGURE 2-6—Hearing Aid.

The RC-coupled amplifier shown in Figure 2-5 might be employed as a hearing aid by transformer-coupling a small crystal microphone to the input circuit and connecting a magnetic-type earpiece in place of  $R_{13}$  and  $C_7$  in the output. However, better power amplification may be obtained with fewer transistors by employing transformers for interstage coupling. Also, a lower operating voltage is permissible and this may be obtained from inexpensive, small-sized batteries.

Figure 2-6 shows the circuit of a hearing aid employing sub-miniature transformers, microphone and earpiece available to the general public, and a single  $1\frac{1}{2}$ -volt penlight cell. A loud ear

signal is delivered, and the unit can be built into a pocket-size container of the builder's choice.

The high impedance of the crystal microphone necessitates the step-down impedance-matching transformer,  $T_1$ . The magnetic earpiece is connected directly in the d-c collector circuit of the output transistor. A crystal-type earpiece thus is not permissible in this position. Emitter degeneration is provided by resistors  $R_2$ ,  $R_7$ , and  $R_{11}$ . This negative feedback provides gain stabilization and some degree of stabilization of transistors against temperature changes, as well as facilitating transistor replacement. Resistor networks  $R_3$ - $R_4$  and  $R_8$ - $R_9$  stabilize base bias current.

The coupling and bypass capacitors,  $C_1$  to  $C_4$ , are miniature Sangamo Type EHT 1-ufd, 6-volt tantalum electrolytic units. These components are only  $\frac{1}{16}$  inch in diameter and  $\frac{5}{8}$  inch long. The gain control,  $R_5$ , is a Chicago Telephone Type X3521 midget potentiometer  $\frac{3}{4}$  inch in diameter. This control appears to be the smallest obtainable in the required resistance. Unfortunately, the much smaller "dime-size" controls, which are more desirable for miniature hearing-aid use, are not available on regular order below  $\frac{1}{2}$  megohm.

## 2.7 Direct-Coupled NPN-PNP Amplifier.

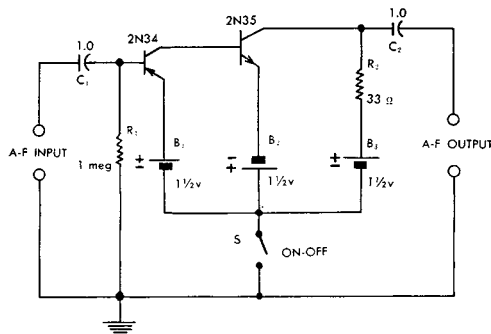

FIGURE 2-7—Direct-Coupled NPN-PNP Amplifier.

The complementary characteristics of NPN and PNP junction transistors may be utilized in many circuits employing the opposite action of these units. Figure 2-7 shows an amplifier circuit

making use of these characteristics to obtain *direct* interstage coupling. Direct coupling is enabled by the fact that an increasing 2N34 collector current (and therefore an increasing 2N35 base current) causes decreasing 2N35 collector current. The circuit in Figure 2-7 is based upon the original design by Sziklai. (See *Symmetrical Properties of Transistors and Their Applications*. George C. Sziklai. Proceedings of the I. R. E., June 1953, p. 717.)

This circuit has no over-all phase reversal, since an increasing base current at the input causes decreasing collector current in the 2N34, direct coupling then causing also decreasing base current and increasing collector current in the 2N35. At 1000 cycles (signal generator impedance = 600 ohms): voltage gain of the circuit shown in Figure 2-7 was measured as 29.5. Maximum rms input voltage before output distortion was 740 millivolts. Input impedance was 5200 ohms. Table 2-G shows frequency response of the amplifier. By dispensing with coupling capacitors  $C_1$  and  $C_2$ , thus obtaining direct coupling throughout, it should be possible to extend operation down to d-c.

FREQUENCY (CPS)	50	100	500	1000	5000	10,000	20,000	50,000
RESPONSE (% of Maximum Voltage Output)	97.2	97.2	100	100	90.4	69.5	41.7	13.9

TABLE 2-G. Frequency Response of NPN-PNP Amplifier.

## 2.8 Single-Ended Pushpull Amplifier Using Complementary Symmetry.

The symmetrical properties of NPN and PNP transistors may be utilized also to obtain a useful type of single-ended pushpull operation. The circuit shown in Figure 2-8 was developed from the original design suggested by Sziklai (See *Symmetrical Properties of Transistors and Their Applications*. George C. Sziklai. Proceedings of the I. R. E., June 1953, p. 717).

In this circuit, the 2N35 NPN transistor supplies the positive peaks of output signal voltage, while the 2N34 PNP unit supplies the negative peaks. Advantages of the arrangement are that no phase inverter nor center-tapped input transformer and no output transformer are required.



At 1000 cycles (signal generator impedance = 600 ohms): measured voltage gain at maximum setting of gain control  $R_2$  was 398. Maximum rms input signal voltage before output distortion was 4.15 mv. Corresponding maximum rms output voltage

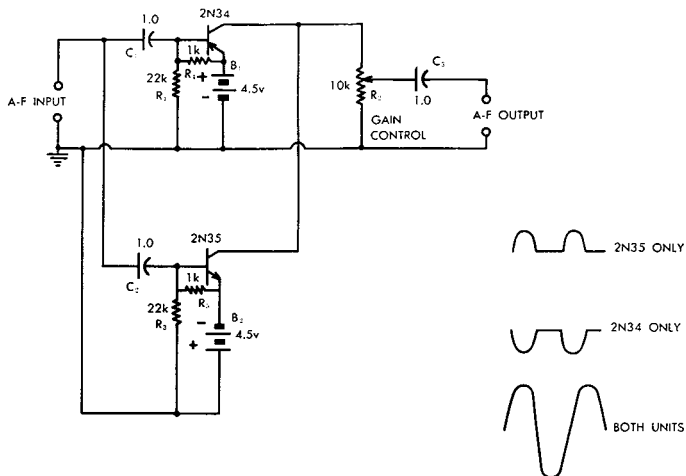

FIGURE 2-8—Single-Ended Pushpull Amplifier Using Complementary Symmetry.

was 1.65 v. Input impedance was measured as 7500 ohms, and noise level with the input terminals short-circuited and the gain control at maximum was 10 mv. Drain of the 2N34 was 1.0 ma and of the 2N35 0.6 ma. Transistors with matched characteristics are recommended for this circuit.  $R_1$  and  $R_3$  should be adjusted for Class B operation. The median value for both is 22K. Table 2-H shows frequency response.

FREQUENCY (CPS)	50	100	500	1000	5000	10,000	20,000	50,000
RESPONSE (% of Maximum Voltage Output)	60	78	100	100	81.3	62.5	43.7	20.6

TABLE 2-H. Frequency Response of Single-Ended Pushpull Amplifier.

## 2.9 Phase Inverter.

Many versions of transistor phase inverters have appeared in the literature. Figure 2-9 shows a simple arrangement utilizing the phase reversal between emitter and collector in the common-

emitter circuit and is seen to resemble the simple triode-tube inverter. Output voltage No. 1 is developed across the collector series resistor,  $R_3$ ; output voltage No. 2 across the emitter series resistor,  $R_2$ .

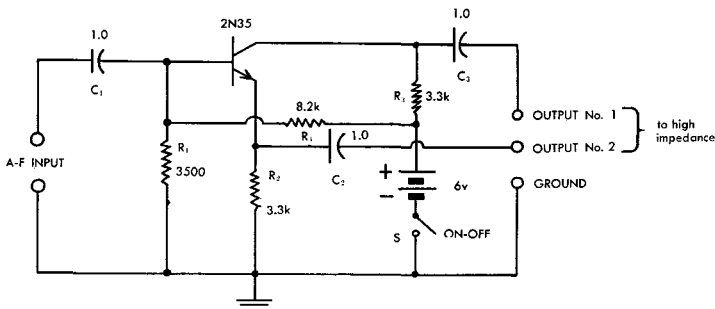

FIGURE 2-9—Phase Inverter.

In a 1000-cycle test of this circuit, good output waveform was obtained with the two output-voltage amplitudes matched within  $7\frac{1}{2}$  percent. With individual transistors, some adjustment of emitter resistor  $R_2$ , collector resistor  $R_3$ , or both may be necessary to obtain equal output voltages.

## 2.10 Medium-Power, Class-A Loudspeaker Amplifier.

Figure 2-10 shows the circuit of a 50-milliwatt-output amplifier suitable for driving a loudspeaker, up to 12-inch diameter, for modest volume requirements. A magnetic phonograph pickup may be operated directly into the input terminals, as may also a microphone or crystal radio receiver. One transistor is used as a single-ended voltage preamplifier and two in pushpull in the output power amplifier. The d-c supply for the input stage is 6 v and for the output stage 12 volts. Inexpensive transformers are employed.

At 1000 cycles, supplied by a 600-ohm signal generator, good sine-wave 50-milliwatt output was obtained, at maximum setting of gain control  $R_1$ , with 1 mv rms input. At full gain, the noise

level was 1.8 mv with the input terminals short-circuited. For individual output transistors, the base bias resistor,  $R_3$ , in the output stage must be adjusted for 5 milliamperes dc per collector under maximum-signal excitation conditions.

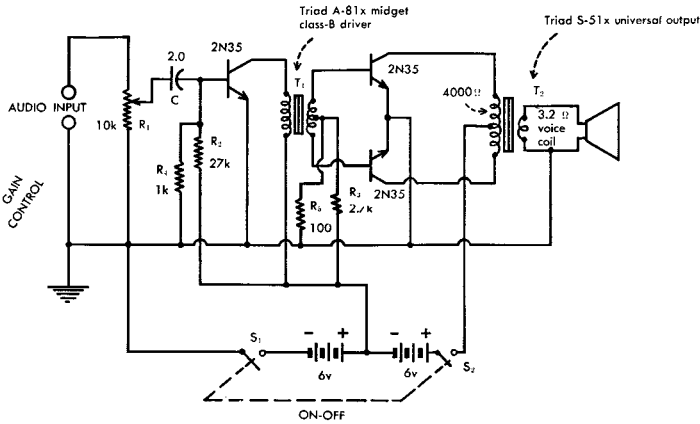

FIGURE 2-10—Medium-Power, Class-A Loudspeaker Amplifier (50 Milliwatts Output).

The loudspeaker amplifier was built into a 6" x 4" x 3" metal box. The transistors are easily mounted by soldering their pig-tails directly to the tie points of 3-lug insulated terminal strips. Signal input is supplied through a coaxial plug while battery and signal-output connections are provided by a tube socket mounted in the rear of the case.

Table 2-I shows frequency response of the loudspeaker amplifier. Somewhat improved response might be expected by using large-size, high-quality transformers.

FREQUENCY (CPS)	50	100	500	1000	5000	10,000	20,000
RESPONSE (% of Maximum Voltage Output)	34.2	68.2	91	100	79.6	52.3	13.3

TABLE 2-I. Frequency Response of Medium-Power Loudspeaker Amplifier.

## 2.11 Class-A Audio Power Amplifier.

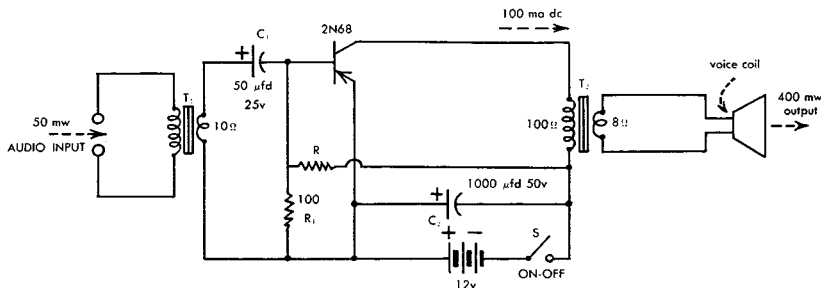

FIGURE 2-11—Class-A Audio Power Amplifier.

The Sylvania Type 2N68 junction power transistor offers many possibilities in applications requiring useful audio power output. Although small in size and operating at low d-c voltage, this transistor is capable of 2.5 watts dissipation in free air and 4 watts when provided with an external heat sink. At  $-12$  v collector potential, a single 2N68 will deliver 0.6 watt output when operated as a class-A amplifier, and a pair in a pushpull class-B amplifier will deliver 5 watts. Class-A collector efficiency is 35 percent, and class-B 75 percent. Power gain is better than 15 db and frequency response greater than 10 kc.

Figure 2-11 shows the circuit of a class-A audio output stage employing a single 2N68 in the common-emitter connection. The required 50 milliwatts driving power may be obtained from a transistor preamplifier of the type shown in Figure 2-10 and described in Section 2.10.

Transformers  $T_1$  and  $T_2$  must be fabricated especially for the low impedances of the 2N68, although  $T_1$  can be a conventional output transformer designed to operate into a loudspeaker voice coil. The primary impedance of  $T_1$  must be selected either to match a low-impedance line from the preamplifier or the collector impedance of a transistor preamplifier. If the medium-power amplifier of Figure 2-10 is used as a preamplifier, the primary of  $T_1$  must be center-tapped. In addition to having a 100-ohm primary, transformer  $T_2$  must be able to handle the 100-ma constant collector current of the transistor.

The base bias resistor,  $R$ , must be adjusted for steady collector current of 100 ma. Its median value should be 3000 ohms. Capacitors  $C_1$  and  $C_2$  both are high-quality electrolytic.

## 2.12 Five-Watt Audio Amplifier.

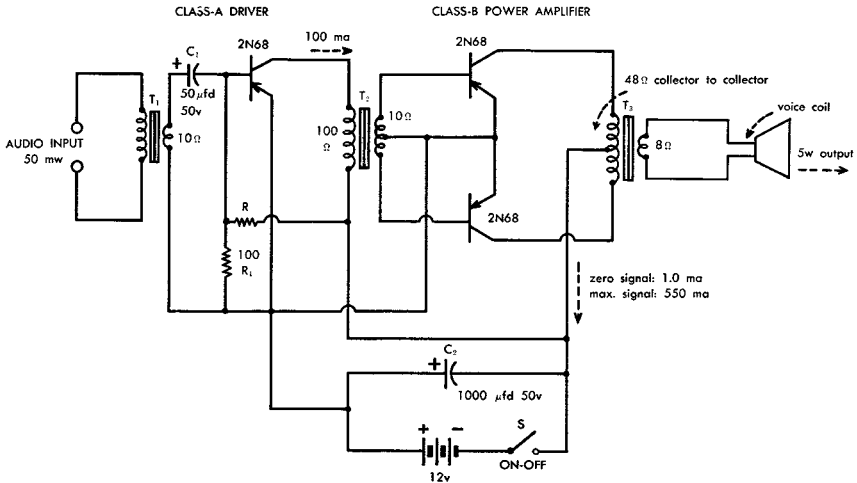

FIGURE 2-12—5-Watt Audio Amplifier.

Two Sylvania Type 2N68 power transistors in a pushpull class-B stage operated at  $-12$  volts DC will deliver 5 watts of audio output power with  $\frac{1}{2}$  watt audio driving power. Figure 2-12 shows the circuit of a class-B amplifier of this type with a class-A 2N68 driver.

Transformers  $T_1$ ,  $T_2$ , and  $T_3$  must be fabricated especially for the low impedances of the 2N68, although transformer  $T_1$  may be a conventional output transformer designed to match a loudspeaker voice coil. The primary impedance of  $T_1$  must be selected to match either a low-impedance line from the preamplifier or the collector impedance of a transistor preamplifier. If the preamplifier output stage is pushpull, the primary of  $T_1$  must be center tapped. The 50 milliwatts a-f power required to drive the class-A 2N68 driver stage may be obtained from the medium-power amplifier shown in Figure 2-10 and described in Section 2.10.

The collector current in the class-A driver stage is constant at 100 ma and is set, as described in Section 2.11, by adjustment of base resistor R. The median value for this resistance will be around 3K ohms. The zero-signal total collector current in the class-B output stage is 1.0 ma and the maximum-signal total collector current 550 ma. The relatively high currents demanded by the 2N68 necessitate that transformer  $T_2$  be able to handle 100 ma and  $T_3$  550 ma.

# CHAPTER 3

## Transistorized Oscillators

### 3.1 Single-Frequency Sine-Wave Oscillator.

Figure 3-1 shows the circuit of a simple, single-frequency sine-wave oscillator which is useful as a general-purpose tone source, impedance bridge generator, audio signal injector, or modulator. An advantage of this particular circuit is its ability to operate without a tapped transformer and without a separate feedback

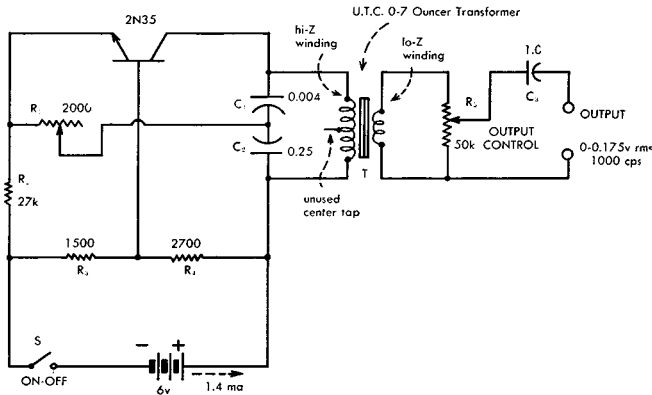

FIGURE 3-1—Single-Frequency Sine-Wave Oscillator.

winding. This makes possible the use of one winding of transformer T in the frequency-determining tank circuit and the other winding for output coupling.

The capacitance values shown for  $C_1$  and  $C_2$  give a frequency of 1000 cycles when the specified transformer is used. The frequency may be varied over a 1.5/1 range by varying  $C_1$  while

holding  $C_2$  constant at the capacitance shown, and over a wider range by varying both  $C_1$  and  $C_2$  but keeping their capacitances in approximately the same 60:1 ratio.

Open-circuit rms output voltage is 0 to 0.175 v with the 6-volt d-c supply, depending upon the setting of the output control,  $R_5$ . Control  $R_1$  is adjusted for the best sine-wave output, viewed with an oscilloscope, as evidenced by absence of negative-peak pointing.

The oscillator can be built into a  $6\frac{1}{2}'' \times 3\frac{1}{2}'' \times 2\frac{1}{4}''$  metal box at the bottom of which is strapped the flat 6-volt battery (Burgess Type 5540).

Although this oscillator has relatively low output, it will be found adequate for most single-frequency purposes. Its good stability and clean waveform suit it very well for use as an impedance bridge generator, in which application its low output may be compensated by using a high-gain bridge null detector of the type described in Section 5.5, Chapter 5.

### 3.2 Self-Excited 100-KC Oscillator.

BATTERY VOLTAGE	D-C DRAIN	R-F OUT-PUT
1.5v	250 $\mu$ a	0.92v rms (open-circuit)
3	320	1.35
4.5	340	1.52
6	370	1.77

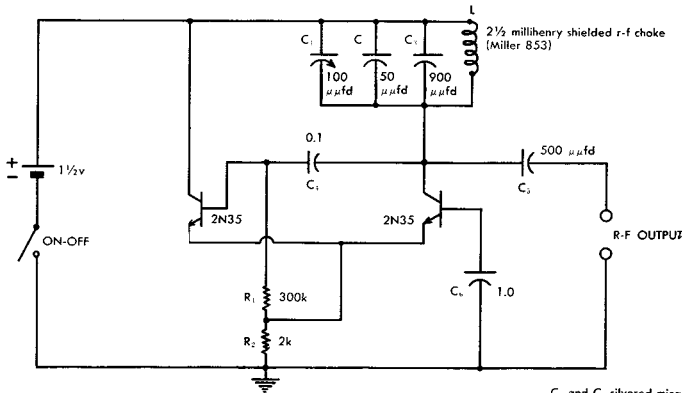

FIGURE 3-2—Self-Excited 100-KC Oscillator.

Where a simple inexpensive, but stable 100-kc standard-frequency oscillator is required, the circuit shown in Figure 3-2 is recommended. This circuit employs two transistors in an emitter-

coupled positive feedback circuit and was developed according to the original design suggested by Alexander. (See *Transistors Use Emitter-Coupled Feedback*. Frank C. Alexander, Jr. *ELECTRONICS*, December 1954, p. 188.)

The tuned circuit is composed of the shielded  $2\frac{1}{2}$ -millihenry r-f choke (L) and capacitors  $C_1$  to  $C_3$  in parallel. Capacitor  $C_1$  is a small air trimmer used to set the oscillator frequency precisely to 100 kc with the aid of WWV signals. An alternative tuning arrangement would be a slug-tuned choke in parallel with a single 1000-uufd silvered mica capacitor.

Reactive loads tend to detune the oscillator, since the high output terminal is connected through coupling capacitor  $C_5$  to one side of the tuned circuit. In most frequency standardizing applications, however, a radiated signal is used instead of direct coupling to the oscillator.

The Table in Figure 3-2 shows open-circuit rms r-f output voltages obtained from the oscillator with various values of d-c supply voltage between 1.5 and 6 volts.

### 3.3 100-KC Crystal Oscillator.

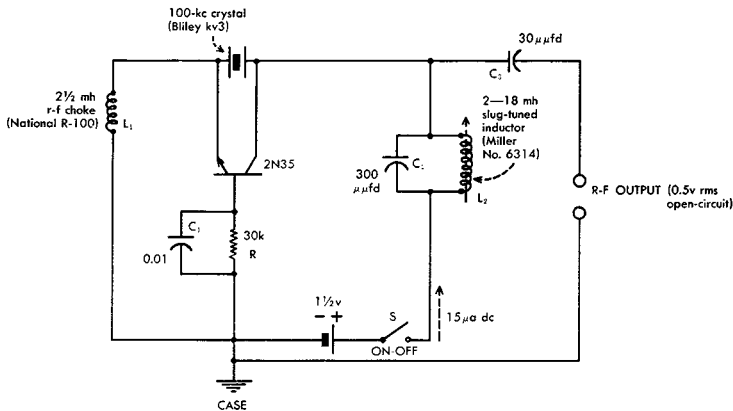

FIGURE 3-3—100-KC Crystal Oscillator.

Where the highest obtainable accuracy and stability are required in a frequency standard, a crystal-controlled oscillator is dictated. Low-frequency transistor oscillators lend themselves readily to crystal control.

Figure 3-3 is the circuit of a simple, low-power-drain, 100-kc crystal-type standard-frequency oscillator. A single transistor



is employed in a common-base, base-biased circuit. Tuning is accomplished by means of the slug-tuned inductor,  $L_2$ , which is shunted by a 300-uufd silvered mica capacitor,  $C_2$ . The resistance of  $R_2$  must be selected for quick-starting oscillation with the individual transistor used. Its value will be close to the 30,000 ohms shown in Figure 3-3. The 100-kc crystal is a small, Bliley Type KV3.

The r-f output of the unit measured with a VTVM is approximately 0.5 v rms. A 2000-ohm load reduces this to 0.1 v rms. Short-circuiting the output coupling capacitor,  $C_3$ , raises the output voltage to 1 volt rms. The low d-c drain of 15 microamperes makes use of a penlight cell entirely feasible. At this low drain, the ON-OFF switch, S, may be eliminated entirely and the oscillator allowed to run continuously with long battery life. On a continuous run of this kind, a mercury cell will last several years.

### 3.4 Code-Practice Oscillator.

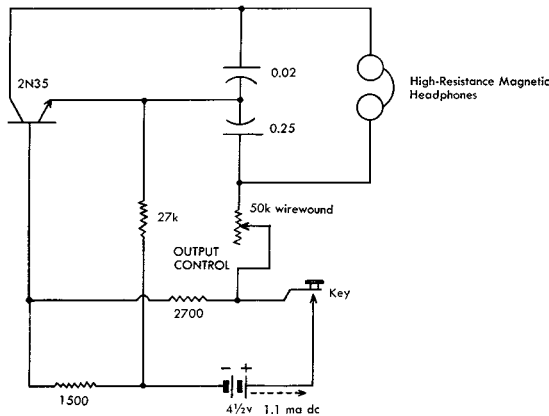

FIGURE 3-4—Code-Practice Oscillator.

Figure 3-4 is the circuit of a simple code-practice oscillator which requires no coils or transformers. The headphones themselves supply the required inductance. This arrangement will be recognized as the same type of circuit shown previously in Figure 3-1. *Magnetic* headphones are necessary in this oscillator, since the transistor collector current must flow through them. No ON-OFF switch is needed, since no voltage reaches the circuit until the key is depressed.

The two capacitance values shown in Figure 3-4 give a frequency of approximately 700 cycles when a pair of Trimm 2000-ohm headphones are in the circuit. This frequency may be changed to suit the ear by selecting other capacitances, as explained in Section 3.1.

This oscillator follows rapid keying, giving smooth response without sharp transients. The low, intermittent current drain of 1.1 ma enables the use of three series-connected flashlight cells with good economy.

### 3.5 Multivibrator.

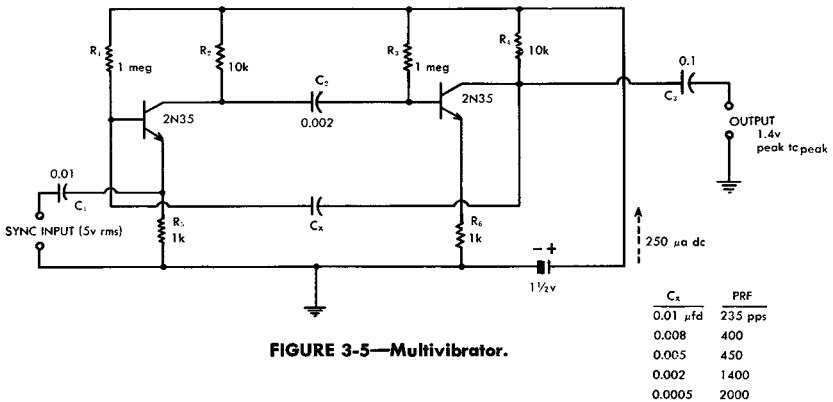

FIGURE 3-5—Multivibrator.

A 2-transistor multivibrator having a rectangular output waveform is shown in Figure 3-5. With a d-c supply voltage of  $1\frac{1}{2}$  v at  $250 \mu$ a, the open-circuit output is 1.4 v peak-to-peak.

Positive synchronization is obtained by means of a 5-volt rms signal applied to the SYNC INPUT terminals. Synchronization is obtained readily at the natural frequency ( $f$ ) of the multivibrator,  $\frac{1}{2}f$ ,  $2f$ , etc. up to  $10f$ .

The circuit is seen to consist of an RC-coupled transistor amplifier with feedback supplied through capacitor  $C_x$ . The Table in Figure 3-5 shows pulse repetition frequencies obtained with various values of  $C_x$  when  $C_2$  is maintained at 0.002 ufd. Capacitors  $C_2$  and  $C_x$  also may have identical values and may be changed simultaneously, as is common in most tube-type multivibrators. Conventional junction transistors will permit assured multivibrator operation at frequencies as high as 200 to 300 kc, either in the free-running or the synchronized state.

# CHAPTER 4

## Transistorized Control Devices

### 4.1 Sensitive DC Relay.

In the circuit shown in Figure 4-1, a d-c input signal current of only 20 microamperes will cause a milliampere-type relay to close. The required current gain of 50 is supplied by a single transistor in the common-emitter connection. Individual transistors will supply current gains (beta) even greater than this value, but amplifications of 40 to 50 are typical.

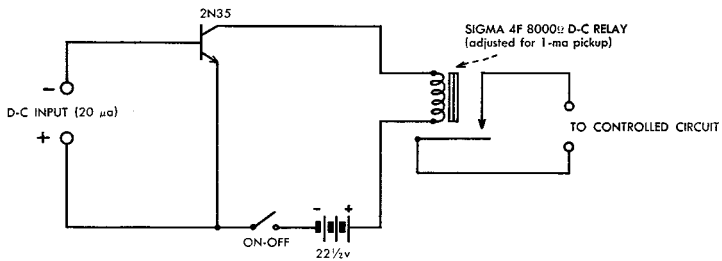

FIGURE 4-1—Sensitive DC Relay.

The relay, a Sigma Type 4F, is an 8000-ohm unit. It is supplied normally for 2-ma closure. However, 1-ma pickup may be obtained easily by rotating its spring-tension screw counter-clockwise for more sensitive response. If the relay is not readjusted in this manner, a 60-microampere input current to the transistor will close the relay. The use of a Burgess Type W30 battery (a tapped 45-22½ volt unit) provides two 22½ volt sections which may be used successively to insure long service.

## 4.2 Sensitive R-F Relay.

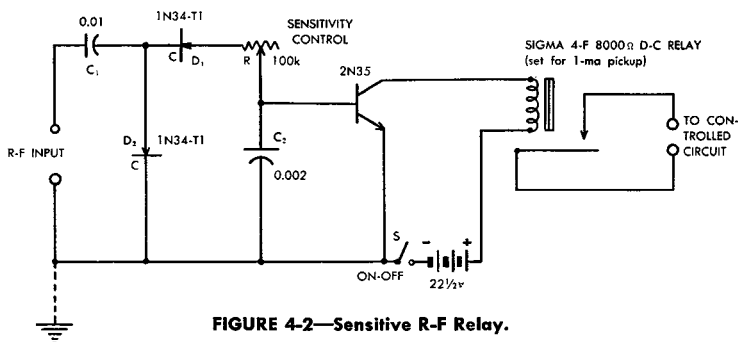

FIGURE 4-2—Sensitive R-F Relay.

A germanium diode rectifier may be added to the sensitive d-c relay shown in Figure 4-1 to enable its operation on AC and RF signals up to 200 mc.

Figure 4-2 shows the complete circuit with a shunt diode detector circuit composed of diodes  $D_1$  and  $D_2$ , capacitors  $C_1$  and  $C_2$ , and rheostat  $R$ . The input coupling capacitor,  $C_1$ , isolates the diodes and transistor from any DC component which might be present in the RF source. Capacitor  $C_2$  forms an RF filter with the sensitivity control,  $R$ .

Negative d-c output from the diode circuit is applied to the base of the transistor. This causes an increase in collector current. An increase of 1 milliamperere will close the relay. Sensitivity control,  $R$ , is included in the circuit for reduction of sensitivity when high r-f signal levels are encountered. Only 20 microamperes of d-c output from the detector circuit are required for closure of the relay. The relay may be set for 1-ma pickup by slight rotation of its spring-tension screw counterclockwise.

## 4.3 Photo Timer.

Tube-type electronic timers, especially those used for timing the light in photographic enlargers and printing boxes, are well known. Figure 4-3 shows the circuit of a transistorized timer.

This circuit embraces the d-c amplifier-type of relay pre-

viously described in Sections 4.1 and 4.2, and the relay is adjusted for 1-ma closure as explained in Section 4.1.

Referring to Figure 4-3, switch  $S_1$  normally is in its B position. When it is thrown momentarily to position A, the 1000-microfarad electrolytic capacitor, C, charges from the  $1\frac{1}{2}$ -volt cell. When  $S_1$  then is thrown back to position B, the capacitor voltage supplies

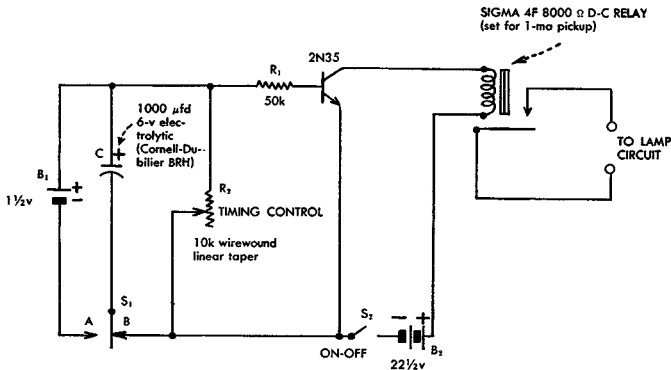

FIGURE 4-3—Photo Timer.

current to the transistor which closes the relay. The capacitor then discharges through the transistor input path and rheostat  $R_2$ . At some later instant, determined by the setting of  $R_2$ , the capacitor has discharged to a point low enough for the relay to open.

The 1000-ufd capacitor and 10,000-ohm timing control provide time intervals from 1 to 30 seconds. Longer intervals can be obtained by using a higher resistance at  $R_2$ . A special calibration must be made for the scale or dial of  $R_2$ . This may be done by timing the relay intervals with an accurate stop watch or other timer, and is necessary because the relay closure interval is not exactly the RC time constant of C and  $R_2$ . Otherwise, the time delay might be calculated with sufficient accuracy.

Resistor  $R_1$  is for current limiting, since the fully-charged capacitor will supply excessive current to the transistor d-c amplifier circuit.

The Sigma 4F relay is adjusted for 1-ma pickup according to instructions given in Section 4.1.

## 4.4 Photoelectric Counter.

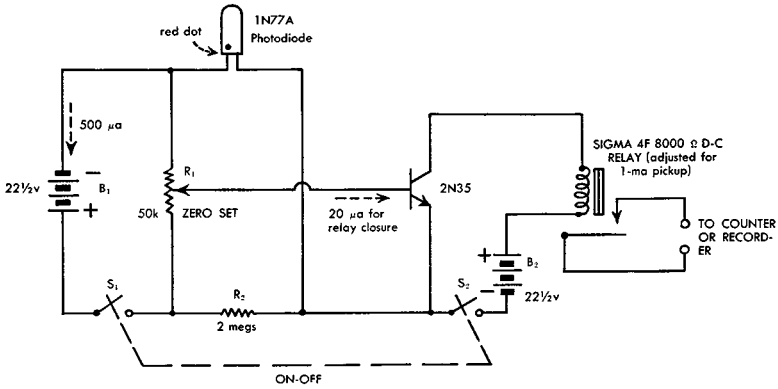

FIGURE 4-4—Photoelectric Counter.

A further application of the d-c amplifier-type of relay is the photoelectric counter shown in Figure 4-4.

In this circuit, the 20-ua current required to operate the transistor relay circuit is supplied by a photoelectric circuit. The light-sensitive circuit is comprised by a Sylvania Type 1N77A germanium junction photodiode in a 4-arm resistance bridge. The bridge arms consist of the photodiode back resistance, resistor  $R_2$ , and the two sections of potentiometer winding  $R_1$  on each side of the slider. The bridge supply voltage is battery  $B_1$ . With the photodiode darkened, this bridge is nulled by adjusting  $R_1$ . Under this condition, the transistor input current is zero. When the photodiode subsequently is illuminated, its resistance changes, the bridge is unbalanced, and current flows into the transistor picking up the relay.

Maximum-signal current drain from the batteries are:  $B_1$  ( $22\frac{1}{2}$  v) 500 ua, and  $B_2$  ( $22\frac{1}{2}$  v) 1 ma. Light sensitivity is such that 70 foot candles at the photodiode will cause the relay to close.

# CHAPTER 5

## Transistorized Instruments

### 5.1 Simple DC Microammeter.

The high value of current amplification (beta) of the common-emitter circuit makes possible a simple, amplifier-type d-c microammeter employing a more rugged, less expensive milliammeter as the indicator. In this unit, a jumbo size flashlight cell is secured to the bottom of the case with a phosphor bronze strap—the transistor is mounted by soldering its pigtailed to the tie points of a 3 lug insulated terminal strip.

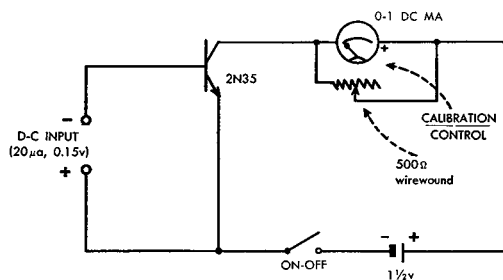

FIGURE 5-1—Simple D-C Microammeter.

Figure 5-1 shows the circuit of a d-c microammeter employing this principle. In this instrument, a d-c input of 20 microamperes (0.15 v) produces full-scale deflection of the 0-1 d-c milliammeter. This corresponds to a beta of 50 which is not hard to obtain in Type 2N34 and 2N35 transistors. Higher amplification values often are obtained in selected units.

The steady no-signal deflection of the meter, due to  $I_{CO}$ , is small. Where it happens to be too large to be ignored, the meter

may be set initially to zero by means of the mechanical zero-set screw.

To adjust the instrument initially, apply an accurately-known current of 20 microamperes to the d-c INPUT terminals, and set the calibration control rheostat for full-scale deflection of the meter.

## 5.2 DC Microammeter with Zero-Set Circuit.

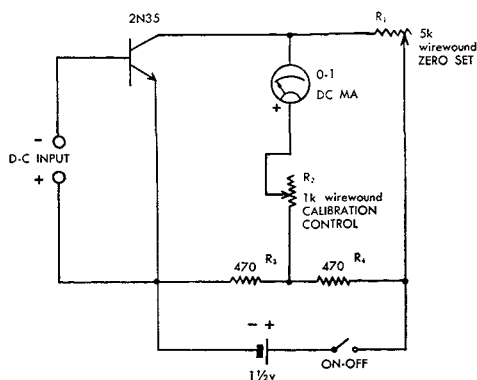

FIGURE 5-2—DC Microammeter with Zero-Set Circuit.

Sensitivity of the d-c microammeter circuit shown in Figure 5-1 and described in Section 5.1 can be increased by changing the indicating meter from a millimeter to a micrometer. However, when this is done, the meter will be deflected full-scale or very nearly so by the static collector current ( $I_{CO}$ ) under no-signal conditions. The meter cannot be zeroed mechanically in the presence of such a large current.

In order to set the meter *electrically* to zero, a bridge-type balancing circuit, similar to those employed in vacuum-tube voltmeters, may be used. This balancing circuit also is useful when a millimeter is used with static current too high to be bucked-out mechanically. Figure 5-2 shows how the balancing circuit is added to the simple microammeter circuit. While a 0-1 d-c millimeter is shown here, a d-c microammeter also can be used. The 4-arm bridge is comprised by the transistor internal collector resistance, rheostat  $R_1$ , and the two 470-ohm resistors



$R_3$  and  $R_4$ . With no input signal, and with the d-c INPUT terminals open, the bridge is balanced (meter zeroed) by adjustment of  $R_1$ . The input d-c signal is applied and the calibration control,  $R_2$ , adjusted for full-scale deflection. The signal then is removed and the meter re-zeroed, if necessary. The calibration signal again is applied and  $R_2$  set for full-scale deflection of the meter. Finally, the signal is removed and  $R_1$  adjusted for meter zero. Jockeying back and forth between the two adjustments will finally give no-signal meter zero and exact full-scale deflection with the signal.

### 5.3 Electronic DC Voltmeter.

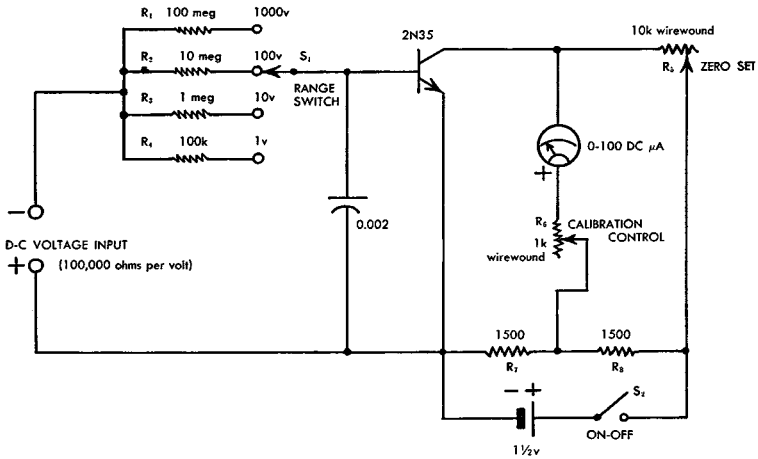

FIGURE 5-3—Electronic DC Voltmeter.

The transistor amplifier-type d-c microammeter may be converted into an electronic voltmeter by the addition of suitable multiplier resistors to the input circuit. This instrument is the transistor counterpart of the vacuum-tube voltmeter and has similar advantages.

Figure 5-3 is the circuit of a transistor-type electronic d-c voltmeter. In this instance, the transistor circuit with a 0-100 d-c microammeter as the indicator has an input-current sensitivity of 10 microamperes d-c for full-scale deflection of the meter. This current range provides a voltmeter sensitivity of 100,000 ohms per volt, which gives the instrument the same input

resistance as most v-t voltmeters on the 10-volt range, and higher input resistance on all higher-voltage ranges.

The current amplifier portion of the circuit will be recognized as the same type shown for the zero-balanced microammeter in Figure 5-2, except for different resistance values for the bridge constants  $R_5$ ,  $R_7$ , and  $R_8$ .

Basic ranges of the instrument are 1, 10, 100, and 1000 volts d-c which may be read on the scale of the 0-100 d-c microammeter. Other ranges may be added by providing the proper multiplier resistors in connection with the voltage range switch,  $S_1$ .

Calibration is carried out in the following manner: (1) Switch-on instrument. (2) With the input terminals open, adjust the meter to zero with control  $R_5$ . (3) Set range switch  $S_1$  to its 10-volt position. (4) Apply an accurately-known potential of 10 volts pure d-c to the input terminals and adjust calibration control  $R_6$  for exact full-scale deflection of the meter. (5) Remove the input-signal voltage and re-set meter zero, if necessary. (6) Reapply the input voltage and adjust  $R_6$  for full-scale deflection, if necessary. (7) Jockey back and forth between the adjustments of  $R_5$  and  $R_6$  until full-scale deflection is obtained upon application of the 10-volt input signal, and the meter returns to zero when the signal is removed.

## **5.4 Sensitive Light Meter with Rugged Indicator.**

Most sensitive light meters necessarily employ delicate microammeters for indicators. By using a transistorized d-c amplifier, a light meter may utilize a more rugged and less expensive milliammeter instead.

Figure 5-4 shows the circuit of such an instrument. This is a combination of the 1N77A photodiode bridge shown previously in Figure 4-4, Chapter 4, and the simple amplifier-type d-c microammeter of the type shown in Figure 5-1. Illumination of 70 foot candles will deflect the 0-1 milliammeter to full scale. Better sensitivity can be obtained by using a d-c microammeter in place of the milliammeter.

Initial adjustment procedure consists of the following steps: (1) Darken the photodiode and switch-on the instrument. (2)

Set the bridge-balance potentiometer,  $R_1$ , for minimum deflection of the meter. (3) Illuminate the photodiode with 70 foot candles of light and adjust the calibration control,  $R_3$ , for exact full-scale deflection of the meter.

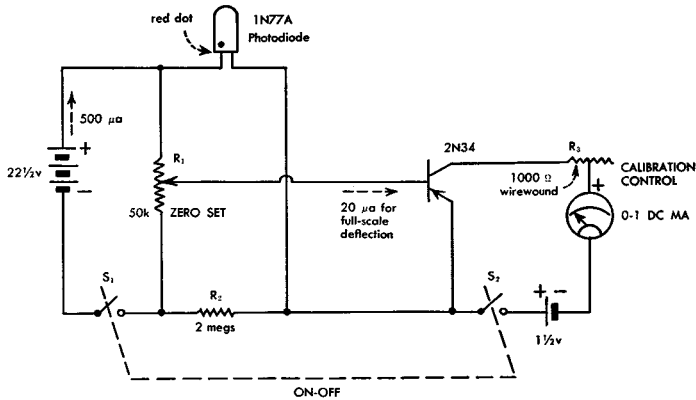

FIGURE 5-4—Sensitive Light Meter with Rugged Indicator.

This instrument is built in a 5" x 4" x 3" metal box. The tiny 1N77A photodiode comes with built-in lens and is mounted in the tip of the probe made from the case of a plastic mechanical pencil. The probe is connected to the input plug with a short length of flexible concentric cable. This arrangement was used for checking the brilliance of illuminated figures and graduations on aircraft instrument dials. The dpst ON-OFF switch,  $S_1$ - $S_2$ , is mounted to the left of the input plug; the calibration control rheostat,  $R_3$ , to the right. The latter is provided with a slotted shaft for screwdriver adjustment and with a shaft-lock nut.

## 5.5 Bridge Null Detector (Peaked 1000-Cycle Amplifier).

A selective bandpass audio amplifier is advantageous as a bridge null detector when followed by an indicating meter. It is invaluable also to have this type of instrument battery-operated to provide complete isolation from the power line.

The transistorized circuit in Figure 5-5 offers both of these advantages. Selectivity is obtained by means of parallel resonant circuits ( $L_1-C_3$  and  $L_2-C_7$ ) in the output circuit of each transistor amplifier stage. Inductors  $L_1$  and  $L_2$  are small, tunable 5-henry units (U. T. C. Type VIC-15). When tuned to 1000 cycles, the amplifier offers 20 db attenuation to 500 and 2000 cycles and somewhat higher attenuation to frequencies beyond these two octaves.

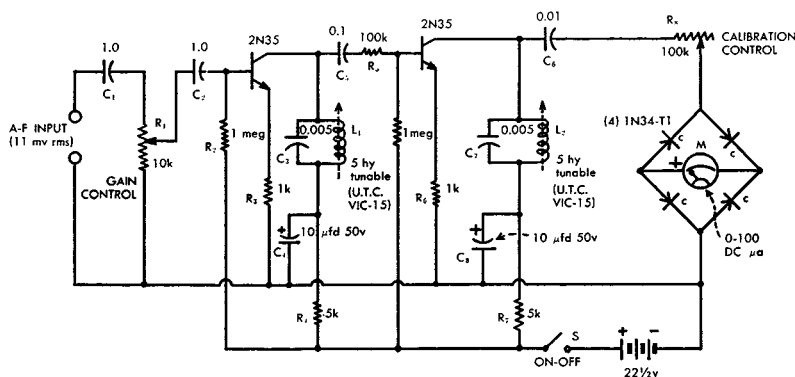

FIGURE 5-5—Bridge Null Detector (Peaked 1000 Amplifier)

With gain control  $R_1$  set for maximum gain, an 11-millivolt rms, 1000-cycle signal will deflect the microammeter,  $M$ , to full scale. This represents an overall voltage gain of 636, since the rms output voltage at the collector of the second transistor is 7 volts. Measured input impedance at 1000 cycles is 7800 ohms. This can be improved by adding a common-collector transistor amplifier as the input stage. Total current drain is 3.4 ma d-c.

The instrument essentially is a 2-stage tuned 1000-cycle amplifier driving a rectifier-type voltmeter. The voltmeter consists of the 0-100 d-c microammeter ( $M$ ), the bridge rectifier comprised by four 1N34-T1 germanium diodes, and multiplier resistor  $R_3$ . The isolating capacitor,  $C_6$ , protects the diodes and meter from the collector voltage. Gain stabilization and increased input impedance are provided by the emitter degeneration resistors,  $R_3$  and  $R_6$ .

To adjust the amplifier initially: (1) Throw switch  $S$  to its ON position. (2) Set control  $R_3$  to maximum resistance. (3) Set

gain control  $R_1$  for maximum gain. (4) Apply a low-level 1000-cycle signal voltage to the A-F INPUT terminals. (5) If meter M is not deflected, carefully reduce the setting of  $R_8$  until deflection is obtained in the first quarter of the meter scale. (6) With an Allen wrench, tune  $L_2$  and then  $L_1$  for peak deflection of the meter, reducing  $R_1$  or increasing  $R_8$ , or both, if the meter is driven off scale. (7) After amplifiers are peaked sharply, adjust the input signal exactly to 11 millivolts rms, set control  $R_1$  for maximum gain, and set control  $R_8$  for exact full-scale deflection of the meter.

## 5.6 Keying Monitor.

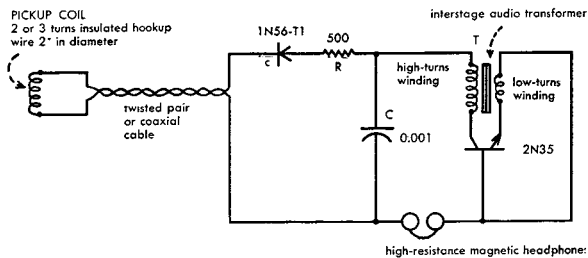

FIGURE 5-6—CW Keying Monitor.

The CW monitor circuit shown in Figure 5-6 utilizes the ability of the junction transistor to oscillate with very low levels of d-c supply voltage.

In this instance, the d-c is supplied by diode rectification of the keyed cw carrier. Radio-frequency carrier energy is picked up from the transmitter by a small coil consisting of 2 or 3 turns of insulated hookup wire 2 inches or so in diameter. Since the transistor requires such a small amount of d-c supply power (a few microwatts) in order to oscillate, the coupling coil need not be placed dangerously close to the live parts of the transmitter in order to obtain sufficient signal pickup.

When the pickup coil is energized, the high-current 1N56-T1 germanium diode applies negative d-c voltage to the collector of the transistor, through the RF filter (RC). The transformer-feedback circuit then oscillates, generating an audio-frequency tone in the headphones. This happens each time the key is depressed.

Any convenient interstage audio transformer having a turns ratio of 2:1 or 3:1 will operate in the circuit. An Ouncer or Sub-ouncer type may be used in miniature instruments. If the circuit does not oscillate readily, the transformer probably is not phased correctly for regenerative feedback. Reversal of *either* the primary or secondary connections will correct this trouble. The natural oscillation frequency will depend largely upon the inductance of the high-turns winding and its self-capacitance. This frequency may be lowered by connecting a capacitor in parallel with this winding.

## 5.7 Field Strength Meter.

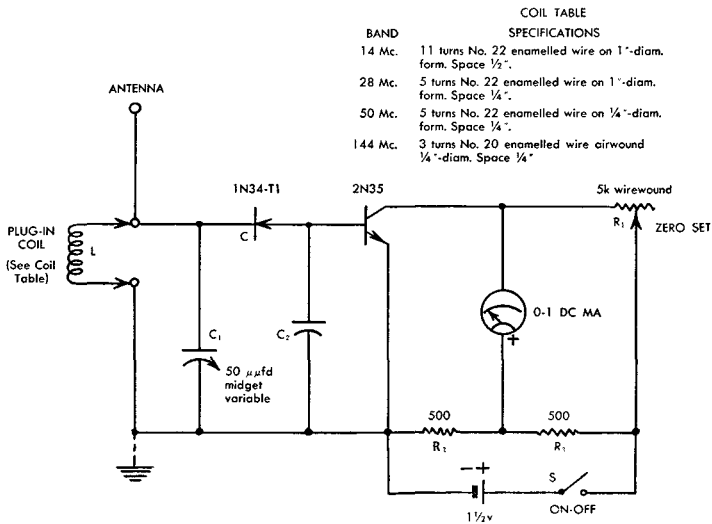

FIGURE 5-7—Field Strength Meter.

Figure 5-7 shows the circuit of a field strength meter which combines a zero-adjusted, amplifier-type DC microammeter of the type described in Section 5.2 and a tuned diode detector.

This instrument has been designed for the amateur 2-, 6-, 10-, and 20-meter bands where it will be useful in the adjustment and measurement of directional antennas, but it may be adapted also to other frequencies by means of suitable additional plug-in coils.

Four plug-in coils cover the amateur bands from 2 to 20 meters. These coils are wound according to specifications given in the COIL TABLE in Figure 5-7. The 14- and 28-mc coils are wound directly on 1-inch-diameter plug-in coils forms (National XR-1). The other two coils are wound on smaller forms and then inserted into 1-inch-diameter plug-in forms for easy handling.

Use of the instrument is simple: (1) Switch-on the d-c supply. Plug-in the coil required for the frequency of interest. (2) Set the meter to zero by adjustment of control  $R_1$ . (3) Attach a short length of busbar or other stiff wire to the antenna terminal and tune-in the signal, noting the meter deflection. Under signal pickup, the diode rectifies the RF energy and delivers a negative d-c voltage to the base of the transistor. The resulting base current is amplified in the transistor and deflects the milliammeter.

A signal of only 100 to 200 millivolts RF will deflect the meter to full scale. This sensitivity is a distinct advantage, since it permits use of very low transmitter power while making antenna adjustments and thus reduces interference. The requirement of only  $1\frac{1}{2}$  volt d-c supply, which can be secured from a flashlight cell, makes an extremely portable instrument for field use and for tracing TV interference.

If high accuracy and direct meter readings in microvolts are desired, an individual calibration of the field strength meter must be made with a microvolt-calibrated RF signal generator. This is necessary, since response of the diode is square law, but not necessarily exactly so, at the low signal levels involved.

---

**For Quality and Dependability**  
**Always Specify**  
**SYLVANIA**



---

---

## SYLVANIA TRANSISTORS

Sylvania Transistors are hermetically sealed against any possible deteriorating effects of moisture or humidity. Long flexible leads are adaptable for solder connections or may be clipped for plug-in applications. Pin dimensions and electrical characteristics are standardized for interchangeability.

**2N34**—PNP Junction type general purpose amplifier for high gain, low power, low frequency applications.

**2N35**—NPN Junction type for general purpose use in the audio to low frequency range.

**2N68**—PNP Junction type for general purpose high power, low frequency applications. Intended for high current, low voltage operation from 6.0 to 24 V batteries. Single unit will deliver up to 750 mw of output (class AO or up to 10 W per class B pair).

**2N94, 2N94A**—NPN Junction type for use in high-frequency amplifier, oscillator and computer applications.

**2N95, 2N102**—NPN Junction type for general purpose, high power applications similar to those of 2N68.



# SYLVANIA TRANSISTORS—Ratings and Characteristics

## RATINGS (Max.)

TYPES ▶	2N34	2N35	2N68	2N94, 2N94A	2N95	2N101	2N102
Basing	Polarized	3-pin	.....	.....	.....	.....	.....
Max. Dissipation (25°C) <sup>1</sup>	50 mw	50 mw	2.5 w Free Air 4.0 w Heat Sink <sup>2</sup>	30 mw	2.5 w Free Air 4.0 w Heat Sink <sup>2</sup>	1.0 w Free Air 4.0 w Heat Sink <sup>2</sup>	1.0 w Free Air 4.0 w Heat Sink <sup>2</sup>
Collector Voltage (V. max.) <sup>3</sup>	—25	25	—25	20	25	25	25
Collector Current (ma. max.)	—10	10	—1500	5 ma.	—1500	—1500	—1500
Ambient Temperature (max.)	50°C	50°C	Derate allowable dissipation to zero @ 70°C.				

## TYPICAL CHARACTERISTICS

	CONDITIONS:					Without Fins
	V <sub>c</sub> = —6 V I <sub>e</sub> = 1.0 ma.	V <sub>c</sub> = 6 V I <sub>e</sub> = —1 ma.	V <sub>c</sub> = 6 V I <sub>e</sub> = 50 ma.	V <sub>c</sub> = 6 V I <sub>e</sub> = —50 ma.	V <sub>c</sub> = 6 V I <sub>e</sub> = —50 ma.	
Current Gain, Emitter to Collector ( $\alpha$ )	0.975	0.975	0.975	0.975	0.975	Electrically identical to 2N68 Electrically identical to 2N95
Current Gain, Base to Emitter ( $\beta$ )	40	40	40	40	40	
Emitter Resistance (R <sub>e</sub> ) $\Omega$	30	30	1	52	1	
Base Resistance (R <sub>b</sub> )	400	600	30	R <sub>b</sub> <sup>1</sup> = 150	30	
Collector Resistance (R <sub>c</sub> ) $\Omega$	1.5 meg.	2.0 meg.	100,000	2.0 meg.	100,000	
Alpha Cut-off Frequency K <sub>c</sub>	600	900	400	3 Mc—2N94 6 Mc—2N94A	400	
Collector Capacitance (C <sub>c</sub> ) $\mu\mu\text{f}$	50	40	300	10	300	
Collector Cut-off Current (I <sub>co</sub> ) $\mu\text{a}$	10 (0.5 V)	10 (0.5 V)	100 (10 V)	3	100 (10 V)	
Noise Figure (N.F.) db	25	20	.....	15	.....	

Typical Small Signal Parameters (25°C). Collector connected to shell on 2N68, 2N95, 2N101 and 2N102.

<sup>1</sup>Derate 1 Mw per °C increase in ambient temperature.

<sup>2</sup>Aluminum chassis  $\frac{1}{16}$ " x 25 sq. in. or equivalent.

<sup>3</sup>Collector to base. (Collector to emitter 25 max.)