

PHILCO

TECHREP
DIVISION
BULLETIN



NOVEMBER
1952

PHILCO TECHREP DIVISION BULLETIN

Published Monthly by
The TechRep Division of Philco Corporation
Philadelphia, Pennsylvania

Volume II

NOVEMBER, 1952

Number 11

CONTENTS

Editorial	3
<i>By John E. Remich</i>	
Electronic Computers—Part I	4
<i>By Warren Kitter</i>	
Modifying the SCR-211 (*) to Provide a Frequency-Shifted Test Signal	8
<i>By Marvin Rosenbluth</i>	
Some Pointers on Frame-Type Building Construction	10
<i>By Carl W. Eastman</i>	
The Use of Non-Magnetic Tools in the Vicinity of a Magnetron	17
Radar Antenna Systems	18
<i>By Merle E. McDougall</i>	
What's Your Answer?	38
Solution to Last Month's "What's Your Answer?"	38
A Simple, Easily Constructed Unit for Pre-Flight Checking of Airborne IFF Transponders ..	39
In Coming Issues	40

Editor
John E. Remich

Managing Editor
Robert L. Gish

Technical Editors
Frederick S. Mohr
Francis R. Sherman
Gail W. Woodward

**EDITORIAL OFFICE:
PHILCO CORPORATION
TECHREP DIVISION
22nd and LEHIGH AVENUE
PHILADELPHIA 32, PA.**

If any information contained herein conflicts with a technical order, manual, or other official publication of the U.S. Armed Forces, the information in the official publication should be used.



Photo courtesy of Remington Rand, Inc. (Eckert-Mauchly Div.)

The UNIVAC — The first electronic digital computer capable of handling both alphabetical and numerical data to reach full-scale operation. (It passed acceptance tests in March, 1951, and was immediately placed in operation by the Bureau of the Census.) For further data on electronic computers, see page 4.

Editorial

The Mounting Cost

by John E. Remich

Manager, Technical Department

Looking back to the early days of World War II one remembers that relatively little importance was attached to the role of the electronic equipment installed in the aircraft of that date. There were many closely associated with flying who felt that the electronic devices were gadgets which should be eliminated in favor of heavier armament or a heavier bomb load, and the total expenditure for all electrical and electronic equipment represented only a small fraction of the overall cost of the aircraft.

Simple as it was, the performance of this equipment was so outstanding that soon pilots were reluctant to fly unless all of their electronic equipment was operating satisfactorily. More and more possibilities were seen for the use of electronics, until the war plane of today contains a variety of equipment which represents approximately 50% of the total cost of the aircraft.

Certainly, the demand for highly capable engineers and technicians can be expected to follow the same course of expansion, and the need for efficient training of many thousands of additional personnel is inevitable. We are in the midst of an age of electronic miracles, but the cost is high—therefore, each of us in the Philco Field Engineering program should do everything possible to improve, accelerate, and make more efficient the training of the personnel who maintain and operate the complex war machines which the present world situation has forced us to build.

ELECTRONIC COMPUTERS PART I

Introduction

By Warren Kitter

Technical Publications Department

The first article of a series discussing electronic computers. This article deals with the binary system of mathematical notation.

MODERN ELECTRONIC COMPUTERS are gigantic multi-tube monsters using as many as 18,000 vacuum tubes and capable of adding and subtracting as many as 1900 eleven-digit numbers per second. However, when analyzed, any computer is found to be composed of various combinations of basic circuits or, as they are sometimes called, elementary potential digital computing components (EPDCC). An EPDCC is defined as a circuit which may assume any one of a number of predetermined stable states, and in the process of changing its state can bring about a change in the state of other components or EPDCC's. It is not necessary to have a Ph. D. from M.I.T. in order to understand the operation of computer circuits, as the underlying theory is not so difficult as may be supposed. Computer circuits utilize pulse techniques and circuits which are surprisingly similar to those used in radar systems, but have the advantage of requiring few circuits

that operate at high radio frequencies (this also simplifies trouble shooting). With the increasing use of electronic computers in modern commerce and industry, it is to the advantage of workers in the electronic field to acquire at least a friendly acquaintanceship with these "super brains."

BASIC COMPUTER

An extremely simplified block diagram of a typical computer system is shown in figure 1. The computer itself is one part of a system consisting of an input, a memory, a central computer, and an output. The function of the input circuits is to receive information pertaining to a problem, and to convert that information into a predetermined series of coded pulses which are capable of energizing the EPDCC's. In order that a problem may be entered into the input system while the computer itself is solving an entirely different problem, it is de-

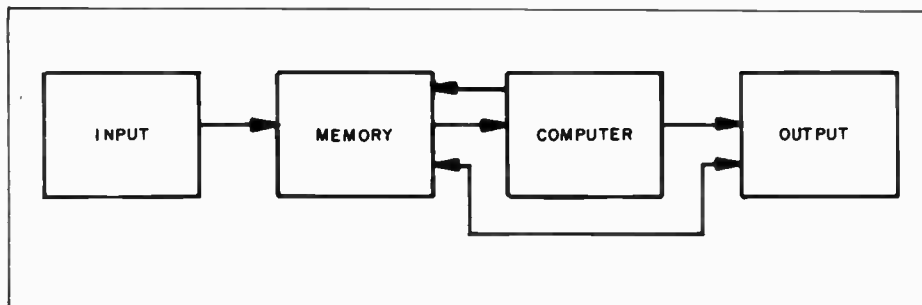

Figure 1. Block Diagram of Typical Basic Computer

sirable to store the input information for long periods of time. Therefore, a flexible computing system is used to record the coded pulses on some long-term storage device such as punched cards or magnetic tape. The memory circuits are designed to store both the coded pulses from the input system and the results of the computer calculations which must be held until a later stage in the solution of the problem. The output system converts the coded pulses into words and figures. It will be seen that pulses enter the output system from both the central computer and from the memory system, all being integrated into the final solution of the problem by controlling pulses from the central computer.

For the most part, computing circuits do not utilize tubes operating on the central portion of the E_k-I_p curve, but rather employ the two stable states of a vacuum tube: cutoff and saturation. Hence, no errors are introduced into the computation by changes in tube parameters with age. By far the most common type of EPDCC in use is the Eccles-Jordan multivibrator, or, as it is more familiarly known, the "flip-flop." The operation of individual circuits used in computers will be more fully covered in future articles. At present, suffice it to say that the flip-flop circuit utilizes two tubes, one of which is conducting heavily (saturated), and by its action holds the second tube at cutoff. A trigger pulse of the correct amplitude and polarity will reverse the condition of the circuit, so that the first tube is held at cutoff by the second tube, which conducts heavily.

BINARY NOTATION

At this point, we must digress from the actual circuit operation, and intro-

duce the mathematical concept of binary notation. An understanding of this subject is essential if the reader is to understand any of the "logic" behind computer operations. Like computer circuitry, this subject is not difficult but it has been a stumbling block to many workers in the computer field. As has previously been explained, computer circuits depend for the most part on flip-flop circuits which utilize the two stable states of a vacuum tube; therefore, if we utilize the binary (or two-digit) system of mathematical notation instead of the usual decimal (or 10-digit) system, it will enable the direct use of a series of cascade-connected flip-flop circuits to indicate any chosen number. The term "binary counter" refers to a counting circuit using the two-digit system.

The present decimal system of notation utilizes 10 figures, or digits, represented by the following symbols: 0, 1, 2, 3, 4, 5, 6, 7, 8, 9. To increase in numerical order from one whole number to the next consecutive whole number for numbers less than ten, it is only necessary to use the symbol of the next highest digit. Thus to advance one number higher than 3, we use the symbol 4. This process is continued until the highest digit in the series, or 9, is reached. At this point a rule is applied which has become so automatic that it is not ordinarily considered. Any number is assumed to be preceded by an infinite number of zeros. Thus, the number 9 can be written as 000000.....00000009. Note that this is not a decimal representation, as the infinite string of zeros in no manner changes the numerical value of the number. The rule for increasing the numerical progression beyond the limit of the highest digit used in that system states that the lowest digit in the series is substituted for the



WARREN M. KITTER, a native Philadelphian, was born on August 16, 1923. After graduating from high school, he attended the RCA Institute, in New York.

He was employed in the Emerson Radio Corporation Laboratories until he enlisted in the Army Air Force, in 1943. While in the Service, he

studied engineering at the University of Iowa, and later taught electronics at Chanute Field, Illinois.

After leaving the Armed Services, in 1946, he joined the Philco Tech-Rep Division as a Field Engineer, and was assigned to the Panama Canal Zone. There he helped set up a radio and radar training program for the Air Force. Mr. Kitter returned to the States in May, 1947, to enter Temple University, where he received the degree of Bachelor of Arts. He then joined the staff of the Eckert-Mauchly Computer Corporation, where he was engaged on a computer development project.

In 1952, Mr. Kitter returned to Philco, and was assigned to Headquarters as a writer in the Ground Electronics Equipment writing section of the Technical Publications Department.

highest digit and the digit immediately preceding it is increased by one. Thus, in the case of 000000009, the lowest digit in the decimal notation series (0) is substituted for the highest digit in the series (9) and the digit immediately preceding 9 (0) is increased to 1. Therefore, the representation of the number following 000000009 becomes 000000010. Advancement in this progression is again simple until 000000019 is reached. Here again the rule, which states that the highest digit is replaced by the lowest digit and the digit immediately preceding it is increased by one, is put into operation, and the next number in the series becomes 000000020, etc. When 000000099 is reached, the process is carried on in the same manner. The last 9 is changed to 0 and the 9 preceding it is increased by one. How-

ever, since 9 is the highest digit in the series, it is reduced to 0 and the digit preceding it is increased to 1; therefore, the representation of the number following 000000099 becomes 000000100.

To make it easier to refer to specific digits in a number, the *place* system is used. The place of a digit indicates its location with respect to the other digits. In any number, the digit at the right-hand end of the number is in the first place, and the remaining digits are numbered consecutively from right to left. For example 5382 is a four-place number in which 2 is in the first place, 8 is in the second place, 3 is in the third place, and 5 is in the fourth place. (The term *place* is sometimes called *order*—such as: first order, second order, etc. The numerical sequence is the same as that used in the place system.)

Binary notation follows the same general pattern found in the decimal system, with the exception that only two symbols (0 and 1) are used. Zero is represented by an infinite string of zeros, as 0000000.....0000000, and one is represented by the digit 1 preceded by an infinite string of zeros, as 0000000.....00000001. The question now is how to represent the number two in the binary system. The answer is derived from applying the rule for advancing from one number to the next in a series of numbers. Change the 1, which is the highest digit in the binary system, to the lowest digit, which is 0, and increase the digit in the next place by one. In this way the number two is represented by 0000010, three by 0000011, four by 0000100, five by 0000101, six by 0000110, seven by 0000111, eight by 0001000, and nine by 0001001. Using this method any number can be represented by a predetermined series consisting of only two symbols.

Another approach to binary notation is to observe that the first place of a binary number has a value of one, and that each place to the left progressively doubles in value as shown in the following example. (In other words, each place denotes a power of two, beginning with the zero power of two at the first place.)

PLACE	8	7	6	5	4	3	2	1
POWER OF 2	2 ⁷	2 ⁶	2 ⁵	2 ⁴	2 ³	2 ²	2 ¹	2 ⁰
NUMERICAL VALUE OF PLACE	128	64	32	16	8	4	2	1

In determining the value of a binary number, it is only necessary to combine (add) the numerical values of the places that are represented by the digit 1. (Places represented by the digit 0 are ignored.) Using this approach, the binary number 0010110 indicates (reading from right to left):

NUMBER	0	0	1	0	1	1	0
POWER OF 2	2 ⁶	2 ⁵	2 ⁴	2 ³	2 ²	2 ¹	2 ⁰
NUMERICAL VALUE OF PLACE	0	0	16	0	4	2	0

Therefore, the total value of the number is $16 + 4 + 2 = 22$. If the same scheme is used, the value of the binary number 0011111 is quickly found as follows:

NUMBER	0	0	1	1	1	1	1
POWER OF 2	2 ⁶	2 ⁵	2 ⁴	2 ³	2 ²	2 ¹	2 ⁰
NUMERICAL VALUE OF PLACE	0	0	16	8	4	2	1

Thus, the combined value is $16 + 8 + 4 + 2 + 1$, or 31.

By this time readers should either understand binary notation or should be hopelessly confused. It wasn't very difficult; was it? In future installments, individual circuits will be investigated, and will then be assembled into a simple but workable computing system.

MODIFYING THE SCR-211(*) TO PROVIDE A FREQUENCY-SHIFTED TEST SIGNAL

By **Marvin Rosenbluth**
Philco Field Engineer

**An easily accomplished modification to enable use of
an SCR-211(*) frequency meter for testing the accuracy
of frequency-shift equipment.**

RADIO-TELETYPE COMMUNICATION by the Air Force is usually accomplished by means of a frequency-shifted radio carrier wave (F-1 emission) in the medium- and high-frequency bands. Frequency-shift radio teletype has the advantages of frequency modulation, and is, therefore, less vulnerable to noise and interference than would be an amplitude-modulated signal. Simplicity of modulation equipment and techniques is another factor that makes this form of transmission desirable. Except for special applications, single-channel radio-teletype operation requires that the assigned carrier frequency be shifted a total of 850 cycles, in the transition from a "mark" condition to a "space" condition.

Radio-teletype circuits incorporate many units of electronic and teletype equipment, usually separated by great distances. Maladjustment of any one unit may cause the entire circuit to be incapable of handling traffic. In maintaining radio-teletype communications, it is essential to determine quickly whether the transmitting or receiving end of the circuit is responsible for circuit outage, and which units or factors, be they teletype equipment, terminal equipment, radio equipment, or radio-propagation characteristics, are at fault.

Isolation of the responsible piece of equipment is readily accomplished at a receiving installation with a modified SCR-211(*) frequency

meter. This instrument is modified so that an output frequency which is shifted 850 cycles from that indicated by the calibration settings is obtainable throughout its entire range. There are many applications for the frequency-shifted test signal in the testing, aligning, and troubleshooting of equipment at a receiving station. The availability of a properly shifted signal at the intermediate frequency of a superheterodyne receiver is especially valuable for testing and aligning a frequency-discriminator type of converter such as the CV-31/TRA-7, a component of the AN/MRC-2 mobile radio-teletype system.

DETAILS OF MODIFICATION

The SCR-211(*) is a heterodyne type of frequency meter using an electron-coupled oscillator as a variable-frequency source. The frequency of such an oscillator is dependent upon many factors, one of which is the screen-grid voltage applied to the tube. Advantage is taken of this fact to produce the desired frequency shift by intermittently inserting and removing a screen-dropping resistor at a rate determined by the contacts of a teletype transmitting device.

Modification of the frequency meter for this purpose requires the insertion of a variable resistor in series with the screen-grid circuit of the oscillator tube. Remove the B+ lead from the screen-grid resistor, and connect it

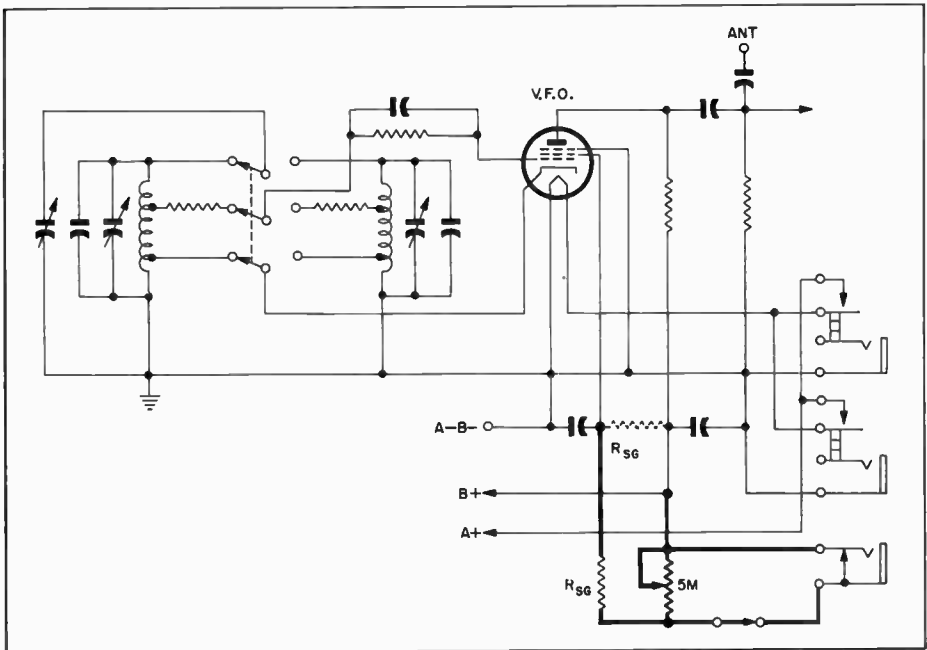

Partial Schematic of SCR-211 Frequency Meter, Showing Modification Details (Heavy Lines)

to one side of a 5-megohm potentiometer. Provide a jumper between that point and the slider of the potentiometer. Connect the other side of the potentiometer to the end of the screen-grid resistor from which the B+ lead was removed. Across the potentiometer, connect the terminals of a closed-circuit jack so that the potentiometer will be shorted. The frequency meter will operate normally when nothing is plugged into the circuit.

A convenient place for mounting the potentiometer and the jack may be found in the headset compartment of the frequency meter. When a plug to which the contacts of a transmitter distributor or any piece of teletype transmitting equipment are connected, is inserted in the jack, the potentiometer will be intermittently shorted or inserted in series with the screen grid, in conformance with the position of the contacts of the applied teletype equipment.

The frequency meter is tuned in the usual manner, with no plug in the jack, for initial frequency determination. To obtain the required shift, a dummy plug must be inserted into the jack, and the potentiometer varied until a signal 850 cycles (or any desired shift) lower in frequency is obtained. (The series switch shown in the schematic may be connected in series with one side of the jack to eliminate the need for removal of the keying-line plug and insertion of a dummy plug in its place.)

Adjustment of the shift is made with the use of an oscilloscope, an audio oscillator, and a frequency meter, in the manner in which any radio-teletype transmitter is adjusted. When a keying line is applied, a keyed, frequency-shifted signal will be produced at the antenna terminal of the frequency meter.

(Editor's Note: The frequency shift must be recalibrated each time the operating frequency is changed.)

SOME POINTERS ON FRAME-TYPE BUILDING CONSTRUCTION

By Carl W. Eastman
Philco Field Engineer

Some major considerations involved in the design and construction of limited-life, frame-type buildings.

ALTHOUGH BUILDING CONSTRUCTION is at first glance entirely remote from electronics, in practice it is frequently allied with electronics systems engineering, and most field engineers are called upon, sooner or later, to demonstrate a knowledge of the subject. With this purpose in mind, some of the major considerations involved in the design and supervision of the construction of such structures, particularly for military use, are presented here.

Military building construction is generally founded upon the following factors: the desired lifetime of the building, the time available for the designing and constructing, the availability of both materials and qualified labor, and the costs. Generally these factors are known before the designing of the building begins, and the limitations imposed by them will not only determine the over-all aspects of the construction, but will, in most cases, indicate the choice of the detail design of the building.

the theoretical strength of dimension lumber and other materials, conventional framing design usually provides tremendous safety factors; that is, the architectural design frequently relies upon standard practices or codes, some of which are centuries old, rather than civil engineering practices such as are employed in steel and masonry structure design. Usually, good reasons are abundant for over-design with respect to the strength standpoint. For example, one concrete block may easily have sufficient compression strength to withstand the weight of the building, yet an extensive foundation is required. Floor-joist requirements are sometimes based upon having a floor which does not deflect perceptibly to live loads (rather than to the maximum weights imposed). Studding is usually more elaborate than necessary due to factors other than roof-support considerations. In short, you don't have to be a stress analyst to design a good frame building.

DESIGN PRINCIPLES

Strength of materials is, of course, a fundamental consideration. Although concrete or cinder-block construction is becoming increasingly popular, the practicability of wood for limited-life construction is evident at practically every military installation. Given proper design and construction, its major disadvantage is the fire hazard. In comparison with

FLOOR PLAN DESIGN

Once the operational requirements are established, whether it be a home, or a transmitter building, the floor plan is the first step. It is highly useful to develop a floor plan by the use of cross-section paper, and to utilize separate paper rectangles labeled to represent the floor-space requirements of the various pieces of equipment to be installed. These rectangles can

be shifted as necessary to make the most effective equipment layout. Then, taking into consideration wall-clearance requirements, traffic patterns, etc., the floor plan will readily indicate the best location for walls, doors, windows, antenna lead-in, floor troughs, etc.

EXPANSION

One of the most difficult things to achieve in military design is an economical allowance for future growth. Two approaches are possible, namely, (1) to make the building big enough in the first place, or (2) incorporation of expandibility in the original design. Such factors as definite requirements by higher authority, availability of funds, construction time, building life, future equipment, and the possibility of female employees all affect future growth. Generally, the building should be larger than absolutely necessary; if this is not possible, incorporate expandibility into the design.

MODULAR DESIGN

Modular design means making dimensions in multiples of a certain length. Since many materials such as sheetrock, celotex, etc. come in 4' x 8' sheets, four feet is a popular module for frame construction. Substantial economies can result by basing the dimensions of ceiling heights and walls on this simple consideration. An eight-foot ceiling will require studs 7'8" long.

DETAIL DESIGN

Once the floor plan is clearly concurred in by all concerned, the detailed architectural design is initiated. This may be accomplished by another agency, such as Air Installations, Corps of Engineers, or an architect-engineer-contractor. If the construction is not going to be effected by

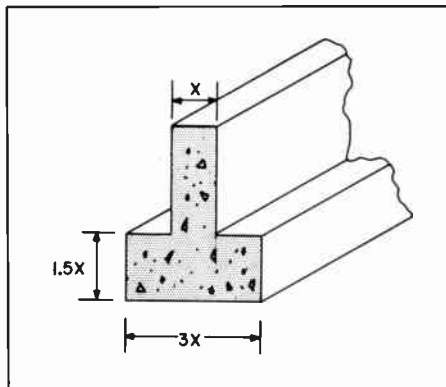

Figure 1. Aspect Ratio of Concrete Foundation

a legal contract, the detail design of smaller structures can readily be accomplished by the using organization. Contract drawings, and specifications are usually beyond the scope of the uninitiated. One should not be surprised to find professionals prudently considering the effects of tides on central Sahara. desert construction contract specifications! The optimum "tightness" of contract specifications is a difficult subject.

FOUNDATIONS

Foundations are a substantial investment. Their design can vary over wide limits, from simple piers, spaced to support the floor girders, to extensive retaining walls and footings (plus columns to support the floor between walls) around the outside perimeters and load-bearing wall partitions of the building. These foundations can be made of 1-2-4 mix concrete.* The foundation can normally have aspect ratios as indicated in figure 1. A value of $x = 8$ inches for walls and piers should support single-frame structures. To prevent cracking of the wall, reinforcing steel is usually employed.

* By volume, 1 part cement, 2 parts sand, 4 parts gravel.

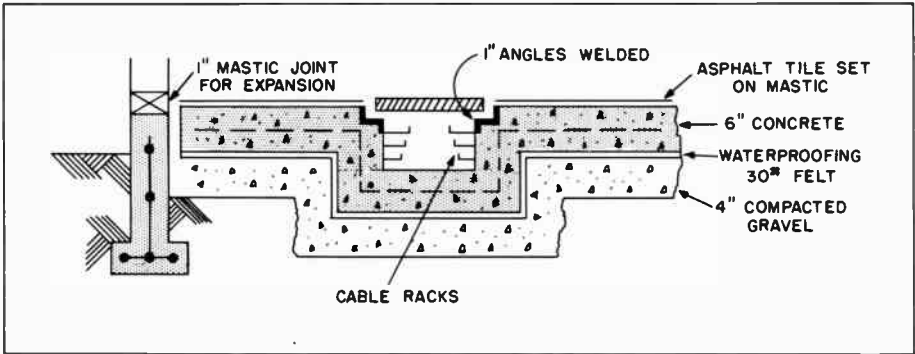

Figure 2. Cross-Sectional View of Typical Concrete Floor

FLOORS

Floors will frequently consist of a subfloor and a finish floor, with a course of 15- or 30-pound building paper in between. Subfloor materials are usually either concrete or wood, and popular finish-floor materials are asphalt tile or wood. Figures 4 and 5 indicate typical wood-floor construction. Of course the exact size and spacing of piers, floor joists, and girders will be determined by the anticipated weights to be imposed on the floor. An examination of existing structures should be a good indication of requirements. The typical floors indicated should safely withstand a distributed load of 50 pounds per square foot. Since a concentrated

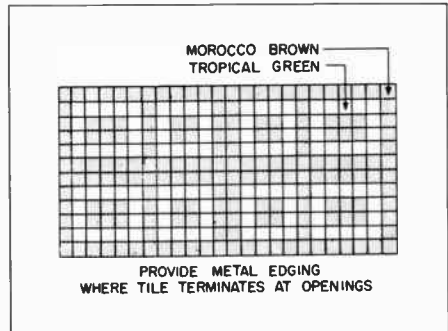

Figure 3. Typical Asphalt-Tile Floor

stress will not, of course, be uniformly distributed throughout the floor, additional strengthening can be incorporated where heavy loads will be imposed. For example, floor joists

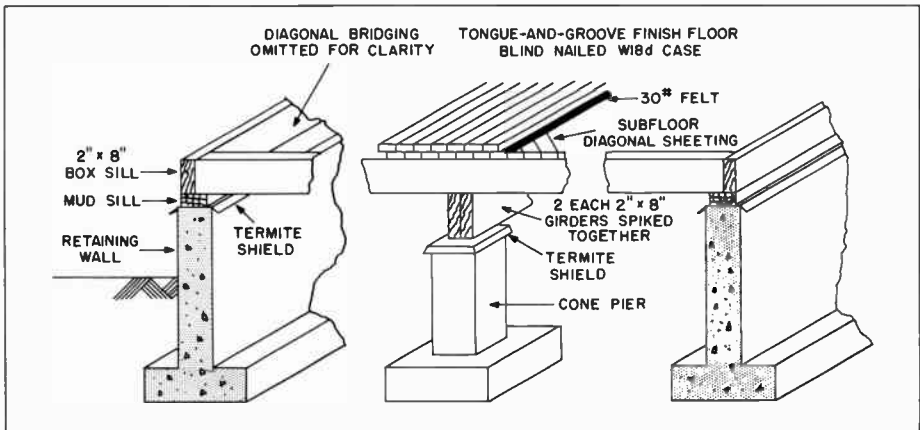

Figure 4. Foundation for Wood Floor

should always be under wall partitions that run parallel to the joists.

Floor joists should parallel floor trenches, where possible.

Table 1. Maximum Spans for Floor Joists for Live Load of 60 Pounds per Square Foot (Unplastered walls; flooring of No. 1 common Douglas fir or soft pine material; deflection limited to 1/360th of the span.)

Nominal Size of Joist (inches)	Distance on Center (inches)	Maximum Span
2 x 8	12	13'4"
	16	11'8"
2 x 10	12	16'10"
	16	14'8"

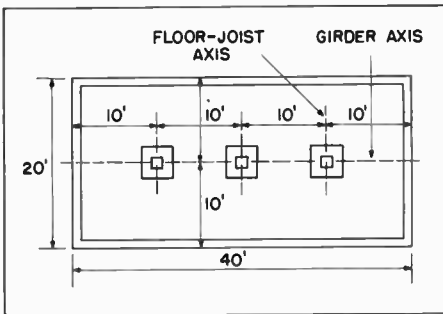

Figure 5. Location and Arrangement of Supports for 20 Ft. x 40 Ft. Floor

WALL FRAMING

The main idea to bear in mind when laying out the studding is that the sheeting will probably be in four-

foot multiples. A studding spacing of 16 inches on centers is usually employed. The two standard-type corners, shown in figure 7, are necessary to provide a nailing surface for the inside-wall construction. The floor plate, studs, and lower top plate for each wall can be assembled with 16-penny nails on the subfloor, and then the entire structure can be erected as a unit. The upper top plate is then nailed to the top plate, making certain that corners overlap as indicated in figure 8. For doors and windows, sufficient width must be allowed for 2" x 4" cripplers to assure a plumb and tight installation. These cripplers are installed at the time the window and door frames are hung.

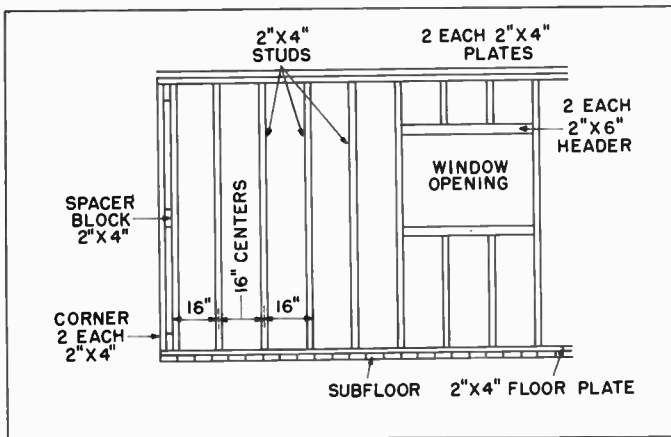

Figure 6. Typical Wall Framing

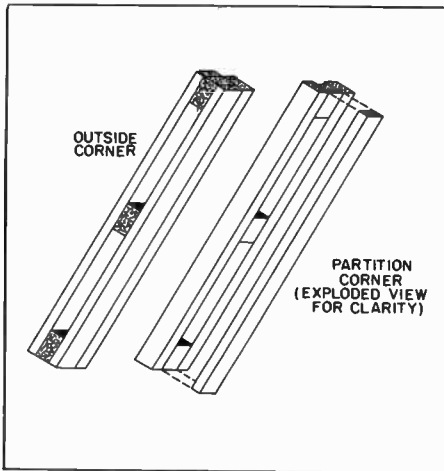

Figure 7. Construction of Standard-Type Corners

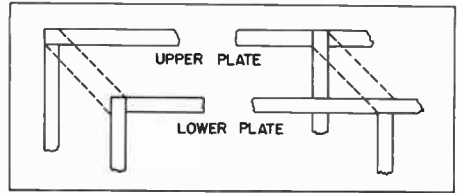

Figure 8. Top Plating (Exploded Plan View)

CEILING JOISTS AND RAFTERS

Common types of roof are pitch, shed, and hip. Figure 10 indicates two typical roof trusses. Although the truss-type support is most common, the flatter-type roofs frequently rely upon load-bearing wall partitions and heavy rafters for roof support.

Table II. Maximum Spans for Rafters (Roof load 30 pounds per square foot uniformly distributed slope of 20 degrees or more; No. 1 common Douglas fir or soft pine material, deflection limited to 1/360th of span; dead load, including weight of rafters and roof sheathing, 2.5 pounds for three-ply roofing.)

Nominal Size of Rafter (inches)	Distance on Center (inches)	Maximum Span, Plate to Ridge (Unplastered)
2 x 4	16	7'8"
	24	6'3"
2 x 6	16	11'9"
	24	9'8"
2 x 8	16	15'7"
	24	12'10"

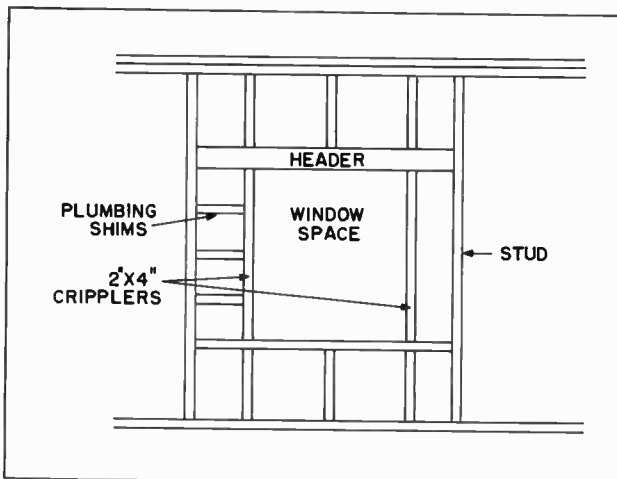

Figure 9. Construction of Wall Framing around Windows

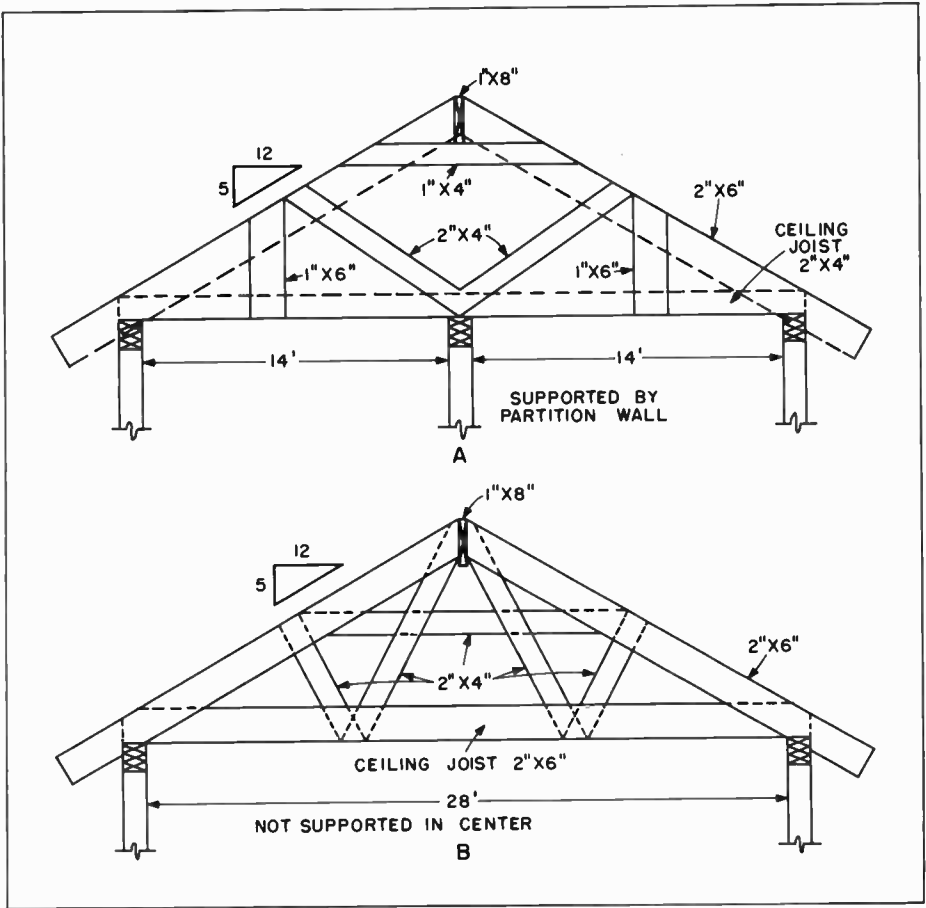

Figure 10. Typical Roof Trusses (A—Supported, B—Non-Supported)

SHEETING

The sheeting requirements will depend upon wind loads, insulation requirements, and the type of outside finish. Diagonal placement of 1" x 8" sheeting utilizing three 8-penny nails per stud is a commonly employed standard. Another material that may be used is outside celotex, which is faster to install but weaker than diagonal wood sheeting.

ROOFING

Decking for composition, or built-up, roofs usually consists of 1" x 8" sheeting (tongue-and-groove material is best); three 8-penny nails per

rafter are used, and the decking is laid horizontally. A built-up roof will frequently consist of one ply each of 30-pound and 60-pound felt, topped with 90-pound mineral-surface roll roofing, and swabbed with hot asphalt between plies. Composition shingles can be laid on one ply of 30-pound felt. No. 1 cedar shingles, of course, make a highly satisfactory roof; the main disadvantage is the greater fire hazard. Cedar shingles can be nailed to 1" x 4" strips with a four-inch opening between strips.

SIDING

Thirty-pound felt is usually first

nailed to the sheeting; then, after the door and window frames have been installed, it is covered with the siding. One of the most attractive and inexpensive materials is asbestos cement shingles, which are available in a variety of colors. Another popular material is drop siding lumber.

WIRING

A single-line schematic diagram, indicating loads and switchgear requirements, is a good first step. Then, various components can be consolidated where possible (such as a load-center panel board), and an electrical drawing can be made indicating power entry, metering, switchgear, grounding, lighting, outlets, and conductor routing. Three types of wiring are in wide use, namely, (1) romex for economical, limited-life construction, (2) rigid or thinwall conduit for long-life construction, and (3) flexible metal conduit. An electric-company catalog, such as GE or Graybar, can be consulted to advantage. In general, No. 12 wire can carry 20 amperes; No. 6, 50 amperes; and No. 0, 120 amperes. Half-inch conduit can contain three No. 12 conductors; one-inch conduit, three No. 6 conductors, two-inch conduit, four No. 0 conductors. Ohm's Law calculations will indicate wire sizes necessary to comply with maximum allowable IR drops.

HEATING

Heating considerations involve the selection of fuel, uniformity of heat distribution and temperature, BTU requirements, and fire safety considerations. Electric heating is highly desirable for small, unattended structures, but it is generally not used because of cost limitations.

A design equation for two air changes per hour is:

$$\text{Kilowatts} = \frac{(0.04V + 1.13G + KA)}{3413} (t_r - t_o)$$

where V is the volume of the room, in cubic feet; A is the area of the ceiling plus that of the exposed walls, in square feet; G is the area of the windows, in square feet; $t_r - t_o$ is the difference between the inside and outside temperatures, in degrees Fahrenheit; and K equals 0.25 for wood, and 0.76 for a six-inch concrete wall.

Since there are 3413 BTU per kilowatt-hour, the above formula can be utilized for other type fuels. About 25 percent should be added if accelerated heating of a cold room is required. Central heating systems can usually be engineered by studying local installations.

PLUMBING

If a water line is available near the site, modern plumbing can readily be included in the building; a septic-tank system can usually be economically built and installed if sewer lines are too distant.

STANDBY POWER

Installation of a required standby generator set within the main building is usually more economical than providing a separate building. Once the power-unit size has been determined, efforts should be coordinated to assure delivery of a standard unit for which a spare-parts supply is established. An individual foundation, on which mounting studs have been cast in the concrete, should be provided for the unit. Provisions must be made for such factors as adjustable ventilating louvres, exhaust, fuel storage and recessed fuel lines, automatic start and/or power-transfer equipment, recessed wiring, and the entry of the generator set.

The design and construction of a frame-type building for use in conjunction with electronic equipment is necessarily variable and complicated, and should not, of course, be oversimplified. Therefore, only generalizations and highlights from the author's personal experience in this type of field work have been presented in this article; for those who are likely to be called upon to undertake the construction of a frame-type building, the books listed below provide more detailed information.

REFERENCES

_____, *Light Frame House Construction*, Vocational Division Bulletin #145, Trade and Industrial Series #41, U. S. Office of Education, Federal Security Agency, U. S. Government Printing Office, Washington, 1941. (See also the Bibliography on p. 207 of this book.)

Ramsey, Charles G., and Sleeper, Harold R., *Architectural Graphic Standards for Architects, Engineers, Decorators, Builders, and Draftsmen*, 4th Ed., John Wiley & Sons, Inc., New York, 1951. (This book is a standard international reference.)

_____, *Contract Drawings and Specifications*, Corps of Engineers, U. S. Army.



The Use of Non-Magnetic Tools in the Vicinity of a Magnetron

MOST FIELD ENGINEERS have been well aware of the dangers involved in using magnetic tools around magnetrons. It is relatively impossible to *gently* touch a steel screwdriver to a powerful magnet. In fact, a magnet can exert sufficient attraction to pull a screwdriver right out of the technician's hand. The result is often damage to the magnetron in the form of breakage, or damage to the magnet in the form of a distortion of the magnetic field. As is pointed out in Philco Training Manual "*Radar System Measurements*" (AN-230), one touch of a screwdriver has been known to cause a loss of 50 gauss in a magnet rated at 2500 gauss.

Philco's Industrial Engineering Department recommends the use of non-magnetic tools when working with or in the vicinity of a magnetron. This would include working upon a transmitter which contains a mounted magnetron. A currently available set of non-magnetic tools can be obtained from:

Ampco Metal Co., Inc.
1745 South 38th Street
Milwaukee 15, Wisconsin

The following items, obtained from Ampco Catalog number 119, are considered to be satisfactory:

Crescent Wrench, Ampco number W-718
Pliers, Ampco number P-31
Screwdriver, Ampco number S-49

RADAR ANTENNA SYSTEMS

By *Merle E. McDougall*
Philco Field Engineer

A discussion of the characteristics of basic radar antennas, scanners, and feed systems.

THERE ARE MANY TYPES of radar antenna systems in use today. The type of antenna system to be used with a piece of radar equipment is primarily dependent on the purpose of the particular radar; that is, whether it is designed for search, navigation, fire control, or other use. This article will deal with the general consideration of radar antennas and their associated equipment, with examples of their application to present radar systems.

CRITERIA OF A RADAR ANTENNA SYSTEM

Mechanical Stability

The antenna must be able to withstand winds of at least 100 miles per hour without damage to, or effect on the accuracy of, the antenna. It must be able to resist vibration due to gunfire nearby. Generally, the antenna must be mechanically stable so that normal shock, vibration, and pressure will not damage it or impair its accuracy.

Weight and Size

Weight and size are important considerations, except for fixed land installations, and are especially important for airborne installations.

Levelness

Generally, an antenna must be level to produce a consistent search pattern, but still must be able to accurately track targets. For land-based equipment this requirement can be easily met, since the equipment is stationary; the equipment is leveled by the use of jacks. For shipborne or airborne

equipment, however, stabilization must be used if the antenna is to remain level.

Radiation Pattern

If the radiation pattern is narrow, a long period of time must be consumed in searching the whole area so that targets will not be missed. The disadvantage of a wide radiation pattern is that the energy from the radar transmitter is spread over a large area and the maximum range of the radar is lessened. For very accurate bearing and elevation determinations, as required for the fire control of guns, a very narrow beam of radiation is desired.

Antenna Gain

The ideal radar antenna would have high gain. The gain of an antenna is the ratio of the energy at a certain distance from a directional antenna to the energy at the same distance from a simple dipole antenna in free space, with the same total power being fed from a transmitter to each antenna. If a radar antenna has high gain, the range at which a given target can be detected is much greater than that for a low-gain antenna. As the gain of an antenna is increased, the width of the radiation pattern is decreased, and therefore the area coverage of the radar beam at any instant is decreased.

Feed Method

There must be a method of feeding r-f energy to an antenna. The device used for this purpose must be mechanically rugged so that it will not

be damaged by wind, rain, or snow. Also, it must be efficient and able to direct the energy to the desired point and in the desired pattern. The energy from the feed point is usually fed into a reflector, where it is focused into a narrow beam.

Scanning Adaptability

If the radiation pattern of the radar is a narrow beam, the antenna system must be adaptable to some method of scanning. Scanning may be defined as a method of sweeping the narrow radar beam in a regular and definite manner over the entire area in which targets are to be found. There are various types of scanning, such as conical, spiral, or helical; the type used depends on the purpose of the radar and the type of radiation pattern it produces.

RADAR ANTENNA REFLECTOR SHAPES

Ordinarily the r-f energy of the radar transmitter is radiated from a relatively small antenna or slot, which for practical purposes may be considered as a point. The energy from this point source strikes a reflector which focuses the energy into a beam and directs it toward the target area. Since radar energy is very similar to light energy, in that both travel in straight lines, a searchlight may be used to illustrate the principles involved in the focusing and directing of electromagnetic energy by antenna reflectors. In a searchlight, the light source is at a point and the reflector is usually parabolic, or to be exact, a paraboloid of revolution. Figure 1 shows various paths followed by the light, which is radiated in all directions from the source. Its reflection from the parabolic reflector causes the light rays to be formed into a beam, so that most of the light energy is sent in the same direction. The principle of the radar antenna reflector is the

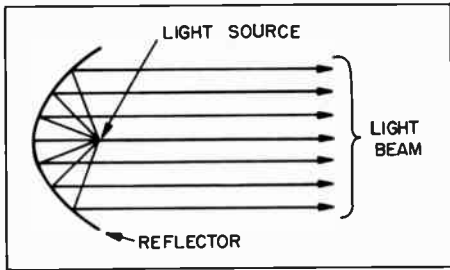

Figure 1. Light Rays Formed into a Beam by a Reflector

same. The reflector for the antenna is not always a paraboloid, because different radiation patterns are required, but the light analogy is still valid.

Bedspring Antenna Reflector

The bedspring antenna reflector is flat and has a large area. Instead of the energy being radiated from a point, it is radiated from a number of dipoles arranged in front of the reflector. An example of the bedspring antenna is that of the SCR-270, an early model aircraft warning radar. The radiating element consists of dipoles stacked eight high and four wide, backed by a reflector, as shown in figure 2. The disadvantages of this type of antenna system result from its large size and broad beamwidth. Because of its large size, it can be easily seen by the enemy, or damaged by wind; it cannot be easily transported and is, therefore, restricted to fixed land locations; and it cannot be rotated in azimuth at a speed greater than one revolution per minute, resulting in a very slow scan of the target area. The broadness of the beam (28 degrees in azimuth and 10 degrees in elevation) results in relatively short maximum range for a given amount of transmitted power and poor accuracy in determining azimuth and elevation angles.

Paraboloid

The paraboloid-type reflector (shown in figure 1), which is used to form

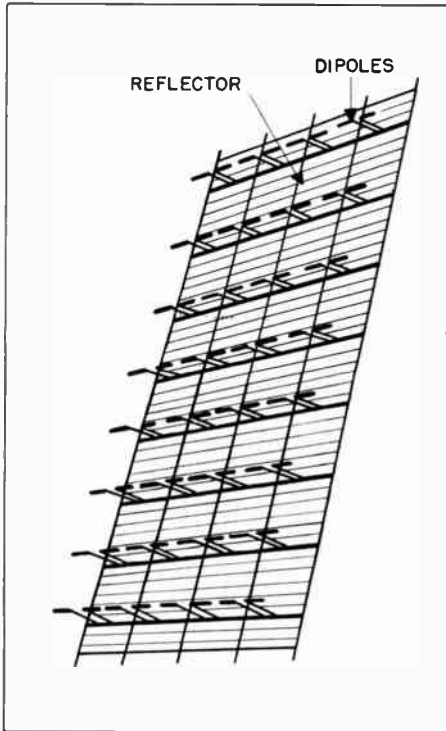

Figure 2. SCR-270 Bedspring Antenna

light rays into a beam, is also used to form radar energy into a beam. For radar sets such as the SCR-584 which operates from 2700 mc. to 2900 mc., the diameter of the paraboloid is six feet. Since weight and wind resistance considerations are important

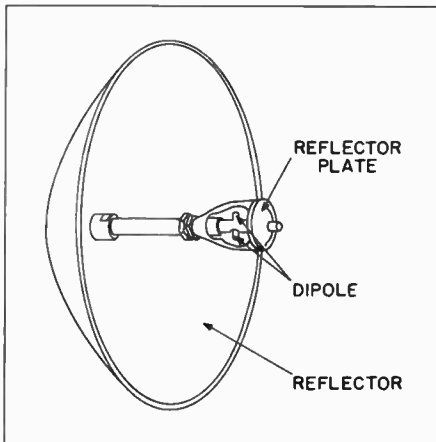

Figure 3. SCR-584 Antenna

with a paraboloid of this size, the metal of the paraboloid of the SCR-584 antenna is perforated to make it lighter and to reduce the amount of surface exposed to the wind. These perforations are small enough in comparison to a wavelength so that electrically the reflector appears to be a solid surface.

The SCR-584 antenna, shown in figure 3, consists of a paraboloid fed by a dipole with a reflector plate spaced a quarter wavelength from the dipole. The purpose of the reflector plate is to cause most of the energy from the dipole to be reflected directly into the paraboloid.

Truncated Paraboloid

The truncated paraboloid, as shown in figure 4, is a section cut from a full paraboloid. The width of the beam in the horizontal plane is not affected by the truncation, but the width in the vertical plane is increased because there is less reflector surface to concentrate the beam in that plane. The resultant radiation pattern is narrow in azimuth and wide in elevation. An antenna with this type of reflector is very useful for aircraft

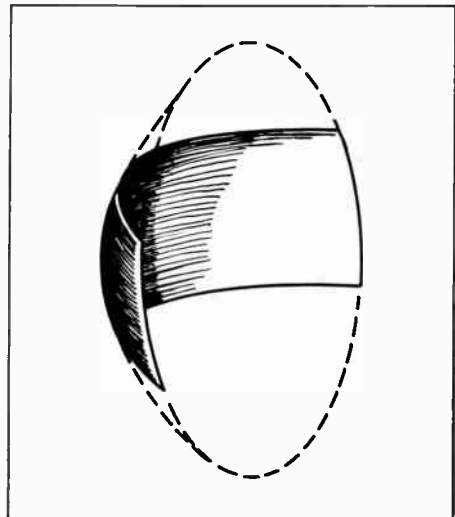

Figure 4. Truncated Paraboloid

search, as the radiation pattern is wide enough in the vertical plane to cover almost all altitudes at the same time, while the paraboloidal antenna, such as that used in the SCR-584, covers only a small segment in the vertical plane. A disadvantage of the truncated paraboloid is that, since the beam is wide in the vertical plane, the reflector picks up reflections from the surface of the earth, producing a confused mass of targets (clutter) on the indicator. However, the disadvantage is not too great, and this type of reflector is often used for shipboard installation.

The SL radar antenna in figure 5 is an example of a truncated paraboloid shipboard installation. The antenna is shown without its housing. The housing is made of a dielectric material which is transparent to the 10-centimeter radiation. The beam is 6 degrees wide horizontally and 12 degrees wide vertically. The antenna is good for both aircraft and surface search. It can be seen in the figure that the waveguide extends to a point in front of the reflector. The energy is radiated from the open end of the waveguide into the truncated paraboloid, where it is formed into a beam and directed toward the target area.

Orange-Peel Paraboloid

The orange-peel paraboloid, so-called because of its shape (see figure 6), is a narrow section of a paraboloid. Quite often it is mounted vertically for height-finding because this position makes possible an accurate determination of the elevation angle and the slant range of a target. The height of the target is then computed electrically. With the reflector mounted in a vertical position, as shown in figure 6, the radiation pattern is wider in the horizontal plane than in the vertical plane, much the same as for the truncated paraboloid.

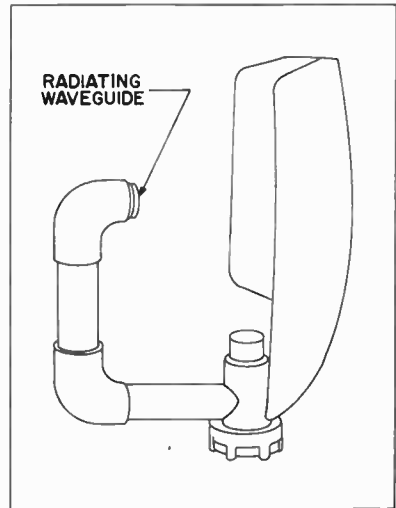

Figure 5. SL Radar Antenna



Figure 6. Orange-Peel Reflector

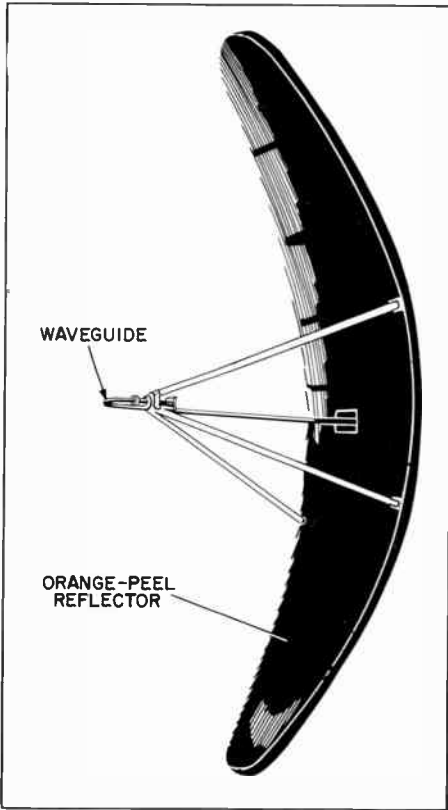

Figure 7. AN/TPS-10 Antenna

The AN/TPS-10 antenna in figure 7 employs an orange-peel reflector. This radar, which uses a higher frequency than the SL, has a wavelength of three centimeters. The width of the beam is 2 degrees in the horizontal plane and 0.7 degree in the vertical plane. It can be seen that

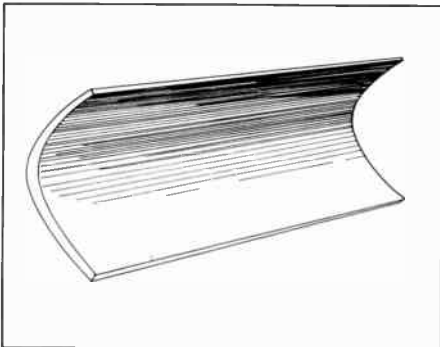

Figure 8. Parabolic-Cylinder Reflector

the antenna reflector is fed by the open end of a waveguide, and that the reflector is not solid, but is made up of strips of metal to reduce the wind resistance and the weight.

Parabolic Cylinder

The parabolic cylinder in figure 8 produces a beam that is relatively wide in the horizontal plane and narrow in the vertical plane. The parabolic cylinder is used at low radar frequencies with search radar and at higher frequencies with fire-control radar. Since the beam is narrow vertically when the parabolic cylinder is oriented horizontally, this type of reflector is used primarily with surface radar.

One of the antenna reflectors used with the Mark 3 radar is a parabolic cylinder 3 feet high and 12 feet long. See figure 9. When it is fed from the dipoles along the focal axis of the cylindrical paraboloid with a frequency between 680 and 720 megacycles, the beam is 6 degrees wide vertically and 30 degrees wide horizontally.

Cosecant-Squared Reflector

The cosecant-squared radiation pattern is similar to the plot of the square of the cosecant of the angle between the horizon and the direction of radiation. The cosecant-squared reflector (sometimes called a barrel stave) consists of a paraboloid with the top section effectively folded forward approximately 10 degrees, as shown in figure 10. The pattern produced by the reflector is very wide vertically (approximately 65 degrees) and narrow horizontally (approximately 3 degrees). The cosecant-squared antenna finds its application in airborne radar used for ground search and bombing. The frequency fed to this antenna for airborne use is usually in the 3-centimeter region, as the over-all antenna size must be

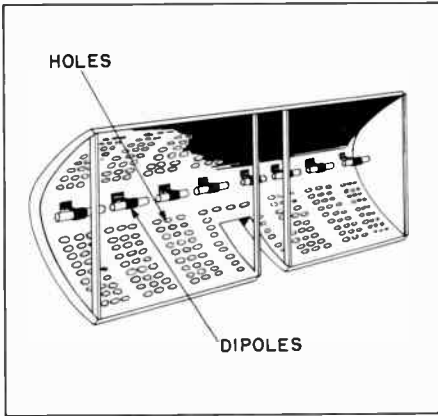

Figure 9. Parabolic-Cylinder Antenna

small. The antenna for airborne use is housed in a plastic dome to prevent its being subjected to wind pressure and to reduce wind drag.

An example of a cosecant-squared reflector is the one used in the early antenna of the AN/APQ-13. The reflector was of the shape shown in figure 10.

METHODS OF FEEDING AND SCANNING

Bedspring Antenna

The bedspring antenna, shown in figure 2, is fed by a stacked array of

dipoles. The radiation pattern of one dipole and one reflector is compared to that of two dipoles and two reflectors in figure 11. It can be seen that as the number of dipoles and reflectors is increased, the beam width of the radiation pattern in the direction of the array stacking is decreased, and the distance at which a certain power is transmitted is increased. Usually there is no method of electrical or mechanical scan employed with the bedspring antenna except azimuth rotation.

Conical Scanning with Dipole Feed

The SCR-584 is an example of an equipment that employs a dipole to feed a parabolic reflector. (See figure 3.) A detailed view of the dipole feed of the SCR-584 antenna is shown in figure 12. One dipole element is connected directly to the outer conductor of the coaxial cable, and the other element is connected to the inner conductor. Each element is a quarter wavelength long, so that the two together form a half-wave dipole. Because of the type of feed, the dipole radiates the energy into the reflector, slightly off the mechanical center of

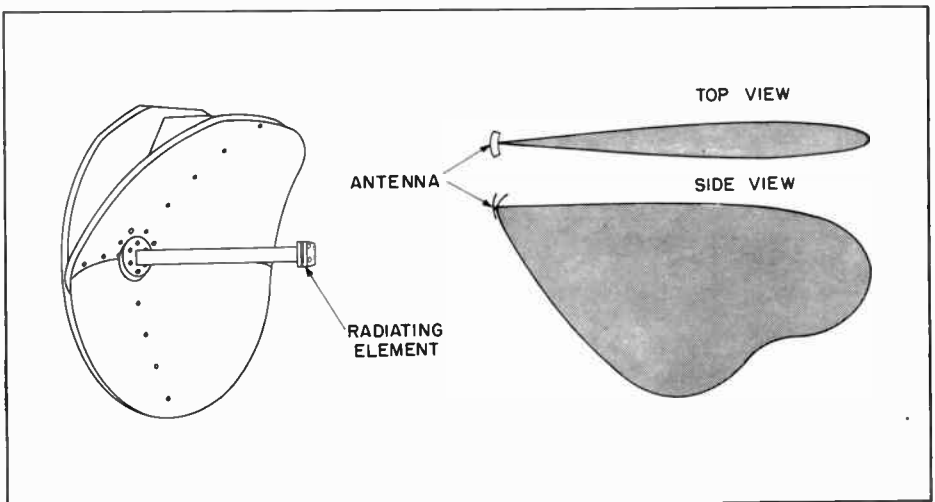

Figure 10. Cosecant-Squared Antenna and its Radiation Pattern

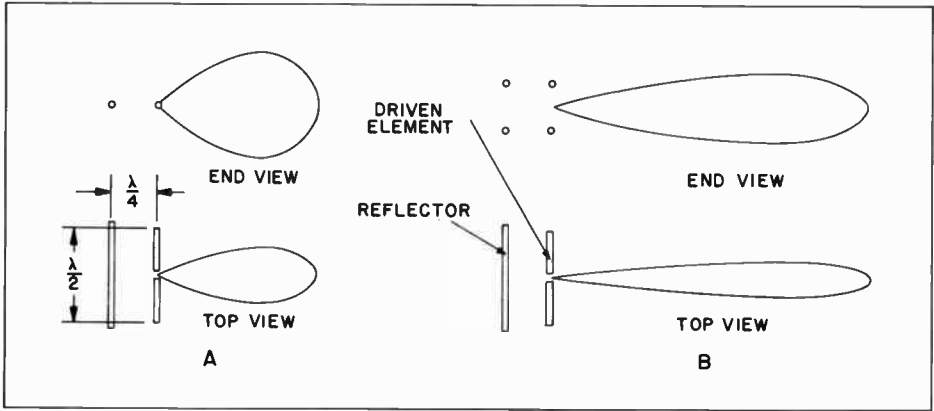

Figure 11. Radiation Pattern of Dipoles and Reflectors

the reflector. The reflector plate, as previously stated, directs most of the energy into the parabolic reflector, and thus prevents the energy from being radiated directly into the atmosphere. Since the energy fed into the reflector is slightly off center, the radiated beam is not exactly on the axis of the reflector. The dipole assembly is rotated at 1800 r.p.m., producing a conical pattern as shown in figure 13. The beam axis is $1\frac{1}{4}$ degrees off center, and therefore scans a $2\frac{1}{2}$ degree cone. If the target is exactly

in the center of the cone, the energy returned to the radar receiver will be of the same intensity at all times; if the target is off near one edge of the cone, the energy returned will vary in intensity at the rate of 1800 times per minute. These variations are used to activate an automatic tracking system. It can be seen that conical scanning increases the coverage of the radar.

Helical Scanning

The SCR-584 also uses another type

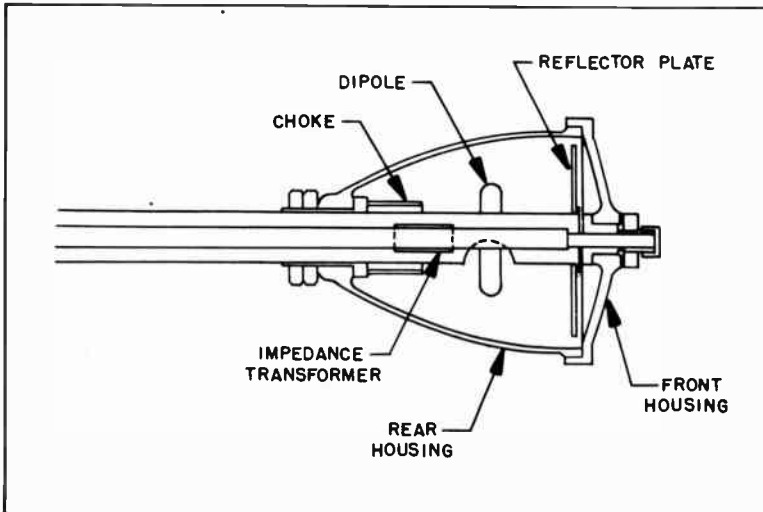

Figure 12. SCR-584 Dipole Assembly

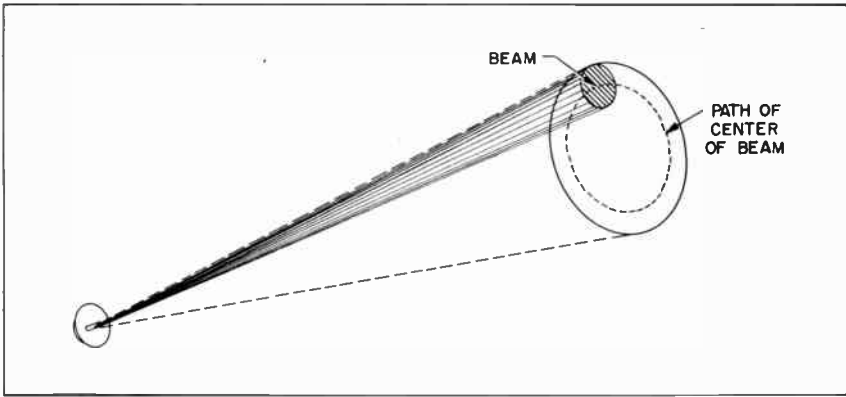

Figure 13. SCR-584 Conical Scanning

of scan called helical scanning. As the antenna turns in azimuth, its radiation pattern is elevated 89 mils per revolution until the angle of elevation is increased to 365 mils (20 degrees); then the antenna drops back to its original elevation and begins the scan cycle again. The helical scanning of the SCR-584 antenna is automatic and is a method of scanning both in azimuth and elevation, while conical scanning is produced simultaneously. The helical scanning pattern of the SCR-584 is shown in figure 14.

Spiral Scanning

A spiral scan is defined as a scan that periodically starts at a point, executes a spiral motion, and returns to the same point. Figure 15 shows the antenna unit of the AN/APS-6, which is an airborne radar used to locate enemy aircraft and to determine their range, relative azimuth angle, and relative elevation angle. On the 3-centimeter band the beam formed by the paraboloid is 5 degrees wide. A motor rotates the antenna assembly, and a sine-wave generator,

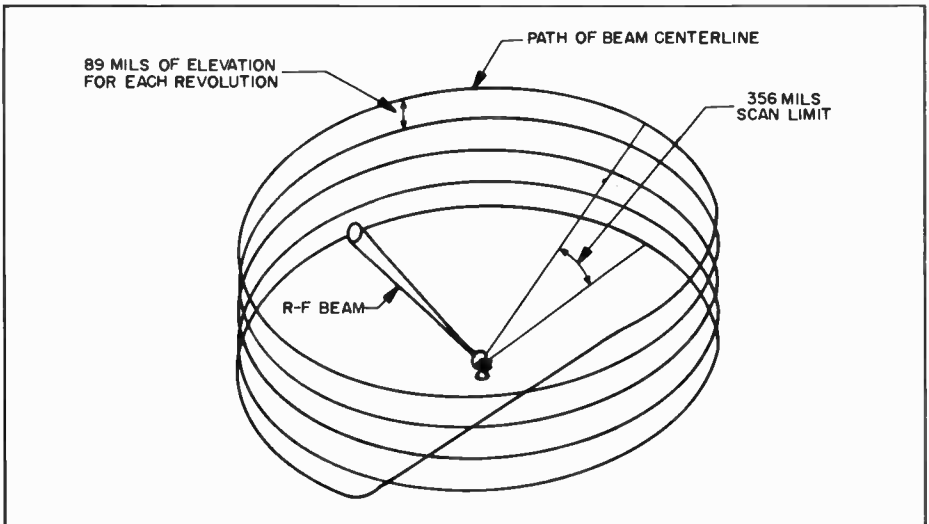

Figure 14. SCR-584 Helical Scanning

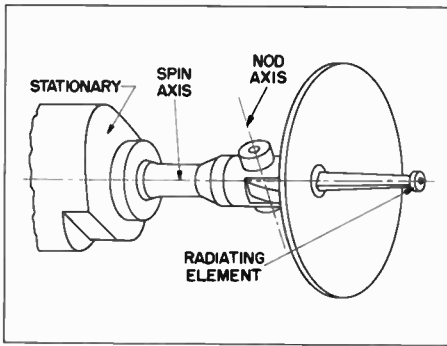

Figure 15. AN/APS-6 Antenna System

driven synchronously with the antenna, provides voltages that indicate the spin angle. The antenna dipoles rotate at 1200 revolutions per minute while completing a spiral every 4 seconds. The antenna, which is pointed in the direction of travel of the airplane, gives a wide angle of scan (120 degrees maximum). A wide angle such as this could not be obtained with a fixed antenna without incurring other disadvantages, such as low maximum range and inaccuracy in elevation and azimuth.

Sector Scanning

The AN/APQ-13 used sector scan with the cosecant-squared antenna in its first models. (See figure 10.)

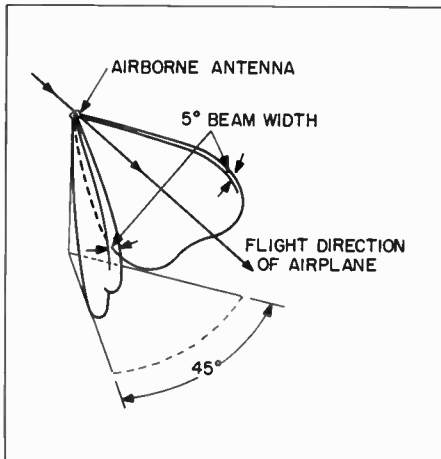

Figure 16. Sector Scan of AN/APQ-13

Sector scan means exactly what the term implies, that is, the antenna scans a certain azimuth angle, or sector, as shown in figure 16. An antenna with a beam that is wide in the vertical plane and narrow in the horizontal plane is adaptable to sector scanning, as it can cover the whole area in the direction of motion of the airplane, and is useful for viewing enemy ground emplacements and for bombing.

Nutating Feed

A nutating feed, as shown in figure 17, has been used with the SCR-584 pedestal for gunlaying. If the dipole is rotated, the polarization of the radiation is also rotated, whereas with nutation only, the polarization of the field is constant. The energy radiated can be vertically polarized; this type of polarization is superior to rotating polarization for resisting such measures as window jamming. The nutating feed shown in figure 17 gives a conical scan. The nutation can be made capable of various types of scan, such as spiral scan or Palmer scan, where the feed is nutated through a wide angle compared to the beam width. The disadvantage of a nutating feed is that the nutating movement of the feed element is mechanically difficult to produce.

Oscillating Beavertail Scan

The AN/TPS-10, shown in figure 7, is an example of a radar set using the beavertail scan. When used for search, the antenna rotates around the azimuth axis at $\frac{1}{8}$ r.p.m. Also, at the same time, the antenna oscillates vertically from -2 degrees to $+23$ degrees at a rate of 60 to 75 cycles per minute. This type of oscillation, termed beavertail oscillation, allows a large elevation angle to be scanned at the same time that the azimuth is scanned. The mechanical drive for the beavertail scan is not complex,

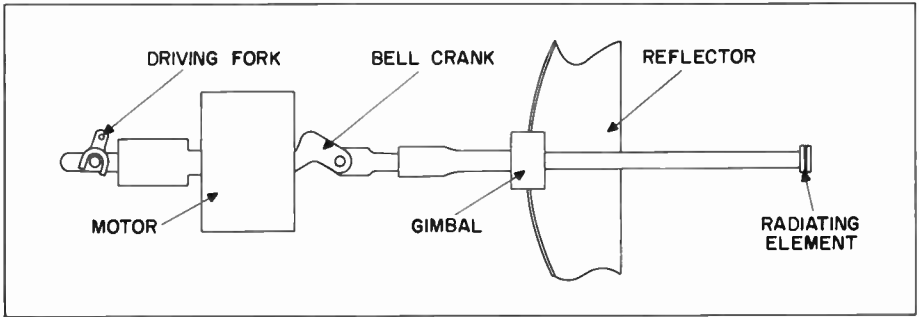

Figure 17. Nutating-Scan Feed for SCR-584

but simply uses a crank arm to oscillate the antenna. The antenna for the AN/TPS-10 is relatively light, which keeps the driving power requirements to a minimum.

Waveguide Feed to a Reflector

The open end of a waveguide will radiate energy, even though the termination is not correct for maximum energy transfer. If the open end of the waveguide is flared to provide the correct termination, it will radiate much more energy and may be used to feed a reflector, which will concentrate the energy into a beam for radiation. The waveguide method of

feed is used primarily in the higher-frequency radar bands; it is seldom used at the lower frequencies because the physical size of the waveguide would be prohibitively large. An example of an equipment that employs a waveguide feed is the AN/TPS-10 antenna. See figure 7.

Slotted Diaphragm Feed (Cutler Feed)

In the Cutler feed, (figure 19), energy is fed from excited slots to a reflector for radiation. The Cutler feed has the advantage that it is rigid, and that its supporting member is the waveguide that feeds the ra-

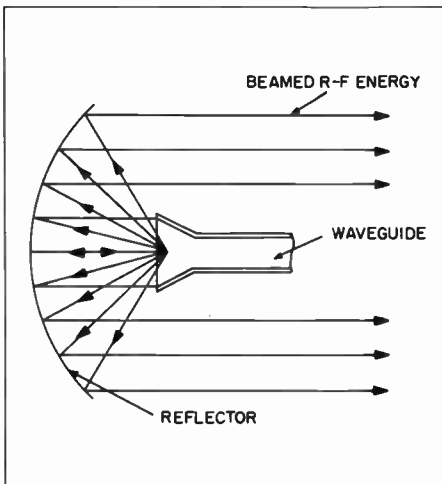

Figure 18. Open-End Waveguide Feeding into a Reflector

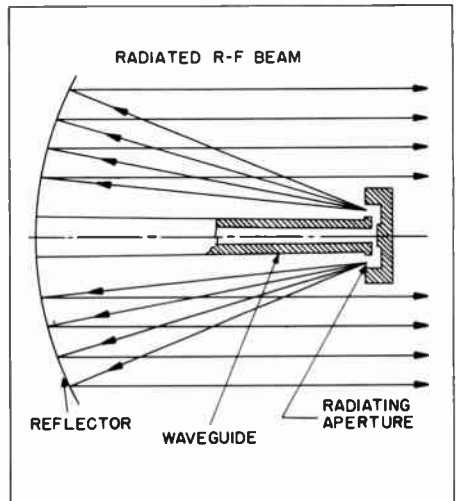

Figure 19. Cutler Feed

diating slots. The openings of the slots for the Cutler feed, as well as the open end of the waveguide feed previously discussed, are ordinarily covered with a dielectric. The waveguide is usually filled with dry air or a gas such as nitrogen. The dielectric has very little effect on the radiation, because it is thin compared to the wavelength of the radiated energy.

Pillbox Feed

This type of feed is usually employed with airborne cylindrical reflectors. The pillbox in figure 20 is formed by two parallel metal plates, with a parabolic cylinder as the back. Energy is fed into the pillbox from the open end of a waveguide, as shown in figure 20. From the parabolic back the energy is reflected out of the pillbox, fed with equal intensity along the entire length of the cylindrical reflector, and thence radiated in a beam.

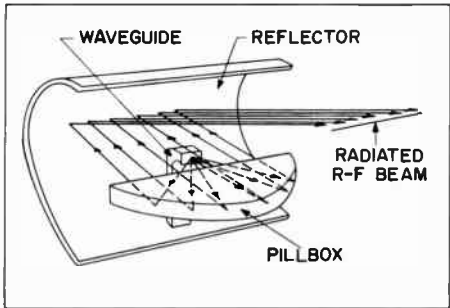

Figure 20. Pillbox Feed to a Cylindrical Reflector

end waveguide were used, the energy would not be fed with equal intensity along the entire length of the reflector, and a wider beam would result.

Robinson Feed Electrical Scan

The Robinson electrical method of scanning makes use of trapezoidal parallel plates. The energy is fed in at the end of the trapezoid, away from the antenna reflector, as shown in figure 21, and is then reflected from

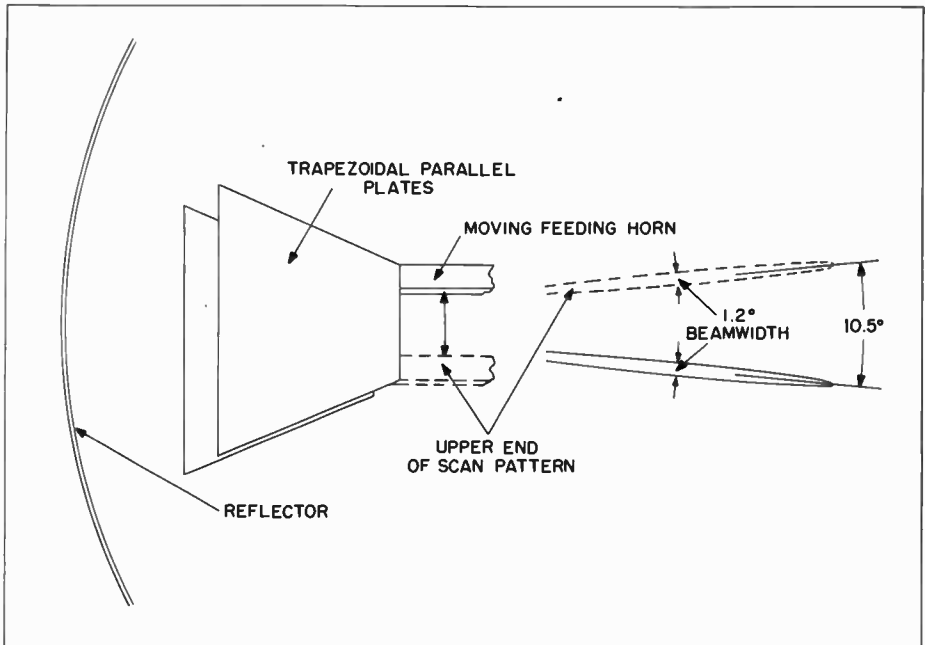

Figure 21. Robinson Electrical Feed for SCI Height-Finder Antenna

the sides of the trapezoidal feed reflector into the antenna reflector, which in the SCI height-finder radar set is of the orange-peel type. As the feed horn of the Robinson scanner is moved along the small end of the trapezoid, the reflection from the trapezoidal walls varies so as to produce a 10.5-degree scan for the SCI height finder.

DIELECTRIC ROD ANTENNAS

When r-f energy is introduced into one end of a polystyrene rod as shown in figure 22, energy is radiated from the other end. Thus, the rod functions as an antenna, and produces an end-fire pattern when the length of the rod is long in comparison to one wavelength. For practical use as an antenna, the polystyrene rod is inserted into the end of the waveguide and is shaped so as to match the impedance of the waveguide to the impedance of the atmosphere. The impedance of the atmosphere is ordinarily taken as 377 ohms. The polystyrene rod element finds application where space or streamlining and not narrow beam width is of prime importance.

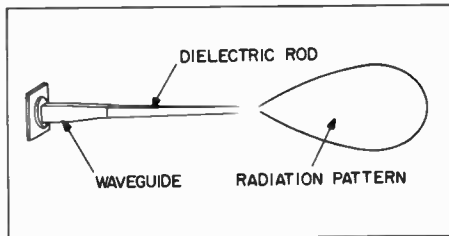

Figure 22. Dielectric-Rod Antenna

Polyrod Arrays

A polyrod array has been developed for use with 10-centimeter radar. The array shown in figure 23 produces a beam which is 6.5 degrees wide vertically and 2 degrees wide horizontally. Scanning is produced with the polyrod array by feeding the units out of phase with each other, and varying the phase shift from one end of the antenna to the other. Much research is being done on dielectric rod antennas concerning radiation patterns and methods of feed.

HORN ANTENNAS

The horn antenna has not been used to any extent on radar equipment because of its disadvantages. The horn must be at least five or six wavelengths long to produce a beam

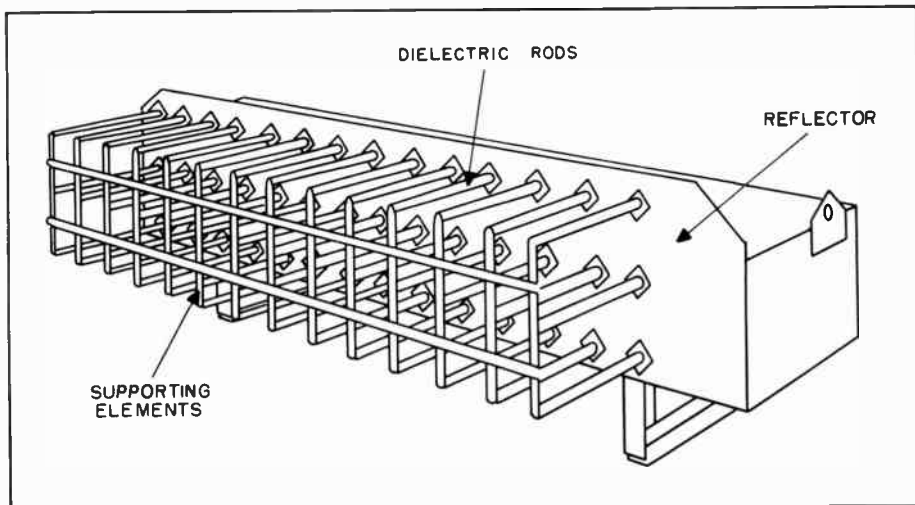

Figure 23. Array of End-Fire Polyrod Radiators

YAGI ANTENNAS

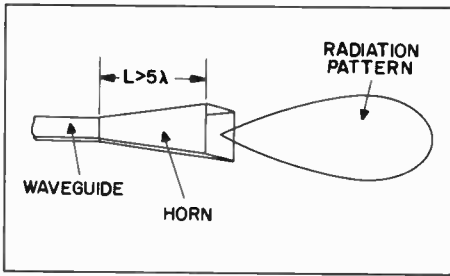

Figure 24. Horn Antenna

narrow enough to be usable. Shorter horns produce a beam that is too wide for radar. The horn is fed at the small end, usually by a waveguide. A horn designed for operation at frequencies where coaxial cable can be used would be too large to be practicable. A typical horn antenna, with its method of feed and its radiation pattern, is shown in figure 24.

The principal application of horn antennas was on Japanese ships during World War II. The antenna, as used by the Japanese, had a wide beam which caused elevation and azimuth inaccuracies. It also had a relatively short maximum range due to the spreading of the transmitted energy in the wide beam. The gain of the antenna was low because of its small frontal area.

The Yagi antenna (figure 25) consists of a driven dipole, a reflector, and several directors. This antenna, named after its inventor, is an end-fire array as is shown by the radiation pattern in figure 25. The beam is too wide for the antenna to be very accurate in elevation. It can be seen from figure 25 that the reflector is longer than the driven element, and that the directors are shorter than the driven element.

The Yagi antenna for aircraft use allows the aircraft to home on a land or air target. Since the beam of the Yagi is too wide for use of one antenna alone, two antennas are used, as shown in figure 26A. A lobing switch causes the antennas to be excited alternately. By comparison of the returned echo heights, as shown in figure 26B, the accuracy can be improved. The Yagi antenna was used with the ASB radar set for homing on a target.

EAGLE SCANNER (AN/APQ-7)

The radiation element of the AN/APQ-7, an aircraft radar, consists of 250 dipoles mounted as shown in figure 27. A number of dipoles lined

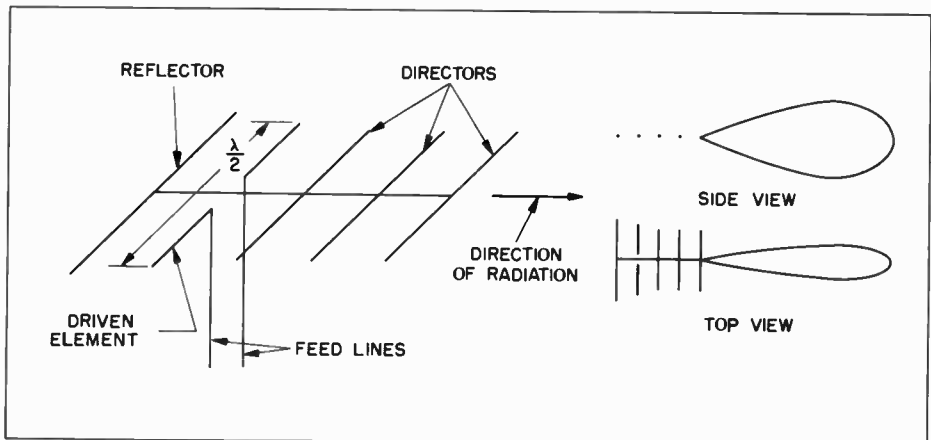

Figure 25. Yagi Antenna and Radiation Pattern

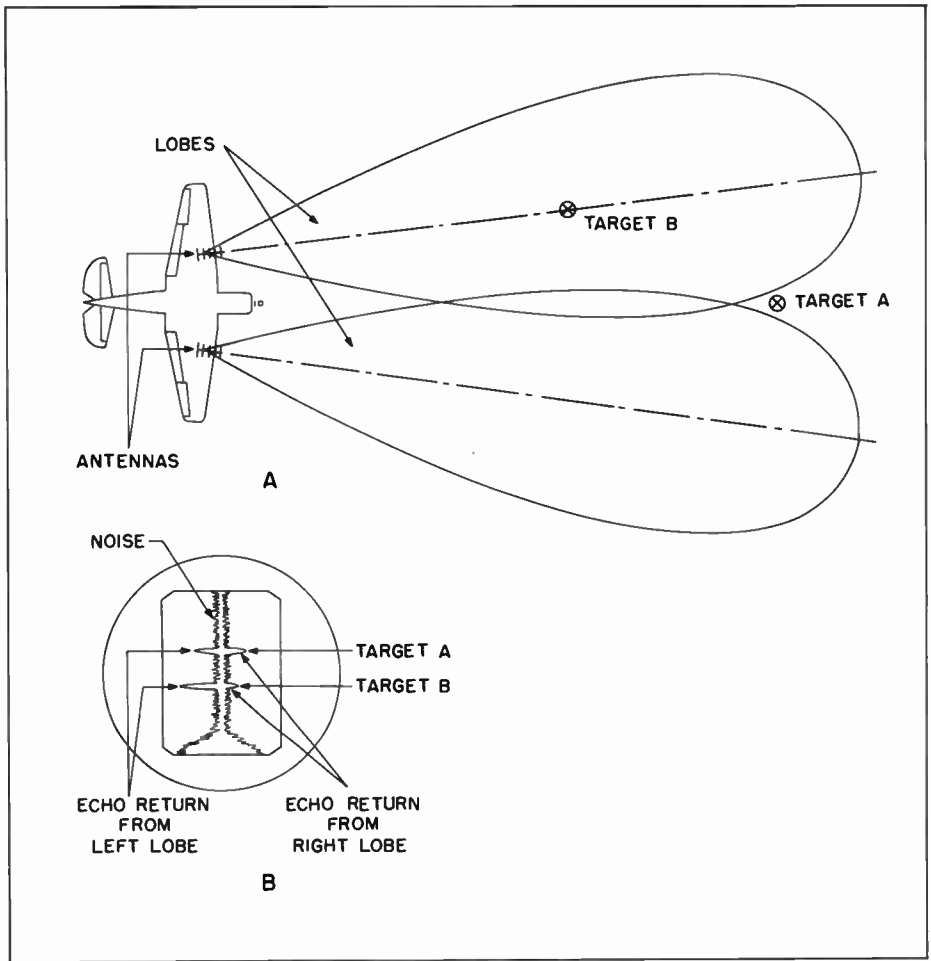

Figure 26. Yagi Antennas Used for Lobing

up in this manner and properly phased gives an azimuth beam of 0.4 to 0.5 degree and a vertical beam of approximately 30 degrees. Alternate dipoles are reversed by 180 degrees to give a spacing less than a wavelength in air, and hence to eliminate higher-order lobes in the radiation pattern. The beam can be made to scan in azimuth if the relative phases of the dipoles are varied. If all of the dipoles are excited in phase, the beam is broadside to the array and is directed straight ahead of the airplane on which it is mounted. The

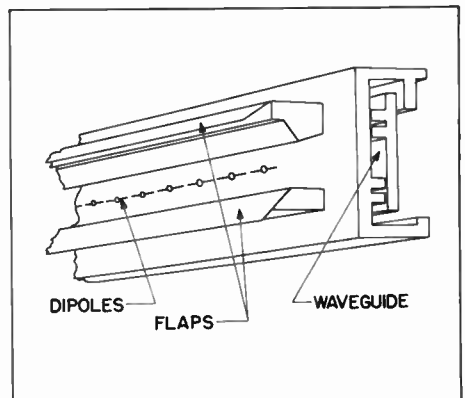

Figure 27. Dipole and Waveguide of AN/APQ-7 Eagle Scanner

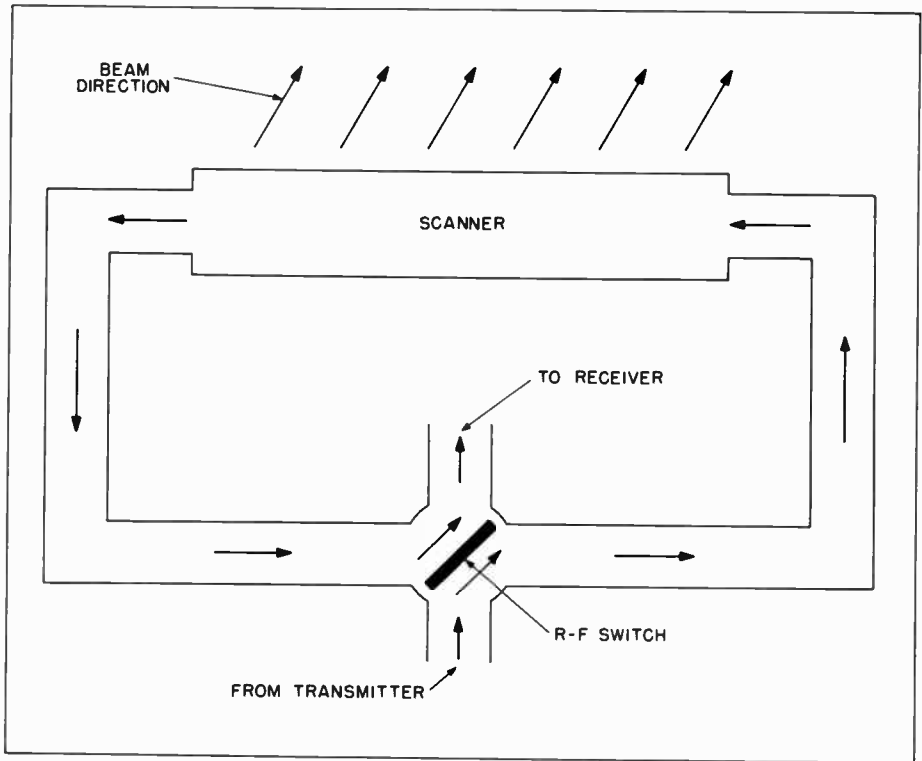

Figure 28. Energy Flow in Waveguide of Eagle Scanner

dipoles are excited by probes inserted into a waveguide back of the dipoles. If the waveguide is 1.2 inches wide, all of the elements are fed in phase, but if the waveguide is narrowed to 0.66 inch, a phase shift is caused to appear as the beam moves along the waveguide. The phase shift used in practice is 30 degrees, which moves the radiation pattern of the antenna by 30 degrees. Assume that the energy is propagated in the waveguide from left to right; then as the width of the waveguide is decreased and increased between the limits mentioned, the beam is scanned from straight ahead to 30 degrees to the left and back again. The opposite is true when the antenna is fed from the opposite end, which produces a 60-degree scan. A simple version of the feed system of the eagle scanner is shown in figure

28. The scanner is alternately fed from the right and the left ends, the energy being directed by the r-f switch. The width of the waveguide is varied by a motor drive, which gives a scanning rate of 60 degrees in $\frac{1}{2}$ second. The eagle scanner can be mounted in the leading edge of an airplane wing or in a separate airfoil. Eagle scanners were installed on about 300 bombers during World War II.

SLOT ANTENNAS

If a slot approximately one-half wavelength long is cut in a waveguide carrying r-f energy, energy will be radiated from the slot, which functions as an antenna. If more slots are cut in the section of waveguide, the radiation is increased to a large amount, and very good directivity is obtained. There is no American radar

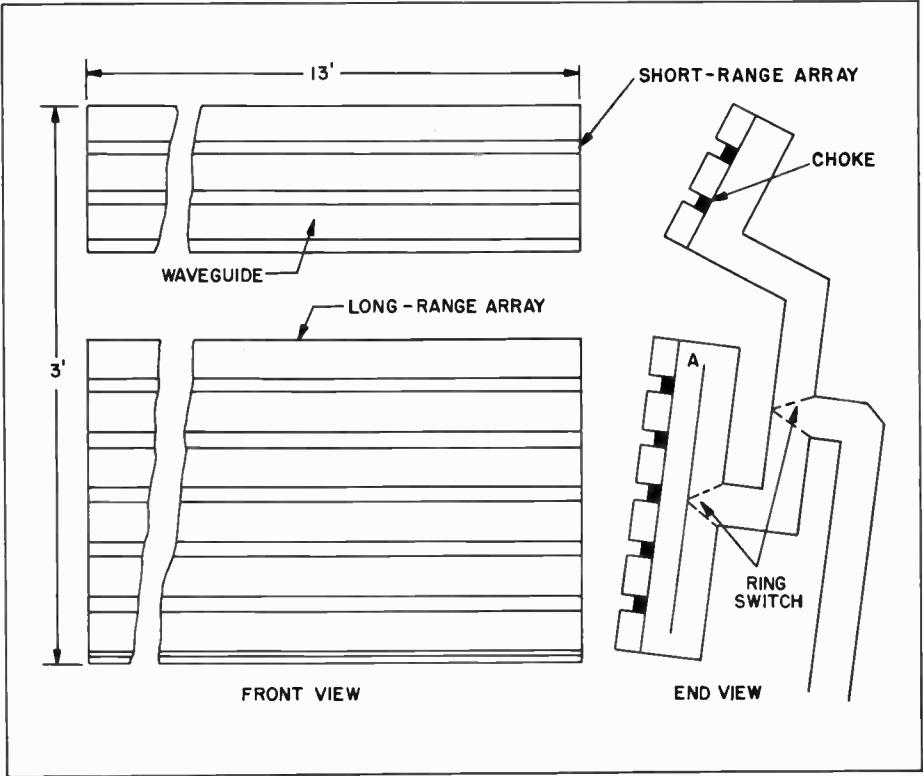

Figure 29. Front and Side Views of MK-6 Antenna

at present which makes use of this principle, but the method has possibilities, as can be shown by an investigation of the Canadian No. 4, Mark 6 anti-aircraft radar.

The Mk 6 radar is used entirely for aircraft search. Its maximum range is 200,000 yards, with dependable target detection at 190,000 yards. This exceptionally great maximum range of the Mk 6 is due primarily to the slot radiator antenna used. The antenna efficiency is very high compared to that of the parabolic reflector type. With the parabolic type, the radiating dipole tends to radiate in all directions. Hence, a reflector plate is used to direct the energy into the reflector. This reflector plate is relatively inefficient because it does not reflect all of the energy in the correct direction, and because it absorbs some of the

energy. When the energy arrives at the parabolic reflector, more inefficiency results because of the absorption of energy by the parabolic reflector and because the paraboloid is not perfect and does not form all of the energy into a beam. The antenna for the Mk 6 has none of these losses; therefore, more of the energy produced by the radar transmitter is formed into a beam and sent into the target area.

The antenna for the Mk 6 consists of two antenna arrays—a long-range array and a short-range array. The long-range array, shown in figure 29, consists of six stacked waveguide radiating units. The waveguide sections are 13 feet long and each has 50 rectangular slots in its front face. The slots act as 0.5-wavelength radiating elements, and are displaced alter-

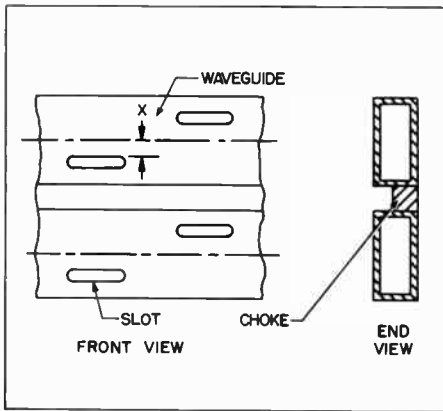

Figure 30. Details of Slots in Waveguide of MK-6 Antenna

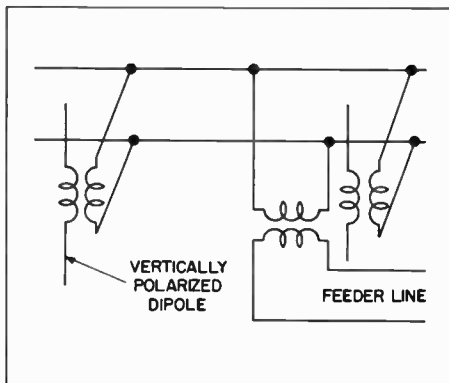

Figure 31. Equivalent Circuit of Antenna System Shown in Figures 29 and 30

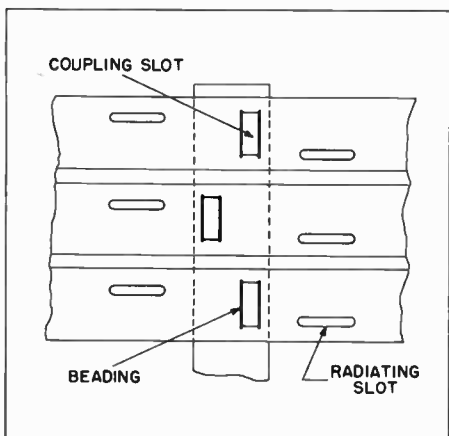

Figure 32. Feeder for Short-Range Array of MK-6 Antenna

nately above and below the center line of the waveguide. The slots are covered by layers of acetate tape, and dry air is circulated through the waveguide sections. The short-range array consists of three similar stacked waveguides.

The feed system consists of waveguide. R-f energy can be fed to either the short- or the long-range array and to either the top or the bottom of the long-range array.

Theory of Operation

Each slot acts as a vertically polarized radiating element 0.5 wavelength long. The length of each slot is corrected slightly to compensate for its shape, position, and covering material. There is a 180-degree phase shift from one slot to the next. The elements are fed in phase; an additional 180-degree phase shift is introduced by staggering them alternately above and below the center line of the waveguide (figure 30).

The series of slots in the waveguide is equivalent to a series of vertically polarized dipoles coupled in parallel through transformers from a transmission line. Varying distance X (figure 30) is equivalent to varying the shunting impedance of the dipoles. Placing the slot above and below the center line of the waveguide is equivalent to reversing the phase of the transformer. The equivalent circuit is shown in figure 31.

Power Feed

Power is fed to the radiating units from a vertical waveguide section located behind the center of the array (figure 32). Coupling to the radiating unit is made by means of slots similar to the radiating slots, except that they are larger and have beading along the edges to prevent r-f breakdown. The r-f feed slots are one-half wavelength apart, and are staggered to

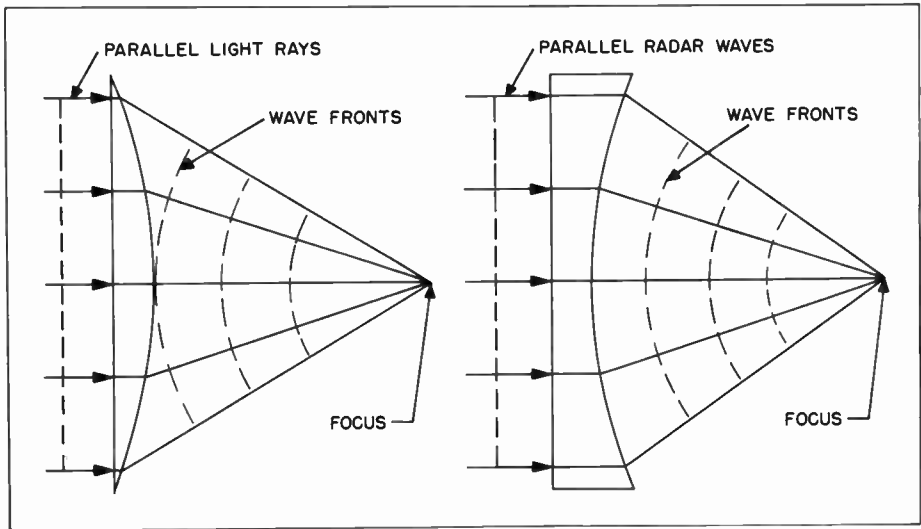

Figure 33. Comparison of Glass Lens Focusing Light to Metal Lens Focusing Radar Energy

feed each unit the correct amount of energy and in the correct phase. To prevent mutual coupling between the radiating units, quarter-wave chokes are employed (figure 30).

The power feed to the long-range array is similar to that for the short-range array. If the antenna is fed at the top (point A, figure 29) there is a progressive phase lag from top to bottom, which tilts the beam down 3.25 degrees. If the array is fed at the bottom, the beam is tilted up 3.25 degrees, giving a 6.5-degree difference between the high and low positions of the beam. A ring switch, (figure 29) is used to switch from the high to the low position. The ring switch consists of a loop in the waveguide, and acts as a series resonant circuit, shorting out the part of the waveguide across which it is placed.

The Mk 6 transmitting tube is a magnetron which has a peak power of 600 kilowatts. The magnetron is conventionally fired by a thyatron and produces a 1-microsecond pulse.

The beam of the long-range array is 2 degrees in azimuth and 15 degrees in elevation. The speed of revolution of the antenna is 18 revolutions per minute. The important result produced by the Mk 6 is the exceptional maximum range of 200,000 yards, which is due mainly to the high efficiency of the antenna.

LENS ANTENNAS

The theory of lens antennas involves the optical properties of short-wavelength radar waves. Light waves have a lower velocity in a dielectric (such as glass) than in free space. Light rays at the edges of a convex glass lens travel through less glass than those at the center and therefore emerge ahead of the center rays, with respect to phase. A wave front, connecting points of the same phase, thus appears concave if parallel light rays are passing through a convex lens. This change in contour of the wave front is due to the refraction of the light rays, and results in the focusing of the light beam at a point (figure 33).



MERLE E. MCDUGALL was born March 14, 1923, in Waterloo, Iowa. After graduating from high school, in 1940, he worked as a teletype technician until entering the U. S. Navy in February, 1943.

During the War, Mr. McDougall gained extensive experience in the maintenance and servicing of fleet radio and radar equipment, in his capacity as Radio Technician.

After his military discharge, in December, 1945, he attended the University of Notre Dame, where, in 1950, he received the degree of Bachelor of Science in Electrical Engineering. During this period of schooling, he gained a great deal of useful experience by servicing radio and television equipment on a part-time basis.

Following graduation, he taught radio and television at the Western Radio Institute (Denver, Colorado) until January, 1951, at which time he joined the Philco TechRep Division as a Field Engineer.

In addition to holding a First-Class Radiotelephone license, Mr. McDougall has been a member of the AIEE and the IRE since 1946.

In the case of short radar waves, the parallel plates of the antenna lens act like waveguides—they increase the phase velocity of the waves. The antenna lens, therefore, must be made concave rather than convex, so that the edge waves pass between the thicker plates, and thus have their phase velocity increased more than the waves at the center of the lens. This results in a concave wave front, as in the case of the glass lens passing light waves, and thus a focusing action takes place. This action holds for parallel rays being focused by the lens. The reverse action can also take place. A wave originating at the focus of the lens emerges from the lens as a beam of parallel rays. For proper focusing action the plates of the metal lens an-

tenna must be spaced greater than a half-wavelength apart. Since the plates are parallel to the electric vector of the electromagnetic radio wave, and since an electromagnetic wave induces currents only in the direction of the electric vector, the supports separating the plate have little effect on the operation of the lens antenna.

The back side of the T33 lens antenna is concave, and the face of the lens is stepped back each time a thickness is reached equal to a phase advance of one wavelength. This is called zoning the lens (figure 34, top view). Zoning has the advantage of reducing the over-all thickness of the lens, and, therefore, the size and weight of the antenna. When the an-

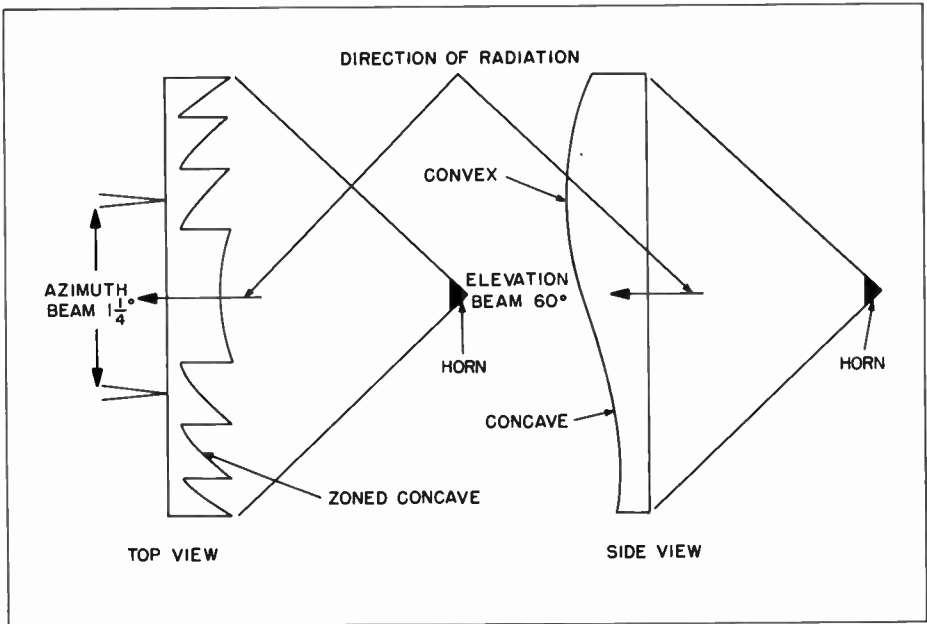

Figure 34. T33 Lens Antenna

tenna is zoned, the tolerance between the metal plates is not as critical as in thicker-lens antenna, this makes the zoned antenna easier to construct.

The front side of the T33 lens affects the vertical distribution of radiated energy. Its surface is effectively concave near the bottom, and convex near the top (figure 34, side view). The lower concave surface pulls the emitted rays together from their normal divergent paths, preventing the antenna radiation from going into the ground. The upper convex surface spreads the waves, giving a broad elevation pattern. The elevation radiation pattern of the T33 lens antenna approaches a cosecant-squared pattern, such as that of the distorted paraboloid shown in figure 10.

SUMMARY

There are many more types of antennas and scans than those described in the preceding discussion. The type to be used with a particular radar is determined primarily by the purpose of the radar. First, the criteria for beam width which will provide the necessary accuracy and range are set up, and an antenna which will fill the qualifications is selected. Other factors must then be considered, of which portability, ruggedness, and ease of manufacture are only a few. This has been only a survey of the available types of antennas and their characteristics; a complete coverage of the theory concerned with antenna design can be obtained from engineering texts on the subject.



What's Your Answer?

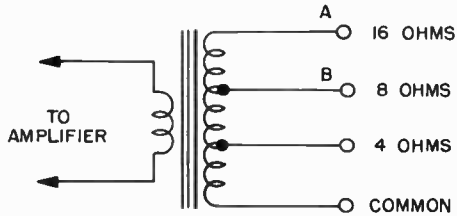

This month's problem, submitted by our own Gail Woodward, looks too simple for most people, but we suggest that you check your answer carefully.

We have a conventional output transformer in an amplifier circuit, as shown in the drawing. 4-, 8-, and 16-ohm taps are available. What impedance would have to be connected between points A and B to afford a proper match?

(Answer next month)

Solution to _____

Last Month's "What's Your Answer?"

The conditions shown in last month's problem could easily be obtained in a vacuum tube containing a secondary emitter. For the tube shown, the element at the 100-volt potential would have to emit 5 ma. more than it received from the cathode, thus providing a plate current which exceeds the *hot* cathode current by 5 ma.

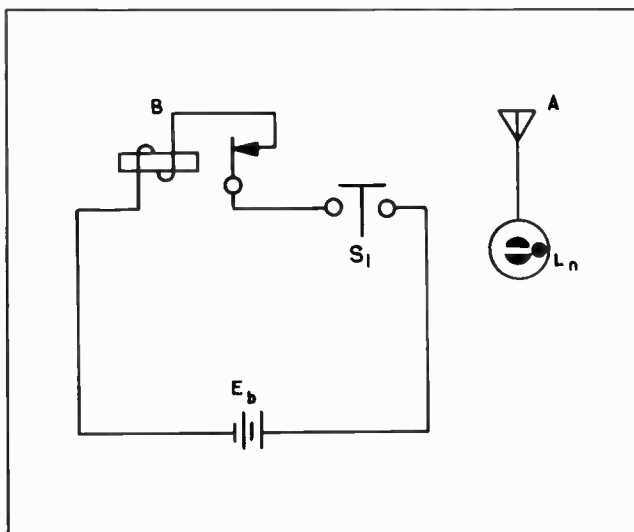

Schematic Diagram of Line Checker for Airborne IFF Transponders

A Simple, Easily Constructed Unit for Pre-Flight Checking of Airborne IFF Transponders

THIS SIMPLE UNIT can be used as a quick check to determine the condition of a transponder. To operate, the unit is held near the aircraft transponder antenna and a push button is pressed. If the transponder is operating, a neon lamp will light.

The schematic diagram is shown in the figure. The parts list is shown in Table I.

TABLE I. PARTS LIST FOR
TRANSPONDER TESTER

QUANTITY	ITEM	SYMBOL
1 each	Switch, pushbutton, SPST	S_1
1 each	Lamp, neon (Ne-2 or Ne-3)	L_n
1 each	Battery, 6-volt (BA-200)	E_b
1 each	Buzzer, 6-volt, door-bell type	B
1 each	Wire, antenna, 25 ga., approx. 7"	A

The parts can be mounted in a small box, or if desired they can be

secured together with masking tape, thus making a very small, compact unit.

The circuit functions as a transmitter when the buzzer operates, because of the noise-like character of an interrupted current. Of course, the output is not at one frequency, but covers an extremely wide band of frequencies. The power produced in this manner is not sufficient to cause the neon lamp to light, but if the transponder sends a reply back, the neon lamp will light (if it is held sufficiently close to the transponder antenna).

This device will show whether a transponder will reply to interrogation, but will not check frequency, power, coding, or sensitivity; therefore, it is recommended that regular test equipment be used for 25-hour and subsequent checks.

Bud Compton
Philco Field Engineer

The BULLETIN is now being planned at least three issues in advance, and we can promise you that some very practical, solidly useful data will appear in each of the issues now being prepared. For example, have you ever wondered about the dangers involved in operating radio and radar equipment in the vicinity of dynamite-blasting operations? We have a complete story on that coming up shortly. Would you like more information on the operation of single-phase and two-phase equipment from three-phase power sources? We are processing another article by Zygmund J. Bara on this pertinent subject.

Perhaps your need is for more information on the use of Signal Corps supply publications. If so, you will find a new article by ex-Philco Field Engineer Cal Graf most worthwhile.

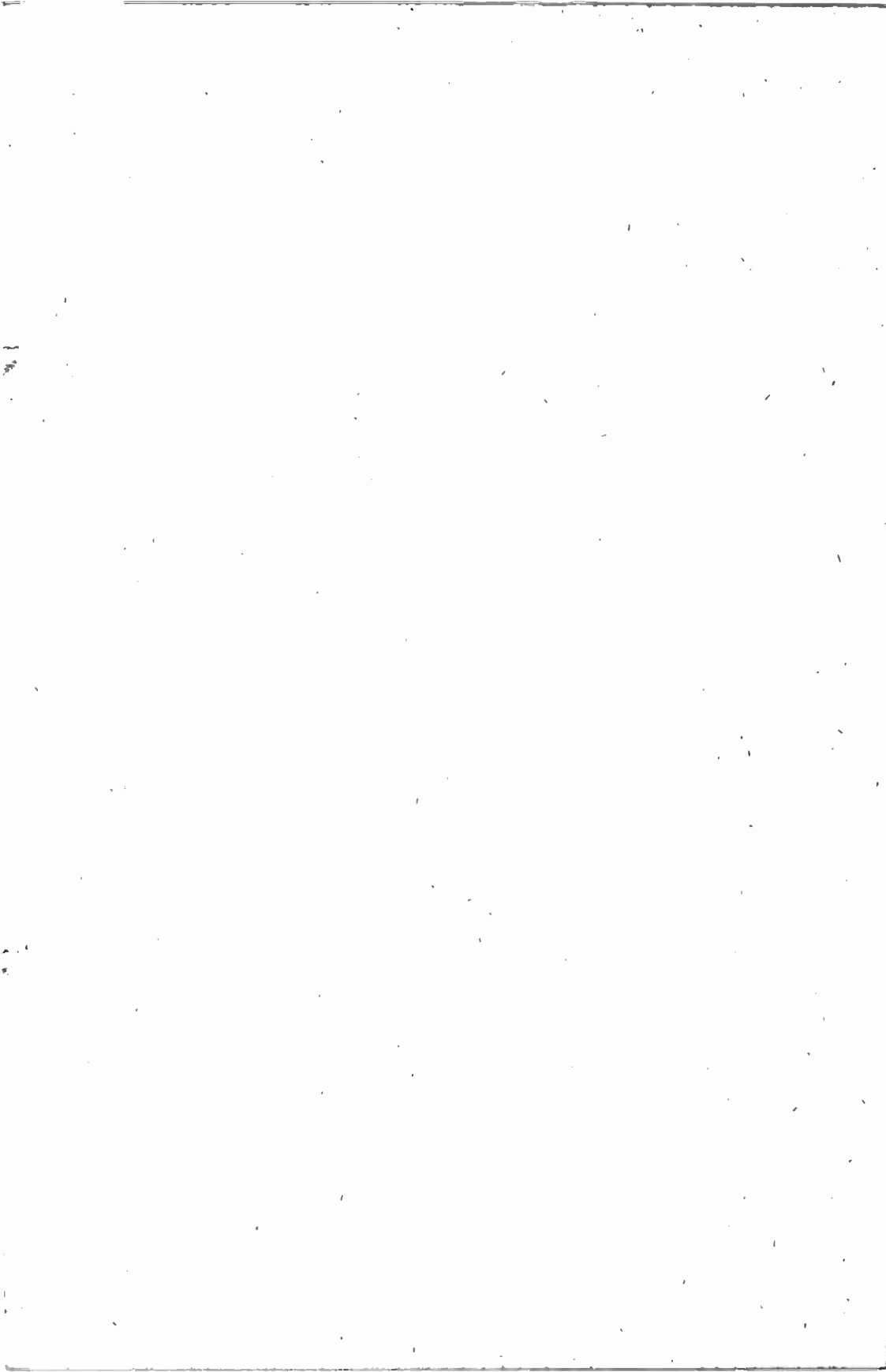



PHILCO

TECHREP DIVISION BULLETIN

Volume 6

March-April, 1956

No. 2

In This Issue...

Editorial.....	<i>John E. Remick</i>	1
Collegiate Use of The Philco Training Materials.....	<i>Harvey Mertz</i>	2
"What's Your Answer?".....		8
D-C Analog Computers (Part 2).....	<i>Allen J. MacKinnon</i>	9
Forward Scatter of Radio Waves (Part 1).....		13
MTI Vectors.....	<i>Robert D. Hunter</i>	21
Solution to January-February "What's Your Answer?".....		27
Screen Room Maintenance.....		28