

Mullard

Outlook

Australian Edition

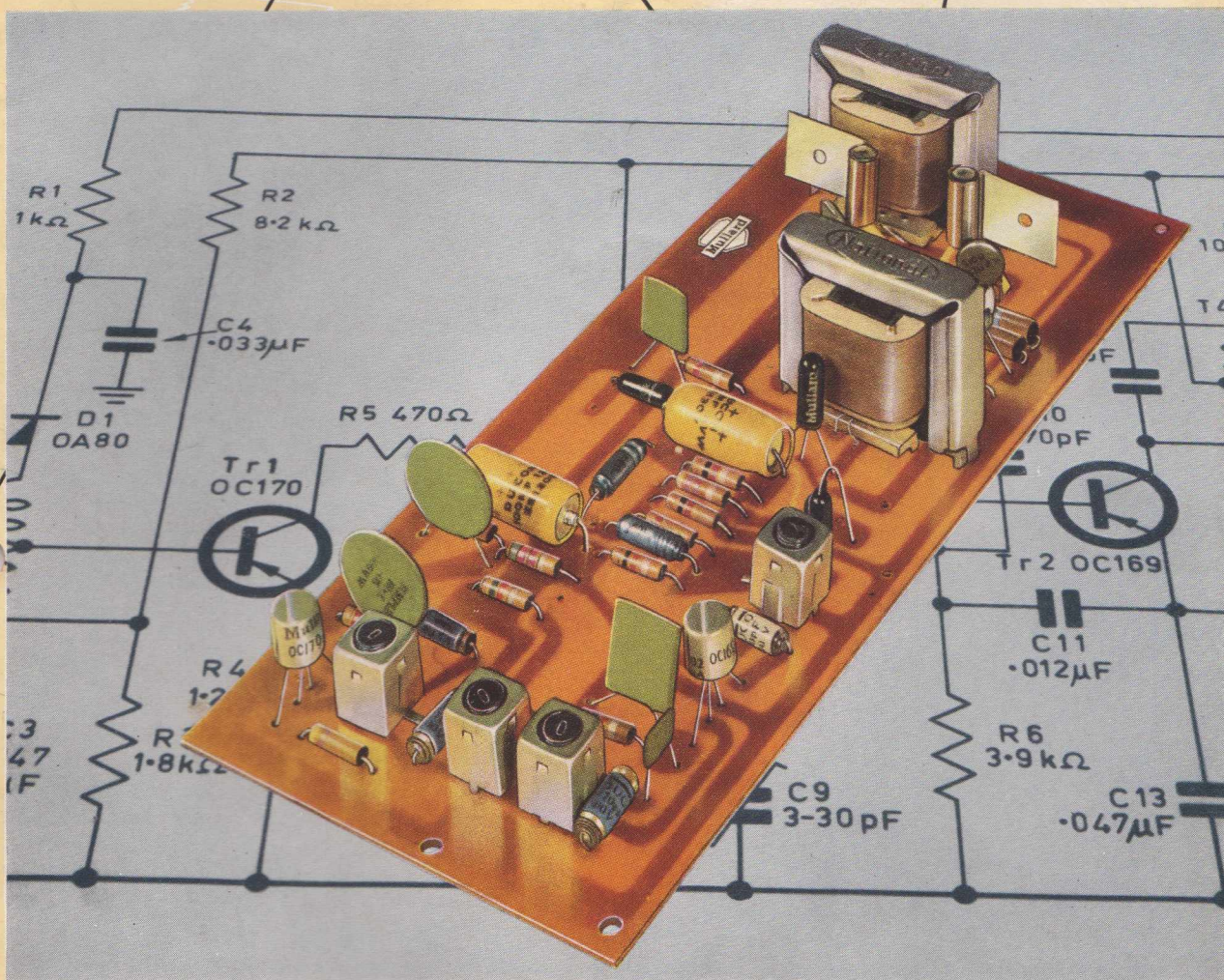

VOL. 4 No.3 MAY-JUNE
1961



MULLARD - AUSTRALIA PTY. LTD.



VOL. 4—No. 3

MAY-JUNE, 1961

Editorial Office:
35-43 Clarence Street, Sydney.
Telephone—BX 2006.

Editor:
JOERN BORK

All rights reserved by Mullard-Australia Pty. Ltd., Sydney. Information given in this publication does not imply a licence under any patent. Original articles or illustrations reproduced in whole or in part must be accompanied by full acknowledgement: Mullard Outlook, Australian Edition.

CONTENTS

	Page
Editorial	26
Viewpoint with Mullard	27
A Cordless Transistor Receiver	28
Quality Control	32
Transistor Radios	34
Simple Oscilloscope Measurements	35
New Photomultiplier Tube for Ultra-Violet Applications	36
New Educational Filmstrip— The History of TV	36
Amateur Experimenters' Column	36

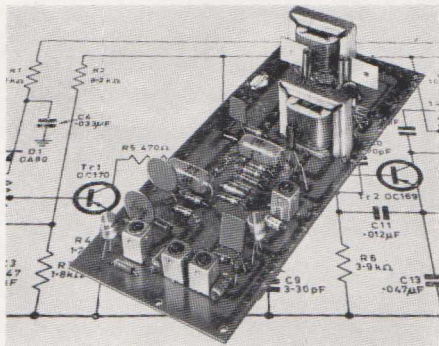

Printed-Circuit 5-Transistor Receiver

This illustration shows the low cost and simplicity of construction attainable in the modern cordless mantel receiver. Design details are given on page 28.

MULLARD-AUSTRALIA PTY. LTD.

35-43 CLARENCE STREET, SYDNEY
Phone: BX 2006

123-129 VICTORIA PDE., COLLINGWOOD, N.5
VICTORIA
Phone: 41 6644

Associated with
MULLARD LTD., LONDON.

The Healthy A M Receiver Market

With the emphasis at the present time on the Commonwealth Census and attention given to market surveys, rate of obsolescence and so on, an appraisal of the A M receiver sales potential is most enlightening, and elsewhere in this issue some figures are given about the possible A M receiver market up to 1970.

With obsolescence one of the factors governing consumer product merchandising, statistics, polls and market surveys indicate that the sales for A M receivers will steadily increase to approximately 700,000 in 1970.

Two of the basic factors in this regard are, first, the efforts of the A M Stations themselves, to strengthen their medium in the light of television and, secondly, the belief in this medium by the retailers and the set manufacturers. For the latter, transistors provide the basis of a new field of opportunity and in this regard, for non-technical and technical readers, in this issue some of the factors of a low cost and adequate performance cordless A M receiver are discussed.

The theme shows that it is possible with five of the latest Mullard transistors to challenge the 4/5 valve mantel of the past. On the other hand, if basic cost permits additional transistors to be used, a new form of entertainment product suitable for deep fringe reception is inevitable, therefore, we must contemplate not only the demise of the 4/5 valve set, but also the sales growth of a complete new approach to receiver performance so good in terms of signal to noise ratio and sensitivity that the deep fringe barrier virtually disappears.

M.A.B.

MULLARD DISTRIBUTORS:-

NEW SOUTH WALES

Martin de Launay Pty. Ltd.
287 Clarence Street, Sydney
Phone: BX 5834
Cnr. King & Darby Streets,
Newcastle Phone: B 4741

SOUTH AUSTRALIA

Agents:
Woollard & Crabbe Limited
180 Wright Street West,
Adelaide Phone: LA 4713

QUEENSLAND

B. Martin Pty. Limited
35 Charlotte Street, Brisbane
Phone: 2 1744

WESTERN AUSTRALIA

Harris, Scarle & Sandovers
Limited
691 Hay Street, Perth
Phone: 23 0131
Sales & Service
495 Newcastle Street, Perth
Phones: 28 1171, 28 0131

TASMANIA

Medhursts Wholesale Ltd.
163 Collins Street, Hobart
Phone: 2 2911
136 Wellington Street,
Launceston Phone: 2 2091
106 Wilson Street, Burnie
Phone: 1919

VICTORIA

Howard Electrical & Radio
Company
Vere Street, Richmond
Phone: JB 4716

and all leading wholesalers throughout the Commonwealth

VIEWPOINT WITH MULLARD

SELLING CORDLESS RECEIVERS

SOMETHING NEW

Most retailers are now alive to this exciting new concept of "Old Faithful"—the A M home radio now proudly uninhibited as a full-blooded home set without the tyranny of a power mains lead or the search for an unoccupied power point; nor the uncertain termination, through multiple two-way adaptors, cluttering the outlets and feeding standard lamps, radiators, clocks, fans and so on.

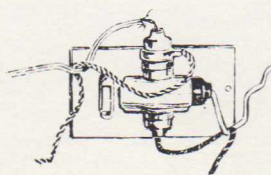

A receiver to place *anywhere* in the room and in *any* room, with performance equal to an A C mains receiver but no longer anchored with a power cord. Something new to demonstrate and sell—this—is a cordless receiver.

(See also *Outlook*, Vol. 3, No. 6, Nov.-Dec., 1960. Ed.)

CASE FOR THE CORDLESS RECEIVER

Some extravagant claims are made regarding the use of portables in the home but the smaller sets and smaller batteries dictate an anaemic, less economic long-term result and highlight the case for a special receiver, battery-powered and styled for the home rather than a portable—and engineered to give a sufficiently large undistorted output. Given receivers of this type, the day can be foreseen when the small A C set will almost disappear, displaced by its battery-operated transistorised counterpart and the portable used mainly for its designed purpose—as a portable.

DEMONSTRATE AS A MAINS RECEIVER

It is most difficult, almost impossible, to tell the difference between a well-engineered cordless receiver and a mains-operated receiver and thus the cordless receiver needs to be demonstrated as a mains-operated set and full capital made of the impression such a receiver will create when filling a room with its clear, round, high level of output, with customers looking for a mains cord only to find there isn't one!

NOT JUST A BATTERY RECEIVER

This must be firmly planted in the minds of prospective customers for the running costs are low and advantages high. Better the theme—a battery set, yes—but what a battery set, and what a life from the low-cost batteries! Make a feature of it and picture them coming perhaps twice a year to your store for a new battery with each time the chance of cementing confidence and making other sales.

SCOPE

If radiograms are considered home programme selection devices; and small A C mains receivers second sets, more recently transistor-operated portable receivers have been taking the place of the "second" set. The obvious advantage of the receiver being that it is portable, on the other hand there are some important disadvantages for, unless large, it does not possess the tone quality to which one is accustomed for home listening and with lower battery life the listener puts up with considerable distortion as the battery runs down. Furthermore, it is in the interests of the retailer and the Industry to endeavour to sell two receivers—one a cordless receiver with good quality sound and extremely long battery life, and the other a true portable for outdoor listening. The cordless receiver opportunity is waiting, virtually untouched, the first receivers have appeared and retail prices are rapidly shaking down to a first-rate 'value for money' level.

CONFIDENCE IN A M RECEIVER MARKET

Whilst cordless receivers are only one section of the future A M receiver market, it is suggested that retailers be not unmindful of just what future the A M market holds, for after these first few years of television and what may have appeared to be the A M broadcasting fraternity bolstering the morale against the onslaught of how TV might affect them, it is now evident that not only is the A M receiver market holding (after a slight reverse) but actually gaining ground and it is estimated that the total A M receiver sales in Australia for 1961-62 will be approximately 460,000 with a steady increase to 700,000 in 1969-70. This,

MULLARD-AUSTRALIA PERSONALITIES

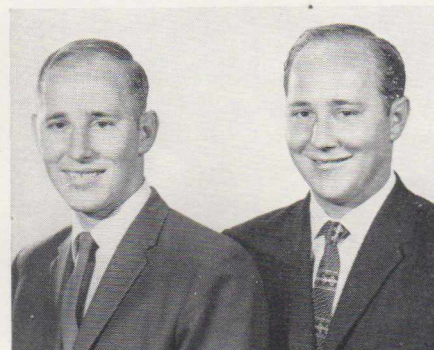

THE BROTHERS DENMEADE

Rather we should say, two of them—Bob and Jim—for there are another six from this well-known and well-respected family of the Parramatta district of N.S.W. Keen cricketers all, seven of the brothers play with the North Rocks Club, in three years defeated only once in the Parramatta District Cricket Association matches.

It is perhaps this co-operative and competitive family spirit that reflects in their helpful, keen and energetic activity as the Mullard entertainment valve sales team for Sydney and the near city areas.

Bob and Jim Denmeade were married about the same time and live within half a mile of each other. Each has a charming wife and three children, each of the same ages—and what else could one expect of twins!

of course, caters for increases in population, replacement of old sets and so on—surely a promising note for the retailer, at least as far as receiver unit sales are concerned.

BELIEVE IN A M RADIO

We must believe in A M radio if we are to sell it and accept that radio and television are two totally different media. Television more closely related to an image of the theatre and group enjoyment—radio more personal, a close and constant companion, used these days not so much to fill in time, but for a specific and positive purpose—a special musical programme, special sports commentary, news and so on, much as one chooses a book by a parti-

Continued on Page 36

A CORDLESS TRANSISTOR RECEIVER

This article shows how, with a total complement of five alloy-diffused junction transistors, it is possible to achieve a performance figure adequate for most purposes. A knowledge of the philosophy responsible for this circuit choice may assist readers to appreciate the engineering finesse which makes possible this inexpensive receiver designed to replace the 4/5-valve mantel set so popular in the past.

The receiver described uses the new alloy diffused junction transistors, types OC170 and OC169, as oscillator-mixer and IF amplifier respectively, in a straight-forward design without neutralizing components. Effective automatic gain control is achieved by damping the antenna circuit, without shifting the operating point of the IF amplifier. The audio frequency stages consist of an OC75 Class A driver followed by 2-OC74 output transistors in Class B push-pull. The maximum undistorted power output is 500 mW 140 μ V/m for 50 mW output. (See note.)

AUDIO FREQUENCY STAGE

The design is conventional except for the use of the OC75 concurrently as the audio driver and as an emitter follower DC amplifier for AGC. The OC74's are biased to a quiescent current of 5mA by a voltage divider network incorporating an NTC resistor for DC stabilisation. In order to limit spread in quiescent current, a variable resistor (R17) is recommended. However, it is possible to select a fixed value for R17 and change the value in the course of manufacture in those cases when the quiescent current may be out of tolerance.

To limit the spread in audio stage gain, 6 dB of negative feedback is applied via R13. Since the value of this resistor is too high to disturb the operating condition of the driver transistor, a blocking capacitor is not required.

Considerations of operating cost might best be covered by the engineering services of the battery manufacturers. For a home receiver of this type with an average use of four to five hours per day, they recommend the use of one of the batteries especially developed for this service, in particular the Eveready type 286.

IF AMPLIFIER

The low impedance diode OA80 is used for high detection efficiency. In order to limit the change in detector circuit impedance with signal level it

Note: This sensitivity is approximately equal to 5 μ V measured through a 400 Ω 'dummy load' into the aerial coil of a typical valve receiver.

is given a forward bias of 90 mV by means of a potential divider network.

The IF amplifier stage must be designed with regard to AGC requirements. It will be seen that the demodulator diode will be required to produce 2 volts DC at the maximum permissible Tr2 collector-voltage-swing of 11V P-P. The required demodulator transformer turns ratio is, therefore, 1.5:1. The diode circuit input conductance (or effective damping) being 290 μ mho, the conductance seen by Tr2 collector is 130 μ mho, plus the conductance of the IF transformer. With the given circuit dimensioning, $Q_o = 160$, $Q_w = 50$; total conductance at Tr2 collector is 196 μ mho.

For a stability factor of four in the IF amplifier:

$$\begin{aligned} G_{in} G_{out} &= 2\omega C G_m \\ &= 2 \times 2\pi \times 455 \times 10^3 \times \\ &\quad 1.8 \times 10^{-12} \times 36 \times 10^{-3} \\ &= 370 \times 10^{-9} \text{ mho}^2 \\ G_{out} &= 196 \mu\text{mho} \\ \therefore G_{in} &= 1.89 \times 10^{-3} \text{ mho} \end{aligned}$$

Since $Y_{11} = 0.4 \text{ mmho}$ plus capacitance, there remains for the source impedance:

$$g_s \geq 1.49 \times 10^{-3} \text{ mho}$$

In order to satisfy the selectivity requirement, a bandpass filter is used in the collector circuit of the mixer.

Miniature pot core assemblies are available providing a Q_o of 190 at 455 kc/s with a tuning capacitor of 470 pF. For $Q_w = 150$, $kQ_w = 1$, the required conductance across the whole secondary winding is 18 μ mho: the turns ratio is then—

$$\sqrt{\frac{1.89 \times 10^{-3}}{18 \times 10^{-6}}} = \sqrt{106} = 10.3:1$$

For a 68-turn winding, the tapping point is chosen at 6 turns.

$$\text{Stage gain: } \frac{G_m^2}{g_i G_{out}} =$$

$$\frac{36 \times 36 \times 10^{-6}}{0.4 \times 10^{-3} \times 196 \times 10^{-6}} =$$

$$16\,500 = 42.2 \text{ dB}$$

Insertion loss of demodulator trans-

$$\text{former: } \frac{196}{130} = 1.51 : 1.8 \text{ dB}$$

$$\text{Hence stage gain} = 40.4 \text{ dB}$$

NOTE ON SELECTIVITY

The receiver selectivity at high field strength when the antenna circuit is damped, is determined by the selectivity at 455 kc/s.

An IF amplifier design of low cost was attempted using a simple isochronous transformer instead of a bandpass filter between Tr1 and Tr2. The skirt rejection of this circuit was:

$$\begin{aligned} \pm 3 \text{ kc/s} &: 5.2 \text{ dB} \\ \pm 10 \text{ kc/s} &: 17.7 \text{ dB} \\ \pm 20 \text{ kc/s} &: 32.4 \text{ dB} \end{aligned}$$

It will be seen that the selectivity is relatively poor, the worst consequence of which is the prevalence of heterodyne whistles over a band of frequencies centred upon the second harmonic of the IF. However, the limits of selectivity obtainable with a carefully designed pair of isochronous tuned circuits (Q_o being equal to or greater than 200) were not attained in this experiment, and improved results could be obtained at the expense of audio frequency response.

MIXER STAGE

The mixer-oscillator operates into a conductance of 18 μ mho. For a stability factor of 3 at $Y_c = 1\text{mA}$, $f = 1.6 \text{ Mc/s}$,

$$\begin{aligned} G_{in} G_{out} &\geq 18.5 \times 10^{-9} \text{ mho}^2 \\ \text{then } G_{in} &\geq 1.03 \times 10^{-3} \text{ mho} \end{aligned}$$

From considerations of the minimum noise factor and reasonable independence of aerial circuit Q of the transistor input conductance, g_s is chosen at $0.8 \times 10^{-3} \text{ mho}$ giving $G_{in} = 1.2 \times 10^{-3} \text{ mho}$.

Taking the mixer conversion conductance $\approx 18 \times 10^{-3} \text{ mho}$,

$$\begin{aligned} \frac{G_m^2}{g_i G_{out}} &= \frac{18 \times 18 \times 10^{-6}}{0.4 \times 10^{-3} \times 18 \times 10^{-6}} \\ &= 4,500 : 46.5 \text{ dB} \end{aligned}$$

Transformer insertion loss =

$$\frac{18 \times 10^{-6}}{2.94 \times 10^{-6}} : 7.9 \text{ dB}$$

Stage gain = 38.6 dB

AGC CIRCUIT

As has been stated, the OC75 driver is used as a DC power amplifier for AGC purposes, being required to produce a change of 2 volts across 1,000 Ω . It is required that AGC action should begin at a field strength of approximately 2 mV/m, when the signal/noise ratio is 40 dB and maintain control to a maximum field strength of 1 V/m. Since without AGC the receiver would overload at a field strength of 3.3 mV/m, the required reduction of gain a 1 V/m is 300:1.

An OA80 diode, placed in parallel with part of the aerial winding and drawing a current of 300 μ A is used to produce this reduction in gain. The total change in voltage across the mixer base potential divider, diode and 1,000 Ω filter resistor is then 1V (the voltage at the mixer base being used to provide the necessary AGC delay). If the quiescent current of the OC75 is 0.5 mA and the load emitter resistance is 1,000 Ω , the AGC action begins when the current in the OC75 reaches 1.5 mA and is at the maximum when it reaches 2.7 mA. Although under low signal conditions the driver is not biased suitably to drive the output stage fully, it is suitably biased when useful signals are available. This method of automatic gain control is

preferred to the customary practice of changing the operating condition of one or more IF amplifiers.

This method has the disadvantage that a change in transistor operating conditions produces a change in input and output admittance thus detuning the IF transformer. A further disadvantage is that a reduction in emitter current does not necessarily result in the required reduction in gain.

“Double spotting” effects on strong signals, which are so prevalent in transistor receivers using conventional methods of automatic gain control, do not appear in this receiver.

MEASURED RESULTS

(i) R.F. Stages

Sensitivity for 50 mW output:

600 kc/s:	145 μ V/m
1000 kc/s:	140 μ V/m
1500 kc/s:	120 μ V/m

Selectivity 455 kc/s:

\pm 3 kc/s:	— 6 dB
\pm 10 kc/s:	— 34 dB
\pm 20 kc/s:	— 50 dB

Selectivity 1000 kc/s:

(low signal input)	
\pm 3 kc/s:	— 6 dB
\pm 10 kc/s:	— 35 dB
\pm 20 kc/s:	— 60 dB

AGC characteristic:

3 dB variation in output level over the range, 1.8 mV/m to 630 mV/m.

(ii) Audio Stages

(All measurements were made with a generator of 5,000 Ω impedance connected between earth and the top of the volume control, the demodulator diode and capacitor being disconnected.)

Maximum power output 620 mW
Total distortion <5%

Input impedance (top of volume control 318 Ω
--	--------------------

Input current for 620 mW output	24 μ A rms
---------------------------------	----------------

Power gain 65 dB
------------	-------------

Negative feedback	6 dB
-------------------	------

(iii) Battery Drain

No Signal 14 mA
50 mW 32 mA
100 mW 45 mA
150 mW 53 mA
500 mW 105 mA

PRINTED CIRCUIT TECHNIQUE

For convenience, printed circuit boards were designed in the Mullard Applications Laboratory. Prototype receivers were also made on punch-boards and, provided that the suggested layout is followed, no difficulty should be encountered in obtaining the stated performance figures.

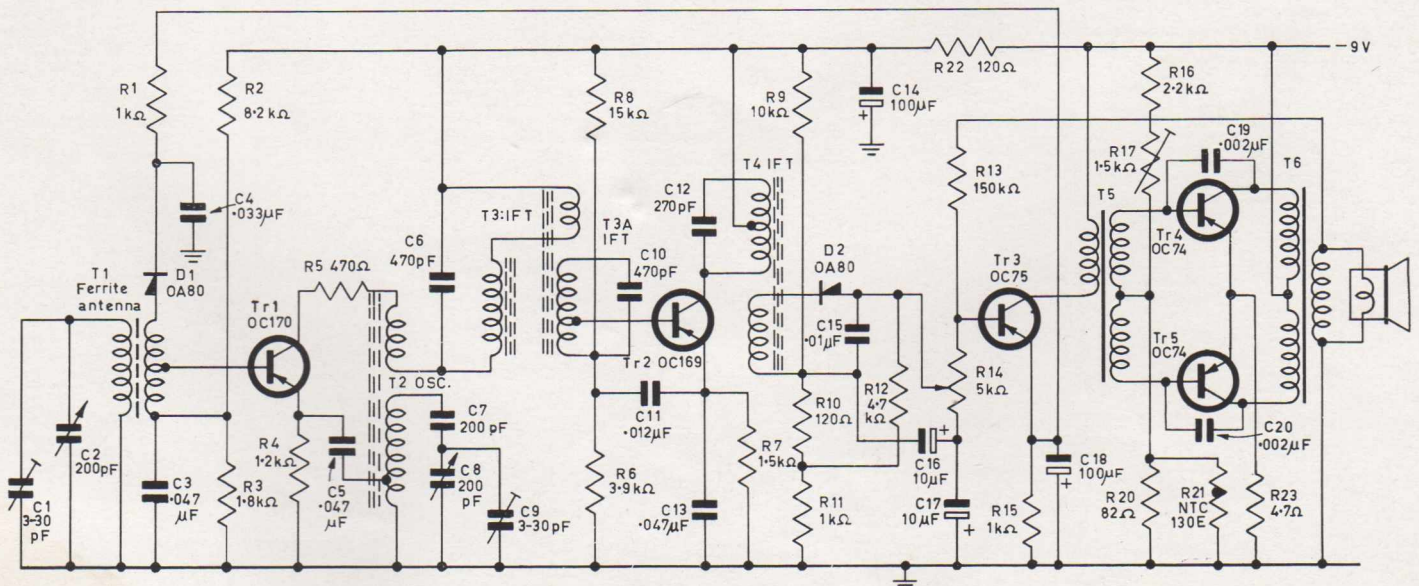

Complete circuit of receiver, incorporating five transistors.



COILS SPECIFICATION:

PARTS LIST

T1 ANTENNA TUNING COIL:

Single layer, wound on FX1247 rod.
 O.D. of former: 0.435"
 Wire: 20/44 B&S Posyn litz nylon covered.
 Primary: 67 turns.
 Secondary: 22 turns tapped at 3 turns from earthy end, secondary to be interwound with first part (earthy end) of primary.
 Overall length of winding: $1\frac{5}{16}$ "
 Q_o (600 kc/s): 270
 Q_o (1500 kc/s): 190

RESISTORS

Circuit Reference	Value	% Tolerance	Watt Rating
R1	1 kΩ	10	$\frac{1}{2}$
R2	8.2 kΩ	10	$\frac{1}{2}$
R3	1.8 kΩ	10	$\frac{1}{2}$
R4	1.2 kΩ	10	$\frac{1}{2}$
R5	470 Ω	20	$\frac{1}{2}$
R6	3.9 kΩ	10	$\frac{1}{2}$
R7	1.5 kΩ	10	$\frac{1}{2}$
R8	15 kΩ	10	$\frac{1}{2}$
R9	10 kΩ	10	$\frac{1}{2}$
R10	120 Ω	10	$\frac{1}{2}$
R11	1 kΩ	10	$\frac{1}{2}$
R12	4.7 kΩ	20	$\frac{1}{2}$
R13	100 kΩ	20	$\frac{1}{2}$
R14	5 kΩ	C _x Potentiometer + SPST switch	
R15	1 kΩ	10	$\frac{1}{2}$
R16	1 kΩ	20	$\frac{1}{2}$
R17	1.5 kΩ	Preset Preset Control	
R20	82 Ω	10	$\frac{1}{2}$
R21	130 Ω	N.T.C. 130E	
R22	120 Ω	20	$\frac{1}{2}$
R23	4.7 Ω	10	$\frac{1}{2}$

T2 OSCILLATOR COIL

Scramble-wound on Ducon miniature pot core assembly.
 Wire: 8/45 B&S waxed litz.
 Primary (tuned winding) wound first.
 Start to tap: $1\frac{1}{2}$ turns.
 Tap to finish: 63 turns.
 Secondary: 3 turns.

CAPACITORS

Circuit Reference	Value	Tolerance	Rating	Type
C1	3-30 pF			trimmer W.W.
C2, C8	200 pF			tuning gang
C3	.047 μF	20	33 V	ceramic
C4	.033 μF	20	33 V	ceramic
C5	.047 μF	10	200 V	paper
C6	470 pF	5	600 V	Polystyrene
C7	200 pF	5	600 V	Polystyrene
C9	3-30 pF			trimmer W.W.
C10	470 pF	5	600 V	Polystyrene
C11	.012 μF	20	33 V	ceramic
C12	270 pF	5	600 V	Polystyrene
C13	.047 μF	20	33 V	ceramic
C14	100 μF		12 V	electrolytic
C15	.01 μF	20	33 V	ceramic
C16	10 μF		3 V	electrolytic
C17	10 μF		3 V	electrolytic
C18	100 μF		3 V	electrolytic
C19	.002 μF		33 V	ceramic
C20	.002 μF		33 V	ceramic

T3 BANDPASS FILTER, PRIMARY

Scramble-wound on Ducon miniature pot core assembly.
 Wire: 8/45 B&S waxed litz.
 68 turns.
 Q_o (455 kc/s): 190.

T3A BANDPASS FILTER, SECONDARY

Scramble-wound on Ducon miniature pot core assembly.
 Wire: 8/45 B&S waxed litz.
 Link: $\frac{1}{2}$ turn (see note below).
 Secondary: Start to tap : 6 turns
 Tap to finish : 62 turns.
 Q_o (455 kc/s): 190.

TRANSFORMERS

T1	Ferroxcube aerial rod FX1247
T2, T3, T3a, T4	Miniature pot core assemblies
T5	Driver transformer (7:1 + 1)
T6	Output transformer (3.81 + 3.81:1)

NOTE:

The $\frac{1}{2}$ turn link is wound by connecting the start to the required base pin and feeding the wire through the pot core to the diagonally opposite lead-out slot on the base. The wire is then taken under the base and terminated to the required pin.

BATTERY Eveready, Type 286, 9V

SEMICONDUCTORS

D1, D2	OA80
Tr1	OC170, Tr2 OC169, Tr3 OC75, Tr4, Tr5 2-OC74*
*Transistors Tr4, Tr5 with heat sinks	
Speaker to suit Output Transformer.	

T4 DEMODULATOR TRANSFORMER

Scramble-wound on Ducon miniature pot core assembly.

Wire: 8/45 B&S waxed litz.

Secondary (wound first):
18 turns.

Primary: Start to tap : 27 turns.

Tap to finish : 63 turns.

(Connect primary start to collector Tr2.)

Q_o (455 kc/s): 160.

SPECIFICATION OF OUTPUT AND DRIVER TRANSFORMERS

DRIVER:

Lamination: $\frac{1}{2}$ " wasteless
 Stack size: 5/16" stack
 Input power: Less than 5mW + 2mA DC primary current
 Primary load: 12k Ω
 Secondary load: 245 Ω + 245 Ω
 Frequency range: 100 c/s to 12 kc/s
 Primary D.C. resistance: 200 Ω
 Secondary D.C. resistance: 10 Ω + 10 Ω

OUTPUT:

Lamination: $\frac{1}{2}$ " wasteless
 Stack size: 5/16" stack
 Input power: 620 mW
 Primary load: 200 Ω collector to collector
 Secondary load: 3.5 Ω
 Frequency range: 100 c/s to 12 kc/s
 Primary DC resistance: < 5 Ω
 Secondary DC resistance: < 0.1 Ω

Abridged Data OC170

Limiting Values (absolute ratings)

Collector voltage, grounded base		
$V_{c(pk)}$ max	-20	V
V_c max (d.c.)	-20	V
Collector current		
$I_{c(pk)}$ max	10	mA
I_c max (d.c.)	10	mA
Emitter current		
$I_{e(pk)}$ max	10	mA
I_e max (d.c.)	10	mA
Collector dissipation at $T_{amb} = 45^\circ\text{C}$		
	50	mW
Max junction temperature	75	$^\circ\text{C}$

Characteristics at $T_{amb} = 25^\circ\text{C}$

Grounded base

$I_{c(o)}$ at $V_c = -6\text{V}, I_e = 0$	2.0	μA
$f_{a(av)}$ at $V_c = -6\text{V}, I_e = 1.0\text{mA}$	70	Mc/s
$f_{a(m in)}$ at $V_c = -6\text{V}, I_e = 1.0\text{mA}$	40	Mc/s

Grounded emitter

I_b at $V_c = -6\text{V}, I_e = 1.0\text{mA}$	20	μA
V_b at $V_c = 6\text{V}, I_e = 1.0\text{mA}$	-300	mV
α' at $V_c = -6\text{V}, I_e = 1.0\text{mA}$	80	

Noise figure at $V_c = -6\text{V}, I_e = 1.0\text{mA}$

$R_s = 500\Omega, f = 1.0\text{kc/s}$	25	dB
$R_s = 200\Omega, f = 450\text{kc/s}$	4	dB
$R_s = 150\Omega, f = 10.7\text{Mc/s}$	5	dB

Max body length 9.5 mm Max diam 9.1 mm

Abridged Data OC169

Limiting Values (absolute ratings)

Collector voltage, grounded base		
$V_{c(pk)}$ max	-20	V
V_c max (d.c.)	-20	V
Collector current		
$I_{c(pk)}$ max	10	mA
I_c max (d.c.)	10	mA
Emitter current		
$I_{e(pk)}$ max	10	mA
I_e max (d.c.)	10	mA
Collector dissipation at $T_{amb} = 45^\circ\text{C}$		
	50	mW
Max junction temperature	75	$^\circ\text{C}$

Characteristics at $T_{amb} = 25^\circ\text{C}$

Grounded base

$I_{c(o)}$ at $V_c = -6\text{V}, I_e = 0$	1.5	μA
$f_{a(av)}$ at $V_c = -6\text{V}, I_e = 1.0\text{mA}$	70	Mc/s
$f_{a(m in)}$ at $V_c = -6\text{V}, I_e = 1.0\text{mA}$	40	Mc/s

Grounded emitter

I_b at $V_c = -6\text{V}, I_e = 1.0\text{mA}$	15	μA
V_b at $V_c = 6\text{V}, I_e = 1.0\text{mA}$	-260	mV
α' at $V_c = -6\text{V}, I_e = 1.0\text{mA}$	80	

Noise figure at $V_c = -6\text{V}, I_e = 1.0\text{mA}$

$R_s = 500\Omega, f = 1.0\text{kc/s}$	25	dB
$R_s = 200\Omega, f = 450\text{kc/s}$	3	dB
$R_s = 150\Omega, f = 10.7\text{Mc/s}$	5	dB

Max body length 9.5 mm Max diam 9.1 mm

For more complete information and admittance parameters contact the Mullard Technical Service.

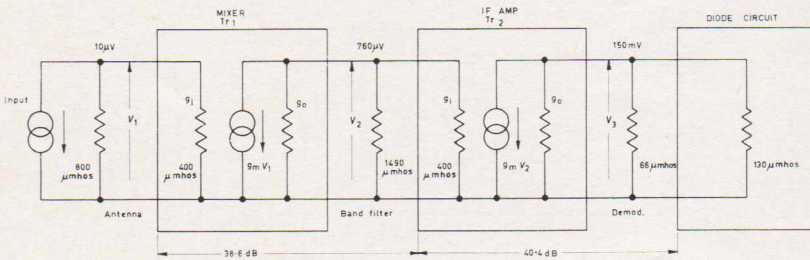

Antenna, bandfilter, conductances referred to base Tr 1, base Tr 2 respectively, Demodulator and diode conductances referred to collector Tr 2.

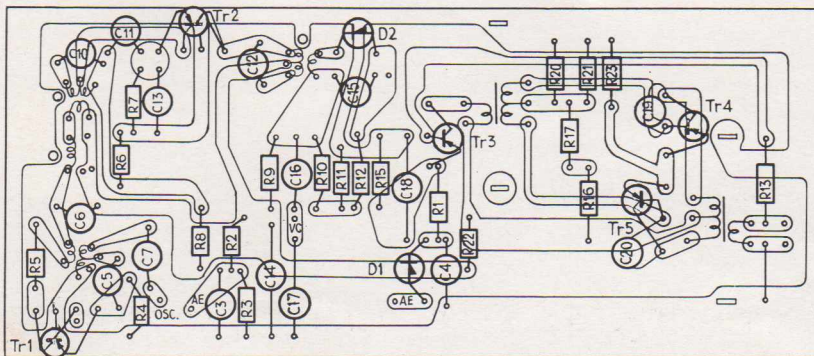

Suggested printed wiring diagram. Finished size approximately 8 $\frac{1}{8}$ " x 3 $\frac{1}{2}$ ".

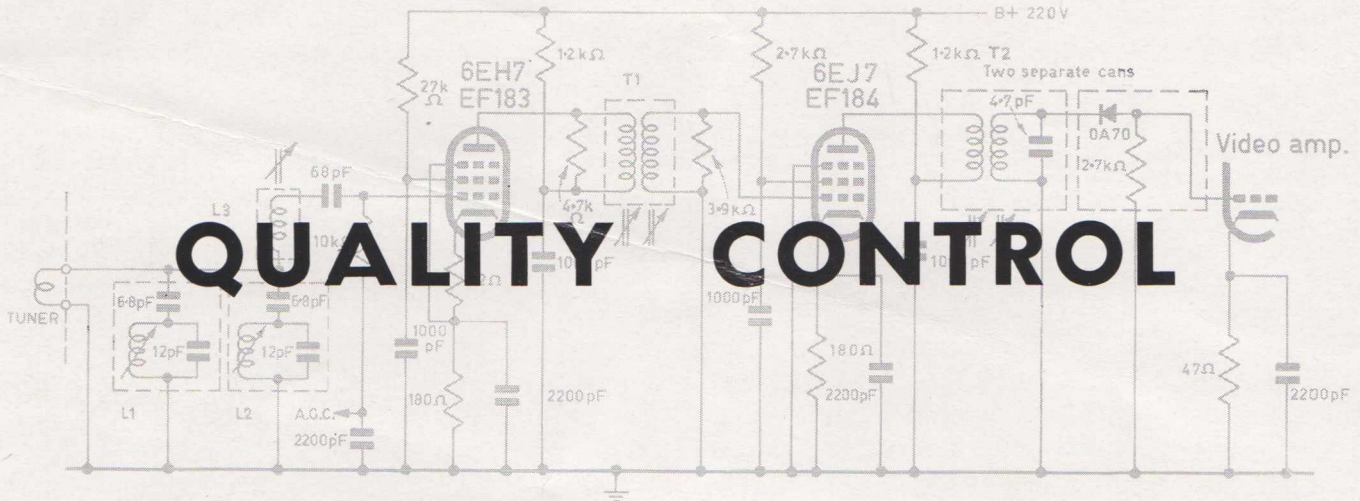

QUALITY CONTROL

Since the electrode structure of modern receiving valves, especially frame grid valves, must be made to very precise limits, it is clear that the electrical characteristics of the valves must be strictly controlled. To produce devices of this nature in the vast numbers required by the television industry, and to produce them economically, a rigorous system of quality control is necessary.

This article outlines the quality control system which is used in Mullard valve factories. It is applied on a batch-sampling basis to the flow of tested valves from the production units. Although particular reference is made to frame grid valves for television receivers, the system is also used in conventional valve manufacture.

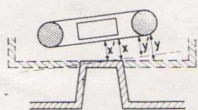

SAMPLING

The flow of completed and factory-tested valves from the production line is divided into batches of 3,000 valves. The final test department, independent of the production departments and responsible to the Quality Laboratory, exists to assess the quality of valves ready for despatch. From each batch of 3,000 valves, samples are taken at random—normally 150 valves—and are subjected to visual inspection and electrical tests to a certain acceptable quality level (AQL). This testing is on a "go no-go" basis.

QUALITY STANDARDS

The AQL is the average percentage of defectives which is tolerated in production or, more accurately, the percentage of defectives which, if maintained during production, would

result in 95% of the production lots being accepted.

A running average of the percentages of defectives is known as the 'process average' and it is more statistically valid than individual batch results.

TYPICAL AQL's are:

Test	AQL
Inoperative (leaks, shorts, no emission, etc.)	0.25%
'Knock' test (RF amplifier test for intermittent shorts or open-circuits)	0.65%
Insulation (interelectrode or cathode-to-heater)	0.65%
Characteristics (static measurement of slope, anode current, etc.)	0.65%

If, on the 150-valve sample, more rejects are found for any of the above groups of tests than are allowed by the corresponding AQL, then the whole batch of 3,000 valves is returned to the factory. Quality control, it should be noted, is not a system of inspecting-out the rejects.

The rejected batch is reprocessed (if appropriate) and retested by the factory. When the batch is then re-inspected by the quality control organisation, a more severe sampling plan (effectively a lower AQL value) is used for the defect which caused the rejection.

Even when the batches are going through without rejection, careful note is taken of any tendency to exceed the AQL. There is, in fact, a tighter limit in the sampling plan, known as the 'critical number.' For an acceptance number of 4, for example, this critical number might be 3. If this figure is reached twice in five consecutive batches, then the production is judged to be dangerously close to the rejection

level, and a tightened inspection procedure is applied. This procedure will soon result in batch rejection if the quality of production does not improve. There is thus a strong incentive to the manufacturing departments to maintain the highest quality.

The characteristics controlled in the manner described above by means of a 150-valve sample are those which are directly linked with production processes, e.g., anode current, mutual conductance and grid current, which are directly dependent on electrode dimensions, cathode coating quality, degree of vacuum, etc. It would not be immediately helpful to inform the factory that a particular type had 'low gain' in a specified circuit. A fault of this kind would need translating into terms such as those indicated above.

FURTHER TESTS

At regular intervals a smaller number of valves (usually 5 or 10) is taken by the Quality Laboratory and subjected first to a more extensive examination and then to life tests. These tests include the following:—

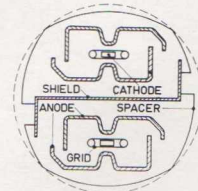

Factory Tests. Actual test readings are recorded, as distinct from the "go no-go" testing already described and the maximum, minimum and arithmetical average values obtained on each test are plotted in graphical form. This gives an indication, for instance, of the spread in slope on a particular day and the departure from the target value. As successive entries are plotted,

statistically valid trends of a particular characteristic may be detected. It may be noticed that the anode current of a particular type of valve is drifting towards the upper limit and will presumably exceed it in time. It is, in this way, possible to give early warning to the factory—well in advance of any actual rejections or any infringement of the 'critical number.' This enables the cause of the trend to be detected and corrective action taken.

Stability. Valves are operated under static conditions for 15 minutes and changes in anode current noted.

Under-heating. Slope and anode current are measured with normal heater conditions and then with reduced heater voltage (say 5.3V instead of 6.3V). The percentage reduction in the characteristic gives a good indication of cathode quality, since emission falls off sharply below a certain cathode temperature. It is desirable, for adequate life, that this fall-off point should be as far as possible from the rated heater conditions.

Dynamic Characteristics. One example is the testing of the 6ES8 in a cascode circuit for slope and anode current at two different bias conditions.

Grid Emission. Valves are operated with the heater voltage increased to approximately 30% above the nominal value. This substantially increases the temperature of the control grid and reveals any tendency to grid emission. The total grid current is analysed into its various components, and a limit of $1.0\mu\text{A}$ is permissible. Grid emission is usually less than $0.1\mu\text{A}$. With this low value at an elevated grid temperature, it is obvious that the possibility of grid emission is remote under normal operating conditions.

Start of Grid Current. The grid voltage at which positive grid current commences (a grid current of $+0.3\mu\text{A}$ is used for convenience in actual testing) is of importance in the selection of valve operating conditions. As this voltage is dependent on the contact potentials of the electrodes, it gives an indication of the purity of materials, and is of assistance to the raw material inspection laboratory and to the processing departments.

Other Static Characteristics. In addition to slope (which is measured in the factory on a routine basis) measurements are made of impedance, amplification factor and anode current.

Capacitance. A large number of capacitance measurements is carried out. Some of these are of vital interest to the user—particularly in RF valves,

others give useful indications of 'geometrical' accuracy in the valve; e.g., capacitances out of limits may often be traced to displacements or distortions of the valve structure and the results of these tests are valuable in valve manufacture and design.

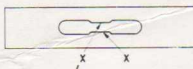

Miscellaneous Applications Tests.

These include cross-modulation, hum, equivalent noise resistance and noise factor. Tests in this category cannot very well be carried out on the production line, mainly because of the relative slowness of the tests and also through difficulties due to interference from eddy-current equipment, etc. Moreover, test results are not always directly useful to manufacturing departments; they are essentially laboratory tests and are carried out on a small sampling basis. The information gained is of primary importance to the valve applications engineer in his liaison with customers, and is also a direct contribution to the technology of valve design. Serious failures on these tests must of course be interpreted in terms of electrode geometry, processing, etc., so that the factory may take corrective action.

Life. Valves are normally run for 600 hours under carefully controlled conditions, with three or four intermediate tests of anode current, slope,

insulation, under-heating, etc. The limits applied allow for an acceptable percentage change in certain characteristics.

Technically, it would be preferable if life tests could be carried out for many thousands of hours on every sample batch taken, but this would involve so much equipment that it would be impractical. It is much more informative to use the available life test positions for 600-hour runs on many batches, rather than runs of thousands of hours on fewer batches. Experience shows that analysis of the results obtained during 600 hours can be sufficient to give a reasonable estimate of life under normal conditions. Periodically, batches of valves may be tested for 2,000 hours.

VALUE OF QUALITY CONTROL

The system described provides a high degree of control over the quality of valve deliveries and is similar in principle to the systems which are imposed by government departments for inspection of special quality valves. Through many years of experience the value of this system to the valve designer, the valve manufacturer and the valve user has been proved.

Experience obtained by the application of this quality control system to valve production is of the greatest importance to the valve designer and assists to ensure high performance and reliability of new valve types.

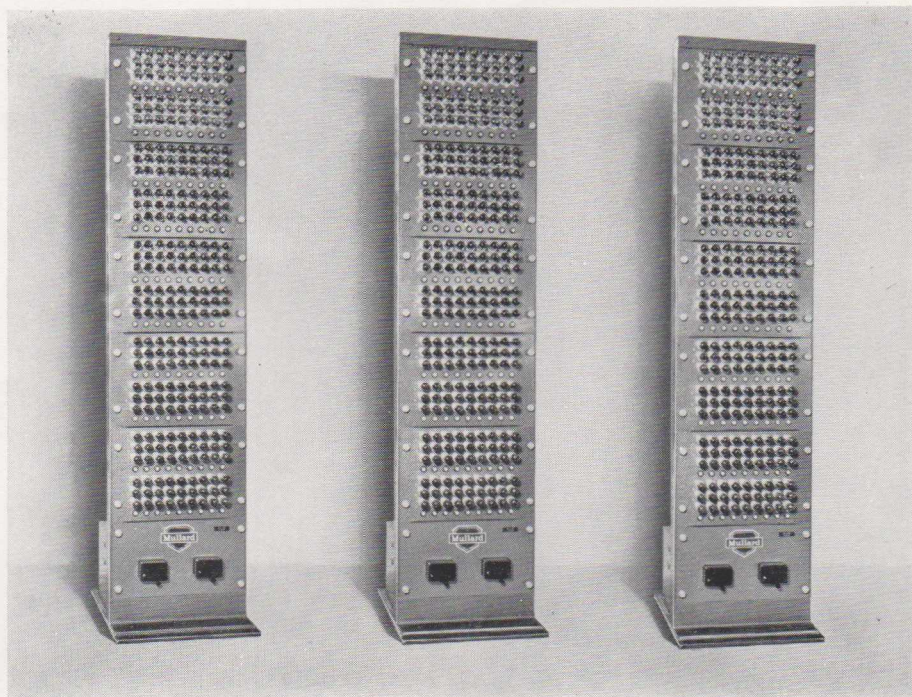

Valves undergoing a life test in the Mullard Valve and Electron Tube Service Centre at 197-199 Trafalgar Street, Petersham, N.S.W.

TRANSISTOR RADIOS

This article is the third of the series on transistor portable receivers and cordless radios. In this issue attention is given to the basic techniques of printed wiring.

Techniques now being encountered by service engineers include printed wiring, a term used to describe electrical circuits which take the form of thin copper strips on insulating board.

Since the techniques necessary in servicing printed wiring are somewhat different from those used in conventional circuitry, it is desirable for service personnel to acquire a thorough knowledge of the subject. There are a number of manufacturing processes including photocopy and offset printing and the following brief description of the most commonly used manufacturing process may help readers to become familiar with the technique.

SILK SCREEN PRINTING

The circuit diagram is first re-arranged so as to form a convenient flat layout which is photographed and transferred to a silk screen. An acid resist paint is then squeezeed through the screen to the copper surface, the painted areas representing the conducting surface required.

The board is then transferred to an acid etch bath where the unwanted copper is removed. After etching, the acid resist is removed and the board thoroughly cleansed. It is then provided with a protective layer of flux so that it may be stored without tarnishing. The board is now ready for component insertion through pre-punched holes.

IMPORTANCE OF PRINTED WIRING

Once a correct layout is achieved in printed wiring, all further models are identical. The complete item is compact, lightweight and reliable. Components are easily added by automatic methods and high production rates are possible.

TYPES OF PRINTED WIRING

Individual manufacturers use different techniques of printing, but the boards will all have much the same appearance. In some processes, the circuit is not etched but punched out of foil and attached to the board. This method is slightly more expensive than the more usual etching process. In others, the bituminous coating is not applied, the ink resist being sufficient for most requirements. Sometimes the wiring is printed onto both sides of the board.

Where the printing technique includes printed inductors, capacitors

and resistors, the name 'printed circuit' is more correctly used.

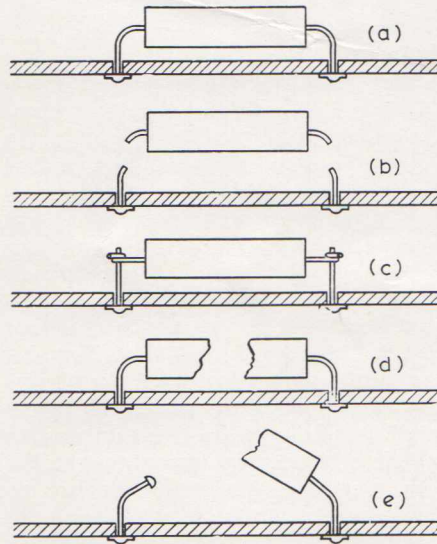

CARE OF BOARDS

The preceding information should assist in appreciating the precautions which are necessary when servicing printed circuits.

The 'wiring' produced on the laminate boards is extremely thin—about 0.0015" to 0.003"—and is bonded to the board. Flexing the board will result in the foil being stretched and the strain may fracture the copper, thus forming hairline cracks in the conductor.

When connections are made to the foil, great care must be taken to prevent excessive heat from melting the adhesive and damaging components. A 25W soldering iron will be quite sufficient to effect repairs and, if applied only long enough to melt the solder, should not damage the circuitry.

Acid fluxes should not be used on printed wiring; however, the more common cored solders do not contain this type of flux.

CIRCUIT TRACING

Due to the single-plane layout used in printed wiring, circuit tracing is somewhat simplified. The components are not normally on the same side of the board as the wiring, however, the problem of locating components when fault-finding may be obviated by placing the board in front of a bright lamp.

Some manufacturers print component references on the same side of the laminate as the wiring, and this of course simplifies circuit tracing.

The use of service information is the best solution; most service sheets include a drawing of the board as it will be seen during servicing, with component references clearly marked.

FAULT-FINDING

Most boards are coated with an insulant after manufacture, therefore, care must be taken to achieve proper contact with the copper foil. The insulant serves not only to prevent accidental short-circuiting of the exposed foil to other parts of the circuit, but also helps to reduce oxidisation.

The protective coating must be removed from the measuring points before any connection can be made—acetone applied with a soft cloth or brush will serve this purpose.

The detection of hairline cracks in the foil is facilitated by the use of a powerful lamp and a magnifying glass.

COMPONENT REPLACEMENT

Faulty components should be removed with great care. Flexing the laminate, peeling the foil or dropping solder onto the remainder of the circuit should be avoided.

SMALL COMPONENTS

Transistors, capacitors and other components may be removed as illustrated in Fig. 1. The leads should be cut as close to the component as possible. The wires left on the board should be cleaned and the leads of the new component looped around them as shown in (c). Solder may then be applied, care being taken to ensure that the heat does not damage the board or component, or melt the solder under the board.

Should the cutting of the leads be too difficult, it may be possible to cut the component in half as shown in Fig. 1 (d). The parts remaining on the leads should be removed and the leads cleaned as in Fig. 1 (e). The new component can then be added as before Fig. 1 (c).

LARGE COMPONENTS

Audio and IF transformers may be removed by heating the soldered connections then lightly brushing-off the solder with a stiff brush. A bristle or camel-hair brush is also suitable but may not survive many operations. Alternatively, a sharp-pointed metal rod, such as a scriber, may be used to pick off the molten solder. With any of these methods, the splashing of solder onto other parts of the circuit must be avoided.

SIMPLE OSCILLOSCOPE MEASUREMENTS

This is the third article of "Simple Oscilloscope Measurements" which is the second of the "Simple Measurement" series being published in Outlook, and contains suggestions for a number of experiments which can be carried out in the laboratory with the aid of a cathode ray oscilloscope and auxiliary equipment.

TUBE GRATICULE

In experiments where the movement of the spot across the screen is to be measured to a fair degree of accuracy, it is convenient to use some form of transparent grid which is affixed to the face of the cathode ray tube. Such a device is illustrated in Fig. 2 and comprises part of a thin perspex rule, masked by a sheet of cardboard. This arrangement can be fixed over the tube face with some form of sticky tape.

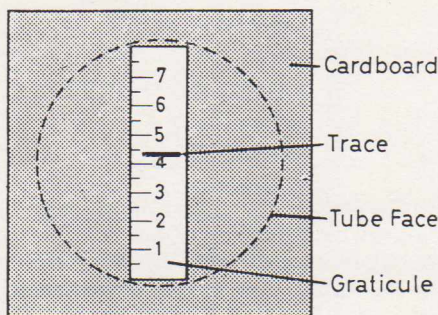

Fig. 2

BRIDGE RECTIFIER

A ready source of half or full wave rectified current can be obtained by making the appropriate connections to a bridge rectifier circuit containing four identical germanium diodes. Fig. 3 shows such a bridge circuit using four Mullard OA81 diodes.

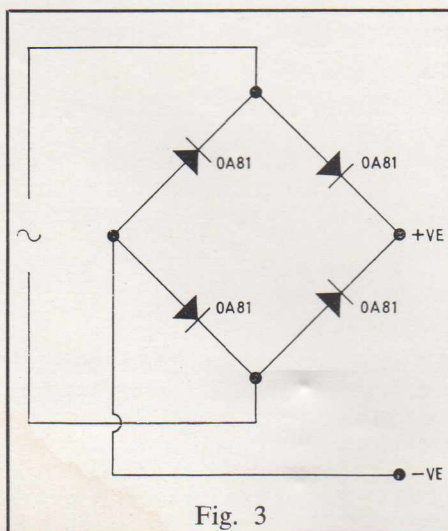

Fig. 3

EXTERNAL AMPLIFIER

If it is found that the degree of amplification available for a particular experiment is insufficient, then it will be necessary to have access to a simple pre-amplifier which can be coupled in tandem with the vertical or horizontal amplifier circuits. Such an amplifier need comprise a single valve only and can give gains of up to one hundred times. A practical pre-amplifier circuit is illustrated (Fig. 4).

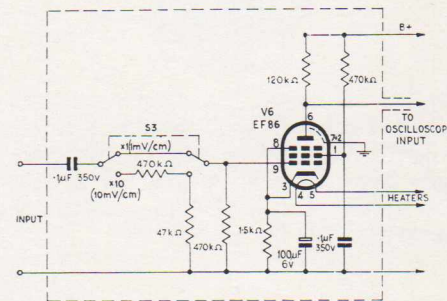

Fig. 4

MEASUREMENT OF SIMPLE DC QUANTITIES

The vertical amplifier of the oscilloscope, if direct coupled, can be considered as an extremely sensitive, high-impedance DC voltmeter and it is this property which makes the instrument suitable for use in the following four experiments.

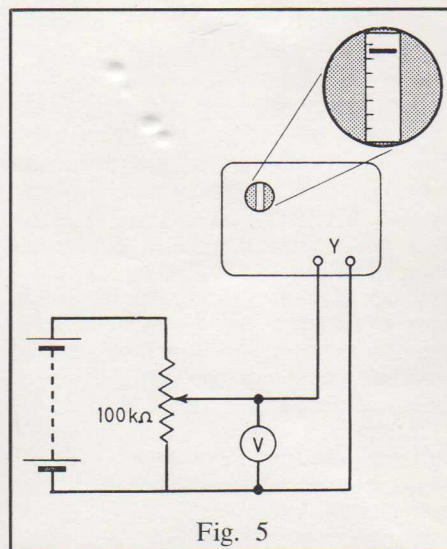

Fig. 5

MEASUREMENT OF DIRECT VOLTAGE

- Set up a circuit as shown in Fig. 5.
- Apply a series of known voltages to the oscilloscope and measure the corresponding vertical deflection in centimetres using the tube graticule (See Fig. 2).
- Plot a calibration curve with deflection as abscissa and voltage as ordinate. (See Fig. 6).
- Replace battery with source of unknown voltage and measure the vertical deflection.
- Read off the corresponding voltage from the calibration curve.

NOTE: With a sensitive Y amplifier, voltages as low as 4mV can be measured.

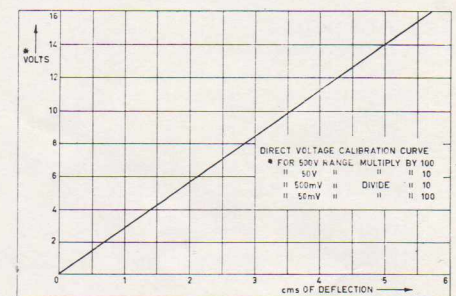

Fig. 6



A typical, simple oscilloscope.

NEW PHOTOMULTIPLIER TUBE FOR ULTRA-VIOLET APPLICATIONS

The new type, 56UVP, is closely similar to the 56AVP, but its spectral response has been extended well into the ultra-violet region. It has a useful response down to 2300Å with a peak at 4000Å (0.4μ).

For high-definition work, very small electron transit time differences are essential and in the 56UVP they have been kept down to 2.0 millimicroseconds at half-pulse height, with a rise time of the same duration.

This substantial reduction of transit time differences is due to the specially designed input electron-optical system in which the photocathode is curved so that the path lengths to the first multiplier stage are approximately equal for electrons leaving any part of its useful area. In fact, the transit time difference between electrons arriving at the first dynode from the periphery of the photocathode, and those arriving from the centre, is only 0.3 millimicroseconds.

Uniformity of transit times through the 14 multiplier stages is maintained by careful shaping of the dynodes and



by the additional focussing electrodes situated between each multiplier stage, which progressively narrow the electron beam from stage-to-stage despite the rapid growth in the number of electrons.

ABRIDGED DATA

Photocathode (end-viewing)

Minimum useful diameter	42	mm
Peak spectral response	4000	Å
Average sensitivity	50	μA/1m

Multiplier (14 stage)

Minimum gain (at total supply voltage of 2 kV)	10 ⁸	
Maximum peak anode current	1A	
Average anode sensitivity (at 2 kV)	5000	A/1m
Dark current (at gain of 10 ⁸)	less than 5.0	μA
Output pulse (at total supply voltage of 2 kV)		
Rise time	2 x 10 ⁻⁹	sec
Width at half height	2 x 10 ⁻⁹	sec

Mechanical

Maximum overall height	190	mm
Maximum seated height	175	mm
Maximum diameter	55	mm
Base	20-pin	(bidecal)

NEW EDUCATIONAL FILMSTRIP

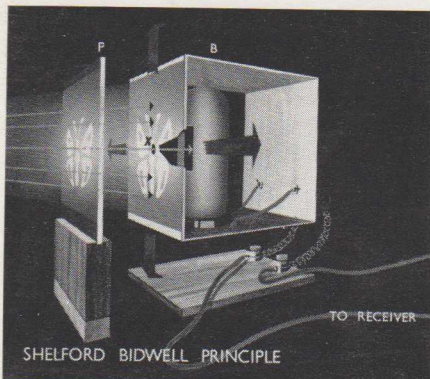

"THE HISTORY OF TELEVISION"

A new filmstrip, "The History of Television," has been added to the range of colour filmstrips introduced by the Mullard Educational Service. It is complementary to an earlier release "The History of Radio" and deals with the history of picture transmission from the middle nineteenth century to the present and explains fundamental principles to show the significance of technical developments.

Its simple approach makes it suitable for use in Secondary Schools or in senior classes where science is taught as a general knowledge subject, rather than one for examination.

AMATEUR EXPERIMENTERS COLUMN

TRANSISTOR CRYSTAL-CONTROLLED OSCILLATOR

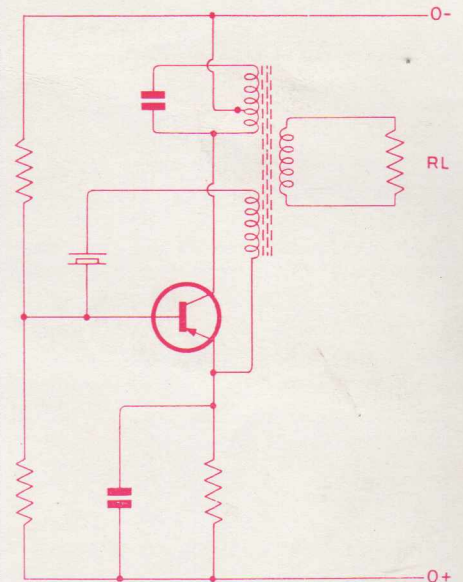

Oscillation is maintained from a transformer winding which couples the parallel-tuned circuit, in the collector, to the base. The crystal is connected in series with the feedback winding and the collector circuit is tuned to the series-resonant frequency of the crystal. For the feedback to be of sufficient magnitude, the turns ratio of the transformer should be of the order of 3:1.

This oscillator operates under Class "A" conditions, base bias being provided by a potential divider in conjunction with an emitter resistor which is by-passed to RF.

SELLING CORDLESS RECEIVERS

Continued from Page 27

cular author or selects a painting or a fine wine. In this regard, one must also include the tastes of some teenagers and their choice of a programme of a certain flavour—in all a selective process—and if this is indeed coming about—and we believe it will continue—then the continued support of this medium is assured.

Cordless receivers and transistor operated receivers will play a dominant part in this trend and we believe will provide a major contribution to the re-birth of radio in the homes that have already encountered their first few years of TV.