

Mullard

Outlook

Australian Edition

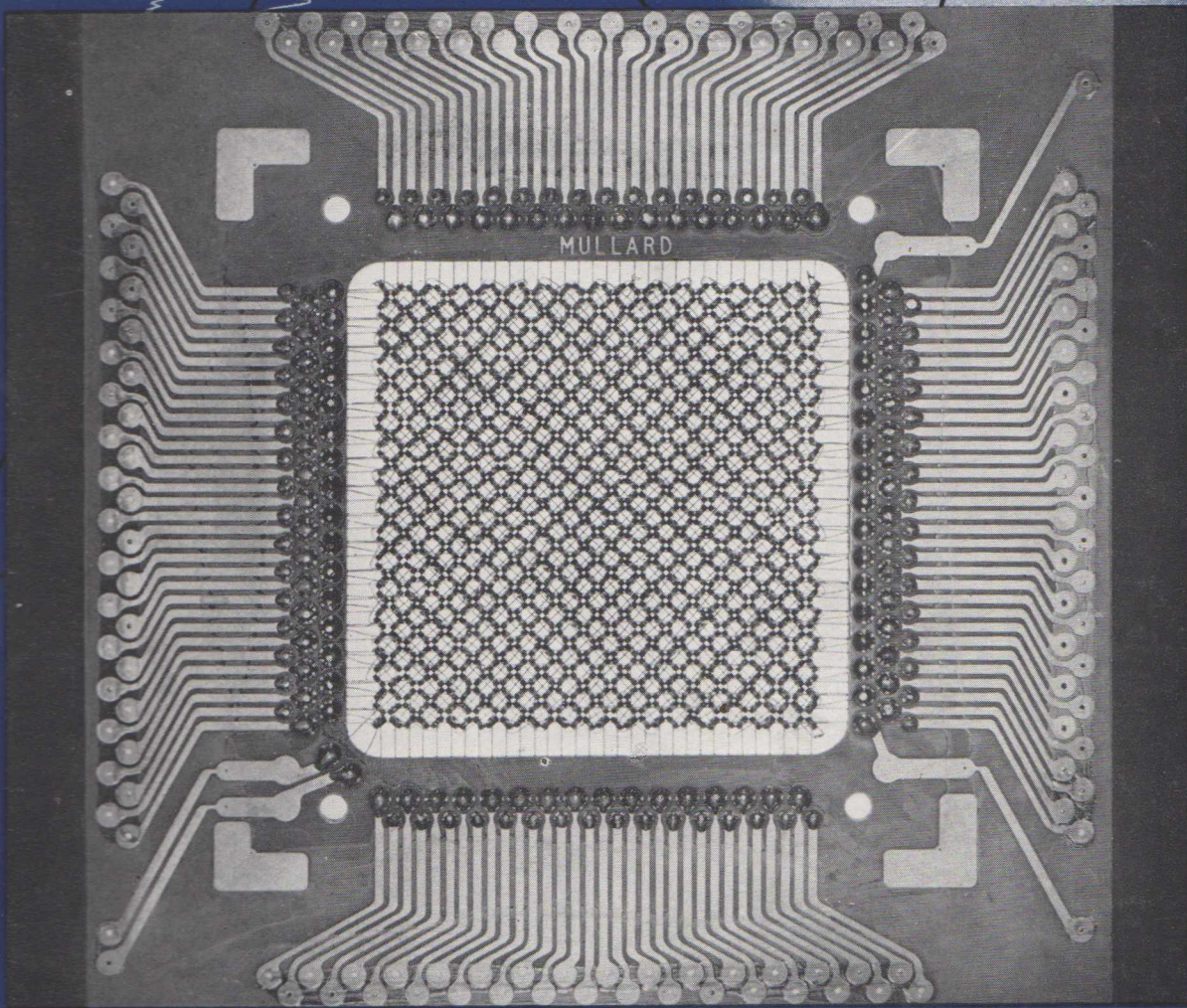

VOL 1 No. 3, MAY-JUNE
1958



MULLARD-AUSTRALIA PTY. LTD.



VOL. 1—No. 3

MAY-JUNE, 1958

Editorial Office:
35-43 Clarence Street, Sydney.
Telephone—BX 2006.

Editorial Staff:
B.P.A. BERESFORD, A.M.I.R.E. (Aust.),
JOERN BORK

All rights reserved by Mullard-Australia Pty. Ltd., Sydney. Information given in this publication does not imply a licence under any patent. Original articles or illustrations reproduced in whole or in part must be accompanied by full acknowledgment: Mullard Outlook, Australian Edition.

CONTENTS:

Editorial	18
Viewpoint with Mullard	19
Oscilloscope Calibration Unit	20
Simplified Approach to Diode Testing	21
6CW5/EL86 Output Pentode	21
Mullard Matrix Assemblies	22
Rotating Anode X-Ray Tubes	22
Hybrid Car Radio Receiver	23
Instrument C.R.T's	26
Power Transistor Dissipation Ratings	27
Atomic Energy Exhibition	28
Subminiature Voltage Indicator	28
Amateur Experimenters Column	28

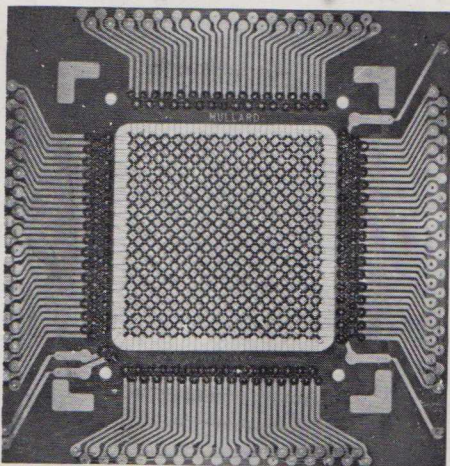

Our front cover shows a "32 x 32 core" Ferroxcube Matrix-Plane, which is used as the memory element in electronic computers.

MULLARD-AUSTRALIA PTY. LTD.

35-43 CLARENCE STREET, SYDNEY
Phone: BX 2006

592 BOURKE STREET, MELBOURNE
Phone: MU 2366

Associated with
MULLARD LTD., LONDON
MULLARD EQUIPMENT LTD.
MULLARD OVERSEAS LTD.

HYBRIDS AND THINGS AND ALICE

Few will deny that for many years the dominant influence in electronic equipment design has been the rate of progress of valve and electronic tube development techniques. Today, semi-conductors and magnetic ferrites alone, have provided entirely new concepts and undoubtedly our future eloquent accolades may well be awarded in the field of solid state physics.

The war of the Trons and the Semi-cons continues unabated in a period perhaps of unsettled harmony—in a cold war of co-existence. A galaxy of new terms has confused the old campaigners and intrigued the new, and a host of professional copy-writers grope for gilded superlatives to promote the end products.

With zest we could perhaps term our new high slope, low noise H.F. valves as Hemispheric Range Probes or our high power transistors as Kingsize but the co-existence of the Trons and the Semi-cons has re-injected hybrids into our technical language—to the lament of line engineers.

Hardly an apt term at any time if one added the now more common "hybridize" and left it at that, but according to the Oxford Concise—

Hybrid: *N. & A. 1. Offspring of two animals or plants of different species or varieties; person of mixed nationality; (fig.) thing, word, composed of incongruous elements. 2. adj. Crossbred, mongrel, heterogeneous; h. bill in Parliament, one combining characteristics of public and private bill, and referred to a h. committee. Hence hybridity n. (f. L hybrida offspring of tame sow and wild boar; etym. dub.)*

Not a particularly flattering description for a range of valves which we believe admirably fills an engineering gap until the Semi-cons definitely cope at low cost. Nevertheless, we must expect other mixtures of thermionic valves and transistors from time to time and as Alice said to herself—"I know something interesting is sure to happen!"

M.A.B.

MULLARD DISTRIBUTORS:—

NEW SOUTH WALES

Martin de Launay Pty. Ltd.
287 Clarence Street.
Sydney. Telephone BX 5834
Cnr. King & Darby Streets,
Newcastle. Phone BM 4741

VICTORIA

Howard Electrical & Radio
Company,
Vere Street,
Richmond. Phone JB 4716

QUEENSLAND

B. Martin Pty. Limited,
35 Charlotte Street,
Brisbane. Telephone B 1744

SOUTH AUSTRALIA

Agents: Woollard & Crabbe
Limited,
180 Wright Street West,
Adelaide. Telephone LA 4713

TASMANIA

Medhursts Wholesale Ltd.,
163 Collins Street,
Hobart. Telephone B 2911.
136 Wellington Street,
Launceston. Phone B 2091.

WESTERN AUSTRALIA

Harris, Scarfe & Sandovers
Limited,
691 Hay Street,
Perth. Telephone BF 0131

and all leading wholesalers throughout the Commonwealth

VIEWPOINT WITH MULLARD

The tenth meeting in the "Viewpoint" series was held at the Central Hotel, Tamworth, N.S.W. on April 11th last. The function was attended by nearly 60 retailers, wholesalers and industrial valve users, many of whom travelled from such widely dispersed centres as Inverell, Glen Innes, Armidale, Gunnedah, Narrabri and Bar-raba.

Welcoming the guests Mr. P. C. Bidence (Mullard Valve Sales) said his company was pleased at being able to have this Viewpoint to coincide with Tamworth's "Festival of Light". He outlined Mullard's policy of service to wholesalers and retailers and detailed the valve guarantee system.

Mullard amplifier designs and other items of interest were reviewed by Mr. J. R. Goldthorp (Senior Valve Application Engineer) and particular interest was shown by the audience in an experimental transistorised low power audio amplifier. This unit utilises a matched pair of Mullard transistors type OC72 in a single ended or asymmetrical push-pull configuration enabling a loud speaker having a voice coil impedance in the vicinity of 33 ohms to be employed as the output stage load, thus eliminating output transformer losses. The sample loud speaker was supplied by courtesy of Magnavox Pty. Limited in Sydney.

MULLARD FESTIVAL EXHIBIT



The Tamworth meeting coincided with the opening of the "Festival of Light" exhibition and Mullard featured the company's latest valve board which displays a wide variety of valve and tube types extending from ordinary entertainment types to highly specialised valves such as klystrons and magnetrons. The Mullard amplifiers were also on display and proved highly popular with the public, whilst the Mullard L.101 dual-trace oscilloscope served to display the waveform of visitors' voices for their interest and entertainment.



Overlooking the City of Tamworth.

Many of the audience at the Tamworth meeting were interested in this Mullard Valve and Electron Tube Display.

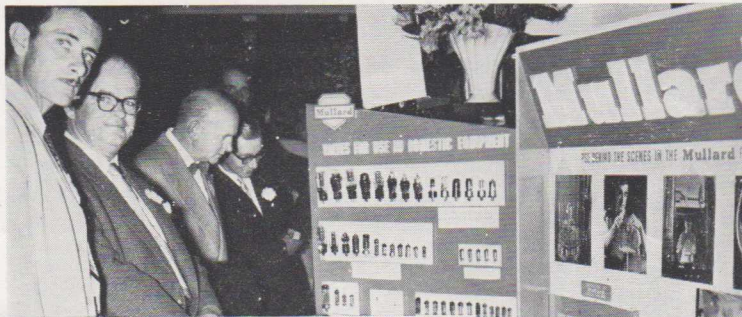

Ladies are always welcome at Viewpoints with Mullard.

Recent Melbourne and Brisbane meetings will be reported in the next issue.

Television - It's Wonderful



This well known booklet was first released during the introduction of television in Australia. The booklet is again available to television retailers together with the Radiant Screen counter display card illustrated. Obtain your requirements from Mullard-Australia Pty. Ltd., 35-43 Clarence Street, Sydney, or 592 Bourke Street, Melbourne.





OSCILLOSCOPE CALIBRATION UNIT

DESIGNED FOR LINE TIME BASE MEASUREMENTS

When the conditions in the line time base circuits of television receivers are being checked, either in the design laboratory or on the service engineer's bench, it is important that the measurements should be made accurately. The service engineer is also especially interested in making his measurements as quickly as possible.

The currents and voltages associated with the valves in the circuit are of particular interest to the designer and the engineer. Voltage waveforms can be displayed directly on the screen of a calibrated oscilloscope. For current measurements a small resistor (of about one ohm) can be included in the circuit, and the voltage drop across it can be similarly displayed. The accuracy of the readings will depend on the accuracy of the voltage calibration of the oscilloscope. It is therefore important to have a convenient method of checking the calibration.

CALIBRATION UNIT

The instrument described in this article produces a square wave whose amplitude is directly proportional to a d.c. voltage which is measured by the best available voltmeter—preferably a substandard model. The waveform can be used for calibration over a range of voltages from 100mV to 100V, with an accuracy of something like $\pm 3.0\%$. For line timebase measurements the frequency of the square wave generator has been fixed at 10kc/s in order to give maximum independence from the frequency response of the oscilloscope amplifier. If the circuit is used in connection with measurements in other fields, then the frequency of the square wave generator should again be made approximately the same as that of the particular waveform being measured. This adjustment can be achieved by suitable changes in the values of C3 and C4 and (for low frequencies) C6.

OPERATION

The two sections of the triode pentode valve (V1A and V1B) operate as a screen-coupled multivibrator at a frequency of about 10kc/s. The square wave which is produced at the pentode anode is d.c. coupled by R8 to the cathode of the diode V2. When the pentode is in the cut-off condition, its anode and the diode cathode are at h.t.+ (which is earth potential). When the pentode conducts, its anode voltage falls to a low value; but the diode cathode voltage can fall only to the potential of the diode anode, which is measured by the voltmeter and is set to 100V by means of the potentiometer RV17. The square wave at the diode cathode therefore has an amplitude of 100V. The resistive divider, R9 to R12, attenuates the square wave to amplitudes of 10V, 1.0V, and 0.1V. The maximum error produced by the contact potential of the diode is less than 0.5%.

The d.c. voltage from the potentiometer RV17 is applied to the cathode follower V3, which provides a low impedance d.c. input to the limiter diode and to the voltmeter. Thus an external meter can be connected in parallel without disturbing the reference voltage at the diode.

ACCURACY

The instrument enables a wide range of voltages to be accurately measured on a normal oscilloscope.

The possible errors are: diode contact potential (0.5% max.), substandard voltmeter (0.3% max. at full-scale deflection), and resistive attenuator errors (2.0% max.). If the voltmeter reading error is taken to be 2%, then the oscilloscope calibration can be guaranteed to be within $\pm 5.0\%$. In practice the error will be considerably less than this.

EQUIVALENTS

Services	Mullard	U.S.A.
CV2797	QQV06-40A	5894/A
CV2799	QQV03-20A	6252
CV5094	EL86	6CW5

NEW C.V. ALLOCATIONS

CV2431	DG7-32	—
CV2432	6205	6205
CV2433	DF63	—
CV2434	Z803U	6779
CV5105	OC45	—
CV5106	E1T	6370
CV5120	20CV	—

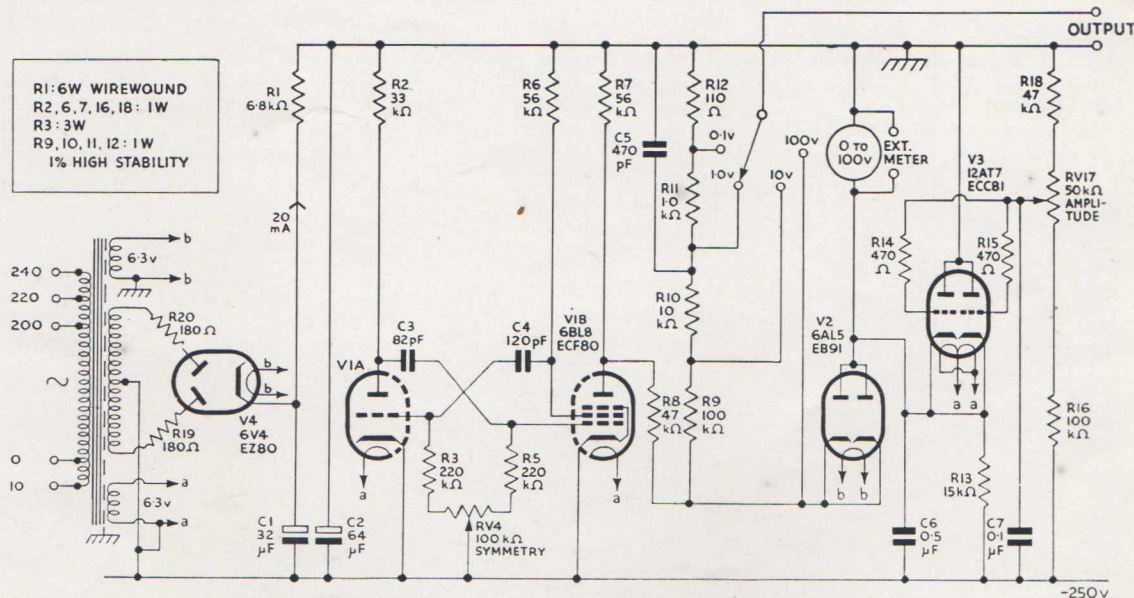

SIMPLIFIED APPROACH TO DIODE TESTING

With the increased application of semiconductor diodes to both industrial and entertainment electronic equipment, the need exists for an instrument which can rapidly evaluate these rectifying devices. Indeed, with the exceedingly wide range of germanium and silicon diodes of both point contact and junction construction now available, and the higher powered junctions competing with selenium and cuprous oxide rectifier stacks, it becomes most difficult to design one instrument to test all diode types. The instrument described was initially developed to check the characteristics of "signal detecting" diodes commonly used in television receivers and similar general purpose types. By a simple modification, however, the instrument provides reliable indication of computer diodes and low power high inverse voltage silicon types.

The evaluation of a rectifying device involves the determination of the forward and reverse characteristics as detailed in figure 1. Although ideally this involves the measurement of a large number of points (variation of current with applied voltage) accurate evaluation with considerable simplification can be obtained if suitable test points on the characteristic are chosen—this selection requiring a knowledge of both the diode characteristics and its application.

The reverse test point should be the current which flows through the diode with maximum working d.c. inverse voltage applied—if not quoted this should be assumed 0.67 times the peak inverse voltage. Thus the "back resistance" of the diode at a stable operating point approaching the "zener" or "turnover" potential may be determined and if a diode passes the test it will comply with this section of the published data.

In the forward direction, although one might be tempted to measure the potential across the diode at maximum forward current, it is more convenient and simulates more closely practical applications to measure the forward current at a volt or so in the forward direction. As a mercury cell has an almost constant voltage-life characteristic, a potential of 1.34V is chosen and the current passed by the diode with this applied potential determines the "forward resistance" of the rectifying device.

As excessive current could flow in either of these measuring circuits

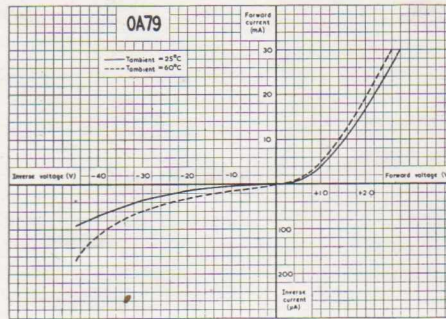

FIG. 1.

should the diode under test be short circuited—and so damage the indicating meter—and the diode itself could be damaged if inadvertently connected to the test instrument with reverse polarity, a reverse direction ohm-meter circuit is incorporated in the central "at rest" position of a spring loaded two-way key switch to preclude these possibilities. This is achieved by suitable choice of circuit constants so that the indicating meter reads "full scale" should a short circuit diode be inserted in the test jig—the diode then being discarded. If the diode be connected with reversed polarity so that it is actually biased in the forward direction rather than the reverse, then a low resistance will be indicated and the meter will show something over one fifth full scale deflection indicating that the diode should be reversed or rejected. Should the diode still indicate more than one fifth full scale deflection when its polarity has been reversed then without proceeding any further we have ascertained that its back resistance is excessively low, i.e., the rectifier has either been overloaded or poisoning has occurred. If the diode

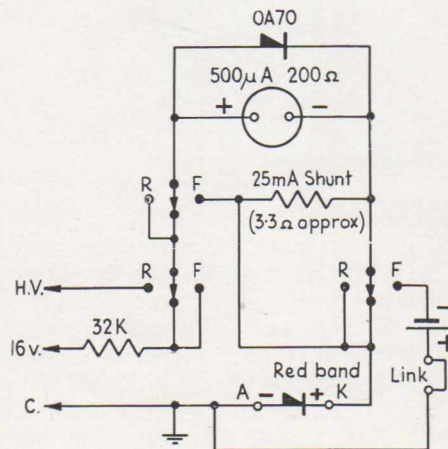

FIG. 2.

passes this reverse ohm-meter check the key switch is moved to the reverse position and the reverse current at the selected voltage is indicated on the 500µA meter movement. If this indication is within tolerance the key switch is then moved across to the forward position and the forward current at 1.34V indicated on the movement which is now shunted to 25mA full scale deflection.

The schematic of the instrument is shown in figure 2.

J. R. GOLDTHORP

6CW5 EL86 OUTPUT PENTODE

The 6CW5/EL86 is eminently suitable for use in series-regulator and cathode-follower circuits, because of its high slope and the relatively high currents which are available at low anode and screen-grid voltages. The valve is also suitable for use in transformerless "single-ended" push-pull audio output stages. The corresponding valve in the 100mA heater series is the 45B5/UL84. The 45B5/UL84 is not a preferred type for industrial and communications use.

This 6CW5/EL86 is also suitable for the 110° frame deflection circuits. 6CW5/EL86 data sheets are in course of preparation.

Advance Data

V_h	6.3	V
I_h	760	mA

Characteristics

Pentode connection		
V_a	100	170 V
V_{g2}	100	170 V
V_{g1}	-6.7	-12.5 V
I_a	43	70 mA
I_{g2}	3.0	5.0 mA
g_m	9.0	10 mA/V
μ_{g1-g2}	8.0	8.0
r_a	23	23 kΩ
Triode connection (g_2 to a)		
V_a	170	V
V_{g1}	-12.5	V
I_a	75	mA
g_m	11	mA/V
μ	8.0	
r_a	730	Ω

Limiting Values

$V_{a(h)}$ max.	550	V
V_a max.	250	V
$V_{g2(h)}$ max.	550	V
V_{g2} max.	200	V
p_a max.	12	W
P_{g2} max.	1.75	W
$p_a + p_{g2}$ max.	13	W
I_k max.	100	mA
R_{g1-k} max. (self bias)	1.0	MΩ
V_{h-k} max. (k negative)	100	V
$*V_{h-k(p,k)}$ max. (k positive)	300	V
R_{h-k} max.	20	kΩ

* max. d.c. component 150V



MULLARD MATRIX ASSEMBLIES

Increasing numbers of electronic digital computing machines are using rectangular hysteresis loop magnetic cores in their high speed random access storage systems. Magnetic matrix storage units, which are essentially static devices, have proved to be extremely reliable, and under normal conditions of use will continue to meet their specifications for many years without any need for special maintenance or replacement. Ferroxcube type D, which has as its main characteristic an approximately rectangular hysteresis loop, has been specially developed for use in this type of magnetic store, although it is equally suitable for use in magnetic logical and switching elements.

Ferroxcube cores type FX1508 are mainly used in matrix storage systems in which each core is threaded by four wires comprising X and Y drive wires,

digit drive wire and output wire. The digit wire links all the cores in the same electrical sense, while the output wire links half the cores in each row or column in one sense and half in the other, and is so arranged that the mutual inductance between it and any drive wire approaches zero.

A matrix store requires one core per bit of information and if the addressing system is sufficiently flexible the time of access to any bit of information is the same, this time being of the order of a few microseconds.

Individual planes containing 16 x 16, 32 x 32 and 64 x 64 cores can be supplied for professional use. These planes can also be supplied stacked and inter-connected as complete assemblies in standard boxes, and these assemblies are designed to meet their specification for many years under normal conditions of use.

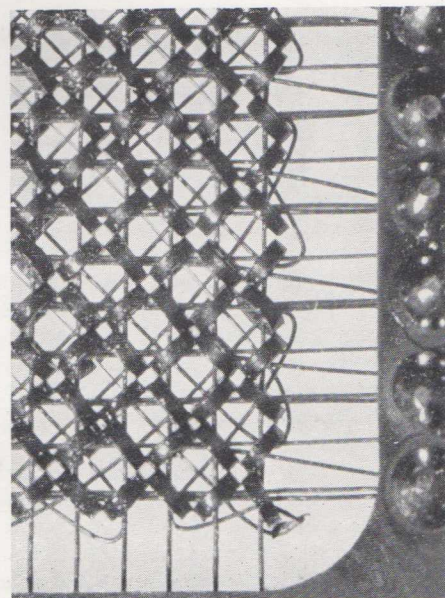

Enlarged section of a Mullard Ferroxcube Matrix-plane, which is shown in its full size on the front cover.

EXCELLENT RESOLUTION OBTAINABLE WITH MULLARD ROTATING ANODE X-RAY TUBES

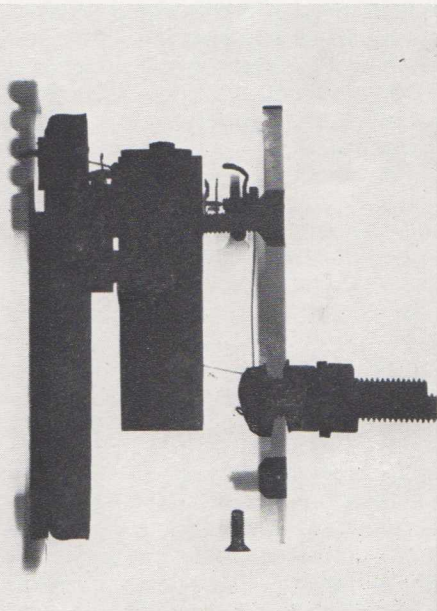
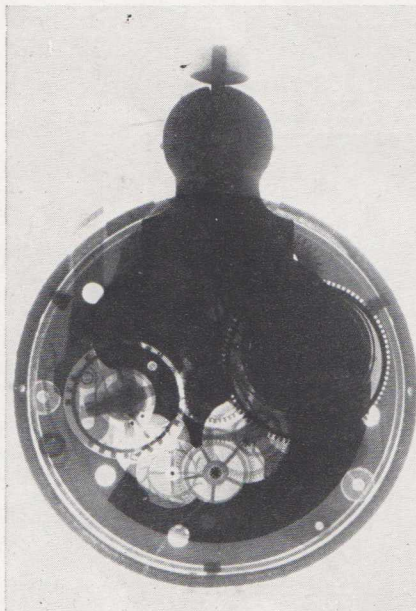

The wide range of Mullard Rotating Anode X-Ray Tubes includes types suitable for the many techniques and varied procedures in the field of medical diagnostic X-Ray work. The extensive use in recent years of X-Ray tubes with tungsten disc anodes rotating at some 2800 R.P.M. has been of considerable benefit to radiologists due to the superior quality of the re-

sultant radiographs. The finer detail and greatly improved resolution possible with this class of tube has contributed greatly to more positive medical diagnosis. The radiograph of the bone structure of the human hand depicted above is typical of the quality and clarity obtainable with the Mullard MRO X-Ray tube. Although primarily designed for medical use, excellent

results are possible with other objects as shown above. Note the fine detail of the complex mechanism of an aircraft clock and moving coil milliammeter.

The co-operation of the staff of one of Sydney's major hospitals is greatly appreciated for their assistance in the preparation of these radiographs.

HYBRID CAR RADIO RECEIVER

USING 12.6V H.T. AND TRANSISTOR OUTPUT

Any valve receiver operated from a low voltage d.c. source such as a car battery has, of necessity, to include some device (usually a vibrator) to provide an h.t. line of about 200V. Valves can, indeed, be readily designed to give a perfectly satisfactory performance in the early stages of a receiver with quite low anode and screen grid voltages; but at this voltage level it is not practicable to obtain sufficient power from a valve output stage. The introduction of power transistors, however, makes possible the design of complete low-voltage receivers since the transistor requires only a low operating voltage.

Thus a complete low voltage receiver, working directly from a car battery without a step-up device, is now possible. Valve types designed for low-voltage operation can be used in the earlier stages, with a power transistor driving the loudspeaker.

LOW VOLTAGE VALVES

A suitable range of valves has been introduced by Mullard. They are used, in conjunction with the OC16 power transistor, in an experimental car radio receiver developed in the Mullard laboratories. The valve stages of the receiver are conventional. They are followed by an output stage consisting of a single valve-driven transistor.

The valves operate from a line voltage of 12.6V, and the transistor from the full voltage of the battery—which, in practice, is about 14V.

The heaters of the four valves are arranged in two parallel pairs 6DS8 + 6DS8, 6DR8 + 6ET6 connected across the 14V supply. A small resistor in series with the heater chains reduces the voltage to 12.6V per pair, so that each valve is run at the correct heater voltage of 6.3V. An interesting feature is that the valve heaters and the dropping resistor are used as a potential divider to provide bias to the output transistor. The non-linear voltage-current characteristic of the heaters reduces the effect which battery voltage changes, under various conditions of charge and load, would have on the transistor bias.

ADVANTAGES

A "hybrid" receiver of this kind, with four valves and a transistor, is a compromise between the conventional all-valve receiver and an all-transistor

design. This latter solution is, for the time being at least, outside the acceptable price range for car radio receivers. The "hybrid" circuit, meanwhile, is a distinct advance on the conventional valve-and-vibrator receiver. The vibrator and its associated components are eliminated. Filtering is simplified. Battery drain is cut (to 1.1A in the experimental receiver, from 2 or 3A or more). Life is prolonged, reliability is increased, and maintenance is reduced.

PERFORMANCE

The experimental receiver is designed for medium-wave and long-wave operation. It provides an a.f. output of 2.4W into the speaker transformer, giving ample sound volume.

Car receivers have a special need for an efficient a.g.c. system, since the field strength is likely to fluctuate severely and rapidly as the car is driven about. This need is adequately met in the design, despite the complication which is introduced by the low available voltage.

Sensitivity, selectivity, and the voltage gains in the valve stages, all compare well with those found in a normal receiver working from a conventional h.t. line.

*6DS8	heptode	r.f. amplifier
6DS8	triode	
	heptode	frequency changer
6DR8	double-diode pentode	i.f. amplifier, detector, and a.g.c. diode
*6DS8	triode	a.f. amplifier
6ET6	pentode	driver
OC16	power transistor	audio power output
		* One valve

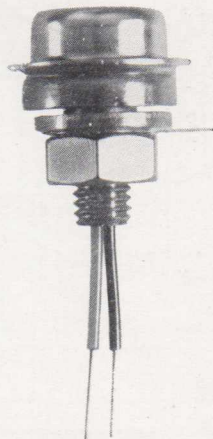

OC16 POWER TRANSISTOR

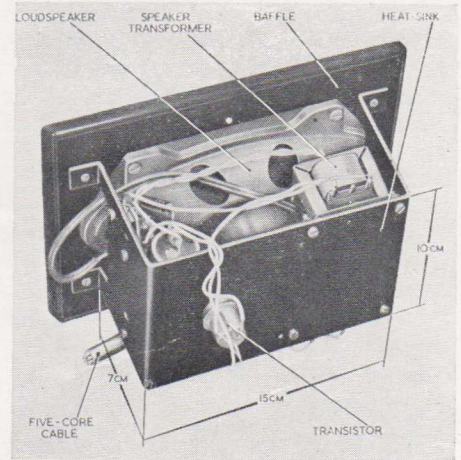

TEMPERATURE PROBLEMS

In the output stage of this kind of receiver the greatest problem is to provide the right temperature conditions for the transistor. Valves generate a considerable amount of heat, and it is desirable to mount transistors away from them. In addition, the designer of a car radio has to contend with the extreme temperatures which may be met in the vehicle itself. In particular, remarkably high temperatures will occur after prolonged parking, with all the windows shut, in strong sunshine. The temperature in the car, and round the transistor, will not fall to a normal level until the car has been moving for some minutes. If the driver has switched on the receiver immediately after getting into the car, then the transistor is liable to be subjected to the possibility of "thermal runaway".

HEAT SINK

Temperature problems can be adequately dealt with, firstly, by mounting the transistor away from the valve stages, and secondly, by providing it with an adequate heat sink. It is convenient, in practice, to mount the whole of the output stage (the loudspeaker, the output transformer, the transistor, and one or two other components) as a separate unit. The heat sink of blackened aluminium can be shaped round the back of the loudspeaker, with the transistor mounted as centrally as possible.

A laboratory version of this arrangement is shown in the photograph. The temperature conditions achieved have been found to give a margin of safety which will carry the transistor, without

adverse effects, through the short intensely hot periods which follow parking.

CIRCUIT DESCRIPTION

The h.t. supply is filtered by means of R15 and C29. This is, in general, adequate; but it is possible that rather more elaborate filtering might be required when the receiver is used in some cars. Decoupling of the h.t. supplies to individual valve stages has not been found necessary. It should be noted that the positive line is taken to the chassis of the receiver. This arrangement enables the receiver to be fixed directly to the frame of the car.

AERIAL CIRCUIT AND R.F. AMPLIFIER

The tuning unit provides separately tuned aerial circuits for medium and long waves. The input circuits are designed to match a low-capacitance aerial. The single tuned r.f. coil has an additional loading coil for long waves. The r.f. amplifier is the heptode section of a 6DS8 operated with g2, g3, and g4 at h.t. potential. A 1.0MΩ grid leak R1 is taken via a 560kΩ resistance R5 to a point which is 1.5V above cathode potential.

FREQUENCY CHANGER

The 6DS8 is operated as a conventional multiplicative mixer with a Colpitts oscillator. The oscillator circuit incorporates a single tuned coil for medium wave operation. An additional loading coil is switched in for long waves. The choke (about 25mH) between the triode anode and h.t. pro-

duces negligible voltage drop but provides sufficient inductance to avoid restriction of the normal frequency swing of the oscillator. The heptode is operated with a 2.2MΩ grid leak R2 taken to the same +1.5V point as the r.f. amplifier grid. An additional positive voltage is applied to the grid via a 10MΩ resistor R3 taken to the +6.3V point in the heater chain.

I.F. AMPLIFIER

The 6DR8 pentode is grid current biased by a 3.3MΩ resistor R6 returned to the cathode. A 3.3kΩ resistor R7 in the cathode circuit provides the positive voltage which is applied to the grid leaks of the r.f. and mixer stages. A normal medium impedance 470kc/s i.f. transformer is used. No a.g.c. is applied to this stage.

DETECTOR AND A.G.C.

The detector and a.g.c. diode loads, RV10 and R8, are returned to the cathode, the detector load being used as the volume control. The a.g.c. voltage is derived from the anode of the i.f. pentode, and is delayed by the positive voltage across the cathode resistor. Further delay is applied to the mixer valve by the 10MΩ resistor R3. In this way the control characteristics of the r.f. and mixer valves are lined up to give optimum signal handling.

A.F. VOLTAGE AMPLIFIER

The output of the detector is fed into the triode section of a 6DS8 (the heptode section of this valve is used in the r.f. stage). The triode is grid current biased by a 10MΩ resistor R11.

DRIVER

A 6DA6 operates as a tetrode with g3 strapped to anode. Negative voltage feedback from the speaker transformer is applied across the small cathode resistor R14. Grid current biasing is provided by R13. The output stage is fed via a stepdown transformer which is phased so that an increase of anode current corresponds to an increase of transistor collector current. This enables maximum power to be obtained from the valve, and reduces second harmonic distortion.

AUDIO OUTPUT

The transistor is used in grounded emitter, with potentiometer base bias provided by RV17 and the valve heater chain, as described in the earlier article. RV17 also serves to drop the supply voltage to 12.6V for the two series-parallel heater chains. The copper-wound series emitter resistor R18 has a small positive temperature coefficient which greatly improves collector current stability. The stage has an adequate safety margin under the extreme supply voltage and temperature conditions which are likely to be met.

Interference voltages in the transistor bias circuit can be bypassed by C20 connected between chassis and the linked centres of the two parallel heater chains.

The single ended production model of the OC16 is featured in the photograph on the previous page.

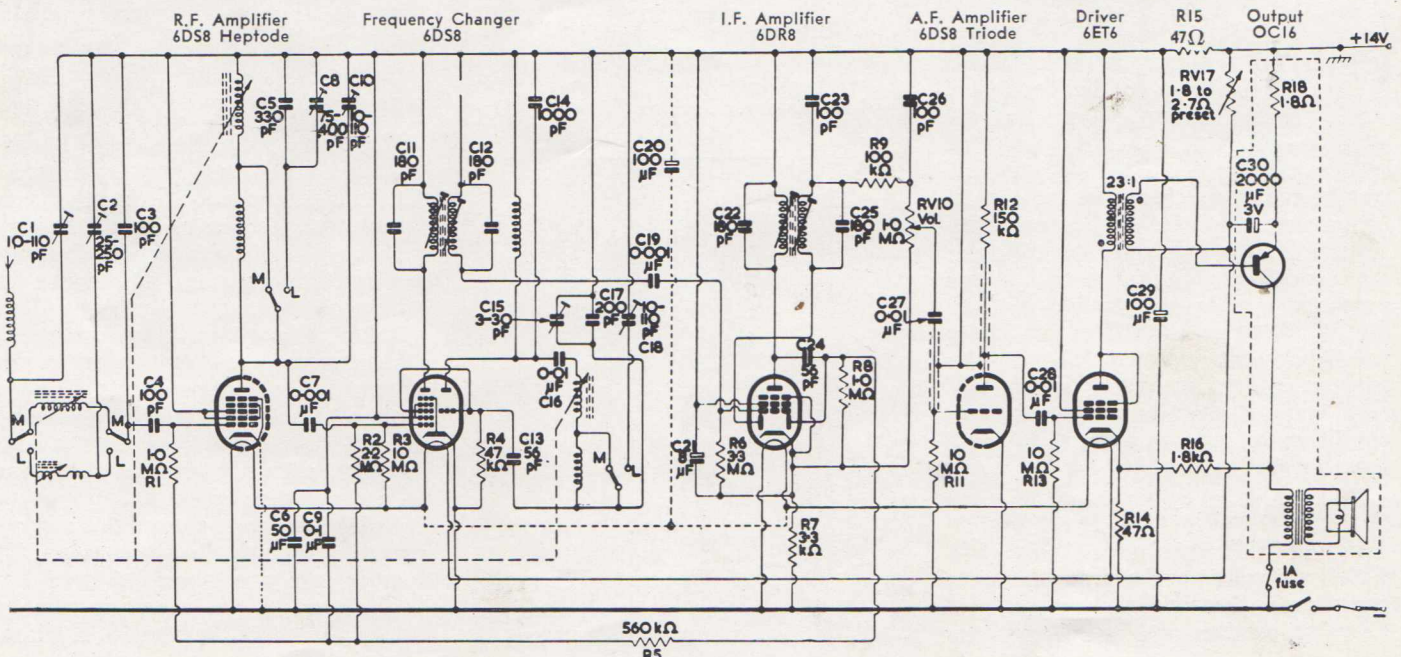

PERFORMANCE OF RECEIVER

Typical r.f. stage gains, from r.f. grid to mixer grid, are: 40 at 1400 kc/s, 55 at 1000 kc/s, 76 at 600 kc/s, and 31 at 200 kc/s. Cross-modulation performance is satisfactory. The mixer stage has a conversion gain of 17 at 1000 kc/s.

The a.g.c. characteristic maintains a delay up to an input of about 100μV at the r.f. grid, and the maximum signal-handling ability of the receiver corresponds to an input of about 1.0V. In a low voltage receiver the control voltage is small, and the grid bases of the controlled valves must also be kept small. In this design, a.g.c. is applied only to the r.f. and mixer stages. It is not applied to the i.f. stage, since it would seriously reduce the available control voltage.

The i.f. amplifier has a gain of 52 at 470 kc/s. The bandwidth is about 7 kc/s for 6dB down. The a.f. amplifier gain is about 6 times at 1000 c/s. The output stage delivers 2.4W to the speaker transformer at the start of clipping, and 2.9W at 10% distortion.

The following sensitivities correspond to a modulation depth of 30% and an audio output of one watt, with negative feedback applied.

Medium Wave—	Aerial	1st grid
1400 kc/s. ...	1.5	10 μV
1000 kc/s. ...	< 1.0	7.0 μV
600 kc/s. ...	< 1.0	4.0 μV

Long Wave (for European conditions only)—

200 kc/s. ...	3.0	12.5 μV
---------------	-----	---------

Signal to noise ratios, measured at 1000 kc/s and 30% modulation, are shown below.

Input (μV)	Signal to noise ratio (dB)
2	10
5	19.5
10	26
20	32
50	39.5
100	44

Additional information and design data may be found in an Applications Research Laboratory report which appeared in the Mullard "Technical Communications", Volume 3, No. 25.

TRIODE HEPTODE 6DS8

R.F. Amplifier Operating Conditions

6DS8 heptode

$V_a = V_{g2,3,4} = V_b$		12.6	V
$V_{g1(b)}^*$	+1.5	-3.0	V
g_m approx.	850	6.5	μA/V
r_a	0.75		MΩ

* voltage at earthy end of grid leak

Frequency Changer Operating Conditions

6DS8 heptode

$V_a = V_{g2,4} = V_b$		12.6	V
V_{osc} (r.m.s.) on g_t and g_3		1.5	V
$R_{g(osc)}$		47	kΩ
$V_{g1(b)}$	+3.0	0	-2.5
g_c	210	160	5
r_a	2.4	3.0	—

6DS8 triode

$V_a = V_b$		12.6	V
V_{g1}		0	V
I_a		1.0	mA
g_m		1.5	mA/V

A.F. Voltage Amplifier Operating Conditions

6DS8 triode

V_b		12.6	V
R_a		150	kΩ
R_{g1}		10	MΩ
R_g of next stage		10	MΩ
V_{out} r.m.s. ($D_{tot} = 5\%$)		1.8	V

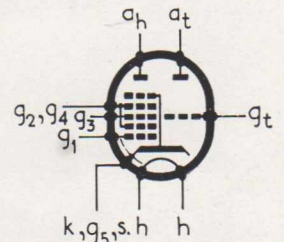
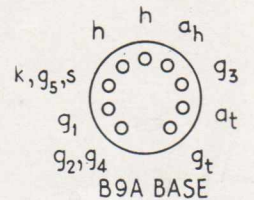
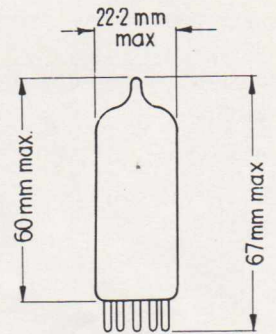

DOUBLE DIODE VARIABLE — MU R.F. PENTODE 6DR8

I.F. Amplifier Operating Conditions

6DR8 pentode

$V_a = V_{g2}$		11	V*
R_{g1}		3.3	MΩ
$V_{g1(b)}$		0	V
g_m		0.95	mA/V
r_a		1.0	MΩ

* dropped from 12.6V by R7

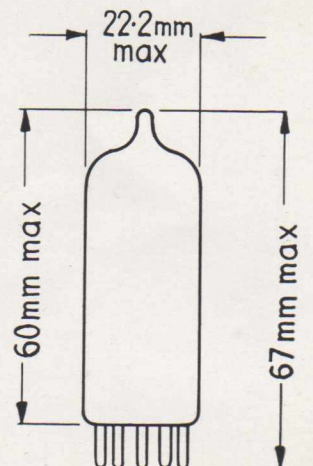
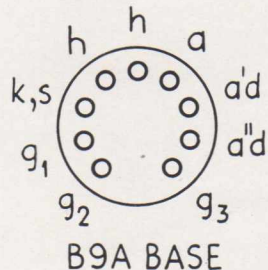
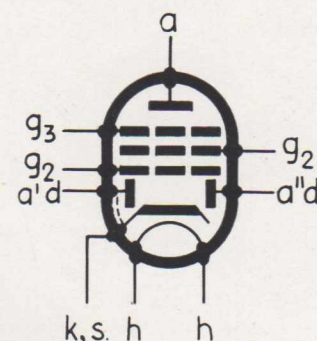



PENTODE 6ET6

Driver Operating Conditions

6ET6

$V_{a, g3}$	12.0	V*
V_{g2}	12.6	V
R_{g1}	10	M Ω
$I_{a, g3}$ quiescent	5.5	mA
I_{g2} quiescent	2.1	mA
R_a	4.5	k Ω
P_{out} ($D_{tot} = 10\%$)	13	Ω

* about 0.6V is dropped in the transformer

Driver transformer

Stepdown ratio	23:1	
I_a	5.5	mA
Primary inductance	6	H
Primary resistance	<200	Ω
Secondary resistance	<2	Ω

JUNCTION TRANSISTOR OC16

Output Stage Operating Conditions

OC16

Supply voltage	14	V
Collector current	475	mA
Base current	6 to 30	mA
Base voltage	1.14 to 1.37	V
Collector dissipation (25 to 45°C)	6.6	W
Emitter resistance (R18, copper-wound)	1.8	Ω
Load	25	Ω
Total thermal resistance	4.5	°C/W

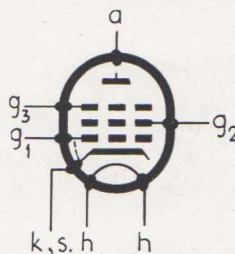
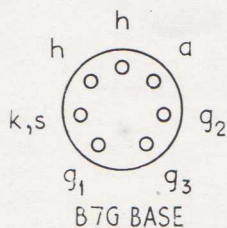
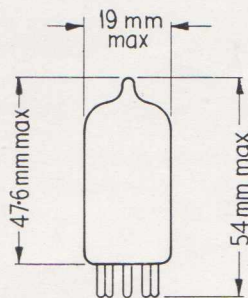

INSTRUMENT CATHODE RAY TUBES

Four instrument tubes with medium-persistence green fluorescence and electrostatic focusing are being added to the Mullard range. Some details, and tentative characteristics, are given below.

DH3-91: A minimum operating final anode voltage of 350V makes this one-inch tube particularly suitable as a built-in waveform monitor, especially in equipment in which either expense or lack of space prohibit the inclusion of an additional e.h.t. supply specifically for the tube. Deflection may be symmetrical or asymmetrical in the x direction, but only asymmetrical in the y direction.

A further feature of this tube is the use of a lens system which gives automatic focus, thus eliminating the need for a focus potentiometer.

DH7-91: This three-inch tube is designed for either symmetrical or asymmetrical deflection in both the x and y directions. It is particularly suitable for use in compact low-priced oscilloscopes.

DH10-94: This is a four-inch tube with optional post-deflection acceleration. A writing speed of 0.3km/sec is achieved when the tube is operated with a post-deflection acceleration voltage of 4kV. The tube is designed for symmetrical deflection in both x and y directions. The deflector plates are brought out to side connections on the neck of the tube, therefore the deflector plate capacitances are reduced to a minimum. A beam trap is provided on the x¹ plate for use when pulse or single stroke phenomena are to be displayed.

DH13-97: The most interesting feature of this five-inch tube is its use of graded post-deflection acceleration. Two successive bands (a₄ and a₅) are used, giving a high ratio between the voltage on the final gun anode and the final acceleration voltage. The large voltage difference enables a high writing speed to be obtained while preserving a high deflection sensitivity. This system of two-stage post-deflection acceleration is equivalent in operation to the widely-known spiral band system. The x plates are for symmetrical operation. The y plates may be either symmetrical or asymmetrical.

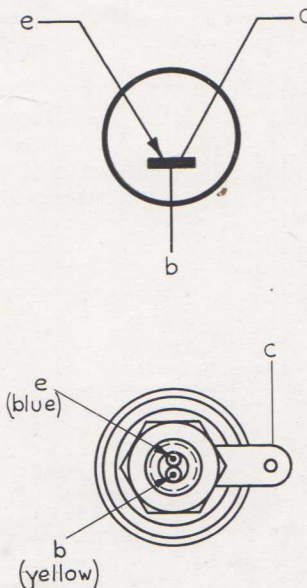
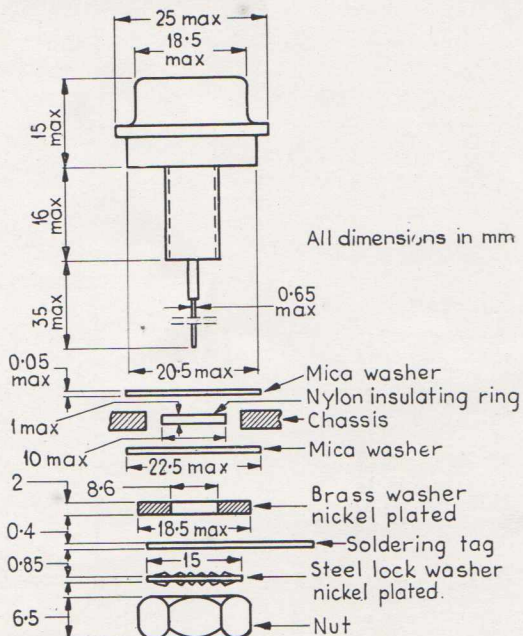



POWER TRANSISTOR DISSIPATION RATINGS

The ultimate power dissipation limit in a power transistor (such as the Mullard OC16) is the maximum junction temperature which will give a good life and a sufficiently low reverse collector leakage current. The OC16, for example, has a maximum junction temperature rating of 75°C, with a higher rating of 90°C which may be used intermittently and for not more than a total time of 200 hours during the life of the transistor. Thus, for the OC16, a junction temperature of 75°C should be used as the basis for normal calculation.

A thermal resistance exists between the point of generation of the heat at the collector junction, and the copper mounting base of the transistor. This thermal resistance is a function of the transistor structure, and the user can do nothing about it. In the OC16 it has a value of 1.0°C per watt; that is, when the thermal conditions have become steady there is, between the two points, a temperature difference of 1.0°C for every watt of continuous collector dissipation.

For a dissipation of 10 watts the temperature difference will be 10°C, and the collector junction will be 10°C hotter than the transistor mounting base.

MOUNTING

In any particular application it is necessary to provide a low heat-resistance path from the transistor mounting base to the place to which the heat is ultimately transferred (perhaps the surrounding air, or a stream of water). This external path is within the control of the equipment designer. It is the object of the transistor data sheet to give him the necessary information for calculating the details.

A series of separate thermal resistances is encountered. First, the thermal resistance of the contact between the mounting base and the mass of metal on which it is mounted. Its value will be 0.3°C/W max. if the transistor is simply bolted on to a sheet of brass, copper, or aluminium. It can be reduced to 0.1°C/W by using a thin tin-plated lead washer under the transistor, and a tapped hole in a thick metal plate. This combination gives good contact between the threads of the mounting stud and the plate, as well as between the surface of the plate and the flat base.

HEAT SINKS

If, on the other hand, the transistor

is electrically insulated from the plate by thin mica washers, the thermal mounting resistance rises to 0.7°C/W.

When the heat has been conveyed from the transistor to the heat sink, it must then be transferred to the surrounding air or water.

A well-designed water-cooled plate can be assumed to be an "infinite" heat sink, in which increased heat flow to the plate does not appreciably increase the plate temperature. In this special case the maximum power dissipation of the transistor is given by subtracting the plate temperature from the maximum junction temperature rating of the transistor (both in °C). The difference is then divided by the sum of the internal thermal resistance of the transistor and the contact resistance (both in °C/W). The answer is the total dissipation in watts.

With an air-cooled heat sink, two additional thermal resistances appear in series with those already considered. First, the spreading resistance which hinders the flow of heat from the mounting point to the periphery of the heat sink, so that it is not always possible to assume that the entire heat sink is at one temperature. Second, the thermal resistance between the surface of the plate and the surrounding air. This last resistance is of a complex nature. It depends not only on the flow of air past the heat sink but also, in most cases, on the texture and colour of the heat sink surface.

In the accompanying table some typical OC16 heat sinks and their thermal resistances are listed, with the appropriate maximum transistor dissipations. The resistance values, for all but the "infinite" heat sink, are for

simple horizontal aluminium plates suspended in still air. They will not apply in detail when the plate becomes part of a practical equipment. However, with the use of a thermocouple or other small temperature-measuring device, it is possible for the user to investigate the design of practical heat sinks, using the published data of the transistor.

The internal thermal resistance of the transistor is known; and, for experimental purposes, its power dissipation can be set at a definite value by adjusting the collector current. It is therefore possible to check that the transistor mounting base temperature does not exceed a value which is arrived at by the following method:

Mounting base temperature maximum junction operating temperature (75°C for the OC16) minus the internal transistor temperature drop (which is the power dissipated in the transistor, divided by 1.3°C/W for a transistor and plain uninsulated mounting).

If the transistor dissipation is 10W, this gives a maximum mounting base temperature of: 75°C - 13°C = 62°C.

If this experiment produces a satisfactory result, then the design can be used. Otherwise it is necessary to increase the heat sink area, the thickness, or the speed of the air-flow past the plate, and to repeat the experiment.

Finally, since the effect of blackening the plate is to increase the dissipation limit, some heat loss by radiation must occur. The effects of adjacent valves or other hot components must therefore be taken into account in the experiment:

Heat sink	Infinite (e.g. water cooled)		Large metal plate		Metal plate 1 sq. ft.		Metal plate 4 X 7 in.	
	Negligible		1°C/W		2°C/W		5.5°C/W	
Washers	Lead	Mica	Lead	Mica	Lead	Mica	Lead	Mica
Power Dissipation in Watts								
T _{amb} 25 C*	45	29	24	18.5	16	13.5	7.6	6.9
T _{amb} 35 C*	36	23	19	15	13	11	6.1	5.6
T _{amb} 45 C*	27	17	14	11	9.7	8.1	4.6	4.2
T _{amb} 55 C*	18	12	9.5	7.4	6.5	5.4	3.0	2.9

Dissipation values in excess of 24W are prohibited by the voltage and current ratings given in the full published data.

* To give T_{junction} of 75° C.



MULLARD AT THE ATOMIC ENERGY EXHIBITION

A major symposium on the Peaceful Uses of Atomic Energy, having particular reference to research and applications in Australia, was held in Sydney on 2nd to 6th June, 1958. The symposium was sponsored by representatives of universities, professional bodies, Commonwealth departments and the Australian Atomic Energy Commission, and papers were presented on a wide range of subjects related to Atomic Energy. In conjunction with the Symposium, a comprehensive exhibition was held at the Lower Sydney Town Hall, and covered the fields of uranium prospecting and mining, the development and use of atomic power, the industrial uses of radio active isotopes and nuclear instrumentation and control.

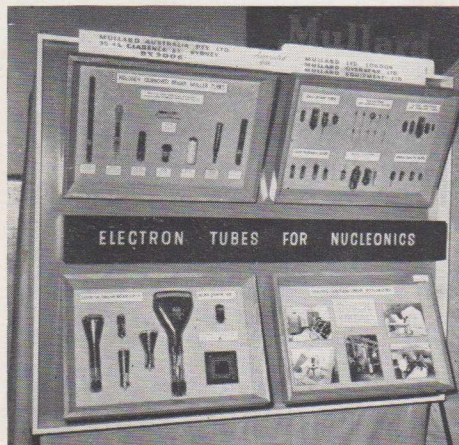

With the rapid development of nucleonics, the electron tube has assumed a major role and is widely used in radiation monitors and measuring equipment. The Mullard exhibit featured a comprehensive range of Geiger-Muller Counter Tubes, Cold Cathode Trigger Tubes, Thyratrons, Cathode Ray Tubes for Instrumentation and special quality valves for use in equipment where long life, reliability and close tolerances are of paramount importance.

Also displayed was a Ferroxcube Matrix-Plane, which is now widely used for information storage in Electronic Digital Computers and Data Processing systems. Of particular interest was the Mullard 4 Million Electron Volt Linear Accelerator recently developed for industrial and medical applications. The irradiation effects with this machine are precisely the same as those produced by radioisotope methods, but the advantages are numerous. For example, the source of radiation is under complete control and can be switched on and off instantly; the amount of irradiation can therefore be measured accurately and the treatment time governed precisely.

Several photographs and a sound film were used to demonstrate the principles of operation and describe typical installations of this equipment.

AMATEUR EXPERIMENTERS COLUMN

TRANSISTOR VOLTMETER

The operation of this circuit can be understood by remembering that, in the grounded emitter connection, a very small input current is required by the transistor. The input resistance on the highest range is $15M\Omega$ which is comparable with that of a valve voltmeter. Before use the zero should be adjusted with the input terminal short circuited. If zero balance cannot be obtained in the "Cool" position of the switch, it should be switched to "Warm". The sensitivity may then be adjusted by connecting a known voltage to the input terminals.

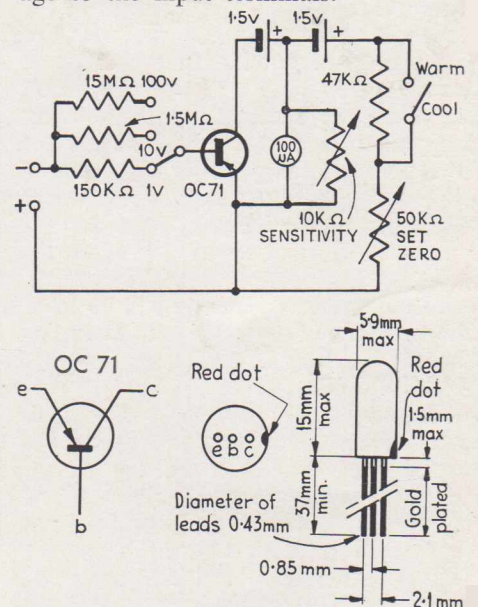

SUBMINIATURE VOLTAGE INDICATOR

The DM160 provides a simple, compact, sensitive, and economical visual indication of the state of two-state circuits.

The device is a directly heated vacuum triode in which the anode serves as a fluorescent screen. The visual display with zero grid voltage is a rectangular green glow about $10mm \times 2mm$. Application of $-3.0V$ to the grid extinguishes the glow.

The low operating voltages and currents make the DM160 of particular interest to designers of transistorised apparatus. Applications include bridge circuits, flip-flops, and computers. The small size of the tube (it is in a 5mm diameter T1 bulb with flying leads) enables it to be incorporated in small, closely-stacked, repetitive units. The fluorescent display is viewed through the side of the bulb.

Advance Data

V_r	$1.0 \pm 5\%$	V
I_r	30	mA
Typical Operating Conditions		
V_a	50	V
V_g (max. light output)	0	V
$*V_g$ (min. light output)	-3.0	V
I_a (max. light output)	585	μA
I_a (min. light output)	<5.0	μA
R_{g-r}	100	$k\Omega$

* centre tap of filament transformer earthed

Limiting Values

V_a max.	65	V
I_a max.	750	μA
R_{g-r} max.	1.0	$M\Omega$
Max. bulb length	28	mm
Max. diameter	5.5	mm
Area of illumination (approx.)	10×2	mm
Min. lead length	38	mm

CIRCULATION

Please circulate this copy of OUTLOOK and sign after reading.

<input type="checkbox"/>	<input type="checkbox"/>
<input type="checkbox"/>	<input type="checkbox"/>
<input type="checkbox"/>	<input type="checkbox"/>
<input type="checkbox"/>	<input type="checkbox"/>
<input type="checkbox"/>	<input type="checkbox"/>

Return copy to office for filing.

If you are on our mailing list and are changing your address, or if you are a new reader wishing to be added to the mailing list, please let us know.