



TUBES

HAM NEWS



THE OMNIVOX

THE OMNIVOX is a feature packed simple, flexible audio preamp/vox/transmitter control and phone patch unit. Integrated into this design project are the following author's dozen features:

1. 6BN6 gated beam VOX tube for positive anti-trip.
2. Automatic Level Control (ALC) of audio amplifier for uniform modulation from microphone and telephone inputs.
3. Hybrid phone patch with 6AL7-GT twin indicator tube to monitor voltage into line and ALC operation.
4. Individual phone and master gain controls.
5. Adjustable VOX Sensitivity, anti-trip and holding time controls.
6. Manual or automatic VOX control.
7. Shaped audio band-pass from 250-3000 cps.
8. Visual indication of ALC bus voltage.
9. Visual indication of "zero-beat" for on-the-nose net operation.
10. Peak compression circuit.
11. Zero audio output until control relay operates.
12. Speaker output attenuated automatically in "Patch On" position.
13. Auxiliary audio output position (with attenuated speaker output) for recorder or oscilloscope.

(continued on page 2)

W4PFQ MONITORS PHONE PATCH being handled through the OMNIVOX (just below receiver) installed in his station. Operating console also includes transmitter exciter (next to receiver), and — on lower level — speaker, power control panel (center) and audio system for transmitter. Large cabinet at left houses a final amplifier with pair of 6L813's, plate modulator and power supplies. W4PFQ operates principally on double sideband.

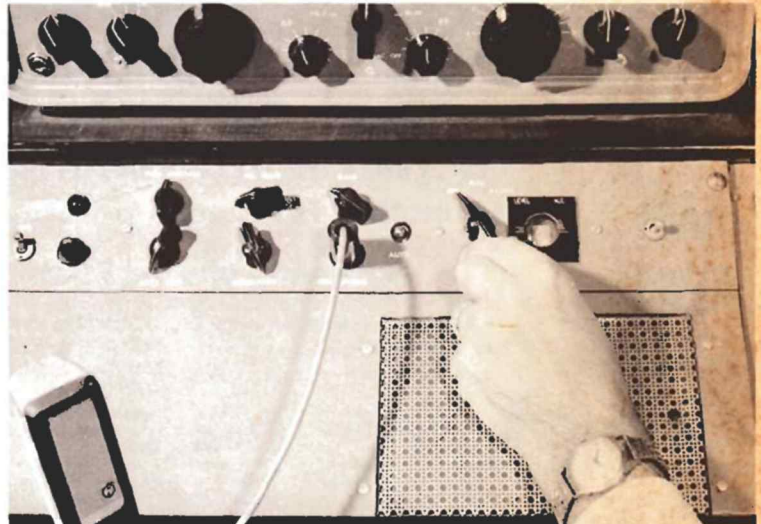

CLOSE-UP VIEW of the OMNIVOX centered on a 3½ x 19-inch rack panel. Switch, fuse and pilot light at left control external power supply for the OMNIVOX.

IN THIS ISSUE

OMNIVOX	page 1
VERSATILE POWER-CONTROL BOX	page 7
SCANNING THE SPECTRUM	page 8

OMNIVOX (continued from page 1)

A block diagram of this system is shown in Fig. 1. Only four tubes are needed in the functional amplifier and control stages. In addition, a 6AL7-GT twin indicator tube provides constant monitoring of the signal applied to the telephone line when using the phone patch. The indicator tube provides a sensitive means for determining optimum balance of the hybrid circuit, gives a visual indication of "zero-beat" and furnishes an indication of the amount of ALC voltage developed.

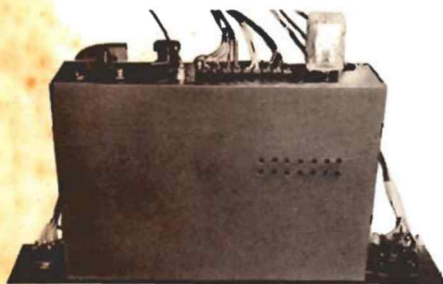

TOP VIEW of the OMNIVOX model with chassis cover in place. Vent holes in cover and chassis deck provide air circulation around tubes.

The gain of the audio system is about 70 decibels, providing adequate amplification from a crystal or other high impedance low level microphone to yield 22 volts at the audio output terminals when no ALC voltage is developed.

The input amplifier in the schematic diagram, Fig. 2, is driven through the master gain control (R₁) which provides the load for the crystal microphone. It also acts with R₂ and R₁₁ as a voltage divider to control the amount of telephone signal fed to V₁.

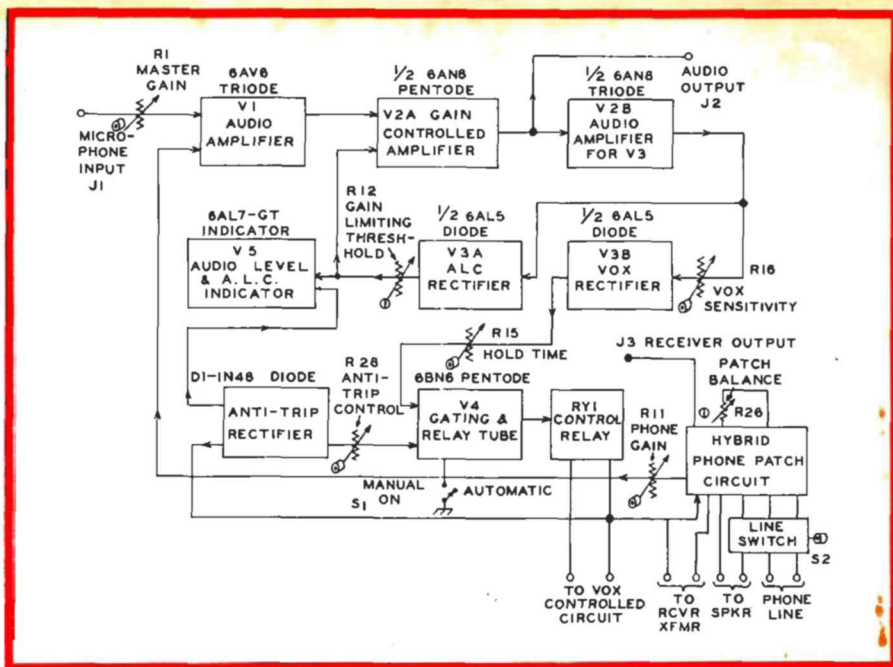

FIG. 1. BLOCK DIAGRAM of the OMNIVOX circuit, showing audio amplifier at top, bias rectifier and indicator tube at center, VOX circuit at bottom and hybrid phone patch at lower right corner. All controls except Gain Limiting Threshold (R₁₂), Calibrate (R₃₃) and Patch Balance (R₂₆) are on the front panel.

Preamplifier V₁ drives the pentode section of a 6AN8 (V_{2A}), connected as a gain controlled audio amplifier. Inter-stage coupling capacitors C₂ and C₃ provide low frequency attenuation. Circuit and tube capacitances coupled with C₃ provide high frequency attenuation, resulting in the audio frequency response characteristic shown in Fig. 3.

The output circuit of V_{2A} is composed of R₇, C₇, C₈, R₉ and R₁₀ in series with the load connected to the output jack (J₂) and the input impedance of V_{2B} connected through

R₂₀. When the OMNIVOX is in the "receive" (R_{Y1} not energized) condition, the audio output jack (J₂) is grounded through one of the normally closed contacts of R_{Y1}.

Thus, no audio output can appear at J₂ from the speaker feeding into the microphone, even though both audio stages may be operating at full gain. The paralleled resistance of R₉ and R₁₀ is 50,000 ohms, and this, in shunt with R₇, provides a load resistance of 33,000 ohms for V_{2A}. The audio voltage developed across this load resistance is coupled to V_{2B} to provide additional gain for the rectifier circuits of V₃ which provide a positive voltage from V_{2A} for driving the gating tube (V₄), and a negative voltage from V_{3B} for the ALC bias on V_{2A}.

In addition, should the positive going output of V_{2A} exceed the 7.5 volts developed by R₂₁ and C₁₄ in the cathode circuit of V_{2B}, the 47,000-ohm resistance of R₂₀ is shunted across the plate load to reduce the peak gain and provide moderate limiting action. Should greater clipping be desired, R₂₀ can be reduced. The peak voltage at which clipping begins can be adjusted by changing the value of R₂₁ to develop more or less DC voltage. (It is recommended that R₂₁ be no less than 600 ohms.)

THE OUTPUT OF V_{2B} is coupled through C₁₃ to V_{3A} where it is rectified and filtered through C₁₀, R₂₁, R₃₇ and C₁ to provide a negative voltage proportional to the amplitude of the



presents **HOW-TO-DO-IT IDEAS**
from the 999 radio amateurs at
GENERAL ELECTRIC

A bi-monthly publication of the RECEIVING TUBE DEPARTMENT
Owensboro, Kentucky, U. S. A. • Editor — E. A. Neal, W4ITC

G-E HAM NEWS is available free from authorized G-E Tube distributors. Some distributors mail copies locally to their customers.

A low-cost direct-mail subscription plan is available to persons residing in the United States and its possessions (including APO and FPO numbers).

Subscription rates are:

One Year (6 issues).....	\$1.00
Two Years (12 issues).....	\$2.00
Three Years (18 issues).....	\$3.00
Five Years (30 issues).....	\$4.00

Enclose check or money order for U. S. currency for the proper amount above made payable to "General Electric Company."

Residents of Canada may subscribe to G-E HAM NEWS for \$1.00 per year from the Canadian General Electric Company, Ltd., Electronic Tube Market-

ing Section, 189 Dufferin Street, Toronto 3, Ontario, Canada. Enclose check or money order made payable to: "Canadian General Electric Company, Ltd."

Distribution of G-E HAM NEWS in more than 40 foreign countries is handled through the International General Electric Company. A listing of outlets is available from the G-E HAM NEWS office. Or, write to: Customer Inquiry Section, International General Electric Company, 150 East 42nd Street, 7th Floor, New York 17, New York, U. S. A.

NOTE: The disclosure of any information or arrangements herein conveys no license under any patents of General Electric Company or others. In the absence of an express written agreement to the contrary, the General Electric Company assumes no liability for patent infringement (or any other liability) arising from the use of such information by others.

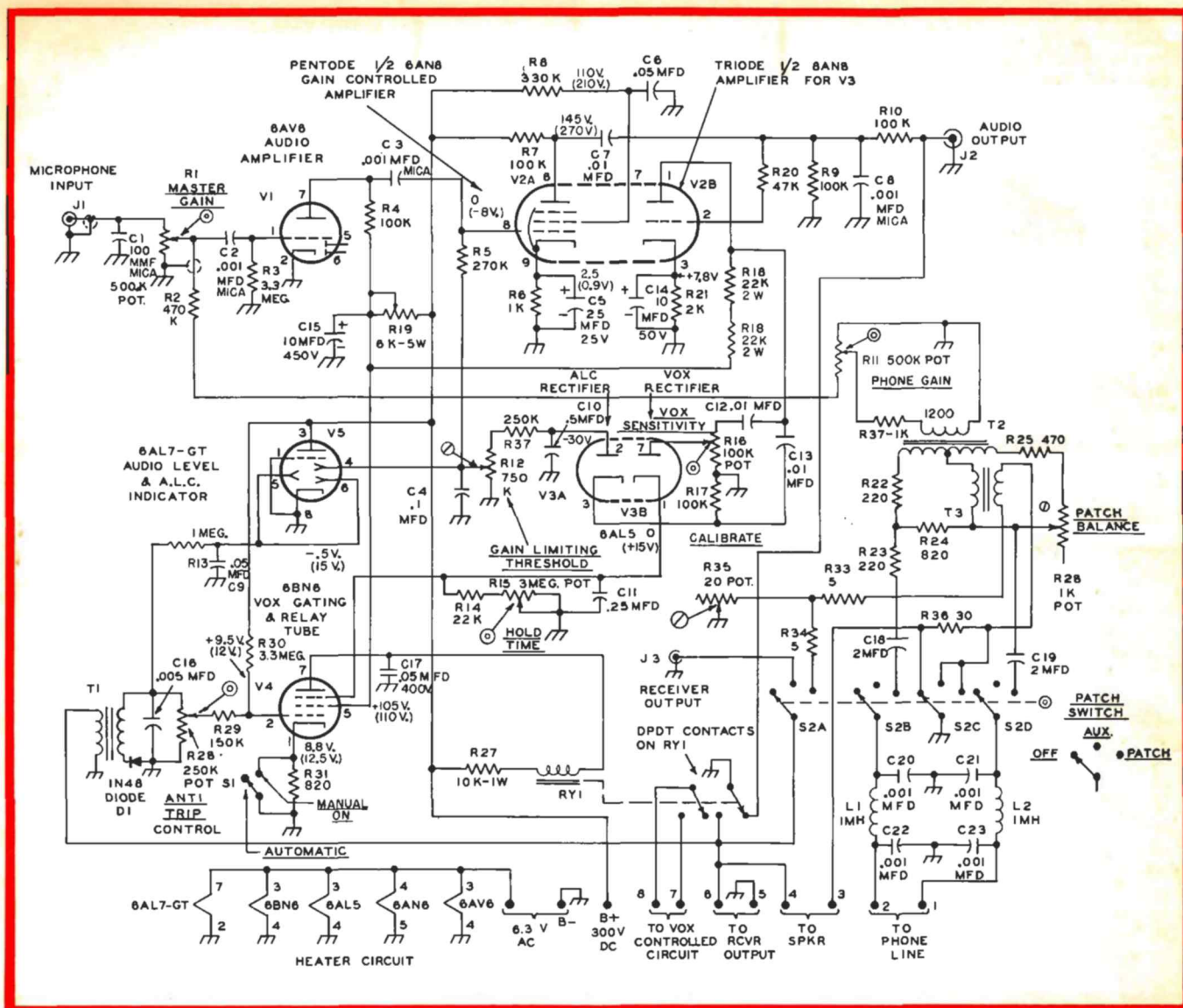

audio output. When this voltage is fed back through R_5 to the grid of V_{2A} , the operating point of this tube is shifted to reduce the gain of the stage. By adjusting the *Gain Limiting Threshold* control, the amount of audio limiting can be varied over a wide range.

The circuit is fast acting and has a control range of more than 20 decibels with a normal threshold setting about $\frac{1}{3}$ open, as shown in Fig. 4. The control voltage is monitored by one section of V_5 and provides a relative indication of the output voltage from V_{2A} . Rectifier V_{3A} is driven from amplifier V_{2B} through C_{12} and the VOX *Sensitivity* control (R_{16}). The DC output of this circuit is developed across R_{11} and R_{15} and charges C_{11} to provide a positive gating voltage for control tube (V_4).

Output from the receiver is applied to the primary of T_1 (a

(continued on page 4)

FIG. 2. COMPLETE SCHEMATIC DIAGRAM of the OMNIVOX. Only those parts which require additional identification are shown in TABLE I — PARTS LIST. Resistances are in ohms, $\frac{1}{2}$ watt rating and ± 10 percent tolerance, unless otherwise marked. Capacitances are in microfarads (mfd), paper types of 600-volt DC rating, except where noted. Base pins of tube diagrams are numbered.

TABLE I — PARTS LIST—OMNIVOX

C_525 mfd, 25-volt electrolytic.	R_{11}DPDT relay, 5,000-ohm 8 ma coil, 8-pin octal plug-in base (Potter-Brumfield KCP-11-5000 DC)
C_{11}10 mfd, 25-volt electrolytic.	S_1SPST toggle switch.
C_{15}10 mfd, 450-volt electrolytic.	S_24-pole, 3-position rotary tap switch.
J_1Chassis type microphone jack.	T_14-watt universal audio output transformer, 10,000-ohm primary to 3.2-ohm secondary.
J_2, J_3Chassis type 1-pin phono jacks, or phone jacks.	T_2matching transformer, 1200-ohm primary, 600-ohm secondary with precision electrical center tap. ¹
L_1, L_21-mh pi-wound r.f. chokes.	T_3matching transformer, 500-ohm primary, 4-ohm secondary.
R_1, R_{11}500,000-ohm potentiometer, linear taper.	¹ Transformer T_2 in the author's model was obtained from a Signal Corps RM-52 Remote Control Unit, part of field telephone equipment which is available from several war surplus electronics distributors. T_2 is labeled "UTC 83718-C-280A."
R_{15}3-Megohm potentiometer, linear taper.	
R_{16}100,000-ohm potentiometer, linear taper.	
R_{19}6,000-ohm, 5-watt adjustable wire wound resistor.	
R_{20}1,000-ohm potentiometer, linear taper.	
R_{25}250,000-ohm potentiometer, linear taper.	
R_{35}20-ohm wire wound potentiometer.	

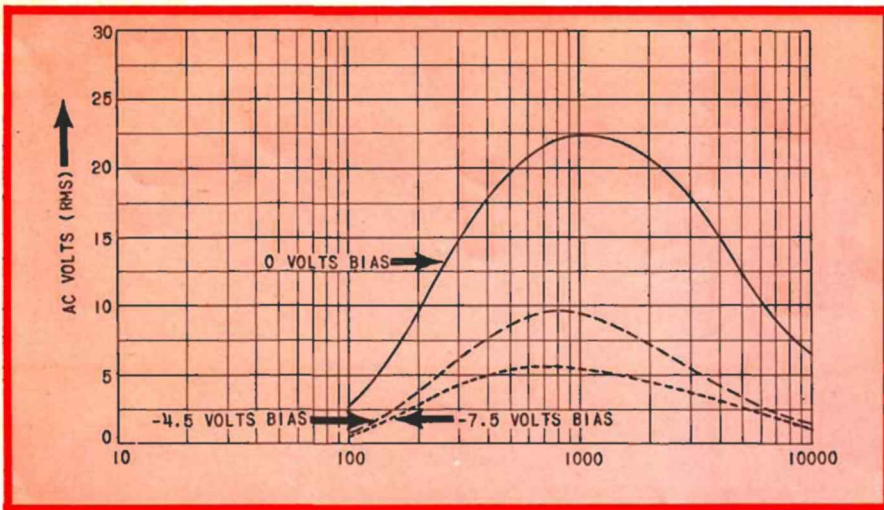

FIG. 3. AUDIO FREQUENCY response characteristic of the preamplifier. Curves show change in output level at constant input level with different values of ALC bias. When converted to decibel scale and normalized, all three curves nearly coincide. This indicates that the bandpass remains constant over wide gain variations.

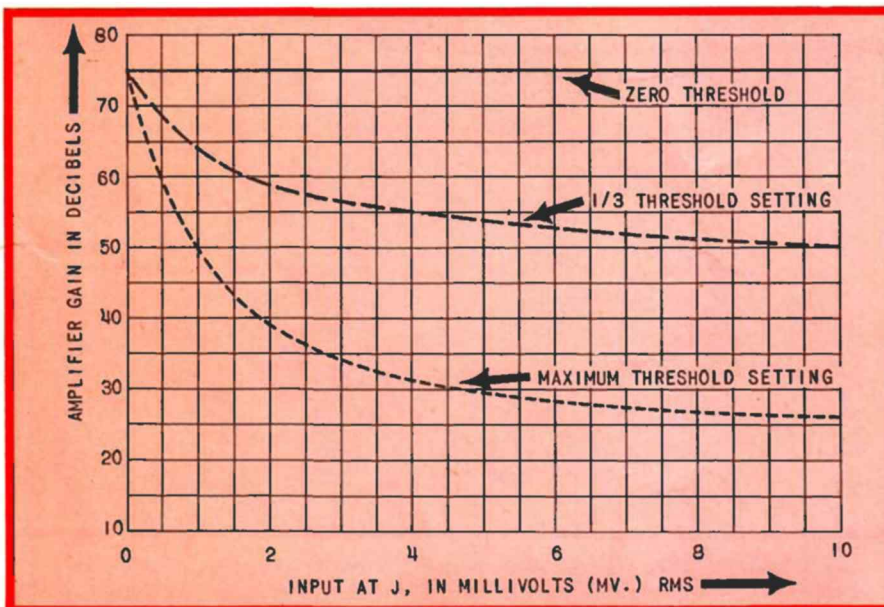

FIG. 4. GRAPH SHOWING range of control provided by ALC system over range of zero threshold voltage, to full threshold voltage.

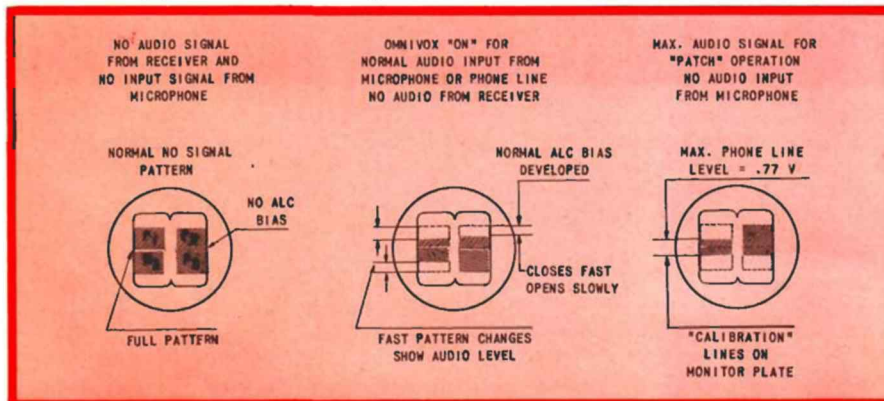

FIG. 5. PATTERN SHOWN on 6AL7-GT indicator tube (V_3) with (left) no audio signal; (middle) audio signal compressed normal amount, with left hand pattern changing at syllabic rate, and right hand pattern changing at slow rate with variations in ALC bias. Maximum phone line level of 0.77 volt is shown in pattern view at right.

OMNIVOX (continued from page 3)

small output transformer operated backwards), where it is stepped up and rectified by a 1N48 diode (D_1). The voltage developed across C_{18} and R_{28} provides negative going pulses of voltage which are superimposed on the positive DC voltage on the No. 1 grid of V_1 by adjusting the *Anti-Trip* control (R_{28}). An additional RC filter (R_{17} and C_9) provides a DC voltage to the deflection electrodes of V_2 which is proportional to the peak audio voltage delivered by the station receiver to the OMNIVOX. Thus the pattern of three sections of V_2 compresses as more audio voltage is fed from the receiver, as shown in Fig. 5.

HEART OF THE CONTROL SECTION

of OMNIVOX is the 6BN6 gated beam tube (V_4). This tube is constructed in such a way that its plate receives current only when *both* of the grids are cut on. Thus an anti-trip voltage at the No. 1 grid can cut off the beam and, regardless of the amount of positive voltage on the second control grid, the plate cannot draw current. By this means, anti-trip action is not a matter of delicate balance between opposing voltages.

The 6BN6 (V_4) operates with nearly constant cathode current, developing 9.5 volts across R_{31} , and providing cut-off voltage for the second control grid. The first grid is connected to a voltage divider made up of R_{30} , R_{29} and R_{28} from plus 300 volts to ground, and is clamped at zero bias. Thus, in the absence of anti-trip voltage derived from receiver output, the input gate is open.

Since the second grid is cut off, no plate current flows until audio voltage applied to V_{2B} develops a positive gating bias at the 6BN6's second grid. This starts plate current flow in the 6BN6, causing R_{31} to close. Its DPDT contacts unground the audio output signal from V_{2A} , mute the speaker and close the external VOX control circuit on terminals 7 and 8.

The gating bias remains on the second control grid of V_4 as long as there is sufficient positive voltage across C_{11} . The *HOLD* control (R_{15}) adjusts the discharge time of C_{11} . Space charge effects in V_4 further modify the discharge characteristics so that the components specified give a range of *Hold* from milliseconds to continuously *on*. In the *Manual* position of S_1 , the cutoff bias for the second gating grid is removed and closes R_{31} .

THE PHONE PATCH SECTION of OMNIVOX is a hybrid circuit made up of a pair of transformers, a balancing network, cou-

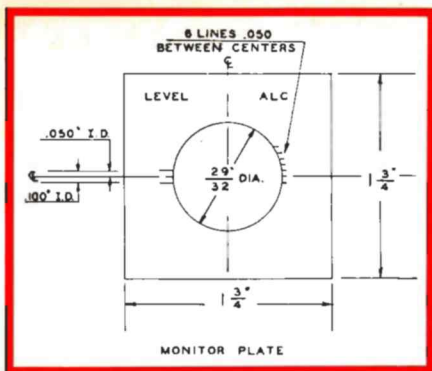

FIG. 6. DIMENSIONAL DIAGRAM of the escutcheon plate for the 6AL7-GT (V_5) indicator eye tube. Calibration marks at left are for maximum phone line level of 0.77 volt. Material used is $\frac{1}{8}$ -inch thick black bakelite.

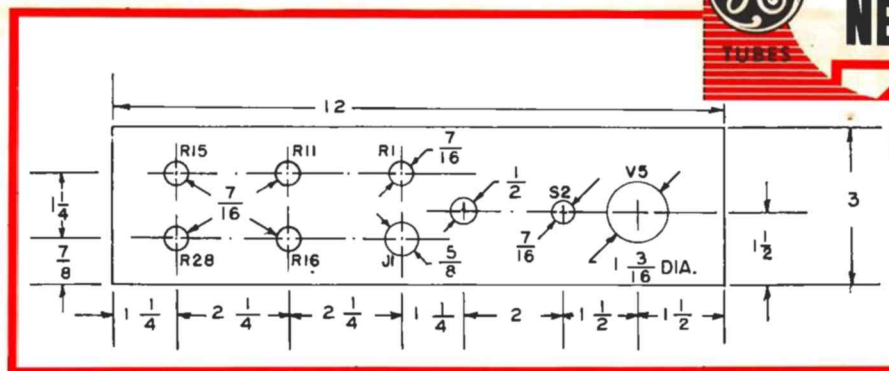

FIG. 7. DRILLING DIAGRAM for the chassis and front panel of the OMNIVOX. Dimensions can be changed to suit individual layout needs, but should follow the same pattern. Small holes for mounting hardware are not shown.

pling capacitors and a pi-section RF filter for the phone extension line. In the OFF position of S_2 , the patch is off and is completely out of the circuit (with the exception of the RF filter which is left in at all times). In the AUX. position of S_2 , the receiver output is switched to the Receiver Output jack (J_3). Simultaneously a 30 ohm resistor is connected in series with the speaker voice coil to attenuate the audio output about 10 decibels.

In the PATCH position of S_2 , the hybrid transformers are connected to the telephone line through low-leakage paper coupling capacitors (C_9 and C_{10}). In addition, while the speaker remains attenuated, a Tee network is connected between the receiver output and the primary of T_3 , which couples audio from the receiver to the telephone line.

Earlier, it was explained that the 6AL7 (V_5) was driven by a negative voltage proportional to the peak receiver output voltage. In the PATCH-ON position of S_2 , R_{26} (in the Tee network) can be adjusted so that the maximum audio voltage supplied to the 'phone line is equal to the maximum allowable line voltage (usually about 0.77 volts) for a specific amount of pattern compression on V_5 . The escutcheon plate shown in Fig. 6 is marked for this purpose. Once this calibration has been accomplished, the 6AL7-GT eye tube monitor provides a direct means for checking the audio level to the line. This makes it possible for the operator to adjust the station receiver audio output to the proper patch operating level.

The Balance control (R_{26}) is used to adjust the current flow through the two sections of the primary of T_2 due to the presence of voltage across the secondary of T_2 , so that receiver output is not coupled through T_2 to the audio amplifier

section of OMNIVOX. To adjust R_{26} , the patch is switched on (after you have dialed an understanding friend on the land line) and the Phone Gain control (R_{11}) is opened to impress voltage from the secondary of T_2 on V_5 . Receiver output is being fed into T_3 in this case and the circuit may tend to oscillate unless the Sensitivity control (R_{16}) is at minimum gain.

With the Threshold control (R_{12}) about mid-point, the Patch Balance control (R_{26}) may be adjusted slowly until the ALC monitoring section of V_5 , indicating the amount of audio voltage out of V_{2A} , shows zero output voltage. The Master Gain control (R_1) may be opened further to increase the system gain for more precise balance. Although this adjustment is quite sensitive, the visual indication provided by V_5 makes this a simple operation. Following the balancing of the hybrid circuit,

the calibration of phone line voltage versus V_5 pattern compression should be rechecked.

The OMNIVOX may now be operated from the phone line by adjusting the Master Gain, Phone Gain (R_{11}), and Sensitivity controls (R_{16}) appropriately. Slight compression of gain by ALC action from the voice input on the line should be indicated by V_5 . When the microphone in the telephone is providing the audio signal, the ALC will reduce the gain of V_{2A} (depending on the setting of the Threshold control) so that the audio output is not excessive even though the output from the handset is many times greater than the usual 'phone line signal.

Note that the reduced speaker output in the Patch-ON position of S_2 helps prevent audio feedback from speaker to the telephone microphone. Changing S_2 from "Patch-ON" to

(continued on page 6)

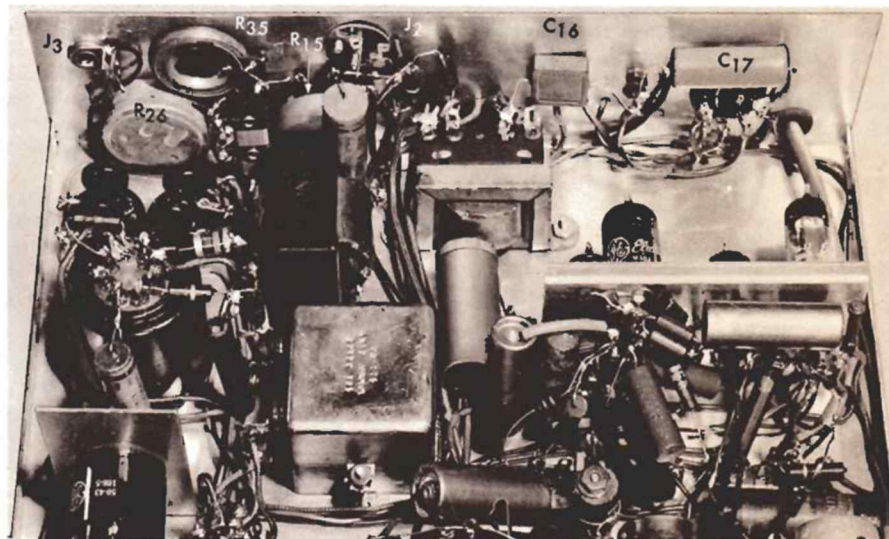

INSIDE VIEW of the OMNIVOX built in an 8 x 12 x 3-inch deep chassis box, looking toward rear side. Locations of major parts should follow the same general layout. Point-to-point wiring method was used, with terminal strips supporting clusters of small components near sub-chassis at right, and phone patch section at left.

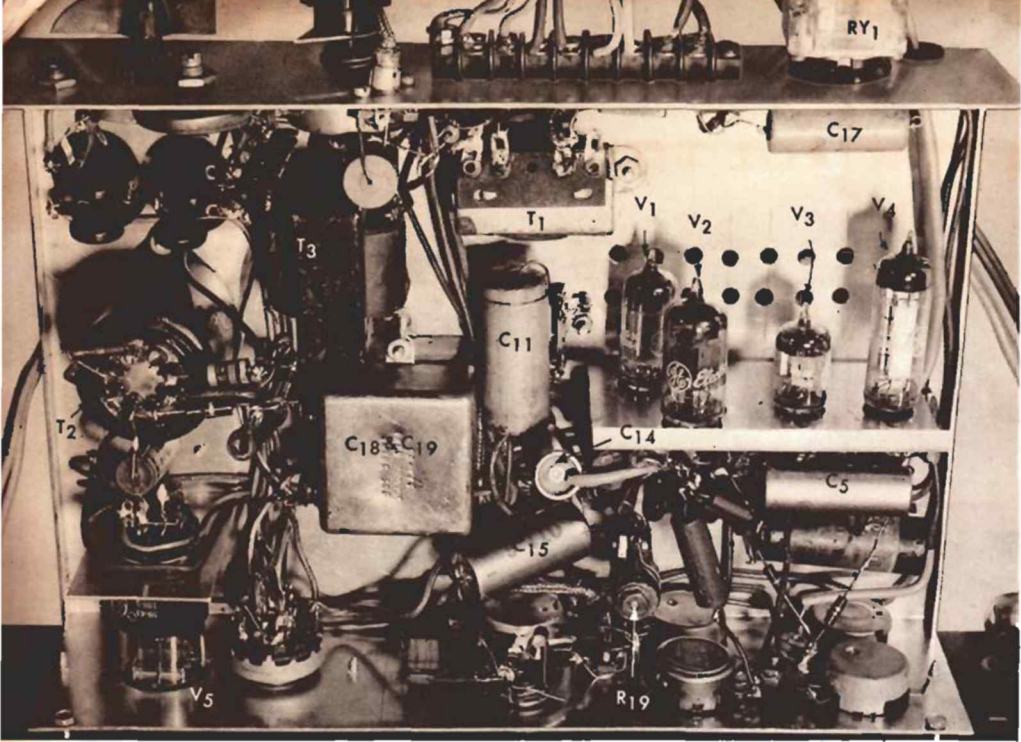

BEHIND-PANEL DETAILS are shown in this view. A small bracket made from $\frac{1}{8}$ -inch thick sheet aluminum supports the socket for the 6AL7-GT indicator eye tube at left. The phone line isolating capacitors (C₁₈ and C₁₉) are stacked and fastened with long machine screws at center of chassis.

OMNIVOX (continued from page 5)

"Aux." provides an immediate disconnect between the phone line and the patch circuit without a blast from the speaker. When running a phone patch through the OMNIVOX, the positive gating action of the VOX control tube and the easy shift from automatic to manual control, provide sufficient flexibility to meet the variety of operating conditions and degree of familiarity with patch procedures likely to be encountered.

The 6AL7-GT monitoring indicator is also useful for frequency checking and zero-beating to net or roundtable frequencies. Since the indicator is DC-coupled to the 1N48 anti-trip diode, and the time constant of the filter is relatively short, the compressed pattern opens abruptly as zero-beat is approached

between the received signal and the beating signal from a transmitter VFO, crystal calibrator, or inter-polarization oscillator.

It is possible to see the beat note down to about 2 cps with this system (this is usually close enough for most tuning). In order to use this feature on SSB it may be necessary to insert some carrier while setting the transmitter on frequency. For DSB (used by the author), or for AM, carrier is readily available at the operating frequency.

CONSTRUCTION of the author's model OMNIVOX was accomplished in an 8 x 12 x 3-inch chassis.

The pictures of the completed unit on pages 2, 5 and 6 show most of the pertinent constructional details. A smaller chassis size could be used if smaller parts than those from the author's junk box are available.

Controls which may be used during normal operation were mounted on the front side of the chassis in the locations shown in the drilling diagram, Fig. 7. The four control tubes (V₁ to V₄) were mounted internally on a small sub-chassis bracket running parallel to the front panel. Fabrication details of this bracket are shown in Fig. 8. The 6AL7-GT indicator tube (V₅) is mounted on another bracket made from $\frac{1}{8}$ -inch thick sheet aluminum, located so that the tube protrudes through the 1 $\frac{1}{8}$ -inch diameter hole in the chassis front (and panel, too).

An 8-terminal barrier strip for external signal connections, the *Gain Limiting Threshold* (R₂), *Patch*

Balance (R₂₀) and *Calibrate* (R₂₅) controls, the *Receiver Output* (J₃) and *Audio Output* (J₂) jacks, and control relay (R_{Y1}), are mounted on the rear side of the chassis. Power for the heater and plate power come in on a 4-wire cable.

Almost all wiring is run with insulated hookup wire. Leads from J₁ to R₁, R₁ to the control grid of V₁, and to the *Phone Gain* control (R₁₁) are run with shielded single conductor wire. Small parts are mounted on lugs of components they connect with, and on terminal strips.

TESTING THE OMNIVOX, when completed consists of connecting it to a power supply furnishing 300 volts DC at 40 milliamperes, and 6.3 volts at 2 amperes. The audio section should be checked out first, and then bias voltage measurements in the ALC circuit are taken to check its operation.

The VOX circuit should then be tested, and calibration of the indicator eye tube is completed. Instructions for adjusting the various controls have been given heretofore in the description of the OMNIVOX circuits, and will not be repeated here. Balancing and testing of the *Phone Patch* circuit should be done last after the other adjustments have been completed.

Finally the chassis cover plate is installed with self-tapping screws, and the OMNIVOX is installed in the position it will occupy in the station. The package has been designed so that it can set under, or on top of, a receiver, speech amplifier, etc. Or, it can be stood on end between units on the operating desk. If the latter position is chosen, vent holes should be drilled in the chassis sides which form the bottom and top. Small rubber feet also should be secured to the bottom side.

Operation of OMNIVOX is pretty much automatic once the *Microphone Gain*, *Telephone Gain*, and *VOX Sensitivity* controls have been set. The *Anti-Trip* control should be adjusted so that speaker noise does not actuate the VOX circuit. The *Hold Time* control should be set to individual tastes, with sufficient hold in time so that R_{Y2} remains closed between spoken sentences.

Portions of the OMNIVOX circuitry may easily be adapted to existing transmitter audio equipment, if desired. The audio gain-controlled amplifier, with its speech frequency range emphasis, and the VOX circuits too, are superior to similar circuits found in some commercial transmitters.

Improve your amateur station by incorporating the complete OMNIVOX, or portions of the circuit, into your equipment.

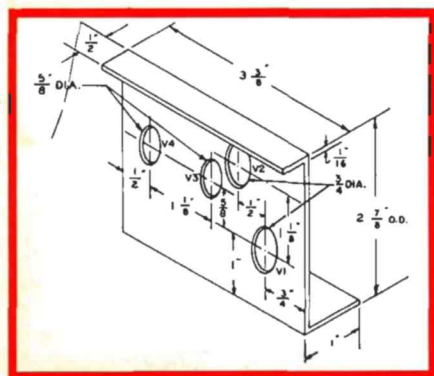

FIG. 8. LAYOUT DIAGRAM for the sub-chassis on which the four miniature tubes are mounted. A sheet of $\frac{1}{8}$ -inch thick aluminum $4\frac{1}{2} \times 3\frac{3}{8}$ inches is required.

VERSATILE POWER-CONTROL BOX

By Philip E. Hatfield, W9GFS

Few amateur stations today have equipment permanently wired to power lines through disconnect switches; rather, the trend toward tabletop units with simple power cord connections has sometimes brought about a tangle of extension cords and cube taps, necessary to connect a receiver, moderate power transmitter, and accessory equipment to the power line.

A useful accessory to lessen the power-line haywire may be easily constructed in the form of an AC outlet box — shown in the accompanying illustrations. The mechanical design can be tailored to fit individual installations. The box shown in use at W9GFS was intended for mounting on the side of a desk. A different layout would permit other mounting positions.

THE SCHEMATIC DIAGRAM, Fig. 1, shows the outlets split into groups: (1) those that remain on as long as the box is plugged in, intended for a desk lamp and clock; and (2) those controlled by a main switch (S₁) and intended for the receiver, transmitter, and accessories. A fuse is included in the circuit for all of the outlets.

The input plug and all of the outlets but one are mounted on the rear of the box, since constant accessibil-

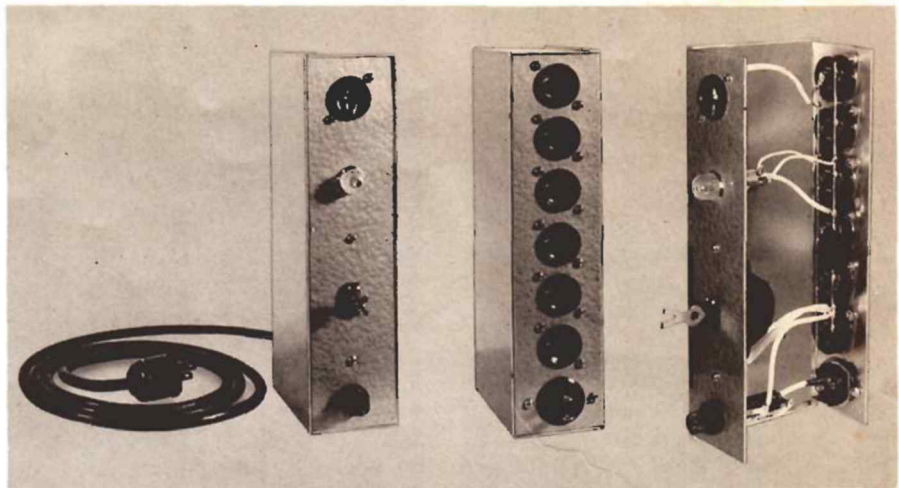

POWER CONTROL BOX constructed by W9GFS, showing (left to right) front, rear and inside views. Note tinned copper wire connections between outlet receptacles.

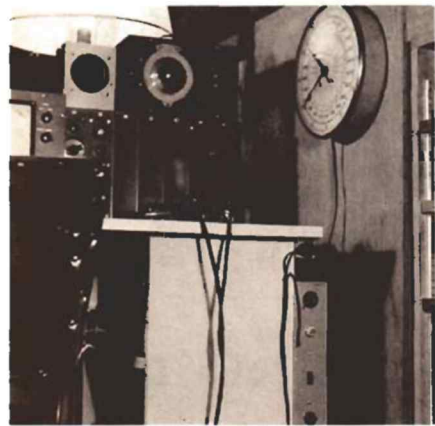

INSTALLATION of power control box at W9GFS fastened to the side of operating console.

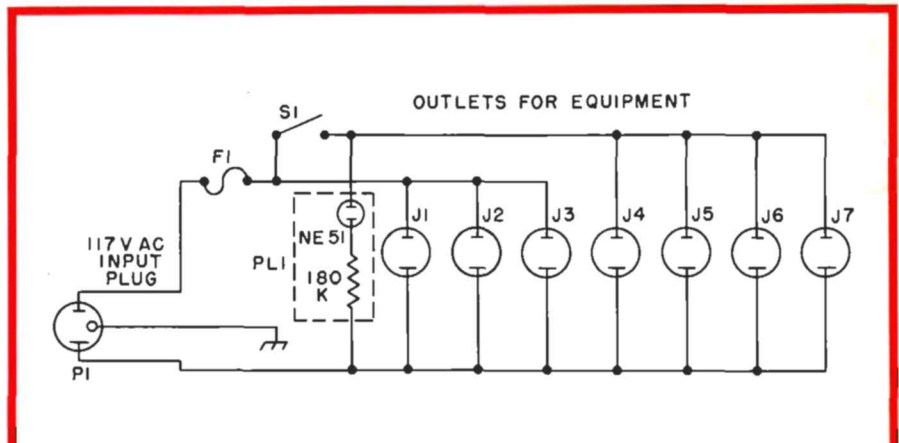

FIG. 1. SCHEMATIC DIAGRAM of the power control box. Wiring should be run with No. 14 or No. 12 wire. The three outlets at left (J₁, J₂, and J₃) have power on them continuously. Polarized receptacles and plugs may be used if available.

TABLE I — PARTS LIST — POWER CONTROL BOX

F1.....Fuse holder for 3AG fuse, and fuse rated at 5 or 10 amperes, depending on load drawn from box.	PL1.....Panel lamp assembly with dropping resistor for NE-51 Neon lamp.
J ₁ to J ₇2-prong female power receptacles for chassis mounting (Amphenol 61-MIP-61F)	S ₁Lock type flush tumbler switch (Bryant 5861-L, or equivalent).
P1.....2-prong male power connector for chassis mounting (Amphenol 61-MIP-1)	Box.....LMB No. 144 box chassis 10 x 4 x 2 1/2 inches.

ity is not necessary. One outlet in the group not controlled by the switch is mounted on the front to allow ready accessibility for a soldering gun. The neon lamp on the front of the box indicates when the *switched* group of outlets are on.

The switch allows all station units to be turned on or off without the use of the switches on the individual units. The switch on the model shown requires a key to turn it on;

this prevents children from energizing the equipment. A conventional wall-switch which has the same dimensions may be substituted.

All of the outlets used are of the polarized type, and care should be taken in connecting the plugs on the attachment cord to preserve the polarity relationship. If the box will be used within reach of a ground, a 3-wire safety type plug should be used to ground the box.

This control box usually will handle transmitters rated at up to 200 watts input. Higher power transmitters, especially those in the kilowatt class, should be powered from a separate circuit. However, all station equipment except a large transmitter can be controlled by the power control box.

Devote one or two evenings to eliminating your line cord haywire by constructing this handy box.

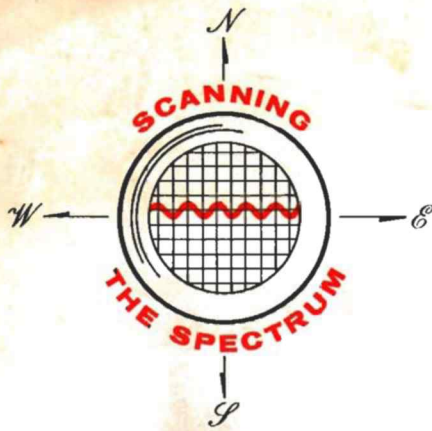

**A New Feature —
MEET OUR AMATEUR
TUBE DISTRIBUTORS —**



Uncle Dave Marks, W2APF (center), visited the amateur radio station at Vatican City, HV1CN, on a trip to Europe recently. At left is Dr. Loris Castaldi, I1CL, who acted as interpreter and, at right, Domenico Petti, Chief Operator and Custodian of HV1CN.

W2APF is widely known as the operator of UNCLEDAVE'S Radio Shack in Albany, New York. During several foreign and globe-girdling tours, Dave has met thousands of radio amateurs, and may well have set a record for this feat.



CAPACITORS FOR HAMS — General Electric's new line of "application rated" Service-Designed Alumatytic® capacitors will replace more than 1,200 different types with only 275 twist-prong and tubular types. Amateurs will find them ideal for replacement, or for new home-built equipment. Ask for them at your G-E Tube distributor's.

MEET OUR AUTHORS —

W9GFS — Philip E. Hatfield, found a solution to the usual tangle of power cords and cube taps in the neat power control box for his station described on page 7.

Phil's previous contributions to **G-E HAM NEWS** have been the **GADGET RACK** and accessories in the September-October, 1958 issue, and "OPERATING G-E HI-FI TUBES AS MODULATORS" in the January-February, 1960 issue.

Vocationally, W9GFS is a technical data engineer with G.E.'s Receiving Tube Department here in Owensboro. He has authorized several articles for *QST*, *Electronics World*, and other publications.

W4PFQ — Allen (Al) P. Haase, needed a combination audio preamplifier, with automatic gain control, voice-controlled break-in circuit, and phone patch. The result, after many hours of construction and testing, is the **OMNIVOX** described in this issue on pages 1 to 6.

Al's fine station is shown on page 1. The transmitter is completely home constructed, including the exciter unit at the right.

W4PFQ is Manager of Advanced Development Engineering for General Electric's Receiving Tube Department in Owensboro. He and his staff are busily engaged in developing exotic new thermionic devices like **TIMMS** circuits, the tiny high-temperature, radiation-resistant packaged electronics circuits described on page 2 of the July-August, 1959 issue.



Available **FREE** from your G-E Tube Distributor

JANUARY-
FEBRUARY
1961
VOL. 16, NO. 1