



HAM NEWS

JANUARY-FEBRUARY, 1959

In this issue

7077 R.F. AMPLIFIERS

for 432 megacycles page 3

for 144 megacycles page 6

also—

Scanning the Spectrum page 2

New Heaterless miniature tube page 2

Technical Information—7077 page 8



The new G-E 7077 micro-miniature ceramic triode opens the door to greater DX for amateurs on the VHF bands through lower noise figures. Read herein how W2ZHI has designed RF amplifiers using this tube for his 144 and 432-megacycle converters.

—Lighthouse Larry

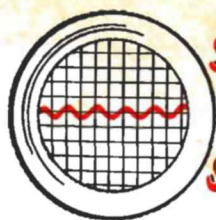

SCANNING the SPECTRUM

AS WE GO TO PRESS—a 7077 in a 200-milliwatt output class B linear amplifier in the Army's 66,000-mile Juno II moonshoot December 14 permitted much greater tracking accuracy. The 10-milliwatt output from a 960.05-megacycle transistor oscillator was thus boosted to a useable level in a new microwave tracking system.

MEET THE DESIGNER . . .

W2ZHI—William (Bill) N. Coffey, developed the 144- and 432-megacycle r.f. amplifiers described herein as part of noise figure studies in his work as a research engineer with General Electric's world-renowned Research Laboratory in Schenectady.

It should be obvious that Bill is a VHF enthusiast, with rigs ranging in power from a few to several hundred watts on these amateur bands. Much of his operating time is spent on the 144-megacycle band. He has been a licensed amateur for 21 years and holds an Extra Class license.

W2ZHI will best be remembered for his pi-network overtone crystal oscillator circuit shown used in our 1955-vintage 50-megacycle equipment.

NEW HEATERLESS MINIATURE CERAMIC TUBES

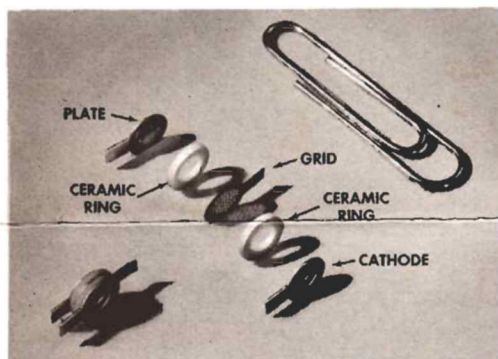

DEVELOPMENT OF AN ELECTRONIC TUBE not much larger than a shirt button has been announced by the General Electric Research Laboratory. The miniature tube is capable of operating at temperatures of from 900° to 1500° Fahrenheit.

THE EXPERIMENTAL MODELS now being evaluated, shaped like flat disks, measure only 1/4 inch in diameter and 1/8 inch thick. Their extremely small size is due in part to the fact that they contain no heater, all the heat necessary being provided by their environment. The design is still in the laboratory stage and *no tubes are commercially available* at this time. They are constructed of layers of *titanium* and a *special ceramic*.

The views at the left (upper) show an exploded tube; and (lower) the heaterless tube actually operating in the flame of a blowtorch (flame temperature about 600 degrees C), producing the characteristic curves visible on the oscilloscope screen in the background. This demonstrates the new tube's ability to withstand high temperatures. Much lighter electronic equipment for military and space vehicles thus is possible by eliminating heavy, bulky cooling equipment.

DEVELOPMENTAL TYPES of the new tube have been made with a wide range of characteristics, of which two are given below.

DESIGN VALUES	No. 1	No. 2
Entire tube temperature	600°	600° Centigrade
Mutual conductance	250	6000 micromhos
Plate current	0.5	5 milliamperes
Grid voltage	0	0
Plate voltage	50	100 volts
Grid current	0.1	0.1 microamperes
Amplification factor	15	100

Look, men—no heater ratings!

—Lighthouse Larry

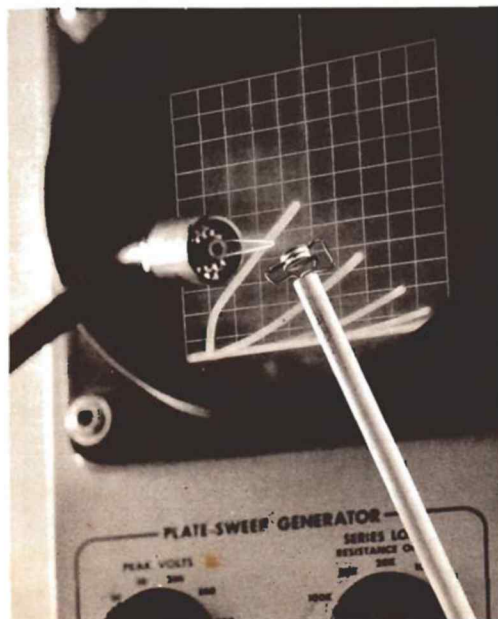

7077 R.F. AMPLIFIER

for the 432-megacycle band

Here are circuit and construction ideas for operating the new 7077 as r.f. amplifiers in converters for the 420-450-megacycle band.

LOWER RECEIVER NOISE FIGURES are now possible on the popular v.h.f. and u.h.f. amateur bands with r.f. amplifiers using General Electric's new 7077 micro-miniature triode. This improvement really shows up above 400 megacycles, where the two-stage grounded-grid r.f. amplifier in the converter described herein has a measured noise figure of 5 decibels, about 3 to 5 decibels lower than similar circuits with conventional tubes. **CIRCUIT TECHNIQUES** not often seen in amateur radio circles were employed in these stages; namely, flat plate type one-quarter wavelength linear tuned circuits. These devices, shown as L_1 , L_2 , and L_3 in the schematic diagram, FIG. 1, consist of a strip of sheet metal $\frac{1}{2}$ -inch wide running parallel to the chassis. One end is joined to the chassis electrically; the other end—having a high r.f. impedance—connects to the tube element. The characteristic impedance of these particular flat plate lines is 115 ohms.

Signals on the 420-450-megacycle band, fed into J_1 , are applied to L_1 and thence to the cathode of the first 7077 tube. The plate of this tube is connected to L_2 , the latter forming an impedance step-down transformer to the cathode of the second 7077 through a 500-mmf capacitor.

The plate of the second 7077 is coupled to the cathode of a 6AM4 triode, operating as a grounded-grid mixer through L_3 . The local oscillator signal—on 406 megacycles in this particular converter—is fed into L_3 , through a small coupling loop, L_4 , on J_2 , next to L_3 .

All tube elements in these stages were tapped onto the tuned circuits at optimum points determined by experiment. The 26- to 30-megacycle difference signal at the mixer tube plate runs through a pi-network broadband tuned circuit—consisting of the 2.2 mmf capacitor from the 6AM4 plate to chassis, C_5 and L_6 —to J_3 . A trap tuned to 406 megacycles— C_4 and L_5 —keeps the local oscillator signal from feeding into the converter output.

Several r.f. chokes are used in these circuits to prevent signal loss: $RFC_{1,2,3,4,5,6,7,8,9,10}$ in cathode bias leads; $RFC_{2,3,4,5,6,7,8}$ in the heater leads; and RFC_X in the mixer stage plate supply lead.

Continued on page 5

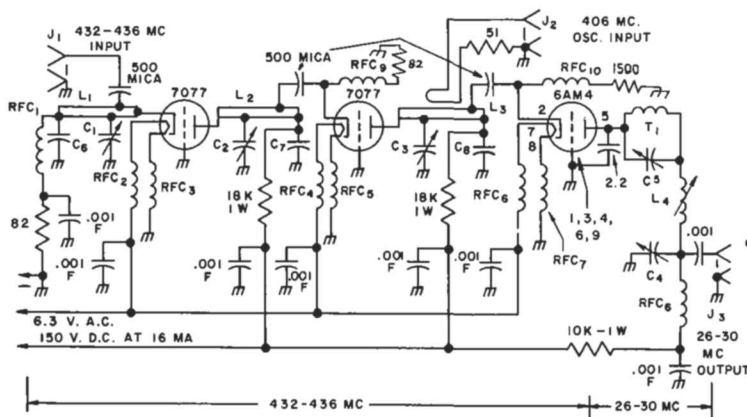
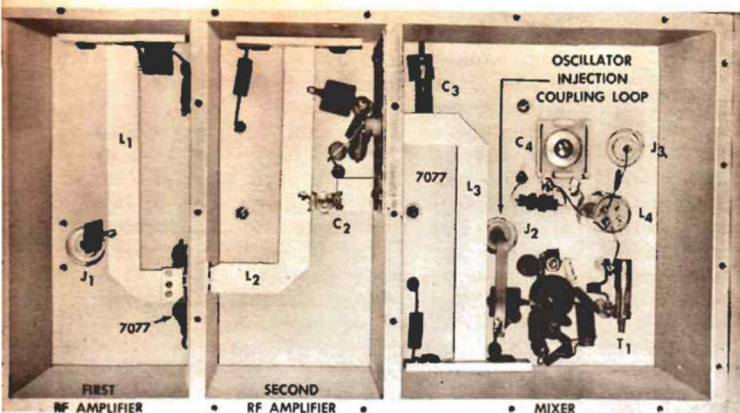

FIG. 1. SCHEMATIC DIAGRAM for the r.f. amplifier and mixer portions of the 432-megacycle converter. All resistances are in ohms, $\frac{1}{2}$ watt unless otherwise specified. All capacitances are in mmf unless otherwise specified.

PARTS LIST—COIL TABLE

C_1, C_2, C_3, C_5 0.5-5.0-mmf piston type midget trimmers.
 C_4 15-130-mmf ceramic-insulated mica trimmer.
 C_6, C_7, C_8 special bypass capacitors formed by chassis and a $\frac{3}{4}$ x2-inch brass plate with a 0.001-inch-thick mica spacer. See FIG. 4 for details.
 J_1, J_2, J_3 chassis type coaxial cable connectors.
 L_1, L_2, L_3 $\frac{1}{4}$ -wavelength flat plate type linear tuned circuits; see FIG. 4 for constructional details.
 L_4 strip type coupling loop; see FIG. 2 for details.
 L_5 4-uh, shielded slug-tuned coil (CTC LS-10, 30 Mc).
 RFC_1 0.58 uh, 9 turns, No. 18 enameled wire, $\frac{3}{8}$ of an inch in inside diameter, $\frac{1}{2}$ inch long.
 $RFC_2, RFC_3, RFC_4, RFC_5$ 0.34 uh, 10 turns, No. 22 enameled wire, $\frac{3}{8}$ of an inch winding length, on $\frac{1}{4}$ -inch diameter polystyrene or Teflon rod.

RFC_6, RFC_7 0.34 uh, bifilar wound choke consisting of two strands of No. 22 enameled wire, 10 turns in each coil, closewound on $\frac{1}{4}$ -inch diameter rod.
 RFC_8 100 uh pi-wound r.f. choke (National R-33, 100 uh).
 RFC_9 0.34 uh, 10 turns, No. 18 enameled wire, $\frac{3}{8}$ of an inch long, on $\frac{1}{4}$ -inch diameter rod.
 RFC_{10} 0.32 uh, 10 turns, No. 18 enameled wire, $\frac{1}{2}$ of an inch long, on $\frac{1}{4}$ -inch diameter rod.
 T_1 406-megacycle trap, consisting of a 0.05-uh coil—3 turns, No. 18 enameled wire $\frac{1}{8}$ of an inch long, wound on the shank of a No. 25 drill (0.146 inches in diameter)—connected across C_5 .



OVER-ALL BOTTOM VIEW of the 432-megacycle converter. Major parts have been identified. Although $\frac{1}{4}$ -inch-thick sheet brass was used for chassis and partitions on this model, $\frac{1}{16}$ -inch-thick brass is suitable. All chassis parts were soldered together and then silver plated for highest conductivity of r.f. currents.

Note that there is a 0.001-inch-thick insulator between the side wall and the mounting plates on L_1 , L_2 and L_3 . The cathode bias circuit for the first 7077 runs through RFC₁ to L_1 . Plate voltage for both 7077's is fed into L_2 and L_3 through 18,000-ohm resistors via 0.001-mfd feedthrough type ceramic capacitors.

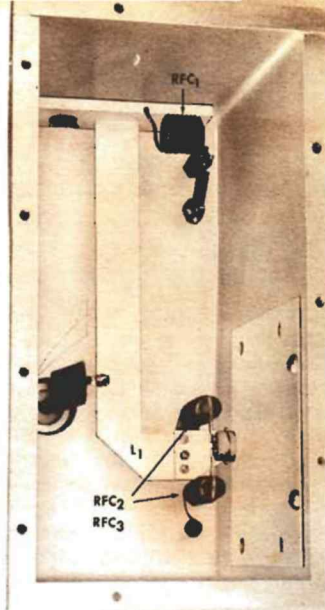

DETAIL VIEW of the first r.f. amplifier compartment, showing L_1 connected to the cathode ring of the 7077 tube. The 82-ohm cathode bias resistor connects between RFC₁ and a ground lug below it.

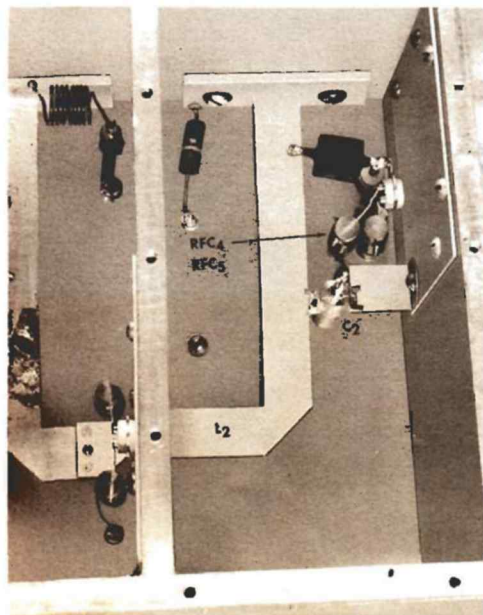

THE SECOND R.F. AMPLIFIER compartment. A small angle bracket formed from $\frac{1}{32}$ -inch-thick sheet brass supports C_2 . The mica capacitor tapped onto L_2 feeds signals into the cathode of the second 7077. Cathode bias for this tube runs through RFC₄, located right underneath the mica coupling capacitor.

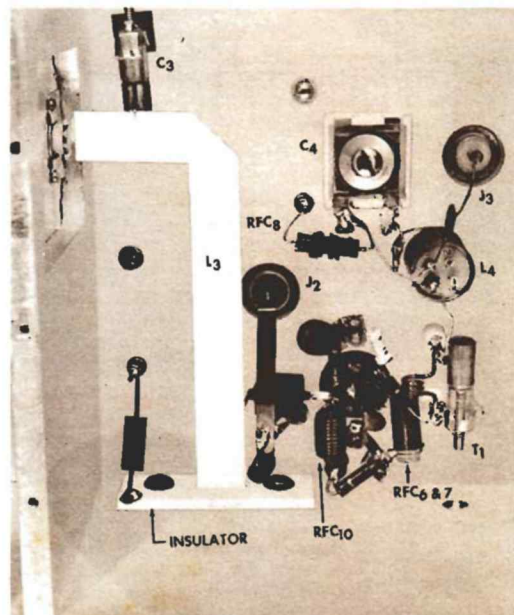

THE MIXER COMPARTMENT, showing L_3 —the oscillator injection loop—running between J_2 and the 51-ohm terminating resistor for the coaxial cable. All grid lugs on the 6AM4 mixer tube socket—pins 1, 3, 4, 6 and 9—have been bent over and soldered to the chassis.

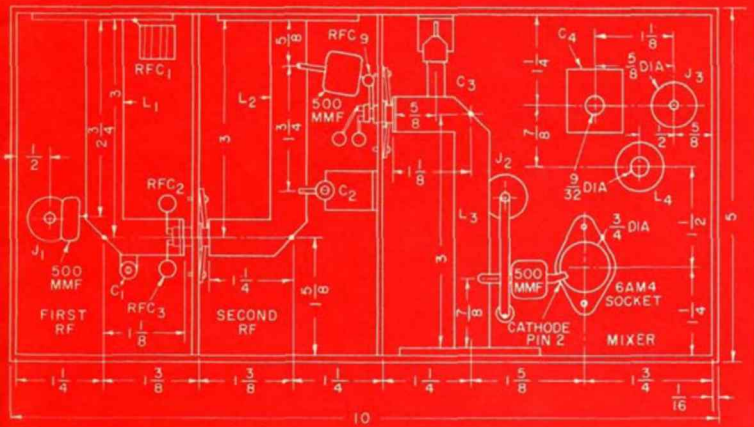

FIG. 2. CHASSIS LAYOUT DIAGRAM for the 432-megacycle converter. Over-all dimensions and positions for taps on L_1 , L_2 and L_3 are shown. Note that a side view of the oscillator injection coupling loop, L_1 , is included in the mixer compartment portion of the diagram.

7077 R.F. AMPLIFIER

Continued from page 3

The 406-megacycle local oscillator—actually a three-stage crystal oscillator-multiplier circuit—is not shown here.¹

CONSTRUCTION of the r.f. amplifier stages—or the complete converter—involves more precise mechanical work than circuitry for the lower frequencies, but is easily handled with the usual home workshop hand tools. The model shown in the views on page 4 has walls and partitions of $\frac{1}{4}$ -inch-thick brass, but $\frac{1}{16}$ -inch-thick brass would be equally suitable. The over-all mechanical layout and principal dimensions are shown in the chassis layout diagram, FIG. 2.

Excellent isolation between the input and output portions of each stage was achieved by mounting the 7077 tubes through holes in the interstage partitions. Details of the 7077 clamping plates are shown in FIG. 3.

Constructional details for the flat plate tuned circuits are shown in the drawing of FIG. 4. Note that the input line (L_1) is slightly shorter than L_2 and L_3 . The spacing between the flat line and the chassis affects the resonant frequency more than the over-all length. This permits bringing the resonant frequency of these circuits to within the adjustment range of the trimmer capacitors (C_1 , C_2 and C_3) simply by bending the strip.

THE ALIGNMENT PROCEDURE is quite simple, once the usual checks for heater voltage and presence of plate current flow in each stage

¹Write to the G-E HAM NEWS office for a bulletin showing the circuit and constructional details of the crystal oscillator-multiplier unit for this converter. This circuit, incidentally, has a 6C4 oscillator with a 67.667-megacycle crystal, a 5763 doubler to 135.334 megacycles, and a 6939 tripler to 406 megacycles.

²See chapter 12, VHF HANDBOOK, by William I. Orr, W6SAI, and H. G. Johnson, W6QKI; A. R. Koch, W2RMA, "Low Noise 220-megacycle Converter," G-E HAM NEWS, September-October, 1954, page 2; E. P. Tiltan, "Noise Generators—their Uses and Limitations," QST, July, 1954, page 10.

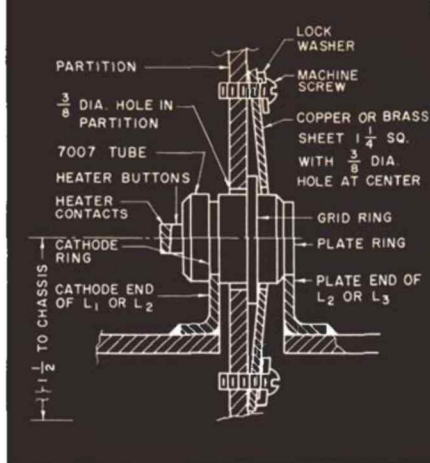

FIG. 3. DETAIL DRAWING for mounting the 7077 tubes. The clamping plate can be fastened either with machine or self-tapping screws $\frac{1}{4}$ -inch long.

have been made. The pi-network circuit in the mixer should be tuned to 28 megacycles and will then pass 26 to 30 megacycles.

Alignment of the flat plate lines, L_3 , L_2 and L_1 should be in that order, using a signal in the 420–450-megacycle range. If you wish to concentrate on the popular 432–436-megacycle section, use a 434-megacycle signal. The antenna input tap position on L_1 , 3.0 inches from the grounded end, was found to provide lowest noise figure when checked with a noise generator. If this instrument is available, try shifting the tap a bit in both directions to see if a lower noise figure results. Much data has been published on making adjustments to receiver input circuits with noise generators,² so this subject will not be covered here.

At 420 megacycles, the 7077 is capable of providing as low a noise figure as any other tube presently available—and it can be used in proven circuits with which most radio amateurs are familiar.

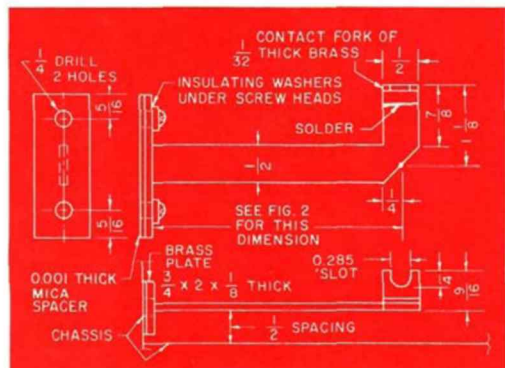
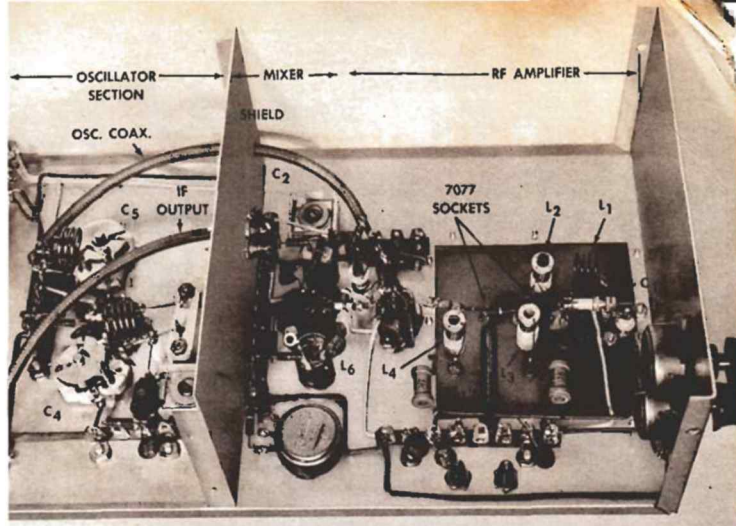
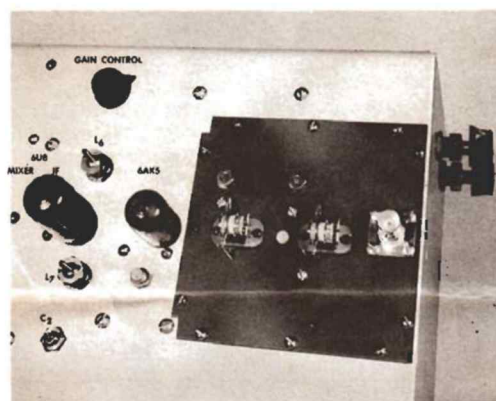

FIG. 4. CONSTRUCTIONAL DETAILS of the flat plate tuned circuits, L_1 , L_2 and L_3 , in this converter. The end of the copper strip is cut to form forks which slip onto the cathode and plate rings of the 7077 tubes.

(RIGHT) BOTTOM VIEW of the 144-megacycle converter. The chassis used on this model was a 12 x 7 x 3-inch Minibox (Bud CU-3011), but all components will fit into a smaller box. The copper plate on which the r.f. amplifier is constructed shows up as a dark area. The potentiometers for adjusting plate current through the 7077 tubes are on the end of the box.



(BELOW) TOP VIEW of the r.f. amplifier portion of the converter. Note how the 7077 tubes slide into the sockets. The large grid plate on the socket at the right was trimmed as outlined in the text.



PARTS LIST—COIL TABLE

C ₁	1—8-mmf midget trimmer.
C ₂	15—115-mmf mica padder.
C ₃	65-315-mmf mica padder.
C ₄ C ₅	3.0—25 mmf air trimmer (Hammarlund APC-25).
J ₁ , J ₂	chassis type coaxial cable connector.
J ₃	4-prong male power connector.
L ₁	0.18 uh; 4 turns, No. 16 wire 3/8 inch inside diameter, 1/2 inch long, wound 8 turns per inch.
NOTE: L ₂ , L ₃ , L ₄ and L ₅ are wound with No. 22 enameled wire on 1/4-inch diameter seatite coil forms with iron tuning slugs, 13/32 of an inch winding length (Millen No. 69048 or equivalent).	
L ₂	0.76 uh; 10 turns, closewound, 1/4 inch long.
L ₃	0.4 uh; 5 1/2 turns, spacewound, 5/16 inch long.
L ₄	0.2 uh; 4 turns, spacewound 3/8 inch long.
L ₅	0.17 uh; 3 turns, spacewound 1/4 inch long, with 2-turn link coil of hookup wire.
L ₆ , L ₇	10 uh; shielded coil wound on cup-core type iron slug tuned form (CTC LS-10, 10 Mc. coil).
L ₈	5 turns, No. 16 wire, 3/8 inch inside diameter, 3/8 inch long, wound 8 turns per inch.
L ₉	3 turns, No. 16 wire, 3/8 inch inside diameter, 3/8 inch long, wound 8 turns per inch, with 2-turn link.
RFC ₁	bi-filar filament r.f. choke; two strands of No. 26 enameled wire wound 1 1/2 inches long on 1/4-inch diameter bakelite rod.
RFC ₂	0.5 mh, 75 ma r.f. choke (National R-50).

tuned circuits may be aligned to obtain a 4-megacycle bandpass; or, a portion of the band may be favored by aligning all tuned circuits at the midpoint of that band segment.

The alignment sequence is as follows: (1) get the crystal oscillator stage working on 65 megacycles; (2) tune the multiplier for maximum output on 130 megacycles; (3) feed 15- and 16.5-megacycle signals into the grid of the 6U8 mixer and align, L₆ and L₇, respectively; (4) feed a 146-megacycle signal into the grid of the 6AK5 and peak L₇; (5) feed a 145-megacycle signal into J₁ and peak L₄; (6) shift the signal to 146 megacycles and peak L₃; (7) shift the signal to 144.5 megacycles and peak L₁.

Finally, remove heater voltage from the first 7077 and adjust L₂ for *minimum* signal at 144.5 megacycles. Adjusting C₁ for lowest noise figure should be done with a noise generator; the calculated capacitance value for this condition is 4 mmf.

The above alignment frequencies will result in a fairly flat bandpass between 144 and 147 megacycles, with best performance between 144 and 145 megacycles.

The 7077 tube should make an excellent r.f. amplifier tube for the 220-megacycle amateur band in either the cascode or grounded-grid circuit. However, we have not checked it out yet, but expect to do so at an early date.

¹ Suggested user price of the 7077 as of press date is \$31.14 each.

² W. N. Coffey, W2ZHI, "6-Meter Transceiver," G-E HAM NEWS, July-August, 1955, pages 3 and 4; also "Simple Sixer Converter," September-October, 1955, pages 3 and 4.

³ Catalog No. 8670, Jettron Products, Inc., Route 10, Hanover, N. J.

NOTE: The disclosure of any information or arrangements herein conveys no license under any patents of General Electric Company or others. In the absence of an express written agreement to the contrary, the General Electric Company assumes no liability for patent infringement (or any other liability) arising from the use of such information by others.

7mo. TECHNICAL INFORMATION—7077

Micro-miniature triode for UHF amplifier applications

ELECTRICAL AND MECHANICAL DATA—MAXIMUM RATINGS

Cathode—Coated Unipotential		
Heater Voltage, AC or DC	6.3 ±5%	Volts
Heater Current	0.24	Ampere
Direct Interelectrode Capacitances		
Plate to Cathode and Heater	0.01	uuf
Cathode and Heater to Grid	1.9	uuf
Plate to Grid	1.0	uuf
Heater to Cathode	1.0	uuf
Plate Voltage	250	Volts
Positive Peak and DC Grid Voltage	0	Volts
Negative Peak and DC Grid Voltage	50	Volts
Plate Dissipation	1.0	Watt
DC Cathode Current	10.0	Milliamperes
TYPICAL OPERATION—GROUNDED-GRID AMPLIFIER—450 MC.		
Plate Supply Voltage	250	Volts
Resistor in plate circuit (by-passed)	18000	Ohms
Cathode-Bias Resistor	82	Ohms
Amplification Factor	80	
Plate Resistance, approximate	8900	Ohms
Transconductance	9000	Micromhos
Plate Current	6.4	Milliamperes
Bandwidth, approximate	7.5	Megacycles
Power Gain, approximate	14.5	Decibels
Noise Figure (Measured with power-matched input, using argon lamp noise source), approximate	5.5	Decibels

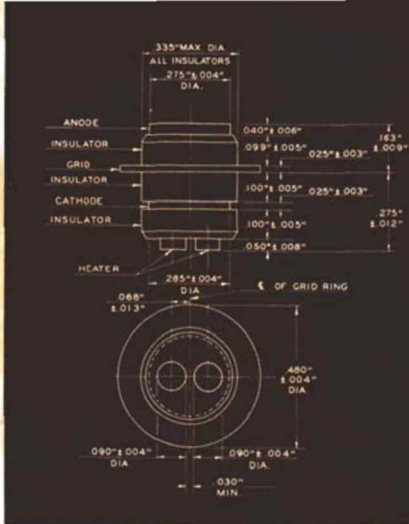

PHYSICAL DIMENSIONS

The 7077 is a high- μ triode of ceramic and metal planar construction primarily intended for use as an r-f amplifier in the 30- to 1200-megacycle frequency range. It features an extremely low noise figure throughout its frequency coverage. The 7077 is especially suited for use where unfavorable conditions of temperature, mechanical shock, and mechanical vibration are encountered.

JANUARY—FEBRUARY, 1959

VOL. 14—NO. 1

E. A. Neal, W2JZK—Editor

published bi-monthly by

ELECTRONIC COMPONENTS DIVISION

GENERAL ELECTRIC

Schenectady 5, N. Y.

Copyright 1959, General Electric Co.

Available FREE from your
G-E Tube Distributor



Electronic Components Division

GENERAL ELECTRIC

Company, Bldg. 267
Schenectady 5, N.Y.

Sec. 34.66 P.L.&R.
U. S. POSTAGE
PAID
Schenectady, N.Y.
Permit No. 148

Mr. Louis Arivello, WOCPI
8829 Moritz Place
Brentwood 17, Mo.
E-233.2

POSTMASTER: If addressee has moved and new address is known, notify sender on Form 3547.
Form 3547 Requested

9-5-58