



MHE transmitter

Thirty Watt Phone Rig for Mobile, Home or Emergency Work on 6 & 10 Meters

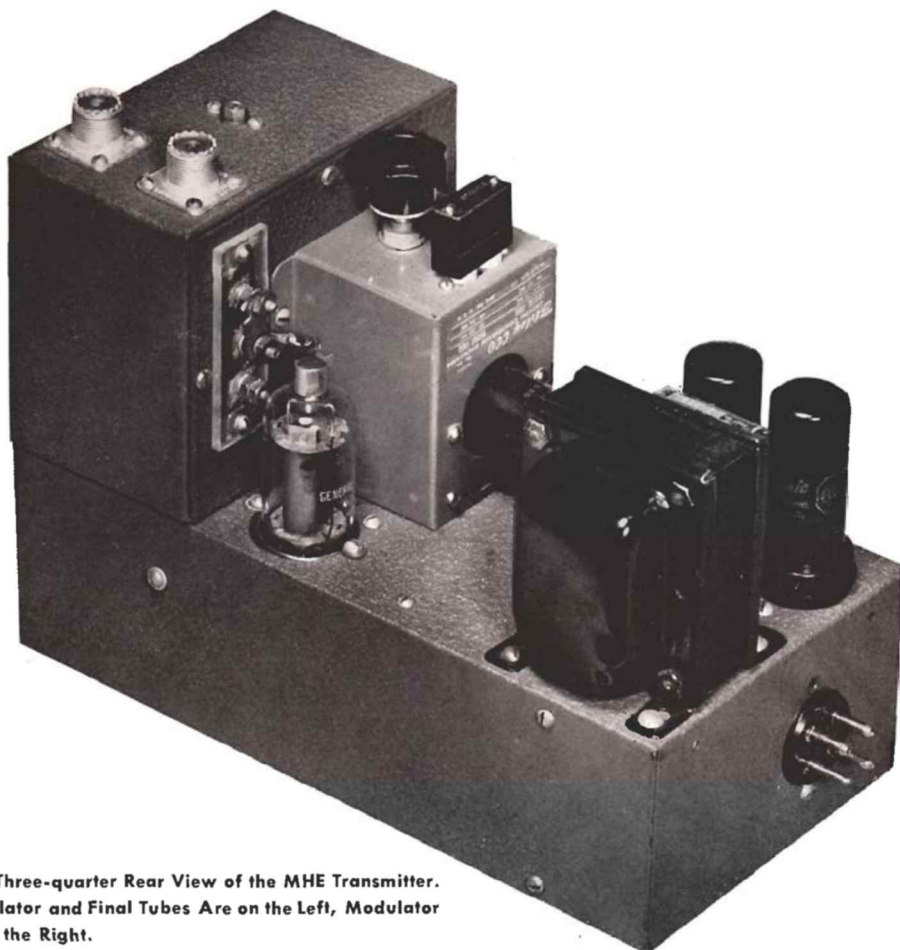

Fig. 1. Three-quarter Rear View of the MHE Transmitter. The Oscillator and Final Tubes Are on the Left, Modulator Tubes on the Right.

CONTENTS

MHE Transmitter (Thirty-watt portable rig)	pages 1-5
Questions & Answers (Tube Operating Position; Testing V-R Tubes; Maximum Grid Resistance)	page 6
Tricks & Topics (Improving a Bug; Improving a Straight Key; Bleeder Economy)	page 6
Sweeping the Spectrum	page 7
Technical Data (GL-2E26)	page 8

ELECTRICAL CIRCUIT

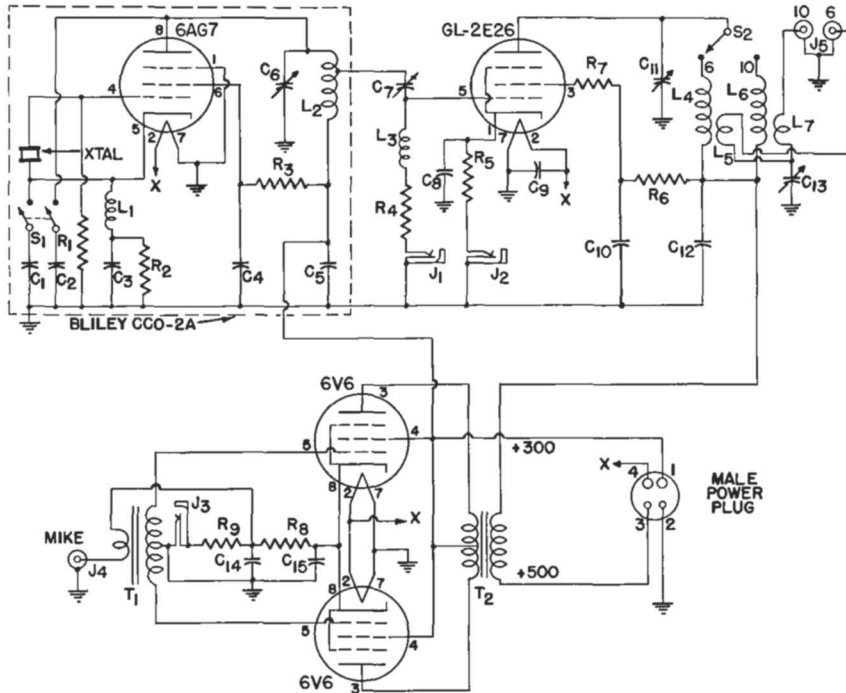

Fig. 2. Circuit Diagram of the MHE Transmitter

CIRCUIT CONSTANTS—TRANSMITTER

BLILEY CCO-2A:

C ₁50 mmf
C ₂40 mmf
C ₃ , C ₄ , C ₅002 mf
C ₆30 mmf variable
L ₁9T #14 enamel wire, close wound, 3/8 in. I. D.
L ₂9T #14 enamel wire, space wound, 1/2 in. I. D. tapped 3T. from plate end
R ₁	33,000 ohm, 1/2 watt
R ₂	220 ohm, 1 watt
R ₃	7500 ohm, 2 watt
S ₁	DPST slide switch
XTAL.....	Bliley 14 mc AX2 for ten meter operation; Bliley 25 mc AX3 for six meter operation

C ₇4-30 mmf trimmer (Erie TS-2A)
C ₈ , C ₉00225 mf mica (600 volt working)
C ₁₀ , C ₁₂00225 mf mica (1000 volt working)
C ₁₁	20 mmf variable (Hammarlund MC-20-MX)
C ₁₃75 mmf variable (Hammarlund APC-75)
C ₁₄ , C ₁₅25 mf 50 volt electrolytic

J ₁ , J ₂ , J ₃	Closed-circuit jacks
J ₄	Mike input jack (Amphenol 80-C)
J ₅	Coaxial cable output jacks for 6 and 10 meters (Amphenol 83-1R)
L ₃ 2.5 mH RF choke
L ₄4T #18, spaced 8T/inch, 3/4 inch I. D. (see L ₅)
L ₅3T #18, spaced 8T/inch, 3/4 inch I. D. Spaced one turn or 3/16 inch from cold end of L ₄ . Both coils made from one B & W #3010 Miniuctor
L ₆7T #20, spaced 16T/inch, 3/4 inch I. D. (see L ₇)
L ₇4T #20, spaced 16T/inch, 3/4 inch I. D. Spaced three turns (or 1/4 inch) from cold end of L ₄ . Both coils made from one B & W #3011 Miniuctor
R ₄	12,000 ohm, 1 watt
R ₅	270 ohm, 2 watt
R ₆	35,000 ohm, 5 watt
R ₇ , R ₉	100 ohm, 1 watt
R ₈	150 ohm, 1 watt
S ₂ see text
T ₁	SB mike to PP grid transformer (Stancor A-4742)
T ₂	Modulation transformer, 15 watt audio, 100 ma primary and secondary, 10,000 ohm to 7400 ohm (Stancor A-3891)

Fig. 1 shows the complete four-tube MHE Transmitter. The 6AG7 oscillator tube and the GL-2E26 final are at the left, and the two 6V6 modulator tubes are on the right. The over-all size is 5 by 8 by 11 inches, making the rig suitable for use in a car, on a corner of the operating table, or as a small transmitter which can be employed practically anywhere in an emergency. Power requirements are 6 volts a-c or d-c at 2.35 amperes and 300 volts at 140 ma. For use as a home station, the final may be run with 500 volts in order to take advantage of the full power capabilities of the GL-2E26.

No coil changing is required. It is only necessary to change the crystal and operate two switches in order to move from six to ten meters, or vice versa. Separate antenna terminals are provided so that two antennas may be connected to the transmitter at all times.

ELECTRICAL DETAILS—TRANSMITTER

With reference to the circuit diagram of the transmitter, Fig. 2, the r-f section consists of a 6AG7

acting as a Tri-tet oscillator and a GL-2E26 as the final. The oscillator unit used in the MHE Transmitter is a Bliley CCO-2A. This unit is indicated on the circuit diagram by the dotted lines. The Bliley unit is very efficient on six and ten meters and it is for this reason that a commercial unit was used. It is possible to duplicate the circuit of the Bliley CCO-2A if desirable.

The output frequency of the oscillator unit will be 27-29.7 megacycles if a 13.5-14.85 megacycle Bliley AX2 crystal is used and direct output on 50-54 megacycles will be achieved by using a 25-27 megacycle Bliley AX3 crystal. The GL-2E26 final amplifier operates as a straight amplifier on both the six and ten meter band.

The Bliley oscillator is normally wired with a link coupled to coil L₂. This link was left in place but it is not used. Instead, a tap is made on coil L₂ three turns down from the plate end. Using this method of feed permits an untuned grid circuit in the final, which simplifies the tuning.

Condenser C₇ is a small ceramic trimmer which

permits a limited range of adjustment of the drive to the GL-2E26. Resistance R_4 and R_5 provide the operating bias and jack J_1 allows grid current to be read for tune-up adjustments. Total cathode current may be read by use of jack J_2 and this jack may also be used as a keying jack for c-w operation. If c-w operation is contemplated as a regular thing, it might be wise to arrange a switch so that the plate current to the final does not have to flow through the secondary of transformer T_2 .

A one-hundred ohm resistor in the screen-grid circuit, R_7 , completely killed a parasitic which occurred when the final operated on six meters. Inclusion of this resistor did not affect operation on ten meters. Resistor R_8 is the screen dropping resistor and C_{10} and C_{12} are the screen and plate by-pass condensers.

Coils L_4 and L_5 are the plate tank coils for six and ten meters. A homemade switch, S_2 , which is described later, selects one of these two coils. Fixed links L_6 and L_7 couple either six or ten meter energy to the output jacks. Condenser C_{13} is a trimming condenser which aids in the loading adjustment. The link coils specified have been adjusted for optimum operation when the final operates at 500 volts with a cathode current of 0.066 ampere and with a 50-ohm feed line to the antenna.

Modulation for the final is obtained from a push-pull 6V6 stage. A single-button microphone provides sufficient drive for the 6V6 tubes. No gain control is used because a small reduction in the output of the microphone drops the modulation down beyond a usable point. Jack J_3 allows measurement of the cathode current of the 6V6 tubes. The mike should not be plugged in when reading cathode current as the mike will tend to shunt the meter.

Mike voltage for the carbon microphone is obtained from the cathode circuit of the 6V6 tubes. Only a carbon mike may be used with the circuit shown.

MECHANICAL DETAILS—TRANSMITTER

Inasmuch as the original idea behind the MHE Transmitter was to provide a unit capable of being used in a car for mobile work, the front panel space is as small as is practical. Fig. 1 shows a side view of the transmitter. The main chassis is a 5 inch by 3 inch by 10 inch metal chassis. On the front section of this chassis is mounted a 3 by 4 by 5 inch box with the five inch side horizontal. The total front panel size is therefore 5 by 7 inches.

The Bliley CCO-2A unit mounts on the rear of the small box as indicated in Fig. 1. A hole is drilled in the large chassis directly beneath the CCO-2A unit to pass the filament and high-voltage leads. This grommeted hole can be clearly seen in Fig. 4. The output lead from coil L_2 is brought through a separate hole and goes directly to C_7 which is mounted on the GL-2E26 socket.

The socket for the GL-2E26 is mounted beneath the chassis by means of two $\frac{3}{4}$ inch metal spacers so that the top of the GL-2E26 tube base is about even with the chassis. Note the cathode, filament and screen by-pass condensers, which connect from the terminals to ground with no leads except their own. It is also important to have a short lead from the grid of the GL-2E26 to the r-f choke (L_3). The remainder of the grid cathode and screen wiring is not critical and may be done as desired.

The small box contains the two GL-2E26 tank circuits and their associated output circuits. Fig. 3 shows the inside details of this arrangement. Condenser C_{11} is mounted on two $\frac{3}{4}$ inch metal spacers, which brings the shaft $1\frac{1}{4}$ inches up from the bottom of the small box. Condenser C_{12} grounds underneath the bottom of the front metal spacer and the other end ties to a one-inch ceramic insulator which is mounted $1\frac{1}{2}$ inches back from the front panel and $\frac{3}{4}$ inch in from the right-hand side of the box. Con-



Fig. 3. Front Panel View of MHE Transmitter with Panel of Top Portion Removed

denser C_{13} mounts in the exact center of the box.

Switch S_2 , which selects the proper output tank, is shown clearly in Fig. 1. A piece of $\frac{1}{8}$ inch polystyrene $\frac{7}{8}$ inch wide by $2\frac{3}{4}$ inches long is mounted over a rectangular slot which is cut into the rear of the box. This rear plate may be removed from the box so that it is not too difficult to cut this slot. The slot is $\frac{5}{8}$ inch wide and 2 inches long. It is cut so that it is $\frac{7}{16}$ inch in from the side and $\frac{5}{8}$ inch down from the top of the back plate.

Three 8-32 brass machine screws are mounted on the piece of poly. The machine screw which forms the center pole of the switch is mounted in the center and the two other screws are mounted on $\frac{5}{8}$ inch centers on each side of the center machine screw. The switch blade itself is made of a piece of brass $\frac{7}{8}$ inch long. A hole is drilled in one end so that it will pivot on the center machine screw. Notches are then filed in the opposite end of the switch blade so that it can be fastened securely under one or the other of the other two machine screws.

The center pole of this switch connects directly to the GL-2E26 plate cap on the outside of the box and to the variable condenser C_{11} on the inside of the box.

As explained under "Circuit Constants-Transmitter," the final tank coils and links are made up from Barker & Williamson Miniductors. The ten meter coil, L_6 , and the ten meter link, L_7 , are made from one B & W No. 3011 miniductor. This coil has a $\frac{3}{4}$ inch I.D. and is wound 16 turns per inch with No. 20 wire. The miniductor should be pruned until only 14 full turns are on the form, making sure that the ends are kept long for leads. Three turns should now be removed from the inside of the coil, leaving 4 full turns on one end for L_7 and 7 full turns on the other end for L_6 .

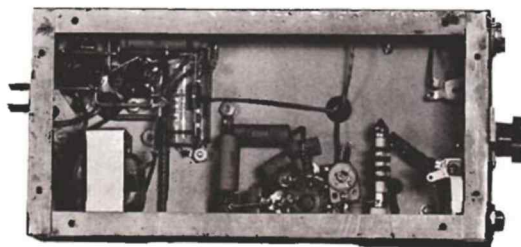

Fig. 4. Underside View of MHE Transmitter

ELECTRICAL CIRCUIT

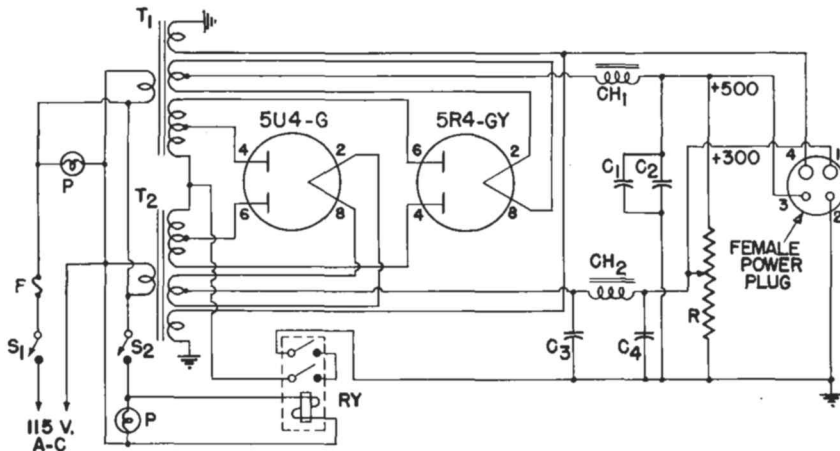

Fig. 5. Circuit Diagram of Power Supply

CIRCUIT CONSTANTS—POWER SUPPLY

C₁, C₂ 8 mf 1000 volt filter condenser (G-E 27F450G102)
C₃, C₄ 10 mf 450 volt electrolytic (Sprague EL-1)
CH₁, CH₂ 8 henry, 200 ma choke (Stancor C-1721)
F 5 amp fuse
P 115 volt pilot lamp (G-E S-6)

R 50,000 ohm 50 watt divider, tapped 30,000 ohms up from ground end
S₁, S₂ SPST toggle switch
T₁, T₂ 338-0-338 volts at 200 ma; 5.0 volts CT at 3 amps; 6.3 volts at 5 amps (Stancor P-5059)
RY DPDT relay, 115 volt coil (Potter-Brumfield MRA-4)

The six meter coil is similarly made from a No. 3010 Miniductor. A total of 8 turns is used, and one turn is removed inside, leaving 4 turns for L₄ and 3 turns for L₆. The No. 3010 coil has a 3/4 inch I.D. and is wound 8 turns per inch with No. 18 wire.

Referring to Fig. 3, the ten meter coil and link are mounted vertically, being supported by their four leads. The leads of L₆ go to the switch (top machine screw) and the ceramic insulator. One link lead goes to the front coaxial connector and the other to the stator of C₁₃.

The six meter coil and link mount directly behind the ten meter coil and at right angles to it. The connections are made in a similar manner to those for the ten meter coil and link.

The modulator circuit is placed on the rear of the

chassis, referring to Fig. 1. The modulation transformer, T₂, and the two 6V6 tubes are placed side by side. These two tubes should be placed as far back as possible so that the 6AG7 may be easily removed from the oscillator unit.

Fig. 4 shows how the microphone transformer is placed under the chassis. The wiring in this section is not critical except that it is advisable to use shielded cable to run from the microphone jack on the front panel to the junction of resistors, R₈ and R₉. The placement of the other front panel jacks is shown in Fig. 3. Upper left, J₃, upper right, J₁, lower left, J₄ and lower right, J₂. The aluminum piece which appears on the front panel is a mounting bracket used to hold the transmitter on the power supply.

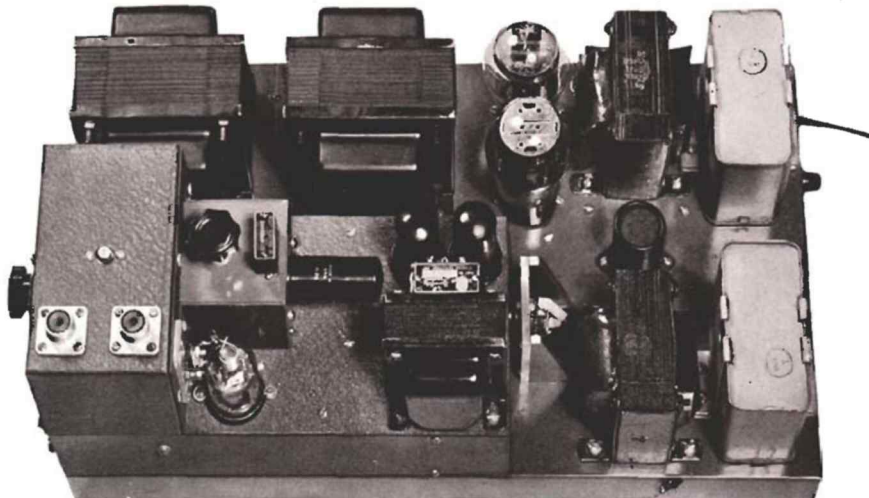

Fig. 6. Top View of MHE Transmitter and Power Supply

ELECTRICAL DETAILS—POWER SUPPLY

The MHE Transmitter requires a dynamotor or vibrator-type power supply when used in a mobile installation, and a regular a-c power supply for home use. Only the latter type of supply will be considered here.

For maximum power input to the GL-2E26 tube 500 volts is needed. The remainder of the circuit requires 300 volts. This could be obtained by using a dropping resistor with a 500-volt supply but a substantial amount of power is lost in this resistor. However, a 500-volt supply capable of approximately 0.170 ampere would be adequate. Conversely, a 500-volt 0.070 ampere supply used with a 300-volt 0.100 ampere supply would do the same job.

Entirely aside from the power supply required for this specific transmitter, a medium voltage power supply of moderate current capabilities is an asset around any shack. For this reason a duplex power supply was designed for the MHE Transmitter. Fig. 5 shows the circuit diagram for this power supply.

Two heavy-duty receiver-type power transformers are used with their high-voltage secondaries in series. The total high-voltage output is fed to a G-E 5R4-GY rectifier. An a-c voltage of one-half the above is also obtained from the center taps of the two transformers, and this voltage is fed to a G-E 5U4-G rectifier tube. With such an arrangement, one d-c voltage will normally be twice the value of the other. In this case the desired voltages were 500 volts and 300 volts and this was made possible by using choke input on the high-voltage supply and condenser input on the low-voltage supply. If the circuit constants indicated are used, and the two power supplies are loaded down with the currents drawn by the MHE Transmitter, the proper voltages will be obtained.

The two 5-volt windings are used to supply power to the filaments of the two rectifier tubes, the two 6.3-volt windings are paralleled and brought to the output connector. The d-c voltage is turned on and off without affecting the filament voltage by breaking the center-tap of the rectifier system with a relay. The contacts of this relay are wired in series to achieve the greatest possible make and break distance.

Resistor R of Fig. 5 serves as the bleeder for both power supplies. The tap at 30,000 ohms may be adjusted by means of an ohmmeter. It is relatively important that this tap be placed accurately to prevent overloading the resistor.

The power supply shown is larger than is actually required. The chokes are specified as 200 ma chokes. A 150 ma choke would suffice in the 300-volt supply

and a 75 ma choke would be large enough for the 500-volt supply. However, made as shown, the power supply is capable of 200 ma output from either voltage, or a total of 200 ma if both voltages are used.

MECHANICAL DETAILS—POWER SUPPLY

Fig. 6 shows the MHE Transmitter in place on the power supply and Fig. 7 is the same view with the transmitter removed. The underside view of the power supply is given in Fig. 8.

The power supply chassis is a 10 by 17 by 2 inch steel chassis. Front panel controls—S₁, S₂ and the pilot lights—are on the left-hand side as seen in Fig. 7. The fuse and a-c power cord may be seen on the right-hand side. Layout of circuit components is not critical and almost any arrangement can be employed.

The female power plug is a four-prong socket mounted on a piece of 1/4 inch aluminum at a height to mate with the male output plug on the transmitter. Two right-angle pieces of aluminum are used to support the socket as illustrated. Spaghetti sleeves cover the socket prongs to keep stray hands away from the high voltage.

USING THE TRANSMITTER

For mobile work a shock-mounted platform should be designed for the MHE Transmitter. The transmitter itself can be mounted under the dashboard and operated directly or it may be placed in a remote spot in the car. Some adjustment of the link coils may be required in order to feed a car antenna properly.

The MHE Transmitter makes an ideal emergency or standby transmitter. If the main rig goes off the air, the MHE rig has enough power to do a decent job by itself.

Beginning amateurs will find this transmitter easy to build. There are no critical parts required and there should be no difficulty getting the rig to operate properly.

OPERATING NOTES

With 300 volts supplied to the CCO-2A oscillator the plate and screen current will run about 30 to 35 ma. With 500 volts on the GL-2E26 plate the measured power output was 22 watts on ten meters and 19 watts on six meters. Under these conditions the GL-2E26 cathode current was 66 ma and the GL-2E26 grid current 2-2.5 ma. Modulator cathode current normally runs 60 ma.

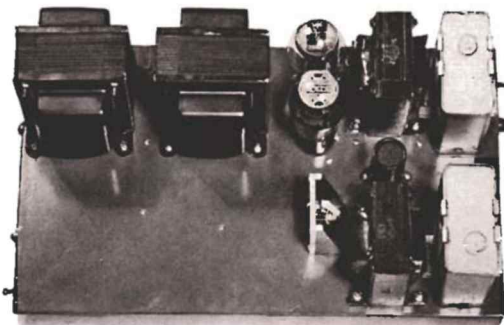

Fig. 7. Top View of Power Supply

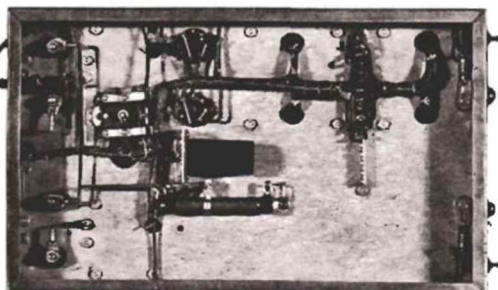

Fig. 8. Underside View of Power Supply

QUESTIONS AND ANSWERS



Do you have any questions about tubes or tube circuits that are of general interest? For each question published you will receive \$10 worth of G-E electronic tubes. Mark your letter "Entry for Questions and Answers" and send to Lighthouse Larry, Tube Division, Bldg. 269, General Electric Company, Schenectady, N. Y., or in Canada, to Canadian General Electric Company, Ltd., Toronto, Ontario.

TUBE OPERATING POSITION

Question: The manufacturer's recommended operating procedure for most mercury-vapor rectifier tubes and the larger high-vacuum rectifier tubes specifies that such tubes should be operated in a vertical position with the base down. Occasionally it is found necessary to employ these tubes in a horizontal position, or an inverted vertical position. May this safely be done if the ratings are reduced or if the plane of the filament is oriented properly?—W7LFL.

Answer: The mercury-vapor rectifier tubes and the large high-vacuum tubes must be treated separately in answering this question. Mercury-vapor tubes are designed to operate properly when there is a given mercury pressure inside the tube. The pressure is maintained because there is an area of condensed mercury at some point on the bulb. Therefore, there must be a cool spot on the bulb where mercury is able to condense. If a tube of this sort were to be operated in a horizontal position or an inverted vertical position there would probably be no cool spot with the result that the mercury could not condense. Under these conditions the tube would not function properly even at greatly reduced ratings.

In the case of large high-vacuum rectifiers the problem is one of filament sag. Most of the latter tube types use a helical thoriated-tungsten filament. It is usually not possible to operate this type of filament in a horizontal position. It might be possible to use a tube of this sort in an inverted vertical position, but this would depend upon which tube type was under consideration. When it is possible to use a

tube in other than a vertical position, the operating data will usually so state.—Lighthouse Larry.

TESTING V-R TUBES

Question: Can a V-R tube that has passed excessive current and still glows be defective? In fact, can a V-R tube become defective? If so, how can one tell whether a V-R tube is good?—W8BWN.

Answer: A V-R tube can be defective, even though it is not leaking air. If a tube does not maintain a specified voltage drop when the specified maximum and minimum values of current are caused to pass through it, then it is a defective tube. This is the normal symptom of a worn-out V-R tube. Excessive current can aggravate this condition and cause shorter life. Glow tubes (V-R tubes) may be tested by applying a d-c voltage through a variable resistor, adjusting the resistor so that the two limits of current can be obtained, and then reading the voltage across the glow tube with a high-impedance voltmeter. For example, the voltage across a GL-OC3/VR-105 should not vary more than one volt when the current is changed from 5 to 30 milliamperes.—Lighthouse Larry.

MAXIMUM GRID RESISTANCE

Question: In the application of certain tube types such as the popular 50L6, why is it considered advisable to use a d-c grid circuit resistance greater than 0.1 megohm with fixed bias and greater than 0.5 megohm with cathode bias?—G. F. Smith.

Answer: It has been found necessary to specify a maximum permissible value of d-c grid resistance for most of the regular types of receiving tubes. The main exception to this is the high- μ triode when it is used as an audio amplifier with high load resistance. When a high value of grid resistor is used on a tube the bias tends to be decreased. This decrease in bias means a greater plate current, which leads to an increase in tube heating. If the effect is great enough, sufficient negative grid current may flow to further reduce the bias, raise the plate current, etc. In other words, a runaway condition may come about which would result in the destruction of the tube, if too high a value of grid resistance is employed. The permissible value is greater when cathode bias is used as the tube in this case is more nearly self-regulating.—Lighthouse Larry.

TRICKS AND TOPICS

How did you solve that last problem that almost had you stumped? Be it about tubes, antennas, circuits, etc., Lighthouse Larry would like to tell the rest of the hams about it. Send it in! For each "trick" published you win \$10 worth of G-E Electronic Tubes. No entries returned. Mark your letter "Entry for Tricks and Topics" and send to Lighthouse Larry, Tube Division, Bldg. 269, General Electric Company, Schenectady, New York, or in Canada, to Canadian General Electric Company, Ltd., Toronto, Ontario.

IMPROVING A BUG

You'll be surprised how much easier your bug key will operate if you keep the knob-handle surfaces dry and smooth with a little talcum powder. The absence of even the slightest drag caused by sticky perspiration will improve your keying, too.—W2ADP.

IMPROVING A STRAIGHT KEY

Many C-W men who spend long hours pounding

brass will find the following trick helpful. Drill a small hole in the center of a plastic poker chip (color is immaterial—Eds. note) and place it between the arm and the knob of a standard key. The result is a "navy" knob which will save wear and tear on the fist.—W1RDD.

BLEEDER ECONOMY

Here is a trick for economy-minded hams. All power supplies should use a bleeder resistor in their output. If two power supplies are constructed on one chassis, use a single bleeder resistor of twice the proper value, connect one end to the one positive voltage and the other end to the second positive voltage. Adjust the slider to mid-position and connect it to ground.—W1LTA. (The slider may also be adjusted off center if the two voltages are not alike in value, in order to use the wattage most economically.—Eds. note)

Sweeping the Spectrum



Amateurs evidently abandon reconstruction work or new rig design work during the Christmas-New Year holiday season—but come back with a vengeance in February. This comment is based on the torrent of mail coming to my desk. If it weren't for the ostrich-egg laid by the poll-takers in the presidential election, I might be tempted to interpret the mail and act as an amateur radio opinion expert.

Fortunately it doesn't take an expert to see that single-sideband is increasing in popularity. The adapter described in the November-December, 1948 *Ham News* has hit the fancy of many amateurs—or to quote a letter, "I'm certainly glad I built the SSB Adapter. I don't know how I ever got along without it before."

Like an example? Your editor dabbles in DX occasionally and recently came across ZB1A in Gibraltar (20 meter phone), accompanied by three other stations, with ZB1A fourth man down on the totem pole. There probably was no more than 200 cycles covered by all four stations. Using the SSB Adapter described in *Ham News*, I rejected the upper sideband and removed two of the offenders. The remaining heterodyne, now effectively weakened because of the exalted carrier action of the adapter, fell in the crystal notch with the turn of a knob on the receiver, leaving ZB1A in the clear.

A page of examples alone won't improve your reception, however, so I apologize if I have made you discontented.

A goodly portion of my correspondents always ask, among other things, for the location of the nearest G-E Tube Distributor where the *Ham News* will be available. If this copy of the *Ham News* you are reading came from a distributor, his name and address probably appears on the last page. (If not he isn't taking advantage of that nice blank space we leave for him.)

To help you further, a list of the G-E Tube Dis-

tributors who handle the *Ham News* is appearing in QST and CQ magazines on page one. By coincidence, that's the same page that advertises G-E Electronic Tubes.

Would you like to have a secondary frequency standard which can be read directly in 40 cycle steps at 4 megacycles? One with only two tubes, no crystal, and only a handful of parts? Then don't miss the May-June, 1949 *Ham News*. Which brings to mind a net control station that asked the others to change frequency to a new spot—only to be told that the specified frequency was the one they were now operating on.

Accurate frequency measuring equipment need not be expensive if you roll your own. The need for such equipment increases daily. The *Ham News* policy is to keep abreast of amateur needs, so, with the able assistance of W2FZW the May-June issue will give complete constructional details of an inexpensive frequency standard using two tubes and capable of being read to 35 cycles at 3.5 megacycles.

Every once in a while your editor gets a slick idea, and then can't publish it in Tricks and Topics. (That's a house rule to prevent me giving myself ten dollars worth of those G-E tubes.) It concerns putting washers and nuts on a bolt which is always found in those "hard-to-get-at" places. This is a problem which comes up often, due to my penchant for designing more and more in less and less space. To solve, place the machine screw in place, then use an icepick or similar weapon and place the nut and washers on it. Hold them on the ice pick with your forefinger until you have gotten the point of the icepick firmly against the end of the machine screw. Release the nut and washers, and they will slide down and on the screw. From here on you are on your own.

—Lighthouse Larry

TECHNICAL INFORMATION

GL-2E26

DESCRIPTION

The GL-2E26 is a five-electrode beam power amplifier tube designed for use in FM transmitters, either in low-power driver stages, or in the output stage when only low-power output is required. It is also useful in audio-frequency power and modulator service. The anode is capable of dissipating 12.5 watts, and cooling is accomplished by radiation. The cathode is the indirectly heated type. Maximum ratings apply up to 125 megacycles.

The 2E26 has high power sensitivity and high efficiency and can be operated at relatively low plate voltage to give large power output with small driving power.

The base of this tube has a short metal sleeve which shields the input to the tube so completely that no other external shielding is required. Separation of input and output circuits is accomplished by bringing the plate lead out of the bulb to a cap opposite the base.

GENERAL CHARACTERISTICS

Number of electrodes.....	5
Electrical	
Heater voltage, a-c or d-c.....	6.3 volts
Heater current.....	0.8 ampere
Transconductance, $I_b = 20$ ma.....	3500 micromhos
Grid-screen amplification factor.....	6.5
Interelectrode capacitances*	
Grid-plate.....	0.20 micromicrofarads
Input.....	13 micromicrofarads
Output.....	7 micromicrofarads
Mechanical	
Mounting position—any	
Net weight, approximate.....	1½ ounces

* With no external shielding and base sleeve connected to ground.

MAXIMUM RATINGS AND TYPICAL OPERATING CONDITIONS

PLATE-MODULATED RADIO-FREQUENCY POWER AMPLIFIER—CLASS C TELEPHONY

Carrier conditions per tube for use with a maximum modulation factor of 1.0

Maximum ratings, absolute values.....	CCS	ICAS
D-c plate voltage.....	400 max	500 max volts
D-c grid No. 2 voltage.....	200 max	200 max volts
D-c grid No. 1 voltage.....	-175 max	-175 max volts
D-c plate current.....	60 max	60 max milliamperes
D-c grid No. 1 current.....	3.5 max	3.5 max milliamperes
Plate input.....	20 max	27 max watts
Plate dissipation.....	6.7 max	9 max watts
Typical operation.....	CCS	ICAS
D-c plate voltage.....	400	500 volts
D-c grid—No. 2 voltage.....	160	180 volts
D-c grid—No. 1 voltage.....	-50	-50 volts
Peak r-f grid—No. 1 voltage.....	60	60 volts
D-c plate current.....	50	54 milliamperes
D-c grid—No. 2 current.....	7.5	9 milliamperes
D-c grid—No. 1 current, approximate.....	2.5	2.5 milliamperes
Driving power, approximate.....	0.15	0.15 watts
Power output, approximate.....	13.5	18 watts
Maximum circuit values		
Grid—No. 1 circuit resistance‡.....	30,000 max	30,000 max ohms

‡Any additional bias required must be supplied by a cathode resistor or a fixed supply.

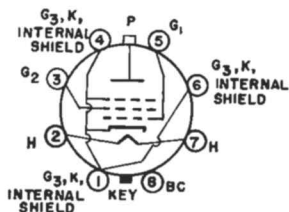

ELECTRONICS DEPARTMENT



SCHENECTADY, N. Y.

(In Canada, Canadian General Electric Company, Ltd., Toronto, Ont.)