



the GENERAL RADIO

# experimenter



VOLUME 39 NUMBER 1

JANUARY 1965

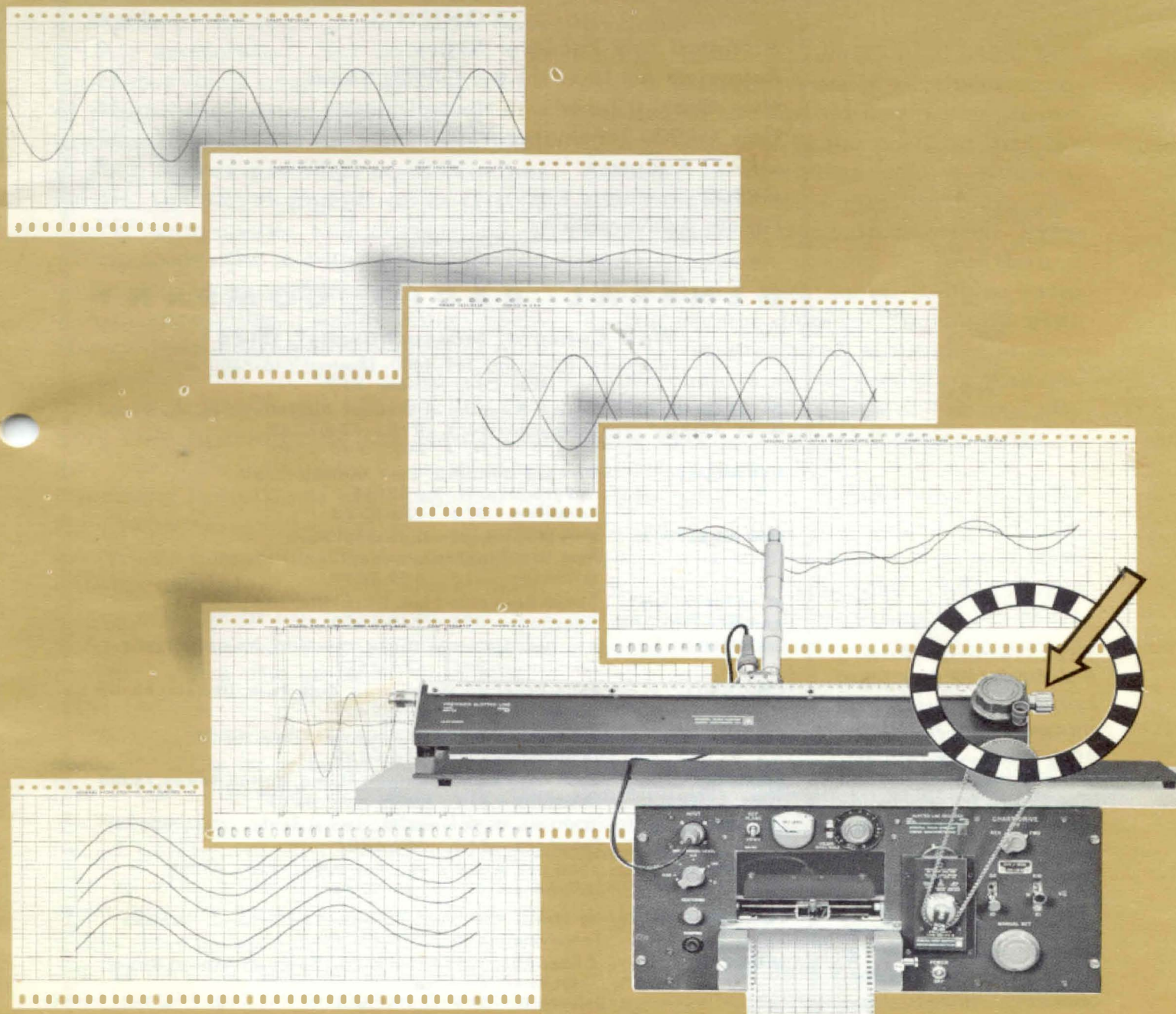

*in this issue*

**SLOTTED LINE RECORDER SYSTEM  
NEW PRECISION COAXIAL ELEMENTS—**

**Reference Air Lines, Tuner, Terminations,  
Adaptors, Connector Kits**





the GENERAL RADIO

# experimenter



©1965—GENERAL RADIO COMPANY, WEST CONCORD, MASS., U.S.A

*Published Monthly by the General Radio Company*

**VOLUME 39                      NUMBER 1                      JANUARY 1965**

## CONTENTS

	Page
A Slotted Line Recorder System . . . . .	3
Reference Air Lines for the GR900 Series . . . . .	11
New Coaxial Tuner with Neutral Setting . . . . .	15
New GR900 Terminations . . . . .	17
GR900 Adaptors . . . . .	17
GR900 Connector Kits . . . . .	18
Fiftieth Anniversary . . . . .	19

## GENERAL RADIO COMPANY

**West Concord, Massachusetts\*, 01781**

Telephone (Concord) 369-4400; (Boston) 646-7400  
Area Code Number 617

**METROPOLITAN NEW YORK:\*** Broad Avenue at Linden, Ridgefield, N. J., 07657  
Telephone—N. Y., 212 964-2722  
N. J., 201 943-3140

**SYRACUSE:** Pickard Building, East Molloy Road,  
Syracuse, N. Y., 13211  
Telephone—315 454-9323

**PHILADELPHIA:** Fort Washington Industrial Park,  
Fort Washington, Pennsylvania 19034  
Telephone—215 646-8030

**WASHINGTON\* and BALTIMORE:** 11420 Rockville Pike, Rockville, Md., 20852  
Telephone—301 946-1600

**ORLANDO:** 113 East Colonial Drive, Orlando, Florida, 32801  
Telephone—305 425-4671

**CHICAGO:\*** 6605 West North Avenue, Oak Park, Illinois, 60302  
Telephone—312 848-9400

**CLEVELAND:** 5579 Pearl Road, Cleveland, Ohio, 44129  
Telephone—216 886-0150

**DALLAS:** 2501-A West Mockingbird Lane, Dallas, Texas, 75235  
Telephone—214 Fleetwood 7-4031

**LOS ANGELES:\*** 1000 North Seward St., Los Angeles, Cal., 90038  
Telephone—213 469-6201

**SAN FRANCISCO:** 1186 Los Altos Ave., Los Altos, Cal., 94022  
Telephone—415 948-8233

**TORONTO:\*** 99 Floral Parkway, Toronto 15, Ontario, Canada  
Telephone—416 247-2171

**MONTREAL:** Office 395, 1255 Laird Blvd., Town of Mount Royal,  
Quebec, Canada  
Telephone—514 737-3673

\*Repair services are available at these offices.

**GENERAL RADIO COMPANY (Overseas), 8008 Zurich, Switzerland**

**GENERAL RADIO COMPANY (U.K.) LIMITED, Bourne End,**

**Buckinghamshire, England**

**Representatives in Principal Overseas Countries**

The General Radio EXPERIMENTER is mailed without charge each month to engineers, scientists, technicians, and others interested in electronic techniques in measurement. When sending requests for subscriptions and address-change notices, please supply the following information: name, company address, type of business company is engaged in, and title or position of individual.

# A SLOTTED LINE RECORDER SYSTEM

With the introduction of the GR900 Precision Coaxial Connector<sup>1</sup> and associated equipment<sup>2</sup>, the trend to greater accuracy and precision in microwave impedance measurements has been greatly accelerated. Not only does the connector itself boast a VSWR an order of magnitude better than that of any previous connector, but the availability of such a true precision connector has led to the development of a GR900 line of components and devices, all of which share the connector's electrical and mechanical excellence.

An expanding, self-refining technology demands improvements not only in devices but in techniques. Given the new tools of the GR900 line, we were able to reappraise the traditional methods of measurement, to see whether remaining limitations were imposed by the procedures themselves, by the available equipment, by the method of data presentation, or by some other factor capable of improvement.

As the basic tool in coaxial impedance measurements, the slotted line remains unsurpassed; its accuracy is absolute, since its standard impedance is the characteristic impedance of a coaxial line. The inherent accuracy of the slotted line, as well as its stability and broad bandwidth, led to the investigation of the limitations of this instrument for low VSWR measurements. As might be expected, we found the limiting factors to be not in the slotted line itself but in the noise level and

limited scale expansion of commercial standing-wave indicators. This conclusion led to the development of the TYPE 1640-A Slotted Line Recorder System.

The combination of a slotted line and a graphic recorder produces a recording of the slotted-line probe output as a function of probe position that far exceeds, in resolution and usefulness, the conventional meter readout. The noise figure of the transistorized TYPE 1640-A System is held to less than 5 dB, and the high signal-to-noise ratio at the crystal detector (normally over 80 dB) is preserved through the amplifier chain and the recording process. The recording of VSWR's as low as 1.001 with excellent signal-to-noise ratio is entirely practical.

The use of a slotted line recorder system not only overcomes the traditional scale-factor and noise problems but also offers the many advantages of a permanent recording. The chart record, for example, can be analyzed graphically for the most accurate measurement of VSWR, position of minimum, and other waveform characteristics. The minima of low-VSWR patterns are particularly difficult to locate by traditional techniques, because of their shallowness and because of the apparent shift of position if tilt exists in the flatness curve. On a chart record, the positions of minima are strikingly easier to locate, not only because the pattern is greatly expanded, but also because the VSWR pattern and the flatness curve are easily disentangled when both are visible together.

<sup>1</sup> A. E. Sanderson, "A Radically New Coaxial Connector for High-Precision Measurements," *General Radio Experimenter*, February-March 1963.

<sup>2</sup> John Zorzy, "Precision Coaxial Equipment — The 900 Series," *General Radio Experimenter*, November 1963.



Several plots can be made on the same chart so that, for example, the positions of minima with short-circuit termination and with unknown at the reference plane can be intercompared directly. Wherever the *difference* between two measurement conditions is important, any irregularities in the slotted line (in constancy of probe penetration, for instance) effectively cancel out in a multiple plot, and the difference shows up clearly as a sinusoidal wobble of one trace about the other (see Figure 1). Because of the effective elimination of slotted line imperfections from the measurement, the substitution method by graphic recording yields the most accurate, repeatable measurements of low vswr — with the TYPE 1640-A, down to 1.001.

Repeatability and comparison measurements are also facilitated by the multiple-recording technique. A series of measurements, for instance, can be plotted on the same section of chart paper as a rapid method of comparison-checking components against a standard. The graphic record also quickly reveals whether the measurement is a true one or whether it is being distorted by a noisy signal generator, a connector that doesn't repeat, or some other unforeseen factor. Finally, as a continuous monitor on equipment op-

eration, the recording far surpasses the usual vswr meter in convenience.

### THE TYPE 1640-A SLOTTED LINE RECORDER SYSTEM

The new Slotted Line Recorder System, shown in Figure 2, comprises a standard TYPE 900-LB Precision Slotted Line and a modified version of the TYPE 1521 Graphic Level Recorder (TYPE 1521-SL), along with the necessary interconnecting linkage and mounting hardware. The slotted line is mounted in its usual bench-top position, and the recorder is beneath the bench, either on a shelf or suspended from the bench top with the bolts provided. The metal mounting plate on which the slotted line rests has four studs, which engage the rubber feet of the slotted line, and a projecting shaft. A gear on one end of this shaft is coupled to the probe-carriage drive, and a sprocket on the front end engages the external chain-link drive of the recorder. The motor that powers the chart drive thus also drives the probe carriage of the slotted line, and the chart paper is automatically given the correct horizontal axis for the desired vswr plot. The vertical axis of the plot is supplied by the audio output of the crystal detector, which is connected by a coaxial cable from the probe

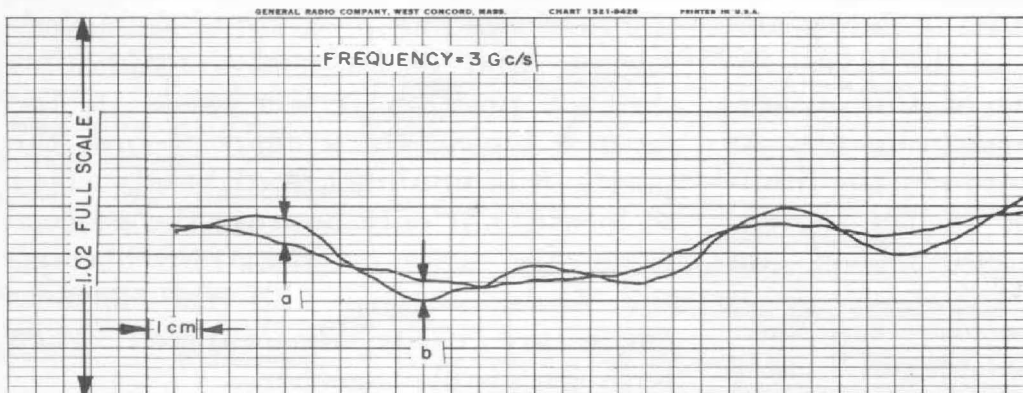
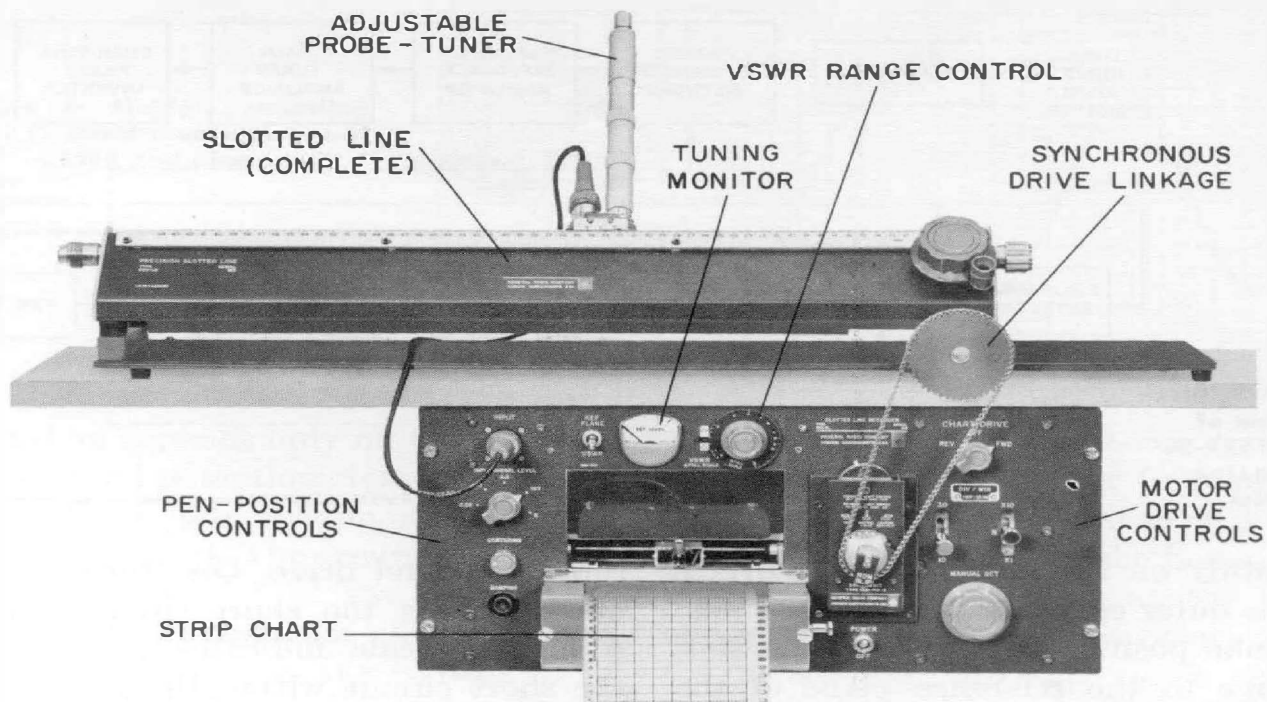

Figure 1. Multiple plot used to measure difference between two measurement conditions. Note that the difference in the recording ( $a + b$ ) is a sine wave corresponding to a VSWR of 1.002!





**Figure 2. Type 1640-A Slotted Line Recorder System. Owners of Type 900-LB Slotted Lines can easily add recorder and connecting linkage. Prices are available on request.**

carriage to the recorder input connector. The recorder suppresses the zero level and applies the resulting greatly expanded vswr pattern to the vertical axis of the strip chart. The degree of scale expansion is remarkable: On a typical vswr meter a vswr of 1.10 takes up two inches of scale, whereas a vswr of 1.008 can be expanded to the full 4-inch width of the chart paper!

### THE SLOTTED LINE

The TYPE 900-LB Precision Slotted Line<sup>2</sup> is the most precise coaxial impedance-measuring instrument available commercially, with a residual vswr of  $1.001 + 0.001f_{Gc}$  from 300 Mc/s to 9 Gc/s; it is, moreover, an extremely rugged, reliable instrument whose calibration can be expected to stay within specification indefinitely. The forged outer conductor joins its connectors smoothly, without the reflection-caus-

ing steps and discontinuities found in noncylindrical coaxial slotted lines.

The chrome-plated outer conductor of the line is a 26-inch, precision-forged, brass tube, lined with a 0.0005-inch layer of pure silver for low loss. The finished inner diameter is 0.5625 inch  $\pm 100$  microinches. The inner conductor is steel with a 0.0005-inch layer of silver and is centerless-ground to a tolerance of  $\pm 50$  microinches. Both inner and outer conductors are stress-relieved to resist diameter changes due to machining.

Two interchangeable electrostatic probe assemblies are supplied: a tunable probe for use with the built-in detector for modulated signals and an rf probe to couple an unmodulated signal to an external detector. Either mounts in the carriage that transports the probe through the entire 50-cm length of the slot. This cast brass carriage, with its honed sleeve bearing, rides

<sup>2</sup> Zorzy, op. cit.

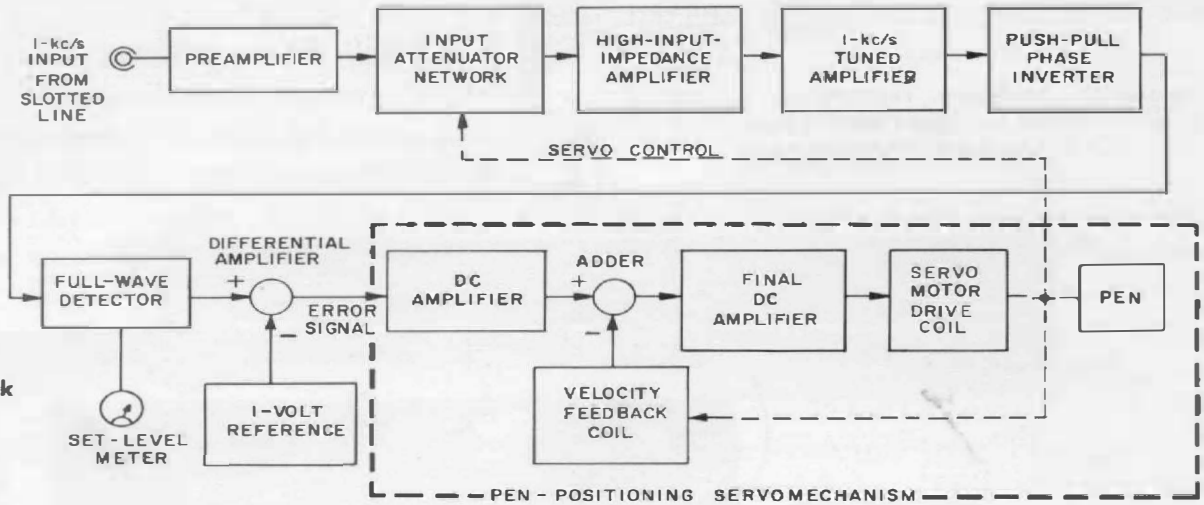

Figure 3. Block diagram of Type 1521-SL Slotted Line Recorder.

smoothly on the finely ground surface of the outer conductor.

Probe position along the 50-cm slot, relative to the reference plane of the GR900 connector, is indicated to within 0.1 millimeter by a calibrated millimeter scale with attached vernier.

Depth of penetration of the tunable probe is controlled and indicated by a micrometer adjustment. The scale is preset to indicate directly the distance between the probe tip and the center conductor (smallest marked interval: 0.001 inch). A positive stop prevents the probe from striking the center conductor.

The probe is tuned to resonance (at any frequency from 300 Mc/s to 9 Gc/s) with a built-in short-circuited stub, whose length is adjusted by means of a

rotating barrel drive. One turn of the barrel moves the short circuit 1 cm. A logging scale indicates position of the short circuit within the barrel.

### SLOTTED LINE RECORDER

The TYPE 1521-SL Slotted Line Recorder is a transistorized, single-frequency, servo-type instrument (see block diagram, Figure 3), which produces, on white chart paper, an ink record of the standing-wave pattern of the slotted line. Scale expansion is continuously adjustable, with the control calibrated in *vswr*, % FULL SCALE (a *vswr* of 1.01 is defined as equivalent to 1%). Standing-wave patterns of 1.2 to 1.008 in *vswr* can be expanded to occupy full scale.

The *vswr* accuracy of the strip-chart

Figure 4. Typical direct recording of *vswr*.

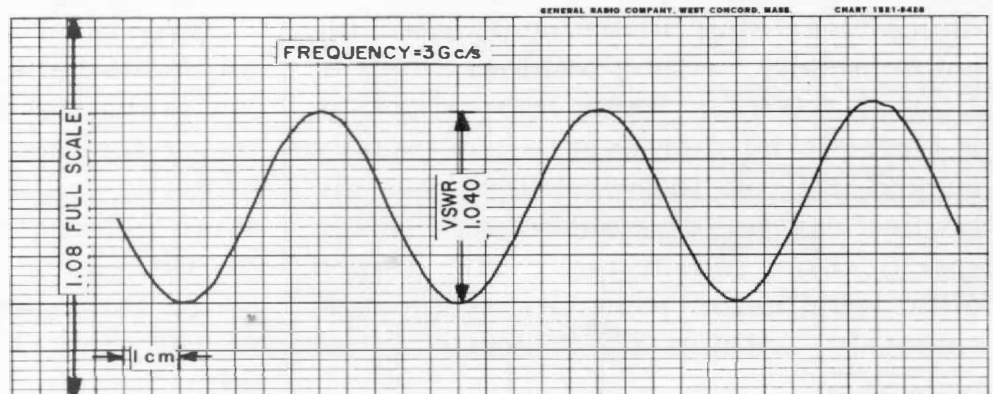



**Figure 5. Multiple recording used in direct measurement of VSWR and phase.**

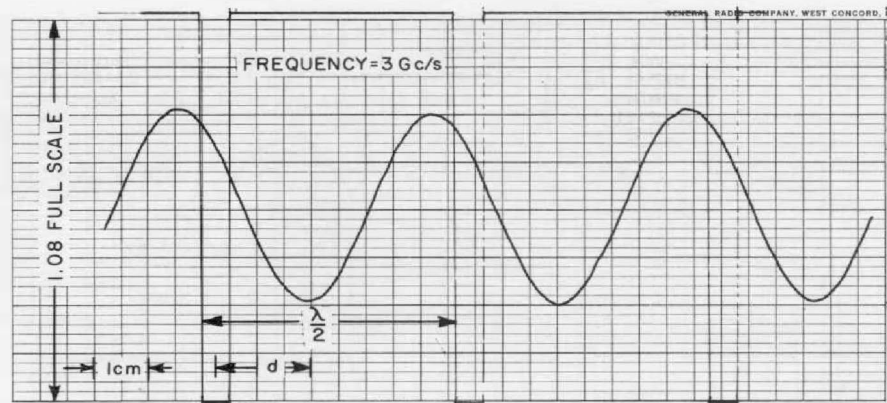

recording depends only on three stable, wire-wound potentiometers in the servo loop. These are custom-calibrated in each instrument. The accuracy is within one minor division of the chart paper (1/40th of full scale) for all positions of the VSWR, % FULL SCALE control.

Sensitivity (the minimum signal level for an on-scale indication) is continuously adjustable from 50 microvolts to 2 millivolts. The 2-millivolt upper limit is set by the square-law characteristic of the crystal detector, the 50-microvolt lower limit by the degradation in signal-to-noise-ratio (which also determines the minimum detectable VSWR).

The amplifier is fixed-tuned to 990 c/s (avoiding harmonics of 60 c/s and 50 c/s) and has a 35-cycle bandwidth. The 5-dB noise figure at this bandwidth results in a VSWR-equivalent noise level of 1.0001 (0.01%) at an audio input signal level of 1.0 millivolt.

#### Chart Drive

The chart drive has four speeds; since two sprockets of 2:1 different sizes are supplied, there are eight possible slotted-line carriage drive speeds, from 5 to 0.08 centimeters per second. One horizontal division on the chart paper corresponds to either 1 or 0.5 centimeter on the slotted-line scale, depending on which sprocket is used.

Fast chart speeds and the 1-cm/division sprocket are used at lower frequencies, while the slower speeds and the 0.5-cm/division sprocket expand the horizontal scale for better precision at the high end of the band. At any frequency from 0.6 to 9 Gc/s, two full cycles of the standing-wave pattern can be scanned in five seconds, without perceptible distortion of the standing-wave pattern.

## APPLICATIONS

### Direct VSWR Measurement

The primary application of the Slotted Line Recorder System is, of course, the measurement of the VSWR of an unknown one-port component by the direct method. If VSWR alone is desired, the recorder motor drive is engaged for at least one cycle of the standing-wave pattern, to produce a record similar to that shown in Figure 4. If the phase of the VSWR pattern is also important, then a TYPE 900-WN Short-Circuit Termination (supplied with the system) is connected in place of the unknown, and a second curve is superimposed on the first (see Figure 5). The distance between positions of minima is then measured directly on the chart paper, as is wavelength, and the value of  $d/\lambda$ , thus determined, is transferred to the Smith chart as wavelengths-toward-load. The ease with which the

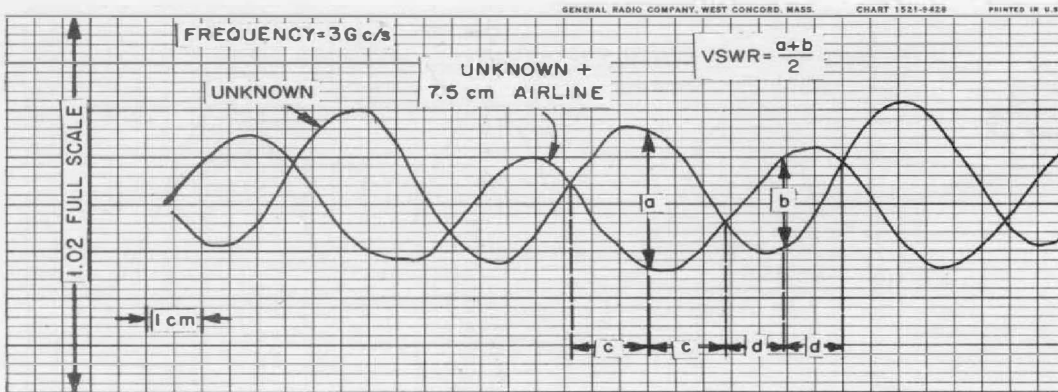

Figure 6. Multiple recording used in substitution - method VSWR measurement.

positions of minima can be located graphically ensures excellent phase measurements, even for vswr's as low as 1.01.

Direct vswr measurements can be made on connector systems other than GR900 by means of GR900 precision, low-vswr adaptors. These are now available to types BNC, C, N, TNC, and GR874 connectors (see page 17).

**Substitution VSWR Measurement**

For even greater accuracy, a substitution technique can be used,<sup>3</sup> with a TYPE 900-LZ Reference Air Line acting as an impedance standard. Accuracy of measurement is increased by a factor of from 2 to 5, depending on frequency, and the position of minimum

can be located accurately for a vswr as low as 1.001.

In the substitution method, a multiple plot is recorded, showing (1) the vswr of the unknown connected directly to the slotted line and (2) the vswr with the reference air line inserted between the unknown and the slotted line. (See Figure 6.) With the impedance transformation of a quarter-wave air-line section, the difference between the two curves represents twice the vswr of the unknown impedance with respect to the reference air line. The residual vswr of the slotted line effectively cancels out.

To determine phase, a curve is run with a short circuit at the reference plane, as before (see Figure 7). The position of minimum of the unknown is halfway between two adjacent intersections on the multiple vswr plot and can thus be located with pinpoint accuracy,

<sup>3</sup> A. E. Sanderson, "A New High-Precision Method for the Measurement of the VSWR of Coaxial Connectors," *IRE Transactions on Microwave Theory and Techniques*, Vol MTT-9, No 6, November 1961, pp 524-528.

<sup>4</sup> A. E. Sanderson, "Calibration Techniques for One- and Two-Port Devices Using Coaxial Reference Air Lines as Absolute Impedance Standards," *Instrument Society of America Preprint 21.6-3-64*.

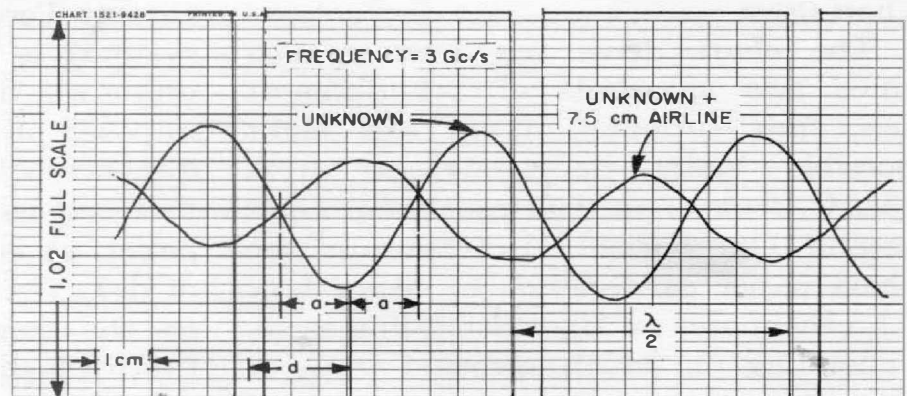

Figure 7. Multiple recording used in substitution-method VSWR and phase measurement.





no matter how low the vswr may be. As before,  $d$  and  $\lambda$  are both on the chart paper, and their quotient becomes the "wavelengths-toward-load" reading on the Smith chart.

### Insertion VSWR

Many of the most common design problems can be cast in the form of two-port unknowns, and the insertion vswr of a two-port unknown can be measured very accurately on the slotted-line recorder system by a substitution method.<sup>3, 4</sup> Examples of design problems centering on the insertion vswr are the design of coaxial connectors, of isolated bead supports, or of transitions between coaxial lines of different diameters. Separating the reflections of the two-port unknown from those of the slotted line and termination has always been difficult in such design problems. In the substitution method with the recorder system, separation is easily achieved, since the undesired reflections cancel out, while the desired reflections do not. The insertion vswr of the two-port is the difference between two curves recorded on the same section of chart paper, just as in the one-port substitution method described above. The short-circuit reference plane marks can also be recorded on the chart paper for Smith-chart plots of the measurement (see Figure 8).

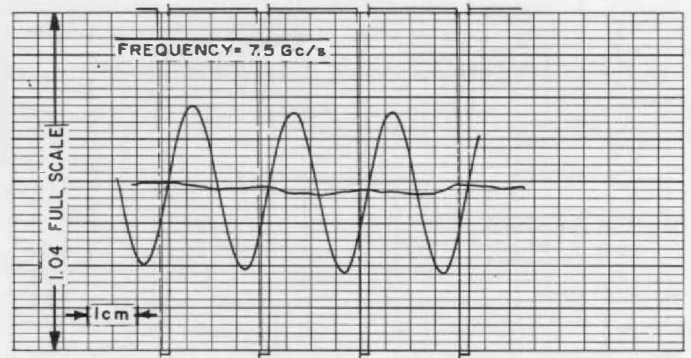

Figure 8. Recording showing insertion VSWR of a mated pair of GR900 adaptors (Types 900-QNJ and -QNP) at 7.5 Gc/s.

### Repeatability

In the process of any vswr measurement it is important to check periodically that the measurement is repeatable, that is, that it can be duplicated several times in succession with a variation no greater than the rated repeatability of the connector (for the GR900, 0.05%). The TYPE 1640-A system is well suited for such checks, because several successive curves can be plotted on the chart for direct inter-comparison, as shown in Figure 9. For this check, it is desirable to match the slotted line to its load by means of the TYPE 900-TUA Tuner (see page 15) for maximum recorder scale expansion (1.008 full-scale). The successive curves are spaced with the recorder CENTERING control and should agree within 0.05%, or 1.0005.

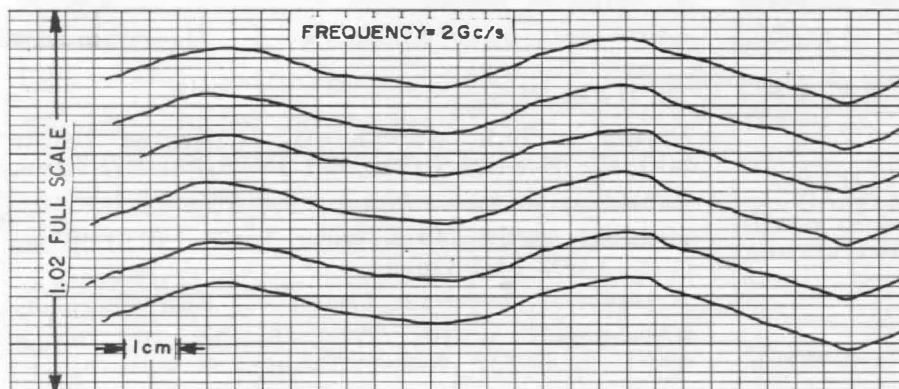

Figure 9. Multiple recording showing excellent repeatability of GR900 joint with connectors at six different orientations, in a very low VSWR measurement.

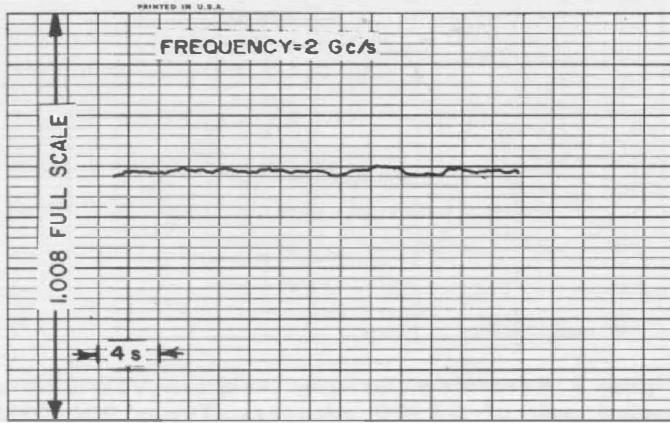

Figure 10. Typical recording of system noise at 2 Gc/s, with Type 1360-B Microwave Oscillator used as signal source. Chart speed was 30 div/min. Note that total excursion over entire 25-second recording is equivalent to VSWR of only 1.0002.

### System Noise Check

The equivalent noise level of the system, all-important in precision vswr measurements, can be checked easily with the TYPE 1640-A Slotted Line Recorder System. Contributing about equally to the system noise are three sources: the signal sources, the crystal detector, and the recorder itself. To measure the vswr equivalent of system noise, the probe carriage drive is declutched, the recorder set for maximum resolution, and the chart drive activated. Since the probe is not moving, the sole cause of any wiggles on the chart is system noise. The peak-to-valley noise excursions can then be translated into an approximately equivalent vswr. In the example of Figure 10, the peak-to-valley ratio is 0.02%,

for a vswr equivalent of 1.0002. This amounts to a basic figure of merit for the system, since the vswr of the unknown must be comfortably above that of the noise level in order to give accurate results.

### SUMMARY

The use of a graphic level recorder greatly enhances the usefulness of the precision slotted line. Among the benefits derived from this synergistic alliance are:

- a scale expansion that makes the recorder the equivalent of a vswr meter with a 10-foot-long scale,
- a signal-to-noise ratio of over 80 dB,
- the pinpoint location of positions of minima,
- the many advantages of multiple recording (in substitution measurements, for example),
- the possibilities of graphical analysis of recordings,
- the availability of permanent recording for reference and later study.

For engineers working on coaxial design problems, for instructors wishing to demonstrate standing-wave phenomena most effectively, for anyone concerned with slotted-line measurements, the TYPE 1640-A Slotted Line Recorder System merits very serious appraisal.

— A. E. SANDERSON

### SPECIFICATIONS

#### SLOTTED LINE (TYPE 900-LB)

- Characteristic Impedance:** 50.0 ohms  $\pm 0.1\%$ .
- Probe Travel:** 50 cm. Scale calibrated in centimeters from reference plane. Attached vernier can be read to 0.1 mm.
- Scale Accuracy:**  $\pm(0.1 \text{ mm} + 0.05\%)$ .
- Frequency Range:** 0.3 to 9 Gc/s. At 300 Mc/s,

- covers a half wavelength. Operates below 300 Mc/s with TYPE 900 Precision Air Line.
- Constancy of Probe Pickup:**  $\pm 0.5\%$ .
- Residual VSWR:** Less than  $1.001 + 0.001f\sigma_c$  (e.g., 1.002 at 1 Gc/s).
- Accessories Required:** Generator and detector.
- Dimensions:** Width  $27\frac{1}{2}$ , height 10, depth  $4\frac{3}{4}$  inches (700, 255, 125 mm).



**RECORDER (TYPE 1521-SL)**

**Sensitivity:** Continuously adjustable from 0.05 to 2.0 mV (on-scale).

**Frequency:** 990 c/s  $\pm$  2%.

**Bandwidth:** 35 c/s  $\pm$  7 c/s (at 3 dB).

**VSWR Range:** Continuously adjustable from 1.008 (0.8%) to 1.20 (20%) full-scale; accurate to within one minor division.

**Noise Level (referred to input):** Short-circuit, less than 0.1  $\mu$ V; open-circuit, less than 3.0 pA. Noise figure less than 5 dB at the optimum source resistance (about 30 kilohms).

**Power Required:** 105 to 125 or 210 to 250 V, 60 c/s, 35 W. TYPE 1521-SLQ1 Recorder, used with TYPE 1640-AQ1 System, 50 c/s.

**Chart Paper:** 4-inch recording on 5-inch paper; 40 minor and 8 major divisions vertically. Horizontal scale ruling,  $\frac{1}{4}$  inch.

**Paper Speeds:** Adjustable, 2.5 to 75 inches per minute; plots correspond to 5- to 300-cm/min carriage travel on slotted line. Two inter-

changeable sprockets advance paper 1 or 2 horizontal divisions per cm probe travel.

**Servo Bandwidth of Pen Drive:** More than 4 c/s.

**Input Connector:** GR874 Coaxial Connector, locking, recessed.

**SYSTEM**

**Accessories Supplied:** TYPE 874-R22A Patch Cord; TYPE 900-WN Precision Short Circuit; TYPE 900-WO Precision Open Circuit; tuning stub — probe assembly (including 1N21C and 1N23C crystals); rf-probe assembly (with TYPE 874-BL Connector); micrometer carriage drive (accurate to 0.01 mm); spare drive cable; storage box; Smith charts; two pens; 2 oz red ink; 2 oz green ink; potentiometer cleaner; 10 100-ft rolls of chart paper; eyedroppers for filling pen; power cord; spare fuses.

**Bench Space Required:** Width 48, depth 14 in (1220 by 355 mm); height above bench, 12 in, depth below bench, 9 in (315 and 230 mm).

**Net Weight:** 67 lb (37 kg).

**Shipping Weight:** 120 lb (55 kg).

Type		Price
1640-A	Slotted Line Recorder System (for 60-cycle supply)	\$1975.00
1640-AQ1	Slotted Line Recorder System (for 50-cycle supply)	1975.00

U.S. Patent No 2,581,133; 2,548,457.

**REFERENCE AIR LINES FOR THE**



New GR900 Reference Air Lines derive exceptionally low vswr chiefly by the elimination of bead supports. The inner conductor is suspended instead by the center contacts of the GR900 connectors with which the air line is mated (see Figure 1 above and Figure 1, page 19). Use of the beadless GR900 connection helps make the accuracy of these air lines several times that of the Type 900-BT Connector. Thus GR900-

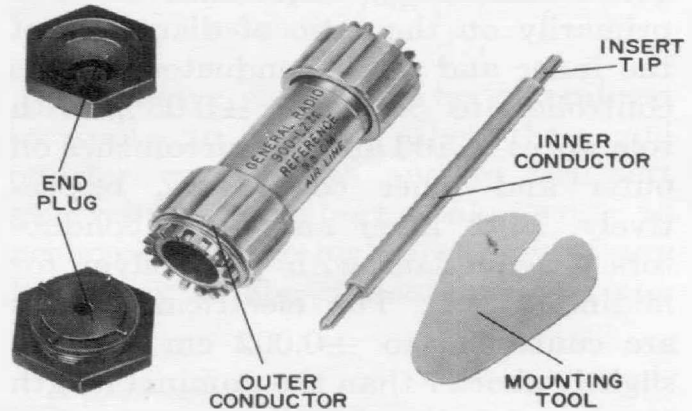

Figure 1.

equipped instruments and components can now be quickly and conveniently calibrated with respect to the new standards. For example, the TYPE 900-LB Precision Slotted Line, whose vswr accuracy specification is  $1.001 + 0.001f_{sc}$ , can typically be calibrated to an accuracy of 1.0008 or better with the TYPE 900-LZ Reference Air Lines and the new TYPE 900-TUA Tuner. With this new calibration sys-







coefficient equals the *vector* sum of the reflection coefficients of the two devices. The equation for small reflection coefficients ( $\Gamma < 0.1$ ) is:

$$\Gamma' = \Gamma_m + \Gamma_l \quad (1)$$

where

$\Gamma'$  = initial indicated reflection coefficient,

$\Gamma_m$  = residual reflection coefficient of the instrument,

$\Gamma_l$  = load reflection coefficient.

The insertion of a reference air line of electrical length  $L$  between the measuring instrument and the load has no effect upon the  $\Gamma_m$  vector, but rotates the phase of the  $\Gamma_l$  vector by  $4\pi L/\lambda$  radians about a point on the Smith chart equal to the characteristic impedance of the air line. This fact is the key to the separation of instrument error from load error and to their measurement with respect to a known and calculable rf impedance, the characteristic impedance of the reference air line.

For calibration purposes, the most convenient lengths of reference air line are the odd quarter wavelengths, for the rotation of the  $\Gamma_l$  vector is then  $\pi$

radians, or 180 degrees, corresponding to a change of sign of the  $\Gamma_l$  vector. The measured value of reflection coefficient after insertion of the reference air line,  $\Gamma''$ , is therefore:

$$\Gamma'' = \Gamma_m - \Gamma_l \quad (2)$$

Vector addition of equations (1) and (2) and rearrangement yield the residual reflection coefficient of the measuring instrument:

$$\Gamma_m = \frac{\Gamma' + \Gamma''}{2} \quad (3)$$

Vector subtraction of equation (2) from equation (3) yields the reflection coefficient of the load:

$$\Gamma_l = \frac{\Gamma' - \Gamma''}{2} \quad (4)$$

The corresponding vswr's are obtained from the formula:

$$vswr = \frac{1 + |\Gamma|}{1 - |\Gamma|}$$

The above results can be generalized to apply to lengths other than odd quarter wavelengths and to two-port as well as one-port unknowns, to achieve the same high accuracy at any frequency in the measurement of any

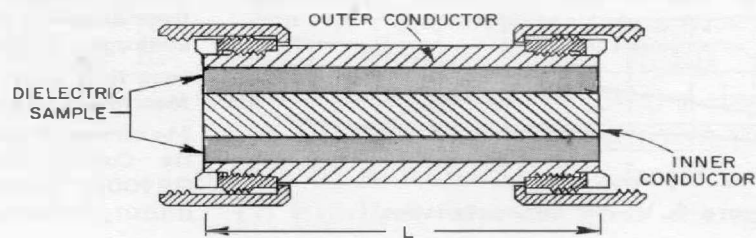

a. SAMPLE IN TYPE 900-LZ

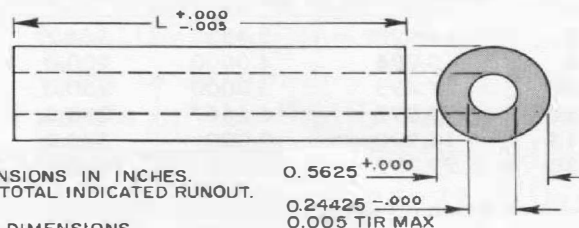

NOTE:  
DIMENSIONS IN INCHES.  
TIR = TOTAL INDICATED RUNOUT.

b. SAMPLE DIMENSIONS

**Figure 3. Dielectric-sample fabrication for measurement in Type 900-LZ Reference Air Line.**



microwave component. The general formulas and required techniques are described fully in References 1 and 2.

The TYPE 900-LZ Air Lines can also be used in the measurement of dielectrics. The air lines, being open at both ends, serve as convenient holders for dielectric samples fabricated in the coaxial cross-section shown in Figure 3. The electrical length and the attenuation of the dielectric-filled line can be measured with high accuracy on the TYPE 900-LB Slotted Line as described in the operating instructions for the Slotted Line, and these quantities are related to the dielectric constant and the loss tangent of the material with the formulas:

$$\epsilon_r = \left(\frac{L_e}{L_p}\right)^2$$

$$\tan \delta = \frac{0.0366 A \lambda}{L_e}$$

where  $\epsilon_r$  = relative dielectric constant,  
 $\tan \delta$  = loss tangent,

$L_e$  = electrical length of dielectric specimen, in cm,

$L_p$  = physical length, in cm,  
 $A$  = attenuation in specimen owing to dielectric losses, in dB,  
 $\lambda$  = wavelength at test frequency, in cm.

All quantities in the formulas can be accurately measured with the TYPE 900-LB Precision Slotted Line and the Micrometer Carriage Drive. The accuracy of this technique is about  $\pm 0.2\%$  in dielectric constant and  $\pm 0.0001/\sqrt{f_{Gc}}$  in loss tangent from 300 Mc/s to 9 Gc/s.

— A. E. SANDERSON

REFERENCES

1. A. E. Sanderson, "Calibration Techniques for One- and Two-Port Devices Using Coaxial Reference Air Lines as Absolute Impedance Standards," Instrument Society of America Preprint 21.6-3-64.
2. A. E. Sanderson, "A New High-Precision Method for the Measurement of the VSWR of Coaxial Connectors," *IRE Transactions on Microwave Theory and Techniques*, Vol MTT-9, No 6, November 1961, pp 524-528.
3. D. Woods, "A Coaxial Connector System for Precision R.F. Measuring Instruments and Standards," *Proceedings of the IEE*, Vol 108, Part B, No 38, March 1961, p 205-213.

SPECIFICATIONS

Frequency Range: Dc to 9 Gc/s.  
 Characteristic Impedance: 50 ohms  $\pm 0.050\%$ .

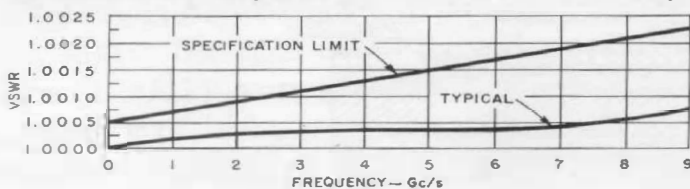

Figure 4. VSWR characteristics.

Additional skin-effect error is calculable.  
**VSWR:** Less than  $1.0005 + 0.0002f_{Gc}$ .  
**Repeatability:** Within  $(0.010 + 0.003f_{Gc})\%$ .  
**Leakage:** Better than 130 dB below signal.  
**Insertion Loss:** Less than  $0.0008 \sqrt{f_{Gc}}$  dB/cm.  
**Maximum Voltage:** 3000 V peak.  
**Maximum Power:** 20 kW/ $\sqrt{f_{Mc}}$ .  
**Dc Contact Resistance (each end, mated with GR900):** Inner conductor, less than 0.5 milliohm; outer conductor, less than 0.07 milliohm.

Type	Electrical Length—cm ( $\pm 0.002$ cm)	Capacitance—pF ( $\pm 0.07\%$ )	Time Delay—ps ( $\pm 0.1$ ps)	Odd $\lambda/4$ Frequencies* —Gc/s	Physical Length in—mm	Net Weight oz—g	Price
900-LZ5	4.997	3.3333	166.7	(2n+1)1.50	2 1/8—55	4.0—115	\$60.00
900-LZ6	5.996	4.0000	200.0	(2n+1)1.25	2 1/2—65	5.0—140	61.00
900-LZ7H	7.495	5.0000	250.0	(2n+1)1.00	3 1/8—80	5.5—160	62.50
900-LZ10	9.993	6.6667	333.3	(2n+1)0.75	4 1/8—105	7.0—200	65.00
900-LZ15	14.990	10.000	500.0	(2n+1)0.50	6—155	10.5—295	70.00
900-LZ30	29.979	20.000	1000.0	(2n+1)0.25	12—305	20—555	85.00

\* Frequencies at which air-line section is an odd multiple of a quarter wavelength, where n is zero or any integer.





# NEW COAXIAL TUNER WITH NEUTRAL SETTING

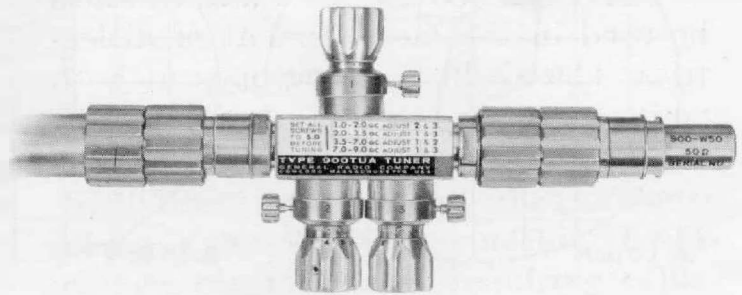

Figure 1. Type 900-TUA Tuner, shown in place between reference air line and Type 900-W50 50-ohm Standard Termination.

In many measurements with the GR900 system, there is the need to tune out the small residual reflections of the GR900 components. For example, by matching the TYPE 900-W50 50-ohm Termination to the TYPE 900-LB Precision Slotted Line, one can effectively upgrade the performance of the termination to the level of the slotted line — a fivefold improvement. In substitution measurements, accuracy and speed are improved considerably when a matching tuner is used to set the initial conditions to a perfect match ( $\Gamma' = 0$  in equations (3) and (4), page 13).

The TYPE 900-TUA Tuner (see Figure 1), designed with the above requirements in mind, has the stability,

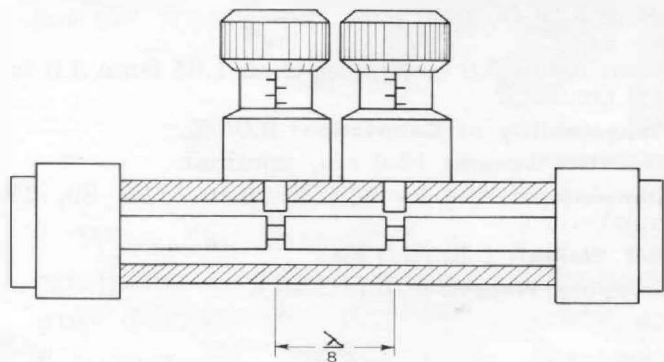
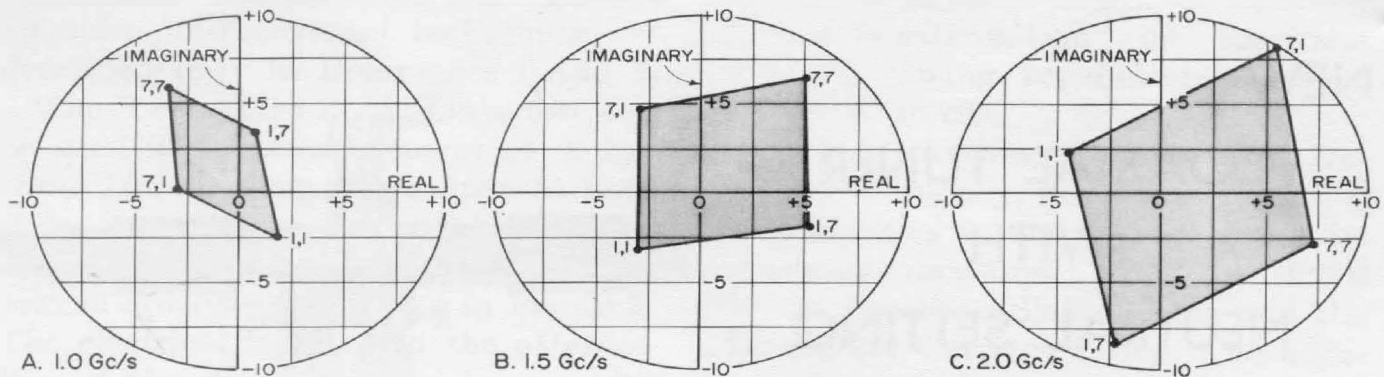

Figure 2. Cross-section view of tuner.

fineness of control, and resettability necessary to tune out vswr's as low as 1.001 or lower and to keep them tuned out. In addition, wide bandwidth (1 to 9 Gc/s), a unique "neutral" position, and reasonably orthogonal tuning adjustments (for easy, rapid balance) have been achieved with the design shown in Figure 2. Each of three tuning adjustments consists of a capacitive tuning screw in the wall of the outer conductor and an inductive groove in the inner conductor, in the same plane as the tuning screw. Turning the screw counterclockwise places a small inductance in series with the line, while turning the screw clockwise adds a small capacitance in shunt with the line; positive or negative increments are thus produced along the imaginary axis of a Smith-chart impedance plot. To produce incremental changes along the real axis, another tuning screw is placed one-eighth wavelength (or an odd multiple of one-eighth wavelength) from the first, for this separation provides orthogonality of the two adjustments on the Smith chart. The Smith-chart coverage of the two adjustments at band center is a square in the middle of the Smith chart. Off center fre-



**Figure 3. Smith-chart plots showing tuning range of Type 900-TUA Tuner. Numbers at corners are settings of screws 2 and 3, respectively. Tuning screw 1 is set at 5.00. Axis values are in terms of percent deviation from match. A 10-percent mismatch corresponds to a VSWR of 1.100.**

quency, the square becomes a diamond of smaller area but is still centered on the Smith chart (see Figure 3). The reduction of matching area limits the useful frequency range of a given pair of screws to the octave between two-thirds and four-thirds of the center frequency.

Each tuning screw can be set so that its shunt susceptance exactly cancels the series inductance of the groove, and the net effect of the two discontinuities is zero. This is called the neutral position of the tuning adjustment. Because the effects of both shunt susceptance and series inductance increase with frequency at the same rate, and because the screw and the groove are placed at the same point in the

transmission line, the neutral setting is independent of frequency. The neutral-setting feature was, in fact, fundamental to the design of the tuner; only with such provision could several screws be placed in the transmission line at different spacings to satisfy the odd-eighth-wavelength condition at many frequencies and to provide reasonably orthogonal tuning adjustments over a broad and continuous frequency range. In operation, two of the three screws in the tuner are adjusted for match (which pair depends on frequency), while the unused screw is simply set to neutral. Each tuning screw can be locked in any position, affording maximum stability and repeatability.

**SPECIFICATIONS**

**Frequency Range:** 1.0 to 9.0 Gc/s.  
**Characteristic Impedance:** 50 ohms, nominal.  
**VSWR Matching Range:**  $1.00 + 0.012f_{Gc}$ , or  $1.2f_{Gc}\%$ , minimum.  
**VSWR Resettability:** Within  $1.0005 + 0.0003 f_{Gc}$  or  $(0.05 + 0.03f_{Gc}) \%$ .  
**Connectors:** GR900 at each end.  
**Residual VSWR:** At neutral, less than 1.03

from 1.0 to 5.0 Gc/s; less than 1.05 from 5.0 to 7.0 Gc/s.  
**Repeatability of Connection:** 0.05%.  
**Electrical Length:** 12.0 cm, nominal.  
**Dimensions:**  $4\frac{1}{2}$  by  $3\frac{1}{2}$  by 1 in (115, 89, 25 mm).  
**Net Weight:** 1 lb (0.5 kg).  
**Shipping Weight:** 4 lb (1.9 kg).

Type		Price
900-TUA	Tuner	\$165.00

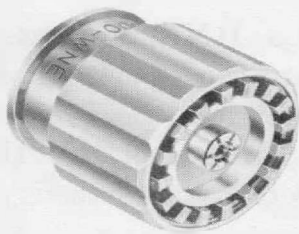

# NEW TERMINATIONS

A new short-circuit termination has been developed specifically for use with the reference air lines described in this issue. The TYPE 900-WNC Short-Circuit Termination is essentially a simple short-circuiting disk with a standard GR900 center contact to support the inner conductor of a beadless TYPE 900-LZ Reference Air Line. The reference plane of the termination occurs exactly at the reference plane of the GR900 connector. Reflection coefficient is 0.999 or greater to 9.0 Gc/s.

Because of the effects of fringing capacitance, the reference plane of the standard TYPE 900-WO Open-Circuit

Termination<sup>1</sup> occurs 0.26 cm (electrical distance) beyond the reference plane of the GR900 connector. To facilitate measurements requiring coplanar short- and open-circuit terminations, we have developed the TYPE 900-WNE Short-Circuit Termination, whose reference plane is also displaced 0.26 cm. This termination, like the TYPE 900-WNC, contains a standard center contact to support the inner conductor of a TYPE 900-LZ Reference Air Line. Reflection coefficient is greater than 0.998 to 9.0 Gc/s.

<sup>1</sup> John Zorzy, "Precision Coaxial Equipment — The 900 Series," *General Radio Experimenter*, November 1963.

Type		Length	Net Weight	Price
900-WNC	Reference-Line Short-Circuit Termination	1 1/16 in (27 mm)	2 1/2 oz (70 g)	\$16.00
900-WNE	Short-Circuit Termination (0.26 cm)	1 1/16 in (27 mm)	2 1/2 oz (70 g)	17.00

# ADAPTORS

NEW ADAPTORS TO  
TYPE BNC, TNC, AND  
C SERIES

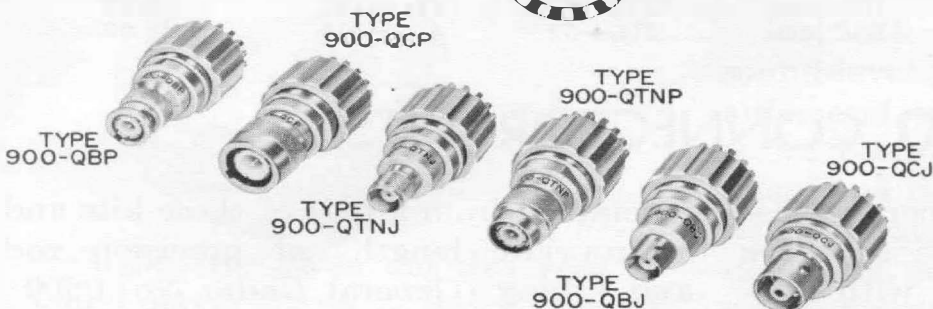

With the introduction of six new adaptors, GR900-equipped instruments and devices can now be quickly and conveniently mated with the most popular coaxial connector types. The

new adaptors are: TYPES 900-QBJ and -QBP (adapt to BNC series); TYPES 900-QCJ and -QCP (adapt to C series); and TYPES 900-QTNJ and -QTNP (adapt to TNC series). In each case,



the suffix J indicates that the adaptor is female (contains a jack), whereas a P suffix denotes a male adaptor (i.e., one containing a plug).

Other GR900 Adaptors, described in an earlier issue, are the TYPE 900-QNJ and -QNP (adapt to N series) and the TYPE 900-Q874 (adapts to GR874 Connectors).

The availability of adaptors from GR900 to nine other coaxial connectors greatly extends the usefulness of all GR900-equipped instruments and components. A TYPE 900-LB Slotted Line with a TYPE 900-QBJ Adaptor, for in-

stance, constitutes a BNC slotted line capable of outstanding performance. Also, since the electrical performance of each adaptor approaches the theoretical limit imposed by the design of the other-series connector, a GR900 adaptor and a GR900 termination can be combined to form an other-series termination of near optimum performance.

Combined vswr specifications for the TYPE 900-LB Precision Slotted Line and the TYPE 900-W50 50-ohm Termination, each equipped with various GR900 Adaptors, are given in the accompanying table.

VSWR OF GR900 DEVICES EQUIPPED FOR OTHER COAXIAL SERIES

	<i>Slotted Line (Type 900-LB Plus GR900 Adaptor)</i>	<i>50-ohm Standard Termination (Type 900-W50 Plus GR900 Adaptor)</i>
Types BNC TNC C	1.006 + 0.016 $f_{Gc}$ to 1 Gc/s 1.016 + 0.006 $f_{Gc}$ from 1 to 9 Gc/s	1.010 + 0.020 $f_{Gc}$ to 1 Gc/s 1.020 + 0.010 $f_{Gc}$ from 1 to 9 Gc/s
Type N	1.005 + 0.005 $f_{Gc}$	1.009 + 0.009 $f_{Gc}$
Type GR874	1.001 + 0.016 $f_{Gc}$ to 1 Gc/s 1.011 + 0.006 $f_{Gc}$ from 1 to 9 Gc/s	1.005 + 0.020 $f_{Gc}$ to 1 Gc/s 1.015 + 0.010 $f_{Gc}$ from 1 to 9 Gc/s

SPECIFICATIONS

<i>Type</i>	<i>Contains GR900 and</i>	<i>Connects to</i>	<i>Length in—mm</i>	<i>Net Weight oz—g</i>	<i>Price</i>
900-QBJ	BNC jack	BNC plug	2 1/16—52	3 1/2—100	55.00
900-QBP	BNC plug	BNC jack	2 1/8—54	4 —115	55.00
900-QJC	C jack	C plug	1 7/8—48	3 1/2—100	55.00
900-QCP	C plug	C jack	2 1/16—52	4 —115	55.00
900-QTNJ	TNC jack	TNC plug	2 1/16—52	3 1/2—100	55.00
900-QTNP	TNC plug	TNC jack	2 1/16—52	4 —115	55.00

 GR900 CONNECTOR KITS

Three new connector kits permit custom fabrication of reference air lines and components compatible with GR-900 connectors.

The Type 900-AP Laboratory Precision Connector Kit is designed for use with coaxial elements with unsupported inner conductors. A reference air line of custom length, for instance, can be

assembled from a pair of these kits and appropriate lengths of precision rod and tubing (General Radio No. 0900-9508 and 0900-9509, respectively).

The Type 900-AC Laboratory Precision Connector Kit contains the coupling hardware and center contact of a standard GR900 connector. It can be used in place of a TYPE 900-BT connector

**Figure 1. Cross-section view of coaxial line sections fitted with Types 900-AP (top) and 900-AB Precision Coaxial Connector Kits. Type 900-AP connection is same as that used in the Type 900-LZ Reference Air Lines.**

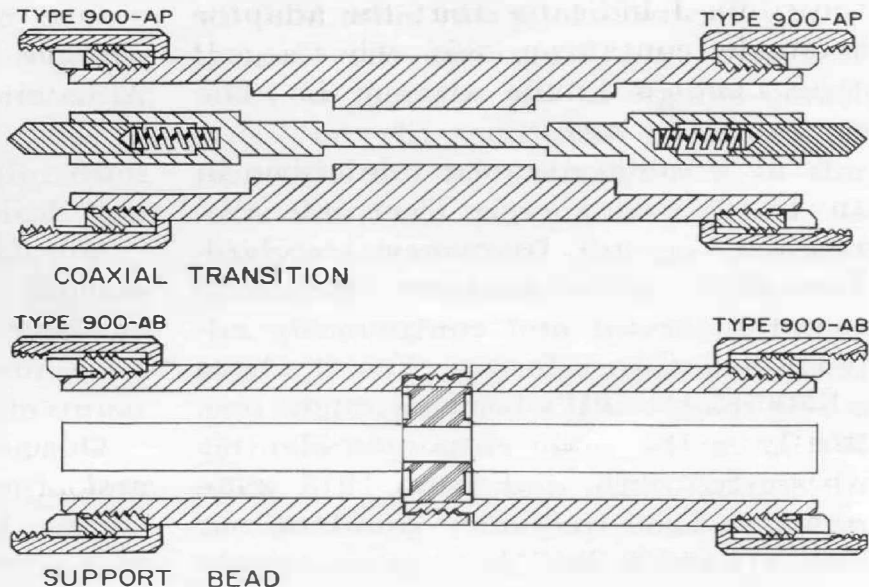

when the component's inner conductor is supported within the component itself. Since it includes only the connector parts necessary for such applications, this kit offers the user superior electrical performance at a considerable saving in cost.

One GR900 center contact is all that is necessary for electrical connection in

a GR900 joint. Therefore, when a component is to be used exclusively with GR900 connectors, the connector kit need not include a center contact. *The Type 900-AB Laboratory Precision Connector Kit*, which contains GR900 coupling hardware, is intended for such applications.

Type		Length	Net Weight	Price
900-AB	Laboratory Precision Connector Kit	1 3/8 in (30 mm)	1 oz (28 g)	4.80
900-AC	Laboratory Precision Connector Kit	1 3/8 in (30 mm)	1 oz (28 g)	7.10
900-AP	Laboratory Precision Connector Kit	1 1/4 in (32 mm)	1 1/4 oz (35 g)	5.40



We'll be fifty years old this year.

You'd never guess it to look at us. We pursue our business with the enthusiasm of youth. Our plants are new, cleanly designed, smartly suburban. Our instruments are modern in shape and color. On appearances, you might take us for a spirited teen-ager.

But look *inside* one of our bridges or sound-level meters or frequency standards, and you know right away that we've been at that sort of thing for a long, long time. Take our new automatic capacitance bridge: it's streamlined, space-age, sophisticated, a state-of-the-art instrument if there ever was one. But somewhere in its marrow is a half century of bridge-designing and bridge-making know-how. We've written off the cost of all this experience; it's yours as a bonus in every GR instrument you buy.





We've come a long way since Melville Eastham first hung out the General Radio shingle in the summer of 1915. Some of the milestones (if you'll permit us a semicentennial reminiscence) are the first commercial electronic stroboscope, crystal frequency standard, heterodyne wave analyzer, standard-signal generator and continuously adjustable autotransformer. Yes, it's been a long road, but it's been a straight one. We have the same corporate identity we started with, and, from 1915 wave meter to 1965 frequency counters, our main product line has unwaveringly been electrical measuring apparatus. End of reminiscence. To us, the success of 50 years isn't a cushion, it's a springboard.

Now to the future. Instruments now in development convince us that, at GR, "the best is yet to be." Here are some examples of what we mean:

The GR<sup>®</sup> automatic capacitance bridge will soon begin working for component makers all over the world, measuring their products at the rate of two or more per second and feeding the answers to the latest data-processing equipment.

Our frequency-synthesizer engineers are synthesizing again, and they talk of having a large family.

New STROBOTAC<sup>®</sup> stroboscopes will flash into view with battery operation and flashing rates to 150,000 rpm.

The GR900 line of precision coaxial components will grow like guppies, with the development of adaptors, important new instruments, terminations, and many other elements.

Our acoustic program is full of sound and fury, signifying, among other things, a precision sound-level meter and a new GR-made, measurement-grade microphone.

For those people who like to hook up pulsers in combinations to make staircases and other interesting designs on a scope, we will make it easy by offering a modular pulse generator.

There's much, much more, but by now you get the idea: Things are really humming at West Concord and Bolton.

For the successes of our past, our sincere thanks to the customers who helped make it possible. The best way we know to repay you is to keep giving you the quality you have learned to expect when you "buy GR."

GENERAL RADIO EXPERIMENTER  
GENERAL RADIO COMPANY  
WEST CONCORD • MASSACHUSETTS • USA



RETURN REQUESTED

