

# General Radio EXPERIMENTER

VOLUME XXVII No. 4

SEPTEMBER, 1952

Copyright, 1952, General Radio Company, Cambridge, Mass., U. S. A.

## THE VACUUM-TUBE BRIDGE AND ITS ACCESSORIES

*Also*

### IN THIS ISSUE

Page

QUIET SHIP..... 6  
DELIVERY SCHEDULES. 6

● **THE TYPE 561-D VACUUM-TUBE BRIDGE**, first described twenty years ago,<sup>1</sup> is used for measuring directly the vacuum-tube coefficients of amplification factor, transconductance, and plate resistance. Not a tube tester, the bridge is a laboratory-type instrument of high accuracy that permits a study of tube performance at widely varying operating conditions.

The method devised by Tuttle<sup>2</sup> substitutes accurately known and controlled individual voltage sources of low internal impedance for the resistive ratio arms of the usual bridge. Several advantages accrue from this departure from previous practice: the impedance of the measuring circuits has a minimum effect on the results, the voltage sources can be connected at convenient circuit points to permit grounding the tube cathode and the "low" side of the heater, control grid, screen, and plate supplies. The flexibility of the method permits the measurement of the tube coefficients referred to *any* pair of electrodes

<sup>1</sup>W. N. Tuttle, "A Bridge for Vacuum-Tube Measurements," *General Radio Experimenter*, Vol. 6, No. 12, May, 1932.

<sup>2</sup>W. N. Tuttle, "Dynamic Measurement of Electron-Tube Coefficients," *Proc. IRE*, Vol. 21, No. 6, June, 1933.

Figure 1. Panel view of the vacuum-tube bridge with adaptor and tube plugged into test position.

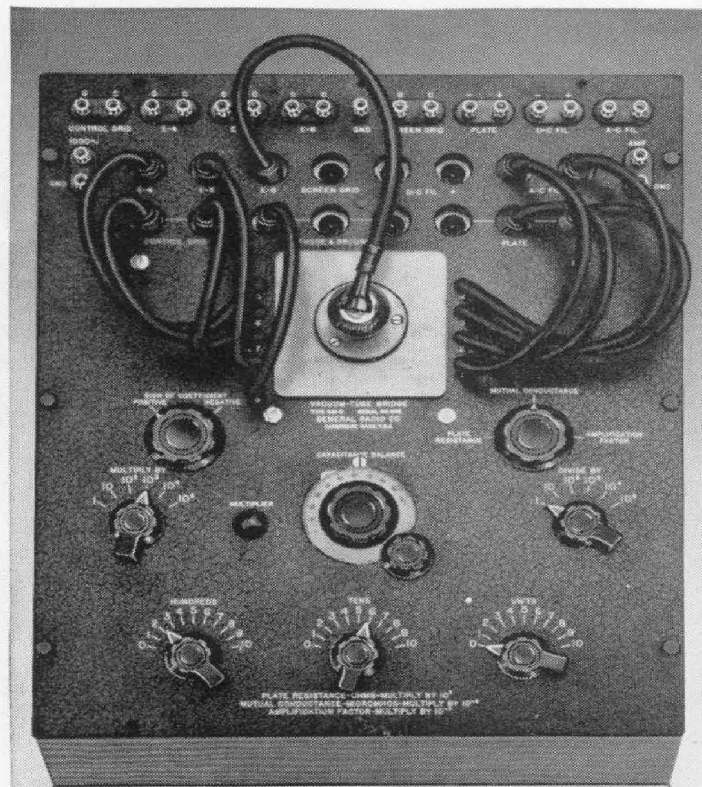

ELECTRICAL MEASUREMENTS AND THEIR INDUSTRIAL APPLICATIONS

and to coefficients of either polarity — positive or negative. The introduction of a third voltage source, in quadrature, has provided a simple means for balancing out the capacitive component introduced by interelectrode and socket capacitances without affecting the coefficient results even at high plate resist-

ance or high transconductance conditions. The circuit, shown schematically in Figure 2, is more fully described in many textbooks and in the I.R.E. Standards on Electron Tubes.<sup>3</sup>

<sup>3</sup>"Standards on Electron Tubes: Methods of Testing, 1950," *Proc. IRE*, Vol. 38, Nos. 8 and 9, August and September, 1950.

### NEW ADAPTORS FOR THE VACUUM-TUBE BRIDGE Sub-Miniature Types Now Available

Although the fundamental circuit has remained unchanged since the first TYPE 561-A Vacuum-Tube Bridge was designed, the mechanism for connecting the tube into the circuit has required considerable modification. The original bridge had 4-, 5-, 6-, and 7-pin sockets on the panel with provision for connecting other types through binding posts.<sup>2</sup> An 8-pin socket was added later, but, as the list of tube bases grew, it became evident that the panel socket system would eventually be inadequate. In later models, therefore, the socket sys-

tem has been made truly universal by supplying for each type of tube base a separate adaptor, which plugs into a single plug-in panel socket, with shielded cables connecting each terminal of the panel socket to the correct point in the measuring circuit.<sup>4</sup> These cables are now doubly shielded to improve performance when tubes with high plate resistance or high transconductance are being measured.

<sup>4</sup>W. N. Tuttle, "A Redesign of the Vacuum-Tube Bridge," *General Radio Experimenter*, Vol. 16, No. 6, November 1941.

Figure 2. Elementary schematic diagram of the circuits used in the vacuum-tube bridge.

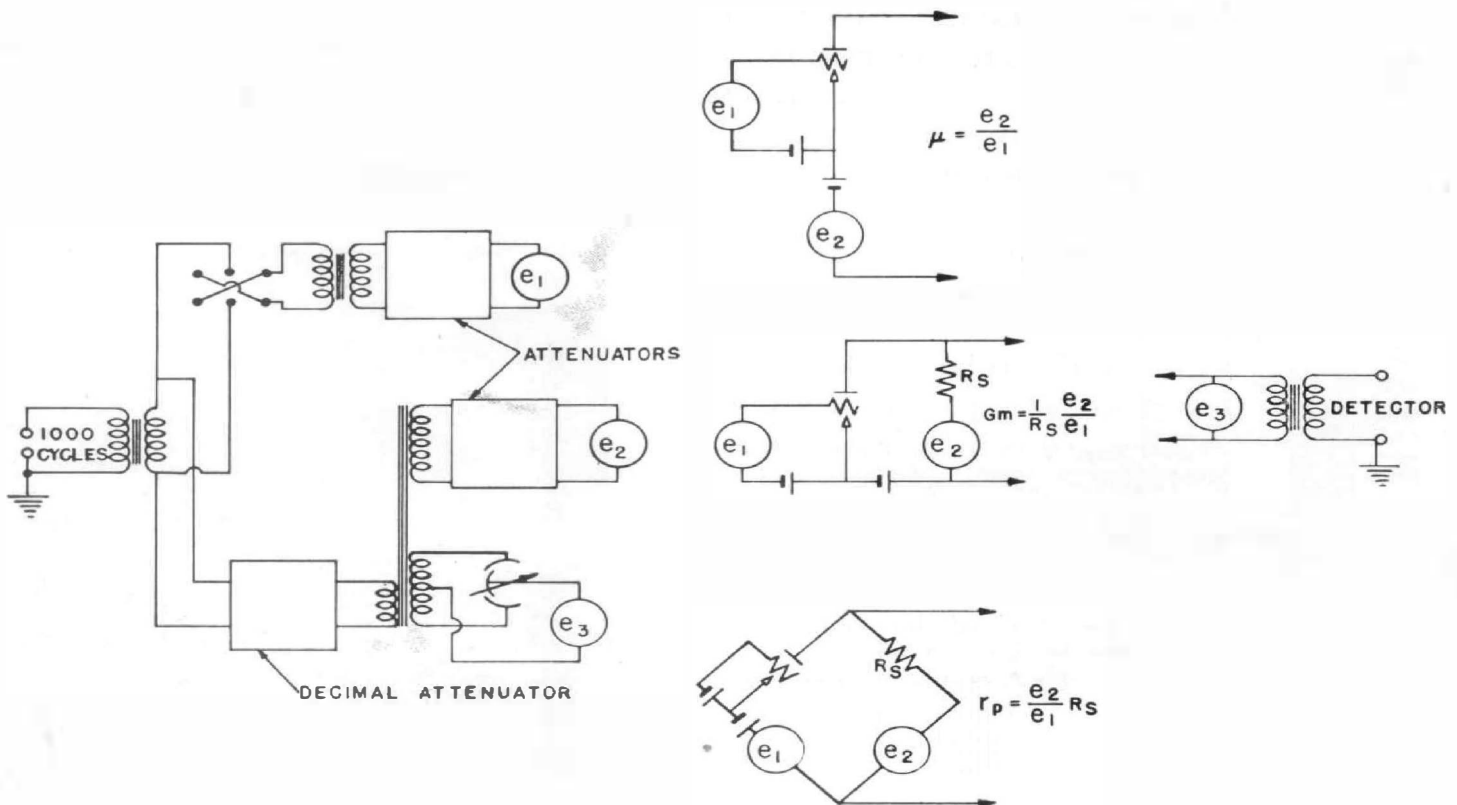



The separate-adaptor method has proved completely satisfactory. When a new type of tube base becomes generally accepted, a new adaptor is added to the list. A convenient storage case, which can be wall-mounted if desired, is supplied for storing the adaptors and the accessory grid-connection cables.

The adaptors now regularly supplied include the Universal adaptor, the 4-pin, 5-pin, 6-pin, small 7-pin, large 7-pin, octal, locking-in, miniature button 7-pin, miniature button 9-pin (noval), acorn (5- and 7-pin with the plate and grid-cap connections at the opposite ends — a challenge to the adaptor designer), 7-wire sub-miniature (for flat-press sub-miniature tubes of any number of leads up to seven), and 8-wire "button-base" sub-miniar (which in addition to the 8-wire sub-miniatures can be used for some of the randomly-oriented wire-lead sub-miniatures).

Figure 4 shows the two sub-miniature adaptors (flat-press and sub-miniar), which are designed to plug into the octal-base adaptor. For those sub-miniature tubes with the short wire leads, there are provided the separate 5-pin, 6-pin, and 7-pin flat-press and 8-pin sub-miniar sockets shown in Figure 5, which can be wired directly to the 9-pin Uni-

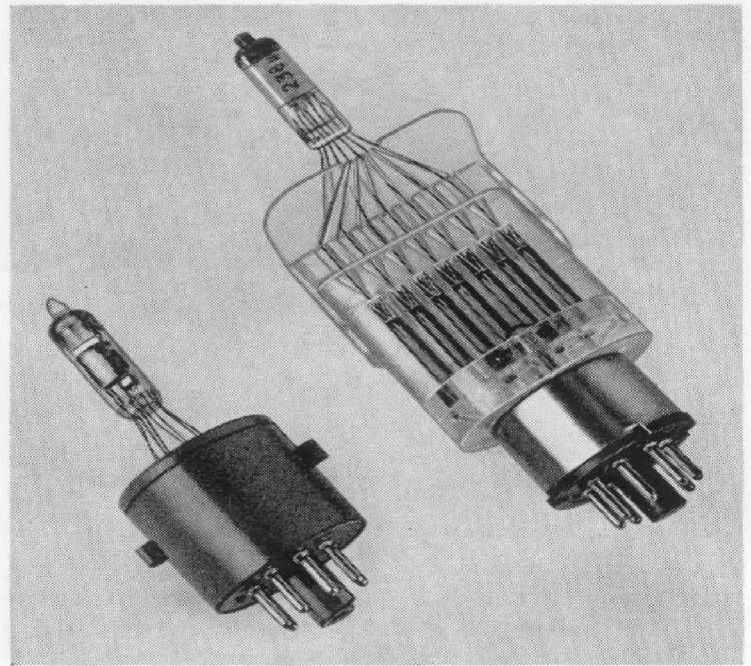
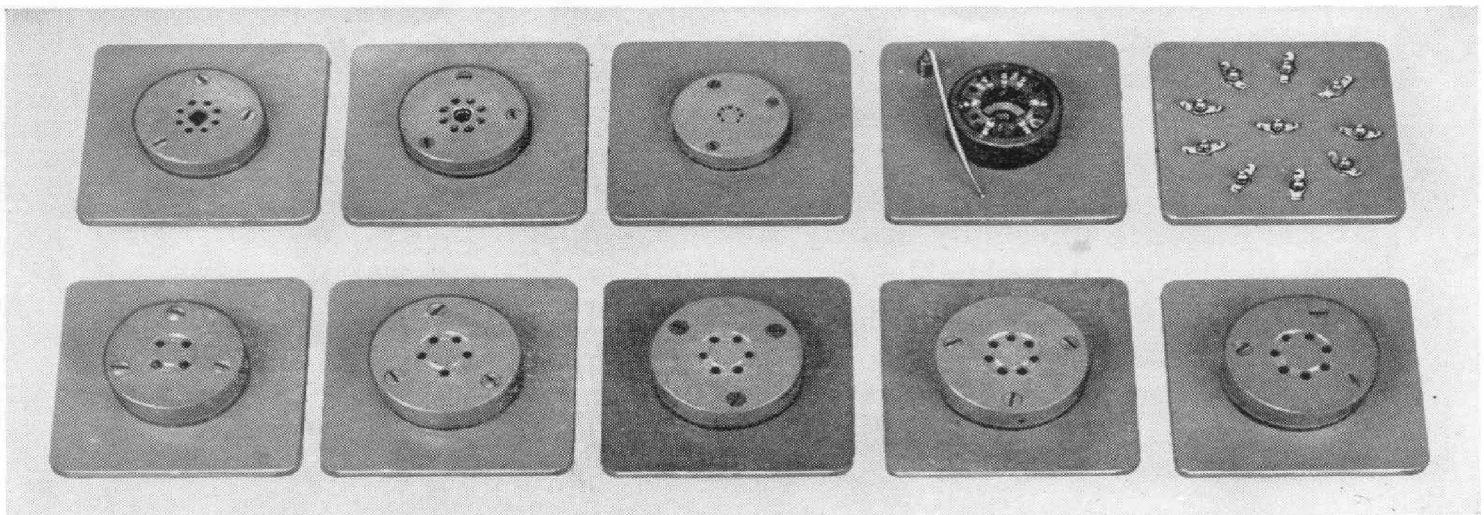

Figure 4. Adaptors for sub-miniature tubes. Flat-press types with up to 7 leads are tested in the Type 561-415-2 Adaptor with a comb-like structure for selecting and guiding the leads into the spring contacts. Eight-wire sub-miniar tubes are tested in the round Type SOA-3 Adaptor, which has provision for locking the leads into the socket. Both types plug into the standard octal adaptor.

versal adaptor. Tubes with which these sub-miniature adaptors or sockets can be used are listed in Tables I and II.

The 7-wire sub-miniature adaptor design is bound to please anyone who has striven to feed the flimsy tube wires in-

Figure 3. Group of adaptors furnished with the bridge. The noval adaptor (not shown) is similar in appearance.



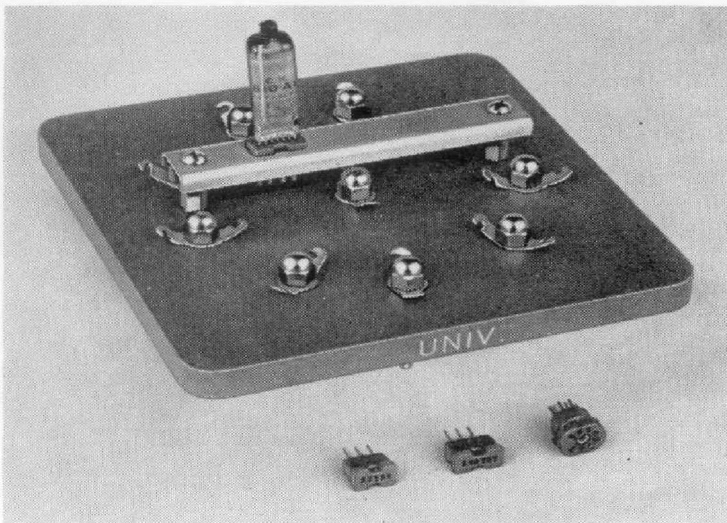

Figure 5 For sub-miniature types with short leads, sockets are supplied which can be mounted on the Universal adaptor. This photograph shows one way of mounting the Type SOT-50 7-pin socket (for flat-press tubes) on a Universal adaptor. In the foreground are shown, left to right, Type SOT-46 for 5-pin tubes, Type SOT-49 for 6-pin tubes, and Type SOT-48 for 8-wire sub-minar tubes.

dividually into a test socket. Part of the adaptor is a molded, tapered, comb-like arrangement which greatly facilitates the separation of the tube leads and guides them into the adaptor contact springs. See Figure 4.

Since there are many TYPE 561 Bridges in the field that do not have this full complement of adaptors and sockets, they have been made available as individual accessories and are listed in the price table below. New adaptors will be added as their need becomes evident.

All of the adaptors and sockets are made of low-loss material to insure a negligible error in the measurement of the plate resistance of special purpose tubes, such as the electrometer tubes. The adaptors are unusually sturdy, designed to stand up under the rigorous demands of production testing.

— A. G. BOUSQUET

The lists of tube types given in Tables I and II below are not necessarily all inclusive. An attempt has been made merely to list all tubes which have been announced prior to the publication of this article. Our intention is to keep the TYPE 561-D Vacuum-Tube Bridge and its complement of adaptors always up to date.

**Table I**

Eight-wire sub-minar tubes. These tubes can be plugged into the TYPE SOA-3 Adaptor. If the wire leads have been cut short, the TYPE SOT-48 Socket with the Universal adaptor should be used.

1AC5	5635	5897	5970
1AD5	5636	5898	5977
1C8	5637	5899	5987
1D3	5639	5900	6021
1E8	5640	5901	6026
1Q6	5643	5902	6110
1S6	5644	5903	6111
1T6	5718	5904	6112
1V5	5719	5905	6153
1W5	5797	5906	6154
2B5	5798	5907	6169
6AK4	5840	5908	6184
6BA5	5851	5916	6193
6BF7	5873	5967	6195
6BG7	5885	5968	6205
6BK7	5896	5969	6206

**Table II**

Flat-press sub-miniature tubes with all leads in a single plane. These tubes, with anywhere from 3 to 7 wire leads, can be measured in the TYPE 561-415-2 Tube Adaptor. If the wire leads are cut short, the SOT-46, SOT-49, or SOT-50 Socket with the Universal adaptor should be used.

1AD4	CK-525AX	CK-547DX	5829
1AE5	CK-526AX	CK-548DX	5854
1AG4	CK-527AX	CK-549DX	5875
1AG5	CK-528AX	CK-551AXA	5884
1V6	CK-529AX	CK-553AXA	5886
2E31	CK-531DX	CK-574AX	5889
2E35	CK-532DX	CK-623CX	5971
2E41	CK-533AX	5672	5972
2G21	CK-534AX	5676	5975
CK-502AX	CK-535AX	5677	5995
CK-503AX	CK-536AX	5678	6029
CK-505AX	CK-537AX	5697	6050
CK-506AX	CK-538DX	5702	6088
CK-510AX	CK-539DX	5703	6148
CK-512AX	CK-541DX	5704	6149
CK-518AX	CK-542DX	5744	6150
CK-522AX	CK-544DX	5784	6151
CK-524AX	CK-546DX	5785	6152



## SPECIFICATIONS FOR THE TYPE 561-D VACUUM-TUBE BRIDGE

**Range:** Amplification factor ( $\mu$ ); 0.001 to 10,000.

Dynamic internal plate resistance ( $r_p$ ); 50 ohms to 20 megohms.

Transconductance ( $g_m$ ); 0.02 to 50,000 micromhos.

Under proper conditions, the above ranges can be exceeded. The various parameters can also be measured with respect to various elements, such as screen grids, etc. Negative as well as positive values can be measured.

**Accuracy:** Within  $\pm 2\%$  for resistances ( $r_p$  switch position) from 1000 to 1,000,000 ohms. At lower and higher values the error increases slightly.

The expression  $\mu = r_p g_m$  will check to  $\pm 2\%$  when the quantities are all measured by the bridge, and when  $r_p$  is between 1000 and 1,000,000 ohms.

**Tube Mounting:** Adaptors are provided as follows: 4-pin, 5-pin, 6-pin, small 7-pin, large 7-pin, octal, locking-in, miniature button 7-pin, miniature button 9-pin (noval), acorn (5- and 7-pin), flat-press sub-miniature up to 7 wires, and 8-wire sub-minar. For short-lead sub-miniature tubes, sockets are supplied which can be mounted on one of the adaptors. Thus all standard commercial receiving tubes can be measured. In addition, a Universal adaptor, with nine soldering lugs, is provided so that unmounted tubes, or tubes with non-standard bases, can be measured conveniently. The panel jack plate and the adaptors are made of low-loss material, usually yellow phenolic, reducing to a minimum the shunting effect of dielectric

losses on the dynamic resistance being measured.

**Current and Voltage Ratings:** The tube circuits have large enough current-carrying capacity and sufficient insulation so that low-power transmitting tubes may be tested in addition to receiving tubes. Maximum allowable plate current is 150 ma and maximum plate voltage is 1500 volts.

**Electrode Voltage Supply:** Batteries or suitable power supplies are necessary for providing the various voltages required by the tube under test.

**Bridge Source:** A source of 1000 cycles is required. The TYPE 1214-A Oscillator, TYPE 813-A Audio Oscillator or the TYPE 723-A Vacuum-Tube Fork is suitable for this purpose.

**Null Indicator:** The TYPE 1231-B Amplifier and Null Detector with TYPE 1231-P2 Filter and a pair of sensitive head telephones are recommended.

**Accessories Supplied:** Adaptors as listed above, all necessary plug-in leads, and shielded patch cords for connecting generator and detector.

**Mounting:** The instrument is mounted in a walnut cabinet. A wooden storage case is provided for the adaptors and leads. Storage space is provided for a spare Universal adaptor, on which any type of socket can be permanently mounted.

**Dimensions:** (Length)  $18\frac{3}{8}$  x (width)  $15\frac{3}{4}$  x (height) 12 inches.

**Net Weight:** 60 pounds.

Type	Code Word	Price
561-D	Vacuum-Tube Bridge.....	BEIGE \$650.00

**Table III**

Socket and Adaptor Accessories currently supplied in the accessory case of the TYPE 561-D Vacuum-Tube Bridge. Adaptors can be purchased separately at the following prices:

	Price
Type 561-413- 2 Adaptor for 4-prong tubes.....	\$ 7.00
Type 561-413- 3 Adaptor for 5-prong tubes.....	7.00
Type 561-413- 4 Adaptor for 6-prong tubes.....	7.00
Type 561-413- 5 Adaptor for small 7-prong tubes.....	7.00
Type 561-413- 6 Adaptor for large 7-prong tubes.....	7.00
Type 561-413- 7 Adaptor for octal tubes.....	7.00
Type 561-413- 8 Adaptor for loctal tubes.....	7.00
Type 561-413- 9 Universal Adaptor.....	7.00
Type 561-413-10 Adaptor for 7-pin miniature tubes.....	7.00
Type 561-413-11 Adaptor for acorn type tubes.....	16.00
Type 561-413-12 Adaptor for 9-pin miniature (noval) tubes.....	9.00
Type SOA-3 Socket Adaptor for 8-lead button-base sub-miniature (sub-minar) tubes.....	3.00
Type 561-415-2 Socket Adaptor for flat-press sub-miniature tubes with up to seven leads in one plane.....	15.00
Type SOT-46 5-pin flat-press sub-miniature socket	} package 1.50
Type SOT-49 6-pin flat-press sub-miniature socket	
Type SOT-50 7-pin flat-press sub-miniature socket	
Type SOT-48 8-pin button-base sub-miniature (sub-minar) socket	
Type 561-140 Adaptor Case.....	25.00

## DELIVERY SCHEDULES

The heavy demands for the rearmament program of the United States and our allies have given us at General Radio a real job to do. As most of our readers know, it takes time to produce precision equipment. The process of manufacturing it is not the kind that can be speeded up quickly to meet increased demand — rather, the production growth is a slow and careful process if quality, accuracy, and satisfactory long-life performance are not to be impaired.

The problem is further complicated by the extensive line of equipment that we manufacture. General Radio makes over 400 different products, ranging in complexity from banana plugs to frequency standards and, in price, from a few cents to several thousand dollars. With few exceptions (Variacs, for one example), instruments are produced not on a continuous production line, but in lots which are carefully scheduled so as to have, in normal times, all four-hundred-plus products always available from stock. A production cycle for a typical instrument, including the time required for delivery to us of outside purchased components, is now from six to ten months.

When new orders outrun manufacture, production lots are sometimes entirely sold before they can be completed. At all times we try to forecast, product by product, based upon experience, what

the probable demand will be, so that no item will ever be oversold, or at least for only a short time. That is, production is scheduled “on spec” in anticipation of orders. Some factors influencing demand are, however, unpredictable. Procurement of a single instrument, in considerable quantity, by one of the military services, if immediate delivery is desired, is one example. Another is the specification of an instrument for making required tests on military equipment made in large quantities by other manufacturers. When this happens, there is little we can do but wait for the next production lot, since all production time is scheduled for many months ahead. Everything possible is done, however, to expedite the next lot.

Add to these the technical difficulties that can arise during manufacture, especially on new products, and the failure of outside purchased material to arrive on schedule or, when it does arrive, to meet specifications, and the result is that our delivery schedules suffer.

Sometimes our delivery promises are not as good as we would like to see them, but we think you, our customers, would rather wait a little longer than in normal times and be sure of getting the quality of product you are accustomed to expect from General Radio.

---

## QUIET SHIP

The United States Lines' new record-breaking ocean liner, *SS United States*, is said to be remarkably quiet. To prove this, a General Radio pocket-size Sound-Survey Meter went along on the trial

runs, to compare sound levels in the various spaces of the ship. Trial runs are short and time is limited, but Gibbs and Cox, Inc., the naval architects who designed the ship, found that with the



The *SS United States*, new holder of the Atlantic blue ribbon, has attained speeds of 35.59 knots on her east-bound voyage, 34.51 knots on her westbound voyage, and an average speed of over 35 knots in her initial voyages.

Sound-Survey Meter the necessary sound-level measurements could be made as rapidly as one could walk

through the ship, and the results confirmed their impression that the ship was unusually quiet.

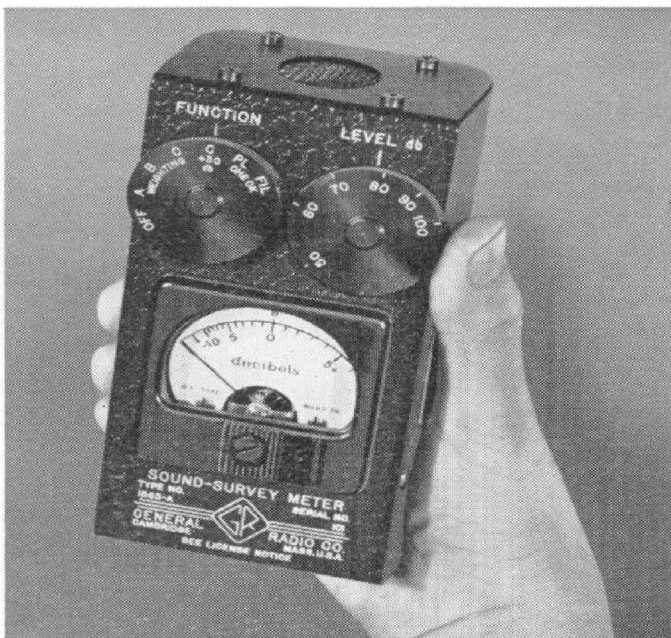

Pictured at the left is the TYPE 1555-A Sound-Survey Meter which proved so convenient for the measurements made on the *SS United States* mentioned above. Since its announcement in the April *Experimenter* this meter has been enthusiastically received. Interesting applications are being found for it and of course many of them are in the field of sound reproduction and reinforcement. One of these is well illustrated on the next page.

The Sound-Survey Meter delivers a lot of information on noise levels for such a small instrument and is well-adapted to measurements of this type (ideal for such purposes, users say).

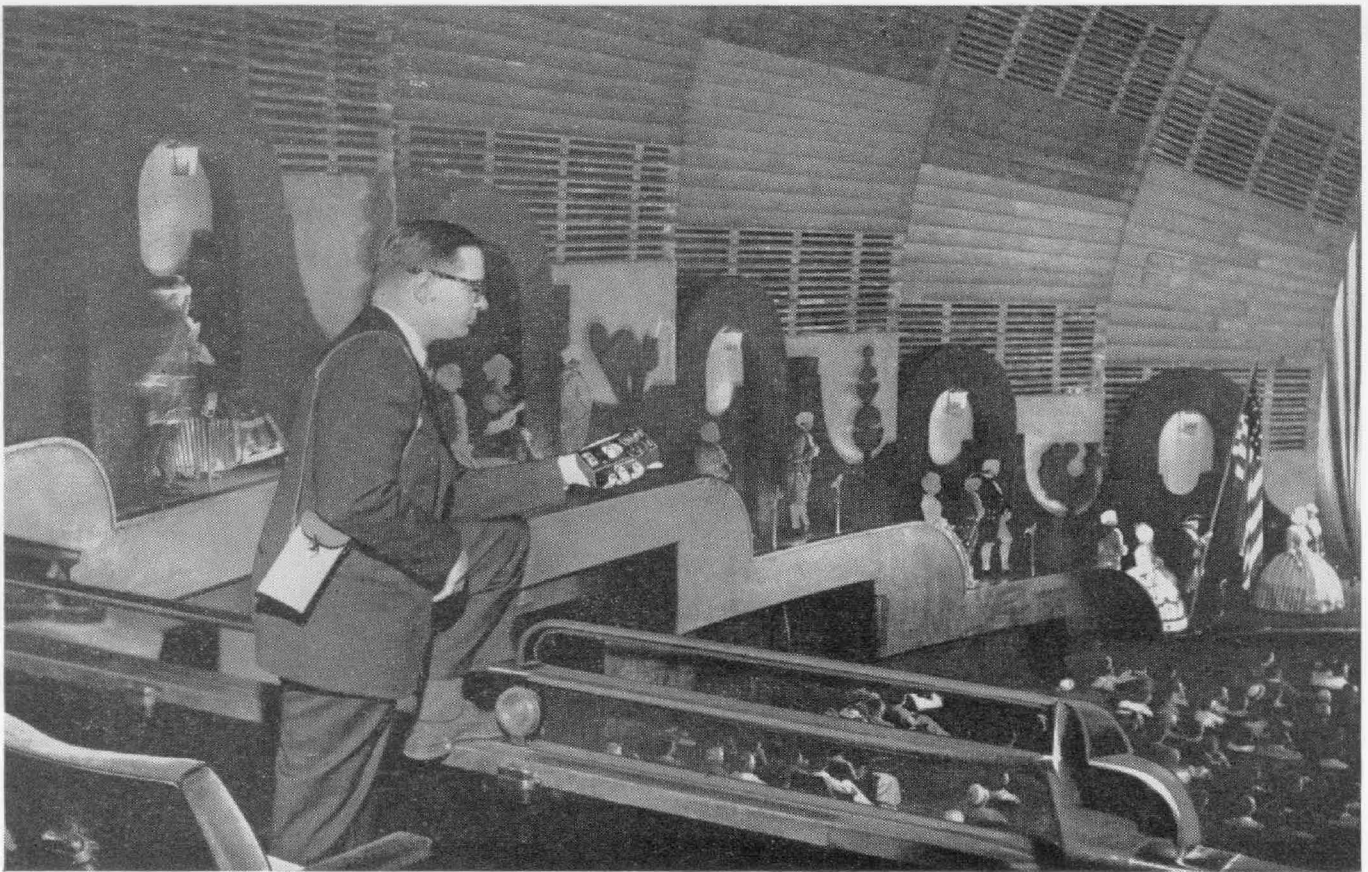

Mr. Warren Jenkins, Sound Engineer at Radio City Music Hall, checks performance of sound reinforcement system at this theater with the General Radio TYPE 1555-A Sound-Survey Meter.

---

***T***HE General Radio *EXPERIMENTER* is mailed without charge each month to engineers, scientists, technicians, and others interested in communication-frequency measurement and control problems. When sending requests for subscriptions and address-change notices, please supply the following information: name, company address, type of business company is engaged in, and title or position of individual.

---

## GENERAL RADIO COMPANY

275 MASSACHUSETTS AVENUE

CAMBRIDGE 39

MASSACHUSETTS

TELEPHONE: TRowbridge 6-4400

## BRANCH ENGINEERING OFFICES

NEW YORK 6, NEW YORK  
90 WEST STREET  
TEL.—Worth 2-5837

LOS ANGELES 38, CALIFORNIA  
1000 NORTH SEWARD STREET  
TEL.—Hollywood 9-6201

CHICAGO 5, ILLINOIS  
920 SOUTH MICHIGAN AVENUE  
TEL.—WAbash 2-3820