

THE

# General Radio EXPERIMENTER

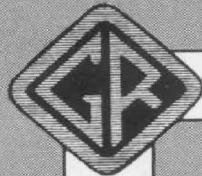

VOLUME XVI No. 3

AUGUST, 1941

ELECTRICAL MEASUREMENTS AND THEIR INDUSTRIAL APPLICATIONS

## Also

### IN THIS ISSUE

Page

IMPEDANCE BRIDGES  
ASSEMBLED FROM  
LABORATORY PARTS  
— PART II..... 2

THE TYPE 757-A  
ULTRA - HIGH -  
FREQUENCY OSCIL-  
LATOR..... 4

● THE GREATLY INCREASED DEMAND for equipment for the defense program made it necessary to call to the attention of our customers through these columns the fact that there would be delays in the supplying of some equipment. Fortunately, due to fairly large stocks that had been built up in anticipation of these requirements, and also due to good stocks of basic materials, these delays have been kept to a minimum.

A new situation has now arisen, and it has become quite acute. Many of the materials going into the manufacture of our products are on the mandatory priority list. This means that in order to obtain such materials we must furnish a preference rating to our suppliers. This is obviously a matter over which we do not have control. It means essentially that we are in a position to fill orders only when the items are in some manner associated with the defense program. Therefore, **BE SURE TO SHOW DEFENSE CONTRACT NUMBER AND PREFERENCE RATING ON ALL PURCHASE ORDERS AND INQUIRIES.**

The Defense Supplies Rating Plan of the Office of Production Management allows us to purchase certain scarce materials under an A-10 priority rating when the material is to be used in the manufacture of General Radio equipment entering into the National Defense Program.

Under this plan, documentary evidence is required to show that the products are almost entirely used for defense. Consequently, we are asking our customers to supply us with affidavits stating the percentage of purchases made by them for defense uses month by month. You may already have received the first of these affidavit forms. They are very simple in form, and we hope that you will return them promptly, as it is only by this means that we can continue to maintain a smooth flow of production to meet your requirements.

# IMPEDANCE BRIDGES

## ASSEMBLED FROM LABORATORY PARTS

### PART II THE SCHERING CIRCUIT

● IN LAST MONTH'S EXPERIMENTER a bench layout of a series-resistance type of capacitance bridge using standard laboratory components was described. An alternative method of balancing the dissipation factor of the unknown arm is the Schering method, which utilizes a capacitance across the opposite ratio arm. This arrangement was first used by Thomas and, following the later work of Schering, came into wide use for the measurement of dielectric constant and power factor of insulating materials and dielectrics.

The advantage of this circuit over the series-resistance and parallel resistance types lies largely in the fact that an initial dissipation factor balance can be easily established, so that the dissipation factor of the unknown can be read as an *increment* of a calibrated condenser. A variable air condenser is commonly used in the *N* arm, one ratio arm being fixed and the other variable in

decade steps. The maximum error that will occur if the initial balances are properly established, and if the condenser  $C_A$  is correctly calibrated in capacitance differences, will be due to the variation in dissipation factor of the standard capacitance as its setting is varied. This variation, for the TYPE 722 Precision Condenser, is less than 0.0004.

In the design of commercial, shielded, self-contained Schering bridges it is customary to place the terminal capacitances of the shielded transformer across the ratio arms, where they are relatively innocuous, becoming a part of the initial dissipation factor balance. In a bench layout, however, this is generally not possible. Figure 1 shows an arrangement wherein the terminal capacitances are placed across the capacitance arms, in the same manner as in the series-resistance bridge.

A TYPE 722-D Precision Condenser (direct reading in capacitance from 100 to 1100  $\mu\mu\text{f}$ , and from 25 to 110  $\mu\mu\text{f}$ ) is ideal for use as the capacitance standard. Any shielded air condenser, such as the TYPE 539-A, may be used for dissipation factor balance. An accurate capacitance calibration of this condenser can be obtained by a direct substitution method, with the TYPE 539 Condenser placed across the standard condenser, and with an appropriate condenser in the *P* arm for balance. Any variable air condenser of suitable size can be used for the dissipation factor balance while  $C_A$  is being calibrated.

As shown, the larger terminal capacitance is placed across the unknown arm while the smaller (5-10  $\mu\mu\text{f}$ ) is placed

FIGURE 1. Connections for a bench layout of a Schering bridge.

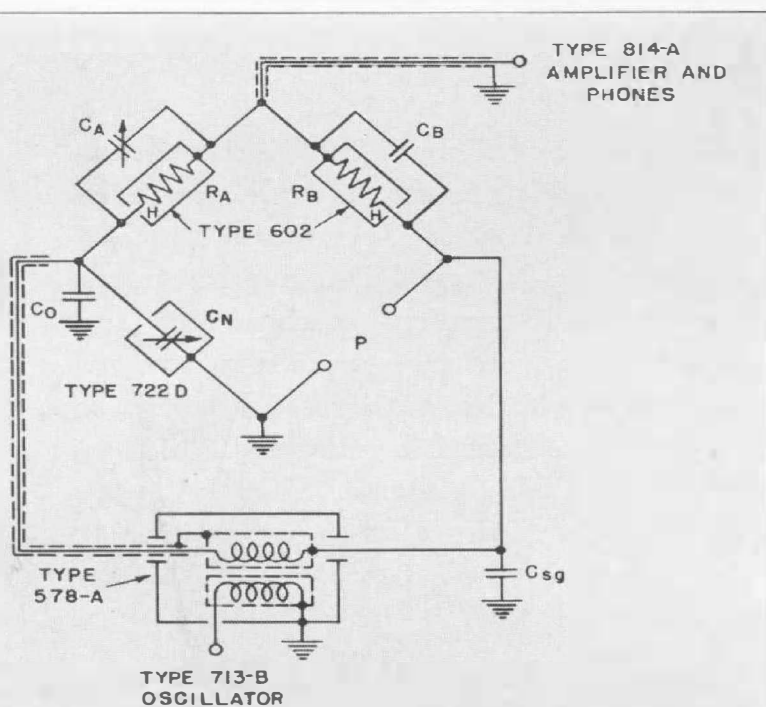

across the standard arm. Both of these terminal capacitances can be measured with good accuracy, as follows:

To measure  $C_o$ , the capacitance across the standard arm ( $C_N$ ), balance the bridge with the ratio arms set equal and with a balancing condenser of from 100–1000  $\mu\mu\text{f}$  in the  $P$  arm. Change the setting of the  $A$  arm and obtain a second balance. Denoting the readings of the standard condenser by  $C_{N1}$  and  $C_{N2}$ , respectively, the value of  $C_o$  is given by

$$C_o = \frac{C_{N1} - \frac{R_A}{R_B} C_{N2}}{\frac{R_A}{R_B} - 1} \dots\dots (1)$$

The initial capacitance ( $C_{SG}$ ) across the unknown arm is obtained by a direct measurement, it merely being necessary to add to  $C_N$  the value of  $C_o$  just obtained. That is

$$C_{SG} = \frac{R_A}{R_B} (C_N + C_o) \dots\dots (2)$$

After these quantities have been determined, a known constant capacitance can be added to the standard arm reading at all times. Similarly, the zero capacitance (approximately 100  $\mu\mu\text{f}$ ) must be subtracted from the measured value of the unknown.

The dissipation factor of the zero capacitance across the  $P$  arm can be determined as follows: Establish an initial balance ( $C_{SG}$ ,  $D_{SG}$ ) with the  $P$  arm open, setting  $C_A$  at some large value (an additional condenser across the  $B$  arm will be necessary). Place a 1000  $\mu\mu\text{f}$  condenser in the  $P$  arm, and rebalance the bridge by means of  $C_N$  and  $C_A$ . The dissipation factor of the zero capacitance will then be given by

$$D_{SG} = \frac{\Delta Q_A - \frac{D_1 C_1}{C_2}}{1 - \frac{C_{SG}}{C_2}} \dots\dots (3)$$

In this equation,  $C_{SG}$  is the zero capacitance,  $C_2$  is the total  $P$  arm capacitance, and  $D_1$  is the dissipation factor of the condenser  $C_1$  placed across the  $P$  arm. If a good condenser is used for  $C_1$ , the ratio  $D_1 C_1 / C_2$  will be very small and can be neglected.

To establish the initial balance for any setting of the ratio arms it is merely necessary to connect a capacitance of known dissipation factor (best obtained by a known resistance in series with a known capacitance) in the  $P$  arm, to set  $C_A$  to the proper value, and to balance by means of  $C_N$  and an additional condenser in parallel with  $B$ . After a reference point on  $C_A$  has been thus determined, it will be possible to compute  $D_P$  directly from any setting of  $C_A$ , or, at any given frequency,  $C_A$  can be calibrated directly in dissipation factor. The accuracy of measurement will be limited by (1) the accuracy of calibration of  $C_A$ , by (2) the accuracy with which the reference dissipation factor was known, and by (3) the variation in the dissipation factor of the TYPE 722 as its setting is varied. A direct-reading accuracy better than 0.001 (at 1000 cycles) can be attained if care is taken.

### SUBSTITUTION METHOD

For the measurement of capacitance below 1000  $\mu\mu\text{f}$ , excellent accuracy for dissipation factor as well as capacitance can be attained by the use of a substitution method in the standard arm. Although the procedure for this type of measurement is fairly obvious, it is outlined here because of its importance.

An initial balance is made with a capacitance of about 1000  $\mu\mu\text{f}$  in the  $P$  arm, with the unknown in place and connected to the standard on the grounded side. The high-potential connection

should be made with a bare self-supporting lead. For the initial balance this lead should be left  $\frac{1}{4}$ " or  $\frac{1}{2}$ " from the high terminal of the unknown. The condenser  $C_A$  must be set at some fairly large value, since its setting must be reduced when the unknown is connected. When the initial balance is made and the settings of  $C_A$  and  $C_N$  noted, the unknown is connected and the bridge re-balanced. Denoting the new settings by  $C_N'$  and  $C_A'$ , and the increments by  $\Delta C_N$  and  $\Delta C_A$  we have (provided  $D_X$  is less than about 10%)\*

$$C_X = C_N - C_N' = \Delta C_N \dots (4)$$

$$D_X = R_A \omega \Delta C_A \left( \frac{C_N}{C_X} \right)^{\frac{1}{2}} \dots (5)$$

Next month's installment of Mr. Easton's article will include numerical examples illustrating the order of magnitude of the stray impedances, and their calculation, as well as typical measurements with both the series resistance and the Schering bridges.

The capacitance so determined will be accurate within  $\pm 2 \mu\mu\text{f}$ , a possible maximum error of  $\pm 1 \mu\mu\text{f}$  for each capacitance setting. The possible error in  $D$  will range from 0.00005 for a 1000  $\mu\mu\text{f}$  condenser to 0.0005 for a 100  $\mu\mu\text{f}$  condenser.

If the LOW section (25-110  $\mu\mu\text{f}$ ) of the TYPE 722-D is used, capacitances up to 85  $\mu\mu\text{f}$  can be measured to  $\pm 0.4 \mu\mu\text{f}$ , and the errors in  $D$  become 0.00005 for an 85  $\mu\mu\text{f}$  condenser, 0.0005 for 10  $\mu\mu\text{f}$ .

— IVAN G. EASTON

\*The complete expressions are:

$$C_X = \Delta C_N \frac{1 + \Delta^2 D \left( \frac{C_N}{\Delta C_N} \right)^2}{1 - \Delta^2 D \left( \frac{C_N}{\Delta C_N} \right)}$$

$$D_X = A \omega \Delta C_A \left( \frac{C_N}{C_X} \right)^{\frac{1}{2}} \frac{1}{1 - \Delta^2 D \left( \frac{C_N}{\Delta C_N} \right)}$$

— EDITOR

## THE TYPE 757 - A ULTRA - HIGH - FREQUENCY OSCILLATOR (150 TO 600 MEGACYCLES)

● **THE RECENT EXTENSIVE APPLICATION** of ultra-high frequencies to communications and allied fields has made desirable the development for those frequencies of commercially available measuring instruments that approach in convenience and reliability the more common instruments operating at lower frequencies. Power sources have logically been first in order for this development, since no physical experiment can be done at a given frequency until energy at that frequency is available. The early work on power sources was naturally directed toward simply obtaining an oscillator that supplied some power at the desired frequency without much regard for its other characteristics. More recently the

technique at ultra-high frequencies has reached the point where power sources of a specialized nature can be developed, and primary emphasis can be placed on some highly desired characteristic, such as large power output, a high degree of frequency stability, or small size. In addition, general-purpose oscillators that satisfactorily effect a compromise among a wide variety of desirable characteristics have resulted from the application of this advanced technique, and descriptions of these oscillators have been given in the literature.<sup>1</sup> In this type of oscil-

<sup>1</sup>L. S. Nergaard, "Electrical Measurements at Wave Lengths Less Than Two Meters," Proc. I.R.E., September, 1936, Vol. 24, No. 9, pp. 1209-1211.

W. L. Barrow, "An Oscillator for Ultra-High Frequencies," Review of Scientific Instruments, June, 1938, Vol. 9, No. 6, pp. 170-174.

Ronold King, "A Variable Oscillator for Ultra-High Frequency Measurement," Review of Scientific Instruments, November, 1939, Vol. 10, No. 11, pp. 325-331.



lator, emphasis is given to the ability to deliver energy over a wide frequency range, a characteristic that is usually difficult to obtain for ultra-high-frequency oscillators unless a series of adjustments is made for each operating frequency.

The General Radio TYPE 757-A Ultra-High-Frequency Oscillator, shown in Figure 1, is an oscillator of this general-purpose type with a convenience for use hitherto unattained in commercial oscillators of its frequency range. The oscillator can be set by means of a single crank control to any frequency between 150 and 600 megacycles (a range of wavelengths in air of 200 cm to 50 cm). In spite of this wide range of frequencies,

the lead-screw drive allows small frequency increments to be easily obtained, a feature that is necessary in using a power source for measurements of phenomena highly dependent on frequency.

The means by which the convenience and the excellent general characteristics are obtained can be seen from Figures 2 and 3. Figure 2 is a cut-away view which illustrates the simplicity of the oscillator and shows certain mechanical details; for instance, the long, horizontal, lead-screw drive; the piston with its spring contacts; and the outer containing cylinder, which serves as the

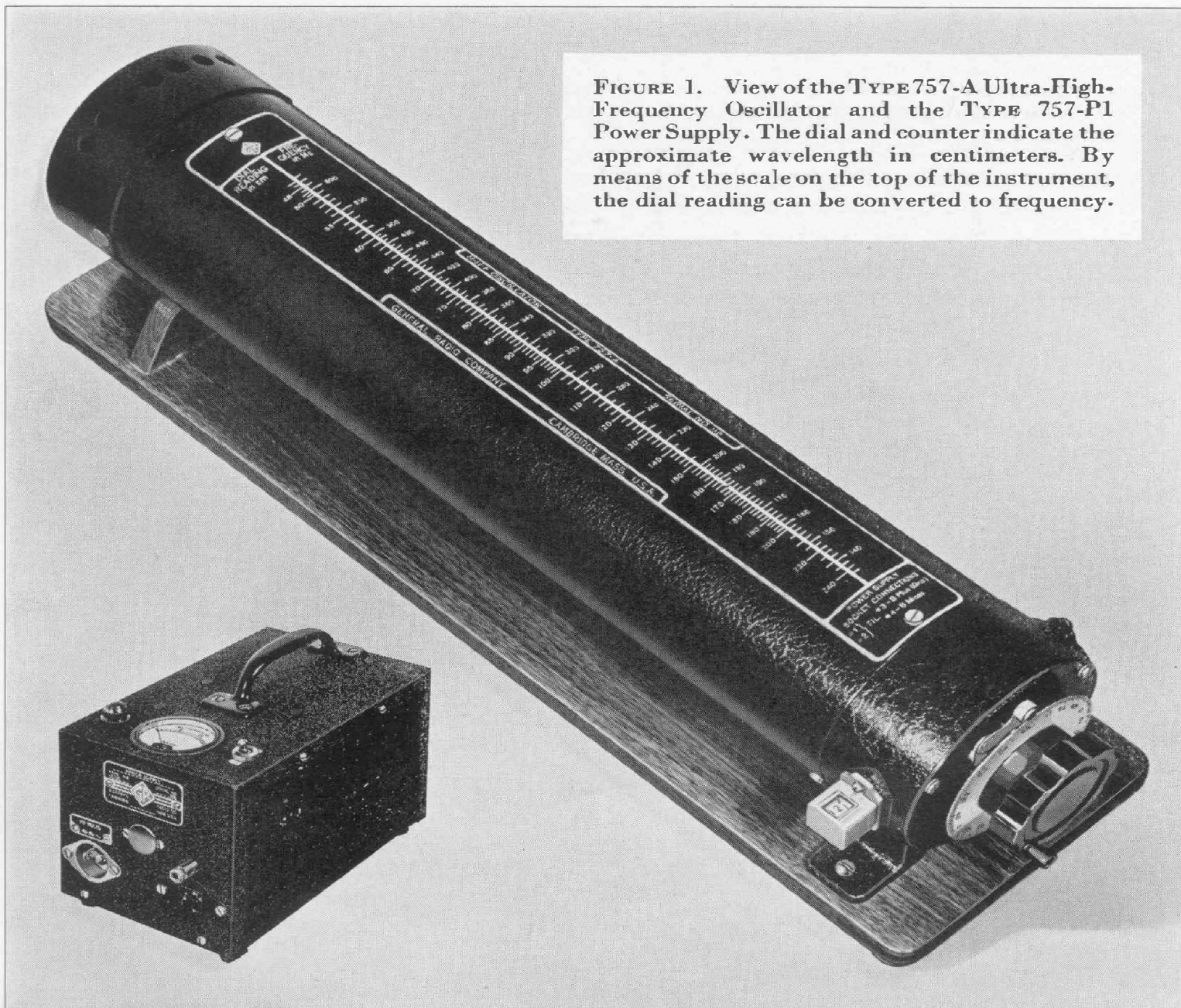

FIGURE 1. View of the TYPE 757-A Ultra-High-Frequency Oscillator and the TYPE 757-P1 Power Supply. The dial and counter indicate the approximate wavelength in centimeters. By means of the scale on the top of the instrument, the dial reading can be converted to frequency.

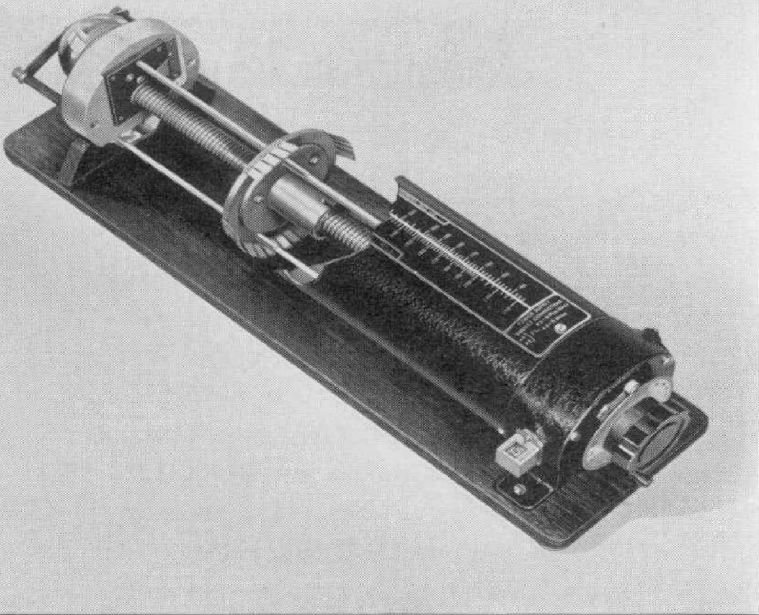

FIGURE 2. Cut-away view of TYPE 757-A Ultra-High-Frequency Oscillator, showing the internal construction.

radio-frequency shield, carries the lengthwise, square key for the keyway of the piston plunger, and forms with the lead screw a coaxial line that is a principal part of the oscillatory circuit.

In order to illustrate the electrical circuit of the oscillator, Figure 3 has been drawn as a simplified schematic diagram. The coaxial line between the oscillator tube and the short-circuiting piston is energized by the tube, a WE-316-A, and variation of the length of this section of the line produces the desired change in wavelength and frequency. This variation is obtained by rotation of the lead screw, which in turn drives the short-circuiting piston along the length of the coaxial line. Backlash in this drive mechanism has been reduced by the use of a double-nut spring take-up in the piston. The pitch of the lead screw and the ratio of the gearing to a counter at the drive end have been adjusted to make the counter indicate the approximate value of the wavelength in air of the generated oscillations. A conversion chart attached to the top of the oscillator makes simple the conversion of this dial reading to frequency.

The output is obtained by coupling inductively to the main oscillatory circuit. At the coaxial outlet jack, which is provided at the tube housing, the source

impedance is about 75 ohms in order to give approximately full output into a properly terminated coaxial line. The coaxial type outlet is in keeping with the shielded oscillator system, and, when coaxial lines are used for coupling the oscillator to the instrument using the high-frequency energy, the combination aids in confining the energy within a shielded system.

When the maximum allowable plate voltage for the tube is used on the oscillator, at frequencies up to 400 Mc (wavelengths down to 75 cm), a power output of about 4 watts can be obtained. The output at higher frequencies decreases gradually with frequency, but considerable power is still available at 600 Mc. This available power is much greater than normally required for measurements, but it permits the use of high voltage levels at the measuring instruments with the concomitant simplification of detection problems.

In order to have the full output of the oscillator available at the outlet terminals, no isolation means have been used. The result is that a reactive load coupled directly to the oscillator shifts the frequency of oscillation,<sup>2</sup> but for the usual conditions of loading the frequency shift is generally less than 2%.

The power supply required for this oscillator is 2 volts at 3.65 amperes for the filament, which may be obtained from the a-c line, and up to 450 volts plate supply with a maximum plate current of 80 milliamperes. The plate supply must be one that permits grounding of the

<sup>2</sup>D. C. Prince, "Vacuum Tubes as Power Oscillators," Chapter V, Proc. I.R.E., August, 1923, Vol. 11, No. 4, pp. 409-418.

"Vacuum Tubes as Oscillation Generators," Part V, General Electric Review, July, 1928, Vol. 31, No. 7, pp. 388-394.

positive side, since the positive side of the high voltage circuit is connected to the outer brass container.

A power supply for the oscillator can be purchased separately. This power supply, the TYPE 757-P1, shown in Figure 1, provides the necessary fixed voltages for the operation of the oscillator. At a slight sacrifice in maximum oscillator output, the plate voltage delivered by the TYPE 757-P1 is arranged to be somewhat less than the maximum

allowable for the oscillator tube in order that the tube will not be damaged even though oscillations should cease. This power supply includes a meter that is connected to indicate the oscillator grid current, a measure of the intensity of oscillation; and, of course, the power cable necessary for connection with the oscillator unit is also supplied.

— ARNOLD PETERSON

### SPECIFICATIONS FOR TYPE 757-A ULTRA-HIGH-FREQUENCY OSCILLATOR

**Frequency Range:** 150 to 600 Mc (200 to 50 cm wavelength).

**Calibration:** The frequency determined from the chart converting dial reading to frequency is accurate to  $\pm 2\frac{1}{2}\%$  with no load connected to the oscillator.

**Output Power:** 3 to 4 watts up to 400 Mc (75 cm) decreasing with frequency to about 1 watt at 600 Mc.

**Output Impedance:** Effectively of the order of 75  $\Omega$ .

**Frequency and Wavelength Control:** A slow-motion drive, which carries a dial calibrated in divisions representing approximately 0.01 cm change in wavelength, is used for changing the wavelength and frequency. A counter to the left of this dial, together with

the reading of this dial, constitutes the dial reading used for the chart to convert dial reading into frequency.

**Tube:** A WE-316-A is required and is furnished with the instrument.

**Power Supply:** Filament: 3.65 amperes at 2 volts. Plate: 450 volts (max.), 80 ma. (max.). The TYPE 757-P1 Power Supply (see below) may be used in place of batteries.

**Accessories Supplied:** One power cable and one TYPE 774-E Cable Plug.

**Mounting:** The oscillator is mounted on a walnut base.

**Dimensions:** (Length) 21 × (width) 6 × (height) 6 inches, over-all.

**Net Weight:** 13 $\frac{1}{4}$  pounds.

Type	Code Word	Price
757-A	SIREN	\$195.00

**PATENT NOTICE.** This instrument is manufactured and sold under patents of the American Telephone and Telegraph Company solely for utilization in research, investigation, measurement, testing, instruction, and development work in pure and applied science.

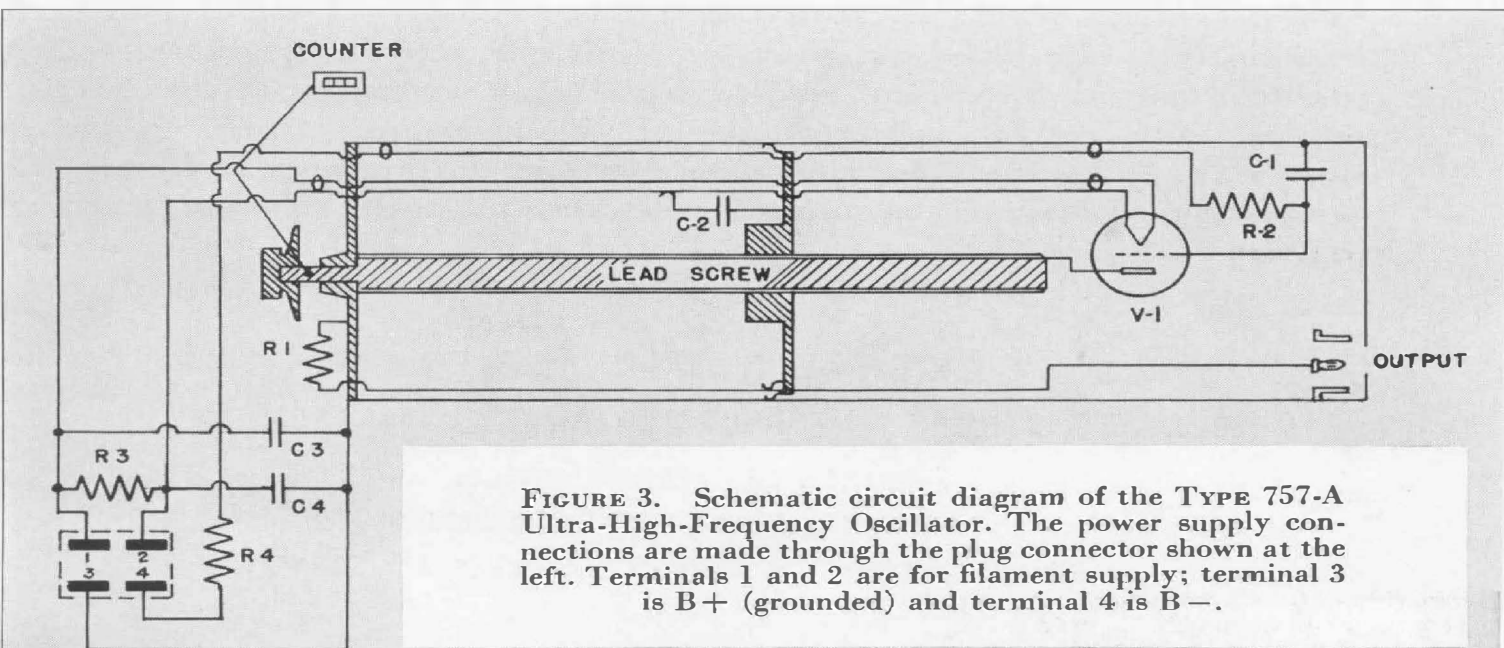

FIGURE 3. Schematic circuit diagram of the TYPE 757-A Ultra-High-Frequency Oscillator. The power supply connections are made through the plug connector shown at the left. Terminals 1 and 2 are for filament supply; terminal 3 is B+ (grounded) and terminal 4 is B-.



**SPECIFICATIONS FOR  
TYPE 757-P1 POWER SUPPLY**

**Power Input:** 105 to 125 volts or 210 to 250 volts, 40 to 60 cycles. At 115 volts, 60 cycles, the power drawn is less than 70 watts.

**Output:** 2 volts a-c, and 300 volts d-c, for the TYPE 757-A U-H-F Oscillator.

**Tube:** 1 TYPE 5Y3-G is supplied.

**Accessories Supplied:** A seven-foot line connector cord, an interconnecting cord and plug, and spare pilot lamps.

**Dimensions:** (Width) 5¾ inches × (height) 6¾ inches × (length) 9¾ inches.

**Net Weight:** 11¼ pounds.

Type		Code Word	Price
757-P1	Power Supply	SIRENAPACK	\$45.00

**NEW PRICES FOR TYPE 274 PLUGS AND JACKS**

● **RIISING COSTS** for screw-machine parts have made necessary a revision of

the prices of TYPE 274 Plugs and Jacks. New prices are as follows:

Type	Unit Price	Package of 10	Package of 100
274-P Plug	\$0.12	\$0.90	\$6.25
274-J Jack	.10	.55	3.50
274-M Double Plug*	.50	3.50	—

\*The TYPE 274-M Double Plug is a new model molded from polystyrene to give low capacitance and low losses.

**ERRATUM—TYPE 761-A VIBRATION METER**

● **IT HAS BEEN CALLED TO OUR ATTENTION** that the caption for Figure 3 of the article describing TYPE 761-A Vibration Meter, appearing in the June *Experimenter*, is incorrect.

Since the response is flat for acceleration, the top oscillogram is acceleration, the middle one velocity, and the lowest, displacement.

**THE General Radio EXPERIMENTER** is mailed without charge each month to engineers, scientists, technicians, and others interested in communication-frequency measurement and control problems. When sending requests for subscriptions and address-change notices, please supply the following information: name, company name, company address, type of business company is engaged in, and title or position of individual.

**GENERAL RADIO COMPANY**

30 STATE STREET - CAMBRIDGE A, MASSACHUSETTS

BRANCH ENGINEERING OFFICES

90 WEST STREET, NEW YORK CITY

1000 NORTH SEWARD STREET, LOS ANGELES, CALIFORNIA