

ELECTRICAL MEASUREMENTS AND THEIR INDUSTRIAL APPLICATIONS

Also

IN THIS ISSUE

Page

INDUCTANCE MEASUREMENTS ON LOOP ANTENNAS 5

MODERNIZATION OF TYPES 605-A AND 605-B STANDARD-SIGNAL GENERATORS 7

A SIGNAL GENERATOR FOR THE ULTRA-HIGH FREQUENCIES

● **RESEARCH** in radio transmission and reception at the ultra-high frequencies continues to foster an increased use of these frequencies for practical radio communication. In addition to their usefulness for television and frequency modulated transmissions, the ultra-high frequencies have an

increasing importance for civil and military aircraft communication and for commercial radio service.

Receiver measurements in the high- and ultra-high frequency ranges have been handicapped by lack of testing equipment, particularly signal generators. The TYPE 804-A U-H-F Signal Generator, shown in Figure 1, is designed for use at these frequencies.

FIGURE 1. Panel view of the TYPE 804-A U-H-F Signal Generator.

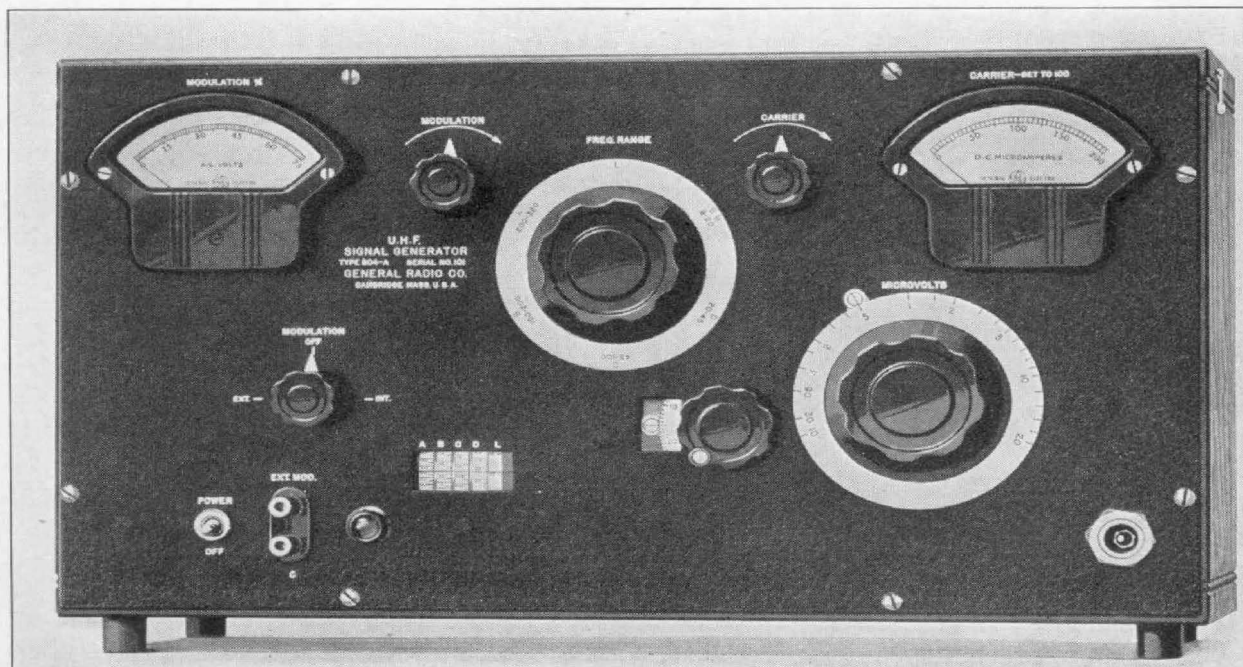

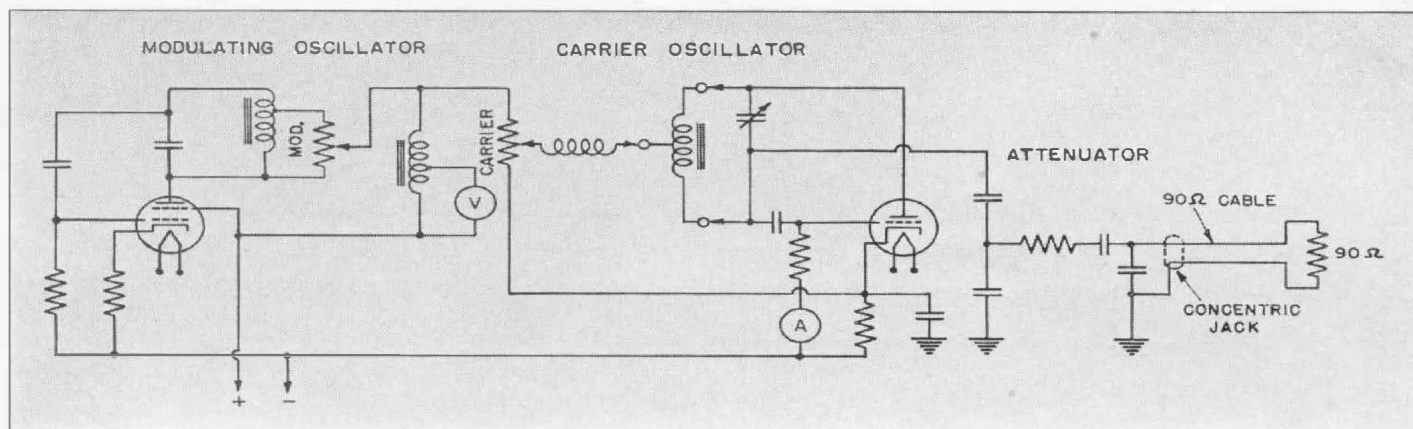

FIGURE 2. Schematic circuit diagram of the signal generator. The a-c power supply is not shown.

GENERAL PERFORMANCE

An important feature of this instrument is its capability of being set accurately to any frequency between 7.5 and 330 megacycles. This wide frequency range is covered by a worm-drive condenser and coil switching system, described below. The output voltage range is from 10 microvolts to 20 millivolts. Internal 400-cycle modulation is provided. An external source of modulating voltage can also be used.

Detailed specifications are given on page 5.

CIRCUIT

Both the carrier and modulating oscillators use a conventional Hartley circuit. Carrier level is indicated by a grid current meter, so arranged as to give an indication of oscillator amplitude. The carrier is modulated directly in the oscillator plate circuit, and modulation percentage is indicated by a rectifier-type voltmeter connected across

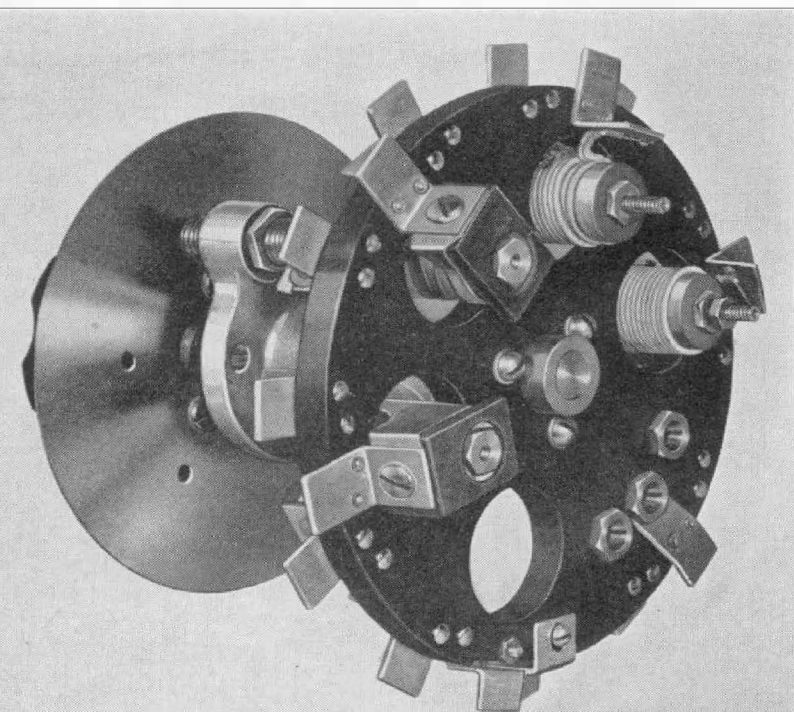
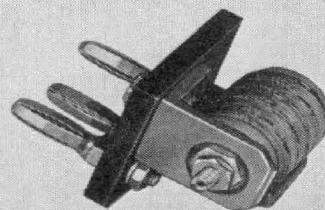

FIGURE 3. Detailed view of the coil assembly. The mounting disc is of mycalex, the coil forms of polystyrene. A blank plug-in coil form (shown at the right) is provided, on which the user may wind a coil for operation at lower frequencies or for any particular band of frequencies. This coil corresponds to the L position on the range switch.



a portion of the modulating choke. Because the plate voltage of the carrier oscillator is held constant by a voltage regulating system, this meter is direct reading in modulation percentage, with a range of 0 to 60%. Both meters are the new fan-shaped models with open, easily read scales.

STABILITY

Through the use of a large tuning capacitance and a voltage-regulated power supply, good frequency stability has been achieved in the carrier oscillator. Since modulation is accomplished in the plate circuit of the oscillator, however, an appreciable degree of frequency modulation occurs when the oscillator is modulated. Allowance should be made for this in testing receivers designed to pass the relatively narrow audio-frequency band.

TUNED CIRCUIT

The tuned circuit is an outstanding feature of this generator. The entire oscillating circuit is compact and has unusually short leads. The condenser is a TYPE 755-A*, designed especially for ultra-high frequency work.

The main condenser dial has 1500 easily read divisions for a frequency spread of about 2.5:1, so that a setting can be made with a precision of considerably better than 0.1%. A frequency calibration is provided directly on the main drum dial. The absolute accuracy of this calibration is $\pm 2\%$.

The coil assembly is shown in Figure 3. Coils are mounted on a mycalex disc which is rotated from the panel. As each coil is moved into position, its silver contacts are engaged by brushes mounted on the condenser frame. These and the 955-type oscillator tube are shown in Figure 4. In the rear view of

the instrument, Figure 5, the entire assembly can be seen.

A blank plug-in coil form is furnished for the L position of the range switch. This can be wound by the user to operate at any desired frequency in or below the calibrated range of the instrument, or to cover a specific frequency band such as the intermediate frequencies used in television or frequency-modulated reception.

OUTPUT SYSTEM

The output of the TYPE 804-A U-II-F Signal Generator is continuously variable between 10 microvolts and 20 millivolts. The output is determined by the reading of the output meter and the setting of the attenuator dial.

The capacitive attenuator is shown in Figure 6. To obtain smooth operation, and to facilitate precise settings, the moving element is driven through a reduction gear train. The alignment screws shown in the photograph are so adjusted

FIGURE 4. Close-up view of the tuning condenser, showing the vacuum tube and the brushes which engage the contacts on the coil mounting. A direct-reading frequency calibration is provided on the drum dial. These scales are shown blank in the photograph.

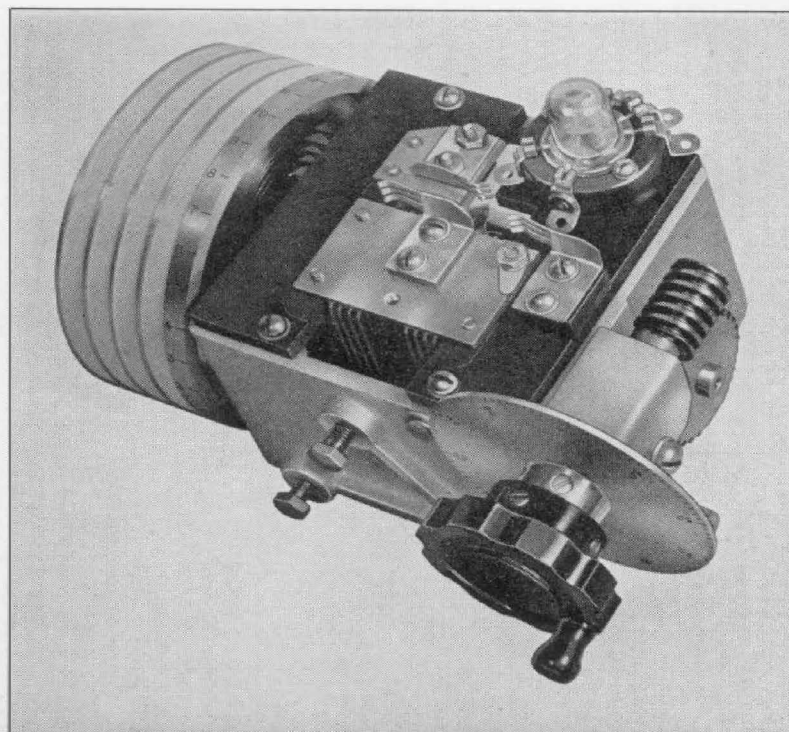

*"A New Condenser for High-Frequency Circuits," *Experimenter*, Vol. XIV, No. 3, August, 1939.

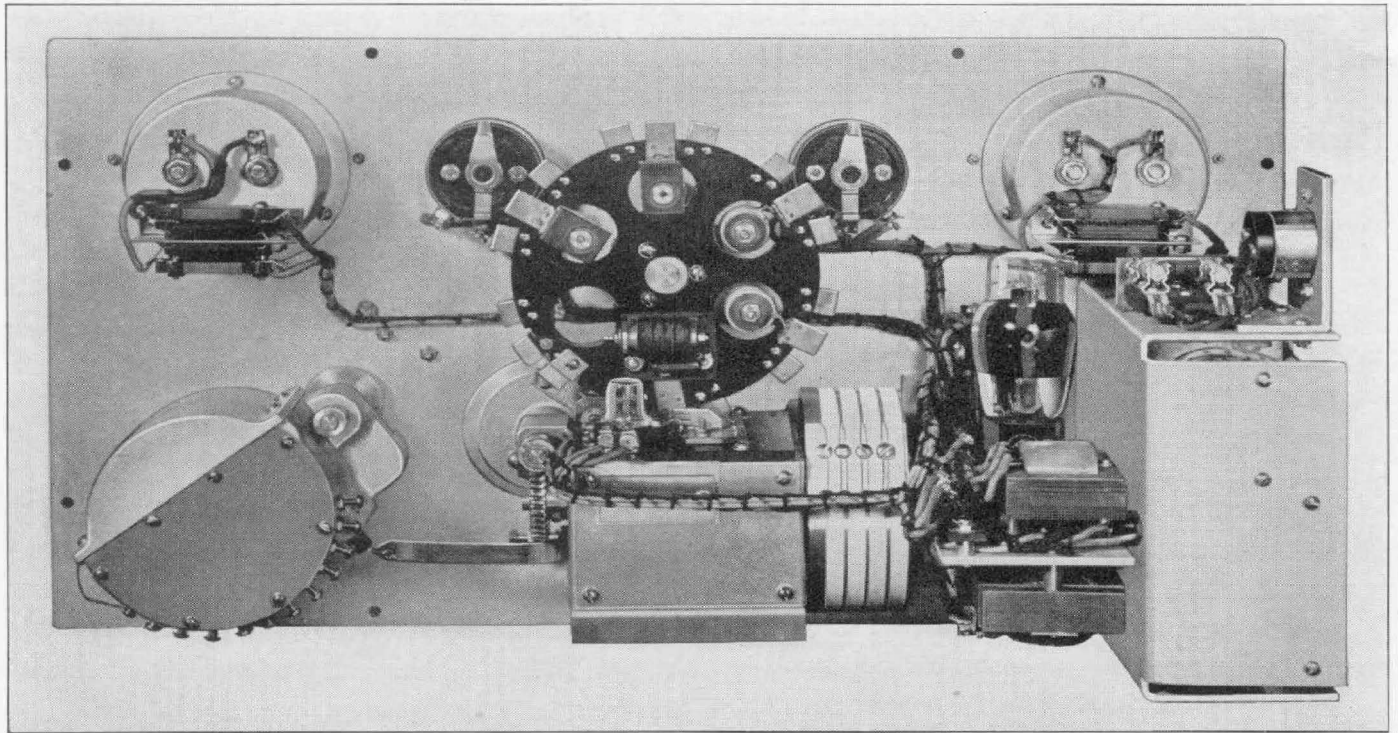

FIGURE 5. Rear view of the signal generator. The coils and condenser are shown in the center, the attenuator at the lower left, the power supply at the extreme right.

that the attenuator presents a constant capacitance to the oscillator circuit, thus eliminating changes in carrier frequency with attenuator setting.

Output voltages are obtained at the output jack at the lower right-hand

corner of the front panel. The voltage is developed across a 100- μmf condenser built into the attenuator housing. The output impedance, therefore, varies between 5 ohms at 320 Mc and 200 ohms at 8 Mc.

A 90-ohm concentric shielded cable with a 90-ohm terminating resistance is furnished. At high frequencies, the voltage at the end of the cable is substantially the same as that at the panel jack. A correction is supplied for use at low frequencies.

FIGURE 6. View of the attenuator with cover removed.

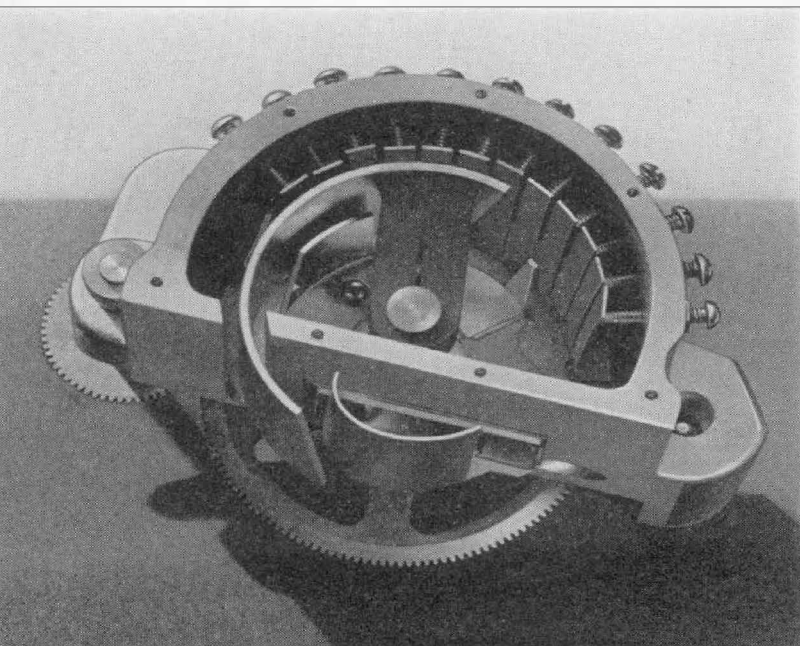

POWER SUPPLY

The power supply operates from the a-c line, 105 to 125 volts, 40 to 60 cycles, regulated to eliminate voltage fluctuations. As with most other General Radio instruments, a 210- to 250-volt winding is provided on the power transformer.

SPECIFICATIONS

Carrier Frequency Range: 7.5-330 Mc in five ranges — 7.5-22, 22-50, 50-120, 120-240, 240-330 Mc.

Frequency Calibration: Direct reading within 2%.

Output Voltage Range: 10 microvolts to 20 millivolts for frequencies between 7.5-120 Mc. Above 120 Mc, the maximum output is less.

Output System: 100µmf output capacitance. 90-ohm cable with 90-ohm termination furnished.

Modulation: Continuously adjustable 0-60%. Internal: 400 cycles ±5%. External: Flat within 2 db from 200 to 20,000 cycles. Five and one-half volts are required for 50% modulation. The input impedance is 0.5 megohm.

Stray Fields: Stray fields will not be noticeable with receivers of less than 10 microvolts sensitivity.

Power Supply: 105-125 (or 210-250) volts, 40-60 cycles, 24 watts.

Tubes: 955, 6G6G, 6X5G, VR150.

Accessories Supplied: Three-foot output cable, 90-ohm impedance. Six-foot cable for line connection. One blank coil form for additional frequency range.

Mounting: Black crackle aluminum panel, walnut cabinet, hinged cover.

Dimensions: (Length) 19½ x (depth) 9 x (height) 11⅝ inches.

Net Weight: 32 pounds.

Type	Code Word	Price
804-A	DENSE	

INDUCTANCE MEASUREMENTS ON LOOP ANTENNAS

● THE LOOP ANTENNA, a familiar sight in the early days of factory-built receivers, is with us again. Completely encased, no longer the unsightly hat rack of 1924, it is now used in all portable receivers and many of the newer home models.

Today's loop is usually smaller than its progenitor, because today's receivers are more sensitive than yesterday's, but it still must be tuned. The tuning condenser for the modern loop is ganged with the other tuning condensers and, in order to make the tuning track with

FIGURE 1. Panel view of the coil comparator. For production testing, the main dial is locked at the standard setting and deviations are read on the LIMITS dial.

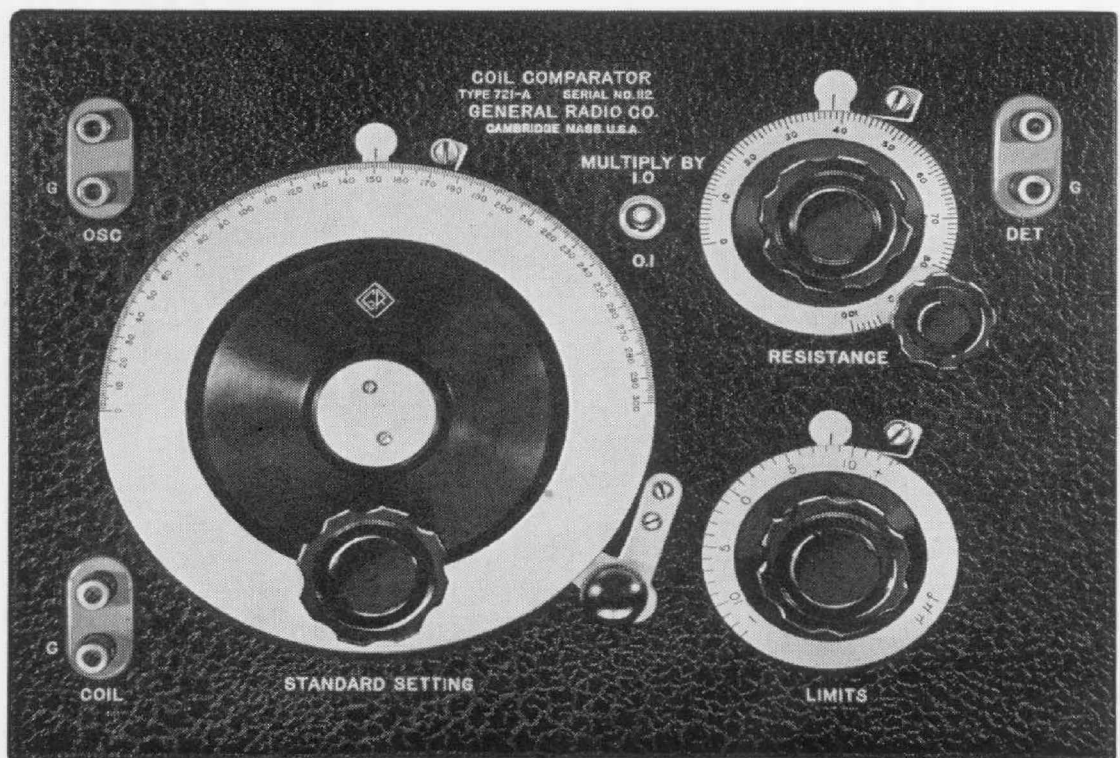

that of the other circuits, the antenna inductance must be known and kept within close limits. Hence, the need for measuring these loops and making sure that their constants are close to those of a standard which has been especially designed for the receiver.

These measurements are important to the loop manufacturer as a production test in order to avoid rejections by the customer, and to the receiver manufacturer as an acceptance test. For both, a rapid and accurate means of test is desirable.

The TYPE 721-A Coil Comparator* meets these requirements of speed and accuracy. Its usefulness for testing r-f antenna, oscillator, and other coils has been proved many times in manufacturing plants where each part must be tested accurately but rapidly at the normal operating frequency. It has also been used for checking tuning and trimmer condensers and low resistances at radio frequencies, and now is finding wide application by parts and set manufacturers for the checking of loop antennas.

The coil comparator combines the simplicity of a resonance method with

*W. N. Tuttle, "A New Instrument and a New Circuit for Coil or Condenser Checking," *General Radio Experimenter*, Vol. XII, Nos. 3 and 4, August-September, 1939.

the precision of setting of a bridge method. Like a bridge, it is capable of being balanced for a perfect null indication, but unlike a bridge, one side of the generator, of the detector, and of the coil under test is connected to a common grounded point. This simplifies considerably the whole arrangement, and the stray capacitance from generator to ground, or from the detector to ground, does not have to be balanced out or otherwise compensated for. Readings are completely independent of both generator and detector impedances. The effective low impedance of the circuit, moreover, makes other effects such as capacitance between input and output and capacitance to the operator's body almost unnoticeable.

The method of using the coil comparator for this new application is the same as for coils and condensers. First a standard loop is set up, and the comparator is adjusted until a null is obtained at the desired frequency. The standard is then removed, and the production units are next set in place in the test jig. There are two methods of noting the allowable deviations from the standard. The first consists in rapidly adjusting the balance for each loop by means of the LIMITS dial, on which the tolerances can be marked directly. The second method is to replace the

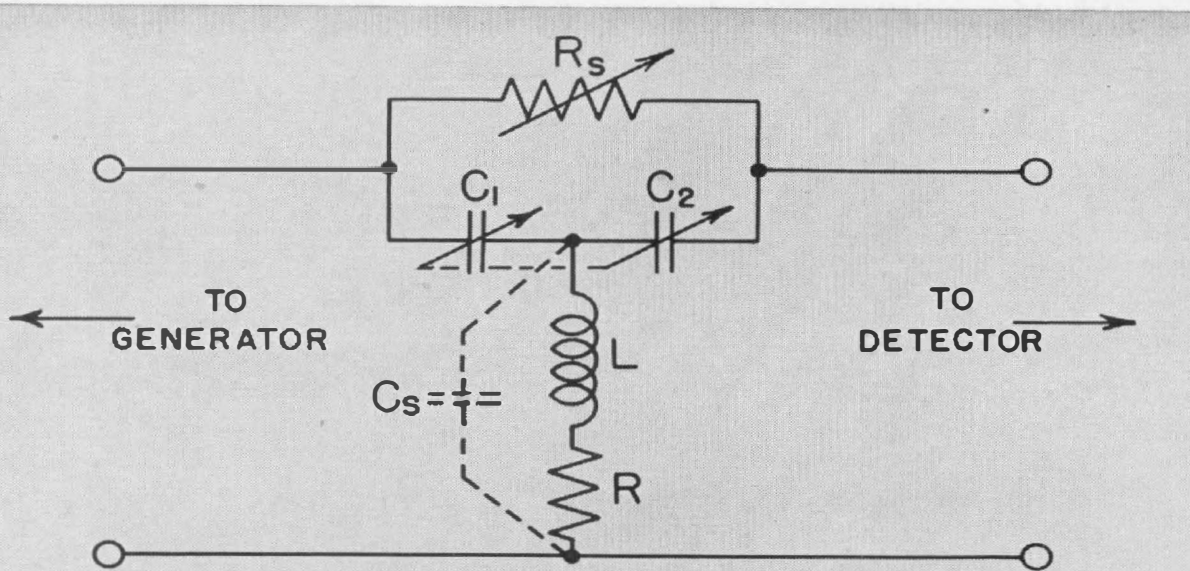

FIGURE 2. Circuit of the TYPE 721-A Coil Comparator. C_1 and C_2 are ganged and operated by a single control. L and R are the inductance and resistance of the coil under test, and C_s is the stray capacitance of the measuring circuit.

speaker or headphones by a voltmeter on whose scale marks may be placed corresponding to limits that can be tolerated. Of course, it will often be desirable to adjust the loop until it is

satisfactory, while it is being checked, rather than have the two operations separate. — MARTIN A. GILMAN

MODERNIZATION OF TYPES 605-A AND 605-B STANDARD-SIGNAL GENERATORS

● PRICES FOR REBUILDING old TYPE 605 Standard-Signal Generators to include later design features were listed in the *Experimenter* for December, 1938. Several months' experience with these reconditioning jobs

has indicated that the prices originally set were too low, chiefly because of the testing and recalibration time and necessary replacement parts not contemplated when the price was originally set. New prices are as follows:

(1) Addition of 1-volt output jack	}	
(2) New ball-bearing condenser and gear drive dial		
(3) 80% modulation		
If change (1) has already been made, deduct		
If (1) and (2) have already been made, deduct		
If (1) is made separately, the charge is		
If (2) is made separately, the charge is		
If (3) is made separately, the charge is		

(Continued on next page)

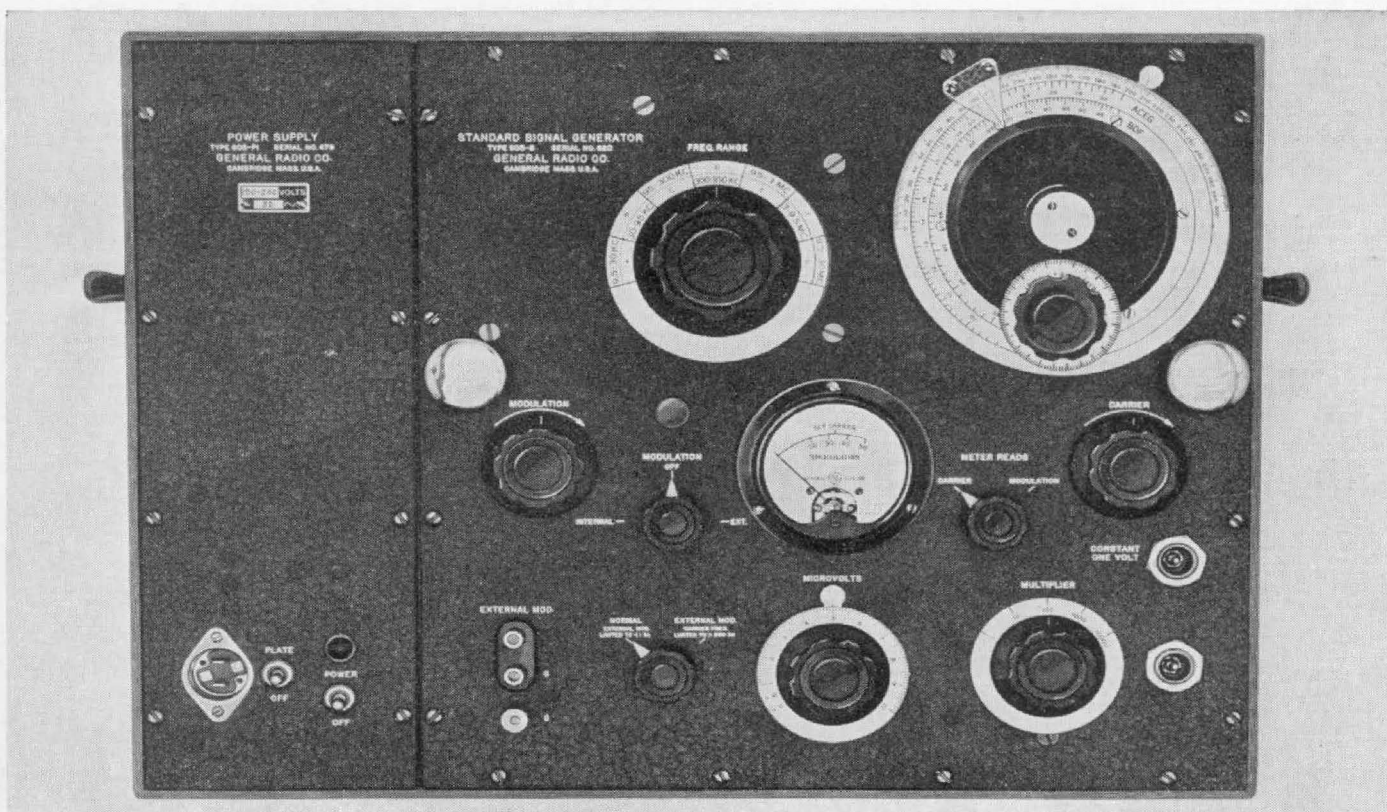

MISCELLANY

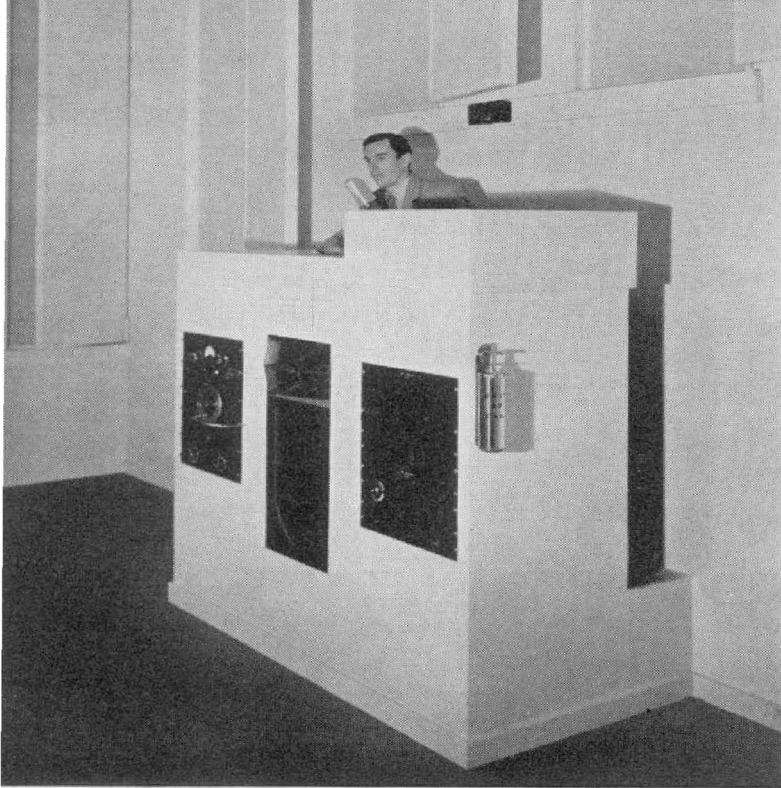

● **THE ACCOMPANYING PHOTOGRAPH** shows the equipment used for the demonstration in acoustics at the University of California Exhibit, Hall of Science, Golden Gate International Exposition. The demonstration contrasted the effects of highly reflective and highly absorbent walls, and gave spectators an opportunity to measure their high-frequency and low-frequency cut-offs. A TYPE 713-B Beat-Frequency Oscillator was used as the tone source.

● **RECENT VISITORS** to the General Radio laboratories included Messrs. W. E. Jackson, H. I. Metz, and J. C. Hromada of the Civil Aeronautics Authority; Dr. H. C. Hayes of the Naval Research Laboratory and Mr. John Sasso, Assistant Editor of *Product Engineering*.

● **AT THE FALL** lecture series, "Modern Methods for Communications Measurement," conducted by the Communications Group of the New York Section of the A. I. E. E., Mr. A. E. Thiessen of the General Radio engineering staff delivered the lecture on "Measuring Circuits."

MODERNIZATION OF STANDARD-SIGNAL GENERATORS

(Continued)

Prices are f.o.b. Cambridge. They include *complete reconditioning, replacement of tubes as necessary, and recalibration*. These reconditioned instruments

carry the same one-year guarantee as a new instrument against defects in material and workmanship.

— H. H. DAWES

GENERAL RADIO COMPANY

30 STATE STREET - CAMBRIDGE A, MASSACHUSETTS

BRANCH ENGINEERING OFFICES

90 WEST STREET, NEW YORK CITY

1000 NORTH SEWARD STREET, LOS ANGELES, CALIFORNIA