

Communication *and* Broadcast Engineering

VOL. 3

NO. 1

Radio Telegraphy

Radio Telephony

Wire and Cable
Telegraphy

Wire and Cable
Telephony

Broadcast
Transmission

Carrier
Transmission

Beam
Transmission

Marine Radio

Police Radio

Aeronautical Radio

Television

Facsimile

JANUARY, 1936

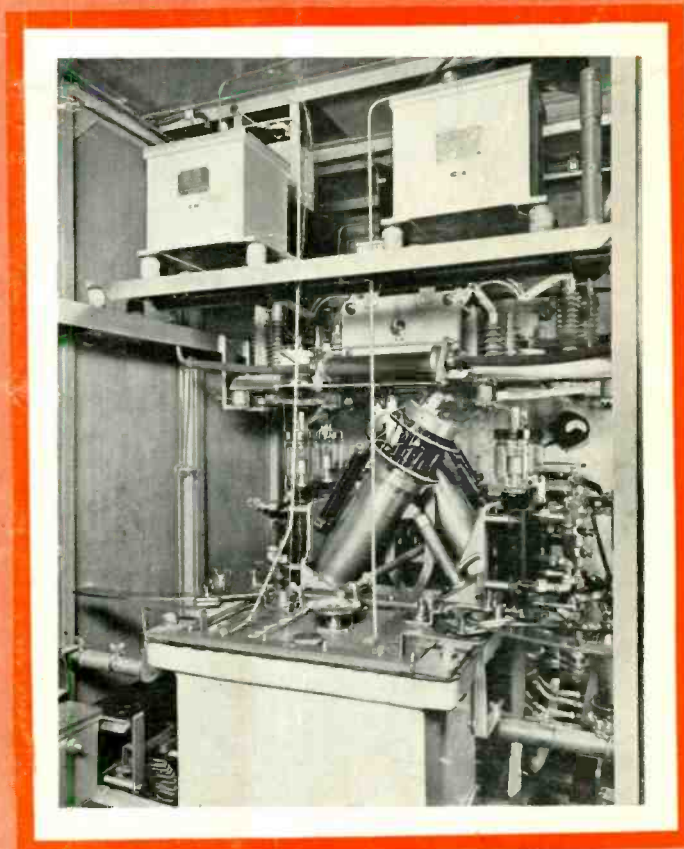

SUBSCRIPTION
\$3.00 YEARLY

The Journal of World Communication

www.americanradiohistory.com

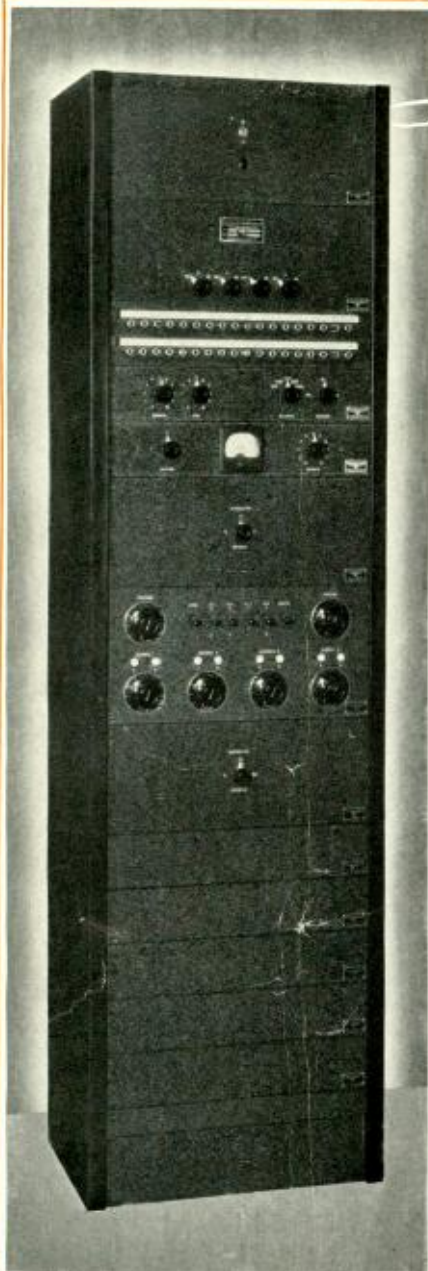

★ Well proportioned cabinets, pleasing in style, with symmetrically placed controls, blend attractively with modern studio appointments.

Increased Flexibility

FOR ★ ★ ★ ★ ★

SMALL OR LARGE STUDIO INSTALLATION

The COLLINS type 12E Speech Input Assembly, because of its flexible circuit design, is easily adapted to the individual requirements of large or small broadcast stations.

The following features of the 12E are an indication of the careful engineering found throughout the entire Series 12 Speech Input Equipment: Completely independent program and monitor circuits

. . . . All units may be isolated or eliminated completely from the circuit by means of jacks

Loud speakers in control room and studios are controlled automatically by microphone control switches

Control operator may "talk back" into rehearsal studio without interrupting program on the air from another studio

Improved type of high-speed volume level indicator used All important controls are grouped on one panel

which may be removed from rack and located on control operators' desk The 12E may be used to feed transmitter directly or to feed program line to transmitter

Standardized construction of units allows equipment to be enlarged, instead of replaced, as the demands of the station increase.

The careful attention which has been given to these and other details of design in the 12E, permit a flexibility of operation never before attained in a factory assembled speech input system.

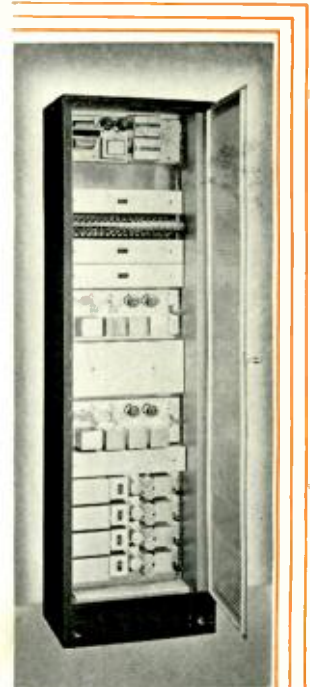

★ The clean cut appearance of the interior emphasizes the dependable performance and sturdy construction.

COLLINS RADIO COMPANY

CEDAR RAPIDS, IOWA



NEW YORK, 11 West Forty-Second Street



*Most Complete Transformer
Line in the World*

QUALITY · RELIABILITY

HIPERM ALLOY

LINEAR STANDARD

The Finest Audio Units Available

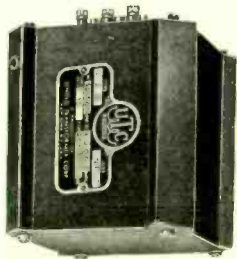

UTC Hiperm alloy audio transformers are the smallest lightweight units available having a guaranteed calibrated response of ± 1 db from 30 cycles to 20,000 cycles. The average coil weighs less than 24 oz. Each coil is enclosed in a Hiperm-alloy outer case so proportioned as to neutralize induced hum pickup. Especially used in wide range portable speech input equipment.



UTC Linear Standard audio transformers are individually calibrated and guaranteed to be ± 1 db from 30 cycles to 20,000 cycles. True hum balancing coil structures used on all input coils to effect complete neutralization of induced voltage. Unequalled magnetic shielding made possible through the use of UTC cast magnetic alloy. Shields symmetrically proportioned externally to obtain maximum hum neutralization in the internal coil structure.



UTC also manufactures more than 500 standard audio filter and power components for commercial and amateur transmitter applications. All units are designed to operate at maximum efficiency, and designs have actually been developed and proven in operating circuits. All audio filter and power components are fully shielded in symmetrically housed cases and present a thoroughly professional appearance when grouped in finished equipment. UTC components are used by Hygrade-Sylvania, General Electric, RCA Mfg. Co., Inc., and Western Electric.

PRESTO RECORDING CORP., LARGEST MANUFACTURERS DEVOTED SOLELY TO THE PRODUCTION OF INSTANTANEOUS SOUND RECORDING APPARATUS AND COATED DISCS, ARE USING UTC LINEAR STANDARD COMPONENTS EXCLUSIVELY



MR. GEORGE SALIBA, Presto's chief sound engineer, says:
"We use UTC Linear Standard transformers exclusively, because we have found them outstandingly dependable in actual service. Besides, they are far superior from the standpoint of uniform response, minimum hum pickup and mechanical ruggedness.
In the 2½ years that we have used UTC transformers, we are happy to report that our customers have not encountered the loss even of a single partial instantaneous radio recording, because of amplifier breakdown. Such amplifier dependability is of paramount importance in instantaneous recordings of radio programs, for once a program is on the air, it is lost forever unless recorded instantaneously."



JUST RELEASED

New 44 page technical bulletin, U1100B, includes data on all types rectifier circuits and amplifiers from ¼ watt to 1,000 watt, also charts on decibel and reactance data, calculation of ripple, etc. . . .

UNITED TRANSFORMER CORP.

72 SPRING STREET

NEW YORK, N. Y.

EXPORT DIVISION - 15 LAIGHT STREET, NEW YORK, N. Y.

COMMUNICATION & BROADCAST ENGINEERING

M. L. MUHLEMAN Editor

RAY D. RETTENMEYER Associate Editor

CONTENTS FOR JANUARY

COVER ILLUSTRATION

POWER-OUTPUT STAGE OF EMPIRE BROADCASTING STATION AT DAVENTRY, ENGLAND. Photo courtesy BBC.

FEATURES

Table listing features with authors and page numbers: Editorial (4), Mixer Circuits (7), High-Fidelity Instantaneous Recording (11), The High-Impedance Velocity Microphone (14), British Plans for Home Television (16), Top-Loading on Small Portable-Mobile Antennas (17), Book Reviews (19), Anglo-European Telephone Communications (25).

DEPARTMENTS

Table listing departments with page numbers: Telecommunication (20), Federal Communications Commission Reports (22), Veteran Wireless Operators Association News (24), Over the Tape (26), The Market Place (27), Index of Advertisers (32).

VOL. 3

NO. 1

PUBLISHED MONTHLY BY THE BRYAN DAVIS PUBLISHING CO., Inc. 19 East 47th Street, New York, N. Y. Telephone: PLaza 3-0483

BRYAN S. DAVIS President

JAMES A. WALKER Secretary

PAUL S. WEIL Advertising Manager

A. B. CARLSEN Circulation Manager

Chicago Office: 608 S. Dearborn St.—C. O. Stimpson, Mgr.—Telephone: Wabash 1903

Cleveland Office: 10515 Wilbur Ave.—J. C. Munn, Mgr.—Telephone: Republic 0905-J.

St. Louis Office: 505 Star Bldg.—F. J. Wright, Mgr.

Wellington, New Zealand: Te Aro Book Depot. Melbourne, Australia: McGill's Agency.

Entered as second class matter October 17, 1934, at the Post Office at New York, N. Y., under the act of March 3, 1879.

Yearly subscription rate: \$3.00 in the United States and Canada, \$4.00 in foreign countries.

BLAW-KNOX VERTICAL RADIATORS FOR MAXIMUM EFFICIENCY



BLAW-KNOX COMPANY
206 5 FARMERS BANK BUILDING, PITTSBURGH, PA.

JANUARY
1936 ●

PRESTO

INSTANTANEOUS RECORDERS

The Presto Instantaneous Recorder fulfills every requirement of the modern broadcast studio. Accurately engineered, Presto has not overlooked the necessity of pioneering a portable, compact unit. The Recorder comes complete in two handsome leather covered cases that can easily be carried by one man.

COMPACT

PORTABLE



The flexibility of this machine makes it an indispensable aid around the studio and transcription laboratories. With Presto to fulfill most requirements, expensive installations are rapidly being replaced by the Presto Recorder.

Although the fine precision mechanism is delicate, carrying from position to position does not damage it. Presto engineers have double-checked the sturdy construction so that even abnormal usage cannot harm the highly sensitive unit.

RECORDING EQUIPMENT IN ITS MOST CONVENIENT FORM

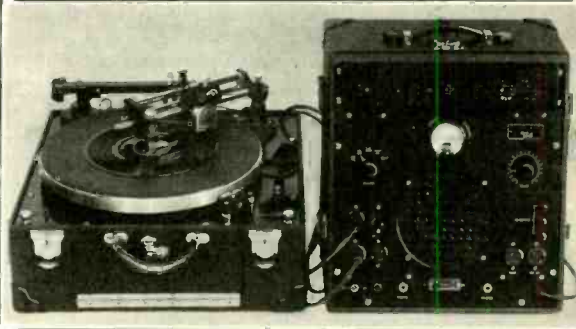

Remember— all Presto equipment is unconditionally guaranteed. If it does not meet with your expectations return within 30 days and your money will be refunded immediately.

Our engineering staff is at your service. Familiarize yourself with their ability to solve even the most difficult problems.

EVERYTHING FOR RECORDING FROM A NEEDLE TO A COMPLETE STUDIO INSTALLATION

California Distributor

NORMAN B. NEELY

1656 N. Serrano St.

Los Angeles, Calif.

PRESTO

RECORDING CORPORATION

139 West 19th Street, New York, N. Y.

COMMUNICATION AND
BROADCAST ENGINEERING

3

EDITORIAL

INCREASING VOLUME RANGE

TRUE FIDELITY of broadcast programs can not be achieved until the listener is able to hear the programs from his loudspeaker exactly as they would be heard in the studio. Naturalness involves the faithful reproduction of all audible frequencies with equal relative intensities, without any additions or subtractions, and with proper directional effects.

While much has been heard about wide frequency ranges, the overcrowded, and hence restricted, conditions existing in the 550—1500 kilocycle band allows little more to be gained in this respect. The range of modulation frequencies that can now be transmitted is limited to about 8,000 cycles, while 5,000 cycles is all that can be transmitted without encountering adjacent-channel interference. Despite its importance, however, a wide frequency range is only one of the requirements for a high-fidelity system. It is equally important that a high-quality system designed for the transmission and reception of entertainment have a wide volume range.

With the present setup there are certain factors that limit the volume range that can be broadcast. These limits are set on one hand by noise, on the other by distortion.

Quite naturally there is a certain amount of noise originating in the transmitting and associated apparatus which is carried along by the carrier and which appears in the loudspeaker. Man-made interference, natural static (which is often quite severe), and noise originating in the receiving equipment also contribute to the background noise appearing in the loudspeaker, and may, if it is attempted to broadcast too wide a volume range, obliterate the low passages entirely.

Distortion is, for the most part, caused by overloading. This factor sets the upper limit for the volume range that may be transmitted.

Between the limits of noise and overloading there is left a range of approximately 45 decibels. This is the range that is broadcast at the present time. When this 45-db range is compared to the 70-db range of a symphony orchestra, it is readily seen why there is considerable room for improvement.

The most obvious method of overcoming this lack of sufficient volume range would

seem to lie in fully modulating the carrier and compressing the volume range to a suitable value before transmitting . . . expanding again at the receiver. Such a compressing-expanding system could be designed to give a 65- to 70-db range . . . it would also effect a considerable reduction in background noise.

Compressing-expanding systems are not new. One such system has been in commercial operation for some time on a long-wave radiotelephone circuit between New York and London, and it has given very satisfactory results. Phonographs with expanders are in use both in this country and abroad, while serious consideration is being given to the incorporation of automatic compression in making phonograph recordings. A volume contracting-expanding system can also be made to give excellent results in the broadcast band. The added naturalness would certainly justify the expense and labor.



NOISE ELIMINATION

AN EDITORIAL appearing in the December, 1935, issue of RADIO ENGINEERING expressed the opinion that the war against noise should be started not at the source but at the receiving end; it also stated that no great headway could be made in this respect until more was known of the character of noise and its relation to radio waves.

It may now be disclosed that Mr. James Lamb, of the technical staff of QST, has developed a simple and practical system of noise elimination, predicated upon the results of his studies of the character of noise impulses.

Mr. Lamb observed that static and man-made interference have sharp peaks, are of high amplitude and of very short duration. In fact the duration of the impulses are so short that he has found that "punching holes of silence" in the signal at the points where the impulses would appear is permissible because the ear is unable to function with sufficient rapidity to note the interruptions.

The system is a supplementary delayed AVC circuit working out of the first detector which is made to function as a quick-action silencing control. The circuit is adjusted to operate only on the noise peaks.

For better broadcasts in '36!

Non-Directional Mike...latest proof that Western Electric is the leader



\$70.
in the U. S. A.
—including jack and
20' of shielded cord.

ACTUAL
SIZE

Non-directional pick-up—long the goal of microphone designers—has been achieved now through the efforts of Bell Telephone Laboratories and Western Electric: recognized leaders in sound-transmission apparatus.

The non-directional dynamic mike gives you highest grade pick-up from every angle—operates into present equipment designed for dynamic microphones—gives you, in even greater degree, all the advantages

of former Western Electric dynamic mikes, plus increased flexibility and performance. And at lower price!

In the large family of Western Electric broadcasting products, you'll find everything you need to put your programs on the air at their best. Whether your station is small or large, rely on Western Electric!

Full information from Graybar Electric Co., Graybar Building, New York.

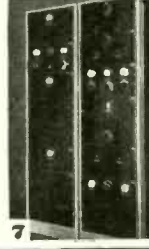
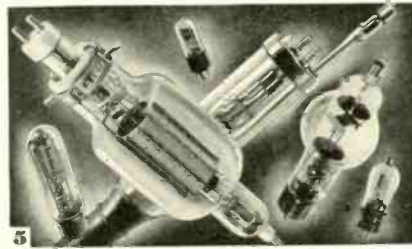
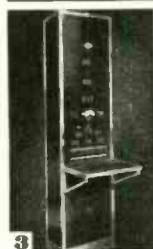
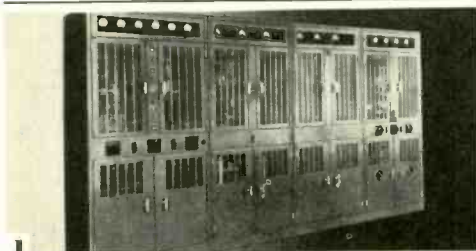

1. 5 KW Transmitter. 2. 50 KW Transmitter and control desk. 3. Studio Speech Input Equipment. 4. Station Speech Input Equipment. 5. Tubes for every broadcasting need. 6. All AC operated high-fidelity audio amplifiers. 7. Synchronizing Systems for common frequency broadcasting.

Western Electric

Distributed by GRAYBAR Electric Company. In Canada: Northern Electric Co., Ltd.

RADIO TELEPHONE BROADCASTING EQUIPMENT

JANUARY
1936 ●

COMMUNICATION AND
BROADCAST ENGINEERING

5

here's

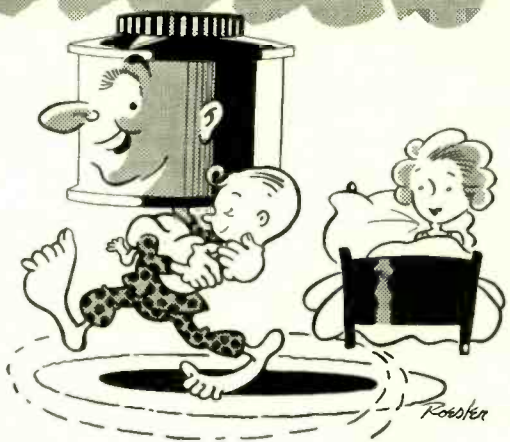

"SOUND" CONTROL

as IS "Sound Control." As quiet as the threshold of silence... and preferred and used by more than a hundred broadcast stations to say nothing of thousands of the P. A. operators.

True to the "smooth, silent" traditions of Centralab Radiohms, the SERIES II Sound Projection Controls are gaining popularity in a big way.

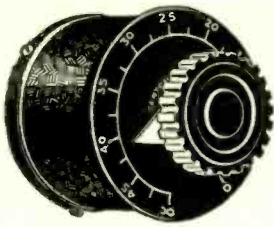

Non-inductive carbon type, tapered for constant impedance. Continuously variable attenuation and practically straight line for 45 db at all frequencies up to 16,000 cycles. **NEVER REQUIRES CLEANING.** Accurate thru years of service.

Centralab

SOUND PROJECTION CONTROLS

MAIL THIS COUPON NOW!

CENTRAL RADIO LABORATORIES
 900 E. KEEFE AVENUE
 MILWAUKEE, WIS.
 SEND ME FREE OF CHARGE YOUR NEW
 BOOK ON SOUND PROJECTION CONTROLS

NAME

BUSINESS

ADDRESS

CITY STATE

CBE

6 JANUARY
 1936 •

HIGH-FIDELITY AMPLIFIERS



AmerTran now offers the three essentials to the construction of high-fidelity amplifiers for broadcasting and recording.

- (a) Highest quality audio transformers.
- (b) Carefully engineered amplifier circuits.
- (c) Drilled chassis to insure correct arrangement of components.

Amplifiers may be assembled at moderate cost for a wide variety of precision requirements using standard parts and circuits.

May we send data on "Series 400" amplifier systems?

AMERICAN TRANSFORMER CO.
 175 EMMET ST. NEWARK, N. J.



"No PUSHEE, No PULLEE"



ACHINAMAN said that when he first saw the street car. Brush products and those of its licensees could be similarly described. They use Rochelle salt crystal as the basic driving or generating unit, and consequently need no button current, polarizing voltage or magnets to make them work.

Brush Strokes, the monthly publication of The Brush Development Company, manufacturers of microphones, headphones, speakers, etc., describes various products utilizing the piezo-electric property of Rochelle salt crystal. If you would like to receive this monthly magazine, all you have to do is write The Brush Development Company, 1860 E. 40th St., Cleveland, on your business letterhead and say, "Put my name on your Brush Strokes mailing list."



COMMUNICATION AND
 BROADCAST ENGINEERING

COMMUNICATION & BROADCAST ENGINEERING



FOR JANUARY, 1936

MIXER CIRCUITS

Their Design and Operation

By LOUIS W. BARNETT

Studio Engineer, WLW, WSAI

A MIXER CIRCUIT is an arrangement of volume controls for combining into one program, in any desired proportions, program elements from several channels. All of the multiple microphone transition, and fading effects, which contribute so much to program continuity, are to be obtained by proper use of mixer circuits.

For instance, separate microphones may be used for a soloist and for the accompanying orchestra, piano, or organ, and the outputs combined to form a well-balanced whole. Similarly, separate microphones may be used to pick up the various sections of a large orchestra. (However, this is not the best engineering practice.) Since the level of each microphone channel can be regulated independently of the others, a method of controlling the balance between the

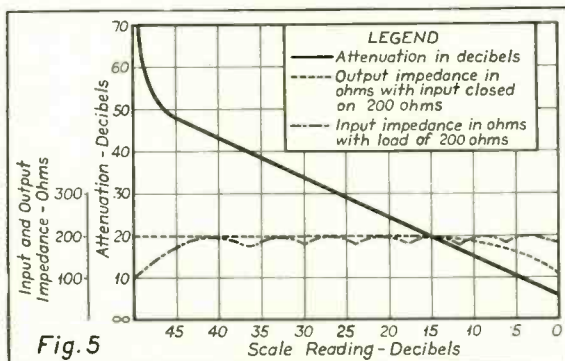
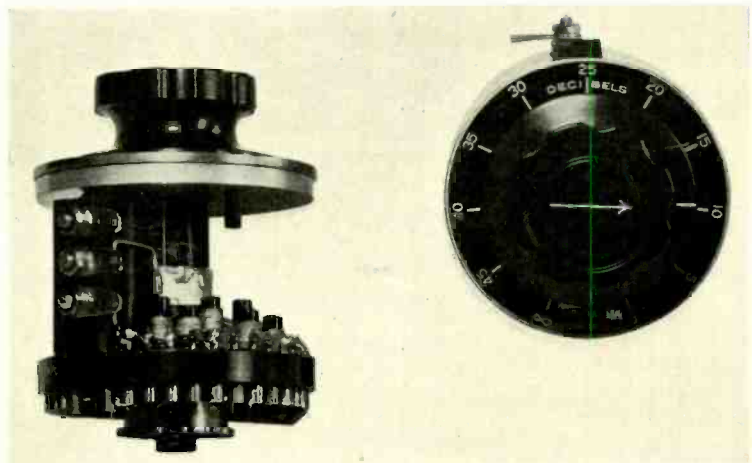

Fig. 5

ABOVE: FIG. 6. TWO VIEWS OF THE TYPE 653 MB CONTROL.

LEFT: THE PERFORMANCE CHARACTERISTICS OF THE TYPE 653 MB.

various sections is obtained which, unlike the usual tone control, does not impair the quality of the reproduced sounds. When high-quality reproduction is required in broadcast transmission, sound recording and projection and multiple-outlet reproduction systems, care must be taken in the selection of volume controls and faders in attenuation systems to eliminate, as much as possible, any distortion which might arise due to the disturbance of the impedance characteristics of the program circuits. Mixers, besides being used to balance various groups, are also used to "fade down" or "up" a musical pickup so that announcements of dramatic sketches

may be superimposed on the original theme or musical background. All of these very necessary effects contribute a great degree of smoothness to a program which would otherwise be impossible.

The choice of a mixer circuit, in the construction or design of control boxes, is determined by the number of channels needed and the impedance requirements of the system. If the mixer is to be used with equipment that is balanced to ground, this factor must be taken into consideration. Mixer controls or attenuation systems for use in such circuits should be of the constant-impedance type which will permit adjustments of one or more circuits independently of each other without disturbing the impedance characteristics of the associated circuits.

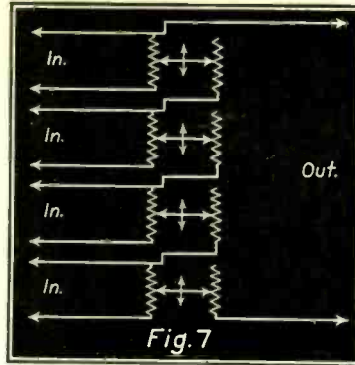

A FOUR-CHANNEL SERIES FADER CIRCUIT.

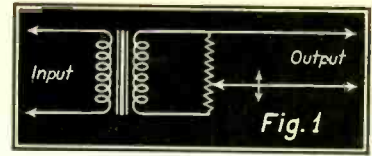

A SIMPLE FADER CIRCUIT.

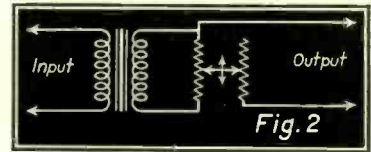

THE L-TYPE FADER CIRCUIT.

In designing mixer circuits, it is advisable to allow a separate input fader

channel for each microphone, line, or phonograph pickup, thus making it unnecessary to patch circuits while a program is in progress. The following is stressed especially—The cost of an extra mixing control is negligible compared with the consequences of even a single program interruption.

EVOLUTION OF THE MIXER

Constant-impedance microphone controls were not in use during the first several years of broadcasting. As with most other broadcast equipment, the final design of the controls now on the market were obtained by a sort of experimental evolution. There are quite a number of companies manufacturing good constant-impedance faders; however, most of these units are essentially alike in internal construction.

The evolution of the microphone fader began first with a fixed resistor placed across the secondary of the microphone transformer to drop the output level of the microphone in use a suitable amount to work into the program amplifier. Then, later, it was found that, to make speech-input circuits more flexible, a variable fader control would have to be developed, which turned out to be nothing more than a variable resistor placed across the secondary of the transformer. This seemed to work fairly well, but when input circuits were "tied together" the action of the fader seemed to resemble a tone control, and seriously disrupted the impedance of the circuit. In any well-designed mixer the volume on each individual channel can be adjusted without altering the volume on any other channel. The simple fader circuit is shown in Fig. 1.

In connecting low-impedance circuits together an almost true constant impedance between the circuits must be maintained throughout the entire audio-frequency band reproduced or serious tonal distortion may result. It was found, through experiment and trial, that a double-resistor network arranged to form an L network would retain the

2-CHANNEL SERIES MIXER

Type of Controls Used	Input Impedance of Each Channel	Output Impedance of Mixer (Z ₁)
653-MA	50 ω	100 ω
653-MB	200 ω	400 ω
653-MC	500 ω	1000 ω

CONNECTIONS FOR 585-C IMPEDANCE - MATCHING TRANSFORMER

Note: Transformer may be operated in either direction, that is, either winding may be used as primary.

4-CHANNEL SERIES-PARALLEL MIXER

Type of Controls on Channels	Input Impedance of Each Channel	Output Impedance of Mixer (Z ₁)	Type of Control Used as Master (M)	Output Impedance with Master (Z ₃)
653-MA	50 ω	50 ω	653-MA	50 ω
653-MB	200 ω	200 ω	653-MB	200 ω
653-MC	500 ω	500 ω	653-MC	500 ω

6-CHANNEL SERIES-PARALLEL MIXER

(This side may be grounded when 585-C trans. is used)

Type of Controls on Channel	Input Impedance of Each Channel	Output Impedance of Mixer (Z ₁)	585-C Connections	Z ₂	Type of Control Used as Master (M)	Output Impedance with Master (Z ₃)
653-MA	50 ω	33 ω	B (1-4 as Sec.)	500 ω	653-MC	500 ω
653-MB	200 ω	123 ω	C	200 ω	653-MB	200 ω
653-MC	500 ω	333 ω	Not Used	—	653-MB	200 ω

TWO-, FOUR- AND SIX-CHANNEL MIXER CIRCUITS.

constant-impedance characteristics beyond "aural" conception. However, frequency-tone tests showed that the circuit used in the L-type pad did not contain all the desirable qualities of a pure constant-impedance network, but that it was a great improvement over the single-resistance mixer control. Fig. 2 shows the L-type fader circuit.

Further experimentation in the design of an "ideal fader control", produced the T-type control. This circuit is essentially flat throughout the entire audio-frequency spectrum used in broadcast and recording work. It will be readily seen, by inspection of the circuit, that the T pad is more constant in impedance than the L pad. (See Fig. 3.)

The latest type mixing control to be introduced to broadcasting and recording practice, is the "Ladder" type control. This circuit was evolved from the well-known H-type pad circuit. (See Fig. 4.)

The advent of the dynamic and ribbon microphones has brought forward a new consideration in the design of microphone mixer controls and new units have been produced for this work. Condenser microphones having a very high impedance must necessarily work directly into the grid of a vacuum-tube booster amplifier located at the condenser head. Incidental to this amplification has been the fact that the mixing is done at a relatively high level. The ribbon and dynamic microphones have a low impedance, and, for this reason, it is possible, if not desirable, to arrange the mixers so that they operate directly from the microphones. This does away with all the pre-amplification, and the microphone faders operate at a much lower level than is the case with the condenser microphones. This method necessitates a group of noiseless mixing controls. (Please note, however, that it is still much better practice to have each dynamic or ribbon microphone pre-amplified before feeding its output into the mixing channel, due to the possibil-

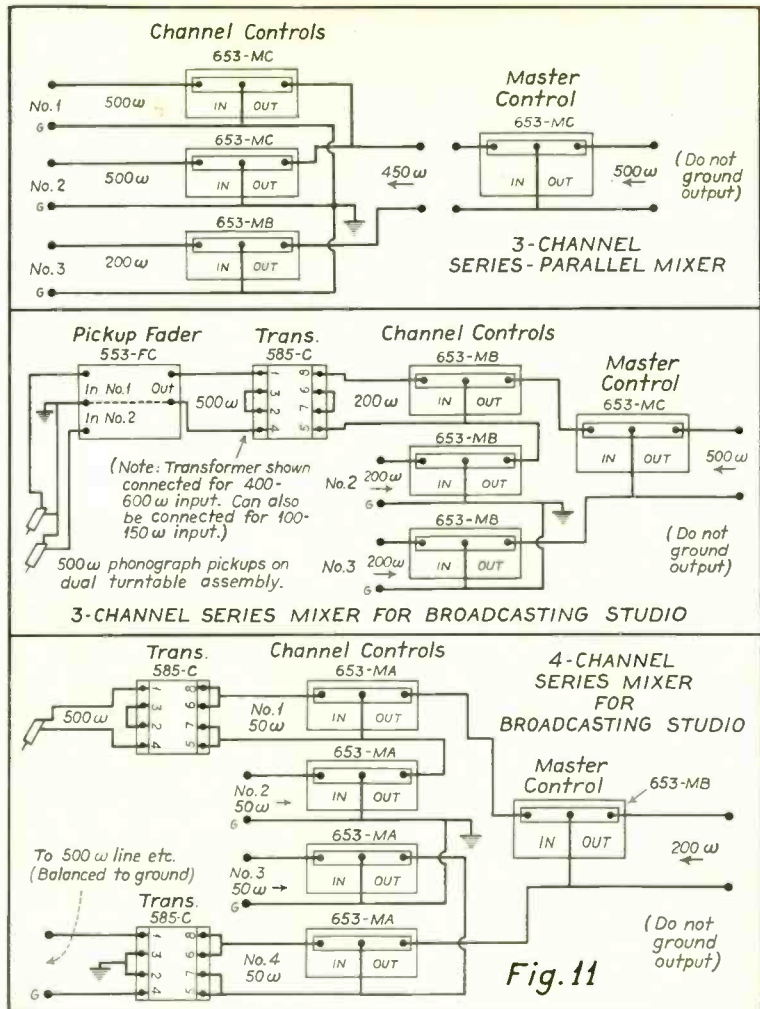

THREE- AND FOUR-CHANNEL MIXER CIRCUITS.

ity of noise and static pickup introduced into the lines from the microphone to the control box.)

The latest volume controls must embody the following design features:

- (1) The most noiseless electrical operation possible.
- (2) Rigid mechanical construction to eliminate any possibilities of mechanical or electrical breakdown.
- (3) Ease of operation (torque), installation, and maintenance.
- (4) Good frequency characteristics.
- (5) Small physical size and low weight for portable installations.
- (6) Low price.

With the above mentioned requisites taken into consideration the "Ladder" control was developed. In this control both the input and output impedances remain constant over the entire range of attenuation between 0 and 45 decibels. Another feature of this circuit is the gradual increase in attenuation to infinity beyond the 45-db point, thus providing a means of fading out the program gradually and noiselessly. In old types of faders it was found that

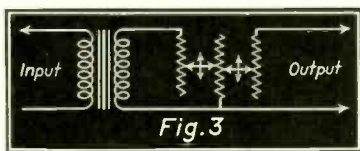

THE T-TYPE FADER.



THE "LADDER" TYPE CONTROL.

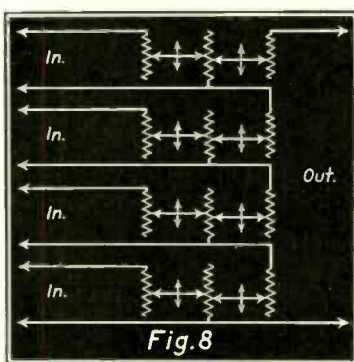

A FOUR-CHANNEL SERIES FADER.

Block Diagram of Switching and Mixer Control System

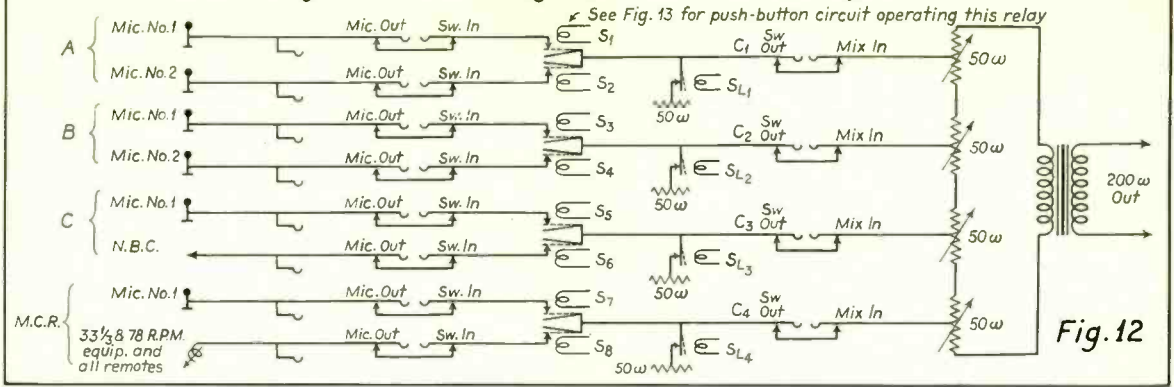

A BLOCK DIAGRAM OF A SMALL STATION LAYOUT. A FOUR-POSITION MIXER SYSTEM ACCOMMODATES EIGHT INCOMING PROGRAM ELEMENTS.

parasitic charges accumulated between slider arm and contact points or windings, so, in the latest developments, where the incoming input level is to be as low as minus 80 db to minus 95 db, the slider arms and contact points were both made of the same metal thus doing away with noises due to difference of metal potential in air.

Fig. 5 shows the performance characteristics of the General Radio type 653 MB control. Fig. 6 shows two views of the 653 MB.

The mixer circuits to be referred to here are in conventional use in broadcast stations, recording, and motion-picture laboratories throughout the country. All of them have proved highly satisfactory and each is adapted to its own various uses—the builder will have to adapt them to suit his own needs. Figs. 7, 8, and 9 shows four-channel series-fader circuits.

It is very evident, however, that in most cases of constructing mixer circuits, more than two inputs will be needed, so it is with this thought in

mind that the following circuits are shown, together with the legend for each figure, enabling anyone to pick out

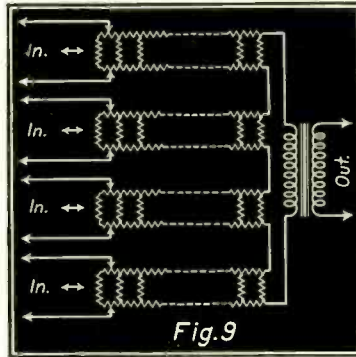

A FOUR-CHANNEL SERIES FADER CIRCUIT. OTHER FOUR-CHANNEL FADERS ARE SHOWN IN FIGS. 7 AND 8.

a circuit suitable to his needs together with the type number and impedance characteristics for any combination. It

must be remembered, however, that all mixer circuits must have an associated switching system combined with them in order to aid in ease of operation and flexibility of circuit. Associated switching circuits and interlock-control systems for control use are quite varied and only a small part of one system will be mentioned here.

In a series-type mixer of more than two channels, some channels must be above ground potential. Naturally this is of little or no consequence if the equipment connected to these channels is not grounded and the leads are comparatively short. If any noise pickup or cross-talk, due to this condition, is encountered, it may be remedied by using impedance-matching or circuit-isolation transformers on these channels. Transformers may, of course, be used equally well with the channels at ground potential in all of the mixer circuits shown, but they are not necessary except for impedance matching, balancing to ground (minor case if at ground)

(Continued on page 18)

Schematic of Individual Control Circuit. Audio Channels, "A," "B" or "C" Studios

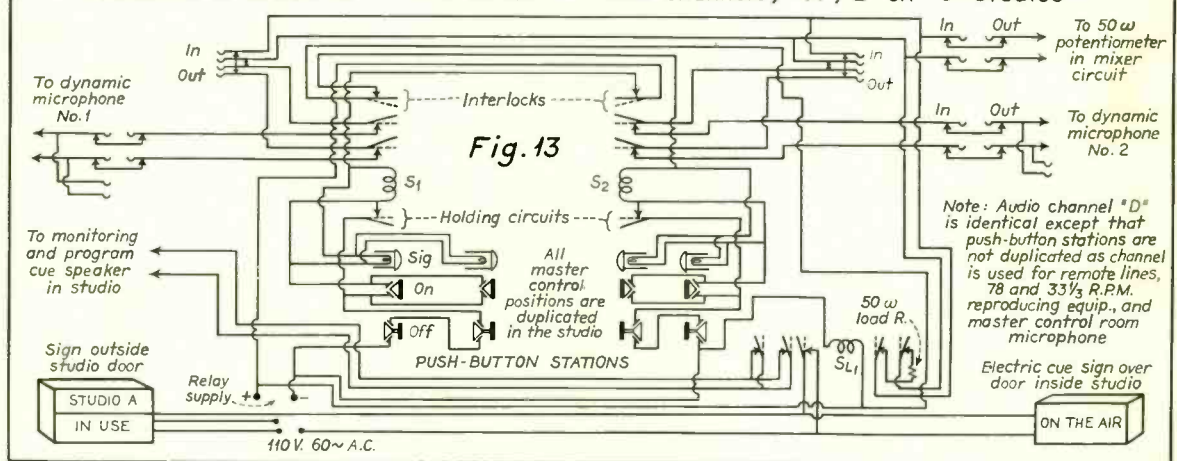

A DUAL-CONTROL CIRCUIT FOR SWITCHING EITHER OF TWO PROGRAM ELEMENTS INTO SAME FADER POSITION.

HIGH-FIDELITY INSTANTANEOUS RECORDING

By GEORGE J. SALIBA

Chief Engineer

PRESTO RECORDING CORPORATION

THE PROGRESS made in instantaneous recording in the last few years has been remarkable. In 1927 about the only method of making instantaneous records was by means of the acoustic phonograph—and the only medium was the pre-grooved metal disc—which was part aluminum and part zinc. In 1928 feed mechanisms were developed which cut their own grooves as they recorded, but metal was still the only recording medium. It was not until 1931 that the interest in this comparatively new industry began to manifest itself in a desire for some method that could be used to simulate approximately the results that were obtainable in commercial wax recording. This meant that the disc had to be cut and a thread removed.

In metal recording the disc was knurled with a round-nose needle and as a result the metal was distorted. No material was removed, with the consequent result that, although the resulting recording sounded satisfactory enough, it was still a comparatively poor imitation of commercial recording results.

The problem resolved itself into finding some material that would be soft enough to be cut and at the same time hard enough to be reproduced a reasonable number of times with a steel needle. To reach this happy medium proved to be the biggest problem of all. Gelatin was tried and used for a time, but gelatin is soluble in water, so that extreme care had to be exercised in the handling of the disc. The life of the record was very short, because gelatin, having a high water content, dried out after a short time, leaving the disc quite brittle.

The next material that was found to have the properties satisfactory for recording was celluloid, and for two years it was used extensively. Unfortunately the greatest disadvantage of this latter material, aside from its inflammability, was its flexibility. This necessitated special handling in reproduction.

After intensive research and experi-

mentation the coated disc was finally developed—today this disc is used almost exclusively where high-quality reproduction is required.

The coated disc is made by applying a smooth coating of cellulose to both sides of a metal disc, the metal being used to give the disc rigidity so that it will lie flat on the turntable. The advantages of such a disc are:

1. A steel recording needle can cut it and any medium tone steel needle can reproduce it.
2. It is non-inflammable.
3. It is non-breakable.
4. It possesses a long life.
5. It can be reproduced a great number of times.
6. It can be used to make masters for pressing.

One of the present-day requirements of high fidelity is that all frequencies between 30 and 10,000 cycles be reproduced uniformly. This means that every component part used must be of the highest quality. Further, the shape of the groove, the needle velocity, the wavelength of the modulated groove, the radius of curvature of the groove and the size of the needle point are all factors which must be considered if high-fidelity requirements are to be met. These are limiting factors which cannot be changed regardless of the fidelity of the component parts.

The microphones and radio receivers of today, as a source of input into a

recording channel, easily meet the 30- to 10,000-cycle requirements (and the same can be said of the audio amplifiers and loudspeakers), but when it comes to the cutting head a difficult problem presents itself. Here the electrical energy must be converted into mechanical energy without any appreciable loss. Unfortunately, at the present time cutting heads do not meet this requirement. Fig. 1 shows a frequency characteristic of an average cutter and the deficiencies at both the low-frequency and high-frequency ends are quickly noted. The low-frequency loss is purposely introduced as will be discussed later, but the high-frequency loss is the real difficulty. The popular belief exists that the comparative hardness of the coated disc with respect to wax is the reason for this loss. To some extent this is true, but the real loss is due to the construction of the cutting head itself. If one were to feed a frequency of 6,000 cycles per second to the coil of the cutter one could hear this frequency very plainly, but when the cut is made the 6,000-cycle tone is found to be 15 or 20 db below that of 3,000 or 4,000 cycles.

A great deal of this loss is due to the amount of play between the cutting needle and needle holder, and at the present time the only way this loss can be eliminated is to seal the cutter into the holder. This is easy enough to do in wax where jewel styli are used and where the wear on the stylus is small due to the softness of the wax, but when coated discs are used, the wear on the needle is comparatively great, due to the harder surface. This necessitates the changing of the steel cutting needle about every 30 minutes. It is because of this constant changing of the needle that sealing is not practical. It has been found after thorough investigation and tests that by extreme care and precision in assembly and by using the highest grade materials obtainable cutters can be made to have extremely high frequency response. It is hoped that such cutters will be available on the market shortly.

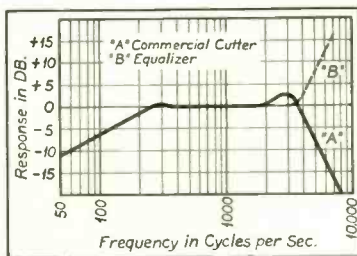

FIG. 1. THE FREQUENCY CHARACTERISTIC OF AN AVERAGE CUTTER.

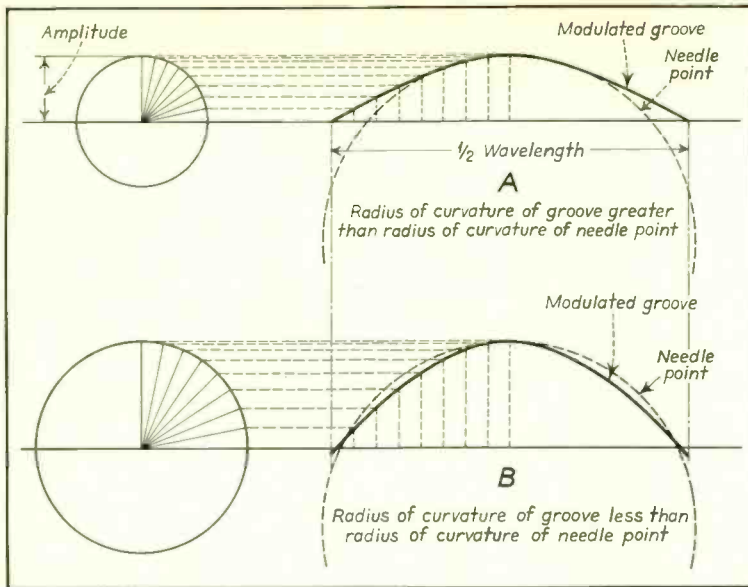

FIG. 2. DIAGRAMS SHOWING THAT THE HIGH-FREQUENCY RESPONSE IS DEPENDENT UPON THE RADIUS OF CURVATURE OF THE MODULATED GROOVE AND THE RADIUS OF CURVATURE OF THE NEEDLE POINT.

Fortunately the use of audio equalizers can compensate for this loss at the high-frequency end. Fig. 1 shows a curve of a cutter before and after equalization. The equalizer used is of the resonance type. When using an equalizer of this nature it is very important that a high-gain amplifier be used as the equalizer introduces an appreciable loss in gain.

The cutting head is a constant-velocity device. This means that for a given input voltage to the coil the amplitude of the wave on the disc at a frequency of 250 cycles will be twice as much as the amplitude for 500 cycles and four times as much as the amplitude for 1,000 cycles. The depth of the groove on the coated disc is about 0.0015 inch and at a pitch of 96 lines per inch the center-to-center spacing of the grooves is about 0.0104 inch. The width of the groove itself is about 0.006 inch, so that 0.0044 inch of wall thickness is available for lateral motion of the needle. Since the adjacent groove is to be modulated also only one-half of this wall is available for modulation.

Below 300 cycles the cutter is made to have constant amplitude because it is at these lower frequencies that the heaviest waves occur with the consequent danger of overcutting.

At a pitch of 96 lines per inch with a wall space of 0.0044 inch the maximum amplitude to either side is 0.0022 inch. Increasing the pitch decreases the wall space, and the amplitude will have to be decreased in proportion if overcutting and distortion are to be avoided. Obviously the greater the am-

plitude the greater will be the signal-to-noise ratio—and the reduction of surface noise is one of the requirements of high fidelity.

To obtain a full 15-minute recording on a 16-inch disc at 33-1/3 rpm a pitch of 112 lines per inch would have to be used if reasonably good quality is to be expected at a starting diameter of 6½ inches. The wall space at this pitch is 0.0029 inch. Therefore the maximum amplitude is about 0.0014 inch at 300 cycles. At 600 cycles the amplitude is 0.0007 inch, at 1,200 cycles it is 0.00035 inch, and at 7,000 cycles the amplitude is 0.00006 inch. Considerable energy is represented in these high-frequency modulations even though the amplitude is low.

At a speed of 33-1/3 rpm and a diameter of 6½ inches the tangential needle velocity is found from the following equation:

$$V = \frac{2\pi RN}{60}$$

Where V = Velocity in inches per second; R = Radius in inches; N = Speed in rpm;

$$V = \frac{(2) (3.1416) (3.25) (33.33)}{60}$$

$$= 11.32 \text{ inches per sec.}$$

On the outside of the disc at a radius of 7.75 inches the needle velocity is

$$V = (2) (3.1416) (7.75) (33.33) / 60 = 27.0 \text{ inches per sec.}$$

Since the needle speed is a function of the radius it follows that the lower the needle speed the shorter will be the total available distance for a given recording. It is because of this fact that the reproducing of the higher frequencies is comparatively difficult at the smaller diameters.

To obtain the wavelength the equation $\gamma = V/F$ is used. Thus, the wavelength of a 7,000-cycle note at 33-1/3 rpm and radius of 3¾ inches is 0.00162 inch. And at a radius of 7.75 inches $\gamma = 0.00386$ inch.

A few years ago it was the belief that the wavelength determined how high a frequency could be reproduced. It was stated that one-half of the wavelength should be equal to or greater than the diameter of the reproducing needle if that frequency was to be properly reproduced. If a disc is cut with maximum lateral amplitude for a number of single frequencies proceeding from low to high, a frequency will be presently reached for which the wavelength is so small, as compared with the amplitude, that the needle cannot follow such a steep wave front.

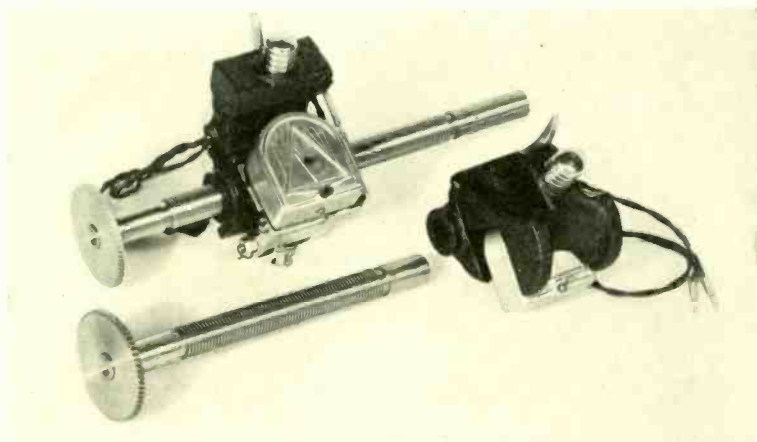

SHOWING REMOVABLE FEED SCREWS AND CUTTING HEADS. THE UPPER CUTTER IS FOR ACETATE, THE LOWER ONE FOR ALUMINUM.

The limiting steepness for satisfactory tracking is an angle of about 40° between the direction of the groove at any point and its mean direction.

It is very obvious therefore that the limit of high-frequency response is not so much dependent on wavelength but is governed mostly by the radius of curvature of the modulated groove and the radius of curvature of the needle point. The wavelength determines the radius of curvature of the modulated groove. The highest frequency that can be reproduced at a given radius will be when the radius of curvature of the modulated groove is equal to the radius of curvature of the needle point. As long as the radius of curvature of the groove is greater than the radius of the needle point that frequency will be reproduced.

Fig. 2 illustrates this point clearly. The diameter of the point of a steel needle is about 0.003 inch. The wavelength is the same for each condition but the amplitude is varied.

Fig. 2-A illustrates conditions existing when the radius of curvature of the modulated groove is greater than the radius of curvature of the needle point. Tracking is possible in this case but impossible as shown in Fig 2-B where the radius of curvature of the modulated groove is less than the radius of curvature of the needle point.

As stated before the maximum amplitude of a 7,000-cycle note using a constant-velocity cutter at a pitch of 112 lines per inch is 0.00006 inch. Now by following the method shown in Fig. 2 and by using the wavelength curves of Fig. 3 the different diameters at which this frequency can be reproduced can easily be found. Since the higher frequencies are more difficult to reproduce at the inside diameters, it has been found advisable to start the recording from the inside. When

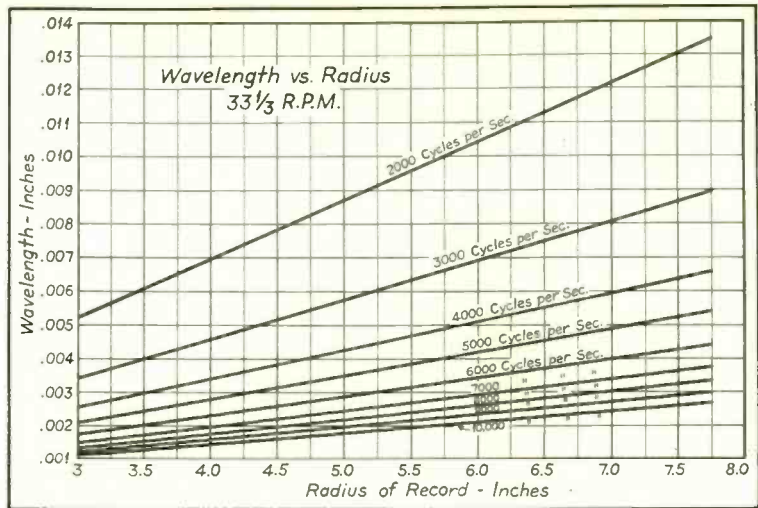

FIG. 3. CURVES SHOWING WAVELENGTH PLOTTED AGAINST RADIUS OF RECORD.

the needle is new its point has the smallest radius of curvature, and it is therefore capable of reproducing comparatively high frequencies. When a needle has played through a 16-inch disc its needle point radius has been increased materially.

Instantaneous recording has advanced far in the past few years, but, in the writer's opinion, the greatest single contributing factor has been the development of the coated disc. These discs have made possible recordings that are the equal of commercial wax pressings. They have a quality of reproduction that makes them suitable for broadcasting. Another application of these discs is for the making of pressings. They can be processed in the same manner that wax is processed—and this means that any number of duplicates can be made at very low cost.

NEW PICTURE-TRANSMISSION METHOD

A METHOD of sending pictures by radio so that they will not be affected by fading—the major obstacle with present systems—has been invented by the Belin Co., according to *The Broadcaster and Wireless Retailer* for November 30, 1935. The system has been used successfully for six months during tests between Algiers and Paris.

At the transmitter the picture is "scanned" in the usual way by a spot of light and photo cell. To facilitate amplification of the signal, however, the light is interrupted 1,300 times per second.

After amplification the signal is fed to an oscillograph, which reflects a beam of light on a diaphragm containing a triangular opening. Behind this is a revolving disc containing a number of slits.

According to whether the light from the oscillograph falls near the point of the triangle or near the wide end, a slit in the revolving disc will take a little or a long time to pass through it. The light passing through the slit is picked up by a photo cell and is then amplified and broadcast in the ordinary way.

Whereas normally the "tone" of any particular spot of the original picture is represented by a signal of certain amplitude, in the Belin system it is represented by a signal of a certain duration. A signal of this type is, of course, unaffected by fading.

At the receiver the light is of constant intensity and the signal is used to control the time the light shines on the sensitized paper. The complete picture, consequently, being composed of a series of dashes of varying width.

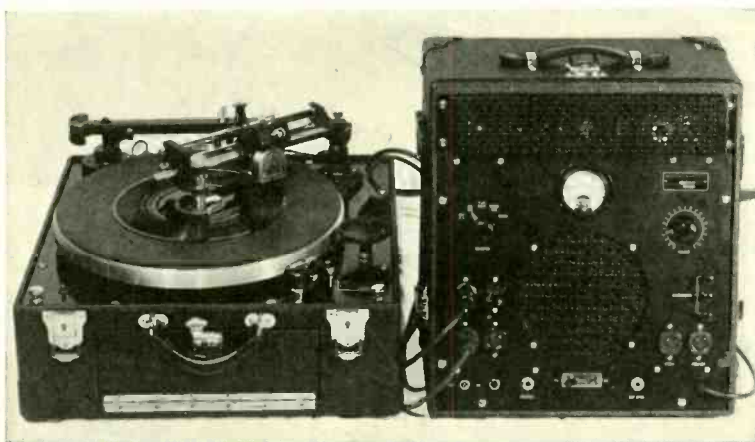

A PORTABLE RECORDING MACHINE. AT LEFT IS SHOWN THE TURNTABLE CASE. THE THREE-STAGE PUSH-PULL AMPLIFIER IS AT THE RIGHT.



SHOWING THE AUTHOR WITH THE VELOCITY MICROPHONE, LINE AMPLIFIER, AND POWER-SUPPLY TESTED AT W.C.A.M.

THE HIGH-VELOCITY

By J. J. CUMMINGS

A.M.I.R.E.

THERE ARE unquestionably many problems which may safely be classified as being common to all broadcasting stations at some time or other. They are problems which may confront engineers in stations at widely separated locations. This paper has to do with one problem which the author feels falls into that classification.

The principal subject of this dissertation is microphones, and incidentally, a particular type of microphone which seems to have certain desirable qualities that might recommend it to the attention of other engineers who have occasion to consider such equipment.

No microphone is really universal in its application. Any specific type on which a station may have standardized is often used for all classes of work primarily because it is the only type available, and not always because it is really the best for the job at hand. Some types of services are better handled by a crystal, others by a dynamic, or by a velocity, but no one type of microphone can truly be said to have all of the attributes of the ideal. The best that can be expected is a closer approach to the desirable ultimate in performance. In order that we may agree on the qualities that might constitute that state, let us for a moment review the characteristics of the familiar varieties.

THE CARBON MICROPHONE

First should probably come the old reliable standby of broadcasting, the carbon-granule filled button type. They still have their place in the picture today, and one will see them in use at many locations, including some remote pickup points as well as control-room-to-studio "talk back" installations. The principal objection to them has always been the background hiss which becomes noticeable when amplifier gain is raised to compensate for weak sound sources. To this one might add the comment that packing, dissimilarity in button currents, and diaphragm characteristics have been noted as contributing to the distortion of the transmitted wave.

THE CONDENSER MICROPHONE

The condenser microphone does away with the background noise of the carbon types, and transmission quality is improved. However, the power-supply requirements are increased, instead of being eliminated, and the need for an intimately associated pre-amplifier adds to the size and weight of the unit as well as requiring a five-wire connecting cable where there had been a three-wire one before.

THE MOVING-COIL MICROPHONE

The number of wires in the connecting cable, and hence the chances for

circuit noises, are reduced by the use of the moving-coil type microphone, which cuts the required number to two. It makes possible locating the pre-amplifier at a point remote from the microphone. Hence we find the pre-amplifier moved into the control room, closer to the main amplifier, where it may be under an operator's surveillance.

THE CRYSTAL MICROPHONE

Crystal microphones of the kind usually recommended for broadcasting are generally of the sound-cell type and hence avoid any criticisms that might be voiced about diaphragms, since they have none. They are high-impedance devices, designed to function into loads of several hundred thousand ohms. Some engineers are reluctant to run high-impedance lines from such units more than a few feet to an amplifier because of occasional difficulties that may be encountered due to pickup of extraneous voltages manifested as hums of various kinds. One of the principal advantages of crystal microphones is the excellent transmission that can be achieved with a good grade unit carefully installed.

THE VELOCITY MICROPHONE

There remains for discussion the velocity type of microphones. The ribbon which functions as does a diaphragm in most other microphones seems unlikely

IMPEDANCE MICROPHONE

Technical Director

WCAM

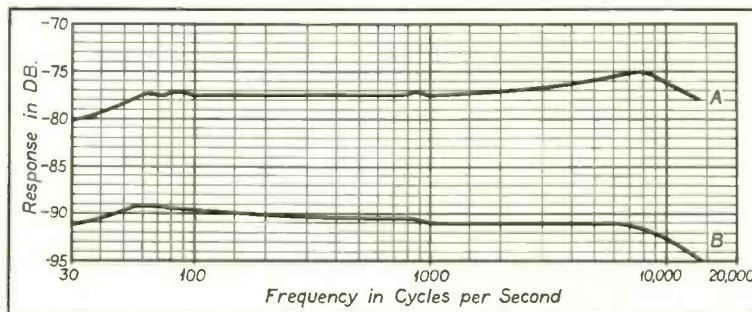
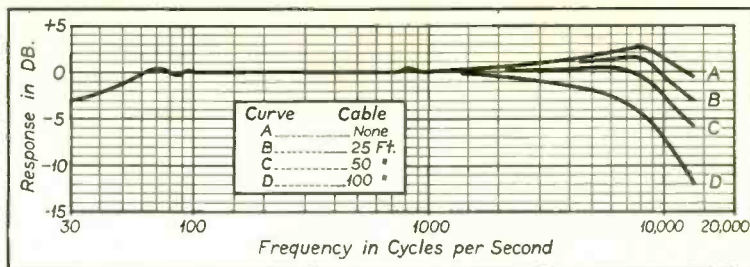

TOP: THE TRANSMISSION CHARACTERISTICS FOR VARIOUS LENGTHS OF MICROPHONE CABLE.

BOTTOM: CURVES SHOWING THE DIFFERENCE IN OUTPUT VOLTAGE AT THE MICROPHONE TRANSFORMER OUTPUT TERMINALS BETWEEN A HIGH-IMPEDANCE TYPE (A) AND A STANDARD 200-OHM OUTPUT TYPE MICROPHONE (B).

to be open to objections concerning the diaphragm, in view of the radically different nature. This belief is supported in practice by the good performance of the type. Unfortunately, great care must be exercised when it is used outdoors where there is wind, and like the moving-coil types, there is a certain minimum distance from mike to performer that must be maintained if bass note emphasis and distortion is to be avoided.

Velocity microphones have a very useful property in their bi-directional qualities, and in their uniform fidelity of reproduction of sounds within the pickup angles. These characteristics can be employed to good advantage in eliminating transmission of undesired sounds, reduction of echo-effects, and general improvement of performance, particularly on remote set-ups where the advantages of a studio installation are conspicuous by their absence. Thorough familiarity with performance characteristics is of inestimable value in the utilization of any type microphone. This is particularly true of the velocity mike.

Being such low-impedance generators, velocity microphones are built with a self-contained transformer to match their characteristics to a realizable line. The practice has been to assume a line with some selected impedance between thirty-five ohms and six hundred ohms, and build the transformer to work from the ribbon into it. This is a very convenient strategem,

since it enables the lines to be carried for quite some distance to the pre-amplifier. There the trouble often begins. Another transformer is needed to alter the circuit impedance, and produce a higher voltage for amplification to the grid of the first tube in the pre-amplifier, which is frequently a two-stage unit. This transformer sometimes contributes undue hum in a-c operated units because of its inductive relationship to other circuit elements. Only the most carefully designed units eliminate this trouble. Frequently the input transformer is kept a few feet from the actual amplifier to reduce such coupling. The point was noted that this trouble is observed in a-c operated amplifiers. While some studio installations can avail themselves of d-c supply, certainly an a-c operated unit will simplify the amount of equipment and the servicing required at remote points. For such work, and for some studios, an a-c supplied unit seems to be satisfactory and desirable.

Thus the problem of hum traceable to the pre-amplifier input transformer remains. One way of eliminating it is to find a way to do away with the transformer altogether. Of course, the crystal microphones do just that, by virtue of its being a high-impedance device to start with; but it will be remembered that we have already noted an objection to high-impedance lines of any length other than very short.

Now let us consider a velocity microphone of the high-impedance type. While the output impedance of this type microphone is higher than normal, it is nowhere near the hundred thousand ohm value. To be specific it is two thousand ohms. This impedance is realized at the secondary of the ribbon-to-line transformer, which is intended to be coupled by means of a low-capacity line directly to the grid of the first tube in the pre-amplifier.

A slight hump in the overall characteristic of the microphone and transformer, reaching a maximum of two and one-half db at 8000 cycles per second, tends to equalize the effects of the cable capacity in attenuating the higher frequencies. The accompanying curves show the transmission characteristic resulting from the use of various lengths of cable, and the curve obtained when no cable at all is used. Also shown is the difference in output voltage, at the microphone transformer output terminals, between the high-impedance type A and the standard 200-ohm output type B. It will be noted first, that the use of one hundred feet of cable produces a loss of only 3.5 db at 7000 cycles, which is about the highest frequency passed by the best phone lines in common use by broadcast stations; and second, that the output voltage is about 10 db higher.

(Continued on page 16)

BRITISH PLANS FOR HOME TELEVISION

By BERNARD H. PORTER

AFTER EXAMINING television systems in their own country and abroad, the British Television Committee have recommended that the British Broadcasting Corporation provide, as soon as possible, official television programs, employing for the purpose apparatus supplied by the companies of Baird and of Marconi, principally among them being the Electrical Musical Instruments, Ltd. The standards of broadcast are to be either a 240-line basis sequential scanning at 25 pictures per second, or a 405-line basis interlaced scanning of 202½-line pictures repeated 50 times a second.

This last August, orders were placed for the necessary television-scanning and radio-transmitting apparatus to be installed at the Alexandria Palace, a site about six miles to the northeast of the center of London. A tower is now being constructed for the purpose of mounting both the vision and sound aerials at a height of 650 feet above sea-level. Progress is also being made by the Broadcast Corporation in providing studios and offices at the Palace, all of which are expected to be in readiness for the first official television broadcasts on or about March 1, 1936. The reported range will be in the order of

25 to 30 miles and will make possible practical home reception for the 405-line transmission standard mentioned above.

The first few months of transmission will, of necessity, be regarded as a trial period inasmuch as experience must be gained in the arrangement of programs and in studio technique. Receiving sets will be available to the general public, at a list price of approximately \$400, as soon as, or possibly a few weeks prior to the time the broadcast service starts. The complete television receiver as it now appears on paper, pending quantity production, contains a kinescope that gives a brilliant black and white picture measuring twelve by nine inches. This size is said to be suitable for entertaining a dozen people or more in the home and capable of being operated in daylight or even with the lights on in the evening. The receiver comprising the vision and sound units, time base or scanning device, power unit, cathode-ray tube and loudspeaker, has in all eighteen tubes. The di-pole form of aerial, found to be best suited for television reception, will be recommended.

The formulation of a definite picture-scanning standard will probably not be

decided until the later months of 1936, although this matter is of considerable importance from the viewpoint of receiver construction of simple operation and reasonable retail price.

Experience gained in operating the first station will then be applied in building other broadcast units throughout the country. It is reported that plans have already been made for covering at least 70 percent of the population of Great Britain by a network of ten television stations erected in the most populous centers. Three to four years will be required to complete such a plan. During this period the price of receivers will be reduced considerably by virtue of the simplification of design and improved production methods* that are now being developed at a very rapid pace. In a recent paper read before the British Association of Engineering it was predicted that "within four years television receivers, available at a price comparable with the present high-grade radio receiver and providing a bright picture of sufficient definition for real entertainment, will occupy the space now devoted in the home to the broadcast receiver."

*See "Cathode-Ray Technique Abroad", RADIO ENGINEERING, December, 1935.

THE HIGH-IMPEDANCE VELOCITY MICROPHONE

(Continued from page 15)

This latter means that the voltage on the line between mike and amplifier is more than three times as great in the case of the high-impedance type, a fact which improves the ratio of signal-to-noise and to extraneous pickup in that circuit. The line impedance is not so high that any great difficulty would be expected from that score anyway. This belief has been substantiated in practice, where it was found that no such difficulties were encountered.

One of the tests of the microphone was conducted in the main studio of WCAM, where it was found that the quality of transmission was suitable for such service. Good use can be made of the bi-directional effect in many cases. This characteristic makes it possible to group sound-sources on both sides of the microphone in some in-

stances. It might also be useful in studios where troublesome echo effects are present, since the "dead" angle of the mike may be turned toward the reflecting surfaces which cause the trouble, and the effect reduced.

Other tests were conducted at remote broadcasting points in regular use by WCAM. In these instances the line amplifier was employed as such. The results were quite acceptable, transmission being uniformly satisfactory. In some instances an improvement in transmission was accomplished through the utilization of the bi-directional qualities of the microphone, to reduce echo effects.

As a result of the tests conducted on several representative remotes, the conclusion was reached that the equipment as tested was suitable for use as

remote equipment, too. The gain of the system was found to be adequate for use on lines of lengths considered representative of those ordinarily used in metropolitan remote service at WCAM. Sufficient signal was received at the monitoring terminal of the line to adequately modulate the speech-input equipment. No objectionable distortion was noted.

"U. S. C. G. AVIATION RADIO"

ON PAGE 8 of the article "U. S. C. G. Aviation Radio", by Herbert Gifford, November, 1935, COMMUNICATION AND BROADCAST ENGINEERING, the comma should be omitted between *Transmitter-Receiver* and *Keys* in the caption for the lower left illustration.

TOP-LOADING ON SMALL PORTABLE-MOBILE ANTENNAS

By JOHN J. LONG, Jr.

Technical Supervisor

WHAM

ACCORDING TO Nickle, Dome, and Brown in the IRE Proceedings for December, 1934, it is possible to get more radiation and a low radiation angle by putting a small capacity and a loading inductance at the top of an antenna whose length does not permit it to be used at a lower frequency with the best possible current distribution for the type of radiation desired.

In mounting an antenna on a mobile unit, it is necessary to get a good signal no matter how the antenna is pointing while in use. This means that a vertical radiator must be used. If a short rod antenna is excited by loading it to a much lower frequency than its fundamental as a quarter-wave radiator, a very strong signal will be obtained close to the antenna, but at a distance the radiation angle is very high and an area of low signal strength quickly sets in.

By using a six-foot aluminum rod and the loaded-top, it is possible to run the current antinode up to the top of the rod, and have the maximum radiation take place where the antenna is out in the clear. The rod may be voltage fed at the bottom by a tuned-feeder system, commonly known as a "Zep" feeder.

At WHAM, we operate our broadcast-pickup transmitter on 2020 kc under the call WJEP and have had much better results since using this type of antenna. It has been possible to install

broadcast while cruising around the grounds of the Rochester Exposition. On election night we installed the equipment in a sedan and drove around the city looking for something rare to put on the air. A fire truck was followed to a fire, and a running description of the event was broadcast while traveling at a fairly high speed.

The WJEP transmitter is operated from a twelve-volt A battery and 500 volts of B battery. It is all contained

the antenna on a regular police motorcycle, and by installing the transmitter in the sidecar we have put on a good

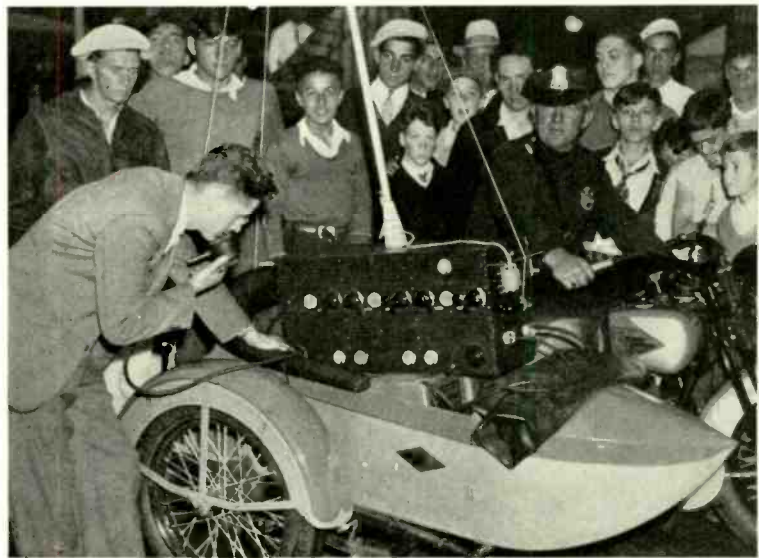

ABOVE: THE LOADED-TOP ANTENNA MOUNTED ON TRANSMITTER CASE IN MOTORCYCLE SIDECAR. THIS IS THE SAME ANTENNA THAT IS SHOWN ON THE CAR.

LEFT: SHOWING THE METHOD OF MOUNTING THE LOADED-TOP ANTENNA ON A CAR. MAXIMUM RADIATION TAKES PLACE AT A POINT WHERE THE ANTENNA IS IN THE CLEAR.

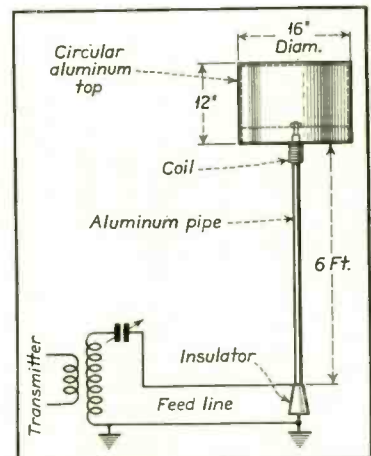

SHOWING CIRCUIT AND GENERAL LAYOUT OF THE PORTABLE-MOBILE ANTENNA USING TOP-LOADING.



WJEP TRANSMITTER SET UP ON COAST GUARD CUTTER "EAGLE" FOR "CANADA CUP" RACES HELD OFF ROCHESTER. THE LOADED-TOP ANTENNA WAS NOT USED FOR THIS SETUP. AS A GOOD ANTENNA WAS ALREADY ON BOARD!

in one unit and consists of an A-cut crystal used with a 210, an 842 buffer, and a pair of 801 tubes in push-pull for

the r-f system. A moving-coil microphone is used with two stages of 76 tubes transformer coupled to a 41 driver,

which works into a pair of 841 tubes in push-pull Class B. This transmitter will deliver twenty-five watts into an antenna with 100 percent modulation.

The only difficulty we experience in broadcasting special events is caused by the high noise level at our receiving location. It is necessary to put a very strong signal into the receiver at all times to ride this noise. This has been corrected to some extent by using a half-wave doublet antenna on top of the ten-story hotel where our studios are located.

We are experimenting with ultra-high-frequency transmission, but have not developed a receiver that will give satisfactory results when located near automobile interference. Nevertheless, the ultra-high frequencies have plenty of possibilities, especially where interference is low, and extreme portability is necessary.

We operate a 75-watt transmitter, W8XAI on 41 mc for experimental broadcasting, and find that we can cover the city with very little trouble from dead spots by locating the transmitter outside of the city and focusing a beam toward the center of population, this procedure eliminating shadows caused by nearby buildings.

MIXER CIRCUITS

(Continued from page 13)

potential), or keeping direct current out of the mixer, which would induce noise into the circuit. Although a master gain control is not an absolute necessity, it is a decided convenience where the monitoring engineer must mix more than two channels and where considerable ranges of gain must be covered. A master gain control is an absolute necessity when the program or recording amplifier is not located within reach of the monitoring engineer.

There are a few minor points to be mentioned. Minor changes in impedance will have no noticeable effect upon the operation of the mixer. It is, however, advisable to have the circuit so wired as to have a low-impedance network still in the circuit when the control is turned to infinity (minimum position). This eliminates the possibility of the mixer opening up if any of the associated equipment is disconnected while the mixer is in the *on* position. In recent design of the actual construction of the fader units, shielding has been found to increase overall rejection

to induction within the mixer and external pickup of noise. Each control should be individually shielded to eliminate cross-talk between fader positions themselves. Another essential characteristic is that each fader should completely cut-off the incoming signal when the fader arm is in the *off* position, thereby eliminating a common fault of poorly-designed faders, namely, leakage.

Because a mixer is usually followed by considerable amounts of amplification, only quiet microphone controls can be used. The determining factor in the selection of any volume control should be its actual performance in service.

Fig. 12 shows a block diagram of a small station layout, whereby a four-position mixer system is designed, with the aid of an adequate switching system, to accommodate eight incoming program elements. Fig. 13 shows one individual dual-control circuit for switching either of two program elements into the same fader position. By tracing the circuit, it will be readily seen that

it is impossible for both program elements to work into the same fader at the same time. An ingenious interlock feature prevents this, thereby maintaining proper impedance characteristics at all times. Fig. 13 is duplicated for each fader position. These circuits were designed by the writer for a station desiring to use one control box housing a four-channel fader system but providing for proper control and simultaneous switching of eight incoming points.

"A STREAMLINED RADIO-COMPASS"

WE ARE INFORMED that all the radio direction-finding equipment described on page 19 of the December, 1935, issue of COMMUNICATION AND BROADCAST ENGINEERING, was built by or under the direction of Edward J. Hefele, and designed for The Airplane and Marine Direction Finder Corp. of Lindenhurst, New York.

BOOK REVIEWS

GRAPHIC COURSE OF PATENT-ABLE INVENTIONS, by H. A. Toulmin, Jr., J.D., Litt.D., LL.D., published by D. Van Nostrand Company, Inc., 250 Fourth Avenue, New York City, N. Y., 40 pages, price \$1.00.

The procedure by which an invention must be cared for from its conception to its final protection in Courts is complicated and as a result has often led to costly mistakes. This book was written to provide a simple, clear explanation of each of the major steps in the life of an invention in its principal phases, which, according to the author, are:

1. The development of an invention from an idea into a tested and completed apparatus or process.

2. The protection of the invention by a patent.

3. The enforcement of the patent in the Courts.

Quoting from the foreword: "The endless questions of clients, the queries of the Courts and the requests for information on these subjects from laymen in all walks of life indicate that such a simple treatment of a complicated subject will be of material help. It is believed the book will also be useful to the engineering fraternity, the general practitioner and the foreign patent agent—all of whom have occasion to deal from time to time with the intricate process of our procedure in granting patents and enforcing patents after they are granted.

"No attempt has been made in this book to provide a practice manual or to create a lawyer out of a layman. It is hoped, however, that this book will provide that enlightened background on the part of the laymen that is necessary for their satisfactory and safe enjoyment of inventions and patent property under the guidance of their general counsel and the practitioners who specialize in the patent law. The best client is a well-informed client."

This book is divided into three chapters. Chapter I is entitled "The Development of the Invention and Its Protection in the Patent Office," while the second chapter covers "Interference Proceedings in the Patent Office." The last chapter deals with the reissue proceedings in the patent office. Each one of these divisions has its appropriate chart, the accompanying text being in

the form of numbered paragraphs referring to the numbered parts of the chart.

For those who are unacquainted with and interested in patent procedure this *Graphic Course of Patentable Inventions* can be recommended.

ELECTRICAL MEASUREMENTS IN PRINCIPLE AND PRACTICE, by H. Cobden Turner and E. H. W. Banner, published by Instruments Publishing Company, Pittsburgh, Pa., 354 Pages, price \$4.50.

As the title implies, this is a practical book covering the field of electrical measurements. It is intended primarily for those technicians who are concerned with the application of electrical measuring devices to specific purposes, but who do not require a textbook involving such mathematical theories of operation as are essential to the student and research worker.

This book presents in a reasonably elementary manner a general account of the types of measurements and measuring instruments with which the application engineer and practical technician are likely to be concerned. The subject matter deals in considerable detail with the common measurements of current, voltage, power and resistance, as well as with the application of electrical devices to the measurement of speed, temperature, illumination, etc., and to numerous miscellaneous measurements of growing commercial importance. In addition, some attention has been given to the more specialized types of measurement involving the use of a-c and d-c potentiometers, a-c bridges, vacuum tubes and the oscillograph.

Electrical units are fully described and lists of symbols and abbreviations for units are given. In general these are the official units recommended by the International Electrochemical Commission and by the British Standards Institution.

Considerations of the accuracy of different measurements are given and the usual limits of accuracy for electrical measuring instruments shown.

The latter part of the book is devoted to instruments as the tools of measurement. Sufficient space is devoted to this topic to indicate their characteristics and limitations. In some instances design data are given for the same purpose.

Electrical Measurements in Principle and Practice is to be highly recommended to all radio engineers, both as a handy reference book and as a practical text.

A FUGUE IN CYCLES AND BELS, by John Mills, published by D. Van Nostrand Co., New York: 269 pages, cloth covers. List price, \$3.00.

The author of this book is well known to most readers for such recent works as "Signals and Speech in Electrical Communications," "Within the Atom" and "The Realities of Modern Science." To the older generation, however, he will always be associated with the earlier work, "Radio Communication." While his best known works are of a strictly non-technical nature, albeit dealing with highly technical subjects, his original work was of a highly technical nature and appeared at a time when literature on radio subjects was anything but plentiful. Few, indeed, of the older men in the radio fraternity have not read and reread his original work.

The author states that this book is written for those who may wish to know what science is doing to music and what it can do for music. This book states the facts in non-technical language, emphasizing not how the wheels go 'round but where they may take us. It is highly readable and interesting both for the material it contains and for the author's inimitable style.

This book is divided into five parts with eighteen chapters in all, dealing with such interesting material as: Electrical Ears, Amplifiers and Engineers, The Power of Music, Electrical Music, and Auditory Perspective. This treatise should have considerable appeal for the non-technical reader, who likes to take his dose of technical information with a coating of non-technical sugar. While there may be no royal road to an understanding of this subject, the author has at least eased the bumps and jolts along the way by the use of homely illustrations taken from every-day life, as well as by his point of attack. The author keeps the reader sufficiently removed from the details so that he can see the forest rather than the trees.

This book is well and entertainingly written and should prove of interest not only to musicians and music lovers, but to the technician as well.

TELECOMMUNICATION

PANORAMA OF PROGRESS IN THE FIELDS OF COMMUNICATION AND BROADCASTING

FACSIMILE SERVICE TO SHIPS

RADIO FACSIMILE will reach out to ships at sea within the next few weeks to transmit weather maps, printed matter and pictures on a regular, scheduled basis. The advance was disclosed recently at the demonstration of receiving apparatus for the service at the Second Annual Marine Exhibition in New York City.

The achievement of a regular facsimile service to ships is a culmination of several years of development by the RCA laboratories, including many experimental tests at sea.

The development of terminal apparatus has been completed, and equipment will be placed on four chosen vessels as they make their next call at the port of New York. The ships are of American, German, Norwegian and Spanish registry, arrangements having been previously made by Charles J. Pannill, President of the Radiomarine Corporation of America when he was in Brussels last summer.

Short waves will be employed for transmission, as in the present commercial transoceanic service of picture transmission. That part of the radio spectrum is best suited to long distance transmission.

The U. S. Weather Bureau will supply the radio company daily with weather maps of the Atlantic, and these will be sent to the ships on two different frequencies, one adapted to transmission up to about 1500 miles, and the other suited to transmission over greater distances. The ship operators will thus be able to select the frequency of most efficient reception for their position. Although the service will at first consist largely of weather maps, the facsimile apparatus will also be tested in the reception of type matter and pictures.

STATION TO STUDY TELEVISION WAVES

THE FEDERAL COMMUNICATIONS COMMISSION has authorized the Columbia Broadcasting System to operate a fifty-watt ultra-short-wave transmitter on channels including 9.5, 8.43, 7.78, and 3.49 meters respectively.

The station, whose call letters are W2XDV, will be located at 485 Madison Avenue and will broadcast from 5 to

10 P. M. daily on 35,600 kilocycles or 8.43 meters.

The new apparatus is especially designed to make a study on the "shadow" effects of skyscrapers upon the ultra-short waves employed for television purposes.

1935 CENSUS OF BUSINESS TO COVER BROADCASTING

THE CENSUS OF BUSINESS, covering the calendar year 1935, which begins January 2, 1936, is the most comprehensive project of its kind ever undertaken, and will, for the first time, include the commercial operations of broadcasting stations.

Comparable projects have been completed in other years, but they were limited. In 1930 a Census of Distribution was taken covering 1929. In 1934 a Census of American Business for 1933 was made, but it was limited to distribution, service businesses, amusement enterprises and hotels.

The rapid changes in our entire economic structure have created a demand on the part of business leaders for more complete data concerning the activities of American Business. Requests from business men and Chambers of Commerce determined the scope of the work. Representative organizations in all business fields are working with the Census Bureau to make the project of maximum value.

It is recognized that the broadcasting industry has already assembled a considerable amount of information dealing with its operations. At no time, however, has a complete canvass been made of revenue, expenses and certain other data. It is the hope of the Bureau of Census to make such a complete canvass in order to provide both the broadcasting industry and the public with a factual picture of this important industry.

Revenue data will be collected in terms of the kind of services rendered by broadcasting stations. Four major breakdowns of gross time sales will be provided; namely, national network, regional network, national non-network spot advertising and local broadcast advertising. The last two will be further divided by revenue received from electrical transcription, live talent, record and spot announcement. Information

covering revenue from the sale of services of talent only will be collected separately.

Total operating expenses will be divided into two groups only, namely, total payroll and all other operating expenses. More detailed information, however, will be collected covering the number of paid employees and weekly payrolls for a sample week (that ending nearest October 26, 1935). Data will be collected separately for full-time and part-time employees who worked during this sample week. Employees will be grouped according to the particular functions performed. The following classifications will be used: Executives and salaried officers, supervisory employees, office and clerical workers, operation and maintenance employees (technicians, repairmen, etc.), those furnishing entertainment (singers, speakers, musicians, script writers, players, etc.), and announcers.

Other information to be collected will include the affiliation of stations with networks, the character of such affiliation and the rated power of the station for both daytime and night broadcasting.

Information is to be collected from individual broadcasting stations. No information will be published which would in any way disclose the identity of an individual broadcaster. The data from these individual organizations will be combined, published and made available to all those interested in the broadcasting field. Stations will be grouped by geographical areas and information published accordingly. It will be possible to know after this Census has been completed the number of broadcasting stations, their operating revenue and expenses, by State areas. Where a State has only one or two stations, however, it will be impossible to give out this information since the identity of such stations would thus be disclosed.

Only sworn employees of the Bureau of the Census are permitted to examine individual returns. No access to them is permitted under the law, not even to other Governmental agencies, and no information will be disclosed which would reveal any of the facts or figures in the returns.

Headquarters for the project have been set up in Philadelphia, with Fred A. Gosnell, experienced head of former business censuses, Chief Statistician in

charge. The field work will be completed within three months after enumeration starts. The first preliminary reports, by States, will be issued about July 1, 1936. Soon after state reports are completed, special statistics for broadcasting will be released as rapidly as possible. (Ralph L. Dewey, Chief, Transportation and Communications Division, Bureau Census Branch, Bureau of Census, Department of Commerce.)

MYSTERIOUS RADIO INTERFERENCE

THAT RADIO EMISSIONS from unknown sources mysteriously invade different parts of the short-wave band at irregular intervals has been disclosed by William A. Winterbottom, Vice-President and General Manager of RCA Communications, Inc.

Because of their unpredictable raids into marine, transoceanic, aircraft, military, naval, amateur, and probably also in the television sections of the radio spectrum, the strange radio signals have become known to engineers as "the shadow." It is a facetious nickname, but the hunt for the source of these sounds in space is nevertheless determined.

These radio waves have not the character of telegraphic or telephonic signals, and are definitely unrelated to any "static" or cosmic-ray phenomena within the experience of engineers. Unlike static, they are usually observed on definite frequencies. Their "fingerprints" have been taken in the form of phonographic recordings of the weird sounds they produce, and the engineers are slowly but surely "closing in" on the answer to the mystery.

Through the past year "the shadow" has been most active in the frequency

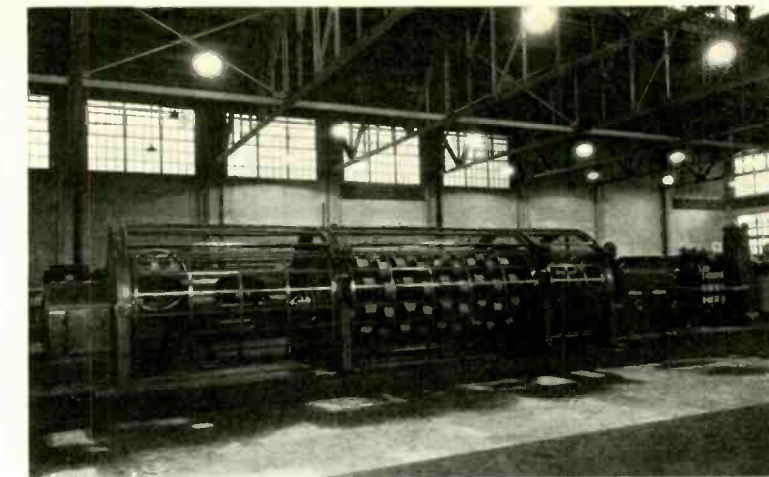

FLYER-TYPE STRANDER AT THE KEARNY, N. J., WORKS OF THE WESTERN ELECTRIC COMPANY.

band between 11,000 and 14,000 kilocycles, although it has been observed as low as 6,000 kilocycles and as high as 18,000.

At stations of the radio companies in the eastern United States the mysterious signals are most frequently observed between the hours of 9 a. m. and 6 p. m. But it is already known that "the shadow's" operations are by no means limited to this section of the country, for they have been observed on both coasts and at points in between.

So far the radio-communication and broadcasting companies have had no serious difficulty in circumventing the interference caused by the mystery signals. But there is little doubt that the public who listen in on short-wave bands have already suffered considerable inconvenience, and may expect still more, for within the last six months "the shadow" has become increasingly active in the United States.

Engineers are confident that, from whatever source the mystery waves may come, they are not being employed in any known form of communication. It is therefore possible, if not probable, that whoever is generating the waves may be entirely unaware of the interference they are setting up. Were they carrying intelligence of any nature, this would supply important clues to their origin. But as it is, the searchers must rely entirely on analysis of waves by scientific devices in their approach to a solution of the mystery. It has already been determined that the power sources of the waves are of two types; on some occasions the signals are produced by half-wave rectified power, and on others by a full-wave rectified source.

ELECTRON IMAGE TUBE

A NEW, electron image tube, enabling man to see through the dark, was described and demonstrated, January 2, 1936, before the American Association for the Advancement of Science meeting in St. Louis, by Dr. V. K. Zworykin and Dr. George A. Morton of the Radio Corporation of America Laboratories.

In the accompanying illustration the image tube (at the right) is used with an infra-red microscope. By means of this device, sensitive to infra-red rays, it is foreseen by some that the development of minute living organisms may be brought within the range of human vision. Such cells have been studied in the past by means of intense light or stains, that often kill them.

The assembled scientists witnessed the projection of motion pictures through a dark glass filter that stopped all visible light rays. An "electron telescope," using the same principle and opening the possibility of seeing through atmospheric haze, also was demonstrated.

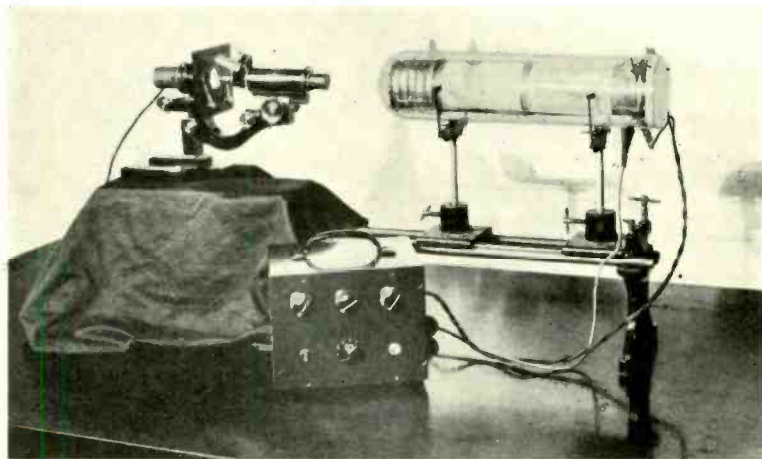

THE ELECTRON IMAGE TUBE.

FEDERAL COMMUNICATIONS COMMISSION REPORTS

FEDERAL RADIO EDUCATION COMMITTEE

THE COMMISSION, Broadcast Division, has announced that in compliance with the statements made by the Commission in its Report to Congress pursuant to Section 307 (c) of the Communications Act of 1934, a committee to be known as the Federal Radio Education Committee has been organized. Dr. John W. Studebaker, United States Commissioner of Education, has accepted the chairmanship of the committee.

Invitations for membership on the committee were sent to eminent persons in the field of education and broadcasting. The letter extending invitations is quoted in part as follows:

"Section 307 (c) of the Communications Act of 1934 provides as follows:

"The Commission shall study the proposal that Congress by statute allocate fixed percentages of radio broadcasting facilities to particular types or kinds of non-profit radio programs, or to persons identified with particular types or kinds of non-profit activities, and shall report to Congress, not later than February 1, 1935, its recommendations together with the reasons for the same."

"As a means of carrying out the wishes of Congress the Broadcast Division, by direction of the Commission, held public hearings from October 1 to 20 and from November 7 to 12, 1934. A total of 1535 notices of the hearing were sent to all parties of record at the Commission and wide publicity was given the matter so that anyone interested might be informed of the hearing. A total of 135 witnesses appeared and 14,000 pages of testimony were presented for the Commission's consideration in addition to several thousand pages of exhibits.

"As a result of these hearings, the Commission, on January 22, 1935, submitted to Congress a report which contained the following recommendation:

"The Federal Communications Commission respectfully recommends that at this time no fixed percentages of radio broadcast facilities be allocated by statute to particular types or kinds of non-profit radio programs or to persons identified with particular types or kinds of non-profit activities."

"In its report to the Congress the Commission proposed to hold an educational conference at which time plans for mutual cooperation between broadcasters and educational organizations could be made. That conference was held on May 15, 1935. It is the sincere belief of the Commission that the hearings, conferences, and constructive thought and experience given to this subject have produced a situation whereby within the present broadcast structure the educators on the one hand, and the broadcasters on the other, can combine forces which will:

"1. Eliminate controversy and misunderstanding between groups of educators and between the industry and educators.

"2. Promote actual cooperative arrangements between educators and broadcasters on national, regional and local bases.

"A sufficient budget for expenses of the committee has been pledged, half of it by the National Advisory Council on Radio in Education on behalf of educational in-

terests and half by the National Association of Broadcasters on behalf of broadcast stations. It is expected that a small planning committee will be organized for the purpose of collecting and correlating data on which the main committee may base its deliberations, thus reducing to a minimum the amount of time the full committee will have to give, consistent with a fair and impartial consideration of the subject. This small committee may also undertake certain definite projects in keeping with the general purposes of the committee.

"The Commission is too familiar with the whole scope of educational broadcasting, its limitations and its possibilities, to expect any panacea, but we do believe that coordination and cooperation at this time will give results to the end that radio broadcasting can be further utilized as an effective medium for education."

The letter was sent to forty persons. The acceptances are listed below:

Mr. Waldo Abbott, University of Michigan.
Mr. Merlin Aylesworth, President, National Broadcasting Company.

Mr. James W. Baldwin, Managing Director, National Association of Broadcasters.

Mr. Edgar Bill, Radio Station WMBD.
Dr. S. Parkes Cadman, Federal Council of Churches of Christ in America.

Dr. Morse A. Cartwright, Director, American Association for Adult Education.

Dr. W. W. Charters, Director, Bureau of Educational Research, Ohio State University.

Dr. Harry W. Chase, Chancellor, New York University.

Mr. Gardner Cowles, Jr., Des Moines Register.

Mr. Lester E. Cox, Radio Station KWTO.
Mr. Edwin Craig, Radio Station WSM.

Dr. A. G. Crane, President, University of Wyoming.

Dr. Walter Damrosch, National Broadcasting Company.

Mr. Milton S. Eisenhower, Director of Information, Department of Agriculture.

Mr. John Elmer, Radio Station WCBM.
Mr. O. B. Fisher, Station KOMO.

Mr. Leo J. Fitzpatrick, President, National Association of Broadcasters.

Mr. Willard Givens, Secretary, National Educational Association.

Mr. Tom C. Gooch, Daily Times Herald.
Mr. William Green, President, America Federation of Labor.

Mrs. Rose Jacobs, President, Hadassah Women's Zionist Organization.

Father Geo. W. Johnson, Catholic University of America.

Dr. C. B. Jolliffe, Radio Corporation of America.

Mr. Lardin Kay, Station WSB.

Mr. John F. Killeen, Director of Broadcast Division, Federal Communications Commission.

Dr. Cline M. Koon, Office of Education, Dept. of Interior.

Mrs. B. F. Langworthy, President, National Congress of Parents and Teachers.

Miss Luella S. Laudin, Women's National Radio Committee.

Mrs. H. B. McCarty, President, National Association of Educational Broadcasters, University of Wisconsin.

Mr. A. J. McCosker, President, Bamberger Broadcasting Service Inc.

Mrs. Harold V. Milligan, President, Women's National Radio Committee.

Dr. Robert A. Millikan, President, California Institute of Technology.

Mr. William S. Paley, President, Columbia Broadcasting System.

Mr. A. D. Ring, Assistant Chief Engineer, Federal Communications Commission.

Mr. John Shepard, III, President, Shepard Broadcasting Company.

Dr. Levering Tyson, Director, National Advisory Council on Radio in Education.

ANNUAL REPORT FORM M

THE TELEPHONE DIVISION has adopted the Annual Report Form M for Telephone Companies for the year 1935. Among the changes incorporated in the report are the following:

(a) A segregation of plant and operating statistics by States or territories is provided for instead of on the basis of aggregate returns as heretofore reported.

(b) In cases where a carrier prepares a report to stockholders containing a consolidated system balance sheet, income statement, and surplus statement, they have been requested to show similar data in their annual report to the Commission.

(c) The address, as well as the name, of controlling and affiliated companies has been requested to permit the identification of the companies and to facilitate the checking of the intercorporate relations.

(d) A new schedule has been inserted, requiring telephone carriers to give detailed information with respect to their relief and pension funds.

(e) Three schedules have been inserted which require carriers to show data concerning private line statistics, teletype-writers on customers' premises in teletype-writers exchange service, and statistics concerning other stations.

(f) Carriers will be required to show the total amount actually paid to each officer and each director earning \$10,000 or more, during the year, in addition to the data previously shown in the report.

(g) A schedule has been inserted requiring telephone carriers to list all contracts and agreements which became effective during the year; and advised that in lieu of giving abstracts, copies of the contracts may be filed.

RADIOTELEGRAPH LICENSES

THE TELEGRAPH DIVISION on November 26 set for hearing in part the applications for renewal of licenses filed by a number of radiotelegraph companies. The parts set for hearing covered points outside of the United States to which, according to the information in the possession of the Commission, no traffic was transmitted during the preceding license period. The Division will entertain motions to reconsider and to grant without hearing the renewal licenses where the applicants can show that the Commission's information was incomplete and that the circuits were active during the preceding license period.

CLASS A AND CLASS B TELEPHONE CARRIERS

COMMUNICATIONS RECEIVED by the Commission from accounting officers of certain tele-

phone carriers indicated that a misunderstanding existed with respect to the status, after December 31, 1935, of the accounting regulations relating to the breakdown of the depreciation reserve account into component parts corresponding to the primary telephone plant accounts.

All provisions of the uniform system of accounts for telephone companies promulgated under Telephone Division Order No. 7-C, of June 19, 1935, including those relating to the breakdown of the depreciation account, became effective on January 1, 1936. Particular attention is directed to the pertinent provisions of paragraph (C) of Account 171, "Depreciation Reserve."

Carriers addressed shall break down the balance of their respective depreciation reserves (Account 171, "Depreciation Reserve") in such manner as to show the amounts embraced therein in accordance with the historical developments of such reserves with respect to each depreciable plant account, and shall report such breakdown in the appropriate schedules of the annual reports to the Commission.

COMMISSION INVESTIGATING CANCELLED GENEVA BROADCAST

THE COMMISSION, on November 15, sent the following letter to the American Telephone and Telegraph Company, the Radio Corporation of America, and the Columbia Broadcasting System:

"During the meeting held by this Commission on October 23, 1935, a motion was adopted directing that the facts be ascertained so far as they relate to the American communications companies under the regulation of this Commission, as to the alleged cancellation of a broadcast to this country from Geneva by Delegate Baron Pompeo Aloisi on October 10, 1935. In connection with the investigation a reply to the following questions should be submitted, together with any additional information pertinent to this incident.

1. On what date or dates were arrangements made for this broadcast and for what hour and date was it set?

2. With whom and by whom were such arrangements made?

3. Did the British Post Office officials authorize this program? If so, was the decision to cancel the transmission made at the last minute?

4. Give the plan of the communications' routing of the speech in question, i. e., from Geneva to the United States, listing each intermediary point and the identity of each transmitting agency along the route of communications.

5. Give a list of the call letters of the stations in this country which had scheduled the speech in question.

6. When was information first received and from whom, indicating that the British Post Office authorities declined to relay the interview? (Quote the communication which contained such information.)

7. After information was received indicating the attitude of the British Post Office authorities, was any attempt made to obtain reconsideration of its decision, and if so, what were the steps taken?

8. If any efforts were made by you to transmit the speech in question through any other routing, submit the facts in detail with regard thereto.

9. Submit certified copies of all contracts, agreements, and correspondence in your possession which in any way relate to the incident in question.

"In connection with the rebroadcast of the Aloisi speech from Rome, on October

13, 1935, the following questions should be answered:

10. On what date were arrangements made to pick up the speech direct from Rome?

11. Through what officials were these arrangements made?

12. Give the name, frequency, call letters, and power of the station transmitting the speech from Rome.

13. What receiving station in the United States was used to pick up this program?

14. What means were used to transmit the program from the American receiving station to the headquarters of the Columbia Broadcasting System and through what official were those arrangements made?

"The specific information answering the above questions should be submitted in the form of an affidavit and should be forwarded so as to reach the Commission not later than November 30, 1935."

PAYNE GIVES ADDRESS AT SYRACUSE

THE FORTH of a series of addresses delivered before prominent universities by George Henry Payne, Federal Communications Commissioner, was given at Syracuse University on December 16, 1935. The previous three addresses were delivered at Harvard University on May 14, 1935, Cornell University, August 21, 1935, and at Columbia University, October 31, 1935, respectively.

APPLICATIONS GRANTED FOR NEW STATIONS

Telegraph Division

November 19, 1935.

DEPARTMENT OF PUBLIC SAFETY, Passaic, New Jersey, granted construction permit, general experimental, 30,100, 33,100, 37,100, 40,100 kc, 50 watts.

AERONAUTICAL RADIO INC., Aberdeen, South Dakota, St. Paul, Minnesota, Sioux City, Iowa, Kansas City, Missouri, Bismarck, North Dakota, Sioux Falls, South Dakota, Omaha, Nebraska, granted construction permits, aviation aeronautical, 5887.5, 2994 kc, 50 watts.

AERONAUTICAL RADIO INC., Shreveport, Louisiana, granted construction permit, aviation aeronautical and aeronautical point-to-point, (a) 2854 kc unlimited, 5707.5 kc day only; (b) 2608 kc; 100 watts, (A1, A2, A3 on (a), A1 on (b)).

TOWN OF WESTERLY, Rhode Island, granted construction permit, general experimental, 30,100, 33,100, 37,100 40,100 kc, 25 watts.

MACKAY RADIO AND TELEG. CO., Palo Alto, California, granted license to cover construction permit, fixed public point-to-point telegraph service, 4665 kc, 2 kw.

CONSOLIDATED TIMBER PROTECTIVE ORGANIZATION, Homer, Georgia, granted construction permit, special emergency, 2726 kc, 100 watts.

LOCKHEAD AIRCRAFT CORPORATION, NC-14971, NC-14972, NC-14973, temporary authority to operate on 2870, 3082.5, 5375, 5692.5, 6570, 8220, 12,330, 16,440 kc unlimited; 2986 kc available for use in Pacific area only; 5165 kc; 20 watts. November 26, 1935.

ALASKA JUNEAU GOLD MINING CO., granted construction permit and license, portable, emergency service, 2726 kc, 3.5 watts.

AERONAUTICAL RADIO INC., Daytona Beach, Florida, Murfreesboro, Ten-

nessee, Indianapolis, Indiana, Vere Beach, Florida, granted construction permits, aeronautical, 2922, 2946, 2986, 4122.5, 5652.5 kc, 40 watts.

THOMAS O. LAIRD, Irvington, New Jersey, granted construction permit and license, 31,100, 31,600, 34,600, 35,600, 37,600, 38,600, 40,600, 41,000, 86,000-400,000, 401,000 kc and above, 100 watts. Also granted construction permit for similar equipment, portable-mobile, 25 watts.

CITY OF NEW LONDON, Connecticut, granted construction permit, emergency police, 2466 kc, 50 watts.

TERRITORY OF ALASKA, Kake, granted authority for point-to-point telegraph and telephone station, 3092.5. 2616 kc, 40 watts.

TOWN OF MORRISTOWN, New Jersey, granted construction permit, general experimental, 30,100, 33,100, 37,100 40,100 kc, 5 watts. Also granted construction permits (2 applications), mobile.

CITY OF ELGIN, Illinois, granted construction permit, general experimental, 30,100, 33,100, 37,100, 40,100 kc, 50 watts. Also granted similar construction permits (4 applications), portable-mobile, 5 watts.

PAN AMERICAN AIRWAYS INC., New York City, NC-15373, granted temporary authority pending receipt and action on application, 20 watts.

SANFORD AIRWAYS INC., NC-15237, granted license, itinerant. December 3, 1935.

J. T. MELTON, NC-14060, granted license to cover construction permit, 3105. 3120 kc, 25 watts.

CITY OF CEDAR RAPIDS, Iowa, Police Department, granted construction permit, portable, general experimental, 30,100 kc, 10 watts.

TERRITORY OF ALASKA, Hoonah, granted construction permit, point-to-point telegraph, 3092.5 kc, 40 watts.

COUNTY OF MONMOUTH, County Welfare House, Brier Hill Road, Freehold, New Jersey, granted construction permit, police service, 2366 kc, 100 watts.

Broadcast Division

November 19, 1935

MONUMENTAL RADIO COMPANY, Baltimore, Maryland, granted construction permit, general experimental, 31,600, 35,600, 38,600, 41,000 kc, 300 watts.

E. ANTHONY AND SONS INC., Fairhaven, Massachusetts, granted construction permit, general experimental, 31,600, 35,600, 38,600, 41,000 kc, 100 watts.

LAKE REGION BROADCASTING CO., Lakeland, Florida, granted construction permit, 1310 kc, 100 watts, 6 AM to local sunset.

HAZELWOOD INC., West Palm Beach, Florida, granted construction permit, 1200 kc, 100 watts, unlimited time.

November 26, 1935.

PAMPA DAILY NEWS INC., Pampa, Texas, granted amended construction permit, 1310 kc, 100 watts, daytime, site to be determined.

NICHOLS AND WARINNER INC., Long Beach, California, granted construction permit, portable-mobile, general experimental, 31,100, 34,600, 37,600, 40,600 kc, 30 watts.

December 3, 1935.

MEMPHIS COMMERCIAL APPEAL INC., Memphis, Tennessee, granted construction permit, broadcast pickup, 31,100, 34,600, 37,600, 40,600 kc, 5 watts.

BAMBERGER BROADCASTING SERVICE INC., Newark, N. J., granted construction permit, general experimental, 31,600, 35,600, 38,600, 41,000 kc, 1 kw.



VETERAN WIRELESS OPERATORS ASSOCIATION NEWS

W. J. McGonigle, Secretary, 112 Willoughby Avenue, Brooklyn, N. Y.

ELECTION OF OFFICERS

AT THE ANNUAL meeting of the Veteran Wireless Operators Association, Inc., held at the Hotel Montclair at 6 p.m. on January 8th, 1936, the following Officers and Directors were elected by sealed ballots which had been sent the membership following the December meeting and returned to the Secretary in time for the Annual meeting—Peter Podell and Charles E. Pearce acted as tellers upon appointment by President Clark—George H. Clark, Radio Corporation of America, President; Charles W. Horn, Director of Development and Research, NBC, Vice-President; William J. McGonigle, New York Telephone Company, Secretary; Paul K. Trautwein, President Mariners Radio Service, Treasurer. The Directors elected are: Harvey Butt, Radiomarine Corp. of America; A. J. Costigan, Traffic Superintendent, Radiomarine Corp. of America; Harry F. Coulter, Comptroller, Radiomarine Corp. of America; Wm. S. Fitzpatrick, Publicity and Advertising, RCA Institutes; Charles D. Guthrie, Mackay Radio and Telegraph Company; Arthur A. Isbell, Manager Commercial Department, RCA Communications, Inc.; William J. McGonigle, New York Telephone Company; Fred Muller, Electrical Reproducers, Inc.

DINNER HOOK-UP

A LETTER on War Department stationery addressed to the Secretary reads in part as follows: "Acknowledging your letter of December 3rd, I am pleased to inform you that the Army Amateur Radio System will be happy to assist in the exchange of greetings between the various dinners given by your organization on February 11, 1936. The plans you have made are satisfactory." Signed—Malin Craig, Chief of Staff.

The Army Amateur Radio System with stations in all of the cities in which Chapters of the Veteran Wireless Operators Association will hold dinners will endeavor to make direct contact between each of the Chapter dinners and the New York affair. They are providing us with a clear channel on both 3497.5 kc and 6990 kc from 10:30 to 11:00 p.m. E. S. T. on the 11th of February, 1936.

HONOLULU CHAPTER

THE HONOLULU CHAPTER of our Association has gotten under way with George Street, Superintendent, RCA Communications in that city, acting as Chairman and Arthur Enderlin of the Mackay Radio and Telegraph Company acting as Secretary. George Street in a recent letter tells us that plans are developing at a great rate and that there are excellent prospects of a record turnout at their dinner on the 11th. The Army Amateur Radio System Station in Honolulu working in the net that evening will be either WVQ, Captain H.

P. Roberts, Fort Shafter, Honolulu, or WVQB-K6ewq, Sgt. Atlas O. Adams, Hqtrs. Company, 21st Brigade, Schofield Barracks, T. H. In writing of the Honolulu Dinner-Cruise, George Street calls it a LUAU—Hawaiian for feast—and in the same communication requests many application blanks.

MIAMI CHAPTER

THE MIAMI CHAPTER is going great guns with V. H. C. Eberlin, former Treasurer of the Association, acting as Chairman and C. J. Corrigan acting as Secretary. "Ebbie" has sent the applications of: Oliver M. Lewis, at present stationed at Miami with the Bureau of Air Commerce and a professional operator since 1923; Lester C. Bishop, who has also operated professionally since 1923 and is at present employed in Miami by the Eastern Air Lines; R. D. Phillips, who saw service on numerous ships of the United States Navy and at present is with the Eastern Air Lines; David Harpley, another Miamian, who has operated professionally since 1930 on several ships and at Goodyear ground stations.

The station in the Army Amateur Radio System to be used as the Miami contact has not yet been decided upon. From present indications, with the excellent support "Ebbie" is getting from C. J. Corrigan and Joseph McKinney, Radio Inspector for the Federal Communications Commission in Miami, the Miami Dinner will be a most successful affair.

News items from the Miami Chairman:

At a recent meeting of the Coast Guard the operators from the S. S. Dixie were given a big hand for their good work and smooth handling of the situation.

The key's radio link, now an emergency unit manned by Naval Reservists, is being taken over by commercial licensed operators.

Karl Baarslag of "S O S To The Rescue" fame is in and about town—he is now attached to a yacht.

C. J. Corrigan received a Testimonial letter from the Navy Department for his recent work in connection with the recent disaster on the keys.

BOSTON CHAPTER

THE BOSTON CHAPTER, under the able leadership of Charles Kolster, Radio Inspector for the Federal Communications in Boston, as Chairman, and Harry R. Chetham, Chief Radio Operator of the Somerville Police Department, as Secretary, progresses rapidly with Harry sending in several applications every couple of days. A few recent ones follow: Samuel Curtis, Director of the Curtis Radio School, who operated in the Navy back in 1913; Wallace A. Battison, who began his professional radio operating career in 1915 and has done experimental and broadcast work

as well as ship operating; Walter Butterworth, a Radio Inspector when the Department of Commerce handled radio communication regulation then with the Federal Radio Commission in the same capacity and now with the FCC as Radio Inspector; R. Keith Bullard who started back in 1920, his experience covering shipboard, amateur, and aviation radio; Herman L. Bruning, who operated in the U. S. Army at various stations from 1908 to 1918 and is at present with HC at Somerville Police Radio; Arthur E. Ridley, a real oldtimer having started with the old United Wireless Company in 1902; Dr. Arthur Summers, shipboard operator and broadcast station technician from 1919 to 1929.

There are numerous other applications which Harry has sent in and we but mentioned their names in previous issues. Some of these men are the real pioneers of the radio art and we shall in a future issue enumerate some of their accomplishments and service dates, some of which go back as far as 1901—as is the case with Arthur Stockellburg and Harry Chetham, himself.

The Boston Army Amateur station will be either WLGL-W1PI, Fred C. Bigelow, 148 Arlington Street, Hyde Park, Mass., or WLGO-W1WV, Miles W. Weeks, 40 Norfolk Road, Brookline, Mass.

Best wishes to the Boston Chapter on their Second Annual Cruise coincident with the 11th Annual Cruise of the New York group.

CHICAGO CHAPTER

PLANS for the Second Annual Cruise of the Chicago Chapter, which will be held at a leading hotel in Chicago on the night of February 11th, 1936, are well underway and under the capable leadership of George I. Martin, Superintendent RCA Institutes in that city, acting as Chairman, and B. R. Donges, Maintenance Supervisor of the National Broadcasting Company, acting as Secretary. They have recently sent in several more applications and requested a goodly number of application blanks. Their dinner will be tied in with the New York affair through one of the Army Amateur stations in that city, probably WLT-W9DOU, Radio Aide Lieut. Charles W. Roth, 329 South Cuyler, Oak Park, Ill.

We look forward with a great deal of pleasure to tying up with the Chicago dinner again this year. Best of luck GIM and BRD.

SAN FRANCISCO CHAPTER

THE SECOND Annual Dinner-Cruise of the San Francisco Chapter bids fair to outdo their first cruise which was held coincident with the Tenth Annual Cruise of the New York group. Ample support for the affair is assured with Fred L. Dewey, Metropolitan Manager for Mackay Radio, Thomas Stevens, General Superintendent Pacific Division of the Radiomarine Corporation, V. Ford Greaves of the Federal Communications Commission, P. D. Phelps of the Mackay Company and Ray Meyers of Radiomarine, who did a splendid job as Secretary last year—all will undoubtedly turn in an equally good performance this year.

The Army Amateur link in that section will be WLVB-W6RJ, J. H. MacLafferty, Jr., Radio Aide, 230 Mathewson Street, Oakland, Calif.

Bon voyage SF and a pleasant trip. We'll be looking for you on the air.

(Continued on page 30)

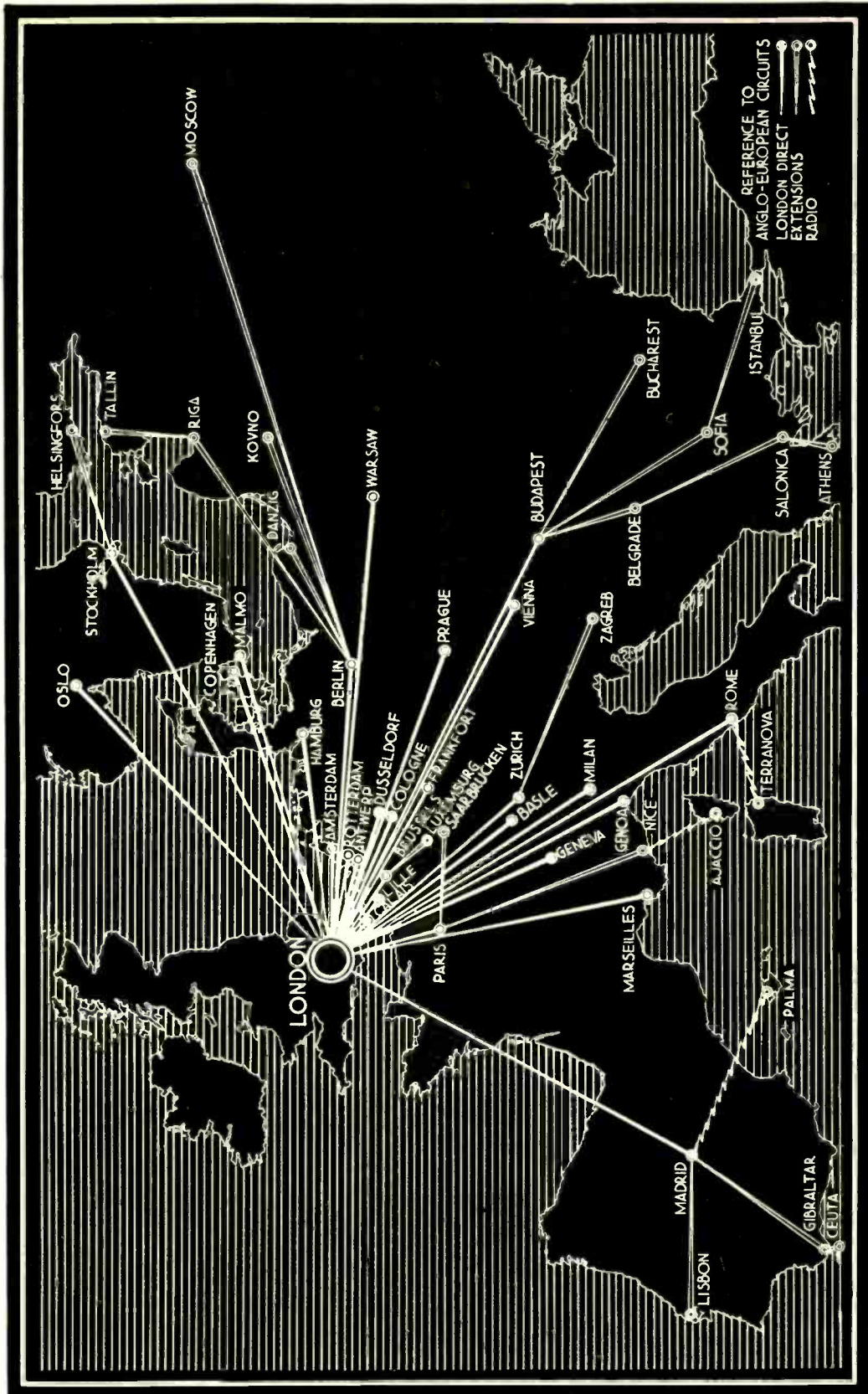

MAP No. 14 -- Anglo-European Telephone Communications.

OVER THE TAPE...

NEWS OF THE RADIO, TELEGRAPH AND TELEPHONE INDUSTRIES

AYLESWORTH RESIGNS

David Sarnoff, President of the Radio Corporation of America and Chairman of the Board of Directors of the National Broadcasting Company, recently made the following statement:

"The National Broadcasting Company, at its regular meeting of Directors held December 27, accepted with regret the resignation tendered by Merlin H. Aylesworth, as President of the NBC. He asked to be relieved from the responsibilities of this office because of the increased duties he has assumed as Chairman of the Board of Directors of the Radio-Keith-Orpheum Corporation, to which office he was elected last month. Mr. Aylesworth remains as a member of the Board of Directors of the NBC, and in order that the Company may continue to have the benefit of his long experience and advice in the field of broadcasting, he has been elected to the newly created office of Vice-Chairman of the Board of the NBC.

"To fill the vacancy created by Mr. Aylesworth's resignation, Mr. Lenox R. Lohr has been elected President of the NBC and assumed his new duties on January 1, 1936."

NEW ORGANIZATION

A new organization, Dencose Incorporated of New York City, has recently been formed for the manufacture of sound-recording and reproducing equipment, aluminum recording discs, public-address systems and the like.

Mr. E. A. Dennis, as vice-president and chief engineer of this organization, will carry on research in the field of instantaneous recording, in the development of new reproducers.

"BRUSH STROKES"

"Brush Strokes" for November, 1935, contains, among other things, some interesting information on the new B-2S sound-cell microphone, an audio noise meter and survey on six different types of microphones, namely the carbon, condenser, soundcell crystals, ribbon, dynamic and diaphragm crystal.

"Brush Strokes" is published monthly by The Brush Development Company, East 40 Street at Perkins Avenue, Cleveland, Ohio.

INCREASED SALES FOR WESTERN ELECTRIC

In a New Year's message to employees issued December 30, Edgar S. Bloom, President of the Western Electric Company, states that sales for 1935 will be over \$104,000,000 as compared with \$91,807,000 for 1934.

As a result of this increase in activity, Mr. Bloom points out, it was possible during the latter part of the year to reengage many of the Company's former employees, and to provide five days of work a week for a substantial majority of its employees.

QUINBY JOINS WESTERN ELECTRIC

Edwin Jay Quinby has joined the public relations department of the Western Electric Company in an editorial capacity. He is located at the Company's headquarters, 195 Broadway, New York.

Mr. Quinby was formerly a member of the publicity and advertising department of RCA-Victor where he founded and edited that Company's sales publication, "Broadcast News." Previously, he was associated with Bell Telephone Laboratories as an engineer.

IRE FORMS NEW SECTION

The eighteenth section of the Institute of Radio Engineers was authorized by the Board of Directors at its December meeting. This section will be known as The Emporium Section with headquarters at Emporium, Pennsylvania. The organization meeting was held on December 12, 1935, with E. Finley Carter, Sylvania division engineer of Hygrade Sylvania Corporation, acting as temporary chairman.

Officers elected for the year were: R. R. Hoffman, chairman; Herbert A. Ehlers, vice-chairman; Lloyd N. West, secretary. Virgil M. Graham, who has recently been elected to membership on the IRE Board of Directors, was appointed chairman of the Meetings and Papers Committee for the Emporium Section.

Harold P. Westman, IRE National Secretary, who made a special trip to Emporium to attend the initial meeting, spoke briefly on the history of the Institute and the responsibilities of a section. George C. Connors, of New York City, and Charles E. Marshall, of Chicago, spoke on "The Work of a Field Engineer". These two papers were discussed by Walter R. Jones of Emporium.

Although the newest, The Emporium Section is far from being the smallest. About forty new applications for membership have been received since the organization. These will bring the total membership of the section up to seventy or more.

The fact that this is the first section in seven years to secure sanction from the Board of Directors for organization is a compliment to the engineering activity in the Emporium District.

HAMMARLUND CATALOG "36"

The Hammarlund Manufacturing Company, Incorporated, 424-438 West 33rd Street, New York City, now have available their new Catalog "36". This 12-page catalog covers condensers, coil forms, sockets, transformers, chokes, shields and other products for ultra-short-wave, short-wave, and broadcast receiving and transmitting use. The numerous items are illustrated, technical descriptions, charts, diagrams, curves, and the like, being included. Of special interest is the new Hammarlund "Super-Pro" Communications Receiver, a 16-tube superheterodyne licensed under RCA and Hazeltine patents.

VANDEBURG RECEIVES APPOINTMENT

Clyde Vandeburg, formerly in charge of the radio and public-address division at the San Diego Exposition, has been appointed to a similar position with the Texas Centennial Exposition, according to Frank Watson, director of promotion for the celebration. Mr. Vandeburg was in charge of the magazine division at the Texas Centennial until the appointment.

WESTINGHOUSE OPENS JUBILEE YEAR

In commemoration of its 50th birthday, on January 8, Westinghouse held a "family" gathering for the 12,000 employees in their Pittsburgh district with simultaneous meetings of Westinghouse employees in every important Westinghouse factory and office in the country. Specifically, the occasion celebrated the 50th Anniversary of the granting of the charter to the Westinghouse Electric Company.

A unique feature of this "family" gathering of 40,000 employees was that the complete Pittsburgh program was broadcast to all of the other meetings in plants and districts over Westinghouse's own short-wave transmitter W8XK (on both 25.26 and 48.83 meters) and was also picked up by International representatives and friends in foreign countries.

At Pittsburgh, the meeting was addressed by Chairman A. W. Robertson, President F. A. Merrick and other national figures from outside the Company. These speakers reviewed the important contributions that Westinghouse has made to the progress of industry and presented a forecast of the future. Westinghouse's new institutional sound picture for its Golden Jubilee called, "The New Frontiers" was shown to employees.

NEW STRUTHERS DUNN CATALOG

An interesting and colorful catalog consisting of twenty-eight pages and cover has just been issued by Struthers Dunn Inc., 139 North Juniper St., Philadelphia, Pa.

It deals with relays, timing devices, thermostats, pots and ladders, resistors, thermal links, insulators, etc.

A copy will be sent free to anyone writing Struthers Dunn Inc., and mentioning this paper.

BULLETIN ON ALUMINUM DISCS

Paul K. Trautwein, President and Treasurer, Mirror Record Corp., 58 West 25th Street, New York City, has announced the mailing of a January 1, 1936, bulletin, giving prices and other information concerning blank aluminum discs for direct recording purposes.

These blanks are said to be processed under certain patents, of which Mirror Record Corp. has the exclusive license. They are ready for use without any further processing.

Readers desirous of obtaining this bulletin can do so by writing to the above organization.

THE MARKET PLACE

NEW PRODUCTS FOR THE COMMUNICATION AND BROADCAST FIELDS

NEW G-E CONDUIT GROUNDING ITEMS

Four new conduit grounding items, one box for fixture mounting and three ground-

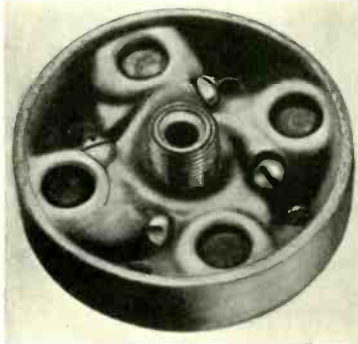

ing fittings which can be quickly installed and afford secure connections, have been announced by the General Electric Company's Merchandise Department, Bridgeport, Conn.

The fixture box, designated as Type SP-5200B (see accompanying illustration), provides a simple and effective method of grounding, and makes possible firm mechanical and electrical connection between the box and the armor.

Two of the fittings, designated as Type SP-825 and SP-826 and intended for 1/2- and 3/4-inch conduit, respectively, are equipped with a reversible shackle which fits three sizes of water pipe—a U-bolt with a wide, flat strap being used to make the connection. This affords high bonding pressure without injury to the pipe and allows the conduit hub to meet the pipe at any angle. The Type SP-828 fitting has a connection which firmly grips and holds the armored cable.

For solderless connection of the fittings, the wire is simply hooked into the groove provided and the lug is screwed tight as a bonding washer. For soldered connection, the grounding wire is run into the soldering lug.

EIMAC TRANSMITTING TUBES

The transmitting tubes manufactured by Eitel-McCullough, Inc., San Bruno, California, are known by the trade name of Eimac. This line of vacuum tubes has three members at the present time with the possibility of some additions in the near future. The type numbers and their plate dissipation ratings follow:

Eimac 50T—A triode having 75 watts of plate dissipation. The design permits high insulation of the electrodes, and the high vacuum, made possible by the use of Tantalum, permits this tube to have power outputs of more than three times its plate dissipation ratings, it is stated. Low inter-electrode capacities makes the tube suitable for ultra-high-frequency work, while the electrical characteristics are said to make

it especially suited for Class B audio work.

Eimac 150T—A triode having a plate dissipation of 150 watts. It is capable of giving Class C outputs up to 450 watts, while a pair of these tubes in Class B audio are capable of delivering 750 watts output. The FCC rating on this tube is 150 watts for high-level modulation, and 50 watts for low-level modulation. Similar to the 50T, the 150T uses Tantalum for electrode material.

Eimac 500T—This is the largest member of the family and has a plate dissipation rating of 500 watts. It has a Class C power output of 1350 watts. Two of these tubes used in Class B audio are capable of 2000 watts of audio power, it is stated. The FCC rating is 500 watts when used as a high-level modulated amplifier. It is capable of 250 watts of carrier when modulation is effected at a lower level. The 500T, shown in the accompanying illustration, is said to be suited for high-frequency broadcasting and police transmitters. Tantalum

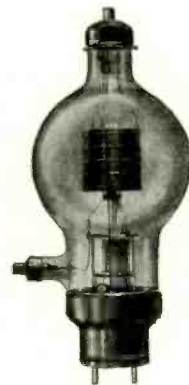

is also used in this tube for electrode material.

NEW BLILEY 20-METER CRYSTAL

The Bliley Electric Company, Erie, Pa., announces a new type mounted quartz fre-

quency-control unit for the 20-meter band covering ranges from 14,000 kc to 14,400 kc.

Over a year has been spent on research and testing this crystal before placing it



on the market. Several new features are incorporated into the design. The crystal itself is said to be thicker than an X-cut would be for this band, which gives it greater power-handling ability and makes it less sensitive to mechanical shock. Likewise the temperature coefficient of the new 20-meter unit is considerably less than that of an X-cut, assuring greater frequency stability.

Known as the type HF-2 unit, the Bliley 20-meter crystal delivers excellent power, will not jump from one frequency to another. The crystal is mounted in a circular holder of Victron G, a special material having extremely low r-f losses.

NEW AUDAK PICKUPS

Higher Range Professional Electric Pickup used in most leading radio stations. The arm is of special length to accommodate records up to 18 inches in diameter. It is counter-balanced by dead weight. The arm is made of special heavy gauge aluminum. This instrument is designed for use with higher range recordings. It works with low needle pressure. It is immune to humidity and temperature changes.

No. 100. A Compact pickup for use in portable midget and larger combinations. Exceptionally flat and light weight—unaffected by temperature and humidity changes, it is said.

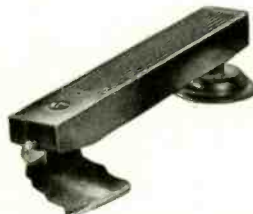

THE AUDAK HR PROFESSIONAL PICKUP IS SHOWN AT THE RIGHT, WHILE THE NO. 100 IS SHOWN ABOVE.

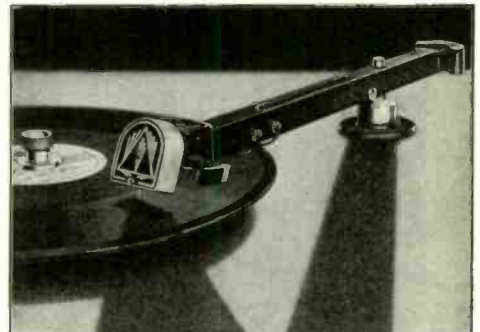

NEW ELECTRAD ATTENUATORS

Electrad Inc., 173-175 Varick Street, New York City, have just announced their new type BN attenuators. These units replace the Electrad Types TN, LN and U attenuators, and they are said to have the advantages of greater attenuation, true logarithmic attenuation and lower noise level.

These attenuators involve a new principle in design which makes it possible to obtain a substantially constant-impedance unit whose attenuation is linear in db and continuously variable over the entire range.

The attenuation is accomplished by means of an infinitely variable ladder network consisting of a series element on which the contact rides, and which has a shunt element connected to it along its entire length.

CERAMIC DIELECTRIC CONDENSERS

Possessing those characteristics of non-porosity and great electrical and mechanical strength, combined with high dielectric constant, a new ceramic development is said to introduce some striking possibilities in the condenser art. Dielectric constants of the order of 50 to more than 170 are reported for this new material by its developers and manufacturers, Henry L. Crowley and Co., of West Orange, N. J.

The high dielectric constant makes possible a simple condenser with say a 1-inch square of crolite dielectric, faced with metal plates on both sides, offering capacities as high as 400 mmfd. Such condenser construction is practically immune to leakage and voltage breakdown, it is stated. Samples have been subjected to voltages of 1200 d-c and 440 a-c, without leakage. Also, they have been placed on potentials as high as 30,000 a-c without breakdown, although, of course, arcing has taken place around the dielectric plate or through the air.

A favorable power factor is said to be obtained with crolite dielectric. Moisture absorption is low. The compactness made possible by high dielectric constant, overcomes normally expected manufacturing difficulties. The material can be fabricated in thin sheets or tubes, for ready application to condenser design.

PERMANENT-MAGNET, MOVEABLE-COIL RELAY

The "Reyman" permanent-magnet moveable-coil type relay is shown in the accompanying illustration.

In this relay there are two moving coils supported by a central hardened pivoted shaft which is held between the poles of a

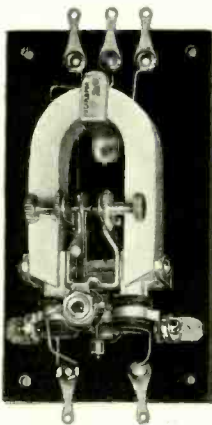

permanent magnet by saphire bearings mounted in screws. Mounted on the central shaft are two spiral springs and the center contact bearing arm. These serve to conduct the applied current to the coils and to the arm bearing the central contact point. They also serve to set the position of the arm in relation to the side adjustable contact screws.

An additional spiral conducting spring is employed when the operating current and the relayed current require separate circuits.

The resistance of the relay coils may measure a few ohms, or as high as 1500 ohms, depending on the number of turns of wire per coil, and may vary from 10 to 2400 turns depending upon the current value required to operate the relay, which may be as low as 100 microamperes. The torque is sufficient to permit 250 milliamperes at 80 volts.

The distributor is Bank Inter-Air Products, 4526 Forty-ninth Street, Woodside, Long Island, N. Y.

JANETTE ROTARY CONVERTERS

The Janette Manufacturing Company, 556-558 West Monroe Street, Chicago, Illinois, have available rotary converters for changing d-c to 110-volt, 60-cycle, single-phase a-c.

Janette converters are designed and built especially for the type of apparatus they are to operate. They are used for operating radio receivers, electric phonographs, power amplifiers, public-address systems, motion-picture projectors, testing equipment, electro-therapeutic machines, gaseous electric signs and airplane radios.

These converters are of the dynamotor (double wound) construction and have two separate windings on the armature. The field frames are of rolled steel; the field poles are laminated to increase efficiency. Grid covers protect the commutators, slip rings and brushes, and are standard equipment on all converters.

Converters which run at 3600 rpm are supplied with bronze bearings which are lubricated by oil-saturated wool yarn. This feature makes frequent oiling unnecessary and results in long bearing life. The 1800 rpm converters have ball bearings, but sleeve-bearing 1800 rpm units of the wool-packed type can be supplied. Low-voltage machines have ball bearings.

The converters for use with radio are equipped with filters.

For complete information write for Bulletin 13-1.

NEW P-A ATTENUATOR

The Tech Laboratories of 703 Newark Avenue, Jersey City, N. J., announce a new improved attenuator specially designed for p-a and portable equipment. This attenuator meets fully the demand for a low priced, compact unit of wide range and high-quality construction, it is stated. Based on their experience in this field it has been possible to construct an attenuator of small dimensions (2½-inch diam, by 1-13/16-inch depth) having 22 steps of attenuation covering a range of 50 decibels.

Besides sound-recording, public-address and broadcasting applications this attenuator is also for use in the laboratory in all types of experiments requiring low d-c or a-c voltages.

A bulletin describing the new attenuator and some of its many uses is now available for distribution. It should be noted that these attenuators can be supplied with

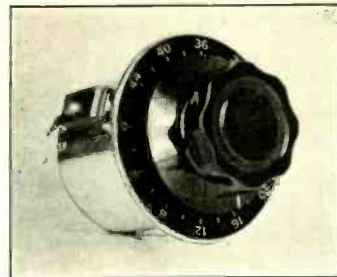

special dial plates permitting the removal of the unit through the front panel for easy servicing.

ANTENNA-COUPLING UNITS

An antenna-coupling unit or a tuning house is necessary wherever an untuned transmission line is used to carry power to an antenna. Doolittle and Falknor, Inc., 1306 West Seventy-fourth Street, Chicago, have two antenna-coupling units available. Their Types A and B antenna units are designed to meet present-day broadcast practice. The circuits used are the simplest which can accomplish the required purpose in order to obtain high efficiency, and at the same time are very easy to adjust, it is stated. They suppress to a high degree harmonics generated in the transmitter.

Type A unit is suitable for coupling a quarter-wave radiator or any small antenna to a concentric transmission line. It operates with any antenna of less than 80 ohms resistance. The circuit consists of a large variable coupling capacity across the end of the transmission line, and an adjustable tuning inductance and capacity, if required, in series with the antenna. Two thermocouple meters are provided, one for reading antenna current and one for reading transmission-line current.

Type B unit is suitable for coupling a half-wave, or any antenna of more than 80 ohms resistance, to a concentric line. The circuit is similar to the Type A unit except that the tuning reactance is in series with the transmission line.

Further information may be obtained from the above organization.

CARBON RESISTORS

To meet the specifications for non-inductive resistors, particularly in high-gain amplifying circuits, a new type of carbon resistor has been developed and introduced by Aerovox Corporation, 70 Washington St., Brooklyn, N. Y.

Of the solid molded type, the new Aerovox carbon resistor is said to be plain, neat, compact, inexpensive. The special molded body is non-hygroscopic, meaning that it is unaffected by humidity changes. It is non-inductive, with no appreciable resistance change at high frequencies. Absolutely noiseless and permanent, on and off full load, it is stated.

A slight positive temperature coefficient is just sufficient to compensate minimum potential coefficient and to protect the unit against heavy short-period overloads. Electrically and mechanically rugged, each unit has stiff pigtailed firmly soldered to the carbon resistor element.

The resistance values and wattage ratings are based on RMA standards. Each unit is color coded for ready identification. Available in three sizes—⅓, ½ and 1 watt. All standard resistances of from 100 ohms to 10 megohms.

AUDAX

Trade-Mark

pick-ups

"The standard by which others are judged and valued"



Models to suit ever demand, from the humblest midget-combination to the **HIGH FIDELITY**—low needle-pressure requirements of fine transcriptions. **AUDAX INSTRUMENTS** are immune to humidity and summer heat. They are chosen on a **PERFORMANCE** basis, as equipment in most of the world's leading Radio Stations, Universities, Laboratories—in fact, wherever quality counts.

List
\$9.50
to
\$390.00
each

Special Recording Heads to Order

AUDAX COMPANY

500 Fifth Avenue

New York, N. Y.

"Creators of High Grade Electrical and Acoustical Apparatus Since 1915"



UNIVERSAL

5-METER HAND SET

A new, 15-ounce, compact hand set. Designed for 5-meter transmitters and 5-meter transceivers. Highly polished, moulded bakelite units—2000 ohm uni-polar receiver. High output, single button Universal microphone of 200 ohms—6 ft. 4-conductor cord with color-coded phone tips. List Price, Single Button microphone, \$8.00.

UNIVERSAL MICROPHONE CO., Ltd.
424 Warren Lane, Inglewood, Calif., U. S. A.

FINEST FOR FIELDWORK

PORTABLE PACK Transmitter and Receiver Type PTR-19

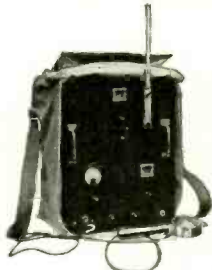

Frequency range 30-41 Mc. front panel control—special Hiperm Alloy Transformers having uniform freq. response 40 to 12000 cycles per second—Transmitter unity coupled push-pull 19 Oscillator, 19 class B Modulator, 19 class A driver and 30 class A microphone amplifier — Carrier power: 2 watts—peak, 8 watts—receiver; one 30 tube in super-regenerative circuit—ample battery provision, carrying case, etc. Weighs only 35 lbs. with batteries and all accessories.

Bulletin C will interest you.
Write for it—it's FREE.

RADIO TRANSCIVER LABORATORIES

8627 - 115th Street, Richmond Hill, N. Y.
Export Division: 15 Laight St., New York, N. Y., U. S. A.

BRUSH SPHERICAL MICROPHONE

features

LIGHT WEIGHT, LOW PRICE and

TYPICAL BRUSH SOUND CELL OPERATION



A specially designed, low price, general purpose microphone for station announcement, "P. A.," police and commercial interstation transmission work. Uses the round case first introduced by Brush engineers in their expensive laboratory microphone. Wide frequency response and typical Brush sound cell operation. Non-directional. No diaphragms. No distortion from close speaking.

Easily installed. No button current or polarizing voltage—no input transformers—and no elaborate stand mountings are needed. Beautifully finished in dull chromium. Size only 2 1/4 inches in diameter. Weight 5 oz. Output level minus 66 D. B. Locking type plug and socket connector and either suspension mounting or stand hickie furnished at no extra cost. Full details, Data Sheet No. 13. Free. Send for it.

The **BRUSH** DEVELOPMENT COMPANY
PIEZO ELECTRIC
1894 E. 40th St. CLEVELAND, O.
MICROPHONES • MIKE STANDS • TWEETERS • HEAD PHONES • LOUD SPEAKERS

TOP PERFORMANCE

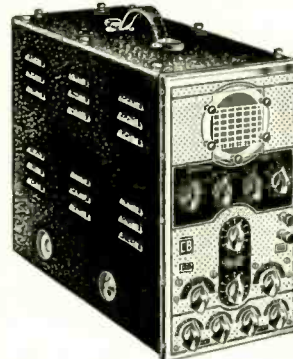

Of Speech Circuits and
Equipment

can be assured by simple routine checks with the C-B Audio Oscillator and Cathode-Ray Oscillo-graph. Frequency response, wave shape distortion, and line noise are easily checked with this low-priced visual indicating equipment.

MODEL CRA Oscillograph

Combines power supply and operating controls for the Cathode-ray tube, linear sweep timing axis, and amplifiers for horizontal and vertical inputs. Synchronizing circuit locks timing axis in with test voltage cycles. Price, complete, with all tubes **\$84.50**

- **MODEL 79 Beat-Note Audio Oscillator** provides sine-wave voltage (50 to 10,000 cycles) for testing speech and modulation equipment. Linear output with low distortion content at all frequencies. Output potential 27 volts. Operates from 60 cycle—*a-c* line. Price, complete, with tubes. **\$51.90**

- **MODEL OB Beat-Note Audio Oscillator**, precision hand calibrated 20 to 15,000 cycles. Output linear within a decibel over entire frequency range. Less than 1/2 of 1% distortion content. Available in portable case or standard rack and panel mounting. Price in portable case, complete, with tubes. **\$112.50**

Write for complete C-B catalog describing these and many other precision test instruments.

Write for Complete Literature

The CLOUGH-BREngle CO.

1130-P W. Austin Ave., Chicago, U. S. A.

NEW MODEL 5-METER HANDSET

Universal Microphone Co., Inglewood, Cal., in November issued a new model of its five-meter handset.

The outstanding feature of the instrument is the fact that it has a magnetic field two and one-half times heavier than formerly which gives a better distribution over the diaphragm area.

The instrument is encased in a highly polished molded bakelite casing with a straight hand-hold. The microphone equipment is high volume in single- or double-button type which allows a maximum modulation in the five-meter equipment.

The Universal hand-set is furnished with four leads, two of which can be combined, enabling it to be used on any circuit, it is said. Besides its usual radio usage, it may be used also in inter-communication systems where a battery is needed. This eliminates the necessity of an amplifier, and is made possible by the high output of the microphone and the sensitivity of the ear receiver.

New uses for the five-meter handset are constantly being developed, according to Universal factory executives. One of the latest is its use by forestry patrols which need two-way communication between fire lookouts and district headquarters.

NEW LINE AMPLIFIER

The RCA Type 55-A Amplifier is a new medium-gain amplifier designed primarily for use as a line amplifier. It is particularly well adapted for a number of special applications, as for instance in master control rooms to increase the level on outgoing lines. Normally it functions to provide the gain necessary to compensate for losses on incoming lines, losses in switching circuits and the like, and allows the outgoing lines to be fed at the most desirable level. Ordinarily this entails operation at inputs ranging down to -40 db, and outputs around zero level.

There are many occasions—particularly in auditioning or monitoring—when a bridging connection is desirable. To allow for such use this new amplifier has a high-impedance input, in addition to the usual line-matching input. Using this connection one or several of these amplifiers may be connected across a line without noticeably reducing the level on that line. Both the high- and low-impedance connections may be connected to jacks for interchangeable use.

The amplifier operates entirely from a 105- to 125-volt, 50- to 60-cycle source, Alternating current is supplied directly to the filament heaters—the first stage filament transformer being provided with a center-tap balancing adjustment. Plate voltages are furnished by a built-in rectifier. Use of an RCA 25Z5 in a voltage-doubling circuit makes a power transformer unnecessary.

The Transmitter Section of the RCA Manufacturing Co., Inc., Camden, N. J., recently issued a bulletin describing this amplifier.

STUDIO SPEECH-INPUT RACK

The Collins Radio Company, Cedar Rapids, Iowa, designers and manufacturers of transmitters, transformers and speech equipment, have just announced the Type 12E studio speech-input rack. This rack is shown in the accompanying illustration.

The Type 12E rack is a complete, self-contained studio speech-input system for one, two, or three studios where the maxi-

imum number of inputs does not exceed eight. Due to the fact that its program and monitoring circuits are completely independent, it is ideal for use in small stations where it is frequently necessary to audition or rehearse a show in one studio while another studio is on the air. This flexibility is equally desirable in larger stations as it allows the maximum use to be made of the equipment. A feature of the design is that the control operator can talk back into the rehearsal studio without interrupting a program on the air from another studio or remote line.

The Type 12E is supplied with four pre-amplifiers for use with crystal microphones, although pre-amplifiers for use with low-impedance microphones can also be furnished. Four additional input sources can be accommodated, and these can be mixed as desired by means of the Type 60H four position mixing panel. Key switches serve to select either of two inputs to each channel attenuator, or to disconnect the channel entirely. The circuit is arranged so that each circuit is at all times terminated in its correct impedance and switching is accomplished without introduction of objectionable clicks or other noises. A signal

light associated with each of the eight inputs is provided on the 60H mixing panel to indicate which channel is in use. A monitor input key allows the monitoring system to be used on the program circuit, for rehearsal or auditioning, or for loud-speaker communication between the control-room operator and the occupants of the studio. Operation of the microphone control keys automatically controls the operation of the loudspeakers in the control room and studios, so that it is impossible to operate a loudspeaker in any location where a microphone is in use. This feature is provided by the Type 272A speaker-control panel, which in addition allows manual control over the loudspeakers.

The volume indicator provided is of the high-speed, critically-damped type, which gives a more accurate indication of instantaneous volume level than any type of meter heretofore obtainable, it is stated. In addition to the rotary range-changing switch provided, a three-position selector switch allows the meter to be used on three different circuits, which may be the program circuit, the monitor circuit, and any other circuit, such as an incoming line.

ARCTURUS 6Q7 AND 6X5

To round out its "Coronet" metal-tube line, the Arcturus Radio Tube Company, Newark, N. J., have announced the addition of the types 6Q7 and 6X5 tubes.

The 6Q7 "Coronet," a double-diode-triode, is the first dual-purpose tube to be built in metal. The diode is similar to that in the type 75. The triode section, having an amplification factor of 70, makes this a desirable tube for avc applications. By using a 3-volt grid bias, instead of 2-volts, the possibilities of positive grid current are minimized.

The 6X5 "Coronet" is a full-wave vacuum rectifier, indirectly heated type. Its characteristics are similar to the type 84.

Additional types in the "Coronet" line are now being developed. Arcturus engineers state. Literature is available.

VWOA

(Continued from page 24)

NEW YORK CHAPTER

AT THE New York Eleventh Annual Dinner-Cruise in the Casino-in-the-Air atop the Hotel Montclair, Forty-ninth Street and Lexington Ave., we expect to have an ultra-modern short-wave phone and cw transmitter and several of the latest type short-wave communications receivers. We will endeavor to make direct contacts with the diners in the various cities. The signals from the other cities will be brought in and amplified over the hotel public-address system.

Arthur Lynch, Veteran member of our Association, has volunteered the necessary aerial equipment—for which thanks AH.

The Army Amateur detail in New York is being handled by Colonel Borris, who is Signal Officer, Governor Island, and Captain Talley, Radio Aide.

EIGHT P.M.—FEBRUARY 11TH—1936—HOTEL MONTCLAIR—FORTY-NINTH STREET AND LEXINGTON AVENUE—NEW YORK CITY. WE HOPE TO GREET YOU THERE!

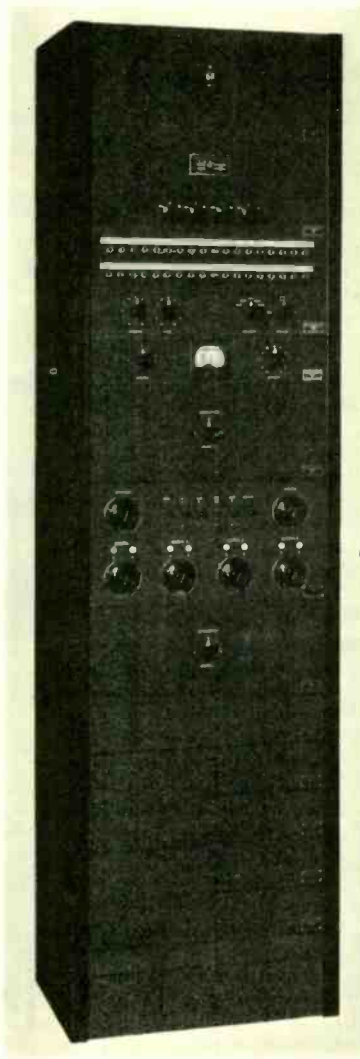

THE Group Subscription Plan for COMMUNICATION AND BROADCAST ENGINEERING enables a group of engineers or department heads to subscribe at two-thirds the usual yearly rate.

The regular individual rate is \$3.00 a year. In groups of 4 or more, the subscription rate is \$2.00 a year. (In foreign countries, \$3.00.) Each subscriber should print his name and address clearly and state his occupation—whether an executive, engineer, department head, plant superintendent, or foreman, etc.

Possibly your associates
would be interested in this
group plan

(Communication and Broadcast Engineering)
BRYAN DAVIS PUBLISHING CO., Inc.
19 East 47th Street, New York, N. Y.

Outstanding in RECORDING

In broadcast stations . . . in professional and private recording . . . **RANGERTONE** recording equipment and records have brought a new and higher standard of excellence.

Two quality-characteristics have led to its use in most exacting studios: extreme fidelity; elimination of surface noise.

With **RANGERTONE** superiority in recording and reproducing . . . with 10 decibels less surface noise . . . fidelity is no longer a mere trade term; it is a scientific fact.

RANGERTONE efficiency lies not only in high quality, but in the correct engineering balance between all co-working units and parts—especially Rangertone Cutting Needles which are hand-lapped Stellite designed to cut Records made of purest materials.

RANGERTONE, INC.
201 Verona Ave., Newark, N. J.

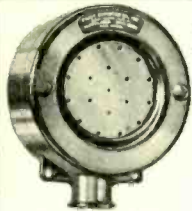

Models 6B and 6C

Write on your letter-head for complete data on all R. R. microphones.

SUPERIOR!

**RADIO RECEPTOR
DYNAMIC MOVING
COIL MICROPHONES**

**GREATER SENSITIVITY
EXTREME RUGGEDNESS**

No extremely high-gain amplifiers needed, no background noise, small and compact, wide angle pickup, uniform, permits close up talking.

RADIO RECEPTOR CO., INC.

Manufacturers of Radio and Sound Equipment Since 1922.
106 SEVENTH AVENUE NEW YORK, N. Y.

BLILEY FREQUENCY MEASURING SERVICE

DEPENDABLE equipment in charge of trained engineers.

ACCURATE to 1 part in 5,000,000.

CONVENIENT schedules and types of notification.

Write for quotation and complete details.

FREQUENCY MEASURING DIVISION,
BLILEY ELECTRIC COMPANY ERIE, PA.

Hi-Power for Sound Equipment

The Carter Genemotor supplies the most Reliable and Economical "B" Power for Class A or B Amplifiers from a 6 or 12 volt battery. Output up to 500 volts. Sturdy—Compact—Quiet operation—No oiling—Guaranteed.

Models for Two-Way Police Radios, Aeroplane Sets, Transmitters, Farm Radios, etc. Write for Bulletin showing complete line of Genemotors or specify your requirements. Also AC output up to 40 watts.



CARTER MOTOR COMPANY

373 West Superior St.

Chicago, Ill.

LEGITIMATE ALUMINUM DISCS FOR RECORDING MIRROR RECORD CORP'N

EXCLUSIVE LICENSEE

PAUL K. TRAUTWEIN 58 WEST 25th STREET
Pres.-Treas. NEW YORK CITY

RECORDING EQUIPMENT RADIOTONE ACETATE DISCS

WRITE FOR COMPLETE INFORMATION

RADIOTONE RECORDING CO.

6103 MELROSE AVENUE

HOLLYWOOD, CAL.

AMERICAN MICROPHONE CO.

A California Corporation

Microphones of Quality

Condensers, Carbon, Crystal, and Electrostatic

New catalogue available upon request.

1915 South Western Avenue, Los Angeles, Calif.

"THE CRYSTAL SPECIALISTS SINCE 1925"

PIEZO-ELECTRIC CRYSTALS

GUARANTEED Accurate to BETTER than .01%

SCIENTIFIC RADIO SERVICE

Send for FREE Booklet and Price List!

UNIVERSITY PARK - - - - - HYATTSVILLE, MD.

INDEX OF ADVERTISERS

A	
American Microphone Co.	32
American Transformer Co.	6
Andak Co., The	29
B	
Blaw-Knox Co.	3
Bliley Elec. Co.	32
Brush Development Co., The	6-20
C	
Carter Motor Co.	32
Centralabs	6
Crough-Brengle Co., The	20

Collins Radio Co.	Second Cover
Cornell-Dubiller Corp.	Fourth Cover
G	
General Radio Co.	Third Cover
M	
Mirror Record Corp'n	32
P	
Presto Recording Corp.	3
R	
Radio Receptor Co., Inc.	32

Radiotone Recording Co.	32
Radio Transceiver Labs.	29
Rangertone, Inc.	32
S	
Scientific Radio Service	32
U	
United Transformer Co., Inc.	1
Universal Microphone Co., Ltd.	29
W	
Western Electric Co.	5



ALWAYS SET UP TO MEASURE

- ★ Resistance: 0.001 ohm to 1 megohm
- ★ Inductance: 1 μ h to 100 h
- ★ Capacitance: 1 μ f to 100 μ f

DIRECT READING
COMPLETELY
SELF-CONTAINED

THE General Radio Type 650-A Impedance Bridge is always ready to operate. It is complete with built-in d-c and 1,000 cycle a-c power source.

It is direct reading with an accuracy, over the major portion of the ranges, of 1% for resistance and capacitance measurements, and 2% for inductance measurements. It directly measures dissipation factor $\frac{R}{X}$ of condensers and energy factor $\frac{X}{R}$ of inductors.

The Type 650-A Bridge is indispensable in any laboratory where routine measurements of inductance, resistance and capacitance are to be made rapidly and has an accuracy more than sufficient for practically all commercial requirements.

Type 650-A Impedance Bridge . . . Price, \$175.00 (In U. S. and Canada)

Write for a copy of our complete Catalog H-K, which describes this and many other laboratory essentials.



GENERAL RADIO COMPANY

CAMBRIDGE

MASSACHUSETTS



Twenty-Six Years of

Leadership

That which is inherited from the years and which the years alone can give—experience, skill, tested performance, call it what you will—is the very essence of products manufactured by the Cornell-Dubilier Corporation. It is something which cannot be hastily added as a surface touch. Tested in the practical laboratory of Time, every C-D capacitor, Dykanol, Paper, Mica or Electrolytic, inherits this quality. Assured by this . . . by the notable record of twenty-six years of leadership . . . by the engineering cooperation and service of a great technical organization, you may with safety specify Cornell-Dubilier capacitors—“proven by the past, improved for the future”.

Industrial catalog No. 127 gladly furnished upon request.

CORNELL-DUBILIER
C O R P O R A T I O N

4598 BRONX BOULEVARD

NEW YORK, N. Y.