

# COMMUNICATIONS

INCLUDING "RADIO ENGINEERING" AND "TELEVISION ENGINEERING"



AUGUST

- ★ THE WDTV FIELD COVERAGE STUDY
- ★ SUPERSONIC CONTROL FM RECEIVER SYSTEM
- ★ FM COMMUNICATIONS FOR UNDERGROUND MINING

1949

# NEW SIGNAL GENERATOR

**FAST DIRECT READINGS**

**800 mc to  
2100 mc**

**NO CHARTS OR INTERPOLATIONS**

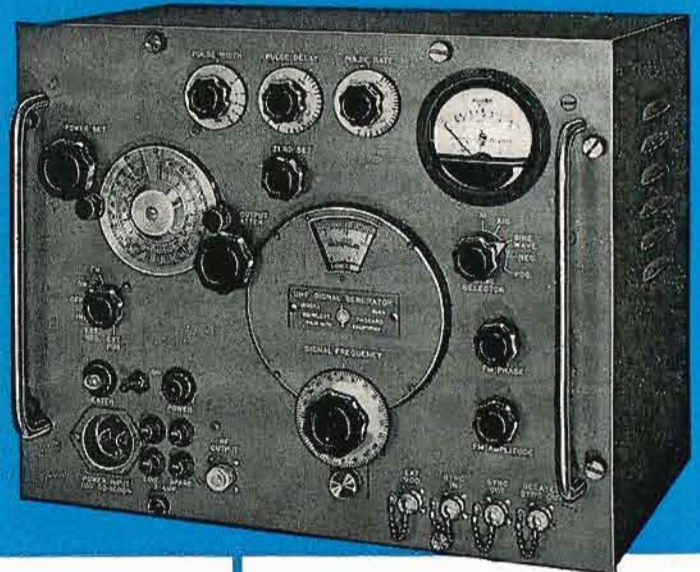

## **-hp- 614A UHF Signal Generator**

**Direct reading output, accuracy  $\pm 1$  db...Constant internal impedance, SWR 3 db...Direct frequency control...External modulation 0.5 microseconds pulses to square waves...CW, FM, pulsed output.**

This new *-hp-* signal generator will save you hours of time and work in making UHF measurements between 800 and 2100 mc. Its many different modulation and pulsing capabilities mean these man-hour economies can be applied to a wide variety of measurements—receiver sensitivity and alignment, signal-to-noise ratio, conversion gain, standing wave ratios, antenna gain and transmission line characteristics, to name but a few.

Carrier frequency in mc can be set and read directly on the large central tuning dial. R-f output from the klystron oscillator is also directly set and read in microvolts or db. No calibration charts or tedious interpolation are necessary. And thanks to the unique *-hp-* automatic tracking mechanism, no voltage adjustments

are needed during operation.

R-f output ranges from 0.1 volt to 0.1 microvolt. Output may be continuous, pulsed, or frequency modulated at power supply frequency. The instrument may be modulated either externally or internally and may be synchronized with positive or negative pulses or sine waves.

Because of its wide range, high stability and versatile usefulness, this new *-hp-* signal generator is adaptable to almost any uhf measuring need. The instrument is available for early delivery. Contact your *-hp-* field representative or write direct to factory for complete details and technical specifications.

**HEWLETT-PACKARD CO.**  
1874-E Page Mill Road, Palo Alto, California  
Export Agents: Frazar & Hansen, Ltd.  
301 Clay Street • San Francisco, Calif., U.S.A.

## **SPECIFICATIONS**

### **FREQUENCY RANGE:**

800 to 2100 mc. Selection is made by means of a single directly-calibrated control covering entire range. No charts are necessary.

**FREQUENCY CALIBRATION ACCURACY:**  
 $\pm 1\%$ .

### **OUTPUT RANGE:**

1 milliwatt or .223 volts to 0.1 microvolt (0 dbm to  $-127$  dbm). Directly calibrated in microvolts and db; continuously monitored.

### **ATTENUATOR ACCURACY:**

Within  $\pm 1$  db without correction charts. A correction chart is provided when greater accuracy is desired.

### **OUTPUT IMPEDANCE:**

50 ohms. SWR 3 db (VSWR 1.4).

### **EXTERNAL MODULATION:**

By external pulses, positive or negative, peak amplitude 40 to 70v., 0.5 microseconds to square wave.

### **FM MODULATION:**

Oscillator frequency sweeps at power line frequency. Phasing and sweep range controls provided. Maximum deviation approximately  $\pm 5$  mc.

### **INTERNAL MODULATION:**

Pulse repetition rate variable from 40 to 4000 per second; pulse length variable from 1 to 10 microseconds. Pulse rise and decay approximately 0.1 microseconds.

### **TRIGGER PULSES OUT:**

1. Simultaneous with r-f pulse.
2. In advance of r-f pulse, variable 3 to 300 microseconds.  
(Both approximately 1 microsecond rise time, height 10 to 40 volts.)

### **EXTERNAL SYNC PULSE REQUIRED:**

Amplitude from 10 to 50 volts of either positive or negative polarity and 1 to 20 microseconds width. May also be synchronized with sine waves.

Data subject to change without notice.

 **laboratory instruments**  
FOR SPEED AND ACCURACY

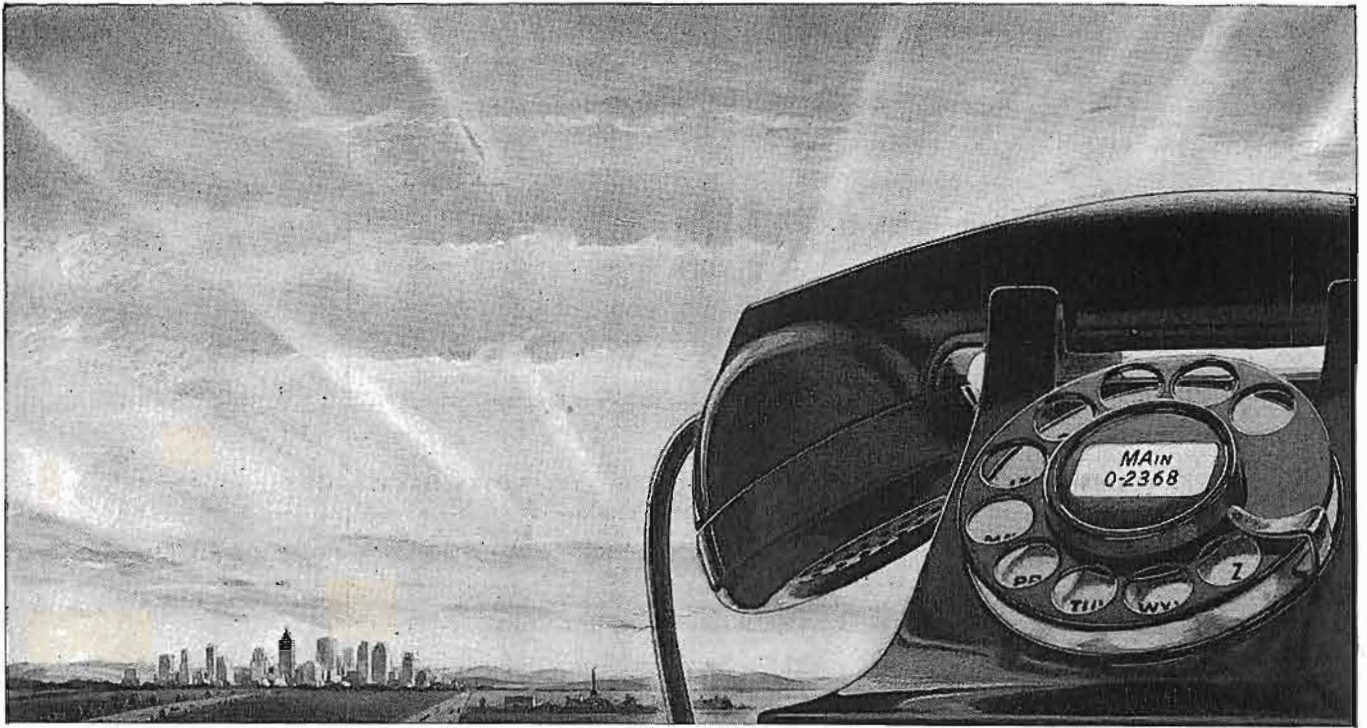

## THE FUTURE HOLDS GREAT PROMISE

Neither chance nor mere good fortune has brought this nation the finest telephone service in the world. The service Americans enjoy in such abundance is directly the product of their own imagination, enterprise and common sense.

The people of America have put billions of dollars of their savings into building their telephone system. They have learned more and more ways to use the telephone to advantage, and have continuously encouraged invention and initiative to find new paths toward new horizons.

They have made the rendering of telephone service a public trust; at the same time, they have given the telephone companies, under regulation, the freedom and resources they must have to do their job as well as possible.

IN THIS climate of freedom and responsibility, the Bell System has provided service of steadily increasing value to more and more people. Our policy, often stated, is to give the best possible service at the lowest cost consistent with financial safety and fair treatment of employees. We are organized as we are in order to carry that policy out.

BELL Telephone Laboratories lead the world in improving communication devices and techniques.

Western Electric Company provides the Bell operating companies with telephone equipment of the highest quality at reasonable prices, and can always be counted on in emergencies to deliver the goods whenever and wherever needed.

The operating telephone companies and the parent company work together so that improvements in one place may spread quickly to others. Because all units of the System have the same service goals, great benefits flow to the public.

Similarly, the financial good health of the Bell System over a period of many years has been to the advantage of the public no less than the stockholders and employees.

It is equally essential and in the public interest that telephone rates and earnings now and in the future be adequate to continue to pay good wages, protect the billions of dollars of savings invested in the System, and attract the

new capital needed to meet the service opportunities and responsibilities ahead.

There is a tremendous amount of work to be done in the near future and the System's technical and human resources to do it have never been better. Our physical equipment is the best in history, though still heavily loaded, and we have many new and improved facilities to incorporate in the plant. Employees are competent and courteous. The long-standing Bell System policy of making promotions from the ranks assures the continuing vigor of the organization.

WITH these assets, with the traditional spirit of service to get the message through, and with confidence that the American people understand the need for maintaining on a sound financial basis the essential public services performed by the Bell System, we look forward to providing a service better and more valuable in the future than at any time in the past. We pledge our utmost efforts to that end.

LEROY A. WILSON, *President*  
American Telephone and Telegraph Company.  
(From the 1948 Annual Report.)

**BELL TELEPHONE LABORATORIES** EXPLORING AND INVENTING, DEVISING  
AND PERFECTING, FOR CONTINUED IMPROVEMENTS AND ECONOMIES IN TELEPHONE SERVICE



# COMMUNICATIONS

Including Television Engineering, Radio Engineering, Communication & Broadcast Engineering, The Broadcast Engineer, Registered U. S. Patent Office.

**LEWIS WINNER**

Editor

F. WALEN

Assistant Editor

Bryan S. Davis, President

Paul S. Weil, Vice Pres.-Gen. Mgr.

F. Walen, Secretary

A. Goebel, Circulation Manager

Cleveland Representatives:

James C. Munn  
2258 Delaware Dr., Cleveland 4, Ohio  
Telephone: Erlwin 1726

Pacific Coast Representative:

Brand & Brand  
1802 W. Sixth St., Los Angeles 14, Calif.  
Telephone: Nishigan 1732  
Suite 1294, Ross Building, San Francisco 4, Calif.  
Telephone: SUTter 1-2251

Wellington, New Zealand: Te Aro Book Depot.  
Melbourne, Australia: McGill's Agency.

Entered as second-class matter Oct. 1, 1937 at the Post Office at New York, N. Y., under the act of March 3, 1879. Subscription price: \$2.00 per year in the United States of America and Canada; 25 cents per copy, \$3.00 per year in foreign countries; 35 cents per copy.

COMMUNICATIONS is indexed in the Industrial Arts Index and Engineering Index.

**COVER ILLUSTRATION**

Dual-transmitter single-antenna cavity-resonator setup of the Indianapolis Fire Department.  
(Courtesy Motorola; see pages 8, 9, 10 and 11 for complete system analysis.)

**TELEVISION ENGINEERING**

- The WDTV Field Coverage Study.....Ralph Lewis 6  
*Highlights of Signal Strength Survey of Pittsburgh TV Station.*
- Triangular High-Band TV Loop Antenna System  
A. G. Kandoian and R. A. Felsenfeld 16  
*Broadband Horizontal-Type Loop Design Achieved by Three Coaxially-Fed Folded Dipoles Arranged Symmetrically Around Supporting Structure of 120° Spacing.*

**FM COMMUNICATIONS**

- Cavity Resonators in Mobile Communications.....Henry Magouski 8  
*Design and Application Features of Circuit Which Provides Unloaded Q's as High as 11,000.*
- FM Receivers With Supersonic Control.....Fred M. Berry 12  
*Receiving System, Featuring Use of 15 to 20-ke Control Filters, Designed for Bus, Food Market, Restaurant and Department Store Service.*
- FM Communications For Underground Mining  
B. E. Parker and G. W. Thompson 20  
*Carrier-Current System Operates on 270-V DC Trolley Line Into Which Are Fed 100-ke FM Signals.*

**COIL DESIGN**

- Corrosion in Multiple Layer-Wound Coils.....Howard Orr 22  
*Part III. . . . Procedures Involved in Evaluating Materials for Electrolytic Corrosion Characteristics.*

**SOUND ENGINEERING**

- The Limitations of Sound Recording.....S. J. Begun 28  
*Lucid Analysis Discloses High Fidelity System Requirements, Causes of Distortion, Characteristics of Powder-Coated Tapes, Economic Considerations, Mechanical Factors, Problems of the Future, Etc.*

**MONTHLY FEATURES**

- News and Views.....Lewis Winner 5
- News Briefs of the Month..... 24
- The Industry Offers.....26, 31, 35
- Veteran Wireless Operators' Association News..... 30
- Last Minute Reports..... 36
- Advertising Index..... 36

Entire Contents Copyright 1949, Bryan Davis Publishing Co., Inc.



Published monthly by Bryan Davis Publishing Co., Inc.  
52 Vanderbilt Avenue, New York 17, N. Y. Telephone MURray Hill 4-0170



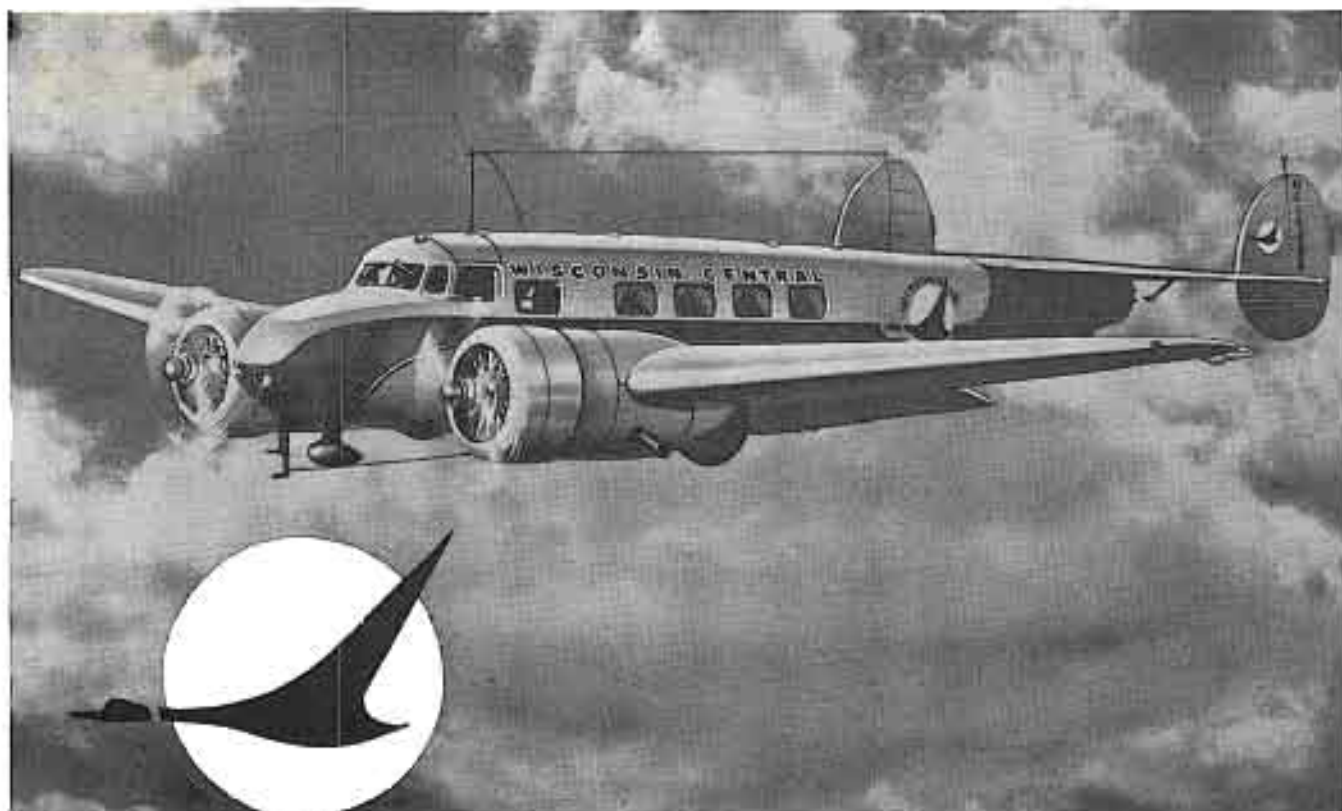

## ...First Choice

**of WISCONSIN CENTRAL AIRLINES**  
**WIS completely equips all ground stations**  
**and aircraft with WILCOX radio**

### **VHF AIR-BORNE COMMUNICATIONS**

**WILCOX TYPE 361A**—50 watt transmitter, high sensitivity receiver, and compact power supply—each contained in a separate 1/2 ATR chassis. Receiver and transmitter contain frequency selector with provisions for 70 channels...ample for both present and future needs.

### **VHF GROUND STATION PACKAGED RADIO**

**WILCOX TYPE 378A**—Complete with Type 364A, 50 watt transmitter, 305A Receiver, common antenna, telephone handset and loudspeaker, desk front, message rack and typewriter well. Type 411A LF Transmitter may be installed in the same cabinet for radiobeacon facilities.

### **MULTI-FREQUENCY GROUND STATION TRANSMITTER**

**WILCOX TYPE 99A**—Provides simultaneous transmission on LF, MHF, and VHF, frequencies. Housed in a single steel cabinet, the rectifier, modulator, remote control, and 4 transmitting channels combine to make the most compact multi-frequency transmitter in the 400 watt field.

**WRITE TODAY**...for complete information on all types of point-to-point, air-borne, ground station, or shore-to-ship communications equipment.



**WILCOX ELECTRIC COMPANY**  
**KANSAS CITY MISSOURI**

The "Gotham" - TV -  
Radio - Phonograph

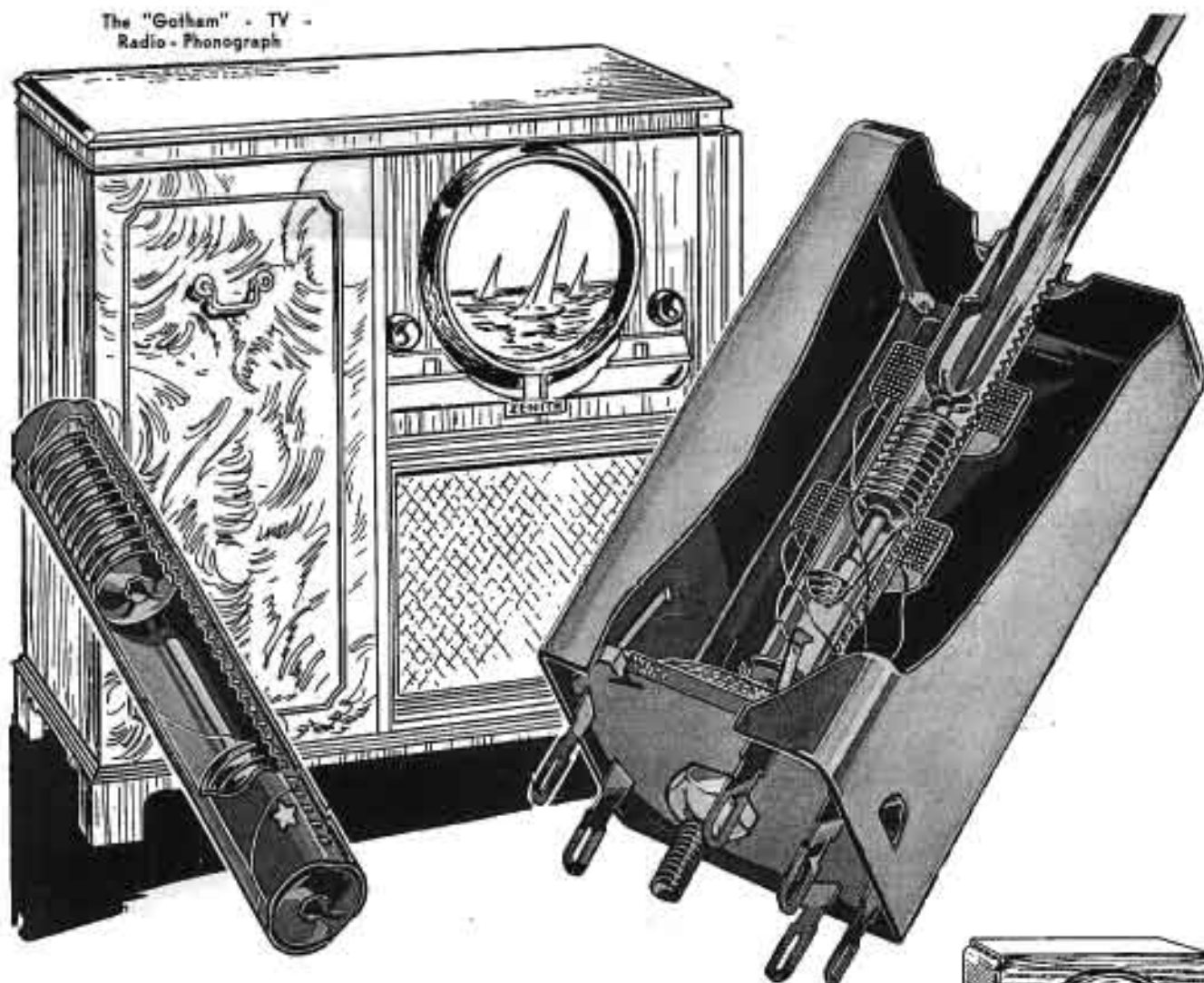

## COSMALITE\* gives STAR performance in the new ZENITH

This internally threaded Cosmalite coil form of cloverleaf design in the very heart of the Zenith Television Transformer permits quick tuning of both primary and secondary frequencies through the upper end. The hexagon shaft of the frequency setter easily passes through the upper core and engages in the lower core . . . adjusting the frequencies of both coils with the greatest ease.



Cosmalite coil forms are also used in transformers of Zenith's table radios, such as the new Super-Sensitive "Major" FM receiver, above.

Consult us on the many uses of Cosmalite (low cost phenolic tubing) in television and radio receivers.

\*Reg. U. S. Pat. Off.



The "Claridge" - TV  
Table Receiver

**The CLEVELAND CONTAINER Co.**  
6201 BARBERTON AVE. CLEVELAND 2, OHIO

PLANTS AND SALES OFFICES at Plymouth, Wis., Chicago, Detroit, Ogdensburg, N.Y., Jennings, N.J.  
ABRASIVE DIVISION at Cleveland, Ohio  
CANADIAN PLANT: The Cleveland Container, Canada, Ltd., Powell, Ontario

#### REPRESENTATIVES

CANADA: Wm. T. BARROW, EIGHTH LINE, RR #1, OAKVILLE, ONTARIO  
METROPOLITAN: S. J. MURRAY, 614 CENTRAL AVE., EAST ORANGE, N.J.  
NEW ENGLAND: E. P. PACK AND ASSOCIATES, 948 FARMINGTON AVE., WEST HARTFORD, CONN.



# The WDTV

FIELD-STRENGTH measurements, with their extremely revealing information, are particularly important in TV broadcasting today, providing not only basic operational and coverage data to the station, but to those studying the current allocations problem.

A study of the field coverage of WDTV, Pittsburgh, recently conducted by Robert P. Wakeman, J. D. O'Neill and Herbert Ferrell of Du Mont Labs research and WDTV, provided quite an assortment of such useful material. The series of tests were unusually thorough, involving a total of 1,148 field measurements between February 20 and March 25.

All the tests were with a receiving antenna height of 28' above the ground and all lying precisely on eight radials approximately uniformly spaced about the transmitter. Measurements were made at 385 cluster points. As has been pointed out in previous reports to the FCC, this type of measurement makes possible the study of correlation between the terrain and the received signal.

The standard WDTV transmitter was used during the tests, the equipment with a 5-kw peak video and 2.5-kw audio, fed into an 815' antenna with a power gain of 3.8, providing an *erp* of 16.6 kw for the video and 8.3 kw for the audio. Diplexer efficiency was 99.5%, and transmission line efficiency, 88%.

Receiving equipment, mounted in a 2½-ton bus, consisted of two receivers,<sup>1</sup> a field strength meter<sup>2</sup> and standard dipole, signal generator,<sup>3</sup> duo-band antenna,<sup>4</sup> forty-foot 72-ohm dual coaxial transmission line, twenty-eight-foot collapsible antenna mast, Exacta camera and built-in 110-volt, 60-cycle, 5-kva generator.

## Method of Measurements

Eight approximately equi-spaced radials were laid out emanating from the WDTV transmitter. The exact azimuths were selected from a consideration of population densities and main arteries of travel. Measurements were made at intersections of roads with these radials at spacings of one-half to two miles, the greater spacings being used at the extremities of the radials. At each cluster point at least three measurements were made within

## Survey of Signal Strength of Pittsburgh Station by Research Division of Allen B. Du Mont Labs and Personnel of Broadcaster, Reveals Many Vital TV Service Factors, Which May Serve as a Basis of Approach in Future Proof-of-Performance Probes.

by RALPH LEWIS

a radius of approximately one hundred feet.

Along the north radial, measurements were made on the two receiving antennas at every point.<sup>5</sup> It was found that, statistically, a linear height-gain relationship exists. This statement must not be construed to mean that at any given location the received signal is linearly related to the height of the receiving antenna but rather that the median value of a large number of measurements will be approximately proportional to the antenna height. On all other radials measurements were made only at the 28' height.

## Monitoring Procedure

During the entire survey the transmission line voltage at the transmitter was monitored with a diode rectifier and a recording meter.<sup>6</sup> An analysis of the tape indicated that no significant variations occurred in this voltage at any time when measurements were actually being taken.

To arrive at results which could be classified as average-type, a very simple dipole antenna was employed and no attempt was made to find the best possible location at each cluster. Of

the total 1,148 measurements, all ghost-free pictures were classified as weak, good or excellent. Where multipath conditions existed, pictures were classified as slight ghost or bad ghost. Using this nomenclature, the received picture quality was:

Weak	Good	Excellent	Slight Ghost	Bad Ghost
31%	10%	47%	8%	4%

Obviously, the installation of a receiving antenna having a reasonable amount of gain and some front-to-back ratio would bring many of the weak and good pictures up into the excellent class and would eliminate many of the slight ghost conditions.

A second count was made to determine the number of locations within the theoretical primary and secondary service areas actually receiving primary or secondary service. Of 507 measurements made within a theoretical 5,000 uv/m contour, 47% actually exceeded 5,000 uv/m. Of 1,081 measurements made within a theoretical 500 uv/m contour, 68% were found to exceed 500 uv/m.

These percentages are rather low, but this was due to the fact that a very large number of the roads on which measurements were made lie along rather deep river valleys, whereas most of the Pittsburgh suburban residential areas are located on the hill tops. Consequently, these figures probably give a rather pessimistic view of the actual useable television signal in the Pittsburgh area.

A detailed study of the results disclosed that whereas measurements made in the New York and other large metropolitan areas have frequently shown considerably greater deviation

<sup>1</sup>Hallcrafters S-36 and Du Mont Chatham.

<sup>2</sup>Model M-58 Measurements Corp.

<sup>3</sup>Model 18-B Measurements Corp.

<sup>4</sup>Du Mont type 72.

<sup>5</sup>A statistical analysis of the height gain relationship obtained in this procedure has been made by Kenneth Norton of Central Radio Propagation Laboratory of the National Bureau of Standards and appears in Reference C of the Ad Hoc Committee report. (See July COMMUNICATIONS.) However, this relationship was not employed in this report.

<sup>6</sup>Esterline-Angus.

# COMMUNICATIONS

LEWIS WINNER, Editor

AUGUST, 1949

## Police Communications

MOBILE RADIO OPERATION, which a few years ago was considered as just an interesting experimental idea and then slowly found itself being accepted in many services as a major medium of contact, is today quite a full-fledged member of the art, with its highly proficient linking features unanimously acclaimed. A striking example of this well-deserved acceptance appears in the police agencies, which, in the main, some years ago felt that two-way radio was a toy. The picture certainly has changed, for today there are over 44,000 active police radio stations.

An enlightening exhibit of this new vigorous interest will be found at the first New York meeting of the Associated Police Communication Officers at the Hotel New Yorker on August 29, 30, 31 and September 1, where many will gather to discuss their problems, visit the various exhibits and listen in to an assortment of pertinent papers on police radio.

Commenting on this interesting turnabout, in a letter to the editor, Neal Jackson of the Detroit Police Department and editor of the *APCO Bulletin* says: "Today police communications, or perhaps we should say police mobile communications, are quite different from the early days when a police department actually ran an amateur station to send messages to moving automobiles.

"It took courage and know-how to overcome the natural and political obstacles of the day. In fact, several years elapsed before our police department launched the weapon that soon changed the operation of our system.

"A few years ago, police radio was a feeble factor, but today it is a strong element in mobile radio service and when the new FCC rules go into effect, it will become an important item in the public safety radio services.

"In the early days, as police mobile radio grew to larger proportions, the various departments realized the value of cooperation. Soon adjacent towns were monitoring one another and the results of general broadcasts were very effective. The recognition of point-to-

point or station-to-station work was a great help to policing. This feature was appreciated by the FCC, who therefore included it in the new rules which are, by the way, highly regarded. And incidentally, with the new FCC rules in effect, mobile radio will have reached an extremely stable position.

"So far this year, equipment manufacturers have announced many advancements, particularly for adjacent-channel operation. This unusual development will provide more channel utilization with less interference. It will soon take its place among the other outstanding developments, such as avc, squelch, selective calling, etc.

"The next big step in police communications might include facsimile and mobile tie-in. Certainly the transmission of photos and handwriting are extremely valuable in police work and particularly important would be the transmission of fingerprints on an enlarged scale. A recent meeting of the Eastern Four-State APCO group saw an effective demonstration of this type of facsimile transmission.

"The use of a microwave system with facsimile should prove extremely useful and perhaps enable the installation of a network among national, state and municipal systems. Such a network would prove invaluable and contribute much to the maintenance of law and order in our land.

"Yes, mobile communications have certainly come of age and paved the way for the substantial strengthening of law enforcement agencies throughout the country."

Thanks, Neal, for so comprehensive a report.

## The Allocation Hearings

THOSE ALL-IMPORTANT hearings on the *shf* and *uhf* channel proposals, originally scheduled for August 29, have been postponed till September 26, in view of the barrage of briefs which have poured into the FCC offices.

Judging from the size and quantity of reports already received, it appears as if the sessions will be both hectic

and of the round-the-clock very-long-week type. There will be many who will applaud the proposals and very many who will tear the plan to shreds. In fact, the FCC Bar Association has indicated that it will strongly oppose the plan on the premise that it violates the Communications Act which stipulates that allocations must be based on demand requirements. Other groups have stated that the power requirements are too rigid, particularly for the smaller municipalities where there might be only several thousand inhabitants who certainly could not support a high-powered installation. Still others have indicated that the allocation of high and low-band facilities in one area might cause confusion among consumers who would be puzzled as to what type of receiver to purchase, a low band or combination type. Such a purchaser might wonder when the *uhf* part of the combination receiver would become useful.

Both the broadcasters and manufacturers have admitted that thus far commercial ultrahigh progress has been quite slow. Very low powers have been used during tests and the possibilities of achieving very much higher outputs before the year is over are not too bright. Practical ultrahigh broadcasts appear to many to be at least a year or two away.

There seems to be a general approval for the use of the *uhf* and *shf* allocation table as perhaps a guide, which might be employed to facilitate formal adoption of higher channel areas as conditions permit.

Such an approach could allow the immediate installation of stations in strategic areas so that urgently needed power and propagation tests could be conducted. Tom Goldsmith, Jr., of Dumont Labs, suggested such a move during the hearings last year and again during the NAB meeting in Chicago. Many at these sessions thought the general plan was very logical and should be adopted early so that a definite ultrahigh policy could be established, a policy, which based on factual exhaustive tests, would provide a sturdy basis of planning for the future.

—L. W.



# Field Coverage Study

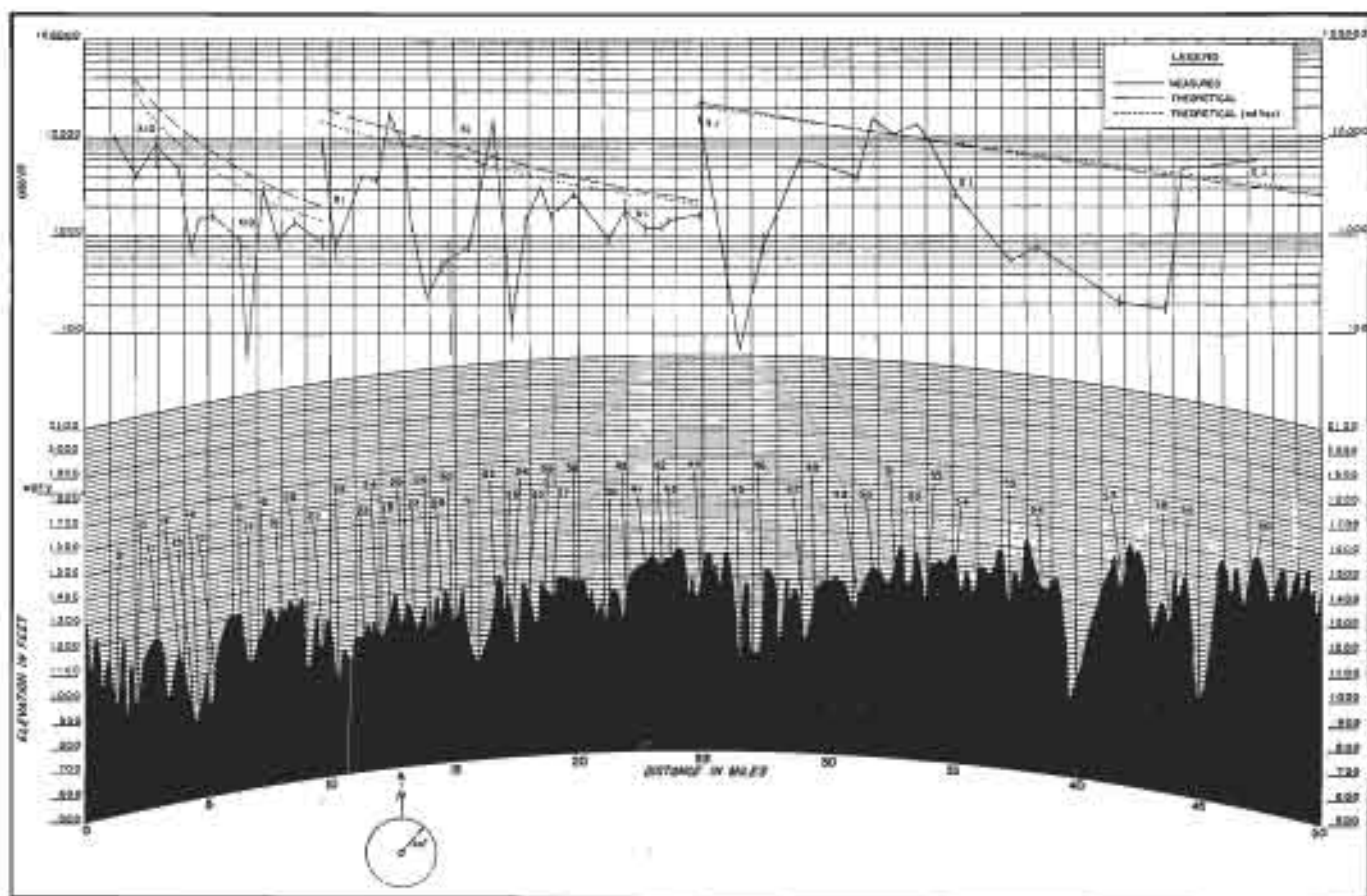

Profile and field strength (measured and theoretical) versus distance curves; curvature based on 4/3 earth radius. This plot represents a test made at Curtsville, Pa., and covers response from radial *A*. The abscissa of these radials indicates the distance from WDTV transmitter. The lower ordinate indicates the elevation above mean sea level and the upper ordinate the field strength in microvolts per meter. The lower portion of the graph is, therefore, a profile of the radial on a four-thirds earth basis. Cluster points are shown at their actual locations (elevation and distance), along the profile. Directly above each cluster at the top of the graph, the several values of field strength measured at that cluster are shown. A vertical line joins the extreme values and the arithmetical averages are connected by straight lines. Because of the extreme roughness of the terrain, points on the curve lying between measured cluster points cannot be expected to indicate true values of signal strength. It will be noted that it was frequently necessary to make measurements at two consecutive points in deep valleys separated by a high hill. Obviously, the straight line connecting the low signal strengths obtained in the valley bears no relation to the probable high signal which would have been obtained on the hill. The same is true, of course, in places where consecutive measurements were made on hill tops separated by a deep valley.

In addition to the measured data plotted, the smooth earth ground wave field strength, as calculated by Norton's curves, is shown at the top of the graph. For comparison, the smooth earth ground wave field strength as corrected by Figure 1 of the Ad Hoc committee report<sup>2</sup> is also shown. As can be seen, this correction in the case of channel 3 results only in a minor decrease in expected signal strengths for points lying within the primary service area and a very slight increase in expected signal strengths in the secondary and fringe areas.

from the theoretical at short distances from the transmitter than at greater distances, this was not particularly true in the Pittsburgh area. In the case of New York measurements, this condition has been explained as being due to the heavily built-up areas close to the transmitter. In the case of the Pittsburgh measurements, however, the absence of large buildings in the secondary service area is entirely counter-balanced by the very hilly terrain. Consequently, it was found that the signal strengths, as a function of distance, frequently varied widely throughout the entire area.

## Sample Computations

To obtain a suitable conversion factor from microvolts at the receiver

terminals to the field strength in microvolts per meter, two locations were selected at which a minimum amount of reflection was experienced. At each of these locations the field strength was obtained by measuring the voltage received on a standard dipole and dividing this value by  $\lambda/\pi$  (the effective length of a half-wave dipole). In each case the field strength was then compared to the voltage measured. The average ratio thus obtained was

$$\bar{E} = 0.87 e$$

<sup>2</sup>Dr. Mont investigators felt that the smooth earth ground wave curves as corrected by the Ad Hoc report were still somewhat optimistic for terrain as irregular as that encountered in the Pittsburgh area. (See plot on page 32)

<sup>3</sup>Made by J. Minder of Measurements Corp.

Where

$\bar{E}$  = field strength in microvolts per meter

and

$e$  = voltage at receiver terminals in microvolts

A laboratory setup to determine the relationship between voltages measured on the field strength meter and rms sync peak voltages was made<sup>3</sup>, calibration being made for both test pattern and typical television program. It was found that the instrument reads essentially pedestal level regardless of modulation.

As the RMA standards specify that this voltage is to be 0.75 times sync

(Continued on page 32)

# CAVITY RESONATORS

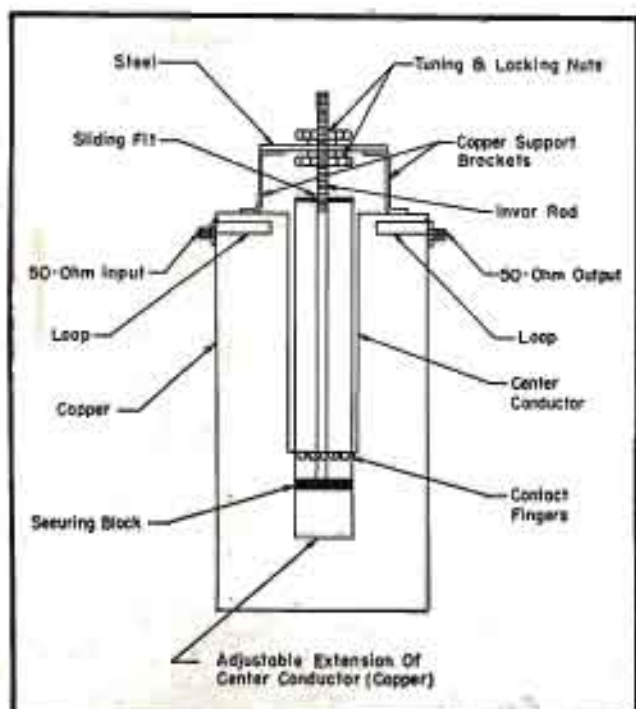

Figure 1

Typical quarter-wave cavity, with the center conductor of the coax line, made out of copper tubing, closed on the bottom and connected to the shorting plate at the top of the cavity.



Figure 2

External views of three types of cavities. The model in the center covers a range of 150 to 180 mc and the one at the left was designed for 25 to 40 mc. This unit has a capacity plate at the end of the center conductor to shorten its length. The third cavity covers the 400 to 600-mc range.

A CAVITY RESONATOR is effectively a very high  $Q$  circuit which can be inserted into a line, connecting the transmitter or receiver with the antenna. When designing such a cavity, especially for frequencies below 200 mc, it is desirable to obtain the highest possible  $Q$  and still keep its mechanical dimensions small. A short section of a coaxial line one quarter-wave long, a *quarter-wave cavity*, shorted on one end and open on the other would constitute the smallest coaxial cavity resonator. At the higher frequencies we are not so much limited by dimensions.

In a typical quarter-wave cavity, the center conductor of the coax line is made out of copper tubing closed on the bottom and connected to the shorting plate at the top of the cavity. The outside conductor is made from another large copper tubing of diameter about three times as large as the center conductor to obtain the optimum  $Q$ . The outside and inside conductors are connected at the top of the cavity by a shorting plate, made also out of copper and no insulating material of any kind is used to build the cavity. To provide frequency adjustment, the center conductor consists of two telescoped

tubes, and thus can be elongated inside the cavity by turning the tuning and locking nuts shown on the top of the cavity. It is necessary to provide temperature compensation in order that the cavity, which has a very high  $Q$ , will not drift off frequency. To do so, a careful choice must be made of materials to process a center rod, which adjusts the length of the center conductor, and the brackets which support the adjusting nuts. The proper dimensioning of these parts yields a temperature compensation which is

Figure 3  
Equivalent circuits of cavity.  $T_1$  and  $T_2$  are ideal energy transformers:  $E_1 \times I_1 = E_2 \times I_2$ .

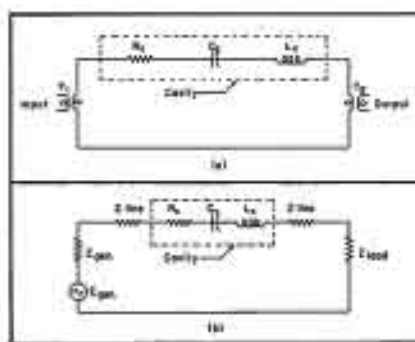

comparable with the stability of a crystal controlled-oscillator.

To couple the cavity to the outside coaxial conductors, two loops are inserted into the cavity close to the shorted end; each loop is soldered to a standard cable connector. By changing the size of these loops, variable loading of the cavity can be obtained.

## Cavity Circuit Analysis

A cavity inserted in a coaxial line can be diagrammed as an equivalent lumped electrical circuit; Figure 3. The cavity can be considered as a series resonant circuit having an inductance  $L_0$ , a capacitance  $C_0$ , and losses represented as a resistance  $R_0$ . This series-resonant circuit is coupled by two ideal energy transformers, to the two ends of the coax line. We assume that there is no loss of the energy in the transformation process and that zero impedance is presented by the ideal transformer when its secondary is open. This assumption is in close agreement with actual measurement, provided the loops are designed properly. If the cavity is inserted be-

# In Mobile Communications

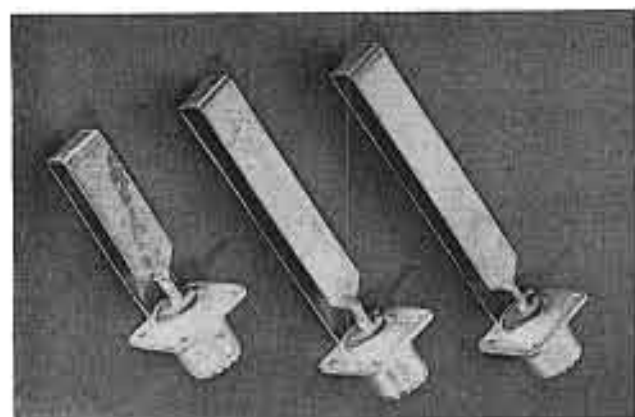

Figure 5  
Three loops used with 160-mc cavity filter.

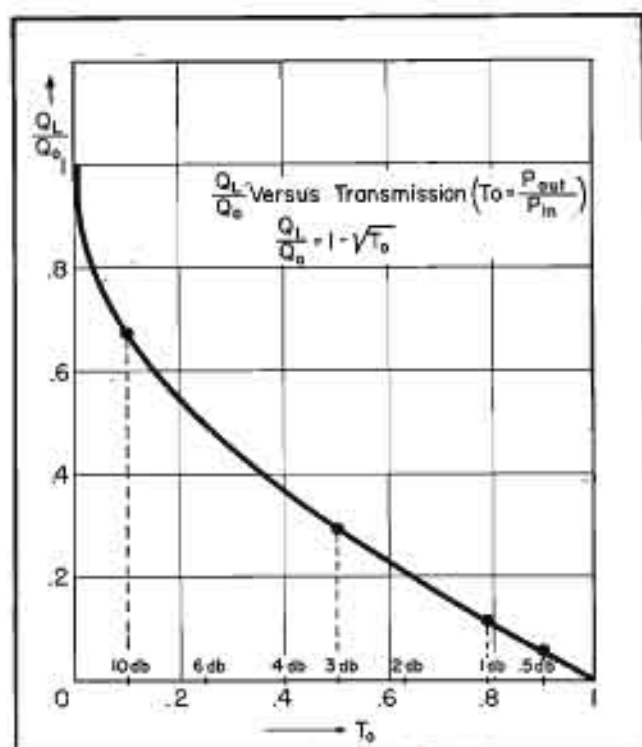

Figure 4  
Ratio of loaded  $Q$  to unloaded  $Q$  of cavity versus insertion loss.

tween a generator of *rf* power and an *rf* load, a further simplification of the corresponding circuit is possible by omitting the ideal energy transformers. Such simplification appears at (b) of Figure 3. Of course, the impedance values of  $R_c$ ,  $L_c$  and  $C_c$  in this circuit, will be different from the circuit illustrated. They have to be reduced by the step-up and step-down ratios of the input and output transformers. If the cavity is at resonance, the impedance of  $L_c$  is cancelled by  $C_c$ , and the coax line sees only a small resistance,  $R_0$ , which corresponds to the losses of the cavity. In general this resistance is small in comparison with the characteristic impedance of the connecting cables. Before calculating the value of the resistance,  $R_c$ , or the insertion loss introduced by the cavity, we must first analyze the  $Q$  of the cavity. From theoretical tables<sup>1</sup> we find that, for example, for a 160-mc cavity with 10" diameter of the outer conductor, a theoretical value of  $Q$  of an order of 12,000 can be obtained.

#### Unloaded $Q$ Measurements

The practical measurements show good agreement with this theoretical value, and unloaded  $Q$ 's of 11,000 have been actually measured. The ratio of

## Design and Application Features of High- $Q$ Circuits Which Provide Unloaded $Q$ s as High as 11,000 and Have Been Very Effective in Decreasing Spurious Radiation.

by **HENRY MAGNUSKI**

Chief Engineer, Research Department  
Communications and Electronics Division  
Motorola, Inc.

loaded  $Q$  to unloaded  $Q$  of a cavity versus insertion loss, appears in the curve of Figure 4. For example, if the insertion loss presented by the cavity to the coax line in which it is inserted is 3 db, then half of the power from the source is consumed by the cavity, and the loaded  $Q$  will be about 30% of the unloaded  $Q$  of the cavity. For a 1-db insertion loss, the loaded  $Q$  is only about 10% of the unloaded  $Q$ . (This curve shows the minimum insertion loss, assuming that a flat impedance match between the generator, the co-

axial line and the load exists. If such a match is not maintained the insertion loss will be greater than the values shown on this curve.) Of course, the construction of the coupling loops has something to do with the insertion loss. The loops should have the same characteristic impedance as the coaxial line in order that no energy be reflected. This requirement is met by constructing the loops from flat copper strips. In Figure 5 appears three loops used with a 106-mc cavity; first, loop designed for a total insertion loss of a half db, the largest loop which is used in the main for transmitter application; second, 1-db loop and third, 3-db

<sup>1</sup>Terman, Radio Engineers' Handbook; McGraw-Hill.

loop. The 3-db loop is used mostly for receiver applications. The  $Q$ 's and resonance curves obtained by using these three loops are shown in Figure 6. It will be noticed that with the 3-db loop a resonance curve corresponding to  $Q$  of about 3,600 is obtained. This is about the highest permissible  $Q$  which can be used with narrow FM since the bandwidth at the 3 db down points is only about 20 kc. For transmitter applications, the loop with  $\frac{1}{2}$  db insertion loss, and corresponding  $Q$  of about 650, is the most popular.

#### Use of the Cavity for Transmitter Purposes

The cavity can be inserted between the transmitter and the antenna to decrease any spurious emissions of the transmitter. If the transmitter is crystal controlled and uses several multipliers to obtain the right frequency at the antenna, in addition to radiating the proper frequency it radiates a small amount of power on other harmonics of the crystal. A cavity can be used to decrease the spurious radiation by some 1,000 times or better and still introduce only a  $\frac{1}{2}$ -db loss to the radiation on the right frequency, which means that the total power lost inside the cavity is about 10%.

Another very important application of the cavity in transmission technique is to multiplex several transmitters on one antenna. Without cavities the transmitters connected to the common antenna will cross-modulate, since a considerable portion of the power from one transmitter will penetrate the output stages of the other transmitter. Also the efficiency of the transmitters will be considerably decreased. If the transmitters differ by some .3% or more in frequency they can be simultaneously and independently used on one antenna by inserting a cavity tuned to the transmitter frequency in each transmitter line; Figure 8. To get maximum independence in transmitter operation, the connecting coax cables have to be cut to the proper lengths. The connecting cables to the transmitter 1 have to prevent energy from transmitter 2 reaching transmitter 1, and therefore they have to be an odd number of quarter wavelengths long for frequency 2. The loop inserted into the cavity presents an almost perfect short circuit for all frequencies except the resonant frequency of the cavity. To transform this short into the open line effect, a quarter-wave section of the coax cable is necessary between the cavity and the point where the two lines meet. This

justifies this arrangement. If both transmitters are working on near-by frequencies, different by only a few per cent, it is not necessary to cut the connecting cables exactly to each frequency, but to an average frequency of the two or more transmitters which are so connected. Such an arrangement is very convenient for well-organized transmitter centers and saves the expense of additional antennas.\*

#### Cavities in Receiving Systems

The application of the cavities in the receiving technique has also many important advantages. Quite often the receiver is desensitized because a strong signal from a nearby transmitter working on quite a different frequency may penetrate into the first grid of the receiving equipment. Such a signal may bias off or otherwise desensitize the first, second and the third tube before the selectivity of the receiver will sufficiently reject it. In such a case, a cavity inserted between

the antenna and the receiver will provide the high selectivity at  $rf$  level, where we need it the most, and will reject the unwanted signal before it reaches any tube in the receiver, thus very effectively preventing the receiver from being desensitized. This can be achieved with a relatively low loss on the order of 1 or 3 db to the receiver sensitivity. In some cases where the receiver sensitivity is limited by an outside disturbance generating noise in the antenna, the sensitivity measured with the cavity is actually better than without one. If necessary, more than one cavity can be inserted and a much higher degree of selectivity can be achieved by doubling the losses. A 6-db loss means that the receiver sensitivity will decrease only two times, if measured in microvolts. On the other hand the desensitizing signal, if 1 or 2 mc off frequency, can easily be decreased by 80 db in this case.

#### Spurious Response Reduction

Another very important advantage obtained by using the cavity in front of the receiver is a substantial decrease of spurious responses of the receiver, such as image response, etc. It must be remembered that the cavity will allow only one frequency to pass through it and will reject all the other frequencies. The spurious frequencies of the cavity lay in a  $vhf$  region, the first one being about three times the basic frequency of the cavity and are not harmonically related. Finally, the most important application of the cavity in receiver technique is an improvement in intermodulation interference. As is generally known, the intermodulation problem is growing in importance because many more transmitters are now on the air, especially in the urban areas.

#### Intermodulation Interference

Intermodulation interference originates in the receiver, particularly in some non-linear part of it, usually in the first mixer stage where the received signals are strong, being amplified by the  $rf$  stage, and where nonlinearities always exist. Let us assume that our receiver is tuned to the frequency  $F$  and the two interfering transmitters are on frequencies  $F + \Delta F$  and  $F + 2\Delta F$ . (The uniform

\*See cover, this issue.

Figure 6  
Selectivity curve of a 15" cavity tunable over the 153-162 mc band. At A appears insertion loss of .5db ( $Q_L = 650$ ); B, insertion loss of 1 db ( $Q_L = 1300$ ); C, insertion loss of 3 db ( $Q_L = 3600$ ).

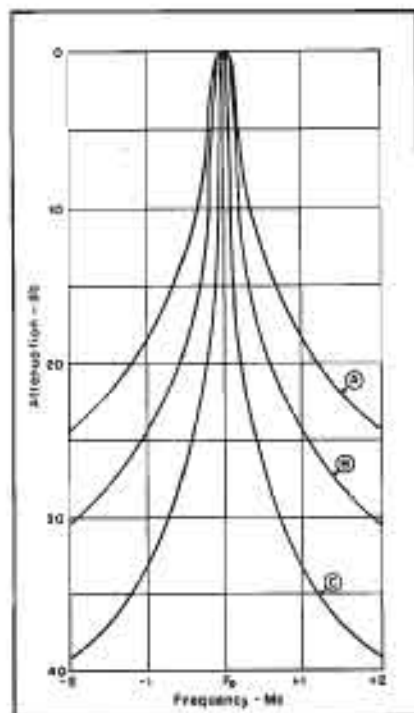

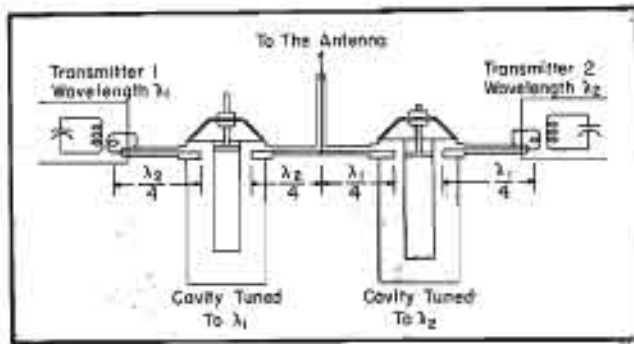

Figure 6  
Schematic illustrating the multiplexing of transmitters or receivers on a single antenna.



Figure 7  
A cavity resonator for the 152-162 mc band connected to a 250-watt transmitter.

channel spacing makes such case a very usual one.) The second harmonic of the first transmitter, namely the frequency  $2F + 2\Delta F$  is definitely generated in the mixer stage, and sometimes in some other stages of the receiver. This second harmonic beats with a frequency of the second transmitter, namely the  $F + 2\Delta F$ , and by subtraction generates the frequency  $F$ . In this case, no selectivity after the mixer stage will help any since the frequency  $F$  is the one to which the receiver is tuned. The rejection of the unwanted frequencies must be achieved ahead of the mixer, either at the antenna circuit, or at the *rf* amplifier. Unfortunately, neither antenna circuit nor *rf* amplifier are selective enough to reject the unwanted frequencies. The cavity resonator does a surprisingly good job of decreasing the intermodulation interference. This is because it rejects both unwanted frequencies. Since the intermodulation thrives on non-linearities, a small decrease in any one of the interfering frequencies causes more than proportional decrease in intermodulation.

In addition to reduction in desensitizing spurious responses and intermodulation, quite often a substantial reduction in the noise level is obtained, particularly if the noise is man-made or an impulse noise with the maximum energy concentrated on some other frequency, and is strong enough to de-

sensitize or interfere with the operation of one of the first tubes of the receiver.

The cavity can also be used to duplex a receiver and transmitter on one antenna. This is possible only when the frequency separation is in the order of 1 mc or more in 160-mc band. The use of two or three cavities is necessary in this case. One cavity should be inserted into the transmitter line to limit the noise created by the

transmitter. This noise at a megacycle off has still sufficient power to choke the receiver of normal sensitivity. The one or two other cavities have to be inserted in the receiver coaxial line to prevent the transmitter power from penetrating the receiver. Such an arrangement has been tested in our lab and found to operate very well with a total loss of 10% of transmitter power and about 6 db in receiver sensitivity.

Figure 8  
Plot of intermodulation interference measurements with and without cavity filter. (Reference level: .5 microvolt at receiver input, for 20 db quieting, assumed 0 db.)

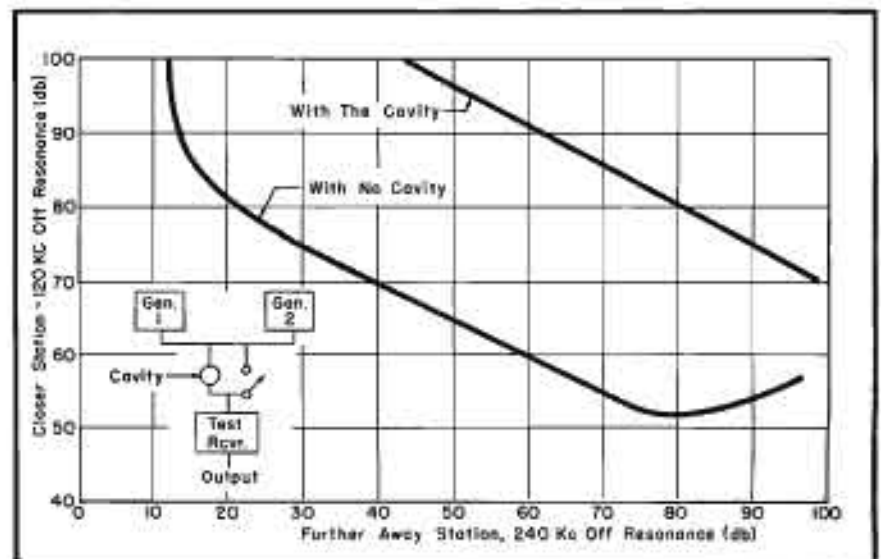

(Right)  
Top view of the supersonic-controlled  
FM receiver.

(Below)  
Cabinet view of receiver.

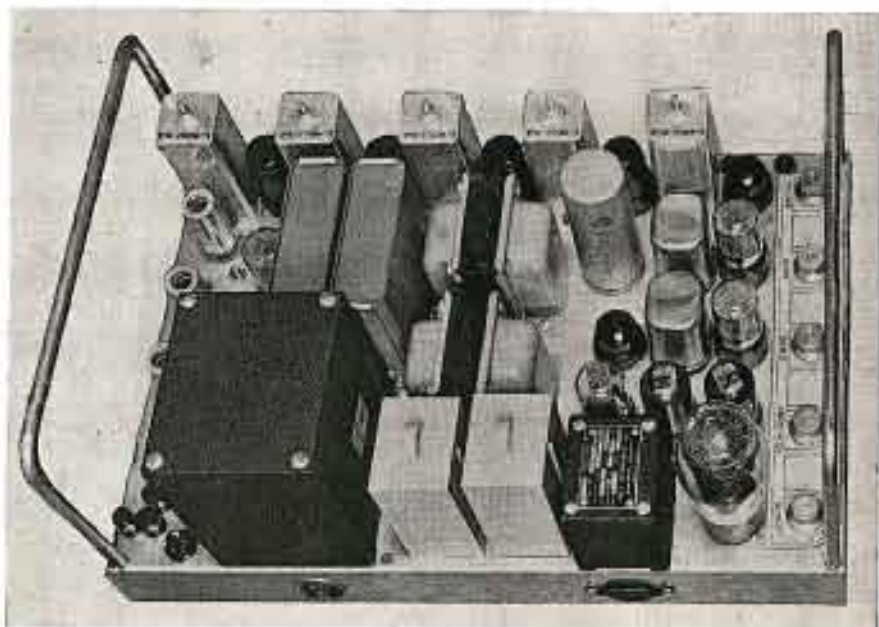
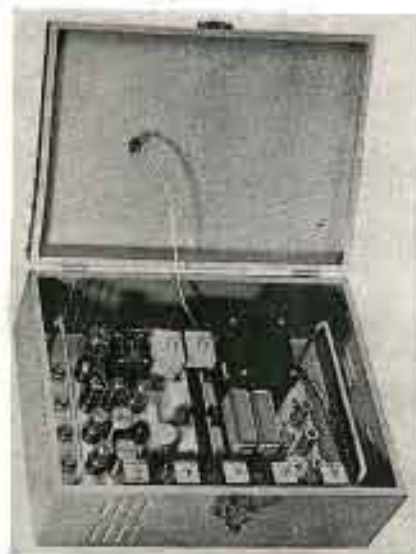

## ***FM Receivers With SUPERSONIC CONTROL***

THE SUPERIOR PERFORMANCE of FM broadcasting, due to its high-frequency allocation and wider bandwidth, unfortunately, has not achieved the popularity it deserves. Competition with the established field of AM has discouraged many FM broadcasters. Recently, however, there have appeared several new services which may be performed ideally by the FM broadcaster, offering new hope of profitable operation in the FM field.

These new services provide unique application possibilities:

(a) Musical entertainment for public service vehicles. Revenue in this case is obtained from advertising spots, the captured audience proving very attractive to the advertiser.

(b) Musical entertainment for food markets or similar establishments, in which advertising announcements are permissible.

(c) High quality music, without advertising, for restaurants, offices and other establishments, in which revenue is obtained by rental. This application offers great possibilities, the FM broadcast station serving as a distributing circuit of wide tonal range, which is normally unobtainable by other means.

In order that the foregoing types of services may be served simultaneously from one transmitter and program ma-

---

**Receiving System, Featuring Use of 15 to 20 Kc Filters, Permits Broadcaster to Predetermine Audio Operation, Boost Levels by 6, 9 or 12 db or Silence Receivers Used in Controlled-Type Service for Busses, Food Markets and Restaurants, Stores, Etc.**

---

**by FRED M. BERRY**

Project Engineer  
Railway Radiotelephone, Inc.

terial, the FM broadcaster must be able to turn on and off, at will, the desired groups of receivers. Boosting the audio level of receivers in the (a) and (b) applications during certain announcements under conditions of high ambient noise, as in public service vehicles, is another desirable control feature. The assurance that the announcements will be heard is quite an attraction to the FM advertiser. All three of these services need not be performed or offered simultaneously; but, it is assumed that the FM operator might care to adopt

a system which is flexible and which would provide for the inclusion of all three services simultaneously.

To serve the (a), (b) and (c) groups, a system of remote control from the transmitter has been devised. In the parlance of the trade this has been named the *beeper system*.

In operation, with this system, audio frequencies higher than that of the program material are introduced at the transmitter. These frequencies are selected at the receiver and are used to actuate relays in the receiving equip-

Figure 1 (Right)

Schematic of the sixteen-tube FM receiver which features supersonic control.

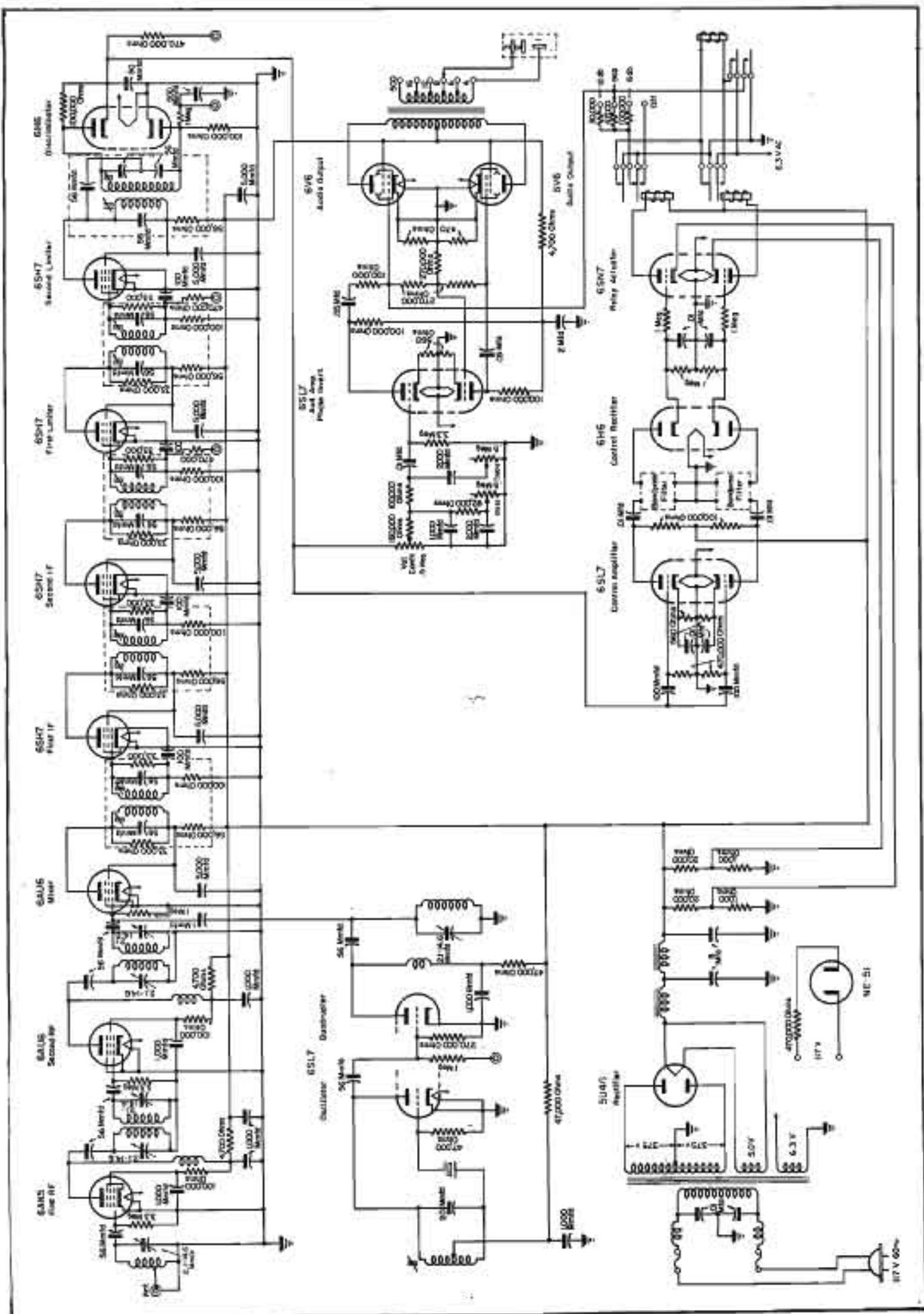

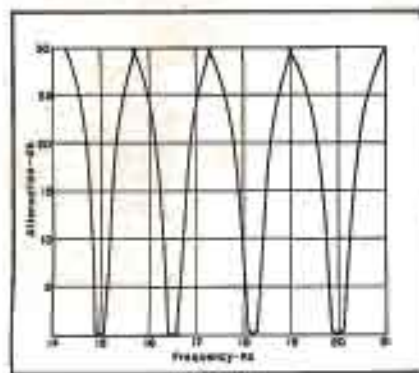

Figure 2  
Selectivity characteristics of supersonic-control filters used in the receiver.

ment. The control frequencies must not interfere with either the program material or adjacent channel operation, and therefore their modulation level must be held low at the transmitter.

Several ways of achieving the control functions are possible. One method, found quite effective, uses four control frequencies: 15, 16.5, 18.2 and 20 kc. A momentary application of 15 kc tone turns on receivers in the (a) group. A momentary application of 16.5 kc turns on receivers in the second or (b) groups, and a 18.2-kc tone turns on receivers in the third (c) group.

It must be noted, of course, that only the audio output of the receiver can be controlled, as the receiver must always be receptive to the control signals.

The momentary tone application actuates a lock-up circuit which holds the receiver on as long as desired.

The 20-kc control frequency is used to actuate a relay in all three groups of receivers. This tone is applied during the time of an announcement. In the (a) and (b) group receivers the relay actuated by this 20-kc tone switches out a pad in the audio portion of the receiver, raising the level the desired amount. In the group (c) receivers, the relay is wired so that it silences the receiver during an announcement. To turn off the groups of receivers, the 20-kc tone is applied simultaneously with one of the other tones. Tones of 15 and 20 kc applied momentarily turn off the (a) group of receivers; 16.5 and 20 kc turn off the (b) group; and 18.2 and 20 kc turn off the (c) group. While other combinations of tones would reduce the number of tones necessary to perform the desired control functions, the method described was found to permit simplicity of design.

The band-pass filters which respond to the control tones are of simple form,

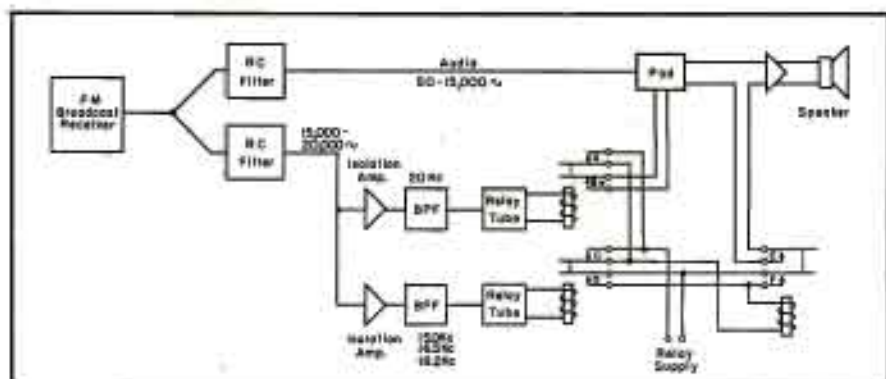

Figure 3  
Block diagram of the FM supersonic control system; \*pad may be adjusted so that control  $\beta$  will boost gain 5 to 15 db or open circuit as required.

and have an attenuation of approximately 35 db to the adjacent tone channels. Molybdenum permalloy toroidal coils having a  $Q$  of 200 or greater make it possible to meet these selectivity requirements. Two band-pass filters have been found necessary for each receiver, the 20-kc filter being used in all three groups, and the second filter depending on the group of service to which the receiver belongs.

#### Transmitter Control Equipment

The additional equipment at the transmitter consists of accurate and stable oscillators of 15, 16.5, 18.2 and 20 kc, and arranged to be bridged across the audio input of the transmitter.

The accuracy of the oscillators must of course be good, and two types have been developed. Flexure mode fundamental crystals were used in one type, and temperature stabilized molybdenum permalloy toroidal coils in the other type, as the frequency control elements. The  $\pi$ c type oscillator did not prove sufficiently stable for this application. In bridging the oscillators to the line, isolation amplifiers and a high-pass filter were employed. Studio control of the desired frequencies was provided by a relay control circuit.

#### Receiver Design

In the early experiments with equipment for these new services attempts were made to use modified FM receivers and tuners. Results were quite disappointing, and quite possibly one of the reasons for a lack of popularity of FM broadcasting to the public. Generally receivers and tuners tested lacked sensitivity, selectivity, stability, and quality of material. Since the FM broadcaster must own and service the receiving equipment it is evident that greater overall economy would result from the use of the highest quality

components. The grade of components required must be similar in quality to that used in the usual broadcast transmitter.

It was demonstrated by trial that even in areas of high signal strength, high sensitivity was necessary to overcome fading conditions. As continuous unattended operation is necessary, crystal control and temperature compensation of  $if$  and discriminator was found imperative. High  $rf$  selectivity was found extremely desirable to provide freedom from cross-modulation effects. Two limiter stages were found necessary to provide effective noise reduction and constant audio level. The audio output level required was subject to varied opinions, but in the selected design a level of 8 watts at 5% or less distortion was adopted.

A design incorporating the aforementioned features resulted in a receiver for the (b) and (c) services, with the following characteristics:

**Sensitivity:** 1.5 to 2.0 microvolts for 20 db quieting, with 50 ohm unbalanced input.

**Selectivity:** 6 db  $\pm$  75 kc, 40 db  $\pm$  200 kc.

**Tuning Range:** Crystal-controlled oscillator adjusted to any frequency in 88 to 108-mc FM broadcast band.

**Audio Power Output:** 8 watts at less than 5% distortion.

**Frequency Response:**  $\pm$  2 db 50 to 15,000 cycles. Separate base and treble controls to allow variation to suit requirements.

**Input Power:** 105-125 v ac, 60 cps, 110 watts.

**Supersonic Control.** The circuit as detailed in the first part of this paper were incorporated. Plug-in filters and a selector switch permitting the announcer boost relay either to boost or silence the receiver enables the receiver to be used interchangeably for (b) or (c) group service.

#### Credits

The writer is grateful for the development and testing assistance provided by the late K. G. Marquardt and the engineering staff of WIBW.



# SPRAGUE KOOLOHM RESISTORS

T.M. Reg. U.S. Pat. Off.

**Tops for TV and other  
difficult applications!**

Available in 5, 10, 25,  
50 and 120 watt  
ratings.



## WIRE-WOUND RESISTORS WITH LOW S.Q.!

S.Q.?? That means "Service Quotient." With dependable, tropicalized Koolohm resistors, it's practically nil!

That's why major television manufacturers specify Sprague Koolohms and avoid unnecessary and expensive service calls due to resistor failures.

Koolohms far outperform and outlast ordinary wire-wound resistors, yet are smaller in size than ordinary units of the same wattage rating. Koolohms are wound with larger diameter wire for the same rating yet are available in far higher resistance values (for example, 70,000 vs 25,000 ohms at a full 10 watts). Koolohms are available in *truly non-inductive* windings when needed. Koolohms have exceptional resistance stability.

Koolohms have all these advantages because they are the *only* resistors wound with ceramic-insulated wire (an exclusive Sprague development) and are enclosed in glazed moisture-resistant ceramic outer shells. Mounted on a metal chassis, Koolohms will withstand a 10,000 volt breakdown test from winding to ground.

Koolohm resistors are ideal for television sets and other tough applications—and are equally good for all ordinary electronic and industrial control uses.

Best of all, premium-quality Koolohm resistors are *competitively priced*.

Sprague Catalog 100E tells The Complete Koolohm Story. Write for your copy today.



**SPRAGUE ELECTRIC COMPANY**  
NORTH ADAMS, MASS.  
PIONEERS IN ELECTRIC AND ELECTRONIC PROGRESS

# TRIANGULAR HIGH-BAND



Figure 1  
Pair of experimental triangular high band (channels 7 to 13) TV loops mounted on steel lattice structure,\* which is 14" on side and built in 10' sections.

Figure 2  
Schematic of the triangular loop illustrating the instantaneous current flow in the radiators.

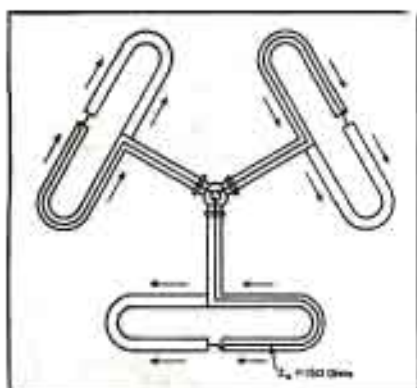

**Broadband Horizontal-Type Loop Design, With All Instantaneous Currents in Phase, Achieved by Three Coaxially-Fed Folded Dipoles Arranged Symmetrically Around a Supporting Structure at 120° Spacing.**

by **A. G. KANDOIAN** and **R. A. FELSENHED**

Head, Radio and Radar Component Div.

Project Engineer

Federal Telecommunication Laboratories, Inc.

IN THE MAJORITY of cases *vhf* and *uhf* broadcasters require as much power gain as practicable. This may be obtained in the transmitter or antenna or preferably both. Under the present state of the art, and within limits, such gain can be achieved much more economically in the antenna system than in the transmitter.

High antenna gain obtained entirely from vertical directivity requires a large antenna aperture in wavelengths, which in turn means a physically long supporting structure for the antenna system. If the supporting structure is long it must have a certain minimum cross-sectional dimension in order to withstand normal requirements of wind and ice loading. The most satisfactory supporting structure is the type of steel lattice used for AM broadcast towers, transmission towers and similar applications. The most economical has been found to be the triangular lattice, of the type illustrated in Figure 1.

The schematic of a triangular loop, developed for high band TV application, appears in Figure 2. It is, in effect, a two-turn current loop, triangular in shape, with all the instantaneous currents in phase (current flow in the clockwise or counter clockwise direction around the axial supporting structure). This is accomplished by

three coaxially-fed folded dipoles arranged symmetrically around the supporting structure at 120° spacing.

A study of typical measured impedance data at each of the three coaxially fed points of this type antenna disclosed that, contrary to a somewhat popular conception, a loop antenna need not necessarily be a sharply resonant circuit. In particular, when its diameter is of the order of one-half wavelength its impedance varies relatively slowly with frequency, the actual value depending on the loop geometry and the feed point. The next problem is to transform this impedance as smoothly as possible to the impedance of the main coaxial line feeding the loop. Whether the full bandwidth characteristics of the loop will be realized depends on how well this transformation is accomplished.

In the triangular-loop case it has been found that the feed-point impedance level is not too different from reasonable size coaxial transmission lines and a number of easily varied parameters are at the disposal of the designer to transform this impedance to the desired nominal 50 ohms, broadbanded over any desired high-band TV channel.

In curves made of the *swr* versus frequency at different channels, with one or two loops set for channel 9, it was found that the voltage *swr* is below 1.1 over the desired channel with a considerable safety margin.

## Radiation Characteristics and Gain

It has been shown<sup>1,2</sup> that the radiation pattern of a horizontal loop, with uniform current distribution, and

\*From a paper presented at the Third Annual NAB Broadcast Engineering Conference.

<sup>1</sup>Blew-Knox.

# TV Loop Antenna System\*

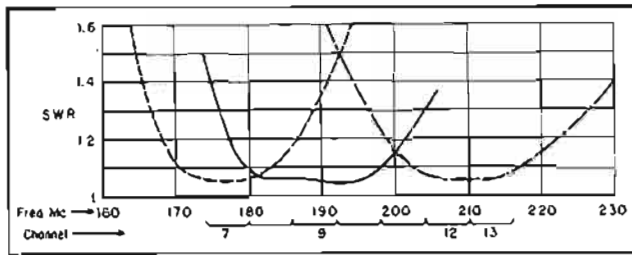

Figure 4  
Typical measured data for a single TV loop operating in channels 7, 9, 12 or 13.

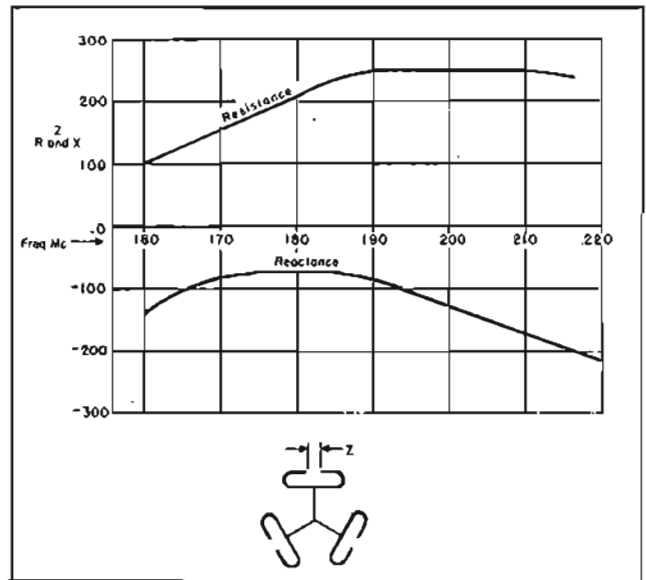

Figure 3  
Plot of the impedance per element in a triangular loop.

diameter small compared to a wavelength, a *magnetic* dipole, is circular in the horizontal plane. In the vertical plane it varies as the cosine of the vertical angle measured from the horizon.

Measured data indicates that the triangular loop behaves substantially as the *magnetic* dipole.

The horizontal pattern is just right for the majority of broadcast applications. The vertical pattern of a single loop however obviously radiates too much energy at high and low angles where it is unnecessary and wasted. This may be corrected by stacking a large number of loops one above the other and feeding them in the proper phase. In a previous paper,<sup>2</sup> it was shown how much power gain may be produced by stacking a large number of horizontal loops. (The data are also applicable to any other radiators with a radiation form factor essentially similar to a loop, such as vertical dipole, discone, etc.) This paper also disclosed that the optimum spacing between loops in a stacked array is one wavelength. It is evident, furthermore, that the amount of antenna power gain that can be produced depends entirely upon the overall permissible aperture of the antenna array. In the final analysis, with a given size of loop and a fixed cross-sectional area of the supporting structure, the limitation on the overall aperture, hence antenna gain, is structural and not electrical.

A further word regarding the stacked antenna analysis. To avoid unnecessarily laborious mathematics, the calculations were based on an *elementary* dipole (electric or magnetic)

and stacking a number of them one above the other, along a common axis. Since an *elementary* dipole has somewhat less directivity than a half-wave dipole, its gain is lower by approximately nine-tenths. Thus, to be on the safe and conservative side, this factor has been applied to the array of the FM square loops and the present triangular loops for television.

In practice the necessity for this factor may well be questioned since it implies that the loops under discussion are equivalent to the *elementary* rather than the half-wave dipole. The only clarification available on the subject, in addition to Figures 7 and 8, are measurements of gain between the present triangular loop and a half-wave dipole properly matched. Within measurement error, their gains were equivalent.

The triangular loop, supporting structure, and two alternate transmission line feed systems for an eight-loop array are illustrated in Figure 9. To avoid different supporting structures for each of the high-band television channels a fixed spacing of 5' was used between the loops for all channels 7 to 13. This represents a change in electrical spacing between loops of 318° to 394°, but a reference to Figure 10 will show relatively small change of power gain in this region.

## Diplexer

The complete TV spectrum for each channel includes a wide band of pic-

Figure 5  
Plot of bandwidth for one or two loops set for channel 9.

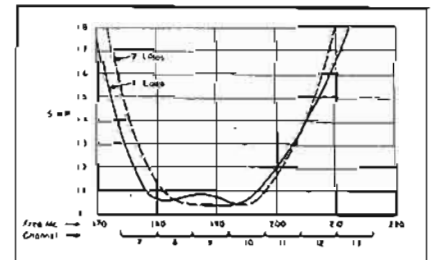
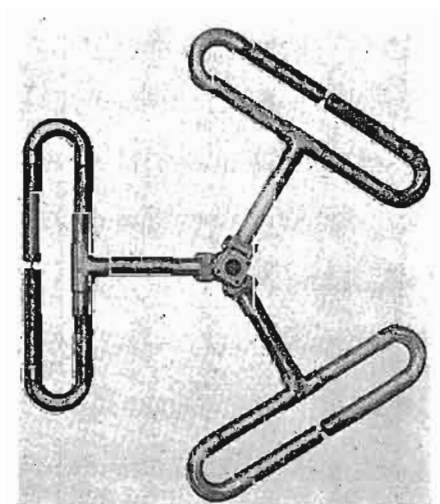

Figure 6  
View of experimental loop consisting of standard 15/16" transmission line outer conductor and fittings.



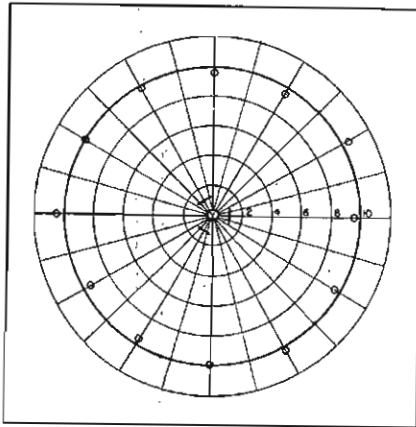

Figure 7  
Horizontal radiation pattern of the triangular loop.

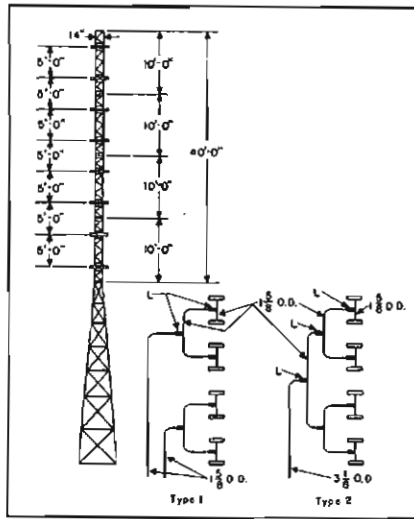

Figure 9  
Eight loop tower and feed line arrangements. In this setup a separate line is used to feed each group of four loops, two lines being joined in proper phase at the ground level or in a transmitter house.  $L = \frac{1}{4}$  wave matching transformer.

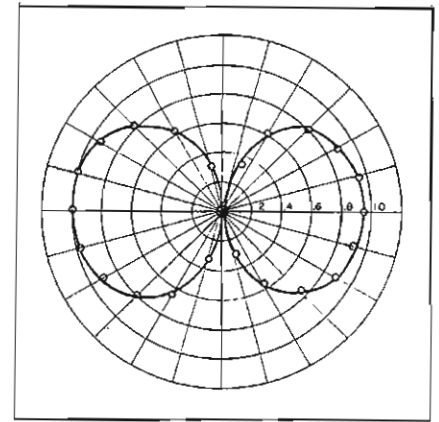

Figure 8  
Vertical radiation pattern of the triangular loop.

ture signal and a narrow band sound signal. The two carrier frequencies are separated by 4.5 mc. It is evident, therefore, that a straightforward filtering technique will provide a means for combining the output of both picture and sound transmitter on the transmission line leading to the antenna without undesirable mutual interference. Because of the frequency range involved, the most convenient form for the filter components are transmission line sections rather than normal coils and capacitors.

The overall schematic of a basic diplexer unit appears in Figure 11. In operation, at picture frequencies, for all practical purposes, the sound transmission line is blocked so that from the common junction point, looking toward the sound transmitter, the impedance is very high compared to that

of the nominal 50 ohms of the antenna line. The disturbance on the line in terms of *swr* introduced by the presence of the stubs is negligibly small.

Sound signal transmission operates in a similar manner.

- |  |                 |
|--|-----------------|
| a) Insertion Loss (Picture),                       | Less than .5 db |
| b) Insertion Loss (Sound),                         | Less than 1 db  |
| c) Rejection of Sound Carrier in Picture Line..... | More than 20 db |
| d) Rejection of Picture Carrier in Sound Line..... | More than 20 db |
| e) VSWR (Picture).....                             | Less than 1.05  |
| f) VSWR (Sound).....                               | Less than 1.5   |

Table 1  
Tabulation of the overall performance characteristics of diplexing unit

### Installation

The loops are assembled in pairs on a 10' triangular structural member. At the junction of the 50-ohm line joining the loops, the impedance is brought back to the nominal value by means of a quarter-wave transformer.

### References

- Andrew Alford and A. G. Kandoian, *Ultra-high-frequency loop antennas*, *Trans. AIEE (Elec. Eng., 1940)*, vol. 59, pp. 843-848; 1940, and *Elec. Commun.* pp. 255-265; April, 1940.
- Donald Foster, *Loop antennas with uniform current*, *Proc. IRE*, pp. 603-607; October, 1944.
- A. G. Kandoian, *Three new antenna types and their applications*, *Proc. IRE*, pp. 70-75; February, 1946.

Figure 10  
Gain of linear array of loops vertically stacked.

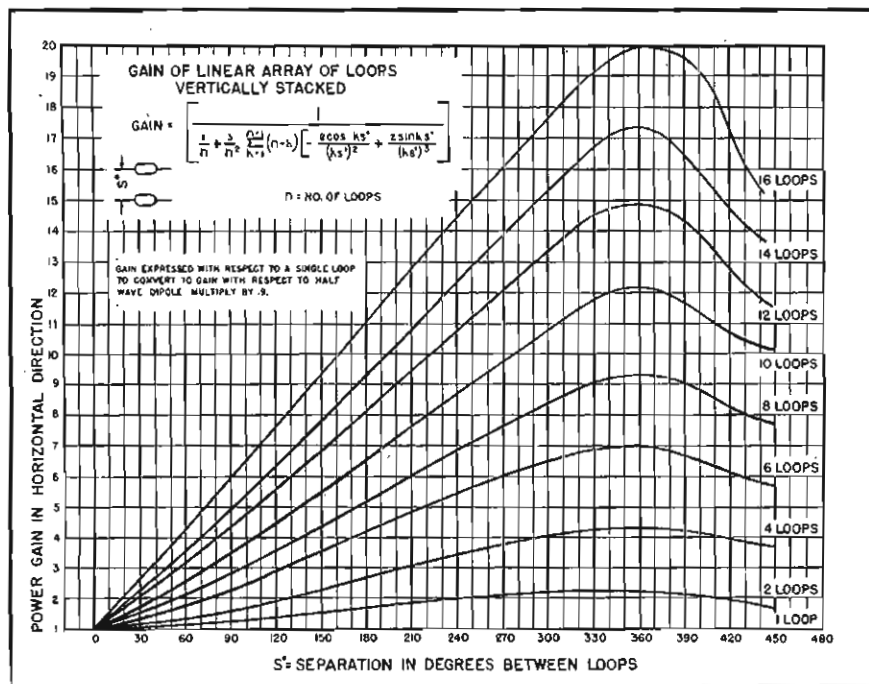

Figures 11 a, b and c  
In (a) appears a schematic of a basic TV diplexer system. The equivalent picture circuit of the diplexer is illustrated in (b) and in (c) appears the equivalent sound circuit.

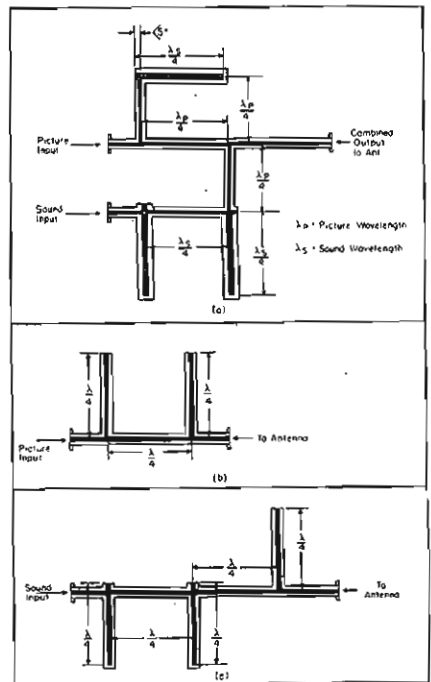

# Motorola meets the challenge!

## announces the new "RESEARCH LINE"

### solves the ADJACENT CHANNEL problem

#### "8" ESSENTIAL INVENTIONS make ADJACENT CHANNEL OPERATIONS PRACTICABLE

- SENSICON circuit (Pat. Pending)
- ISO-Q cavities (Pat. Pending)
- STATOMIC oscillator (Pat. Pending)
- PERMAKAY filter (Pat. Pending)
- BRIDGE BALANCED CRYSTAL OVEN (Pat. Pending)
- CAPACITANCE DISCRIMINATOR (U.S. Pat. 2,404,359)
- DIFFERENTIAL SQUELCH (U.S. Pat. 2,343,115)
- I.D.C. slope filter (Pat. Pending)

**DESIGN**—Today! The ideal two-way mobile radio communications equipment is here.

Research experimentation, development and field testing in systems operation produced this scientific answer to the adjacent channel operations problem.

The minor problem of super-precision selectivity was solved in six months, but two years of research and the creation of five major inventions were required to solve the major problem of intermodulation before same-area adjacent channel operation became practicable.

**PERFORMANCE**—Here is equipment that is new all through, with the amazing circuits which provide a new standard of performance for the industry. Here is equipment to give you the most modern communications system you can own—actually anticipating the standards of good engineering practice for the future. This startling departure from the conventional offering new simplicity of maintenance and a new standard of reliability—this engineering and scientific achievement is the new MOTOROLA.

Remember! Selectivity alone is not the answer to adjacent channel operation. The integrated systems combination of these new inventions is the modern engineering answer to full channel utilization.

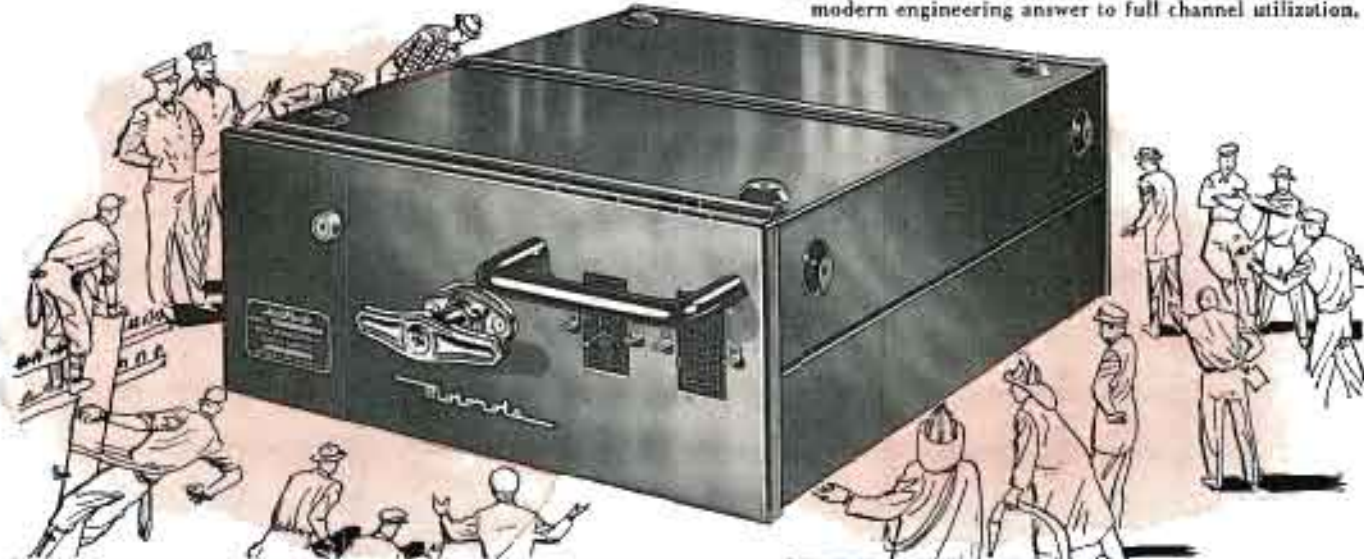

the BEST is now BETTER than ever before . . .

## Motorola FM 2-WAY RADIO

COMPARE feature for feature with any other equipment on the market . . . GET THE COMPLETE STORY . . . MAIL THIS COUPON TODAY . . .

MOTOROLA, INC., 4545 Augusta Blvd., Chicago, Ill.  
Communications Division

Name \_\_\_\_\_

Position \_\_\_\_\_

Firm \_\_\_\_\_

Address \_\_\_\_\_

City \_\_\_\_\_ Zone \_\_\_\_\_ State \_\_\_\_\_

Dept Com—Aug

# FM COMMUNICATIONS For Underground Mining

Figure 1 (Below)

View of the complete transmitter-receiver, shock mounted and suspended on five guide rails.

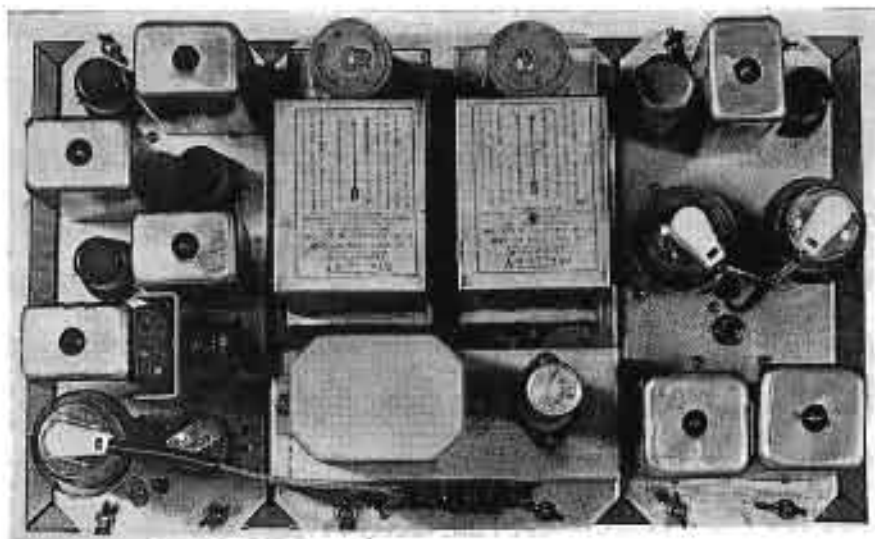

Figure 2

Interior of equipment with receiver at left, power supply in center and transmitter at right.

IN UNDERGROUND MINING operations radio communications facilities have been found invaluable in assuring a reliable method of rapid contact so essential in dispatching and the maintaining of speedy delivery of coal to the shaft entrance. And in the event of disaster or explosion, the circuit provides a vital line of communication between any unit and the main station.

## Use of 100-Kc

Since direct radiation is impractical underground, some other form of propagation must be employed. The 270-volt *dc* trolley line, used to power the coal car engine, conveniently lends itself to this usage. It has been found that a frequency-modulated signal, of approximately 100 kc fed back into the power line in a type of carrier current system, affords excellent results. The use of FM successfully combats the high noise level present due to motors and machinery used across the line. It also makes possible the full utilization of receiver sensitivity. This is a very important factor because often the transmitted signal looks into almost a short circuit, due to the heavy current

load on the line. Under normal working conditions the resistance will seldom rise above  $2\frac{1}{2}$  ohms, and often will be much less than this. During several tests, despite the apparent adverse conditions, it has been found possible to maintain communication in excess of five miles, with units of comparatively low power.

## Shock-Mounted Equipment

For this type service a complete transmitter-receiver unit was developed. It was shock mounted and suspended by five guide rails, to provide a degree of isolation from the vibration of the locomotive. All aluminum construction was used on the equipment to prevent excessive oxidation due to the high humidity encountered underground.

## Rapid Servicing Design

To facilitate rapid servicing each unit was divided into three separate chassis; the receiver on the left side, power supply in the center, and the transmitter on the right side. This type of construction allows replacement of the inoperative unit while in

the mine and proper repair of the unit at the service bench later.

## Transmitter Output

The transmitter has a power output of 25 watts as measured into a dummy load of 2.5 ohms. The high transformation ratio of 7,000 to 2.5 ohms necessitated the design of a special network to couple the *pa* tubes to the power line. Due to the high circulating current, space limitation, and low frequency, considerable time was spent in the design of a small efficient transformation-coupling network which would handle the output of 25 watts.

## Signal-to-Noise Ratio

It was found that a frequency swing of  $\pm 3$  kc provided a good signal-to-noise ratio and permitted the use of handpass coils of relatively simple and straightforward design.

## Voice Frequency Response

Frequency response was limited to the voice frequencies between 300 and

# Carrier Current System, Developed for Subsurface Operations, Operates on 270-Volt DC Trolley Line, Into Which Are Fed 100 kc FM Signals. Uses a 25-Watt Transmitter With a Fixed Tuned RF Receiver.

by **B. E. PARKER** and **G. W. THOMPSON**

Head, FM Engineering Dept.  
Gates Radio Company

Project Engineer

2,500 cycles to enable efficient and practical utilization of speech power distribution.

A cathode resistor drop was used in the *pa* stage to provide a source of noise-free *dc* for the carbon microphone.

## Transmitter Tubes

A 14C5 (similar to 6V6 except for filament voltage) was installed as a reactance-modulated oscillator, a 12SG7 serving as a reactance modulator. A pair of 1625s, connected in parallel, were found to be ideal in the *pa* stage. Incidentally, the 12SG7 also serves to control the center frequency of the oscillator. The necessary *afc* voltage was brought in from the receiver discriminator.

## The Receiver

The receiver, of the fixed tuned *rf* type, features three stages of *rf* amplification, which precede the discriminator type detector, the last of which serves as an amplitude limiter. Each of the coupling transformers was used as an over-coupled bandpass network to provide the necessary bandwidth for the modulated signal. Permeability

tuning was employed to assure stability under the high humidity and heavy vibration to which the units are subjected in operation.

## Squelch Circuit

A double action squelch circuit was included to quiet the receiver in the absence of a transmitted signal; one section operates from AM noise present, and the other section operates from the transmitted signal. The combined action was found to provide a more positive squelch action. A 1625 (807 equivalent), used as the audio output stage, provides an audio capability of 10 watts. A high audio output level was found necessary to override the high sound levels encountered in mining operations.

## Push-to-Talk System

A push-to-talk button on the mike operates a change-over relay which transfers the *antenna* from receiver to transmitter. Relay capacity and stray capacities were found to provide sufficient *rf* pickup for the receiver dis-

criminator action (*afc*) during transmitting. This *afc* voltage, applied to the oscillator tube, provides a means for maintaining the correct operating center frequency.

## 12-Volt Supply

The unit was designed for operation off a 12-volt storage battery supply, the battery being *trickle charged* from the 270-volt *dc* trolley line through a dropping resistor. This was found to provide operation for four hours of full-time service if the trolley supply should be broken or shut off because of disaster.

## Vibrator Pack Application

Two 12-volt vibrator packs were installed to supply the plate voltage, only one being used when the receiver is in operation. During transmitting the output of the two supplies are connected in parallel to provide a *dc* supply of 300 volts at 200 *ma*.

Figure 3  
The impedance-matching network designed to couple the power-amplifier tubes to the power line, a system used because of the high transformation ratio of 7,000 to 2.5 ohms.

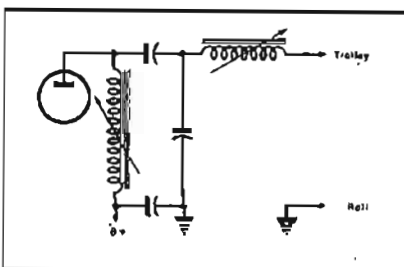
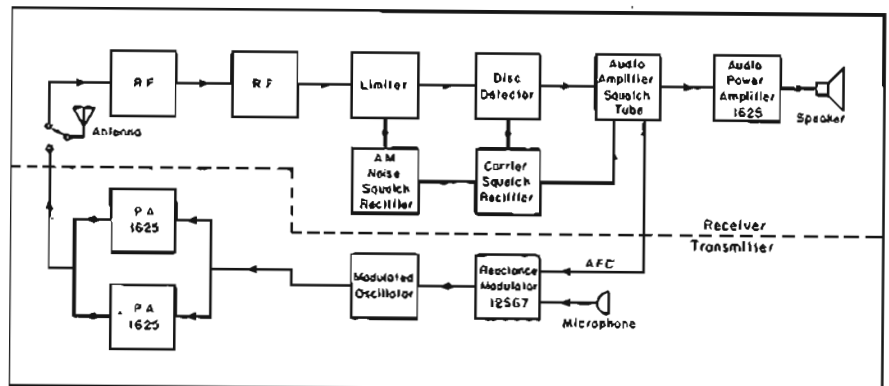

Figure 4  
Block diagram of the 100-kc FM transmitter-receiver.



# Corrosion In Multiple

IN OUR previous analysis\* of humidity and corrosion, it was pointed out that one school of thought advances 98 to 100 per cent plus periodic cycles of dew, the theory being that much electrolyte will be produced quickly, current flows will be heavy, answers would be fast and the test would represent the worst condition coils could be subjected to. The disadvantages are, that due to the severity of the test many materials which are entirely adequate for their purpose might be rejected. The condensation or dew precipitated on the material may dissolve a large amount of airborne impurities to form electrolytes which are not produced by the material under test.

The second school of thought on test conditions makes use of humidity between 90 and 95 per cent. Under this condition, the electrolyte formed, which is all produced within, and by the material under test, will show the degree of corrosion, thereby allowing closer control in separation and classification of materials. The formation of heavy current carrying electrolytes on the surface of the material being tested is minimized.

The disadvantages of these lower relative humidities are that some materials may be pronounced non-corrosive, which on a very long time test would produce some corrosion. In acceptance test work, material will be withheld from production for a longer period of time if the lower humidities are used.

In general, engineers seem to be in agreement that if assemblies or components using multiple layer coils are tested for electrolytic corrosion, the 100 per cent relative humidity plus dew condition, which represents the worse service conditions, should be used, but in testing materials to be used in coil construction, the lower humidities which do a better job of indicating degree of corrosion. At present it seems highly desirable that test conditions within a range of 90 to 95 per cent and which is a compromise of the two schools of thought ought to be specified.

The techniques for obtaining and placing numerical values on electrolytic corrosion are numerous. It has been established that true electrolytic corrosion must take place in the presence of a *dc* potential gradient. Therefore, most of the techniques and fix-

## Part III . . . Procedures Involved in Evaluating Materials for Electrolytic Corrosion Characteristics . . . Calculating Corrosion Distribution.

by HOWARD ORR

Works Laboratory  
General Electric Company  
Fort Wayne, Ind.

tures make use of two parallel copper wires spaced a small distance apart and each contacting the material under test. These are energized open circuits with a *dc* potential of proper value, and the entire fixtures, or at least the test specimens, are placed in a controlled atmosphere. Current flows through the electrolyte, formed by the moisture, from the plus to the minus wire and the plating action described earlier takes place.

In order that some idea may be obtained as to the complicated procedures involved in evaluating materials for electrolytic corrosion characteristics, two of the methods submitted to ASTM Sub 7 committee will be described. While these methods are primarily for pressure-sensitive tape, they are also entirely suitable with small changes in technique for other insulations.

### Cylinder Method<sup>1</sup>

**Apparatus:** A plastic cylindrical drum is used, approximately 6" in diameter and sufficiently long to accommodate at least five specimens (minimum 4"). The plastic used should have very high surface and volume resistivities, and drum should be equipped with terminals consisting of four rows of No. 4 brass machine screws and associated nuts spaced  $\frac{1}{2}$ " apart in each row.

One row (*A*) should begin  $\frac{1}{4}$ " from the edge of the drum, with a second row (*B*) located  $\frac{3}{8}$ " around the drum from row *A* and beginning  $\frac{1}{4}$ " from the edge of the drum. A third row *C* should be located 14" around the drum from row *A*, and should begin  $\frac{1}{4}$ " from the edge of the drum. A fourth row (*D*) should then

be located 14" around the drum from row *C*, and should begin  $\frac{1}{4}$ " from the edge. All terminals in rows *A* and *C* should be connected and wired to a common terminal, and all terminals in rows *B* and *D* to a second common terminal.

A spool of soft copper wire approximately 0.008" in diameter and having an elongation between 20 and 30 per cent, is also needed.

A humidity cabinet capable of maintaining  $96\frac{1}{2} \pm \frac{1}{4}$  per cent relative humidity at a temperature of  $77 \pm 2^\circ F$  ( $25 \pm 1.1^\circ C$ ) is used. In maintaining this humidity, it is essential that the cabinet be sealed against all possible loss of water vapor and that every precaution should be taken to avoid condensation. Provision should be made for making connections to the two common terminals on the drum from outside the cabinet.

A source of *dc* potential at 120 volts  $\pm 2$  volts is also required.

A testing machine of suitable capacity is used to break the copper wire. This should be a constant rate of loading machine (inclined plane), equipped with a recording device for measuring the elongation of the wire.

**Specimens:** The specimens required are  $\frac{1}{2}$ " or  $\frac{3}{4}$ " wide or an integer multiple of these figures. The first complete turn on a roll of tape should be discarded and samples approximately 14" long selected from the remainder of the roll. Extreme care should be exercised in handling the wire, so that not more than 1" at the end of any specimen is handled, or touches any object other than the drum. This method is not applicable to tapes less than  $\frac{1}{8}$ " wide.

**Conditioning:** The drum with the specimens and the wires mounted on it should be maintained at  $96\frac{1}{2} \pm \frac{1}{4}$  per cent relative humidity at a temperature of  $77 \pm 2^\circ F$  ( $25 \pm 1.1^\circ C$ ) for the period required.

**Procedure:** Preparation of the wires is the first step. At least fifteen approximately 17" lengths of wire, carefully unwound from the spool so as to avoid kinks or stretching, should be cleaned in a bath of petroleum ether or an equivalent solvent. At least five lengths should be set aside for tension and elongation tests on the uncorroded wire. The remainder

<sup>1</sup>Bell Laboratories.

\*COMMUNICATIONS, July, 1949.



# Layer Wound Coils

should be kept clean for the corrosion test.

In the second step we have the preparation for testing the backing. The drum should be cleaned with petroleum ether and set on its side with the terminals down, and the tape specimens picked up by the ends and placed adhesive side down on the drum with the edges parallel to the edges of the drum. One edge of each specimen should be located  $\frac{1}{4}$ " from a circle passing through two terminals. The sample should lay flat. The edges of two adjacent specimens may touch. The specimens should be cut back to not less than 11" by cutting approximately equal lengths from each end of the specimen, which should be laid down by means of a clear roller and should not be touched with the hands.

In the third step we have the preparation for testing of the adhesive side. The drum should be cleaned with petroleum ether. The specimens are best prepared by setting them in their relative positions in a separate fixture. Their positions will be determined by their width and the spacings of the wires. The edges of two adjacent specimens may touch or overlap. The specimens must be held together with cellulose-acetate-backed pressure sensitive adhesive tape run perpendicular to the specimens. There should be a clear length of at least 11" between the supporting tapes. The supporting tapes may be used to attach the setup to the drum. Care should be taken to cut off the handled portions of the specimens. The wires may be applied in the fixture, if desired.

The specimens may also be attached, one by one, on the drum by means of cellulose-acetate-backed pressure sensitive adhesive tape with the precautions described above.

Application of the wires is the next step. Clean white gloves can be used in applying the wires; if they are not, care should be taken to touch only the ends of the wires which will not be in contact with the specimens. The wires should be applied in groups of two, one positive and one negative, spaced approximately  $\frac{3}{4}$ " apart. There should be at least one pair of terminals on the same circle left blank between each set of positive and negative wires so that adjacent wires have the same sign.

Each wire must be wound around one terminal, say in row *A* or *B*, then wrapped around the cylinder parallel to the edge and in contact with the specimen, using only enough tension to keep the wire straight, and then wound around the corresponding terminal on the other side in row *C* or *D*. Care should be taken to keep the wire in contact with the sample but not to use a tension in excess of the elastic limit of the wire. The spacing of the wires on the backing may be adjusted so that the wires of a pair are approximately parallel and are approximately  $\frac{3}{8}$ " apart.

The test cycle follows, with the drum placed in the humidity cabinet, the two lead wires connected and the cabinet

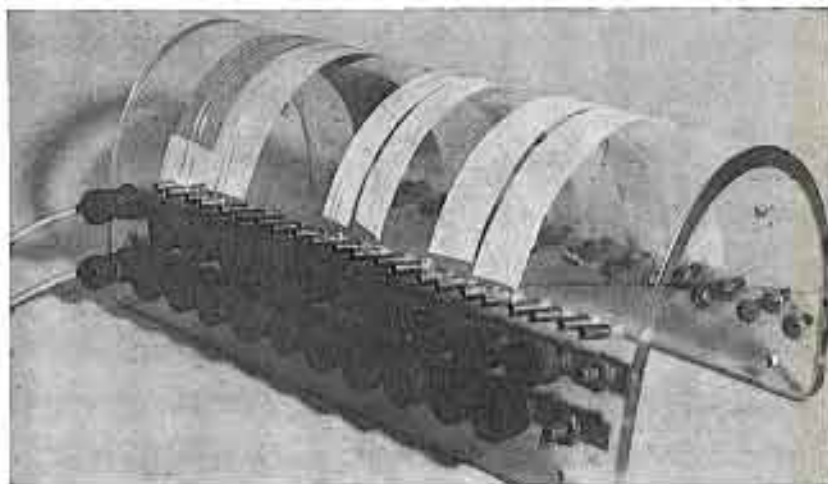

Figure 1  
A fixture for testing electrolytic corrosion.

sealed. The test cycle consists of  $24 \pm 2$  hours without potential, followed by 48 hours  $\pm \frac{1}{2}$  with potential. If wires are broken in 48 hours, 16 hours  $\pm \frac{1}{2}$  hour should be used. At the end of this period, the potential is taken off, the cabinet opened and the fixtures removed. Care should be taken to keep a record of the polarity that was applied to each wire.

Removing the wires is the next step. The wires in contact with the backing can be unwound from the terminals and lifted off the backing. The positive and negative wires should be segregated. However, in tests on the adhesive side, the adhesive should be dissolved or softened in a suitable solution.

Wire testing is the final step. The uncorroded wires, the positive wires, and the negative wires should be tested for tensile strength and elongation. Where it has been established that the negative wires are not appreciably corroded, they can be used in place of the uncorroded wires. The breaking load and the load-elongation curve should be determined on the tensile machine. The distance between the jaws should be 10".

## Calculations

When it is desired to obtain a numerical estimate of the distribution of corrosion, this method is suggested:

The average elongation of the uncorroded (or negative) wires is first determined at their breaking load; step *A*.

Then we read off the elongation of the corroded wire at the breaking load; step *B*.

The average elongation of the uncorroded (or negative) wires are then

determined at the breaking load of each corroded specimen; step *C*.

The approximate per cent of the original length that has been eroded can be computed by

$$\text{Distribution factor in \%} \\ = \frac{B - C}{A - C} \times 100.$$

The distribution factors should be averaged.

When severe local corrosion and pitting occurs, it will be obvious that the elongation of the corroded wires at their breaking points is approximately equal to that of the uncorroded (or negative) wires at the same loads.

For extensive computations with the same grade of wire whose elongation at break has been established, a graphical method giving the corroded length in inches and the corresponding per cent that has been corroded (the distribution factor) can be worked out.

The report should include:

- (1) The per cent retention of the breaking load for the positive wires.
- (2) The per cent retention of the breaking load for the negative wires when this differs from 100 per cent.
- (3) The distribution factor in per cent when this is desired.
- (4) The breaking load and elongation of the uncorroded wire.

# AMPERITE

Studio Microphones  
at P.A. Prices

Ideal for BROADCASTING

- RECORDING
- PUBLIC ADDRESS

"The ultimate in microphone quality," says Evan Rushing, sound engineer of the Hotel New Yorker.

- Shout right into the new Amperite Microphone—or stand 2 feet away—reproduction is always perfect.
- The only type microphone that is not affected by any climatic conditions.
- Guaranteed to withstand more "knocking around" than any other type mike.

**Special Offer:** Write for Special Introductory Offer, and 4-page illustrated folder.

**AMPERITE Company, Inc.**

361 BROADWAY • NEW YORK 12, N. Y.

In Canada: Atlas Radio Corp., Ltd., 560 King St. W., Toronto



Models  
RBLG—200 ohms  
RBHG—Hi imp.  
List \$42.00



"Kontak" Mikes  
Model SKH, list \$12.00  
Model KKH, list \$18.00

Wayne C. Bittel, formerly with the Webster-Chicago Corp., has joined Eicor, Inc., as sales manager of the tape recorder division.

Rudy Poucher is now with the field engineering staff of Neely Enterprises, 7422 Melrose Ave., Hollywood 46, Calif. Poucher will be attached to the San Francisco office, which is under the management of Jack Ingersoll.

James T. Buckley, who was president of Philco from 1939 to 1941, and has since served as chairman of the executive committee, was elected recently chairman of the board of directors to succeed the late John Ballantyne. William Baldeston, president, will continue to serve in that capacity as the chief executive officer of Philco.

George R. Sommers, formerly director of Pacific Coast sales for Sylvania Electric Products, Inc., has been appointed assistant to C. W. Shaw, general sales manager of the Radio Tube Division.

Joseph H. McConnell has been elected executive vice president of RCA.

Seymour S. Sterling, who heads the S. Sterling Company, Detroit, will represent Ampere Electronic Corp., Brooklyn, N. Y., in the Michigan area.

Carlson Morse, formerly general merchandise manager for the lamp division of Sylvania Electric Products, Inc., has been appointed director of Pacific Coast sales for all product divisions of the company.

Ross Gasford has been appointed chief engineer for the television picture tube division of Sylvania Electric Products, Inc.

Gasford joined the engineering staff of Sylvania's Radio Division at Emporium, Pa., in 1937 and has been continuously associated with research, development and engineering of radio and cathode-ray tubes since that time.



R. Gasford

Ernest Clover has been named to head the geographical Transformer Division of the Tidal Mfg. Co., Los Angeles.

Clover has been continuously engaged in geographical transformer development and manufacture since 1939.

F. B. Atwood, formerly supervisor of industrial engineering and production control, has been appointed manufacturing superintendent for the radio tube plant of Sylvania Electric Products, Inc.

L. H. Jansen has been named designing engineer for product engineering of the G. E. transmitter division.

H. B. Fancher has been appointed section engineer of broadcast studio equipment for the G. E. transmitter division.

C. M. Heiden has been named section engineer of radio communication equipment for the G. E. transmitter division.

## LITERATURE

The Radiart Corporation, Cleveland, Ohio, now has available for distribution an eight page catalog on its *Simpson-Flies* television and FM antennas. Catalog covers the line of TV and FM antennas, adapter kits, add-on arrays, accessories and antenna parts.

Cannon Electric Development Company, 3226 Humboldt Street, Los Angeles 11, Calif., have released a 19"x24" desk chart of insert arrangements of the K series of electric oscillators. Chart contains 21 layouts, with wire, contact and clearance data.

The Simpson Electric Company, 5300-18 West Kinzie Street, Chicago 44, Ill., have issued a 50-page spiral-bound catalog, No. 14. Several new products are listed, including the 480 FM-TV gnoscope, which provides all of the necessary signal sources for the proper alignment and servicing of FM and TV receivers.



MODEL	FREQUENCY RANGE	CRYSTAL CALIBRATOR	PRICE
103	100kc-56mc	no	\$129.00
103-A	100kc-175mc	no	138.00
105	100kc-56mc	yes	193.00
105-A	100kc-175mc	yes	202.00

## MICROMETER FREQUENCY METER

Especially useful with police, public utility, taxicab, and relay-broadcast services. Any model will monitor any number of frequencies, present or future, FM or AM, with accuracy 0.005%.

Calibrations read directly in percent deviation from FCC assignments. Write for data.

**LAMPKIN LABORATORIES, INC.**  
BRADENTON, FLA.

## News Briefs

### INDUSTRY NOTES

Isolantite Manufacturing Corp., formerly of Warren Street, Lyndhurst, N. J., is now located in a recently completed new plant in Stirling, N. J.

The RCA Service Co., Inc., Camden, N. J., recently introduced a repair plan for RCA microphones and transcription pickups. Also announced are facilities for repair and calibration of all types of RCA test and measuring equipment.

Under the plan, the time required for a complete factory reconditioning, from the time the equipment arrives at the factory until it is shipped out, is four days for microphones and two days for transcription pickups. Units sent in for such service should be addressed to the RCA Service Co., Inc., Return Apparatus Control, Bldg. 8-2, Camden, N. J.

### PERSONALS

Dr. Sergei A. Schellkunoff of Bell Labs was awarded recently the Stuart Ballantine Medal of the Franklin Institute in Philadelphia for his outstanding contributions in the extension of the electromagnetic wave theory.

The RCA Engineering Products Department, Camden, N. J., have announced release of five brochures covering microphones and accessories, magnetic tape recorders, portable remote amplifier, duo-cone monitoring loudspeaker, and a professional recorder.

Brochures are entitled *Broadcast Microphones and Accessories* (form 2J-4864), a 20-page booklet covering AM-FM and television studio microphones and accessories; *Magnetic Tape Recorders* (form 2J-4910), a 12-page booklet on portable and studio tape recorders; *Professional Recorder* (form 2J-4784), an 8-page brochure containing information on the RCA type 73B high-fidelity professional recorder; *Portable Remote Amplifier* (form 2J-4770), a booklet on type BN2A lightweight remote amplifier; and *Duo-Cone Monitoring Loudspeaker* (form 2J-4771), a 4-page brochure, listing performance specifications of the LC-1A speaker.

Condenser Products Company, 1375 N. Branch Street, Chicago 22, Ill., have released a specification sheet on laboratory-grade capacitors. Presented are data on dimensions, capacitance, etc.

The Cambridge Thermionic Corporation, 44 Concord Ave., Cambridge, Mass., has released a 70-page catalog, 300, on electronic and electrical components.

Catalog is subdivided into sections on terminal lugs, terminal boards, swagers, hardware, insulated units and coils and chokes.

Kato Engineering Co., 3415 First Ave., Mankato, Minn., have published two bulletins on generators. Bulletin 3149 describes ac generators ranging in capacities of 5 kw to 375 kw at 60 cycles and speeds from 720 to 1,800 rpm. Bulletin 21709 describes ac generators ranging in capacities of 150 to 300 kw, and speeds from 720 to 1,800 rpm.

Department 522, RCA Engineering Products, Camden, N. J., has released an 8-page brochure (2J-4085) with data on a TV 35 mm projector.

Presented are operating data, suggested studio layout, simplified line drawings, and information on such features as a pulsed light source and optical system, single control switching from control rack, etc.

The Mico Instrument Co., 80 Truebridge St., Cambridge, Mass., have prepared two bulletins describing a dimensional engraver and accessories.

Bulletins detail operation of equipment and attachments such as hand engraving spindle, pen fixture, constant depth attachment, etc.

Sorenson and Company, Inc., 375 Fairfield Avenue, Stamford, Conn., is now publishing a bi-monthly house organ, *Currently*, devoted to new developments in the voltage regulation field. For copies, write Ed McCarthy, editor of *Currently*.

Cannon Electric, 3209 Humboldt Street, Los Angeles 11, Calif., have published a 12-page supplement to the *K* bulletin which includes information on the *K* and *RR* types aircraft firewall connectors; *K315L* wall mounting receptacle, *K* pressurized receptacles, and 16 insert arrangements in various shell sizes for all types of radio, sound, electronic and electrical equipment.

Howard W. Sams & Co., Inc., 955 North Rural Street, Indianapolis, Indiana, have released Volume 2, 1948 *Record Changer Manual*, which features exploded view diagrams for forty-six changers, detailed operational and adjustment instructions, trouble shooting check-charts, and keyed photographs and diagrams.

Manual also includes new types of lp mechanisms and their associated pickup, stylus and cartridge requirements.

Price \$6.75.

The Hewlett-Packard Company, Palo Alto, Calif., have released a 17-page proof-of-performance manual, *Manual* states each requirement for both AM and FM broadcasters, lists equipment needed to make appropriate measurements, and gives in step-by-step detail proper procedures for measuring, recording, tabulating and presenting the required data.

Also contains blank charts for simplified recording of all required measurements and plotting of required curves, and is designed for filing with permanent station records in compliance with FCC requirements.

for REAL STABILITY in HIGH-VOLTAGE STANDARDS

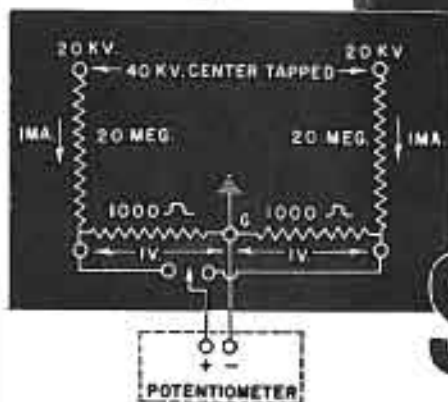

Schematic diagram  
No. 791 kilovoltmeter  
multiplier

# Shallcross

HIGH-RANGE  
KILOVOLT METER  
MULTIPLIERS  
and voltage dividers

Types to 200,000 volts

Whether for direct high-voltage measurements or for use as standards in determining the exact voltage of a fractional segment of a high-voltage supply, Shallcross Kilovoltmeter Multipliers combine close accuracy with safety and dependability.

The No. 791 kilovoltmeter multiplier illustrated above provides a ready and accurate means of determining a-c and d-c potentials up to 40,000 volts with outstanding accuracy. Other Shallcross types have been supplied for voltages of 200,000 volts and higher. Whether your need is for a unit designed for ordinary voltage ranges or for nuclear research development, chances are that Shallcross standard designs or adaptations thereof can fill the bill. Write for recommendations, stating details of your application.

## SHALLCROSS MFG. CO.

Resistors • Instruments • Switches • Attenuators  
Dept. C-89  
COLLINGDALE, PA.

52 VANDERBILT AVENUE  
NEW YORK 17, N. Y.

# Group Subscription Plan

Saves Fifty Per Cent of the Yearly Subscription Price if Four or More Subscriptions (Including Your Own) Are Properly Entered on This Form.

1 Year—\$1.00

2 Years—\$2.00

(Foreign: Add \$1.00 for postage)

Please enter annual subscriptions (12 issues) for each of the undersigned for which payment is enclosed at the rate of \$1.00 each. (This rate applies only on 4 or more subscriptions when occupations are given.)

Name .....  
Address .....  
City-State .....  
Occupation .....  
Employed by .....  
Nature of Business .....  
(State if Manufacturer, Broadcast Station, etc.)  
Your Title .....  
Your Department .....

Name .....  
Address .....  
City-State .....  
Occupation .....  
Employed by .....  
Nature of Business .....  
(State if Manufacturer, Broadcast Station, etc.)  
Your Title .....  
Your Department .....

Name .....  
Address .....  
City-State .....  
Occupation .....  
Employed by .....  
Nature of Business .....  
(State if Manufacturer, Broadcast Station, etc.)  
Your Title .....  
Your Department .....

Name .....  
Address .....  
City-State .....  
Occupation .....  
Employed by .....  
Nature of Business .....  
(State if Manufacturer, Broadcast Station, etc.)  
Your Title .....  
Your Department .....

Business or professional classifications are required to complete our records. Each subscriber should write one of the following classifications in space indicated. Use separate sheet of paper for additional names.

CHIEF ENGINEER                      ENGINEER                      EXECUTIVE  
PURCHASING AGENT                      DEPARTMENT MANAGER

State your classification if not listed.

This Group Sent In By—

Name .....  
Address .....

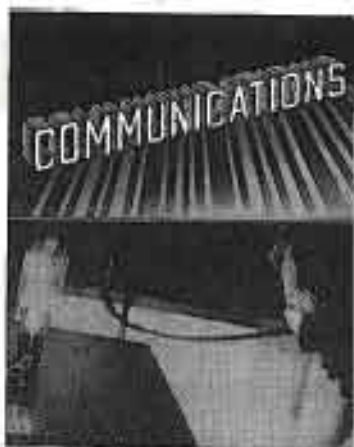

1. COMMUNICATIONS  
2. TELEVISION ENGINEERING  
3. RADIO ENGINEERING  
4. ELECTRONIC ENGINEERING

## The Industry Offers

[See pages 31 and 32 for additional news product news.]

### ANDREW FIXED RF INDUCTORS

A line of heavy duty rf inductors, available in 10, 20 and 30 ampere current ratings, has been announced by the Andrew Corp., 363 East 76th St., Chicago 19, Ill.

Inductors are variable by means of tapping clips which may be either of the shorting or non-shorting type. 10 ampere inductors are available with nominal inductances of 19, 36, and 65 microhenries; 20 ampere inductors are rated at 36, 53 and 76 microhenries, while a 30 ampere series are rated at 35, 49 and 71 microhenries.

The coils are wound of No. 6 solid copper wire in the 10-ampere range, 1/4" copper tubing in the 20-ampere range and 3/8" copper tubing in the 30-ampere range. Dielectric material in the coil proper is kept to a minimum, thus accounting for the high coil Qs which vary from 300 to 700 at 1000 kc for the various inductors.

When operated at maximum current ratings at 1000 kc, the coil temperature rise is limited to approximately 79° F.

Bulletin 85 contains complete details.

### G.E. TV STABILIZING AMPLIFIER

A stabilizing amplifier (type TV-16-A) has been announced by the transmitter division of G.E.

Designed for use in studios and at transmitters as a picture line amplifier, or as an amplifier for remote line and radio relay links. The amplifier will remove low-frequency interference from the signal, stretch and clip super-synch, and restore dc to improve low-frequency response.

Amplifier frequency response is said to be flat within 5 per cent from 0 to 5 mc. Input voltage range 2 to 1 v, peak to peak, composite video, 10 per cent to 40 per cent super-synch. Output voltage range 1.5 to 2.5 v, peak to peak, adjustable, also 0.1 to 0.5 v, monitor output.

Uses a double-diode circuit which clamps the video at the back-porch level. This circuit is said to remove 60-cycle hum and also corrects the sloping vertical blanking pedestal resulting from poor phase or amplitude response at frequencies below 60-cycles.

Equipment has a sync-stretching circuit which will restore a deficient input synchronizing signal to normal 25 per cent.

Associated with the sync mixer is a circuit arrangement which automatically feeds local sync to the transmitter if the remote video fails. The video gain can be controlled without disturbing the sync amplitude, and the bias on the first stage of the picture amplifier can be varied remotely to compensate for changes in video signal amplitude.



### CANNON RADIO TERMINAL CONNECTOR SERIES

A series of connectors, RTC, for disconnect applications on chassis, wall or rack mounting installations has been announced by the Cannon Electric Development Co., 3309 Humboldt St., Los Angeles 11, Calif.

Connectors are said to feature separation force; simplicity of mounting on chassis; moisture-drain holes provided to receptacle section; provisions in plug section for lacing down wires to plug after subjecting to contacts, two types of terminals—crimp-on and soldered; light-weight.

Plug shells are phenolic which also serves as insulation, with metal parts limited to clips, clamps, and contacts.

Available in five sizes and several styles having the following complements of contacts for 18 and 20 wire; 12, 20, 24, 32, 36 contact combinations. Mechanical spacing on all contacts is 3/32" with a minimum flashover of 250 volts and a recommended amperage of 2 amps.

# How is YOUR company doing in this "EVERYBODY-BENEFITS" plan?

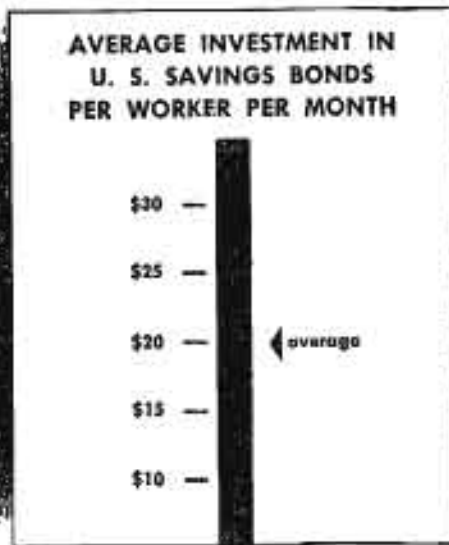
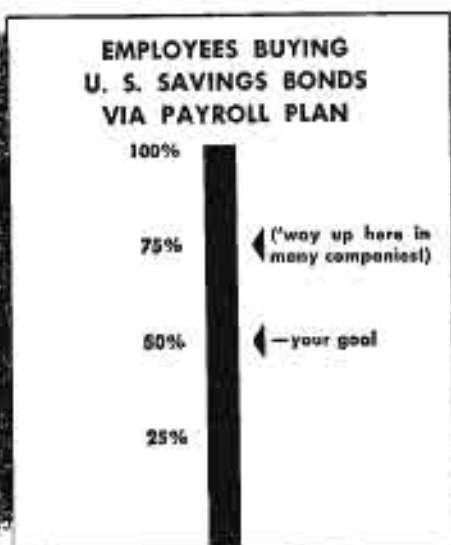

## Compare your employee participation with others who have Payroll Savings

If the figures for your company fall below those shown above, you're missing your share of benefits of the Payroll Savings Plan! These benefits are described below. Nation-wide experience proves that when top management puts the "OK" on the Plan, its benefits rise sharply.

**BENEFITS TO EMPLOYEES:** Every \$3 invested in Savings Bonds pay \$4 at maturity. Workers gain a 33% return on their money—enabling them in the future to buy more of the things they will want—plus the peace of mind that goes with regular saving.

**BENEFITS TO EMPLOYERS:** The feeling of security that goes with participation in Payroll Savings makes workers more contented. Worrying less, they work better. Among the more than 20,000 large companies with Payroll Savings, records show that—following installation of the Plan—production increased, absenteeism and accidents decreased!

**BENEFITS TO THE NATION:** The Payroll Savings Plan is a powerful deterrent to inflationary forces. Every Savings Bond dollar built up in the Treasury withdraws a dollar

from the swollen spending stream. The Plan thus contributes to national security—which affects *your* security!

**WHAT CAN YOU DO?** If your company has the Payroll Savings Plan, make sure it's being adequately promoted—backed by your top executives—to bring your company its full measure of benefits. If you haven't yet installed the Plan, why pass up its benefits any longer? All the help you need is available from your State Director, Savings Bonds Division, U. S. Treasury Department. He is listed in your telephone book. Call him now!

**Do You Realize...?**

- Over \$75,000,000,000 worth of Savings Bonds have been bought since 1941.
- More than 3/4 of this volume—over \$50,000,000,000—is still held by the purchasers.
- During 3 months of 1948, 1,500 additional large firms installed the Payroll Savings Plan.
- Via this plan, 7,500,000 workers are each investing on the average of \$20 per month of their pay—more than \$150,000,000 per month—in Bonds.

The Treasury Department acknowledges with appreciation the publication of this message by

## COMMUNICATIONS

This is an official U. S. Treasury advertisement prepared under the auspices of the Treasury Department and the Advertising Council.



# The Limitations of SOUND RECORDING

FROM TIME TO TIME it is appropriate to evaluate the extent of knowledge in a field. An appraisal of the accomplishments in sound recording can best be made by stating the ultimate goal of a sound recording system. In an ideal sound recording system, the signal appearing at the output terminals should be a facsimile of that applied to the input terminals, independent of the time interval which might have passed between the act of applying the signal (recording) and recreating the signal (reproduction). An ideal sound recording system might thus be likened to a perfect transmission link with an adjustable transmission time delay.

In practice, where economic considerations have to be taken into account, compromises must be made. Such compromises are acceptable, as long as they do not affect the quality of the recorded program beyond a permissible amount. Experience has shown that a satisfactory sound recording system which still can be labelled as a *high fidelity* system should meet four requirements:

- (1) A response versus frequency characteristic within a fraction of a db for the complete audio spectrum, or to express it in numerical values, from 30 to 15,000 cps.
- (2) A signal-to-noise ratio as high as possible so that there will be no noise contributed by the recording system which is noticeable above the inherent noise of the transmission link; the signal-to-noise ratio should be better than 60 db.
- (3) No variation in the frequencies of reproduced sounds compared with the frequencies of the sounds originally recorded.
- (4) No harmonic and intermodulation or other similar distortion introduced during the recording and reproducing processes. Phase distortion, on the other hand, can be tolerated to a moderate degree.

When reviewing these four points which have not been necessarily listed in the order of importance, the re-

sponse versus frequency requirement is the easiest to meet. It is more difficult to reduce the noise in relation to the signal level to an acceptable value. The elimination of frequency variations poses a sizable problem. But most difficulties are encountered in eliminating distortion. It might be noticed that no tolerances have been stated with regard to points 3 and 4, in contrast to points 1 and 2. The reason for this is that the study of permissible frequency variations and distortions is by no means completed. Furthermore, there are many types of distortion which are objectionable even when the magnitude is small. Indeed, too little is known at the present about some types of distortion to determine their annoyance value intelligently.

In fact, all four of the aforementioned requirements are interrelated and it might be said that an unsatisfactory response versus frequency characteristic, a high noise level and frequency variations can also be classified as one form of distortion. When looking at a sound-recording system from this very general point of view, it is important that the major causes which produce distortion be understood. There are seven such causes:

- (1) The nonlinear transfer characteristic of the recording and reproducing device.
- (2) The nonlinear transfer characteristic of the medium itself.
- (3) The dimensional changes of the recording medium which affect the signal impressed on the medium while recording the reproducing or with time only.
- (4) Lack of uniformity of the physical properties of the recording medium.
- (5) The small physical dimensions of the recorded signal on the medium, which, for short wavelengths, approach the resolving power of the scanning device.
- (6) The speed variations of the drive mechanism which cause any section of the sound track to move under the recording head with a speed different from that at which it moves under the reproducing head.

Nonlinearities of the recording and reproducing device can be held to a minimum by proper design. Cutters for mechanical recording, particularly of the feedback variety, have been built having only a fraction of one per cent of harmonic distortion and having a frequency response well extended to 15,000 cps. Magnetic recording heads can easily be designed so that the magnetizing field at any specified point within the recording gap is linearly related to the signal current. There is little difficulty in building light modulators which will vary the light radiating from a light source without introducing distortion. Similarly, transducers employed in reproducing an optical, magnetic, or mechanical recording can be made to have an almost distortion-free characteristic. In addition, a reproducer for mechanical recording should preferably be so designed that its motional impedance is as low as possible. If this is not the case, the vibratory elements of the cartridge will exercise forces upon the modulated groove which will destroy the modulations, with distortions resulting from such action.

It is somewhat more of a problem to find recording mediums which meet stringent requirements. A satisfactory material for mechanical recording should exhibit no spring-back elasticity. Neither should it be affected by humidity and cold flow. In reproduction, the elasticity properties of the recording medium are of greatest importance since the dynamic forces exerted by the stylus can produce an undesirable deformation of the modulation pattern, even if the motional impedance of the connected vibratory system is low. These elastic deformations cause what is usually called *translation loss*.

With the present quality of photographic emulsions, and with proper control of the development process, there is no problem of retaining an optical record in which the impressed signal is essentially free of distortion.

As far as magnetic recording goes, the objectionable features of the magnetic hysteresis effects of the recording medium can be counteracted by the use

---

## Lucid Analysis Reveals High-Fidelity System Requirements, Major Causes of Distortion, Results to Be Expected from a Practical Recording Setup, Characteristics of Powder-Coated Tapes, Economic Considerations in Recording, Mechanical Factors and Problems of the Future.

---

by **S. J. BEGUN**

Vice President and Chief Engineer  
The Brush Development Company

of biasing. In the biasing process the magnetic recording medium is simultaneously subjected to the signal magnetic field and an additional field. In recent years, ac biasing has been extensively used for magnetic sound recording. In ac biasing a high-frequency magnetizing field is the additional field. By using magnetic biasing, good linearity can be obtained between the signal and the magnetic remanent induction left in the recording medium. The presence of the reproducing head, however, can distort the recorded flux pattern, a situation somewhat analogous to the effect of the reproducing stylus on a modulated groove.

In optical as well as in magnetic recording using powder-coated tapes the elasticity and cold flow of the recording medium can adversely affect the recorded signal, sometimes resulting in considerable deterioration of the performance. Careful choice of the physical properties and dimensions of the base material is essential. In many instances one characteristic of the base material must be evaluated in the light of other properties. In magnetic tape recording, it is desirable that the recording medium be as thin as possible. The thinner the tape, the more can be wound on a reel of any given diameter and the easier it will conform to the contour of the recording and reproducing head, thus assuming intimate contact with the pole pieces. On the other hand, the thinner the tape the greater will be the elastic deformation from any force acting on it. Plastic tape has usually a much smoother surface than paper, but paper shows less tendency to cold flow and usually has a higher modulus of elasticity. In optical recording, the somewhat thicker and unusually wider cellulose nitrate or acetate base of motion picture film can

be subjected to greater forces for an equivalent elastic deformation.

For a recording medium to be satisfactory, it is required that its physical properties be uniform along its sound track. Wherever coated mediums are used, like in cellulose-nitrate discs, in magnetically-coated tapes and in films, the coating thickness must be carefully controlled and the surface of the coating should be mirror-like. Wherever one deals with dispersions, as in magnetically-coated materials, uniform particle distribution and proper choice of particle size is of greatest importance.

The mechanical properties of the coating must be selected in accordance with the recording method employed. A uniform and smooth coating of a disc for instantaneous mechanical recording is not the only requirement. The material must be easily removable by the recording stylus without tearing. A material which is too soft is undesirable, since the recorded modulations may be destroyed by even the limited forces exerted by the reproducing stylus. A material which is too hard will result in prematurely dulling the recording stylus.

In magnetic recording, the magnetic characteristics, particularly the coercivity of the recording medium, must be properly selected. A coercivity which is too high makes it difficult to erase a previous recording and a coercivity which is too low imposes limitations upon the response to high frequencies. With presently available erasing heads, a coercivity of between 200 and 300 oersteds seems to offer the best compromise.

Economic considerations generally make it a necessity to use the recording medium sparingly. This requires that the recording medium travels relative to the recording and reproducing

device, with the slowest possible speed. Thus, the recorded wavelength which corresponds to a high-frequency signal is short and approaches dimension-wise the physical size of the effective portion of the recording and reproducing device. To illustrate this point, the inner groove of a long-playing disc record travels with a speed of about 10" per second. A frequency of 10,000 cps will thus correspond to a wavelength of .001". A wavelength of about equivalent length is recorded on a magnetic recording medium moving with a speed of 15" per second, when a frequency of 15,000 cps is impressed thereon. Experience seems to indicate that a wavelength of about .001" is about the shortest which should be used regardless of the recording method.

The slit width of the optical recording and reproducing systems and the gap length of the magnetic recording and reproducing head affect the frequency response. Only if the slit width or gap length are substantially smaller than that of the shortest wavelength is their undesirable effect negligible, a condition which cannot always be met in a practical system. It is also important that both gaps, namely, that of the recording and that of the reproducing head, make exactly the same angle with regard to the direction of motion of the medium. It can be shown that high-frequency reproduction suffers if the gap of the reproducing head is tilted with respect to that of the recording head.

In mechanical recording the stylus tip diameter provides an effect similar to that provided by the slit width or gap length in optical and magnetic recording. The stylus tip dimension limits the frequency response. There is an additional effect in mechanical recording which results from improper tracing and tracking. The curves traced by the motion of the reproducing stylus are not an exact replica of the modulations of the groove. Tracing distortion is brought about by the fact that a spherical stylus tip cannot exactly follow the modulation of a groove which was cut by a chisel-shaped tool.

Irregular motion of the recording medium results in flutter and wow, both extremely annoying. Speed changes of the recording medium are usually caused by the drive mechanism, but vibrations of the recording and reproducing devices with regard to the recording medium and elastic deformations of the medium can have an equally undesirable effect. By ap-

*(Continued on page 33)*



At the recent VVOA spring meeting held in New York City: Edward Droo, Warden of Hurts Island Penitentiary; Major C. S. Morris; L. B. Victor, manager of radio department, Moore and McCormick SS. Co.; E. H. Fryca, vice president and general manager, Mackay Radio and Telegraph Co.; E. C. Cosbrans, chief inspector, FCC, New York; H. L. Cornell, manager, radio department, Standard Oil Co., and Arthur Sand, owner of the Fireplace Inn, where the meeting was held.

### Personals

VVOA HONORARY MEMBER E. M. Webster won his reappointment recently as a commissioner in the FCC and will serve for seven years until 1956. EMW was praised by the Senate group who renamed him for his outstanding achievements as a member of the Commission and other government groups during the past, covering more than two decades of active service. . . . VVOA life member Brig-General David Sarnoff, chairman of the board, RCA, has been quite active during the past year as a featured orator at dozens of national and international meetings and conferences. Appearing a few weeks ago before the International Congress on Rheumatic Diseases at the Waldorf-Astoria. DS told the celebrated audience that . . . "Only through a concerted scientific study of man, as well as machines, can we make full use of our God-given powers to improve man's mental capacity and his spiritual outlook. . . . It is my belief that controlled atomic energy puts us on the threshold of new opportunities. Coupled with electronics, it

offers vast possibilities to look inside of man and perhaps to discover what makes him function and why he behaves as he does." During graduation ceremonies at RCA Institutes, General Sarnoff offered some extremely wise counsel to the graduates, telling them that . . . "We live in an era of high speed transportation and communication. . . . We may well think of this as a century not only of great speed and great power, but also of master controls. . . . As television spreads across the nation opportunities for servicing and installation will expand. Industrial and theatre television are big fields that are beginning to open. . . . Progress calls for not only research scientists, experimenters, development and design engineers, but also for operators, technical repairmen, mechanics and testers. Each field offers chance for advancement and it is encouraging to realize that from each branch of radio and electronics new trails will be blazed. . . . The most important factor to keep in mind is to continue your education. Science and industry will reward you for your tal-

ents and energy. . . . There is everything good yet to be accomplished in our lives and in our work. What man has done man can do better."

### The Guthrie Story

IN ADDITIONAL LIFETIME notes to ye correspondent, oldtimer C. D. Guthrie reveals that he was on the S. S. Commonwealth, when 2,000 Massachusetts State Militia Men came aboard to go to Washington for President Taft's inauguration. About a month later CDG was detached and assigned to the S. S. Ossabaro, which made a voyage to Texas City, Texas, stopping at Brunswick, Georgia. There was a 2-kw transmitter on this ship and Guthrie's job was to get one T R through each night to the New York Herald. Unfortunately CDG was only able to get one through Key West because the Navy operator was a classmate of his. The rest of the Navy stations ignored him, he says. After a session on the Ossabaro he went back to the Commonwealth and remained there until July 31, 1909, when

(Continued on page 34)



# The Industry Offers

## SORENSEN SATURABLE CORE REACTORS

Saturable core reactors are now being produced by Sorensen & Company, Inc., 275 Fairfield Ave., Stamford, Conn. Two types are being made:

(1) DC control circuit which operates through the dc coil. The dc coil provides the dc control which saturates the iron core. Its saturating effect depends on the amount of dc power available. Reactors are designed for about 50 to 150 ma maximum current and a dc resistance of about 2,000 to 4,000 ohms (5 to 90 watts of power). The standard line is designed to work from the plate circuit of a vacuum-tube control.

(2) AC power circuit which operates through ac coils. The ac circuit consists of two dc coils internally connected in series. Circuit of the reactor is rated by four characteristics: Maximum current-carrying capacity of the coils; maximum voltage and rated frequency which may be applied across the coils; minimum impedance available with the reactor saturated (maximum dc power input); and maximum impedance available with the reactor completely unsaturated (minimum dc power input).

\*\*\*

## G.E. 25-50 MC MOBILE COMMUNICATION EQUIPMENT

Mobile radio communication equipment for 25 to 50 mc has been announced by G. E.

Equipment is available for 20-ke or 40-ke channel widths. The narrow-band units are said to make 40-ke adjacent channel operation a practical possibility in the same service area.

\*\*\*

## LENKHURT CARRIER SYSTEM

A carrier system, type 33B, which is said to provide up to seven talking circuits with associated ringdown or dial-signaling channels from a two-way radio link, has been produced by the Lenkhurt Electric Co., 1124 County Road, San Carlos, Calif.

Spectrum utilized is 0 to 35 kc. Channel response is said to be uniform within 5 db or less from about 250 to 2,800 cps, and limiters in all modulator circuits tend to prevent overloading of radio equipment. Pilot regulation and automatic modulator-demodulator-oscillator synchronization can be provided for a number of the higher-frequency channels.

Additional features are said to include maximum terminal loop gain of 26 db; receiving-branch sensitivity of -19 dbm for a 3-db net-loss circuit; signaling-channel bias less than 5 per cent up to 14 pps over an input-level range of 15 db; noise and crosstalk 60 db below 0 dbm; inert modulator-demodulators; and single-sideband suppressed-carrier transmission.

\*\*\*

## TUNG-SOL 5A6 TUBE

A miniature power pentode, type 5A6, intended for use as class C power amplifier or oscillator, has been announced by the Tung-Sol Lamp Works, Inc., 95 Eighth Ave., Newark 6, N. J.

Uses a multi-strand filament designed for operation in mobile equipment where the battery voltage is expected to range between 5 and 8 volts. Carries a nominal filament voltage rating of 5 permitting the use of regulating devices.

The tube is said to be capable of a power output of 3 watts at frequencies up to 70 mc. Uses 9-pin miniature all-glass envelope and button stem;  $\frac{3}{16}$ " in diameter and  $2\frac{3}{4}$ " seated height.

\*\*\*

## STACKPOLE 2-WATT FIXED RESISTOR

Two-watt molded carbon composition resistors have been announced by The Electronic Components Division, Stackpole Carbon Co., St. Marys, Penna. Available from 10 to 100,000 ohms and in standard tolerances of  $\pm 5$ , 10 or 20%.

A new anchoring method is said to assure lead strength that will exceed the standard 10-pound pull test. Resistors are  $1\frac{1}{16}$ " long by  $\frac{5}{12}$ " in diameter.

## SPRAGUE DISC CERAMIC CAPACITORS

Water-thin disc ceramic capacitors have been announced by the Sprague Electric Company, North Adams, Mass.

Capacitors consist of a half-dime or dime-sized ceramic plate of extremely high dielectric constant with silvered electrodes fired on both faces of the disc. Uni-directional leads are soldered to the silvering and the capacitors are coated with a moisture-resistant insulating resin.

Capacitors are available in ratings up to .01 or  $2 \times .004$  mfd., 500 volts dc working. Complete details appear in Engineering Bulletin 601A.

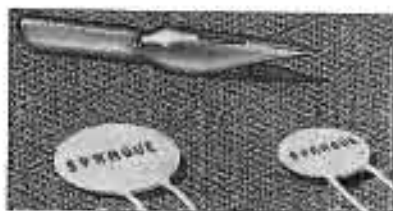

\*\*\*

## ADVANCE MIDGET ANTENNA RELAY

A 100-ohm transmit-receive relay, with silicone glass material for insulation on the armature and stationary contact assemblies, has been announced by the Advance Electric and Relay Co., 1260 West 26th St., Los Angeles 26, Calif.

Tests on reasonably flat lines are said to have shown a capacity up to 500 watts *wf* (measured on input).

Coils for ac available up to 220 volts; dc coils up to 110 volts. The ac coils consume approximately 4 volt-amperes and dc coils consume 1 to 2 watts. Overall dimensions  $1\frac{1}{2} \times 1\frac{1}{2} \times \frac{9}{16}$ .

\*\*\*

## SHALLCROSS BRIDGED-T ATTENUATORS

Two types of bridged-T attenuators which are said to be interchangeable with, but smaller than, the present industry standards, have been produced by Shallcross Manufacturing Company, Collingdale, Pennsylvania. One is the 412-2B5a 12-step sw meter multiplier which has a range of +4 to +26 and off in 2 sw steps. This unit has a detent, 12" contact spacing, and a  $2\frac{1}{4}$ " overall diameter. Available with either a 3,900 or 7,500-ohm input impedance and a 3,900-ohm output impedance to match Western 30B or G. E. DC61 sw meters. The 7,500-ohm type can be supplied with a 0 sw (1 milliwatt) position.

The second unit, 430-1,5C3, is a 30-step bridged-T meter control which increases attenuation in 1.5 db steps and is tapered to off. Can also be supplied with a linear attenuation characteristic. These stock types are available with 150, 500, or 600-ohm impedances. The control has 337.5° rotation, 11 $\frac{3}{4}$ " contact spacing, and a  $2\frac{1}{4}$ " overall diameter.

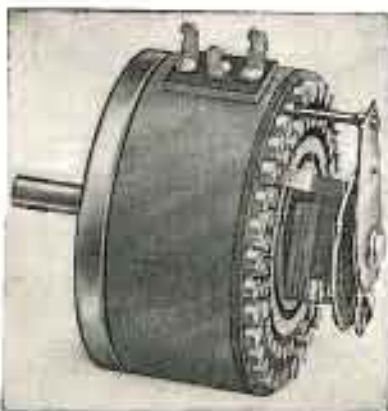

## RAYTHEON FUSE AND RESISTOR LOCKS

Fuse and resistor clips with locking features have been announced by the Raytheon Manufacturing Company, Waltham 24, Mass.

Locking device is said to hold the ferrule firmly in place regardless of vibration, to insure an uninterrupted flow of current at all times.

An ejector is also attached to the clip, to simplify removal of the fuse with a single tip of the ejector spring.

\*\*\*

## CLARKE FIELD STRENGTH METER

A field strength meter, operating in the 200 to 350-ke range has been announced by Clarke Instruments Corporation, 910 King Street, Silver Spring, Maryland.

The instrument is self-contained and weighs 12 $\frac{1}{4}$  pounds. Field strengths between 10 microvolts per meter and 10 volts per meter can be read directly.

\*\*\*

## ROANWELL MOBILE MIKE

A 7-ohm microphone, with the microphone element fashioned in rubber, and switch and other internal parts enclosed in an aluminum alloy case, has been announced by Roanwell Corp., 662 Pacific St., Brooklyn, New York.

Has a double button switch mechanism which provides instantaneous press-to-talk operation with either thumb or forefinger of either hand.

For transferring microphone from speaking to hang-up position, a stainless steel button is pivoted on the face of the microphone.

Designed to match 50-300-ohm circuits and to operate at 5-100 ma, according to circuit. Two models available: 9900 with an output level of 33 db below 1 volt for 30 bars; 9901 with output level of 25 db below 1 volt for 30 bars.

Neoprene cord covering is said to seal eod. age entrance end, at the same time, protect cordage a full 1 $\frac{1}{4}$ " beyond microphone case.

## ADC AMPLIFIERS

A series of four high-fidelity 8-watt amplifiers, type 71, have been announced by Audio Development Company, 8833 13th Avenue South, Minneapolis, Minn.

Amplifiers are said to have been designed for use by broadcasting studios, wired music applications, recording studios and similar installations where bridging or line inputs are required. Output impedances are provided for either line or voice coil connections.

May be used in either a console or rack. Plug-in connections are said to permit rapid exchange of units for servicing or change of terminal impedances.

Amplifiers are said to have a nominal distortion of not more than 2 per cent at any frequency between 50 and 12,000 cps.

Noise levels are said to be held to more than 26 db below full output; gain control range is 38 db for bridging or 50 db for line applications.

Overall dimensions are  $3\frac{1}{4} \times 1\frac{1}{2} \times 2\frac{3}{4}$ " including plugs and control knob; net weight is 1 $\frac{1}{4}$  pounds.

\*\*\*

## DAVEN TRANSMISSION MEASURING SET

A transmission measuring set, type 11A, designed for checking frequency response, impedance matching characteristics and gain and loss measurements, has been announced by the Daven Co., Newark, N. J.

Frequency range is said to be 20 to 20,000 cps. Measurements can be made to 111 db in steps of 0.1 db.

\*\*\*

## AEROVOX MIDGET-CAN ELECTROLYTICS

Midget-can electrolytic capacitors, type PPS, have been announced by Aerovox Corporation of New Bedford, Mass.

Available in single-section ratings from 25-750  $\mu$  f, 4 to 100 mfd, and from 25 to 450 volts  $\mu$  f, 8-8 to 100-100 mfd dual-section units. In high-capacitance low-voltage series units are available in voltage ratings from 6 to 25  $\mu$  f, 100 to 2,000 mfd.

# NEW... Improved Wiring Eliminates Leakage

## TYPE 12AT & TYPE 12ATK (KIT) TRANSMISSION MEASURING SET

Range: 111 db. in 0.2 steps.  
Frequency resp.: 0.1 db. from 0 to 20 kc.  
Accuracy: 0.1 db.  
Impedance, load section: 4, 8, 16, 50, 150, 200, 300, & 600 ohms.  
Impedance, trans. sect.: 50, 150, 200, 300 & 600 ohms.  
Reference level: 1mw. into 600 ohms.  
Circuit: "T", unbalanced.  
Attenuators: 10x10, 10x1 & 5x0.2 db.  
Load corr. cap.: Transm. sect. 1 w. Load section 10 w.

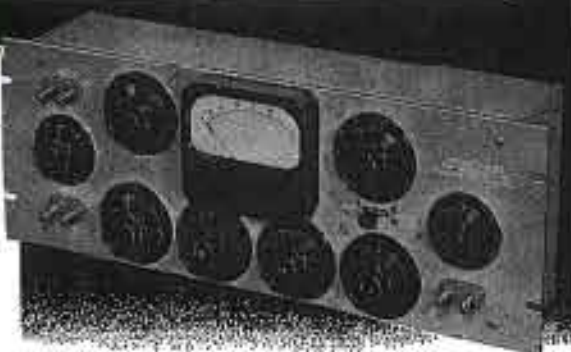

A precision Gain Set with specially developed wiring that permits no troublesome leakage and provides improved frequency characteristics. Available completely assembled, or in kit form—which permits the sale of a high accuracy instrument at a low price.

WRITE FOR DESCRIPTIVE BULLETIN



Manufacturers of Precision Electrical Resistance Instruments  
PALISADES PARK, NEW JERSEY

## WDTV Field Coverage

(Continued from page 7)

peak voltage, a factor of 1.33 was used to convert from meter reading to sync peak. It is believed that the error resulting from a deviation from the RMA standard is a second order effect. A second factor of 1.07 was employed to convert from the 28' height at which the measurements were made to the 30' height on which the theoretical curves are based.

The final conversion factor was, therefore, obtained as follows:

$$\bar{E}_{(s,30)} = 0.87 \times 1.33 \times 1.07 \times e = 1.24 e$$

Where

$$\bar{E}_{(s,30)} = \text{Field strength of sync peaks at 30' in microvolts per meter}$$

and

$$e = \text{Voltage at receiver terminals in microvolts}$$

### Conclusions

This is probably the first time that a complete field survey has been made in an area having terrain of the type found around Pittsburgh. As indicated the ground elevation varies con-

## BIRTCHEr STAINLESS STEEL - LOCKING TYPE TUBE CLAMPS

Stainless Steel

Corrosion Proof



83 VARIATIONS

Where vibration is a problem, Birtcher Locking TUBE CLAMPS offer a foolproof, practical solution. Recommended for all types of tubes and similar plug-in components.

More than three million of these clamps in use.

### FREE CATALOG

Send for samples of Birtcher stainless steel tube clamps and our standard catalog listing tube base types, recommended clamp designs, and price list.

THE BIRTCHEr CORPORATION  
5037 HUNTINGTON DR. LOS ANGELES 32

Plot of spatial distribution, for 37 to 41 miles. In this plot all measurements within an annulus four miles wide, having a mean radius of thirty-nine miles and centered about the transmitter were compared to the smooth earth ground wave theoretical value at thirty-nine miles corrected in accordance with the Ad Hoc recommendations. There were eighty-seven measurements lying within this area. The ratios were then converted to db and plotted on normal distribution paper. Although the values thus obtained represent spot measurements rather than sector median values, the distribution compares quite well with Figure 7 of the Ad Hoc report.<sup>1</sup> This figure shows the slope of  $R(L)$  to be 22 db between the 10% and 90% values. As shown here, a slope of 26 db was obtained for this value. The slightly greater slope is readily understandable in view of the extreme roughness of the terrain. The median value shown is, however, approximately 11 db below theoretical.<sup>2</sup> This may be due, in part, to the fact that many of the roads on which measurements had to be made, follow the river valleys.

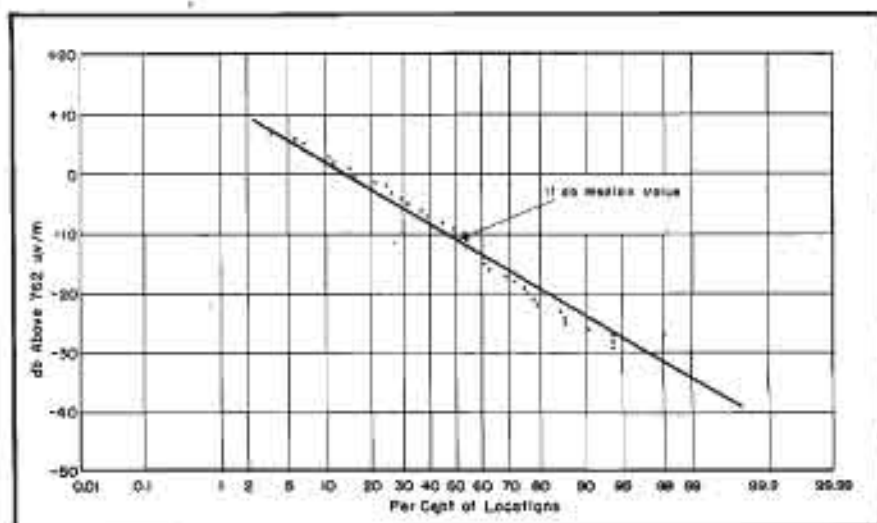

tinually, frequently as much as 300' to 400' in distances as small as one-half mile. This results in variations in field strength as great as 40 to 50 db for locations essentially the same distance from the transmitter. The cluster type of measurement emphasized the relationship between signal strength and terrain. Almost without exception, the high signal strengths were found on the illuminated slopes and the low signals encountered on the shaded slopes.

## Sound Recording

(Continued from page 29)

plying good engineering techniques, recording equipment can be so designed that speed variations of the recording medium from the normal speed will not exceed  $\pm 1\%$  from peak to peak, a variation which is in many cases considered acceptable.

Where requirements call for a stereophonic system and where, therefore, more than one channel is employed, it becomes essential that the phase relationship between the various transmission links be maintained. This means that the various sound tracks must be recorded and reproduced in the proper time relationship. It also necessitates that all corresponding elements must have uniform performance characteristics, not only with respect to frequency response and nonlinear distortion but also with regard to phase distortion.

A problem common to all recording methods is the presence of background noise in the process of reproduction. The magnitude of this noise determines the lower limit of the signal which can be recorded, while the upper limit is determined by the overload point. As stated previously, it is vital to secure a maximum range, possible better than 60 db, between the inherent background noise and the overload point.

An analysis of the various causes of noise in the different recording methods is a subject matter much beyond the scope of this article. Briefly, however, it can be stated that in mechanical recording the groove must be free from any unwanted surface irregularity; in optical recording, the emulsion should be wholly transparent in the absence of a recorded signal; and in magnetic recording, the recording medium should be magnetically uniform from point to point.

But noise is not generated only by the medium. Another source of noise might be found in the undetermined relationship between the medium on

## IT'S KINGS FOR CONNECTORS

Pictured here are some of the more widely used R. F. co-axial, U. H. F. and Pulse connectors. They are all Precision-made and Pressurized when required. Over 300 types available, most of them in stock.

Backed by the name **KINGS**—the leader in the manufacture of co-axial connectors. Write for illustrated catalogs, Department "T"

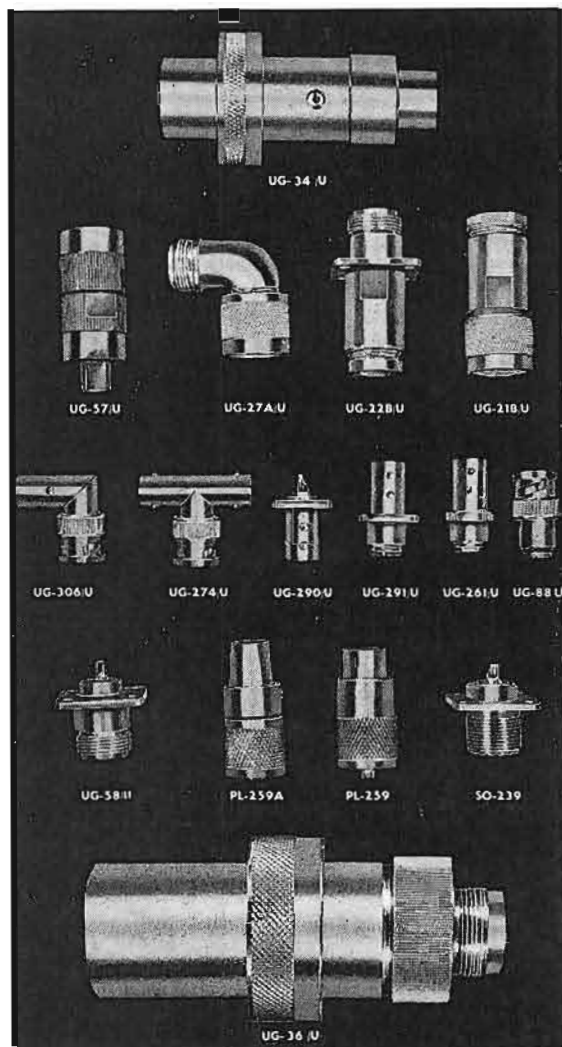

Manufacturers of Radar, Whip, and Aircraft antennas  
Microphone Plugs and Jacks  
Radar Assemblies, Cable Assemblies, Microwave and  
Special Electronic Equipment

one hand and the recording and reproducing device on the other hand. This might best be illustrated, in the case of magnetic recording, by a condition where changes in the effective contact between the medium and the recording or reproducing head alter the magnetic coupling between these two elements with a corresponding increase of noise. The presence of a magnetic field, as might exist around the gap of a permanently magnetized reproducing head, will raise the noise level in magnetic recording. Instability of the light source in optical recording and

reproduction is the cause of additional noise.

In practice, high signal-to-noise ratio cannot always be attained because of the inherent characteristics of the medium, as for example in optical recording, where the grain structure of the photographic emulsion imposes basic limitations. In this case some help is found from the use of noise reduction methods, a process whereby the average light transmission of the sound track of the print is decreased for low level signals and in-

(Continued on page 34)

**POLICE FM ALARM** FOR POLICE CALLS TAXI CABS AND OTHERS

**Radio Receiver Tunes  
Emergency Communications  
Band ... 152-162 Megacycles**

**NEW IMPROVED MODEL PR-7**  
True F.M. superheterodyne, 6 miniature tubes, including rectifier. 110 volts, AC-DC, 5-inch speaker, highest quality components.

Attached Antenna →

- \* Clear Vision dial
- \* Size 10 1/2" x 6 1/2" x 4"
- \* Radio detector

**\$39.95**



LIST PRICE includes excise tax, F.O.B. Indianapolis. \$10. cash with order, balance C.O.D.

Also available Model PR-30 for 30-44 megacycles band **\$44.95**

See your DEALER first, or write Dept. CU-1.

**RADIO APPARATUS CORP.**  
303 FOUNTAIN SQUARE THEATER BLDG.  
INDIANAPOLIS 3, INDIANA

**Serving a FAST  
Expanding Industry,  
Advertising in  
COMMUNICATIONS  
is highly productive!**

By all means reserve  
space in the important  
Fall and Winter Issues just  
ahead!

COMMUNICATIONS  
52 Vanderbilt Avenue, New York 17, N. Y.

**WHEN YOU CHANGE  
YOUR ADDRESS**

Be sure to notify the Subscription Department of COMMUNICATIONS, 52 Vanderbilt Avenue, New York 17, N. Y., giving the old as well as the new address, and do this at least four weeks in advance. The Post Office Department does not forward magazines unless you pay additional postage, and we cannot duplicate copies mailed to the old address. We ask your cooperation.

**Sound Recording**

(Continued from page 33)

creased by high level signals. But such tricks only improve the apparent signal-to-noise ratio. With increase of the recorded signal strength, the noise increases too, leading to a form of noise usually called *modulation noise* or noise behind the signal.

**AC Biasing and Noise**

This type of noise is also found in magnetic recording when ac biasing is employed. It is not as objectionable as steady background noise, since modulation noise is at least partially masked by the signal. But its effects are still highly undesirable. Much work is now being done, as far as magnetic recording is concerned, to find ways to reduce it.

**Present Equipment Characteristics**

With this analysis of limitations in mind, one is almost compelled to conclude that one cannot build, at the

present time, recording equipment which can rightfully carry the high fidelity label. It is fortunate, however, that some degree of quality deterioration cannot be detected, even by a trained listener. The designers of recording equipment will find it necessary to make most concessions with regard to harmonic and intermodulation distortion. As long as the harmonic distortion does not exceed 3% for full modulation and as long as intermodulation distortion does not exceed 5%, the recording equipment can still be considered as satisfactory for many applications. Were it not for the fact that certain tolerances are permissible, the only answer to the problem would be to strive for perfection. A more realistic view of the situation indicates, however, that present-day good recording equipment comes close to the goal. Many listening tests have been performed where observers found it difficult, if not impossible, to say whether or not a recorder was used as part of the transmission link.

**VWOA NEWS**

(Continued from page 30)

he resigned and just stopped going to sea. Shortly after Guthrie went to work for American Marconi as an inspector and from February to April, 1915, carried on experiments with wireless telephone, both tube (British) and a singing arc from the Wanamaker stations. At a later date the oldtimer took an exam for assistant radio inspector in what is now the FCC. He won his appointment in April, 1917, and remained there until October, 1919, when he transferred to the U. S. Shipping Board. During his radio inspector tenure (World War I) he worked closely with the Department of Justice, and Army and Navy Intelligence. The session at the U. S. Shipping Board as radio supervisor lasted from October, 1919, to June, 1932, when the job was abolished. Guthrie reports that he then drifted into the employ of the Mackay Radio Co., where he remained three years. And in October, 1936, when the Shipping Board became the Maritime Commission he was reappointed by Civil Service to his old job but with the title of radio inspector, instead of radio super-

## FIELD TESTED Installation Information on



**TV  
and  
FM**

## RECEIVING ANTENNAS

TV... FM Antenna Installation

by Ira Kamen

Manager, Antennas and TV Dept.  
Commercial Radio Sound Corp.  
and Lewis Winner

Editorial Director,  
Bryan Davis Pub. Co., Inc.  
Editor, Service and Communications

The only practical book on the all-important item in TV and FM reception... based entirely on actual experiences in the most active TV and FM areas in the country.

Over 35,000 words of vital data with over 130 photos and drawings.

Ten chapters covering:

**Installation Tools**  
**Antenna Installation Procedures**  
**Securing 12-Channel Coverage**  
**HF Antenna Installations**  
**TV Interference**  
**Fringe Reception**  
**Master Antenna Systems**  
**FM Antennas**  
**Installation Business Practices**  
**Tricks of the Trade**

The first book in which you'll find complete design and installation information on every type of TV and FM receiving antenna.

Contains detailed illustration and subject index for rapid reference.

Available direct or through your distributor **\$2.00**

Send coupon below to your distributor or direct to:

Bryan Davis Publishing Co., Inc.  
(Book Dept.)

52 Vanderbilt Avenue, N.Y. 17, N.Y.

Please send me a copy of "TV-FM Antenna Installation," postpaid, for which I am enclosing \$2.00.

(Please Print)

NAME .....

ADDRESS .....

CITY AND STATE .....

visor and remained there until December 31, 1946, when he retired on pension. The oldtimer tells us that his training as an enlisted man in the Navy paid big dividends, enabling him to begin in the early days of radio and grow up with the industry. In his closing comments CDG offers some sage advice to young radio operators going to sea. Reports the oldtimer: "Keep up to date and abreast of the times with your equipment; make repairs if it is physically possible and keep batteries charged at all times; and don't be afraid of soiling your hands."

A thousand thanks, CDG, for these entertaining and informative facts, covering the pioneering era in the wireless world.

## The Industry Offers

[See page 31 for additional new product news.]

### FTR MOBILE RADIOTELEPHONE UNIT

A mobile radiotelephone unit, the FT-145-10, with a power output of 10 watts in the 152-162 mc band, which features modulation limiting, has been developed by FTR.

Modulation limiting is said to eliminate interference due to over-deviation which causes so-called *spill-over* from the operating channel to adjacent channels.

Designed to meet RMA test recommendations, the mobile set draws 7.3 amperes standby and 23.9 amperes transmit. Has an overall size of 5 5/16" high by 12 3/16" wide by 1 1/2" deep. Weighs 29 1/2 pounds without cables and control unit.

\*\*\*

### G. E. MARKER GENERATOR

A marker generator, type ST-2A, has been developed by the specialty division of G. E.

Separate crystals for each TV channel are selectable by a rotary switch. Picture and audio carrier markers are available simultaneously. From one to five markers also may be used simultaneously. Frequency range from 79 to 50 mc.

Only one dial setting is said to be required for complete receiver alignment, and band pass and trap circuits can be aligned in one operation. There is no rf output, as the markers are not passed through the circuit under test.

\*\*\*

### CENTRAL RESEARCH MICROWAVE DIELECTROMETER

A microwave dielectrometer for measuring the dielectric constant and loss of a wide variety of materials at nominal frequencies of 1000, 3000, and 9000 mc has been developed by the Central Research Labs., Inc., Red Wing, Minnesota. Instrument consists of a slotted wave guide, precision traveling probe, modulated klystron oscillators, probe output amplifier, associated power supplies and equipment. The sample to be measured is inserted ahead of a short-circuiting plug and the effect of this arrangement on the standing-wave pattern in the guide provides data for calculating the dielectric constant and loss of the material.

At 1000 and 3000 mc the wave guide is used as a coaxial line operating in the TEM mode, and at 9000 mc either as a circular pipe operating in the TE<sub>11</sub> mode or as a coaxial line operating to the TE<sub>02</sub> mode. Solids are measured directly in the wave guide in the form of cylindrical samples 1" in diameter and about 1" to 2" long with a 3/8" hole coaxial with the outer surface except when the guide is operated as a circular pipe at 9000 mc.

# Cannon Plugs

## FOR PUBLIC ADDRESS SYSTEMS



MICROPHONES

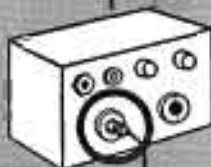

AMPLIFIERS



LOUD SPEAKERS



"XL" SERIES "P" SERIES



"O" SERIES

Available at jobbers everywhere or write  
PA Plug Catalog, Address Dept. H-121.

SINCE 1915  
**CANNON**  
**ELECTRIC**

Development Company

3709 HUMBOLDT ST., LOS ANGELES 31, CALIF.

In Canada - CANNON ELECTRIC CO., LTD., TORONTO

Designed for



Application



**THE NO. 37001  
SAFETY TERMINAL**

An old favorite in the line of exclusive Millen "Designed for Application" products. Combination high voltage terminal and thru-washing. Tapered contact pin fits firmly into contact socket providing large area, low resistance connection. Pin is swivel mounted in cap to prevent twisting of lead wire. Easy to use. 1/2" v.d. Insulates high voltage cable fits into opening in cap. Bare conductor passes thru pin for easy soldering to pre-tinned tip of contact slug.

Standard 37001 available in either black or red bakelite. No. 37501 is low loss mica filled yellow bakelite for R.F. applications.

**JAMES MILLEN  
MFG. CO., INC.**

MAIN OFFICE AND FACTORY

**MALDEN  
MASSACHUSETTS**



**Last Minute Reports . . .**

QUARTZ CRYSTAL aging, a difficult control problem, has been virtually overcome, according to a report from the Frequency Control Branch of the Signal Corps Engineering Laboratories at Fort Monmouth, New Jersey, who say that crystals subjected to a process they recently developed will hold to the desired channel indefinitely. The process, involving superheating to approximately 900° F, followed by slow cooling, was developed by three Signal Corps physicists: Arthur C. Prichard, Maurice A. A. Druenne and Dr. Davis G. McCaa. In the process, crystals are placed on a conveyor belt and are drawn through an electrically heated oven for periods of from two to three hours, after which they are subjected to controlled cooling for twenty-four hours.

A television symposium will be featured at the forthcoming West Coast IRE Convention, which will be held in the Civic Auditorium in San Francisco; Al Towne, director of engineering KSFQ-KPIX, will discuss the engineering problems of the pioneer TV station; Harry Jacobs, KGO-TV, will cover network TV station operation; Harold See, director of TV at KRON-TV, will analyze the organization and administration of a TV station; Larry Reed, chief engineer of TV California, will present an analysis of TV propagation tests in the Bay area, and Al Isberg, chief engineer, KRON-TV, will cover safety considerations in TV station design and operation. Royal V. Howard, former NAB director of engineering, will serve as moderator.

Dr. H. S. Osborne, AT&T chief engineer, has been elected by the United States International Committee of the International Electrotechnical Commission, to serve as chairman for the coming year. F. B. Llewellyn, representing IRE, and W. R. G. Baker, representing RMA, have been named to serve on the USNC executive committee. . . . Mayor Martin H. Kennedy of Chicago has designated the week of October 1 to 9 as National Electrical Living Week as a tribute to the Second Annual National Television and Electrical Living Show which will be held during that week at the Chicago Coliseum. . . . James T. Buckley, chairman of the board of Philco, has been appointed to the board of Drexel Institute of Technology, Philadelphia. . . . WPJB, the Providence Journal's FM station, will soon have an all-steel master control room console. The console, containing three sections, built by RCA, has provisions for feeding four outgoing channels and control of ten input circuits. . . . M. J. Minor, chief engineer of WBT, will serve in a similar capacity for WBTW, Charlotte, North Carolina. . . . Robert Kuhl has become the Gates Radio Co. field engineer for Arkansas, Mississippi, Louisiana and western Tennessee, with headquarters in Memphis. . . . Edwin I. Guthman and Co. of Chicago, have been licensed by G. E. to manufacture horizontal sweep and high voltage transformers for TV receivers. According to G. E., this transformer will sweep a 60" 16" picture tube with a single 6BG6G and produce up to 13 kv anode supply. . . . Earl Hadley, formerly with Bendix and Spartron, has been named advertising and sales promotion manager for Westinghouse Electric.

**INCREASED  
INSULATION  
BETTER  
CONNECTIONS  
JONES BARRIER**

**Terminal Strips**

Leakage path is increased—direct shorts from frayed terminal wires prevented by bakelite barriers placed between terminals. Binder head screws and terminals brass, nickel plated. Insulation, molded bakelite.



No. 3142



No. 3142-W



No. 3142-Y

Shows Screw Terminals—Screw and Solder Terminals—Screw Terminal above, Panel with Solder Terminal below. For every need.

Six series meet every requirement No. 140, 5-40 screws; No. 141, 6-32 screws; No. 142, 8-32 screws; No. 150, 10-32 screws; No. 151, 12-32 screws; No. 152, 1/4-28 screws.

Catalog No. 17 lists complete line. Send for your copy.

**HOWARD B. JONES DIVISION**  
Cinch Mfg. Corp.  
1026 SOUTH HOMAN AVE. CHICAGO 24, ILL.

**ADVERTISERS IN THIS ISSUE**

**COMMUNICATIONS INDEX  
AUGUST, 1949**

AMPERITE CO. . . . .	24
Agency: B. J. Gale Co.	
BELL TELEPHONE LABORATORIES . . . . .	1
Agency: N. W. Ayer & Son, Inc.	
BIRTNER CORPORATION . . . . .	32
Agency: W. C. Jeffries Co.	
DANNON ELECTRIC DEVELOPMENT CO. . . . .	25
Agency: Dana Jones Co.	
THE CLEVELAND CONTAINER CO. . . . .	4
Agency: The Nashbit Service Co.	
GENERAL RADIO CO. . . . . Inside Back Cover	
Agency: The Barta Press	
HEWLETT-PACKARD CO. . . . . Inside Front Cover	
Agency: L. C. Cole Advertising	
HOWARD B. JONES DIV. CINCH MFG. CORP. . . . .	38
Agency: Bronson, MacKenzie & Co.	
KINGS ELECTRONICS CO. . . . .	33
Agency: Howard Adv. Associates, Inc.	
LAMPKIN LABORATORIES, INC. . . . .	24
JAMES MILLEN MFG. CO., INC. . . . .	36
MOTOROLA, INC. . . . .	16
Agency: Gouffain-Cole Adv. Agency	
RADIO APPARATUS CORP. . . . .	34
Agency: Fritsch Adv. & Merchandising Enterprises	
RADIO CORPORATION OF AMERICA . . . . . Back Cover	
Agency: J. Walter Thompson Co.	
SHALLCROSS MFG. CO. . . . .	23
Agency: The Barry P. Briggs Co.	
SPRAGUE ELECTRIC CO. . . . .	15
Agency: The Barry P. Briggs Co.	
TECH LABORATORIES . . . . .	32
Agency: Lewis Adv. Agency	
U. S. TREASURY DEPT. . . . .	28
WILCOX ELECTRIC CO. . . . .	43
Agency: Arthur B. Hoyer & Co.	

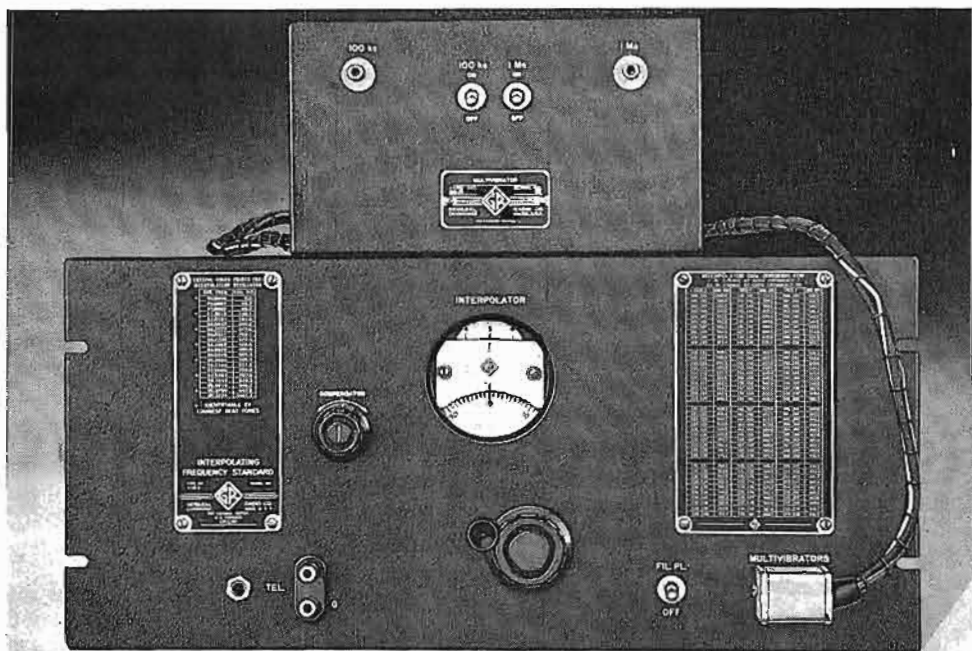

## FREQUENCY MEASUREMENTS UP TO 3,000 MC WITH ACCURACY OF $\pm 25$ PARTS PER MILLION

• Between 100 and several thousand megacycles, the present accuracy of heterodyne frequency meters ranges between 0.01 and 0.1 per cent. Continually increasing importance of frequencies within this range call for increased accuracy of measurements.

A reference standard and precise interpolation offer the simplest, most inexpensive and most direct method of increasing the accuracy of heterodyne frequency meters.

The Type 1110-A Interpolating Frequency Standard is composed of two units: a frequency standard variable over a range of 1000 to 1010 kc (1%), and a multivibrator unit for frequencies of 1 Mc and 100 kc. The frequency standard consists of a temperature-controlled 950 kc crystal oscillator, a highly-stable 50-60 kc bridge-type variable-frequency L-C oscillator, a modulator and a filter for selecting the sum of the two frequencies at the final output.

When the 100 kc multivibrator is used, the 100th harmonic has a range of 1% as the standard frequency is changed over the full range of the dial, covering 10.0 to 10.1 Mc. The multivibrator harmonics give complete frequency coverage from 100 Mc upward for the 1 Mc unit, and from 10 Mc upward for the 100 kc unit.

### FEATURES

**ACCURACY OF MEASUREMENT:** over-all accuracy is  $\pm 25$  parts per million using oscillator dial directly. If oscillator is carefully trimmed in terms of the crystal, the over-all accuracy is limited principally by the error of the crystal, or about  $\pm 10$  parts per million at room temperatures.

**SIMPLE TO CHECK ABSOLUTE ACCURACY:** harmonics of multivibrators fall at all WWV standard frequencies. With suitable receiver the absolute accuracy, including that of the 950-kc crystal, may be checked readily.

**ZERO BEAT ADJUSTMENTS:** no need for wide-band circuits or wide-band interpolating methods.

The Type 1110-A Interpolating Frequency Standard can be used for frequency measurements with high-frequency receivers provided the receiver calibrations can identify frequencies if separated by as little as 1 per cent.

**TYPE 1110-A INTERPOLATING FREQUENCY STANDARD..... \$725.00**

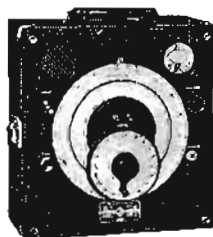

### TYPE 720-A HETERODYNE FREQUENCY METER

As a companion to the Type 1110-A instrument, this heterodyne frequency meter will be found to be particularly useful at frequencies up to at least 3000 Mc. It employs a butterfly-type tuning circuit, the oscillator frequency being continuously adjustable and direct-reading, from 100 to 300 Mc. A silicon crystal detector is used, with a 3-stage audio amplifier. The output of the amplifier operates a panel meter and a built-in loud-speaker. For hand-telephone detection of weak signals, a jack is provided on the panel. The entire unit is battery-operated and completely self-contained.

**TYPE 720-A HETERODYNE  
FREQUENCY METER..... \$360.00**

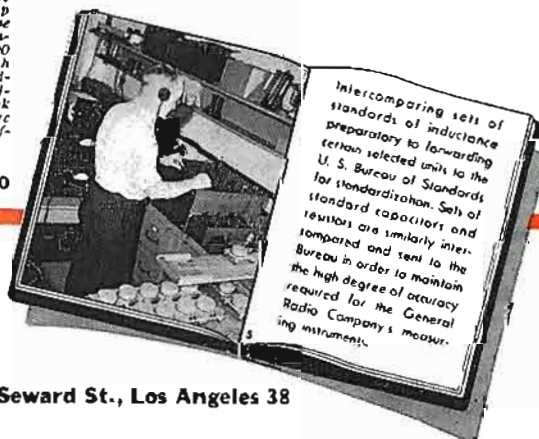

# GENERAL RADIO COMPANY

Cambridge 39, Massachusetts

90 West St., New York 6    920 S. Michigan Ave., Chicago 5    1000 N. Seward St., Los Angeles 38

**RCA Type WX-2B**  
**540-1600 kc.**



The new *Portable Field-Intensity Meter*, RCA Type WX-2B shown one-third actual size. A loop antenna is built right into the lid!

## a truly portable **Field-Intensity Meter**

• Weighing only 12½ pounds—including batteries, here's a small, compact field-intensity meter of high accuracy that carries around like a portable radio . . . and operates almost as simply. You tune in a signal, adjust a *built-in* calibrating oscillator and receiver gain . . . and *read signal intensity directly in microvolts-per-meter*. No charts, curves, or correction factors to worry about. No computations to make.

Designed with a wide sensitivity range of 10 microvolts/meter to 10 volts/meter, Type WX-2B enables you to make field-strength readings anywhere—from the very shadow of your transmitter, to the toughest location "down-in-the-

noise." Plenty of front-end selectivity, too. Loop antenna Q is approximately 100 at one megacycle; An r-f amplifier stage provides a very high order of image rejection.

Power supply; Ordinary flashlight dry cells for the quick-heating tube filaments—and a 67-volt battery of the size used in camera-type radios for the B supply.

A lot easier now to get the facts on your coverage, service area, and antenna efficiency . . . with RCA's new portable WX-2B. Ask your RCA Broadcast Sales Engineer for the facts. Or write Department 23-H, RCA Engineering Products, Camden, New Jersey.



**BROADCAST EQUIPMENT**  
**RADIO CORPORATION of AMERICA**  
**ENGINEERING PRODUCTS DEPARTMENT, CAMDEN, N.J.**

In Canada: RCA VICTOR Company Limited, Montreal