

# COMMUNICATIONS

INCLUDING "RADIO ENGINEERING" AND "TELEVISION ENGINEERING"

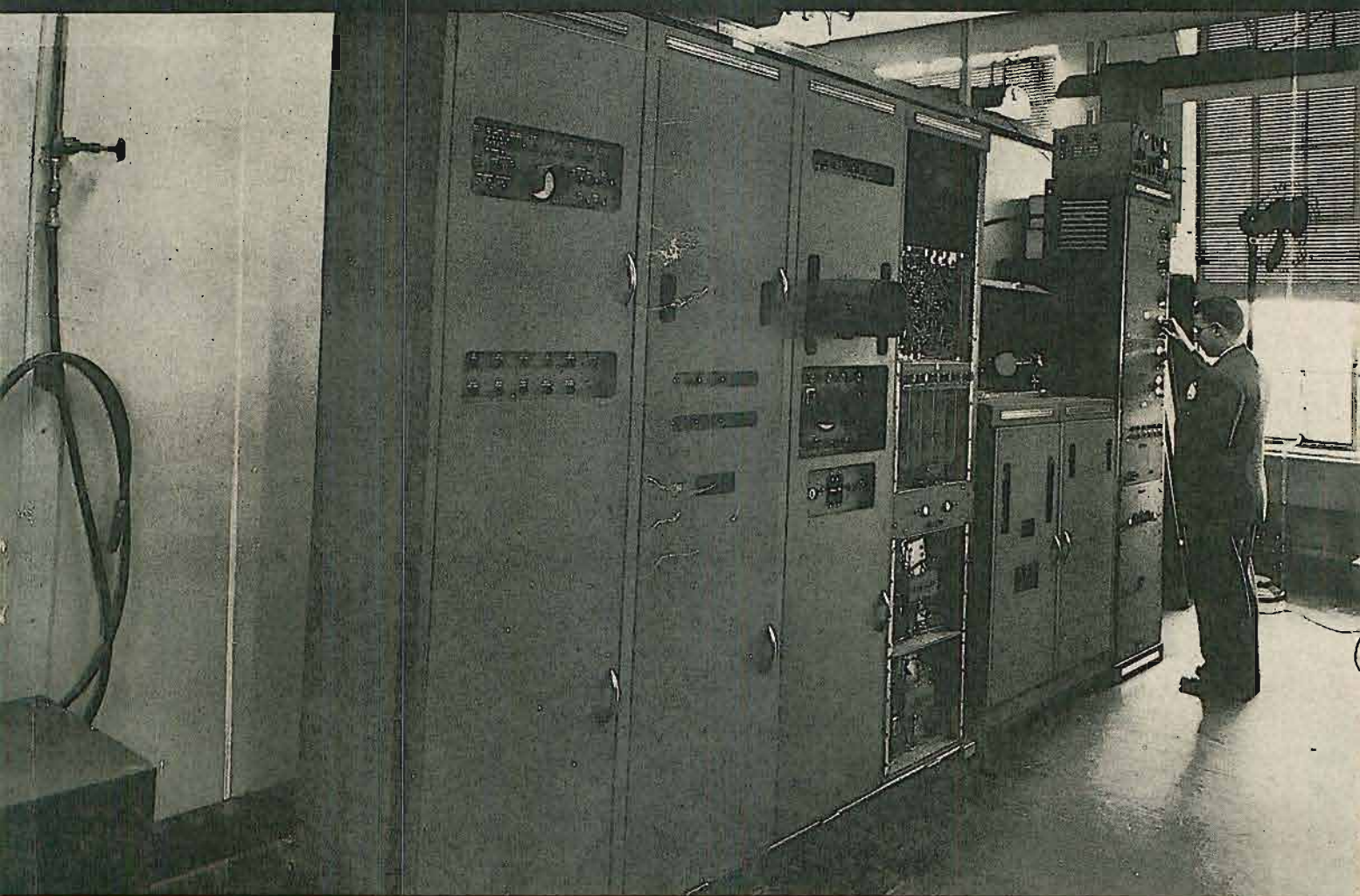

FEBRUARY

- ★ TV MONITOR RECEIVER DESIGN
- ★ AUTOMATIC TELETYPE BULLETIN ALARM
- ★ A TV DISTRIBUTION SYSTEM FOR LABORATORY APPLICATIONS

1949



# PHILCO

## MAKES HISTORY IN TELEVISION TEST EQUIPMENT



For the Radio and Television Serviceman — for the Experimenter — for the Amateur — for the Radio-Electronics Engineer

### PHILCO 7008 VISUAL ALIGNMENT GENERATOR

The only completely self-contained and moderately priced instrument for aligning television and FM receivers. Includes 5 different signal generators with their associated controls; a complete oscilloscope with centering, gain, focus, intensity, phasing and blanking controls, and power supplies; separate RF probe for measurements of sensitive high frequency circuits. Removable crosshatch screen for ultra-short 3" cathode-ray tube. Compartment for cables and RF probe.

#### WRITE FOR TECHNICAL LITERATURE

Philco Corporation, Philadelphia 34, Pa.

No. 7008 Philco Visual Alignment Generator

No. 7001 Philco Electronic Circuit Master

No. 7070 Philco RF Signal Generator

No. 5072 Philco Crosshatch Generator

No. 7030 Philco Dynamic Tester

No. 7019 Philco Junior Scope

### PHILCO TEST EQUIPMENT SERVES MANY INDUSTRIAL & COMMUNICATIONS NEEDS

Today's wide use of electronic devices in industrial plants, laboratories and communications services requires new precision instruments for radio measurements, in compact, portable, inexpensive form. Here, Philco has long been a leader—providing equipment for radio's best informed group of service technicians, the 25,000 members of Philco Service. For fast, accurate work experience-wise servicemen choose Philco Test Equipment. Know the reasons why Philco is preferred, by writing for technical literature.

PHILCO CORPORATION • Philadelphia 34, Pa.



# electrolytics

for really dependable  
performance for  
television and other  
exacting uses

## SPRAGUE

PIONEERS OF

ELECTRIC AND ELECTRONIC PROGRESS

**BUILT FOR LONG, TROUBLE-FREE PERFORMANCE  
UP TO 450 VOLTS AT 85°C.**

These sturdy little dry electrolytics have what it takes to match the toughest capacitor assignments in television and other exacting equipment where the use of ordinary components may only be inviting trouble. They're compact, easy to mount. They'll

withstand plenty of heat. Thanks to a recently developed processing technique, they are outstandingly stable, even after extended shelf life. In every respect, they are designed for better-than-average service on tougher-than-average jobs.

**SPRAGUE ELECTRIC COMPANY, NORTH ADAMS, MASSACHUSETTS**

COMMUNICATIONS FOR FEBRUARY 1949 • 7



# COMMUNICATIONS

Including Television Engineering, Radio Engineering, Communication & Broadcast Engineering, The Broadcast Engineer, Registered U. S. Patent Office.

**LEWIS WINNER**

Editor

F. WALEN

Assistant Editor

Bryan S. Davis, President

Paul S. Wall, Vice Pres.-Gen. Mgr.

F. Walen, Secretary

A. Goebel, Circulation Manager

**Cleveland Representatives:**

James O. Mann  
2232 Delaware Dr., Cleveland 4, Ohio  
Telephone: Esterline 1728

**Pacific Coast Representative:**

Braad & Braad  
1032 W. Sixth St., Los Angeles 14, Calif.  
Telephone: Michigan 1732  
Suite 1284, Ross Building, San Francisco 4, Calif.  
Telephone: SUTter 1-2231

Wellington, New Zealand: Te Aro Book Depot.  
Melbourne, Australia: McGill's Agency.

Entered as second-class matter Oct. 1, 1937 at the Post Office at New York, N. Y., under the act of March 3, 1879. Subscription price: \$3.00 per year in the United States of America and Canada; 25 cents per copy. \$3.00 per year in foreign countries; 25 cents per copy.

COMMUNICATIONS is indexed in the Industrial Arts Index and Engineering Index.

**COVER ILLUSTRATION**

Centralized TV distribution system room with, left to right, sync generator, monoscope chain, monitors, video distribution amplifiers, crt flying spot video signal generator and picture and sound of television generators. (See page 8, this issue, for complete discussion of the system.)

(Courtesy Philips)

**TELEVISION ENGINEERING**

TV Distribution System for Laboratory Use.....Joseph Fisher 8  
*Terminal Equipment Setup at Research Labs Affords Composite Video Signal and Means for Modulation on a Number of Standard RF Carriers Aiding in the Development of Video Amplifiers, Deflection Circuits, HV Pulse Supplies, etc.*

A TV Monitor Receiver.....F. Cecil Grace 10  
*See Features Protection Against Overloading, Insensitivity to RF Fields, High Input Level, etc.*

**BROADCAST FACILITIES**

Automatic Teletype Bulletin Alarm.....George Inge 14  
*Device Automatically Indicates Arrival of Bulletins Via a Visual Signal in Control Room.*

**FM BROADCASTING**

Super Power FM (546 kw erp) at WBRC-FM..... 18

The Installation of WSJS-FM.....William E. East 21  
*Ten kw FM-Transmitter, with Six-Bay Circular Antenna, Ideally Located in Hills of North Carolina, Provides Coverage of Approximately 63 Miles in 50-Microvolt Contour.*

FM Broadcast Monitor.....Martin Silver 40  
*Concluding Installation with Data on Power Supply and Voltage Regulating System.*

**MEASUREMENT TECHNIQUES**

Pulse Power Measurement by a Heterodyne Method..Leonard S. Schwartz 26  
*Peak-Reading Method, Facilitating Determination of Pulse Powers, Eliminates Need for Pulse-Width and Repetition-Rate Data.*

**HF/VHF INSTRUMENT DESIGN**

A Self-Checking Wobbulator.....Joseph H. Vogelstein 28  
*Portable 5 to 100-mc Test Set Contains FM Signal Generator, Frequency Monitor and Scope.*

**BROADCAST STATION INSTALLATIONS**

Recent AM/FM/TV Installations..... 32

**MONTHLY FEATURES**

News and Views.....Lewis Winner 7

Veteran Wireless Operators' Association News..... 24

News Briefs of the Month..... 36

The Industry Offers..... 38

Last Minute Reports..... 44

Advertising Index ..... 44

Entire contents Copyright 1949, Bryan Davis Publishing Co., Inc.



Published monthly by Bryan Davis Publishing Co., Inc.  
52 Vanderbilt Avenue, New York 17, N. Y. Telephone Murray Hill 4-0170



CITIZENS RADIO  
TRANSCEIVER USES

*Sylvania  
sub-miniature  
tubes!*



The farmer in the field and his wife at home will be able to converse with ease by using these new, lightweight transceivers equipped with Sylvania sub-miniature tubes!

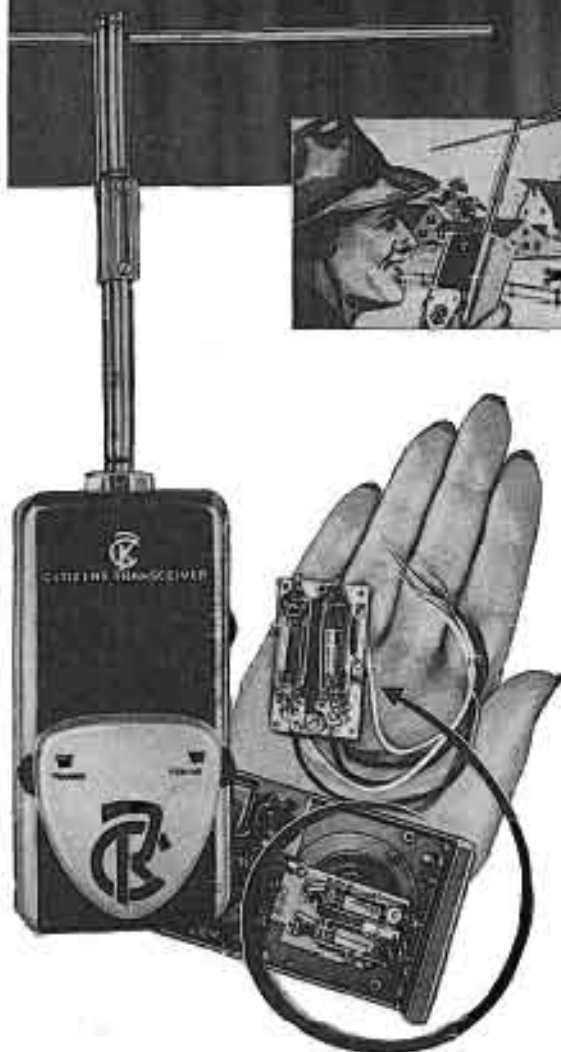

Tiny Sylvania sub-miniature radio tubes, smaller than a lady's little finger, are big reasons why the Citizens Radio Transceiver measures only 6" long, not quite 3" wide, 1 1/4" deep, and weighs only eleven ounces!

Sold in sets of two, these tiny two-way transceivers with a range of several miles are tuned to 465 mc. Among the many who want these handy units are police and fire departments, surveyors, farm-

ers, hunters, industrial users, rangers and those who wish boat-to-home and auto-to-home communications.

Sylvania's extensive radio tube research and manufacturing skill have made Sylvania sub-miniature tubes the choice of Citizens Radio Corporation, Cleveland, for this revolutionary, civilian transceiver. Sylvania Electric Products Inc., Radio Tube Division, Emporium, Pennsylvania.

# SYLVANIA ELECTRIC

RADIO TUBES, CATHODE RAY TUBES, ELECTRONIC DEVICES, FLUORESCENT LAMPS, FIXTURES, WIRING DEVICES, LIGHT BULBS, PHOTOLAMPS

COMMUNICATIONS FOR FEBRUARY 1949 • 3



# How is YOUR company doing in this "EVERYBODY-BENEFITS" plan?

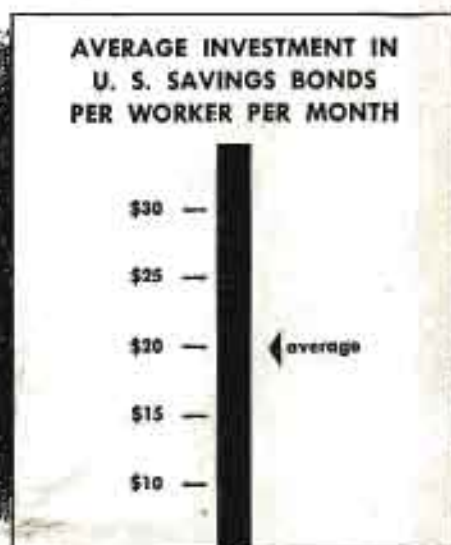
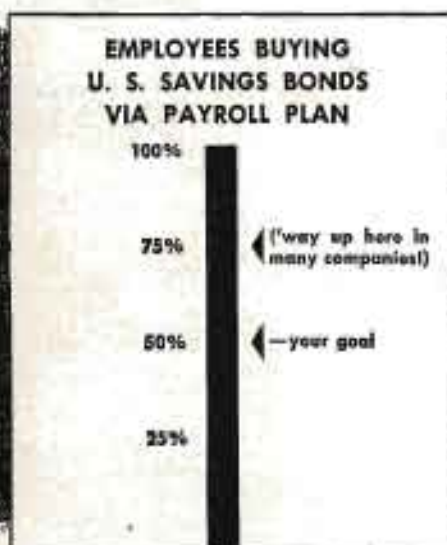

## Compare your employee participation with others who have Payroll Savings

If the figures for your company fall below those shown above, you're missing your share of benefits of the Payroll Savings Plan! These benefits are described below. Nation-wide experience proves that when top management puts the "OK" on the Plan, its benefits rise sharply.

**BENEFITS TO EMPLOYEES:** Every \$3 invested in Savings Bonds pay \$4 at maturity. Workers gain a 33% return on their money—enabling them in the future to buy more of the things they will want—plus the peace of mind that goes with regular saving.

**BENEFITS TO EMPLOYERS:** The feeling of security that goes with participation in Payroll Savings makes workers more contented. Worrying less, they work better. Among the more than 20,000 large companies with Payroll Savings, records show that—following installation of the Plan—production increased, absenteeism and accidents decreased!

**BENEFITS TO THE NATION:** The Payroll Savings Plan is a powerful deterrent to inflationary forces. Every Savings Bond dollar built up in the Treasury withdraws a dollar

from the swollen spending stream. The Plan thus contributes to national security—which affects *your* security!

**WHAT CAN YOU DO?** If your company has the Payroll Savings Plan, make sure it's being adequately promoted—backed by your top executives—to bring your company its full measure of benefits. If you haven't yet installed the Plan, why pass up its benefits any longer? All the help you need is available from your State Director, Savings Bonds Division, U. S. Treasury Department. He is listed in your telephone book. Call him now!

**Do You Realize...?**

- Over \$75,000,000,000 worth of Savings Bonds have been bought since 1941.
- More than 3/4 of this volume—over \$50,000,000,000—is still held by the purchasers.
- During 3 months of 1948, 1,500 additional large firms installed the Payroll Savings Plan.
- Via this plan, 7,500,000 workers are each investing on the average of \$20 per month of their pay—more than \$150,000,000 per month—in Bonds.

The Treasury Department acknowledges with appreciation the publication of this message by

## COMMUNICATIONS

This is an official U. S. Treasury advertisement prepared under the auspices of the Treasury Department and the Advertising Council.





only inches of sound!

When you talk by telephone, far or near, the actual sound travels much less than when you talk across the room!

That's because the telephone system carries not sound itself but an electrical facsimile of sound. When you speak into a telephone transmitter your voice is converted into electrical vibrations which are not changed back into sound until they reach the receiver diaphragm.

Conversion of sound into its electrical equivalent, through the invention of the telephone, opened the way to the measurement of sound by accurate electrical methods. In developing means to make the telephone talk farther and sound clearer, the scientists of Bell Telephone Laboratories had to develop the tools for sound-wave analysis and measurement.

The condenser microphone, the wave filter, the amplifier — each the product of telephone research — have helped to reveal the structure of sound as never before. Each has helped to build the world's finest telephone system.

**BELL TELEPHONE LABORATORIES**



EXPLORING AND INVENTING, DEVISING AND PERFECTING, FOR CONTINUED IMPROVEMENTS AND ECONOMIES IN TELEPHONE SERVICE.





# WILCOX

FIRST CHOICE OF  
**BRANIFF** *International* **AIRWAYS**

## BRANIFF EQUIPS GROUND STATIONS WITH WILCOX TYPE 364A TRANSMITTER

### DESIGN SIMPLIFIES SERVICE

Conventional circuit design, fewer numbers and types of tubes, plus open mechanical construction simplify tube stocking problems and speed maintenance. The entire transmitter portion of the Type 364A is built on a drawer-type chassis, instantly withdrawable from the front of the panel.

### RELAY RACK MOUNTING SAVES SPACE

Compact design requires only 15 inches of rack space for installation, frequently utilizing space already available.

### .005% FREQUENCY STABILITY WITHOUT TEMPERATURE CONTROL

Through the use of a newly developed crystal, troublesome thermostatic temperature controls and crystal ovens are no longer necessary to provide adequate frequency stability.

### SIMPLIFIED CONTROL FOR REMOTE LOCATION

Modulation over a single telephone pair and carrier control by means of a simplex circuit allow the transmitter to be readily located at a remote point.

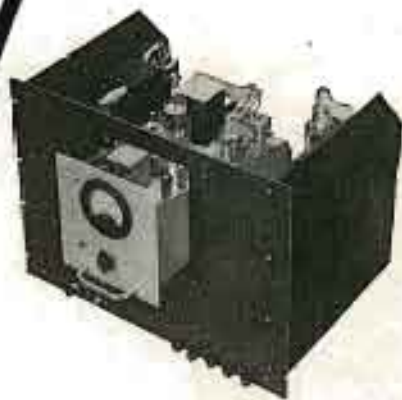

**WILCOX**  
ELECTRIC COMPANY  
KANSAS CITY 1, MISSOURI



WILCOX  
Type 364A Transmitter  
118-136 MC. Band

*Write Today...* for  
Complete Information



# COMMUNICATIONS

LEWIS WINNER, Editor

FEBRUARY, 1949

## It's Show Time

THE BIG THREE, the IRE, NAB and RMA, will roll their drums and ring up the asbestos on their annual spectacles in March and April in New York, Chicago and Philadelphia, and set the stage for a round of the most informative meetings ever planned.

All three get-togethers will be of particular interest to management and engineers in communications and broadcasting. In New York at the IRE (March 7 to 10) there'll be quite an assortment of papers on those spotlight topics, *vhf* and *uhf* in TV. One of the timely presentations will be made by Kenneth Bullington of Bell Labs who will analyze propagation variations at *vhf* and *uhf*, showing how the variations of received signal with location (*shadow losses*) and with time (*fading*), affect the usable service area and the geographical separation between co-channel stations. With an empirical method, he will illustrate that the required separation between co-channel stations is from three to ten times the average radius of the usable coverage area.

In another propagation study, Joseph Fisher of Philco, whose paper on a TV distribution system appears in this issue, will reveal the results obtained on 500 and 3,300 mc over varied terrain in Washington and Philadelphia.

George H. Brown, Wendell C. Morrison, W. L. Behrend and J. G. Reddeck, of RCA Labs, will describe a combining network, which allows two tubes to be operated simultaneously into a common load without interaction between tubes and without reduction in bandwidth, in an 850-mc transmitter, employing four tubes in multiple.

Thomas T. Goldsmith, Jr., of DuMont, will continue the *uhf* TV discourse with a complete report on the status of the 475 to 890-mc operational possibilities at this time.

Antennas, a particularly important phase of current engineering, will be featured in a series of sessions. During one of these meetings Arthur E. Marston and M. D. Adcock of Naval

Research will analyze the theory of end fire helical antennas and provide a formula for the radiation field of a helix which yields a definite condition to be satisfied by the geometry of the helix and the propagation constant of the traveling wave of current in order that the radiation field of the helix be end fire with circular polarization on the axis. O. M. Woodward, Jr., of RCA Labs, will present another extremely interesting TV antenna paper and disclose a unidirectional dipole element receiving antenna with the elements united by a transmission line network which yields a directive pattern. This antenna has been effectively used during the sync-carrier tests between Washington, Princeton and New York.

Relays, another extremely pertinent factor in TV, will be a subject of several papers. One presentation, by William H. Forster, of Philco, will cover systems which employ second detection at each repeater which are said to be most suitable for intracity work and remote pickups, and heterodyne remodulation at the repeaters for intercity long line service. J. Z. Millar and W. B. Sullinger of Western Union will provide details on a 6,000-mc link between New York and Philadelphia. The relay analyses will continue with a description of a 10-repeater link setup by M. Silver, H. French and L. Staschover of Federal Telecommunication Labs.

AM broadcasting will also be covered liberally at the conference. In one paper by H. R. Summerhayes, Jr., of General Electric, will be described an AM monitor which features a local oscillator synchronized in constant phase relation with the carrier component of the modulated signal from the transmitter. The local oscillator signal energizes a quartz crystal discriminator which indicates deviation from the assigned frequency. The local oscillator signal from this monitor can also be added to the modulated wave to reduce the effective percentage of modulation and thus eliminate negative peak clipping in the detector.

The all-important 60 or 120-ke

spacing problem in the 152 to 162 mc band will also be a topic of discussion at the IRE meeting. R. C. Shaw, P. V. Dimock, W. Strack and W. C. Hunter, of Bell Labs, will describe a mobile system now operating in Chicago using 60-ke spacing of carrier frequencies and featuring off-channel squelch in the land receivers, *agc* in the mobile equipment and connection of six land receivers to a common antenna.

At the NAB engineering conference in Chicago in April, there'll be three days of papers covering TV, recording and reproducing, and a variety of projects in AM and FM broadcasting. The conference, which will run from April 6 to 9, will be highlighted by an address by former IRE prexy Dr. William L. Everitt, head of the University of Illinois Department of Electrical Engineering, who for many years conducted the outstanding broadcast engineering conferences at Ohio State University.

In Philadelphia on April 25, 26 and 27, at the Benjamin Franklin Hotel, the RMA and IRE will hold their annual spring meeting and present twelve papers covering a 3-kw *mf* transmitter with iron-core interstage and output circuits; cavity resonators in mobile communications; *symmetron* 50-kw FM amplifier; instantaneous deviation control for PM transmitters; TV recording techniques; a TV visual modulator; high efficiency coolers for forced air-cooled power tubes; audio power amplifiers with positive and negative feedback, and commercial PTM telephone microwave link setups.

Seems as if March and April will be bristling with lively topical meetings for everyone in the broadcast and communications fields!

## The Annual WVOA Soiree

ON FEBRUARY 26 at the Hotel Astor, New York City, the Veteran Wireless Operators Association will hold their annual dinner-cruise, where oldtimers will rub shoulders, reminisce and do a bit of peering into the future.

A must event for the month!—L.W.



# TV Distribution System

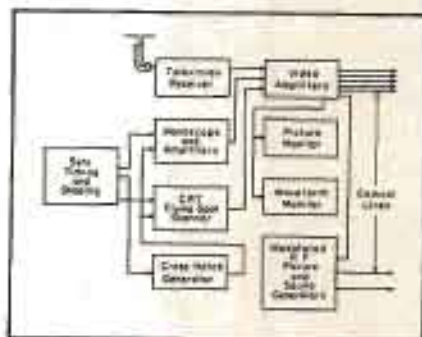
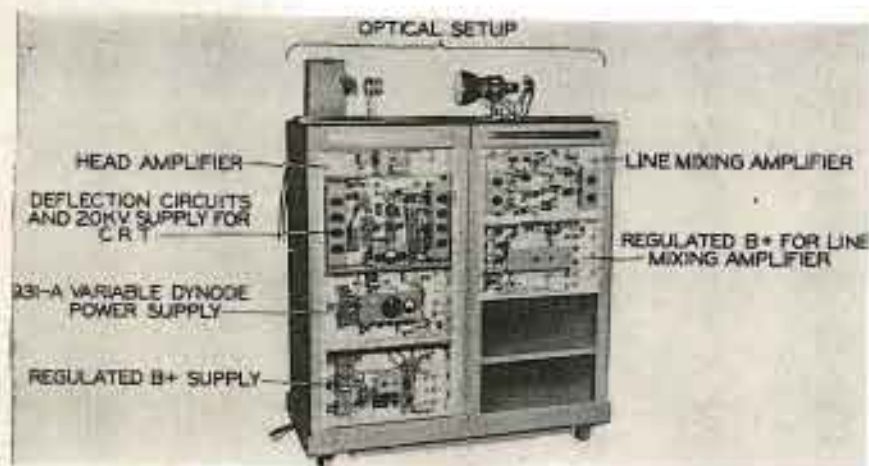

Figure 1  
Block diagram of terminal equipment.

Figure 2 (left)  
View of flying spot video signal generator.

A CENTRALIZED SYSTEM for producing the standard RMA composite video signal, and a means for distributing this signal with a minimum of distortion is a necessity for a large organization engaged in television research. To attempt to duplicate the terminal equipment in each laboratory would result in an overcrowding of floor space, a large increase in capital investment, and an increased maintenance cost. It is desirable that the terminal equipment produce both the composite video signal and means for modulating this signal on a number of the standard *rf* carriers. Many projects such as the development of video amplifiers, deflection circuits, high-voltage pulse supplies, and analysis of *crt* performance can be carried out by using the composite video signal, which is the same signal as that produced at the second detector output of a standard television receiver. Studies of the performance of the *rf* and *if* circuits are greatly enhanced by having an *rf* generator modulated with composite video, the output not being affected by noise or multipath transmission.

On the cover of this issue appears a view of a centralized equipment setup at our labs. Vertical mounting of chassis is used so that all components may be serviced from the front of the units while tubes may be changed from the rear. Each rack is a complete unit in itself containing all the power supplies necessary for its operation. The only interconnections between racks are *ac* power lines and coaxial signal lines. With a layout of this type a particular rack may be taken out of

operation and serviced while the other units are providing signal.

The various units associated with the terminal equipment are indicated in Figure 1. Three sources of composite video signal are available for distribution: (1) Air signal from either of the three television stations, serving the Philadelphia area, operating on channels 3, 6, and 10; (2) monoscope signal; and (3) picture signal from a *crt flying spot scanner*. A cross-hatch generator producing a pattern of twenty vertical bars and fourteen horizontal bars is provided for deflection linearity adjustments. In addition a six-channel television *rf* generator which may be modulated with either of the video signals is provided. This generator provides both picture and sound signals conforming to television standards and has output attenuators by means of which the output level may be adjusted from 1 to 100,000  $\mu$ v. The output of the *rf* generator is distributed to the television laboratories by means of coaxial cable.

The monoscope tube is a useful source of video signal, and since its output voltage is in the order of 5,000  $\mu$ v the noise developed by the first amplifying stage is almost completely masked. A good monoscope is capable of resolution better than 400 lines; however, for general laboratory work one limitation is that only one pattern may be produced from a given tube.

## CRT Flying Spot Scanner

Shown in Figure 2 is the *crt flying spot scanner* video generator. This

unit is capable of producing an excellent quality picture, with a resolution of 600 lines or better, low noise, and a linear transfer characteristic between black and white. Combining the three aforementioned standards into a figure of merit for camera tubes, it is highly probable that the flying spot scanner is not excelled by any present television camera tube as a laboratory source of signal.

The concept of using a flying spot scanner is over twenty years old and some of the earliest television experiments were conducted with such a system. The developments over the past years of projection tubes operating at over 20 *kv*, photo-multiplier tubes such as the 931-A, and zinc oxide phosphor with very short decay time, have made possible the present high quality unit. The source of the flying spot is a four-inch *crt*, operating at 20 *kv*, utilizing magnetic deflection and focus, and a zinc oxide phosphor. The zinc oxide decays to approximately 50% of its initial light intensity in one microsecond. A standard television raster with blanking is applied to the face of the cathode ray tube, and this raster is focused by means of a lens on a double frame 35-mm transparent slide. The light passing through the transparency is collected by means of a condensing lens onto the cathode of a 931A photo-multiplier tube. The video signal produced by this tube at any instant of time is proportional to the light passing through the slide. A video level of about one-half volt is produced across the 931A plate load resistor. Equalization for the phosphor decay is provided by two *rc* networks in the



# For Laboratory Use

Terminal Equipment Setup Employed at Research Lab Affords Composite Video Signal and Means for Modulating This Signal on a Number of Standard *RF* Carriers, Facilitating the Development of Video Amplifiers, Deflection Circuits, High Voltage Pulse Supplies, Analysis of CRT Performance, etc.

by **JOSEPH FISHER**

Project Engineer, Research Division  
Philco Corp.

head amplifier. The output of the flying spot generator is a composite video signal containing sync signals, blanking, and the *dc* component.

### Line Mixing Amplifier

Associated with both the monoscope chain and the flying spot generator is a line mixing amplifier. The output circuit of the line mixing amplifier is illustrated in Figure 3. The composite video signal is built up of four basic building blocks: (1) Sync pulses, (2) blanking, (3) video, and (4) *dc* component. A dual-input circuit, with gain controls in each channel, is pro-

vided at the input to the line mixing amplifier so that cross hatch signal may be blended in with picture video to adjust the linearity of deflection circuits. Referring to Figure 3, four volts of video with white negative are applied to the grid of the top 6V6. The plate of this tube is connected to the plate of the 6V6 which has 15 volts of positive blanking signal applied to its grid. Across the common load resistor appears a mixed signal of blanking and video which is capacity coupled to the grid of a cathode follower and adjusts itself about the bias set by the black level control. Another 6V6 having four volts of

negative sync applied to its grid has its cathode connected to the cathode of the tube admitting video and blanking. During the blanking interval, the top 6V6 is cut off and black level voltage across the terminating resistor is the result of the plate current of the lower cathode follower.

The horizontal sync pulses drive this tube to cut off and the voltage across the terminating resistor drops to zero (*ground level*). The video signal averages around the bias set by the black level control, the setting of which produces the *dc* component. For a 75% modulated television carrier the composite video signal would be as illustrated (*one unit of sync and two units of picture*).

### Composite Video Signal Distribution

Figure 4 illustrates the method used to distribute the composite video signal. Six amplifiers, each having a gain of two, and a frequency response flat to 7 mc are used. Each amplifier uses two 6AC7s and a 6V6 cathode follower output stage. The amplifiers operate at 360 volts *dc* and draw 60 ma each. By means of the switching arrangement shown, different video signals may be applied to the various distribution lines. Another switch is provided to monitor any of the outgo-

(Continued on page 42)

Figure 3  
Line mixing amplifier: output circuit.

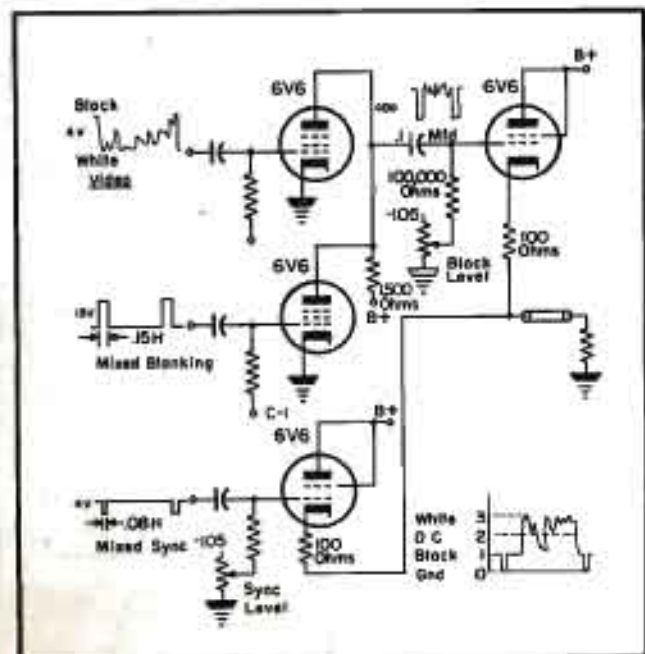
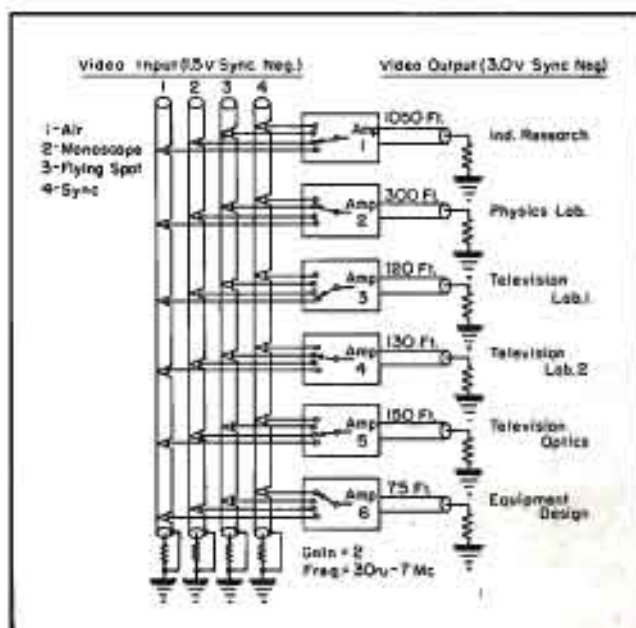

Figure 4  
Block diagram of distribution lines.









# Monitor Receiver

the first tube to provide discrimination against possible interfering signals of such strength that cross-modulation would result in spite of the attenuator.

In the input circuit, the resistive termination and variable attenuation are provided by a carbon potentiometer,  $R_1$ . The tuned circuit consists of  $L_1$  resonating with tube and stray capacitances. It is coupled to the arm of the potentiometer by a capacitor,  $C_1$ . This capacitor must be very small so that, on the one hand, there is negligible shunting effect on the potentiometer at any frequency within the pass band, and on the other hand, the tuned circuit is not so heavily loaded by the potentiometer and the line as to be ineffective. Only a small portion of the voltage on the line appears at the grid of the *rf* stage, with the result that this circuit is one in which gain is sacrificed to obtain other features.

The converter, like the *rf* stage, uses a 6AK5. The tuned circuit in its grid, together with the tuned circuit of the input, form a staggered pair. To facilitate flattening the response of this pair, the  $Q$  of the input circuit is made adjustable by shunting it with a potentiometer,  $R_2$ . This potentiometer as well as one other used in the receiver is a hearing-aid type. The use of such miniature type components allows considerably more compact construction and shorter *rf* paths than is possible with larger types.

The design of the *if* amplifier differed from standard receiver *if* design in that only a relatively low gain was required, although the usual bandpass characteristics and sound traps were needed. The gain requirement allowed the use of only two amplifier stages, but immediately presented the problem of obtaining the necessary transmission characteristic with only three interstage networks. The manner in which this problem was solved is shown in Figure 3. The first two coupling circuits utilized a principle of combining a single humped curve with a lightly damped double humped curve to obtain an essentially flat triple humped curve.<sup>2</sup> The first coupling network is a single humped one, consisting of a single coil,  $L_1$ , resonating with the circuit and tube capacity. Since the  $Q$  of this circuit must bear a fixed relation to the effective  $Q$  of the second coupled circuit to produce a flat overall response, a potentiometer  $R_3$  was included in the grid of the sound *if* amplifier to provide adjustment.

---

**Receiver Which Can Be Located in High-Signal Transmitter Area, Features Protection Against Overloading by Strong Signals, Intensity to RF Fields in Which It May Be Placed, and High Input Level With Receiver Input Termination a Resistor to Eliminate Transmission-Line Reflections. Cross Modulation and Overloading Avoided by Use of Variable Attenuator Ahead of First Tube Which Controls the Visual Output Level.**

---

by F. CECIL GRACE

Engineer, Special Projects Group,  
Transmitting Equipment Division  
Allen B. Du Mont Laboratories

The first picture *if* amplifier, a 6BA6, was provided with a sound trap in its cathode. This is one of three traps which attenuate the sound *if* so that the output will not contain a 4.5-mc beat. This trap consists of  $L_2$  resonating with a series capacitor combination of  $C_2$  and  $C_3$ .

The second coupling network consists of a primary coil  $L_3$ , a secondary  $L_4$  and a coupling coil  $L_5$ . The loading is all on the secondary side, consisting of  $R_4$ . This loading is light, resulting in a deep valley between the humps. As previously explained, this valley is filled in by the single hump from the first coupling network. The fact that the loading is all on one side means that a small change in the resonant frequency of either primary or

secondary will produce a tilt in the response curve. This is an advantage since any tilt due to the sound traps can be compensated simply by changing the resonant frequency of the primary slightly in one direction and that of the secondary in the other. In standard television receivers, this effect is not desired because changes in tube capacitances will cause a tilt. In this receiver, this danger has been circumvented (at a sacrifice in gain) by shunting the tube capacitances with a pair of 15-mmfd capacitors,  $C_4$  and  $C_5$ . This coupling circuit also contains a sound trap, consisting of  $L_6$ ,  $C_6$  and  $C_7$ . This trap has both series and parallel resonance to prevent reduction of gain at frequencies near the end of the pass band. The difference

Figure 4  
The *if* amplifier response curve.

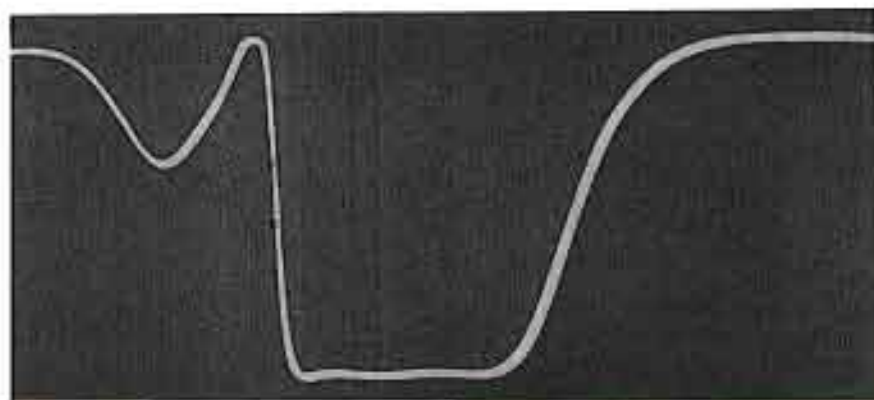



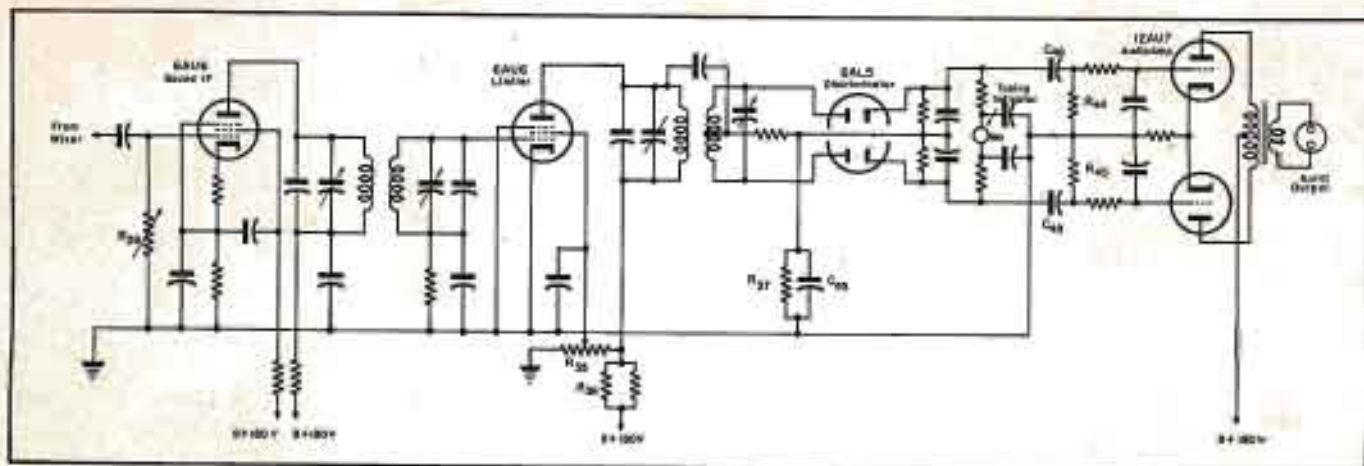

Figure 5  
Circuit of the sound *if* and audio amplifier.

in frequency between the series and parallel resonant points depends on the value of  $C_{11}$ . This capacitor has been made variable to provide adjustment of the frequency difference.

The third coupling network is similar to the second, except that it is more heavily loaded and so produces a more nearly flat response. The slight valley remaining may be compensated by reducing the loading on the first (single humped) coupling network. The secondary loading is the detector itself, and there is also primary loading ( $R_{26}$ ) so that the shunt capacitors are not necessary. Since the 6AK6 plate is shunt fed through an *rf* choke,  $L_{21}$ , grounding of the coupling coil  $L_{22}$  is permitted so that the coupling network presents a low video impedance to the detector. The sound trap in this circuit is identical to that previously described. The overall *if* response is shown in Figure 4.

A 6AK6 power tube, used as the second picture *if* amplifier, insures sufficient power to drive the detector without compressing sync. Cathode degeneration is used to improve linearity.

The picture detector uses a 6AL5 with both sections in parallel. It feeds directly into a 2C51 cathode follower also with both sections in parallel. An

exhaustive test of currently available miniatures as cathode followers showed the 2C51 to be the only one capable of delivering 1 volt peak to peak into a 75-ohm load resistance with good linearity and without requiring such a low value of grid resistor that an excessively large coupling capacitor would be required. Furthermore, it was found that by reducing the plate voltage to 140 (by means of dropping resistor  $R_{28}$ ), the tube would operate within ratings when the 75-ohm load was the cathode bias resistor, thus considerably simplifying the circuit.

#### Sound Channel Circuit

The sound channel, Fig. 5, can be best described by working backwards from the output transformer. To avoid unbalanced *dc* in the windings, a push-pull output stage with a 12AU7 was used. The balanced audio voltage for the 12AU7 grids was obtained by taking a balanced output directly from the detector.

A Foster-Seely discriminator circuit was included with neither output terminal grounded. The circuit is, in

fact, completely isolated from ground except for the coupling capacitor in the discriminator transformer and a 27-mmf, capacitor  $C_{26}$ , both of which are so small that they are effective only to *if* and a 10-megohm resistor,  $R_{26}$ , which is so large that it has negligible effect. Therefore, the output of the detector appears without reference to ground between the cathodes of the 6AL5. These cathodes, however, are connected through coupling capacitors,  $C_{24}$  and  $C_{25}$  to resistors  $R_{24}$  and  $R_{25}$ . Since these resistors are equal and the junction is grounded, the detector output voltage will divide equally producing two voltages of opposite phase for application to the 12AU7 grids. A 75-microsecond deemphasis network is duplicated on both sides of the circuit.

In this receiver, the setting of the aural output level is accomplished by adjusting the level of limiting. Although this function could have been accomplished by the use of a dual potentiometer in the 12AU7 grids, past experience indicated that such units rarely track very well, thus introducing unbalance. An aural level control,  $R_{28}$ , changes the limiting level by varying the screen voltage on the 6AU6 limiter stage. The function of the limiter in this receiver is not to suppress noise, since close proximity

Figures 6 (left) and 7 (right)  
Front and top views of the TV monitor receiver.

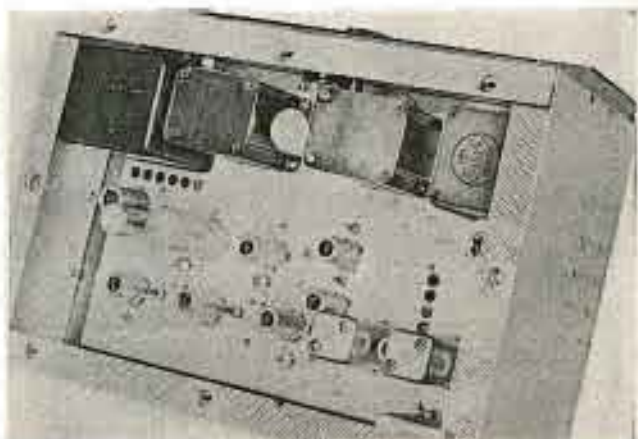



to the transmitter guarantees noise-free reception without limiting. Instead, it serves to flatten the sound *rf* response curve thus eliminating a possible cause of distortion.

In a receiver of this type, circuit details alone are not the only items of importance. Careful attention must be given to the details of bonding and shielding so that the receiver will not respond to stray *rf* fields. To achieve this objective, double shielding was used throughout the instrument; Figures 7 and 8. An inner shield consists of the chassis with its bottom plate (the latter is removed in Figure 8). All objects mounted above the chassis such as the transformers, capacitors, etc., have grounded metal cases, and the tubes all have metal shields, so that the inner shield is not broken. The outer shield consists of the panel and the case with its top and bottom covers.

Double shielding is ineffective unless the two shields are connected together in only one region. If this precaution is not observed, there will be circulating currents through the connections and shields, and these will induce small fields inside the inner shield. The chassis is, therefore, secured to the case by two insulating blocks at the ends. One of these may be seen in Figure 7. The aural and visual output connections and the antenna connection are made to coaxial and twinaxial feed-through connectors which go through both the chassis and the case. These three connectors are located close together and their outer

threaded tubes make the only connection between inner and outer shield.

*Rf* which may be on the power line is kept out by capacitors of the feed-through type used wherever such lines must pass through shielding. One pair of such capacitors is mounted on a shield box which covers the line-cord connector. From here the power travels along wires fastened to the outer shield through the fuse and power switch, and to the tuning meter light. To get into the chassis, it goes through *rf* chokes to a second pair of feed-through capacitors, which go through the chassis. A third pair which also go through the chassis, permit connection to the tuning meter mounted on the panel. As a further precaution, both the power transformer and the aural output transformer have electrostatic shields. The power supply uses selenium rectifiers, and the low heat dissipation of these units makes it possible to mount them within the chassis, a few small holes being punched for ventilation. Thus, there is no break in the shield as there would be if a glass rectifier tube were used.

It is of interest to note that in certain operating applications less shielding appears to be required than that actually incorporated. For example, this receiver has operated satisfactorily both at television stations WABD in New York and WTTG in Washington with the shield covers removed. Inasmuch as the receiver was designed as a general purpose instrument, however, it is believed that the additional shielding is desirable until such time

as more definite information exists concerning the magnitude of fields surrounding commercial transmitters.

The question might well be raised as to why a simple diode detector, which is used to monitor most amplitude modulated transmitters, could not be used for the visual portion of television. Such diodes are useful for certain measurements, but when used for monitoring in a vestigial sideband system a degraded picture results. The reason may be noted from a study of Figure 9. In *A* is shown the ideal frequency response curve of the amplifiers, filters or other networks that the modulated *rf* signal passes through before reaching the radiating antenna. The effect is that the upper sideband corresponding to all video frequencies up to 4 mc is transmitted without attenuation, while only that portion of the lower sideband corresponding to video frequencies up to .75 mc is similarly unattenuated. Beyond this .75-mc point, the ideal curve allows 5 mc for the transition from zero to infinite attenuation, so that video frequencies below 1.25 mc produce no lower sideband and the portion of the spectrum thus saved may be assigned to another station.

When this ideal vestigial sideband signal is rectified by a diode which is equally responsive to all frequencies, the amplitude-frequency response of the resulting video will be as shown in *B*. Frequencies below .75 mc will have twice the amplitude of frequencies above 1.25 mc, because the former are

(Continued on page 33)

Figure 9

Ideal frequency-response curves. At *A* appears the transmitter *rf* response; *B*, diode output; *C*, receiver *rf* response; and *D*, receiver output. Frequencies are in mc and  $f_c$  is the carrier frequency.

Figure 8

Bottom view of the receiver. Note the double shielding.

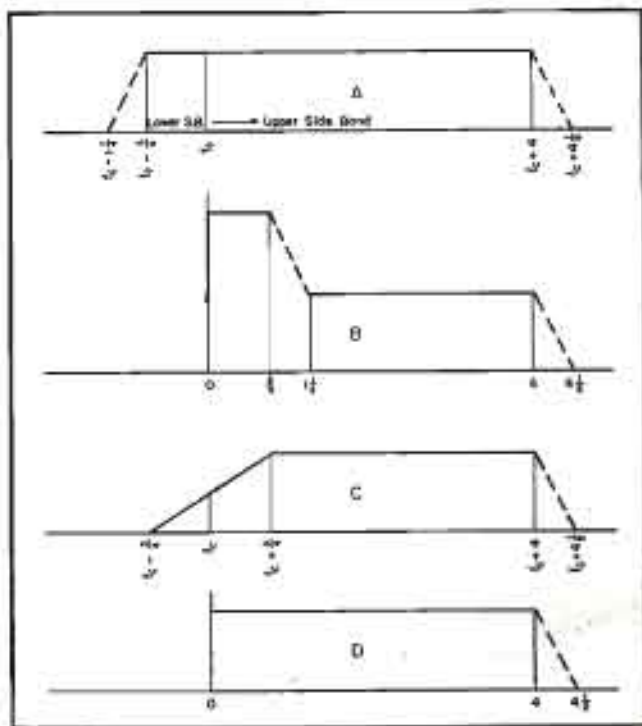
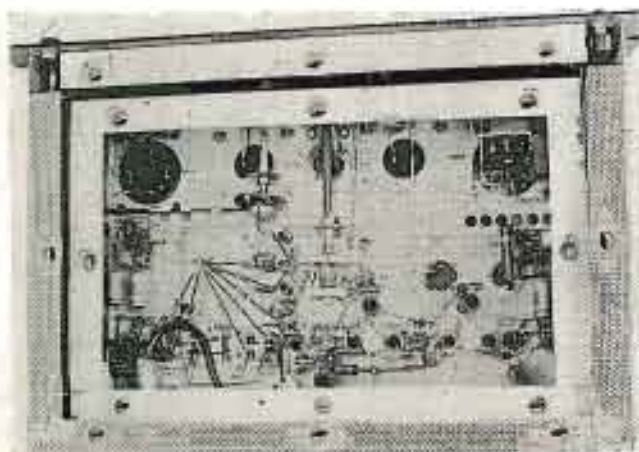



# Automatic Teletype

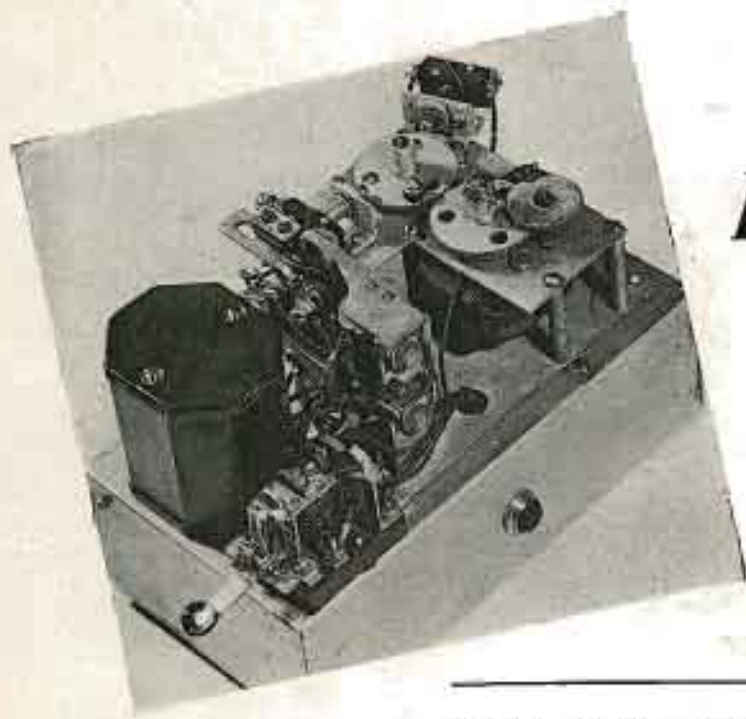

## BULLETIN

## ALARM

---

Device Automatically Signals Arrival of Bulletin Via a Visual Signal in Control Room Obviating Need for Watch in Teletype Room.

---

TODAY, THE TELETYPE PRINTER has become a necessary adjunct to the modern broadcasting station. Large stations have several machines and an elaborate newsroom with a staff of newsmen. Most small stations have only one machine, and usually no one to watch it most of the time. At the smaller stations the news is gathered from the machine just before a regular newscast and someone is delegated to glance at the machine at other intervals to see if a *bulletin* has come in.

The big stories, however, have a habit of breaking when no one is watching the machine. Inasmuch as teletypes are rather noisy machines and are usually located some distance from the studios and control room and usually are unattended, it occurred to our news editor that a device that would automatically signal the arrival of a bulletin by means of a red light in the control room would be an ideal solution. We therefore decided to probe the problem and came up with an alarm system (Figure 1) which has worked out very well.

### Bulletin and Flash Signals

As is well known, the teletype provides an audible alarm when news of

importance are about to come through; five bells for a *bulletin* and ten bells for a *flash*. The flash is reserved for news of the utmost importance only. Our device was not designed to signal a flash because of the rare occurrence. Furthermore, a bulletin always follows a flash in a matter of seconds. However, if desired, the device can be modified to signal the arrival of a flash.

### Bulletin Alarm Components

The main parts required for alarm are an ordinary telephone-type stepping switch, small motor driven timer and a latching relay with mechanical

reset. The original alarm was built from war surplus parts at a total cost of \$15. However, even if new parts are used, our experience has shown that the expense is well worthwhile.

The power source for the unit is 115 volts ac. Because the stepping switch was designed for 24-volt dc operation, a selenium rectifier with an rc type filter was used to excite the stepping and reset coils. Everything else was designed to operate from the 115-volt ac source.

### Operation of System

In operation, a micro-switch is attached to the teletype machine in such a manner that the lever which operates the bell clapper also operates the switch. The micro-switch is in series with the 24-volt supply and the stepping coil. The instant the teletype bell

by **GEORGE ING**

Chief Engineer  
KONO and KONO-FM  
San Antonio, Texas

---

### Above

View of the first model teletype bulletin alarm. In a later model, the switches were slightly repositioned to facilitate operation.





*Save Time and Money...  
Increase Operating Efficiency*

*with* **PHILCO**

**2-WAY F-M MOBILE RADIOPHONE  
COMMUNICATIONS SYSTEMS**

30 to 44 Mc. and 152 to 162 Mc. Sensational new developments . . . advanced engineering . . . proven reliability . . . new operating efficiency and economy for F-M Radiophone Communications Systems, permitting clear, crisp, two-way voice communications under all conditions.



**POLICE**



**TAXICABS**



**FIRE**



**UTILITIES**



**BUSES**



**TRUCKING**

**PHILCO**

**INDUSTRIAL DIVISION  
PHILADELPHIA 34 • PENNSYLVANIA**

Philco Industrial Division Dep't JN9  
Tioga and C Sts., Philadelphia 34, Pa.

Gentlemen:

Please send me information about the  
new PHILCO F-M Radiophone Com-  
munications Systems

NAME .....

ADDRESS .....

CITY .....



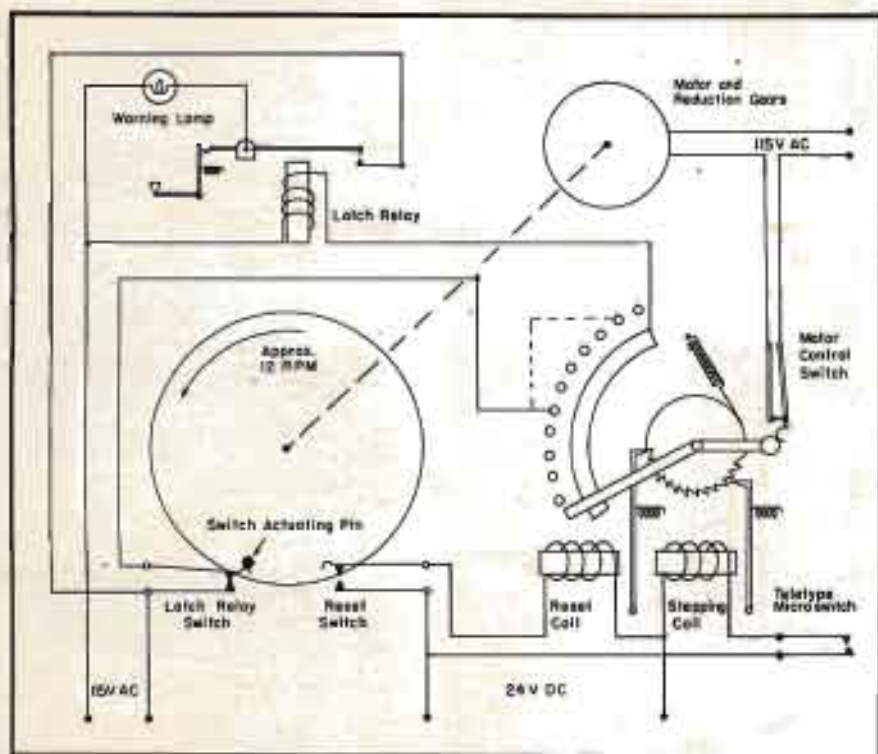

Figure 1

Circuit of the teletype bulletin-alarm system. If it is desired that the alarm work on both *bulletins* and *flashes*, the stepping switch must have more than ten contacts. Consequently contacts 3 and 10 must be connected together as shown by the dotted line.

is struck, the micro-switch closes the circuit to the stepping coil and the switch arm moves off the *home* position to the first contact. This initial motion of the switch arm starts the timer motor by allowing the motor control switch contacts to close. If a bulletin is about to arrive, the bell is struck five times in quick succession and the stepping action will advance the switch to contact number five.

#### Timing Disc Action

When the timing disc on the shaft of the reduction gear has made almost a full revolution (approximately five seconds), the switch actuating pin on the disc will close the latch relay switch, which is wired in series with the latching relay coil, contact number five on the stepping switch and the 115-volt supply. The latching relay contacts then close, lighting the warning lamp.

#### Motor Control

A moment after the switch actuating pin has passed the latch relay switch, it closes the reset switch which in turn energizes the reset coil on the stepping switch. The resetting action returns the switch arm to the home position

and automatically opens the contacts of the motor control switch, stopping the motor.

#### Alarm Positions

The warning light will stay on until the latching relay has been reset manually by means of a pushbutton. In our particular installation the teletype alarm unit is placed in the teletype room and the warning light in the control room. When the warning lamp lights the control operator must visit the teletype room to reset the device.

#### False Alarms

For various reasons the teletype bell will ring many times during the day, but, normally, the unit will respond only to five bells in quick succession. When the teletype circuit opens due to trouble in the telephone lines, the teletype bell will ring continuously until the break is corrected. Occasionally, if this happens, a group of five bells will ring within the operating period of the timer and a false alarm will be registered. This was not considered a serious defect because management believed that the more trips to the newsroom the better. The announcers and control room men were instructed

to inspect the machines at intervals even with an automatic alarm in operation.

The stepping switch which was used had only ten contacts. This is one reason no provision was made for flashes. If it is desired to use the alarm for flashes (ten bells) the stepping switch must have at least eleven contacts. If such a switch is used, then contacts five and ten can be wired together and the alarm will work for both bulletins and flashes.

#### Two Teletypes Used

Since KONO subscribes to two different wire services, there are two teletypes in operation. It seems that the policy of one service is to send bulletins only when the news is of great importance. The other service sends bulletins much more often. This is mentioned because when more than one machine is in operation there is a question as to which machine to attach the alarm. In our case it was decided to attach the alarm system to the teletype of the wire service which sent bulletins only on events of more than usual importance.

#### Wire and Mike Applications

Although no trouble with the wire service company was experienced at this station, there may be cases where the radio station will not be permitted to attach any device directly to the teletype. If this should be the case, an inexpensive microphone may be placed near the teletype to pick up the sound of the bell. The microphone signal may then be amplified through an amplifier, which through filter action, eliminates all frequencies except the fundamental bell tone. This amplified signal is rectified and applied to a relay whose contacts then can take the place of the micro-switch which was attached to the teletype machine.

#### Old and New Models

The illustration shows the first model of the teletype alarm. In a later model the latch relay switch and the reset switch were moved closer together as shown in the diagram and other minor changes were made to improve the operation.

This unit has been in operation for almost a year and has proved to be of great value to our news service.



a NEW and SENSATIONAL *Motorola* "FIRST" that makes  
2-WAY RADIO more valuable than ever before!

**NOW**...Your cars  
hear only your  
calls!



**Motorola**  
**"QUIK-CALL"**  
SELECTIVE  
SIGNALING  
EQUIPMENT

**Just press a button to call your  
cars—individually, or by groups**

Now you can control and direct calls to your fleet, or to any one car in your fleet with the new Motorola "QUIK-CALL" selective signaling equipment! Your cars can be called only by your base station. Another "FIRST"—Motorola "Quik-Call" prevents your cars from receiving calls sent by other transmitters on the same or adjacent channels...they need not hear any calls except those coded from your station alone. Interference from diathermy is completely locked out during standby and, most important, skip interference false calling and squelch opening is eliminated.

Motorola "QUIK-CALL" prevents nuisance interference from stations in nearby communities, reducing driver fatigue and increasing the utility of any radio system.

Developed after two and one half years of exacting research, Motorola "QUIK-CALL" is based upon the use of a pure tone generator of instrument precision, called the Vibrasender, and a responding resonant responder—called the Vibrasponder. These "electro-mechanisms" in various combinations, are capable of calling your fleet (with the single-key system) or of selectivity calling up to 1,350 individual units (with the 24-key system) with the precision and speed of adding machine operation.

**A product of Motorola Research Laboratories**

**Motorola "QUIK-CALL" can be added  
to your present Motorola equipment**

It doesn't matter whether you're installing a whole new communications system, or if you already have 2-way radio...the Motorola "QUIK-CALL" can be adapted to your system in bringing it up to date. Enjoy the advantages of this new kind of 2-way radio.

**FREE!**

**GET THE COMPLETE DETAILS  
DESCRIPTIVE BOOKLET  
MAIL THIS COUPON TODAY**



COMMUNICATIONS DIVISION  
4545 West Augusta Boulevard  
Chicago 51, Illinois Dept. C.

Please mail me a FREE copy of the descriptive booklet on  
Motorola "QUIK-CALL" selective signaling equipment.

Name ..... Position.....

Address.....

City..... Zone..... State.....



# Super-Power FM (546 Kw ERP) At WBRC-FM

THE DEVELOPMENT of high-gain antennas has afforded unusually high *erp's*. An interesting example of the extremely high powers which can be obtained was indicated recently when WBRC-FM, in Birmingham, Alabama, went on the air with its 50-kw job on 102.5 mc. Feeding into an eight-bay pylon<sup>2</sup> with a power gain of 12, an *erp* of 546 kw was secured.

The antenna was mounted atop Red Mountain, over a thousand feet above the metropolitan area of Birmingham.

The 50-kw transmitter<sup>3</sup> at WBRC-FM features a concentric-line tank assembly which provides shielding of the driver and power amplifier grounded-grid circuits. The driver amplifier feeds two parallel-connected final sections. Electrically and mechanically, each one of these concentric-line tanks forms an integral part of the grounded-grid circuit. Thus, one unit that eliminates neutralization, radiation, and *rf* pickup in adjacent *rf* circuits is provided. Each section is similar in design and uses a 5592 forced-air-cooled triode in a grounded-grid circuit. The base of the concentric-line units form a plenum chamber for cooling air and contains the control wiring and high voltage bus. Front-panel tuning of the plate line is provided by shorting bars (with contact fingers) which move vertically along the center conductor by means of motor-driven lead screws. Input tuning is accomplished by two flat plate air-capacitors, one motor driven and the other manually operated.

Output coupling is accomplished by motor-driven rotatable loops which are reactance tuned by series capacitors.

The supervisory console supplied with the transmitter has many interesting features. Essential operational controls and indicator lamps are duplicated on an *rf* turret. The audio turret has all the controls needed for program handling. Complete switching, mixing and control-circuit metering facilities are provided. Im-

(Continued on page 41)

<sup>1</sup> RCA. <sup>2</sup> RCA BTP-50A.



The 50-kw FM transmitter at WBRC-FM.



(D)

(B) Closeup view of pylon showing trombone impedance arrangement and two-stub matches.



(B, left; C, above)

(B)

(C)

Rear view of the direct FM exciter cabinet. Vertical construction is used to provide accessibility to wiring and components.

(D)

Rear view of low power grounded-grid *rf* amplifiers showing concentric-line construction employed. All four units use 7C24s. Left to right: 1 kw, 5 kw and 10 kw amplifiers.

(E)

Open door view of, left to right: 10 kw *rf* amplifier with parallel 7C24 concentric-line tanks visible, 250 w *rf* amplifier (with 1 and 5-kw amplifier as rear, not visible), and direct FM exciter, at far right.

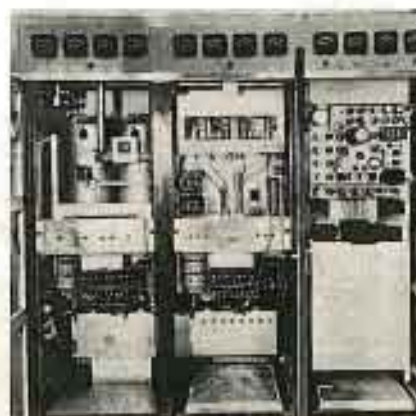
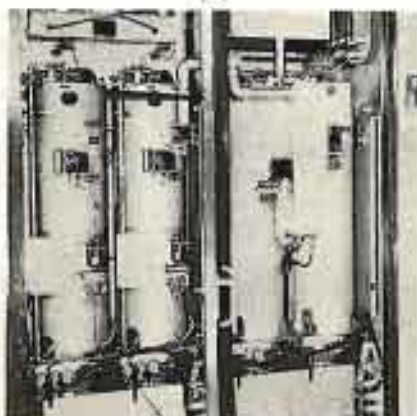



# IMPROVED



CONTINUOUS  
TUNING FROM  
FRONT PANEL

20 KW  
TRANSMITTER  
C. W., F. S., PHONE

## Improved Continuous Tuning

Continuously tunable from the front panel over a frequency range of 10 to 1. Tuning circuits simple to operate.

## Maximum Operating Continuity

Recycling overload relays insure against loss of operating time due to temporary overloads. Control circuits fulfill rigid broadcast requirements.

## Cool Operation

Electrical short circuiting of sources of resistance assures unusually cool and efficient operation.

## Safe Operation

Automatic-safety grounding switches used on all cabinet doors and housing openings. All operating controls are grounded. Interlocked control circuits.

## Easy to Maintain and Service

Components are readily accessible and individually removable for replacement and repair.

## Continuous Tuning Plate Circuit

- Frequency changes can be made in a few seconds.
- Alternate paths for current around moving parts of circuit provide high efficiency and cool operation.
- Glass-bonded mica assembly supports inductances by holding coils rigid — permits precision adjustment of coil relationship.
- All parts removable and easily accessible to operating personnel.



**J. H. BUNNELL & Co.**

215 FULTON STREET • NEW YORK 8, N. Y.

**BUNNELL—A KEY WORD IN  
COMMUNICATIONS EQUIPMENT**

Research, Engineering, Production, and Testing facilities for equipment for: Wire lines • Submarine Cables • Railroad Communication • Radio Airway Systems • Municipal Signaling • Army and Navy Signaling • Carrier Current • Automatic Telegraph • Facsimile



# NOW ON THE PRESS

THE FIRST PRACTICAL BOOK

ON THE INSTALLING OF TV and FM RECEIVER ANTENNAS

## TV...FM ANTENNA INSTALLATION



OVER 100 PAGES OF PROFUSELY  
DIAGRAMMED, PRACTICAL,  
UP-TO-THE-MINUTE  
INFORMATION COVERING—

by IRA KAMEN  
and LEWIS WINNER

### Antenna Tools

(Basic Tools Required . . . Application of the Correct Tools for Specific Types of Installations, Involving Flat-top Roofs, Slate Roofs, Tile Roofs, Chimneys, Etc.)

### The TV Antenna Installation Problem

(Fundamentals of All TV Installations . . . Judging Specific Application Features of the Various Types of Antennas Which Can Be Used for TV Work . . . Solving Reflection Problems . . . Improving Signal-to-Noise Ratio.)

### Solving the Problems of 12-Channel Reception

(Factors With Which Service Men Must Be Familiar to Accurately Install Antennas For Full-Band Coverage . . . Typical Problems Analyzed.)

### High Frequency TV Antenna Installations

(Antennas and Installation Procedures Which Afford Best Results. Solving Major Installation Problems Involving Tuned Indoor and Outdoor Antennas. Application of Stub Filters.)

### TV Interference

(Analysis of Nine Sources of Interference and Solutions Which Have Proved Effective.)

### Fringe Reception

(Selecting and Installing Antennas for Maximum Reception in Areas Over 45 Miles From Stations . . . Tower Installations . . . Estimating Tower Costs.)

### TV Master Antenna Systems

(Typical Multiple Dwelling Antenna Systems for Simultaneous Operation of Many Receivers From a Single Antenna Array and Amplifier Setup.)

### FM Antennas

(Analysis of Practical FM Antennas . . . Selecting Proper Antenna for Rural and Urban Jobs.)

### The Business of TV Antenna Installations

(How to Conduct Successfully TV Installation and Service Work Today . . . Proper Use of Correct Types of Installation and Servicing Agreements and Warranties.)

### TV Antenna Tricks of the Trade

(Antenna Installation Devices Which Will Improve Picture Fidelity.)

(Indexed for Quick Reference)

BRYAN DAVIS PUBLISHING CO., INC., Book Dept.  
52 Vanderbilt Avenue, New York 17, N. Y.

Send me a copy of TV . . . FM Antenna Installation, post-paid, for which I am enclosing \$2.00.

NAME .....

ADDRESS .....

CITY AND STATE .....

● The first edition, now on the press, is limited in quantity. Order Your Copy NOW!

**Price \$2 Post Paid**





View of the main operating console, auxiliary turntable and other equipment at WSJS-FM. The bottom of the antenna may be seen through the window.



Modern building which houses the transmitter of WSJS-FM.

# The Installation of WSJS-FM

WHEN THE PIEDMONT Publishing Company decided to make its venture into FM broadcasting, it was faced with that all-important problem of selecting the best place for its transmitter for maximum coverage.

The company, publisher of the *Winston-Salem Journal*, morning daily newspaper, and the *Twin City Sentinel*, an afternoon daily newspaper, first had entered broadcasting in 1930 when it established WSJS. And Piedmont Publishing Company president Gordon Gray had quite a bit of personal FM experience, with his famous experimental FM transmitter WMIT atop Mount Mitchell in western North Carolina.

In considering the commercial FM project, it was found that it would be

10-Kw FM Transmitter, With a 6-Bay Circular Antenna, Ideally Located in Hills of North Carolina, Providing Coverage of Approximately 65 Miles in 50-Microvolt Contour.

by WILLIAM E. EAST

The Twin-City Sentinel  
Winston-Salem, N. C.

best to locate on a site which would serve the tri-cities of Greensboro, High Point and Winston-Salem, which form a triangle in the northern part

of Piedmont, North Carolina. In addition, it was also felt that the site should be favorable for TV, which it

(Continued on page 34)

Test equipment and the tool room.

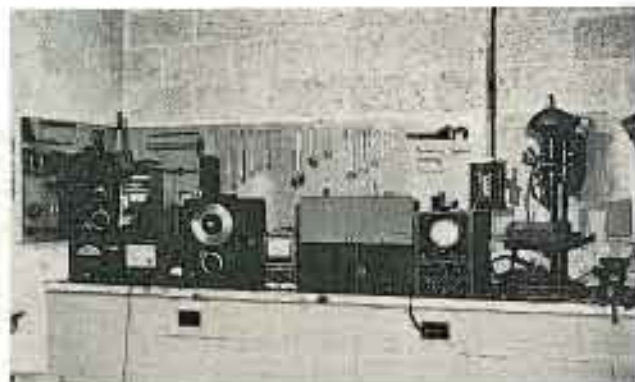

Station wagon which houses a portion of WSJS-FM equipment in its rear.





# World's first super-power

*all three...* use **RCA 50-kw's**



**SUPER-POWER FM STATION WTMJ-FM, MILWAUKEE.**  
Operates an RCA BTF-50A FM transmitter in conjunction with a high-gain antenna. Total effective radiated power, 349 kw—on 93.3 Mc!



**SUPER-POWER FM STATION WBRC-FM, BIRMINGHAM.**  
Operates a type BTF-50A FM transmitter in conjunction with an RCA 8-section Pylon—880 feet above average terrain. Total effective radiated power, 546 kw—on 102.5 Mc!



**SUPER-POWER FM STATION WMCF, MEMPHIS.**  
Operates an RCA BTF-50A FM transmitter in conjunction with an RCA 4-section Pylon antenna mounted on a 750 foot tower. Total effective radiated power, 260 kw—on 99.7 Mc!

**T**HESE PIONEER STATIONS are making FM service over wide areas a **PRACTICAL REALITY**—with the world's first commercial 50-kw FM transmitter, the RCA BTF-50A!

This is the transmitter that makes it possible to link 50 kilowatts of FM power to a high-gain Pylon antenna and deliver up to 600 kilowatts of effective radiated power—enough radiated power to serve primary areas out to 200 miles radius from mountain elevations.

Here are some of the transmitter features:

50,000 watts output on any specified frequency in the 88-108 Mc band. Grounded-Grid amplifiers and simplified single-end r-f circuits (all class C) for extreme stability and easy tuning. Direct FM

to give high-fidelity FM simply and directly (less than 1% output distortion over the range of 30-15,000 c.p.s.). Only 43 tubes in the entire transmitter—and emergency operation may be maintained with only 24 tubes. Only 16 different tube types all told. One high-voltage supply for all high-power needs. Hi-lo power switching for emergency 8-kw operation. Complete air-cooling ... using two independently-operated blowers.

• • •

Type BTF-50A ... immediately available from stock ... can be used with an RCA FM Pylon to improve your station coverage materially. For the facts, see your RCA Broadcast Sales Engineer. Or write Dept. 23B, RCA Engineering Products, Camden, N. J.



# FM's . . .



*Ready to ship*

RCA 50-KW FM Transmitter, Type BTF-50A. Easiest-handling high-power transmitter ever built—with handsome unified front-panel design that

fits any station layout. BTF-50A transmitters are delivered with pre-emphasis network, harmonic attenuator, transmission line monitor, power cut-back and supervisory console

Transmitter photo by courtesy  
WBRC-FM, Birmingham, Alabama.



**BROADCAST EQUIPMENT**  
**RADIO CORPORATION OF AMERICA**  
**ENGINEERING PRODUCTS DEPARTMENT, CAMDEN, N.J.**

In Canada: RCA VICTOR Company Limited, Montreal



**Personals**

THREE NEW MEMBERS, all *old timers*, were recently approved for VWOA membership: Fred D. Boyd, Sam Cisenfeld and W. Milton King. . . . Boyd began his brass-pounding career by working for Marconi of London in 1920. He joined Tropical Radio in 1921 where he served on United Fruit ships for fourteen years. In '35 he became chief operator at HJW, Santa Marta, Col. For six years, 1935 to 1941, he operated his own radio sales and service business, Ridge Radio Research and Repair Lab., at Wilmette, Ill. In '42 he was commissioned a Major in the USAF serving at Churchill, Manitoba, Alaska, and the Aleutian Islands. He commanded the 119th Army Airways Communication Squadron from '43 to '45. In '47 he joined Lear as a radio engineer and in '48 he became affiliated with the CAA and is now assigned to duty in San Juan, P. R. . . . Sam Cisenfeld took to the keys back, back in 1910 (we probably should call him an *old old timer*), with United Wireless, sailing on the Chesapeake Line vessels between Baltimore and New York and without a license, too, his application stating that he received his *Certificate of Skill* in 1911 in Baltimore. Government inspectors were not so active in those days. He then moved over to the Merchants and Miners Line and extended his voyages to Jacksonville and Boston. In 1912 he started working at the Baltimore Coast station until 1915, when he was assigned to the Northern Pacific, which was the first passenger ship to pass through the Panama Canal. Arriving at San Francisco during the World's Fair he operated between that port and Flavel, Oregon, seaport for Portland in those days. He traveled east on a tanker which was routed via the Magellan Straits due to a landslide in Culebra. In 1916 he was assigned to a tug bound for Cardiff. During this voyage fire broke out, leaks developed and to cap the troubles mutiny followed, forcing the tug to dock at Fayal Horta, Azores. A little later SC joined the Naval Reserves and was assigned to Tuckerton. After World War I he followed the sea for a few more years and in '34 retired from wireless operations. He is presently



L. H. Marshall, who recently received the Mariner's medal from the Maritime Commission and a gold medal from the state of South Carolina for his heroism in saving the crew of the S.S. Atlas, which was torpedoed in 1942.

located in Washington. . . . King also began his wireless days by working for Marconi from 1925 to 1929. In '29 he joined Tropical Radio, sailing on United Fruit ships until 1932. He then went with WBIX, Utica, and remained there for a year. He then joined the IRE. From '35 to '37 he worked at broadcast stations WCHB and WNEL. In '37 he returned to the United Fruit line and in '38 started with the American Airlines where he is now working as assistant chief operator at Boston. During World War II he was navigator and Flight Radio Officer with the U. S. Air Transport Command. . . . Shocked to hear of the death of old time member E. W. Kreis, who resided at Milwaukee, Wis. . . . Congratulations to Rod Chipp upon his promotion from assistant chief engineer to director of engineering for the DuMont Television network. Rod was formerly with NCB. . . . Tom Brown writes to say that he is now representing Motorola in Bloomfield, Ill. . . . Wylie Paul reports that he was in Tangier, Morocco, but expects to be on hand for the annual dinner cruise. . . . Just received the good news that Henry Hayden and Fred Muller received leaves of absence from the hospital to enjoy the holidays at home. Both are doing nicely, but expect to spend a few more days in the sickbay for further treat-

ment. Good luck, Fred and Henry. . . . G. V. Willets has dropped us a note saying that he has left the hectic life of San Francisco and has taken up residence at his new country home at Villa Grande, Sonoma County, Calif., where he will continue many of his activities. . . . Congrats to Bob Pheysey whose lovely daughter, Gail, recently won a prize in a beauty contest at Hempstead, L. I. Bob lives in Massapequa, L. I. . . . VWOA members continue to receive rewards for their outstanding radio work. There's R. W. Rentzel, who was appointed by President Truman to head the CAA as chairman; Jack Poppele, reelected president of TBA; and at the recent Radio Club of America thirty-ninth anniversary dinner, Paul Godley was honored for his work with amateur station IBCG back in 1921. . . . Fred Klingenschmitt, another VWOA old timer, was also at the RC of A affair. Fred is a director of the club and on the banquet committee. . . . L. H. Marshall recently forwarded a few interesting biographical notes. When the Titanic struck the iceberg he received the SOS calls on a home-made receiver. In 1942, while on the S.S. Atlas, he was torpedoed off Cape Lookout and compelled to swim through water covered with burning high octane gas. He was so badly burned that for many months he was unable to use his hands. His wife played a major role in his recovery by forcing him to carry pails of water and sand as an exercise. He was awarded the Mariners' medal from the Maritime Commission, as well as a gold medal from the state of South Carolina for saving the S.S. Atlas crew. We are proud of men like Marshall! . . . G. W. Ahrens of Galveston, Tex., is still with RMCA and hopes to make a *cruise* soon. . . . J. H. Appel, Jr., now with FCC in Washington, misses the ship boys and sends season's greetings. . . . G. B. Angle of TRT's Miami WAX, since 1929, is now at their new location in Fort Lauderdale. He is a member of Naval Reserve V3. . . . Sorry to hear that C. S. Anderson, honorary member of VWOA, is very ill at his home in Brooklyn. CSA retired from RCA two years ago. Hope you recover soon, very soon, old timer.



# NEW 805A SLOTTED LINE!

PRECISION ACCURACY FOR  
STANDING WAVE MEASUREMENTS

**\$475<sup>00</sup>**

F. O. B. PAID ADD.



**RADICAL NEW "PARALLEL-PLANE"  
DESIGN GIVES -hp- SLOTTED LINE  
UTMOST ELECTRICAL STABILITY**

The new -hp- 805A Slotted Line employs two parallel planes and a large, circular central conductor, instead of the conventional coaxial configuration. This new design makes possible an electrically stable precision instrument capable of fast, easy measurements of unvarying accuracy. Parallel planes and central conductor are both mechanically rigid. Penetration depth of the probe is less

critical than in coaxial slotted lines, and leakage is low because the effective slot opening is less than .001 referred to the coaxial system. Residual VSWR is held to less than 1.04. Probe position may be read to 0.1 mm.

This new approach to the Slotted Line problem makes possible the manufacture of an instrument of maximum accuracy at moderate cost.

## SPECIFICATIONS

**Frequency Range:** 500 to 4,000 mc.

**Impedance:** 50 ohms.

**Connections:** Special Type "N" fittings designed for minimum VSWR.

**Residual VSWR:** 1.04 or better.

**Slope:** Negligible.

**Calibration:** Metric, in cm and mm. Vernier reads to 0.1 mm.

**Size:** 27" long, 8" high, 6" wide.

**Carriage:** Probe moved by cable drive. Probe depth adjustable. Probe resonant circuit tunable over freq. range of line. Detector may be standard crystal or employ barretters.

Data subject to change without notice.

WRITE FOR DETAILS

**HEWLETT-PACKARD COMPANY**

1824-E Page Mill Road • Palo Alto, California

 **laboratory instruments**  
FOR SPEED AND ACCURACY



## NEW -hp- 415A Standing Wave Indicator

The new -hp- 415A Standing Wave Indicator is used with the -hp- Slotted Line to determine coaxial flatness or measure impedance. It consists of a high gain amplifier of low noise level, operating at a fixed audio frequency. Amplifier output is measured by a voltmeter with a square-law calibration in db and voltage standing wave ratio. The -hp- 415A is direct reading, compact and easy to use.

### SPECIFICATIONS

**Frequency:** Fixed at 1,000 cps.  $\pm 2\%$ . Other frequencies 300 to 2,000 cps supplied on special order. Amplifier "Q" is  $20 \pm 5$ .

**Sensitivity:** 0.3  $\mu$ v gives full scale deflection. Noise level-to-input equivalent is 0.04  $\mu$ v.

**Calibrations:** For use with square-law detector. 60 db level covered in 6 ranges. Accuracy  $\pm 0.1$  db per 10 db step.

**Gain Control:** Adjust meter to convenient level. Range is 50 db  $\pm 5$  db.

**Detector Input:** Connects to Xial rectifier or bolometer. Bias of  $8 \times 10^{-5}$  v, delivers approx. 3.75 ma. to a 200 ohm barretter.

**Size:** 12" long, 9" wide, 6" high.

Data subject to change without notice.



# Pulse Power Measurement By A Heterodyne Method

IN THE DETERMINATION of pulse powers by a method which reads average power it is necessary to accurately estimate the pulse width. This estimation is difficult if the pulse is not square. In the method to be described it is not necessary to know the pulse width and the repetition rate.

In the square-law detector of a synchroscope receiver, the *rf* pulse frequency is heterodyned with a *cw* frequency. Since grid circuit detection is employed the following formula, derived by Chaffee,<sup>2</sup> will be used as the basis for the argument.

$$\overline{\Delta^2 E_p} = \frac{-U_p \bar{R}_c}{r_0 \bar{R}_c} \cdot \frac{1}{2k_g} \frac{\partial k_g}{\partial \omega_0} (\Delta E_g)^2 \quad (1)$$

In the expression,  $\overline{\Delta^2 E_p}$  is the voltage of detection appearing in the plate circuit of a grid circuit detector. The 2 over the delta does not mean square but rather is Chaffee's notation for the voltage of detection. The bar over  $\Delta^2 E_p$  means that this is the steady *dc* voltage resulting from the detection of an unmodulated carrier voltage.

$$U_p, \bar{R}_c, r_0, \frac{1}{k_g} \frac{\partial k_g}{\partial \omega_0}$$

may be regarded as constants of the tube and circuit, assuming small signal detection. Let us replace all of them by a single overall constant *K*. In this formula  $\Delta E_g$  is the rms amplitude of the *rf* carrier voltage. If we replace this by the peak voltage, the expression becomes

$$\overline{\Delta^2 E_p} = \frac{K}{2} (\Delta E_g)^2 \quad (2)$$

This formula now represents a constant voltage of detection. But in the present case the input signal to the detector is the resultant of an *rf* pulse voltage and a *cw* voltage of nearly the same frequency. This resultant has an instantaneous amplitude given by

$$\Delta e_p = \sqrt{\hat{E}_p^2 + \hat{E}_c^2 + 2\hat{E}_p \hat{E}_c \cos \Delta \omega t} \quad (3)$$

where  $\hat{E}_p$  is the peak of the *rf* pulse voltage,  $\hat{E}_c$  is the peak of the *cw* wave, and  $\Delta \omega$  is the beat angular frequency. If the instantaneous value  $e_p$  replaces  $(\Delta E_g)$  in equation (2), then the expression for the voltage of detection becomes

$$\overline{\Delta^2 E_p} = \frac{K}{4} (\hat{E}_p^2 + \hat{E}_c^2 + 2\hat{E}_p \hat{E}_c \cos \Delta \omega t) \quad (4)$$

$$= \frac{K}{4} (\hat{E}_p^2 + \hat{E}_c^2) + \frac{K}{4} (2\hat{E}_p \hat{E}_c \cos \Delta \omega t)$$

## Peak-Reading Method\*, Facilitating Determination of Pulse Powers, Eliminates Need For Pulse-Width and Repetition-Rate Data.

by LEONARD S. SCHWARTZ

Senior Development Engineer  
Hazeltine Electronics Corp.

and we notice that the averaging bar is no longer over  $\Delta^2 E_p$ . The first term on the right is the *dc* voltage produced by the *cw* plus the envelope of *rf* voltage, and the second, the variable beat frequency term of the voltage of detection. This is the output of the rectifier tube, but the coupling capacitors of the video amplifier will not allow the *dc* part of the first term to pass, so the actual voltage applied to the deflecting plates of the scope is

$$(\Delta E)' = \frac{K'}{4} \hat{E}_c^2 + \frac{K'}{4} (2\hat{E}_p \hat{E}_c \cos \Delta \omega t) / 5$$

(The prime sign over the *K*'s takes account of the amplification of the intermediate stages)

The *cw* voltage is adjusted so that the beat voltage appearing in the pulse extends all the way to the base line, as shown in Figure 1. When this happens, the peak value of the variable component of detection equals the amplitude of the envelope of the *rf* pulse. Therefore,

$$\frac{K'}{4} (2\hat{E}_p \hat{E}_c) = \frac{K'}{4} \hat{E}_p^2 \text{ and } \hat{E}_p = 2\hat{E}_c \quad (6)$$

In terms of power input to the square-law detector it means that for this adjustment the *rf* pulse power is

\*Method originally employed by J. L. Lawson and J. H. Ferry at Radiation Laboratory.

<sup>1</sup>This article was prepared while the author was a member of the Naval Research Laboratory.

<sup>2</sup>E. L. Chaffee, *Theory of Thermionic Vacuum Tubes*, p. 545, McGraw-Hill Book Company, Inc., 1932.

6 db above the *cw* power at the point of entrance into the detector.

### Frequency Adjustment

The difference in frequency is adjusted to one or two megacycles, that is one or two beat voltage cycles, so that operation will be within the flat portion of the gain-versus-frequency characteristic of the video amplifier of the synchroscope.

### Effect of CW Frequency Change

It is interesting to note that if the *cw* frequency is changed from that of the pulse transmitter until the beat voltage level passes from the base line to a point half way down the pulse, as shown in Figure 2, then approximately six cycles of beat voltage appear. This means that there is a frequency difference of 6 mc between the transmitter pulse frequency and the *cw*, and the half-power position of the top of the beat voltage swing must correspond to the half-power position on the gain-versus-frequency curve of the video amplifier of the synchroscope. As a matter of fact a gain-versus-frequency curve obtained on another similar scope in the usual way gave a bandwidth of 6 mc, so it would appear that an incidental application of this method might be to make a quick check on the bandwidth of a video amplifier.

### Experimental Data

Comparison measurements were made under the same conditions for



Figure 2  
Peak cw voltage adjusted to 1/2 peak-pulse voltage.

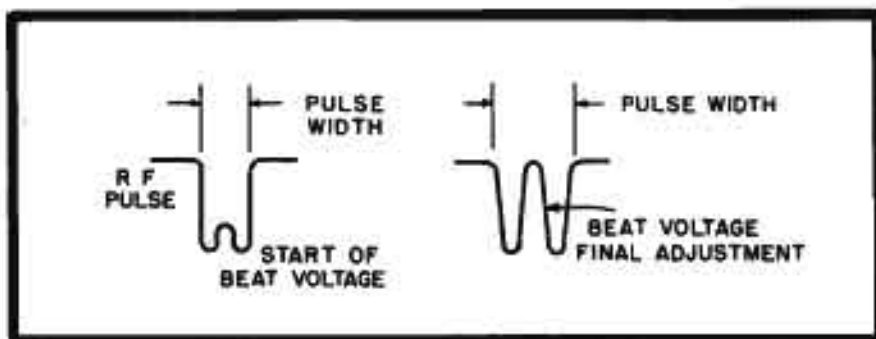
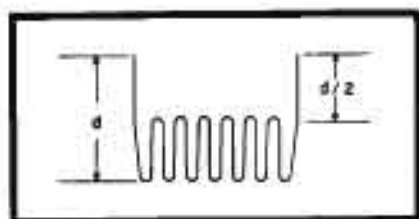

Figure 1  
Cw voltage beating with pulse voltage.

the heterodyne and the usual average-power reading method. The same thermistor bridge served as the wattmeter in each case. A square rf pulse insured fairly reliable power readings for the second method. The results are shown in Table 1.

#### Discussion of Data

The sources of error in the heterodyne method, as used in this experiment, were:

(a) Errors in determination of the insertion loss of the cables which served as the fixed attenuators, particularly the Bell Lab. variable attenuator,

(b) Frequency modulation in the beat voltage.

(c) A sloping-gain-versus-frequency characteristic for the video amplifier in the synchroscope.

Tube	Voltage	Heterodyne Method	Average Power Method	% of Deviation from Method of Average Power Readings
G. E. Lighthouse, (699)	RCA 2C42 3.0 kv	1150 watts	1250 watts	8%
	3.5	1610	1700	5%
G. E. Lighthouse, (698)	RCA 2C42 2.0	400	476	16%
	2.5	657	666	2%
	3.0	866	820	5%
	3.5	1160	1125	3%
G. E. Lighthouse, (676)	GE 2C42 2.0	510	518	2%
	2.5	650	725	10%
	3.0	1100	1070	3%
	3.5	1490	1520	2%

#### Conclusion

If sufficient precautions are taken to limit the errors arising from the sources listed, it would seem that the heterodyne method would insure greater accuracy than the average power method without unduly complicating the procedure.

Table 1  
Results obtained in a series of comparison measurements under the same conditions for the heterodyne and the usual power-reading method. The same thermistor bridge served as the wattmeter in each case.

Figure 3  
Equipment used to measure peak power by heterodyne method. At least 10 db attenuation is required for adequate isolation of the power detected gear from the standing waves set up at the T.

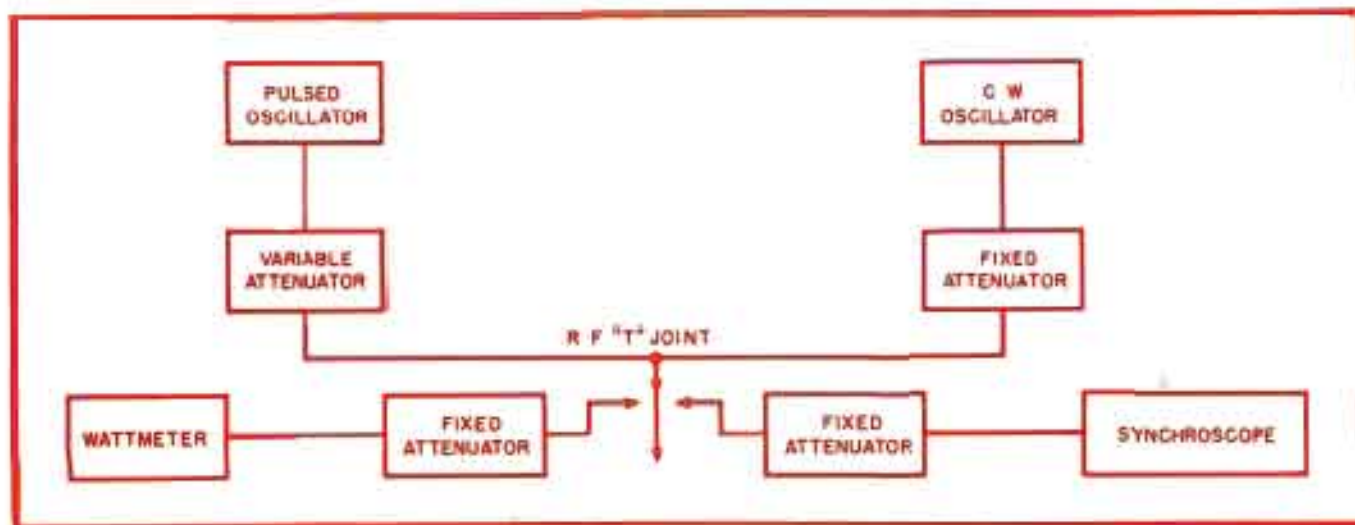
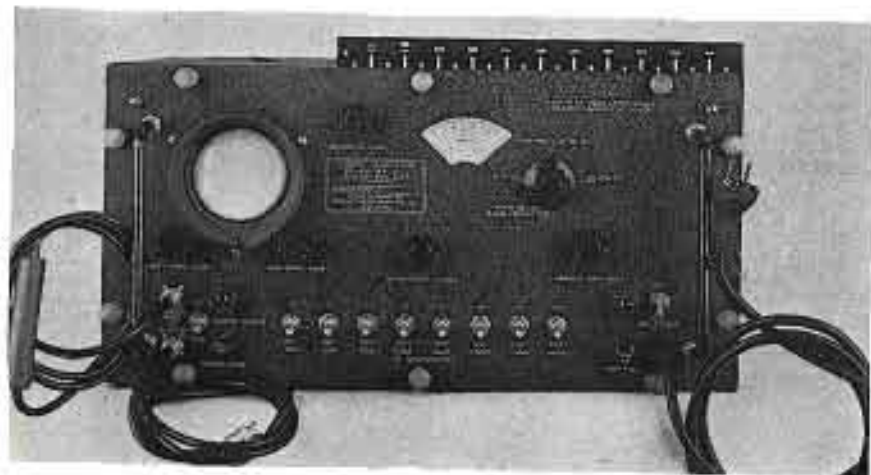



Figure 2  
Front view of the test instrument.

# A Self-Checking



by JOSEPH H. VOGELMAN

Engineer-In-Charge  
Development Branch  
Watson Labs, Air Materiel Command

WITH THE ADVENT of wide band *rf* amplifiers in high resolution radar systems, navigational aids, relay systems and similar devices for military application, it became necessary to have a test set to facilitate field servicing of wide pass-band receivers. To meet this requirement, a self-checking wobulator, which incorporated an FM signal generator, frequency meter, and a 'scope, in a single unit, was developed recently.

The test set, which covers a range of 5 to 100 mc in six bands, incorporates a signal source, the frequency of which is caused to vary over a band of approximately  $\pm 20\%$  about a fixed center frequency. The center frequencies are so selected that adequate overlap is provided for all possible center frequencies of the apparatus under test. FM is obtained from a motor driven capacitor whose rate of sweep is variable from 0 to 200 cps. The *rf* output level is held constant over the range by means of an *agr* circuit, and the output level is adjusted with an accurately calibrated step at-

tenuator. The motor drive mechanically synchronizes the oscillator sweep with the baseline sweep produced on a *crt*. The output of the *if* amplifier or receiver under test, or of any stage thereof is fed to the *V* axis of the *crt* through a probe, containing a germanium crystal rectifier, and a 'scope amplifier. A built-in frequency meter produces a blanking marker on the *Z* axis of the *crt* to permit frequency and band-width measurements. The width of the blanking marker is adjustable so as to permit easy location of the relative frequency and at the same time provide precision measurements when required.

#### The Oscillator

A balanced push-pull oscillator, employing a 6J6 double triode, was chosen because of its low even harmonic content. Frequency band selection is provided by means of six plug-in coils which have the following ranges: 5-12 mc; 8-20 mc; 15-36 mc; 19-48 mc; 30-75 mc; and 40-100 mc.

These coils, when used with the oscillator, provide sufficient frequency overlap for all applications, so that with the proper coil the desired frequency will fall at approximately the center of the frequency sweep without the aid of an additional parallel variable capacitor for tuning. This arrangement has the advantage of simplicity of tuning, and permits very wide frequency sweeps. The frequency is swept through the range by means of a motor driven capacitor. A fractional horsepower *dc* motor is used to drive the capacitor, the *dc* motor being selected so that its speed would be independent of the input power source frequency, which would vary from 50 to 1,600 cps, depending on the application. The *dc* required to operate the motor is obtained directly from the 115-volt power source through a selenium rectifier. A rheostat is incorporated in the *dc* power circuit to the motor to permit varying the rate of sweep.

#### CRT Sweep and Synchronization

The sweep for the *crt* horizontal deflection plates is obtained from a variable reluctance generator. An eccentric cam revolving in a magnetic field produces a sine wave sweep for the *crt*. The cam is mounted on the same shaft as the motor driven capacitor so as to

**Portable Test Set, Designed for the 5 to 100 Mc Bands, Contains a Frequency Modulated Signal Generator, Frequency Meter and 'Scope Which Can Be Used to Observe, Check and Measure Stage-Per-Stage Gain, Frequency, Bandwidth, and Tuning Characteristics of Broadband *IF* and *RF* Amplifiers and Receivers.**

<sup>1</sup>Developed under the sponsorship of the Watson Laboratories of the Air Materiel Command and designated by Army Navy nomenclature as Signal Generator 7.5-4527/D.

<sup>2</sup>An additional coil has been designed to extend the frequency to 125 mc.







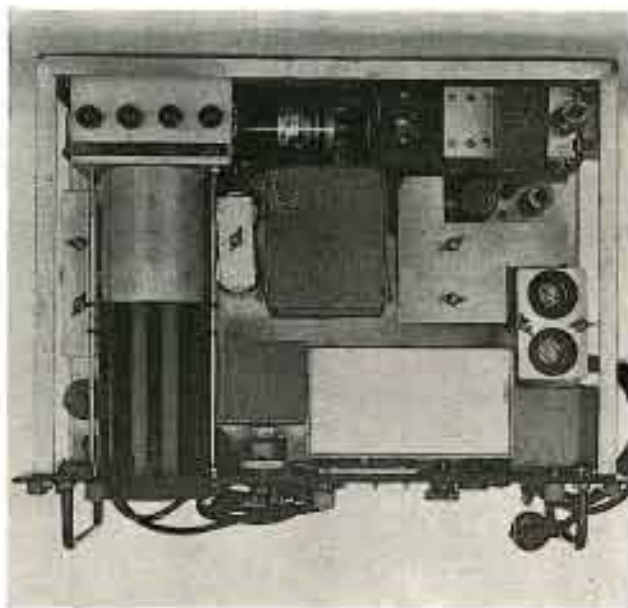
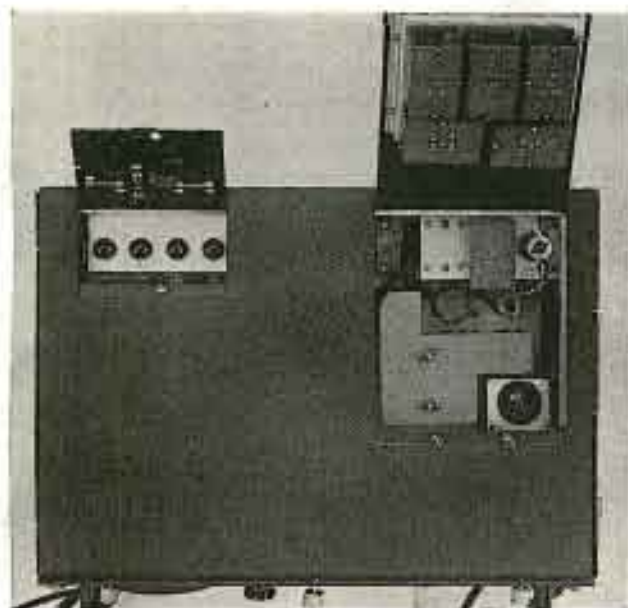

Figures 3 (left) and 4 (right)

In Figure 3 appears a top view of the test set and in Figure 4 a top view of the chassis showing the *crt* housing and motor-driven oscillator. The *crt* beam controls are mounted under a cover on top of the instrument. Oscillator coils are stored in cover of a second compartment on top of the test set and it is through this opening that the coils are changed to switch the bands.

for tuning. The frequency band from 5 to 105 mc is covered in four bands with band switching control (5-12, 11-25, 21-55 and 40-105 mc). The frequency meter is loosely coupled to the oscillator output, and is designed to accept a small portion of the oscillator output as it passes through the frequency to which the frequency meter is tuned. The output of the frequency meter is then rectified and amplified and inserted on the *Z* axis grid of the *crt* to produce a blanking marker. The frequency meter output is differentiated to provide a narrow blanking pulse. A rheostat in the cathode of one of the amplifier stages serves to vary the grid bias thereby varying the pulse width.

The instrument is housed in an aluminum cabinet, having an aluminum front panel upon which are mounted the *crt* light shield, attenuator, and grid blanking wavemeter controls, together with the necessary controls, jacks, switches, power cable, pilot light indicators, and fuses. Separate

switches are provided on the front panel for controlling the main power input and the *dc* power to the motor, which drives the sweeping tuning capacitor and the sine wave sweep generator for the cathode-ray tube. Separate pilot light indicators are provided across each of the switches. A travelling crystal diode detector is supplied for direct connection to the output circuit under test. The travelling detector has an input blocking capacitor and its input is shunted by a 270-ohm resistor. The detector assembly is housed in a small diameter, shielded, bakelite covered test probe on the end of a 4' length of RG-59/U coaxial cable. The cable is equipped with a

standard type *BNC* connector for connection to the vertical deflection amplifier input jack located on the front panel.

The test set may be connected directly to the input of the equipment under test, and the output of any of the *if* stages may be connected directly to the travelling detector. The connection between the receiver and the output or input cables of the test set provides a positive *rf* connection at all times.

#### Check on Own Performance

The test set has a particularly unique feature; it is capable of checking its own performance. By connecting the travelling detector directly to the output of the *rf* oscillator, the output of the signal generator over the frequency band of the sweep can be viewed on the 'scope. The frequency meter marker can then be used to determine if the oscillator is covering the proper frequency band. The calibration of the various attenuator steps can be checked, one against the other, by observing the decrease in amplitude caused by a particular step, and comparing it to the decrease caused by several steps of lesser value combined to give the same total. The constant output achieved by means of the *apc* circuit affords a distinctive 'scope pattern as an indication of correct operation. Before making any measurements the output of the signal generator is fed directly into the travelling probe to the vertical amplifier. If a pattern in the shape of a rectangle appears on the 'scope, then the operation of the test set is satisfactory and meas-

The motor driven sweep oscillator, sweep capacitor and sine wave generator.

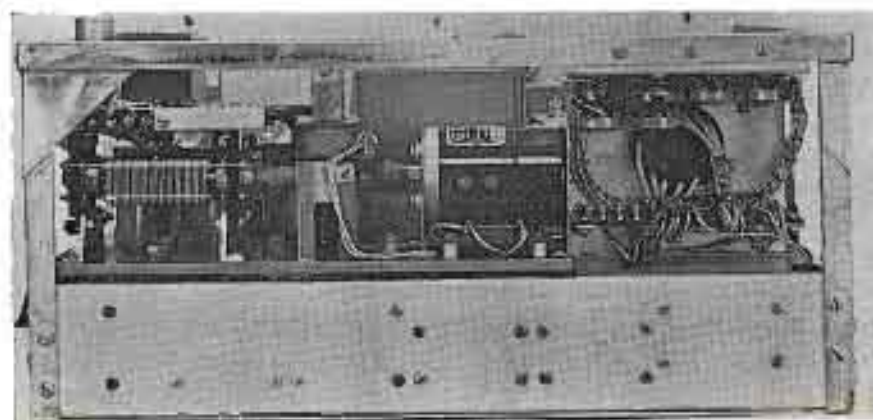



urements can proceed without further calibration.

### Test Set Applications

(a) **Frequency Measurements:** The test set can be used to determine the frequency of a tuned circuit by feeding into it the output of the signal generator, and feeding the output through the travelling probe and applying it to the vertical amplifier. A pattern resembling the band-pass characteristic of the tuned circuit will appear on the 'scope, and by adjusting the blanking marker of the frequency meter so that it appears on the peak of the pattern, the center frequency of the tuned circuit can be read from the frequency meter dial. By the same technique, the frequency of individual *if* or *rf* tuned circuits can be measured. In the process of frequency measurement, the circuit can be tuned to any desired value, using the frequency marker to check the tuning.

(b) **Band-Pass Measurements:** Probably the most useful application of the test set is its ability to plot the band-pass characteristics of tuned circuits in *rf* and *if* amplifiers in broadband systems such as radar and television. With the same arrangement of connections as is employed in frequency measurements, the band-pass characteristics of the circuit under investigation can be displayed as a plot of amplitude against frequency, on the face of the 'scope *crt*. By means of the pattern, the circuitry can be adjusted to give the desired bandwidth, and the broadband characteristic desired. It has been found that only by means of the test set can a stagger-tuned *if* amplifier be successfully measured.

(c) **Stage-by-Stage Amplification Measurements:** The test set is particularly suitable as a design tool for the electronics engineer, since it permits stage-by-stage measurements of gain, and at the same time permits the experimenter to view the frequency response of the circuitry. By connecting the signal generator to the input of the stage under investigation, and connecting the travelling probe to the output, the various parameters of the circuit can be varied while their effect on the performance can be viewed on the built-in 'scope. By establishing a reference level with the signal generator output fed directly into the trav-

elling probe, the gain of the stage or stages can be measured in terms of the amount of attenuation required to decrease the output signal to the original reference level.

(d) **IF Amplifier and Discriminator Alignment:** For *if* amplifier alignment, the *rf* output of the test set is fed into the stage under investigation, and the frequency meter blanking marker is adjusted to the desired intermediate frequency. The band-pass curve is moved across the face of the 'scope by adjusting the capacity or the inductance of the circuit until the peak coincides with the frequency marker. If required the characteristics of the band-pass can be adjusted to give the correct flat-topped response. In this manner each stage can be independently aligned. As a final step in the alignment procedure, the overall band-pass characteristic can be checked, and further alignment, broadbanding or other improvements can be made. In the case of stagger-tuned *if* systems used to achieve flat-topped broadband response curves, this system of alignment is almost mandatory. Transformer coupling can also be adjusted, by the same method, to give desired response. To align a discriminator, the output of the discriminator is fed directly into the vertical amplifiers rather than to the travelling probe. The standard discriminator characteristic curve will be seen on the 'scope. If the frequency meter blanking marker is set to the desired center frequency, the response can be adjusted to be symmetrical about this frequency.

(e) **Overall Sensitivity Measurements:** Sensitivity measurements on complete receivers or on *if* amplifiers are possible if the output of the signal generator is first calibrated with a *v/m* with the attenuator adjusted for zero attenuation. The signal is then fed into the unit under test, and attenuation is added until the signal on the 'scope becomes equal to the noise level. The amount of attenuation required to achieve this level gives the value of signal in decibels below the calibration level. This can readily be converted to microvolts. In the same manner, attenuation can be removed until the signal seen on the 'scope ceases to increase. The value of attenuation still remaining in the circuit is used to calculate the signal amplitude which will saturate the receiver.

Though the test set was originally designed to operate over the frequency

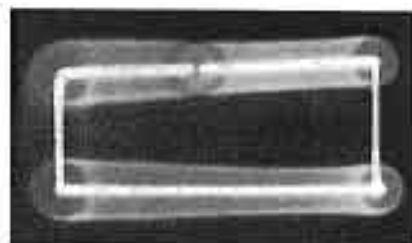

Figure 6  
CRT indication with output of test set fed directly into probe showing frequency marker.

band of 5 to 100 mc with broadband frequency sweep, two modifications have been designed which increase the usefulness of the set for special applications. An additional coil has been made available for both the oscillator and the frequency meter which permits extension of the range to beyond 120

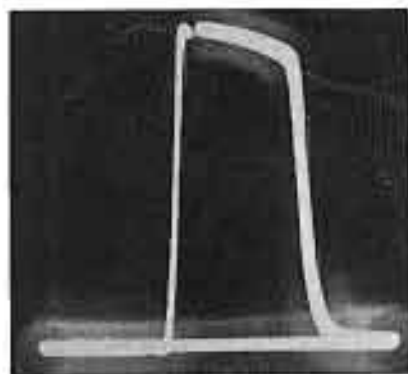
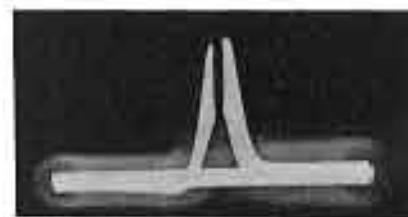

Figure 7  
CRT indication response of 7 mc wide stagger-tuned *if* amplifier centered at 30 mc.

mc. The second modification consists of a replacement oscillator circuit which parallels a tunable air capacitor with a much lower capacity rotary capacitor. With the existing coils, it is then possible to cover the same frequency range with the variable capacitor, but with the sweep is now only

Figure 8  
CRT indication of 1 mc wide 36-mc amplifier stage, variation in gain of stage with power supply change causing wide trace.





Designed for



Application



90921

**The No. 90921  
'SCOPE AMPLIFIER-SWEEP  
UNIT**

The No. 90921 comprises horizontal and vertical amplifiers, a hard tube saw tooth sweep generator and power supply mounted on a standard 5 1/4" rack panel for use with the 2, 3, or 5 inch Millen basic 'scopes.

**JAMES MILLEN  
MFG. CO., INC.**

MAIN OFFICE AND FACTORY  
MALDEN  
MASSACHUSETTS



**Recent AM/FM/TV  
Installations**



Transmitting room of WVNJ, Livingston, New Jersey, which recently went on the air. Transmitter is a 5-kw job and feeds into a five-element in-line system consisting of four towers 300' high, with the central tower 483' to the top. (Courtesy Federal Telephone and Radio Corp.)



Interior view of equipment room at WTAL and WTAL-FM, Tallahassee, Florida. The AM transmitter at this station is a 5-kw job and the FM a 710-watt affair. A six-bay cloverleaf antenna is used with the FM transmitter. (Courtesy Caterpillar Tractor Company)

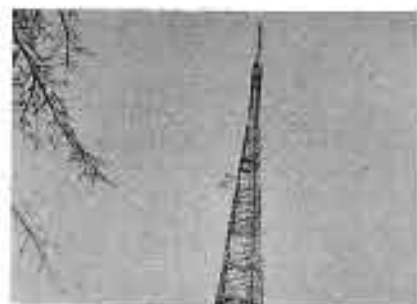

TV tower of WDTV, Pittsburgh, Pa. Structure, 500' high, weighs 100 tons, and is 60' square at the base, tapering to a 5 1/2' square. (Courtesy Blaw-Knox)

The TV mobile truck of WKY-TV, which was recently placed in operation. (Courtesy The Flexible Company)



**BIRTCHEER**  
STAINLESS STEEL - LOCKING TYPE

**TUBE  
CLAMPS**

Stainless  
Steel

Corrosion  
Proof



**83 VARIATIONS**

Where vibration is a problem, Birtcher Locking TUBE CLAMPS offer a foolproof, practical solution. Recommended for all types of tubes and similar plug-in components.

More than three million of these clamps in use.

**FREE CATALOG**

Send for samples of Birtcher stainless steel tube clamps and our standard catalog listing tube base types, recommended clamp designs, and price list.

THE BIRTCHEER CORPORATION  
5087 HUNTINGTON DR. LOS ANGELES 32

**FREE**



send today for this big book of values in

**TELEVISION**  
RADIO, ELECTRONIC,  
INDUSTRIAL, SOUND &  
AMATEUR EQUIPMENT

**NEW 1949  
NEWARK CATALOG**

20,000 items including everything in STANDARD BRAND equipment! 148 pages packed with pictures, charts, and vital information!

**KITS! SETS! PARTS! ACCESSORIES!**  
No matter how tiny the part, how tremendous the system... it's listed in this mammoth catalog... the one easy, satisfactory way to always get top-performing, top-value equipment! The most complete essential reference book for pros, hams, hobbyists, novices, oldtimers... anyone, everyone interested in TV, radio and sound equipment!

24-HR. MAIL SERVICE • ONE YEAR TO PAY

**3 GREAT STORES!** Uptown at 115 West 45th Street and Downtown at 212 Fulton Street in NEW YORK  
323 West Madison Street in the heart of CHICAGO

**NEWARK** RADIO & TELEVISION MAIL COUPON TODAY  
Newark Electric Co.  
242 W. 55th St., NYC

Dept. B-7 Please send FREE Newark Catalog to:

NAME \_\_\_\_\_

ADDRESS \_\_\_\_\_

CITY \_\_\_\_\_ STATE \_\_\_\_\_



## TV Monitor

(Continued from page 13)

produced by the combined efforts of two sidebands beating with the carrier in the detector, while the latter are produced by only one sideband. Thus, the high frequencies producing the fine detail are attenuated as compared to the frequencies producing the bold outlines. The result is a picture in which the detail, although present, lacks contrast, appearing as though the objects were covered with a film of dirt or mud. This boosting of the lower frequencies is avoided when the detecting device has a frequency response curve of the type standardized for television receivers. The ideal form of this curve is shown in C. The carrier, it will be noted, is attenuated 50%. The upper sideband corresponding to frequencies between .75 and 4 mc is unattenuated, while there is no sensitivity to lower sideband signals in this range. The sidebands corresponding to frequencies below .75 mc are attenuated in varying amounts, but it can be shown by geometry that for any given such frequency, the sum of the fractional responses to the two sidebands equals unity. Thus the two sidebands of frequencies below .75 mc combine to produce the same effect on the detector as the single sideband of frequencies above .75 mc and the result is a curve flat to 4 mc as shown in D. The response is brought to zero at 4.5 mc to prevent interference from the sound transmitter.

### Ideal Curves

The curves of Figure 9 are ideal, as it is impossible in practice to produce the sharp corners and the infinite attenuation regions shown. Furthermore, if the corners were made as sharp as possible, excessive phase shift would result. In practice, therefore, it is desirable to have rounded corners, and also to have the flat portion of the curve extend to somewhat less than 4 mc, so that there will be a more gradual slope into the 4.5-mc sound trap.<sup>9</sup> It is to provide adjustment of this slope that sound trap capacitors  $C_1$  and  $C_2$  (Figure 3) were made adjustable.

### Acknowledgments

The author wishes to express his gratitude to his associates in the Transmitting Equipment Division, particularly Dr. J. H. Mulligan, Jr., who offered many suggestions for re-arranging and rewording the manu-

(Continued on page 34)

# FEATURES NEVER BEFORE AVAILABLE IN A V.U. METER MULTIPLIER

FIVE STEP STRAIGHT "T" CIRCUIT  
ONLY 1 3/4" DIAMETER

IN ATTENUATOR "OFF" POSITION:

1. Extra pair of Terminals for separate use of V.U. Meter.
2. "T" Network completely disconnected from line and meter.

TWO STANDARD ATTENUATION RANGES:

1. 0 (1mw) to +16 V.U. and OFF in 4 V.U. steps
2. +4 to +20 V.U. and OFF in 4 V.U. steps

CONTACT SPACING:  
30" between adjacent steps

SHALLCROSS  
TYPE C35-4A3



ILLUSTRATED  
ACTUAL SIZE

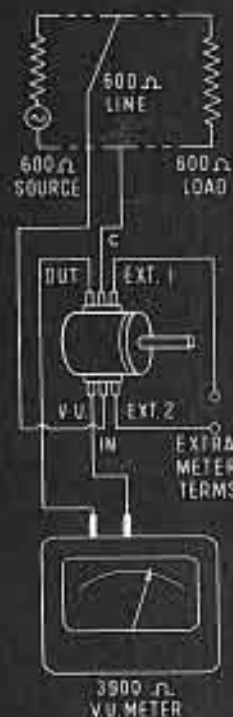

The ingenious electrical-mechanical design of these new type C35 V.U. Meter Multiplier Attenuators provides five step Straight T performance in a control size normally limited to ladder and potentiometer circuits.

A pair of extra terminals greatly increases the utility of this unit, since in the OFF position the V.U. Meter Multiplier network is automatically disconnected from the line which it normally bridges, and the V.U. Meter—completely isolating both.

As illustrated in the circuit at the left, the V.U. Meter is connected to the auxiliary pair of terminals on the Multiplier when in the OFF position, thus enabling the meter to be used for volume indication on another line, for tube checking and other purposes. Use of additional V.U. Meter Multipliers permits a single meter to be used for any number of lines with each line isolated from all others. The size and technical features of this new unit suit it ideally for use in consolettes.

Prices and delivery of this unit as described or as modified to meet your requirements available on request. Address: Dept. C-29, Shallcross Manufacturing Company, Collingdale, Pa.

# Shallcross



## YOU CAN TELL THE QUALITY OF THE PLUG BY THE EQUIPMENT IT CONNECTS ↓



RCA microphone with Type PG-CG-118 Plug and PG-42 Receptacle on P-416 speaker mounted over in Radio Station KMG of the Mutual Network in Hollywood.



The Type 'P' Series is widely recognized by radio stations and sound technicians everywhere as not only the standard, but the leading series of microphone connector. Prominent among its many desirable qualities is the patented latchlock which provides positive engagement and requires only the slight pressure of the thumb for release to disconnect. It will not pull apart accidentally.

Stocked or available from such radio parts distributors as Hughes-Peters in Dayton, Specialty Distributing in Atlanta, Lew Bonn in Minneapolis, Almo Radio in Philadelphia and more than 250 others.

For full information on the Type 'P', ask for Bulletin PO-248. And for prices, RAC's... Address Department P-131.

SINCE 1913

**CANNON**

**ELECTRIC**

*Development Company*

CANNON ELECTRIC COMPANY

2009 HUMBOLDT ST., LOS ANGELES 21, CALIF.  
IN CANADA & BRITISH EMPIRE:  
CANNON ELECTRIC CO., LTD., TORONTO 13, ONT.  
WORLD EXPORT (Incorporating British Empire)  
FRASER & NEAVE, 201 CLAY ST., SAN FRANCISCO

## TV Monitor

(Continued from page 33)

script, and to G. E. Hamilton and P. F. Brown, who reviewed the manuscript and whose help was invaluable. He is also grateful to those members of the receiver division, without whose help the project could not have been completed, particularly Cleo Marsh, Bernard Amos and Fred Schmidt.

### References

- John Rasmus, *Control Circuit for a Television Transmitter*, *Communications*, October, 1947.
- Edo Sano, *Lab. On Single and Coupled Tuned Circuit Matching Constant Resistor-based Characteristic*, *Proc. IRE*, April, 1938.
- Leo Marx, *Recent Advances in the Design of Intermediate Frequency Amplifiers for Television Receivers*, a paper presented before the 1947 Winter meeting of the IRE.

## WSJS-FM

(Continued from page 21)

is hoped will come to the Tar Heel state.

The site finally selected has proved just about as perfect as it could be under the many existing circumstances which arose. Phil Hedrick, chief of the engineering staff, believes after the first year of operation, WSJS-FM first went on the air full time December 1, 1947.

The transmitter was located directly on U. S. Highway 421 seven miles east of Winston-Salem. This highway links Winston-Salem and Greensboro 29 miles away.

The ground level at the transmitter site, 956' above mean sea level, is the second highest area in Forsyth County; the highest being 1,026', a short distance further east towards the community of Kernersville, which lies approximately three miles away.

The airways and airports came in for some special figuring when the transmitter site was chosen. There is only one existing airport within 10 miles of the transmitter site, the Smith Reynolds Airport on the northern city limits of Winston-Salem, approximately five miles west of the transmitter. Another airport at Greensboro-High Point, located to the east of the transmitter site, is farther away, but had to be considered in the location selection. In addition, there are two existing airways, the center lines of which are within 10 miles of the transmitter location of the FM station.

They are Green Airway No. 6, the center line of which is approximately eight miles southeast of the location, and Red Airway No. 34, the center

# See you of the I.R.E. CONVENTION!

March 7-10  
Grand Central Palace  
New York

Yes, The James Knights  
Company will display their  
products in

Booth 33  
at the  
I. R. E. CONVENTION

Hope to see you there.

THE JAMES KNIGHTS CO.  
SANDWICH, ILL.

line of which is approximately 8.5 miles northeast of the location.

After both of these airways had been cleared according to current regulations, it was found that only a small area remained for the projected transmitter site.

In addition, it was found necessary to consider a location which would provide the best accessibility to existing power and telephone lines. This was important since the programs for WSJS-FM were to originate in the WSJS Radio Center on North Spruce Street in Winston-Salem.

A 10-kw transmitter and auxiliary equipment was housed in a modern-design building which was also equipped with one small studio for use in the event of an emergency, and shop, garage, furnace and auxiliary power plant rooms. In the transmitting room is an operating console with the cabinets housing the transmitter immediately in front of the operator. An auxiliary turntable is at the operator's right, with a loudspeaker above to his rear. To his left rear are two cabinets containing the frequency and modulation monitors and line and monitor amplifiers, also a patch panel to facilitate switching equipment.

The shop is in the rear of the building. G. E.



ing and is fully equipped with tools and equipment needed for spot repairs. An assortment of standard checking instruments also are on hand, one being an external standard for measuring the frequency of the AM and FM transmitters. This equipment is standardized on the Bureau of Standards' standard WWV.

Approximately seven miles of telephone miles from the studio to the transmitter building have been equalized by Southern Bell from 30 to 15,000 cycles within 1 db, with noise level being 68 db down from program level which meets FCC requirements.

The base of the antenna, a 6-bay circular type, is approximately 50 feet west of the transmitter building. The antenna is supported on a structural steel tower, so that the center of the radiating portion of the antenna system is supported approximately 321' above ground level, or 1,277' above mean sea level. The height of the supporting structural steel tower is approximately 268'. The overall height of the antenna system above ground level is 348', and the overall height above mean sea level is 1,304'.

Power is fed to the antenna system through a 400' length of coaxial transmission line, having an outside diameter of 3 1/2" and an estimated efficiency of 87 per cent.

The power delivered to the antenna system is 8.7 kw, the effective radiated power being approximately 48 kw.

To insure continued operation in the event of a power failure, a 40 kw 4-wire power plant with automatic change has been installed. A gasoline-driven motor cranks up and delivers power within approximately 45 seconds in the event of a commercial power failure.

WSJS-FM now operates on a 17-hour day, from 8 A.M. to 1 A.M. In addition to local programs which originate in Winston-Salem, the station also carries NBC network programs.

Incidentally this area has become quite FM conscious, one out of every five families in the county owning an FM receiver.

Tract of land (outlined) along United States Highway 421 east of Winston-Salem selected as the site of WSJS-FM.



## Laboratory and Research Instruments

ENGINEERED FOR ENGINEERS

### OSCILLOSYNCHROSCOPE Model OL-15B

Designed for maximum usefulness in laboratories doing a variety of research work, this instrument is suited to radar, television, communication, facsimile, and applications involving extremely short pulses or transients. It provides a variety of time bases, triggers, phasing and delay circuits, and extended-range amplifiers in combination with all standard oscilloscope functions.



#### THESE FEATURES ARE IMPORTANT TO YOU

- Extended-range amplifiers: vertical, flat within 3 db 5 cycles to 8 megacycles; horizontal, flat within 1 db 5 cycles to 1 megacycle.
- High sensitivity: vertical, 0.05 RMS volts per inch; horizontal 0.1 RMS volts per inch.
- Single-sweep triggered time base permits observation of transients or irregularly recurring phenomena.
- Variable delay circuit usable with external or internal trigger or separate from scope.
- Sawtooth sweep range covers 5 cycles to 500 kilocycles per second.
- 4,000-volt acceleration gives superior intensity and definition.

For complete data, request Bulletin WO-92.

### SWEEP CALIBRATOR



Model GL-22

This versatile source of timing markers provides these requisites for accurate time and frequency measurements with an oscilloscope:

- Positive and negative markers at 0.1, 0.5, 1.0, 10, and 100 microseconds.
- Marker amplitude variable to 50 volts.
- Gate having variable width and amplitude for blanking or timing.
- Trigger generator with positive and negative outputs.

Further details are given in Bulletin WC-92.

### SQUARE-WAVE MODULATOR AND POWER SUPPLY



Model TVN-7

Here in the heart of a super high frequency signal generator with square-wave, FM, or pulse modulation. Provides for grid pulse modulation to 60 volts, reflector pulse modulation to 100 volts, square-wave modulation from 500 to 2,500 cycles. Voltage-regulated power supply continuously variable 200-480 or 100-300 volts dc. For additional data and application notes, see Bulletin WM-92.

### STANDING WAVE RATIO METER AND HIGH GAIN AUDIO AMPLIFIER

Model TAA-16



Write for Bulletin WA-92 containing full details of this useful instrument.

- Standing wave voltage ratios are read directly on the panel meter of this sensitive, accurate measuring instrument.
- Frequency range 500 to 5,000 cycles per second.
- Two input channels with separate gain control for each.
- "Wide-band" sensitivity 15 microvolts full scale.
- "Selective" sensitivity 10 microvolts full scale.
- Balometer/crystal switch adjusts input circuit to signal source.

In Canada, address Measurement Engineering Ltd., Arraport, Ontario.



**BROWNING**  
Laboratories, Inc.  
Winchester, Mass.  
ENGINEERED FOR ENGINEERS





# STANDARDIZED READY-TO-USE METAL EQUIPMENT

ADAPTABLE FOR EVERY REQUIREMENT

Par-Metal Equipment offers many features, including functional streamlined design, rugged construction, beautiful finish . . . plus ADAPTABILITY. Eliminates need for special made-to-order units on many jobs.

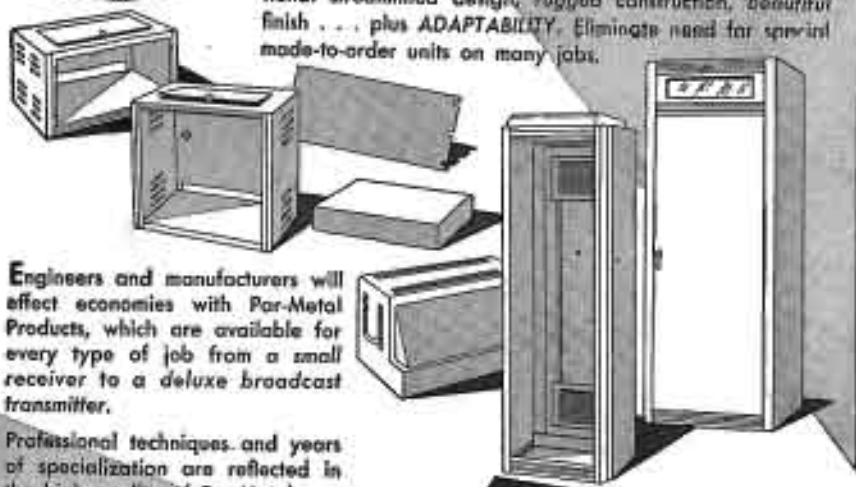

Engineers and manufacturers will effect economies with Par-Metal Products, which are available for every type of job from a small receiver to a deluxe broadcast transmitter.

Professional techniques and years of specialization are reflected in the high quality of Par-Metal. . .

**CABINETS • CHASSIS  
PANELS • RACKS**

*Write for Catalog*



# News Briefs

## INDUSTRY ACTIVITIES

The Polytechnic Research and Development Company, Inc., formerly located at 96 Court Street, Brooklyn, New York, has opened research laboratories at 302 Tillary Street, Brooklyn, New York. The research group is headed by Dr. H. S. Rogers, president of the Polytechnic Institute of Brooklyn, and is under the technical direction of P. J. Gaffney.

Cornell-Dubilier Electric Corp., South Plainfield, N. J., has purchased from Maguire Industries, Incorporated, all of the stock of Radiart Corp., Cleveland, Ohio. Established in the early 1920's, Radiart manufactures auto radio vibrators and TV and auto antennas.

The Radiart plants will be operated in Cleveland as a separate division of Cornell-Dubilier. New officers of Radiart are: Octave Blask, president; L. K. Wildberg, vice president; Verne Mitchell, vice president, and E. A. Seyouh, treasurer and assistant secretary.

WKRC-TV, Cincinnati, will soon install a 5-kw C.E. television transmitter. The unit is designed to operate on channel 11.

The Acro Electric Company, Cleveland, manufacturer of rolling spring snap-action switches, has been purchased by a group of Pittsburghers including Willard F. Rockwell, Jr., president of the Rockwell Manufacturing Co., Pittsburgh.

F. G. McCloskey is the new president of Acro, while Fred Lynn remains as vice president and general manager.

## PERSONALS

W. H. Magee has been appointed general sales manager of Russell Electric Co., Chicago, subsidiary of Rasthean Manufacturing Co.

Joseph B. Elliott is now vice president in charge of all RCA Victor consumer products, and L. W. Torgarden has been named vice president in charge of all RCA technical products. Henry C. Baker has been appointed general manager of the Home Instrument Department, and Richard T. Orth has become general manager of the Tube Department.



J. B. Elliott



L. W. Torgarden

H. C. Baker

R. T. Orth



Palmer M. Craig has been appointed director of engineering, electronics division of the engineering department, Philco Corp.

Craig, who has been with Philco for 15 years, served as chief engineer in charge of radar and military radio development during the war and was named chief engineer of the company's radio division in 1943.

Sterling C. Spielman is now chief engineer of Philco TV receiver development; Luke E. Clouston has been named chief engineer of home receiver design; Arthur V. Nichol has become chief engineer of auto radio development; Dr. James F. Koehler has been appointed chief engineer of a relatively new phase of the company's development activities, the design of specialized government and industrial electronics equipment.

Ideal for  
ANTENNA CONNECTIONS  
PHOTO-CELL WORK  
MICROPHONE CONNECTIONS

## JONES SHIELDED TYPE PLUGS & SOCKETS

LOW LOSS PLUGS AND SOCKETS FOR HIGH FREQUENCY CONNECTIONS. SUPPLIED IN 1 AND 2 CONTACT TYPES:

101 Series can be furnished with 1/4", 290°, 5/16", 3/8" or 1/2" ferrule for cable entrance. Knurled nut securely fastens unit together. Plugs have ceramic insulation and sockets have bakelite. Quality construction. Fine finish. Assembly meets Navy specifications.

For full details and engineering data ask for Jones Catalog No. 17.

**JONES MEANS  
Proven QUALITY**



P-101-1/4

S-101

**HOWARD B. JONES DIVISION**  
Czech Mfg. Corp.  
1440 W. GEORGE ST. CHICAGO 18, ILL.

## MOORE SET SCREWS

*Straight Progressive Industry*



**GEORGE W. MOORE, Inc.**  
100 BEAVER ST. WALTHAM, MASS.



Terry F. Cunningham has become director of advertising and sales promotion for Sylvania Electric Products Inc. Cunningham will direct advertising and sales promotion for the lighting fixture, lamp, radio tube and electronics divisions and the Wabash Corp.



T. P. Cunningham

Robert M. Hanson is now chief engineer of the engineering department at Audio Development Co., Minneapolis, Minn. Hanson was formerly chief engineer of the Thorntson Electric Company, Chicago.



R. M. Hanson

Frank J. Stevens has been elected president of the recently reorganized Isolantite, Inc. Paul H. Mouraud is now vice president and treasurer; and John Simons, secretary. Isolantite is now located at Warren Street, Lyndhurst, N. J.

Frank Casanova Jones, president and general manager of The Onosec Company, Passaic, New Jersey, died recently.

C. J. Burnside, associated with Westinghouse radio and electronic activities for 24 years, has resigned and organized an independent industrial consultant service with headquarters in Baltimore. He will continue his association with Westinghouse as a consultant.

Frank Lester has been appointed head of the engineering staff of the Insuline Corporation of America, 36-02 35th Ave., L. I. City, N. Y. Lester was formerly chief engineer for Electronic Corp. of America and Radio Wire & Television, Inc.

Sidney L. Chertok is now on the application engineering staff of Sprague Electric Co., North Adams, Mass., and will also serve as sales promotion manager of the Sprague Products Co.

#### LITERATURE

Walsby Electronic Components, Inc., 234 East 40th St., New York 17, N. Y., have released an 8-page catalog covering technical data and price schedules on high stability carbon resistors, and pyrometric resistors.

Engineering data on the construction, tolerance and range, stability, as well as temperature and voltage coefficient are included.

The Broadcast Equipment Section of RCA Victor, Camden, N. J., has prepared three brochures describing an AM transmitter and AM/FM/TV console-type equipment.

One brochure (24 pages; form 2J-4267) describes the BTA-50F1 50-kw AM broadcast transmitter.

Another, a 20-page booklet (form 2J-4604), provides detailed information on a two-studio console-type (type 76C). Featured are pictures of typical installations for AM-FM and television use and suggested studio layout for a small or medium size FM or AM station with one or two studios.

The third brochure (form 2J-4822) contains 16 pages of information on console-type switching systems, models BCS-1A, -2A, and -3A, for AM-FM and TV networks.

General Radio Co., Cambridge 39, Mass., has released an 8-page catalog describing the design and applications of the Parrier continuous ly adjustable transformers.

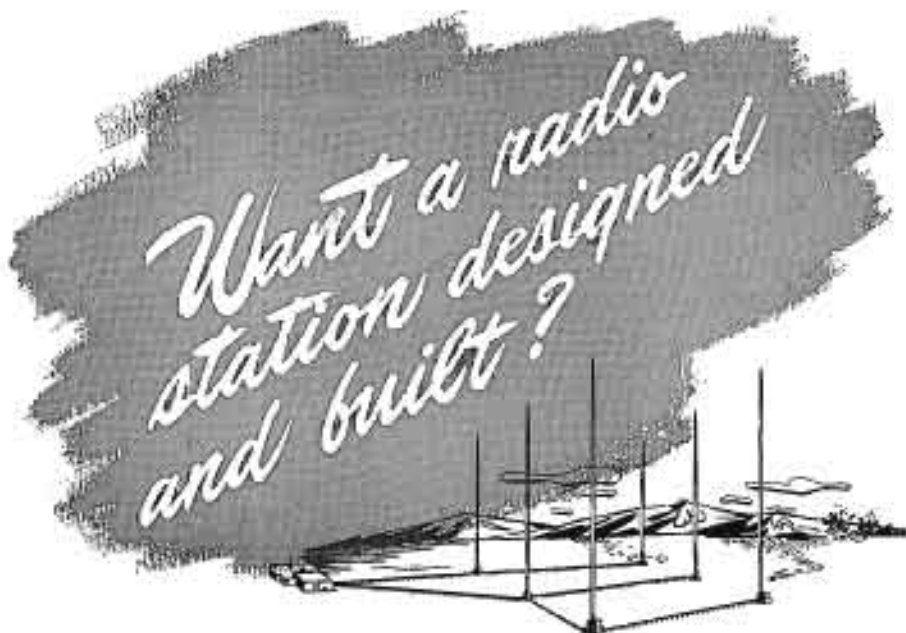

## LET Andrew DO IT!

The Monona Broadcasting Company, Madison, Wisconsin, had the money but no station. Faced with "impossible" allocation difficulties, they called on Andrew engineers, who succeeded in finding a frequency and designing a directional antenna system. Thus, WKOW was born. Within ten months after the construction permit was granted, Andrew engineers completely designed, built, tuned, and proved performance of a six-tower 10 kw. station — an unusually difficult engineering feat accomplished in record-smashing time. A complete "package" of Andrew transmission line and antenna equipment was used, again emphasizing Andrew's unique qualifications: Complete

engineering service with unsurpassed equipment.

Mr. Harry Packard, General Manager of WKOW, wrote:

"Speaking for the entire staff of WKOW, I would like to congratulate the Andrew Corporation on the remarkable engineering job it performed in helping us get WKOW on the air.

We feel that the technical perfection of our installation is due in great part to the efficiency of Andrew equipment and engineering service.

In particular we wish to thank Mr. Walt Kean of the Andrew Broadcast Consulting Division who was responsible for conceiving and designing the installation, supervising construction of all antenna equipment, and doing the final tuning and coverage surveys."

A total of 13,618 feet of Andrew transmission line and complete phasing, antenna tuning, phase sampling and tower lighting equipment went into this job, complementing the best in engineering with the ultimate in radio station equipment.

So, just write Andrew when you are ready to enter the broadcasting field. Andrew will get you on the air.

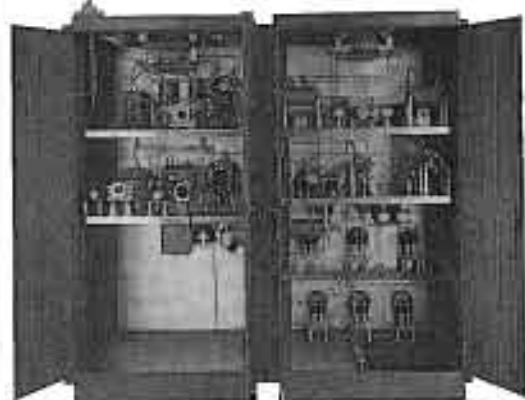



**Andrew CORPORATION**

103 EAST 75th STREET CHICAGO 19

TRANSMISSION LINES FOR AM, FM, TV • DIRECTIONAL ANTENNA EQUIPMENT • ANTENNA TUNING UNITS • TOWER LIGHTING EQUIPMENT • CONSULTING ENGINEERING SERVICE



## Rooftop Definition with Table-Top Convenience!

**NEW**  
**ICA WASP**  
INDOOR ALL-CHANNEL  
**ANTENNA**  
FOR TELEVISION  
AND FM

**INSTALLED  
IN AN INSTANT!**

**\$6<sup>95</sup>**

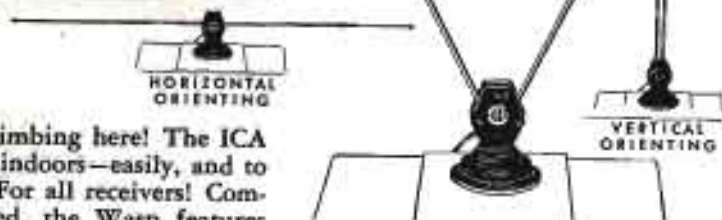

No rooftop climbing here! The ICA Wasp adjusts indoors—easily, and to all channels! For all receivers! Compactly designed, the Wasp features a smoothly engineered swivel base, combined with exclusive adjustable dipoles. Once adjusted, special spring action assures firm anchoring of dipoles and perfect electrical contact.

The heavily chrome-plated brass dipoles and antique bronzed swivel base blend well with living room décor. A non-scratch felt base protects furniture finish.

*The Wasp is packaged with 8 feet of 300 Ohm lead.  
19" high closed; base 3 1/4" diameter.*

Latest Television Antenna and Accessory Catalog Available.



**insuline** CORPORATION OF AMERICA

INSULINE BUILDING • 36-02 35th AVENUE • LONG ISLAND CITY, N. Y.  
West Coast Branch and Warehouse: 1225 South Flower Street, Los Angeles, Calif.



### ANDREW FM ANTENNA

A *Multi-V* antenna for FM, which consists of two elements or bays of a folded V type antenna, spaced approximately one wavelength. Has been announced by the Andrew Corp., 363 East 75th St., Chicago 19.

Antenna is said to have a power gain of 1.6 and a rating of 10 kw.

Can be mounted on top or sides of standard tower.

Each radiator is essentially an unbalanced folded dipole, with arms formed to resemble a truncated V. The effect of the V configuration is to produce circular horizontal radiation pattern.

Antenna is tuned at the factory by adjusting telescoping members in the radiators. These members are then soldered in place. If desired, the antenna may readily be tuned to a new frequency by unsoldering the telescoping members, changing the lengths, and resoldering.

To feed the two bays in phase, the transmission line between them is supplied in one of two lengths—one for the upper half of the FM band and one for the lower half. A quarter wave matching section below the bottom element matches the antenna to the 51.5 ohm coaxial transmission line.

Insulation resistance of the feed line may be checked at the transmitter. This isolation of the grounded antenna from its feed line is due to a series capacitor between the inner conductor and each end seal.

Voltage standing wave ratio in the antenna is said to be less than 1.6 from 88 to 91 mc, less than 1.3 from 91 to 93 mc, and less than 1.2 from 93 to 108 mc.

Elements are made of hard temper copper tubing. The mast for the self-supporting model is a twenty foot steel H beam, galvanized. Radiating elements are mounted on one side of the H beam, and climbing steps are attached to the beam on the opposite side.

### RCA STUDIO CAMERA PEDESTAL AND DOLLY

A studio camera pedestal and studio camera dolly, TD-1A, have been announced by the RCA Engineering Products Department.

The pedestal provides mounting for the TV camera in the studio or other indoor telecast locations. Has three rubber-tired wheels. Crank handle on the pedestal raises or lowers the camera between levels 40" and 60" above the floor. Panning and tilting of the camera can be facilitated by means of a friction head which is supplied separately.

The studio dolly is similar to those used in Hollywood film production sites, except that the rear wheels of the television dolly can be turned at right angles. This allows the rear end of the dolly to be swung around while the front end of the chassis pivots on a caster. The crane boom on which the camera is mounted can be raised to a height of 74" or lowered to 23" above the floor.

# The Industry Offers

## GUTHMAN TV TUNER AND CHANNEL SELECTOR

A television tuner and channel selector, model 34-1034, designed in collaboration with the Hazeltine Laboratories is now being manufactured by Edwin I. Guthman & Co., Inc., Chicago. Has a tuned transformer input with adjustable slug tuning, plus a separate vernier for fine tuning.

Tuner can be used as a remote control tuner through the use of an accessory converter transformer.

Three tubes are used: 6BH6 *r/f* amplifier, 6AG5 mixer and a 6C4 local oscillator. A 300-ohm twin-lead is used for input to the antenna matching transformer.

Tuner is said to have a gain of approximately 10 to 11 db per 100 ohms of modulator plate *if* impedance on the low frequency channels; on the high frequency channels the gain is 3 to 4 db lower. Power requirements are 4 amp. at 6.3 volts for the heaters and 30 ma at 190 volts for plate and screen supply. The intermediate frequencies are 21.25 mc for the sound carrier and 35.75 for the picture carrier.

Illustrated circular containing data and schematic circuits is available from Guthman International Corp., 75 West Street, New York 6, N. Y.

## CHATHAM ELECTRONICS REGULATED POWER SUPPLY

A laboratory-type regulated power supply, model E-48, has been announced by Chatham Electronics of 476 Washington Street, Newark, N. J.

Input . . . 100-125 volts, 60 cycle, 750 watts; output . . . variable 150 to 1900 volts, 125 milliamperes *dc*. Ripple is said to be less than .03 volt peak-to-peak; less than .15% variation in output from no load to full load; less than .025% variation in output voltage per volt of primary source.

## RAYTHEON TUBES

The special tube section of Raytheon Manufacturing Company, Newton, Mass., has announced the availability of a 6AN5 miniature pentode which may be used in many of the applications for which the metal type 6AG7 was previously used, and a CR5654, a ruggedized version of the 6AK5.

The 6AN5 can be used as high frequencies as a frequency multiplier, wide band *r/f* and *if* amplifier and class *c/f* amplifier. The 6AN5 has a normal plate current rating of 35 ma and a transconductance of 8000  $\mu$ hos.

Heater of the CR5654 was designed to withstand at least 1,000 on and off cycles at 7.5 volts. Tube was developed especially for applications such as in aircraft equipment where it is claimed the standard type 6AK5 had not proved sufficiently dependable.

## B & W PLUG-IN LINKS

Plug-in links to afford matching of standard tank coils to a variety of impedances, have been designed by Barker & Williamson, Inc., 237 Fairfield Avenue, Upper Darby, Pa. On present swinging link assemblies, it is only necessary to replace the swinging link arm with a new one into which the link coils are plugged. Links now available are made in 1-1/2 and 10 turns.

Type 3750 fits the HDV tank coil; type 3550 is made to fit TVH, TVL, and BVL types.

## MICROWAVE SIGNAL GENERATOR

A broadband microwave signal generator covering the frequency range from 4,200 to 30,300 mc, TS-902/U, has been announced by The Polytechnic Research & Development Company, Inc., 203 Tillary Street, Brooklyn 2, N. Y.

Instrument includes a direct reading frequency meter and a variable attenuator calibrated directly in db below one milliwatt. Provisions are made for both continuous wave and pulse operation with rise time of 1/10th microsecond.



## EIMAC POWER TETRODE

An external anode power tetrode, 4X150A, for use as a *r/f* amplifier or oscillator at *mf* and *shf*, has been announced by Eitel-McCullough, Inc., San Bruno, Calif.

Although it is capable of withstanding up to 1,250 volts on its plate, the 4X150A operates well at plate voltages of 600 to 500 volts, making it suited for high-power mobile applications. Said to have a high ratio of transconductance to capacitance and a maximum plate dissipation capability of 150 watts which makes it applicable as a wide-band amplifier for video applications.

A single 4X150A operating in a coaxial amplifier circuit will deliver up to 140 watts output at 500-mc.



### BROWNING AMPLIFIER

An all-triode amplifier, model AA-30, which features all triode voltage gain and power stages for response within 1 db from 10 to 17,000 cycles with less than 1% harmonic distortion at 1/4 of the rated 15 watts output, has been announced by Browning Laboratories, Inc., Winchester, Mass. Hum level is said to be 65 db below maximum rated output. Voice coils from 1.2 to 30 ohms can be matched by tap selection. In the output stage are pushpull 6B4Gs driven by two triode sections of a 6SN7 in cascade with separate bias rectifier.

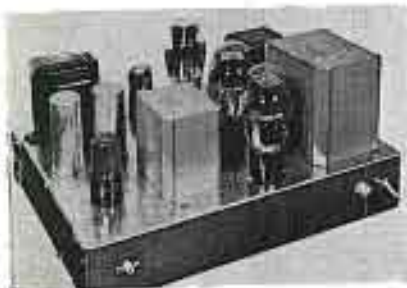

### HEWLETT-PACKARD STANDING WAVE INDICATOR

A standing wave indicator to measure relative audio voltages detected by a crystal rectifier or bolometer, model 415A, has been announced by Hewlett-Packard Co., 395 Page Mill Road, Palo Alto, Calif. Designed for use with the model 805A parallel-plate slotted line, but may also be used with other slotted line systems. In conjunction with a slotted line it will determine flatness of a coaxial or waveguide system, measure impedance, locate sources of reflection and determine percentage of reflected power.

Instrument consists of a high-gain amplifier which is said to have a very low noise level and operating at a fixed audio frequency. The output of the amplifier is measured with a square-law indicating vacuum tube voltmeter. The meter face of this voltmeter is calibrated both in decibels and in voltage standing wave ratio. Input circuits are provided for use with either a crystal or bolometer.

As normally supplied, the indicator operates on a single fixed tuned frequency of 1,000 cps. However, other frequencies from 300 to 2,000 cycles per second can be supplied on special order. Equivalent Q of the overall amplifier is  $30 \pm 5$ .



### MILLEN SCOPE AMPLIFIER-SWEEP UNIT

A scope amplifier-sweep unit, 90821, for use with any of a line of basic 2", 3", and 5" rack panel scopes, has been announced by The James Milen Manufacturing Co., Inc., Malden, Mass.

Unit comprises horizontal and vertical amplifiers, a hard tube saw tooth sweep generator and power supply mounted on a standard 5 1/2" rack panel.



### TELEX TWINSET

A lightweight twin headset, the Twinset, weighing 1.6 ounces, has been announced by Telex, Inc., Minneapolis, Minn.

Headset delivers sound directly into each ear canal through two miniature receivers. Receivers are connected to a sound arm by a locking ball and socket joint, permitting adjustment so that only plastic ear tips enter the ear openings.

Single-card connection is used.



### CLARKSTAN TONE ARM

A Triode arm for transcriptions and records, which permits replacement of the cartridge without soldering and instantaneous adjustment of needle force, has been announced by Clarkstan Corporation, 11927 West Pico, Los Angeles 34. The arm will accommodate any pick-up cartridge, magnetic or crystal, not over 3/4" wide. Silver plated plunger contacts are said to obviate soldering. A thumb screw clamp holds pickup cartridge in place. A quick-acting weight adjustment is said to make possible any needle force from 3 grams up.

Arm is made in two sizes, one to accommodate 12" records, the other for 16" and 17" transcriptions and acetates.

### MILLIVAC MICRO-MICROAMMETER

A micro-microammeter, type MV-171, with 23 ranges, for use with model MV-17A vacuum-tube millivolt meter has been announced by Millivac Instruments, P. O. Box 3027, New Haven, Conn. Measures currents from 10 micro-micro amperes up to 10 amperes.

### KAY ELECTRIC MEGA-MARKER

A wider frequency range, of from 20 to 39 mc has been incorporated in the Mega-Marker, marker oscillator, made by Kay Electric Co., Pine Brook, N. J. Model is identical with the standard model, which has a frequency range of 19 to 29 mc. All models are said to have accuracy of 25% and a crystal oscillator for calibrating the variable oscillator and providing a marker at 4.5 mc for adjusting TV sound discriminator.

### FAIRCHILD TAPE RECORDER

A tape recorder, with 15 inches per second speed, which is said to deliver high-fidelity performance formerly thought possible only at 30 inches per second, has been announced by Fairchild Recording Equipment Corporation, 89-06 Van Wyck Blvd., Jamaica 1, N. Y.

Specially-designed synchronous motor drive is said to provide an overall time accuracy of better than one-half second in 30 minutes playing time.

Features of the instrument also include plug-in type construction, both mechanical and electrical, for uninterrupted service; interlock system to prevent accidental erasing; volume indicator for reading recording level, etc.; adjustment of playback head during operation; and automatic control in event of tape break.

A unit developed by Dr. D. G. C. Hare is the basis for the new recorder.



### CARTER CONVERTERS FOR DC TV

A converter, model D1010CT, providing ac power to tv sets from dc lines, has been announced by the Carter Motor Co., 2847 N. Maplewood Ave., Chicago 47.

Has a picture control which is said to regulate converter frequency and eliminate frequency waver and picture flutter.

Picture control is designed as a separate unit and should be located near the television screen for visual control and adjustment. The Converter can then be operated in another room or closet if desired, to eliminate completely the slight audible converter hum, if necessary.

Converter is designed to operate 7" television receivers of 125 watts power or less.

Equipped with leather carrying handle, output receptacle mounted in the end cover, and dc cord for immediate operation. Complete details and specifications are presented in bulletin 948.



### GOODELL MAGNETIC NOISERASER

An instrument designed to eliminate signals and background noise from entire reels of magnetic tape in a few seconds, the Goodell magnetic noiseraser, has been announced by the Minnesota Electronics Corporation, 6th and Minnesota Streets, St. Paul 1, Minnesota. Removes saturation signals and recoditions old tape to permit an indefinite useful life with minimum of background noise.

Noiseraser consists of a tuned magnetic circuit which provides optimum erasing flux densities, suitably oriented for maximum effect.

### PLASTICON CAPACITORS

Plasticon TS capacitors and TS polar-forming networks have been announced by Condenser Products Co., 1375 North Branch Chicago, Illinois.

TS capacitors are recommended for ultra high temperature ac applications and for rf bypassing and coupling duty. Typical example is TSG103-3, an .01 mfd, 3,000 v dc capacitor in a Glasstek style container 29/32" OD x 3/4" long. The dc resistance is in excess of 100,000 megohms at 150° C; dissipation factor at 1 mc is .0005 at 70° C and .001 at 150° C. The temperature coefficient is negative, 300-400 parts per million per degree C.

### JOHNSON CRYSTAL SELECTOR

An Instant Crystal Selector, providing selection of ten frequencies, has been announced by E. F. Johnson Co., Waseca, Minn.

The unit accommodates all crystals with 1/4" spacing. With adaptors it is possible to use up to six of upright 1/4" spaced crystals, plus four with 5/8" spacing. There is an extra position on the switch for vac.

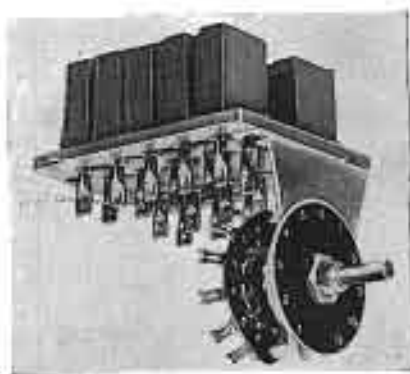





## ANTENNA

*phasing equipment*

Designed especially for your station, incorporating the recommendations of your consulting engineers, JOHNSON phasing equipment offers:

1. Optimum circuit design.
2. Heavier components, wider range of tuning adjustments.
3. Individually designed and built by E. F. JOHNSON for YOUR existing installation.
4. Automatic switching from directional to non-directional operation.

**E. F. JOHNSON CO.**  
WASECA, MINNESOTA

## FM Broadcast Monitor\*

by MARTIN SILVER

Federal Telecommunication Labs.

### Part II

IN ANALYZING the voltage regulation circuit,<sup>1</sup> it was pointed out that the circuit is so designed that the increased voltage drop is exactly equal to the voltage increase so that there is no net change.

If there is a drop in the original dc output, each step is reversed giving the same final result. To make sure that the characteristics of amplifiers  $V_2$  and  $V_3$  will not be effected by changes in filament current caused by a varying line voltage, a constant current tube,  $V_4$ , was placed in series with the filament transformer.

### Constant Voltage Tube

$V_4$ , the constant voltage tube, has two functions. In the first place it is a voltage dropping media so that the cathode bias of  $V_2$  will not be too high. Secondly, it increases the sensitivity of the circuit. This is best explained by an example. Let us assume that the normal potential between the plate of  $V_2$  and ground is 200 volts. Now, due to a change in line voltage, this is increased to 205 volts. The voltage drop across  $V_4$  is always 150 volts so that the normal cathode bias is 50 volts. When the aforementioned voltage increase occurs this is stepped up to 55 volts. Thus the full 5 volts increment is reflected across  $R_2$ .

Now let us consider what would have happened if a conventional volt-

\*Illustration of monitor which appeared last month was presented through the courtesy of FTR.

<sup>1</sup>COMMUNICATIONS, January, 1949.

## AMPERITE

Studio Microphones  
at P.A. Prices

Ideal for  
BROADCASTING  
RECORDING  
PUBLIC ADDRESS

"The ultimate in microphone quality," says Evan Rushing, sound engineer of the Hotel New Yorker.

- Shoot right into the new Amperite Microphone—or stand 2 feet away—reproduction is always perfect.
- Not affected by any climatic conditions.
- Guaranteed to withstand severe "knocking around."



Models  
RBLG—200 ohms  
RBHG—Hi-imp.  
List \$42.00



"Kontak" Mikes  
Model SKH, list \$12.00  
Model KKH, list \$18.00

**Special Offer:** Write for Special Introductory Offer, and 4-page illustrated folder.

**AMPERITE Company, Inc.**

541 BROADWAY • NEW YORK 12, N. Y.

Canada: Atlas Radio Corp., Ltd., 360 King St. W., Toronto

# 205

### Exhibiting Manufacturers

are showing this label on their letters, literature and advertising. The spotlight is on the new at the Radio Engineering Show, come and see—

### Communications Equipment

Registration \$3, non-members,  
\$1. to IRE members.



## MICROMETER FREQUENCY METER, TYPE 105-A

— is used with hundreds of taxicab, police, and public-utility transmitters in the 152-162-megacycle band.

— will monitor any number of transmitters, FM or AM, from 100 kc. to 175 mc.—price \$202.00 net—delivery from stock.

— the published accuracy is .01%, with plenty of safety factor— with reasonable care the limit of error is .005%, suitable for 162-mc. stations with .005% tolerance—write for engineering data.

**LAMPKIN LABORATORIES, INC.**

BRADENTON,  
FLORIDA



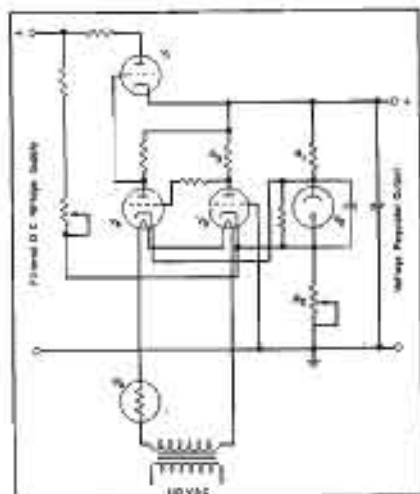

Figure 1

Voltage regulation circuit used in monitor.

age divider circuit were used. Instead of  $V_2$  we would have a resistor whose resistance would be three times that of  $R_2$  to give the same cathode bias. When the 5 volts increase occurred, the voltage increased across  $R_2$  would only be 1.25 volts. Obviously the sensitivity of the circuit is thereby reduced.

To reduce the ripple voltage to a minimum of ripple a feedback circuit is utilized. This circuit, feeding from the cathode of  $V_1$  to plate of  $V_2$ , presents a high impedance to slow changes in the  $dc$  output but is virtually a short circuit for ripple voltage frequencies. As before changes in the  $dc$  output are reflected across the  $V_1$  cathode bias, but now these fluctuations are fed back directly into the plate circuit, 180° out of phase with the original ripple.

## WBRC-FM

(Continued from page 18)

portant control-circuit keys such as transmitter on, studio and local switches are protected from accidental tripping by chromium-plated guards.

Antenna cutback equipment consisting of triple-latch transmission line switches is provided. Electrical switching is accomplished by utilizing impedance characteristics of shorted, quarter-wave transmission line sections.

A single control switch transfers the antenna to the 10- $\mu$ v stage, and at the same time isolates the final amplifier, driver, and high-power blower. Final and driver tube changes or maintenance are thus possible in safety while program continuity is maintained.

A harmonic attenuator is provided to insure maximum suppression of harmonic radiation. A self-contained unit, it consists of a pre-tuned low-pass filter capable of 38 db attenuation. Use of generous size line elements assures low-insertion loss. A transmission line monitor acts as a watch dog over the antenna and transmission line. Any unwarranted change in signal intensity actuates the monitor and shuts down the transmitter. A reclosing mechanism returns the transmitter to air, if the fault is cleared. If fault persists, process is repeated and locks out on third attempt.



☆  
2 new stars in the field



☆  
For  
TELEVISION  
RECEIVERS

# Specify COSMALITE\*

Cosmalite Coil Forms give exceptional performance at a definite saving in cost to you.

Punched, threaded, notched and grooved to meet your individual specifications.

See our Exhibit

**NO. 220**

at the

**I. R. E. RADIO  
ENGINEERING  
SHOW**

Ask us about the many various punching dies we have available.

Inquiries given quick action and specialized attention.

\*Reg. U. S. Pat. Off.

**The CLEVELAND CONTAINER Co.**

6201 BARBERTON AVE. CLEVELAND 2, OHIO

- All-Fibre Cans • Combination Metal and Paper Cans
- Spirally Wound Tubes and Cores for all Purposes
- Plastic and Combination Paper and Plastic Items

PRODUCTION PLANTS also at Plymouth, Wis., Eggenburg, N.Y., Chicago, Ill., Detroit, Mich., Greenville, S.C.,  
PLASTIC DIVISION at Plymouth, Wis. • ABRAHAM DIVISION at Cleveland, Ohio  
SALES OFFICES: Kansas City, Mo., Cincinnati, Ohio, New York 17, N.Y., Los Angeles 12, Calif.,  
CLEVELAND PLANT: The Cleveland Container Co., Inc., 6201 Barberton Ave., Cleveland, Ohio





52 Vanderbilt Avenue  
New York 17, N. Y.

# Group Subscription Plan

Saves Fifty Per Cent of  
the Yearly Subscription  
Price if Four or More  
Subscriptions (Including  
Your Own) Are Properly  
Entered on This Form.

1 Year — \$1.00  
2 Years — \$2.00



Please enter annual subscriptions (12 issues) for each of the undersigned for which payment is enclosed at the rate of \$1.00 each. (This rate applies only on 4 or more subscriptions when occupations are given.)

Name .....  
Address .....  
City-State .....  
Occupation .....  
Employed by .....  
Nature of Business .....  
(State if Manufacturer, Broadcast Station, etc.)  
Your Title .....  
Your Department .....

Name .....  
Address .....  
City-State .....  
Occupation .....  
Employed by .....  
Nature of Business .....  
(State if Manufacturer, Broadcast Station, etc.)  
Your Title .....  
Your Department .....

Name .....  
Address .....  
City-State .....  
Occupation .....  
Employed by .....  
Nature of Business .....  
(State if Manufacturer, Broadcast Station, etc.)  
Your Title .....  
Your Department .....

Name .....  
Address .....  
City-State .....  
Occupation .....  
Employed by .....  
Nature of Business .....  
(State if Manufacturer, Broadcast Station, etc.)  
Your Title .....  
Your Department .....

Business or professional classifications are required to complete our records. Each subscriber should write one of the following classifications in space indicated. Use separate sheet of paper for additional names.

CHIEF ENGINEER      ENGINEER      EXECUTIVE  
PURCHASING AGENT      DEPARTMENT MANAGER

State your classification if not listed.

This Group Sent In By—

Name .....

Address .....

## TV Distribution System

(Continued from page 9)

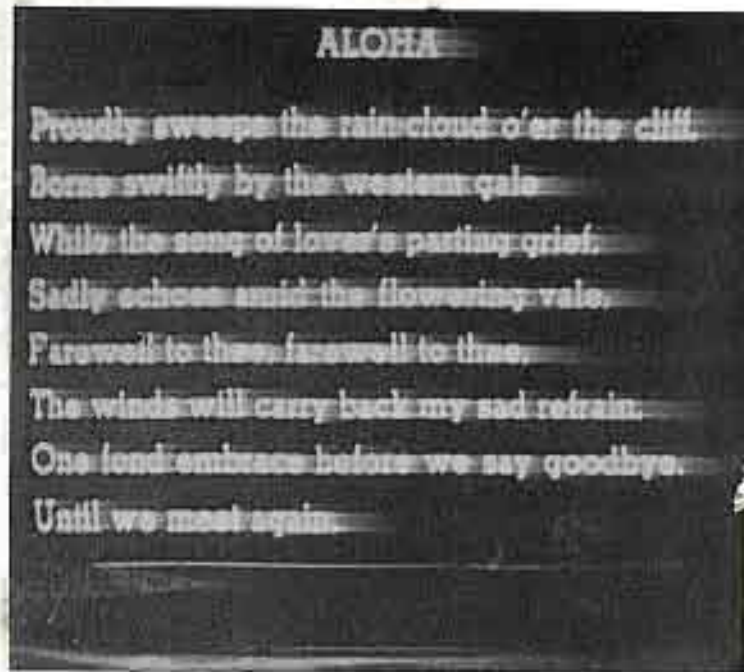
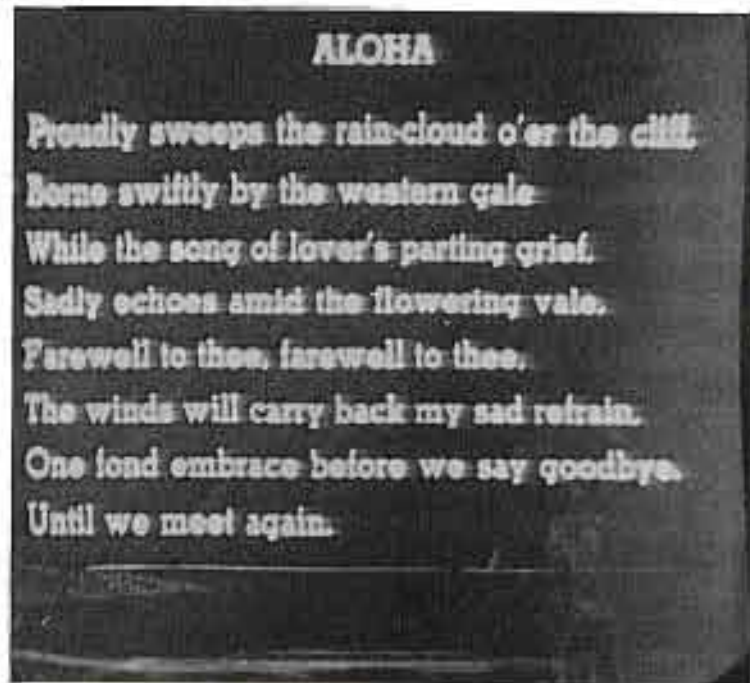

Figure 5  
Picture transmitted over 1000' of unequalized coaxial line.

ing lines both for picture quality and oscilloscope presentation. When video distribution lines are run more than 300', the series resistance of the inner conductor of the coaxial line causes a phase shift of midrange frequency components resulting in a smearing appearance of the picture. Figure 5 is a picture produced by the flying spot generator, running through 1,000' of uncompensated RG6/U coaxial cable. This picture was photographed from a 10" CRT monitor bridged across the input to the line. The method used to equalize long

Figure 7  
Picture transmitted over 1000' of equalized coaxial line.





# There are more Simpson 260

high sensitivity  
Volt-Ohm-Milliammeters  
in use Today  
than all others  
combined!

- your Parts Jobber  
can tell you why

SIMPSON ELECTRIC COMPANY

1230 21st St. Kline Bldg., Chicago 41, Ill.

In Canada: South Limited, Ltd., London, Ont.



Model 260 is  
all-purpose  
and top  
accuracy meter

RANGES at 20,000 ohms per volt DC, 1000 ohms per volt AC

VOLTS: AC & DC—2.5, 10, 50, 250, 1,000, 5,000

OHMS: 0-2,000 (12 center), 0-200,000 (1200 center), 0-20 MEGOHMS (120,000 ohms center)

DC CURRENT: 10, 100, 500 MA—10 AMP—100 MICRO AMP

DECIBELS: (5 ranges) -10 to +52 DB

## WHEN YOU CHANGE YOUR ADDRESS

Be sure to notify the Subscription Department of COMMUNICATIONS, 52 Vanderbilt Avenue, New York 17, N. Y., giving the old as well as the new address, and do this at least four weeks in advance. The Post Office Department does not forward magazines unless you pay additional postage, and we cannot duplicate copies mailed to the old address. We ask your cooperation.

## 2ND ANNUAL PENNY SALE!

The biggest money saving sale you ever saw. For 12 more, you get 2.

For Example:

PRICE ROTARY 34r cool 80' rotation, 81c ea.—in straps. Single water, \$1.49—2 for \$1.30.

ANTENNA SWITCHING RELAY 115v A.C. DPDT 10 amp contacts, manual release latch 200 ohms. Allied, \$1.49, 2 for \$1.30.

Send for complete Penny Sale Catalog, Biggest electrical and radio deals sale in history. Prices Not FOB our plant. Include postage and insurance.

UNIVERSAL GENERAL CORP.

165 Canal St., N. Y. 13 (Dept. C) Walker 5-9542



video lines is illustrated in Figure 6.

A coaxial cable using copperweld wire was selected because the variation of  $R$  caused by skin effect is much less than with copper. This means that all of the parameters effecting the characteristic impedance of the line can be considered as approximately constant. Since the conductance of polyethylene at video frequencies is practically zero a finite value can be assigned to it which makes the numerator under the radical equal the de-

Figure 6  
Formula for line equalization.

<p>RG 6/U Coaxial Cable</p> <p>Wire— 21 AWG Copperweld</p> <p>Resistance— 43.5 Ohms per 1000 Ft.</p> <p>Capacitance— 18.5 pF per Ft.</p> <p>Inductance— 0.125 microhenry per Ft.</p> <p>Dielectric— Polyethylene</p> <p>Velocity— 66% of Free Space</p>	$Z_0 = \sqrt{\frac{L}{C}}$ $Z_0 = \sqrt{\frac{0.125 \times 10^{-6}}{18.5 \times 10^{-12}}}$ $Z_0 = \sqrt{\frac{125}{18.5 \times 10^{-6}}}$ $Z_0 = \sqrt{6.75 \times 10^6}$ $Z_0 = 2.6 \times 10^3 \text{ ohms}$ <p>is equal with Line Equalizer 80 Ft. to Equalization</p>
---	--

nominator. Solving the equation for  $R$  shows that substantially perfect equalization can be attained if a shunt resistance of 132,000 ohms is placed across the line every foot. Actually a shunt resistor of 2,600 ohms was used every fifty feet (approximately a quarter wave at 4 mc). Figure 7 shows the picture produced by the flying spot generator after passing through 1,000' of compensated coaxial line.

Cathode follower boxes, pictured in Figure 8, are used to bridge the lines for picking off video signal. These units have a built-in power supply and utilize a 6SN7 operating as a cathode follower. The gain of the follower is 0.8, and has an output impedance of 200 ohms. Three volts peak-to-peak of composite video signal is transmitted over the coaxial distribution lines and 2.4 volts is available at the output of each box. A control is provided on each box so the output level may be varied from zero to maximum.

This system is augmented by sepa-

rate antennas mounted on the roof fed into the various TV laboratories by feed line. There is a distinct advantage, for research and development work, in having a video distribution system employing a number of short lines rather than one long line, since various video signals can be fed into different laboratories at the same time; also trouble on one line can be localized and repaired without putting the whole system out of operation.

Figure 8  
Bridging amplifier; cathode follower box.







Jim Lansing Signature Speakers embody exclusive design features that provide unusual tonal realism, high efficiency and true reproduction quality. These speakers are the result of the experience gained through the more than a quarter of a century of leadership in this field. For maximum dynamic range and frequency response listen and compare Jim Lansing Signature Speakers before you buy.



**MODEL D 1002**  
Two Way System

This fine two way unit is designed and recommended for FM monitoring and top quality home sound reproduction and is recommended for operation at frequencies from 40

to 10,000 CPS with a maximum useable range from 30 to 18,000 CPS.

**MODEL D 130**

Designed especially for music systems and public address use. Has exceptionally wide frequency and dynamic range. Magnet is housed in a heavy field case to prevent stray magnetic fields. Can be safely used near Cathode Ray or Television Tubes without affecting their performance.



Write for descriptive catalog containing full line and complete specifications.

**JAMES B. LANSING SOUND INC.**  
4221 SOUTH LINCOLN BLVD  
VENICE, CALIFORNIA

## Last Minute Reports...

TAPE RECORDING has become quite a factor in broadcasting. ABC has not only established complete tape recording facilities for its own use, but its clients too, with \$15.00, \$20.00 and \$35.00 rates selected for 1/4-hour, 1/2-hour and one-hour recordings. These charges include an original and protection tape recording which may be used for broadcast, dubbing to disc, or for editing and assembling. Supplemental service charges have also been established for editing and assembly and re-recording. For editing requiring one engineer and a recorder, the charge is \$25.00 for the first hour and \$10.00 for any additional half hour or portion, and for re-recording tape-to-tape or tape-to-disc, the first hour charge is \$7.00, half hour, \$5.00, and 1/4 hour or less \$3.00. . . . Sixty-nine broadcast engineers attended the recent sixth RCA TV technical training program at Camden. Among those at the meeting were:

F. Crandon, WCSH, Portland, Me.; E. Littlejohn and E. J. Kern, WFIL, Philadelphia; N. R. Oding, CBC, Montreal; M. L. Poole, CBC, Montreal; W. J. Carter, CKLN, Windsor, Ont.; James Carlisle, CBC, Montreal; W. H. Fasting and R. L. Newton, WCOB, Atlanta; J. W. Keller, Jr., WKOK, Sunbury; Robert Schroeder, WBNS, Columbus, O.; I. V. Sanderson, WSGN, Birmingham; George Cutbert, Famous Players Canadian Corp., Toronto; T. A. M. Craven, Craven, Holmes & Culver, Washington, C. Eastwood, CFRB, Toronto; E. L. Markman, Western Comm. B/C Co., Stamford; E. L. Coedes, WTMJ, Milwaukee; Chester Beachell, CPRA, Ottawa; Jack Siegel, WLOW, Norfolk; Edwin S. Bushy, WJAR, Norfolk; C. F. Halle, WXEL, Cleveland; William George, WXEL, Cleveland; N. L. Straub, WJAC, Johnstown; Orest Erwin, WJAC, Johnstown; R. E. Cannon, Jr., WINX, Washington; A. Bates, KFAB, Omaha; Vinton Wight, KFAB, Omaha; H. E. Wehrman, KJLZ, Denver; C. Harris, WIP, Philadelphia; L. E. Kilpatrick, WSAZ, Huntington, W. Va.; Wilfred Hines, WKY, Oklahoma City; W. A. Smith, WROR, Rockford, Ill.; G. E. Ryan, WBBC, Flint; H. J. Nafziger, WBNS, Columbus, O.; William Orr, WELD, Columbus, O.; Francis Jacobi, WWL, New Orleans; D. F. Hynes, WWL, New Orleans; J. D. Bloom, WWL, New Orleans; R. J. Stonett, WHBF, Rock Island; J. T. Hetland, WDAY, Fargo; C. F. Quentin, KRNT, Des Moines; D. G. Smirkin, KVPD, Ft. Dodge; Roger Perry, WFOR, Portland, Me.; Roland Hale, WGOB, Boston; Harold Durschang, WEEI, Boston; J. M. Burke, WAAM, Baltimore; G. W. Fordham, KFKU, Lawrence, Kansas; A. H. Chismark, WTRV, Troy; E. W. McCrae, CBC, Montreal; L. G. Stevens, WLAV, Grand Rapids; Jack Jiraska, KCRG, Cedar Rapids. . . .

G. H. Felt, professor of electrical engineering, University of Illinois, has been elected president of the 1949 National Electronics Conference which will be held at the Edgewater Beach Hotel in Chicago on September 26, 27 and 28.

R. W. Wassenberg is now operations manager of KPIX in San Francisco. . . . Bernard J. Kellon is chief engineer of WYNJ which recently went on the air with its transmitter in Livingston, New Jersey, on 620 kc. . . . Brigadier General David Sarnoff, chairman of the board of RCA, will officiate at the third annual meeting of the Armed Forces Communications Association, of which he is president, in Washington March 28 and 29.



At the recent TV clinic conducted by CBS: CBS vice president Larry Lowman, W. B. Lodge, CBS vice president in charge of general engineering and former FCC Commissioner E. K. Jett, now vice president and general manager of WMAR-TV, Baltimore.

## ADVERTISERS IN THIS ISSUE

### COMMUNICATIONS INDEX

FEBRUARY, 1949

AMPERITE CO. ....	49
Agency: H. J. Gold Co.	
ANDREW CO. ....	37
Agency: Burton Brown, Advertising	
BELL TELEPHONE LABORATORIES.....	1
Agency: R. W. Aiken & Son, Inc.	
THE BIRCHER CORPORATION.....	32
Agency: W. C. Jaffee Co.	
BROWNING LABORATORIES, INC.....	23
Agency: Engineering Advertising	
J. H. RUNNELL & CO.....	19
Agency: J. H. Runnell	
CANNON ELECTRIC DEVELOPMENT CO.....	34
Agency: Dona Jones Co.	
THE CLEVELAND CONTAINER CO.....	41
Agency: The Nesbitt Service Co.	
GENERAL RADIO CO..... Inside Back Cover	
Agency: The Barta Press	
HEWLETT-PACKARD CO.....	35
Agency: L. C. Cole, Advertising	
THE INSTITUTE OF RADIO ENGINEERS.....	40
INSULINE CORPORATION OF AMERICA.....	38
Agency: S. B. Less Co.	
E. F. JOHNSON CO.....	43
Agency: Hutchins Adn. Co.	
HOWARD B. JONES DIV. GINCH MFG. CORP.....	38
Agency: Birmingham, MacKenzie & Co.	
THE JAMES KNIGHTS CO.....	24
Agency: Hutchins Adn. Advertising	
LAMPKIN LABORATORIES, INC.....	40
JAMES B. LANSING SOUND, INC.....	44
Agency: Julian D. Beel & Associates	
JAMES MILLEN MFG. CO., INC.....	32
GEORGE W. MOORE, INC.....	36
Agency: Julian Brightman Co.	
MOTOROLA, INC.....	17
Agency: Gouffain-Cole Adn. Assoc.	
NEWARK ELECTRIC CO., INC.....	31
Agency: The Chesser Co., Inc.	
PAR-METAL PRODUCTS CORP.....	36
Agency: H. J. Gold Co.	
PHILGO CORPORATION..... Inside Front Cover	
Agency: Hutchins Adn. Co.	
PHILGO INDUSTRIAL DIV.....	15
Agency: Hutchins Adn. Co.	
RADIO CORPORATION OF AMERICA.....	22, 23, Back Cover
Agency: J. Walter Thompson Co.	
SHALLCROSS MFG. CO.....	33
Agency: The Harry P. Bridge Co.	
SIMPSON ELECTRIC CO.....	43
Agency: Burton Brown, Advertising	
SPRAGUE ELECTRIC CO.....	1
Agency: The Harry P. Bridge Co.	
SYLVANIA ELECTRIC PRODUCTS, INC.....	3
Agency: Newell-Essence Co.	
U. S. TREASURY DEPT.....	4
UNIVERSAL GENERAL CORP.....	41
Agency: Van Diver & Carlyle	
WILCOX ELECTRIC CO.....	8
Agency: Arthur G. Rippey & Co.	



# 100 to 500 Mc OSCILLATOR



The tuned circuit of the Type 857-A Oscillator is our well-known Butterfly type. The difficulty of sliding contacts in any part of the oscillator circuit is avoided in this unique construction. The photograph above shows the output coupling loop and output jack. Coupling can be changed from maximum to almost zero by rotating the output jack.

**T**HIS oscillator, designed for use as a power source for general laboratory measurements and testing, covers the frequency range of 100 Mc to 500 Mc. With its associated power supply it is small, lightweight and compact. The entire range is covered with a single-dial frequency control with a slow-motion drive equipped with an auxiliary scale.

## FEATURES

- Dial calibrated directly in megacycles to an accuracy of  $\pm 1\%$
- Vernier dial with 100 divisions, covering the oscillator range in ten turns
- Output through a coaxial jack with provision for varying coupling
- Output of  $\frac{1}{2}$ -watt at 500 Mc
- Electron-ray tube in power supply to indicate grid current and furnish indication of oscillation
- Filament and plate power furnished by the Type 857-P1 Power Supply which is furnished with the oscillator

**TYPE 857-A U-H-F OSCILLATOR (with power supply) . . . \$285**

WRITE FOR COMPLETE DATA



# GENERAL RADIO COMPANY

Cambridge 39,  
Massachusetts

30 West 51, New York 6 190 E. Michigan Ave., Chicago 5 1000 N. Seward St., Los Angeles 38



*Another RCA First...*



**... the economy of thoriated-tungsten filaments and improved cooling in high-power tubes**

*Here is unparalleled tube value...*

Five new RCA tubes, ranging in power input from 1.5- to 150-kw, and successfully utilizing economical thoriated-tungsten filaments which offer marked savings in filament power and the cost of associated power equipment.

Five tubes with proved features of previous similar types. Two—the 5762 and 5786—have efficient newly designed radiators that permit the use of less expensive blowers.

Five tubes with improved internal constructions that contribute to their more efficient operation and longer service life.

These five new RCA tube types are "musts" for designers of broadcast, communications and industrial electronic equipment where design and operating economies alike are important considerations.

Forced-air-cooled assemblies and

water-jacket assemblies are available for most RCA power tubes.

RCA Application Engineers are ready to consult with you on the application of these improved tubes and accessories to your specific designs. For complete technical information covering the types in which you are interested, write RCA, Commercial Engineering, Section 58BR, Harrison, New Jersey.

**THE FOUNTAINHEAD OF MODERN TUBE DEVELOPMENT IS RCA**



**TUBE DEPARTMENT**

**RADIO CORPORATION of AMERICA**

**HARRISON, N. J.**