

COMMUNICATIONS

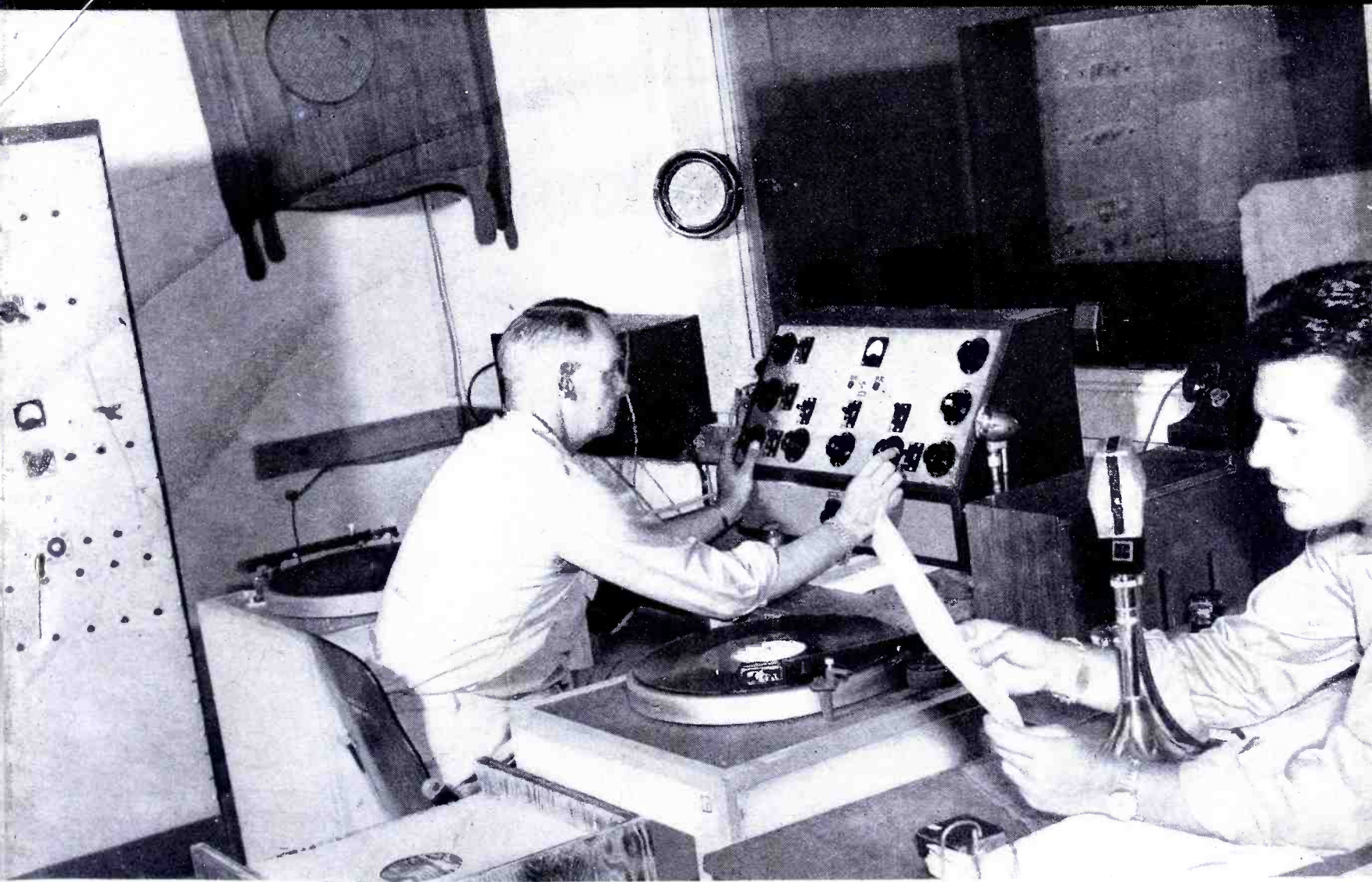

★ RADIO ENGINEERING

★ EMERGENCY COMMUNICATION SYSTEMS

★ COUPLED CIRCUIT DESIGN

★ AERONAUTICAL COMMUNICATIONS

★ TBA CONFERENCE REPORT

★ TELEVISION ENGINEERING

JANUARY

1945

Why

AMPEREX

WATER AND AIR COOLED TRANSMITTING AND RECTIFYING TUBES

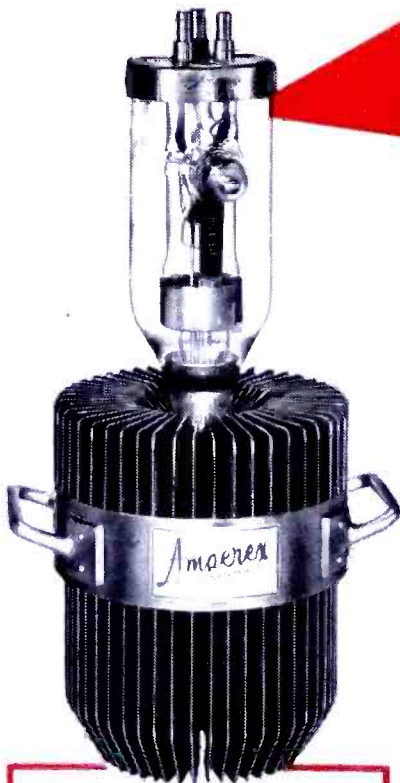

AMPEREX

... the high performance tube



The ILLINOIS TOOL WORKS has made tremendous strides in the design and development of dielectric heating equipment for such applications as moulding bakelite, heating pre-forms, joining thermoplastics, etc. AMPEREX tubes are used in all such equipment produced by this well-known concern.

With the ILLINOIS TOOL WORKS, as with many other leading concerns working with electronic tubes, it's the "Amperextra" of longer life and low-cost efficiency that has made our products a first and exclusive choice. AMPEREX pioneered in the field of tubes for industrial applications. We are familiar with the needs of industry, and we have the tubes to meet all requirements. Consult AMPEREX for assistance with your present or postwar problems.

IMPORTANT! AMPEREX tubes are now available through leading radio equipment distributors. This new arrangement may save valuable time for busy engineers by enabling them to obtain many of our standard tube types from their local supply sources.

AMPEREX ELECTRONIC CORPORATION

79 WASHINGTON STREET BROOKLYN 1, N. Y.
Export Division: 13 E. 40th St., New York 16, N. Y., Cables: "Arlab"

THE WAR ISN'T OVER YET...BUY AND HOLD MORE WAR BONDS

108 SERIES

Amplifiers

WITH MOUNTING ACCESSORIES

TYPE 108-B two-stage Amplifier provides transformer input impedances for either 30 or 250 ohms with nominal output impedance 500 or 8 ohms. Variable gain 65/105 db. with electronic volume control. Frequency response better than ± 1 db. 30/16,000 c.p.s. Power output +43 V.U. (20 watts) with less than 5% RMS harmonic content. Noise level full gain 56 db. below full output.



THE 108 SERIES consist of four different amplifiers available simply by changing one or two small input panels on the master chassis. Except for these input panels all amplifiers have the same transmission characteristics. Input impedance, gain and noise level depending on types listed below.

These units are designed for the highest type audio service having gain-frequency characteristics better than ± 1 db. 30/16,000 c.p.s. Power output +43 V.U. (20 watts) with less than 5% RMS harmonic content.

TYPE 108-A two-stage Amplifier provides transformer input for either 600 ohm or bridging. 600 ohm input fixed gain 61 db. Bridging input variable gain 6/46 db. Noise level 68 db. below full output.

Bridging input variable gain 2/42 db. Channel 2—high gain 30/250 ohm input variable gain 62/102 db. with electronic volume control. Noise level 56 db. below full output.

TYPE 108-B as illustrated and described above.

TYPE 108-C combines the input channels of the 108-A and 108-B Amplifiers. Channel 1—600 ohm input variable gain 20/60 db.

TYPE 108-D two-channel each 30/250 ohm input. Either channel variable gain 62/102 db. with electronic volume control. Noise level 56 db. below full output.

MOUNTING ACCESSORIES

TYPE 202-A Wall Mounting Cabinet permits universal installation of 108 Series Amplifiers to any flat surface. Well ventilated and designed for maximum accessibility, servicing and convenience of installation. Standard aluminum gray finish.

TYPE 9-A Modification Group permits 108 Series Amplifiers to mount on standard 19" telephone relay racks. Occupies 7" rack space. Allows servicing from front of rack. Standard aluminum gray finish.

The Langevin Company

INCORPORATED

SOUND REINFORCEMENT AND REPRODUCTION ENGINEERING

NEW YORK

37 W. 65 St., 23

SAN FRANCISCO

1050 Howard St., 3

LOS ANGELES

1000 N. Seward St., 38

We See...

AN EPOCHAL EVENT LAUNCHED the New Year . . . the FCC reallocation proposal covering the 25 to 30,000-mc spectrum . . . a proposal that provides for the greatest expansion in communications history. The FCC plan calls for new frequency assignments to railroads, rural telephones, general mobile services (trucks, buses, taxicabs, ambulances) and walkie-talkies for Mr. and Mrs. Public.

F-m received 90 channels between 84 and 102 mc. Twenty of these channels (84 to 88 mc) are for educational stations. A band of from 102 to 108 mc was set aside for f-m expansion. Television was given six 6-mc channels from 44 to 84 mc and six 6-mc channels from 180 to 216. And to permit development of high definition and color pictures, bands between 480 and 960 mc were also set aside for experimental television. The air services received substantial grants . . . almost exactly as requested. In offering these frequencies, FCC officials said . . . "aviation operations are wholly dependent upon the use of radio for insuring the safety of life and property in the air."

Twenty-two channels between 25 and 28 mc were proposed for relay broadcast operations. Studio-transmitter links were moved to the 900 to 960 mc band. Here incidentally f-m will be used.

The 460- to 470-mc band was set aside for a walkie-talkie service which will be available to practically anyone. Operators will have to abide by only the minimum requirements of the Communications Act and a few traffic rules. But no technical knowledge will be necessary, says the FCC. Doctors, farmers, sportsmen, department stores, boatmen and countless others will find this quite a handy service.

Police, fire, forestry and railroad services were assigned the 148- to 162-mc bands.

The proposal in its present or modified form will become a final program soon after oral hearings with industry specialists are held during the middle of February.

Congratulations to the FCC for a comprehensive appraisal and sturdy approach to a complex problem.

—L. W.

COMMUNICATIONS

Including Television Engineering, Radio Engineering, Communication & Broadcast Engineering, The Broadcast Engineer. Registered U. S. Patent Office.
 Member of Audit Bureau of Circulations.

JANUARY, 1945

VOLUME 25 NUMBER 1

COVER ILLUSTRATION

In the control room of AES at Noumea, New Caledonia.
 (Courtesy U. S. Army Signal Corps)

POLICE COMMUNICATION SERVICES

Police Communication Problems Facing Engineers Today . . . Lewis J. Boss 33

TELEVISION ENGINEERING

A Report on the Technical Panel Session at the TBA Conference
 Lewis Winner 34

Camera and Picture Tube Developments (M. A. Trainer) 34
 Satellite Television Stations (J. E. Keister) 35
 Relay Systems (Walter S. Lemmon) 75

AIRBORNE EQUIPMENT

British Airborne Communications Equipment 36

CIRCUIT DEVELOPMENT

Coupled Circuit Design A. J. Maynard 38

TRANSMITTER TUBE DESIGN AND APPLICATION

External Anode Triodes (*Characteristics and Applications*) . . . A. James Ebel 44

AERONAUTICAL COMMUNICATIONS

Aeronautical Communications in the Postwar Era McMurdo Silver 48

SOUND ENGINEERING

Resistive Attenuators, Pads and Networks (*Part III*) Paul B. Wright 50

ANNUAL INDEX

Index to COMMUNICATIONS, 1944 62

U-H-F LABORATORY RESEARCH

U-H-F Power Supply (*Part II*) Iredell Eachus, Jr. 96

MONTHLY FEATURES

Editorial (We See) 2
 Veteran Wireless Operators' Association News 70
 News Briefs of the Month 89
 The Industry Offers 99
 Advertising Index 106

Published Monthly by the Bryan Davis Publishing Co., Inc.

BRYAN S. DAVIS, President

PAUL S. WEIL, General Manager

F. WALEN, Secretary

A. GOEBEL, Circulation Manager

Advertising and Editorial offices, 19 East 47th St., New York 17, N. Y. Telephone PLaza 3-0483. Cleveland 6, Ohio; James C. Munn, 10515 Wilbur Avenue. Pacific Coast Representative: Brand & Brand, 816 W. Fifth St., Los Angeles 13, Calif.; Telephone, Michigan 1732. Wellington, New Zealand: Te Aro Book Depot. Melbourne, Australia: McGill's Agency. Entire Contents Copyright 1945, Bryan Davis Publishing Co., Inc. Entered as second-class matter October 1, 1937, at the Post Office at New York, N. Y., under the act of March 3, 1879. Yearly subscription rate: \$2.00 in the United States and Canada; \$3.00 in foreign countries. Single copies, twenty-five cents in United States and Canada; thirty-five cents in foreign countries.

SYLVANIA NEWS

ELECTRONIC EQUIPMENT EDITION

JANUARY

Published in the Interests of Better Sight and Sound

1945

Electronic Devices Broaden Sylvania's Service to Industry

The manufacture of electronic equipment for certain specialized communications and industrial applications is an important phase of Sylvania service. Manufacture of this type of equipment is carried

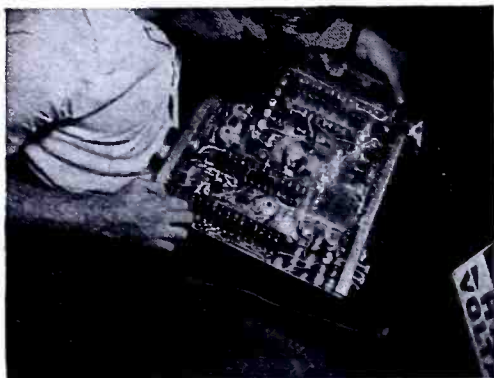

An electronic device undergoes test in the laboratories of Sylvania's Industrial Apparatus Plant.

on in a separate Industrial Apparatus Plant located at Williamsport, Pa.

This aspect of Sylvania's activities is a natural outgrowth of the company's intensive experience in the design and application of electron tubes.

DID YOU KNOW...

That Sylvania Tungsten Lamps are standard equipment for signaling purposes on many telephone switchboards? They are made in a range of electrical characteristics for use in any type of switchboard.

* * *

That Sylvania Near Ultra-Violet Lamps activate the fluorescent dials on airplane instrument panels? Lamps are small, compact, designed to operate from a 24-28 volt direct current source.

Sylvania Begins Survey of Public Interest in Television Receivers

Findings Will Assist Manufacturers in Gaging Markets, Determining Price Range

Thousands of personal interviews and an intensive advertising campaign in the pages of leading consumer publications form the twin phases of a comprehensive survey which Sylvania is launching to gage the interest of consumers in the purchase of television sets, and to learn the extent of the

potential market for receivers in various selling price ranges. The results of this survey are expected to be of great value in guiding the planning of the manufacturers of television sets.

Television, moreover, is but one of the aspects which will be covered in this

LOCK-IN TUBES IDEAL FOR UHF

The trend toward the use of ultra-high frequencies brings to the fore the outstanding advantages of Sylvania's Lock-In Tubes. While the name of this line of tubes has tended to emphasize the physical details of mounting, one of the chief motivating forces in their design was the desire of Sylvania engineers to improve the electrical characteristics of tubes, particularly at the higher frequencies.

The Lock-In feature itself has been responsible for the extensive use of these tubes, particularly in automobile radios; electrical features point to wide utilization in television and FM.

SYLVESTER SURVEY



"I wonder if I could have your views on what the postwar radio will be like."

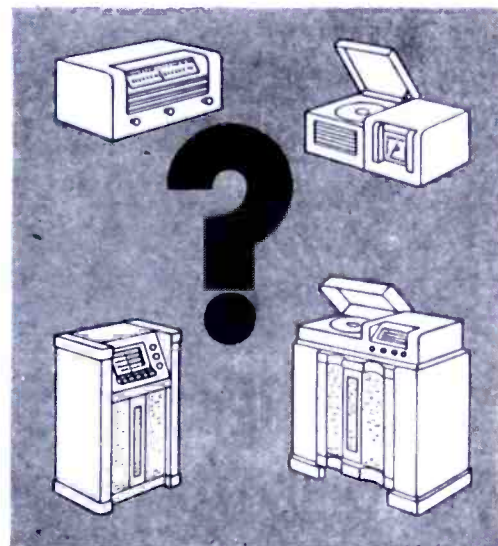

The type of set people prefer—floor or table model, radio only or radio-phonograph combination—will also be studied in the Sylvania survey.

nation-wide poll. Consumers will also be queried on such points as their interest in FM; the desirability of short-wave bands; reaction to push button tuning. The reasons why people decide on new set purchases will also come in for scrutiny.

As the survey progresses, findings will be reported from time to time in future issues of SYLVANIA NEWS.

SYLVANIA ELECTRIC

SYLVANIA ELECTRIC PRODUCTS INC., Radio Division, Emporium, Pa.

MAKERS OF RADIO TUBES, CATHODE RAY TUBES, ELECTRONIC DEVICES, FLUORESCENT LAMPS, FIXTURES, ACCESSORIES, INCANDESCENT LAMPS

COMMUNICATIONS FOR JANUARY 1945 • 3

Now! EXTRA HUMIDITY PROTECTION IS STANDARD

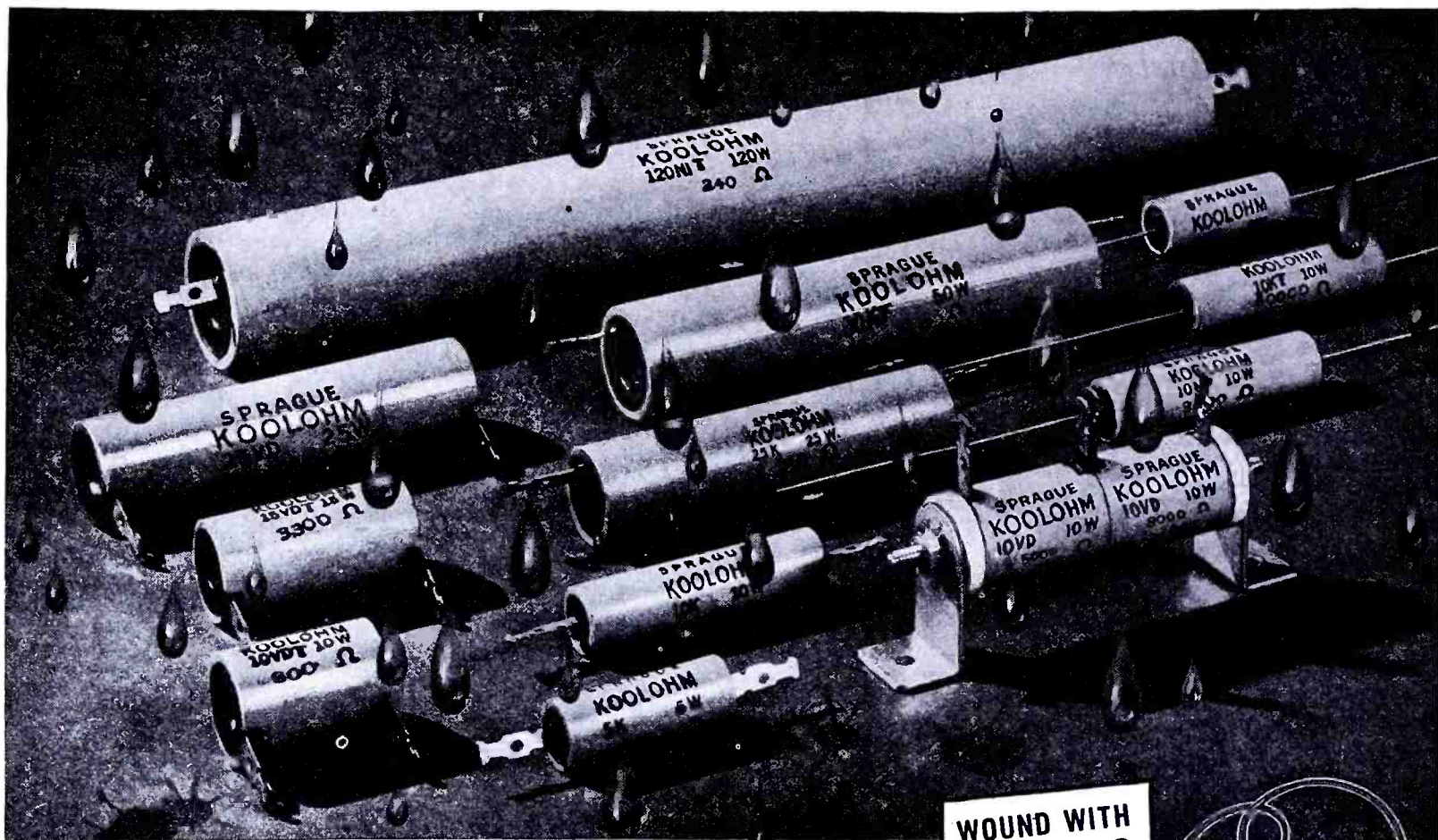

... designed for tropical conditions
 ... unbeatable on ANY job

Standard Sprague Koolohm Wire Wound Resistors now offer the same high degree of humidity protection formerly obtainable only on special order to match exacting military specifications. This construction, newly adopted as standard, includes a glazed ceramic outer shell and a new type of end seal. These features give maximum protection against even the most severe tropical humidity conditions. Type numbers remain the same ex-

cept for the fact that the letter "T" has been added to designate the new standard construction.

Thus, again, Sprague leads the way in practical, truly modern wire wound resistor construction. Your job of resistor selection is greatly simplified. No need to study and choose between types or coatings. One type of Koolohms, the *standard* type, does the job—under any climatic condition, anywhere in the world!

SPRAGUE ELECTRIC COMPANY, North Adams, Mass.
 (formerly Sprague Specialties Co.)



SPRAGUE KOOLOHM RESISTORS

TRADEMARK REGISTERED U.S. PAT. OFF.

The Greatest Wire-Wound Resistor Development in 20 Years

Seven years ago we started out as a west coast distributor of aircraft parts. We named our company Aircraft Accessories Corporation. • Then we started developing aircraft hydraulics. The next thing we knew we were full-fledged manufacturers—and out of the parts business. • Later, someone came along with an embryo electronic plant in Kansas City. Being young and ambitious—we bought it. To everyone's amazement—and somewhat to our own—we made it grow. And pay.

NEW NAME NEW HORIZONS

We're still young, ambitious. Our explorations in hydraulics, electronics and other fields promise post-war growing pains. And so we've outgrown our name. Aircraft Accessories Corporation no longer adequately describes our operations. We couldn't think of a name that did. So we coined one: Aireon. It's a name that's partly aircraft, partly electronics; but it will be largely what we make it. We hope—and intend—to make Aireon worthy of a place among America's most honored corporate and trade names.

Aireon

MANUFACTURING CORPORATION
Formerly AIRCRAFT ACCESSORIES CORPORATION

Radio and Electronics • Engineered Power Controls

NEW YORK • CHICAGO • KANSAS CITY • BURBANK

a New and Superior DIAL LIGHT SOCKET

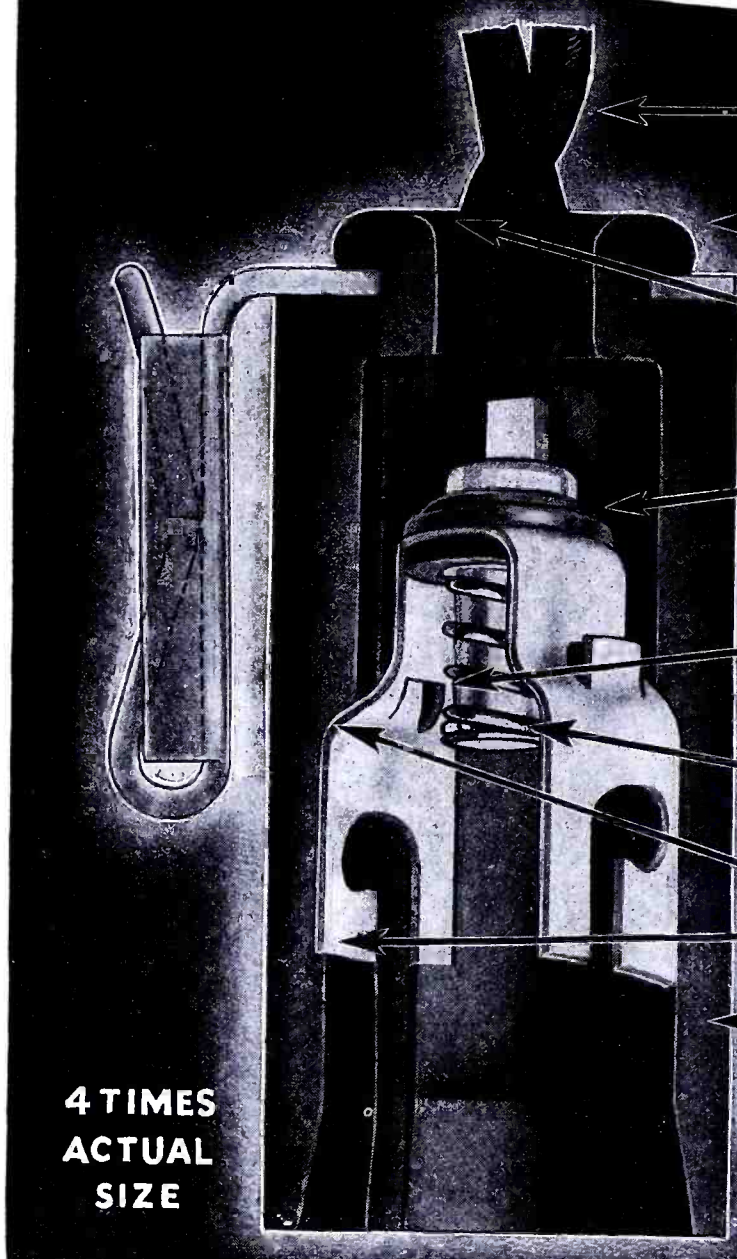

**4 TIMES
ACTUAL
SIZE**

Tensile strength of leads and connections far in excess of requirements.

Tough, plastic shell molded around bracket providing a secure bond with mechanical strength far beyond any normal requirement.

Rounded edge will not cut or fray wire insulation.

Voltage Breakdown between contacts—1200 Volts. Voltage Breakdown to ground—5000 Volts.

Lug on contact fits in groove in shell so that contact cannot be turned or twisted when inserting lamp.

Center contact mounted so that it cannot protrude from shell and short on chassis when lamp is removed.

Plastic shell is recessed for contacts, which cannot be pushed or pulled out of position.

Stronger, tougher, heavy walled plastic shell.

A variety of different mounting bracket styles available, suitable for practically any mounting.

For Your Present and Post-War Production

**40TH ANNIVERSARY
1904-1944**

This year Lenz celebrates its 40th year of service to the communications industry.

Lenz Dial Light Sockets have always been known for their superior mechanical qualities and electrical characteristics.

Now these sockets are still further improved, with even greater mechanical strength. A stronger, tougher plastic shell is attached to the bracket with a new type of construction that provides a virtually unbreakable bond between shell and bracket. Its excellent electrical characteristics are maintained.

Consider these Lenz Dial Sockets for your present and post war production. Write for sample today.

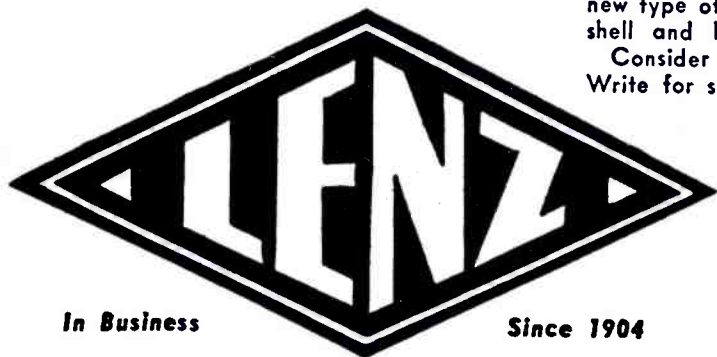

In Business

Since 1904

**LENZ ELECTRIC
MANUFACTURING CO.**

1751 N. WESTERN AVE.

CHICAGO 47, ILLINOIS

ELECTRIC CORDS, WIRES AND CABLES

A NEW -hp- AUDIO OSCILLATOR

3 OUTSTANDING NEW FEATURES:

1. ACCURATE CONTROL DIAL
EASY TO READ • NO PARALLAX

2. RUGGED CONSTRUCTION

3. IMPROVED CIRCUIT

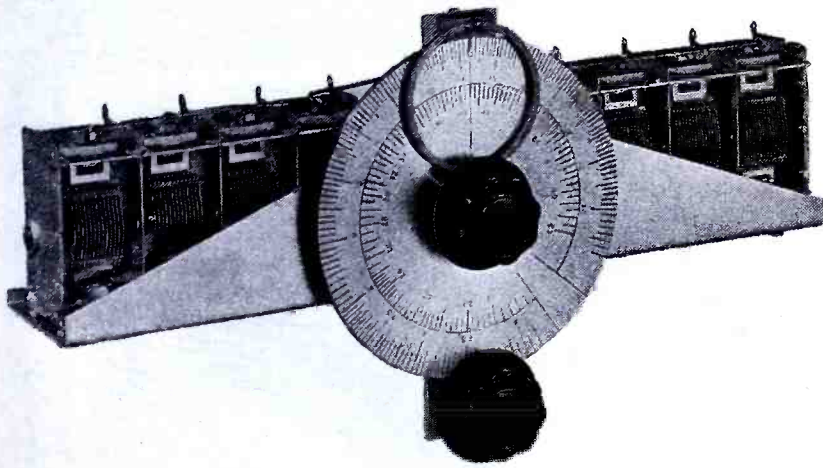

New friction driven dial provides hair-line accuracy

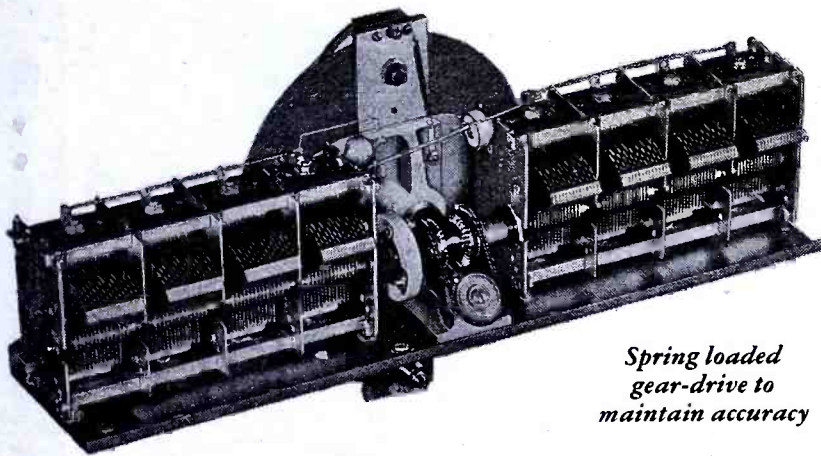

Spring loaded gear-drive to maintain accuracy

Rugged chassis construction on heavy cast frame

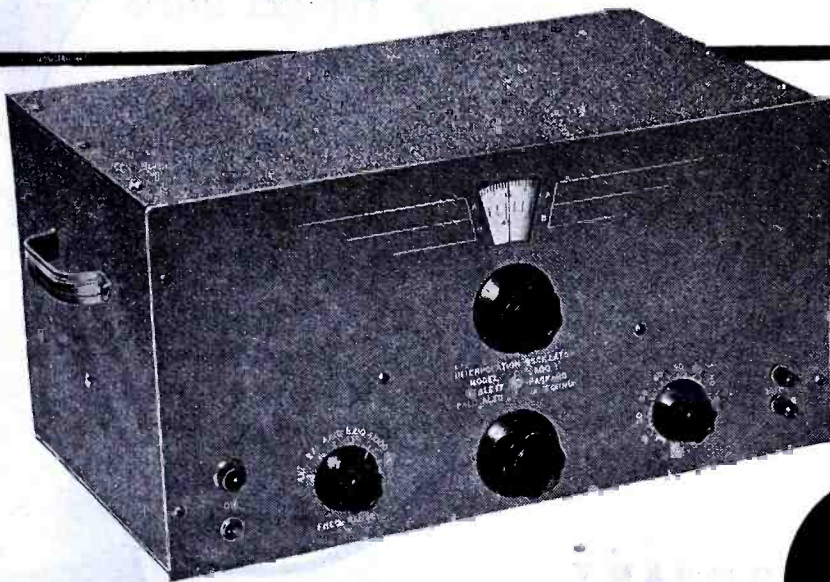

The Model 200-I is a resistance-tuned audio oscillator designed to provide high stability and accuracy for use in frequency measurements. It has a range from 6 cps to 6000 cps,* divided into six frequency ranges as follows: 6 to 20, 20 to 60, 60 to 200, 200 to 600, 600 to 2000 and 2000 to 6000 cps. Each of these ranges has an individual frequency adjustment so that the instrument may be set to a frequency standard such as the -hp- Model 100-B.

The large, 6-inch diameter, main frequency dial is calibrated over approximately 300 degrees, making possible a large number of calibrated points to cover the entire range. The dial itself rotates behind a fine wire locator which is visible through an opening in the panel. Parallax is completely eliminated and calibrations are spread over an effective scale length of nearly eight feet. Fast and extremely accurate settings are made easily with this dial. There are two manual controls: one direct action, and the second for vernier adjustments. An electronically regulated power supply is included to assure greatly improved stability.

The Model 200-I -hp- Audio Oscillator is but one among many new -hp- instruments which are to make public appearance as the cloak of military secrecy is removed. Preliminary technical information is available on this instrument now...write for it! And watch for the early release of other new -hp- instruments.

**This frequency coverage was selected for interpolation work. Other frequency ranges can be supplied from 6 cps to 100 kc on special order.*



HEWLETT-PACKARD COMPANY

Box 930E - Station A - Palo Alto, California

OHMITE RESISTORS

Many Types and Sizes
Assure the Right Resistor
for Each Control Job

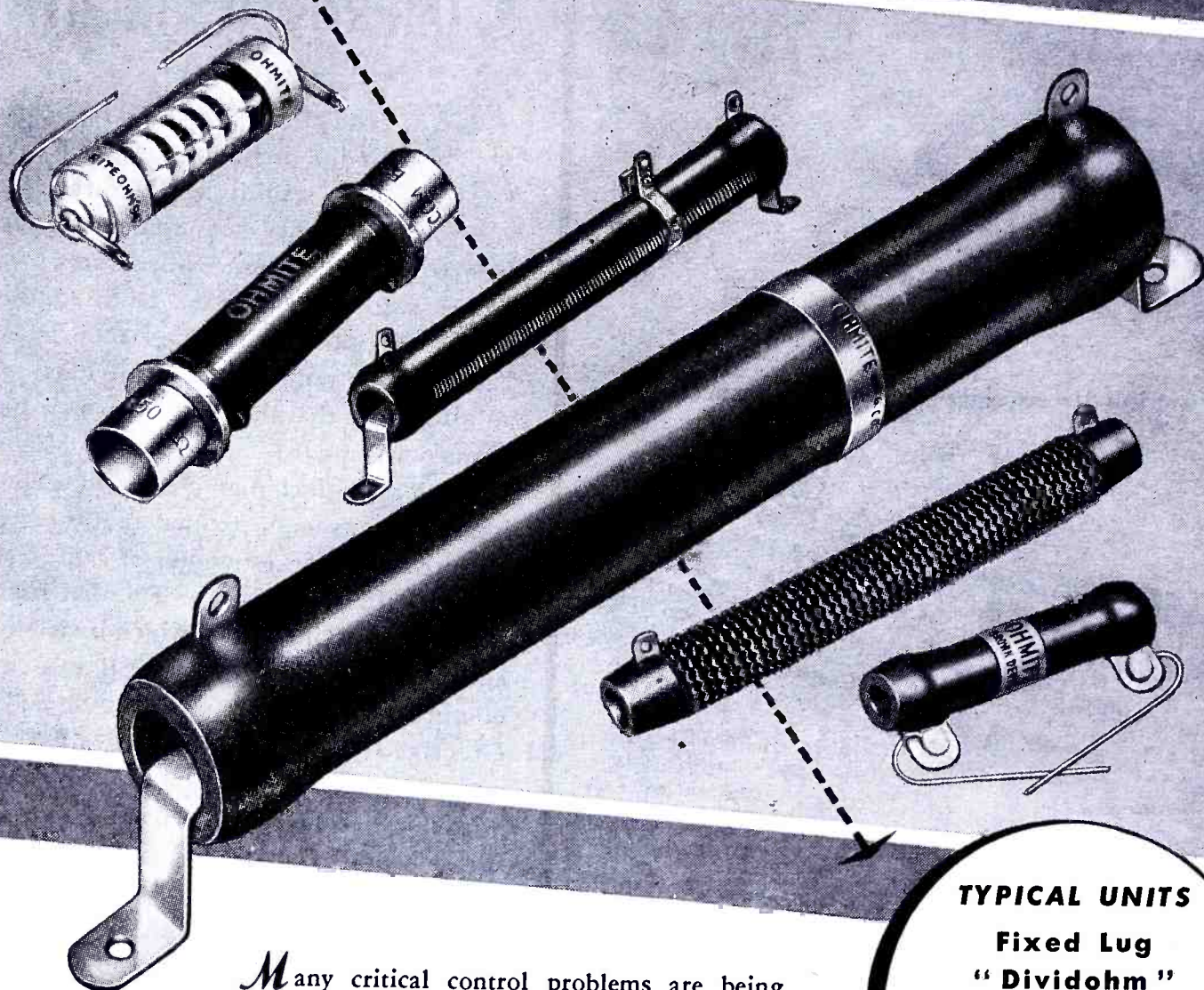

Many critical control problems are being readily and successfully solved with Ohmite Resistors. That's because the extensive range of Ohmite types and sizes makes possible an almost endless variety of regular or special units to meet each need best.

Ohmite core sizes range from 2½" diameter by 20" long to 5/16" diameter by 1" long. Wide selection of stock units are available.

These rugged resistors have proved their worth under toughest operating conditions, in every field of action. Ohmite engineers are glad to help on today's and tomorrow's control problems.

OHMITE MANUFACTURING COMPANY
4869 Flournoy Street • Chicago 44, U.S.A.

TYPICAL UNITS

Fixed Lug
"Dividohm"
Wire Lead
"Corrib"
Ferrule
Edison Base
Precision
Bracket
Non-Inductive
Tapped
Cartridge
Strip

Be Right with **OHMITE**
RHEOSTATS • RESISTORS • TAP SWITCHES

Send for Catalog and Engineering Manual No. 40

Write on company letterhead for this complete, helpful guide on resistors, rheostats, tap switches. Address OHMITE, 4869 Flournoy, Chicago 44.



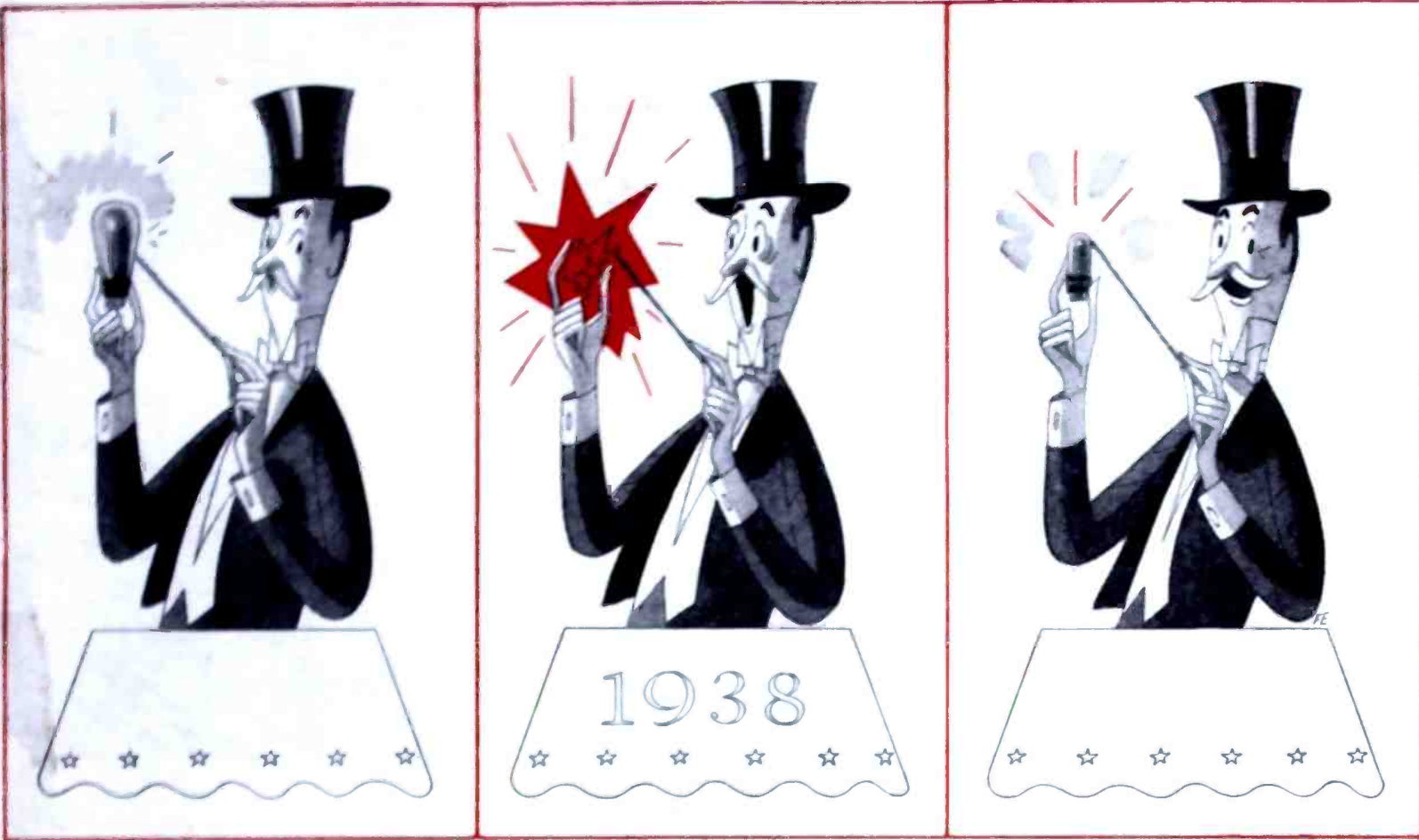

THEY SAID IT COULDN'T BE DONE!

Back in 1938, Hytron began designing new dies and converting production machinery for the first BANTAM GT tubes. The industry said in effect: "You're crazy; it won't work. You can't telescope standard glass tubes to BANTAM size and get the same results." Beam tetrodes, such as the 50L6GT, particularly were considered impossibilities. The intense heat developed during normal operation would warp the elements and crack the small glass bulb.

But Bruce A. Coffin, originator of the BANTAM GT, stuck to his guns. In a few short years, Hytron developed over fifty GT types. The GT became the most popular receiving tube.* Short leads, low capaci-

ties, advantages of shorter bombardment at lower temperatures, ruggedness of compact construction plus both top and bottom mica supports, smaller size, standardized envelopes and bases — all contributed to that popularity.

The BANTAM GT permitted new space economies in pre-war receivers. Only its universal acceptance as standard by all manufacturers makes possible fulfillment of the Services' demands for receiving tubes. In increasing numbers, as this war draws to its ultimate conclusion, Hytron will continue to supply you with the popular BANTAM GT tubes which everyone said just couldn't be made.

**1941 industry production figures: GT—52,000,000; metal—27,000,000; standard glass, G, and local — 56,000,000.*

OLDEST EXCLUSIVE MANUFACTURER OF RADIO RECEIVING TUBES

HYTRON

CORPORATION ELECTRONIC AND RADIO TUBES

SALEM AND NEWBURYPORT, MASS.



BUY ANOTHER WAR BOND



A Word About Reconversion

RECONVERSION already is getting started in a few plants. For others, it may be just "around the corner", but Radio still is completely absorbed in its wartime job.

That's the situation at Rola today. The things made here . . . transformers, coils and other intricate parts for Military Communications . . . still are being required in gigantic quantities, and since Rola is one of the few plants of its kind equipped to make those things, the obligation to produce *in maximum amounts* cannot be slighted.

This means we may not be able, now, to give

our old customers the kind of service they have learned to expect from Rola . . . *all* the experimental models, *all* the technical assistance and *all* the other things we used to provide. This we should regret, for we are proud of our quarter-century reputation for Service, but there is no alternative and we hope our friends in the Radio Industry will understand our present position.

No one can predict how long this intervening period may be, but Rola's reconversion . . . when it comes . . . will be speedy, and at that time set makers again can look to Rola for the "Finest in Sound Reproducing Equipment."

THE ROLA COMPANY, INC. • 2530 SUPERIOR AVENUE, CLEVELAND 14, OHIO

ROLA



MAKERS OF THE FINEST IN SOUND REPRODUCING AND ELECTRONIC EQUIPMENT

10 • COMMUNICATIONS FOR JANUARY 1945



The Greeks gave us a word for it . . . now we give it to *you*

WHEN Sperry first developed its velocity-modulated, ultra-high-frequency tube, the word "KLYSTRON" was registered as the name of the new device.

This name — from the Greek, as coined by scientists of Stanford University — is an apt description of the bunching of electrons between spaced grids within the tube.

"Klystron" is a good name. So good, that it has come into widespread use as the handy way to designate *any* tube of its general type,

whether a Sperry product or not.

This is perfectly understandable. For the technical description of a Klystron-type tube is unwieldy, whether in written specifications, in conversation, or in instructing members of the Armed Forces in the operation of devices employing such tubes.

These conditions have prompted many requests from standardization agencies—including those of the Army and Navy—for unrestricted use of the name Klystron. In the public interest, Sperry has been glad to

comply with these requests . . .

From now on, the name KLYSTRON belongs to the public, and may be used by anyone as the designation for velocity-modulated tubes of any manufacture.

Sperry will, of course, continue to make the many types of Klystrons it now produces, and to develop new ones.

On request, information about Klystrons will be sent, subject to military restrictions.

SPERRY GYROSCOPE COMPANY, INC. GREAT NECK, N. Y.

Division of the Sperry Corporation



LOS ANGELES • SAN FRANCISCO • NEW ORLEANS
HONOLULU • CLEVELAND • SEATTLE

GYROSCOPICS • ELECTRONICS • RADAR • AUTOMATIC COMPUTATION • SERVO-MECHANISMS

COMMUNICATIONS FOR JANUARY 1945 • 11

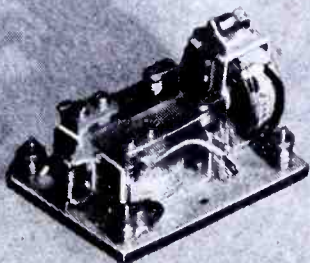
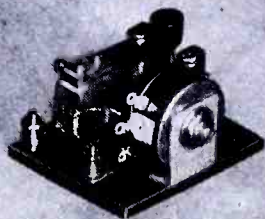
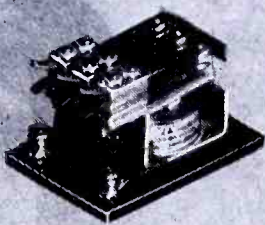
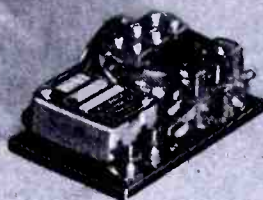
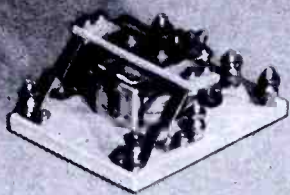

In every branch of the Army and Navy, Advance Relays are dependable components of many types of electrical equipment. Factory production is still all-out for War, but Engineering Service for Post-War products is available *now*.



CO-OPERATIVE ENGINEERING FOR NEW RELAY APPLICATIONS

SIMPLIFY your product development and manufacturing problems by calling on Advance Engineers for the close co-operation they are prepared to give you *immediately*. This service not only applies to adaption of one or more of the forty basic types of Advance Relays, which are usually directly applicable to most modern electrical control requirements, but may be utilized for the development of special test models. In any event, you will have the best of relays, exactly as you want them. Write today



ADVANCE ELECTRIC & RELAY CO.
1260 WEST SECOND STREET • LOS ANGELES 26, CALIFORNIA

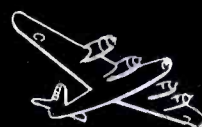

Crystal Blanks TO YOUR SPECIFICATIONS

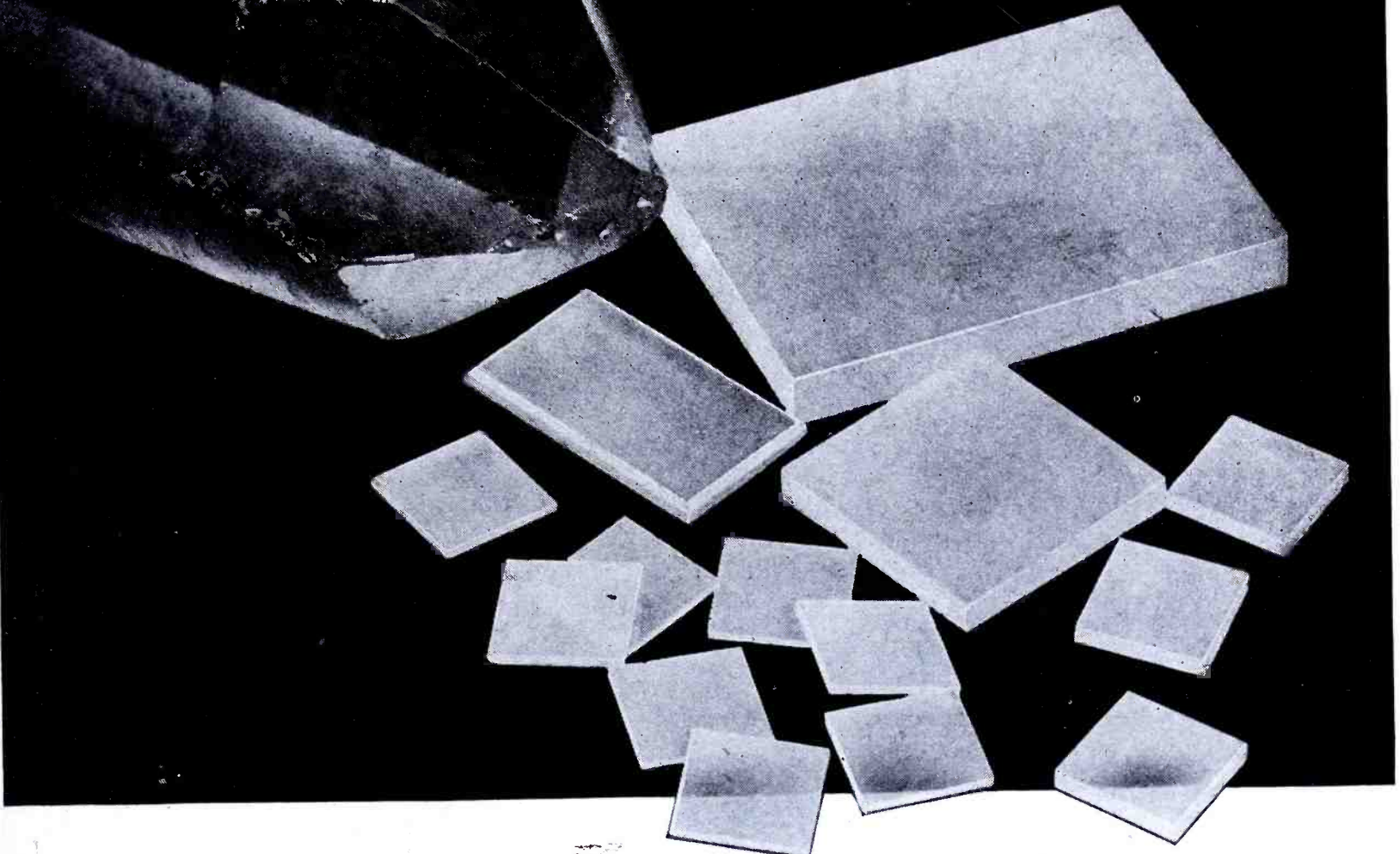

Crystal Products Company can supply Quartz Crystal blanks in any of the three stages of manufacture: (1) "rough-sawed" blanks, (2) "semi-finished" blanks, and (3) "electrically finished" blanks.

"Rough-sawed" blanks are cut to the specified angles and roughly sawed to dimensions.

"Semi-finished" blanks are blanks which have been brought to approximate dimensions by machine lapping, allowance being made for final hand finishing.

"Electrically-finished" blanks are finished by hand to the frequency desired and electrically tested.

All crystal blanks are cut to specifications from selected Brazilian quartz and guaranteed free from all impurities such as optical twinning, electrical twinning, bubbles, fractures, scratches, mineral inclusions, and other mechanical and electrical imperfections. Dimensions, temperature coefficients, and frequencies are guaranteed within specifications listed. **Send us your holders for replacement of crystal blanks to exact specifications.**



1519 McGee Street, Kansas City, Mo.
Producers of Approved Precision Crystals
for Radio Frequency Control

HUDSON AMERICAN

*A Complete Line of
Standard and Hermetically Sealed*
TRANSFORMERS

Secret

Many products and processes of Hudson American's war time engineering are still strictly secret — and must remain so for the duration. However, there is no secret to Hudson American's success in transformer engineering.

Not Secret

Only the best in men and machines can provide the best in transformer design and construction.

These Hudson American transformers have proven reliable under the tests of battle — the Arctic cold of bomber flights, the brutal beatings of amphibious landings, and the dust and mud of jungle trails.

Hudson American transformers have successfully met these war imposed tests with the same absolute reliability that they show in industrial applications.

WRITE

FOR YOUR
COPY OF
THE NEW
1945
HUDSON
AMERICAN
TRANSFORMER
CATALOG

HUDSON AMERICAN CORPORATION

25 WEST 43rd STREET • NEW YORK 18, N. Y.

More than **35** Years of Service

to the
**RADIO
INDUSTRY**



Whether Amplitude Modulation . . . Frequency Modulation . . . or Television — dependability is a *must* for all broadcast equipment.

Federal broadcast equipment has earned a reputation for that dependability because *it stands up*.

For more than thirty-five achievement-studded years . . . from the Poulsen Arc to the new CBS Television Station . . . Federal has served the broadcast industry with superior equipment.

Federal's background includes such milestones of electronic progress as the 1000 Kw Bordeaux Transmitter; Micro-ray, the forerunner of modern television technique; and the first UHF multi-channel telephone and telegraph circuits, part of a world-wide communications system . . .

All this, plus the war-sharpened techniques that are the result of ability *and* experience, combine to give you craftsmanship . . . the kind of craftsmanship that builds dependability into all Federal equipment.

In AM . . . FM . . . TV . . .

. . . your prime need in broadcast equipment is dependability — *look to Federal for it*.



Federal Telephone and Radio Corporation



Newark 1, N. J.



History of Communications. Number Thirteen of a Series

MILITARY RADIO COMMUNICATIONS

Today the allied military radio equipments represent the "tops" engineering design. Progress from the spark transmitter of World War I to present-day equipment is, indeed, a far cry. Taking up where the war left off December 7, 1941, Universal Engineers, with their added experience with precision military equipment, shall produce for the public electronic devices not of fantastic design — but of proven utility and quality.

After Victory is ours, radio amateurs, affectionately known as "hams" will be back after their experience with military radio equipment with an even greater desire to operate their own "rigs." It will be then that Universal will again have Microphones and recording components available on dealers' shelves.

◀ *FREE—History of Communications Picture Portfolio. Contains over a dozen pictures suitable for office, den, or hobby room. Write for your "Portfolio" today.*



UNIVERSAL MICROPHONE COMPANY
INGLEWOOD, CALIFORNIA



FOREIGN DIVISION: 301 CLAY STREET, SAN FRANCISCO 11, CALIFORNIA • CANADIAN DIVISION: 560 KING STREET WEST, TORONTO 1, ONTARIO, CANADA

16 • COMMUNICATIONS FOR JANUARY 1945



MEC-RAD

MANUFACTURERS OF MECHANICAL-ELECTRICAL
COMPONENTS FOR RADIONICS

A NEW NAME ON THE ELECTRONICS POST-WAR HORIZON

The period after the war may well become known as the "Electronic Era". In the development of the many ingenious post-war products, there will be a need for specialized engineering of precise and intricate high frequency components. This is our field. Our organization, with years of experience designing and making such products is at present devoting its manufacturing facilities 100% to war work. These unusual facilities will soon be available for the peacetime needs of our industry, and our engineering "know-how" is at your service now to help you with your post-war planning.

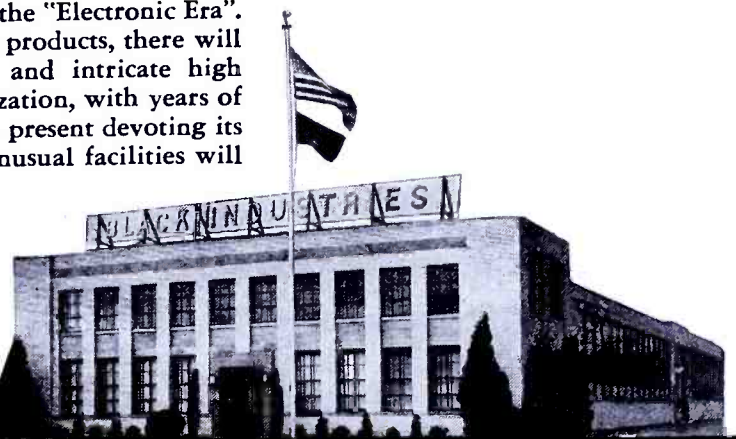

MEC-RAD

DIVISION-BLACK INDUSTRIES

1400 EAST 222ND STREET ☆ CLEVELAND 17, OHIO



**A liberal choice
of types to meet most electrical
and mechanical requirements...**

AEROVOX *Electrolytics*

● Along with pioneering the dry electrolytic capacitor for radio, electronic and motor-starting functions, Aerovox has always maintained an outstanding choice of types.

The new Aerovox Capacitor Catalog now off the press lists 17 types of electrolytics—round-can, square-can, cardboard-case, tubulars, plug-ins, twist-prong base, etc. You will usually find a type listed that precisely meets your capacitance, voltage, mounting, terminal and container requirements. But if your requirements happen to be very unusual, this wide variety of designs enables Aerovox to work out a special type to meet those high-priority needs quickly, satisfactorily, economically.

● Write for Literature ...

Write on your business stationery for latest catalog on electrolytics. Submit that capacitance problem for our engineering collaboration, specifications, quotations.



Capacitors

INDIVIDUALLY TESTED

AEROVOX CORPORATION, NEW BEDFORD, MASS., U. S. A.
Export: 13 E. 40 St., New York 16, N. Y. • Cable: 'ARLAB' • In Canada: AEROVOX CANADA LTD., HAMILTON, ONT.
SALES OFFICES IN ALL PRINCIPAL CITIES

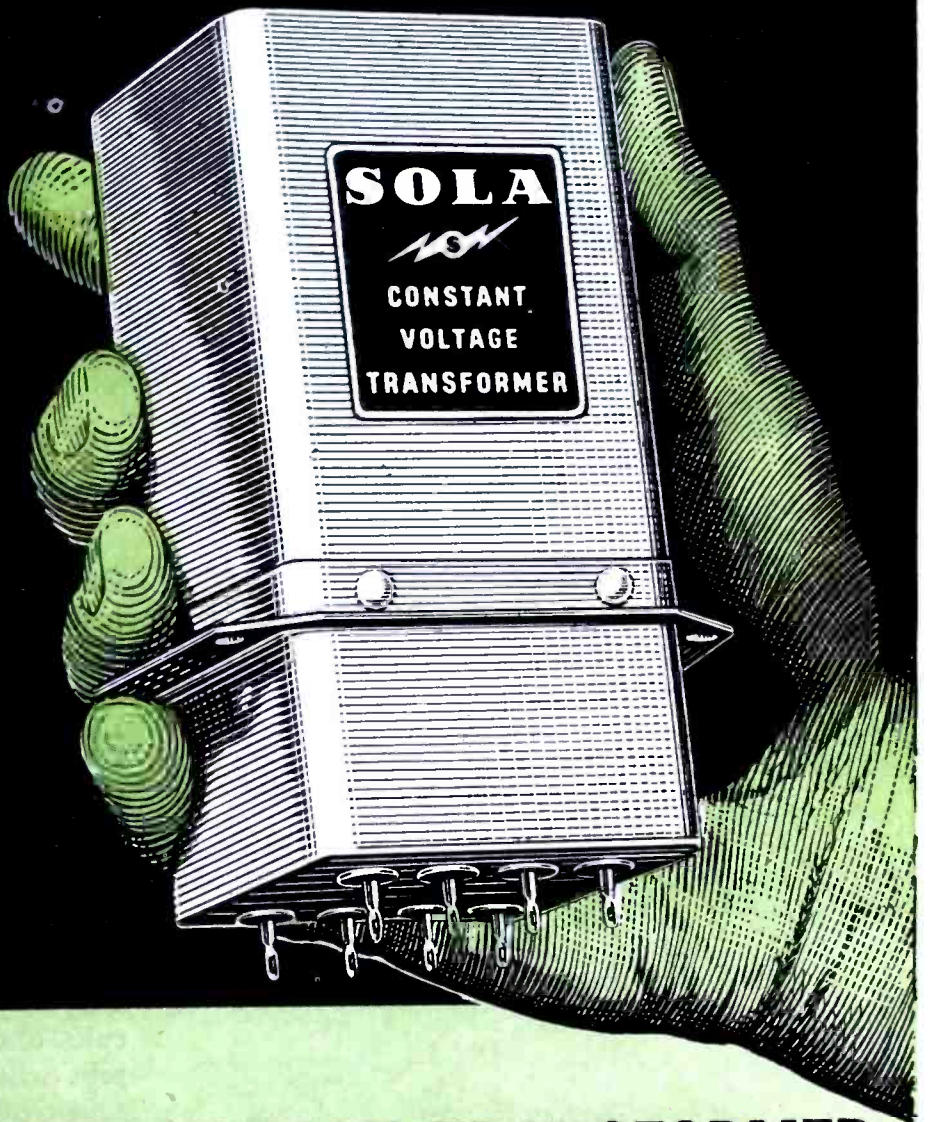
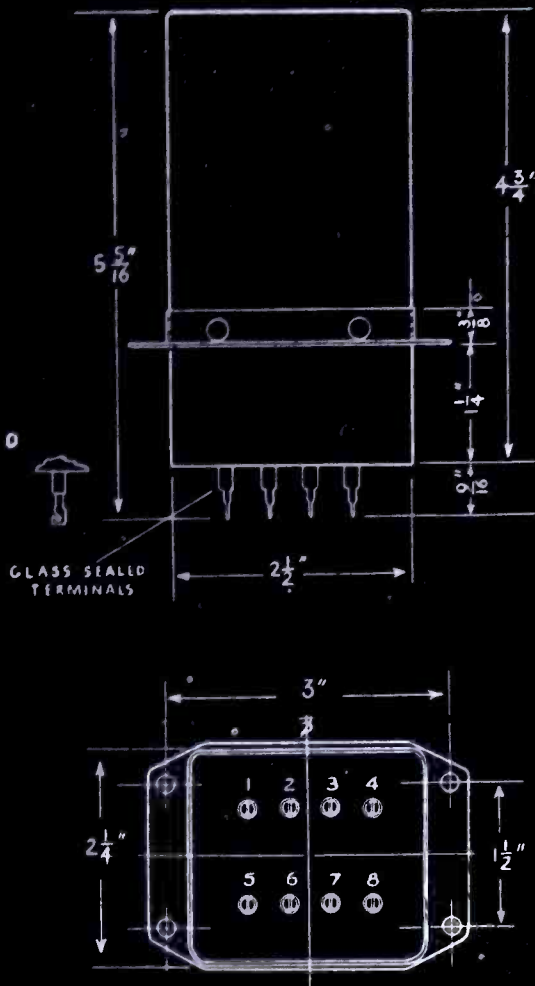

Another SOLA CONSTANT VOLTAGE TRANSFORMER that has an important future in *YOUR* postwar plans

There may be one vulnerable spot in the design of *your* equipment that this SOLA Constant Voltage Transformer will correct.

Your customers do not have the stable line voltage called for on your label. They will blame *your* equipment for inefficient operation, *not* the fluctuating voltages that really cause it.

Build this SOLA Constant Voltage Transformer into your product and you can be certain that the operating voltages will always be within $\pm 1\%$ of rated require-

ments regardless of line fluctuations as great as 30%.

This SOLA Constant Voltage Transformer is built to fit your equipment. (Note the small, compact dimensions.) Its low cost will fit your production budget. Its automatic operation will eliminate the need for other costly components, and relieve your customers of the responsibility of making manual voltage adjustments.

There's a powerful sales story behind a product equipped with a SOLA Constant Voltage Transformer.

Constant Voltage Transformers S O L A

To Manufacturers:

Built-in voltage control guarantees the voltage called for on your label. Consult our engineers on details of design specifications.

Ask for Bulletin ECV-103

Transformers for: Constant Voltage • Cold Cathode Lighting • Mercury Lamps • Series Lighting • Fluorescent Lighting • X-Ray Equipment • Luminous Tube Signs • Oil Burner Ignition • Radio • Power • Controls • Signal Systems • Door Bells and Chimes • etc. SOLA ELECTRIC CO., 2525 Clybourn Ave., Chicago 14, Ill.

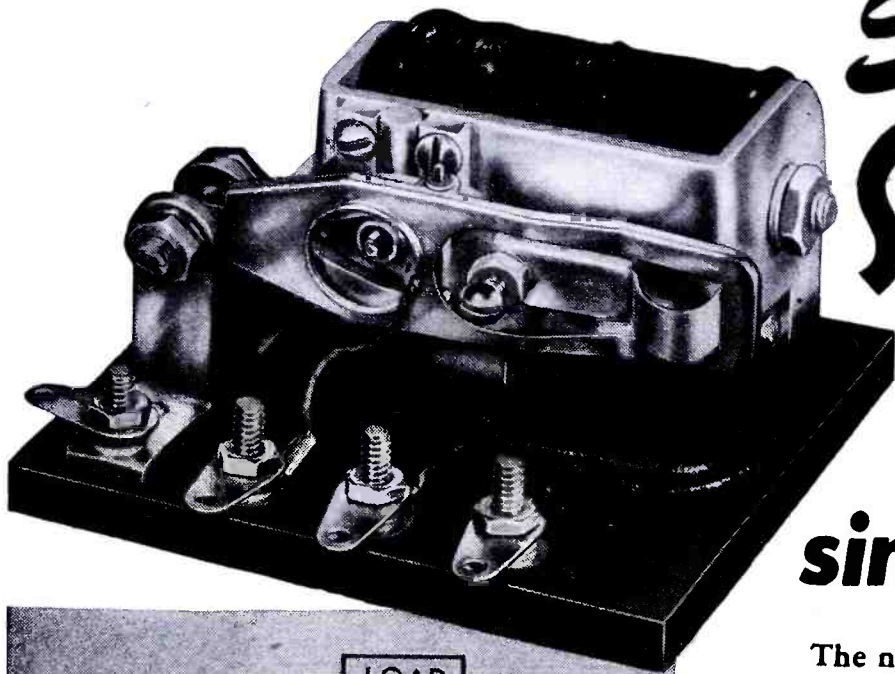

Sensitive **SNAP-ACTION**

**...in a new,
simplified design**

The new, simplified construction of the Struthers-Dunn Type 79XAX Sensitive Snap-Action Relay makes it particularly suitable for a wide range of applications because of its ease of adjustment. Snap-action contacts eliminate the erratic, undependable action normally encountered in ordinary sensitive relays when a slowly varying coil current tends to balance the armature tension spring, and to hold closed the normally closed contacts.

The armature of the 79XAX almost completes its travel in either direction before the contacts snap into the new position. This feature permits an unusually broad range of use from vacuum tube circuits, to overcurrent protection, pulsing circuits, and jobs where extremely close differential or extreme sensitivity of operation is required.

The standard adjustment using 60 ampere turns in the coil at approximately .02 watts results in contact pressures of 5 grams with contacts rated 5 amperes, 115 volts a-c; or 0.5 amperes, 115 volts d-c, non-inductive. Contact ratings up to 10 amperes, 115 volts a-c may be obtained with 100 or more ampere turns and a corresponding increase in power. A sensitivity of 0.005 watts, with 30 ampere turns, is obtainable with reduced contact pressures and ratings, and at an increase in price of the unit.

STRUTHERS - DUNN INCORPORATED
1321 ARCH STREET, PHILADELPHIA 7, PA.

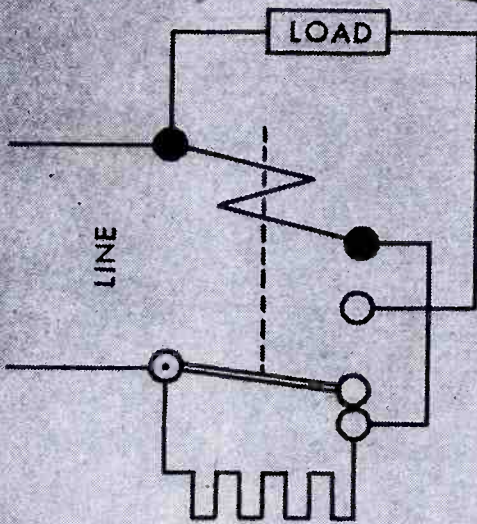

A TYPICAL CLOSE DIFFERENTIAL APPLICATION

In using the Struthers-Dunn 79XAX Relay, extremely close differential between pick-up and drop-out may be obtained for potential operation as shown above. The resistor is chosen so that, when the armature closes, the coil current is automatically reduced to a value just sufficient to hold it closed. Any further decrease in voltage will cause the relay to return to its normal de-energized position as shown.

STRUTHERS-DUNN

5,312 RELAY TYPES

DISTRICT ENGINEERING OFFICES: ATLANTA • BALTIMORE • BOSTON • BUFFALO • CHICAGO • CINCINNATI • CLEVELAND
DALLAS • DENVER • DETROIT • HARTFORD • INDIANAPOLIS • LOS ANGELES • MINNEAPOLIS • MONTREAL
NEW YORK • PITTSBURGH • ST. LOUIS • SAN FRANCISCO • SEATTLE • SYRACUSE • TORONTO • WASHINGTON

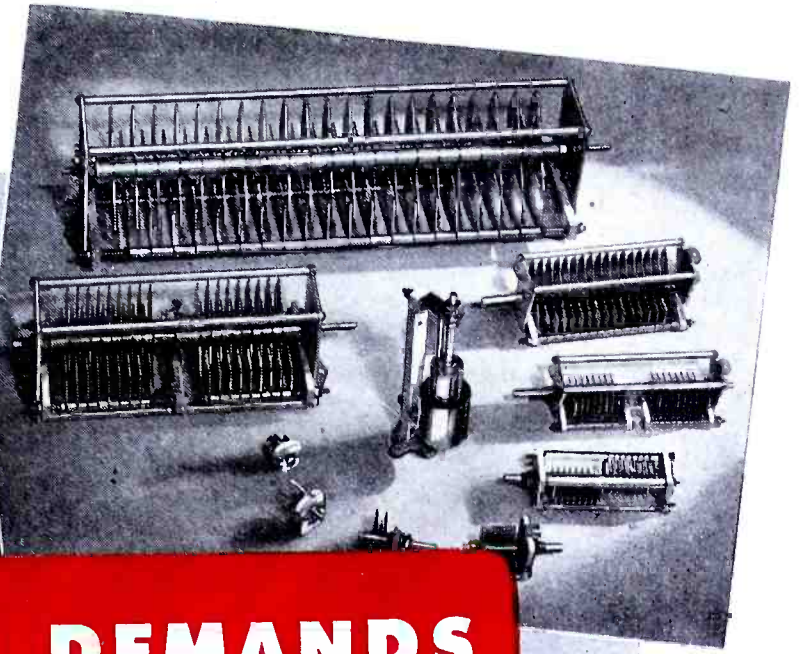

GEARED TO WAR DEMANDS

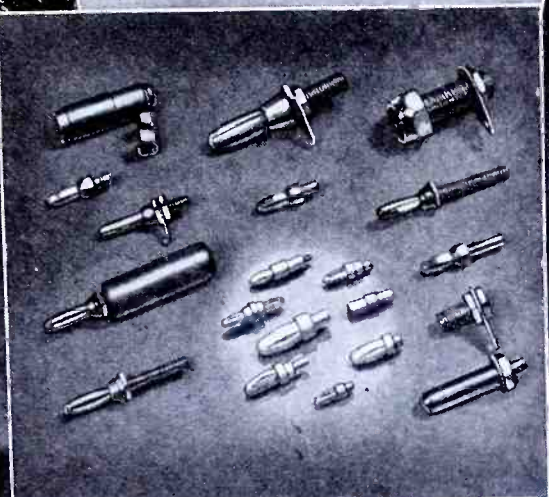
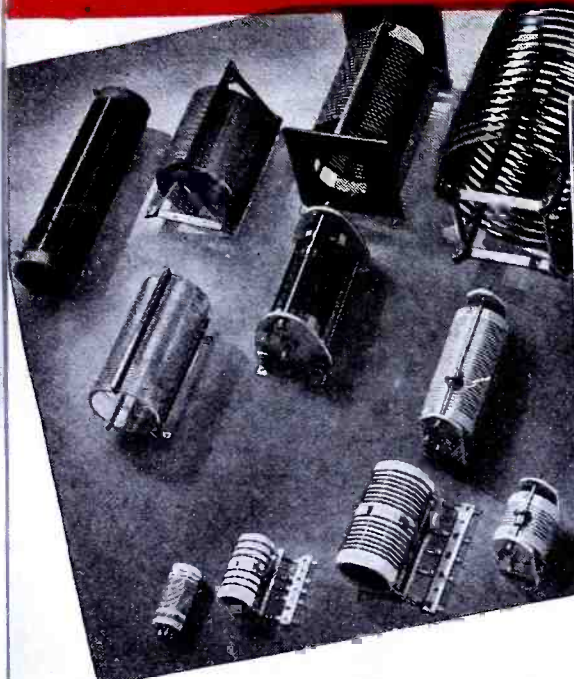

Johnson production facilities are flexible - -
 10 or 10,000 - - standard specifications or
 special - - repeat items or new - - any plating
 - - any metal or alloy - - any insulation. If it's
 metal or insulation or a combination of both,
 try Johnson first.

Ask for Catalog 968 (E)

SPECIALISTS IN

- Fixed and Variable Condensers
- Porcelain and Steatite Insulators
- Plugs, Jacks, Clips and Connectors
- Fixed and Variable Inductors
- Radio Frequency Chokes
- Flexible and Rigid Insulated Couplings
- Antenna Systems and Equipment
- Mycalex Machining and Parts
- Special Insulated Assemblies
- Broadcast Station Equipment



JOHNSON

a famous name in Radio

E. F. JOHNSON COMPANY • WASECA • MINNESOTA

Breeze Flexible Conduit

for shielding or ducts



Breeze Flexible Tubing, manufactured in many diameters from a wide variety of metals, is used as ventilation and exhaust ducting in industrial, aircraft, marine and automotive applications. The same basic tubing, with the addition of a braided metal covering, becomes light-weight shielding conduit, used extensively for shielding ignition systems and any electrical circuit to insure dependable radio communication.

Manufactured from a continuous strip of metal, Breeze Flexible Tubing and Conduit can be furnished cut to length, with necessary end-fittings for any conduit installation.

Many different types of interlock construction—plain, packed, and soldered—are available to meet varying use requirements. A few of these are illustrated below.

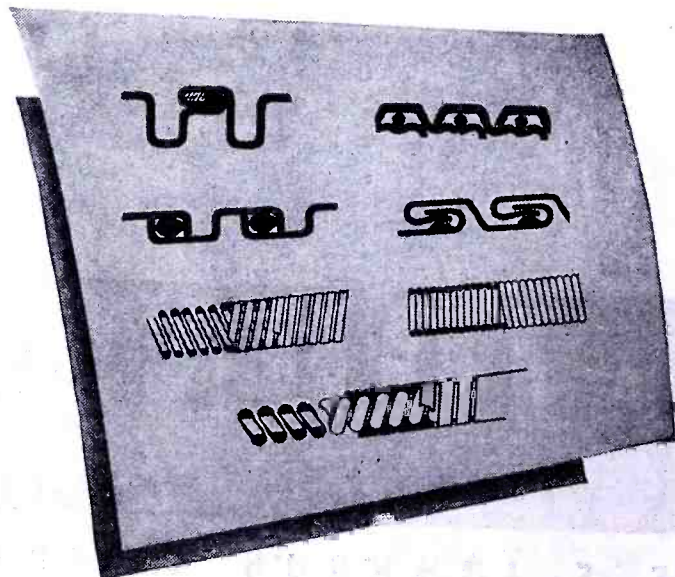

Breeze 
CORPORATIONS, INC.
 Newark, New Jersey

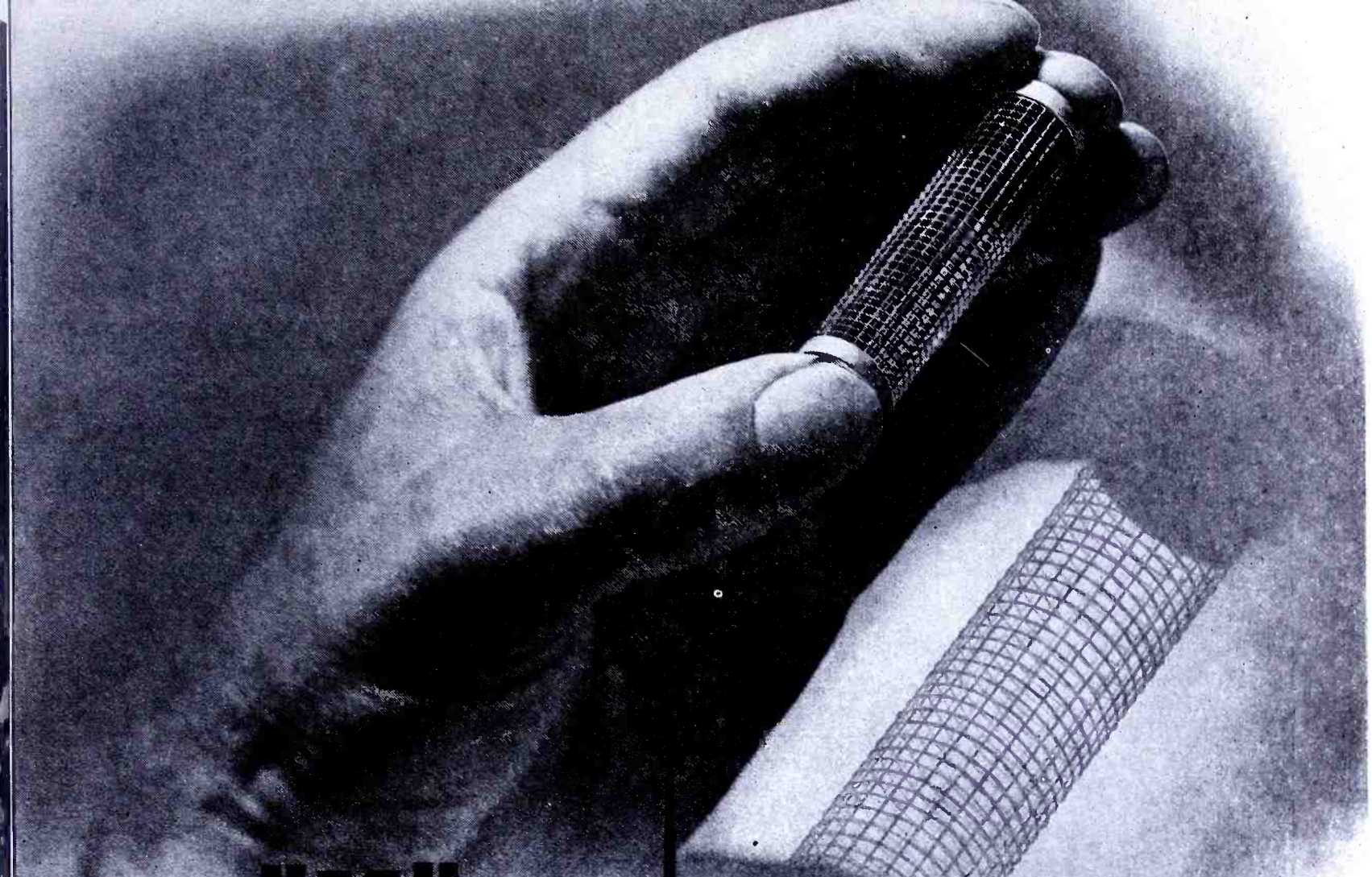

Eimac "X" Grid

Solves grid emission problem!

Grid emission, with the resulting instability of operation, parasitic oscillations and prematurely burned out filaments, has become a thing of the past. The new Eimac "X" grid will not emit electrons even when operated at incandescent heat.

The solution to the problem of grid emission lifts a great barrier which has long stood in the path of electron vacuum tube development and the progress of electronics. Eimac Engineers in developing the "X" grid have made a real contribution . . . and a very important one . . . toward the development of new and more efficient vacuum tubes. It is such heads-up Engineering that has made Eimac first choice of leading electronic engineers throughout the world . . . and maintained them in that position year after year.

Follow the leaders to



**ELECTRONIC
TELESIS**

The layman's handbook of Electronics will be sent you upon request without cost or obligation.

EITEL-McCULLOUGH, INC., 874 San Mateo Avenue, SAN BRUNO, CALIF.
Plants located at: Son Bruno, California and Salt Lake City, Utah

Export Agents: **FRAZAR & HANSEN, 301 Clay St., San Francisco 11, Calif., U.S.A.**

The Science Behind the Science of Electronics
is the focusing of all branches of science upon the development and improvement of electron vacuum tubes.



PHYSICS... Especially designed electron microscope enables operator actually to view electron emission.



OPTICS... Photomicrographic studies help achieve perfection in processing.



POWDER METALLURGY... Compounding special alloys.

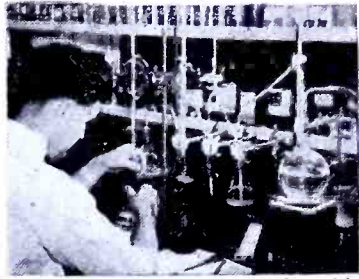

CHEMISTRY... Experimentation with metallic components and preparation of chemical compounds.

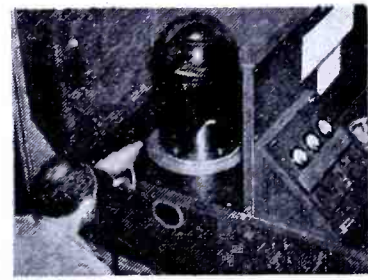

THERMO-DYNAMICS... Vacuum furnaces heat materials to exceedingly high temperatures.

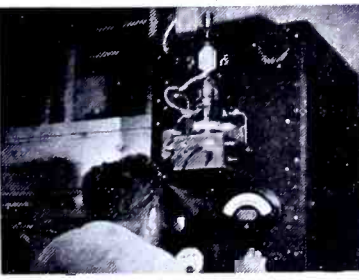

ELECTRONICS... Determining facts about and recording data on vacuum tube capabilities.

A HIGH HONOR FOR

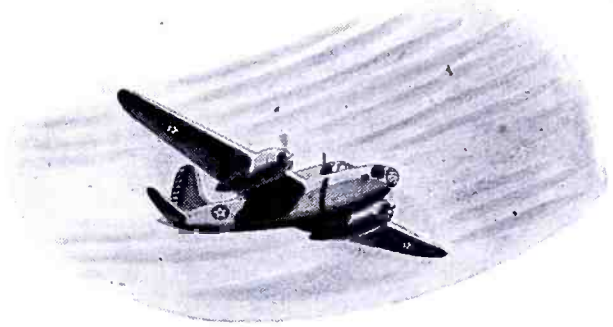

THE DeJUR INSPECTION PERSONNEL

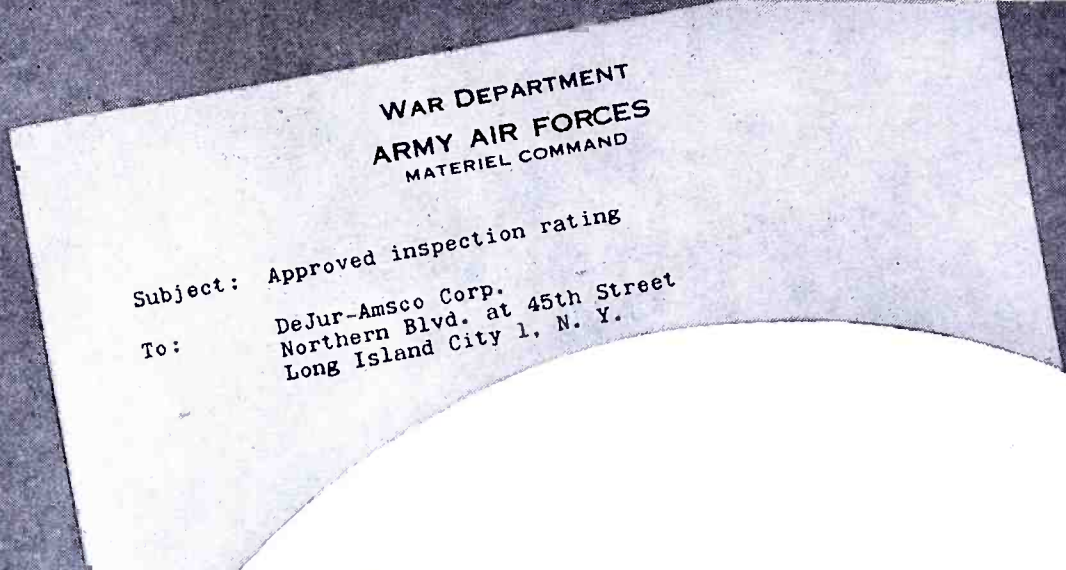

United States Army Air Forces' Approved Quality Control Rating

"As a result of the efficiency of your inspection personnel and procedures in production of equipment for the Army Air Forces, your company has been given an 'approved' quality control rating"—this is a direct quotation from the letter received by the DeJur-Amsco Corporation from the District Supervisor, Eastern Procurement District, AAF Technical Service Command.

This rating is the Army Air Forces' official recognition of the ability of the DeJur inspection personnel to meet all AAF inspection requirements. And it means that in future fabrication of DeJur products, Air Corps inspectors will not function in the same capacity as heretofore but will stand by merely for supervisory purposes. The men and women inspectors of the DeJur-Amsco Corporation are extremely pleased with this new honor, and pledge unrelenting care in the performance of their duties.

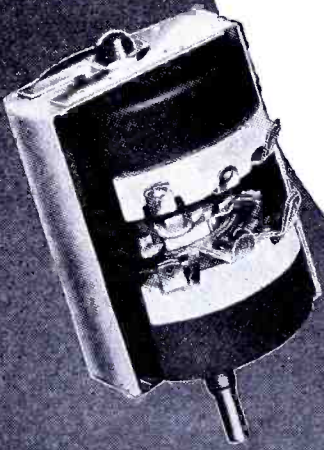
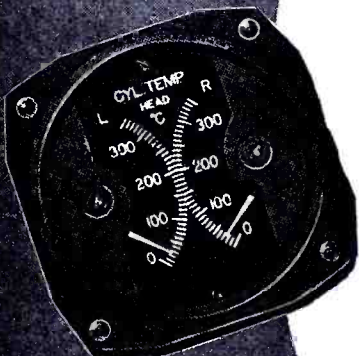

BUY MORE WAR BONDS... HOLD ON TO THEM

DeJur-Amsco Corporation

NORTHERN BOULEVARD AT 45th STREET
Long Island City 1
New York



PRECISION AT

2,000,000

VOLTS

ANOTHER
MACHLETT
TECHNIQUE

WE ARE not going to tell you here why this tube was made, what it does, or what it is for. The important thing about it to you as a user of radio oscillator, amplifier and

rectifier tubes for communications or induction heating is that it represents the toughest assignment ever handed the electronic tube industry, and that of all tube makers only Machlett perfected the techniques that made the tube possible.

The tube is sealed-off, vacuum-tight, and operates at 2,000,000 volts, direct current. These and other difficult conditions were essential to assure high and constant power, reduction of heat, and precise focusing of the electron beam.

Electrical and mechanical problems presented by the tube were so severe that some scientists doubted they could be solved, but Machlett, drawing upon its long experience, met every requirement in a little over two years.

This is significant to you because every electronic tube, whether it produces X-rays, or radio waves, or is a rectifier, depends for its success in your service upon correct design, proper vacuum, adequate insulation, and precision-made parts, to assure precise control of the electrons that make any such tube function.

The perfection of this 2,000,000-volt direct-current tube is the best proof we can offer of the value of the Machlett skills that go into the design and manufacture of every tube bearing our name . . . Machlett Laboratories, Inc., Springdale, Connecticut.

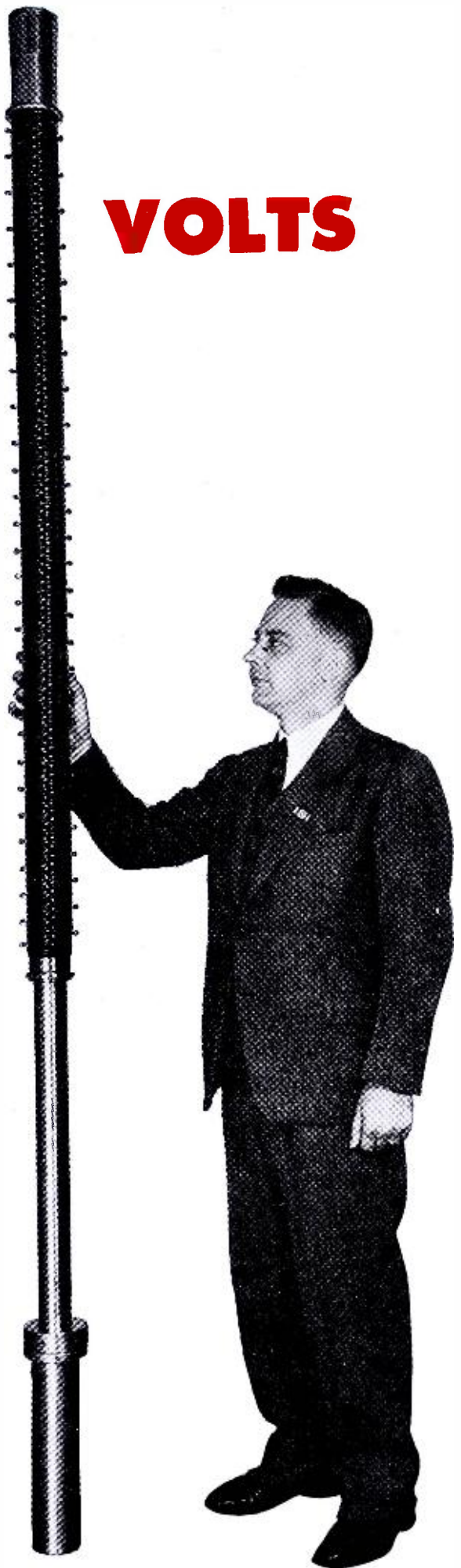

MACHLETT

APPLIES TO RADIO ITS 46 YEARS
OF X RAY TUBE EXPERIENCE

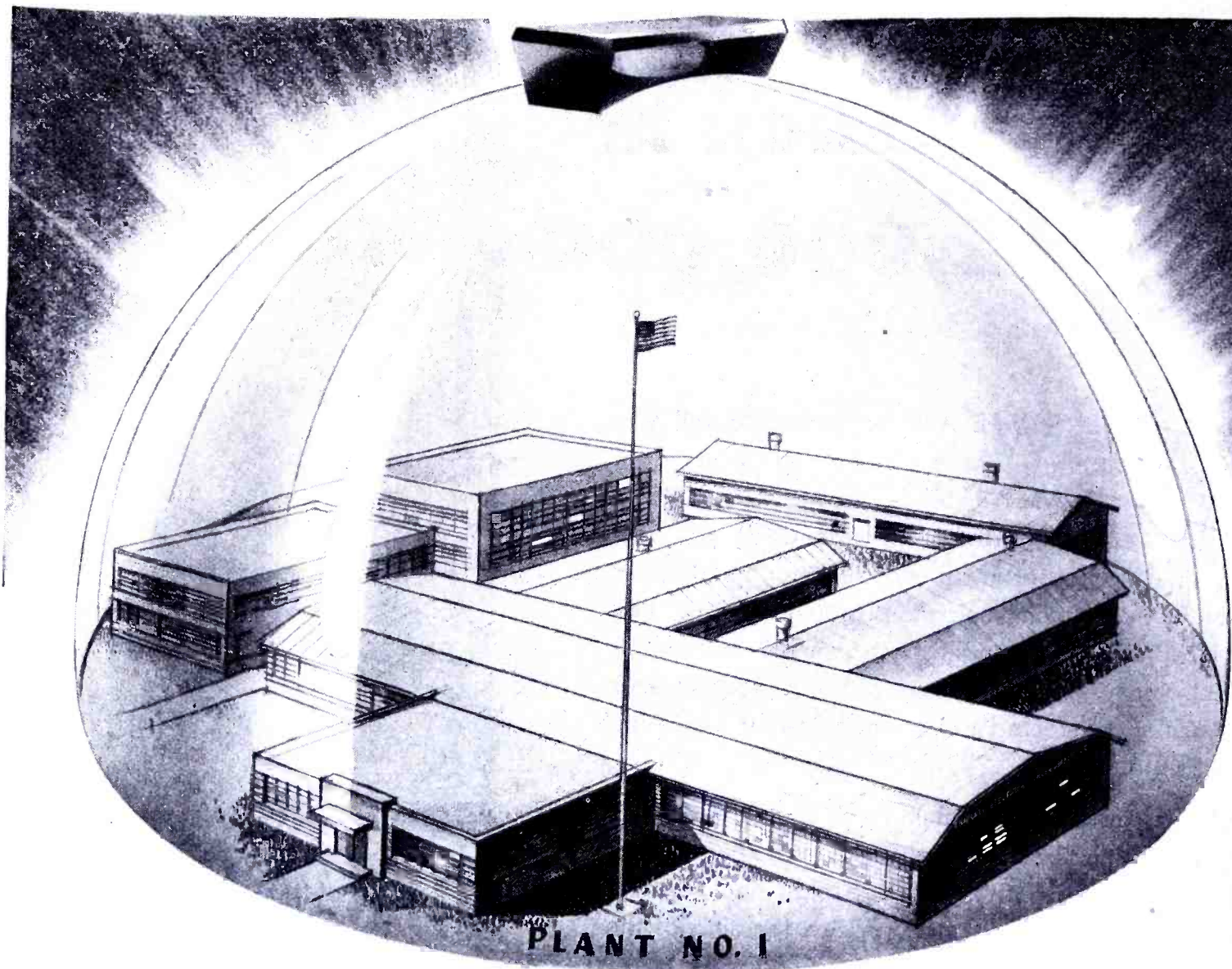

" DUSTLESSTOWN, OHIO "

● It's the little things that loom biggest in the manufacture of delicate electrical measuring instruments. Little things like specks of dust or breath condensation can play havoc with accuracy. That's why Triplett Instruments are made in spotless manufacturing departments; why the air is washed clean, de-humidified and

temperature-controlled; why every step in their mass production is protected. As a result Triplett Instruments perform better, last longer and render greater service value.

Extra Care in our work puts Extra Value in your Triplett Instrument.

*Precision first
...to last*



Triplett

ELECTRICAL INSTRUMENT CO. BLUFFTON, OHIO

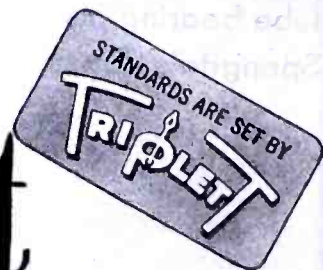

A *GUIDING HAND*

FLIES WITH HIM



American airmen never fly alone! Riding with them go the combined skills and efforts of many thousands of war workers and technicians. To their targets... and safely back to their bases . . . the finest equipment that man can produce flies with them.

Eastern is proud of the part its equipment plays in these great missions. Before the war, amplifiers were thought of only for their use in sound amplification. Today, thanks to the

tremendous advancement in Army and Navy practice, amplification finds new fields of service in step with vital war instruments.

Our contribution to this development has broadened the long-standing experience of Eastern engineers, who are looking ahead to your post-war needs . . . not only in sound reinforcement, but also in special amplification related to industrial instruments. But first, Eastern is applying every resource to its war-time production.



EASTERN



AMPLIFIER CORPORATION

794 East 140th Street, New York 54, N.Y.

Buy MORE War Bonds

EASTERN

AMPLIFIERS

Exhaustive DuMONT quality control and life tests take all the guesswork out of CATHODE-RAY TUBE

Life

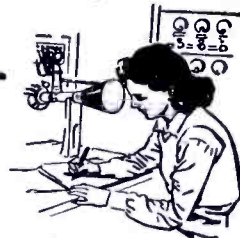
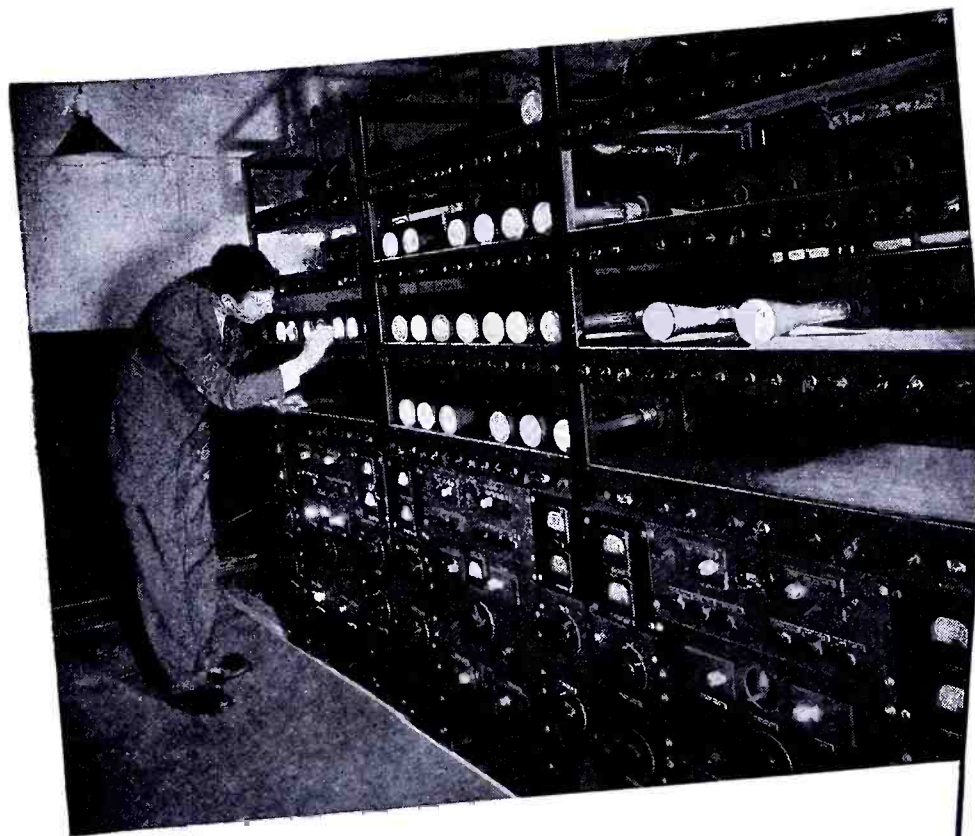

DuMONT Quality-Control Checkup

Percentage sample tests—some 100%—are made on production runs for the following:

Brilliance and screen condition—color, spots, burns, etc.

Examination of cathode by using tube as an electronic microscope. The few thousandths of an inch diameter gun aperture is magnified to 1/2 inch circle to check uniformity of emitting surface. Cathode emission current is measured.

Deflection sensitivity is tested to determine amplitude of signal required to deflect beam by given amount.

Maximum electrode current. Check for excess anode current (to avoid overloading power supply of equipment using tube.)

Determining grid cutoff (when too low, tube life is shortened; too high, might exceed range of intensity control of equipment using tube).

Leakage current of various electrodes. And other critical and vital factors entering into satisfactory, long, economical tube performance.

▶ DuMont never gambles. Thus each batch of fluorescent material is thoroughly tested in sample tubes. All new metals and other materials are likewise tested. New designs are thoroughly checked with sample production runs. The same with new processes—even to supposedly minor details such as washing and drying of glass envelopes.

DuMont life-test racks eliminate the greatest gamble of all—probable life. Percentage samples are operated in these life racks for 500 hours. A time totalizer keeps score. Tubes are tested weekly for brightness and cathode condition. And at the end of 500 hours the tubes are checked for all characteristics that might be affected by such intensive operation.

So again we repeat: there is no guesswork regarding performance and life with DuMont cathode-ray tubes.

▶ Write for literature . . .



DUMONT

Precision Electronics & Television

ALLEN B. DUMONT LABORATORIES, INC., PASSAIC, NEW JERSEY • CABLE ADDRESS: WESPEXLIN, NEW YORK

... How MYCALEX Solved a Tough Insulating Problem for HAZELTINE ELECTRONICS and the NAVY ...



HAZELTINE ELECTRONICS CORPORATION
 EXECUTIVE OFFICES
 1775 BROADWAY
 NEW YORK 19, N. Y.



TELEPHONE
 COLUMBUS 5-0791
 TELETYPE NY 1-2880

September 15, 1944

Mycalex Corporation of America
 30 Rockefeller Plaza
 New York, N. Y.

Attention: Mr. Jerome Taishoff, President
 Gentlemen:

In the development of special apparatus, to be supplied on a Navy contract by Hazeltine Electronics Corporation, it was found necessary to utilize a material with a dielectric constant of 12-15.

We put our problem in the hands of your company.

The cooperation which we received from your organization is to be very highly commended. The special material, which was developed after much experimentation and research on your part, has maintained a constant dielectric all through production.

We have delivered a quantity of these units to the Navy, and we wish to again thank you for the large part you played in making the delivery of these vital equipments possible.

Very truly yours,

J. E. Gray
 J. E. GRAY
 Co-ordinating Eng.



The products of Mycalex Corporation of America are: (a) MYCALEX 400—the most highly perfected form of MYCALEX insulation, approved by Army and Navy as Grade L-4. In sheets, rods and fabricated form. (b) MYCALEX K, an advanced capacitor di-electric with di-electric constant of 10 to 15. (c) Molded MYCALEX, available to specifications in irregular shapes. Write for details.

MYCALEX CORPORATION OF AMERICA

"OWNERS OF 'MYCALEX' PATENTS"

CLIFTON,
 NEW JERSEY

Executive Offices: 30 ROCKEFELLER PLAZA
 NEW YORK 20, N. Y.

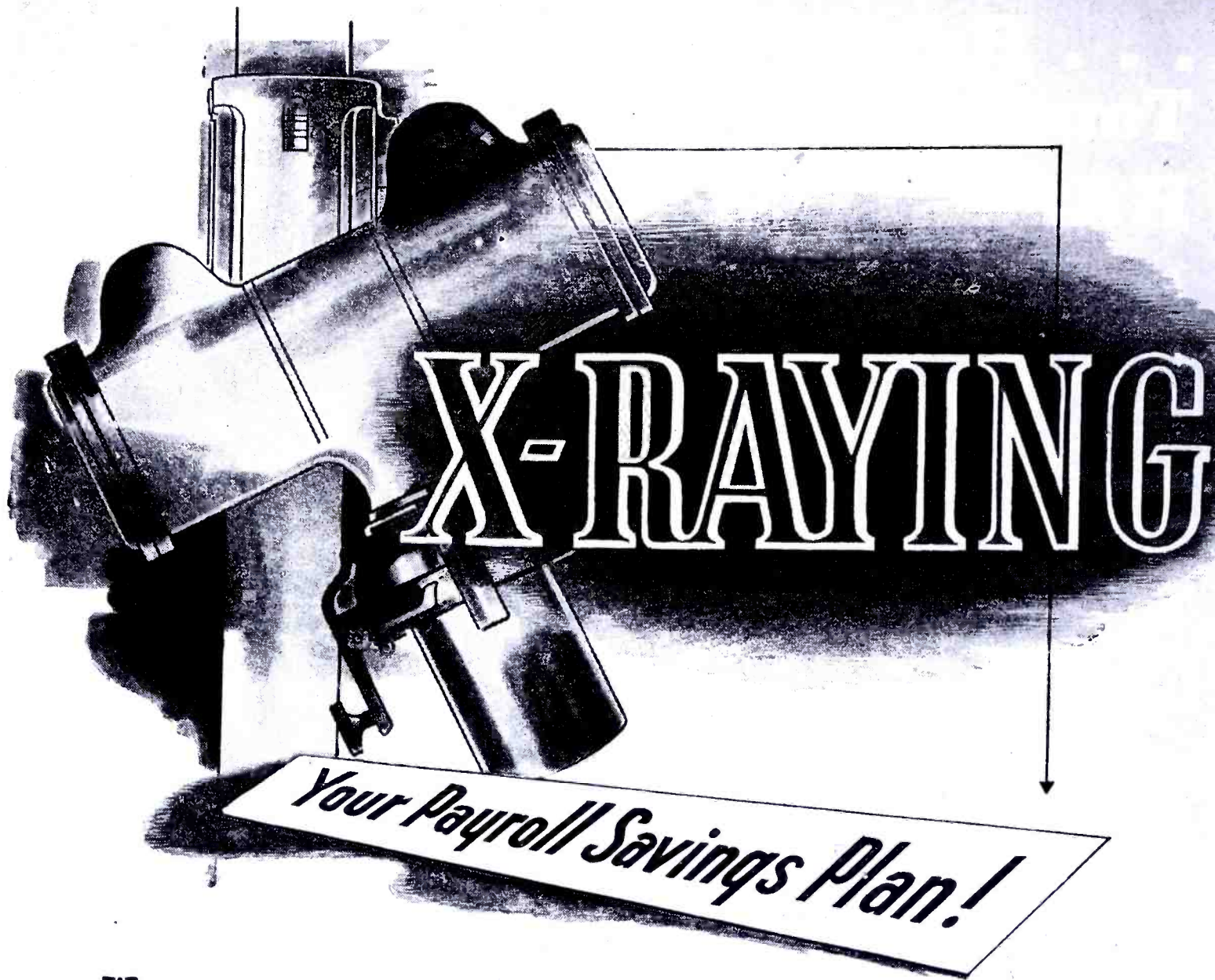

We can all see with the naked eye that the Payroll Savings Plan provides the most stable method of war financing. Analyze it under the X-ray of sound economics and other important advantages are evident.

A continuous check on inflation, the Payroll Savings Plan helps American Industry to build the economic stability upon which future profits depend. Billions of dollars, invested in War Bonds through this greatest of all savings plans, represent a "high level" market for postwar products. Meanwhile, putting over Payroll Savings Plans *together* establishes a friendlier re-

lationship between management and labor.

To working America the Payroll Savings Plan offers many new and desirable opportunities. Through this systematic "investment in victory," homes, education for their children and nest eggs for their old age are today within the reach of millions.

The benefits of the Payroll Savings Plan to both management and labor are national benefits. Instilling the thrift principle in the mind of the working men and women, the Payroll Savings Plan assures their future security—and is a definite contribution to the prosperity of postwar America!

The Treasury Department acknowledges with appreciation the publication of this message by

COMMUNICATIONS

AMPHENOL

... Ready to Contribute
to the Age of Electronics



Depend upon

AMPHENOL

Quality

• Amphenol offers highly developed ability to design and produce electrical components of the most critically engineered type. This skill is based on many years of experience in radio since its pioneering stages—now deepened and strengthened by the extreme demands of war production.

Fortunately Amphenol's great capacity is available at a time when the whole science of Electronics is coming into its own. Amphenol is ready to play as big a part in its own phase of the Electronic Industry, as Electronics will play in the post-war world.

AMERICAN PHENOLIC CORPORATION • Chicago 50, Illinois
In Canada • AMPHENOL LIMITED • Toronto

Connectors — AN, British, U. H. F. • Fittings
Conduit • Cable Assemblies • U. H. F. Cable
Radio Parts • Plastics for Industry

PLATING

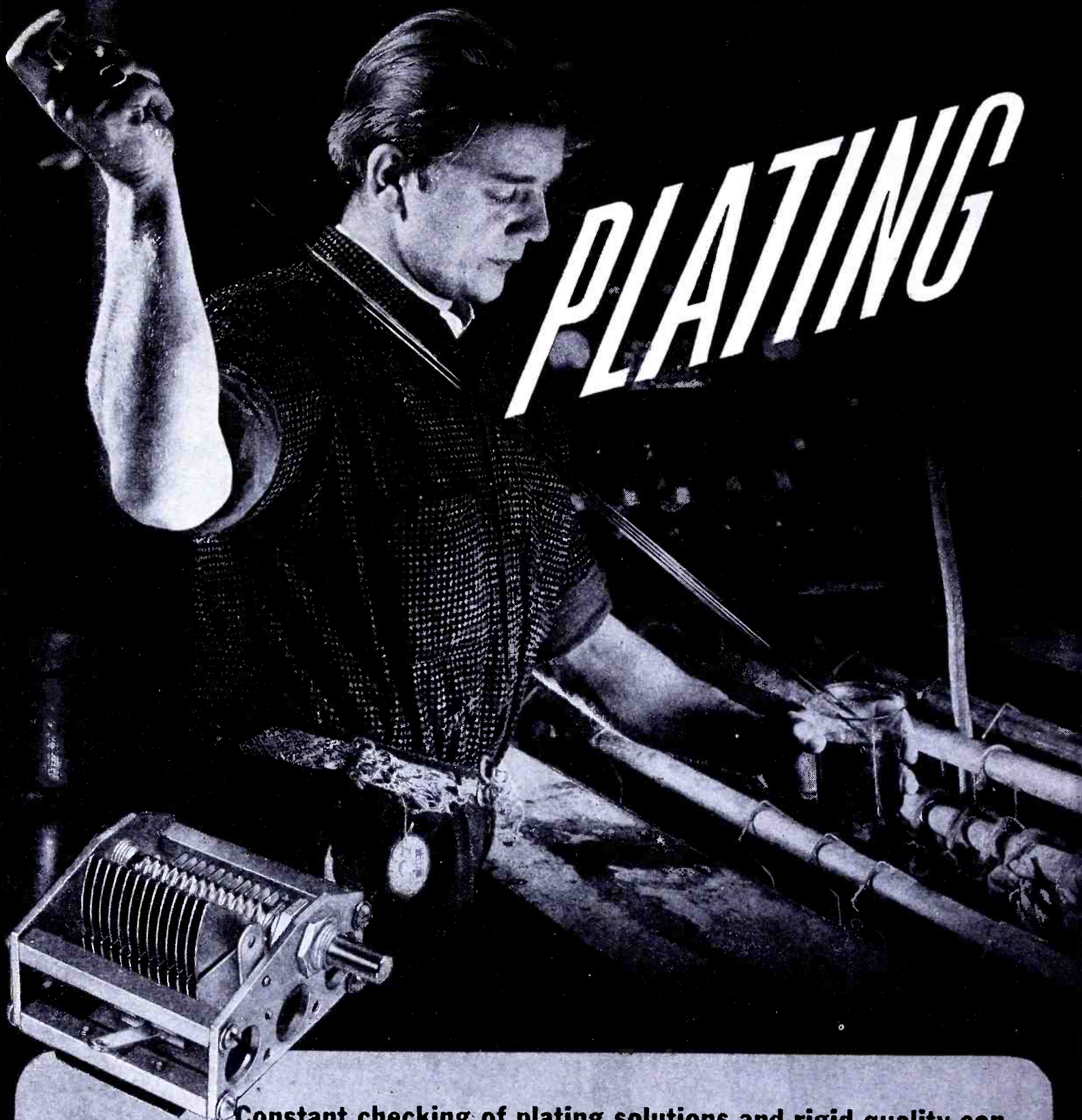

Constant checking of plating solutions and rigid quality control gives Hammarlund variable capacitors a finish that will last a lifetime under practically every operating condition.

HAMMARLUND

THE HAMMARLUND MFG. CO., INC., 460 W. 34TH ST., N. Y. C.
MANUFACTURERS OF PRECISION COMMUNICATIONS EQUIPMENT

THE SIGN OF QUALITY

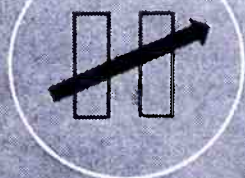

ESTABLISHED - 1910

COMMUNICATIONS

LEWIS WINNER, Editor

* * JANUARY, 1945 * *

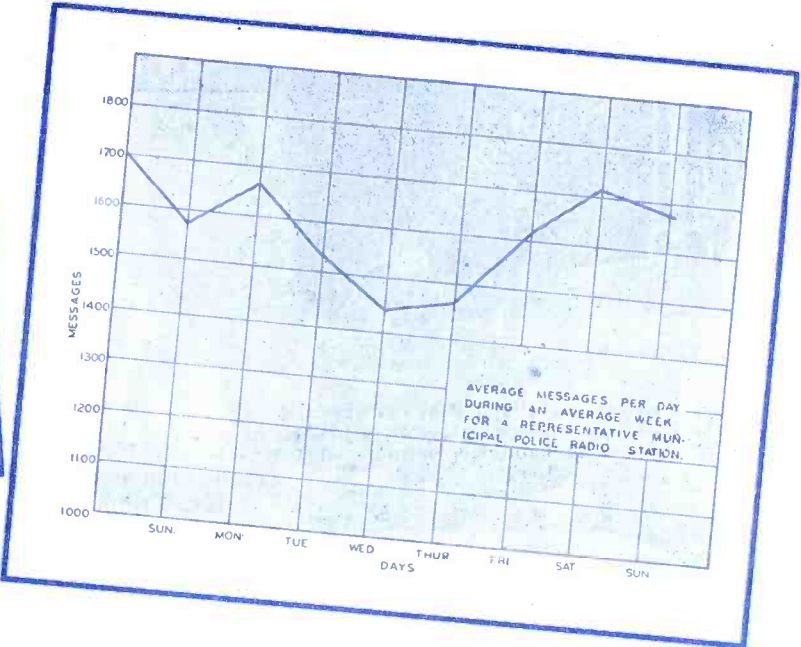
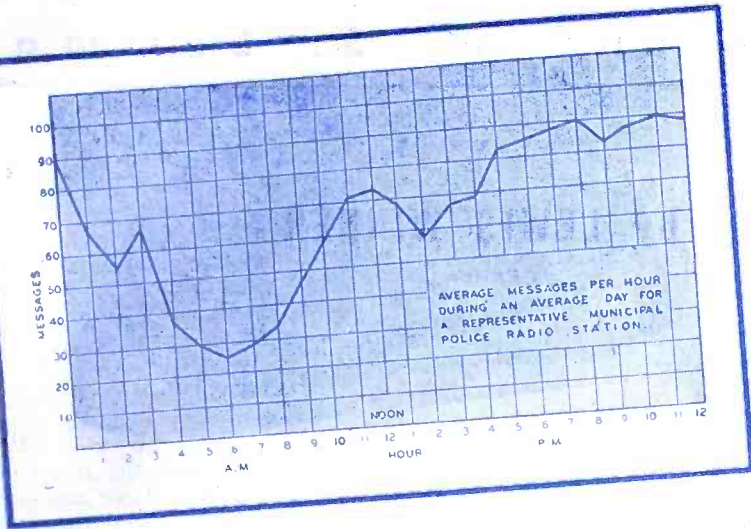

Figures 1 and 2
Graphs illustrating daily and hourly message traffic of a typical municipal police radio station.

POLICE COMMUNICATION PROBLEMS FACING ENGINEERS TODAY

by LEWIS J. BOSS

Captain, Radio Supervisor
Warwick Police Department
Apponaug, R. I.

the areas protected by them must necessarily depend upon an adequate com-

munication system if they are to successfully combat crime. Without adequate and reliable means of communication their organizations and equipment are helpless and will fail to achieve their intended purpose in exactly the same degree as their communication systems are inadequate and unreliable.

Metropolitan Area Problems

Approximately 68,403,000 persons live in the metropolitan areas of the United States. In these heavily congested areas there is a vital necessity for immediate and direct communication between headquarters and those peace officers assigned to duty throughout the area. In these localities, cities and towns closely adjoin each other and their respective police departments use the radiotelephone for communication to police cars very extensively.

In the metropolitan New York area there are instances where fifteen or more police radio systems are trying to communicate on the same frequency. It is estimated that there are some 3,000 po-

(Continued from page 77)

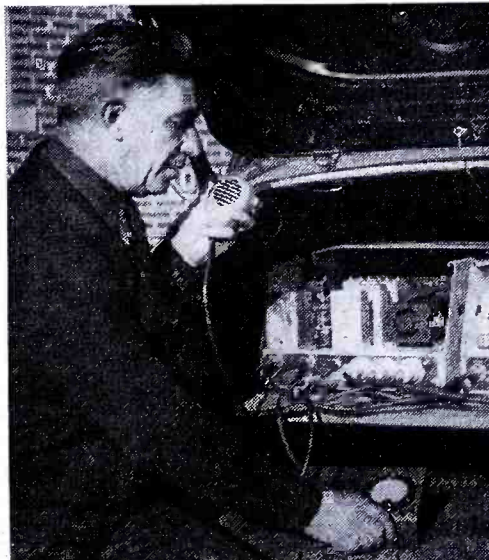
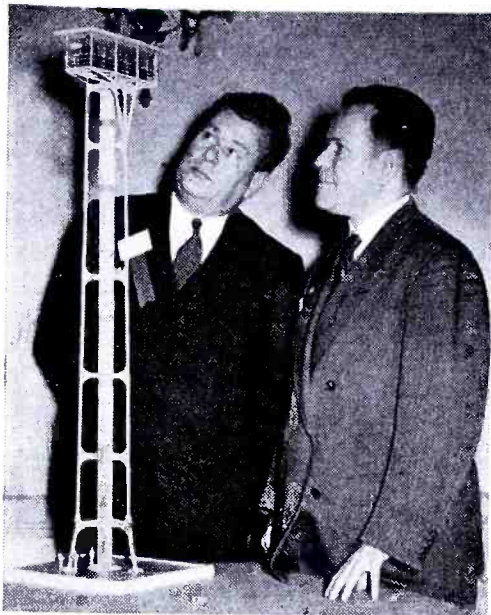

Figure 3

Captain Boss testing an h-f f-m two-way unit used by the Warwick police.

A REPORT ON THE TECHNICAL PANELS



Walter S. Lemmon, right, and Paul Chamberlain with model of the automatic relay tower I.B.M. and G.E. propose to build for multiplex operation.

Highlights of Comment

By M. A. Trainer, J. E.

Keister and W. S. Lemmo

by LEWIS WINNER

Editor

THE first annual TBA conference, held in New York City recently, saw over 1000 in attendance. Among the many interesting features offered was a technical panel meeting presided over by C. A. Priest of General Electric.

Among those appearing on the panel were: Merrill A. Trainer, RCA; J. E. Keister, G.E.; Walter S. Lemmon, International Business Machines; Dr. Peter C. Goldmark, CBS; Paul Chamberlain, G. E.; and David B. Smith, Philco.

Camera and Picture Tube Developments

Mr. Trainer introduced his phase of analysis with data on television pickup tubes that were in general use before the war. He pointed out that the most important of these have been the iconoscope, the image dissector tube and the orthicon.

He said that wherever sufficient light was available the iconoscope has been the first choice, because of its superior resolution capability and its desirable gamma characteristic. The iconoscope's light range and gamma property make it particularly suitable for scenes with ample lighting without any difficulties due to high light saturation, he stated. Thus it is quite useful for out-door pickup.

He also pointed out that the general cleanness of the picture obtained with an iconoscope had made it almost universally used as the camera tube for live talent studios. Describing resolution of the iconoscope, he said that it is sufficient at the present time to reproduce practically any picture detail which can be transmitted over the standard television channel. And, he continued, because of its storage property, the iconoscope has also been generally used in film cameras. Modified intermittent type projectors are used in this application, he explained. That is, the picture is flashed on the mosaic during the vertical blanking time

and the mosaic is scanned during the following dark period.

Mr. Trainer also discussed some of the undesirable features of the iconoscope. There are, he said, spurious shading signals and flare which must be electrically compensated in producing a good picture. At times such compensation represents an added complication in a practical setup, he explained. In addition, he said, the relatively large size mosaic used in an iconoscope requires the use of large camera lenses. For telephoto shots this may result in relatively unwieldy cameras. Another requirement for the iconoscope is the use of keystone correction scanning, he said. This was once a more serious problem from the circuit standpoint than it is at present. He said that this draw-back might be classified more as a nuisance than a limitation.

Large orthicons are generally used for out-of-door events where the lighting is usually more unfavorable, according to Mr. Trainer. He said that its sensitivity is 4 to 5 times better than that of the iconoscope. However, he pointed out, the picture as compared to an iconoscope picture has a tendency to lack snap because of the strictly linear gamma characteristic. Accordingly, an increase of picture detail brightness by a factor two in the orthicon will increase the video signal by a factor two, explained Mr. Trainer. In the iconoscope this increase can be much less. This gamma characteristic, tending to compress whites appears to be very desirable, said Mr. Trainer. And in an orthicon camera it can be obtained by the introduction of gamma correction in the video amplifiers, but at the expense of increased noise in the picture. Mr. Trainer also pointed out that the smaller mosaic not only allows the use of shorter focal length lenses for a given field but the use of longer focal length lenses of large effective aperture for telephoto effects. The limited light range was described as one of the major and somewhat annoying limitations of the orthicon.

According to Mr. Trainer, when viewing a scene, the mosaic will charge up

with picture highlights above a rather definite value, and unless the beam current is increased under these conditions the charge can spread over the entire mosaic, completely obliterating the picture. A spot pickup such as is encountered at a football game offers a practical example of this limitation. He said that it is very possible to have a scene which may consist of part sky and part ground or a highly illuminated section of the field together with a shadowed portion. In such a case explained Mr. Trainer the operator has a choice of allowing the highly illuminated portion to stick to some degree, wiping out detail in the highlights rather completely, or stopping down the lens to the point where the highly illuminated portion is satisfactorily transmitted, but generally at the expense of insufficient illumination in the low lights. The iconoscope automatically provides for this range characteristic which can be so troublesome, continued Mr. Trainer.

The so-called S distortion and ion spot formation, a prewar orthicon limitation was also analyzed. Mr. Trainer said that this distortion, has been due mainly to practical limitations of the electron-optical design, which is relatively more complicated than in other pickup tubes. With new developments it is probable that the distortion introduced by an orthicon pickup of a scene can be reduced to very acceptable value.

Discussing the image dissector, Mr. Trainer pointed out that it has not been used extensively as a live talent camera tube because of its relatively low sensitivity. However, he said, because of the absence of shading signal from the dissector tube it has found use as a film camera tube. This is because the tube inherently does not have memory storage. Thus it is used with a continuous film projector to produce satisfactory pictures free of shading.

Improvements in tube design were also analyzed by Mr. Trainer. He showed that the resolution capability of the iconoscope has been increased by the use of an improved gun design to produce a better

SESSION AT THE TBA CONFERENCE

efined scanning spot. In addition, special processing and electrode arrangement have helped to reduce edge flare and fading troubles. He said that a large factor in the improved performance of the iconoscope has been our increased appreciation of the role of bias and edge lighting.

The orthicon tube appears to provide the greatest possibility for radical improvement in pickup tube performance according to Mr. Trainer. Thus far great strides have been made mainly in the direction of increased sensitivity and range.

Covering factors which represent goals for performance, Mr. Trainer offered four factors. These were:

(1)—Increased sensitivity, allowing for operation under adverse lighting conditions or reduced studio lighting.

(2)—Resolution, which should be sufficiently good to reproduce at least all detail which can be transmitted over assigned frequency channels. This resolution requirement may be tempered by the performance of a tube under low light conditions. That is, a tube which has extremely good sensitivity may have somewhat less resolution than the ideal and still be a very useful device for picking up spot broadcasts.

(3)—The operating light range shall be sufficient to reproduce satisfactorily scenes in which illumination can vary widely. The tube shall be free from flicking in the highlights and yet give detail in the darker portions of the picture. The gamma characteristic should be under control so as to give desirable white signal compression.

(4)—The geometrical distortion such as S distortion in the orthicon shall be so low as to be unnoticeable on the average transmitted scene.

Picture Tubes

Mr. Trainer said that the most significant development in picture tubes has been the combination of a high-voltage projection type kinescope with a Schmidt-optical system to make a practical projection receiver for home use. He explained that a 4" or 5" kinescope operating at 25 to 30 kilovolts in a Schmidt-optical system having a 12" to 14" spherical mirror and a suitable correcting lens will produce a very satisfactory 15" x 20" picture. Such a picture, he said, has a brightness of approximately 100 foot-lamberts in the highlights and, at the present time, a contrast range of 5 to 1. He pointed out that experiments with many types of translucent projection screens used with this system indicate that it may be possible to increase the contrast ratio to approximately 40 to 1, which is about as good as can be obtained in a direct viewing kinescope. Describing the Schmidt optical system, he said it has an equivalent f number of 0.9 and a throw of 34" to 36"; capable of 1500-line resolution and should therefore introduce no loss in detail with a 525-line picture. He explained that a polished and aluminized glass spherical mirror with a molded-plastic correcting lens represented the most satisfactory Schmidt sys-

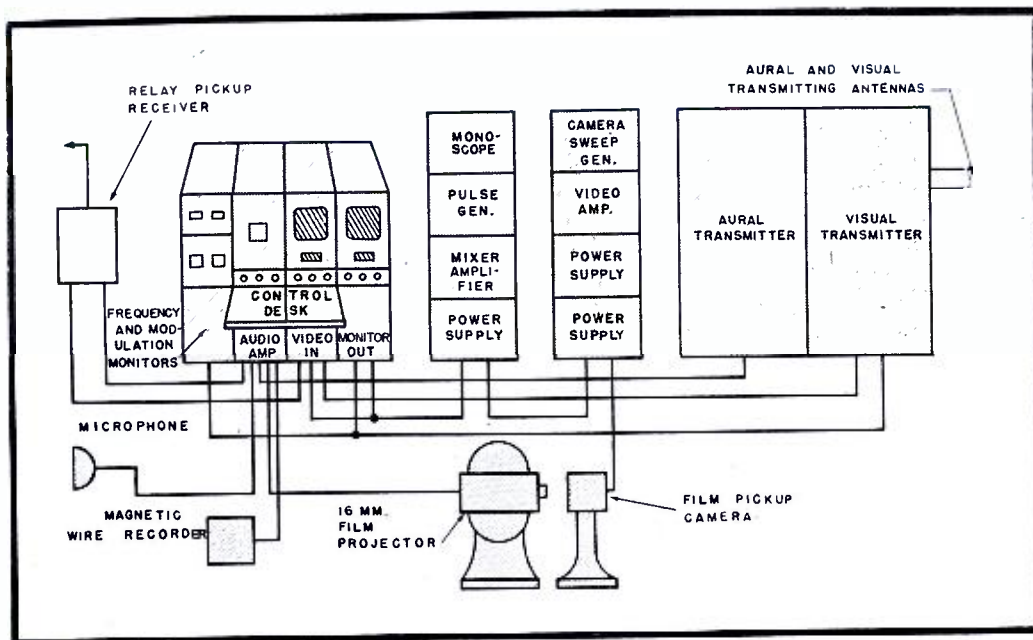

Typical setup of equipment that will be employed by satellite stations, according to J. E. Keister of General Electric.

tem combination for projection receivers at the present time.

Postwar direct-viewing picture tube improvement trends include operation of the kinescope with 12,000 volts or more on the second anode instead of the 6000 volt rating used before the war, according to Mr. Trainer. This voltage provides a substantially brighter picture. Horizontal back-kick rectifier systems will probably provide the necessary d-c voltage, he said. Flat-faced tubes appear to be another trend. Two types which give promise of being widely used according to Mr. Trainer, are the 10" flat-face round tube and the 14" diagonal flat-face rectangular tube. Mr. Trainer said that the use of these tubes will allow for a more pleasing picture of larger size than was practical with tubes of prewar design.

Ion spot formation common to prewar kinescopes, will probably be greatly retarded or eliminated completely in postwar kinescopes, disclosed Mr. Trainer.

SATELLITE TELEVISION STATIONS

THE place of satellite stations in a television system served as a basis of a discussion by J. E. Keister. He said that a satellite station in its simplest form is one which originates no local live talent programs, serving its locality by broadcasting programs fed to it by a network. In some localities satellite stations may be installed by the television network operators themselves to serve the smaller communities he said. Thus, he explained, stations serving smaller communities can supply the quality of entertainment or educational programs which otherwise could only be justified by a few installations in densely populated areas.

Mr. Keister explained that most relay systems contemplated at present expect to supply at least two channels in each

direction on the main artery. Thus two sources of programs can be originated simultaneously on a single network set-up. A satellite station then has a choice of programs with the accompanying benefit of variety to fit its own particular needs, he said.

It usually can be assumed that the satellite station is off the main artery and so a simple one-way branch relay will be used, according to Mr. Keister. In many cases a single jump from the main relay tower to the satellite station will suffice, he explained. If not, simple one-way repeater stations would be installed at the required intervals.

Describing the satellite station itself, he said that it consists essentially of a receiving antenna to pick up the relayed signal, receiver for amplifying and demodulating both the aural and visual components, monitor to provide a running check on the signal, and finally the main transmitter for broadcasting the sound and picture to the surrounding area. The actual power output will depend on the topography and area served, he said. Since the FCC in authorizing the construction of satellite stations doubtless will require some means of both aural and visual station identification, equipment for such identification will be necessary, Mr. Keister stated. This would involve the inclusion of a monoscope signal generator, as associated pulse generator and sweeps, and suitable audio and transcription equipment; personalized monoscopes can be anticipated with the stations own call letters inscribed.

Since the interest shown in local news events will usually justify the addition of equipment for the origination of film programs, many satellites will require a motion picture projector, film pick-up camera, camera amplifier and control equipment. With these film origination facilities available, said Mr. Keister, the local satellite station operator can, with a 16-mm silent motion picture camera, take pictures of local events.

By capitalizing on this simplified type of station to augment the stations serving

(Continued on page 75)

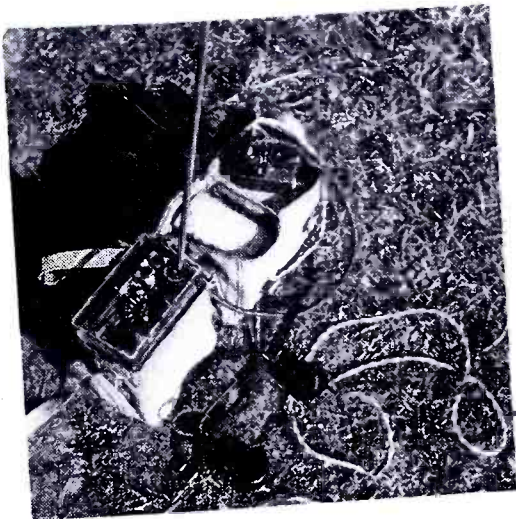

Radiotelegraph pack set used by the infantry.

Equipment shown in these British Official photos was designed for airborne operations, such as those recently carried out in Holland.

(Crown Copyright Reserved)

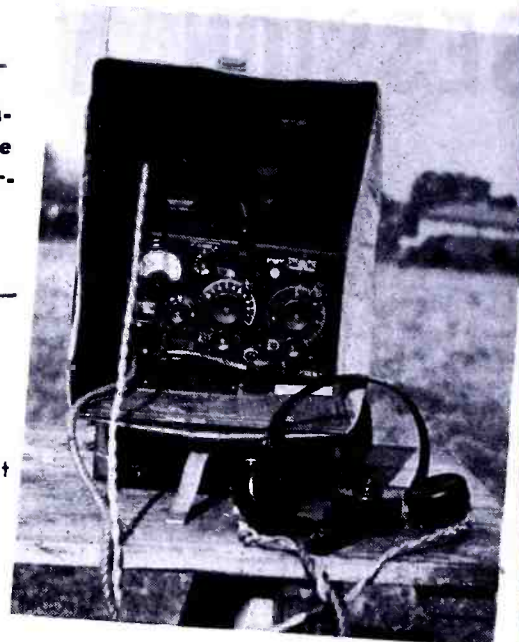

Right, a short-range radiotelegraph unit used by the infantry.

BRITISH AIRBORNE COMMUNICATIONS EQUIPMENT

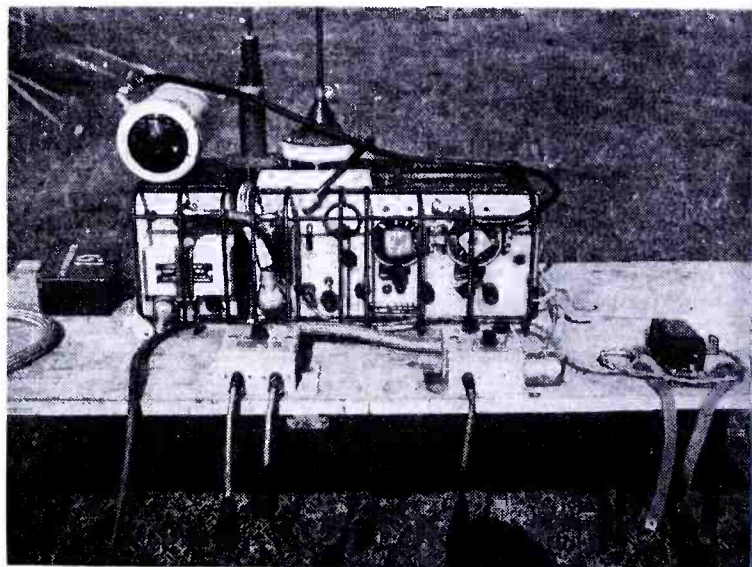
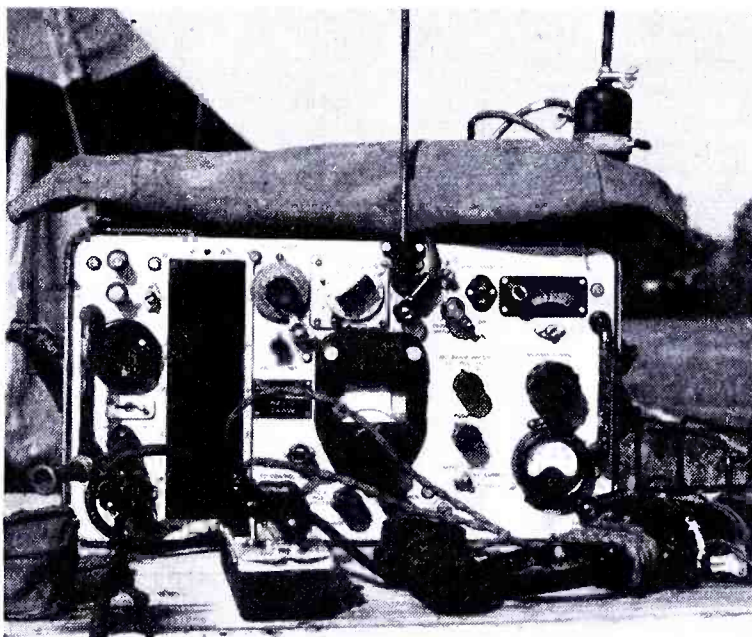

Left, above: A medium-range unit for telephony and teletography used in vehicles and by ground stations. Left, below: Medium range radiotelephone set for tanks or trucks.

Above, a medium-range radiotelephony set similar to that shown mounted in command car at lower left. Below, the telephony and teletography unit, shown at left above, in container for dropping by parachute.

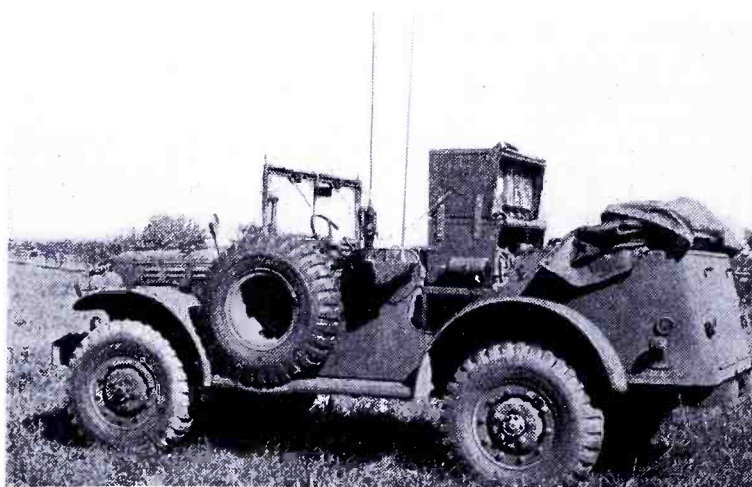

(Truck view, courtesy U. S. Signal Corps)



"Meet Your Navy"

Now Carries the RAYTHEON Name
Into 3,500,000 Radio Homes Each Week!!

Free!

Ask your Raytheon distributor for colorful, attention-getting "Meet Your Navy" display to tie in with this great program. Easel-mounted, 17 1/2 inches x 20 1/2 inches.



All Four Raytheon Divisions Have Been Awarded Army-Navy "E" with Two Stars

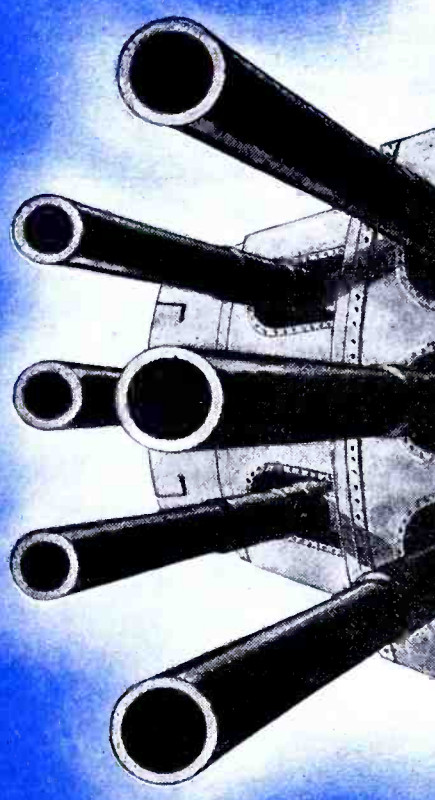

Every Saturday Night

ENTIRE BLUE NETWORK

Coast to Coast 181 Stations

RAYTHEON MANUFACTURING COMPANY

Waltham and Newton, Massachusetts

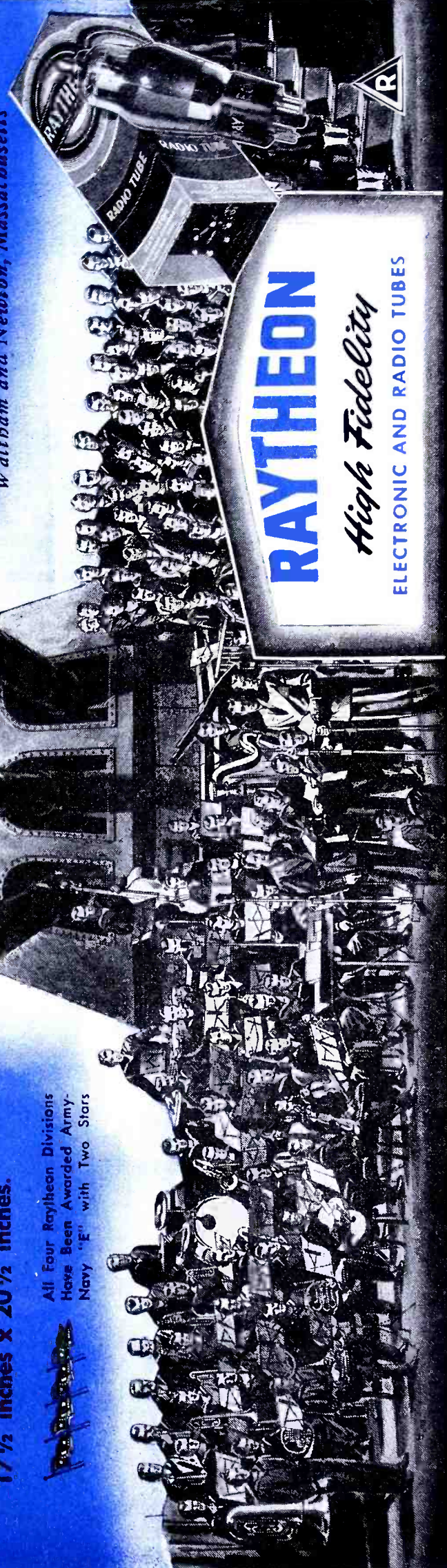

DEVOTED TO RESEARCH AND THE MANUFACTURE OF TUBES AND EQUIPMENT FOR THE NEW ERA OF ELECTRONICS

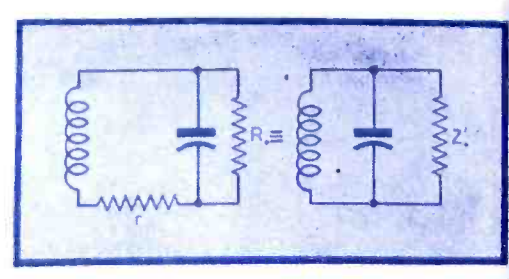
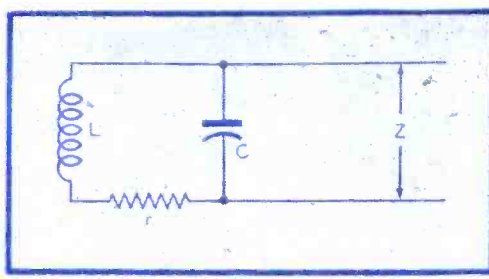
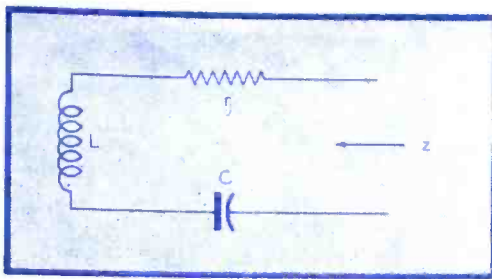

Figures 1, 2 and 3 (left to right, above)

Figure 1, a single-tuned circuit with a series impedance z . Figure 2, the single-tuned circuit with a parallel impedance Z . Figure 3, circuit with a resistor across to reduce effective Q , providing a resonant impedance Z' .

C O U P L E D C I R C U I T S

by J. E. MAYNARD

Transmitter Division
Electronics Department
General Electric Company

ONE of the subjects treated in some detail in the ESMWT RPI course was that of tuned and coupled circuits. It may be shown that a single tuned circuit has the series impedance z , Figure 1,

$$z = r(1 + jS) \quad (1)$$

and has the parallel impedance Z , Figure 2,

$$Z = Z_0 / (1 + jS) \quad (2)$$

$$S = Q_0 (\Delta f / f_0) (1 + f_0 / i)$$

in which zero subscripts refer to values

This paper is based on notes taken for the most part from a course, "Radio Engineering II," developed by the author for the ESMWT program at Rensselaer Polytechnic Institute. An objective of the course was to develop the quantitative approach to radio circuits, to correlate theory and practice. In laboratory experiments and problems the prediction of results by calculation was emphasized.

at resonant frequency f_0 , where, by definition, $X_L = X_C = X_0$. Frequency deviation $(f - f_0)$ is represented by Δf , and Q_0 is the quality factor of the circuit at f_0 . The impedance Z_0 is parallel impedance at resonance, $Z_0 = X_0 Q_0$. Equation 2 is a very close approximation if Q_0 is 10 or more, which covers essentially all coils used in tuned cir-

cuits. If Δf is 10% of f_0 or less we can make a further simplification by the approximation

$$S = (2\Delta f / f_0) Q_0 \quad (3)$$

Now if we place a resistor across the circuit, which is often done to reduce the effective Q of the circuit, its effect may be accounted for by considering the circuit to be one having a new resonant impedance Z'_0 .

$$Z'_0 = Z_0 R_0 / (Z_0 + R_0) \quad (4)$$

Since $Z_0 = X_0 Q_0$, the new circuit has a new quality factor

$$Q'_0 = Q_0 R_0 / (Z_0 + R_0) \quad (5)$$

The reactance X_0 is, of course, the same in either case under the approximations we have made.

Coupled Circuits

Any pair of tuned circuits may be coupled in several ways, Figure 4. Pi networks may always be reduced to equivalent T networks² and circuits coupled by inductive fields may always be reduced to an equivalent T of inductive coupling, although it may require a fictitious negative inductance for reversal of polarity.

Now if we disregard the case in which capacitive and inductive coupling become equal and opposite, a possibility for one polarity in circuit (f), then all these cases may be represented by one general circuit, Figure 5.

This represents a primary resonant circuit of series impedance z , coupled to a secondary resonant circuit of series impedance z_2 by a common impedance z_m . It will be assumed that z_m contains no resistive components and further that its value remains fixed at its resonant frequency reactance. The result of these assumptions is symmetry about f_0 . This conforms closely to practical performance when Δf is less than 10% of f_0 , and when the coupling impedance has a normal quality factor.

The circuit of Figure 5 may be solved for either i_1 or i_2 in terms of the driving voltage e . Starting from the circuit equations

$$e = i_1 z_1 - i_2 z_m \quad 0 = i_2 z_2 - i_1 z_m \quad (6)$$

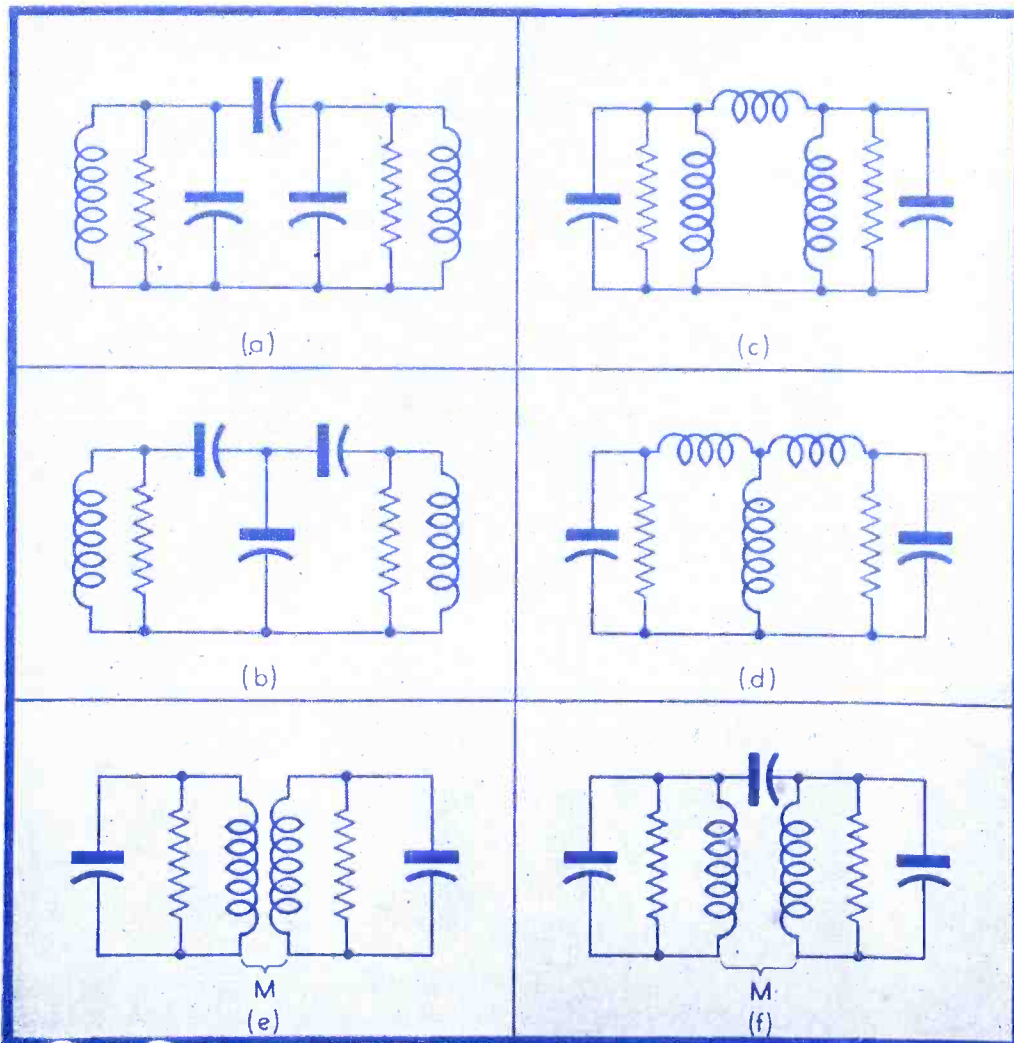

Figure 4

Various methods used to couple circuits.

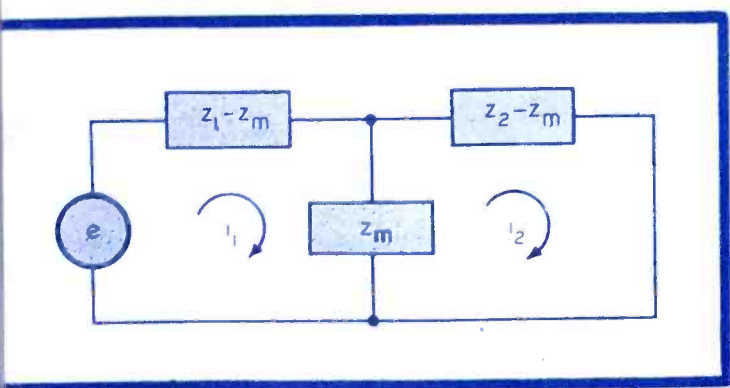

Figure 5
A general circuit, covering all cases, if we disregard the case in which capacitive and inductive coupling become equal and opposite.

DESIGN

e obtain

$$= i_1(z_1 - z_m^2/z_2) \quad (7)$$

$$(z_m/z_1) = i_2(z_2 - z_m^2/z_1) \quad (8)$$

These solutions illustrate a concept of the circuit operation which is often convenient. The impedance in the primary and also in the secondary has been changed by a *coupled-in* impedance z_m^2/z_2 in the primary and z_m^2/z_1 in the secondary. The driving voltage in the secondary may be considered as the driving voltage e divided in the ratio z_m/z_1 . These two equations are the fundamentals of a pair of coupled circuits. From equation 8 we can determine what happens to a signal as it passes through; from equation 7 we can determine what sort of impedance the primary presents to the driving circuit.

Coupled Circuit Selectivity

The values of z_1 and z_2 are the series impedances $r(1 + jS)$ for the primary and secondary respectively. The common impedance z_m becomes $+jX_m$ for inductive coupling or $-jX_m$ for capacitive coupling. Using the coefficient of coupling $K = X_m/\sqrt{X_1X_2}$ and defining the following new terms

geometric mean $Q = Q_k = \sqrt{Q_1Q_2} \quad (9)$

arithmetic mean $Q = Q_a = (Q_1 + Q_2)/2 \quad (10)$

equivalent equal $Q = Q = Q_k (Q_k/Q_a) \quad (11)$

selective variable $S = (Q/Q_1)S_1 = (Q/Q_2)S_2 \quad (12)$

proportional coupling $C, 1 + C^2 = (Q_k/Q_a)^2 + K^2Q^2 \quad (13)$

attenuation $U = (\text{gain at } f_0)/(\text{gain at } f)$

It may be shown¹ that the attenuation or selectivity curve for a pair of coupled circuits is

$$U = \frac{\sqrt{(1 + C^2 - S^2)^2 + 4S^2}}{1 + C^2} \quad (15)$$

It follows from equation 8 and is a general expression for attenuation which may be utilized for circuits having the same or different Q in primary and secondary. The proportional coupling C has a value of 1.0 for a flat characteristic at the transition from single to double peaks.

To reduce Figure 5 to a practical system, let us consider the circuit of Figure 6. The tube is now providing the driving voltage e of Figure 5, all circuit loading is lumped in the resistors R_1 and

R_2 so that $Q_{o1} = R_1/X_{o1}$ and $Q_{o2} = R_2/X_{o2}$. It is, however, notable that the tube is driving across the primary, whereas e in Figure 5 is a series driving voltage. The two situations may be reconciled. A tube driving a load may be represented as a voltage source or as a current source, Figure 7.

The voltage e_g developed across Z must be the same by either representation.

$$\mu e_g Z / (R_p + Z) = g_m e_g [Z R_p / (Z + R_p)] \quad (16)$$

Since $g_m = \mu/R_p$ the identity of results is apparent. Figure 6 may therefore be represented by a current $g_m e_g$ operating into the primary with R_p absorbed in R_1 . Now we can relate Figures 5 and 6 through Figure 8. Circuit (a) represents Figure 5 and circuit (b) represents Figure 6.

The relation to be established is that the current i be identical in the two cases. This means that the voltage drop $g_m e_g Z_1$ must equal the driving voltage e . The impedance Z_1 may represent the reactance of C_1 , and Z_x the impedance of the remainder of the circuit including R_1 and the coupled-in impedance from the secondary. Z_1 , of course, varies with

Figure 6
Figure 5 reduced to a practical system, with the tube providing the driving voltage e and all circuit loading lumped in resistors R_1 and R_2 .

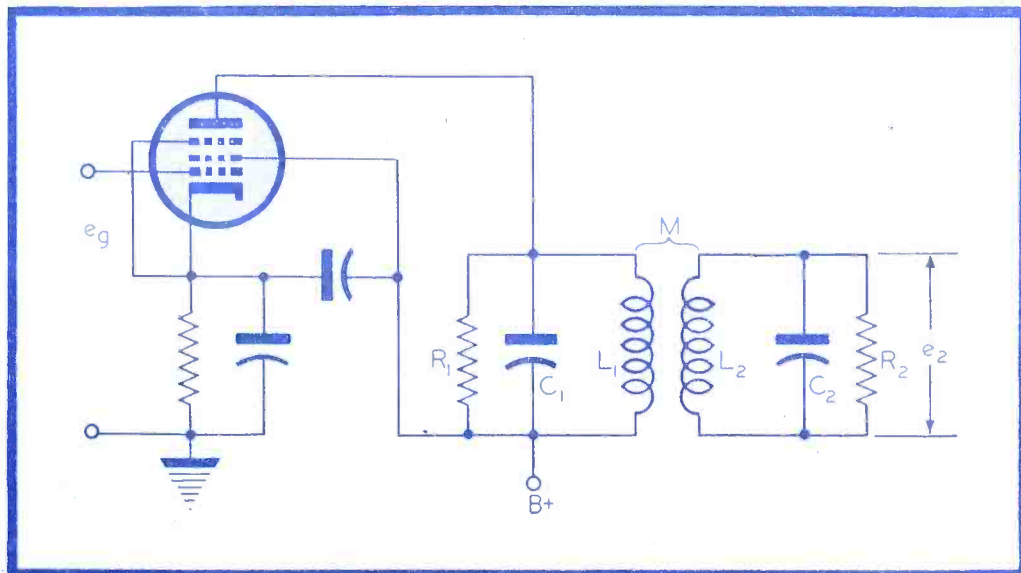

frequency; this produces non-symmetry which will be neglected so that e may be assumed constant with frequency variation for practical calculations

$$e = -jg_m e_g X_{o1} \quad (17)$$

Primary Impedance

If we are interested in the plate voltage appearing at the primary circuit either for determining overload conditions or for determining performance of such circuits as discriminators, AVC rectifiers, etc., we will want to know the impedance at the primary from plate to ground. Suppose, therefore we identify the a-c plate current in Figure 6 as i_p and a-c plate voltage as e_p , then primary impedance $Z_p = e_p/i_p$. In equation 7 the driving voltage $e = -jX_{o1}i_p$ and the primary circuit current $i_1 = e_p/-jX_{o1}$. From these relations we find

$$Z_p = -X_{o1}^2(i_1/e) \quad (18)$$

or, using equation 7

$$Z_p = -X_{o1}^2 z_2 / (z_1 z_2 - z_m^2) \quad (19)$$

From equation 8

$$z_m(e/i_2) = z_1 z_2 - z_m^2 \quad (20)$$

Secondary voltage $e_2 = -jX_{o2}i_2$. Substituting for e and i_2

$$-X_{o1}X_{o2}(i_p/e_2)z_m = z_1 z_2 - z_m^2 \quad (21)$$

Using $i_p = g_m e_g$ and substituting for $z_1 z_2 - z_m^2$ in equation 19

$$Z_p = (X_{o1}/X_{o2})(z_2/z_m)(e_2/g_m e_g) \quad (22)$$

From equation 22 we can anticipate the shape of the primary impedance curve with frequency variation. Thinking in terms of a constant applied grid voltage e_g , the secondary voltage e_2 will trace out the familiar coupled circuit response. We may assume everything constant except e_2 and z_2 and z_2 is the series resonant characteristic of the secondary circuit, $r_2(1 + jS_2)$. The z_2 multiplier serves to produce a dip in the characteristic at resonance. Physically the secondary is acting as an absorption circuit, reducing primary impedance at resonance. The primary impedance will always have a deeper dip at resonance than the overall response curve.

The attenuation on a selectivity curve, U , has been defined as the ratio of gain at resonance, A_o , to gain at another frequency, A_f . Since e_2/e_g is gain at any frequency, it may be replaced by A_o/U . A_o may be obtained from equation 21.

At resonance $z_1 z_2 = r_1 r_2$, using $i_p = g_m e_g$ and $z_m = \pm j X_m$,

Figure 7 (right) Tube as a voltage source (a); and as current source (b).

$$e_2/e_g = -g_m z_m X_{o1} X_{o2} / (r_1 r_2 - z_m^2) = \pm j g_m (X_{o1} X_{o2} / r_1 r_2) [X_m / (1 + X_m^2 / r_1 r_2)] \quad (23)$$

Substituting $K = X_m / \sqrt{X_{o1} X_{o2}}$ the resonant gain becomes

$$A_o = e_2/e_g = \pm j g_m Z_{og} [K Q_g / (1 + K^2 Q_g^2)] \quad (24)$$

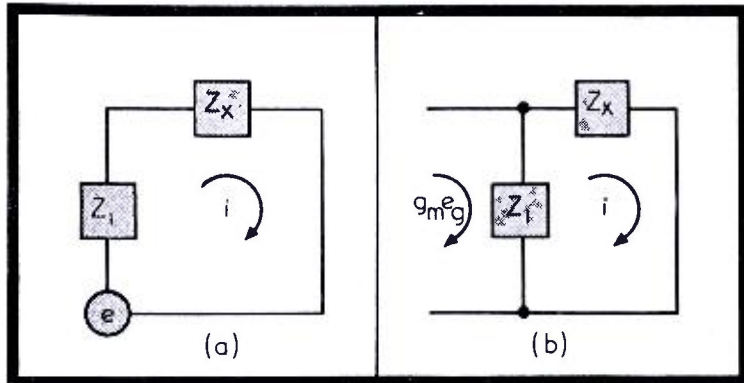
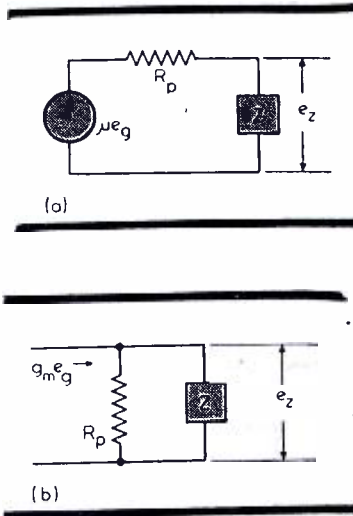

Figure 8 Representations of Figure 5(a) and Figure 6(b). Figure 6 can be represented by a current $g_m e_g$ operating in to the primary with R_p absorbed in R_1 .

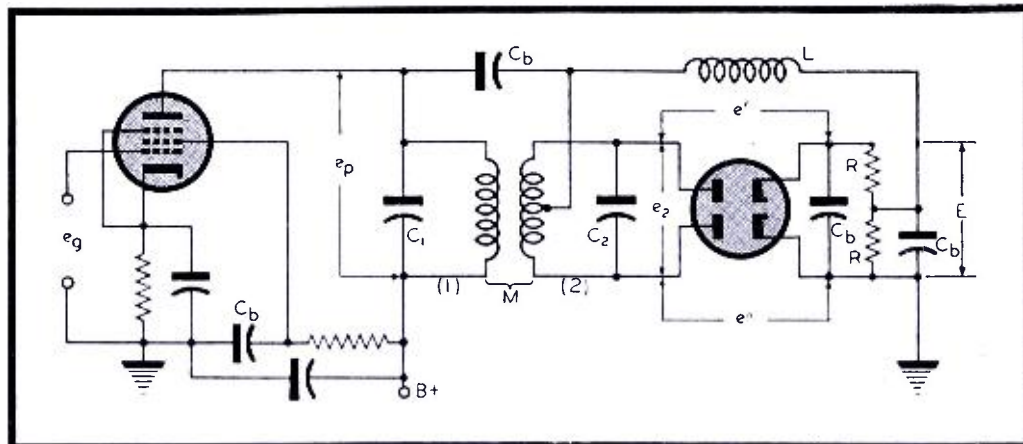

Figure 9 A form of the Foster-Seeley discriminator circuit.

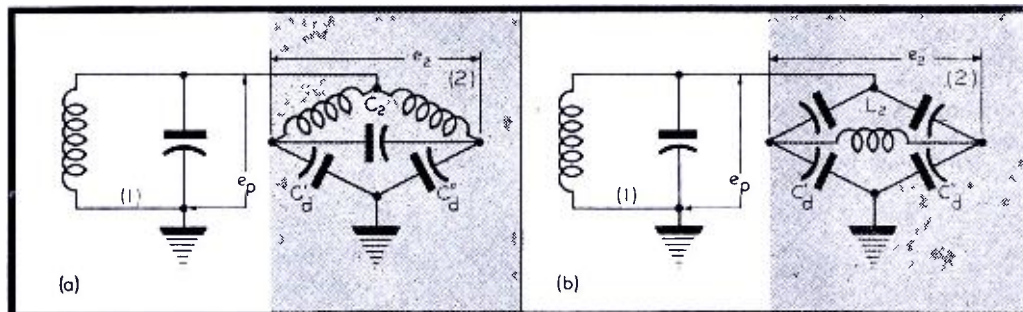

Figure 10 Fundamental i-f circuit involved in Figure 9, redrawn as a bridge and omitting M . In (a), primary is connected to center of secondary coil; (b), primary is connected to center of secondary capacitor.

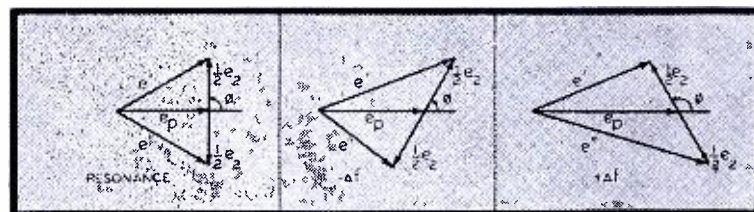

Figure 11 Resultant vector voltage relations.

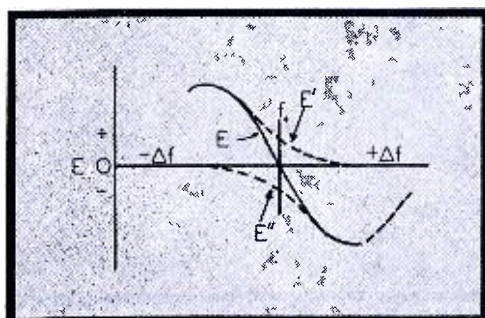

Figure 12 The discriminator S curve. In plotting this curve, the following data and Figure 11 were used: The voltage e' is rectified to produce a positive d-c voltage E' , and e'' is rectified to produce a negative d-c voltage E'' . The resultant voltage E is the algebraic sum of E' and E'' . And at the larger frequency deviations, the selectivity of the circuits reduces all voltages.

where $Z_{og} = X_{og} Q_g$, $X_{og}^2 = X_{o1} X_{o2}$. From equations 24 and 11 it can be deduced that the greater the difference between secondary and primary Q , the greater is the bandwidth (less equivalent equal Q) that will be obtained for a given amount of gain.

Equation 22 may be rewritten with the aid of equation 24 and some algebraic manipulation

$$Z_p = [Z_{o1} / (1 + K^2 Q_g^2)] [(1 + j S_2) / U] \quad (25)$$

The expression for U given in equation 15 omits phase; if phase relations are retained, it may be shown that

$$U = (1 + C^2 - S^2 + 2jS) / (1 + C^2) \quad (26)$$

With this information we can readily calculate the impedance in phase and magnitude into which a tube works with any pair of coupled circuits at its plate. This impedance may then be plotted on the tube characteristics as a load line or ellipse to determine maximum power output and overloading point at any frequency.

Discriminator Circuit

One form of the Foster-Seeley discriminator is shown in Figure 9. L is a choke coil which provides a d-c return path for the diodes and C_b is in each case a blocking or a bypass capacitor. The coupling in this circuit is shown as existing in the inductive field between primary and secondary. Capacitive coupling is also possible in a discriminator circuit. In fact both types of coupling will ordinarily exist simultaneously in circuit such as figure 9. To understand the nature of the capacitive coupling is best to view the circuit as a bridge. The fundamental i-f circuit involved, omitting M , is redrawn as a bridge in Figure 10. Two possibilities are shown in circuit (a) the primary is connected to the center of the secondary coil, while in circuit (b) it is connected to the center of the secondary capacitor. The driving voltage for the bridge is e_p and its output voltage is e_2 . C_a and C_b are the stray capacities to ground from the plates of the two diodes. If the arms of the bridge are perfectly balanced no secondary voltage is produced and we have zero coupling. If the center of the coil or capacitor is not electrically true, we have inductive or capacitive coupling respectively. If C_a and C_b are unbalanced we have capacitive coupling. Any mutual coupling between coils will, of course, add algebraically with coupling due

F. MACENULTY, President
Pressed Steel Car Company, Inc.

"As manufacturers of transportation equipment we are constantly alert for the new developments that mean advancement and progress. We look for factors of efficiency, safety and comfort, and any development that provides these factors is a definite step forward. It would seem that..."



"VIBRATOR POWER SUPPLIES MAKE A VITAL CONTRIBUTION TO PROGRESS"

Mr. MacEnulty, Vibrator Power Supplies are truly contributing not only to the transportation industry but to many other industries as well. Wherever direct current must be changed in voltage, or to alternating current, for fluorescent lighting or other applications they have proved their advantages. They offer efficiency, versatility and economy in current conversion; and as they are now serving the armed forces with dependability, so in the electronic and electrical era of tomorrow, they will benefit many fields: Transit, railroad, aviation, marine, radio, electronic and electrical, and will have many individual applications within those fields for power outputs of up to 1000 watts. Electronic Laboratories are pioneers in the field of vibrator conversion of current, and have developed many exclusive advantages in the heavy and light-duty power supply field. For radio telephone, aircraft radio, fluorescent lighting and electrical appliance operation and other specialized applications, Vibrator Power Supplies are the superior type of current conversion unit... Consult with E-L engineers concerning your power supply problem.

E-L STANDARD POWER SUPPLY MODEL S-1050

Model S-1050 is a typical military model Vibrator Power Supply which may easily be adapted for peacetime mobile radio transmitters. Input voltage: 12 or 24 volts DC. Output voltage: 475 volts DC at 200 MA, 8 volts DC at 4.5 MA. Dimensions: 9 1/2 x 8 3/4 x 13 13/16 inches. Weight: 52 pounds.

Write for further information of this and other models.



Electronic

LABORATORIES INC.

INDIANAPOLIS

VIBRATOR POWER SUPPLIES FOR LIGHTING, COMMUNICATIONS, AND ELECTRIC MOTOR OPERATION • ELECTRIC, ELECTRONIC AND OTHER EQUIPMENT

SOCKETS



Miniature
Octal
Diheptal
Bayonet Tube
Lockin
Glass Tube
Acorn
Crystal Holder
Battery
Cathode Ray Tube

Consult FRANKLIN on your next Socket problem—be it mounting, contact size or the utility of your socket application.

FRANKLIN SOCKETS are made of either LAMINATED or MOULDED LOW LOSS or CERAMIC construction.

A. W. FRANKLIN MANUFACTURING CORP.

175 VARICK STREET, NEW YORK 14, N. Y.

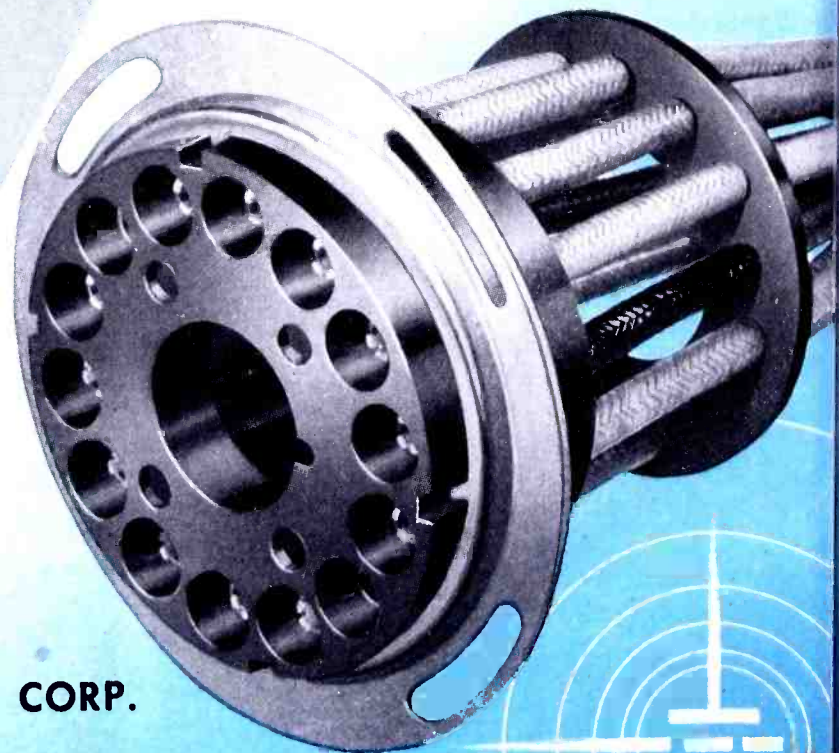

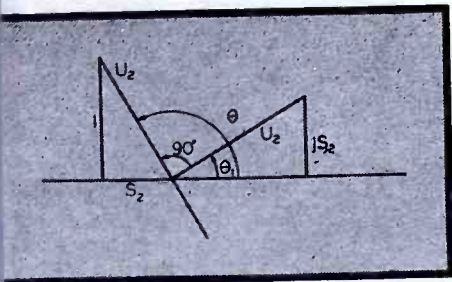

Figure 13
Evaluating $\cos \phi$ in terms of $\theta = \tan^{-1} S_2$.

bridge unbalance. Coupling by bridge unbalance can often be used to advantage, for obtaining a discriminator characteristic from such devices as crystals⁴.

Discriminator Analysis

The Foster-Seeley discriminator transformer develops the S curve of voltage against frequency by rectifying, in opposition, voltages resulting from the vector addition of the primary and secondary voltages in the coupled circuits. From Figures 9 and 10a the vector a-c voltages from the diode plates to ground are seen to be

$$e_p = e_p + e_2/2 \quad (27)$$

$$e_n = e_p - e_2/2 \quad (28)$$

For one polarity of coupling; signs will be reversed for a reversal of coupling. These voltages must, of course, be added vectorially. We must, therefore, determine the vector primary and secondary voltages. The primary voltage is a-c plate current ($g_m e_g$) multiplied by primary impedance, Z_p . Using equations 25 and 26, and letting $1 + jS_2 = U_2$, we have

$$e_p = [g_m e_g Z_{o1} / (1 + K^2 Q_s^2)] (U_2 / U) \quad (29)$$

Since $A_t = A_o / U$, equation 24 may be used to determine the vector voltage e_2 .

$$e_2 = (j g_m e_g Z_{o2} / U) [K Q_s / (1 + K^2 Q_s^2)] \quad (30)$$

The variations in phase positions of these voltages are dependent on U_2 and θ . At resonance ($S = 0$), U_2 and U are both real and unity so that primary and secondary voltages are in quadrature. The ratio of magnitudes and the phase angle between the two voltages can be obtained from the quotient of the vectors.

$$e_p / e_2 = j (U_2 / K Q_s) \sqrt{Z_{o1} / Z_{o2}} \quad (31)$$

Figures 16 (below) and 17 (right)
A loaded i-f circuit representing the discriminator circuit of Figure 9. The effect of the diode loads is incorporated in the fictitious resistors $1/2 R$. Figure 17, a discriminator curve plot.

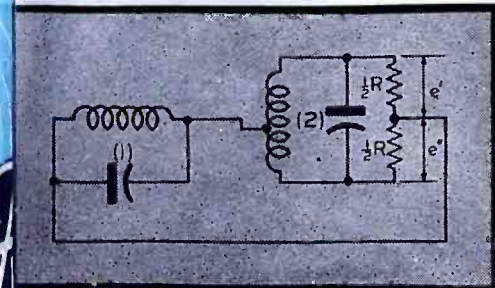
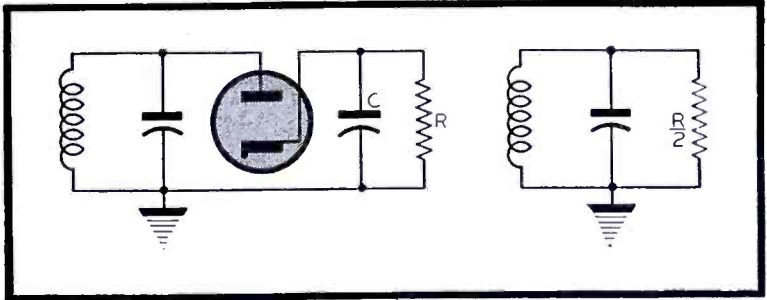

Figure 14
A diode rectifier circuit where the peak d-c voltage developed is 1.414 E; the i-f voltage driving the diode is represented by an rms value E.



Since $U_2 = 1 + jS_2$ the phase angle between e_p and e_2 is

$$\phi = \tan^{-1} S_2 + 90^\circ \quad (32)$$

The resultant vector voltage relations are shown in Figure 11.

Figure 15
Another diode rectifier circuit. Here, however, with the same R-C time constant the performance will be the same as that of Figure 14, except for the appearance of i-f, as well as the d-c voltage across R.

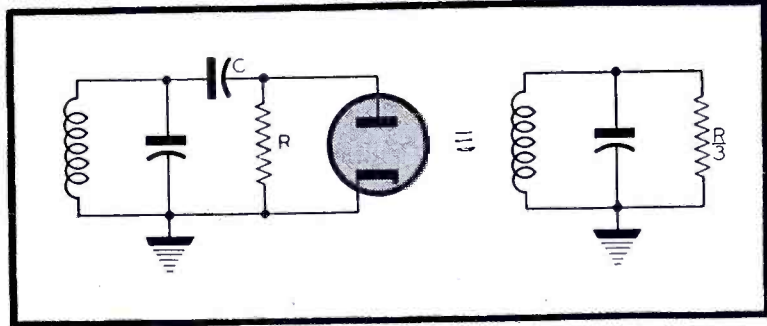

The voltage e' is rectified to produce a positive d-c voltage E' , and e'' is rectified to produce a negative d-c voltage E'' . The resultant voltage E is the algebraic sum of E' and E'' . At the larger frequency deviations, the selectivity of the circuits reduces all voltages. From these considerations and Figure 11 the manner in which the discriminator S curve is obtained will be apparent, Figure 12.

Discriminator Equations

A method of calculation may be obtained from Figure 11.

$$(e')^2 = e_p^2 + (e_2/2)^2 + e_p e_2 \cos \phi \quad (33)$$

$$(e'')^2 = e_p^2 + (e_2/2)^2 - e_p e_2 \cos \phi \quad (34)$$

$\cos \phi$ may be evaluated in terms of $\theta = \tan^{-1} S_2$, Figure 13.

$$U_2^2 = 1 + S_2^2 \quad (35)$$

$$\cos \phi = -S_2 / U_2 \quad (36)$$

And we have

(Continued on page 68)

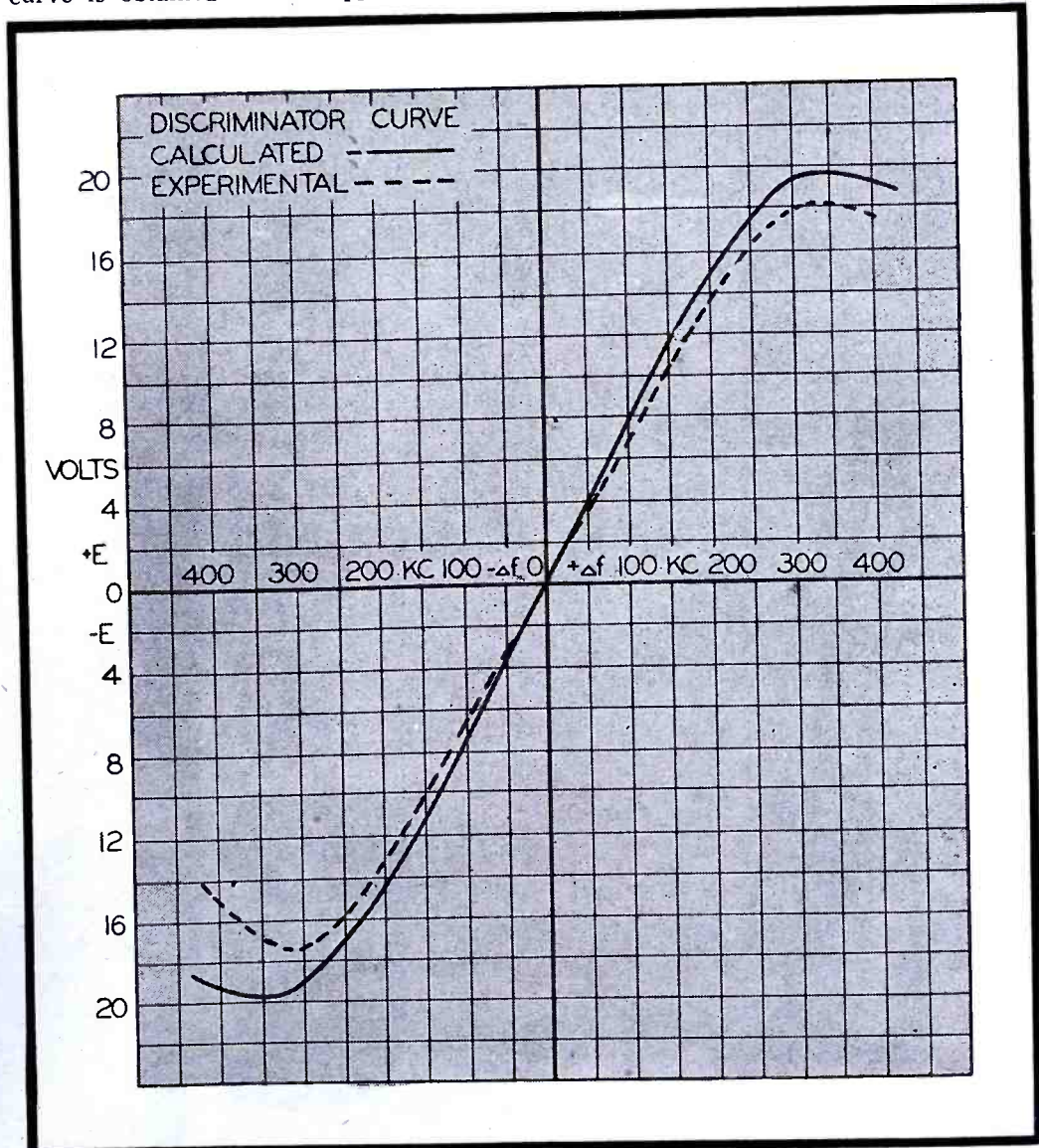
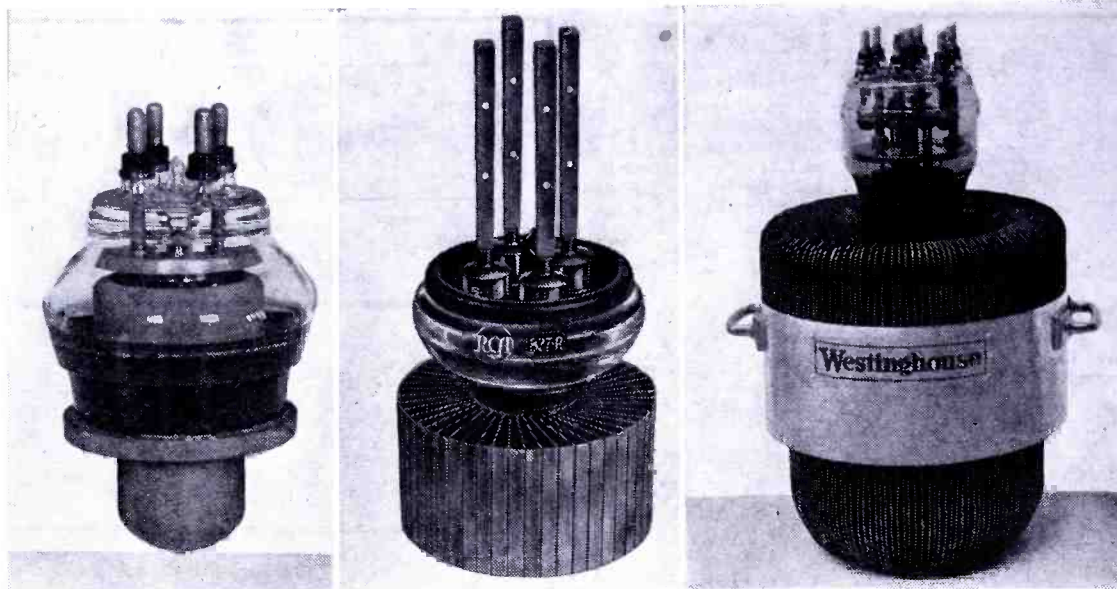

Figure 1a
Extreme left, an external anode-type tube (GL-880) made by G.E.



Figures 1b and c
Center, RCA 827-R; and right, Westinghouse WL 895R, external anode-type tubes.

EXTERNAL ANODE TRIODES CHARACTERISTICS AND APPLICATIONS

[PART I OF A FOUR-PART PAPER]

by **A. JAMES EBEL**

Chief Engineer
WILL, University of Illinois

EARLY in the development of high-power radiotelephone transmitters it became apparent that vacuum tubes cooled by direct radiation could never fulfill the dissipation requirements imposed by operation in the kilowatt-power ranges. First, the dissipation of each tube was limited by certain physical factors in

the tube design; and second, the operation of a number of tubes in parallel led to the well-known parasitic instabilities of such circuits. A solution to the problem was found in the external anode type of tube. The perfection of the metal-to-glass seal paved the way for the development of these high-dissipation power tubes.

Today there are many types of external-anode vacuum tubes varying greatly in size and design. Some are cooled by circulating water, and others by forced air. The dissipation for the various types ranges from 1.2 kilowatts to 250 kilowatts. The smallest can be held in the palm of the hand, whereas the largest stands nearly as tall as a man. A representative cross section of these tubes is

shown in Figure 1a, b, c, d, e and f.

Until recently such tubes were used principally in radio transmitters. But the recent introduction of high-frequency heating technique into many industrial operations has opened up a new field of application that promises to surpass the utilization in radio. It is important that the operators of equipment using external anode tubes understand fully their characteristics, their proper care, and something of their general construction. The purpose of this paper is to offer such information.

With the scarcity of materials and manufacturing facilities during war comes the necessity for increased attention to any details which tend to prolong the life

Figures 1d, e and f

Extreme left, Western Electric 240B; below, Amperex; and right, FTR 3067A (with water jacket and truck) external anode-type tubes.

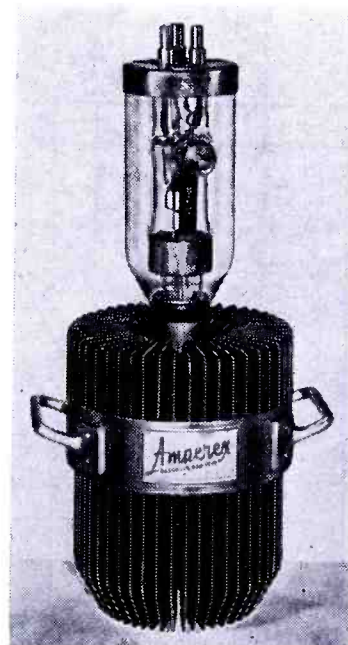
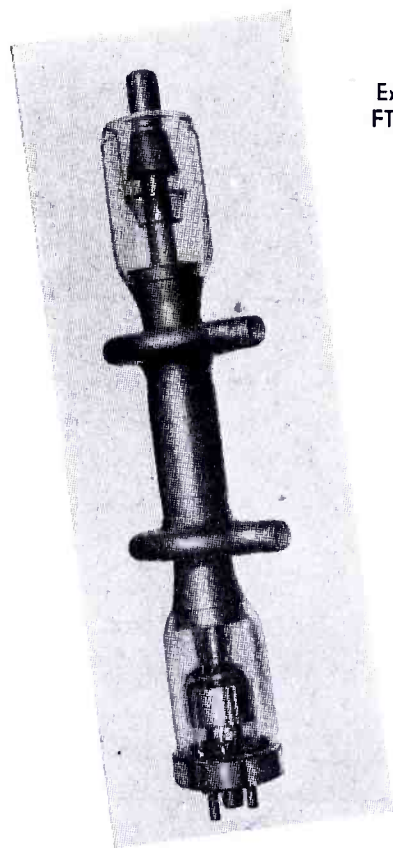



HARVEY UHX-25

A 25-Watt General Purpose Radio-Telephone Transmitter— Available for operation between 1.5 M.C. and 30 M.C.



HARVEY "AMPLI-STRIP"

For I-F and AUDIO Amplification.

HARVEY OF CAMBRIDGE

RADIO AND ELECTRONIC EQUIPMENT

The units illustrated are representative of HARVEY OF CAMBRIDGE design and construction "know-how" as well as precision of manufacture and testing. Each is a precision product designed and developed by HARVEY OF CAMBRIDGE to fill specific needs in the radio-electronic fields.

Some, like the 206 PA Power Supply and the "Ampli-Strip" are new developments resulting from HARVEY's one-hundred per cent war work.

Others, like the UHX-25 Transmitter and

Marine 25 Radio Telephone are typical of HARVEY OF CAMBRIDGE products which have long been recognized as standards of quality and dependability.

Years of exclusive specialization in the manufacture and development of this type of equipment are your guarantee of complete satisfaction from all HARVEY OF CAMBRIDGE products and of competent, intelligent assistance in bringing to a successful solution any of your present or projected radio-electronic problems.

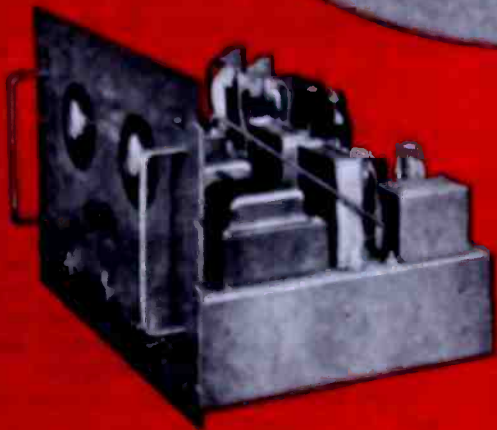

HARVEY Regulated Power Supply 206 PA

For Laboratory D.C. Source—Range 500 to 1000 volts

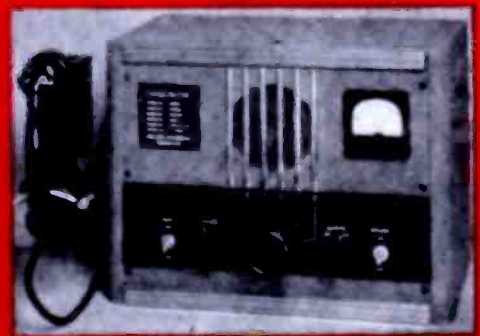

HARVEY MARINE 25

A 6-Channel Marine-Radio Telephone.

HARVEY OF CAMBRIDGE

HARVEY RADIO LABORATORIES, INC.

442 CONCORD AVENUE • CAMBRIDGE 38, MASSACHUSETTS

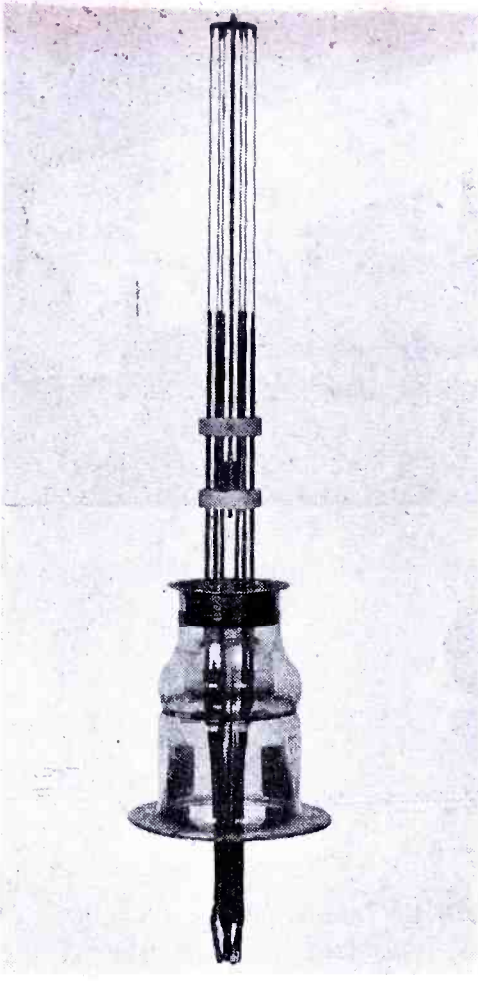

Figures 2 (above) and 3 (below).
 Figure 2, six-strand filament of a high-power triode. (Courtesy G.E.) Figure 3, detailed view of high-powered triode grid structure. (Courtesy FTR.)

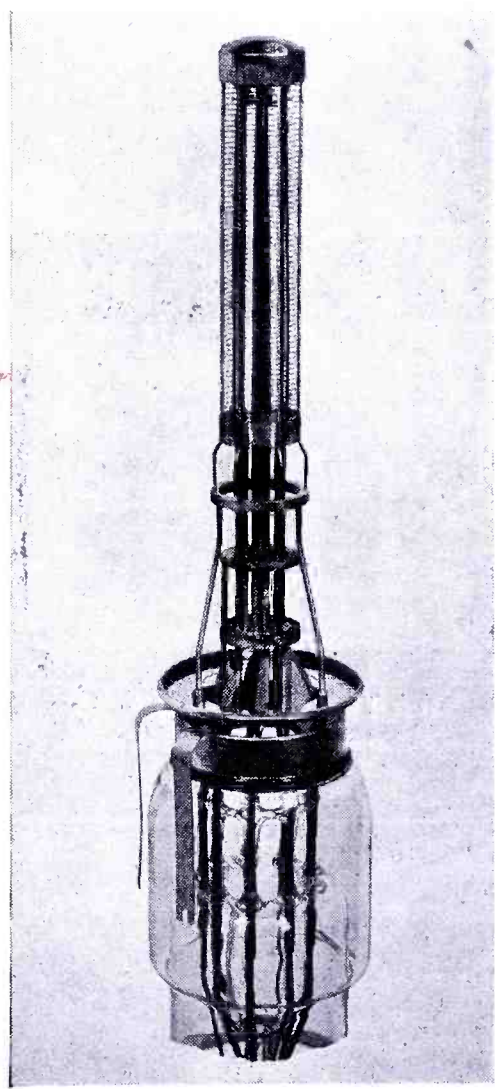
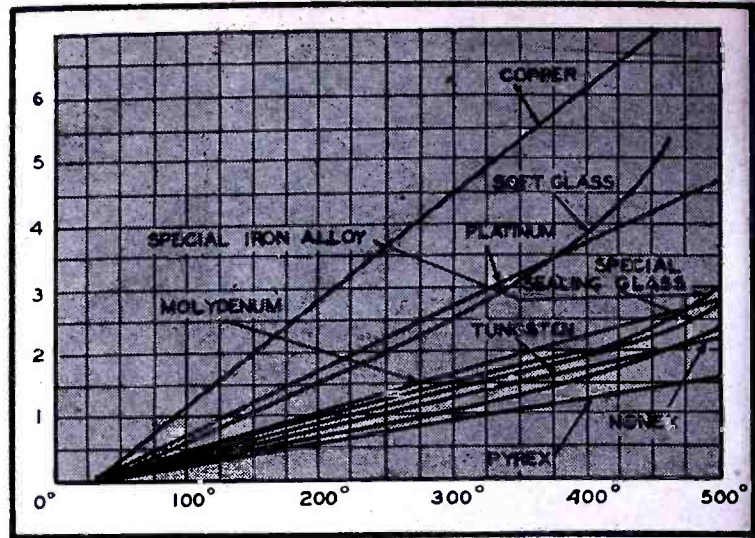

Figure 4.

Plot illustrating thermal expansion of selected metals and glass.

(Courtesy FTR).



of such tubes. A wealth of valuable material has been published^{1, 2, 3} on this phase of tube operation and will be referred to, in this paper, from time to time.

The filaments of external-anode tubes are composed of pure tungsten. In its pure form this element has the highest melting point of any ductile metal (3655° K) and emits electrons in satisfactory quantities when operated at temperatures at which exaporation is not impractically great. Figure 2 shows the construction of a six-strand filament for a high-power triode. It will be noted that leads are brought out from each of the strands so that the filament may be connected for single-, three-, or six-phase operation. The pure metal becomes ductile when properly worked and can be drawn into strands of the proper size. After being heated to incandescence, the metal returns to a crystalline form as it cools, and becomes very brittle. To prevent these brittle strands from shattering, they are mounted with springs at either end to take up the slack caused by expansion when the filament is heated and to protect the strands from physical shock. One of the fundamental necessities in the care of tungsten emitters is to protect them from all shocks because they are so easily fractured. At least one leading transmitter maintenance authority⁴ recommends that the tubes not be removed from their sockets during their entire life. Other considerations bearing on the advisability of this procedure will be mentioned later.

The grid structure is generally a helix wound around several supporting rods so that the spacing between the grid wires and the geometrical configuration of the filament strands are uniform. The grid operates at a fairly high temperature and is called upon to dissipate considerable power. The grid size is a compromise between a thick strand, which is best for heat dissipation purposes, and a fine strand, which has the best electrical characteristics. The material must have a high melting point and a high work function for mechanical stability and low secondary emission. Such metals as tungsten, tantalum, and molybdenum are normally used for both the grid wires and the supports of these wires. Special consideration must be given to the grid lead to provide high insulation, low capacity to other elements, and low I²R loss. In Figure 3 we have a detailed picture of the grid structure of a high-power triode. The supports for the grid and filament structure must be carefully machined to provide accurate spacing and to maintain that spacing. Any warping will cause

a change in tube characteristics and may lead to interelectrode shorts. In the case of some ultrahigh-frequency tubes this spacing is as low as .06", indicating the necessity for carefully maintaining the correct alignment.

Since it is particularly important that the copper used be oxygen-free, the anodes of these tubes are made of the purest copper available. The metal used in each tube must be from stock that has been carefully analyzed for foreign materials and gases, and throughout the manufacturing process careful checks must be made to see that no gas, especially oxygen, has been introduced into the copper. Pure copper is necessary to effect a good metal-to-glass seal, to give proper strength, and to maintain the vacuum within the tube. For a successful metal-to-glass seal the glass must wet the metal; that is to say, it must flow over the metal rather than collect in a globule as water does on a greasy surface. Furthermore, it is necessary to provide for the differential expansion of the metal and the glass. Figure 4 shows the expansion of the normally used metals and glasses as related to temperature changes. Note that the expansion of glass and copper are decidedly different. In spite of this differential, the high ductility and the low yield point of copper make possible the successful combination of these two materials. It is necessary, however, that the copper be thin at the junction, a fact which tends to produce mechanical weakness in the tube. This is another reason for careful handling of the tube. The seal of the external anode tube is mechanically its weakest point and must be treated as such. In a typical 5-kw tube the anode wall thickness is .065". This thinness is required almost entirely by thermal considerations.

High temperature is destructive to the seal. Fortunately there is generally a noticeable discoloration of the seal as the temperature becomes too high. This is especially noticeable in the copper-to-glass seals where the change is from the normal reddish copper hue through green to a dark metallic color.

As has been stated, there are two methods of cooling the anodes of these tubes, water cooling and forced-air cooling. The water-cooled tube is mounted in a jacket with provision for water entering the bottom of the jacket and leaving the top. Since the anode of the tube operates at a high d-c potential, it is necessary to provide adequate insulation in the water circulating system be-

(Continued on page 104)

"THINKING" MACHINES



Machine designed by Remler to perform multiple operations: automatic slotting; indexing; drilling; milling and reaming.

REMLER ENGINEERS design and build robots with "brains" to improve production techniques. Ingenious jigs and dies, and in many instances entire machines are constructed to combine intricate operations. These innovations contribute to the precision accuracy of Remler products; release manpower for other tasks; reduce costs and speed up deliveries. For complete sound transmitting systems; radio; plugs and connectors and other electronic components in metal and plastic, consult . . .

REMLER COMPANY, LTD. • 2101 Bryant St. • San Francisco, 10, Calif.

REMLER

SINCE 1918

Announcing & Communication Equipment



PLUGS & CONNECTORS

Signal Corps • Navy Specifications

Types:		PL				NAF	
50-A	61	74	114	150	1136-1	No. 212938-1	
54	62	76	119	159			
55	63	77	120	160			
56	64	104	124	291-A			
58	65	108	125	354			
59	67	109	127				
60	68	112	149				

PLP		PLQ		PLS	
56	65	56	65	56	64
59	67	59	67	59	65
60	74	60	74	60	74
61	76	61	76	61	76
62	77	62	77	62	77
63	104	63	104	63	104
64		64			

OTHER DESIGNS TO ORDER

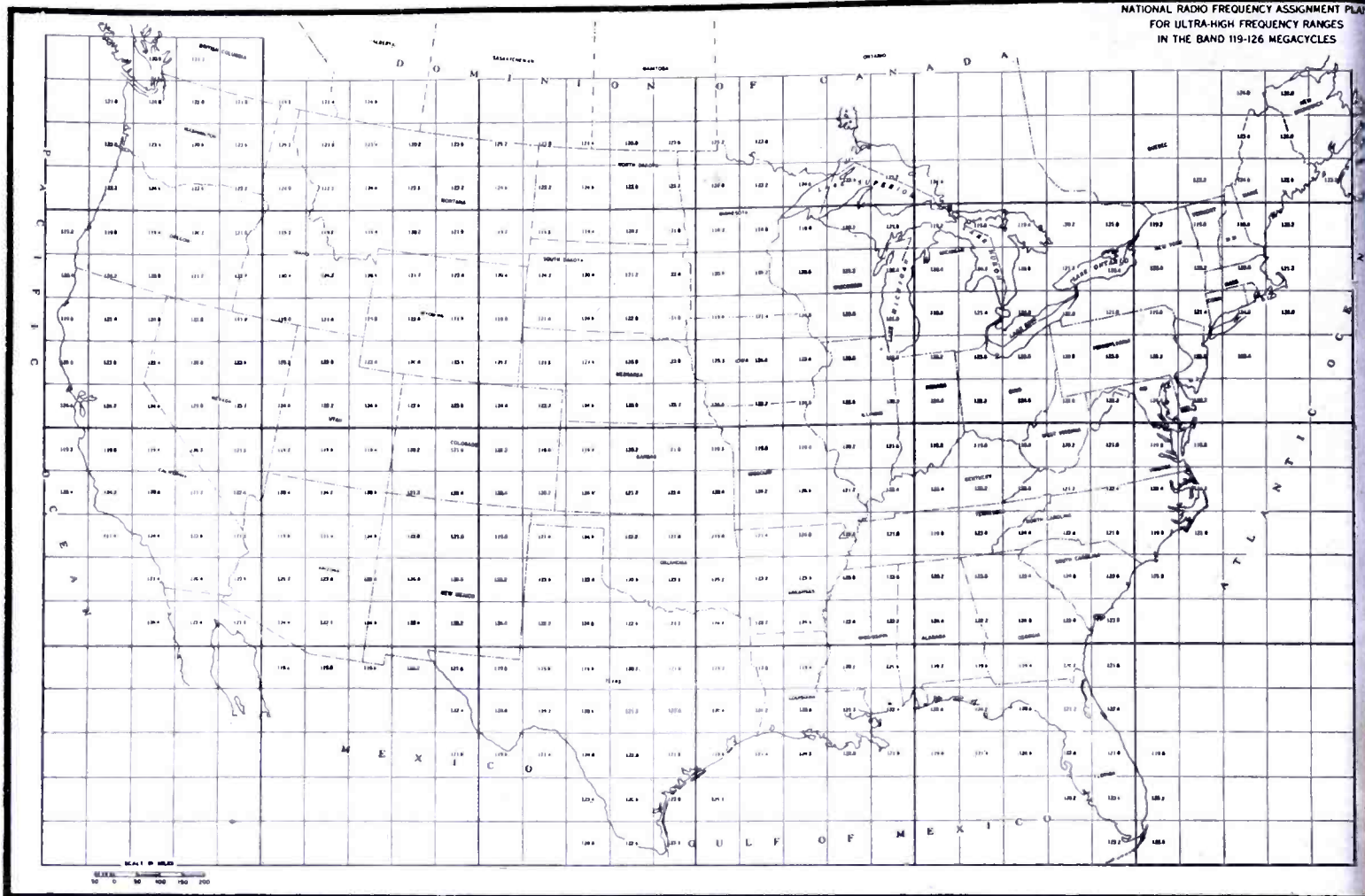

CAA checker-board radio-range frequency assignment plan dividing the country into 100-mile squares with one range station within each square.

AERONAUTICAL COMMUNICATIONS IN THE POSTWAR ERA

by **McMURDO SILVER**
Consulting Engineer

FROM War I up to about 1940 aeronautical radio communications seems to have "just grown." It can hardly be said, since no one could prophesy the extent of character of aviation as of 1940 at any significantly earlier date, that any particularly intelligent planning for the future could have been engaged in. Thus the assignment of aircraft communication and navigation frequencies, establishment of policies for regulation of aeronautical radio communication and a host of other details had, of necessity, to await the development of a sufficiently clear-cut aviation situation.

By approximately 1940 the aviation communications and navigation outlook for at least the immediate future had crystallized sufficiently to permit of intelligent long-range planning. The results of such government planning were partially set forth in *FCC Rules and Regulations Governing Aviation Services*, (Title 47—Telecommunication—Chapter I, Part G), effective August 1, 1939 and revised to November 1, 1942. This pub-

lication, available from the Superintendent of Documents, Washington, D. C., at a price of five cents, together with a copy of the *National Allocation Plan For Assigning Radio-Range Frequencies in the Band 119-126 Megacycles* which was printed by CAA as *Technical Development Report No. 28* in May, 1941, and which was prepared by L. H. Simson of CAA constitute *must* information for anyone seriously interested in the probable extensive expansion of aeronautical communications after V-Day.

Desiring not to explore in detail the data set forth in referenced publications, but rather to consider briefly a number of aspects of *postwar* aeronautical radio communications the writer will pass lightly over the *postwar* frequency situation, particularly as, while in principle it will probably conform to the excellent plan already devised, it is possible that actual frequencies may be somewhat different.

In the prewar period government and commercial aeronautical radio services operated upon a number of different bands. Possibly most familiar is the 200- to 400-kc low-frequency band in which were located radio-range, communication and navigation services. In this band

278 kc was uniformly assigned to a port control stations for communication with civilian, itinerant and other aircraft in flight. Such aircraft were expected to call and work the airport within range on 3105 kc in daylight or 6210 kc after dark. In practice, 6210 kc was little used, probably because 3105 kc provided sufficient distance range even after dark to satisfy the limited-range flight of an average civilian flyer—and it is with him and his brothers-legion that the writer is primarily concerned.

Experience having indicated these low and medium frequencies to offer interference possibilities incompatible with the future concept of one or more airports in almost every community, and the thousands of civilian-itinerant aircraft flying simultaneously, the *u-h-f* allocation plan was wisely devised. Under this plan it was proposed to shift all such aeronautical radio communication and navigation services up into the range of 119 to 126 megacycles—a far cry indeed from the older low and medium frequencies which were to be progressively abandoned. Such a shift was most logical and sensible, for frequencies within the range

(Continued on page 76)

Bring Your Electronic Projects to NATIONAL UNION

ELECTRONIC RESEARCH FOR INDUSTRY



LET'S GET YOUR POST-WAR PRODUCT READY NOW

Now you don't have to postpone that important electronic research job your company may have shelved for lack of engineering manpower or equipment. National Union Laboratories offer you something you couldn't buy for "love nor money" these days . . . completely equipped modern electronic research laboratories, staffed by an outstanding group of experienced engineers.

You can strengthen your whole development program by making use of National Union facilities. You'll find National Union engineers trained in every science allied with electronics: physics, chemistry, metallurgy, mechanical and electrical engineering, glass technology. That's why National Union can provide you with a *complete* electronic service . . . from laboratory to final production . . . your own Electronic Research Department!

Let us start working with you *now*, whether on a single project or your entire research program. Arranging a consultation with National Union involves no obligation, whatever. Just write to Department C—today!



NATIONAL UNION RESEARCH LABORATORIES

NATIONAL UNION RADIO CORPORATION • NEWARK 2, NEW JERSEY



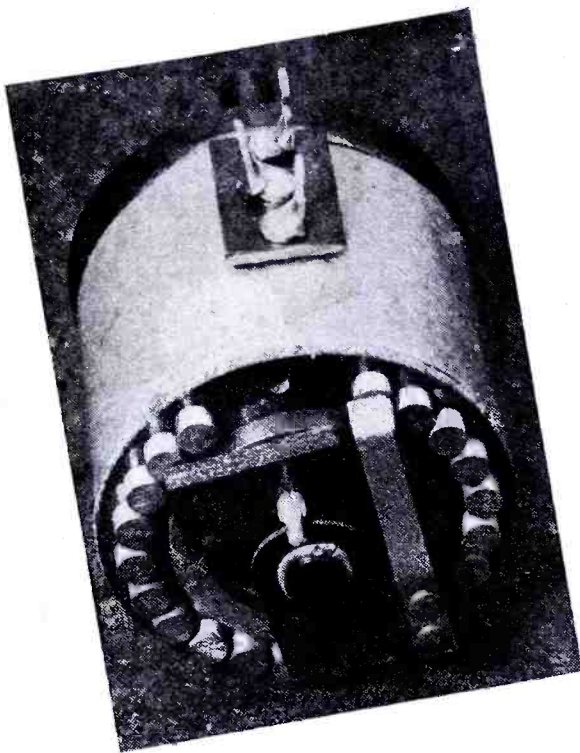

Left, mixer attenuator. (Courtesy Cinema Engineering Company)
Above, precision attenuator box. (Courtesy General Radio Company)

RESISTIVE ATTENUATOR, PAD AND NETWORK

Theory and Design

In part II, the fundamental method of procedure in the design of the various types of attenuating networks was briefly outlined and a few of the more elementary forms of networks were considered. The second set of *Tables of Hyperbolic Functions of a Real Variable* was also presented, accompanied by charts showing in compact form all of the information needed for the use and design of the simpler types of networks. The series, shunt, series and shunt, and the L-type taper pads were described. The two charts also contained formulas, in explicit form, and are particularly applicable to the tables presented in the first three parts of this series.

In this installment, part III, two additional charts are shown with explicit formulas for the complete design of the *T*, π , bridged-*T*, lattice, and the multiple-bridge types of networks. These charts, like those in part II have been designed for specific use in connection with the *Tables of Hyperbolic Functions of a Real Variable*. The first two sets of these tables were presented in parts I and II. The third set of tables appears with this installment. The design of attenuators proceeds with a continuation of the L-taper networks, followed by the *T*-type network.

Appendix I shows the hyperbolic formulas which were used for the calculation of all of the *Tables of Hyperbolic Functions of a Real Variable* presented in this series of papers.

Appendix II describes a useful mathematical tool, little known by radio or communication engineers, the *Gudermannian Function*, which may be used for the calculation and interpolation

[PART THREE OF A FOUR-PART PAPER]

by **PAUL B. WRIGHT**
Communications Research Engineer

of hyperbolic functions of a real variable. When any one of these is known, all of the remaining functions may be found by direct application of common tables of the natural trigonometric functions from circular function theory.

It is convenient for design purposes to utilize the unbalanced form of network configuration on a unit basis for

T-pad, 600-600 ohms; 20 steps, 2 db per step.
(Courtesy Tech Laboratories)

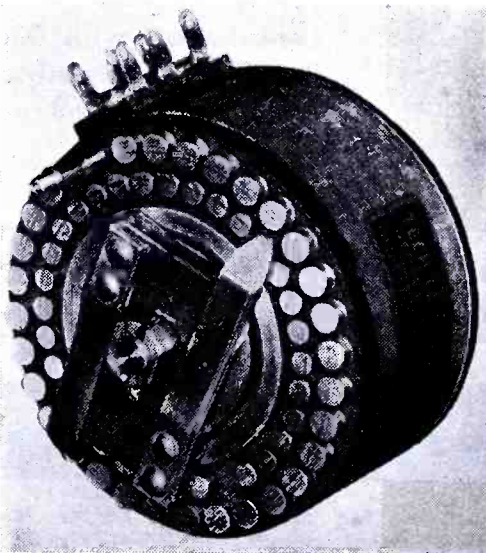

the *T*, π , and bridged-*T* structures. These configurations are shown in the accompanying charts, as well as those of the lattice and multiple bridge types of networks. Complete design information is contained in these charts to enable the engineer to obtain the transmission loss incurred by their use in any system when operated between image impedances having the values given in the charts. The network elements are presented in symbolical form so that the equations may be solved in the most direct manner through use of the *Tables of Hyperbolic Functions of a Real Variable* presented in parts I, II and this installment. The definitions and requirements which must be met for the equations to be valid appeared in charts accompanying part II and this presentation, also.

It should be noted that the impedance ratio shown in the charts and development of equation is $s^2 = Z/z$. The ratio of the terminating image impedances can of course be replaced by an ideal transformer having an impedance transformation ratio of s^2 to 1. This procedure places the network proper upon an unconditionally unit basis, with the high side of the transformer terminated by an impedance of s^2 ohms, and gives unit or one-ohm terminations to the network. The reduction of a network to a unit basis is known as *normalizing*. However, throughout this paper, the ideal transformer will be omitted and the more direct approach of the actual terminations used for the network will be used. The image impedance theory usage results in considerable simplification of the final form of the derived equations. The image propagation function, θ , is sometimes referred to as the image transfer constant. Numerically, it is equal to

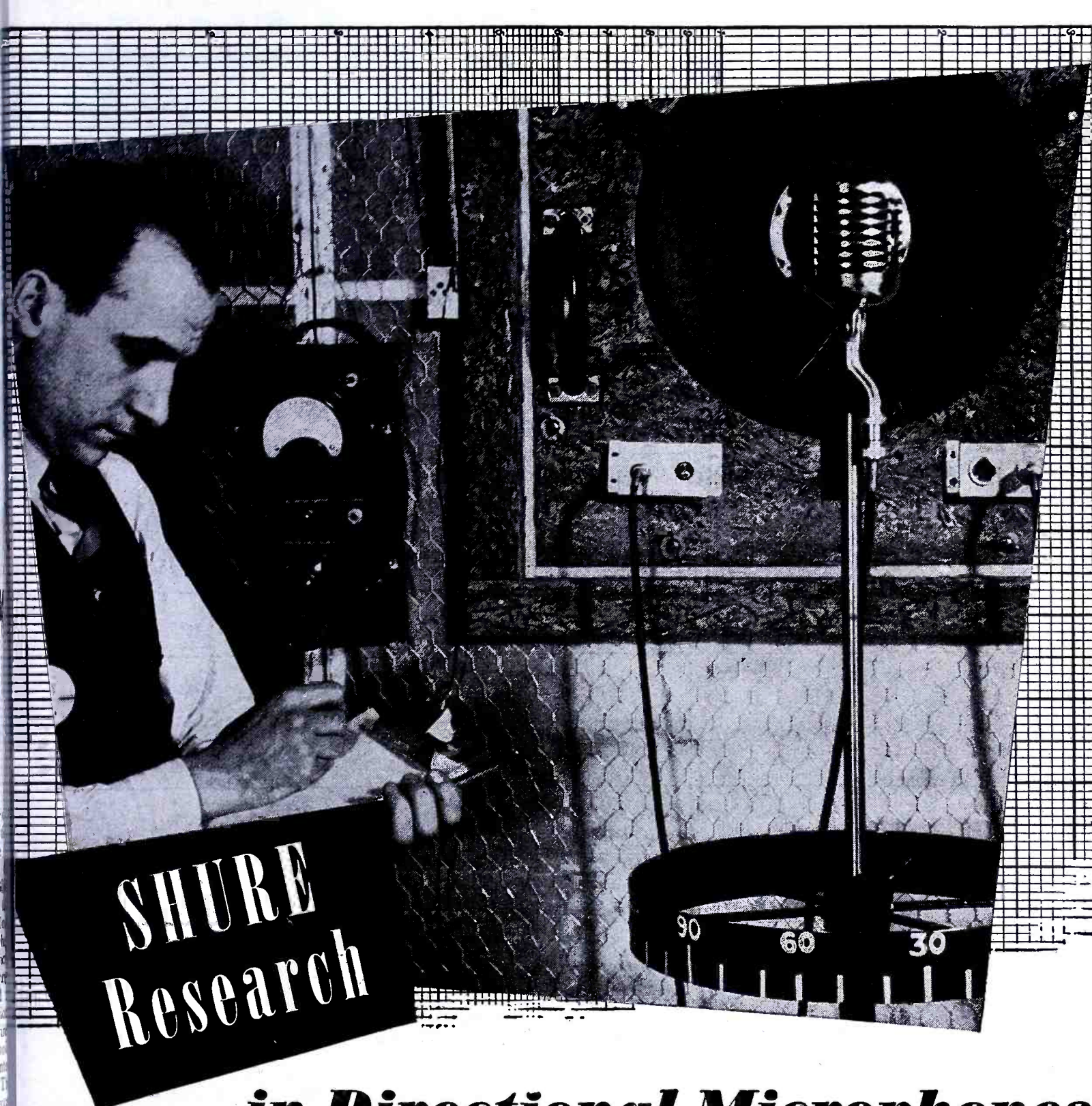

**SHURE
Research**

... in Directional Microphones

It is not enough to design a Microphone that merely converts sound waves into electrical impulses. A Microphone, to be truly useful in modern broadcasting, should be discriminating enough to accept wanted sounds — and reject unwanted sounds. Shure Research was the first to develop a single unit uni-directional Microphone, both crystal and dynamic.

Shure Research is the reason why practically every major broadcasting station uses the Shure 556 Unidyne. Shure Research is your assurance of postwar microphone superiority.

SHURE BROTHERS, 225 West Huron Street, Chicago
Designers and Manufacturers of Microphones and Acoustic Devices



NETWORK CONFIGURATION	TYPE	IMPEDANCE BASIS	DECIBELS TRANSMISSION LOSS 20 Log ₁₀ k	IMAGE IMPEDANCES	NETWORK ELEMENTS	DEFINITIONS AND REQUIREMENTS
	T	FULL MATCHED IMAGE IMPEDANCES	$k = s(1 + \frac{v+z}{w})$	$Z = (\frac{\phi}{\beta})^{\frac{1}{2}}$ $z = (\frac{\phi}{\beta})^{\frac{1}{2}}$	$u = cZ - w$ $v = cZ - w$ $w = ay$	$Z \geq z$ $c = \coth \theta$ $\phi = uv + uw + vw$ $s^2 = Z/z \geq 1$ $a = \operatorname{csch} \theta$ $y = \sqrt{Zz}$ $\beta = \frac{u+w}{v+w}$
			$k = (1 + \frac{v+z}{w})$	$z = [u(u+2w)]^{\frac{1}{2}}$	$u = v = Dz$ $w = az$	$Z = z$ $D = \tanh \frac{\theta}{2}$ $\phi = 0.115129 \times \text{No}(\text{db})$ $a = \operatorname{csch} \theta$
	T	UNIT MATCHED IMAGE IMPEDANCES	$k = s(1 + \frac{v'+1}{w'})$	$s^2 = (\frac{\phi'}{\beta'})^{\frac{1}{2}}$ $l = (\frac{\phi'}{\beta'})^{\frac{1}{2}}$	$u' = cs^2 - w'$ $v' = c - w'$ $w' = as$	$Z \geq z$ $u' = u/z$ $\phi' = u'v' + u'w' + v'w'$ $s^2 = Z/z \geq 1$ $a = \operatorname{csch} \theta$ $w' = w/z$ $\beta' = \frac{u'+w'}{v'+w'}$
			$k = (1 + \frac{u'+1}{w'})$	$l = [u'(u'+2w')]^{\frac{1}{2}}$	$u' = v' = D$ $w' = a$	$Z = z$ $D = \tanh \frac{\theta}{2}$ $a = \operatorname{csch} \theta$ $u' = u/z$ $v' = v/z$ $w' = w/z$
	Π	FULL MATCHED IMAGE IMPEDANCES	$k = (1 + \frac{v}{w} + \frac{v}{z})/s$	$Z = u(\sigma\rho)^{\frac{1}{2}}$ $z = w(\sigma/\rho)^{\frac{1}{2}}$	$u = y^2/(cz - ay)$ $v = Ay$ $w = y^2/(cZ - ay)$	$Z \geq z$ $A = \sinh \theta$ $\sigma = v/(u+v+w)$ $s^2 = Z/z \geq 1$ $c = \coth \theta$ $y^2 = Zz$
			$k = (1 + \frac{v}{w} + \frac{v}{z})$	$z = \frac{uv}{[v(v+2u)]^{\frac{1}{2}}}$	$u = w = dz$ $v = Az$	$Z = z$ $d = \coth \frac{\theta}{2}$ $\phi = 0.115129 \times \text{No}(\text{db})$ $A = \sinh \theta$
	Π	UNIT MATCHED IMAGE IMPEDANCES	$k = (1 + v' + \frac{v'}{w'})$	$s^2 = \frac{u'(\sigma'\rho')^{\frac{1}{2}}}{l}$ $l = \frac{w'(\sigma'/\rho')^{\frac{1}{2}}}{s}$	$v' = As$ $w' = s/(cs - a)$	$Z \geq z$ $u' = u/z$ $w' = w/z$ $s^2 = Z/z \geq 1$ $\rho' = \frac{v'+w'}{u'+v'+w'}$ $c = \coth \theta$ $\sigma' = v'/(u'+v'+w')$ $A = \sinh \theta$
			$k = (1 + v' + \frac{v'}{u'})$	$l = \frac{u'v'}{[v'(v'+2u')]^{\frac{1}{2}}}$	$u = w = d$ $v' = A$	$Z = z$ $u' = u/z$ $v' = v/z$ $d = \coth \frac{\theta}{2}$ $w' = w/z$ $A = \sinh \theta$
	MULTIPLE BRIDGE	FULL MATCHED IMAGE IMPEDANCES	$k = n_m s$	INFINITE	$R = \frac{1}{2}[cZ - ay]$ $r = \frac{1}{2}[z - ay]$	$Z \geq z$ $a = \operatorname{csch} \theta$ $n_m = \text{No. of branches in multiple}$ $s^2 = Z/z \geq 1$ $c = \coth \theta$ $y^2 = Zz$
			$k = n_m$	INFINITE	$R = r = \frac{1}{2}Dz$	$Z = z$ $D = \tanh \frac{\theta}{2}$ $s^2 = Z/z = 1$
	MULTIPLE BRIDGE	UNIT MATCHED IMAGE IMPEDANCES	$k = n_m s$	INFINITE	$R' = \frac{1}{2}[cs^2 - as]$ $r' = \frac{1}{2}[c - as]$	$Z \geq z$ $c = \coth \theta$ $n_m = \text{No. of branches in multiple}$ $s^2 = Z/z \geq 1$ $a = \operatorname{csch} \theta$
			$k = n_m$	INFINITE	$R' = r' = \frac{1}{2}D$	$Z = z$ $R' = R/z$ $r' = r/z$ $D = \tanh \frac{\theta}{2}$ $s^2 = 1$

0.115129 × No. (db) loss of the network. It is also equal to one-half the natural logarithm of the ratio of the power delivered to the network to the power delivered to the load. This ratio has been designated a factor, k^2 .

Charts

The charts which have been prepared giving detailed design information for all of the standard as well as non-standard attenuating types of resistive networks were especially designed for direct application of the *Tables of Functions* that are described in Appendix I.

In the application of the formulas involving networks placed upon a unit basis, the use of primes or subscripts is undesirable and unnecessary, but to avoid some confusion which might arise in transcribing formulas from the chart, the subscript or the prime has been used. In practice, the network would be designed on the unit basis with simple regard to designation, then the multiplying factor, z , would be applied to all elements and terminations of the network to place it on a full impedance basis.

To reduce the unwieldy form of some expressions to a form more suitable for writing and manipulation, some compression has been made possible by the use of Greek symbols as well as English symbols. This was necessary to avoid duplication of the meaning of English characters and the pitfalls resulting from placing various subscripts with the same

Figures 1 to 6

The transmission losses and element values for the *T*, *Pi* and *Multiple Bridge* networks in terms of the *Hyperbolic Functions*.

characters to designate different things. This method of writing expressions frequently permits a minimum of operations to be performed with the equations of the network, completely devoid of the cumbersome algebraic expressions which frequently obscure the objective. As examples of this method, by inspection, one may write for the product and quotient of the image impedances of the *T* network, from Figure 1, $Zz = \phi = uv + uw + vw$, and $Z/z = \beta = (u + w)/(v + w)$; and for the π network, of Figure 3, $Zz = uw\sigma = uvw/(u + v + w)$, and $Z/z = u\rho/w = u(v + w)/(w(u + v))$. Other useful relationships may be utilized to quickly check the accuracy of the calculations of the network elements obtained from the tables. An example of this may be shown from Figure 7, where $t = Dz$ and $u = dz$; hence, $tu = z^2$, since $Dd = 1$, or from Figure 3,

$$\frac{1}{w} - \frac{1}{u} = c \left(\frac{1}{z} - \frac{1}{z} \right), \text{ etc.}$$

T Network

Referring to Figure 2 and the nota-

tion used for the element values, t image impedances on a unit basis may written,

$$s^2 = u' + \frac{w'(v' + 1)}{v' + w' + 1}$$

and

$$l = v' + \frac{w'(u' + s^2)}{u' + w' + s^2}$$

The power delivered to the network from a constant current generator producing unit current and having an internal impedance of Z ohms is

$$W = i^2 Z = Z$$

The power delivered from the network output terminals to the load impedance $w = i_z^2 z = (w'/(v' + w' + 1))^2 z$. From expressions 3 and 4 the power ratio is

$$W/w = k^2 = ((v' + w' + 1)/w)^2 s^2$$

where

$$\phi = k \geq 1$$

and

$$s^2 = Z/z \geq 1$$

Since the loss in

$$\text{db} = 10 \text{Log}_{10}(W/w)$$

A knack for making difficult tubes

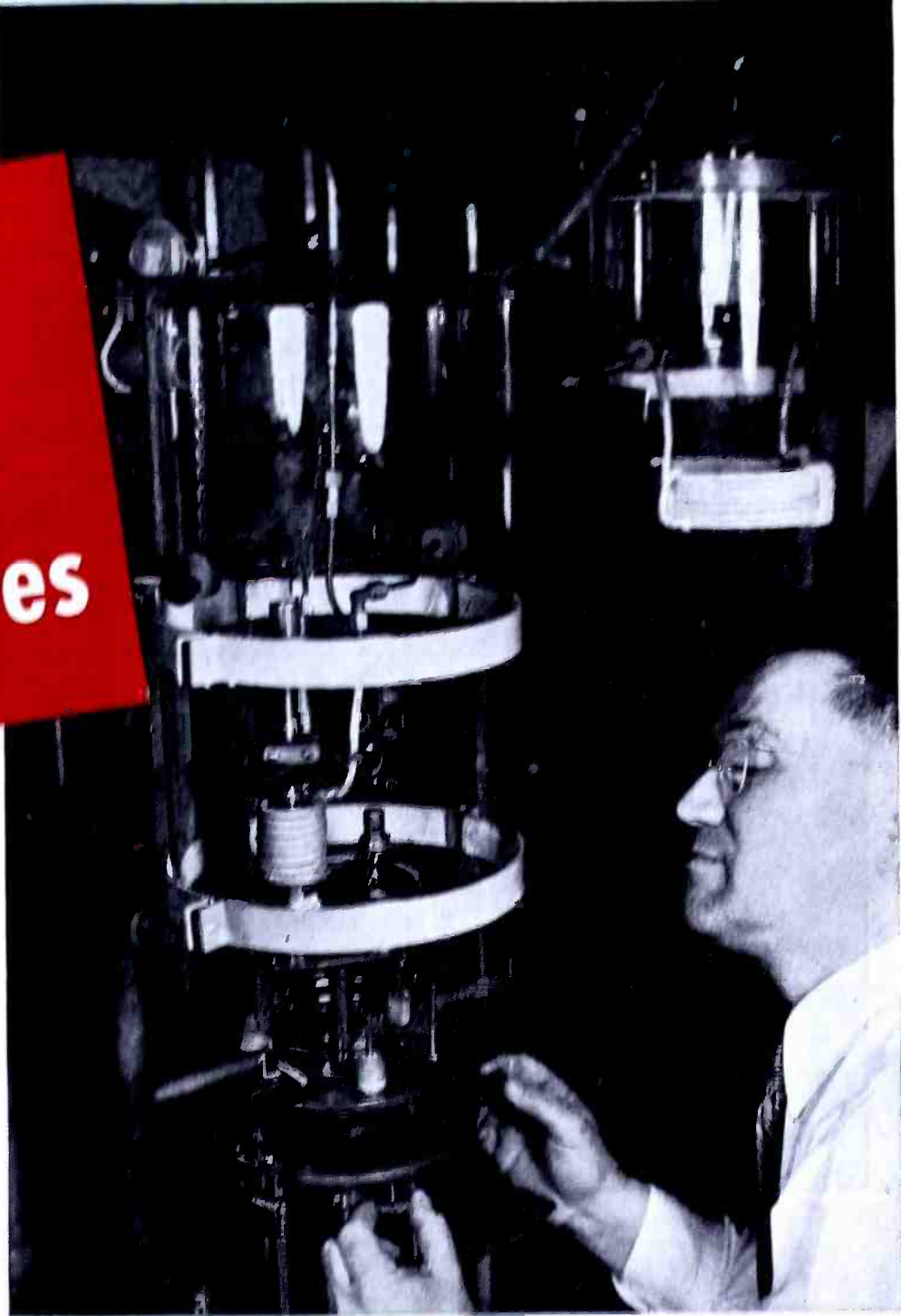

The metal plate and grid terminal posts of an 833-A being bonded to the glass envelope by means of radio-frequency heating in a nitrogen atmosphere.

NORTH AMERICAN PHILIPS is one of the few producers of electronic tubes successfully manufacturing the type 833-A transmitting triode tube in quantity. The assembly alone is for unusual skill and resourcefulness on the part of our engineers and craftsmen, and specially designed equipment. Due to the unique design of the 833-A, the tube is supported from its own terminal post at the top of the glass envelope and the remaining elements from the base or stem. The tube must therefore be assembled in two sections and accurately joined on a glass lathe. Bonding of the metal grid and plate terminal posts to the glass envelope is done by r-f induction heating, which is confined to the sealing points only. This operation, as illustrated, is completed in a matter of seconds. The ability to produce such difficult tubes is the result of experience gained by an organization with a background of over half a century of research and development in the electrical field. That is one of the reasons why

manufacturers look to North American Philips as a reliable source of electronic tubes for their postwar requirements. Although all the **NORELCO** tubes we produce now go to the armed forces, we invite inquiries from prospective users. A list of the tube types we are especially equipped to produce will be sent on request. Write today for interesting booklet, describing the background of North American Philips in the science of electronics.



Norelco Electronic Products by
Reg. U. S. Pat. Off.

NORELCO PRODUCTS: Quartz Oscillator Plates; Amplifier, Transmitting, Rectifier and Cathode Ray Tubes; Searchray (Industrial X-ray) Apparatus; X-ray Diffraction Apparatus; Medical X-ray Equipment, Tubes and Accessories; Tungsten and Molybdenum products; Fine Wire; Diamond Dies. • When in New York, be sure to visit our Industrial Electronics Showroom.

NORTH AMERICAN PHILIPS COMPANY, INC.

Dept. E-1, 100 East 42nd Street, New York 17, N. Y.
 Factories in Dobbs Ferry, N. Y.; Mount Vernon, N. Y. (Metallix Div.); Lewiston, Me. (Elmet Div.)
COMMUNICATIONS FOR JANUARY 1946 • 53

NETWORK CONFIGURATION	TYPE	IMPEDANCE BASIS	DECIBELS TRANSMISSION LOSS = 20 Log ₁₀ k	IMAGE IMPEDANCES	NETWORK ELEMENTS	DEFINITIONS AND REQUIREMENTS
	LATTICE	FULL MATCHED IMAGE IMPEDANCES	$k = s \left[\frac{z \psi + x_2 y_2}{uv - tw} \right]$	$Z = \left[tu \frac{x_1 y_1}{x_2 y_2} \right]^{1/2}$ $z = \left[tu \frac{x_2 y_2}{x_1 y_1} \right]^{1/2}$	$t = [y(s+cx)/(c+as)]$ $u = [y(s-cx)/(c-as)]$ $v = [y(s+cx)/(c-as)]$ $w = [y(s-cx)/(c+as)]$	$Z \geq z$ $\psi = (x_1 + y_1) = (x_2 + y_2) = (t+u+v+w)$ $x_1 = t+u$ $x_2 = t+v$ $y_1 = u+w$ $y_2 = v+w$ $a = cs \csc \theta$ $c = \coth \theta$ $k = \epsilon^\theta$
	LATTICE	UNIT MATCHED IMAGE IMPEDANCES	$k = \left[\frac{\psi + x_2 y_2'}{uv - tw} \right]$	$s^2 = \left[tu \frac{x_1 y_1'}{x_2 y_2'} \right]^{1/2}$ $l = \left[tu \frac{x_2 y_2'}{x_1 y_1'} \right]^{1/2}$	$t' = [s(s+cx)/(c+as)]$ $u' = [s(s-cx)/(c-as)]$ $v' = [s(s+cx)/(c-as)]$ $w' = [s(s-cx)/(c+as)]$	$Z \geq z$ $\psi = (x_1 + y_1) = (x_2 + y_2) = (t'+u'+v'+w')$ $x_1 = t'+u'$ $x_2 = t'+v'$ $y_1 = u'+w'$ $y_2 = v'+w'$ $a = cs \csc \theta$ $c = \coth \theta$ $\theta = 0.115129 \times \text{No. (db)}$
	BRIDGED T	FULL MATCHED IMAGE IMPEDANCES	$k = \left[1 + \frac{z[v(s^2+1)+2s^2z]}{w(v+2s^2z)+s^2z^2} \right]$	$z = \left[vs^2z \frac{s^2z+2w}{v+2s^2z} \right]^{1/2}$	$v = 2zs^2/(ds^2-1)$ $w = z(d-s^2)/2$	$Z \geq z$ $d = \coth \frac{\theta}{2}$
	BRIDGED T	UNIT MATCHED IMAGE IMPEDANCES	$k = \left[1 + \frac{v'(s^2+1)+2s^2z}{w'(v'+2s^2z)+s^2z^2} \right]$	$l = \left[v's^2 \frac{s^2z+2w'}{v'+2s^2z} \right]^{1/2}$	$v' = 2s^2/(ds^2-1)$ $w' = (d-s^2)/2$	$Z \geq z$ $d = \coth \frac{\theta}{2}$
	BRIDGED T	FULL MATCHED IMAGE IMPEDANCES	$k = \left[1 + \frac{v}{z} \right]$ $k = \left[1 + \frac{z}{w} \right]$ $k = \left[1 + \left(\frac{v}{w} \right)^2 \right]$	$z = (vw)^{1/2}$	$v = Nz$ $w = nz$	$Z = z$ $N = (k-1) = \epsilon^\theta - 1 = (\cosh \theta + \sinh \theta - 1)$ $n = 1/(k-1) = 1/(\epsilon^\theta - 1) = 1/(\cosh \theta + \sinh \theta - 1)$
	BRIDGED T	UNIT MATCHED IMAGE IMPEDANCES	$k = \left[1 + v \right]$ $k = \left[1 + \frac{1}{w} \right]$ $k = \left[1 + \left(\frac{v}{w} \right)^2 \right]$	$l = (v'w')^{1/2}$	$v' = N$ $w' = n$	$Z = z$ $N = (k-1) = (\epsilon^\theta - 1)$ $n = 1/(k-1) = 1/(\epsilon^\theta - 1)$ $v' = v/z$ $w' = w/z$ $\theta = 0.115129 \times \text{No. (db)}$

from expressions 5 and 8, the transmission loss is

$$\text{db} = 20 \text{Log}_{10} k = 20 \text{Log}_{10} \left(s \frac{v' + w' + 1}{w'} \right) \quad (9)$$

Since,

$$v' = v/z, w' = w/z \text{ and } u' = u/z \quad (10)$$

the loss of the network in terms of the full impedance values is from 9 and 10

$$\text{db} = 20 \text{Log}_{10} k = 20 \text{Log}_{10} (s(v+w+z)/w) \quad (11)$$

Solving equations 1 and 2 for u' and equating, then simplifying, we obtain

$$(2v'w' + v'^2 - 1)s^2 = w'^2(1 - s^2) \quad (12)$$

From 9, the factor

$$k = ((v' + w' + 1)s/w') \quad (13)$$

which solved for w' becomes,

$$w' = s(v'+1)/(k-s) \quad (14)$$

Substituting this into 12 and solving for v' , the unit series impedance adjacent to the unit termination,

$$v' = \frac{(k^2 + 1 - 2ks)/(k^2 - 1)}{\frac{k^2 + 1}{k^2 - 1} - s \frac{2k}{k^2 - 1}} \quad (15a)$$

Using 6 in 15,

$$v' = \frac{\epsilon^{2\theta} + 1}{\epsilon^{2\theta} - 1} - s \frac{2}{\epsilon^\theta - \epsilon^{-\theta}} \quad (16a)$$

Figures 7 to 12

The power transmission losses and required element values for the *Lattice* and *Bridged-T* networks in symbolical notation, as shown by the headings of the *Tables of Hyperbolic Functions*.

$$v' = \coth \theta - s \csc \theta \quad (17a)$$

$$= c - as = c - w' \quad (18a)$$

where: $k^2 = \epsilon^{2\theta}$, $c = \coth \theta$, $a = \csc \theta$, and $s^2 = Z/z$.

The full series impedance is obtained by multiplying each side of equation 15a to 18a inclusive, by z , getting

$$v = z \left(\frac{k^2 + 1}{k^2 - 1} - s \frac{2k}{k^2 - 1} \right) \quad (15b)$$

$$= z \left(\frac{\epsilon^{2\theta} + 1}{\epsilon^{2\theta} - 1} - s \frac{2}{\epsilon^\theta - \epsilon^{-\theta}} \right) \quad (16b)$$

$$= z(\coth \theta - s \csc \theta) \quad (17b)$$

$$= z(c - as) = cz - ay = cz - w \quad (18b)$$

where: $y = (Zz)^{1/2}$.

From 13 and 15a, eliminating v' , the unit shunt impedance is

$$w' = s \frac{2k}{k^2 - 1} = s \frac{2}{\epsilon^\theta - \epsilon^{-\theta}} = s \csc \theta = a \quad (19a)$$

Multiplying each side of equations 19 by z , the full shunt impedance is obtained as

$$w = zs \frac{2k}{k^2 - 1} = zs \frac{2}{\epsilon^\theta - \epsilon^{-\theta}} = zs \csc \theta = asz = ay \quad (19b)$$

Substituting 15a and 19a into equation and solving for the unit impedance adjacent to the termination s^2 ,

$$u' = s^2 \frac{k^2 + 1}{k^2 - 1} - \frac{2k}{k^2 - 1} \quad (20a)$$

$$= s^2 \frac{\epsilon^{2\theta} + 1}{\epsilon^{2\theta} - 1} - \frac{2}{\epsilon^\theta - \epsilon^{-\theta}} \quad (21a)$$

$$= s(s \coth \theta - \csc \theta) \quad (22a)$$

$$= s(cs - a) = cs^2 - w' \quad (23a)$$

The full series impedance is found b

[Text, continued on page 72; hyperbolic function tables appear on pages 57, 58 and 60.]

RAYTHEON VOLTAGE STABILIZERS

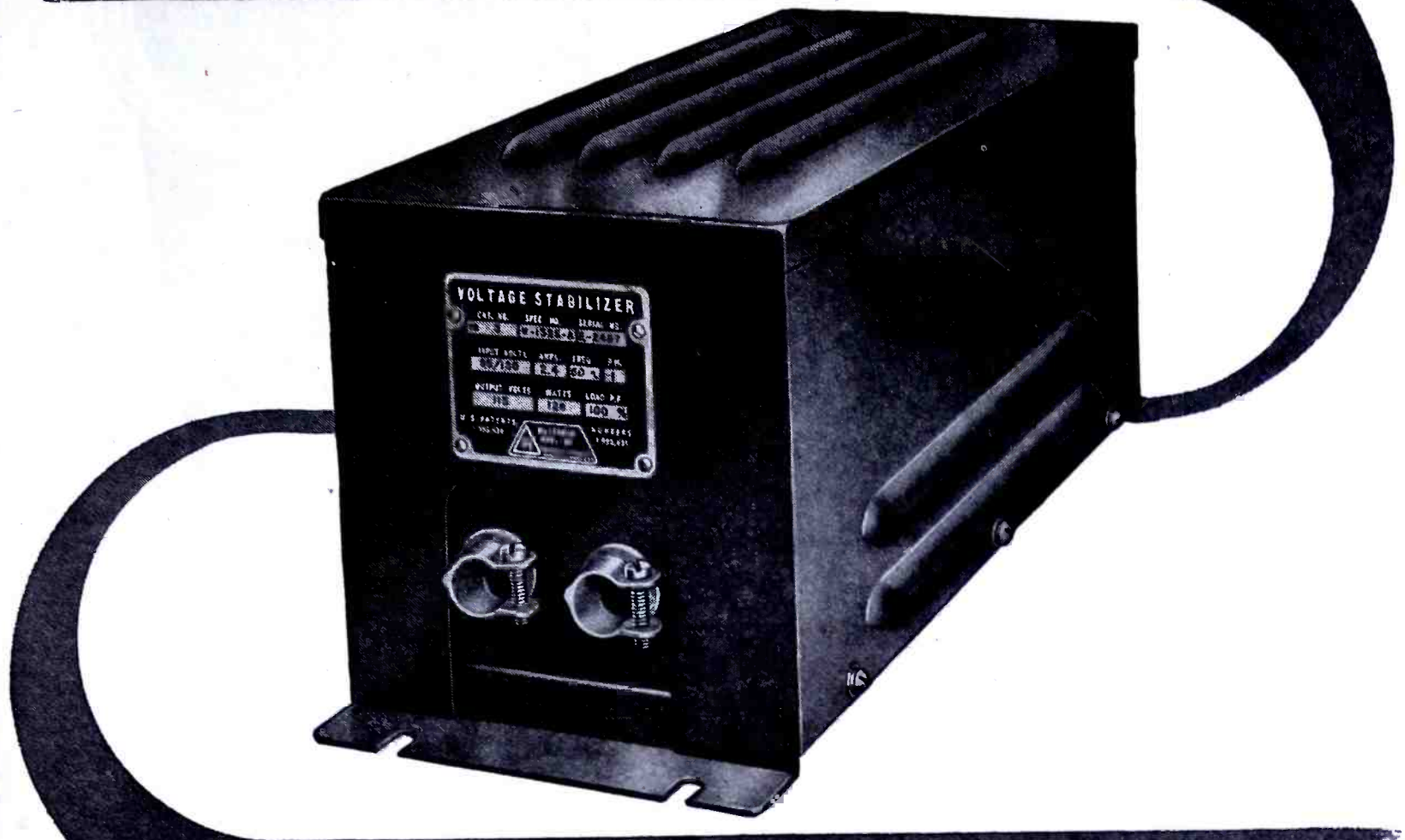

CONTROL VARYING LINE VOLTAGES

TO 115 VOLTS $\pm 1/2\%$

Ordinary A.C. line voltages as taken from supply mains often vary as much as from 95 to 130 volts. This impairs the precision operation of electrical equipment.

A Raytheon Voltage Stabilizer, built into new products or incorporated into equipment already in use, overcomes the disadvantage of fluctuating voltages by providing an accurately controlled source of power to $\pm 1/2\%$.

Here's what a Raytheon Stabilizer does—stabilizes varying input voltage from 95 to 130 volts to 115 volts $\pm 1/2\%$ within 2 cycles.

Raytheon Voltage Stabilizers are entirely automatic. They require no adjustments or repeated maintenance. No moving parts assure long life. Write for bulletin DL 48-537.

EFFECT OF VARIABLE FREQUENCY

Since partial resonance is a requisite design feature, these devices are sensitive to frequency changes. The output voltage will vary in the same direction and 1.4 times the percentage change in frequency, over a range of 5% of the normal frequency.

Stabilization, however, will be within $\pm 1/2\%$ at the output voltage which is established by the frequency.

TYPE VR 2
INPUT VS OUTPUT VOLTAGE
FOR VARIOUS FREQUENCIES

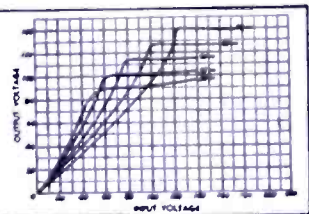

Tune in the Raytheon radio program: "MEET YOUR NAVY," every Saturday night on the Blue Network. Consult your local newspaper  for time and station



RAYTHEON
MANUFACTURING COMPANY

Electrical Equipment Division

190 WILLOW STREET, WALTHAM, MASS.

The coveted Army-Navy "E," for Excellence in the manufacture of war equipment and tubes, flies over all four Raytheon Plants where over 16,000 men and women are producing for VICTORY.

Devoted to research and manufacture of complete electronic equipment; receiving, transmitting and hearing aid tubes; transformers; and voltage stabilizers.

HIGH Q COILS *by*

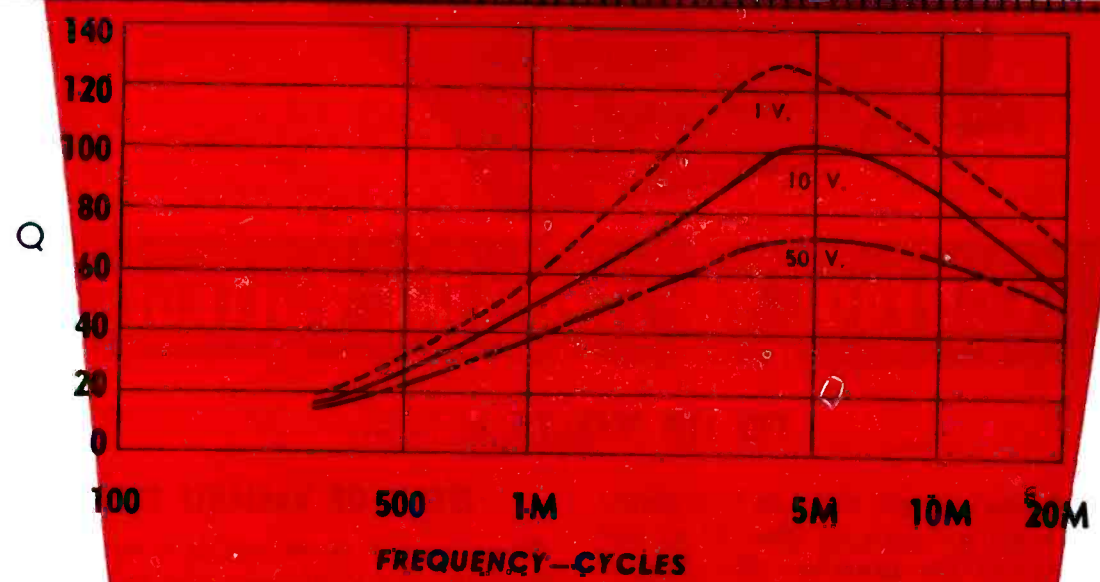
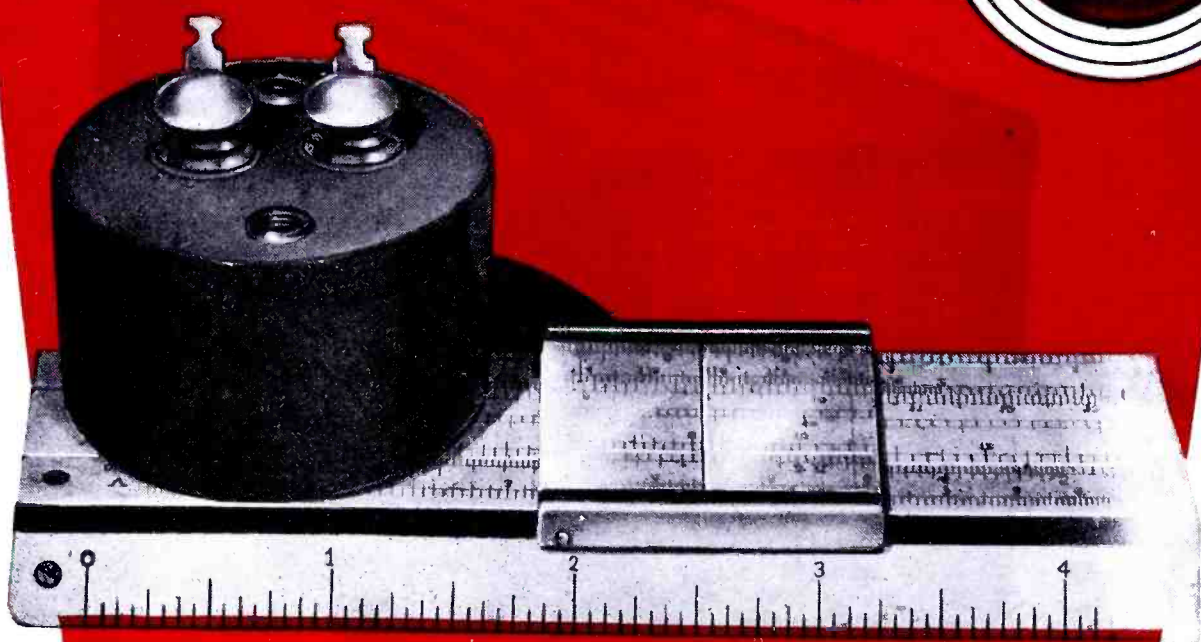

There are many applications in the audio field requiring coils of high Q and good stability. UTC coils of the type HQA series are ideal in this respect. Q CHARACTERISTICS of a typical .14 Mh. coil at three voltages are illustrated. VOLTAGE STABILITY is high. At 1,000 cycles, for applied voltages from 1 to 25 volts, the change in inductance is less than 1%. DC current change in inductance is approximately 1% per 1.0 Ma. linearly. HUM PICKUP is low due to a self shielding structure: . . . 70 microvolts per gauss at 60 cycles. TEMPERATURE effects are negligible. From -60 degrees C. to plus 85 degrees C., inductance variation is less than 1/3%. MECHANICALLY, these units are hermetically sealed in a drawn steel case 1-13/16" diameter by 1-3/16" high. Weight . . . 5 ounces. VIBRATION effects are not evident over entire range of normal aircraft tests. HQA UNITS are available in any inductance value from 5 Mhy. to 2 Hy., and are ordered as: HQA followed by value in Mhy. Typical semi-standard values are:

HQA-12.5 \$3.00 net	HQA-200 \$8.00 net
HQA-30 \$6.00 net	HQA-500 \$9.00 net
HQA-60 \$7.00 net	HQA-1250 \$10.00 net

United Transformer Co.
 150 VARICK STREET NEW YORK 13, N. Y.
 EXPORT DIVISION: 13 EAST 40th STREET, NEW YORK 16, N. Y., CABLES: "ARLAB"



No (db)	G	H	M	P	Q	T	g	h	m	P	q	r	No (db)
$20 \log_{10} e^{\theta}$	$\frac{\sinh 2\theta}{k^2 - 1}$	$\tanh^2 \theta$	$1 - e^{-\theta}$	$\frac{\sinh^2 \theta}{4k^2}$	$\frac{\cosh 2\theta}{2k^2}$	$\frac{\tanh^2 \theta}{\left(\frac{k-1}{k+1}\right)^2}$	$\frac{2k^2}{k^2 - 1}$	$\frac{\coth^2 \theta}{\left(\frac{k^2+1}{k^2-1}\right)^2}$	$\frac{1}{1 - e^{-\theta}}$	$\frac{4k^2}{(k^2 - 1)^2}$	$\frac{2k^2}{k^2 + 1}$	$\frac{\coth^2 \theta}{2}$	$20 \log_{10} e^{\theta}$
$20 \log_{10} k$													$20 \log_{10} k$
0.00	0.000000	0.000000	0.000000	0.000000	0.000000	0.000000	434.216	7548.30	870.565	7548.29	9999974	301.4083	0.00
0.01	0.02303	0.0000132	0.001151	0.0000132	1.0000264	3.31776x10 ⁻⁷	217.155	188.544	435.783	188.543	9999894	7548.30	0.01
0.02	0.04605	0.0000530	0.002303	0.0000530	1.0000106	1.32480x10 ⁻⁶	144.760	83.821.8	290.017	83820.8	9999763	335.286	0.02
0.03	0.06908	0.0001192	0.003448	0.0001192	1.00002384	2.98253x10 ⁻⁶	108.566	47.157.6	217.450	47156.6	9999576	188.544	0.03
0.04	0.09211	0.0002120	0.004595	0.0002120	1.00004240	5.30381x10 ⁻⁶	86.8583	30.176.0	174.310	30175.0	9999372	120.731	0.04
0.05	0.11513	0.0003314	0.005540	0.0003314	1.00006628	8.28288x10 ⁻⁶	62.0386	20.955.4	145.264	20955.3	9999046	83.821.8	0.05
0.06	0.13816	0.0004772	0.006884	0.0004772	1.00009544	1.19301x10 ⁻⁵	48.2529	15.397.1	117.86.5	15396.8	9998700	61.572.9	0.06
0.07	0.16119	0.0006500	0.008627	0.0006500	1.00013000	1.62409x10 ⁻⁵	36.1860	11.786.5	97.0120	11786.4	9998304	47.156.5	0.07
0.08	0.18422	0.0008478	0.009368	0.0008478	1.00016960	2.12060x10 ⁻⁵	28.9218	8.4254	87.3558	9313.49	9997852	37.253.9	0.08
0.09	0.20725	0.0010739	0.010308	0.0010739	1.0002148	2.68428x10 ⁻⁵	25.5402	6.39471	79.4660	7543.50	9997349	30.176.0	0.09
0.10	0.23028	0.001326	0.011447	0.001326	1.0002652	3.31430x10 ⁻⁵	22.8504	5.239.85	72.8863	6233.54	9996793	24.941.3	0.10
0.11	0.25331	0.0016017	0.012584	0.0016017	1.0003208	4.00942x10 ⁻⁵	20.9218	4.46649	67.3174	5238.85	9996185	20.955.4	0.11
0.12	0.27635	0.0019076	0.013720	0.0019076	1.0003816	4.77205x10 ⁻⁵	19.3620	3.94971	62.5430	4463.99	9995522	17.853.9	0.12
0.13	0.29938	0.0022393	0.014855	0.0022393	1.0004480	5.60103x10 ⁻⁵	18.420	3.4024	58.4146	3849.78	9994807	15.397.1	0.13
0.14	0.32242	0.0025976	0.015989	0.0025976	1.0005196	6.49475x10 ⁻⁵	17.7070	3.01514	54.7885	3352.86	9994040	13.411.4	0.14
0.15	0.34546	0.0029811	0.017119	0.0029811	1.0005964	7.45632x10 ⁻⁵	17.3620	2.89218	51.5943	2946.63	9993216	11.786.5	0.15
0.16	0.36850	0.0033939	0.018252	0.0033939	1.0006788	8.48425x10 ⁻⁵	16.3620	2.611.27	48.7567	2610.27	9992346	10.442.1	0.16
0.17	0.39154	0.0038285	0.019382	0.0038285	1.0007660	9.57538x10 ⁻⁵	15.4992	2.5402	46.2171	2328.15	9991415	9.315.32	0.17
0.18	0.41459	0.0042928	0.020510	0.0042928	1.0008592	1.07350x10 ⁻⁴	14.4649	2.4202	44.314	2089.60	9990439	8.359.94	0.18
0.19	0.43763	0.004783	0.021637	0.004783	1.0009570	1.19618x10 ⁻⁴	13.950	2.28504	43.9369	1885.08	9989401	7.544.38	0.19
0.20	0.46068	0.005302	0.02276	0.005302	1.0010610	1.32549x10 ⁻⁴	13.420	2.17070	43.9369	1706.29	9988347	6.827.88	0.20
0.25	0.57597	0.008283	0.02893	0.008283	1.0016580	2.07130x10 ⁻⁴	12.950	2.07130	43.9369	1545.98	9987195	6.353.63	0.25
0.30	0.69113	0.011917	0.03395	0.011917	1.0023862	2.98184x10 ⁻⁴	12.4906	1.94745	43.9369	1446.49	9985963	5.981.464	0.30
0.35	0.80678	0.016225	0.03949	0.016225	1.0032502	4.05821x10 ⁻⁴	12.3950	1.8552	43.9369	1371.52	9984670	5.681.79	0.35
0.40	0.92234	0.021174	0.04501	0.021174	1.0042438	5.30012x10 ⁻⁴	12.8420	1.791108	43.9369	1315.38	9983210	5.427.27	0.40
0.50	1.1538	0.033065	0.05594	0.033065	1.0066350	8.28001x10 ⁻⁴	12.4906	1.721007	43.9369	1260.29	9981667	5.202.179	0.50
0.60	1.3860	0.047570	0.06759	0.047570	1.0095594	1.19198x10 ⁻³	12.3950	1.677415	43.9369	1209.217	9980031	5.005.311	0.60
0.70	1.6188	0.064684	0.07743	0.064684	1.0130210	1.62200x10 ⁻³	12.3950	1.646811	43.9369	1160.600	9978310	4.827.179	0.70
0.80	1.8525	0.084351	0.08799	0.084351	1.0170136	2.11784x10 ⁻³	12.3950	1.627910	43.9369	1114.552	9976503	4.672.179	0.80
0.90	2.0872	0.106620	0.09843	0.106620	1.0215338	2.67930x10 ⁻³	12.3950	1.61993	43.9369	1072.910	9974633	4.537.232	0.90
1.00	23230	0.13139	0.10875	0.13139	1.026628	3.30636x10 ⁻³	12.3950	1.61993	43.9369	1035.109	9972703	4.411.788	1.00
1.10	25600	0.15868	0.11895	0.15868	1.032248	3.99892x10 ⁻³	12.3950	1.61993	43.9369	1002.020	9970733	4.302.447	1.10
1.20	27984	0.18949	0.12904	0.18949	1.038422	4.75658x10 ⁻³	12.3950	1.61993	43.9369	972.053	9968733	4.200.068	1.20
1.30	30383	0.22068	0.13901	0.22068	1.045132	5.57785x10 ⁻³	12.3950	1.61993	43.9369	944.314	9966703	4.108.179	1.30
1.40	32797	0.25341	0.14886	0.25341	1.052420	6.46689x10 ⁻³	12.3950	1.61993	43.9369	918.153	9964633	4.026.634	1.40
1.50	35230	0.28924	0.15861	0.28924	1.060240	7.41907x10 ⁻³	12.3950	1.61993	43.9369	893.197	9962523	3.945.778	1.50
1.60	37681	0.33191	0.16824	0.33191	1.068660	8.43532x10 ⁻³	12.3950	1.61993	43.9369	869.495	9960373	3.865.474	1.60
1.70	40151	0.37341	0.17776	0.37341	1.077578	9.51581x10 ⁻³	12.3950	1.61993	43.9369	846.931	9958183	3.785.931	1.70
1.80	42643	0.41745	0.18717	0.41745	1.087128	1.06601x10 ⁻²	12.3950	1.61993	43.9369	825.495	9955953	3.707.167	1.80
1.90	45158	0.46363	0.19647	0.46363	1.097234	1.18677x10 ⁻²	12.3950	1.61993	43.9369	805.178	9953683	3.632.263	1.90
2.00	47696	0.51200	0.20567	0.51200	1.10792	0.13139	12.3950	1.61993	43.9369	785.965	9951373	3.559.522	2.00
2.10	50260	0.56247	0.21476	0.56247	1.11920	0.14472	12.3950	1.61993	43.9369	767.778	9949023	3.487.889	2.10
2.20	52851	0.61504	0.22375	0.61504	1.13108	0.15868	12.3950	1.61993	43.9369	750.631	9946633	3.417.464	2.20
2.30	55470	0.66963	0.23264	0.66963	1.14356	0.17326	12.3950	1.61993	43.9369	734.527	9944203	3.348.263	2.30
2.40	58118	0.72623	0.24142	0.72623	1.15664	0.18849	12.3950	1.61993	43.9369	719.463	9941733	3.280.263	2.40
2.50	60797	0.78471	0.25011	0.78471	1.17032	0.20428	12.3950	1.61993	43.9369	705.436	9939223	3.213.263	2.50
2.60	63509	0.84509	0.25869	0.84509	1.18464	0.22068	12.3950	1.61993	43.9369	692.446	9936673	3.147.263	2.60
2.70	66253	0.90728	0.26718	0.90728	1.19954	0.23773	12.3950	1.61993	43.9369	680.495	9934083	3.082.263	2.70
2.80	69032	0.97118	0.27556	0.97118	1.21514	0.25541	12.3950	1.61993	43.9369	669.583	9931453	3.018.263	2.80
2.90	71849	1.03681	0.28386	1.03681	1.23132	0.27358	12.3950	1.61993	43.9369	659.717	9928783	2.955.263	2.90
3.00	74704	1.10412	0.29205	1.10412	1.24818	0.29242	12.3950	1.61993	43.9369	650.899	9926073	2.893.263	3.00
3.10	77599	1.17295	0.30017	1.17295	1.26568	0.31181	12.3950	1.61993	43.9369	643.131	9923323	2.832.263	3.10
3.20	80537	1.24332	0.30817	1.24332	1.28412	0.33191	12.3950	1.61993	43.9369	636.415	9920533	2.772.263	3.20
3.30	83511	1.31514	0.31610	1.31514	1.30280	0.35234	12.3950	1.61993	43.9369	630.747	9917703	2.713.263	3.30
3.40	86533	1.38828	0.32392	1.38828	1.32240	0.37341	12.3950	1.61993	43.9369	626.120	9914833	2.655.263	3.40

$\theta = 0.115129 \times \text{No (db)}$, $k \approx 1$, $\epsilon = 2.71828$

(Continued on page 58)

No (db)	G	H	M	P	Q	T	g	h	m	P	q	t	No (db)
$20 \log_{10} e^{\theta}$	$\frac{\sinh 2\theta}{k^2 - 1}$	$\frac{\tanh^2 \theta}{\left(\frac{k^2 - 1}{k^2 + 1}\right)^2}$	$1 - \frac{\epsilon - \theta}{k}$	$\frac{\sinh^2 \theta}{4k^2}$	$\frac{\cosh 2\theta}{2k^2}$	$\frac{\tanh^2 \theta}{\left(\frac{k-1}{k+1}\right)^2}$	$\frac{2k^2}{k^2 - 1}$	$\frac{\coth^2 \theta}{\left(\frac{k^2 + 1}{k^2 - 1}\right)^2}$	$\frac{1 - \epsilon - \theta}{k}$	$\frac{4k^2}{(k^2 - 1)^2}$	$\frac{2k^2}{k^2 + 1}$	$\frac{\coth^2 \theta}{\left(\frac{k+1}{k-1}\right)^2}$	$20 \log_{10} e^{\theta}$
$20 \log_{10} k$	$\frac{2k^2}{k^2 - 1}$	$\left(\frac{k^2 - 1}{k^2 + 1}\right)^2$	$\frac{k-1}{k}$	$\frac{(k^2 - 1)^2}{4k^2}$	$\frac{k^2 + 1}{2k^2}$	$\left(\frac{k-1}{k+1}\right)^2$	$\frac{2k^2}{k^2 - 1}$	$\left(\frac{k^2 + 1}{k^2 - 1}\right)^2$	$\frac{k-1}{k}$	$\frac{4k^2}{(k^2 - 1)^2}$	$\frac{2k^2}{k^2 + 1}$	$\left(\frac{k+1}{k-1}\right)^2$	$20 \log_{10} k$
3.50	.89602	.146288	.33166	.17126	1.34252	.039519	1.11609	6.83583	3.015195	5.83583	.744768	25.3043	3.50
3.60	.92717	.153862	.33931	.18185	1.36770	.041745	1.07851	6.49933	2.88292	5.49933	.733299	23.9550	3.60
3.70	.95883	.161569	.34687	.19269	1.38338	.044026	1.04292	6.18931	2.82209	5.18931	.721824	22.7138	3.70
3.80	.99098	.169382	.35435	.20389	1.40778	.046363	1.00913	5.90081	2.76448	4.90081	.710338	21.5689	3.80
3.90	1.02366	.177305	.36173	.21551	1.43102	.048734	.97690	5.64000	2.70972	4.64000	.698802	20.5111	3.90
4.0	1.05689	.185335	.36904	.22750	1.45500	.051200	.94617	5.39568	2.65419	4.39568	.687287	19.5312	4.0
4.5	1.23178	.226782	.40434	.29329	1.58660	.064211	.81183	4.40952	2.47319	3.40952	.630282	15.5737	4.5
5.0	1.42303	.269876	.43766	.36963	1.73925	.078471	.70274	3.70541	2.28488	2.70541	.574957	12.7436	5.0
5.5	1.633146	.313890	.46912	.45750	1.914984	.093901	.61212	3.18583	2.13167	2.18583	.522197	10.6495	5.5
6.0	1.864943	.358178	.49881	.55808	2.116131	.110412	.53622	2.79191	2.00476	1.79191	.472561	9.05698	6.0
6.5	2.121482	.402156	.52685	.67268	2.345354	.127902	.47136	2.48660	1.89808	1.48660	.426375	7.81848	6.5
7.0	2.406174	.445323	.55332	.80284	2.605700	.146288	.41560	2.24556	1.80728	1.24556	.383774	6.83583	7.0
7.5	2.72782	.487257	.57830	.95030	2.900622	.165463	.36726	2.05230	1.72920	1.05230	.344757	6.04365	7.5
8.0	3.075339	.527634	.60189	1.11702	3.234026	.185335	.32515	1.89525	1.66142	.89525	.309214	5.39563	8.0
8.5	3.469103	.566192	.62416	1.30517	3.610357	.205806	.28826	1.76619	1.60215	.76619	.276983	4.85894	8.5
9.0	3.906891	.602741	.64510	1.51730	4.034583	.226782	.25584	1.65909	1.54994	.65909	.247862	4.40952	9.0
9.5	4.400154	.637176	.66503	1.75620	4.512356	.248168	.22726	1.56942	1.50368	.56942	.221616	4.02953	9.5
10.0	4.950000	.669428	.68377	2.02499	5.050000	.269876	.20202	1.49382	1.46247	.49382	.198015	3.70541	10.0
10.5	5.56553	.699458	.70146	2.32733	5.65466	.291808	.179682	1.42968	1.42559	.42968	.176846	3.42691	10.5
11.0	6.25491	.727310	.71816	2.66716	6.33434	.313890	.159870	1.37493	1.39244	.37493	.157870	3.18583	11.0
11.5	7.02729	.753028	.73393	3.04904	7.09808	.336038	.142246	1.32797	1.36253	.32797	.140883	2.97585	11.5
12.0	7.89282	.776686	.74881	3.47801	7.95592	.358178	.126696	1.28752	1.33545	.28752	.125691	2.79191	12.0
12.5	8.86328	.798378	.76286	3.95975	8.91951	.380239	.112826	1.25254	1.31085	.25254	.112113	2.62992	12.5
13.0	9.95125	.818205	.77613	4.50068	10.00137	.402156	.100492	1.22219	1.28845	.22219	.0999863	2.48660	13.0
13.5	11.17128	.836283	.78865	5.10797	11.21595	.423869	.089514	1.19577	1.26799	.19577	.0891587	2.35922	13.5
14.0	12.53953	.852717	.80047	5.78967	12.57934	.445323	.079748	1.17272	1.24926	.17272	.0794954	2.24556	14.0
14.5	14.07418	.867634	.81163	6.55482	14.10966	.466468	.071052	1.15256	1.23208	.15256	.0708734	2.14376	14.5
15.0	15.79558	.881141	.82112	7.41361	15.82720	.487257	.063109	1.13491	1.21629	.13491	.0631832	2.05230	15.0
15.5	17.72658	.893360	.82922	8.37738	17.75476	.507642	.056412	1.11936	1.20175	.11936	.0563229	1.96981	15.5
16.0	19.89281	.904390	.84151	9.45892	19.91793	.527634	.050269	1.10572	1.18834	.10572	.0502060	1.89525	16.0
16.5	22.32298	.914330	.85038	10.6727	22.34537	.547156	.044797	1.09370	1.17595	.09370	.0447520	1.82763	16.5
17.0	25.04940	.923281	.85875	12.0347	25.06935	.566192	.039921	1.083094	1.16449	.083094	.0398893	1.76619	17.0
17.5	28.0819	.931333	.86665	13.5630	28.12597	.584731	.035577	1.073729	1.15387	.073729	.0355333	1.71018	17.5
18.0	31.53990	.938568	.87411	15.2729	31.55575	.602741	.031706	1.065453	1.14402	.065453	.0316899	1.65909	18.0
18.5	35.39017	.945062	.88115	17.2021	35.40442	.620233	.028256	1.058131	1.13488	.058131	.0282451	1.61229	18.5
19.0	39.71007	.950886	.88798	19.3611	39.72266	.637176	.025183	1.051650	1.12638	.051650	.0251745	1.56942	19.0
19.5	44.55694	.956108	.894075	21.7841	44.56816	.653575	.022443	1.045905	1.11847	.045905	.0224375	1.53004	19.5
20.0	49.99500	.960788	.90000	24.3025	50.00500	.669428	.020002	1.040812	1.11111	.040812	.0199980	1.49382	20.0
20.5	56.0965	.964976	.905594	27.528	56.10535	.684715	.017826	1.036295	1.104248	.036295	.0178236	1.46047	20.5
21.0	62.9423	.968726	.910875	30.9752	62.95017	.699458	.015888	1.032282	1.097846	.032282	.0158836	1.42968	21.0
21.5	70.6233	.972080	.915861	34.8153	70.63044	.713650	.014160	1.028721	1.091869	.028721	.0141582	1.42967	21.5
22.0	79.2406	.975077	.920567	39.1239	79.24780	.727310	.012620	1.025561	1.086287	.025561	.0126186	1.37493	22.0
22.5	88.9112	.977757	.925011	43.9585	88.91676	.740431	.011247	1.022748	1.081069	.022748	.0112465	1.35057	22.5
23.0	99.7606	.980153	.929205	49.3827	99.76560	.753028	.010024	1.020247	1.076186	.020247	.0100235	1.32797	23.0
23.5	111.9339	.982293	.93166	55.4691	111.9384	.765111	.0089338	1.018027	1.071621	.018027	.0089335	1.30700	23.5
24.0	125.5923	.984201	.936904	62.2967	125.5963	.776886	.0079623	1.016053	1.067345	.016053	.0079620	1.28752	24.0
24.5	140.9174	.985910	.940434	69.9604	140.9209	.787773	.0070964	1.014291	1.063339	.014291	.0070962	1.26940	24.5
25.0	158.1123	.987432	.943766	78.5576	158.1155	.798378	.0063246	1.012728	1.059585	.012728	.0063245	1.25254	25.0
25.5	177.4051	.988788	.946911	88.2041	177.4079	.808505	.0056368	1.01133	1.0556065	.011337	.0056367	1.23685	25.5
26.0	199.0524	.990001	.949881	99.0274	199.0549	.818205	.0050238	1.010100	1.052763	.010100	.0050237	1.22219	26.0
26.5	223.3408	.991084	.952685	111.1716	223.3428	.827445	.0044775	1.008996	1.049665	.008996	.0044774	1.20854	26.5
27.0	250.5927	.992057	.955332	124.7975	250.5947	.836283	.0039905	1.008014	1.046757	.008014	.0039905	1.19577	27.0
27.5	281.1699	.992913	.957830	140.0857	281.1717	.844704	.0035566	1.007138	1.044026	.007138	.0035565	1.18385	27.5
28.0	315.4775	.993660	.960189	157.2398	315.4790	.852717	.0031698	1.006360	1.041462	.006360	.0031698	1.17272	28.0
28.5	353.9722	.994366	.962416	.176.4866	353.9737	.860351	.0028251	1.005666	1.039051	.005666	.0028251	1.16232	28.5

$\theta = 0.115129 \times \text{No (db)}$, $k \approx 1$, $\epsilon = 2.718282$

Gammatron **MATCHED PERFORMANCE**

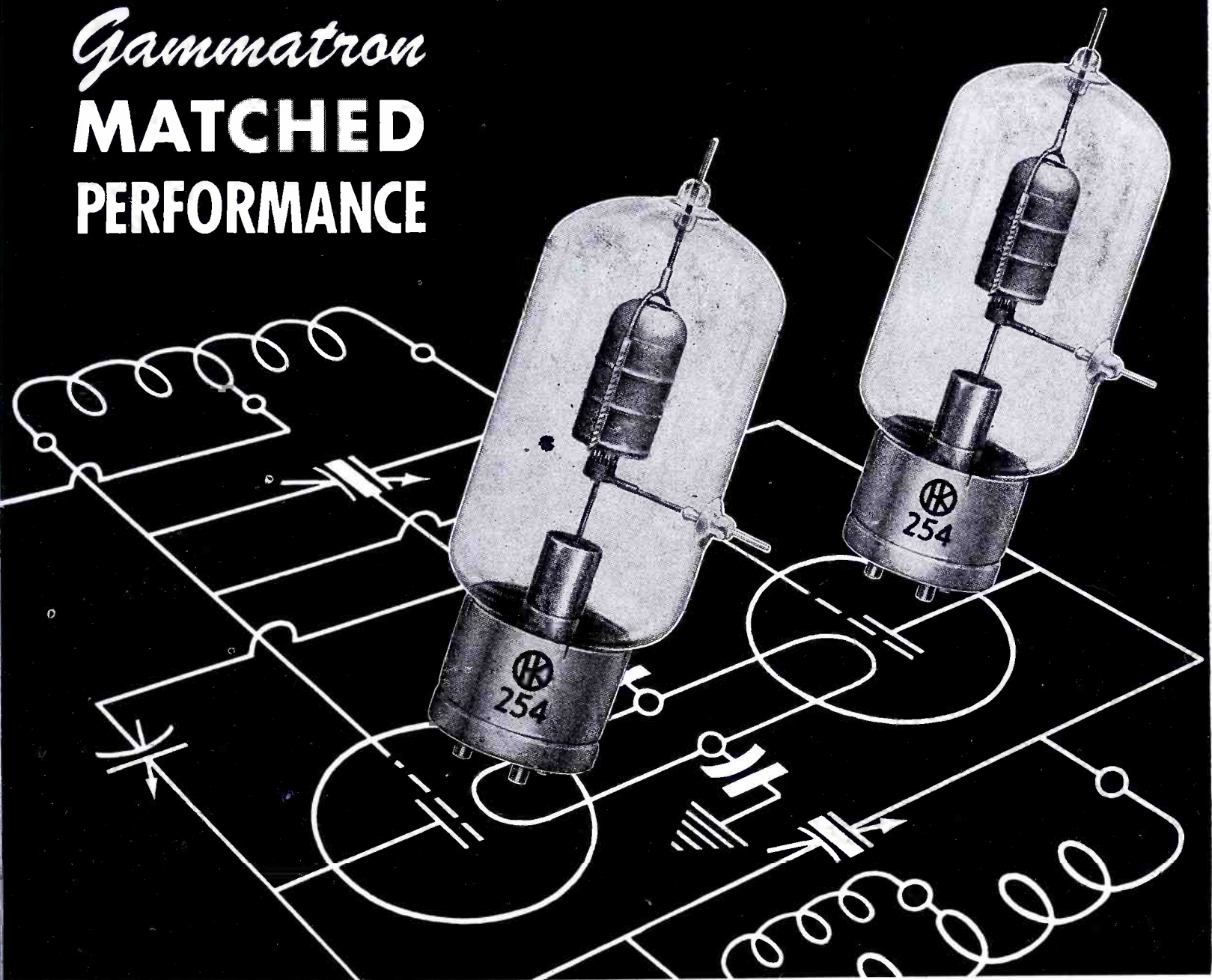

Gammatron **UNIFORMITY MEANS LONGER TUBE LIFE**

Heintz and Kaufman engineers have continually developed closer electrical and physical tolerances for Gammatron tubes over the past 16 years, knowing that matched characteristics result in better operation and longer tube life.

Today the importance of tube uniformity, especially in the very high frequencies, is widely recognized; and many of the peacetime standards we have established for Gammatrons are now contained in the wartime specifications for all tubes of the Gammatron type... When you design a transmitter around a pair—or even a dozen—Gammatrons, you will get the full benefit of our years of experience in pioneering constantly higher standards of transmitting tube performance.

HEINTZ AND KAUFMAN LTD.
SOUTH SAN FRANCISCO • CALIFORNIA

Gammatron Tubes

HK-254 Matched CHARACTERISTICS

MAXIMUM RATINGS

Power Output	500 Watts
Plate Dissipation	100 Watts
Amplification Factor	25
DC Plate Voltage	4000 Volts
DC Plate Current	225 M. A.
DC Grid Current	40 M. A.
Max. Frequency	175 Mc

INTER-ELECTRODE CAP. :

C grid-plate	3.6 uuf
C grid-filament	3.3 uuf
C plate-filament	1.0 uuf

Filament Voltage	5 Volts
Filament Current	7.5 Amps.



**KEEP IT UP
BUY WAR BONDS**

No (db)	G	H	M	F	Q	T	g	h	m	P	q	No (db)
$20 \log_{10} \epsilon \theta$	$\frac{\sinh 2\theta}{k^2 - 1}$	$\frac{\tanh^2 \theta}{\left(\frac{k^2 - 1}{k^2 + 1}\right)^2}$	$1 - e^{-\theta}$	$\frac{\sinh^2 \theta}{(k^2 - 1)^2}$	$\frac{\cosh 2\theta}{k^2 + 1}$	$\frac{\tanh^2 \theta}{\left(\frac{k-1}{k+1}\right)^2}$	$\frac{\csc h 2\theta}{k^2 - 1}$	$\frac{\coth^2 \theta}{\left(\frac{k^2 + 1}{k^2 - 1}\right)^2}$	$\frac{1}{1 - e^{-\theta}}$	$\frac{\csc h^2 \theta}{(k^2 - 1)^2}$	$\frac{2k^2}{k^2 + 1}$	$20 \log_{10} \epsilon \theta$
$20 \log_{10} k$	$\frac{2k^2}{k^2 - 1}$	$\frac{4k^2}{(k^2 - 1)^2}$	$\frac{k-1}{k}$	$\frac{4k^2}{(k^2 - 1)^2}$	$\frac{2k^2}{k^2 + 1}$	$\frac{(k-1)^2}{(k+1)^2}$	$\frac{2k^2}{k^2 - 1}$	$\frac{(k^2 + 1)^2}{(k^2 - 1)^2}$	$\frac{k}{k-1}$	$\frac{4k^2}{(k^2 - 1)^2}$	$\frac{2k^2}{k^2 + 1}$	$20 \log_{10} k$
29.0	397.16302	.994976	.964519	198.0825	397.16428	.867634	.00251786	1.005049	1.036787	.005049	.0025178	29.0
29.5	445.62494	.995521	.966503	242.3313	445.62606	.874550	.00224464	1.004499	1.034657	.004499	.0022446	29.5
30.0	499.99950	.996008	.968377	229.5003	500.00050	.881141	.00200000	1.004008	1.032655	.004008	.0020000	30.0
31.0	629.43465	.996829	.971816	314.2315	629.46300	.893360	.00158873	1.003181	1.029001	.003181	.0015886	31.0
32.0	792.44719	.997480	.974881	.395.7239	792.44789	.904390	.00126191	1.002526	1.025766	.002526	.0012619	32.0
33.0	997.63050	.997997	.977613	498.3156	995.63112	.914330	.00100238	1.002007	1.022900	.002007	.0010043	33.0
34.0	1255.94435	.998409	.980047	627.4723	1255.94446	.923281	.000796214	1.001594	1.020359	.001594	.0007962	34.0
35.0	1581.13884	.998736	.982217	790.0702	1581.1404	.931333	.000632456	1.001266	1.018105	.001266	.0006324	35.0
36.0	1990.53040	.998996	.984151	994.7654	1990.5308	.938568	.000502379	1.001005	1.016104	.001005	.0005023	36.0
37.0	2505.93688	.999202	.985875	1252.4730	2505.9460	.945062	.000399052	1.000799	1.014328	.000799	.0003990	37.0
38.0	3154.77922	.999366	.9874107	1.5769x10 ³	3154.7794	.950886	.000316979	1.000634	1.012866	.000634	.0003169	38.0
39.0	3971.64166	.999496	.9887798	1.9853x10 ³	3971.6418	.956108	.000251785	1.000504	1.011347	.000504	.0002517	39.0
40.0	4999.99995	.999600	.990000	2.4995x10 ³	5000.0000	.960788	.000200000	1.000400	1.010101	.000400	.0002000	40.0
41.0	6294.41998	.999682	.9910875	3.1468x10 ³	6.2946x10 ³	.964976	1.5887x10 ⁻⁴	1.000318	1.008993	.000318	1.5887x10 ⁻⁴	41.0
42.0	7924.45697	.999750	.9920567	3.9617x10 ³	7.9244x10 ³	.968726	1.2619x10 ⁻⁴	1.000250	1.008007	.000250	1.2619x10 ⁻⁴	42.0
43.0	9976.30951	.999800	.9929205	4.9876x10 ³	9.9762x10 ³	.972080	1.00237x10 ⁻⁴	1.000200	1.007130	.000200	1.0024x10 ⁻⁴	43.0
44.0	12559.2864	.999840	.9936904	6.2791x10 ³	1.2559x10 ⁴	.975077	7.9622x10 ⁻⁵	1.000160	1.006350	.000160	7.9622x10 ⁻⁵	44.0
45.0	15811.3917	.999874	.9943766	7.9052x10 ³	1.5811x10 ⁴	.977757	6.3245x10 ⁻⁵	1.000126	1.005655	.000126	6.3245x10 ⁻⁵	45.0
46.0	19905.3522	.999900	.9949881	9.9521x10 ³	1.9905x10 ⁴	.980153	5.02377x10 ⁻⁵	1.000100	1.005037	.000100	5.0238x10 ⁻⁵	46.0
47.0	25059.4033	.999918	.9955332	1.2529x10 ⁴	2.5059x10 ⁴	.982293	3.9905x10 ⁻⁵	1.000082	1.004487	.000082	3.9906x10 ⁻⁵	47.0
48.0	31547.8564	.999936	.9960189	1.5773x10 ⁴	3.1547x10 ⁴	.984201	3.16979x10 ⁻⁵	1.000064	1.003997	.000064	3.1699x10 ⁻⁵	48.0
49.0	39716.4137	.999950	.9964519	1.9858x10 ⁴	3.9717x10 ⁴	.985910	2.5178x10 ⁻⁵	1.000050	1.003561	.000050	2.5178x10 ⁻⁵	49.0
50.0	50000.0107	.999960	.9968376	2.4999x10 ⁴	4.9999x10 ⁴	.987432	2.0000x10 ⁻⁵	1.000040	1.003172	.000040	2.0000x10 ⁻⁵	50.0
51.0	62946.1325	.999968	.9971816	3.1473x10 ⁴	6.2947x10 ⁴	.988788	1.58866x10 ⁻⁵	1.000032	1.002826	.000032	1.5886x10 ⁻⁵	51.0
52.0	79244.7111	.999974	.9974881	3.9622x10 ⁴	7.9245x10 ⁴	.990001	1.26191x10 ⁻⁵	1.000026	1.002518	.000026	1.2619x10 ⁻⁵	52.0
53.0	99763.1192	.9999820	.9977613	4.9881x10 ⁴	9.9763x10 ⁴	.991084	1.00237x10 ⁻⁵	1.0000180	1.002244	.0000180	1.0024x10 ⁻⁵	53.0
54.0	125594.405	.9999840	.9981047	6.2796x10 ⁴	1.25593x10 ⁵	.992050	7.9624x10 ⁻⁶	1.0000160	1.001999	.0000160	7.9622x10 ⁻⁶	54.0
55.0	158132.320	.9999872	.9982217	7.9056x10 ⁴	1.58113x10 ⁵	.992913	6.43905x10 ⁻⁶	1.0000128	1.001781	.0000128	6.3246x10 ⁻⁶	55.0
56.0	199053.052	.9999904	.9985151	9.9526x10 ⁴	1.99053x10 ⁵	.993680	5.02379x10 ⁻⁶	1.0000096	1.001587	.0000096	5.0238x10 ⁻⁶	56.0
57.0	250593.699	.9999916	.9985875	1.25296x10 ⁵	2.50593x10 ⁵	.994366	3.9905x10 ⁻⁶	1.0000084	1.001415	.0000084	3.9905x10 ⁻⁶	57.0
58.0	315477.930	.9999936	.9987411	1.57738x10 ⁵	3.15477x10 ⁵	.994976	3.16979x10 ⁻⁶	1.0000064	1.001261	.0000064	3.1698x10 ⁻⁶	58.0
59.0	397164.172	.9999950	.9988780	1.98582x10 ⁵	3.97165x10 ⁵	.995521	2.5178x10 ⁻⁶	1.0000050	1.001123	.0000050	2.5178x10 ⁻⁶	59.0
60.0	5x10 ⁵	.9999960	.9990000	2.49999x10 ⁵	4.99999x10 ⁵	.996008	2x10 ⁻⁶	1.0000040	1.001001	.0000040	2x10 ⁻⁶	60.0
65.0	1.5811x10 ⁶	.99999874	.99943766	7.90569x10 ⁵	1.58114x10 ⁶	.997751	6.32456x10 ⁻⁷	1.00000126	1.000563	.00000126	6.3246x10 ⁻⁷	65.0
70.0	5x10 ⁶	.99999960	.99968377	2.499999x10 ⁶	5x10 ⁶	.998736	2x10 ⁻⁷	1.00000040	1.000316	.00000040	2x10 ⁻⁷	70.0
75.0	1.5811x10 ⁷	.99999986	.99982217	7.905694x10 ⁶	1.58114x10 ⁷	.999288	6.32456x10 ⁻⁸	1.00000014	1.000178	.00000014	6.3246x10 ⁻⁸	75.0
80.0	5x10 ⁷	.99999996	.99990000	2.4999999x10 ⁷	5x10 ⁷	.999600	2x10 ⁻⁸	1.00000004	1.000100	.00000004	2x10 ⁻⁸	80.0
85.0	1.5811x10 ⁸	.99999998	.999943766	7.9056954x10 ⁷	1.58114x10 ⁸	.999774	6.32456x10 ⁻⁹	1.00000002	1.0000562	.00000002	6.3246x10 ⁻⁹	85.0
90.0	5x10 ⁸	1.00000000	.999968377	2.49999999x10 ⁸	5x10 ⁸	.999874	2x10 ⁻⁹	1.00000000	1.0000316	.00000000	2x10 ⁻⁹	90.0
95.0	1.5811x10 ⁹	1.00000000	.999982217	7.90569547x10 ⁸	1.58114x10 ⁹	.999928	6.32456x10 ⁻¹⁰	1.00000000	1.0000188	.00000000	6.3246x10 ⁻¹⁰	95.0
100.0	5x10 ⁹	1.00000000	.999990000	2.5x10 ⁹	5x10 ⁹	.999960	2x10 ⁻¹⁰	1.00000000	1.0000100	.00000000	2x10 ⁻¹⁰	100.0
105.0	1.5811x10 ¹⁰	1.00000000	.9999943766	7.90569548x10 ⁹	1.58114x10 ¹⁰	.999978	6.32456x10 ⁻¹¹	1.00000000	1.0000056	.00000000	6.3246x10 ⁻¹¹	105.0
110.0	5x10 ¹⁰	1.00000000	.9999968377	2.5x10 ¹⁰	5x10 ¹⁰	.9999872	2x10 ⁻¹¹	1.00000000	1.0000032	.00000000	2x10 ⁻¹¹	110.0
115.0	1.5811x10 ¹¹	1.00000000	.9999982217	7.90569548x10 ¹⁰	1.58114x10 ¹¹	.9999926	6.32456x10 ⁻¹²	1.00000000	1.0000018	.00000000	6.3246x10 ⁻¹²	115.0
120.0	5x10 ¹¹	1.00000000	.9999990000	2.5x10 ¹¹	5x10 ¹¹	.9999960	2x10 ⁻¹²	1.00000000	1.0000010	.00000000	2x10 ⁻¹²	120.0
125.0	1.5811x10 ¹²	1.00000000	.9999994377	7.90569548x10 ¹¹	1.58114x10 ¹²	.9999974	6.32456x10 ⁻¹³	1.00000000	1.00000056	.00000000	6.3246x10 ⁻¹³	125.0
130.0	5x10 ¹²	1.00000000	.9999996838	2.5x10 ¹²	5x10 ¹²	.99999874	2x10 ⁻¹³	1.00000000	1.00000032	.00000000	2x10 ⁻¹³	130.0
135.0	1.5811x10 ¹³	1.00000000	.9999998222	7.90569548x10 ¹²	1.58114x10 ¹³	.99999916	6.32456x10 ⁻¹⁴	1.00000000	1.00000018	.00000000	6.3246x10 ⁻¹⁴	135.0
140.0	5x10 ¹³	1.00000000	.9999999000	2.5x10 ¹³	5x10 ¹³	.99999960	2x10 ⁻¹⁴	1.00000000	1.00000010	.00000000	2x10 ⁻¹⁴	140.0
150.0	1.5811x10 ¹⁴	1.00000000	.9999999684	2.5x10 ¹⁴	5x10 ¹⁴	.99999986	2x10 ⁻¹⁵	1.00000000	1.00000003	.00000000	2x10 ⁻¹⁵	150.0

$\theta = 0.115129 \times \text{No (db)}$, $k \cong 1$, $\epsilon = 2.71828$



**the newest member of the family
makes the loudest noise!**

The newcomer in the G. I. family of radio components is a lusty youngster bound to make itself heard. Set manufacturers who have long looked to us for high precision, high performance, high production standards in condensers, tuning units, actuators and record changers will welcome our latest arrival — Speakers!

When the mammoth capacity, the engineering genius and production know-how developed by our large-scale participation in the

war effort can be diverted to peacetime activities, we are prepared to do a real job on speakers.

Set manufacturers who, like us, are figuring ahead, will undoubtedly be interested to know that we plan to make our new speaker subsidiary a dominant industry factor and an important part of G. I.'s production of precision radio components.

GENERAL ELECTRONIC APPARATUS CORPORATION
A SUBSIDIARY OF

GENERAL INSTRUMENT CORPORATION

829 Newark Avenue • Elizabeth 3, New Jersey



INDEX TO COMMUNICATIONS, 1944

JANUARY

A Modernized Tube Index
J. R. Schoenbaum 17

Experimental 225.6-mc A-M Relay Transmitter
W. L. Widlar 22

Index to COMMUNICATIONS, 1943..... 54

IRE Winter Technical Meeting..... 26

Nomogram for Solving Parallel Circuit Problems.....*Sgt. Bon L. Wong* 28

Phase Monitors.....*Dr. Victor J. Andrew* 32

The Wheatstone Bridge.....*Paul B. Wright* 34

Quartz Lapping and Finishing
Sidney X. Shore 46

WERS Receiver Considerations
Walter J. Stiles 42

FEBRUARY

A Report on the IRE Winter Technical Meeting.....*Lewis Winner* 28

Amplidyne System of Control (*Alexander-son*)..... 28

Orthicon Cameras in Television Studio Work (*Lubcke*)..... 29

The Limitations Imposed by Quantum Theory on Resonator Control of Electrons (*Smith*)..... 29

The Piston Attenuator (*Wheeler*)..... 30

Equivalent Circuits for Discontinuity in Transmission Lines (*Whinnery-Jamieson*)..... 30

Intermittent Behavior in Oscillators (*Edson*)..... 31

Equivalent Circuit of the Field Equations of Maxwell—I (*Kron*)..... 100

A New Approach to the Solution of High-Frequency Field Problems (*Whinnery-Ramo*)..... 101

A-C Network Analyzer Studies of Electromagnetic Cavity Resonators (*Whinnery-Concordia-Ridgway-Kron*)..... 101

FCC Engineering (*Jett*)..... 102

Combination A-M/F-M Detector
Frederick C. Everett 25

Design and Operation of Radio-Range Beacons.....*Capt. W. G. McConnell* 40

Quartz Testing.....*Sidney X. Shore* 58

Impedance Transformation.....*Paul J. Selgin* 50

Signs of Voltages and Currents
H. Stockman 32

Wheatstone Bridge Applications (Methods Used in Location of Faults in Lines and Loops).....*Paul B. Wright* 68

MARCH

Design and Operation of Radio Range Beacons (Part II)
Capt. W. G. McConnell 54

Highlights of Dr. Roters' AIEE Paper on D-C Electromagnet Design Considerations
Colin A. Campbell 33

RAF Communications.....*Roy Norris* 25

Impedance Transformation (Part II, Graphical Methods of U-H-F Transmission Line Analysis).....*Paul J. Selgin* 40

Loss in Coaxial Cables at U-H-F
Dr. Victor J. Andrew 27

Negative Capacitance
Clelio Brunetti and Leighton Greenough 28

Wheatstone Bridge and Its Applications (Part III).....*Paul B. Wright* 46

APRIL

Demodulation Waves.....*Paul K. Hudson* 46

Energy Wasted in Charging a Condenser
Dr. Victor Wouck 48

Evolution of the DB and VU
Paul B. Wright 54

Highlights of AIEE-IRE Lectures on Aeronautical Communications and Television Engineering..... 32

Radio in Aviation (*Charles I. Stanton*)..... 32

Television Principles (*P. Mertz*)..... 34

Television Pickups (*R. E. Shelby*)..... 36

F-M Antennas..... 44

The Q Lap.....*T. W. M. Schaffers* 40

V-H-F Coil Construction.....*Art H. Meyerson* 29

MAY

Black-White and Color Television Transmission (*IRE-AIEE Television Lectures Review*)..... 30

Color Television (*Dr. P. C. Goldmark*)..... 32

Television Broadcasting (*J. E. Keister and H. D. Fancher*)..... 30

Coil Q Factors at V-H-F.....*Art H. Meyerson* 36

Evolution of the DB and VU (Part II, VU Analysis).....*Paul B. Wright* 44

Field Testing with Equipment Limitations
Dr. Otto J. Smith 28

Harmonic Attenuation with a Pi Network
Obra W. Harrell 40

Telegraph's Centennial..... 42

Vibrator-Condenser Type Power Supplies.
M. A. Honnell 25

JUNE

Acoustic Consideration in 2-Way Loudspeaker Communications.....*A. H. Sanial* 33

Characteristics of the Transitron Oscillator
Clelio Brunetti 40

Laboratory Techniques Developed for ESMWT Communication Courses
Thomas A. Benham 62

Power Amplifier Pi-Network Tank Design.....*H. A. Brown* 36

Resonant Coiled Transmission Lines
Robert C. Paine 46

Television Reception (*IRE-AIEE Television Lecture Review*).....*Dr. T. T. Goldsmith* 60

JULY

Cathode-Ray Tube Development (Early History... Mathematical Concepts... Present day Problems).....*J. R. Beers* 43

Electrical Differentiation and Integration of Current or Voltage Waveforms
George B. Hoadley and William A. Lynch 48

F-M and A-M Transmitter Analysis (Based on a Recent Study of "On-the-Air" Operating and Maintenance Characteristics)
Scott Helt 36

The Design and Application of Multivibrators (Employing the Abraham-Bloch System as a Basis of Planning)
Wilton R. Abbott 38

U-H-F Directive Antennas
Dr. Howard N. Maxwell and Clayton Alway 33

V-H-F Bursts Analyzed by FCC Engineers 61

AUGUST

Broadcast Antennas and Arrays (Calculation of Radiation Patterns)
Wilson Pritchett 42

Communications Today and Tomorrow (*A COMMUNICATIONS NAB Executive War Conference Feature*)..... 40

Enemy Airborne Radio..... 51

Fixed Mica Capacitors in the Army-Navy Electronics Standardization Program
Lieut. George A. Osmundsen 36

Highlights of Olsen and Leonard Papers (Presented at New York Meeting of Acoustical Society of America)..... 38

Pre-Flight Installation Tests of Automatic Radio Compasses.....*Charles W. McKee* 33

Resistive Attenuator, Pad, and Network Theory and Design.....*Paul B. Wright* 49

SEPTEMBER

A Report on the NAB Executive War Conference Symposium (Covering the Postwar Future of Broadcasting)..... 36

Television and F-M (*William B. Lodge*)..... 36

Postwar Television (*T. S. Joyce*)..... 37

Broadcast Problems (*Paul F. Godley*)..... 38

Frequency Modulation (*Major E. H. Armstrong*)..... 38

F-M Transmitters (*Paul Chamberlain*)..... 64

Postwar Broadcasting Challenge (*William S. Hedges*)..... 66

Facsimile (*J. V. L. Hogan*)..... 80

Cathode-Ray Tube Manufacturing Problems
J. R. Beers 46

Communications and the Fire Fighter
Herbert A. Friede 41

Impedance Relationships of Broadcast Antenna Arrays.....*Wilson Pritchett* 54

V-H-F "V" Antenna for Aircraft
Henry Jasik 33

OCTOBER

CAA Worldwide Activities in Communications.....*C. C. Richelieu* 33

Developing a General-Purpose Commercial Aircraft Receiver.....*C. A. Harvey* 48

Cathode-Ray Tube Testing.....*J. R. Beers* 56

High Voltage R-F Insulator Design Notes
Sidney Wald 40

Rebuilding Broadcast Directional Antenna Systems.....*Wilfred A. Wood* 36

Resistive, Attenuator, Pad and Network Theory and Design (Part II)
Paul B. Wright 62

NOVEMBER

A Report on the FCC Allocation Hearings on Television (*Highlights of statements by E. W. Engstrom, Dr. P. C. Goldmark, and G. L. Beers*).....*Lewis Winner* 42

C-R Tubes—Special Problems.....*J. R. Beers* 46

A Compilation of Transducer Formulae
W. R. McLean 58

Graphical Solution for CAA Course Alignment.....*G. L. Brewer* 38

Quarter-Wavelength Insulators
Lawrence A. Ware 51

The OWI 200-kw H-F Transmitters at Bethany, Ohio.....*R. J. Rockwell* 33

DECEMBER

A Report on the 1944 Rochester Fall Meeting.....*Lewis Winner* 40

Filament Design (*H. J. Dailey*)..... 40

Pulse Time Modulation (*E. Labin*)..... 42

Resonators (*W. R. MacLean*)..... 42

U-H-F Measurements (*Dr. W. T. Dakin*)..... 46

Silicones (*Dr. S. L. Bass*)..... 48

Video Amplifiers (*Dr. M. J. Larsen*)..... 41

Bethany 200-kw H-F Transmitters (Part II).....*R. J. Rockwell* 58

Dielectrics in U-H-F Flexible Coaxial Cables.....*A. J. Warner* 33

Graphical Solution for CAA Course Alignment (Part II, Charts).....*G. L. Brewer* 52

Power Supply for U-H-F Velocity-Modulated Tubes.....*Iredell Eachus, Jr* 62

Signal Intensity Tests on a Mountain Top
Donald Phillips 36

Transmitter Design Yesterday and Today
Donald McNichol 64

CUMULATIVE INDEX

ALPHABETICALLY ARRANGED

FOR AUTHORS AND SUBJECTS

A

Abbott, Wilton R.; The Design and Application of Multivibrators..... July 38

Abraham-Bloch System, Application to Multivibrators; *Wilton R. Abbott*..... July 38

Acoustic Consideration in 2-Way Loudspeaker Communications; *A. H. Sanial*..... June 33

Aeronautical Communications and Television Engineering, Highlights of AIEE-IRE Lectures on..... Apr. 32

Airborne Radio, Enemy, Photographs of..... Aug. 51

Aircraft Receiver, Developing a General-Purpose Commercial; *C. A. Harvey*..... Oct. 48

Aircraft, V-H-F "V" Antenna for; *Henry Jasik*..... Sept. 33

A-M/F-M Transmitter Analysis; *Scott Helt*..... July 36

A-M/F-M Detector, Combination; *Frederick C. Everett*..... Feb. 25

Amplifier, Power, Pi-Network Tank Design; *H. A. Brown*..... June 36

A-M Relay Transmitter, Experimental 225.6 mc.; *W. L. Widlar*..... Jan. 22

Amplidyne System of Control (*Alexander-son*); See *IRE Winter Technical Meeting Report*..... Feb. 28

Amplifiers, Video (*Dr. M. J. Larsen*) See *1944 Rochester Fall Meeting Report*..... Dec. 41

Andrew, Dr. Victor J.; Phase Monitors..... Jan. 32

Andrew, Dr. Victor J.; Loss in Coaxial Cables at U-H-F..... Mar. 27

Antennas and Arrays, Broadcast, Calculation of Radiation Patterns; *Wilson Pritchett*..... Aug. 42

Antenna Arrays, Impedance Relationships of Broadcast; *Wilson Pritchett*..... Sept. 54

Antennas, F-M Photographs of..... Apr. 44

Antennas, U-H-F Directive; *Dr. H. N. Maxwell and C. Alway*..... July 33

Antenna Systems, Directional, Rebuilding Broadcast; *Wilfred A. Wood*..... Oct. 36

Antenna, V-H-F "V", for Aircraft; *Henry Jasik*..... Sept. 33

Armstrong, Major E. H.; Frequency Modulation (*NAB War Conference*)..... Sept. 38

Attenuator, Pad and Resistive Network Theory and Design; *Paul B. Wright*..... Aug. 49

Attenuator, Pad and Resistive Network Theory & Design (Part II); *Paul B. Wright*..... Oct. 62

Attenuator, The Piston; (*Wheeler*); See *IRE Winter Technical Meeting Report*..... Feb. 30

Attenuation of Harmonics with a Pi Network; *Obra W. Harrell*..... May 40

Audio Reactor, High-Q, Design and Production; *Colin A. Campbell*..... Mar. 33

LONG LIFE

is built into every

Tobe Capacitor



In War, Long Life Saves Lives
 In Peace, Long Life Saves Customers



SPECIFICATIONS OF JUST ONE TYPE OF THE MANY TOBE OIL-IMPREGNATED AND OIL-FILLED PAPER CAPACITORS...

OM-CAPACITORS

TYPE	OM-*
RATINGS	.05 to 2.0 mfd. 600 V.D.C. .05 mfd. to 1.0 mfd. 1,000 V.D.C.
STANDARD CAPACITY TOLERANCE	20%**
TEST VOLTAGE	Twice D. C. rating
GROUND TEST	2,500 Volts D. C.
OPERATING TEMPERATURE	-55° F to 185° F
SHUNT RESISTANCE	.05 to 0.1 mfd. 20,000 megohms .25 to 0.5 mfd. 12,000 megohms 1.0 to 2.0 mfd. 12,000 megohms
POWER FACTOR	At 1,000 cycles—.002 to .005
CONTAINER SIZE	Width 5/8", length 1-5/16", height 2 1/4"
MOUNTING HOLE CENTERS	1 1/2"

MIDGET OM-CAPACITORS

TYPE	OMM-*
RATINGS	.05, .1 and 2 x .05 600 V.D.C. .05 x .1 1,000 V.D.C.
STANDARD CAPACITY TOLERANCE	20%**
GROUND TEST	2,500 V.D.C.
OPERATING TEMPERATURES	-55° F to 185° F
SHUNT RESISTANCE	20,000 megohms
POWER FACTOR	At 1,000 cycles—.0075
CONTAINER SIZE	Width 5/8", length 1-5/16", height 1-11/64"
MOUNTING HOLE CENTERS	1 1/2"

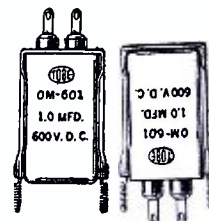

This new separate mounting is stronger and helps prevent leaks caused by breaks in can. This outstanding Tobe design takes the minimum amount of space.

*Data sheets showing complete code number for units having a specific capacitance value and voltage rating available on request. **Other tolerances available.

A SMALL PART IN VICTORY TODAY... A BIG PART IN INDUSTRY TOMORROW

I N D E X

<p>B</p> <p>Beacons, Radio Range, Design and Operation of; <i>Capt. W. G. McConnell</i>...Feb. 40</p> <p>Beacons, Radio Range, Design and Operation of, (Part II); <i>Capt. W. G. McConnell</i>...Mar. 54</p> <p><i>Beers, J. R.</i>; Cathode-Ray Tube Development...July 43</p> <p><i>Beers, J. R.</i>; Cathode-Ray Manufacturing Problems...Sept. 46</p> <p><i>Beers, J. R.</i>; Cathode-Ray Tube Testing...Oct. 56</p> <p><i>Beers, J. R.</i>; C-R Tubes-Special Problems...Nov. 46</p> <p><i>Benham, Thomas A.</i>; Laboratory Techniques Developed for ESMWT Communication Courses...June 62</p> <p>Bethany 200-kw H-F Transmitters (Part II); <i>R. J. Rockwell</i>...Dec. 58</p> <p><i>Brewer, G. L.</i>; Graphical Solution for CAA Course Alignment (Part I)...Nov. 38</p> <p><i>Brewer, G. L.</i>; Graphical Solution for CAA Course Alignment (Part II, Charts)...Dec. 52</p> <p>Bridge, The Wheatstone; <i>Paul B. Wright</i>...Jan. 34</p> <p>Bridge, Wheatstone, Applications to Methods used for Fault Locations on Lines and Loops; <i>Paul B. Wright</i>...Feb. 68</p> <p>Bridge, Wheatstone, Applications to Fault Location on Lines and Loops (Part III); <i>Paul B. Wright</i>...Mar. 46</p> <p>Broadcast Antennas and Arrays, Radiation Patterns, Calculation of; <i>Wilson Pritchett</i>...Aug. 42</p> <p>Broadcast Antenna Arrays, Impedance Relationships of; <i>Wilson Pritchett</i>...Sept. 54</p> <p>Broadcast Directional Antenna Systems, Rebuilding; <i>Wilfred A. Wood</i>...Oct. 36</p> <p>Broadcasting, Postwar Challenge; <i>Wm. S. Hedges (NAB Postwar Symposium)</i>...Sept. 66</p> <p>Broadcast Problems; <i>Paul F. Godley (NAB Postwar Symposium)</i>...Sept. 38</p> <p><i>Brown, H. A.</i>; Power Amplifier Pi-Network Tank Design...June 36</p> <p><i>Brunetti, Cleo</i> and <i>Leighton Greenough</i>; Negative Capacitance...Mar. 28</p> <p><i>Brunetti, Cleo</i>; Characteristics of the Transitron Oscillator...June 40</p> <p>Bursts, V-H-F, Analyzed by FCC Engineers...July 61</p> <p>C</p> <p>CAA-Course Alignment, Graphical Solution of; (Part I) <i>G. L. Brewer</i>...Nov. 38</p> <p>CAA-Course Alignment, Graphical Solution for, (Part II, Charts); <i>G. L. Brewer</i>...Dec. 52</p> <p>CAA Worldwide Activities in Communications; <i>C. C. Richelieu</i>...Oct. 33</p> <p>Cables at U-H-F, Loss in Coaxial; <i>Dr. Victor J. Andrew</i>...Mar. 27</p> <p><i>Campbell, Colin A.</i>; High-Q Audio Reactor Design and Production...Mar. 33</p> <p>Capacitance, Negative; <i>Cleto Brunetti and Leighton Greenough</i>...Mar. 28</p> <p>Capacitors, Fixed Mica, in the Army-Navy Electronics Standardization Program; <i>Lieut. Geo. A. Osmundsen</i>...Aug. 36</p> <p>Cathode-Ray Manufacturing Problems; <i>J. R. Beers</i>...Sept. 46</p> <p>Cathode-Ray Tube Development, History, Concepts, Problems; <i>J. R. Beers</i>...July 43</p> <p>Cathode-Ray Tube Testing; <i>J. R. Beers</i>...Oct. 56</p> <p><i>Chamberlain, Paul</i>; F-M Transmitter (<i>NAB Postwar Symposium</i>)...Sept. 64</p> <p>Characteristics of the Transitron Oscillator; <i>Cleto Brunetti</i>...June 40</p> <p>Coaxial Cables at U-H-F, Loss in; <i>Dr. Victor J. Andrew</i>...Mar. 27</p> <p><i>Cohen, Arthur</i> (Biography)...Nov. 68</p> <p>Coil Construction at V-H-F; <i>Art H. Meyerson</i>...Apr. 29</p> <p>Coil Q Factors at V-H-F; <i>Art H. Meyerson</i>...May 36</p> <p>Communication Courses, Laboratory Technique Developed for ESMWT; <i>T. A. Benham</i>...June 62</p> <p>COMMUNICATIONS, Index to, 1943...Jan. 54</p> <p>Communications and the Fire Fighter; <i>Herbert A. Friede</i>...Sept. 41</p> <p>Communications, CAA Worldwide Activities in; <i>C. C. Richelieu</i>...Oct. 33</p> <p>Communications, 2-Way Loudspeaker; <i>A. H. Sanial</i>...June 33</p> <p>Communications, RAF; <i>Roy Norris</i>...Mar. 25</p> <p>Communications Today and Tomorrow (<i>NAB Conference</i>)...Aug. 40</p> <p>Compasses, Automatic Radio, Installation Tests of; <i>Charles W. McKee</i>...Aug. 33</p> <p>Condensers, Energy Wasted in Charging; <i>Dr. Victor Wouck</i>...Apr. 48</p> <p>Conference, NAB Executive War, Report...Sept. 36</p>	<p><i>Cose, John H.</i> (Biography)...Nov. 68</p> <p><i>Coulter, Harry</i>; (Biography)...June 70</p> <p><i>Crowley, Louis</i> (Biography)...Dec. 68</p> <p>Currents and Voltages, Signs of; <i>H. Stockman</i>...Feb. 32</p> <p>D</p> <p>DB and VU, Evolution of the; <i>Paul B. Wright</i>...Apr. 54</p> <p>DB and VU, Evolution of the, (Part II); <i>Paul B. Wright</i>...May 44</p> <p>Demodulation Waves; <i>Paul K. Hudson</i>...Apr. 46</p> <p>Detector, Combination A-M/F-M; <i>Frederick C. Everett</i>...Feb. 25</p> <p>Dielectrics in U-H-F Flexible Coaxial Cables; <i>A. J. Warner</i>...Dec. 33</p> <p>Differentiation and Integration of Current or Voltage Waveforms; <i>G. B. Hoadley & W. A. Lynch</i>...July 48</p> <p>Directional Antenna Systems, Rebuilding Broadcast; <i>Wilfred A. Wood</i>...Oct. 36</p> <p>Directive Antennas, U-H-F; <i>Dr. H. N. Maxwell & C. Alway</i>...July 33</p> <p><i>Duffy, John B.</i> (Biography)...Jan. 62</p> <p>E</p> <p><i>Eachus Jr., Iredell</i>; Power Supply for U-H-F Velocity-Modulated Tubes...Dec. 62</p> <p>Electrical Differentiation & Integration; <i>Geo. B. Hoadley & Wm. A. Lynch</i>...July 48</p> <p>Electromagnet Design Considerations, Highlights of <i>Dr. Roters' AIEE Paper</i>...Mar. 85</p> <p>Electrons, The Limitations Imposed by Quantum Theory on Resonator Control of (Smith); See <i>IRE Winter Technical Meeting Report</i>...Feb. 29</p> <p>Energy Wasted in Charging a Condenser; <i>Dr. Victor Wouck</i>...Apr. 48</p> <p>Engineering, FCC (Jett); See <i>IRE Winter Technical Meeting Report</i>...Feb. 102</p> <p>Equivalent Circuits for Discontinuity in Transmission Lines (<i>Whinnery-Jamieson</i>); See <i>IRE Winter Technical Meeting Report</i>...Feb. 30</p> <p>Equivalent Circuit of the Field Equations of Maxwell (<i>Kron</i>); See <i>IRE Winter Technical Meeting Report</i>...Feb. 100</p> <p><i>Everett, Frederick C.</i>; Combination A-M/F-M Detector...Feb. 25</p> <p>Evolution of the DB and VU; <i>Paul B. Wright</i>...Apr. 54</p> <p>Evolution of the DB and VU (Part II); <i>Paul B. Wright</i>...May 44</p> <p>F</p> <p>Facsimile; <i>J. V. L. Hogan (NAB Postwar Symposium)</i>...Sept. 80</p> <p>FCC Allocation Hearings on Television, A Report on; <i>Lewis Winner</i>...Nov. 42</p> <p>FCC Engineering (Jett); See <i>IRE Winter Technical Meeting Report</i>...Feb. 102</p> <p>Field Testing with Equipment Limitations; <i>Dr. Otto J. Smith</i>...May 28</p> <p>Filament Design (<i>H. J. Dailey</i>); See <i>1944 Rochester Fall Meeting Report</i>...Dec. 40</p> <p>Fire Fighter, Communications and the; <i>H. A. Friede</i>...Sept. 41</p> <p><i>Fitzpatrick, William S.</i> (Biography)...May 62</p> <p>F-M Antennas, Photographs of...Apr. 44</p> <p>F-M/A-M Detector, Combination; <i>Frederick C. Everett</i>...Feb. 25</p> <p>F-M/A-M Transmitter Analysis; <i>Scott Helt</i>...July 36</p> <p>F-M and Television; <i>Wm. B. Lodge (NAB Postwar Symposium)</i>...Sept. 36</p> <p>F-M Transmitters; <i>Paul Chamberlain (NAB Postwar Symposium)</i>...Sept. 64</p> <p>Frequency Modulation; <i>Major E. H. Armstrong (NAB Postwar Symposium)</i>...Sept. 38</p> <p><i>Friede, Herbert A.</i>; Communications and the Fire Fighter...Sept. 41</p> <p>G</p> <p><i>Godley, Paul F.</i>; Broadcast Problems (<i>NAB Postwar Symposium</i>)...Sept. 38</p> <p><i>Goldsmith, Dr. T. T.</i>; Television Reception (<i>IRE-AIEE Lecture Review</i>)...June 60</p> <p>Graphical Solution for CAA-Course Alignment, (Part I); <i>G. L. Brewer</i>...Nov. 38</p> <p>Graphical Solution for CAA-Course Alignment, (Part II, Charts); <i>G. L. Brewer</i>...Dec. 52</p> <p>H</p> <p>Harmonic Attenuation with a Pi Network; <i>Obra W. Harrell</i>...May 40</p> <p><i>Harvey, C. A.</i>; Developing a General-Purpose Commercial Aircraft Receiver...Oct. 48</p> <p><i>Hedges, William S.</i>; Postwar Broadcasting Challenge (<i>NAB Postwar Symposium</i>)...Sept. 66</p> <p><i>Helt Scott</i>; F-M/A-M Transmitter Analysis...July 36</p> <p><i>Hoadley, George B. and William A. Lynch</i>; Electrical Differentiation and Integration of Current or Voltage Waveforms...July 48</p> <p><i>Hogan, J. V. L.</i>; Facsimile (<i>NAB Postwar Symposium</i>)...Sept. 80</p> <p><i>Honnell, M. A.</i>; Vibrator-Condenser Type Power Supplies...May 25</p> <p><i>Hudson, Paul K.</i>; Demodulation Waves...Apr. 46</p> <p><i>Harrell, Obra W.</i>; Harmonic Attenuation with a Pi Network...May 40</p>
---	--

RCA's New 170-A

Audio Chanalyst

Tests Everything
from Microphones
to Multiple Speakers



THE new 170-A Audio Chanalyst is a combination testing unit which includes the famous Voltohmyst circuit, a new diode flat through the audio range, a B.F.O. signal source, a gain calibrated amplifier, and speaker and line output connections.

The various channels of the RCA Type 170-A can be used independently or in unison to check

all common defects in audio amplifiers and sound systems. Polarity indication and a.c. can be determined instantly with the new electronic indicator, without danger of overload!

A pamphlet containing full description and specifications of the 170-A Audio Chanalyst will be sent gladly, on request.

Please use this coupon ↘

BUY MORE WAR BONDS



Test & Measuring Equipment, Dept. 97-87 A
Radio Corp. of America, Camden, N. J.

Please send the bulletin describing the new RCA 170-A Audio Chanalyst to:

Name
Position
Company
Street City

RADIO CORPORATION OF AMERICA

RCA VICTOR DIVISION • CAMDEN, N. J.

In Canada:

RCA VICTOR COMPANY, LTD., MONTREAL

I N D E X

Osmundsen, Lieut. George A.; Fixed Mica Capacitors in the Army-Navy Electronic Standardization Program Apr. 36
 OWI-200-kw H-F Transmitters at Bethany, Ohio; R. J. Rockwell Nov. 33

P

Pad, Attenuator, Resistive, Network Theory and Design of; Paul B. Wright Aug. 49
 Pad, Attenuator, and Resistive Network Theory & Design (Part II); Paul B. Wright Oct. 62
 Paine, Robert C.; Resonant Coiled Transmission Lines June 46
 Parallel Circuit Problems, Nomogram for Solving; Sgt. Bon L. Wong Jan. 28
 Phase Monitors; Dr. Victor J. Andrew Jan. 32

Phillips, Donald; Signal Intensity Tests on a Mountain Top Dec. 36
 Power Supply for U-H-F Velocity-Modulated Tubes; Iredell Eachus, Jr. Dec. 62
 Pulse Time Modulation (E. Labin); See 1944 Rochester Fall Meeting Report Dec. 42
 Postwar Broadcasting Challenge; Wm. S. Hedges (NAB Postwar Symposium) Sept. 66

Power Amplifier Pi-Network Tank Design; H. A. Brown June 36
 Power Supplies, Vibrator-Condenser Type; M. A. Honnell May 25
 Piston Attenuator, The (Wheeler); See IRE Winter Technical Meeting Report Feb. 29
 Pritchett, Wilson; Broadcast Antennas and Arrays (Part I) Aug. 42
 Pritchett, Wilson; Impedance Relationships of Broadcast Antenna Arrays (Part II) Sept. 54

Q

Q Factors at V-H-F, in Coil Design; Art H. Meyerson May 36
 Q Lap, The; T. W. M. Schaffers Apr. 40
 Quartz Lapping and Finishing; Sidney X. Shore Jan. 46
 Quartz Testing; Sidney X. Shore Feb. 58
 Quantum Theory on Resonator Control of Electrons, The Limitations Imposed by (Smith); See IRE Winter Technical Meeting Report Feb. 29

R

Radio Compasses, Installation Tests of; C. W. McKee Aug. 33
 Radio, Enemy Airborne, Photographs of Aug. 51
 Radio in Aviation (Charles I. Stanton); See Highlights of AIEE-IRE Lectures on Aeronautical Communications and Television Engineering Apr. 32
 RAF Communications; Roy Norris Mar. 25
 Receiver Considerations, WERS; Walter J. Stiles Jan. 42
 Reception, Television; Dr. T. T. Goldsmith June 60
 R-F Insulator Design Notes, High Voltage; Sidney Wald Oct. 40
 Resonant Coiled Transmission Lines; R. C. Paine June 46
 Resonators (W. R. MacLean); See 1944 Rochester Fall Meeting Report Dec. 42
 Relay Transmitter Experimental 225.6-mc, A-M; W. L. Widlar Jan. 22
 Resistive Attenuator, Pad, and Network Theory and Design; Paul B. Wright Aug. 49

Resistive, Attenuator, Pad and Network Theory & Design (Part II); Paul B. Wright Oct. 62
 Resonator Control of Electrons, The Limitations Imposed by Quantum Theory on (Smith); See IRE Winter Technical Meeting Report Feb. 29
 Resonators, Electromagnetic Cavity, A-C Network Analyzer Studies of (Whinnery-Concordia-Ridgway-Kron); See IRE Winter Technical Meeting Report Feb. 101
 Richelieu, C. C.; CAA Worldwide Activities in Communications Oct. 33
 Rochester Fall Meeting, Report on the 1944; Lewis Winner Dec. 40
 Rockwell, R. J.; The OWI-200-kw H-F Transmitters at Bethany, Ohio (Part I) Nov. 33
 Rockwell, R. J.; Bethany 200-kw H-F Transmitters (Part II) Dec. 58

S

Sanial, A. H.; Acoustic Consideration in 2-Way Loudspeaker Communications June 33
 Schaffers, T. W. M.; The Q Lap Apr. 40
 Schoenbaum, J. R.; A Modernized Tube Index Jan. 17
 Selgin, Paul J.; Impedance Transformation (Part I) Feb. 50
 Selgin, Paul J.; Impedance Transformation (Part II) Mar. 40
 Shore, Sidney X.; Quartz Lapping and Finishing (Part IV) Jan. 46

Shore, Sidney X.; Quartz Testing (Part V) Feb. 58
 Signal Intensity Tests on a Mountain Top; Donald Phillips Dec. 36
 Silicones (Dr. S. L. Bass); See 1944 Rochester Fall Meeting Report Dec. 48
 Smith, Dr. Otto J.; Field Testing with Equipment Limitations May 28
 Stiles, Walter J.; WERS Receiver Considerations Jan. 42
 Stockman, H.; Signs of Voltages and Currents Feb. 32

Tank Design, Power Amplifier Pi-Network; H. A. Brown June 36
 Telegraph's Centennial May 42
 Television and F-M; William B. Lodge (NAB Postwar Symposium) Sept. 36
 Television Broadcasting (J. E. Keister and H. D. Fancher); See IRE-AIEE Television Lectures Review May 30
 Television, Color (Dr. P. C. Goldmark); See IRE-AIEE Television Lectures Review May 32
 Television Engineering and Aeronautical Communications, Highlights of AIEE-IRE Lectures on Apr. 32
 Television Pickups (R. E. Shelby); See Highlights of AIEE-IRE Lectures on Aeronautical Communications and Television Engineering Apr. 36
 Television, Postwar; T. S. Joyce (NAB Postwar Symposium) Sept. 37
 Television Principles (P. Mertz); See Highlights of AIEE-IRE Lectures on Aeronautical Communications and Television Engineering Apr. 34
 Television Reception (Dr. T. T. Goldsmith); See IRE-AIEE Television Lectures Review June 60
 Television, Report on the FCC Allocations Hearings (G. L. Beers) Nov. 42
 Television, Report on the FCC Allocations Hearings (E. W. Engstrom) Nov. 42
 Television, Report on the FCC Allocations Hearings (Dr. P. C. Goldmark) Nov. 42
 Television Studio Work, Orthicon Cameras in (Lubcke); See IRE Winter Technical Meeting Report Feb. 29
 Television Transmission, Black-White and Color (See IRE-AIEE Television Lectures Review) May 30
 Transducer Formulae, A Compilation of; W. R. MacLean Nov. 58
 Transformation, Impedance; Paul J. Selgin Feb. 50
 Transformation, Impedance (Part II), Graphical Methods of U-H-F Transmission Line Analysis; Paul J. Selgin Mar. 40
 Transmission Lines, Resonant Coiled; R. C. Paine June 46
 Transistron Oscillator, Characteristics of; Cleo Brunetti June 40
 Transmitter Analysis, F-M/A-M; Scott Helt July 36
 Transmitter, the OWI 200-kw H-F, at Bethany, Ohio (Part I); R. J. Rockwell Nov. 33
 Transmitters, Bethany 200-kw H-F (Part II); R. J. Rockwell Dec. 58
 Transmitter Design Yesterday and Today; Donald McNichol Dec. 64
 Transmitter, Experimental 225.6-mc A-M Relay; W. L. Widlar Jan. 22
 Transmitters, F-M; Paul Chamberlain (NAB Postwar Symposium) Sept. 64
 Transmission Lines, Equivalent Circuits for Discontinuity in (Whinnery-Jamieson) Feb. 30
 Tube, Cathode-Ray, Development, History, Concepts, Problems; J. R. Beers July 43
 Tube, Cathode-Ray, Testing; J. R. Beers Oct. 56
 Tubes, C-R, Special Problems; J. R. Beers Nov. 46
 Tube Index, A Modernized; J. R. Schoenbaum Jan. 17

U-H-F Directive Antennas; Dr. Howard N. Maxwell and Clayton Alway July 33
 U-H-F Measurements (Dr. W. T. Dakin); See 1944 Rochester Fall Meeting Report Dec. 46

Velocity-Modulated Tubes, Power Supply for U-H-F; Iredell Eachus, Jr. Dec. 62
 V-H-F Bursts Analyzed by FCC Engineers July 61
 V-H-F Coil Construction; Art H. Meyerson Apr. 29
 V-H-F "V" Antenna for Aircraft; Henry Jasik Sept. 33
 Vibrator-Condenser Type Power Supplies; M. A. Honnell May 25
 Video Amplifiers (Dr. M. J. Larsen); See 1944 Rochester Fall Meeting Report Dec. 41
 Voltages and Currents, Signs of; H. Stockman Feb. 32
 VU and DB, Evolution of the; Paul B. Wright Apr. 54
 VU and DB, Evolution of the (Part II, Analysis); Paul B. Wright May 44

W

Ware, Lawrence A.; Quarter-Wavelength Insulators Nov. 51
 Warner, A. J.; Dielectrics in U-H-F Flexible Coaxial Cables Dec. 33
 Waveforms, Differentiation and Integration of; George B. Hoadley and William A. Lynch July 48
 Wald, Sidney; High Voltage R-F Insulator Design Notes Oct. 40
 WERS Receiver Considerations; Walter J. Stiles Jan. 42
 Wheatstone Bridge, The; Paul B. Wright Jan. 34
 Wheatstone Bridge Applications to Location of Faults in Lines and Loops; Paul B. Wright Feb. 68
 Wheatstone Bridge and its Applications (Part III); Paul B. Wright Mar. 46
 Widlar, W. L.; Experimental 225.6-mc Relay Transmitter Jan. 22
 Winner, Lewis; Report on FCC Allocation Hearings on Television Nov. 42
 Winner, Lewis; Report on the IRE Winter Technical Meeting Feb. 28
 Winner, Lewis; Report on the 1944 Rochester Fall Meeting Dec. 40
 Winterbottom, William A.; (Biography) Aug. 60
 Wong, Sgt. Bon L.; Nomogram for Solving Parallel Circuit Problems Jan. 28
 Wood, Wilfred A.; Rebuilding Broadcast Directional Antenna Systems Oct. 36
 Wouch, Dr. Victor; Energy Wasted in Charging a Condenser Apr. 48
 Wright, Paul B.; Evolution of the DB and VU (Part I) Apr. 54
 Wright, Paul B.; Evolution of the DB and VU (Part II) May 44
 Wright, Paul B.; The Wheatstone Bridge (Part I) Jan. 34
 Wright, Paul B.; Wheatstone Bridge Applications (Part II) Feb. 68
 Wright, Paul B.; Wheatstone Bridge and its Applications (Part III) Mar. 46
 Wright, Paul B.; Resistive Attenuator, Pad and Network Theory and Design (Part I) Aug. 49
 Wright, Paul B.; Resistive, Attenuator, Pad and Network Theory and Design (Part II) Oct. 62

TABLES, CHARTS

Attenuator Element Values for Standard Volume Unit Measuring Instruments at Various Levels; Paul B. Wright May 48
 Coil Q, as Effected by Grooving of the Form at V-H-F; Art H. Meyerson May 84
 Coil Q Factors at V-H-F for Coils of Various Turns per Inch; Art H. Meyerson May 37
 Constants for Calculating the Loss of Coaxial Cable Conductors at U-H-F; Dr. Victor J. Andrew Mar. 27
 Course Alignment, Nomogram (Chart I); G. L. Brewer Dec. 52
 Course Alignment, Nomogram (Chart II); G. L. Brewer Dec. 53
 Course Alignment, Nomogram (Chart III); G. L. Brewer Dec. 56
 Decibel Gains and Losses for 500- and 600-ohms Impedance Levels for Voltages, Currents and Powers on 1- and 6-Milliwatt Bases; Paul B. Wright May 46
 Decibels versus the Exponential Function, e^{θ} from which the Hyperbolic Functions of a Real Variable May Be Calculated; Paul B. Wright Aug. 52
 Dielectric Properties, Measurement Results (Dr. W. T. Dahin) Dec. 48
 Hyperbolic Functions of a Real Variable versus No (db) from 0.00 to 150 Decibels, for the Hyperbolic Sine, Cosine, Tangent, Tangent of the Half-angle, Cosine-Squared and the Reciprocal Functions of each; Paul B. Wright Oct. 64
 Insertion Losses and Network Element Values for Series, Shunt and Series-Shunt Networks; Paul B. Wright Oct. 70
 Parallel Circuit Problems, Nomogram for Solving; Sgt. Bon L. Wong Jan. 28
 Signal Strength of Television Stations Received at Mt. Greylock, Mass.; Donald Phillips Dec. 38
 Television, Postwar, Probable Growth (T. S. Joyce); See Report on the NAB Executive War Conference Symposium Sept. 37
 Tolerances and Designations of Fixed Mica-Dielectric Capacitors; Lt. Geo. A. Osmundsen Aug. 91
 Transmission Losses and Element Values for "L"-Type Taper Networks; Paul B. Wright Oct. 72
 U-H-F Q's Obtained for Enamelled, Bare and Silver Plated Copper Conductors on Lucite and Polystyrene Coil Forms; Art H. Meyerson April -30
 Vacuum Tube Coding System; J. R. Schoenbaum Jan. 20

(Continued on page 103)



You Can Buy This Amplifier TODAY.

Under a recent ruling of the War Production Board radio station owners may buy up to \$500.00 worth of new capital equipment, using their AA-1 MRO CMP-5 priority.

Here is a piece of equipment that will make a vast improvement in the quality of your instantaneous recordings. And it can be delivered to you promptly.

It is the Presto 88-A amplifier, designed especially for use with Presto 1-C and similar high fidelity cutting heads.

Maximum power output is 50 watts with 4% distortion, measured by the inter-modulation method. Feed back circuits maintain the output impedance essentially constant when driving a cutting head, thus reducing overall distortion. Three frequency response curves are available on a selector switch. (1) Flat response, 30 to 15,000

c.p.s. \pm 1 db. (2) NBC ORTHACOUSTIC recording response. (3) World-AMP lateral recording response.

Designed for relay rack mounting; panel height 14"; input, 500 ohms; output, optional, 15 ohms or 500 ohms; gain, maximum, 85 db. Shipment 4 to 5 weeks after receipt of order placed with your electronic distributor.



**Buy Bonds. Keep on Buying.
Keep 'Em Flying.**

PRESTO RECORDING CORPORATION

242 WEST 55th STREET, NEW YORK 19, N. Y., U. S. A.

Walter P. Downs Ltd., in Canada

COMMUNICATIONS FOR JANUARY 1945 • 67

3 Views OF THE FUTURE

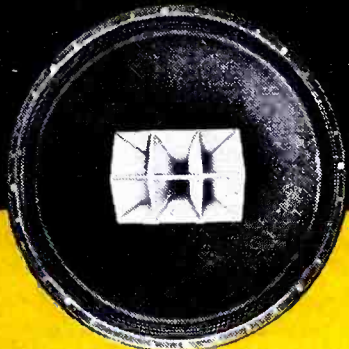

DUPLEX SPEAKER

The Speaker that
Revolutionizes the
Methods of Sound
Reproduction!

SEND FOR BULLETINS

ALTEC

LANSING CORPORATION

1210 TAFT BLDG., HOLLYWOOD 28, CALIF.

COUPLED CIRCUIT DESIGN

(Continued from page 43)

$$(e')^2 = e_p^2 + \frac{1}{4}e_s^2 - e_p e_s S_2 / U_2 \quad (37)$$

$$(e'')^2 = e_p^2 + \frac{1}{4}e_s^2 + e_p e_s S_2 / U_2 \quad (38)$$

Assuming the diodes to be operating as peak rectifiers, the rectified voltages are

$$E' = 1.414e' \quad E'' = 1.414e''$$

$$E = 1.414(e'' - e') \quad (39)$$

For the moment suppose we let $(e')^2 = \alpha - \beta$ and $(e'')^2 = \alpha + \beta$ so that

$$E^2 = 2[(\alpha + \beta)^{1/2} - (\alpha - \beta)^{1/2}]^2$$

$$= [2\alpha - 2(\alpha^2 - \beta^2)^{1/2}]^2$$

$$E = \pm 2[\alpha - (\alpha^2 - \beta^2)^{1/2}]^{1/2} \quad (40)$$

From equations 37 and 38, $\alpha = e_p^2 + \frac{1}{4}e_s^2$ and $\beta = e_p e_s S_2 / U_2$. Using equations 29 and 30 for e_p and e_s , the d-c output voltage may be written in terms of grid voltage at the driving tube. We are dealing now with scalar values only so the j is dropped. First using equation 31 the d-c voltage may be expressed in terms of secondary voltage

$$E = \pm 2e_s \sqrt{(Z_{o1}/Z_{o2})(U_2/KQ_g)^2 + \frac{1}{4} - \sqrt{[(Z_{o1}/Z_{o2})(U_2/KQ_g)^2 - \frac{1}{4}]^2 + (Z_{o1}/Z_{o2})(1/KQ_g)^2}} \quad (41)$$

A calculation constant is apparent here which is a function of coupling Q , and impedance ratio. Let us call it

$$B = (Z_{o1}/Z_{o2})(1/KQ_g)^2 \quad (42)$$

From equation 30, at resonance

$$A_o = e_s/e_g = g_m Z_{og} [KQ_g / (1 + K^2 Q_g^2)] \quad (43)$$

and we may now write the discriminator equation in terms of two variables and two constants

$$E = \pm (2A_o e_g / U) \sqrt{BU_s^2 + \frac{1}{4} - \sqrt{(BU_s^2 - \frac{1}{4})^2 + B}} \quad (44)$$

where

U_s is the selectivity of a single circuit of Q_s

U is the selectivity of a coupled pair of $Q = Q_s^2 / Q_a$

A_o is the grid-to-grid gain of the loaded transformer used as a coupled circuit amplifier (at resonance).

This reduces discriminator performance to a conveniently calculable formula.

Diode Loads

In the case of a discriminator or any diode-driving transformer, the diode load must be considered in arriving at an effective circuit Q^b . We will assume that full peak rectification is obtained. Bypass capacitors will, in all usual designs, be sufficient to develop very nearly peak voltage. Where the diode load resistors are low in value, a loss of voltage due to internal diode resistance will need to be anticipated, and this internal diode resistance will also reduce the loading effect of the resistors. Neglecting the

losses in the diode, the d-c power generated in the diode load must come from the i-f power supplied by the transformer since no external source of power is available. We can, therefore, equate the power the i-f would produce in a fictitious resistor to the power it does supply in d-c form across the diode load resistor. If we represent the i-f voltage driving the diode by an rms value E , then the peak d-c voltage developed will be 1.414E.

$$E^2/R' = 2E^2/R = E^2/(R/2) \quad (45)$$

where R' is the fictitious a-c load across the transformer, which is equal to $\frac{1}{2}R$, R being the resistor in the diode load circuit. This applies to a circuit as shown in Figure 14. Another diode rectifier circuit often used is shown in Figure 15. With the same R - C time constant the performance will be the same as that of Figure 14 except for the appearance of i-f as well as the d-c voltage across R . The resulting power required of the transformer will be

$$E^2/R'' = 2E^2/R + E^2/R = E^2/(R/3) \quad (46)$$

so that, in this case, the equivalent loading on the i-f circuit is $(1/3)R$.

The discriminator circuit, Figure 9, may be represented by a loaded i-f circuit, Figure 16, in which the effect of the diode loads is incorporated in the fictitious resistors $\frac{1}{2}R$. The total power de-

livered to the diodes is

$$P = (e')^2/(R/2) + (e'')^2/(R/2) \quad (47)$$

Using equation 37 and 38 this becomes

$$P = 4e_p^2/R + 4(e_s/2)^2/R$$

$$= e_p^2/(R/4) + e_s^2/R \quad (48)$$

This means that the power required from the secondary (at any frequency) may be determined from a fictitious resistor of value R across the secondary circuit. The driving voltage for the diodes is

partly provided by the primary, and from equation 48 it is apparent that the power required from the primary at any frequency may be accounted for by a fictitious resistor of value $\frac{1}{4}R$ across the primary. R is the resistance in one diode load.

Let us now apply a sample calculation for Figure 9 with the following circuit constants: Diode load $R = 40,000$ ohms; Q_1 (coil only) = 90; $C_1 = 40$ mmf; Q_2 (coil only) = 70; $C_2 = 15$ mmf; $f_o = 4.0$ mc; $g_m = 3500 \mu\text{mho}$; and R_2 (a resistance load across C_2) = 40,000 ohms. The resistance load, R_s , is not shown in Figure 9.

First we must determine effective circuit Q and impedance.

Resonant impedance:

$$\text{Primary alone } Z_1 = X_1 Q_1$$

$$= (1000)(90) = 90,000 \text{ ohms}$$

$$\text{Secondary alone } Z_2 = X_2 Q_2$$

$$= (2667)(70) = 186,600 \text{ ohms}$$

The loading on the secondary is 40,000 ohms in parallel with a fictitious resistor (Continued on page 74)

how high is very high?

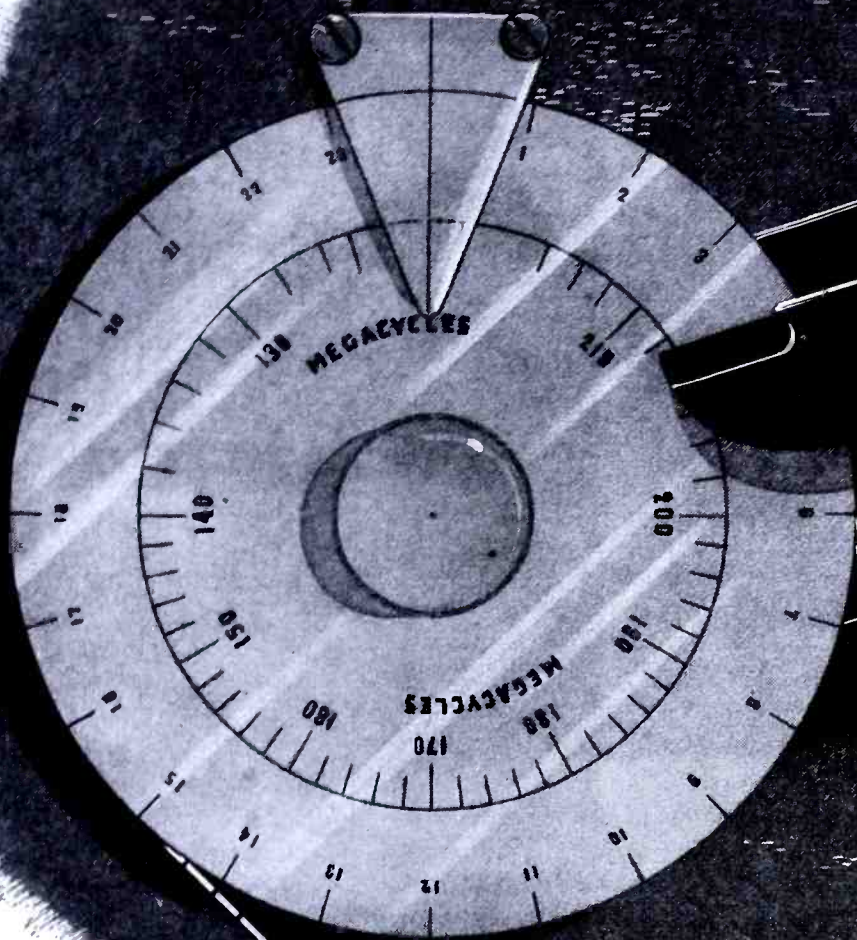

★ Engineers at Hallicrafters are continually striving for new heights of perfection in high frequency development work. The Model S-37 is one example of the progress they have made. This is the first and only set of its kind — covering both AM and FM and operating in the range of 130 to 210 Mc. Two r.f. stages are used and in conjunction with an intermediate frequency of 18 Mc., assure an amazingly high ratio of image rejection. It is becoming a valuable instrument in the hands of all exploring the upper reaches of the high frequency ranges.



Model S-37. The highest frequency range of any continuous tuning commercial type receiver.

hallicrafters RADIO



Buy a War Bond Today!



THE HALLICRAFTERS CO., MANUFACTURERS OF RADIO AND ELECTRONIC EQUIPMENT, CHICAGO 16, U. S. A.



Personals

FROM Colonel Robert B. Woolverton, veteran of over forty years in the wireless art and inventor of the spark transmitter for which he was made a Fellow of the IRE in 1915, we've received an interesting note describing his early experiences. Col. Woolverton states that his experiments with the Slaby-Arco coherers appeared quite trivial when he began working with electrolytic detectors improvised from miniature lamp bulbs and pieces of Wollestone wire with a pair of headphones, way back in 1904. For the first time, he says, he heard signals! . . . Another real pioneer has also written in . . . Greenleaf W. Pickard. Mr. Pickard began sending out dots and dashes at Blue Hill in 1898-1899, and Providence in 1899. On the schooner *Maid of the Mist* he reported the 1901 yacht races using the *Pickard-Shoemaker* ten-second-dash code. Frequent unlicensed wireless communication went on between the Pickard station *HY* at Amesbury, Mass., and operator Charles C. Kolster (now, incidentally, the Inspector-in-Charge for the FCC in Boston) at the *Stone Isles of Shoals* station *S* off the coast of New Hampshire. Mr. Pickard received his first official license in 1913.

Commander Fred Muller has written in asking for letters. He says he "gets lonesome at times for home and my old pals." His address is USNR Navy No. 116, c/o Fleet P. O. New York, N. Y. . . . VWOA members H. H. Parker and Ladaveze sent in Christmas greetings. Thanks. HHP continues active up Westchester way with the lighting company and brother Ladaveze continues his technical duties at RCAC at Rocky Point.

Oldtimers

C. D. GUTHRIE informs us that one of the first men to aid Marconi in his early wireless experiments was, until recently, a resident of New York . . . Captain Arturo Hugo. Captain Hugo served aboard the American Shipping Board vessels in the 1920's. In 1896 he was



Jack Poppele, chief engineer of WOR, who was recently elected president of TBA. He will receive the Marconi Memorial Plaque for TBA at the 20th anniversary dinner-cruise in February.

a Chief Signaller in the Royal Italian Navy serving on the *HMS Carlo Alberta*. Upon Marconi's arrival aboard the *Alberta* to carry on his experiments, Captain Hugo was assigned to assist Marconi, in view of his code knowledge. His work so pleased Marconi that a request to make him a permanent assistant was made. However, Captain Hugo had just passed his examination for a Third Mate's license to enter the Italian Merchant Marine. Later Captain Hugo came to America. Mr. Guthrie recalls meeting him often when he was master of various Shipping Board vessels back in the '20's. . . . William L. Lawson's thirteen-year professional radio record is most interesting. His assignments include service aboard the steamship *Fluor Spar*, airlines of the Eastern Air Transport, Tropical Radio, Eastern Air Lines, and Pan American Airways. He is now with the Civil Aeronautics Administration.

Los Angeles

A LETTER from Leroy Bremer discloses that he had moved from Alaska down to the Solomon Islands during the year. He is now back in Alaska. Recalling his experiences since Pearl Harbor, he says that he has spent 29 months out of the last 33 outside of the continental United States and covered a half-

million miles, plus plenty of action on all fronts.

Continuing, he says: "Of course I keep in touch with what's going on, and where the boys are, through the pages of *COMMUNICATIONS* which always gets to me no matter where I go. Keep up the good work, Bill."

Lieutenant Leroy Bremmer's address is: USMS, Communications Officer, Naneen, Alaska (Bristol Bay).

20th Anniversary

OUR twentieth anniversary dinner-cruise in the Belvedere Roof of the Hotel Astor on Saturday evening, Feb. 17, 1945, will feature the presentation of our Marconi Memorial Plaque to the Television Broadcasters Association, of which our own 'Jack' Poppele is the 1945 president. Many additional awards will be made. A full representation of the top ranking personnel of the various Armed services and some of the *communications* heroes of this war is also planned. . . . We'd like to hear from you regarding your reservations at the earliest possible moment.

Biographical Notes

LIEUT. COL. THOMPSON H. MITCHELL who succeeded the late William A. Winterbottom as vice president and general manager of R. C. A. Communications, Inc., has had a varied wireless training.

He was Hawaiian general manager for RCAC from 1930 to 1935, and on the latter date was made manager of the Southern California District offices. He is a graduate of the U. S. Naval Academy at Annapolis (class of '25). He resigned from the Navy in 1927 to enter the communications field. In 1942, he accepted a commission as Major in the Office of the Chief Signal Officer of the Army, and in March, 1943, he was promoted to Lieutenant Colonel.

During his Los Angeles operations Colonel Mitchell was exceedingly active in VWOA activities. Now, he is with our New York chapter. Recently he was awarded the Legion of Merit by the War Department.

36 **HIGHWAYS OF THE AIR** 99

Important to everyone interested in airports and aviation

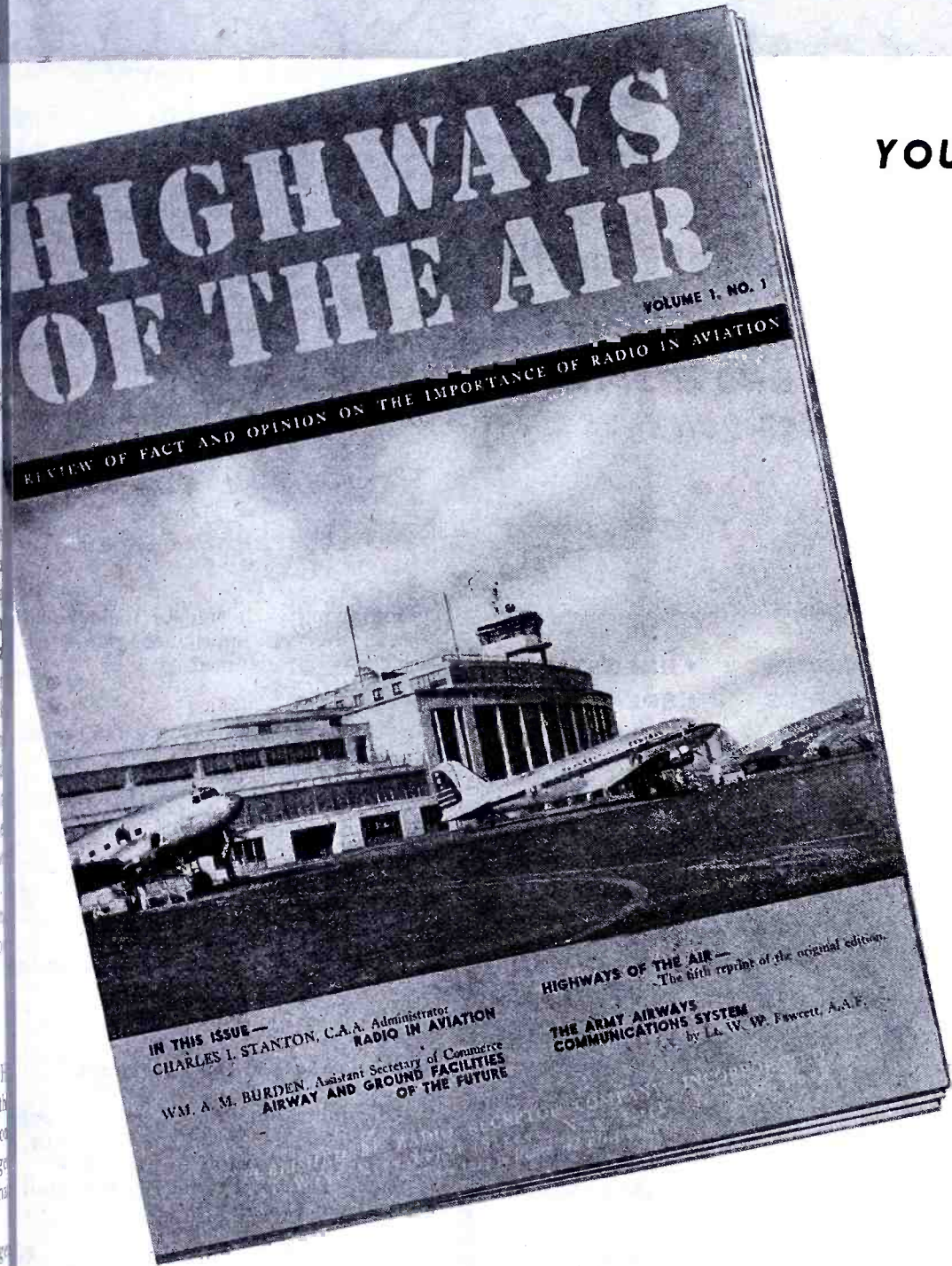

YOU SHOULD KNOW - - -

What is the "bottle-neck" in post-war expansion of civil aviation See page 8

Why CAA is installing Ultra High Frequency radio ranges. See page 8

What anti-collision devices are being developed . . . See page 9

What electronic aircraft detectors are See page 9

What can civil aviation learn from the A.A.C.S. . . . See page 2

What goes into an instrument landing system . . . See page 11

What is approach control. See page 11



These questions and dozens of others of vital import to all those interested in the development of radio in aviation for increased safety of human life and property are discussed in the pages of **"HIGHWAYS OF THE AIR"**



This issue is No. 1, Volume 1—others will follow if you request them. Contents are authoritative—but non-technical—designed to inform the layman on a subject which is becoming of increasing importance.

Send for your copy on your letterhead—we are glad to send it as our contribution to a greater Air-America.

RADIO RECEPTOR CO., INC.

251 West 19th Street • New York 11, N. Y.

Engineers and Manufacturers of Airway and Airport Radio Equipment • Communications Equipment • Industrial Electronics • Electronic Heating Equipment
S I N C E 1 9 2 2 I N R A D I O A N D E L E C T R O N I C S

HURRY!

THEY'RE GOING FAST

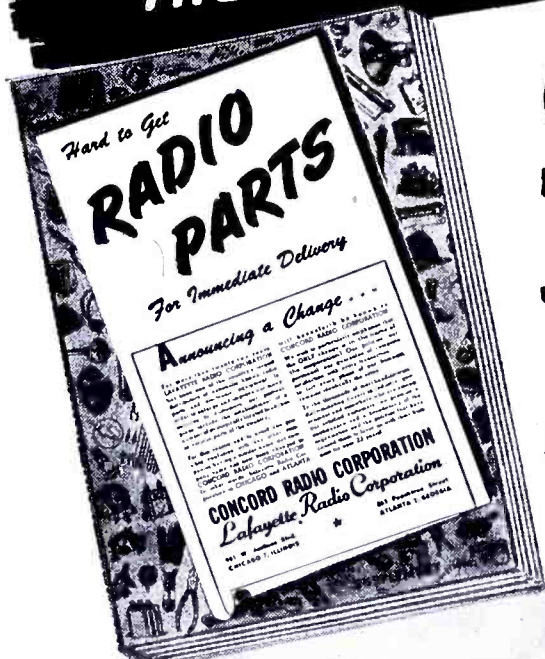

CONCORD

RADIO CORPORATION'S

New

"SPECIAL SUPPLEMENT"

HARD-TO-FIND RADIO AND ELECTRONIC COMPONENTS

16 PAGES CROWDED WITH LISTINGS AND DESCRIPTIONS OF SUCH WARTIME ESSENTIALS AS...

- METERS
- VOLUME CONTROLS
- RHEOSTATS
- RESISTORS
- TEST ACCESSORIES
- SPEAKERS
- SWITCHES
- TRANSFORMERS
- RELAYS

...and hundreds of others!

Each page overflows with critical parts and equipment . . . urgently needed by industry, laboratories, government agencies, training schools, radio servicemen, military services, etc. Everything is the product of a leading American manufacturer. All are first quality. And all are marked at prices typical of startling Concord values! Hurry! Our edition of these supplements is moving fast. And, since all items are subject to prior sale, we suggest that you wait no longer. Send for your FREE copy today!

Rush this coupon
and we, in turn,
will get the new 16-
page Supplement to
you by the fastest
possible means.

CONCORD RADIO CORPORATION
901 W. Jackson Blvd., Chicago 7, Ill., Dept. R-15

Please rush me the new 16-page "Special Supplement" just published by the Concord Radio Corporation.

NAME

ADDRESS

CITY..... STATE.....

CONCORD RADIO CORPORATION

265 Peachtree Street
ATLANTA 3, GA.

901 W. Jackson Blvd.
CHICAGO 7, ILL.

RESISTIVE NETWORKS

(Continued from page 54)

multiplying each side of these equations by z , obtaining,

$$u = z \left(s^2 \frac{k^2 + 1}{k^2 - 1} - \frac{2k}{k^2 - 1} \right) \quad (20b)$$

$$= z \left(s^2 \frac{\epsilon^{2\theta} + 1}{\epsilon^{2\theta} - 1} - \frac{2}{\epsilon^\theta - \epsilon^{-\theta}} \right) \quad (21b)$$

$$= sz (\operatorname{coth} \theta - \operatorname{csch} \theta) \quad (22b)$$

$$= (cZ - y \operatorname{csch} \theta) \quad (23b)$$

For the special, but most common case when the terminating impedances are equal, $Z = z$, or $s^2 = 1$, the unit impedances become

$$u' = \frac{k-1}{k+1} = \frac{\epsilon^\theta - 1}{\epsilon^\theta + 1} = \tanh \frac{\theta}{2} = D \quad (24)$$

$$v' = \frac{k-1}{k+1} = \frac{\epsilon^\theta - 1}{\epsilon^\theta + 1} = \tanh \frac{\theta}{2} = D \quad (25)$$

and

$$w' = \frac{2k}{k^2 - 1} = \frac{2\epsilon^\theta}{\epsilon^{2\theta} - 1} = \operatorname{csch} \theta = a \quad (26)$$

Multiplying each side of these equations by z , the full impedance values of the elements are obtained as

$$u = z \frac{k-1}{k+1} = z \frac{\epsilon^\theta - 1}{\epsilon^\theta + 1} = z \tanh \frac{\theta}{2} = D \quad (27)$$

$$v = z \frac{k-1}{k+1} = z \frac{\epsilon^\theta - 1}{\epsilon^\theta + 1} = z \tanh \frac{\theta}{2} = D \quad (28)$$

$$w = z \frac{2k}{k^2 - 1} = z \frac{2}{\epsilon^\theta - \epsilon^{-\theta}} = z \operatorname{csch} \theta = d \quad (29)$$

Minimum Loss of the T Network

The minimum loss of this network obtained as the series arm adjacent to the smaller terminating impedance approaches zero. Passing to the limit zero, from 17a or 17b

$$s \operatorname{csch} \theta = \operatorname{coth} \theta \quad (30)$$

from which

$$s = \cosh \theta = B \quad (31)$$

or

$$s^2 = \cosh^2 \theta = E \quad (32)$$

Hence, from either column B or E the tables in part II of this series, the minimum loss for a pad having any desired ratio of terminating impedances may be found by inspection. Instead of interpolating for any odd values not given explicitly, some engineers may prefer to use the relationship between the factor, and the impedance ratios arising from equating equation 15a or 15b, to zero. Use of the quadratic formula, the result

$$k = s + (s^2 - 1)^{1/2} \quad (33)$$

By the use of equation 9, 33 gives

$$\ln_{10} s = 20 \log_{10}(s + (s^2 - 1)^{1/2}) \quad (34)$$

Large Impedances of the T Network

Considering Figure 1, the square root of the product of open- and short-circuited impedances taken from the large impedance end is

$$Z = \left((u + w) \left(u + \frac{vw}{v + w} \right) \right)^{1/2} \quad (35a)$$

$$Z = \left((uv + uw + vw) \frac{u + w}{v + w} \right)^{1/2} \quad (35b)$$

$$Z = (\Phi\beta)^{1/2} \quad (36)$$

where:

$$Z = uv + uw + vw \quad (37)$$

$$\frac{u + w}{v + w} \quad (38)$$

and from the small impedance end, is

$$Z = \left((v + w)v + \frac{uw}{u + w} \right)^{1/2} \quad (39a)$$

$$Z = \left((uv + uw + vw) \frac{v + w}{u + w} \right)^{1/2} \quad (39b)$$

$$Z = \left(\frac{\Phi}{\beta} \right)^{1/2} \quad (40)$$

The image impedances on a unit basis are identical in form but with the primes associated with each element, indicating division by z the small terminating impedance; the corresponding forms are shown in the chart with Figure 2.

When the terminating impedances are equal, 35b and 39b reduce to an identity, and all become equal to

$$Z = z = (u(u + 2w))^{1/2} \quad (41)$$

Since any generalized network may be resolved to an equivalent T, (and as shown in part I of this series) the image impedances may be found by consideration of the open and short circuited impedances of the network, or

$$Z = (Z_{o1}Z_{s1})^{1/2} \quad (42)$$

$$Z = (Z_{o2}Z_{s2})^{1/2} \quad (43)$$

where the Z's have the meanings given in part I.

APPENDIX I

Hyperbolic Functions

The hyperbolic functions of a real variable which are being presented in this series of articles (with parts I, II and III) in tabulated form were obtained from the definitions of the sine and cosine of a rectangular hyperbola. These are in turn each defined by an infinite series

(Continued on page 82)

PORTABLE POWER PROBLEMS

THIS MONTH—BRISTOL PYROMASTER

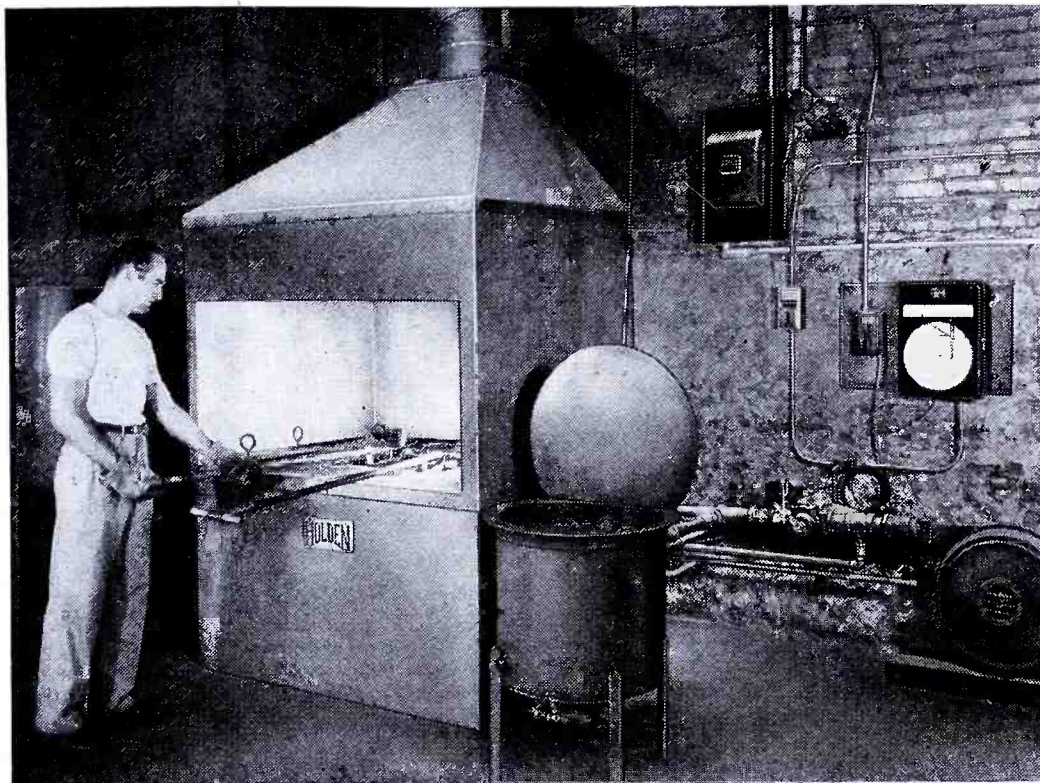

INDUSTRIAL PROCESSES are accurately recorded, indicated and controlled by the Bristol Pyromaster Self-Balancing Potentiometer. In the illustration above, a Pyromaster maintains temperature control of a gas-fired furnace, used for case hardening steel parts.

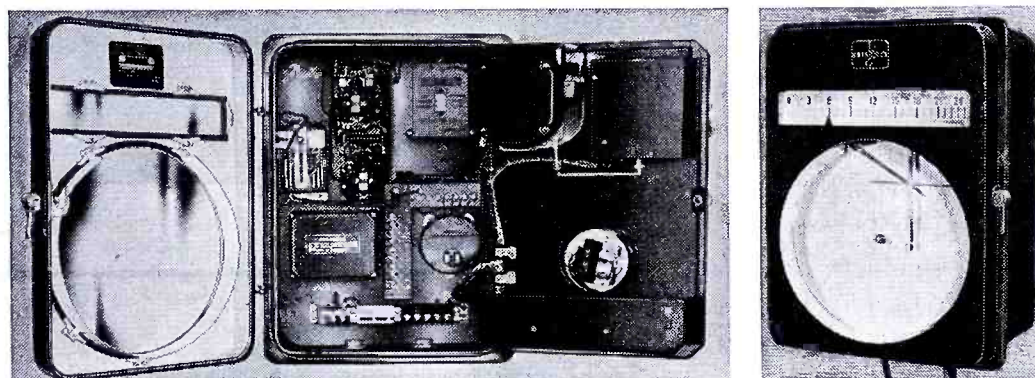

DIRECT MARKING pen moves instantly and continuously at the rate required to follow temperature variations. A 1½ volt Burgess Battery supplies constant current to the potentiometer circuit. Burgess Industrial Batteries are designed to meet the exacting specifications of many special instruments. Your portable power problems can be solved by Burgess engineers. Write us today about your specific needs, or send coupon for free Engineering Manual. Burgess Battery Company, Freeport, Illinois.

FREE . . . 80-PAGE ENGINEERING MANUAL!

31 descriptive pages, 25 charts and 36 data tables on dry battery characteristics for electronic applications. Tabbed for ready reference. Write Dept. 6 for your free copy. Burgess Battery Company, Freeport, Ill.

Name

Company

Address

City State

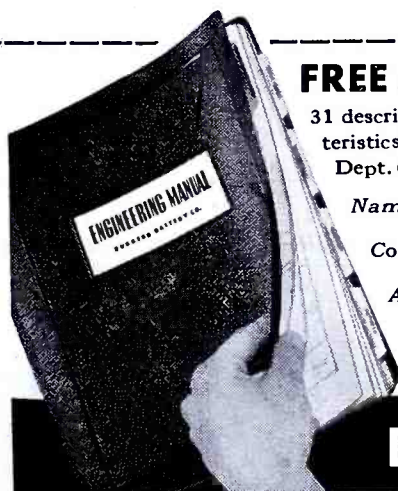

BURGESS BATTERIES

COUPLED CIRCUIT DESIGN

(Continued from page 68)

of 40,000 ohms representing diode load, so that the effective secondary impedance is 20,000 ohms in parallel with the circuit impedance.

$$Z_{o2} = (20,000)(186,600)/206,600 = 18,030 \text{ ohms}$$

The primary is loaded by a fictitious resistance of 10,000 ohms representing the diode load. It is also effectively shunted by the choke L , Figure 9, the losses of which would have to be accounted for by another parallel resistor if the primary were not so heavily loaded by the diode. With 10,000-ohms load we may neglect the losses in L . The effective primary impedance is therefore

$$Z_{o1} = (10,000)(90,000)/100,000 = 9000 \text{ ohms.}$$

$$Z_{og} = \sqrt{(9000)(18,030)} = 12,750 \text{ ohms.}$$

Effective Q as loaded:

$$\begin{aligned} Q_1 &= Z_{o1}/X_1 = 9.0 \\ Q_2 &= Z_{o2}/X_2 = 6.76 \\ Q_g &= \sqrt{9}(6.76) = 7.8 \\ Q_a &= 15.76/2 = 7.88 \\ Q &= Q_g^2/Q_a = 60.8/7.88 = 7.72 \end{aligned}$$

For all practical purposes we could use Q_g in place of Q for this data, but for purposes of illustration that approximation will not be made. A somewhat overcoupled pair of circuits will give the closest approach to a linear discriminator characteristic; in this case we will use 25% overcoupling, $C = 1.25$. From equation 13 we find

$$1 + C^2 = (Q_g/Q_a)^2(1 + K^2Q_g^2) \quad (49)$$

$$K^2Q_g^2 = (1 + C^2)(Q_a/Q_g)^2 - 1 = (2.563)(1.02) - 1 = 1.72 \quad (50)$$

and from equations 42 and 43

$$\begin{aligned} B &= (9000/18,030)(1/1.72) = 0.29 \\ A_o &= (3500/10^9)(12,750)(\sqrt{1.72}/2.72) = 21.5 \end{aligned}$$

If we calculate the discriminator output for a constant input of $e_g = 1.0$ volt, equation 44 will be:

$$E = \pm (43/U) \sqrt{0.29U^2 + \frac{1}{4} - \sqrt{(0.29U^2 - \frac{1}{4})^2 + 0.29}}$$

U and U_2 are functions of frequency deviation from resonance. From equation 15

$$\begin{aligned} U &= (1/2.563)\sqrt{(2.563 - S^2) + 4S^2} \\ S &= (2\Delta f/f_o)Q = [2(7.72)/4000]\Delta f = 0.00386\Delta f \text{ in kc} \end{aligned}$$

From equation 35

$$\begin{aligned} U_2^2 &= 1 + S_2^2 \\ S_2 &= (2\Delta f/f_o)Q_2 = [2(6.76)/4000]\Delta f = 0.00338\Delta f, \text{ kc} \end{aligned}$$

The complete discriminator curve may be calculated from these formulas; however, charts have been prepared to re-

Tabulation of data from the charts and the resultant discriminator voltage. Measured data for the same circuit are also presented.

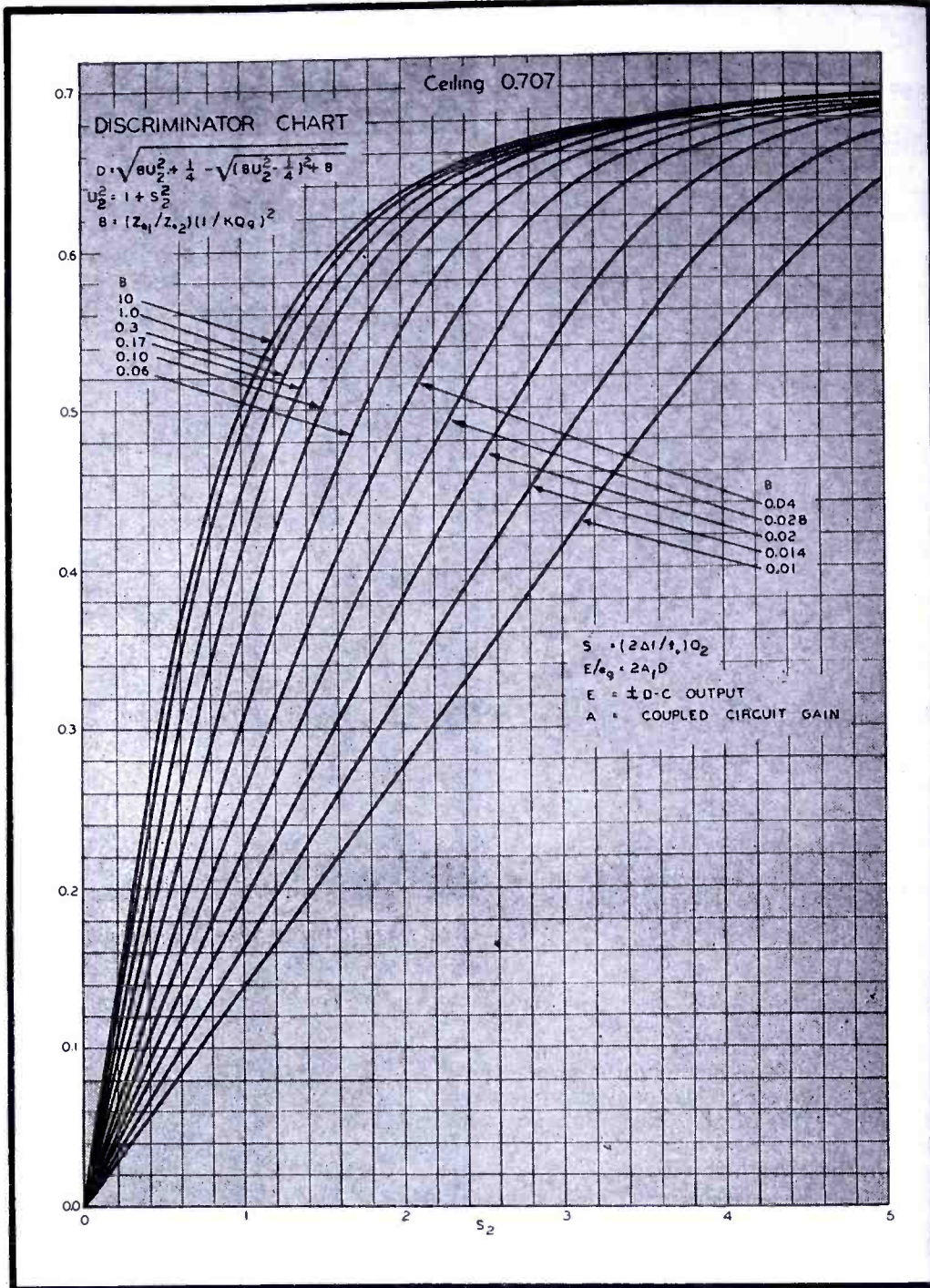

Figure 18
Discriminator chart.

move much of the labor and obtain rapid results with less chance of error. If we rewrite equation 44

$$E = 2A_o e_g (D/U) \quad (51)$$

or

$$\begin{aligned} E &= 2A_o e_g D, \\ D &= \sqrt{BU_2^2 + \frac{1}{4} - \sqrt{(BU_2^2 - \frac{1}{4})^2 + B}} \quad (52) \end{aligned}$$

it will be noted that the function D con-

tains one variable, U_2 , and one parameter, B . This suggests the possibility of producing a universal family of curves, D versus U_2 for specific values of B . This may be carried a step farther by using the variable S_2 instead of U_2 . This has been done, assuming values of S_2 and B in their useful range. The resulting family of curves are plotted in the discriminator chart.

For the example outlined, the solution for chart use will be

$$E = \pm 43(D/U) \text{ volts, for } e_g = 1.0 \text{ volt}$$

where D is taken from the discriminator chart and B is obtained from a universal

(Continued on page 92)

Δf kc	S		S ₂		D	± E	Measured	
	.00386Δf	U	.00338Δf	U ₂			+ E	- E
50	.193	1.0	.169	.088	3.77	3.3	3.5	
100	.386	0.99	.338	.174	7.55	6.8	6.8	
150	.579	0.98	.507	.254	11.10	10.1	10.2	
200	.772	0.97	.676	.328	14.50	13.4	13.5	
250	.965	0.99	.845	.396	17.20	16.1	16.2	
300	1.158	1.01	1.014	.452	19.20	17.8	17.5	
350	1.351	1.09	1.183	.498	19.60	18.2	16.8	
400	1.544	1.20	1.352	.535	19.20	17.6	15.0	

TBA CONFERENCE

(Continued from page 35)

ensely populated areas there is good reason to believe that a solution is in sight for television's severest handicap—the cost and difficulty of supplying the insatiable appetite of the public for high-quality entertainment, stated Mr. Keister.

RELAY SYSTEMS

THE relay and satellite problem was also discussed by Walter S. Lemmon. He said that at the present stage of the art there appear to be only two methods of transmitting television images from city to city; the coaxial cable which seems to require a very heavy investment and development for wide area and service, and the chain of relay stations or automatic booster stations strung across the country.

The latter method is not inexpensive, he said, because to furnish a reliable relay system these booster stations will have to be substantially constructed to withstand all kinds of weather, and contain complex control apparatus. And to be economical they must simultaneously carry other forms of communication from city to city as *pay load* along with the precious freight of undistorted television images, he pointed out.

Therefore, said Mr. Lemmon, it is my opinion that the economical growth of relay television systems will depend on the provision of some other form of *pay load* for some time to come, at least until television is fullgrown.

Describing this *pay load* activity, Mr. Lemmon said that IBM have recently received construction permits from the FCC to set up an experimental relay system between New York and Washington and also New York and Schenectady, and if the initial experimental operation proves satisfactory, an extension of the system across the country to Chicago and other points West is planned.

Mr. Lemmon said that inter-city relay systems for television should be designed to accommodate more than one network at a time in order to best serve the public interest. These experimental relay systems are being designed to carry simultaneously at least two high-definition television images in each direction, explained Mr. Lemmon.

Mr. Lemmon indicated that the present relay system will carry bandwidths of 10 to 12 megacycles, which can be widened to 20 megacycles. F-m transmission will be used along this relay system.

The relay stations will be fully automatic, said Mr. Lemmon. Over average terrain these automatic relay stations will be located about every twenty-eight to thirty miles, he said. And over mountainous territory it is probable that the distance between stations may be increased to forty or fifty miles depending upon the topography of the country.

In multiplexing, it should be possible to carry television programs, several facsimile channels for picture transmission and a number of high speed circuits for transmitting the fast impulses of various business machines, explained Mr. Lemmon. The IBM Radiotype, developed just before the war, is already transmitting typewritten messages at speeds of

(Continued on page 76)



Faster, more efficient operation

with CANNON D.C. SOLENOIDS

With Cannon Electric D.C. Solenoids you get automatic, trigger-action. Solenoid pull is positive. Cannon Solenoids may be operated without damage to a maximum temperature of approximately 150 degrees C.

A wide selection of Cannon Solenoids are built for various combinations of voltages, pull, armature travel, duty cycle, etc. to suit design requirements. Nominal voltages are 12 and 24; others by special order. Eight types have "holding" features.

As a reliable means of controlling or operating various devices, they are used for retarding magnetos in starting engines, operating hydraulic valves and mechanical clutches, firing machine guns, arming and releasing bombs, dropping auxiliary fuel tanks, locking retracting gears, film-winding mechanisms for shutter control on special cameras. These are only a few of the possible applications. *Let us know your needs.*

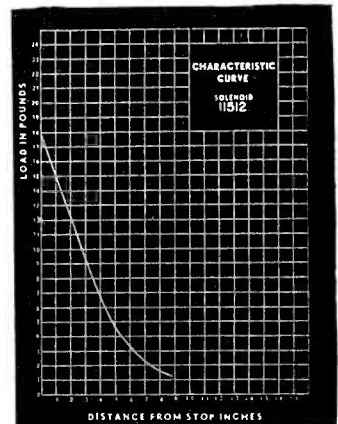

Response characteristic charts like the above (test at 28 volts) together with wiring diagrams are found in Solenoid Bulletin.

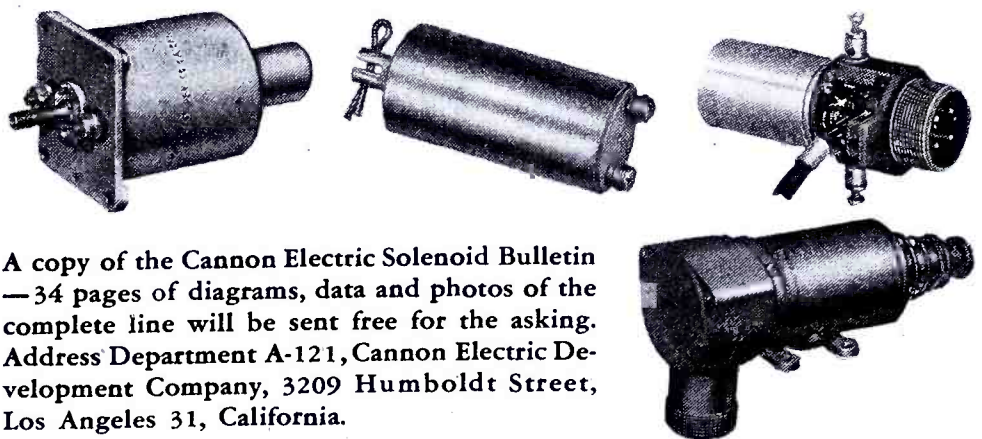

A copy of the Cannon Electric Solenoid Bulletin — 34 pages of diagrams, data and photos of the complete line will be sent free for the asking. Address Department A-121, Cannon Electric Development Company, 3209 Humboldt Street, Los Angeles 31, California.

Also manufacturers of Electrical Connectors

CANNON ELECTRIC

Cannon Electric Development Company
3209 Humboldt St., Los Angeles 31, Calif.

Canadian Factory and Engineering Office:
Cannon Electric Company, Limited, Toronto



REPRESENTATIVES IN PRINCIPAL CITIES — CONSULT YOUR LOCAL TELEPHONE BOOK

COMMUNICATIONS FOR JANUARY 1945 • 75

Designed for

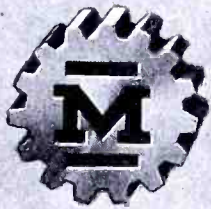

Application

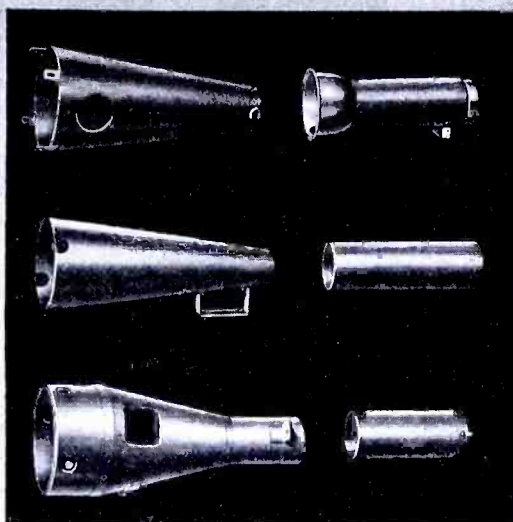

CATHODE RAY TUBE SHIELD

For many years we have specialized in the design and manufacture of magnetic metal shields of nicoloi and mumetal for cathode ray tubes in our own complete equipment as well as for applications of all other principal complete equipment manufacturers. Stock types as well as special designs to customers' specifications promptly available.

**JAMES MILLEN
MFG. CO., INC.**

MAIN OFFICE AND FACTORY
**MALDEN
MASSACHUSETTS**



(Continued from page 75)

one-hundred words per minute over ordinary radio circuits disclosed Mr. Lemmon. He expected an increase in this speed with the new methods planned.

TBA Elections

J. R. POPPELE, secretary and chief engineer of WOR was elected TBA president at the annual meeting of the board of directors held at the conclusion of the conference. He succeeds Dr. Allen B. Du Mont. Mr. Poppele was also elected a member of the board of directors.

Robert L. Gibson, assistant to the vice president in charge of advertising and publicity at the General Electric Company, was elected vice president; Will Baltin was reelected secretary-treasurer and O. B. Hanson, vice president of the National Broadcasting Company, was elected assistant secretary-treasurer. Mr. Gibson succeeds Lewis Allen Weiss as vice president.

Three members of the TBA board, whose terms of office expired, were re-elected. They are Dr. Du Mont, Curtis W. Mason of Earle C. Anthony, Inc., and F. J. Bingley of the Philco Radio and Television Corporation.

AERONAUTICAL COMMUNICATIONS

(Continued from page 48)

bands behaving in essentially quasi-optical manner, it became possible to duplicate them at relatively short geographical intervals with little or no possibility of serious interference. In addition, as technical skill advanced, the number of channels available in such a band would increase markedly over what at first seemed available. As the ability to increase usable receiver selectivity in terms of improved transmitter frequency stability developed, separation between channels could be decreased, thereby yielding additional usable channels in what at first had to be left as *guard bands* between adjacent channels.

About 1941 to 1942, fifteen frequencies between 129 and 131.8 mc were assigned, upon an approximately 500-mile duplication basis, to replace the single old 278 kc ground-to-plane communication frequency. Each channel was separated 200 kc. Thus between frequency separation, geographical separation and line-of-sight transmission range limitations the possibility of interference, so prevalent upon the old single 278-kc frequency, were virtually eliminated.

Under this plan an aircraft in flight would call and work ground upon a frequency of 140.1 mc. At the start, with a few aircraft in flight, this single frequency would probably serve adequately due to limited aircraft transmitter range, geographical separation and the rule that no aircraft should attempt to communicate with an airport control station until within 10 minutes flight (presumed to be approximately 30 miles) of the airport. With the inescapable tremendous expansion in civilian flying which now seems certain to follow the war, this single frequency will probably have to be expanded to many more, since it is quite conceivable that there may be many airports within some 30-mile areas, not to mention probable need of more than a

(Continued on page 90)

Easy to Erect



MASTS
AND
TOWER

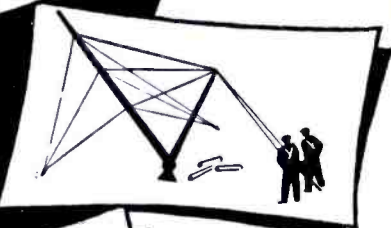

When writing for information please send complete engineering data
Address Dept. X

HARCO
STEEL
CONSTRUCTION CO.
Elizabeth 4, N. J.

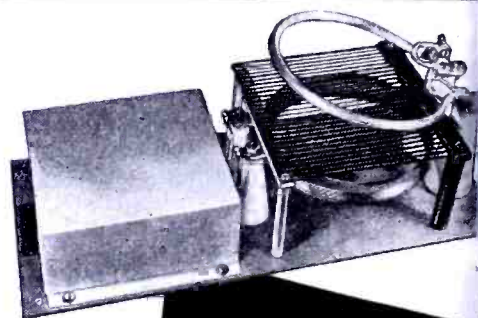

SAMPLING
TRANSFORMERS

One model is available for phase monitoring with directional antenna systems. Easy to install and adjust. Results are more constant and installation and maintenance much simpler than with other sampling methods.

Another model is widely used for remote metering, giving antenna current at the antenna instead of at the transmitter. Write today for more information and prices.

JOHNSON
a famous name in Radio

E. F. Johnson Co. Waseca, Minn.

POLICE COMMUNICATIONS

(Continued from page 33)

tential police radio licensees in this metropolitan region. The probable number of transmitters, fixed and mobile, might approach 10,000. Some of the local police radio engineers claim 500 potential police licensees within a fifty-mile radius of New York city. Additional channels would provide freedom from present interference.

In the Boston metropolitan area similar conditions prevail and similarly in the localities surrounding all large cities in the nation. There are, at present, 27 police radio systems within a 10-mile radius of Boston and 60 stations within a 20-mile radius. Thus it is evident that the actual allocation of frequencies in such an area is a problem for study by competent engineers familiar with the localities in question. In almost every instance these individuals will be found to be the radio engineers for the police departments operating in these areas.

The congested area problem has come about through no fault of the communications engineer. He has had to install police radio systems into an inflexible governmental and police system. The instrumentalities of government, their police, fire, water and sewer systems, their geography and their political and legal organizations are all the product of decades of growth. They are not flexible nor can they be changed to suit the needs of radio engineers. This condition is not defended here but is mentioned because it is a fact so basic in its implications that it is respected and no attempt to revise it is even suggested. The revision of the present governmental set-up is not a problem for the radio-communications engineer.

Wire Facilities Inadequate

Since police radio systems must be engineered to handle peak traffic load; and since their importance increases with the increase in traffic and becomes paramount during natural disasters, large conflagrations and serious civil disturbances, when wire communication generally fails, it is imperative that some other means of communication, other than that depending upon wire lines, be employed. Examples of such situations where ordinary wire facilities were of absolutely no use to the police and emergency organizations are: 1938 hurricane in New England; Cocoanut Grove fire in Boston; Detroit race riots; Port Chicago explosion in California and the recent circus fire in Hartford, Connecticut.

It is a well substantiated fact, supported by evidence in hundreds of cases, that commercial wire facilities cannot handle emergency police traffic within the time factors involved nor can they supply the area coverage necessary. The cost of a wired system producing results at all comparable to a radio-communications system is practically prohibitive to the majority of police departments. Furthermore, communication with moving vehicles at great distances is impossible by means of a wired system and lastly these wired-communication systems are subject to many faults and failures and are particularly vulnerable to weather, accident, sabotage, etc., to which, radio systems are, to a large extent, immune.

Throughout the midwest, south, south-

(Continued on page 78)

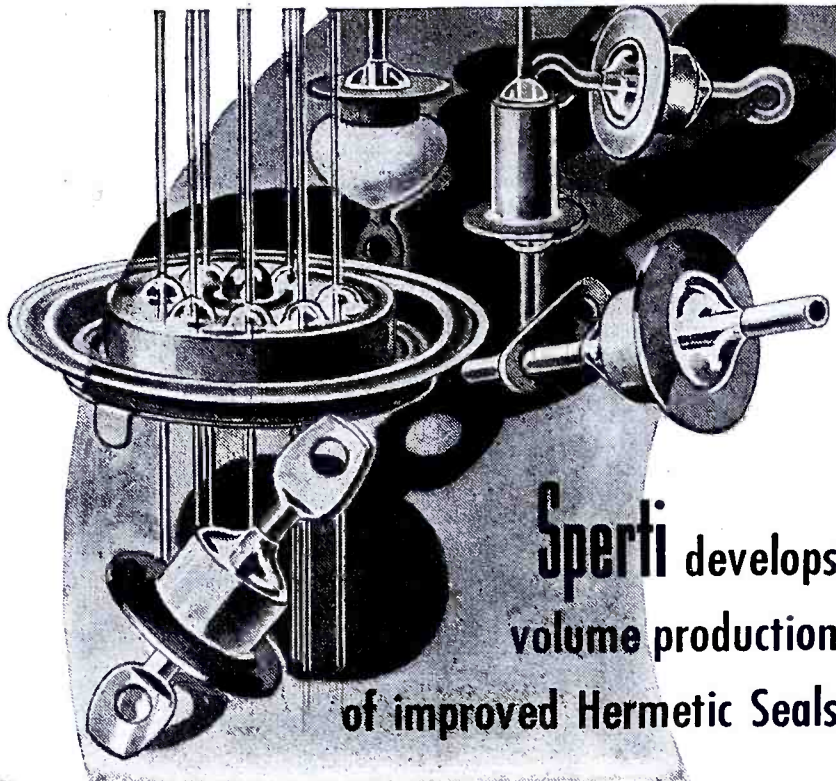

**Sperti develops
volume production
of improved Hermetic Seals**

**Conforming to Army-Navy requirements
for critical field conditions**

Transformers, condensers, relays, vibrators and various component parts can now be protected against heat and tropical humidity, salt spray, sand infiltration, fumes, fungus attack and other varied conditions that cause sensitive equipment to fail under critical conditions.

In the laboratories beyond Sperti, Inc., techniques have been discovered which permit volume production of improved Hermetic Seals at low cost, safeguarded by unique inspection methods.

Principal features of the improved Sperti Hermetic Seal are:

1. Small, occupies little space, one piece, no other hardware needed, simple and easy to attach. (Soldering temperature not critical.)
2. Vacuum tight hermetic bond, hydrogen pressure tested for leaks.
3. Resistant to corrosion.
4. High flash-over voltage. Does not carbonize.
5. Insulation resistance, 30,000 megohms, minimum, after Navy immersion test.
6. Thermal operating range—70° C. to 200° C. Will withstand sudden temperature changes as great as 140° C.

Wire or phone for information, today. Give as complete details as possible so that samples and recommendations may be sent promptly.

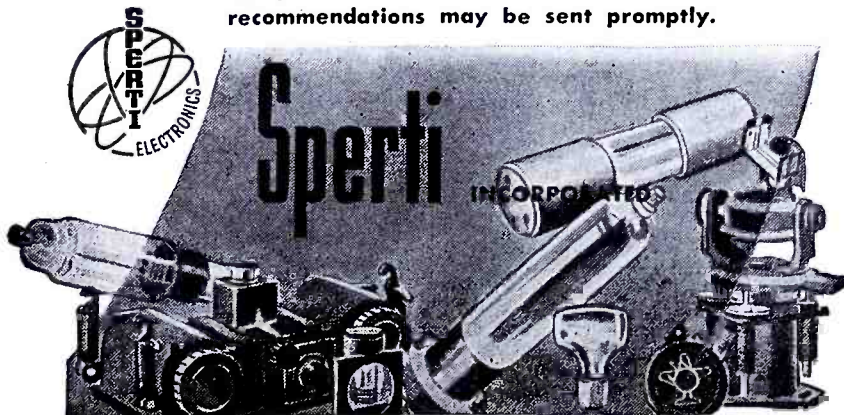

**RESEARCH, DEVELOPMENT, MANUFACTURING, CINCINNATI, OHIO
COMMUNICATIONS FOR JANUARY 1945 • 77**

STOP VIBRATION GREMLINS WITH BIRTCHER STAINLESS STEEL - LOCKING TYPE TUBE CLAMPS

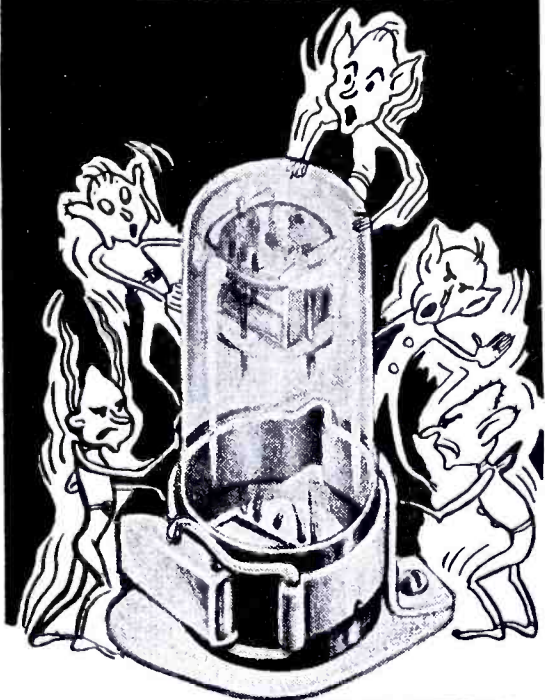

Where vibration is a problem, Birtcher Locking TUBE CLAMPS offer a foolproof, practical solution. For ALL types of tubes and similar plug-in components.

83 VARIATIONS

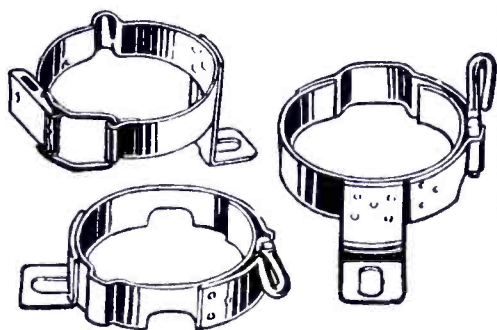

OVER TWO MILLION IN USE
Send for our standard catalog and samples of corrosion-proof Birtcher Tube Clamps.



THE BIRTCHER CORPORATION
Manufacturers of AIRCRAFT
and RADIO PARTS

5087 HUNTINGTON DR. LOS ANGELES 32

(Continued from page 77)

west and western states, hundreds of police agencies not only make full use of radiotelephone systems for communication to their police cars but must depend, because of the inadequacy, as well as the expense of wired facilities, almost entirely on the radiotelegraph for point-to-point communications. These radiotelephone and radiotelegraph networks are highly developed and handle hundreds of thousands of messages yearly.

Cooperation Between Police

The modern criminal does not confine his activity to one community, to one city, or even to one state. As means of superhigh-speed transportation are developed it becomes more and more necessary that communication between police agencies be as fast, as dependable, and as immediately available, as the communication between the central station and the police cruiser is today.

The criminal recognizes no boundaries and, as a result, the police can operate within no rigid limits. Catching criminals in a radio network woven by instructions and information transmitted to radio-equipped police cars, has become a matter of minutes. Time is precious to the law-breaker—it spells the difference between escape and capture to him. With the use of radio communication between patrol cars and headquarters the criminal is, many times, caught red-handed. Indisputable proof of guilt is frequently obtained, when only circumstantial evidence could otherwise be found.

In cases involving continuous pursuit by a police car in a metropolitan area it is usual to rebroadcast the transmissions from the car. Instructions change so rapidly, as the cars speed past corners and make turns, that no interruption of these communications can be tolerated. These pursuits sometimes last many minutes and happen frequently. Since continuous pursuits in metropolitan areas in many instances lead out into adjacent municipalities, it is well if that town or city can direct their own cars to help. This requires separate channels. Duplex operation is an urgent necessity in large cities for prosecuting fresh pursuit.

Speedy, reliable radio communication between law-enforcement agencies makes possible the direct apprehension of criminals; fast recovery of property; prevention of crime; quick release of innocent persons; prompt aid to the victims of criminal activity and intent; a greater degree of internal efficiency in the police departments and in general, a more effective protection of life and property is afforded the tax payer.

Present Status of Police Radio

At the present there are thirty-one frequencies allocated between 1600 kc and 2490 kc for use by municipal and state police radio stations. Assignment of these frequencies is made within specified geographical areas, to municipal and state police departments.

In the very-high frequencies the FCC rules allocate a total of twenty-nine channels for use by state and municipal police departments. The channels are separated into four groups as follows:

Group A

30700 kc 31900 kc 33940 kc 37500 kc 39900 kc
31100 kc 33100 kc 35500 kc 39100 kc

To Serve You Better
**AN ALTERNATE SOURCE
OF GENUINE BIRTCHER
TUBE CLAMPS**

Prompt Delivery

We are fully licensed to manufacture the complete BIRTCHER line of locking type, stainless steel tube clamps. Orders placed with us for prompt delivery using BIRTCHER part and identification numbers will be filled at prices as favorable as those to which you are accustomed. All clamps will be identical with those manufactured by the Birtcher Corporation.

SOLE LICENSED MANUFACTURER
OF BIRTCHER TUBE CLAMPS

**THE GEORGE S. THOMPSON
CORPORATION**

5240 HUNTINGTON DR.
LOS ANGELES 32, CALIF.

Permanent
MAGNETS
By
Thomas & Skinner

ALL SHAPES... ALL SIZES
Cobalt • Chrome • Tungsten
Stamped, Formed or Cast.

ALNICO

(Cast or sintered, under G. E. license)

Also: LAMINATIONS for output transformers of highest permeability. Standard stocks in a wide range of sizes for Audio, Choke, Output and Power Transformers. Write for dimension sheet. . . . TOOLS . . . DIES . . . STAMPINGS . . . HEAT TREATING.
44 YEARS' SPECIALIZED EXPERIENCE

Thomas & Skinner

STEEL PRODUCTS CO.
1113 E. 23rd St., Indianapolis 5, Ind.

Group B

31500 kc	35900 kc	37900 kc
33500 kc	37100 kc	39500 kc

Group C

0580 kc	31780 kc	33780 kc	35220 kc	37780 kc
0980 kc	33220 kc	35100 kc	37220 kc	39380 kc

Group D

5780 kc	37380 kc	39180 kc	39780 kc
---------	----------	----------	----------

Groups A and B are available for assignment to land and portable municipal and state police stations. Portable and portable-mobile stations may be authorized to operate on the same frequency as that assigned to the land station with which their communications are coordinated. Groups C and D are available for assignment to municipal and state police mobile and portable-mobile stations, respectively.

There are at present three medium frequencies and six high frequencies allocated for use by zone and inter-zone police stations:

804 kc	Calling	5195 kc	Calling
808 kc	Working	7480 kc	Day only
812 kc	Working	7805 kc	Day only
835 kc	Working	7935 kc	Day only
840 kc	Working		

There are also seven frequencies in the 116-to-119-megacycles band and one frequency in the 158-megacycle band, allocated to the police service and available for assignment on an experimental basis only.

[The new FCC reallocation proposals provide for 56 channels in the 30 to 44-mc bands. The 152-156-m band was also assigned to this service.]

Up to June 30, 1944, the FCC had licensed 1906 municipal-police stations, 52 state-police stations, 88 zone-police stations, 31 interzone-police stations and 2 experimental Class 2 police stations. The number of transmitters licensed, up to the same date, including fixed, portable and portable-mobile stations, were: Municipal police, 15,014; state police, 844; zone police, 93; inter-zone police, 2; and experimental, 72.

Generally speaking, police departments should operate a separate and distinct communication system and should be allocated specific channels for their exclusive use. This conclusion is predicated upon several important factors:

(1)—Peak loads occur in every one of the police services, whether in communication with mobile units or in point-to-point communication. Peak loads must be considered as an important factor in allocating frequencies to the police service. Other emergency services, such as fire departments, transit companies and public utilities, frequently experience peak message traffic conditions at the same time as the police departments, as say, a multiple alarm fire in a downtown district or a great natural disaster, hurricane, etc.

When such an emergency arises, all safety and police agencies must act promptly and efficiently. The police department must control the traffic on the way to, and at the scene of, the trouble. If a fire, the fire department must coordinate its forces for the prompt extinguishing of the conflagration, the electric power company must get an emergency crew to the scene to disconnect live wires and the transit company will probably wish to notify its vehicles of re-routing and schedule changes.

There is always congestion of vehicular and pedestrian traffic at a fire and

(Continued on page 80)

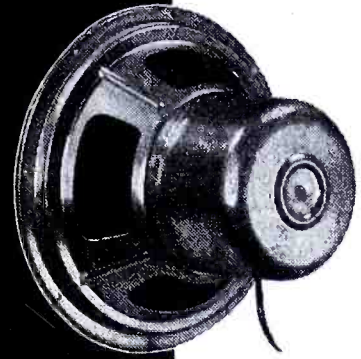

RADIO SPEAKERS *for all applications*

Recently expanded production facilities combined with complete engineering "know-how" enable Consolidated Radio Products Co. to supply the finest radio speakers available. Speakers can be furnished in the following ranges:

Dynamic Speakers from 2 inches to 18 inches

Permanent Magnet Speakers from 2 inches to 18 inches

Headsets

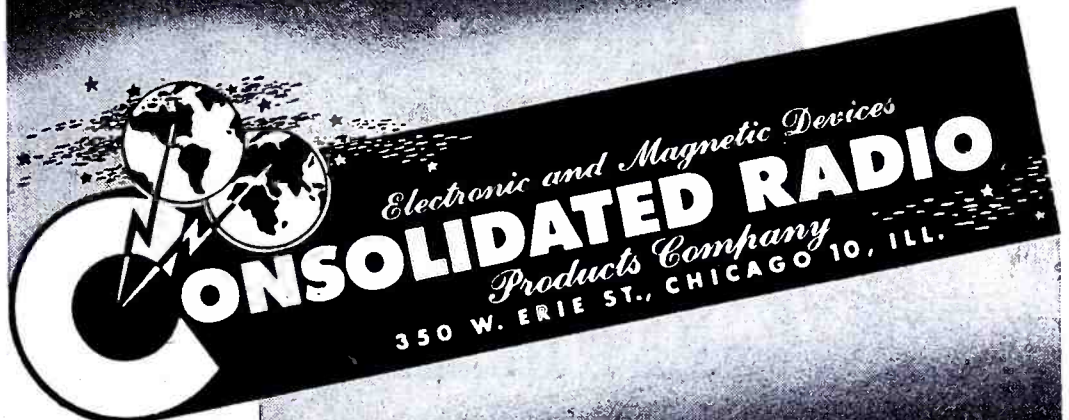
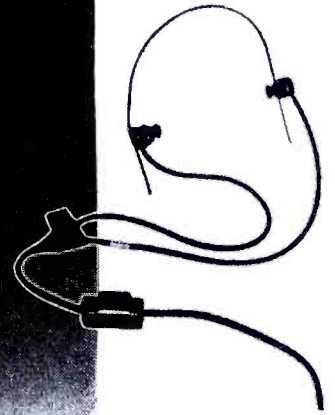

Small and Medium TRANSFORMERS

Consolidated Radio is also a nationally known manufacturer of small and medium transformers including Pulse Transformers, Solenoid and Search Coils.

Engineering service is available to design transformers and speakers for special applications, or to your specifications.

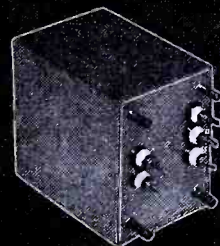
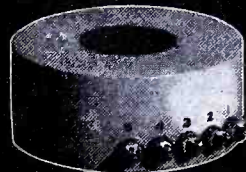
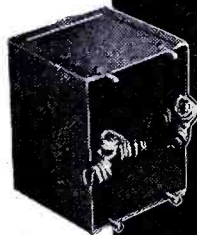

the police must relieve this situation at once or it will seriously hamper the response of the fire apparatus as well as contributing to heavy damage and possible loss of life.

Other conditions where peak message traffic occurs, not only in the police department but in other agencies as well, are large public gatherings outdoors, large parades, serious civil disturbances and natural disasters such as floods and tornadoes. In any of these emergency situations the number of messages required to be transmitted by each agency alone may seriously overload its facilities. Consequently, to attempt to transmit them all over one radio-communication system is obviously inadequate and futile.

(2)—The operating personnel of one service should not be required to give or receive orders from another service. The dissimilarity of operating methods and terminology are such that serious and vital errors are apt to be made. Radio operating personnel familiar with the procedure of their own service and accustomed to executing orders issued in a familiar manner will act as an efficient communication service, which cannot otherwise be achieved.

It should also be recognized that the fact that a police department has a police wire telephone system, if installed in a municipality, has nothing to do with the departments need for a radio-communication system.

Police departments are usually notified of an emergency by public telephone and upon receipt of such messages, they go into action and radio becomes immediately an important part of the police communication system. Mobile units on patrol often call in information of pertinent character with regard to suspiciously acting automobiles or persons and receive instructions at once as to the course of action they are to pursue.

There are some instances of small, isolated rural communities where the maximum peak message load may never reach the point where the radio communication system is overloaded. In these rare cases a coordinated communication system, comprising both police and fire departments may be desirable, both from an operating and an economic point of view. However, if the fire department in such a community is a part of an organized *mutual aid*¹ network, operating within a fire district, it should then, have its radio communications operating on the *fire department* frequency allocated to the district or it should cooperate with other small adjacent communities and operate the fire service on a common *fire frequency* with them.

Economic Factors

The extremely large investment by police agencies all over the country in radio transmitting and receiving equipment would render it highly uneconomical to initiate any large scale changes of frequency allocation.

While the general trend of police radio installation is toward the higher frequencies there are some localities, which because of geographical situation and peculiarity of terrain to be covered, require the use of low frequencies and their attendant propagation characteristics to

¹ H. A. Friede, COMMUNICATIONS; September 1944.



THERMOSTATIC METAL TYPE DELAY RELAYS PROVIDE DELAYS RANGING FROM 1 TO 120 SECONDS

Other important features include:—

1. Compensated for ambient temperature changes from -40° to 110°F.
2. Contact ratings up to 115V-10a AC.
3. Hermetically sealed — not affected by altitude, moisture or other climate changes . . . Explosion-proof.
4. Octal radio base for easy replacement.
5. Compact, light, rugged, inexpensive.
6. Circuits available: SPST Normally Open; SPST Normally Closed.

WHAT'S YOUR PROBLEM? Send for "Special Problem Sheet" and Descriptive Bulletin.

AMPERITE CO. 561 BROADWAY
NEW YORK 12, N. Y.

In Canada: Atlas Radio Corp., Ltd.
560 King St. W., Toronto

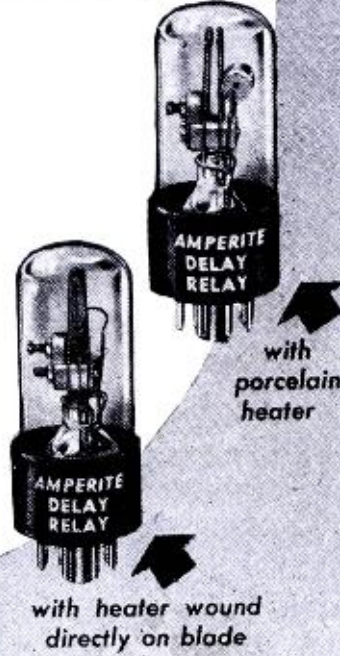

ENGINEERS

Are You Concerned With YOUR POST WAR FUTURE ?

The Federal Telephone & Radio Corporation, the manufacturing unit of the International Telephone & Telegraph Corporation with its multiple business activities extending to all parts of the civilized world, will accept applications from experienced men for immediate employment with almost limitless post war possibilities. These positions should interest those with an eye to the future and whose interest lies in forging ahead with this internationally known organization whose expansion plans for post war are of great magnitude covering all types of radio and telephone communications. Advancement as rapid as ability warrants. Majority of positions are located in the New York area!

We need the following personnel! Men with long experience or recent graduates considered.

- ENGINEERS
ELECTRONICS
ELECTRICAL
RADIO
MECHANICAL
CHEMICAL
TRANSFORMER DESIGN
- SALES AND APPLICATION
ENGINEERS
PHYSICISTS
DESIGNERS
DRAFTSMEN
TOOL DESIGNERS
TECHNICAL WRITERS

Look Ahead With Federal!

If inconvenient to apply in person, write letter in full, detailing about yourself, education, experience, age, etc., to Personnel Manager.

FEDERAL TELEPHONE & RADIO CORP.
39 Central Avenue

EAST NEWARK

NEW JERSEY

adequately service their area. Such localities are common in California, New Hampshire and other states having mountainous regions within which police radio communication must be maintained.

As present equipment becomes obsolete in the metropolitan areas and in municipalities it is expected that it will be replaced with veryhigh, or ultrahigh-frequency apparatus. Some municipal radio equipment is already operating very satisfactorily in the region near 118 megacycles.

Any proposal to move police and emergency services from their present location to parts of the radio spectrum where the propagation characteristics are radically different must be spaced over a long period of years and should be regarded as a *last ditch* expedient only.

Allocation Needs

Panel 13, of RTPB, requested that police agencies be allocated 31 channels, 8-kc wide, between 1601 and 2490 kc for radiotelephone use. These medium frequencies are, as previously noted, urgently needed in special cases of geographical location and over difficult terrain, where the propagation characteristics of these frequencies especially fit them for solving the communication problems at hand.

In the 30- to 40-megacycle region a total of 86 channels, 40-kc wide, were requested as the minimum number necessary to relieve the terrific congestion in the crowded metropolitan areas. A number of state wide police agencies are now using channels in this region for point-to-point service also.

In the higher portion of the radio spectrum, above 100 megacycles, the panel requested 122 channels, 50-kc wide, between 116 and 156 megacycles. This will permit many municipalities to move from the densely crowded lower frequencies and attain more favorable operating conditions with no loss of efficiency in servicing their areas. The possibility of *skip* interference at these frequencies has been found, in over eighteen months of observation, to be virtually non-existent.

A band of frequencies 10 megacycles wide, from 320 to 330 megacycles, was also requested for miscellaneous police use and experimental communication. It is not expected that this region will become immediately useful but it was thought advisable, in the light of certain restricted information, to reserve some channels in this region for police use.

Certain other channels near 600 mc; 1200 mc; 2400 mc; 4800 mc; and 9600 mc were requested. These requests are new proposals and were not in the RTPB's schedule of frequency assignments. The value of these channels will remain problematical for some time.

The proper perspective for viewing the needs of the law-enforcement agencies of the country for adequate radio-communication facilities can be attained by placing police radio services in their proper category as the nation's *most important* public service organization.

Police departments need *adequate communication facilities*, not just emergency facilities. This is necessary and essential to the operation of the police departments if they are to render adequate service to the public in police protection. In the final analysis, it is to the adequacy and efficiency of the radio-communication systems of the police departments to which we must look for the promotion of public safety and the protection of property.



YOURS for SUCCESS in 1945

Success in our fight for freedom and in production at home. Merit transformers will be serving on both fronts . . . in the weapons of our Army and Navy and in the development of new products for postwar use.

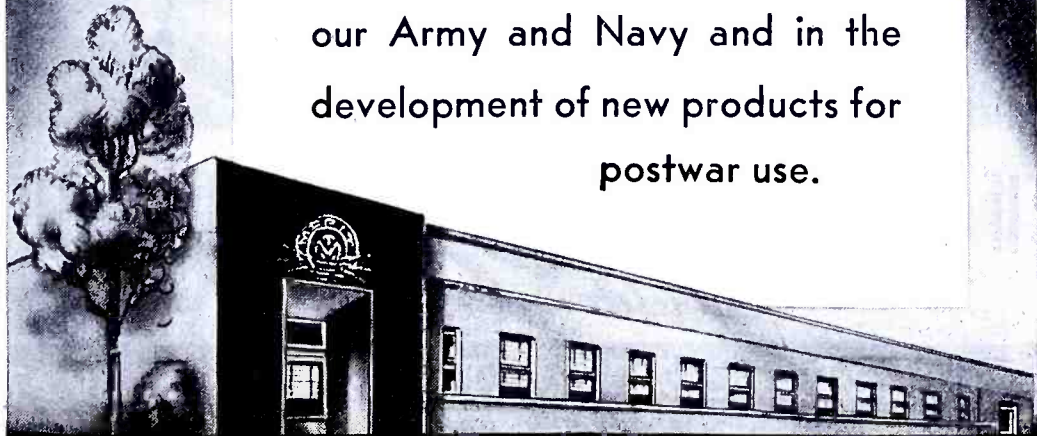

MERIT COIL & TRANSFORMER CORP.

TELEPHONE

4427 North Clark St.

Long Beach 6311

CHICAGO 40, ILL.

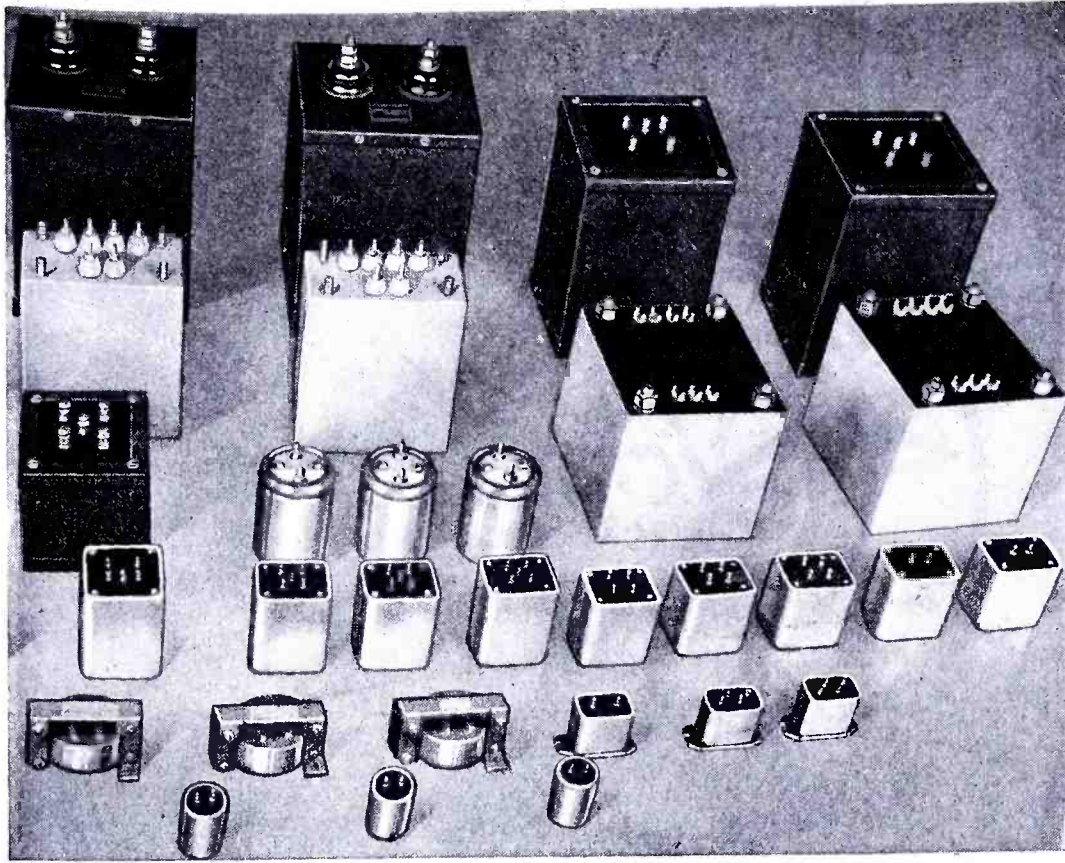

Performance Engineered Electronic Transformers
 THE ACME ELECTRIC & MANUFACTURING CO. • CUBA, N. Y. • CLYDE, N. Y.

Acme  **Electric**

CRYSTALS

HOLLISTER  **CRYSTAL CO.**
Boulder Colorado

QUARTZ OSCILLATORS SINCE 1927

RESISTIVE NETWORKS

(Continued from page 73)

in terms of the mathematical base, ϵ . These series in terms of ϵ are

$$\epsilon = 1 + \frac{1}{1!} + \frac{1}{2!} + \frac{1}{3!} + \frac{1}{4!} + \dots \quad (1)$$

$$\epsilon^\theta = 1 + \theta + \frac{\theta^2}{2!} + \frac{\theta^3}{3!} + \frac{\theta^4}{4!} + \dots \quad (2)$$

$$\epsilon^{-\theta} = 1 - \theta + \frac{\theta^2}{2!} - \frac{\theta^3}{3!} + \frac{\theta^4}{4!} - \dots \quad (3)$$

The value of theta, θ , as used in this paper is found from the definition of the power ratio which is given in terms of a factor, k . This is

$$k^2 = W/w = \epsilon^{2\theta} \quad (4)$$

The number of decibels gain or loss of any network on a power transmission loss basis is found by taking ten times the logarithm to the common base, 10, of each side of the equalities in equation 4; hence

$$db = 10 \text{Log}_{10} k^2 = 10 \text{Log}_{10} (W/w) = 10 \text{Log}_{10} \epsilon^{2\theta} \quad (5a)$$

or

$$db = 20 \text{Log}_{10} k = 10 \text{Log}_{10} (W/w) = 20 \theta \text{Log}_{10} \epsilon \quad (5b)$$

Where: W = power input to the network, and w = power delivered to the load.

The common logarithm of the mathematical base, $\epsilon = 2.71828 \dots$ is 0.43429 \dots , therefore 5b may be written

$$db = 20 \text{Log}_{10} k = 10 \text{Log}_{10} (W/w) = 8.685889 \theta \quad (5c)$$

or

$$\theta = 0.115129 \times \text{No}(db) \quad (6a)$$

also from 5a

$$\theta = \text{Log}_{\epsilon} k \quad (6b)$$

Calculations of the functions ϵ^θ and $\epsilon^{-\theta}$ given by equations 2 and 3 for wide ranges of the variable and for small increments of the angle, θ , were obtained by interpolation from *Tables of The Exponential Function, e^x* , by the Federal WPA for the City of New York, sponsored by the National Bureau of Standards, Washington, D. C.

The hyperbolic sine and cosine functions (written, sinh and cosh to distinguish them from the well known trigonometric sine and cosine of circular functions which are usually written sin and cos), are defined in terms of equations 2 and 3 as

$$\sinh \theta = \frac{\epsilon^\theta - \epsilon^{-\theta}}{2} \quad (7a)$$

and

$$\cosh \theta = \frac{\epsilon^\theta + \epsilon^{-\theta}}{2} \quad (8b)$$

From these two equations, by addition and subtraction, there results

$$\cosh \theta + \sinh \theta = \epsilon^\theta \quad (7b)$$

and

$$\cosh \theta - \sinh \theta = \epsilon^{-\theta} \quad (8b)$$

The sinh and cosh functions of the tables in part II were calculated from equations

and θ . The hyperbolic tangent, written \tanh , was obtained from the relation

$$\tanh \theta = \frac{\epsilon^\theta - \epsilon^{-\theta}}{\epsilon^\theta + \epsilon^{-\theta}} = \frac{\sinh \theta}{\cosh \theta} \quad (9a)$$

From 7b, 8b and 9a

$$\frac{\cosh \theta + \sinh \theta}{\cosh \theta - \sinh \theta} = \epsilon^{2\theta}$$

$$= \frac{1 + \tanh \theta}{1 - \tanh \theta} = \frac{\coth \theta + 1}{\coth \theta - 1} \quad (9b)$$

The double angle functions were obtained by change of the variable θ to 2θ and the definitions as given.

The half angle functions were found from the relationships existing between the \sinh and \cosh functions of a whole angle, namely,

$$\sinh \frac{\theta}{2} = \sqrt{\frac{\cosh \theta - 1}{2}} \quad (10)$$

$$\cosh \frac{\theta}{2} = \sqrt{\frac{\cosh \theta + 1}{2}} \quad (11)$$

$$\tanh \frac{\theta}{2} = \sqrt{\frac{\cosh \theta - 1}{\sinh \theta}} \quad (12a)$$

or

$$\tanh \frac{\theta}{2} = \sqrt{\frac{\sinh \theta}{\cosh \theta + 1}} \quad (12b)$$

The double angle functions used were:

$$\sinh 2\theta = 2 \sinh \theta \cosh \theta \quad (13)$$

$$\cosh 2\theta = \cosh^2 \theta + \sinh^2 \theta \quad (14a)$$

or

$$\cosh 2\theta = 2 \cosh^2 \theta - 1 \quad (14b)$$

or

$$\cosh 2\theta = 1 + 2 \sinh^2 \theta \quad (14c)$$

$$\tanh 2\theta = \frac{\sinh 2\theta}{\cosh 2\theta} \quad (15a)$$

or

$$\tanh 2\theta = \frac{2 \tanh \theta}{1 + \tanh^2 \theta} \quad (15b)$$

The reciprocals of the various functions in equations 7 to 15 were taken, and these are defined as

hyperbolic cosecant,

$$\operatorname{csch} \theta = \frac{1}{\sinh \theta} = \frac{2}{\epsilon^\theta - \epsilon^{-\theta}} \quad (16)$$

hyperbolic secant,

$$\operatorname{sech} \theta = \frac{1}{\cosh \theta} = \frac{2}{\epsilon^\theta + \epsilon^{-\theta}} \quad (17)$$

hyperbolic cotangent,

$$\operatorname{coth} \theta = \frac{1}{\tanh \theta} = \frac{\epsilon^\theta + \epsilon^{-\theta}}{\epsilon^\theta - \epsilon^{-\theta}} \quad (18)$$

The half- and double-angle reciprocal

(Continued on page 84)

Extremes Meet

THOUSANDS of these coils have gone to war . . . in the far corners of the earth . . . under the sea and in the sky . . . under the worst conditions.

Imagine . . . six miles of hair-size wire in a coil suddenly lifted from a jungle temperature of 120°F to a rarefied atmosphere of -40° F and "taking it" day after day.

Only experience can wind coils like these . . . to do the job required of them.

Their use cannot be told but statistics may be interesting. In producing this one type of coil for the Army and Navy we have consumed one-half million miles of wire . . . 136,000 pounds of copper. The machines used in winding them have turned 3 TRILLION, 360 BILLION revolutions.

We hope soon to be able to put some of this production capacity and experience to work on YOUR postwar problems.

COIL SPECIALISTS SINCE 1917

COTO-COIL CO., INC.

65 PAVILION AVE. PROVIDENCE 5, R. I.

HARVEY



CAN LOCATE



CAN DELIVER

...urgently needed
Radio and Electronic
Components and
Equipment
from America's leading
manufacturers!

CAPACITORS
RESISTORS
TRANSFORMERS
RELAYS
TUBES
TEST EQUIPMENT
...and 1001 others!

Now, more than ever, HARVEY stands ready to supply you with what you need to help win this war, and to get it to you as fast as possible. We specialize in locating hard-to-find items. We can advise as to the effectiveness of substitutes. We can discuss technical and priority problems with you. HARVEY, with 18 years experience in the field, is now, as always, your safe bet.



Telephone Orders to Longacre 3-1800

HARVEY
RADIO COMPANY
HARVEY
103 WEST 43rd ST., NEW YORK 18, N. Y.

(Continued from page 83)

functions of equations 10 to 15 are written in similar manner.

The squared functions were obtained either directly by squaring the value of the function itself, or from derivations of the definitions, from which were found

$$\cosh^2 \theta - \sinh^2 \theta = 1 \quad (19)$$

$$\operatorname{sech}^2 \theta + \tanh^2 \theta = 1 \quad (20)$$

and

$$\coth^2 \theta - \operatorname{csch}^2 \theta = 1 \quad (21)$$

Through the relationships given in 5a and 5b of

$$k^2 = e^{2\theta} \quad (22)$$

and

$$k = e^{\theta} \quad (23)$$

in conjunction with equations 5c and 6b, the complete interrelatedness between the network transmission power loss, the parameters or elements of the network, and the *Hyperbolic Functions of a Real Variable* was established.

A system or symbolical notation was then set up which would further compress the relationships between the parameters of the network and the terminating impedances. This notation makes use of the upper and lower case English letters only without either sub or superscripts. A choice was made arbitrarily for assignment of basic functions involving the full, double and half angles for both hyperbolic and exponential functions. These were denoted symbolically by upper case or *capital* English letters; for example $A = \sinh \theta$, $B = \cosh \theta$, $C = \tanh \theta$, etc. Their reciprocals were assigned the same letter in the lower case or *small* English letters; thus, $a = \operatorname{csch} \theta$, $b = \operatorname{sech} \theta$, $c = \coth \theta$, etc.

Identities between the symbolical, exponential, algebraic and hyperbolic forms are shown by the headings at the top of each column throughout the tables. Thus, with the multiple headings given, all of the transformations from one form to another for any function are given without reference to any text material. For those who prefer to deal with power ratios equal to or less than unity, an additional relationship may be written for each heading by substituting $k = 1/r$. For example, in the heading involving the hyperbolic sine of the angle, there results the identities, $A = \sinh \theta = (k^2 - 1)/2k = (1 - r^2)/2r = (e^{2\theta} - 1)/2e^{\theta}$.

APPENDIX II

Gudermannian Functions

Tables of the natural trigonometric functions are usually available from the pages of nearly every electrical, radio or mathematical handbook, whereas tables of the hyperbolic functions are seldom found except in special books or treatises rarely available to the average engineer. Most of the tables on hyperbolic functions have too large an interval for the argument of the angle and are not carried out to enough significant places to be of value for accurate work.

A relationship, well known to mathematicians, but unfamiliar to the average engineer, exists between the numerical values of the circular and the hyperbolic functions. These relationships are im-

PREMAX



Premax Antennas

The same type of dependable Tubular Metal Antennas . . . the Premax type now used by the Armed Services . . . will be available for commercial use when VE-Day comes. Get particulars on the antenna you will need.

Premax Products

Division Chisholm-Ryder Co., Inc.
4501 Highland Avenue, Niagara Falls, N. Y.

PLASTIC
NAME
PLATES

SCALES, GAUGES,
CALCULATORS,
CHARTS,
DIALS,
ETC.

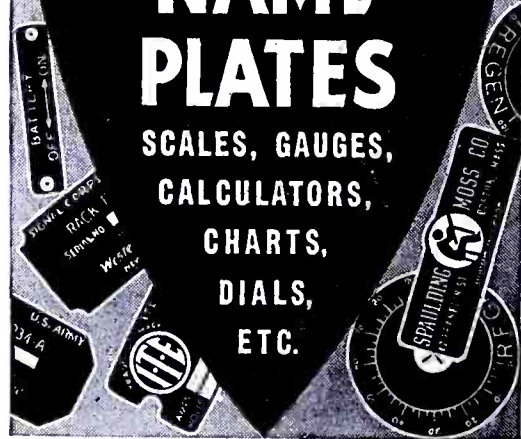

- Impervious to moisture, grease, oils, acids, alkalis.
- Printing guaranteed not to wash or rub off.
- Non-inflammable, non-corrosive plastic.
- Printed and laminated vinylite and cellulose acetate.

SAMPLES AND ESTIMATES GLADLY SUPPLIED ON REQUEST
WRITE DEPARTMENT C.

THE HOPP PRESS, INC.

PRINTING - FABRICATING - FORMING

460 W. 34th STREET, N. Y. C.

ESTABLISHED 1893

portant, convenient and easily applied in practice.

If the angle or argument assumes values between zero and infinity, the hyperbolic sine, $\sinh \theta$, assumes successive values between zero and plus infinity just as the circular tangent, $\tan a$, does when a is varied from 0 to 90° . The hyperbolic cosine, $\cosh \theta$, assumes values from one to plus infinity like the circular secant, $\sec b$, and the hyperbolic tangent, $\tanh \theta$, assumes values from zero to unity in the same manner as the circular sine, $\sin c$.

Each of the hyperbolic functions give only singly periodic values, and therefore there must be some single value of the circular angles, a , b , and c which corresponds to a particular value of θ , such that,

$$\sinh \theta = \tan a \quad (1)$$

$$\cosh \theta = \sec b \quad (2)$$

and

$$\tanh \theta = \sin c \quad (3)$$

Squaring each side of equations 1 and 2, and using 19 from Appendix I, we obtain,

$$\sec^2 b - \tan^2 a = 1 \quad (4)$$

remembering that, $\sec b = 1/\cos b$ and $\tan a = \sin a/\cos a$, 4 becomes, after clearing of fractions,

$$\cos a = \cos b \quad (b)$$

or

$$a = b \quad (6)$$

In a like manner, using 2 and 3 with equation 20 from Appendix I, and remembering that $\cos^2 b + \sin^2 b = 1$, after simplifying, we have

$$\sin c = \sin b \quad (7)$$

or

$$c = b \quad (8)$$

hence, from 6 and 8,

$$a = b = c = \varphi \quad (9)$$

The angle φ is called the Gudermannian of θ , and is written

$$\varphi = \text{gd} \theta \quad (10)$$

Therefore, the set of relationships may now be written for the circular and hyperbolic functions which show their inter-relatedness, as

$$\sinh \theta = \tan \text{gd} \theta = \tan \varphi \quad (11)$$

$$\cosh \theta = \sec \text{gd} \theta = \sec \varphi \quad (12)$$

$$\tanh \theta = \sin \text{gd} \theta = \sin \varphi \quad (13)$$

$$\text{csch} \theta = \cot \text{gd} \theta = \cot \varphi \quad (14)$$

$$\text{sech} \theta = \cos \text{gd} \theta = \cos \varphi \quad (15)$$

$$\text{coth} \theta = \csc \text{gd} \theta = \csc \varphi \quad (16)$$

As an example of the application of these relationships, for 10 db, from table I, part I, $\theta = 1.15129$; and from table 2, part II, $\sinh \theta = 1.42303$. From 11, this equals the tangent of the Gudermannian. From a table of natural or circular trigonometric functions, $\varphi = 54.902^\circ$. Using equations 12 to 16 inclusive successively, from the table of circular functions of a 54.902° angle, the hyperbolic functions of the circular angle $\theta = 54.902^\circ$ are found to be:

$$\cosh \theta = \sec \varphi = 1.7392$$

$$\tanh \theta = \sin \varphi = 0.81817$$

(Continued on page 86)

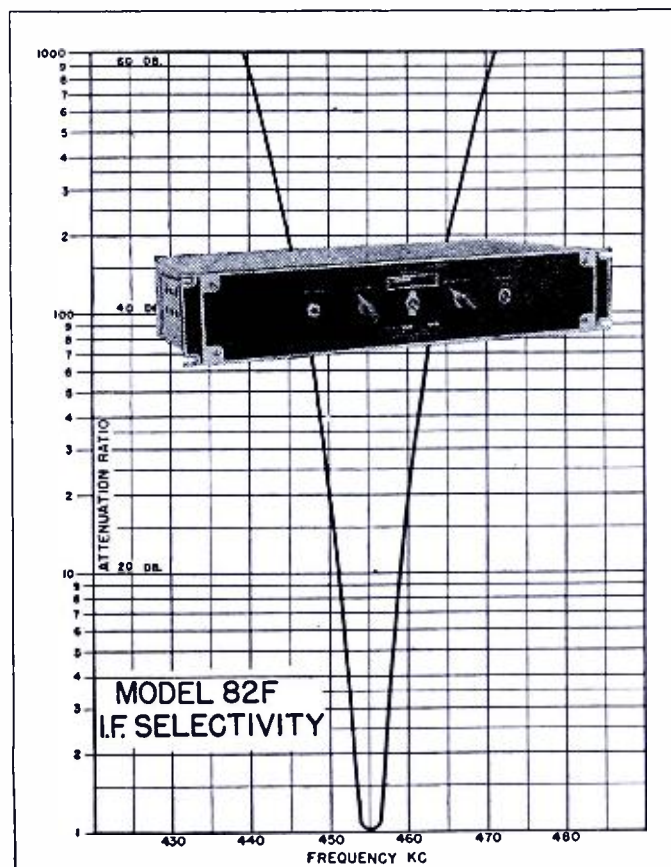
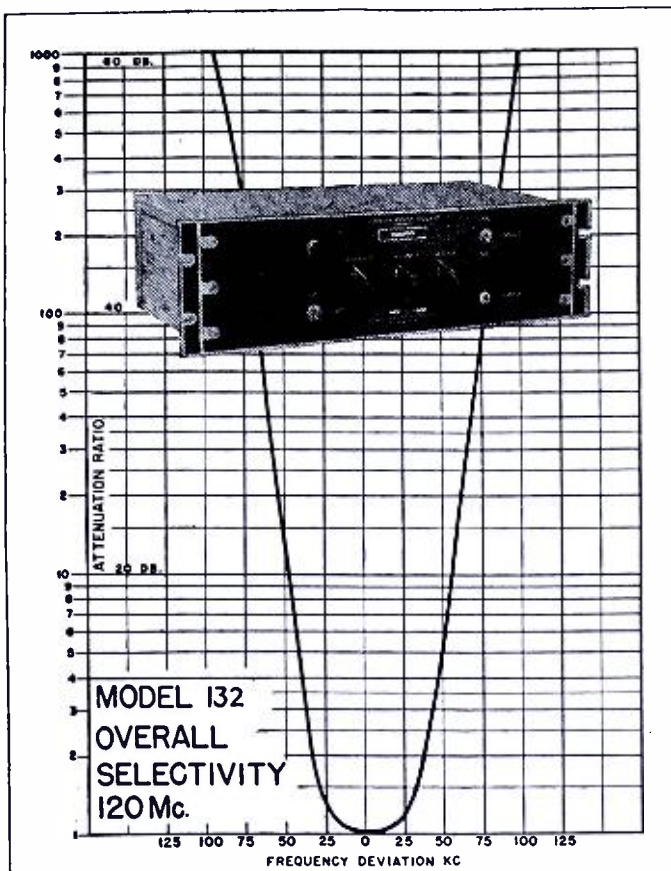

Performance

Comco Receiver MODEL 132

Frequency Range:
100 — 156 Mc.

Image Ratio:
300 to 1 (50 db.)
at 100 — 128 Mc.
100 to 1 (40 db.)
at 128 — 156 Mc.

A.V.C. Action:
Constant within 3 db.
from 100 microvolts
to 100,000 microvolts

Sensitivity:
7.5 microvolts 30%
modulated for 6 mw.
output

Signal-to-Noise:
13 db. at 7 microvolts
Input 30% modulated

Comco Receiver MODEL 82-F

Frequency Range:
2.0 to 8.0 Mc.

Image Ratio:
50,000 to 1 (94 db.)
at 2.5 Mc.
55,000 to 1 (95 db.)
at 3.6 Mc.
45,000 to 1 (93 db.)
at 4.8 Mc.
10,000 to 1 (80 db.)
at 6.5 Mc.

A.V.C. Action:
Constant within 3 db.
from 10 microvolts to
1 volt

Sensitivity:
3 microvolts 30% mod-
ulated for 50 mw.
output

Signal-to-Noise:
9 db. at 3 microvolts
Input 30% modulated

THE radio telephone receivers illustrated above are of the fixed tuned, crystal controlled, superheterodyne type, for aeronautical ground stations, airport control towers, police radio stations or point-to-point service.

We invite your inquiries as to use of these receivers in conjunction with your present or post-war planning. Our facilities are at your service, whether you need complete transmitters, receivers, or some electronic component which we can help design and manufacture for you.

COMMUNICATIONS COMPANY, Inc.

Manufacturers of Radio and Electronic Equipment

CORAL GABLES  34, FLORIDA

STAYS *Round* ON THE SPOOL



SURCO-AMERICAN PLASTIC TUBING

... holds its round shape, layer by layer, all the way from the core to the outside of the spool, whatever the size of the tubing. Surprenant's specially constructed spools, pre-winding treatment, and the method of winding are exclusive features.

Our own formulations are laboratory tested to meet every possible condition and specification, as for example: high frequency, non fogging clear tubing with a low power factor—or non fogging tubing either clear or in any color with temperature resistance from 80°F to plus 295°F—or non fogging tubing, clear or in any color, also temperature resistant, with dielectric strength which averages 1500 volts per mil. thickness—or tubing especially resistant to abrasion—or semi-rigid tubing—or a nylon formulation. These are but a few. Ask us to match your own specifications.

"Surco-American" tested products also include plastic insulated wire, #12 to #48 A.W.C., insulating tape, and special tubing. Request complete technical data.

Address Dept. L.

Surprenant
ELECTRICAL INSULATION CO.
84 Purchase St., Boston 10, Mass.

(Continued from page 85)

$$\operatorname{csch} \theta = \cos \varphi = 0.70275$$

$$\operatorname{sech} \theta = \cos \varphi = 0.57497$$

and

$$\operatorname{coth} \theta = \csc \varphi = 1.22223$$

These values were found by use of *Mathematical Tables* by H. B. Dwight. These tables are well suited for this purpose as the sin, cos, tan and their reciprocal functions are given directly in hundredths of a degree. This makes it possible to check the hyperbolic functions of the tables or those found elsewhere to an accuracy as great as that of the circular functions, which are usually carried to about five significant figures.

The importance of the *Gudermannian* function is that given any single hyperbolic function of a real variable; all of the remaining hyperbolic functions may be obtained directly using the relationships shown in equations 11 to 16 from a common trigonometric table of circular functions.

Although, in this series of articles, all of the desired hyperbolic functions are given directly in the tables for relatively small increments of the variable, θ , there will be instances when the interpolation of some function will give greater accuracy than another one. In these cases, the *Gudermannian* is particularly useful. By this, it is implied that for any specified loss, if the incremental changes either side of that chosen loss are not approximately equal or linear for any desired function, it would be more advantageous to choose another function entirely which was more linear in the desired range of loss. Then, by use of the *Gudermannian Function*, the actual desired hyperbolic function can be found to a much greater degree of accuracy.

The inverse operation of finding the natural trigonometric functions from tables of hyperbolic functions can of course be done, but the occasion would seldom arise in network design to use the *Gudermannian Function* in this manner.

APPENDIX III

[Data on L-taper networks, types 2 and 3, are presented in this appendix. Figures referred to appeared in Part II, October, Communications.]

L-Taper Network, Type 2

This is an impedance-transforming network matched by a terminating image impedance at the shunt end only and is shown in Figures 9 and 10, on a full and unit impedance basis, respectively.

Assuming a zero-impedance generator delivering unit current into the unit impedance through a unit external impedance, referring to Figure 10, the power ratio is

$$P_z/P_L = \frac{v_1 + s^2}{s^4} s^2 \quad (39)$$

where $w_1 = w/z$ and $s^2 = Z/z$. Since $k^2 = P_z/P_L$,

$$k = \frac{v_1 + s^2}{s^2} s = s \left(1 + \frac{v}{Z} \right) \quad (40)$$

From 40, we may solve for the unit impedance and get

$$w_1 = v/z = s(k - s) \quad (41)$$

Specialists in . . .

FEATHER EDGING

COPPER MACHINE PARTS

on RADIO TUBES

Why not try us?

We also do plastic injection
molding up to 6 ounces

ARPIN PRODUCTS, Inc.

422 Alden St.

Orange, N. J.



WAXES

AND

COMPOUNDS

FOR

INSULATING and WATERPROOFING of ELECTRICAL and RADIO COMPONENTS

Also for
**CONTAINERS and PAPER
IMPREGNATION**

FUNGUS RESISTANT WAXES

ZOPHAR WAXES and COMPOUNDS
MEET ALL ARMY AND NAVY
SPECIFICATIONS
Inquiries Invited

ZOPHAR MILLS, INC.
(FOUNDED 1846)
120 - 26th ST., BROOKLYN, N. Y.

from which, the full value impedance is

$$v = zs(k - s) \quad (42)$$

The matched input impedance from Figure 10 is

$$1 = \frac{w_1(v_1 + s^2)}{v_1 + w_1 + s^2} \quad (43)$$

Eliminating v_1 from equation 40 and 43, the unit impedance is found to be

$$w_1 = w/z = ks/(ks - 1) = s/(s - r) \quad (44)$$

from which

$$w = zks/(ks - 1) = \sqrt{Zz}/(s - r) \quad (45)$$

The transmission loss of this type network is, from 40,

$$db = 20 \text{Log}_{10}[s(1 + v/Z)] \quad (46)$$

When this network is matched on its shunt end and the terminating impedances are equal, $Z = z$, or $s = 1$. Then equations 40, 41, 42, 44, 45 and 46 become,

$$k = 1 + v/Z \quad (47)$$

$$v/z = k - 1 = N \quad (48)$$

$$v = z(k - 1) = Nz \quad (49)$$

$$w/z = k/(k - 1) = m \quad (50)$$

$$v = z(k - 1) = mz \quad (51)$$

and the transmission power loss is

$$db = 20 \text{Log}_{10}(1 + v/Z) \quad (52)$$

Minimum Loss for L-Taper Networks of Type 2

For a match of impedances to exist on the low impedance side and at the same time have minimum loss, this can only occur if the series arm equals zero; hence from equation 42,

$$v = zs(k - s) = 0 \quad (53)$$

from which, we obtain the condition for minimum transmission power loss that

$$k = s. \quad (35)$$

This is the same condition for L-taper networks of Type 1 to have minimum loss. Only in this case, the network has degenerated into a simple shunt-impedance having a value of

$$w = zk/(k - 1) = akz/2 \quad (54)$$

where $a = \text{Csch } \theta = 2k/(k - 1)$.

L-Taper Network, Type 3

This type of network is commonly referred to as an impedance matching pad, and is used to transform impedances on a matched basis so that no reflections take place at either of the junctions of the terminating impedances and the network. It is matched on an impedance basis at both ends by the terminations, and is shown on both a full and a unit impedance basis in Figures 11 and 12, respectively. From Figure 12, we may write for the image impedances,

$$s^2 = \frac{v_1(w_1 + 1)}{v_1 + w_1 + 1} \quad (55)$$

and

$$1 = \frac{w_1(v_1 + s^2)}{v_1 + w_1 + s^2} \quad (56)$$

(Continued on page 88)



48-page Catalogue describes Insuline's vast line of Radio-Electronic Products.

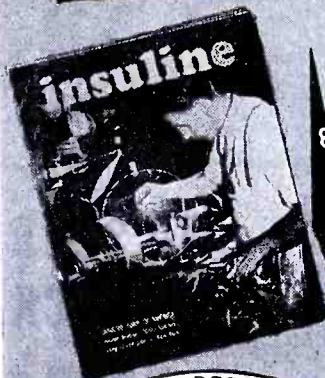
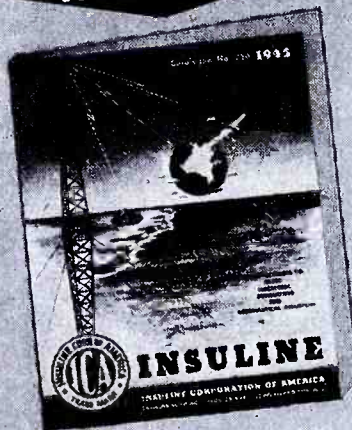

8-page Brochure presents Insuline's organization and manufacturing facilities.

2nd Award! Yes, Insuline is proud to announce it. For today, more than ever, our Armed Forces are urgently calling for *sustained* effort and *greater* production of Radio-Electronic Products.

It is the duty of all of us to render *exceptional performance*—and to *sustain* it consistently with every ounce of our strength until the great job is done.

That is why we look upon our 2nd Army-Navy Award as a *renewed* challenge, saying: "*Back up our fighting men... Give them the material strength with which to implement their fighting hearts!*"

Again we shall answer this call with stepped-up production...with *new records of exceptional performance* worthy of the trust placed in us by the Armed Forces.

WRITE FOR OUR CATALOGUES describing the extensive ICA line of Radio-Electronic Products, as well as the organization and facilities behind our records of exceptional performance for the armed forces.



HEADQUARTERS FOR RADIO-ELECTRONIC PRODUCTS



INSULINE

CORPORATION OF AMERICA

INSULINE BUILDING • LONG ISLAND CITY, N.Y.

NEW IMPROVED

T-PAD ATTENUATORS BY TECH LAB

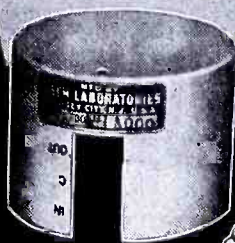

- Stainless Silver Alloy contacts and wiper arms.
- Rotor hub pinned to shaft prevents unauthorized tampering and keeps wiper arms in perfect adjustment.
- Can be furnished in any practical impedance and db. loss per step upon request.
- Write for our Bulletin No. 431.

TECH LAB MICROHMMETER



Direct and instantaneous resistance readings down to 5 microhms and up to 1,000,000 megohms. Write for Bulletin No. 432.



1 LINCOLN STREET
JERSEY CITY 7, N. J.

(Continued from page 87)

where $v_1 = v/z$ and $w_1 = w/z$.

Eliminating w_1 from this pair of equations, and solving the resultant for the series impedance,

$$v_1 = v/z = s\sqrt{(s^2-1)} = \sqrt{s^2(s^2-1)} \quad (57)$$

or

$$v = zs\sqrt{(s^2-1)} = \sqrt{Z(Z-z)} \quad (58)$$

Eliminating v_1 from equations 55 and 56, and solving the resultant equation for the shunt impedance, we obtain,

$$w_1 = w/z = s/\sqrt{(s^2-1)} = Z/v = Z/\sqrt{Z(Z-z)} \quad (59)$$

or

$$w = zs^2/\sqrt{s^2(s^2-1)} = Zz/v = Zz/\sqrt{Z(Z-z)} \quad (60)$$

Thus, it may be seen that the element values in this type network are a function of the terminations only.

This network is a special case of a so-called minimum loss *T-network*. When the *T-network* fulfills this condition, it has been degenerated into a *L-taper* network of type 3, and is accomplished by allowing the element adjacent to the smaller impedance to be reduced to zero. This element may conveniently be represented by hyperbolic functions, and is

$$u = z (\text{Coth } \theta - s \text{Csch } \theta) = 0 \quad (61a)$$

$$= cz - asz = 0 \quad (61b)$$

when the minimum transmission loss condition is applied. From 61, a most useful relationship is obtained, that is

$$s = \text{Cosh } \theta = B, \quad \text{or} \quad (61c)$$

$$s^2 = \text{Cosh}^2 \theta = E \quad (61d)$$

and

$$\theta = \text{Cosh}^{-1}s \quad (61e)$$

where

$$a = \text{Csch } \theta = 2k/(k^2-1) = 1/\text{Sinh } \theta;$$

$$c = \text{Coth } \theta = (k^2-1)/(k^2+1);$$

$$s^2 = Z/z = \text{Cosh}^2 \theta = E,$$

and

$$s = \text{Cosh } \theta = B = (k^2+1)/2k.$$

Substituting 61d into equations 57, 58, 59 and 60 respectively, we find

$$\text{the unit series impedance, } v_1 = \frac{1}{2} \text{Sinh } 2\theta$$

$$= \frac{1}{2} G = \sqrt{Z/z} \text{Sinh } \theta = As \quad (62)$$

$$\text{the full series impedance, } v = \frac{z}{2} \text{Sinh } 2\theta$$

$$= -G = \sqrt{Zz} \text{Sinh } \theta = AVZz \quad (63)$$

$$\text{the unit shunt impedance, } w_1 = 2 - \frac{Z}{z} \text{Csch } 2\theta$$

$$= 2s^2g = \sqrt{Z/z} \text{Csch } \theta = as \quad (64)$$

(Continued on page 89)

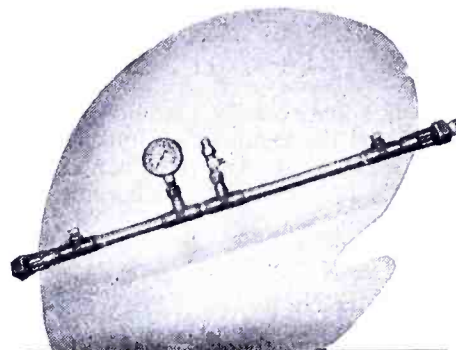

COPPER TUBING CONCENTRIC LINE

Standard stock sizes include 5/16", 1/2", 7/8", 1-5/8" and 2-5/8". Other sizes can be manufactured on special order. Johnson concentric line is accurately designed for uniform impedance and manufacturing methods insure accurate diameters of both outer and inner conductors and maintenance of spacing ratios within close limits. Insulation is Alsmag 196, conductors are pure copper, and special manufacturing techniques at joints insure lower losses.

Complete lines of fittings, gauges, valves, expansion joints, and gas equipment are also available. Write today for recommendations and prices.



E. F. Johnson Co. Waseca, Minn

JONES 500 SERIES PLUGS AND SOCKETS

Designed for 5,000 volts and 25 amperes. All sizes polarized to prevent incorrect connections, no matter how many sizes used on a single installation. Fulfill every electrical and mechanical requirement. Easy to wire and instantly accessible for inspection. Sizes: 2, 4, 6, 8, 10, and 12 contacts. Send for a copy of Bulletin 500 for complete information. Write today.

HOWARD B. JONES CO.
2460 W. GEORGE STREET
CHICAGO 18, ILL.

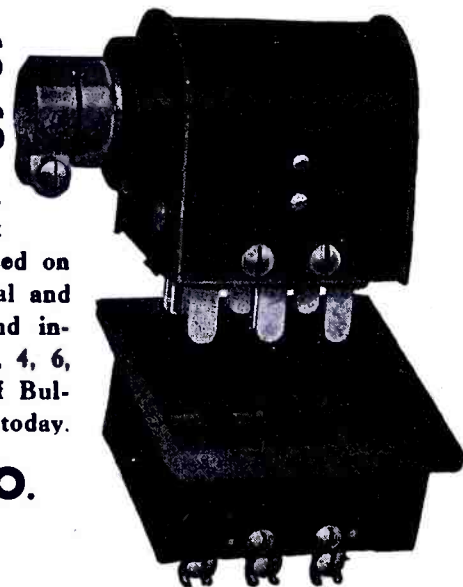

IRE CHAPTER FORMED IN CEDAR RAPIDS

The IRE has approved a Cedar Rapids, Iowa, section. About 100 will be members of the new section. Temporary officers of the section are: Chairman, T. A. Hunter, Collins Radio Co., and secretary-treasurer, John A. Green, Collins Radio Co. The area in the section includes thirty counties in Iowa and two counties in Illinois.

W. L. NELSON JOINS ANDREW

Wilbur L. Nelson has become mechanical design engineer of the Andrew Company, Chicago 9. Mr. Nelson was formerly with Western Electric.

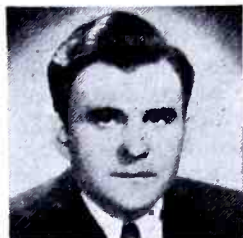

BURLINGTON R.R. TO EMPLOY RADIO

The Chicago, Burlington and Quincy Railroad is preparing to install a radio communications system to direct switching operations in its Chicago and other large yard terminals, as soon as the FCC assigns frequencies. U-h-f equipment made by the radio division of Bendix Aviation Corporation will be used.

FARADAY ELECTRIC BUYS HOLTZER-CABOT SIGNALS UNIT

The Holtzer-Cabot Electric Company, Boston, has sold its signal systems department to the Faraday Electric Corporation, Chicago.

Included in the sale, which involves no sale or exchange of capital stock, are the company's patents on signal systems, its signal-systems inventories and movable tools used in the manufacture of this equipment.

The Holtzer-Cabot Company will continue to manufacture fractional-horsepower motors, and motor generators. In August, 1942, the company became a wholly-owned subsidiary of Commercial Investment Trust Corporation, of New York.

IRAQ AWAITS TELEVISION SAYS RCA DISTRIBUTOR

Sayid Hafidh of Hafidh Al-Kadi, RCA Victor distributor in Iraq, reported recently that television is one of the developments of modern science in which the people of Iraq are most keenly interested.

Mr. Hafidh stated that the Iraq government which provides programs over three stations, one of which is the powerful Baghdad transmitter, well-known throughout the Middle East, is keenly interested in television.

PEERLESS CATALOG

A 20-page catalog, 431, containing photographs and illustrations, diagrams, full construction details, and prices on transformers, windings, and reactors, has been published by the Peerless Electrical Products Co., 6920 McKinley Avenue, Los Angeles 1, California.

Industrial personnel may secure a free copy by requesting on company letterhead.

BENDIX RADIO APPOINTS CLAUDE LEACH

Claude Leach, Jr., has been named sales-promotion manager for the home radio division of Bendix.

CELANESE CELLULOID CORPORATION CHANGES NAME

Celane Celluloid Corporation has changed its name to Celanese Plastics Corporation.

MYKROY BULLETIN

A bulletin, 102, discussing the 1 7/8" x 2 3/4" (Continued on page 93)

Basic Design

makes the difference!

Smudge-voice

While these two columns read identically, word for word, the smudged column is a visual representation of an acoustical condition when background noise interferes with transmitted speech.

The words may be readable, but effort and concentration are required for accuracy. And so with reproduced sound: with general purpose microphones, articulation is lowered even though ambient noises do not completely override speech. The Electro-Voice Differential is specifically designed to erase interfering background noise. Speech is clean, clear, crisp... unadulterated by stray pickup or distracting background.

Electro-Voice

While these two columns read identically, word for word, the smudged column is a visual representation of an acoustical condition when background noise interferes with transmitted speech.

The words may be readable, but effort and concentration are required for accuracy. And so with reproduced sound: with general purpose microphones, articulation is lowered even though ambient noises do not completely override speech. The Electro-Voice Differential is specifically designed to erase interfering background noise. Speech is clean, clear, crisp... unadulterated by stray pickup or distracting background.

Electro-Voice DIFFERENTIAL MICROPHONES



Electro-Voice engineers have years of experience in the elimination of ambient noise. We designed and developed the now-famous "Lip-Mike," the first successful Differential microphone. Our new Model 205-S for aircraft, railroad, industrial and police applications is another Differential achievement. Soon there will be Electro-Voice Differential microphones for all communication services. Watch for them.



If any of your limited quantity needs can be met by standard model Electro-Voice microphones, with or without minor modifications, contact your local radio parts distributor.

BLOOD DONORS ARE URGENTLY NEEDED... SEE YOUR LOCAL RED CROSS

Electro-Voice MICROPHONES

ELECTRO-VOICE CORPORATION • 1239 SOUTH BEND AVENUE • SOUTH BEND 24, INDIANA
Export Division, 13 East 40th Street, New York 16, N. Y., U. S. A. Cable: Arlab

RESISTIVE NETWORKS

(Continued from page 88)

the full shunt impedance, $w = 2Z \operatorname{Csch} 2\theta$

$$2Zg = \sqrt{Zz} \operatorname{Csch} \theta = a\sqrt{Zz} \quad (65)$$

where $A = \operatorname{Sinh} \theta = (k^2 - 1)/2k$;

$$a = 2k/(k^2 - 1);$$

$$G = (k^4 - 1)/2k^2,$$

and $g = 2k^2/(k^4 - 1)$

$$\text{Since } s = \operatorname{Cosh} \theta = (k^2 + 1)/2k \quad (66)$$

we may express k in terms of s by solving 66 by means of the quadratic formula and taking the positive sign of the square root since $k > 1$, and get

$$k = s + \sqrt{s^2 - 1} \quad (67)$$

The minimum attenuation for this net-

work to match both of its terminations is, therefore,

$$\text{db} = 20 \operatorname{Log}_{10} (s + \sqrt{s^2 - 1}) \quad (68)$$

If the ratio of the terminating impedances is given, the minimum-loss pad that must be used for the network to provide a perfect match with no reflections, can be found by inspection from the column headed E which is symbolical notation for $\operatorname{Cosh}^2 \theta$. After locating the ratio in this column, the number of decibels loss may be read from the table either at the right hand or left hand margin. Conversely, if the maximum loss that can be permitted is known, the reverse procedure will give immediately the maximum impedance ratio that may be matched and not exceed the given loss.

BACK THE INVASION — BUY MORE BONDS NOW!

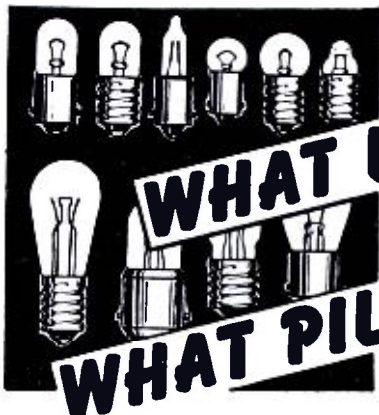

WHAT LAMP? WHAT PILOT LIGHT?

ANSWERS TO BOTH QUESTIONS WAITING FOR YOU AT DIALCO

Let us solve your problem with a complete unit — fitted with the proper G.E. or Westinghouse Lamp. We manufacture the most extensive line of Pilot Lights . . . Special emphasis on Neon applications. Write for Catalog today.

**YOU CAN DEPEND ON DELIVERIES
WHEN YOU DEAL WITH THE**

*World's Largest
Manufacturer
of Pilot Lights*

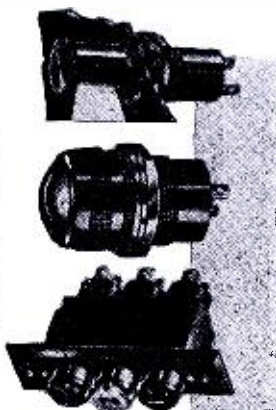

DIAL LIGHT CO. of America, Inc.

900 BROADWAY - NEW YORK 3, N. Y.
Telephone: ALgonquin 4-5180-1-2-3

BACK THE INVASION — BUY MORE BONDS NOW!

AERONAUTICAL COMMUNICATIONS

(Continued from page 76)

single party-line to control the number of aircraft which will desire to take off from and land at some of the larger airports alone during rush hours.

The allocation of frequencies within this new u-h-f aviation radio band is well depicted in Figure 1. This figure has been abstracted from the *CAA Technical Development Report No. 28*, May, 1941. The famous checker-board pattern of assignment of radio-range frequencies is shown here. It is based upon dividing the continental United States up into 100-mile squares, with one radio-range station located within each square, then grouping twenty-five such 100-mile squares into one major 500-mile square for purposes of frequency assignment. Upon the seemingly sound theory that each of the twenty-five frequencies which would suffice for the 500-mile square may be duplicated 500 miles away, it became possible to divide the country up into 500-mile major squares, with each such square using identical but discreetly spaced frequencies. A study of this map will reveal that not only has this been accomplished, but that, most adroitly, frequencies individually spaced 200 kc have not been assigned to adjacent squares, but within the 500-mile major square have been juggled so as to give an average separation in frequency between adjacent 100-mile squares the country over of nearly 2500 kc. In no case are adjacent 100-mile-square frequencies closer than 400 kc. This operates effectively to minimize interference, although it is stated that with frequencies repeated only at 500-mile intervals, interference is not anticipated below altitudes of 29,000', which few civilian planes may be expected to reach very soon. Eleven auxiliary frequencies all between 119 and 126 mc, are held in reserve to supplement or replace the twenty-five basic frequencies charted.

So much for a brief glance at the postwar civilian aviation frequency assignment plan as it existed before Pearl Harbor. Since then the frequencies involved have been occupied by war services, and there may be some question as to whether they will ever be returned to their originally intended service after V-Day. Should they not be so returned, some other spot in the u-h-f spectrum will probably have to be found which will accommodate an equivalent frequency assignment plan. Whether such a step will be necessary it is too early to guess. If needed, it today seems reasonable to assume that the assignments will probably be lifted up to somewhere between 300 and 600 mc.

[The FCC reallocation proposal provides for the following new assignments: 108-118 mc (air navigation); 118-132 mc (aeronautical mobile service); 420-450 mc (amateurs and air navigation); 450-460 mc (air navigation, temporarily); 1450-1500 mc (air navigation); and 1550-1650 mc (experimental aeronautical mobile services).]

It appears inescapable that a practically certain tremendous increase in civilian aircraft in use in the United States is to be anticipated beginning after V-Day. And the vital importance of radio communications to safety of life in the air is believed to be apparent. There appear to be substantial reasons that an expansion in civilian aircraft will occur. Ignoring completely the popularity of aircraft and flying, significant part air power is playing in the war, complete catching of popular fancy, interest of demobilized military flyers, and strong appeal to

IT'S DA



— and so is your
equipment when

it's been pressurized with an **ANDREW DRY AIR PUMP**

● Dry Air Pumps provide simple, inexpensive source of dehydrated air for your pressurized electronic products. You can avoid component failure due to humidity by enclosing the entire apparatus in an air tight chamber and maintaining dry air pressure.

For air-borne equipment, too! Condenser plates will not spark over at high altitudes if the apparatus is pressurized with dry air, because then moisture condensation is no longer a problem.



Type 876-A

FOR DETAILED INFORMATION
WRITE FOR BULLETIN No. 30

ANDREW CO.



363 East 75th Street
Chicago 19, Illinois

American youth, there seem to be two paramount reasons for anticipating such expansion, an expansion that will open up on a significant scale, a major new field for radio-equipment engineering, production and sale.

Possibly the first, and most immediately compelling reason is that aircraft production is today America's No. 1 industry. During the war, this is probably as it should be, but after cessation of hostilities a few years hence and with probable rapidly dwindling demand for military aircraft, what does America's No. 1 industry then do to fully utilize its productive plant? What does it do to contribute to national welfare through continuing its employment of the large number of employable Americans today engaged in aircraft production? A glance at aircraft figures as of Pearl Harbor, Dec. 7, 1941 is suggestive. As of Dec. 1, 1941, inquiry has revealed that there were but approximately 486 commercial air transports and 26,500 civilian itinerant and other non-military aircraft in the United States. Presumed correct, these figures provide food for thought. With government borrowing of significant numbers of commercial aircraft to aid the war effort, they suggest that the first postwar demand upon the aircraft industry will be for commercial transport and cargo planes. Approximately 15,000 transport or like aircraft now utilized by the government may offset the possible production which this initial demand could create. In event of release of these aircraft to commercial users in an orderly manner, their number would go far to satisfy initial demand. Conversion of these aircraft to be suitable for commercial use could create a new and temporary business in competition with the original producers, who might advantageously devote some of their productive capacity initially to such conversion.

Such demand alone cannot preserve current activity-rate in the aircraft industry after V-Day, even without the threat represented by 15,000 government-held transport craft. Heavy as the initial, and continuing commercial demand may be, in character it is unsuited to support plants specializing in smaller types of aircraft which may find it not feasible to convert rapidly to production of large transport cargo aircraft. It is reasonably certain, in any event, that the demand, domestic and export, for large aircraft cannot keep the entire industry operating at anywhere near its present rate indefinitely in terms of number of aircraft produced and number of workers employed. The search for survival alone by the many plants producing smaller aircraft will force intensive cultivation of the civilian market. The average American is ready for such cultivation in terms of conventional aircraft, seems to anxiously await the practical helicopter, and industry need can find long-time relief only in civilian volume-sale possibilities.

If, for unfavorable reasons of cost and convenience which may be envisaged, the private plane market should prove unable over time to support the expanded industry, the second reason comes to its aid. This takes the form of a combination of heavier, probable annual military aircraft procurement than before the war, and the opportunity inherent in developing government-sponsored flying clubs. So great is the romance of flying that

The name to remember in ANTENNAS for every radio purpose



Since the beginning of radio broadcasts 25 years ago, BRACH Antennas for Home and Automobile have been the acknowledged pace-setters in their field.

Today  Antennas

are doing their part for victory
on land, on sea, and in the air

And when peace comes . . .

BRACH Puratone* ANTENNAS, tested and perfected to meet Army and Navy standards, will again resume their established leadership for Home and Auto Radios, Television, Marine, F.M. and other services.

*Reg. Patent Trade Mark

L. S. BRACH MFG. CORP.

World's Oldest and Largest Manufacturers of Radio Antennas and Accessories
55-65 DICKERSON STREET • NEWARK N. J.

American youth will dream of being able to fly for years to come, a dream in most cases not to be satisfied for economic reasons. Uncle Sam may require trained pilots; the pilot material is ready and waiting for training. At some future date, the capacity to produce small trainer planes may even be begging for business. Flying clubs all over the country sponsored by the government appears to offer a possible solution. It supports an industry which it must preserve against future need in purchasing the required planes, preliminarily trains at nominal cost to them the pilots it must also have in reserve, and simultaneously provides outlets for the air-enthusiasm of its youth.

Twice now the allocation of radio frequencies to amateur investigation and employment has stood Uncle Sam in good

stead, when as a result the government has found ready and waiting a substantial body of technically skilled radio amateurs in its hours of need—1917-18 and 1941-?. The numerous benefits of government flying clubs should be as potentially, maybe even more, valuable.

It is believed that consideration of the foregoing will indicate conclusively the inseparability of aircraft and radio in all the aspects of the former after V-Day. In the face of a steadily increasing number of aircraft going into service, communication (which may satisfactorily be only by radio to an aircraft in flight) becomes even more essential to safety of life in the air—yes, on the ground too—than is the motor of an aircraft. Just one glider out of control-contact can be a

(Continued on page 92)

If you want

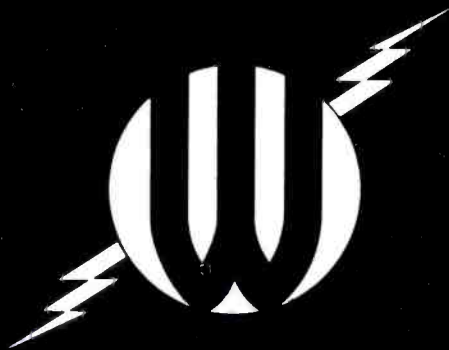

- CRYSTALS
- CABLES
- HARNESES
- ELECTRONIC ASSEMBLIES
- CABINETS

Telephone Peru, Indiana

151

Serving the Radio and Electronic Industries with precision engineered products.

Wm. T. WALLACE MFG. CO.

General Offices: PERU, INDIANA

Cable Assembly Division: ROCHESTER, INDIANA



YOURS
..FOR THE
ASKING

Available from local dealers or by writing factory direct.

UNIVERSAL STROBOSCOPE

This handy phonograph turntable speed indicator, complete with instructive folder, is now available gratis to all phonograph and recorder owners through their local dealers and jobbers. As a recorder aid the Universal Stroboscope will assist in maintaining pre-war quality of recording and reproducing equipment in true pitch and tempo.

Universal Microphone Co., pioneer manufacturers of microphones and home recording components as well as Professional Recording Studio Equipment, takes this means of rendering a service to the owners of phonograph and recording equipment. After victory is ours—dealer shelves will again stock the many new Universal recording components you have been waiting for.



AERONAUTICAL COMMUNICATIONS

(Continued from page 91)

lethal weapon indeed in a crowded air.

The following proposition is therefore respectfully propounded; in civilian aircraft, radio communication equipment is the first and primary requisite. This may appear to be a bold statement, but a little contemplation of possible confusion at a major airport on a Sunday afternoon with but *one* aircraft bereft of contact with the control tower makes it almost inescapable.

On the assumption that it has been indicated that civilian aircraft expansion after V-Day will be on a major scale, and that the need of radio communication equipment in operative condition is the essential prerequisite to civilian flight, it may be concluded that the radio industry is in the position of being given a new and sizable outlet for its skill.

What the radio and aeronautical industries and the government do with this opportunity is the acute concern of radio engineers, for in this expanded field, life itself is the price of inadequate radio equipment. The primary justification here for radio communication is neither pleasure nor convenience, but the preservation of life itself. It is unthinkable that quality may ever be allowed to fall, engineering or production-wise, into the classification of broadcast receivers. Yet, the makers of broadcast receivers are the seemingly logical producers of aeronautical radio equipment in terms of the probable considerable output which will be required.

There is something of a limit, fortunately, upon the sales expansion possible for aeronautical radio receivers, transmitters, direction finders, positioning

equipment, etc., as the reward for reduced selling price, bringing, as price reduction seems almost invariably to do, deterioration of quality. At least two limits exist: One, little more equipment can be profitably sold than there are aircraft made to use them; second, the equipment must be such quality that it is in operative condition when, properly inevitably, government inspection of aircraft and accessories takes place at frequent periodic intervals.

Only engineering refinement, increased production skill, diminished distribution costs would seem to be the proper devices to be employed to reduce selling price. If these alone be given free reign, the essential of preservation of human life in the air will be better served.

The writer feels that we should have government regulation now, rather than later, after abuses have made it inescapable and punitive in possible effect, to insure maintenance in all airborne radio equipment of a minimum standard of quality and serviceability. It would seem this may be accomplished through modification of the present CAA Approved Type Certificate plan. Under the ATC plan the manufacturer may submit his product to CAA for test, and when and if it is found suitable for air-borne use, an Approved Type Certificate is issued indicating its suitability for use by commercial air lines, and civilians, should they be interested.

The writer is convinced that if it may be made mandatory by Federal law that no aircraft, powered or glider, may take off without radio equipment in operative condition, and that such equipment must have previously measured up to rational minimum standards of technical excellence, that a significant service will have been rendered to the American people and the radio industry.

It would seem wise to establish from within the radio industry an aeronautical radio advisory committee to collaborate with the responsible government agency in the formulation and interpretation of technical standards governing engineering and production best calculated to serve the flying public, and through it the radio industry itself.

COUPLED CIRCUIT DESIGN

(Continued from page 74)

*selectivity chart.*⁶ Data from the charts and the resultant discriminator voltage are tabulated on page 74, with measured data for the same circuit.

Calculated data are, of course, symmetrical about f_0 . The data in the tabulation are plotted in Figure 17.

References:

¹J. E. Maynard, *Tuned Transformers*, General Electric Review, Part I, pp. 559-561; October, 1943; Part II, pp. 606-609; November, 1943.

²Terman, *Radio Engineering*; p. 93.

³D. E. Foster and S. W. Seeley, *Automatic Tuning, Simplified Circuits and Design Practice*, Proc. IRE, vol. 25, pp. 289-313; March, 1937.

⁴J. E. Maynard, U. S. Patents 2,338,526, 2,338,527.

⁵H. Roder, *Theory of the Discriminator Circuit for Automatic Frequency Control*, Proc. IRE vol. 26, pp. 590-611; May, 1938.

⁶Paul C. Gardiner and J. E. Maynard, *Aids in the Design of Intermediate Frequency Systems*; Proc. IRE vol. 32, pp. 674-678; Nov., 1944.

NEWS BRIEFS

(Continued from page 89)

...ts of glass-bonded mica ceramic insulation, ...wn as Mykroy, has been published by Elec- ...tric Mechanics, Inc., 70 Clifton Boulevard, ...on, New Jersey. ...e new sheets are made in thicknesses rang- ...from 1/8" to 1/2".

EXPERIMENTAL TELEVISION LICENSE FOR FARNSWORTH

...icense to erect an experimental television ...tion has been granted to the Farnsworth ...vision & Radio Corporation by the FCC. ...e station will be used solely for experi- ...mentation and research.

EITEL-MC CULLOUGH ADVANCES WUNDERLICH, PIERRI AND BROWN

...rge F. Wunderlich has been named general ...anager of Eitel-McCullough, Inc., of San ...no, Calif., and Salt Lake City, Utah. ...uis Pierri, manager of the Salt Lake City ...nt, has become production manager of the ...e plant at San Bruno. Hewitt V. Wilson, ...stant manager of the Salt Lake City plant, ...a named manager there. ...rbert C. Becker, liaison engineer, has re- ...tained to his post as field representative. ...trin H. Brown, industrial relations and ...onnel director for the past two years, has ...ome head of the sales engineering de- ...partment. ...n V. Young, assistant to O. H. Brown, ...been assigned to the sales engineering de- ...partment to handle public relations. He will ...work with Leigh Norton, of the labora- ...tory research division, in the publication of a ...e company industrial magazine to appear ...tly.



Herbert Becker

G. F. Wunderlich

PHENOL A-N INSERT CHART

...hart of molded A-N insert arrangements ...electrical connectors has been published by ...merican Phenolic Corporation, Chicago 50, ...ois. ...serts are grouped by total number of con- ...acts in vertical columns, in numerical order, ...eading from top to bottom and left to right. ...al standard inserts from one contact to ...a hundred contacts are shown full size. ...et or pin arrangements are indicated to- ...gether with wire sizes. Also included are ...dial cable connections and grounded or ...luted inserts. Mechanical spacing of con- ...tacts and alternative positioning of the in- ...serts with new position numbers are given in ...a case. Chart is 50" x 38". ...opy will be sent on receipt of a request ...company letterhead.

M.C. PRICE LIST DATA

...price-list bulletin, 1460, covering twenty- ...en carbon, dynamic and velocity types in ...n, stand, throat, lip, hand and cartridge ...types, has been issued by Universal Micro- ...phone Co., Inglewood, Cal.

TELEVISION PRODUCTIONS FILES 8 APPLICATIONS

...vision Productions, Inc., a subsidiary of ...amamount Pictures, has filed eight applica- ...tions with the Federal Communications Com- ...mission for permission to erect a series of ex- ...perimental television relay stations in the east, ...west and far west. ...hannels 13, 14, 15 and 16 were sought in the ...New York City; Buffalo; Peru, Vt.; and De- ...troit, Mich., areas, and channels 9, 10, 11 and ...12 were requested in the El Paso, Texas; Des ... Moines, Iowa; Chicago, Ill.; and Los Angeles, ...Calif., areas.

MARY MINTER AN R.C. OF A. SPEAKER

...dio distortion was the subject of a paper ...
(Continued on page 94)

SPARE PARTS BOXES

Made as per specification—42 B 9 (Int) for shipboard use, Electrical and Mechanical. Navy grey finish. Immediate Delivery.

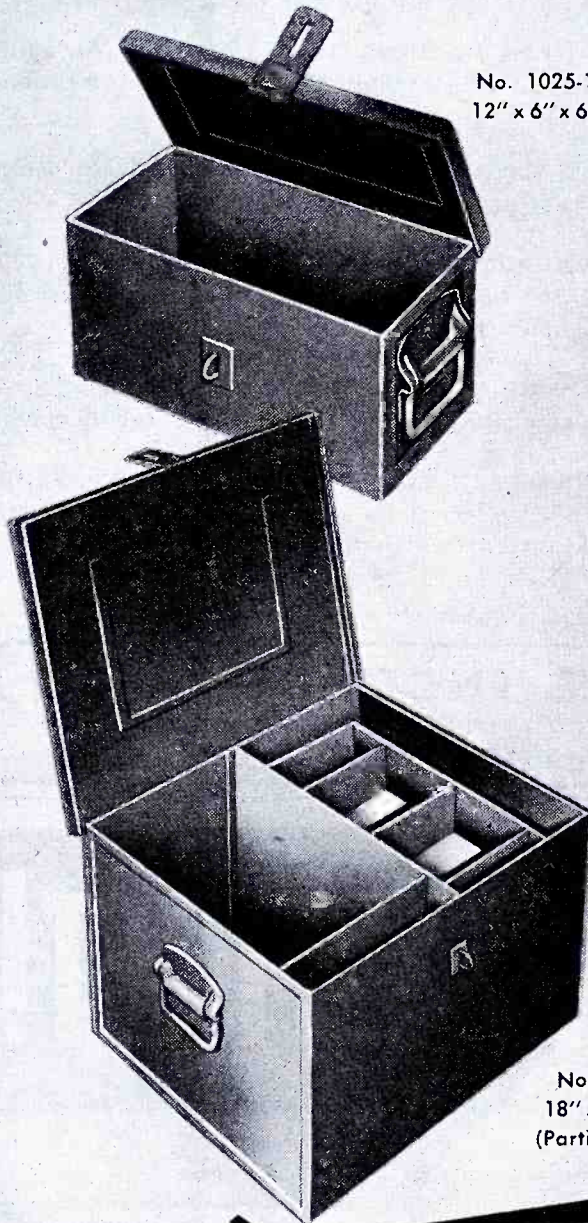

No. 1025-1
12" x 6" x 6"

24 STOCK SIZES			
Number	Length	Width	Height
1025-1	12	6	6
1025-2	12	9	6
1025-3	12	12	6
1025-4	12	9	9
1025-5	18	9	6
1025-6	18	9	9
1025-7	18	12	9
1025-8	18	6	6
1025-9	18	15	9
1025-10	18	12	6
1025-11	18	15	12
1025-12	18	12	12
1025-13	18	18	12
1025-15	24	15	12
1025-16	24	15	15
1025-17	24	18	12
1025-18	24	18	15
1025-19	24	18	18
1025-20	24	12	9
1025-23	30	15	9
1025-14	30	15	12
1025-22	36	12	9
1025-21	42	9	9
1025-24	42	12	9

WRITE FOR PRICE LIST

No. 1025-11
18" x 15" x 12"
(Partitions extra)

Cole Steel
office equipment
will again be available
after the war

COLE

STEEL EQUIPMENT COMPANY

349 Broadway, New York 13, N. Y. Factory: Brooklyn

Littelfuse FUSE MOUNTINGS

for 3 AG FUSES



Single, double and multiple pole mountings.



OPEN TYPE SINGLE POLE MOUNTING No. 351001 (old No. 1060). Black bakelite base. Overall length, 2 1/8". Shakeproof terminals. One mounting hole.



OPEN TYPE DOUBLE POLE MOUNTING No. 351006 (old No. 1068). Same as above but double pole.



LIGHT WEIGHT SINGLE POLE MOUNTING No. 351003 (old No. 1128). 1 1/2" x 9/16" x 9/16". Bakelite mounting strip, fibre insulator bottom for metal panel mounting. One mounting hole.

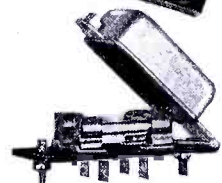

UNIVERSAL FUSE PANEL, NO. 1505 SERIES Standardized units for 10 fuse sizes, any practicable number of poles. Send for blueprints.

COVERED TYPE DOUBLE POLE MOUNTINGS Double Pole No. 351009 (old No. 1237-B). Underwriters' Approved. Fibre-lined, metal-shielded cover hinged to bakelite base.

Littelfuse Mountings made for all fuse sizes. Ask for details.

LITTELFUSE INCORPORATED
4757 RAVENSWOOD AVENUE, CHICAGO 40, ILLINOIS
200 ONG STREET, EL MONTE, CALIF.

Another DX FIRST!



For more than a year DX Crystals have been automatically deep-etched by a new process. Both the method and machines were perfected by DX Engineers so that all DX Xtals can have the nth degree of stability and endurance necessary to wartime operation.

Think about DX Products for your new receivers and transmitters.



DX CRYSTAL CO.

GENERAL OFFICES: 1200 N. CLAREMONT AVE., CHICAGO 22, ILL., U. S. A.

NEWS BRIEFS

(Continued from page 93)

by Jerry B. Minter, chief engineer of Measurements Corporation, Boonton, N. J., presented at a recent meeting of the Radio Club of America.

This paper analyzed amplitude versus frequency characteristics and harmonic distortion. Practical methods of measurement were suggested and data on several practical systems were offered.

G. E. BUYS KEN-RAD RADIO TUBE INTERESTS

The General Electric Company has purchased the radio tube manufacturing and plant facilities of the Ken-Rad Tube and Lamp Corporation at Owensboro, Kentucky, and at Huntington and Rock Port, Indiana, and will take over operation of government-owned plants at Tell City, Indiana, and Bowling Green, Kentucky.

The sale does not include the Ken-Rad electric lamp manufacturing business.

Carl J. Hollatz, formerly executive vice president of Ken-Rad, will manage the new G. E. operation, which will be known as the Ken-Rad division of the electronics department of G. E.

RMA ISSUES 1944-45 DIRECTORY

The new annual 1944-45 RMA membership and trade directory, with data on personnel, products, etc., was issued recently. The RMA membership now totals 227.

A. M. WIGGINS NOW WITH ELECTRO-VOICE

A. M. Wiggins has been appointed chief research engineer of the Electro-Voice Corporation, South Bend, Indiana.

Mr. Wiggins was formerly with RCA Laboratories in Princeton, New Jersey.



CONCORD PARTS SUPPLEMENT

A 16-page supplement 97, with data on meters, resistors, switches, speakers, relays, volume controls, test accessories, transformers, rheostats, etc., has been issued by the Concord Radio Corp., 901 West Jackson Blvd., Chicago 7, Illinois.

"E" AWARDS

The United Transformer Company, 150 Varot Street, New York City, and the Hoffman



H. L. Hoffman of Hoffman Radio with the "E" flag.

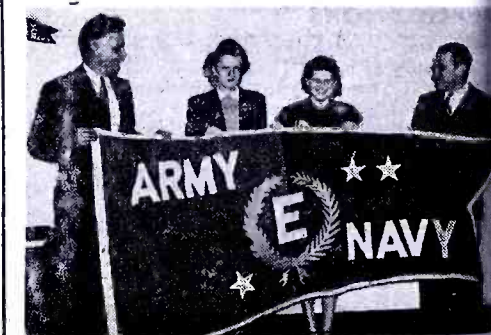

F. D. Bliley (right) of Bliley Electric and the three-starred "E" flag.

Radio Corporation, 3430 South Hill Street, Los Angeles, California, were recently awarded the Navy-Navy "E."

The second white star for the "E" flag has been won by United Electronics Company, Newark, N. J. The Sprague Electric Company, North Adams, Mass., and the Bliley Electric Company, Erie, Pa., received their third white star for the "E" flag.

BARASCH JOINS SHERRON ELECTRONIC

Les V. Barasch has become chief engineer of Sherron Electronics Company, 1201 Flushing Avenue, Brooklyn, New York. Mr. Barasch was formerly with Western Electric in charge of the cathode-ray and electronic tube equipment design section.

PRINCE PROMOTES SUITS

David C. Prince, vice president of General Electric has been appointed head of the general engineering laboratory. Mr. C. G. Suits, assistant to the director of research laboratory, has been elected a vice president and head of the research laboratory. Mr. W. D. Coolidge, vice president and director of the research laboratory, since 1940, is retired.

BEAR NOW RADIART S-M

Al Bear has been appointed distributor sales manager of The Radiart Corporation, Cleveland, Ohio. Mr. Bear has been with Radiart for seven years. Recently he has been acting as operations manager.



SINCLAIR IN NEW G.R. POST

Donald B. Sinclair is now assistant chief engineer in charge of circuit development at General Radio Company, 275 Massachusetts Avenue, Cambridge 39, Mass. Prior to joining the General Radio engineering staff in 1936, Dr. Sinclair was a research assistant at MIT from 1932 to 1935, and a research associate in 1935 and 1936.



PRESS WIRELESS SCHOOL TRAINING NAVY STUDENTS

The Press Wireless-Signal Corps radio school (Continued on page 97)

WUNDERLICH RUNS 118-MC TESTS

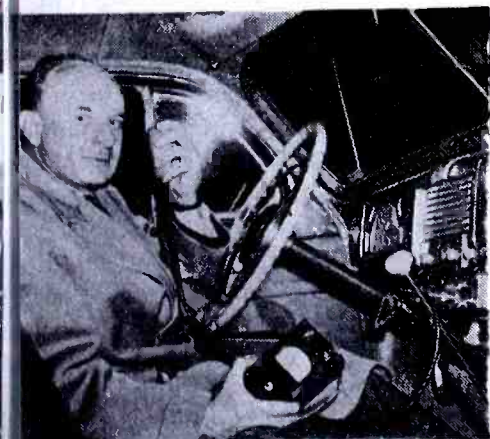

Norman B. Wunderlich, of the Motorola communications division, conducting 118-mc mobile tests in Chicago recently. Mr. Wunderlich reported that 118-mc was better than 30 to 40 mc.

Only "AIR WOUND" Coils Give You All These Advantages

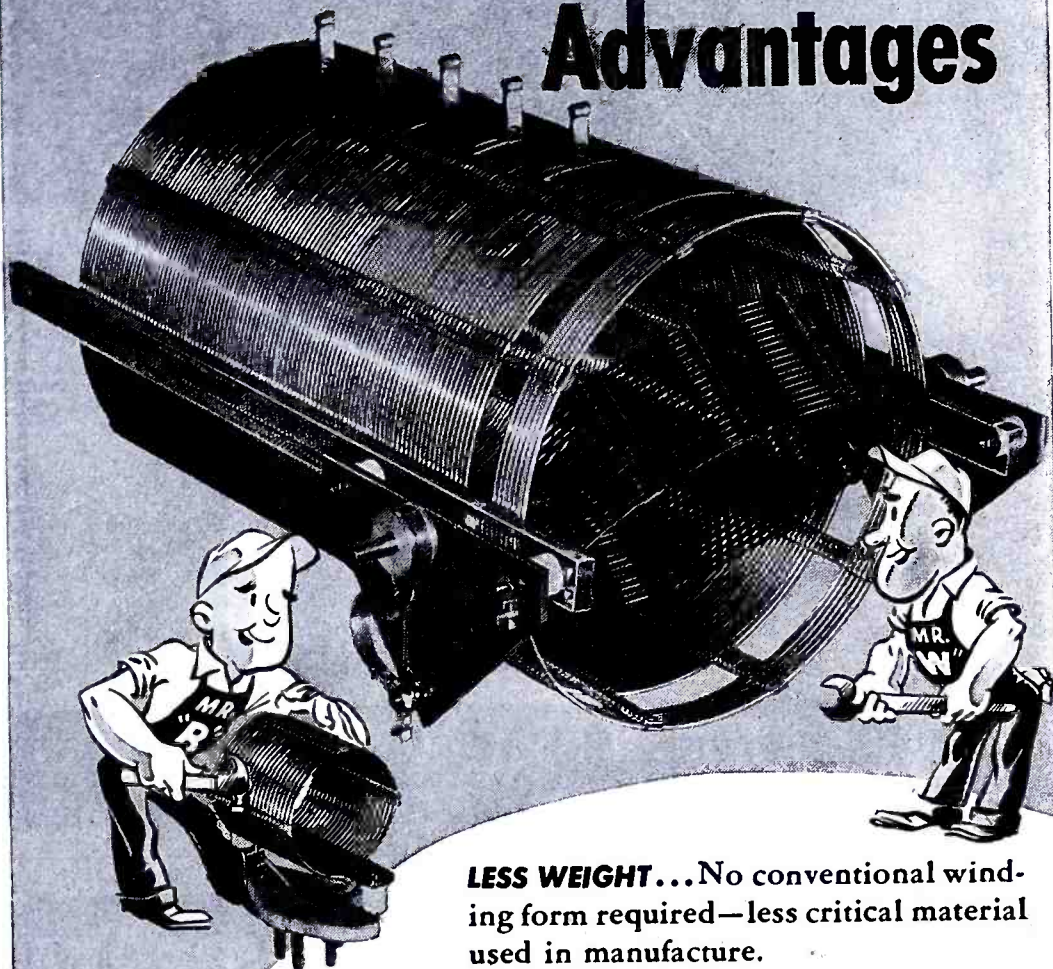

LESS WEIGHT... No conventional winding form required—less critical material used in manufacture.

LOW DIELECTRIC LOSS... Design incorporates an absolute minimum of extraneous material in winding field.

ADAPTABLE TO ANY MOUNTING... Ideal for plug-in or other services where mounting problems are involved.

LESS SUBJECT TO DAMAGE... Nothing much to break. Can easily be repaired without tools, even if bent completely out of shape. Bumper rings or other protective features available for extreme services.

GREATER DESIGN ADAPTABILITY... Can be equipped with fixed or variable internal or external coupling links, special indented turns for easy tapping, and many other special features.

MORE ACCURATE... Can be wound to more uniform pitch. Easier to tap at the exact desired point. No coil form to cause dielectric loss.

WIDE RANGE... Sizes and types for any application. 10 watts to 10 KW.

Samples to your specifications. Write for details.



BARKER & WILLIAMSON

Dept. C-15, 235 Fairfield Ave., Upper Darby, Pa.

Air Inductors, Variable Condensers, Electronic Equipment Assemblies

Exclusive Export Representatives: Lindetoves, Inc., 10 Rockefeller Plaza, New York, N.Y., U.S.A.



U.H.F. STANDARD SIGNAL GENERATOR MODEL 84

SPECIFICATIONS

CARRIER FREQUENCY: 300 to 1000 megacycles.

OUTPUT VOLTAGE: 0.1 to 100,000 microvolts.

OUTPUT IMPEDANCE: 50 ohms.

MODULATION: SINEWAVE: 0—30%, 400, 1000 or 2500 cycles. PULSE: Repetition—60 to 100,000 cycles. Width—1 to 50 microseconds. Delay—0 to 50 microseconds. Sync. input—amplifier and control. Sync. output—either polarity.

DIMENSIONS: Width 26", Height 12", Depth 10".

WEIGHT: 125 pounds including external line voltage regulator.

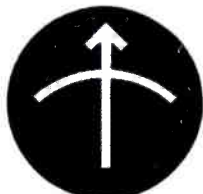

*Laboratory
Standards*

MEASUREMENTS CORPORATION

BOONTON • NEW JERSEY

CRYSTAL MANUFACTURERS!

Here is a **NEW** Holder,
approved by the Signal Corps.



Featuring new materials and designs, the new Nemco Crystal Holders have easily passed every test to which they have been subjected by the Signal Corps. and crystal manufacturers.

Nemco Holders are designed to prevent deterioration of the crystal by repelling water vapor under tropical conditions.

Because we specialize in the manufacture of Crystal Holders exclusively, we can give you the quality and service to help speed your production.

Write for samples and prices; also request quotations on your requirements for imprinting holders with metallic ink.



**NATIONAL ELECTRONIC
MANUFACTURING CORP.**

22-78 STEINWAY ST., LONG ISLAND CITY, N. Y.

New NEMCO N5X in No. 6105 and 592 may be obtained in all types of FT-243 Holders.

U-H-F POWER SUPPLY

BY IREDELL EACHUS, JR.

Formerly ESMT Communications Instructor, Moore School of Electrical Engineering, University of Pennsylvania; now on leave.

This paper is based on work carried on by the author at the Moore School

PART II

[In the first installment (December, 1944, COMMUNICATIONS), Mr. Eachus described the design and construction of a power supply for a general purpose r-f source operating on approximately 3000 mc. In this, the concluding installment, Mr. Eachus describes some of the characteristics of the klystron, which is used in the u-h-f r-f system.]

THE klystron oscillator is similar to most other electronic apparatus in that its ruggedness is electrical, *not-mechanical*. The most easily disturbed part of a klystron is the resonator which is made pliable to facilitate adjustment. It is to this that the concentric lines are attached and by which the tube itself is supported. It is therefore necessary to exercise continuous care in avoiding any strain on the tuner by pulling on the coaxial connectors or by jarring the tube. Short flexible leads fastened to rigid connectors must be used to make the external r-f connections to the tube. Strains on the tuner will not only cause the tube to go out of oscillation but will, if repeated too often, break one of the several glass-to-metal seals, rendering the tube completely useless.

Electrical damage to the klystron may be prevented if but one rule is observed; at no time should the accelerating grid current exceed its rated value. The Sperry S-410 klystron has an accelerating grid rated at a maximum current of 15 milliamperes.

There are several values of accelerating voltage and grid current at which the klystron will operate. A typical group of settings, chosen for maximum power output shows that values of accelerating grid current from 2 to 3 milliamperes is optimum.

Much the same as a gas engine will stall when fed too rich a mixture, the klystron will fail to operate on too high a beam current; therefore, when bringing a klystron into operation low values of grid current should be tried for the best results. The klystron may often be made to operate with the control grid negative although, as the output is reduced, it is not usually operated in this condition.

NEWS BRIEFS

(Continued from page 95)

icksville, Long Island, which has given
 ction to Army men during the past two
 one-half years, has begun courses for
 s of U. S. Navy seamen.
 school will hereafter be known as the
 Wireless Institute, a division of Press
 less, Inc.
 Army curriculum will be followed, spe-
 emphasis being placed on high power
 mitter work, antenna technique, "trouble
 ing" and other practical courses directed
 d utility and service in the field.

MAC TUBE PACKAGING METHOD

ethod of packaging large electronic power
 for overseas shipments has been de-
 veloped by Eitel-McCullough, Inc., at its San
 Diego, Calif., plant. It is said to have been
 approved by the Signal Corps and the Navy
 as the specification standard for all shipments,
 domestic and foreign, of certain tube types.
 The original package was designed for ship-
 ping the Eimac 450-T.
 The package consists of a set of interlocked
 stainless-steel springs suspended in a gal-
 vanneled steel X-frame which fits diagonally
 in a corrugated cardboard box.

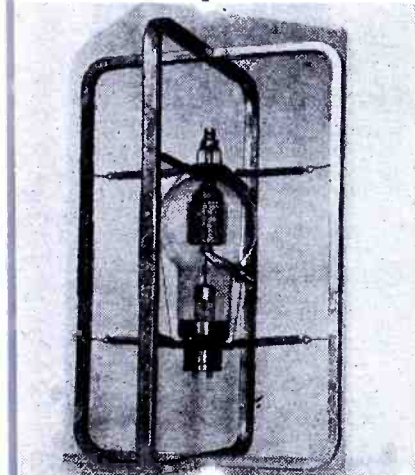

MARKELL JOINS RCA

E. Markell, for the past four years chief
 of the vacuum tube section of the U. S. Signal
 Corps at Camp Evans, has joined the RCA
 tube and equipment division as a specialist on
 industrial tube applications.
 E. Markell will work under the direction of
 E. Thees, manager of the equipment tube
 division at Harrison, New Jersey.

RCA BECOMES AIREON MANUFACTURING CORPORATION

The Aircraft Accessories Corporation will
 hereafter be known as the Aireon Manufac-
 turing Corporation.
 E. Franke has been appointed director of
 advertising and public relations. His head-
 quarters for the present will be in Kansas
 City, Kansas.



GENERAL ELECTRONICS CATALOG

Catalog, 101, covering d-c voltmeters, am-
 meters, milliammeters, microammeters and
 radio-frequency ammeters of the a-c thermo-
 couple type, has been published by the General
 Electronics Manufacturing Company, 6014 West
 Washington Boulevard, Culver City, California.

BENDIX-MARINE LAB SHIP

60-foot ocean-going marine laboratory to aid
 in the development of instruments and controls
 is under construction by Bendix-Marine.
 Among the equipment to be tested in this

Modern Components for the Modern Radio by Micarta Fabricators

Call in a
 Micarta engineer
 to consult with you on
 your postwar planning.
 Our complete facilities
 are at your service for the
 manufacture of Terminal Strips, Coil
 Forms, Jack Plugs, Battery Plug
 Assemblies, Resistor Boards, Dialites,
 and other modern components.



Write for our new Catalog No.101.

Serving the Radio and Electronic Industries for over 20 years

Micarta Fabricators, Inc.



5324 RAVENSWOOD AVENUE, CHICAGO 40, ILLINOIS, TELEPHONE LONGBEACH 9700

lab will be radio direction finders, hydraulic
 equipment, weather forecasting equipment, etc.
 The 60-foot floating laboratory will have a
 beam of 16', a 7' 6" draft, and weigh 59 tons.
 Its cruising speed will be 10 knots and cruis-
 ing range, 1,600 miles.

M.I.T. TO OFFER ELECTRONICS COURSES

Plans for a professional course in electronics
 at M. I. T., emphasizing applications to televi-
 sion and highly developed production methods
 in which Philco will cooperate, were announced
 recently by Dr. Karl T. Compton, M. I. T.
 president.

Under the new cooperative course, which fol-
 lows a plan established at the Institute many
 years ago, leading to the master of science de-
 gree, students in the department of electrical
 engineering will spend alternate terms at the
 Institute and at Philco. Plant experience is

(Continued on page 98)

THERMISTORS

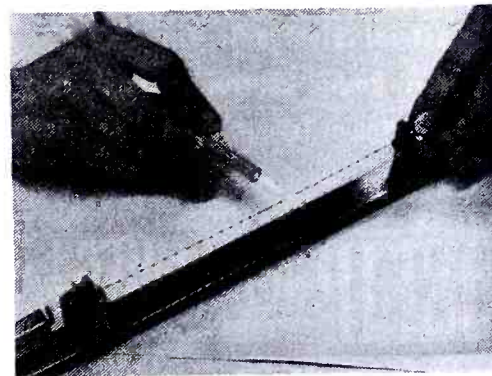

(Courtesy Western Electric)

Drying metallic oxide beads for thermistors.

STAMINA



The inherent stamina of Cinaudagraph Speakers is due to experience in design and manufacturing plus highest inspection standards. In all types of Cinaudagraph Speakers, from small watch-like Handie-Talkie units to large auditorium speakers, you'll find the same precision, the same painstaking workmanship and the same long-lived faithful reproduction.

Watch Cinaudagraph Speakers after Victory!



Cinaudagraph Speakers, Inc.

3911 S. Michigan Ave., Chicago
Export Div., 13 E. 40th St., New York 16, N. Y.

"No Finer Speaker Made in all the World"

*For Radio
as you want it!*

**We're still up to our ears
in critical war work but
when the war's won we
will again be ready**

**. . To DESIGN, DEVELOP
and MANUFACTURE . .**

Radio Receivers and Transmitters
Industrial Electronic Equipment
Airport Radio Control Equipment
Marine Radio Telephone Equipment

Your inquiries will receive immediate action

**ISLIP RADIO MFG.
CORPORATION**

ISLIP, L. I., NEW YORK

Wanted ENGINEERS

Radio

* Electrical

Electronic

* Mechanical

Metallurgical

* Factory Planning

Materials Handling

Manufacturing Planning

Work in connection with the manufacture of a wide variety of new and advanced types of communications equipment and special electronic products.

Apply (or write), giving full qualifications, to:

R.L.D., EMPLOYMENT DEPT.,

Western Electric Co.
100 CENTRAL AV., KEARNY, N. J.

*Also: C. A. L.

Locust St.,

Haverhill, Mass.

Applicants must comply with WMC regulations

NEWS BRIEFS

(Continued from page 97)

thoroughly integrated with professional theoretical instruction.

The new course is established as an option in the department of electrical engineering, which has conducted parallel courses for more than 25 years in conjunction with the General Electric Company, the American Telephone and Telegraph Company, the Boston Edison Company, the Boston Elevated Railway, and the General Radio Company.

KEN BURCAW BECOMES S-M AT C-D

K. C. Burcaw has been appointed sales manager of the jobber division, Cornell-Dubilier Electric Corporation.

Mr. Burcaw was formerly sales manager Radiart.



MONACK NOW MYCALEX V-P

A. J. Monack has been elected vice president in charge of engineering, of the Mycalex Corporation of America. Mr. Monack has been chief engineer since February of 1942. He has also served with the Radio Corporation of America and the Western Electric Company.



ED CONTENT DEVELOPS ACOUSTICAL METHOD FOR WOR

A new method of compensation for acoustical defects in large auditoriums has been developed by Edward J. Content, assistant chief engineer of WOR.

Mr. Content's method provides for the rejuvenation of overtones.

R. M. WISE IN NEW SYLVANIA POST

Roger M. Wise has been appointed to a newly created post of vice president in charge of engineering of Sylvania Electric Products, Inc.

Sylvania's director of engineering for the past two years, Mr. Wise previously served as the company's chief radio engineer for ten years.



WHITE NOW JENSEN RADIO PRESIDENT

Thomas A. White has been elected president and general manager of Jensen Radio Manufacturing Company. He succeeds W. E. Maxson, who has retired.

Mr. Maxson will remain on the board of directors.

HAVENS BECOMES S-M OF NOMA CONDENSER DIV.

B. H. Havens has been appointed sales manager of the condenser division of Noma Electric Corporation, 55 W. 13 Street, N. Y. 11, N. Y.

Mr. Havens will direct merchandising of Noma condensers through sales representatives and parts jobbers in key cities throughout the United States.

THE INDUSTRY OFFERS . . .

COMPARISON BRIDGE

Comparison bridge for measurement of resistors, capacitors and inductors by comparison with a standard has been developed by Gurevics of Freed Transformer Company, 72 Spring St., New York, N. Y. An accuracy of .5% to 20% is said to be available. The instrument consists of an a-c bridge, phase-locked oscillator and vacuum-tube voltmeter. A meter indicator in conjunction with a calibrated scale indicates percentage of difference between unknown and the standard. The comparison bridge is supplied with 3 frequencies: 60 cycles, 1,000 cycles, 10,000 cycles. Resistors, capacitors and condensers being compared to a standard range are: capacitors from 25 pfd to 20 mfd; inductors 5 microhenries to 5 henries; resistors from 10 ohms to 5 megohms. The unit measures 10"x7 1/2"x8 1/4". For a-c, 125 volts, 50-60 cycles.



CAPACITRON ELECTROLYTICS

Electrolytic capacitors are scheduled for production by The Capacitron Company, 849 North LaSalle Avenue, Chicago 51, Illinois.

STRUTHERS-DUNN RELAYS

New snap-action relays and vacuum switching relays have been announced by Struthers-Dunn, Inc., 1321 Arch St., Philadelphia 7. The snap-action relay, 79 XAX, employs an armature that is said to almost complete its travel in either direction before the contacts snap into the new position. This feature is said to permit its use for vacuum-tube circuits, overcurrent protection, pulsing circuits, etc. The standard adjustment using 60-ampere turns in the coil at approximately .02 watt results in contact pressures of 5 grams with contacts rated 5 amperes, 115 volts a-c; or 0.5 ampere, 115 volts d-c, noninductive. Contact ratings up to 10 amperes, 115 volts a-c may be obtained with 100 or more ampere turns and corresponding increase in power. A sensitivity of 0.005 watt with 30 ampere turns is also obtainable with reduced contact pressures and ratings.

The vacuum-switch keying relay, 78CCA100 has seven poles, including one double-throw pole which handles high-voltage r-f currents by means of a vacuum switch. All high-voltage parts are rounded to reduce corona.

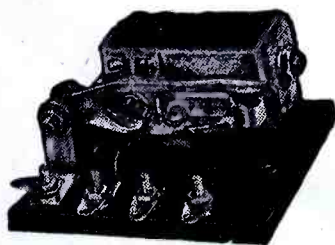

79 XAX Relay

CENTER CONTACT RECTIFIERS

Center contact, a patented plate construction in metal-plate rectifiers, which is said to allow

(Continued on page 100)

FROM THE HOUSE OF JACKS

. . . and other radio and electronic components!

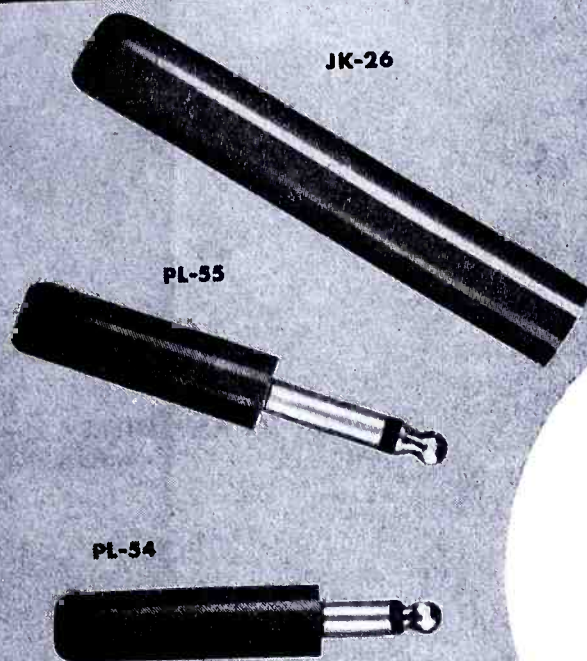

America's largest producer of JK-26 jacks. All models built to strict Signal Corps specifications.

Experience for Sale!

Amalgamated Radio, pioneers in the field, maintain experimental and development laboratories for post-war radio and television equipment. Our components are completely engineered in a self-contained factory equipped with tools of our own design. Years of specialized experience assure high quality products at low cost. Inquiries are invited.

ADDITIONAL JACKS & PLUGS FOR IMMEDIATE DELIVERY
JK-55 JK-48 PL-291 PL-291A PL-204

AMALGAMATED RADIO TELEVISION CORP.

476 BROADWAY • NEW YORK 13, N. Y.

NO. 51N

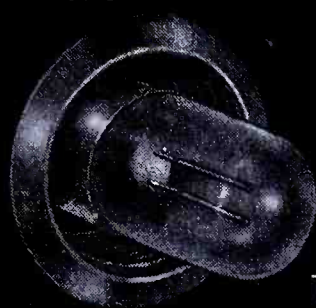

NO. 50N

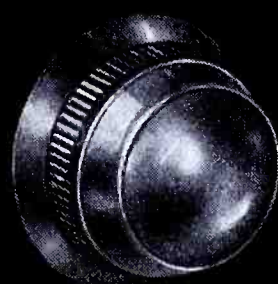

NEWEST DRAKE NEON LIGHT ASSEMBLIES

DEPENDABLE SERVICE

LONGER LIFE



Drake No. 50N NEON Jewel Min. Bayonet Assembly is ideal where a distinct signal is required and observer is directly in front of instrument panel. Its 1/2" smooth clear jewel magnifies and intensifies the illumination from the Neon lamp. Red glass jewel can also be supplied. The No. 51N (without jewel) is applicable where 180° visibility is desirable. Both units have built-in resistors for NE51 Neon Lamps operating on standard 105 to 125 volt circuits. These rugged units offer BIG savings in power (1/25 watt), long life (3000 hours), wide voltage range, and great reliability.

SOCKET AND JEWEL LIGHT ASSEMBLIES

DRAKE MANUFACTURING CO.

1713 WEST HUBBARD ST., CHICAGO 22, U. S. A.

Gothard NEON PILOT LIGHT

Neon Lamp Provides 3000
Hour Continuous Operation

Warm Glow
Visible from All Angles

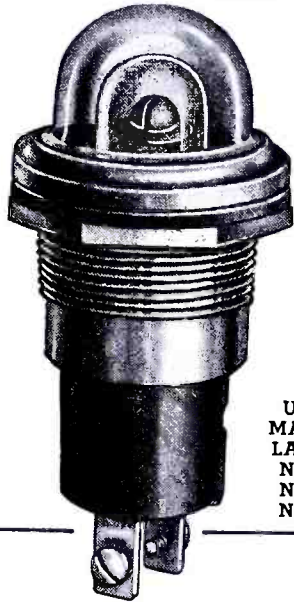

USES
MAZDA
LAMPS
NE-45
NE-51
NE-15

The Ultimate in Light
Penetration and Diffusion

This Gothard Pilot Light assembly accommodates neon lamps which will burn continuously for approximately 3000 hours, as compared with the approximate 500 hour life of ordinary lamps. It operates on 110 volts and consumes only 1/4 watt. The unbreakable lucite protective cap, designed and made for Gothard exclusively, provides perfect light dispersion of the warm neon glow in all directions. Lucite cap unscrews for lamp change. Bakelite socket. Polished and chrome plated jewel holder. 1" mounting hole. Colors: red, green, amber, blue and clear. Ask for complete information on this and wide range of other Gothard Lights.

Gothard

MANUFACTURING COMPANY
1335 NORTH NINTH STREET
SPRINGFIELD, ILLINOIS

Export Division—25 Warren Street,
New York 7, N. Y.

Cables—Simonrice, New York

THE INDUSTRY OFFERS . . . —

(Continued from page 99)

coating protection against destructive atmospheres, is available in units now being manufactured by Selenium Rectifier Products, Federal Telephone and Radio Corporation, Newark, New Jersey.

The center-contact construction is available in the same range of sizes and capacities as the standard petal-type contact.

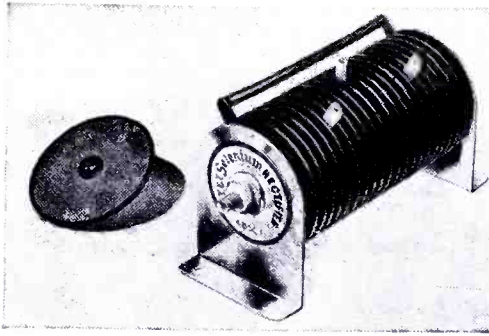

*** LANGEVIN 101 AMPLIFIERS

Amplifiers, 101 types, for medium gain, high-power bridging applications, have been designed by The Langevin Company, Inc., of 37 West 65th Street, New York.

All models are said to deliver 50 watts to a nominal load impedance with less than 3% rms harmonic distortion at 400 cycles. The gain control provides adjustment over a 40 db range and bridging connections. Chassis is 16-gauge welded steel, zinc plated, and bonderized. Weight approximately 45 pounds.

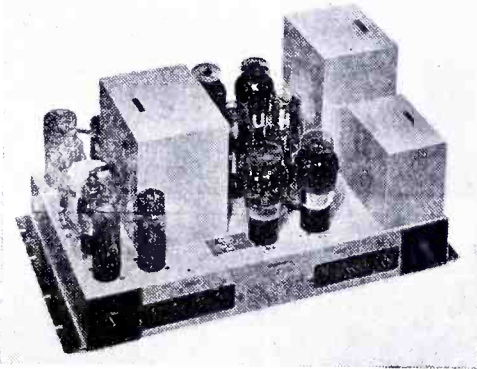

*** G.R. U-H-F OSCILLATOR

A 100 to 500-mc oscillator, type 857-A, has been announced by General Radio Company, 275 Massachusetts Avenue, Cambridge 39, Mass. Maximum output is said to be 1/2 watt or better over the entire frequency range.

The frequency-determining element in this oscillator is a "butterfly," a tuned-circuit developed by General Radio. In the butterfly, inductance and capacitance are varied simultaneously with a single control and no electrical contact to the moving element is said to be necessary.

The dial is said to read directly in frequency with an accuracy of ±1%. A slow-motion drive is provided.

The output circuit is inductively coupled to

the oscillator and the output is controlled by varying the coupling. Output terminal is a coaxial jack.

Type 857-P1 power supply, supplied with the oscillator, furnishes filament and plate power and operates from a 115- or 230-volt a-c line, 42 to 60 cycles. An electron-ray tube is used to indicate oscillation.

Oscillator is 6 1/4" x 7 5/8" x 7 1/4" overall and weighs 6 1/4 pounds. Dimensions of the power supply unit are 5 1/2" x 6 5/8" x 7 5/8", weight, 9 1/2 pounds.

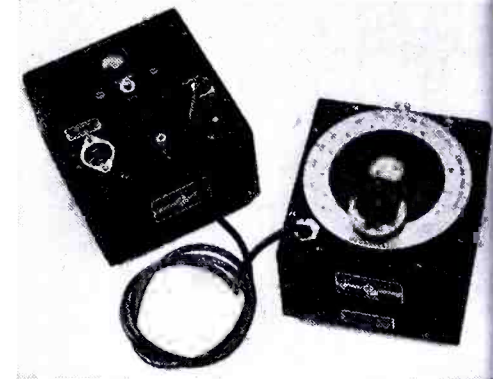

*** WESTINGHOUSE THIN HIPERSIL

Ultra-thin thicknesses of grain-oriented Hipersil have been produced by the engineers of American Rolling Mill and Westinghouse.

Prewar standard Hipersil laminations were 29 gauge, or about 14-mils thick. This was followed by 7-mil Hipersil, used for 400-cycle aircraft transforming equipment. A 5-mil thick sheet was then developed. Recently 2-mil and 1-mil thick Hipersil for h-f transformers have been developed.



*** AMALGAMATED RADIO TELEVISION PLUGS AND JACKS

Plugs and jacks are now being produced by the Amalgamated Radio Television Corp., 476 Broadway, New York, N. Y.

Jack types are JK-48, JK-26, JK-55; plug types are PL-54, PL-55, PL-204, PL-291, and PL-291A.

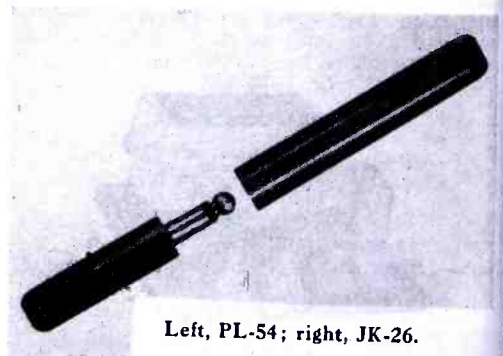

Left, PL-54; right, JK-26.

AVERY MASKING PROCESS

Die-cut masking stickers have been announced by Avery Adhesives, 451-453 East Third

50

**YEARS OF DEPENDABLE
TRANSFORMER
SERVICE!**



THORDARSON

TRANSFORMER DIVISION
THORDARSON ELECTRIC MFG. CO.
500 WEST HURON STREET, CHICAGO, ILL.

Transformer Specialists Since 1895

ORIGINATORS OF TRU-FIDELITY AMPLIFIERS

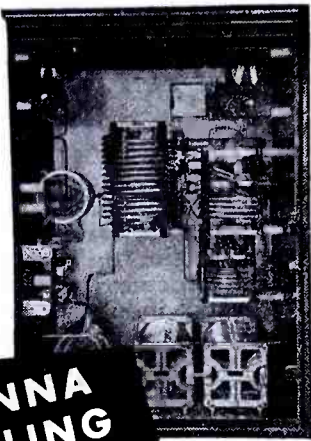

ANTENNA COUPLING EQUIPMENT

If it's an antenna problem, Johnson Engineers can give you the answer. Don't waste power. Johnson antenna coupling units insure a perfect match and maximum power transfer. Housed in weather-proof cabinets, they provide an inner door with glass window for observing meter, thereby protecting observer from high voltage.

Other Johnson products include phasing equipment, concentric line, tower lighting chokes, sampling transformers, inductors, condensers, insulators and similar items. Write for more information and prices.



JOHNSON
a famous name in Radio

F. Johnson Co. Waseca Minn



WIRES

MADE BY

*Engineers FOR
Engineers*

VICTORY

concentrating upon
for the duration

cornish

WIRE COMPANY, INC.

15 Park Row, New York City, New York



Street, Los Angeles 13, California.
The masking stickers can be applied without moistening.

RADIO CITY PRODUCTS SIGNAL GENERATOR

A signal generator, model 704, covering from 95 kilocycles to 100 megacycles, has been produced by Radio City Products Company, 127 West 26th Street, New York 1, N. Y. Fundamental frequencies are said to be continuously variable from 95 kilocycles to 25 megacycles in 5 bands. Calibration is said to be accurate to 2% per band up to the broadcast band and within 3% for high-frequency bands. Model has a planetary-drive condenser with direct reading calibration. Output can be modulated or unmodulated.

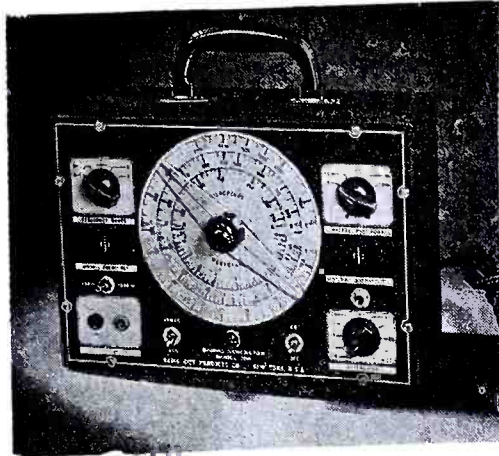

G.E.M. METERS

Meters featuring linear scales and unit construction have been announced by General Electronics Manufacturing Company, Culver City, California.

Unit construction is said to consist of jewel bearings, armature and core assembled as a unit construction that maintains accurate alignment and permits almost instant removal. Alnico magnet and pole piece used are said to be brazed together. Meter weighs .5 pound.

Standard meters include d-c voltmeters, ammeters, milliammeters, microammeters, and radio-frequency ammeters of the a-c thermo-couple type.

THREAD PROTECTORS

Internal and external safeguards for threaded and machined parts, fittings, etc., have been developed by Precision Paper Tube Company, 2033 West Charleston St., Chicago 47, Illinois.

They are made of spiral-wound fibre, kraft paper, or cellulose acetate, under heat-treated compression.

Protectors are cylindrical, square, rectangular or tapered, crimped, flared or perforated. Tolerances are said to be $\pm .003$ ".



I.C.C. CONDENSER MOUNTING

Brackets, M type, designed to permit the mounting of oil capacitors in either vertical or inverted position, have been developed by Industrial Condenser Corporation, 3243-65 North California Avenue, Chicago 18, Illinois.

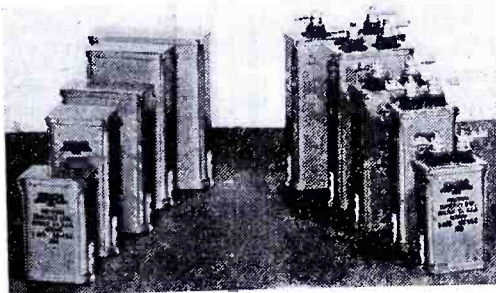

G. E. DELTABESTON FLAMENOL LEAD WIRE

A new deltabeston flamenol thermoplastic in-
(Continued on page 103)

STANDARD

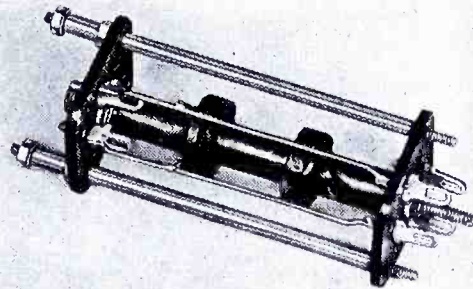

*Premability Tuned
9.F. Transformer*

PROFICIENCY

Because we are specialists . . . because we concentrate all our research engineering and production skill on meeting difficult coil requirements . . . we have achieved a degree of Proficiency that commands your investigation. Our engineering staff is available for consultation without obligation.

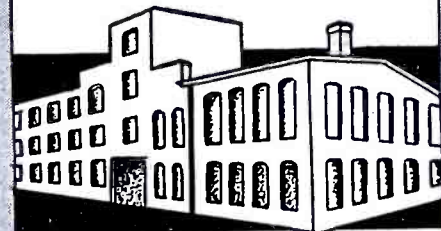

WE INVITE YOUR
INQUIRIES

STANDARD WINDING CO.

44-62 Johnes Street
NEWBURGH, NEW YORK
NEW YORK OFFICE: 53 PARK PLACE

REctor 2-5334

RELAYS by KURMAN

Twenty-five years' experience in solving all types of Relay Problems. Complete facilities for Designing, Engineering, Manufacturing, Special-ists in producing Relays of excep-tional power and sensitivity for Air-craft, Intercommunications Systems, Electronic Devices. Exclusive Kurman features provide greater depend-ability, longer life, more precise per-formance.

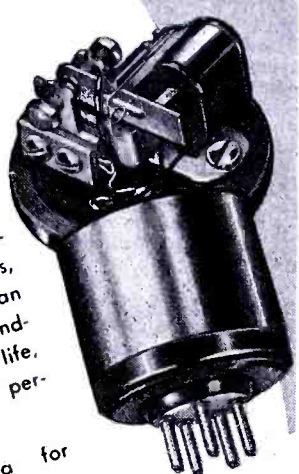

Send data for quotations.

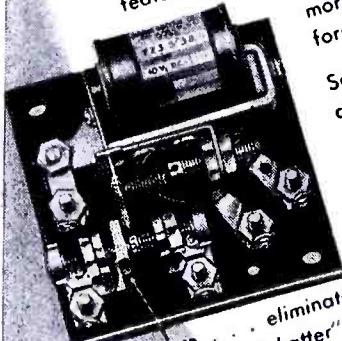

New Feature eliminates "bounce" and "chatter"

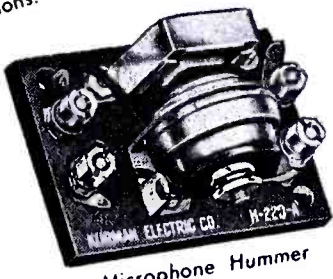

Microphone Hummer

KURMAN ELECTRIC CO.



35-18 37th STREET • LONG ISLAND CITY 1, N. Y.



CRYSTALS FOR THE CRITICAL

For years, The James Knights Com-pany has specialized in quantity pro-duction of an exceptionally wide variety of Quartz Crystals. James Knights patents on precision cuts and improved mechanical processes are in general use throughout the crystal industry. We make samples nearly every day for some new customer so that he can design his equipment to fit a crystal that is now a standard of comparison. Why not let us help you?

The JAMES KNIGHTS Co.
SANDWICH, ILLINOIS

Filters and Transformers ...for Unusual Jobs

Our new Catalog covering the specialized line of ADC Transformers, Filters, Equalizers, Key Switch-es, Jacks, Plugs and other electronic components is now ready.



Write for ADC Catalog No 14.

Audio Development Co.

2833 13th Ave. S., Minneapolis, Minn.

**INSTRUMENTS
THAT STAY ACCURATE**

Simpson

SIMPSON ELECTRIC COMPANY

5200-18 W. Kinzie St. Chicago 44, Illinois

**NATION-WIDE MAIL
ORDER DISTRIBUTORS
SINCE 1928**



**RADIO AND ELECTRONIC
DEVICES** For Trade... Industry... Vocational
... Communication... Public Utility and Ex-
perimental Applications

BURSTEIN-APPLEBEE CO.

1012-14 McGee St. Kansas City 6, Missouri

PRODUCERS of:

- Variable Resistors
- Selector Switches
- Ceramic Capacitors,
Fixed and Variable
- Steatite Insulators
- Silver Mica Capacitors



Centralab

Division of GLOBE-UNION INC., Milwaukee

WANTED RADIO-ELECTRONIC ENGINEER A KEY-MAN

We are looking for a man with wide experience in design and development of radio-electronic parts and components. To such a man this large corporation, established over 21 years, offers an exceptional opportunity in war and post-war work. Applications in full confidence. State qualifications fully. Box 145-G, Com-mUNICATIONS, 19 E. 47th St., New York 17, N. Y.

● **Ted McElroy**

World's Largest Manufacturer of
Wireless Telegraphic Apparatus
COMPLETE CENTRAL OFFICE EQUIPMENT
McElroy Manufacturing Corp.
82 Brookline Avenue • Boston, Massachusetts

THE INDUSTRY OFFERS . . . —

(Continued from page 101)

ted lead wire for use in all types of fluorescent lamp ballasts has been announced by E.

he insulation of this new wire is said to be eraging and resistant to flame, oils, acids and alkalies. The wire is available in solid and stranded conductors, sizes 16 and 18 AWG in any colors, including black, white, red and green.

FOR NARROW LEVER KEY

1/16" wide lever key, FTR-810, is now being produced by Federal Telephone and Radio Corporation, Newark, New Jersey.

aid to have 18-spring capacity. Designed for one or two way, locking or non-locking operation. Entire key assembly is said to be held together by a single screw. The spring mounts on one side of the two-piece pressed steel frame, with all front position springs in one group and all back position springs in another.

Contact springs are of nickel silver with cadmium cross-bar contacts, and brass back-spring springs are provided for tension adjustment. Non-click buffer springs are supplied for use in circuits where spring backlash is to be avoided. All springs are interchangeable and the pile-ups may be rearranged. Can be supplied fungus and moisture proofed according to Signal Corps specifications.

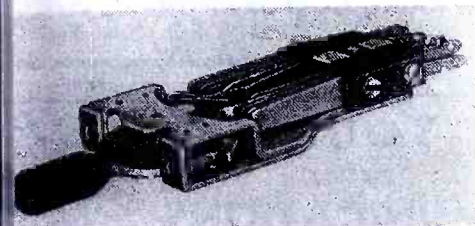

TELECHRON RADIO PRESELECTOR

A semi-automatic radio clock preselector, that works on the alarm clock principle, for installation in radio receivers, has been developed by the Warren Telechron Company (Ashland, Mass.).

The telechron alarm clock provides the basic mechanism for the new device. It is operated by a two-watt telechron a-c synchronous motor and can be furnished for 115-volt or 220-volt operation in any standard commercial frequency.

WESTINGHOUSE OSCILLOGRAPH

A self-contained electronic oscillograph has been developed by Westinghouse Electric and Manufacturing Company, P. O. Box 868, Pittsburgh, Pa.

Cathodes of the tubes are energized from a 1-kv d-c rectifier.

Unit consists of the oscillograph proper in front of the cabinet and the cabinet proper

which houses all energizing and control circuits.

In addition to fluorescent screen for direct observation, the instrument contains a stationary film holder taking a standard film for recording 1/1000 of a second or less. May be operated with a rotating film drum for use from 1/1000 to 1/10 of a second.

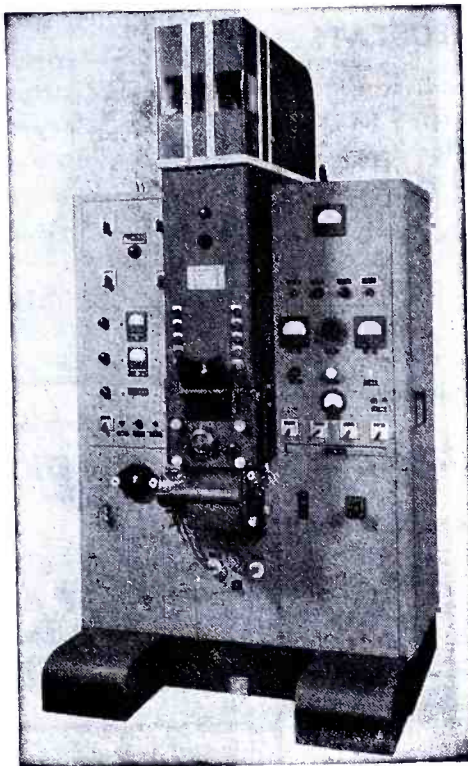

OHMITE ARMY-NAVY AIRCRAFT RHEOSTATS

Two approved power rheostats for aircraft made in accordance with the latest Army-Navy Aeronautical Specifications AN-R-14a, have been announced by Ohmite Manufacturing Co., 4835 Flournoy St., Chicago 44, Ill.

The rheostats are light weight. Two sizes are available: model "J" 50-watt and model "H" 25-watt; linear or taper wire-wound, in various resistances, with "off" position, as required.

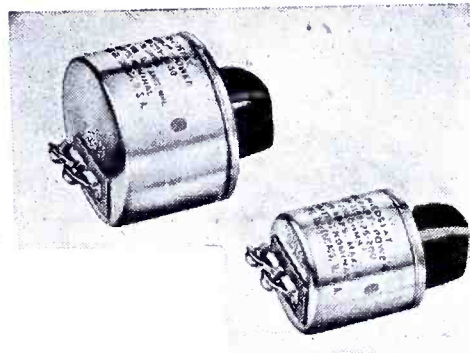

CLARK LEVER-LOCK BORING BAR

Lever-lock boring bars, available in sets of four . . . 3/16"x5", 1/4"x6", 3/8"x7" and 1/2"x8", have been announced by Robert H. Clark Company, 9330 Santa Monica Boulevard, Beverly Hills, California.

These bars are said to be designed for use without bushings or adaptors.

One precision ground high-speed threading bit and one boring bit are provided, with each bar. The lever-lock holds the tool bit at a right angle on one end and at a 15° angle on the opposite end.

INDEX

(Continued from page 66)

Vacuum Tube—Cross Reference Indices of New and Old Designations; J. R. Schoenbaum	Jan. 19
Values of the Function: cos(h sin V)cos V; Wilson Pritchett	Aug. 42
Wire, Hard Drawn Copper, Copper Weld and BB Galvanized Iron as Used for Open Wire and Cable Circuits; Paul B. Wright	Feb. 68
Voltage Ratings of Jan Specifications C-5 Fixed Mica-Dielectric Capacitors; Lt. Geo. A. Osmundsen	Aug. 37

Power Rheostat
as engineered
by
CLAROSTAT

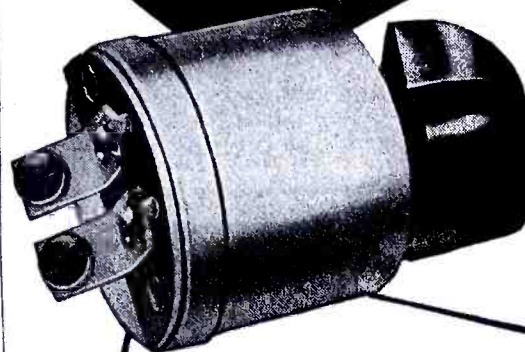

★ Insulated metal core supports resistance winding. Element imbedded in cold-setting inorganic cement. Maximum heat conduction and radiation.

★ Normal current rating may be exceeded by 50% at any setting up to 1/3 total rotation, without damage.

★ Rotor design provides smooth rotation and positive conduction at all settings.

★ Exceptionally rugged, electrically and mechanically.

★ 25- and 50-watt ratings. Enclosed type here shown. Also in non-enclosed type.

★ Hundreds of thousands of these Clarostat power rheostats are now in daily use. Especially so in aircraft assemblies. Indeed, they are standard equipment in planes, radio, electronic and industrial equipment. They are proving that "They can take it"—and then some.

★ Write for Literature



CLAROSTAT MFG. CO., Inc. • 285-7 N. 6th St., Brooklyn, N. Y.

KEEP YOUR RED CROSS AT HIS SIDE



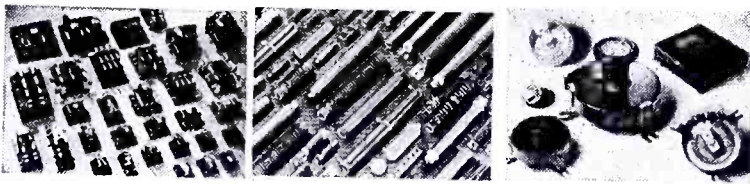

RELAYS • RESISTORS • RHEOSTATS

These controls are carefully designed and conscientiously made. They are conservatively rated to insure dependability and long life. Send for data bulletins describing the products of interest to you.

WARD LEONARD

Electric control (WL) devices since 1892.

WARD LEONARD ELECTRIC CO., 75 South St., Mount Vernon, N. Y.

Lister Electronic Products

1814 E. 40TH ST. CO. CLEVELAND 3, OHIO

Development and Manufacture of
**TRANSMITTERS AND RECEIVERS, AM AND FM
 INDUCTION HEATING FURNACES
 ELECTRONIC GAUGING EQUIPMENT
 INDUSTRIAL ELECTRONIC EQUIPMENT**

**CRYSTALS
 EXCLUSIVELY**



**SINCE
 1934**

ORDERS SUBJECT TO PRIORITY

PETERSEN RADIO CO., Council Bluffs, Iowa

SENIOR ELECTRONIC ENGINEERS

Preferably graduates of communication engineering courses are required for designing receiving-type electronic equipment covering all frequency ranges, and other specialized electronic apparatus.

Design experience necessary, and knowledge of production is desirable. Excellent post-war opportunities. Salary open. Requirements urgent. Proof of citizenship and certificate of availability are necessary.

Write giving detailed qualifications, and if satisfactory, interview will be arranged at our expense.

SUBMARINE SIGNAL CO.

175 State St., Dept. 420, Boston, Mass.

DRAFTSMEN WANTED

**MECHANICAL DESIGNERS
 CHECKERS FOR LAYOUTS
 DETAILING AND CHECKING**

*Radio and Electronic Equipment
 War Plant with Post-War Future*

HAMILTON RADIO CORPORATION

510 Sixth Avenue (14th St.), New York

**SHARE YOUR COPY
 OF
 COMMUNICATIONS**

Your Associate Engineers and Technicians will appreciate your courtesy. Uncle Sam will also.

EXTERNAL ANODE TRIODES

(Continued from page 46)

tween the anode and the cooling mechanism, which is normally at ground potential. Porcelain or rubber tubing is used to insulate the jacket from the rest of the cooling system electrically. Provision must be made also for controlling

electrolysis. This is usually accomplished by providing a metallic electrolysis target which can be replaced after it has been disintegrated. The necessity for pure water in the system is obvious, since impurities lead to increased conductivity, in-

creased electrolysis, and increased deposits which are formed on the anode of the tube.

In forced-air cooled tubes the heat is conducted away from the anode by a copper-fin structure that is soldered to the anode. The heat in the fins is in turn dissipated into the air which is forced through the fin structure. Such a tube is set in an insulated socket which provides a duct for the air flow from the blowers. It is important that the air be clean so that no dust collects in the various parts of the circulating system. Such dust may reduce the efficiency of the cooling apparatus to a dangerous point.

The other seals of the tube which provide for connection through the glass envelope to the filament strands and the grid are made by using a metal with essentially the same expansion coefficient as that of glass. Care must be taken that the temperature of these seals is kept below the danger point. In certain tubes air-blast cooling of the seals may be necessary. Too much cooling, however, may set up strains in the glass, which is a poor conductor of heat.

Although the filament of an external-anode vacuum tube is little more than a strand of tungsten arranged so that it can be heated to incandescence, its operational characteristics have furnished material for many pages of discussion. The resistance of a tungsten filament at 2500° K is thirteen times as great as the resistance of the same filament at room temperature. When it is realized that many of these filaments draw up to 100 amperes at normal operating temperature, the difficulties in designing a starting

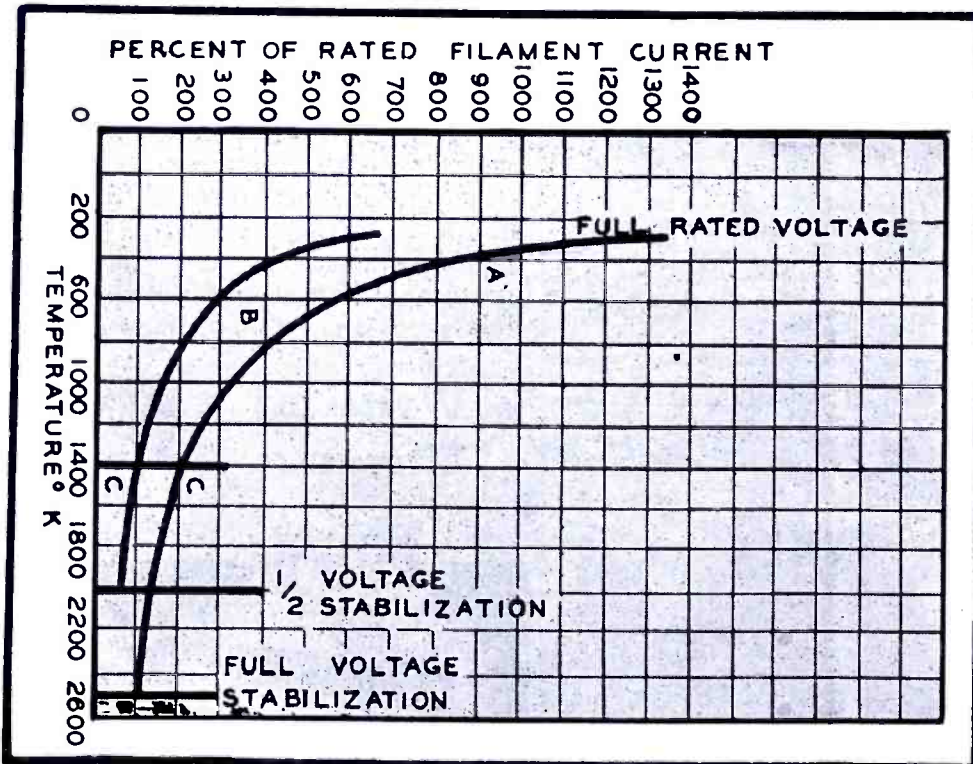

Figure 5

Variation of current with temperature for tungsten filament for half (B) and full (A) applied voltage. Normal operating temperature equals 2500° K. (Courtesy FTR).

the degree

Figure 6

Relationship between tungsten filament temperature and length of life.

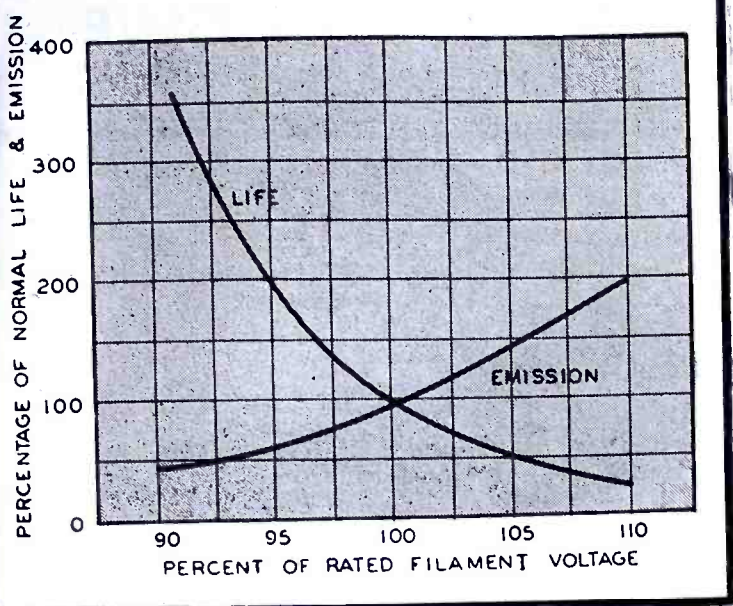

to which your communications problems are solved may determine the degree of your postwar business success.

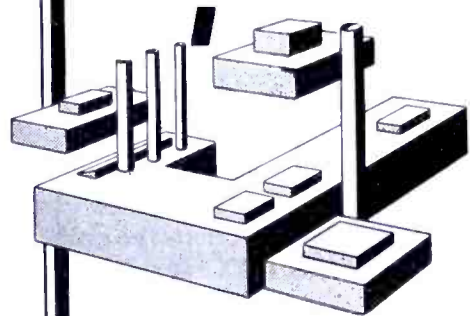

The First of a New Series of Bulletins Introducing FREQUENCY CONTROL UNITS . . . Now Ready. Also an Attractive Binder to Hold Bulletins . . . On Request

WRITE NOW FOR "CRYSTIONICS" INFORMATION AND BULLETIN

VALPEY

Crystal Corp.

CRAFTSMANSHIP IN CRYSTALS SINCE 1931
HOLLISTON, MASSACHUSETTS

circuit to bring these tubes to this temperature become apparent. The problem is two-fold. First, the cold filament is in effect a direct short on the supply; therefore, some means for current limitation must be supplied. Second, shock to the filament caused by such a high current transient must be prevented.

Figure 5 shows how the current of tungsten filament varies with temperature for full and half voltage. It has been known that such a set of curves can supply the information necessary to design the usual filament starting circuit. The two factors to be considered in such design are first, a means of limiting the current surges to twice the rated current; and second, the total time necessary to bring the filament to operating temperature. Since there is very little call for rapid-start circuits using external anode tubes, the first design requirement is most important. It may be seen from Figure 5 that if the series starting resistance is shorted out at point C, the current surge will be within the requirements. The resistance necessary to give half voltage at this temperature, 1400°, is given by

$$R = \frac{E_F}{2 I_F} \quad (1)$$

where E_F is the rated filament voltage, and I_F is the rated filament current

Since this resistance is usually inserted in series with the primary of the filament heating transformer, the above relation must be modified to give the necessary primary resistance:

$$R = \frac{E_L^2}{2 E_F I_F} \quad (2)$$

where E_L is the primary voltage. This resistor also limits to a safe value

the starting current when the filament is cold. The total current through the cold filament must be less than 200% normal, since the resistance determined in 1 is half the operating resistance. High reactance transformers may also be used to limit starting current.

The time necessary for the filament to come to the 1400° temperature with the starting resistance determined from 1 or 2 is difficult to determine because of the number of thermal factors involved.

Jones and Langmuir⁶ have derived an expression for the heating time for tungsten filaments which is accurate where small temperature changes are involved. Experimental determination of the actual heating time for each filament is generally necessary, however. It is interesting to note that, in general, the heating time varies with the square of the strand diameter and with the first power of the length. Since there is no reason for hurrying the process, it is possible to make the first part of the heating cycle long enough to bring the filament to a stable temperature, a condition which can be visually noted by the operator.

To obtain maximum life from a tungsten emitter the operating temperature should be kept as low as possible. Figure 6 shows graphically this relationship between temperature and length of life. The extent to which the filament voltage may be reduced is limited by the available emission. In the fundamental design of the tube a compromise is made between the life expectancy on the one hand and filament heating power required on the other. Although tubes with a life of 50,000 hours are within the realms of possibility, they would be very uneconomical because of the increased filament heating capacity necessary, the increased power consumption, and the increased filament heat dissipation.

It is apparent from Figure 6 that the filament life of an external-anode vacuum tube depends not only on the tube design itself, but also on the design of the equipment into which it is installed. This fact is illustrated by the long life obtained from the tubes used in high-level modulated broadcast transmitters where the design has been very generous. Because the external anode tubes are expensive items it is important that the designer consider this life factor in equipment design and balance it against increased costs of conservative operation.

[To be continued]

Professional Services
Rates on Request

ELECTRONIC DESIGN SERVICE
• Electronic Devices
• Transmitters
• Receivers
COMMUNICATIONS BOX DE
19 E. 47th St., New York 17, N. Y.

AUDAX

RELAYED-FLUX
Microdyne

The Importance of SPECIALIZATION

Aside from outstanding and long-acknowledged technical skill — our "Specialization Formula" is probably as fully responsible for the world-renowned AUDAX quality as any other single factor.

We proudly concentrate all our energies and resources upon producing the BEST pick-ups and cutters. Because we are specialists in this field, much more is expected of us. Because the production of fine instruments like MICRODYNE is a full time job, it stands to reason that we could not afford to jeopardize our reputation—EVER—by making pick-ups a side-line.

After Victory, you may expect AUDAX improvements, refinements . . . master-touches to heighten the marvelous *fac simile* realism of AUDAX reproduction.

AUDAX COMPANY

500-C Fifth Ave., New York 18, N. Y.

Creators of High Grade Electrical and Acoustical Apparatus Since 1915

Send for your copy of our informative "PICK-UP FACTS"

★ BUY WAR BONDS

"The Standard by Which Others Are Judged and Valued"



ADVERTISERS IN THIS ISSUE

COMMUNICATIONS—JANUARY, 1945*

THE ACME ELECTRIC & MFG. CO. 82	'SLIP RADIO MFG. CORP. 98
Agency: Scheel Adv. Agency	Agency: The Kotula Co.
ADVANCE ELECTRIC & RELAY CO. 12	E. F. JOHNSON CO. 21, 76, 88, 101
Agency: John H. Riordan Co.	Agency: David, Inc.
AEROVOX CORPORATION 18	HOWARD B. JONES CO. 88
Agency: Austin C. Lescarboura & Staff	Agency: Merrill Symonds, Advertising
AIREON MFG. CORP. 5	THE JAMES KNIGHTS CO. 102
Agency: Erwin Wasey & Co., Inc.	Agency: Turner Adv. Agency
ALTEC-LANSING CORP. 68	KURMAN ELECTRIC CO. 102
Agency: Erwin, Wasey & Co. of The Pacific Coast	Agency: H. J. Gold Co.
AMALGAMATED RADIO TELEVISION CORP. 99	THE LANGEVIN CO. 1
Agency: Shappe-Wilkes Inc.	Agency: Terrill Belknap Marsh Associates
AMERICAN PHENOLIC CORP. 31	LENZ ELECTRIC MFG. CO. 6
Agency: Evans Associates, Inc.	Agency: Triangle Adv. Agency, Inc.
AMPEREX ELECTRONIC CORP. Inside Front Cover	LISTER ELECTRONIC PRODUCTS CO. 104
Agency: Shappe-Wilkes Inc.	LITTELFUSE, INC. 94
AMPERITE CO. 80	Agency: Merrill Symonds, Advertising
Agency: H. J. Gold Co.	McELROY MFG. CORP. 104
VICTOR J. ANDREW CO. 90	Agency: Shappe-Wilkes Inc.
Agency: Burton Browne, Advertising	MACHIETT LABORATORIES, INC. 25
ARPIN PRODUCTS, INC. 74	Agency: St. Georges & Keyes, Inc.
Agency: Gallard Adv. Agency	MEC-RAD DIV. BLACK INDUSTRIES. 17
THE AUDAX CO. 106	Agency: G. M. Basford Co.
Agency: Hart Lehman, Advertising	MEASUREMENTS CORP. 96
AUDIO DEVELOPMENT CO. 102	Agency: Frederick Smith
Agency: Turner Adv. Agency	MERIT COIL & TRANSFORMER CORP. 81
BARKER & WILLIAMSON. 95	Agency: Ross Llewellyn, Inc.
Agency: The Harry P. Bridge Co.	MICARTA FABRICATORS 97
THE BIRTCHEP CORPORATION 78	Agency: Sander Rodkin, Advertising
Agency: Robert F. Dennis, Inc.	JAMES MILLEN MFG. CO., INC. 76
L. S. BRACH MFG. CORP. 91	MYCALEX CORPORATION OF AMERICA. 29
Agency: United Adv. Agency	Agency: Rose-Martin, Inc.
BREEZE CORPORATIONS INC. 22	NATIONAL ELECTRONIC MFG. CO. 96
Agency: Burke Dowling Adams	Agency: H. J. Gold Co.
BURGESS BATTERY CO. 73	NATIONAL UNION RADIO CORP. 49
Agency: Howard H. Monk & Associates	Agency: Hutchins Adv. Co., Inc.
BURSTEIN-APPLEBEE CO. 102	NORTH AMERICAN PHILIPS CO., INC. 53
Agency: Frank E. Whalen Adv. Co.	Agency: Erwin, Wasey & Co., Inc.
CANNON ELECTRIC DEVELOPMENT CO. 75	OHMITE MFG. CO. 8
Agency: Dana Jones Co.	Agency: Henry H. Tepplitz, Advertising
CENTRALAB 102	PETERSEN RADIO CO. 104
Agency: Gustav Marx Adv. Agency, Inc.	PREMAX PRODUCTS DIV. CHISHOLM-RYDER CO., INC. 84
CINAUDAGRAPH SPEAKERS, INC. 98	Agency: Norton Adv. Service
Agency: Michael F. Mayger	PRESTO RECORDING CORP. 67
CLAROSTAT MFG. CO., INC. 103	Agency: The M. H. Hackett Co.
Agency: Austin C. Lescarboura & Staff	RADIO CORPORATION OF AMERICA 65
COLE STEEL EQUIPMENT CO. 93	Agency: Kenyon & Eckhardt, Inc.
Agency: Ehrlich & Neuwirth	RADIO RECEPTOR CO., INC. 71
COMMUNICATIONS CO., INC. 85	Agency: Shappe-Wilkes Inc.
Agency: Moran & Webb	RAYTHEON MFG. CO. 37
CONCORD RADIO CORP. 72	Agency: Burton Browne, Advertising
Agency: Shappe-Wilkes Inc.	RAYTHEON MFG. CO. 55
CONSOLIDATED RADIO PRODUCTS CO. 79	Agency: Sutherland-Abbott
Agency: Burton Browne, Advertising	REMLER CO., LTD. 47
CORNISH WIRE CO. 101	Agency: Albert A. Drennan
Agency: Hart Lehman, Advertising	THE ROLA CO., INC. 10
COTO-COIL CO., INC. 83	Agency: Foster & Davies, Inc.
Agency: Frank E. Dodge & Co., Inc.	SHURE BROTHERS CO. 51
CRYSTAL PRODUCTS CO. 13	Agency: Henry H. Tepplitz, Advertising
Agency: R. J. Potts-Calkins & Holden	SIMPSON ELECTRIC CO. 102
D-X CRYSTAL CO. 94	Agency: Kreicker & Melan, Inc.
Agency: Michael F. Mayger	SOLA ELECTRIC CO. 19
DeJUR-AMSCO CORP. 24	Agency: Hardy Advertising
Agency: Shappe-Wilkes Inc.	SPERRY GYROSCOPE CO., INC. 11
DIAL LIGHT COMPANY OF AMERICA 90	Agency: Young & Rubicam
Agency: H. J. Gold Co.	SPERTI, INC. 77
DRAKE MFG. CO. 86	Agency: Stockton-West-Burkhart, Inc.
Agency: The Vandan Co., Inc.	SPRAGUE ELECTRIC CO. 4
ALLEN B. DuMONT LABS., INC. 28	Agency: The Harry P. Bridge Co.
Agency: Austin C. Lescarboura & Staff	STANDARD WINDING CO. 101
EASTERN AMPLIFIER CORP. 27	Agency: Sternfeld-Godley, Inc.
Agency: Roberts & Riemers, Inc.	STRUTHERS-DUNN, INC. 20
EITEL-McCULLOUGH, INC. 23	Agency: The Harry P. Bridge Co.
Agency: L. C. Cole, Advertising	SUBMARINE SIGNAL CO. 102
ELECTRONIC LABORATORIES, INC. 41	Agency: The H. L. Moore Co.
Agency: Burton Browne, Advertising	SURPRENANT ELECTRICAL INSULATION CO. 74
ELECTRO-VOICE MFG. CO., INC. 89	Agency: C. Jerry Spaulding, Inc.
Agency: Shappe-Wilkes Inc.	SYLVANIA ELECTRIC PRODUCTS INC. 3
FEDERAL TELEPHONE & RADIO CORP. 15	Agency: Newell-Emmett Co.
Agency: Marschalk & Pratt	TECH LABORATORIES 88
FEDERAL TELEPHONE & RADIO CORP. 80	Agency: Lewis Adv. Agency
Agency: Commerce Agency, Inc.	THOMAS & SKINNER STEEL PRODUCTS CO. 78
A. W. FRANKLIN MFG. CO. 42	Agency: The Caldwell-Baker Co.
Agency: Sam J. Gally	THE GEORGE S. THOMPSON CORP. 78
Agency: Sam J. Gally	Agency: Robert F. Dennis, Inc.
GENERAL INSTRUMENT CORP. 61	THORDARSON ELECTRIC MFG. CO. 100
Agency: H. W. Fairfax Agency, Inc.	Agency: Duane Wanamaker, Advertising
GENERAL RADIO CO. Inside Back Cover	TOBE DEUTSCHMANN CORP. 63
GOTHARD MFG. CO. 100	Agency: Franklin Bruck Adv. Corp.
Agency: Merchandising Advertisers	TRIPLETT ELECTRICAL INSTRUMENT CO. 26
HALLICRAFTERS CO. 69	Agency: Western Adv. Agency, Inc.
Agency: Burton Browne, Advertising	U. S. TREASURY DEPT. 30
HAMILTON RADIO CO. 104	UNITED TRANSFORMER CORP. 56
Agency: Newmark's Adv. Agency, Inc.	Agency: Shappe-Wilkes Inc.
HAMMARLUND MFG. CO., INC. 32	UNIVERSAL MICROPHONE CO. 16, 92
Agency: Roeding & Arnold, Inc.	Agency: Ralph L. Power Agency
HARCO STEEL CONSTRUCTION CO., INC. 76	VALPEY CRYSTAL CORP. 105
Agency: Lewis Adv. Agency	Agency: Cory Snow, Inc.
HARVEY RADIO CO. 84	WM. T. WALLACE MFG. CO. 92
Agency: Shappe-Wilkes Inc.	Agency: Michael F. Mayger
HARVEY RADIO CO. 84	WARD-LEONARD ELECTRIC CO. 104
Agency: Walter B. Snow & Staff	Agency: E. M. Freystadt Associates, Inc.
HEINTZ & KAUFMAN, LTD. 59	WESTERN ELECTRIC CO. 98
Agency: The Conner Co.	Agency: Deutsch & Shea Adv. Agency, Inc.
HEWLETT-PACKARD CO. 7	WESTINGHOUSE ELECTRIC & MFG. CO. Back Cover
Agency: L. C. Cole, Advertising	Agency: Fuller & Smith & Ross, Inc.
HOLLISTER CRYSTAL CO. 82	ZOPHAR MILLS, INC. 74
Agency: Merrill Owens Adv. Agency	Agency: J. G. Proctor Co., Inc.
THE HOPP PRESS, INC. 84	
Agency: Gallard Adv. Agency	
HUDSON-AMERICAN CORP. 14	
HYTRON CORPORATION 9	
Agency: Henry A. Loudon—Advertising	
INSULINE CORPORATION OF AMERICA. 87	
Agency: H. J. Gold Co.	

*Due to paper restrictions several advertising pages had to be omitted from this issue.

for the **5th** time

ARMY **E** NAVY



GENERAL RADIO was granted the coveted Army-Navy "E" Production Award for the fifth time in December of last year. G-R is one of the very few in the electronic industry to receive this honor five times.

The production of precision electrical test equipment is a highly specialized business, demanding maintenance of close tolerances in all inspection, manufacturing and calibrating operations. Constant and close supervision by highly trained personnel is required to produce equipment of the precision and reliability of G-R instruments.

In order to meet the greatly increased production called for by the war, G-R has expanded to its limit, both in space and in personnel. We have subcontracted machining operations to several local firms; we have transferred our entire VARIAC production to leased space in another building; we have obtained considerable space in another building where we have contracted for a large number of war-time workers under our own foremen; we have let out the complete manufacture of several instruments to other manufacturers; we have turned over the design, drawings and models of several critical instruments to other manufacturers for their exclusive use.

G-R is proud that it has been able to meet the urgent production requirements of the war effort. It is equally grateful that the substantial contributions from its Development and Engineering Departments, through many thousands of hours of consulting engineering on secret war projects, have directly assisted in the solution of technical problems of the greatest urgency.

GENERAL RADIO COMPANY Cambridge 39, Massachusetts
NEW YORK CHICAGO LOS ANGELES

4 NEW *Fact-Ful* GUIDES FOR DESIGNERS OF COMMUNICATIONS EQUIPMENT



D-C CAPACITORS—Lists and describes a complete range of capacitors for d-c applications from 400 to 250,000 volts. Booklet 3300.



PRESTITE INSULATOR GUIDE—Blueprints of **SOLDER-SEALED** bushing assemblies, terminal boards and many other items available for communications equipment. Booklet 3244.

HIGH VOLTAGE D-C CAPACITORS . . .

SOLDER-SEAL CERAMIC INSULATORS FOR HIGH-FREQUENCY APPLICATIONS . . .



FASTER HF COIL ASSEMBLIES . . .

PREASSEMBLED HIPERSIL CORES—Lists sizes and applications of new 2-piece, thin-lamination cores for High-Frequency equipment. Booklet 3229-A.

STEPPED-UP D-C VOLTAGES . . .

WESTINGHOUSE DYNAMOTORS—A full description and listing of dynamotors available for aviation and communications equipment. Booklet 3242.



SEND FOR THESE NEW BOOKLETS TODAY!



Westinghouse
PLANTS IN 25 CITIES . . . OFFICES EVERYWHERE

Communications Products