

\$1.00

# COMMUNICATIONS

a merger of  
RADIO ENGINEERING  
...  
COMMUNICATION &  
BROADCAST ENGINEERING  
...  
THE BROADCAST ENGINEER

DECEMBER  
1937



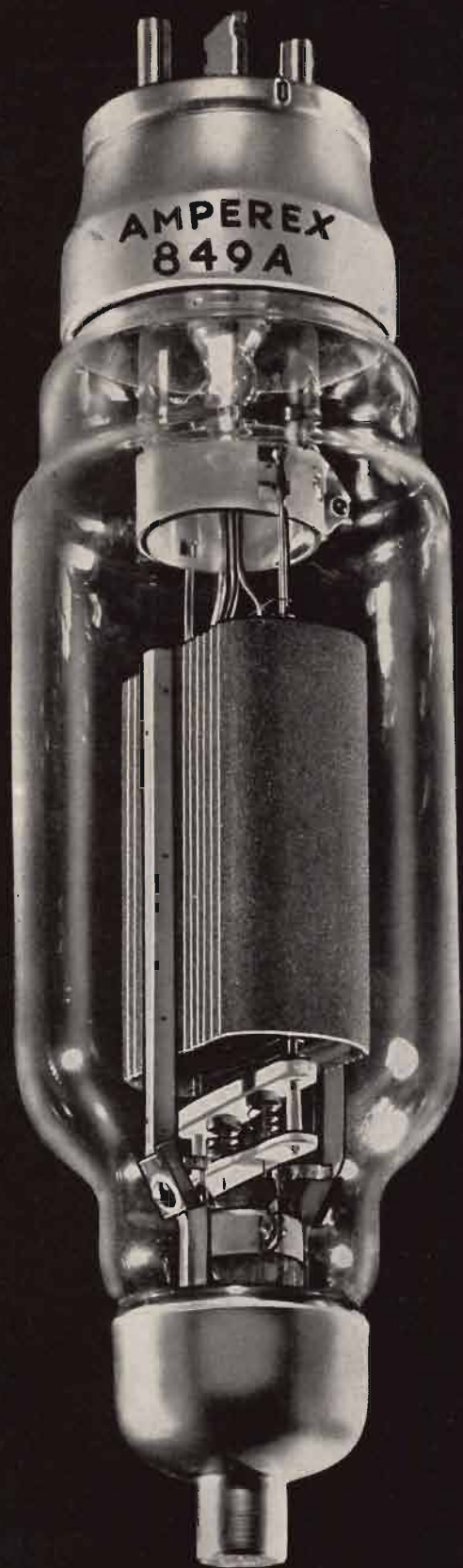

# Modernized AMPEREX 849A

and AMPEREX \*849H

Greater Power Output  
Higher Plate Dissipation  
Longer Operating Life

\*Higher Ratings at High Frequency

The application by Amperex of the modern engineering concept of the space relationship of electrodes in a vacuum tube has resulted in the design of a new type with far greater performance capabilities than the standard 849. Simplification of structure because of this new design has also made possible considerable economies in manufacturing processes which are reflected in the price of these tubes.

THE OUTSTANDING FEATURES OF  
THESE NEW TUBES ARE AS FOLLOWS:

- GREATER FILAMENT AREA
- LARGER PLATE SURFACE
- MORE UNIFORM ANODE HEAT DISTRIBUTION
- A MINIMUM OF INTERELECTRODE INSULATING SPACERS
- 1500 WATTS maximum power output per tube as a Class C, CW amplifier
- 750 WATTS Carrier Power Output, as a plate modulated Class C amplifier
- 250 WATTS Carrier Power Output as a grid bias modulated Class C amplifier
- 250 WATTS Carrier Power Output as a Class B Linear R.F. amplifier
- 1600 WATTS maximum signal power output per pair as Class B, A.F. modulator
- 150 WATTS Undistorted Power Output as a Class A A.F. Modulator

The features enumerated above clearly demonstrate that not only can these tubes be used profitably to replace 849's in existing equipment but that they also fill a gap in the air cooled line of tubes for use in equipment where severe derating at high frequencies forced the use of much larger and costlier tubes.

\* The 849H can be operated at full ratings up to 30 megacycles in many classes of service. It is identical in its characteristics with the 849A. The only point of difference is the grid lead terminal which in the 849H terminates in an arm extending from the side of the bulb.

\$135

**AMPEREX ELECTRONIC PRODUCTS, Inc.**

79 WASHINGTON STREET

BROOKLYN, NEW YORK



The 1938 Coronet Model "Silvertone" Radio is completely housed in a lustrous black one-piece Bakelite Molded cabinet. Product of Sears Roebuck & Co. Molder, American Insulator Corp.

# STYLING THAT KEEPS PACE with Technical Advances



**A**S EACH year's improved models are brought out by leading radio manufacturers, an increasing number are housed in up-to-the-minute cabinets of lustrous Bakelite Molded. Every advance in technical design finds this material fully competent to express equal progress in styling.

One reason for this, is that the lustre, self-contained color, fine texture, and moldability of Bakelite Molded offer unlimited opportunity for originality in styling. Another, is that the use of this material affords important simplifications and economies in the production and assembly of sets.

Bakelite Molded cabinets for either large or small table radios may be completely formed in a single molding operation. In the same operation, all lugs, bosses and through-holes are formed; metal inserts are permanently embedded; and the final lustrous finish is imparted to all surfaces.

Radio engineers and designers are urged to consider the outstanding merits of Bakelite Molded for electrical parts as well as cabinets. Special types of this material offer special advantages such as low power loss, high impact strength, or unusual heat resistance. Write for comprehensive reference booklet 50M, "Bakelite Molded".

BAKELITE CORPORATION, 247 PARK AVENUE, NEW YORK, N.Y.  
BAKELITE CORPORATION OF CANADA, LIMITED, 163 DUFFERIN STREET, TORONTO, CANADA West Coast: Electrical Specialty Co., Inc., 316 ELEVENTH STREET, SAN FRANCISCO, CAL.

# BAKELITE

REGISTERED U.S. PAT. OFF.



**THE MATERIAL OF A THOUSAND USES**

COMMUNICATIONS FOR DECEMBER 1937 • 1

# COMMUNICATIONS

Member of Audit Bureau of Circulations

RAY D. RETTENMEYER • Editors • W. W. WALTZ

## CONTENTS FOR DECEMBER

Cover Illustration: RCA ultra-short-wave antenna for the transmission of wide frequency bands.

	Page
With the Editors.....	4
Limiting Amplifiers.....By John P. Taylor	7
Rectifier Types and Applications.....By Bernard H. Porter	11
Modern Design of the 849.....By Robert Lord	15
Instantaneous Recording Needles.....By Major R. H. Ranger	16
Laminated Iron-Core Coils with Air-Gap at High Frequencies, By R. K. Hellmann	18
The Harmonic Producer.....By C. H. Bidwell	19
Remote Receiving Antennas.....By Dr. Victor J. Andrew	23
Telecommunication.....	25
An Ultra-High-Frequency Oscillator.....By Arnold Peterson	26
Notes and Comment.....	28
Veteran Wireless Operators Association News.....	30
The Market Place.....	32
Over the Tape.....	44
Index of Advertisers.....	48

VOLUME 17

NUMBER 12

BRYAN S. DAVIS  
President

JAMES A. WALKER  
Secretary

Chicago Office—608 S. Dearborn St.  
Telephone: Wabash 1903.

Published Monthly by the  
BRYAN DAVIS PUBLISHING CO., INC.

19 East 47th Street  
New York City  
New York Telephone: PLaza 3-0483



SANFORD R. COWAN  
Manager

PAUL S. WEIL  
Advertising Manager

A. B. CARLSEN  
Circulation Manager

Wellington, New Zealand—Te Aro Book Depot.  
Melbourne, Australia—McGill's Agency.

*Entered as second class matter October 1, 1937, at the Post Office at New York, N. Y., under the act of March 3, 1879. Yearly subscription rate: \$2.00 in the United States and Canada, \$3.00 in foreign countries. Single copies: twenty-five cents in United States and Canada, thirty-five cents in foreign countries.*

# They took our word

Even before the Western Electric 110A Program Amplifier was officially announced, orders began pouring in from broadcasters. They'd heard what we said it would do—and they bought on faith. Now they've been using it for some months—and some of them have written us what it has done for them. Today you need not take our word . . .

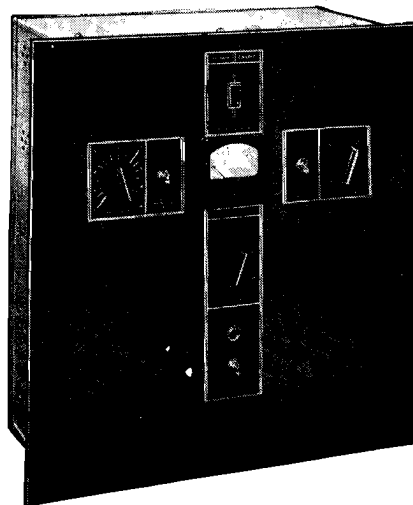

## . . . you can take THEIRS!

**WINS:** "marked improvement in signal . . . certain dead-spots eliminated . . . both quality and volume improved."

**WKBH:** "signal at outer edge of service area noticeably improved . . . a great help in maintaining high program level without over modulation."

**WOR:** "areas where signal was hashed with monkey chatter now cleared considerably . . . 3 db audio increase has definitely aided in clearing this condition."

**WTAG:** "no difficulty in normal operation at level 3 to 4 db higher than previously used."

**WAIM:** "a very good investment . . . has increased fidelity of signal."

**WDAE:** "normal coverage increased 25% . . . quite possible to use 5 db of compression without any particular change in quality of transmission . . . never worry any more about any conceivable sort of line surge."

**WISN:** "Materially aids in maintaining higher average percentage of modulation . . . signal boosted between 3 and 4 db."

**WMBD:** "better signal to noise ratio."

**KFYR:** "average modulation percentage very much higher . . . interruptions due to high audio surges have ceased to exist . . . stations separated 10 KC can be tuned in without monkey chatter."

**KXRO:** "any station without it can hardly be called modern . . . makes it possible to broadcast most any voice, ballyhoo or shouting without spoiling effect."

**WMBH:** "unsolicited reports from localities and distances never or rarely heard from before, best prove the 110A is really doing its stuff."

**WDAY:** "unsolicited reports that we come-in much better . . . average modulation level about 3.5 db higher."

**WJBO:** "consider the 110A the outstanding development during the past 5 years . . . decided increase in signal . . . practical abolition of monkey chatter."

**WHAM:** "no fear of distortion from over modulation . . . will raise standards of any station which has one."

**KQW:** "has improved signal about 100% . . . much favorable comment from listeners and sponsors."



# Western Electric

Distributed by GRAYBAR Electric Co. In Canada: Northern Electric Co., Ltd.

RADIO TELEPHONE BROADCASTING EQUIPMENT

# WITH THE EDITORS

---

## FAIR TRADE PRACTICE HEARING

THE PROPOSED fair trade practice rules for radio receiver manufacturers are again under indefinite advisement by the Federal Trade Commission following a public hearing in Washington, D. C., on December 7. The gathering was attended by a large number of manufacturers as well as other interested groups.

The rules proposed last month by the Commission were formally "disapproved" by the Radio Manufacturers Association. A revised draft, previously presented by the RMA, was submitted. This revised draft included additional rules to prohibit "spiffs," P.M.'s and dummy tubes.

The recommendations were presented by James M. Skinner, Chairman of RMA's Trade Practice Rules Committee. Mr. Skinner stated that the fair trade merchandising principles of the FTC and the RMA rules were not at variance, but that the questions involved were ones of detail and verbiage.

Special objection was made by Mr. Skinner to the Commission's proposed rule requiring "origin and manufacture" of receiving sets to be identified. General merchandising practices in the sale of many special brand products do not require labels of the manufacturer, according to the RMA statement, and manufacturer's names in such distribution convey no useful information to the purchaser.

The Commission's hearing lasted some three hours and was conducted by Chairman George McCorkle and Assistant Chairman Henry Miller of the Commission's Trade Practice Conference Section. They announced that the various rules proposed would be considered further. However, no indication was given as to when a final decision might be expected.

## AUTOMATIC GAIN CONTROL

LAST SPRING one of the large broadcast equipment manufacturers announced an apparatus to automatically limit volume. This device, which was designed primarily to prevent excessive peaks of over-modulation, has been well received by the broadcast stations.

Recently, other manufacturers have announced automatic gain control units, while a number of stations have been testing original apparatus of a similar nature. In view

of this, we believe that Mr. Taylor's article on page 7 of this issue should be of considerable interest, since it covers all the commercial equipments announced to date.

## PROTECTED INTERMEDIATE FREQUENCY

IN CONNECTION with our editorial on "Protected Intermediate Frequency" in the October, 1937, issue of COMMUNICATIONS, it is interesting to note that in a report made by the Radio Manufacturers Association to the Federal Communications Commission it was pointed out that most radio receiver manufacturers in both the United States and Canada will use the 455-kilocycle intermediate frequency during the coming year.

An RMA questionnaire disclosed that only four manufacturers were not yet ready to adopt the standard intermediate frequency. The report, however, indicated future adoption by these manufacturers when interference difficulties were removed. The Federal Communications Commission is endeavoring to protect the standard frequency by not authorizing any new assignments in the band from 450 to 460 kilocycles.

## CONCERNING TELEVISION

DURING the past month there has been a number of events of interest in the field of television. Let us review them briefly.

On December 8, the Federal Communications Commission granted a construction permit to the Philco Radio & Television Corporation for the erection of a new television station in Philadelphia. The new station is on an experimental basis.

In New York, the RCA Manufacturing Company delivered a mobile television transmitter to the National Broadcasting Company. NBC will begin conducting experiments immediately with the new mobile unit.

On December 9, Peck Television Corporation demonstrated a mechanical television system which is capable of operation over standard wire lines.

## NAB CONVENTION

WE UNDERSTAND that the Sixteenth Annual Convention of the National Association of Broadcasters will be held in Washington, D. C. The meetings will be at the Hotel Willard from February 14 to 16, inclusive.



## CONDENSERS

ENLARGED FACILITIES enable improved deliveries, in all types and sizes. Semi-regulating dries are available. The current drain is extremely low, especially important for battery operation. These condensers are very rugged and will stand up under very severe service conditions.

## MAGICORES

THIS COMING YEAR appears to be a "core" year. Current redesigns of receivers are incorporating many new and extremely important magicore applications. Auto sets are almost universally using I-F and antenna cores. Many new materials and shapes have been produced. We would appreciate the opportunity to familiarize you with the engineering possibilities.

**CROLITE**

PATENTED

PROCESS

## CERAMICS

Molded. Extruded. Machined.  
Increased production facilities.  
Low loss material.

### CERAMIC CEMENT

Low loss ceramic cement with new possibilities.  
Why not investigate them?

### LIQUID CROLITE SUPER QUARTZ

An impregnating and covering liquid with losses lower than fused quartz.

**HENRY L. CROWLEY & CO., INC.**

1 CENTRAL AVENUE

WEST ORANGE

N. J.



# NEWS ACROSS THE SEVEN SEAS

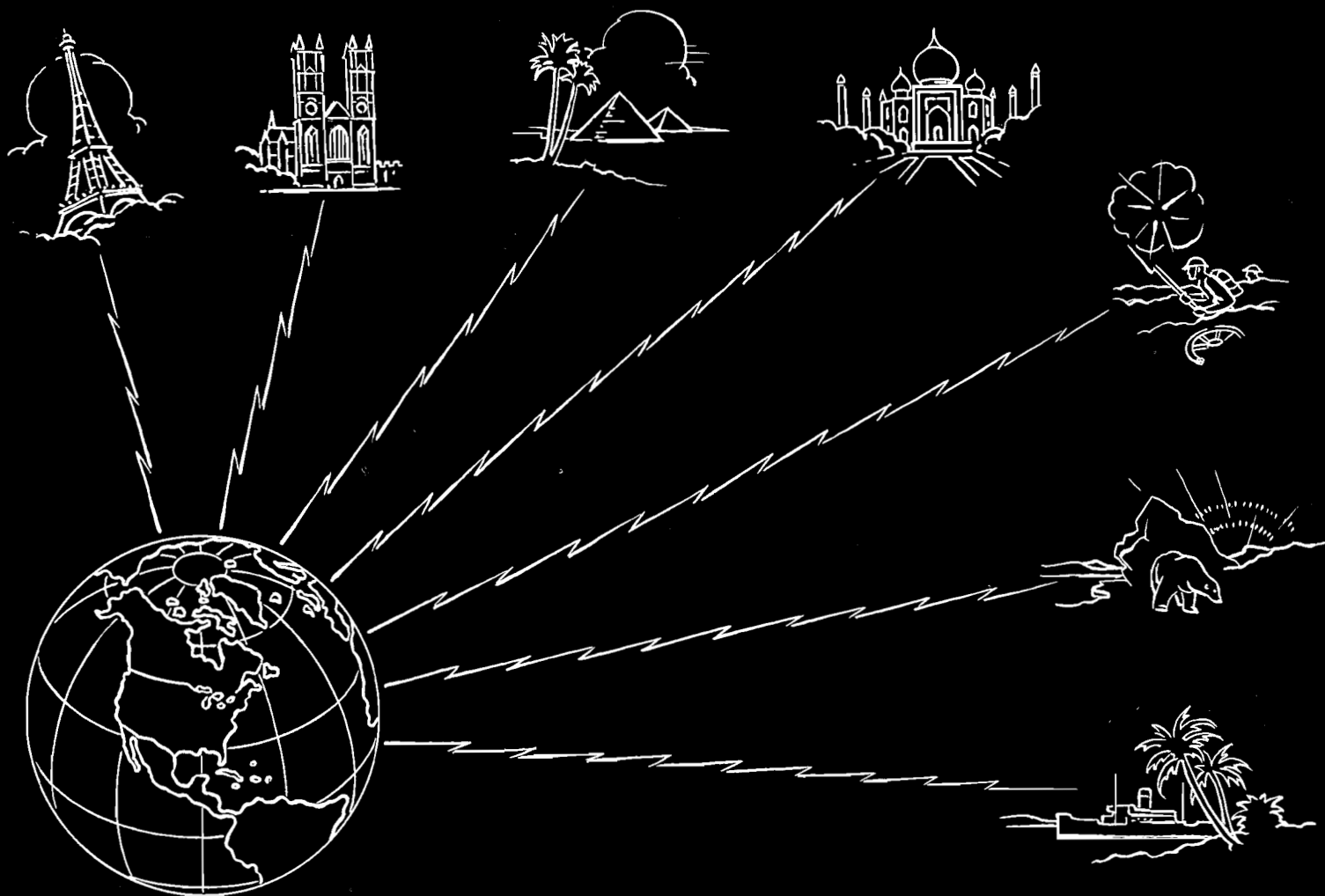

**T**O AND FROM every continent in the world messages are constantly being flashed across the seas via radio telegraph. News . . . business correspondence . . . private messages—all must reach their destination with minimum delay, maximum economy, and accurate transcription.

In commercial radio communication equipment Isolantite\* ceramic insulators function with complete reliability...reducing dielectric losses...providing efficient insulation of transmission lines and antennae.

Again, at the receiving end Isolantite's dependable insulating properties provide the highest

operating efficiency throughout the entire circuit.

To all branches of the radio communications field Isolantite engineers offer the benefits of their long experience in the manufacture and application of ceramic insulators. If you are planning new installations of radio equipment you will find this experience of great practical value.

\* Registered Trade-name for the products of Isolantite Inc.

## ISOLANTITE INC.

### CERAMIC INSULATORS

Factory: Belleville, N. J. • Sales Office: 233 Broadway, New York, N. Y.



# COMMUNICATIONS

FOR DECEMBER, 1937

## LIMITING AMPLIFIERS

By JOHN P. TAYLOR

SOME MONTHS AGO one of the larger broadcast equipment manufacturers (Western Electric) introduced a speech-input amplifier designed to provide automatic compression of program peaks. Recently other manufacturers have announced more or less similar units. The interest in, and flood of orders for these equipments, indicates that they are likely to become a broadcast fixture. The manufacturers, in a burst of conservatism, started out by referring to units of this type as "program" amplifiers. However, an industry noted for its realistic nomenclature has irrevocably dubbed them "limiting" amplifiers. Nor does this seem unjustified, for a study of the three units announced to date indicates that they are built, essentially, around the limiting feature—with secondary considerations—as, for instance, their use in place of the usual "program" amplifier—falling pretty much under the

heading of making virtue out of necessity.

Recognition of the possibilities of applying automatic gain control to trans-

mitter circuits is far from being a new development. More or less successful circuits to this end were devised some ten years ago. And a limiting amplifier practically duplicating the operations of those now offered for broadcast purposes has been in regular use in motion-picture studios for several years. Why the practical application to broadcasting was so long delayed is something of a mystery. That there was, and is, a demand for such a device is well-proven by the fact that, in a period of a few months, more than half the stations in the country have placed orders for these units.

No doubt part of the reluctance to introduce such a device can be attributed to the hush-hush attitude toward "compression" which formerly prevailed. There was a time, and not so long ago, that the very mention of the subject was almost a misdemeanor. However, this

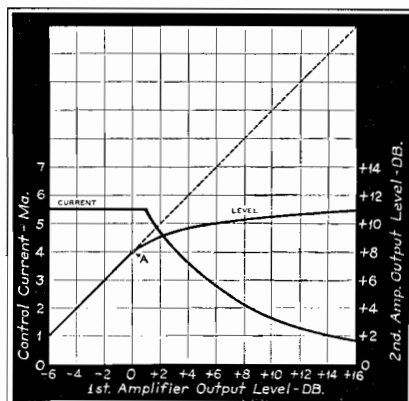

Fig. 1. Operating characteristic of the Type 110-A amplifier.

Fig. 2. Front view of 110-A unit. Controls include level adjustments, peak-flash lamp, and power, VI meter and time-constant switches.

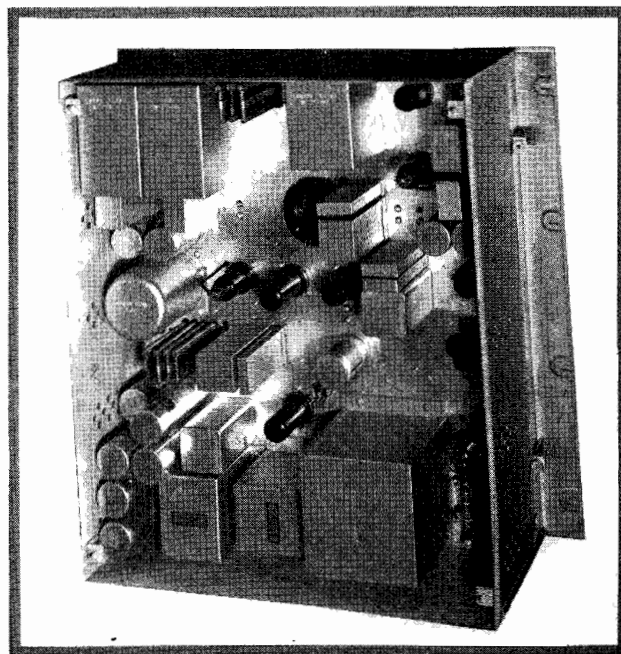
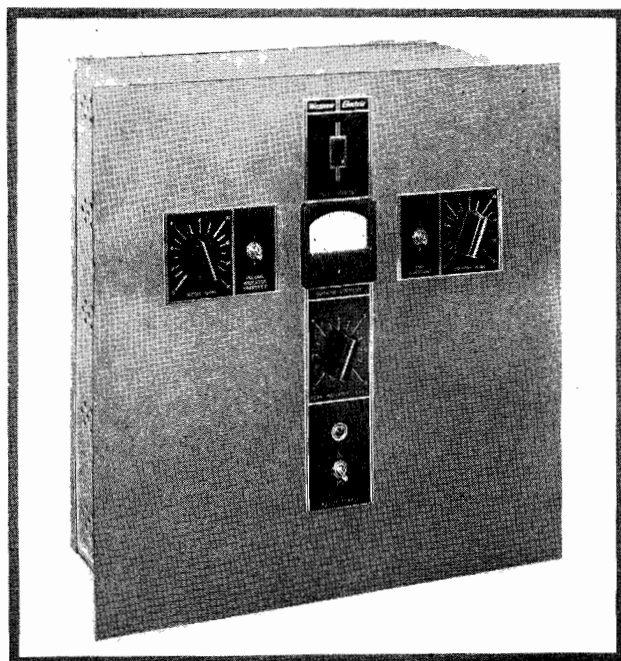

Fig. 3. Rear view of 110-A amplifier with cover removed. Mounting of tubes and main components can be seen. Terminals and wiring are covered.

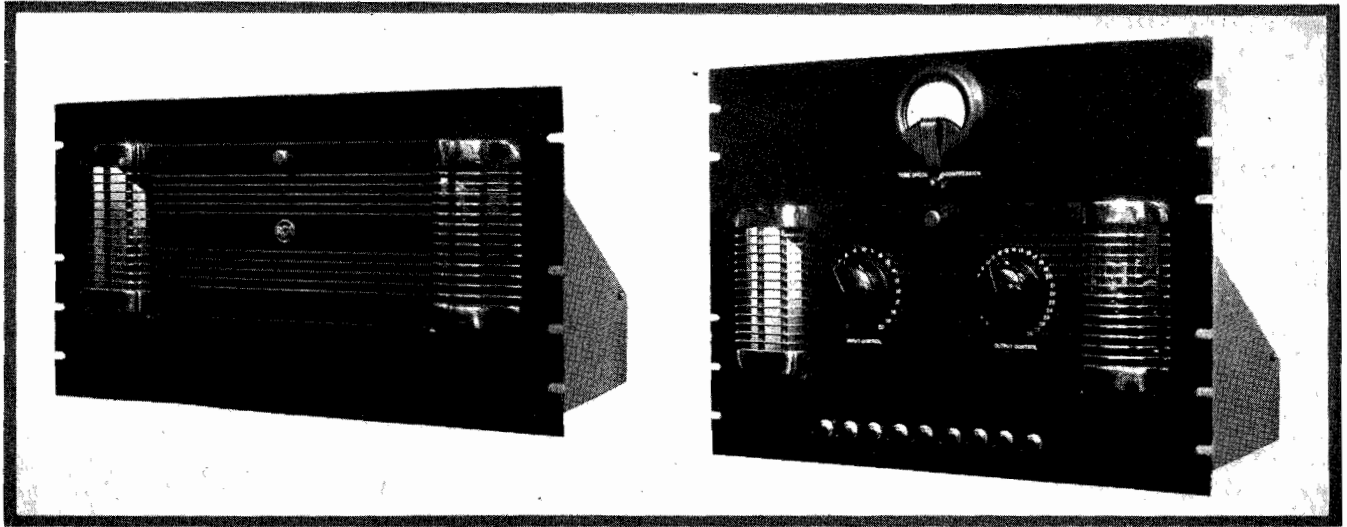

Fig. 5. Front views of the 96-A amplifier and power-supply unit.

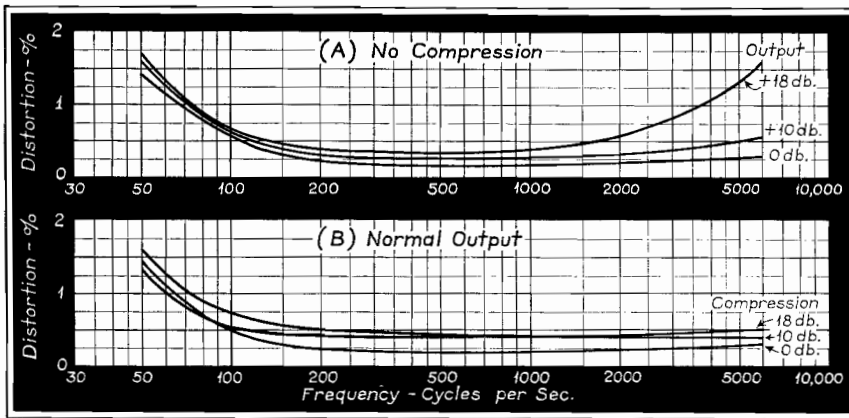
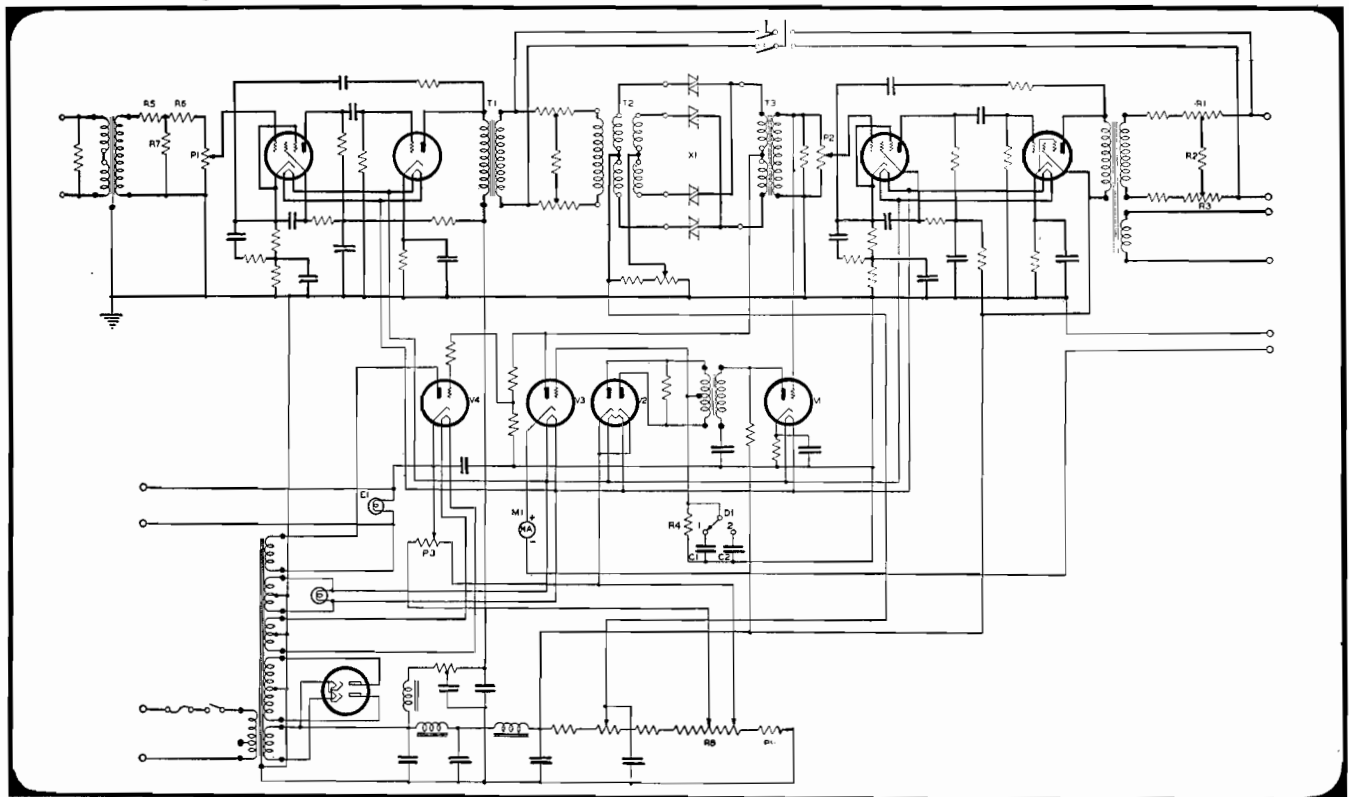

Fig. 8. Performance of 96-A amplifier. (A) Distortion at no compression. (B) Distortion for various degrees of compression (0 db output level).

has gradually given way to a more common-sense viewpoint of the problem. After all, where acoustic levels ranging up to 90 db must be fitted into transmitter receiving systems limited to 50 db or less, compression—voluntary or involuntary—is inescapable. Either the modulating degree is greatly reduced, and part of the low-level range thereby lost in the background, or else high levels are ridden down and lows brought up (by the control operator) until the spread approximates the transmissible range. Allowing for differences of opinion as to degree, there seems to be general agreement that the latter course is preferable. The point of this is not to

Fig. 4. Schematic diagram of the 110-A unit. The Varistor control elements are marked XI.



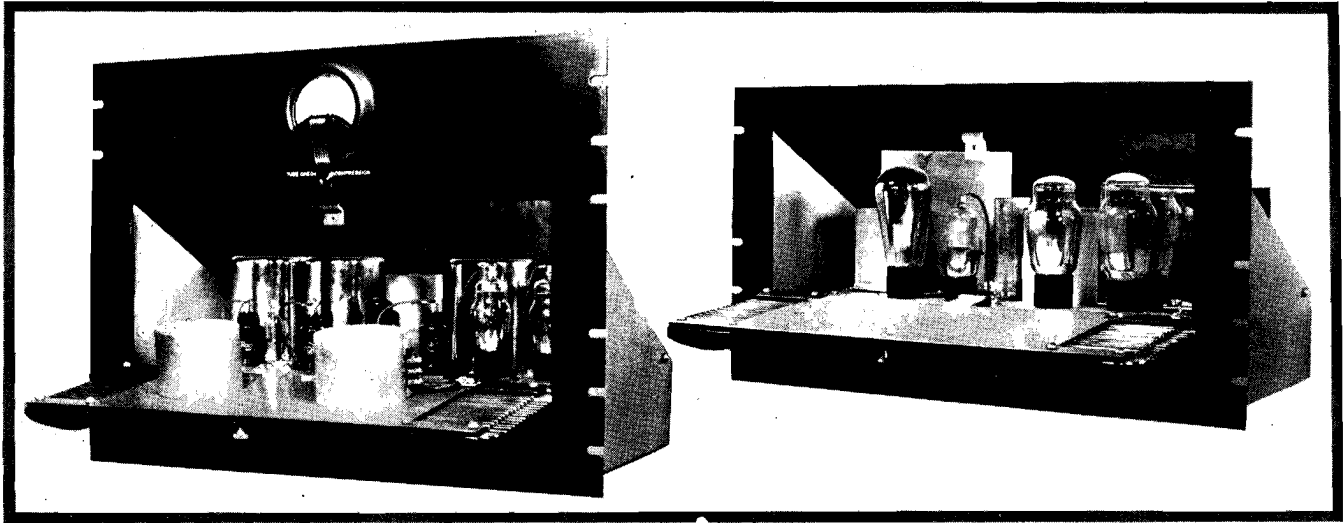

Fig. 6. The 96-A amplifier and power supply with front doors open.

make a direct comparison between the operations of the control-room operator and that of the limiting amplifier—since there is, as noted below, an essential difference—but simply to bring out the fact that now there is no objection to compression per se.

THE IDEA

At first glance the operations performed by a limiting amplifier seem much like those of the studio control operator in riding gain. The only actual similarity, however, is in that both entail compression of the volume range. The function of the control operator is to manually adjust the gain in accord-

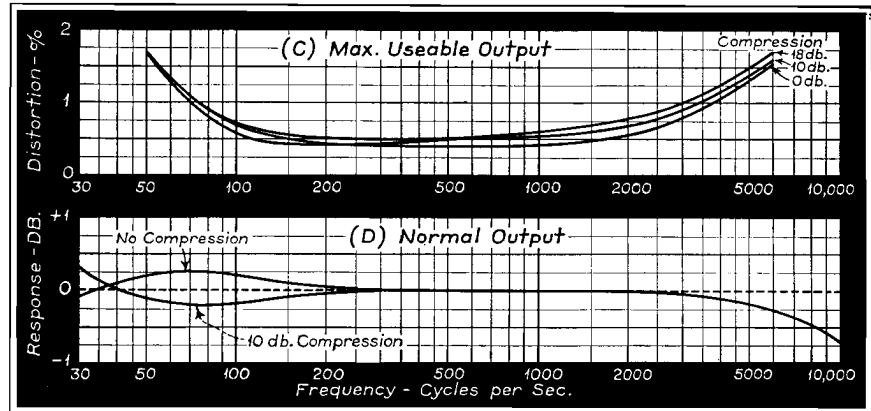
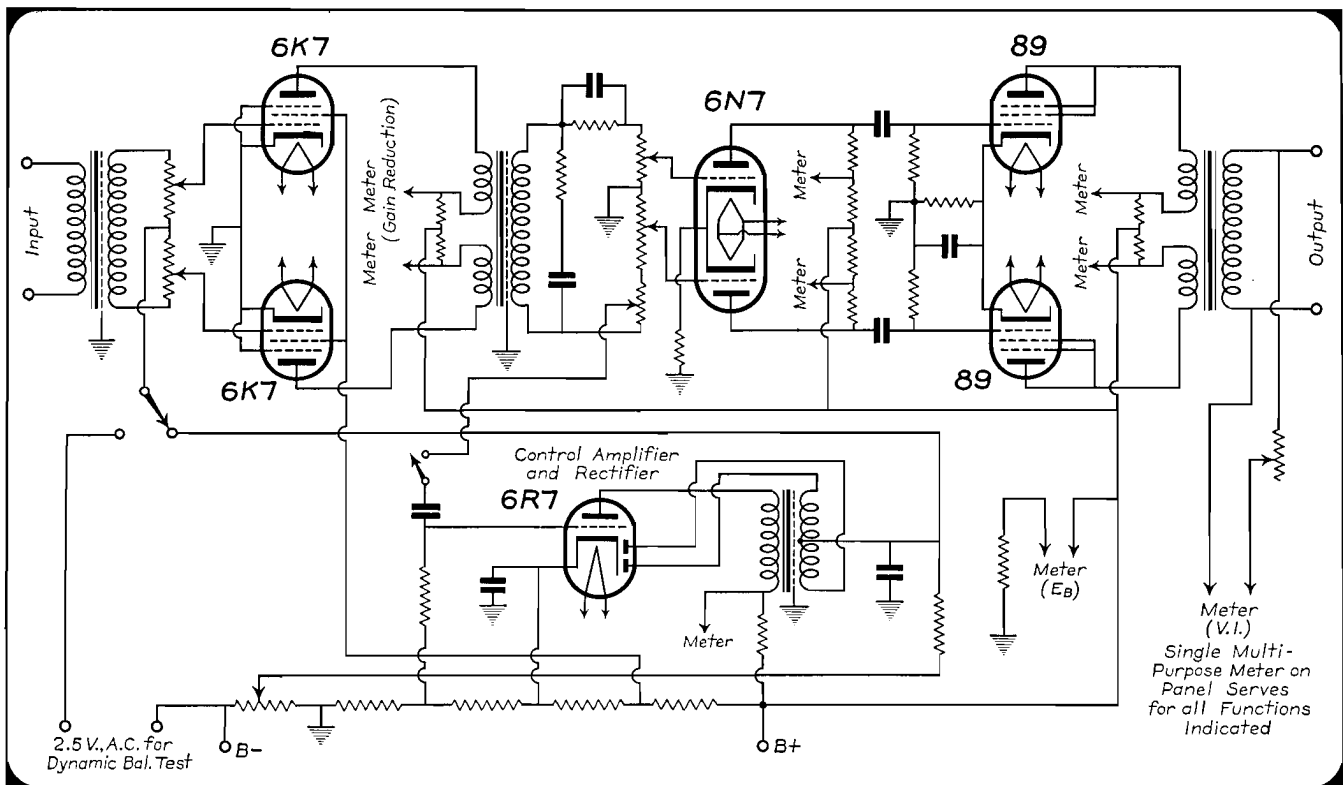

Fig. 8. Performance characteristic of 96-A. (C) Distortion for various degrees of compression (plus 18 db output level). (D) Frequency characteristic.

Fig. 7. Schematic diagram of the 96-A amplifier. The amplifier proper composes 3 push-pull audio stages.



ance with the average level of the program. He can raise a low passage, or reduce a loud one; but he cannot, as a rule, act quickly enough to cut down loud peaks of short duration. If he is adept in following the score, or has had the benefit of many rehearsals, he may indeed anticipate some of these. But most operating is not accomplished under such conditions, and even when it is there will remain occasional peaks not suppressed as desired. Hence, if the effects of overmodulation—carrier shift, distortion, adjacent-channel interference—are to be avoided, it is necessary to keep the average modulation sufficiently low that these peaks do not greatly exceed 100 percent modulation. But, since these peaks may represent levels several times the average level, such operation necessarily means very ineffective use of the available power. It is this situation which the limiting amplifier is intended to improve. The method is to provide a gain reduction system which, coming into play at high audio levels, automatically reduces the gain of the system and thereby keeps peak levels within a predetermined limit. Properly used, this allows the average modulation to be stepped up to something like half again as much—say from 30 percent to 45 percent. Output at the receiver is, of course, proportionately increased.

#### THE OPERATION

It will be well to note that while the operation of the limiting amplifier is essentially that of an automatic gain control system, it is a control which functions only at high levels. At all ordinary levels it is inoperative. In this respect

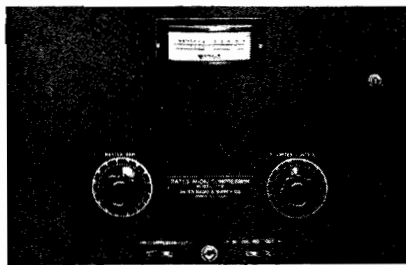

Fig. 9. Front view of the Type 17-B audio compressor.

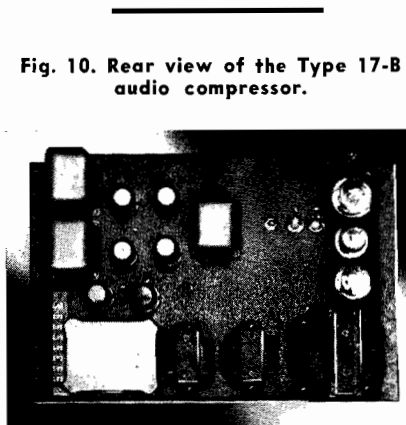

Fig. 10. Rear view of the Type 17-B audio compressor.

it may be likened to the "delayed a-v-c" action used in some receivers. In Fig. 11 is shown a curve which illustrates this operation. It should be noted that this is a plot of audio levels—inputs, to the control stage, vs. output—rather than the usual dynamic characteristic, with which it may be easily confused. Looking at this curve, it will be seen that up to a preset point (marked A on the curve) results in a corresponding increase in output. Above this point, however, only slight increases in output

occur for even very large increases in input level. If the input is adjusted so that this point ("A" on the curve) corresponds to ordinary peak program levels, and the output adjusted so that, at this same point, the transmitter will be modulated up toward maximum (say 80 percent), then excessive peaks, giving inputs above this, will cause the gain reduction system to function, with the result that a graduated compression will be applied and likelihood of overmodulation practically eliminated. At the same time, however, the operation at all levels below this predetermined point is unaffected. Moreover, this type of compression—which is comparatively severe—must be applied only to peaks of the short excessive-level type; it should never be used to reduce gain on high passages of continued duration. Thus the limiting amplifier in no way takes the place of the control operator. It does supplement his efforts, and helps him to achieve better results. But any idea that it will replace or eliminate "gain-riding" is erroneous and should be carefully eschewed.

#### THE VARISTOR TYPE

While the three standard types of limiting amplifiers so far made available are quite similar as to characteristics, and almost exactly so as to mode of application, they show a very interesting contrast in the manner in which the desired gain reduction is obtained. The Western Electric Type 110-A amplifier, which was the first of these equipments to make its appearance—and which is shown in Fig. 2 and Fig. 3—depends for its essential operation on the use

(Continued on page 39)

Fig. 11. Schematic diagram of the 17-B audio compressor.

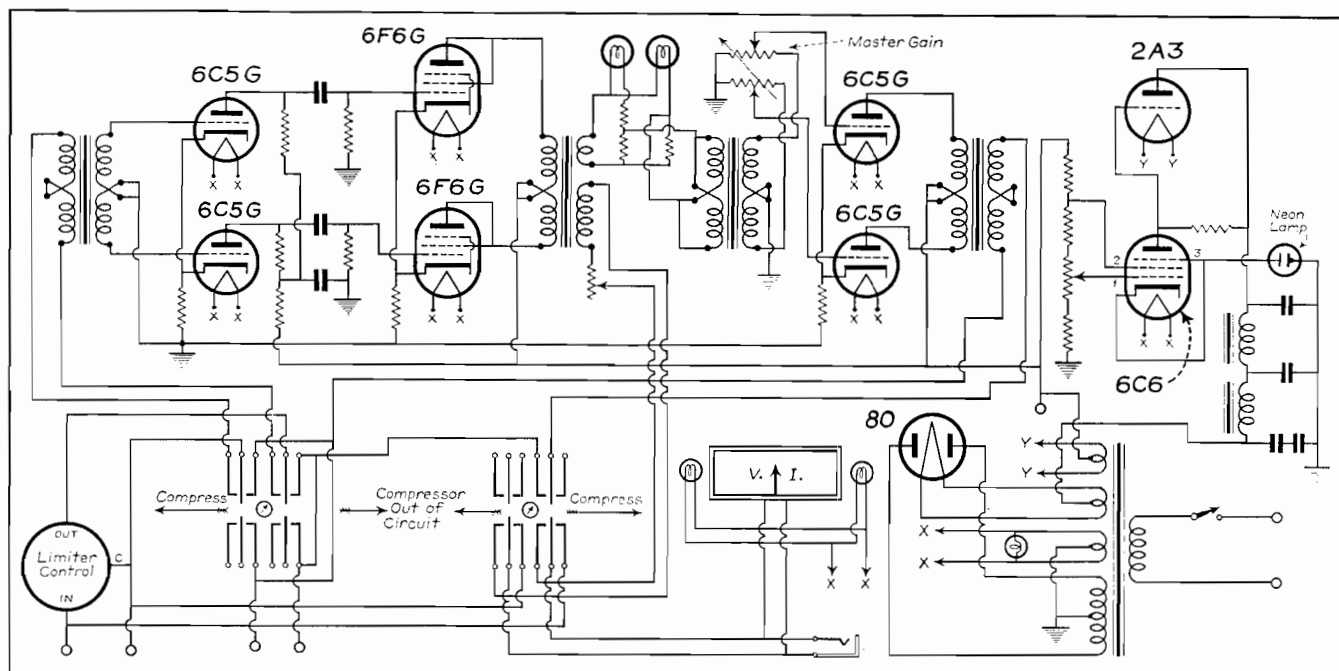

# RECTIFIER TYPES AND APPLICATIONS

By **BERNARD H. PORTER**

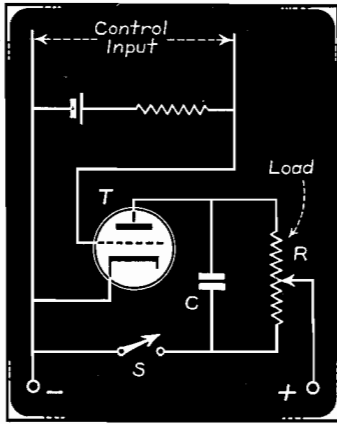

Fig. 2. Circuit for d-c operated, grid rectifier.

THE RECTIFIER, briefly, is not a generator of voltages, but rather is a uni-directional valve offering relatively low resistance to a flow of current in one direction as opposed to a high resistance to similar passage in the other. The manifold mechanical forms this electrical principle has assumed in recent years include not only the original purpose of converting alternating to direct current but also a variety of related and extended applications having wide industrial use. The communications field now consumes a major volume of rectifier sales, a fact that is better appreciated from the descriptive resume that follows about these devices, their applications, and production techniques.

## MERCURY-ARC RECTIFIERS

The nature of the cathode spot formed on the mercury pool determines the rectifying action of mercury-arc rectifiers. As the cathode in this device is the only electrode to which current can flow from the ionized space, any inverse currents to the anode are neglected. Subject to variations with temperature and circuit conditions, cathode spots usually require a current of four or five amperes for their maintenance. When this current is no longer sufficient, the spot extinguishes rapidly, a condition causing potential surges in the circuit from energy

TABLE I—CHARACTERISTIC RATINGS OF HOT-CATHODE, GAS & VAPOR RECTIFIERS

Amperes output	0.6	2.0	6.0
Voltage rectified	7.5	75.0	75.0
Filament volts	1.8	2.0	2.2
Filament amperes	6.0	12.0	18.0
Starting volts	8-12	9-15	12-18
Volts arc-drop	5-8	5-9	6-11

stored in any inductances that may be in series with the rectifier. To overcome the high-potential gradient in cathode spots, special starting means consist of an electrode dipping in a mercury reservoir connecting with the cathode when the tube is dipped. A conducting path on the tube's exterior and formed with the aid of aqueous colloidal graphite serves the same purpose.

In the smaller units as used in communications work, glass vessels house the rectifier. For output voltages less than 100 volts no anode shielding is required. Current ranges cover 10-300 amperes and can be increased somewhat for short periods without failure. The arc-drop for rectifiers having unshielded anodes is about 15 volts, a condition that increases the operating temperature and hence affects the potential handled. The arc-drop also changes with the load and is dependent on temperature. Moreover, if the surfaces directly above the anode are not at a sufficiently high temperature to discourage the condensation of mercury upon them, a local area of high

Fig. 1. Direct-current arc back of a glass mercury-arc rectifier.

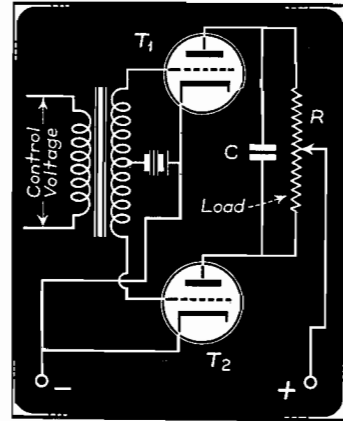
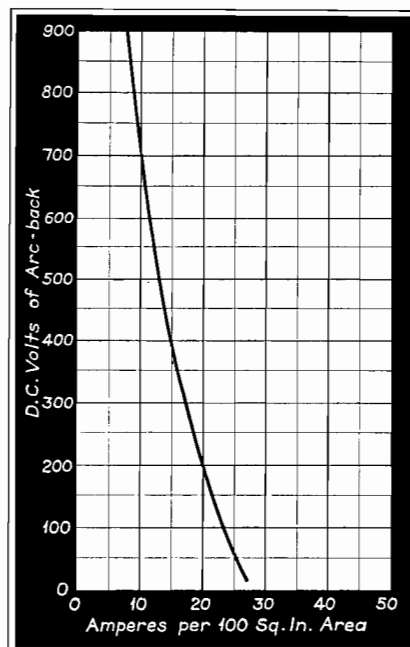

Fig. 3. Use of one rectifier tube to control a second.

vapor pressure results to cause arc-back. The formation of a cathode spot on the anode, breakdown voltage, vapor pressure, flashing at low temperatures, and the presence of foreign gases all have their effect on the rectifier's arc-back or failure to rectify. (Fig. 1.)

## HIGH-VACUUM, HOT-CATHODE UNITS

A positive potential applied to a cold electrode will collect, under conditions of an electrical field and corresponding potential drop, the electrons emitted by a heated pole and thereby cause a non-reversal flow of current. By insuring a highly evacuated space for this transfer a rectifying device can be made to withstand a high inverse voltage. Within the limits governed by space-charge effects and resulting power losses, the cathode can be made larger and the currents carried thereby increased. In general, however, this type of rectifier serves well only for high voltage outputs and is not suited to heavy currents carried with a maximum of efficiency. Its range of a few watts to 100 kw make it applicable for transmitting purposes, high-potential cable-testing sets, and precipitation processes.

Somewhat smaller types of hot-cathode valves, more popularly known as high-vacuum half-wave rectifiers are most efficient in supplying the d-c volt-

TABLE II—CHARACTERISTIC RATINGS OF ELECTROLYTIC TYPE OF RECTIFIERS

FLUID CAPACITY	OPERATING HOURS	CONTINUOUS CURRENT
1 gal.	2750	1-3
1 qt.	750	0.5
1 pt.	375	0.5
6 oz.	150	0.25



tential of the valve in question above the critical voltage thus causing it to arc while other tubes still heavily biased are not affected.

Although these general principles have been known for some time, full advantage of the grid-controlled rectifiers have not yet been developed or taken, particularly in their ability to select oncoming surges of varying voltages for the release of relays and similar devices. In the field of pure science this capacity has been utilized for the automatic recording of radioactive and high-speed radiations. (Fig. 4).

Grid-controlled rectifiers can effect relay control due to light action on photo-electric cells, regulate signal and traffic communications, and measure short time intervals accurately. Their regulation of generators and motors, as well as conversion of direct to alternating current is well known.

#### ELECTROLYTIC TYPES

Aluminum in concentrated ammonium sulphate, magnesium in an alkaline fluoride, and tantalum in sulphuric acid are three examples of the combined materials known to pass at their junction or interface a current in one direction. A lead electrode is the second contact in each case. Adjuncts like ferrous sulphate and cobaltous sulphate minimize lead's erosion in the presence of acids.

When an unformed cell is subjected to an alternating current, a spongy film containing excess oxygen forms on the tantalum electrode. Electrons pass only in the direction of metal to oxide layer. The passage of current both decomposes the aqueous content of the electrolyte and maintains the desired oxide film.

Fig. 8. Circuit recently patented for telephone signalling.

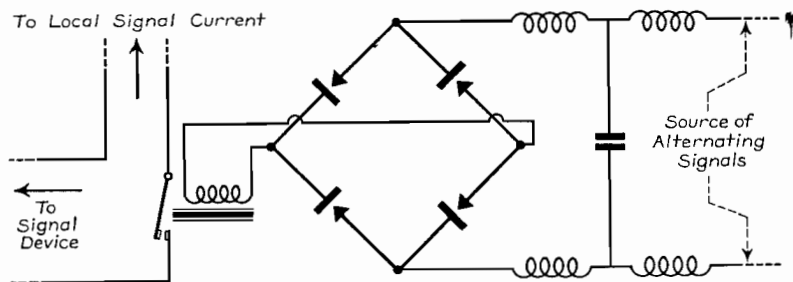

The former condition is solved by the frequent addition of distilled water. When employing this device other than for charging radio batteries and similar purposes demanding high potentials and currents, the individual cells are not connected in series but are used singly in the circuit with transformers. Characteristic ratings are given in Table II.

#### JUNCTION DESIGNS

The junction type of rectifier has grown out of the deficiencies of some of the above discussed rectifiers for all-

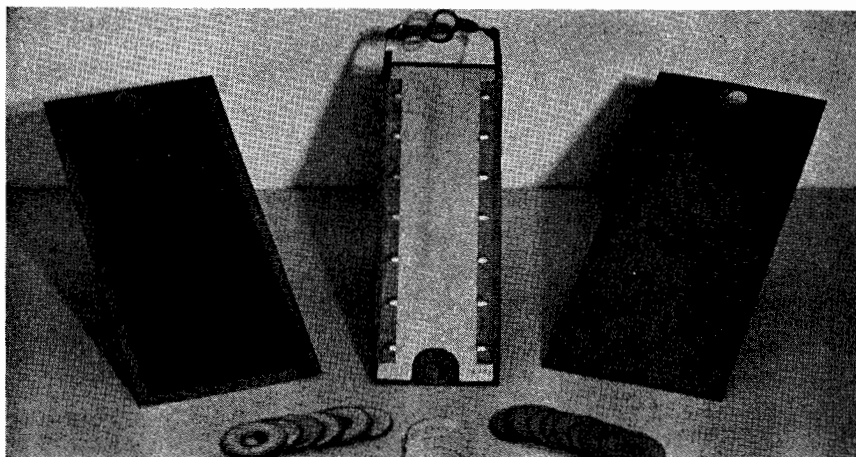

Photo Courtesy Westinghouse Electric & Mfg. Co.

Fig. 9. A comparison of disc and plate type elements in oxide and colloidal graphite treated stages.

purpose radio work. In an attempt to relate given materials for a non-mechanical relay, Grondahl first noticed (1920) the asymmetric conductance of a mother copper bearing a cuprous oxide layer. As the voltage is applied to this device a potential hedge, as it were, is instantaneously set up causing a resistance to electric flow in one direction and an assistance to it in the other, thereby effecting the corresponding high and low resistances.

Rectifying efficiencies as high as 70 percent can be obtained in usual practice with these devices. In general, very high frequencies can be rectified, although some capacitance effect is then said to be encountered. Theoretically, a large number of units can be assembled into rectifiers of any desired rating, the maximum space being a cubic foot to every 4 kilowatts and of weight equal to

density of 0.07 ampere per sq cm may be considered normal when no special ventilation is provided, while under conditions of forced ventilation, by the use of extra large fins, the density can be raised to 0.6 ampere per sq cm without undue heating.

Disc size varies from 1½-inch diameter for low-impedance values, to ¾-inch diameter for medium and higher impedances. The assembly of these rectifiers is carried out in such a manner that the number of discs is sufficient to withstand the alternating-current voltage necessary to produce the required direct-current voltage, and the number of parallel groups will carry the necessary direct current, each unit being designed for half- or full-wave rectification. A circuit with four junctions of the usual size will supply a rectified potential of 3 to 6 volts and an output current of 0.125 to 3.5 amperes, depending on the area of the exposed radiating surface of the discs, the cell-life anticipated, and the care taken in cooling the units.

The copper-oxide disc design of rectifiers is especially versatile; its applications are best summarized as follows:

(1) Automatic volume control is effected by the rectifier with the aid of vacuum-tube amplifiers, the minute power of the last stage being used to control the grid bias of the previous stages.

(2) To make the current supplies of telephone apparatus, audio repeaters, amplifiers, operators' speaking batteries, and the like free of ripples within the audio range, low-frequency chokes and bridging condensers are inserted in the circuit between a rectifier and its load. (Fig. 5.)

(3) Series or shunt rectifier units are employed in variable-attenuation networks of a-c signal circuits with voice-operating switches. In the series or unbalanced network (Fig. 6) the controlling current results in a low impedance in one direction and a simultaneous high

twenty pounds per kilowatt. Of the commercial sizes manufactured at present, trickle chargers have a 13 to 6-watt output (½-to-1 ampere at 6 volts), while railway signal rectifiers are constructed that have a 200-watt output. In applications where high currents and small size are essential requirements, the so-called dry disc rectifiers furnish a watt output per cubic inch four to five times that of other types.

The limit to current-carrying capacity depends on the provision for radiating the developed rectifier heat. A current

value in the reverse order. Thus a high or low attenuation in the signal-transmission circuit can be effected. When the network is balanced, or the rectifiers shunted, the control currents do not pass into the signal circuit and the inductances of the transformers, therefore, do not vary or prevent a rapid change of the currents in question. Variable networks are used in valveless differential echo-suppressors

(4) Cable tests and x-ray applications require half-inch discs mounted in tubes a foot long, the rectifier units being connected in series and mounted in oil for proper insulation.

(5) Since the rectifier responds to a wide range of frequencies it can be used to measure these quantities up to millions of cycles per second provided the circuits are so matched that the current density is sufficiently large to make the

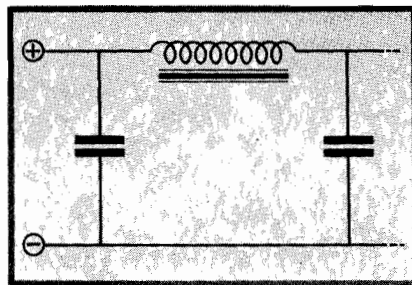

Fig. 5. A typical filter circuit used with a rectifier.

that, while speech energy is applied to double-balanced groups symmetrically, the carriers oscillator-supply is applied differentially to cause modulation. (Fig. 7.) Rectifiers, or modems as they are called in this application, are said to supply a quality of modulation and demodulation superior to that obtainable from vacuum tubes.

## REFERENCES

"Copper-Oxide Rectifiers," address of L. O. Grondahl before Electrochemical Society, St. Louis, Oct., 1937.

"Radiation-Counting Circuits," B. H. Porter, *Electronics*, July, 1936.

"The Rectox Rectifier Grows," I. R. Smith, *Elec. Journal*, Westinghouse, May, 1937.

"Junction Rectifiers," B. H. Porter, *Radio Engineering*, November, 1936.

Manufacturer's Material and Reports.

"Recent Developments in Telephone Transmission," L. E. Ryall, *P. O. Elec. Eng. Journal*, April, 1935.

"The Rectifier, A Versatile Conversion Unit," C. C. Levy, the Electrochemical Society, St. Louis, Oct., 1937.

resistance small in comparison with the rectifier's capacity impedance.

(6) No device as yet has been developed with the insured ability to supply constant currents to d-c relays. Half-wave rectifiers in parallel with a relay coil produces a slow pickup when voltage is impressed. For slow release the rectifier is so connected as to oppose the input current yet to allow its discharging current, as formed by the opened supply circuit, to pass in the low resistance direction. By these principles signal systems are made possible. Similarly, relays may be energized through the rectifier by low frequencies ( $\frac{1}{2}$ -2 cycles per second) selected with a tuned circuit.

(7) Rectifiers in series with apparatus requiring polarized control serve the purpose effectively, whether used singly with d-c to energize a combine of relays individually, or employed in duplicate on a-c for operating them simultaneously. Thus by polarization, circuits and combinations thereof in complicated networks can be selected.

(8) In place of the usual grid-voltage modulation of the triode valve, four groups of rectifiers can be so arranged

(9) Battery-charging circuits employ rectifiers for both full-rate and trickle charging, automatic-switching arrangements being used so that the load can be supplied by the rectifier and battery acting together, by the battery constantly maintained at a given value through the rectifier, and by a battery subject to constant current charging independent of line-voltage changes.

(10) Rectifiers connected to ordinary telephone relays also permit decisive

Fig. 6. Circuit of unbalanced, variable attenuation network.

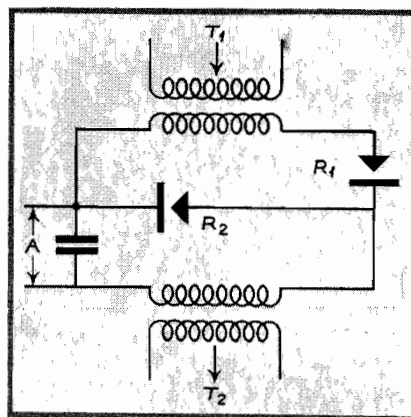

operation on low-frequency ringing currents when the relay is adjusted to operate on small currents without chatter.

(11) Other applications of a miscellaneous nature include spark-quench circuits, frequency doublers, remote control of a-c/d-c supplies, production of even harmonics in rectified a-c, magnetic separators and brakes, field currents for dynamic speaker fields, vacuum-tube supplies, and varied uses in radio-transmitter stations, telephone (Fig. 8) and telegraph systems, railway, police, and fire depots.

## Mg-COPPER SULPHIDE MODEL

The magnesium-cupric sulphide rectifier is somewhat similar to the copper-oxide design. While no film-forming action is required for the device just described, apart from the oxidizing treatment of the discs, it is felt that a film which later provides the rectifying act-

ion of the magnesium, copper-sulphide type, is formed at their junctions by the initial passage of current. The inverse current is said to be one seventy-fifth of the useful current, corresponding to resistances per unit of 30 and 0.4 ohms in two directions. Four volts is given as the safe operating potential per junction in this design, the maximum temperature to be attained without injury is 150 degrees C., and reputed life is in the order of thousands of hours, provided the units are not left idle in a moist atmosphere. After minor accidents the film between the cupric sulphide and magnesium is said to be self-healing. The present commercial sizes are from 0.2 to 3 amperes and 2 to 50 volts using the bridge circuits with a varying number of junctions.

## PLATE TYPE RECTIFIERS

Recent developments in the rectifier field have centered about the flat or plate type of rectifier. The necessity for producing heavy-output units with an economy in mounting space has resulted in a rectifier element having minimum measurements of three by ten inches. Their entire surface is active. Actually, these  
(Continued on page 42)



# MODERN DESIGN OF THE 849

By **ROBERT LORD**

Engineering Department  
AMPEREX ELECTRONIC PRODUCTS, INC.

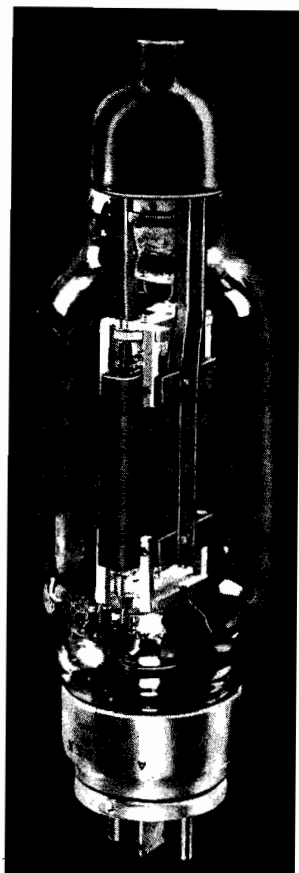

The 849.

THE EFFECTIVENESS of high-vacuum tubes used as power amplifiers both from the standpoint of their possible efficiencies in converting the d-c power supplied to the tubes into either audio or radio-frequency power, and the ease of control, or their power amplifying ability, depends largely upon the mutual conductance (or the grid-to-plate transconductance) of the tube.

When the frequency to be generated or amplified by the tube become high, additional factors that become of importance in determining the possible operating efficiency are the magnitude of interelectrode capacitances of the tube, the inductance and effective resistance of the leads to the elements of the tube, and the mass and disposition of insulating material used to maintain the interelectrode spacings.

Though these factors have long been recognized, a fallacious concept as regards the dependence of mutual conductances on interelectrode spacing, has resulted in the production of power vacuum tubes, of unduly limited capability, durability and restricted applicability. The standard type 849 tube is an example of this type of design.

In order to give this tube a high mutual conductance, old design principles dictated the use of a very narrow plate, so that both the grid-to-filament separation and the plate-to-filament separation are small. Since the power to be hand-

led by this tube also requires a large total area of the plate, the resultant structure demands the use of many inter-element spacers, with complicated provision for freedom of relative motion of the plate with respect to the grid and filament due to temperature changes.

Even with the best physical design, the resultant structure demands a large mass of insulating material in the vicinity and sometimes directly in the electric fields between the elements. In addition the close spacing of the grid to the plate results in the following limitations.

(1) Non-uniformity of characteristics, because even small misalignment or changes in alignment in processing cause large changes in amplification constant.

(2) Very high grid-to-plate capacitance to further limit utility at high frequencies.

(3) Non-uniform heating of the plate, due to concentration of electron bombardment about the center of the plate.

(4) High interelectrode leakage due to deposits on insulators.

Furthermore the shape of the anode makes it difficult to degas effectively.

A thorough investigation of the relationship of interelectrode spacings to the characteristics and performance capabilities of tubes, has led to the conclusion that short of ultra-high-frequency applications the separation between grid and plate of a tube may be made very large without appreciable effect on its mutual conductance and consequently its operating effectiveness—as long as the grid-to-filament separation is kept small. To maintain a given amplification constant, the pitch of the grid must of course be reduced as the grid-to-plate separation is increased.

Re-designing the 849 tube on the basis of this new concept, has resulted in the following improvements.

(1) The plate is now independently supported from a separate stem, and all insulating tie-over and spacing members are eliminated.

(2) The total area of the plate has been increased from 135 sq cm to 250 sq cm.

(3) The wider spacing between the plate and grid results in a more dif-

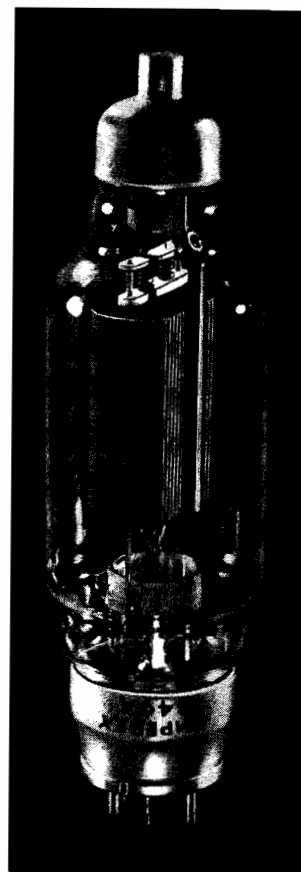

The 849A.

fused electron bombardment so that more of the total anode area is subjected to direct bombardment at a relatively reduced density.

(4) The combination of a larger anode area with the more uniform heat distribution over the anode, reduced both the maximum anode temperature and the average anode temperature. This in turn reduces the maximum and average bulb temperature.

(5) The same size tube may now be rated to handle much higher plate dissipations for all classes of service and does not require as severe de-rating for Class A applications.

In addition, the wider grid-to-plate separation coupled with a new grid design, minimizes the magnitude of possible variations in characteristics.

The elimination of insulators plus the reduction in interelectrode capacitances due to the increased grid-to-plate separation and the modified form of grid, in combination with more uniform bulb heating and other improvements in details of design, allow the use of the re-designed tube at much higher radio frequencies.

In the process of re-design changes were also made in the filament so that the new tube known as the Amperex type 849A or Amperex type 849H utilizes an 11-volt 7.7-ampere filament in place of the old 11-volt, 5-ampere

*(Continued on page 43)*

# INSTANTANEOUS RECORDING NEEDLES

By MAJOR R. H. RANGER

RANGERTONE, INC.

SHARPNESS is not the only requirement in a cutting needle for instantaneous recording. As might well be expected, a needle ground in the shape of a fine chisel would cut a record with great facility and with practically no weight on the cutting head, but the surface noise resulting on the finished record would be terrific. A stylus for instantaneous recording must do double duty; first it must present a keen edge against the advancing recording material and second it must burnish the resultant groove with a ball-like surface directly back of the cutting edge.

To make such a stylus, a hard material must be selected which is free of blow holes, homogeneous, and which will take a cutting edge that will not fracture. Sapphire, both natural and synthetic, is the hardest material yet available that will fulfill these requirements. The diamond is, of course, much harder, but its crystal structure does not lend itself to the sharp angles required in groove cutting, without extreme care in grinding and use. The sapphire itself is none too rugged against misuse and flaws in records; but it does give the neatest recordings yet achieved. For sturdiness, the cobalt-chromium-tungsten alloys are particularly serviceable as proven by tests on the stelli recording needles. This alloy takes a high polish and has a low coefficient of friction, which makes for an ideal stylus.

The needle material is mounted in a shank for grinding and use. In grinding, the first operation is to grind the chisel like shape. This gives the correct angles to the sides and back. Automatic guides determine these angles, al-

**TABLE I**

F	Designation	Recording	Playback Percentage	
			Sharp Stelli	Dull Stelli
500.00	fund. 1	100%	100%	100%
2000.00	fund. 2	50%	50%	50%
1500.00	diff. f.	2%	3%	12%
2500.00	sum f.	1.5%	5%	10%
1000.00	second 1	2.5%	5%	5%
4000.00	second 2	1.5%	3%	4%

**This table shows clearly the effect that a dull recording needle has on the amount of distortion introduced into the recording. The cross-modulation is especially affected.**

though the actual grinding is hand fed. The development of a keen edge between each of the chisel faces is observed microscopically. First, relatively coarse diamond dust is used in the grinding, and then the very finest diamond dust obtainable for the final lapping.

After the chisel shape has been attained, it is then necessary to break back the cutting edge in a very accurate and precise way. This is done on a very fine, small, high-speed diamond-dust lapping wheel, with the progress observed directly under a high-power microscope. The actual point is first rounded off carefully, and then the edge around the front face of the chisel is ground back in a curve which goes slightly downward from the front cutting edge of the needle, and gives a distinct highly polished ball shape to the bottom of the finished needles.

The action with this needle is as follows: the record material is cut at the front edge of the needle face with a one to three degree drag, the resulting groove is then polished by the ball curve

which is pushed down into the groove by the weight of the cutting head. This action is necessary on all types of material; some require a little more of it than others. It is quite necessary in cutting the so-called "acetate type" records, which are really lacquer coated. No lacquer has yet been found which will leave a smooth shiny cut when engraved with a sharp tool. It is the very toughness of the lacquer which is the characteristic that makes the record durable that makes it tend to pull apart rather than be actually cleaved. But this is what mitigates against the polished cut. To produce the polish in the rough cut, the burnishing action is necessary. This is best done by the stylus itself in the double function of first cutting and then burnishing. The burnishing ball on the bottom of the stylus also reacts back to keep the cutting edges at exactly the right uniform depth in the material, exactly as the advance ball does in wax recording.

Now, the larger the burnishing ball on the bottom of the stylus, the higher the polish and the lower the surface noise, which is all very well if one is concerned only in getting low surface noise. But obviously the main function of recording is not just in making golden silences. It corresponds in this sense to the best method of eliminating static, which is to disconnect the antenna! For high-fidelity recording, all the useful frequencies must be registered. The particular difficulty comes with the highs. With too large a ball, the highs disappear. Of course, it is possible to "compensate" by over-emphasizing the highs both in the recording and the spring suspension,

**TABLE II**

F	Designation	Recording	Playback Percentage			
			1	2	3	4
700.00	fund. 1	100%	100%	100%	100%	100%
1000.00	fund. 2	100%	92%	117%	133%	142%
300.00	diff. f.	2%	4%	7%	2%	2%
1700.00	sum f.	1%	4%	5%	11%	2%
1400.00	second 1	4%	8%	10%	11%	10%
2000.00	second 2	2%	4%	8%	6%	10%

Four recordings made with four stelli needles with final angles varied slightly give a clear picture of the importance of the correct angles in the finished product to give the best reproduction. The cross-modulation frequencies are the most important to keep down.

which holds the needle armature. But as in all engineering, this compromise may easily be carried to the point of distortion.

The second quality factor and one which has not been given the attention it deserves is cross-modulation. When two tones are presented to any amplifier system, there is a certain amount of cross-modulation which gives rise to the production of sum and difference tones. For example, if seven hundred cycles and one thousand cycles enter an amplifier, there will be found in the output not only the seven hundred cycles and the one thousand cycles, but also the sum, seventeen hundred cycles, and the difference, three hundred cycles. Besides the resulting unharmonious tones which are thus introduced, there are the double and triple frequencies introduced by non-linearity in the amplifier. These also cross-modulate. If all these harsh tones have an rms value greater than two percent of the desired tones, there is a marked deterioration in the quality.

Now, when the two steps of recording and play-back are added, a new and very ready means of introducing further cross-modulation is inserted. With too large a burnishing ball on the bottom of the stylus, twelve percent cross-modulation may easily be realized. The play-back needle and amplifier itself are often accused of being the weak spots when it is just the cutting needle. Distortion is caused in the case of too large a ball by obliteration of a higher frequency by a lower at certain points of travel of the needle. If the obliteration were continuous it would not be so bad, but being non-uniform introduces the frequencies.

The best value of ball size will reduce the cross-modulation to one percent over the straight amplifier. This may be considered excellent recording at the present state of the art. Cases have been observed where there is actually less cross-modulation after the introduc-

**TABLE IV**

F	Designation	Recording	Playback Percentage		
			1	2	3
1000.00	fund. 1	100.00%	100.00%	100.00%	100.00%
2000.00	fund. 2	100.00%	80.00%	80.00%	80.00%
3000.00	fund. 3	100.00%	120.00%	120.00%	120.00%
4000.00	fund. 4	100.00%	60.00%	65.00%	60.00%
5000.00	fund. 5	100.00%	10.00%	15.00%	1.50%
6000.00	fund. 6	100.00%	2.00%	5.00%	.20%

**Each frequency is recorded separately so there is no cross-modulation in this chart. The first two columns under playback were made using fine playback needles, and the last one, using loud playing needle. In the latter case the high frequencies are attenuated very badly. This table was made from the results obtained on a portable recorder.**

tion of the recording play-back step than with the straight amplifier; due, no doubt, to the production of sum and difference frequencies out of phase with each other in first, the amplifier, and second, the recording.

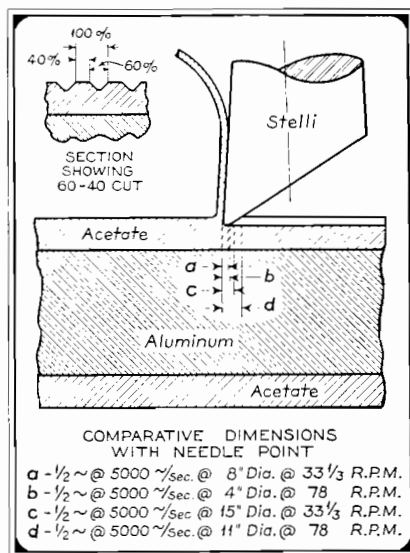

But the small amount of ball for the best work means that there is very little tolerance in the adjustment of the cutting angle of the stylus to the advancing record material. The recording engineer must place the needle accurately

in position to be sure that the needle presents the proper angle to the record. This adjustment may well be made by eye, after a little experience. The spring adjustment on the cutter head brings the groove depth to the desired sixty percent width of cut to forty percent wall between cuts. But a nice shiny bottom and sides to the groove must be observed by the hand or fixed microscopes to be sure that the needle is the right angle to the record.

Obviously with the adjustment limits confined to such a narrow range, it is not possible to obtain good recordings if the recording head is bobbing up and down as the turntable revolves, changing the angle of the cutting needle all the time. The turntable must be true, and the record must be flat. If they are not, the readily recognized swish on each revolution of the play-back turntable is obtained, indicating the positions on the record where the cutting stylus was not in its correct angular position. Also the depth of the cut will vary at these swish points. Both are most undesirable effects.

Another good result of having the small burnishing ball, is the reduction in "echo" caused by the recording in one groove affecting the adjacent grooves. This phenomena is again due to the fact that the lacquer is not a completely "dead" material, and instead has a certain amount of resiliency. To bring the echo to the vanishing point and still make the sides of the groove quiet, a nice adjustment in the size of the ball diameter is required to polish the sides of the groove and still not pile up the material which produces strains affecting the adjacent grooves. This is done in the final lapping of the stylus.

While these precautions have been given rather strenuous emphasis, they make for the possibility of a very good signal level "packed" on the record. High-level recording leads to the obvious advantages of requiring less amplification, and the pickup and the relative reduction of undesired noise energies such that they are completely ridden over by the desired signal energies.

**TABLE III**

F	Designation	Recording	Playback Percentage		
			1	2	3
680.00	fund. 1	100.00%	100.00%	100.00%	100.00%
1000.00	fund. 2	100.00%	80.00%	70.00%	60.00%
320.00	diff. f.	.35%	2.00%	1.60%	2.00%
1680.00	sum f.	.30%	2.00%	.80%	3.50%
1360.00	second 1	.30%	1.60%	.60%	2.00%
2000.00	second 2	.80%	1.60%	1.00%	2.00%

The column under recording shows the percentage of frequencies applied to the recording head. Column 1 gives the percentage of frequencies in the output of the play-back amplifier, when the play-back needle has a fine point and the recording was made near the center of the record. Column 2 has the same conditions, except that the recording was made on the outside of the record. These first two were made at 78 rpm of the turntable. Column 3 has the same original conditions, except that the recording was made with a turntable speed of 33 rpm on the inside of the record.

# LAMINATED IRON-CORE COILS

## With Air Gap at High Frequencies

By R. K. HELLMANN

COILS with laminated iron cores are very frequently used in tuned a-f and r-f circuits. They are often provided with an air gap chiefly for two reasons: (1) in order to reduce magnetic instability and the influence of temperature, and (2) to decrease losses. The electric and magnetic properties of such coils can easily be determined at low frequencies. The frequency range, in which laminated iron-core coils are applicable at all, is limited towards higher frequencies by the position of the "upper critical frequency" where the imaginary component of the coil resistance becomes equal to the real component, so that  $\tan \delta = 1$ . This behavior which is essentially due to eddy currents circulating in the iron laminations is, unfortunately, rather difficult to calculate.\* With respect to the importance of this upper limit in filter and radio circuits, this article is to make clear by means of comparatively simple, approximative calculations the behavior of such coils at high frequencies and to propose a chart simplifying practical work. Since in most practical cases the eddy-current losses in the neighborhood of the critical frequency are by far more important than copper and hysteresis losses, it will

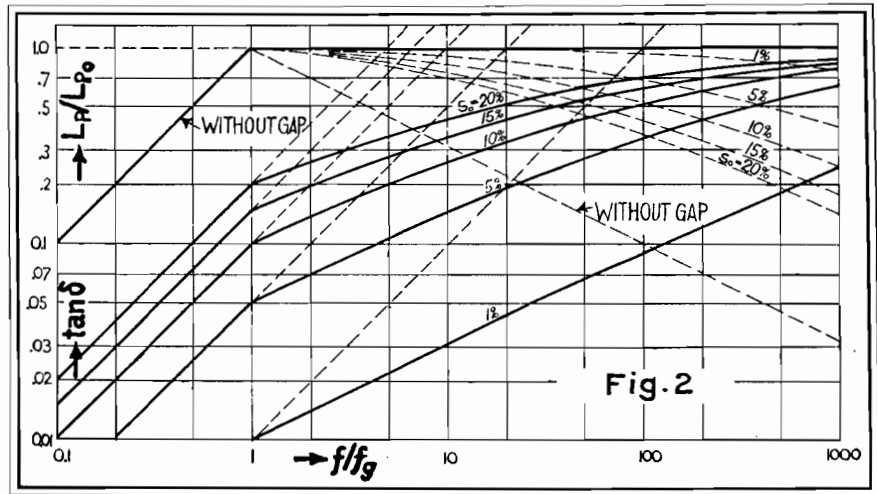

A chart showing the variations of inductivity.

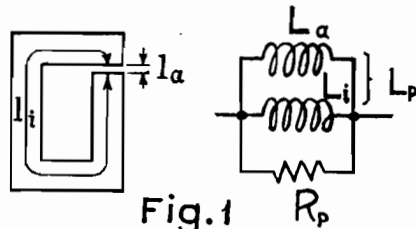

Illustrating the magnetic path of a coil and its equivalent circuit.

Showing  $\tan \delta$  with overlapping laminations. The critical frequency  $f_c$  is 4500 cycles.

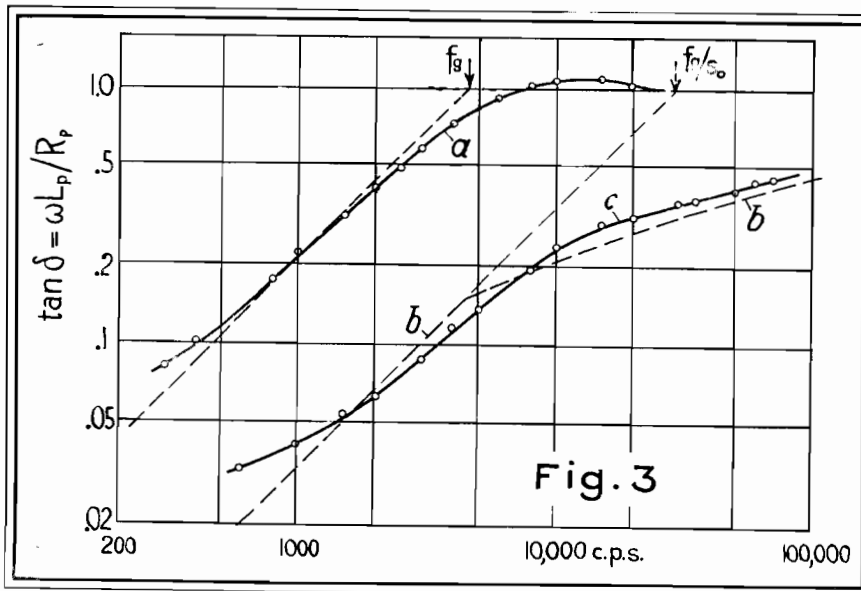

Fig. 3

be advisable to confine ourselves to the case where the induction in the core and hence hysteresis losses are low.

If the magnetic path is completely closed, the critical frequency is given by

$$f_c = 10^5 \frac{\rho}{\mu \cdot d^2} \text{ in cps} \dots\dots\dots (1)$$

( $\rho$  = resistivity of core materials in ohms/m/mm<sup>2</sup>,  $d$  = plate thickness in cm,  $\mu$  = relative permeability).

Let us first consider the behavior of the coil sufficiently below  $f_c$  (indicated by index 0). In most cases, the problem is to find in any tuned circuit a coil with a given inductivity  $L_0$ , the losses of which are kept sufficiently low by means of an air gap. Now, we can represent the magnetic path of such a coil as a series connection of two magnetic resistances (see Fig. 1). One of these,  $R_a$ , which is formed by the air gap, is a real quantity while the other,  $R_l$ , has a phase angle due to the reaction of the eddy currents in the laminations. In electric terms this is equivalent to a parallel connection of the two coils having an inductivity of  $L_a$  and  $L_l$  respectively, so that the total inductivity is

$$L_p = \frac{L_n L_l}{L_n + L_l} \dots\dots\dots (2)$$

(Continued on page 28)

# THE HARMONIC PRODUCER

By C. H. BIDWELL

BELL TELEPHONE LABORATORIES

MOST communications engineers are accustomed to thinking of harmonics only as a source of distortion in telephone and radio circuits but harmonics can be made to serve a useful purpose in certain cases. This is true, for instance, of the harmonics generated by the recently developed "Harmonic Producer," for these can be used either as carrier frequencies for the modulating circuits of a multi-channel carrier telephone or for synchronizing the carrier used in a radio transmitter.

The harmonic producer<sup>1</sup> develops a large number of harmonics of a single fundamental frequency by making use of the non-linear characteristic of a special retard coil. Since such harmonics are a series of frequencies spaced at regular intervals in the frequency spectrum, the interval being determined by the fundamental, the harmonic producer can be adapted to give the correct frequencies for either the radio or carrier-telephone application by choosing the proper frequency for the fundamental.

This is best illustrated by the group modulating circuits of the million-cycle experimental coaxial telephone system<sup>2</sup> which use the 19 carrier frequencies 216, 264, 312, etc., (in steps of 48) to 1,080 kilocycles. The harmonic producer uses a 24-kilocycle fundamental and these carriers appear as its 9th, 11th, 13th, etc., to its 45th harmonic. Each of these carriers is used to modulate one of 19 different 60 to 108 kc bands; each band comprising 12 separate voice channels which have been placed in this 60- to 108-kc range by a previous modulation. This, the second modulation, converts these 19 bands into a series of different high-frequency bands occupying adjacent spaces of 48 kc in a wide band ranging from 108 to 1,020 kc. These 19 bands, together with a 20th which remains at 60 to 108 kc, may then all be transmitted simultaneously over the same coaxial cable without interfering with each other.

The carrier of a radio transmitter is usually fixed, and, for the ordinary broadcasting station, may be any fre-

quency between 550 and 1,500 kilocycles. The harmonic producer can be used for synchronizing the carrier of almost any station in this broadcast range by choosing the fundamental frequency so that the most commonly used carriers are multiples of it (and will, therefore, be present among the harmonics). At each station the desired frequency can be separated from the other unwanted harmonics and used as a "standard frequency" for adjusting the carrier. In one circuit for automatically adjusting the carrier to the standard frequency<sup>3</sup>, the two frequencies are "beat" together and the resulting current (whose frequency is the difference between the two high frequencies) is used to run a variable reluctance type synchronous

stability of all frequencies generated in the harmonic producer depend solely on that of the fundamental. This reduces the problem to the relatively simple one of obtaining a single accurate low frequency; a problem which has been solved for the highest accuracy required by these applications. In case the fundamental is too high, it can in turn be obtained as a harmonic of a still lower frequency which can be made more accurate, as is done in the case of the 24 kc mentioned.

For the carrier-telephone application where many frequencies are required, this harmonic-producer circuit obviously requires a smaller amount of equipment than other methods. In the case just discussed a single harmonic-generating circuit, together with nineteen small filters for separating the carriers, will be used instead of nineteen separate vacuum-tube oscillators, which would be required if the practice of open-wire carrier systems were followed.

## CONTROLLING THE AMPLITUDE OF THE HARMONICS

The latter advantage of the harmonic producer would be partially lost, however, if it could not produce all (or most) of the desired frequencies at approximately the same amplitude, for it would then be necessary to use amplifiers for some of them. (This is because the carriers must all have nearly the same amplitude.) However, while it is relatively easy to control each harmonic as far as the number of cycles is concerned, it is quite another matter to control the amplitude of each—as this depends upon quite a few factors. It was in fact the most difficult problem in the development of this harmonic producer to determine how the amplitude of each harmonic varied with the several constants of the retard coil and other circuit elements; in order that these elements might be designed to meet the requirements. Since many of the relationships involved were too complex to deal with on a straightforward mathematical basis, this problem had to be attacked by empirical methods. An important part of this empirical analysis proved to be that of getting a simple but fairly accurate "physical picture" (as distinguished from a mathematical formula) of how the harmonics are de-

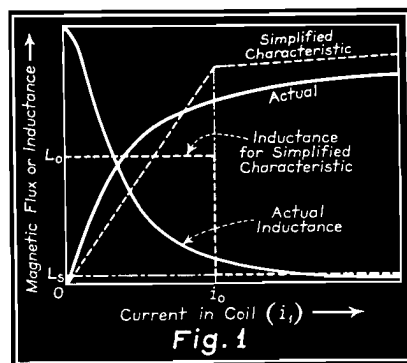

Fig. 1  
Comparison of simplified and actual magnetic characteristic and inductance of the harmonic producing coil.

motor, which, in turn, drives a tuning condenser in the carrier oscillator circuit. When the carrier is too high, the motor drives the condenser in such a direction as to lower its frequency and when the carrier is too low the motor rotates in the opposite direction. When the carrier reaches the frequency of the standard, the motor stops, as the frequency of the current operating it is then zero.

## ACCURATE FREQUENCIES

This harmonic generator is well adapted to meet the strict requirements of both of these applications for accurate and stable frequencies. Because harmonics are exact multiples of their fundamental frequency, the accuracy and

<sup>3</sup>F. A. Polkinghorn and N. F. Schlaack, *IRE Proceedings*, July, 1935, p. 711.

<sup>1</sup>The complete mathematical record of this "Harmonic Producer" appears in *Electrical Engineering*—August 1937, p. 995 under the names of E. Peterson, J. M. Manley and L. R. Wrathall, who are the engineers responsible for this development.

<sup>2</sup>Espenschied and Strieby, *Electrical Engineering*, Oct., 1934, p. 1371.

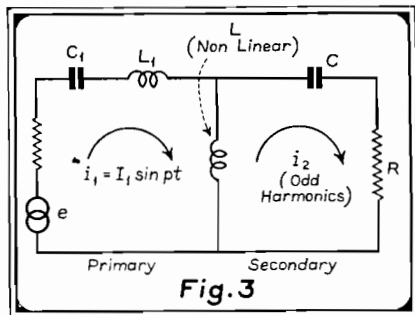

Harmonic producing circuit.

veloped in the circuit; because without this it would have been very difficult to obtain mathematical results and design the circuit.

#### SIMPLIFYING THE MAGNETIC CHARACTERISTICS OF THE COIL

Because the retard coil is the element in the circuit having a non-linear characteristic, it would be natural to think that it alone produces the harmonics. While this did not prove to be the case, the non-sinusoidal emf induced in this coil furnishes the "driving force" for producing the output current containing the harmonics and it will be advisable to see what its general wave pattern is before studying the complete harmonic-producing circuit. In order to simplify the process of producing this output current so that a mathematical analysis can be applied, we shall find it necessary to assume that the magnetic characteristic of the coil is much simpler than the actual curve shown in Fig. 1—where both the magnetic flux and the inductance are complex functions of the magnetizing current.<sup>4</sup> The approximation of the magnetic characteristic which has been chosen is that shown by the dotted lines in Fig. 1. This consists of eliminating the "knee" of the curve to give a characteristic of two straight lines. The line from zero to the point where the current has the critical value " $i_0$ " has a steep slope, and the line from this point on has a very small slope; which means that the coil becomes nearly "saturated" with a current of  $i_0$  and a further increase in the current will cause very little increase in flux. The inductance of the coil (the slope of the characteristic) is also shown on Fig. 1. The solid curve is the actual inductance and the dotted lines represent the inductance corresponding to the simplified characteristic. In the latter case, the inductance has only two values—the high value  $L_0$  for currents less than  $i_0$  and the low value  $L_s$  for greater currents. (We shall see later how essential it is

<sup>4</sup>Since the curves in this part of the discussion will be "qualitative" curves, for purposes of simplicity, we have plotted flux and inductance directly against current. We can therefore consider the inductance as the slope of the flux characteristic instead of a quantity proportional to it.

to reduce the inductance from a complex function of the current to one of only two values.)

#### THE NON-SINUSOIDAL EMF INDUCED IN THE RETARD COIL

The simplified magnetic characteristic and the inductance are replotted in Fig. 2 for comparison with the fundamental current in the coil. They are shown for both positive and negative values of the current in the coil, but, because of the simplification, the usual hysteresis loop does not appear. The magnetic characteristic is curve (1) at the top of the figure and the inductance is curve (2) just below it. Below these curves, the fundamental current (curve 3) is plotted with a vertical time axis—so that we can read directly the corresponding values of flux and inductance for any instantaneous value of the current. The

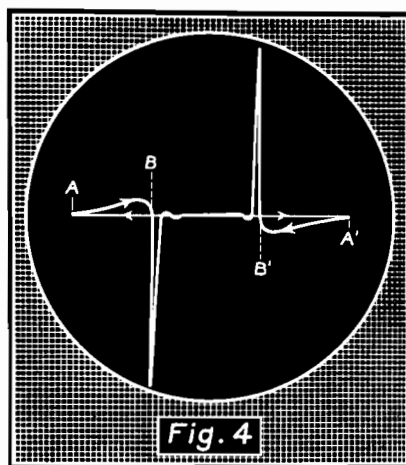

Typical waveform of the output current " $i_2$ " as recorded by oscillograph.

two light vertical lines, for example, indicate the critical values —  $i_0$  and  $+i_0$  on all three curves. As shown, the peak value of this current is much greater than  $i_0$  and so the coil is considerably "overloaded."

The non-sinusoidal emf induced in the coil by this sine-wave current is shown by curve (4), which is plotted on the same time axis as the current. The most important part of this counter emf is the series of voltage pulses which occur during the time intervals (shown shaded) when the current is passing through zero between values of  $+i_0$  and  $-i_0$ .<sup>5</sup> During these intervals the inductance  $L_0$  is high and the fundamental current is changing most rapidly. These two factors cause the flux to change rapidly and generate these voltage pulses. During the rest of each half period, the fundamental current is larger than  $i_0$  and the inductance has the low value  $L_s$ . Consequently there is little change in flux and the generated voltage

<sup>5</sup>The effect of the output current  $i_2$ , which will be discussed later, is not indicated in Fig. 2.

is low; though it is not zero except at  $\frac{\pi}{2}$ ,  $\frac{3\pi}{2}$ , etc. For our purposes we can

assume that the emf is a series of alternately positive and negative voltage pulses which occur only during the shaded time intervals.

While this emf induced in the coil furnishes the "driving force," other elements in the circuit play a part in producing the output current containing the harmonics. In studying the harmonic-generator circuit we can omit that part of the circuit which produces the fundamental current and assume that it consists of a tuning fork and vacuum-tube oscillator (or some other source) and whatever amplification is required to raise the current to the proper amplitude. We can then confine our attention to that part of the circuit which is the actual "harmonic-producing" circuit; the essential elements of which are shown in the laboratory circuit of Fig. 3. The condenser  $C_1$  and the retard coil  $L_1$  form a series-tuned circuit which gives the fundamental as pure a sine-wave shape as possible and keeps the harmonics from feeding back into the primary circuit. The retard coil  $L$  is the harmonic-producing coil and the condenser  $C$  is used to keep the fundamental out of the secondary circuit (and, incidentally, will play an important part in producing the harmonics). In this laboratory circuit, the resistance  $R$  simulates the load; though in one actual circuit this load consists of a number of coils and filters in parallel.

#### ANALYZING THE OUTPUT CURRENT—THE TWO STAGES OF EACH PULSE

This circuit looks so simple that it might seem possible to solve the dif-

#### Magnetic characteristic, inductance and fundamental current plotted to show how the emf is induced.

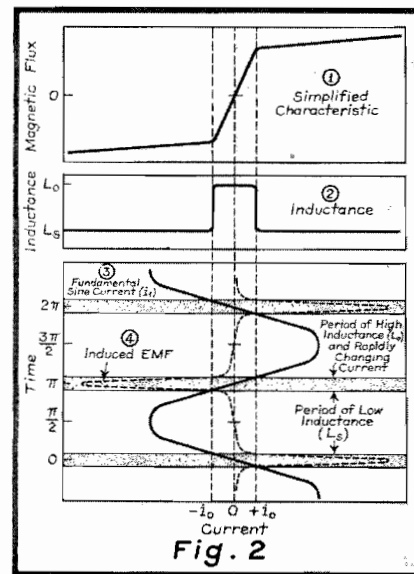

ferential equation for the current  $i_2$  in the secondary, assuming the current in the primary  $i_1$  to be a pure sine wave. This would be rather premature, however, because of the variable inductance of the coil. An empirical method of analysis proved much better at this point. The circuit shown in Fig. 3 was set up in the laboratory and the actual output current was recorded by cathode-ray oscillographs. A careful study of a typical waveform, such as that shown in Fig. 4, will enable us to see how this current is produced. (Since the current reverses itself along the time axis on the oscillograph it will be well to refer also to the approximation of this series of pulses in Fig. 5.) At first glance this wave shape seems to correspond roughly to that of the emf generated in the coil, since the most prominent part of this current wave is a series of alternately positive and negative peaks which occur every half period of the fundamental. A closer inspection shows, however, that these peaks are only a part of each pulse. For reasons which will be evident shortly, each pulse of current may be divided into two distinct stages: (1) the slowly increasing current, from the point "A" to point "B" in Fig. 4; (2) the current rapidly increasing from point "B" in the opposite direction to the conspicuous high peak and then falling to zero, also rapidly, but oscillating as it dies out. Each of these two stages, if separately considered, resembles a familiar transient current. The first stage looks like a current which is charging a condenser through a circuit containing, among other things, a high inductance, while the second stage looks like the discharge of a condenser through a resistance and an inductance, since the oscillating, exponentially

**Inductance of coil, fundamental current " $i_1$ " and output current " $i_2$ " plotted to the same time scale.**

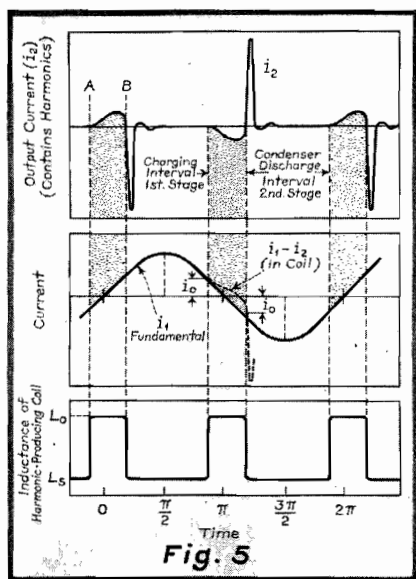

damped current is one of three forms which such a transient may take.

**EXPLAINING THE OUTPUT CURRENT—THE "PHYSICAL PICTURE"**

To assist us in reconstructing the process of producing this series of pulses, each of which is thus composed of two recognizable transient currents, we have plotted (in Fig. 5) three variables to the same time scale—the output current  $i_2$ , the fundamental current of sine waveform  $i_1$ , and the inductance of the retard coil  $L$ . We have already discussed the emf induced in the coil and can readily refer back to Fig. 2 for it, since the shaded time intervals in that figure are approximately the same as the "shaded" time intervals in Fig. 5. If we disregard the primary circuit and the fundamental current, we can see that the voltage pulses generated during these "shaded" time intervals will cause a current to flow in the secondary circuit which will charge the condenser C.

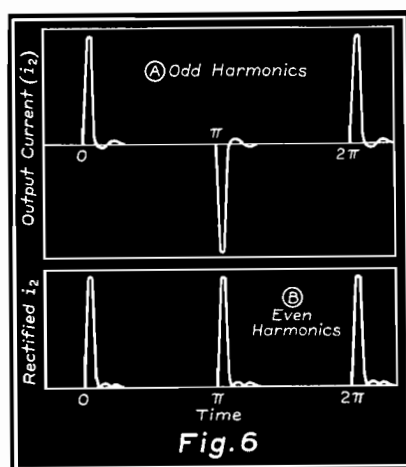

**"Odd" and "even" harmonics, output current " $i_2$ " and same current after rectification.**

Since the inductance of the coil will have the high value  $L_0$  at this time, it will retard the growth of this charging current and thus give it the form of the transient found in the first stage of each pulse.

For the physical picture of this charging process<sup>6</sup> we can consider that the fundamental will not contribute appreciably to the charge on the condenser. Though a small portion of this current will flow through the secondary during these "shaded" time intervals (because the inductance of the coil is high) its effect will be nullified because it will first oppose the charging current due to the emf and then, after it has passed through zero, it will aid this charging current. (This fundamental current cannot charge the condenser at other

<sup>6</sup>The curves in Fig. 5 are of course not suitable for exact mathematical analysis of the charging process. For this the reader should refer to Fig. 6 in the article by Peterson, Manley and Wrathall.

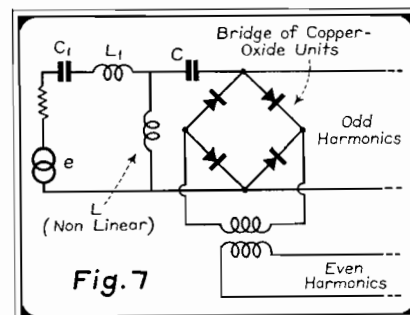

**"Odd" and "even" harmonic producing circuit.**

times, when it has a large value, because then the coil has the very low inductance  $L_s$  which acts as an effective shunt across the secondary circuit.)

At the end of each "shaded" time interval, when the current in the coil becomes greater than  $i_0$ ,<sup>7</sup> the inductance of the coil switches to the low value  $L_s$ , and this allows the charged condenser C to discharge through the secondary circuit. For certain values of the condenser C, the inductance  $L_s$  and resistance R, this discharge will take the form of the oscillating, damped transient which we observed (in the oscillograph) for the second stage of each pulse. There will be no "over-lapping" of pulses if such values are chosen because this exponentially-damped discharge current becomes negligible before the time for the next charging current to begin, as shown in Fig. 4 or 5.

The harmonics in which we are interested (usually higher than the 10th) are actually contained only in these discharge currents of the second stage, since we know from general knowledge of transients that only waves with steep slopes contribute appreciably to the higher harmonics. The current in the 1st stage may be considered, then simply as a means of periodically charging the condenser C. We can see, therefore, how erroneous it would be to assume that the "overloaded" coil was alone responsible for producing harmonics, for the voltage pulses developed in this coil merely furnish the driving force for charging the condenser and the actual harmonics in the output current are contained in the discharge pulses from the condenser. It would be more correct, therefore, to regard the condenser as the immediate "source" of harmonics, since the only function of the coil during the discharge intervals is to obligingly change to a low inductance so that the discharge may take place.

It has been taken for granted that the series of discharge pulses in the current

<sup>7</sup>It should be noted that the current in the coil at this time is composed of both the fundamental current  $i_1$  and the transient current  $i_2$ , as shown by the dotted curve in Fig. 5. The effect of the current  $i_2$  is to prolong the charging interval, because it opposes the current  $i_1$  (in the coil) during the last part of this interval and so keeps the current below the critical value  $i_0$  for a longer time.

$i_2$  (see curve A, Fig. 6) contains a large number of pure sine-wave currents whose frequencies are harmonics of the fundamental. While we know this is the case, because it is true of any non-sinusoidal current that periodically repeats itself, there is, unfortunately, no good non-mathematical way of showing why it is so. Curves can be used to illustrate certain simple cases (such as a fundamental and its 3rd and 5th harmonics combining to approximate an alternating "square" wave) but our case is not one of these. One must either know the principles of Fourier series analysis or accept them on faith. We might observe that text books usually explain the Fourier principle the other way; that is, they show how a number of sine-wave currents might be combined to give a series of pulses like our current  $i_2$ . It is equally true, however (both theoretically and practically) that the current  $i_2$  can be broken down into the same sine-wave currents—by means of filters.

One of the general principles of Fourier analysis which is of particular importance here is that any wave composed of alternately positive and negative pulses, like the current  $i_2$ , contains only the odd-numbered harmonics of the fundamental; i.e., the 1st, 3rd, 5th, etc. We should therefore, qualify an earlier statement by saying that it is best to select the fundamental frequency so that the desired frequencies are not only multiples of it, but are odd multiples. This is desirable, however, only when the frequencies are widely separated, as in the case of the carriers 216, 264, 312,

<sup>8</sup>See, p. 399, T. E. Shea's "Transmission Networks."

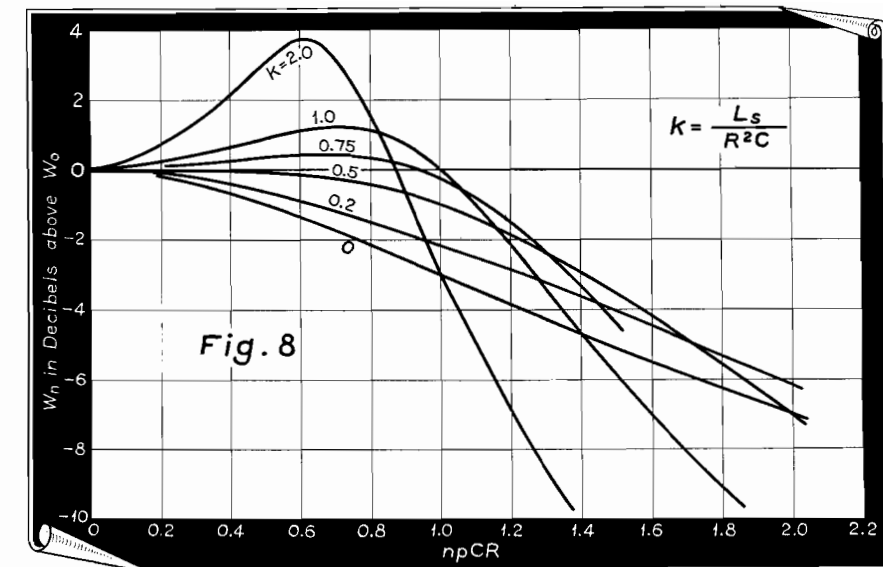

Power level of the harmonics plotted against frequency (multiplied by  $RCp$ ). Curves for several values of "k".

etc., to 1,080 kc (48 kc apart) which are produced as the odd harmonics of 24 kc. When the frequencies are fairly close together, on the other hand, there are some practical advantages to be obtained by employing an apparently more complicated method.

For another carrier-telephone application, which requires all the harmonics of 4 kc between the 16th and 27th, a 4-kc fundamental is used and the even harmonics are produced in a supplementary circuit, as shown in Fig. 7. These even harmonics are obtained from a copper-oxide bridge which rectifies part of the output current  $i_2$  containing the odd harmonics. This converts the output current, with its alternately positive and negative pulses, into a

similar current with all of the pulses positive (as shown in curve B, Fig. 6). This gives the desired result because, by a corollary principle of Fourier series, a current with this waveform will contain only the even-numbered harmonics. The chief advantage of this method is that it separates the outputs of odd and even harmonics and so the filters are only required to separate frequencies 8-kc apart, which permits the use of much cheaper filters than if the frequencies were only 4-kc apart.

With this qualitative picture of the output current in mind, we can briefly discuss the very difficult mathematical problem mentioned earlier—that of determining the relationship between the amplitude of the various harmonics and the constants of the harmonic producing coil, condenser and other elements.

Comparison of measured and calculated curves for the power level of the various harmonics.

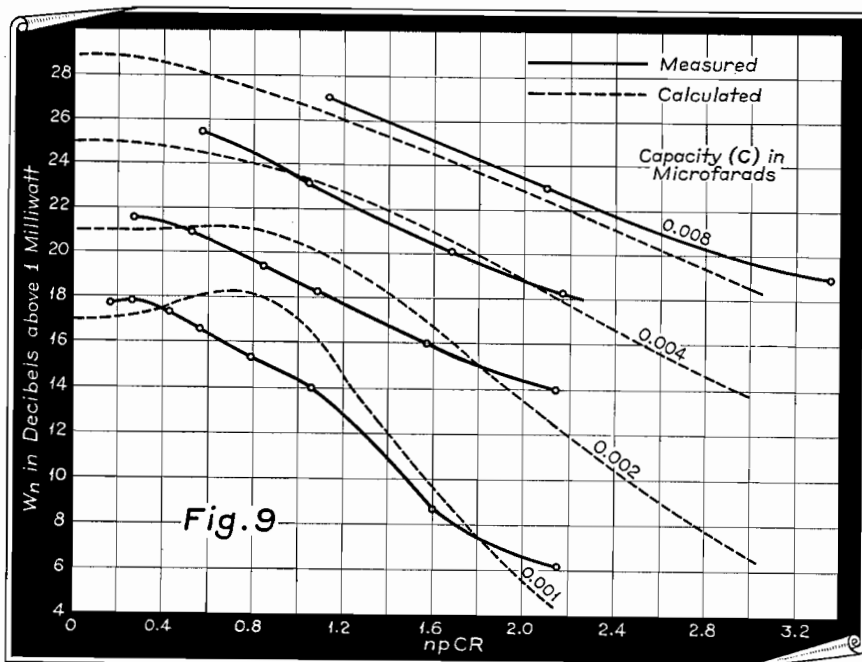

#### THE DIFFERENTIAL EQUATION OF THE OUTPUT CURRENT

Since the first stage of each pulse, the charging current, may be disregarded in so far as the harmonics are concerned, the output current  $i_2$  is reduced to a series of simple pulses, each of which is the discharge of the condenser  $C$  through an inductance  $L_s$  and a resistance  $R$  (see Fig. 6). The charge on the condenser  $Q$  is the same quantity of electricity for each half cycle, but is alternately positive and negative like the discharge pulses. (This quantity  $Q$  must be calculated from an analysis of the charging current, as will be indicated later.)

The differential equation for each of these single discharge pulses is rather well known, since it is used in electrical textbooks as an example of a transient current whose differential equation can be solved; and in mathematics textbooks

(Continued on page 24)



# REMOTE RECEIVING ANTENNAS

By VICTOR J. ANDREW, Ph.D.

IN COMMERCIAL communication circuits, such as those used by the air lines, reduction of noise at the receiving point is a very acute problem. All of the larger airports have many sources of radio interference, usually including several radio transmitters belonging to various air lines and the government. Furthermore, there are stringent limitations on the heights of antennas at airports. For several years past, the better air line installations have used remote receivers, from one to ten miles from the field. The receivers are operated unattended, with remote control of all necessary controls such as frequency-changing switches. The audio output of the receivers is carried to the operator over a telephone line.

This kind of installation has several disadvantages. One of considerable importance is the cost of rental of telephone lines. Another is the inconvenience of maintenance work. When this system is operating at its best, an unattended receiver can not quite equal the performance of one in the hands of an experienced operator. With the use of greater numbers of frequencies, the circuits necessary to switch remote receivers have become increasingly complex.

In order to satisfy the requirements of the expanding communication system of American Airlines, a new receiving system was developed which uses remote antennas with the advantage of quiet receiving location, and receivers in the control room, where they are always accessible to the operator on duty.

In the average installation of this kind, the r-f transmission line from the antenna to the receiver is about a half mile long. A ceramic insulated coaxial cable is used in order to obtain the lowest possible loss consistent with a completely shielded transmission line. The loss in this type of transmission line may be accurately calculated. For instance, a half of line 5/16 inch in diameter at 20 megacycles has a loss of 12 decibels.

In order to take care of various frequencies, it was considered best to have the antennas and antenna-coupling unit functioning on all necessary frequencies

at all times. All frequencies are brought into a single transmission line. This is necessary because of the relatively high cost of transmission line. The signals are then separated to any desired number of receivers at the receiving end. The provision for coupling several frequencies into the transmission line introduces a rather uncertain amount of loss in comparison with an antenna connected directly to a receiver.

In order that transmission line and coupling losses should not impair the

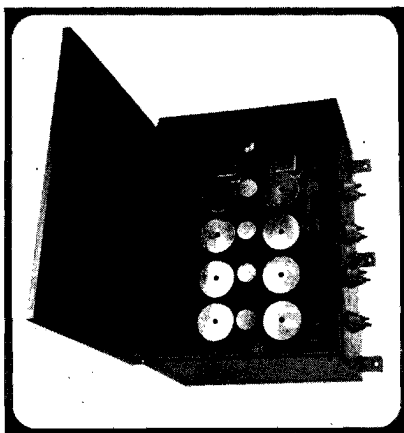

One of the units described in the accompanying text.

performance of the receiver, it was decided to use one stage of radio-frequency amplification directly after the antenna, and before the various frequencies are mixed and connected into a single transmission line. A one-stage amplifier using a pentode, and a tuned-grid and tuned-plate circuit is used for each frequency to be received. As many as twelve frequencies are used on one installation. Each nominal frequency may actually consist of several frequencies within 3 percent of each other, since resonance of the tuned circuits is broad enough to pass all of these frequencies.

In some cases a separate dipole antenna is used for each frequency. It is connected to the input of one pre-amplifier. However, where a number of dipole antennas are close together, the coupling between them prevents them from functioning as independent

antennas. In actual practice a large Marconi antenna or large (non-resonant) dipole is a very effective receiving antenna. Consequently most of the installations using these coupling units have one large antenna connected to all of the inputs various preamplifiers. In some installations, the preamplifier is installed primarily to effect the economy resulting from eliminating all but one receiving antenna.

To facilitate tuning the antenna-coupling unit, provision is made for transmitting audio frequencies over the coaxial cable simultaneously with r-f transmission. Connections are made with a jack at each end. Either the output from the receiver is sent over the cable to allow the man at the antenna end to listen while tuning, or a portable telephone may be plugged into this circuit.

At the receiving end of the transmission line, it is necessary to separate the several frequencies and send them to different receivers. This is just the reverse of the coupling problem at the antenna end. Consequently it was thought best to use a distributing amplifier consisting of another set of tuned r-f preamplifiers.

The amplifier assemblies are made with four or six amplifiers and one power pack on each chassis. The amplifier chassis is the same for the unit at either end of the transmission line, it being adapted for mounting either in the locked weatherproof box at the antenna end, or on a relay rack at the receiving end.

Each individual amplifier has an insulated input circuit. This makes it possible to operate the input of the amplifier assembly from one transmission line when it is used at the receiving end, or from one or more antennas when it is used at the antenna end. The inputs are suitable for either balanced or unbalanced lines.

The output circuits are individually insulated, giving the same freedom in connecting as with the input circuits. In a typical six-frequency installation, with frequencies A, B, C, D, E, and F, connections may be made to bring frequencies A, B, C, and D to the first receiver, A and E to the second re-

ceiver, A to the third receiver, and F to the fourth receiver.

These installations are now in use at frequencies between 2,000 and 20,000 kilocycles. Plug-in coils are used, which permits operation at practically any communication frequency. The coils are tuned by miniature variable condensers mounted in coil form. There are several standard coils, each tuning over approximately a 2:1 frequency range. In order to maintain a mini-

mum number of parts, the design permits the use of identical coils in the input and output of each amplifier.

The gain of a system consisting of one antenna amplifier and one distributing amplifier is in excess of 50 decibels. This far exceeds the loss in the transmission line, even at 20,000 kilocycles. The loss in each channel due to connecting or tuning any or all other channels was found to be insignificant, probably less than one

decibel. There is consequently a very substantial increase in the sensitivity of the receiving system when these amplifiers are installed. The four tuned circuits between the antenna and the receiver also considerably increase selectivity.

American Airlines now have these antenna systems in service at a large number of their receiving stations, and are finding very substantial improvements in their communication service.

## THE HARMONIC PRODUCER

(Continued from page 22)

as an example of a practical application of a linear differential equation of the second order with constant coefficients.<sup>9</sup> The equation is usually written:

$$L_s \frac{di}{dt} + R i + \frac{1}{C} \int i dt = 0$$

The wave pattern for one complete cycle of the periodic but non-sinusoidal current  $i_2$  is given mathematically by applying the formula for the solution of this differential equation to one positive pulse and one negative pulse. There is a standard integral in Fourier series analysis which can be used with this wave pattern to find the amplitude of any one of the harmonics contained in the current  $i_2$ . While this procedure is simple to state, the integration and other mathematical operations involved are difficult and tedious. For our purpose we need only note the resulting formula, which is given below in the form of the power for the  $n$ th harmonic.

$$W_n = \frac{W_0}{1 + (1 - 2k)(RCpn)^2 + k^2(RCpn)^4}$$

Where  $W_0$  represents several factors which are constant for all harmonics;  $L_s = \frac{L_s}{R^2 C}$  and  $p = 2\pi$  times the fundamental frequency.

This expression shows that the relative values for the various harmonics are determined by a rather complicated relationship between  $k$ ,  $RCp$  and  $n$ ; and  $k$  itself is an expression containing all the constants of our secondary circuit  $L_s$ ,  $R$  and  $C$ . To use this formula for  $W_n$ , it is necessary to resort to a rather indirect graphical process. A series of curves (see Fig. 8) were plotted for different values of  $k$  and then the curve, and the portion of that curve, were selected which would give the most uniform level for the harmonics required, which would include all between

<sup>9</sup>See, for example, page 120 of A. Cohen's "Differential Equations," (first edition).

the 9th and 45th in the coaxial application. The selection of the best curve determines  $k$  and selection of the best portion of the curve determines  $RCp$ .

### OBTAINING HARMONICS OF SUFFICIENT POWER

Only the relative values of the harmonics are fixed by the above process. The absolute value of all of them is determined by the factor  $W_0$ , which is given by the expression;

$$W_0 = \frac{2}{\pi^2} p^2 Q^2 R$$

This looks fairly simple, but is not, because the charge on the condenser  $Q$  is a complex, empirically derived, function<sup>10</sup> of a number of factors; including the several constants of the harmonic producing coil, the amplitude of the fundamental and  $RCp$ . Instead of giving the complete formula for  $W_0$  we will simply state that all the factors in it will be determined by the preceding calculations, or other conditions, with the exception of the constants of the coil. The constants of the coil may be divided into those which are fixed by the characteristic of the special ferro-magnetic material used in the core of the coil and those which can be varied—the diameter of the toroid of the core, the cross section of the core and the number of turns in the winding of the coil. Since the number of turns is usually determined by the impedance of the load, this leaves only two variables in this formula for  $W_0$ , and values can therefore be selected for them (thus fixing the size of the core) to give the desired value of  $W_0$ .

These calculations establish the values of all the elements in the harmonic producing circuit—the capacity of the condenser  $C$ , the load resistance  $R$ , and the several constants of the retard coil ( $L_s$ ,  $L_m$ , the size of the core

<sup>10</sup>This expression for  $Q$  is derived by solving the differential equation for the charging current and this involves some so-called "higher mathematics" of a very difficult nature. (Covered in article by Peterson, Manley and Wrathall.)

and the number of turns in the winding). The last step is to set up a circuit using these constants and see how closely the actual power of each harmonic corresponds to the values expected from the calculations. Such a comparison is given in the curves of Fig. 9—where the measured values are shown by solid line curves and the calculated values by dotted curves. In view of the fact that these calculations were based on a simplification of the actual magnetic characteristic, the measured and calculated performances of this circuit seem closer than we might expect and in any case thoroughly justify this simplification.

### RESUMÉ

To sum up: The carrier frequencies for a carrier-telephone system, or for synchronizing a radio-transmitter carrier, can be generated as the harmonics of a single fundamental frequency by using the non-linear characteristic of a retard coil. By choosing the proper fundamental frequency this will not only give the right series of frequencies but will also give frequencies of sufficiently accurate values, because the accuracy of all harmonics depends only on that of the fundamental frequency and this can be kept within the necessary limits.

The most difficult problem in developing this harmonic-producer circuit was that of obtaining a retard coil, condenser and load resistance which would give nearly the same amplitude for all of the desired frequencies. This proved no simple task because the amplitude of each harmonic depends on so many factors, and the relationships are so complex, that no straightforward mathematical analysis could be applied.

Consequently the problem was tackled by empirical methods. A circuit was set up (with arbitrary values for the elements) and the actual output current recorded on cathode-ray oscillographs. A study of the wave-shape of this output current made it possible to reconstruct the operation of the circuit and make some simplifying assumptions,

(Continued on page 41)

# TELECOMMUNICATION

PANORAMA OF PROGRESS IN COMMUNICATIONS

## WOR'S RECORDING LABORATORY

WOR'S RECORDING LABORATORY has played an important part in the rebroadcasting of a variety of programs during the past year-and-a-half, offering to listeners descriptions of horse races, Presidential talks, boat races, special events—including a broadcast of an interview with the legless swimmer Charles Zimmy, who swam from Albany to New York, the Merrill-Richman Trans-Atlantic take-off at Floyd Bennett field, the Coronation of England's King George VI and the abdication speech of King Edward VIII among others. Many of the above programs were aired twice in one day so that those who were at work and unable to hear the original program were able to keep abreast of the news highlights of the day.

Along with functioning as a medium to convey news, WOR's recording laboratory, under the direction of research engineer Ray Lyon, has also invaded the commercial field within the last ten months and is being utilized by the station itself and many of the leading advertising agencies to record spot programs which are heard over WOR and other stations as well as providing a library of auditioned programs available for sponsorship.

At the right is pictured an innovation in the selection of a site for the radiator used by radio station WFOY at St. Augustine, Florida. This Truscon vertical radiator, some 200 feet in height, is built on a solid rock foundation 9½ feet below the salt water marsh. . . . In the background of this picture can be seen the Atlantic Ocean which affords a salt water covering for the extensive ground system of some 20,000 feet of copper wiring which extends out some 200 feet in straight lines in all directions from the base of the radiator.

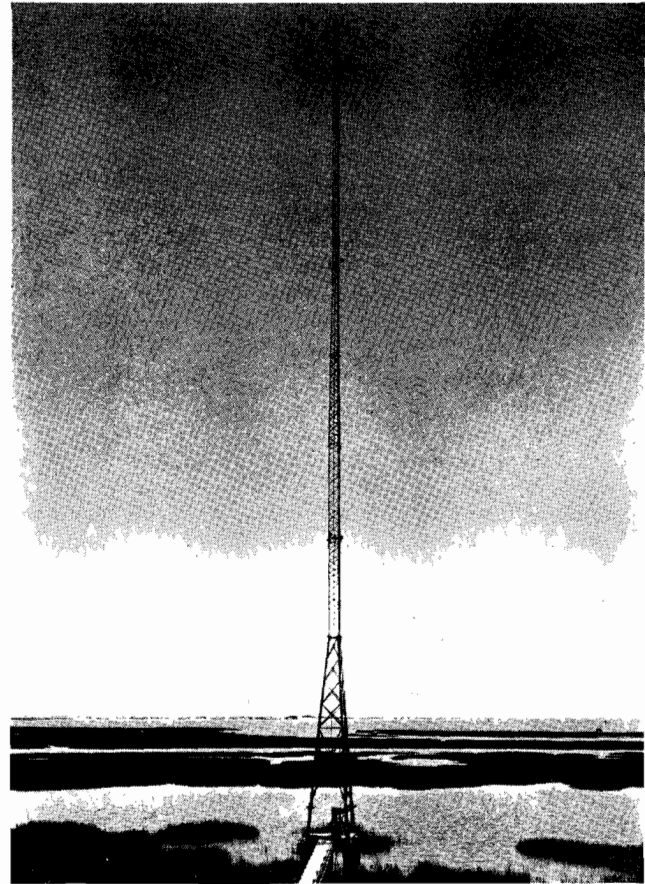

This quaint old "tabby" house, built of oyster shells and covered with logs and Spanish moss, houses the transmitter of WFOY.



## ELECTRIC EYES PROTECT HUMAN EYES

REALIZING the vital part played by adequate and uniform illumination in any work requiring close concentration and mental effort, General Electric engineers have devised an inexpensive photoelectric lighting control that keeps the light in a room or building at the proper level for satisfactory work.

Fatigue and poor work because of eye-strain can easily be eliminated when sufficient light is provided. Persons working in a room where automatic lighting control is installed are free to go about their work without being interrupted or annoyed by poor light. When artificial light is needed to keep the illumination at a predetermined level, the lights are turned on automatically. When enough natural light is available to provide this amount of illumination, the artificial light is turned off.

# AN ULTRA-HIGH-FREQUENCY OSCILLATOR\*

By **ARNOLD PETERSON**

MASSACHUSETTS INSTITUTE OF TECHNOLOGY

VACUUM-TUBE OSCILLATORS for operation at ultra-high frequencies have received considerable attention in the last few years. Improved vacuum tubes have permitted the use of circuits which govern the frequency of oscillation to a much greater degree than is possible at these frequencies with the older and more conventional tubes. Several tank circuits for frequency stabilization have been developed, notably the parallel-wire and coaxial transmission lines and the Kolster toroid. None of these, however, meets all the requirements for a satisfactory laboratory source. These requirements are as follows: (1) A high degree of frequency stability under varying external conditions, (2) a confined electromagnetic field, (3) ample output for use as a source for high-frequency measurements, and (4) a convenient physical size. A good compromise between these conflicting requirements has been achieved in a new oscillator utilizing a vacuum tube<sup>1</sup> especially designed for ultra-high frequencies coupled to a lumped concentric-element tank circuit.

This tank circuit consists of an outer containing-cylinder with a cylindrical piston-shaped insert. Referring to Figs. 2 and 3, it is perhaps simplest

---

The oscillator described here — a joint research project of M. I. T. and the General Radio Co. — is particularly useful at ultra-high frequencies. — Editor.

---

to consider the oscillatory tank circuit as an L-C circuit, whose capacitance is that formed by the outer cylinder and the large inner copper tube, and whose inductance is that obtained by the field surrounding the inner copper rod. The dimensions of the tuned circuit are sufficiently small in comparison with the wavelength to permit its treatment as a lumped circuit.

The effectiveness of this oscillatory circuit for frequency stabilization is the result of the low losses in its component elements and of its connection to the vacuum tube in such a manner as to appear as a circuit with elements of low reactance. For the oscillator illustrated, which has an outside diameter of slightly more than 4 inches, the tank capacity is about 130 mmfd, and the tank inductance, about 18 cm ( $18 \times 10^{-9} \text{h}$ ). At its operating frequency

of 100 mc the  $Q$  of the resonant circuit is approximately 2,500.

The properties of this oscillator which are of interest here are the effect on the frequency of oscillation of variations in electrode voltages and other external conditions, the effect of loading, and the drift in frequency during the warming-up period.

The change in the frequency of oscillation produced by a variation in the applied plate voltage is given in Fig. 4. There is also given in the same figure a similar curve obtained when the oscillator was connected to a resistive

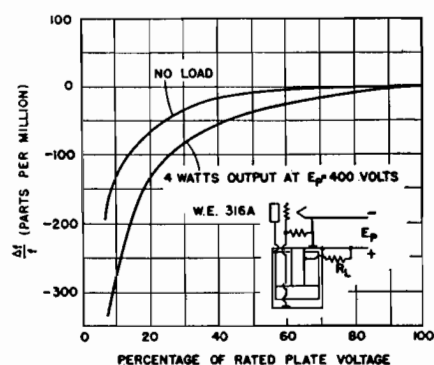
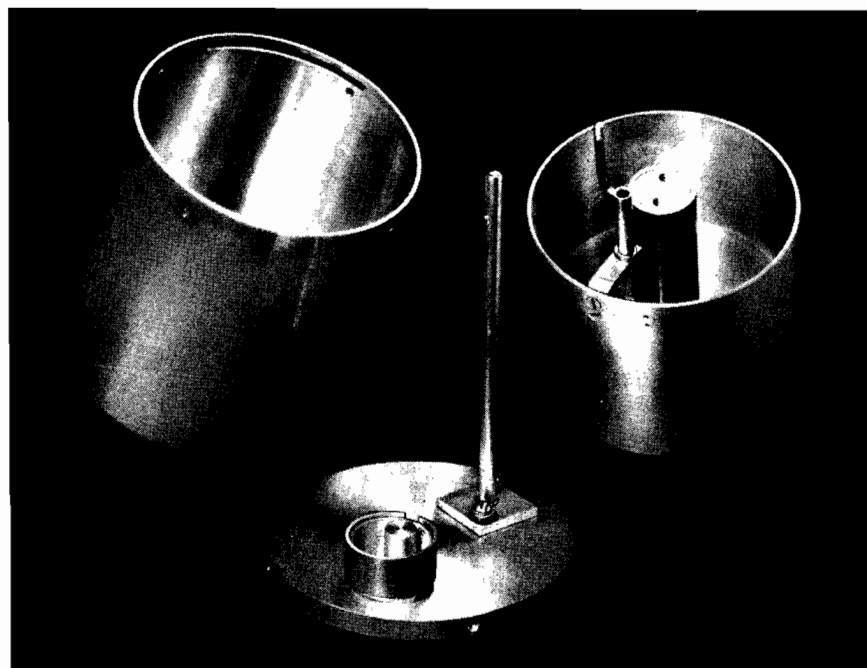

Fig. 4. Change in frequency produced by a variation in applied plate voltage.

Fig. 3. The concentric-element tank circuit taken apart. The outer brass shell is at left, the inner copper cylinder at right



load so as to produce 4 watts output to the resistor with a plate-circuit efficiency of 20 percent with a plate voltage of 400 volts. The stability for the loaded condition is naturally not so good as that obtained for the oscillator unloaded because of the increased losses of the complete system, but it is much better than the stabilities of earlier types of oscillators for this frequency region.<sup>2</sup>

Because of the methods used in the measurement of these changes in frequency, the results contain no appreciable drift effect and can be considered as essentially dynamic measurements. That is, the effect of physical changes in the oscillator as a result of varying thermal conditions was minimized in order not to mask the effect of dynamic changes in the tube parameters.

A rapid variation of the applied filament voltage produced only a very

\*Reprinted from October, 1937, *General Radio Experimenter*.

<sup>1</sup>M. J. Kelly and A. L. Samuel, "Vacuum Tubes as High-Frequency Oscillators," *E.E.*, Vol. LIII, No. 11, Nov. 1934, pp. 1504-1517.

small shift in the frequency. However, a slow variation in the filament voltage which permitted the thermal equilibrium of the filament to readjust itself produced a change in frequency opposite in sense to, and somewhat greater in magnitude than that produced during the rapid variation of the plate voltage shown in Fig. 4.

The ambient temperature coefficient of frequency of the oscillator has been made less than the temperature coefficient of expansion of the individual metals which are used in the tank circuit. This reduction has been accomplished by the proper utilization of the differing temperature coefficients of expansion of brass and copper to produce a tank capacitance with a negative temperature coefficient which approximately balances the positive temperature coefficient of the inductance. By this means, an ambient temperature coefficient of frequency of less than 5 parts per million per degree Centigrade is readily

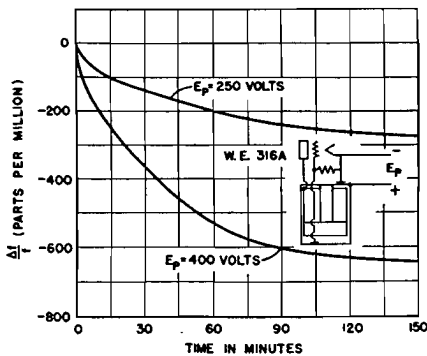

Fig. 5. Drift in frequency of oscillation during warm-up period.

achieved. The drift in frequency of oscillation during the warming-up period for the unit illustrated is given in Fig. 5. This drift, which is approximately proportional to the input power of the plate circuit, is primarily a result of changes in the spacing of the tank condenser because of the temperature differential developed in the oscillator. By a change in the design of the given tank circuit, this drift can be materially reduced. However, to accomplish this reduction, the physical size should be increased, or the resultant frequency stability during varying electrode voltage conditions will be lessened. Thus, for a given application of this type of oscillator, unless compensation means are used, a design which effects the best compromise for that application should be adopted.

<sup>2</sup>A. Dennhardt, "Ueber Mehrrohrschaltungen für sehr hohe Frequenzen," *Zeitschrift für Hochfrequenztechnik*, Vol. 35, No. 6, June 1930, pp. 212-223.

W. H. Wenstrom, "An Experimental Study of Regenerative Ultra-Short-Wave Oscillators," *PIRE*, Vol. 20, Jan. 1932, pp. 113-130.

Fig. 1. The complete oscillator consisting of tank circuit and vacuum tube. The overall height is 7 inches. A small copper cylinder, located eccentrically on a shaft passing through a disc (see Fig. 3), is used in conjunction with a large copper cylinder to form a small variable condenser for the adjustment of the frequency to a particular value

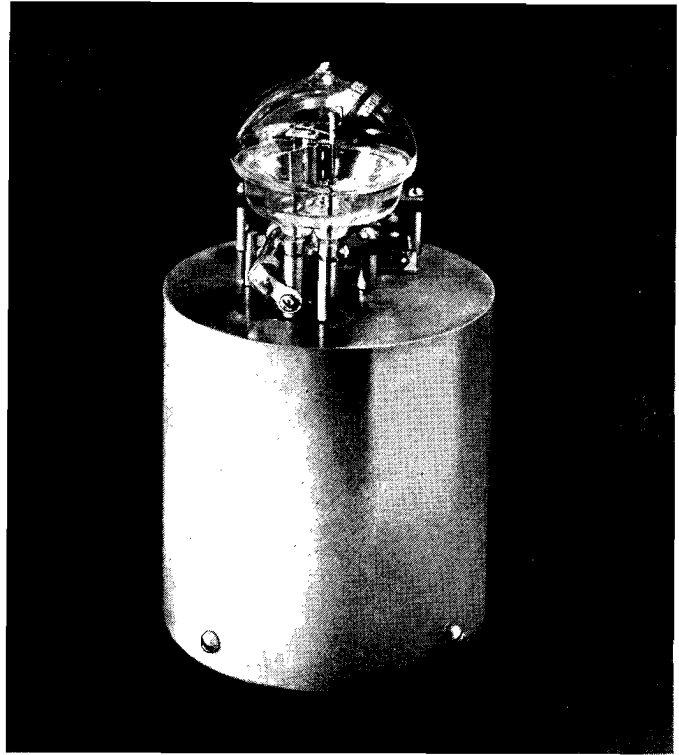

## WORLD RADIO CONVENTION

ORGANIZED by the Institution of Radio Engineers (Australia) of which Sir Ernest Fisk is the President, a World Radio Convention will be held at Sydney, commencing Monday, April 4 to Thursday, April 14, during the final period of the celebrations in connection with the 150th Anniversary of the Foundation of Australia.

It is believed this is the first World Radio Convention ever held anywhere to discuss all phases of radio engineering, embracing all persons interested in radio. Hitherto radio conferences have been held in various parts of the world, the majority of which have only included governmental delegates to discuss frequency allocations and control.

This World Radio Convention will

cover all the technical subjects that are common to all radio engineers, including (a) *Wave Propagation*, (b) *Telecommunication*, (1) Land, (2) Marine, (3) Aircraft; (c) *Broadcast Transmission*, (d) *Broadcast Receivers*, (e) *Sound Projection* (Talking Pictures, Recording and Amplification), (f) *Electromedical*, (g) *Television*, (h) *General and Allied Subjects*. There is hardly any phase of radio engineering that will be omitted from this Convention of World Radio people.

During the week-end arrangements are being made for country tours, so that visitors will have an opportunity of seeing some of the Australian country life and scenery.

The Australian Broadcasting Commission and also the Commercial Broadcasting Stations are co-operating by way of arranging special concerts.

The Wireless Amateurs, through their Wireless Institute, have also arranged to hold their Federal Conference in Sydney at the same time as the Convention. Delegates from all parts of Australia will be in Sydney at that time, and the amateurs are organizing a comprehensive program that will fit in with the rest of the Convention plans.

The Convention will officially terminate on Thursday, April 14, with a big function of a semi-social character.

All interested persons, who might be able to arrange to visit Sydney on that occasion, particularly for the Convention, are asked to communicate with the Convention Secretary, O. F. Mingay, 30 Carrington Street, Sydney.

Fig. 2. Sectional view of the tank circuit.

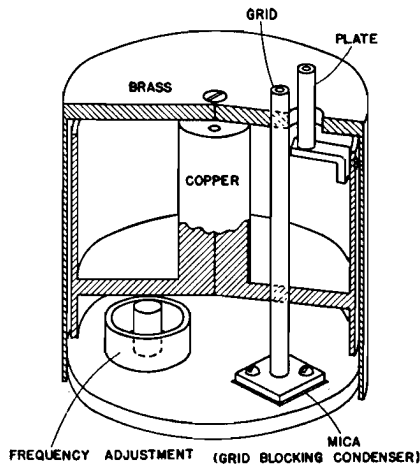

## ULTRA - HIGH - FREQUENCY DESIGN CONSIDERATIONS

CONSIDERABLE improvement is possible in parts now in use at wavelengths below 10 meters. Many of the parts now in use must be entirely redesigned before very satisfactory results will be obtained near 5 meters. Many years of research in this field point to general considerations for such improvements.

Before the advent of the special ultra-high-frequency tubes, perhaps 75 percent of the difficulties were due to comparatively high values of inductance and capacitance in the tubes used. The first consideration for ultra-high-frequency work is the selection of a tube suited to the high frequencies.

Ultra-short-wave equipment of the future will employ parts smaller in "volume." The reduction of the size of a part usually increases its efficiency at the higher frequencies. For example, a large-size variable condenser, though its capacity value is correct, may introduce losses because of its internal inductance, and its large metal plates; its size will require longer leads to reach the desired circuit points, and its capacity to other parts of the circuit and to ground will be higher. A careful design for this purpose is smaller, with perhaps plates closer together and smaller, and with metal end-plates replaced with insulating ones of good dielectric.

In tests using air-dielectric condensers as blocking condensers, instead of mica-dielectric condensers, no efficiency increase is noticeable because the air-dielectric condensers require longer leads and have within themselves more metal (see later discussion of this effect) and are larger in volume. The smallest type of mica fixed-condensers prove to be the most efficient near 3 meters, as blocking condensers.

The "volume" consideration proves in general to be an important one for the usual part. A set composed of large parts, requiring long leads, has an overall capacity to ground much higher than a set made up of small parts, placed closer together and requiring shorter leads.

Large parts, because of higher inductance values, allow in general lower L-C ratios in the tuned circuits and lower efficiency results. When all parts are very small, and shorter leads are used, the coils can be made of higher induct-

ance and better results are in general secured. At 5 meters, coils  $\frac{3}{8}$  inches in diameter are very satisfactory, but the rest of the circuit must also be carefully designed.

The minimum possible amount of metal should be used in any part designed for use at ultra-short waves. If it is possible to reverse the leads to a part and thus place the most metal at a low r-f potential, this should be done. Fig. 1 shows the importance of removing as much metal as possible from the high r-f potential parts of ultra-short-wave apparatus. With a 5-inch lead of bare copper wire connected to the plate of the oscillator, various lengths of 1/16-inch aluminum plate, 2½-inches wide, were connected. The d-c grid current in the oscillator gives an idea of the efficiency of the oscillator. Notice that short lengths of the plate greatly reduce the grid current. An 8-inch length of plate kills the oscillation entirely under the existing conditions. These tests were made near 60 mc. At higher frequencies the effect is greater, and at  $\frac{3}{4}$  meters, even an ordinary soldering lug reduces the efficiency. The effect of short lengths of wire at 5 meters is noticeable. It should be especially noted that the metal already in the circuit such as the stator of the variable condenser used also has considerable effect on satisfactory operation. Often, the results can be improved by connecting that half of the condenser with the largest amount of metal, to the low potential part of the circuit. The importance of the proper design of parts is therefore evident.

For a given condenser capacity, select the condenser having the minimum amount of metal and the smallest size. Mica condensers are entirely satisfactory for by-pass and blocking purposes, but air condensers must be used in tuned circuits. For transmitters, where plate-spacing is important, two parallel plates are quite efficient if the leads to them are short. In general, small air condensers with short, direct leads to the plates are satisfactory.

The circuit of Fig. 1 is an example of a good, practical design. The reasons for effective operation at 60 mc and higher frequencies are: All leads are of comparatively small wire and are short and direct; the grid blocking condenser, C, is small and has two small metal "plates"; the chokes, rfc, as far as possible are connected at points of

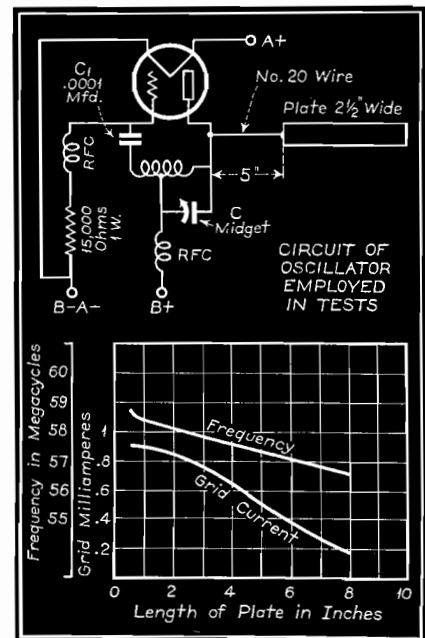

Fig. 1. Above: circuit of oscillator employed in tests. Below: showing variation of grid current and frequency with length of plate.

low potential and are designed for use at these frequencies; the tuning condenser, C, is small, has thin plates (and no unused ones), and has the stator grounded; all superfluous metal lugs, leads, etc., are removed from high potential parts of the circuits. These factors go a long way toward increasing the efficiency, but a tube designed for the purpose should be used if possible.

A. BINNEWEG, JR.

## LAMINATED IRON-CORE COILS

(Continued from page 18)

Here, the components  $L_a$  and  $L_1$  are yet to be determined. Let us further state that only the coil which represents the iron path  $R_1$  has losses which, in the electrical representation, may be taken into consideration by a shunt resistance  $R_p$ .

If our coil were provided with a closed magnetic circuit, its inductivity  $L_a$  would be obtained with, say,  $n_0$  turns. Since, by means of the air gap, the magnetic characteristic is sheared over and the inductivity is decreased, we

# COMMENT . . Production

have, in order to obtain the proper value  $L_o$ , to increase the number of turns to  $n_o^2/s_o$ , where  $s_o$  is the "shearing factor"

$$s_o = \frac{R_i}{R_i + R_a} = \frac{1}{1 + \frac{l_a}{l_i} \mu_i}$$

$l_a$  and  $l_i$  being the lengths of the iron and air paths, respectively. After splitting  $L_p$  into the two components according to the magnetic resistances of these paths, we get

$$\left. \begin{aligned} L_i &= \frac{n_o^2}{s_o R_i} = \frac{L_o}{s_o} ; \\ L_a &= \frac{n_o^2}{s_o R_a} = \frac{L_o}{1 - s_o} \end{aligned} \right\} \dots\dots\dots (3)$$

It is only necessary to know, how the values of  $L_i$ ,  $L_a$  and  $R_p$  depend on the frequency.

$L_a$ , as a pure inductivity, is constant. For  $L_i$  and  $R_p$ , very simple approximations have been given by Wolman and Loebner.† According to their results, the value  $L_{i0}$  and  $R_{p0} = 2\pi f_g L_o/s_o$  may be put constant up to  $f_g$ , while beyond

this critical frequency we have to write

$$L_i = \frac{L_o}{s_o} \sqrt{\frac{f_g}{f}} \text{ and } R_p = \frac{2\pi L_o}{s_o} \sqrt{f \cdot f_g} \quad (4)$$

Thus, the total inductivity of the parallel connection is above  $f_g$  and relative to its value  $L_o$ , corresponding to low frequencies:

$$\frac{L_p}{L_o} = \frac{1}{1 + (\sqrt{f/f_g} - 1) s_o} \quad \dots\dots\dots (5)$$

This relation has been represented for some values of  $s_o$  in Fig. 2. From this chart, the variations of inductivity can easily be seen. It is only necessary to determine the critical frequency of the coil (without air gap), and then, the result can be read for any air gap and any frequency. A rule easy to remember is: at the fourfold value of the critical frequency of the (unsheared) core, the relative variation of the inductivity is as great as indicated by the shearing factor.

For the loss-angle  $\tan \delta = \omega L/R_p$ , which is of still greater interest, the following formula, valid above  $f_g$ , results

from equations (3), (4) and (5):

$$\begin{aligned} \tan \delta &= 2\pi f (L_p/L_o) (L_o/R_p) \\ &= s_o \sqrt{f/f_g} \frac{1}{1 + (\sqrt{f/f_g} - 1) s_o} \end{aligned} \quad (6)$$

Starting from  $f_g$ , the loss angle increases initially only with the root of the frequency, later on still slower, according to the value of the shearing factor. From this may be concluded that by means of shearing, the frequency range of the coil is enlarged. If, for instance, the shearing factor is made one percent, the lower "critical frequency" (where  $\omega L$  equals the copper resistance) is increased by 100, while 100 times the upper critical frequency the loss-angle is only  $\tan \delta = 0.09$ , as shown in Fig. 2.

In order to verify equations (5) and (6) some impedance measurements have been carried out with several laminated permalloy core coils (thickness of laminations .015 inch). The magnetic field strength, except with the lowest frequencies, was so small that hysteresis losses were negligible. Curve (a), Fig. 3, shows  $\tan \delta$  with overlapping laminations, the critical frequency being  $f_g = 4500$  cycles. Then, the laminations were arranged so as to form an air gap of .03 inches, the shearing factor being 15.4 percent. The theoretical approximation is plotted as curve (b) (dotted lines). The points connected by curve (c) are the results of measurements with different coils. The agreement is rather good, and the deviations from curve (b) are obviously caused by the application of said approximation. In fact, the strict theory would yield a slightly curved line instead of the broken one, which until  $1.2 f_g$  would run below (b), and then above.

At the lowest frequencies used, the losses caused by copper resistance and hysteresis must no longer be neglected, while at the other end of the frequency range, the angle is somewhat increased by dielectric losses in the capacity of the winding. Since the calculation of these losses is well known, it is not necessary to deal with them here in detail.

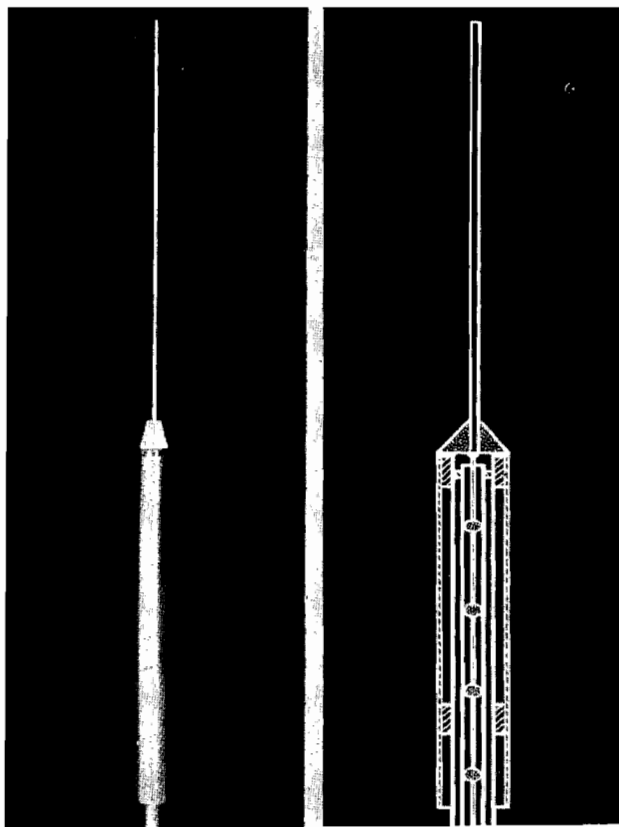

Among recent developments is a coaxial antenna designed by the Bell Telephone Laboratories for use with ultra-high-frequency radio transmitters. . . . This antenna is a vertical half-wave radiator, energized from a concentric transmission line at its center. It is so designed that a proper impedance match is obtained at the concentric line termination. Above this point, the top rod section is one-quarter wave long, and below this point the tubular section is also one-quarter wave long. This tubular section is coaxially disposed about the supporting pipe, so that no offset mechanical load is applied to the pipe.

\*Scott, *Proc. IRE* 18, p. 1750 (1930).  
 †W. Wolman, *Z. f. techn. Phys.* 10, p. 595 (1929).  
 F. Loebner, *Veröff. Nachrichten technik*, 3, p. 253 (1933).



# VETERAN WIRELESS OPERATORS ASSOCIATION NEWS



W. J. McGONIGLE, President

RCA Building, 30 Rockefeller Plaza, New York, N. Y.

H. H. PARKER, Secretary

## SEASON'S GREETINGS

WE ARE PLEASED to report in this the final issue for the year 1937 that our Association is in excellent financial and moral condition. Our resources have been continuously increased and our membership becomes ever larger.

For the support we have received from you, our members and friends, we are deeply grateful. Without your cooperation our efforts would have been fruitless. To the publishers of COMMUNICATIONS, particularly to Bryan Davis, President; Ray D. Rettenmeyer—ever cooperative Editor; James Walker their Secretary, and Circulation Manager A. B. Carlsen, sincere thanks for their efforts in our behalf.

In behalf of the Officers, Directors and membership of our Association I extend heartiest greetings for the Merriest of Christmases and the Happiest of New Years. 73.—William J. McGonigle, President.

## ANNUAL MEETING

THE ANNUAL MEETING of the Veteran Wireless Operators Association will be held on Monday evening, January 3, 1938, at 6 p.m. at the Castle Garden Cafe, 62 Pearl Street, New York, N. Y.

The Ballots sent in by the members in the annual election of officers and directors will be counted by tellers appointed by the President from among the members present and the results announced. The new officers and directors will be mentioned in the next issue. We urge you to attend this meeting and lend your support to our forthcoming cruise.

## THIRTEENTH ANNUAL CRUISE

IT IS with a great deal of pleasure that we announce the return of our Annual Dinner-Cruise to the scene of our first several cruises which were so eminently successful—the Hotel Astor.

On Friday, February 11, 1938, our members and friends will join in an evening of jollification and good fellowship—renewing old friendships and making new ones—in the beautiful Roof Garden of the Hotel Astor, Times Square, New York City.

A delicious full-course dinner will be served, preceded by an Astorian Martini cocktail and accompanied by two bottles of delicious Sauterne per table of ten persons. There will be dancing and entertainment until the wee sma' hours. Several highlights will be featured and announcement of their nature will be forthcoming in literature to follow. A well-known dance orchestra will furnish the music for the entertainment and dancing.

There will be a door prize for both the ladies and gentlemen. We earnestly request you to inform us at the earliest possible moment regarding the number attending in your party. Tables of ten may be reserved and the choice locations will be given those making reservations in advance

and particularly when a complete table is requested.

The subscription price, which is extremely moderate when you consider all you will receive, is \$4.00 per person. Ladies and Gentlemen. Dress Optional. Drinks moderately priced—and delicious.

CRUISES will be held simultaneously in Boston, Miami, Honolulu, Washington, D. C., San Francisco, New Orleans, Chicago, Omaha, London, England and several other places where chapters are organized. Communicate with your local representative for details.

## YEAR BOOK

AT THE MOST recent Board of Directors meeting, Mr. Arthur A. Isbell, Director, and Commercial Manager of RCA Communications, again initiated our Year Book advertising solicitation activity by pledging on behalf of Mr. W. A. Winterbottom, Vice-president and General Manager of RCA Communications, a full page advertisement on the inside front cover of our 1938 Year Book for RCA Communications at \$100 net.

For years past RCA Communications through Mr. Winterbottom and Mr. Isbell have evinced their interest in our Association and have generously supported this activity and have always been the No. 1 subscriber for space. Our heartfelt thanks for their support and kind encouragement. We request the cooperation of each and every member in making this project a success. Your suggestions and comments will be welcomed.

## IN MEMORIAM

IT IS with deep regret that we record the passing of two well liked veteran radiomen during the past few months—both Radiomarine Veterans, Mr. John Gregg after an illness of several months and one of the best liked inspectors in the New York area, and Mr. W. G. Logue, Commercial Representative for Radiomarine in New York, after a very short illness. We mourn their loss and extend to their families our deepest sympathies and condolences.

## MIAMI

MIAMI CHAPTER SECRETARY, V. H. C. Eberlin II, reports concerning activity in his section: "The 'Sunshine' Chapter held a 'stag' party at the residence of our genial Chairman, C. J. Corrigan. It would have done your Northern'd souls good to have been here. A freely flowing 'keg' kept the spirits at high wattage and a Master Master of Ceremonies, an ex-marine, E. G. Schwartzman, did a job of entertaining par excellence.

"For the well oiled appetites, the Chairman prepared a 'free lunch' not unlike the real old days. Everything plus with quadruple helpings for all. It was a gala

affair and a turn-out of 100 percent plus—seemed as though all passersby dropped in.

"Among the more prominent attendants were L. C. Bishop, C. Shianland, P. Henson, T. A. Wheelock, R. G. MacKenzie, David Harpley, J. A. Chapman, D. G. Patterson, C. Barr, I. L. Pratt, P. A. DeClaive, E. G. Schwartzman, C. J. Corrigan, V. C. Eberlin, Dad, The Pup and a well worked piano."

And Ebbie closes with—"No wonder the Miami Chapter is building up its membership."

## BOSTON

THE DECEMBER MEETING of the Boston Chapter was held at the Manger Hotel in Boston and was preceded by a dinner in the Canadian Room. The committee appointed by retiring Chairman Kolster submitted in nomination Harry R. Chetham for Chairman (Harry was formerly Secretary of the Boston Chapter), Guy R. Entwistle, renominated for Vice-chairman, Bart McCarthy of the FCC staff for Secretary and the incumbent Raymond F. Trop for Treasurer. We go to press too early to include a complete report of the meeting.

NEW JOB. We quote from the RCA Family Circle: "The promotion of James F. Rigby to the newly created position of Personnel Director of RCA Communications, Inc., with headquarters at 66 Broad Street, was announced by W. A. Winterbottom, Vice-president and General Manager, on October 23. Mr. Rigby started his career with the company in 1920, as secretary to W. E. Wood, at Chatham, Mass. By 1924 his excellent record and qualifications brought him the job of Manager of the new Boston office where he remained until his recent promotion. Mr. Rigby has been succeeded by J. S. Carter as Manager of the Boston office."

HARRY CHETHAM forwards a very interesting item: "Made a trip to Chicago for the Sunday, 9 p.m., Zenith Foundation Program, November 21, to tell the story of the Dr. Thierry—David Noble murder case in which I was the 'key man.' Asleep aboard the S.S. *City of Bangor* bound from Boston to Gardiner, Maine, I saw the murder take place and Dr. Thierry hide the gun. The authorities could not find the gun and four days after the crime I went to the Chief of Police and told him of my dream and upon the information furnished by me the Police inspectors went to the closet and looked under the flooring, exactly where I had dreamed the gun was placed, and they found it there. Subsequently Dr. Thierry was convicted of first degree murder and sentenced to life imprisonment in the Bridgewater Criminal Insane Hospital.

"During my stay in Chicago, met Charles Hahne, Mr. Davis at NBC and the Chief Operator there and former Boston resident. All in all a pleasant trip."



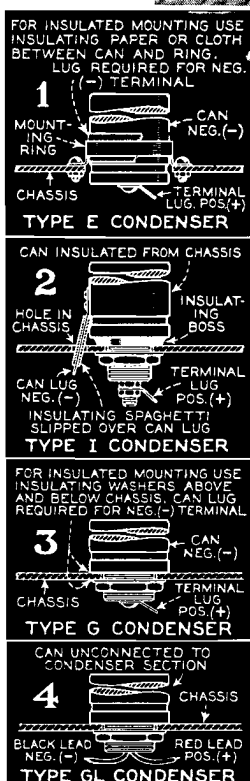
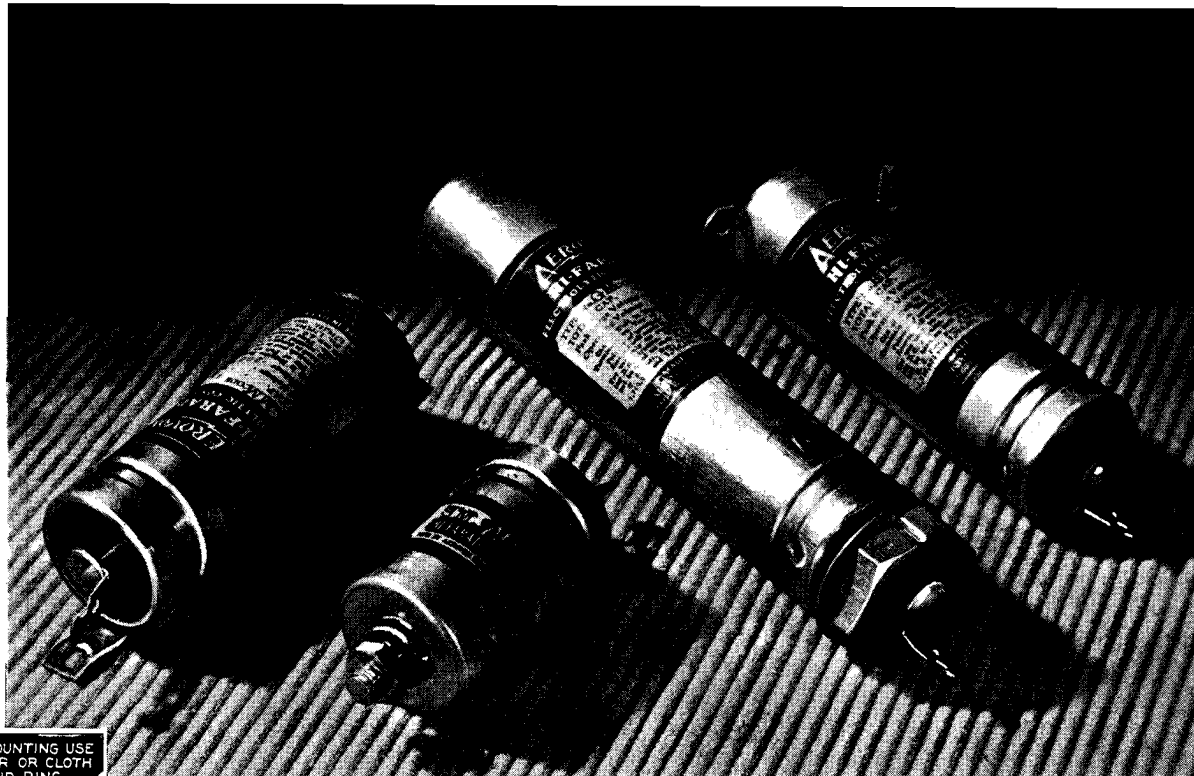

• Four types of AEROVOX electrolytic condensers, showing choice of four mountings and connection arrangements.

## Fitted to Your Job . . . .

**T**HERE'S no need to improvise when you specify AEROVOX. Fitting the condenser to your job rather than expecting you to fit your job to the condenser, is the AEROVOX engineering way.

Electrolytic condensers, for instance: AEROVOX provides the largest selection offered by the industry. Wet or dry; metal-can inverted, upright or flat mounted; widest choice of terminal arrangements; also cardboard-case and

tubular types.

No matter what your particular job may be, AEROVOX Application Engineering helps you select the right condenser for the best results at the least cost. Our engineers study your circuit and other components in arriving at their condenser recommendation.

And it's the same story with other AEROVOX types — paper, oil and mica.

### Submit Your PROBLEM . . . .

*Tell us about your capacitance problem, and our engineers will work out the best solution. Meanwhile, be sure you have our catalog in your working library.*



# AEROVOX CORPORATION

70 WASHINGTON STREET, BROOKLYN, N. Y.

Sales Offices in All Principal Cities

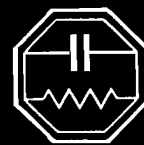

# THE MARKET PLACE

NEW PRODUCTS FOR THE COMMUNICATIONS FIELD

## RAYTHEON TUBES

Two new Raytheon tubes have recently been announced. These tubes are known as the 6G6G and the 6AC5G.

The 6G6G is a low-drain heater type requiring 150 ma at 6.3 volts. This tube may be used in home battery receivers where low heater consumption is desired . . . with the same plate voltage it will give greater output than a type such as the 38. The power sensitivity is said to be four times that of the 38.

The 6AC5G is a high-mu triode which is similar to the output section of a 6B5 and it may be satisfactorily driven by a type 76 or similar tube.

Raytheon tubes are produced by the Raytheon Production Corporation, 55 Chapel Street, Newton, Mass.—COMMUNICATIONS.

## HUSHATONE

A new crystal-operated radio-set accessory has recently been announced. This new device is known as the "Hushatone" (pillow-speaker). The unit is an accessory for midget radio receivers as well as for the typical home radio. Persons enjoying a "Hushatone" do so by placing it under a pillow and reclining in a chair, on a couch, or in bed.

Literature is available by addressing Dept. H of The Brush Development Company, 3311 Perkins Ave., Cleveland, Ohio.—COMMUNICATIONS.

## LINE-NOISE ELIMINATORS

Offering a wide choice of condenser, inductance and ground connection arrangements in the form of six convenient plug-in devices, Aerovox engineers have worked out solutions for various kinds of line noise.

The selection of the proper type of filter is made positive by means of the Aerovox noise analyzer. This instrument contains the various filter circuits contained in the line-noise eliminators. A switch introduces any of these filter arrangements in the circuit. When best results are obtained, the switch setting indicates which type filter to use.

Literature on the Aerovox line-noise filters and noise analyzer may be had by addressing Aerovox Corporation, 70 Washington St., Brooklyn, New York.—COMMUNICATIONS.

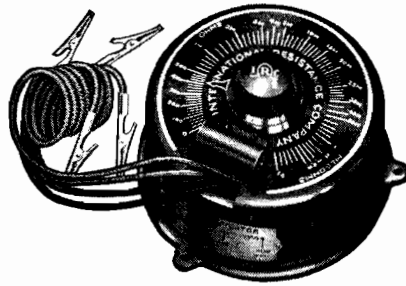
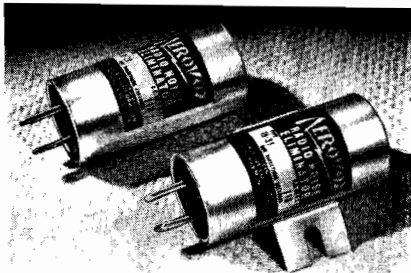

## RESISTANCE ANALYZER & INDICATOR

Designed in handy circular form for either bench use or panel mounting and continuously variable in a range from 0 to 1.0 megohm with a direct-reading calibrated dial, the new IRC resistance analyzer and indicator will be found to be of value for use wherever fixed and variable resistances are involved.

Among its many uses are: voltmeter multiplier; resistance or volume-control analyzer, for the measurement and determination of resistance values by either substitution or voltage measurement method; determination of the proper control or resistance value in almost any radio circuit; wire-wound rheostat or potentiometer (0 to 30,000 ohms); carbon rheostat or potentiometer (0 to 1 megohm); volume or tone control on radio sets; calibrated gain control or attenuator; voltage divider and countless others. A complete instruction manual, furnished with each instrument, gives detailed information as to its use in a wide variety of work.

This instrument is a product of the International Resistance Co., 401 N. Broad St., Philadelphia, Pa.—COMMUNICATIONS.

## ULTRA-SENSITIVE D-C METER

An instrument for use in laboratories and for many product tests is a new ultra-sensitive d-c meter developed by the RCA



electronic research laboratory of Dr. V. K. Zworykin.

The meter was developed for accurate measurements of ionic and electronic currents, employing a new electronic circuit which operates with unusual stability and accuracy, approaching that of the average reflecting galvanometer. It cannot be easily damaged or burned out by overload currents.

In current measurements the new meter provides for twelve scale ranges for measurement to 10,000 microamperes, the lowest full-scale reading being .02 microampere. For voltage measurements, eight other scale ranges are provided, from .1 volt to 500 volts, with a meter resistance of 5 megohms. For resistance measurements, two scale ranges are provided for measurements of from .1 to 100 megohms, and from 20 to 1000 megohms, with less than .5 volt across resistance. With 90 volts in series, up to 200,000 megohms can be measured. Conversion of the meter for the three forms of operation is accomplished by means of a selector switch.

The meter is a self-contained, battery-operated precision instrument, utilizing three RCA 1B-4 tubes. No external resistances or shunts are required. It is of great value for laboratory work, and is so easily portable as to be even more useful for field or location work, since it requires no special set-up or balancing.

Announcement of the meter is being made by the Engineering Products Division, RCA Manufacturing Co., Inc., Camden, N. J.—COMMUNICATIONS.

## SIGNAL GENERATOR

The Model 22A signal generator is a small but versatile unit for general radio laboratory use, where convenience of operation and adaptability to a wide variety of measurements are more important than the greater precision found in larger and more expensive units.

The frequency range of the 22A is from 100 kc to 25 mc, covered with six coils. It features a direct-reading, individually calibrated dial on the tuning condenser. A gear-driven reduction drive gives a total scale length of approximately 4 feet. The output voltage is continuously variable up to 1 volt. All units are contained in one case.

For further information write to the Ferris Instrument Corporation, Boonton, N. J.—COMMUNICATIONS.

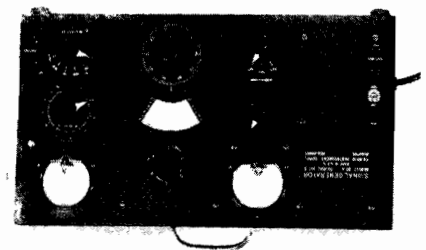

# For Higher Fidelity

## UTC EQUALIZERS

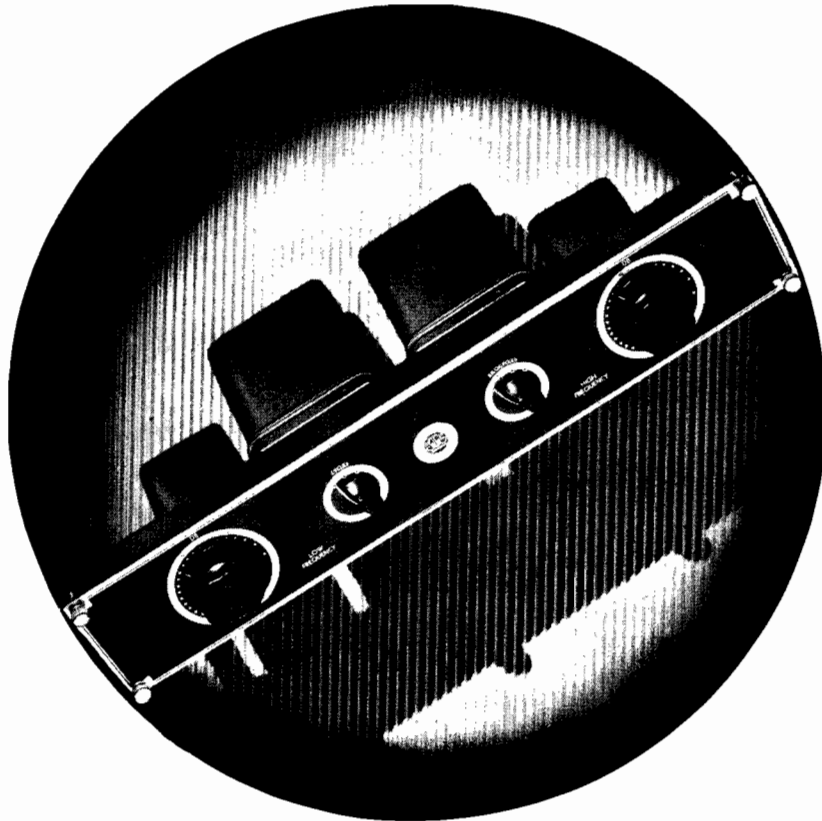

Appearance of 3A, 3D, 3R, 4B equalizers

### UTC MODEL 3A EQUALIZER

The UTC 3A equalizer is an ideal universal equalizer for broadcast and recording service. It combines tap switches and pad controls permitting accurately controlled equalization up to 25 DB at both low and high frequencies. This unit will equalize telephone lines, pickups, cutting heads, sound on film, and other applications of similar nature. Net price to broadcast stations..... **\$85**

### MODEL 3D UNIVERSAL ATTENUATOR

The UTC model 3D attenuator is similar to the 3A equalizer, but is designed to ATTENUATE the low or high frequencies. The low frequency control consists of a switch for adjusting the point at which cutoff starts to 100, 175 or 250 cycles, and a calibrated pad control to adjust the slope of the attenuation curve. The high frequency portion is tapped at 4000, 6000, 8000 and 10000 cycles with a similar attenuation control. This type of equalizer finds many applications in recording, dialogue equalization, and P. A.—theatre applications. Net price to broadcast stations..... **\$75**

### UTC MODEL 3R EQUALIZER

The UTC Model 3R equalizer combines the high frequency equalizer sections of the 3A unit and the low frequency attenuator section of the 3D unit into one equalizer ideal for disc recording. The low end can be attenuated to the exact degree to prevent overrunning the track and still obtain the best low frequency response possible. The high frequency equalizer compensates for the loss of highs normally encountered in the mechanical part of disc or film recording and also increases the ratio of signal to noise at the scratch frequencies. Net to broadcast stations..... **\$75**

### MODEL 4B SOUND EFFECTS FILTER

The UTC model 4B filter is an improved design based on the sound effects filter developed by UTC for the Columbia Broadcasting System. The low pass control has cutoff frequencies of 500, 1000, 2000, and 3000 cycles and incorporates a pad control to govern the rapidity of attenuation. The high pass section has a switch for cutoff frequencies of 500, 1000, 2000 and 4000 cycles, with a calibrated attenuator. Net price to broadcast stations..... **\$70**

**UNITED TRANSFORMER CORP.**

72 SPRING STREET

NEW YORK, N. Y.

EXPORT DIVISION: 100 VARICK STREET

NEW YORK, N. Y. CABLES: "ARLAB"

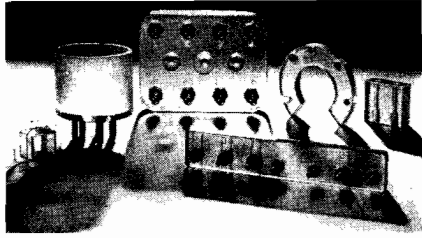

#### BAKELITE POLYSTYRENE

After several years of research announcement has been made of a thermoplastic material for low-loss purposes—bakelite polystyrene molding material (XMS-10023).

Bakelite polystyrene possesses a loss factor of less than .00053, a power factor of less than .0002, and a dielectric constant of 2.60 at 60 cycles, 1,000 cycles and 1,000,000 cycles. This new bakelite molding material offers advantages for many electrical products and equipment parts. Its dielectric strength is more than 500 volts per mil; its resistivity  $10^8$  megohm-centimeters; and its arc resistance 240-250 seconds. Tests indicate that no noticeable change occurs in electrical properties with an increase in temperature or humidity.

In addition to these electrical advantages this molding material provides: uniformity in molding; freedom from crazing or surface difficulties; permanence of dimension, and high resistance to water, acids and alkalis. Its durability and toughness are indicated by its A.S.T.M. impact strength of .16 to .20 foot pounds; flexural strength of more than 7,000 pounds per square inch; and tensile strength of 5,000 to 5,500 pounds per square inch.

Further information may be secured from the *Bakelite Corporation*, 247 Park Avenue, New York City.—COMMUNICATIONS.

#### DYNAMIC MICROPHONES

The airport land station dynamic microphones, shown here, are equipped with attractive chrome stands, aluminum microphone cases mounted at telephone height and with rubber ring cushion bases.

The instruments will be manufactured in 33 ohms, and follows the government regulations as to frequency response. The three-prong plug constitutes a portion of the tubular section of the stand. A microphone can be removed and another substituted in a few seconds.

More detailed information may be secured from the *Universal Microphone Co.*, Inglewood, Calif.—COMMUNICATIONS.

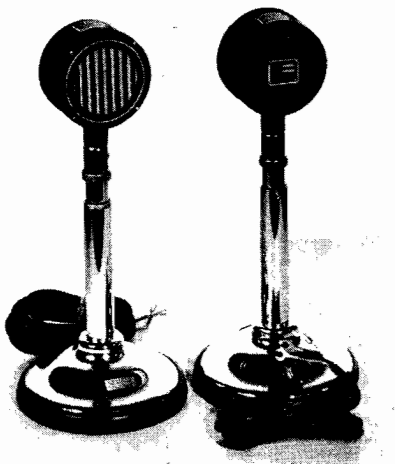

#### AUTOMATIC DEGREASER

The complete Detrex line of standard and special degreasing machines has been augmented by a large, completely automatic degreaser. It is used for the cleaning of miscellaneous metal stampings.

This special vapor-spray-vapor machine is equipped with a two-strand, cross-rod type conveyor arranged for loading and unloading at the same end. The work is placed in perforated baskets which are hung from the cross-rods of the conveyor. In passing through the degreaser, work is lowered into the hot solvent vapors which wet the work and remove part of the contamination. As the conveyor moves horizontally along the machine beneath the water-jacketed condenser, clean warm solvent is pressure-sprayed on to the work from banks of spray nozzles. This mechanical action forcibly removes and drives off the solids.

Additional information on this degreaser may be secured from *Detroit Rex Products Co.*, 13005 Hillview Ave., Detroit, Michigan.—COMMUNICATIONS.

#### PEAK-INDICATING POWER-LEVEL INDICATOR

The Type 686-A power-level indicator gives an accurate, easy-to-read, indication of the audio-frequency peaks occurring in broadcast and sound-picture recording systems.



A high-speed meter movement is used in conjunction with an electrical storage circuit which delays the return swing of the meter needle. As a result, the meter reaches its maximum reading quickly, with practically no overshoot, but does not return to zero with equal speed. This gives an indication in which the needle appears to float on the peaks without the erratic, fatiguing motion which is characteristic of unmodified high-speed movements.

Ease of reading is still further aided by the scale. The background is yellow, with black figures reading in percent utilization of the available channel. Above 100 percent the scale is red to indicate that safe limits have been exceeded. An auxiliary decibel scale is provided. The operating range is from -40 db to +33 db, based on a zero level of 6 milliwatts in a 500-ohm line.

The circuit is that of a vacuum-tube voltmeter with a linear preamplifier. Power supply is obtained from a 115-volt line, 50/60 cycle a-c. No inductances are used in the power supply, eliminating the possibility of magnetic hum being induced into surrounding equipment.

Complete information may be secured from the *General Radio Company*, 30 State Street, Cambridge, Mass.—COMMUNICATIONS.

#### AUDAX PICKUP

Audak Co., makers of pickups and sound apparatus, who developed the Microdyne relayed-frequency pickup, now announce that this magneto-inductive unit has been made available in a low-price model. Audax Microdyne RF-1 is for records up to 12 inches, with 10-inch overall length,



and measures  $8\frac{1}{2}$  inches from center to needle. It may also be had with offset arm.

Additional information may be secured from the *Audak Company*, 500 Fifth Avenue, New York, N. Y.—COMMUNICATIONS.

#### ARCTURUS TUBES

The following 16 types of tubes have been added to the Arcturus line: 1E7G, 1G5G, 1J5G, 6A3, 6A5G, 6C8G, 6D8G, 6L5G, 6N5, 6S7G, 6T5, 6T7G, 6U5, 6Z5, 25B6G, 25Y5.

These additions of glass, "G" and Majestic types make Arcturus one of the most complete lines on the market. The *Arcturus Radio Tube Co.*, is located at 740 Frelinghuysen Ave., Newark, N. J.—COMMUNICATIONS.

#### RCA-814

A new transmitting beam power amplifier, designated as RCA-814, is now available through RCA transmitting-tube distributors.

Designed according to principles involving the use of directed electron beams, the 814 features low power absorption by the screen, and efficient suppressor action supplied by space-charge effects produced between the screen and the plate.

The resultant high power sensitivity makes this new tube suited for use as an r-f power amplifier, oscillator, and frequency multiplier. In Class C service, it is capable of giving a power output of 130 watts, or better, with a driving power of only 1.5 watts.

Mechanical features of the 814 include a ceramic base, top-cap plate connection to insure high insulation and low grid-plate capacitance, and effective shielding to minimize the need for neutralization.

The RCA-814 is a product of the *RCA Radiotron Division, RCA Manufacturing Co., Inc.*, Harrison, N. J.—COMMUNICATIONS.



# CHEAPER... yes, but—

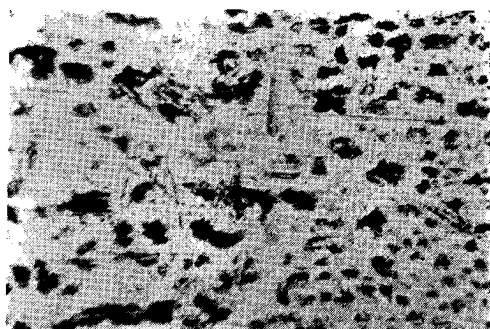

➡ This photomicrograph shows why we do not offer electroplated strip. Note the effect of corrosion on this nickel plated strip as sold for radio tube use.

## WE CANNOT AFFORD THE RISK! CAN YOU?

**YOUR PROTECTION IS SVEACOTE** which is well worth the slight additional cost

Here is a photomicrograph of Sveacote with the same magnification (100X) made after the same corrosion test.

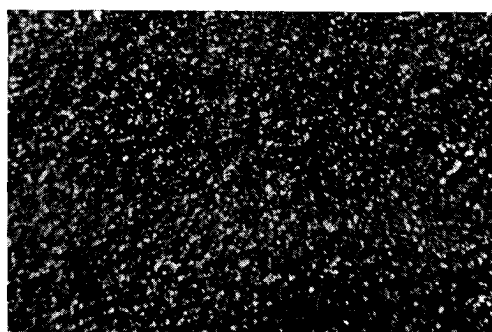

(Darkness due to low reflection from matte surface.)

### THE REASON

Sveacote is a definite alloy made by a special process to resist rust. Note compact structure, uniformity and freedom from impurities.

## Swedish Iron & Steel Corporation

17 BATTERY PLACE

NEW YORK, N. Y.

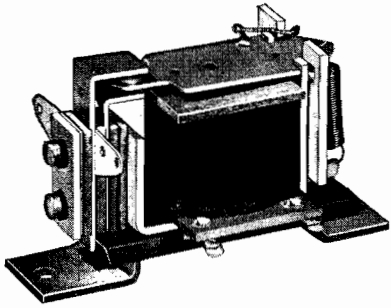

#### COMPACT RELAY

Engineers in the electronic, radio, and electrical equipment fields are offered a standardized and compact relay in the Type D model, just released.

Type D is an electromagnetic relay for operation on either a-c or d-c. Small in size, its dimensions are:  $2\frac{5}{8} \times 1\frac{5}{16} \times 1\frac{1}{2}$  inches. With a-c coils it is furnished for use up to 120 volts, and with d-c coils up to 60 volts without series resistors. Contact capacity is 10 amps a-c and 2 amps d-c. Contact pressure and contact travel are readily adjustable, which means that the relay is suited to marginal operation requirements. Solder lugs are provided for coil terminals and contact connections. The frame and armature are made entirely of silicon steel.

The d-c relay can be furnished with a slow acting armature to give a delay up to  $\frac{5}{100}$  second on either pickup or release time. It can be furnished for operation in the plate circuit of a vacuum tube with a coil resistance up to 2,000 ohms and operating current as low as 2 milliamperes.

This relay is a product of the *G-M Laboratories, Inc.*, 1731 Belmont Ave., Chicago, Illinois.—COMMUNICATIONS.

#### MATCHED DIAL PLATES

These new dial plates are marked in 100 divisions of the active rotation, and are calibrated numerically from 1 to 10. The rotation covered by the terminals and the switch short out is clearly marked so that it is easy to set the plates in their proper position on the panel. The new Yaxley matched dial plates are  $2\frac{1}{4}$  inches in diameter and are finished with polished aluminum markings against a satin black background.

If the control is of the linear type, a setting of "5" on the dial plate indicates that one-half of the resistance is in the circuit. A setting of "1" indicates that one-tenth of the resistance is in the circuit, etc. When a Yaxley matched dial plate is used with a tapered control in the proper circuit, the calibration is in proportion to the audible intensity of the signal.

Further information may be secured from *P. R. Mallory & Co., Inc.*, Indianapolis, Ind.—COMMUNICATIONS.

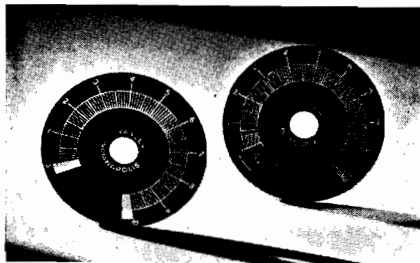

#### RECORDING BLANKS

The Simplat record is developed along the fundamental principle of commercial phonograph recordings, i.e., cutting soft and playing back hard. Among the features of this record are: wide frequency response due to the soft colloidal coating which is hardened before reproduction; flatness because of the glass base used (said to be less breakable than commercial records); and simple hardening with a fluid.

Literature is available from *Recoton Corporation*, 178 Prince Street, New York, N. Y.—COMMUNICATIONS.



#### VOLTAGE REGULATOR

A voltage regulator designed to permit manual compensation of fluctuating a-c lines has been developed. This new device, known as the Type "RH" Transtat, provides smooth uninterrupted control of voltage in steps of approximately 1.0 volt each. Designs have been developed for correcting voltage throughout a range of plus or minus 20 volts from normal (40-volt total range) on lines of 230-volt nominal rating

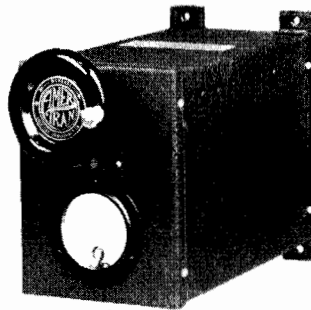

or lower. Line currents up to 35 amperes can be handled with this equipment and types can be furnished for either single-phase or polyphase operation.

This new product is an adjustable auto-transformer of unique design and, being a transformer, it offers several advantages over other methods of control. It has a high electrical efficiency, low exciting current, and practically no effect upon either power factor or waveform. Control of voltage, which is accomplished by means of sliding carbon brushes, is without sudden changes, circuit interruptions, line surges, arcing at contacts or interference to radio receivers. The output voltage is practically independent of the amount of load.

This voltage regulator is a product of *American Transformer Company*, 178 Emmet St., Newark, N. J.—COMMUNICATIONS.

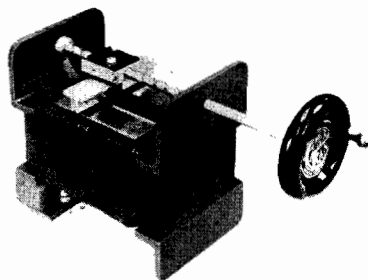

#### ADJUST-A-VOLT

The Adjust-A-Volt variable transformer is shown in an accompanying illustration. It has been designed to provide smooth control of voltage. Control is from 0 to 140 volts. The scale is calibrated in 5-volt steps. The output voltage is said to be essentially independent of load.

For further information write to *Standard Electrical Products Co.*, 317 Sibley St., St. Paul, Minn.—COMMUNICATIONS.

#### RECORDING MACHINE

The Universal Microphone Co., early this month started to manufacture a new 1938 model of its professional recording machine for delivery in December. A new development will be an adjustable and illuminated microscope with 0.006-inch spaced hair lines. This will be mounted on a slide bar assembly and will move with the cutting head, thus enabling the cutting action to be observed at all times. The new machine will also include a playback pickup mount incorporated in the main assembly of the recorder together with wiper bars.

For additional information write to the *Universal Microphone Company*, Inglewood, California.—COMMUNICATIONS.

#### ELECTRIC SOLDERING PLIERS

In answer to the increasing demand for a smaller low-capacity soldering unit, that would heat electrically and sweat joints without unsweating adjacent connections, the new No. 2 "midget" type Thermo-Grip pliers, have been introduced.

This tool has been designed especially for soldering small objects, for work in restricted spaces and for ease of operation. A few typical applications are: soldering small lugs and terminals up to 150 amperes, in close quarters on switchboards, motors, generators—various small radio and appliance soldering—sweating joints on small copper tubing and fittings up to  $\frac{3}{8}$ -inch diameter.

The small power requirement (300 watts) permits the use of the unit on any standard lighting circuit without danger of overloading the circuit or burning out fuses.

Further information can be obtained by writing the manufacturer, the *Ideal Commutator Dresser Co.*, 4025 Park Ave., Sycamore, Illinois.—COMMUNICATIONS.

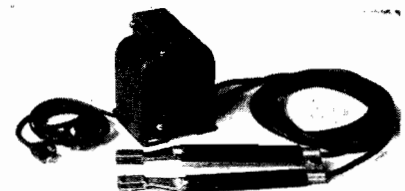

Let CLAROSTAT

Solve

YOUR RESISTANCE PROBLEM

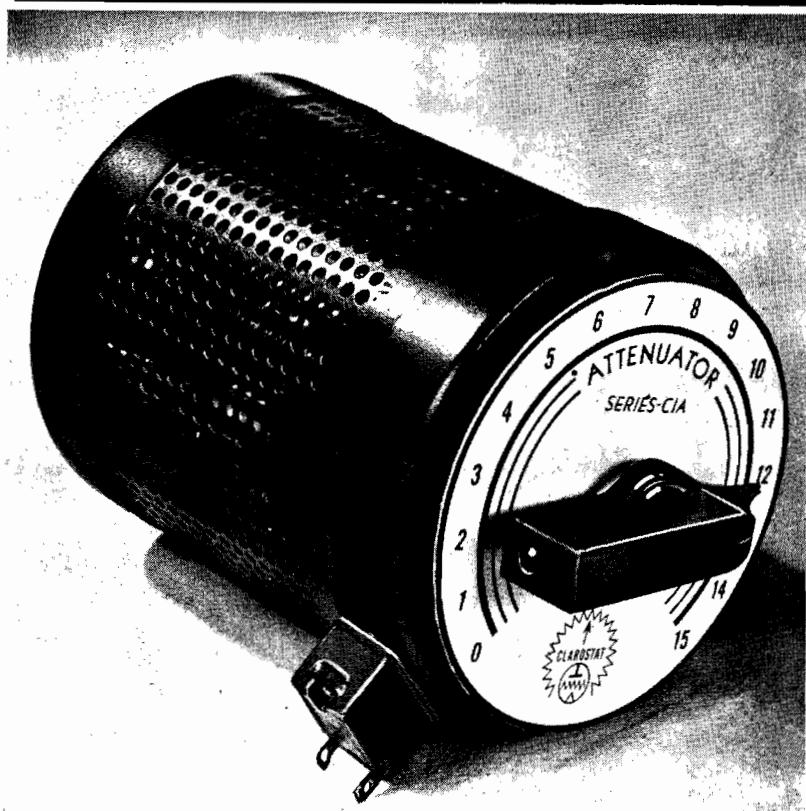

## WIRE-WOUND Controls

Constant-impedance output attenuator (shown at left) for controlling loud-speakers of any sound system. 25-watt rating. Linear up to 45 db. in 3 db. steps.

Compensated ladder type network maintains constant input and output impedances. Infinite attenuation at end position. Single-hole mounting.  $4\frac{1}{2}$ " long.  $3\frac{3}{4}$ " diameter. Optional speaker field switch.

The CLAROSTAT line also includes wire-wound mixers, L-pads, T-pads, input attenuators, etc., in single, double (shown below) and triple units.

And for the higher resistance values, CLAROSTAT offers the NEW midjet type carbon-element controls with accuracy, permanency and immunity to climatic conditions heretofore unknown in the non-wire controls.

**I**N the control rooms of leading broadcasting stations and major networks . . . in powerful public-address systems . . . in sound recording equipment of movie studios—there and elsewhere you will find CLAROSTAT wire-wound controls in daily use. • Such is the most critical service expected of any controls. The slightest imperfection assumes gigantic proportions. Quality is imperative. • Your requirements can likewise be met with CLAROSTAT wire-wound potentiometers and rheostats, L-pads, T-pads, faders, output attenuators and other resistance devices.

Write for  
DATA . . .

*Loose-leaf engineering bulletins on all types of resistors and resistance devices is yours for the asking. Write on business letterhead. Also, submit your resistance problems.*

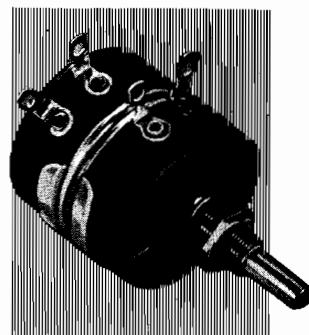

**CLAROSTAT** *Manufacturing Co. Inc.*



285-287 NORTH SIXTH STREET  
BROOKLYN, NEW YORK, U.S.A.

• OFFICES IN PRINCIPAL CITIES •

*"The Standard by which others are Judged and Valued"*

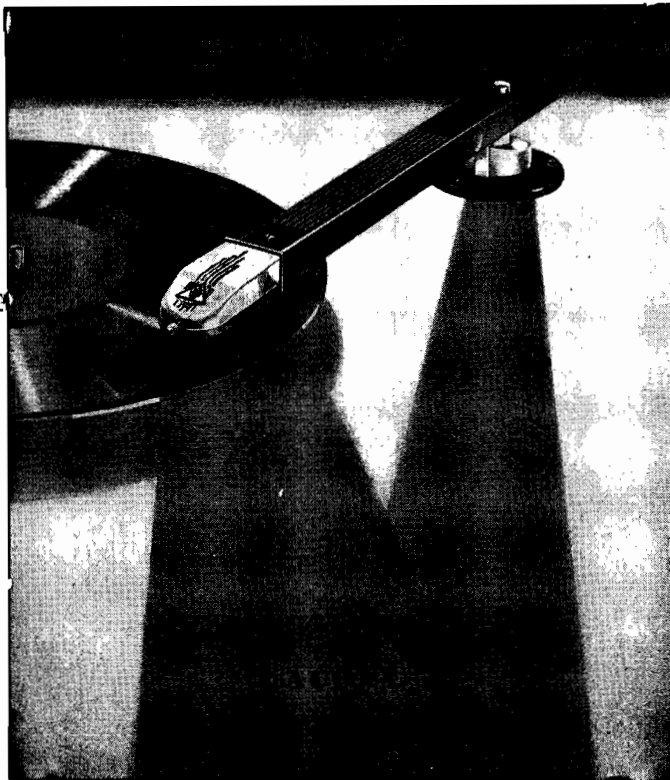

**W**HEN MICRODYNE's remarkable *facsimile* performance was first demonstrated, the most blasé sound experts welcomed it as the answer to their **WIDE-RANGE** problem. Steadily waxes the prestige of this inspired reproducing system which has made recording-microphone fidelity **AT THE PICK-UP** an accomplished fact. Not since pick-ups first went "commercial" in 1926 has there been so far-reaching an improvement.

*Look to a leader for leadership!*

**AUDAX MICRODYNE RF-1.....List \$40.00**

Except that its range is not quite so high, this model is identical with RF-2, for records up to 12 inches. Center to needle, 9½ ins.; overall length 11 ins.; shipping weight 4 lbs.

**AUDAX MICRODYNE RF-2.....List \$80.00**

This, too, is a feather-touch model (relayed frequency); same specifications as RF-4, except that range is not quite so high. Shipping weight 4½ lbs.

**AUDAX MICRODYNE RF-4.....List \$125.00**

For records up to 18 inches. Special arm has ball-bearing compound movement. Feather touch on record. Low or high impedance. 14¼ ins. overall length; center to needle 12 ins.; shipping weight 5 lbs.

A pick-up for every need, delivering wider range and greater stability than you can secure elsewhere at the price . . . listing from

**\$ 7<sup>50</sup> to \$ 260<sup>00</sup>**

NEW CUTTING HEADS FOR PROFESSIONAL RESULTS IN INSTANTANEOUS RECORDING

Write for a copy of "PICK-UP FACTS"

**AUDAX COMPANY**

500 Fifth Avenue, New York

"Creators of High Grade Electrical and Acoustical Apparatus Since 1915"



**PI-WOUND RESISTORS**

Ohmite announces the new Riteohm "81," a vacuum impregnated, non-inductively pi-wound precision resistor of 1 percent accuracy and 1 watt rating. This unit extends the line of Ohmite precision resistances to values not reached by the Riteohm "71," the recently announced vitreous enameled 1 percent resistor. The Riteohm "81," like the "71," is suited for use in voltmeter multipliers, in laboratory equipment, radio and electrical test sets, and in many similar applications.

Bulletin No. 108, describing the Riteohm "81" and Riteohm "71," may be had from the *Ohmite Manufacturing Company*, 4835 W. Flournoy Street, Chicago, Illinois.—COMMUNICATIONS.

**TRANSMITTING CAPACITORS**

The Solarex line of transmitting capacitors have been announced in eleven ratings from 1 mfd, 1000 d-c operating volts to 2 mfd, 3,000 d-c operating volts. They are said to feature high grade construction throughout. Sections are impregnated in



a special oil of high dielectric characteristics and stability under wide temperature variation. Black-sprayed metal containers and high grade porcelain stand-off insulators are used on all units. (Insulators, extending fully through the can tops, give ample protection beneath as well as on top.)

Solarex transmitting capacitors are individually packaged and fully guaranteed. Distribution is through jobbers. A new catalog embracing the entire line of solar transmitting capacitors may be had by writing the *Solar Manufacturing Corp.*, 599 Broadway, New York City.—COMMUNICATIONS.

**RADIO-INTERFERENCE PROOF INSULATORS**

Radio-interference proof pin-type insulators for power and distribution lines have been announced after several years of field experience and study. A metallized crown and a high-resistance glaze with copper oxide as a base is said to eliminate radio interference caused by arcing flow of charging current from the conductor and tie-wire into the insulator or from the insulator to the pin in the pin-hole.

The copper-oxide glaze possesses many natural advantages. It is prepared and applied in manufacture in a manner similar to regular silicate glaze and is matured in the regular firing operation for the porcelain.

Further information may be secured from the *Westinghouse Electric and Manufacturing Co.*, East Pittsburgh, Pa.—COMMUNICATIONS.



## LIMITING AMPLIFIERS

(Continued from page 10)

of Varistor control elements. The resistance of these varies inversely with the d-c voltage through them. The placement of these elements, of which there are four altogether, is shown in Fig. 4, which is the schematic of this amplifier. Referring to this diagram, it will be seen that the audio circuits (heavy lines) compose a two-stage input amplifier, followed by the gain adjustment network, and this by a two-stage output amplifier. The control circuit operates as follows. An amplifier V-1 (6C5G) feeds a full-wave rectifier V-2 (6H6G), which rectifies the audio wave and applies the resulting d-c voltage to the grid of the control tube V-3 (6C5G). The bias supplied the latter determines the point at which the compressing action begins. When rectified signal voltage exceeds this bias the plate resistance of the control tube is increased, the potential across the Varistors is reduced, and the loss through these is correspondingly increased. The use of four Varistor elements in a series-parallel arrangement keeps the terminating resistances constant.

### THE TUBE TYPE

The RCA Type 96-A amplifier (shown in Figs. 5 and 6) depends for its operation on the variable-mu characteristic of tubes of the remote cut-off type. Looking at the schematic of this amplifier (Fig. 7) it will be seen that the amplifier proper consists of three push-pull stages. The gain control is exercised in the first stage. The method of operation follows. A portion of the audio output of the first amplifier stage is tapped off the secondary of the interstage transformer and fed to the triode section of a 6R7. The output of this section of the tube is rectified by the diode section. The resultant d-c voltage appears across a resistance in series with the bias voltage supplied the grids of the first-stage tubes. The resulting increased bias moves the operating point of these tubes further negative, i.e., to a point on the  $i_p-e_g$  characteristic having a lesser slope, and thereby reduces the gain of the system.

### THE BRIDGE TYPE

Still another method of obtaining compression is illustrated by the Gates Type 17-B audio compressor (shown in Figs. 9 and 10). While the information on this unit has just been received, and no reports on its performance in the field are yet available, the method of operation can be understood by ref-

(Continued on page 40)

# The Gates Studio'er

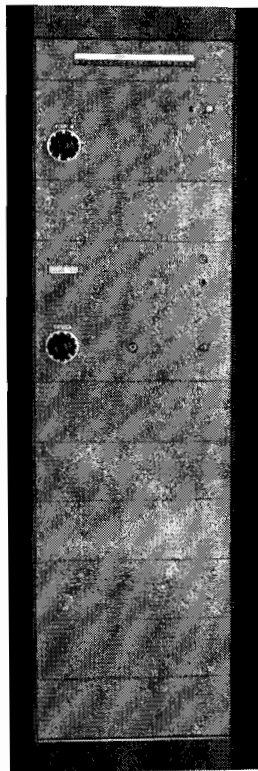

### Main Equipment Cabinet

Contains 20 position interlock patching system, monitor amplifier with self contained power supply, relay talk back and bridging panel, high gain high fidelity line amplifier with self contained power supply, three pre-amplifiers with universal input (room for two additional pre-amplifiers), rectifier for relays and studio warning lights and so constructed that entire equipment may be placed into service after a few minutes time.

Write on your station letterhead for Bulletin 82.

In new speech input equipment an experienced engineer will require (1) excellent quality of all parts, (2) a flat response curve and hum free output, (3) proper segregation of the various departments of the equipment such as line amplifier, monitoring amplifier, etc., and (4) neat modernistic appearance so that his equipment may be placed in that part of the studios that he desires without creating unsightly appearance.

The new Gates Studio'er is built exactly as experienced broadcast engineers want equipment. Loads of features—many exclusive, full size massive design, with plenty of room for use of full sized parts and proper segregation of these parts plus that type of appearance that will immediately take the eye as strikingly beautiful.

We suggest that before you purchase any speech equipment you investigate the Gates Studio'er. You will marvel at such fine equipment at the low price tag attached.



### CONTROL CONSOLE

Has four wiping contact mixing positions, master gain, keys for handling eight input circuits direct as well as talk back and studio warning light system and the new exclusive 5" edgewise V. I. meter. Panel at 45° slope for ease of control.

**GATES RADIO & SUPPLY CO.**  
MANUFACTURING ENGINEERS SINCE 1922  
**QUINCY, ILLINOIS, U.S.A.**  
CABLE ADDRESS (GATESRADIO)

*The Time Proven Line*

# 12Y REMOTE AMPLIFIER



The 12Y is the smallest and most compact single channel amplifier. It more than meets every exaction which can be placed upon it by modern broadcasting.

**COLLINS**  
RADIO COMPANY  
CEDAR RAPIDS IOWA  
NEW YORK, N. Y.: 11 WEST 42 STREET

## LIMITING AMPLIFIERS (Continued from page 39)

erence to the schematic diagram (Fig. 11). The unit consists, essentially, of a two-stage push-pull input amplifier, followed by a control network, and this in turn by a single-stage push-pull output amplifier. The control network makes use of an arrangement in which a series-bridge circuit, with lamps as control elements, is utilized to effect the desired compression. A regulated-type power supply provides the necessary stability. Since this unit is intended to be used in conjunction with an external amplifier, gain provided is considerably less than in the two previous equipments.

It will be immediately evident that one of the most important characteristics of these limiting amplifiers will be found in the time required for the gain reduction to take hold, and, to a somewhat lesser extent, for removal of the loss after the program has returned to normal levels. These time constants must necessarily represent a compromise. If the action is too rapid the gain control may try to follow the cyclic variation at low audio frequencies—producing what one engineer has called “echoburps.” On the other hand, if it is not sufficiently rapid in application, the transmitter may well be over-modulated before the gain reduction can take effect. The best approach to a solution seems to be to make the action take hold relatively quickly, but to release quite slowly. This can be compared to the operator who, caught napping on a sudden peak, makes a quick lunge to reduce his gain, then returns it gradually to normal again. Even so, there is not particularly good agreement as to the best time-action—at least in so far as the published characteristics are concerned. For the two equipments on which they are available these are:

	<i>Time for reduction</i>	<i>Time for release</i>
110-A Amplifier		
Position 1 . . . .	.020 sec.	.250 sec.
Position 2 . . . .	.010 sec.	.125 sec.
96-A Amplifier . . . .	.001 sec.	7.0 sec.

If these figures represent comparable methods of measurement, it is hard to account for the rather surprising differences, particularly since both equipments are said to have been given exhaustive tests in actual use.

Of the arguments given, at one time or another, against limiting amplifiers, the only one warranting serious consideration—at least from a practical viewpoint—is that of the possible introduction of distortion. It has been rather widely-held that low-frequency distortion must necessarily be excessive.

In view of this, the curves given in Fig. 8 are of considerable interest. These are the characteristic operating curves of a typical 96-A amplifier—taken in the usual manner for speech-amplifying equipment. Looking first at Curve (A), which is with no compression, it will be seen that at normal output level (0 db) the distortion content figure is very good—except that at the low end it rises to 1.5 percent at 50 cycles, which, however, is still hardly objectionable, although not quite equal to that of the best of recent program-amplifier designs. Observe now Curves degrees of compression, at normal and maximum outputs, respectively. Noting that the small differences shown for various compression levels are close to the limit of accuracy, it can be concluded that there is no real increase in distortion as compression is applied. This certainly refutes the argument in so far as this particular unit is concerned. Of course, these characteristics can show only what might be termed the “steady-state” distortion. The transient distortion is quite a different problem. But then, very little is known of the transient distortion introduced by even the commonest of broadcast units.

### OPERATING LEVELS

In all of these three amplifiers the actual level at which the gain reduction is introduced is fixed. The necessity of this is obvious from the difficulty which would be encountered in trying to make variable circuit elements of this type operate satisfactorily at various levels. The limitation which would otherwise result from this is reduced by provision of input and output amplifiers having a wide range of gain. The 96-A and 110-A amplifiers will operate with inputs of the order of -35 db and furnish outputs of up to approximately +20 db. Since both inputs and outputs are separately adjustable, these amplifiers may be used in almost any way desired within the range of these levels. Because of this, and since their obvious point of application is at the transmitter, they may well be used in place of the so-called “program” or “line” amplifiers which are ordinarily employed to raise the incoming line levels to the level required to feed the transmitter. The 17-B requires a minimum input of -10 db and furnishes a maximum output of +6 db. It is intended to be used in conjunction with a program amplifier previously installed, or with a fixed-gain amplifier which the manufacturer makes available. Such a combination will be approximately the equivalent, in so far as gain and application are concerned, of the larger equipment.

THE  
HARMONIC PRODUCER

(Continued from page 24)

which, in turn, permitted the use of a strictly mathematical analysis. We found that an emf is induced in the retard coil chiefly during the short intervals of time when the fundamental current is passing through 0; and that this serves to charge a condenser in the output circuit during these time intervals (shown shaded in Figs. 2 and 5). At the end of each of these intervals, the inductance of the coil shifts to a very low value and allows the condenser to discharge through it and the resistance representing the load. These discharge pulses are alternately positive and negative and occur every half period of the fundamental. Each pulse has a steep slope initially and then dies out rapidly with exponential damping. Because the charging current does not have a steep slope it can be disregarded, in so far as its contributions to the higher harmonics are concerned, and so the output current can be reduced to a series of discharge pulses (see Fig. 6). The discharge of a condenser through a resistance and an inductance is a well known transient whose differential equation can be solved. This gives the wave pattern for the output current which can then be used in the "Fourier integral" to get an expression for the amplitude of any harmonic. While this Fourier integral is quite difficult to solve, and the result of this integration is a rather complicated expression, it can be used to calculate the values for the circuit elements which will give a fairly uniform power level for the harmonics required.

A circuit was set up with the calculated constants for the circuit elements and the power of each harmonic was measured for comparison with the calculated values. The actual and calculated performances proved to be closer together than might be expected in view of the simplification assumed for the magnetic characteristic of the coil. It would appear from this check of the calculations that it would be quite easy to design a circuit giving the desired level of harmonics. In one actual circuit, however, the load consists of a set of coils and filters in parallel, and the copper-oxide bridge for the "even" harmonics, instead of a simple resistance load. While the mathematics for this condition have not yet been fully worked out, the calculations for the resistance load give approximate values and these have been corrected by experimentation to give a satisfactory carrier generator for carrier-telephone systems now in operation.



To do a job most efficiently common sense tells you to pick equipment of the size best suited to the task. When specifying Relays, Stepping Switches, Solenoids, mercury switches and electrical control accessories, insist on GUARDIAN . . . and be sure of getting equipment specifically engineered for the work expected of them. Not too big . . . nor yet too small. Ample in contact capacity . . . but low in current drain. Sturdily built . . . but compact in size.

As an aid in selecting the right types of Relays, stepping switches, mercury switches, solenoids, etc., WRITE TODAY FOR CATALOG C 12, and details of Guardian Free Engineering service.

There's a RELAY by Guardian to fit your job!

Model shown is No. 110 AC. When ordering specify current, voltage, amperage, contact combination and load thru contacts.

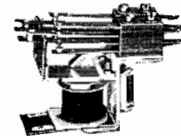

**GUARDIAN  ELECTRIC**  
[62] W. WALNUT STREET CHICAGO, ILLINOIS

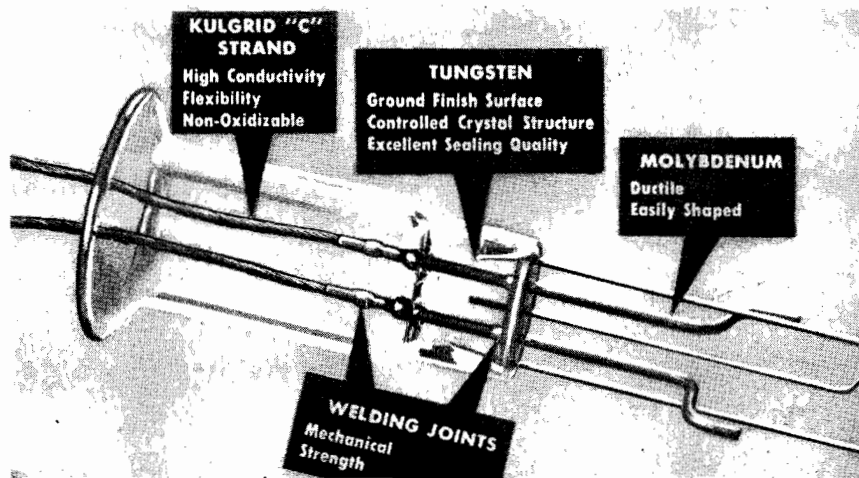

**HARD GLASS STEM**  
MADE WITH  
**CALLITE LEAD-IN WIRES**  
of Tungsten • Molybdenum • Kulgrid

The TUNGSTEN in Callite Hard Glass Welds is specially processed to give a compact fibrous structure, free from longitudinal cracks and is centerless ground to eliminate surface imperfections.

The KULGRID "C" STRAND has none of the objectionable features of regular copper strand. Kulgrid "C" does not oxidize. Therefore, no oxide flakes off to deposit in the tube press as is the case with copper strand. Kulgrid "C" is flexible and does not become brittle. It welds more readily to tungsten than ordinary copper strand and forms a strong joint. *Accept no inferior substitutes.*

Pure metals of best quality are used for any third component part.

**CALLITE PRODUCTS DIVISION**  
EISLER ELECTRIC CORPORATION

542 - 39th STREET

UNION CITY, N. J.

# SIMPLAT



10 inch  
12 inch  
16 inch

200-shot  
RECORDS

**Cut 'em soft—play 'em hard**

Stratified colloidal coating on a flat glass base gives a more durable and uniform blank with extremely wide frequency response. After recording soft, SIMPLAT is easily hardened and can be played back immediately. Under proper treatment, 200 plays may be had from a disc. We highly recommend this scientific record for studio and all professional work. Write for further information.

We also supply sapphire stylus, steel CUTTING NEEDLES—and superior PLAYBACK NEEDLES.

## RECOTON

CORPORATION

178 Prince Street New York City



HUMAN HAIR

$\frac{1}{100}$  AMP. FILAMENT

MAGNIFIED  
200 TIMES

**900 times finer  
than a human hair**

A 1/100 amp. Instrument LITTELFUSE platinum filament is 1/30 the diameter of a human hair. (A 1/200 amp. Littelfuse filament is just 1/2 that size!) It's 16,800 times heavier than air yet floats in it. These super-fine wires are HAND SOLDERED to the Littelfuse Bridge Construction, which is inserted in a hermetically sealed glass tube and then inspected rigidly—to ensure it will unflinchingly do its work—the protection of delicate instruments.

Instrument Littelfuses 1/200 amp. up; Hi Voltage Littelfuses 1,000, 5,000, 10,000 volts, ranges 1/16 amp. up. Fuse Mountings, Etc. Write for quotations—ask for catalog.

**LITTELFUSE LABORATORIES**

4242 LINCOLN AVENUE, CHICAGO, ILLINOIS

## RECTIFIER TYPES

(Continued from page 14)

units have less effective radiating properties than the disc-fin type at ordinary ventilation owing to the large cuprous-oxide surface; yet their usefulness is due to construction methods whereby forced draft can be used, as the individual plates are arranged on edge vertically and separated one from another.

The electrical characteristics of the plates are similar to those of discs. In the forward direction, the resistance at various voltages is the same as obtained from an equivalent number of 1.5-inch diameter discs. In the back direction, the plate offers some improvements over the identical number of discs, as it has higher back resistance than might be expected considering the area involved. It happens, however, that the back resistance is not a function entirely of area, but is also related to edge length. The plate, naturally, gives a more favorable ratio of edge length to area than does the disc.

The large plates displace many discs and hence simplify the assembly of a high-capacity rectifier. The individual plates in a set of six are rated at 20 amperes each at six volts output when connected three-phase. That is, six such plates in a full-wave, three-phase bridge connection could deliver 20 amperes continuously at six volts d-c. Each of the elements has a rectifying area equivalent to 42 of the standard 1.5-inch diameter discs.

It is expected that the flat type rectifier will broaden existing fields of use, i. e., in the same applications as before but in larger capacities; electroplating and other electrolytic processes requiring large currents at low voltages, large battery chargers for transportation and telephone work, arc-lamp supplies, field excitator, electromagnetic loads and the like.

In view of the technical importance of the disc and plate type rectifiers in the communications and related fields today, this discussion is concluded appropriately with a resumé of current production practices. Briefly the steps are as follows:

(1) As no material has yet been found equivalent to pure copper for the fabrication of the copper-oxide type of unidirectional current-carrying device, the discs and plates are cut or stamped from quality copper.

(2) The copper parts are degreased and cleansed by the boiling action of caustic soda and are subsequently bright-dipped in an acid bath.

(3) During the third stage, the parts are oxidized at a suitable temperature in order that the resulting cuprous oxide forms so intimate a bond with the mother copper that, upon later flexing



## Microphone Control

*In the Palm of the Hand*

**Astatic Grip-to-Talk Model CD-104** responds to instant operation of palm-control switch, cutting microphone in or out, at will. Designed especially for air-way ground stations, inter-office, inter-factory, amateur and other similar communicating systems. Chrome and black finish. Full year guarantee.

Write for Literature List Price, \$27.50

# ASTATIC

Astatic Microphone Laboratory, Inc.  
Dept. M-4 Youngstown, Ohio  
Licensed Under Brush Development Co. Patents

of the plate, the oxide crystals crack rather than separate from the base itself. In this close molecular bond between the copper and its oxide that permits a pre-regulated and directed flow of electrons in the completed unit.

(4) In the oxidation treatment, cupric oxide forms over the cuprous layer. This is later removed by dissolution in potassium cyanide or by other means.

(5) It has been found that the characteristics of the rectifier can be varied by changing the heat treatment of the parts after oxidation. High-resistance values are obtained by slow cooling in air and low resistance results from rapid quenching.

(6) The cuprous surface of the elements are then coated by hand and mechanical means with a ball-milled mixture of finely divided coke and colloidal graphite in aqueous dispersion.

(7) To provide better contact between the copper-oxide discs as they are mounted under pressure on a common bolt, metal foils or lead washers are employed between the graphite-oxide layer and the metal area of two adjacent discs. Metals that are non-reactive to cuprous oxide (tin) are sometimes hot-sprayed directly to the layer for contact purposes.

(8) Contact is made to the large plates by sprayed metal coatings to the

colloidal-graphited surfaces; contact to the copper is made at a small area surrounding the mounting hole and the paralleling spring connectors.

**CONCLUSION**

The manifold types of rectifiers developed through the years suggest the increasing importance and utility of these devices in all branches of electrical and communication engineering. Though many types of rectifiers have been made, comparatively few have wide commercial value. Of these discussed above, the grid-controlled, copper-oxide disc, and plate type rectifiers are especially noteworthy. In fact, with the latter two designs coming into their own, as it were, within the last year or so, the field of applications has expanded increasingly. The continued development of the plate type rectifier now receives the careful attention of the best engineering minds.

**MODERN DESIGN OF 849**

*(Continued from page 15)*

filament. This change provides a much huskier filament with a sufficient increase in the total electrode emission to allow a balanced utilization of the higher performance capabilities of the tube.

The new tube type 849A is identical in dimension and basing arrangement with the old 849, and may advantageously be used as a replacement for the old tube in all classes of service. The electrical characteristics are identical so no changes will be required in Class A and Class B modulator applications, though re-neutralization may be required in r-f power-amplifier applications. In replacement applications the 849 will be worked with so great a margin from the maximum ratings as to insure considerably longer life.

In applications to new broadcast transmitters, the 849A will fill the gap in available tubes for use as linear final amplifiers. The tube carries an FCC rating for use in the final stage of low-level modulated broadcast transmitters of 250 watts. In many transmitters a pair of 849A's will replace a water-cooled tube with substantial savings in initial maintenance and operating costs, as well as increased reliability. Its FCC rating of 750 watts output in high-level modulated equipments allows its use to replace much larger air-cooled tubes of old design.

The 849H tube, which differs from 849A in that the grid is brought out of the side of the bulb, extends the capabilities of the new tube to frequencies as high as 30 megacycles, so that it may be used in the design of transmitters for commercial, ship and police communication.

# Du Mont *type* 168

*5 inch all-purpose*

## OSCILLOGRAPH

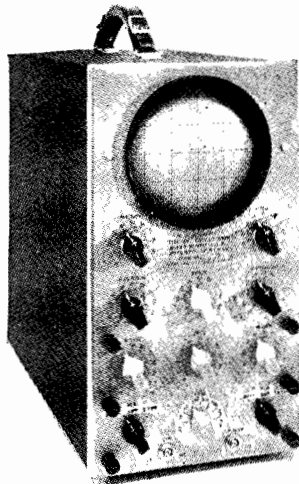

The most precise and convenient method of studying phase relation.

An accurate method of observing the translation of non-electrical phenomena in graphical form.

For studying the limits of vacuum tube characteristics without the danger of long-time overloads.

*For Complete Specifications  
— Write —*

**ALLEN B. DU MONT LABORATORIES, INC.**  
UPPER MONTCLAIR NEW JERSEY



### Frequency Measuring Service



Many stations find this exact measuring service of great value for routine observation of transmitter performance and for accurately calibrating their own monitors.

**MEASUREMENTS WHEN YOU NEED THEM MOST**  
*at any hour every day in the year*

**R.C.A. COMMUNICATIONS, Inc.**

*Commercial Dept.*

A RADIO CORPORATION OF AMERICA SERVICE

66 BROAD STREET

NEW YORK, N. Y.

### A DYNAMIC PICK-UP

*for Lateral Reproducing*

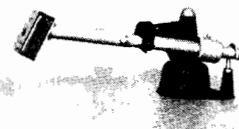
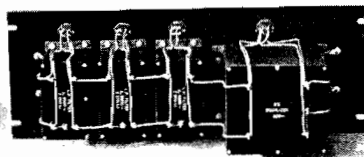

**We Are Offering a Complete Reproducing System Consisting of**  
A Neumann Dynamic Pick-Up Head with a precision built pick-up arm.  
A standard rack panel with equalizer and set of low pass filters.  
Ask for our latest "Sound Apparatus Bulletin" on Modern Reproducing.

**SOUND APPARATUS COMPANY**

150 WEST 46th STREET

NEW YORK CITY

# OVER THE TAPE . . .

## NEWS OF THE COMMUNICATIONS FIELD

### GENERAL CERAMICS BULLETIN

"Ultra-Steatite for High-Frequency Service" is the title of a new 23-page booklet available from General Ceramics Company, RCA Building, 30 Rockefeller Plaza, New York City. Ultra-Steatite is an insulating material especially designed for high-frequency service. Properties as well as representative types of insulators are covered in the bulletin.

### SOLAR CATALOG

The complete Solar line of transmitting capacitors are described in a 16-page catalog which has just been made available. The catalog includes data on the Transoil, Solarex, Domino, Transmica, Type XM Mica, and Type XB Mica condensers. Write to the Solar Manufacturing Corporation, 599-601 Broadway, New York, N. Y., for Catalog 2-X.

### RAYTHEON BULLETIN

Raytheon Manufacturing Co., 190 Willow St., Waltham, Mass., have made available a bulletin describing voltage regulators. Complete details and specifications are given. Write for Bulletin No. DL48-71-E.

### BOONTON RADIO BULLETIN

Bulletin A, a catalog of measuring and testing instruments for the laboratory design and control of r-f components and materials, is available from Boonton Radio Corporation, Boonton, N. J. The units covered are the 100-A Q meter, 10A converter test oscillator, and the 110-A Q-X checker.

### SHURE LITERATURE

Literature is now available from Shure Brothers, 225 W. Huron St., Chicago, describing the Shure Tri-Polar crystal microphone. This instrument may be used as a uni-directional, bi-directional or non-directional microphone.

### AMERTRAN FACTORY

American Transformer Company announces that it is now manufacturing in its new branch factory at 273-301 Emmet St., Newark, N. J. This latest addition to the company's plant is located on a siding of the Pennsylvania Railroad and is fully equipped for the assembly of heavy industrial transformers.

### HARVEY CATALOG

Catalog No. 52, covering high-frequency radio transmitters for commercial and amateur services, has been made available by Harvey Radio Laboratories, Inc., 25 Thorndike St., Cambridge, Mass. Complete descriptions and specifications are given for each unit described. Write to the above organization.

### TUNG-SOL DISTRIBUTOR

A new branch of Radio Tubes Distributing Company of Cleveland, distributors for Tung-Sol radio tubes, has recently been opened in Akron. The address is 270 Water Street and Mr. Schutz is in charge.

### MAGNAVOX BULLETINS

A number of bulletins have been issued by The Magnavox Company, Fort Wayne, Indiana. One bulletin covers the Model 305 15-inch dynamic speaker, while another gives details of the Model 505 15-inch dynamic unit. The title of the third bulletin is "Dynamic Speakers" and gives standard specifications on the Magnavox line of speakers.

### ALADDIN CATALOG

Catalog No. 937 has recently been issued by the Aladdin Radio Industries, Inc., 466 West Superior St., Chicago, Illinois. Complete descriptions and specifications are given on the Aladdin line of Polyiron inductors. Copies may be secured from the above organization.



**A candid shot of Sidney A. Wood, genial Sales Manager of the Wilbur B. Driver Company.**

### NEW TECH FACTORY

The Tech Laboratories announce that due to greatly increased customer demand, they have been forced to move to larger quarters. In their new factory at 7 Lincoln Street, Jersey City, N. J., they have three times the space of their former plant, with option on more as required.

### FROST IS NAMED HONORARY DIRECTOR OF RMA

Lt. Col. Herbert H. Frost of New York City, a founder and first President of the Radio Manufacturers Association, has been honored by election as an Honorary Director and also member of the Association. "Herb" Frost served three-terms as President of the RMA and was largely instrumental in its organization in 1924. As an industry pioneer and in recognition of his many years of service for the industry, resolutions electing Colonel Frost an Honorary Director and also a member were adopted unanimously by the RMA directorate at its meeting on November 17 in Chicago.

### CROWE BULLETIN

Crowe Name Plate & Manufacturing Co., 3701 Ravenswood Avenue, Chicago, have made available an interesting 4-page bulletin covering their Series 700 on-the-panel kits for auto radios. This bulletin may be secured from the above organization.

### NATIONAL UNION BULLETIN

The National Union Radio Corporation, 570 Lexington Ave., New York, N. Y., have issued a bulletin covering their line of electrolytic and paper condensers, tubes, cathode-ray tubes, radio-panel lamps, photoelectric cells, exciter lamps, etc. This bulletin may be secured from the above organization.

### WROUGHT WASHER CATALOG

A new catalog bulletin entitled, "Over 20,000 Varieties," has been published by the Wrought Washer Mfg. Co., 2100 South Bay St., Milwaukee, Wis. This new release describes the company's products and services which are available to manufacturers. Copies can be had upon written request to the company.

### CINAUDAGRAPH CATALOG

The Cinaudagraph Corporation, Stamford, Connecticut, has just announced the release of Catalog No. 137, describing in detail their new line of permanent-magnet speakers. These speakers, utilizing the magnetic steel alloy "Nipermag" in their construction, are amply illustrated and described in this book, with graphs, showing frequency response curves and tables.

### TOBE REPRESENTATIVE

The Tobe Deutschmann Corporation, of Canton, Mass., have appointed the Rowe Radio Research Laboratory Company, 1103 Bryn Mawr Avenue, Chicago, as their technical sales representative for the Chicago area. Mr. Harry Rowe, head of the company, has been in the radio field for a number of years.

### BEAL RECEIVES APPOINTMENT

Ralph R. Beal, supervisor for the past year and a half of RCA's television field tests, has been placed in the newly created position of Research Director of that company. The announcement was made November 16 by David Sarnoff, President.

### WARD LEONARD REPRESENTATIVES

The Ward Leonard Electric Co., Mount Vernon, N. Y., have announced the appointment of the following representatives: Mr. Fred Stevens, 528 Maccabees Bldg., Detroit, Michigan, for the state of Michigan. Mr. Ted Keller, 111 Morningside, Council Bluffs, Iowa, for the states of Missouri, Kansas, Nebraska, South Dakota and Iowa. Mr. William Corduna, 17 Warren Street, New York City, for the states of Maine, New Hampshire, Vermont, Massachusetts, Rhode Island, Connecticut, New York, Pennsylvania, New Jersey, Maryland and Delaware.

#### RMA CREDIT SERVICE

Several improvements in the RMA credit information service, for which the National Credit Office of New York is the official agency of the Association, have been ordered by the Association's Board of Directors. Monthly meetings of the RMA eastern and western credit committees, in New York and Chicago respectively, will be continued, but with an improved procedure and confined exclusively to RMA members. Attendance of non-member companies will be prohibited. RMA members are requested again to file requests with the NCO office, 2 Park Avenue, New York City, to receive the detailed monthly credit clearances and information.

#### LEIPZIG FAIR

The historic Leipzig Trade Fair will hold its 1,979th session from March 6th to 14th. To accommodate new exhibits two halls, with over 200,000 square feet of display space, will be added to the fifty-one exhibition halls heretofore in use. The Spring Fair will include some 10,000 exhibits of every industrial and art product assembled from twenty-one countries including the United States.

#### RMA CABLE ADDRESS

"Ameradio" is the new international cable address of the Radio Manufacturers Association. Foreign and domestic wire companies have been advised of the change, to facilitate trade inquiries and other cablegrams to RMA headquarters. Association members are requested to advise their export and foreign connections of the new RMA code name.

#### RCA BULLETIN

The RCA 1-G 1000-watt broadcast transmitter is described in a recent bulletin issued by the Transmitter Section of RCA Manufacturing Co., Inc., Camden, N. J. A complete description is given of the transmitter, including schematic wiring diagram, distortion and frequency response curves. This bulletin may be secured by writing to the above organization.

#### MERCOID BULLETIN

The Mercoird Corporation, 4201 Belmont Ave., Chicago, have made available literature dealing with the Mercoird line of mercury switches, switch clips, etc. Specifications are given. Write for Bulletin No. 500B.

#### BURTON-ROGERS LITERATURE

Burton-Rogers Company, 755 Boylston St., Boston, Mass., have available literature describing their test bench Cyclops meter, a pocket-size volt-ohm-milliammeter, and automobile antennas. This literature may be secured on request. Write to the above organization.

#### STAHL ELECTED PRESIDENT OF ARCTURUS

Charles E. Stahl, former Vice-president and General Manager of the Arcturus Radio Tube Company, Newark, N. J., was elected President of the Company at a Board of Directors meeting held December 1, 1937. J. A. Stobbe was elected a Vice-president while Jack Geartner was appointed Sales Manager in charge of all sales, including export.

#### RCA PROMOTES BONFIG, DEAKINS, WOODCOX AND SHANNON

The Board of Directors of the RCA Manufacturing Company has elected three new Vice-presidents and increased the responsibilities of another, according to an announcement by George K. Throckmorton, President of the RCA Manufacturing Company.

Henry C. Bonfig, formerly Sales Manager of package goods, has been elected Commercial Vice-president heading the company's commercial activities in all fields. Frank R. Deakins, formerly Sales Manager of engineering products and RCA Photophone sound recording and reproducing activities, has been elected Vice-president and will continue to direct the same activities. Robert Shannon, formerly Vice-president in charge of manufacturing, has been elected Vice-president and General Manager. He will coordinate and have general direction of all activities except those under the Commercial Vice-president. Vance C. Woodcox, formerly engaged in supervisory sales activities, as assistant to the package goods Sales Manager, has been elected Vice-president, succeeding Mr. Bonfig as head of all package goods merchandise activities.

#### G-E PLASTICS DEPARTMENT OPENS NEW PLANT

The Plastics Department of the General Electric Company has recently opened a new molding plant at 1 Plastics Avenue, Pittsfield, Mass., which is entirely devoted to the research, development, design, and manufacture of molded plastics products. Representing an investment of approximately one million dollars, the new plant is the scene of the major part of its plastics activities.

#### ARMCO APPOINTMENT

Murray B. Wilson, associated with Armco since 1923, has been named Manager of the New York sales district of The American Rolling Mill Company, Middletown, Ohio, according to H. M. Richards, Manager of the sheet and strip sales division. Mr. Wilson succeeds Cliff Spear, who was forced to curtail his activities because of continued ill health.

#### TRAV-LER CATALOG

A new Trav-ler catalog gives complete listings of the Trav-ler line for 1938, including the sixteen models with automatic tuning and the ten other models without automatic tuning. The catalog gives complete specifications for each set. Copies may be had free by addressing the Trav-ler Radio & Television Corporation, 1036 W. Van Buren Street, Chicago.

#### TURNER APPOINTMENT

The Turner Company has announced the appointment of Mr. Sam M. Harper, Suite 602-605, 53 Park Place, New York City, as their representative in New York City, Pennsylvania, Delaware, Maryland, Washington, D. C., and New Jersey.

#### ERIE BULLETIN

Specifications of Erie Ceramicons, ceramic dielectric condensers, are contained in an interesting bulletin issued by Erie Resistor Corporation, 644 West 12th St., Erie, Pa. Copies of this bulletin may be secured by writing to the above organization.

#### ALLOY BOOKLET

The Alloy Metal Wire Company of Prospect Park, Pa., has just published for all users of wire, rod and strip in the electrical, chemical and mechanical fields, a helpful handbook of information and data on alloys. This booklet contains fingertip facts on the wide variety of alloys used in wire, rod and strip form. In addition to listing the description, application, and price per pound of alloys, it contains wire data, the range of uses, current temperature characteristics of wire, resistance, and feet per pound.

#### WHAT IS A RADIO "TUBE"?

To prevent public deception in purchase of radio sets and tubes, the RMA is considering promulgation of an industry definition of what actually constitutes a radio "tube." An exact definition is being considered by the Association's engineering organization and Tube Division, for final consideration by the RMA Board of Directors.

Characterization of ballast resistors as "tubes" is a merchandising practice of which the RMA has taken cognizance and also the Federal Trade Commission in its proposed rules for the set industry which would prohibit advertising of so-called "ballast tubes" or dummy or fake tubes. The RMA also has received complaints from several Better Business Bureaus.

Suggestions for industry definition of a "tube" were received by the RMA Board of Directors at Chicago on November 17 from the Association's Engineering Committee and referred to the Tube Division for an early report to the Board of Directors on a tube definition.

#### STANDARD TRANSFORMER TO BUILD

The Standard Transformer Corp., 850 Blackhawk Street, Chicago, Ill., has acquired property at Halstead and Blackhawk Streets, to which location the plant will be moved in February, 1938.

#### FORREST VISITS U. S.

Chas. E. Forrest, Managing Director of International Radio Company Pty. Ltd., 254 Castlereagh St., Sydney, N. S. W., Australia; International Radio Company Pty. Ltd., 403 Bourke St., Melbourne, Victoria, Australia; International Radio Company Pty. Ltd., 178 Rundle St., Adelaide, Sth. Australia; International Radio Company Pty. Ltd., Elizabeth Street, Brisbane, Queensland, Australia; International Radio Company Ltd., Grey Buildings, Courthouse Lane, Auckland, N. Z.; Jensen (Aust.) Pty. Ltd., 254 Castlereagh St., Sydney, N. S. W., Australia, arrived in Los Angeles on November 29, and will be in the United States and Canada for approximately four months. Mr. Forrest visits the United States yearly for the purpose of obtaining satisfactory lines for distribution on the Australian and New Zealand markets. He may be addressed c/o International Forwarding Co., 431 S. Dearborn St., Chicago.

#### CONVEYOR BULLETIN

A 4-page bulletin on roller gravity conveyors has been made available by the Samuel Olson Mfg. Co., Inc., 2418 Bloomington Ave., Chicago, Ill. Dimensions, types of roller mountings and construction details are given.

**A  
One Year  
Subscription**  
(12 issues)

**to  
COMMUNI-  
CATIONS**

**Costs  
Only  
\$1.00**

**on  
the "Group  
Subscription  
Plan"**

**E**very qualified radio, electrical, communications and industrial engineer, executive, department head or factory technician can secure a year's subscription to COMMUNICATIONS (twelve issues) for only \$1.00 by using the Group subscription Plan.

Regularly a yearly subscription to COMMUNICATIONS is \$2.00—but in groups of four or more, the subscription rate is only \$1.00 each per year when your occupation is stated.

Use the convenient form printed herewith. Your co-workers will sign up with you at the half-price rate if you tell them about this "G.S.P." All the important news about every phase of radio and communications appears *first* in COMMUNICATIONS. Sign up your group today.

**COMMUNICATIONS:—Enter subscriptions for:**

Name .....  
Address .....  
City-State .....  
Classification .....  
Employed by .....

Name .....  
Address .....  
City-State .....  
Classification .....  
Employed by .....

Name .....  
Address .....  
City-State .....  
Classification .....  
Employed by .....

Name .....  
Address .....  
City-State .....  
Classification .....  
Employed by .....

**TEAR OUT  
AND MAIL**

**COMMUNICATIONS: 19 E. 47th ST.,  
NEW YORK, N. Y.**

**When mailing a check (or money order) for a group of subscriptions, use this convenient form.**



## SPEAKER GRILLE CLOTH

Complete assortment of patterns.  
Special colors and patterns made to order.  
Samples and prices furnished upon request.  
Shipments made from stock.

**A. G. HINTZE**

300 WEST ADAMS STREET

CHICAGO, ILL.

## RADIO IN ITS ENTIRETY!



"B-A" serves the trade with every need in radio—complete 160-page catalog of nationally known radio receivers, public address, parts, supplies and equipment. Orders shipped same day received.



**BURSTEIN-APPLEBEE CO.**

1012-14 McGEE ST. -- KANSAS CITY, MO.

**UP-TO-DATE CATALOG AVAILABLE**

## USED LABORATORY EQUIPMENT

Weston — G.R. — L&N — G.E., Etc.

Meters — Bridges — Torsion balances — Inductors.  
Decade boxes — Analytical balances — Oscillographs.  
Tubular rheostats — Signal generators — Condensers.

Write for new list

**Louis J. Winslow**

200 PENNSYLVANIA AVENUE

HILLSIDE, N. J.

## CHAS. EISLER'S

EQUIPMENT HAS PRODUCED

# MILLIONS

spot welders up to 250 KVA, butt, and arc welders, get in touch with us. Write for our "college and glass working laboratory units" catalog.

**EISLER ENGINEERING CO.**

750 S. 13th STREET (Near Avon Ave.)

NEWARK, N. J.

FOREMOST IN THE ELECTRONICS FIELD FOR OVER 20 YEARS!

Charles Eisler's equipment for the production of radio and electronic tubes, incandescent lamps, X-Ray and cathode ray tubes, photoelectric cells, and neon signs has met the severest demands of industry in operating at maximum production and minimum cost. If you are in the market for any of the above or allied equipment including electric

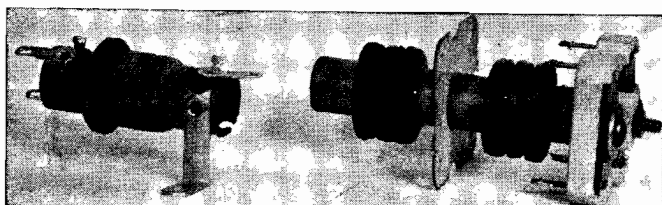

IF-RF WINDINGS—All types, your tolerance—prompt delivery any quantity—send samples or specifications for quotations—Export Division: 100 Varick St., New York City  
**PRECISION INDUCTANCE CORPORATION, 591 BROADWAY, NEW YORK**

## "THE CRYSTAL SPECIALISTS SINCE 1925" PIEZO-ELECTRIC CRYSTALS

GUARANTEED Accurate to BETTER than .01%

**SCIENTIFIC RADIO SERVICE**

Send for **FREE Booklet and Price List!**

UNIVERSITY PARK - - - - - HYATTSVILLE, MD.

## PAPER TUBES

SPIRAL WRAPPED

Square—Rectangular—Round  
**FOR COIL WINDING**

Write for Samples and Prices

**PARAMOUNT PAPER TUBE CO.**

801 GLASGOW AVENUE

FORT WAYNE, IND.

## BLILEY

Type BC 46 Isolantite variable air-gap oven mounting maintains its temperature within 1°C. at 50°C. Approved by F. C. C.

## QUARTZ

Type BC 10 Isolantite variable air-gap holder. A precision mounting for Bliley Crystals between 100 KC. and 5,000 KC.

## CRYSTALS

Type VP 4 Steatite body adjustable pressure holder. For all Bliley Crystals from 300 KC. to 25 MC.

## HOLDERS

Type VP 5 Steatite body variable pressure holder designed for installations where space is at a premium.

FOR GENERAL COMMUNICATION FREQUENCIES FROM 20KC. to 25MC.

Bliley Broadcast Crystals are approved by F. C. C. Write for complete Catalog, G-9.

**BLILEY ELECTRIC COMPANY**  
UNION STATION BUILDING  
ERIE, PA.

## 36 years experience in PERMANENT MAGNETS

We make Permanent Magnets for All Purposes — Stamped, Formed and Cast Magnets — Chrome... Tungsten... Cobalt... Alnico (cast only)

**THOMAS & SKINNER  
STEEL PRODUCTS CO.**

1120 E. 23rd ST. - INDIANAPOLIS

WRITE FOR PRICES

LAMINATIONS FOR RADIO TRANSFORMERS  
TOOLS - DIES - STAMPINGS

## LOWER COSTS

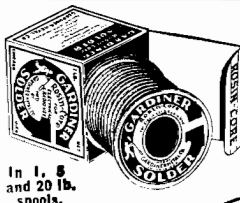

In 1, 5 and 20 lb. spools.

are made possible through the use of Gardiner Rosin-Core Solder. Its uniform high quality permits experienced workers to do faster work and inexperienced help to do better, neater work. It saves both time and material.

Made in various alloys and in gauges as fine as 1/32 of an inch. Because of modern production methods Gardiner Solder costs less than even ordinary kinds.

We also make bar and solid wire solders, and dipping and casting metals.

Eastern Sales Office and Warehouse:  
**DAVID M. KASSON & CO.**  
264 Canal St., New York



4819 S. CAMPBELL AVENUE, CHICAGO

COMMUNICATI

## Waxes Compounds Varnishes

FOR INSULATION  
OF CONDENSERS

Transformers, coils, power packs, pot heads, sockets, wiring devices, wet and dry batteries, etc. Also WAX SATURATORS for braided wire and tape. WAXES for radio parts. Compounds made to your own specifications if you prefer.

### ● ZOPHAR MILLS, INC.

Founded 1846  
120—26th Street  
Brooklyn, N. Y.



■ The facilities and experience of this organization in both the engineering and construction of radio broadcasting radiators assure the efficiency of your radiator. Compare the cost of radiators on the basis of field strength—you will find IDECO offers highest efficiency per dollar invested. Write for special data information and prices.



THE INTERNATIONAL  
DERRICK & EQUIPMENT CO.  
DIVISION OF INTERNATIONAL TRACY CORPORATION  
Columbus, Ohio

## Advertising Index

A	
Aerovox Corp. ....	31
Amperex Electronic Products, Inc. ....	Second Cover
Amperite Corp. ....	48
Astatic Microphone Laboratory, Inc. ....	42
Audak Co., The. ....	38
B	
Bakelite Corp. ....	1
Billey Electric Co. ....	47
Burstein-Applebee Co. ....	47
C	
Callite Products Division. ....	41
Cinaudagraph Corp. ....	48
Clarostat Mfg. Co., Inc. ....	37
Collins Radio Co. ....	40
Crowley Co., Inc., H. L. ....	5
D	
Du Mont Labs., Allen B. ....	43
E	
Eisler Engineering Co. ....	47
G	
Gardiner Metal Co. ....	47
Gates Radio & Supply Co. ....	39
General Radio Co. ....	Thrd Cover
Guardian Electric Co. ....	41
H	
Hintze, A. G. ....	47
I	
Int'l Derrick & Equipment Co. ....	48
Isolantite, Inc. ....	6
L	
Littelfuse Labs. ....	42
P	
Paramount Paper Tube Co. ....	47
Precision Inductance Corp. ....	47
R	
RCA Communications, Inc. ....	43
RCA Mfg. Co., Inc. ....	Back Cover
Recoton Corp. ....	42
S	
Scientific Radio Service. ....	47
Sound Apparatus Co. ....	43
Swedish Iron & Steel Corp. ....	35
T	
Thomas & Skinner Steel Prod. Co. ....	47
U	
United Transformer Corp. ....	33
W	
Western Electric Co. ....	3
Winslow, Louis J. ....	47
Z	
Zophar Mills, Inc. ....	48

# AMPERITE

presents  
**THE ACOUSTIC COMPENSATOR**

### 3 IMPORTANT USES

- (1) The Acoustic Compensator enables you to lower or raise the response of the microphone by the mere flip of the finger!
- (2) Makes the Velocity immediately adjustable to close talking or distant pickup.
- (3) Immediately adjustable to any type of job or occasion.

MODELS RBHk, RBMk, with acoustic compensator. Frequency range 40 to 11,000 Cps. Output, —65 db. Switch, cable connector, 25' of cable. **\$42.00 LIST**

MODELS RBHn, RBMn, without acoustic compensator. **\$42.00 LIST**

MODELS RAH-RAL, excellent for speech and music. Reduces feedback. Output, —68 db. **\$22.00 LIST**

**NEW!** AMPERITE CONTACT MICROPHONE for use on all string instruments. . . **\$22.00 LIST**

AMPERITE "HAND-I-MIKE," smallest velocity made; used as hand, desk, or stand mike. **\$22.00 LIST**

Write for new Illustrated Bulletins.  
FREE: Window Decal & Window Display; also new scales helps.

**AMPERITE CO.** 561 BROADWAY, N. Y.

**AMPERITE** *velocity* **MICROPHONE**

## CINAUDAGRAPH

# Speaker

### CINAUDAGRAPH Magic Magnet Speakers

—extensively utilized by all leading radio receiver and P. A. equipment manufacturers—are available in a complete range of sizes from 5½ to 18 inches, to meet your every radio requirement.

If you demand utmost dependability and fidelity of reproduction from your equipment—in-ist on Cinaudagraph P. M. speakers. Carried in stock by all progressive distributors. Free descriptive literature on request.

**CINAUDAGRAPH CORPORATION**  
Speaker Division • Stamford, Conn.

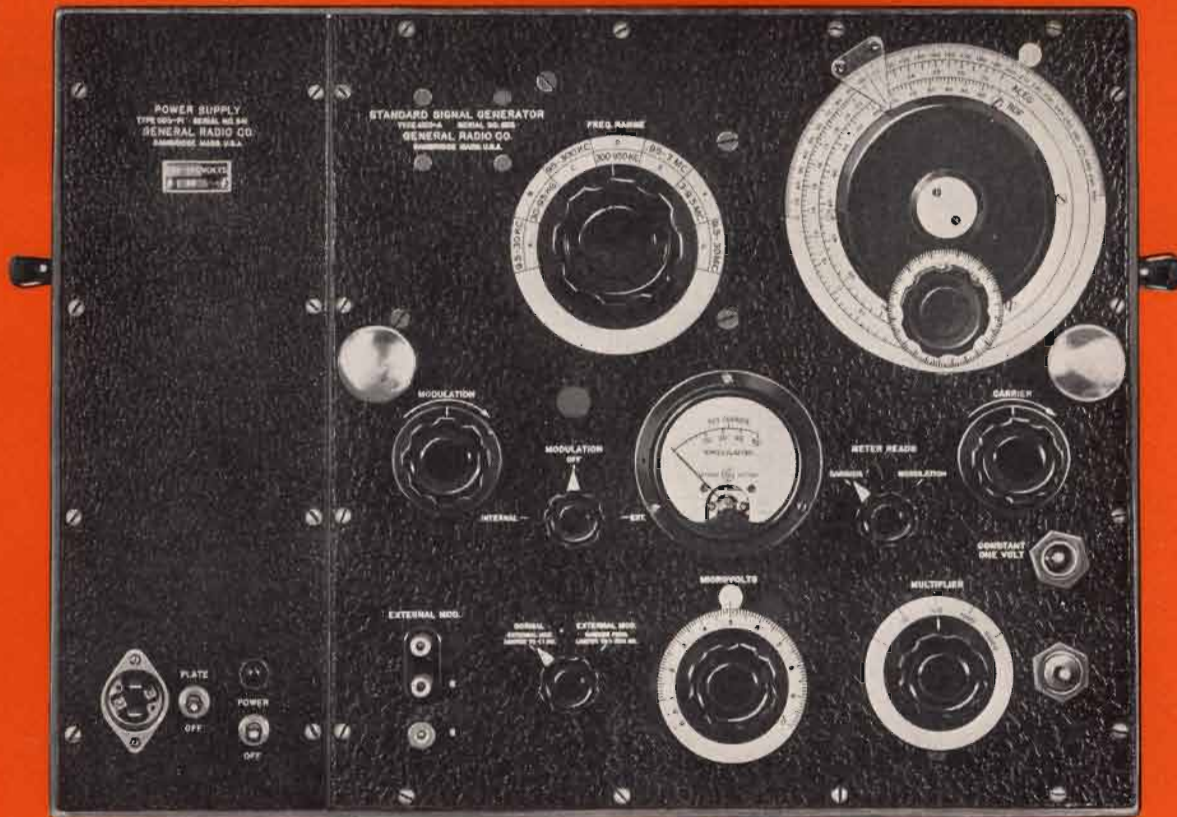

## IMPROVED STANDARD-SIGNAL GENERATOR

The new Type 605-B Standard-Signal Generator has a number of mechanical and electrical improvements which increase its usefulness many-fold. Included in these improvements are: geared slow-motion drive for more precise setting and for obtaining selectivity curves; new condenser of better construction; range extended to 50 Mc; constant one-volt output; improved output cable.

This new generator is available in both a-c and battery operated models. The a-c model is supplied with built-in voltage-regulated power supply which assures constant output over normal line voltage fluctuations.

TYPE 605-B STANDARD-SIGNAL GENERATOR (either a-c or battery operated model) ..... \$415.00

### NEW CONDENSER

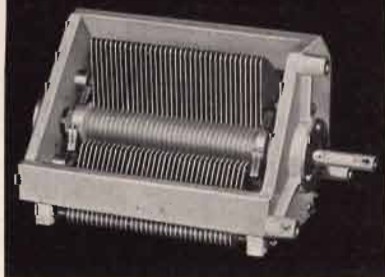

**1** Better mechanical and electrical stability; one-piece cast aluminum frame; ball bearings; smoother running; four rotor spring contacts for equi-potential plates; lower r-j resistance.

### GEARED DIAL

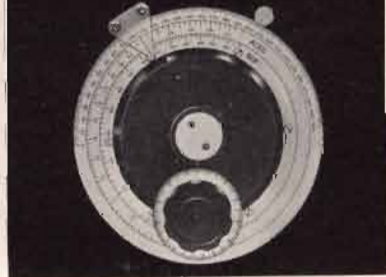

**2** Slow-motion dial geared and engraved; one division on small dial equals 0.1% of carrier frequency; effective scale-length between 9.5 kc and 30 Mc is 38 FEET; direct reading from 9.5 kc to 30 Mc, calibration curve 30 Mc to 50 Mc.

### HIGHER OUTPUT



**3** Constant one-volt output; general load work, resonance woltmeter and other instruments; direct reading for modulation.

• WRITE FOR BULLETIN 211 FOR COMPLETE



GENERAL RADIO COMPANY

# RCA CARTRIDGE TYPE PHOTOTUBES *Ring the Bell* ON EVERY COUNT!

SMALLER IN SIZE...only 1¼" long

LOWER IN PRICE...only \$2 list

SIMPLIFIED CONSTRUCTION

NO SACRIFICE OF ELECTRICAL  
PERFORMANCE

HIGH SENSITIVITY

LOW INTERELECTRODE  
CAPACITANCE

LOW LEAKAGE

EASY MOUNTING...with either  
end up so that tube's glass envelope  
insulates upper terminal



ACTUAL  
SIZE

RCA's new cartridge-type phototubes are the 921 and 922. Shown here in actual size is RCA 922. A vacuum-type tube, its sensitivity is 20 microamperes per lumen. Interelectrode capacitance—0.6 uuf. The RCA 921 looks the same as the tube shown, is the same size, but is a gas-type tube, with sensitivity of 100 microamperes per lumen—Interelectrode capacitance 1.1 uuf.

## OTHER RCA PHOTOTUBES

**RCA 868**..A gas-type phototube, especially designed for sound-on-film equipment.

**RCA 917**..A vacuum-type phototube, provides high resistance to leakage currents between electrodes. Excellent for use where high resistance load is desirable to give maximum circuit sensitivity. Offers stable operation, permanent calibration in light-measuring and light-relay devices.

**RCA 918**..A gas-type phototube, especially designed for use in sound-on-film equipment. The tube has a diffusion cathode which makes it extremely sensitive to illumination levels.

**RCA 919**..A vacuum-type phototube similar to 917, chief difference being terminal arrangement which is reverse of that in 917. 919 can be used in series with 917 to give small leakage current and high over-all sensitivity.

**RCA 920**..A twin phototube, gas type. Has two separate phototube units in one bulb. Designed primarily for use with double-sound-track film in sound reproduction system having high signal-to-noise ratio.

**RCA 923**..A gas-type phototube for use in sound-on-film equipment. Except for shorter over-all length, 923 has characteristics similar to those of 918.

*Listen to the "Magic Key of RCA" every Sunday, 2 to 3 p. m., E. S. T., on NBC Blue Network.*

FOR TECHNICAL DETAILS ABOUT ANY OR ALL OF THESE TUBES, WRITE TO

*in Tubes*

FIRST IN METAL  
FOREMOST IN GLASS  
FINEST IN TONE

New Jersey