

Western Electric

**25B SPEECH INPUT
EQUIPMENT**



**Instruction Bulletin No. 1130
Issue 1**

**Addendum for
Instruction Bulletin No. 1130, Issue 1
25B Speech Input Equipment**

NOTE: The terminal numbers in the 40A Console agree in numbering and circuit function with the same numbered terminals in the junction boxes.

Page 5, paragraph 2 should read:

“As indicated in Figure 1, a loss of approximately 17 db is incurred in the mixer network, the sum of 11 db in the 7 channel mixer and 6 db minimum attenuation in the ladder mixer controls.”

Page 5, after paragraph 4 add:

“When using the 25B to operate into a telephone line it is necessary to insert a repeating coil (119C or 111C) between the output circuit and the telephone line since one side of the output circuit is grounded.”

Page 7, under 4-3 “Power Supply Circuits” add paragraph:

“The 18B Rectifier is provided with a tapped primary to enable proper operation from different line voltages. In order to assure positive operation of the loudspeaker cut-off relays in the 131A Amplifier, it is neces-

sary to use the low voltage tap when the line voltage is below normal.”

Page 8, under “Remote Line Inputs to Line Outputs” (bottom of page) add note:

“Input pads can be altered for desired value of attenuation as noted on page 12 under 5-6 ‘Wiring Audio Circuits,’ paragraph 3.”

Page 9, under “Mixer Network Loss” (top of page) should read:

“Mixer Loss . . . Approximately 17 db (mixer volume control on minimum loss)”

Page 13, under 5-83, next to last line should read “Note 1” instead of “Note 3.”

Page 15, under 6-21 “Normal Volume Control Settings” paragraph 2 should read:

“For optimum operation with respect to noise and range of control, the loss should be about equally divided between the master gain control and the mixer volume controls, resulting in approximate settings of 16 db in the master gain control and 14 db in the mixer volume controls.”

Spare Conductors

Spare Shielded Pairs in 7A Junction Box

BR in 7A Junction Box to C on AN 3106 28 12S to J52
WH in 7A Junction Box to D on AN 3106 28 12S to J52
S in 7A Junction Box to E on AN 3106 28 12S to J52
W in 7A Junction Box to F on AN 3106 28 12S to J52

Spare Coaxial Wire in 7A Junction Box

R-BL in 7A Junction Box to A on AN 3106 28 16S to J51

Spare Shielded Pairs in 7B Junction Box

W in 7B Junction Box to L on AN 3106 28 8S to J55
W-BL in 7B Junction Box to M on AN 3106 28 8S to J55

Spare Wires in 7B Junction Box

W-R in 7B Junction Box to X on AN 3106 40 2S to J53
W-BL in 7B Junction Box to Z on AN 3106 40 2S to J53
W-Y in 7B Junction Box to E on AN 3106 40 2S to J53
W-BR in 7B Junction Box to A on AN 3106 28 12S to J54
W-O in 7B Junction Box to B on AN 3106 28 12S to J54

MODIFICATION OF 40A CONSOLE FOR ADDITION OF STUDIO "ON AIR" INDICATOR LIGHT RELAYS

When it is required to operate studio ON AIR lights concurrently with the operation of the microphone keys on the 40A Console, the modification described below will be satisfactory.

Additional Equipment Required

- 2—Relays, 12 or 24 volts d-c, single contact.
(The relays selected will correspond with the voltage supplied by the rectifier used.)
- 2—0.1 mfd., 600 volt capacitors.
- 2—1000 ohm, 1/2 watt, composition carbon resistors.
- 1—KS-5653, 24 volt rectifier, or KS-7593, 12 volt rectifier, for operation of relays.
Wire, as required.

The steps for making this modification are as follows:

1. Connect the 0.1 mfd capacitors and the 1000 ohm resistors to the relay windings as shown on the attached schematic.
2. Mount the relays in a convenient box, such as an electrician's pull box. The relays should not be mounted in the 40A Console.
3. Connect the relay windings, as shown on the attached schematic, to terminals 129 and 133 of the 7B Junction Box, and connect the common relay connection to terminal 137 of the 7B Junction Box. Connect

these terminals 129 and 133 to spare terminals of AN 3106-40-2S Connectors. (See Figure 11, Bulletin No. 1130.)

4. At the 40A Console, connect from spare wires used in (3) above of J53, to terminals 129 and 133.
5. In the 131A Amplifier, remove the ORANGE wire from capacitor C4 to common connection of speaker cut-off relay windings. (See attached schematic, and 131A Amplifier wiring diagram.)
6. In the 131A Amplifier, connect a new wire from the common connection on the speaker cut-off relays, from which the ORANGE wire was removed, to terminal 137 in the 40A Console.
7. Connect the KS-5653, or KS-7593, Rectifier (whichever is used) to terminals 137(+) and 138(—) of the 7B Junction Box.
8. Connect studio ON AIR signs to relay contacts as desired.

The lamps used in the 40A Console (E1 to E10) operate from 12 volts. If the 24 volt rectifier is used, these lamps must be removed and replaced with 24 volt lamps, type 2U.

The three relays in the 131A Amplifier will operate satisfactorily at 12 volts minimum. If a 12 volt rectifier is used, the full load voltage must not drop below 12 volts for proper operation of the relays.

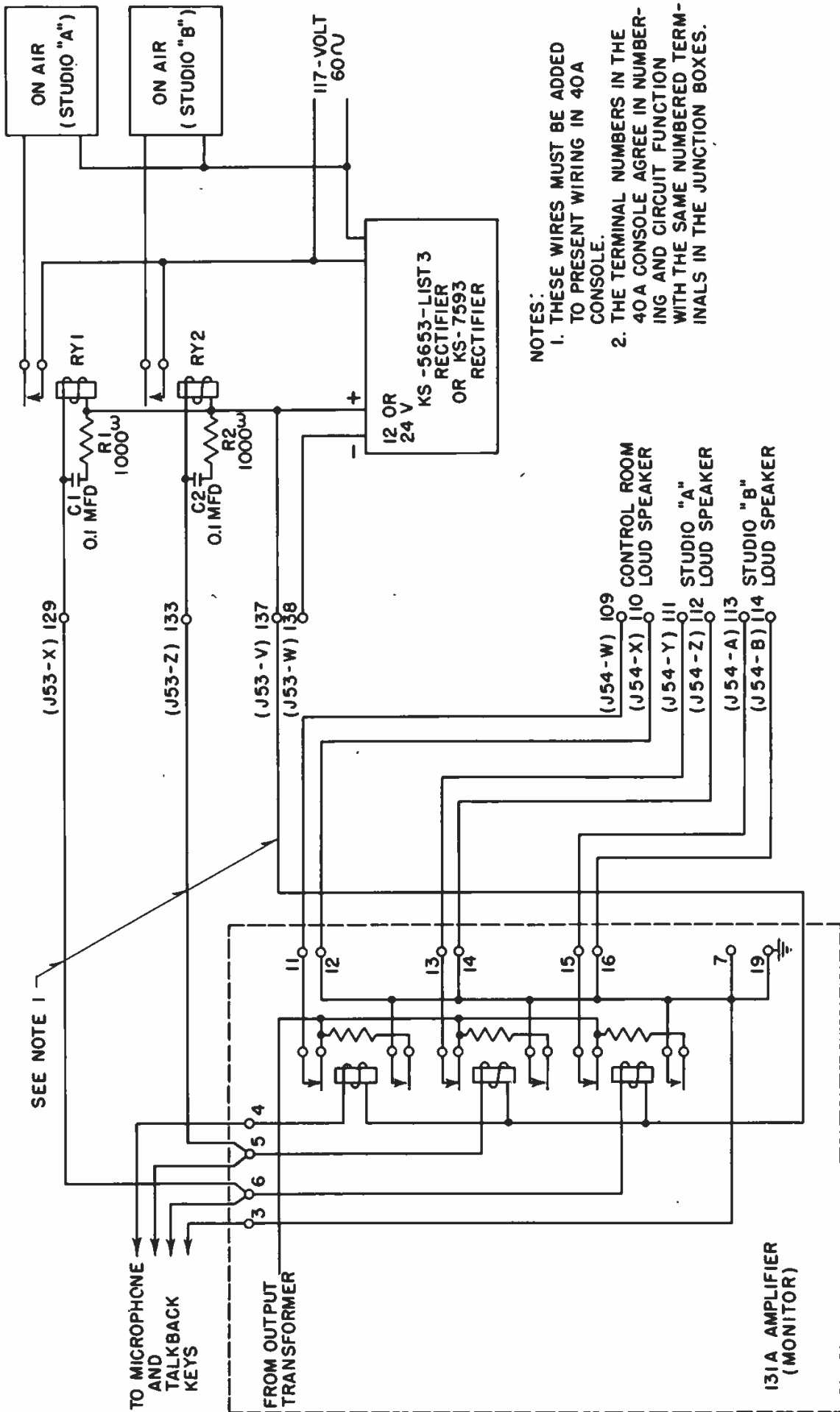

NOTES:

1. THESE WIRES MUST BE ADDED TO PRESENT WIRING IN 40A CONSOLE.
2. THE TERMINAL NUMBERS IN THE 40A CONSOLE AGREE IN NUMBERING AND CIRCUIT FUNCTION WITH THE SAME NUMBERED TERMINALS IN THE JUNCTION BOXES.

40A CONSOLE CONTROL UNIT

Typical Apparatus List

<i>Designation No.</i>	<i>Apparatus</i>
K1, K3, K5, K19, K20, K21, K28	2 BD Key Unit
K2, K4, K6, K8, K10, K12, K14, K16, K18, K24, K25, K29, K30	2 GR Key Unit
K15, K17	2 R Key Unit
K7, K9, K11, K13	D-171058 Key Unit
K22, K23	D-171059 Key Unit
K26, K27	2 AEJ Key Unit
K31, K32	576A Key
K33, K34	552A Key
Handles for K1 to K30	KS-10011 Key Handle—Black KS-10011 Key Handle—Red
M1, M2	KS-8218, L1 Meter
M3	KS-9872 Meter
P1, P2, P3, P4, P5, P6, P7, P10, P11	{ BA-73987, 1 or 2 Attenuator { 600:600 ohm
P8, P9	{ BA-73987, 3 or 4 { 100,000 ohm Potentiometer
D1	32117J Yaxley Switch 7/8" long shaft
Knobs for P1 to P9	KS-10088, L2 Knob
Knobs for P10, P11, D1	KS-10283 Knob 129A Amplifier 130B Amplifier 131A Amplifier
T1, T2, T2	170B Repeating Coil
E1 to E14	2F Lamp
Sockets for E1 to E14	47B Lamp Socket
Cap for E1, E4, E5	72L Lamp Cap marked L1
Cap for E6, E9, E10	72L Lamp Cap marked L2
Cap for E2	72M Lamp Cap marked L1

40A CONSOLE CONTROL UNIT (continued)

Typical Apparatus List

<i>Designation No.</i>	<i>Apparatus</i>
Cap for E7	72M Lamp Cap marked L2
Cap for E3	72N Lamp Cap marked L1
Cap for E8	72N Lamp Cap marked L2
Cap for E11, E12	72N Lamp Cap marked A
Cap for E13, E14	72N Lamp Cap marked B
J1 to J40	218J Jack
J41, J42	221E Jack
For Blank jack spaces	39B Apparatus Blank
Mounting for Jacks, Lamps, etc.	Jack Mountings per ESO-677991-1

Allen-Bradley Co.
Resistance Values as Specified $\pm 5\%$
Type EB

<i>Designation No.</i>	<i>Apparatus</i>
R1 to R14 R27, R28	1100 ohms
R15 to R20	620 ohms
R21 to R26 R58 to R64	510 ohms
R29, R30	4700 ohms
R31, R32	2000 ohms
R33, R34	5600 ohms
R35, R36	6200 ohms
R37, R38, R51, R52	2700 ohms
R39, R40	6800 ohms
R41 to R46	200 ohms
R47, R48	100,000 ohms
R49, R50	7500 ohms
R53, R54	1500 ohms
R55 to R57	120 ohms
Terminal Strip Units	P-250833

40A CONSOLE CONTROL UNIT (continued)

Typical Apparatus List

<i>Designation No.</i>	<i>Apparatus</i>	
Receptacles for connections from 7A and 7B Junction Boxes	AN-3102-40-2P	} Gold plated contacts .0002 inch thick
	AN-3102-28-16P	
	AN-3102-28-12P	
	AN-3102-28-8P	
	American Phenolic Corp.	
Plugs on 7A Junction Box	AN-3106-28-16S	} *
	AN-3106-28-12S	
Plugs on 7B Junction Box	AN-3106-40-2S	} Gold plated contacts .0002 inch thick
	AN-3106-28-12S	
	AN-3106-28-8S	
	American Phenolic Corp.	
Single Conductor Shielded Wire	D-169970 Colors Red Blue, Red Orange, Red Slate, Red Green, Red Brown	
Twisted Pair Shielded Wire	D-169970 Colors White & Brown, White & Slate, White & Blue, White & Orange, White & Green, White & Red	
Potentiometer Cable	RG-62/U Per JAN C17	
Repeating Coil	BL-73884	
Mounting Plate		
Rep. Coil Mtg. Plate		
Bracket	BA-73883	

*NOTE: These plugs are not part of the 40A Console Control Unit but are the mating parts for the receptacles and are part of the 7A and 7B Junction Boxes.

All apparatus is Western Electric unless otherwise specified.

NO. 129A AMPLIFIER

Typical Apparatus List

<i>Designation No.</i>	<i>Apparatus</i>
C1A, C10A C10A, C10B	Mallory type FP Electrolytic Cond. with Bakelite mounting plate number A93410-1 50-50 mfd. 150V in 1" dia. x 3" Can Cat. No. FPD-214
C2A, C5A C2B, C5B	Mallory type FP Electrolytic Cond. with Bakelite mounting plate No. A93410-1, 10-10-10 mfd.—450V in 1" dia. x 3" Can Cat. No. FPT-3B9
C3A, C6A C3B, C6B	0.5 mfd. Cornell Dubilier Dykanol Cond. PC-1728
C4A, C7A C4B, C7B	230A Cond.
C8A, C9A C8B, C9B	0.00005 MF Cond. Cornell Dubilier type 5R
R4A, R15A R4B, R15B	International Resistance Company 0.1 meg. WW-3 resis. with lug terms.
R9A, R20A R9B, R20B	0.1 meg. $\pm 5\%$ BT-1
R1, R12	1000 ohms BW-1 $\pm 5\%$ Resis.
R2, R13	3000 ohms BW-1 $\pm 5\%$ Resis.
R3, R14	200 ohms BW-1 $\pm 5\%$ Resis.
R7, R18	500 ohms BW-1 $\pm 5\%$ Resis.
R8, R19	20 ohms BW-1 $\pm 5\%$ Resis.
R5, R16	1 meg. BT-1 $\pm 5\%$ Resis.
R6, R10 R17, R21	50000 ohms BT-1 $\pm 5\%$ Resis.
R11, R22	10000 ohms BT-1 $\pm 5\%$ Resis.
T1A, T3A T1B, T3B	618B Input Transformer
T2A, T4A T2B, T4B	197A Output Transformer
TS1, TS2 TS4, TS5	700A Terminal Strip
VS1A, VS3A VS1B, VS3B	Vacuum tube socket #33-1-C per KS-7741
VS2A, VS4A VS2B, VS4B	KS-10067, type 39-PG-1-E socket Aerovox Special Type E mounting ring 1½ dia. furnished with a 1 lg. clamp scr.

All apparatus is Western Electric unless otherwise specified.

NO. 130B AMPLIFIER

Typical Apparatus List

<i>Designation No.</i>	<i>Apparatus</i>
	Mallory Type FP Electrolytic Condenser in 1 $\frac{3}{8}$ x 3 can with Bakelite Mtg. Plate A-93423-1
C1A, C1B	50-50-50-50 Mfd. 150V
C2A, C2B	40MF — 450V 20MF — 450V 20MF — 450V
C3A, C5A, C6A C3B, C5B, C6B	0.5 Mfd. Cornell Dubilier Dykanol Cond. PO-1728
C4A, C7A C4B, C7B	230-A Cond.
C8	.01 MF Cornell Dubilier Type 3W Cond.
L1A, L1B L2A, L2B	221A Ret. Coil 221H Ret. Coil
	International Resistance Company BT-1 Resistances
R1	1 meg. \pm 5%
R2	.25 meg. \pm 5%
R3	5000 ohms \pm 5%
	International Resistance Company BW-1 Resistances
R4	1500 ohms \pm 5%
R5	60 ohms \pm 5%
	International Resistance Company BT-1 Resistances
R6A, R6B	1.25 meg. \pm 5%
R7	20,000 ohms \pm 5%
	International Resistance Company BW-1 Resistances
R8	160 ohms \pm 5%
R9	2000 ohms \pm 5%
R10	180 ohms \pm 5%

NO. 130B AMPLIFIER (continued)

Typical Apparatus List

<i>Designation No.</i>	<i>Apparatus</i>
	International Resistance Company BT-1 Resistances
R11	1 meg. $\pm 5\%$
R12	.25 meg. $\pm 5\%$
R13	.5 meg. $\pm 5\%$
R14A, R14B	.1 meg. $\pm 5\%$
R15	50000 ohms $\pm 5\%$
	International Resistance Company BW-1 Resistances
R16	450 ohms $\pm 5\%$
R17	4.5 ohms $\pm 5\%$
R18A, R18B	340 ohms $\pm 5\%$ BT1/2 International Resistance Company
T1A, T1B	618B Input Transformer
T2A, T2B	185A Output Transformer
TS1, TS2	700A Term. Strip
TS4, TS5	
TS7A, TS7B } TS8A, TS8B }	#2002 Terminal Strip H. B. Jones—Chicago
VS1A, VS1B	V. T. Socket #33-1-C per KS-7741
VS2A, VS2B	KS-10067 type 33-PG-1-B Socket
VS3A, VS3B	

NO. 131A AMPLIFIER

Typical Apparatus List

<i>Designation No.</i>	<i>Apparatus</i>
C1, C2	.03 MFD. type 1455 Aerovox Cond.
C3	Mallory type FP Condenser $\frac{3}{4}$ dia. x 2 Can with Bakelite mtg. plate A-93416-1 10 MF—450V Cat. No. FPS-142
C4	Mallory type FP Condenser $\frac{3}{4}$ dia. x 2 Can with Bakelite mtg. plate A-93416-1 30 MF—150V Cat. No. FPS-113
C5	313-B Condenser
	International Resistance Company Type BW-1 Resistances
R1, R2	1600 ohms $\pm 5\%$
	International Resistance Company Type BT-1 Resistances
R3	1 megohm $\pm 5\%$
R4, R5	.5 megohm $\pm 5\%$
R6, R7	.3 megohm $\pm 5\%$
R8, R9	.05 megohm $\pm 5\%$
R10	250 ohms $\pm 5\%$ I.R.C. BW-1 Resistances
R11	50000 ohms $\pm 5\%$ I.R.C. BT-1 Resistances
R12, R13, R14	10 ohms $\pm 5\%$ I.R.C. BW-2 Resistances
R15, R16, R17	1000 ohms $\pm 5\%$ I.R.C. BT-1 Resistances
R18, R19	1200 ohms $\pm 5\%$ I.R.C. BT-1/2 Resistances
S1, S2, S3	U83 Relay with U3 Relay Cover
T1	618B Input Transformer
T2	171-C Output Transformer
TS1, TS2	700-A Term. Strip.
VS1, VS2	KS-10067 Type 39-PG-1-E Socket
VS3, VS4	
	Aerovox Special type E mounting ring $1\frac{1}{2}$ dia. furnished with 1" lg. clamp screw

All apparatus is Western Electric unless otherwise specified.

NO. 18B RECTIFIER

Typical Apparatus List

<i>Designation No.</i>	<i>Apparatus</i>
C1	Aerovox Type 610 Condenser, 4 MF.
C2	Sprague Type FP Electrolytic Condenser, 10 MF, 450 Volts DC Working Voltage Can Size $\frac{3}{4}$ " Dia. by 2" Long, Supply with Bakelite Mounting Plate.
FM1	Bussman Mfg. Co., St. Louis, Mo. Type D-01 Fuse
F1	Receptacle with 1 Ampere Fustat #901
L1	221H Retardation Coil
T1	360E Transformer
VS1	KS-7741 Type 33-11-A Vacuum Tube Socket
D1	ESA-676800-17 Switch
TS1	BA-44197 Terminal Strip Assembly
TS2	BA-44195 Terminal Strip Assembly

All apparatus is Western Electric unless otherwise specified.

NO. 20B RECTIFIER

Typical Apparatus List

<i>Designation No.</i>	<i>Apparatus</i>
C1	Cornell Dubilier Corp. Type TJH-10040 Dykanol Condenser 4 MF. 1000 V.
C2	Cornell Dubilier Corp. Type TJH-10100 Dykanol Condenser 10 MF. 1000 V.
C3	227A Condenser 0.5 MF.
C4	Solar Capacitor, Type XTIMSW2 - .25 MFD
D1	H. & H. S.P.S.T. Switch per ESO-676800-22
FM1	Bussman Mfg. Co. St Louis. Type D-02
F1	Fuse Receptacle with 12" Lg. Leads & 2.0 Amp. Fustat #962
L1	221G Retardation Coil
L2	Automatic Winding Co. #400-38 R.F. Coil International Resistance Company
P1	Type W Wire Wound Potentiometer 10,000 Ohms $\pm 10\%$. Standard Taper, No Switch and No Taps. Steel Shaft 9/16" Lg. (Dim. "A") with Screwdriver Slot and One Hex. Nut. International Resistance Company Type MW5 Resistances
R1, R3	32500 Ohms $\pm 10\%$ International Resistance Company Type BW2 Resistances
R2, R7, R8, R9	.4700 Ohms $\pm 5\%$ International Resistance Company Type BTA Resistances
R4	1 Megohm $\pm 10\%$
R5	5.1 Megohms $\pm 10\%$
R6	0.1 Megohm $\pm 10\%$
T1	KS-8940 Transformer

All apparatus is Western Electric unless otherwise specified.

NO. 20B RECTIFIER (continued)

Typical Apparatus List

<i>Designation No.</i>	<i>Apparatus</i>
TS1	Terminal Strip per ESO-676682-1
TS2	700A Terminal Strip
VS1, VS2	A.W. Franklin C. Type 34-27-AA V.T. Socket
VS3, VS4	ES-13364 - List 3 V.T. Socket
VS5	KS-7741 Type 33-1-A V.T. Socket
	UNITED CARR FASTENER CORP. #51177 Plug Button, Nic.Plt.Fin. (For 1/2" Dia. Cable Holes) #48133 Plug Button, Nic.Plt.Fin. (For 1-5/32" Dia. Cable Holes).
	AMERICAN PHENOLIC CORP., CHICAGO, ILL. #78-1P Tip Jacks (1 Red and 1 Black) with #2-11 Retainer Ring.

All apparatus is Western Electric unless otherwise specified.

**REFERENCED INSTRUCTION
BULLETINS AND INFORMATION**

No. 129A Amplifier	Instruction Bulletin No. 1097
130B Amplifier	Instruction Bulletin No. 1142
131A Amplifier	Instruction Bulletin No. 1099
18A and B Rectifiers	Instruction Bulletin No. 1143
20B Rectifier	Instruction Bulletin No. 1103
25B S.I.E. Sales Bulletin	No. WECO-T-2197
21A Cabinet	Instruction Sheet BERX-156
190 Type Mounting Plate	Instruction Sheet BERX-155

Apparatus Lists*

- 129A Amplifier
- 130B Amplifier
- 131A Amplifier
- 18A and B Rectifiers
- 20B Rectifier
- 40A Console

*Enclosed with Equipment

INDEX TO CONTENTS

(Text)

<i>Section</i>	<i>Page</i>
1. GENERAL DESCRIPTION OF FACILITIES	1
2. LIST OF EQUIPMENT	2
2—1. List of Components	2
2—2. Vacuum Tubes Required	2
3. OTHER ACCESSORY EQUIPMENT	2
3—1. Patching Cords	2
3—2. Monitoring Headset	2
3—3. Repeating Coils and Mounting Plates	2
3—4. 12-Volt Signal Supply	3
3—5. External Preamplifiers	3
3—6. Talkback Microphone	4
4. DESCRIPTION OF OPERATION AND TECHNICAL DATA	4
4—1. Audio Circuits	4
4—2. Signal Circuits	6
4—3. Power Supply Circuits	7
4—4. Technical Data	8
5. INSTALLATION	9
5—1. Assembly and Handling Precautions	9
5—11. Assembly of Table	9
5—12. Internal Access to Console	10
5—13. Assembly of Console to Table	10
5—2. Location of 40A Console and 7 Type Junction Boxes	10
5—3. Installation of Junction Boxes	10
5—4. Installation of 12A Power Supply	11
5—5. Conduit Layout	11
5—6. Wiring—Audio Circuits	11
5—7. Wiring—Control Circuits	12
5—8. Adjustments and Special Features	13
5—81. Talkback Microphone	13
5—82. Balanced Inputs	13
5—83. Talkback Circuit and Loudspeaker Cut-Off Relays	13

INDEX TO CONTENTS
(continued)

<i>Section</i>	<i>Page</i>
5--84. Loudspeakers	14
5--85. VI Meter Sensitivity	14
5--86. AC Line Voltage Adjustments	14
5--87. Input Impedances	14
6. OPERATION	14
6--1. Application of AC Power	14
- 6--11. Plate Current Readings	15
6--2. Operating Precautions	15
6--21. Normal Volume Control Settings	15
6--22. Overloading	15
7. MAINTENANCE	16
7--1. Contacts	16
7--2. Potentiometers	16
7--3. Location of Trouble	16
7--4. Replacement Parts.	16

LIST OF ILLUSTRATIONS AND DRAWING INDEX

<i>Figure No.</i>	<i>Title</i>
Fig. 1	Functional Schematic Diagram
Fig. 2	Equipment Assembly and Installation Information
Fig. 3	Signal and Audio Schematic
Fig. 4	Control Layout on 40A Console
Fig. 5	Wiring and Circuit Assignment Information
Fig. 6	Balanced Input Modification
Fig. 7	Schematic Loudspeaker Cutoff Circuits in 40A Console
Fig. 8	Power Supply Schematic
Fig. 9	Power Supply Wiring Diagram
Fig. 10	Wiring Diagram 7A Junction Box
Fig. 11	Wiring Diagram 7B Junction Box
Fig. 12	Wiring Diagram 40A Console
Fig. 13	Wiring Diagram 12A Power Supply

Western Electric

25B SPEECH INPUT EQUIPMENT

SECTION 1 – GENERAL DESCRIPTION

The 25B Speech Input Equipment is a complete AC operated console type, program production unit for the amplification, control, and monitoring of programs originated by microphones, transcriptions, remote inputs, or equivalent sources. It has two main program channels, capable of simultaneous operation on separate programs without interference. In addition, it has an independent monitoring channel for loudspeaker listening to programs being transmitted through either of the two main channels, or direct from incoming lines or cue circuits. The monitor channel may also be used to feed cue program back to the remote line circuits, or talkback to one or the other of two studio loudspeakers.

Other facilities provided are an audition, or sound reinforcement output with volume control, two VI meters, headset monitoring jacks, and studio light and signalling control circuits; jack termination for 4 other lines in addition to those mentioned above. In addition to provision for use of an external talkback microphone, a mounting is also provided in the console for such a microphone.

The equipment has a 7 channel parallel mixer. Four of these mixer volume controls are associated with four preliminary amplifiers provided in the equipment for operation from a maximum of eight connected microphones (4 simultaneously), or equivalent low level sources. The other three mixers are associated with higher level inputs which may be incoming program lines. By the use of three externally mounted preamplifiers, three additional microphones or other low level inputs may be operated into these mixers. Any combination of the seven simultaneous inputs may be con-

nected to either one or the other of the two main amplifier channels.

A functional schematic diagram showing these facilities and indicating the operation of the equipment, is given on Figure 1. This diagram also shows levels at various points in the system based on a +8 VU level into a 600 ohm outgoing line. It should be noted, however, that the input levels shown are based on minimum loss in the volume controls and that normal input levels will be higher than those shown. A maximum net gain of about 100 db is provided from the low level input terminals to the output line terminals, about 38 db from the high level lines, and about 58 db from the utility inputs to the outgoing line. The monitor amplifier has a gain of about 50 db.

The 25B Speech Input Equipment consists of four principal units. The main unit is a desk style Control Console mounted on a table; this unit contains all the amplifiers and the controls. The table top stands 27½ inches from the floor and is about 55 inches long by about 28 inches deep. The console occupies about 13½ inches in depth at the rear of the table top, and the amplifiers are housed in hinged tray type enclosures below the table top. The over-all height of the console on the table is 36 inches. The control and amplifier enclosures are hinged so that complete and easy access is obtained to all internal wiring and components. The second unit is a wall mounted cabinet containing the filament transformers and plate supply rectifiers. This unit is about 28 inches wide by 10 inches deep by 16½ inches high.

Two flush type wall mounting connection or junction boxes also form part of the equipment. These are furnished with terminal strips

to which the permanent connections are made. Extending from the front of the boxes are flexible cables terminated in plug-in connectors, with which all connections to the control con-

sole may be made. Outline dimensions are shown on Figure 2; the construction and other equipment characteristics are described in more detail below:

SECTION 2—LIST OF EQUIPMENT

The 25B Speech Input Equipment consists of the following separate components:

2-1. List of Components

40A Control Console
KS-10284 Table
7A Junction Box
7B Junction Box
12A Power Supply

Vacuum Tube Designation	Number Required		
	40A Console	12A Power Supply	Total for Equipment
349A	4	—	4
351A	—	1	1
313C	—	1	1
300B	—	1	1
274A	—	2	2

Outline dimensions of this equipment are shown on Figure 2.

2-2. Vacuum Tubes

The following vacuum tubes are required for operation of this equipment but are not furnished with it and they should be specifically called for on the order:

Vacuum Tube Designation	Number Required		
	40A Console	12A Power Supply	Total for Equipment
1603	6	—	6
348A	8	1	9

Where the recommended tubes are not available, certain substitutes may be employed. These are listed in the particular referenced instruction books which cover the amplifiers and rectifiers which form part of the 25B Speech Input Equipment, in accordance with the following.

Unit of 25B S.I.E.	Component of Unit	
40 A Console	} 129A Amplifier } 130B Amplifier } 131A Amplifier	
		} 18B Rectifier } 20B Rectifier

SECTION 3—OTHER ACCESSORY EQUIPMENT

The following accessory equipment not furnished as part of the 25B Speech Input Equipment is recommended:

3-1. Patching Cords

The 40A Console is equipped for 3 incoming high level remote program lines and 3 utility inputs which feed through jacks. Also 4 additional line inputs are terminated in jacks on the control console. The use of the P-2AA Cord, 1 foot long, equipped with 241A (black) plugs, or 241B (red) plugs is recommended for patching purposes.

3-2. Monitoring Headset

Jacks connected across the outputs of each of the two main amplifier channels are provided for headset monitoring. These are high impedance (100,000 ohms) outputs. A suitable headset is the D-97690 (high quality) Headset equipped with D-90944 Cord and 47B Plug. The 1002F Headset may also be used.

3-3. Repeating Coils

Comments on the use of repeating coils for providing impedance matching or for changing from balanced to unbalanced circuits are given

in more detail elsewhere in this bulletin. The Western Electric Company No. 177C Repeating Coil is a general purpose coil designed for high quality program circuits and specifically for use with the 25B Speech Input Equipment; brackets and mounting plates for mounting 8 such coils are provided in the 40A Console. Space is available for adding additional brackets to mount 5 more coils if desired.

Winding data on the 177C Repeating Coil is shown below:

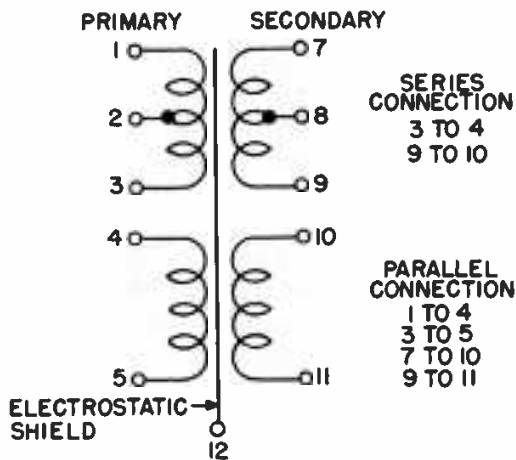

All windings are identical except that windings 1-3 and 7-8 have a mid-tap (terminals 2 and 8 respectively). These may be used to provide a mid-ground point for the parallel connection; for the series connection terminals 3 and 9 may, of course, be used. The following connections should be used for impedances between 25 ohms and 600 ohms:

Windings		Operating
Primary	Secondary	Impedance Ratios
Series	Series	600 ohms to 600 ohms or 150 ohms to 150 ohms
Parallel	Parallel	25 ohms to 25 ohms
Series	Parallel	150 ohms to 25 ohms

Terminal 12 is the insulated electrostatic shield. The coil is also equipped with an electromagnetic shield. For severe electromagnetic exposures, an additional shield (No. 42A) may be added externally.

Both repeating coils and shields should be ordered separately as required.

Additional coil mounting brackets and plates may be ordered as follows:

- 2 Brackets per BA-73883
- 1 or 2 Coil Mounting Plates per BA-73884

3-4. 12 Volt Signal Power Supply

The 25B Speech Input Equipment includes all plate rectifier supplies, filament supply transformers, and voltage supply for the three loud-speaker relays provided in the 131A Amplifier. No supply is provided however, for the 12-volt signal and lamp circuits provided in the 40A Console. The KS-7593 Rectifier which will supply up to 1.2 amperes at 12 volts can be ordered for this purpose.

If a 24-volt supply is wanted, the KS-5653 List 3 Rectifier may be employed. In this case the 12-volt signal lamps in the 40 A Console would have to be changed to 24 volts.

3-5. External Pre-Amplifiers

For use of the "Utility" inputs for additional microphone or low level transcription sources, pre-amplifiers mounted externally may be provided. The following equipment is available for this purpose.

For 19" Relay Rack or Cabinet Mounting, the following apparatus is recommended.

- | | | |
|-----------------------------|--------|-----------------------------|
| 3-120B Amplifiers | } or { | 1-129A Amplifier |
| 1-177 Type Mounting Plate | | 1-190 B Mounting Plate |
| 1-296 Type Panel (Face Mat) | | 1-296 Type Panel (Face Mat) |

For mounting in a 21A Cabinet the following apparatus is recommended:

- 1-21A Cabinet
- 1-Terminal Strip per BA-44609 (has 3 terminals)
- 2-Terminal Strips per BL-44607 (each has 10 terminals)
- 1-190A Mounting Plate
- 3-120B Amplifiers, or 1-129A Amplifier
- 1-Mounting Plate per BO-74389 (for mounting up to 4-177C repeating Coils in 21A Cabinet)

The three external 120B Amplifiers, or one 129A Amplifier, may be operated from the 20B Rectifier in the 12A Power Supply in addition to the 129A Amplifier and 130B Amplifier it operates in the 40A Console. The 20B Rectifier will be more heavily loaded by this addition, however, and rectifier tube life will be reduced to some extent.

The instruction sheets on the 21A Cabinet and 190 type Mounting Plate should be referred to for assembly of this apparatus.

3-6. Talkback Microphone

The 40A Console includes a mounting for a 633A Microphone but the microphone itself is not furnished and should be ordered separately.

SECTION 4 — DESCRIPTION OF OPERATION AND TECHNICAL DATA

The operation of the 25B Speech Input Equipment will be described in some detail to assist in the installation, use, and maintenance of the equipment.

4-1. Audio Circuits

The functional schematic diagram, Figure 1, is a simplified version of the complete signal audio schematic shown on Figure 3. Initial reference to Figure 1 will be helpful in following through the more detailed circuits of Figure 3; Figure 4 showing the actual location of the various keys, jacks, volume controls, etc., on the console may also be of interest in this connection. Control designations, K for keys, etc., are the same on all diagrams.

Low Level Inputs to Mixer Circuit. Each of the four microphone keys (K7, K9, K11 or K13) provide a means of selecting either of two microphones, one in Studio A or the other in Studio B, and connecting this source to a preliminary amplifier, one of which is associated with each microphone key. In the mid-position of these keys, the sources and the amplifier inputs are short circuited and grounded. The output of each preliminary amplifier is connected to a 600:600 ohm ladder type mixer volume control (P4 to P7 inclusive).

In addition to the audio circuits on these keys, contacts are provided in the loudspeaker relay control circuit so that when the keys are thrown to the "STUDIO" position the loudspeaker in the studio is cut off, preventing operation of a loud-speaker with a live microphone. Operation of this circuit is described in more detail under "Talkback".

All these circuits are identical, except that the

Talkback Key (K22), is interposed between the key (K7), for microphone No. 1, and the input of preliminary amplifier No. 1.

Line Inputs and Utility Inputs to Mixer. Connections for 7 incoming lines are provided. Four of these are terminated in jacks on the control console. The other three are each normalled through a set of jacks, a 600 ohm to 600 ohm repeating coil (T1 to T3 inclusive) to the "cue-line mixer" keys, (K19, K20 and K21). In the normal or mid-position of these keys, the lines are shorted and the other circuits connected to these keys are open.

In the "line-mix" position of these keys (K19, K20 or K21) the line input is connected through a pad of 20 db loss to the "line-utility" keys. In the "CUE" position of these keys, cue is fed to the line as discussed in more detail later.

The "line-utility" keys (K1, K3 and K5) provide a means for transferring the input to the 3 line mixers (P1, P2 and P3) either to a "line" or a "utility" source. The arrangement of the "utility" input circuits, contemplates levels comparable with the output of the microphone preliminary amplifiers and by use of externally mounted preliminary amplifiers 3 additional microphone inputs or low level transcriptions, are provided for.

The patching jacks associated with the line and utility inputs provide means for substitution of inputs in a variety of combinations.

Seven Channel Mixer. Each of the mixer volume controls (P1 to P7) inclusive, is associated with an individual mixer transfer key, (K2, K4, K6, K8, K10, K12 and K14), which provides means for connecting the output of each mixer to

either of the two line or main amplifier channels, in any desired combination.

Resistance of 1100 ohms (R1, R3, etc.) are substituted across the line amplifier input in place of each actual mixer volume control output when it is off, or when it is connected to the other line amplifier, so that each amplifier input is always terminated in approximately 150 ohms, i.e., the equivalent of 7 mixer volume controls. The 600 ohm ladder mixer volume controls are built out to 1100 ohms by series resistance R58, R59, etc., to provide proper impedance terminations.

As indicated in Figure 1, a loss of about 16 db is incurred in the mixer network.

Line Amplifier to Output Lines. Two simultaneous programs may be handled separately by the two line amplifiers, each channel being governed in over-all level by separate master gain controls (P8 and P9), between the 1st and 2nd stages of each line amplifier channel.

Output line keys (K15 for Line 1 and K17 for Line 2) provide means for connecting either of the two channels to either or both of the two outgoing lines.

In any combination of positions of the output line keys, both amplifiers and lines are always terminated in 600 ohms by the output network, made up of resistances R15 to R20 inclusive and R41 to R46 inclusive.

Keys K16 and K18, mechanically coupled to Keys K15 and K17 respectively, provide additional contacts for operation of signals, described in more detail below.

Monitor Output. A monitor output is provided in each channel of the 130B Line Amplifier. This output is isolated electrically by 20 db from the program output through a separate winding on the output transformer, and the input level to the monitor amplifier circuit is that much lower than program level.

Audition Channel. Audition key (K30) provides a means of feeding the output of either main program channel to a separate local amplifier system external to the 25B Speech Input Equipment for audition circuits or sound reinforcement in large audience studios.

Monitor Channel. The monitor key, (K29), permits the output of either main program channel to be fed through a volume control, (P10), to the monitor amplifier input (131A Amplifier). Referring to Figure 7, which is a partial schematic showing the talkback control circuits, the monitor amplifier output is normally connected to the loudspeakers in the control room, Studio A and Studio B, except under the following conditions:

- (1) When the talkback keys, (K22 and K23), are operated to Studio A or B thus operating relay S1 in the 131A Amplifier and cutting off the control room loudspeaker, or
- (2) When any microphone key (K7, K9, K11, or K13) is operated to Studio A or B, operating relay S2 or S3 (respectively) thus cutting off Studio A or B loudspeakers as indicated on Figure 7.

Operation of these circuits is further discussed below in connection with the talkback facilities.

Talkback. Talkback to either of the two studios is provided through the use of one of the 4 preliminary amplifiers (preliminary amplifier associated with microphone No. 1), either one of the line amplifier channels and the monitor amplifier. The audio circuit is indicated in simplified form on Figure 1. Transmission from the studio to the control room is through normal monitoring means as already described above. As already described, the operation of the microphone key on the console to connect the studio microphone, disconnects the studio loudspeaker as indicated on Figure 7.

In talking back to the studio from the control room, the talkback key (K22 and K23) is operated from its normal position to the Studio A or Studio B position. In either position, the operation of the talkback key opens the circuit to Studio microphone No. 1, short-circuits and grounds all other microphones in that studio, and connects the control room talkback microphone to the input of preliminary amplifier No. 1. Also, referring to Figure 7, it removes the relay operating voltage from the relay control contacts of the microphone keys for Studio A or B (depending upon the position to which the talkback key is thrown), thus removing the

operating voltage from relay S2 or S3. This reconnects the studio loudspeaker to the output of the monitor amplifier. At the same time, operation of the talkback key to either Studio A or B position, operates relay S1, cutting off the control room loudspeaker to prevent feedback.

Cue Circuits. Line-cue programs can be fed to the studio and control room loudspeakers (operation of which is automatically prevented in the same room as a live microphone as described above), by operation of a line-key (K19, etc.) to the "cue" position, and the cue key (K28) to the "line" position, with the monitor key (K29) on normal.

Air cue is fed to the monitor loudspeakers with the cue key (K28) to "air cue," with the monitor key on normal, and also to the incoming lines if the line keys (K19, etc.) are operated to the "cue" position.

Also in the normal position of the cue-key (K28) monitor output can be fed to the incoming lines.

VI Circuits. Two volume indicator meters are provided, one connected across each program output. A range key (K24 and K25) for each meter is provided, whereby the sensitivity can be decreased or increased by 5 db. Normally with the 10 db pad in, the meter reads "0" VU when +8 VU is being delivered to the output line. Cutoff keys (K33 and K34) are also provided for each meter.

4-2. Signal and Light Control Circuits

The signal and control circuits provided in the 40A Console consist of keys K26, K27, K16 and K18 (the last two being mechanically coupled to the output line keys K15 and K17 respectively), K31 and K32, signal lamps E1 to E14 inclusive, and associated terminals. These circuits may be used for signalling between the control room and master control, for operating relays or energizing signal indicators at master control, and for operating light signals in the studios. Signal facilities are provided for dispatch of two simultaneous programs.

These facilities may be employed in a number of ways depending upon the method of operation. This, however, is beyond the scope of this

Instruction Bulletin, and this discussion will be confined to the operation of the controls in the 40A Console and a description of the control and signal voltages made available for operation of the external circuits. In many cases, some or all these facilities will not be used.

The signal or control circuits in the 40A Console may be broken down into 3 separate functions, described in turn below. Reference should be made to FIG. 3 in connection with this description.

Studio Light Controls. The "Studio A" and/or "Studio B" keys (K26 and K27 respectively) are thrown to the position "CHANNEL 1" or "CHANNEL 2" depending upon the studio channel assignment.

In either position of the "STUDIO A" key, operating voltage is placed on terminal 130 to operate a "Ready" or "Standby" light in Studio A. Similarly, operating voltage is placed on the "Ready" or "Standby" light circuit for STUDIO B when the STUDIO B key is operated, (terminal 134).

Operation of keys K26 and K27 also cause signal lamps E11 to E14 (one for each of the 4 possible key positions) to light, indicating the position of these keys; i.e., E11 (Channel 1 Studio A) lights with the "STUDIO A" key (K26) in the "Channel 1" position, etc.

The studio "ON AIR" light circuits (terminals 131, 132, 135 and 136) are energized through contacts on the studio keys, K26 and K27, but only if the output line keys (K15 and 16, and K17 and 18) are operated. This is because operating voltage for these circuits is fed through the "STUDIO" and "OUTPUT LINE" keys in series. It will be noted that two "ON AIR" light circuits are provided for each studio to indicate which output line is being fed from the studio.

Signalling Control Room to Master Control. Signal lamps E3, E1, and key K31 provide a signal arrangement for output line No. 1, and corresponding circuit elements for output line No. 2. Key K31 (for output line No. 1) applies the 12-volt signal voltage to terminal 107 and may be used to transmit a signal to master control. At the same time with the strap be-

tween terminals 107 and 108, lamp E1 is lighted. As provided, this lamp merely indicates that key K31 has been operated so as to make contact. The strap between terminals 107 and 108 may be removed and this circuit wired through circuits at Master Control, if desired. Circuits associated with K-32 and E6 provide similar facilities for output line No. 2.

When voltage is applied to terminal 104 from master control, lamp E3 is lighted. Terminal 124 and lamp E8 function similarly for line No. 2.

Signal or Control voltage is applied to terminals 101, 102 and 103 (associated with output line No. 1) depending upon the position of output line key (K15 and K16) as follows:

<i>Terminal</i>	<i>Condition</i>
101	Output line 1 connected to Channel 2
102	Output line 1 connected to Channel 1
103	Output line 1 not connected

Signal and Control voltages are produced at terminals 121, 122 and 123 similarly, corresponding to the position of the output line key (K17 and K18) for line No. 2.

Output Line Signals at 40A Console and Studio On Air Light Controls. Operation of the output line keys also controls signal lamps on the 40A Console and the Studio "On AIR" light controls. This will be described for circuits associated with output line No. 1.

Operating voltage is fed through a strap connection, terminal 106 to terminal 105, to the output line key for line No. 1 (K16). Signal lamp indication on the 40A Console for the three positions of the key are as follows:

<i>Circuit Condition</i>	<i>Lamp Indication</i>
Line to Channel 1	E4 (Channel 1, Line 1) lighted
Off or Mid-Position of Key	E2 (Go Ahead 1) lighted
Line to Channel 2	E5 (Channel 2, Line 1) lighted

It will also be seen from FIG. 3 that with the output line key operated to either channel that voltage is fed to the contacts of keys K26 and

K27, in such a way that with these latter keys operated, output line indication is furnished on the Studio "ON AIR" light circuits.

The above operation is obtained when the strap between terminals 105 and 106 is in place. By removing this strap and wiring the circuits to master control, the above operation can be made dependent upon control circuits at master control.

Similar facilities are provided for output line No. 2.

4-3. Power Supply Circuits

The schematic of the power supply circuits is shown on Figure 8. Filament and plate voltages for the 131A Amplifier in the 40A Console are supplied from the 18B Rectifier in the 12A Power Supply, and filament and plate voltages for the 129A and 130B Amplifiers in the 40A Console are supplied from the 20B Rectifier in the 12A Power Supply. Loudspeaker cutoff relays in the 131A Amplifier obtain their operating voltages from the 18B Rectifier through circuits in the amplifier (see Instruction Bulletin of 131A Amplifier). The illuminating lamps for the VI meters operate from the 6.3-volt AC filament supply in the 20B Rectifier.

It has recently been determined that biasing the center tap of the filament transformer (either positive or negative) with respect to ground results in noise improvement in some 1603 vacuum tubes. The method used to obtain this bias voltage in the 25B Speech Input Equipment is to strap from terminal 8 of transformer T1 in the 20B Rectifier to terminal 10 of the terminal strip TS1 of the 20B Rectifier, and removing the straps from terminals 6 and 7, and 9 and 10 of TS1 of the 20B Rectifier. The connection from terminal 3 of the 12A Power Supply and terminal 84 of the 7A Junction Box is also removed.

This change was not made in early production of the 25B Speech Input Equipments and can readily be made at the time of installation. Before adding the connection from terminal 8 of the transformer T1 to terminal 10 of TS1 of the 20B Rectifier, make sure the straps from terminals 6 and 7, and 9 and 10 are removed. Also, if this change in wiring is made, no con-

nection should be made from terminal 3 of the 12A Power Supply to terminal 84 of the 7A Junction Box or to terminal 84 of the 40A Console Control Unit, or to any other ground. Unless such ground is avoided damage to the 313C Vacuum Tube (V5), the reference voltage vacuum tube of the 20B Rectifier, or to other circuit elements of this rectifier may result.

4-4. Technical Data

The functional schematic shown on Figure 1, indicates the system levels when all gain and volume controls are set for minimum loss, i.e., complete clockwise rotation of the control. Insertion losses of the mixer networks, pads, volume controls, etc. may be readily determined from this data. Detailed data on component amplifier and rectifier units will be found in the separate instruction bulletins covering these components. The principal characteristics of the 25B Speech Input Equipment are as follows: All data are typical.

Typical Frequency Response.

Within 1 db—50 cycles to 15,000 cycles per second.

Signal to Noise Ratio

Normally the 40A Console will be operated with about a total of 30 db attenuation divided between the mixer volume controls and the master gain control giving a normal operating overall gain from microphone input to line output of about 70 db. With a peak signal, or single frequency output level of +18 dbm into the line as a reference, the signal to noise ratio is about 70 db, unweighted. For noise levels of individual amplifiers, refer to the amplifier Instruction Bulletins.

Distortion

Less than 1.0 percent for single frequency fundamentals from 50 to 15,000 cycles at a normal output level of +8 dbm. When allowing for a ten db peak factor, less than 1.0 percent for single frequency fundamentals from 100 to 7,500 cycles and less than 1.5 percent for fundamentals from 50 to 15,000 cycles at an output level of +18 dbm.

Source Impedances

Microphone Inputs.....	} 30 ohms nominal. See 129A Amplifier Instruction Bulletin for other input impedances available.
Line Inputs.....	
Utility Inputs.....	
Air Cue Input.....	

Load Impedances

Line Outputs.....	} 600 ohms, nominal.
Audition Output.....	} 600 ohms, nominal.
Monitor Amplifier Outputs.....	} Furnished adjusted for loudspeaker impedances of 3 to 10 ohms. May be adjusted to a wide range of impedances. See Instruction Bulletin on 131A Amplifier. Cue output circuit is 600 ohms.

Over-All Gains

Microphone Inputs to Line Outputs.....	} Approximately 100 db maximum gain.
Remote Line Inputs to Line Outputs.....	} Approximately 38 db maximum gain.
Utility Inputs to Line Outputs.....	} Approximately 58 db maximum gain.
Cue Input to Monitor Output Loudspeakers.	} Approximately 38 db maximum.
Air Cue to Remote Line.....	} Approximately 6 db maximum.

Sectional Gains and Network Losses (Refer to Figure 1)

Microphone Input to Mixer Input (Gain of 129A Amplifier Channel).....	41 db gain, maximum.
Line Input to Mixer Input.....	} 21 db loss, approximately.
Utility Input to Mixer Input.....	} 0 db loss.
Mixer Network Loss.....	} Approximately 16 db (mixer volume control on minimum loss).
Mixer Volume Controls (600 ohms to 600 ohms ladder type attenuator).	} 20 steps total; 34 db loss in steps of 2 db, then tapered to "infinity" in 3 steps (one of about 8 db and one of about 10 db and last step to off).
Mixer Output to Line Amplifier Output (130B Amp.).	} 81 db gain maximum.
Master Gain Control (100,000 ohm potentiometer).	} Has same steps as mixer volume control.
Line Amplifier Output to Line Output (Network Loss).	} 6 db loss.

SECTION 5 — INSTALLATION

The 7A and 7B Junction Boxes, and the 12A Power Supply are completely assembled equipments and are shipped ready for installation. The 40A Console, and the KS-10284 Table and the two table legs are shipped separately and are required to be assembled.

5 1. *Assembly and Handling Precautions*

An assembled view of the equipment is shown in Figure 2. Parts required to assemble the table and console are furnished as follows:

With KS-10284 Table:

12 RHM Screws $\frac{1}{4}$ "—20 \times $1\frac{1}{4}$ " long.....	} For securing legs to table.
12 Washers $\frac{1}{4}$ " \times $\frac{1}{8}$ " \times $\frac{1}{16}$ ".....	
2 Straps (BA-71660).....	} For tying table legs to rear of console.
2 RHM Screws $\frac{1}{4}$ "—20 \times $\frac{7}{8}$ " long.....	
2 Washers $\frac{1}{4}$ " \times $\frac{1}{8}$ " \times $\frac{1}{16}$ ".....	} For fastening straps to rear of legs.
2 Hex Nuts $\frac{1}{4}$ "—20.....	

With 40A Console:

2 Washers $\frac{1}{4}$ " \times $\frac{1}{8}$ " \times $\frac{1}{16}$ ".....	} For attaching table leg straps to cabinet.
2 RHM Screws $\frac{1}{4}$ "—20 \times $\frac{1}{2}$ " long.....	
2 Hex Nuts $\frac{1}{4}$ "—20.....	
5 RHM Screws $\frac{1}{4}$ "—20 \times $1\frac{1}{4}$ " long.....	} For securing console cabinet to table top.

5-11. Assembly of Console and Table. To assemble the KS-10284 Table proceed as follows: The legs are assembled to the underside of the Table top as shown in Figure 2 (view C) by means of 6— $\frac{1}{4}$ "—20 \times $1\frac{1}{4}$ " long round head machine screws and 6— $\frac{1}{4}$ " \times $\frac{1}{8}$ " \times $\frac{1}{16}$ " washers for each leg. These screws should

be screwed up tightly into the threaded inserts in the table top.

The 40A Console may now be placed to fit into the cut-out portion of the table top by sliding it in from the rear.

The two bend straps should now be attached to

the rear of the legs and to the cabinet as shown in Figure 2 (view B). To secure the screws and nuts holding the straps, and to fasten the console to the table top, the console should be opened up.

5-12. Internal Access to Console. To accomplish this, loosen the 2 Phillips Head Screws (one of each are at the lower corners of the mixer panel on the console) see view A Figure 2. Lift up the top, using the two knobs at the ends of the mixer panel, making sure the stay hinges lock in place.

The amplifier trays may now be lowered. **PRECAUTION:** First make sure that the trays are locked in place by inspecting the latching handles inside the console. One handle is provided for each tray inside the console at the rear. When the handle is parallel to the back of the cabinet, the tray is locked in place. Each tray is also held in place by two thumb screws underneath the tray at the rear (see figure 2, view A). These should be loosened. By grasping the latch handles inside the cabinet and turning the handle clockwise, the trays may be lowered. Each tray is provided with two hooks, one at each side. By lifting up the tray from the front and engaging the hooks with strike plates underneath the table top, the trays may be held in the open position (see end view A, Figure 2). Normally the thumb screws are not needed to hold the amplifier trays in the closed position and the inside latches are all that are necessary. To restore the trays, the hooks in front are disengaged, and the trays are lifted into place by reaching inside the opened top of the console and grasping the latch handles.

5-13. Assembly of Console and Table Top.

With the console opened up as described above the console cabinet may be secured to the table top from the inside with 5 round head machine screws ($\frac{1}{4}$ -20 \times 1 $\frac{1}{4}$ "') as shown on Figure 2 (views C and D).

5-2. Location of 40A Console and 7A and B Junction Boxes. It is intended that the wiring permanently installed in conduit be terminated in the 7A and 7B Junction Boxes. From the junction boxes connections are made to the console by means of flexible shielded cables terminated in connectors which plug

into receptacles on the ends of the 40A Console, as shown in view A, Figure 2. This illustration indicates which plug connects to which receptacle. The plugs and receptacles are so chosen that it is impossible to plug into the wrong receptacle.

Due to the fixed length of the cables (approximately 34 inches) the choice of location of the 7A and 7B Junction Boxes relative to the console is limited. These limitations are indicated in views E and F, Figure 2. View E shows the location if the boxes are located outside of the table legs (as in view A), and view F, the location of the boxes, if located inside the legs.

The optimum location is either inside or outside the legs but as close to the legs as possible. From the appearance standpoint the junction boxes should be located within the legs.

The 7A Junction Box should be located at the left end of the console and the 7B at the right end of the console. The boxes differ only in terminal designations, wiring and the fact that the 7B Box has one more cable than the 7A Box. As indicated in view G, the 7A Box handles the incoming circuits (microphones, remote lines, transcription inputs, etc.) and the 7B junction box is used for outgoing circuits, power, and signal circuits.

5-3. Installation of Junction Boxes. **PRE-**

CAUTION: While the cables of the junction boxes will withstand many flexings in normal use, the shields have a definite minimum bending radius, and forcing beyond this point may result in breakage of the shield. Owing to the length of the cables it is possible to exert considerable leverage on the joint at the 90° elbow entrance to the junction boxes, and care must be exercised in handling the boxes to avoid excessive strain on the cables.

The terminal strips, associated wiring, and the cables may be completely removed from the box as a subassembly, when the boxes are installed in the wall. This may be done by removing the upper front cover, removing the two screws which hold the tops of each of the brackets, on which the terminal strips are fastened, to the box. The screws holding the lower portion of the front cover on the box are

then removed, and the cables and terminal strips can then be removed entirely as a complete unit.

The 7A & 7B Junction Boxes are given only a primer coat of paint so that after installation they may be finished by the customer to match the wall or as desired.

5-4. Installation of 12A Power Supply. The 12A Power Supply, consisting of the rectifiers for plate supply and transformers for filament supply, is contained in a wall mounted box shown on Figure 2. A front door hinged on the right gives access to the vacuum tube and apparatus side, and the terminal connections. The rectifiers are mounted on a hinged rack inside the box. Loosening the screws at the top of the upright mounting flanges allows the rectifiers to be hinged down for access to the wiring side and for access to the mounting holes in the back of the box. The box should be secured to the wall with 4— $\frac{1}{2}$ " or $\frac{3}{16}$ " bolts, or equivalent. Washers should be provided underneath the heads of the bolts inside the box. Mounting dimensions, location of terminal strips, clearance requirements for opening the door, and hinging out the rectifiers, are indicated in Figure 2.

5-5. Conduit Layout. The conduit layout will be determined largely by individual studio requirements. In general, however, various types of circuits should be segregated in separate conduits following the same segregation scheme as used in the cables of the 7A and 7B Junction boxes. This is shown on Figures 5 and 9 where the segregation of circuits is indicated by the cable plug and receptacle designation. Additional conduits will, of course, be necessary to provide the desired conduit runs to different locations. A typical arrangement is listed below: Figures 5 and 9 should be referred to in this connection:

Conduits from 7A Junction Box

1. Microphone Inputs
2. Incoming Lines
3. Utility Inputs

Conduits from 7B Junction Box

4. Outgoing Lines
5. Loudspeaker Circuits
6. Warning Light and Signal Control Circuits
7. Audition Output
8. Air Cue
9. Filament Supply } From 12A Power
10. Plate Supply } Supply

Conduits from 12A Power Supply

9. Filament Supply
10. Plate Supply
11. 115 V 60 Cycles AC

5-6. Wiring Audio Circuits. All audio circuits in the 25B Speech Input Equipment (with the exception of the line side of the remote line inputs) have one side of the circuit grounded. The advantages of utilizing input circuits with one side grounded in assembled equipments where the method of grounding is controlled by design, have long been recognized. These advantages are: Freedom from radio frequency disturbances, control of the high frequency response of the system, relative simplicity of switching circuits where such circuits are necessary, low and controlled crosstalk in two channel systems, and lower maintenance particularly as to switching and control elements. Furthermore, input circuits having no ground or a center tap ground may be achieved by the use of a suitable repeating coil. Such measures are, of course, only essential where (1) long input circuits on which longitudinal noise may exist, are used; (2) where jack circuits are used in inputs and care is not exercised in proper insertion of plugs; or (3) where care is not exercised in the installation of microphone input wiring to insure shield continuity and segregation of the shield from the input circuit, except at the one point where it connects to the system ground. Ordinarily, except for incoming circuits involving telephone lines, the input sources for studio audio facilities are close to the equipment and the wiring from them is subject to controlled installation. In the 25B Speech Input Equipment all audio

circuits are of the unbalanced type with one side grounded with the exception of incoming (remote) lines Nos. 1 to 7, inclusive. Lines 1, 2 and 3 are ungrounded on the input side of the repeating coils provided in each of these three lines; on the equipment side of these lines the circuits have one side grounded. Incoming lines 4, 5, 6 and 7 terminating in jacks, are also ungrounded.

In some operating conditions, particularly where lines 1, 2 or 3 are heavily equalized for transmission over a wide frequency range, the gain from the incoming telephone lines may not be sufficient for maximum operating ease. As much as 14 db of additional gain is available by replacing the resistors making up the pads associated with these three incoming lines. The maximum amount of attenuation should be used at all times, with a minimum of 6 db, to avoid the possibility of overloading the first stage of the 130B Amplifier.

The following is a list of resistors for alternate pads for three amounts of attenuation:

	<i>Series</i>		<i>Shunt</i>	
6 db	200 ohms	}	750 ohms	}
10 db	300 ohms		430 ohms	
15 db	430 ohms		220 ohms	
			R21 to R26	R55, R56 and R57

All resistors are carbon type, and values should be $\pm 5\%$ RMA Standard.

As described in more detail later, mounting facilities are provided, in the 40A Console for mounting up to 8 Western Electric No. 177C Repeating Coils for providing balanced circuits if desired. Additional brackets may be ordered and added to the equipment to mount 5 more coils.

For the external audio wiring, twisted shielded pairs should be employed and the shield should be well insulated so it may be grounded at the 25B Speech Input Equipment only.

The following illustrations will be of assistance in wiring the system:

Fig. 3 Signal and Audio Schematic

Fig. 5 Wiring and Circuit Assignment Information

Fig. 8 Power Supply Schematic

Fig. 9 Power Supply Wiring Diagram

Fig. 10 Wiring Diagram 7A Junction Box

Fig. 11 Wiring Diagram 7B Junction Box

Fig. 12 Wiring Diagram 40A Console

Fig. 13 Wiring Diagram 12A Power Supply

Figures 5 and 9 consolidate this information with respect to external wiring. Figures 5 and 9 are based on the use of the 7A and B Junction Boxes, but the 7A and 7B Junction Boxes need not be used if they do not fit the installation. In this case, the receptacles J51, J52, J53, J54, and J55 in the 40A Console may be removed and connections may be made directly to the terminal strips in the 40A Console. It should be noted that the terminals in the junction boxes are designated the same as the terminals in the 40A Console, and terminals with the same number have the same circuit function.

Figure 9 shows the power supply wiring required between the 12A Power Supply and the 7B Junction Box.

5-7. Wiring Control Circuits. In devising and installing the control and signal lamp circuits, the description in Section 4-2 should be referred to and the following precautions should be noted:

12 Volt DC Supply. A 12 volt signal supply should be used. A 24 volt supply may be used, however, if the 2F lamps (12 volts) in the 40A Console are changed to 2U lamps, or similar 24 volt lamps. All switching contacts in the control circuits are from the "Ground" side of the 12 volt supply connected to terminal 138. It should be noted that all signal circuits in the 40A Console obtain both sides of the 12 volt DC supply from the supply connected to terminals 137 and 138 in the 7B Junction Box (or 40A Console), with the exception of lamps E3 and E8 which are energized by connection to the "Ground" of the supply at master control.

Key Contact Ratings. The control circuits should not be used to operate signal lamps directly (unless having low current requirements) and the current through any key contact should not exceed 0.25 ampere. The Studio "ON AIR"

and "Ready" lights should therefore be operated through relays, with one side of the relay connected to the circuits from the 40A Console (or 7B Junction Box) and the other side of the relays wired to the side of the 12 volt supply which is connected to terminal 137 in the console. "Spark Killer" filters consisting of a condenser and resistance in series should be connected across all inductive circuits.

Conduit. The control circuits should be run as single conductors in a separate metallic conduit from the 7B Junction Box.

Studio Light Controls. As indicated above these lights should be operated through relays. The "ON AIR" light controls provide for 2 light circuits to indicate the output line in use. If only one such light is desired, 2 relays with their contacts paralleled and their windings connected separately to the signal circuits should be employed. Otherwise false operation of signal lamps in the 40A Console may be obtained. For example, if terminals 131 and 132 are connected together to operate a single relay, operation of, say, the output line key for line 1 applies voltage to terminal 132, and through the cross connection, to terminal 131 also, which would energize the signal lamp for output line No. 2, as well as output line No. 1.

5-8. Adjustments and Special Features. Certain special features and adjustments required before placing the equipment in operation are described below:

5-81. Talkback Microphone. An external microphone connected to terminals 17 and 18 may be employed, or a Western Electric No. 633A Microphone may be added to the 40A Console. A mounting for such a microphone is provided between the two volume indicator meters. A single conductor shielded (red-green) lead connected to the 40A Console terminals 19 and 20 at one end and taped up at the other end near the microphone mounting, is provided for connection to a microphone in the 40A Console. Terminals 17 and 19, and 18 and 20 are strapped together at the terminal strip in the 40A Console to provide a parallel connection of the microphones.

To install a 633A Microphone in the 40A

Console, the rear end of the microphone housing should be removed to expose the terminals, and this part of the housing should be left off, since sufficient clearance is not otherwise available inside the 40A Console. The microphone housing in the console includes a cylindrical rubber pad and a clamp. The screw, by which the clamp is tightened, should be loosened and the microphone inserted within the rubber pad until it is felt to touch the metal screen which closes the opening in the cabinet. It should then be withdrawn about $\frac{1}{8}$ " so that it does not touch the screen and the clamp tightened to hold the microphone in place.

5-82. Balanced Inputs. As mentioned above, the audio circuits (with the exception of incoming lines) have one side grounded. Ungrounded, or balanced inputs can be employed if repeating coils are added. Brackets are provided inside the 40A Console for adding up to 8 No. 177C Repeating Coils. Circuit and wiring modifications required for the microphone inputs are shown on Figure 6.

The repeating coil brackets are located inside the cabinet on the left hand side on the rear wall of the cabinet. Coils on the upper bracket should be mounted with their terminals down and coils on the lower bracket with their terminals up.

Figure 6 shows the electrostatic shield connected to the shield of the input wiring. Other possible connections include connection to the shield of secondary wiring or to the repeating coil primary mid tap, when a mid tap ground is used, etc. The connection giving minimum noise should be employed.

Additional brackets may be ordered as described elsewhere in this bulletin and installed in the 40A Console for additional repeating coils if desired in other output and input circuits.

5-83. Talkback Circuit and Loudspeaker Cut-Off Relays. In order to operate the studio and control room loudspeaker cut-off relays, terminals 69 to 78 should be strapped together as required at the terminal strips in the 40A Console. The description of the operation of this circuit and note 3 on Figure 7, should be referred to in this connection.

5-84. Loudspeakers. As supplied, the 131A Amplifier is wired to operate loudspeakers having impedances of about 3 to 10 ohms. If the loudspeakers have other impedances, it will be necessary to change the connections and substitute resistance loads in the 131A Amplifier. The bulletin covering the 131A Amplifier should be referred to in this connection.

5-85. VI Meter Sensitivity. Referring to Figure 3, the VI meters are provided with a range key (K24 and K25) such that there are 3 selections of meter sensitivity differing by 5 db, i.e., an increase in sensitivity of 5 db or a decrease of 5 db. In the normal or mid-position of the VU Range Key, and with a +8 VU level into the output line, the line amplifier output level is +14 VU, and loss in the meter circuit and the meter sensitivity is such that the meter reads "0 VU". The VU Range Keys then provide a means to also obtain a "0 VU" reading with either +13 VU into the line or +3 into the line.

The circuit associated with this meter may be changed to provide other sensitivity adjustments if desired by changing the loss in the pads associated with keys K24 and K25. The proper meter characteristics are obtained when the resistance of the circuit external to it matches its own resistance, i.e., 3900 ohms. Hence when operating across a 600 ohm line, 3600 ohms should be connected in series with

the meter so that the meter looks back at 3900 ohms. The sensitivity of the meter with this series resistance is such that with a level of +4 VU in the 600 ohm circuit, the meter reads "100%" or "0 VU". With a +14 VU level at the line amplifier output (+8 VU at the output line), a 10 db loss in a pad is therefore required for "0 VU" meter reading.

New resistance pad values for any desired loss, can be calculated by determining the series and shunt arms of a symmetrical T pad having the desired loss for matched input and output impedances of 3900 ohms. A resistance of 3600 ohms is then added to the series arm which is connected to the amplifier output. As a result the combination looks like 7500 ohms from the amplifier.

5-86. AC Line Voltage Adjustments. Adjustments may be required for the AC line voltage in the 18B Rectifier (part of 12A Power Supply), and the instruction bulletin on this rectifier should be referred to.

5-87. Input Impedances. As described in the Bulletin for the 129A Amplifier microphone input impedances of 250 ohms and 600 ohms nominal are also available by changing the terminal connections in the 129A Amplifier. If any changes are made, however, and repeating coils are used, a different connection of the repeating coil may also be necessary.

SECTION 6 — OPERATION

After wiring is complete and before putting AC power on the system, vacuum tubes should be placed in the component amplifiers and rectifiers which are listed below in accordance with the instructions given in the individual instruction books covering these units.

129A Amplifier (in left hand tray of 40A Console).

130B and 131A Amplifiers (in right hand tray of 40A Console).

18B and 20B Rectifiers (in 12A Power Supply).

The vacuum tube sockets in these units are marked with the designation of the tubes required.

Also before applying power for the first time all volume controls on the 40A Console should be turned to minimum volume, i.e., full counter-clockwise position, so that in event excessive input exists on any of the inputs, damage will not be done to the VI meters, etc.

6-1. Application of AC Power. A power switch controlling the AC power to the 18B and 20B Rectifiers is located on the front of the 12A Power Supply. In addition the 18B and 20B Rectifiers each has an individual power supply switch which is located on the wiring side of the rectifier units. A check should be made to make sure that these switches are "ON".

Also, before turning on the power, the potentiometer P1 on the 20B Rectifier should be adjusted as described in the instruction book covering this rectifier.

The main power switch on the front of the 12A Power Supply may now be turned to "ON". The lamps illuminating the VI meters in the 40A Console should light. The plate voltage of the 20B Rectifier may now be adjusted to 275 volts as described in its Instruction Bulletin.

<i>Switch Position</i>	<i>Designation</i>	<i>Amplifier</i>	<i>Tube</i>	<i>Channel</i>
1	PM-1-1	129A	V1A	Preamplifier No. 1
2	PM-1-2	"	V2A	Preamplifier No. 1
3	PM-2-1	"	V3A	Preamplifier No. 2
4	PM-2-2	"	V4A	Preamplifier No. 2
5	PM-3-1	"	V1B	Preamplifier No. 3
6	PM-3-2	"	V2B	Preamplifier No. 3
7	PM-4-1	"	V3B	Preamplifier No. 4
8	PM-4-2	"	V4B	Preamplifier No. 4
9	LN-1-1	130B	V1A	Line Amp. No. 1
10	LN-1-2	"	V2A	Line Amp. No. 1
11	LN-1-3	"	V3A	Line Amp. No. 1
12	LN-2-1	"	V1B	Line Amp. No. 2
13	LN-2-2	"	V2B	Line Amp. No. 2
14	LN-2-3	"	V3B	Line Amp. No. 2

The meter is of the percentage type and normal reading of all tubes is 100%. A variation of $\pm 15\%$ from this reading may be considered normal, and an even greater deviation does not necessarily indicate trouble. For actual plate currents and further comments, the individual amplifier and rectifier bulletins should be referred to.

After application of power as described above the 25B Speech Input Equipment is ready for operation.

6-2. Operating Precautions. It is important that the operator have a thorough understanding of the operation and functioning of all controls as described in this bulletin.

6-21. Normal Volume Control Settings. For normal average input levels, the system

6-11. Plate Current Readings. After this adjustment has been made, the plate currents of the tubes in the amplifiers in the 40A Console may be checked by means of the plate current meter located on the left hand side of the console. A rotary switch associated with the meter permits all plate currents (except for the 131A Amplifier) to be read in turn. Switch positions and the tubes whose plate currents are indicated, are as follows, starting from the "OFF" position of the switch:

gain from microphone input to line output will be about 70 db., i.e., there will be about 30 db loss in the volume controls.

For optimum operation with respect to noise and range of control, this total should be about equally divided between the master gain control and the mixer volume controls, say about a setting of 16 db in the master gain control and 14 db in the mixer volume controls. This will give a working range of about ± 14 to 16 db in each control.

6-22. Overloading. The preliminary amplifiers are designed with adequate margin so that they are not liable to be overloaded by any input source or condition normally encountered. It is possible, however, that with a dispropor-

tionate setting of controls and with a high line level that the first amplifier stage in the line amplifier (130B) may be overloaded.

Overloading of the last stage of the line amplifier may be avoided by observing the VI meters. It is usual to operate at a VU level not exceeding about 10 db below the single frequency load carrying capacity of the amplifier. In the 25B Speech Input Equipment, this corresponds to about +12 VU at the output terminals. For peaks 10 db higher than this the amplifier output stage would introduce about 1% harmonic distortion (on the peaks

only, however,); comparable additional distortion would be introduced in the line amplifier input stages for levels of about -29 VU or higher at the input.

From the amplifier gain and network loss data, it can be determined that such an input level would exist if, with a +12 VU output level, the master gain control was set for about 34 db loss or more. Hence, danger of overloading exists on signal peaks, at output line levels of more than about +12 VU, or if the sum of the line level in VU plus the master gain control loss setting in db exceeds a figure of about 44.

SECTION 7 — MAINTENANCE

In addition to this bulletin, reference should also be made to the bulletins covering the 129A, 130B and 131A Amplifiers and those covering the 18B and 20B Rectifiers.

Normal maintenance will consist of a check of plate current readings at regular intervals as directed under operation, and replacement of vacuum tubes when required. At longer intervals key, jack and relay contacts may require cleaning and potentiometers may require cleaning and lubrication.

7-1. Contacts. Carbon tetrachloride applied with a toothpick may be used to clean relay and key contacts. If this does not clear up noise or poor contact, the contacts should be burnished using a Western Electric 374A Tool.

7-2. Potentiometers. Cleaning of contacts with a cloth moistened with light mineral oil is recommended. A slight film of oil should be left to provide lubrication.

7-3. Location of Trouble. Trouble in the 25B Speech Input Equipment is readily traced and localized by means of the normal operating controls and switches, etc. For example, if the trouble is in one of the two channels of the 130B Amplifier, transfer of all inputs and the output to the other channel would clear the trouble and indicate that the trouble is in the other channel. Similar lines of reasoning apply

2-D-47-12C-WECC-T 2255B

to tracing down trouble in other parts of the system.

Schematics and wiring diagrams of the 40A Console, the 7 type Junction Boxes and 12A Power Supply needed for maintenance of this equipment form part of this instruction bulletin. Similar information on the component amplifiers and rectifiers is included in the separate bulletins on these units.

Attention is called to the DC Voltage Data given on the schematic diagrams included in the instruction books on the 129A, 130B and 131A Amplifiers and the 18B, and 20B Rectifiers. In event of trouble a check of the operating voltages will assist in tracing the defect.

Access to the wiring of the component amplifiers is obtained by opening the console and hinging out the amplifier trays. Removal of the cover plates on the bottom of the trays will give access to the amplifier wiring.

CAUTION: Voltages of 275 volts exist at the terminals in the 7B Junction Box, the 40A Console 12A Power Supply (including component rectifiers) and on the wiring side of the amplifiers in the 40A Console.

7-4. Replacement Parts. If replacement parts are required they may be procured through the nearest distributor. Apparatus lists giving ordering information for all component parts of the equipment are shipped with the apparatus.

Instruction Bulletin No. 11301 Issue 1

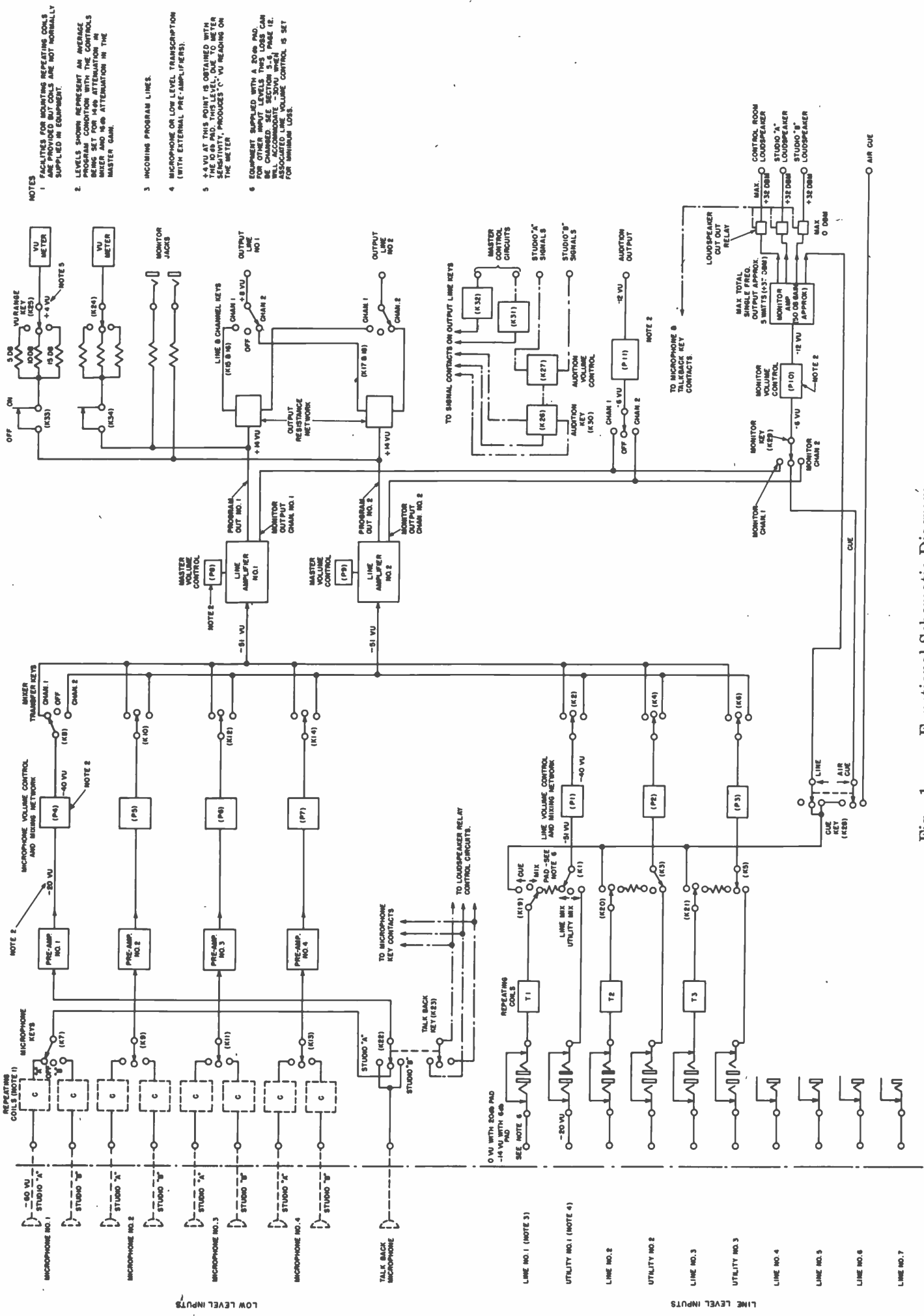

- NOTES**
1. SWITCHES FOR INDICATING REPEATING COILS ARE PROVIDED BUT COILS ARE NOT NORMALLY SUPPLIED IN EQUIPMENT.
 2. LEVELS SHOWN REPRESENT AN AVERAGE PROGRAM CONDITION WITH THE CONTROLS SET FOR 40 DB ATTENUATION IN THE MIXER AND 10 DB ATTENUATION IN THE MASTER GAIN.
 3. INCOMING PROGRAM LINES.
 4. MICROPHONE OR LOW LEVEL TRANSCRIPTION (WITH EXTERNAL PRE-AMPLIFIERS).
 5. +4 VU AT THIS POINT IS OBTAINED WITH THE 10 DB PAD. THIS LEVEL, DUE TO METER SENSITIVITY, PRODUCES \sim VU READING ON THE METER.
 6. EQUIPMENT SUPPLIED WITH A 20 DB PAD. THIS LEVEL, DUE TO METER SENSITIVITY, PRODUCES \sim VU READING ON THE METER. THIS LOSS CAN BE COMPENSATED BY 10 DB ATTENUATION IN THE MIXER AND 10 DB ATTENUATION IN THE MASTER GAIN.

Fig. 1 Functional Schematic Diagram

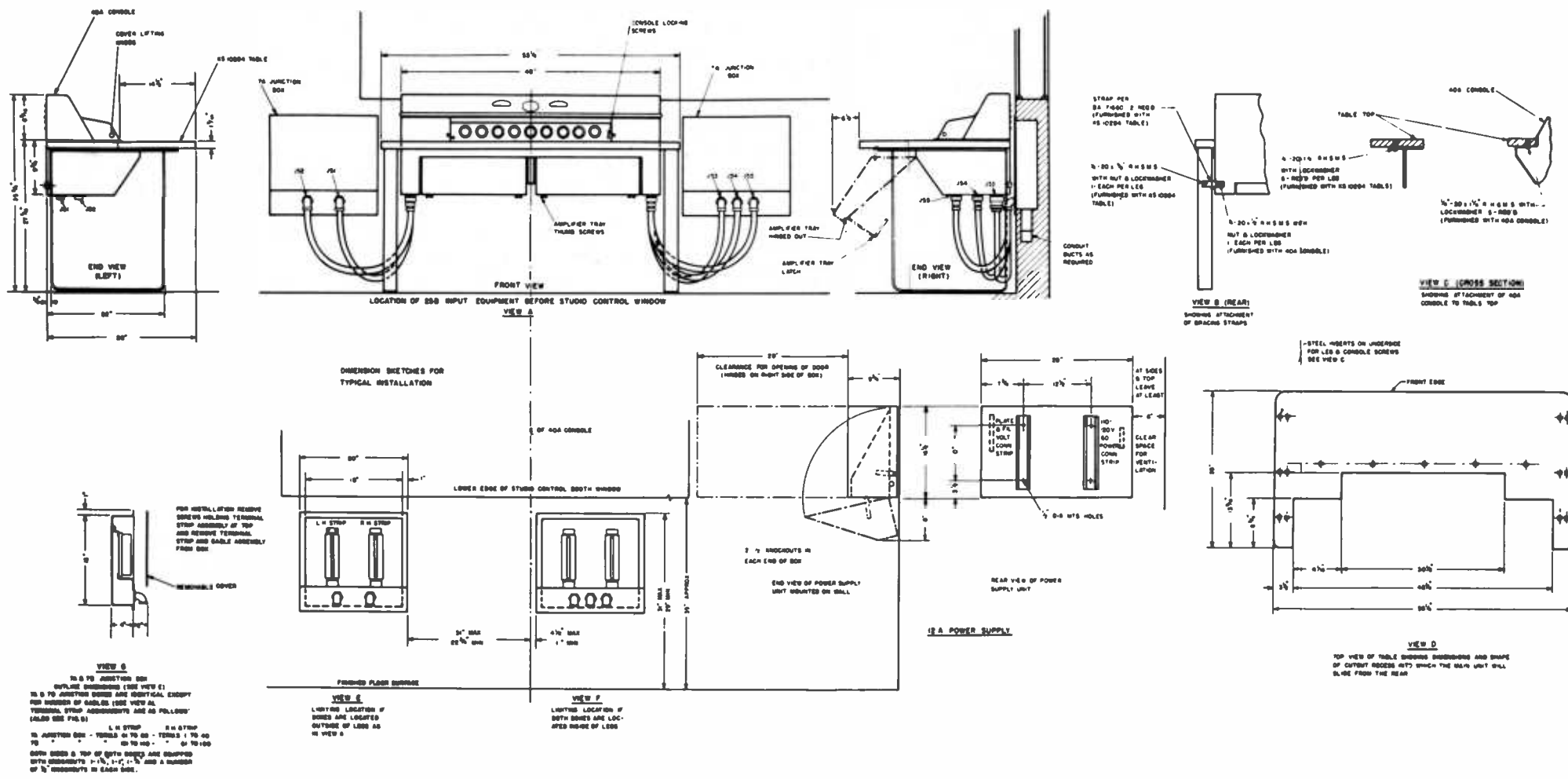

Fig. 2 Equipment Assembly and Installation Information

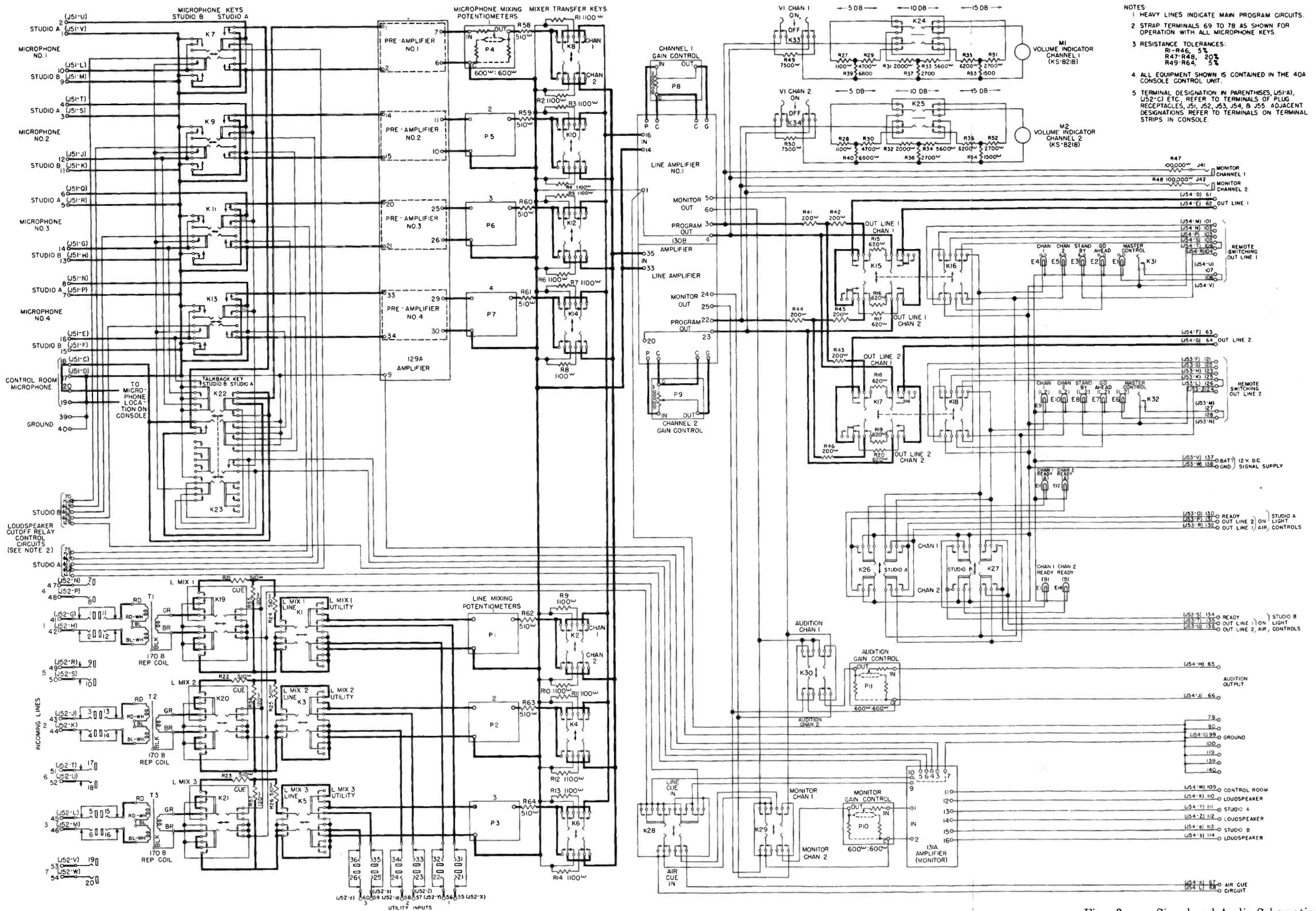

Fig. 3 Signal and Audio Schematic

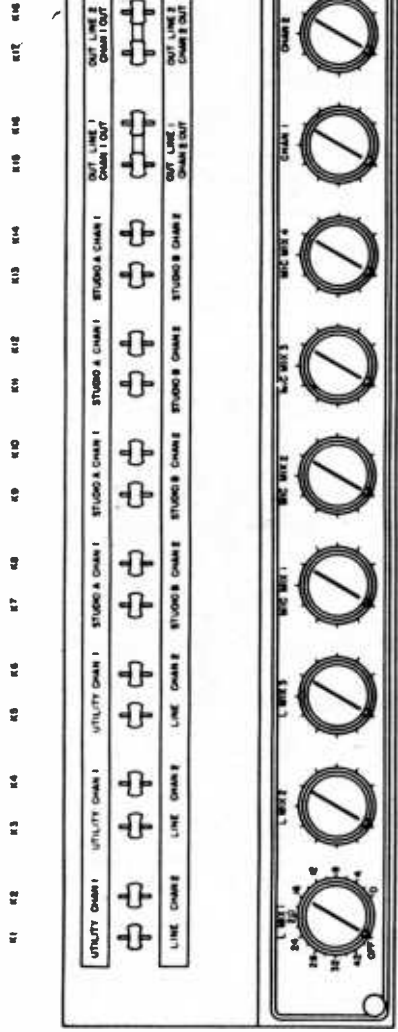
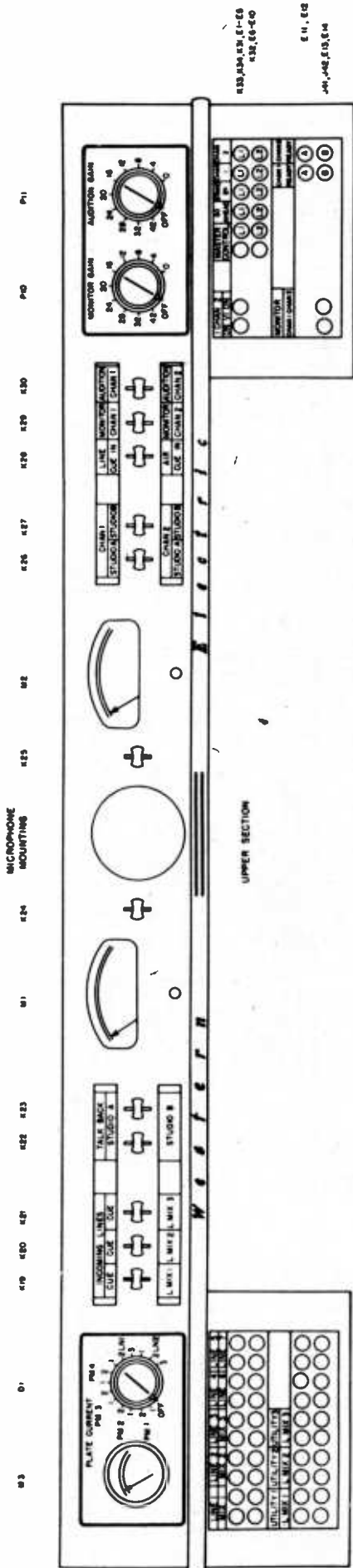

Fig. 4 Control Layout on 40A Console

INPUTS		INPUT WIRING (SEE NOTE 1)		TERMINALS (NOTE 1)		WIRING INFORMATION	
MICROPHONE	STUDIO	JUNCTION BOX NO.	TER. NO.	RECEPTACLE NO.	TER. NO.	OUTPUT	OUTPUT WIRING
MICROPHONES OR TRANSCRIPTIONS	NO. 1	7A	1, 2, 3, 4, 5, 6, 7, 8, 9, 10, 11, 12	1, 2, 3, 4, 5, 6, 7, 8, 9, 10, 11, 12	-V, -U, -M, -L, -T, -S, -K, -J, -R, -Q, -G	OUTPUT LINE NO. 1	Diagram showing microphone wiring to junction box 7A. Terminals 1-12 are connected to junction box terminals 1-12. A note states: "FOR BALANCED INPUT MODIFICATION SEE FIG. 6 & INSTRUCTION BOOK. ODD NUMBERED TERMINALS ARE 'GROUND' SIDE OF CIRCUIT. GROUNDED WITHIN 40A CONSOLE. OTHER MICROPHONES WIRE IN A SIMILAR MANNER. . . . SEE NOTE 3."
	NO. 2	7A	13, 14, 15, 16, 17, 18	13, 14, 15, 16, 17, 18	-M, -L, -T, -S, -K, -J, -R, -Q, -G	OUTPUT LINE NO. 2	Diagram showing microphone wiring to junction box 7A. Terminals 13-18 are connected to junction box terminals 13-18. A note states: "TO SHIELDS OF OTHER INPUT PAIRS"
	NO. 3	7A	19, 20, 21, 22, 23, 24	19, 20, 21, 22, 23, 24	-M, -L, -T, -S, -K, -J, -R, -Q, -G	AUDITION OUTPUT	Diagram showing microphone wiring to junction box 7A. Terminals 19-24 are connected to junction box terminals 19-24. A note states: "TER. 66 IS 'GROUND' SIDES. SEE NOTE 3."
	NO. 4	7A	25, 26, 27, 28, 29, 30	25, 26, 27, 28, 29, 30	-M, -L, -T, -S, -K, -J, -R, -Q, -G	LOUDSPEAKER OUTPUTS	Diagram showing microphone wiring to junction box 7A. Terminals 25-30 are connected to junction box terminals 25-30. A note states: "OTHER LOUDSPEAKERS ARE WIRING SIMILARLY TO TERMINALS 62 & 64 ARE 'GROUND' SIDE. ALSO SEE NOTE 3. SEE FIG. 7. FOR FURTHER WIRING INFORMATION ASSOCIATED WITH LOUDSPEAKERS OUTPUT RELAYS"
TALK BACK	CONTROL ROOM	7B	31, 32, 33, 34, 35, 36, 37, 38, 39, 40	31, 32, 33, 34, 35, 36, 37, 38, 39, 40	-A, -B, -Y, -Z, -W, -R	STUDIO "B" OUTPUTS	Diagram showing microphone wiring to junction box 7B. Terminals 31-40 are connected to junction box terminals 31-40. A note states: "TO SHIELDS OF OTHER PAIRS"

INPUTS		INPUT WIRING (SEE NOTE 1)		TERMINALS (NOTE 1)		WIRING INFORMATION	
MICROPHONE	STUDIO	JUNCTION BOX NO.	TER. NO.	RECEPTACLE NO.	TER. NO.	OUTPUT	OUTPUT WIRING
LOW LEVEL MICROPHONES OR TRANSCRIPTIONS	LINE NO. 1	7A	41, 42, 43, 44, 45, 46, 47, 48, 49, 50, 51, 52, 53, 54	41, 42, 43, 44, 45, 46, 47, 48, 49, 50, 51, 52, 53, 54	-G, -M, -K, -L, -M, -N, -P, -R, -S, -T, -U, -V, -W	OUTPUT LINE NO. 1	Diagram showing microphone wiring to junction box 7A. Terminals 41-54 are connected to junction box terminals 41-54. A note states: "TO SHIELDS OF OTHER INCOMING PAIRS"
	LINE NO. 2	7A	55, 56, 57, 58, 59, 60	55, 56, 57, 58, 59, 60	-G, -M, -K, -L, -M, -N, -P, -R, -S, -T, -U, -V, -W	OUTPUT LINE NO. 2	Diagram showing microphone wiring to junction box 7A. Terminals 55-60 are connected to junction box terminals 55-60. A note states: "OTHER LINE INPUT WIRE IN A SIMILAR MANNER. ALSO SEE NOTE 3"
	LINE NO. 3	7A	61, 62, 63, 64, 65, 66, 67, 68, 69, 70	61, 62, 63, 64, 65, 66, 67, 68, 69, 70	-G, -M, -K, -L, -M, -N, -P, -R, -S, -T, -U, -V, -W	OUTPUT LINE NO. 3	Diagram showing microphone wiring to junction box 7A. Terminals 61-70 are connected to junction box terminals 61-70. A note states: "WIRE AS FOR LOW LEVEL MICROPHONE INPUTS. OTHER LINE INPUT WIRE IN A SIMILAR MANNER. SIDE FOR BALANCED CONNECTION SEE INSTRUCTION BOOK AND REFER TO FIG. 6"
	UTILITY	7B	71, 72, 73, 74, 75, 76, 77, 78, 79, 80	71, 72, 73, 74, 75, 76, 77, 78, 79, 80	-X, -Y, -Z, -B, -C, -D, -E, -F, -G	OUTPUT LINE NO. 4	Diagram showing microphone wiring to junction box 7B. Terminals 71-80 are connected to junction box terminals 71-80. A note states: "SEE NOTE 3. TER. 68 IS 'GROUND' SIDE"
	LINE NO. 4	7A	81, 82, 83, 84, 85, 86, 87, 88, 89, 90	81, 82, 83, 84, 85, 86, 87, 88, 89, 90	-G, -M, -K, -L, -M, -N, -P, -R, -S, -T, -U, -V, -W	OUTPUT LINE NO. 5	Diagram showing microphone wiring to junction box 7A. Terminals 81-90 are connected to junction box terminals 81-90. A note states: "TO SHIELDS OF OTHER PAIRS"
	LINE NO. 5	7A	91, 92, 93, 94, 95, 96, 97, 98, 99, 100	91, 92, 93, 94, 95, 96, 97, 98, 99, 100	-G, -M, -K, -L, -M, -N, -P, -R, -S, -T, -U, -V, -W	OUTPUT LINE NO. 6	Diagram showing microphone wiring to junction box 7A. Terminals 91-100 are connected to junction box terminals 91-100. A note states: "TO SHIELDS OF OTHER PAIRS"
	LINE NO. 6	7A	101, 102, 103, 104, 105, 106, 107, 108, 109, 110	101, 102, 103, 104, 105, 106, 107, 108, 109, 110	-G, -M, -K, -L, -M, -N, -P, -R, -S, -T, -U, -V, -W	OUTPUT LINE NO. 7	Diagram showing microphone wiring to junction box 7A. Terminals 101-110 are connected to junction box terminals 101-110. A note states: "TO SHIELDS OF OTHER PAIRS"
LINE LEVEL	CONTROL ROOM	7B	111, 112, 113, 114, 115, 116, 117, 118, 119, 120	111, 112, 113, 114, 115, 116, 117, 118, 119, 120	-A, -B, -Y, -Z, -W, -R	AIR CUE	Diagram showing microphone wiring to junction box 7B. Terminals 111-120 are connected to junction box terminals 111-120. A note states: "TER. 66 IS 'GROUND' SIDES. SEE NOTE 3."

NOTE 1: TERMINAL NUMBERS IN 40A CONSOLE AGREE IN NUMBERING AND CIRCUIT FUNCTION WITH SAME NUMBERED TERMINALS IN JUNCTION BOX.

NOTE 2: THIS INFORMATION NOT NECESSARY TO INSTALL EXTERNAL WIRING AND IS INCLUDED ONLY TO ASSIST IN MAINTENANCE.



NOTE 3: SHIELD INDICATES SHIELDED TWISTED PAIR. THE SHIELD SHOULD BE INSULATED FROM GROUND.

NOTE 4: FOR POWER SUPPLY WIRING SEE FIG. 6

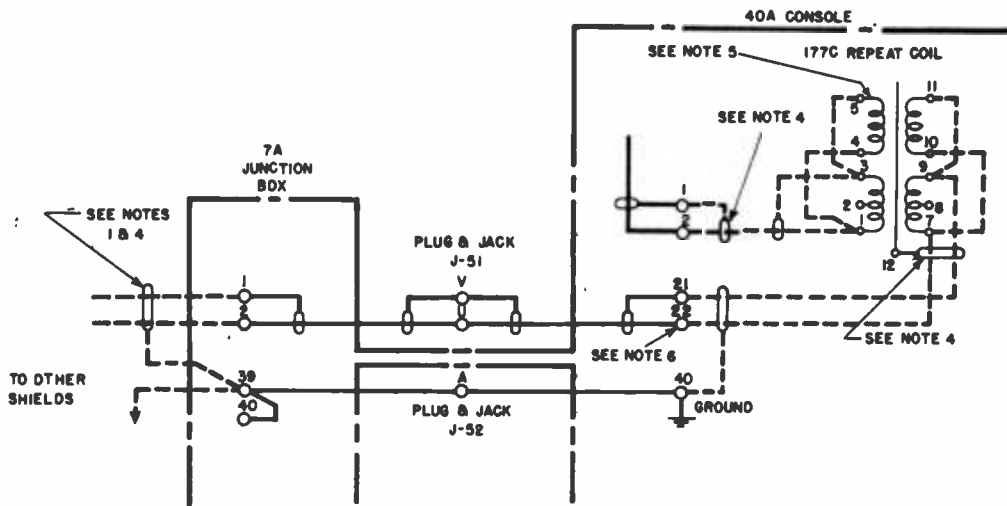
Fig. 5 Wiring and Circuit Assignment Information



NOTES:

1. ARRANGEMENT IS FOR MICROPHONE NO. 1 STUDIO "A." WIRE OTHER INPUT TERMINALS 3 TO 18 IN A SIMILAR MANNER. SHIELDS OF INPUT PAIRS SHOULD BE CONNECTED TO TERMINAL 39 OR 40 AS SHOWN.
2. ——— INDICATES WIRING IN EQUIPMENT
3. - - - - INDICATES EXTERNAL WIRING OR WIRING ADDED IN 40A CONSOLE IN CONNECTION WITH ADDITION OF REPEATING COILS.
4.  DENOTES SHIELDED TWISTED PAIRS WITH CONNECTION TO SHIELD.
 DENOTES SHIELDED SINGLE CONDUCTOR.
 IN BOTH CASES SHIELD SHOULD BE INSULATED SO THAT SHIELDS MAY BE GROUNDED ONLY AS SHOWN
5. AS SHOWN REPEATING COIL IS CONNECTED FOR A 1:1 RATIO FOR OPERATION OVER A RANGE OF 25 TO 150 OHMS. TERMINAL 8 MAY BE CONNECTED TO THE 40A CONSOLE GROUND TO GROUND THE MIDPOINT OF THE

5. (CONT.) INPUT TO THE REPEATING COIL. TERMINAL 12 OF THE COIL IS THE ELECTROSTATIC SHIELD, AND IT MAY BE CONNECTED TO THE SHIELD OF THE INCOMING CONDUCTORS OR TO THE SHIELD OF THE CONDUCTOR TO THE SECONDARY WINDING.
6. IN ORDER TO INSERT REPEATING COIL IN CIRCUIT IT IS NECESSARY TO SHIFT WIRING FROM THE RECEPTACLE WHICH RUNS TO THE TERMINAL STRIP, TO ADJACENT SPARE TERMINALS. REPEATING COIL MAY THEN BE WIRED BETWEEN THESE TWO SETS OF TERMINALS. IN THE DIAGRAM, THE WIRES FROM TERMINALS U & V OF J-51 HAVE BEEN SHIFTED FROM TERMINALS 1 & 2 TO TERMINALS 21 & 22 RESPECTIVELY, AND THE REPEATING COIL CONNECTION INTERPOSED.

Fig. 6 Balanced Input Modification

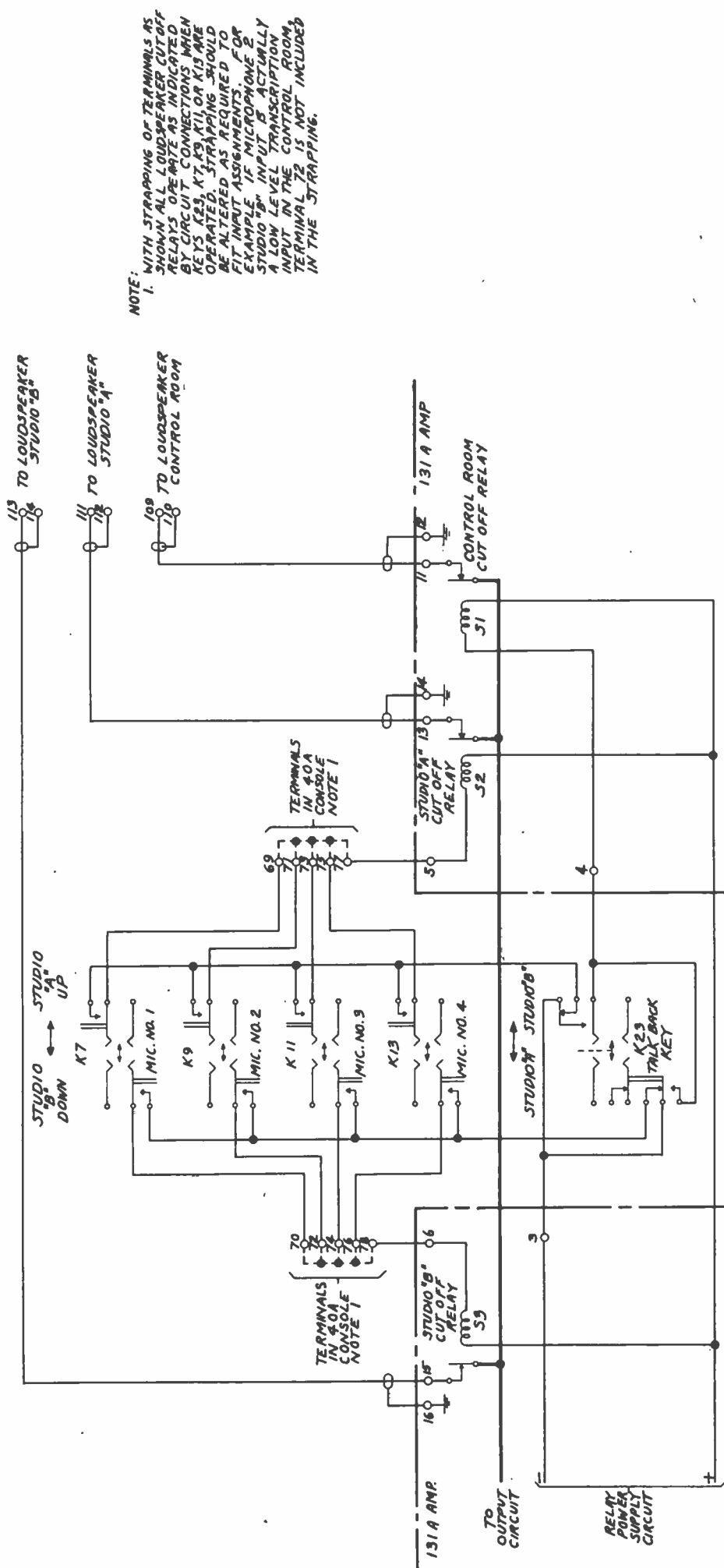

NOTE: 1. WITH STRAPPING OF TERMINALS AS SHOWN ALL LOUDSPEAKER CUTOFF RELAYS OPERATE AS INDICATED BY CIRCUIT CONNECTIONS. WHEN KEYS K23, K13, K11, OR K9 ARE OPERATED, STRAPPING SHOULD BE ALTERED AS REQUIRED TO FIT INPUT ASSIGNMENTS. FOR EXAMPLE, IF MICROPHONE 2 STUDIO "B" INPUT IS ACTUALLY A LOW LEVEL TRANSCRIPTION INPUT IN THE CONTROL ROOM, TERMINAL 72 IS NOT INCLUDED IN THE STRAPPING.

Fig. 7 Schematic Loudspeaker Cutoff Circuits in 40A Console

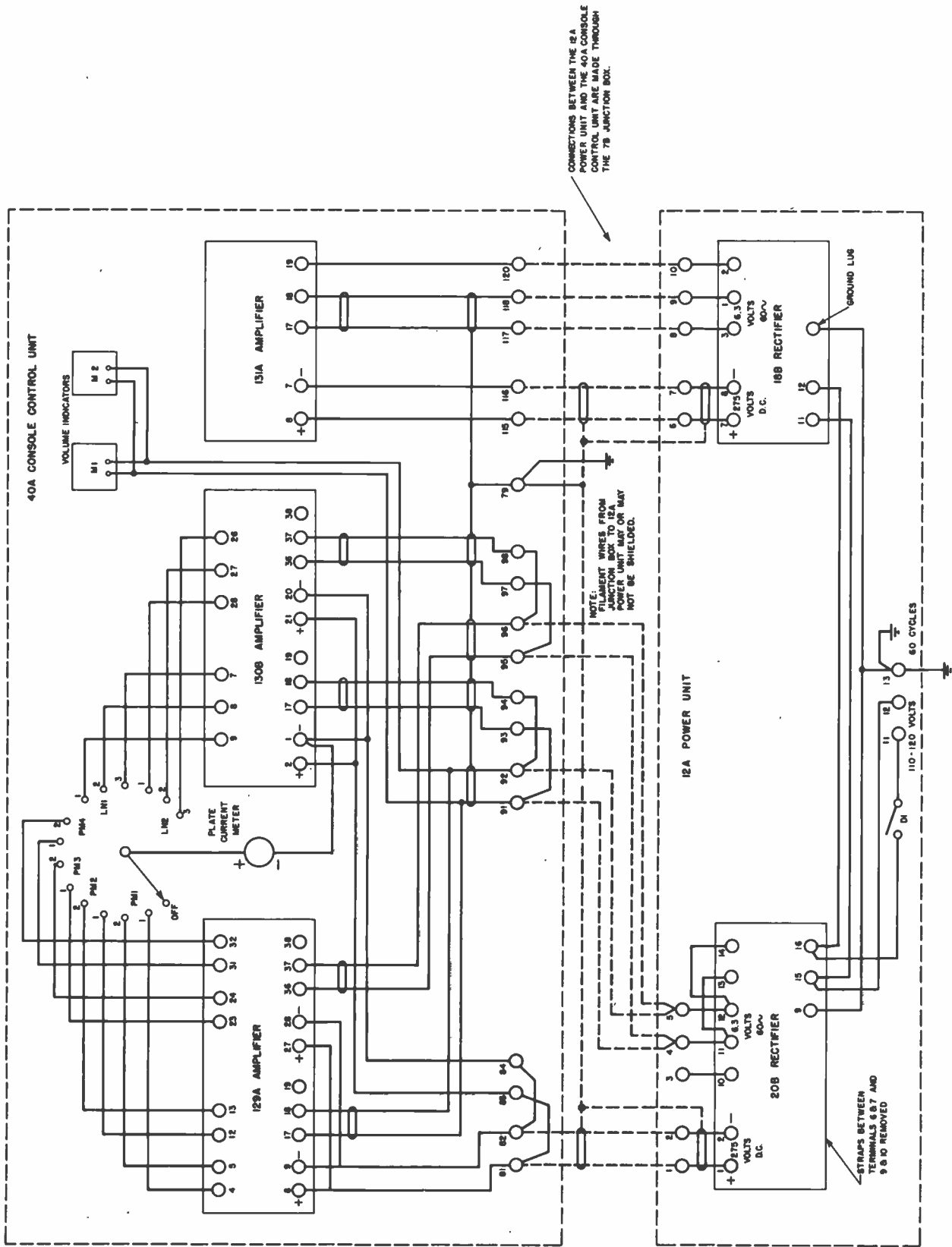

Fig. 8 Power Supply Schematic

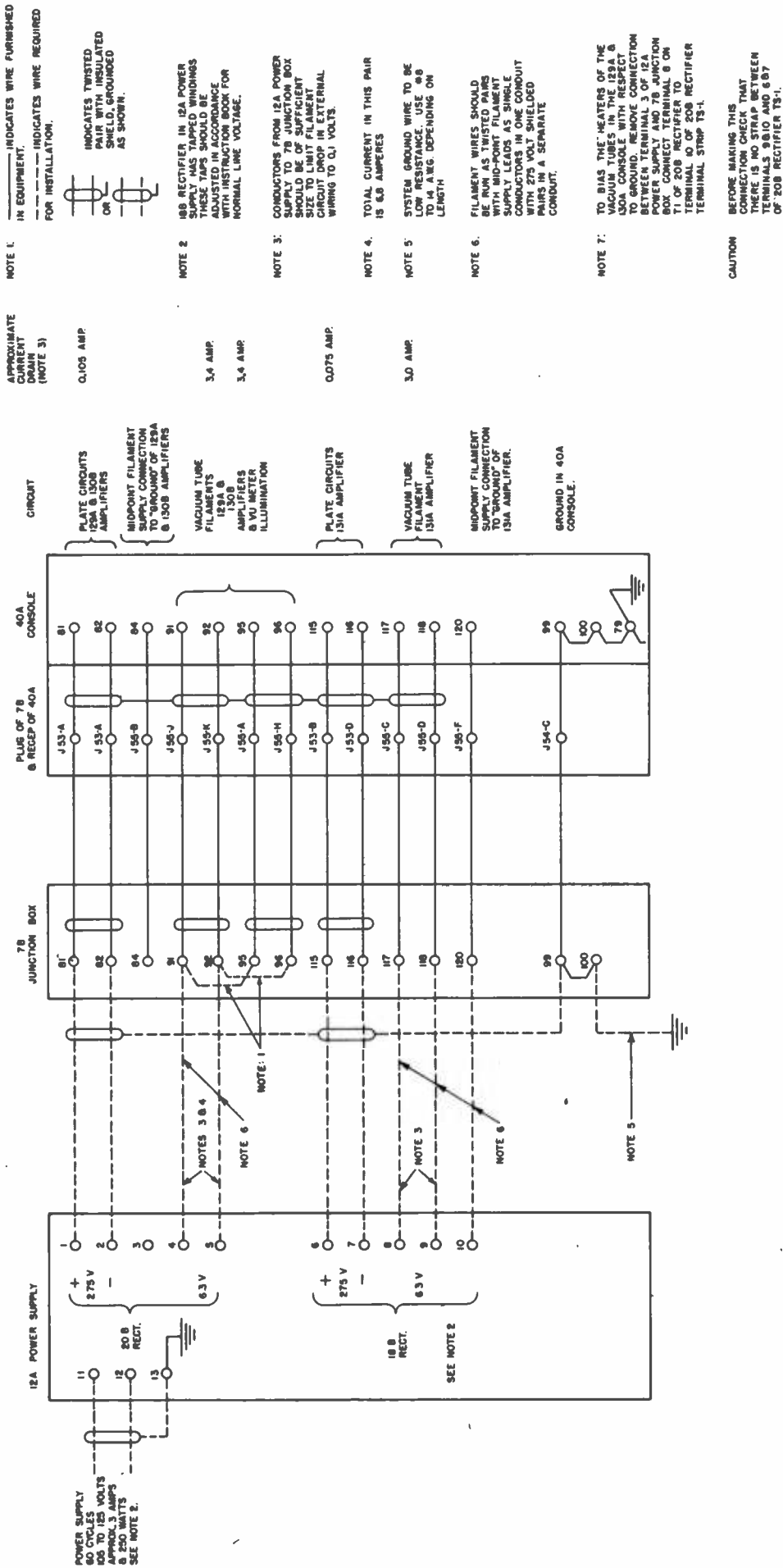

Fig. 9 Power Supply Wiring Diagram

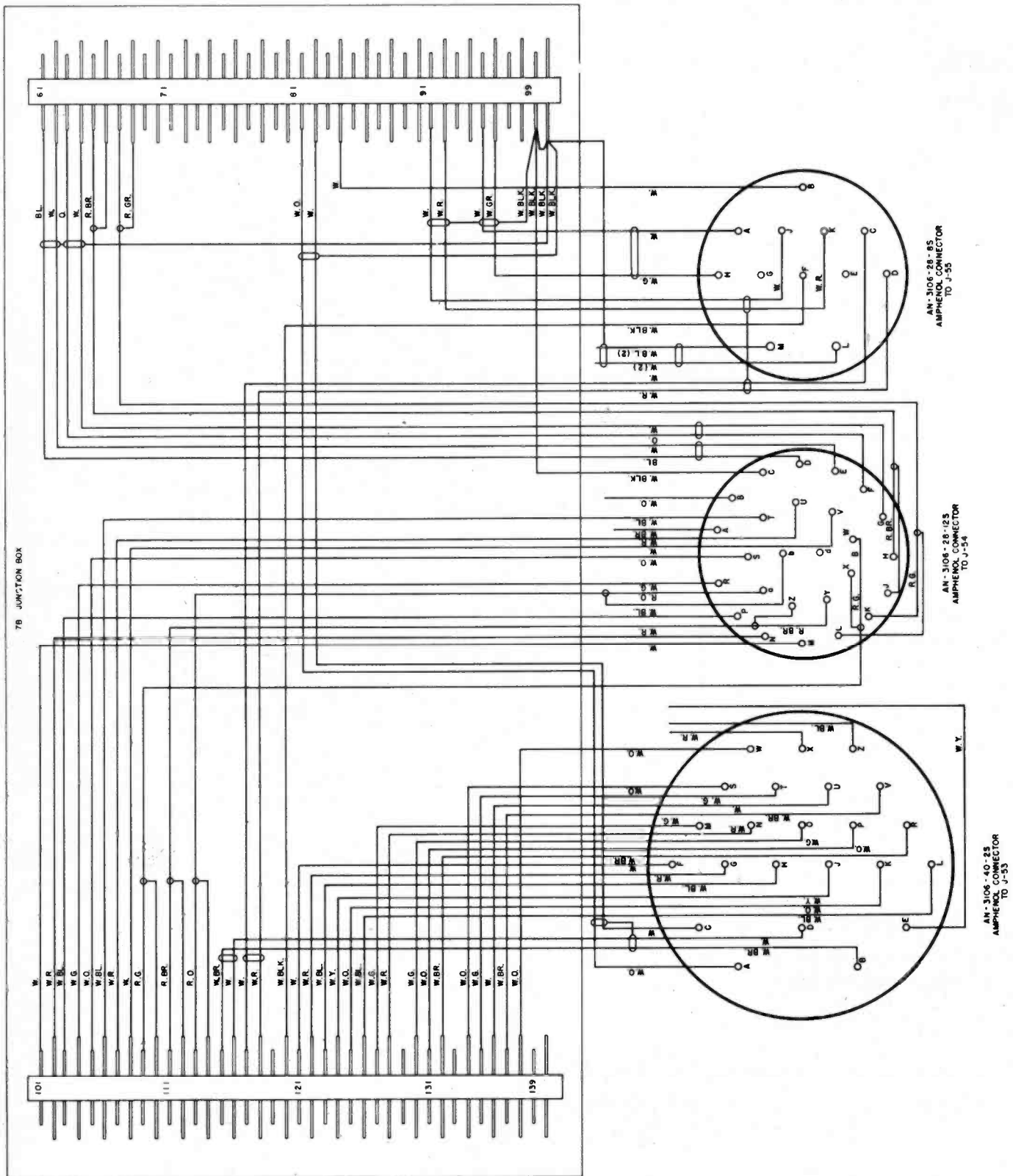

Fig. 11 Wiring Diagram 7B Junction Box

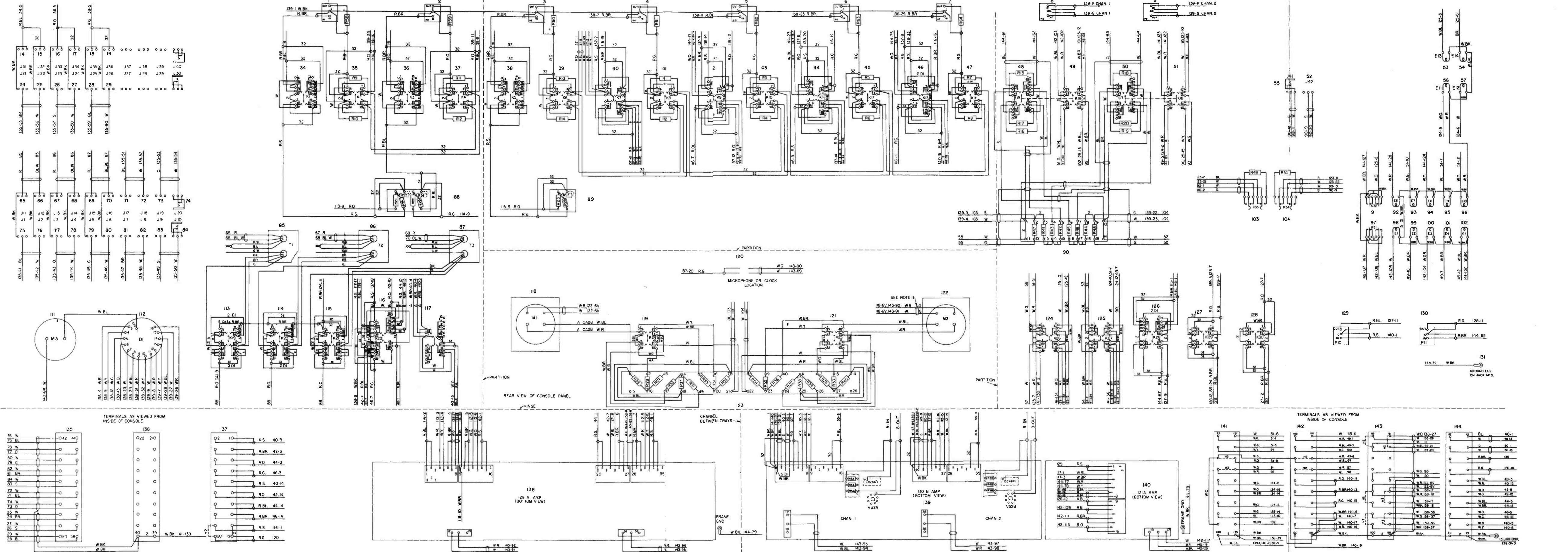

Fig. 12 Wiring Diagram 40A Console

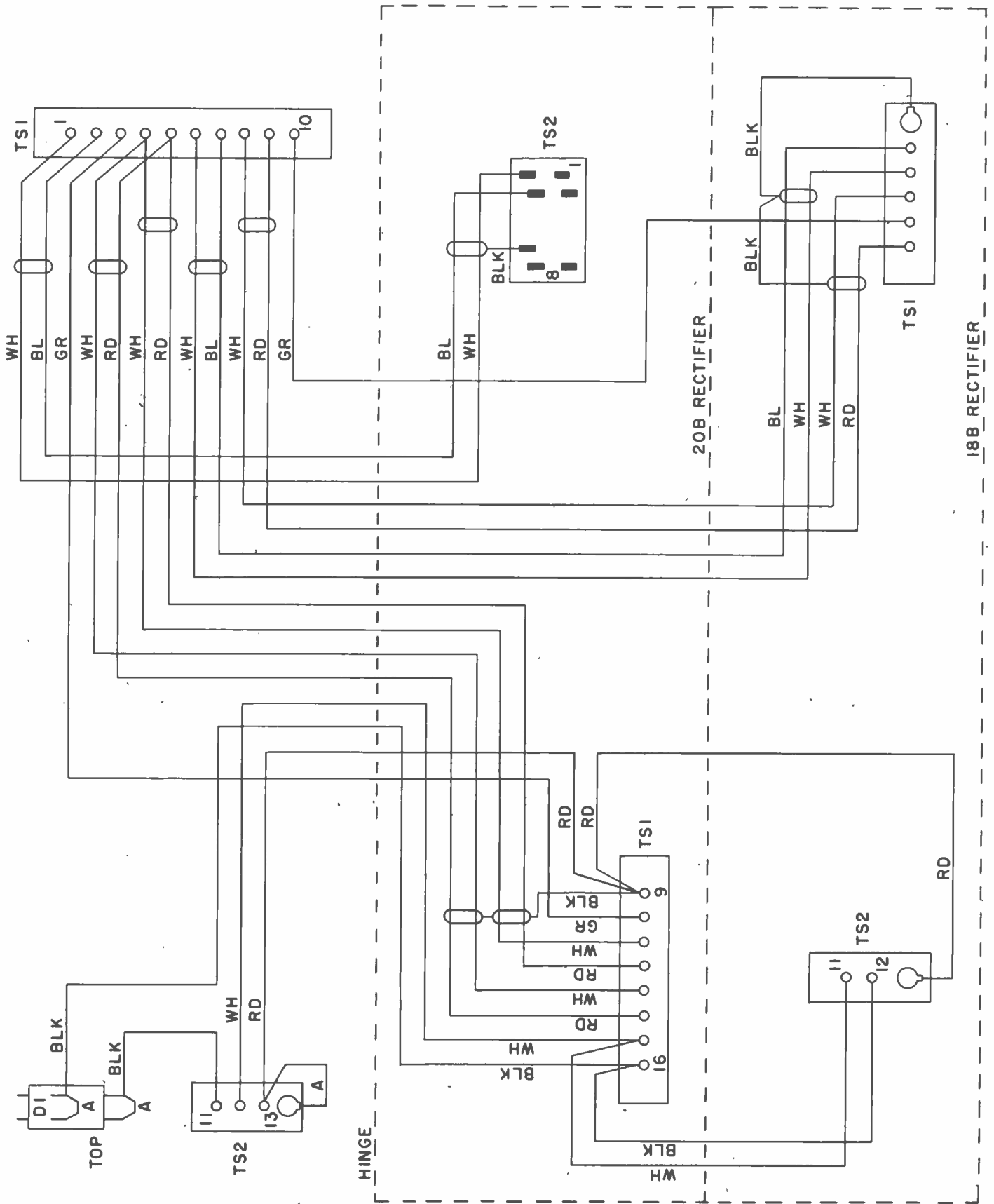

Fig. 13 Wiring Diagram 12A Power Supply

DISTRIBUTOR IN THE UNITED STATES

Graybar

ELECTRIC COMPANY

Executive Offices: 420 Lexington Avenue, New York 17, N. Y.

ALABAMA
Birmingham

ARIZONA
Phoenix

ARKANSAS
Little Rock

CALIFORNIA
Los Angeles
Oakland
Sacramento
San Diego
San Francisco

COLORADO
Denver

CONNECTICUT
Hartford
New Haven

DELAWARE
Wilmington

DIST. OF COLUMBIA
Washington

FLORIDA
Jacksonville
Miami
Orlando
Tampa

GEORGIA
Atlanta
Savannah

IDAHO
Boise

ILLINOIS
Chicago
Peoria

INDIANA
Evansville
Hammond
Indianapolis

IOWA
Des Moines

KANSAS
Wichita

KENTUCKY
Louisville

LOUISIANA
New Orleans

MAINE
Portland

MARYLAND
Baltimore

MASSACHUSETTS
Boston

Springfield
Worcester

MICHIGAN

Detroit
Flint
Grand Rapids
Lansing

MINNESOTA
Duluth
Minneapolis
St. Paul

MISSISSIPPI
Jackson

MISSOURI
Kansas City
St. Louis

NEBRASKA
Omaha

NEW HAMPSHIRE
Manchester

NEW JERSEY
Newark

NEW YORK
Albany
Buffalo
New York
Rochester
Syracuse

NO. CAROLINA
Asheville
Charlotte
Durham
Winston-Salem

OHIO

Akron
Cincinnati
Cleveland
Columbus
Dayton
Toledo
Youngstown

OKLAHOMA
Oklahoma City
Tulsa*

OREGON
Portland

PENNSYLVANIA
Allentown
Harrisburg
Philadelphia
Pittsburgh
Reading

RHODE ISLAND
Providence

SO. CAROLINA
Columbia

TENNESSEE
Chattanooga
Knoxville
Memphis
Nashville

TEXAS
Amarillo
Beaumont
Corpus Christi
Dallas
Fort Worth
Houston
San Antonio

UTAH
Salt Lake City

VIRGINIA
Richmond
Roanoke
Norfolk

WASHINGTON
Seattle
Spokane
Tacoma

WISCONSIN
Milwaukee

*Sales Office

A NATIONAL ELECTRIC SERVICE

DISTRIBUTOR FOR CANADA AND NEWFOUNDLAND

Northern Electric

COMPANY LIMITED

General Offices: 1620 Notre Dame Street, W.

Plant: 1261 Shearer Street,
Montreal, P. Q., Canada

TWENTY-FIVE BRANCHES FROM COAST TO COAST

Western Electric

Western Electric

129A AMPLIFIER



Instruction Bulletin No. 1097, Issue 1

Western Electric

129A AMPLIFIER

Description

The 129A Amplifier is comprised of four identical, electrically separate two-stage fixed-gain amplifiers mounted on a common chassis. They are intended for use as premixing or low level amplifiers in high quality audio frequency amplifying channels for Speech Input or Sound Systems. The amplifier is designed for operation from an external power supply source (Preamplifiers A and B, common source; preamplifiers C and D, common source; all can be common).

Typical Electrical Characteristics for Each of the Four Amplifier Channels:

Frequency Characteristic—Flat within ± 1 db over the range 30 to 15,000 cycles.

Output Noise—

82 dbm Unweighted	} When operated from 18 or 20 type Rectifiers.
87 dbm Weighted	

Gain—Approximately 41 db.

Output Power—

Normal—.01 watt (+ 10 dbm)

Maximum—.038 watt (+ 16 dbm) with approximately 1% total harmonic distortion.

Operates from—30, 250 or 600 ohms.

Operates into—600 ohm load.

Power Supply Required for Complete Amplifier—(four preamplifiers):

Filament—6.3 volts 3.2 amperes.

Plate—275 volts, 30 ma.d.c. (Preamplifiers A and B can be supplied from one source while C and D are supplied from another—1.6 amp. filament and 15 milliamps plate required for each half of amplifier.)

(Filament and plate supply may be obtained from 18A, 18B or 20B Rectifiers.)

Equipment Characteristics:

Panel Size—Approximately $17\frac{7}{8}$ inches by 10-5/16 inches. The apparatus extends approximately 5 inches from the front and 2 1/4 inches from the rear of the panel.

Weight—Approximately 20 1/4 pounds.

Mounting—Designed for use in the 25 type Speech Input Equipments. The 129A Amplifier can also be mounted on a 190 type Mounting Plate for installation on 19" relay rack type frames in cabinet enclosures, where a front mat is not required.

Installation

Mounting:

The 129A Amplifier is designed primarily for mounting in the 25A or 25B Speech Input Equipment. Figure 3 shows the outline dimensions of the panel on which the amplifier

apparatus is mounted. Apparatus and vacuum tubes on the panel extend about 5 inches from the outside surface, with wiring on the other side (apparatus on this side extends about 2 1/4 inches from the panel).

Instruction Bulletin No. 1097, Issue 1

As mounted in the 25 type Speech Input Equipment, the amplifier chassis is mounted on 12 rubber vibration mounts (U. S. Rubber Co. A-301 Cylindrical Mounts) using the 12 (0.180") holes along edges of the panel. In addition to providing isolation from shock and vibration, these mounts insulate the amplifier chassis electrically from the cabinet. This permits this and other associated amplifiers and circuits all to be grounded at a single point in the system, which is desirable to control noise and crosstalk. Care should be used to see that this insulation is not made ineffective by contact between the chassis and the cabinet or other mounting.

Suitable mounting brackets or frameworks, such as the 190 type Mounting Plate, are necessary for other applications of the 129A Amplifier. Such brackets may be attached by means of the 6 holes (0.180") along opposite edges of the amplifier. Mounting precautions as indicated above should be observed. Other precautions are discussed below.

Avoid exposure to magnetic fields which might induce noise in the equipment.

When equipment such as 18 or 20 type Rectifiers or Amplifiers with self-contained a-c power supplies are mounted near 129 Amplifiers it is desirable to have maximum sep-

aration (10 inch minimum) between the input transformers of the 129A Amplifier and the power transformer of the a-c operated equipment.

Hum caused by pick-up in the input transformers can often be reduced by loosening the clamping ring and rotating the transformers to the position of minimum hum. To avoid damaging the leads the transformers should not be rotated more than 180 degrees in either direction from their original positions.

External Connections:

Locations:

Terminals 1 to 8 inclusive located on Terminal Strip TS1.

Terminals 9 to 16 inclusive located on Terminal Strip TS2.

Terminals 17 to 19 inclusive located on Terminal Strip TS3.

Terminals 20 to 27 inclusive located on Terminal Strip TS4.

Terminals 28 to 35 inclusive located on Terminal Strip TS5.

Terminals 36 to 38 inclusive located on Terminal Strip TS6.

Terminal Numbers	External Connections
1 and 2	30 ohm input, Preamplifier A
2 and 3	250 ohm input, Preamplifier A
1 and 3	600 ohm input, Preamplifier A
4	Plate Current Meter positive, First Stage, Preamplifier A
5	Plate Current Meter positive, Second Stage, Preamplifier A
6 and 7	600 ohm output, Preamplifier A
8	Plate Supply + 275 volts d-c, Preamplifiers A and B
9	Plate supply—275 volts d-c for Preamplifiers A and B; also Plate Current Meter Negative for Preamplifiers A and B

10 and 11	600 ohm output, Preamplifier B
12	Plate Current Meter positive, First Stage, Preamplifier B
13	Plate Current Meter positive, Second Stage, Preamplifier B
14 and 15	30 ohm input, Preamplifier B
15 and 16	250 ohm input, Preamplifier B
14 and 16	600 ohm input, Preamplifier B
17 and 18	6.3 volts a-c or d-c Filament supply, Preamplifiers A and B
19	Ground (See System Grounding)
20 and 21	30 ohm input, Preamplifier C
21 and 22	250 ohm input, Preamplifier C
20 and 22	600 ohm input, Preamplifier C
23	Plate Current Meter positive, First Stage, Preamplifier C
24	Plate Current Meter positive, Second Stage, Preamplifier C
25 and 26	600 ohm output, Preamplifier C
27	Plate Supply + 275 volts d-c, Preamplifiers C and D
28	Plate Supply — 275 volts d-c; for Preamplifiers C and D, also Plate Current Meter Negative for Preamplifiers C and D
29 and 30	600 output, Preamplifier D
31	Plate Current Meter positive, First Stage, Preamplifier D
32	Plate Current Meter positive, Second Stage, Preamplifier D
33 and 34	30 ohm input, Preamplifier D
34 and 35	250 ohm input, Preamplifier D
33 and 35	600 ohm input, Preamplifier D
36 and 37	6.3 volts a-c or d-c filament supply, Preamplifiers C and D
38	Ground (See System Grounding)

All electrical connections to the amplifier should be made with shielded twisted pair copper wire with insulation over the shields and all joints should be securely soldered with rosin flux solder. The shields should be electrically continuous and should be grounded at the amplifier end *only*. This grounding should be by connection to the amplifier chassis, or to terminal 9 for preamplifiers A and B or terminal 28 for preamplifiers C and D. The shields for the output leads should be grounded only at the input of the succeeding amplifier or repeating coil.

The amplifier chassis is insulated from its mounting and hence from the cabinet or rack by the flexible rubber supports and care should be used in all wiring to avoid shorting out this insulation by uninsulated shields or other connections. Ground to the audio ground for each circuit group supplied from a common power supply source should be made at a single point as covered under system grounding.

System and Power Source Grounding:

The chassis, the shielding, and the negative side of the plate supply should be grounded by connecting terminal 19 or 38 to the audio ground lug on the rack or bay cabinet. When several amplifiers obtain plate power from a common source, the ground should be applied at only one point in each system supplied from each source. The center tap of the transformer filament winding should also be grounded to the audio ground.

It is sometimes desirable to operate these amplifier elements with one side of the outputs grounded. In all cases where the outputs are grounded, terminals 6, 10, 25 and 29 should be used for connection to the ground side of the circuit.

Frequency Response Equalization:

The frequency response of the amplifier is uniform within 1 db over the range of 30 to 15,000 cycles per second. Working from 600 ohms, no equalization is required, but when operating from 30 ohms, adjustment of the values of a condenser which shunts the 100,000 ohm feedback resistor from the plate of the second stage to the cathode of the first stage is required for uniform response.

As normally supplied this condenser is adjusted during manufacture to give uniform response when the amplifier is operated from a 30 ohm input. Accordingly this condenser may have various values over the range of 0 to about 90 mmfd depending upon how much equalization has been required.

For operation from 600 ohms, equalization is not required and this condenser should be disconnected. This condenser in the 4 amplifier channels is designated as follows:

- C8A for Channel A
- C9A for Channel B
- C8B for Channel C
- C9B for Channel D

Plate Current Measuring Circuits:

The plate currents of the vacuum tubes may be measured by wiring terminals 4, 5, 12, 13, 23, 24, 31 and 32 to an external selector switch which is connected to the positive terminal of a plate current meter. The negative terminal of the meter should be connected to terminals 9 and 28. Terminals 9 and 28 should not be connected together if preamplifier A and B are supplied from a plate power source different from that supplying preamplifiers C and D.

Suitable meters which may be used for this purpose are listed below:

Meter	Full Scale	Normal Reading when Used With 129A Amplifier	Actual Meter Current
KS-9872	150%	100%	0.133 ma
KS-10,003	0.2 ma	0.133 ma	0.133 ma
Milliammeter with series resistance*	0.2 ma	0.133 ma	0.133 ma

*Series resistance such that total of meter and resistance is 1000 ohms.

The actual vacuum tube cathode currents corresponding to the above meter readings

are as follows:

Tube	Normal Current Per Tube
1st stage of each Channel (V1)	0.68 milliampere
2nd stage of each Channel (V2)	6.8 milliampere

The above currents are average values and variations of the order of $\pm 15\%$ may be expected among tubes without such a departure indicating unsatisfactory tubes. The significant indication is any appreciable change in the tube currents from previous readings.

Vacuum Tubes:

After connections have been made, the tube shields should be removed and an RCA 1603 Vacuum Tube should be inserted in each of

the first stage sockets and a Western Electric 348A Vacuum Tube should be inserted in each of the second stage sockets.

WARNING: The tube shields are locked to the panel by screw threads at the bottom of the shields and can only be removed without damage by rotating the shields counter-clockwise.

The flexible grid leads should be attached to the tube caps and the tube shields should be replaced over the tubes.

Operation

A period of approximately one minute should be allowed for the vacuum tube cathodes to reach their operating temperatures after the power is applied. The vacuum tube plate currents may then be measured and checked with the above normal readings.

Associated Parts:

The following vacuum tubes required for operation must be specified separately on the order:

- ✓ 4—RCA 1603 Vacuum Tube
- ✓ 4—Western Electric 348A Vacuum Tube

In an emergency, if these tubes are not available, the following may be used:

- 6C6 or 77 in place of RCA 1603
- 6J7 or RCA 1620 in place of 348A

The following accessory equipment is recommended:

KS-10003 or KS-9872 Meter (for measuring plate currents of vacuum tubes).
190 type Mounting Plate.

Replacement Parts:

If replacement parts are required for the 129A Amplifier they may be procured through the nearest distributor. Lists of all replaceable parts of the amplifier are packed with each amplifier.

In the case of replacement of condenser C8A, C8B, C9A or C9B, the same value as supplied in the amplifier should be ordered. A different value of this condenser may be required if the input transformer T1A, T1B, T3A or T3B is replaced, in which case the discussion under "Frequency Response" in this bulletin should be referred to.

NOTE: When the 129A Amplifier is used as a component of the 25B Speech Input Equipment, the filament center tap is connected at the 20B Rectifier to a point approximately 60 volts above ground; therefore the filament should not be grounded for this application.

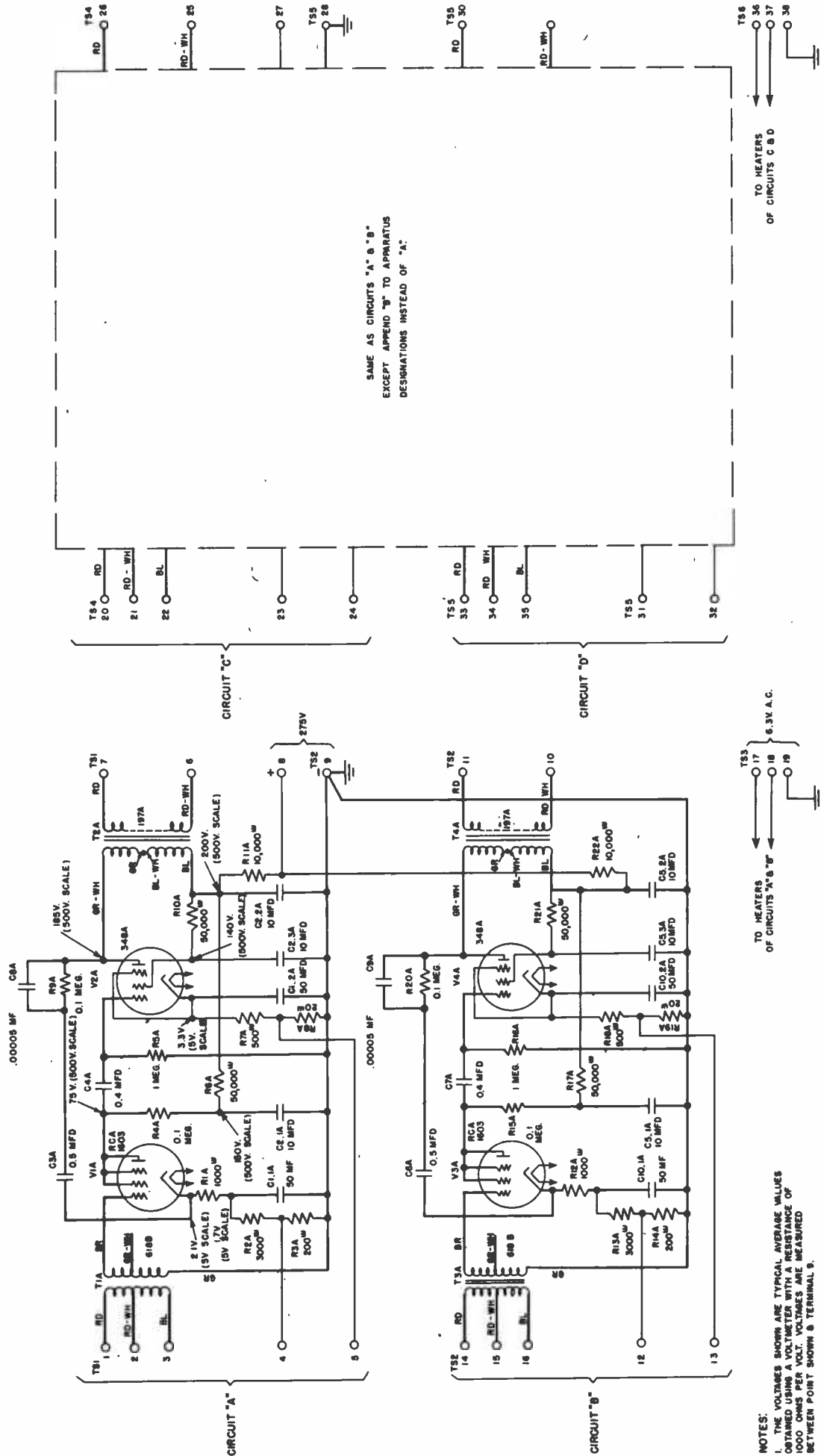
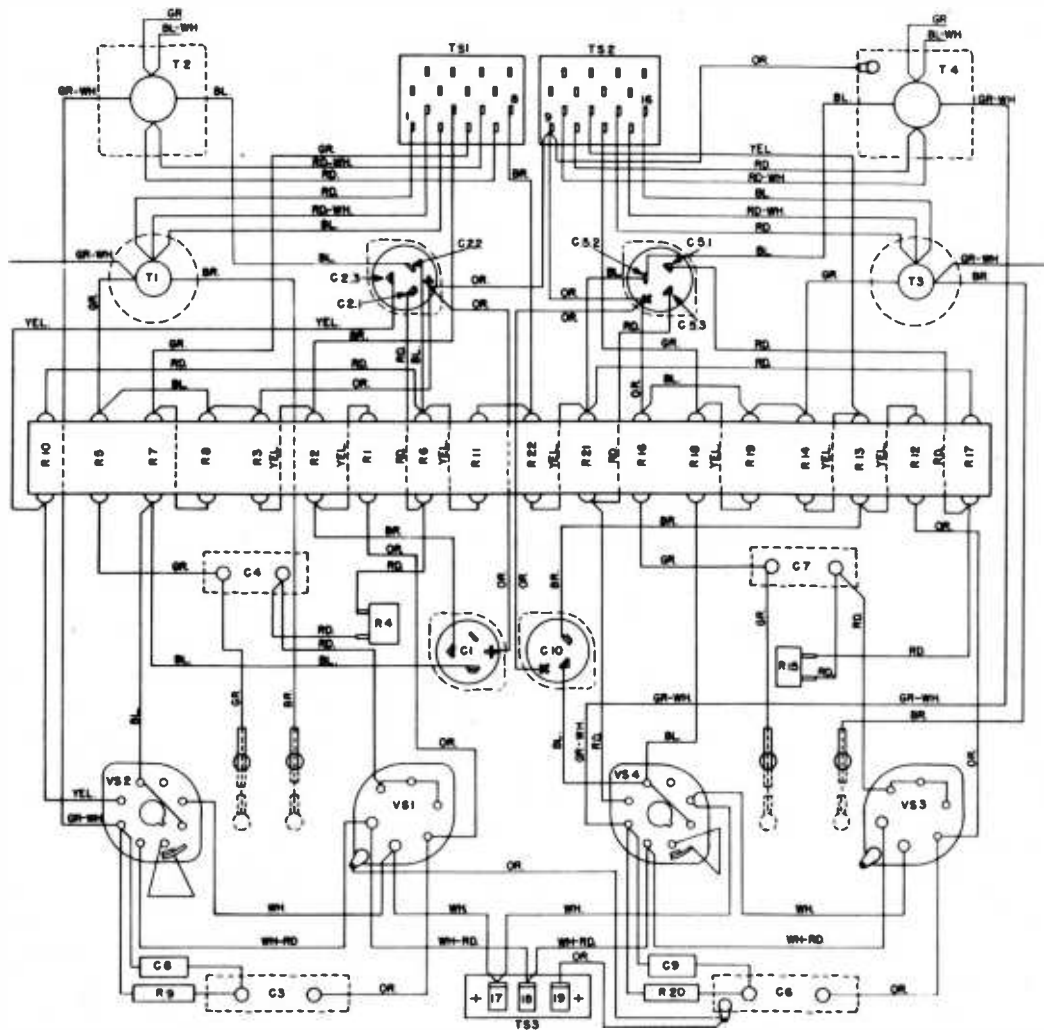

Fig. 1 — Schematic



WIRING VIEW
 THIS IS ONE-HALF OF THE PANEL WIRING DIAGRAM
 THE WIRING FOR THE OTHER HALF OF THE PANEL IS THE SAME.

FIG. 2 — Wiring Diagram

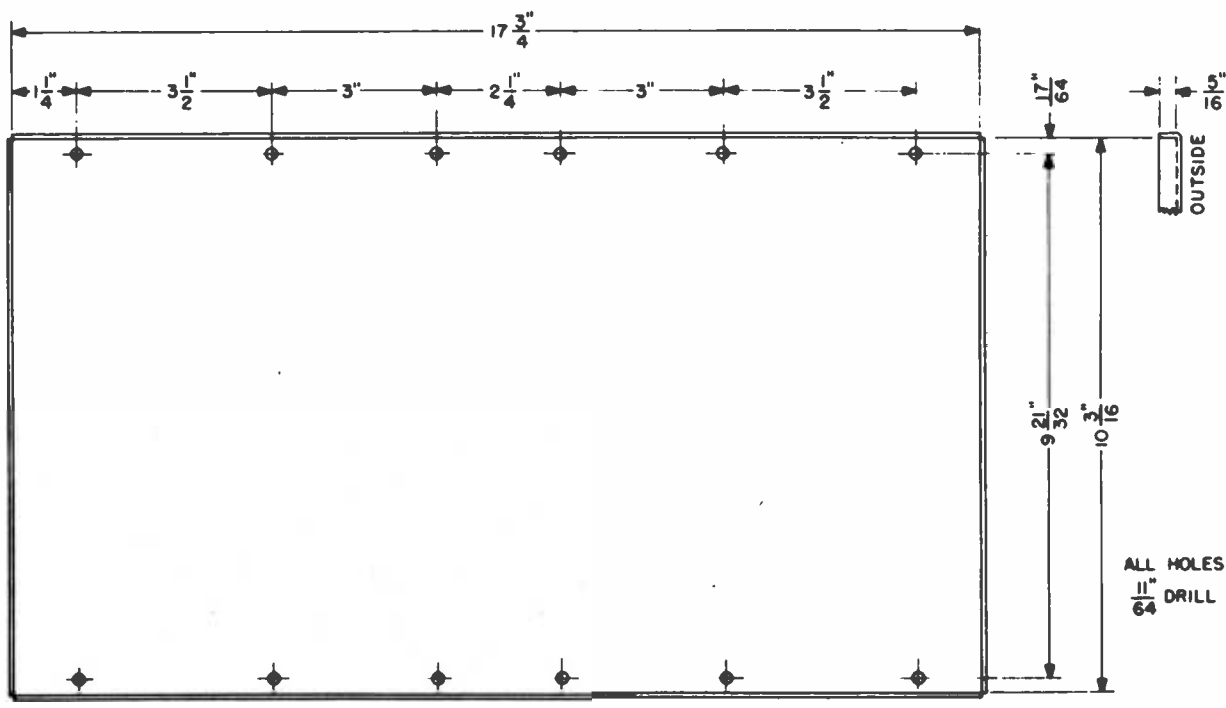

FIG. 3 — Chassis Detail

DISTRIBUTOR IN THE UNITED STATES

Graybar

ELECTRIC COMPANY

Executive Offices: 420 Lexington Avenue, New York 17, N. Y.

ALABAMA
Birmingham

ARIZONA
Phoenix

ARKANSAS
Little Rock

CALIFORNIA
Los Angeles
Oakland
Sacramento
San Diego
San Francisco

COLORADO
Denver

CONNECTICUT
Hartford
New Haven

DELAWARE
Wilmington

DIST. OF COLUMBIA
Washington

FLORIDA
Jacksonville
Miami
Orlando
Tampa

GEORGIA
Atlanta
Savannah

IDAHO
Boise

ILLINOIS
Chicago
Peoria

INDIANA
Evansville
Hammond
Indianapolis

IOWA
Des Moines

KANSAS
Wichita

KENTUCKY
Louisville

LOUISIANA
New Orleans

MAINE
Portland

MARYLAND
Baltimore

MASSACHUSETTS
Boston

Springfield
Worcester

MICHIGAN

Detroit
Flint
Grand Rapids
Lansing

MINNESOTA

Duluth
Minneapolis
St. Paul

MISSISSIPPI
Jackson

MISSOURI
Kansas City
St. Louis

NEBRASKA
Omaha

NEW HAMPSHIRE
Manchester

NEW JERSEY
Newark

NEW YORK

Albany
Buffalo
New York
Rochester
Syracuse

NO. CAROLINA

Asheville
Charlotte
Durham
Winston-Salem

OHIO

Akron
Cincinnati
Cleveland
Columbus
Dayton
Toledo
Youngstown

OKLAHOMA
Oklahoma City
Tulsa*

OREGON
Portland

PENNSYLVANIA

Allentown
Harrisburg
Philadelphia
Pittsburgh
Reading

RHODE ISLAND
Providence

SO. CAROLINA
Columbia

TENNESSEE
Chattanooga
Knoxville
Memphis
Nashville

TEXAS

Amarillo
Beaumont
Corpus Christi
Dallas
Fort Worth
Houston
San Antonio

UTAH
Salt Lake City

VIRGINIA
Richmond
Roanoke
Norfolk

WASHINGTON
Seattle
Spokane
Tacoma

WISCONSIN
Milwaukee

*Sales Office

A NATIONAL ELECTRIC SERVICE

DISTRIBUTOR FOR CANADA AND NEWFOUNDLAND

Northern Electric

COMPANY LIMITED

General Offices: 1620 Notre Dame Street, W.

Plant: 1261 Shearer Street,
Montreal, P. Q., Canada

TWENTY-FIVE BRANCHES FROM COAST TO COAST

Western Electric

Western Electric

130B AMPLIFIER



Instruction Bulletin No. 1142
Issue 1

Western Electric

130B AMPLIFIER

The 130B Amplifier is comprised of two identical, electrically separate, three stage amplifiers mounted on a common chassis. These amplifiers are for use as main amplifiers in high quality audio frequency amplifying channels for Speech Input or Sound Systems. Each amplifier is arranged for its own high impedance interstage gain control which is intended as master gain control for its channel. The amplifier is designed for operation from an external power supply source.

Typical Electrical Characteristics for each Amplifier Unit

Frequency Characteristic—Flat within 1 db over the range 30 to 15,000 cycles.

Distortion—Less than .5% 50 to 7500 cycles at normal program level.

Output Noise — (Main output) — Output noise is a function of the power supply. Operated from the Western Electric 20 Type Rectifier, the output noise is approximately as follows:

Gain	51 db	61 db	71 db	81 db
Noise Level (unweighted)	—64 dbm	—60 dbm	—50 dbm	—40 dbm
Signal to Noise Ratio with Normal +24 dbm output	88 db	84 db	74 db	64 db

Gain—Approximately 81 db maximum.

Gain Control—Requires two (one for each amplifier channel) 100,000 ohm potentiometers (not furnished) mounted externally. This is a high impedance interstage gain control requiring low capacity cables for each amplifier. These cables are not furnished.

Operates From—150 ohms—as furnished, but may be reconnected to operate from 600 ohms.

Operates Into—Main output 600 ohms.

Monitor output 40 ohms (approximately).

Output Power—Main Output.

Normal—0.25 watt (+24 dbm).

Maximum—0.6 watt (+28 dbm) with approximately 1 per cent harmonic distortion.

Monitor output 20 db less than main output. (Isolation between main and monitor outputs is 20 db).

Power Supply for complete amplifier (2 amplifier units)

Filament—6.3 Volts, 3.6 Amperes, total.

Plate—275 Volts, 71 ma, dc total.

(Each amplifier channel can be supplied from a separate source if desired, the power requirement of each channel being $\frac{1}{2}$ the above total.)

(Filament and plate supply may be obtained from the 18A, 18B or 20B Rectifiers.)

Equipment Characteristics

Panel Size — Approximately 12 by 10 $\frac{5}{16}$ inches. The apparatus extends approximately 5 inches from the front and 2 $\frac{1}{4}$ inches from the rear of the panel.

Weight—Approximately 19 pounds.

Mounting—Designed primarily for use in 25B Speech Input Equipment. The 190 type Mounting Plate may also be used for mounting one 130B Amplifier on standard 19" relay rack type frames.

INSTALLATION

Mounting

The 130B Amplifier is designed primarily for mounting in the 25B Speech Input Equipment. Figure 3 shows the outline dimensions of the panel on which the amplifier apparatus is mounted. Apparatus and vacuum tubes on the panel extend about 5" from the outside surface. Apparatus on the other side extends about 2¼ inches.

As mounted in the 25B Speech Input Equipment, the amplifier chassis is mounted on 8 rubber vibration mounts (U. S. Rubber Co. A-301 Cylindrical rubber mounts) using the 8 (0.180") holes along edges of the panel (see Figure 3). In addition to providing isolation from shock and vibration, these mounts insulate the amplifier chassis electrically from the cabinet. This permits this, and other associated amplifiers and circuits all to be grounded at a single point in the system, which is desirable to control noise and cross talk. Care should be used to see that this insulation is not made ineffective by contact between the chassis and the cabinet or other mounting.

Suitable mounting brackets or frameworks are necessary for other applications of the 130B Amplifier, or the 190 type Mounting Plate may be used. Mounting precautions as indicated above should be observed; other precautions are discussed below.

Avoid exposure to magnetic fields which might induce noise in the equipment. When equipment such as 18 or 20 type Rectifiers or amplifiers with self-contained a-c power supplies are mounted on the same bay, they should be separated by at least 10 inches from the 130B Amplifier. Where possible, it is desirable to orient both the amplifier and a-c operated equipment to give maximum separation between the input transformers of the 130B Amplifier and the power transformer of the a-c operated equipment. The 42A Shield (not furnished) can be added over the input transformers of the 130B Amplifier, if necessary, to reduce hum pickup under very severe exposure conditions.

External Connections

Terminals 1 to 8 inclusive located on Terminal Strip TS1.

Terminals 9 to 16 inclusive located on Terminal Strip TS2.

Terminals 17 to 19 inclusive located on Terminal Strip TS3.

Terminals 20 to 27 inclusive located on Terminal Strip TS4.

Terminals 28 to 35 inclusive located on Terminal Strip TS5.

Terminals 36 to 38 inclusive located on Terminal Strip TS6.

Terminal Numbers

1	Plate Supply —275 Volts d-c for Amplifier A; also Plate Current Meter—negative—for Amplifier A
2	Plate Supply +275 Volts d-c for Amplifier A
3 and 4	600 ohm output to line for Amplifier A
5 and 6	600 ohm output to monitor, Amplifier A
7	Plate Current Meter positive, third stage, Amplifier A
8	Plate Current Meter positive, second stage, Amplifier A
9	Plate Current Meter positive, first stage, Amplifier A
10, 11 and 12	Spare—can be connected to supplement Terminal 13
13	Terminal for connection of shields of shielded leads
14 and 16	150 ohm input Amplifier A (see below for 600 ohm input connections).
15	Spare
17 and 18	6.3 Volt a-c or d-c Filament supply, Amplifier A
19	Ground (see system grounding).

Terminal Numbers**External Connections**

20	Plate Supply -275 Volts d-c for Amplifier B; also Plate Current Meter—negative—for Amplifier B
21	Plate Supply +275 Volts d-c for Amplifier B
22 and 23	600 ohm output to line for Amplifier B
24 and 25	600 ohm output to monitor, Amplifier B
26	Plate Current Meter positive, third stage, Amplifier B
27	Plate Current Meter positive, second stage, Amplifier B
28	Plate Current Meter positive, first stage, Amplifier B
29, 30 and 31	Spare—can be connected to supplement Terminal 32
32	Terminal for connection of shields of shielded leads
33 and 35	150 ohm input, Amplifier B (See below for 600 ohm input.)
34	Spare
36 and 37	6.3 Volt a-c or d-c Filament supply, Amplifier B
38	Ground (see system grounding)

All electrical connections to the amplifier should be made with shielded twisted-pair copper wire with insulation over the shields, and all joints should be securely soldered with rosin flux solder. The shields should be electrically continuous and all except the shield for the output lead should be grounded at the amplifier end only. This grounding should be by connection to the amplifier chassis or to Terminals 13 or 1 for Amplifier A or Terminal 32 or 20 for Amplifier B. The shields for the output leads should be grounded only at the input of the succeeding amplifier or repeating coil. Grounds for each circuit group supplied from a common power supply source should be made at a single point.

Gain Control Connections

The 130B Amplifier is furnished without gain controls and the circuit between the plate of the first amplifier stage and the grid of the second amplifier stage is left open.

A 100,000 ohm potentiometer should be used connected as follows for each channel of the amplifier.

Amplifier Terminals	
Input to Potentiometer (Ter. "IN" & "C")	Connect to Terminals Marked "P" & "C" respectively.
Output of Potentiometer (Ter. "OUT" & "C")	Connect to Terminals Marked "G" & "C" respectively.

On the underside of the chassis, the letter "P" is marked adjacent to one terminal of condenser C4 in each amplifier channel. The grid connection of the second stage tube is wired to an unused terminal on its vacuum tube socket. The chassis next to this terminal is marked with the letter "G" in each of the two channels. The common or ground side of the circuit may be picked up at any convenient circuit element, such as at resistances on the resistance mounting strip; two points, one at the end of resistance R3 and at one end of resistance R5 are marked with the letter "C" to denote circuit points to which external connections to the potentiometer may be made.

This part of the circuit is high impedance and the length of cables, i.e., the distance the potentiometer may be from the amplifier, is limited by the capacity of the cables. To avoid excessive loss at frequencies up to as high as 15,000 cycles per second the following type and lengths of cable will be found satisfactory.

Type of Cable	Maximum Recommended Cable Length or Distance
RG62/U	10 feet

In the 10 foot length, this cable has a capacity of about 140 mmfd.

Two holes equipped with rubber grommets are provided in each section of the chassis of the amplifier for bringing in these cables from the top through the chassis.

Input Connections (and change to 600 ohms input)

The amplifier is normally supplied for use in the 25B Speech Input Equipment with the two windings of the input transformers con-

nected in parallel for a 150 ohm input. By changing these connections a 600 ohm input may be obtained as indicated below:

Transformer Leads	Terminal Connection for 150 ohm input (Normal)		Terminal Connection for 600 ohm input	
	Amp. A	Amp. B	Amp. A	Amp. B
Red	14	33	14	33
Red-White	16	35	15	34
Blue	14	33	15	34
Blue-White	16	35	16	35
Black (electrostatic shield,	14	33	(See below)	(See below)

As normally supplied (for use in 25B Speech Input Equipment) it will be noted that the electrostatic shield is connected to one side of the input for an unbalanced input, terminal 14 (or 33) being the grounded side.

For the 600 ohm termination the input may be operated either unbalanced, or balanced and in the latter case either with a mid-point ground or with the input ungrounded. For a mid-point ground the "black" lead from the input transformer should be connected to terminal 15 in Amplifier A and terminal 34 in Amplifier B, and these terminals grounded. For an unbalanced input the ground points may be terminals 14 and 33 respectively. For ungrounded input the black lead should be

connected to terminal 13 for channel A (or terminal 32 for channel B).

Plate Current Measuring Circuits

The plate currents of the vacuum tubes can be measured by wiring terminals 7, 8, 9, 26, 27 and 28 to an external selector switch which is connected to the positive terminal of the plate current meter. The negative terminal of the meter should be connected to terminals 1 and 20. (Terminals 1 and 20 should not be connected together if Amplifier A is supplied from a plate power source different from that supplying Amplifier B.) Suitable meters which may be used for this purpose are listed below.

Meter	Full Scale	Normal Reading When Used with 130B Amplifier	Actual Current through meter
KS-9872	150%	100%	0.133 ma
KS-10,003	0.2 ma	0.133	0.133
Milliammeter with series resistance*	0.2 ma	0.133 ma	0.133 ma

*Series resistance such that total of meter and resistance is 1000 ohms.

The actual vacuum tube cathode currents corresponding to the above readings are as follows:

Tube Amplifier A	Amplifier B	Normal Cathode Current Per Tube
V1A	V1B	1.95 milliamperes
V2A	V2B	0.60 "
V3A	V3B	33.00 "

The above currents are average values and variations of the order of $\pm 15\%$ may be expected among tubes without such a departure indicating unsatisfactory tubes. The signifi-

cant indication is any appreciable change in the tube current from previous original readings.

Vacuum Tubes

An RCA 1603 Vacuum Tube should be inserted in each of the first stage sockets, and a Western Electric 348A Vacuum Tube should be inserted in each of the second stage sockets. The flexible grid leads should be attached to the tube caps, and the tube shields should be placed over the tubes. A Western Electric 349A Vacuum Tube should be inserted in each of the third stage sockets.

WARNING

The tube shields are locked to the panel by screw threads at the bottom of the shields and can only be removed without damage by rotating the shields counterclockwise.

Operation

After the power is applied, a period of approximately one minute should be allowed for the vacuum tube cathodes to reach their operating temperatures. The vacuum tube plate currents may then be measured and checked with the above normal readings.

Associated Parts

The following vacuum tubes are required for the operation of this amplifier and must be ordered separately.

- ✓ 2—RCA 1603 Vacuum Tubes
- 2—Western Electric 348A Vacuum Tubes
- 2—Western Electric 349A Vacuum Tubes

In an emergency, if these tubes are not available, the following may be used:

- First Stage—6C6 or 77 for RCA 1603
- ✓ Second Stage—6J7 or RCA 1620 for 348A
- ✓ Third Stage—6F6 for 349A

The following accessory equipment is recommended for use with this amplifier:

- 2—100,000 ohm Potentiometers (Western Electric BA-73987-3 or BA-73987-4).
- 4—lengths of RG62/U Coaxial Cable, as required up to 10 feet max. each for potentiometer connections.
- 1—KS-10003 Meter or KS-9872 (for measuring plate currents of vacuum tubes).
- 1—190 type Mounting Plate.

Maintenance

If replacement parts are required for the 130B Amplifier they may be procured through the nearest distributor. Lists of all replaceable parts of the amplifier are packed with each amplifier:

NOTES:
 1. THE VOLTAGES SHOWN ARE TYPICAL AVERAGE VALUES OBTAINED USING A VOLTMETER WITH A RESISTANCE OF 1000 OHMS PER VOLT. VOLTAGES ARE MEASURED BETWEEN POINT SHOWN & TERM 1.
 2. POINTS MARKED P, G & C ARE CONNECTION POINTS FOR EXTERNAL 100,000 OHM GAIN CONTROL AS FOLLOWS:
 POT. INPUT P & C - POT. OUTPUT G & C.

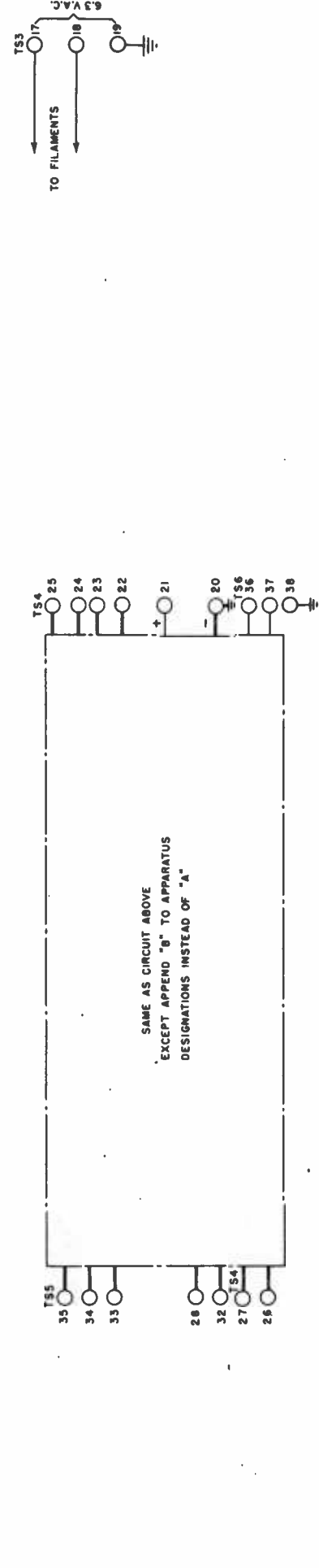
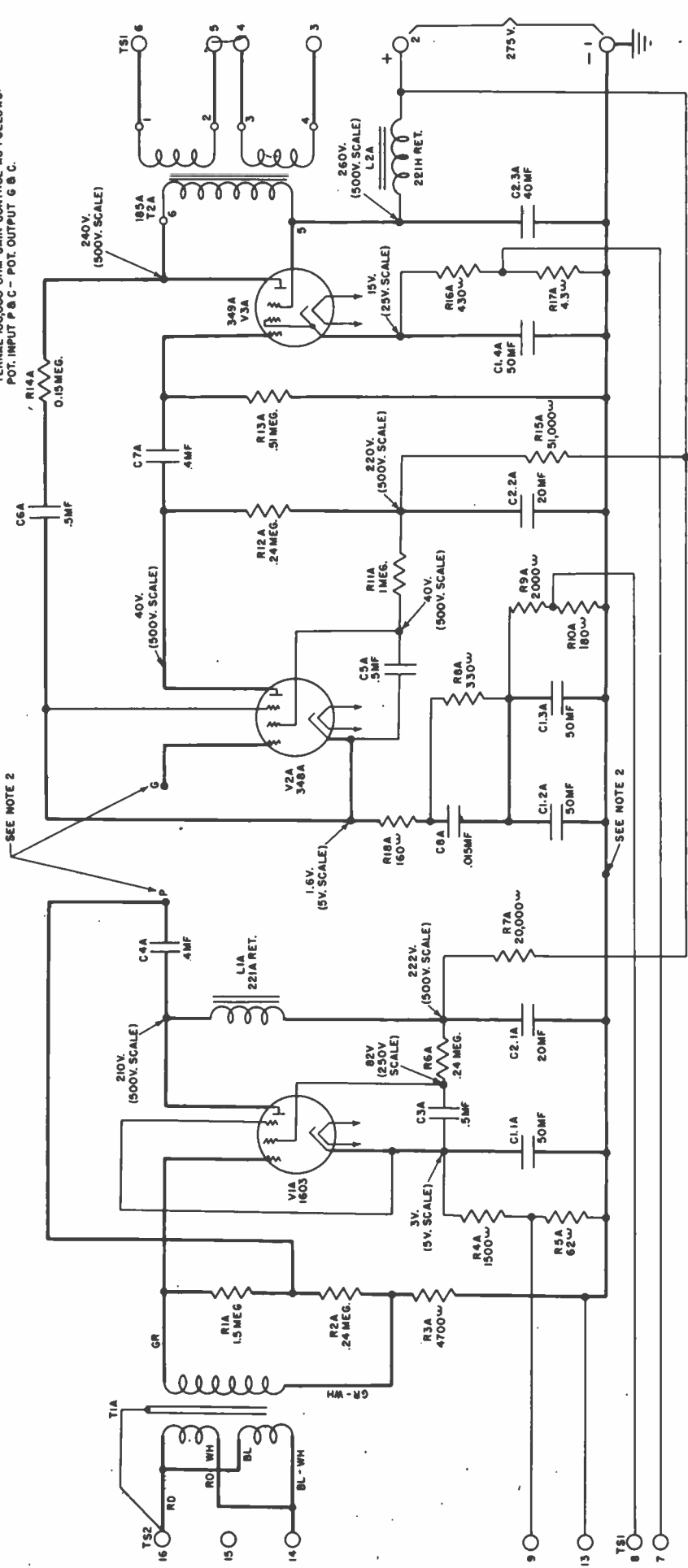

Fig. 1—Schematic

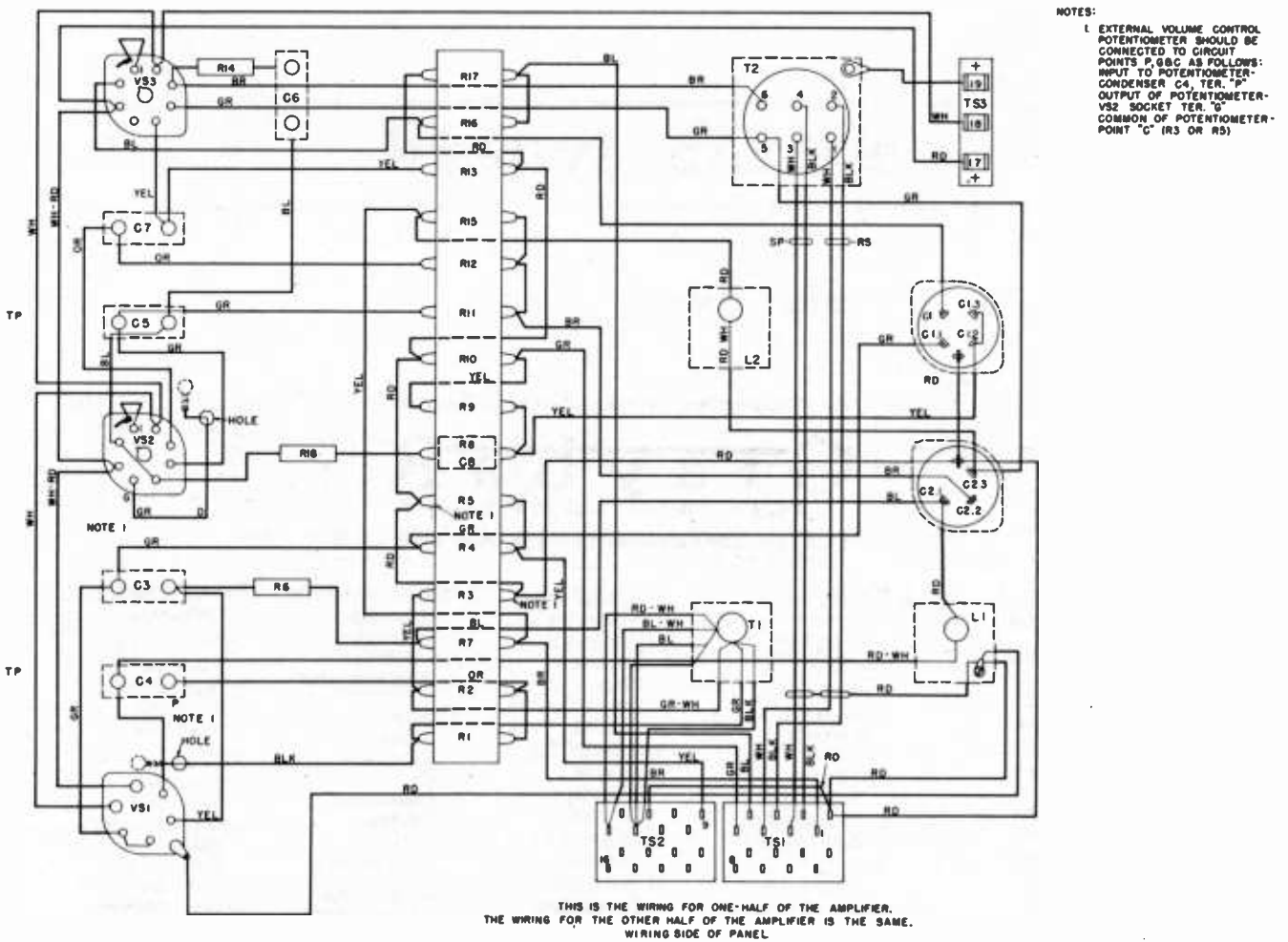

Fig. 2—Wiring Diagram

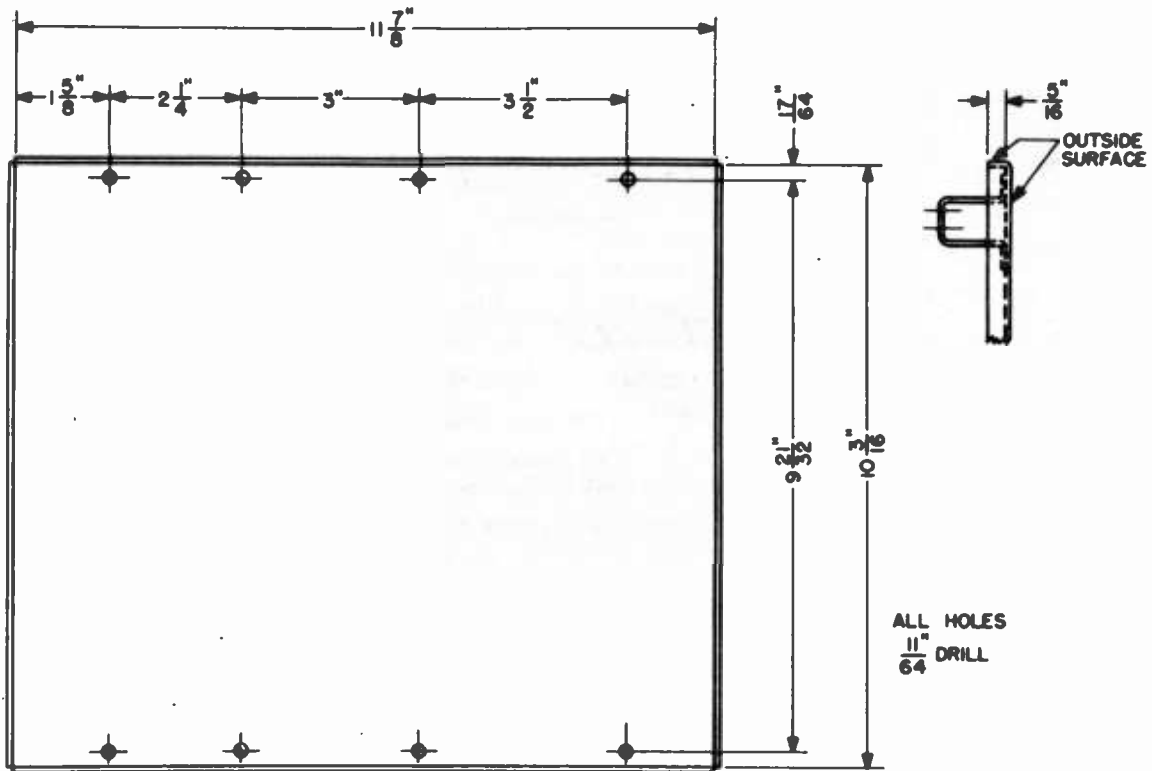

Fig. 3—Mounting Dimensions

DISTRIBUTOR IN THE UNITED STATES

Graybar

ELECTRIC COMPANY

Executive Offices: 420 Lexington Avenue, New York 17, N. Y.

ALABAMA
Birmingham

ARIZONA
Phoenix

ARKANSAS
Little Rock

CALIFORNIA
Los Angeles
Oakland
Sacramento
San Diego
San Francisco

COLORADO
Denver

CONNECTICUT
Hartford
New Haven

DELAWARE
Wilmington

DIST. OF COLUMBIA
Washington

FLORIDA
Jacksonville
Miami
Orlando
Tampa

GEORGIA
Atlanta
Savannah

IDAHO
Boise

ILLINOIS
Chicago
Peoria

INDIANA
Evansville
Hammond
Indianapolis

IOWA
Des Moines
Des Moines

KANSAS
Wichita

KENTUCKY
Louisville

LOUISIANA
New Orleans

MAINE
Portland

MARYLAND
Baltimore

MASSACHUSETTS
Boston

Springfield
Worcester

MICHIGAN
Detroit
Flint
Grand Rapids
Lansing

MINNESOTA
Duluth
Minneapolis
St. Paul

MISSISSIPPI
Jackson

MISSOURI
Kansas City
St. Louis

NEBRASKA
Omaha

NEW HAMPSHIRE
Manchester

NEW JERSEY
Newark

NEW YORK
Albany
Buffalo
New York
Rochester
Syracuse

NO. CAROLINA
Asheville
Charlotte
Durham
Winston-Salem

OHIO
Akron
Cincinnati
Cleveland
Columbus
Dayton
Toledo
Youngstown

OKLAHOMA
Oklahoma City
Tulsa*

OREGON
Portland

PENNSYLVANIA
Allentown
Harrisburg
Philadelphia
Pittsburgh
Reading

RHODE ISLAND
Providence

SO. CAROLINA
Columbia

TENNESSEE
Chattanooga
Knoxville
Memphis
Nashville

TEXAS
Amarillo
Beaumont
Corpus Christi
Dallas
Fort Worth
Houston
San Antonio

UTAH
Salt Lake City

VIRGINIA
Richmond
Roanoke
Norfolk

WASHINGTON
Seattle
Spokane
Tacoma

WISCONSIN
Milwaukee

*State Office

A NATIONAL ELECTRIC SERVICE

DISTRIBUTOR FOR CANADA AND NEWFOUNDLAND

Northern Electric

COMPANY LIMITED

General Offices: 1620 Notre Dame Street, W.

Plant: 1261 Shearer Street,
Montreal, P. Q., Canada

TWENTY-FIVE BRANCHES FROM COAST TO COAST

Western Electric

Western Electric

131A AMPLIFIER



Instruction Bulletin No. 1099, Issue 2

Western Electric

131A AMPLIFIER

Description

Type:

The 131A Amplifier is a special purpose two-stage push-pull 5 watt amplifier for booth and studio loud speaker monitoring in high quality Speech Input or Sound Systems. It incorporates three loud speaker cut-off relays and an output network for serving a booth and two studio loud speakers and a cue feed circuit. The amplifier is designed for operation from an external power supply source.

Typical Electrical Characteristics:

Frequency Characteristic—Flat within 1 db over the range 50 to 15,000 cycles.

Output Power—Approximately 5 watts (+37 dbm) with 5% harmonic distortion; approximately 3.2 watts (+35 dbm) with 1% harmonic distortion.

Output Noise— -55 dbm, unweighted, with maximum gain. Signal to noise ratio over 90 db under conditions of normal gain and output level.

Gain—Approximately 50 db Maximum.

Operates from—600 ohms.

Operates into—Tapped output transformer provides for operation into any impedance from 1 ohm to 1200 ohms. (See output circuit description.)

Power Supply—Filament 6.3 volts, 3 amperes a-c or d-c. Plate 275 volts, 75 milliamperes, d-c. (Filament and plate supply may be obtained from 18 or 20 type Rectifiers.)

Equipment Characteristics:

Panel size—Approximately 6 $\frac{3}{8}$ " x 10-5/16". The apparatus extends approximately 5" from the front and 2 $\frac{1}{4}$ " from the rear of panel.

Weight—Approximately 7 $\frac{3}{4}$ lbs.

Mounting—Designed for mounting in the 25B type Speech Input Console Unit. The 190 type Mounting Plate may also be used for mounting two 131A Amplifiers on standard 19" relay rack type frames.

Installation

Mounting:

The 131A Amplifier is designed primarily for mounting in the 25A or B Speech Input Equipment. Figure 3 shows the outline dimensions of the panel on which the amplifier apparatus is mounted. Apparatus and vacuum tubes mounted on the panel extend about 5" from the outside surface, with the wiring

on the other side, or bottom of the panel; apparatus on this side of the panel extends about 2 $\frac{1}{4}$ " from the panel.

As mounted in the 25 type Speech Input Equipment, the Amplifier chassis is mounted on 8 rubber vibration mounts (U. S. Rubber Company A-301 Cylindrical Mount). In addition to providing isolation from shock and

vibration the rubber mounts insulate the chassis electrically from the cabinet or framework. This permits this and other associated amplifiers and circuits all to be grounded at a single point in the system which is desirable to control noise and crosstalk. Care should be used to see that this insulation is not rendered ineffective by contact between the chassis and the cabinet or other mounting.

Suitable mounting brackets are necessary for other applications of the 131A Amplifier, or the 190 type Mounting plate may be used. Mounting precautions as indicated above should be observed. Other precautions include the following:

Mounting Precautions:

Avoid exposure to magnetic fields which might induce noise in the equipment. When equipment such as 18 or 20 type Rectifiers, or amplifiers with self-contained a-c power supplies are mounted near 131A Amplifiers it is desirable to have maximum separation (10 inch minimum) between the input transformer of the 131A Amplifier and the power transformer of the a-c operated equipment.

Hum caused by pick-up in the input trans-

former can often be reduced by loosening the clamping ring and rotating the transformers to the position of minimum hum. To avoid damaging the leads the transformer should not be rotated more than 180 degrees in either direction from its original position.

Power Supply Considerations:

Both filament and plate power supply can be obtained from either the Western Electric 18A or B Rectifiers (one rectifier for each amplifier). When the 18 type Rectifier is used, a 4 or 5 db improvement in signal to noise ratio can usually be obtained, if required, by equipping the rectifier with an extra filter section as described in the Instruction Bulletin for that rectifier.

External Connections:

Locations:

Terminals 1 to 8 inclusive located on Terminal Strip TS1.

Terminals 9 to 16 inclusive located on Terminal Strip TS2

Terminals 17 to 19 inclusive located on Terminal Strip TS3.

Terminal Numbers	External Connections
1 and 2	600 ohm input.
3	Common lead (ground)—to key contacts for loud speaker cut-off.
4	Booth Microphone Key—to key contacts for booth loud speaker cut-off.
5	Studio A Microphone Keys—to key contacts for Studio A loud speaker cut-off.
6	Studio B Microphone Keys—to key contacts for Studio B loud speaker cut-off.
7	—275 Volts d-c plate supply.
8	+275 Volts d-c plate supply.
9 and 10	Cue feed circuit to remote lines through repeating coil (10 ground side).
11 and 12	Booth Loud Speaker (12 ground Side).
13 and 14	Studio A Loud Speaker (14 ground Side).
15 and 16	Studio B Loud Speaker (16 ground Side).
17 and 18	6.3 Volts a-c or d-c filament supply.
19	Ground (See System Grounding).

All electrical connections to the Amplifier should be made with shielded, twisted-pair copper wire with insulation over the shields, and all joints should be securely soldered with rosin flux solder. The shields should be electrically continuous and should be grounded at the amplifier end only. This grounding should be by connection to the amplifier chassis or to Terminal 19. The shield enclosing the output leads to the cue circuit should not be grounded at the Amplifier but should be grounded only at the input of the succeeding repeating coil.

The Amplifier chassis is insulated from its mounting and hence from the cabinet or rack by the flexible rubber supports, and care should be used in all wiring to avoid shorting out this insulation by uninsulated shields or other connections. Ground to the Audio Ground for each circuit group supplied from a common power supply source should be made at a single point as covered under System Grounding.

System and Power Source Grounding:

The chassis, the shielding, and the negative side of the plate supply should be grounded by connecting Terminal 19 to the Audio Ground lug on the rack or cabinet. When several Amplifiers obtain plate power from a common source, the ground should be applied at only one point in each system supplied from each source. The center tap of the transformer filament winding should also be grounded to the Audio Ground.

Output Circuit Considerations:

The output circuit of this Amplifier consists of an output transformer T2, which feeds four branch circuits. Three of these branch circuits are for connection to the voice coils of three separate loud speakers, while the fourth branch is for connection through an external repeating coil to feed cue program transmission to remote lines or other similar destinations.

The number of loud speakers and their voice coil impedances are likely to differ for different locations so that it is necessary during installation to adjust this output circuit to operate properly with the conditions encountered.

As furnished, the tapped secondary winding of Transformer T2 is connected for the impedance range 1 to 3 ohms, which will satisfactorily feed the four parallel branch circuits when a 3 to 10 ohm loud speaker or equivalent resistance is connected to each of the three loud speaker branches, and the fourth (cue feed) branch is terminated in approximately 600 ohms.

NOTE: To maintain proper network balance, loud speaker branch circuits not equipped with a loud speaker must be terminated instead by connecting in place of the speaker a 2 watt resistance equal in value to the speaker impedance.

Where speakers having other impedances are used the secondary of transformer T2 should be restrapped in accordance with Table I to the proper range to match the combined impedance of the three speaker branches.

TABLE I

Rated Load Impedance	Working Range of Load Impedance	Strap Terminals Connected by Dash	Output Connections
600 ohms	300 ohms to 1200 ohms	7-8, 9-10, 11-12	5 & 14
150 ohms	70 ohms to 300 ohms	7-8, 9-14, 11-12, 5-10	5 & 14
30 ohms	20 ohms to 70 ohms	7-8, 9-10, 11-12	6 & 13
16 ohms	10 ohms to 20 ohms	7-8-10, 9-11-12	6 & 13
7.5 ohms	3 ohms to 10 ohms	7-9-10-12, 6-8, 11-13	6 & 13
*1.75 ohms	1 ohm to 3 ohms	6-8-10-12, 7-9-11-13	6 & 13

*Amplifier as supplied is wired for this load.

Although it is not necessary that the speakers connected to the speaker branches have identical impedances, it can be expected that more energy and consequently higher program level will be fed to the speaker or speakers having the lower impedance. This may be altered by connecting a resistance in series with the low impedance speaker. In some cases, however, this may result in an appreciable lowering of the level available from the system.

The cue feed branch normally has an impedance so much greater than the combined impedance of the three loud speaker branches, that it usually meets all impedance conditions without modification. For some applications a change in the cue feed circuit resistances may become desirable to obtain either a higher or lower average program level. As long as a high ratio is maintained between the impedance of the cue feed branch and the combined impedance of the loud speaker branches, such adjustment can usually be carried out by a cut and try method until a satisfactory cue feed level is obtained without affecting the loud speaker branches.

Loud Speaker Cut-Off Feature:

Each loud speaker branch circuit is equipped with a cutoff relay which may be connected to operate from a pair of contacts on external keys such as microphone keys or talk back keys so that operation of the key to turn the microphone on will, at the same time automatically silence the loud speaker located in the same room with the microphone. This prevents acoustic feed back, (or singing) caused by a microphone picking up sound from a loud speaker connected to the same amplifier channel.

Power for operating these cut-off relays is obtained from the power stage cathode circuit which in turn obtains energy from the

plate supply source. Because of this feature, it is unnecessary to obtain this power from a special signal power supply source. To operate these relays therefore, it is only necessary to connect terminal No. 3 (common terminal) to terminal No. 4 to silence the booth speaker; to terminal No. 5 to silence Studio A Speaker, and to terminal No. 6 to silence Studio B Speaker. Each of these connections should be made through a "make" contact pair on the key or keys assigned to control the associated speaker.

In operation, each cut-off relay substitutes for its speaker load a compensating resistance load, which should have approximately the same number of ohms as the impedance of the associated speaker. This tends to hold the level constant on the speaker or speakers remaining in operation. Resistances R12, R13 and R14 are these compensating resistance loads associated respectively with the Booth Speaker, Studio A Speaker and Studio B Speaker cut-off relays. As shipped, each of these resistances has a value of 10 ohms $\pm 5\%$. If other than 10 ohm speakers are used these resistances should be replaced by other 2 watt resistances having approximately the same value as the impedance of the associated speaker.

Vacuum Tubes:

Two Western Electric 348A Vacuum Tubes should be inserted in the first stage sockets. The flexible grid leads should be attached to the tube caps and the tube shields should be placed over the tubes. Two Western Electric 349A Vacuum Tubes should be inserted in the second stage sockets.

Warning: The tube shields are locked to the bases (which are fastened to the panel) by screw threads at the bottom of the shield and can only be removed without damage by rotating the shield counter-clockwise.

Operation

A period of approximately one minute should be allowed for the vacuum tube cathodes to reach their operating temperature after pow-

er is applied. As this amplifier is of the push-pull type throughout, it is desirable for best operation to pair off tubes on opposite sides

of the same stage so that they have as nearly identical characteristics as possible. This test is not critical and the trial of several pairs of tubes will usually indicate which pair gives the best performance.

No special plate current measuring facilities are provided in this amplifier. However, operation may be checked by measuring the voltages as indicated on the schematic, Figure 1.

Associated Parts:

The following vacuum tubes are required for the operation of this Amplifier and must be specified separately on the order.

2—Western Electric 348A Vacuum Tubes

2—Western Electric 349A Vacuum Tubes

In an emergency, if the above tubes are

not available, the following tubes may be substituted:

First Stage—6J7 or RCA 1620 for 348A

Second Stage—6F6 for 349A

(For best results the same make of tube should be used in both sides of each push-pull stage.)

The following accessory equipment is recommended for use with this Amplifier.

190 type Mounting Plate

Western Electric 18A, 18B or 20B

Rectifier

Maintenance Parts:

If replacement parts are required for the 131A Amplifier they may be procured through the nearest distributor. Lists of replaceable parts of the amplifier are packed with each amplifier.

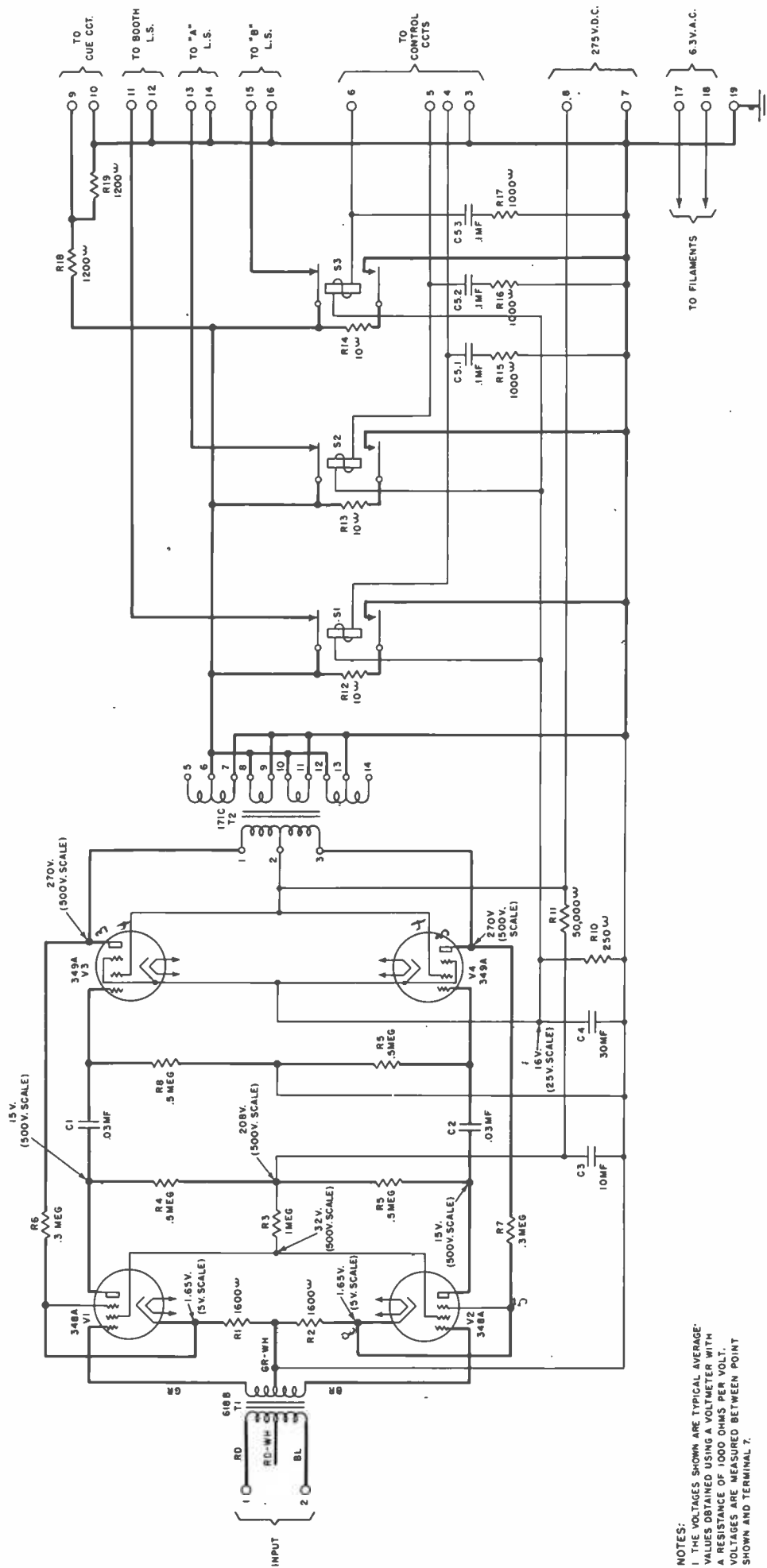

NOTES:
 1. THE VOLTAGES SHOWN ARE TYPICAL AVERAGE VALUES OBTAINED USING A VOLTMETER WITH A RESISTANCE OF 1000 OHMS PER VOLT. VOLTAGES ARE MEASURED BETWEEN POINT SHOWN AND TERMINAL 7.

FIG. 1 — Schematic

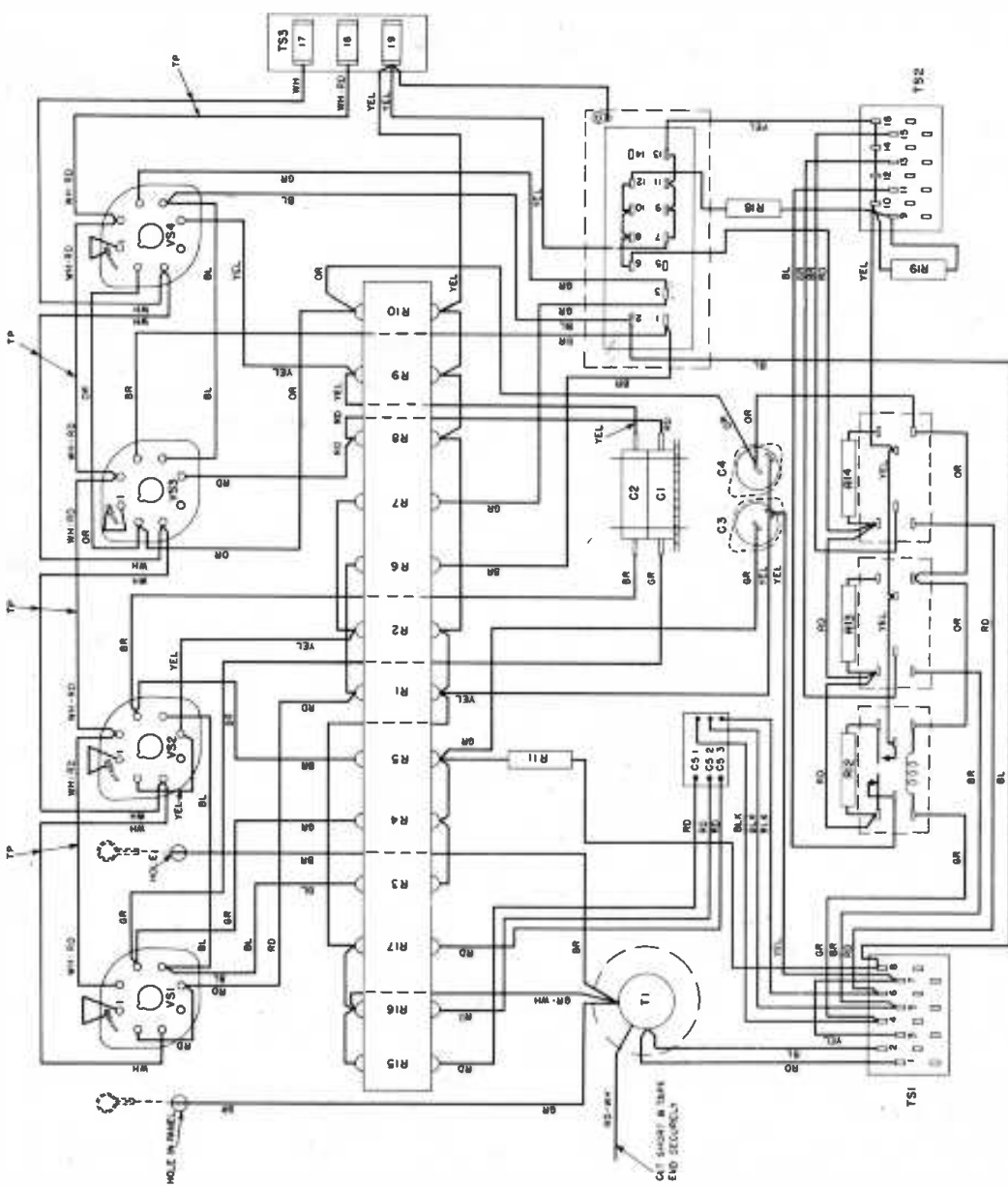

FIG. 2 — Wiring Diagram

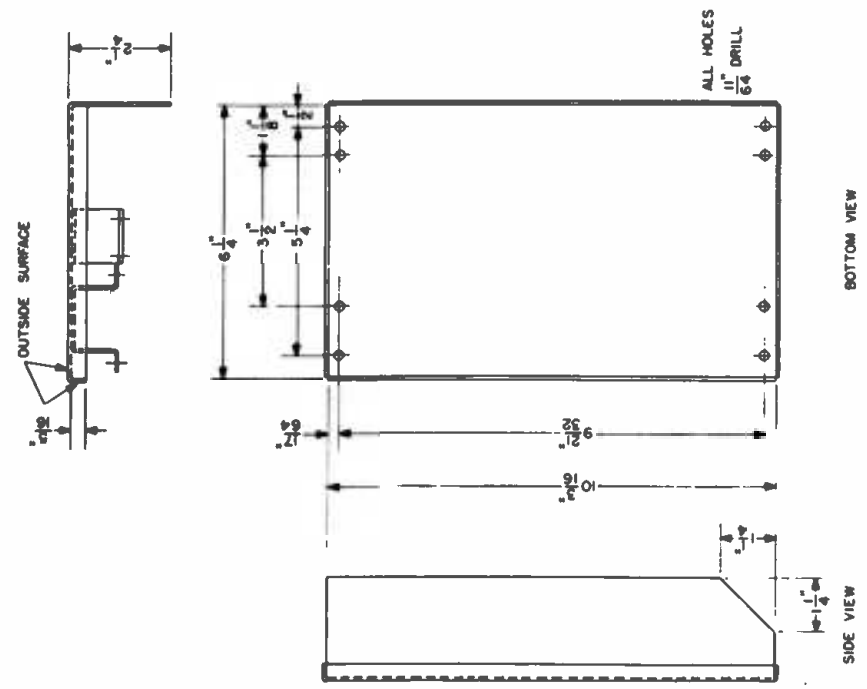

FIG. 3 — Chassis Detail

DISTRIBUTOR IN THE UNITED STATES

Graybar

ELECTRIC COMPANY

Executive Offices: 420 Lexington Avenue, New York 17, N. Y.

ALABAMA
Birmingham

ARIZONA
Phoenix

ARKANSAS
Little Rock

CALIFORNIA
Los Angeles
Oakland
Sacramento
San Diego
San Francisco

COLORADO
Denver

CONNECTICUT
Hartford
New Haven

DELAWARE
Wilmington

DIST. OF COLUMBIA
Washington

FLORIDA
Jacksonville
Miami
Orlando
Tampa

GEORGIA
Atlanta
Savannah

IDAHO
Boise

ILLINOIS
Chicago
Peoria

INDIANA
Evansville
Hammond
Indianapolis

IOWA
Des Moines

KANSAS
Wichita

KENTUCKY
Louisville

LOUISIANA
New Orleans

MAINE
Portland

MARYLAND
Baltimore

MASSACHUSETTS
Boston

Springfield
Worcester

MICHIGAN
Detroit
Flint
Grand Rapids
Lansing

MINNESOTA
Duluth
Minneapolis
St. Paul

MISSISSIPPI
Jackson

MISSOURI
Kansas City
St. Louis

NEBRASKA
Omaha

NEW HAMPSHIRE
Manchester

NEW JERSEY
Newark

NEW YORK
Albany
Buffalo
New York
Rochester
Syracuse

NO. CAROLINA
Asheville
Charlotte
Durham
Winston-Salem

OHIO
Akron
Cincinnati
Cleveland
Columbus
Dayton
Toledo
Youngstown

OKLAHOMA
Oklahoma City
Tulsa*

OREGON
Portland

PENNSYLVANIA
Allentown
Harrisburg
Philadelphia
Pittsburgh
Reading

RHODE ISLAND
Providence

SO. CAROLINA
Columbia

TENNESSEE
Chattanooga
Knoxville
Memphis
Nashville

TEXAS
Amarillo
Beaumont
Corpus Christi
Dallas
Fort Worth
Houston
San Antonio

UTAH
Salt Lake City

VIRGINIA
Richmond
Roanoke
Norfolk

WASHINGTON
Seattle
Spokane
Tacoma

WISCONSIN
Milwaukee

*Sales Office

A NATIONAL ELECTRIC SERVICE

DISTRIBUTOR FOR CANADA AND NEWFOUNDLAND

Northern Electric

COMPANY LIMITED

General Offices: 1620 Notre Dame Street, W.

Plant: 1261 Shearer Street,
Montreal, P. Q., Canada

TWENTY-FIVE BRANCHES FROM COAST TO COAST

Western Electric

Western Electric

20B RECTIFIER



Instruction Bulletin No. 1103
Issue 2

Western Electric

20B RECTIFIER

Type

Full-wave vacuum-tube rectifier incorporating a vacuum-tube voltage-regulating circuit with provision for preventing the plate voltage from rising above its final value during the warm-up period of the voltage-regulator tube.

Typical Characteristics

Input—105-130 volts, 50 to 60 cycles. Power consumption approximately 55W.-.7A at 115 volts for no load and 196W.-1.7A for rated load.

Output—Rated load-plate supply $\textcircled{110}$ milliamperes at 275 volts d-c and filament supply 10 amperes at 6.3 volts a-c.
20B ~ 300C

Plate Supply Regulation—3 volts max. voltage change from no load and +10 per cent line voltage to rated load and -10 per cent line voltage.

Plate Supply Ripple—Approximately 5 millivolts rms at rated load.

Equipment Characteristics

Dimensions—Mat— $19\frac{5}{32}$ x $6\frac{1}{32}$ inches.

Chassis—Overall including mounting flanges, $18\frac{5}{16}$ x $6\frac{1}{16}$ x 2 inches. Width of recessed section, 17 inches.

Maximum Depth of Apparatus— $6\frac{7}{8}$ inches, from front edge of chassis.

Weight—26 pounds.

Mounting—Recessed panel type designed to mount vertically on standard relay rack or speech-input cabinet where it occupies 7 inches of panel space. May also be mounted horizontally on a flat surface by moving the power switch and potentiometer to either

side wall of the chassis utilizing knock-outs provided.

Mat Finish—Aluminum gray (20B-15 Rectifier); black japan (20B-3 Rectifier). Aluminum gray furnished unless otherwise specified.

Chassis Finish—Bright gray enamel.

Protection

A 2-ampere No. 902 Fustat (which is furnished) accessible from the rear of the chassis provides protection in the power input circuit for rated output load plus allowance for 10 per cent high line voltage. The fustat socket is arranged to prevent the use of higher amperage Fustats, but will accommodate one other Fustat of lower rating, the 1.8 ampere No. 9018 Fustat, which will permit somewhat closer adjustment for loads less than rated output.

NOTE—Fustats must be screwed in with appreciable pressure to insure circuit continuity.

Mounting

Ten .216-24 x $\frac{1}{2}$ inch Phillips recessed binding head screws are furnished with each rectifier. A corresponding Phillips No. 2 Point screwdriver will be required for use with these screws in mounting the rectifier. The chassis, less the mat, should first be mounted with four of the screws. The mat may then be mounted over the chassis and fastened directly to the cabinet using four more of the screws. The remaining two screws are spares. However, the mat should not be mounted until the adjustments described under "Operation" are completed.

If desired, the rectifier may be mounted

horizontally on a flat surface. This necessitates moving the power switch D1 and the adjustment potentiometer P1 to one or the other of the long side walls of the chassis. Knockouts are provided at these alternate positions for mounting the switch and the potentiometer. The bracket on which the potentiometer is mounted must be removed if the nearby alternate position in the side wall is used. After mounting the controls in the new positions, the wiring (which is of sufficient length to reach these positions) should be reconnected in accordance with the wiring diagram.

Connections-External

Terminals	Circuits
15-16	A-C power, 15 to grounded side of line
13-14	6.3 volt amplifier filaments, max. 5 amperes
11-12	6.3 volt amplifier filaments, max. 5 amperes
7-9	Ground terminals—connect one to a good ground
1-3-5	Plate supply, positive
2-4-6	Plate supply, negative

NOTE — Negative plate supply is grounded at the rectifier by a strap to terminal 7. In some cases, quieter operation may be obtained by grounding the negative at one of the amplifiers being supplied by the rectifier, in which case disconnect the strap from terminal 6 to 7.

Use 14-gauge twisted-pair copper wire for a-c power. Use shielded twisted-pair copper wire for amplifier filaments and plate supply—22 gauge or larger for plate supply.

If individual pairs are used for the filament of each amplifier the wire may be as small as No. 18 gauge if the length is such that the voltage drop in the wire does not exceed 0.2 volt. If one pair of wires is used for more than one amplifier, its size should be such that the current-carrying capacity of the wire is not exceeded and the voltage

drop in the wire is not more than 0.2 volt. When the total filament load is taken on a number of pairs, the connections of these pairs should be distributed between the two sets of filament supply terminals so as not to exceed approximately 5 amperes per set.

Vacuum Tubes

The following vacuum tubes are required for operation of this rectifier and must be ordered separately.

- 1 Western Electric 274A or type 5Z3
- 1 Western Electric 300B or type 2A3
- 1 Western Electric 351A or type 6X5 or type 6X5G
- 1 Western Electric 348A or type 6J7 or type 6J7G
- 1 Western Electric 313C

NOTE—Special instructions when Type 2A3 tube is used:

1. Limit 275 volts output load to 75 milliamperes for optimum tube life.
2. Make sure filament voltage at socket VS2 is 2.5 volts instead of 5 volts as furnished. 2.5 volts are obtained by moving the WHITE-GREEN wire, normally on terminal 5 of transformer T1, to terminal 6. The WHITE-RED wire normally connected to terminal 6 should remain connected.

CAUTION—High voltages are exposed to the operator's touch whenever the mat is removed. High voltages may be present even with the a-c power off or disconnected. For example, across the filter condensers C1 and C2 after failure or removal of the 300B or 2A3 tube during operation. Exercise extreme care at all times when mat is not in place to avoid contact with dangerous voltages.

Operation

After the rectifier has been installed and connected it should be equipped with vacuum tubes as listed above. The locations of the tubes in their respective sockets can be ascertained by the tube markings stamped beside each vacuum-tube socket.

WARNING—Before operating the power switch to turn on the rectifier for the first time, be sure that the potentiometer P1 has been turned to the extreme counterclockwise (min. voltage) position, to avoid delivering a higher voltage at the output than the external apparatus connected to the output can stand.

To place the rectifier and associated amplifiers in operation, connect a 1000 ohms per volt voltmeter across the d-c output and operate the power switch to the "ON" position. After allowing 10 or 15 minutes for the rectifier to reach stable operating temperature, adjust the potentiometer P1 until 275 volts is obtained at the output. Turn off power switch, disconnect the voltmeter, replace the mat over the chassis, and the equipment is ready for use.

Circuit Description

A brief description of the functions of the more important elements in this rectifier will clarify the manner in which it operates. Referring to the schematic Figure 1, V1, C1, L1 and C2 comprise a conventional full-wave rectifier with filter delivering approximately 700 volts to the 300B tube, V2, which acts as a variable impedance in series with the positive output circuit reducing this voltage to the value determined by the setting of P1, normally 275 volts. During operation, a fraction of the output voltage is taken by the voltage divider, R1, R2.1, P1 and R2.2, amplified by the 348A tube, V4, and applied to the grid of V2 where it varies the plate impedance of this tube in accordance with small changes in output voltage, thus com-

pensating for the change and maintaining the output voltage constant.

The 313C tube, V5, is a cold-cathode gas-filled tube whose function is to establish a reference voltage against which variations in the a-c line and output voltages can be corrected. This tube requires about 70 volts for initial ionization, after which the voltage sustained across the control gap is approximately 60 volts independent of the current.

The function of V3, the 351A tube, is to limit the output voltage at terminal 1 during the warm-up period of V4. This prevents excessive voltage on the plates of the vacuum tubes in the associated amplifiers while the filaments are heating. When the rectifier is first turned on and V1 and V2 become operative the gas tube V5 is ignited at once by voltage applied through V2, R5, R3 and R2.3, and a potential of approximately 60 volts is established across V5. The resistance of R3 and R2.3 combined is low relative to the resistance of R5 so that the cathode and plate of V4, and the grid of V2 are also at a potential of approximately 60 volts. Under these conditions V4 is inoperative and the grid of V2 is highly negative in respect to its filament, consequently its plate resistance is high, limiting the voltage on output terminal 1. During this period V3, being a heater type tube, is non-conducting. As V3 warms up simultaneously with V4 and passes current, R5 is effectively shorted out; current flows through R4 to the plate of V4 creating a potential difference between the plate and cathode of this tube so it can function normally. At the same time this increase of voltage on the plate of V4 is equivalent to a reduction in bias between the filament and plate of V2 which lowers the plate resistance and increases the output voltage until equilibrium is established by the regulator circuit at the voltage determined by the setting of P1.

In this connection, it should be noted that P1 is provided primarily to adjust for aging of the gas tube V5 and for commercial variations in the resistors used in the regulator circuits. However, output voltages higher or lower than 275 volts may be obtained by adjustment of P1 with the following limita-

tions. As the output voltage is increased the load current which can be obtained without loss of regulation will be reduced. Typical maximum load current values are 20 milliamperes at 450 volts and 70 milliamperes at 375 volts. The output voltage should not be adjusted to more than 450 volts otherwise the current through the 313C tube will exceed its rated value of 10 milliamperes. As the output voltage is decreased the load which must be absorbed by the 300B tube V2 increases and the output current capacity must correspondingly be reduced to avoid overloading the 300B tube. Typical limiting values of output current for several output voltages below 275 volts which will give the same dissipation in the 300B tube as at rated load are 90 milliamperes at 250 volts and 72 milliamperes at 204 volts. At very low output currents and low output voltage some loss in regulation will result. On a typical rectifier supplying a load at 225 volts, 5

milliamperes, the output voltage varied only 0.4 volt for a change in line voltage from 100 to 130 volts. At 210 volts, 5 m.a., the d-c output followed a-c line voltage fluctuations above 122 volts with variations as much as 2 volts.

Maintenance

Test points are provided for determining the operating characteristics of V5. The voltage across this tube when measured with a voltmeter of at least 1000 ohms per volt should not exceed 65. While the tube may function when the voltage drop across it is in excess of 65, the noise level of the rectified voltage will become excessive and the regulating circuit may oscillate. Consequently, the tube should be replaced.

If replacement parts are required for the 20B rectifier they may be procured through the nearest distributor.

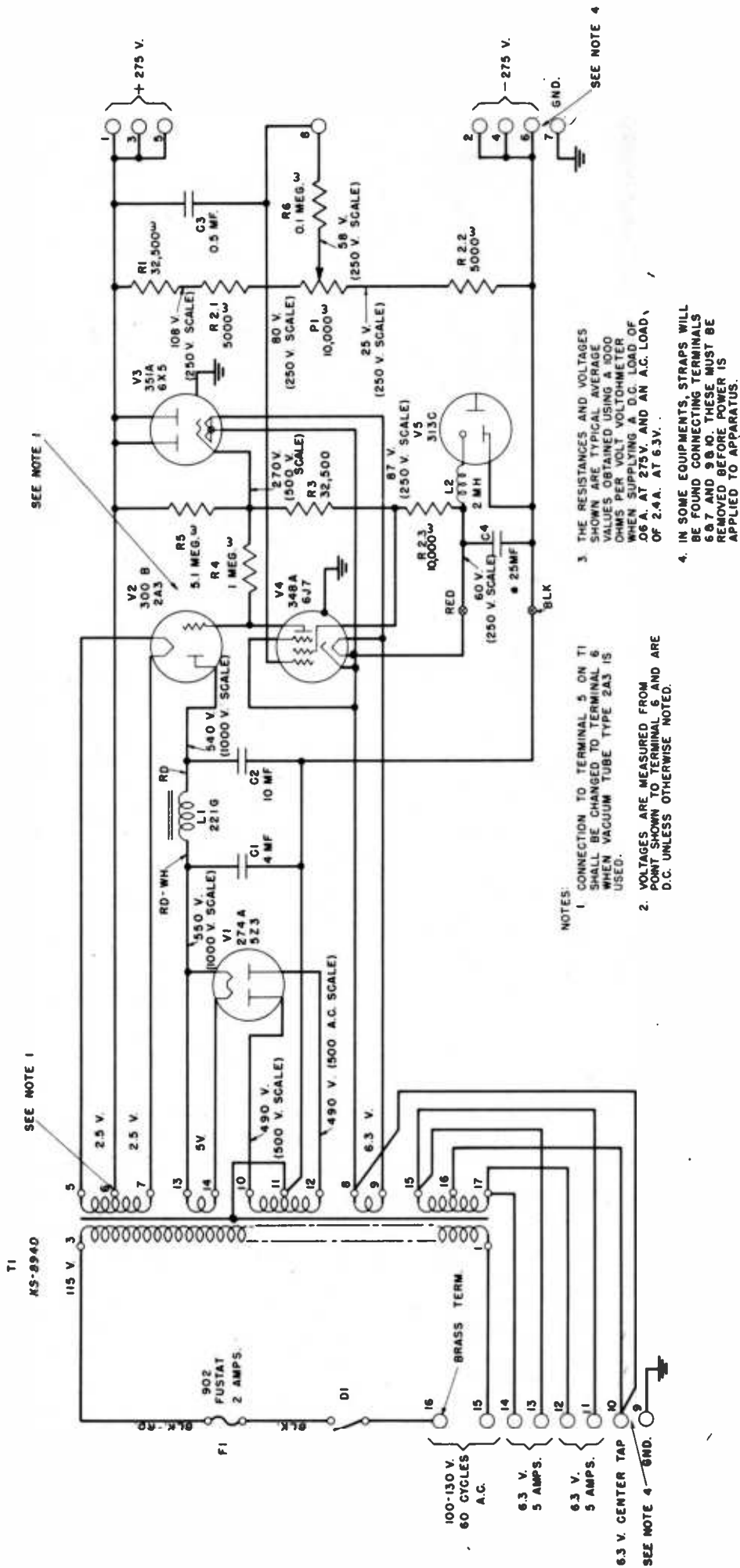

Fig. 1—Schematic

DISTRIBUTOR IN THE UNITED STATES

Graybar

ELECTRIC COMPANY

Executive Offices: 420 Lexington Avenue, New York 17, N. Y.

ALABAMA Birmingham	GEORGIA Atlanta Savannah	Springfield Worcester	NO. CAROLINA Asheville Charlotte Durham Winston-Salem	SO. CAROLINA Columbia
ARIZONA Phoenix	IDAHO Boise	MICHIGAN Detroit Flint Grand Rapids Lansing	TENNESSEE Chattanooga Knoxville Memphis Nashville	
ARKANSAS Little Rock	ILLINOIS Chicago Peoria	MINNESOTA Duluth Minneapolis St. Paul	OHIO Akron Cincinnati Cleveland Columbus Dayton Toledo Youngstown	TEXAS Amarillo Beaumont Corpus Christi Dallas Fort Worth Houston San Antonio
CALIFORNIA Los Angeles Oakland Sacramento San Diego San Francisco	INDIANA Evansville Hammond Indianapolis	MISSISSIPPI Jackson	OKLAHOMA Oklahoma City Tulsa*	UTAH Salt Lake City
COLORADO Denver	IOWA Davenport Des Moines	MISSOURI Kansas City St. Louis	OREGON Portland	VIRGINIA Richmond Roanoke Norfolk
CONNECTICUT Hartford New Haven	KANSAS Wichita	NEBRASKA Omaha	PENNSYLVANIA Allentown Harrisburg Philadelphia Pittsburgh Reading	WASHINGTON Seattle Spokane Tacoma
DELAWARE Wilmington	KENTUCKY Louisville	NEW HAMPSHIRE Manchester	RHODE ISLAND Providence	WISCONSIN Milwaukee
DIST. OF COLUMBIA Washington	LOUISIANA New Orleans	NEW JERSEY Newark		
FLORIDA Jacksonville Miami Orlando Tampa	MAINE Portland	NEW YORK Albany Buffalo New York Rochester Syracuse		
	MARYLAND Baltimore			
	MASSACHUSETTS Boston			

*Sales Office

A NATIONAL ELECTRIC SERVICE

DISTRIBUTOR FOR CANADA AND NEWFOUNDLAND

Northern Electric

COMPANY LIMITED

General Offices: 1620 Notre Dame Street, W.

Plant: 1261 Shearer Street,
Montreal, P. Q., Canada

TWENTY-FIVE BRANCHES FROM COAST TO COAST

Western Electric

**STANDARD AUDIO FACILITIES
FOR
HIGH QUALITY BROADCASTING**

25B SPEECH INPUT EQUIPMENT

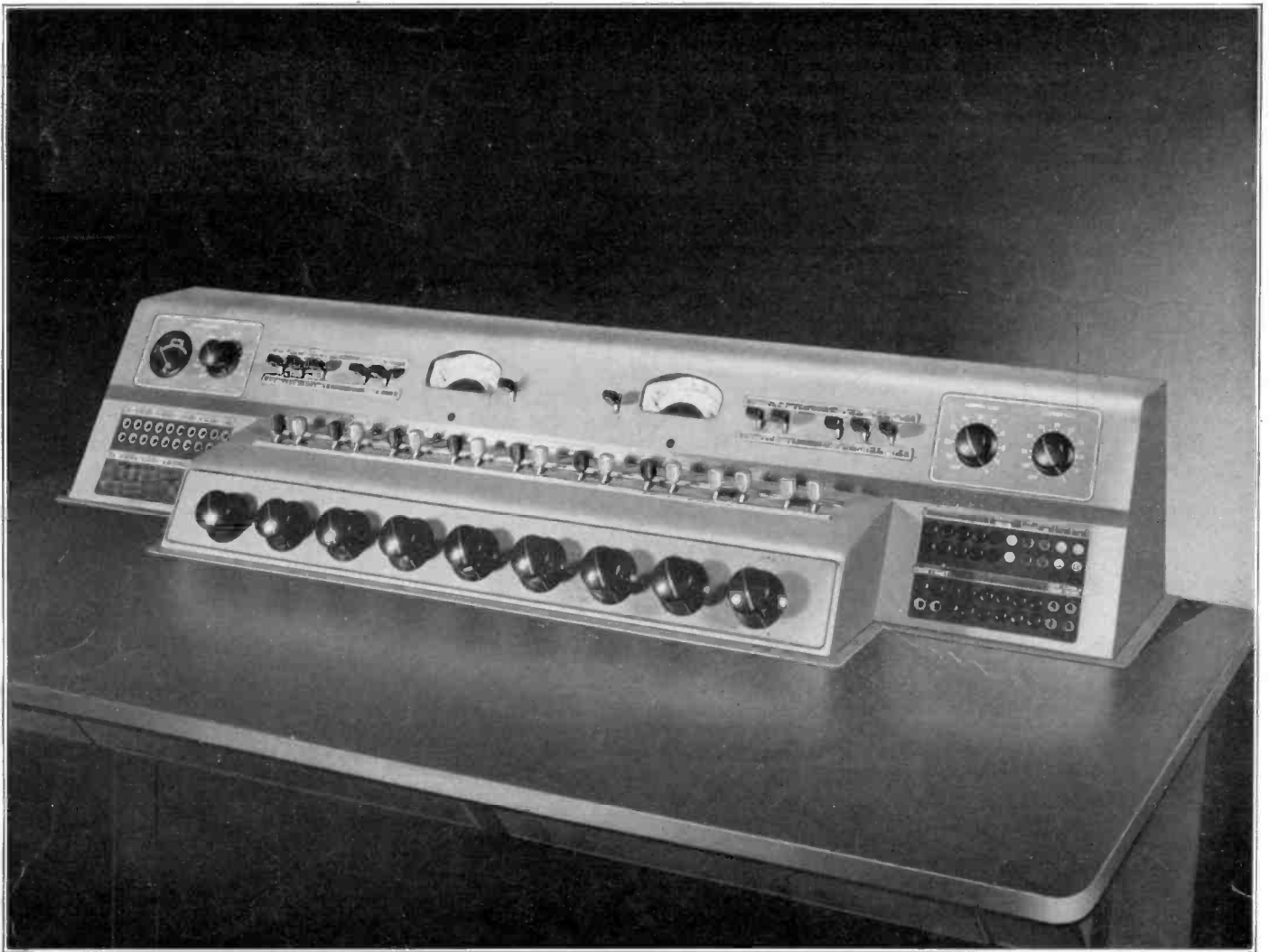

Western Electric

STANDARD CONSOLE TYPE AUDIO FACILITY FOR BROADCASTING

A HIGHLY FLEXIBLE UNIT CAPABLE OF HANDLING TWO PROGRAMS SIMULTANEOUSLY

SEVERAL basically new ideas in speech input console design and operation have been built into the Western Electric 25 type equipment. This console was designed by Bell Telephone Laboratories for use at broadcast stations using FM transmission or at AM stations planning to provide for FM at some future time. Accordingly, high-fidelity service for FM broadcasters is provided by the 25 type's uniform, noise-free, and distortionless operation over a 15,000-cycle range.

The 25B Speech Input Equipment provides a seven channel mixer circuit and more facilities than its predecessor, the 25A, together with improved mechanical and cabling arrangements.

The design is greatly simplified as to mounting and installation, requiring only a minimum of effort to put the two fully assembled and wired units into service.

The main unit houses two complete high-quality main amplifier channels, capable of simultaneous operation on different programs without interference or cross talk. Also in this desk console are pre-amplifiers, mixers, switching, indicating, monitoring, cue feeding, and other control apparatus, arranged and coordinated to provide maximum operating flexibility and convenience.

A compact power supply unit serves the 25B equipment. This is arranged for wall mounting, and is generally located away from the console. The power supply unit, mounted on a swinging frame for easy inspection and maintenance access, contains the power supply units for plate and filament power to all vacuum tubes, and also for the loudspeaker cut-off relays. Thus the only need for any other auxiliary power supply is the usual D. C. Signal supply for operation of indicating lights and external relay systems where employed.

Built into the main housing of the console are eight microphone or low-level transcription input circuits and four pre-amplifiers, with switching keys for ready selection of either of two low-level inputs for each pre-amplifier. These are shown diagrammatically in the schematic circuit. Four of these circuits can be used simultaneously, with four in reserve available at a moment's notice, enabling the engineers to schedule programs of eight sources, or to dispatch two successive four-source programs. Three additional microphone or transcription sources can be introduced simultaneously through the three line mixers as explained below. Optional addition of jacks, lamps, or jack-sized keys

for system control and indicating circuits give the 25B still greater utility.

Especially valuable to stations operating both AM and FM transmitters, or simultaneously originating both local and network programs, are the line facilities of this speech console. The two main amplifier channels, capable of simultaneous operation on separate programs, permit concurrent dispatch of audio signals to each of two transmitters or out-going lines through the one console, each channel being governed by a separate master gain control for adjusting overall level. This set-up obtains flexibility through two line switching keys which allow either of the two main channels to be fed to either or both of two outgoing lines.

Three remote line input-circuits with repeating coils feed incoming line programs to three separate line mixer-controls. Ready and rapid selection of remote or network programs is speeded by three remote line switching keys, usable in selecting any one of three lines, for monitoring incoming programs, or for connecting to the associated mixer input. Patching jacks, with which four additional remote lines can be substituted on a line-for-line basis, make available a total of seven input lines or trunks.

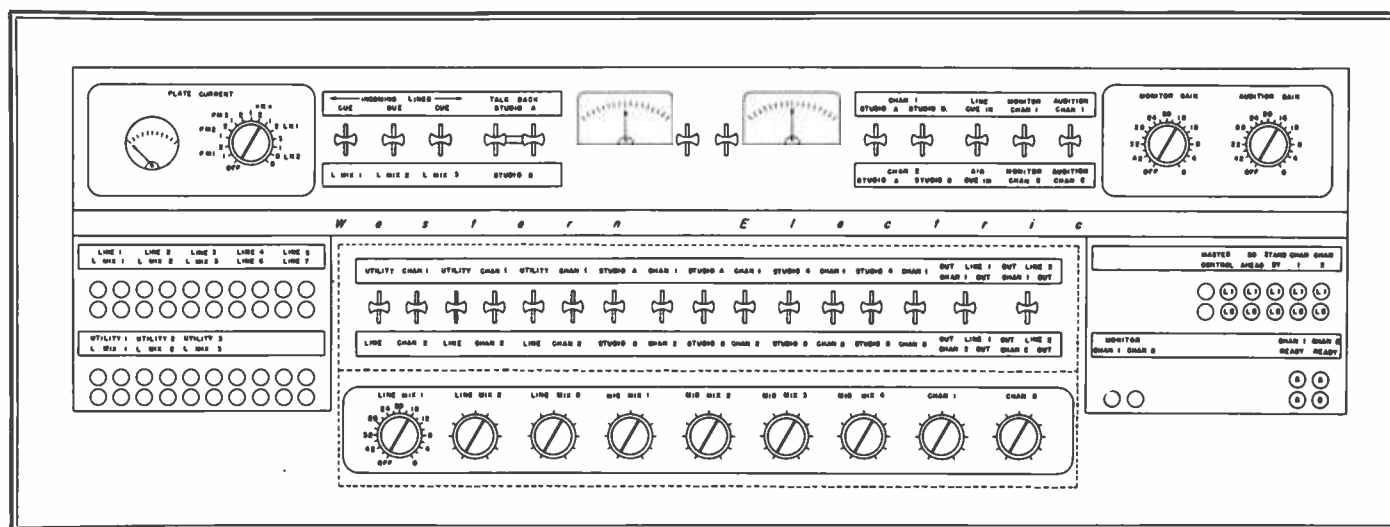

FACE EQUIPMENT AND DESIGNATION LAYOUT OF 25B SPEECH INPUT EQUIPMENT

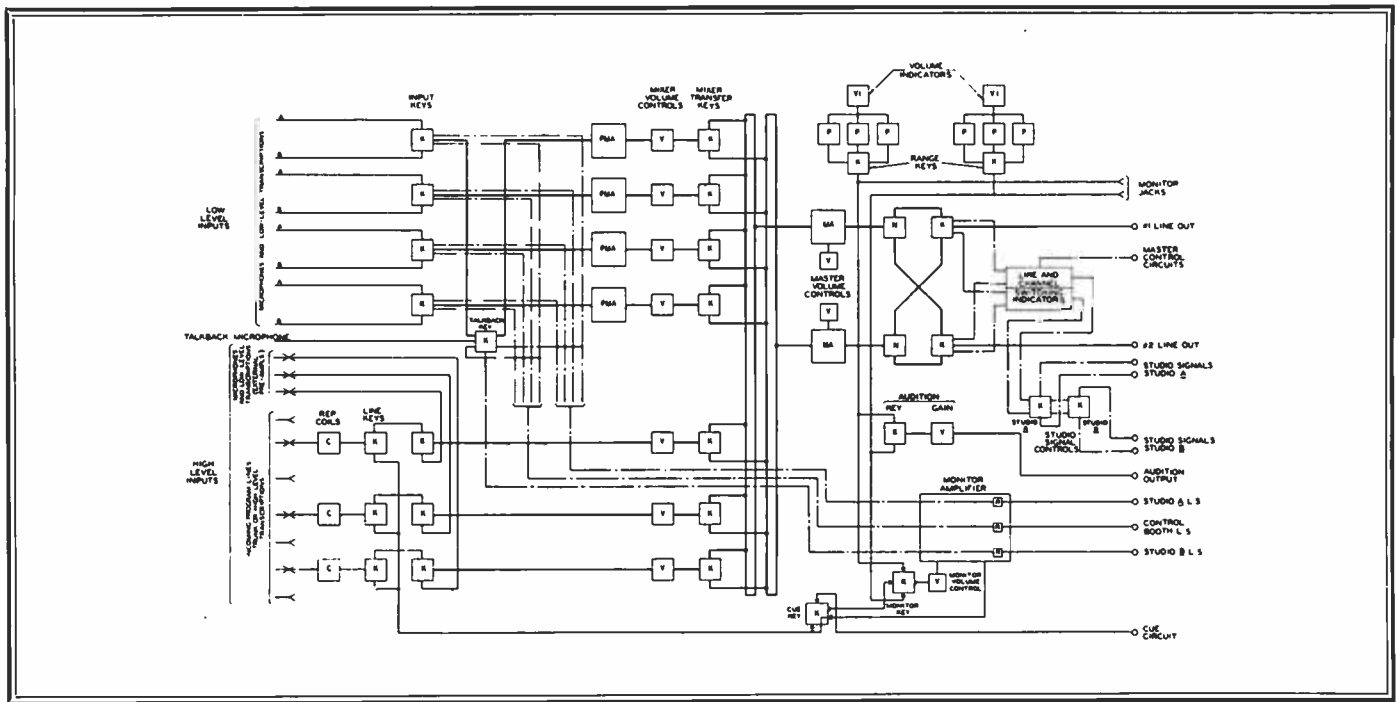

FUNCTIONAL SCHEMATIC OF WESTERN ELECTRIC 25B EQUIPMENT WHICH PROVIDES VERSATILE CONTROL OF STUDIO FACILITIES

Each of the line mixer inputs is provided with a transfer key which will allow an external utility circuit such as a transcription source or output of microphone preamplifier to be switched in place of a line program source. Thus three additional microphone or transcription sources (a total of seven simultaneously) can be accommodated where required by providing externally mounted preamplifiers.

With seven mixer potentiometers for individual level adjustment on the three line or utility input circuits and on the four microphone input circuits, the 25B makes extensive provision for blending programs under a wide variety of operating situations. These potentiometers operate on either of the two main amplifier channels through a seven-channel mixer circuit with individual mixer transfer keys for association with either main amplifier channel input.

Mounted on the console are two volume indicators for visual monitoring of program levels of the two main channels. In addition, headphone jacks for each channel are mounted on the housing for occasions when both channels are being used and monitored simultaneously, making headphone monitoring necessary on one of the channels. A built-in monitor amplifier which may be connected to either main channel is included for aural monitoring.

The important operations of cueing are thoroughly controlled. The monitor amplifier feeds cue programs into a studio speaker and the remote line circuits, while a monitor transfer key gives access to programs on either of the two main

channels or to the cue transfer key. This key switches between the conditions of monitoring on the remote lines, receiving cue from master control, or feeding cue to remote lines. Operation of a loudspeaker in the same room with a live microphone is automatically prevented by loudspeaker cut-off relays for the booth and two studio loudspeakers. Contacts are also provided for operating equipment outside the system, such as studio warning signs, buzzer cut-offs, and other auxiliaries.

Other important features include an additional circuit with a gain control and a channel switching key to feed either main channel output to a separate local amplifier system external to the speech input equipment. This is invaluable for audition circuits, sound re-enforcement in large audience studios and similar applications. Normal operation of the amplifier tubes can be checked quickly by a plate-metering circuit with a meter and rotary tap switch for individual plate current measurement.

When this equipment was in the planning stage, emphasis was put upon the convenience afforded by low height and small overall size. Accordingly, the dimensions of the console were held down to 36 ins. overall height and a width of 55¼ ins. Overall depth is 28¼ ins.—of which only 13½ ins. at the rear is the control cabinet. The table top stands 27½ ins. from the floor. The separate power supply unit is 16½ ins. high, 28 ins. wide, and 10 ins. deep.

Although extremely useful in small installations, large stations will find the 25B an even greater boon. A number of

these consoles, one installed in each studio control room or in a control room common to two studios will, with the help of master coordinating equipment, provide complete speech input facilities for an entire station.

This speech input console should bridge a long-standing gap in broadcasting apparatus, for it is more flexible than table-top units, and less expensive than custom-built equipment.

12A POWER UNIT

The power supply unit is separate and is designed for wall mounting. It is approximately 15 inches high, 28 inches wide and 10 inches deep. It contains the power supply units for plate and filament power to all vacuum tubes and is intended for location near the main unit, but separate from it. Louvers are provided for ventilation and the equipment is mounted on a swinging frame which allows easy access for inspection and maintenance. Power supply is also incorporated for operation of the loud speaker cut-off relays so that no auxiliary power supply unit is necessary for that purpose. (The usual D. C. Signal power source is needed where indicating lights or external control relays are required.)

The 25B SPEECH INPUT CONSOLE

PROVIDES A WHOLE ALPHABET OF FEATURES

- A** Eleven microphone or low level input circuits, seven of which can be used simultaneously.
- B** Four microphone preamplifiers.
- C** Switching keys, for selecting either of two low level inputs for each preamplifier.
- D** Three remote line input circuits, with repeating coils.
- E** Three remote line switching keys, for selecting any one or combination of three lines, for monitor, or for program feed.
- F** Three utility keys for selecting any one or all of the three line mixers for microphone or transcription inputs (using external preamplifiers) or for other line level sources.
- G** Patching jacks, for substituting four additional remote lines, on a line-for-line basis. Thus a total of seven input lines or trunks are available to the operator.
- H** Seven mixer potentiometers, for individual level adjustment on four microphone input circuits, and three line input circuits.
- I** A seven channel mixer circuit, with individual mixer transfer keys, for switching each of the seven mixer potentiometers between the two main amplifier channels.
- J** Two main amplifier channels capable of simultaneous operation on separate programs without interfering cross-talk.
- K** Two master gain controls, one for adjusting the over-all level of each main channel.
- L** Two output switching keys, allowing either of the two main channels to be fed to either or both of two outgoing lines.
- M** Line isolation pad for each line, which serves to stabilize line impedance, and aids in maintaining high grade transmission.
- N** Two volume indicators for each main channel for visual monitoring of program level to the lines.
- O** Jacks for individual head phone monitoring on each of the two main amplifier channels.
- P** A monitor amplifier for aural monitoring, with the booth loudspeaker, of programs on the two main amplifier channels, on the incoming line circuits, or on an external cue feed circuit from master control; also for feeding cue programs to the studio speaker and to the remote line circuits.
- Q** Monitor transfer key, giving the monitor amplifier input access to programs on either of the two main amplifier channels, and to the cue transfer key.
- R** Cue transfer key, for switching between the conditions of monitoring on the remote lines, receiving cue from master control, and feeding cue to the remote lines.
- S** Gain control for monitor amplifier.
- T** Loudspeaker cut-off relays, for the booth and two studio loudspeakers, with strapping board for interlock with regular microphone input keys to automatically prevent operation of loudspeaker in same room with a live microphone.
- U** Contacts for closing control circuits to relays outside this equipment for operation of studio warning signs, buzzer cut-offs, master control equipment and other auxiliaries.
- V** A branching circuit, with gain control and channel switching key, for feeding a separate local amplifier system external to this equipment. This is useful for audition purposes or for sound reenforcement in large audience studios and similar applications.
- W** A plate metering circuit with meter and rotary tap switch, for quickly checking individual plate currents, to determine that all amplifier tubes between microphones and broadcast lines are normal.
- X** Power supply for operating loudspeaker cut-off relays.
- Y** Adequate terminal facilities to accommodate incoming and outgoing line and program circuits and power supply feeds.
- Z** Talk-back control key for switching one microphone input circuit and the loudspeaker control circuits for talk-back from the control room into the associated studio.

DISTRIBUTOR IN THE UNITED STATES

Graybar
ELECTRIC COMPANY

Executive Offices: 420 Lexington Avenue, New York 17, N. Y.

Offices in more than 80 principal cities

A NATIONAL ELECTRIC SERVICE

DISTRIBUTOR FOR CANADA AND NEWFOUNDLAND

Northern Electric Company
LIMITED

General Offices: 1620 Notre Dame Street, W. Plant: 1261 Shearer Street,
Montreal, P. Q., Canada

TWENTY-THREE BRANCHES FROM COAST TO COAST

Tops for FM

TWO CHANNEL SPEECH INPUT CONSOLE

SPEECH INPUT EQUIPMENT

25A

Western Electric

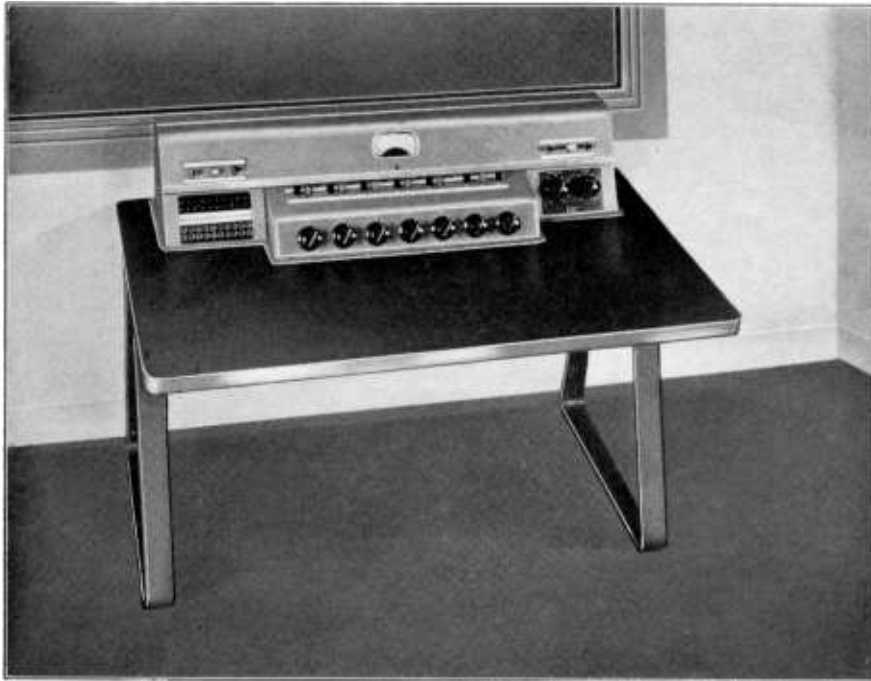

STYLE

QUALITY

ACCESSIBILITY

DIMENSIONS

49" long, 26 $\frac{1}{2}$ " deep, 35 $\frac{1}{2}$ " overall height above floor. Writing surface 27" above floor and 14 $\frac{1}{2}$ " from front edge to nearest sloping panel.

Featuring compactness, its main unit houses two, complete, high quality, main amplifier channels, capable of simultaneous operation on different programs without interference or cross talk. It also houses preamplifier, mixer, switching, indicating, monitoring, cue feeding, and other control apparatus indicated on the schematic drawing.

FOR routine maintenance and inspection of the top side apparatus such as vacuum tubes, gain control potentiometers, keys and switches, of the 25A Desk, it is only necessary to lift the upper panel and fold back the potentiometer panel.

During installation and at infrequent intervals when access to the smaller amplifier parts and wiring may be desired, it may easily be obtained by swinging the amplifier rack down into a position just below the front edge of the table as shown in the illustration at the right.

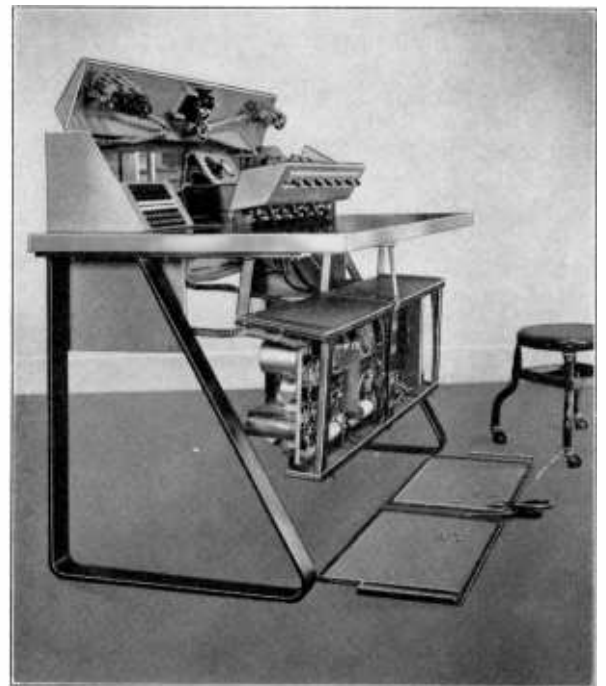

Western Electric

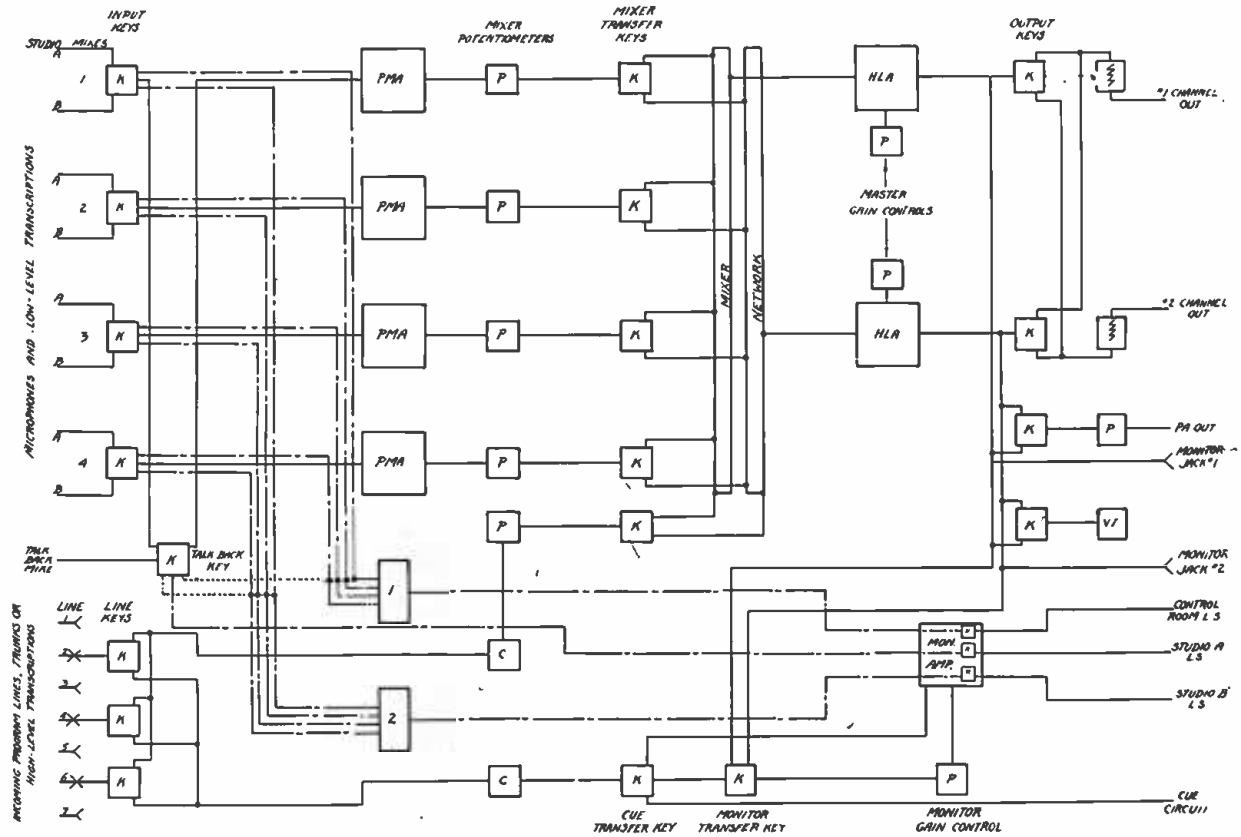

Functional Schematic of 25A Speech Input Equipment

POWER SUPPLY

The power supply unit is separate and is designed for wall mounting. It is approximately 15 inches high, 23 inches wide and 8 inches deep. It contains the power supply units for

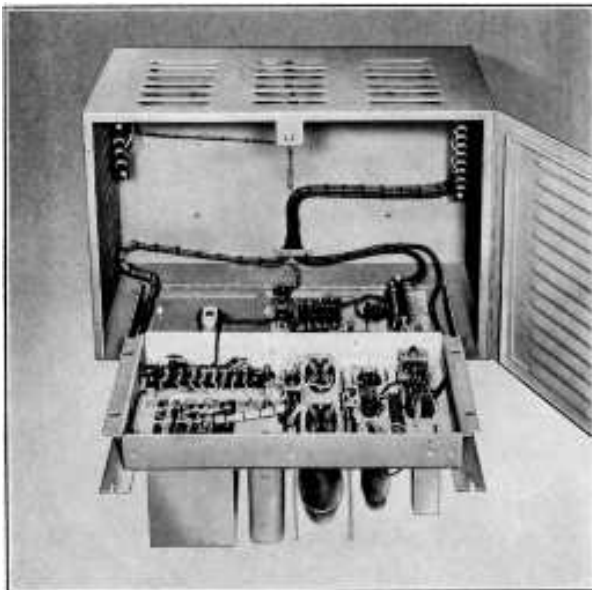

plate and filament power to all vacuum tubes and is intended for location near the main unit, but separate from it. Louvers are provided for ventilation and the equipment is mounted on a swinging frame which allows easy access for inspection and maintenance. Power supply is also incorporated for operation of the loud speaker cut-off relays so that no auxiliary power supply unit is necessary for that purpose.

FEATURES

- 1 Eight microphone or low level input circuits, four of which can be used simultaneously.
- 2 Four microphone preamplifiers.
- 3 Switching keys, for selecting either of two low level inputs for each preamplifier.
- 4 A remote line input circuit, with repeating coils.
- 5 Three remote line switching keys, for selecting any one of three lines, for monitor, or for program feed.
- 6 Patching jacks, for substituting four additional remote lines, on a line-for-line basis. Thus a total of seven input lines or trunks are available to the operator.
- 7 Five mixer potentiometers, for individual level adjustment on four microphone input circuits, and the line input circuit.
- 8 A five channel mixer circuit, with individual mixer transfer keys, for switching each of the five mixer potentiometers between the two main amplifier channels.
- 9 Two main amplifier channels capable of first grade simultaneous operation on separate programs.
- 10 Two master gain controls, one for adjusting the over-all level of each main channel.
- 11 Two output switching keys, allowing either of the two main channels to be fed to either of two outgoing lines.
- 12 Line isolation pad for each line, which serves to stabilize line impedance, and aids in maintaining high grade transmission.
- 13 A volume indicator, for visual monitoring of program level to the lines, with switching key for connecting to the output of either of the two main channels.
- 14 Jacks for individual head phone monitoring on each of the two main amplifier channels.
- 15 A monitor amplifier for aural monitoring, with the booth loudspeaker, of programs on the two main amplifier channels, on the incoming line circuits, or on an external cue feed circuit from master control; also for feeding cue program to the studio speaker and to the remote line circuits.
- 16 Monitor transfer key, giving the monitor amplifier input access to programs on either of the two main amplifier channels, and to the cue transfer key.
- 17 Cue transfer key, for switching between the conditions of monitoring on the remote lines, receiving cue from master control, and feeding cue to the remote lines.
- 18 Gain control for monitor amplifier.
- 19 Loudspeaker cut-off relays, for the booth and two studio loudspeakers, with strapping board for interlock with microphone input keys to automatically prevent operation of loudspeaker in same room with a live microphone.
- 20 Contacts for closing control circuits to relays outside this equipment for operation of studio warning signs, buzzer cut-offs, and other auxiliaries.
- 21 A branching circuit, with gain control and channel switching key, for feeding a separate local amplifier system external to this equipment. This is useful for sound reenforcement in large audience studios and for similar applications.
- 22 A plate metering circuit with meter and rotary tap switch, for quickly checking individual plate currents, of all amplifier tubes to determine that they are normal.
- 23 Power supply for operating loudspeaker cut-off relays.
- 24 Space for addition of 20 jacks, lamps or jack-sized keys as required for system control, and indicating circuits.
- 25 Adequate terminal facilities to accommodate incoming and outgoing line and program circuits and power supply feeds.
- 26 Talk-back control key for switching one microphone input circuit and the loudspeaker control circuits for talk-back from the control room into the associated studio.

OK for F.M.

DISTRIBUTOR IN THE UNITED STATES

Graybar
ELECTRIC COMPANY

Akron
Albany
Allentown
Asheville
Atlanta
Baltimore
Beaumont
Birmingham
Boston
Buffalo
Butte
Charlotte
Chattanooga
Chicago
Cincinnati
Cleveland
Columbia

Columbus, O.
Dallas
Davenport
Dayton
Denver
Des Moines
Detroit
Duluth
Durham
Flint
Fort Worth
Fresno
Grand Rapids
Hammond
Harrisburg
Hartford
Houston

Indianapolis
Jacksonville
Kansas City
Knoxville
Lansing
Los Angeles
Louisville
Memphis
Miami
Milwaukee
Minneapolis
Nashville
Newark
New Haven
New Orleans
New York
Norfolk
Oakland

Oklahoma City
Omaha
Orlando
Peoria
Philadelphia
Phoenix
Pittsburgh
Portland, Me.
Portland, Ore.
Providence
Reading
Richmond
Roanoke
Rochester
Sacramento
St. Louis
St. Paul

Salt Lake City
San Antonio
San Diego
San Francisco
Savannah
Seattle
Spokane
Springfield, Mass.
Syracuse
Tacoma
Tampa
Toledo
Washington
Wichita
Winston-Salem
Worcester
Youngstown

A NATIONAL ELECTRIC SERVICE

GENERAL DISTRIBUTOR FOR CANADA AND NEW FOUNDLAND

Northern Electric Company
LIMITED

General Offices and Plant: 1261 Shearer Street, Montreal, P. Q.

TWENTY-THREE BRANCHES FROM COAST TO COAST

DISTRIBUTOR IN OTHER COUNTRIES

International Standard Electric Corporation

67 Broad Street

New York, U. S. A.

Offices in all principal cities