

# STUDER

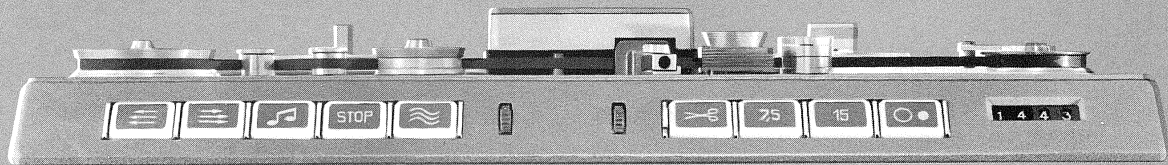

Studio -  
Tape Recorder

# C37



**Willi Studer Regensdorf Zurich**  
**Manufacturer of Magnetic Tape Recorders**

## Studio Tape Recorder Studer C 37

Advanced design and skilled craftsmanship have created the professional TAPE RECORDER STUDER C-37. A machine which is adaptable to the many different requirements of today's modern sound recording techniques.

The novel idea of the "building block principle", on which the design of this recorder is based, allows easy access to any part of the machine and replacing a faulty assembly is a matter of seconds. Servicing and maintenance have been simplified and reduced to a minimum. By just adding and/or replacing amplifiers and head-mount the fully pre-wired recorder accommodates a second channel for two-track recordings. Special versions equipped with cueing-head for variable-pitch disk recording, or for Pilotone controlled playback are also available.

Please observe that the 50 cycle model is design to work from mains of 220 volts nominal, whereas the 60 cycle model is to be operated on 117 volts power-lines. For all other voltages step-up or step-down transformers of proper power handling capacity m u s t be used.

It is strongly suggested to carefully read this Instruction Manual before connecting up the STUDER C-37 Recorder for the first time. Only by knowing and understanding its principles of operation is it possible to get the full benefit of the exceptional recording quality which is obtainable from this machine.

Following and observing the instructions given herein, a perfect match from recorder to recorder can be assured, an essential pre-requisite for international Program-Exchange.

**The Professional Tape Recorder**  
**Studer C 37**



# Table of Contents

- A. TECHNICAL DATA
- B. OPERATION
  - 1 Installation
  - 2 Recording
  - 3 Reproducing
  - 4 Editing and cueing
  - 5 Timer
  - 6 Indexing and cutting
  - 7 Remote control
  - 8 Tape tension selector
- C. TAPE TRANSPORT
  - 1 Head mount
  - 2 Spooling motors and brakes
  - 3 Tape tension balance
  - 4 Fly wheel
  - 5 Tape lift mechanism
  - 6 Capstan assembly
  - 7 Power supply for tape transport
  - 8 Relay box
  - 9 Tape cutter
  - 10 Tape timer
  - 11 Guide rollers
  - 12 Console
- D. ELECTRONIC ASSEMBLIES
  - 1 Record amplifier
  - 2 Oscillator with testmeter
  - 3 Playback Amplifier
  - 4 Power supply
    - a Rectifier unit
    - b Regulating unit
- E. ALIGNMENT PROCEDURES
  - 1 Reproduce channel
    - a Head alignment
    - b Playback circuit alignment
  - 2 Record channel
    - a Head alignment
    - b Bias adjustment

- c Record level
- d Response check
- e Distortion
- f Noise level measurements
- g Erase efficiency
- 3 Wow and flutter measurements, tape slip
- 4 Starting- and stopping time adjustment

F. MAINTENANCE SCHEDULE

G. PARTS LIST

H. SCHEMATIC DIAGRAMS, LEAFLETS

## A Technical Data

Dimensions:	Chassis length	25,8" (655 mm)
	depth	20,7" (525 mm)
	Height under table top	13,0" (330 mm)
	Height above table top, highest point	4,13" (105 mm)
Weight:	approx. 170 lbs. chassis, stereo equipped.	
Power requirement:	220 V $\pm$ 10% 50 cycle, approx. 250 VA or 110 V $\pm$ 10% 60 cycle, approx. 250 VA.	
Tape speed, nominal:	15 ips and 7,5 ips, selected by push-buttons with simultaneous record- and replay equaliza- tion change.	
Tape speed, absolute:	$\pm$ 0,2% of nominal.	
Tape slip:	max. 0,1% from the start of a 12 inch reel down to a diameter of 2,4 inches.	
Wow and flutter, overall: (peak to peak values read on EMT 420)	unweighted:	weighted:
	15 inch. $\pm$ 0,075%	$\pm$ 0,04%
	7,5 inch. $\pm$ 0,1%	$\pm$ 0,06%
	This will correspond to less than 0,1% rms total wow and flutter, if measured with a meter which is calibrated to read the rms value of sine wave flutter.	
Starting-time:	less than 1,0 sec. to reach a motion stability of $\pm$ 0,2%.	
Stopping tape run-out when from regular forward speed:	< 2 inch.	
Stopping-time from fast wind:	< 2 sec.	
Rewind-time:	max. 3,0 minutes for 3.300 ft of standard tape.	
Reel dimensions:	max. diameter 12 inch. Interchangeable adapters for European core DIN 45515, cine-reel, or NAB hub.	
Tape timer:	99 minutes 59 seconds driven by tape, accuracy better than 0,2%. 0,3% at all running speeds, including fast wind.	
Input:	0,7 to 7,00 V adjustable, balanced, impedance greater than 15 kilohms between 30 to 15000 cps.	
Output:	0,7 to 7,00 V adjustable, balanced, designed to work into loads from 200 to 600 ohms, (max. +24 dbm into 200 ohms). Effective output impedance less than 25 ohms from 40 - 15000 cps.	
Frequency response: (equalized to CCIR recommandations)	+1db to -2db, from 30 - 15000 cps at both tape speeds.	

A

Distortion:  
 a) amplifiers: < 0,1%  
 b) overall: less than 2% at a tape flux of 200 milli Maxwell  
 at 1000 cps. (≈320 nWb/m according CEI)

Signal to Noise Ratio:  
 The values indicated  
 were measured with  
 Siemens Noise Meter  
 Type Rel 3 U 33, while  
 Drive- and Take-up  
 Motors were running.  
 They are with reference  
 to a signal level of  
 200 milli Maxwell

	<u>15 ips</u>	<u>7,5 ips</u>
rms unweighted	70(62) db	66 (58) db
rms weighted	75(61) db	70 (57) db
peak value unweighted	67(60) db	63 (56) db
peak value weighted	75(59) db	70 (54) db

The values in parenthesis were  
 measured off tape with all re-  
 cord circuits switched on, but  
 in the absence of an audio  
 signal. Due to the reduced  
 track width on Stereo Recorders  
 the above indicated signal to  
 noise ratios will be reduced by  
 approx. 5 db.

Stereo channel to channel  
 crosstalk at 1000 cps: 45 db

Channel to channel  
 Phase Shift at 10 Kc better than 10°

Record and playback  
 heads: Vacodur (Alfenol) for minimum head wear

Erase head: Ferrite

Oscillator: 80 kc, one frequency only.

Running hour counter: 6 digit counter, records operating hours of  
 capstan motor.

Stray field: max. 50 milligauss at a distance of 2,0 inch.  
 from the motor-deck.

Tubes:

Recording amplifier:	2 x E 188 CC
Playback amplifier:	3 x E 188 CC 1 x E 283 CC
Oscillator:	2 x E 188 CC mono 3 x E 188 CC stereo
Power supply for amplifiers:	1 x E 130 L 1 x E 283 CC 3 x 85 A 2 1 x ASZ 18
Power supply for tape transport:	1 x ASZ 15

## B Operation

### B 1 INSTALLATION.

Carefully unpack the recorder following the step by step instructions which are supplied with each machine and check accessories against the packing-slip.

Lift the motor-deck by depressing the recessed push-buttons on the front end of the left and right-hand side of the top-plate, while exerting a slight downward pressure with the palms of both hands on the front corners of the machine.

This releases the latches, allowing the deck to be lifted. A brace on the right hand side will hold it securely in the opened position. Make certain that all tubes, fuses and plugs, are seated properly in their sockets and check plug-in amplifiers, oscillator and power supply for being pushed home into their respective receptacles.

#### Attention!

Do not connect the recorder to the power line before being sure that the machine will meet the conditions of your electric power supply. (Check designation plate just below power receptacle). Use step-up or step-down transformer for deviations of more than 10 volts. Connect System-Ground to the recorder via the power plug and power receptacle. In some installations adequate grounding may be provided by the neutral conductor of the power line, but often these are carrying to high a potential of parasitic voltages, causing clicks and hum.

The audio in-and outgoing lines are to be connected via the supplied cannon plugs XLR-3-11C and XLR-3-12C respectively. Pin 1 of these connectors carries ground, whereas the balanced audio-lines connect to pins 2 and 3 of the same. A strap in the Regulating-Unit connects minus of the power-supply to chassis and ground. Better performance with respect to hum may sometimes be obtained by opening this strap.

Least interference to the audio-signal from random strayfield will be caused if special EMT cables are used for the inter-equipment wiring. More information about the outstanding shielding properties of these cables can be found in the leaflet which is enclosed with this manual.

#### Power.

Power to the recorder is turned on by depressing either of the two speed selecting Push Buttons - 7,5 or 15 ips.

#### Checking supply voltages.

The condition of the fuses is checked by glancing at the eight fuse-holders in the machine. A glowing neon-light will indicate a burnt or missing fuse. Quick-test the supply voltages on the test meter in the oscillator-unit. For this, the tension balance is to be turned into its operating position and the "play" and "record" buttons are to be depressed, (items 3 and 5, fig. 1). Rotating the selector switch through its eight positions, the pointer must swing to the center of the tolerance mark in positions 1 to 4 and 6. The indication in position 5 will depend on the setting of the tape tension balance potentiometer. A more accurate description can be found under D 2 "Oscillator and Test-Meter".



### Closing the Motor-Deck.

Raise the motor-deck slightly with one hand until the hinged brace can be pulled forward. Carefully lower the deck taking care not to pinch any of the interconnecting cables. With the deck returned to near horizontal position, press firmly downwards with the palms of both hands on the front end corners until the latches audibly lock into place.

### Operating Controls.

The function of each push-button can best be seen from fig. 1. The speed selector buttons 7, 5 and 15 are simultaneously serving as "Power On" switches.

- 1 Fast reverse (two speeds)
- 2 Fast forward (two speeds)
- 3 Play
- 4 Stop
- 5 Record
- 6 Tape Lift Mechanism
- 7 Head Shield
- 8 Cutter
- 9 Speed Selector, Power "on"
- 10 Speed Selector, Power "on"
- 11 Power "off"
- 12 Timer
- 13 Timer Re-set
- 14 Safety catch for cutter control
- 15 Indexing Stamp
- 16 Splicing Block

#### Note:

A change of tape speed, or turning off the recorder, can be effected only after the tape tension balance has returned to its resting position.

### Tape Threading.

The tape threading path can clearly be seen from fig. 1 and the tape should be threaded as indicated. Adapters to accommodate the various spools and cores generally used with tape recorders are supplied with each machine. They are easily exchanged and fig. 3 shows the Locking-bars which have to be depressed by thumb and index-finger when lifting them from their seating. When inserting an adapter on the machine, press firmly downwards, making certain that both bars lock into place.

### Important:

Use only reels or cores of the same type and dimensions on the supply and take-up side, as faulty braking action will otherwise invariably result.

## B 2 RECORDING.

In order to start the machine in the record mode, the "play" and "record" buttons have to be pressed simultaneously. Both buttons are electrically interlocked and depressing them individually is of no effect on the record-circuits, thus eliminating the possibility of accidental erasure.

### Special Recording Techniques.

If it happens that during the recording of spoken words (radioplay, interview etc.) one of the participants makes a mistake that would ruin the take, part of the already recorded material may be saved by applying one of the techniques which are described below.

The recording may be continued - after a short pause or cue has been determined from where on continuation is feasible - by replaying the tape up to that cue, while constantly depressing the "play" button. The very moment the cue has passed, the "record" button is to be pressed also, the record mode is now turned on again and both buttons may be released. A sign, quickly given to the actors etc. makes them continue the play.

An alternate method would be, to lift the tape off the erase- and record heads by rotating the knurled disk next to the record button, (item 6, fig. 1), and then starting the machine in the record mode in the regular manner. No erasure is taking place as the tape is not yet in contact with the erase head. However, immediately the cue has passed, the knurled disk is released, the tape comes into contact with erase- and record head and the recording may be continued as described earlier.

These techniques could of course be applied to more complex tasks also and skilled technicians have helped to save considerable sums of money in recording sessions where expensive talent was engaged.

Sometimes pencils are used to lift the tape off the heads and with skill and training, applause from different recording has been successfully cross-faded, giving a realistic air to a well edited and assembled concert-hour.

## B 3 REPRODUCING.

Once the recorder has been turned on, the reproduce mode can be started by simply depressing the "play" button, (item 3, fig. 1).

The "play" button is ineffective during fast wind, either forward or reverse, and the recorder has first to be stopped.

When stopping from fast wind the "play" button remains electrically blocked until all tape motion has come to a halt, a feature which eliminates the possibility of tape-spills or tape breakage. There is no danger in switching to fast forward or reverse while the recorder is running at regular forward speed.

For optimum signal to noise ratio during replay, the mu-metal shield should be moved over the play back head by rotating the knurled disk, (item 7, fig. 1), which is located next to the cutter control. The effect of this shield will of course greatly depend on whether or not there is any interfering strayfield present in the room.

Tapes which have been recorded emulsion outside can be played on the STUDER C-37 by twisting them through 180° in clockwise direction between supply-reel and the first guide-roller on the left hand corner.

To turn on the capstan motor, the tape must be wound onto the take-up spool tight enough to turn the tape-tension balance approx. half way into its operating position.



FIG.1

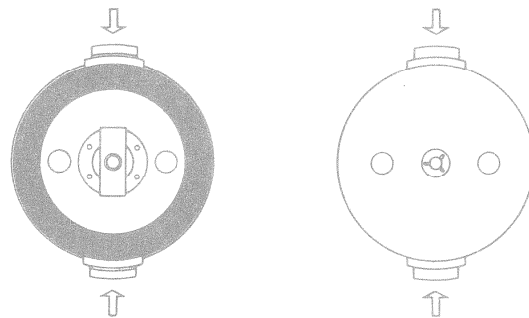

FIG.3

To reduce the Echo Effect caused by print through, which is particularly bothersome in recorded speech, the following points should be observed, especially if a recording is to be stored for long periods:

- a) use "Low Print" tape
- b) avoid a tight wind
- c) store the tape tail up and rewind just before playing
- d) wind and rewind the tape just before playing (loosens also sticky splices).

#### B 4 EDITING AND CUEING.

The push buttons for fast wind "forward" and "reverse", (items 1 and 2, fig. 1), have two operating positions each (trigger action). Depressing them only half way, tape motion is relatively slow and will stop as soon as the button is released. The buttons are not illuminated during this operation. Holding down both buttons simultaneously and then alternating between the two, the tape can be "inched" to locate any desired point in a recording. The Tape Timer, (item 12, fig. 1), may be usefully employed in searching for a desired point. If the modulation on the running tape is to be monitored aurally, the tape can be brought into contact with the playback head by rotating the left hand knurled disk, (item 6, fig. 1).

To wind large portions or the full capacity of a reel, the button for the desired direction needs to be fully depressed momentarily. Tape motion sets in at high speed and the tape gets lifted off all three heads. Change of direction is possible by depressing the appropriate button without any danger of damaging the tape. Fast wind can be stopped only by pressing the "stop" button.

A safety switch in the tension balance turns off the spooling motor at the end of a reel or in the event of tape breakage.

By operating the knurled disk, (item 6, fig. 1), an aural check on the modulation is possible during fast wind. See C 5 "Tape Lift Mechanism".

#### B 5 TIMER.

The Timer is inasmuch a novelty as it does not indicate the length of the recorded program in terms of tape footage, but accurately reads-out program time in minutes and seconds.

At 15 ips = absolute time  
At 7,5 ips = one half of actual time

The Timer works with exceptional accuracy and the maximum error will not exceed 0,3% irregardless of tape condition or operating speed. This accuracy is also maintained during the Fast Wind modes, which will eliminate the need of a stop-watch in timing programs.

The four-digit counter is driven by the large guide roller on the right-hand corner of the machine. Maximum indication is 99 minutes and 59 seconds. The reset-lever is accessible through a slot on the right hand side of the machine. In order to start timing from the beginning of a recording, the reset-lever may be kept depressed on the running machine up to a cue, or the start of the program.

#### Note:

For correct zeroing of the counter the reset-lever must be depressed firmly to its stop. When installing several recorders side by side, the reset-lever is difficult to reach. For such cases, an extension piece can be had as an extra. See C 10 "Tape Timer".

## B 6 INDEXING AND CUTTING.

With the electrically operated scissors, which are a feature of the STUDER C-37 Tape Recorder, the tape can be cut clean and always at the same angle, without the necessity of removing it from its regular path.

The whole Cutter Assembly is mounted on the underside of the motor-deck. It can be operated by depressing the push-button which carries the scissors symbol while simultaneously releasing the safety-catch, (items 8 and 4, fig. 1).

The scissor blades emerge - driven by an excentric disk - to cut the tape and they recede again automatically. The entire operation takes less than one second.

To correctly place a desired point at which the tape has to be cut over the electrically operated scissors a reference line has been engraved on the right hand guide roller. The plexi-glass dial on this guide roller works in conjunction with the engraved line. The dial carries the following symbols:

⤵	playback head
⤴	record head
✂	cutter
⤵	erase head

With this arrangement it will be possible to speed-up all editing operations. Any point on the tape - once determined by listening - can quickly be placed over the cutter, or the record- or erase-head.

With the desired point standing over the playback head, turn the guide roller - without moving the tape - to align the red reference line with the symbol ⤵ on the plexi dial. Now transport the tape by rotating the take-up or supply reel by hand to move it in the desired direction, (observe arrows on plexi dial), so as to align the reference line with one of the other symbols, depending on the operation which is intended to be performed.

During these movements some bothersome interference may be caused by the springy behaviour of the tape tension balance. It can therefore be locked by rotating it fully CCW, which eliminates any "soft element" in the tape path. The tension balance is automatically released from its locked position when switching the recorder into a running mode.

### Indexing Device.

When editing calls for the removal of only a short section of tape, the above described procedure is perhaps too difficult to follow. Using the indexing-stamp will definitely be more convenient:

For marking the tape over the playback head, place the index-finger onto the dimpled button on the Indexing-Device and rotate the lever clockwise through 180 degrees. By pushing forward the dimpled button, a narrow line will be stamped onto the tape at an angle of 30 degrees. The stamp is of a special porous material which is saturated with non-evaporating ink, providing an adequate supply for several thousands of markings.

### Splicing Block.

Clean and accurate splices are best made on the Splicing Block which is mounted on the motor-deck. The profile of the groove has been designed to hold the tape securely in place after pressing it to the groove bottom.

B 7 REMOTE CONTROL.

Remote Control operation for Recording Sessions:

A Remote Control Box, containing five push-buttons, is to be connected to the 11-pin Amphenol Receptacle on the rear of the recorder. The wiring for Remote Control Operation may be seen from fig. 4:

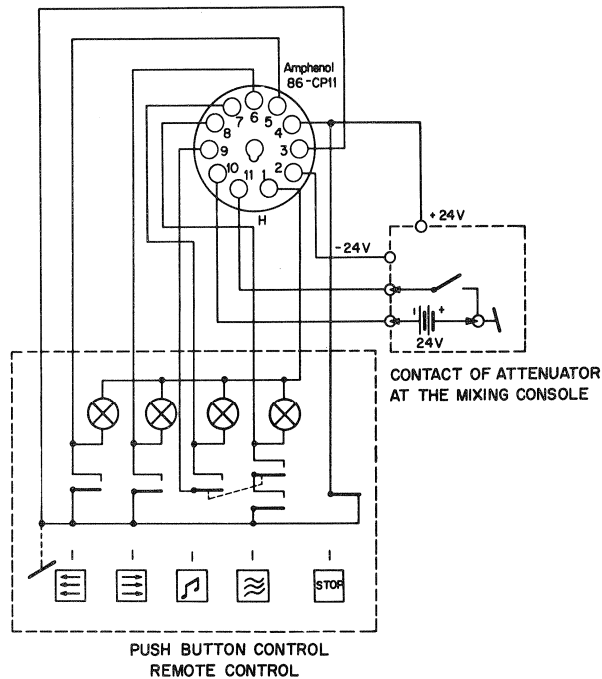

FIG.4

Remote controlled Playback:

The playback mode can be remote-controlled by a contact on the audio fader of a control desk. The contact must be open with the fader set to infinite attenuation. It controls the supply of an external 24 V source to a relay in the recorder. With this circuit the machine will start when opening the fader and stop when closing it again.

Where instead of an external 24 V source the machine's own supply is to be utilized, pins 2 and 11 have to be strapped and the fader contact must be connected to pins 9 and 10.

Pilot lights arranged in the indicated order will show the selected operating mode.

B 8 TAPE TENSION SELECTOR.

In exceptional cases where Extended Play- or Double Play Tapes on 3 inch plastic reels have to be run on the recorder, a reduced tape tension may be selected. The selector switch is accessible through an opening in the dust cover under the left-hand turntable and it can be operated with a coin.

Reduced tape tension adversely effects the start- and spooling characteristics of the recorder and it should therefore be returned to normal tape tension as soon as practicable.

# Studer C 37

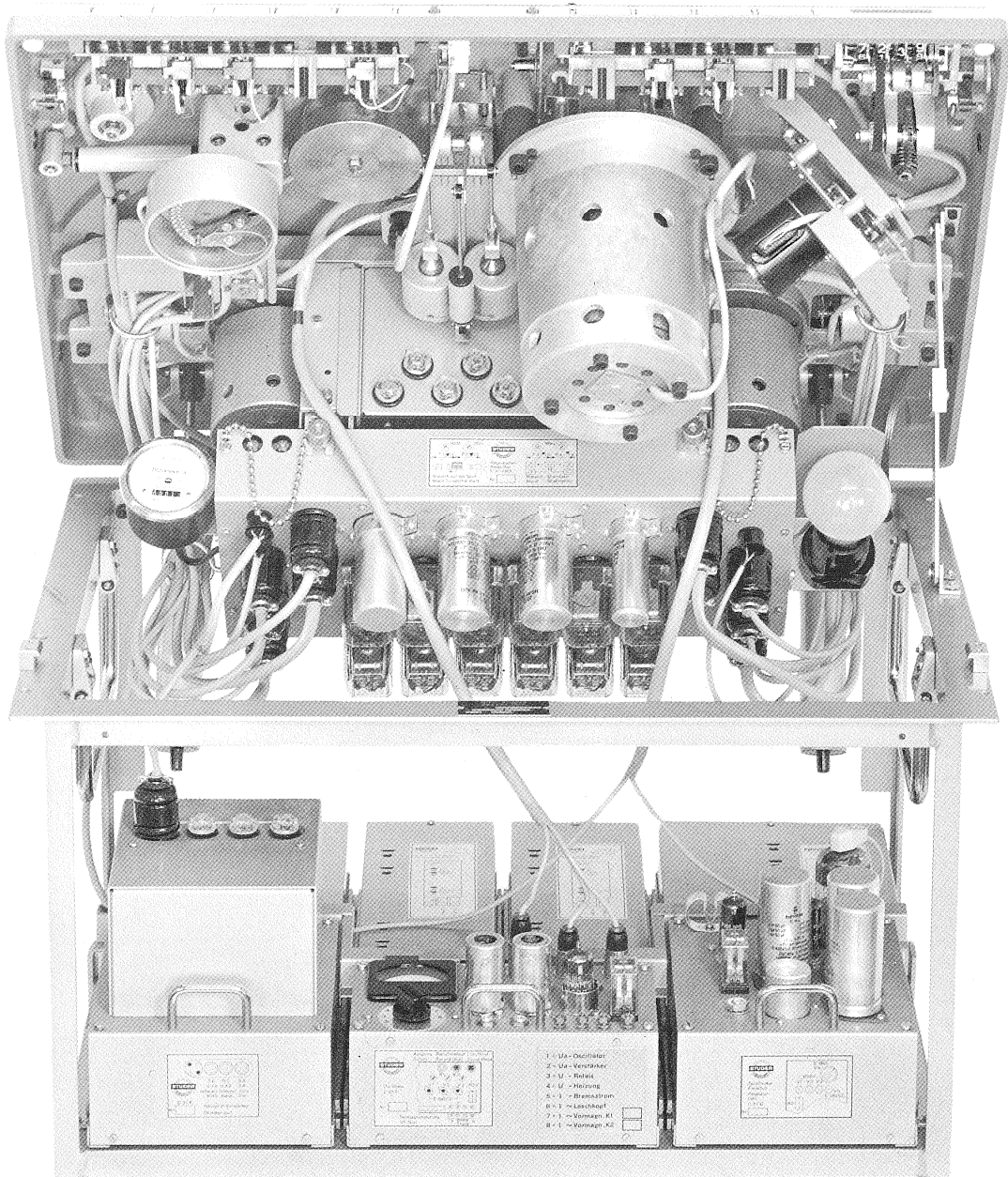



# The Main Parts and Assemblies

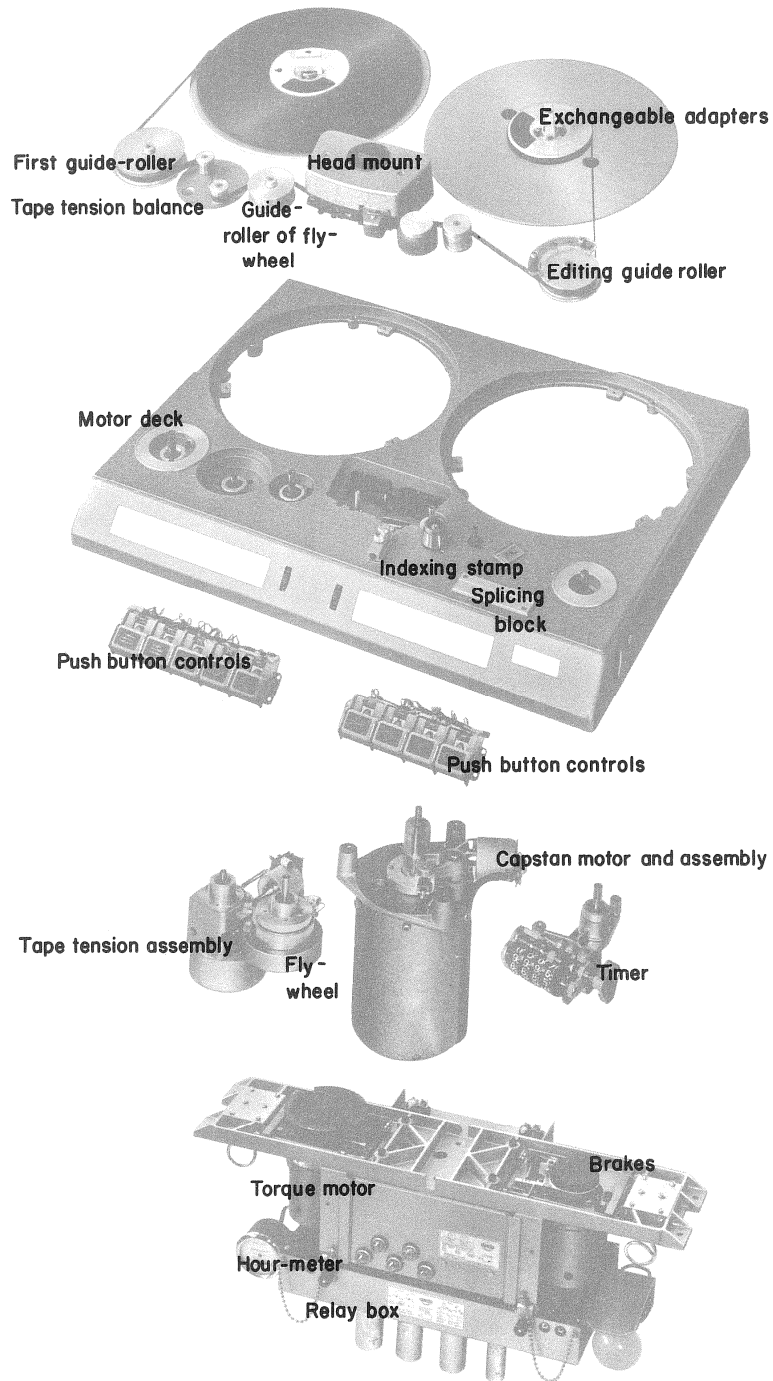

## C Tape Transport

The preferred operating position for the Tape Transport Mechanism is horizontal. However, it can also be mounted in an angular position with the rear raised to slope forward at an angle of  $30^{\circ}$  at the maximum. The recorder remains fully operational with the motor-deck opened. In this position the capstan-idler will drop by its own weight against the capstan shaft. This will exert some tension on the threaded tape, should the capstan motor be running. Wow- and Flutter readings should not be taken with the motor-deck open.

The electrical interconnections of all sub-assemblies are plugable. Replacement and exchange of a sub-unit is a matter of minutes, as only a few screws have to be undone.

Excellent motion stability could be achieved in the STUDER C-37 by paying careful attention to minute design and manufacturing details on all parts which are in contact with the moving tape.

By keeping the distances between the flywheel roller, heads and capstan as short as possible, any longitudinal vibrations of the tape that may occur will fall into the super-sonic frequencies. Smoothing rollers, which are often found between the magnetic heads and which could themselves give rise to motion disturbances are thus rendered superfluous.

### C 1 HEAD MOUNT.

The Head Mount is made of heavy cast-aluminium. The whole assembly can be easily replaced or exchanged. Three magnetic heads are mounted in this aluminium casting in such a way that adjustment around their horizontal and vertical axes is possible. To assure even wear of the magnetic heads, the cores of the record- and playback heads are narrower than the tape by approx. 4 thou. of one inch.

Heads and head-shields are so dimensioned, that there are no detrimental effects on the extreme low frequency response. Mu-metal shields around the record- and playback heads prevent interferences from external stray-fields. Guide pins are mounted at both ends of the head mount to avoid any lateral weave of the tape. The width of these guide pins is exactly 0.252 thou., corresponding to the standard tape width of  $0,250 \pm 0,002$  thou. Pins of greater width are available for applications where tape libraries with large stocks of non-standard tape are still on existence.

The electrical connections from the head mount to the electronics of the recorder are carried via two well shielded TUCHEL Connectors with ample free contacts so that stereophonic-, Pilotone- and Multitrack Head Mounts can be accommodated.

To remove the Head Mount from the recorder, access to three allen-head mounting screws can be gained by undoing the two screws which are securing the cover plate and removing them. After having taken out the three-allen screws, the Head Mount may be pulled from the machine. Each head is attached to the Head Mount by five screws which serve to perform the following functions:

- a) In the illustration below the screw carrying the designation "A" is the actual mounting screw firmly attaching the head to the head mount. DO NOT loosen this screw unless the head needs to be replaced.
- b) Alignment of the head-face parallel to the passing tape (indicated by even wear pattern) is achieved by adjusting the two screws marked "B". Turning the screw on the front end will move the head vertically, while the one in the rear is to adjust the tilt.
- c) The nut "C" is for aligning the head-azimuth. Correct performance will be obtained when the angle of the head-gap does not deviate by more than 3 minutes of arc from a position  $90^{\circ}$  against the direction of tape travel. This alignment is carried out with the aid of a Test Tape and an accurate description can be found in section E "Alignment and Performance Checks".

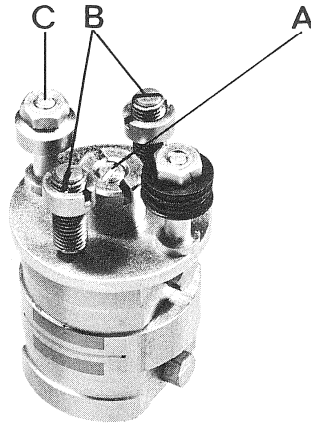

FIG.5

Caution:

Power to the recorder must be switched off when removing or re-installing the head mount, as an unbalanced pulse may pass through the head windings, causing the heads to become magnetized. After installation or exchange of a head mount or an individual head, it is recommended to demagnetize all heads in a gradually diminishing AC-field. Commercially available Demagnetizing-Coils are best suitable for this operation.

C 2 SPOOLING MOTORS AND BRAKES.

Power Torque Motors are used for take-up and rewind. They are of the "inside-out" type, producing smooth and even torque over a whole rotation without any jerks. The shaft of each motor carries a brake-drum and the base for the various reel- and core adapters. The height of the turntables can be adjusted by a vertical movement of the brake-drums on the motor shafts. Should such alignment become necessary, proceed as follows:

Remove the turntable and the underlying dust-cover, which is held by three screws. Two set-screws can now be reached from the side, just below the black anodized adapter-base. After loosening the two set-screws, brake drum and adapter-base can be adjusted to the desired height.

The STUDER C-37 Magnetic Tape Recorder has three independent Brake Systems. During the regular forward speeds, braking (hold back tension) is purely electrical by a DC current through the supply motor. The magnitude of this current is controlled by the Tape Tension Balance. As tape tension is held constant throughout a reel, its absolute value can be held low, which effectively reduces wear on tapes and magnetic heads. The mechanical brakes are utilized to assist in stopping the spooling motors, as well as to hold the turntables in their stopped position. Nylon brake-linings assure of high reliability. Brake bands and linings have a high life expectancy as they are adjusted to produce a relatively low brake-tension.

Brake tension is adjusted with no power applied to the spooling motors. The procedure is as follows:

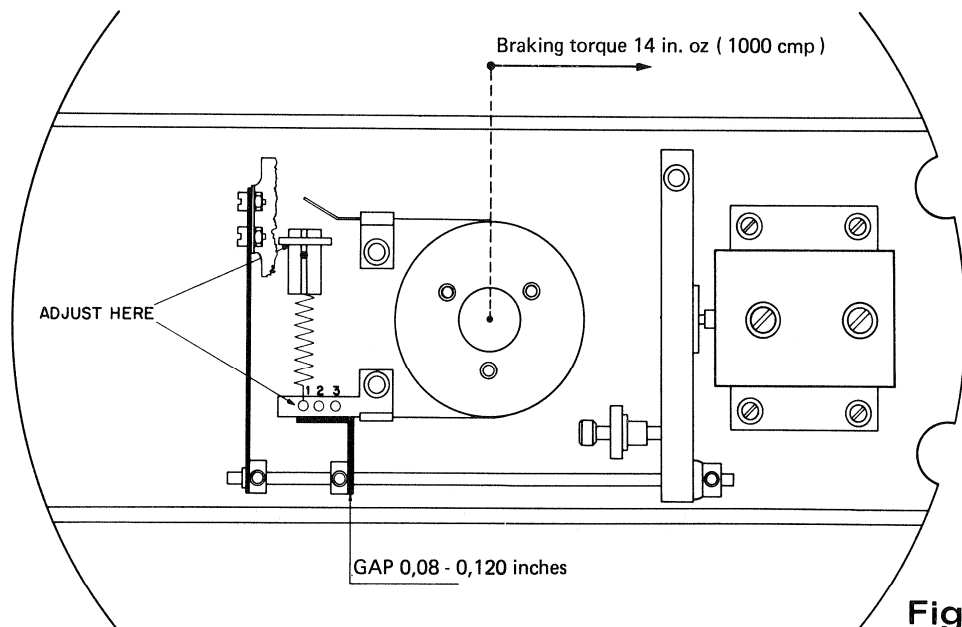

**Fig. 6**

Remove turntable and underlying dustcover. Insert adapter for Cine Reels and place a Cine Reel (RMA Reel) on the adapter shaft. Attach a spring-scale to the reel at a point approx. 2 inches from the centre. Brake tension is correct when by pulling on the spring-scale a reading of 7 ounces is obtained before the reel starts to turn. Coarse adjustments can be made by connecting the spiral spring to one of the three holes as shown in fig. 6. For fine-adjustment the red knurled nut needs to be turned.

When stopping the recorder, an electrical braking force comes into effect in addition to the mechanical brakes. A relay circuit switches DC onto the two spooling motors for a short period. This circuit operates selective and the braking force produced is four times higher on the trailing spindle as on the leading one, resulting in quick and spill-free stops.

If the tape is to be moved slowly (inched) in either direction, motion can be reduced to a creep by depressing both "wind" buttons simultaneously half way and alternating between them, depending on which direction tape travel is required. All motion will stop when both buttons are released. To eliminate the possibility of depressing the buttons too deep, there is a point where increased spring pressure sets in and a firm and decided push is required before a fast wind-mode locks in (trigger action). The reduced or slow wind speeds may be altered from their factory setting. Details under C 7 "Power supply for Tape Transport Mechanism".

During any of the wind modes, the tape gets lifted off all three magnetic heads, but monitoring of the recorded material is possible by rotating the knurled disk, (item 6, fig. 1), next to the record button.

When rewinding great lengths of tape, a very high spooling speed may be reached and it is then often advisable to first switch into the opposite wind mode to slow down the tape before actually pressing the Stop Button. Practicing this technique when rewinding full-length reels, the usually torn tape ends can thus be avoided.

### C 3 TAPE TENSION BALANCE.

A characteristic feature of all STUDER Professional Tape Recorders is the Tape Tension Balance. With this device, tape tension on the especially critical supply side is being kept constant at the regular forward speeds, irregardless of spool or reel diameter. It reduces greatly any jerks as caused by splices or other similar irregularities in the tape. A built-in safety switch will stop the machine after the end of a reel, or in the event of excessive loop formation or tape breakage. The Capstan Motor is turned on by the same safety-switch after the tape has been properly threaded. The machine should not be started in the "play" or "record" mode immediately after the tape has been threaded, as about 10 sec. are required for the capstan motor to reach synchronous speed.

The Tape Tension Balance is operated by the tape itself, adjusting a potentiometer which is mounted on the shaft of the tension balance. This controls the gain of a power transistor, thereby regulating the DC braking-current through the supply motor to achieve a tape tension of approx. 2 to 3 ounces. The low tension effectively reduces wear on tapes and magnetic heads. For editing and cueing operations the tension balance may be locked by rotating it fully clockwise, eliminating any "soft" element in the tape path. It is automatically released from this position when the recorder is started. However, if it is important that the starting time is as short as possible, the tension balance should first be turned into its operating position by hand.

In the event that the safety switch is not operating properly, it can be readjusted - after loosening a set screw - by slight rotational movement of the potentiometer housing. With the tension balance at rest, the potentiometer-wiper must be over the first contact. In this position the push-buttons 7, 5 and 15 are to remain functional. The adjusting screw of the double-draw spring is set correctly when the safety switch is actuated as soon as the tension balance has returned to rest. As long as tape is threaded on the recorder, the safety switch must not be actuated, irregardless of the selected sequence operating modes.

A dashpot connected to the tension balance suppresses any possibility of mechanical oscillations. A red knurled disk on the left end of the dashpot allows adjustment of its damping action. Adjustment is carried out by aligning two holes on the bottom of the cylinder to a greater or lesser degree. This is a very delicate operation and the disk should be turned by small fractions only. The setting is correct when full return travel of the tension balance is accomplished in somewhat less than one second. When exchanging the tension balance, proceed as follows:

- a) remove electrical connections
- b) unscrew piston-rod of dash-pot
- c) remove socket screw from the top centre of the idler-plate and carefully lift off the plate
- d) remove the three screws holding the complete balance assembly to the motor-deck and withdraw the unit from the machine.

Attention:

The Tension Balance is a precision instrument and should be handled with proper care.

C 4 FLYWHEEL IDLER (Impedance Drum.)

The Flywheel Idler is located between the tape tension balance and the head mount. The idler shaft extends below the motor deck and carries on its bottom-end a metal cone on which the Flywheel sits.

To reduce friction and tape wear the Flywheel gets lifted off this cone by an electro-magnet during the fast wind modes and when the recorder is stopped. The Flywheel engages via this taper during Record and Play only. With the motor-deck raised to its open position, positive engagement of the Flywheel is not assured any more. Wow and Flutter readings should therefore not be taken in this position. Care should be taken to avoid any cables from interfering with the Flywheel. An occasional rattling noise when turning on the recorder is caused by the Flywheel and is of no significance.

C 5 TAPE LIFT MECHANISM.

A pin, linked to two solenoids, is fitted between the erase- and record heads. The two solenoids - when energized - can thus lift the tape off the heads in two steps:

1. During fast wind (high speed and reduced speed) the tape is lifted off all three heads.
2. Rotating the knurled disk, (item 6, fig. 1), will return the tape half way towards the heads and bring it into contact with the playback-head to allow some form of monitoring during fast wind.

To prevent an abrupt return of the Tape Lift Mechanism, its movements are damped by a dashpot. A red knurled disk on the bottom-end of the dashpot allows the adjusting of its damping action. Adjustment is carried out by aligning two holes on the bottom of the cylinder to a greater or lesser degree. This is a very delicate operation and the disk should be turned by small fractions only.

The distance between tape and playback head in the "half way" position is adjustable and should be pre-set to bring the tape into contact with the playback head only. For this adjustment the recorder is threaded with tape containing a pre-recorded signal, e.g. 1000 cps. The locking nut on the connecting rod from the Lift Mechanism to the right hand solenoid is to be loosened and the recorder is then started in the play mode. Turning the hexagonal section on the solenoid end of the rod, the linkage is adjusted to leave the tape in contact with the playback head when operating the Lift Mechanism by rotating the knurled disk next to the record button.

## C 6 CAPSTAN ASSEMBLY.

The tape is transported by the capstan which is connected to the 6/12 pole hysteresis synchronous motor without any intermediate gearing. The motor has two windings to provide the two tape speeds. A heavy fly-wheel which is attached to the capstan shaft is locked to the capstan motor via an elastic coupling.

Mounted on the same frame, which holds capstan-shaft and drive motor is the capstan idler with its swiveled arm and the capstan solenoid. Capstan idler pressure can be adjusted on the running machine through a small opening in the motor-deck. When checking capstan idler pressure, fuse S 2 has to be removed to interrupt the drive motor circuit. Connecting a spring-scale to the dust-cap of the idler, idler pressure can be measured after pressing the PLAY Button. (The Tension Balance has to be held in its operating position to prevent the safety switch from being actuated). Capstan Idler Pressure is supplied by the Idler Pressure Spring only and it is therefore most important that the solenoid has fully bottomed before taking any reading. Idler pressure is correct when a force 3,3...4,0 lbs (1500...1800 p) is required to just lift the idler off the capstan shaft. The tension of the Idler Pressure Spring can be adjusted with the allen-screw which is accessible through the small opening next to the Capstan Idler.

Should replacing of the Capstan Idler become necessary, unscrew the dust-cap and lift the rubber-idler off its conical seating.

If the whole Capstan Assembly is to be replaced, proceed as outlined below :

- a) pull idler-bearing after removing its mounting screw
- b) disconnect motor cable
- c) remove the three allen-head screws which are holding motor and capstan assembly to the motor-deck. During this operation it is best to have an assistant supporting the bottom end of the drive motor housing. Withdraw motor and capstan assembly, taking great care not do damage the delicate surface of the capstan-shaft.

Exchange of the capstan shaft is now possible. This is a precision machined part which must be replaced together with its carefully fitted sleeve-bearings. A factory inspected replacement shaft, with already mounted bearings is available under the part number C37 1.337.162 (Capstan Shaft complete with bearing). When replacing the Capstan Shaft proceed as follows :

- a) remove the three mounting screws of the motor housing
- b) remove the four screws on the engaging bolts, disconnect the elastic coupling strips and withdraw motor housing.
- c) remove flywheel and dismount the Idler Pressure Assembly
- d) take off the true-arc ring from the capstan bearing and remove shaft and bearings.

To re-assemble proceed in the reversed order. The last action is to fix the elastic coupling - strips on the four bolts by the screws.  
(Attention: all the strips have to be fixed on the bolts by cyclic permutation : one end above and the second below the adjacent strip.)

If the whole capstan motor was replaced the new one has to be aligned exactly to the center line of the capstan shaft. To achieve the correct position proceed as outlined below:

1. Loose the four screws on the bottom of the motor housing until the motor itself can be moved (e.g. after unscrewing with a screwdriver fix the screws by hand without tool.)
2. Switch machine on with tape speed 15 ips (38 cm/s) in normal position, i.e. vertical capstan drive, and connect a wow and flutter meter to measure speed deviations. Use a meter with weighting network (see chapter E3). Adjust the three centering screws on the circumference of the motor housing till you get a minimum of flutter.
3. Make a control at tape speed 7,5 ips (19 cm/s) and readjust if necessary.
4. After optimum adjustment tighten the four screws on bottom of motor housing. (Carefully and stepwise always diagonally opposite screws.)

Do not check excentricity of the capstan shaft without idler pressure applied, as bearing play may cause erroneus readings.

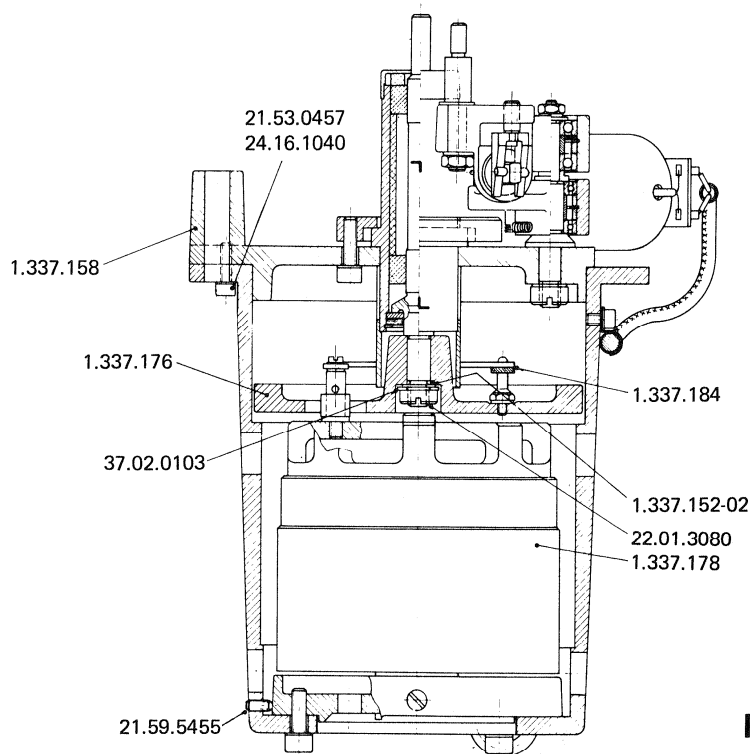

Fig. 7



## C 7 POWER SUPPLY FOR TAPE TRANSPORT MECHANISM.

Power for the Tape Transport Mechanism and the tape tension control circuits is supplied by a separate rectifier-unit which is mounted in the centre of the cross-member carrying the spooling motors. See exploded-view of Major Assemblies and Sub-Units.

To gain access to the mounting screws of this Rectifier-Unit, the turntables and underlying dust covers have to be removed.

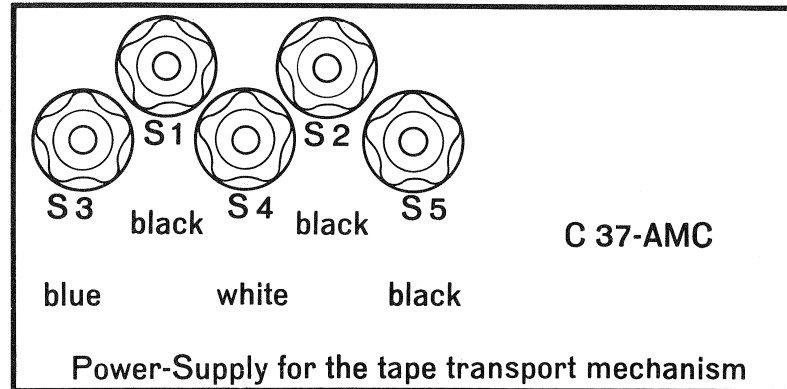

Fig. 8

The rectifier unit can be withdrawn from the machine after releasing the safety-chains and swinging down the relay-box on its hinges. All inter-connecting cables have to be removed from their receptacles. The following fuses are located in this supply (220 V model):

- S1 1,0 Amp., black, main fuse, transport mechanism
- S2 0,4 Amp., black, capstan motor
- S3 3,15 Amp., blue, relay supply (primary)
- S4 2,0 Amp., white, tension control rectifier (primary)
- S5 0,63 Amp., black, spooling motor

In the 117 V model, fuse S1 has a rating of 2,0 Amp. All fuses are of the same dimensions (5 x 20 mm) and they are of the "slo-blo" type.

### Caution:

When replacing a burnt fuse, special attention must be paid to the colour marking on the fuse holder and associated cap. A Neon indicator is contained in each fuse cap to facilitate the finding of a blown fuse. These Indicators are calibrated to work on a specific voltage and it is important to replace them according to their colour marking.

The torque of the spooling motors for the "slow-wind" mode can be altered by changing a connection in the Tape Transport Power Supply. By re-connecting the green wire (Schematic AMC 2,5) to one of the transformer taps marked 5,6 and 7 the operating voltages 120 V, 135 V or 150 V can be selected.

## C 8 RELAY BOX.

The Relay Box contains the control circuits for the various running modes. It is mounted just below the tape transport power supply. A printed circuit-board - mounted on hinges - carries the plug-in relays type SIEMENS 154 d/93n. Twelve plug-in power relays, type SCHRACK, have their sockets on the underside of the relay-box.

Silicon diodes are used on all relay windings for click suppression. The relay-box also carries the receptacles for the interconnecting cables to the various sub-units of the recorder.

A 150 V / 25 W Light Bulb with bayonet base is mounted to the right of the relay box. The bayonet base has been chosen as it will keep the bulb securely locked in its socket when transporting the recorder, or during any other form of vibration which the machine may be subjected to. It is advisable to keep a spare bulb available, as a replacement may sometimes be difficult to get. In an emergency, any 150 V / 25 W bulb can be utilized in a temporary hook-up.

Four potentiometers P1 to P4 are mounted on the front-side of the relay-box and these are for adjusting the starting- and stopping times of the recorder. Each potentiometer shaft is secured by a lock-nut, to avoid an accidental alteration of its setting.

The following functions can be adjusted with these potentiometers :

### 1. Start.

When depressing the "play button", the mechanical brakes are released immediately and 220 V are supplied to the take-up motor. In this way the take-up function quickly accelerates the tape and with little delay thereafter capstan idler pressure is applied. This time delay is adjustable with potentiometer P1 and it should be set to energize the capstan idler solenoid the very moment when the tape has reached nominal speed. The take-up motor - after having accelerated the tape - must now be switched to the reduced operating voltage, this is achieved by opening a contact which is short circuiting the 25 W incandescent bulb, connecting it in series with the take-up motor winding. By changing the resistance of the bulb from cold to hot the take-up torque is reduced smoothly. The time delay over which the contact remains closed is adjusted with potentiometer P2.

The best way to achieve the adjustments is described by the following procedure :

#### Capstan idler solenoid :

Remove fuse S2 for the capstan-motor and rotate potmeter P2 to the left stop position. Wind a tape onto the take-up side until a diameter of approx. 6 in. is left on the supply side. Bring the tape tension balance in the locked end position. Put the red indexing line of the right hand guide roller to the symbol "erase head" on the plexi-glass dial and be sure that the tape is firmly tensioned (no loose loops). Now fix the tape balance by hand in the given position and start machine in the play mode, thus by a short movement of the tape the reference mark on the guide roller has to be turned to the symbol "cutter". By repeating this test and adjusting potmeter P1 optimum regulation can be achieved.

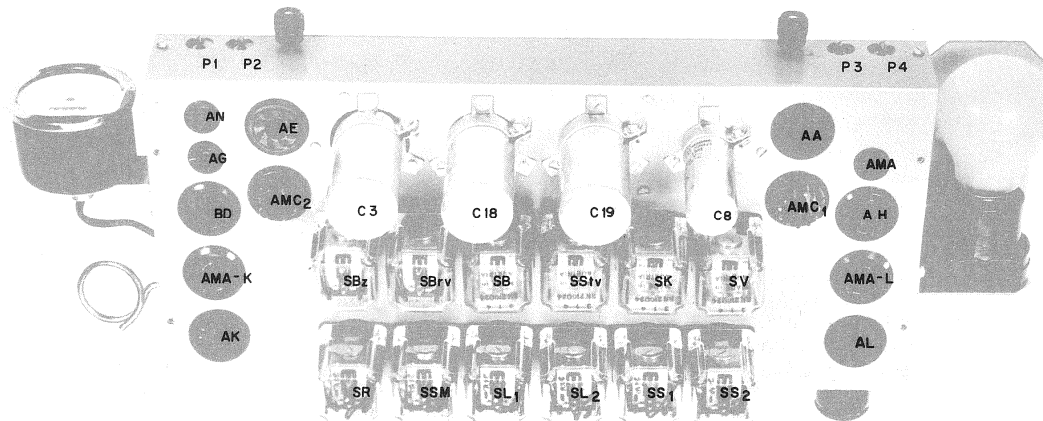
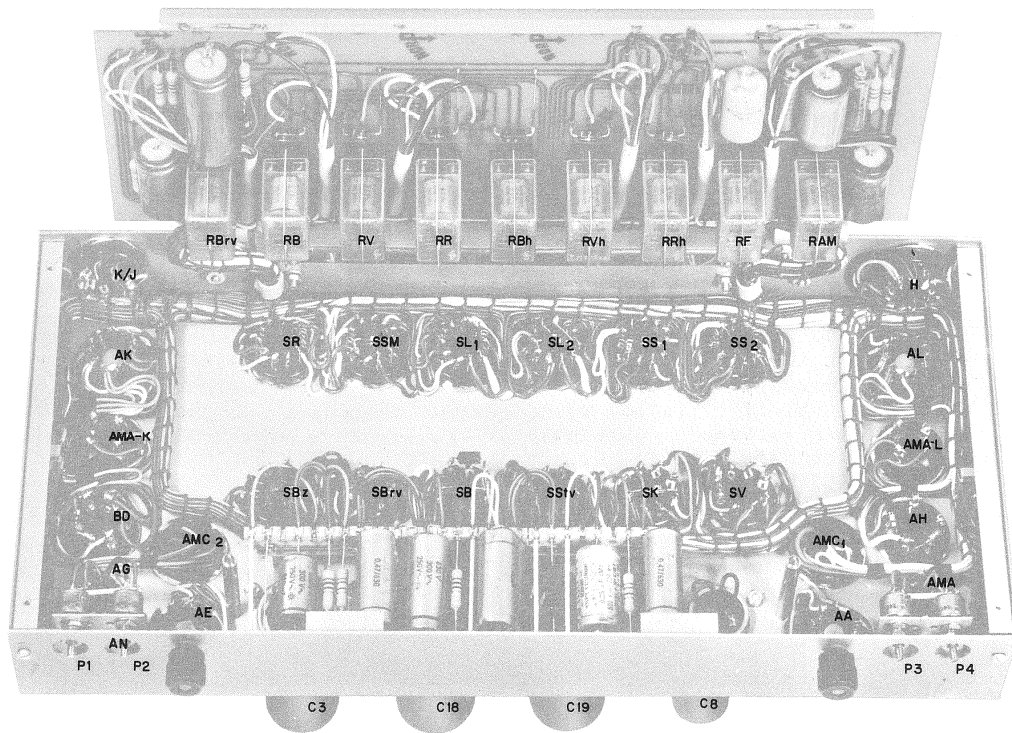

Start with a 3300 ft. (1000 m) tape reel

Insert fuse S2 for the capstan motor and set potmeter P2 to a position about 90° open (approx. mid-position). The damping action of the dash-pot for the tension balance is adjusted for a return time of approx. 1 second (see chapter C3 tension balance) now wind a 3300 ft reel from the supply side until on the take-up side a diameter of approx. 6 in. is reached. If the machine from this position is started in the play mode there should not be noted any sign of loop formation (or jerk) between capstan and small guide roller. Repeat this test until there is no loop or only a very small one by adjusting potmeter P2 to reach optimum of starting function.

There is some interaction between the two above described adjustments and they should therefore be repeated until the optimum is reached.

## 2. Braking.

Braking is effected by applying a relatively high DC current to the spooling motors for a short period of time, (see C 2 "Spooling Motors and Brakes"). The length of time during which braking current is applied, when stopping from Play or Record, is adjustable with potentiometer P3. The required adjustment is correct when the tape Lift Pin removes the tape from direct contact with the magnetic heads exactly until all tape motion has stopped. Braking time from Fast Wind is adjusted with P4 and should be set for spill-free stops from the highest attainable winding speed. Adjustment is again carried out by observing that the tape remains lifted off the heads until all tape motion has ceased, which should take not more than 2 sec. at the maximum. During this time the Play function remains electrically blocked, so as to eliminate the possibility of tape spills or tape breakage.

## C 9 TAPE CUTTER.

The tape Cutter is mounted on the underside of the motor deck, between Capstan-Shaft and the right-hand Guide Roller. An excentric disk, driven by a Berger Motor, operates the cutter blades. Electrical connection is made directly to the Relay Box. Should re-sharpening of the cutter blades become necessary, the whole Cutter Assembly is to be dismantled by removing the two allen-screws. After undoing the two mounting screws of the scissor-blades, the blades may be removed for sharpening. No other maintenance is required.

## C 10 TAPE TIMER.

The Tape Timer should be lubricated only sparingly with a high grade Instrument Oil. Due to accumulation of dust it may in time become necessary to clean the moving parts of the counter mechanism with alcohol after which they should be lubricated with only a few drops of Instrument Oil. The timer may be dismantled by undoing its three mounting screws, access to which can be gained after the plexiglass dial over the guide-roller and the guide-roller have been removed. If several recorders are to be installed side by side the timer re-set lever will be difficult to reach. For such cases an extension piece (part No. 1.337.100-03) is available.

## C 11 GUIDE ROLLERS.

The two Guide Rollers which have not been mentioned so far (one on the extreme left and one immediately to the right of the capstan) have self-lubricating bearings which normally should not require any attention.

## C 12 CONSOLE.

For the STUDER C 37 a console is available and if required must be ordered separately. It is an all-wood construction covered with scratch resistant material (Arborite). The front-panel of the console -hinged on the centre- may be swung downwards to form a convenient shelf for tools and test equipment.

## D Electronic Assemblies

All units provided with plug - in type connectors and can easily be exchanged : Simply by depressing the associated red locking - bar while pulling the unit out of the frame. When re-installing the interlock is activated automatically.

Before replacing any section of the electronics all power must be switched off as a pulse may be generated during such manipulations causing the heads to become magnetized. The different units are interconnected by wires running in a cabletrough. (Schematic diagram 7.337.514)

To allow testing and servicing of the different plug - in units outside of the recorder, two adapter cables are available on request. (part Nr. 1.337.960 for 14 poles, Nr. 1.337.964 for 24 poles.)

The amplifiers contain a relay operated switch for the equalization of the frequency response according to CCIR and NAB standards for both speeds. The equalization switch is mounted on the front part of the stabiliser unit. All frequency response and level settings for both speeds and standards can be set up separately.

A sliding switch is provided on the rear part of each amplifier unit. It should be set to mono or stereo depending how the recorder is being used. In case of any deviations of the specified frequency response the setting of this switch should be controlled first.

The switchable amplifiers can be used in older generations of this recorder model too. However, in this case they will only provide CCIR equalization (relay deenergized). If NAB is required the relay in the amplifier in operation should be connected permanently to the - 24v line.

In addition the resistors R11 and R16 (both 39 Kohm) of the bias oscillator unit are to be shorted. (Schematic diagram S-C 37 -F)

A modification of earlier models to switchable equalization requires alterations in the cabletrough and the front panel units in accordance with the circuit diagrams attached to these operating instructions. The alterations should be done by a skilled technician.

### D 1 Record Amplifier

The symmetrical input is passed through a 1:1 input transformer to a four stage amplifier. Four 100 Kohm potentiometers ( $P_1 - P_4$ ) allow individual record level adjustments for both speeds and equalization standards. The switchover is achieved automatically by contacts on the RLA and  $RE_3$  relay according to the selected speed and equalization. The frequency response in record mode is equalized in the three stage preamplifier by a negative feed back network ( $P_5 - P_8$ )

Equalization pots :	P 5	15 ips	CCIR
	P 7	7,5 ips	CCIR
	P 6	15 ips	NAB
	P 8	7,5 ips	NAB

The contact no. 11 of relay  $RE_3$  connects an additional RC - filter for NAB equalization of the low end.

The necessary high frequency pre-emphasis at 7,5 ips tape speed is achieved by inserting a capacitor into the cathode feed back (relay RLA)

Following the blocking capacitor C 20 a bias trap (tuned to about 80 Kc) is provided, (1.337.582) from there the signal is fed to the oscillator unit where the bias frequency signal is added.

The record amplifier is so dimensioned that its overload-point is approximately 15 db above the level required for normal tapes.

It is therefore also possible to utilise high output tapes (e.g. AGFA PER 555). See section E (Alignment Procedures) and section E 2e (Distortion) for details on the possible compromise between distortion and signal to noise ratio.

**Recording-Amplifier**

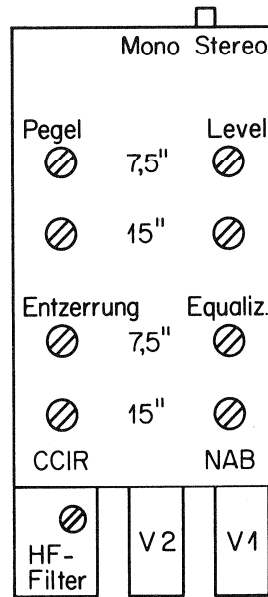

**Fig. 9**

**Output: record-head Erase-head**

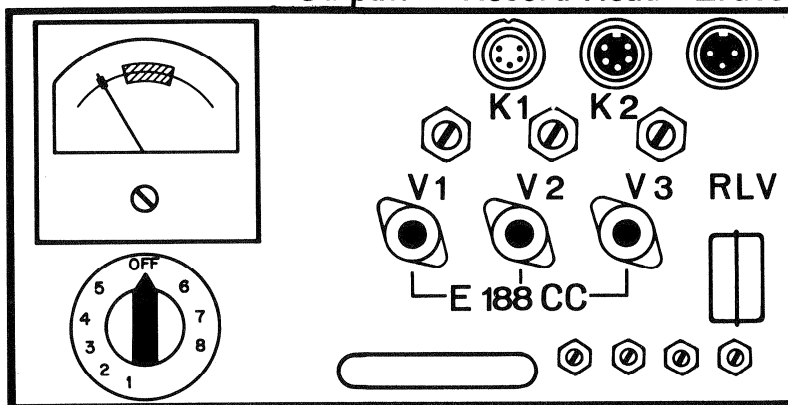

**HF-Bias**

7,5" 15" 7,5" 15"  
1 Track 2

**Fig. 10**

## D 2 OSCILLATOR AND TEST METER.

The high frequency of approx. 80 Kc for erase and bias currents is being generated in the very stable and carefully balanced push-pull oscillator stage employing the twin-triode V 2 (E 188 CC). The feedback winding 3,4 and 5, the tuned coil 6,7 and 8 and the secondary-winding 1 and 2, which feeds the erase-head, are wound on one ferrite-core (C 37-FBB). The erase current can be checked across the resistor R 6, with the built-in test meter via the connection marked VI. To achieve optimum performance with respect to noise, bias to the record head or heads is not branched off the oscillator directly, as commonly found in other recorders. Before reaching the record heads the bias signal passes a push-pull isolation stage (V 1 and V 3 respectively) with tuned coil in the plate circuit, thereby reducing any distortion which may possibly be contained in the high-frequency signal to a value far below that, which could be responsible for any increase in tape noise.

These tuned isolation stages eliminate the need for any noise balancing control, which is rather unstable and would require frequent re-alignment.

Any noise reading off tape which is in excess of the values specified in the technical data can only be caused by magnetized parts in the tape path. Demagnetizing of all steel parts, including the magnetic heads, in a gradually diminishing AC field will restore the specified noise performance.

The Oscillator is designed for stereo- or two channel operation. Bias current can be individually adjusted for each of the two tape speeds in each of the two channels by four potentiometers ( P1 to P4). Changeover to the pre-set bias values for either speed is performed by the contacts of the relay RLV. The Bias currents can then be checked in the positions 7 and 8 of the test-meter selector-switch. As these currents depend on the brand of tape which is used, it is suggested to mark the indicated values in the rectangular fields of the designation plate for easy reference.

For a detailed description of the alignment procedure in adjusting for optimum bias, read section E 2b "Bias Adjustment" and E 2e "Distortion Measurement".

The receptacles for the cable connections to the erase head and the record heads of channels 1 and 2 are mounted on the top of the oscillator chassis. A Test Meter and associated selector switch are also located there, allowing to check the following voltages and currents:

1. B-voltage, oscillator  
(record button must be depressed)
2. B-voltage, amplifiers
3. Relay voltage
4. DC A-voltage, play amplifier input stages
5. Braking current
6. Erase current  
(record button must be depressed)
7. Bias current, track 1
8. Bias current, track 2

In the switch position 1-4 and 6 all readings should be approximately in the centre of the tolerance mark on the meter-scale.

Braking current depends on the setting of the tape tension balance potentiometer : With the tension balance set just before actuating the safety switch, the reading must be in the centre of the tolerance mark on the meter scale. With the tension balance locked into its counter-clock-wise position, the reading is to be zero. For both tests the "play" button must be depressed. When depressing the "stop" button or releasing the tension balance to actuate the safety switch the pointer will reach full scale for appr. 2 seconds.

Bias currents for stereo operation can be read in positions 7 and 8 (channels 1 and 2 respectively ). If monaurally equipped, only position 7 (for channel 1) will indicate.

### D 3 PLAYBACK AMPLIFIER

The Playback Amplifier consists of three stages of voltage amplification with liberal feedback, followed by a phase inverter and the push-pull output stage. By using a cascode circuit in the first two stages (V 1.1 and V 2.1) and by operating their filaments on DC, excellent performance with respect to noise could be obtained. The third stage is working as cathode follower to provide the necessary low impedance source for the feedback loop, which contains the RC network for playback de-emphasis.

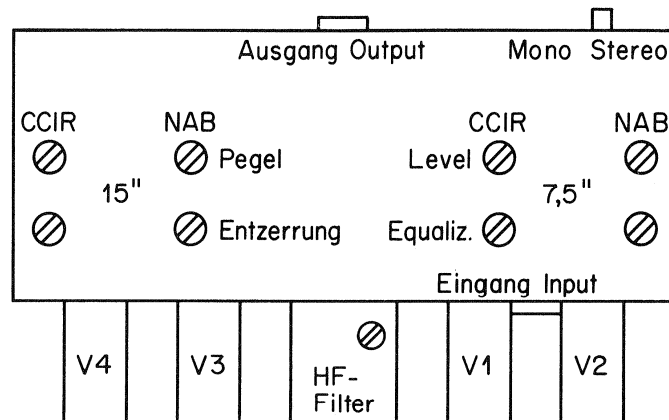

**Fig. 11**

Equalization is changed automatically with speed selection by the relays RLW + RE<sub>2</sub>. A high frequency trap (1.337.582) -tuned to the bias frequency of 80 Kc- and a RC combination, with trimmers C 14, C 15, C 18, C 19, correcting for head wear and gap length dependent losses, has been provided between stage three and the level controls P 1 - P 4. Adequate output voltage for all applications is delivered by the push-pull output stage at an effectively low internal impedance. The signal then appears on the output connector located on the rear panel of the Playback Amplifier.



Should it become necessary to reproduce a full-track monaurally recorded tape on a stereo equipped machine, one may choose between playing through one channel only, or connecting the outputs of both channels in series, (never parallel), without reversing signal polarity. This form of operation is possible, as on the STUDER C 37 the noise level of the amplifiers lies far below the noise generated by the tape. When connecting the amplifier outputs in series a theoretical increase of 3 dB in signal to noise ratio over that of a single unit can be obtained. This value of 3 dB is derived from the fact that the noise level of the two amplifiers increases only by 3 dB, while the two signals add up to an increase of 6 dB, which results in the theoretical gain of 3 dB.

A detailed description of alignment procedures can be found under E 1 "Playback Amplifier Alignment".

#### D 4 POWER SUPPLY.

The power supply consists of two plug-in units feeding all supply voltages to the amplifier- and oscillator sections.

Stable operation of the electronics of the recorder over long periods of time is assured by electronic regulation of the total B supply.

#### D 4a RECTIFIER UNIT.

All supply voltages for the electronics of the recorder are derived from the power transformer contained in the rectifier-unit. Its special core structure cuts strayfield interference to a minimum. The A and B voltages are being rectified by silicon power diodes; a selenium rectifier supplies

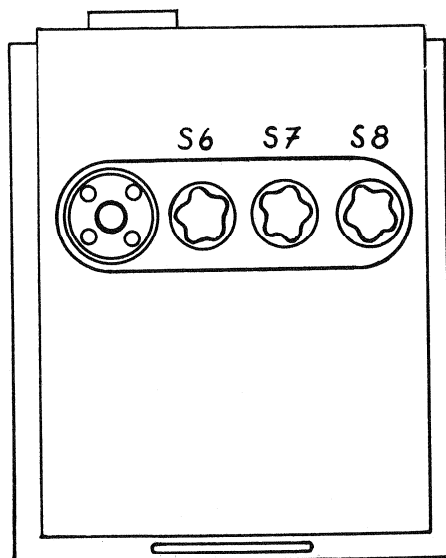

Fig. 12

B voltage to the regulating unit. The filter capacitors are of the metallized paper type and assure of high operating reliability. Three fuses, all of the "slo-blo" type are located on the top side of the rectifier unit. Each fuse cap contains a neon indicator which will glow whenever a fuse is blown. Finding and replacing a faulty fuse is thus greatly facilitated .

Important :

When replacing a blown fuse, attention must be paid to the colour marking on the fuse holder and associated cap. Always put them back according to their colour coding, as the neon indicators in the caps are calibrated to operate on different voltages.

S 6 black 0,63 amp. 5 x 20 mm - "slo-blo"

S 7 black 0,2 amp. 5 x 20 mm - "slo-blo"

S 8 blue 2,0 amp. 5 x 20 mm - "slo-blo"

The above indicated values are valid for 220 V models only.

Three of the four filament supply windings of 6,3 VAC are balanced with two 100 ohm resistors each. The fourth winding is free of ground, as it supplies the filament voltage to the regulating tube (V 4 - E 130 L), whose cathode is at + 260 V with respect to ground.

D 4 b REGULATING UNIT.

The regulating unit contains stabilizing circuits for the plate supply to all amplifiers and the oscillator as well as for the DC-filament voltage to the replay amplifier input stages. Excellent smoothing and stable supply voltages - independent of power line fluctuations and surges - are thus achieved and maintained over long periods of operation. This also holds the critical adjustment of bias current constant, thereby eliminating any variations in the recorded frequency response characteristics, a feature which is of particular interest at the low tape speed.

Only high reliability type professional tubes are employed, such as the pentode E 130 L as plate supply stabilizer and the twin-triode E 283 CC in a cascode circuit in the control stage. Due to the high gain of this tube, ripple is held to an absolute minimum.

As plate voltage to the record amplifier and oscillator is required in the record-mode only, the supply for these is switched by the relay RA. With the RC-network R 16 and C 11 (on schematic C-37-F) a smooth rise and decay of the oscillator amplitude is assured, as any abrupt pulse would cause clicks and magnetization of the record head. A similar effect is achieved with the network R 15/C5 controlling the rise and decay of the plate voltage to the input stages of the record amplifier. The DC filament voltage for tubes V 1 and V 2 in the reproduce amplifier is regulated by the power transistor OC 27/ASZ 18, with the Zener Diode ZL 7 functioning as voltage reference.

Whenever any one of the tubes V 1 to V 5 have been replaced, check the B-voltage in the record mode and adjust resistor RW 11 to obtain a reading of 255 volts.

Important :

When replacing tubes in the regulating-unit, make certain that all power has been disconnected. Before turning on the equipment, check and be sure that the plate-cap is seated properly on the E 130 L tube, as otherwise the screengrid current will rise to an excessive value and damage the tube.

Regulator-  
Unit  
C 37-G

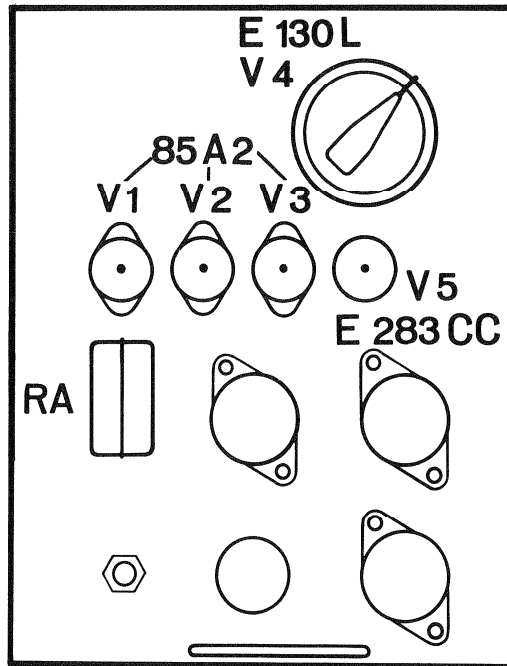

Fig. 13

## E Alignment Procedures

Any checks on the performance of the Audio Sections of a Magnetic Tape Recorder generally include measurements of the frequency Response as nationally or internationally standardized. Further readings aim at finding the optimum compromise between tolerable Distortion and useful Signal to Noise Ratio. The present state of the art dictates, that a "flat overall response" can only be achieved by introducing a certain amount of Frequency Distortion on the recording process. Similarly, a specified response has to be maintained in the playback chain of a recorder. It can be seen that not just any amount of Pre-emphasis or De-emphasis can be chosen arbitrarily, as this would make it impossible to carry a recording from Tape Recorder to Tape Recorder without getting unbearable variations in the reproduced frequency response.

National and International Committees have studied these problems and the outcome of their recommendations is laid down in the specified frequency response characteristics of the Standard Reproduce Amplifier for Magnetic Sound Recording. Not specified is the Recording Characteristic, as it will be governed by the type of tape and emulsion used for recording and it has to be adjusted to obtain a "flat overall response". The Transmission Characteristics for reproduce amplifiers have been laid down by international agreement in the CCIR Recommendations No. 135 (London, 1953) and No.209 (Warsaw, 1956). A similar Standard exists in other parts of the world and it is generally referred to as the NAB Equalization. Unless otherwise specified, the STUDER C-37 Recorder is shipped with equalization characteristics to CCIR recommendations. NAB Equalization is available on request.

In some special cases a modified form of one of these two commonly found characteristics may be more advantageous, especially if the Energy Distribution of the material which is to be recorded appreciably differs from the one generally encountered. To achieve a linear overall response alignment of the playback amplifier - using a standard calibration tape - has to be completed before adjusting the recorder equalization to the requirements of a particular brand of tape.

All information required in aligning the playback section, such as identification of frequencies and reference levels, is normally announced on good-quality calibration tapes. To maintain their value as Secondary Standard they need to be handled and stored with extreme care.

One of the most important sections on a calibration tape is the Azimuth Alignment Band. Good high frequency response is only possible when the gaps of the record- and playback heads are parallel to each other. However, this alone would not guarantee that identical quality in reproduction is obtainable from various machines. It has therefore been specified that the gaps of the magnetic heads must be aligned to 90° against the direction of tape travel.

The following list suggests the Test Equipment required for proper alignment of the recorders :

- Audio Oscillator with inherently low distortion
- Vacuum Tube Voltmeter, preferable SIEMENS & HALSKE
- Type Rel U 33 Noise Meter with Weighting Network or
- General Radio Noise and Distortion Meter, Type 1932-A
- Calibration Tapes for 7 1/2 ips and 15 ips
- Wow and Flutter Meter EMT 420 with Graphic Recorder EMT he 1b or
- High-, Lowpass Filter EMT 421
- Third Harmonic Tester EMT 126
- Head Demagnetizer
- Wave Analyzer or Bandpass-Filter 1000 cps

## E 1 PLAYBACK AMPLIFIER ALIGNMENT.

The following routine procedure has proven itself practical:

With power to the recorder turned off demagnetize all heads

Run calibration tape at its specified tape speed

Adjust output from the reference signal to the desired level (e.g. + 8 dbm) with the potentiometers marked "Level" 7,5 and "Level" 15 on the playback amplifier.

These potentiometers do not interact. Playback distortion may now be checked and the reading should be less than 2% (predominantly 3rd harmonic).

### E 1a PLAYBACK HEAD ALIGNMENT.

The Azimuth of the playback head is adjusted by slowly rotating the nut C, fig. 5, until a maximum reading is obtained on the VTVM.

The level of the azimuth adjust frequency is generally recorded at 10 db below reference level, thus already providing a good indication of the frequency response of the equipment.

### E 1b PLAYBACK RESPONSE CHECK.

Take readings of the frequency bands for the response check and, if necessary, adjust the trimmer capacitors "Equalisation" - 7,5 and 15 respectively - at 10 or 12 kc to obtain specified frequency response.

Playback Amplifier Noise can now be checked with the machine running, but tape removed from the magnetic heads. The signal to noise ratio must be equal to, or better than that specified in the technical data.

## E 2 RECORD CIRCUIT ALIGNMENT.

BEFORE MAKING ANY ADJUSTMENTS ON THE RECORD AMPLIFIER, BE SURE THAT THE REPRODUCE SECTION HAS BEEN CHECKED AND THAT IT IS PERFORMING SATISFACTORILY.

### E 2a RECORD HEAD ALIGNMENT.

Thread the recorder with blank tape

Connect Audio Oscillator to the input of the recorder, set frequency to 10 or 12 kc respectively

Start machine in the record mode and adjust oscillator, send level to obtain a signal output from the machine which is approx. 10 db below reference level.

While recording this frequency, slowly rotate nut C on the record head, fig. 5, and find a setting which yields maximum level on the output meter. If several peaks appear, slowly rotate the nut until a pronounced maximum is indicated. The effect of any alteration in the record head setting will appear with slight delay on the recorder output (distance record-, play-back head) and adjustment should therefore be made very slowly.

## E 2b BIAS ADJUSTMENT.

IT IS EXTREMELY IMPORTANT THAT ALL TESTS DESCRIBED IN THE PRECEEDING PARAGRAPHS HAVE BEEN COMPLETED AND THAT THE ADJUSTMENTS ARRIVED AT HAVE BEEN LEFT UNALTERED.

The Magnetic Tape Recorder STUDER C 37 is shipped from the factory with Bias adjusted to obtain optimum performance with the brand of tape which is noted on the final Test Report. If tapes with other emulsions are used in the field bias should be readjusted as outlined below.

Any change in Bias Current is effecting the performance figures of the recorder with regard to High Frequency Response and Distortion as well. The alignment procedure described here, will yield the optimum compromise between these two. If so called High Output- or Hard Emulsion Tapes are used, the recorder may be aligned to arrive at one of two alternatives:

- a) Reduced harmonic distortion while maintaining the normal signal to noise ratio. as obtainable from regular tapes
- b) Increased signal to noise ratio by working to a specified amount of distortion (e.g. 3% third harmonic).

The standard alignment procedure is as follows:

Thread the recorder with blank tape, select operating speed and start the machine in the record mode

Adjust oscillator to 400 or 1000 cps respectively and set send level to produce a signal output from the recorder, which is approx. 10 db below the reference level as measured under E 1. DO NOT RECORD AT HIGHER LEVEL, AS IT MAY CAUSE TAPE SATURATION AND PRODUCE ERRONEOUS READINGS

Loosen the lock nut on the one of the four bias-adjust potentiometers on the oscillator chassis, which is marked for the tape speed and track position under test. Turn the potentiometer fully counter clockwise

Turn potentiometer slowly clockwise and observe output level from the recorder on the VTVM

At the low tape speed the potentiometer is to be locked in the position which yields maximum signal output

At the high tape speed, bias is further increased by CW-rotation of the potentiometer until the signal at the recorder output drops by approx. 1,5 db. The potentiometer is to be locked in this position

A reference reading of the so adjusted bias current can now be taken on the Test Meter (switch position 7 and/or 8) and this reading should be marked for quick reference in the rectangular fields of the oscillator designation plate.

## E 2c RECORD LEVEL CALIBRATION.

As can be seen from the Technical Data at the head of this book, a wide range of input- and output levels can be chosen on the STUDER C-37 Recorder. These are of course purely electrical levels of the respective amplifiers, the tape itself gets always modulated to one and the same level of magnetization. In paragraph E 1 the procedure has been described for adjusting the playback amplifier to a selected output level from a fully modulated tape. The gain of the record amplifier is now to be adjusted to a value which will produce a fully modulated tape from a given input level. This adjustment is carried out as follows:

With blank tape threaded on the recorder, select desired tape speed and start the machine in the record mode

Adjust audio oscillator send level at 1000 cps to your standard transmission level (e.g. + 8 dbm)

While observing the level indication on the recorder output, the record amplifier level controls (Level) 7,5 or 15 respectively, are now to be adjusted until the same output level as from the reference signal of the calibration tape is obtained

All settings on the playback amplifier must of course be left undisturbed.

#### E 2d RECORD EQUALIZATION AND OVERALL RESPONSE.

Adjust audio oscillator send level at 400 or 1000 cps respectively to obtain an output level from the machine, which is at least 20 db below reference level

Without altering the send level, record 10 kc at both tape speeds and adjust the trimmers "Equalization" in the record amplifier - 7,5 and 15 respectively - until the output level indication is identical to the one which was read at the reference frequencies of 400 and 1000 cps

Using the same send level at frequencies between 30 cps and 15 kc, an overall response check is to be run. If necessary re-adjust the trimmer capacitors slightly to obtain a frequency response which is within the specified tolerance limits.

#### E 2e DISTORTION.

After all of the above described alignment procedures have been completed, distortion of the recorded signal may be measured. Most accurate readings can be obtained if a Distortion Meter of the high-pass type can be made available for this test. Slight frequency variations which could cause erroneous readings on meters with narrow band elimination filters are of no effect on the high-pass type Distortion Meter.

Distortion readings, when taken while recording, may also be effected by some bias signal which could be leaking through. It is therefore good practice to rewind the recorded section and to take the distortion reading during playback.

In high quality professional tape recorders the obtainable values with regard to distortion and signal to noise ratio are limited by the tape and not by the amplifiers. In order to get a signal to noise ratio as high as possible, tapes are often modulated to a harmonic distortion content, which is considered as generally acceptable and not to a certain value of magnetic flux.

When approaching magnetic saturation of the recording tape, distortion is predominantly of 3 rd order harmonics and these are very bothersome, as they are harmonically unrelated to the fundamental frequencies. For this reason it is often practiced to measure the 3 rd harmonic content only and to consider it as the criterion for full tape modulation.

For this purpose the very compact and simple to operate EMT 126 Third Harmonic Tester has been designed.

Varying with quality demands, a 3 rd harmonic content from 1 to 2% is the generally accepted value. With modern tape emulsions this amount of distortion will correspond to a remanent flux of approx. 200 milli Maxwell. Other tape emulsions, which can be modulated to a higher flux, are known and manufactured, but they often have other shortcomings.

It is general practice to measure distortion at 1000 cps at both tape speeds. If for some reason distortion at higher frequencies is to be measured, the record level must be reduced by the amount of recording pre-emphasis used. The reason for this is to be found in the deficiencies of the tape and it has no bearing on the quality of the recorder.

Recording pre-emphasis at the high frequencies can be used for voice and music, as it can be shown by analysis of the Energy Distribution that high frequencies do generally occur at much reduced amplitudes.

It was mentioned under paragraph E 2b "Bias Adjustment" that distortion largely depends on the amount of bias current which has been chosen. The alignment procedure described under the above mentioned heading follows the generally accepted practice. Special requirements can sometimes be met by altering the bias adjustment, under careful observation of the changes in the 3rd harmonic content and signal to noise ratio as well. A very useful tool for such tests will be the EMT 126 Third Harmonic Tester, as its readings will not be influenced by changes in the signal level, providing the audio voltage supplied to its input is 4.0 volts or higher.

#### E 2f NOISE LEVEL MEASUREMENTS.

Optimum readings will be obtained if the following points are carefully observed:

Demagnetize the magnetic heads as well as all steel parts which are in contact with the tape in a gradually diminishing AC field. This should be done at regular intervals to maintain the recorder at optimum performance with respect to noise.

Any bias signal leaking into the playback amplifier should be filtered out by tuning the bias-trap in that amplifier. For this alignment a wide band oscilloscope may best be used as an indicating device on the output of the playback channel.

Select tube V 1 (first stage of playback amplifier) for best noise reading. Variations in the order of 2 to .3 db can sometimes be observed from tube to tube.

For taking noise readings, the VTVM or other indicating device should have its frequency response limited to little above 15 kc.

Noise readings are first taken without tape threaded on the recorder. Power should be applied to the capstan- and spooling motors for this test. Secure tape tension balance in its operating position to keep the safety switch from being actuated.

Now thread the recorder with tape and start the machine in the record mode with no signal applied to the input.

The values now indicated will be markedly higher and this is a characteristic of the STUDER C-37 Recorder, from which can be seen, that the obtainable overall signal to noise ratio is limited by the qualities of the tape and not by the recorder. Where it is customary to take weighted readings also, this may be done in a similar manner.

For the sake of interest it shall be mentioned here, that in various countries the noise readings are taken with meters having characteristics which will produce a so called peak-evaluation. In areas which are influenced by anglo-american methods and techniques, it is customary to measure the rms value of the noise voltage, using meters whose characteristics are similar to the standard VU-Meter. Both methods have been used in compiling the Technical Data for the STUDER C-37 and the readings obtained are listed accordingly.



### E 2g ERASE EFFICIENCY.

To measure Erase Efficiency a 1000 cps narrow band-pass filter or wave analyzer must be available. The reading is taken at the recorder output, while erasing a previously recorded 1000 cycle tone in the absence of a new signal. Erase Efficiency is influenced to some degree by the position, which the gap of the erase head takes at the point where it is in contact with the tape.

### E 3 WOW AND FLUTTER, TAPE SLIPPAGE.

Wow and Flutter are caused by minute deviations from a perfectly constant tape speed and are due to slight imperfections in the transport mechanism.

The frequency deviations thus occurring are expressed in percent of the mean test frequency, this being the value of wow and flutter. By their rate of occurrence they are recognized as either wow or flutter. The human ear is not equally sensitive to the various rates of frequency changes as caused by motion irregularities and a realistic reading will only be obtained if a weighting network, which simulates the human ear response, is introduced into the measuring device.

On a recorder with very stable motion the wow and flutter frequencies will have a random distribution without any one single frequency being predominant. However, as soon as a distinct frequency appears in a flutter analysis, this is to be taken as a warning sign.

Regular routine checks on the flutter performance of a machine will not only keep it in top-notch mechanical condition, but will also ensure a long and satisfactory life, as any fault which may be developing can already be detected in its early stages.

The minute irregularities in the motion of the tape, find their sources in the condition of bearings and rollers. A bent shaft or slightly excentric roller will cause a near sinusoidal disturbance, whereas dirt or rust in a bearing will show up more as a spiky pulse. It is therefore good practice not only to measure wow and flutter, but to also record it graphically - a technique which finds more and more wide spread use. The graphical record will show at a glance whether or not a basic change has occurred on the machine against a previous test. From the paper speed and the wavelength of the disturbances, as they appear on the record, the diameter of the interfering part can be shown by a simple calculation. Replacing or reconditioning the faulty part in time, will avoid costly repairs and equipment break down.

Motion irregularities can also be analyzed with aid of filters by isolating and determining the frequency that predominates. However, this method lacks the exactness and precision of the graphical record, a reason why the latter is being preferred in practical application.

Values for Wow and Flutter should always be stated as weighted readings. In contrast to this, no weighting should be used when making a graphical record of the motion irregularities. The precise indication of the interferences which can be obtained under linear evaluation will greatly facilitate the identification of a faulty component. In the past, flutter has mostly been stated as an rms value, but nowadays it becomes more and more accepted to take these readings under peak to peak evaluation. Because of the complex waveshape of the flutter interference, a relationship between the values obtained under the two methods of measurement can not be found. In compiling data from both test methods it was found that a peak to peak reading may be between 2,5 to 5 times as high as the one which was measured with an rms meter. As these discrepancies could lead to a misjudgement of the quality of a particular recorder, it is important always to state clearly which method of measurement has been used.

Readings are best taken with EMT 420, Wow and Flutter Meter, which has been redesigned to meet the latest revision of an international standards recommendation on Wow and Flutter Measurements. For an accurate analysis of the flutter frequencies the Graphic Recorder EMT He 1 b, or the High-Low Pass Filter EMT 421 should be used in conjunction with the EMT 420. Ideally, the flutter of a recorder should be checked with the aid of a test tape whose own flutter content is low compared with that of the device under test. However, such tapes can not be produced for a high quality professional recorder, as a machine of that class has itself already a negligible amount of flutter. The only method that remains possible, is to record the test tape directly on the machine which is under test and to take readings after this recording has been rewound and while playing it back again. Under no circumstances should readings be taken, when recording this tape, as entirely false values may be obtained. If the distance between record- and playback head is equal to one half of the capstans circumference, or even multiples thereof, Flutter will be compensated to a large degree; odd multiples may cause the flutter signal to rise to near twice its true value.

Therefore, the measured value should be the resultant of the vector quantities which could be assigned to flutter during record and flutter during playback. The published values for the STUDER C-37 are based on this method of measurement.

Tape slip - the change in absolute tape speed from the beginning to the end of a reel - is measured by recording a test signal at both ends of a reel of tape. Turning the tape head to tail places the section which was recorded at the start of the reel on its end and it is now played backwards.

This reverses the conditions of holdback tension under which the recording was made and the slight difference in recorded wavelength will now be reproduced as a frequency which differs from the one that has been recorded. The difference between the two frequencies in the reversed reel condition can be measured on the EMT 420, Wow and Flutter Meter, in position "slip". One half of the indicated value is the amount of Tape Slip.

Note: Tape Slip will depend on the brand of tape which is used and will greatly vary with the thickness of its backing.

#### E 4 STARTING- AND STOPPING TIME ADJUSTMENT.

See C 8 "Relay Box".

## F Maintenance Schedule

Assuming a daily operation of the recorder of 8 - 10 hours, it is suggested to carry out the following routine maintenance work at the time intervals indicated :

<u>Daily :</u>	clean heads	using a soft lint free cloth, clean head face and remove any hardened deposits with trichlorethylene.
		If high quality tapes are used, leaving only a negligible deposit, this work may be reduced to a weekly operation.
<u>Weekly :</u>	demagnetise heads and all steel parts in the tape path	using a head demagnetiser or other suitable demagnetising coil, subject all steel parts to an AC field. Remove coil gradually before disconnecting from power line.
	check operating voltages and currents	Turn selector switch on the oscillator chassis from step one through eight and observe whether pointer still indicates within the tolerance mark. Check if bias readings in position 7 and 8 still correspond to the readings found as described under E 2 b.
	cleaning of the pinch wheel	If a brown deposit has formed on the surface of the pinch wheel, the latter should be removed from the machine and cleaned with trichlorethylene.  Important ! The pinch wheel must be removed for cleaning. The highly volatile tri-chlor may otherwise attack the oil reservoir of the capstan or damage the paint on the tape recorder.
	cleaning of the capstan	The capstan should also be cleaned carefully and frequently with a clean piece of linen.
		NEVER USE HARD OBJECTS.
	<u>After the first 100 working hours:</u>	
	control and adjustment of brakes	see chapter C 2.
<u>Monthly :</u>	alignment and performance checks	Check levels and bias as per section E " Alignment Procedures "
<u>Quarterly :</u>	adjust brake tension	Check brakes for proper tension as per section C 2.
	capstan idler pressure	Check as per section C 6.
	lubricate tape lift mechanism	Place a few drops of a good oil on all moving parts. (e.g. MOBIL - see capstan bearing.)

After 2000 working hours:

The capstan axle is lubricated from the oil retaining felt under the plastic cap with "MOBIL DTE Extra Heavy". Generally the oil reservoir is sufficient for about 2000 working hours. Under the translucent plastic cap on the upper side of the bearing there is a felt washer which has to be soaked with "MOBIL DTE Extra Heavy".

After 8000...10000 working hours:

If necessary the capstan should be replaced together with the bearing housing. For removal of the capstan, refer to section C 6.

I m p o r t a n t !

All other moving parts of the recorder, especially spooling motors and all ball bearings in the guide rollers are lubricated for the expected life (approx. 20000 h) and must not be oiled. Should running noises develop before this period of time has elapsed, it is best to replace the faulty bearing or motor, the stock number for which can be found in the parts list.

(For ball-bearing use the factory approved low noise type only).

## G Parts List

### Electrical - and Audio Connector

Power Receptacle	54. 04.0102
Power Cord Plug	54. 04.0101

### Cannon

Chassis Receptacle, socket insert	54. 02.0283
Cannon Cord Plug, pin insert	54. 02.0280
Cannon Chassis Receptacle, pin insert	54. 02.0282
Cannon Cord Plug, socket insert	54. 02.0281
Remote Control Connector, (Amphenol Cord Plug)	54. 02.0226
Metal cover	54. 02.0234
Strain relief Clamp	54. 02.0236

### Tape Transport Mechanism

Tape reel flange	1.013.050
Adapter for DIN core	1.013.003
Adapter for plastic reel, (Cine or RMA reels)	1.013.001
NAB Adapter	1.013.005

### Headmount, and heads

Headmount, full track heads with epoxy body	1.020.001
Headmount, full track heads with full metal body	1.020.002
Headmount, Stereo 2 mm / heads with epoxy body	1.020.003
Headmount, Stereo 2 mm / heads with full metal body	1.020.004
Headmount, full track Neo - Pilotton System Nagra / heads with epoxy body	1.020.005
Headmount, full track / Pilotton DIN, heads with epoxy body	1.020.008
Headmount, two track ATV / heads with epoxy body	1.020.009
Headmount, full track / pre - monitoring heads with epoxy body	1.020.011
Headmount, full track / only Playback - heads with epoxy body	1.020.015
Headmount, Stereo 2 mm / only Playback - heads with epoxy body	1.020.017
Headmount, Stereo 0,75 mm / only Playback - heads with full metal body	1.020.019
Headmount, Stereo 0,75 mm - heads with full metal body	1.020.021
Erase Head, full track / epoxy body	1.017.400
Record Head, full track / epoxy body	1.017.410
Playback Head, full track / epoxy body	1.017.420
Record Head, two track / for old amplifiers	1.017.250
Record Head, two track, for new amplifiers CCIR / NAB	1.017.360
1.337.970/990 Playback two track / epoxy body	1.017.260
Erase head, two track / epoxy body	1.017.450
Playback two track ATV / epoxy body	1.017.265

Record Head full track / heads with full metal body	1.016.105
Playback full track / heads with full metal body	1.016.110
Record Head two track Tr. sp. 2 mm / heads with full metal body	1.016.125
Playback two track Tr. sp. 2 mm / heads with full metal body	1.016.130
Record Head two track Tr. sp. 0,75 mm / heads with full metal body	1.016.135
Playback two track Tr. sp. 0,75 mm / heads with full metal body	1.016.140
Guide Roller	1.337.190
Ball Bearing EL 7 - P 5	41. 02.2205
Tape Tension Control Ass'y	1.337.192
Ball Bearing EL 6 ZZ	41. 02.0104
Ball Bearing EL 7 ZZ	41. 02.0105
Tape tension Potentiometer printed circuit board wired	1.337.204
Wiper Arm, compl.	1.337.206
Tension spring small	1.337.192-10
Tension spring	1.337.192-11
Solenoid, tension control	1.337.208
Dash - Pot, tension control	1.337.394
Cord compl. for tension control	1.337.212
Idler Plate, complete with idlers	1.337.216
Idler Bearing for tape tension control Assembly	1.337.218
Linkage spring for tape tension control Assembly	1.337.201
Roller for tape tension control Assembly	1.337.216-08
Flywheel and flywheel idler assembly, compl.	1.337.224
Ball Bearing EL 8 - P 5	41. 02.2206
Flywheel magnet for Flywheel idler assembly	1.337.226
Tape Lift Mechanism	1.337.380
Pin tape, lift complete	1.337.381
Dash - Pot, tape lift	1.337.390
Solenoid, tape lift	1.014.400
Marking devise	1.337.954
Rubber Stamp	1.337.958-05
Splicing Block	1.337.101-54
Capstan Ass'y complete 50 cps	1.337.152
Capstan Ass'y compl. 60 cps	1.337.154
Capstan Bearing, complete 50 cps	1.337.162
Capstan Bearing, complete 60 cps	1.337.164
Capstan Motor and case for screening incl. cable	1.337.178
Flexible coupling strips for flywheel	1.337.184
Capstan Idler	1.337.188
Capstan Idler Bearing	1.337.186
Capstan Solenoid	1.337.174
Ball Bearing EL 6 Z	41. 02.1104
Guide Roller small	1.337.396
Ball Bearing EL 6 - P 5	41. 02.2204
Tape Cutter Ass'y complete	1.337.234

Synchronous Motor incl. gears	1.337.236-01
Cutter Blades	1.337.240-02
Cutter Blades	1.337.240-03
Tape Timer	1.337.248
Spur wheel	1.337.248-12
Belt for timer	1.337.248-32
Ball Bearing EL 4 ZZ	41. 02.0102
Ball Bearing EL 5 ZZ	41. 02.0103
Ball Bearing EL 7 - P 5	41. 02.2205
Torque Motor	1.337.311
add to each spooling motor Serie 1 -3 : 50 cps capacitor 4 mfd	59. 99.0153
60 cps capacitor 3 mfd	59. 99.0171
Spacer 1.337.316-09 for 60 cps (capacitor 59.99.0171)	
Light Bulb, bayonet base (Osram) 25 W / 150 V 51.02.0191 (for 50 cps and 60 cps)	
Brake Band, special	1.337.296
Brake Drum, complete	1.337.300
Brake Tension, spring	1.337.282-15
Brake Solenoid	1.014.200
Push Button Ass'y, left	1.337.252
Push Button " fast forward "	1.337.254
Push Button " fast reverse "	1.337.256
Push Button " play "	1.337.258
Push Button " stop "	1.337.260
Push Button " record "	1.337.262
Push Button Ass'y right	1.337.266
Push Button Ass'y left, for Remote Control	1.337.265
Push Button " cutter "	1.337.268
Push Button " 15 "	1.337.272
Push Button " 7,5 "	1.337.270
Push Button " off "	1.337.274
Push Button without indication	1.337.254-01
Snap action Switch (Marquardt) 1 A / 250 V	55. 01.0121
Pilot lamp holder	53. 04.0101
Pilot lamp F 9 - 24 V / 0,08 A (Rafi)	51. 02.0122
Fluted Bakelite Disk for head shield mechanism	1.337.418
Fluted Bakelite for tape lift mechanism	1.337.424
<b>Electronic components and Assemblies</b>	
Power Supply, tape transport 50 cps	1.337.342
Power Supply, tape transport 60 cps	1.337.344
Power Transformer, tape transport 50 cps	1.337.354
Power Transformer, tape transport 60 cps	1.337.356
Silizium Diode OY 5062 (4x)	50. 04.0504
Silizium Diode OY 5063 (4x)	50. 04.0505
Transistor Philips ASZ 18	50. 03.0201
Relay Box	1.337.314
Silizium Diode 1 S 130	50. 04.0110

Relay Schrack 3 U (SBz, SR, SSM, SL <sub>1</sub> , SL <sub>2</sub> , SS <sub>1</sub> , SS <sub>2</sub> )	56. 02.0102
Relay Schrack 2 U (SBrv, SB, SStv, SK, SV)	56. 02.0101
Relay 3a + 3r (RBrv, RB, RV, RR, RBh, RVh, RRh, RF, RAM)	56. 01.0102
Horometer compl. 50 cps	1.337.333
Horometer compl. 60 cps	1.337.335
Light Bulb, bayonet base (Osram) 25 W / 150 V off Serie 4	51. 02.0191
Light Bulb, bayonet base (Osram) Serie 1-3 60 W / 220 V	51. 02.0190
 Rectifier Unit, amplifier section 50 cps	 1.337.710
Rectifier Unit, amplifier section 60 cps	1.337.712
Power Transformer for rectifier unit	1.337.720
Silizium Diode (4x) 1 N 4721	50. 04.0507
Silizium Diode (Philips) (4x) By 100	50. 04.0503
Selenium Rectifier (Siemens Flachgleichrichter) B 250 C 75	70. 01.0111
 Regulating Unit, compl.	 1.337.830
Transistor (Philips) ASZ 18	50. 03.0201
Zenerdiode (Intermetall) Z L 7	50. 04.1501
Relays 3 a + 3 r (RAA)	56. 01.0102
Amphenol Connector, female, 24 contacts	54. 02.0133
Amphenol Connector, male, 14 contacts	54. 02.0130
Oscillator, bias and erase Mono	1.337.750
Oscillator, bias and erase Stereo	1.337.752
Oscillator, bias and erase ATV	1.337.754
Relays 3a + 3 r (RA <sub>1</sub> , RA <sub>2</sub> )	56. 01.0102
Coil Oscillator	1.337.764
Bias Transrormer	1.337.822
Symmetry Coil	1.337.804
Relay 3 a + 3 r (RLV)	56. 01.0102
 Record Amplifier, complete	 1.337.970
Input Transformer (TR 145 / BV 35590)	1.062.770.03
RF Trap	1.337.980
Potentiometer 100 K $\Omega$ / log.	58. 10.2104
Cannon - Chassis Receptacle XLR - 3 - 31	54. 02.0282
Amphenol - Connector 14 contacts	54. 02.0131
Indication Plate " Record Amplifier	1.337.970-01
 Playback Amplifier compl.	 1.337.990
Output Transformer	1.337.993
Metal-Film Resistor (R 3) 270 K $\Omega$ 1/2 W - 2%	57. 33.3274
Relay -form C ( double throw ) ( RLW RE <sub>1</sub> )	56. 01.0101
Relay -form C ( quadruple throw ) RE <sub>2</sub> )	56. 01.0111
Potentiometer 100 K $\Omega$ / log.	58. 10.2104



Variable Air Capacitor 20 - 250 pF	1.337.974-02
Silizium Diode 1 S 130	50. 04.0110
Amphenol Connector, female, 14 contacts	54. 02.0131
RF Trap	1.337.980
Cannon - Chassis Receptacle XLR - 3 - 32	54. 02.0283
Tuchel - Connector T 3282	54. 02.0253
Indication Plate " Playback Amplifier "	1.337.990-01
 Cable Trough	 1.337.514
Amphenol Connector, male, 24 contacts	54. 02.0132
Chassis-Receptacle 6 contacts	54. 02.0223
Cap for Chassis - Receptacle	54. 02.0234
Cord Grip	54. 02.0236
Compression spring	1.337.514-06
Pin	1.337.514-07
 Extra Accessories	
Adapter Cable for testing amplifiers, 14 contacts	1.337.960
Adapter Cable for testing amplifiers, 24 contacts	1.337.964
Head Alignment Tool, (double screw driver)	1.337.944
Extension Piece, timer reset lever	1.337.100-03
Lubricant press	89. 01.0250
Tape altitude gauge 1/4"	1.337.951
Indexing stamp	1.337.954
Degaussing coil	1.337.945
Mobil DTE Extra Heavy Oil	99. 01.0114

## **H Schematic Diagrams, Leaflets**

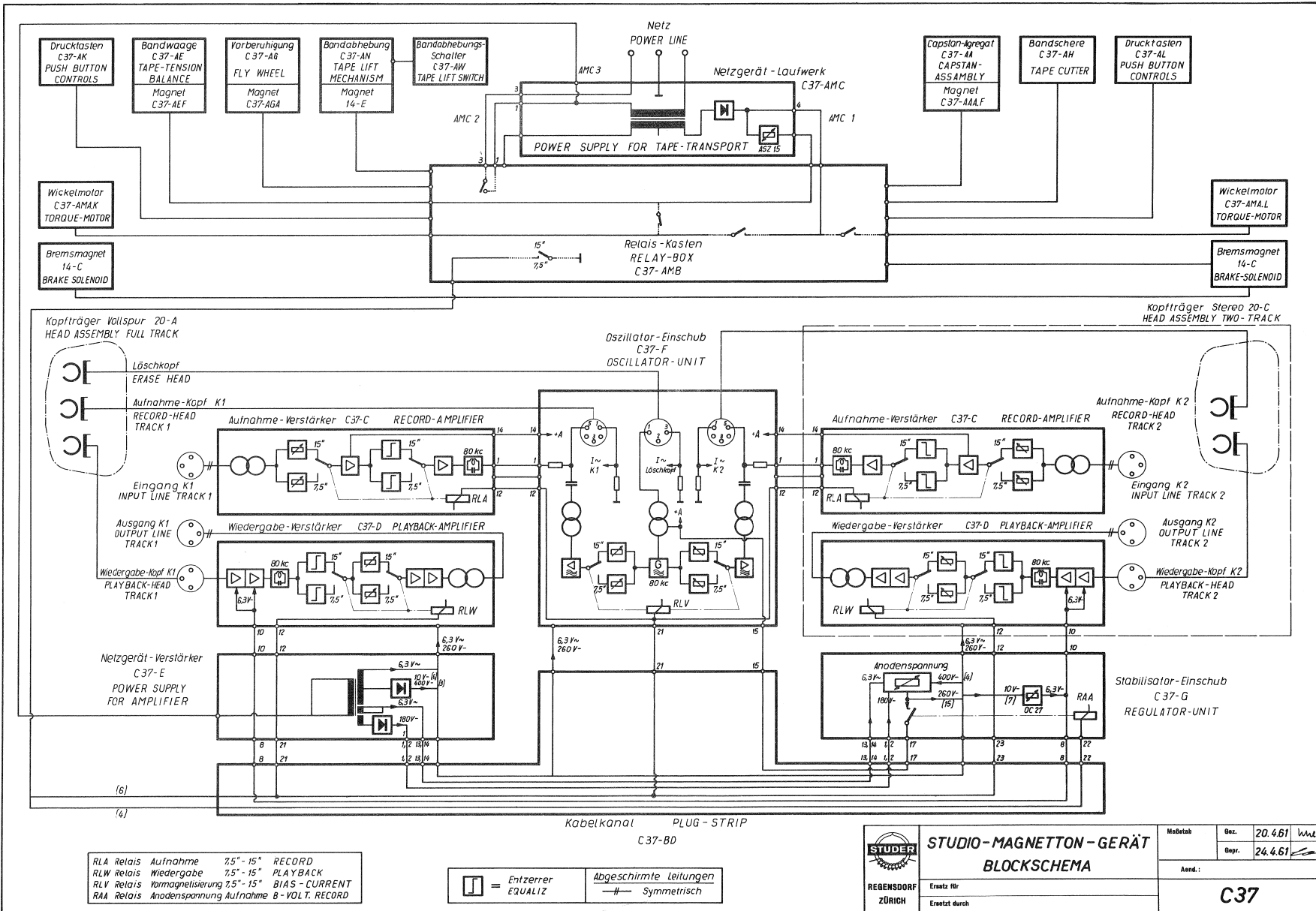

RLA Relais Aufnahme 7,5" - 15" RECORD  
 RLW Relais Wiedergabe 7,5" - 15" PLAYBACK  
 RLV Relais Vormagnetsierung 7,5" - 15" BIAS - CURRENT  
 RAA Relais Anodenspannung Aufnahme B - VOLT, RECORD

= Entzerrer EQUALIZ  
 = Abgeschirmte Leitungen  
 —#— Symmetrisch

 <b>STUDER</b> REGENSDORF ZÜRICH	<b>STUDIO-MAGNETTON-GERÄT</b> <b>BLOCKSCHEMA</b>		Modelab Bez. 20.461 Gepr. 24.461
	Ersatz für Ersatz durch		Anm.: <b>C37</b>

**Kopfträger (Vollspur-Ausf.)  
HEAD ASSEMBLY (FULL-TRACK)**

**Achtung !**

Nicht mit Gleichstrom belasten. Vorschrift!

**ATTENTION !**

DO NOT APPLY ANY DC.

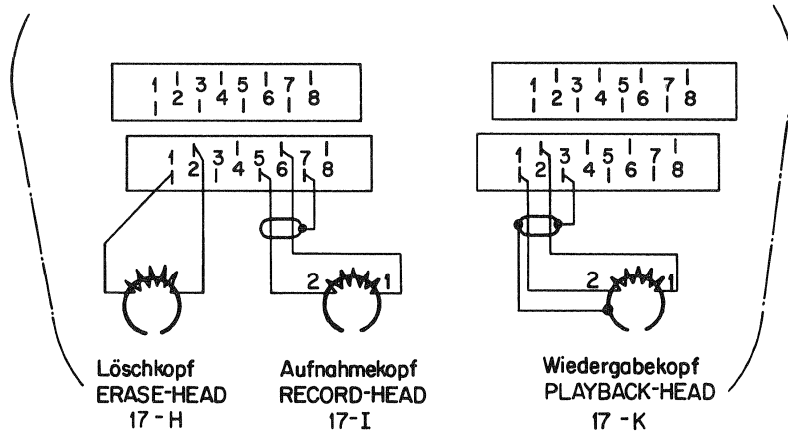
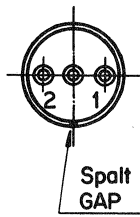

**Kopfträger (Stereo-Ausf.)  
HEAD ASSEMBLY (STEREO)**

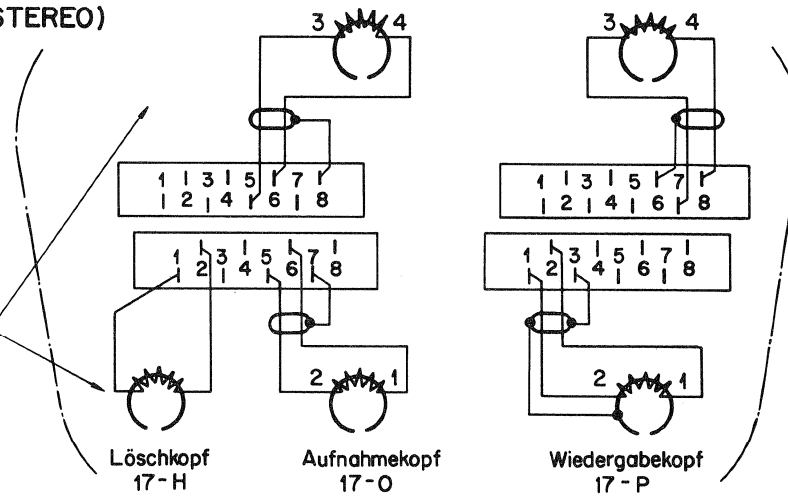
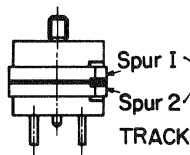
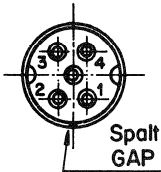

Farbbezeichnung auf Kernblech:  
COLOURCODE ON HEAD-LAMINATION

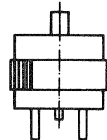

Aufnahmekopf = grün RECORD-HEAD = GREEN  
Wiedergabekopf = rot PLAYBACK-HEAD = RED

	<b>KOPFTRÄGER</b>		Maßstab	Bez.	30.4.62	1/2
				Gepr.		
REGENSDORF ZÜRICH	Ersetzt für Ersetzt durch		Gültig ab C37 Serie 3			
			<b>B-20-A/C</b>			

**Achtung !**

Nicht mit Gleichstrom belasten.

**ATTENTION!**

DO NOT APPLY ANY DC.

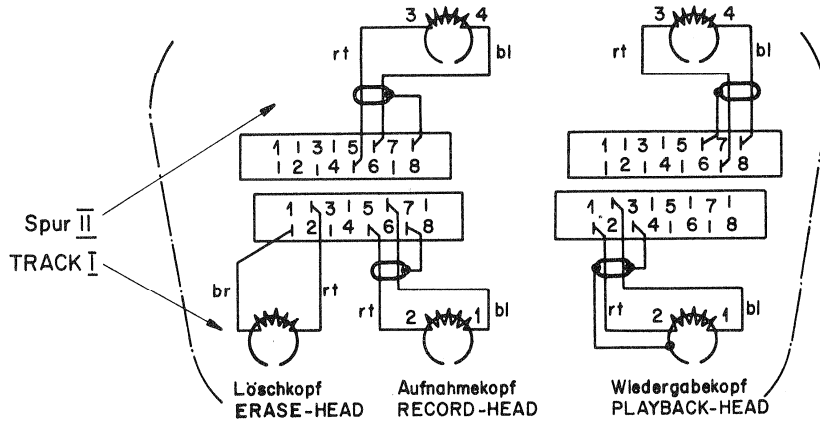

**Metallköpfe  
METAL - HEAD**

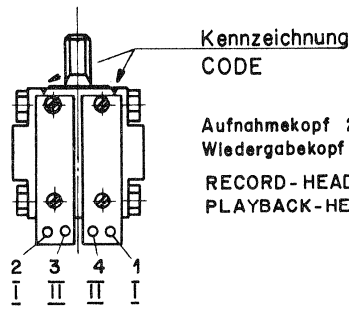
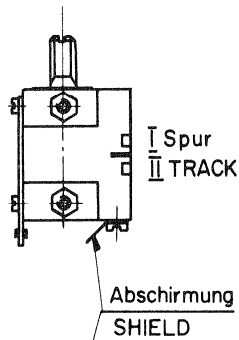

**Epoxydharzköpfe  
EPOXY - HEAD**

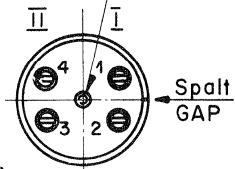

Farbkennzeichnung (Punkt auf Kernblech oder Epoxyd-Farbe)  
COLOURCODE ( DOT ON HEAD-LAMINATION OR COLOUR OF EPOXY )

Aufnahmekopf = grün  
Wiedergabekopf = rot  
Löschkopf = weiss

RECORD-HEAD = GREEN  
PLAYBACK-HEAD = RED  
ERASE-HEAD = WHITE

<b>STUDER</b> REGENSDORF ZÜRICH	<b>Kopfträger HEAD - ASSEMBLY</b>  für <b>FOR C 37 - Stereo</b>	Maßstab	Gez. 203.67	10/69
		Gepr.		
		Norm.		R/L
Kopie für:	Ersatz für:	7. 020. 003		
	Ersetzt durch:			

**Achtung!**

Nicht mit Gleichstrom belasten. Vorschrift!

**ATTENTION!**

DO NOT APPLY ANY DC.

**Kopfträger (Vollspur-Ausf.)  
HEAD ASSEMBLY (FULL-TRACK)**

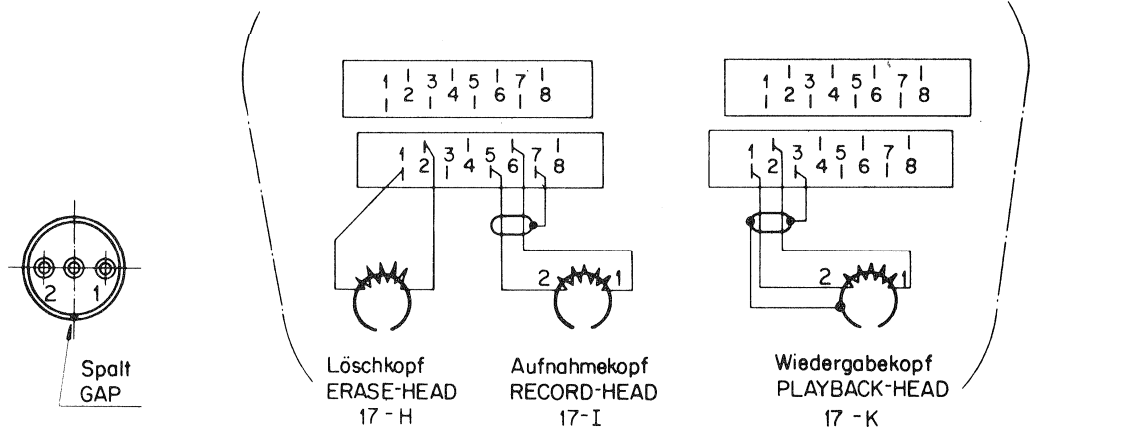

**Kopfträger (2Kanal)  
HEAD ASSEMBLY (2 TRACK)**

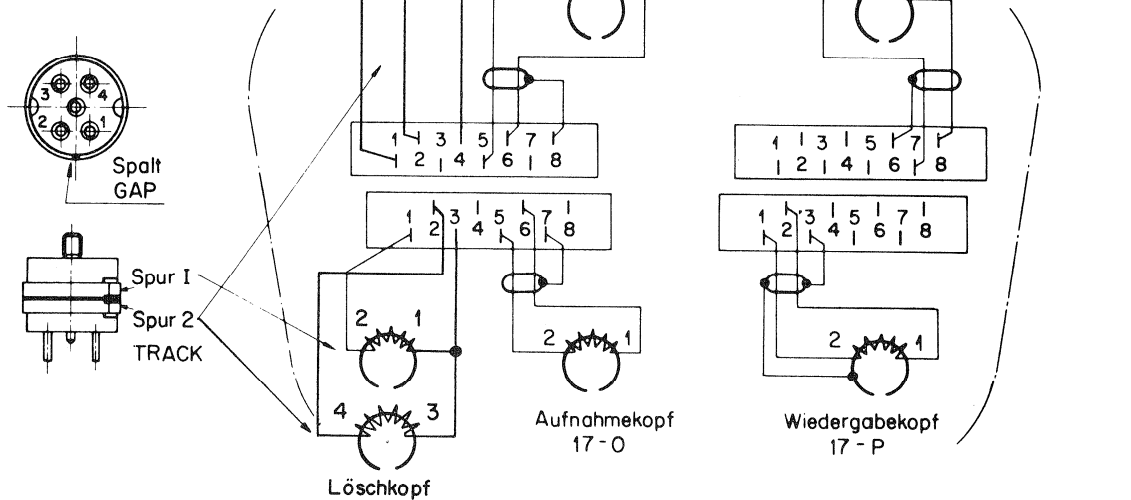

Farbbezeichnung auf Kernblech:  
COLOURCODE ON HEAD-LAMINATION

Aufnahmekopf = grün RECORD-HEAD = GREEN  
Wiedergabekopf = rot PLAYBACK-HEAD = RED



**KOPFTRÄGER ATV**

REGENSDORF  
ZÜRICH

Ersatz für **1371**  
Ersetzt durch

Maßstab	Bez.	304 2 1/2
	Gepr.	17.12.62 / 62

**7.020.009**

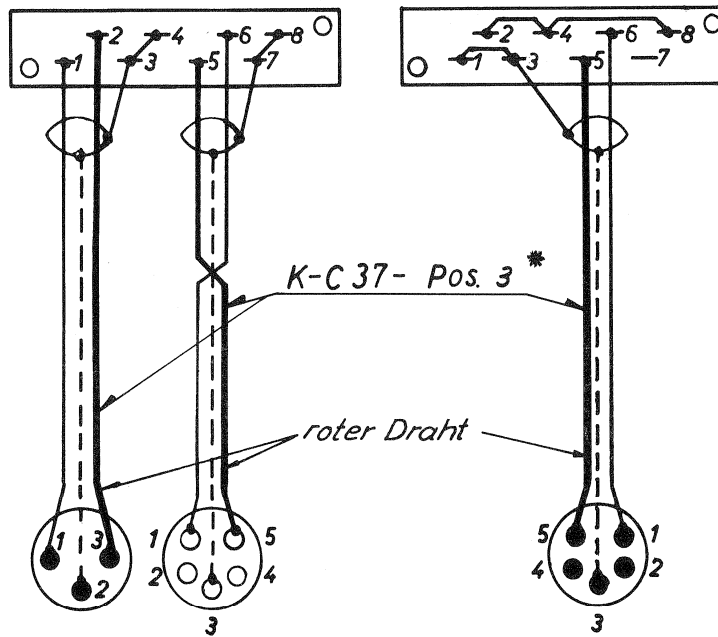

*Gemeinsam mit Isolierschlauch überziehen.*

*Stecker und Kupplungen von den Lötösen aus gesehen.*

Stück	Pos.	No.	Gegenstand	Mat.	Bemerkung
 <b>STUDER</b> REGENSDORF ZÜRICH	<h1>Aufnahme-Kabel</h1>			Maßstab	Gez. 23.8.60
					Gepr. 24.8.60
Ersatz für			<h2>B-C37-ARB</h2>		
Ersetzt durch					

Aend.: *Korr: 25.9.62 / korr: 12.6.63*

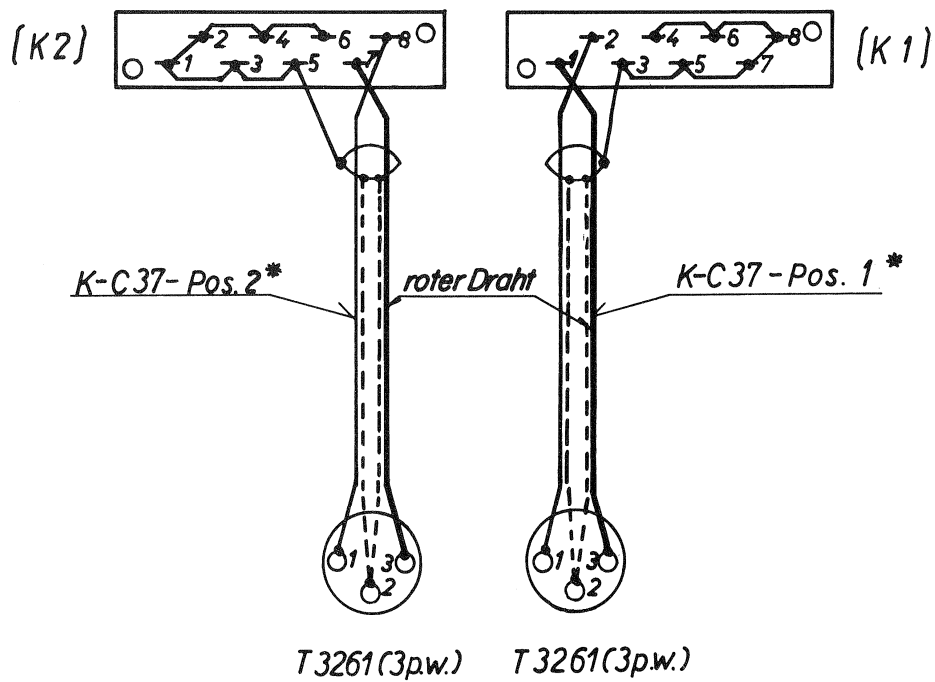

\*Beide Kabel gemeinsam mit Isolierschlauch überziehen!

Stück	Pos.	No.	Gegenstand	Mat.	Bemerkung
 REGENSdorf ZÜRICH	<b>Wiedergabe-Kabel</b>			Maßstab	Gez. 23.8.60 <i>Vogel</i>
					Gepr. 24.8.60 <i>W</i>
				Aend.: a) 22.2.61 Rosset Novr. 12.6.63 b) 11.4.61 <i>W</i>	
Ersatz für			<b>B-C37-ARA</b>		
Ersetzt durch					



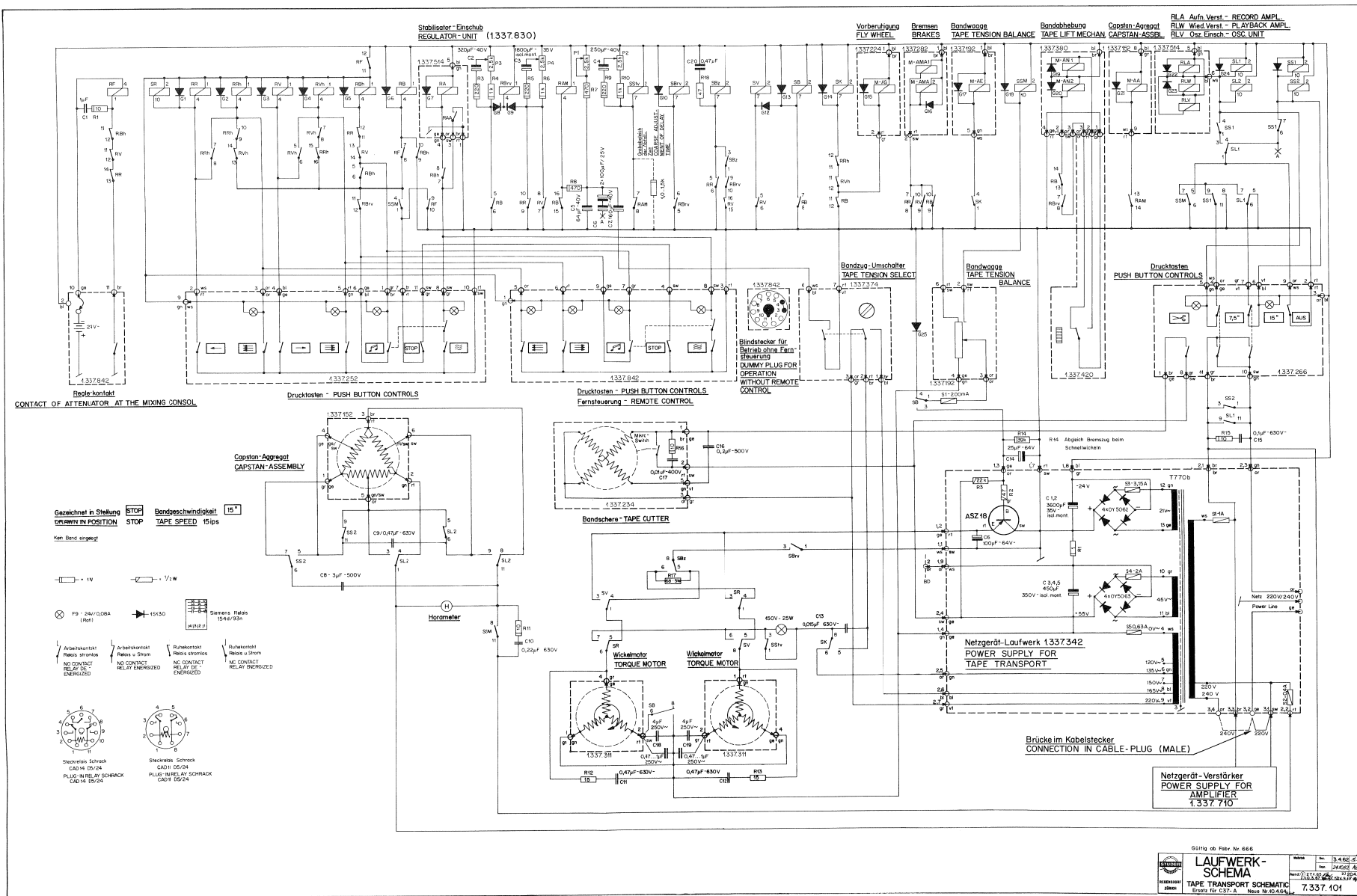

Göting ab Fabr. Nr. 666

**LAUFWERK-SCHEMA**

TAPE TRANSPORT SCHEMATIC

Stapa für C37.7 A Netz Nr. 65.416.1

7.337.101

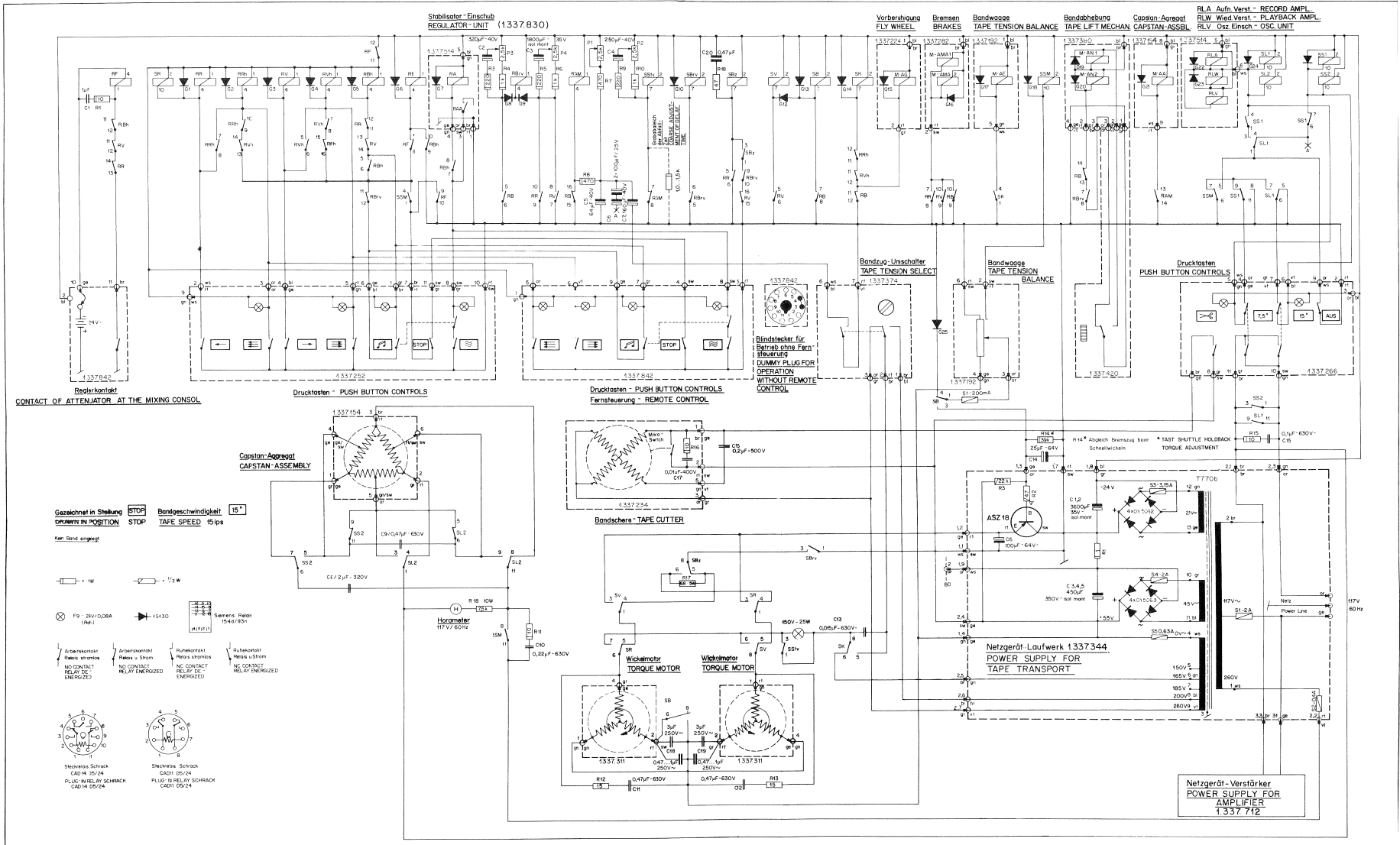

Gezeichnet in Stellung STOP Bandgeschwindigkeit 15" STOP  
 current in position STOP TAPE SPEED 15 ips

Ken Band anliegt  
 FS 3V u. 0.08A  
 1-13130  
 Siemens-Relais 5x6x9.5

Schleifenkontakt Relaisstromlos NO CONTACT RELAY DE-ENERGIZED  
 Ankerkontakt Relais u. Strom NO CONTACT RELAY ENERGIZED  
 Rührkontakt Relaisstromlos NC CONTACT RELAY DE-ENERGIZED  
 Schubkontakt Relais u. Strom NC CONTACT RELAY ENERGIZED

Siemens-Schrack CAD 14 05/24  
 Siemens-Schrack CAD 14 05/24  
 Siemens-Schrack CAD 14 05/24  
 Siemens-Schrack CAD 14 05/24

- |           |            |
|-----------|------------|
| 1 = braun | 1 = BROWN  |
| 2 = rot   | 2 = RED    |
| 4 = gelb  | 4 = YELLOW |
| 5 = grün  | 5 = GREEN  |
| 6 = blau  | 6 = BLUE   |

PLUGNUMBER IDENTICAL TO COLOURNUMBER  
Steckernummer = Farbnummer

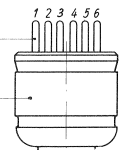

53-L-86-CP6

Isolierschlauch

SOLDER TERMINALS VIEWED FROM THE REAR  
Von hinten auf die Lötanschlüsse gesehen

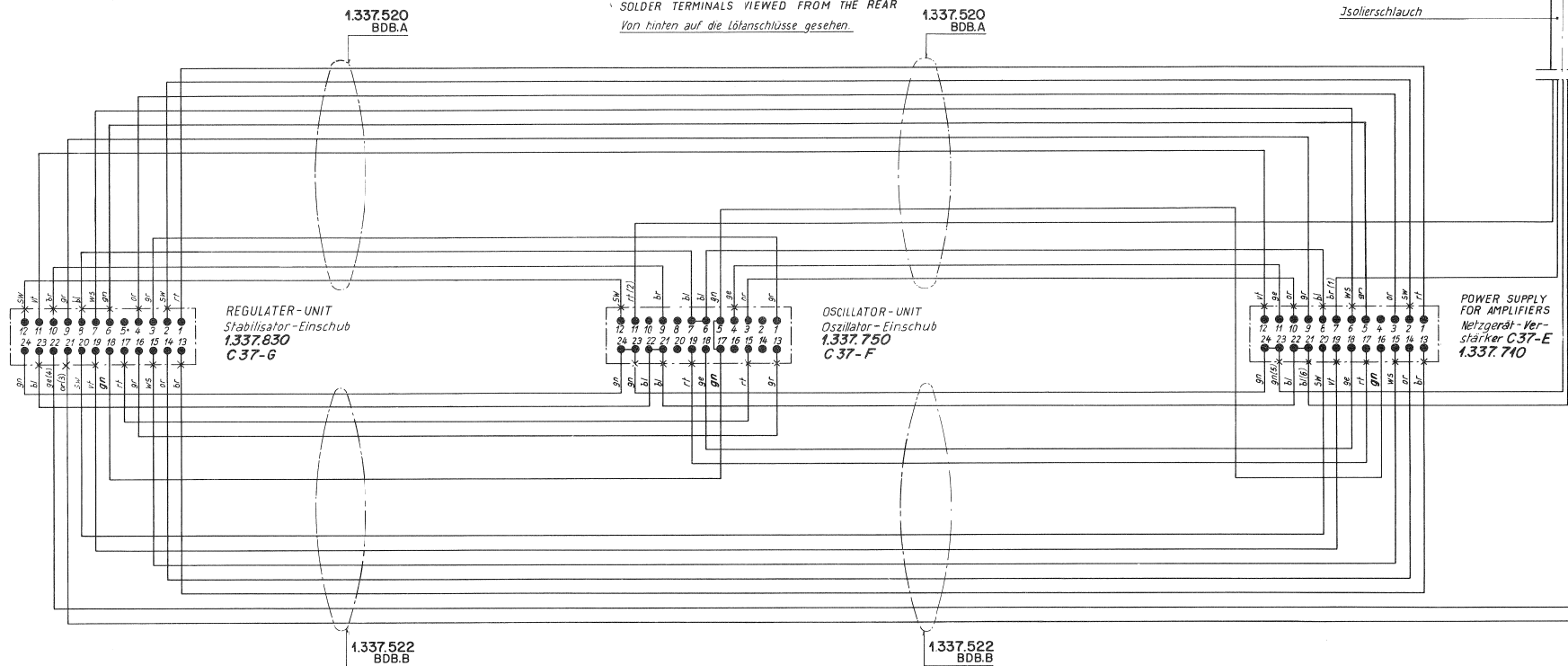

\* Bougierohr über Lötanschlüsse

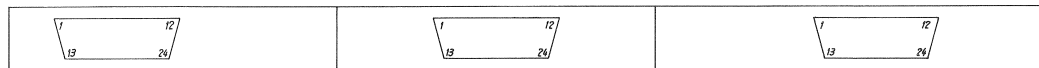

Stück	Pos.	No.	Gegenstand	Mat.	Bemerkung
			<b>Kabelbund</b> zu Kabelkanal Ersatz für <b>B-C37-BD</b> Ersetzt durch	Maßstab Gez. 4.11.60 <i>Kus</i> Dopr. 10.3.61. <i>Kus</i> Annd.: neue Nr. 7.4.64 <i>62</i>	
					<b>7.337.514</b>

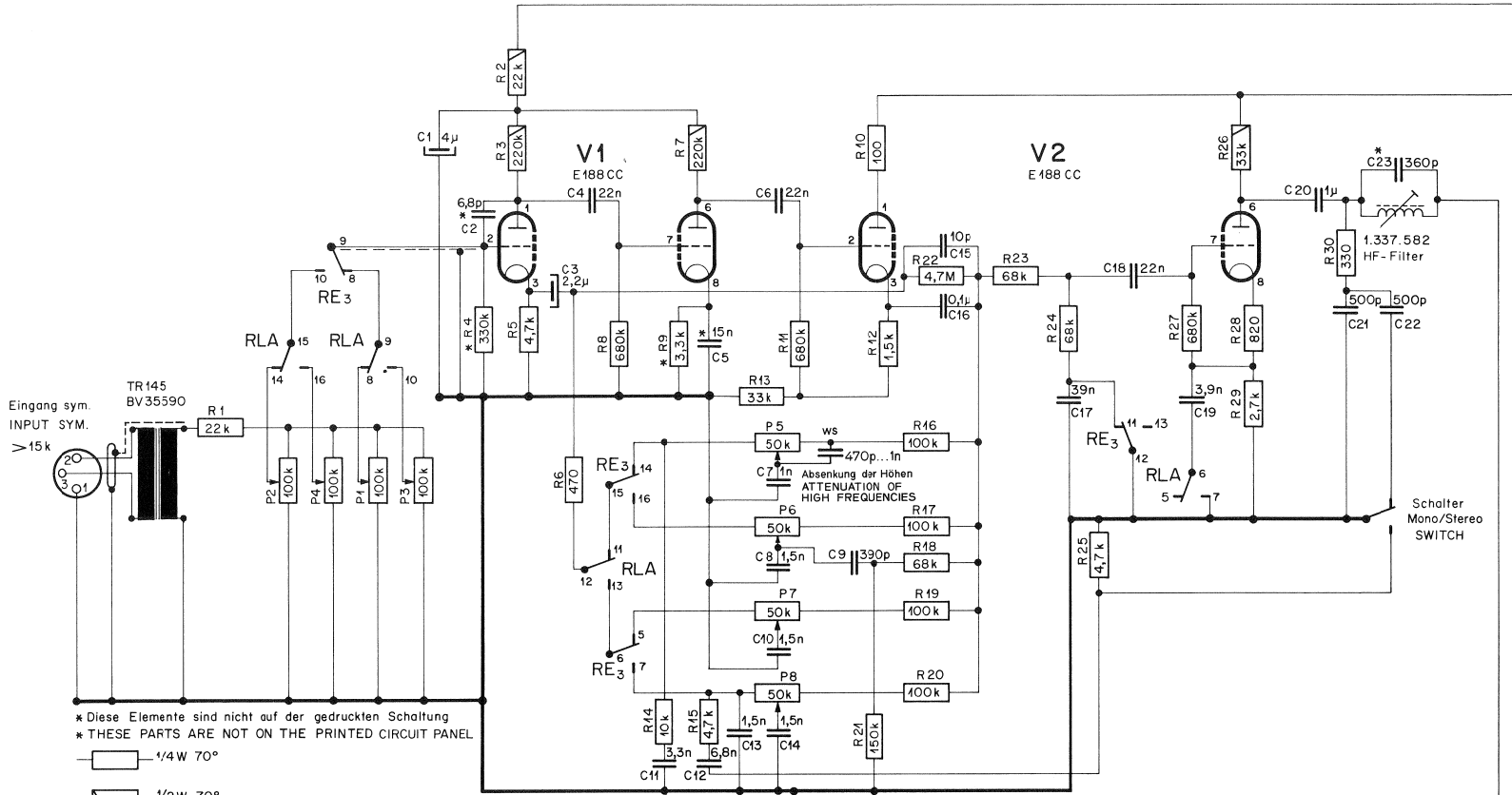

\* Diese Elemente sind nicht auf der gedruckten Schaltung  
 \* THESE PARTS ARE NOT ON THE PRINTED CIRCUIT PANEL

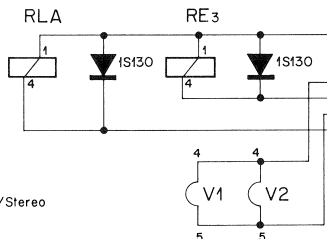
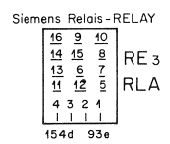
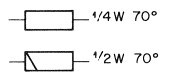

Gezeichnet in Stellung  
 DRAWN IN POSITION CCIR/15ips/Stereo

gn	vt	ge	bl	r1	sw	gr	ge	or	br
14	13	12	11	10	9	8	7	6	5
4	3	2	1						
+240V	OVRL	6,3V~	OVRE	+255V	OV	-24V(R)	6,3V~	Chassis	NF/Audio

	Pegel LEVEL	Entzerrung EQUALIZ.
ips	15 7,5	15 7,5
CCIR	P1 P3	P5 P7
NAB	P2 P4	P6 P8

Kopie für:	Ersatz für:	Ersetzt durch:	Maßstab	Gez.	3.11.64	<i>[Signature]</i>
				Gepr.	4.11.64	<i>[Signature]</i>
				Norm.		
<b>STUDDER Aufnahme-Verstärker</b> REGENDORF ZÜRICH CCIR - NAB RECORD - AMPLIFIER C 37			<b>7.337.970</b>			

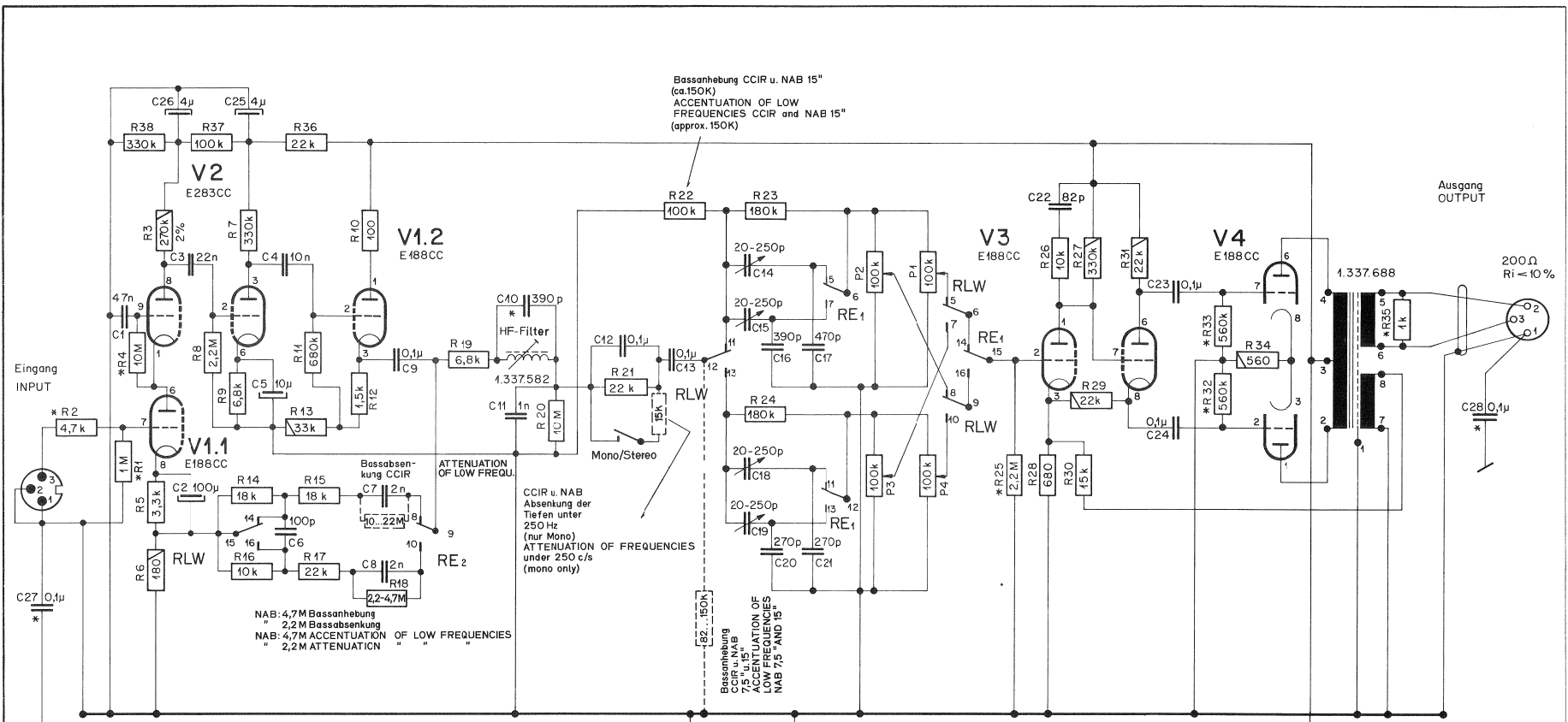

\* THESE PARTS ARE NOT ON THE PRINTED CIRCUIT PANEL  
 \* Diese Elemente sind nicht auf der gedruckten Schaltung

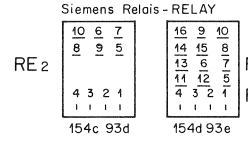
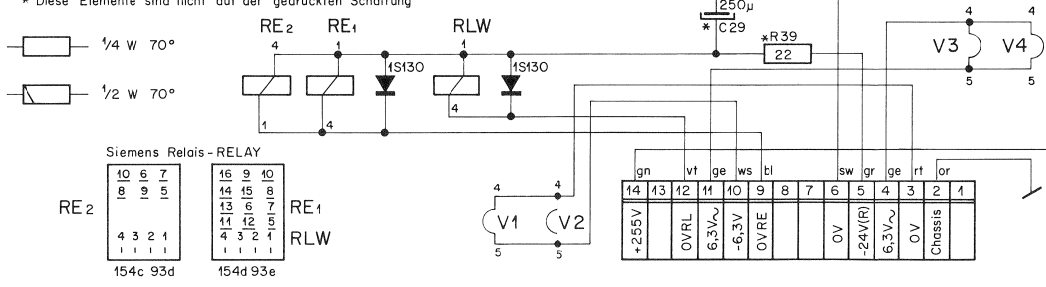

	Pegel LEVEL		Entzerrung EQUALIZ.	
ips	15	7,5	15	7,5
CCIR	P1	P3	C14	C18
NAB	P2	P4	C15	C19

Gezeichnet in Stellung  
 DRAWN IN POSITION CCIR/15ips/Stereo

<b>STUDER</b> REGENSDORF ZÜRICH	<b>Wiedergabe-Verstärker</b> CCIR - NAB PLAYBACK - AMPLIFIER		Maßstab Gez. 2.11.64 Gepr. 3.11.64 Norm.
	Kopie für:		
Ersetzt für:		Ersetzt durch:	

Netzgerät  
TAPE - TRANSPORT  
Laufwerk  
POWER - SUPPLY

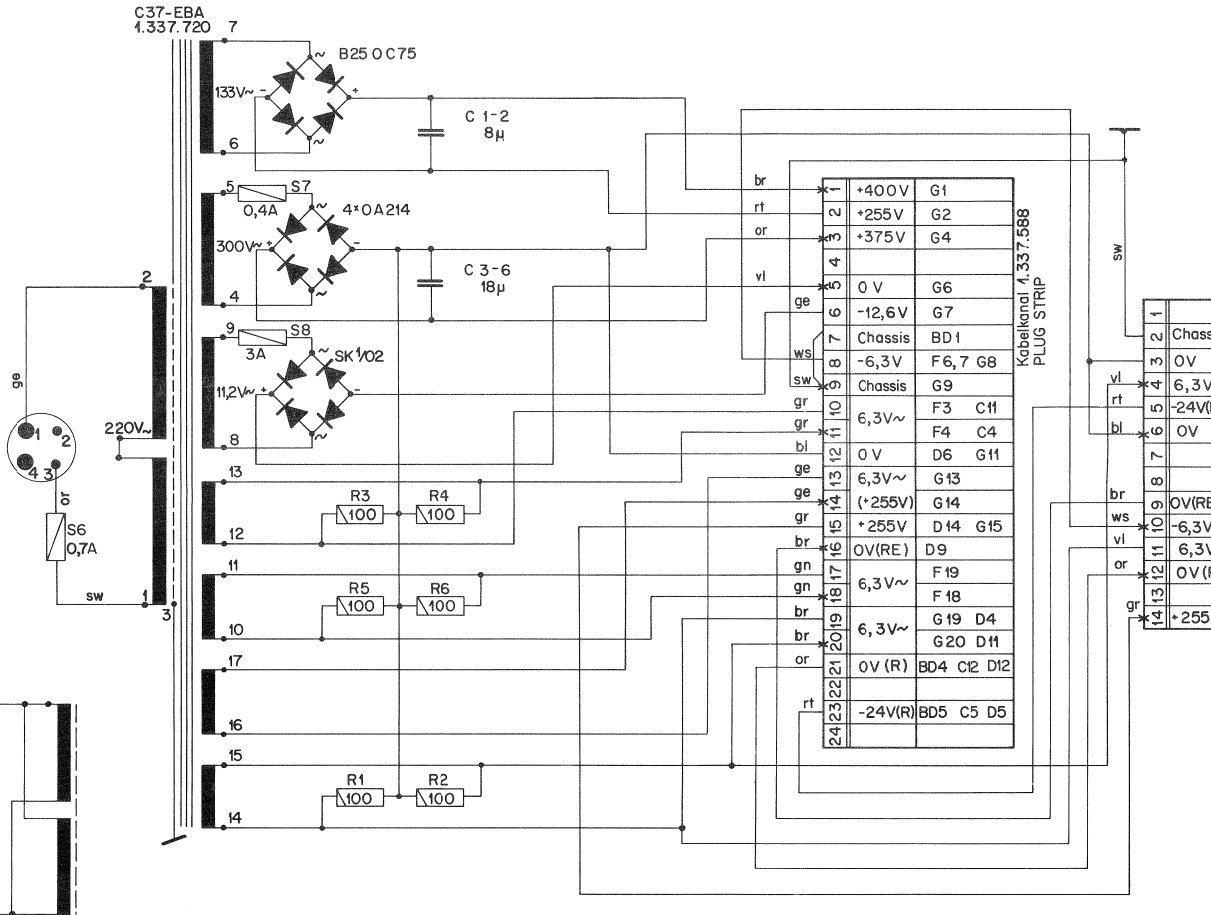

Schaltung für  
110V~

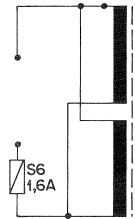

- = 1/2 W
- = 1 W
- = Isolierschlauch
- = Sicherungen träge

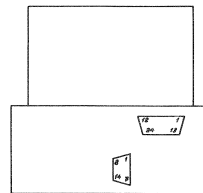
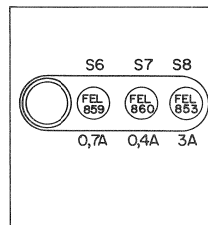

br	1	+400V	G1
rt	2	+255V	G2
or	3	+375V	G4
vl	4		
ge	5	0 V	G6
ws	6	-12,6V	G7
sw	7	Chassis	BD 1
gr	8	-6,3V	F 6, 7 G8
gr	9	Chassis	G9
gr	10	6,3V~	F3 C11
gr	11	6,3V~	F4 C4
bl	12	0 V	D6 G11
ge	13	6,3V~	G13
gr	14	(*255V)	G14
gr	15	+255V	D 14 G15
br	16	0V(RE)	D9
gn	17	6,3V~	F 19
gn	18	6,3V~	F 18
br	19	6,3V~	G19 D4
br	20	6,3V~	G20 D11
or	21	0 V (R)	BD4 C12 D12
rt	22		
rt	23	-24V(R)	BD5 C5 D5
rt	24		

Kabelkanal 4.337.588  
PLUG STRIP

sw	1	
vl	2	Chassis
rt	3	0V
vl	4	6,3V~
bl	5	-24V(R)
bl	6	0V
br	7	
br	8	0V(RE)
ws	9	-6,3V
vl	10	6,3V~
or	11	0 V (R)
gr	12	6,3V~
gr	13	+255V

Wiedergabe - Verstärker  
4.337.620 K1 /C37-D  
PLAYBACK - AMPLIFIER  
TRACK 1

Gültig ab Fabr. Nr. 666

 <b>STUDER</b> REGENSDORF ZÜRICH	<b>NETZGERÄT - VERSTÄRKER</b>		Maßstab	Gez.	4 4 02	
	Ersatz für S - C37-E		Bepr.			
Ersetzt durch		Gültig ab Serie 3 neue Nr. 7.464 K-1		<b>7.337.710</b>		

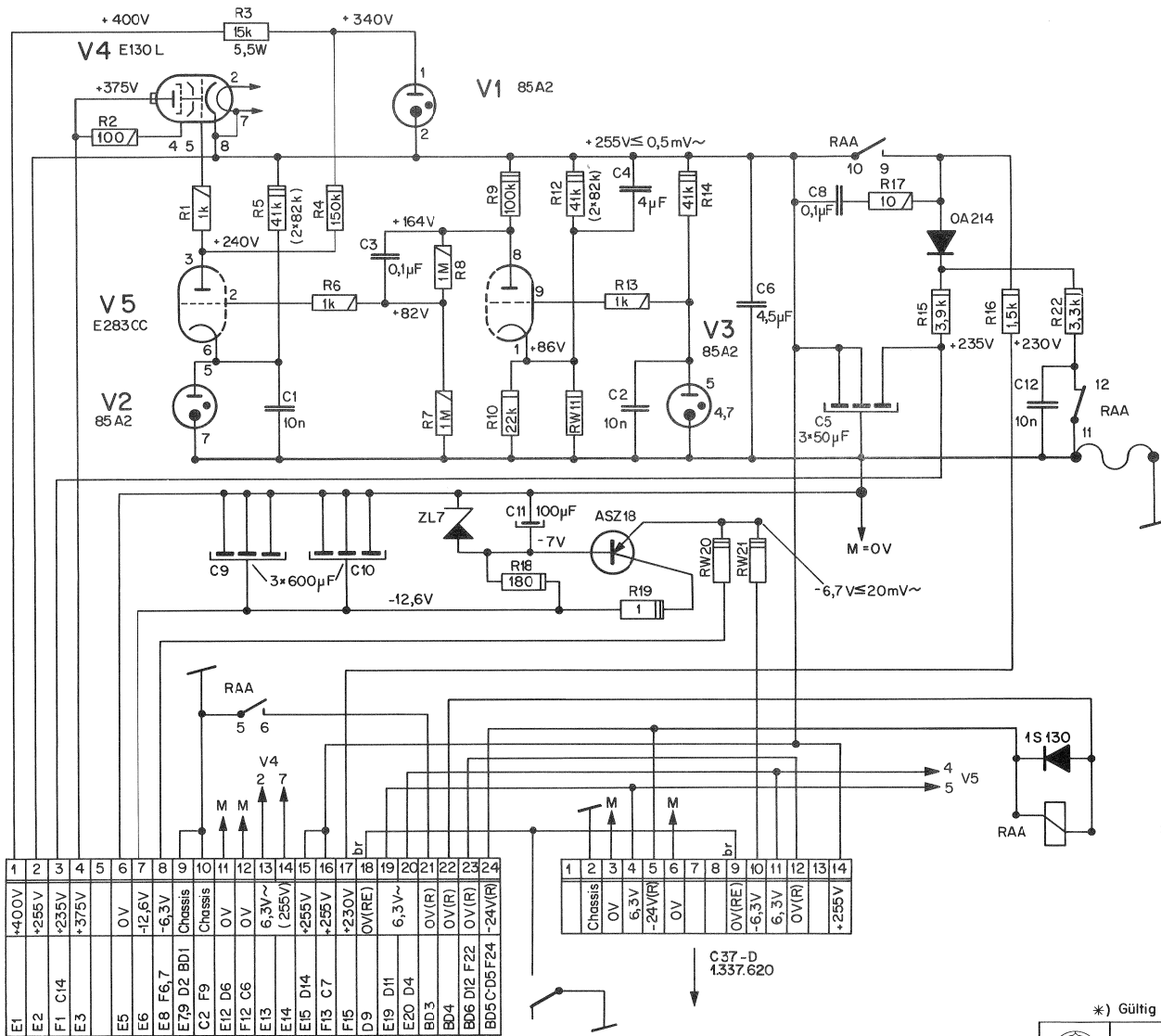

ALL VOLTAGES MEASURED IN THE RECORD-MODE WITH OSCILLATOR, ONE RECORD-AMP. AND ONE PLAYBACK AMP. AS LOAD. DC-VOLTMETER 10 K $\Omega$ /VOLT.

Spannung gemessen in Stellung Aufnahme mit Instrument 10'000  $\Omega$ /V Belastet mit 1 Aufnahme, 1 Wieder-gabeverstärker und Oszillator.

RW11 - Abgleich auf 255 - 260V  
 RW20 - Abgleich auf 6,3V-  
 RW21 - Abgleich auf 6,3V-  
 RW11 - ADJUST FOR 255 - 260V  
 RW20 - ADJUST FOR 6,3V-  
 RW21 - ADJUST FOR 6,3V-

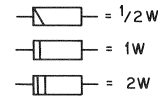
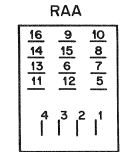
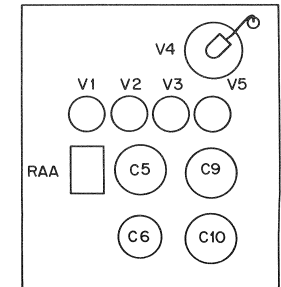

Siemens-Relais-RELAY 154d/93n

C37-G  
1.337.830

1	+40 OV
2	+255 V
3	+235 V
4	+375 V
5	OV
6	-12,6 V
7	-6,3 V
8	Chassis
9	OV
10	OV
11	OV
12	6,3V~
13	(255V)
14	+255 V
15	D14
16	C7
17	+230 V
18	OV(RE)
19	D11
20	D4
21	OV(R)
22	OV(R)
23	D12 F22
24	D12 F24

1	Chassis
2	OV
3	6,3V~
4	-24 V(R)
5	OV
6	OV(RE)
7	-6,3V
8	6,3V
9	OV(R)
10	OV(R)
11	OV(R)
12	OV(R)
13	OV(R)
14	+255 V

Entzerrungs-Umschalter

\*) Gültig ab Fabr.-Nr. 666

 <b>STUDER</b> REGENSDORF ZÜRICH	<b>STABILISATOR-EINSCHUB</b> REGULATING-UNIT		Maßstab Gez. 26.4.62 Gepr. <i>RA</i>
	Ersatz für <b>S-C37-G</b> Ersetzt durch		a. 10.10.62 Aend.: 15 Neue Nr. 7.4.64 <i>RA</i>
			<b>7.337.830</b>

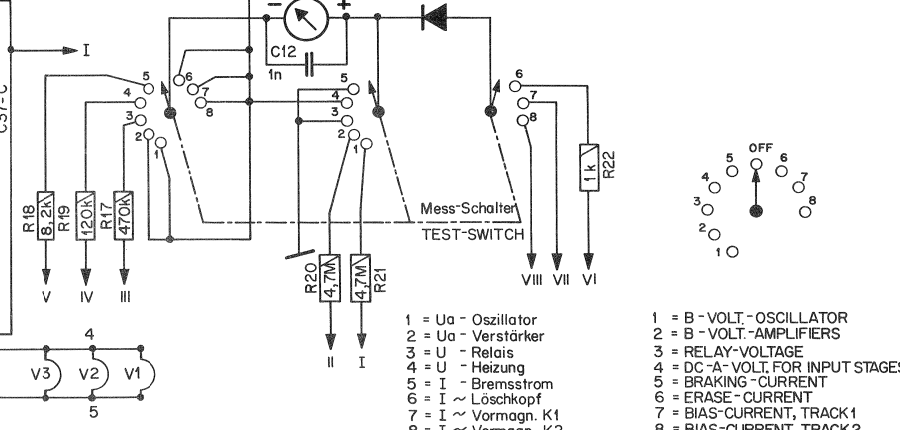
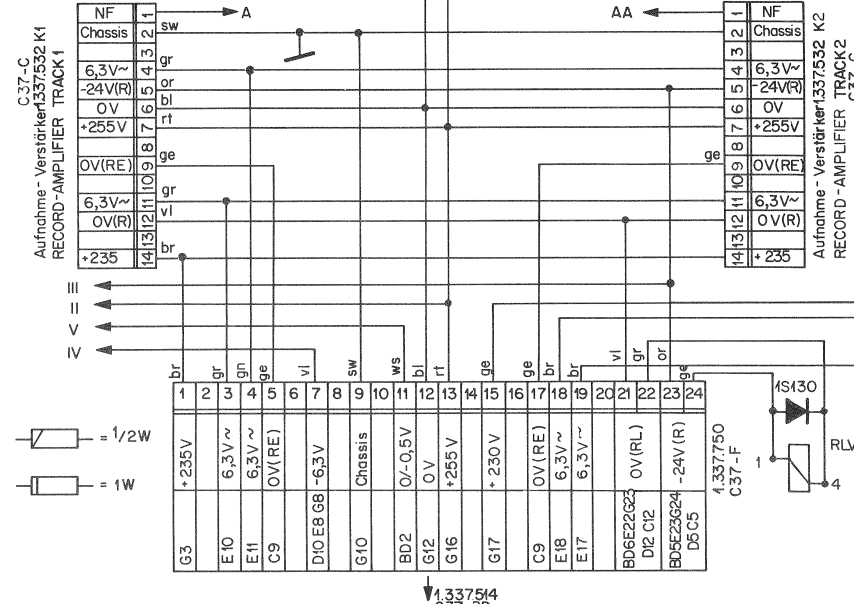
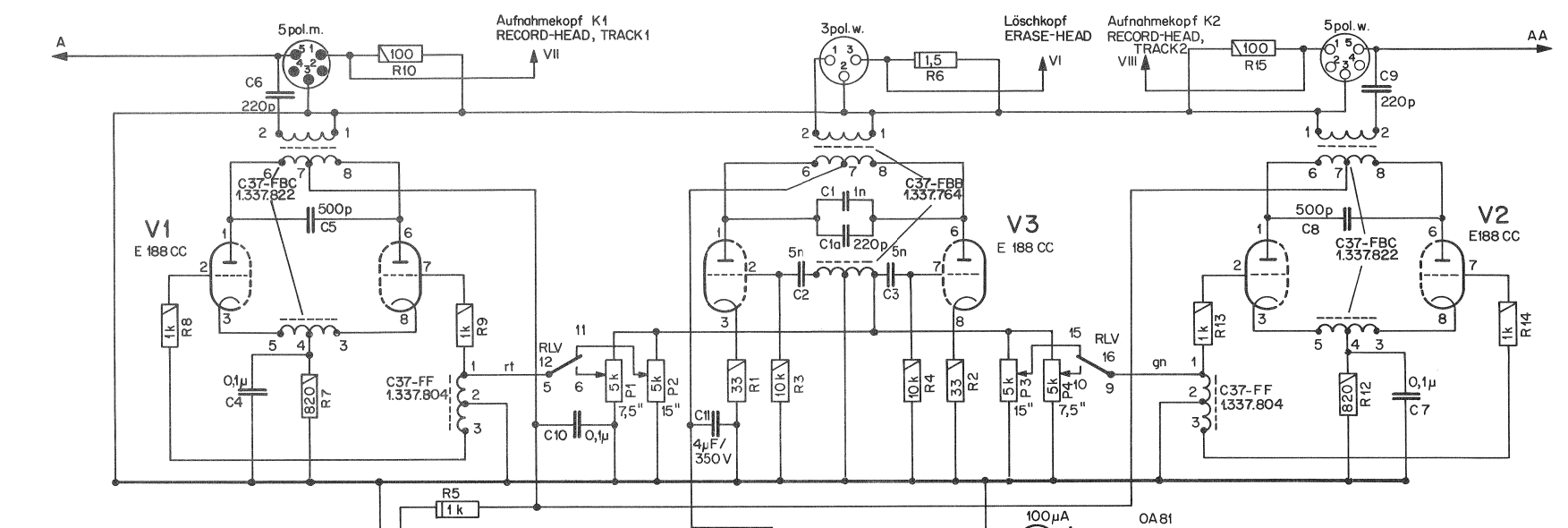

- 1 = B - VOLT - OSCILLATOR
- 2 = B - VOLT - AMPLIFIERS
- 3 = U - Relais
- 4 = U - Heizung
- 5 = I - Bremsstrom
- 6 = DC - A - VOLT. FOR INPUT STAGES
- 7 = BRAKING - CURRENT
- 8 = ERASE - CURRENT
- 9 = BIAS - CURRENT, TRACK 1
- 10 = I ~ Löschkopf
- 11 = I ~ Vormagn. K1
- 12 = I ~ Vormagn. K2

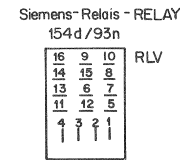

\*) Gültig ab Fabr.-Nr. 366

	<b>OSZILLATOR - EINSCHUB</b>		Maßstab	Gez.	19.4.62
	<b>OSCILLATOR</b>		Bepr.		h.a.
REGENSDORF ZÜRICH		Ersetzt für S-C37-F	Aend. 9.10.10.62		
		Ersetzt durch	7337.750		

↓ 1.3375/4 C37-BD



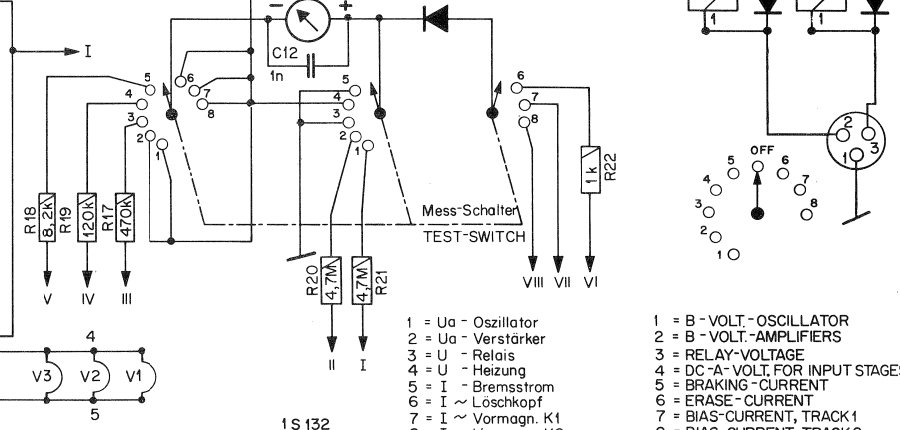
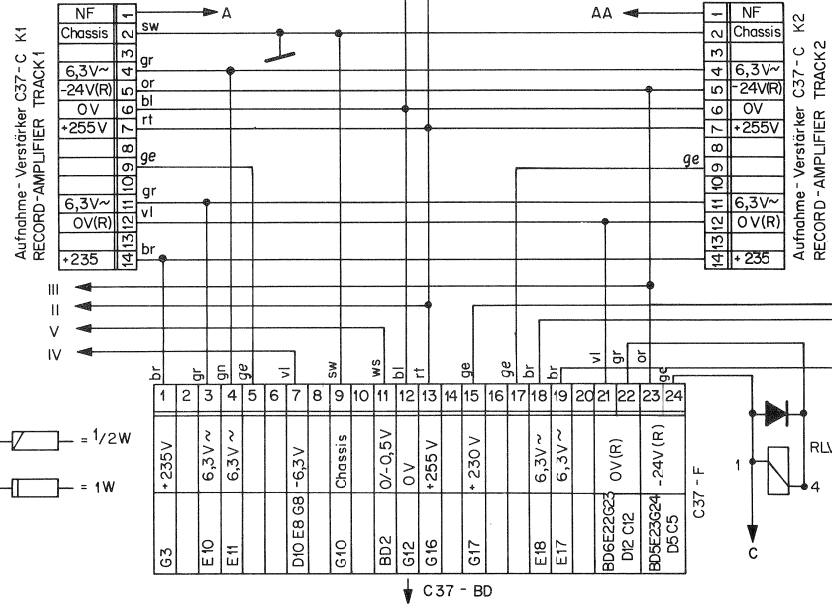
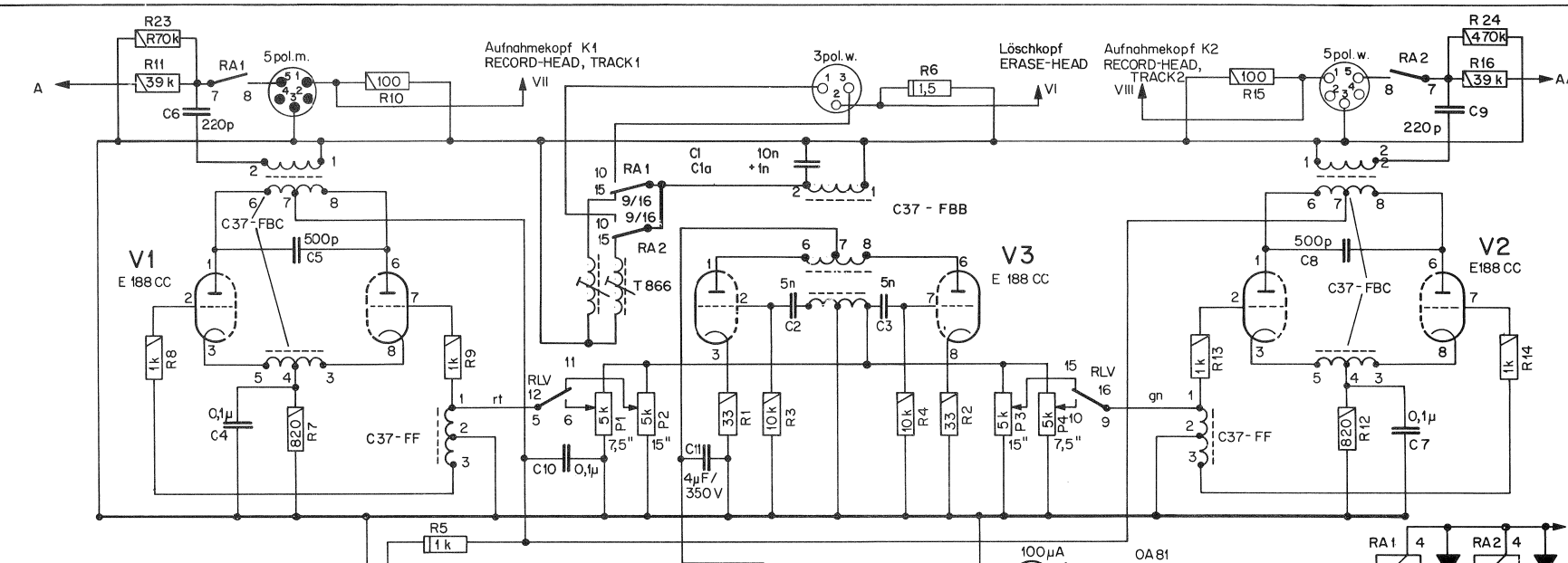

- 1 = U<sub>a</sub> - Oszillator
- 2 = U<sub>a</sub> - Verstärker
- 3 = U - Relais
- 4 = U - Heizung
- 5 = I - Bremsstrom
- 6 = I - Löschkopf
- 7 = I ~ Vormagn. K1
- 8 = I ~ Vormagn. K2

- 1 = B - VOLT-OSCILLATOR
- 2 = B - VOLT-AMPLIFIERS
- 3 = RELAY-VOLTAGE
- 4 = DC-A-VOLT. FOR INPUT STAGES
- 5 = BRAKING-CURRENT
- 6 = ERASE-CURRENT
- 7 = BIAS-CURRENT, TRACK1
- 8 = BIAS-CURRENT, TRACK2

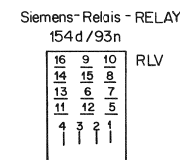

	ATV	Meßstab	Grz.	19.4.62
	<b>OSZILLATOR-EINSCHUB</b>	Ersetzt für	Grpr.	17.12.62
	<b>OSCILLATOR</b>	Ersetzt durch		Re
			Aend.: ① 19.1.65	
				<b>7.337.754</b>

Tabelle der Relais- und Magnetfunktionen  
TABLE OF RELAYS AND MAGNET FUNCTIONS

x Relais oder Magnet unter Strom  
RELAY OR SOLENOID ENERGIZED

Bandwaage in Arbeitsstellung  
TAPE TENSION BALANCE IN MIDPOSITION

RELAYS	← →				STOP	Regler FADER	NAB	7,5 "	15 "	eingebaut in LOCATED IN	Schem. Nr. SCHEMATIC NO.
	←	→	←	→							
RA = Relay recording						x				Stabilisator - Einschub REGULATOR - UNIT	1.337.830
RLA = Relay 7,5" record amplifier								x		Aufnahme - Verstärker RECORD AMPLIFIERS	1.337.970
RE <sub>3</sub> = Relay equalization record							x				
RLV = Relay 7,5" oscillator								x		Oszillator - Einschub OSCILLATOR - UNIT	1.337.750
RLW = Relay 7,5" playback amplifier								x		Wiedergabe - Verstärker PLAYBACK AMPLIFIERS	1.337.990
RE <sub>1</sub> = Relay equalization playback							x				
RE <sub>2</sub> = Relay equalization playback							x				
RF = Relay remote control						x					
RR = Relay backward sense	x	x									
RRh = Auxiliary relay backward		x									
RV = Relay forward sense			x	x							
RVh = Auxiliary relay forward			x								
RB = Relay operation					x	x					
RBh = Auxiliary relay operation					x	x					
RBrv = Relay brake delay	x	x	x	x	x	x					
RAM = Relay capstan idler pressure	x	x	x	x	x						
SR = Contactor backward sense	x	x								Relaiskaste. RELAY BOX	1.337.314
SStv = Contactor start delay	x	x	x	x	x						
SBrv = Contactor relay brake delay	x	x	x	x	x						
SBz = Contactor brake tension	x	x									
EV = Contactor forward sense			x	x	x	x					
SB = Contactor operation					x	x					
SK = Contactor motor voltage	x		x		x					Endschalter SAFETY - SWITCH	
SSM = Contactor synchronous motor											
SL 1 = Contactor 7,5"							x				
EL 2 = Contactor 7,5"							x				
ES 1 = Contactor 15"									x		
ES 2 = Contactor 15"									x		
M AA = Solenoid capstan idler pressure					x	x				CAPSTAN	1.337.152 / 154
M AE = Solenoid tape balance		x	x		x	x				Bandwaage TAPE TENSION BALANCE	1.337.192
M AMA 1 = Solenoid brakes	x	x	x	x	x					Vorberuhigung FLYWHEEL	1.337.224
M AG = Solenoid flywheel idler	x	x	x	x	x					Bremsen BRAKES	1.337.282
M AMA 2 = Solenoid brakes	x	x	x	x	x						
M AN 1 = Solenoid brakes release									x		
M AN 2 = Solenoid brakes release	x	x	x	x						Bandabhebung TAPE LIFT MECHANISM	1.337.380