

STUDER

A807

OPERATING AND SERVICE INSTRUCTIONS



Prepared and edited by
STUDER INTERNATIONAL
TECHNICAL DOCUMENTATION
Althardstrasse 10
CH-8105 Regensdorf-Zürich
Switzerland

We reserve the right to make alterations

Copyright by WILLI STUDER AG
Printed in Switzerland

Order No. 10.27.0453 (Ed. 0290)

STUDER is a registered trade mark of STUDER INTERNATIONAL AG Regensdorf
STUDER ist ein eingetragenes Warenzeichen der STUDER INTERNATIONAL AG Regensdorf

1	GENERAL REFERECES	Quick reference description Versions, options Accessories and service aids Technical specifications Maintenance hints for the service personnel
2	STARTUP PROCEDURES	Installation Putting into operation Operating instructions Operation with serial interface
3	POWER SUPPLY, TAPE TRANSPORT CONTROL	Circuit description Removal of assemblies Tape deck adjustments Programming the operating parameters
4	AUDIO	Circuit descriptions Calibration Audio adjustments
5	WIRING LISTS	Explanation to wiring lists Explanations of signal names Wiring lists
6	DIAGRAMS TAPE TRANSPORT	Power supply Tape transport block diagram Tape transport control PCB's
7	DIAGRAMS AUDIO SECTION	Level diagrams Audio block diagram Audio
8	SPARE PARTS	Drawing of mechanical subassemblies Order numbers of spare parts
9	DIAGRAMS ACCESSORIES	Parallel remote controls Varispeed Remote timer Spare parts
10	OPTIONS, CONVERSION KITS	Mounting instructions

SICHERHEIT UND ERSTE HILFE**SICHERHEIT**

Durch Entfernen von Gehäuseteilen, Abschirmungen etc. werden stromführende Teile freigelegt. Aus diesem Grunde müssen die folgenden Sicherheitsvorschriften unbedingt beachtet werden:

1. **Eingriffe in ein Gerät** dürfen nur von Fachpersonal vorgenommen werden.
2. **Vor Entfernen von Gehäuseteilen:** Gerät ausschalten und vom Netz trennen.
3. **Bei geöffnetem Gerät:**
 - Netzteil- oder Motorkondensatoren mit einem passenden Widerstand entladen.
 - Bauteile grosser Leistung, wie Leistungstransistoren und -widerstände sowie Magnetspulen und Wickel-motoren erst nach dem Abkühlen berühren.
4. **Servicearbeiten bei geöffnetem, unter Spannung stehendem Gerät:**
 - Keine blanken Schaltungsteile berühren
 - Isolierte Werkzeuge verwenden
 - Metallene Halbleitergehäuse nicht berühren, da sie hohe Spannungen aufweisen können.

ERSTE HILFE (bei Stromunfällen)

1. **Bei einem Stromunfall die betroffene Person raschmöglichst vom Strom trennen:**
 - Durch Ausschalten des Gerätes
 - Ausziehen oder Unterbrechen der Netzzuleitung
 - Betroffene Personen mit isoliertem Material (Holz, Kunststoff) von der Gefahrenquelle wegstossen
 - Nach einem Stromunfall sollte immer ein Arzt aufgesucht werden.

ACHTUNG

EINE UNTER SPANNUNG STEHENDE PERSON DARF NICHT BERÜHRT WERDEN, SIE KÖNNEN DABEI SELBST ELEKTRISIERT WERDEN!

2. **Bei Bewusstlosigkeit des Verunfallten:**
 - Puls kontrollieren,
 - bei ausgesetzter Atmung künstlich beatmen,
 - Seitenlagerung des Verunfallten und Arzt verständigen.

SAFETY AND FIRST AID**SAFETY**

There are no user serviceable components inside the equipment, live parts are laid open when removing protective covers and shieldings. It is essential therefore to ensure that the subsequent safety rules are strictly observed when performing service work or repairs.

1. **Service of electronic equipment** must be performed by qualified personnel only.
2. **Before removing covers:** Switch off the equipment and unplug the mains cable.
3. **When the equipment is open:**
 - Discharge power supply- and motor capacitors through a suitable resistor.
 - Components, that carry heavy electrical loads, such as power transistors and resistors as well as solenoid coils and motors should not be touched before a cooling off interval, as a precaution to avoid burns.
4. **Service unprotected and operating equipment:**
 - Never touch bare wires or circuitry
 - Use insulated tools only
 - Never touch metal semiconductor cases because they may carry high voltages.

FIRST AID (in case of electric shock)

1. **Separate the person as quickly as possible from the electric power source:**
 - by switching off the equipment,
 - unplugging or disconnecting the mains cable,
 - pushing the person away from the power source by using dry insulating material (such as wood or plastic).
 - After having sustained an electric shock, always consult a doctor.

WARNING:

DO NOT TOUCH THE PERSON OR HIS CLOTHING BEFORE POWER IS TURNED OFF, OTHERWISE YOU STAND THE RISK OF SUSTAINING AN ELECTRIC SHOCK AS WELL!

2. **If the person is unconscious**
 - Check the pulse,
 - reanimate the person if respiration is poor,
 - lay the body down and turn it to one side, call for a doctor immediately.

SÉCURITÉ ET PREMIERS SECOURS**SÉCURITÉ**

Si les couvercles de protection sont enlevés, les parties de l'appareil qui sont sous tension ne sont plus protégées. Il est donc d'une nécessité absolue de suivre les instructions suivantes:

1. **Les interventions dans les appareils électriques** doivent être faites uniquement que par du personnel qualifié
2. **Avant d'enlever les couvercles de protection:** Couper l'interrupteur principal et débrancher le câble secteur.
3. **Après avoir enlevé les couvercles de protection:**
 - Les condensateurs de l'alimentation et des moteurs doivent être déchargés à l'aide d'une résistance appropriée.
 - Il est prudent de laisser refroidir les composants de haute puissance, par ex.: transistors de puissance, résistances de puissances de même que des électroaimants et les moteurs de bobinage.
4. **S'il faut que l'appareil soit sous tension pendant les réglages internes:**
 - Ne jamais toucher les circuits non isolés
 - Travailler seulement avec des outils isolés

PREMIERS SECOURS (en cas d'électrocution)

1. **Si la personne est dans l'impossibilité de se libérer:**
 - Couper l'interrupteur principal
 - Couper le courant
 - Repousser la personne de l'appareil à l'aide d'un objet en matière non conductrice (matière plastique ou bois)
 - Après une électrocution, consulter un médecin.

ATTENTION

NE JAMAIS TOUCHER UNE PERSONNE QUI EST SOUS TENSION, SOUS PEINE DE SUBIR ÉGALEMENT UNE ÉLECTROCUTION

2. **En cas de perte de connaissance de la personne électrocutée:**
 - Contrôler le pouls
 - Si nécessaire, pratiquer la respiration artificielle
 - Mettre l'accidenté sur le coté latérale et consulter un médecin.

Preliminary information



This document describes the standard STUDER A 807. The information concerning the new 1000 m version, the 1/2" version, or one of the timecode versions is in the process of being completed.

















In the meantime the following pages (together with the standard A 807 manual) will certainly serve you as preliminary information for the new versions.



New 1/4" program jumpers (for units with serial numbers above 10.000)

Software number: 26/89

Hardware jumpers:

JUMPER		H	L	(H = ON, L = OFF)
06	ADJUST KEY			H = DISABLED L = ENABLED

JUMPER		H	L	(H = ON, L = OFF)
10	CHANNEL VERSION			H = 4 CHANNEL L = 2 CHANNEL
11	SPEED VERSION			H = 7.5, 15, 30 ips L = 3.75, 7.5, 15 ips
12	PLAYBACK ONLY VERSION			H = STANDARD (REC/REPRO) L = PLAYBACK ONLY
13	READY-KEY VERSION			H = WITHOUT READY KEY L = WITH READY KEY
14	ERASE HEAD GAP			H = INLINE L = STAGGERED
15	MICROPHONE INPUT(S)			H = WITH MIC INPUT L = WITHOUT MIC INPUT
16	TIME CODE VERSION			H = WITH TC CHANNEL L = WITHOUT TC CHANNEL
17	Not yet assigned			



JUMPER		H	L	(H = ON, L = OFF)
46		hard wired		
48	INSERT KEY S 48			H = KEY 48 NOT ACTIVE L = KEY 48 ACTIVE

















The shown jumper settings correspond to the standard settings of a A 807 1/4" VUK version and should normally not be changed.



New 1/2" - 4 Channel program jumpers

Software number: 26/89

Hardware jumpers:

JUMPER		H	L	(H = ON, L = OFF)
06	ADJUST KEY			H = DISABLED L = ENABLED

JUMPER		H	L	(H = ON, L = OFF)
10	CHANNEL VERSION			H = 4 CHANNEL L = 2 CHANNEL
11	SPEED VERSION			H = 7.5, 15, 30 ips L = 3.75, 7.5, 15 ips
12	PLAYBACK ONLY VERSION			H = STANDARD (REC/REPRO) L = PLAYBACK ONLY
13	READY-KEY VERSION			H = WITHOUT READY KEY L = WITH READY KEY
14	ERASE HEAD GAP			H = INLINE L = STAGGERED
15	MICROPHONE INPUT(S)			H = WITH MIC INPUT L = WITHOUT MIC INPUT
16	TIME CODE VERSION			H = WITH TC CHANNEL L = WITHOUT TC CHANNEL
17	Not yet assigned			



JUMPER		H	L	(H = ON, L = OFF)
46	INSERT KEY S 46			H = KEY 46 NOT ACTIVE L = KEY 46 ACTIVE

















The shown jumper settings correspond to the standard settings of a A 807-4-1/2" VUK version and should normally not be changed.



New timecode versions program jumpers

Software number: 26/89

Hardware jumpers:

JUMPER		H	L	(H = ON, L = OFF)
06	ADJUST KEY			H = DISABLED L = ENABLED

JUMPER		H	L	(H = ON, L = OFF)
10	CHANNEL VERSION			H = 4 CHANNEL L = 2 CHANNEL
11	SPEED VERSION			H = 7.5, 15, 30 ips L = 3.75, 7.5, 15 ips
12	PLAYBACK ONLY VERSION			H = STANDARD (REC/REPRO) L = PLAYBACK ONLY
13	READY-KEY VERSION			H = WITHOUT READY KEY L = WITH READY KEY
14	ERASE HEAD GAP			H = INLINE L = STAGGERED
15	MICROPHONE INPUT(S)			H = WITH MIC INPUT L = WITHOUT MIC INPUT
16	TIMECODE VERSION			H = WITH TC CHANNEL L = WITHOUT TC CHANNEL
17	Not yet assigned			

JUMPER		H	L	(H = ON, L = OFF)
46		hard wired		
48	INSERT KEY S 48			H = KEY 48 NOT ACTIVE L = KEY 48 ACTIVE

The shown jumper settings correspond to the standard settings of a A 807 1/4" Timecode version and should normally not be changed.

Software jumpers (all versions)

JUMPER		STATUS
00	MUTE TIME FOR EACH SPEED	<u>000</u> - 950 milliseconds in steps of 50 millisec.
01	RS 232 BAUD RATE	<u>12</u> = 1200 BAUD <u>96</u> = 9600 BAUD
02	RS 232 ECHO MODE	<u>0</u> = OFF 1 = ON
03	TAPE STOP WITH TRANSPARENT TAPE	<u>0</u> = OFF 1 = ON
04	MONO/STEREO CHANGEOVER switches automatically to mono at speed 3.75 and 7.5 ips	<u>0</u> = OFF 1 = ON
05	COUNTER STOP IN DUMP MODE	<u>0</u> = OFF 1 = ON
06	RETURN OF PINCH ROLLER (when no tape is loaded)	<u>0</u> = OFF 1 = ON
07	SPEED CHANGE	<u>0</u> = DIRECT SPEED CHANGE <u>1</u> = SPEED CHANGE WITH SHIFT ONLY
08	TAPE DUMP MODE	<u>0</u> = KEY "TAPE DUMP" PRE- SELECTS FUNCTION, ACTIVATION WITH "PLAY" 1 = DIRECT ACTIVATION
09	MODE ASSIGNMENT SOFTKEY 1 (Default status = 1)	0 = LOOP 1 = LOC START 2 = LOC 2 3 = LOC 3 4 = BACKSPACE
10	MODE ASSIGNMENT SOFTKEY 2 (Default status = 4)	5 = FADER READY 6 = LIFTER AS MOMENTARY KEY 7 = LIFTER FLIP-FLOP KEY 8 = REHEARSE
11	RECORD COMMAND DEFINITION	<u>0</u> = KEY "REC" AND "PLAY" TO BE PRESSED TOGETHER 1 = IF MACHINE IN PLAY, PRESS "REC" ONLY
12	FADER START DEFINITION	<u>0</u> = A <u>1</u> = B (see truth table 2 = C on following page) 3 = D

The underlined settings in the status field are the default values.

Software jumpers: (cont.)

JUMPER		STATUS
13	MODE ASSIGNMENT OF AUDIO SOFT KEY	2 CHANNEL VERSION 0 = TAPE A/B CCIR 1 = TAPE A/B NAB 2 = REPRO HEAD A/B CCIR 3 = REPRO HEAD A/B NAB 4 = CHANGE EQUALIZATION CCIR/NAB
		4 CHANNEL VERSION 0 = CCIR 1 = NAB
		TC 1/4" VERSION 0 = TAPE A/B CCIR 1 = TAPE A/B NAB 4 = CHANGE EQUALIZATION CCIR/NAB
14	CHANNEL CONTROL	not yet implemented
15	LOCAL TIME CODE UNIT ELECTRONICS	0 = ACTIVE 1 = BYPASSED
16	TIME CODE REFERENCE IN REPRO/SYNC MODE * not available in 2-channel versions	0 = NO REFERENCE 1 = CHANNEL 1 2 = CHANNEL 2* 3 = CHANNEL 3* 4 = CHANNEL 4

FADER MODE TRUTH TABLE:

FADER MODE	A	B	C	D
FADER READY KEY REQUIRED		■	■	■
FADER READY KEY NOT REQUIRED	■			
INTERNAL MONITOR MUTED	■	■	■	■
FADER CLOSED: TRANSPORT DECK KEYS ENABLED: TRANSPORT DECK KEYS DISABLED	■	■	■	■
FADER OPEN: TRANSPORT DECK KEYS ENABLED: TRANSPORT DECK KEYS DISABLED	■	■	■	■

TAPE DECK ELECTRONICS 1.727.650.00

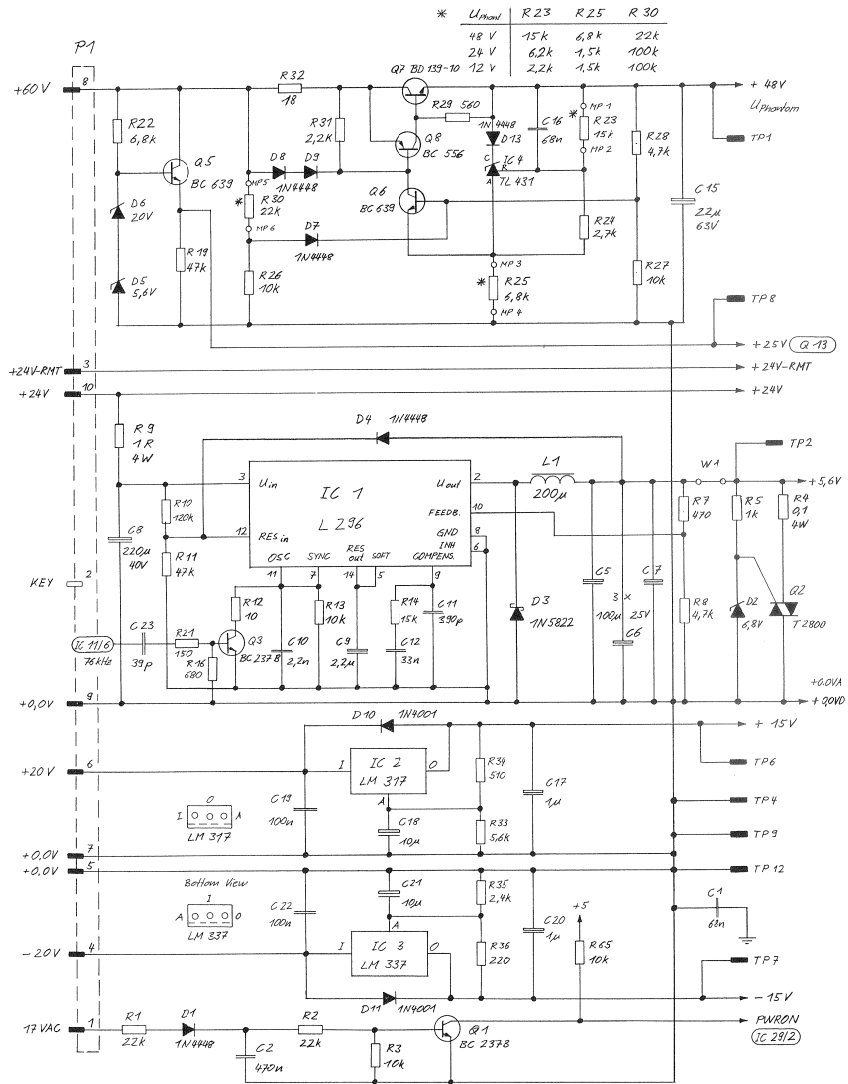

① 1,12,88 W/A	② . . .	③ . . .	④ . . .	⑤ . . .
A 807 GR 10				PAGE 1 OF 5
STUDER Tape Deck Electronics		SC	1.727.650.20	

TAPE DECK ELECTRONICS 1.727.650.00

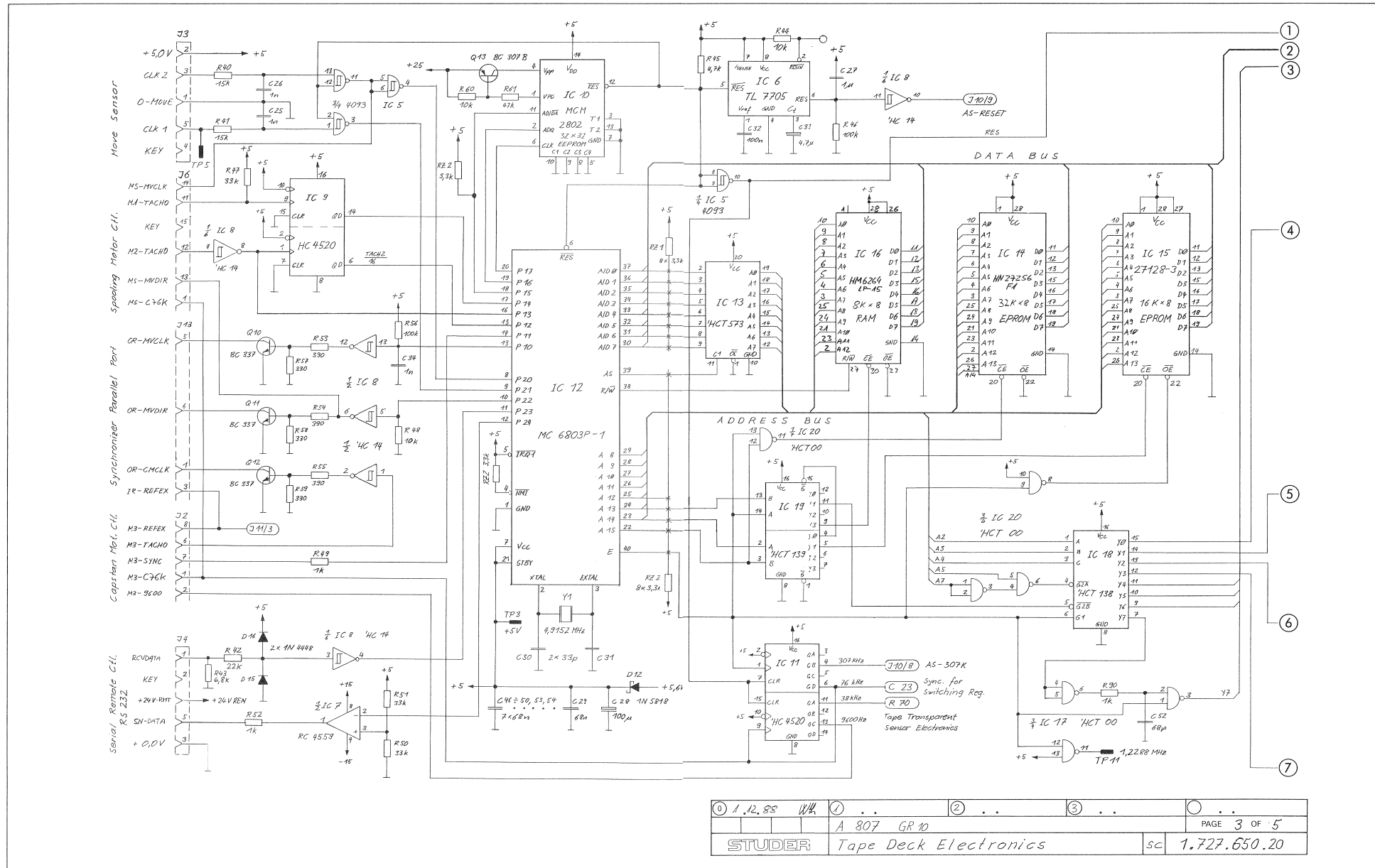

TAPE DECK ELECTRONICS 1.727.650.00

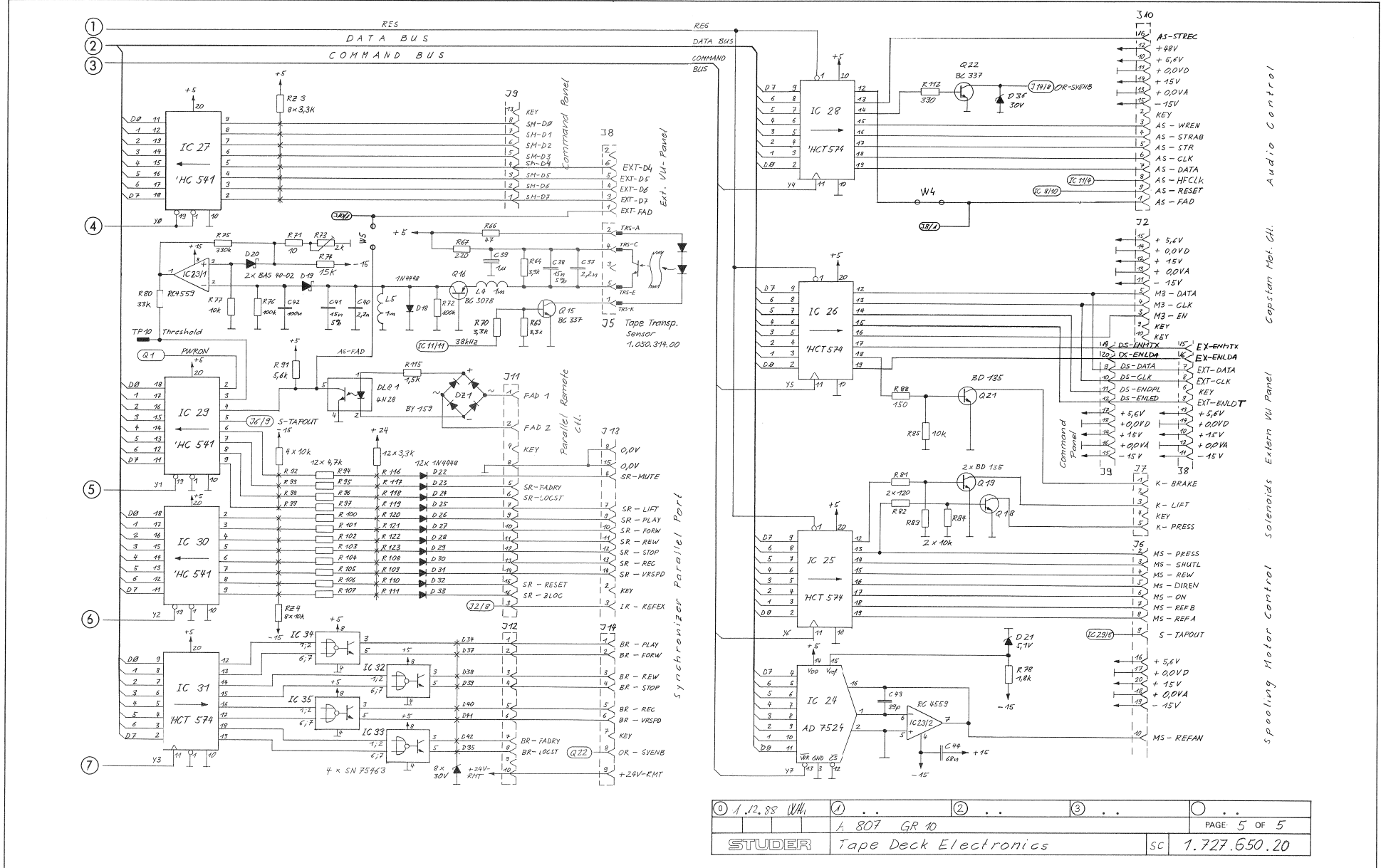

Audio Control
Capstan Mot. Cl.
Extern VI Panel
Solenoids
Spooling Motor Control

①	1.12.88 W11	②	...	③	...	④	...
STUDER		A 807 GR 10		PAGE 5 OF 5			
Tape Deck Electronics		SC		1.727.650.20			

TAPE DECK ELECTRONICS 1.727.650.00

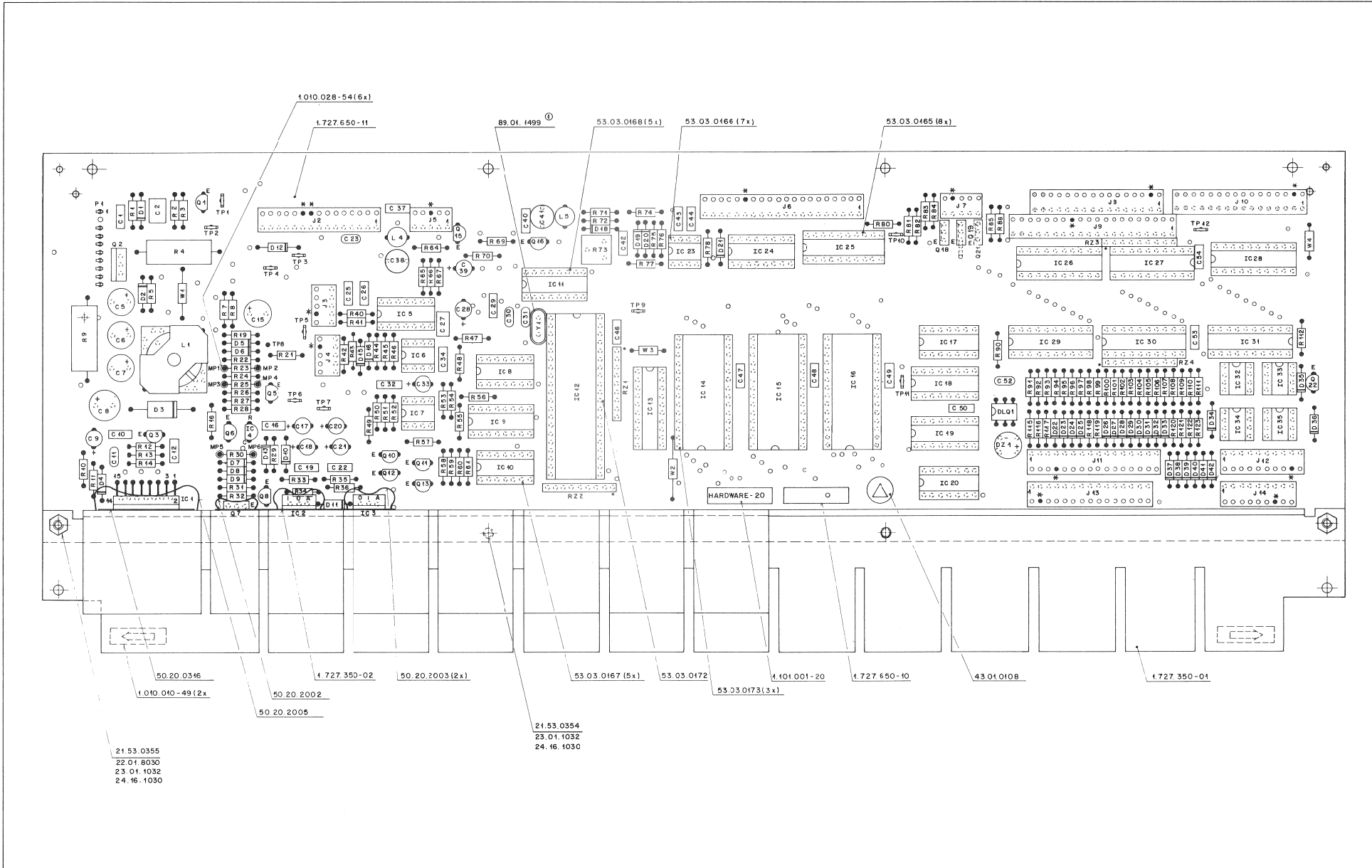

COMMAND PANEL BOARD 2VU 1.727.662.00

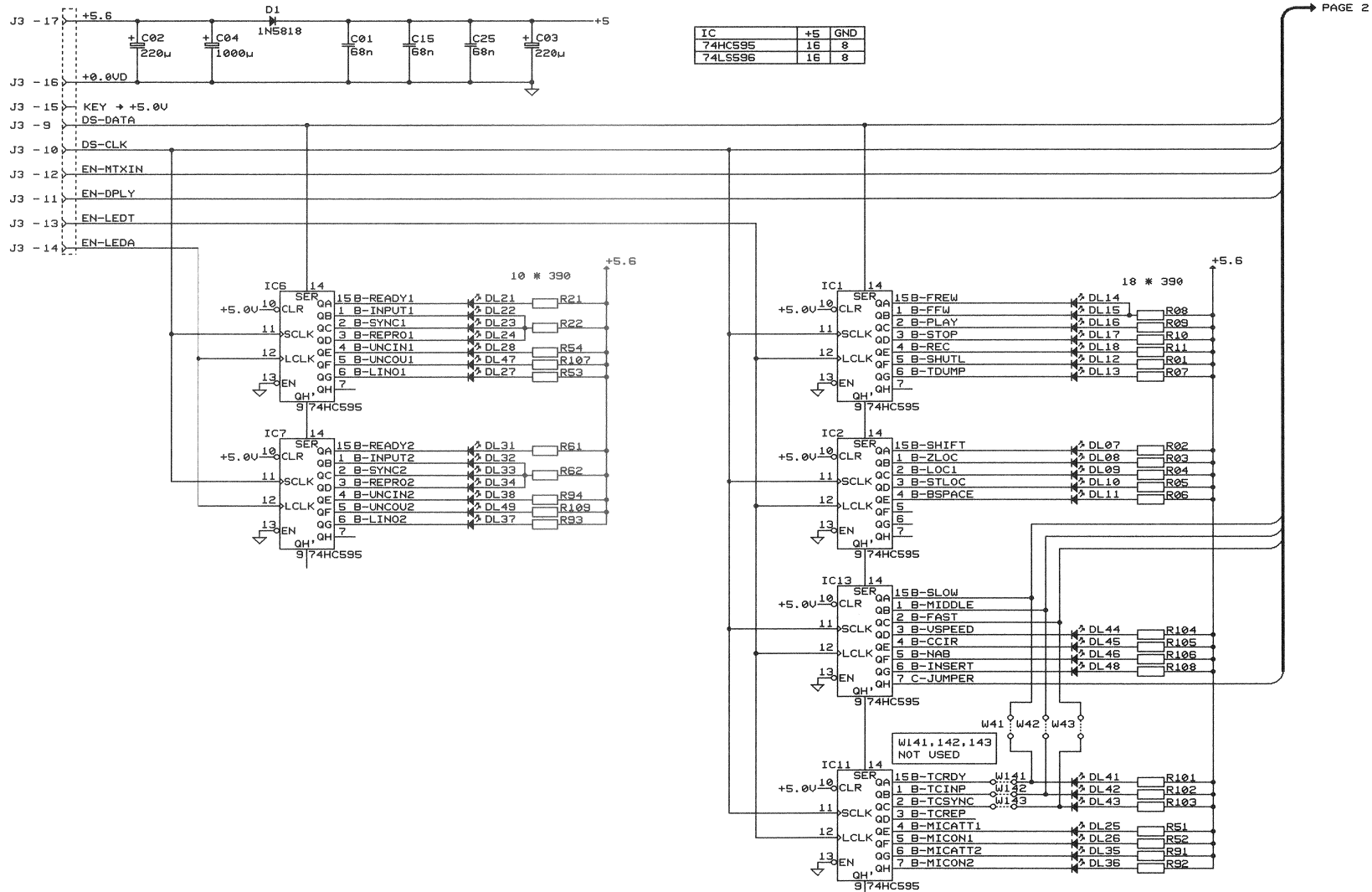

IC	+5	GND
74HC595	16	8
74LS596	16	8

© 29.1.90 GP			
WAL	A 807 UU GRP 30		PAGE 1 OF 3
STUDER	COMMAND PANEL BOARD 2VU	SCH	1.727.662-00

STUDER A807

COMMAND PANEL BOARD 2VU 1.727.662.00

PAGE 1

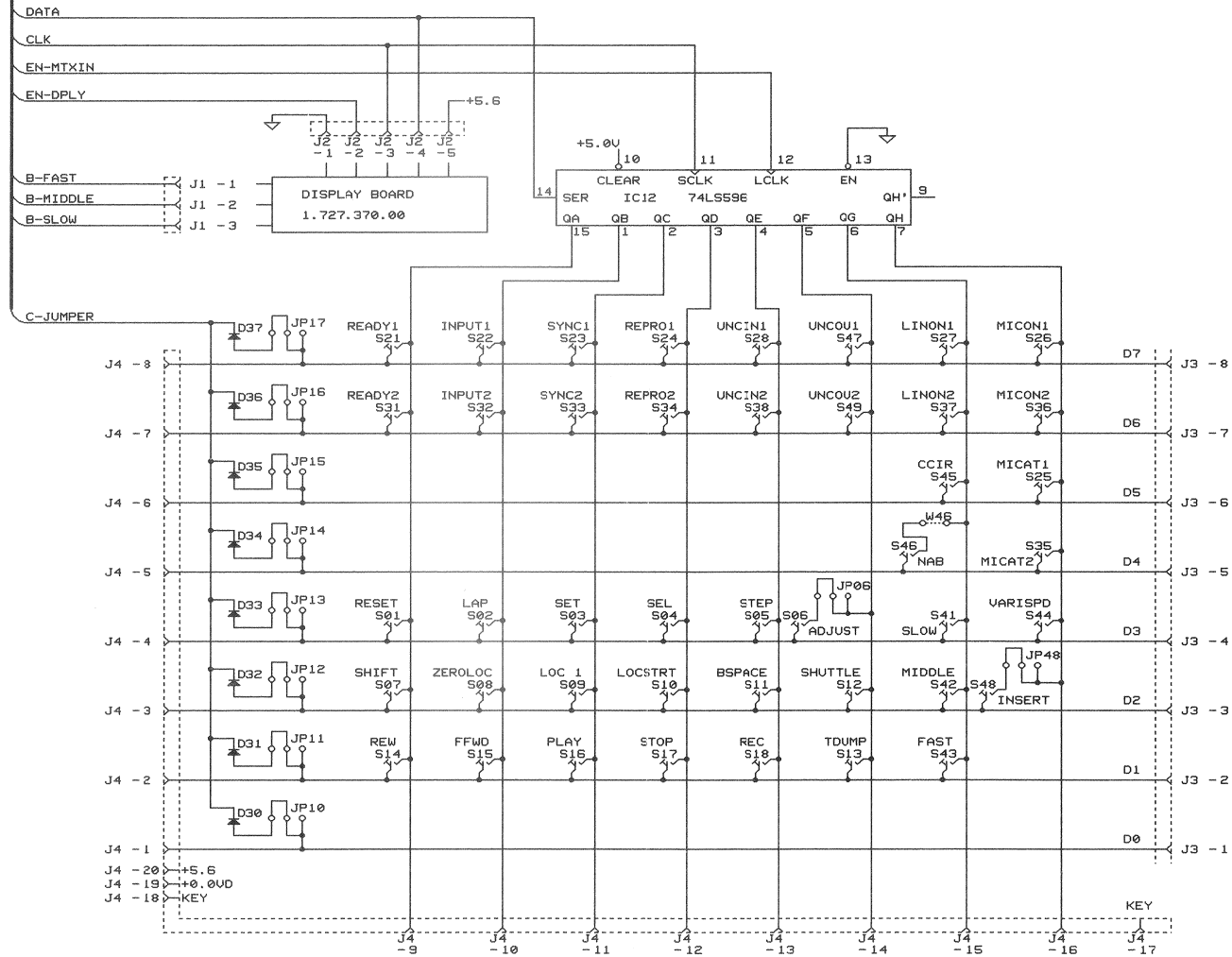

© 29.1.90 GP			
WV	A 807 UU GRP 30		PAGE 2 OF 3
STUDER	COMMAND PANEL BOARD 2VU	SCH	1.727.662-00

COMMAND PANEL BOARD 2VU 1.727.662.00

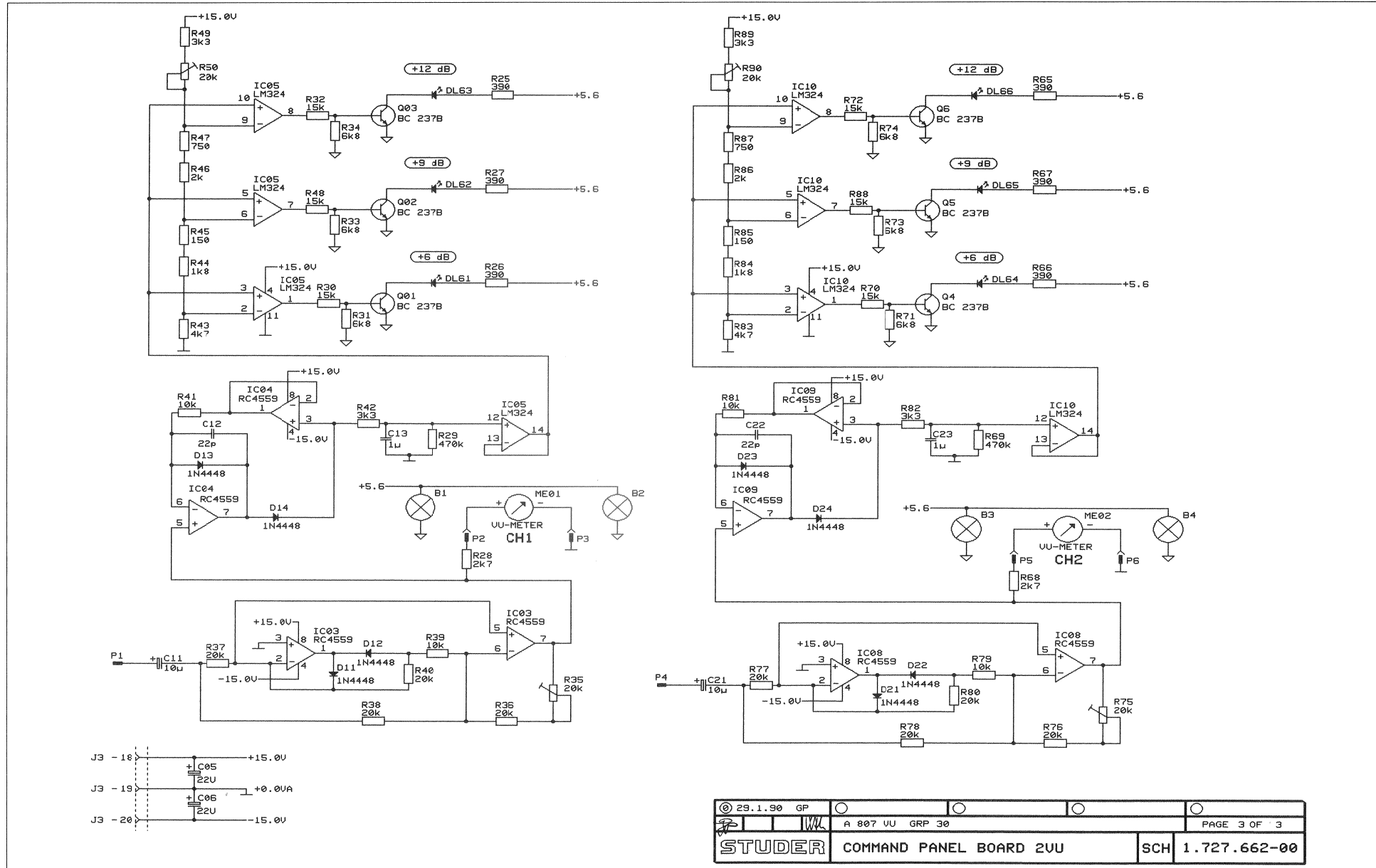

© 29.1.90 GP				
		A 807 UU GRP 30		PAGE 3 OF 3
STUDER		COMMAND PANEL BOARD 2VU	SCH	1.727.662-00

COMMAND PANEL BOARD 2VU 1.727.662.00

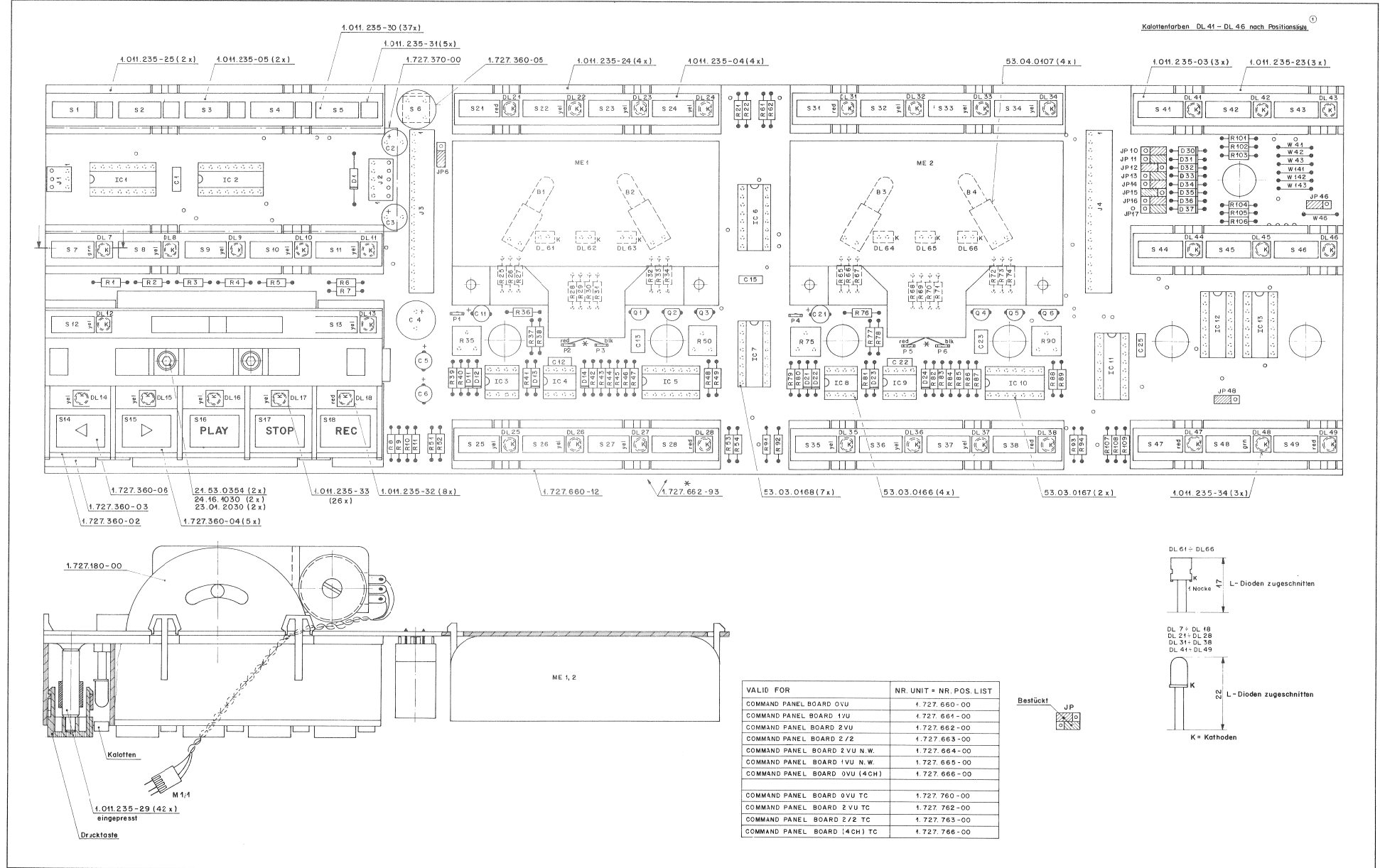

STUDER A807

COMMAND PANEL BOARD 2VU 1.727.662.00

IND.	POS.NO.	PART NO.	VALUE	SPECIFICATIONS / EQUIVALENT	MANUF.	IND.	POS.NO.	PART NO.	VALUE	SPECIFICATIONS / EQUIVALENT	MANUF.	IND.	POS.NO.	PART NO.	VALUE	SPECIFICATIONS / EQUIVALENT	MANUF.
A.....1	1.727.370.00			Display Board		JP...16	54.01.0021			Bridge		R....82	57.11.3332	3.3 Kohm	1% 0.25W MF		
A.....2	1.727.480.00			Shuttle Control		JP...17	54.01.0021			Bridge		R....83	57.11.3472	4.7 Kohm	1% 0.25W MF		
B.....1	51.02.0144	6 V	0.03 A	Leap		JP...46	54.01.0021			not used		R....84	57.11.3102	1.0 Kohm	1% 0.25W MF		
B.....2	51.02.0144	6 V	0.03 A	Leap		JP...48	54.01.0021			not used		R....85	57.11.3151	150 Ohm	1% 0.25W MF		
B.....3	51.02.0144	6 V	0.03 A	Leap		ME.....1	1.727.360.01			VU Meter		R....86	57.11.3302	2 Kohm	1% 0.25W MF		
B.....4	51.02.0144	6 V	0.03 A	Leap		ME.....2	1.727.360.01			VU Meter		R....87	57.11.3791	750 Ohm	1% 0.25W MF		
C.....1	59.06.0068	50 W	10X	50 W PTFP		ME.....1	54.01.0020	30 ppc		Contact Pin		R....88	57.11.3153	15 Kohm	1% 0.25W MF		
C.....2	59.22.3221	220 W	10X	10 W EL		ME.....2	1.011.235.03	3 ppc		Push Button case 3a		R....89	57.11.3392	3.3 Kohm	1% 0.25W MF		
C.....3	59.22.3221	220 W	10X	10 W EL		ME.....3	1.011.235.04	4 ppc		Push Button case 4a		R....90	58.01.0203	20 Kohm	10% 0.5 W P-Ceram		
C.....4	59.22.3220	22 W	10X	25 W EL		ME.....4	1.011.235.05	5 ppc		Push Button case 5a		R....91	57.11.3391	390 Ohm	1% 0.25W MF		
C.....5	59.22.3220	22 W	10X	25 W EL		ME.....5	1.011.235.23	3 ppc		Conductive rubber 3a		R....92	57.11.3391	390 Ohm	1% 0.25W MF		
C.....6	59.22.3220	22 W	10X	25 W EL		ME.....6	1.011.235.24	4 ppc		Conductive rubber 4a		R....93	57.11.3391	390 Ohm	1% 0.25W MF		
C.....11	59.22.6100	10 W	10X	25 W EL		ME.....7	1.011.235.25	2 ppc		Conductive rubber 5a		R....94	57.11.3391	390 Ohm	1% 0.25W MF		
C.....12	59.06.0068	60 W	10X	50 W PTFP		ME.....8	1.011.235.29	42 ppc		Boit		R....101	57.11.3391	390 Ohm	1% 0.25W MF		
C.....13	59.06.0105	1 W	10X	50 W PTFP		ME.....9	1.011.235.30	37 ppc		Push button 1445		R....102	57.11.3391	390 Ohm	1% 0.25W MF		
C.....15	59.06.0068	60 W	10X	50 W PTFP		ME.....10	1.011.235.31	45 ppc		Dummy Calotte		R....103	57.11.3391	390 Ohm	1% 0.25W MF		
C.....21	59.22.6100	10 W	10X	25 W EL		ME.....11	1.011.235.32	8 ppc		Calotte red		R....104	57.11.3391	390 Ohm	1% 0.25W MF		
C.....22	59.06.2200	22 W	10X	25 W EL		ME.....12	1.011.235.33	26 ppc		Calotte yell		R....105	57.11.3391	390 Ohm	1% 0.25W MF		
C.....23	59.06.0105	1 W	10X	50 W PTFP		ME.....13	1.011.235.34	2 ppc		Calotte grn		R....106	57.11.3391	390 Ohm	1% 0.25W MF		
C.....25	59.06.0068	60 W	10X	50 W PTFP		ME.....14	1.727.360.02	1 ppc		Push button case with Shuttle		R....107	57.11.3391	390 Ohm	1% 0.25W MF		
D.....1	50.04.0512	1R5818	30 V	Shuttlay		ME.....15	1.727.360.03	1 ppc		Conductive rubber with Shuttle		R....108	57.11.3391	390 Ohm	1% 0.25W MF		
D.....11	50.04.0125	1R4448	50 V	SI		ME.....16	1.727.360.04	1 ppc		Push Button 1916		S.....6	55.15.0130		Push button Switch	ITT	
D.....12	50.04.0125	1R4448	50 V	SI		ME.....17	1.727.360.05	1 ppc		Push Button AD3		R....41	64.01.0106		Wire Bridge		
D.....13	50.04.0125	1R4448	50 V	SI		ME.....18	1.727.662.10	1 ppc		Kn Label		R....42	64.01.0106		Wire Bridge		
D.....14	50.04.0125	1R4448	50 V	SI		ME.....19	1.727.662.12	1 ppc		Cosnard Panel PCB		R....43	64.01.0106		Wire Bridge		
D.....21	50.04.0125	1R4448	50 V	SI		ME.....20	53.05.0221	43 ppc		Triple LED Socket		R....46	64.01.0106		Wire Bridge		
D.....22	50.04.0125	1R4448	50 V	SI		ME.....21	1.727.362.93	2 ppc		1-57T Cosnard Panel PCB		R....46	64.01.0106		Wire Bridge		
D.....23	50.04.0125	1R4448	50 V	SI		ME.....22	25.15.0364	2 ppc		Empson socket head cap screw E346		R....46	64.01.0106		Wire Bridge		
D.....24	50.04.0125	1R4448	50 V	SI		ME.....23	29.01.2932	2 ppc		Washer		R....46	64.01.0106		Wire Bridge		
D.....25	50.04.0125	1R4448	50 V	SI		ME.....24	28.16.1030	2 ppc		Pin washer		R....46	64.01.0106		Wire Bridge		
D.....30	50.04.0125	1R4448	50 V	SI		ME.....25	43.01.0108	1 ppc		ISE Warning label		XB....1	53.04.0107		Lamp holder		
D.....31	50.04.0125	1R4448	50 V	SI		F.....1	54.02.0320	1 ppc		Push Button labela (C=PLAY,STOP,REC)		XB....2	53.04.0107		Lamp holder		
D.....32	50.04.0125	1R4448	50 V	SI		F.....2	54.02.0320	1 ppc		Push Button labela		XB....3	53.04.0107		Lamp holder		
D.....34	50.04.0125	1R4448	50 V	SI		F.....2	54.02.0320	1 ppc		Push Button labela		XB....4	53.04.0107		Lamp holder		
S T U D E R	(00) 89/03/16 GP	CORNARD PANEL BOARD 2VU	PL 1.727.662.00	PAGE 1		S T U D E R	(00) 89/03/16 GP	CORNARD PANEL BOARD 2VU	PL 1.727.662.00	PAGE 4		S T U D E R	(00) 89/03/16 GP	CORNARD PANEL BOARD 2VU	PL 1.727.662.00	PAGE 7	
IND.	POS.NO.	PART NO.	VALUE	SPECIFICATIONS / EQUIVALENT	MANUF.	IND.	POS.NO.	PART NO.	VALUE	SPECIFICATIONS / EQUIVALENT	MANUF.	IND.	POS.NO.	PART NO.	VALUE	SPECIFICATIONS / EQUIVALENT	MANUF.
D.....35	50.04.0125	1R4448	50 V	SI		F.....3	54.02.0320			Ilug 2.8x0.8	AMP	XIC....1	53.03.0163	16-Pole	IC Socket		
D.....36	50.04.0125	1R4448	50 V	SI		F.....4	54.02.0320			Ilug 2.8x0.8	AMP	XIC....2	53.03.0163	16-Pole	IC Socket		
D.....37	50.04.0125	1R4448	50 V	SI		F.....5	54.02.0320			Ilug 2.8x0.8	AMP	XIC....3	53.03.0165	8-Pole	IC Socket		
D.....7	50.04.2501	W5452	LED yel D5 mm	01		F.....6	54.02.0320			Ilug 2.8x0.8	AMP	XIC....4	53.03.0165	8-Pole	IC Socket		
D.....8	50.04.2500	W5352	LED yel D5 mm	01		E.....1	50.03.0436	BC237B	IC547B, BC550B	WFR	XIC....5	53.03.0167	14-Pole	IC Socket			
D.....9	50.04.2500	W5352	LED yel D5 mm	01		E.....2	50.03.0436	BC237B	IC547B, BC550B	WFR	XIC....6	53.03.0168	16-Pole	IC Socket			
D.....10	50.04.2500	W5352	LED yel D5 mm	01		E.....3	50.03.0436	BC237B	IC547B, BC550B	WFR	XIC....7	53.03.0168	16-Pole	IC Socket			
D.....11	50.04.2500	W5352	LED yel D5 mm	01		E.....4	50.03.0436	BC237B	IC547B, BC550B	WFR	XIC....8	53.03.0165	8-Pole	IC Socket			
D.....12	50.04.2500	W5352	LED yel D5 mm	01		E.....5	50.03.0436	BC237B	IC547B, BC550B	WFR	XIC....9	53.03.0167	14-Pole	IC Socket			
D.....13	50.04.2500	W5352	LED yel D5 mm	01		E.....6	50.03.0436	BC237B	IC547B, BC550B	WFR	XIC....10	53.03.0168	16-Pole	IC Socket			
D.....14	50.04.2500	W5352	LED yel D5 mm	01		E.....1	57.11.3391	390 Ohm	1% 0.25W MF		XIC....11	53.03.0169	16-Pole	IC Socket			
D.....15	50.04.2500	W5352	LED yel D5 mm	01		R....1	57.11.3391	390 Ohm	1% 0.25W MF		XIC....12	53.03.0169	16-Pole	IC Socket			
D.....16	50.04.2500	W5352	LED yel D5 mm	01		R....2	57.11.3391	390 Ohm	1% 0.25W MF								
D.....17	50.04.2500	W5352	LED yel D5 mm	01		R....3	57.11.3391	390 Ohm	1% 0.25W MF								
D.....18	50.04.2115	W5752	LED yel D5 mm	01		R....4	57.11.3391	390 Ohm	1% 0.25W MF								
D.....21	50.04.2115	W5752	LED yel D5 mm	01		R....5	57.11.3391	390 Ohm	1% 0.25W MF								
D.....22	50.04.2500	W5352	LED yel D5 mm	01		R....6	57.11.3391	390 Ohm	1% 0.25W MF								
D.....23	50.04.2500	W5352	LED yel D5 mm	01		R....7	57.11.3391	390 Ohm	1% 0.25W MF								
D.....24	50.04.2500	W5352	LED yel D5 mm	01		R....8	57.11.3391	390 Ohm	1% 0.25W MF								
D.....25	50.04.2500	W5352	LED yel D5 mm	01		R....9	57.11.3391	390 Ohm	1% 0.25W MF								
D.....26	50.04.2500	W5352	LED yel D5 mm	01		R....10	57.11.3391	390 Ohm	1% 0.25W MF								
D.....27	50.04.2500	W5352	LED yel D5 mm	01		R....11	57.11.3391	390 Ohm	1% 0.25W MF								
D.....28	50.04.2115	W5752	LED yel D5 mm	01		R....12	57.11.3391	390 Ohm	1% 0.25W MF								
D.....31	50.04.2115	W5752	LED yel D5 mm	01		R....22	57.11.3391	390 Ohm	1% 0.25W MF								
D.....32	50.04.2500	W5352	LED yel D5 mm	01		R....23	57.11.3391	390 Ohm	1% 0.25W MF								
D.....33	50.04.2500	W5352	LED yel D5 mm	01		R....26	57.11.3391	390 Ohm	1% 0.25W MF								
D.....34	50.04.2500	W5352	LED yel D5 mm	01		R....27	57.11.3391	390 Ohm	1% 0.25W MF								
D.....35	50.04.2500	W5352	LED yel D5 mm	01		R....28	57.11.3272	2.7 Kohm	1% 0.25W MF								
D.....36	50.04.2500	W5352	LED yel D5 mm	01		R....29	57.11.3474	470 Kohm	1% 0.25W MF								
D.....37	50.04.2500	W5352	LED yel D5 mm	01		R....30	57.11.3123	15 Kohm	1% 0.25W MF								
D.....38	50.04.2115	W5752	LED yel D5 mm	01		R....31	57.11.3602	6.8 Kohm	1% 0.25W MF								
D.....41	50.04.2500	W5352	LED yel D5 mm	01		R....32	57.11.3123	15 Kohm	1% 0.25W MF								
D.....42	50.04.2501	W5452	LED yel D5 mm	01		R....33	57.11.3602	6.8 Kohm	1% 0.25W MF								
D.....43	50.04.2500	W5352	LED yel D5 mm	01		R....34	57.11.3602	6.8 Kohm	1% 0.25W MF								
D.....44	50.04.2115	W5752	LED yel D5 mm	01		R....35	58.01.0203	20 Kohm	10% 0.5 W P-Ceram								
D.....45	50.04.2500																

STUDER A807

AUDIO CONTROL BOARD 2CH 1.727.670.81

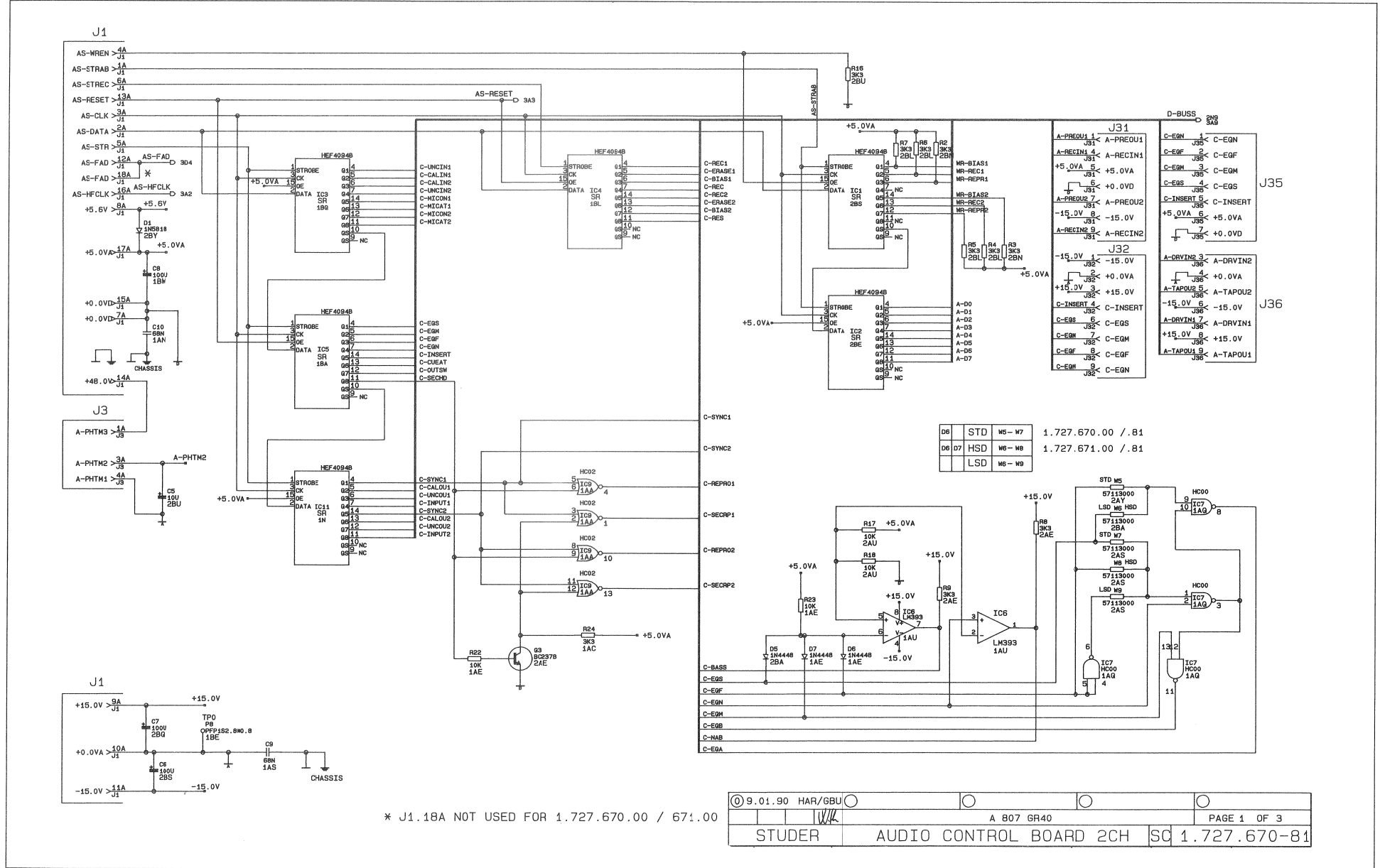

* J1.18A NOT USED FOR 1.727.670.00 / 671.00

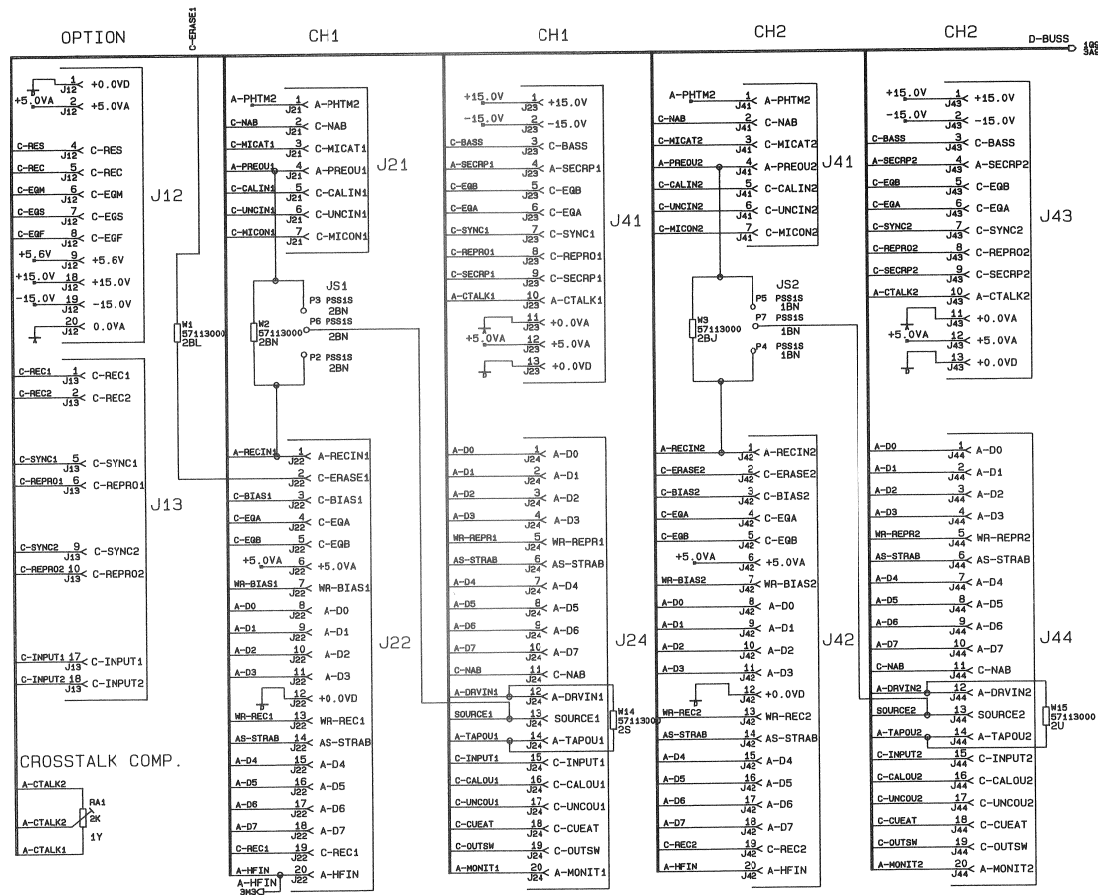

9.01.90 HAR/GBU			
STUDER	A 807 GR40	PAGE 2 OF 3	
AUDIO CONTROL BOARD 2CH		SC 1.727.670-81	

AUDIO CONTROL BOARD 2CH 1.727.670.81

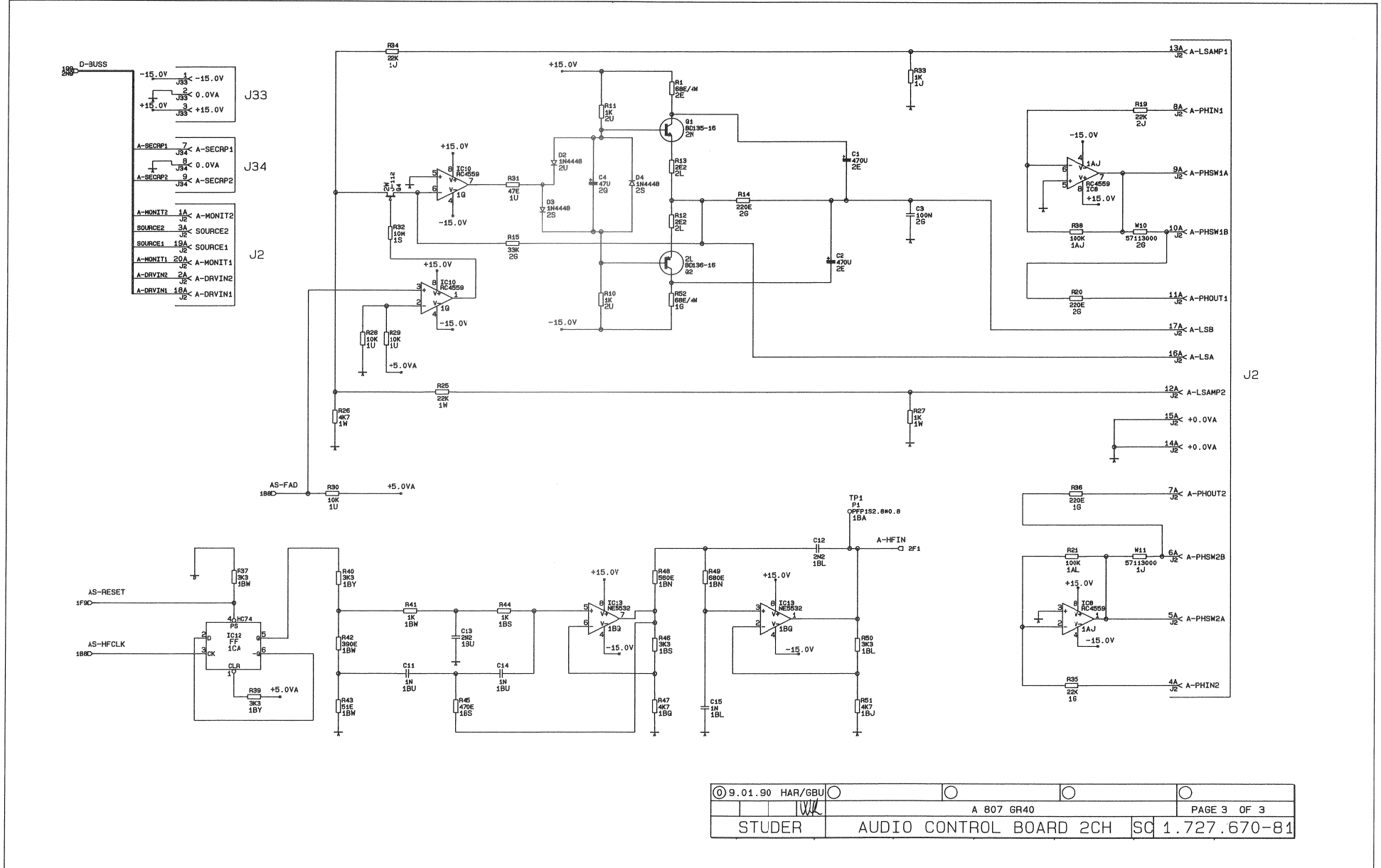

9.01.90 HAR/GBU				
		A 807 GR40		PAGE 3 OF 3
STUDER	AUDIO CONTROL BOARD 2CH	SC	1.727.670-81	

AUDIO CONTROL BOARD 2CH 1.727.670.81

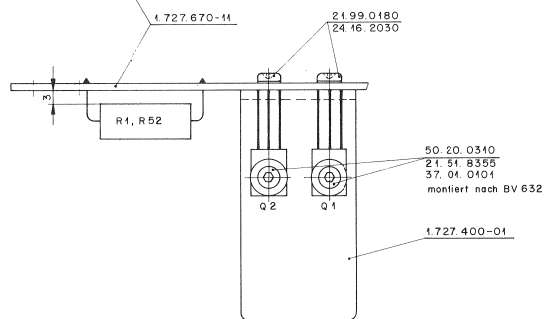
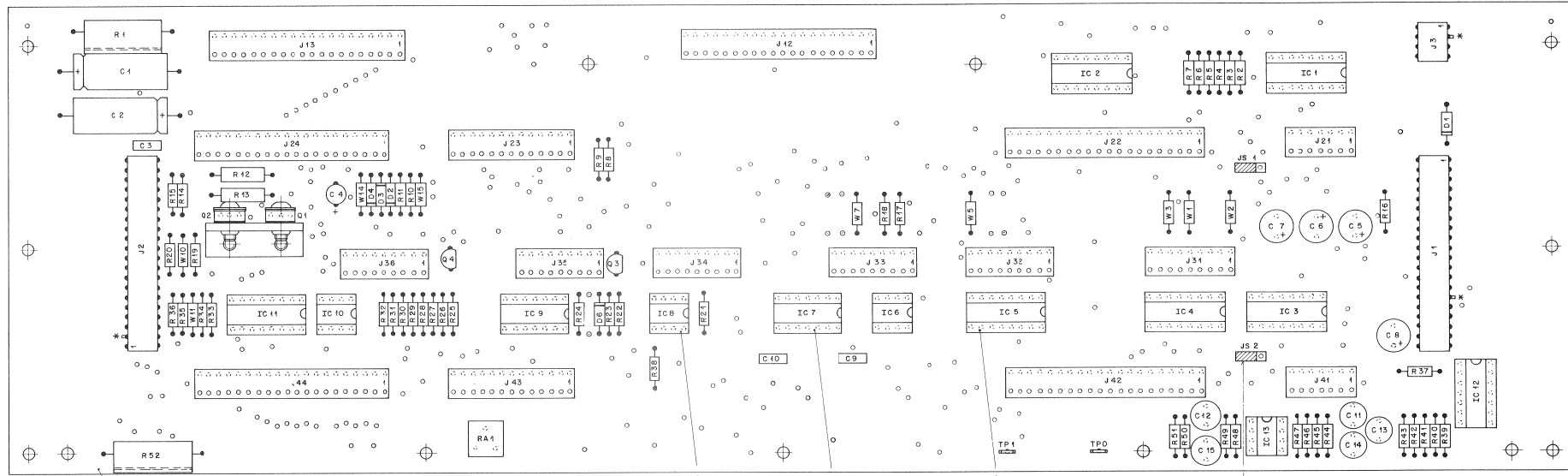

53.03.0166 (4x) 53.03.0167 (3x) 53.03.0168 (6x) Bestückt

* Codierung : Schaltdraht 64.01.0108 $\varnothing 0,8 \times 8$ mm
(muss 1mm vorstehen)

AUDIO CONTROL BOARD 2CH 1.727.670.81

IND.	POS.NO.	PART NO.	VALUE	SPECIFICATIONS / EQUIVALENT	MANUF.	IND.	POS.NO.	PART NO.	VALUE	SPECIFICATIONS / EQUIVALENT	MANUF.
C.....1	59.25.3471	470 uF	-20%	16 V EL		R....36	57.11.3221	220 Ohm	2%, 0.25W, MF		
C.....2	59.25.3471	470 uF	-20%	16 V EL		R....37	57.11.3332	3.3 kOhm	2%, 0.25W, MF		
C.....3	59.06.0104	0.1 uF	10%	63 V PETP		R....38	57.11.3104	100 kOhm	2%, 0.25W, MF		
C.....4	59.22.3470	47 uF	-20%	10 V EL		R....39	57.11.3332	3.3 kOhm	2%, 0.25W, MF		
C.....5	59.22.3470	10 uF	-20%	63 V EL		R....40	57.11.3332	3.3 kOhm	2%, 0.25W, MF		
C.....6	59.22.5101	100 uF	-20%	25 V EL		R....41	57.11.3102	1 kOhm	2%, 0.25W, MF		
C.....7	59.22.5101	100 uF	-20%	25 V EL		R....42	57.11.3391	390 Ohm	2%, 0.25W, MF		
C.....8	59.22.5101	100 uF	-20%	25 V EL		R....43	57.11.3510	51 Ohm	1%, 0.25W, MF		
C.....9	59.06.0683	68 nF	10%	63 V PETP		R....44	57.11.3102	1 kOhm	2%, 0.25W, MF		
C.....10	59.06.0683	68 nF	10%	63 V PETP		R....45	57.11.3471	470 Ohm	2%, 0.25W, MF		
C.....11	59.05.1102	1 nF	1%	160 V PP		R....46	57.11.3332	3.3 kOhm	2%, 0.25W, MF		
C.....12	59.05.1222	2.2 nF	1%	160 V PP		R....47	57.11.3472	4.7 kOhm	2%, 0.25W, MF		
C.....13	59.05.1222	2.2 nF	1%	160 V PP		R....48	57.11.3561	560 Ohm	2%, 0.25W, MF		
C.....14	59.05.1102	1 nF	1%	160 V PP		R....49	57.11.3681	680 Ohm	2%, 0.25W, MF		
C.....15	59.05.1102	1 nF	1%	160 V PP		R....50	57.11.3332	3.3 kOhm	2%, 0.25W, MF		
D.....1	50.04.0512	1N5819		30V	Mot	R....52	57.56.5680	68 Ohm	2%, 4 W, DR		
D.....2	50.04.0125	1N4448		50V		RA....1	58.01.8202	2 kOhm	Potmeter PHG		
D.....3	50.04.0125	1N4448		50V		TP....0	54.02.0320		PLUG 2.8x0.8		
D.....4	50.04.0125	1N4448		50V		TP....1	54.02.0320		PLUG 2.8x0.8		
D.....5			not used			W....1	57.11.3000		Wire Bridge		
D.....6	50.04.0125	1N4448		50V		W....2	57.11.3000		Wire Bridge		
D.....7			not used			W....3	57.11.3000		Wire Bridge		
IC....1	50.07.0018	MC14094		CMOS	Mot	W....4	57.11.3000		Wire Bridge		
IC....2	50.07.0018	MC14094		CMOS	Mot	W....5	57.11.3000		Wire Bridge		
IC....3	50.07.0018	MC14094		CMOS	Mot	W....6			not used		
IC....4	50.07.0018	MC14094		CMOS	Mot	W....7	57.11.3000		Wire Bridge		
IC....5	50.07.0018	MC14094		CMOS	Mot	W....8			not used		
IC....6	50.05.0283	LM393		Dual Comparator		W....9			not used		
IC....7	50.17.1000	74HC00		HCMOS		W....10	57.11.3000		Wire Bridge		
IC....8	50.09.0107	RC4559		Dual Op. Amp.		W....11	57.11.3000		Wire Bridge		
IC....9	50.17.1002	74HC02		Dual Op. Amp.		W....14	57.11.3000		Wire Bridge		
IC....10	50.09.0107	RC4559		Dual Op. Amp.		W....15	57.11.3000		Wire Bridge		
IC....11	50.07.0018	MC14094		CMOS	Mot	XIC...1	53.03.0168	16 pol	IC Socket		
IC....12	50.17.1074	74HC74		HCMOS							
IC....13	50.09.0105	NE5532		Dual Op. Amp.							
S T U D E R (00) 89/03/21 Wth AUDIO CONTROL BOARD PL 1.727.670.00 PAGE 1						S T U D E R (00) 89/03/21 Wth AUDIO CONTROL BOARD PL 1.727.670.00 PAGE 4					
IND.	POS.NO.	PART NO.	VALUE	SPECIFICATIONS / EQUIVALENT	MANUF.	IND.	POS.NO.	PART NO.	VALUE	SPECIFICATIONS / EQUIVALENT	MANUF.
J.....1	54.01.0248	20-POLE		CIS Socket Strip	AMP	XIC...2	53.03.0168	16 pol	IC Socket		
J.....2	54.01.0248	20-POLE		CIS Socket Strip	AMP	XIC...3	53.03.0168	16 pol	IC Socket		
J.....3	54.01.0304	4-POLE		CIS Socket Strip	AMP	XIC...4	53.03.0168	16 pol	IC Socket		
J.....11			not used			XIC...5	53.03.0168	16 pol	IC Socket		
J.....12	54.01.0226	20-POLE		CIS Socket Strip	AMP	XIC...6	53.03.0166	8 pol	IC Socket		
J.....13	54.01.0226	20-POLE		CIS Socket Strip	AMP	XIC...7	53.03.0167	14 pol	IC Socket		
J.....21	54.01.0218	7-POLE		CIS Socket Strip	AMP	XIC...8	53.03.0166	8 pol	IC Socket		
J.....22	54.01.0226	20-POLE		CIS Socket Strip	AMP	XIC...9	53.03.0167	14 pol	IC Socket		
J.....23	54.01.0292	13-POLE		CIS Socket Strip	AMP	XIC...10	53.03.0166	8 pol	IC Socket		
J.....24	54.01.0226	20-POLE		CIS Socket Strip	AMP	XIC...11	53.03.0168	16 pol	IC Socket		
J.....31	54.01.0217	9-POLE		CIS Socket Strip	AMP	XIC...12	53.03.0167	14 pol	IC Socket		
J.....32	54.01.0217	9-POLE		CIS Socket Strip	AMP	XIC...13	53.03.0166	8 pol	IC Socket		
J.....33	54.01.0217	9-POLE		CIS Socket Strip	AMP						
J.....34	54.01.0217	9-POLE		CIS Socket Strip	AMP						
J.....35	54.01.0217	9-POLE		CIS Socket Strip	AMP						
J.....36	54.01.0217	9-POLE		CIS Socket Strip	AMP						
J.....41	54.01.0218	7-POLE		CIS Socket Strip	AMP						
J.....42	54.01.0226	20-POLE		CIS Socket Strip	AMP						
J.....43	54.01.0292	13-POLE		CIS Socket Strip	AMP						
J.....44	54.01.0226	20-POLE		CIS Socket Strip	AMP						
JS....1	54.01.0021			Bridge							
JS....2	54.01.0021			Bridge							
MP....1	1.727.670.11	1 pce		Audio Control PCB	St						
MP....2	1.727.400.01	1 pce		Headsink	St						
MP....3	1.727.670.10	1 pce		No. label	St						
MP....4	21.99.0180	2 pce		Screw M3 x 5							
MP....5	21.83.0355	4 pce		Screw M3 x 8							
MP....6	24.16.2030	2 pce		Lock washer							
MP....7	37.01.0101	4 pce		Lock washer	St						
MP....8	43.01.0108	1 pce		ESD warning label	St						
MP....9	54.01.0020	6 pce		Contact pin	St						
Q.....1	50.03.0495	BD135-16		NPN							
Q.....2	50.03.0510	BD136-16		NPN							
Q.....3	50.03.0436	BC237B		BC547B, BC550B	NPN						
S T U D E R (00) 89/03/21 Wth AUDIO CONTROL BOARD PL 1.727.670.00 PAGE 2						S T U D E R (00) 89/03/21 Wth AUDIO CONTROL BOARD PL 1.727.670.00 PAGE 5					
IND.	POS.NO.	PART NO.	VALUE	SPECIFICATIONS / EQUIVALENT	MANUF.	IND.	POS.NO.	PART NO.	VALUE	SPECIFICATIONS / EQUIVALENT	MANUF.
Q.....4	50.03.0350	MFP4392		J112 FET	Not Six						
R....1	57.56.5680	68 Ohm	2%	4 W, DR							
R....2	57.11.3332	3.3 kOhm	2%	0.25W, MF							
R....3	57.11.3332	3.3 kOhm	2%	0.25W, MF							
R....4	57.11.3332	3.3 kOhm	2%	0.25W, MF							
R....5	57.11.3332	3.3 kOhm	2%	0.25W, MF							
R....6	57.11.3332	3.3 kOhm	2%	0.25W, MF							
R....7	57.11.3332	3.3 kOhm	2%	0.25W, MF							
R....8	57.11.3332	3.3 kOhm	2%	0.25W, MF							
R....9	57.11.3332	3.3 kOhm	2%	0.25W, MF							
R....10	57.11.3102	1 kOhm	2%	0.25W, MF							
R....11	57.11.3102	1 kOhm	2%	0.25W, MF							
R....12	57.13.4229	2.2 Ohm	2%	0.5 W, MF							
R....13	57.13.4229	2.2 Ohm	2%	0.5 W, MF							
R....14	57.11.3221	220 Ohm	2%	0.25W, MF							
R....15	57.11.3333	33 kOhm	2%	0.25W, MF							
R....16	57.11.3332	3.3 kOhm	2%	0.25W, MF							
R....17	57.11.3103	10 kOhm	2%	0.25W, MF							
R....18	57.11.3103	10 kOhm	2%	0.25W, MF							
R....19	57.11.3223	22 kOhm	2%	0.25W, MF							
R....20	57.11.3221	220 Ohm	2%	0.25W, MF							
R....21	57.11.3104	100 kOhm	2%	0.25W, MF							
R....22	57.11.3103	10 kOhm	2%	0.25W, MF							
R....23	57.11.3103	10 kOhm	2%	0.25W, MF							
R....24	57.11.3332	3.3 kOhm	2%	0.25W, MF							
R....25	57.11.3223	22 kOhm	2%	0.25W, MF							
R....26	57.11.3472	4.7 kOhm	2%	0.25W, MF							
R....27	57.11.3102	1 kOhm	2%	0.25W, MF							
R....28	57.11.3103	10 kOhm	2%	0.25W, MF							
R....29	57.11.3103	10 kOhm	2%	0.25W, MF							
R....30	57.11.3103	10 kOhm	2%	0.25W, MF							
R....31	57.11.3470	47 Ohm	2%	0.25W, MF							
R....32	57.11.5106	10 MOhm	5%	0.25W, MF							
R....33	57.11.3102	1 kOhm	2%	0.25W, MF							
R....34	57.11.3223	22 kOhm	2%	0.25W, MF							
R....35	57.11.3223	22 kOhm	2%	0.25W, MF							
S T U D E R (00) 89/03/21 Wth AUDIO CONTROL BOARD PL 1.727.670.00 PAGE 3											

AUDIO CONTROL BOARD 4CH HS 1.727.681.81

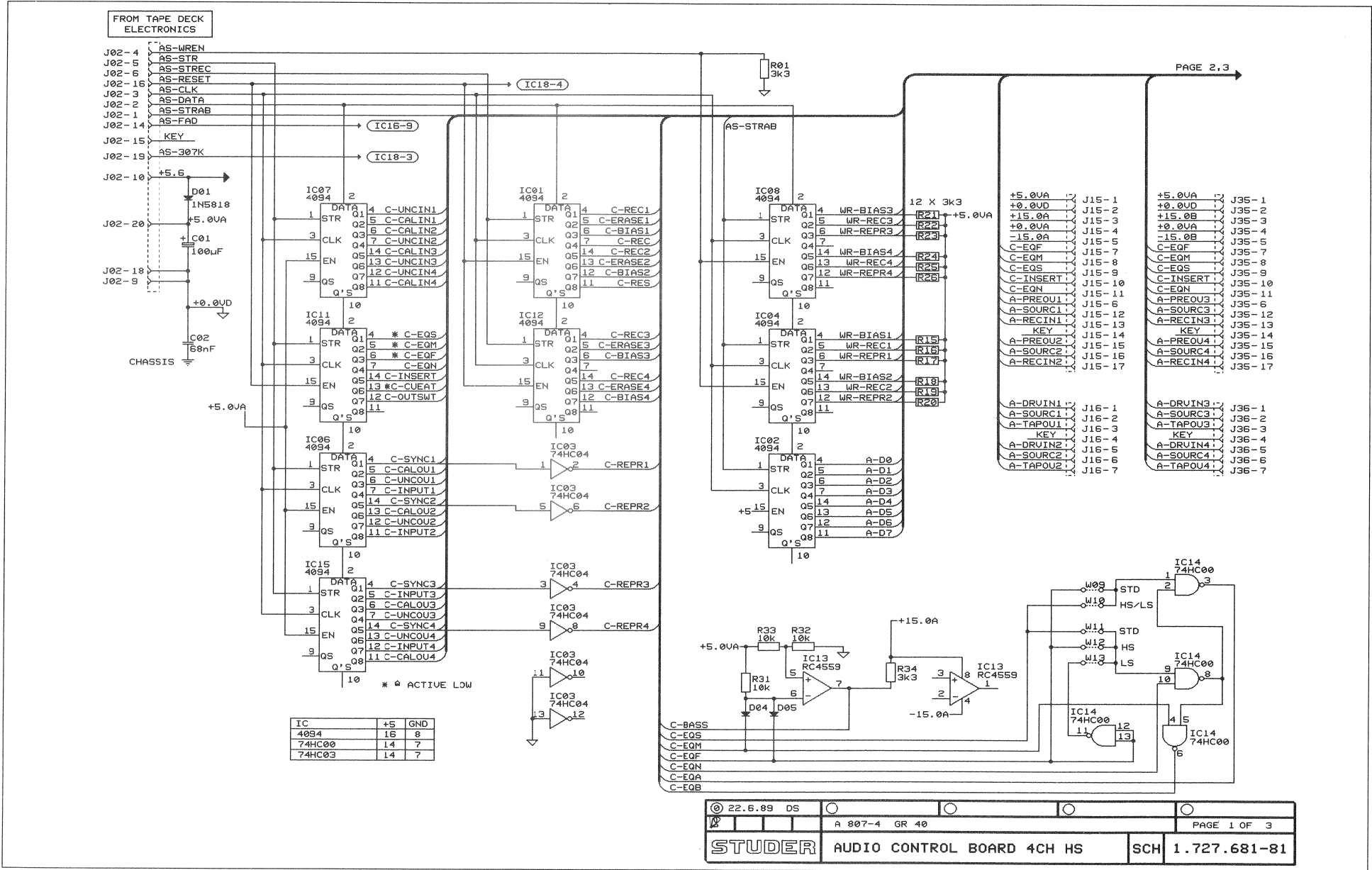

AUDIO CONTROL BOARD 4CH HS 1.727.681.81

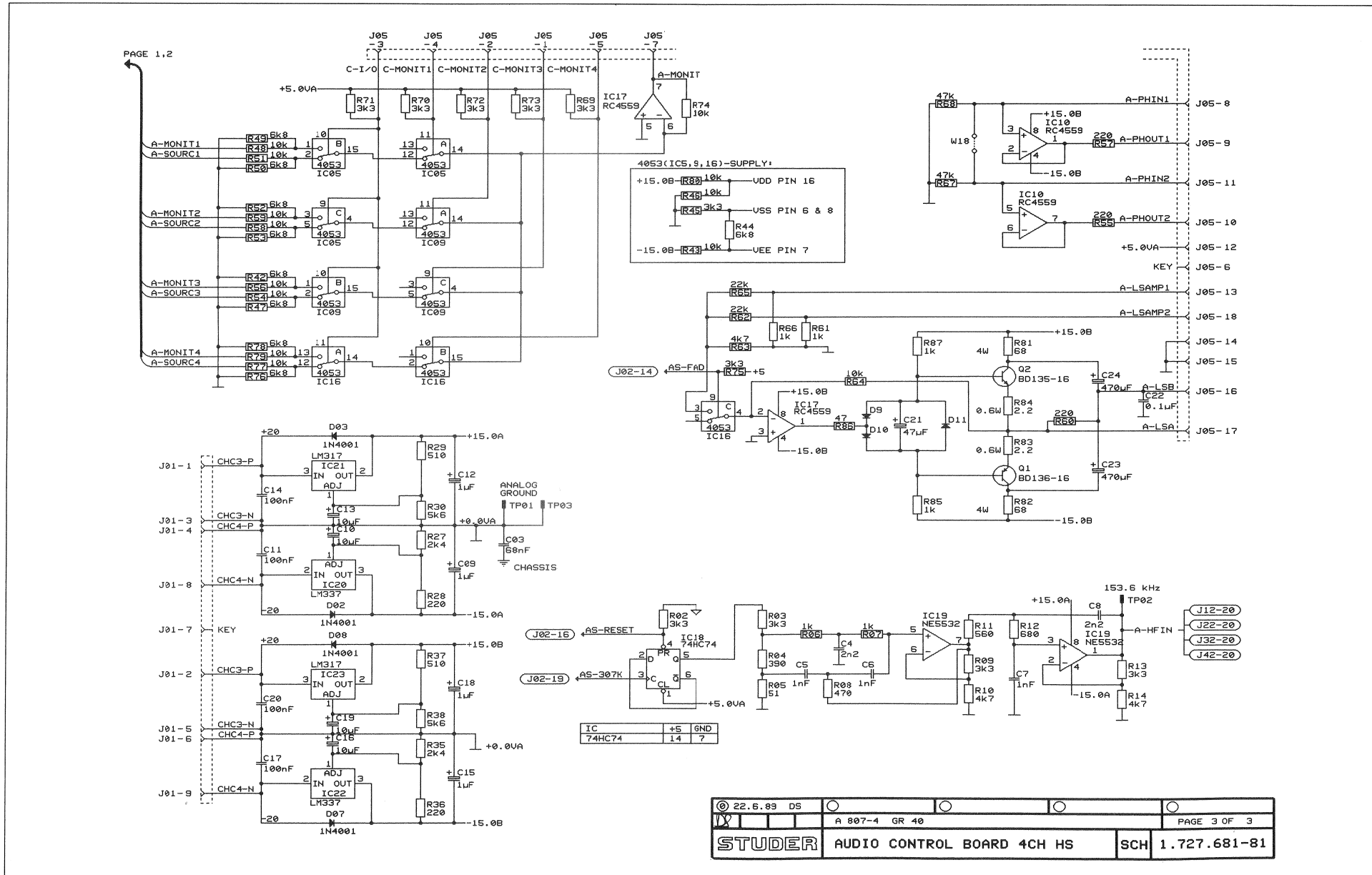

AUDIO CONTROL BOARD 4CH HS 1.727.681.81

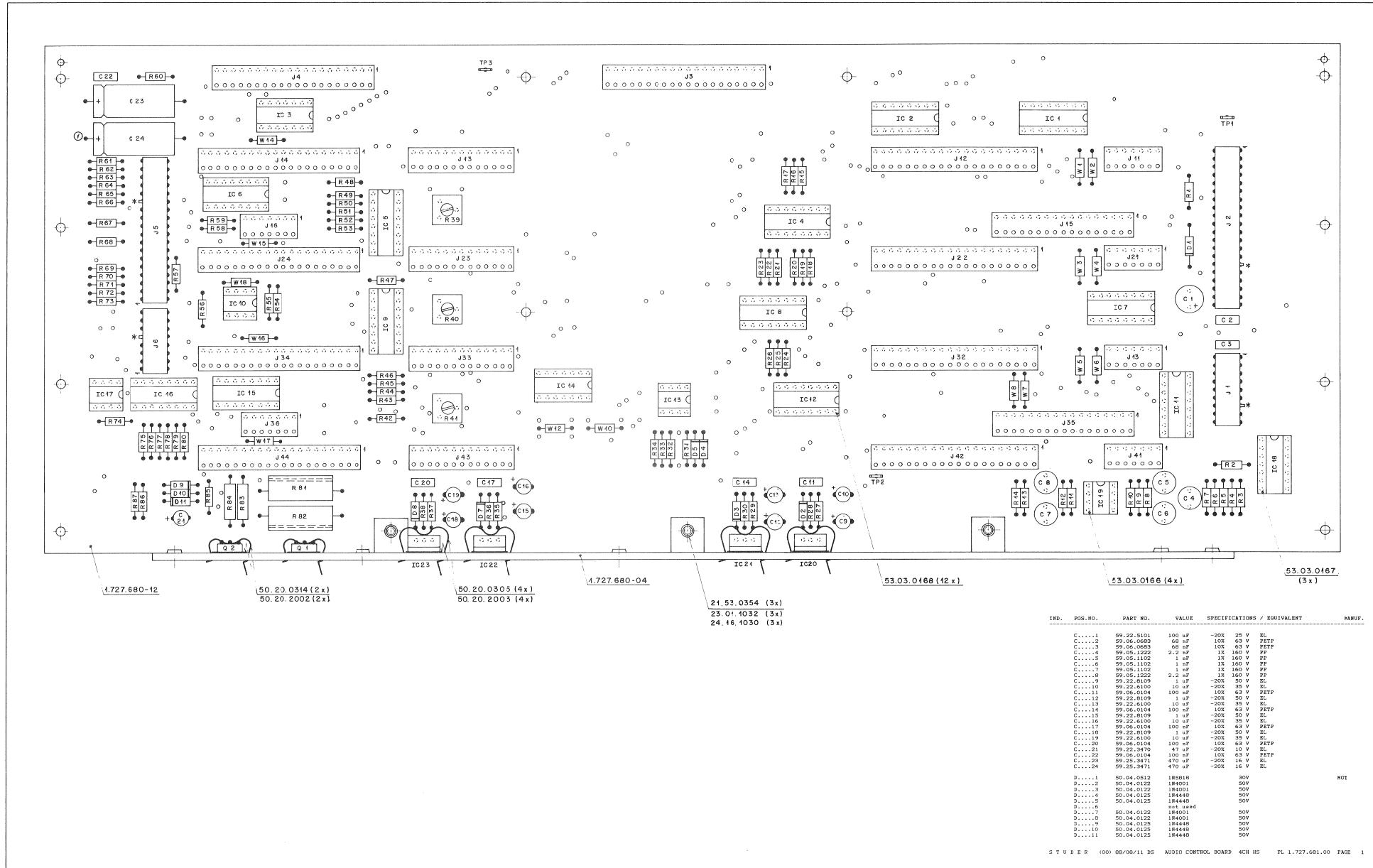

AUDIO CONTROL BOARD 4CH HS 1.727.681.81

IND.	POS. NO.	PART NO.	VALUE	SPECIFICATIONS / EQUIVALENT	MANUF.	IND.	POS. NO.	PART NO.	VALUE	SPECIFICATIONS / EQUIVALENT	MANUF.
IC...1	50.07.0018	MC14094		8-Bit Shift/Store Register	CMOS	MOT	R...47	57.11.3682	6.8 kOhm	1%, 0.25W, MF	
IC...2	50.07.0018	MC14094		8-Bit Shift/Store Register	CMOS	MOT	R...48	57.11.3103	10 kOhm	1%, 0.25W, MF	
IC...3	50.17.1004	74HC04		Hex Inverter	HCMOS	MOT	R...49	57.11.3682	6.8 kOhm	1%, 0.25W, MF	
IC...4	50.07.0018	MC14094		8-Bit Shift/Store Register	CMOS	MOT	R...50	57.11.3682	6.8 kOhm	1%, 0.25W, MF	
IC...5	50.07.0018	MC14094		8-Bit Shift/Store Register	CMOS	MOT	R...51	57.11.3103	10 kOhm	1%, 0.25W, MF	
IC...6	50.07.0018	MC14094		8-Bit Shift/Store Register	CMOS	MOT	R...52	57.11.3682	6.8 kOhm	1%, 0.25W, MF	
IC...7	50.07.0018	MC14094		8-Bit Shift/Store Register	CMOS	MOT	R...53	57.11.3682	6.8 kOhm	1%, 0.25W, MF	
IC...8	50.07.0018	MC14094		8-Bit Shift/Store Register	CMOS	MOT	R...54	57.11.3103	10 kOhm	1%, 0.25W, MF	
IC...9	50.07.0015	MC14053		Triple 2-Ch Analog Multiplexer		MOT	R...55	57.11.3221	220 Ohm	1%, 0.25W, MF	
IC...10	50.09.0107	RC4559		Dual OpAmp		RCA	R...56	57.11.3103	10 kOhm	1%, 0.25W, MF	
IC...11	50.07.0018	MC14094		8-Bit Shift/Store Register	CMOS	MOT	R...57	57.11.3221	220 Ohm	1%, 0.25W, MF	
IC...12	50.07.0018	MC14094		8-Bit Shift/Store Register	CMOS	MOT	R...58	57.11.3103	10 kOhm	1%, 0.25W, MF	
IC...13	50.09.0237	RC4559		Dual OpAmp		RCA	R...59	57.11.3103	10 kOhm	1%, 0.25W, MF	
IC...14	50.17.1000	74HC00		Quad NAND-Gate	HCMOS	MOT	R...60	57.11.3221	220 Ohm	1%, 0.25W, MF	
IC...15	50.07.0018	MC14094		8-Bit Shift/Store Register	CMOS	MOT	R...61	57.11.3102	1 kOhm	1%, 0.25W, MF	
IC...16	50.07.0015	MC14053		Triple 2-Ch Analog Multiplexer		MOT	R...62	57.11.3223	22 kOhm	1%, 0.25W, MF	
IC...17	50.09.0107	RC4559		Dual OpAmp		RCA	R...63	57.11.3472	4.7 kOhm	1%, 0.25W, MF	
IC...18	50.17.1074	74HC74		Dual D-Flip-Flop		MOT	R...64	57.11.3103	10 kOhm	1%, 0.25W, MF	
IC...19	50.09.0105	NE 5532		Dual OpAmp Low Noise		NS	R...65	57.11.3223	22 kOhm	1%, 0.25W, MF	
IC...20	50.10.0105	LM 337		Negative Voltage Regulator		MOT	R...66	57.11.3102	1 kOhm	1%, 0.25W, MF	
IC...21	50.10.0104	LM 317		Positive Voltage Regulator		MOT	R...67	57.11.3473	47 kOhm	1%, 0.25W, MF	
IC...22	50.10.0105	LM 337		Negative Voltage Regulator		MOT	R...68	57.11.3473	47 kOhm	1%, 0.25W, MF	
IC...23	50.10.0104	LM 317		Positive Voltage Regulator		MOT	R...69	57.11.3332	3.3 kOhm	1%, 0.25W, MF	
J...1	54.01.0212	9-Pole		CIS Socket Strip		AMP	R...70	57.11.3332	3.3 kOhm	1%, 0.25W, MF	
J...2	54.01.0248	20-Pole		CIS Socket Strip		AMP	R...71	57.11.3332	3.3 kOhm	1%, 0.25W, MF	
J...3	54.01.0226	20-Pole		CIS Socket Strip		AMP	R...72	57.11.3332	3.3 kOhm	1%, 0.25W, MF	
J...4	54.01.0226	20-Pole		CIS Socket Strip		AMP	R...73	57.11.3332	3.3 kOhm	1%, 0.25W, MF	
J...5	54.01.0247	18-Pole		CIS Socket Strip		AMP	R...74	57.11.3103	10 kOhm	1%, 0.25W, MF	
J...6	54.01.0306	8-Pole		CIS Socket Strip		AMP	R...75	57.11.3332	3.3 kOhm	1%, 0.25W, MF	
J...7	54.01.0226	20-Pole		CIS Socket Strip		AMP	R...76	57.11.3682	6.8 kOhm	1%, 0.25W, MF	
J...8	54.01.0226	20-Pole		CIS Socket Strip		AMP	R...77	57.11.3103	10 kOhm	1%, 0.25W, MF	
J...9	54.01.0226	20-Pole		CIS Socket Strip		AMP	R...78	57.11.3682	6.8 kOhm	1%, 0.25W, MF	
J...10	54.01.0292	13-Pole		CIS Socket Strip		AMP	R...79	57.11.3103	10 kOhm	1%, 0.25W, MF	
J...11	54.01.0226	20-Pole		CIS Socket Strip		AMP	R...80	57.11.3103	10 kOhm	1%, 0.25W, MF	
J...12	54.01.0295	17-Pole		CIS Socket Strip		AMP	R...81	57.56.5680	68 Ohm	1%, 4 W DR	
J...13	54.01.0218	7-Pole		CIS Socket Strip		AMP	R...82	57.56.5680	68 Ohm	1%, 4 W DR	
J...14	54.01.0218	7-Pole		CIS Socket Strip		AMP	R...83	57.13.4229	2.2 Ohm	1%, 0.5 W, MF	

S T U D E R (00) 88/08/11 DS AUDIO CONTROL BOARD 4CH HS PL 1.727.681.00 PAGE 2 S T U D E R (00) 88/08/11 DS AUDIO CONTROL BOARD 4CH HS PL 1.727.681.00 PAGE 5

IND.	POS. NO.	PART NO.	VALUE	SPECIFICATIONS / EQUIVALENT	MANUF.	IND.	POS. NO.	PART NO.	VALUE	SPECIFICATIONS / EQUIVALENT	MANUF.
J...22	54.01.0226	20-Pole		CIS Socket Strip	AMP	R...84	57.13.4229	2.2 Ohm	1%, 0.5 W, MF		
J...23	54.01.0292	13-Pole		CIS Socket Strip	AMP	R...85	57.11.3102	1 kOhm	1%, 0.25W, MF		
J...24	54.01.0226	20-Pole		CIS Socket Strip	AMP	R...86	57.11.3470	47 Ohm	1%, 0.25W, MF		
J...25	54.01.0218	7-Pole		CIS Socket Strip	AMP	R...87	57.11.3102	1 kOhm	1%, 0.25W, MF		
J...26	54.01.0226	20-Pole		CIS Socket Strip	AMP	TP...1	54.02.0320		Plug 2.8x0.8		
J...27	54.01.0292	13-Pole		CIS Socket Strip	AMP	TP...2	54.02.0320		Plug 2.8x0.8		
J...28	54.01.0226	20-Pole		CIS Socket Strip	AMP	TP...3	54.02.0320		Plug 2.8x0.8		
J...29	54.01.0218	7-Pole		CIS Socket Strip	AMP	W...1	57.11.3000		Wire Bridge		
J...30	54.01.0295	17-Pole		CIS Socket Strip	AMP	W...2	57.11.3000		Wire Bridge		
J...31	54.01.0218	7-Pole		CIS Socket Strip	AMP	W...3	57.11.3000		Wire Bridge		
J...32	54.01.0226	20-Pole		CIS Socket Strip	AMP	W...4	57.11.3000		Wire Bridge		
J...33	54.01.0292	13-Pole		CIS Socket Strip	AMP	W...5	57.11.3000		Wire Bridge		
J...34	54.01.0226	20-Pole		CIS Socket Strip	AMP	W...6	57.11.3000		Wire Bridge		
J...35	54.01.0295	17-Pole		CIS Socket Strip	AMP	W...7	57.11.3000		Wire Bridge		
J...36	54.01.0218	7-Pole		CIS Socket Strip	AMP	W...8	57.11.3000		Wire Bridge		
J...37	54.01.0226	20-Pole		CIS Socket Strip	AMP	W...9	57.11.3000		Wire Bridge		
J...38	54.01.0292	13-Pole		CIS Socket Strip	AMP	W...10	57.11.3000		Wire Bridge		
J...39	54.01.0226	20-Pole		CIS Socket Strip	AMP	W...11	57.11.3000		Wire Bridge		
J...40	54.01.0226	20-Pole		CIS Socket Strip	AMP	W...12	57.11.3000		Wire Bridge		
J...41	54.01.0226	20-Pole		CIS Socket Strip	AMP	W...13	57.11.3000		Wire Bridge		
J...42	54.01.0226	20-Pole		CIS Socket Strip	AMP	W...14	57.11.3000		Wire Bridge		
J...43	54.01.0292	13-Pole		CIS Socket Strip	AMP	W...15	57.11.3000		Wire Bridge		
J...44	54.01.0226	20-Pole		CIS Socket Strip	AMP	W...16	57.11.3000		Wire Bridge		
J...45	54.01.0226	20-Pole		CIS Socket Strip	AMP	W...17	57.11.3000		Wire Bridge		
J...46	54.01.0226	20-Pole		CIS Socket Strip	AMP	W...18	57.11.3000		Wire Bridge		
MF...1	21.53.0354	3 pcs		Screw IS M3x6		XIC...1	53.03.0168		16-Pole IC Socket		
MF...2	23.01.1032	3 pcs		Washer D 3.2/6x0.5		XIC...2	53.03.0168		16-Pole IC Socket		
MF...3	24.16.1030	3 pcs		Washer D 3.2/5.5		XIC...3	53.03.0167		14-Pole IC Socket		
MF...4	43.01.0108	1 pcs		ESD-WARNING Label		XIC...4	53.03.0168		16-Pole IC Socket		
MF...5	50.20.0305	4 pcs		Thermoplastic TG220		XIC...5	53.03.0168		16-Pole IC Socket		
MF...6	50.20.0314	2 pcs		Thermoplastic TG126		XIC...6	53.03.0168		16-Pole IC Socket		
MF...7	50.20.2002	2 pcs		Mounting clip TG126		XIC...7	53.03.0168		16-Pole IC Socket		
MF...8	50.20.2003	4 pcs		Mounting clip TG220		XIC...8	53.03.0168		16-Pole IC Socket		
MF...9	1.727.680.11	1 pcs		AUDIO CONTROL PCB 4CH	ST	XIC...9	53.03.0168		16-Pole IC Socket		
MF...10	1.727.680.10	1 pcs		Nr. Label	ST						
G...1	50.03.0510	PNP		BD136-16							
G...2	50.03.0495	NPN		BD135-16							
R...1	57.11.3332	3.3 kOhm	1%, 0.25W, MF								
R...2	57.11.3332	3.3 kOhm	1%, 0.25W, MF								
R...3	57.11.3332	3.3 kOhm	1%, 0.25W, MF								
R...4	57.11.3391	390 Ohm	1%, 0.25W, MF								
R...5	57.11.3510	51 Ohm	1%, 0.25W, MF								
R...6	57.11.3102	1 kOhm	1%, 0.25W, MF								
R...7	57.11.3102	1 kOhm	1%, 0.25W, MF								
R...8	57.11.3471	470 Ohm	1%, 0.25W, MF								
R...9	57.11.3332	3.3 kOhm	1%, 0.25W, MF								

S T U D E R (00) 88/08/11 DS AUDIO CONTROL BOARD 4CH HS PL 1.727.681.00 PAGE 3 S T U D E R (00) 88/08/11 DS AUDIO CONTROL BOARD 4CH HS PL 1.727.681.00 PAGE 6

IND.	POS. NO.	PART NO.	VALUE	SPECIFICATIONS / EQUIVALENT	MANUF.	IND.	POS. NO.	PART NO.	VALUE	SPECIFICATIONS / EQUIVALENT	MANUF.
R...10	57.11.3472	4.7 kOhm	1%, 0.25W, MF			XIC...10	53.03.0166		8-Pole IC Socket		
R...11	57.11.3561	560 Ohm	1%, 0.25W, MF			XIC...11	53.03.0168		16-Pole IC Socket		
R...12	57.11.3681	680 Ohm	1%, 0.25W, MF			XIC...12	53.03.0168		16-Pole IC Socket		
R...13	57.11.3332	3.3 kOhm	1%, 0.25W, MF			XIC...13	53.03.0166		8-Pole IC Socket		
R...14	57.11.3472	4.7 kOhm	1%, 0.25W, MF			XIC...14	53.03.0167		14-Pole IC Socket		
R...15	57.11.3332	3.3 kOhm	1%, 0.25W, MF			XIC...15	53.03.0168		16-Pole IC Socket		
R...16	57.11.3332	3.3 kOhm	1%, 0.25W, MF			XIC...16	53.03.0168		16-Pole IC Socket		
R...17	57.11.3332	3.3 kOhm	1%, 0.25W, MF			XIC...17	53.03.0166		8-Pole IC Socket		
R...18	57.11.3332	3.3 kOhm	1%, 0.25W, MF			XIC...18	53.03.0167		14-Pole IC Socket		
R...19	57.11.3332	3.3 kOhm	1%, 0.25W, MF			XIC...19	53.03.0166		8-Pole IC Socket		
R...20	57.11.3332	3.3 kOhm	1%, 0.25W, MF								
R...21	57.11.3332	3.3 kOhm	1%, 0.25W, MF								
R...22	57.11.3332	3.3 kOhm	1%, 0.25W, MF								
R...23	57.11.3332	3.3 kOhm	1%, 0.25W, MF								
R...24	57.11.3332	3.3 kOhm	1%, 0.25W, MF								
R...25	57.11.3332	3.3 kOhm	1%, 0.25W, MF								
R...26	57.11.3332	3.3 kOhm	1%, 0.25W, MF								
R...27	57.11.3242	2.4 kOhm	1%, 0.25W, MF								
R...28	57.11.3221	220 Ohm	1%, 0.25W, MF								
R...29	57.11.3511	510 Ohm	1%, 0.25W, MF								
R...30	57.11.3562	5.6 kOhm	1%, 0.25W, MF								
R...31	57.11.3103	10 kOhm	1%, 0.25W, MF								
R...32	57.11.3103	10 kOhm	1%, 0.25W, MF								
R...33	57.11.3103	10 kOhm	1%, 0.25W, MF								
R...34	57.11.3332	3.3 kOhm	1%, 0.25W, MF								
R...35	57.11.3242	2.4 kOhm	1%, 0.25W, MF								
R...36	57.11.3221	220 Ohm	1%, 0.25W, MF								
R...37	57.11.3511	510 Ohm	1%, 0.25W, MF								
R...38	57.11.3562	5.6 kOhm	1%, 0.25W, MF								
R...39	58.01.8202	2 kOhm		Potmeter PMG							
R...40	58.01.8202	2 kOhm		Potmeter PMG							
R...41	58.01										

STUDER A807

TC PROCESSOR BOARD 1.727.710.20

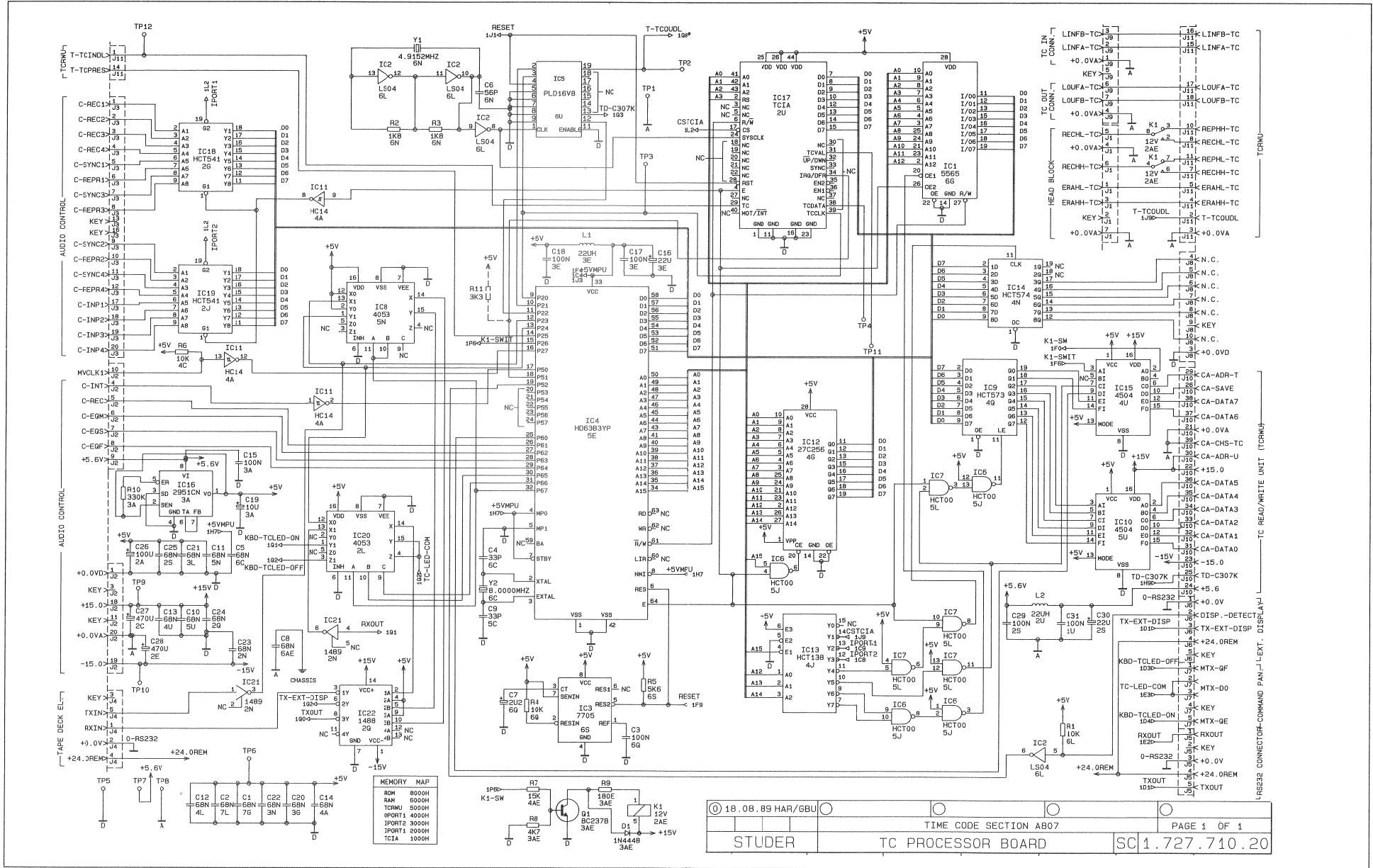

TC PROCESSOR BOARD 1.727.710.20

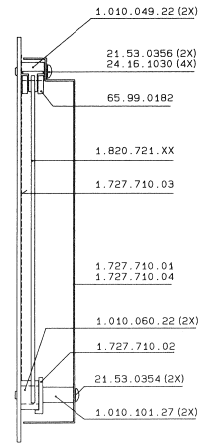
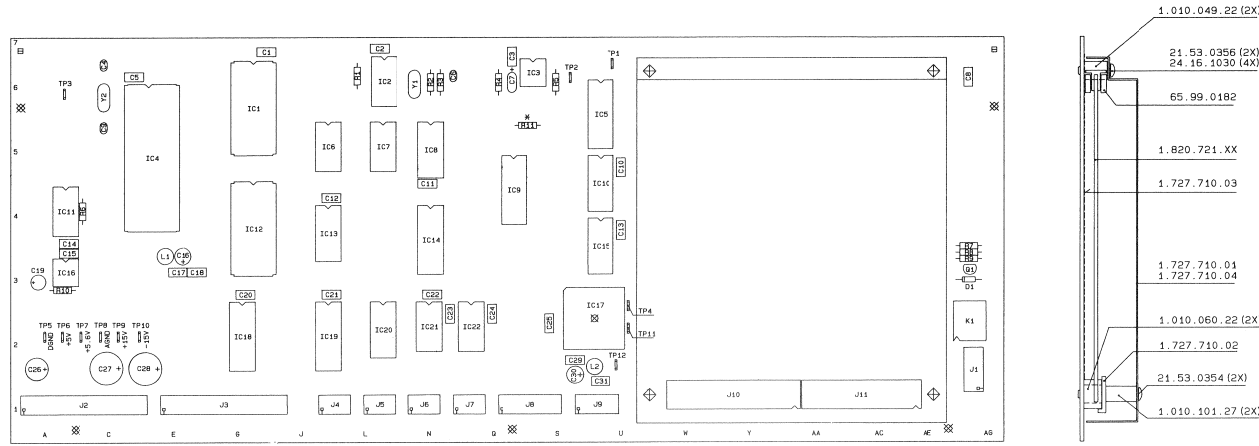

STECKER	CODIERUNG IN LOCH NR.
J1	1
J2	2
J3	13
J4	3
J5	2
J6	5
J7	2 UND 4
J8	9
J9	5

* MANUELL BESTUECKT

NR. ETIKETTE 1.727.710-10.43.010108.1.101.001-20
AUFGEKLEBT NACH FABRIKATIONSMUSTER

CODIERUNG: SCHALTDRAHT 69.01.0108 0.B X 8MM
(MUSS IMM VORSTEHEN)

IND.	POS.NR.	PART NO.	VALUE	SPECIFICATIONS / EQUIVALENT	MANUF.
TP...	7	54.02.0320		Test Point	AMP
TP...	8	54.02.0320		Test Point	AMP
TP...	9	54.02.0320		Test Point	AMP
TP...	10	54.02.0320		Test Point	AMP
TP...	11	54.02.0320		Test Point	AMP
TP...	12	54.02.0320		Test Point	AMP
XIC...	1	53.03.0173	28 Poles	IC Socket	
XIC...	2	53.03.0167	14 Poles	IC Socket	
XIC...	3	53.03.0166	8 Poles	IC Socket	
XIC...	4	53.03.0364	64 Poles	IC Socket	
XIC...	5	53.03.0165	20 Poles	IC Socket	
XIC...	6	53.03.0167	14 Poles	IC Socket	
XIC...	7	53.03.0167	14 Poles	IC Socket	
XIC...	8	53.03.0168	16 Poles	IC Socket	
XIC...	9	53.03.0165	20 Poles	IC Socket	
XIC...	10	53.03.0168	16 Poles	IC Socket	
XIC...	11	53.03.0167	14 Poles	IC Socket	
XIC...	12	53.03.0173	28 Poles	IC Socket	
XIC...	13	53.03.0168	16 Poles	IC Socket	
XIC...	14	53.03.0165	20 Poles	IC Socket	
XIC...	15	53.03.0168	16 Poles	IC Socket	
XIC...	16	53.03.0166	8 Poles	IC Socket	
XIC...	17	53.03.0164	44 Poles	IC Socket	
XIC...	18	53.03.0165	20 Poles	IC Socket	
XIC...	19	53.03.0165	20 Poles	IC Socket	
XIC...	20	53.03.0168	16 Poles	IC Socket	
XIC...	21	53.03.0167	14 Poles	IC Socket	
XIC...	22	53.03.0167	14 Poles	IC Socket	
Y....	1	89.01.0560	4.9152 MHz	Quartz TD 18	
Y....	2	89.01.1008	8.0000 MHz	Quartz TD 18	

S T U D E R (01) 89/09/05 W4h TC PROCESSOR BOARD PL 1.727.710.20 PAGE 4

IND.	POS.NR.	PART NO.	VALUE	SPECIFICATIONS / EQUIVALENT	MANUF.	IND.	POS.NR.	PART NO.	VALUE	SPECIFICATIONS / EQUIVALENT	MANUF.	IND.	POS.NR.	PART NO.	VALUE	SPECIFICATIONS / EQUIVALENT	MANUF.	
A....	1	1.820.721.86		Time Cod: Read-Write Unit	ST	IC....	1	50.14.0133	CB62641P15	Hex Inverter		IC....	1	62.02.3220	22 MH			
C....	1	59.06.0683	68 nF	10% 63 V PEP		IC....	2	50.06.0004	74 LS 04	Hex Direct		IC....	2	62.02.3220	22 MH			
C....	2	59.06.0683	68 nF	10% 63 V PEP		IC....	3	50.11.0122	74795AKP	8-Bit Microprocessor		MP....	1	1.727.710.11	1 pin	TC Processor PCB	ST	
C....	3	59.06.0104	100 nF	10% 63 V PEP		IC....	4	50.16.0121	H163805FP	8-Bit Microprocessor		MP....	2	1.010.049.22	2 pins	Rivet bolt: M3 x 10	ST	
C....	4	59.34.2330	33 pF	5% 63 V CER		IC....	5	50.18.0130	6AL 16 V	TC Biphas Conv. SM 36/89, 1.727.712.20	St	MP....	3	1.010.060.22	2 pins	Mounting profile	ST	
C....	5	59.34.2330	33 pF	5% 63 V CER		IC....	6	50.17.0000	74 HCT 00	Quad 2-Input NAND Gate		MP....	4	1.727.710.01	1 pin	Green Socket	ST	
C....	6	59.34.2330	33 pF	5% 63 V CER		IC....	7	50.17.0000	74 HCT 00	Quad 2-Input NAND Gate		MP....	5	21.23.0334	4 pins	Green RD x 6		
C....	7	59.34.2330	33 pF	5% 63 V CER		IC....	8	50.07.0015	MC 14548	Triple 3-Ohm Analog Switch, CMOS		MP....	6	24.16.1030	4 pins	Header RD		
C....	8	59.34.2330	33 pF	5% 63 V CER		IC....	9	50.17.0015	74 HCT573	Quad D-Type Trans. Latch		MP....	7	53.01.0102	4 pins	Header RD		
C....	9	59.34.2330	33 pF	5% 63 V CER		IC....	10	50.17.0015	74 HCT573	Quad D-Type Trans. Latch		MP....	8	24.16.1030	4 pins	Header RD		
C....	10	59.34.2330	33 pF	5% 63 V CER		IC....	11	50.17.0104	74 HC 14	Hex Invert-Voltage Level Shifter		MP....	9	1.010.101.27	1 pin	Green bolt: M3 x 12		
C....	11	59.34.2330	33 pF	5% 63 V CER		IC....	12	50.14.0204	DM95C06	DM95C06 SW A807 TCIP 36/89, 1.727.711.20	St	MP....	10	65.99.0182	3 pins	Fast rubber wstripe: 1*94		
C....	12	59.34.2330	33 pF	5% 63 V CER		IC....	13	50.17.0130	74 HCT138	4-Cross 3/8 Decoder		MP....	11	1.727.710.03	1 pin	Labeling		
C....	13	59.34.2330	33 pF	5% 63 V CER		IC....	14	50.17.0130	74 HCT138	4-Cross 3/8 Decoder		MP....	12	1.727.710.04	1 pin	Test Label	St	
C....	14	59.34.2330	33 pF	5% 63 V CER		IC....	15	50.15.0103	MC 145048	Hex Invert-Voltage Level Shifter								
C....	15	59.34.2330	33 pF	5% 63 V CER		IC....	16	50.10.0115	MC 145048	Hex Invert-Voltage Level Shifter								
C....	16	59.34.2330	33 pF	5% 63 V CER		IC....	17	50.05.0220	TC1A	MP/PP/RSBI Firm Code Interface Adapter		Q....	1	50.03.0436	BC2378	NPN		
C....	17	59.34.2330	33 pF	5% 63 V CER		IC....	18	50.17.0541	74 HCT541	4-CMOS Data Buffer		R....	1	59.11.3103	1.8 kOhm	15% 0.25W MF		
C....	18	59.34.2330	33 pF	5% 63 V CER		IC....	19	50.17.0541	74 HCT541	4-CMOS Data Buffer		R....	2	59.11.3102	1.8 kOhm	15% 0.25W MF		
C....	19	59.34.2330	33 pF	5% 63 V CER		IC....	20	50.07.0015	MC 14053	Triple 3-Ohm Analog Switch, CMOS		R....	3	59.11.3102	1.8 kOhm	15% 0.25W MF		
C....	20	59.34.2330	33 pF	5% 63 V CER		IC....	21	50.15.0116	MC 1489 F	Quad Line Receiver RS 232		R....	4	59.11.3103	1.8 kOhm	15% 0.25W MF		
C....	21	59.34.2330	33 pF	5% 63 V CER		IC....	22	50.15.0106	MC 1489 F	Quad Line Receiver RS 232		R....	5	59.11.3102	1.8 kOhm	15% 0.25W MF		
C....	22	59.06.0683	68 nF	10% 63 V PEP		J....	1	54.01.0218	7-Poles	CIS Socket Strip	AMP	R....	6	59.11.3102	1.8 kOhm	15% 0.25W MF		
C....	23	59.06.0683	68 nF	10% 63 V PEP		J....	2	54.01.0226	20-Poles	CIS Socket Strip	AMP	R....	7	59.11.3103	1.8 kOhm	15% 0.25W MF		
C....	24	59.06.0683	68 nF	10% 63 V PEP		J....	3	54.01.0226	20-Poles	CIS Socket Strip	AMP	R....	8	59.11.3103	1.8 kOhm	15% 0.25W MF		
C....	25	59.06.0683	68 nF	10% 63 V PEP		J....	4	54.01.0288	5-Poles	CIS Socket Strip	AMP	R....	9	59.11.3181	180 Ohm	15% 0.25W MF		
C....	26	59.06.0683	68 nF	10% 63 V PEP		J....	5	54.01.0288	5-Poles	CIS Socket Strip	AMP	R....	10	59.11.3284	330 Ohm	15% 0.25W MF		
C....	27	59.06.0683	68 nF	10% 63 V PEP		J....	6	54.01.0288	5-Poles	CIS Socket Strip	AMP	R....	11	59.11.3332	3.3 kOhm	15% 0.25W MF		
C....	28	59.22.5471	470 uF	20% 25 V EL		J....	7	54.01.0288	5-Poles	CIS Socket Strip	AMP	(00)	TP...	54.02.0320		Test Point	AMP	
C....	29	59.22.5471	470 uF	20% 25 V EL		J....	8	54.01.0288	5-Poles	CIS Socket Strip	AMP	TP...	2	54.02.0320		Test Point	AMP	
C....	30	59.22.5471	470 uF	20% 25 V EL		J....	9	54.01.0218	7-Poles	CIS Socket Strip	AMP	TP...	3	54.02.0320		Test Point	AMP	
C....	31	59.06.0104	100 nF	10% 63 V PEP		J....	10	54.10.0226	20-Poles	Test Socket Strip		TP...	4	54.02.0320		Test Point	AMP	
C....	32	59.06.0104	100 nF	10% 63 V PEP		J....	11	54.10.0215	19-Poles	Test Socket Strip		TP...	5	54.02.0320		Test Point	AMP	
C....	33	59.06.0104	100 nF	10% 63 V PEP		J....	12	54.10.0215	19-Poles	Test Socket Strip		TP...	6	54.02.0320		Test Point	AMP	

EL=Electrolytic, PEP=Polymer, PP=Polypropylene, Si=Silicon /
MP=Metal Film, PMS=Carrier, PSC=Carrier, SAL=Solid Aluminum
MANUFACTURER: AMP=AMP, FN=Philips, ST=Studer

S T U D E R (01) 89/09/05 W4h TC PROCESSOR BOARD PL 1.727.710.20 PAGE 5

TIME CODE READ-WRITE UNIT 1.820.721.87

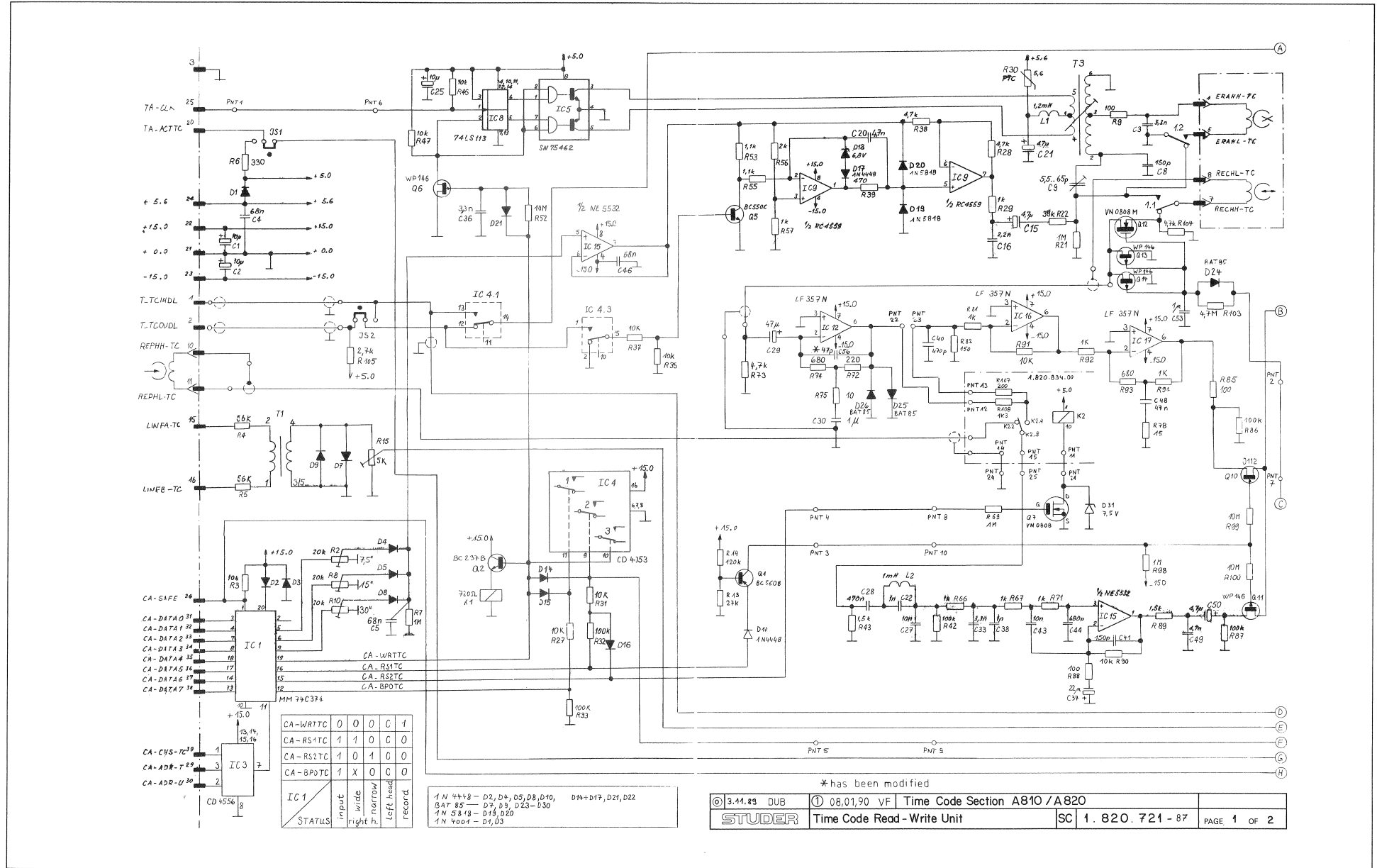

TIME CODE READ-WRITE UNIT 1.820.721.87

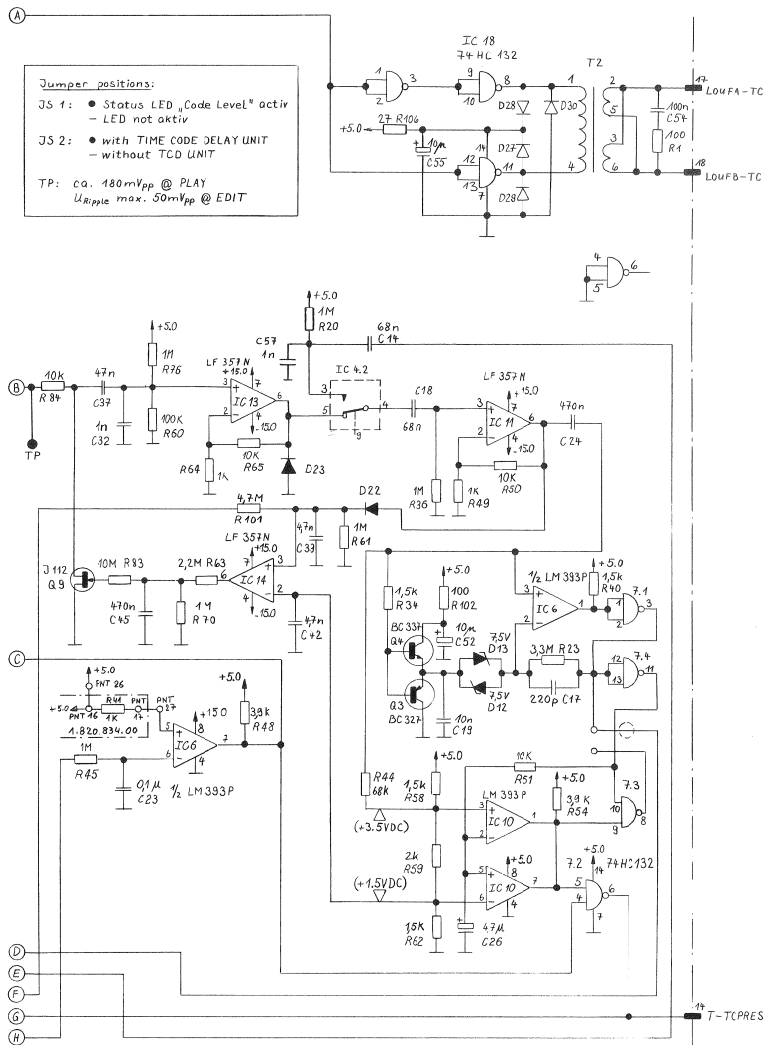

© 3.11.83 DUB	① 08.0.90 VF	Time Code Section A 810 / A 820	
STUDER	Time Code Read-Write Unit	SC 1.820.721-87	PAGE 2 OF 2

COMMAND PANEL BOARD 2VU TC 1.727.762.00

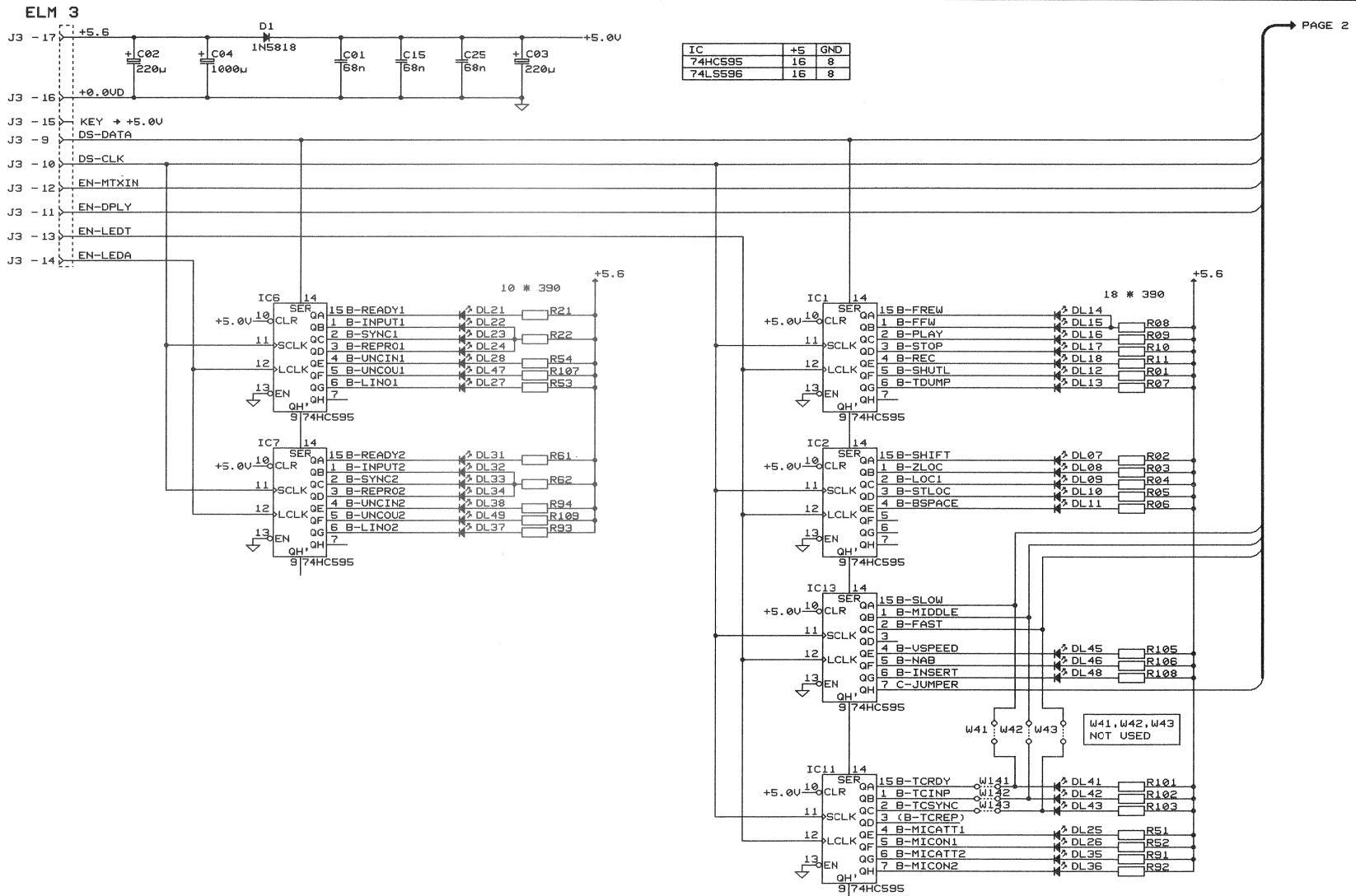

PAGE 2

COMMAND PANEL BOARD 2VU TC 1.727.762.00

PAGE 1

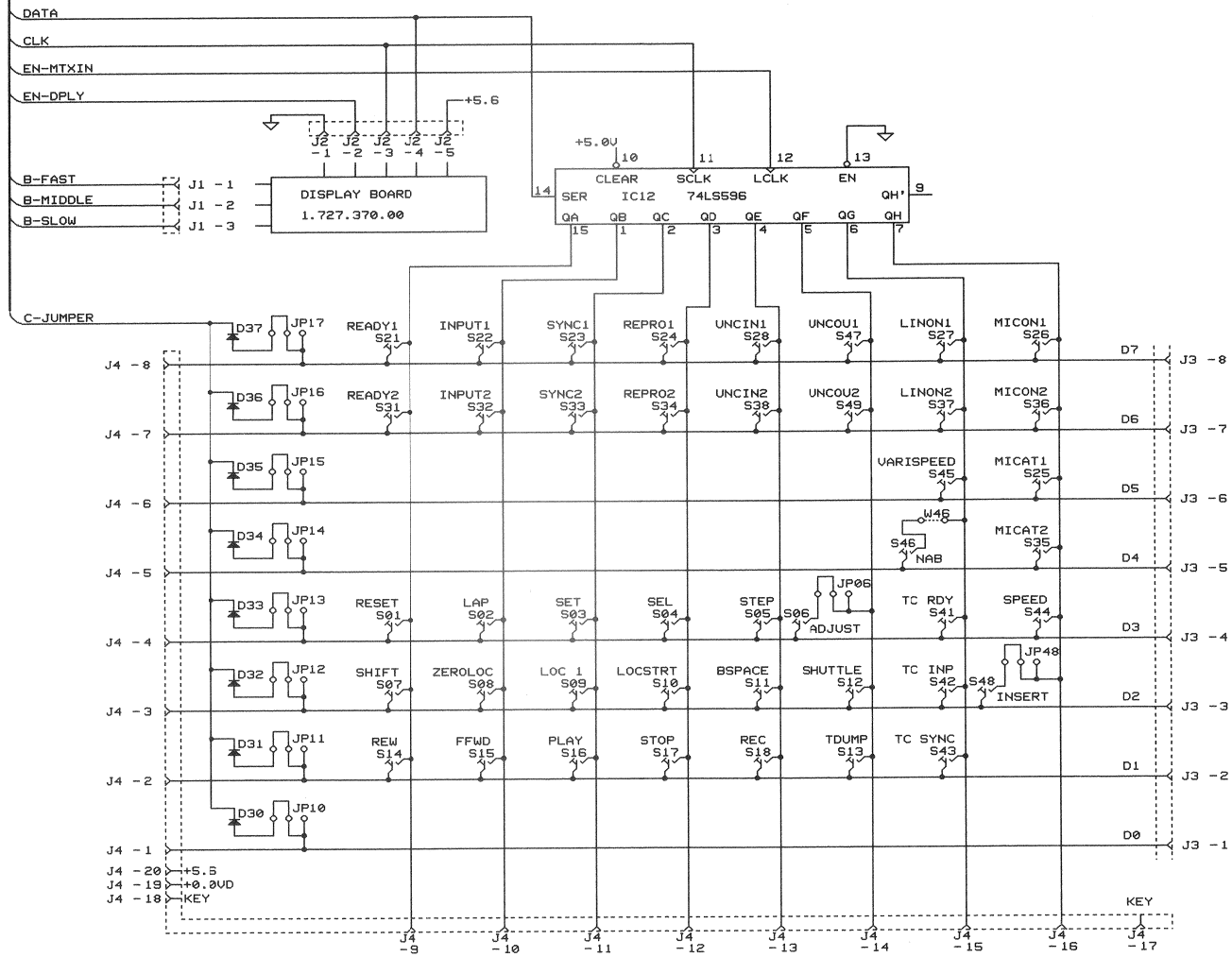

© 26.1.90 GP			
STUDER	A 807-TC GRP 30		PAGE 2 OF 3
STUDER COMMAND PANEL BOARD 2VU TC		SCH	1.727.762-00

COMMAND PANEL BOARD 2VU TC 1.727.762.00

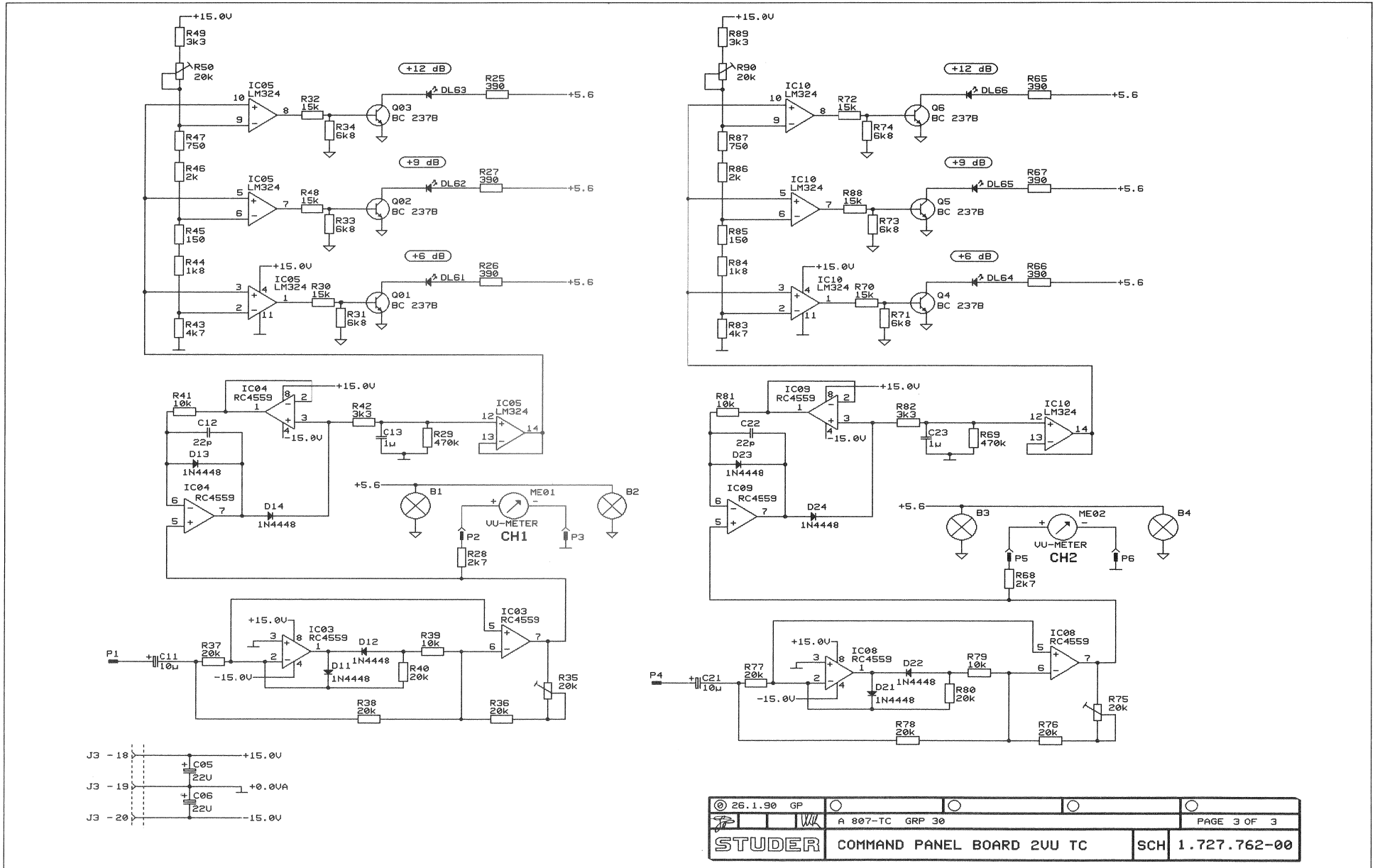

TABLE OF CONTENTS **SECTION 1**

1.	GENERAL INFORMATION	1
1.1	QUICK-REFERENCE DESCRIPTION	1
1.2	STANDARD VERSIONS	2
1.2.1	Full-track versions A807-1	2
1.2.2	Stereo versions A807-0.75	2
1.2.3	Two-track versions A807-2	3
1.2.4	1/4-track, 2-channel versions A807-4/2	5
1.3	OPTIONS	6
1.4	ACCESSORIES AND SERVICE AIDS	7
1.4.1	Standard accessories	7
1.4.2	Consoles	7
1.4.3	Remote control systems	7
1.4.4	Remote counter	8
1.4.5	Adapters and tape reels	8
1.4.6	Aids	8
1.4.7	Accessories	8
1.5	TECHNICAL DATA	9
1.5.1	Dimensions (in mm)	13
1.5.2	Packing	14
1.6	INSTRUCTIONS FOR THE SERVICE PERSONNEL	15
1.6.1	Abbreviations	15
1.6.2	Powers of ten	15
1.6.3	Letter and color codes	15
1.6.4	Electrostatically sensitive components	16

1. GENERAL INFORMATION

1.1 QUICK REFERENCE DESCRIPTION

With its compact and rugged design, its system flexibility, and the high operating convenience afforded by its microprocessor, the STUDER A807 tape recorder satisfies all requirements of a universal studio machine, be it radio or television studios, recording studios, theater, film, auditoriums, or scientific institutes.

Its salient features are:

- Highly stable die-cast aluminum alloy chassis for the tape transport, the headblock, and other assemblies.
- Hall-commutated brushless DC capstan motor with capacitive tachometer sensor for highly accurate tape speed and outstanding acceleration and deceleration rates.
- Fast tape deck with high tape spooling speeds and gentle handling of the tapes by electronically controlled tape tension, 2 controlled AC spooling motors with photoelectric tachometer sensors and noncontacting tape tension sensor.
- Precision electronic tape counter with real-time indication. Photoelectric scanning of the guide roller rotation.
- Easy editing: motor-assisted with variable spooling speed (SHUTTLE mode) or manually by turning the right-hand reel (one-handed editing). For cueing in spooling mode, the high end of the frequency response is lowered.
- Monitor speaker below the tape deck cover or in the penthouse.
- Manually operable shield above the reproduce head; can remain closed in spooling mode.

Due to the enormous system flexibility, a suitable A807 version is available for any type of application:

- The basic version is available as a mono, 2-channel or stereo machine with or without external instrument panel.
- Can be operated in horizontal, inclined, or vertical position.
- Three of four available tape speeds can be selected: 3.75 / 7.5 / 15 / 30 ips. Depending on the configuration either the slowest or the fastest speed is not available.
- The inputs and outputs are balanced and floating, with input/output transformers.
- Either with selector switch for two tape types with different calibration data, or with selector switch for NAB/CCIR equalization.
- Zero locator and transfer locator for up to 3 addresses as standard features.
- Dolby HX PRO noise reduction system as standard feature.
- Equipped with varispeed (variable tape speed).
- Keys for input and output selection on models equipped with VU meters:
Input selection: MIC ON (microphone input; this input does not exist on units equipped with external instrument panel); LINE ON (line input). The microphone inputs are always equipped with a 48 V phantom power (changeover to 24 or 12 V possible). Output selection: INPUT, REPRO, and SYNC (reproduction via record head).

- VU-meter panel with input and output selection keys, level potentiometer for recording.
- Adjustable for line voltages of 100 to 140 V / 200 to 240 VAC, $\pm 10\%$, 50...60 Hz.
- Can be remote controlled from a terminal or personal computer via an RS232 interface.
- Connection facilities for fader start circuit, parallel and serial remote control.

High operating convenience afforded by microprocessor control:

- The last operating state is saved when the machine is switched off: tape counter, locator addresses, tape speed, setting of the input and output selectors. The STOP mode is automatically activated when the machine is powered on again.
- Drop in by pressing only the REC key in play mode (internally programmable)
- Drop out by pressing PLAY during a recording.
- Reduced spooling speed (LIBRARY WIND):
A lower spooling speed can be selected for producing pancakes that are to be saved in the library.
- REVERSE PLAY
- TAPE DUMP (waste basket mode with disabled take-up motor).
- LAP TIME (second time level for measuring individual tape segments without influencing the main tape counter).
- Adjustment of the audio parameters and setting of "soft jumpers" via the keyboard.
- LOC START positions the magnetic tape automatically at the address at which the last play or record command (for standstill) was entered.

The following options are available:

- Mono/stereo switch with or without test generator (60, 125 Hz, 1, 10, 16 kHz).
- Tape scissors and tape marker as well as a headblock cover plate with integrated scissors/splicing block.
- Additional splicing block for units without VU-meter.
- Synchronizer interface.

1.2 STANDARD VERSIONS**1.2.1 Full-track versions A807-1****A807-1**

Order No. 60.116.07011

- Machine for 1/4" tape
- Mono with full-track erase head.
- Without channel control.
- Monitor speaker built into tape deck cover.
- Maximum reel diameter 282 mm (11.1").
- Three tape speeds (3.75 / 7.5 / 15 ips).
- Varispeed (variable tape speed).
- Chassis version.

A807-1 VU

Order No. 60.116.07012

- Machine for 1/4" tape.
- Mono with full-track erase head.
- With channel control.
- Microphone input with phantom power
- Monitor speaker built into tape deck cover.
- VU-meter with input level potentiometer integrated in the operator panel
- Maximum reel diameter 282 mm (11.1").
- Three tape speeds (3.75 / 7.5 / 15 ips).
- Varispeed (variable tape speed).
- Chassis version.

A807-1 VUK *

Order No. 60.116.07013

- Machine for 1/4" tape.
- Mono with full-track erase head.
- With channel control.
- Monitor speaker and VU-meter with an input level potentiometer and channel control as well as output level potentiometer built into the instrument panel.
- Maximum reel diameter 282 mm (11.1").
- Three tape speeds (3.75 / 7.5 / 15 ips).
- Varispeed (variable tape speed).
- Console version.

A807-1 VUK HS *

Order No. 60.116.07015

- Machine for 1/4" tape.
- Mono with full-track erase head.
- With channel control.
- Monitor speaker and VU-meter with input level potentiometer and channel control as well as output level potentiometer built into the instrument panel.
- Maximum reel diameter 282 mm (11.1").
- Three tape speeds (7.5 / 15 / 30 ips).
- Varispeed (variable tape speed).
- Console version.

A807-1 VU PBO

Order No. 60.116.07017

- Machine for 1/4" tape.
- Mono, reproduce-only (recording electronics not retrofittable).
- Without channel control.
- Monitor speaker built into tape deck cover.
- VU-meter and output level potentiometer integrated in operator panel.
- Maximum reel diameter 282 mm (11.1").
- Three tape speeds (3.75 / 7.5 / 15 ips).
- Varispeed (variable tape speed).
- Chassis version.

1.2.2 Stereo versions A807-0.75**A807-0.75**

Order No. 60.116.07021

- Machine for 1/4" tape.
- Stereo with 0.75 mm track separation, full-track erase head.
- Without channel control.
- Monitor speaker built into tape deck cover.
- Maximum reel diameter 282 mm (11.1").
- Three tape speeds (3.75 / 7.5 / 15 ips).
- Varispeed (variable tape speed).
- Chassis version.

A807-0.75 VU

Order No. 60.116.07022

- Machine for 1/4" tape.
- Stereo with 0.75 mm track separation, overlapping erasure.
- Microphone input with phantom power.
- Monitor speaker built into tape deck cover.
- VU-meter with input level potentiometer and channel control as well as output level potentiometer built into the operator panel.
- Maximum reel diameter 282 mm (11.1").
- Three tape speeds (3.75 / 7.5 / 15 ips).
- Varispeed (variable tape speed).
- Chassis version.

A807-0.75 VUK *

Order No. 60.116.07024

- Machine for 1/4" tape.
- 2-Track/stereo with 0.75 mm track separation, overlapping erasure.
- Monitor speaker and VU-meter with input level potentiometer and channel control as well as output level potentiometer built into the instrument panel.
- Maximum reel diameter 282 mm (11.1").
- Three tape speeds (3.75 / 7.5 / 15 ips).
- Varispeed (variable tape speed).
- Console version.

A807-0.75 VUK HS *

Order No. 60.116.07025

- Machine for 1/4" tape.
- 2-Track/stereo with 0.75 mm track separation, overlapping erasure.
- Monitor speaker and VU-meter with input level potentiometer and channel control as well as output level potentiometer built into the instrument panel.
- Maximum reel diameter 282 mm (11.1").
- Three tape speeds (7.5 / 15 / 30 ips).
- Varispeed (variable tape speed).
- Console version.

A807-0.75 PBO

Order No. 60.116.07026

- Machine for 1/4" tape.
- Stereo with 0.75 mm track separation, reproduce-only (recording electronics not retrofittable).
- Without channel control.
- Monitor speaker built into tape deck cover.
- Maximum reel diameter 282 mm (11.1").
- Three tape speeds (3.75 / 7.5 / 15 ips).
- Varispeed (variable tape speed).
- Chassis version.

A807-0.75 VU PBO

Order No. 60.116.07027

- Machine for 1/4" tape.
- Stereo with 0.75 mm track separation, reproduce-only (recording electronics not retrofittable).
- Without channel control.
- Monitor speaker built into tape deck cover.
- VU-meter with output level potentiometer integrated in operator panel.
- Maximum reel diameter 282 mm (11.1").
- Three tape speeds (3.75 / 7.5 / 15 ips).
- Varispeed (variable tape speed).
- Chassis version.

A807-0.75/4 VU

Order No. 60.116.07054

- Machine for 1/4" tape.
- 2-Track/stereo with 0.75 mm track separation, overlapping erasure.
- Second reproduce head for 1/4 track format.
- Microphone input with phantom power.
- Monitor speaker built into tape deck cover.
- VU-meter with input level potentiometer and channel control as well as output level potentiometer built into operator panel.
- Maximum reel diameter 282 mm (11.1").
- Three tape speeds (3.75 / 7.5 / 15 ips).
- Varispeed (variable tape speed).
- Chassis version.

A807-0.75/4 VUK *

Order No. 60.116.07052

- Machine for 1/4" tape.
- 2-Track/stereo with 0.75 mm track separation, overlapping erasure.
- Second reproduce head for 1/4 track format.
- Monitor speaker and VU-meter with input level potentiometer and channel control as well as output level potentiometer built into instrument panel.
- Maximum reel diameter 282 mm (11.1").
- Three tape speeds (3.75 / 7.5 / 15 ips).
- Varispeed (variable tape speed).
- Console version.

1.2.3 Two-track versions**A807-2****A807-2 F**

Order No. 60.116.07030

- Machine for 1/4" tape.
- 2-Track/stereo with 2 mm track separation, full-track erase head.
- Without channel control.
- Monitor speaker built into tape deck cover.
- Maximum reel diameter 282 mm (11.1").
- Three tape speeds (3.75 / 7.5 / 15 ips).
- Varispeed (variable tape speed).
- Chassis version.

A807-2/2

Order No. 60.116.07031

- Machine for 1/4" tape.
- 2-Track/stereo with 2 mm track separation, overlapping erasure.
- With channel control, without VU-meter and input/output level potentiometers.
- Monitor speaker built into tape deck cover.
- Maximum reel diameter 282 mm (11.1").
- Three tape speeds (3.75 / 7.5 / 15 ips).
- Varispeed (variable tape speed).
- Chassis version.

A807-2/2 VU

Order No. 60.116.07032

- Machine for 1/4" tape.
- 2-Track/stereo with 2 mm track separation, overlapping erasure.
- Microphone input with phantom power.
- Monitor speaker built into tape deck cover.
- VU-meter with input level potentiometers and channel control as well as output level potentiometer integrated in the operator panel.
- Maximum reel diameter 282 mm (11.1").
- Three tape speeds (3.75 / 7.5 / 15 ips).
- Varispeed (variable tape speed).
- Chassis version.

A807-2/2 VUK *

Order No. 60.116.07034

- Machine for 1/4" tape.
- 2-Track/stereo with 2 mm track separation, overlapping erasure.
- Monitor speaker and VU-meter with input level potentiometer and channel control as well as output level potentiometer built into the instrument panel.
- Maximum reel diameter 282 mm (11.1").
- Three tape speeds (3.75 / 7.5 / 15 ips).
- Varispeed (variable tape speed).
- Console version.

A807-2/2 VUK HS *

Order No. 60.116.07065

- Machine for 1/4" tape.
- 2-Track/stereo with 2 mm track separation, overlapping erasure.
- Monitor speaker and VU-meter with input level potentiometer and channel control as well as output level potentiometer built into the instrument panel.
- Maximum reel diameter 282 mm (11.1").
- Three tape speeds (7.5 / 15 ips / 30 ips).
- Varispeed (variable tape speed).
- Console version.

A807-2

Order No. 60.116.07033

- Machine for 1/4" tape.
- Stereo with 2 mm track separation, overlapping erasure.
- Without channel control.
- Monitor speaker built into tape deck cover.
- Maximum reel diameter 282 mm (11.1").
- Three tape speeds (3.75 / 7.5 / 15 ips).
- Varispeed (variable tape speed).
- Chassis version.

A807-2 PBO

Order No. 60.116.07036

- Machine for 1/4" tape.
- Stereo with 2 mm track separation, reproduce-only (recording electronics not retrofittable)
- Without channel control.
- Monitor speaker built into tape deck cover.
- Maximum reel diameter 282 mm (11.1").
- Three tape speeds (3.75 / 7.5 / 15 ips).
- Varispeed (variable tape speed).
- Chassis version.

A807-2 VU PBO

Order No. 60.116.07037

- Machine for 1/4" tape.
- Stereo with 2 mm track separation, reproduce-only (recording electronics not retrofittable)
- Without channel control.
- Monitor speaker built into tape deck cover.
- VU-meter with output level potentiometer built into tape deck cover.
- Maximum reel diameter 282 mm (11.1").
- Three tape speeds (3.75 / 7.5 / 15 ips).
- Varispeed (variable tape speed).
- Chassis version.

A807-2/4 VU

Order No. 60.116.07053

- Machine for 1/4" tape.
- Stereo with 2 mm track separation, overlapping erasure.
- Second reproduce head for 1/4-track format.
- Microphone input with phantom power.
- Monitor speaker built into tape deck cover.
- VU-Meter with input level potentiometers and channel control as well as output level potentiometer integrated in the operator panel.
- Maximum reel diameter 282 mm (11.1").
- Three tape speeds (3.75 / 7.5 / 15 ips).
- Varispeed (variable tape speed).
- Chassis version.

A807-2/4 VUK *

Order No. 60.116.07051

- Machine for 1/4" tape.
- 2-Track/stereo with 2 mm track separation, overlapping erasure.
- Second reproduce head for 1/4-track format.
- Monitor speaker and VU-meter with input level potentiometer and channel control as well as output level potentiometer built into the instrument panel.
- Maximum reel diameter 282 mm (11.1").
- Three tape speeds (3.75 / 7.5 / 15 ips).
- Varispeed (variable tape speed).
- Console version.

**1.2.4 1/4-Track,
2-channel versions A807-4/2**

A807-4/2 VU

Order No. 60.116.07038

- Machine for 1/4" tape.
- 1/4-Track format, 2-track/stereo, with 1/4-track erasure.
- Microphone input with phantom power.
- Monitor speaker built into tape deck cover.
- VU-meter with input level potentiometer and channel control as well as output level potentiometer integrated in the operator panel.
- Maximum reel diameter 282 mm (11.1").
- Three tape speeds (3.75 / 7.5 / 15 ips).
- Varispeed (variable tape speed).
- Chassis version.

A807-4/2 VUK

Order No. 60.116.07039

- Machine for 1/4" tape.
- 1/4-Track format, 2-track/stereo, with 1/4-track erasure.
- Monitor speaker and VU-meter with input level potentiometer and channel control as well as output level potentiometer built into the instrument panel.
- Maximum reel diameter 282 mm (11.1").
- Three tape speeds (3.75 / 7.5 / 15 ips).
- Varispeed (variable tape speed).
- Console version.

*** Notes**

On request, special instrument panels for 19" rack mounting (in place of the wooden side panels) are available for all VUK versions. The rack mounting brackets 1.727.071.00 must be ordered in this case.

1.3 OPTIONS

Tape scissors

Order No. 20.807.894.00

- Kit for all versions except:
A807-2/4; A807-2/4 VUK; A807-0.75/4 VU; A807-0.75/4 VUK.

Tape marker

Order No. 20.807.896.00

- Kit for all versions.

Tape scissors and tape marker

Order No. 20.807.895.00

- Kit for all versions except:
A807-2/4; A807-2/4 VUK; A807-0.75/4 VU; A807-0.75/4 VUK.

cutting/splicing block

Order No. 20.807.173.00

- For installation on the operator panel.
- For versions with VU-meters installed in the instrument panel or for versions without VU-meter.

Cutting/splicing block

Order No. 20.807.172.00

- Headblock cover designed as a cutting/splicing block. For all versions.

Mono/stereo switch

Order No. 20.807.176.00

- For all record/reproduce versions.

Mono/stereo switch with test generator

Order No. 20.807.174.00

- For all versions. With built-in booster amplifier for 10 and 20 dB and test generator (60, 125 Hz; 1, 10, 6 kHz).

Mono/stereo switch for (PBO) reproduce-only versions

Order No. 20.807.168.00

- For all (PBO) reproduce only versions.

12 V Phantom power conversion kit (instead of 48V)

Order No. 20.807.175.00

- For all versions with balanced microphone input.

Synchronizer control port

Order No. 20.807.177.00

- Kit for all versions.

Penthouse with stereo monitor

Order No. 20.807.171.00

- For all versions without instrument panel.
- Contains: Stereo monitor speaker, volume control and source selector for input, reproduce, and auxiliary input signal. Including wiring and connection components. Only installable on consoles with penthouse (20.020.205.05/.15).

Reel shelf

Order No. 21.811.560.00

- Serves as a storage area; in place of the penthouse. Only installable on consoles suitable for penthouse (20.020.205.05/.15).

1.4 ACCESSORIES AND SERVICE AIDS**1.4.1 Standard accessories**

Order No. 20.020.302.32

1	Power cord 2.5 m, EURO connector	10.223.001.01
1	Set of audio connectors, XLR (per channel)	20.020.302.02
1	Allen screwdriver 2.0 mm	26.06.1020
1	Allen screwdriver 2.5 mm	10.258.003.09
1	Allen screwdriver 3.0 mm	10.258.003.10
1	Allen screwdriver 4.0 mm	26.06.1040
5	Fuses 5x20 mm, 1.0 A SLOW	51.01.0117
5	Fuses 5x20 mm, 1.6 A SLOW	51.01.0119
5	Fuses 5x20 mm, 2 A SLOW	51.01.0120
5	Fuses 5x20 mm, 3.15 A SLOW	51.01.0122
5	Fuses 5x20 mm, 4 A SLOW	51.01.0123
2	VU-meter bulbs 6 V/30 mA	51.02.0144
1	Label set	1.727.100.58

1.4.2 Consoles

A807 consoles are supplied assembled with wooden side panels, tilt mechanism, and lockable casters. Working height: 840 mm

Consoles with penthouse

■	With traverse	Order No. 20.020.205.05
■	With 19" rack base for three 19" modules with a height of 40.58 mm each.	Order No. 20.020.205.15

Consoles without penthouse

■	With traverse	Order No. 20.020.205.25
■	With 19" rack base for three 19" modules with a height of 40.58 mm each.	Order No. 20.020.205.35

19" Rack base

■	Retrofit kit for three 19" modules with a height of 40.58 mm each.	Order No. 1.058.057.00
---	--	------------------------

Blanking panels for rack base

Aluminum, transparent anodization:

■	1 Unit high	Order No. 1.918.001.00
■	2 Units high	Order No. 1.918.002.00
■	3 Units high	Order No. 1.918.003.00

1 Height unit = 40.58 mm

Aluminum, grey lacquering:

■	1 Unit high	Order No. 1.918.011.00
■	2 Units high	Order No. 1.918.012.00
■	3 Units high	Order No. 1.918.013.00

1 Height unit = 40.58 mm

Screws for rack mounting:

■	M6 x 12	Order No. 21.99.0164
■	M6 x 16	Order No. 21.99.0167
■	M6 washers	Order No. 23.99.0121

1.4.3 Remote controls

■ **Parallel tape deck control** in desktop housing, with 15 m cable.

Order No. 20.820.366.00

■ **Varispeed kit** for installation in desktop housing of the parallel tape deck remote control, with connection cable

Order No. 21.328.253.00

■ **25-Pin connector**, type D, for installation in desktop housing of the parallel remote control. (Through-connection of the remote control signals for a second remote control terminal).

Order No. 21.328.254.00

■ **Parallel tape deck control** in STUDER standard module, 1 unit wide, with 15 m cable.

Order No. 20.820.367.00

■ **Parallel varispeed remote control** in STUDER standard module, 1 unit wide, without connection cable.

Order No. 21.328.290.00

■ **Connection cable 0.3 m** for connecting the parallel varispeed remote control module to the parallel tape deck remote control (20.820.367.00)

Order No. 1.023.102.03

■ **Connection cable 15 m** for direct connection of the parallel varispeed remote control module to the A807 tape recorder.

Order No. 1.328.292.00

■ **Parallel varispeed remote control** in STUDER standard module, 1 unit wide, with digital input of the speed deviation and real-time indication in percent or semitones. Without connection cable.

Order No. 10.403.050.00

■ **Connection cable 0.3 m** for connecting the parallel varispeed remote control module (10.403.050.00) to the parallel tape deck remote control (20.820.367.00)

Order No. 1.023.730.00

■ **Connection cable 15 m** for direct connection of the parallel varispeed remote control module (10.403.050.00) to the A807 tape recorder.

Order No. 1.023.731.00

■ **Desktop housing for Studer standard-module remote controls**, for installation of up to 6 STUDER remote controls.

Order No. 1.328.095.00

■ **Blanking panels for desktop housing**

Aluminum, transparent anodization:

■	1 Module wide	Order No. 1.038.341.00
■	2 Modules wide	Order No. 1.038.342.00
■	3 Modules wide	Order No. 1.038.343.00

Aluminum, grey lacquering:

■	1 Module wide	Order No. 1.328.185.00
■	2 Modules wide	Order No. 1.328.186.00
■	3 Modules wide	Order No. 1.328.187.00
■	5 Modules wide	Order No. 1.328.189.00

1.4.4 Remote counters

- Chassis/desktop model incl. 15 m connection cable (for connection to the RS232 interface of the tape recorder).

Order No. 20.020.100.30

Masks, standard module 5 units (190 x 202.9 mm):

- for one remote counter Order No. 1.328.275.31
- for two remote counters Order No. 1.328.275.32
- for three remote counters
Order No. 1.328.275.33

Connectors for remote Control ports

No connectors are needed for STUDER remote controls.

- Serial Order No. 20.020.303.07
- Parallel Order No. 20.020.303.16
- Synchronizer Order No. 20.020.303.15

1.4.5 Adapters and tape reels

- NAB reel adapter with control grip
Order No. 1.013.332.00
- NAB reel adapter, standard
Order No. 89.01.0354
- NAB metal reel, 1/4", without tape
Order No. 10.213.001.01
- DIN open-reel hub
Order No. 10.200.003.01
- DIN open-reel pancake platter
Order No. 1.013.046.00

1.4.6 Aids**STUDER tape splicing kit**

Comprising a cutting and editing block, one antimagnetic cutting blade, splicing tabs, and a grease pen for marking the tape.

Order No. 10.030.452.40

STUDER cleaning kit in carrying case

Contains 1 bottle of head cleaner, 1 bottle of aluminite cleaner, lint-free nonwoven fleece squares, and a piece of buckskin.

Order No. 10.496.010.00

Head cleaner:

- Replacement bottle Order No. 10.496.021.00
- 1 litre Order No. 10.496.022.00

Aluminite cleaner:

- Replacement bottle Order No. 10.496.025.00
- 1 litre Order No. 10.496.026.00

Service aids

Tool case (basic kit) with soldering iron and demagnetizing choke for 110 V.

Order No. 20.020.001.20

Tool case (basic kit) with soldering iron and demagnetizing choke for 220 V.

Order No. 20.020.001.21

Supplementary tool kit for A807 tape recorder, including extension cord for the capstan motor (1.727.216.00) and the spooling motors (1.727.217.00)

Order No. 20.020.001.38

Additional manuals

Operating and service instructions:

- English Order No. 10.27.0452
- German Order No. 10.27.1280
- French Order No. 10.27.1290

1.4.7 Accessories**Wooden side panels, transport cover**

Wooden side panels with recessed carrying grips.

Order No. 1.727.070.00

Transport cover, also offers space for two tape reels and the connection cables. (Wooden side panels 1.727.070.00 are required).

Order No. 1.727.074.00

Carrying case

Made of aluminum, extremely sturdy, requires rack mounting kit (1.727.071.00). The tape recorder can be operated directly when the lid is opened.

Order No. 10.386.001.01

Rack mounting kit

Contains two mounting brackets and mounting accessories for installing an A807 into a 19" rack. This kit is not required for STUDER consoles.

Order No. 1.727.071.00

Handrest and wooden side panels

Wooden side panels with handrest made of leather, for operating the tape recorder on a desk top.

Order No. 1.727.072.00

1.5 TECHNICAL DATA**Spooling motors:**

Two direct driving external-rotor AC asynchronous motors with active 3-phase control, controlled frequency correction, and switched motor output stages.

Capstan motor:

Brushless DC motor with Hall element commutation

Tape deck control:

Via microprocessor, for all functions and function transitions.

Tape counters:

5-Position LED indication in hours, minutes, and seconds at all tape speeds, from zero in reverse direction with negative sign, decrementing.
Range: -9 h 59 min 59 s ... 29 h 59 min 59 s

Starting time:

At 15 ips tape speed, 1000 m tape with DIN hub or 762 m (2500 ft) tape with NAB reel (for reaching 200% of the specified wow-and-flutter rating)

approx. 0.8 s

Winding time:

for 760 m tape <90 s
for 1000 m tape <120 s

Braking times:

from winding speed approx. 3 s

Winding at reduced speeds:

LIBRARY WIND mode approx. 5 m/s

Tape reels:

Max. reel diameter 11,1" / 282 mm
Min. hub diameter, left 1.8" / 45 mm
Min. hub diameter, right 2.4" / 60 mm
Reel adapter NAB/DIN, Ciné, 3-prong
The maximum pancake capacity with professional magnetic tape (thickness 50 µm) is 3280 ft / 1000 m

Tape width: 1/4" / 6.3 mm

Tape speeds:**Normal versions:**

Switch-selectable: cm/s 38.1 19.05 9.525
ips 15 7.5 3.75

HS versions:

Switch-selectable: cm/s 76.2 38.1 19.05
ips 30 15 7.5

Tape speed deviation: max. ±0.2%

Varispeed:

Variable tape speed in semitones (ST)

3.75 ips +7...-1.5 ST
7.5 ips +7...-7 ST
15 ips +7...-7 ST
30 ips +7...-7 ST

Wow and flutter:

Peak value weighted, according to DIN 45507 or IEC publ. 386. Ambient air temperature 0...+40°C
Nominal tape speeds.

3.75 ips ±0.10%
7.5 ips: 0.07%
15 ips: 0.05%
30 ips: 0.05%

Tape slip: Max. 0.1%

Tape tension:

Controlled in all tape transport functions, measured with spring dynamometer, in record and play mode. Factory setting based on horizontal operating position.

Nominal: 0.7 N (70 p)
Adjustable: 0.5...1.8 N

Line inputs:

Via transformer, balanced, floating

Input impedance 30 Hz ... 20 kHz ≥10 kΩ

Input levels:

- NAB:
 - For operating level (0 VU) +4 dBu
 - Internally adjustable -30 ... +12 dBu
- CCIR:
 - For peak level (0 VU + 6 dB) +6 dBu
 - Internally adjustable -24 ... +18 dBu
- UNCAL: (for versions with VU meters and input/output level potentiometers)
 - Max. increase of the input sensitivity 10 dB
 - Max. admissible input level +24 dBu

Internal adjustment range of the working magnetic flux with the above input levels:
100 ... 1000 nWb/m

Microphone inputs:

Via transformer, balanced, floating

Input impedance: >1.2 kΩ

Input level:

Without attenuator (max. -26 dBu) -82 dBu
 With attenuator (max. 2.6 dBu/1 kHz) -54 dBu
 0 dBu/40 Hz)

Noise factor:

Rq = 200 Ω <5 dB

Phantom power: (convertible to +12 V) +48 V

Output meters:

VU versions: VU-meter
 LED peak program meter: 0 VU +6 / +9 / +12 dBu
 Indication 0 dB at: 0 VU

Line outputs:

Via transformer, balanced, floating
 Source impedance: <50 Ω

Output level:

- NAB
 For operating level (0 VU, into 600 Ω load + 4 dBu Internally adjustable -17 ... +12 dBu
- CCIR:
 For peak level (+ 6 dB) into 600 Ω load + 6 dBu
 Internally adjustable -11 ... + 18 dB
- UNCAL: (for versions with VU meters and input/output level potentiometers).
 Max. increase of the reproduce gain 10 dB
 Max. output level into 600 Ω load +24 dBu
 into 200 Ω load +22 dBu

Internal adjustment range of the reproduce gain
 for working magnetic flux of 100 ... 1000 nWb/m

Headphones output:

Short-circuit-proof, RL > 600 Ω / Ri = 220 Ω
 max. 5.0 V

Monitor speaker: max. 0.7 W

Equalizations:

Switch-selectable CCIR / NAB

Equalization time constants:

	9.5 cm/s 3.75 ips	19 cm/s 7.5 ips	38 cm/s 15 ips	76 cm/s 30 ips
CCIR	90/3180 μs	70/ μs	35/ μs	17.5/ μs
NAB	90/3180 μs	50/3180 μs	50/3180 μs	17.5/ μs

Frequency response, record/reproduce mode:

	9.5 cm/s 3.75 ips	19 cm/s 7.5 ips	38 cm/s 15 ips	76 cm/s 30 ips
±2dB	30Hz..12kHz	30Hz..16kHz	30Hz..20kHz	
±1dB	30Hz.. 8kHz	30Hz..12kHz	50Hz..18kHz	

Frequency response, clock track reproduction

	9.5 cm/s 3.75 ips	19 cm/s 7.5 ips	38 cm/s 15 ips	76 cm/s 30 ips
±2dB	40Hz..6kHz	40Hz..10kHz	40Hz..12kHz	40Hz..12kHz

Signal-to-noise ratio, record/reproduce mode:**CCIR:**

Equalization according to CCIR, measured with tape type AGFA PER528, BASF LGR50 or equivalent tape.

- Full track, 6.3 mm track width:

	9.5 cm/s 3.75 ips	19 cm/s 7.5 ips	38 cm/s 15 ips	76 cm/s 30 ips
nWb/m	250	320	320	320
unweighted according to CCIR468-II	57 dB	61 dB	61 dB	
weighted according to CCIR468-II	49 dB	51 dB	52 dB	
weighted according to ASA-A (IEC179)	62 dB	64 dB	65 dB	

- Stereo 2.75 mm track width:

	9.5 cm/s 3.75 ips	19 cm/s 7.5 ips	38 cm/s 15 ips	76 cm/s 30 ips
nWb/m	400	510	510	510
unweighted according to CCIR468-II	57 dB	61 dB	62 dB	
weighted according to CCIR468-II	49 dB	51 dB	53 dB	
weighted according to ASA-A (IEC179)	62 dB	65 dB	66 dB	

■ 2-Track, 2 mm track width:

	9.5 cm/s 3.75 ips	19 cm/s 7.5 ips	38 cm/s 15 ips	76 cm/s 30 ips
nWb/m	400	510	510	510
unweighted according to CCIR468-II	56 dB	60 dB	61 dB	
weighted according to CCIR468-II	48 dB	50 dB	52 dB	
weighted according to ASA-A (IEC179)	61 dB	64 dB	65 dB	

NAB:

Equalization according to NAB, measured with magnetic tape SCOTCH 3M 226 or equivalent type.

■ Full track, 6.3 mm track width:

	9.5 cm/s 3.75 ips	19 cm/s 7.5 ips	38 cm/s 15 ips	76 cm/s 30 ips
nWb/m	510	1040	1040	1040
Linear, RMS, 30 Hz...20 kHz	62 dB	72 dB	71 dB	
RMS value ASA-A weighted according to DIN 45633; IEC 179	66 dB	76 dB	74 dB	

■ Stereo, 2.75 mm track width:

	9.5 cm/s 3.75 ips	19 cm/s 7.5 ips	38 cm/s 15 ips	76 cm/s 30 ips
nWb/m	510	1040	1040	1040
Linear, RMS, 30 Hz...20 kHz	57 dB	69 dB	67 dB	
RMS value, ASA-A weighted, according to DIN 45633; IEC 179	62 dB	72 dB	71 dB	

■ 2-Track, 2 mm track width:

	9.5 cm/s 3.75 ips	19 cm/s 7.5 ips	38 cm/s 15 ips	76 cm/s 30 ips
nWb/m	510	1040	1040	1040
Linear, RMS, 30 Hz...20 kHz	56 dB	68 dB	66 dB	
RMS value, ASA-A weighted, according to DIN 45633; IEC 179	61 dB	72 dB	70 dB	

SYNC:

- All versions:
RMS value, ASA-A (IEC179 / DIN 45633):
Same values as measured with tape
Record - sync - play mode

Harmonic distortion K₃: (RL = 600 Ω)

CCIR:

Peak level, record/reproduce, measured with tape type PER528.

3.75 ips / 315 Hz (400 nWb/m)	≤1.5 %
7.5 ips / 1 kHz (510 nWb/m)	≤1.5 %
15 ips / 1 kHz (510 nWb/m)	≤1.0 %
30 ips / 1 kHz (510 nWb/m)	≤1.0 %

NAB:

Peak level, record/reproduce, measured with tape type 3M226.

3.75 ips / 315 Hz (400 nWb/m)	≤1.0 %
7.5 ips / 1 kHz (510 nWb/m)	≤1.0 %
15 ips / 1 kHz (510 nWb/m)	≤1.0 %
30 ips / 1 kHz (510 nWb/m)	≤1.0 %

Channel separation:

According to DIN 45521, at 15 ips/1 kHz ≥55 dB

Erase depth:

With 2-track erase head, at 15 ips/1 kHz ≥75 dB
With full track erase head,
at 15 ips / 1 kHz ≥78 dB

Erase and bias frequency:

At all tape speeds 153.60 kHz

Power requirements:

Switch-selectable: 100/120/140/200/220/240 V ±10%
50...60 Hz

Power fuse:

100...140 V 3.15 A / 250 V slow
200...240 V 1.60 A / 250 V slow

Power consumption:

Idle	approx. 70 VA
Recording (2 CH)	approx. 150 VA
Fast forward/rewind	approx. 180 VA
Maximum connected load	300 VA

Admissible power failure:

For retaining the operational state max. 100 ms

Parallel interface:

For controlling the tape transport functions, the variable tape speed (varispeed), and the fader start input.

Serial interface:

(RS232) for remote control of all functions.

Ambient temperature range:

Operation: (32...104°F) 0...40°C

Relative humidity:

Noncondensing 20...90%

Operating positions: From horizontal to vertical

Safety standards:

According to IEC recommendation, publication 65, protection category (power filter, power switch, power fuse, power transformer, and voltage selector according to categories I and II).

Weight:

Chassis version approx. 30 kg

1.5.1 Dimensions (in mm)

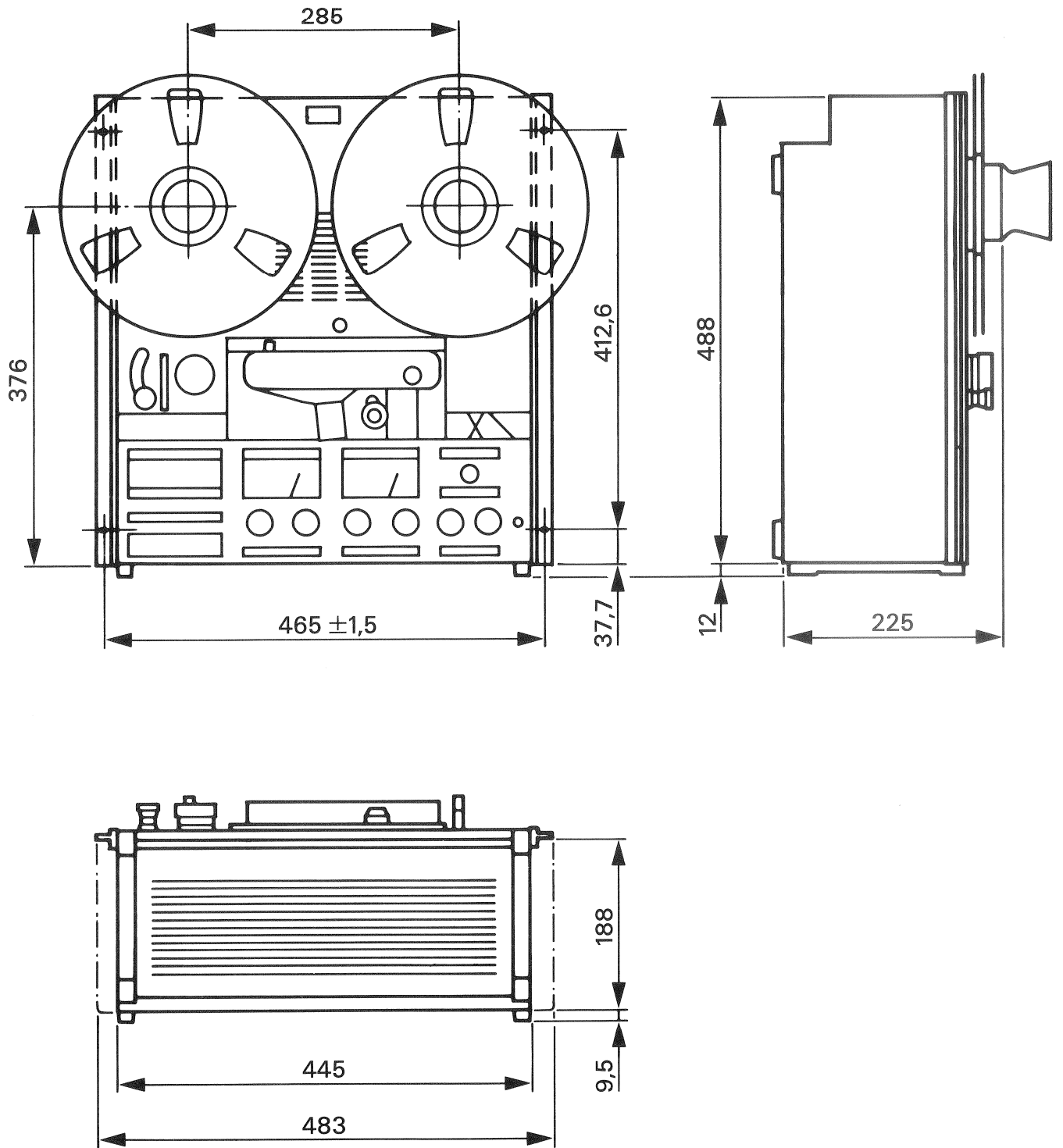
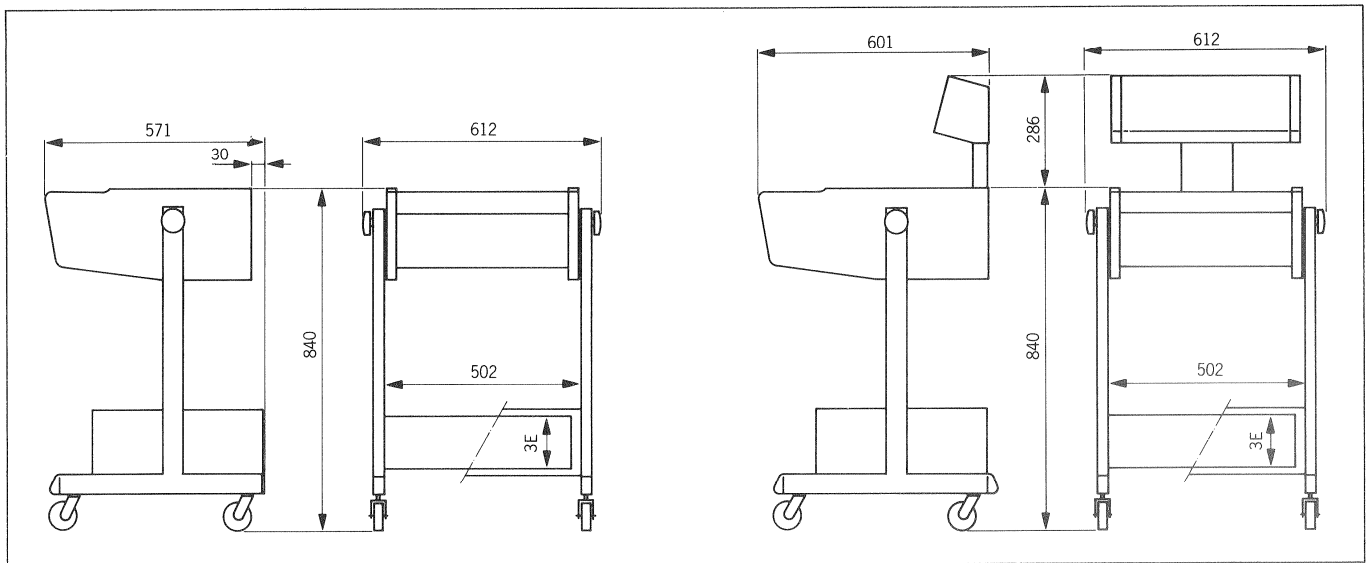

Fig. 1.5.1



1.5.2 Packing

A807 tape recorders with monitor overbridge and "ECO" console

Box for tape recorder: 64x62x46
Box for "ECO" console: 87x67x17
Box for monitor overbridge: 55x25x21

A807-VUK with "ECO" console

Box for tape recorder: 64x62x46
Box for "ECO" console: 87x67x17
Box for VU-meter overbridge: 55x25x21

Gross weight:

Depending on configuration: 32.5 kg - 63.5 kg.

1.6 INSTRUCTIONS FOR SERVICE PERSONNEL

1.6.1 Abbreviations

A	Assembly
ANT	Antenna
B	Bulb
BA	Battery
BR	Optocoupler (bulb --> LDR)
C	Capacitor
D	Diode, DIAC
DL	LED
DLQ	Optocoupler (LED --> phototransistor)
DLR	Optocoupler (LED --> LDR)
DLZ	LED-Array, 7-segment display
DP	Photodiode
DZ	Rectifier
E	Electronic component
EF	Headphones
F	Fuse
FL	Filter
H	Head (audio, erase)
HC	Hybrid circuit (thick/thin film)
HE	Hall element
IC	Integrated circuit
J	Socket (female)
JS	Jumper
K	Relay, contactor
L	Inductor
LS	Loudspeaker
M	Motor
ME	Meter
MIC	Microphone
MP	Mechanical part
P	Connector (male)
PU	pickup
Q	Transistor, FET, Thyristor, TRIAC
QP	Phototransistor
QPZ	Phototransistor array
R	Resistor
RP	Light-sensitive resistor, LDR
RT	Temperature-dependent resistor
RZ	Resistor network
S	Switch
T	Transformer
TL	Delay line
TP	Test point, test socket
W	Wire, stranded wire
X	Base, holder
XB	Lamp base
XF	Fuse holder
XIC	IC socket
Y	Crystal, Piezo-Element
Z	Network, Array

1.6.2 Powers of ten

Designation	Abbreviaton	Value
Tera-	T	10 ¹²
Giga-	G	10 ⁹
Mega-	M	10 ⁶
Kilo-	k	10 ³
Milli-	m	10 ⁻³
Mikro-	μ	10 ⁻⁶
Nano-	n (nμ)	10 ⁻⁹
Pico-	p (pμ)	10 ⁻¹²
Femto-	f	10 ⁻¹⁵

0 = Abbreviation used in the USA

1.6.3 Letters and color codes

Resistors

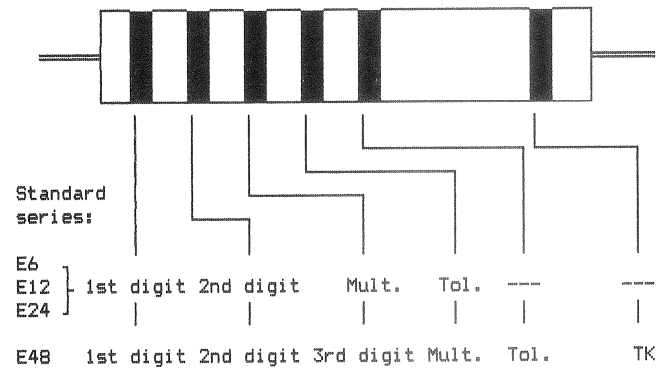

Color	Digit	Multiplier	Tolerance	TK
Gold	-	0.01	5 %	-
Silver	-	0.1	10 %	-
Black	0	1	-	-
Brown	1	10	1 %	100·10 ⁻⁶ /K
Red	2	100	2 %	50·10 ⁻⁶ /K
Orange	3	1 k	-	15·10 ⁻⁶ /K
Yellow	4	10 k	-	25·10 ⁻⁶ /K
Green	5	100 k	0.5 %	-
Blue	6	1 M	0.25 %	-
Violet	7	10 M	0.1 %	-
Grey	8	-	-	-
White	9	-	-	-

No TK designation = 50 · 10⁻⁶/K
 Only 1 black ring = 0 Ω (jumper)

Capacitors:

Frequently, the tolerance is specified by a letter after the printed capacitance:

D	=	0,5 %
F	=	1 %
G	=	2 %
J	=	5 %
K	=	10 %
M	=	20 %

Mould RF coils:

For identifying mould RF coils, a wide silver ring and four narrow rings of different colors are used. The wide silver ring marks the start of the counting direction. The second, third, and fourth ring specify the inductance in Microhenry (μH). The second and the third ring designate the numeric value and the fourth ring is either a multiplier, or if its color is gold, the decimal point. The fifth ring designates the tolerance in percent (\pm).

Color	Digit	Multiplier	Tolerance
Gold	,	-	5 %
Silver	-	-	10 %
Black	0	1	-
Brown	1	10	1 %
Red	2	100	2 %
Orange	3	10^3	-
Yellow	4	10^4	-
Green	5	10^5	0.5 %
Blue	6	10^6	-
Violet	7	10^7	-
Grey	8	10^8	-
White	9	10^9	-
any	-	-	20 %

Example:

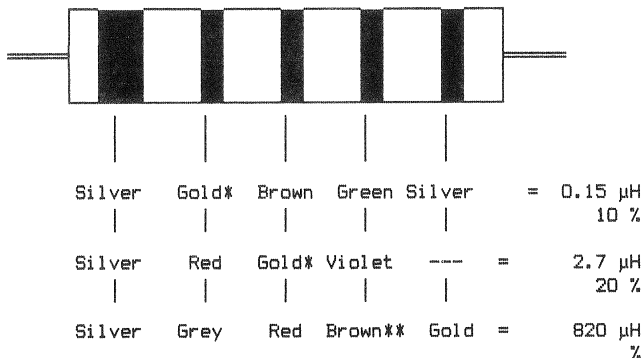

* Decimal point

** Multiplier

Inductors, transformers on ferrite cores:

Inductors and transformers on ferrite cores are marked with three colored dots (color coding same as in the two left-hand columns of the Section "Resistors"). These dots designate the last three digits of the STUDER standard number. The large dot marks the start. The first digits of the Standard-number (10.022.---)

E.g. Driver transformer, 150 kHz.

Standard number: 1.022.211

Color code: red (large dot), brown, brown

Terminal 1 of the winding form is usually identified with a lobe; if not, the winding form is marked with a yellow dot near terminal 1.

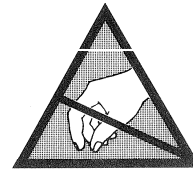
1.6.4 Electrostatically sensitive components

MOS (metal oxide semiconductor) devices are highly sensitive to electrostatic charges. The following precautions should be followed:

1. Electrostatically sensitive components and assemblies ("ESE") are stored and transported in protective packing material. The label shown above is affixed to this protective packing.
2. It is important to avoid any contact of the terminals with plastic bags and foils and other statically chargeable material.
3. Touch the terminals only when your wrist is connected to ground.
4. As a work surface, use a special conductive plastic mat.
5. Never install or unplug printed circuit boards when the tape recorder is switched on! The tape recorder should be switched off for at least 5 seconds before any circuit boards are installed or removed!

TABLE OF CONTENT		SECTION 2
2.	START-UP PROCEDURE, OPERATING	1
2.1	UNPACKING AND CHECKING	1
2.2	INSTALLATION AND SETUP	1
2.2.1	Assembling the console	1
2.3	CONNECTORS	2
2.3.1	Power connection, voltage selector	2
2.3.2	Line inputs and outputs	3
2.3.3	Microphone inputs	3
2.3.4	Remote control socket	4
2.3.5	Headphones socket	5
2.4	OPERATING INSTRUCTIONS	6
2.4.1	Operator controls	6
2.4.2	Power switch [1]	14
2.4.3	Indications at power on time	14
2.4.4	Inserting the tape	14
2.4.5	Tape speeds [64/65/66]	15
2.4.6	Play mode [28]	15
2.4.7	Reverse play mode	15
2.4.8	Varispeed control [64/67]	16
2.4.9	Record mode REC [30]	16
2.4.10	SYNC reproduction SYNC [40/51]	16
2.4.11	Spooling mode < > [26/27]	17
2.4.12	Producing pancakes at reduced spooling speeds, LIBRARY WIND	17
2.4.13	Stop mode STOP [29]	17
2.4.14	Locator Z-LOC, LOC1 (-3 [19-22]	17
2.4.15	Programmable functions	18
2.4.16	Fader start	19
2.4.17	Tape timer [17]	19
2.4.18	Auxiliary timer LAP [15]	19
2.4.19	MONO / INSERT [55]	20
2.4.20	Remote control	20
2.4.21	VU-meter panel	21
2.4.22	External monitor	22
2.4.23	Test generator (option)	22
2.4.24	Editing, cutting the tape	23
2.4.25	"Waste basket mode" TAPE DUMP [25]	23
2.5	PROGRAMMING	25
2.5.1	Fader start mode	26
2.5.2	Programming the audio parameters	26
2.5.3	Programming the soft jumpers	27
2.5.4	Selecting the soft jumper program	28
2.6	SERIAL INTERFACE RS232	29
2.6.1	RS 232 Standard interface	29
2.6.2	RS 232 Interface of the A807	29
2.6.3	Working with the serial interface	29
2.7	CARE INSTRUCTIONS	32

2. START-UP PROCEDURE, OPERATING

2.1 UNPACKING AND CHECKING

The A807 tape recorder is shipped in a special packing that protects the machine from damage in transit. Care should be exercised when unpacking the machine so that its surfaces do not become marred.

Check that the material is complete by comparing the packing content with the shipping list. Save the original packing material because it provides the best protection in case your tape recorder needs to be transported again.

Check all items for possible damage in transit. If you discover any damage, immediately notify the forwarding agent as well as the nearest STUDER dealer.

2.2 INSTALLATION AND SETUP

The A807 should be installed in a dust-free and an adequately ventilated environment. The performance data of the tape recorder are guaranteed for an ambient temperature range of 0°C to +40°C with a relative humidity of 20% to 90% (noncondensing). Install the tape recorder in such a way that sufficient space is available all around the machine for unobstructed cooling. Particularly in recessed locations there is a possibility of heat accumulation. When the machine is in operation, the air circulation zone should neither be misused as a storage area nor be obstructed with manuals etc.

The tape recorder must not be installed in the vicinity of strong electromagnetic fields. General sources of interference are: strong load fluctuations on adjacent power circuits, high-power transformers, elevator motors, electrical welding plants, as well as nearby radio and television transmitters.

The rear of the unit should remain readily accessible for service work. When the recorder is installed in a niche, sufficient space should be available for shifting the machine even when the cables are attached.

2.2.1 Assembling the console

The console is shipped in disassembled condition. First the side panels of the console are to be fastened to the traverse (or the base rack) by means of the four large, nickel-plated screws (yellowish) with 5.0 mm hexagon socket heads. The mounting holes are to be covered with the four plastic caps.

Subsequently insert the casters into the holes of the side panels. The two lockable caster wheels should be installed on the longer, front pieces. The height of the caster wheels can be adjusted with the four hexagon-socket (2.5 mm) headless screws. Remove any rack mounting brackets or side panels that may possibly be attached to the recorder. Also remove the skirting on the underside of the recorder.

Install the leather handrest by means of the four smaller, nickel-plated screws (lock washers are installed only with the upper 2 screws).

Fasten each wooden side panel to the recorder by means of four of the shorter burnished screws (hexagon-socket head 4.0 mm). Then suspend the tape recorder in the console and secure it on each side with two long screws.

After the special pan head screws have been unfastened by means of the hexagon socket screw key (5.0 mm), the tape recorder can be tilted around its suspension axis. If frequent adjustment is necessary, the two pan head screws can be replaced with the screws that are fitted with a knob. Ensure that the disc spring washer and the plain washer are reinstalled and aligned in exactly the same sequence (the pin must engage in the hole of the brass disc).

2.3 CONNECTORS

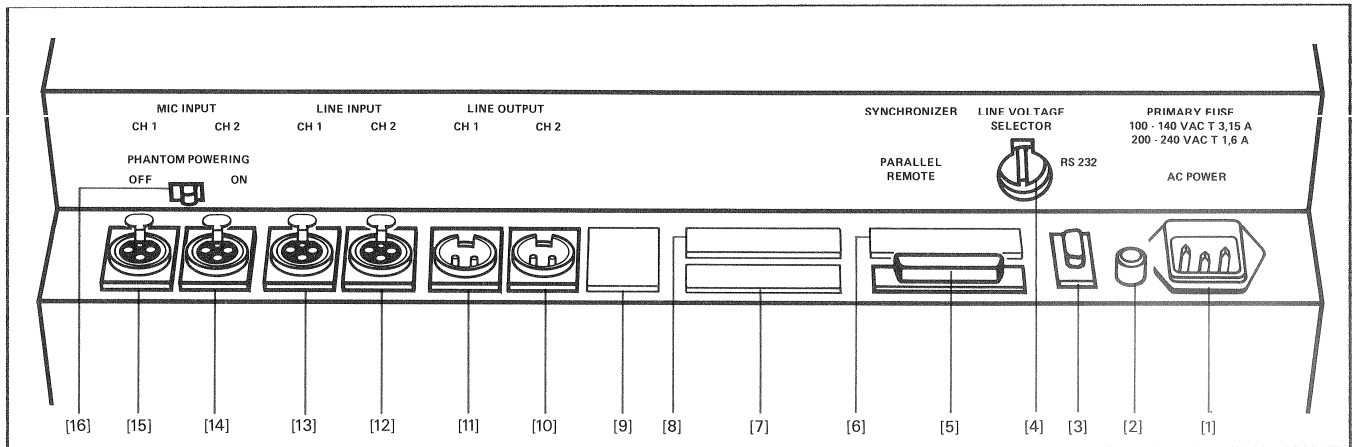

Fig. 2.3.1

- [1] AC POWER Power inlet with primary fuse
- [2] ⏏ Ground socket
- [3] RS 232 Serial interface
- [4] Volt. sel. Line voltage selector
- [5] P.-REMOTE Connector for parallel remote control
- [6] SYNCHRON. Connector for optional synchronizer
- [7] VU PANEL CONTROL Connector for instrument panel (only VUK versions)
- [8] VU PANEL AUDIO Connector for instrument panel (only VUK versions)
- [8] MONITOR PANEL Connector for external monitor for units equipped with monitor panel
- [9] AUX INPUT For units with stereo monitor penthouse an additional auxiliary input (stereo) is available for listening via the monitor speaker.
- [10] LINE OUT Output channel 2
- [11] LINE OUT Output channel 1
- [12] LINE IN Input channel 2
- [13] LINE IN Input channel 1
- [14] MIC IN Microphone input channel 2
- [15] MIC IN Microphone input channel 1
- [16] PHAN.POW. Switches the phantom power on and off.

2.3.1 Power connection, voltage selector

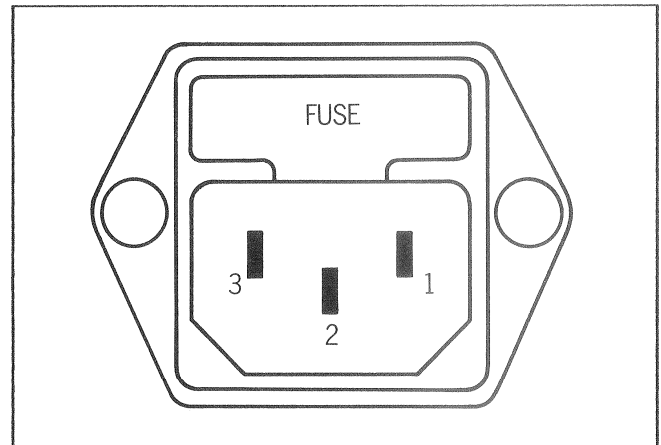

Fig. 2.3.2

- No. 1 Phase ("hot")
- No. 2 Protective ground
- No. 3 Neutral

Important:

Before you connect the recorder to the AC power source for the first time, check that the setting of the line voltage selector [4] agrees with your local line voltage. The following voltages can be set: 100, 120, 140, 200, 220, 240 VAC, ±10%; 50 to 60 Hz.

Disconnect the recorder from the AC outlet before you make any changes! Adjust the line voltage selector [4] with a screwdriver so that the required voltage rating becomes visible through the cutout in the housing.

After the line voltage has been adjusted, the power fuse in the power inlet may possibly have to be replaced with a correctly rated fuse. Lift the cap with the aid of a screw driver. The upper of the two fuses is the spare fuse.

100 V ... 140 VAC: 3.15 A / 250 V (SLOW)
 200 V ... 240 VAC: 1.60 A / 250 V (SLOW)

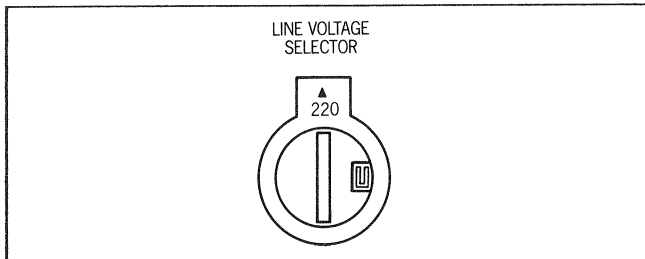

Fig. 2.3.3

2.3.2 Line inputs and outputs

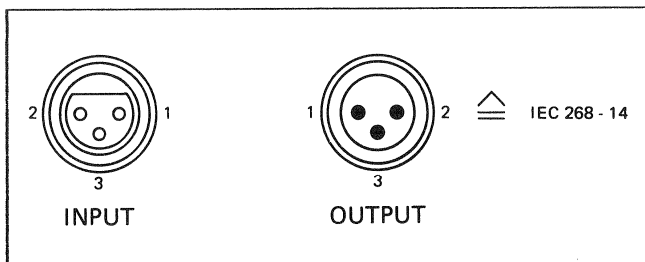

Fig. 2.3.4

The balanced inputs and outputs are terminated on XLR sockets or connectors (described in the IEC recommendation 268-14).

- No. 1 Audio ground
- No. 2 A-line ("hot")
- No. 3 B-line ("cold") *

* For asymmetrical wiring conductor 3 and 1 must be linked.

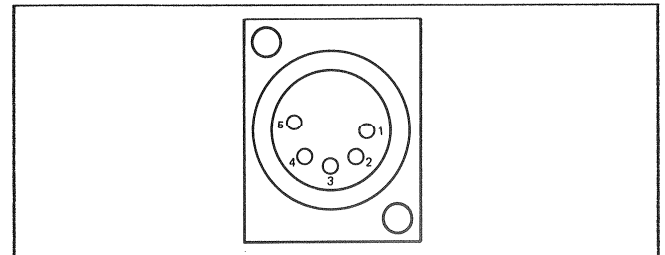

Fig. 2.3.5

The unbalanced AUX INPUT on tape recorders equipped with a stereo monitor penthouse is terminated on a 5-pin XLR connector.

- No. 1 Audio ground
- No. 2 CH1; A-line ("hot")
- No. 3 CH1; B-line ("cold")
- No. 4 CH2; A-line ("hot")
- No. 5 CH2; B-line ("cold")

2.3.3 Microphone inputs

The balanced MIC inputs are terminated on XLR sockets (described in the IEC recommendation 268-14).

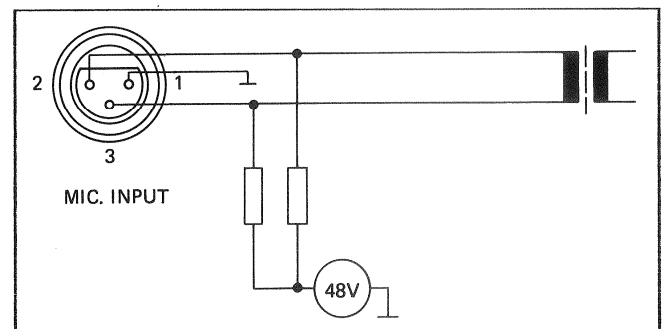

Fig. 2.3.6

- No. 1 Audio ground
- No. 2 A-line ("hot")
- No. 3 B-line ("cold")*

* For asymmetrical wiring conductor 3 and 1 must be linked.

The microphone phantom power (48 V or optionally 12V) can be enabled or disabled with switch [16].

2.3.4 Remote control socket

Parallel remote control connector

A parallel remote control with the following capabilities can be connected to this 25-pin connector (female, type D):

- Remote control of the tape transport functions with feedback (<, >, PLAY, STOP, REC).
- RESET TIMER (resets the tape timer to 00.00.00).
- ZERO LOC (automatically searches the tape timer address 00.00.00).
- LOC START (automatically searches the tape address at which the last PLAY or RECORD command was entered).
- LIFTER (disables the tape lifter in spooling mode).
- FADER (enables the fader start circuit).
- VARISPEED (variable tape speed).

Connector set Part No. 20.020.303.16
 Connector housing, 25-pin Part No. 54.13.7022
 Connector, 25-pin, coded Part No. 10.217.001.06

Pin assignment of the PARALLEL REMOTE connector:

Pin	Signal name	Designation
01	+ 0.0	Ground (GND, 0 V)
02	BR-REW *	Status indicator lamp REWIND
03	BR-FORW *	Status indicator lamp FORWARD
04	BR-VRSPD *	Status indicator lamp VARISPEED (alternatingly LOW and HIGH, when active)
05	SR-VRSPD -	Switch for VARISPEED command
06	SR-FADRY -	Switch for FADER START READY command
07	BR-LOCST *	Status indicator lamp LOC START
08	BR-FADRY *	Status indicator lamp FADER START READY
09	BR-REC *	Status indicator lamp RECORD
10	ST-RESET -	Switch for RESET TIMER command
11	FAD1	Input FADER START command, line A
12	FAD2	Input FADER START command, line B (FADER START is active when 5V to 24V DC or AC are applied across pins 11 and 12)
13	IR-REFEX	Input for external capstan PLL-reference (nominal: 9,6 kHz, TTL level recommended; max. input voltage +10V)
14	SR-OLOC -	Switch for ZERO LOC command
15	BR-PLAY *	Status indicator lamp PLAY
16	BR-STOP *	Status indicator lamp STOP
17	SR-LIFT -	Switch for LIFTER command
18	SR-LOCST -	Switch for LOC START command
19	SR-REC -	Switch for RECORD command
20	SR-REW -	Switch for REWIND command
21	SR-FORW -	Switch for forward COMMAND
22	SR-PLAY -	Switch for PLAY command
23	SR-STOP -	Switch for STOP command
24	KEY	Connector coding
25	+ 24VRMT	+24V supply (max. 300 mA)

* Open collector output, active LOW. No internal pull-up resistor. Maximum HIGH level +30 V, maximum current 200 mA.

- Switch input. LOW level activates the command. Internal pull-up resistor, 3.3 kΩ to +24 V. Maximum HIGH level = +30 V.

Logical levels: LOW = 0 V to +7,5 V; HIGH = +12 V to +30 V.

Connector for external synchronizer

A 25-pin connector (female, type D) is available for connecting an external synchronizer.

Connector set Part No. 20.020.303.15
 Connector housing, 25-pin Part No. 54.13.7022
 Connector 25-pin, coded Part No. 10.217.001.05

Pin assignment of the SYNCHRONIZER connector:

Pin	Signal name	Designation
01	+ 0.0	Ground (GND, 0 V)
02	BR-REW *	Status indicator lamp REWIND
03	BR-FORW *	Status indicator lamp FORWARD
04	BR-VRSPD *	Status indicator VARISPEED (alternatingly LOW and HIGH when active)
05	SR-VRSPD -	Switch for VARISPEED command
06		
07	OR-MVCLK *	Output for TAPE MOVE CLOCK signal (16 pulses/s at 7.5 ips, pulse duty factor 50%)
08	KEY	Connector coding
09	BR-REC *	Status indicator lamp RECORD
10	OR-MVDIR *	Output for TAPE MOVE DIRECTION signal (REW. = LOW, FORW. = HIGH).
11	OR-CMCLK *	Output for CAPSTAN MOTOR MOVE CLOCK signal (1200 pulses/s at 7.5 ips)
12	OR-SYENB *	Output for SYNCHRONIZER ENABLE signal (LOW when tape is tensioned and the recorder is operational, HIGH when the tape is not tensioned).
13	IR-REFEX	Input for external capstan PLL reference (nominal: 9.6 kHz, TTL level recommended; max. input voltage +30 V).
14	+ 0.0	Ground (GND, 0 V)
15	BR-PLAY *	Status indicator lamp PLAY
16	BR-STOP *	Status indicator lamp STOP
17	SR-LIFT -	Switch for LIFTER command
18	SR-MUTE -	Switch for MUTE command (no influence on time code channel)
19	SR-REC -	Switch for RECORD command
20	SR-REW -	Switch for REWIND command
21	SR-FORW -	Switch for FORWARD command
22	SR-PLAY -	Switch for PLAY command
23	SR-STOP -	Switch for STOP command
24	KEY	Connector coding
25	+ 24VRMT	+24V supply (max. 300 mA)

* Open collector output, active LOW. No internal pull-up resistor. Maximum HIGH level +30 V, maximum current 200 mA.

- Switch input. LOW level activates the command. Internal pull-up resistor, 3.3 kΩ to +24 V. Maximum HIGH level = +30 V.

Logical levels: LOW = 0 V to +7.5 V; HIGH = +12 V to +30 V.

Connector for RS232 serial interface

A terminal with RS232 interface or a serial remote control unit can be interfaced to this connector.

Connector set Part No. 20.020.303.07

Pin assignment of the RS 232 connector

Pin	Signal name	Designation
01	---	
02	SN-DATA	DATA signal output from transp.
03	---	
04	---	
05	+24VRMT	+24V supply (max. 300 mA)
06	---	
07	---	
08	RCVDATA	Data signal input to transp.
09	0,0 V	GROUND

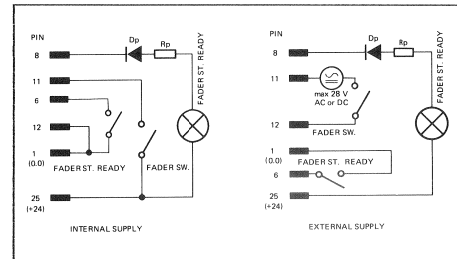

Fig. 2.3.9 Connection diagram, fader start circuit

Important:
When incandescent bulbs are used as status indicator lamps, their surge current must not exceed 0.3 A!

2.3.5 Headphones socket

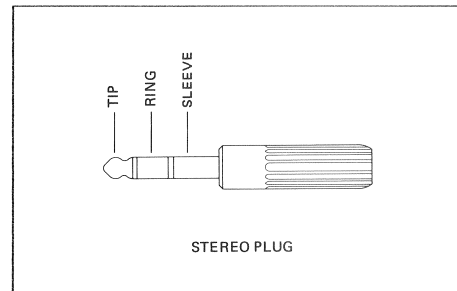

Fig. 2.3.10

TIP = Left-hand channel
RING = Right-hand channel
SLEEVE = Ground

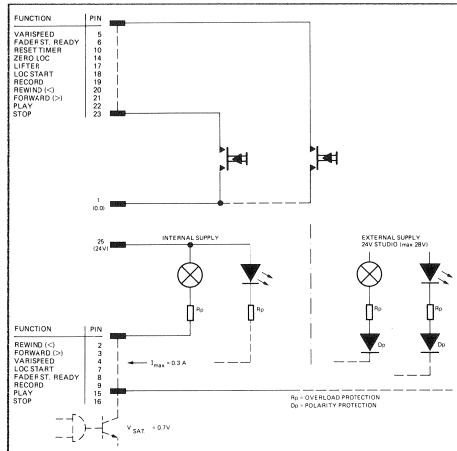

Fig. 2.3.7 Connection diagram, parallel remote control

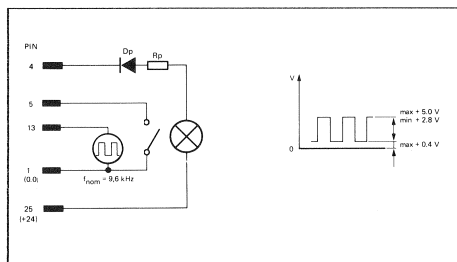
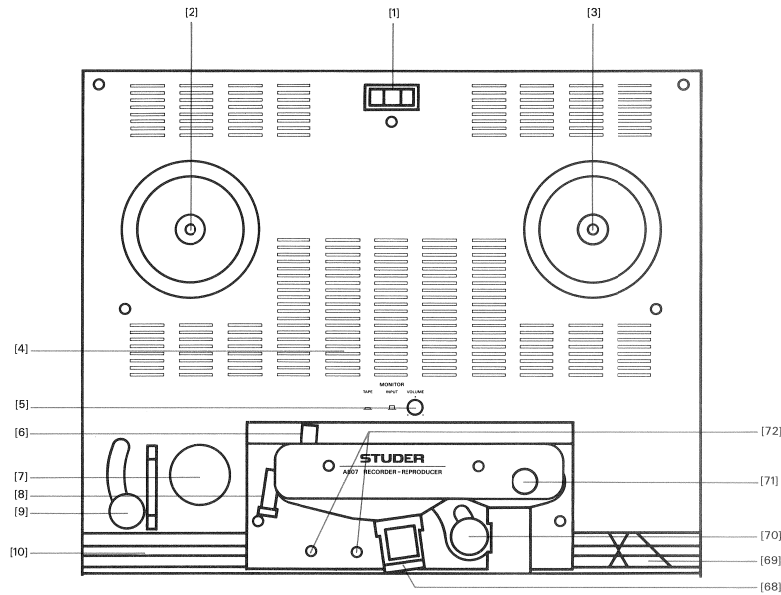

Fig. 2.3.8 Connection diagram, varispeed control

2.4 OPERATING INSTRUCTIONS

2.4.1 Machine handling



- [1] Power switch, switches the tape recorder on and off.
- [2] Left-hand reel support, supply motor.
- [3] Right-hand reel support, take-up motor.
- [4] Monitor speaker (only in versions without instrument panel).
- [5] VOLUME
Volume control for the monitor speaker [4] or for the headphone [58]. When this button is pressed, the tape reproduce signal is selected; when the button is out, the input signal is selected.
- [6] Tape lift slide.
- [7] Tacho roller, tape move sensor.
- [8] Light barrier for detecting the transparent leader or a torn tape. Also stops the tape timer.
- [9] Tape sensor lever, monitors the tape tension.
- [10] Splicing block.
- [11] adj
Microswitch, switches the tape recorder to alignment mode for programming the audio parameters or, when pressed together with the SHIFT [18] key, switches to the soft jumper program (refer to paragraph 2.5.3 and 2.5.4).
Use a pencil or an other pointed tool to operate the microswitch "adj". Press microswitch adj again to go back to the normal operating status.
Some of the keys change there function after pressing the microswitch "adj.", the yellow printed function of those keys are now valid.

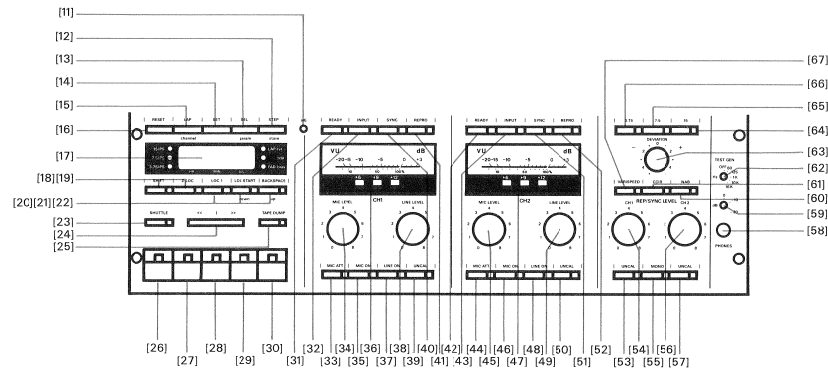

Normal key functions:	Key function in "adj" mode:	Key function in "SHIFT" & "adj" mode:
[12] STEP In SET mode [14] increases by one the number selected by key [13].	store Stores the adjusted audio Parameter.	store Stores the selected condition of the desired Softjumper - function.
[13] SEL Selects in SET-mode [14] a digit to be changed. The selected digit flashes.	param Selects in the audio - alignment mode the next parameter (level, treble, bias).	
[14] SET In STOP mode changes between normal time indication and the SET - (input) mode (first digit flashes). In play - or wind mode it freezes time display to be transferred into Locate-memory (time freeze). It works in LAP - mode [15] as well.		

Normal key function:	Key function in "adj" mode:	Key function in "SHIFT" & "adj" mode:
<p>When the SHIFT [18] key and subsequently a locator key is pressed, the stored address is displayed for approx. 4 seconds, without the locate function being performed.</p> <p>[19] Z-LOC Zero locator. Positions the tape at the tape address 00.00.00. When this key is pressed in LAP mode [15], the LAP function is switched off and the tape is positioned at the actual zero address of the main timer. The reproduce mode as well as the record mode can be preselected while the tape is positioning. The LEDs of the preselected functions flash.</p> <p>[20] LOC 1 Address locator 1. Positions the tape at the address stored with the key combination SET [14] and LOC 1 [20]. The reproduce mode as well as the record mode can be preselected while the tape is positioning; the LEDs of the preselected functions flash. The locator address is displayed for as long as this key is held down, and the two decimal points flash. If this key is pressed in LAP mode [15], the LAP function is switched off and the tape is positioned at the actual LOC 1 address of the main timer. The stored address always relates to the actual tape address i.e. when the tape timer is set to zero with RESET [16], the locator address is automatically converted.</p> <p>When the key combination SHIFT [18] and accordingly LOC 1 [20] is pressed, the stored locator address is displayed briefly without causing the tape to be positioned at the displayed address.</p>		

Normal key function:	Key function in "adj" mode:	Key function in "SHIFT" & "adj" mode:
<p>[21] LOC START LOC 2 LOOP</p> <p>In the LOC START setting, the programmable key [21] positions the tape automatically at the address at which the last PLAY or record command was entered (from standstill of the tape). The reproduce mode as well as the record mode can be preselected while the tape is positioning (provided a channel has been switched to READY); the LEDs of the preselected functions flash.</p> <p>When LOC 2 is programmed, a second address locator is available as for LOC 1 [20].</p> <p>When LOOP is programmed, a loop between the tape address 00.00.00 and the address stored in LOC 1 is executed. The loop always starts at the lower of the two tape addresses.</p> <p>When the key combination SHIFT [18] and accordingly LOC START / LOC 2 [21] is pressed, the stored address is briefly displayed without causing the tape to be positioned at this address.</p>	<p>down</p> <p>Decreases the value of the active alignment parameter (level, treble, bias) selected with key [13] (param) of the corresponding channel chosen by key [15].</p>	<p>down</p> <p>Decreases the value of the softjumper status selected with key [15] or switches the corresponding function off.</p>
<p>[22] BACKSPACE LOC 3 FADER READY LIFTER LOC START</p> <p>In the BACKSPACE setting the programmable key [22] activates the rewind function at approx. the 4-time reproduce speed for as long as this key is held down. The tape will not be lifted off the soundheads. The machine switches to PLAY mode as soon as this key is released.</p> <p>In the LOC 3 programming setting a third address locator is available that functions analogously to LOC 1 [20].</p> <p>In the FADER READY setting the key can be used to ready the fader start. This function is acknowledged by the red FAD LED in the display window [17].</p>	<p>up</p> <p>Increases the value of the active alignment parameter (level, treble, bias) selected with key [13] (param) of the corresponding channel chosen by key [15].</p>	<p>up</p> <p>Increases the value of the softjumper status selected with key [15] or switches the corresponding function off.</p>

Normal key function:	Key function in "adj" mode:	Key function in "SHIFT" & "adj" mode:
<p>If at least one channel is switched to READY [31/42], the machine can be readied for recording by simultaneously pressing SHIFT [18] and FADER READY [22] (the yellow LED next to the FADER READY key flashes). When the fader potentiometer is opened, the machine starts immediately in record mode.</p> <p>The LIFTER function defeats the tape lift in spooling mode. This key can either be programmed as an on/off switch or as a momentary action push button.</p> <p>When LOC START is programmed, this key performs the same functions as LOC START [21].</p> <p>[23] SHUTTLE Editing mode, tape tension control is enabled and the audio path is active. The tape can be moved forward or backward to the desired position by manually turning the right-hand tape reel [3]. When the SHUTTLE key is pressed a second time, the editing mode is cancelled.</p> <p>[24] SHUTTLE CONTROL Rotary wheel for motor-assisted editing mode with activated SHUTTLE function [23].</p> <p>[25] TAPE DUMP Switches the "waste basket mode" on and off. The right-hand spooling motor is disabled. Mode A or B can be selected by changing over the programming switch (jumper JS4) below the cover.</p> <p>Mode A: The TAPE DUMP [25] key functions as a preselector switch. The "waste basket" mode is activated with the PLAY [28] key. The tape is played but not wind up. The loose tape can be rewound onto the left-hand tape reel [2] by pressing the < [26] key. In this mode it is possible to play a loose piece of tape without winding the tape onto the reel (described in paragraph 2.4.25).</p> <p>Mode B: The "waste basket" mode is activated directly with the TAPE DUMP [25] key. The machine stops when this key is pressed a second time.</p>	<p>input In models without output selector, the input signal is connected directly to the output for setting the internal audio level when this key is pressed.</p>	

[26] <

Key for rewinding of the tape at high speed. The tape is wound on the left-hand reel. Rewinding at reduced speed (librarywind) is possible by simultaneously pressing SHIFT [18] and < [26].

[27] >

Key for spooling the tape forward at high speed. The tape is wound on the right-hand reel. Spooling forward at reduced speed is possible by simultaneously pressing SHIFT [18] and > [27].

[28] PLAY

Key for replaying the tape. This key is pressed together with the REC [30] key for activating the recording mode. REVERSE PLAY is activated by pressing SHIFT [18] and PLAY [28] simultaneously. If no tape is inserted (tape tension sensor in idle position, light barrier not covered), the capstan motor can be switched on with the PLAY key [28] for cleaning the capstan shaft.

[29] STOP

This key cancels all tape transport functions and all selected operating modes except the preselection of the TAPE DUMP [25] mode A.

[30] REC

Record key. Depending on the programming it may only be effective in conjunction with the PLAY [28] key. Recordings can only be made on the enabled channel(s) (READY [31/42]). If no channel is switched to READY, the record command will be ignored. Mode A or B can be selected by changing over the programming switch (jumper JS3) below the cover.

Mode A:

Both keys, PLAY [28] and REC [30] must be pressed for activating the record mode.

Mode B:

To switch from reproduce to record mode, only the REC [30] key needs to be pressed; but for activating the record function from STOP mode, the PLAY [28] and the REC [30] key have to be pressed.

Please note:

The operating controls 31-57 are not equipped on all tape recorder versions

[31] READY

Readies channel 1 (left) for recording. The red LED next to the key flashes. While a recording is in progress, this LED is continuously lit.

[32] INPUT

Output selector channel 1. The level of the input signal is indicated on the VU-meter [36]. This signal can also be heard via the XLR output, the monitor speaker [4], and the headphones [58].

[33] MIC ATT

Microphone attenuator channel 1. The input signal on the MIC INPUT CH1 socket is attenuated by approx. -28 dB.

[34] MIC LEVEL

Input volume potentiometer channel 1 for adjusting the sensitivity of the microphone input MIC INPUT CH1.

[35] MIC ON

Switches the microphone input channel 1 on and off. When the line input is simultaneously activated with the LINE ON [37] key, the two signals will be mixed.

[36] VU-METER

Output meter for channel 1 with three peak indicator LEDs for +6, +9, and +12 dB relative to 0 VU.

[37] LINE ON

Switches the LINE INPUT CH1 on and off. When the microphone input is simultaneously activated with the MIC ON [35] key, the two signals will be mixed.

[38] LINE LEVEL

Input level potentiometer for the LINE INPUT CH1. Only enabled when the UNCAL [39] key has been selected for uncalibrated record mode.

[39] UNCAL

Activates the uncalibrated record mode for channel 1. The record level can be adjusted with the LINE LEVEL [38] potentiometer.

[40] SYNC

Output selector channel 1. The audio signal is reproduced from the record head with limited frequency response. Synchronous recording of channel 2 to an existing recording on channel 1 is possible. The VU-meter [36] indicates the level of the SYNC reproduce signal. The SYNC signal can also be monitored via the XLR output, the speaker [4], and the headphones [58].

[41] REPRO

Output selector channel 1. The audio signal is reproduced from the reproduce head. The VU-meter [36] indicates the level of the reproduce signal. The REPRO signal can also be monitored via the XLR output, the speaker [4], and the headphones [58]. This function can also be activated while a recording is in progress in order to continuously monitor the quality of the recording (tape/source monitoring).

[42] READY

Record ready for channel 2 (right), the red LED next to the key flashes. This LED is continuously lit while a recording is in progress.

[43] INPUT

Output selector channel 2. The VU-meter [47] indicates the level of the input reproduce signal. This input signal can also be monitored via the XLR output, the speaker [4], and the headphones [58].

[44] MIC ATT

Microphone attenuator channel 2. The input signal on the MIC INPUT CH2 socket is attenuated by approximately -28dB.

[45] MIC LEVEL

Input level potentiometer channel 2 for adjusting the sensitivity of the MIC INPUT CH2.

[46] MIC ON

Switches the microphone input channel 2 on and off. When the line input is simultaneously activated with the LINE ON [48] key, the two signals will be mixed.

[47] VU-METER

Output meter for channel 2 with three peak indicator LEDs for +6, +9, and +12 dB relative to 0 VU.

[48] LINE ON

Switches the LINE INPUT CH2 on and off. When the microphone input is simultaneously activated with the MIC ON [46] key, the two signals will be mixed.

[49] LINE LEVEL

Input level potentiometer for the LINE INPUT CH2. Only enabled when the UNCAL [50] key has been selected for uncalibrated record mode.

[50] UNCAL

Activates the uncalibrated record mode for channel 2. The record level can be adjusted with the LINE LEVEL [49] potentiometer.

[51] SYNC

Output selector channel 2. The audio signal is reproduced from the record head with limited frequency response. Synchronous recording of channel 1 to an existing recording on channel 2 is possible. The VU-meter [47] indicates the level of the SYNC reproduce signal. The SYNC signal can also be monitored via the XLR output, the speaker [4], and the headphones [58].

[52] REPRO

Output selector channel 2. The audio signal is reproduced from the reproduce head. The VU-meter [47] indicates the level of the reproduce signal. The REPRO signal can also be monitored via the XLR output, the speaker [4], and the headphones [58]. This function can also be activated while a recording is in progress in order to continuously monitor the quality of the recording (tape/source monitoring).

[53] UNCAL

Activates the uncalibrated record mode. The output level of channel 1 can be adjusted with the REPRO/SYNC LEVEL CH1 [54] potentiometer.

[54] REPRO/SYNC LEVEL CH1

Output level potentiometer for channel 1. In the UNCAL [53] position, the reproduce amplifier output level (LINE OUTPUT CH1) can be adjusted.

[55] MONO / INSERT

This key activates the internal audio insertion point (in stereo models for the optional mono/stereo switch). To prevent unintentional operation, it can only be selected in conjunction with the SHIFT [18] key (press and hold SHIFT, then also press MONO / INSERT). The MONO/INSERT mode is signalled by a green LED. When the insert point is not used, this key is disabled by means of JUMPER JP17 located below the cover.

[56] REPRO/SYNC LEVEL CH2

Output level potentiometer for channel 2. In the UNCAL [57] position the reproduce amplifier output level (LINE OUTPUT CH2) can be adjusted.

[57] UNCAL

Activates the uncalibrated reproduce mode. The output level of channel 2 can be adjusted with the REPRO/SYNC LEVEL CH2 [56] potentiometer.

[58] PHONES

Headphones socket. The built-in monitor speaker is automatically switched off when the headphones jack is inserted. The Tape/source reproduce level of the headphones can be adjusted with the VOLUME [5] potentiometer.

[59] dB

Booster amplifier (only on models with optional TEST GENERATOR). Depending on the switch setting the input signal is attenuated by -10 or -20 dB and the output signal boosted by +10 or +20 dB.

[60] NAB

TAPE B

SECOND REPRO HEAD (RIGHT)

Programmable key for changing over the equalization to the NAB standard, the calibration data of a second tape type TAPE B, or for activating the optional second reproduce head (HEAD B). To prevent unintentional operation, it can only be changed over in conjunction with SHIFT [18] (press and hold SHIFT key and also press NAB key). The method of programming key [60] is described in paragraph 2.5.

[61] CCIR

TAPE A

REPRO HEAD LEFT

Programmable key for changing over the equalization to the CCIR standard, the calibration data of type TAPE A, or for activating the main reproduce head (HEAD A) if two reproduce heads are installed. To prevent unintentional operation, it can only be changed over in conjunction with SHIFT [18] (press and hold SHIFT key and also press CCIR key). The method of programming key [61] is described in paragraph 2.5.

[62] Hz

Test generator (only on models with the optional TEST GENERATOR). Depending on the switch setting a sine wave signal (0 VU) with a frequency of 60 Hz, 125 Hz, 1 kHz, 10 kHz or 16 kHz is fed to the input. In the OFF position the test generator is disabled. To prevent mixing of the test generator signals with the inputs, the functions MIC ON [35/46] and LINE ON [37/48] should be switched off.

[63] DEVIATION

Potentiometer for continuously varying the tape speed in "varispeed" mode (VARISPEED [67] key) within the range of ± 7 semitones (-35%, +54%) relative to the selected nominal speed (at 3.75 ips the range is: +7, -1.5 semitones).

[64] 15 (30)

Speed selector 15 ips (30 ips for HS versions). To prevent unintentional operation, jumper JP13 below the cover can be set in such a way that this key is only enabled in conjunction with the SHIFT [18] key (press and hold SHIFT key and also press 15 (30) key).

[65] 7.5 (15)

Speed selector 7.5 ips (15 ips for HS versions). To prevent unintentional operation, jumper JP13 below the cover can be set so that this key is only enabled in conjunction with the SHIFT [18] key (press and hold SHIFT key and also press 7.5 (15) key).

[66] 3.75 (7.5)

Speed selector 3.75 ips (7.5 ips for HS versions). To prevent unintentional operation, jumper JP13 below the cover can be set in such a way that this key is only enabled in conjunction with the SHIFT [18] key (press and hold SHIFT key and also press 3.75 (7.5) key).

[67] VARISPEED

Activates the varispeed mode. In this mode the tape speed can be varied with the DEVIATION [63] potentiometer. To prevent unintentional activation, this key is only effective when pressed in conjunction with SHIFT [18] (press and hold SHIFT and also press the VARISPEED key).

[68]

Head shield in front of the reproduce head(s). Can be opened and closed by hand.

[69]

Cutting block for cutting the tape.

[70]

Pinch roller. Presses the tape against the capstan shaft. In spooling mode, cueing of the tape is possible by pressing the pinch roller toward the capstan shaft. The closer the tape is moved to the capstan shaft, the louder the signal. The pinch roller cannot be pressed completely against the capstan!

[71]

Scissors are available as an option, but can only be installed in place of the optional second reproduce head. The tape is cut by antimagnetic scissors at an angle of 30° ($\pm 30^\circ$) when the cutter button is pressed.

[72]

Optional tape marker for identifying a splicing point in front of the reproduce head.

2.4.2 Power switch [1]

Caution:

Before you connect the tape recorder to the AC outlet, check that the setting of the line voltage selector agrees with the local mains voltage. The fuse rating must be checked whenever the setting of the line voltage selector has been changed (paragraph 2.3.1).

The power switch [1] is located at the top edge of the tape deck cover.

When the tape recorder is switched on, the operating state that existed when the machine was switched off is automatically reestablished and displayed. The software release date (WW.YY = week year) is shown on the display [17] for a few seconds. The last timer reading is subsequently displayed.

Exceptions:

Tape transport functions that were active when the machine was switched off are not restarted, and the channels that were set to READY and the varispeed mode are disabled. The tape recorder is always switched to STOP [29]. When a tape is inserted, the yellow LED of the STOP key is continuously lit. If there is no tape or if the tape is slack, the LED flashes for approx. 10 seconds and then switches off.

2.4.3 Indications at power on time

After the machine has been switched on, the VU-meters [36/47] are illuminated and the software date is shown on the display [17]. The following indications are also possible. They signal the current operating state of the tape recorder:

- Display: The last tape address is indicated.
- Locator addresses are saved.
- STOP: The stop function is active. If the LED flashes for approx. 10 s and then switches off, there is no tape inserted or the inserted tape is slack.
- CCIR (TAPE A / REPRO HEAD LEFT) or NAB (TAPE B / REPRO HEAD RIGHT): the selected equalization standard (tape type / reproduce head) is indicated.
- 3.75 7.5 15 or 30: The selected tape speed is indicated next to the display [17] and on the speed selector keys [64/65/66].
- Input selector: The selected input is indicated with MIC ATT [33/44], MIC ON [35/46], LINE ON [37/48] or UNCAL [39/50].
- Output selector: The selected output is indicated with INPUT [32/43], SYNC [40/51], or REPRO [41/52].
- Output level: Uncalibrated output level is indicated by the red LED next to the UNCAL [53/57] keys.
- MONO/INSERT [55] is indicated if a corresponding option is installed and if it was selected before the machine was powered off. On models equipped with an instrument panel the channel selection for the monitor output is also indicated.

2.4.4 Inserting the tape

The tape recorder is normally equipped with 3-pronged adapters. For NAB reels and self-supporting pancakes with hubs, special adapters are available.

Three-pronged reel (DIN 45514, 45517)

Mount the full reel on the left-hand spindle [2], the empty reel on the right-hand spindle [3]. Pull out the three-pronged guide and lock it with a 60° turn.

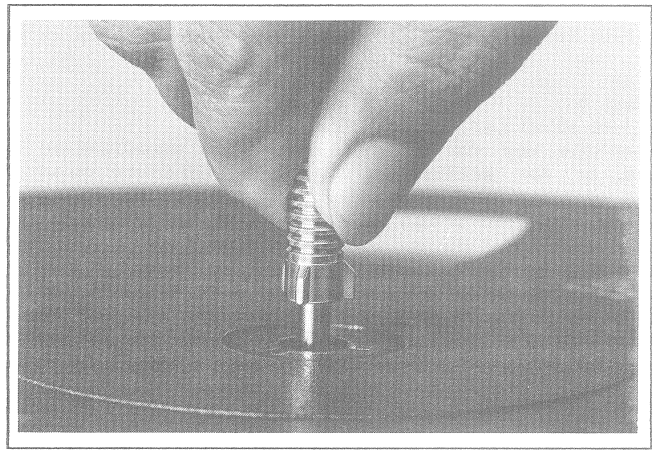

Fig. 2.4.2

NAB reel

Mount the NAB adapters on the two spindles [2/3] and lock them by pulling out the three-pronged guides and giving a 60° turn. Mount the full NAB reel on the left-hand NAB adapter, the empty reel on the right-hand NAB adapter. To lock the tape reels turn the top section of the adapter clockwise until it engages.

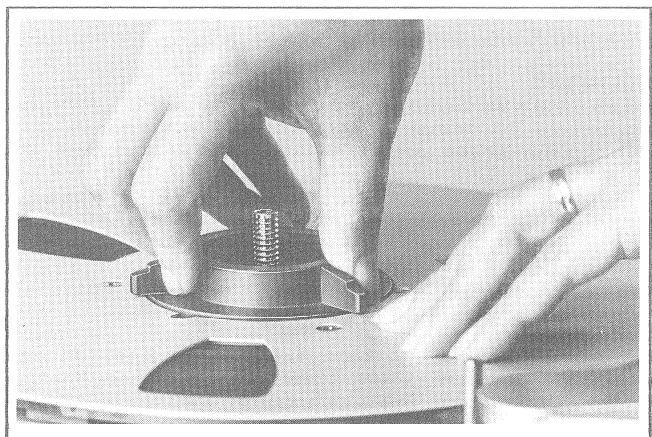

Fig. 2.4.3

Self-supporting pancakes with hub (DIN45515)

Mount the adapter discs on the reels [2/3] in such a way that the two pins engage in the spindle. Lock the discs by pulling out the three-pronged guides and giving a 60° turn. Mount the full pancake on the left-hand adapter disc and the empty hub on the right-hand adapter disc. To lock the hubs give the adapter lug a 90° turn.

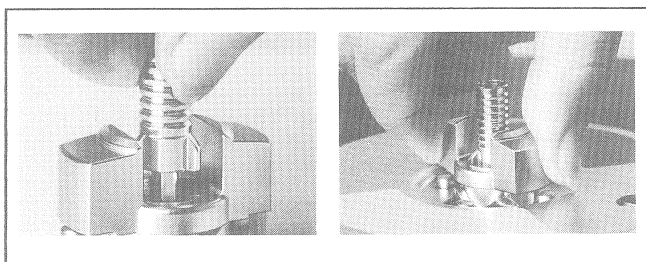

Fig. 2.4.4

Threading the tape

Thread the tape as illustrated. It must be threaded exactly around the tape tension sensor [9], the tachometer roller [7], through the light barrier [8], and over the soundheads. Pull the leading end of the tape over the pinch roller [70] (the pinch roller can be moved to the idle position by actuating the tape lifter [6]), and around the right-hand guide roller. Thread the tape on the right-hand reel and secure the tape by giving the right-hand reel a few counterclockwise turns. If the tape starts with a transparent leader, continue to press the pushbutton >[27] or PLAY [28] until the oxide coating has passed the light barrier [8]. Set the tape timer to zero by pressing the RESET [16] key.

If the tape is always set to zero at the same address, the tape can be repeatedly positioned at any address by means of the real-time tape counter [17].

If necessary, raise the head shield [68] in front of the reproduce head(s).

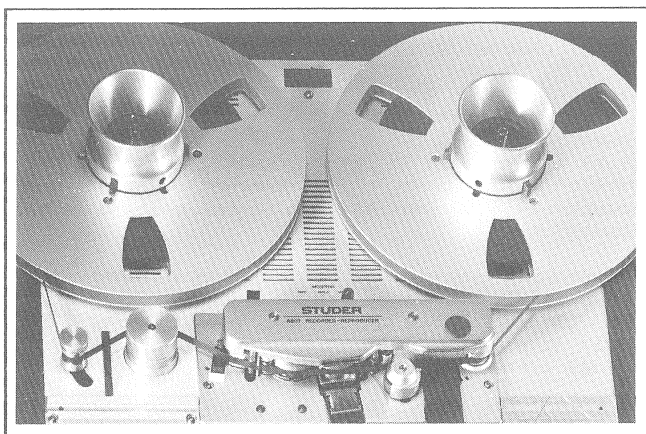

Fig. 2.4.5

2.4.5 Tape speeds [64/65/66]

Three tape speeds are available. Depending on the model, three of the following four speeds can be selected: 3.75/7.5/15/30 ips. The speed is selected by pressing the corresponding key [64/65/66]. The LED in the key lights up. If correspondingly programmed, the speed selection is interlocked with the SHIFT [18] key. In this case a speed can only be selected by holding the SHIFT [18] key down while you select the desired tape speed.

2.4.6 Play mode PLAY [28]

When the local PLAY key [28], a corresponding remote control button, or a fader start device is actuated (possibly via the FADER READY key), the tape recorder switches to play mode. The yellow LED above the PLAY key lights up.

The play mode can be cancelled by pressing the STOP [29] key or any other tape command key (except fader start mode A, B or C).

If the PLAY key is pressed while a recording is in progress (REC), the machine switches to play without interruption and the record mode is cancelled.

If the PLAY key is pressed in spooling mode, the tape is immediately decelerated and the play function is preselected. As soon as the tape has come to a standstill or achieved the nominal speed in the play direction, the machine switches to play mode.

Any tape transport function can be selected independently of the current operating state of the machine. The microprocessor checks automatically the validity of the command and protects the tape by first decelerating it before the opposite sense of rotation or a slower speed is activated. A SHUTTLE or locator function can also be selected directly.

When no tape is mounted (tape tension sensor in idle position, light barrier not covered), you can switch on the capstan motor for cleaning the shaft by pressing the PLAY [28] key. The motor rotates for as long as the key is pressed.

2.4.7 Reverse play mode REVERSE PLAY

By simultaneously pressing the SHIFT [18] and PLAY [28] keys, the tape recorder can be switched to REVERSE PLAY for searching a tape location or for achieving special effects. Any tape transport command, including the SHUTTLE and the locator function can be selected directly from reverse play mode.

2.4.8 Varispeed control [64/67]

In reproduce as well as record mode, the variable tape speed can be selected by simultaneously pressing the two keys SHIFT [18] and VARISPEED [67]; the red LED next to the VARISPEED key flashes.

The deviation from the nominal tape speed can be selected with the DEVIATION [63] potentiometer within the range of ± 7 semitones (+7 to -1.5 semitones at 3.75 ips). The tape speed can also be altered by means of an external varispeed control (option). When the external varispeed control is activated, the internal control frequency is automatically disabled.

Notes:

The delay time for the drop-in and drop-out is matched to the corresponding nominal speed; these delays are not adjusted in varispeed mode! The indication of the tape timer no longer corresponds to the true elapsed time but rather to the playing time at nominal speed.

2.4.9 Record mode REC [30]

The information in this Section does not apply to "playback only" models (PBO) !

When the REC [30] and the PLAY [28] keys are pressed simultaneously, the tape recorder switches to record mode provided at least one channel has been enabled with the READY [31/42] key and the red LED next to the key flashes. During a recording the LEDs of the REC [30], PLAY [28], and READY [31/42] keys are continuously lit.

The setting of jumper JPO3 below the front cover can be changed in such a way that the record mode can be activated from play mode by simply pressing the REC [30] key (but PLAY and REC still have to be pressed to enable recording from the STOP condition).

From record mode it is possible to switch directly to fast wind, play or a locator function by pressing the corresponding key. The STOP [29] command immediately interrupts the record mode. Channels that are switched to SYNC reproduction automatically switch to INPUT with the drop in and back to SYNC with the drop out.

Drop-in

Click-free changeover from SYNC reproduction to record mode is possible. Depending on the jumper setting, this is possible by either pressing REC [30] together with PLAY [28] or only the REC [30] key.

The record head is switched on with a speed-dependent delay so that the erase head and the record head are enabled at exactly the same tape location.

Drop-out

Click-free changeover from record mode to SYNC play mode is possible by pressing the PLAY [28] key.

The record head is switched off with a speed-dependent delay so that the erase head and the record head are switched off at exactly the same tape location.

Notes:

Since the machine interrupts a recording immediately when the STOP [29] key is pressed, the drop-out process can no longer be executed. For joining recorded segments without a gap it is necessary to switch from record to PLAY before STOP is activated. For the drop-in we recommend that you first switch to PLAY [28] and then to record (in order to prevent inaccuracies caused by the tape start).

Overlapping drop in

If e.g. applause is to be faded in with overlap at the end of a recording, the tape can be lifted off the erase head by means of the tape lifter [6].

The machine is then restarted in record mode and the tape lifter slowly released. The tape first contacts the record head and the applause is added to the existing modulation. When the tape lifter is released, the tape also contacts the erase head. The existing modulation is erased and only the applause is recorded.

2.4.10 SYNC reproduction SYNC [40/51]

The SYNC [40/51] key switches the corresponding channel to SYNC reproduction. This means that the audio signals are not supplied by the reproduce head but by the record head via the reproduce amplifier.

Since there is no time offset between record and reproduce in this mode, it is possible to add a synchronous recording to a channel with an existing recording (e.g. vocalization of instrumental music).

Procedure: Synchronous recording to channel 1

- Switch channel 1 to SYNC [40].
- Switch channel 2 to READY [42] and connect MIC to CH2. Select MIC ON [46] and adjust the sensitivity with the potentiometer [45]. (Possibly activate the attenuator [44], switch the phantom power on or off).
- Start the machine in record mode
- Monitor the music of channel 1 via the headphones [58] and add the vocal part via the microphone.

For technical reasons, the reproduce frequency response is limited to approx. 6 kHz at 3.75 ips, 10 kHz at 7.5 ips, 12 kHz at 15 ips, and 12 kHz at 30 ips. A degradation in quality is, therefore, inevitable with SYNC reproduction.

SYNC preselection:

SYNC reproduction can be preselected for a channel that has been readied for record mode. When the SYNC [40/51] key is pressed during a recording, the corresponding channel is connected to INPUT. This channel is automatically switched to SYNC reproduction when the drop-out occurs (PLAY, STOP).

2.4.11 Spooling mode < > [26/27]

The < [26] key activates fast wind in the reverse direction, the > [27] key in the forward direction. The tape will be wound at the maximum spooling speed.

The spooling functions are cancelled by STOP [29], PLAY [28], REC+PLAY [30,28], SHUTTLE [23], TAPE DUMP [25], LOC functions and by spooling in the opposite direction.

It is admissible to switch from spooling directly to play or record mode. The LED of the preselected function flashes; the tape is decelerated, and the preselected function is only activated when the tape has come to a stop or reached nominal speed.

Tape lifting:

In spooling mode the tape is automatically lifted off the soundheads in order to minimize wear of the tape and audio heads.

- Automatic cueing:
When the programmable LIFTER [22] key is actuated (different functions can be assigned to the keys [21] and [22] by setting the jumpers JPD0, JPD1, and JPD2, see paragraph 2.5) the tape lifter is retracted so that the tape makes contact with the audio heads. Depending on the setting of jumper JP10, tape lifting is defeated either for as long as the key is pressed or until the key is pressed again.
- Manual cueing:
Cueing in spooling mode is possible by manually pressing the pinch roller [70] toward the capstan shaft. The closer the tape is pushed to the reproduce head, the stronger the output signal. For safety reasons it is not possible to press the pinch roller completely against the capstan shaft.

Note:

In order to protect the treble speaker of the monitor system from overloads when the cueing function is active in spooling mode, the reproduce level is automatically attenuated by -12 dB.

2.4.12 Producing pancakes at reduced spooling speeds, LIBRARY WIND

The reduced spooling speed is intended for pancakes that are to be saved in a library. The tape is wound more gently and, due to the absence of an air cushion between the individual layers, also more tightly.

The library wind function is activated by pressing and holding down the SHIFT [18] key and simultaneously pressing the spooling key < [26] or > [27]. The library wind function is cancelled as soon as any tape transport function is selected.

To ensure that a smooth pancake can be produced with any type of tape, the reduced spooling speed can be individually adjusted with the trimmer potentiometer SHTL located below the left-hand tape splicing block [10].

2.4.13 Stop mode STOP [29]

The STOP [29] key has the highest priority and cancels all operating states such as play, record, spooling, SHUTTLE, and the LOC functions. The tape is immediately decelerated after this function has been selected.

Any new command entered during the deceleration phase of the tape is stored and immediately activated when the tape speed required for this function is achieved.

2.4.14 Locator Z-LOC, LOC1 (-3) [19-22]

Depending how the keys [21] and [22] are programmed, up to three transfer locators and one zero locator are available (for programming refer to paragraph 2.5). All locator addresses refer to the main tape timer. When a locator function is called with auxiliary timer (LAP [15]) activated, the machine switches from the auxiliary timer to the main timer before the locator function is executed. The LAP function remains switched off.

Z-LOC:

When the Z-LOC [19] key is pressed, the tape is wound forward or backward at high speed until the tape location corresponding to timer address 00.00.00 is reached.

LOC START:

Pressing the LOC START [21/22] key initiates fast rewind mode. The tape is then wound to the point where the previous Play- or Record command was entered providing the tape was at stand still when entering the command. The play or record function can be preselected by pressing the corresponding key while the tape is being positioned. The LED of the selected function flashes until the function is performed.

LOC1...LOC3:

At least one transfer locator is always available with the LOC1 [20] key. One additional transfer locator each (LOC2, LOC3) can be assigned through corresponding programming of keys [21] and [22]. In this way up to three tape addresses can be stored and automatically searched at high speed by pressing the corresponding key. The locate function can be cancelled by pressing [29], < [26], > [27] or by selecting a different LOC function. As is the case for the LOC START function, the play and record functions can be preselected.

Programming the locator addresses:

■ Storing the current tape address:

Position the tape at the desired tape address, press the SET [14] (the first digit in the display [17] flashes), and then the key of the transfer locator (LOC1...LOC3) in which the tape address is to be stored.

■ Storing a known tape address:

The locator address can also be entered via the keyboard without positioning the tape. Press the SET [14] key; the first digit in the display flashes. With the STEP [12] key you can now alter the value of the digit in single steps. Then press the SEL [13] key to access the next digit and alter it with the STEP [12] key. Repeat these steps until the tape address to be stored is shown on the display. Store the tape address by pressing one of the locator keys (LOC1...LOC3).

Reading out a LOC address:

During a LOC process: Press the corresponding LOC key a second time. In any other operating mode: Press the SHIFT [18] key and then the corresponding LOC key. Whenever the display [17] does not indicate the current tape address, the two dots are flashing.

Note:

The locator addresses always relate to the actual tape address and are automatically converted when the tape counter is set to zero (RESET [16] key). When a different tape speed is selected, the current counter content as well as all locator addresses are recomputed and remain stored even when the tape recorder is switched off.

2.4.15 Programmable functions

The programmable keys [21] and [22] (JPO0, JPO1 and JPO2) as well as [60] and [61] (JPO5, JPO6, and JPO7) can be assigned to different functions by changing the jumper positions below the front cover. The programming method is described in paragraph 2.5.

Key [21]: LOC START, LOC2 or LOOP.

Key [22]: BACKSPACE, LOC3, LOC START, LIFTER, or FADER READY

Key [60]: NAB, TAPE B, or REPRO HEAD RIGHT.

Key [61]: CCIR, TAPE A, or REPRO HEAD LEFT.

The locator functions are described in paragraph 2.4.14.

LOOP:

This function performs a continuous loop between tape address 00.00.00 and the address stored in LOC 1. The lower of the two addresses (timer reading 00.00.00) or a negative address in LOC 1 is taken as the starting address. When the LOOP key is pressed the tape is positioned at the starting address and the play mode is activated until the ending address is reached. At this point the tape is automatically rewound to the starting address and the play mode is reactivated. This procedure is repeated until the LOOP function is cancelled with the input of a new tape deck command.

BACKSPACE:

In this function the tape is rewound at approx. 4 times the reproduce speed (relative to the selected nominal speed) but the tape is not lifted off the soundheads. The reproduce paths are enabled. As soon as this key is released, the machine switches automatically to PLAY.

LIFTER:

The LIFTER key defeats the tape lifter function in spooling mode, either continuously, i.e. until this key is pressed again, or for as long as this key is pressed. The mode of this switch depends on the setting of jumper JP10 below the front cover. For a detailed description of the LIFTER function refer to paragraph 2.4.11, Tape lifter.

FADER READY:

Depending on the selected fader start mode (set with jumpers JP11 and JP12 below the front cover), a FADER READY KEY may be required for enabling or disabling the fader start circuit (such a switch is required for mode B, C, and D).

Rather than with an external switch, this function can also be performed with key [22]. When the fader start circuit is enabled (FADER READY), the yellow LED next to the key as well as the FAD LED in the display window [17] are lit to signal the fader ready condition. When this key is pressed again, the circuit is disabled, the LEDs switch off, i.e. opening of the fader has no effect on the tape recorder. When the SHIFT [18] key is pressed together with the built-in fader ready key, the tape recorder starts in record mode when the fader is opened, provided at least one channel is switched to READY [31,42].

NAB / CCIR:

These keys are used for changing over between NAB [60] and CCIR [61] equalization standard which can be individually calibrated. The method of programming the keys [60/61] is described in paragraph 2.5.

TAPE A / TAPE B:

In this mode the keys [60/61] are used for changing over between two individually calibrated tape types (type A and type B). The method of programming is described in paragraph 2.5.

HEAD A / HEAD B:

In this mode the keys [60/61] are used for switching from the standard reproduce head to the optional second reproduce head. The reproduce level for each reproduce head is individually adjustable. The method of programming is described in paragraph 2.5.

2.4.16 Fader start

With the fader start circuit, the tape recorder can be started in PLAY mode by means of 5V...24V DC or AC applied by a remote control unit between pins 11 and 12 of the parallel remote control socket. In the operating modes (FADER B, C, or D), the fader start must be readied ("FADER START READY") by a switch that interconnects pin 6 (SR-READY signal) and 1 (ground) of the same socket. Direct fader start selection without a ready key is only possible in FADER A mode.

The fader can also be readied with the programmable FADER READY [22] key of the local keypad or on the optional remote control. The function programmed in the tape recorder (FADER B, C, or D) is then performed.

When the SHIFT [18] key is pressed together with the local fader ready key [22], the machine is started in record mode when the fader is opened, provided at least one channel has been set to READY [31/42].

Important:

When the FADER READY function is switched off or when both READY [31/42] are cancelled, fader start ready is automatically cancelled.

FADER A:

Fader start without FADER START READY key.

After the fader start the local keypad and the remote control keys are disabled, the built-in monitor speaker is muted (but not the headphones!). When the fader is pulled back (the fader switch opens), the tape recorder stops, but the built-in monitor speaker is only unmuted when the tape has come to a standstill. The machine can now again be operated.

FADER B:

Fader start with FADER START READY key.

In order to activate the fader start function, the FADER READY key must be selected (FAD LED in the display window [17] is on). After the fader start, the local keypad and the remote control keys are disabled, the built-in monitor speaker is muted (but not the headphones!). When the fader is pulled back (the fader switch opens), the tape recorder stops, but the built-in monitor speaker is only unmuted when the tape has come to a standstill. The machine can now again be operated. If the fader switch is actuated but the fader ready key has not been pressed (FAD LED is dark), the operating state of the tape recorder does not change. Exception: in play mode the built-in monitor speaker is muted when the fader is opened and unmuted when the fader is closed.

FADER C:

Fader start with FADER START READY key.

After the fader ready key has been pressed, the local keypad and the remote control keys are disabled. The machine can only be started by opening the fader. The built-in monitor speaker is muted (but not the headphones!). If the fader switch is actuated but the fader ready key has not been pressed, the operating state of the tape recorder does not change. Exception: in play mode the built-in monitor speaker is muted when the fader is opened and unmuted when the fader is closed.

FADER D:

Fader start with FADER START READY key.

Regardless of the position of the fader read switch, the local keypad and the remote control keys remain enabled, even after the fader start. The built-in monitor speaker is muted (but not the headphones!). If the fader switch is actuated but the fader ready key has not been pressed, the operating state of the tape recorder does not change. Exception: in play mode the built-in monitor speaker is muted when the fader is opened and unmuted when the fader is closed.

2.4.17 Tape timer

[17]

The electronic tape timer always displays the real tape time in hours, minutes, and seconds, relative to the selected nominal tape speed (exception: varispeed mode).

The timer has a display range -9 h 59 min 59 s to 99 h 59 min 59 s. The timer can be set to zero (00.00.00) by pressing the RESET [16] key. When the end of the tape, a torn tape, or the tape leader is detected, the timer stops automatically. In waste basket mode (TAPE DUMP [25]) the timer continuous to run or stops, depending on the setting of the soft jumper 05 (paragraph 2.5.3). Tape segments can also be timed (paragraph 2.4.18 Auxiliary timer). In "adj" mode (paragraph 2.5.2) the tape timer display shows the setting of the audio parameters; in soft jumper programming mode (paragraph 2.5.3) it shows the setting of the selected software switch. When the SHIFT key is pressed followed by a LOC key, the tape timer displays the content of the locator assigned to the corresponding key.

Note:

The locator addresses always relate to the actual tape address and are automatically recomputed when the tape timer is set to zero (RESET [16] key).

2.4.18 Auxiliary timer

LAP [15]

The LAP [15] key activates a second (auxiliary) tape timer with a user-selectable reference (zero setting). The auxiliary timer mode is signalled by the LAP LED in the display window. The auxiliary timer can be set to zero (RESET [16] key) at any tape address and can thus be used for determining the exact playing time of a selection without influencing the main timer or having to compute the difference between the start and the end time. When the LAP [15] key is pressed a second time, the display switches back to the main timer, the LAP LED switches off.

Note:

When the LAP function is active, it is not possible to set a locator address. The locator addresses always relate to the main timer. When a locator key is pressed, the LAP function is automatically cancelled, the main timer is activated, and the tape is positioned at the selected locator address.

2.4.19 MONO / INSERT**[55]**

On two-channel and stereo models with channel selector buttons, this key is labelled with MONO; on all other models with INSERT. However, the actual function is always the same: the internal insert point of the 0 dB amplifier is activated in the audio input and output path. On stereo models the optional MONO/STEREO switch can be connected into the circuit at this point. A noise reduction system (Dolby) or a supplementary circuit of a different type can also be connected here.

The function of the MONO (INSERT) [55] key is enabled by moving the jumper JP17 on the COMMAND PANEL BOARD 1.727.36X.XX to position "B". In addition the straps W2, W3, W7, and W8 on the AUDIO CONTROL BOARD 1.727.40X.XX must be opened so that the audio signals can be looped via the INPUT or the OUTPUT INSERT BOARD (MONO/STEREO SWITCH). With the jumpers JS1 and JS2 on the AUDIO CONTROL BOARD (1.727.400.81 / 401.00) the user can define whether the signal for the built-in monitor speaker is to be tapped before or after the insert point.

To enable this function, the SHIFT [18] key must be pressed and held while the MONO or INSERT [55] key is pressed. When SHIFT and MONO/INSERT are pressed again, the function is switched off.

The various modes of the MONO/STEREO switch are programmed by changing jumper settings:

on the input by setting the jumpers JP1 and JP2 on the M/S INPUT AMPLIFIER 1.727.441.00 / 451.00.

MONO MODE A:

The input signal of channel 1 is recorded simultaneously on channel 1 and channel 2 (JP1 = A, JP2 = B).

MONO MODE B:

The input signals of channel 1 and channel 2 are added and the aggregate signal recorded simultaneously on both channels (JP1 = A, JP2 = A).

MONO MODE C:

The input signal of channel 2 is simultaneously recorded on channel 1 and channel 2 (JP1 = B, JP2 = A).

on the output side by changing the jumpers JP1 and JP2 on the M/S OUTPUT AMPLIFIER 1.727.442.00 / 452.00.

MONO MODE A:

The mono reproduce signals of channel 1 and channel 2 are added and reproduced via the output channel 1 (OUTPUT CH1) (JP1 = A, JP2 = B), the output channel 2 (OUTPUT CH2) remains muted.

MONO MODE B:

The signals of both channels are added and the aggregate signal is simultaneously reproduced via both outputs (OUTPUT CH1, CH2) (JP1 = A, JP2 = A).

MONO MODE C:

The mono reproduce signals of channel 1 and channel 2 are added and reproduced via the output channel 2 (OUTPUT CH2) (JP1 = B, JP2 = A), the output channel 1 (OUTPUT CH1) remains muted.

2.4.20 Remote control

The following functions can be remote controlled by means of the parallel remote control unit: play, record, fast wind, stop, reset timer, zero loc, loc start, lifter, varispeed on/off, and fader (fader ready), as well as indirectly also backspace (PLAY + <).

Status indicator outputs (for external bulbs or LED's) for all above functions are available from the remote plug of the tape recorder. Exception: Reset-timer, zero-Locate and Lifter. The status indicate output for Fader start ready goes active low to indicate the fader-start-operation possibility. The pin assignment of the remote control socket as well as the connection configuration are described in paragraph 2.3.4.

2.4.21 VU-Meter-Panel

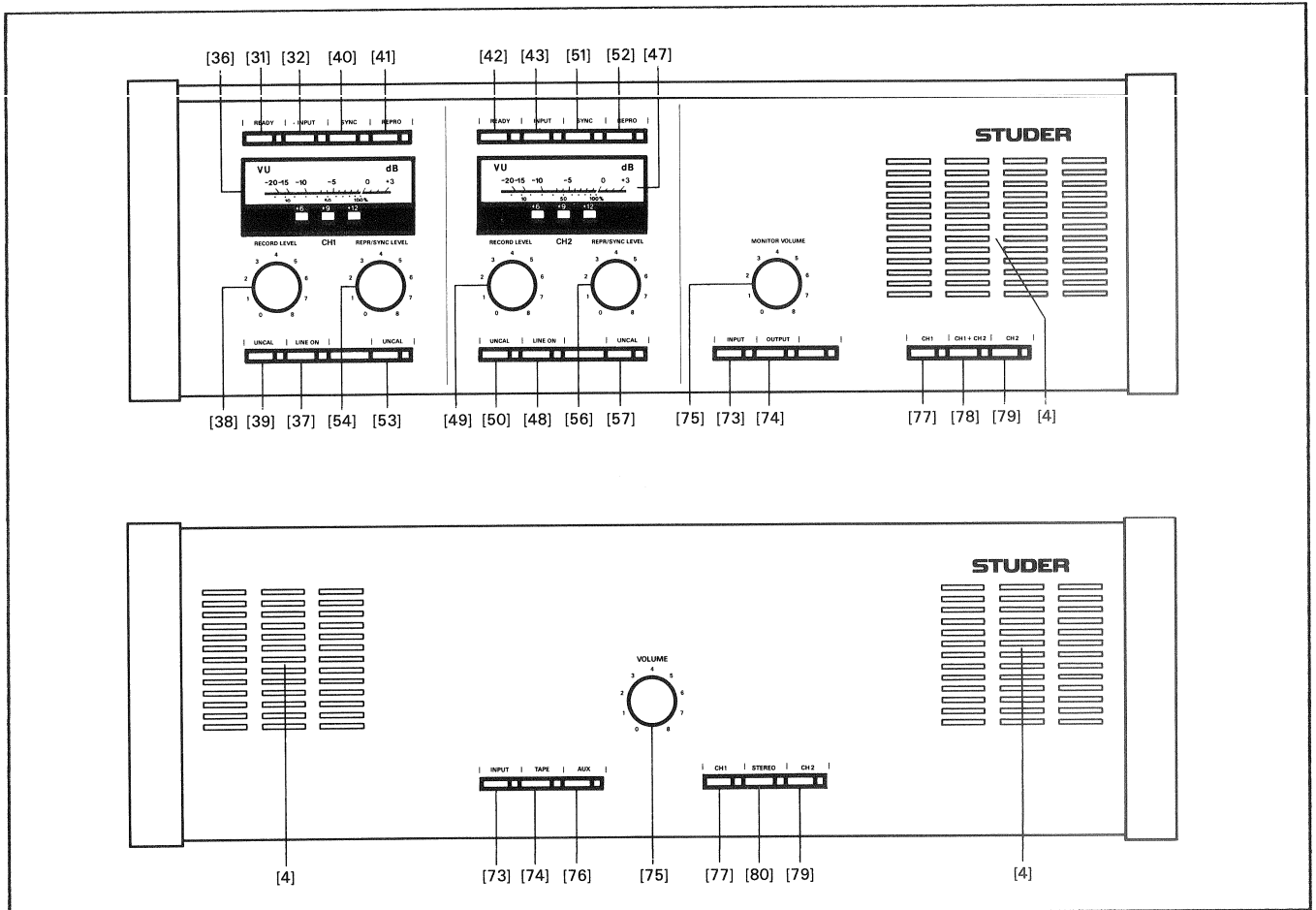

Fig. 2.4.6

On models equipped with an instrument panel (VUK), some of the operator controls and the monitor speaker are installed in a box above the unit. Depending on the machine type, some of the following elements are either installed in an internal or external instrument panel.

READY [31/42]

Record ready for the corresponding channel, the red LED next to the key flashes. This LED is continuously lit while a recording is in progress. No signals can be recorded on a channel that is not switched to READY.

INPUT [32/43]

Output selector for the corresponding channel. The input signal from the balanced input (INPUT CH1/CH2) and/or from the microphone (MIC INPUT CH1/CH2, if present), is taken directly to the balanced output (OUTPUT CH1/CH2), to the VU-meter [36/47], and to the monitor speaker [4] and the headphones socket [58] (source monitoring). The monitor switch [5] is therefore permanently connected to INPUT in both settings.

SYNC [40/51]

Output selector for the corresponding channel. The signal is reproduced from the record head with limited frequency response (paragraph 2.4.10). The signal is taken to the balanced output (OUTPUT CH1/CH2), to the VU-meter [36/47], and to the monitor speaker [4] and the headphones socket [58]. For the duration of the recording it is automatically switched to INPUT. With the monitor selector switch INPUT/OUTPUT or TAPE [5/73/74], the monitor signal of a SYNC reproduction can be switched between tape and source without influencing the output signal on the balanced output (OUTPUT CH1/CH2).

REPRO [41/52]

Output selector for the corresponding channel. The signal is reproduced from the reproduce head. The signal is taken to the balanced output (OUTPUT CH1/CH2), to the VU-meter [36/47], and to the monitor speaker [4] and the headphones socket [58]. With the monitor selector switch INPUT/OUTPUT or TAPE [5/73/74], the monitor signal can be switched between tape and source without influencing the output signal on the balanced output (OUTPUT CH1/CH2).

LINE LEVEL / RECORD LEVEL [38/49]

Input level potentiometer for the LINE INPUT CH1/CH2. When the input amplifier is uncalibrated (UNCAL [39/50] key pressed), the input level can be attenuated or increased by up to 10 dB above the calibrated value.

MIC LEVEL [34/45]

Input level potentiometer for the MIC INPUT CH1/CH2. The level potentiometers are always enabled when the microphone inputs are switched on (MIC ON [35/46] key). For high-sensitivity microphones, an additional input attenuator (approx. 28 dB) can be connected (MIC ATT [33/44] key).

REPRO/SYNC LEVEL [54/56]

Output level potentiometer for the LINE OUTPUT CH1/CH2. When the input amplifier is uncalibrated (UNCAL [53/57] key pressed), the input level can be attenuated or increased by up to 10 dB above the calibrated value.

2.4.22 External monitorMONITOR VOLUME [75]

Volume control of the monitor amplifier. Influences the output level of the monitor speaker built into the instrument panel. When the machine is equipped with a stereo monitor panel, the output level of the headphones socket PHONES [58] built into the panel is also influenced.

INPUT / OUTPUT or INPUT / TAPE [73/74]

Signal selector of the monitor speaker. When the INPUT [73] key is pressed, the signal available on the input is reproduced via the monitor speaker, if the OUTPUT or TAPE [74] key is pressed, the reproduce or SYNC signal from the tape is reproduced via the monitor speaker. If the output selector is set to INPUT [32/43], the input signal will always be reproduced via the monitor speaker, regardless of whether the INPUT [73] or OUTPUT [74] switch is set.

AUX [76]

On the stereo monitor panel, the AUX [76] can be pressed so that the signal fed to the AUX input of the recorder can be heard via the monitor speaker or the PHONES [58] socket. This signal has no further connection to the recorder. The AUX input is strictly a monitoring channel.

CH1 / CH1+CH2 / CH2 [77/78/79]

On two-track or stereo recorders, the channels for the monitor reproduction are selected with these keys. When the CH1 [77] key is pressed, only the signal of channel 1 is reproduced via the monitor speaker. When the CH1+CH2 [78] key is pressed, the signals of both channels are added and reproduced. When the CH2 [79] key is pressed, the second channel is connected to the monitor speaker, analogously to the CH1 [77] key. The signal selected with the INPUT [73], TAPE (or OUTPUT) [74], or AUX [76] key is reproduced.

When CH1 [77] or CH2 [79] is selected on models equipped with a stereo monitor instrument panel, only the left-hand or the right-hand channel is reproduced via the two monitor speakers and the two headphone channels.

STEREO [80]

When the STEREO [80] key is pressed on the stereo monitor instrument panel, both channels are reproduced stereophonically over the two built-in monitor speakers and the headphones socket PHONES [58].

2.4.23 Test generator (option)

On all 2-channel versions of the A807, a test generator with booster amplifier can be installed (in conjunction with the MONO/STEREO switch [55]) on the right-hand side of the operator panel. The MONO/INSERT [55] key, with which the internal insert point is controlled, can be activated by changing the position of the jumper JP17 (below the front cover) to position B, in this case the generally built in mono/stereo switch is required. To deactivate the built-in Mono/Stereo Switch change Jumper JP17 to position A.

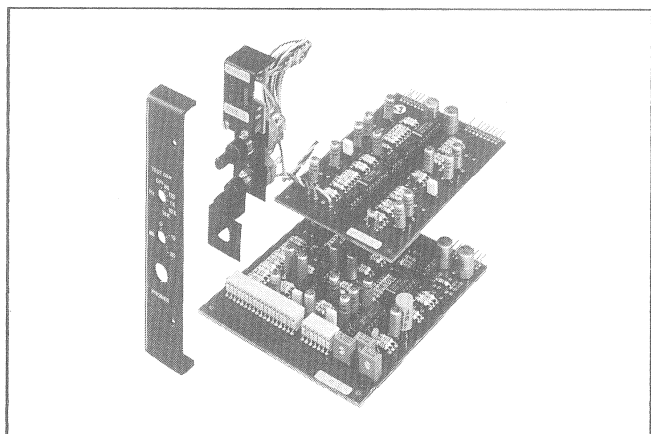

Fig. 2.4.7

The controls of the test generator are accessible from the operator panel and can be adjusted with a screwdriver. The test generator is switched on and the test frequency (60 Hz, 125 Hz, 1 kHz, 10 kHz, 16 kHz) of the sine wave generator is set with the Hz [62] switch. The test generator is disabled when this switch is in the OFF position.

Note:

Note:

When operating with the test generator, make sure that no signals are available on the inputs (MIC INPUT and LINE INPUT). This signal would be mixed with the generator signal and could lead to measurement errors.

- On models without input selector, the signal cables on the inputs should be detached.
- On models with input selector the inputs should be switched off (MIC ON [35/46] and LINE ON [37/48] in off position).

The booster amplifier is operated with the dB [59] switch. The generator level can be attenuated by 10 or 20 dB. At the same time the gain in the reproduce path is automatically increased by 10 dB or 20 dB; in this way the reference value of the VU-meter is the same as for nominal level. The booster amplifier can also be used when the test generator is switched off, e.g. when playing a reproduce test tape.

2.4.24 Editing, cutting the tape**Searching a tape address with fast wind**

Any tape address can be searched by means of fast forward > [27] and rewind < [26] keys. However, additional facilities have been provided that may be more convenient:

SHUTTLE [23/24], Z-LOC [19], LOC1 [20], and, depending on the internal programming (Jumpers JF00 to JF02), the keys [21] and [22] which support the following functions:

[21]	[22]
LOC2	LOC3
LOC START	BACKSPACE
	LOC START
	LIFTER

The locator functions are described in paragraph 2.4.14, the BACKSPACE function in paragraph 2.4.15.

SHUTTLE [23/24]

The SHUTTLE [23] key activates the editing mode. The tape is not lifted so that cueing is always possible. Editing under assistance of the spooling motors is possible with the aid of the SHUTTLE CONTROL [24] wheel. When this wheel is turned, the tape is spooled in the corresponding direction. The greater the deflection of the wheel from its home position, the faster the spooling speed. An edit point can thus be conveniently searched and approximately aligned.

For fine-positioning of the edit point, the tape can be moved forward or backward by manually turning the right-hand tape reel [3]. The tape tension control and the reproduce paths are enabled.

Marking the tape

The center of the reproduce head (head gap) can be marked on the reverse side of the tape by means of a grease pen or a soft pencil.

A tape marker [72] is available as an accessory. A light pressure on the marking lever marks the tape with a stamp exactly at the reproduce head gap.

The tape can subsequently be cut at the marked position.

Cutting the tape

The tape can be easily lifted off the reproduce head by means of antimagnetic scissors and cut exactly in front of the head gap.

If the position of the reproduce head gap has previously been marked, the tape can be transported up to the optional scissors [71] and cut or be inserted manually into the optional cutting block on the head shield or below the head block, and cut with a razor blade.

Splicing the tape

The two tape sections to be joined are inserted with the reverse (marked) side facing upwards the splicing block [10] or the cutting block [69]. The ends are butted together without overlap and spliced with an adhesive tab that is approx. 20 mm long and ¼" wide.

**2.4.25 "Waste basket mode"
TAPE DUMP [25]**

In "waste basket mode" (TAPE DUMP [25] key) the right-hand spooling motor [3] is disabled. Unwanted tape segments can thus be played into the waste basket.

When the TAPE DUMP [25] key is pressed, the machine switches either to play or preselects the "waste basket mode", depending on the programming with the jumper JP4 below the front cover.

- **Mode A** (JP4 in position L):

The TAPE DUMP [25] key functions as a preselector. The "waste basket mode" is activated by pressing the PLAY [28] key. The tape is played but not wound up.

The STOP [29] key interrupts the tape feed, but the TAPE DUMP function remains active until it is cancelled by pressing the TAPE DUMP [25] key again.

When the "waste basket mode" is active, all tape transport functions except < [26], PLAY [28], and STOP [29] are disabled.

- **Mode B** (JP4 in position H):

The "waste basket" mode is activated directly by pressing the TAPE DUMP [25] key. The machine stops when this key is pressed again.

Retraction of a loose tape segment
(only possible in TAPE DUMP mode A)

If too much tape has been unwound in "waste basket" mode, it is not necessary to rewind it manually. Simply tension the tape with two fingers of your right hand (preferably gloved) and continually hold down the < [26] key. The left-hand spooling motor [2] rotates and slowly takes up the loose tape. This process can be stopped by releasing the < key.

The motor torque is limited and controlled in such a way that the tape can be easily decelerated by hand. As soon as the tape is released, the motor continuous to run only very slowly. The motor speed can be increased by lightly tensioning the tape segment.

In order to wind up a loose tape segment with the right-hand spooling motor [3], the TAPE DUMP mode must be switched off by pressing the TAPE DUMP [25] key; the yellow led is no longer light. The tape can then be wound on the right-hand reel in short pieces by repetitively pressing the PLAY [28], < [26], or > [27] key.

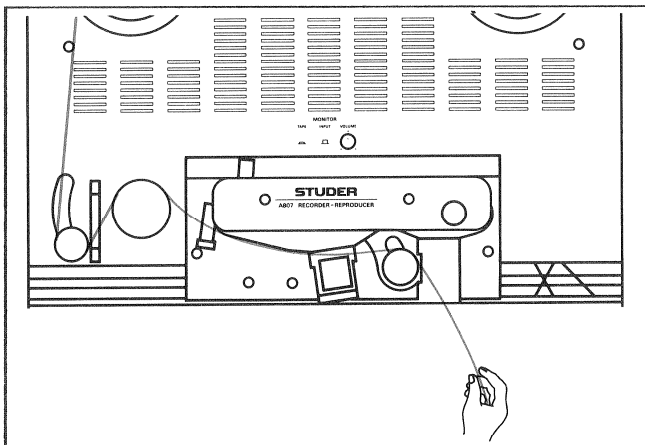

Fig. 2.4.8

Playing a discarded tape segment

After a long editing session it may happen that many tape sections have been cut and that it is no longer clear as to which piece belongs where and which end of the tape is the beginning or the end. With the A807 tape recorder you can play cut segments without first joining them and winding them on a reel.

Procedures:

- Thread the tape according to Fig. 2.4.9 and select the TAPE DUMP [25] function.
- With two fingers of your left hand tension the left-hand tape end in such a way that the tape makes contact with the head.
- In TAPE DUMP mode A start the reproduction by pressing the PLAY [28] key. The PLAY function can be cancelled by pressing the STOP [29] key.

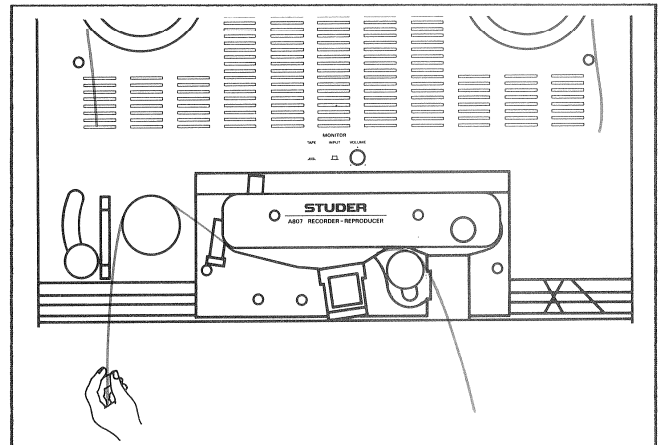

Fig. 2.4.9

2.5 PROGRAMMING

The four keys [21], [22], [60] and [61] of the A807 tape recorder can be assigned to different functions by changing jumper settings. After the round knobs have been removed by pulling them off and the four fixing screws have been unfastened, the cover of the operator panel can be removed and the jumpers become accessible.

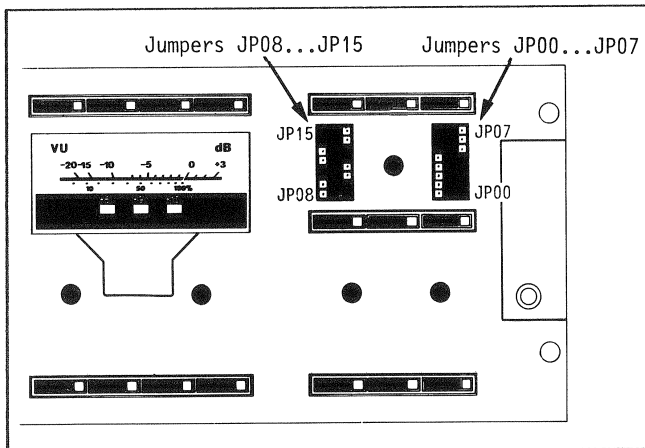

Fig. 2.5.1

For the sake of completeness, the functions of all jumpers are listed in the following table. To reassign the functions of keys [21] and [22], only the jumpers JP00, JP01, and JP02 need to be changed; for the keys [60] and [61] the jumpers JP05, JP06, and JP07 have to be changed. The listed jumper positions correspond to the standard settings of an A807 2 mm VU versions as shipped ex factory (software release 30/88).

		LEFT		(H = ON / L = OFF)	
		H	L		
VERSION	JP15	<input type="checkbox"/>	<input type="checkbox"/>	L = Standard speed version (3 ³ / ₄ /7 ¹ / ₂ /15 ips)	H = High speed version (7 ¹ / ₂ /15/30 ips)
VERSION	JP14	<input type="checkbox"/>	<input type="checkbox"/>	H = Standard version (Record/Reproduce)	L = PBD (PLAYBACK ONLY)
SPEED SWITCH	JP13	<input type="checkbox"/>	<input type="checkbox"/>	CHANGE-OVER H = WITH SHIFT	L = DIRECTLY
FADER START MODE	JP12	<input type="checkbox"/>	<input type="checkbox"/>	L L H H	SETTING
	JP11	<input type="checkbox"/>	<input type="checkbox"/>	A B C D	MODE
				L H L H	SETTING
LIFTER	JP10	<input type="checkbox"/>	<input type="checkbox"/>	H = MOMENTARY	L = FLIP-FLOP
VERSION	JP09	<input type="checkbox"/>	<input type="checkbox"/>	H = WITHOUT KEY	L = WITH READY KEY
ERASE HEAD GAP	JP08	<input type="checkbox"/>	<input type="checkbox"/>	H = IN-LINE	L = STAGGERED

Fig. 2.5.2

All jumper settings will be enabled only when tape recorder is switched off an on again.

		RIGHT			
		H	L		
CHANGE-OVER REPRO HEAD LEFT/RIGHT, NAB		X	L	L	H
CHANGE-OVER TAPE A/TAPE B, NAB					
CHANGE-OVER REPRO HEAD LEFT/RIGHT, CCIR					
CHANGE-OVER TAPE A/TAPE B, CCIR					
STANDARD POS., CHANGE-OVER NAB/CCIR					
PROGRAMMABLE AUDIO KEYS [60] AND [61]	JP07	<input type="checkbox"/>	<input type="checkbox"/>	H	L
	JP06	<input type="checkbox"/>	<input type="checkbox"/>	H	L
	JP05	<input type="checkbox"/>	<input type="checkbox"/>	H	L
TAPE DUMP	JP04	<input type="checkbox"/>	<input type="checkbox"/>	H = DIRECTLY	L = PRESELECTION
RECORD KEY	JP03	<input type="checkbox"/>	<input type="checkbox"/>	H = INDIVIDUALLY	L = WITH PLAY
PROGRAMMABLE COMMAND KEYS [21] AND [22]	JP02	<input type="checkbox"/>	<input type="checkbox"/>	H H H H L L L L	
	JP01	<input type="checkbox"/>	<input type="checkbox"/>	H H L L H H L L	
	JP00	<input type="checkbox"/>	<input type="checkbox"/>	H L H L H L H L	
KEY [21]	KEY [22]			1 2 3 4 5 6 7 8	
1 LOC 2	LOC 3				
2 LOOP	BACKSPACE				
3 LOC START	BACKSPACE				
4 LOC START	FADER READY				
5 LOC 2	LOC START				
6 LOOP	FADER READY				
7 LOOP	LIFTER				
8 LOOP	LOC START				

Fig. 2.5.3

2.5.1 Fader start mode

Four different fader start modes can be set with the jumpers JP11 and JP12.

FADER mode:	A	B	C	D
FADER READY KEY required		■	■	■
FADER READY KEY not required	■			
BUILT-IN MONITOR SPEAKER muted	■	■	■	■
FADER CLOSED: Tape recorder operable Tape recorder not operable	■	■	■	■
FADER OPEN: Tape recorder operable Tape recorder not operable	■	■	■	■

When one or both audio channels are switched to READY [31/42]:

- The tape recorder starts in record mode when the fader is opened, provided the SHIFT [18] key and the built-in FADER READY [22] key have been pressed (the yellow LED next to the key flashes to signal that record has been preselected).

Important:

If the machine is put into the so-called safe condition by deselecting the ready function with the READY key [31/42], or if the FADER READY function is reset by pressing [22], the record preselection is also cancelled.

2.5.2 Programming the audio parameters

When you press the microswitch adj [11] by means of a pointed tool, the A807 tape recorder is switched to audio alignment mode.

In this mode the display [17] of the tape timer no longer shows the current tape address but information concerning the audio parameters. The three red LEDs to the right of the display indicate which parameter is being displayed (functions identified with lower case letters: lvl, trbl, and bias). In addition the functions of the keys LAP [15], SEL [13], STEP [12], LOC START [21], and BACKSPACE [22] change to the functions specified in yellow lettering below the keys.

LAP = channel
SEL = parameter
STEP = store
LOC START = down
BACKSPACE = up
TAPE DUMP = input (only in models without output signal selector)

In adj mode the machine remains operable so that play and record commands can be entered and different tape speeds can be selected, and for switching over between CCIR/NAB, TAPE A/B, or HEAD A/HEAD B. The tape timer also continues to run internally.

Procedure:

A detailed description concerning the alignment of the audio parameters can be found in Section 4 of this manual. Only the method for entering the parameters is described here.

- Switch the machine to the alignment mode by pressing the adj [11] key.
- Select the desired tape speed, equalization standard, tape type or reproduce head by pressing the appropriate keys.
- Select the desired operating mode (REPRO, SYNC or READY+REC).
- Select the audio channel to be calibrated by pressing the channel [15] key.
- Select the parameter to be adjusted by pressing the param [13] key.
 - lvl = level adjustment
 - trbl = treble correction
 - bias = bias adjustment
- With the down [21] and up [22] key you can modify in the desired direction the decimal value and consequently the level selected with param [13].
- When the setting is correct, save the value by pressing the store [12] key.
- Press the adj [11] key again to quit the alignment mode. All modified values that have not been stored yet (identified by a flashing dot) will be lost. The machine continues to operate with the old data.

The display [17] e.g. shows the following information:

A1 .025 LED: lvl

The letter A in the first position of the display signals the "adj" mode.

The digit in the second position of the display specifies the audio channel: 1 = CH1 (left), 2 = CH2 (right).

The last three digits of the display specify the decimal value of the setting. (min. = 000, max = 255).

The dot between the numbers indicates whether or not the value has been stored.

- If the dot is continuously lit, the value has been stored.
- If the dot flashes (*), the value has been entered but not stored.

The program can be terminated by pressing the adj [11] key again. All values that have not been stored yet (flashing dot) will be lost.

However the newly updated parameter values become effective immediately. Those that have not been stored are only effective for as long as the program is not terminated.

Function chart

Function		Key		Indic.	Comment
panel	adj.	CH	LED		%flashing dot continuously lit
REPRO or SYNC or READY+ RECORD	up up up : up down store	1	lvl	A1 .025	Program call, last stored setting
				A1 #026	Level at 026
				A1 #027	Level at 027
				:	:
				A1 #255	Max. level
				A1 #254	Level at 254
	channel up : up down store channel param up store	2	lvl	A2 .030	Level at 030
				A2 #031	Level at 031
				:	:
				A2 #122	Level at 122
				A2 #121	Level at 121
				A2 .121	121 stored
channel down store	1	trbl	A1 .254	indic. level from CH1	
			A1 .122	treble setting CH1	
			A1 #123	treble at 123	
			A1 .123	123 stored	
channel down store	2	trbl	A2 .153	treble at 153	
			A2 #152	treble at 152	
			A2 .152	152 stored	
ONLY in READY+ RECORD	param up store	2	bias	A2 .089	Bias at 089
				A2 #090	Bias at 090
				A2 .090	090 stored
channel down store	1	bias	A1 .112	Bias at 112	
			A1 #111	Bias at 111	
			A1 .111	111 stored	
	adj				Quit program

Soft jumper 03 = light barrier

Soft jumper 03 switches the light barrier [8] on and off. When the light barrier is enabled, the machine switches to STOP when the transparent tape section is reached. The tape recorder responds as follows in the various modes:

- In PLAY mode the machine stops immediately when the transparent tape section is detected. If transparent tape is in front of the light barrier when the machine is in STOP mode, the desired tape transport function (e.g. PLAY) must be pressed until the tape with the oxide coating covers the light barrier.
- In spooling mode (< or >) the tape recorder stops immediately when the transparent tape is reached. If the spooling key is continuously pressed, the transparent tape section will be skipped.
- In fader start mode the tape recorder also stops when the transparent tape is detected. If the transparent tape is in front of the light barrier when the fader is closed, the tape recorder starts in play mode when the fader is opened, and stops when the next transparent tape section is reached.
- Transparent tape sections are ignored in all LOCATE functions (Z-LOC, LOC1, etc.). The tape is positioned directly at the target address.
- Transparent tape sections are ignored in waste basket mode (TAPE DUMP).
Indication: 03. 0 Light barrier disabled
03. 1 Light barrier enabled

Soft jumper 04 = mono/stereo changeover

Soft jumper 04 controls the mono/stereo changeover as a function of the selected tape speed (only active when MONO/STEREO switch is installed). When the changeover is enabled, the MONO priority is automatically activated when the machine is switched to either 3.75 or 7.5 ips. STEREO mode is automatically selected when the machine is started with 15 ips or 30 ips.

The selected status can always be changed by pressing the SHIFT [18] and MONO [55] keys.

- Indication: 04. 0 Speed-dependent M/S, priority setting disabled
04. 1 Speed-dependent M/S, priority setting enabled

Soft jumper 05 = timer stop for TAPE DUMP

With the soft jumper 05 a timer stop can be set in TAPE DUMP mode. In this case the content of the tape timer is frozen when the TAPE DUMP [25] is selected. It is not updated as long as the "waste basket" mode is active. As soon as this mode is terminated, the tape timer continues to run from the frozen reading.

- Indication: 05. 0 timer stop disabled
05. 1 timer stop enabled

Soft jumper 06 = retracting the pinch roller

With the soft jumper 06 the pinch roller [70] can be retracted to the idle position when an "out-of-tape" condition is detected. An out-of-tape condition is recognized when there is no tape tension (tape tension sensor [9] in the idle position) and if no tape is detected by the light barrier [8] (both conditions exist e.g. during tape editing).

When the STOP [29] function is initiated or when the tape is edited with TAPE DUMP [25], the pinch roller stays in the cueing position.

- Indication: 06. 0 retraction disabled
06. 1 retraction enabled

2.3.3 Programming the soft jumpers

Since the introduction of the software release 40/87, so-called soft jumper functions can be programmed in addition to other function changes. Soft jumpers are software switches that can be changed over in the "adj" mode.

The functions 04/05 and 06 are only implemented in software release 30/88.

Soft jumper 00 = mute time

With the soft jumper 00, the mute time during the STOP-PLAY transition can be individually entered for each of the three tape speeds within the range of 00 ms to 950 ms.

- Indication: 00. 100 100 ms mute time
00. 250 250 ms mute time

Soft jumper 01 = baud rate

The transmission rate (baud rate) of the serial RS232 interface can be set with the soft jumper 01. Two speeds can be set: 1200 or 9600 baud.

- Indication: 01. 12 baud rate = 1200
01. 96 baud rate = 9600

Soft jumper 02 = echo mode

Soft jumper 02 switches the echo mode of the serial RS232 interface on and off.

- Indication: 02. 0 no echo mode
02. 1 echo mode enabled

2.5.4 Selecting the soft jumper program

In order to activate the soft jumper program, the SHIFT [18] key must be held down while the adj [11] button is pressed with a pointed tool. The display [17] indicates e.g.:

00.150

The first two numbers of the display specify the number of the soft jumper (in our example: 00 = mute time).

The following number(s) specify the status of the selected soft jumper (in our example: 150 ms mute time).

The dot between the numbers indicates whether or not the setting is stored:

- Dot continuously lit (.) = value stored
 - Flashing dot (*) = value set but not stored yet.
- The keys with the yellow lettering on the operator panel change their functions as follows:
- Channel [15]. The soft jumpers are selected with this key. Each time this key is pressed the next soft jumper is selected (00 ... 01 ... 02 ... 03 ... etc. After the last jumper it wraps around to jumper 00).
 - The up [22] and down [21] keys change the status of the soft jumper (150 ms ... 200 ms ... 250 ms ... 200 ms).
 - The store [12] key saves the current jumper setting in memory.

The soft jumper program can be terminated by pressing the adj [11] key again. All settings that have not been stored yet (flashing dot) will be lost. However the newly updated soft jumper settings become effective immediately. Those that have not been stored are only effective for as long as the program is not terminated.

Funktion chart

Function	Key	Indic.	Comment
Program	SHIFT & adj	00. 150	Program call
Mute time:	up	00* 200	Mute time 200 ms
	up	00* 250	Mute time 250 ms
	:	:	:
	up	00* 950	Mute time 950 ms
	down	00* 900	Mute time 900 ms
	store	00. 900	900 ms stored
other speed:	up	00. 050	Mute time 50 ms
	up	00* 100	Mute time 100 ms
	store	00. 100	for other speed stored
Baud rate:	channel	01. 96	Baud rate 9600
	down	01* 12	Baud rate 1200
	up	01. 96	9600 Baud already stored!
Echo mode:	channel	02. 0	No echo mode
	up	02* 1	Echo mode
	store	02. 1	Echo mode stored
Light barrier:	channel	03. 0	Enabled
	up	03* 1	Disabled
	store	03. 1	Enabled is stored
* MONO/ STEREO CHANGE OVER:	channel	04. 0	enabled
	up :	04* 1	Disabled
	:	:	:
	:	:	:
	:	:	:
	etc.	etc.	etc.

* Can only be called up, if the equipment is accordingly equipped.

2.6 SERIAL INTERFACE RS232

The STUDER A807 tape recorder is equipped with a serial interface (RS232) for operation with a terminal, a computer, or for remote control of the tape deck functions.

2.6.1 RS 232 Standard interface

The term "RS232" defines a connection between a "terminal" (computer) and a "modem" (A807) for the purpose of exchanging data. In addition this standard defines the:

- Electrical characteristics (level, lines)
- Mechanical characteristics (connector)
- Signal descriptions
- Standard connections.

The interface can operate with a data rate of up to 19.2 k baud (On the A807/A810/A812/A820 up to 9.6 k baud) and cable lengths of up to 15 m. The signal levels are defined as follows

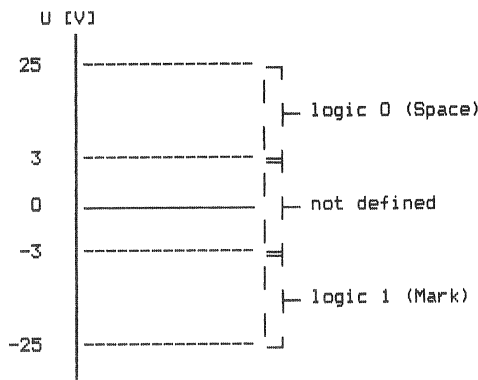

The 25-pin connector defined in this standard supports various interface structures. The full pin assignment is rarely used nowadays. Modern systems frequently use a minimal structure according to Fig. 2.5.4 for the terminal-modem or terminal-terminal connection and consequently need only a smaller 9-pin connector.

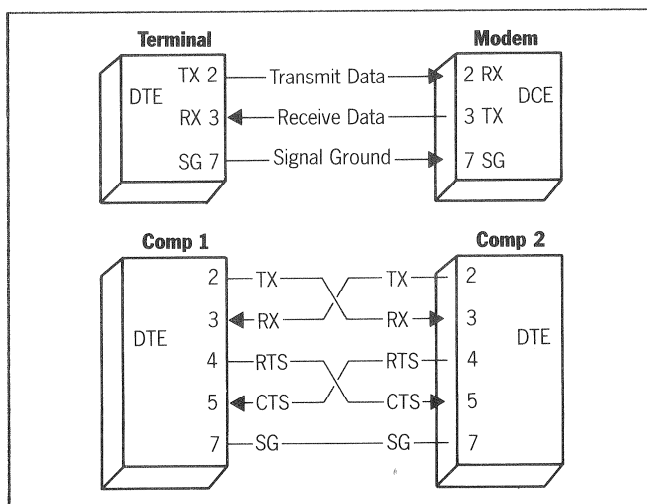

Fig. 2.5.4

All parameters (e.g. baud rate, code, synchronous/asynchronous connections, number of start/stop bits, parity, hardware/software handshake) are defined by the manufacturer.

2.6.2 RS 232 Interface of the A807

A 9-pin connector is used for the serial interface of the A807 tape recorder. With a correspondingly prepared adapter cable it is possible to define whether a unit should function as a terminal or a modem.

Recorder 9-pin		Terminal 25-pin		Modem 25-pin	
Signal	Pin no.	Signal	Pin no.	Signal	Pin no.
SNDATA	2	Trans. Data	2	Trans. Data	3
RCVDATA	8	Rec. Data	3	Rec. Data	2
GROUND	9	Signal-Ground	7	Signal-Ground	7

No additional handshake lines are used. A software handshake (X ON / X OFF protocol) is implemented for all transmission rates, however it is only required for 9.6 k baud.

X ON = 0001 0001 (ASCII: DC1) = resume

X OFF = 0001 0011 (ASCII: DC3) = interrupt

Upon receipt of an X OFF, the tape recorder still transmits up to 2 characters. After the tape recorder itself has transmitted X OFF, it can still receive five characters without losing a command.

Fixed settings:

- 1 start bit
- 1 stop bit
- 8 data bits
- No parity bit

The baud rate can be set with the aid of soft jumper 01 (1200 or 9600 baud). Only ASCII characters are admissible as data!

2.6.3 Working with the serial interface RS 232

The computer or the terminal are to be connected to the tape recorder by means of an adapter cable fitted with a 9-pin socket.

The computer or the terminal must be set as follows:

1 start bit, 8 data bits, 1 stop bit, no parity bit, no echo mode, baud rate 1200 or 9600 baud. The handshake lines CTS and RTS are to be connected to "LOW".

After a RESET of the tape recorder (switching the tape recorder off and on again), the following message is displayed on the screen: A807

The desired commands can now be entered via the terminal keyboard according to the table below. Most commands are not executed until the ENTER or LINE FEED key is pressed.

Command list:

Tape deck commands		
Command (_ =blank, / = CR, * = blank or CR)	Response of the A807	Explanation
STP*	<CR><LF>	Stop
RWD*	<CR><LF>	Rewind
FWD*	<CR><LF>	Fast forward
PLY*	<CR><LF>	Play
REC*	<CR><LF>	Record (directly without PLAY)
SSA* #1	<CR><LF>	3,75 ips (9,5 cm/s)
SSB* #1	<CR><LF>	7,5 ips (19 cm/s)
SSC* #1	<CR><LF>	15 ips (38 cm/s)
SSD* #1	<CR><LF>	30 ips (76 cm/s)
NS?*	X<CR><LF> X = 1 Byte HEX	Inquiry of nom. speed where:
	X = 00	9,5 cm/s (3.75 ips)
	X = 01	19 cm/s (7.5 ips)
	X = 02	38 cm/s (15 ips)
	X = 03	76 cm/s (30 ips)
VEN*	<CR><LF>	Varispeed external on
VEF*	<CR><LF>	Varispeed ext. off
FEN* #2	<CR><LF>	FADER START ENABLE on
FEF* #2	<CR><LF>	FADER START ENABLE off
EDT*	<CR><LF>	Lifter disabled during spooling
LFT*	<CR><LF>	Lifter enabled during spooling
LOC_<hh:mm:ss>	<CR><LF>	Positioning at the ti- mer reading hh:mm:ss e.g.: LOC_01:20:15 or : LOC_-1_03_22
LMV_<XXXXXX>	<CR><LF>	Positioning at the number of tacho- roller pulses <XXXXXX> = 3 Byte HEX e.g.: LMV_00AE4F
MV?*	XXXXXX<CR><LF> 3 Byte HEX	Read out the number of tacho roller pulses
STM_<hh:mm:ss>	<CR><LF>	Set timer to hh:mm:ss e.g.: STM_-0:43:57 or : STM_00_55_12
TM?*	hh:mm:ss,xx <CR><LF> xx = xx/256 s	Read out timer content

Tape deck commands (continuation)		
Command (_ =blank, / = CR, * = Blank or CR)	Response of A807	Explanation
ST?*	X<CR><LF> X = 1 Byte HEX X = 81 X = 01	Tape deck status where: Tape out position Tape mounted, no tension
	X = 82	STOP,tape tension yes
	X = 02	STOP not achieved
	X = 83	Rewind achieved
	X = 03	Rewind not achieved
	X = 84	Fast forward achieved
	X = 04	Fast forward not achieved
	X = 85	PLAY achieved
	X = 05	PLAY not achieved
	X = 86	Varispeed
	X = 89	Record achieved
	X = 09	Record not achieved
	X = 8A	Reverse play achieved
	X = 0A	Reverse play not achieved
	X = 59	TAPE DUMP selected
	X = 09	TAPE DUMP active
	X = C0	SHUTTLE active
	X = 40	SHUTTLE not achieved
	X = C2	Positioning at LOC
DST* #3	<CR><LF><_hh:mm :ss,xx_Y> xx = xx/256 s	Continuous indication of the tape deck status with counter reading and status
	Y = Status 1 Byte HEX	
LCD*	<CR><LF>	Local keypad off
LCE*	<CR><LF>	Local keypad on
SD?*	00.WW.YY WW = Woche YY = Jahr	Inquiry of soft- ware release date

Notes:

- #1 Only possible if speed changeover is not interlocked with the SHIFT [15] key by means of jumper JP13 (below the front cover).
- #2 Only feasible in FADER START MODE B, C, or D
- #3 Terminate continuous status indication with Control X.

Audio commands		
Command (_ = blank, / = CR, * = blank oder CR)	Response of the A807	Explanation
SNB*	<CR><LF>	Select NAB
SCR*	<CR><LF>	Select CCIR
REA_i*	<CR><LF>	channel i to READY
SAF_i*	<CR><LF>	Cancel READY of channel i
INP_i*	<CR><LF>	Set channel i to INPUT
SYN_i*	<CR><LF>	Set channel i to SYNC
REP_i*	<CR><LF>	Set channel i to REPRO
MTN_i*	<CR><LF>	Set channel i to MUTE
MTF_i*	<CR><LF>	Cancel MUTE of channel i i = 1, 2 or F 1 = channel 1 2 = channel 2 F = both channel
ION*	<CR><LF>	Switch on INSERT (MONO)
IOF*	<CR><LF>	Switch off INSERT (STEREO)
AP?_i,j*	XX<CR><LF> XX=1 Byte HEX	Inquire audio parameter i = channel 1 or 2 j = D/A converter 0 = Level REPRO/SYNC 1 = Treble REPRO/SYNC 4 = Level RECORD 5 = Treble RECORD 6 = Bias
PAP_i,j,xx* xx = 1 Byte HEX	<CR><LF>	Set audio parameters without storing i = channel 1 or 2 j = D/A converter 0 = Level REPRO/SYNC 1 = Treble REPRO/SYNC 4 = Level RECORD 5 = Treble RECORD 6 = Bias
SAP_i,j,xx* xx = 1 Byte HEX	<CR><LF>	Set audio parameters and store i = channel 1 or 2 j = D/A converter 0 = Level REPRO/SYNC 1 = Treble REPRO/SYNC 4 = Level RECORD 5 = Treble RECORD 6 = Bias

THE ABOVE LIST COMMANDS MAY NOT NECESSARILY BE COMPLETE.
IT WILL BE UPDATED OR EXTENDED AS REQUIRED.

2.7 CARE INSTRUCTIONS

Daily care is limited to cleaning the soundheads, the capstan shaft, and all elements that come in contact with the tape.

Dust and oxide particles of the magnetic coating accumulate principally on soundheads and the tape guidance elements. This can lead to drop outs.

Cleaning should, therefore, be performed daily, or if contamination is visible, even more frequently.

For proper care of the tape recorder we recommend the STUDER CLEANING KIT (part No. 10.496.010.00). It contains everything required for cleaning a tape recorder:

- Head cleaner
- Aluminite cleaner
- Felt sticks
- Cleaning rag

Procedure:

Moisten a felt stick or the cleaning rag with a small amount of head cleaner and clean the soundheads and all elements that come in contact with the tape. Use a second felt stick or a dry section of the cleaning rag to wipe the cleaned parts dry.

Normally, the capstan shaft does not rotate when the recorder is not switched to play mode. For cleaning purposes a special function has been provided: When the magnetic tape is unthreaded (tape tension sensor in idle position, light barrier not covered), the capstan shaft continues to rotate for as long as the PLAY [28] key is pressed.

For cleaning aluminum surfaces use the special aluminite cleaner. It removes the dirt and restores the metallic lustre of the aluminum.

Caution:

Make sure that neither head cleaner nor aluminite cleaner penetrates into the bearing of the capstan shaft!

The acrylic panels of the VU-meters are not resistant to solvents!

Lubricating the capstan bearing:

The capstan motor and its sintered-sleeve bearing are virtually maintenance-free. To replenish the oil or grease in the bearing, oil lubricated sintered-sleeve capstan bearings should be re-oiled semiannually, and grease lubricated sintered-sleeve capstan bearings should be re-greased annually or after a prolonged idle period.

Particularly in the case of oil lubricated sintered-sleeve bearings, the oil can eventually escape through the bearing gap when the shaft is aligned vertically.

For relubrication use only the recommended lubricants!

For oil lubricated capstan motors the synthetic oil ISOFLEX PDB 65 (Part No. 20.020.401.04) should be used.

For grease lubricated capstan motors (in production since 1.1.1988, identified with a **red label**), only the liquid grease CONSTANT GLY 2100 (Part No. 20.020.401.10) should be used.

Procedure:

On oil lubricated capstan motors lift off the upper plastic bearing cap and apply a few drops of oil to the felt.

On grease lubricated capstan motors (red label) lift off the upper plastic bearing cap and apply a few drops of liquid grease into the bearing gap (between the capstan shaft and the bearing).

Note:

The bearing seat of capstan shafts is ground to the internal diameter of the pressed-in sintered-sleeve bearing within very close tolerances. For this reason it is impossible to replace the capstan shaft in the field if any service is needed.

Capstan motors should always be shipped to the national STUDER dealer for overhaul.

CONTENTS	SECTION 3
3. TAPE DECK ELECTRONICS	1
3.1 CIRCUIT DESCRIPTION	1
3.1.1 Introduction	1
3.1.2 Power supply	1
3.1.3 Control (TAPE DECK ELECTRONICS, GR 10)	1
3.1.4 TAPE TENSION SENSOR BOARD 1.727.320. (GR13)	2
3.1.5 SPOOLING MOTOR CONTROL 1.727.340.XX	2
3.1.6 CAPSTAN MOTOR CONTROL 1.727.330. (GRP 20)	4
3.1.7 Command panel	6
3.2 DISMANTLING THE ASSEMBLIES	7
3.2.1 Headblock assembly	7
3.2.2 COVERS	7
3.2.3 TAPE DECK ELECTRONICS PCB 1.727.350 GR10	8
3.2.4 Amplifier module	8
3.2.5 Panel	9
3.2.6 Tape lifter	9
3.2.7 Pinch roller assembly	10
3.2.8 Tape tension and tape move sensor	10
3.2.9 Tape brakes	11
3.2.10 Spooling motors	11
3.2.11 Spooling motor control	11
3.2.12 Spooling motor filter	11
3.2.13 Spooling motor Tacho	11
3.2.14 Capstan motor	11
3.2.15 Capstan motor control	12
3.2.16 Power transformer	12
3.3 MECHANICAL ALIGNMENT	12
3.3.1 Brake maintenance	12
3.3.2 Brake adjustment	12
3.3.3 Pinch force adjustment	13
3.3.4 Head adjustment check	14
3.3.5 Tape lift solenoid	14
3.3.6 Tape tension sensor	14
3.3.7 Tape tension	15
3.3.8 Lifting Pin	15
3.3.9 Capstan motor control	15
3.3.10 Varispeed circuit	15
3.3.11 Transparent tape sensor	15

3. TAPE DECK ELECTRONICS

3.1 CIRCUIT DESCRIPTION

Note: A summary of all electronic assemblies is given in the following Section 3.1.1, "Introduction". The assemblies are described individually in the Section 3.1.2 and following. A description of the AUDIO CONTROL and AUDIO ELECTRONICS assemblies can be found in Section 4.

3.1.1 Introduction

The entire electronics can be subdivided into function blocks (refer to block diagram):

- Power supply unit comprising the power transformer, rectifier, filtering (GR 2...6), and stabilization (part of GR 10).
- TAPE DECK ELECTRONICS (GR 10) which is the heart of the machine; it supplies control commands to all other assemblies.
- SPOOLING MOTOR CONTROL, GR 11.
- CAPSTAN MOTOR CONTROL, GR 20.
- COMMAND PANEL, GR 30.
- Audio assemblies (refer to Section 4.1).

In addition there is a number of peripheral devices such as sensors, remote control interfaces, and feedback which are described in conjunction with the assemblies in which they are incorporated.

3.1.2 Power supply

The power supply is connected via an IEC connector with built-in primary fuse and an RF rejection filter to a voltage selector with which the line voltage can be set within the range of 100...140 V and 200...240 V.

Five electrically isolated secondary windings are connected individually via secondary fuses to the rectifiers and filtered. The smoothing is so efficient that power interruptions of up to approx. 100 ms duration do not adversely affect the operation. Each secondary voltage is produced individually; only the +60 V is cascaded from +20 V and +40 V.

The stabilized phantom supply for the microphone socket is derived from the +60 V. It normally is 48 V but it can also be changed to 24 V or 12 V by changing the resistors R23, R25, and R30 (refer to circuit diagram). The circuit is current limited; if due to excessive current the voltage drop across R 18 is larger than on D8 (D 9 is required for compensating the voltage drop across the basis/emitter link of Q8), Q8 blocks and consequently also Q9.

From the same non-attenuated voltage also the 25 V for controlling the EEPROMs is derived. The voltage reference is implemented with the Zener diodes D5 and D6.

The operating voltage for the logic is derived from a non-attenuated voltage of 24 V by a switching regulator (IC1) whose pulse duty factor is controlled as a function of the load. This switching regulator is clocked by the 76 kHz equipment clock (from IC 11/6). The filter circuit comprising L1 and C 5..7 are used for smoothing the output voltage. Because the TTL circuit is very sensitive to surge voltages, a crowbar circuit (Q2) has been provided which is triggered by D2 in the event of a voltage surge.

The operating voltage of ± 15 V is produced via normal three-step regulators (IC2 and 3).

The logical PWRON, signal derived from Q1, is of particular importance because 40 ms after a power failure it initiates a data protection routine via the switching regulator, i.e. at a time when the logic still functions correctly. Certain equipment states such as the tape speed and the selected equalization are saved in the EEPROMs so that this information is available when power returns. Other functions, particularly RECDRD and READY are not saved but are set to the default setting after power is restored. Example: If the machine was in record mode, STOP mode is activated after the power is switched on again.

3.1.3 Control (TAPE DECK ELECTRONICS, GR 10)

For the block diagram of this section please refer to page 6/4.

The CPU is a microprocessor type 6803 (IC12) that is clocked with a frequency of 4.9 MHz. It processes the various inputs and outputs corresponding commands to the connected assemblies.

The resident microprocessor program is stored in two EPROMs (IC14 and 15); a RAM chip (IC16) with a capacity of 2 x 8k is used for working storage. Data and parameters that should automatically be reestablished after power is switched on again are saved in EEPROM IC10 each time the power is switched off (refer to table).

Input signals are supplied by the following assemblies:

- a.) MOVE SENSOR GR 24. The sensor signals are produced on the Move Sensor board; the light produced by the LEDs DLQ1 and 2 is switched off rhythmically by a rotating disc with rectangular serrations. The disc is driven by a tape guide roller which means that the frequency of the move sensor signal is a measure of the tape speed. The tape move direction can also be determined from the overlapping of the signals. The receiving photo transistors control Q1 or Q2 respectively; when they are through-connected, the current through the diode is increased by R3 or R7 respectively, causing the square-wave signal to become steeper.

The final signal shape is produced by the Schmitt trigger stages IC5 when they are input to the tape deck electronics board.

b.) SPOOLING MOTOR TACHO GR 17...18. Each spooling motor has its own tachometer whose circuit corresponds largely to the one of the move sensor. Since the signal frequency is proportional to the spooling motor speed, the pancake diameter can be measured by comparing the signals from the spooling motor tachometer and the move sensor.

The tachometer signals 1 M1-TACHO and M2-TACHO are taken to IC8 and IC9. The tachometer signal 2 is divided by 16 in IC9; in spooling mode the CPU can thus determine whether it wants to track the individual tachometer signals (input P13) or the divided signal (input P12).

- c.) Operator entries from the control panel are buffered in coded form in register IC 27 (see 3.1.6).
- d.) The M3-SYNC signal (input P11) indicates that the capstan motor has synchronized to its control frequency.
- e.) Commands can also originate from outside the machine:
- From the remote control (PARALLEL REMOTE CONTROL) or the SYNCHRONIZER PARALLEL PORT with buffer in registers IC29 and 30.
 - From the connected bidirectional RS 232 interface.

Commands are output via the registers IC 25, 26, 28 and 31 as well as the RS 232 interface and the SYNCHRONIZER PARALLEL PORT. IC 18 functions as an address decoder for the ports in both directions.

Unconventional is the control of the take-up spooling motor. Normally the tape tensions are controlled on both sides by means of tape tension sensors or similar devices. However, there is no such sensor on the right-hand side of the STUDER A807; for this reason the control information for the right-hand motor must be obtained in a different way. The CPU knows the speed of the tape (move sensor) and the rotational frequency of the take-up motor (tachometer 2). From these values it computes the required tape tension which is output to the spooling motor control via the D/A converter IC24. From the move sensor information the CPU also knows the spooling speed and limits it to approx. 10 m/sec.

3.1.4 TAPE TENSION SENSOR BOARD 1.727.320. (6R13)

The tape tension sensor is equipped with an oscillator that oscillates with a frequency of approx. 833 kHz. The coupling of this signal from L1 to L2 is more or less damped by a shaped part mounted on the tape tension sensor so that a DC voltage proportional to the tape tension is obtained on C3 after rectification by D2. Through summation in C2 with the reference voltage for full tape tension sensor deflection set with R16, and subsequent inversion, the following voltage should be available on TP1 if the alignment is correct:

+4 V in the absence of any tape tension
0 V for maximum tape tension

The gain of IC2 is adjusted with R11.

3.1.5 SPOOLING MOTOR CONTROL 1.727.340.XX

For the block diagram of this section please refer to page 6/25.

The principle is as follows:

The tape tension sensor controls the unwinding motor. From the ratio of the tape move speed (move sensor pulse) and the rotational frequency of the take-up motor the microprocessor computes the control voltage for the take-up motor.

The allocation of the control voltage to the corresponding motor is

achieved with the commutation IC7.

The output voltage of the TAPE TENSION SENSOR BOARD (AN-TTENS) is taken via pin 4 of connector J2 to the spooling motor control 1.727.340.XX. IC1/2 adds the tape tension reference value selected by IC2 to the ACTUAL tape tension value. The following reference values can be connected in accordance with the tape deck function:

- Reference value for PLAY tape tension
- Reference value for fast forward (FORW) tape tension
- Reference value for fast rewind (REW) tape tension
- Reference value for library wind speed (LIBR)

These four references are selected by means of the two signals MS-REFA and MS-REFB from register IC25 of the TAPE DECK ELECTRONICS BOARD 1.727.350.XX.

The aggregate signal of IC1/2 is now taken to the input of IC1/1 which normally functions as a buffer. Via the FET Q4 the control voltage is taken to the previously mentioned commutation IC7 which in fast forward mode supplies the tape tension sensor signals to the summation IC11/2. This IC functions as an inverter, except in shuttle mode. The (M1-CTL) signal can be measured on test point 4 and is taken via the comparator IC13/2 to the positive input of the pulse width modulator IC14/2.

The negative input of IC14/2 receives a saw tooth voltage of 76 kHz which is produced from the 76 kHz microprocessor clock (MS-C76k). This square-wave signal is converted by C12 to needle pulses. The wiring of the current source Q9 ensures that the capacitor C21 is charged to operating voltage. With each needle pulse, transistor Q8 becomes conductive, causing the capacitor C21 to be discharged and recharged. The result is a saw tooth voltage that is available on the negative inputs of the pulse width modulators IC14/1 and IC14/2. The pulse duration on the output of the pulse width modulator IC14/2 is determined by the deflection of the tape tension sensor, i.e. the magnitude of the DC voltage. The higher the DC voltage the larger the pulse width on the output.

The pulse width modulated signal connects the small-signal transistor Q12, and the power transistors Q6 and Q7 connect the operating voltage for the spooling motors (+50 V) in the 76 kHz rhythm. The L/C element integrates the signal so that the required power for the spooling motor is available in the U-M1 signal.

The voltage for the other motor is supplied in a similar way, except that the DC voltage does not originate from the tape tension sensor but from the microprocessor (refer to block diagram).

The DC voltage M2-REFAN, computed by microcomputer from the ratio of the rotational speeds of the tape move sensor and the take-up motor is taken via pin 14 of connector J3 to the potentiometer R35 so that the maximum control voltage (10 V on TP5) can be set.

Via the amplifier IC5/1 and the commutation IC7 the signal is applied to the negative input of the summation amplifier IC11/1. The M2-CTL signal is taken via the comparator IC13/1 to the pulse width modulator IC14/1 and connects the operating voltage +50 V via the transistors Q13, Q10, and Q11. The U-M2 voltage filtered by the storage choke L2 and by C25 is now taken to the corresponding spooling motor.

The three phases R, S, and T of the two 3-phase asynchronous spooling motors are controlled via the complementary power transistors BWD47 and BDW42.

For the left-hand motor M1 the transistors Q15, Q19 or Q23 connect one of the three phases to the positive voltage, and a second phase is connected to 0 Volt by one of the three transistors Q17, Q21, or Q25.

The PROM IC15 (IC18) ensures that the transistors switch in the correct sequence so that always one phase of the spooling motor is connected to the positive voltage, while the second phase is connected to 0 Volt. The third phase remains de-energized. Through the correct sequential commutation of the individual phases by means of the PROM, a rotary field is produced that puts the motor into motion.

The sense of rotation of the spooling motor is determined by the two signals M1-DIR and M2-DIR. The following rules apply:

- With a high signal the motor rotates in the take-up direction
- With a low signal the motor rotates in the supply direction.

The speed with which the individual phases are changed over determines the rotational frequency of the take-up motor.

The square-wave signal M1-TSENS of the left-hand spooling motor on pin 4 of connector J5 of the SPOOLING MOTOR TACHO LEFT 1.727.315 board and the square-wave signal M2TSENS of the right-hand spooling motor on pin 4 of connector J5 of the SPOOLING MOTOR TACHO RIGHT 1.727.316 board are taken via a Schmitt trigger IC4 to the commutation IC8 which connects the signal of the take-up motor to the mono flop IC6, depending on the tape move direction. For each incoming control edge this mono flop supplied a pulse of constant width.

After the integrator C9/1 a DC voltage (FRQ-CTL) is produced that controls the VCO IC17 (voltage controlled oscillator). On output 3 a frequency depending on the input voltage of the VCO is produced that is subsequently divided by the frequency divider IC16 and which is used by the two PROMs as the clock for controlling the individual motor phases.

The following rule applies:

The higher the speed of the take-up motor the larger the number of constant-width pulses that appear on the output of IC6. This results in a smaller DC voltage after the integrator which in turn leads to a higher control frequency of the spooling motor that ranges from 35 to 70 Hz.

The result is that the commutation frequency of the spooling motors is adjusted so that an even higher speed is achieved.

In play mode the MS-PRESS signal disables the mono flop via the inputs 3/13. The resulting DC voltage GRQ-CTL is 12 V which corresponds to a motor frequency of 35 Hz.

To prevent "singing" of the motor due to fast commutation of the phases, the spooling motor control has been equipped with the SPOOLING MOTOR FILTER 1.727.342 board.

Each phase R, S, T is allocated a 47 µF capacitor that is connected to 0 Volt. In play mode the MS-PRESS signal, which after the inverter IC4 is called C-MOTFLT, connects a 100 µF parallel capacitor (C1, 3, 5 as well as C 7, 9, 12) via the transistor Q7 by means of the transistors Q1 to Q6 so that the individual phases are loaded with 147 µF.

In rewind mode the MS-REW signal trips the commutation IC7. The tape tension sensor is now allocated to the right-hand (supply) motor, and the reference voltage from the MPU is allocated to the left-hand (take-up) motor.

The following functions are responsible for smooth changeover of the tape deck functions without creating tape loops:

- The comparator IC3/1 checks the position of the tape tension sensor and via transistor Q3 supplies the tape end signal (S-TAPOUT) when the tape tension sensor returns to the neutral position. (comparison with 3.7 V reference). At the same time the FET Q4 interrupts the control signal to the supplying motor.

- However, if the tape tension becomes too high (tape tension sensor fully deflected, i.e. the voltage on pin 5 of IC5/2 is lower than 0 V), the comparator IC5/2 short circuits the control voltage of the MPU via the FET Q5.

- To prevent excessive tape tensions, particularly when the tape is accelerated, a starting aid is activated:

In order to keep the output of IC1/1 always positive, this IC functions as a buffer (non-inverting amplifier when Q1 is high impedance), but it can also operate as an inverter (controlled by voltage level) when Q1 is conductive.

This changeover occurs when the tape tension is so high that the output voltage of IC1/2 changes to zero and the MS-DIR signal is high. In this case the sense of rotation of the supply motor is reversed via the capstan direction dependent commutator IC7. This means that during the brief start-up phase the supplying motor pushes the tape rather than back tensioning it which results in greater acceleration (start kick).

The MS-SHUTL signal activates the shuttle mode via the switch IC8. This switch connects the R-SHUTL2 voltage, tapped on the shuttle potentiometer, to the comparator IC10/2. If the output voltage on IC10/2 is zero, the tape tensions are the same as in play mode. The tape does not move.

If the shuttle voltage on test point TP6 is positive, the right-hand motor is controlled with the M2-CTL voltage via the summing amplifier IC11/1, i.e. the tape moves to the right. If the shuttle voltage is negative, IC11/2 controls the left-hand motor via the M1-L voltage so that the tape is transported to the left.

The TTA-SHT potentiometer can be aligned to prevent the tape from standing still in the neutral position of the shuttle wheel.

A negative feedback circuit ensures that the spooling speed in shuttle mode is limited and kept constant. The pulses of the move sensor MS-MVCLK are taken from pin 12 to the mono flop (IC6) which in turn supplies constant width pulse that is integrated by IC12 and IC9/2. The tape direction dependent MS-MVDIR signal connects the integrated signal either directly by means of IC8 or via the inverter IC10/1 and is thus added to the shuttle voltage.

3.1.6 CAPSTAN MOTOR CONTROL 1.727.330. (GRP 20)

For the block diagram of this section please refer to page 6/39.

The capstan motor is equipped with a capacitive tachometer ring which is connected to pins 1 and 2 of the connector J3/EL3.

IC1 is an FM demodulator IC which is supplied by a 5.5 MHz oscillator (circuit with Q1). The frequency can be aligned with L2. Pins 5 and 6 are connected to the demodulator circuit that comprises coil L1 and the capacitive tachometer ring. When the capstan motor rotates, the mid frequency of the demodulator circuit changes in the rhythm of the rotation. This frequency is available on the AF output signal 8 as a sine-shaped signal that is amplified by IC3/2. The output signal can be by L1 aligned to maximum amplitude on test point TP 2.

The frequency on test point TP 2 depends on the selected tape speed and in synchronous operation is:

- 300 Hz at 3 3/4 ips
- 600 Hz at 7½ ips
- 1200 Hz at 15 ips
- 2400 Hz at 30 ips

IC3/1 is wired as a Schmitt trigger and IC4/1 as an amplifier. When the tape speed is 3 3/4 ips the square-wave signal is taken directly to the output 13 of the analog switch IC14.

At the other three tape speeds the square-wave voltage is divided in the frequency divider IC13, and the switching IC14 selects the dividing ratio as a function of the speed in such a way that 300 Hz are always available at the output 13 when synchronism is achieved.

The correct dividing ratio is selected by IC12 which actuates the changeover switch by decoding the data line via the transistors Q16, Q17. The logic table above the switch contains information on the two control bits and the corresponding switch setting.

IC17 is a data register which is controlled via a serial data input (M3-DATA), a clock signal (M3-CLK), and a strobe signal (M3-EN). These control signals are converted from serial to parallel in the IC and buffered.

Since the original square-wave signals are available on the output 13 of IC14 only at 3 3/4 ips tape speed, R20 must be aligned to a symmetrical pulse/pause ratio (wow and flutter).

The tachometer signal is now taken to the frequency-to-voltage converter. IC18 is a monoflop that is controlled with both signal edges so that the frequency is doubled. A pulse of approx. 16 µs is available on output 6 and a pulse of approx. 42 µs on output 9 which controls a sample/hold circuit.

- The longer pulse charges the capacitor C47 via the transistor Q22.
- The shorter pulse closes the analog switch IC19/4 which transfers the current charge voltage of C47 to the hold capacitor C44. This capacitor retains its charge until the next sample is loaded to the hold capacitor via switch 19/4.

The sampled DC voltage is subsequently taken to the inverting input of the comparator IC16/1 which compares the ACTUAL tachometer signal value with the reference.

The reference frequency can be either the MPU clock frequency M3-9600 divided down to 9600 Hz, or the output frequency M3-REFEX of an external varispeed remote control, or an internal varispeed frequency. The latter is generated in the VCO (voltage controlled oscillator) IC6 from the DC voltage tapped on the varispeed potentiometer RE1.

At 3 3/4 ips the transistor Q34 connected by the commutator IC14 limits the lower varispeed range to approx. minus 1.5 semitones (approx. 8%) at the summing input of 2/2.

The analog switch IC8 selects the reference signal (9600 Hz for nominal speed) via the transistor Q2 on the frequency divider IC10 which divides the frequency by 16. As a result, the reference signal and the tachometer signal after the monoflops IC11 and IC18 have the same frequency, i.e. 600 Hz for nominal speed.

The reference signal is now taken via the frequency-to-voltage converter Q3 and IC19/2 comprising the charging capacitor C35 and the holding capacitor C36 to the positive input of the comparator IC16/1.

When synchronism is achieved the sampled DC voltages on the outputs of IC17/1 (TP-9) and IC15/2 are approx. 7 V. When the tachometer voltage and reference voltage are approximately within 5% of each other after the start or a speed changeover, the comparator IC22/1 responds and outputs a synchronism signal.

During the capstan start phase or extreme speed changes, control is principally performed by the frequency-to-voltage converter by comparing the reference frequency and the tachometer frequency.

The phase comparison of the two frequencies compensates minor fluctuations in synchronous operation.

The phase comparison circuit consists of an integrator IC15/1 that is cyclically short-circuited by the reference signal via IC19/3. This results in a saw tooth signal. This circuit is followed by a differentiating element IC19/1 and C42 which is cyclically enabled by the tachometer signal. Similar to the frequency-to-voltage converter this is a sample/hold circuit with C37 serving as the charging capacitor and C42 as the holding capacitor. Refer to the following detail diagram.

The correction signal which is proportional to the phase comparison is now available at the output of IC17/1 and is added to the positive input of the comparator IC16/1. The control voltage resulting from the frequency and phase comparison now passes through a passive integrator IC16/2 and is taken via the summing amplifier IC20/1 to the pulse width modulator IC22/2.

IC21 converts the 76 kHz clock M3-C76k to needle pulses which via the transistor Q23 periodically discharge the capacitor C58 that has been charged by the current source C24. A saw tooth voltage is again generated.

The DC voltage from the summing amplifier IC20/1 determines the pulse duty factor which controls the switching regulator (Q25 to Q33) via the input transistor Q31.

The operating voltage (+50.0 V) clocked by the power FETs (Q32 and Q33) is smoothed by the storage choke L3 and C56 and supplied to the capstan motor M3.

The capstan motor is a three-phase synchronous motor that features the same type of control as the spooling motors, i.e. one phase (M3-R, M3-T or M3-S) is connected via the corresponding transistor Q15, Q11 or Q7 respectively to the positive voltage of the switching regulator. A second phase is connected to ground by one of the three transistors Q14, Q10 or Q6 while the third phase remains de-energized.

Three Hall elements built into the motor detect the magnet field of the rotor and signal it via the three amplifiers IC5/1, IC5/2, and IC4/2 to the PROM IC9 which cyclically controls the individual phases as a function of the momentary rotational motor speed. The effect is that the electrical rotating field and the mechanical position of the motor are in harmony which is essential for a synchronous motor.

The PROM read-out direction for reverse play is determined by the M3-DIR signal from the decoder C12.

The supply voltage for the three Hall elements is decoupled from the 5 V by the two diodes D1 and D2.

When a capstan motor stop command is initiated, the M3-STOP signal short-circuits the input and the output of IC16/1 with the transistors Q21 and Q18 respectively to ensure that no control voltage is supplied to the pulse width modulator IC22/2. The M3-STOP signal prevents control of the individual motor phases at the input 13 of PROM IC19.

The comparator IC2/1 monitors the supply voltage of the PROM IC9 to prevent simultaneous through-connection of all three phases.

The resistor R130 measures the total current through the motor and supplies this value to the comparator IC20/2. Via IC12 the two signals (current select) connect the maximum admissible starting current through the two transistors Q19, Q20, defined at the outputs 4 and 5 of the microprocessor, to the inverting input 6 of IC20/2.

Both comparators (IC2/1 and IC20/2) add their output currents directly to the control current Uout of the summing amplifier IC20/1.

Circuit changes effective with modification index .22:

To improve the wow-and-flutter performance at 15 ips and 30 ips, the SPEED-B signal increases the gain of IC16/1 by 6 dB via the transistors Q37 (Q2*) and Q36 (Q3*).

During the start phase the uncharged capacitor C53 which determines the control voltage causes an interruption. For this reason the transistor Q35 (Q1*) supplies the starting voltage until the M3-SYNC signal indicates synchronism of the capstan motor with the preset reference frequency. At this point the capacitor C53 has also been charged with the control voltage.

*The transistor designation in parentheses apply to the capstan PCBs 1.727.330.22 with the supplementary board 1.727.332.00 (Capstan Start CTL Board).

3.1.7 Command panel

The command panel (COMMAND PANEL BOARD, GR 30) processes the operator entries and indicates the states by means of various displays.

The displays are controlled by chips type SAA 1061 which also perform a latching function. The chip control is implemented with the signals:

- DS-DATA: serial data with a leading 2-bit address
- DS-CLK: clock and
- DS-ENLED: enable function

Up to four SAA 1061 chips can be accessed with the leading 2-bit address; in the maximum system configuration three such chips are used in the tape deck itself and a fourth one in the console pen-house.

The keyboard is arranged as a matrix. In order to prevent continuous scanning of the keyboard by the CPU, the keyboard does not become active until a key has been pressed and consequently a bit of the line byte D0 ... D7 has changed. At this moment the CPU starts to scan the columns by means of Q10 through Q16 while simultaneously decoding the answer of the line byte. From this information it is possible to determine the exact key that has been pressed.

When the machine is powered on, the columns Q8 and Q9 are activated. As a result all default conditions set with the jumpers JP0 to JP15 will be scanned.

The VU-meters (if configured) are controlled by the precision rectifiers IC 2/1 and 2/2 as well as IC 6/1 and 6/2 respectively. The three LEDs per channel for indicating peak values at +6 dB, +9 dB, and +12 dB are driven by individual comparators. As is customary for peak indicators, the resetting time of all three LEDs is delayed by C8 (C11).

3.2 DISMANTLING THE ASSEMBLIES

WARNING:

UNPLUG THE AC POWER CORD BEFORE YOU REMOVE ANY HOUSING PANELS OR BEFORE YOU REMOVE ANY ELECTRICAL ASSEMBLY!

3.2.1 Headblock assembly

Head cover

- Unfasten two screws [A] (hexagon-socket-screw key size 3)

Headblock cover

- Remove the head cover. Swing up the hinged headshield in front of the reproduce head.
- Unfasten four screws [B] (hexagon-socket-screw key size 2.5)

Headblock

It is not necessary to remove the head cover and the headblock cover in order to deinstall the headblock!

IMPORTANT! IN ORDER TO PREVENT INADMISSIBLE MAGNETIZATION OF THE HEADS, THE TAPE RECORDER MUST BE SWITCHED OFF WHEN YOU REMOVE OR INSTALL THE HEADBLOCK.

- Unscrew the pinch roller cover (hexagon-socket-screw key size 2.5).
- Unfasten the three screws (accessible through the holes [C] in the headblock cover) with the aid of a hexagon-socket-screw key size 3. Before removing the headblock check whether the pinch roller is in its rest position; if not, push lever D.
- Carefully lift off the headblock so that the capstan shaft will not become damaged.

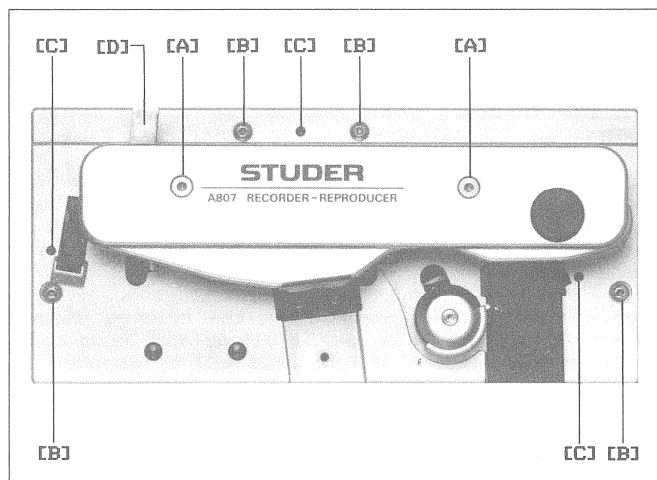

3.2.2 COVERS

Transport cover

- Remove the guide roller (small guide roller of the tape tension sensor) without any tool. The pinch roller can be removed with a screwdriver size 2.5.
- Remove the headblock cover (or headblock).
- Unfasten seven screws (two of these are accessible through one hole each in the to slicing rails) with the aid of a hexagon-socket-screw key size 2.5.
- Lift off the cover.

Operating panel

- Turn the knobs (1 to 7, depending on recorder model) to the clockwise limit position and pull them off.
- Unfasten 4 screws (hexagon-socket-screw key size 2.5)
- Lift off the panel

Monitor panel

- Unfasten 2 screws (hexagon-socket-screw key size 2.5)

Rear panel

- Set the recorder in upright position.
- Unfasten seven screws (hexagon-socket-screw key size 2.5)
- When you reinstall the rear panel make sure that the position of the two serrated lock washers is correct: on the left and right-hand side in the middle.

End panel/power supply cover

- Turn the recorder in upright position.
- Remove the rear panel
- Unfasten the mounting screws of the slide switch PHANTOM POWERING (if this option is installed) with the aid of a hexagon-socket-screw key size 2.
- Unfasten the screening plate below the MIC INPUT sockets (this plate is fastened with the same screws on the PHANTOM POWERING switch).
- Unfasten the XLR input sockets (MIC and LINE INPUT). One screw each is accessible through a fourth hole in the socket (without contact); approximately one 90° counterclockwise turn (screwdriver size 00) is required. Carefully push the inserts inward.
- Power inlet: Disconnect the stranded wire of the protecting ground (yellow/green) as well as the two stranded wires (brown and blue, in grey plastic tube) from the power inlet.
- Unfasten eight screws (hexagon-socket-screw key size 2.5).
- Also unfasten the ninth screw on the ground terminal while gripping the nut and the washer on the bottom.
- Slide the cover lightly backward.

- Unfasten the inserts of the XLR output connectors (LINE OUTPUT). The screw is well visible (same position as for the input sockets). Approximately one 90° counterclockwise turn (screwdriver size ØØ) is required. Carefully push the inserts inward.
- On reinstallation make sure that first the XLR output connectors (LINE OUTPUT) are installed with the cover in place but lightly shifted to the back. The cover can subsequently be screwed on and the remaining connectors can be mounted to this cover.
- On reinstallation make sure that the position of the two serrated lock washers is correct: on the left and right-hand side next to the connectors.

Wooden side panels

- Unfasten four screws each (hexagon-socket-screw key No. 4)

3.2.3 TAPE DECK ELECTRONICS PCB 1.727.35Ø GR1Ø

The TAPE DECK ELECTRONICS PCB with its heat sink is located in the middle of the rear part of the recorder and extends across its full width. It can be swung down in order to gain better accessibility.

- Remove the rear panel
- At the right-hand and left-hand rear corner of this assembly there is one latch each (accessible through the cutouts in the heat sink contour). Press both latches inward and swing down the printed circuit.

Dismantling:

- Separate all plug connections.
- Open or separate all cable ties that fix the cables against the inside of the frame.
- The pivots also consist of latches; these have to be released in order to deinstall the assembly.
- On reinstallation make sure that the latches are engaged in the corresponding recesses of the unit. The cable must be reattached to the frame by means of cable ties (Part No. 35.Ø3.Ø1Ø9).

If repairs are necessary please return the circuit board together with its frame for replacement.

3.2.4 Amplifier module

- AUDIO CONTROL PCB 1.727.4ØØ.GR 4Ø
- AUDIO ELECTRONICS PCB 1.727.42Ø GR 41/42
- AUDIO ELECTRONICS PCB 1.727.421 GR 41/42
- AUDIO ELECTRONICS PCB 1.727.425 GR 41/42 (PBO version)
- INSERT, e.g. MONO/STEREO SWITCH INPUT PCB 1.727.44Ø GR 44 OUTPUT PCB 1.727.445 GR 45

a.) Pulling out the amplifier module

- Remove the rear panel (see 3.2.2)
- The amplifier board is located below the TAPE DECK ELECTRONICS PCB and extends across the full width of the tape recorder. A latch is located at the lower right and lower left corner of the module. Press in both latches so that the module can be pulled back to the rear stop position.
- Separate all plug connections
- The stop consists of two additional latches.

b.) Removing the AUDIO ELECTRONICS PCB

- Unfasten all plug connections on both AUDIO ELECTRONICS PCBs.
- Certain PCB versions feature two retaining brackets; unfasten them with a hexagon-socket-screw key size 2.5.
- To remove the PCB channel 1 GR 41 (located closer to the front panel) the retaining bar of the INSERT PCB(s) (if configured) must first be unfastened, otherwise its removal will be obstructed by the heat sink.
- One nut pin each is pressed into the upper left and right corner of the AUDIO ELECTRONICS PCB. Lift the circuit board simultaneously on both pins by means of a suitable tool (screwdriver). To prevent damage, utmost care is necessary because of the numerous plug contacts.

c.) Removing the INSERT PCBs (if configured)

- These modules (e.g. MONO/STEREO switch) which can be switched on and off by means of the INSERT key on the front panel are located on the AUDIO CONTROL PCB 1.727.4ØØ between the two AUDIO ELECTRONICS PCBs 1.727.42Ø...
- Separate all plug connections on the rear AUDIO ELECTRONICS PCB and on the INSERT PCB.
- Unfasten two screws each to the left and the right of the mounting rail and carefully lift the assembly.
- In order to remove the INSERT PCB we recommend that you remove the AUDIO ELECTRONICS PCB GR 42 (channel 2) located closer to the rear panel. This provides better access to the INSERT PCB.

d.) Removing the amplifier module

- Remove the AUDIO ELECTRONICS PCBs and the INSERT PCBs (see above).
- Unfasten the plug connection on the narrow side of the AUDIO CONTROL PCB 1.727.4ØØ.
- The two latches that form the stop of the drawer mechanism can now be released one at the time.

e.) Installing the amplifier module

- The installation is performed in the reverse order. When you plug in the connecting cables make sure that the connector assignment is correct (labelling on the connectors, numbering from left to right, viewed from the rear toward the recorder:

EL 1, EL 2b, EL 2A, EL 3, EL4...EL 7

GR 41 = channel 1, front (front panel)
GR 42 = channel 2, rear

- On reinstallation also make sure that the latches engage in the corresponding guide rails.

3.2.5 Panel

- COMMAND PANEL PCB 1.727.360 GR 30 (without VU meter)
- COMMAND PANEL PCB 1.727.361 GR 30 (with one VU-meter)
- COMMAND PANEL PCB 1.727.362 GR 30 (with two VU-meters)
- COMMAND PANEL PCB 1.727.363 GR 30 (2/2 version, without VU-meters)
- COMMAND PANEL PCB 1.727.364 GR 30 (PBO version, reproduce only)
- DISPLAY PCB 1.727.370.00 GR 31

COMMAND PANEL

The COMMAND PANEL PCB is inserted into the recorder from the front and is fixed by the command panel.

In order to remove this board proceed as follows:

- Set the recorder upright
- Remove the rear panel, swing down the TAPE DECK ELECTRONICS PCB.
- Unplug the 3-pin connector (brown/red/orange connector labelled "GR 11, EL 06") on the SPOOLING MOTOR CONTROL PCBs above the pinch solenoid.
- Remove the operating panel (see 3.2.2).
- Unplug the VU-meter connections, if existing (brown stranded wire).
- Pull the assembly slightly toward the front, separate the multiple plug connection, and carefully pull the connecting cable (brown/red/orange) from the SHUTTLE potentiometer to the SPOOLING MOTOR CONTROL PCB through the slot toward the front.

SHUTTLE UNIT

- Unfasten 2 screws on the front of the push button unit (hexagon-socket-screw key size 2.5).
- Carefully pull out the SHUTTLE UNIT toward the back.

DISPLAY PCB:

Carefully pull the PCB out of the socket. Make sure that the pins are not bent.

Narrow key housing:

- Squeeze the clips (on the solder side) and simultaneously pull the key housing from the component side toward the circuit board in order to cancel the mechanical pretension. The key housing can be lifted off after all clips have been released.
- Considerable pressure is required for reinstalling the housing. For correct engagement of the clips some assistance with a screwdriver may be necessary. Make sure that all clips are engaged properly.

Wide key housing (with large tape command keys)

- Release the four clips on the solder side. Lift off the key housing.

VU-meters, lamps for VU-meter illumination

- Unplug the stranded red (left) and black (right) connecting wires. Release the two clips on the solder side. Remove the measuring instrument.
- The bulbs (6 V, 30 mA, glass socket T 1½) are located in the sockets below the measuring instrument.

Pilot LEDs

- All LEDs on the COMMAND PANEL PCB are of the plug-in type. The cathodes of the LEDs always point either toward the right or the top.

Switching mats

- The rubber contact mats can be lifted over the LED sockets after the key housings and the LEDs have been removed.
- On reinstallation make sure that the protrusions on the underside of the contact mat engage in the corresponding holes of the COMMAND PANEL PCB.

3.2.6 Tape lifter

The explanations are enhanced by the illustration on page 8/4. The number in brackets refer to the information in this illustration. The same numbers can also be found on the on the opposite page.

Tape lifter assembly:

- Set the tape recorder in upright position.
- Remove the headblock (3.2.1).
- Remove the transport cover (3.2.2)
- Unscrew the monitor speaker, if configured (1 x IS screwdriver size 2, 1 x size 2.5). Do not detach the connecting cable (no plug connection).
- Remove the circlip of the driving pin [4.3].
- Unhook the tension spring of the latch on the pin of the pinch roller arm, unhook the tension rod on the left-hand tape lift lever.
- Unfasten 2 screws [2.18] (hexagon-socket-screw key size 2.5)
- Remove the tape lifter assembly while simultaneously released the plastic clips from the pin of the pinch roller arm.
- On reinstallation make sure that first the plastic clips and then the tension spring of the latch are hooked into the pin of the pinch roller arm; subsequently engage the tension rod of the latch in the left-hand tape lift lever.

Tape lift solenoid

- Remove the circlip of the driving lever [4.3], remove the driving lever.
- Unfasten 2 screws [5.6] (hexagon-socket-screw key size 3)
- Carefully remove the solenoid toward the front. Do NOT tilt it, otherwise the armature drops out.
- Unplug the stranded connecting wires (grey, violet) at the solenoid.
- On reinstallation make sure that the polarity is correct! (violet = +).

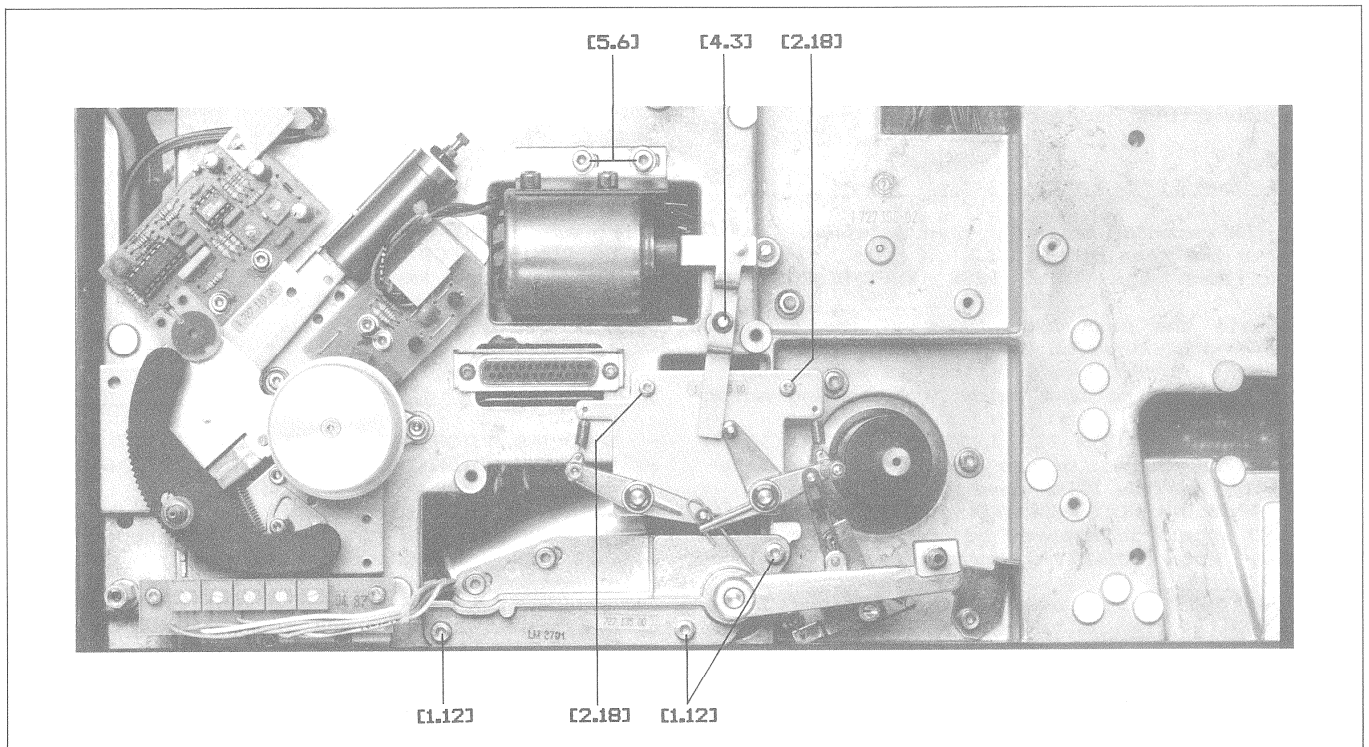
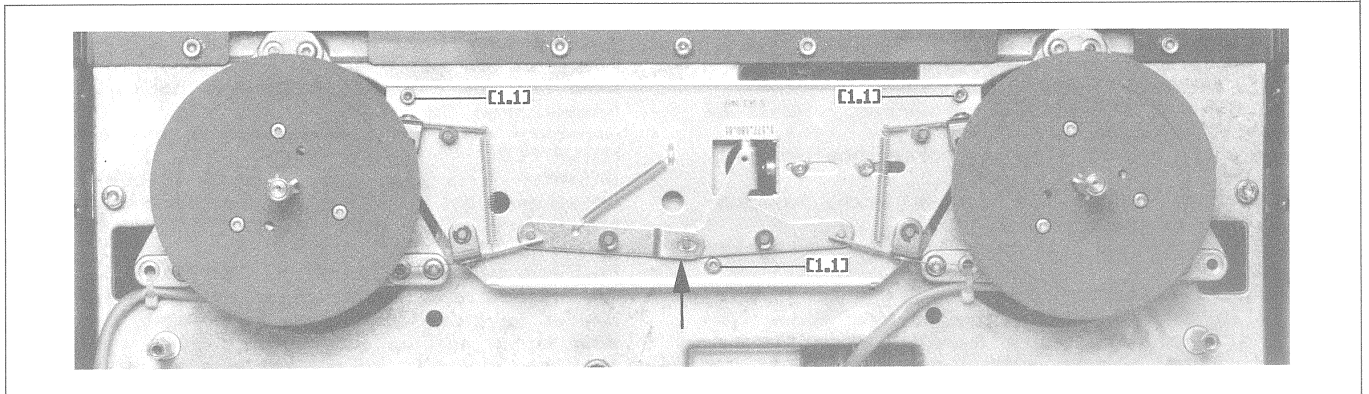

3.2.7 Pinch roller assembly

- Set the record in the upright position.
- Remove the headblock (3.2.1)
- Remove the transport cover and the rear panel (3.2.2).
- Unscrew the monitor speaker, if configured (1 x hexagon-socket-screw size 2, 1 x size 2.5). Do not detach the connecting cable (no plug connection).
- Remove the circlip of the drive lever [4.3].
- Remove the tape lifter (3.2.6)
- Unplug the stranded wires (grey, violet) from the solenoid.
- Unfasten 3 screws [1.12] (hexagon-socket-screw key size 3).
- Carefully remove the pinch roller assembly toward the front and observe the positioning of the tension lever.
- On reinstallation make sure that the polarity of the connections is correct! (violet = +).

3.2.8 Tape tension and tape move sensor

- TAPE TENSION SENSOR PCB 1.727.320 GR 13
- TAPE MOVE SENSOR PCB 1.727.321 GR 24
- Remove the transport cover (3.2.2)
- Unplug one connecting cable each on the TAPE TENSION SENSOR PCB and on the TAPE MOVE SENSOR PCB.
- Unfasten 3 screws (only the one without locking paint!) (hexagon-socket screw key size 2.5)
- Lift off the assembly.

3.2.9 Tape brakes

- Set the recorder in upright position.
- Remove the rear panel (3.2.2)
- Unplug the 2 stranded wires (brown, violet) of the brake solenoid.
- Restore the recorder to its normal position.
- Remove the transport cover (3.2.2).
- Remove the spindles (3 screws each, hexagon-socket-screw key size 2.5).
- Unfasten 3 screws [1.1] (hexagon-socket-screw key size 2.5).
- Unplug the connecting cable.
- Apply light pressure to the movable connection of the two brake levers from the front to disengage the brakes sufficiently so that the brake chassis can be carefully lifted off (see picture).

The brake bands should be neither kinked nor touched on the inside with ungloved hands! Kinked brake bands should be replaced. If they are contaminated they can be cleaned with ethanol.

- On reinstallation make sure that the polarity of the connections is correct! (violet = +).

3.2.10 Spooling motors

- Set the recorder to the upright position.
- Remove the rear panel (3.2.2).
- Swing down the TAPE DECK ELECTRONICS PCB (3.2.3).
- Separate the plug connections of the spooling motor feeder lines on the SPOOLING MOTOR FILTER PCB. This circuit board is located in the right-hand half of the unit below the spooling motor (viewed from the back).
- The CAPSTAN MOTOR PCB 1.727.330 GR 20 (3.2.14) should be removed before you remove the take-up motor (on the left, viewed from the rear).
- The SPOOLING MOTOR CONTROL PCB 1.727.340 GR 11 (3.2.11) should be removed before you remove the supply motor (on the right, viewed from the rear).
- Guide out the spooling motor feeder lines through the chassis toward the front.
- Swing up the TAPE DECK ELECTRONICS PCB and lock it.
- Restore the recorder to the normal position.
- Remove the spindles (3 screws each, hexagon-socket-screw key size 2.5).
- Remove the brake chassis (3.2.9). After reinstallation the brakes must be readjusted (see 3.3.2). Do not touch the brake lining (reddish fabric) with ungloved hands!
- Unfasten three screws on each spooling motor, screwdriver size 3.
- Lift out the spooling motor toward the top.
- On reinstallation make sure that neither the ring gear nor the light barrier into which the former engages, become damaged.

3.2.11 Spooling motor control

- SPOOLING MOTOR CONTROL PCB (1.727.340 GR 11)
- Set the recorder in the upright position.
- Remove the rear panel (3.2.2).
- Swing down the TAPE DECK ELECTRONICS PCB (3.2.3).
- Pull out the amplifier module to the stop position (3.2.4).

- Separate the plug connections of the spooling motor feeder lines on the SPOOLING MOTOR FILTER PCB. This circuit board is located in the right-hand half of the unit below the spooling motor (viewed from the rear).
- Separate all plug connections on the SPOOLING MOTOR PCB.
- Unfasten 4 screws. The lower 3 screws can be unfastened by inserting the screwdriver between the lowered TAPE DECK ELECTRONICS PCB and the pulled out amplifier module.
- Pull out the SPOOLING MOTOR CONTROL PCB.
- On reinstallation make sure that the serrated washer is placed below the right-hand, upper fixing screw (ground connection). Also make sure that the polarity of the supply voltage feeder line is correct: the plus marking on the circuit board corresponds to the red positive line. Also make sure that the position of the insulated cover is correct: no connecting cables should be routed between the insulating cover and the circuit board.

3.2.12 Spooling motor filter

- SPOOLING MOTOR FILTER PCB 1.737.342 GR 12

This subassembly is plugged into the SPOOLING MOTOR CONTROL PCB and fixed with 2 screws (hexagon-socket-screw key size 2.5). It should be unplugged after the SPOOLING MOTOR CONTROL PCB has been removed.

3.2.13 Spooling motor Tacho

- SPOOLING MOTOR TACHO LEFT PCB 1.737.315 GR 17
- SPOOLING MOTOR TACHO RIGHT PCB 1.727.316 GR 18

The infrared light barriers on the SPOOLING MOTOR TACHO PCBs scan the ring gear on the spooling motor. 64 pulses are generated for each revolution.

For field repairs we recommend that only the fixing screws are unfastened and the circuit board with its cable harness should be left inside the unit.

- Unfasten 2 screws (hexagon-socket-screw key size 2.5).
- For complete removal of the left-hand SPOOLING MOTOR TACHO PCB it is necessary to remove the CAPSTAN MOTOR CONTROL PCB and the SPOOLING MOTOR CONTROL PCB (3.2.11 and 3.2.14).
- For complete removal of the right-hand SPOOLING MOTOR TACHO PCB it is necessary to remove the SPOOLING MOTOR CONTROL PCB (3.2.11).
- Unplug the connecting cables (yellow/green/black) on the SPOOLING MOTOR CONTROL PCB 1.727.340 GR 11 and unthread the cable.

3.2.14 Capstan motor

- Set the recorder in the upright position.
- Remove the headblock (3.2.1).
- Remove the transport cover and the rear panel (3.2.2).
- Disengage all latches of the TAPE DECK ELECTRONICS PCB 1.727.350 GR 10 and slide the circuit board to the back and down as far as the cable connections allow it.
- Separate the cable connections of the capstan motor control feeder lines on the CAPSTAN MOTOR CONTROL PCB.
- From the front unfasten three fixing screws of the capstan motor (hexagon-socket-screw key size 3) while supporting the motor on the back. When removing the motor toward the back and the reinstalling the motor proceed carefully to prevent any damage to the capstan shaft.

3.2.15 Capstan motor control

- CAPSTAN MOTOR CONTROL PCB 1.727.330 GR 20
 - Set the recorder in the upright position.
 - Remove the transport cover (3.2.2).
 - Swing out the TAPE DECK ELECTRONICS PCB toward the back.
 - The CAPSTAN MOTOR CONTROL PCB is located to the left and above the capstan motor (viewed from the back of the recorder).
 - Unplug all connecting cables, unfasten 4 screws (hexagon-socket-screw key size 2.5).
 - On reinstallation make sure that a serrated washer is inserted under each of the four fixing screws (ground connection). Also make sure that the polarity of the feeder lines is correct: the plus marking on the circuit board corresponds to the red positive line. Also make sure that the position of the insulated cover is correct: no connecting cables should be routed between the insulating cover and the circuit board.

3.2.16 Power transformer

- Set the recorder in the upright position.
- Remove the transport cover (3.2.2)
- Remove the power supply cover (3.2.2)
- Unplug the multiple connector of the RECTIFIER PCB 1.727.310 GR 6 on the right-hand face (viewed from the back of the recorder).
- Unfasten the RECTIFIER PCB (4 screws, hexagon-socket-screw key size 2.5) and turn it to the left.
- Remove four shock protection tabs from the transformer terminals.
- Unplug the cable connections leading from the transformer to the voltage selector; sequence from left to right:

brown, red, orange, yellow, green, blue, violet, grey

- Unfasten the 4 fixing screws of the power transformer (hexagon-socket-screw key size 3).
- Lift out the power transformer.

When returning the power transformer for repair, please send only the transformer 1.727.305.00 without the bottom plate and cover plate.

3.3 MECHANICAL ALIGNMENT

Prior to mechanical alignments please check whether all connectors are correctly inserted and properly seated.

Check supply voltage and switch on.

3.3.1 Brake maintenance

Brakes which lack appropriate checking and alignment can cause damage to tapes. Please check frequently if braking is smooth and constant and if there are no tape loops even with very different spool diameters.

Brakes and brake bands have to be clean and free of grease. Cleaning can be performed with methylated alcohol. Please take care that brakes or brake bands are not touched with fingers after having been cleaned.

Brake bands must not be kinked and should touch the brakes on their full width.

3.3.2 Brake adjustment

a) Height of brakebands

When turning the reel flanges the brake bands must always be in the middle of the brake lining.

b) Brake chassis alignment

The brake bands are supported by a common chassis, the brake chassis.

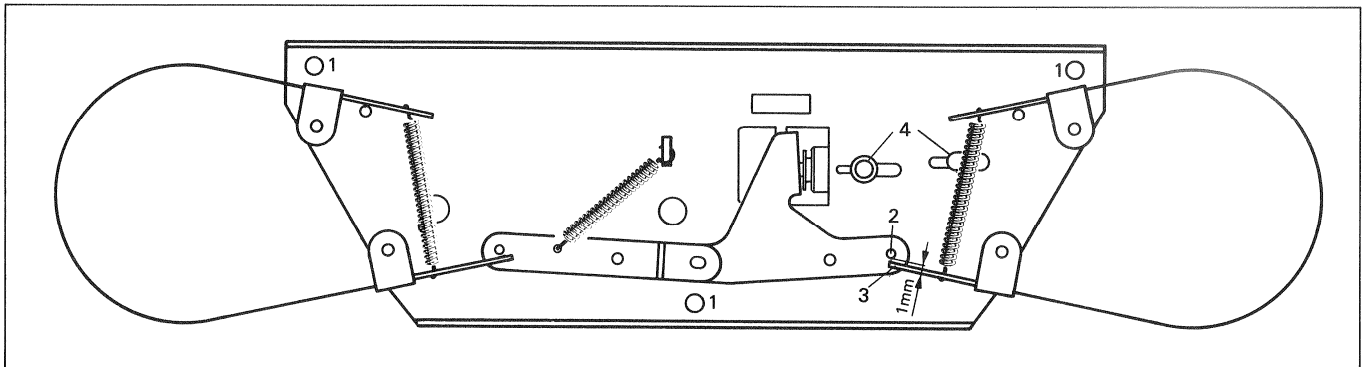

By pulling the brake chassis in direction to the rear of the unit it can be aligned in such a way that the brake levers [3] have a clearance of approx. 1mm to the lifting pin [2] when braked. If a clearance of 1 mm is not adjustable the front brake lever has to be gently bent.

By shifting the brake chassis parallel to the front edge of the unit lifting of both pins can be adjusted to be equal.

c) Brake solenoid adjustment

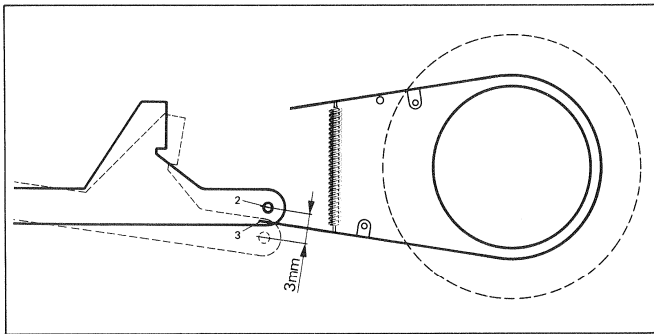

Move the tape tension sensor out of its idle position and press the "SHUTTLE" key. The brake will open; the lifting pin will travel 2 to 3 mm out of its rest position (see figure). The brake bands must not touch the brake drum when the reel flange is turned. Adjust by shifting the solenoid; tighten the screws [4] again firmly.

When turning the reel flanges the brake bands must always be in the middle of the brake lining.

d) Checking the brake torque

After alignment a measurement of the brake torque is advisable (see figure).

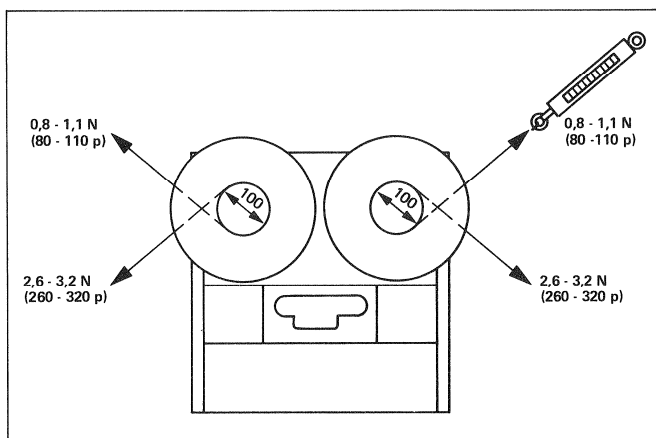

Are the obtained results different from the data in the figure and you are sure that the brakes and brake bands are absolutely clean, try to hook the springs at a different position.

3.3.3 Pinch force adjustment

- Remove the pinch roller cover (Allen key 2.5) and turn the screw back into the shaft.
- Move the tape tension sensor out of its rest position. Press the TAPE DUMP key (if thy TAPE DUMP key has been jumper-programmed to a preselection key, the PLAY key must be pressed also).

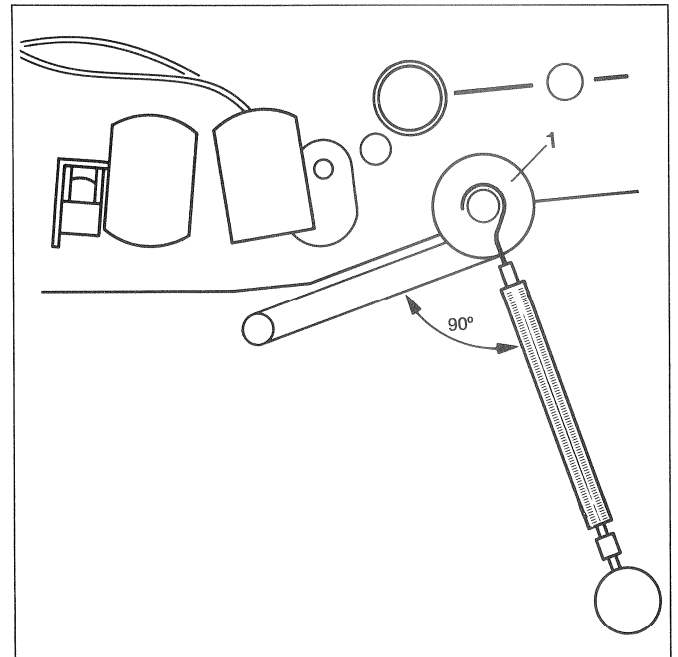

- Hook the spring dynamometer into the screw and pull the spring dynamometer perpendicularly to the pinch roller arm until the pinch roller lifts off the capstan shaft. The dynamometer should give a reading of 8 .. 10 N (800 .. 1000 p). If the reading is above or below this range, lightly loosen the two fixing screws of the pinch roller solenoid (Allen key No. 3) and carefully shift the solenoid until the normal value is attained. Retighten the solenoid screws.

Make sure that the arm moves smoothly to the rest position; if not, the solenoid is out of line.

Verifying the adjustment:

- Move the tape tension sensor out of the rest position.
- Press the pinch roller arm lightly with one finger against the capstan until the pinch roller just starts to turn.
- Press the TAPE DUMP key (depending on programming together with PLAY).

Now the pinch roller should again move slightly but clearly visibly towards the capstan. This ensures that the pinch roller solenoid pulls through completely so that only the tension spring in the solenoid armature constitutes the coupling between the solenoid lever and the pinch roller arm. Check by repetition that this process is clearly visible.

If no perceptible play can be observed the pinch roller force must be increased by shifting the solenoid in line.

3.3.4 Head adjustment check

Check the headblock on a levelling plate or on a flat glass plate. Height and perpendicularity may be tested by means of the gauge order no. 10.010.001.02 and the reference block order no. 10.010.001.01.

When fixing the head block again push the headblock completely towards the rear of the unit while tightening the fixing screws.

Be absolutely sure to have power off during removing or installation of the headblock (danger of magnetizing the heads).

3.3.5 Tape lift solenoid

- Switch power on and load a tape. Press a wind key.
- Loosen the two lower screws of the tape lift solenoid and adjust that the tape is lifted 2 mm off the heads but without touching the raised headshield.
- Check that the armature moves freely in the solenoid. The internal monitor speaker must be dismantled for that check.
- After alignment tighten screws again firmly. Reinstall the speaker.

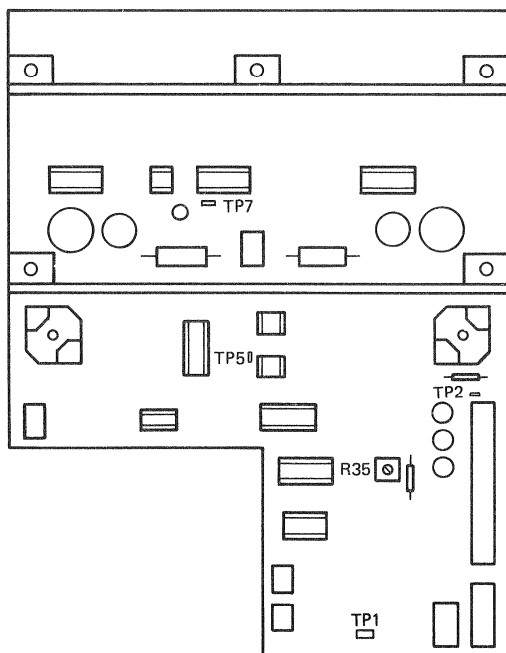

3.3.6 Tape tension sensor

At first put machine in upright position:

- Load tape.
- Connect Voltmeter to TP 5 (+) and TP 2 (ground) on the SPOOLING MOTOR CONTROL PCB 1.727.340 (GR 11).
- Hold the right tape pancake with your hand and switch the machine to FAST FORWARD.
- Adjust 10.0 Volt DC by means of R 35 on this board.
- Stop the machine.

Then put machine to the horizontal position:

- Connect voltmeter to TP 1 (+) and TP 2 (ground) on the TAPE TENSION SENSOR PCB 1.727.320 (GR 13).
- Press tape tension sensor to the rear until distance "X" (see figure) is 85 mm. With the upper trimmer pot R 16 adjust to 0.0 V; with the tape tension sensor released to the rest position (approx. distance of "X" = 46 mm) adjust +4.0 V by means of the lower trimmer pot R 11. The allowed tolerance is ± 0.05 V.
- Re-check both readings and correct, if necessary.

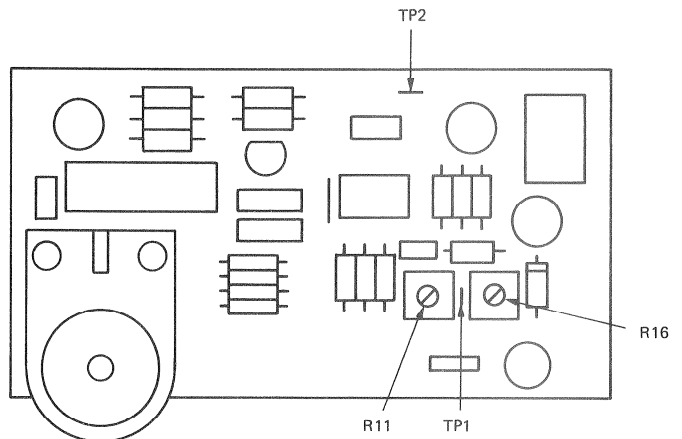

3.3.7 Tape tension

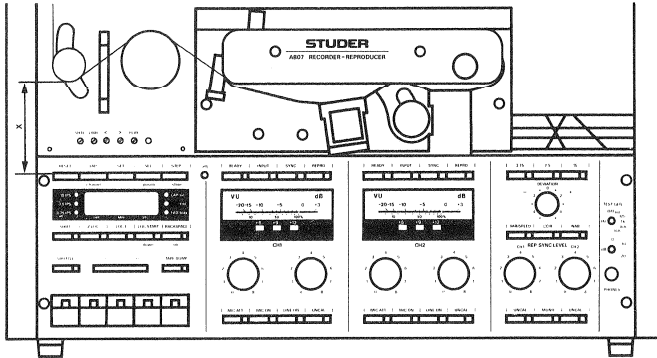

- Load tape (100 mm hub) and spool up to the middle.
- Unscrew left splicing block. The potentiometers for the tape tension adjustment will become accessible.
- Adjust the following values:

PLAY: Insert a tape tension meter between the left reel and the tape tension sensor. Press the key PLAY. By means of the trimmer "Play" adjust to $60 \mu \pm 2 \mu$; the distance "X" should be in the range of 58 to 62 mm.

WIND: Press the key WIND. Adjust "X" equal to 57 mm by means of the trimmer "Wind".

REWIND: Press the key REWIND. Adjust "X" equal to 67 mm by means of the trimmer "Rewind".

LIBRARY WIND: Set this mode by pressing SHIFT and REWIND together. Adjust for best pancake with your preferred brand by means of the trimmer "Libr". Factory setting is "X" equal to 65 mm.

SHUTTLE: Press the key SHUTTLE. Adjust so that the tape does not move. After a slight kick of the right hand spool in either direction the tape should come evenly to stop both ways.

3.3.8 Lifting Pin

During spooling adjust the height of the two lifting pins thus the tape would not move up or down when the tape is lifted off the heads.

3.3.9 Capstan motor control

- Connect counter to TP 1 (0 V to TP 4) on the CAPSTAN MOTOR CONTROL PCB 1.727.330 (GR 20).
- Adjust the frequency to 5.5 MHz (± 200 kHz) by means of L 2.
- Switch the machine to 7.5 ips and press PLAY. Connect Oscilloscope or Multimeter (AC range) to TP 2 (0 V to TP 4). Adjust maximum reading by means of L 1 (approx. 2 Volt RMS)

If you have a Wow and Flutter Meter, adjust flutter minimum by means of R 20 (Switch machine to 3 3/4 ips).

Alternatively (if no W+F Meter is available):

- Connect oscilloscope to TP 5 (0 V to TP 4). Select AC range. Adjust to minimal jitter by means of R 20.
- Listen with a big screwdriver or a stethoscope to the capstan motor. The screwdriver blade should be pressed to the motor housing, the shaft to the ear. Try to minimize the mechanical noise by means of R 20.

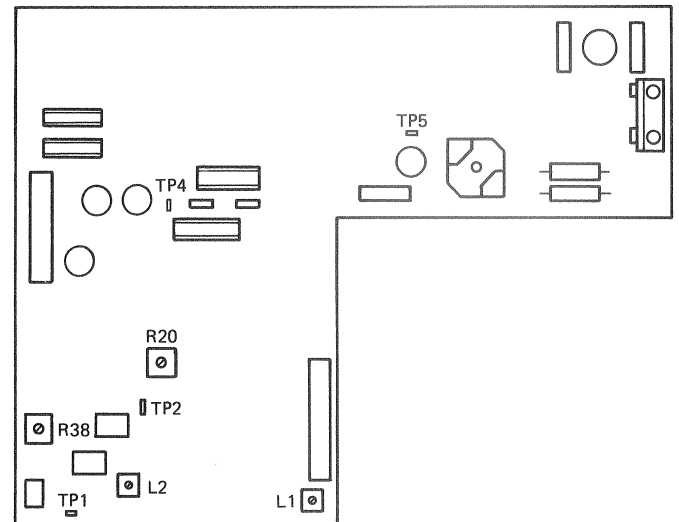

3.3.10 Varispeed circuit

- Connect counter to TP 2 (0 V to TP 4) on the CAPSTAN MOTOR CONTROL PCB 1.727.330 (GR 20).
- Knob "DEVIATION" to 0; Switch Varispeed on, machine to 15 ips.
- Adjust frequency by means of R 38 to 1200 Hz.

3.3.11 Transparent tape sensor

- Connect DC voltmeter to TP 10 (0 V to TP 4) on TAPEDECK ELECTRONICS PCB 1.727.350 (GR 10).
- If there is no tape or clear tape in the sensor gap, the voltage at TP 10 should be approx. 5.6 V; with tape (or colored tape) approx. 10 V.

Adjustment by R 73.

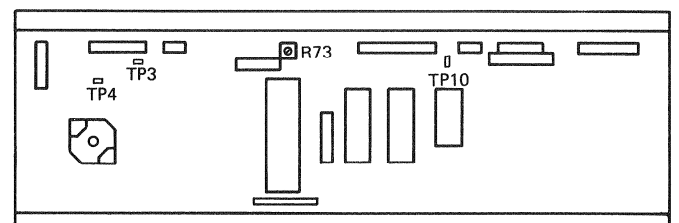

CONTENTS	SECTION 4	
4.	AUDIO	1
4.1	CIRCUIT DESCRIPTION	1
4.1.1	Introduction	1
4.1.2	Level diagram	2
4.1.3	Input amplifier	4
4.1.4	Record amplifier	4
4.1.5	Reproduce amplifier	4
4.1.6	Line amplifier	5
4.1.7	Monitor (standard version)	5
4.1.8	Stereo monitor (special version)	5
4.1.9	Mono switch and test generator (option)	5
4.1.10	Control logic (AUDIO CONTROL BOARD, GR 40)	6
4.1.11	Preparation of the erase and bias signals	6
4.1.12	Audio Control Board	7
4.2	CALIBRATION	13
4.2.1	Introduction	13
4.2.2	Level definition	13
4.2.3	Equalizations	14
4.2.4	Magnetic reference flux, standard calibration data	14
4.2.5	Calibration tapes	15
4.2.6	Input keyboard	17
4.2.7	Audio PCB layout	19
4.2.8	Matching the internal level to the corresponding operating level	19
4.2.9	VU - Meters	20
4.2.10	LED peak indicator	20
4.2.11	PLAYBACK ONLY tape players	20
4.3	REPRODUCE ALIGNMENTS	23
4.3.1	Preparation	23
4.3.2	Azimuth alignment	23
4.3.3	Reproduce treble adjustment	24
4.4	RECORD ALIGNMENT	25
4.4.1	Adjusting the erase current	25
4.4.2	Adjusting the bias trap	25
4.4.3	Record audio alignments	25
4.4.4	Record preadjustment	26
4.4.5	Aligning the azimuth of the record head	26
4.4.6	Bias adjustment	26
4.4.7	Azimuth alignment STEREO	27
4.4.8	Record level adjustment	27
4.4.9	Frequency response alignment	27
4.4.10	Adjusting the channel separation	27
4.5	SYNC ALIGNMENTS	28
4.5.1	Preparations	28
4.5.2	Sync reproduce level adjustment	28
4.5.3	Sync frequency response alignment	28
4.6	MONO/STEREO SELECTOR SETTINGS	29
4.6.1	Preparations	29
4.6.2	Mono reproduce level adjustment	31
4.6.3	Mono record level adjustment	32
4.7	BIAS - ADJUSTMENT PARAMETERS	32

4. AUDIO

4.1 CIRCUIT DESCRIPTION

Notes:

Information concerning the design of the audio electronics can be found in 4.1.1. Introduction; the basic function is subsequently described with the aid of level diagrams (4.1.2. a and b). Information concerning the functional details, as well as the alignment and programming instructions, can be found beginning with Section 4.1.3.

4.1.1 Introduction

The complete audio electronics are implemented on a pull-out chassis. It comprises the:

- AUDIO CONTROL BOARD, GR 40 which contains the control electronics as well as the connectors for the channel boards,
- Channel boards (AUDIO ELECTRONICS BOARD, GR41/42).

Each of these channel boards (in stereo versions there are two) contains the record, reproduce, and sync amplifier, depending on the model.

The audio electronics board for the left-hand channel is located nearest the front (viewed from the front of the machine), the board for the right-hand channel is located nearest the back. In addition to the amplifiers, these audio electronics boards also contain the control elements for adjusting the operating parameters. Some of these are implemented as conventional trimmer potentiometers: for matching the input and output levels to the internal reference level. All other adjustments, particularly those for changing over to other tapes, other flux values or for compensating the loss at high frequencies are performed with DACs. These have the advantage that the parameters can be stored and retrieved from memory at any time.

The audio electronics boards are available in different configurations. The descriptions in this section refer to the fully configured boards. The numbers of the audio electronics boards are coded as follows:

1.727.4ab.xx

where:

- a = 2 :for use with high- μ heads 1.317.xxx.xx
- a = 6 :for use with glass metal heads 1.318.xxx.xx
- b = 0 :fully configured version
- b = 1 :stereo without VU-meters (without MIC and SYNC)
- b = 2 :2-channel with VU-meters, console version (without MIC)
- b = 3 :2-channel without VU meters, but with output selector
- b = 5 :playback only
- b = 7 :same as 2, but with high tape speed
- b = 9 :same as 0, but with high tape speed

The digital circuits required for controlling the DAC's on the audio electronics boards as well as other control circuits are located on the audio control board. In addition to the connectors for the audio electronics boards, it features additional slots into which other options can be plugged, i.e.:

- Pre-amplifier for a second reproduce head (GR 43),
- Mono/stereo switch for record and reproduce mode with built-in test generator (GR 43 - 46).

The parameters for controlling the DACs are set and retrieved via the front panel (refer OPERATION, Section 2).

4.1.2 Level diagram

The signal flow through the unit can best be described using on the level diagram with a greatly simplified block diagram:

a) Record path

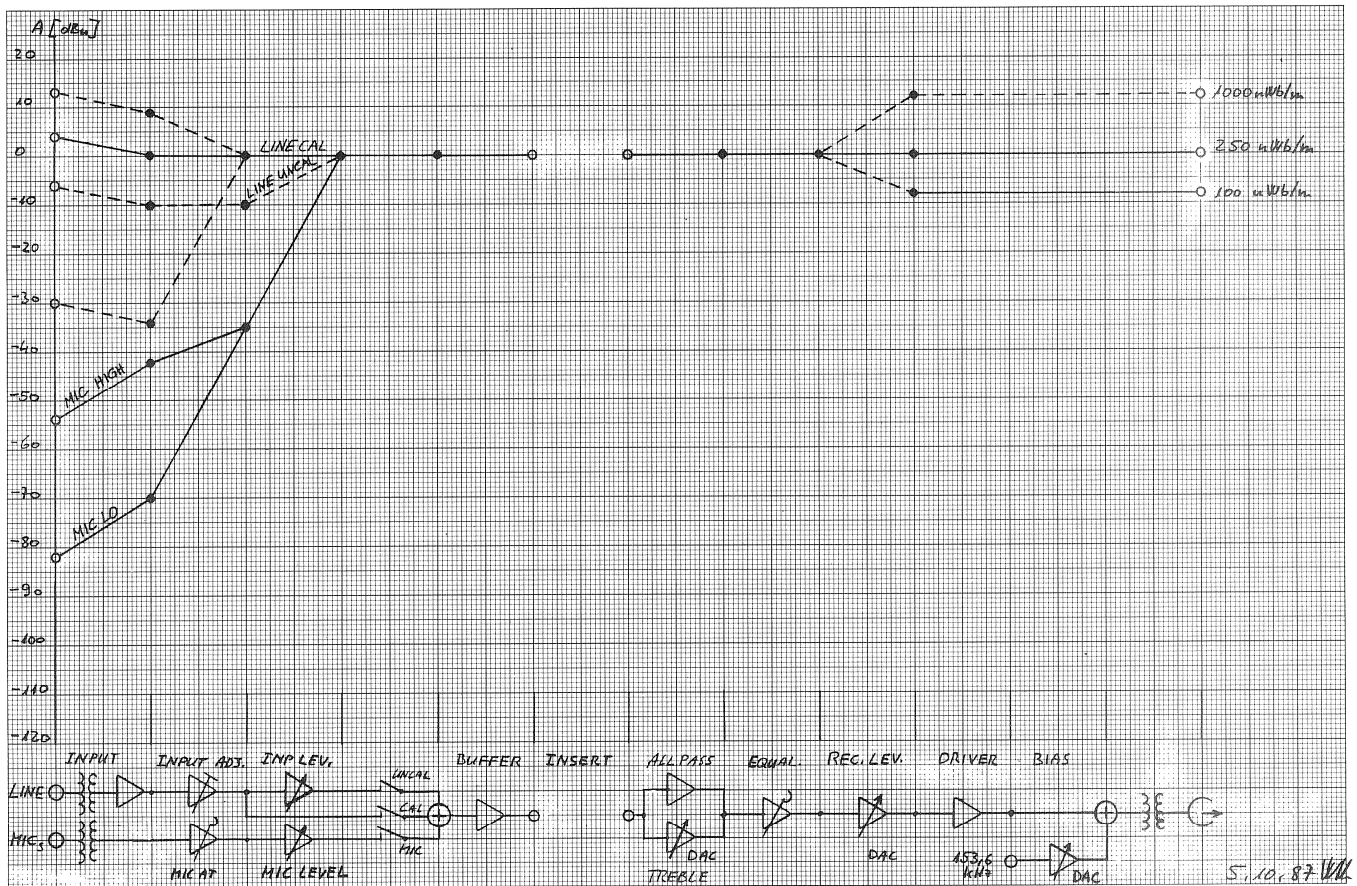

The unit is equipped with a balanced line input and a balanced microphone input. Both signals first pass through separate amplifiers; the basic gain (Input Adj. or Mic. Att) can be adjusted individually for each path. In the case of the line input, this adjustment is used for matching the external levels to the internal reference level of 0 dBu; for operation according to CCIR standard and for studio installations which are monitored with peak reading meters, it should be noted that all calibration levels are 6 dB below the peak levels.

Example: peak recording level: +6dBu
 Input level: 0dBu
 Internal ref. level: 0dBu

The microphone input level can be controlled with the MIC LEVEL potentiometer. Also in the UNCAL position the line input can be adjusted with the INPUT LEVEL potentiometer. Since the microphone path and the line path to the summation point are independent, both inputs can be operated in mixed mode (example: voice announcement to music).

After the summation amplifier, a level of 0 dBu is available at the "Insert" point if the calibration is correct. Either the monitoring path or the output amplifier is connected to this point when the input signal is to be monitored. An additional circuit such as the mono/stereo switch can also be brought into the circuit at this point.

The signal path is subsequently split: a high-pass (TREBLE) path with DAC controllable gain for treble adjustment, and a wide-band path with group delay equalized by an all pass filter. This element is followed by the fixed, selectable standard equalization networks, the record level controller for determining the desired tape flux (also implemented with DACs), the bias superposition, and the record head.

b) Reproduce path

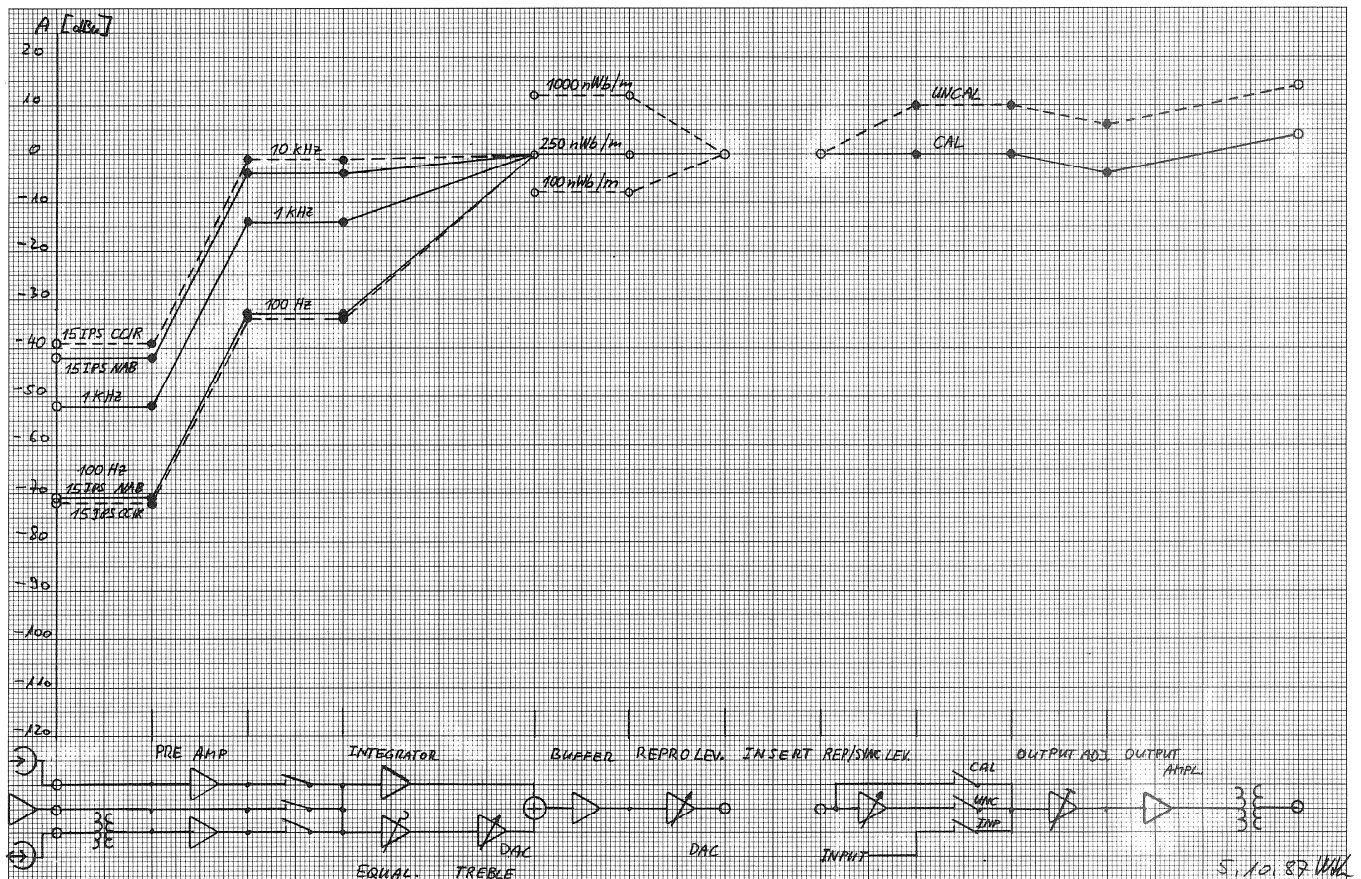

The reproduce amplifier has three selectable inputs:

- from the normal reproduce head via the preamplifier to the audio electronics board,
- from a supplementary reproduce head (if configured) via a separate preamplifier which is plugged into the audio control board, or
- from the record head (sync function, if configured).

The reproduce equalization can be adjusted by means of a DAC; an integrator is responsible for the basic compensation of the amplitude response which increases proportionally with the frequency. Also the reproduce level can be matched via DAC to the previously selected tape flux. After this DAC an insert point with internal reference level is reached. In the input mode the input signal from that insert point is picked up here. The output line level can also be adjusted (UNCAL position) or be selected with a fixed setting (CAL position).

4.1.3 Input amplifier

See circuit diagram 1.727.42x.xx or 1.727.46x.xx

The line input and the microphone input are each taken via a low pass filter in order to suppress high-frequency noise signals.

The basic gain for the line input is adjusted with R18; however the unit must be operated in CAL mode. In order to simplify the alignment, three adjustment ranges can be selected

Input level range: Jumper JP 1 in position:

-4 to +12 dBu	A
-17 to -1 dBu	B
-30 to -14 dBu	C

The signal from the microphone is taken via an input transformer to the amplifier. In order to prevent overloading of the amplifier when high-level microphones are used, the gain can be decreased by approx. 28 dB by means of the MIC ATT key. The three paths Line cal, Line uncal, and Microphone are selected by the logical control signals:

C - CALINX	(line cal)
C - UNCINX	(line uncal)
C - MICONX	(microphone)

This selection takes place in IC 4. Since several signals can be selected at the same time, mixdowns are also possible (example: voice announcement to music).

4.1.4 Record amplifier

See circuit diagram 1.727.42x.xx or 1.727.46x.xx

From the insert point the audio signal A - RECINX is split into two paths: a high-pass path (TREBLE) in which the treble adjustment is made by the DAC IC 11/2, and a wide-band path (IC 5/1 with connected all-pass filter IC 6/2 for compensating the group delay). In IC 6/1 the two paths are summed again. The signal now passes through the standard equalization stage (IC 8/2) in which the equalization is changed, as a function of the selected standard and speed, by the control signals C-EQA and C-EQB.

Certain standard equalizations contain the 3180 μ s time constant which becomes active at low frequencies (See Fig.4.2.1a).

This bass equalization is enabled by the jumpers W4 to W7 which are configured depending on the speed version. On standard models shipped by the factory the jumpers W5 and W7 are installed.

The STUDER A807 professional tape recorder is equipped with a facility for optimizing the output level at high frequencies according to the DOLBY HX PRO system. This system is enabled with the jumper JP 2; when it is in the ON position (factory setting), HX PRO is active.

The time constants for the buildup and decay of the RF bias and the voltage for the erase head are generated by the circuits around IC 7/1 and 7/2 respectively. The RF bias is adjusted with the DAC IS 12; it produces a DC voltage at the output which causes the voltage of the RF bias to be adjusted in the OTA (Operational Transconductance Amplifier). The DOLBY HX PRO control circuit intervenes at this point.

The erase head voltage is controlled via the OTA IC 16/1. For calibration it is adjusted with R 139 (measurement on test point TP 3).

It should be noted that the erase circuit is aligned to minimum current with the aid of T 3 (measurement on TP 4).

4.1.5 Reproduce amplifier

See circuit diagram 1.727.42x.xx or 1.727.46x.xx

The signal from the reproduce head is first amplified in a low-noise preamp (Q 26 and IC 19).

The analog switch IC 17 selects between the normal reproduce head, the record head, as the sync reproduce head, or an optional second reproduce head. The sync preamplifier and the preamplifier for the second reproduce head, that can be plugged into the audio control board, basically have a similar design to the reproduce amplifier.

The filter with L 6 and C 95 to C 97 is used to suppress bias components in the output voltage.

The signal path is subsequently split into two. IC 20/2 is wired as an integrator and thus equalizes the reproduce frequency response, which basically increases in proportion to the frequency when the reproduce head is connected into a high impedance. At low frequencies a small amount of ripple is produced in the frequency response by the head face. This ripple is compensated by the combination of R 219 and C 129. At low tape speeds this RC time constant is bypassed by FET Q 24.

The resistors selected by the analog switch IC 18/2 limit the integration behavior at very low frequencies; the standard equalization of 3180 μ s is thus activated (for NAB).

The upper signal path is laid out in such a way that it dominates, starting with medium frequencies. This means that as the frequency rises the response changes from integrator characteristic to a linear condition. This transition frequency corresponds to the standard equalization. At even higher frequencies the signal is again branched off via C 99 and amplified by IC 21/1. The gain of this path can be influenced with DAC IC 23/3 (TREBLE adjustment).

All three paths are summed in IC 25/1. It is followed by the DAC IC 23/1 for controlling the total reproduce level.

4.1.6 Line amplifier

See circuit diagram 1.727.42x.xx or 1.727.46x.xx

The line amplifier (output amplifier) receives its input signal A - DRVINX from the reproduce insert point. This signal first passes through a voltage divider which is activated when FET Q 28 conducts. This FET is activated as soon as double the nominal tape speed is exceeded in spooling mode. With cueing enabled, this prevents the occurrence of high output levels and high frequencies which are annoying and could even destroy the connected speaker. This voltage divider decreases the signal level by approx. 12 dB and also limits the frequency response.

With the analog switch IC 26, one of three line amplifier sources are selected:

- Normal reproduce path
- Reproduce path via repro level control and IC22/1 which provides a basic gain of 10 dB, or
- directly from the insert point of the input amplifier (signal A - PREMUX).

In certain modes, IC 26 can disable (mute) all three inputs.

To prevent clicks at the output when the unit is switched on or off, the relay K 2 interrupts the signal path before and after the output amplifier.

At the output the adjustment of the output level (with R 246) can be changed by selecting different adjustment ranges.

Output level range: Jumper JP 3 in position:

-4 to +12 dBu	A
-17 to -1 dBu	B

4.1.7 Monitor (standard version)

See circuit diagram 1.727.120.xx

With the monitor it is possible to monitor either the input or the reproduce signal. The source signal is tapped at the insert points. If the input signal is monitored, the position of jumper JS 1 (left-hand channel) or JS 2 (right-hand channel) on the audio control board defines whether the signal is monitored before or after the insert point. This selection is only meaningful if internal or external options are connected to the insert points and if the jumper connections W 2 or W3 (on the audio control board) are consequently open.

The desired signal (input or reproduce) is selected by pulling out (input) or pushing in (output) the knob of a logarithmic potentiometer which is also responsible for the volume control. The output signal is tapped after the output selector, in parallel with the VU-meters. The selected signals are subsequently amplified by 20 dB by means of one amplifier per channel (IC 11/1 left, IC 11/2 right). The monitor signal is available at a stereo jack socket; if headphones are not plugged in, the signals are fed to the speaker amplifier.

4.1.8 Stereo monitor (special version)

See circuit diagram 1.727.910.xx

With this monitor it is also possible to monitor either the input or the reproduce signal picked up at the corresponding insert points. The explanations given in 4.1.7 similarly apply to this version.

In addition two auxiliary inputs (AUX 1 or AUX 2) can be selected. By changing the setting of jumper JP 1 on the monitor board, it is possible to determine whether Aux 1 is used as the source for both monitoring channels or whether AUX 1 and AUX 2 are to be considered as a stereo pair.

The inputs are selected by IC 4. The logical control for this IC is also located on the monitor board. The signals of the momentary-action push buttons Input, Tape, and Aux are stored in the NOR flip-flops IC 14 and 15. The stored states are indicated by the LEDs DL 1 through 3. The logical gating before the flip flops prevents double assignment and causes a reset when new input signals become available. The monitoring left, right, or stereo, is enabled in a second analog switch IC 6. The logical control of IC 6 is similar in design to that of the source selection. The monitoring volume is determined by a stereo potentiometer. If no headphones are plugged in, the socket contact connects the input to the output amplifier. A muting circuit (Q 1 or Q 2) is located at the input of the speaker amplifier. It interrupts the signal path in the event of a remote fader start. The monitor speaker thus cannot interfere when the program is on the air.

4.1.9 Mono switch and test generator (option)

a.) Test generator

See circuit diagram 1.727.441.xx

The test generator produces the following frequencies by changing the ext. components to IC 5:

60, 125, 1k, 10k, and 16 kHz

The level is attenuated in steps of 0, -10dB, -20dB, and OFF by the analog switch IC 6. IC 7 is the output amplifier.

The test signal is mixed down to the audio channels via IC 1/1 or 1/2.

b.) Mono switch, input

See circuit diagram 1.727.441.xx or 1.727.451.xx
From the outputs of the two amplifiers IC 1/1 and 1/2, signals are branched off and added by the summing amplifier IC 2/1. A prerequisite for proper mono signal creation is that the jumpers JP 1 and JP 2 are in position A. Stereo or mono is selected with the analog switch IC 3/1 and 3/2.

c.) Mono switch, output

See circuit diagram 1.727.442.xx or 1.727.452.xx
At the outputs of the two amplifiers IC 4/1 and 4/2, signals are branched off and combined to a mono signal by the summing amplifier IC 3/1. Depending on the position of jumpers JP 1 and JP 2, the mono signal appears either at the left-hand, the right-hand, or both outputs (this selection is performed by the analog switches IC 2/1 and 2/2).

4.1.10 Control logic (AUDIO CONTROL BOARD, GR 40)

See circuit diagram 1.727.400.xx or 1.727.401.xx
The microprocessor is responsible for all control functions of the audio electronics. The control signals and the data are generated in the CPU (IC12, TAPE DECK ELECTRONICS, GR10) and output serially via IC 28 on five lines.

The signals on these lines are as follows:

AS - WREN	Write enable
AS - STRAB	Strobe for data register and chip select AB
AS - CLK	Clock
AS - DATA	Serial data
AS - STR	Strobe for the other registers

The data arrives via the AS - DATA line, all other lines carry control signals.

The valid data records are latched into the instruction registers IC 1 through 5 and IC 9, depending on the control signal. The individual registers fulfill the following functions:

IC3 register	1: Input control	see Fig.4.1.1
IC5 register	2: EQ control	see Fig.4.1.2
IC4 register	3: Record control	see Fig.4.1.4
IC9 register	4: Output control	see Fig.4.1.5
IC1 register	5: Address register	see Fig.4.1.6
IC2 register	6: Data register	see Fig.4.1.7

The last two registers are used in conjunction with the AS - STRAB control signal for controlling the DACs.

The truth tables of the registers are summarized below; commands with the prefix C (control) are control commands for the audio boards, commands with the prefix S (switch) are initiated when an input function (e.g. key) is actuated.

However, these do not occur individually because the keys are read out from a matrix. The commands with prefix S are sent to the CPU already in coded form.

The generation of the commands C - EQA and C - EQB depend on whether the machine is a standard, a high-speed or a low speed version. The truth table is as follows:

VERSION:	Jumper W5 in pos.	Jumper W6 in pos.
Standard	A	A
High-speed	B	B
Low-speed	B	C

Jumper W 1 is not needed when a mono erase head is used.

4.1.11 Preparation of the erase and bias signals

See circuit diagram 1.727.400.xx or 1.727.401.xx
The 307 kHz clock frequency derived from the internal clock signal (IC 11 TAPE DECK ELECTRONICS, GR 10) is supplied to the AUDIO CONTROL BOARD (AS-HFCLK). IC 12 functions as a frequency divider, IC 13/1 and 13/2 as a low-pass filter. From the 153 kHz square-wave signal, this circuit filters out the basic frequency for the bias. A distortion of less than 0.1% is achieved.

4.1.12 Audio Control Board

Logic tables:

REGISTER 1: Input Control CH1 (IC 3)				C-MICAT 1 C-MICON 1 C-CALIN 1 C-UNCIN 1									
S-MICAT 1	S-MICON 1	S-LINON 1	S-UNCAL 1									Notes :	
0	0	0	0	x	x	x	x	0	0	0	0	Line off, Mic off	*
0	0	0	1	x	x	x	x	0	0	0	0	Line off, Mic off	*
0	0	1	0	x	x	x	x	0	0	1	0	Line on Cal	*
0	0	1	1	x	x	x	x	0	0	0	1	Line on Uncal	*
0	1	0	0	x	x	x	x	0	1	0	0	Mic on	*
0	1	0	1	x	x	x	x	0	1	0	0	Mic on	*
0	1	1	0	x	x	x	x	0	1	1	0	Mic on, Line on Cal	*
0	1	1	1	x	x	x	x	0	1	0	1	Mic on, Line on Uncal	*
1	0	0	0	x	x	x	x	1	0	0	0	Line off, Mic off	#
1	0	0	1	x	x	x	x	1	0	0	0	Line off, Mic off	#
1	0	1	0	x	x	x	x	1	0	1	0	Line on Cal	#
1	0	1	1	x	x	x	x	1	0	0	1	Line on Uncal	#
1	1	0	0	x	x	x	x	1	1	0	0	Mic on attenuated	#
1	1	0	1	x	x	x	x	1	1	0	0	Mic on attenuated	#
1	1	1	0	x	x	x	x	1	1	1	0	Mic on att., Line on Cal	#
1	1	1	1	x	x	x	x	1	1	0	1	Mic on att., Line on Uncal	#

Mic sensitivity : * = -82 dBu / # = -54 dBu

- S-MICAT 1 The microphone input level sensitivity changes.
- S-MICON 1 The microphone input will be switched on or off.
- S-LINON 1 The line-input will be switched on or off.
- S-UNCAL 1 The line level control potentiometer will be switched on or off.

REGISTER 1: Input Control CH2 (IC 3)				C-MICAT 2 C-MICON 2 C-CALIN 2 C-UNCIN 2									
(same as CH1 exept)												Notes :	
S-MICAT 2	S-MICON 2	S-LINON 2	S-UNCAL 2										
0	0	0	0	0	0	0	0	x	x	x	x	Line off, Mic off	*
..
..
1	1	1	1	1	1	0	1	x	x	x	x	Mic on att., Line on Uncal	#

Fig.4.1.1

REGISTER 2: EQ Control (IC 5)				C-EQ-N C-EQ-F (Activ LOW) C-EQ-M (Activ LOW) C-EQ-S (Activ LOW)									
S-NAB	S-SPD-F	S-SPD-M	S-SPD-S	Notes :								HS-Version:	
0	0	0	1	x	x	x	x	0	1	1	0	CCIR 3.75ips	CCIR 7.5ips
0	0	1	0	x	x	x	x	0	1	0	1	CCIR 7.5 ips	CCIR 15 ips
0	1	0	0	x	x	x	x	0	0	1	1	CCIR 15 ips	CCIR 30 ips
1	0	0	1	x	x	x	x	1	1	1	0	NAB 3.75ips	NAB 7.5ips
1	0	1	0	x	x	x	x	1	1	0	1	NAB 7.5 ips	NAB 15 ips
1	1	0	0	x	x	x	x	1	0	1	1	NAB 15 ips	NAB 30 ips

REGISTER 2: Output Control (IC 5)				C-SECHD C-OUTSW C-CUEAT (Activ LOW) C-INSERT								
S-SECHD	S-POWER	S-LIFTER	S-INSERT	Notes :								
0	0	0	0	0	0	0	0	x	x	x	x	Power-ON
0	1	0	0	0	0	1	0	x	x	x	x	2 sec after Power-ON
0	1	0	0	0	1	1	0	x	x	x	x	INSERT enabled
0	1	0	1	0	1	1	1	x	x	x	x	Lifter disabled, Cue att.active
0	1	1	0	0	1	0	0	x	x	x	x	Lifter disabled, INSERT enabled
0	1	1	1	0	1	0	1	x	x	x	x	Second REPRO-Head enabled
1	1	0	0	1	1	1	0	x	x	x	x	Immediately after Power-OFF
0	0	x	x	x	0	x	x	x	x	x	x	

- S-NAB NAB equalisation is chosen with S-CCIR selected, S-NAB will be cancelled and vice versa.
- S-SPD-F High tape speed
- S-SPD-M Medium tape speed
- S-SPD-S Low tape speed
- S-SECHD Enabling of the second reproduce head
- S-POWER Tape recorder switched on
- S-LIFTER Tape - lifter enabled
- S-INSERT Insertation (or enabling) of an option like Mono/Stereo switch or testgenerator etc.

Fig.4.1.2

For the subsequent processing of the command C-SECHD refer to Decoder IC 8. (Fig.4.1.3)

DECODER IC 8: REPRODUCE MODE LOGIC			C-REPRO1 C-SYNC1 C-SECRP1 C-REPRO2 C-SYNC2 C-SECRP2							
C-SECHD	C-SYNC1	C-SYNC2					CH 1		CH 2	
0	0	0	1	0	0	1	0	0	Reproduce	Reproduce
0	0	1	1	0	0	0	1	0	Reproduce	Sync
0	1	0	0	1	0	1	0	0	Sync	Reproduce
0	1	1	0	1	0	0	1	0	Sync	Sync
1	0	0	0	0	1	0	0	1	2. Head, Repro	2. Head, Repro
1	0	1	0	0	1	0	1	0	2. Head, Repro	Sync
1	1	0	0	1	0	0	0	1	Sync	2. Head, Repro
1	1	1	0	1	0	0	1	0	Sync	Sync

Fig.4.1.3

REGISTER 3: Record Control (IC 4)			■ ■ ■ ■ ■ ■ ■ ■ Reserve C-BIAS2 C-ERASE2 C-REC2 Reserve C-BIAS1 C-ERASE1 C-REC1								
S-READY1	S-READY2	S-REC	Notes :								
0	0	0	x	0	0	0	x	0	0	0	Refer to drop in/ drop out time table
1	0	0	x	0	0	0	x	0	0	0	
0	1	0	x	0	0	0	x	0	0	0	
1	1	0	x	0	0	0	x	0	0	0	By activating the signal S-PLAY again, S-REC will become = 0 (LOW)
0	0	1	x	0	0	0	x	0	0	0	
1	0	1	x	0	0	0	x	1	1	1	
0	1	1	x	1	1	1	x	0	0	0	
1	1	1	x	1	1	1	x	1	1	1	

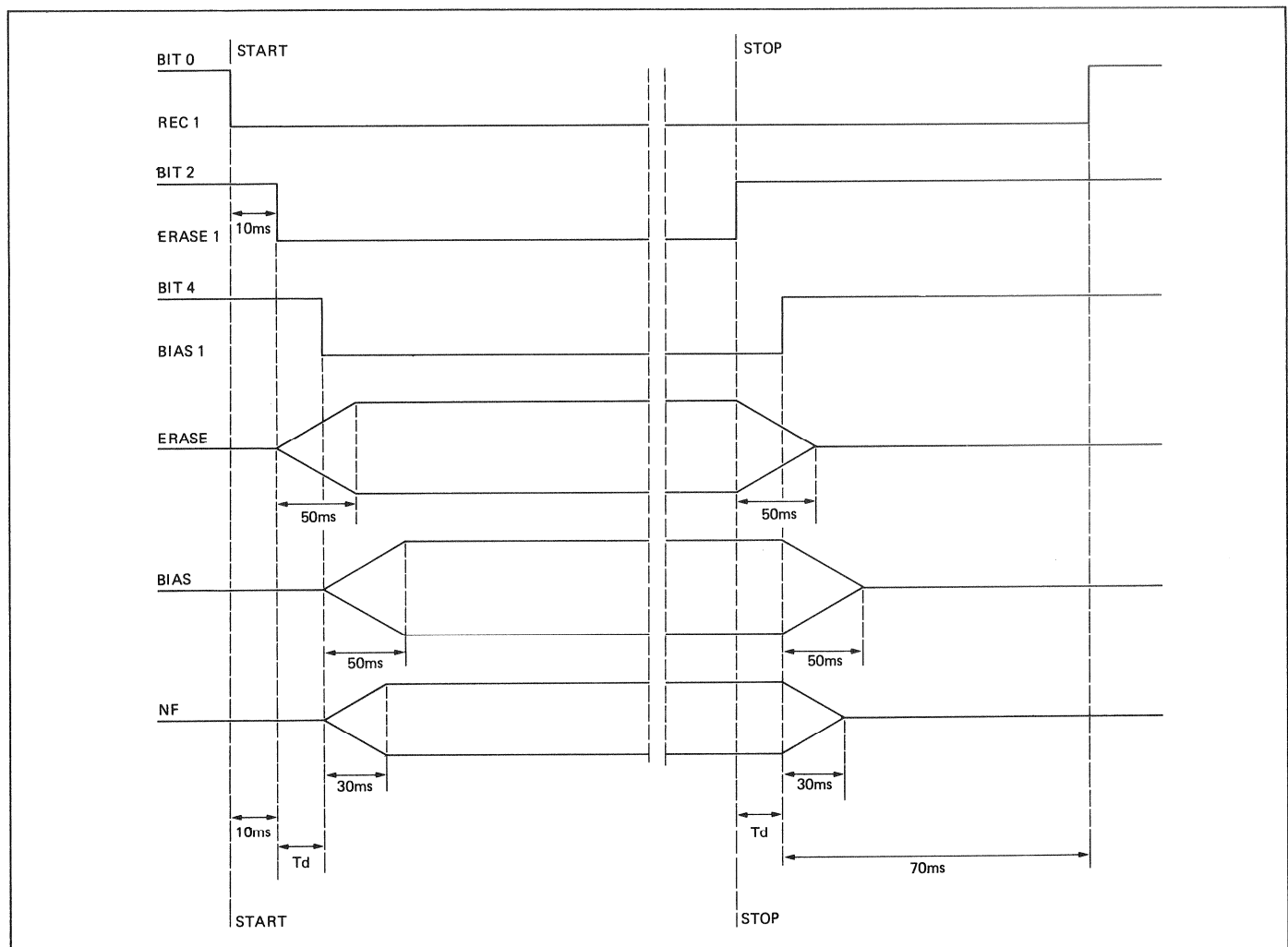

Td = Timedelay in ms
 Lh = Distance between erase - and record head
 Vt = Tape speed in cm/s

Example:
 (Td = 115ms)
 (Lh = 43.8mm)
 (Vt = 38.1cm/s)

Fig.4.1.4

REGISTER 4: Output Control (IC 9)												C-INPUT2 C-UNCOU2 C-CALOU2 C-SYNC2 C-INPUT1 C-UNCOU1 C-CALOU1 C-SYNC1
S-INPUT1	S-SYNC1	S-REPRO1	S-UNCOU1									Notes :
1	0	0	0	x	x	x	x	1	0	0	1	See note 1 and note 2
0	1	0	0	x	x	x	x	0	0	1	1	Input 1 calibrated note 2
0	0	1	0	x	x	x	x	0	0	1	0	Sync 1 calibrated
1	0	0	1	x	x	x	x	1	0	0	0	Repro 1 calibrated
0	1	0	1	x	x	x	x	0	1	0	1	Input 1 calibrated
0	0	1	1	x	x	x	x	0	1	0	0	Sync 1 uncalibrated
												Repro 1 uncalibrated
S-INPUT2	S-SYNC2	S-REPRO2	S-UNCOU2									Notes :
1	0	0	0	1	0	0	1	x	x	x	x	See note 1 and note 2
0	1	0	0	0	0	1	1	x	x	x	x	Input 2 calibrated note 2
0	0	1	0	0	0	1	0	x	x	x	x	Sync 2 calibrated
1	0	0	1	1	0	0	0	x	x	x	x	Repro 2 calibrated
0	1	0	1	0	1	0	1	x	x	x	x	Input 2 calibrated
0	0	1	1	0	1	0	0	x	x	x	x	Sync 2 uncalibrated
												Repro 2 uncalibrated

The above push buttons will cancel their function when pressing them again.

Note 1: MUTE CONTROL

The output signal will be muted during each transient Status like starting and braking phase.

Note 2: SYNC/INPUT change over

By entering the record command while the machine is in SYNC - mode, the record enable signal S-READY automatically switches off the signals CALOU1 , CALOU2 , UNCOU1 and UNCOU2 and enables the INPUT1 resp. INPUT2 signals instead. Entering the PLAY - Command again will cancel the above signals and the previous status will return.

Fig.4.1.5

REGISTER 5: Address Register (IC 1)

To control the audio parameters

- Parameter: - TREBLE channel 1,2 ; Rec, Repr
 - LEVEL channel 1,2 ; Rec, Repr
 - BIAS channel 1,2 ; Rec
- Control signals: - AS-STRAB (A/B)
 - WR-REC_x , WR-BIAS_x , WR-REPR_x
 - A-DO...A-D7

		Reserve WR-BIAS2 WR-REC2 WR-REPR2 Reserve WR-BIAS1 WR-REC1 WR-REPR1
STROBE	A/B	Notes :
x	0	Level , channel 1, reproduce
0	x	Treble, channel 1, reproduce
1	x	Level , channel 1, record
0	x	Treble, channel 1, record
1	x	Bias , channel 1
x	0	Level , channel 2, reproduce
0	x	Treble, channel 2, reproduce
1	x	Level , channel 2, record
0	x	Treble, channel 2, record
x	1	Bias , channel 2

After pressing one of the following push buttons, new audio parameters will be read into the DAC's :

- S - Speed-x (Tape speed)
- S - CCIR (Equalization)
- S - NAB (Equalization)
- S - TAPE-x (Tape sort)
- etc.

Fig.4.1.6

The timing can be seen from the following diagram of the Data Register (Fig.4.1.7)

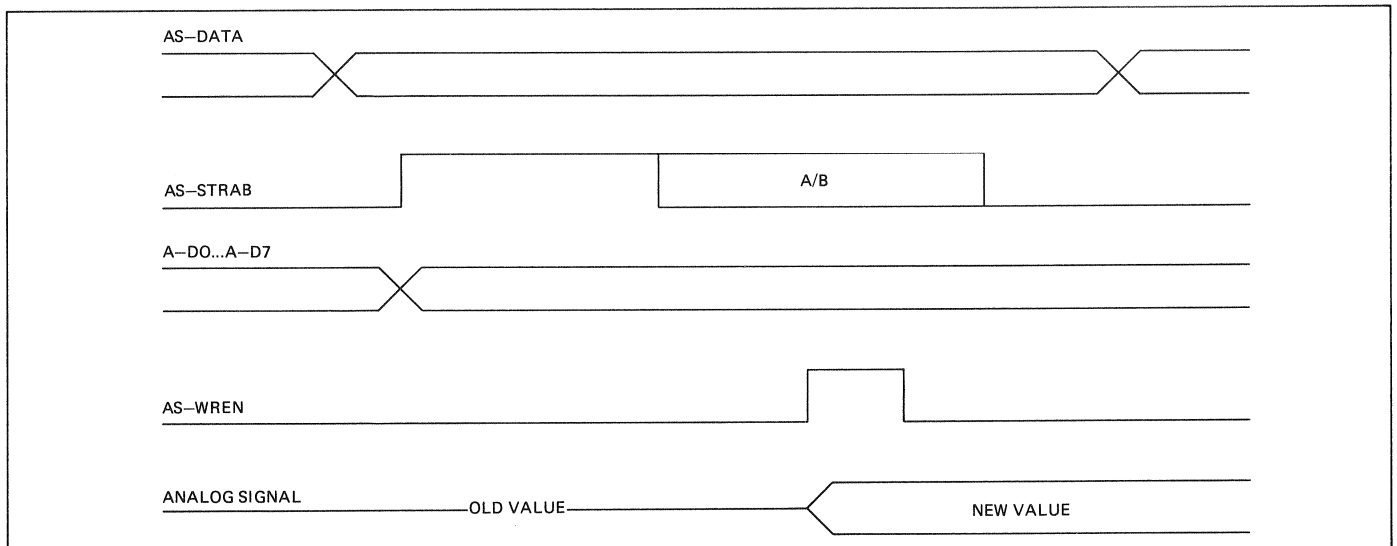

Fig.4.1.7

4.2 CALIBRATION

The audio parameters are read from RAM into the registers of the audio amplifier whenever the tape speed, the tape type, or the equalization standard is changed.

When new parameters are set with the UP/DOWN [21/22] key or via the serial interface, the stored parameters in the RAM and in the registers of the audio amplifiers are overwritten.

The audio parameters are also stored in an EEPROM when the machine is switched off. This nonvolatile memory retains the data also while the machine is switched off. The data are recopied into the RAM when the machine is switched on again.

If the data in the RAM are lost, all parameters are set to zero, i.e. all registers are closed.

4.2.1 Introduction

General

The assumption is that the tape recorder to be calibrated has been mechanically adjusted to specifications (particularly with respect to the tape tensions and the tape transport). Before you start with the calibration of the tape recorder, clean and demagnetize the soundheads and the tape guidance elements.

The calibration of the tape recorder should always be performed in the following order:

REPRODUCE ALIGNMENTS:

Preferred studio tape speed:

- Level
- Azimuth alignment of the reproduce head gap (see note 1)
- Frequency response (see note 2)

All other tape speeds:

- Level
- Frequency response (see note 2)

Note 1:

Depending on the reference tape, minor deviations can occur between the different speeds. In this case the final azimuth alignment should be made with the preferred studio speed.

Note 2:

Normally the studio tape recorders are calibrated with full-track reference tapes. Due to fringing, frequency response errors occur in stereo and 2-channel machines at low frequencies, i.e. the low frequencies appear to be overemphasized.

This measurement error does not occur on tapes with correct guard track width or when a recording with tape is made.

RECORD ALIGNMENTS

Preferred studio tape speed:

- Record level preadjustment
- Azimuth alignment of the record head gap (bias parameter at approximately the same value for both channels!)
- Bias
- Record level
- Frequency response

All other tape speeds:

- Record level preadjustment
- Bias
- Record level
- Frequency response

SYNC REPRODUCTION

- Level
- Frequency response

4.2.2 Level definition

Voltage level 0 dBu = 0.775 V

Also refer to Figs. 4.2.1 and 4.2.2

Voltage level 0 dBm = 0.775 V:

It is based on the voltage drop with an output of 1mW into any load resistance. Across a load of 600ohms, the voltage drops by 775 mV. This voltage has been defined (without reference to a load) as a voltage level of 0 dBm.

More correct is, however:

0 dBu = 0.775 V: corresponds to the voltage of 775 mV without reference to a load resistance.

Line level

The level that,

- appears on the output of a tape recorder when a tape with reference flux is reproduced.
- fed to the input of a tape recorder produces reference flux on the tape.

Voltage reference level:

CCIR designation for line level; this level produces an indication of 0 dB on a quasi peak program meter (PPM).

Standard reference level (operating level):

Designation commonly used in the USA for the level required for a tape flux of 250 nWb/m (for recording on high-quality tapes) or 200 nWb/m (for recording on standard tapes); this level gives a reading of 0 VU on a VU-meter.

Peak level:

Designation commonly used in the USA for a level that is 8 to 10 dB higher than the operating level. For reasons of simplicity, a peak level of +6 dB relative to the operating level (double the voltage value) is used for calibrating a tape recorder.

dB	Voltage	dB	Voltage
0	0,775V	0	775mV
+1	0,869V	-1	691mV
+2	0,975V	-2	615mV
+3	1,09V	-3	548mV
+4	1,23V	-4	489mV
+5	1,38V	-5	436mV
+6	1,55V	-6	388mV
+7	1,73V	-7	346mV
+8	1,95V	-8	308mV
+9	2,18V	-9	275mV
+10	2,45V	-10	245mV
+11	2,75V	-11	218mV
+12	3,08V	-12	195mV
+13	3,46V	-13	173mV
+14	3,88V	-14	155mV
+15	4,36V	-15	138mV
+16	4,89V	-16	123mV
+17	5,48V	-17	109mV
+18	6,15V	-18	97,5mV
+19	6,91V	-19	87mV
+20	7,75V	-20	77,5mV

Fig.4.2.1

■ IEC/CCIR-Alignment

Definition:	Line Level [dBm]	VU Meter Ind. [VU]
"Bezugspegel":	+6	+6

■ NAB-Alignment

Definition:	Line Level [dBm]	VU Meter Ind. [VU]
Oper. Level:	+4	0
"Peak Level":	+10	+6

4.2.3 Equalizations

Equalization networks that correct the frequency response are installed in the record and reproduce path.

The attack points of the correction are referred to as the transition frequencies or the transition time constants ($1 / 2 \pi f$) and have been standardized by various organizations (IEC, NAB, AES, CCIR).

Tape Speed	Transition Frequencies, LOW and HIGH (Transition Time Constants)		
	IEC-1968	NAB-1965	NAB-1975
9,53 cm/s 3,75 ips	50Hz; 1800Hz (3180µs; 90µs)	50Hz; 1800Hz (3180µs; 90µs)	- (-)
19,05 cm/s 7,5 ips	0Hz; 2240Hz (∞ ; 70µs)	50Hz; 3150Hz (3180µs; 50µs)	0Hz; 3150Hz (∞ ; 50µs)
38,10 cm/s 15 ips	0Hz; 4500Hz (∞ ; 35µs)	50Hz; 3150Hz (3180µs; 50µs)	- (-)
76,20 cm/s 30 ips	0Hz; 9000Hz (∞ ; 17,5µs)	AES 1971 0Hz; 9000Hz (∞ ; 17,5µs)	- (-)

Fig.4.2.1a

4.2.4 Magnetic reference flux, standard calibration data

When a recording with reference flux is reproduced, line level is produced on the output of the tape recorder.

The following standard settings are made by the factory:

CCIR settings:

- Line voltage: 220 V
- Line frequency: 50 Hz
- Line level: + 6 dBu
- Reading of the VU-meter at line level: + 6 VU
- Load impedance: 10 kohm
- Tape type: AGFA PER 528

Tape flux with line level:

3,75 ips, stereo:	400 nWb/m
3,75 ips, mono:	250 nWb/m
7,5 ips, stereo:	510 nWb/m
7,5 ips, mono:	320 nWb/m
15 ips, stereo:	510 nWb/m
15 ips, mono:	320 nWb/m
30 ips, stereo:	510 nWb/m
30 ips, mono:	320 nWb/m

NAB settings:

- Line voltage: 220 V
- Line frequency: 50 Hz
- Line level: + 4 dBu
- Reading of the VU-meter at line level: + 0 VU
- Load impedance: 10 kohm
- Type tape: Scotch 3M 226

Tape flux with line level:

for mono and stereo:	3,75 ips	200 nWb/m
	7,5 ips	250 nWb/m
	15 ips	250 nWb/m
	30 ips	250 nWb/m

Until further notice the machines leaving the factory will be calibrated to one of these two standards.

4.2.5 Calibration tapes

Calibration tapes are used for aligning the reproduce path of tape recorders. They are generally magnetized across their full width. A separate tape is used for each tape speed.

IMPORTANT:

In order to prevent unintentional erasure of these costly tapes, all channels should be switched to SAFE (i.e. the READY keys [31/42] are to be deselected so that the red LED is dark).

The reference tapes contain the following sections:

Level tone section:

(Reference flux = 320 nWb/m for 7½, 15, and 30 ips; 250 nWb/m for 3¾ ips) produces line level in play mode on the output of the tape recorder.

The output level should be adjusted to the specified line level, while the approx. 60 to 180 sec. level tone section is being played.

NAB calibration tapes with a reference flux of 200 nWb/m produce an output level of -4 dB relative to 320 nWb/m; CCIR calibration tapes with a reference flux of 320 nWb/m produce in stereo mode an output level of -4 dB relative to the line level and 510 nWb/m.

Reference frequency: 333 Hz or 500 Hz at 3¾ ips; 1 kHz at 7½ to 30 ips (there are also NAB calibration tapes with 700 Hz reference frequency).

Level adjustment:

If the tape recorder is to be calibrated with a different (usually higher) reference level, the reference flux difference is computed according to the following formula:

$$20 \log_{10} \frac{\text{desired ref. flux.}}{\text{ref. flux. of tape}} = \text{Difference (dB)}$$

Example:

Reference flux on the tape = 200 nWb/m
desired reference flux, e.g. for a tape with high dynamic range = 510 nWb/m.

$$\text{Difference} = 20 \log_{10} \cdot \frac{510 \text{ nWb/m}}{200 \text{ nWb/m}} = 8 \text{ dB}$$

Refer also to Fig.4.2.2

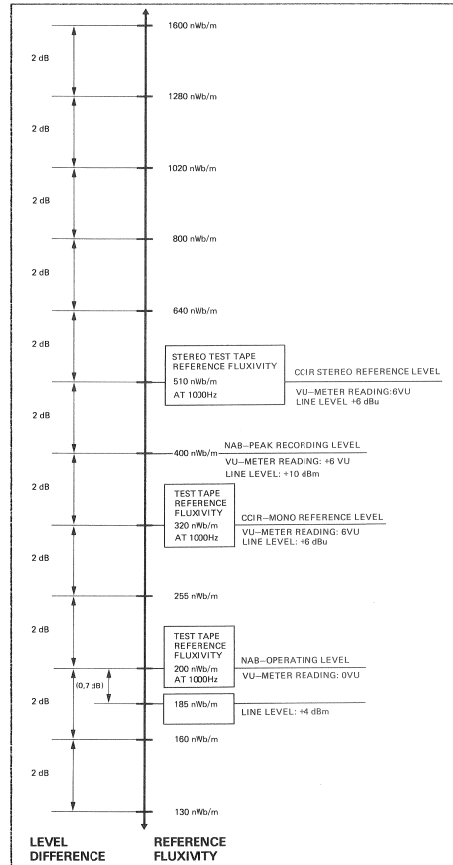

Fig.4.2.2

Azimuth alignment section:

Used for correcting the perpendicularity (azimuth alignment) of the reproduce head gap. This section comprises a shorter section with the reference frequency (for coarse adjustment) and a longer section with 10 kHz for fine-adjustment. NAB calibration tapes can be arranged differently. The level of this section is normally 10 dB below the reference level.

The alignment is made by means of the azimuth adjustment screw until the normal output voltage is achieved. In two-channel and stereo recorders, alignment to minimum phase difference between the two channels is possible with the aid of a 2-channel oscilloscope or an AF millivoltmeter with two inputs and summation.

Important:

If major adjustments on the reproduce head are made, additional voltage peaks occur, however with lower level!

If the reproduce amplifier operates with correct equalization, there is no difference between the reproduce levels of the reference frequency and the 10 (8; 16) kHz recording.

Frequency alignment sections:

Used for determining and adjusting the operational reproduce frequency. NAB calibration tapes exist on which the frequencies differ from the following table.

Reference Tape	CCIR				NAB			
	9,5	19	38	76	3,75	7,5	15	30 AES
Tape-Speed [cm/s/ips]								
Rev.Lev.Sec.: Ref.Freq. Ref.Flux Density	315Hz 257Hz	1kHz 320nWb/m	500Hz 200	1kHz(700Hz) 200nWb/m				
Azimuth Alignment Section: (-10dB)	315Hz 10kHz	1kHz 10kHz	250Hz 4kHz 8kHz	500(700)Hz 8kHz 16kHz				
Frequency Response Section: (CCIR: -20dB) (NAB: -10dB)	315Hz 31½Hz 40 63 125 250 500 1kHz 2 4 6,3 8 10 12,5 14 16 18 315Hz	1kHz 31½Hz 40 63 125 250 500 1kHz 2 4 6,3 8 10 12,5 14 16 18 1kHz	63 125 250 500 1kHz 2 4 5 6,3 8 10 500Hz	63 125 250 500 1kHz 2 4 8 10 20 1kHz				

Fig.4.2.3

Audio - Operating - pushbuttons

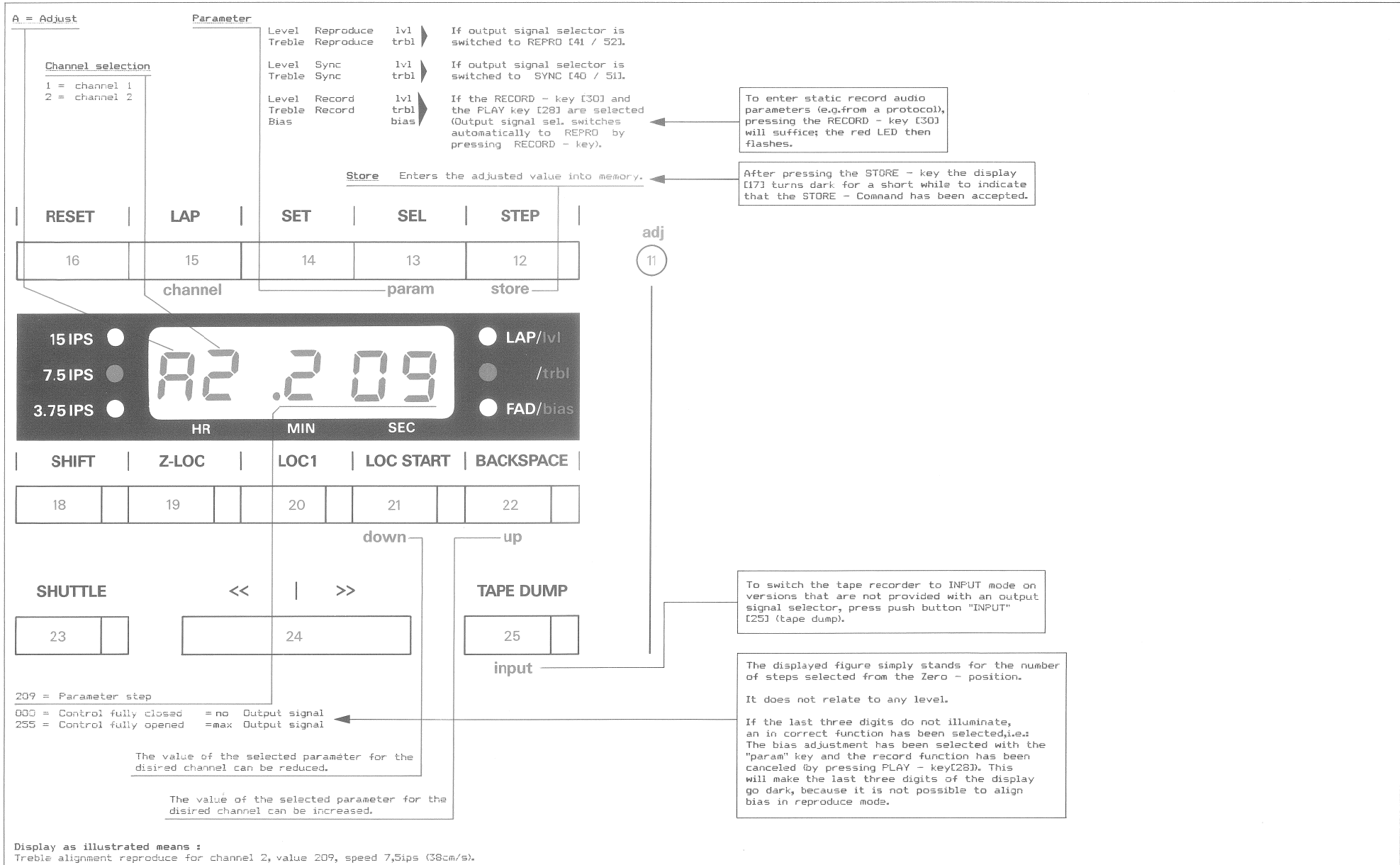

Fig.4.2.4

4.2.6 Input keyboard

Keys with additional yellow lettering are dual function keys:

When the "adj" [11] key is pressed, these keys are assigned to the function specified by the yellow lettering. (In the preceding audio setup key summary, these functions are shown in red).

With these keys it is possible to perform all audio setups (except line level adjustment and RF circuit alignment) from the outside without any tools.

When the "adjust" [11] key is pressed, the display changes to:



The tape recorder is now prepared for adjusting the reference level based on a reproduce calibration tape.

If output function selector keys are available, it is possible to determine in play mode whether the reproduce channel or the sync reproduce channel (reproduce signal read from the record head) is to be adjusted.

READY	INPUT	SYNC	REPRO
31 [42]	32 [43]	40 [51]	41 [52]

If the INPUT function is selected, the last three digits on the display disappear because the internal level cannot be adjusted to the external line level by means of the keyboard.

For alignment instructions refer to Section 4.2.8.

Notes:

In "adjust mode" the output function selector keys for stereo channels 1 and 2 are switched in parallel, i.e. when the function key of one channel is pressed, the other channel switches automatically to the same function.

If, for example, the reproduce level for channel 1 is to be adjusted, the left-hand section of the display [17] should show A1, otherwise press the CHANNEL [15] key for this display. The reproduce level can only be changed if the lvl LCD to the right of the display window glows; this state can be selected by pressing the PARAM [13] key. Of course, the output selector keys must be switched to REPRO [keys 41,52] for modifying the reproduce level.

Displaying the set value:

The amplifier gain can be adjusted between 0 and the maximum in 255 steps (corresponds to 256 discrete values).

These 256 values correspond to range between the minimum and the maximum setting of a potentiometer.

The adjusted value is displayed on the tape timer:

e.g. A1 .209

Important:

From the displayed figure (e.g. 209) the user can determine the range in which the corresponding amplifier operates. No conclusions concerning the actual voltage values can be drawn from this reading!

Modifying and storing the parameters:

Pressing the UP [22] key increases the gain, the DOWN [21] key decreases the gain.

Pressing UP or DOWN has the same effect as the clockwise or counterclockwise adjustment of a potentiometer.

The gain changes continually when the UP or DOWN key is held down.

The amplifiers immediately operate with the changed level (same as with conventional potentiometer settings).

In contrast to conventional potentiometers, the original value stored in the RAM can be retrieved at any time by pressing the "adj" [11] key.

When the desired value has been attained (e.g. operating level +10 dBu = 2.5 V), it can be stored in RAM by pressing the STORE [12] key; the display [17] turns dark for a brief moment and thus acknowledges that the setting has been stored.

Buffering the parameters

As soon as a value has been modified with the UP or DOWN key, the dot in front of the 3-digit number on the display [17] flashes to indicate that for the corresponding function the audio amplifier no longer works with the value stored in RAM but with the modified value.

The modified value is stored in a buffer and is retained even when the next adjustment is started before you have pressed the STORE [12] key. For example different bias and treble equalization values for linearizing the frequency response can be tried without losing the original values stored in RAM.

Important:

If new values are to be stored in the RAM, all modified setup functions must be selected individually and be stored separately by pressing the STORE [12] key.

Example:

- Select treble adjustment (trbl) channel 1 and press STORE.
- Select bias adjustment channel 1 and press STORE.
- Select treble adjustment channel 2 and press STORE.
- Select bias adjustment channel 2 and press STORE.

The value in the buffer memory is deleted when the STORE [12] is pressed.

When the "adj" [11] key is pressed, all parameters in the buffer memory are deleted and the original RAM values are reactivated!

For comparison purposes, the gain settings shown on the display can be recorded in a log.

(Example:)

A 807		Tape Speed						Remarks
Ser.No.....		30ips		15ips		7½ips		
NAB	<input type="checkbox"/>							
CCIR	<input type="checkbox"/>							
Tape A	<input type="checkbox"/>							
Tape B	<input type="checkbox"/>							
Head A	<input type="checkbox"/>							
Head B	<input type="checkbox"/>							
		CH1	CH2	CH1	CH2	CH1	CH2	
Repro	Level	
	Treble	
Record	Level	
	Treble	
	Bias	
Sync	Level	
	Treble	

Fig.4.2.5

Two such logs are required for the complete documentation of a tape recorder if a different calibration was performed for NAB and CCIR (or for tape type A, type B; or reproduce head A, head B).

4.2.7 Audio PCB layout

After the rear panel has been removed, the audio module can be pulled out by pressing the two locking springs marked with arrows.

In stereo models the circuit board facing the rear panel is for channel 1, the other is for channel 2. The following potentiometers and test points are needed for the following adjustment of the internal levels:

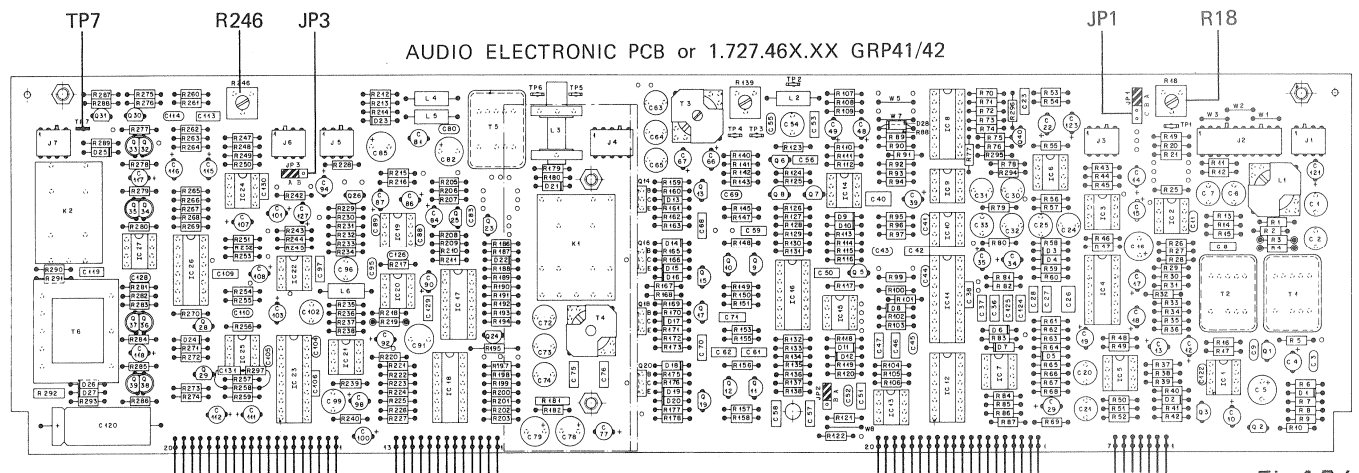

Fig.4.2.6

4.2.8 Matching the internal level to the corresponding operating level

For record/reproduce models

Preparatory steps:

- Remove the rear panel
- Switch the machine to INPUT by pressing the keys [32/43].
On models without INPUT key, actuate the microswitch "adj" [11] with a pointed instrument (pencil). (If disabled, change the setting of jumper JS 16 below the front panel!).
- Press the TAPE DUMP [25] key in order to switch the machine to INPUT.

If existing:

- Switch all UNCAL keys [39, 50, 53, 57] to calibrated mode.
- Select LINE ON [37, 48] keys.
- Deselect MIC ON [35, 46] keys.
- Set MONO/STEREO [55] switch to stereo.

Connect the audio frequency generator to the line input to be calibrated (CH 1, CH 2) and feed 1 kHz with operating level (corresponds to input level for a recording of 0 VU).

This corresponds to the following standard values:

CCIR	0,775	V _{eff}	(0 dBu)
NAB	1,23	V _{eff}	(+4 dBu)

Notes:

If the input sensitivity should be higher (e.g. for operation with hi-fi equipment), the setting of jumper JP 1 can be changed.

- Position A: input sensitivity -4 to +12dBu (standard)
- Position B: input sensitivity -17 to -1dBu
- Position C: input sensitivity -30 to -14dBu

Adjustment procedure:

- On the AUDIO ELECTRONICS PCB 1.727.420/421 1.727.422/423/425 or 1.727.460/461/462 1.727.463/465/467 (GR41 or GR42), measure the 1 kHz signal on test point TP 7 of the channel to be calibrated and adjust the signal with the aid of R18 to 0,775 V (0 dBu).
This value is identical for NAB and CCIR.

(Important: measure with high impedance, i.e. without termination resistor)

- Connect the AF millivoltmeter to the output to be calibrated.

With the aid of R 246 adjust the output signal to the desired operating level.

This corresponds to the following standard values:

CCIR	0,775	V _{eff}	(0 dBu)
NAB	1,23	V _{eff}	(+4 dBu)

Note:

If the output level should be smaller (e.g. for operation with hi-fi equipment), the setting of jumper JP3 can be changed.

- Position A: output level range -4 to +12dBu (standard)
- Position B: -17 to -1 dBu

4.2.9 VU - Meters

(Not applicable to machines without VU-meters)

Pull off the MIC level knobs on the VU-meter panel (or the RECORD LEVEL knobs on the external VU-meter panel. The trimmer potentiometers on the COMMAND PANEL PCB 1.727.361/362/364/365 (GR30) or the external VU-meter panel PCB 1.727.925/935 thus become accessible.

Feed the same 1 kHz input level for an indication of 0 VU on the input as described in 4.2.8.

Adjustment procedures:

- With R16 (channel 1) and R46 (channel 2) adjust to a reading of 0 VU.

4.2.10 LED peak indicator

(Not applicable to machines without VU-meters)

The trimmer potentiometers for the LED peak meters become accessible after the line level knobs on the VU-meter panel or the REPR/SYNC LEVEL knobs on the external VU-meter panel have been removed.

Increase the input level by 6 dB according to Section 4.2.8.

Standard values for CCIR and NAB:
 CCIR 1,55 V_{eff} (+6 dBu)
 NAB 2,46 V_{eff} (+10 dBu)

Adjustment procedures:

- Adjust R32 for channel 1 and R63 for channel 2 in such a way that the "+6" peak LED just lights up.

The peak program LEDs "+9" and "+12" cannot be adjusted. They follow automatically the setting of the "+6" LED.

Note:

In the VUK version these two potentiometers are numbered R18 and R48 respectively.

4.2.11 PLAYBACK ONLY tape players

Alignment instructions for:

- Internal level
- External level
- VU and peak meter display

Preparatory steps:

- Actuate the "adj" [11] microswitch with the aid of a pointed tool (pencil). If it is disabled, change the setting of jumper JS16 below the front panel!
- Switch the UNCAL [53/57] keys for the output level potentiometer to the calibrated position. If existing: set the MONO/STEREO [55] switch to the stereo position.

Level adjustments if the desired tape flux corresponds to the reference tape flux

Because the nominal (reference) flux and the nominal level according to NAB relate to the operating level, and for CCIR to the peak recording level, different adjustments result for NAB and CCIR as shown in the following table:

Adjustment procedure:

Flux density from Testtape	NAB ○		CCIR ●	
	200 nWb/m	320 nWb/m	320 nWb/m	510 nWb/m
required Level	200 nWb/m	320 nWb/m	320 nWb/m	510 nWb/m
1# internal Level (on TP7)	0dBu = 0,775V	0dBu = 0,775V	6dBu = 1,55V	6dBu = 1,55V
2# external Level (on XLR)	4dBu = 1,23V★	4dBu = 1,23V★	6dBu = 1,55V☆	6dBu = 1,55V☆
3# VU Meter Indication	0 VU	0 VU	6 VU	6 VU

Fig.4.2.7

★+4 dBu corresponds to the standard operating level for NAB

☆+6 dBu corresponds to the standard peak recording level for CCIR

○ NAB standard: 200 nWb/m = 0VU +4dBu operating level

● CCIR standard: 320 nWb/m = 6VU +6dBu peak recording level

- Mount the calibration tape, section: level tone
- Connect the AF millivoltmeter to test point TP 7 of the circuit board AUDIO CONTROL ELECTRONICS PCB 1.727.425 or 1.727.465.
- Start the recorder in play mode.

The internal level on TP 7 can be adjusted with the UP and DOWN keys [21,22] to 0VU for NAB and +6dBu for CCIR (refer to Table 4.2.7 in 1#)

Important:

After the correct value has been set with the UP and DOWN keys, it must be saved in memory by pressing the STORE [12] key.

- Connect the AF millivoltmeter to the output to be measured and adjust the output signal to the desired line level by means of R246:

NAB to operating level / CCIR to peak recording level

Standard values:

for NAB +4dBu (1,23V) = operating level =0VU
 for CCIR +6dBu (1,55V) = peak rec. level =6VU

(also refer to Table 4.2.7 under 2# external level)

Note:

If the output level range should be smaller (e.g. for operation with hi-fi equipment), the position of jumper JP3 can be changed.(See Fig.4.2.6)

Position A: output level range -4 to +12 dBu (standard)

Position B: output level range -17 to -1 dBu

VU and peak meter adjustment for playback only tape players

Preparatory steps:

- Remove the front panel
- Same measurement arrangement as above
- Connect the AF millivoltmeter to the output to be measured and play the level tone section of the calibration tape:

The trimmer potentiometers R16, R46, R32, and R62 are located on the command panel PCB 1.727.364.00 or 1.727.365.00 respectively.

Adjustment procedures:

NAB:

- Adjust R16 for channel 1 and R46 for channel 2 to 0 VU (refer to Table 4.2.7 under 3# VU-meter reading).
- Activate the UNCAL [53,55] key and increase the output level of the channel to be measured by 6dB with the aid of the output level potentiometer [54,56]. (For NAB standard calibration this corresponds to a level of +10dBu (2.45 V) on the AF millivoltmeter).
- Adjust R32 for channel 1 and R63 for channel 2 in such a way that the "+6" peak LED just lights up.

CCIR:

- Adjust R32 for channel 1 and R63 for channel 2 in such a way that the "+6" peak LED just lights up.
- Activate the UNCAL [53,55] key and lower the output level of the channel to be measured by 6dB with the aid of the output level potentiometer [54,56]. (For CCIR standard calibration this corresponds to a level of 0 dBu (0.775 V) on the AF millivoltmeter).
- Adjust R16 for channel 1 and R46 for channel 2 to 0 VU. (See Table 4.2.7 under 3# VU-meter indication).

The peak program LEDs "+9" and "+12" cannot be adjusted. They automatically follow the setting of the "+6" LED.

Adjusting the level when the desired tape flux does not correspond to the one on the calibration tape

If the desired magnetic tape flux does not correspond to the one recorded on the calibration tape, the tape flux correction value (ΔU) must be determined.

The tape flux correction value (ΔU) is positive when the desired tape flux is smaller than the one recorded on the calibration tape. Conversely, it is negative when the desired tape flux is greater than the one recorded on the calibration tape.

The tape flux correction value (ΔU) can be determined from Table 4.2.2:

(e.g. desired tape flux 250 nWb/m
Available calibration tape 200 nWb/m
Tape flux correction value ΔU = -2 dB).

The tape flux correction value ΔU computed according to Table 4.2.2 is to be added to or deducted from the values 1#, 2#, 3# in Table 4.2.7 (depending on the sign).

For the above example (NAB) this means:

- Internal level 0 dBu - 2 dBu = -2 dBu
- External level 4 dBu - 2 dBu = +2 dBu
- VU meter reading 0 VU - 2 dBu = -2 VU

Other common settings can be determined from the table Fig.4.2.8 (all others can be computed with the aid of Table 4.2.2):

Adjustment procedures:

The adjustments are performed similarly to those described in 4.2.11 .

Play the level tone section of the calibration tape and aligne as follows :

- Internal level: set it to the computed value
- External level: desired line level + (-) tape flux correction value
- VU-meter: set it to the computed value.

Note:

If the value to be set is greater than the VU-meter reading (+3 VU) or much below the 0 VU mark, connect the millivoltmeter to the XLR output and adjust the gain with the output level trimmer potentiometers [54, 56] (enabled with the UNCAL keys [53,57]) in such a way that a 0 VU reading can be obtained.(Refer to example 2.)

Test - Tape	CCIR				NAB		
	320 nWb/m	320 nWb/m	510 nWb/m	510 nWb/m	185 nWb/m	200 nWb/m	320 nWb/m
required flux density	510 nWb/m	640 nWb/m	320 nWb/m	640 nWb/m	250 nWb/m	320 nWb/m	250 nWb/m
Tape flux correction value	-4 dBu	-6 dBu	+4 dBu	-2 dBu	-3 dBu	-4 dBu	+2 dBu
internal Level (on TP 7)	+2 dBu	0 dBu	+10 dBu	+4 dBu	-3 dBu	-4 dBu	+2 dBu
external Level (on XLR)	+2 dBu	0 dBu	+10 dBu	+4 dBu	+1 dBu	0 dBu	+6 dBu
VU Meter Indication	+2 VU	0 VU	+10 VU	+4 VU	-3 VU	-4 VU	+2 VU

Fig.4.2.8

Peak LED

The Peak LED should light up at Peak-recording level (= 6dB above 0VU).

Because the nominal-tapeflux for CCIR-tape recorders is related to the Peak recording level (6VU), the calculated value of the external Line level (see Table 4.2.8) is also the treshold point of the "+6" Peak LED.

The nominal-tapeflux for NAB-tape recorders is related to the operating level (0VU), i.e. add 6dB to the computed value of the external Line level to achieve the treshold point of the "+6" Peak LED.

Example 1 :

NAB Testtape 185nWb/m	} Tapeflux correction value -3dB
required tapeflux 250nWb/m	
Standard Line level +4dBu	

VU-Meter indication -3VU corresponds to an external Line level of +1dBu.

Peak LED indication at (-3VU + 6dB =) +3VU which corresponds to the external Line level of (+1dBu + 6dB =) +7dBu.

- Connect the millivoltmeter to the XLR output to be measured and increase the external level by 6dB with the aid of the output level trimmer potentiometers [54,56] (enabled with UNCAL keys [53, 57]). In the above example, increase the external level by 6dB to +7dBu.

Afterwards adjust potentiometer R32 for channel 1 on the command panel board (below frontpanel cover) and R62 for channel 2 in such a way that the "+6" Peak LED just lights up.

Example 2 :**Requirement:**

320nWb/m = 6VU = 6dBu line level
Available calibration tape 510nWb/m
Standard Line level (external level) +6dBu

With the definition of 6VU we know that the 6dBu line level corresponds to peak recording level, i.e. the internal level is also at the peak value (6dB above 0VU).

The tape flux correction value (computed according to Table 4.2.2) is +4dB.

Consequently, when the 510nWb/m calibration tape is played, the internal level on TP7 of the corresponding audio electronics board must be adjusted to (+6dBu standard Line level + 4dB flux correction value =) 10dBu = 2.45V (by means of the UP [22] and DOWN [21] keys.

- The external level is at +6 dBu + 4dBu = 10dBu. Adjustable with R246 on the corresponding audio electronics board. The VU-meter reading should also be at 6VU + 4dB = 10VU. Because this value is not adjustable, the level must be lowered by 10dB with the aid of the output level trimmer potentiometers [54, 56] (enabled with the UNCAL keys [53,57]). The VU-meter is subsequently calibrated to 0VU by means of R16 for CH1 and R46 for CH2 on the command panel PCB.

The peak LED is always lit at Peak recording level (6dB above 0VU).

For this example, the Peak LED "+6" must light up with an external Line level of +10dBu. (Standard Line level 6dBu + 4dB tapeflux correction value).

Therefore release the UNCAL pushbuttons again into calibrate position and adjust the potentiometers R32 for channel 1 and R62 for channel 2 on the command panel PCB in such a way that the corresponding LED just lights up.

Note:

If no AF millivoltmeter with dB scale is available, the voltage values can be derived from Table 4.2.1.

4.3 REPRODUCE ALIGNMENTS

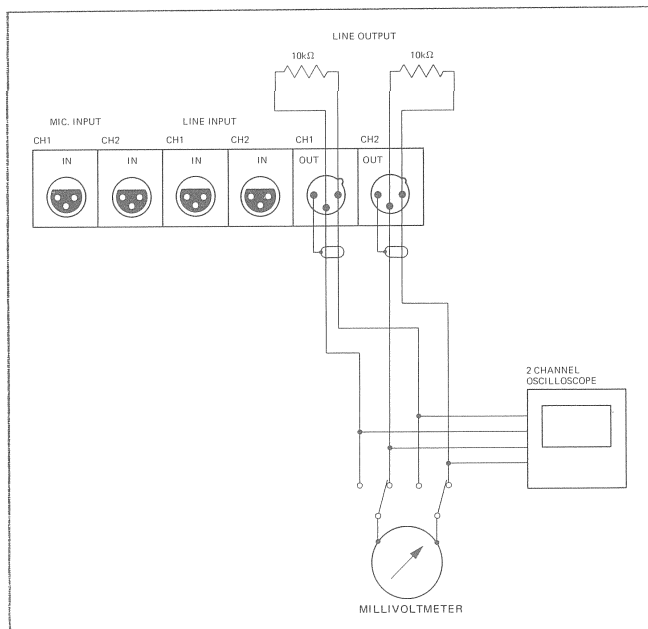

Fig.4.3.1

4.3.1 PREPARATION

The alignment is performed with the aid of the front-panel keyboard. See Fig. 4.2.4.

Preparatory steps:

- Press the REPRO [41/52] key (only on models with output selector switches)
- Actuate the "adj" key (possibly interlocked with jumper 16 below the front cover). The following picture appears on the display [17]:



- Select the preferred studio speed.

If existings:

- Select the READY [31/42] key (the red LED should not flash)
- Deselect all UNCAL [53/57] keys so that calibrated level can be set.
- Deselect Mono [55] by simultaneously pressing shift and mono.
- Set the programmable keys [60/61] to the desired calibration mode:
 - NAB or CCIR equalization
 - Tape type A or B (Tape A / Tape B)
 - Reproduce head left or right (HEAD A / HEAD B)
- Connect the AF millivoltmeter to the XLR output to be calibrated, possibly terminated with 200 or 600 ohm (factory termination 10 kohm).
- Mount the corresponding reproduce calibration tape and play the level tone section.

Adjustment procedure:

- Read the output level and set the desired operating level with the aid of the UP or DOWN [22/21] keys.
- Save the found value by pressing the STORE [12] key.
- On stereo models connect the millivoltmeter to the line output channel 2. Press the channel [15] key for switching to channel 2 (display [17] shows A2 .XXX). Set the desired operating level with the UP or DOWN key. Press STORE.

The factory calibrates the machine to the following reference tape flux values:

for NAB calibration the internal level of 0.775V corresponds to 0VU and to an operating level of 1.23V on the output of mono and stereo units.

at:	3.75 ips	200 nWb/m
	7.5 ips	250 nWb/m
	15 ips	250 nWb/m
	30 ips	250 nWb/m

For CCIR calibration a reference level of +6 dBu corresponds to 1.55 V at the output of mono and stereo units (VU-meter reading: 6VU).

	Stereo	Mono
at:	3.75 ips 400 nWb/m	250 nWb/m
	7.5 ips 510 nWb/m	320 nWb/m
	15 ips 510 nWb/m	320 nWb/m
	30 ips 510 nWb/m	320 nWb/m

If the desired tape flux does not correspond to the one on the available calibration tape, the difference can be computed by means of the formula in paragraph 4.2.5 or be derived from the table (Fig.4.2.2).

Important:

If the desired magnetic flux is higher than on the available calibration tape, the value obtained from table 4.2.2 must be subtracted from the desired line level.

Examples:

Desired setting 510 nWb/m = +6 VU = 6 dBu line level.
Available calibration tape: 320 nWb/m
Difference $\Delta U = 4$ dB

The line level to be set is therefore:

$$+6\text{dB} - 4\text{dB} = +2\text{dB}$$

Indications: +2 VU

4.3.2 Azimuth alignment

Spool the reproduce calibration tape forward to the azimuth alignment section.

The head gap is adjusted by swivelling the reproduce head. For this purpose the calibration tapes contain an azimuth alignment section that has been recorded with a tape flux that is down by 10dB (20dB).

The objective of the adjustment is to achieve the maximum output voltage at the head gap reference frequency (10 kHz on CCIR calibration tapes, 8 or 16kHz on NAB calibration tapes). The adjustment is most accurate when performed at the slowest speed.

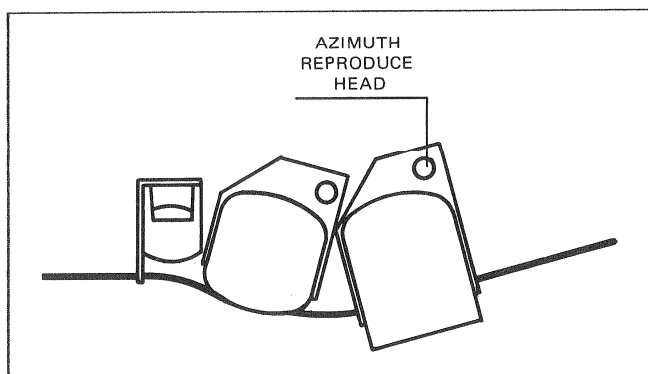

Fig. 4.3.2

Coarse adjustment:

While the recording with reference frequency is being played, adjust the reproduce head until the highest output voltage is achieved.

Fine-adjustment:

- Connect the line outputs of both channels either
- to the inputs of a 2-channel oscilloscope. While a recording with 8, 10, or 16 kHz is being played, align for minimum phase difference of the output signals on the audio channels with the aid of the azimuth adjustment screw, or
 - to the inputs of an AF millivoltmeter with summation facility. While the recording with 8, 10 or 16 kHz is being played, align for maximum level of the sum of the audio channels with the aid of the azimuth adjustment screw.

Minor deviations in the gap position can occur between the calibration tapes of different manufacturers or for different tape speeds. We therefore recommend to optimize for the most frequently used speed.

Important:

Always adjust for maximum level and then to minimum phase difference! If major adjustments are made to the reproduce head, other maxima but with lower levels can occur. Check: measure the phase with a slightly changed frequency.

Level check:

Rewind the calibration tape to the LEVEL TONE section and switch the machine to play mode. Check the level of channels 1 and 2. Correct it, if necessary.

4.3.3 Reproduce treble adjustment

- Spool the calibration tape forward to the FREQUENCY RESPONSE 16 kHz section (applies to 30 ips; 14 kHz for 15 ips; 12.5 kHz for 7½ ips). The level of this section is approx. 20 dB (CCIR) lower than in the level tone section.
- Connect the millivoltmeter to the line output channel 1.
- Start the tape recorder in play mode.
- With the CHANNEL [15] key, select the channel to be calibrated (A1 .XXX appears on the display [17] for channel 1).

- Press the PARAM [13] key so that the red "lv1" LED on the right-hand side of the display [17] lights up.
- Alignment to optimum frequency response is possible with the UP and DOWN keys [21/22].
- Press STORE [12] to save the setting.

Note:

These frequencies are intended as reference points for matching the high frequencies to those of the line level. These are empirical values for which a more or less linear frequency response should result. The final setting should be made individually for each unit in such a way that when the entire frequency response test is played from tape, a linear, symmetrical pattern (deviation from the desired value identical in the positive and negative area) is obtained, regardless of the reference frequency.

On stereo machines connect the millivoltmeter to the line output channel 2. Press the CHANNEL [15] key, the display shows A2 .XXX. With the UP or DOWN key align for optimum frequency response. Press store.

Note:

Bass adjustment:

The A807 tape machine is not equipped with a bass trimmer potentiometer. Machines with serial numbers below 2141 are equipped with the audio electronics PCB 1.727.42X.00.

This circuit board has been matched to the deviations in the bass range caused by the various head formats.

If repairs become necessary and particularly if this circuit board is replaced, the different resistor configuration should be noted. These resistors are socket mounted so that they can be easily replaced.

Resistor configuration for bass alignment of the 1.727.420/421/423/425.00 board:

Config.	R 195	R 197
2 / 2	560 kΩ	820 kΩ
0.75	1.5 MΩ	1.5 MΩ
MONO	not equipped	1.5 MΩ

Fig.4.3.3

Audio electronics boards with 1.727.460/461/462 1.727.463/465 and boards with 1.727.420/421/423.81 1.727.425.81 have been manufactured in such a way that bass alignment is not necessary.

Note:

If the optional test generator is installed, reproduce levels 10 or 20 dB below the reference level can be amplified in the 10 or 20dB setting by this amount so that they can again be adjusted to 0 VU with the aid of the VU-meter.

4.4 RECORD ALIGNMENT

4.4.1 Adjusting the erase current

- Mount a blank tape
- Press the ready keys [31/42], the red LEDs flash.
- Start the machine in record mode.

Adjustment procedure:

Turn R139 on the AUDIO ELECTRONICS PCB 1.727.420/421/422/423 or 1.727.460/461/462/463/467 (GR 41 or GR 42) to the minimum. (See Fig.4.4.1)

- Connect the oscilloscope or the vacuum tube voltmeter to TP 4 (0 V to TP 2).
- With the trimmer T3 adjust the voltage on TP 4 to the minimum. A screwdriver with a narrow blade is needed for this purpose.
- Connect the voltmeter to TP 3 (0 V to TP 2) and adjust to the following values with the aid of R139:

- 2-Channel erase head 44 V
- Mono erase head 75 V
- 4-Track 2-channel erase head 36 V

Note:

- On 2-channel units with separate erase head, the adjustments must be performed on both channels.
- On 2-channel units with mono erase head, jumper W1 must be removed on the AUDIO ELECTRONICS PCB 1.727.400/401 (GR 40). In this case the adjustments for channel 2 are made on the AUDIO ELECTRONICS PCB 1.727.420/421/422/423/ or 1.727.460/461/462/ 463/467 (GR 42).

4.4.2 Adjusting the bias trap

- Insert the tape and start the machine in record mode.

Adjustment procedure:

- Connect the vacuum-tube voltmeter to TP6 (0V to TP2) of the AUDIO ELECTRONICS PCB 1.727.420/421 1.727.422/423 or 1.727/460/461/462/463/467 (GR 41 or GR 42 respectively). (See Fig.4.4.1)
- With the trimmer screw on L3, adjust the voltage to the minimum; a screwdriver with a plastic blade is required for this purpose.

Note:

On all 2-channel machines, the channels must be aligned individually.

4.4.3 Record audio alignments

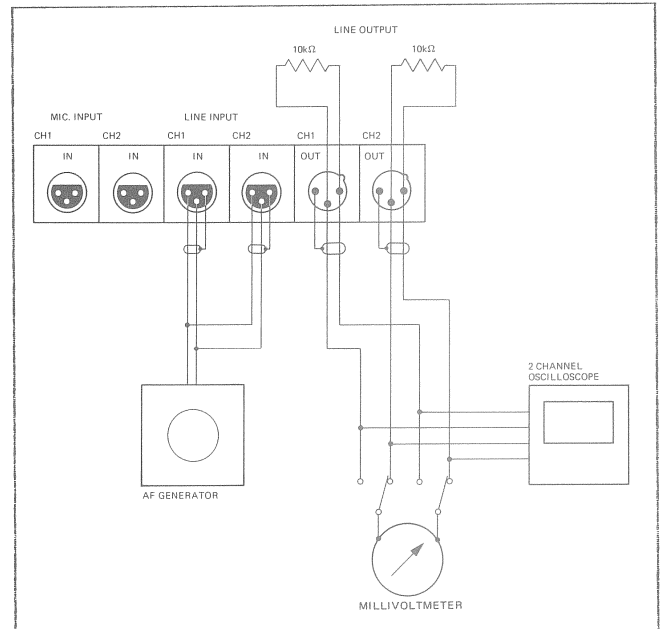

Fig.4.4.2

Preparatory steps:

- Actuate the "adj" key (possibly interlocked with jumper 16 below the front cover).

The display shows:



- With the CHANNEL [15] key, select the channel to be measured. A1 .XXX on the display [17] means channel 1.
- With the PARAM [13] key, select the "lvl" position; the "lvl" LED on the right-hand side of the display [17] lights up.

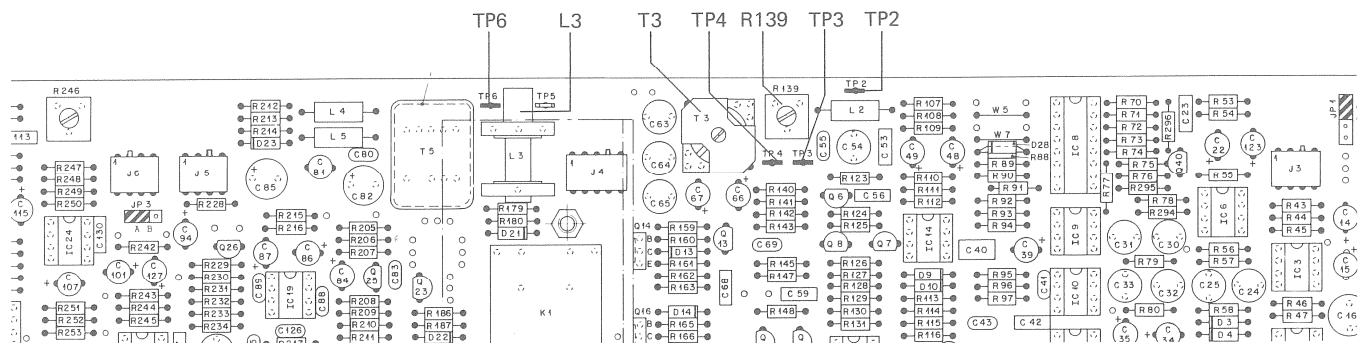

Fig.4.4.1

If existing:

- Select the REPRO [41/52] key
- Release all UNCAL [39/50/53/57] keys to switch to calibrated level
- Deselect Mono [55]
- Select the LINE ON [37/48] keys
- Deselect the MIC ON [35/46] keys (the yellow LEDs should be dark)
- Press the READY [31/42] keys (the red LEDs flash)

Install a new or practically new tape of the desired type.

- With the keys [60/61]
 - Select the correct equalization(NAB or CCIR), or
 - Select the correct tape type A or B, or
 - Select the reproduce head (head A).
- Connect the AF generator with 1 kHz and operating level to the line input channel 1 (on stereo machines to channels 1 + 2), and connect the millivoltmeter to the line output of channel 1. For NAB calibration feed a reference frequency of 700 Hz.

4.4.4 Record preadjustment

- With the PARAMETER [13] key select the level adjustment function, i.e. the "lvl" LED on the right-hand side of the display [17] should be light.
- With the CHANNEL [15] key, select the channel to be calibrated (A1 .XXX = channel 1, A2 = channel 2)
- Start the machine in record mode.
- Read the output level and adjust to operating level by pressing the UP or DOWN [21/22] key.
- Press STORE [12].

On stereo machines connect the millivoltmeter to the line output channel 2. Press the CHANNEL [15] key (display shows A2). Adjust to operating level with the UP or DOWN key. Press STORE [12].

4.4.5 Aligning the azimuth of the record head

- Switch the audio generator to 10 kHz and decrease the level by 20 dB (or if available, set the test generator to the -20 dB position).
- Connect the millivoltmeter to the line output channel 1.
- Start the machine in record mode.

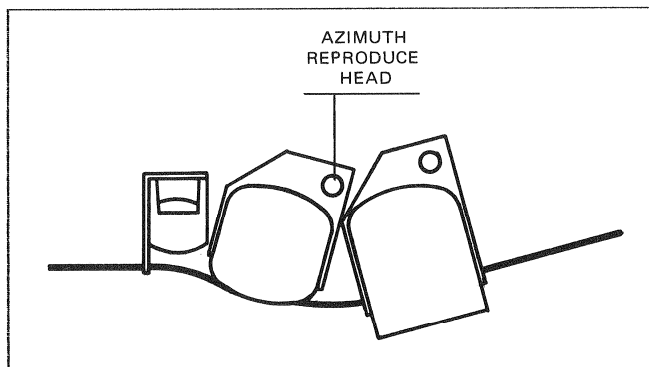

Fig.4.4.3

- With the azimuth alignment screw, adjust the position of the record head until the highest output voltage and simultaneously the lowest level fluctuations are attained.

If major corrections are made with the azimuth alignment screw, the record preadjustment (Section 4.4.4) must be repeated.

Note:

If the bias has not been adjusted yet, the bias parameters of 2-channel and stereo machines should be set to the same or at least similar values for both channels, refer to 4.4.6. (Reason: the mechanical and the "electrical" head/gap of the record head are not in the same location; the offset depends on the magnitude of the bias current. For this reason an azimuth correction is made after the bias adjustment).

4.4.6 Bias adjustment

- Audio generator at 10 kHz and level 20 dB below operating level. Connect the millivoltmeter to the line output channel 1.
- Start the machine in record mode
- With the CHANNEL [15] key select the channel to be calibrated (A1 = channel 1)
- Press the PARAM [13] key repetitively until the red bias LED on the right-hand side of the display window [17] lights up. (Note: only possible when the machine is in record mode).
- Press the DOWN [21] key repetitively until the value A1 000 appears on the display. Then search the maximum output voltage with UP [22] and write down this value. Continue with UP until the output voltage drops by the value ΔU (dB) specified in the bias Table (at the end of this Section). This value depends on the tape type and the speed.
- Press STORE [12].

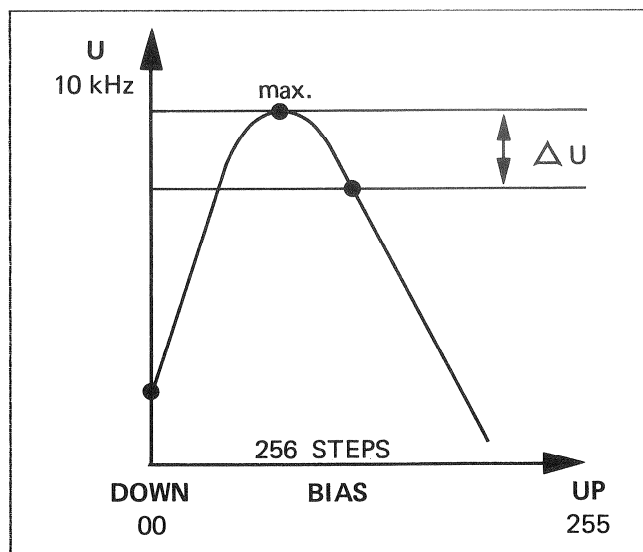

Fig.4.4.4

On stereo machines connect the millivoltmeter to the line output channel 2. Press the CHANNEL [15] key (A2 .XXX appears on the display [17]). Perform the bias adjustment as specified for channel 1. Press STORE.

4.4.7 Azimuth alignment STEREO

On stereo machines, the output signals on channels 1 and 2 are adjusted to minimum phase difference with the aid of the oscilloscope and by carefully turning the azimuth alignment screw of the record head.

4.4.8 Record level adjustment

- Set audio generator at 1kHz (possibly 700Hz for NAB, 333Hz for 3 3/4 ips), and operating level.
- Connect the millivoltmeter to the line output channel 1.
- With the CHANNEL [15] key select the channel to be calibrated (A1 = channel 1)
- Repetitively press the PARAM [13] key until the red "lvl" LED on the right-hand side of the display window [17] lights up.
- Start the machine in record mode.
- With the UP or DOWN [21/22] adjust the output level to operating level.
- Press STORE [12].

On Stereo machines connect the millivoltmeter to the line output channel 2. Press CHANNEL [15] (A2 .XXX appears on the display [17]). With the UP or DOWN key adjust the output level to operating level. Press STORE.

4.4.9 Frequency response alignment

- Set the AF generator to operating level -20 dB.
- Connect the millivoltmeter to the line output channel 1.
- With the CHANNEL [15] key select the channel to be calibrated (A1 = channel 1)
- Repetitively press the PARAM [13] key until the red "trbl" LED on the right-hand side of the display window [17] lights up.
- Start the machine in record mode.
- With the UP or DOWN [21/22] keys, align for optimum treble frequency response (above 1 kHz):

The reference points for matching the treble frequency to the reference level are specified in the following table. These are empirical values which produce a more or less linear frequency response.

Tape Speed [cm/s] [ips]		Adjusting Freq. [kHz]
9,5	3,75	8
19	7,5	10
38	15	12,5
76	30	16

Fig.4.4.5

The final adjustment should be made individually for each machine in such a way, that with a continuous increase of the input frequency a linear, symmetrical pattern (deviation from the desired value identical in the positive and the negative area) is attained, regardless of the above alignment frequencies.

- Press the STORE key [12]

Stereo models:

- Connect the millivoltmeter to the line output channel 2.
- Press the CHANNEL [15] key (A2 .XXX appears on the display).
- Start the machine in record mode.
- With the UP or DOWN key align to optimum treble frequency response (above 1 kHz).
- Press STORE.

4.4.10 Adjusting the channel separation

(only on 2-channel and stereo machines)

- Connect the audio generator (operating level, 1kHz) to the line input channel 1;
- connect the millivoltmeter (preferably a selective meter because the value is within the noise level) to the line output channel 2.
- Switch both channels to READY and start the machine in record mode.
- With the CROSSTALK potentiometer on the audio base board 1.727.400 or 1.727.401 (see Fig. 4.4.6), align for minimum output voltage. Repeat the same measurement with swapped channels. If large deviations occur, find an optimum value for both channels.

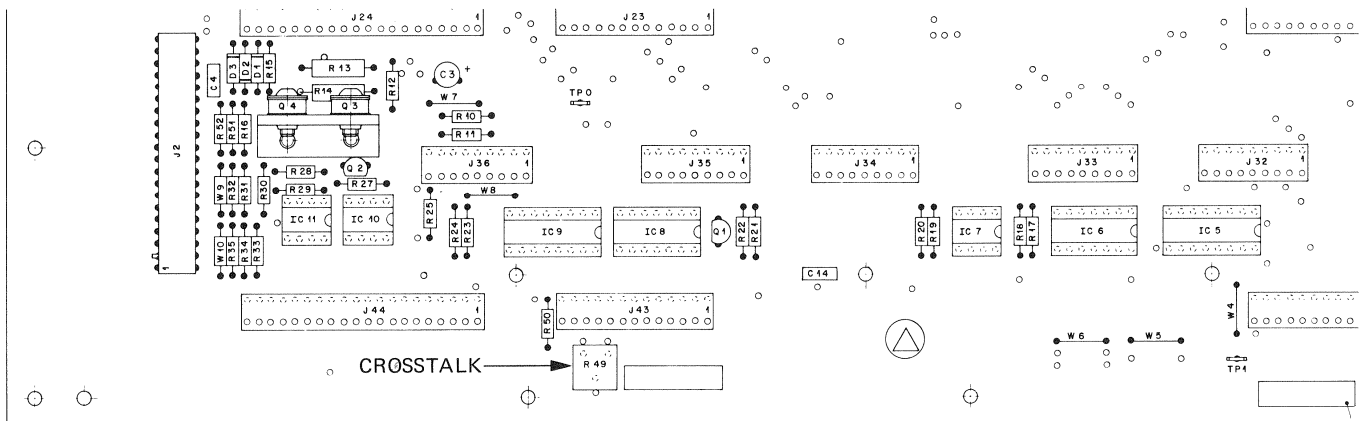

Fig.4.4.6

AUDIO CONTROL 1.727.40X.XX GRP40

4.5 SYNC ALIGNMENTS

4.5.1 Preparations

- Connect the millivoltmeter to the line output channel 1.
- Switch on the tape recorder.
- Select the tape speed, equalization, tape type, and the corresponding reproduce head with the keys [60/61].
- Deselect READY [31/42] (the red LEDs should not flash).
- Press the SYNC keys [40/51] of Ch 1 or Ch 2.
- Release all UNCALL keys [53/57] (cal. level).
- Mount a reference tape of the corresponding speed and spool forward to the LEVEL TONE SECTION.

4.5.2 Sync reproduce level adjustment

- With the CHANNEL [15] key select the channel to be calibrated (A1 = channel 1).
- Repetitively press the PARAM [13] key until the red "lvl" LED on the right-hand side of the display window [17] lights up.
- Start the machine in play mode.
- Read the output level and adjust to operating level by pressing the UP or DOWN [21/22] key.
- Press STORE [12].

On stereo machines connect the millivoltmeter to the line output channel 2.

- Press the CHANNEL [15] key (the display shows A2 for channel 2).
- With the UP or DOWN key align to operating level.
- Press STORE .

4.5.3 Sync frequency response alignment

- Spool the reference tape forward to the FREQUENCY RESPONSE section. The level of this section is approx. 20 dB below the level tone section.
- Connect the millivoltmeter to the line output channel 1.
- Press the CHANNEL [15] key so that A1 (=channel 1) appears on the display.
- Repetitively press the PARAM key until the "trbl" LED on the right-hand side of the display window [17] lights up.
- Start the machine in play mode.
- With the UP or DOWN [21/22] key align for optimum frequency response.
- Press STORE [12].

On stereo machines connect the millivoltmeter to the line output channel 2.

- Press the CHANNEL [15] key (the display shows A2 for channel 2).
- With the UP or DOWN key align to optimum frequency response.
- Press STORE.

Note:

Bass-Sync:

- There are no trimmer potentiometers for the bass frequencies.

Normally the studio tape recorders are calibrated with full-track reference tapes. Bass frequency response errors occur on stereo and 2-channel machines due to fringing.

For this reason the sync reproduce frequency response for the bass frequencies should be checked with tape, i.e. the sync reproduce frequency response should be repeated with a user produced test tape, if no reference tapes with the correct guard track width are available (approx. 3 minutes each: 1 kHz (NAB 700 Hz), 10 kHz (8 kHz for 7½ ips) and 6 kHz for 3 3/4ips), 50 Hz.

To minimize cross talk (considerable at high frequencies) from the record channel into the SYNC reproduce channel, the frequency response has been limited. The following cutoff frequencies result:

3 3/4 ips 6 kHz; 7½ ips 10 kHz; 15 and 30 ips 12 kHz each.

4.6 MONO/STEREO SELECTOR SETTINGS

A mono/stereo selector switch is available as an option. In this case the mono level must be aligned. A precondition for this alignment is that the recorder has been correctly calibrated in stereo mode.

4.6.1 Preparations

Set the jumper on the mono stereo switch to the desired setting.
 The input amplifier can optionally be fitted with the test generator.
 By setting the jumpers JS1 and JS2 on the mono/stereo input amplifier it is possible to define the channel that is to supply the mono signal to be recorded.
 It is also possible to mix both input signals and to record them in mono mode.

M/S INPUT AMPLIFIER
 1.727.451.00 GRP44

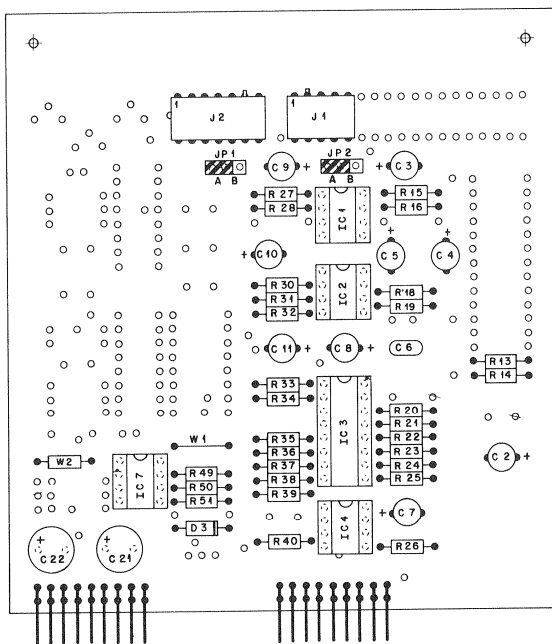

M/S INPUT AMPLIFIER WITH TEST GENERATOR
 1.727.441.00 GRP44

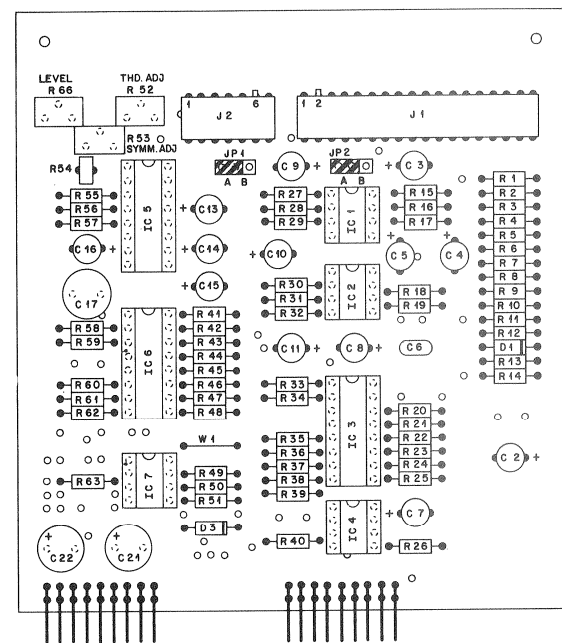
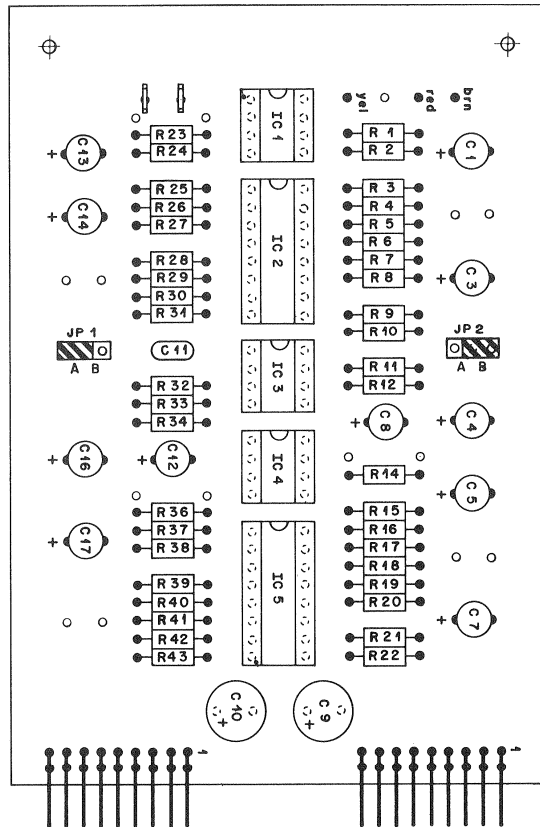

Fig.4.6.1

- | | | | |
|------------|---------------|---|--|
| Jumper JP1 | in position A | ▶ | The input signal of channel 1 and the input signal of channel 2 are mixed. The resulting monophone signal is recorded on channel 1 and on channel 2. |
| Jumper JP2 | in position A | | |
| Jumper JP1 | in position A | ▶ | The input signal of channel 1 is recorded on channel 1 and on channel 2. |
| Jumper JP2 | in position B | | |
| Jumper JP1 | in position B | ▶ | The input signal of channel 2 is recorded on channel 1 and on channel 2. |
| Jumper JP2 | in position A | | |
| Jumper JP1 | in position B | ▶ | Both input signals are short-circuited to ground. No mono recording can be made. |
| Jumper JP2 | in position B | | |

By setting the jumpers JS1 and JS2 on the mono/stereo output amplifier it is possible to define the channel on which the aggregate signal (mono signal) of the tape recording is available. It is also possible to make the signal available on both channels. (See Fig.4.6.2)

M/S OUTPUT AMPLIFIER WITH TEST GENERATOR 1.727.442.00 GRP45



M/S OUTPUT AMPLIFIER PBO 1.727.452.00 GRP45

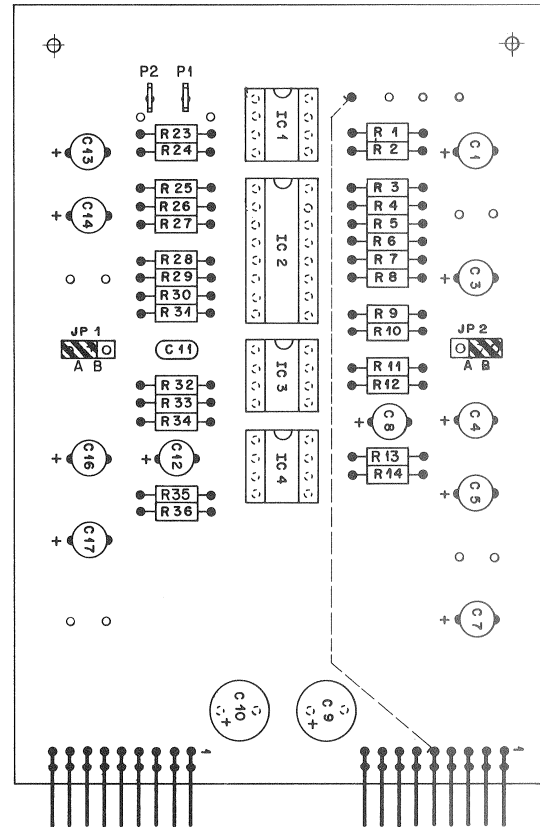

Fig.4.6.2

- | | | |
|--------------------------|--------------------------------|---|
| Jumper JS1
Jumper JS2 | in position A
in position A | ▶ The aggregate signal of the reproduce channels 1,2 are available on the XLR output channels 1,2. |
| Jumper JS1
Jumper JS1 | in position A
in position B | ▶ The aggregate signal of the reproduce channels 1,2 is only available on the XLR output channel 1. |
| Jumper JS1
Jumper JS2 | in position B
in position A | ▶ The aggregate signal of the reproduce channels 1,2 is only available on the XLR output channel 2. |
| Jumper JS1
Jumper JS2 | in position B
in position B | ▶ Both reproduce channels are short-circuited to ground, i.e. the XLR outputs are muted. |

4.6.2 Mono reproduce level adjustment

Prepare the recorder as follows:

- Select mono mode by simultaneously pressing the MONO [55] and the SHIFT [18] keys.
- If existing:**
 - Deselect all UNCAL keys [39,50,53,57] → cal. level
 - Press REPRO [41/52].
 - Deselect the READY [31/42] keys.
 - Select the desired equalization (NAB/CCIR) or the desired tape type (TAPE A / TAPE B) or the desired reproduce head (HEAD A / HEAD B).

Note:

Change over is only possible by simultaneously pressing the SHIFT [18] key and the corresponding key [60/61].

- Select the preferred studio speed.
- Mount the corresponding calibration tape.
- Unfasten the small cover plate on the right-hand side of the mono key by unfastening two hexagon-socket-head screws (2.5 mm).
- Connect the audio millivoltmeter to the output that supplies the mono signal.

Adjustments:

- Play the level tone section of the reproduce calibration tape and adjust the desired mono tape flux by means of the R2 REPRO LEVEL potentiometer (below the small right-hand cover above the headphones socket). See Fig.4.6.3

For different Mono-flux setting use tape flux difference table 4.2.2.

Note:

For heads with 0.75 mm guard track, the MONO level can be adjusted to 1.1 dB below the standard mono level in order to compensate the guard track loss.

For example:

Calibration tape 320 nWb/m
 Desired mono tape flux 320 nWb/m = 6VU = 6dBu line level.

Mono level adjustment without compensation of the guard track loss:

- Adjust R2 to line level, +6 dBu on the line output.

Mono level adjustments with compensation of the guard track loss:

- Adjust R2 to the line level less the guard track loss value: i.e. to 6 dBu -1.1 dB = 4.9 dBu on the line output.

**M/S ADJUSTMENT WITH TEST GENERATOR
 1.727.443.00 GRP46**

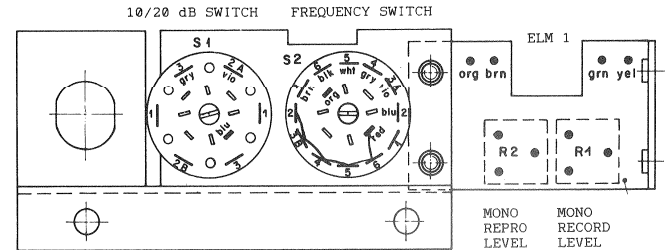

M/S ADJUSTMENT 1.727.453.00 GRP46

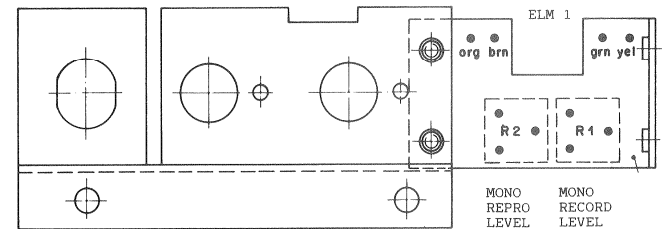

M/S ADJUSTMENT PBO 1.727.454.00 GRP46

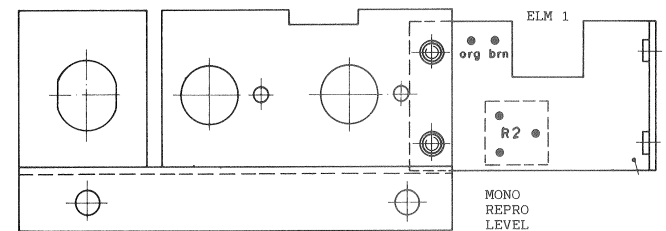

Fig.4.6.3

4.6.3 Mono record level adjustment

- Connect the audio generator (1 kHz and line level according to the jumper configuration as shown in Fig. 4.6.1) to the corresponding line input.

If both channels are mixed to produce the mono signal, feed line level to both inputs.

- Mount a new or practically new tape.
- Press the READY keys [31/42] (the red LEDs flash).
- If the machine is equipped with the corresponding options, make sure that the HEAD A [61] is selected.
- The following key selections are identical to the sequence described 4.6.2

Adjustment procedure:

- With the RECORD LEVEL trimmer R1 below the small cover above the headphones socket align to line level.

Important: measure with -20 dB!

4.7. BIAS - ADJUSTMENT PARAMETERS

("Delta U" values)

Tape speed Tape type	ΔU [dB]			
	9,5cm/s 3,75ips	19cm/s 7,5ips	38cm/s 15ips	76cm/s 30ips
Agfa PEM 468	6	6	3,5	1,5
Agfa PEM 469	7	7	5	2
Agfa PER 525	6	6	3	1
Agfa PEM 526	--	6	3	--
Agfa PER 528	6	6	3,5	1,5
Ampex 406	6	5	3	1,5
Ampex 456 Grand Master	5	6,5	3,5	1,5
Ampex 457	7	7	4	2
Ampex 478	8	7	3	1
BASF LGR 30P	6	6	4	1,5
BASF LGR 35P	--	4	3	1,5
BASF LGR 50P	6	6	4	1,5
BASF LGR 51	6	6	4	2,5
BASF SPR SOLH/SOLHL	6	5,5	3,5	1,5
BASF Studio Master 910	5	6	4,5	1,5
BASF Studio Master 911	6	6	4,5	3
EMI 816/817	6	6,5	4	1,5
Pyral CJ90	6	6,5	3,5	1,5
Revox 641	6	5	4	--
Scotch (3M) 206	5,5	5,5	3	1,5
Scotch (3M) 226	6	6	3,5	1,5
Scotch (3M) 250	5	6	3,5	1
Scotch (3M) 256	6	6,5	3,5	1
Scotch (3M) 263	6	6	3	1

TABLE OF CONTENTS SECTION 5

GROUP SUMMARY	2
5. WIRING LISTS	2
5.1 WIRING	4
5.1.1 Groups	
5.1.2 Elements, points	4
5.1.3 Principal connection types	4
5.1.4 Cable designations, color scheme	4
5.1.5 Explanations to the LOCATION PIN LIST	4
5.1.6 Explanations to the SIGNAL WIRE LIST	5
5.1.7 Explanations of the signal name abbreviations and their specification	6
STUDER - WIRING	
GROUP SUMMARY	15
LOCATION PIN LIST	16
SIGNAL WIRE LIST	27

SURVEY OF GROUPS (PART 1, FRONT-VIEW)

GRP, GRP/ELM DESIGNATION OF ASSEMBLIES

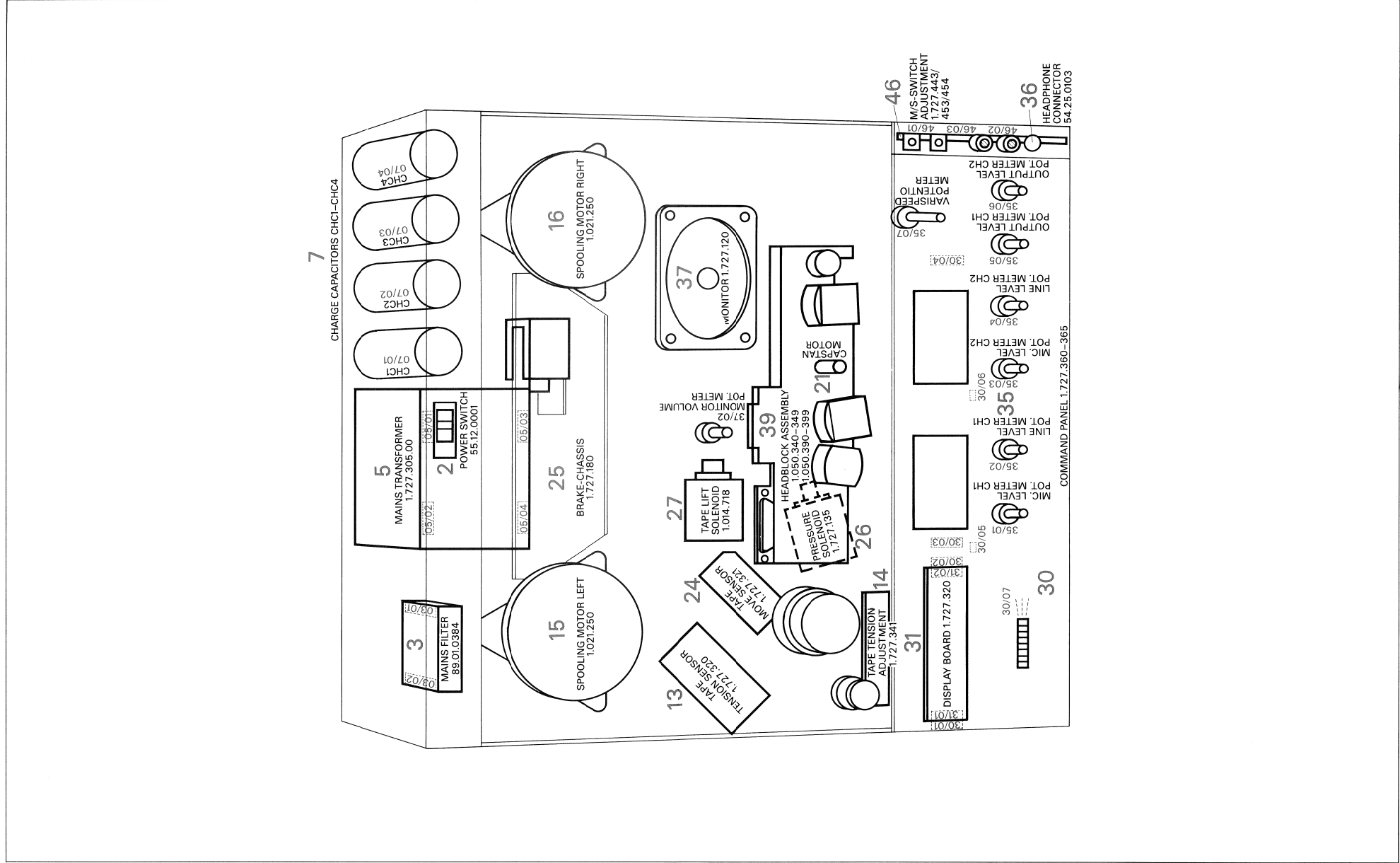

SURVEY OF GROUPS (PART 2 REAR VIEW)

GRP, GRP/ELM DESIGNATION OF ASSEMBLIES

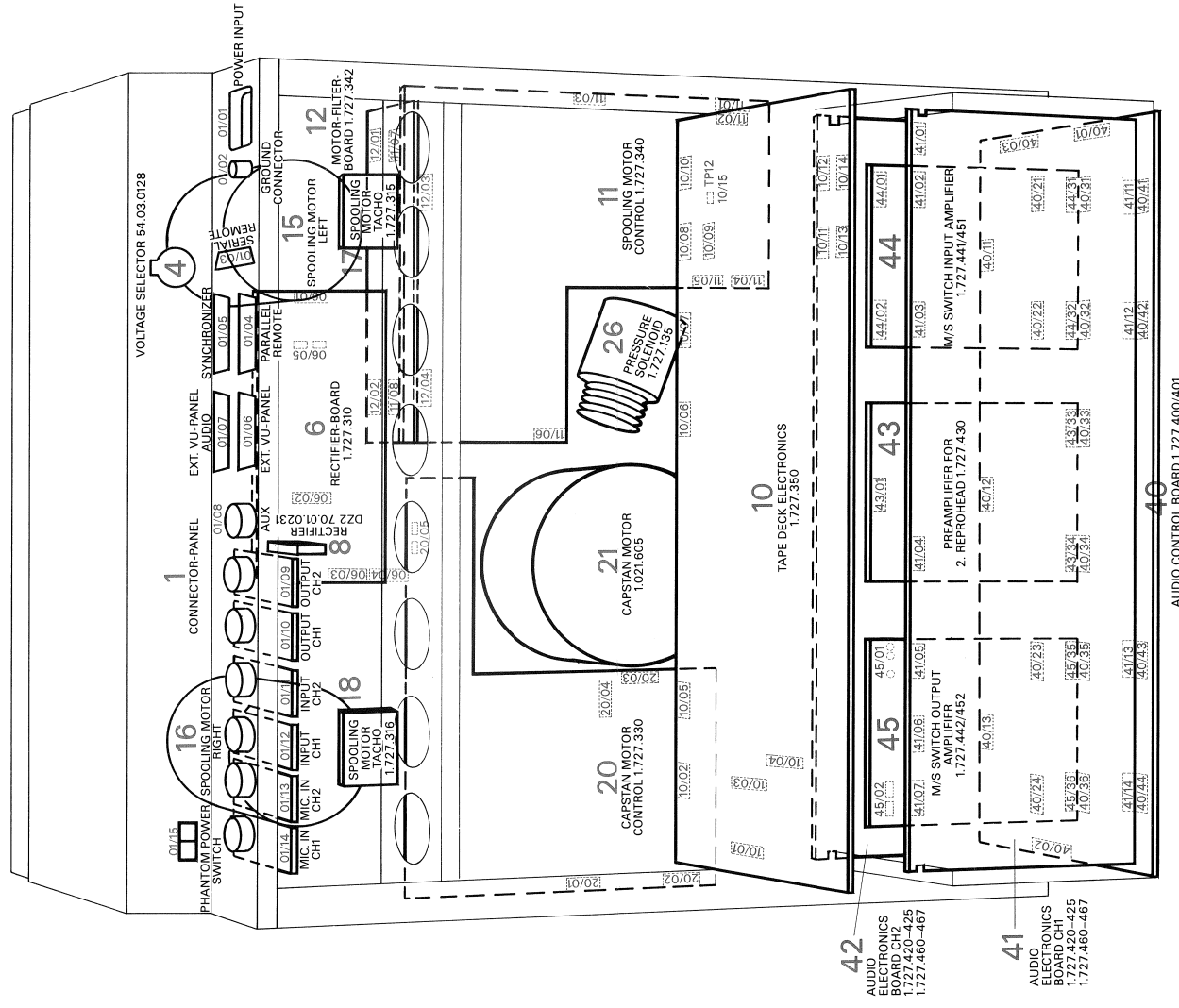

5. WIRING LISTS

5.1 WIRING

For equipment with complex electronics, wiring diagrams are difficult to follow and can cause misinterpretations. For this reason we have chosen a more reliable method based on automatically generated computer wiring lists. These provide comprehensive information on all electrical connections within the equipment. For the sake of clarity, the power supply, the tape transport control system, and the audio section have been subdivided into groups (GRP) which in turn comprise elements (ELM) and connecting points (PNT). The signals carry designations that have been constructed from various abbreviations and which identify their function.

5.1.1 Groups

The electrical part of the A807 tape recorder has been subdivided into groups (GRP01...GRP92). These groups are interconnected by cables and connectors that are identified with the corresponding group number. The group summary (foldout page at the beginning of this Section) illustrates the group allocation and the physical location within the unit.

5.1.2 Elements, points

Groups that comprise several plug-in circuit boards or other elements, are subdivided into elements (ELM). The elements accommodate the connecting points (PNT).

5.1.3 Principal connector types

Type	Designation	STUDER-No.
A	Connector, D-type, crimp	54.02.0451
AA	Contact pin, for thin stranded wires	54.02.0455
B	Contact pin, for thick stranded wires	54.02.0450
BB	Contact sleeve, for thick stranded wires	54.02.0454
C	CIS-Connector	54.01.0402
D	Contact sleeve	54.01.0401
F	MOLEX connector: Contact sleeve, for thin stranded wires	54.02.0412
FF	Contact sleeve, for thick stranded wires	54.02.0413
G	soldering pin	29.21.6002
H	Stranded/solid wire, tin-coated (6 mm)	---,---,----
I	Connector, D-type, crimp, contact pin	54.02.1112

Type	Designation	STUDER No.
JM	Blad terminal AMP FASTON, crimp, 0,8 x 6,3 mm: Connector sleeve, for thin stranded wires	54.02.0337
J	Connector sleeve, for thick stranded wires	54.02.0332
JJ	Connector sleeve, for very thick stranded wires	54.02.0338
K	Stranded/solid wire, skinned (8 mm), tin coated (1 mm)	---,---,----
L	Stranded/solid wire, tin-coated (4 mm)	---,---,----
M	MOLEX contact pin, for thin stranded wires	54.02.0411
MM	MOLEX contact pin for thick stranded wires	54.02.0410
MY	AMP blade terminal (blace)	54.02.0344
N	CIS connector, contact pin	54.01.0225
O	Contact spring, for EU card edge connector	54.01.0376
P	Card edge connector: Contact spring, for thin stranded wires	54.06.4512
PP	Contact spring, for thick stranded wires	54.06.4510
Q	Female multipoint connector, contact sleeve	54.01.0451
R	Connector, D-type, crimp, contact sleeve	54.02.1111
S	Stranded/solid wire, skinned (4mm) and tin-coated	---,---,----
T	TERMI-POINT plug contact on WIRE WRAP pin	---,---,----
U	Detent solder contact, crimp	54.03.0201
UU	Detent solder contact, crimp	54.34.6002
V	Connector sleeve, for thick stranded wires	54.02.0432
VV	Connector sleeve, for thin stranded wires	54.02.0474
W	Wrapped	---,---,----
X	Blad connector AMP FASTON, crimp, 0,5 x 2,8 mm: Connector sleeve, for thin stranded wires	54.02.0325
XX	Connector sleeve, for thick stranded wires	54.02.0329
Y	Blade connector AMP FASTON, crimp, 0,8 x 2,8 mm: Connector sleeve, for thin stranded wires	54.02.0326
YY	Connector sleeve, for thick stranded wires	54.02.0327
Z	Not tin-coated	---,---,----

5.1.4 Cable designations, color scheme

The most important connecting lines of the cabling are labelled. The wire ends carry three numbers which identify the group, the element, and the corresponding connecting point. The flat-cable connectors have labels that specify the:

- Group and element numbers where the connector is plugged in, and either the
- - name of the module into which the opposite end of the cable is plugged in, or the
- name of the module into which the connector itself is plugged in.

Examples:

- TAPE DECK ELECTRONICS, GRP10, CIS connector ELM03. The conductors at this connector are black (0), green (5), red (2), and brown (1). The wires are labelled in this sequence as 10-3-1, 10-3-2, 10-3-3, and 10-3-5, i.e. the black wire is connected to contact 1 of element 03 of group 10, the green wire to contact 2, the red wire to contact 3, and the brown wire to contact 5 (contact 4 is the coding). The opposite end, e.g. of the green conductor, is labelled as 24-1-5 which means that the wire is connected in group 24 (TAPE MOVE SENSOR) at element 1 to contact 5.
- The labelling of the same CIS connector on the TAPE DECK ELECTRONICS, GRP20, ELM03 (connection to the TAPE MOVE SENSOR) is as follows:

```
GR 10
EL 03
```

The connector at the opposite end carries the designation:

```
GR 24
EL 01
```

Color schemes

0	black	(blk)
1	brown	(brn)
2	red	(red)
3	orange	(org)
4	yellow	(yel)
5	green	(grn)
6	blue	(blu)
7	violet	(vio)
8	grey	(grt)
9	white	(wht)
-	uncolored	(unc)

5.1.5 Explanations to the LOCATION PIN LIST

The LOCATION PIN LIST provides information on all connecting points and their signal names as well as the type of connection and if possible also the color of the connecting wire. This list is arranged by groups and contains all connecting points of a group, sorted by element number. However, it does not provide any information on the connections of an individual point. To trace the cable connection of a known signal name (on a certain group and the corresponding element), the SIGNAL WIRE LIST must be used. If only the signal name is known, the SIGNAL WIRE LIST (paragraph 5.1.6) must again be used.

Examples: (see LOCATION PIN LIST, page 8)

GRP 10	1.727.350.20	<--- GROUP	
	<--- <--- <--- CONTINUATION		
=====			
ELM 4	CONN. SERIAL CTRL	<--- ELEMENT	
	J04		

PNT	SIGNAL NAME	COLOR LV TYPE F	
1	RCVDATA	1 N	
2	KEY		
3	+0.0V	0 B	
4	+24V-RMT	8 B	
5	SN-DATA	2 B	

	L color	L connector type	
	signal name		
	connection point		

Groups:
GRP10, 1.727.350.20
TAPE DECK ELECTRONICS

Element:
ELM04 Serial remote control connectors (CIS)

Connection type:
N CIS connector, contact pin

Connecting points:
PNT01, PNT03, PNT04, and PNT05

Signal names:
RCVDATA, +0.0V, +24V-RMT, and SN-DATA

Colors:
brown, black, grey, and red

5.1.6 Explanations to the SIGNAL WIRE LIST

The SIGNAL WIRE LIST provides information on which connecting points are linked to each other. It is principally used for explaining the connection of a signal found in the diagram to the corresponding assembly(ies). This list is arranged alphabetically by signal name. The alphabetic section is preceded by the signal names of the zero Volt points as well as the supply voltages.

The signal name can be found in the first column (SIGNAL NAME). The second column specifies the wire COLOR. The fourth column specifies the groups (GRP), elements (ELM), and connecting points at which the signal appears. This column is arranged by assembly number and does not provide any information on the signal path through the equipment.

Example: (see SIGNAL WIRE LIST, p.31)

SIGNAL NAME	COLOR	M1	ASY	GRP	ELM	PNT	S	LV	TYPE	DESCRIPTION OF ELEMENT
-15.0V	6			1	6	16			B	CONN. EXT. VU PANEL, CTL
				10	2	11			N	CONN. CAPSTAN CTL.
				10	6	19			N	CONN. SPOOLING MOTOR CTL.
				10	8	11			N	CONN. EXT. VU-PANEL
				10	9	15			N	CONN. COMMAND PANEL
				10	10	15			N	CONN. AUDIO CTL.
				11	2	3			N	CONN. TAPE TENS. SENSOR
				11	3	10			N	CONN. TAPE DECK CTL.
				13	1	4			N	CONN. SP. MOTOR CTL. JO2
				20	1	10			N	CONN. TAPE DECK CTL.
				30	3	18			D	CONN. TAPE DECK CTL. J10
				40	1	13			N	CONN. TAPE DECK ELECTRONICS
				40	12	3			N	CONN. OPTION
				40	23	2			N	CONN. AUDIO ELECTRONICS CH1
				40	31	8			N	CONN. INSERT, INPUT CIRCUIT
				40	32	1			N	CONN. INSERT, INPUT CIRCUIT
				40	33	1			N	CONN. PREAMPLIFIER, SECOND REP
				40	36	6			N	CONN. INSERT, OUTPUT CIRCUIT
				40	43	2			N	CONN. AUDIO ELECTRONICS CH2
				41	13	2			N	CONN. AUDIO CTL, J23
42	13	2			N	CONN. AUDIO CTL, J43				
43	23	1			N	CONN. AUDIO CTL, J33				
44	32	1			N	CONN. AUDIO CTL, J32				
45	36	6			N	CONN. AUDIO CTL, J36				
92	1	10			N	CONN. VU PANEL, CTL				
-20.0V	6			5	4	15			N	CONN. TAPE DECK ELECTRONICS
				10	1	4			C	CONNECTOR POWER SUPPLY
A-TALK1				40	23	10			N	CONN. AUDIO ELECTRONICS CH1
				41	13	10			N	CONN. AUDIO CTL, J23
A-TALK2				40	43	10			N	CONN. AUDIO ELECTRONICS CH2
				42	13	10			N	CONN. AUDIO CTL, J43
A-DRIVE1				40	74	17			N	CONN. AUDIO ELECTRONICS CH1

SIGNAL NAME: -15.0 V

COLOR: 6 blue (blu) or none (internal connection on the PCB).

TYPE of connection:

- B (Contact sleeve for thin stranded wires), or
- D (Contact pin), or
- N (CIS connector, contact pin)

Partial listing of the signal path:

GRP	ELM	PNT	
1	06	16	Socket, VU PANEL CONTROL;
10	02	11	CIS connector on TAPE DECK ELECTRONICS;
10	06	19	CIS connector on auf TAPE DECK ELECTRONICS;
10	08	11	CIS connector on auf TAPE DECK ELECTRONICS;
10	09	15	CIS connector on auf TAPE DECK ELECTRONICS;
10	10	15	CIS connector on auf TAPE DECK ELECTRONICS;
11	02	03	CIS connector on auf SPOOLING MOTOR CONTROL
11	03	10	CIS connector on auf SPOOLING MOTOR CONTROL

All of the above connecting points carry the -15.0 V signal. However, this does not mean that the signal is actually wired in the listed sequence from point to point.

5.1.7 Explanation of the signal name abbreviations and their specifications

Signalnamen	Beschreibung	Spezifikation
Signal	Description	Specification
0-AUDIO	GROUND from AUDIO BOARD	0.0 V
0-MOTFL	GROUND to Motor Filter	0.0 V
0-MOVES	GROUND to Tape Move Sensor	0.0 V
0-MSPLY	GROUND to Motor Supply	0.0 V
0-TACH1	GROUND to Sp. Motor Tacho Left	0.0 V
0-TACH2	GROUND to Sp. Motor Tacho Right	0.0 V
0-TTA	GROUND to Tape Tension Adjustment	0.0 V
0-TTS	GROUND to Tape Tension Sensor	0.0 V
17VAC	Ctl.Voltage f. POWER ON/OFF Switch	
+0.0V	Zero Referency	0.0 V
+0.0VA	Zero Referency f. Audio Circuits	0.0 V
+0.0VD	Zero Referency f. Digital Circuits	0.0 V
+1.2V	Supply Voltage	
+15.0V	Supply Voltage	
+20.0V	DC Supply Voltage f. +15 V	
+24.0V	Supply Voltage	
+24V-RMT	DC Supply Voltage f. Remote Ctl.	
+48.0V	Supply Voltage f. Microphones	
+5.0V	Supply Voltage	
+5.0VA	Supply Voltage f. Analog Circuits	
+5.0VMF	Supply Voltage f. Motor Filter Ctl.	
+5.0VD	Supply Voltage f. Digital Circuits	
+5.6V	Supply Voltage	
+50.0V	Supply Voltage f. Motors	
+60.0V	DC Supply Voltage f. +48 V	
-15.0V	Supply Voltage	
-20.0V	DC Supply Voltage f. -15 V	

Signal	Description	Specification
A-CTALKx	Audio, Crosstalk Compensation	
A-DRVINx	Audio, Driver Input	0.775 V @ 0 VU
A-DO	Audio Ctl, Data for DACs	H-Aktiv
:		
A-D7		
A-HFINx	Audio, HF Signal Input	2.0 V / 153,60 kHz
A-LINAx	Audio, Line Input A	
A-LINBx	Audio, Line Input B	
A-LINSx	Audio, Line Input Ground	
A-LOUTAx	Audio, Line Output A	
A-LOUTBx	Audio, Line Output B	
A-LOUTSx	Audio, Line Output Ground	
A-LSA	Audio, Loudspeaker Ampl. Output A	
A-LSAMPx	Audio, Loudspeaker Ampl. Input	
A-LSB	Audio, Loudspeaker Ampl. Output B	
A-LVINAx	Audio, to Input Level Ctl. Pot.	0.775 V @ 0 VU
A-LVINBx	Audio, from Input Level Ctl. Pot.	
A-LVINCx	Audio, Ground for Input Level Pot.	
A-LVMIAx	Audio, to Mic Level Ctl. Pot.	13.6 mV @ 0 VU
A-LVMIBx	Audio, from Mic Level Ctr. Pot.	
A-LVMICx	Audio, Ground for Mic Level Pot.	
A-LVMONx	Audio, to Monitor Level Ctl. Pot.	0.775 V @ 0 VU
A-LVOUAX	Audio, to Output Level Ctl. Pot.	0.775 V @ 0 VU
A-LVOUBx	Audio, from Output Level Ctl. Pot.	
A-LVOUCx	Audio, Ground for Output Level Pt.	
A-MIASCx	Audio, Asym. Mic Input Ground	
A-MICSAx	Audio, Sym. Mic Input A	
A-MICSBx	Audio, Sym. Mic Input B	
A-MICSSx	Audio, Sym. Mic Input Ground	
A-MICSWx	Audio, MIC Input Switch	
A-MONITx	Audio, Monitor Signal	0.775 V @ 0 VU
A-PHINx	Audio, Phones Ampl. Input	0.775 V @ 0 VU
A-PHOUTx	Audio, Phones Ampl. Output	
A-PHSWxx	Audio, Phones Mode Switch	
A-PHTMx	Audio, Phantom Powering Switch	
A-PREOUx	Audio, Preampl. Output	0.775 V @ 0 VU
A-RECINx	Audio, Record Ampl. Input	0.775 V @ 0 VU
A-SECRPx	Audio, Second Repro Signal	0.160 V @ 0 VU/1kHz
A-TAPOUx	Audio, Tape Ampl. Output	0.775 V @ 0 VU
A-VUMTRx	Audio, VU Meter Ampl.	0.775 V @ 0 VU

Signal	Description	Specification
ACA-17N	AC Voltage for -20 V	
ACA-17P	AC Voltage for +20 V	
ACA-20	AC Voltage for +24 V	
ACA-36	AC Voltage for +48 V	
ACA-40	AC Voltage for +50 V	
ACB-17N	AC Voltage for -20 V	
ACB-17P	AC Voltage for +20 V	
ACB-20	AC Voltage for +24 V	
ACB-36	AC Voltage for +48 V	
ACB-40	AC Voltage for +50 V	
ACC-17N	Trafo Bridge	
ACC-17P	Trafo Bridge	
ACC-20	Trafo Bridge	
ACC-36	Trafo Bridge	
ACC-40	Trafo Bridge	
AN-TTENS	Analog Signal, Tape Tension	4.0 V without Tape
AS-CLK	Audio Ser.Ctl, Data Clock	
AS-DATA	Audio Ser.Ctl, Serial Data	
AS-FAD	Loudspeaker Ampl. Ctl.	L @ FADER activ
AS-HFCLK	Audio, CLK for HF Driver	307.20 kHz
AS-RESET	Audio Ctl. Reset	
AS-STR	Audio Ser.Ctl, Strobe (Latch EN)	H @ on
AS-STRAB	Audio Ser.Ctl, Strobe and A/B Ctl. f DACs	H @ on
AS-WREN	Audio Ser.Ctl, Write Enable	H @ on

Signal	Description	Specification
B-FAST	LED, FAST SPEED	L @ on
B-MID	LED, MIDDLE SPEED	L @ on
B-SLOW	LED, SLOW SPEED	L @ on
BR-FADRY	Remote Control, LED	L 2 on
BR-FORW	"	L @ on
BR-LOCST	"	L @ on
BR-PLAY	"	L @ on
BR-REC	"	L @ on
BR-REW	"	L @ on
BR-STOP	"	L @ on
BR-VRSPD	"	L @ on
C-BASS	Control, Bass switch @ FAST	+15V=ON, -15V=OFF
C-BIASx	Control, Bias on	H @ on command
C-CALINx	Control, Calibrated Input	H @ on
C-CALOUx	Control, Calibrated Output	H @ on
C-CUEAT	Control, Signal Attenuation	L @ on
C-EQA	Control, Equalisation, A	H @ on
C-EQB	Control, Equalisation, B	H @ on
C-EQF	Control, Equalisation, Fast	L @ on
C-EQM	Control, Equalisation, Middle	L @ on
C-EQN	Control, Equalisation, Norm	H @ NAB
C-EQS	Control, Equalisation, Slow	L @ on
C-ERASEx	Control, Erase on	H @ on
C-INPUTx	Control, Input signal at output	H @ on
C-INSERT	Control, Insert electronic	H @ on
C-MICATx	Control, Microphon attenuator	H @ on
C-MICONx	Control, Microphon input	H @ on
C-MONOA	Control, Mono/Stereo Switch	H @ MONO
C-MONOB		not used
C-MOTFLT	Control, Sp. Motor Filter	L @ PLAY
C-NAB	Control, Level switch @ NAB	+15V=ON, -15V=OFF
C-OUTSWT	Control, Output line	H @ on
C-RECx	Control, Record relais	H @ on
C-REPROx	Control, Reproduce	H @ on
C-SECHD	Control, Second Head	H @ on
C-SECRPx	Control, Second Reproduce	H @ on
C-SYNCx	Control, Sel Sync	H @ on
C-UNCINx	Control, Uncalibrated input	H @ on
C-UNCOUx	Control, Uncalibrated output	H @ on
CAP-GRD		not used
CHC1-N	Charge Capacitor	0.0 V
CHC1-P	"	+ 50 V
CHC2-N	"	0.0 V
CHC2-P	"	+ 24 V
CHC3-N	"	0.0 V
CHC3-P	"	+ 20 V
CHC4-N	"	- 20 V
CHC4-P	"	0.0 V

Signal	Description	Specification
DS-CLK	Display serial Ctl., CLOCK , DATA , ENABLE DPL , ENABLE LED	
DS-DATA		
DS-ENDPL		
DS-ENLED		
ERAHH-x	Erase Head, high	40 V @ 153.6 kHz
ERAHL-x, low		
EXT-CLK	Extern Panel, CLOCK , DATA , Keyboard Matrix , ENABLE LED , LS MUTE	
EXT-DATA		
EXT-D5		
EXT-D6		
EXT-D7		
EXT-ENLD		
EXT-FAD		
F-ACA40	AC Voltage f. + 50 V	
F-ACB40	"	
F-LINEx	Power line after fuse	
FAD1	FADER START Signal 1	
FAD2	FADER START Signal 2	
GND	GROUND	
HALL1A	Capstan Motor HALL Element	
HALL1B	"	
HALL2A	"	
HALL2B	"	
HALL3A	"	
HALL3B	"	
IR-REFEX	INPUT, Ext. Referency f. Capstan	9600 Hz
K-BRAKE	Magnet, Brake	L @ on
K-LIFT	Magnet, Tape lift	L @ on
K-PRESS	Magnet, Tape press	L @ on
LINE1	Power Line 1	
LINE2	Power Line 2	

Signal	Description	Specification
MRX-Q10	Keyboard Matrix Colone	L @ on
MRX-Q11		L @ on
MRX-Q12		L @ on
MRX-Q13		L @ on
MRX-Q14		L @ on
MRX-Q15		L @ on
MRX-Q16		L @ on
MS-C76K	Sp. Motor Ctl. SR. Clock	76 kHz
MS-DIREN	DIR Ctl. Eneble	L @ PLAY
MS-MVCLK	MOVE CLOCK	
MS-MVDIR	MOVE DIRECTION	L @ FORW
MS-ON	Sp. Motor Ctl. ON Switch	L @ on
MS-PRESS	PLAY Mode	H @ PLAY
MS-REFA	Tape Tension Ref. Switch A	
MS-REFB		B
MS-REW	Sp. Motor REW Ctl.	H @ REW
MS-SHUTL	Sp. Motor SHUTTLE Ctl.	H @ SHUTTLE
MV-CLKx	Move Sensor Signal	16 Hz / 7.5 IPS
M1-R	Supply Motor,	Pole R
M1-S		Pole S
M1-T	Pole T	
M1-TACHO	Tacho Signal	
M1-TSENS	Tacho Sensor Signal	
M2-R	Take up Motor,	Pole R
M2-REFAN		Referency Voltage
M2-S	Pole S	
M2-T	Pole T	
M2-TACHO	Tacho Signal	
M2-TSENS	Tacho Sensor Signal	
M3-CLK	Capstan Motor Ctl, Clock	
M3-C76K	, SR Clock	
M3-DATA	Capstan Motor Ctl, Data	
M3-EN	Capstan Motor Ctl, Enable	
M3-R	, Ploe R	
M3-REFEX	Ctl, Ext. Referency	9.6 kHz
M3-S	, Pole S	
M3-SYNC	Ctl, Synchron	H @ Sync
M3-T	, Pole T	
M3-TACHO	Ctl, Tacho Signal	600 Hz @ 7.5 IPS
M3-9600	Ctl, Ref. Frequency	9.6 kHz

Signal	Description	Specification
OR-CMCLK	Synchronizer Port, Capstan Tacho	600 Hz @ 7.5 IPS
OR-MVCLK	Move Clock	16 Hz @ 7.5 IPS
OR-MVDIR	Move Direction	H @ Forw.
OR-SYENB	Eneble	
PRIMW-x	Mains Trafo Primer Winding	
R-SHUTLx	Shuttle Control Potmeter	
R-RECLVA	M/S Adjustment	
R-RECLVB	"	
R-REPLVA	"	
R-REPLVB	"	
R-VRSPD	Varispeed Control Potmeter	
RECHH-x	Record Head, High	
RECHL-x	, Low	
REPHH-x	Reproduce Head, High	
REPHL-x	, Low	
RVCDATA		

Signal	Description	Specification
S-LINEx	Power Line, switched	
S-TAPOUT	Tape Out Switch	L @ Tape Out
S-TGATT	Test Generator Command	
S-TGINHI	"	
S-TGOFF	"	
S-TG0	"	
S-TG1K	"	
S-TG10DB	"	
S-TG10K	"	
S-TG125	"	
S-TG16K	"	
S-TG20DB	"	
S-TG60	"	
SF-LINEx	Power Line after Filter	
SM-D0	Keyboard Matrix, Data	
SM-D7		
SN-DATA		
SR-FADRY	Remote Control, Switch	L @ on command
SR-FORW	"	L @ on
SR-LIFT	"	L @ on
SR-LOCST	"	L @ on
SR-MUTE	"	L @ on
SR-PLAY	"	L @ on
SR-REC	"	L @ on
SR-RESET	"	L @ on
SR-REW	"	L @ on
SR-STOP	"	L @ on
SR-VRSPD	"	L @ on
SR-ZLOC	"	L @ on
SRPHH-x		
SRPHL-x		
TACHO-3x	Capstan Tacho	
TRS-A	Tape Transparent Sensor, Anode	
TRS-C	Collector	
TRS-E	Emitter	
TRS-K	Kathode	
TTA-FORW	Tape Tension Adjustment	
TTA-LIBR	"	
TTA-PLAY	"	
TTA-REW	"	
TTA-SHT1	"	
TTA-SHT2	"	
TTA-SHT3	"	
WR-BIASx	Write, Data for bias adjustment	L @ on
WR-RECx	Write, Data for record adjustment	L @ on
WR-REPRx	Write, Data for repro adjustment	L @ on

```

*****          *          *          *          *          *          *          *          *          *          *          *
*          *          *          *          *          *          *          *          *          *          *          *
*          *          *          *          *          *          *          *          *          *          *          *
*****          *          *          *          *          *          *          *          *          *          *          *
*          *          *          *          *          *          *          *          *          *          *          *
*****          *          *          *          *          *          *          *          *          *          *          *

```

```

*****
*
* PART NUMBER: 1.727.010.00 * STUDER A 807 * TAPE RECORDER * [NDFX: 0] *
*
*****

```

PAGE 1 OF 53

S U M M A R Y

```

-----
ASSEMBLYS      0
GROUPS        37
ELEMENTS      157
PINS (TOTAL) 1214 ( UNUSED PINS  93 )
MULTIPLE PINS  0
CODING KEYS   61
SIGNALS      362 ( UNUSED SIGNALS 25 )

RECORDS READ  1472

```

DATE OF ORIGIN : 88/03/21
DATE OF PROC. : 88/06/09

```

GROUP NODE      = *
INTER GROUP NODE = #
DIRECT WIRE TO # = <
WIRING NOT COMPUTED = @

```

OPTIONS SPECIFIED : LOCLIS, SIGLIS, ALLCOL, WIRALL

OPTIONS USED : LOCLIS, SIGLIS, ALLCOL, WIRALL

LISTINGS GENERATED :	PAGE	ERR	WRN
GROUP SUMMARY	2	0	0
LOCATION PIN LIST	3	0	0
SIGNAL WIRE LIST	27	0	0

====>> NO PUNCH GENERATED <<====

```

*****
* WILLI STUDER AG * G R O U P S U M M A R Y * 88/06/09 * 13:38 * P A G E 7 *
*****
* 1.727.010.00 * STUDER A 807 * TAPE RECORDER * 88/03/21 - 01 *
*****

```

ASY	GRP	PART NUMBER	DESCRIPTION	UNUSED PINS	USED PINS	TOT.PINS	MULT.PINS	COD.KEYS	TOT.FLM	REM
1			CONNECTOR PANEL	23	109	132	0	4	15	
2		55.12.0001	POWER SWITCH	0	4	4	0	0	1	
3		89.01.0384	MAINS FILTER	0	4	4	0	0	2	
4		53.03.0128	VOLTAGE SELECTOR	0	8	8	0	0	1	
5		1.727.305.00	MAINS TRANSFORMER	4	28	32	0	0	4	
6		1.727.310.00	RECTIFIER BOARD	6	40	46	0	1	5	
7			CHARGE CAPACITORS	0	8	8	0	0	4	
8		70.01.0231	RECTIFIER D22	0	4	4	0	0	1	
10		1.727.350.23	TAPE DECK ELECTRONICS	1	146	147	0	16	15	
11		1.727.340.21	SPOOLING MOTOR CONTROL	0	58	58	0	6	9	
12		1.727.342.00	SP. MOTOR FILTER	0	22	22	0	0	4	
13		1.727.320.00	TAPE TENSION SENSOR	0	4	4	0	1	1	
14		1.727.341.00	TAPE TENS. ADJUSTMENT	0	8	8	0	0	1	
15		1.021.250.00	SPOOLING MOTOR, LEFT	0	3	3	0	0	1	
16		1.021.250.00	SPOOLING MOTOR, RIGHT	0	3	3	0	0	1	
17		1.727.315.00	SP. MOTOR TACHO, LEFT	0	3	3	0	0	1	
18		1.727.316.00	SP. MOTOR TACHO, RIGHT	0	3	3	0	0	1	
20		1.727.330.24	CAPSTAN MOTOR CONTROL	0	32	32	0	4	5	
21		1.021.605.00	CAPSTAN MOTOR	0	14	14	0	2	2	
24		1.727.321.00	TAPE MOVE SENSOR	0	4	4	0	1	1	
25		1.177.180.81	BRAKE CHASSIS	0	2	2	0	0	1	
26		1.727.135.81	PRESS SOLENOID	0	2	2	0	0	1	
27		1.014.718.00	TAPE LIFT SOLENOID	0	2	2	0	0	1	
30		1.727.362.00	COMMAND PANEL	0	47	47	0	2	7	
31		1.727.370.00	DISPLAY BOARD	0	8	8	0	0	2	
35			LEVEL CONTROL PANEL	0	21	21	0	0	7	
36		54.24.0103	PHONES CONNECTOR	0	5	5	0	0	1	
37		1.727.120.00	MONITOR	0	14	14	0	0	2	
39		1.050.341.00	HEAD BLOCK ASSEMBLY	1	24	25	0	0	1	
40		1.727.400.00	AUDIO CONTROL BOARD	24	195	219	0	4	20	
41		1.727.420.00	AUDIO ELECTRONICS CH1	0	88	88	0	7	11	
42		1.727.420.00	AUDIO ELECTRONICS CH2	0	88	88	0	7	11	
43		1.727.430.00	PREAMPLIFIER F. SECOND HEAD	12	12	24	0	1	3	
44		1.727.441.00	MONO/STEREO SWITCH, INPUT AMPL.	10	31	41	0	2	4	
45		1.727.442.00	MONO/STEREO SWITCH, OUTPUT AMPL.	4	20	24	0	0	4	
46		1.727.443.00	MONO/STEREO SWITCH, ADJUSTMENT	2	20	22	0	0	3	
92		1.727.920.00	EXT. VU PANEL	6	37	43	0	3	3	

DISTRIBUTED IN 37 GRP				TOTAL :	93	1121	1214	0	61	157

* WILLI STUDER AG * L O C A T I O N P I N N L I S T * 88/06/09 * 13:38 * P A G E 3 *
* 1.727.010.00 * STUDER A 807 * TAPE RECORDER * 88/03/21 - 01 *

GRP 1
CONNECTOR PANEL
ELM 1
CONN. POWER INPUT P01
PNT SIGNAL NAME COLOR LV TYPE F
1 LINE1 1
2 LINE2 6
3 GND 5-4
4 LINE1 1
5 F-LINE1 1
ELM 2
CONN. GROUND
PNT SIGNAL NAME COLOR LV TYPE F
1 GND
ELM 3
SERIAL CTL. CONNECTOR
PNT SIGNAL NAME COLOR LV TYPE F
1 SN-DATA 2 B
2 +24V-RMT 8 B
3
4
5 +24V-RMT 8 B
6
7
8 RCVDATA 1 B
9 +0.0V 0 B

GRP 1 <-- <-- <-- CONTINUATION
ELM 4
PARALLEL REMOTE CONNECTOR
PNT SIGNAL NAME COLOR LV TYPE F
1 +0.0V 8 B
2 BR-FRW 3 B
3 BR-FDRW 2 B
4 BR-VRSPD 6 B
5 SR-VRSPD 4 B
6 SR-FADRY 5 B
7 BR-LOGST 8 B
8 BR-FADRY 7 B
9 BR-REC 5 B
10 SR-RESE 5 B
11 FAD1 1 B
12 FAD2 2 B
13 IR-REFEX 3 B
14 SR-ZLOC 6 B
15 BR-PLAY 1 B
16 BR-STOP 4 B
17 SR-LIFT 7 B
18 SR-LOGST 6 B
19 SR-REC 3 B
20 SR-REW 1 B
21 SR-FDRW 0 B
22 SR-PLAY 9 B
23 SR-STOP 2 B
24 KEY 2 B
25 +24V-RMT 0 B

GRP 1 <-- <-- <-- CONTINUATION
ELM 5
CONN. SYNCHRONIZER
PNT SIGNAL NAME COLOR LV TYPE F
1 +0.0V 8 B
2 BR-FRW 3 B
3 BR-FDRW 2 B
4 BR-VRSPD 6 B
5 SR-VRSPD 4 B
6
7 OR-MVCLK 5 B
8 KEY 5 B
9 BR-REC 5 B
10 OR-MVDIR 6 B
11 OR-CMCLK 1 B
12 OR-SYENB 8 B
13 IR-REFEX 3 B
14 +0.0V 5 B
15 BR-PLAY 1 B
16 BR-STOP 4 B
17 SR-LIFT 7 B
18 SR-MUTE 4 B
19 SR-REC 3 B
20 SR-REW 1 B
21 SR-FDRW 0 B
22 SR-PLAY 9 B
23 SR-STOP 2 B
24 KEY 2 B
25 +24V-RMT 9 B

* WILLI STUDER AG * L O C A T I O N P I N N L I S T * 88/06/09 * 13:38 * P A G E 4 *
* 1.727.010.00 * STUDER A 807 * TAPE RECORDER * 88/03/21 - 01 *

GRP 1 <-- <-- <-- CONTINUATION
ELM 6
CONN. EXT. VU PANEL, CTL
PNT SIGNAL NAME COLOR LV TYPE F
1 +0.0VD 0 B
2 +5.6V 5 B
3 +15.0V 2 B
4
5 EXT-D5 5 B
6 EXT-D6 6 B
7 EXT-D7 7 B
8
9
10 EXT-DATA 3 B
11 EXT-CLK 1 B
12 EXT-ENLD 9 B
13
14 +0.0VA 0 B
15
16 -15.0V 6 B
17
18
19
20
21
22
23
24
25

GRP 1 <-- <-- <-- CONTINUATION
ELM 7
CONN. EXT. VU PANEL, AUDIO
PNT SIGNAL NAME COLOR LV TYPE F
1 A-LVQUA1 9 A
2 A-LVOUC1 5 A
3 A-LVINB1 6 A
4 O-AUDIO 0 A
5 A-MONIT1 1 A
6 A-PHIN1 8 A
7 A-LSA 6 A
8 A-LVQUA2 9 A
9 A-LVOUC2 5 A
10 A-LVINB2 6 A
11
12 A-MONIT2 2 A
13
14 A-LVQUB1 6 A
15 A-LVINC1 5 A
16 A-LVINA1 9 A
17
18 A-PREOU1 5 A
19 A-PHIN2 4 A
20 A-LSB 7 A
21 A-LVQUB2 6 A
22 A-LVINC2 5 A
23 A-LVINA2 9 A
24 KEY 4 A
25 A-PREOU2 3 A

GRP 1 <-- <-- <-- CONTINUATION
ELM 10
CONN. LINE OUTPUT, CH1
PNT SIGNAL NAME COLOR LV TYPE F
1 A-LOUTS1 5
2 A-LOUTA1 2
3 A-LOUTB1 3
ELM 11
CONN. LINE INPUT, CH2
PNT SIGNAL NAME COLOR LV TYPE F
1 A-LINS2 5
2 A-LINA2 9
3 A-LINB2 6

ELM 12
CONN. LINE INPUT, CH1
PNT SIGNAL NAME COLOR LV TYPE F
1 A-LINS1 5
2 A-LINA1 9
3 A-LINB1 6

ELM 13
CONN. MIC INPUT, CH2
PNT SIGNAL NAME COLOR LV TYPE F
1 A-MICSS2 5
2 A-MICSA2 9
3 A-MICSB2 6

ELM 14
CONN. MIC INPUT, CH1
PNT SIGNAL NAME COLOR LV TYPE F
1 A-MICSS1 5
2 A-MICSA1 9
3 A-MICSB1 6

 * WILLI STUDER AG * L O C A T I O N P I N N L I S T * 88/06/09 * 13:38 * P A G E 5 *

 * 1.727.010.00 * STUDER A 807 * TAPE RECORDER * 88/03/21 - 01 *

 <-- <-- <-- CONTINUATION

GRP 1
 <-- <-- <-- CONTINUATION

ELM 15
 PHANTOM POWERING SWITCH

PNT	SIGNAL NAME	COLOR	LV	TYPE	F
1	A-PHTM1	0		L	
2	A-PHTM2	8		L	
3	A-PHTM3	9		L	

GRP 2 55.12.0001
 POWER SWITCH

ELM 1
 POWER SWITCH

PNT	SIGNAL NAME	COLOR	LV	TYPE	F
1	F-LINE1	1		J	
2	LINE2	6		J	
3	S-LINE1	1		J	
4	S-LINE2	6		J	

GRP 3 89.01.0384
 MAINS FILTER

ELM 1
 MAINS FILTER, INPUT

PNT	SIGNAL NAME	COLOR	LV	TYPE	F
1	S-LINE1	1		J	
2	S-LINE2	6		J	

ELM 2
 MAINS FILTER, OUTPUT

PNT	SIGNAL NAME	COLOR	LV	TYPE	F
1	SF-LINE1	1		J	
2	SF-LINE2	6		J	

 * WILLI STUDER AG * L O C A T I O N P I N N L I S T * 88/06/09 * 13:38 * P A G E 6 *

 * 1.727.010.00 * STUDER A 807 * TAPE RECORDER * 88/03/21 - 01 *

 <-- <-- <-- CONTINUATION

GRP 4 53.03.0128
 VOLTAGE SELECTOR

ELM 1
 VOLTAGE SELECTOR

PNT	SIGNAL NAME	COLOR	LV	TYPE	F
1	SF-LINE2	6-8		L	
2	PRIMW-3	3		L	
3	PRIMW-7	7		L	
4A	PRIMW-4	4-4		L	
4B	PRIMW-6	6-4		L	
5	PRIMW-1	1		L	
6	PRIMW-5	5		L	
7	SF-LINE1	2-1		L	

GRP 5 1.727.305.00
 MAINS TRANSFORMER

ELM 1
 PRIMARY 1 P01

PNT	SIGNAL NAME	COLOR	LV	TYPE	F
1	PRIMW-1	1		Y	
2	SF-LINE1	2		Y	
3	PRIMW-3	3		Y	
4	PRIMW-4	4		Y	

ELM 2
 PRIMARY 2 P02

PNT	SIGNAL NAME	COLOR	LV	TYPE	F
5	PRIMW-5	5		Y	
6	PRIMW-6	6		Y	
7	PRIMW-7	7		Y	
8	SF-LINE2	8		Y	

ELM 3
 SECONDARY 1 P03

PNT	SIGNAL NAME	COLOR	LV	TYPE	F
9	ACC-40	4		L	
10	ACC-20	4		L	
11	ACC-17N	4		L	
12	ACC-17P	4		L	
13	ACC-36	4		L	
14	ACC-36	4		L	
15	ACB-36	5		L	
16	ACB-17P	6		L	
17	ACB-17N	7		L	
18	ACB-20	8		L	
19	ACB-40	9		L	
20					

GRP 5 1.727.305.00
 <-- <-- <-- CONTINUATION

ELM 4
 SECONDARY 2 P04

PNT	SIGNAL NAME	COLOR	LV	TYPE	F
9	ACA-40	0		L	
10	ACA-20	1		L	
11	ACA-17N	2		L	
12	ACA-17P	3		L	
13	ACA-36	4		L	
14	ACC-36	4		L	
15	ACC-36	4		L	
16	ACC-17P	4		L	
17	ACC-17N	4		L	
18	ACC-20	4		L	
19	ACC-40	4		L	
20					

./.

* WILLI STUDER AG * L O C A T I O N P I N N L I S T * 88/06/09 * 13:38 * P A G E 7 *

* 1.727.010.00 * STUDER A 807 * TAPE RECORDER * 88/03/21 - 01 *

<-- <-- <-- CONTINUATION

GRP 6 1.727.310.00
RECTIFIER BOARD
ELM 1
CONN. TRANSFORMER J01
PNT SIGNAL NAME COLOR LV TYPE F
1 ACA-20 1 N
2 ACA-17P 3 N
3 ACA-17N 2 N
4 ACB-40 9 N
5 ACB-40
6 KEY
7 ACB-17N 7 N
8 ACB-17P 6 N
9 ACB-20 8 N
10 ACB-36 5 N
11 ACA-40 0 N
12 ACA-40
13 ACA-36 4 N
ELM 2
CONN. TO CHARGE CAPACITORS J02
PNT SIGNAL NAME COLOR LV TYPE F
1 CHC2-N 8 N
2 CHC3-N 3 N
3 CHC4-P 4 N
4 CHC2-P 7 N
5 CHC3-P 2 N
6
7 CHC4-N 6 N
ELM 3
CONN. FROM CHARGE CAPACITORS J03
PNT SIGNAL NAME COLOR LV TYPE F
1 CHC4-P 4 N
2 CHC3-N 3 N
3
4 CHC2-N 8 N
5 CHC4-N 6 N
6 CHC3-P 2 N
7 CHC2-P 7 L

GRP 6 1.727.310.00
CONTINUATION
ELM 4
CONN. TAPE DECK ELECTRONICS J04
PNT SIGNAL NAME COLOR LV TYPE F
1 +20.0V
2 +60.0V 5 N
3 17VAC 3 N
4 +24V-RMT 8 N
5
6
7
8
9 +24.0V 7 N
10 +24.0V 7 N
11 +24.0V 7 N
12 +24.0V 7 N
13 +24.0V 7 N
14 +20.0V 2 N
15 -20.0V 6 N
16 +0.0V 1 N
17 +0.0V 4 N
18 +0.0V 0 N
ELM 5
CONN. RECTIFIER DZ2
PNT SIGNAL NAME COLOR LV TYPE F
11 F-ACB40 1 Y
12 F-ACA40 8 Y

GRP 7
CHARGE CAPACITORS
ELM 1
CHARGE CAPACITOR CHC1
PNT SIGNAL NAME COLOR LV TYPE F
1 +50.0V 2 L
2 0-MSPLY 0 L
ELM 2
CHARGE CAPACITOR CHC2
PNT SIGNAL NAME COLOR LV TYPE F
1 CHC2-P 7 L
2 CHC2-N 8 L
ELM 3
CHARGE CAPACITOR CHC3
PNT SIGNAL NAME COLOR LV TYPE F
1 CHC3-P 2 L
2 CHC3-N 3 L
ELM 4
CHARGE CAPACITOR CHC4
PNT SIGNAL NAME COLOR LV TYPE F
1 CHC4-P 4 L
2 CHC4-N 6 L

* WILLI STUDER AG * L O C A T I O N P I N N L I S T * 88/06/09 * 13:38 * P A G E 8 *

* 1.727.010.00 * STUDER A 807 * TAPE RECORDER * 88/03/21 - 01 *

<-- <-- <-- CONTINUATION

GRP 8 70.01.0231
RECTIFIER DZ2
ELM 1
RECTIFIER DZ2
PNT SIGNAL NAME COLOR LV TYPE F
1 F-ACA40 1 J
2 F-ACB40 8 J
3 +50.0V 2 J
4 0-MSPLY 0 J
ELM 2
CONN. CAPSTAN CTL. J02
PNT SIGNAL NAME COLOR LV TYPE F
1 M3-C76K 1 N
2 M3-9600 2 N
3 M3-EN 3 N
4 M3-CLK 4 N
5 M3-DATA 5 N
6 M3-TACHO 6 N
7 M3-SYNC 7 N
8 M3-REFEX 8 N
9 KEY
10 KEY
11 -15.0V 6 N
12 +15.0V 2 N
13 +0.0VA 0 N
14 +0.0VD 0 N
15 +5.6V 5 N
ELM 3
CONN. MOVE SENSOR J03
PNT SIGNAL NAME COLOR LV TYPE F
1 0-MOVES 0 N
2 +5.0V 5 N
3 MV-CLK2 2 N
4 KEY
5 MV-CLK1 1 N

GRP 10 1.727.350.20
TAPE DECK ELECTRONICS
ELM 1
CONNECTOR POWER SUPPLY J01
PNT SIGNAL NAME COLOR LV TYPE F
1 17VAC 3 C
2 KEY C
3 +24V-RMT 8 C
4 -20.0V 6 C
5 +0.0V 0 C
6 +20.0V 2 C
7 +0.0V 4 C
8 +60.0V 5 C
9 +0.0V 1 C
10 +24.0V 7 C
ELM 2
CONN. CAPSTAN CTL. J02
PNT SIGNAL NAME COLOR LV TYPE F
1 M3-C76K 1 N
2 M3-9600 2 N
3 M3-EN 3 N
4 M3-CLK 4 N
5 M3-DATA 5 N
6 M3-TACHO 6 N
7 M3-SYNC 7 N
8 M3-REFEX 8 N
9 KEY
10 KEY
11 -15.0V 6 N
12 +15.0V 2 N
13 +0.0VA 0 N
14 +0.0VD 0 N
15 +5.6V 5 N
ELM 3
CONN. MOVE SENSOR J03
PNT SIGNAL NAME COLOR LV TYPE F
1 0-MOVES 0 N
2 +5.0V 5 N
3 MV-CLK2 2 N
4 KEY
5 MV-CLK1 1 N

GRP 10 1.727.350.20
CONTINUATION
ELM 4
CONN. SERIAL CTL. J04
PNT SIGNAL NAME COLOR LV TYPE F
1 RCVDATA 1 N
2 KEY N
3 +0.0V 0 B
4 +24V-RMT 8 B
5 SN-DATA 2 B
ELM 5
CONN. TAPE TRANSPARENT SENSOR J05
PNT SIGNAL NAME COLOR LV TYPE F
1 TRS-K 2 N
2 TRS-A 3 N
3 KEY N
4 TRS-C 4 N
5 TRS-E 5 N
ELM 6
CONN. SPOOLING MOTOR CTL. J06
PNT SIGNAL NAME COLOR LV TYPE F
1 MS-C76K 1 N
2 MS-PRESS 2 N
3 MS-SHUTL 3 N
4 MS-REW 4 N
5 MS-DIREN 5 N
6 MS-ON 6 N
7 MS-REFB 7 N
8 MS-REFA 8 N
9 S-TAPOUT 9 N
10 M2-REFAN 0 N
11 M1-TACHO 1 N
12 M2-TACHO 2 N
13 MS-MVDIR 3 N
14 MS-MVCLK 4 N
15 KEY
16 +5.6V 5 N
17 +0.0VD 0 N
18 +0.0VA 0 N
19 -15.0V 6 N
20 +15.0V 2 N

* WILLI STUDER AG * L O C A T I O N P I N N L I S T * 88/06/09 * 13:38 * P A G E 9 *

* 1.727.010.00 * STUDER A 807 * TAPE RECORDER * 88/03/21 - 01 *

<-- <-- <-- CONTINUATION

GRP 10 1.727.350.20
<-- <-- <-- CONTINUATION

ELM 7
CONN. SOLENOIDS J07
PNT SIGNAL NAME COLOR LV TYPE F
1 K-BRAKE 1 N
2
3 K-LIFT 8 N
4 KEY
5 K-PRESS 9 N

ELM 8
CONN. EXT. VU-PANEL J08
PNT SIGNAL NAME COLOR LV TYPE F
1 EXT-FAD N
2 KEY
3 EXT-D7 7 N
4 EXT-D6 6 N
5 EXT-D5 5 N
6 KEY
7 EXT-DATA 3 N
8 EXT-CLK 1 N
9 EXT-ENLD 9 N
10 +15.0V 2 N
11 -15.0V 6 N
12 +0.0VA 0 N
13 +5.6V 5 N
14 +0.0VD 0 N

GRP 10 1.727.350.20
<-- <-- <-- CONTINUATION

ELM 9
CONN. COMMAND PANEL J09
PNT SIGNAL NAME COLOR LV TYPE F
1 SM-D7 1 N
2 SM-D6 2 N
3 SM-D5 3 N
4 SM-D4 4 N
5 SM-D3 5 N
6 SM-D2 6 N
7 SM-D1 7 N
8 SM-D0 8 N
9 DS-DATA 9 N
10 DS-CLK 9 N
11 DS-ENDPL 1 N
12 DS-ENLED 2 N
13 KEY
14 +15.0V 2 N
15 -15.0V 6 N
16 +0.0VA 0 N
17 +5.6V 5 N
18 +0.0VD 0 N

ELM 10
CONN. AUDIO CTL. J10
PNT SIGNAL NAME COLOR LV TYPE F
1 AS-FAD 1 N
2 KEY
3 AS-WREN 3 N
4 AS-STRAB 4 N
5 AS-STR 5 N
6 AS-CLK 6 N
7 AS-DATA 7 N
8 AS-HFCLK 8 N
9 AS-RESET 9 N
10 +5.6V 5 N
11 +0.0VD 0 N
12 +48.0V 7 N
13 +0.0VA 0 N
14 +15.0V 2 N
15 -15.0V 6 N

GRP 10 1.727.350.20
<-- <-- <-- CONTINUATION

ELM 11
CONN. PARALLEL REMOTE A J11
PNT SIGNAL NAME COLOR LV TYPF F
1 FAD1 1 N
2 FAD2 2 N
3 IR-REFEX 3 N
4 KEY
5 SR-FADRY 5 N
6 SR-LOCST 6 N
7 SR-LIFT 7 N
8 +0.0V 8 N
9 SR-PLAY 9 N
10 SR-FORW 0 N
11 SR-REW 1 N
12 SR-STOP 2 N
13 SR-REC 3 N
14 SR-VRSPD 4 N
15 SR-RESET 5 N
16 SR-ZLOC 6 N

ELM 12
CONN. PARALLEL REMOTE B J12
PNT SIGNAL NAME COLOR LV TYPF F
1 BR-PLAY 1 N
2 BR-FORW 2 N
3 BR-REW 3 N
4 BR-STOP 4 N
5 BR-REC 5 N
6 BR-VRSPD 6 N
7 BR-FADRY 7 N
8 BR-LOCST 8 N
9 KEY
10 +24V-RMT 0 N

* WILLI STUDER AG * L O C A T I O N P I N N L I S T * 88/06/09 * 13:38 * P A G E 10 *

* 1.727.010.00 * STUDER A 807 * TAPE RECORDER * 88/03/21 - 01 *

<-- <-- <-- CONTINUATION

GRP 10 1.727.350.20
<-- <-- <-- CONTINUATION

ELM 13
CONN. SYNCHRONIZER A J13
PNT SIGNAL NAME COLOR LV TYPE F
1 OR-CMCLK 1 N
2 KEY
3 IR-REFEX 3 N
4 SR-MUTE 4 N
5 OR-MVCLK 5 N
6 OR-MVDIR 6 N
7 SR-LIFT 7 N
8 +0.0V 8 N
9 SR-PLAY 9 N
10 SR-FORW 0 N
11 SR-REW 1 N
12 SR-STOP 2 N
13 SR-REC 3 N
14 SR-VRSPD 4 N
15 +0.0V 5 N

ELM 14
CONN. SYNCHRONIZER B J14
PNT SIGNAL NAME COLOR LV TYPE F
1 BR-PLAY 1 N
2 BR-FORW 2 N
3 BR-REW 3 N
4 BR-STOP 4 N
5 BR-REC 5 N
6 BR-VRSPD 6 N
7 KEY
8 OR-SYENB 8 N
9 +24V-RMT 9 N

ELM 15
CONN. GROUND (TP 12)
PNT SIGNAL NAME COLOR LV TYPE F
1 GND Y

GRP 11 1.727.340.20
SPoolING MOTOR CONTROL

ELM 1
CONN. TAPE TENS. ADJUSTMENT J01
PNT SIGNAL NAME COLOR LV TYPE F
1 O-TTA 1 N
2 KEY
3 TTA-LIBR 3 N
4 TTA-PLAY 4 N
5 TTA-REN 5 N
6 TTA-FORW 6 N
7 TTA-SHT1 7 N
8 TTA-SHT2 8 N
9 TTA-SHT3 9 N

ELM 2
CONN. TAPE TENS. SENSOR J02
PNT SIGNAL NAME COLOR LV TYPE F
1 O-TTS 0 N
2 KEY
3 -15.0V 6 N
4 AN-TTENS 9 N
5 +15.0V 2 N

GRP 11 1.727.340.20
<-- <-- <-- CONTINUATION

ELM 3
CONN. TAPE DECK CTL. J03
PNT SIGNAL NAME COLOR LV TYPF F
1 MS-PRESS 2 N
2 MS-MVCLK 4 N
3 S-TAPOUT 9 N
4 KEY
5 MS-MVDIR 3 N
6 MS-C76K 1 N
7 M2-TACH0 2 N
8 M1-TACH0 1 N
9 MS-REFA 8 N
10 -15.0V 6 N
11 MS-REFB 7 N
12 +0.0VA 0 N
13 MS-DIREN 5 N
14 M2-REFAN 0 N
15 MS-DN 6 N
16 +15.0V 2 N
17 MS-REW 4 N
18 +0.0VD 0 N
19 +5.6V 5 N
20 MS-SHUTL 3 N

ELM 4
CONN. SP. MOTOR TACH0, RIGHT J04
PNT SIGNAL NAME COLOR LV TYPF F
1 O-TACH2 0 N
2 +5.0V 5 N
3 KEY
4 M2-TSENS 4 N

ELM 5
CONN. SP. MOTOR TACH0, LEFT J05
PNT SIGNAL NAME COLOR LV TYPF F
1 O-TACH1 0 N
2 KEY
3 +5.0V 5 N
4 M1-TSENS 4 N

 * WILLI STUDER AG * L O C A T I O N P I N L I S T * 88/06/09 * 13:38 * P A G E 11 *

 * 1.727.010.00 * STUDER A 807 * TAPE RECORDER * 88/03/21 - 01 *

 <-- <-- <-- CONTINUATION

GRP 11 1.727.340.20
 <-- <-- <-- CONTINUATION

ELM 6
 CONN. SHUTTLE CTL. J06

PNT	SIGNAL NAME	COLOR	LV	TYPE	F
1	R-SHUTL1	1	N		
2	R-SHUTL2	2	N		
3	KEY				
4	R-SHUTL3	3	N		

ELM 7
 CONN. SP. MOTOR FILTER, LEFT J07

PNT	SIGNAL NAME	COLOR	LV	TYPE	F
1	0-MOTFL		N		
2	M1-R		N		
3	M1-R		N		
4	M1-S		N		
5	M1-S		N		
6	+5.0VMF		N		
7	C-MOTFLT		N		
8	M1-T		N		
9	M1-T		N		

ELM 8
 CONN. SP. MOTOR FILTER, RIGHT J08

PNT	SIGNAL NAME	COLOR	LV	TYPE	F
1	M2-R		N		
2	M2-R		N		
3	M2-S		N		
4	M2-S		N		
5	M2-T		N		
6	M2-T		N		
7	0-MOTFL		N		

ELM 9
 CONN. SP. MOTOR SUPPLY, P1, P2

PNT	SIGNAL NAME	COLOR	LV	TYPE	F
1	+50.0V	2	Y		
2	0-MSPLY	0	Y		

GRP 12 1.727.342.00
 SP. MOTOR FILTER

ELM 1
 CONN. SP. MOTOR CTL, P01

PNT	SIGNAL NAME	COLOR	LV	TYPE	F
1	0-MOTFL		N		
2	M1-R		N		
3	M1-R		N		
4	M1-S		N		
5	M1-S		N		
6	+5.0VMF		N		
7	C-MOTFLT		N		
8	M1-T		N		
9	M1-T		N		

ELM 2
 CONN. SP. MOTOR CTL, P02

PNT	SIGNAL NAME	COLOR	LV	TYPE	F
1	M2-R		N		
2	M2-R		N		
3	M2-S		N		
4	M2-S		N		
5	M2-T		N		
6	M2-T		N		
7	0-MOTFL		N		

ELM 3
 CONN. SP. MOTOR LEFT J01

PNT	SIGNAL NAME	COLOR	LV	TYPE	F
1	M1-R	2			
2	M1-S	9			
3	M1-T	6			

ELM 4
 CONN. SP. MOTOR RIGHT J02

PNT	SIGNAL NAME	COLOR	LV	TYPE	F
1	M2-R	2			
2	M2-S	9			
3	M2-T	6			

 * WILLI STUDER AG * L O C A T I O N P I N L I S T * 88/06/09 * 13:38 * P A G E 12 *

 * 1.727.010.00 * STUDER A 807 * TAPE RECORDER * 88/03/21 - 01 *

 <-- <-- <-- CONTINUATION

GRP 14 1.727.341.00
 TAPE TENS. ADJUSTMENT

ELM 1
 CONN. SP. MOTOR CTL, J01

PNT	SIGNAL NAME	COLOR	LV	TYPE	F
1	TTA-SHT1	7	N		
2	TTA-SHT2	8	N		
3	TTA-SHT3	9	N		
4	TTA-LIBR	3	N		
6	TTA-REN	5	N		
8	TTA-FORW	6	N		
10	TTA-PLAY	4	N		
11	0-TTA	1	N		

GRP 15 1.021.250.00
 SPOOLING MOTOR, LEFT

ELM 1
 CONN. SP. MOTOR FILTER, J01

PNT	SIGNAL NAME	COLOR	LV	TYPE	F
1	M1-R	2			
2	M1-S	9			
3	M1-T	6			

GRP 16 1.021.250.00
 SPOOLING MOTOR, RIGHT

ELM 1
 CONN. SP. MOTOR FILTER, J01

PNT	SIGNAL NAME	COLOR	LV	TYPE	F
1	M2-R	2			
2	M2-S	9			
3	M2-T	6			

* WILLI STUDER AG * L O C A T I O N P I N N L I S T * 88/06/09 * 13:38 * P A G E 13 *

* 1.727.010.00 * STUDER A 807 * TAPE RECORDER * 88/03/21 - 01 *

<-- <-- <-- CONTINUATION

GRP 17 1.727.315.00
SP. MOTOR TACHO, LEFT
ELM 1
CONN. SP. MOTOR CTL, J05
PNT SIGNAL NAME COLOR LV TYPE F
1 0-TACH1 0 N
2 +5.0V 5 N
3 M1-TSENS 4 N

GRP 18 1.727.316.00
SP. MOTOR TACHO, RIGHT
ELM 1
CONN. SP. MOTOR CTL, J04
PNT SIGNAL NAME COLOR LV TYPE F
1 0-TACH2 0 N
2 +5.0V 5 N
3 M2-TSENS 4 N

GRP 20 1.727.330.20
CAPSTAN MOTOR CONTROL
ELM 1
CONN. TAPE DECK CTL. J01
PNT SIGNAL NAME COLOR LV TYPF F
1 M3-CLK 4 N
2 M3-DATA 5 N
3 M3-EN 3 N
4 M3-C76K 1 N
5 M3-SYNC 7 N
6 +5.6V 5 N
7 +0.OVD 0 N
8 +15.0V 2 N
9 +0.OVA 0 N
10 -15.0V 6 N
11 KEY 2 N
12 M3-9600 8 N
13 M3-REFEX 6 N
14 M3-TACHD 6 N

ELM 2
CONN. VARI SPEED CTL. J02
PNT SIGNAL NAME COLOR LV TYPF F
1 +0.0V 0 N
2 KEY 8 N
3 R-VRSPD 2 N
4 +15.0V 2 N

ELM 3
CONN. CAPSTAN TACHO J03
PNT SIGNAL NAME COLOR LV TYPF F
1 TACHD-3A 1 N
2 TACHD-3B 9 N
3 KEY 7 N
4 HALL1A 8 N
5 HALL1B 5 N
6 HALL2A 6 N
7 HALL2B 3 N
8 HALL3A 4 N
9 HALL3B 0 N
10 +0.0V 2 N
11 +1.2V 2 N
12 CAP-GRD

* WILLI STUDER AG * L O C A T I O N P I N N L I S T * 88/06/09 * 13:38 * P A G E 14 *

* 1.727.010.00 * STUDER A 807 * TAPE RECORDER * 88/03/21 - 01 *

<-- <-- <-- CONTINUATION

GRP 20 1.727.330.20
<-- <-- <-- CONTINUATION
ELM 4
CONN. CAPSTAN MOTOR J04
PNT SIGNAL NAME COLOR LV TYPE F
1 M3-R 9 N
2 KEY 2 N
3 M3-S 0 N
4 M3-T 0 N

GRP 21 1.021.605.00
CAPSTAN MOTOR
ELM 1
CONN. CAPSTAN CTL, J04
PNT SIGNAL NAME COLOR LV TYPE F
1 M3-R 9 N
2 KEY 2 N
3 M3-S 0 N
4 M3-T 0 N

GRP 24 1.727.321.00
TAPE MOVE SENSOR
ELM 1
CONN. TAPE DECK CTL. J03
PNT SIGNAL NAME COLOR LV TYPF F
1 MV-CLK2 2 N
2 0-MOVES 0 N
3 MV-CLK1 1 N
4 KEY 5 N
5 +5.0V 5 N

ELM 5
CONN. CAPSTAN MOTOR SUPPLY P1, P2
PNT SIGNAL NAME COLOR LV TYPE F
1 +50.0V 2 Y
2 0-MSPLY 0 Y

ELM 2
CONN. CAPSTAN CTL, J03
PNT SIGNAL NAME COLOR LV TYPE F
1 TACHD-3A 1 N
2 TACHD-3B 9 N
3 KEY 7 N
4 HALL1A 8 N
5 HALL1B 5 N
6 HALL2A 6 N
7 HALL2B 3 N
8 HALL3A 4 N
9 HALL3B 0 N
10 +1.2V 2 N
11 +0.0V 2 N
12 CAP-GRD

* WILLI STUDER AG * L O C A T I O N P I N N L I S T * 88/06/09 * 13:38 * P A G E 15 *

* 1.727.010.00 * STUDER A 807 * TAPE RECORDER * 88/03/21 - 01 *

<-- <-- <-- CONTINUATION

GRP 25 1.177.180.00
BRAKE CHASSIS
ELM 1
CONN. TAPE DECK CTL. J07
PNT SIGNAL NAME COLOR LV TYPE F
1 K-BRAKE 1 X
2 +24.0V 7 X

GRP 26 1.727.135.81
PRESS SOLENOID
ELM 1
CONN. TAPE DECK CTL. J07
PNT SIGNAL NAME COLOR LV TYPE F
1 +24.0V 7 X
2 K-PRESS 9 X

GRP 27 1.014.718.00
TAPE LIFT SOLENOID
ELM 1
CONN. TAPE DECK CTL. J07
PNT SIGNAL NAME COLOR LV TYPF F
1 +24.0V 7 X
2 K-LIFT 8 X

 * WILLI STUDER AG * L O C A T I O N P I N L I S T * 88/06/09 * 13:38 * P A G E 16 *

 * 1.727.010.00 * STUDER A 807 * TAPE RECORDER * 88/03/21 - 01 *

 <-- <-- <-- CONTINUATION

GRP 30 1.727.362.00
 COMMAND PANEL

GRP 30 1.727.362.00
 <-- <-- <-- CONTINUATION

GRP 31 1.727.370.00
 DISPLAY BOARD

ELM 1
 CONN. SPEED INDICATORS

PNT	SIGNAL NAME	COLOR	LV	TYPE	F
1	B-FAST		N		
2	B-MID		N		
3	B-SLOW		N		

ELM 4
 CONN. KEYS MATRIX

PNT	SIGNAL NAME	COLOR	LV	TYPE	F
1	+5.6V		N		
2	SM-D7		N		
3	SM-D6		N		
4	SM-D5		N		
5	SM-D4		N		
6	SM-D3		N		
7	SM-D2		N		
8	SM-D1		N		
9	SM-D0		N		
10	MRX-Q14		N		
11	MRX-Q10		N		
12	MRX-Q13		N		
13	KEY		N		
14	+0.0VD		N		
15	MRX-Q12		N		
16	MRX-Q16		N		
17	MRX-Q11		N		
18	MRX-Q15		N		

ELM 1
 CONN. COMMAND PANEL J01

PNT	SIGNAL NAME	COLOR	LV	TYPE	F
1	B-FAST		N		
2	B-MID		N		
3	B-SLOW		N		

ELM 2
 CONN. DISPLAY EL.

PNT	SIGNAL NAME	COLOR	LV	TYPE	F
1	+0.0VD		N		
2	DS-ENDPL		N		
3	DS-CLK		N		
4	DS-DATA		N		
5	+5.6V		N		

ELM 2
 CONN. COMMAND PANEL J02

PNT	SIGNAL NAME	COLOR	LV	TYPE	F
1	+0.0VD		N		
2	DS-ENDPL		N		
3	DS-CLK		N		
4	DS-DATA		N		
5	+5.6V		N		

ELM 3
 CONN. TAPE DECK CTL. J10

PNT	SIGNAL NAME	COLOR	LV	TYPE	F
1	+5.6V	5	D		
2	SM-D7	1	D		
3	SM-D6	2	D		
4	SM-D5	3	D		
5	SM-D4	4	D		
6	SM-D3	5	D		
7	SM-D2	6	D		
8	SM-D1	7	D		
9	SM-D0	8	D		
10	+0.0VD	0	D		
11	KEY		D		
12	DS-ENDPL	1	D		
13	DS-ENLED	2	D		
14	DS-DATA	9	D		
15	DS-CLK	9	D		
16	+15.0V	2	D		
17	+J.0VA	0	D		
18	-15.0V	6	D		

ELM 5
 CONN. VU-INPUT CH1

PNT	SIGNAL NAME	COLOR	LV	TYPE	F
1	A-VUMTR1	1	Y		

ELM 6
 CONN. VU-INPUT CH2

PNT	SIGNAL NAME	COLOR	LV	TYPE	F
1	A-VUMTR2	1	Y		

ELM 7
 SHUTTLE POTMETER

PNT	SIGNAL NAME	COLOR	LV	TYPE	F
1	R-SHUTL1	1	L		
2	R-SHUTL2	2	L		
3	R-SHUTL3	3	L		

 * WILLI STUDER AG * L O C A T I O N P I N L I S T * 88/06/09 * 13:38 * P A G E 17 *

 * 1.727.010.00 * STUDER A 807 * TAPE RECORDER * 88/03/21 - 01 *

 <-- <-- <-- CONTINUATION

GRP 35 54.24.0103
 LEVEL CONTROL PANEL

GRP 35 <-- <-- <-- CONTINUATION

GRP 36 54.24.0103
 PHONES CONNECTOR

ELM 1
 MIC LEVEL POTM. CH1

PNT	SIGNAL NAME	COLOR	LV	TYPE	F
1	A-LVMIC1	0	L		
2	A-LVMIB1	6	L		
3	A-LVMIA1	9	L		

ELM 6
 OUTPUT LEVEL POTM. CH2

PNT	SIGNAL NAME	COLOR	LV	TYPE	F
1	A-LVCUC2	0	L		
2	A-LVCUB2	6	L		
3	A-LVQUA2	9	L		

ELM 1
 CONN. HEAD PHONES

PNT	SIGNAL NAME	COLOR	LV	TYPE	F
1	+0.0VA	0	L		
2	A-LSAMP2	3	L		
3	A-PHOUT2	2	L		
4	A-PHOUT1	1	L		
5	A-LSAMP1	8	L		

ELM 2
 LINE LEVEL POTM. CH1

PNT	SIGNAL NAME	COLOR	LV	TYPE	F
1	A-LVING1	0	L		
2	A-LVINB1	2	L		
3	A-LVINA1	9	L		

ELM 7
 VARIO SPEED POTM.

PNT	SIGNAL NAME	COLOR	LV	TYPE	F
1	+0.0V	0	L		
2	R-VRSPD	8	L		
3	+15.0V	2	L		

ELM 3
 MIC LEVEL POTM. CH2

PNT	SIGNAL NAME	COLOR	LV	TYPE	F
1	A-LVMIC2	0	L		
2	A-LVMIB2	6	L		
3	A-LVMIA2	9	L		

ELM 4
 LINE LEVEL POTM. CH2

PNT	SIGNAL NAME	COLOR	LV	TYPE	F
1	A-LVING2	0	L		
2	A-LVINB2	4	L		
3	A-LVINA2	9	L		

ELM 5
 OUTPUT LEVEL POTM. CH1

PNT	SIGNAL NAME	COLOR	LV	TYPE	F
1	A-LVQUC1	0	L		
2	A-LVQUB1	5	L		
3	A-LVQUA1	9	L		

* WILLI STUDER AG * L O C A T I O N P I N L I S T * 88/06/09 * 13:38 * P A G E 18 *

* 1.727.010.00 * STUDER A 807 * TAPE RECORDER * 88/03/21 - 01 *

<-- <-- <-- CONTINUATION

GRP 37 1.727.120.00 MONITOR
ELM 1 LOUDSPEAKER
PNT SIGNAL NAME COLOR LV TYPE F
1 A-LSA 6 L
2 A-LSB 7 L
ELM 2 MONITOR VOLUME POTM.
PNT SIGNAL NAME COLOR LV TYPE F
1 +0.OVA 0 L
2 A-PHIN2 4 L
3 A-LVMON2 9 L
4 +0.OVA 0 L
5 A-PHIN1 8 L
6 A-LVMON1 9 L
7 A-LVMON2 9 L
8 A-PREOU2 3 L
9 A-MONIT2 2 L
10 A-PREOU1 5 L
11 A-MONIT1 1 L
12 A-LVMON1 9 L

GRP 39 1.050.341.00 HEAD BLOCK ASSEMBLY
ELM 1 CONN. AUDIO ELECTRONICS
PNT SIGNAL NAME COLOR LV TYPE F
1 REPHL-01 6 B
2 REPHH-01 9 B
3 REpsc-01 5 B
4 SRPHL-01 6 B
5 SRPHH-01 9 B
6 SRpsc-01 5 B
7 RECHL-01 7 B
8 RECHH-01 8 B
9 ERAHL-01 9 B
10 ERAHH-01 1 B
11
12 TRS-K 2 B
13 TRS-A 3 B
14 REPHL-02 6 B
15 REPHH-02 9 B
16 REpsc-02 5 B
17 SRPHL-02 6 B
18 SRPHH-02 9 B
19 SRpsc-02 5 B
20 RECHL-02 0 B
21 RECHH-02 1 B
22 ERAHL-02 2 B
23 ERAHH-02 3 B
24 TRS-C 4 B
25 TRS-E 5 B

GRP 40 1.727.400.00 AUDIO CONTROL BOARD
ELM 1 CONN. TAPE DECK ELECTRONICS
PNT SIGNAL NAME COLOR LV TYPE F
1 AS-STRAB 4 N
2 AS-DATA 7 N
3 AS-CLK 6 N
4 AS-WREN 3 N
5 AS-STR 5 N
6
7
8
9 +0.OVD 0 N
10 +5.6V 5 N
11 +15.OV 2 N
12 +0.OVA 0 N
13 -15.OV 6 N
14 AS-FAD 1 N
15 KEY 9 N
16 AS-RESET 7 N
17 +48.OV 7 N
18 KEY 8 N
19 AS-HFCLK 8 N
20
ELM 2 CONN. MONITOR
PNT SIGNAL NAME COLOR LV TYPE F
1 A-MONIT2 2 N
2 KEY 3 N
3 A-PREOU2 4 N
4 A-PHIN2 4 N
5 A-PHSW2A N
6 A-PHSW2B N
7 A-PHOUT2 2 N
8 A-PHIN1 8 N
9 A-PHSW1A N
10 A-PHSW1B N
11 A-PHOUT1 1 N
12 A-LSAMP2 3 N
13 A-LSAMP1 8 N
14 +0.OVA 0 N
15 +0.OVA 0 N
16 A-LSA 6 N
17 A-LSB 7 N
18
19 A-PREOU1 5 N
20 A-MONIT1 1 N

* WILLI STUDER AG * L O C A T I O N P I N L I S T * 88/06/09 * 13:38 * P A G E 19 *

* 1.727.010.00 * STUDER A 807 * TAPE RECORDER * 88/03/21 - 01 *

<-- <-- <-- CONTINUATION

GRP 40 1.727.400.00
ELM 3 CONN. PHANTOM POWERING SWITCH
PNT SIGNAL NAME COLOR LV TYPE F
1 A-PHTM3 9 N
2 KEY 8 N
3 A-PHTM2 8 N
4 A-PHTM1 0 N
ELM 11 CONN. OPTION
PNT SIGNAL NAME COLOR LV TYPE F
ELM 12 CONN. OPTION
PNT SIGNAL NAME COLOR LV TYPE F
1 +15.OV N
2 +0.OVA N
3 -15.OV N
4 +0.OVD N
5 +5.OVA N
ELM 13 CONN. OPTION
PNT SIGNAL NAME COLOR LV TYPE F
ELM 21 CONN. AUDIO ELECTRONICS CH1
PNT SIGNAL NAME COLOR LV TYPE F
1 +48.OV N
2 C-NAB N
3 C-MICAT1 N
4 A-PREOU1 N
5 C-CALIN1 N
6 C-UNCIN1 N
7 C-MICON1 N

GRP 40 1.727.400.00
ELM 22 CONN. AUDIO ELECTRONICS CH1
PNT SIGNAL NAME COLOR LV TYPE F
1 A-RECIN1 N
2 C-ERASE1 N
3 C-BIAS1 N
4 C-EQA N
5 C-EQB N
6 +5.OVA N
7 WR-BIAS1 N
8 A-DO N
9 A-D1 N
10 A-D2 N
11 A-D3 N
12 +0.OVD N
13 WR-REC1 N
14 AS-STRAB N
15 A-D4 N
16 A-D5 N
17 A-D6 N
18 A-D7 N
19 C-REC1 N
20 A-HFIN1 N
ELM 23 CONN. AUDIO ELECTRONICS CH1
PNT SIGNAL NAME COLOR LV TYPE F
1 +15.OV N
2 -15.OV N
3 C-BASS N
4 A-SECRP1 N
5 C-EQB N
6 C-EQA N
7 C-SYNC1 N
8 C-REPRO1 N
9 C-SECRP1 N
10 A-CTALK1 N
11 +0.OVA N
12 +5.OVA N
13 +0.OVD N

GRP 40 1.727.400.00
ELM 24 CONN. AUDIO ELECTRONICS CH1
PNT SIGNAL NAME COLOR LV TYPE F
1 A-D0 N
2 A-D1 N
3 A-D2 N
4 A-D3 N
5 WR-REPR1 N
6 AS-STRAB N
7 A-D4 N
8 A-D5 N
9 A-D6 N
10 A-D7 N
11 C-NAB N
12 A-DRVIN1 N
13 A-PREOU1 N
14 A-TAPOU1 N
15 C-INPUT1 N
16 C-CALOU1 N
17 C-UNCOU1 N
18 C-CUEAT N
19 C-OUTSW N
20 A-MONIT1 N
ELM 31 CONN. INSERT INPUT CIRCUIT
PNT SIGNAL NAME COLOR LV TYPE F
1 A-PREOU1 N
2
3
4 A-RECIN1 N
5 +5.OVA N
6 +0.OVD N
7 A-PREOU2 N
8 -15.OV N
9 A-RECIN2 N

* WILLI STUDER AG * L O C A T I O N P I N L I S T * 88/06/09 * 13:38 * P A G E 20 *
* 1.727.010.00 * STUDER A 807 * TAPE RECORDER * 88/03/21 - 01 *

<-- <-- <-- CONTINUATION

GRP 40 1.727.400.00
<-- <-- <-- CONTINUATION

ELM 32
CONN. INSERT, INPUT CIRCUIT
PNT SIGNAL NAME COLOR LV TYPE F
1 -15.0V N
2 +0.0VA N
3 +15.0V N
4 C-INSERT N
5 C-EQS N
6 C-EQM N
7 C-EQF N
8 C-EQN N

ELM 33
CONN. PREAMPLIFIER, SECOND REPRO
PNT SIGNAL NAME COLOR LV TYPE F
1 -15.0V N
2 +0.0VA N
3 +15.0V N
4 N
5 N
6 N
7 N
8 N
9 N

ELM 34
CONN. PREAMPLIFIER, SECOND REPRO
PNT SIGNAL NAME COLOR LV TYPE F
1 N
2 N
3 N
4 N
5 N
6 N
7 A-SECRP1 N
8 +0.0VA N
9 A-SECRP2 N

GRP 40 1.727.400.00
<-- <-- <-- CONTINUATION

ELM 35
CONN. INSERT, OUTPUT CIRCUIT
PNT SIGNAL NAME COLOR LV TYPE F
1 C-EQN N
2 C-EQF N
3 C-EQM N
4 C-EQS N
5 C-INSERT N
6 +5.0VA N
7 +0.0VD N
8 N
9 N

ELM 36
CONN. INSERT, OUTPUT CIRCUIT
PNT SIGNAL NAME COLOR LV TYPE F
1 N
2 N
3 A-DRVIN2 N
4 +0.0VA N
5 A-TAPOU2 N
6 -15.0V N
7 A-DRVIN1 N
8 +15.0V N
9 A-TAPOU1 N

ELM 41
CONN. AUDIO ELECTRONICS CH2
PNT SIGNAL NAME COLOR LV TYPE F
1 +48.0V N
2 C-NAB N
3 C-MICAT2 N
4 A-PREOU2 N
5 C-CALIN2 N
6 C-UNCIN2 N
7 C-MICON2 N

GRP 40 1.727.400.00
<-- <-- <-- CONTINUATION

ELM 42
CONN. AUDIO ELECTRONICS CH2
PNT SIGNAL NAME COLOR LV TYPE F
1 A-RECIN2 N
2 C-ERASE2 N
3 C-BIAS2 N
4 C-EQA N
5 C-EQB N
6 +5.0VA N
7 WR-BIAS2 N
8 A-D0 N
9 A-D1 N
10 A-D2 N
11 A-D3 N
12 +0.0VD N
13 WR-REC2 N
14 AS-STRAB N
15 A-D4 N
16 A-D5 N
17 A-D6 N
18 A-D7 N
19 C-REC2 N
20 A-HFIN2 N

ELM 43
CONN. AUDIO ELECTRONICS CH2
PNT SIGNAL NAME COLOR LV TYPE F
1 +15.0V N
2 -15.0V N
3 C-BASS N
4 A-SECRP2 N
5 C-EQB N
6 C-EQA N
7 C-SYNC2 N
8 C-REPRD2 N
9 C-SECRP2 N
10 A-CTALK2 N
11 +0.0VA N
12 +5.0VA N
13 +0.0VD N

* WILLI STUDER AG * L O C A T I O N P I N L I S T * 88/06/09 * 13:38 * P A G E 21 *
* 1.727.010.00 * STUDER A 807 * TAPE RECORDER * 88/03/21 - 01 *

<-- <-- <-- CONTINUATION

GRP 40 1.727.400.00
<-- <-- <-- CONTINUATION

ELM 44
CONN. AUDIO ELECTRONICS CH2
PNT SIGNAL NAME COLOR LV TYPE F
1 A-D0 N
2 A-D1 N
3 A-D2 N
4 A-D3 N
5 WR-REPR2 N
6 AS-STRAB N
7 A-D4 N
8 A-D5 N
9 A-D6 N
10 A-D7 N
11 C-NAB N
12 A-DRVIN2 N
13 A-PREOU2 N
14 A-TAPOU2 N
15 C-INPUT2 N
16 C-CALOU2 N
17 C-UNCOU2 N
18 C-UEAT N
19 C-OUT SW N
20 A-MONIT2 N

GRP 41 1.727.420.00
AUDIO ELECTRONICS CH1

ELM 1
CONN. MIC LEVEL POT, CH1
PNT SIGNAL NAME COLOR LV TYPE F
1 A-LVMIA1 9 N
2 KEY N
3 A-LVMIB1 6 N
4 A-LVMIC1 5 N

ELM 2
CONN. MIC AND LINE INPUTS, CH1
PNT SIGNAL NAME COLOR LV TYPE F
1 A-LINA1 9 N
2 A-LINB1 6 N
3 A-LINS1 5 N
4 KEY N
5 A-MICSS1 5 N
6 A-MICSB1 6 N
7 A-MICSA1 9 N
8 +0.0VA N
9 A-MICSW1 N
10 A-MICAS1 N

ELM 3
CONN. LINE LEVEL POT, CH1
PNT SIGNAL NAME COLOR LV TYPE F
1 A-LVINA1 9 N
2 A-LVINB1 2 N
3 KEY N
4 A-LVINCL 0 N

ELM 4
CONN. HEAD BLOCK, RECORD
PNT SIGNAL NAME COLOR LV TYPE F
1 RECHH-01 8 N
2 RECHL-01 7 N
3 ERAHH-01 1 N
4 KEY N
5 ERAHL-01 9 N

GRP 41 1.727.420.00
<-- <-- <-- CONTINUATION

ELM 5
CONN. HEAD BLOCK, REPRO
PNT SIGNAL NAME COLOR LV TYPE F
1 REPHL-01 6 N
2 REPHH-01 9 N
3 KEY N
4 REpsc-01 5 N

ELM 6
CONN. OUTPUT LEVEL POT, CH1
PNT SIGNAL NAME COLOR LV TYPE F
1 A-LVOUA1 9 N
2 KEY N
3 A-LVOUB1 5 N
4 A-LVOUC1 0 N

ELM 7
CONN. LINE OUTPUT CONNECTOR, CH1
PNT SIGNAL NAME COLOR LV TYPE F
1 A-LOUTB1 3 N
2 A-LOUTA1 2 N
3 KEY N
4 A-VUMTR1 1 N

ELM 11
CONN. AUDIO CTL, J21
PNT SIGNAL NAME COLOR LV TYPE F
1 +48.0V N
2 C-NAB N
3 C-MICAT1 N
4 A-PREOU1 N
5 C-CALIN1 N
6 C-UNCIN1 N
7 C-MICON1 N

 * WILLI STUDER AG * L O C A T I O N P I N L I S T * 88/06/09 * 13:38 * P A G E 22 *

 * 1.727.010.00 * STUDER A 807 * TAPE RECORDER * 88/03/21 - 01 *

 <-- <-- <-- CONTINUATION

GRP 41 1.727.420.00
 <-- <-- <-- CONTINUATION

ELM 12
 CONN. AUDIO CTL, J22

PNT	SIGNAL NAME	COLOR	LV	TYPE	F
1	A-RECIN1		N		
2	C-ERASE1		N		
3	C-BIAS1		N		
4	C-EQA		N		
5	C-EQB		N		
6	+5.0VA		N		
7	WR-BIAS1		N		
8	A-D0		N		
9	A-D1		N		
10	A-D2		N		
11	A-D3		N		
12	+0.OVD		N		
13	WR-REC1		N		
14	AS-STRAB		N		
15	A-D4		N		
16	A-D5		N		
17	A-D6		N		
18	A-D7		N		
19	C-REC1		N		
20	A-HFIN1		N		

ELM 13
 CONN. AUDIO CTL, J23

PNT	SIGNAL NAME	COLOR	LV	TYPE	F
1	+15.0V		N		
2	-15.0V		N		
3	C-BASS		N		
4	A-SECRP1		N		
5	C-EQB		N		
6	C-EQA		N		
7	C-SYNC1		N		
8	C-REPRO1		N		
9	C-SECRP1		N		
10	A-CTALK1		N		
11	+0.0VA		N		
12	+5.0VA		N		
13	+0.OVD		N		

GRP 41 1.727.420.00
 <-- <-- <-- CONTINUATION

ELM 14
 CONN. AUDIO CTL, J24

PNT	SIGNAL NAME	COLOR	LV	TYPE	F
1	A-D0		N		
2	A-D1		N		
3	A-D2		N		
4	A-D3		N		
5	WR-REPR1		N		
6	AS-STRAB		N		
7	A-D4		N		
8	A-D5		N		
9	A-D6		N		
10	A-D7		N		
11	C-NAB		N		
12	A-DRVIN1		N		
13	A-PREOU1		N		
14	A-TAPOU1		N		
15	C-INPUT1		N		
16	C-CALOU1		N		
17	C-UNCOU1		N		
18	C-CUEAT		N		
19	C-OUTSW		N		
20	A-MONIT1		N		

GRP 42 1.727.420.00
 AUDIO ELECTRONICS CH2

ELM 1
 CONN. MIC LEVEL POT, CH2

PNT	SIGNAL NAME	COLOR	LV	TYPE	F
1	A-LVMIA2	9	N		
2	KEY		N		
3	A-LVMIB2	6	N		
4	A-LVMIC2	5	N		

ELM 2
 CONN. MIC AND LINE INPUTS, CH2

PNT	SIGNAL NAME	COLOR	LV	TYPE	F
1	A-LINA2	9	N		
2	A-LINB2	6	N		
3	A-LINS2	5	N		
4	KEY		N		
5	A-MICSS2	5	N		
6	A-MICSB2	6	N		
7	A-MICSA2	9	N		
8	+0.0VA		N		
9	A-MICSW2		N		
10	A-MICAS2		N		

ELM 3
 CONN. LINE LEVEL POT, CH2

PNT	SIGNAL NAME	COLOR	LV	TYPE	F
1	A-LVINA2	9	N		
2	A-LVIND2	4	N		
3	KEY		N		
4	A-LVINC2	0	N		

ELM 4
 CONN. HEAD BLOCK, RECORD

PNT	SIGNAL NAME	COLOR	LV	TYPE	F
1	RECHH-02	1	N		
2	RECHL-02	0	N		
3	ERAHH-02	3	N		
4	KEY		N		
5	ERAHL-02	2	N		

 * WILLI STUDER AG * L O C A T I O N P I N L I S T * 88/06/09 * 13:38 * P A G E 23 *

 * 1.727.010.00 * STUDER A 807 * TAPE RECORDER * 88/03/21 - 01 *

 <-- <-- <-- CONTINUATION

GRP 42 1.727.420.00
 <-- <-- <-- CONTINUATION

ELM 5
 CONN. HEAD BLOCK, REPRO

PNT	SIGNAL NAME	COLOR	LV	TYPE	F
1	REPHL-02	6	N		
2	REPHH-02	9	N		
3	KEY		N		
4	REPSC-02	5	N		

ELM 6
 CONN. OUTPUT LEVEL POT, CH2

PNT	SIGNAL NAME	COLOR	LV	TYPE	F
1	A-LVQUA2	9	N		
2	KEY		N		
3	A-LVQUB2	6	N		
4	A-LVQUC2	0	N		

ELM 7
 CONN. LINE OUTPUT CONNECTOR, CH2

PNT	SIGNAL NAME	COLOR	LV	TYPE	F
1	A-LOUTB2	3	N		
2	A-LOUTA2	2	N		
3	KEY		N		
4	A-VUMTR2	1	N		

ELM 11
 CONN. AUDIO CTL, J41

PNT	SIGNAL NAME	COLOR	LV	TYPE	F
1	+48.0V		N		
2	C-NAB		N		
3	C-MICAT2		N		
4	A-PREOU2		N		
5	C-CALIN2		N		
6	C-UNCIN2		N		
7	C-MICON2		N		

GRP 42 1.727.420.00
 <-- <-- <-- CONTINUATION

ELM 12
 CONN. AUDIO CTL, J42

PNT	SIGNAL NAME	COLOR	LV	TYPE	F
1	A-RECIN2		N		
2	C-ERASE2		N		
3	C-BIAS2		N		
4	C-EQA		N		
5	C-EQB		N		
6	+5.0VA		N		
7	WR-BIAS2		N		
8	A-D0		N		
9	A-D1		N		
10	A-D2		N		
11	A-D3		N		
12	+0.OVD		N		
13	WR-REC2		N		
14	AS-STRAB		N		
15	A-D4		N		
16	A-D5		N		
17	A-D6		N		
18	A-D7		N		
19	C-REC2		N		
20	A-HFIN2		N		

ELM 14
 CONN. AUDIO CTL, J44

PNT	SIGNAL NAME	COLOR	LV	TYPE	F
1	A-D0		N		
2	A-D1		N		
3	A-D2		N		
4	A-D3		N		
5	WR-REPR2		N		
6	AS-STRAB		N		
7	A-D4		N		
8	A-D5		N		
9	A-D6		N		
10	A-D7		N		
11	C-NAB		N		
12	A-DRVIN2		N		
13	A-PREOU2		N		
14	A-TAPOU2		N		
15	C-INPUT2		N		
16	C-CALOU2		N		
17	C-UNCOU2		N		
18	C-CUEAT		N		
19	C-OUTSW		N		
20	A-MONIT2		N		

ELM 13
 CONN. AUDIO CTL, J43

PNT	SIGNAL NAME	COLOR	LV	TYPE	F
1	+15.0V		N		
2	-15.0V		N		
3	C-BASS		N		
4	A-SECRP2		N		
5	C-EQB		N		
6	C-EQA		N		
7	C-SYNC2		N		
8	C-REPRO2		N		
9	C-SECRP2		N		
10	A-CTALK2		N		
11	+0.0VA		N		
12	+5.0VA		N		
13	+0.OVD		N		

* WILLI STUDER AG * L O C A T I O N P I N L I S T * 88/06/09 * 13:38 * P A G E 24 *

* 1.727.010.00 * STUDER A 807 * TAPE RECORDER * 88/03/21 - 01 *

<-- <-- <-- CONTINUATION

GRP 43 1.727.430.00
PREAMPLIFIER F. SECOND HEAD

ELM 1
CONN. HEAD BLOCK, SEC REPRO
PNT SIGNAL NAME COLOR LV TYPE F
1 SRPHL-02 6 N
2 KEY 2 N
3 SRPHH-02 9 N
4 SRPSC-02 5 N
5 SRPHL-01 6 N
6 SRPHH-01 9 N
7 SRPSC-01 5 N

ELM 33
CONN. AUDIO CTL, J33
PNT SIGNAL NAME COLOR LV TYPE F
1 -15.0V N
2 +0.0VA N
3 +15.0V N
4 N
5 N
6 N
7 N
8 N
9 N

ELM 34
CONN. AUDIO CTL, J34
PNT SIGNAL NAME COLOR LV TYPE F
1 N
2 N
3 N
4 N
5 N
6 N
7 A-SECRP1 N
8 +0.0VA N
9 A-SECRP2 N

GRP 44 1.727.441.00
MONO/STEREO SWITCH, INPUT AMPL.

ELM 1
CONN. M/S ADJUSTMENT
PNT SIGNAL NAME COLOR LV TYPE F
1 KEY 2 N
2 KEY 3 N
3 R-RECLVA 4 N
4 R-RECLVB 5 N
5 S-TG60 6 N
6 S-TG125 7 N
7 S-TG1K 8 N
8 S-TG10K 9 N
9 S-TG16K 0 N
10 S-TG0FF 1 N
11 S-TGO 2 N
12 S-TGINHI 3 N
13 N
14 N
15 N
16 S-TGATT 6 N
17 S-TG10DB 7 N
18 S-TG20DB 8 N

ELM 2
CONN. M/S OUTPUT APML.
PNT SIGNAL NAME COLOR LV TYPE F
1 S-TG20DB 1 N
2 S-TG10DB 2 N
3 C-MONDB N
4 C-MONDA 4 N
5 N
6 KEY N
7 N

GRP 44 1.727.441.00
MONO/STEREO SWITCH, INPUT AMPL.

ELM 31
CONN. AUDIO CTL, J31
PNT SIGNAL NAME COLOR LV TYPE F
1 A-PREOU1 N
2 +0.0VA N
3 N
4 A-RECIN1 N
5 +5.0VA N
6 +0.0VD N
7 A-PREOU2 N
8 N
9 A-RECIN2 N

ELM 32
CONN. AUDIO CTL, J32
PNT SIGNAL NAME COLOR LV TYPE F
1 -15.0V N
2 +0.0VA N
3 +15.0V N
4 C-INSERT N
5 N
6 C-EQS N
7 C-EQM N
8 C-EQF N
9 C-EQN N

* WILLI STUDER AG * L O C A T I O N P I N L I S T * 88/06/09 * 13:38 * P A G E 25 *

* 1.727.010.00 * STUDER A 807 * TAPE RECORDER * 88/03/21 - 01 *

<-- <-- <-- CONTINUATION

GRP 45 1.727.442.00
MONO/STEREO SWITCH, OUTPUT AMPL.

ELM 1
CONN. M/S INPUT AMPL. J01
PNT SIGNAL NAME COLOR LV TYPE F
1 S-TG20DB 1 L
2 S-TG10DB 2 L
3 C-MONDB L
4 C-MONDA 4 L

ELM 2
CONN. M/S ADJUSTMENT
PNT SIGNAL NAME COLOR LV TYPE F
1 R-REPLVB 3 Y
2 R-REPLVA 1 Y

ELM 35
CONN. AUDIO CTL, J35
PNT SIGNAL NAME COLOR LV TYPE F
1 C-EQN N
2 C-EQF N
3 C-EQM N
4 C-EQS N
5 C-INSERT N
6 +5.0VA N
7 +0.0VD N
8 N
9 N

ELM 36
CONN. AUDIO CTL, J36
PNT SIGNAL NAME COLOR LV TYPE F
1 N
2 N
3 A-DRVIN2 N
4 +0.0VA N
5 A-TAPDU2 N
6 -15.0V N
7 A-DRVIN1 N
8 +15.0V N
9 A-TAPDU1 N

GRP 46 1.727.443.00
MONO/STEREO SWITCH, ADJUSTMENT

ELM 1
CONN. M/S INPUT AMPL. J01
PNT SIGNAL NAME COLOR LV TYPE F
1 R-RECLVA 4 L
2 R-RECLVB 5 L
3 R-REPLVA 1 L
4 R-REPLVB 3 L

ELM 2
TEST GEN. LEVEL SWITCH
PNT SIGNAL NAME COLOR LV TYPE F
1 S-TG10DB 2 L
2 S-TG20DB 1 L
3 S-TGATT 6 L

ELM 3
TEST GEN. FREQUENCY SWITCH
PNT SIGNAL NAME COLOR LV TYPE F
1 S-TG60 6 L
2 S-TG125 7 L
3 S-TG1K 8 L
4 S-TG10K 9 L
5 S-TG16K 0 L
6 S-TGO 2 L
7 S-TG0FF 1 L
8 S-TGO L
9 S-TGO L
10 S-TGO L
11 S-TGO L
12 S-TGO L
13 S-TGO L
14 S-TGO L
15 S-TGO L
16 S-TGO L
17 S-TGINHI L

GRP 92 1.727.920.00
EXT. VU PANEL

ELM 1
CONN. VU PANEL, CTL
PNT SIGNAL NAME COLOR LV TYPE F
1 EXT-D7 7 N
2 EXT-D5 5 N
3 EXT-D6 6 N
4 EXT-ENLD 9 N
5 EXT-DATA 3 N
6 EXT-CLK 1 N
7 KEY N
8 +15.0V 2 N
9 -15.0V 6 N
10 +0.0VA 0 N
11 +5.6V 5 N
12 +0.0VD 0 N

ELM 2
CONN. VU PANEL, AUDIO
PNT SIGNAL NAME COLOR LV TYPE F
1 N
2 N
3 A-PREOU1 9 N
4 A-PROSC1 5 N
5 A-MONIT1 9 N
6 A-MONSC1 5 N
7 N
8 N
9 A-MONIT2 9 N
10 A-MONSC2 5 N
11 A-PREOU2 9 N
12 A-PROSC2 5 N
13 A-PHIN2 9 N
14 A-PHISC2 5 N
15 A-PHIN1 9 N
16 A-PHISC1 5 N
17 N
18 KEY N
19 A-LSA 6 N
20 A-LSB 7 N

 * WILLI STJDER AG * L O C A T I O N P I N L I S T * 88/06/09 * 13:38 * P A G E 26 *

 * 1.727.010.00 * STJDER A 807 * TAPE RECORDER * 88/03/21 - 01 *

 <-- <-- <-- CONTINUATION

GRP 92 1.727.920.00
 <-- <-- <-- CONTINUATION

ELM 5
 CONN. LEVEL CONTROL, AUDIO

PNT	SIGNAL NAME	COLOR	LV	TYPE	F
1	A-LVINA2	9		N	
2	A-LVINB2	6		N	
3	A-LVINC2	5		N	
4	A-LVOUA2	9		N	
5	A-LVOUB2	6		N	
6	A-LVOUC2	5		N	
7	A-LVIN1	9		N	
8	A-LVINB1	6		N	
9	A-LVINC1	5		N	
10	A-LVOUA1	9		N	
11	KEY			N	
12	A-LVOUB1	6		N	
13	A-LVOUC1	5		N	

 * WILLI STJDER AG * S I G N A L W I R E L I S T * 88/06/09 * 13:38 * P A G E 27 *

 * 1.727.010.00 * STJDER A 807 * TAPE RECORDER * 88/03/21 - 01 *

SIGNAL NAME	COLOR	MI	ASY	GRP	ELM	PNT	S	LV	TYPE	DESCRIPTION OF ELEMENT	REMARK	ELEMNT NR.
0-AUDIO	0				1	7	4		A	CONN. EXT. VU PANEL, AUDIO		
0-MOTFL					11	7	1		N	CONN. SP. MOTOR FILTER, LEFT	J07	
					11	8	7		N	CONN. SP. MOTOR FILTER, RIGHT	J08	
					12	1	1		N	CONN. SP. MOTOR CTL.	P01	
					12	2	7		N	CONN. SP. MOTOR CTL.	P02	
0-MOVES	0				10	3	1		N	CONN. MOVE SENSOR	J03	
	0				24	1	2		N	CONN. TAPE DECK CTL. J03		
0-MSPLY	0				7	1	2		L	CHARGE CAPACITOR CHC1		
	0				8	1	4		J	RECTIFIER DZ2		
	0				11	9	2		Y	CONN. SP. MOTOR SUPPLY.	P1, P2	
	0				20	5	2		Y	CONN. CAPSTAN MOTOR SUPPLY	P1, P2	
0-TACH1	0				11	5	1		N	CONN. SP. MOTOR TACHO, LEFT	J05	
	0				17	1	1		N	CONN. SP. MOTOR CTL. J05		
0-TACH2	0				11	4	1		N	CONN. SP. MOTOR TACHO, RIGHT	J04	
	0				18	1	1		N	CONN. SP. MOTOR CTL. J04		
0-TTA	1				11	1	1		N	CONN. TAPE TENS. ADJUSTMENT	J01	
	1				14	1	11		N	CONN. SP. MOTOR CTL. J01		
0-TTS	0				11	2	1		N	CONN. TAPE TENS. SENSOR	J02	
	0				13	1	1		N	CONN. SP. MOTOR CTL. J02		
17VAC	3				6	4	3		N	CONN. TAPE DECK ELECTRONICS	J04	
	3				10	1	1		C	CONNECTOR POWER SUPPLY	J01	
+0.0V	0				1	3	9		B	SERIAL CTL. CONNECTOR		
	8				1	4	1		B	PARALLEL REMOTE CONNECTOR		
	8				1	5	1		B	CONN. SYNCHRONIZER		
	5				1	5	14		B	CONN. SYNCHRONIZER		
	1				6	4	17		N	CONN. TAPE DECK ELECTRONICS	J04	
	4				6	4	17		N	CONN. TAPE DECK ELECTRONICS	J04	
	0				6	4	18		N	CONN. TAPE DECK ELECTRONICS	J04	
	0				10	1	5		C	CONNECTOR POWER SUPPLY	J01	
	4				10	1	7		C	CONNECTOR POWER SUPPLY	J01	
	1				10	1	9		C	CONNECTOR POWER SUPPLY	J01	
	0				10	4	3		B	CONN. SERIAL CTL.	J04	
	8				10	11	8		N	CONN. PARALLEL REMOTE A	J11	
	8				10	13	8		N	CONN. SYNCHRONIZER A	J13	
	5				10	13	15		N	CONN. SYNCHRONIZER A	J13	
	0				20	2	1		N	CONN. VARI SPEED CTL.	J02	
	0				20	3	10		N	CONN. CAPSTAN TACHO	J03	
	2				21	2	11		N	CONN. CAPSTAN CTL. J03		
	0				35	7	1		L	VARIO SPEED POTM.		
+0.0VA	0				1	6	14		B	CONN. EXT. VU PANEL. CTL		
	0				10	2	13		N	CONN. CAPSTAN CTL.	J02	
	0				10	6	18		N	CONN. SPOOLING MOTOR CTL.	J06	
	0				10	8	12		N	CONN. EXT. VU-PANEL	J08	
	0				10	9	16		N	CONN. COMMAND PANEL	J09	

 * WILLI STUDER AG * S I G N A L W I R E L I S T * 88/06/09 * 13:38 * P A G E 28 *
 * 1.727.010.00 * STUDER A 807 * TAPE RECORDER * 88/03/21 - 01 *

SIGNAL NAME	COLOR	MI	ASY	GRP	ELM	PNT	S	LV	TYPE	DESCRIPTION OF ELEMENT	REMARK	ELEMNT NR.
<<-- CONT.OF	0			10	10	13			N	CONN. AUDIO CTL.		J10
+0.OVA	0			11	3	12			N	CONN. TAPE DECK CTL.		J03
	0			20	1	9			N	CONN. TAPE DECK CTL.		J01
	0			30	3	17			D	CONN. TAPE DECK CTL. J10		
	0			36	1	1			L	CONN. HEAD PHONES		
	0			37	2	1			L	MONITOR VOLUME POTM.		
	0			37	2	4			L	MONITOR VOLUME POTM.		
	0			40	1	12			N	CONN. TAPE DECK ELECTRONICS		
	0			40	2	14			N	CONN. MONITOR		
	0			40	2	15			N	CONN. MONITOR		
	0			40	12	2			N	CONN. OPTION		
	0			40	23	11			N	CONN. AUDIO ELECTRONICS CH1		
	0			40	32	2			N	CONN. INSERT, INPUT CIRCUIT		
	0			40	33	2			N	CONN. PREAMPLIFIER, SECOND REPRO		
	0			40	34	8			N	CONN. PREAMPLIFIER, SECOND REPRO		
	0			40	36	4			N	CONN. INSERT, OUTPUT CIRCUIT		
	0			40	43	11			N	CONN. AUDIO ELECTRONICS CH2		
	0			41	2	8			N	CONN. MIC AND LINE INPUTS, CH1		
	0			41	13	11			N	CONN. AUDIO CTL, J23		
	0			42	2	8			N	CONN. MIC AND LINE INPUTS, CH2		
	0			42	13	11			N	CONN. AUDIO CTL, J43		
	0			43	33	2			N	CONN. AUDIO CTL, J33		
	0			43	34	8			N	CONN. AUDIO CTL, J34		
	0			44	32	2			N	CONN. AUDIO CTL, J32		
	0			45	36	4			N	CONN. AUDIO CTL, J36		
	0			92	1	11			N	CONN. VU PANEL, CTL		
+0.OVD	0			1	6	1			B	CONN. EXT. VU PANEL, CTL		
	0			10	2	14			N	CONN. CAPSTAN CTL.		J02
	0			10	6	17			N	CONN. SPOOLING MOTOR CTL.		J06
	0			10	8	14			N	CONN. EXT. VU-PANEL		J08
	0			10	9	18			N	CONN. COMMAND PANEL		J09
	0			10	10	11			N	CONN. AUDIO CTL.		J10
	0			11	3	18			N	CONN. TAPE DECK CTL.		J03
	0			20	1	7			N	CONN. TAPE DECK CTL.		J01
	0			30	2	1			N	CONN. DISPLAY EL.		
	0			30	3	10			D	CONN. TAPE DECK CTL. J10		
	0			30	4	14			N	CONN. KEYS MATRIX		
	0			31	2	1			N	CONN. COMMAND PANEL J02		
	0			40	1	9			N	CONN. TAPE DECK ELECTRONICS		
	0			40	12	4			N	CONN. OPTION		
	0			40	22	12			N	CONN. AUDIO ELECTRONICS CH1		
	0			40	23	13			N	CONN. AUDIO ELECTRONICS CH1		
	0			40	31	6			N	CONN. INSERT, INPUT CIRCUIT		
	0			40	35	7			N	CONN. INSERT, OUTPUT CIRCUIT		
	0			40	42	12			N	CONN. AUDIO ELECTRONICS CH2		
	0			40	43	13			N	CONN. AUDIO ELECTRONICS CH2		
	0			41	12	12			N	CONN. AUDIO CTL, J22		
	0			41	13	13			N	CONN. AUDIO CTL, J23		
	0			42	12	12			N	CONN. AUDIO CTL, J42		
	0			42	13	13			N	CONN. AUDIO CTL, J43		
	0			44	31	6			N	CONN. AUDIO CTL, J31		
	0			45	35	7			N	CONN. AUDIO CTL, J35		
	0			92	1	13			N	CONN. VU PANEL, CTL		

 * WILLI STUDER AG * S I G N A L W I R E L I S T * 88/06/09 * 13:38 * P A G E 29 *
 * 1.727.010.00 * STUDER A 807 * TAPE RECORDER * 88/03/21 - 01 *

SIGNAL NAME	COLOR	MI	ASY	GRP	ELM	PNT	S	LV	TYPE	DESCRIPTION OF ELEMENT	REMARK	ELEMNT NR.
+1.2V	2			20	3	11			N	CONN. CAPSTAN TACHO		J03
	0			21	2	10			N	CONN. CAPSTAN CTL, J03		
+15.0V	2			1	6	3			B	CONN. EXT. VU PANEL, CTL		
	2			10	2	12			N	CONN. CAPSTAN CTL.		J02
	2			10	6	20			N	CONN. SPOOLING MOTOR CTL.		J06
	2			10	8	10			N	CONN. EXT. VU-PANEL		J08
	2			10	9	14			N	CONN. COMMAND PANEL		J09
	2			10	10	14			N	CONN. AUDIO CTL.		J10
	2			11	2	5			N	CONN. TAPE TENS. SENSOR		J02
	2			11	3	16			N	CONN. TAPE DECK CTL.		J03
	2			13	1	3			N	CONN. SP. MOTOR CTL, J02		
	2			20	1	8			N	CONN. TAPE DECK CTL.		J01
	2			20	2	4			N	CONN. VARI SPEED CTL.		J02
	2			30	3	16			D	CONN. TAPE DECK CTL. J10		
	2			35	7	3			L	VARIO SPEED POTM.		
	2			40	1	11			N	CONN. TAPE DECK ELECTRONICS		
	2			40	12	1			N	CONN. OPTION		
	2			40	23	1			N	CONN. AUDIO ELECTRONICS CH1		
	2			40	32	3			N	CONN. INSERT, INPUT CIRCUIT		
	2			40	33	3			N	CONN. PREAMPLIFIER, SECOND REPRO		
	2			40	36	8			N	CONN. INSERT, OUTPUT CIRCUIT		
	2			40	43	1			N	CONN. AUDIO ELECTRONICS CH2		
	2			41	13	1			N	CONN. AUDIO CTL, J23		
	2			42	13	1			N	CONN. AUDIO CTL, J43		
	2			43	33	3			N	CONN. AUDIO CTL, J33		
	2			44	32	3			N	CONN. AUDIO CTL, J32		
	2			45	36	8			N	CONN. AUDIO CTL, J36		
	2			92	1	9			N	CONN. VU PANEL, CTL		
+20.0V	2			6	4	1			N	CONN. TAPE DECK ELECTRONICS		J04
	2			6	4	14			N	CONN. TAPE DECK ELECTRONICS		J04
	2			10	1	6			C	CONNECTOR POWER SUPPLY		J01
+24.0V	7			6	4	9			N	CONN. TAPE DECK ELECTRONICS		J04
	7			6	4	10			N	CONN. TAPE DECK ELECTRONICS		J04
	7			6	4	11			N	CONN. TAPE DECK ELECTRONICS		J04
	7			6	4	12			N	CONN. TAPE DECK ELECTRONICS		J04
	7			6	4	13			N	CONN. TAPE DECK ELECTRONICS		J04
	7			10	1	10			C	CONNECTOR POWER SUPPLY		J01
	7			25	1	2			X	CONN. TAPE DECK CTL. J07		
	7			26	1	1			X	CONN. TAPE DECK CTL. J07		
	7			27	1	1			X	CONN. TAPE DECK CTL. J07		
+24V-RMT	8			1	3	5			B	SERIAL CTL. CONNECTOR		
	0			1	4	25			B	PARALLEL REMOTE CONNECTOR		
	9			1	5	25			B	CONN. SYNCHRONIZER		
	8			6	4	4			N	CONN. TAPE DECK ELECTRONICS		J04
	8			10	1	3			C	CONNECTOR POWER SUPPLY		J01
	8			10	4	4			B	CONN. SERIAL CTL.		J04
	0			10	12	10			N	CONN. PARALLEL REMOTE B		J12
	9			10	14	9			N	CONN. SYNCHRONIZER B		J14

 * WILLI STUDER AG * S I G N A L W I R E L I S T * 88/06/09 * 13:38 * P A G E 30 *

 * 1.727.010.00 * STUDER A 807 * TAPE RECORDER * 88/03/21 - 01 *

SIGNAL NAME	COLOR	MI	ASY	GRP	ELM	PNT	S	LV	TYPE	DESCRIPTION OF ELEMENT	REMARK	ELEMNT NR.
+48.0V	7				10	10	12		N	CONN. AUDIO CTL.	J10	
					40	1	17		N	CONN. TAPE DECK ELECTRONICS		
					40	21	1		N	CONN. AUDIO ELECTRONICS CH1		
					40	41	1		N	CONN. AUDIO ELECTRONICS CH2		
					41	11	1		N	CONN. AUDIO CTL, J21		
					42	11	1		N	CONN. AUDIO CTL, J41		
+5.0V	5				10	3	2		N	CONN. MOVE SENSOR	J03	
					11	4	2		N	CONN. SP. MOTOR TACHO, RIGHT	J04	
					11	5	3		N	CONN. SP. MOTOR TACHO, LEFT	J05	
					17	1	2		N	CONN. SP. MOTOR CTL, J05		
					18	1	2		N	CONN. SP. MOTOR CTL, J04		
					24	1	5		N	CONN. TAPE DECK CTL, J03		
+5.0VA					40	12	5		N	CONN. OPTION		
					40	22	6		N	CONN. AUDIO ELECTRONICS CH1		
					40	23	12		N	CONN. AUDIO ELECTRONICS CH1		
					40	31	5		N	CONN. INSERT, INPUT CIRCUIT		
					40	35	6		N	CONN. INSERT, OUTPUT CIRCUIT		
					40	42	6		N	CONN. AUDIO ELECTRONICS CH2		
					40	43	12		N	CONN. AUDIO ELECTRONICS CH2		
					41	12	6		N	CONN. AUDIO CTL, J22		
					41	13	12		N	CONN. AUDIO CTL, J23		
					42	12	6		N	CONN. AUDIO CTL, J42		
					42	13	12		N	CONN. AUDIO CTL, J43		
					44	31	5		N	CONN. AUDIO CTL, J31		
45	35	6		N	CONN. AUDIO CTL, J35							
+5.0VMF					11	7	6		N	CONN. SP. MOTOR FILTER, LEFT	J07	
					12	1	6		N	CONN. SP. MOTOR CTL.	P01	
+5.6V	5				1	6	2		B	CONN. EXT. VU PANEL, CTL		
					10	2	15		N	CONN. CAPSTAN CTL.	J02	
					10	6	16		N	CONN. SPOOLING MOTOR CTL.	J06	
					10	8	13		N	CONN. EXT. VU-PANEL	J08	
					10	9	17		N	CONN. COMMAND PANEL	J09	
					10	10	10		N	CONN. AUDIO CTL.	J10	
					11	3	19		N	CONN. TAPE DECK CTL.	J03	
					20	1	6		N	CONN. TAPE DECK CTL.	J01	
					30	2	5		N	CONN. DISPLAY EL.		
					30	3	1		D	CONN. TAPE DECK CTL, J10		
					30	4	1		N	CONN. KEYS MATRIX		
					31	2	5		N	CONN. COMMAND PANEL J02		
40	1	10		N	CONN. TAPE DECK ELECTRONICS							
92	1	12		N	CONN. VU PANEL, CTL							
+50.0V	2				7	1	1		L	CHARGE CAPACITOR CHC1		
					8	1	3		J	RECTIFIER D22		
					11	9	1		Y	CONN. SP. MOTOR SUPPLY,	P1, P2	
					20	5	1		Y	CONN. CAPSTAN MOTOR SUPPLY	P1, P2	
+60.0V	5				6	4	2		N	CONN. TAPE DECK ELECTRONICS	J04	
					10	1	8		C	CONNECTOR POWER SUPPLY	J01	

 * WILLI STUDER AG * S I G N A L W I R E L I S T * 88/06/09 * 13:38 * P A G E 31 *

 * 1.727.010.00 * STUDER A 807 * TAPE RECORDER * 88/03/21 - 01 *

SIGNAL NAME	COLOR	MI	ASY	GRP	ELM	PNT	S	LV	TYPE	DESCRIPTION OF ELEMENT	REMARK	ELEMNT NR.
-15.0V	6				1	6	16		B	CONN. EXT. VU PANEL, CTL		
					10	2	11		N	CONN. CAPSTAN CTL.	J02	
					10	6	19		N	CONN. SPOOLING MOTOR CTL.	J06	
					10	8	11		N	CONN. EXT. VU-PANEL	J08	
					10	9	15		N	CONN. COMMAND PANEL	J09	
					10	10	15		N	CONN. AUDIO CTL.	J10	
					11	2	3		N	CONN. TAPE TENS. SENSOR	J02	
					11	3	10		N	CONN. TAPE DECK CTL.	J03	
					13	1	4		N	CONN. SP. MOTOR CTL, J02		
					20	1	10		N	CONN. TAPE DECK CTL.	J01	
					30	3	18		D	CONN. TAPE DECK CTL, J10		
					40	1	13		N	CONN. TAPE DECK ELECTRONICS		
					40	12	3		N	CONN. OPTION		
					40	23	2		N	CONN. AUDIO ELECTRONICS CH1		
					40	31	8		N	CONN. INSERT, INPUT CIRCUIT		
					40	32	1		N	CONN. INSERT, INPUT CIRCUIT		
					40	33	1		N	CONN. PREAMPLIFIER, SECOND REPRO		
					40	36	6		N	CONN. INSERT, OUTPUT CIRCUIT		
					40	43	2		N	CONN. AUDIO ELECTRONICS CH2		
					41	13	2		N	CONN. AUDIO CTL, J23		
42	13	2		N	CONN. AUDIO CTL, J43							
43	33	1		N	CONN. AUDIO CTL, J33							
44	32	1		N	CONN. AUDIO CTL, J32							
45	36	6		N	CONN. AUDIO CTL, J36							
92	1	10		N	CONN. VU PANEL, CTL							
-20.0V	6				6	4	15		N	CONN. TAPE DECK ELECTRONICS	J04	
					10	1	4		C	CONNECTOR POWER SUPPLY	J01	
A-CTALK1					40	23	10		N	CONN. AUDIO ELECTRONICS CH1		
					41	13	10		N	CONN. AUDIO CTL, J23		
A-CTALK2					40	43	10		N	CONN. AUDIO ELECTRONICS CH2		
					42	13	10		N	CONN. AUDIO CTL, J43		
A-DRVIN1					40	24	12		N	CONN. AUDIO ELECTRONICS CH1		
					40	36	7		N	CONN. INSERT, OUTPUT CIRCUIT		
					41	14	12		N	CONN. AUDIO CTL, J24		
45	36	7		N	CONN. AUDIO CTL, J36							
A-DRVIN2					40	36	3		N	CONN. INSERT, OUTPUT CIRCUIT		
					40	44	12		N	CONN. AUDIO ELECTRONICS CH2		
					42	14	12		N	CONN. AUDIO CTL, J44		
45	36	3		N	CONN. AUDIO CTL, J36							
A-D0					40	22	8		N	CONN. AUDIO ELECTRONICS CH1		
					40	24	1		N	CONN. AUDIO ELECTRONICS CH1		
					40	42	8		N	CONN. AUDIO ELECTRONICS CH2		
					40	44	1		N	CONN. AUDIO ELECTRONICS CH2		
					41	12	8		N	CONN. AUDIO CTL, J22		
					41	14	1		N	CONN. AUDIO CTL, J24		
					42	12	8		N	CONN. AUDIO CTL, J42		
42	14	1		N	CONN. AUDIO CTL, J44							

 * WILLI STUDER AG * S I G N A L W I R E L I S T * 88/06/09 * 13:38 * P A G E 32 *
 * 1.727.010.00 * STUDER A 807 * TAPE RECORDER * 88/03/21 - 01 *

SIGNAL NAME	COLOR	MI	ASY	GRP	ELM	PNT	S	LV	TYPE	DESCRIPTION OF ELEMENT	REMARK	ELEMNT NR.
A-D1				40	22	9			N	CONN. AUDIO ELECTRONICS CH1		
				40	24	2			N	CONN. AUDIO ELECTRONICS CH1		
				40	42	9			N	CONN. AUDIO ELECTRONICS CH2		
				40	44	2			N	CONN. AUDIO ELECTRONICS CH2		
				41	12	9			N	CONN. AUDIO CTL, J22		
				41	14	2			N	CONN. AUDIO CTL, J24		
				42	12	9			N	CONN. AUDIO CTL, J42		
			42	14	2			N	CONN. AUDIO CTL, J44			
A-D2				40	22	10			N	CONN. AUDIO ELECTRONICS CH1		
				40	24	3			N	CONN. AUDIO ELECTRONICS CH1		
				40	42	10			N	CONN. AUDIO ELECTRONICS CH2		
				40	44	3			N	CONN. AUDIO ELECTRONICS CH2		
				41	12	10			N	CONN. AUDIO CTL, J22		
				41	14	3			N	CONN. AUDIO CTL, J24		
				42	12	10			N	CONN. AUDIO CTL, J42		
			42	14	3			N	CONN. AUDIO CTL, J44			
A-D3				40	22	11			N	CONN. AUDIO ELECTRONICS CH1		
				40	24	4			N	CONN. AUDIO ELECTRONICS CH1		
				40	42	11			N	CONN. AUDIO ELECTRONICS CH2		
				40	44	4			N	CONN. AUDIO ELECTRONICS CH2		
				41	12	11			N	CONN. AUDIO CTL, J22		
				41	14	4			N	CONN. AUDIO CTL, J24		
				42	12	11			N	CONN. AUDIO CTL, J42		
			42	14	4			N	CONN. AUDIO CTL, J44			
A-D4				40	22	15			N	CONN. AUDIO ELECTRONICS CH1		
				40	24	7			N	CONN. AUDIO ELECTRONICS CH1		
				40	42	15			N	CONN. AUDIO ELECTRONICS CH2		
				40	44	7			N	CONN. AUDIO ELECTRONICS CH2		
				41	12	15			N	CONN. AUDIO CTL, J22		
				41	14	7			N	CONN. AUDIO CTL, J24		
				42	12	15			N	CONN. AUDIO CTL, J42		
			42	14	7			N	CONN. AUDIO CTL, J44			
A-D5				40	22	16			N	CONN. AUDIO ELECTRONICS CH1		
				40	24	8			N	CONN. AUDIO ELECTRONICS CH1		
				40	42	16			N	CONN. AUDIO ELECTRONICS CH2		
				40	44	8			N	CONN. AUDIO ELECTRONICS CH2		
				41	12	16			N	CONN. AUDIO CTL, J22		
				41	14	8			N	CONN. AUDIO CTL, J24		
				42	12	16			N	CONN. AUDIO CTL, J42		
			42	14	8			N	CONN. AUDIO CTL, J44			
A-D6				40	22	17			N	CONN. AUDIO ELECTRONICS CH1		
				40	24	9			N	CONN. AUDIO ELECTRONICS CH1		
				40	42	17			N	CONN. AUDIO ELECTRONICS CH2		
				40	44	9			N	CONN. AUDIO ELECTRONICS CH2		
				41	12	17			N	CONN. AUDIO CTL, J22		
				41	14	9			N	CONN. AUDIO CTL, J24		
				42	12	17			N	CONN. AUDIO CTL, J42		
			42	14	9			N	CONN. AUDIO CTL, J44			

 * WILLI STUDER AG * S I G N A L W I R E L I S T * 88/06/09 * 13:38 * P A G E 33 *
 * 1.727.010.00 * STUDER A 807 * TAPE RECORDER * 88/03/21 - 01 *

SIGNAL NAME	COLOR	MI	ASY	GRP	ELM	PNT	S	LV	TYPE	DESCRIPTION OF ELEMENT	REMARK	ELEMNT NR.
A-D7				40	22	18			N	CONN. AUDIO ELECTRONICS CH1		
				40	24	10			N	CONN. AUDIO ELECTRONICS CH1		
				40	42	18			N	CONN. AUDIO ELECTRONICS CH2		
				40	44	10			N	CONN. AUDIO ELECTRONICS CH2		
				41	12	18			N	CONN. AUDIO CTL, J22		
				41	14	10			N	CONN. AUDIO CTL, J24		
				42	12	18			N	CONN. AUDIO CTL, J42		
			42	14	10			N	CONN. AUDIO CTL, J44			
A-HFIN1				40	22	20			N	CONN. AUDIO ELECTRONICS CH1		
				41	12	20			N	CONN. AUDIO CTL, J22		
A-HFIN2				40	42	20			N	CONN. AUDIO ELECTRONICS CH2		
				42	12	20			N	CONN. AUDIO CTL, J42		
A-LINA1	9			1	12	2			N	CONN. LINE INPUT, CH1		
	9			41	2	1			N	CONN. MIC AND LINE INPUTS, CH1		
A-LINA2	9			1	11	2			N	CONN. LINE INPUT, CH2		
	9			42	2	1			N	CONN. MIC AND LINE INPUTS, CH2		
A-LINB1	6			1	12	3			N	CONN. LINE INPUT, CH1		
	6			41	2	2			N	CONN. MIC AND LINE INPUTS, CH1		
A-LINB2	6			1	11	3			N	CONN. LINE INPUT, CH2		
	6			42	2	2			N	CONN. MIC AND LINE INPUTS, CH2		
A-LINS1	S			1	12	1			N	CONN. LINE INPUT, CH1		
	S			41	2	3			N	CONN. MIC AND LINE INPUTS, CH1		
A-LINS2	S			1	11	1			N	CONN. LINE INPUT, CH2		
	S			42	2	3			N	CONN. MIC AND LINE INPUTS, CH2		
A-LOUTA1	2			1	10	2			N	CONN. LINE OUTPUT, CH1		
	2			41	7	2			N	CONN. LINE OUTPUT CONNECTOR, CH1		
A-LOUTA2	2			1	9	2			N	CONN. LINE OUTPUT, CH2		
	2			42	7	2			N	CONN. LINE OUTPUT CONNECTOR, CH2		
A-LOUTB1	3			1	10	3			N	CONN. LINE OUTPUT, CH1		
	3			41	7	1			N	CONN. LINE OUTPUT CONNECTOR, CH1		
A-LOUTB2	3			1	9	3			N	CONN. LINE OUTPUT, CH2		
	3			42	7	1			N	CONN. LINE OUTPUT CONNECTOR, CH2		
A-LOUTS1	S			1	10	1			N	CONN. LINE OUTPUT, CH1		
A-LOUTS2	S			1	9	1			N	CONN. LINE OUTPUT, CH2		
A-LSA	6			1	7	7			A	CONN. EXT. VU PANEL, AUDIO		
	6			37	1	1			L	LOUDSPEAKER		
	6			40	2	16			N	CONN. MONITOR		
	6			92	2	19			N	CONN. VU PANEL, AUDIO		
A-LSAMP1	8			36	1	5			L	CONN. HEAD PHONES		
	8			40	2	13			N	CONN. MONITOR		

 * WILLI STUDER AG * S I G N A L W I R E L I S T * 88/06/09 * 13:38 * P A G E 34 *

 * 1.727.010.00 * STUDER A 807 * TAPE RECORDER * 88/03/21 - 01 *

SIGNAL NAME	COLOR	MI	ASY	GRP	ELM	PNT	S	LV	TYPE	DESCRIPTION OF ELEMENT	REMARK	ELEMNT NR.
A-LSAMP2	3				36	1 2			L	CONN. HEAD PHONES		
	3				40	2 12			N	CONN. MONITOR		
A-LSB	7				1	7 20			A	CONN. EXT. VU PANEL, AUDIO		
	7				37	1 2			L	LOUDSPEAKER		
	7				40	2 17			N	CONN. MONITOR		
	7				92	2 20			N	CONN. VU PANEL, AUDIO		
A-LVINA1	9				1	7 16			A	CONN. EXT. VU PANEL, AUDIO		
	9				35	2 3			L	LINE LEVEL POTM. CH1		
	9				41	3 1			N	CONN. LINE LEVEL POT, CH1		
	9				92	5 7			N	CONN. LEVEL CONTROL, AUDIO		
A-LVINA2	9				1	7 23			A	CONN. EXT. VU PANEL, AUDIO		
	9				35	4 3			L	LINE LEVEL POTM. CH2		
	9				42	3 1			N	CONN. LINE LEVEL POT, CH2		
	9				92	5 1			N	CONN. LEVEL CONTROL, AUDIO		
A-LVINB1	6				1	7 3			A	CONN. EXT. VU PANEL, AUDIO		
	2				35	2 2			L	LINE LEVEL POTM. CH1		
	2				41	3 2			N	CONN. LINE LEVEL POT, CH1		
	6				92	5 8			N	CONN. LEVEL CONTROL, AUDIO		
A-LVINB2	6				1	7 10			A	CONN. EXT. VU PANEL, AUDIO		
	4				35	4 2			L	LINE LEVEL POTM. CH2		
	4				42	3 2			N	CONN. LINE LEVEL POT, CH2		
	6				92	5 2			N	CONN. LEVEL CONTROL, AUDIO		
A-LVINC1	S				1	7 15			A	CONN. EXT. VU PANEL, AUDIO		
	0				35	2 1			L	LINE LEVEL POTM. CH1		
	0				41	3 4			N	CONN. LINE LEVEL POT, CH1		
	S				92	5 9			N	CONN. LEVEL CONTROL, AUDIO		
A-LVINC2	S				1	7 22			A	CONN. EXT. VU PANEL, AUDIO		
	0				35	4 1			L	LINE LEVEL POTM. CH2		
	0				42	3 4			N	CONN. LINE LEVEL POT, CH2		
	S				92	5 3			N	CONN. LEVEL CONTROL, AUDIO		
A-LVMIA1	9				35	1 3			L	MIC LEVEL PCTM. CH1		
	9				41	1 1			N	CONN. MIC LEVEL POT, CH1		
A-LVMIA2	9				35	3 3			L	MIC LEVEL POTM. CH2		
	9				42	1 1			N	CONN. MIC LEVEL POT, CH2		
A-LVMI81	6				35	1 2			L	MIC LEVEL POTM. CH1		
	6				41	1 3			N	CONN. MIC LEVEL POT, CH1		
A-LVMI82	6				35	3 2			L	MIC LEVEL POTM. CH2		
	6				42	1 3			N	CONN. MIC LEVEL POT, CH2		
A-LVMIC1	0				35	1 1			L	MIC LEVEL POTM. CH1		
	S				41	1 4			N	CONN. MIC LEVEL POT, CH1		
A-LVMIC2	0				35	3 1			L	MIC LEVEL POTM. CH2		
	S				42	1 4			N	CONN. MIC LEVEL POT, CH2		

 * WILLI STUDER AG * S I G N A L W I R E L I S T * 88/06/09 * 13:38 * P A G E 35 *

 * 1.727.010.00 * STUDER A 807 * TAPE RECORDER * 88/03/21 - 01 *

SIGNAL NAME	COLOR	MI	ASY	GRP	ELM	PNT	S	LV	TYPE	DESCRIPTION OF ELEMENT	REMARK	ELEMNT NR.
A-LVMDN1	9				37	2 6			L	MONITOR VOLUME POTM.		
	9				37	2 12			L	MONITOR VOLUME POTM.		
A-LVMDN2	9				37	2 3			L	MONITOR VOLUME POTM.		
	9				37	2 7			L	MONITOR VOLUME POTM.		
A-LVQUA1	9				1	7 1			A	CONN. EXT. VU PANEL, AUDIO		
	9				35	5 3			L	OUTPUT LEVEL POTM. CH1		
	9				41	6 1			N	CONN. OUTPUT LEVEL POT, CH1		
	9				92	5 10			N	CONN. LEVEL CONTROL, AUDIO		
A-LVQUA2	9				1	7 8			A	CONN. EXT. VU PANEL, AUDIO		
	9				35	6 3			L	OUTPUT LEVEL POTM. CH2		
	9				42	6 1			N	CONN. OUTPUT LEVEL POT, CH2		
	9				92	5 4			N	CONN. LEVEL CONTROL, AUDIO		
A-LVOUB1	6				1	7 14			A	CONN. EXT. VU PANEL, AUDIO		
	5				35	5 2			L	OUTPUT LEVEL POTM. CH1		
	5				41	6 3			N	CONN. OUTPUT LEVEL POT, CH1		
	6				92	5 12			N	CONN. LEVEL CONTROL, AUDIO		
A-LVOUB2	6				1	7 21			A	CONN. EXT. VU PANEL, AUDIO		
	6				35	6 2			L	OUTPUT LEVEL POTM. CH2		
	6				42	6 3			N	CONN. OUTPUT LEVEL POT, CH2		
	6				92	5 5			N	CONN. LEVEL CONTROL, AUDIO		
A-LVOUC1	S				1	7 2			A	CONN. EXT. VU PANEL, AUDIO		
	0				35	5 1			L	OUTPUT LEVEL POTM. CH1		
	0				41	6 4			N	CONN. OUTPUT LEVEL POT, CH1		
	S				92	5 13			N	CONN. LEVEL CONTROL, AUDIO		
A-LVOUC2	S				1	7 9			A	CONN. EXT. VU PANEL, AUDIO		
	0				35	6 1			L	OUTPUT LEVEL POTM. CH2		
	0				42	6 4			N	CONN. OUTPUT LEVEL POT, CH2		
	S				92	5 6			N	CONN. LEVEL CONTROL, AUDIO		
A-MICAS1					41	2 10			N	CONN. MIC AND LINE INPUTS, CH1		
A-MICAS2					42	2 10			N	CONN. MIC AND LINE INPUTS, CH2		
A-MICSA1	9				1	14 2			N	CONN. MIC INPUT, CH1		
	9				41	2 7			N	CONN. MIC AND LINE INPUTS, CH1		
A-MICSA2	9				1	13 2			N	CONN. MIC INPUT, CH2		
	9				42	2 7			N	CONN. MIC AND LINE INPUTS, CH2		
A-MICSB1	6				1	14 3			N	CONN. MIC INPUT, CH1		
	6				41	2 6			N	CONN. MIC AND LINE INPUTS, CH1		
A-MICSB2	6				1	13 3			N	CONN. MIC INPUT, CH2		
	6				42	2 6			N	CONN. MIC AND LINE INPUTS, CH2		
A-MICSS1	S				1	14 1			N	CONN. MIC INPUT, CH1		
	S				41	2 5			N	CONN. MIC AND LINE INPUTS, CH1		

 * WILLI STUDER AG * S I G N A L W I R E L I S T * 88/06/09 * 13:38 * P A G E 36 *

 * 1.727.010.00 * STUDER A 807 * TAPE RECORDER * 88/03/21 - 01 *

SIGNAL NAME	COLOR	MI	ASY	GRP	ELM	PNT	S	LV	TYPE	DESCRIPTION OF ELEMENT	REMARK	ELEMNT NR.
A-MICSS2	S			1	13	1				CONN. MIC INPUT, CH2		
	S			42	2	5			N	CONN. MIC AND LINE INPUTS, CH2		
A-MICSW1				41	2	9			N	CONN. MIC AND LINE INPUTS, CH1		
A-MICSW2				42	2	9			N	CONN. MIC AND LINE INPUTS, CH2		
A-MONIT1	1			1	7	5			A	CONN. EXT. VU PANEL, AUDIO		
	1			37	2	11			L	MONITOR VOLUME POTM.		
	1			40	2	20			N	CONN. MONITOR		
				40	24	20			N	CONN. AUDIO ELECTRONICS CH1		
				41	14	20			N	CONN. AUDIO CTL, J24		
	9			92	2	5			N	CONN. VU PANEL, AUDIO		
A-MONIT2	2			1	7	12			A	CONN. EXT. VU PANEL, AUDIO		
	2			37	2	9			L	MONITOR VOLUME POTM.		
	2			40	2	1			N	CONN. MONITOR		
				40	44	20			N	CONN. AUDIO ELECTRONICS CH2		
				42	14	20			N	CONN. AUDIO CTL, J44		
	9			92	2	9			N	CONN. VU PANEL, AUDIO		
A-MONSC1	S			92	2	6			N	CONN. VU PANEL, AUDIO		
A-MONSC2	S			92	2	10			N	CONN. VU PANEL, AUDIO		
A-PHIN1	8			1	7	6			A	CONN. EXT. VU PANEL, AUDIO		
	8			37	2	5			L	MONITOR VOLUME POTM.		
	8			40	2	8			N	CONN. MONITOR		
	9			92	2	15			N	CONN. VU PANEL, AUDIO		
A-PHIN2	4			1	7	19			A	CONN. EXT. VU PANEL, AUDIO		
	4			37	2	2			L	MONITOR VOLUME POTM.		
	4			40	2	4			N	CONN. MONITOR		
	9			92	2	13			N	CONN. VU PANEL, AUDIO		
A-PHISC1	S			92	2	16			N	CONN. VU PANEL, AUDIO		
A-PHISC2	S			92	2	14			N	CONN. VU PANEL, AUDIO		
A-PHOUT1	1			36	1	4			L	CONN. HEAD PHONES		
	1			40	2	11			N	CONN. MONITOR		
A-PHOUT2	2			36	1	3			L	CONN. HEAD PHONES		
	2			40	2	7			N	CONN. MONITOR		
A-PHSW1A				40	2	9			N	CONN. MONITOR		
A-PHSW1B				40	2	10			N	CONN. MONITOR		
A-PHSW2A				40	2	5			N	CONN. MONITOR		
A-PHSW2B				40	2	6			N	CONN. MONITOR		
A-PHTM1	0			1	15	1			L	PHANTOM POWERING SWITCH		
	0			40	3	4			N	CONN. PHANTOM POWERING SWITCH		

 * WILLI STUDER AG * S I G N A L W I R E L I S T * 88/06/09 * 13:38 * P A G E 37 *

 * 1.727.010.00 * STUDER A 807 * TAPE RECORDER * 88/03/21 - 01 *

SIGNAL NAME	COLOR	MI	ASY	GRP	ELM	PNT	S	LV	TYPE	DESCRIPTION OF ELEMENT	REMARK	ELEMNT NR.
A-PHTM2	8			1	15	2			L	PHANTOM POWERING SWITCH		
	8			40	3	3			N	CONN. PHANTOM POWERING SWITCH		
A-PHTM3	9			1	15	3			L	PHANTOM POWERING SWITCH		
	9			40	3	1			N	CONN. PHANTOM POWERING SWITCH		
A-PREOU1	5			1	7	18			A	CONN. EXT. VU PANEL, AUDIO		
	5			37	2	10			L	MONITOR VOLUME POTM.		
				40	2	19			N	CONN. MONITOR		
				40	21	4			N	CONN. AUDIO ELECTRONICS CH1		
				40	24	13			N	CONN. AUDIO ELECTRONICS CH1		
				40	31	1			N	CONN. INSERT, INPUT CIRCUIT		
				41	11	4			N	CONN. AUDIO CTL, J21		
				41	14	13			N	CONN. AUDIO CTL, J24		
				44	31	1			N	CONN. AUDIO CTL, J31		
	9			92	2	3			N	CONN. VU PANEL, AUDIO		
A-PREOU2	3			1	7	25			A	CONN. EXT. VU PANEL, AUDIO		
	3			37	2	8			L	MONITOR VOLUME POTM.		
	3			40	2	3			N	CONN. MONITOR		
				40	31	7			N	CONN. INSERT, INPUT CIRCUIT		
				40	41	4			N	CONN. AUDIO ELECTRONICS CH2		
				40	44	13			N	CONN. AUDIO ELECTRONICS CH2		
				42	11	4			N	CONN. AUDIO CTL, J41		
				42	14	13			N	CONN. AUDIO CTL, J44		
				44	31	7			N	CONN. AUDIO CTL, J31		
	9			92	2	11			N	CONN. VU PANEL, AUDIO		
A-PROSC1	S			92	2	4			N	CONN. VU PANEL, AUDIO		
A-PROSC2	S			92	2	12			N	CONN. VU PANEL, AUDIO		
A-RECIN1				40	22	1			N	CONN. AUDIO ELECTRONICS CH1		
				40	31	4			N	CONN. INSERT, INPUT CIRCUIT		
				41	12	1			N	CONN. AUDIO CTL, J22		
				44	31	4			N	CONN. AUDIO CTL, J31		
A-RECIN2				40	31	9			N	CONN. INSERT, INPUT CIRCUIT		
				40	42	1			N	CONN. AUDIO ELECTRONICS CH2		
				42	12	1			N	CONN. AUDIO CTL, J42		
				44	31	9			N	CONN. AUDIO CTL, J31		
A-SECRP1				40	23	4			N	CONN. AUDIO ELECTRONICS CH1		
				40	34	7			N	CONN. PREAMPLIFIER, SECCND REPRO		
				41	13	4			N	CONN. AUDIO CTL, J23		
				43	34	7			N	CONN. AUDIO CTL, J34		
A-SECRP2				40	34	9			N	CONN. PREAMPLIFIER, SECCND REPRO		
				40	43	4			N	CONN. AUDIO ELECTRONICS CH2		
				42	13	4			N	CONN. AUDIO CTL, J43		
				43	34	9			N	CONN. AUDIO CTL, J34		
A-TAPOU1				40	24	14			N	CONN. AUDIO ELECTRONICS CH1		
				40	36	9			N	CONN. INSERT, OUTPUT CIRCUIT		
				41	14	14			N	CONN. AUDIO CTL, J24		
				45	36	9			N	CONN. AUDIO CTL, J36		

 * WILLI STUDER AG * S I G N A L W I R E L I S T * 88/06/09 * 13:38 * P A G E 38 *
 * 1.727.010.00 * STUDER A 807 * TAPE RECORDER * 88/03/21 - 01 *

SIGNAL NAME	COLOR	MI	ASY	GRP	ELM	PNT	S	LV	TYPE	DESCRIPTION OF ELEMENT	REMARK	ELEMNT NR.
A-TAPOU2					40 36 5				N	CONN. INSERT, OUTPUT CIRCUIT		
					40 44 14				N	CONN. AUDIO ELECTRONICS CH2		
					42 14 14				N	CONN. AUDIO CTL, J44		
					45 36 5				N	CONN. AUDIO CTL, J36		
A-VUMTR1	1				30 5 1				Y	CONN. VU-INPUT CH1		
	1				41 7 4				N	CONN. LINE OUTPUT CONNECTOR, CH1		
A-VUMTR2	1				30 6 1				Y	CONN. VU-INPUT CH2		
	1				42 7 4				N	CONN. LINE OUTPUT CONNECTOR, CH2		
ACA-17N	2				5 4 12				L	SECONDARY 2	P04	
	2				6 1 3				N	CONN. TRANSFORMER	J01	
ACA-17P	3				5 4 13				L	SECONDARY 2	P04	
	3				6 1 2				N	CONN. TRANSFORMER	J01	
ACA-20	1				5 4 11				L	SECONDARY 2	P04	
	1				6 1 1				N	CONN. TRANSFORMER	J01	
ACA-36	4				5 4 14				L	SECONDARY 2	P04	
	4				6 1 13				N	CONN. TRANSFORMER	J01	
ACA-40	0				5 4 10				L	SECONDARY 2	P04	
	0				6 1 11				N	CONN. TRANSFORMER	J01	
					6 1 12				N	CONN. TRANSFORMER	J01	
ACB-17N	7				5 3 17				L	SECONDARY 1	P03	
	7				6 1 7				N	CONN. TRANSFORMER	J01	
ACB-17P	6				5 3 16				L	SECONDARY 1	P03	
	6				6 1 8				N	CONN. TRANSFORMER	J01	
ACB-20	8				5 3 18				L	SECONDARY 1	P03	
	8				6 1 9				N	CONN. TRANSFORMER	J01	
ACB-36	5				5 3 15				L	SECONDARY 1	P03	
	5				6 1 10				N	CONN. TRANSFORMER	J01	
ACB-40	9				5 3 19				L	SECONDARY 1	P03	
	9				6 1 4				N	CONN. TRANSFORMER	J01	
					6 1 5				N	CONN. TRANSFORMER	J01	
ACC-17N	4				5 3 12				L	SECONDARY 1	P03	
	4				5 4 17				L	SECONDARY 2	P04	
ACC-17P	4				5 3 13				L	SECONDARY 1	P03	
	4				5 4 16				L	SECONDARY 2	P04	
ACC-20	4				5 3 11				L	SECONDARY 1	P03	
	4				5 4 18				L	SECONDARY 2	P04	
ACC-36	4				5 3 14				L	SECONDARY 1	P03	
	4				5 4 15				L	SECONDARY 2	P04	

 * WILLI STUDER AG * S I G N A L W I R E L I S T * 88/06/09 * 13:38 * P A G E 39 *
 * 1.727.010.00 * STUDER A 807 * TAPE RECORDER * 88/03/21 - 01 *

SIGNAL NAME	COLOR	MI	ASY	GRP	ELM	PNT	S	LV	TYPE	DESCRIPTION OF ELEMENT	REMARK	ELEMNT NR.
ACC-40	4				5 3 10				L	SECONDARY 1	P03	
	4				5 4 19				L	SECONDARY 2	P04	
AN-TTENS	9				11 2 4				N	CONN. TAPE TENS. SENSOR	J02	
	9				13 1 5				N	CONN. SP. MOTOR CTL, J02		
AS-CLK	6				10 10 6				N	CONN. AUDIO CTL	J10	
	6				40 1 3				N	CONN. TAPE DECK ELECTRONICS		
AS-DATA	7				10 10 7				N	CONN. AUDIO CTL	J10	
	7				40 1 2				N	CONN. TAPE DECK ELECTRONICS		
AS-FAD	1				10 10 1				N	CONN. AUDIO CTL	J10	
	1				40 1 14				N	CONN. TAPE DECK ELECTRONICS		
AS-HFCLK	8				10 10 8				N	CONN. AUDIO CTL	J10	
	8				40 1 19				N	CONN. TAPE DECK ELECTRONICS		
AS-RESET	9				10 10 9				N	CONN. AUDIO CTL	J10	
	9				40 1 16				N	CONN. TAPE DECK ELECTRONICS		
AS-STR	5				10 10 5				N	CONN. AUDIO CTL	J10	
	5				40 1 5				N	CONN. TAPE DECK ELECTRONICS		
AS-STRAB	4				10 10 4				N	CONN. AUDIO CTL	J10	
	4				40 1 1				N	CONN. TAPE DECK ELECTRONICS		
					40 22 14				N	CONN. AUDIO ELECTRONICS CH1		
					40 24 6				N	CONN. AUDIO ELECTRONICS CH1		
					40 42 14				N	CONN. AUDIO ELECTRONICS CH2		
					40 44 6				N	CONN. AUDIO ELECTRONICS CH2		
					41 12 14				N	CONN. AUDIO CTL, J22		
					41 14 6				N	CONN. AUDIO CTL, J24		
					42 12 14				N	CONN. AUDIO CTL, J42		
					42 14 6				N	CONN. AUDIO CTL, J44		
AS-WREN	3				10 10 3				N	CONN. AUDIO CTL	J10	
	3				40 1 4				N	CONN. TAPE DECK ELECTRONICS		
B-FAST					30 1 1				N	CONN. SPEED INDICATORS		
					31 1 1				N	CONN. COMMAND PANEL J01		
B-MID					30 1 2				N	CONN. SPEED INDICATORS		
					31 1 2				N	CONN. COMMAND PANEL J01		
B-SLOW					30 1 3				N	CONN. SPEED INDICATORS		
					31 1 3				N	CONN. COMMAND PANEL J01		
BR-FADRY	7				1 4 8				B	PARALLEL REMOTE CONNECTOR		
	7				10 12 7				N	CONN. PARALLEL REMOTE B	J12	
3R-FORW	2				1 4 3				B	PARALLEL REMOTE CONNECTOR		
	2				1 5 3				B	CONN. SYNCHRONIZER		
	2				10 12 2				N	CONN. PARALLEL REMOTE B	J12	
	2				10 14 2				N	CONN. SYNCHRONIZER B	J14	

 * WILLI STJDER AG * S I G N A L W I R E L I S T * 88/06/09 * 13:38 * P A G E 40 *
 * 1.727.010.00 * STJDER A 807 * TAPE RECORDER * 88/03/21 - 01 *

SIGNAL NAME	COLOR	MI	ASY	GRP	ELM	PNT	S	LV	TYPE	DESCRIPTION OF ELEMENT	REMARK	ELEMENT NR.
BR-LOCST	8				1 4 7				B	PARALLEL REMOTE CONNECTOR		
	8				10 12 8				N	CONN. PARALLEL REMOTE B	J12	
BR-PLAY	1				1 4 15				B	PARALLEL REMOTE CONNECTOR		
	1				1 5 15				B	CONN. SYNCHRONIZER		
	1				10 12 1				N	CONN. PARALLEL REMOTE B	J12	
	1				10 14 1				N	CONN. SYNCHRONIZER B	J14	
BR-REC	5				1 4 9				B	PARALLEL REMOTE CONNECTOR		
	5				1 5 9				B	CONN. SYNCHRONIZER		
	5				10 12 5				N	CONN. PARALLEL REMOTE B	J12	
	5				10 14 5				N	CONN. SYNCHRONIZER B	J14	
BR-REW	3				1 4 2				B	PARALLEL REMOTE CONNECTOR		
	3				1 5 2				B	CONN. SYNCHRONIZER		
	3				10 12 3				N	CONN. PARALLEL REMOTE B	J12	
	3				10 14 3				N	CONN. SYNCHRONIZER B	J14	
BR-STOP	4				1 4 16				B	PARALLEL REMOTE CONNECTOR		
	4				1 5 16				B	CONN. SYNCHRONIZER		
	4				10 12 4				N	CONN. PARALLEL REMOTE B	J12	
	4				10 14 4				N	CONN. SYNCHRONIZER B	J14	
BR-VRSPD	6				1 4 4				B	PARALLEL REMOTE CONNECTOR		
	6				1 5 4				B	CONN. SYNCHRONIZER		
	6				10 12 6				N	CONN. PARALLEL REMOTE B	J12	
	6				10 14 6				N	CONN. SYNCHRONIZER B	J14	
C-BASS					40 23 3				N	CONN. AUDIO ELECTRONICS CH1		
					40 43 3				N	CONN. AUDIO ELECTRONICS CH2		
					41 13 3				N	CONN. AUDIO CTL, J23		
					42 13 3				N	CONN. AUDIO CTL, J43		
C-BIAS1					40 22 3				N	CONN. AUDIO ELECTRONICS CH1		
					41 12 3				N	CONN. AUDIO CTL, J22		
C-BIAS2					40 42 3				N	CONN. AUDIO ELECTRONICS CH2		
					42 12 3				N	CONN. AUDIO CTL, J42		
C-CALIN1					40 21 5				N	CONN. AUDIO ELECTRONICS CH1		
					41 11 5				N	CONN. AUDIO CTL, J21		
C-CALIN2					40 41 5				N	CONN. AUDIO ELECTRONICS CH2		
					42 11 5				N	CONN. AUDIO CTL, J41		
C-CALOU1					40 24 16				N	CONN. AUDIO ELECTRONICS CH1		
					41 14 16				N	CONN. AUDIO CTL, J24		
C-CALOU2					40 44 16				N	CONN. AUDIO ELECTRONICS CH2		
					42 14 16				N	CONN. AUDIO CTL, J44		
C-CUEAT					40 24 18				N	CONN. AUDIO ELECTRONICS CH1		
					40 44 18				N	CONN. AUDIO ELECTRONICS CH2		
					41 14 18				N	CONN. AUDIO CTL, J24		
					42 14 18				N	CONN. AUDIO CTL, J44		

 * WILLI STJDER AG * S I G N A L W I R E L I S T * 88/06/09 * 13:38 * P A G E 41 *
 * 1.727.010.00 * STJDER A 807 * TAPE RECORDER * 88/03/21 - 01 *

SIGNAL NAME	COLOR	MI	ASY	GRP	ELM	PNT	S	LV	TYPE	DESCRIPTION OF ELEMENT	REMARK	ELEMNT NR.
C-EQA					40 22 4				N	CONN. AUDIO ELECTRONICS CH1		
					40 23 6				N	CONN. AUDIO ELECTRONICS CH1		
					40 42 4				N	CONN. AUDIO ELECTRONICS CH2		
					40 43 6				N	CONN. AUDIO ELECTRONICS CH2		
					41 12 4				N	CONN. AUDIO CTL, J22		
					41 13 6				N	CONN. AUDIO CTL, J23		
					42 12 4				N	CONN. AUDIO CTL, J42		
C-EQB					42 13 6				N	CONN. AUDIO CTL, J43		
					40 22 5				N	CONN. AUDIO ELECTRONICS CH1		
					40 23 5				N	CONN. AUDIO ELECTRONICS CH1		
					40 42 5				N	CONN. AUDIO ELECTRONICS CH2		
					40 43 5				N	CONN. AUDIO ELECTRONICS CH2		
					41 12 5				N	CONN. AUDIO CTL, J22		
					41 13 5				N	CONN. AUDIO CTL, J23		
C-EQF					42 12 5				N	CONN. AUDIO CTL, J42		
					42 13 5				N	CONN. AUDIO CTL, J43		
					40 32 8				N	CONN. INSERT, INPUT CIRCUIT		
					40 35 2				N	CONN. INSERT, OUTPUT CIRCUIT		
					44 32 8				N	CONN. AUDIO CTL, J32		
C-EQM					45 35 2				N	CONN. AUDIO CTL, J35		
					40 32 7				N	CONN. INSERT, INPUT CIRCUIT		
					40 35 3				N	CONN. INSERT, OUTPUT CIRCUIT		
C-EQN					44 32 7				N	CONN. AUDIO CTL, J32		
					45 35 3				N	CONN. AUDIO CTL, J35		
					40 32 9				N	CONN. INSERT, INPUT CIRCUIT		
					40 35 1				N	CONN. INSERT, OUTPUT CIRCUIT		
C-EQS					44 32 9				N	CONN. AUDIO CTL, J32		
					45 35 1				N	CONN. AUDIO CTL, J35		
					40 32 6				N	CONN. INSERT, INPUT CIRCUIT		
					40 35 4				N	CONN. INSERT, OUTPUT CIRCUIT		
C-ERASE1					44 32 6				N	CONN. AUDIO CTL, J32		
					45 35 4				N	CONN. AUDIO CTL, J35		
					40 22 2				N	CONN. AUDIO ELECTRONICS CH1		
C-ERASE2					41 12 2				N	CONN. AUDIO CTL, J22		
					40 42 2				N	CONN. AUDIO ELECTRONICS CH2		
C-INPUT1					42 12 2				N	CONN. AUDIO CTL, J42		
					40 24 15				N	CONN. AUDIO ELECTRONICS CH1		
C-INPUT2					41 14 15				N	CONN. AUDIO CTL, J24		
					40 44 15				N	CONN. AUDIO ELECTRONICS CH2		
C-INSERT					42 14 15				N	CONN. AUDIO CTL, J44		
					40 32 4				N	CONN. INSERT, INPUT CIRCUIT		
					40 35 5				N	CONN. INSERT, OUTPUT CIRCUIT		
					44 32 4				N	CONN. AUDIO CTL, J32		
					45 35 5				N	CONN. AUDIO CTL, J35		

 * WILLI STUDEF AG * S I G N A L W I R E L I S T * 88/06/09 * 13:38 * P A G E 42 *

 * 1.727.010.00 * STUDEF A 807 * TAPE RECORDER * 88/03/21 - 01 *

SIGNAL NAME	COLOR	MI	ASY	GRP	ELM	PNT	S	LV	TYPE	DESCRIPTION OF ELEMENT	REMARK	ELEMNT NR.
C-MICAT1					40 21	3			N	CONN. AUDIO ELECTRONICS CH1		
					41 11	3			N	CONN. AUDIO CTL, J21		
C-MICAT2					40 41	3			N	CONN. AUDIO ELECTRONICS CH2		
					42 11	3			N	CONN. AUDIO CTL, J41		
C-MICON1					40 21	7			N	CONN. AUDIO ELECTRONICS CH1		
					41 11	7			N	CONN. AUDIO CTL, J21		
C-MICON2					40 41	7			N	CONN. AUDIO ELECTRONICS CH2		
					42 11	7			N	CONN. AUDIO CTL, J41		
C-MONOA	4				44 2	4			N	CONN. M/S OUTPUT AMPL.		
	4				45 1	4			L	CONN. M/S INPUT AMPL. J01		
C-MONOB					44 2	3			N	CONN. M/S OUTPUT AMPL.		
					45 1	3			L	CONN. M/S INPUT AMPL. J01		
C-MOTFLT					11 7	7			N	CONN. SP. MOTOR FILTER, LEFT	J07	
					12 1	7			N	CONN. SP. MOTOR CTL.	P01	
C-NAB					40 21	2			N	CONN. AUDIO ELECTRONICS CH1		
					40 24	11			N	CONN. AUDIO ELECTRONICS CH1		
					40 41	2			N	CONN. AUDIO ELECTRONICS CH2		
					40 44	11			N	CONN. AUDIO ELECTRONICS CH2		
					41 11	2			N	CONN. AUDIO CTL, J21		
					41 14	11			N	CONN. AUDIO CTL, J24		
					42 11	2			N	CONN. AUDIO CTL, J41		
				42 14	11			N	CONN. AUDIO CTL, J44			
C-OUTSW					40 24	19			N	CONN. AUDIO ELECTRONICS CH1		
					40 44	19			N	CONN. AUDIO ELECTRONICS CH2		
					41 14	19			N	CONN. AUDIO CTL, J24		
					42 14	19			N	CONN. AUDIO CTL, J44		
C-REC1					40 22	19			N	CONN. AUDIO ELECTRONICS CH1		
					41 12	19			N	CONN. AUDIO CTL, J22		
C-REC2					40 42	19			N	CONN. AUDIO ELECTRONICS CH2		
					42 12	19			N	CONN. AUDIO CTL, J42		
C-REPRO1					40 23	8			N	CONN. AUDIO ELECTRONICS CH1		
					41 13	8			N	CONN. AUDIO CTL, J23		
C-REPRO2					40 43	8			N	CONN. AUDIO ELECTRONICS CH2		
					42 13	8			N	CONN. AUDIO CTL, J43		
C-SECRP1					40 23	9			N	CONN. AUDIO ELECTRONICS CH1		
					41 13	9			N	CONN. AUDIO CTL, J23		
C-SECRP2					40 43	9			N	CONN. AUDIO ELECTRONICS CH2		
					42 13	9			N	CONN. AUDIO CTL, J43		
C-SYNC1					40 23	7			N	CONN. AUDIO ELECTRONICS CH1		
					41 13	7			N	CONN. AUDIO CTL, J23		

 * WILLI STUDEF AG * S I G N A L W I R E L I S T * 88/06/09 * 13:38 * P A G E 43 *

 * 1.727.010.00 * STUDEF A 807 * TAPE RECORDER * 88/03/21 - 01 *

SIGNAL NAME	COLOR	MI	ASY	GRP	ELM	PNT	S	LV	TYPE	DESCRIPTION OF ELEMENT	REMARK	ELEMNT NR.
C-SYNC2					40 43	7			N	CONN. AUDIO ELECTRONICS CH2		
					42 13	7			N	CONN. AUDIO CTL, J43		
C-UNCIN1					40 21	6			N	CONN. AUDIO ELECTRONICS CH1		
					41 11	6			N	CONN. AUDIO CTL, J21		
C-UNCIN2					40 41	6			N	CONN. AUDIO ELECTRONICS CH2		
					42 11	6			N	CONN. AUDIO CTL, J41		
C-UNCOU1					40 24	17			N	CONN. AUDIO ELECTRONICS CH1		
					41 14	17			N	CONN. AUDIO CTL, J24		
C-UNCOU2					40 44	17			N	CONN. AUDIO ELECTRONICS CH2		
					42 14	17			N	CONN. AUDIO CTL, J44		
CAP-GRD					20 3	12				CONN. CAPSTAN TACHO	J03	
					21 2	12				CONN. CAPSTAN CTL, J03		
CHC2-N	8				6 2	1			N	CONN. TO CHARGE CAPACITORS	J02	
	8				6 3	4			N	CONN. FROM CHARGE CAPACITORS	J03	
	8				7 2	2			L	CHARGE CAPACITOR CHC2		
CHC2-P	7				6 2	4			N	CONN. TO CHARGE CAPACITORS	J02	
	7				6 3	7			L	CONN. FROM CHARGE CAPACITORS	J03	
	7				7 2	1			L	CHARGE CAPACITOR CHC2		
CHC3-N	3				6 2	2			N	CONN. TO CHARGE CAPACITORS	J02	
	3				6 3	2			N	CONN. FROM CHARGE CAPACITORS	J03	
	3				7 3	2			L	CHARGE CAPACITOR CHC3		
CHC3-P	2				6 2	5			N	CONN. TO CHARGE CAPACITORS	J02	
	2				6 3	6			N	CONN. FROM CHARGE CAPACITORS	J03	
	2				7 3	1			L	CHARGE CAPACITOR CHC3		
CHC4-N	6				6 2	7			N	CONN. TO CHARGE CAPACITORS	J02	
	6				6 3	5			N	CONN. FROM CHARGE CAPACITORS	J03	
	6				7 4	2			L	CHARGE CAPACITOR CHC4		
CHC4-P	4				6 2	3			N	CONN. TO CHARGE CAPACITORS	J02	
	4				6 3	1			N	CONN. FROM CHARGE CAPACITORS	J03	
	4				7 4	1			L	CHARGE CAPACITOR CHC4		
DS-CLK	9				10 9	10			N	CONN. COMMAND PANEL	J09	
					30 2	3			N	CONN. DISPLAY EL.		
	9				30 3	15			D	CONN. TAPE DECK CTL. J10		
					31 2	3			N	CONN. COMMAND PANEL J02		
DS-DATA	9				10 9	9			N	CONN. COMMAND PANEL	J09	
					30 2	4			N	CONN. DISPLAY EL.		
	9				30 3	14			D	CONN. TAPE DECK CTL. J10		
					31 2	4			N	CONN. COMMAND PANEL J02		
DS-ENDPL	1				10 9	11			N	CONN. COMMAND PANEL	J09	
					30 2	2			N	CONN. DISPLAY EL.		
	1				30 3	12			D	CONN. TAPE DECK CTL. J10		
					31 2	2			N	CONN. COMMAND PANEL J02		

 * WILLI STUDER AG * S I G N A L W I R E L I S T * 88/06/09 * 13:38 * P A G E 44 *

 * 1.727.010.00 * STUDER A 807 * TAPE RECORDER * 88/03/21 - 01 *

SIGNAL NAME	COLOR	MI	ASY	GRP	ELM	PNT	S	LV	TYPE	DESCRIPTION OF ELEMENT	REMARK	ELEMNT NR.
DS-ENLED	2				10	9 12			N	CONN. COMMAND PANEL	J09	
	2				30	3 13			D	CONN. TAPE DECK CTL. J10		
ERAHH-01	1				39	1 10			B	CONN. AUDIO ELECTRONICS		
	1				41	4 3			N	CONN. HEAD BLOCK, RECORD		
ERAHH-02	3				39	1 23			B	CONN. AUDIO ELECTRONICS		
	3				42	4 3			N	CONN. HEAD BLOCK, RECORD		
ERAHL-01	9				39	1 9			B	CONN. AUDIO ELECTRONICS		
	9				41	4 5			N	CONN. HEAD BLOCK, RECORD		
ERAHL-02	2				39	1 22			B	CONN. AUDIO ELECTRONICS		
	2				42	4 5			N	CONN. HEAD BLOCK, RECORD		
EXT-CLK	1				1	6 11			B	CONN. EXT. VU PANEL, CTL		
	1				10	8 8			N	CONN. EXT. VU-PANEL	J08	
	1				92	1 6			N	CONN. VU PANEL, CTL		
EXT-DATA	3				1	6 10			B	CONN. EXT. VU PANEL, CTL		
	3				10	8 7			N	CONN. EXT. VU-PANEL	J08	
	3				92	1 5			N	CONN. VU PANEL, CTL		
EXT-D5	5				1	6 5			B	CONN. EXT. VU PANEL, CTL		
	5				10	8 5			N	CONN. EXT. VU-PANEL	J08	
	5				92	1 2			N	CONN. VU PANEL, CTL		
EXT-D6	6				1	6 6			B	CONN. EXT. VU PANEL, CTL		
	6				10	8 4			N	CONN. EXT. VU-PANEL	J08	
	6				92	1 3			N	CONN. VU PANEL, CTL		
EXT-D7	7				1	6 7			B	CONN. EXT. VU PANEL, CTL		
	7				10	8 3			N	CONN. EXT. VU-PANEL	J08	
	7				92	1 1			N	CONN. VU PANEL, CTL		
EXT-ENLD	9				1	6 12			B	CONN. EXT. VU PANEL, CTL		
	9				10	8 9			N	CONN. EXT. VU-PANEL	J08	
	9				92	1 4			N	CONN. VU PANEL, CTL		
EXT-FAD					10	8 1			N	CONN. EXT. VU-PANEL	J08	
F-ACA40	8				6	5 12			Y	CONN. RECTIFIER DZ2		
	1				8	1 1			J	RECTIFIER DZ2		
F-ACB40	1				6	5 11			Y	CONN. RECTIFIER DZ2		
	8				8	1 2			J	RECTIFIER DZ2		
F-LINE1	1				1	1 5				CONNECTOR POWER INPUT	P01	
	1				2	1 1			J	POWER SWITCH		
FAD1	1				1	4 11			B	PARALLEL REMOTE CONNECTOR		
	1				10	11 1			N	CONN. PARALLEL REMOTE A	J11	
FAD2	2				1	4 12			B	PARALLEL REMOTE CONNECTOR		
	2				10	11 2			N	CONN. PARALLEL REMOTE A	J11	

 * WILLI STUDER AG * S I G N A L W I R E L I S T * 88/06/09 * 13:38 * P A G E 45 *

 * 1.727.010.00 * STUDER A 807 * TAPE RECORDER * 88/03/21 - 01 *

SIGNAL NAME	COLOR	MI	ASY	GRP	ELM	PNT	S	LV	TYPE	DESCRIPTION OF ELEMENT	REMARK	ELEMNT NR.
GND	5-4				1	1 3				CONNECTOR POWER INPUT	P01	
					1	2 1				CONN. GROUND		
					10	15 1			Y	CONN. GROUND (TP 12)		
HALL1A	7				20	3 4			N	CONN. CAPSTAN TACHO	J03	
	7				21	2 4			N	CONN. CAPSTAN CTL, J03		
HALL1B	8				20	3 5			N	CONN. CAPSTAN TACHO	J03	
	8				21	2 5			N	CONN. CAPSTAN CTL, J03		
HALL2A	5				20	3 6			N	CONN. CAPSTAN TACHO	J03	
	5				21	2 6			N	CONN. CAPSTAN CTL, J03		
HALL2B	6				20	3 7			N	CONN. CAPSTAN TACHO	J03	
	6				21	2 7			N	CONN. CAPSTAN CTL, J03		
HALL3A	3				20	3 8			N	CONN. CAPSTAN TACHO	J03	
	3				21	2 8			N	CONN. CAPSTAN CTL, J03		
HALL3B	4				20	3 9			N	CONN. CAPSTAN TACHO	J03	
	4				21	2 9			N	CONN. CAPSTAN CTL, J03		
IR-REFEX	3				1	4 13			B	PARALLEL REMOTE CONNECTOR		
	3				1	5 13			B	CONN. SYNCHRONIZER		
	3				10	11 3			N	CONN. PARALLEL REMOTE A	J11	
	3				10	13 3			N	CONN. SYNCHRONIZER A	J13	
K-BRAKE	1				10	7 1			N	CONN. SOLENOIDS	J07	
	1				25	1 1			X	CONN. TAPE DECK CTL. J07		
K-LIFT	8				10	7 3			N	CONN. SOLENOIDS	J07	
	8				27	1 2			X	CONN. TAPE DECK CTL. J07		
K-PRESS	9				10	7 5			N	CONN. SOLENOIDS	J07	
	9				26	1 2			X	CONN. TAPE DECK CTL. J07		
LINE1	1				1	1 1				CONNECTOR POWER INPUT	P01	
	1				1	1 4				CONNECTOR POWER INPUT	P01	
LINE2	6				1	1 2				CONNECTOR POWER INPUT	P01	
	6				2	1 2			J	POWER SWITCH		
MRX-Q10					30	4 11			N	CONN. KEYS MATRIX		
MRX-Q11					30	4 17			N	CONN. KEYS MATRIX		
MRX-Q12					30	4 15			N	CONN. KEYS MATRIX		
MRX-Q13					30	4 12			N	CONN. KEYS MATRIX		
MRX-Q14					30	4 10			N	CONN. KEYS MATRIX		
MRX-Q15					30	4 18			N	CONN. KEYS MATRIX		
MRX-Q16					30	4 16			N	CONN. KEYS MATRIX		

* WILLI STUDER AG * S I G N A L W I R E L I S T * 88/06/09 * 13:38 * P A G E 46 *

* 1.727.010.00 * STUDER A 807 * TAPE RECORDER * 88/03/21 - 01 *

SIGNAL NAME	COLOR	MI	ASY	GRP	ELM	PNT	S	LV	TYPE	DESCRIPTION OF ELEMENT	REMARK	ELEMENT NR.
MS-C76K	1			10	6	1			N	CONN. SPOOLING MOTOR CTL.	J06	
	1			11	3	6			N	CONN. TAPE DECK CTL.	J03	
MS-DIREN	5			10	6	5			N	CONN. SPOOLING MOTOR CTL.	J06	
	5			11	3	13			N	CONN. TAPE DECK CTL.	J03	
MS-MVCLK	4			10	6	14			N	CONN. SPOOLING MOTOR CTL.	J06	
	4			11	3	2			N	CONN. TAPE DECK CTL.	J03	
MS-MVDIR	3			10	6	13			N	CONN. SPOOLING MOTOR CTL.	J06	
	3			11	3	5			N	CONN. TAPE DECK CTL.	J03	
MS-ON	6			10	6	6			N	CONN. SPOOLING MOTOR CTL.	J06	
	6			11	3	15			N	CONN. TAPE DECK CTL.	J03	
MS-PRESS	2			10	6	2			N	CONN. SPOOLING MOTOR CTL.	J06	
	2			11	3	1			N	CONN. TAPE DECK CTL.	J03	
MS-REFA	8			10	6	8			N	CONN. SPOOLING MOTOR CTL.	J06	
	8			11	3	9			N	CONN. TAPE DECK CTL.	J03	
MS-REFB	7			10	6	7			N	CONN. SPOOLING MOTOR CTL.	J06	
	7			11	3	11			N	CONN. TAPE DECK CTL.	J03	
MS-REW	4			10	6	4			N	CONN. SPOOLING MOTOR CTL.	J06	
	4			11	3	17			N	CONN. TAPE DECK CTL.	J03	
MS-SHUTL	3			10	6	3			N	CONN. SPOOLING MOTOR CTL.	J06	
	3			11	3	20			N	CONN. TAPE DECK CTL.	J03	
MV-CLK1	1			10	3	5			N	CONN. MOVE SENSOR	J03	
	1			24	1	3			N	CONN. TAPE DECK CTL. J03		
MV-CLK2	2			10	3	3			N	CONN. MOVE SENSOR	J03	
	2			24	1	1			N	CONN. TAPE DECK CTL. J03		
M1-R				11	7	2			N	CONN. SP. MOTOR FILTER, LEFT	J07	
				11	7	3			N	CONN. SP. MOTOR FILTER, LEFT	J07	
				12	1	2			N	CONN. SP. MOTOR CTL,	P01	
				12	1	3			N	CONN. SP. MOTOR CTL,	P01	
	2			12	3	1			N	CONN. SP. MOTOR LEFT	J01	
	2			15	1	1			N	CONN. SP. MOTOR FILTER, J01		
M1-S				11	7	4			N	CONN. SP. MOTOR FILTER, LEFT	J07	
				11	7	5			N	CONN. SP. MOTOR FILTER, LEFT	J07	
				12	1	4			N	CONN. SP. MOTOR CTL,	P01	
				12	1	5			N	CONN. SP. MOTOR CTL,	P01	
	9			12	3	2			N	CONN. SP. MOTOR LEFT	J01	
	9			15	1	2			N	CONN. SP. MOTOR FILTER, J01		
M1-T				11	7	8			N	CONN. SP. MOTOR FILTER, LEFT	J07	
				11	7	9			N	CONN. SP. MOTOR FILTER, LEFT	J07	
				12	1	8			N	CONN. SP. MOTOR CTL,	P01	
				12	1	9			N	CONN. SP. MOTOR CTL,	P01	
	6			12	3	3			N	CONN. SP. MOTOR LEFT	J01	
	6			15	1	3			N	CONN. SP. MOTOR FILTER, J01		

* WILLI STUDER AG * S I G N A L W I R E L I S T * 88/06/09 * 13:38 * P A G E 47 *

* 1.727.010.00 * STUDER A 807 * TAPE RECORDER * 88/03/21 - 01 *

SIGNAL NAME	COLOR	MI	ASY	GRP	ELM	PNT	S	LV	TYPE	DESCRIPTION OF ELEMENT	REMARK	ELEMENT NR.
M1-TACHD	1			10	6	11			N	CONN. SPOOLING MOTOR CTL.	J06	
	1			11	3	8			N	CONN. TAPE DECK CTL.	J03	
M1-TSENS	4			11	5	4			N	CONN. SP. MOTOR TACHD, LEFT	J05	
	4			17	1	3			N	CONN. SP. MOTOR CTL, J05		
M2-R				11	8	1			N	CONN. SP. MOTOR FILTER, RIGHT	J08	
				11	8	2			N	CONN. SP. MOTOR FILTER, RIGHT	J08	
				12	2	1			N	CONN. SP. MOTOR CTL,	P02	
				12	2	2			N	CONN. SP. MOTOR CTL,	P02	
	2			12	4	1			N	CONN. SP. MOTOR RIGHT	J02	
	2			16	1	1			N	CONN. SP. MOTOR FILTER, J01		
M2-REFAN	0			10	6	10			N	CONN. SPOOLING MOTOR CTL.	J06	
	0			11	3	14			N	CONN. TAPE DECK CTL.	J03	
M2-S				11	8	3			N	CONN. SP. MOTOR FILTER, RIGHT	J08	
				11	8	4			N	CONN. SP. MOTOR FILTER, RIGHT	J08	
				12	2	3			N	CONN. SP. MOTOR CTL,	P02	
				12	2	4			N	CONN. SP. MOTOR CTL,	P02	
	9			12	4	2			N	CONN. SP. MOTOR RIGHT	J02	
	9			16	1	2			N	CONN. SP. MOTOR FILTER, J01		
M2-T				11	8	5			N	CONN. SP. MOTOR FILTER, RIGHT	J08	
				11	8	6			N	CONN. SP. MOTOR FILTER, RIGHT	J08	
				12	2	5			N	CONN. SP. MOTOR CTL,	P02	
				12	2	6			N	CONN. SP. MOTOR CTL,	P02	
	6			12	4	3			N	CONN. SP. MOTOR RIGHT	J02	
	6			16	1	3			N	CONN. SP. MOTOR FILTER, J01		
M2-TACHD	2			10	6	12			N	CONN. SPOOLING MOTOR CTL.	J06	
	2			11	3	7			N	CONN. TAPE DECK CTL.	J03	
M2-TSENS	4			11	4	4			N	CONN. SP. MOTOR TACHD, RIGHT	J04	
	4			18	1	3			N	CONN. SP. MOTOR CTL, J04		
M3-CLK	4			10	2	4			N	CONN. CAPSTAN CTL.	J02	
	4			20	1	1			N	CONN. TAPE DECK CTL.	J01	
M3-C76K	1			10	2	1			N	CONN. CAPSTAN CTL.	J02	
	1			20	1	4			N	CONN. TAPE DECK CTL.	J01	
M3-DATA	5			10	2	5			N	CONN. CAPSTAN CTL.	J02	
	5			20	1	2			N	CONN. TAPE DECK CTL.	J01	
M3-EN	3			10	2	3			N	CONN. CAPSTAN CTL.	J02	
	3			20	1	3			N	CONN. TAPE DECK CTL.	J01	
M3-R	9			20	4	1			N	CONN. CAPSTAN MOTOR	J04	
	9			21	1	1			N	CONN. CAPSTAN CTL, J04		
M3-REFEX	8			10	2	8			N	CONN. CAPSTAN CTL.	J02	
	8			20	1	13			N	CONN. TAPE DECK CTL.	J01	
M3-S	2			20	4	3			N	CONN. CAPSTAN MOTOR	J04	
	2			21	1	3			N	CONN. CAPSTAN CTL, J04		

SIGNAL NAME	COLOR	MI	ASY	GRP	ELM	PNT	S	LV	TYPE	DESCRIPTION OF ELEMENT	REMARK	ELEMNT NR.
M3-SYNC	7			10	2	7			N	CONN. CAPSTAN CTL.	J02	
	7			20	1	5			N	CONN. TAPE DECK CTL.	J01	
M3-T	0			20	4	4			N	CONN. CAPSTAN MOTOR	J04	
	0			21	1	4			N	CONN. CAPSTAN CTL, J04		
M3-TACHO	6			10	2	6			N	CONN. CAPSTAN CTL.	J02	
	6			20	1	14			N	CONN. TAPE DECK CTL.	J01	
M3-9600	2			10	2	2			N	CONN. CAPSTAN CTL.	J02	
	2			20	1	12			N	CONN. TAPE DECK CTL.	J01	
OR-CMCLK	1			1	5	11			B	CONN. SYNCHRONIZER		
	1			10	13	1			N	CONN. SYNCHRONIZER A	J13	
OR-MVCLK	5			1	5	7			B	CONN. SYNCHRONIZER		
	5			10	13	5			N	CONN. SYNCHRONIZER A	J13	
OR-MVDIR	6			1	5	10			B	CONN. SYNCHRONIZER		
	6			10	13	6			N	CONN. SYNCHRONIZER A	J13	
OR-SYENB	8			1	5	12			B	CONN. SYNCHRONIZER		
	8			10	14	8			N	CONN. SYNCHRONIZER B	J14	
PRIMW-1	1			4	1	5			L	VOLTAGE SELECTOR		
	1			5	1	1			Y	PRIMARY 1	P01	
PRIMW-3	3			4	1	2			L	VOLTAGE SELECTOR		
	3			5	1	3			Y	PRIMARY 1	P01	
PRIMW-4	4-4			4	1	4A			L	VOLTAGE SELECTOR		
	4			5	1	4			Y	PRIMARY 1	P01	
PRIMW-5	5			4	1	6			L	VOLTAGE SELECTOR		
	5			5	2	5			Y	PRIMARY 2	P02	
PRIMW-6	6-4			4	1	4B			L	VOLTAGE SELECTOR		
	6			5	2	6			Y	PRIMARY 2	P02	
PRIMW-7	7			4	1	3			L	VOLTAGE SELECTOR		
	7			5	2	7			Y	PRIMARY 2	P02	
R-RECLVA	4			44	1	4			N	CONN. M/S ADJUSTMENT		
	4			46	1	1			L	CONN. M/S INPUT AMPL. J01		
R-RECLVB	5			44	1	5			N	CONN. M/S ADJUSTMENT		
	5			46	1	2			L	CONN. M/S INPUT AMPL. J01		
R-REPLVA	1			45	2	2			Y	CONN. M/S ADJUSTMENT		
	1			46	1	3			L	CONN. M/S INPUT AMPL. J01		
R-REPLVB	3			45	2	1			Y	CONN. M/S ADJUSTMENT		
	3			46	1	4			L	CONN. M/S INPUT AMPL. J01		
R-SHUTL1	1			11	6	1			N	CONN. SHUTTLE CTL.	J06	
	1			30	7	1			L	SHUTTLE POTMETER		

SIGNAL NAME	COLOR	MI	ASY	GRP	ELM	PNT	S	LV	TYPE	DESCRIPTION OF ELEMENT	REMARK	ELEMNT NR.
R-SHUTL2	2			11	6	2			N	CONN. SHUTTLE CTL.	J06	
	2			30	7	2			L	SHUTTLE POTMETER		
R-SHUTL3	3			11	6	4			N	CONN. SHUTTLE CTL.	J06	
	3			30	7	3			L	SHUTTLE POTMETER		
R-VRSPD	8			20	2	3			N	CONN. VARI SPEED CTL.	J02	
	8			35	7	2			L	VARI SPEED POTM.		
RCVDATA	1			1	3	8			B	SERIAL CTL. CONNECTOR		
	1			10	4	1			N	CONN. SERIAL CTL.	J04	
RECHH-01	8			39	1	8			B	CONN. AUDIO ELECTRONICS		
	8			41	4	1			N	CONN. HEAD BLOCK, RECORD		
RECHH-02	1			39	1	21			B	CONN. AUDIO ELECTRONICS		
	1			42	4	1			N	CONN. HEAD BLOCK, RECORD		
RECHL-01	7			39	1	7			B	CONN. AUDIO ELECTRONICS		
	7			41	4	2			N	CONN. HEAD BLOCK, RECORD		
RECHL-02	0			39	1	20			B	CONN. AUDIO ELECTRONICS		
	0			42	4	2			N	CONN. HEAD BLOCK, RECORD		
REPHH-01	9			39	1	2			B	CONN. AUDIO ELECTRONICS		
	9			41	5	2			N	CONN. HEAD BLOCK, REPRO		
REPHH-02	9			39	1	15			B	CONN. AUDIO ELECTRONICS		
	9			42	5	2			N	CONN. HEAD BLOCK, REPRO		
REPHL-01	6			39	1	1			B	CONN. AUDIO ELECTRONICS		
	6			41	5	1			N	CONN. HEAD BLOCK, REPRO		
REPHL-02	6			39	1	14			B	CONN. AUDIO ELECTRONICS		
	6			42	5	1			N	CONN. HEAD BLOCK, REPRO		
REPSC-01	5			39	1	3			B	CONN. AUDIO ELECTRONICS		
	5			41	5	4			N	CONN. HEAD BLOCK, REPRO		
REPSC-02	5			39	1	16			B	CONN. AUDIO ELECTRONICS		
	5			42	5	4			N	CONN. HEAD BLOCK, REPRO		
S-LINE1	1			2	1	3			J	POWER SWITCH		
				3	1	1				MAINS FILTER, INPUT		
S-LINE2	6			2	1	4			J	POWER SWITCH		
	6			3	1	2			J	MAINS FILTER, INPUT		
S-TAPOUT	9			10	6	9			N	CONN. SPCOLING MOTOR CTL.	J06	
	9			11	3	3			N	CONN. TAPE DECK CTL.	J03	
S-TGATT	6			44	1	16			N	CONN. M/S ADJUSTMENT		
	6			46	2	4			L	TEST GEN. LEVEL SWITCH		
S-TGINHI	3			44	1	13			N	CONN. M/S ADJUSTMENT		
				46	3	17			L	TEST GEN. FREQUENCY SWITCH		

 * WILLI STUDER AG * S I G N A L W I R E L I S T * 88/06/09 * 13:38 * P A G E 50 *

 * 1.727.010.00 * STUDER A 807 * TAPE RECORDER * 88/03/21 - 01 *

SIGNAL NAME	COLOR	MI	ASY	GRP	ELM	PNT	S	LV	TYPE	DESCRIPTION OF ELEMENT	REMARK	ELEMNT NR.
S-TGOFF	1				44	1 11			N	CONN. M/S ADJUSTMENT		
	1				46	3 11			L	TEST GEN. FREQUENCY SWITCH		
S-TGO	2				44	1 12			N	CONN. M/S ADJUSTMENT		
	2				46	3 7			L	TEST GEN. FREQUENCY SWITCH		
					46	3 12			L	TEST GEN. FREQUENCY SWITCH		
					46	3 13			L	TEST GEN. FREQUENCY SWITCH		
					46	3 14			L	TEST GEN. FREQUENCY SWITCH		
					46	3 15			L	TEST GEN. FREQUENCY SWITCH		
					46	3 16			L	TEST GEN. FREQUENCY SWITCH		
S-TG1K	8				44	1 8			N	CONN. M/S ADJUSTMENT		
					46	3 4			L	TEST GEN. FREQUENCY SWITCH		
S-TG10DB	7				44	1 17			N	CONN. M/S ADJUSTMENT		
	2				44	2 2			N	CONN. M/S OUTPUT AMPL.		
	2				45	1 2			L	CONN. M/S INPUT AMPL. J01		
	2				46	2 2			L	TEST GEN. LEVEL SWITCH		
S-TG10K	9				44	1 9			N	CONN. M/S ADJUSTMENT		
	9				46	3 5			L	TEST GEN. FREQUENCY SWITCH		
S-TG125	7				44	1 7			N	CONN. M/S ADJUSTMENT		
	7				46	3 3			L	TEST GEN. FREQUENCY SWITCH		
S-TG16K	0				44	1 10			N	CONN. M/S ADJUSTMENT		
	0				46	3 6			L	TEST GEN. FREQUENCY SWITCH		
S-TG20DB	8				44	1 18			N	CONN. M/S ADJUSTMENT		
	1				44	2 1			N	CONN. M/S OUTPUT AMPL.		
	1				45	1 1			L	CONN. M/S INPUT AMPL. J01		
	1				46	2 3			L	TEST GEN. LEVEL SWITCH		
S-TG60	6				44	1 6			N	CONN. M/S ADJUSTMENT		
	6				46	3 2			L	TEST GEN. FREQUENCY SWITCH		
SF-LINE1	1				3	2 1			J	MAINS FILTER, OUTPUT		
	2-1				4	1 7			L	VOLTAGE SELECTOR		
	2				5	1 2			Y	PRIMARY 1	P01	
SF-LINE2	6				3	2 2			J	MAINS FILTER, OUTPUT		
	6-8				4	1 1			L	VOLTAGE SELECTOR		
	8				5	2 8			Y	PRIMARY 2	P02	
SM-D0	8				10	9 8			N	CONN. COMMAND PANEL	J09	
	8				30	3 9			D	CONN. TAPE DECK CTL. J10		
					30	4 9			N	CONN. KEYS MATRIX		
SM-D1	7				10	9 7			N	CONN. COMMAND PANEL	J09	
	7				30	3 8			D	CONN. TAPE DECK CTL. J10		
					30	4 8			N	CONN. KEYS MATRIX		
SM-D2	6				10	9 6			N	CONN. COMMAND PANEL	J09	
	6				30	3 7			D	CONN. TAPE DECK CTL. J10		
					30	4 7			N	CONN. KEYS MATRIX		

 * WILLI STUDER AG * S I G N A L W I R E L I S T * 88/06/09 * 13:38 * P A G E 51 *

 * 1.727.010.00 * STUDER A 807 * TAPE RECORDER * 88/03/21 - 01 *

SIGNAL NAME	COLOR	MI	ASY	GRP	ELM	PNT	S	LV	TYPE	DESCRIPTION OF ELEMENT	REMARK	ELEMNT NR.
SM-D3	5				10	9 5			N	CONN. COMMAND PANEL	J09	
	5				30	3 6			D	CONN. TAPE DECK CTL. J10		
					30	4 6			N	CONN. KEYS MATRIX		
SM-D4	4				10	9 4			N	CONN. COMMAND PANEL	J09	
	4				30	3 5			D	CONN. TAPE DECK CTL. J10		
					30	4 5			N	CONN. KEYS MATRIX		
SM-D5	3				10	9 3			N	CONN. COMMAND PANEL	J09	
	3				30	3 4			D	CONN. TAPE DECK CTL. J10		
					30	4 4			N	CONN. KEYS MATRIX		
SM-D6	2				10	9 2			N	CONN. COMMAND PANEL	J09	
	2				30	3 3			D	CONN. TAPE DECK CTL. J10		
					30	4 3			N	CONN. KEYS MATRIX		
SM-D7	1				10	9 1			N	CONN. COMMAND PANEL	J09	
	1				30	3 2			D	CONN. TAPE DECK CTL. J10		
					30	4 2			N	CONN. KEYS MATRIX		
SN-DATA	2				1	3 2			B	SERIAL CTL. CONNECTOR		
	2				10	4 5			B	CONN. SERIAL CTL.	J04	
SR-FADRY	5				1	4 6			B	PARALLEL REMOTE CONNECTOR		
	5				10	11 5			N	CONN. PARALLEL REMOTE A	J11	
SR-FORW	0				1	4 21			B	PARALLEL REMOTE CONNECTOR		
	0				1	5 21			B	CONN. SYNCHRONIZER		
	0				10	11 10			N	CONN. PARALLEL REMOTE A	J11	
	0				10	13 10			N	CONN. SYNCHRONIZER A	J13	
SR-LIFT	7				1	4 17			B	PARALLEL REMOTE CONNECTOR		
	7				1	5 17			B	CONN. SYNCHRONIZER		
	7				10	11 7			N	CONN. PARALLEL REMOTE A	J11	
	7				10	13 7			N	CONN. SYNCHRONIZER A	J13	
SR-LOCST	6				1	4 18			B	PARALLEL REMOTE CONNECTOR		
	6				10	11 6			N	CONN. PARALLEL REMOTE A	J11	
SR-MUTE	4				1	5 18			B	CONN. SYNCHRONIZER		
	4				10	13 4			N	CONN. SYNCHRONIZER A	J13	
SR-PLAY	9				1	4 22			B	PARALLEL REMOTE CONNECTOR		
	9				1	5 22			B	CONN. SYNCHRONIZER		
	9				10	11 9			N	CONN. PARALLEL REMOTE A	J11	
	9				10	13 9			N	CONN. SYNCHRONIZER A	J13	
SR-REC	3				1	4 19			B	PARALLEL REMOTE CONNECTOR		
	3				1	5 19			B	CONN. SYNCHRONIZER		
	3				10	11 13			N	CONN. PARALLEL REMOTE A	J11	
	3				10	13 13			N	CONN. SYNCHRONIZER A	J13	
SR-RESET	5				1	4 10			B	PARALLEL REMOTE CONNECTOR		
	5				10	11 15			N	CONN. PARALLEL REMOTE A	J11	

SIGNAL NAME	COLOR	MI	ASY	GRP	ELM	PNT	S	LV	TYPE	DESCRIPTION OF ELEMENT	REMARK	ELEMNT NR.
SR-REW	1			1	4	20			B	PARALLEL REMOTE CONNECTOR		
	1			1	5	20			B	CONN. SYNCHRONIZER		
	1			10	11	11			N	CONN. PARALLEL REMOTE A	J11	
	1			10	13	11			N	CONN. SYNCHRONIZER A	J13	
SR-STOP	2			1	4	23			B	PARALLEL REMOTE CONNECTOR		
	2			1	5	23			B	CONN. SYNCHRONIZER		
	2			10	11	12			N	CONN. PARALLEL REMOTE A	J11	
	2			10	13	12			N	CONN. SYNCHRONIZER A	J13	
SR-VRSPD	4			1	4	5			B	PARALLEL REMOTE CONNECTOR		
	4			1	5	5			B	CONN. SYNCHRONIZER		
	4			10	11	14			N	CONN. PARALLEL REMOTE A	J11	
	4			10	13	14			N	CONN. SYNCHRONIZER A	J13	
SR-ZLOC	6			1	4	14			B	PARALLEL REMOTE CONNECTOR		
	6			10	11	16			N	CONN. PARALLEL REMOTE A	J11	
SRPHH-01	9			39	1	5			B	CONN. AUDIO ELECTRONICS		
	9			43	1	6			N	CONN. HEAD BLOCK,SEC REPRO		
SRPHH-02	9			39	1	18			B	CONN. AUDIO ELECTRONICS		
	9			43	1	3			N	CONN. HEAD BLOCK,SEC REPRO		
SRPHL-01	6			39	1	4			B	CONN. AUDIO ELECTRONICS		
	6			43	1	5			N	CONN. HEAD BLOCK,SEC REPRO		
SRPHL-02	6			39	1	17			B	CONN. AUDIO ELECTRONICS		
	6			43	1	1			N	CONN. HEAD BLOCK,SEC REPRO		
SRPSC-01	5			39	1	6			B	CONN. AUDIO ELECTRONICS		
	5			43	1	7			N	CONN. HEAD BLOCK,SEC REPRO		
SRPSC-02	5			39	1	19			B	CONN. AUDIO ELECTRONICS		
	5			43	1	4			N	CONN. HEAD BLOCK,SEC REPRO		
TACHO-3A	1			20	3	1			N	CONN. CAPSTAN TACHO	J03	
	1			21	2	1			N	CONN. CAPSTAN CTL, J03		
TACHO-3B	9			20	3	2			N	CONN. CAPSTAN TACHO	J03	
	9			21	2	2			N	CONN. CAPSTAN CTL, J03		
TRS-A	3			10	5	2			N	CONN. TAPE TRANSPARENT SENSCR	J05	
	3			39	1	13			B	CONN. AUDIO ELECTRONICS		
TRS-C	4			10	5	4			N	CONN. TAPE TRANSPARENT SENSCR	J05	
	4			39	1	24			B	CONN. AUDIO ELECTRONICS		
TRS-E	5			10	5	5			N	CONN. TAPE TRANSPARENT SENSCR	J05	
	5			39	1	25			B	CONN. AUDIO ELECTRONICS		
TRS-K	2			10	5	1			N	CONN. TAPE TRANSPARENT SENSCR	J05	
	2			39	1	12			B	CONN. AUDIO ELECTRONICS		
TTA-FORW	6			11	1	6			N	CONN. TAPE TENS. ADJUSTMENT	J01	
	6			14	1	8			N	CONN. SP. MOTOR CTL, J01		

SIGNAL NAME	COLOR	MI	ASY	GRP	ELM	PNT	S	LV	TYPE	DESCRIPTION OF ELEMENT	REMARK	ELEMNT NR.
TTA-LIBR	3			11	1	3			N	CONN. TAPE TENS. ADJUSTMENT	J01	
	3			14	1	4			N	CONN. SP. MOTOR CTL, J01		
TTA-PLAY	4			11	1	4			N	CONN. TAPE TENS. ADJUSTMENT	J01	
	4			14	1	10			N	CONN. SP. MOTOR CTL, J01		
TTA-REW	5			11	1	5			N	CONN. TAPE TENS. ADJUSTMENT	J01	
	5			14	1	6			N	CONN. SP. MOTOR CTL, J01		
TTA-SHT1	7			11	1	7			N	CONN. TAPE TENS. ADJUSTMENT	J01	
	7			14	1	1			N	CONN. SP. MOTOR CTL, J01		
TTA-SHT2	8			11	1	8			N	CONN. TAPE TENS. ADJUSTMENT	J01	
	8			14	1	2			N	CONN. SP. MOTOR CTL, J01		
TTA-SHT3	9			11	1	9			N	CONN. TAPE TENS. ADJUSTMENT	J01	
	9			14	1	3			N	CONN. SP. MOTOR CTL, J01		
WR-BIAS1				40	22	7			N	CONN. AUDIO ELECTRONICS CH1		
				41	12	7			N	CONN. AUDIO CTL, J22		
WR-BIAS2				40	42	7			N	CONN. AUDIO ELECTRONICS CH2		
				42	12	7			N	CONN. AUDIO CTL, J42		
WR-REC1				40	22	13			N	CONN. AUDIO ELECTRONICS CH1		
				41	12	13			N	CONN. AUDIO CTL, J22		
WR-REC2				40	42	13			N	CONN. AUDIO ELECTRONICS CH2		
				42	12	13			N	CONN. AUDIO CTL, J42		
WR-REPR1				40	24	5			N	CONN. AUDIO ELECTRONICS CH1		
				41	14	5			N	CONN. AUDIO CTL, J24		
WR-REPR2				40	44	5			N	CONN. AUDIO ELECTRONICS CH2		
				42	14	5			N	CONN. AUDIO CTL, J44		

6. GENERAL DIAGRAMS

CONTENTS

SECTION 6

	Page
CONTENTS OF DIAGRAM SECTIONS IN NUMERICAL ORDER	6/2
TAPE TRANSPORT LOGIC BLOCK DIAGRAM	6/3
TAPE TRANSPORT BLOCK DIAGRAM	6/4
TAPE TRANSPORT WIRING DIAGRAM	6/5
POWER SUPPLY	1.727.300.00 GRP02/3/4/5/6 ... 6/7
- RECTIFIER	1.727.310.00 GRP06 6/7
TAPE DECK ELECTRONICS	1.727.350.20/21/22 GRP10 6/9
TAPE DECK ELECTRONICS	1.727.350.23 GRP10 6/14
TAPE MOVE SENSOR	1.727.321.00 GRP24 6/19
SPOOLING MOTOR TACHO LEFT	1.727.315.00 GRP17 6/21
SPOOLING MOTOR TACHO RIGHT	1.727.316.00 GRP18 6/21
TAPE TENSION SENSOR	1.727.320.00 GRP13 6/23
SPOOLING MOTOR BLOCK DIAGRAM 6/25
SPOOLING MOTOR CONTROL	1.727.340.20 GRP11 6/27
- SHUTTLE CONTROL	1.727.180.00
- TAPE TENSION ADJUST	1.727.341.00 GRP14
- SPOOLING MOTOR FILTER	1.727.342.00 GRP12
SPOOLING MOTOR CONTROL	1.727.340.21 GRP11 6/31
- SHUTTLE CONTROL	1.727.180.00
- TAPE TENSION ADJUST	1.727.341.00 GRP14
- SPOOLING MOTOR FILTER	1.727.342.00 GRP12
TAPE TENSION ADJUST	1.727.341.00 GRP14 6/35
SHUTTLE CONTROL	1.727.180.00 6/36
SPOOLING MOTOR FILTER	1.727.342.00 GRP12 6/37
CAPSTAN SERVO SYSTEM BLOCK DIAGRAM 6/39
CAPSTAN MOTOR CONTROL	1.727.330.20/21 GRP20 6/41
CAPSTAN MOTOR CONTROL	1.727.330.22 GRP20 6/45
- CAPSTAN START CONTROL	1.727.332.00 6/49
CAPSTAN MOTOR CONTROL	1.727.330.23 GRP20 6/51
CAPSTAN MOTOR CONTROL	1.727.330.24 GRP20 6/55
CAPSTAN MOTOR CONTROL HS	1.727.335.20 GRP20 6/59
COMMAND PANEL (WITHOUT VU-METERS)	1.727.360.00 GRP30 6/63
COMMAND PANEL (1 VU)	1.727.361.00 GRP30 6/65
COMMAND PANEL (2 VU)	1.727.362.00 GRP30 6/69
COMMAND PANEL (2-2)	1.727.363.00 GRP30 6/73
COMMAND PANEL (2 VU, REPRO ONLY)	1.727.364.00 GRP30 6/75
COMMAND PANEL (1 VU, REPRO ONLY)	1.727.365.00 GRP30 6/79
DISPLAY	1.727.370.00 GRP31 6/83

(■ = ELECTROSTATICALLY SENSITIVE ASSEMBLY)

CONTENTS OF DIAGRAM SECTIONS IN NUMERICAL ORDER

	Page	
1.050.340.00	HEAD BLOCK ASSEMBLY	7/5
1.727.120.00	MONITOR INTERNAL	7/25
1.727.180.00	SHUTTLE CONTROL	6/36
1.727.240.00	LINE OUTPUT CONNECTOR	7/32
1.727.241.00	LINE INPUT CONNECTOR	7/33
1.727.242.00	MIC INPUT CONNECTOR	7/34
1.727.300.00	POWER SUPPLY	6/7
1.727.310.00	RECTIFIER	6/7
1.727.315.00	SPOOLING MOTOR TACHO LEFT	6/21
1.727.316.00	SPOOLING MOTOR TACHO RIGHT	6/21
1.727.320.00	TAPE TENSION SENSOR	6/23
1.727.321.00	TAPE MOVE SENSOR	6/19
1.727.330.20/21	CAPSTAN MOTOR CONTROL	6/41
1.727.330.22	CAPSTAN MOTOR CONTROL	6/45
1.727.330.23	CAPSTAN MOTOR CONTROL	6/51
1.727.330.24	CAPSTAN MOTOR CONTROL	6/55
1.727.332.00	CAPSTAN START CONTROL	6/49
1.727.335.20	CAPSTAN MOTOR CONTROL HS	6/59
1.727.340.20	SPOOLING MOTOR CONTROL	6/27
1.727.340.21	SPOOLING MOTOR CONTROL	6/31
1.727.341.00	TAPE TENSION ADJUST	6/35
1.727.342.00	SPOOLING MOTOR FILTER	6/37
1.727.350.20/21/22	TAPE DECK ELECTRONICS	6/9
1.727.350.23	TAPE DECK ELECTRONICS	6/14
1.727.360.00	COMMAND PANEL (WITHOUT VU-METERS)	6/63
1.727.361.00	COMMAND PANEL (1 VU)	6/65
1.727.362.00	COMMAND PANEL (2 VU)	6/69
1.727.363.00	COMMAND PANEL (2-2)	6/73
1.727.364.00	COMMAND PANEL (2 VU, REPRO ONLY)	6/75
1.727.365.00	COMMAND PANEL (1 VU, REPRO ONLY)	6/79
1.727.370.00	DISPLAY	6/83
1.727.400.00	AUDIO CONTROL	7/9
1.727.400.81	AUDIO CONTROL	7/13
1.727.400.82	AUDIO CONTROL	7/17
1.727.401.00	AUDIO CONTROL HS	7/21
1.727.420.00	AUDIO ELECTRONICS (VU)	7/27
1.727.420.81	AUDIO ELECTRONICS (VU)	7/41
1.727.421.00	AUDIO ELECTRONICS (0 VU)	7/49
1.727.421.81	AUDIO ELECTRONICS (0 VU)	7/61
1.727.423.00	AUDIO ELECTRONICS (2-2 WITH CH. SELECTORS ONLY)	7/75
1.727.423.81	AUDIO ELECTRONICS (2-2 WITH CH. SELECTORS ONLY)	7/87
1.727.425.00	AUDIO ELECTRONICS (PBO)	7/95
1.727.425.81	AUDIO ELECTRONICS (PBO)	7/103
1.727.430.00	REPRODUCE PREAMPLIFIER	7/7
1.727.441.00	M/S INPUT AMPLIFIER WITH TEST GENERATOR	7/117
1.727.442.00	M/S OUTPUT AMPLIFIER WITH TEST GENERATOR	7/119
1.727.443.00	M/S ADJUSTMENT WITH TEST GENERATOR	7/121
1.727.451.00	M/S INPUT AMPLIFIER	7/123
1.727.452.00	M/S OUTPUT AMPLIFIER	7/125
1.727.453.00	M/S ADJUSTMENT	7/127
1.727.454.00	M/S ADJUSTMENT PBO	7/128
1.727.460.00	AUDIO ELECTRONICS (VU)	7/35
1.727.460.81	AUDIO ELECTRONICS (VU)	7/41
1.727.461.00	AUDIO ELECTRONICS (0 VU)	7/55
1.727.461.81	AUDIO ELECTRONICS (0 VU)	7/61
1.727.462.81	AUDIO ELECTRONICS VUK (2 VU)	7/69
1.727.463.00	AUDIO ELECTRONICS (2-2 WITH CH. SELECTORS ONLY)	7/81
1.727.463.81	AUDIO ELECTRONICS (2-2 WITH CH. SELECTORS ONLY)	7/87
1.727.465.00	AUDIO ELECTRONICS (PBO)	7/99
1.727.465.81	AUDIO ELECTRONICS (PBO)	7/103
1.727.467.00	AUDIO ELECTRONICS VUK (2 VU/HS)	7/109
1.727.910.00	CONSOLE MONITOR	7/131
1.727.910.81	CONSOLE MONITOR	7/135
1.727.925.00	VU PANEL (2 VU)	7/139
1.727.935.00	VU PANEL (1 VU)	7/143
1.727.965.00	MONITOR WITH VU-METERS (STEREO)	7/149
1.727.966.00	LS AMPLIFIER (STEREO)	7/153

TAPE TRANSPORT LOGIC BLOCK DIAGRAM

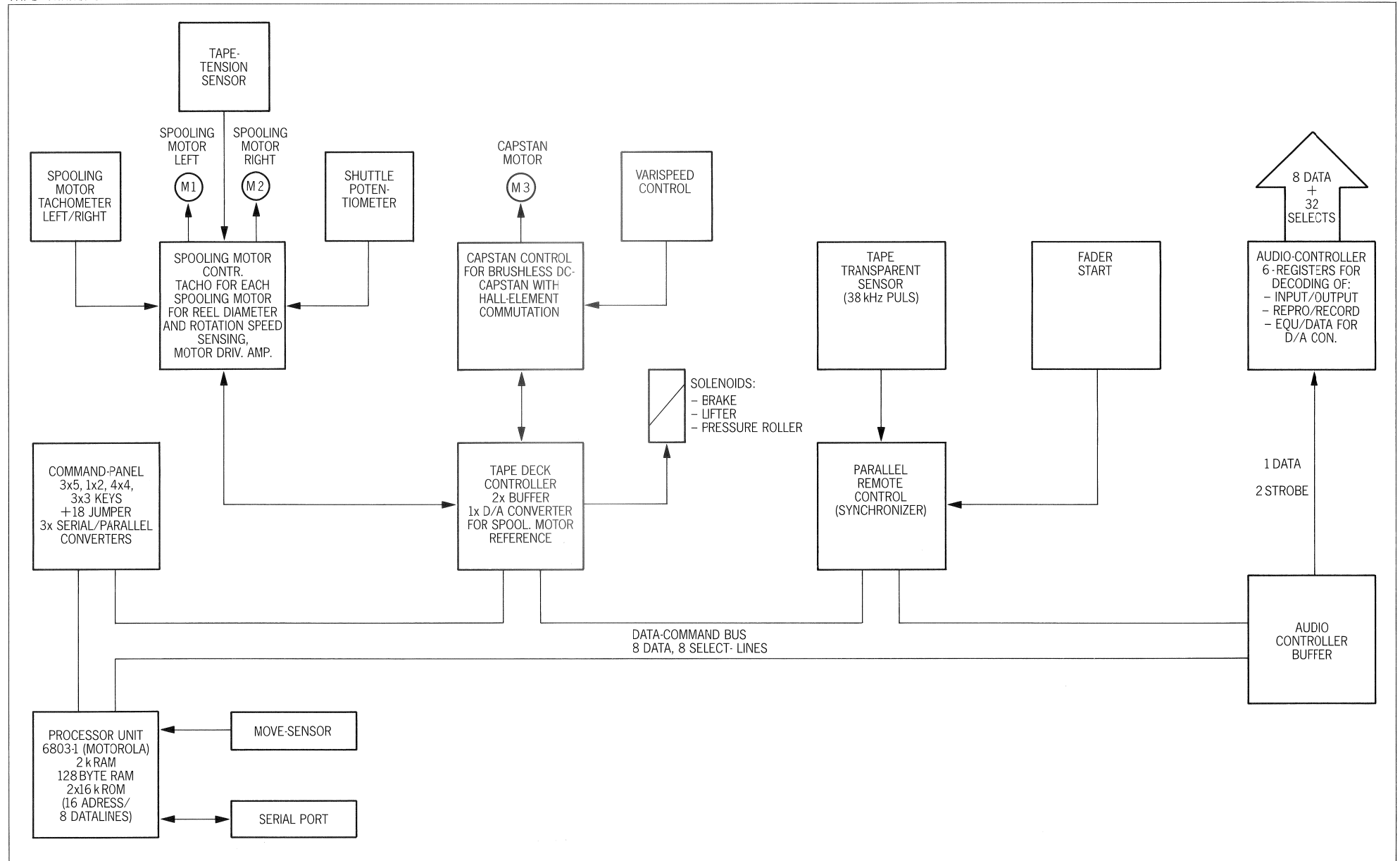

TAPE TRANSPORT BLOCK DIAGRAM

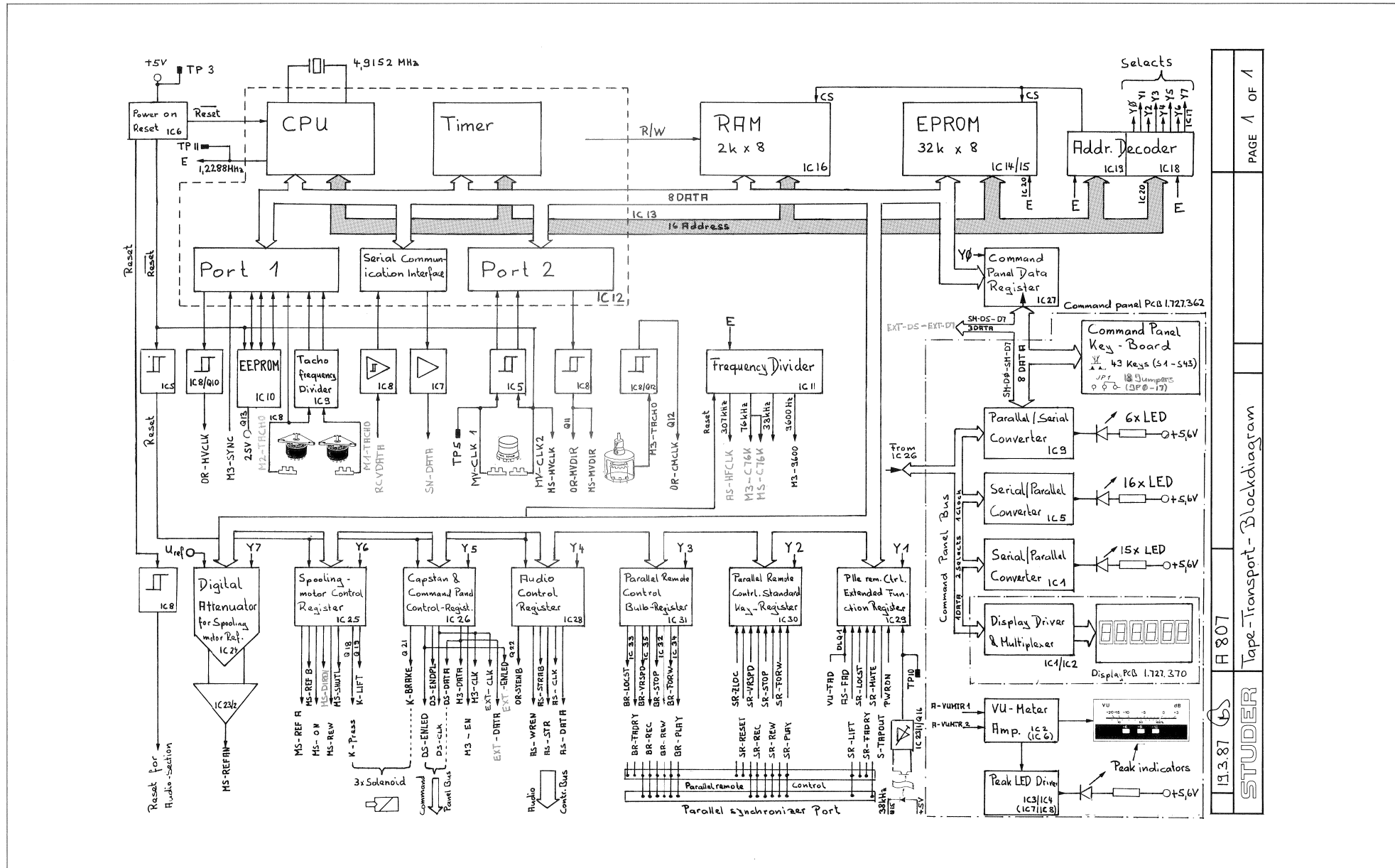

TAPE TRANSPORT WIRING DIAGRAM

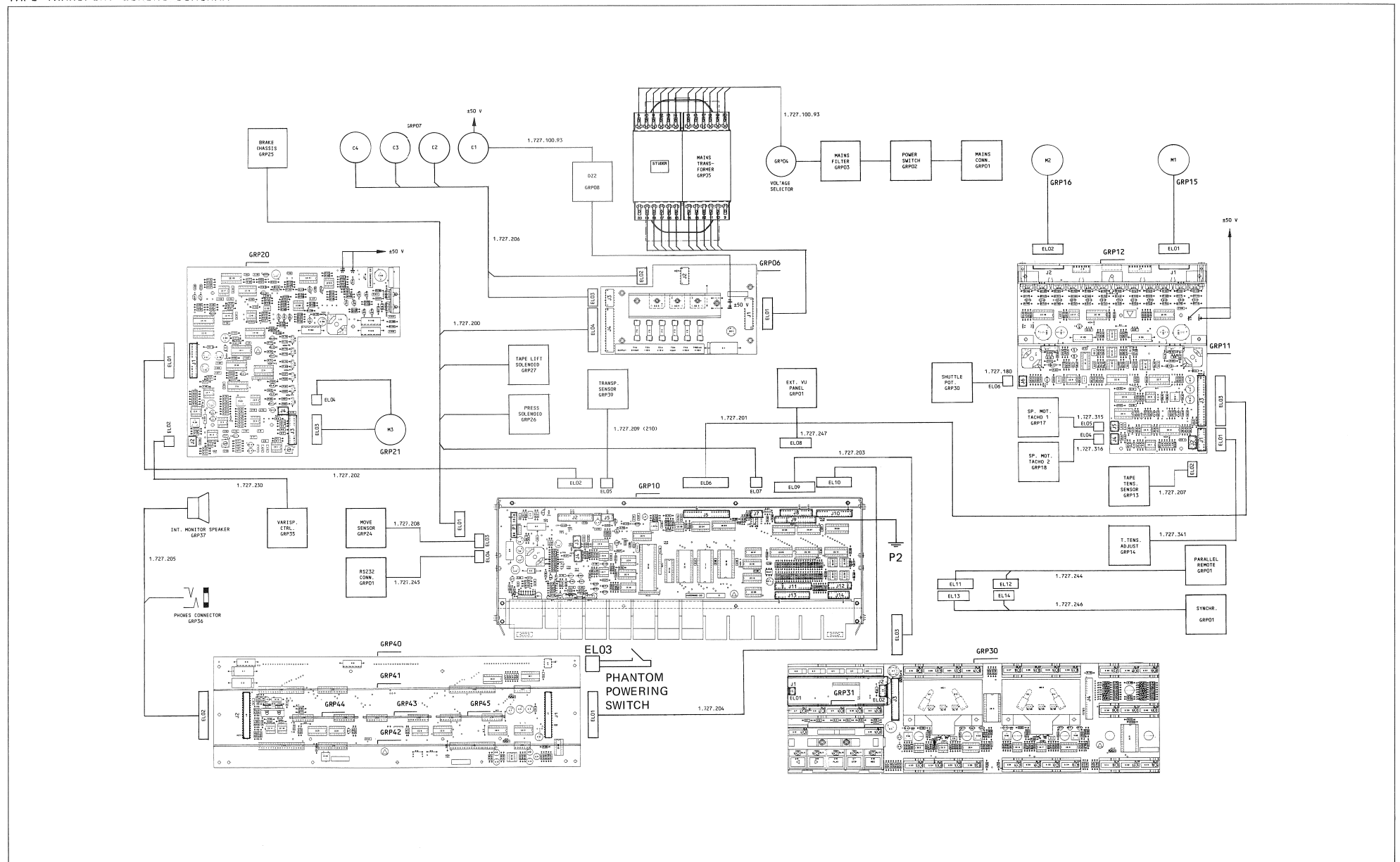

POWER SUPPLY 1.727.300.00 GRP2/3/4/5/6
- RECTIFIER 1.727.310.00 GRP6

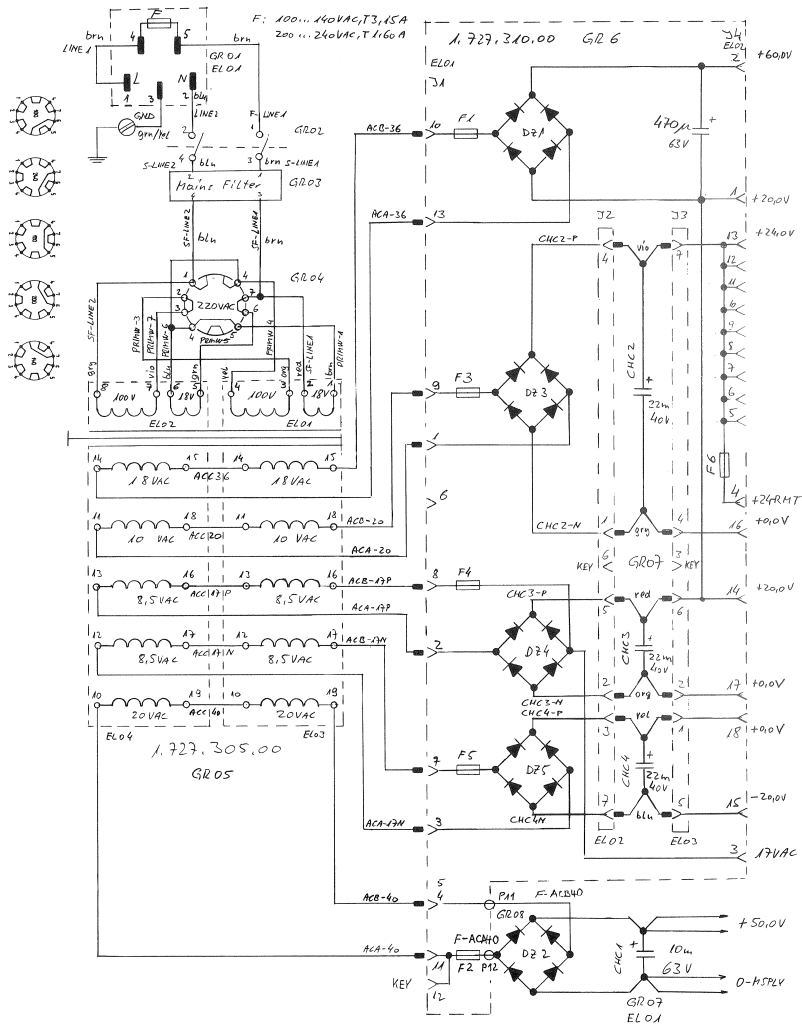

04.11.86	WM.				
A 807 GR 2/3/4/5/6		PAGE 1 OF 1			
STUDER	POWER SUPPLY	1.727.300.00			

POWER SUPPLY 1.727.300.00 GRP2/3/4/5/6

RECTIFIER 1.727.310.00 GRP6

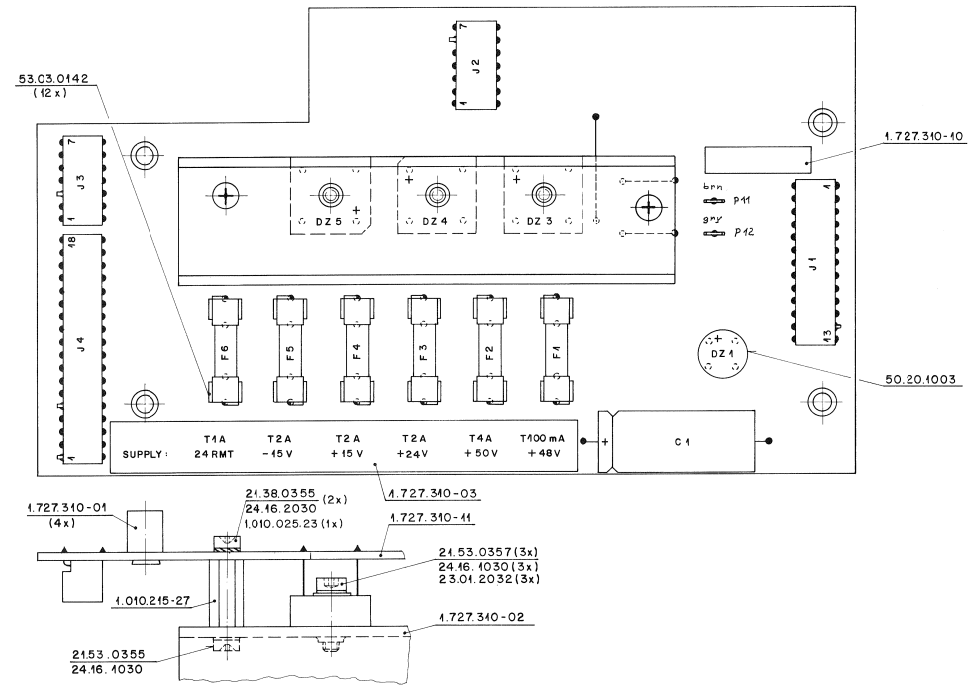
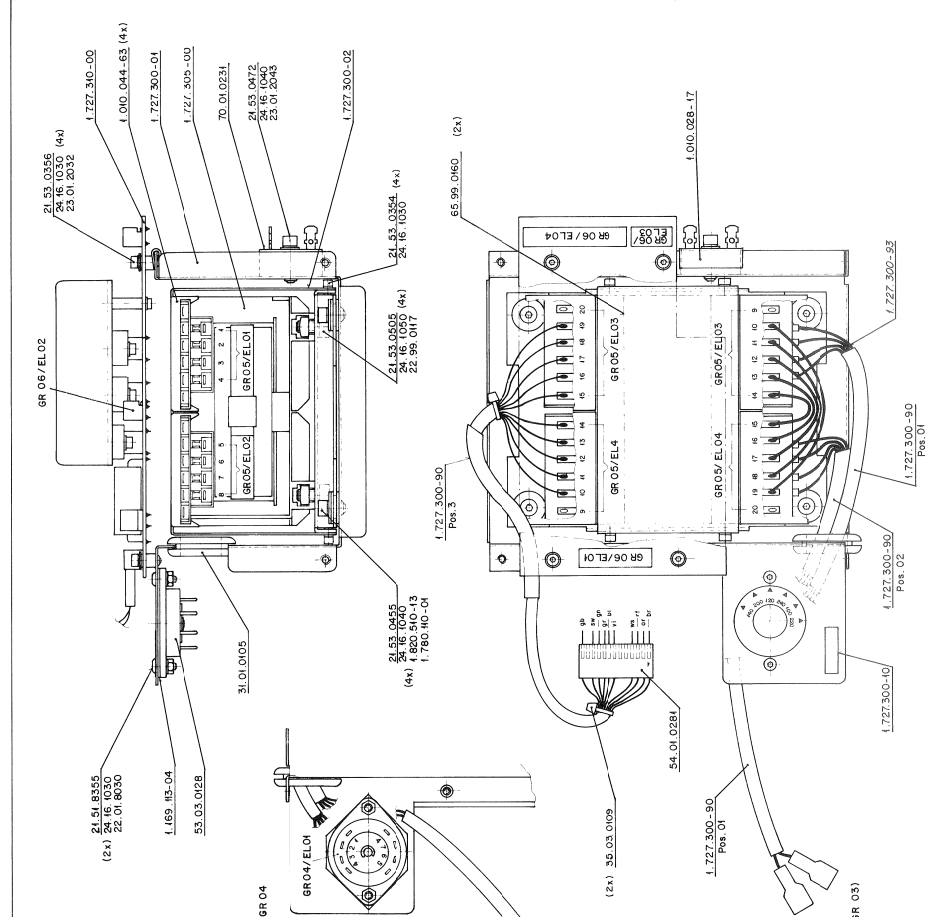

IND.	POS.-NO.	PART NO.	VALUE	SPECIFICATIONS / EQUIVALENT	MANUF.
A.....		1.727.310-00		Rectifier board	GRP6 St
CHE.....		59-26-7103	10 MF	-10% 63 V EL	GR07+ Note 1
CHE.....		59-26-0233	22 MF	-10% 40 V EL	GR07+ Note 1
CHE.....		59-26-0223	22 MF	-10% 40 V EL	GR07+ Note 1
CHE.....		59-26-0233	22 MF	-10% 40 V EL	GR07+ Note 1
DZ.....		70-01-0231		Bridge Rect. 100V 35A	GR8
F.....		89-01-0304		Mains filter. 1EG 65 cl.2	GR03+ Note 1
S.....		55-13-0001		Mains switch	GR02+ Note 1
S.....		53-03-0128		Voltage selector	GR04
P.....		54-42-0003		Mains connector	GR01+ Note 1
T.....		1.727.305-00		Mains transformer	GR05 St

Note 1: In Assembly 1.727.300 not included
 EL=Electrolytic; SI=Silicon
 MANUFACTURER: St=Studer
 ORIG 86/12/03
 S T U D E R (00) 86/12/03 MEN POWER SUPPLY 1.727.300.00 PAGE 1

IND.	POS.-NO.	PART NO.	VALUE	SPECIFICATIONS / EQUIVALENT	MANUF.
C.....		59-25-0471	470 uF	-10% 63 V EL	
DZ.....		70-01-0223		Bridge Rect. 250V 0.5A SI	
DZ.....		70-01-0227		not used	
DZ.....		70-01-0230		Bridge Rect. 250V 2 A SI	
DZ.....		70-01-0230		Bridge Rect. 35V 2 A SI	
F.....		51-01-0307	T100MA	Fuses 5 x 20	
F.....		51-01-0303	T 1 A	Fuses 5 x 20	
F.....		51-01-0320	T 2 A	Fuses 5 x 20	
F.....		51-01-0320	T 2 A	Fuses 5 x 20	
F.....		51-01-0320	T 2 A	Fuses 5 x 20	
F.....		51-01-0317	T 3 A	Fuses 5 x 20	
J.....		54-01-0309	13 Pol	C15 Socket Strip	AMP
J.....		54-01-0244	7 Pol	C15 Socket Strip	AMP
J.....		54-01-0244	7 Pol	C15 Socket Strip	AMP
J.....		54-01-0247	18 Pol	C15 Socket Strip	AMP
MP.....		1.727.310-11	1 PCS	Rectifier PCB	St
MP.....		53-03-0182	12 PCS	Fuse holder	St
MP.....		1.727.310-01	4 PCS	Rivet tube	St
MP.....		1.727.310-02	1 PCS	Heat sink	St
MP.....		1.010.215-27	1 PCS	Nut bolt	St
MP.....		21-38-0355	2 PCS	Screw M3 x 8	
MP.....		24-16-2030	1 PCS	Flat washer	
MP.....		21-38-0357	3 PCS	Screw M3 x 12	
MP.....		23-01-2032	3 PCS	Flat washer	
MP.....		24-16-2030	4 PCS	Lock washer	
MP.....		1.727.310-03	1 PCS	Shield	St
MP.....		1.727.310-10	1 PCS	Not Label	St
MP.....		50-20-1003	1 PCS	Transistor support	
F.....		54-02-0320	2-890-B	Flat Pin	AMP
F.....		54-02-0320	2-890-B	Flat Pin	AMP

S T U D E R (00) 86/08/08 MEN RECTIFIER BOARD 1.727.310.00 PAGE 1 S T U D E R (00) 86/08/08 MEN RECTIFIER BOARD 1.727.310-00 PAGE 2



TAPE DECK ELECTRONICS 1.727.350.20/21/22 GRP10

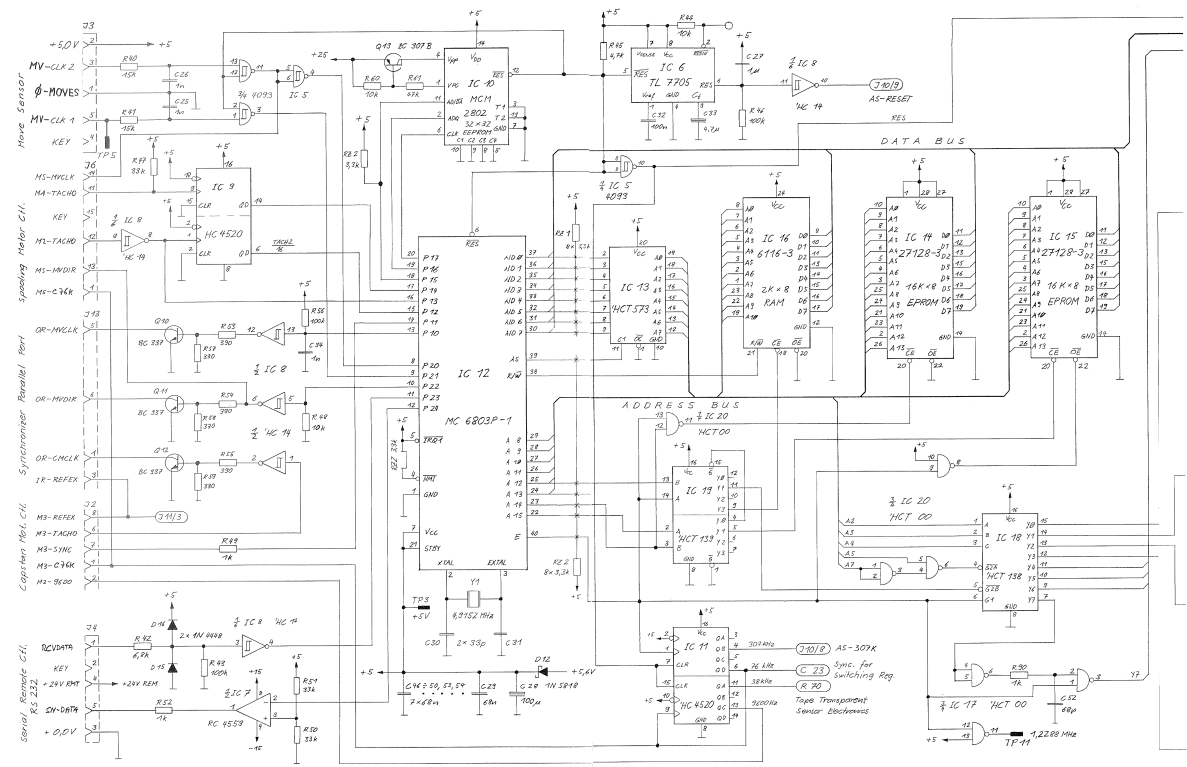
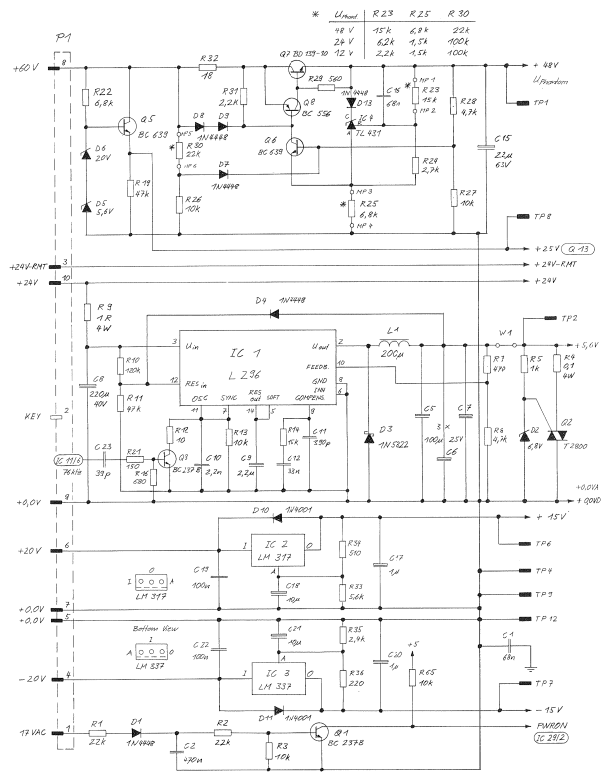

5.9.86 Rev	13.10.86 WH	10.11.86 Rev	9.2.87 EP	
A 807 GR 10		PAGE 3 OF 5		
STUDER Tape Deck Electronics		SC	1.727.350.22	



TAPE DECK ELECTRONICS 1.727.350.20/21/22 GRP10

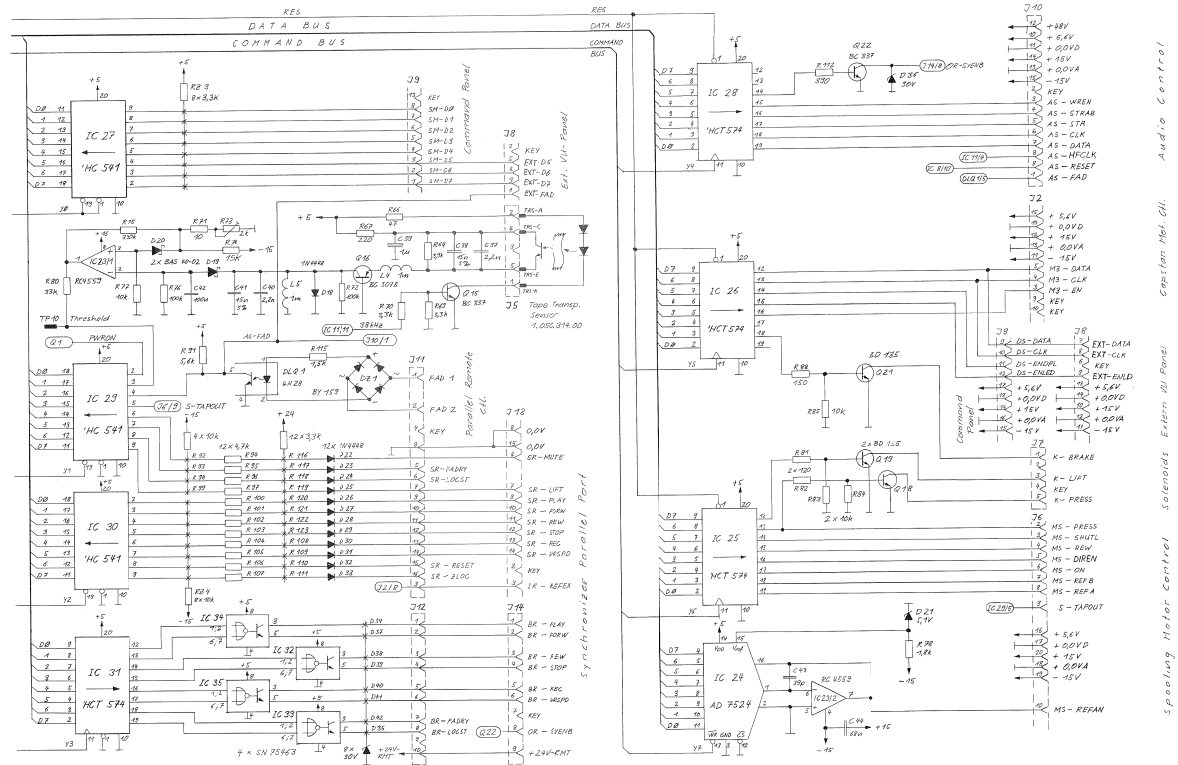

① 5.9.86	REV	② 13.10.76	WJK	③ 10.11.86	REC	④ 9.2.87	GP	...
STUDER								...
Tape Deck Electronics								...
SC								...
1.727.350.20								...

TAPE DECK ELECTRONICS 1.727.350.20 GRP10

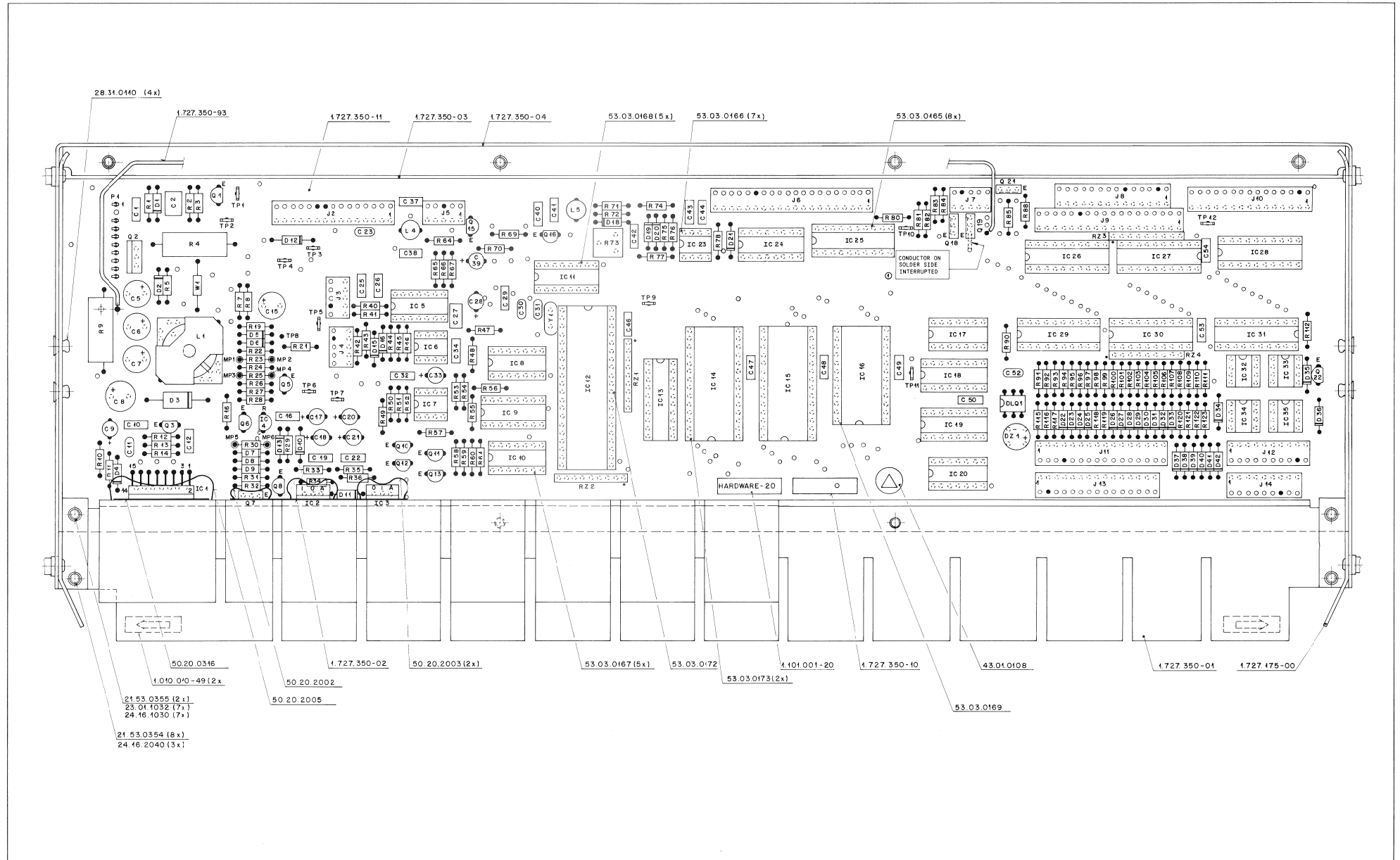

TAPE DECK ELECTRONICS 1.727.350.20/21/22 GRP10

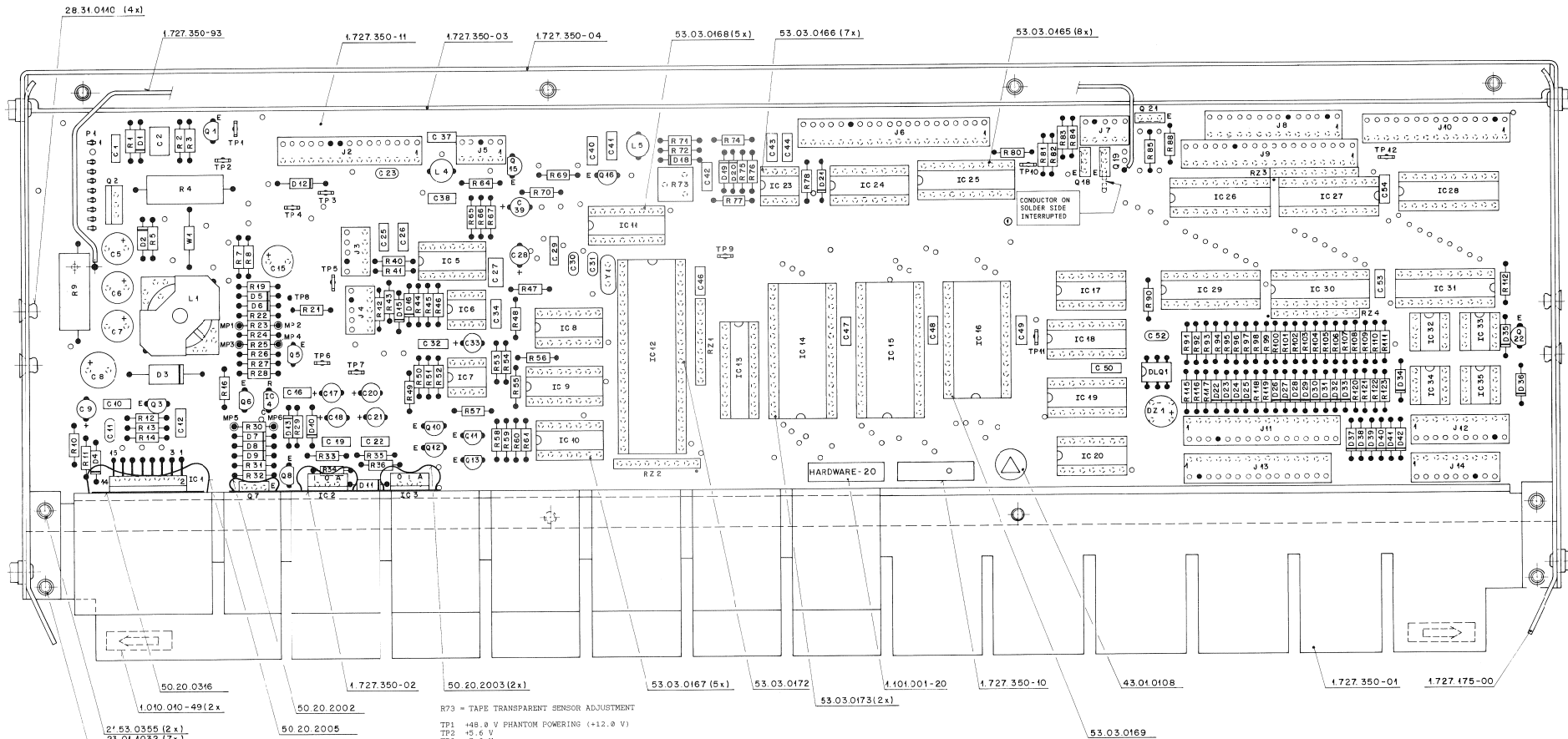

- 21 53.0355 (2x)
- 23.01.1032 (7x)
- 24.16.1030 (7x)
- 21 53.0354 (8x)
- 24.16.2040 (3x)

- R79 = TAPE TRANSPARENT SENSOR ADJUSTMENT
- TP1 +48.0 V PHANTOM POWERING (+12.0 V)
- TP2 +5.6 V
- TP3 +5.0 V
- TP4 0.0 V
- TP5 NOVS. SENSOR CLOCK
- TP6 -15.0 V
- TP7 -15.0 V
- TP8 +25.0 V
- TP9 0.0 V
- TP10 TAPE TRANSPARENT SENSOR (H-TRANS. / L-TAPE)
- TP11 PROCESSOR CLOCK (f=1.2288 MHz)
- TP12 0.0 V



TAPE DECK ELECTRONICS 1.727.350.20/21/22 GRP10

Table with 12 columns: IND., POS.NO., PART NO., VALUE, SPECIFICATIONS / EQUIVALENT, MANUF., and a blank column. It contains multiple rows of component data for a tape deck, including resistors, capacitors, and integrated circuits.

S T U D E R (05) 87/09/23 MHN TAPE DECK ELECTRONICS 1.727.350.20 PAGE 1 S T U D E R (05) 87/09/23 MHN TAPE DECK ELECTRONICS 1.727.350.20 PAGE 4 S T U D E R (05) 87/09/23 MHN TAPE DECK ELECTRONICS 1.727.350.20 PAGE 7 S T U D E R (05) 87/09/23 MHN TAPE DECK ELECTRONICS 1.727.350.20 PAGE 10

Table with 12 columns: IND., POS.NO., PART NO., VALUE, SPECIFICATIONS / EQUIVALENT, MANUF., and a blank column. This section continues the component list from the previous page, including various electronic components and their specifications.

S T U D E R (05) 87/09/23 MHN TAPE DECK ELECTRONICS 1.727.350.20 PAGE 2 S T U D E R (05) 87/09/23 MHN TAPE DECK ELECTRONICS 1.727.350.20 PAGE 5 S T U D E R (05) 87/09/23 MHN TAPE DECK ELECTRONICS 1.727.350.20 PAGE 8 S T U D E R (05) 87/09/23 MHN TAPE DECK ELECTRONICS 1.727.350.20 PAGE 11

Table with 12 columns: IND., POS.NO., PART NO., VALUE, SPECIFICATIONS / EQUIVALENT, MANUF., and a blank column. This section contains the final part of the component list, including various electronic components and their specifications.

S T U D E R (05) 87/09/23 MHN TAPE DECK ELECTRONICS 1.727.350.20 PAGE 3 S T U D E R (05) 87/09/23 MHN TAPE DECK ELECTRONICS 1.727.350.20 PAGE 6 S T U D E R (05) 87/09/23 MHN TAPE DECK ELECTRONICS 1.727.350.20 PAGE 9

TAPE DECK ELECTRONICS 1.727.350.23 GRP10

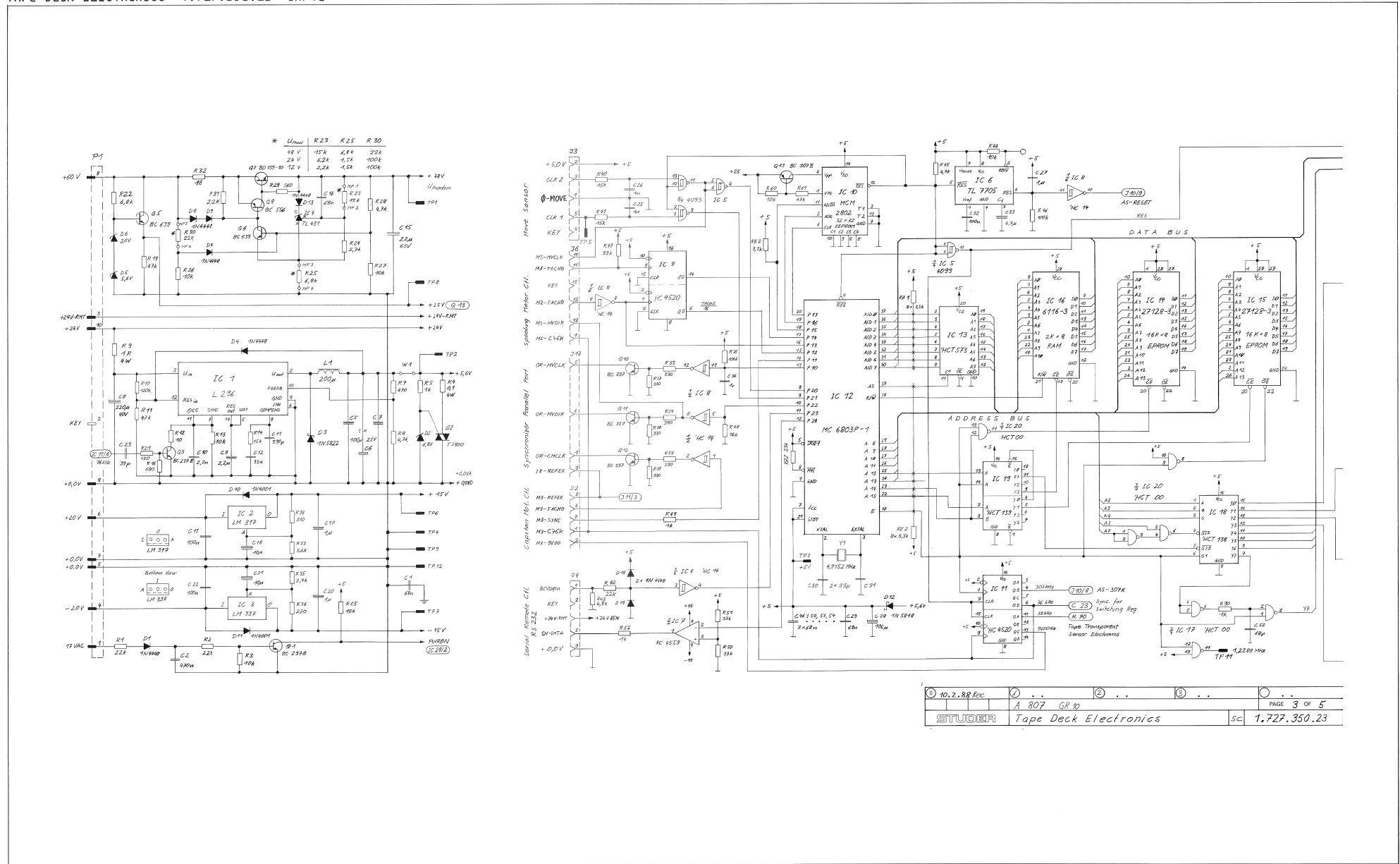

TAPE DECK ELECTRONICS 1.727.350.23 GRP10

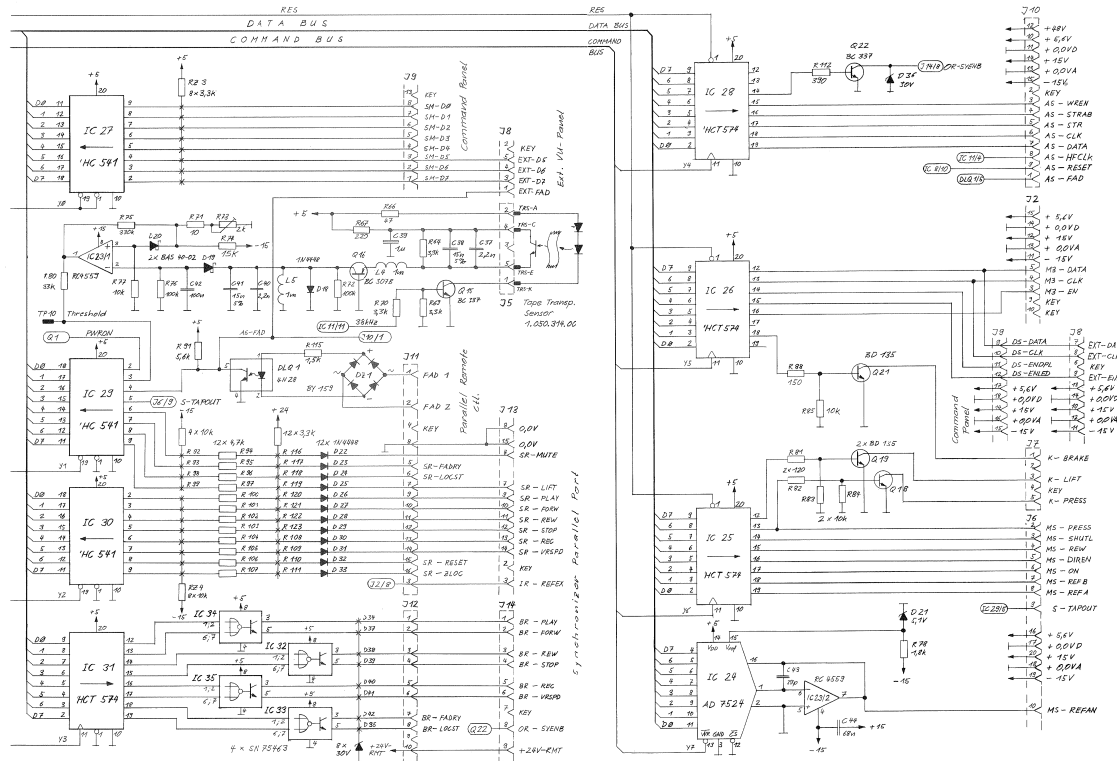

Audio Control
 Cassette Motor, Clk.
 Solenoids
 External Panel
 Speeding Motor Control

10.12.88	Pac	A 807 GR 10	PAGE 5 OF 5
STUDER	Tape Deck Electronics		SC 1.727.350.23



TAPE DECK ELECTRONICS 1.727.350.23 GRP10

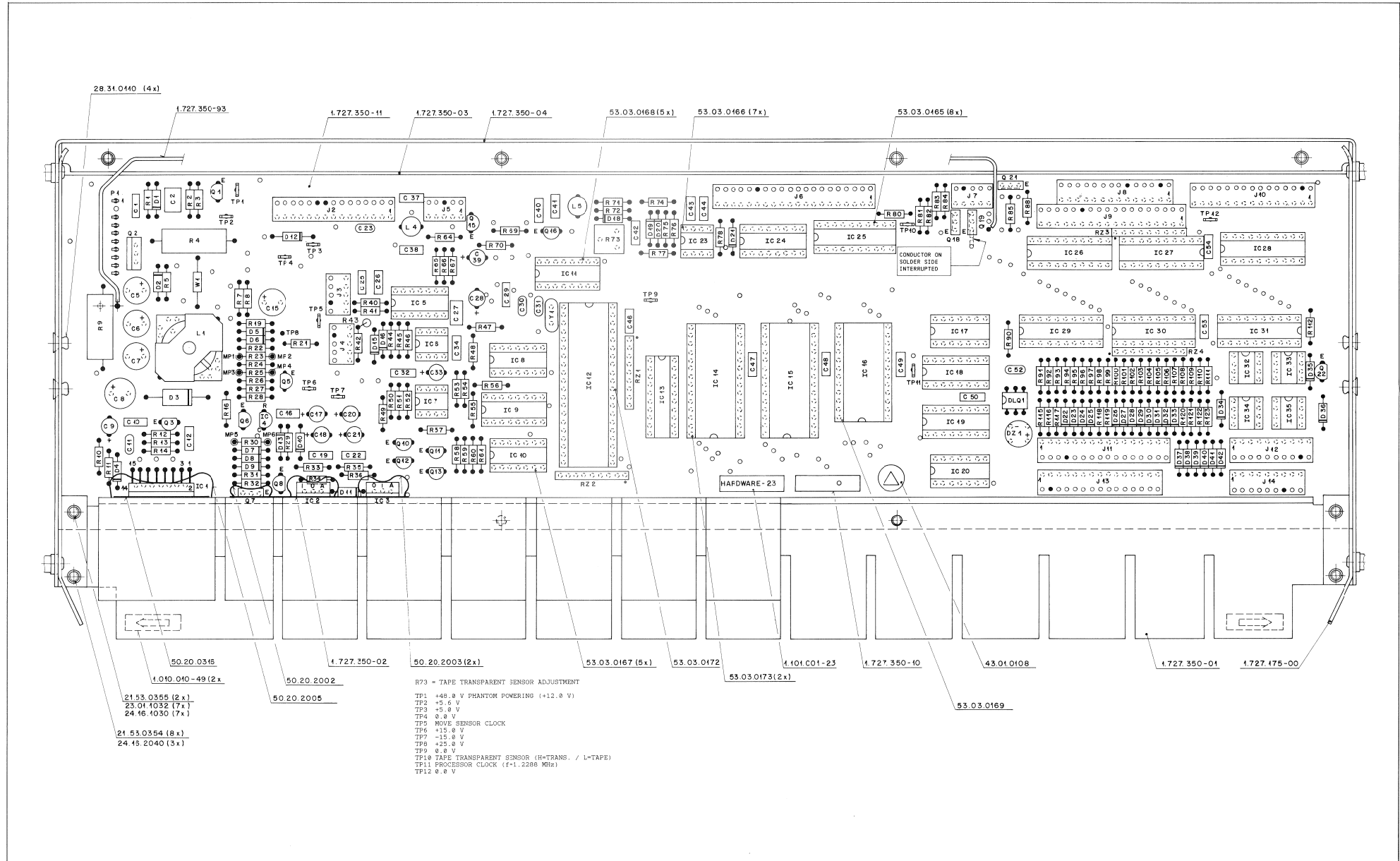

TAPE MOVE SENSOR 1.727.321.00 GRP24

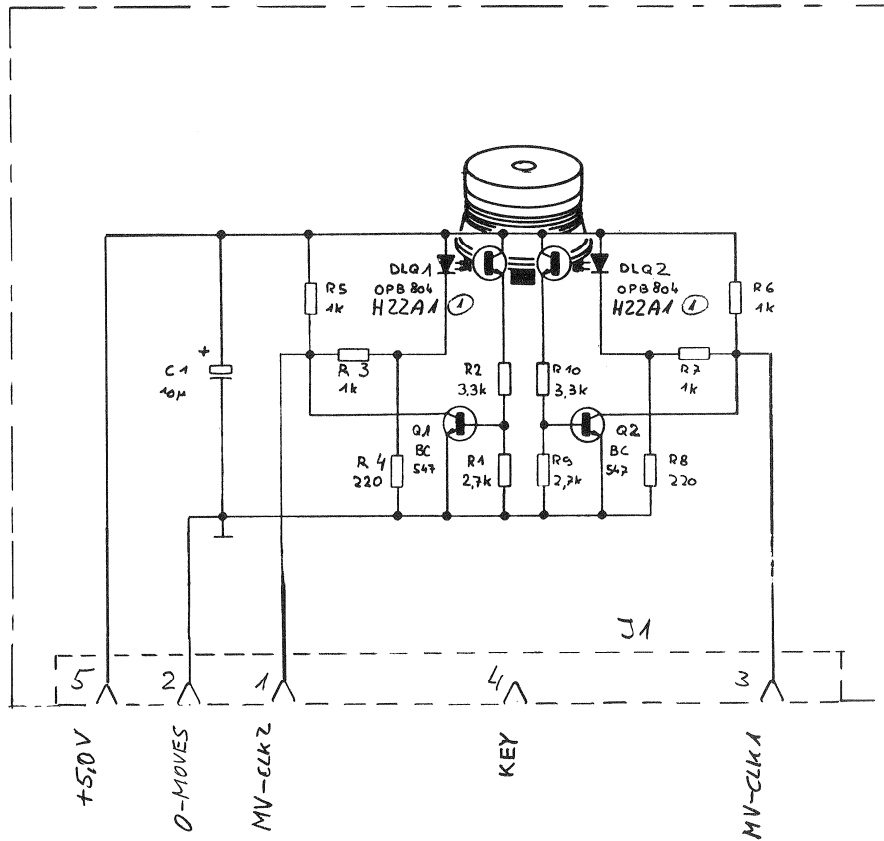

① 18.8.86 W.H.	② 13.11.87 W.H.	○ ..	○ ..	○ ..
A 807 GR24				PAGE 1 OF 1
STUDER		Move Sensor Board		1.727.321.00

TAPE MOVE SENSOR 1.727.321.00 GRP24

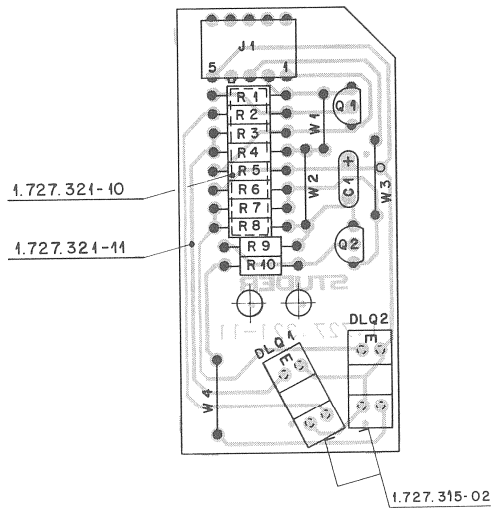

IND.	POS.ND.	PART NO.	VALUE	SPECIFICATIONS / EQUIVALENT	MANUF.	IND.	POS.ND.	PART NO.	VALUE	SPECIFICATIONS / EQUIVALENT	MANUF.
	C.....1	59.26.2100	10 uF	20%, 16V, Sal	Ph						
{00}	DLQ...1	50.04.2128	DP9804		Op						
{01}	DLQ...1	50.04.2128	H22 A1		GE						
{00}	DLQ...2	50.04.2128	DP9804		Op						
{01}	DLQ...2	50.04.2128	H22 A1		GE						
J.....1	54.01.0305	5 Pol		CIS Par.							
MP...1	1.727.321.11	1 pce		Move Sensor PCB	St						
MP...2	1.727.371.10	1 pce		Not Label	St						
{01}	MP...3	1.727.315.02	4 pce	Spacer	St						
Q.....1	50.03.0436	BC237B		BC547B; BC550B	ITT;Mot;Ph;Sie;If						
Q.....2	50.03.0436	BC237B		BC547B; BC550B	ITT;Mot;Ph;Sie;If						
R.....1	57.11.4272	2.7 kOhm		2%, 0.25W, MF							
R.....2	57.11.4332	3.3 kOhm		2%, 0.25W, MF							
R.....3	57.11.4102	1 kOhm		2%, 0.25W, MF							
R.....4	57.11.4221	220 Ohm		2%, 0.25W, MF							
R.....5	57.11.4102	1 kOhm		2%, 0.25W, MF							
R.....6	57.11.4102	1 kOhm		2%, 0.25W, MF							
R.....7	57.11.4102	1 kOhm		2%, 0.25W, MF							
R.....8	57.11.4221	220 Ohm		2%, 0.25W, MF							
R.....9	57.11.4272	2.7 kOhm		2%, 0.25W, MF							
R.....10	57.11.4332	3.3 kOhm		2%, 0.25W, MF							
W.....1	64.01.0106			Wire Bridge							
W.....2	64.01.0106			Wire Bridge							
W.....3	64.01.0106			Wire Bridge							
W.....4	64.01.0106			Wire Bridge							

ORIG 05/08/08 (01) 07/11/13

SPOOLING MOTOR TACHO LEFT 1.727.315.00 GRP17
 SPOOLING MOTOR TACHO RIGHT 1.727.316.00 GRP18

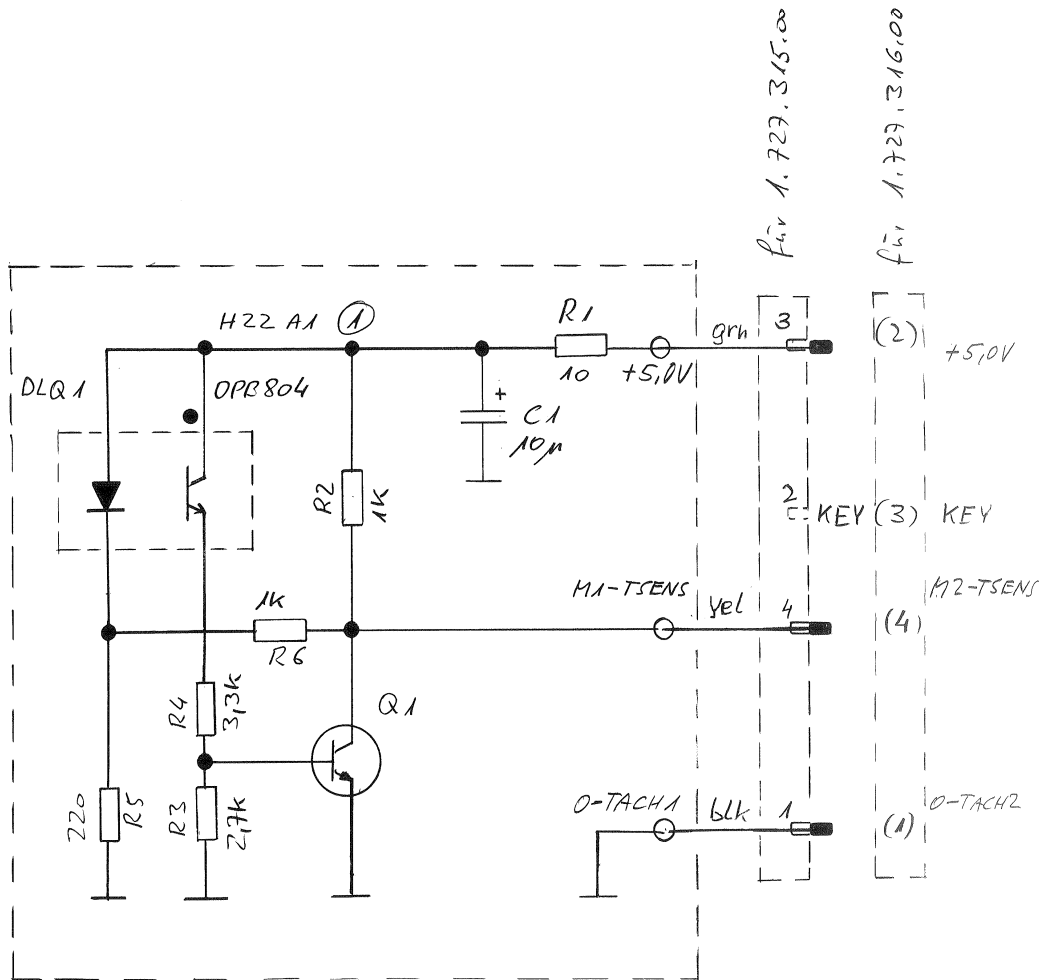

① 04.11.86 Wth	① 13.11.87 Wth	○ ..	○ ..	○ ..
	A 807			PAGE 1 OF 1
STUDIER	SPOOLING MOTOR TACHO LEFT		1.727.315.00	
	RIGHT		1.727.316.00	

SPOOLING MOTOR TACHO LEFT 1.727.315.00 GRP17
 SPOOLING MOTOR TACHO RIGHT 1.727.316.00 GRP18

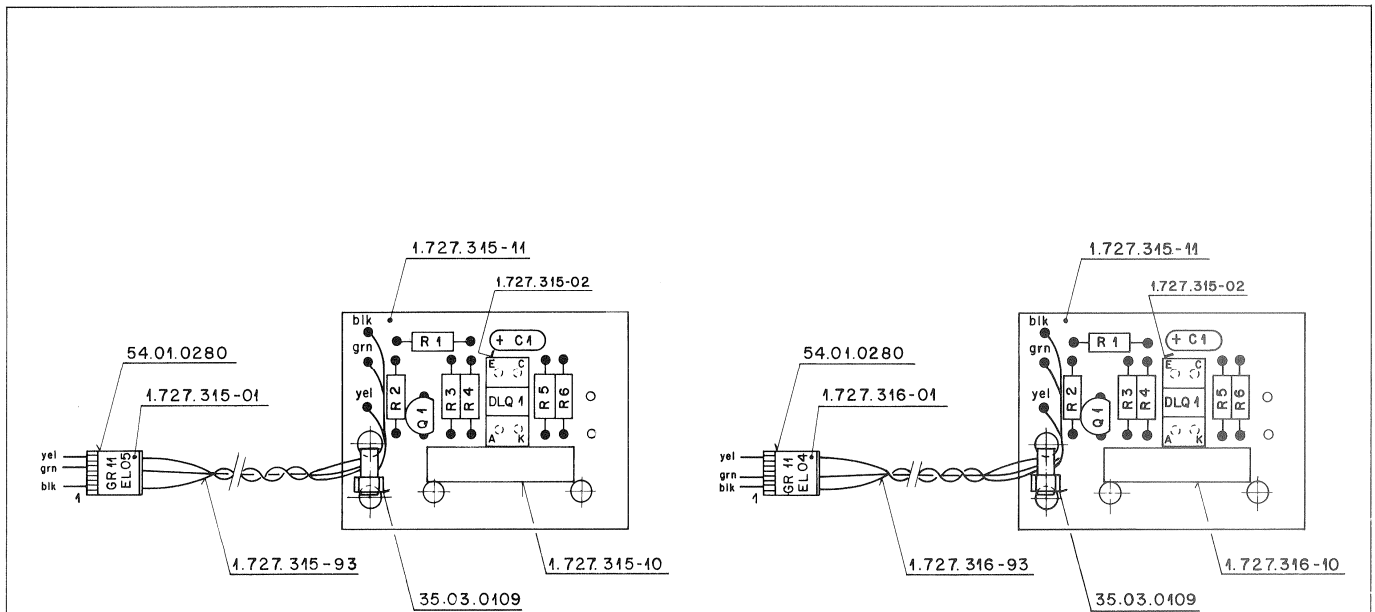

IND.	POS.ND.	PART NO.	VALUE	SPECIFICATIONS / EQUIVALENT	MANUF.
	C.....1	59*26*2100	10 uF	20%, 16V, Sa1	Ph
(00)	DLQ...1	50*04*2128	OPB804		Op
(01)	DLQ...1	50*04*2128	H22 A1		GE
	MP....1	1.727.315.11	1 pce	Sp.Motor Tacho PCB	St
	MP....2	1.727.315.93	1 pce	L-LS1 Sp.Motor Tacho:left	St
	MP....3	54.01.0280	1 pce	CIS Case, 4 Pol	AMP
	MP....4	1.727.315.10	1 pce	No. Label	St
	MP....5	1.727.315.01	1 pce	Label, GR 11 EL 05	St
(01)	MP....6	1.727.315.02	1 pce	Spacer	St
	Q.....1	50*03*0436	BC237B	BC547B, BC550B	ITT*Mo*Ph*Sie*Tf
	R.....1	57*11*4100	10 Ohm	2%, 0.25W, MF	
	R.....2	57*11*4102	1 kOhm	2%, 0.25W, MF	
	R.....3	57*11*4272	2.7 kOhm	2%, 0.25W, MF	
	R.....4	57*11*4332	3.3 kOhm	2%, 0.25W, MF	
	R.....5	57*11*4221	220 Ohm	2%, 0.25W, MF	
	R.....6	57*11*4102	1 kOhm	2%, 0.25W, MF	

(01) Type change

Sa1=Solid aluminium

MANUFACTURER: ITT=Intermetall, Mot=Motorola, Op=Optron, Ph=Philips, Sie=Siemens, Tf=Telefunken, St=Studer

ORIG 85/08/08 (01) 87/11/13

S T U D E R (01) 87/11/13 Wch SP.MOTOR TACHO BOARD*LEFT 1.727.315.00 PAGE 1

IND.	POS.ND.	PART NO.	VALUE	SPECIFICATIONS / EQUIVALENT	MANUF.
	C.....1	59*26*2100	10 uF	20%, 16V, Sa1	Ph
(00)	DLQ...1	50*04*2128	OPB804		Op
(01)	DLQ...1	50*04*2128	H22 A1		GE
	MP....1	1.727.315.11	1 pce	Sp.Motor Tacho PCB	St
	MP....2	1.727.316.93	1 pce	L-LS1 Sp.Motor Tacho:right	St
	MP....3	54.01.0280	1 pce	CIS Case, 4 Pol	AMP
	MP....4	1.727.316.10	1 pce	No. Label	St
	MP....5	1.727.316.01	1 pce	Label, GR 11 EL 04	St
(01)	MP....6	1.727.315.02	1 pce	Spacer	St
	Q.....1	50*03*0436	BC237B	BC547B, BC550B	ITT*Mo*Ph*Sie*Tf
	R.....1	57*11*4100	10 Ohm	2%, 0.25W, MF	
	R.....2	57*11*4102	1 kOhm	2%, 0.25W, MF	
	R.....3	57*11*4272	2.7 kOhm	2%, 0.25W, MF	
	R.....4	57*11*4332	3.3 kOhm	2%, 0.25W, MF	
	R.....5	57*11*4221	220 Ohm	2%, 0.25W, MF	
	R.....6	57*11*4102	1 kOhm	2%, 0.25W, MF	

(01) Type change

Sa1=Solid aluminium

MANUFACTURER: ITT=Intermetall, Mot=Motorola, Op=Optron, Ph=Philips, Sie=Siemens, Tf=Telefunken, St=Studer

ORIG 86/08/08 (01) 87/11/13

S T U D E R (01) 87/11/13 Wch SP.MOTOR TACHO BOARD*RIGHT 1.727.316.00 PAGE 1



TAPE TENSION SENSOR 1.727.320.00 GRP13

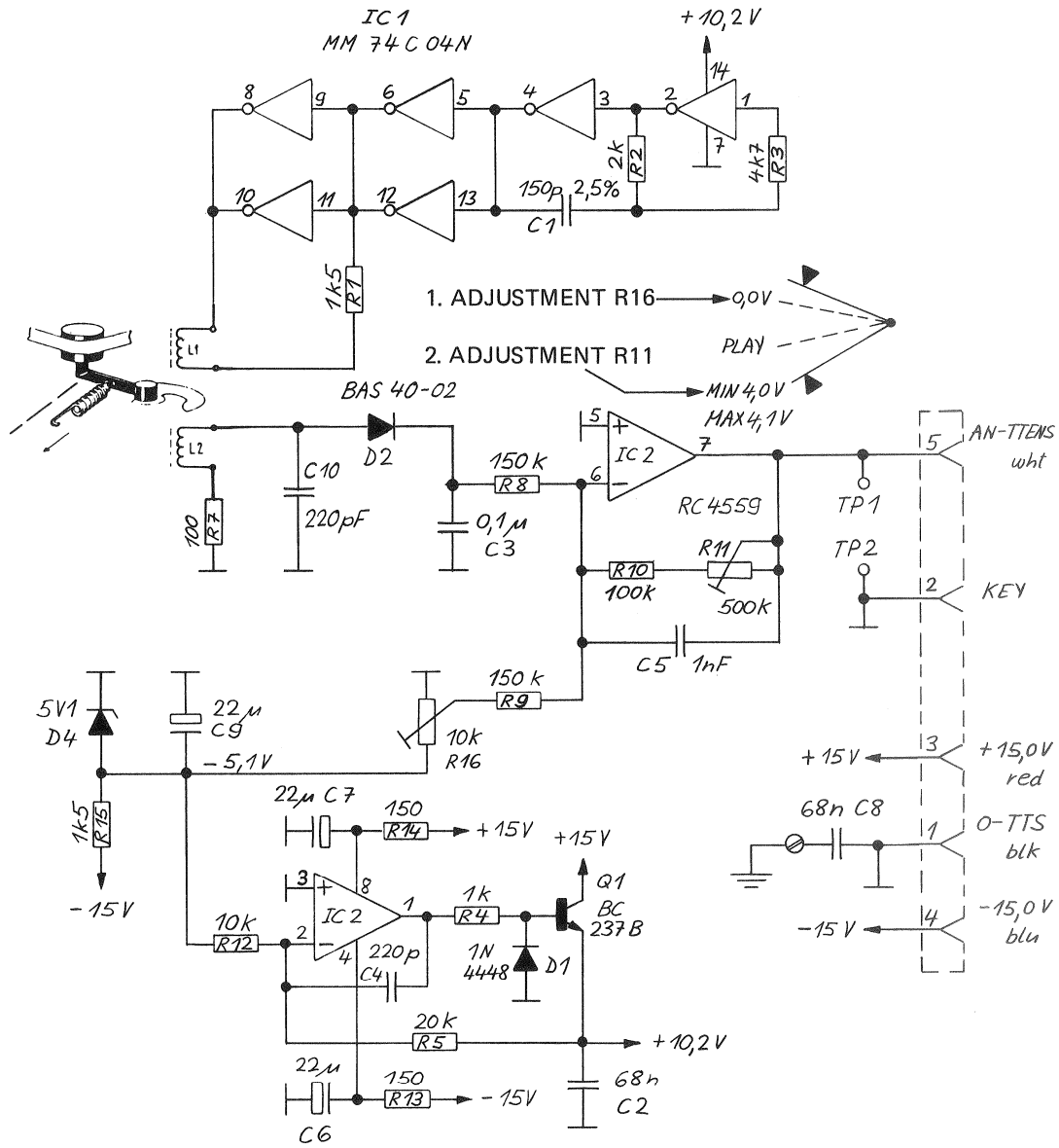

TP1=TAPE TENSION CONTROL VOLTAGE (+4V-0V)
TP2=0V

① 20.11.85 GP	① 29.10.86 GP	○ ..	○ ..	○ ..
	A 807 GR13			PAGE 1 OF 1
STUDER	TAPE TENSION SENSOR BOARD	SC	1.727.320.00	

TAPE TENSION SENSOR 1.727.320.00 GRP13

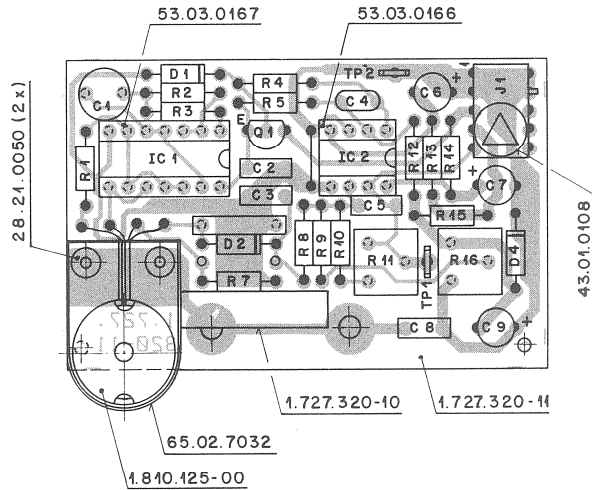

IND.	POS.-NO.	PART NO.	VALUE	SPECIFICATIONS / EQUIVALENT	MANUF.	IND.	POS.-NO.	PART NO.	VALUE	SPECIFICATIONS / EQUIVALENT	MANUF.
	C.....1	59.05.2151	150 pF	2.5%, 50V, PP		(00)	R.....6	57.11.4472	4.7 kOhm	2%, 0.25W, MF	
	C.....2	59.06.0683	68 nF	10%, 50V, PETP		(01)	R.....6		not used		
	C.....3	59.06.0104	0.1 uF	10%, 50V, PETP		(00)	R.....7	57.11.4472	4.7 kOhm	2%, 0.25W, MF	
	C.....4	59.32.1221	220 pF	10%, 50V, Cor		(01)	R.....7	57.11.4101	100 Ohm	2%, 0.25W, MF	
	C.....5	59.06.0102	1 nF	10%, 50V, PETP		(00)	R.....8	57.11.4223	22 kOhm	2%, 0.25W, MF	
	C.....6	59.22.5220	22 uF	-20%, 25V, E1		(01)	R.....8	57.11.4154	150 kOhm	2%, 0.25W, MF	
	C.....7	59.22.5220	22 uF	-20%, 25V, E1		R.....9	57.11.4154	150 kOhm	2%, 0.25W, MF		
	C.....8	59.06.0683	68 nF	10%, 50V, PETP		K.....10	57.11.4104	100 kOhm	2%, 0.25W, MF		
	C.....9	59.22.5220	22 uF	-20%, 25V, EL		R.....11	58.01.8504	500 kOhm	10%, 0.5 W, PCerm		
(01)	C.....10	59.11.6221	220 pF	5%, 50V, PC		R.....12	57.11.4103	10 kOhm	2%, 0.25W, MF		
	D.....1	50.04.0125	1N4448	50V, SI		R.....13	57.11.4151	150 Ohm	2%, 0.25W, MF		
	D.....2	50.04.0127	BAS 40-02	BAT 42, 9AT B5		R.....14	57.11.4151	150 Ohm	2%, 0.25W, MF		
(00)	D.....3	50.04.0127	BAS 40-02	BAT 42, BAT B5		R.....15	57.11.4152	1.5 kOhm	2%, 0.25W, MF		
(01)	D.....3		not used			R.....16	58.01.8103	10 kOhm	10%, 0.5 W, PCerm		
	D.....4	50.04.1112	5.1 V	5%, 0.4W, Zener		TP.....1	54.02.0320		Plug 2.80*0.8		
	IC.....1	50.99.0167	HM74C04N	CMOS, C-MOS		TP.....2	54.02.0320		Plug 2.80*0.8		
	IC.....2	50.09.0107	RC4559	Dual Op-Amp		XIC.....1	53.03.0167	14-Pole	IC-Socket		
	J.....1	54.01.0305	5-Pole	CIS Socket Strip		XIC.....2	53.03.0166	8-Pole	IC-Socket		
	L.....1	1.810.125.00		Coil							
	L.....2	1.810.125.00		Coil							
	MP.....1	28.21.0050	2 pcs	tubular rivet 2-5217							
	MP.....2	1.727.320.10	1 pcs	No. Label							
	MP.....3	1.727.320.11	1 pcs	TAPE TENSION SENSOR PCB							
	MP.....4	43.01.0108	1 pcs	ESE Warning Label							
	Q.....1	50.03.0436	BC237B	BC547B, BC550B							
	R.....1	57.11.4152	1.5 kOhm	2%, 0.25W, MF							
	R.....2	57.11.3202	2 kOhm	2%, 0.25W, MF							
	R.....3	57.11.4472	4.7 kOhm	2%, 0.25W, MF							
	R.....4	57.11.4102	1 kOhm	2%, 0.25W, MF							
	R.....5	57.11.3203	20 kOhm	2%, 0.25W, MF							
S T U D E R (01) 86/10/29 GP TAPE TENSION SENSOR BOARD 1.727.320.00 PAGE 1						S T U D E R (01) 86/10/29 GP TAPE TENSION SENSOR BOARD 1.727.320.00 PAGE 2					

SPOOLING MOTOR BLOCK DIAGRAM

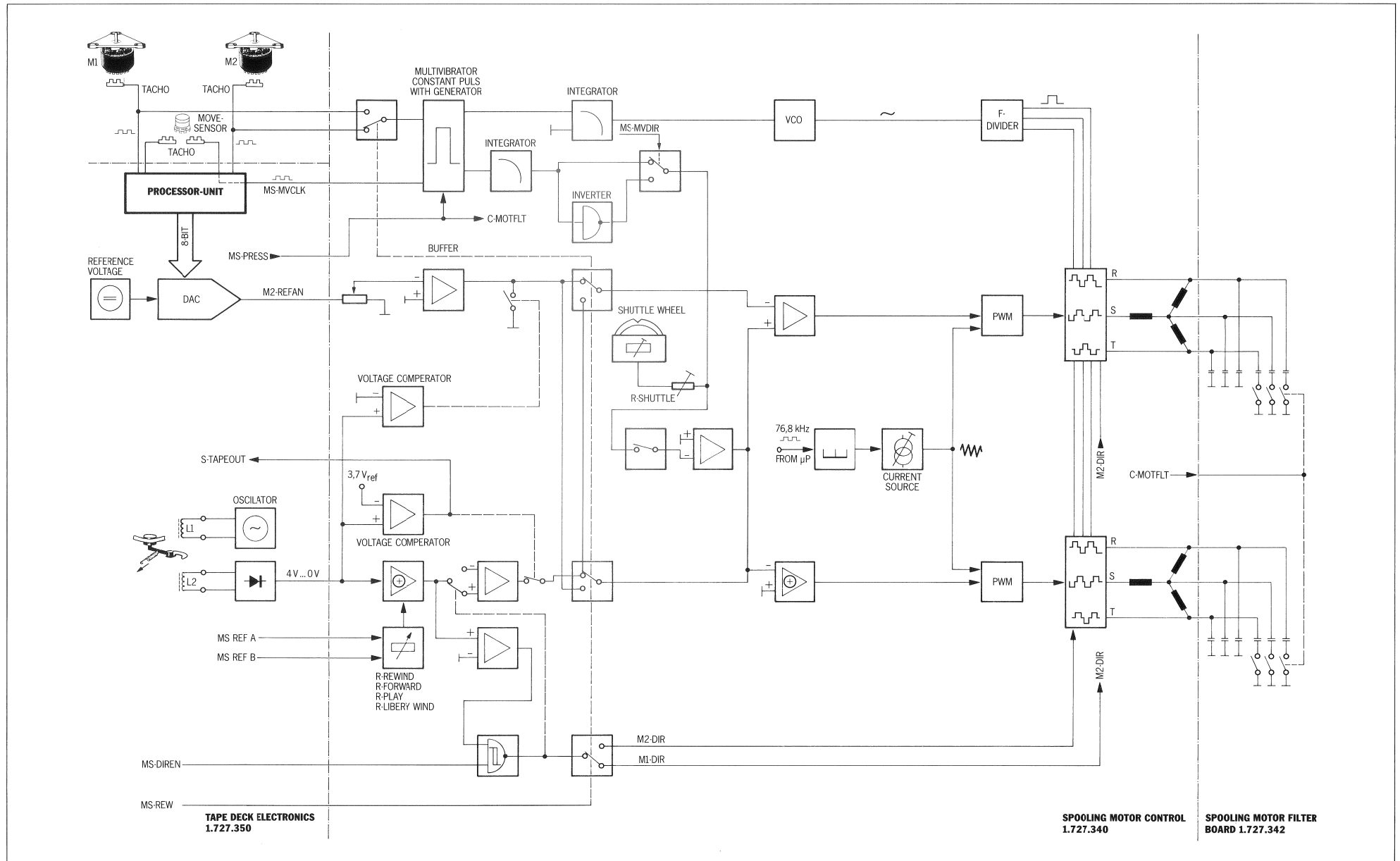

- SPOOLING MOTOR CONTROL 1.727.340.20 GRP11
- SHUTTLE CONTROL 1.727.180.00
- TAPE TENSION ADJUST 1.727.341.00 GRP14
- SPOOLING MOTOR FILTER 1.727.342.00 GRP12

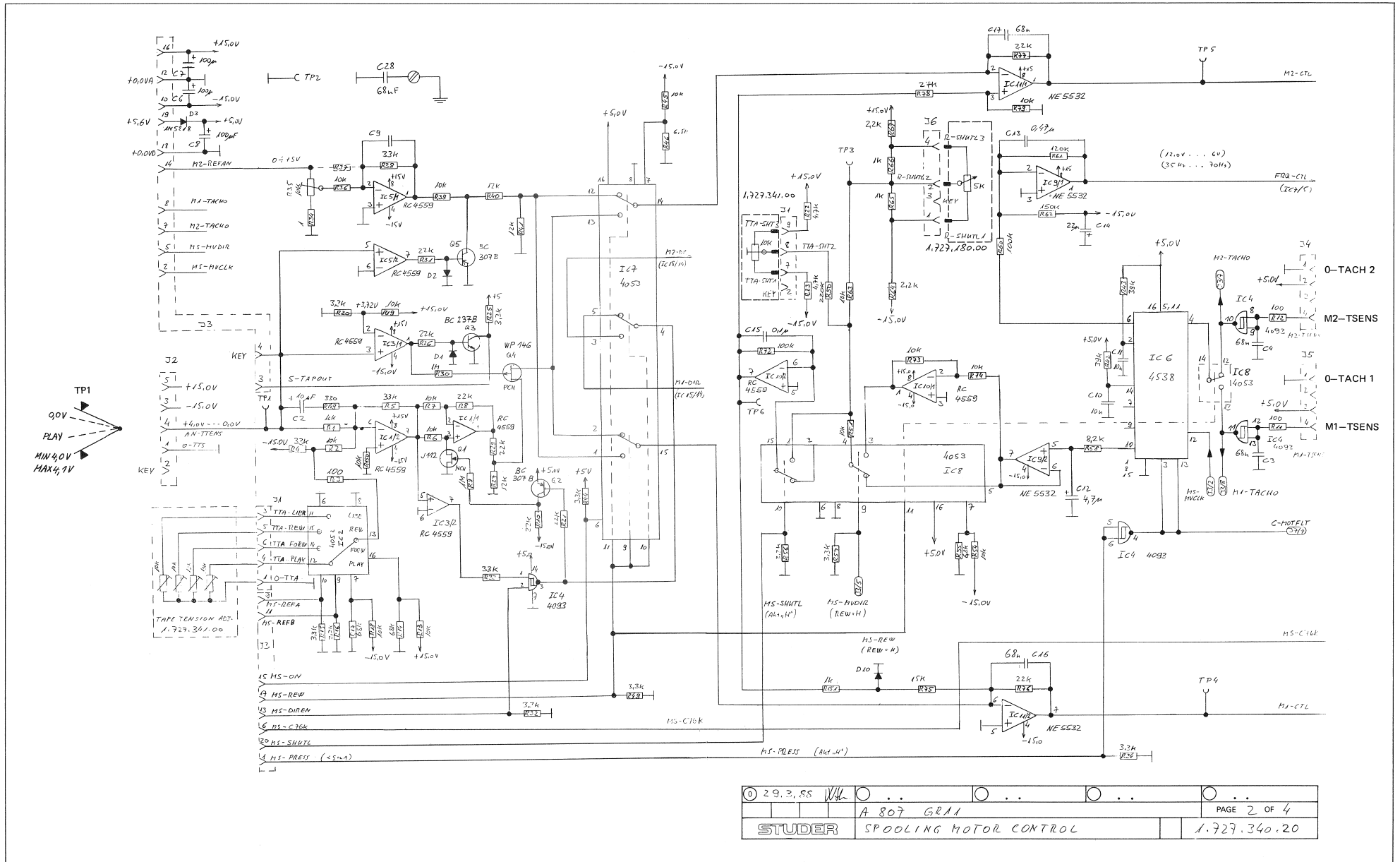

29.3.88	WHL
A 807 GR11			PAGE 2 OF 4		
STUDER			SPOOLING MOTOR CONTROL		
			1.727.340.20		

- SPOOLING MOTOR CONTROL 1.727.340.20 GRP11
- SHUTTLE CONTROL 1.727.180.00
- TAPE TENSION ADJUST 1.727.341.00 GRP14
- SPOOLING MOTOR FILTER 1.727.342.00 GRP12

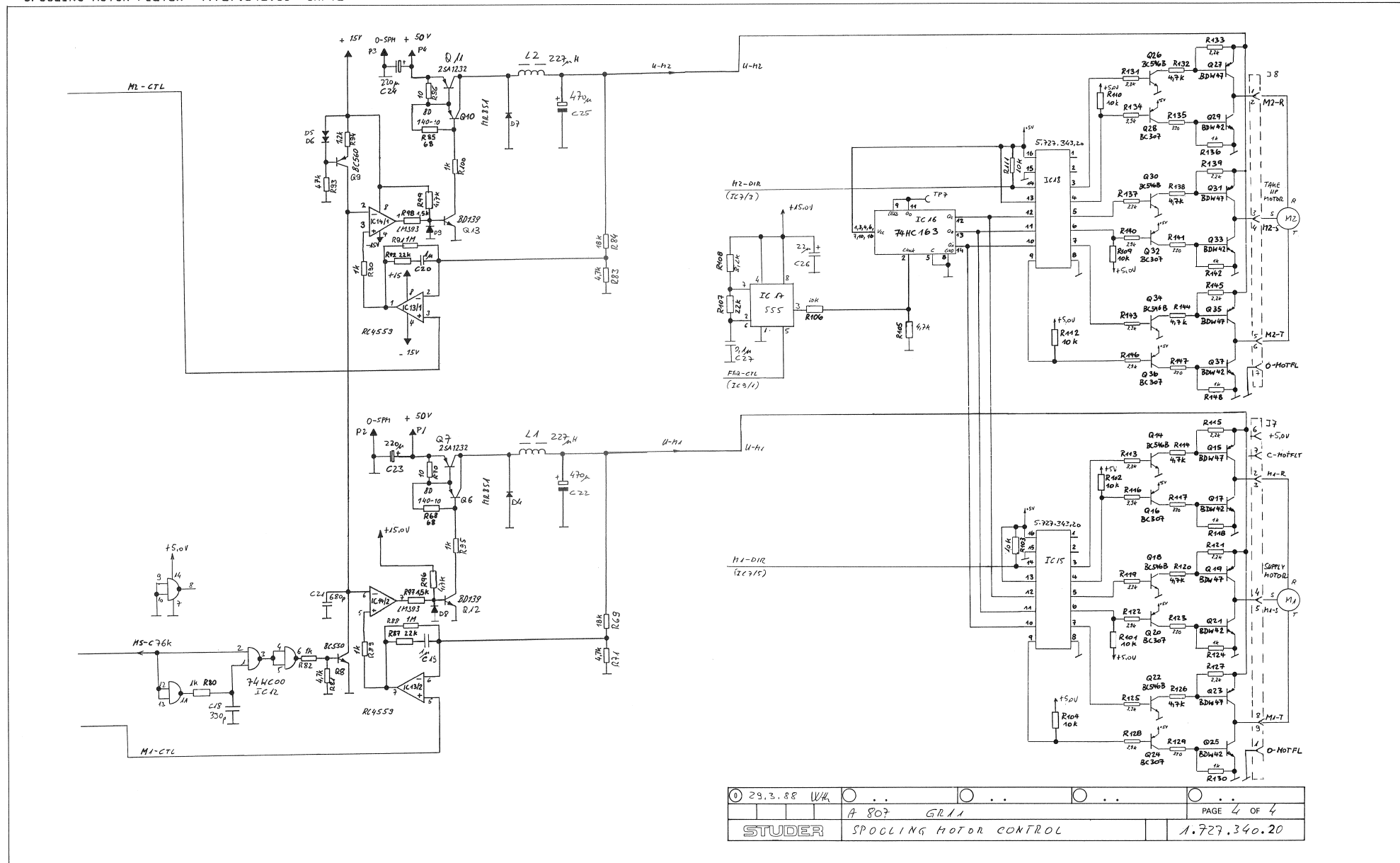

① 29.3.88 WK	○ . . .	○ . . .	○ . . .	○ . . .
	A 807	GR11		PAGE 4 OF 4
STUDER	SPOOLING MOTOR CONTROL			1.727.340.20

SPOOLING MOTOR CONTROL 1.727.340.20 GRP11

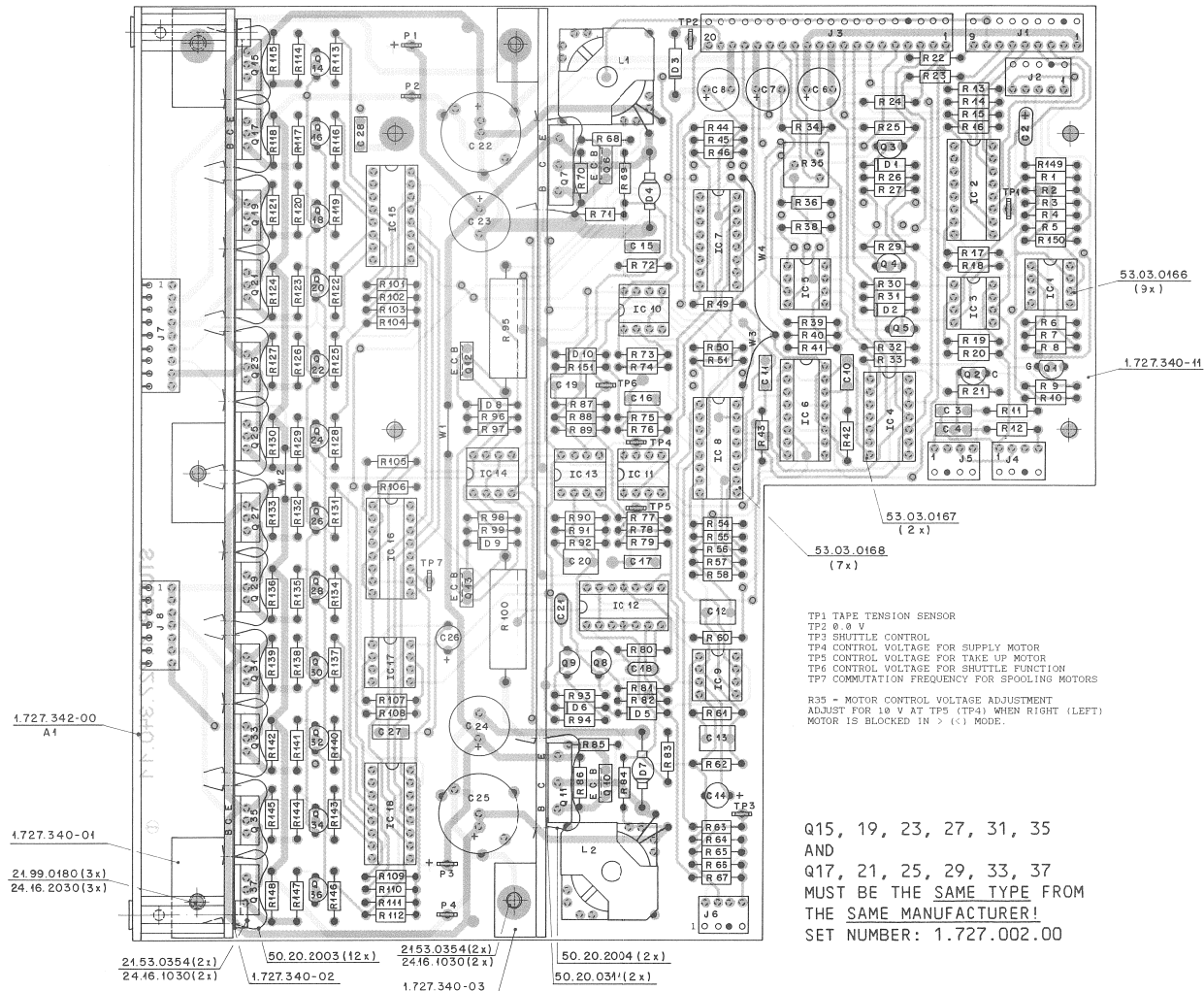



SPOOLING MOTOR CONTROL 1.727.340.20 GRP11

IND.	POS.NO.	PART NO.	VALUE	SPECIFICATIONS / EQUIVALENT	MANUF.
.....1	1.727.340.00			Sp. Motor Filter Board	SE
.....2	59.26.2100	10 UF	not used		
.....3	59.06.0683	68 MF	20K 16 V S&L	PH	
.....4	59.06.0683	68 MF	10K 63 V P&P		
.....5			not used		
.....6	59.22.5101	100 UF	-20K 25 V EL		
.....7	59.22.5101	100 UF	20K 25 V EL		
.....8	59.22.5101	100 UF	20K 25 V EL		
.....9			not used		
.....10	59.06.0103	10 MF	10K 63 V P&P		
.....11	59.06.0103	10 MF	10K 63 V P&P		
.....12	59.06.0176	0.47UF	10K 63 V P&P		
.....13	59.06.0176	0.47UF	10K 63 V P&P		
.....14	59.22.5200	22 MF	20K 25 V EL		
.....15	59.06.5104	100 MF	5K 63 V P&P		
.....16	59.06.0683	68 MF	10K 63 V P&P		
.....17	59.06.0683	68 MF	10K 63 V P&P		
.....18	59.26.331	330 UF	5K 63 V CER		
.....19	59.06.0105	1 UF	10K 63 V P&P		
.....20	59.06.0105	1 UF	10K 63 V P&P		
.....21	59.32.1841	840 PF	10K 50 V CER		
.....22	59.22.4871	470 UF	-20K 63 V EL		
.....23	59.22.4821	220 UF	-20K 63 V EL		
.....24	59.22.4821	220 UF	-20K 63 V EL		
.....25	59.22.4871	470 UF	-20K 63 V EL		
.....26	59.22.5101	100 UF	20K 25 V EL		
.....27	59.06.5104	100 MF	5K 63 V P&P		
.....28	59.06.0683	68 MF	10K 63 V P&P		
.....29					
.....30					
.....31					
.....32					
.....33					
.....34					
.....35					
.....36					
.....37					
.....38					
.....39					
.....40					
.....41					
.....42					
.....43					
.....44					
.....45					
.....46					

IND.	POS.NO.	PART NO.	VALUE	SPECIFICATIONS / EQUIVALENT	MANUF.
.....47	59.03.0915	RC307		NPW	
.....48	59.03.0777	RC307		NPW	
.....49	59.03.0915	RC307		NPW	
.....50	59.03.0777	RC307		NPW	
.....51	59.03.0915	RC307		NPW	
.....52	59.03.0777	RC307		NPW	
.....53	59.03.0915	RC307		NPW	
.....54	59.03.0777	RC307		NPW	
.....55	59.03.0915	RC307		NPW	
.....56	59.03.0777	RC307		NPW	
.....57	59.03.0915	RC307		NPW	
.....58	59.03.0777	RC307		NPW	
.....59	59.03.0915	RC307		NPW	
.....60	59.03.0777	RC307		NPW	
.....61	59.11.4103	10 kOhm	2% 0.25W MF		
.....62	59.11.4103	10 kOhm	2% 0.25W MF		
.....63	59.11.4103	10 kOhm	2% 0.25W MF		
.....64	59.11.4331	33 kOhm	2% 0.25W MF		
.....65	59.11.4331	33 kOhm	2% 0.25W MF		
.....66	59.11.4103	10 kOhm	2% 0.25W MF		
.....67	59.11.4103	10 kOhm	2% 0.25W MF		
.....68	59.11.4223	22 kOhm	2% 0.25W MF		
.....69	59.11.4103	10 kOhm	2% 0.25W MF		
.....70	59.11.4223	22 kOhm	2% 0.25W MF		
.....71	59.11.4103	10 kOhm	2% 0.25W MF		
.....72	59.11.4101	100 Ohm	2% 0.25W MF		
.....73	59.11.4101	100 Ohm	2% 0.25W MF		
.....74	59.11.4332	33 kOhm	2% 0.25W MF		
.....75	59.11.4332	33 kOhm	2% 0.25W MF		
.....76	59.11.4332	33 kOhm	2% 0.25W MF		
.....77	59.11.4332	33 kOhm	2% 0.25W MF		
.....78	59.11.4103	100 Ohm	2% 0.25W MF		
.....79	59.11.4103	100 Ohm	2% 0.25W MF		
.....80	59.11.4103	100 Ohm	2% 0.25W MF		
.....81	59.11.4103	100 Ohm	2% 0.25W MF		
.....82	59.11.4103	100 Ohm	2% 0.25W MF		
.....83	59.11.4103	100 Ohm	2% 0.25W MF		
.....84	59.11.4103	100 Ohm	2% 0.25W MF		
.....85	59.11.4103	100 Ohm	2% 0.25W MF		
.....86	59.11.4103	100 Ohm	2% 0.25W MF		
.....87	59.11.4103	100 Ohm	2% 0.25W MF		
.....88	59.11.4103	100 Ohm	2% 0.25W MF		
.....89	59.11.4103	100 Ohm	2% 0.25W MF		
.....90	59.11.4103	100 Ohm	2% 0.25W MF		
.....91	59.11.4103	100 Ohm	2% 0.25W MF		
.....92	59.11.4103	100 Ohm	2% 0.25W MF		
.....93	59.11.4103	100 Ohm	2% 0.25W MF		
.....94	59.11.4103	100 Ohm	2% 0.25W MF		
.....95	59.11.4103	100 Ohm	2% 0.25W MF		
.....96	59.11.4103	100 Ohm	2% 0.25W MF		
.....97	59.11.4103	100 Ohm	2% 0.25W MF		
.....98	59.11.4103	100 Ohm	2% 0.25W MF		
.....99	59.11.4103	100 Ohm	2% 0.25W MF		
.....100	59.11.4103	100 Ohm	2% 0.25W MF		

IND.	POS.NO.	PART NO.	VALUE	SPECIFICATIONS / EQUIVALENT	MANUF.
.....93	59.11.4472	4.7 kOhm	2% 0.25W MF		
.....94	59.11.4122	1.2 kOhm	2% 0.25W MF		
.....95	59.11.4102	10 kOhm	2% 0.25W MF		
.....96	59.11.4472	4.7 kOhm	2% 0.25W MF		
.....97	59.11.4152	1.5 kOhm	2% 0.25W MF		
.....98	59.11.4152	1.5 kOhm	2% 0.25W MF		
.....99	59.11.4472	4.7 kOhm	2% 0.25W MF		
.....100	59.11.4103	10 kOhm	2% 0.25W MF		
.....101	59.11.4103	10 kOhm	2% 0.25W MF		
.....102	59.11.4103	10 kOhm	2% 0.25W MF		
.....103	59.11.4103	10 kOhm	2% 0.25W MF		
.....104	59.11.4103	10 kOhm	2% 0.25W MF		
.....105	59.11.4472	4.7 kOhm	2% 0.25W MF		
.....106	59.11.4103	10 kOhm	2% 0.25W MF		
.....107	59.11.4223	22 kOhm	2% 0.25W MF		
.....108	59.11.4472	4.7 kOhm	2% 0.25W MF		
.....109	59.11.4103	10 kOhm	2% 0.25W MF		
.....110	59.11.4103	10 kOhm	2% 0.25W MF		
.....111	59.11.4103	10 kOhm	2% 0.25W MF		
.....112	59.11.4103	10 kOhm	2% 0.25W MF		
.....113	59.11.4332	33 kOhm	2% 0.25W MF		
.....114	59.11.4103	10 kOhm	2% 0.25W MF		
.....115	59.11.4222	2.2 kOhm	2% 0.25W MF		
.....116	59.11.4332	33 kOhm	2% 0.25W MF		
.....117	59.11.4331	330 Ohm	2% 0.25W MF		
.....118	59.11.4102	1 kOhm	2% 0.25W MF		
.....119	59.11.4332	33 kOhm	2% 0.25W MF		
.....120	59.11.4472	4.7 kOhm	2% 0.25W MF		
.....121	59.11.4222	2.2 kOhm	2% 0.25W MF		
.....122	59.11.4332	33 kOhm	2% 0.25W MF		
.....123	59.11.4331	330 Ohm	2% 0.25W MF		
.....124	59.11.4102	1 kOhm	2% 0.25W MF		
.....125	59.11.4332	33 kOhm	2% 0.25W MF		
.....126	59.11.4102	1 kOhm	2% 0.25W MF		
.....127	59.11.4222	2.2 kOhm	2% 0.25W MF		
.....128	59.11.4332	33 kOhm	2% 0.25W MF		
.....129	59.11.4331	330 Ohm	2% 0.25W MF		

S T U D E R (00) 86/10/14 MSH SPOOLING MOTOR CTL. BOARD * 1.727.340.20 PAGE 1

S T U D E R (00) 86/10/14 MSH SPOOLING MOTOR CTL. BOARD * 1.727.340.20 PAGE 4

S T U D E R (00) 86/10/14 MSH SPOOLING MOTOR CTL. BOARD * 1.727.340.20 PAGE 7

IND.	POS.NO.	PART NO.	VALUE	SPECIFICATIONS / EQUIVALENT	MANUF.
.....7	50.04.0509	MR851	Diode 100 V S1		
.....8	50.04.0125	1N4448	Diode 50 V S1		
.....9	50.04.0125	1N4448	Diode 50 V S1		
.....10	50.04.0125	1N4448	Diode 50 V S1		
.....11	50.09.0107	IC4559	Dual Op. Amp.		
.....12	50.01.0024	IC14052	Dual 4-Ch Analog Switch, CMOS		
.....13	50.09.0107	IC4559	Dual Op. Amp.		
.....14	50.01.0028	IC4565	Quad 2-Input NAND Sw/Tri-Trigger CMOS		
.....15	50.09.0107	IC4559	Dual Op. Amp.		
.....16	50.01.0038	IC518	Non-Inv Op. CMOS		
.....17	50.01.0015	IC14053	Triple 3-Ch Analog Switch, CMOS		
.....18	50.01.0015	IC14053	Triple 3-Ch Analog Switch, CMOS		
.....19	50.09.0107	IC4559	Dual Op. Amp.		
.....20	50.09.0107	IC4559	Dual Op. Amp.		
.....21	50.09.0107	IC4559	Dual Op. Amp.		
.....22	50.01.1000	IC4559	Quad 2-Input NAND Gate		
.....23	50.09.0107	IC4559	Dual Op. Amp.		
.....24	50.09.0107	IC4559	Dual Op. Amp.		
.....25	50.09.0107	IC4559	Dual Op. Amp.		
.....26	50.01.1000	IC4559	Quad 2-Input NAND Gate		
.....27	50.09.0107	IC4559	Dual Op. Amp.		
.....28	50.01.1000	IC4559	Quad 2-Input NAND Gate		
.....29	50.09.0107	IC4559	Dual Op. Amp.		
.....30	50.01.1000	IC4559	Quad 2-Input NAND Gate		
.....31	50.09.0107	IC4559	Dual Op. Amp.		
.....32	50.01.1000	IC4559	Quad 2-Input NAND Gate		
.....33	50.09.0107	IC4559	Dual Op. Amp.		
.....34	50.01.1000	IC4559	Quad 2-Input NAND Gate		
.....35	50.09.0107	IC4559	Dual Op. Amp.		
.....36	50.01.1000	IC4559	Quad 2-Input NAND Gate		
.....37	50.09.0107	IC4559	Dual Op. Amp.		
.....38	50.01.1000	IC4559	Quad 2-Input NAND Gate		
.....39	50.09.0107	IC4559	Dual Op. Amp.		
.....40	50.01.1000	IC4559	Quad 2-Input NAND Gate		
.....41	50.09.0107	IC4559	Dual Op. Amp.		
.....42	50.01.1000	IC4559	Quad 2-Input NAND Gate		
.....43	50.09.0107	IC4559	Dual Op. Amp.		
.....44	50.01.1000	IC4559	Quad 2-Input NAND Gate		
.....45	50.09.0107	IC4559	Dual Op. Amp.		
.....46	50.01.1000	IC4559	Quad 2-Input NAND Gate		
.....47	50.09.0107	IC4559	Dual Op. Amp.		
.....48	50.01.1000	IC4559	Quad 2-Input NAND Gate		
.....49	50.09.0107	IC4559	Dual Op. Amp.		
.....50	50.01.1000	IC4559	Quad		

- SPOOLING MOTOR CONTROL 1.727.340.21 GRP11
- SHUTTLE CONTROL 1.727.180.00
- TAPE TENSION ADJUST 1.727.341.00 GRP14
- SPOOLING MOTOR FILTER 1.727.342.00 GRP12

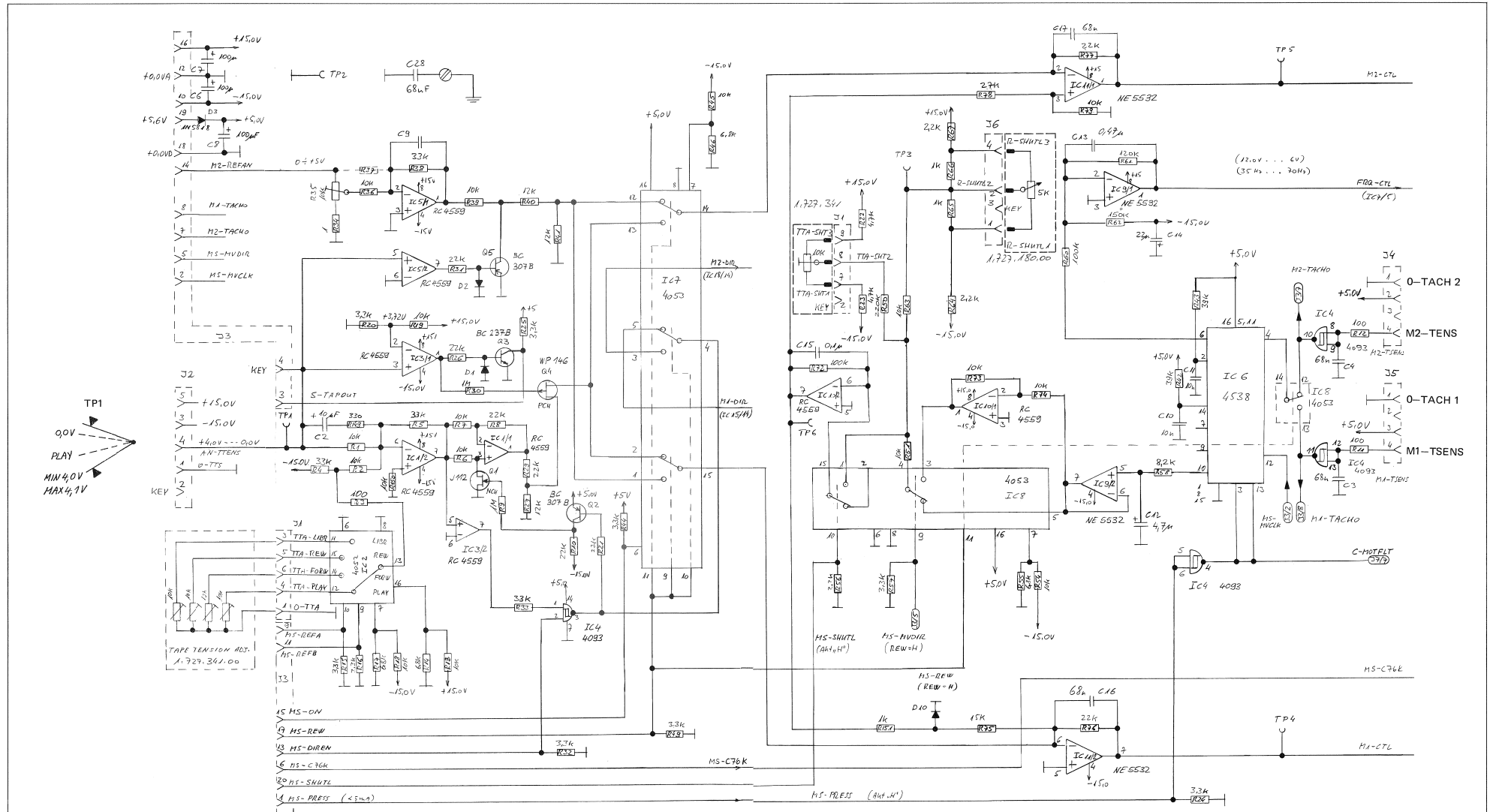

6.4.87	W.H.
A 807 GRP11			PAGE 2 OF 4		
STUDER SPOOLING MOTOR CONTROL			1.727.340.21		

- SPOOLING MOTOR CONTROL 1.727.340.21 GRP11
- SHUTTLE CONTROL 1.727.180.00
- TAPE TENSION ADJUST 1.727.341.00 GRP14
- SPOOLING MOTOR FILTER 1.727.342.00 GRP12

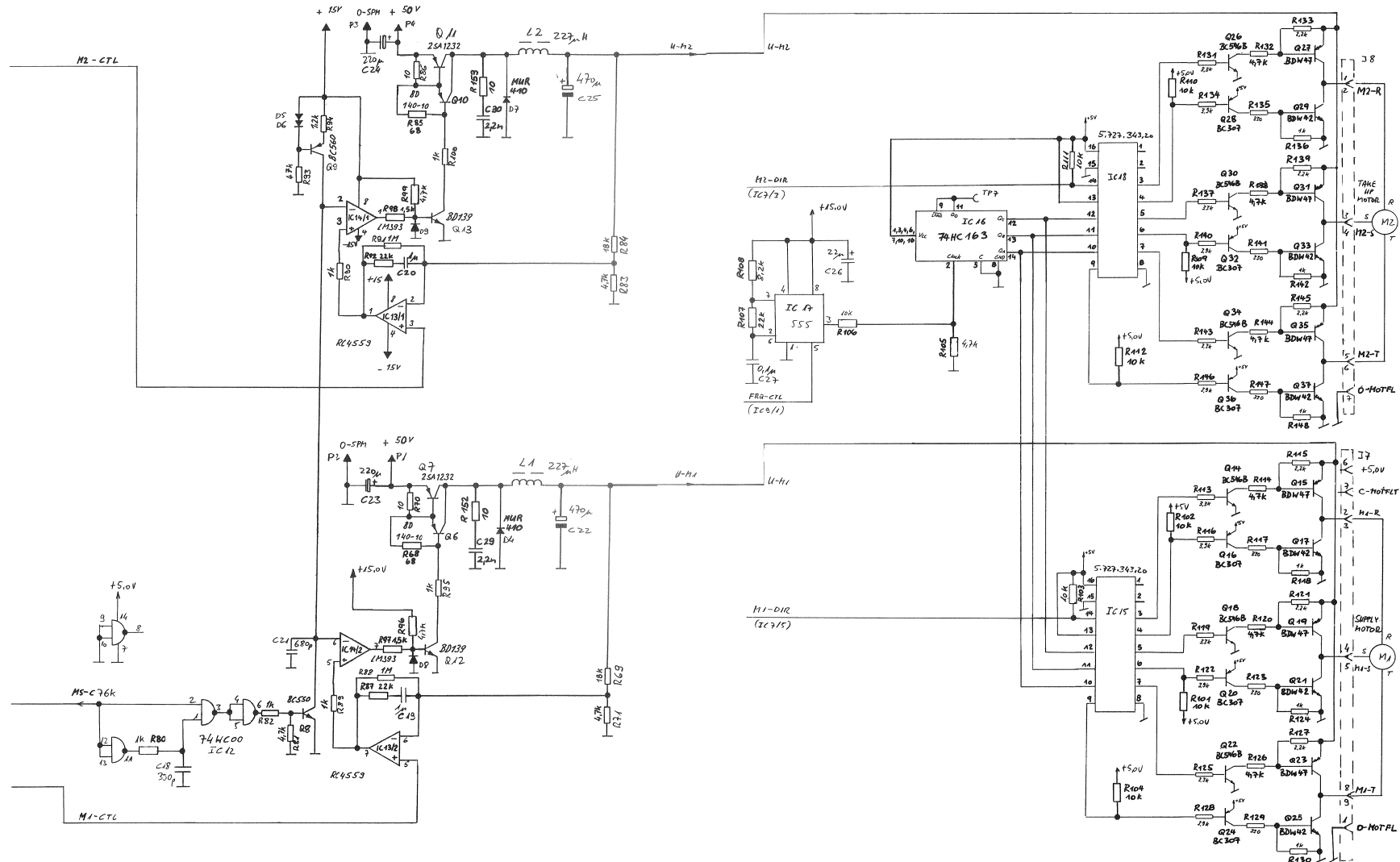

① 6.4.87	W/K
A 807 GRP11							PAGE 4 OF 4
STUDER SPOOLING MOTOR CONTROL							1.727.340.21

SPOOLING MOTOR CONTROL 1.727.340.21 GRP11

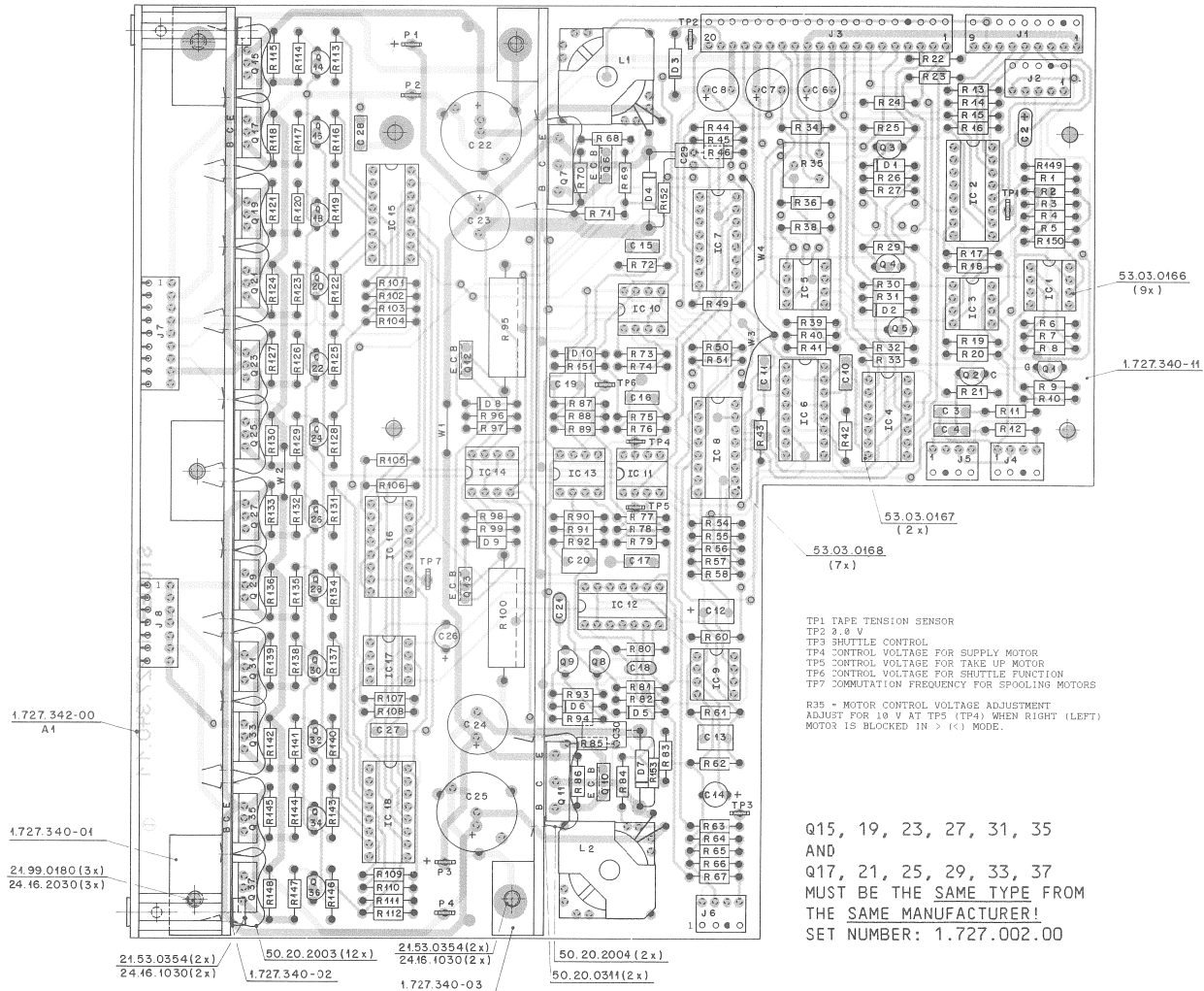



SPOOLING MOTOR CONTROL 1.727.340.21 GRP11

Table with 5 columns: IND., POS.NO., PART NO., VALUE, SPECIFICATIONS / EQUIVALENT, MANUF. It lists various electrical components like resistors, capacitors, and diodes with their respective values and manufacturer part numbers.

S T U D E R (01) 88/01/11 MEN SPOOLING MOTOR CTL. BOARD 1.727.340.21 PAGE 1 S T U D E R (01) 88/01/11 MEN SPOOLING MOTOR CTL. BOARD 1.727.340.21 PAGE 4 S T U D E R (01) 88/01/11 MEN SPOOLING MOTOR CTL. BOARD 1.727.340.21 PAGE 7 S T U D E R (01) 88/01/11 MEN SPOOLING MOTOR CTL. BOARD 1.727.340.21 PAGE 10

Table with 5 columns: IND., POS.NO., PART NO., VALUE, SPECIFICATIONS / EQUIVALENT, MANUF. It lists various electrical components like diodes, capacitors, and resistors.

S T U D E R (01) 88/01/11 MEN SPOOLING MOTOR CTL. BOARD 1.727.340.21 PAGE 2 S T U D E R (01) 88/01/11 MEN SPOOLING MOTOR CTL. BOARD 1.727.340.21 PAGE 5 S T U D E R (01) 88/01/11 MEN SPOOLING MOTOR CTL. BOARD 1.727.340.21 PAGE 8

Table with 5 columns: IND., POS.NO., PART NO., VALUE, SPECIFICATIONS / EQUIVALENT, MANUF. It lists various electrical components like relays, switches, and connectors.

S T U D E R (01) 88/01/11 MEN SPOOLING MOTOR CTL. BOARD 1.727.340.21 PAGE 3 S T U D E R (01) 88/01/11 MEN SPOOLING MOTOR CTL. BOARD 1.727.340.21 PAGE 6 S T U D E R (01) 88/01/11 MEN SPOOLING MOTOR CTL. BOARD 1.727.340.21 PAGE 9

TAPE TENSION ADJUST 1.727.341.00 GRP14

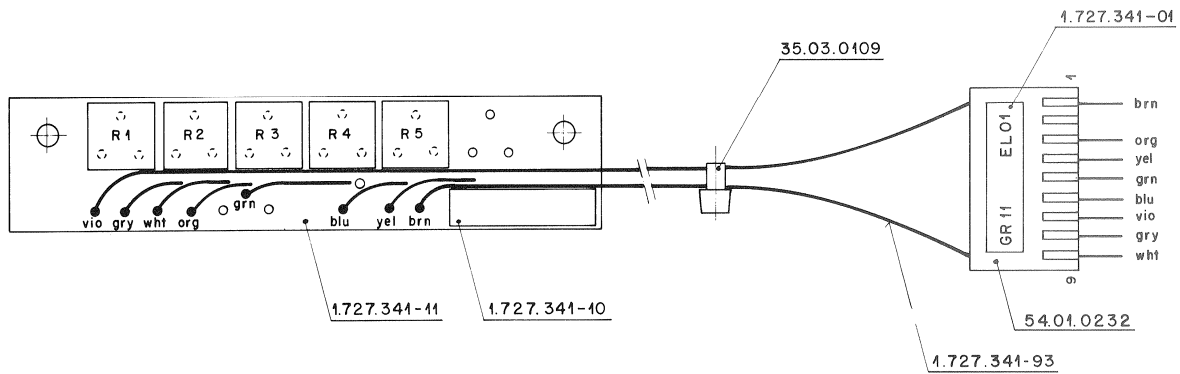

IND.	POS.NO.	PART NO.	VALUE	SPECIFICATIONS / EQUIVALENT	MANUF.
MP....1		1.727.341.11	1 pce	Tape Tension Adj. PCB	St
MP....2		1.727.341.93	1 pce	L-LSI Tape Tension Adj.	St
MP....3		54.01.0232	1 pce	CIS Case, 9 Pol	
MP....4		1.727.341.10	1 pce	No. label	St
R.....1		58.01.8103	10 kOhm	Potmeter	PMG
R.....2		58.01.8103	10 kOhm	Potmeter	PMG
R.....3		58.01.8103	10 kOhm	Potmeter	PMG
R.....4		58.01.8103	10 kOhm	Potmeter	PMG
R.....5		58.01.8103	10 kOhm	Potmeter	PMG
R.....6		58.01.8103	10 kOhm	not used	

MANUFACTURER: St=Studer

ORIG 86/08/08

S T U D E R (00) 86/08/08 Mth TAPE TENSION ADJ. BOARD 1.727.341.00 PAGE 1

SHUTTLE CONTROL 1.727.180.00

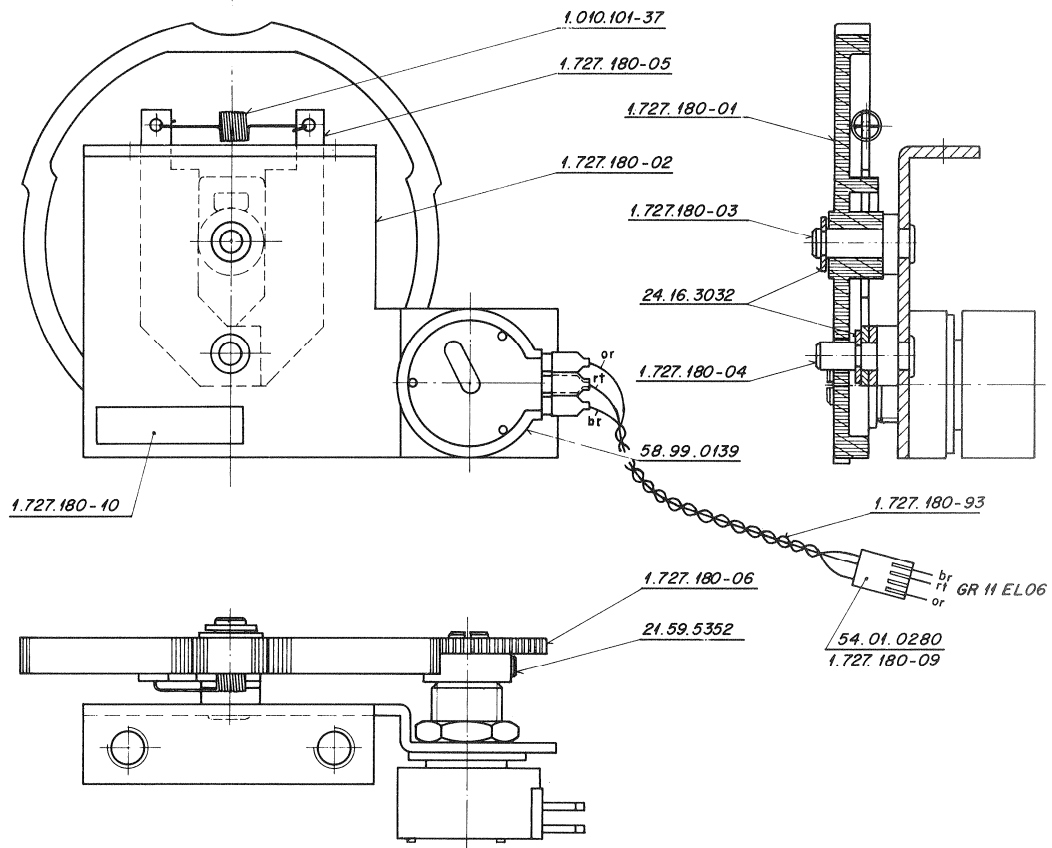

SPOOLING MOTOR FILTER 1.727.342.00 GRP12

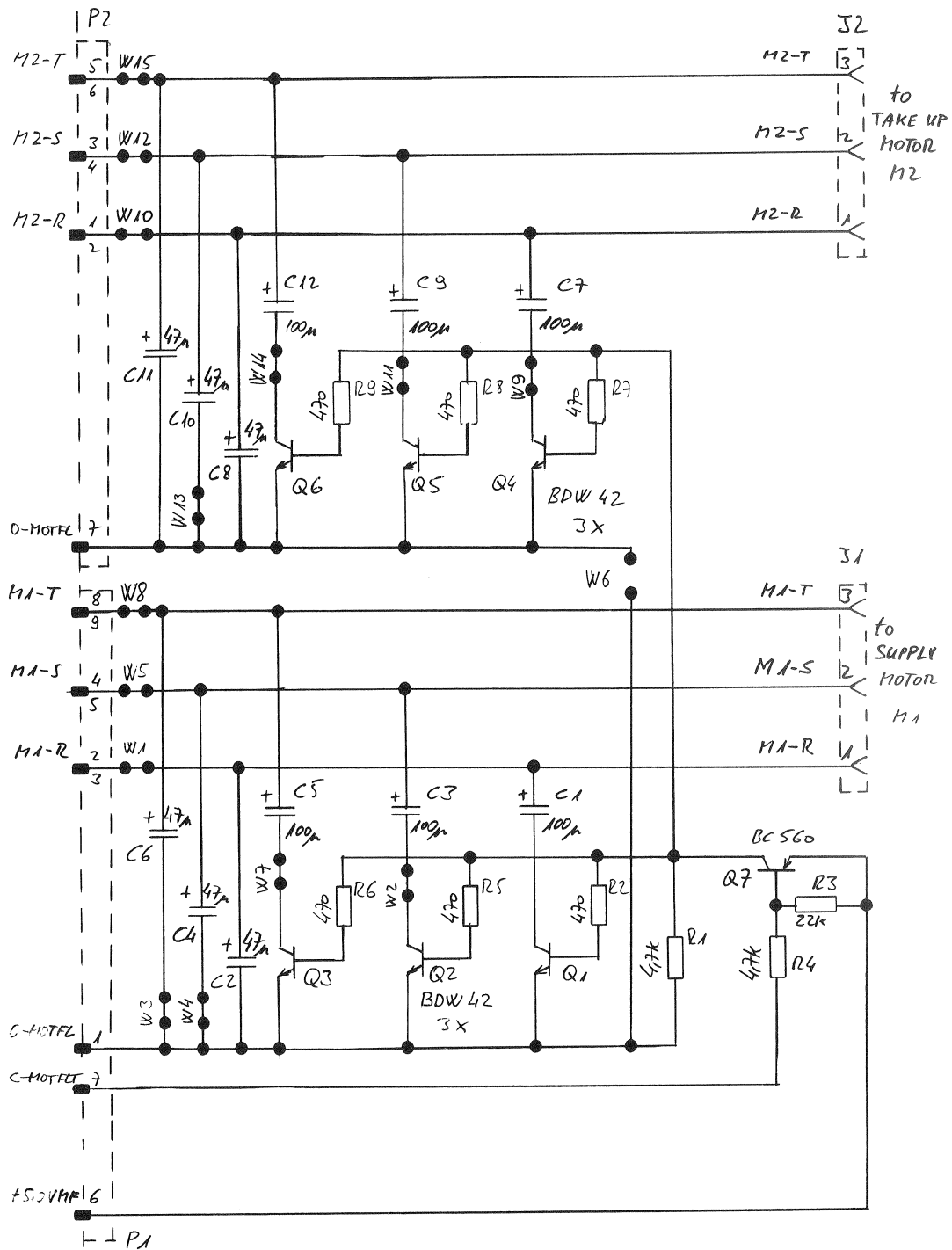

04.11.86	WHL	○ ..	○ ..	○ ..	○ ..
A 807					PAGE OF
STUDER			SP. MOTOR FILTER BOARD		1.727.342.00

SPOOLING MOTOR FILTER 1.727.342.00 GRP12

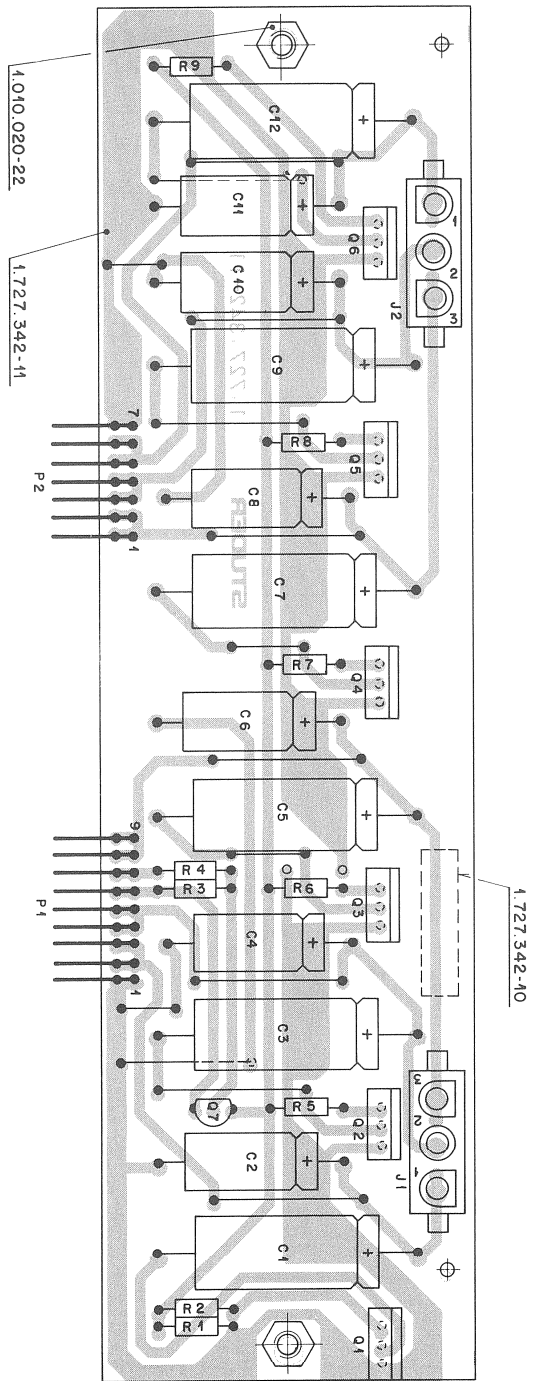

IND.	POS. NO.	PART NO.	VALUE	SPECIFICATIONS / EQUIVALENT	MANUF.
C.....1		59.25.6101	100 uF	-20%, 63 V EL	
C.....2		59.25.6470	47 uF	-20%, 63 V EL	
C.....3		59.25.6101	100 uF	-20%, 63 V EL	
C.....4		59.25.6470	47 uF	-20%, 63 V EL	
C.....5		59.25.6101	100 uF	-20%, 63 V EL	
C.....6		59.25.6470	47 uF	-20%, 63 V EL	
C.....7		59.25.6101	100 uF	-20%, 63 V EL	
C.....8		59.25.6470	47 uF	-20%, 63 V EL	
C.....9		59.25.6101	100 uF	-20%, 63 V EL	
C.....10		59.25.6470	47 uF	-20%, 63 V EL	
C.....11		59.25.6470	47 uF	-20%, 63 V EL	
C.....12		59.25.6101	100 uF	-20%, 63 V EL	
J.....1		54.25.0003	3-Pol	Power Connector	AMP
J.....2		54.25.0003	3-Pol	Power Connector	AMP
MP.....1		1.727.342-11	1 pcs	SP. MOTOR FILTER PCB	St
MP.....2		1.727.342-10	1 pcs	No. label	St
MP.....3		1.010.020-22	2 pcs	Rivetnut I=15	St
P.....1		54.01.0220	9 Pol	CIS Pin Strip	
P.....2		54.01.0223	7 Pol	CIS Pin Strip	
Q.....1		50.03.0777	80W 42	TU 220 NPN	
Q.....2		50.03.0777	80W 42	TU 220 NPN	
Q.....3		50.03.0777	80W 42	TU 220 NPN	
Q.....4		50.03.0777	80W 42	TU 220 NPN	
Q.....5		50.03.0777	80W 42	TU 220 NPN	
Q.....6		50.03.0777	80W 42	TU 220 NPN	
Q.....7		50.03.0515	BC307B	BC251B AC500B PNP	
R.....1		57.11.4472	4.7 kOhm	2%, 0.25W, MF	
R.....2		57.11.4471	470 Ohm	2%, 0.25W, MF	
R.....3		57.11.4223	22 kOhm	2%, 0.25W, MF	
R.....4		57.11.4472	4.7 kOhm	2%, 0.25W, MF	
R.....5		57.11.4471	470 Ohm	2%, 0.25W, MF	
R.....6		57.11.4471	470 Ohm	2%, 0.25W, MF	

S T U D E R (00) 86/08/08 Wth SP. MOTOR FILTER BOARD 1.727.342.00 PAGE 1

IND.	POS. NO.	PART NO.	VALUE	SPECIFICATIONS / EQUIVALENT	MANUF.
R.....7		57.11.4471	470 Ohm	2%, 0.25W, MF	
R.....8		57.11.4471	470 Ohm	2%, 0.25W, MF	
R.....9		57.11.4471	470 Ohm	2%, 0.25W, MF	

EL=Electrolytic, MF=Metal Film
 MANUFACTURER: AMP=AMP, St=STUDER
 ORIG 86/08/08

S T U D E R (00) 86/08/08 Wth SP. MOTOR FILTER BOARD 1.727.342.00 PAGE 2

CAPSTAN SERVO SYSTEM BLOCK DIAGRAM

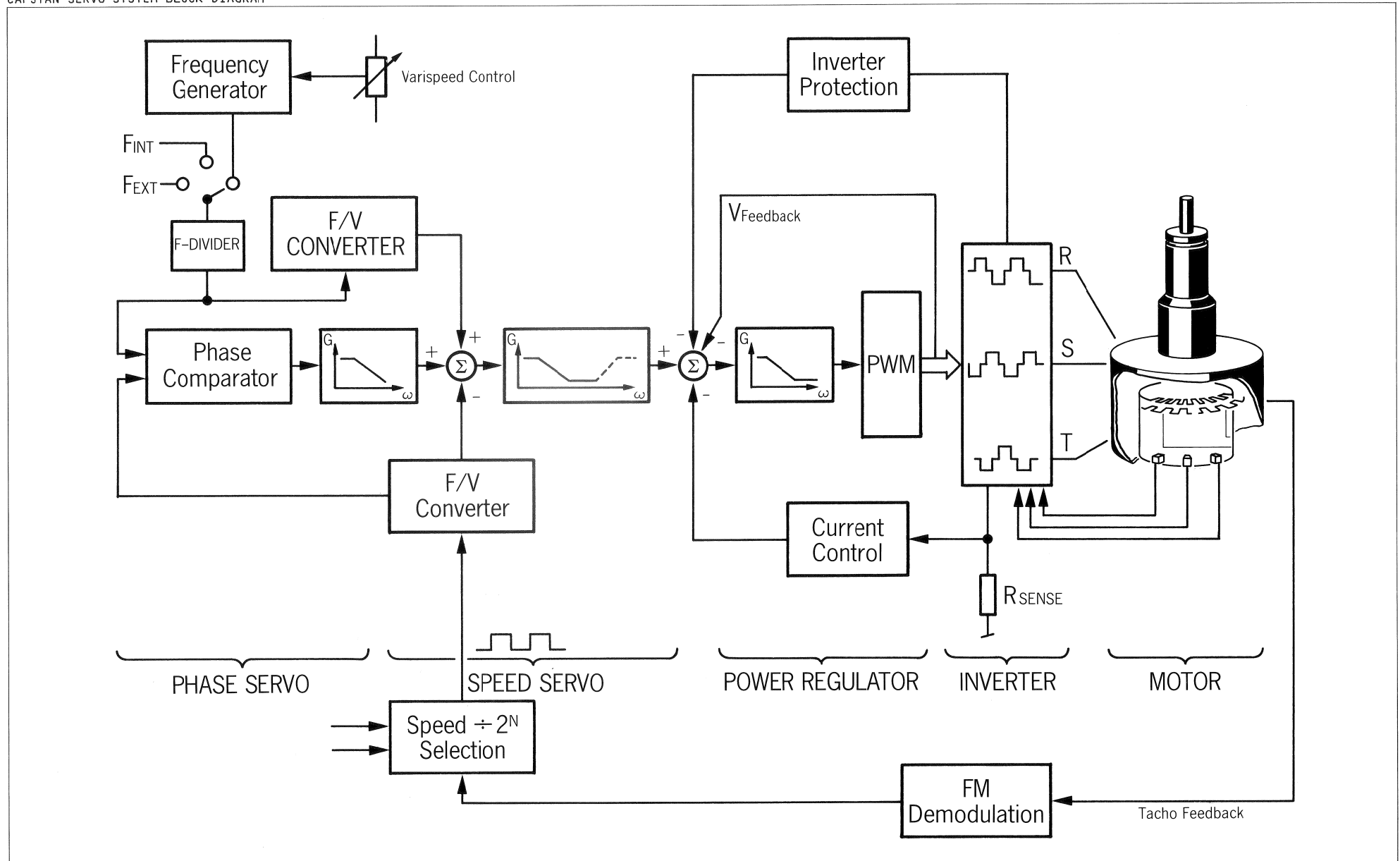



CAPSTAN MOTOR CONTROL 1.727.330.20/21 GRP20

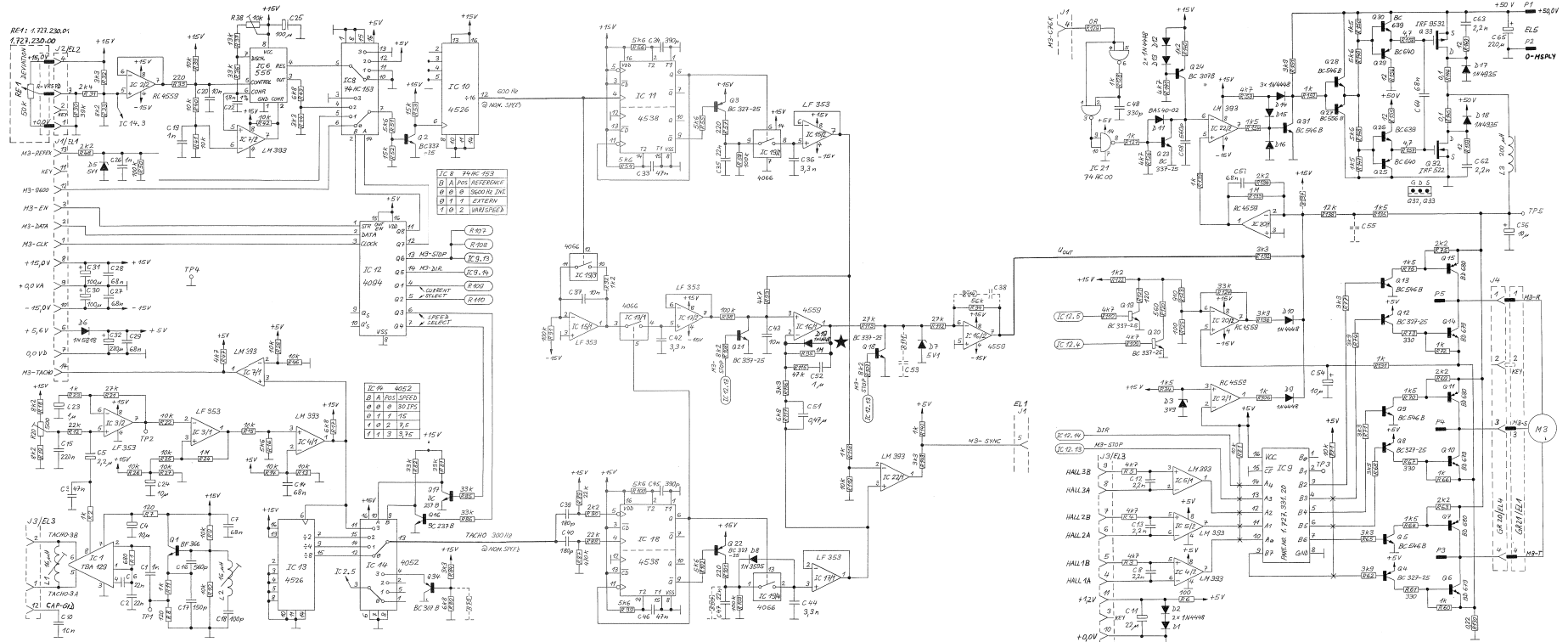

★ D19: NOT USED FOR 1.727.330.20

30.6.89 GP	A 807 GR 20	PAGE 3 OF 3
STUDER	CAPSTAN MOTOR CONTROL	SC 1.727.330.21

CAPSTAN MOTOR CONTROL 1.727.330.20/ .21 GRP20

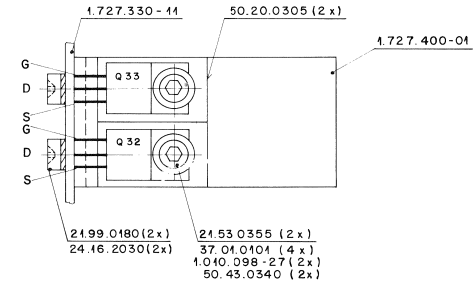
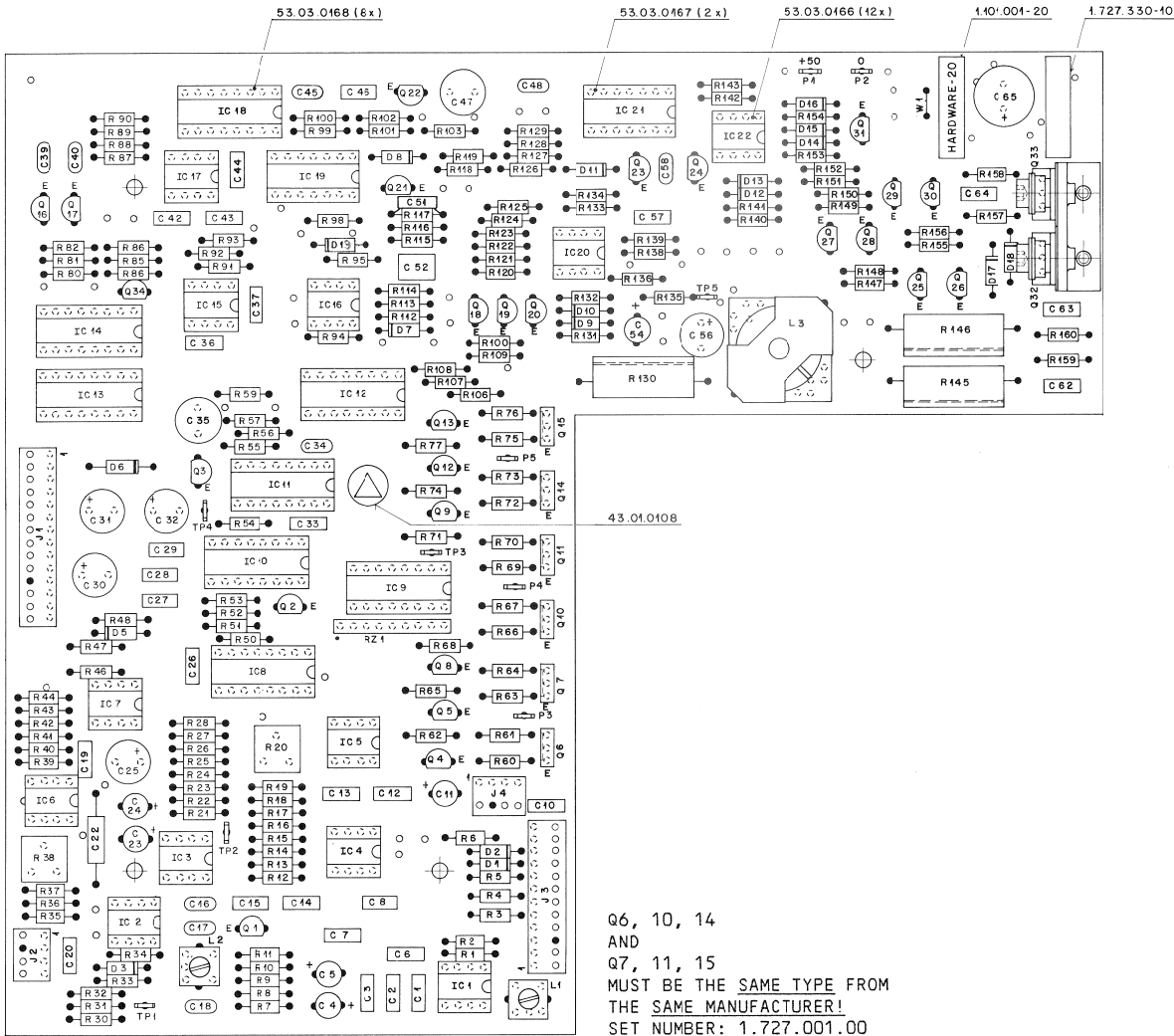

Q6, 10, 14
AND
Q7, 11, 15
MUST BE THE SAME TYPE FROM
THE SAME MANUFACTURER!
SET NUMBER: 1.727.001.00

CAPSTAN MOTOR CONTROL 1.727.330.20/.21 GRP20



Table with 10 columns: IND., POS. NO., PART NO., VALUE, SPECIFICATIONS / EQUIVALENT, MANUF., IND., POS. NO., PART NO., VALUE, SPECIFICATIONS / EQUIVALENT, MANUF. Rows include parts like 59.06.0102, 59.06.0223, etc.

S T U D E R (01) 87/02/04 Wth CAPSTAN MOTOR CONTROL 1.727.330.21 PAGE 1 S T U D E R (01) 87/02/04 Wth CAPSTAN MOTOR CONTROL 1.727.330.21 PAGE 4

Table with 10 columns: IND., POS. NO., PART NO., VALUE, SPECIFICATIONS / EQUIVALENT, MANUF., IND., POS. NO., PART NO., VALUE, SPECIFICATIONS / EQUIVALENT, MANUF. Rows include parts like 59.06.0332, 59.06.0103, etc.

S T U D E R (01) 87/02/04 Wth CAPSTAN MOTOR CONTROL 1.727.330.21 PAGE 2 S T U D E R (01) 87/02/04 Wth CAPSTAN MOTOR CONTROL 1.727.330.21 PAGE 5

Table with 10 columns: IND., POS. NO., PART NO., VALUE, SPECIFICATIONS / EQUIVALENT, MANUF., IND., POS. NO., PART NO., VALUE, SPECIFICATIONS / EQUIVALENT, MANUF. Rows include parts like 50.11.0137, 50.09.0107, etc.

S T U D E R (01) 87/02/04 Wth CAPSTAN MOTOR CONTROL 1.727.330.21 PAGE 3 S T U D E R (01) 87/02/04 Wth CAPSTAN MOTOR CONTROL 1.727.330.21 PAGE 6

CAPSTAN MOTOR CONTROL 1.727.330.20/.21 GRP20



IND.	POS.NO.	PART NO.	VALUE	SPECIFICATIONS / EQUIVALENT	MANUF.	IND.	POS.NO.	PART NO.	VALUE	SPECIFICATIONS / EQUIVALENT	MANUF.
R....66	57.11.4102	1	kOhm	2%, 0.25W, MF		XIC..17	53.03.0166	8 Pole	IC socket		
R....67	57.11.4331	330	Ohm	2%, 0.25W, MF		XIC..18	53.03.0168	16 Pole	IC socket		
R....68	57.11.4392	3.9	kOhm	2%, 0.25W, MF		XIC..19	53.03.0167	14 Pole	IC socket		
R....69	57.11.4222	2.2	kOhm	2%, 0.25W, MF		XIC..20	53.03.0166	8 Pole	IC socket		
R....70	57.11.4152	1.5	kOhm	2%, 0.25W, MF		XIC..21	53.03.0167	14 Pole	IC socket		
R....71	57.11.4332	3.3	kOhm	2%, 0.25W, MF		XIC..22	53.03.0166	8 Pole	IC socket		
R....72	57.11.4102	1	kOhm	2%, 0.25W, MF							
R....73	57.11.4331	330	Ohm	2%, 0.25W, MF							
R....74	57.11.4392	3.9	kOhm	2%, 0.25W, MF							
R....75	57.11.4222	2.2	kOhm	2%, 0.25W, MF							
R....76	57.11.4152	1.5	kOhm	2%, 0.25W, MF							
R....77	57.11.4332	3.3	kOhm	2%, 0.25W, MF							
R....80	57.11.4682	6.8	kOhm	2%, 0.25W, MF							
R....81	57.11.4333	33	kOhm	2%, 0.25W, MF							
R....82	57.11.4333	33	kOhm	2%, 0.25W, MF							
R....84	57.11.4332	3.3	kOhm	2%, 0.25W, MF							
R....85	57.11.4333	33	kOhm	2%, 0.25W, MF							
R....86	57.11.4333	33	kOhm	2%, 0.25W, MF							
R....87	57.11.4476	470	kOhm	2%, 0.25W, MF							
R....88	57.11.4223	22	kOhm	2%, 0.25W, MF							
R....89	57.11.4223	22	kOhm	2%, 0.25W, MF							
R....90	57.11.4222	2.2	kOhm	2%, 0.25W, MF							
R....91	57.11.4104	100	kOhm	2%, 0.25W, MF							
R....92	57.11.4122	1.2	kOhm	2%, 0.25W, MF							
R....93	57.11.4472	4.7	kOhm	2%, 0.25W, MF							
R....94	57.11.4563	56	kOhm	2%, 0.25W, MF							
R....95	57.11.4103	1	MOhm	2%, 0.25W, MF							
R....98	57.11.4104	100	kOhm	2%, 0.25W, MF							
R....99	57.11.4562	5.6	kOhm	2%, 0.25W, MF							
R....100	57.11.4562	5.6	kOhm	2%, 0.25W, MF							
R....101	57.11.4221	220	Ohm	2%, 0.25W, MF							
R....102	57.11.4562	5.6	kOhm	2%, 0.25W, MF							
R....103	57.11.3104	100	kOhm	1%, 0.25W, MF							
R....106	57.11.4102	1	kOhm	2%, 0.25W, MF							
R....107	57.11.4822	8.2	kOhm	2%, 0.25W, MF							
R....108	57.11.4822	8.2	kOhm	2%, 0.25W, MF							
R....109	57.11.4472	4.7	kOhm	2%, 0.25W, MF							

(01) 04.02.1987 Better wow and flutter values at 15 ips

Note 1 - For excellent wow and flutter values at 3.75 ips the NPN - respective the PNP - Transistors should be from the same manufacturer.

MATERIALS: CER = Ceramic, EL = Electrolytic, MF = Metalfilm, PETP = Polyesterfoil, PS = Polystyrol, PP = Polypropylen

MANUFACTURER: AMP = AMP Incorporated, Ph = Philips, FC = Fairchild, Ra = Raytheon, GI = General Instruments, SGS = SGS/Ates, IR = International Rectifier, Sie = Siemens, Mot = Motorola, Sig = Signetics, NEC = Nippon Electric Corp., St = Studer, NS = National Semiconductor, TI = Texas Instruments

DRIG 87/06/30 (01) 87/02/04

S T U D E R (01) 87/02/04 Wth CAPSTAN MOTOR CONTROL 1.727.330.21 PAGE 7 S T U D E R (01) 87/02/04 Wth CAPSTAN MOTOR CONTROL 1.727.330.21 PAGE 10

IND.	POS.NO.	PART NO.	VALUE	SPECIFICATIONS / EQUIVALENT	MANUF.
R....110	57.11.4472	4.7	kOhm	2%, 0.25W, MF	
R....112	57.11.4273	27	kOhm	2%, 0.25W, MF	
R....113	57.11.4273	27	kOhm	2%, 0.25W, MF	
R....115	57.11.4473	47	kOhm	2%, 0.25W, MF	
R....116	57.11.4332	3.3	kOhm	2%, 0.25W, MF	
R....117	57.11.4682	6.8	kOhm	2%, 0.25W, MF	
R....118	57.11.4102	1	kOhm	2%, 0.25W, MF	
R....119	57.11.4103	10	kOhm	2%, 0.25W, MF	
R....120	57.11.4561	560	Ohm	2%, 0.25W, MF	
R....121	57.11.4121	120	Ohm	2%, 0.25W, MF	
R....122	57.11.4122	1.2	kOhm	2%, 0.25W, MF	
R....123	57.11.3911	910	Ohm	1%, 0.25W, MF	
R....124	57.11.4333	33	kOhm	2%, 0.25W, MF	
R....125	57.11.4101	100	Ohm	2%, 0.25W, MF	
R....126	57.11.4472	4.7	kOhm	2%, 0.25W, MF	
R....127	57.11.4102	1	kOhm	2%, 0.25W, MF	
R....128	57.11.4102	1	kOhm	2%, 0.25W, MF	
R....129	57.11.4000	0	Ohm		
R....130	57.56.5228	0.22	Ohm	5%, 4.0 W, Wire	
R....131	57.11.4102	1	kOhm	2%, 0.25W, MF	
R....132	57.11.4332	3.3	kOhm	2%, 0.25W, MF	
R....133	57.11.4105	1	MOhm	2%, 0.25W, MF	
R....134	57.11.4222	2.2	kOhm	2%, 0.25W, MF	
R....135	57.11.4152	1.5	kOhm	2%, 0.25W, MF	
R....136	57.11.4332	3.3	kOhm	2%, 0.25W, MF	
R....138	57.11.4123	12	kOhm	2%, 0.25W, MF	
R....139	57.11.4102	1	kOhm	2%, 0.25W, MF	
R....140	57.11.4122	1.2	kOhm	2%, 0.25W, MF	
R....141	57.11.4472	4.7	kOhm	2%, 0.25W, MF	
R....142	57.11.4102	1	kOhm	2%, 0.25W, MF	
R....143	57.11.4332	3.3	kOhm	2%, 0.25W, MF	
R....145	57.56.5108	0.1	Ohm	10%, 4.0 W, Wire	
R....146	57.56.5108	0.1	Ohm	10%, 4.0 W, Wire	
R....147	57.11.4152	1.5	kOhm	2%, 0.25W, MF	
R....148	57.11.4562	5.6	kOhm	2%, 0.25W, MF	
R....149	57.11.4562	5.6	kOhm	2%, 0.25W, MF	
R....150	57.11.4152	1.5	kOhm	2%, 0.25W, MF	

S T U D E R (01) 87/02/04 Wth CAPSTAN MOTOR CONTROL 1.727.330.21 PAGE 8

IND.	POS.NO.	PART NO.	VALUE	SPECIFICATIONS / EQUIVALENT	MANUF.
R....151	57.11.4392	3.9	kOhm	2%, 0.25W, MF	
R....152	57.11.4102	1	kOhm	2%, 0.25W, MF	
R....153	57.11.4472	4.7	kOhm	2%, 0.25W, MF	
R....154	57.11.4152	1.5	kOhm	2%, 0.25W, MF	
R....155	57.11.4120	12	Ohm	2%, 0.25W, MF	
R....156	57.11.4120	12	Ohm	2%, 0.25W, MF	
R....157	57.11.4479	4.7	Ohm	2%, 0.25W, MF	
R....158	57.11.4479	4.7	Ohm	2%, 0.25W, MF	
R....159	57.11.4120	12	Ohm	2%, 0.25W, MF	
R....160	57.11.4120	12	Ohm	2%, 0.25W, MF	
RZ....1	57.88.4103	8*10	kOhm	5%, Single Line	
TP....1	54.02.0320	1	Pole	Tab	
TP....2	54.02.0320	1	Pole	Tab	
TP....3	54.02.0320	1	Pole	Tab	
TP....4	54.02.0320	1	Pole	Tab	
TP....5	54.02.0320	1	Pole	Tab	
W....1	1.010.321.64			Wire Bridge	
XIC...1	53.03.0166	8	Pole	IC socket	
XIC...2	53.03.0166	8	Pole	IC socket	
XIC...3	53.03.0166	8	Pole	IC socket	
XIC...4	53.03.0166	8	Pole	IC socket	
XIC...5	53.03.0166	8	Pole	IC socket	
XIC...6	53.03.0166	8	Pole	IC socket	
XIC...7	53.03.0166	8	Pole	IC socket	
XIC...8	53.03.0168	16	Pole	IC socket	
XIC...9	53.03.0168	16	Pole	IC socket	
XIC...10	53.03.0168	16	Pole	IC socket	
XIC...11	53.03.0168	16	Pole	IC socket	
XIC...12	53.03.0168	16	Pole	IC socket	
XIC...13	53.03.0168	16	Pole	IC socket	
XIC...14	53.03.0168	16	Pole	IC socket	
XIC...15	53.03.0166	8	Pole	IC socket	
XIC...16	53.03.0166	8	Pole	IC socket	

S T U D E R (01) 87/02/04 Wth CAPSTAN MOTOR CONTROL 1.727.330.21 PAGE 9

CAPSTAN MOTOR CONTROL 1.727.330.22 GRP20
 - CAPSTAN START CONTROL 1.727.332.00

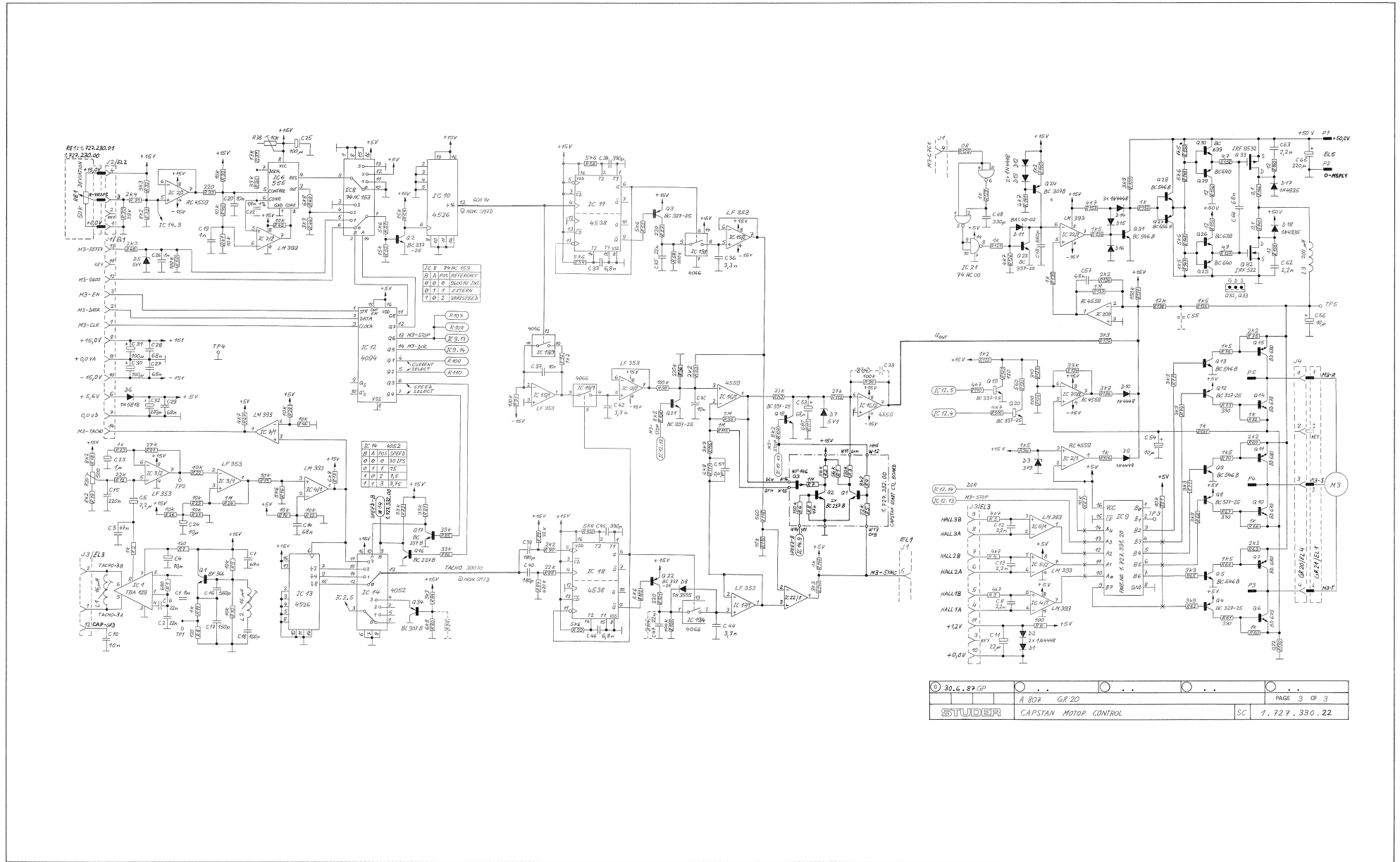

30.6.87 GP	A 807 GR 20	PAGE 3 OF 3
STUDER	CAPSTAN MOTOR CONTROL	SC 1.727.330.22

CAPSTAN MOTOR CONTROL 1.727.330.22 GRP20

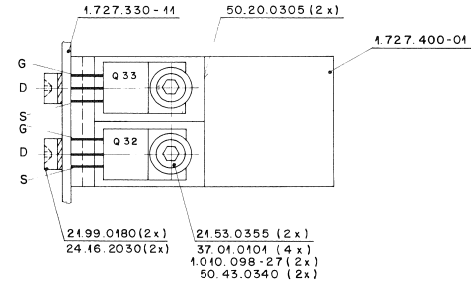
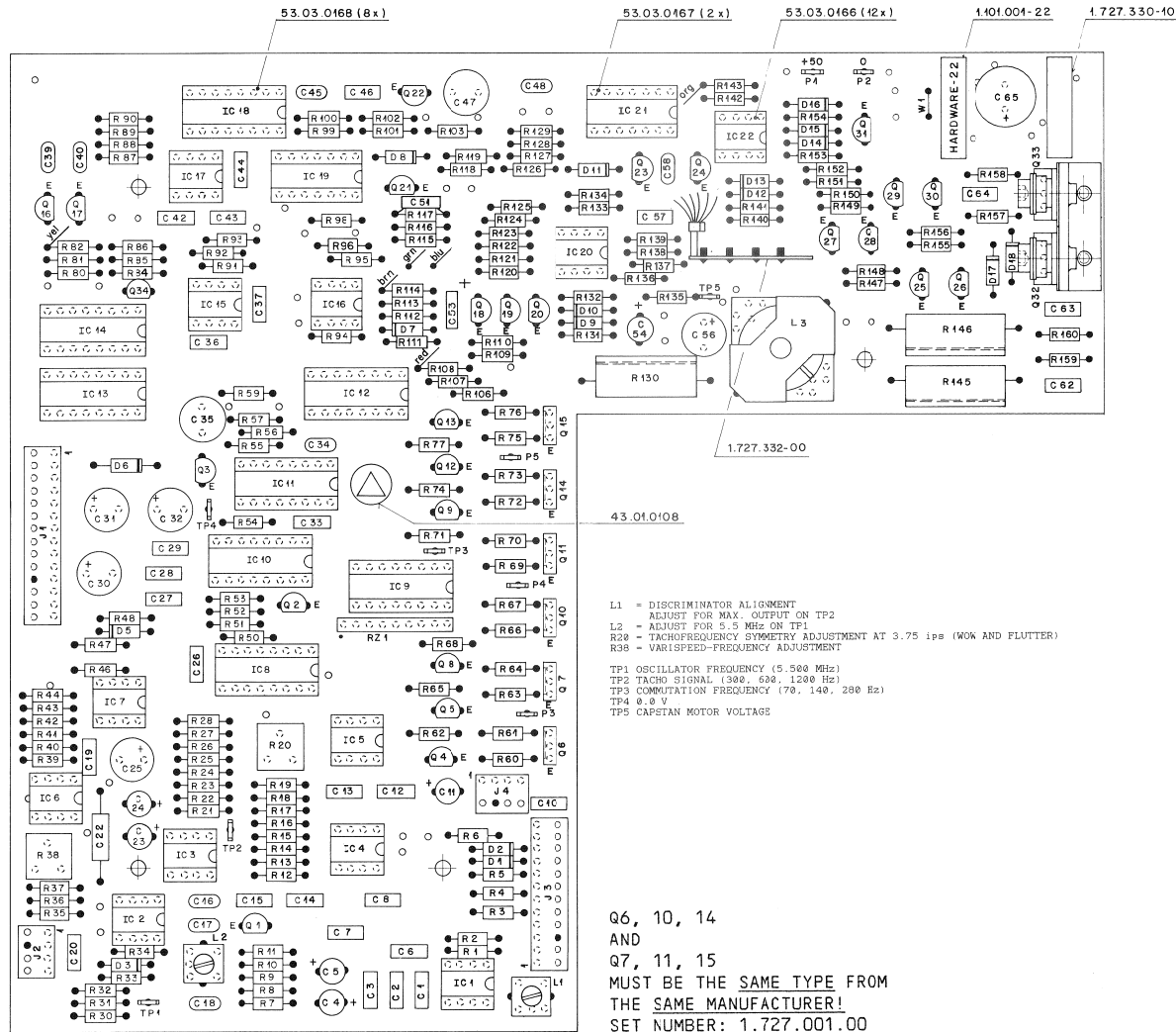

- L1 = DISCRIMINATOR ALIGNMENT
ADJUST FOR MAX. OUTPUT ON TP2
- L2 = ADJUST FOR 5.5 MHz ON TP1
- R20 = TACHOFREQUENCY SYMMETRY ADJUSTMENT AT 3.75 ips (WOW AND FLUTTER)
- R38 = VARIOSPEED-FREQUENCY ADJUSTMENT
- TP1 OSCILLATOR FREQUENCY (5.500 MHz)
- TP2 TACHO SIGNAL (300, 600, 1200 Hz)
- TP3 COMMUTATION FREQUENCY (70, 140, 280 Hz)
- TP4 0.0 V
- TP5 CAPSTAN MOTOR VOLTAGE

Q6, 10, 14
AND
Q7, 11, 15
MUST BE THE SAME TYPE FROM
THE SAME MANUFACTURER!
SET NUMBER: 1.727.001.00



CAPSTAN MOTOR CONTROL 1.727.330.22 GRP20

Table with columns: IND., POS.-NO., PART NO., VALUE, SPECIFICATIONS / EQUIVALENT, MANUF. Contains component list for CAPSTAN MOTOR CONTROL.

S T U D E R (00) 87/06/30 Wch CAPSTAN MOTOR CONTROL 1.727.330.22 PAGE 1

Table with columns: IND., POS.-NO., PART NO., VALUE, SPECIFICATIONS / EQUIVALENT, MANUF. Contains component list for CAPSTAN MOTOR CONTROL.

S T U D E R (00) 87/06/30 Wch CAPSTAN MOTOR CONTROL 1.727.330.22 PAGE 4

Table with columns: IND., POS.-NO., PART NO., VALUE, SPECIFICATIONS / EQUIVALENT, MANUF. Contains component list for CAPSTAN MOTOR CONTROL.

S T U D E R (00) 87/06/30 Wch CAPSTAN MOTOR CONTROL 1.727.330.22 PAGE 2

Table with columns: IND., POS.-NO., PART NO., VALUE, SPECIFICATIONS / EQUIVALENT, MANUF. Contains component list for CAPSTAN MOTOR CONTROL.

S T U D E R (00) 87/06/30 Wch CAPSTAN MOTOR CONTROL 1.727.330.22 PAGE 5

Table with columns: IND., POS.-NO., PART NO., VALUE, SPECIFICATIONS / EQUIVALENT, MANUF. Contains component list for CAPSTAN MOTOR CONTROL.

S T U D E R (00) 87/06/30 Wch CAPSTAN MOTOR CONTROL 1.727.330.22 PAGE 3

Table with columns: IND., POS.-NO., PART NO., VALUE, SPECIFICATIONS / EQUIVALENT, MANUF. Contains component list for CAPSTAN MOTOR CONTROL.

S T U D E R (00) 87/06/30 Wch CAPSTAN MOTOR CONTROL 1.727.330.22 PAGE 6

CAPSTAN MOTOR CONTROL 1.727.330.22 GRP20



IND.	POS. NO.	PART NO.	VALUE	SPECIFICATIONS / EQUIVALENT	MANUF.	IND.	POS. NO.	PART NO.	VALUE	SPECIFICATIONS / EQUIVALENT	MANUF.
R....66		57.11.4102	1 kOhm	2% 0.25W, MF		XIC..14		53.03.0168	16 Pole	IC socket	
R....67		57.11.4331	330 Ohm	2% 0.25W, MF		XIC..15		53.03.0166	8 Pole	IC socket	
R....68		57.11.4392	3.9 kOhm	2% 0.25W, MF		XIC..16		53.03.0166	8 Pole	IC socket	
R....69		57.11.4222	2.2 kOhm	2% 0.25W, MF		XIC..17		53.03.0166	8 Pole	IC socket	
R....70		57.11.4152	1.5 kOhm	2% 0.25W, MF		XIC..18		53.03.0168	16 Pole	IC socket	
R....71		57.11.4332	3.3 kOhm	2% 0.25W, MF		XIC..19		53.03.0167	14 Pole	IC socket	
R....72		57.11.4102	1 kOhm	2% 0.25W, MF		XIC..20		53.03.0166	8 Pole	IC socket	
R....73		57.11.4331	330 Ohm	2% 0.25W, MF		XIC..21		53.03.0167	14 Pole	IC socket	
R....74		57.11.4392	3.9 kOhm	2% 0.25W, MF		XIC..22		53.03.0166	8 Pole	IC socket	
R....75		57.11.4222	2.2 kOhm	2% 0.25W, MF							
R....76		57.11.4152	1.5 kOhm	2% 0.25W, MF							
R....77		57.11.4332	3.3 kOhm	2% 0.25W, MF							
R....80		57.11.4682	6.8 kOhm	2% 0.25W, MF							
R....81		57.11.4333	33 kOhm	2% 0.25W, MF							
R....82		57.11.4333	33 kOhm	2% 0.25W, MF							
R....84		57.11.4332	3.3 kOhm	2% 0.25W, MF							
R....85		57.11.4333	33 kOhm	2% 0.25W, MF							
R....86		57.11.4333	33 kOhm	2% 0.25W, MF							
R....87		57.11.4674	470 kOhm	2% 0.25W, MF							
R....88		57.11.4223	22 kOhm	2% 0.25W, MF							
R....89		57.11.4223	22 kOhm	2% 0.25W, MF							
R....90		57.11.4222	2.2 kOhm	2% 0.25W, MF							
R....91		57.11.4104	100 kOhm	2% 0.25W, MF							
R....92		57.11.4122	1.2 kOhm	2% 0.25W, MF							
R....93		57.11.4222	2.2 kOhm	2% 0.25W, MF							
R....94		57.11.4104	100 kOhm	2% 0.25W, MF							
R....95		57.11.4105	1 MOhm	2% 0.25W, MF							
R....96		57.11.4224	220 kOhm	2% 0.25W, MF							
R....98		57.11.4104	100 kOhm	2% 0.25W, MF							
R....99		57.11.4562	5.6 kOhm	2% 0.25W, MF							
R....100		57.11.4562	5.6 kOhm	2% 0.25W, MF							
R....101		57.11.4221	220 Ohm	2% 0.25W, MF							
R....102		57.11.4562	5.6 kOhm	2% 0.25W, MF							
R....103		57.11.4104	100 kOhm	1% 0.25W, MF							
R....106		57.11.4102	1 kOhm	2% 0.25W, MF							
R....107		57.11.4822	8.2 kOhm	2% 0.25W, MF							
R....108		57.11.4822	8.2 kOhm	2% 0.25W, MF							

Note 1 - For excellent wow and flutter values at 3-75 ips the NPN - respective the PNP - Transistors should be from the same manufacturer.

MATERIALS: CER = Ceramics EL = Electrolytic MF = Metalfilm PEP = Polyesterfoil PS = Polystyrol PP = Polypropylen

MANUFACTURER: AMP = AMP Incorporated Ph = Philips FC = Fairchild Ra = Raytheon GI = General Instruments SGS = SGS/Ates IR = International Rectifier Sie = Siemens Mot = Motorola Sig = Signetics NEC = Nippon Electric Corp. St = Studer NS = National Semiconductor TI = Texas Instruments

ORIG 87/06/30

S T U D E R (00) 87/06/30 Wth CAPSTAN MOTOR CONTROL 1.727.330.22 PAGE

S T U D E R (00) 87/06/30 Wth CAPSTAN MOTOR CONTROL 1.727.330.22 PAGE 10

IND.	POS. NO.	PART NO.	VALUE	SPECIFICATIONS / EQUIVALENT	MANUF.
R....109		57.11.4472	4.7 kOhm	2% 0.25W, MF	
R....110		57.11.4472	4.7 kOhm	2% 0.25W, MF	
R....111		57.11.4681	680 Ohm	2% 0.25W, MF	
R....112		57.11.4273	27 kOhm	2% 0.25W, MF	
R....113		57.11.4273	27 kOhm	2% 0.25W, MF	
R....115		57.11.4105	1 MOhm	2% 0.25W, MF	
R....116		57.11.4332	3.3 kOhm	2% 0.25W, MF	
R....117		57.11.4682	6.8 kOhm	2% 0.25W, MF	
R....118		57.11.4561	560 Ohm	2% 0.25W, MF	
R....119		57.11.4103	10 kOhm	2% 0.25W, MF	
R....120		57.11.4561	560 Ohm	2% 0.25W, MF	
R....121		57.11.4121	120 Ohm	2% 0.25W, MF	
R....122		57.11.4122	1.2 kOhm	2% 0.25W, MF	
R....123		57.11.3911	910 Ohm	1% 0.25W, MF	
R....124		57.11.4333	33 kOhm	2% 0.25W, MF	
R....125		57.11.4101	100 Ohm	2% 0.25W, MF	
R....126		57.11.4472	4.7 kOhm	2% 0.25W, MF	
R....127		57.11.4102	1 kOhm	2% 0.25W, MF	
R....128		57.11.4102	1 kOhm	2% 0.25W, MF	
R....129		57.11.4000	0 Ohm		
R....130		57.56.5228	0.22 Ohm	5% 4.0 W Wire	
R....131		57.11.4102	1 kOhm	2% 0.25W, MF	
R....132		57.11.4332	3.3 kOhm	2% 0.25W, MF	
R....133		57.11.4105	1 MOhm	2% 0.25W, MF	
R....134		57.11.4222	2.2 kOhm	2% 0.25W, MF	
R....135		57.11.4152	1.5 kOhm	2% 0.25W, MF	
R....136		57.11.4332	3.3 kOhm	2% 0.25W, MF	
R....137		57.11.4154	150 kOhm	2% 0.25W, MF	
R....138		57.11.4123	12 kOhm	2% 0.25W, MF	
R....139		57.11.4102	1 kOhm	2% 0.25W, MF	
R....140		57.11.4122	1.2 kOhm	2% 0.25W, MF	
R....141		57.11.4472	4.7 kOhm	2% 0.25W, MF	
R....142		57.11.4102	1 kOhm	2% 0.25W, MF	
R....143		57.11.4332	3.3 kOhm	2% 0.25W, MF	
R....145		57.56.5108	0.1 Ohm	10% 4.0 W Wire	
R....146		57.56.5108	0.1 Ohm	10% 4.0 W Wire	
R....147		57.11.4152	1.5 kOhm	2% 0.25W, MF	

S T U D E R (00) 87/06/30 Wth CAPSTAN MOTOR CONTROL 1.727.330.22 PAGE 8

IND.	POS. NO.	PART NO.	VALUE	SPECIFICATIONS / EQUIVALENT	MANUF.
R....148		57.11.4562	5.6 kOhm	2% 0.25W, MF	
R....149		57.11.4562	5.6 kOhm	2% 0.25W, MF	
R....150		57.11.4152	1.5 kOhm	2% 0.25W, MF	
R....151		57.11.4392	3.9 kOhm	2% 0.25W, MF	
R....152		57.11.4102	1 kOhm	2% 0.25W, MF	
R....153		57.11.4472	4.7 kOhm	2% 0.25W, MF	
R....154		57.11.4152	1.5 kOhm	2% 0.25W, MF	
R....155		57.11.4120	12 Ohm	2% 0.25W, MF	
R....156		57.11.4120	12 Ohm	2% 0.25W, MF	
R....157		57.11.4479	4.7 Ohm	2% 0.25W, MF	
R....158		57.11.4479	4.7 Ohm	2% 0.25W, MF	
R....159		57.11.4120	12 Ohm	2% 0.25W, MF	
R....160		57.11.4120	12 Ohm	2% 0.25W, MF	
RZ....1		57.88.4103	8*10 kOhm	5% Single Line	
TP....1		54.02.0320	1 Pole	Tab	
TP....2		54.02.0320	1 Pole	Tab	
TP....3		54.02.0320	1 Pole	Tab	
TP....4		54.02.0320	1 Pole	Tab	
TP....5		54.02.0320	1 Pole	Tab	
W....1		1.010.321.64		Wire Bridge	
XIC...1		53.03.0166	8 Pole	IC socket	
XIC...2		53.03.0166	8 Pole	IC socket	
XIC...3		53.03.0166	8 Pole	IC socket	
XIC...4		53.03.0166	8 Pole	IC socket	
XIC...5		53.03.0166	8 Pole	IC socket	
XIC...6		53.03.0166	8 Pole	IC socket	
XIC...7		53.03.0166	8 Pole	IC socket	
XIC...8		53.03.0168	16 Pole	IC socket	
XIC...9		53.03.0168	16 Pole	IC socket	
XIC...10		53.03.0168	16 Pole	IC socket	
XIC...11		53.03.0168	16 Pole	IC socket	
XIC...12		53.03.0168	16 Pole	IC socket	
XIC...13		53.03.0168	16 Pole	IC socket	

S T U D E R (00) 87/06/30 Wth CAPSTAN MOTOR CONTROL 1.727.330.22 PAGE 9

CAPSTAN START CONTROL 1.727.332.00 (DIAGRAM SEE PAGE 6/45)

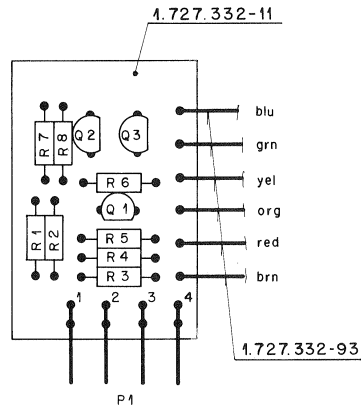

IND.	POS.NO.	PART NO.	VALUE	SPECIFICATIONS / EQUIVALENT	MANUF.
MP....1		1.727.332-11		Capstan Start Ctl. PCB	
MP....2		1.727.332-10		No. Label	
MP....3		1.727.332-93		Wiring List	
P....1		54-01-0223	4 Pin	CIS Pin Strip	
Q....1		50-03-0436	BC237B	BC547B, BC550B	NPN ITT-Mot+Ph+Sie+Tf
Q....2		50-03-0436	BC237A	BC547B, BC550B	NPN ITT-Mot+Ph+Sie+Tf
Q....3		50-03-0329	WP 146	FET	P-CH
R....1		57-11-4563	56 kOhm	2%, 0.25W, MF	
R....2		57-11-4563	56 kOhm	2%, 0.25W, MF	
R....3		57-11-4124	120 kOhm	2%, 0.25W, MF	
R....4		57-11-4922	8.2 kOhm	2%, 0.25W, MF	
R....5		57-11-4223	22 kOhm	2%, 0.25W, MF	
R....6		57-11-4154	150 kOhm	2%, 0.25W, MF	
R....7		57-11-4105	1 kOhm	2%, 0.25W, MF	
R....8		57-11-4473	47 kOhm	2%, 0.25W, MF	

MANUFACTURER:

ORIG 87/06/30

S T U D I E R (00) 87/06/30 Whh CAPSTAN SRART CTL. BOARD 1.727.332.00 PAGE 1

CAPSTAN MOTOR CONTROL 1.727.330.23 GRP20

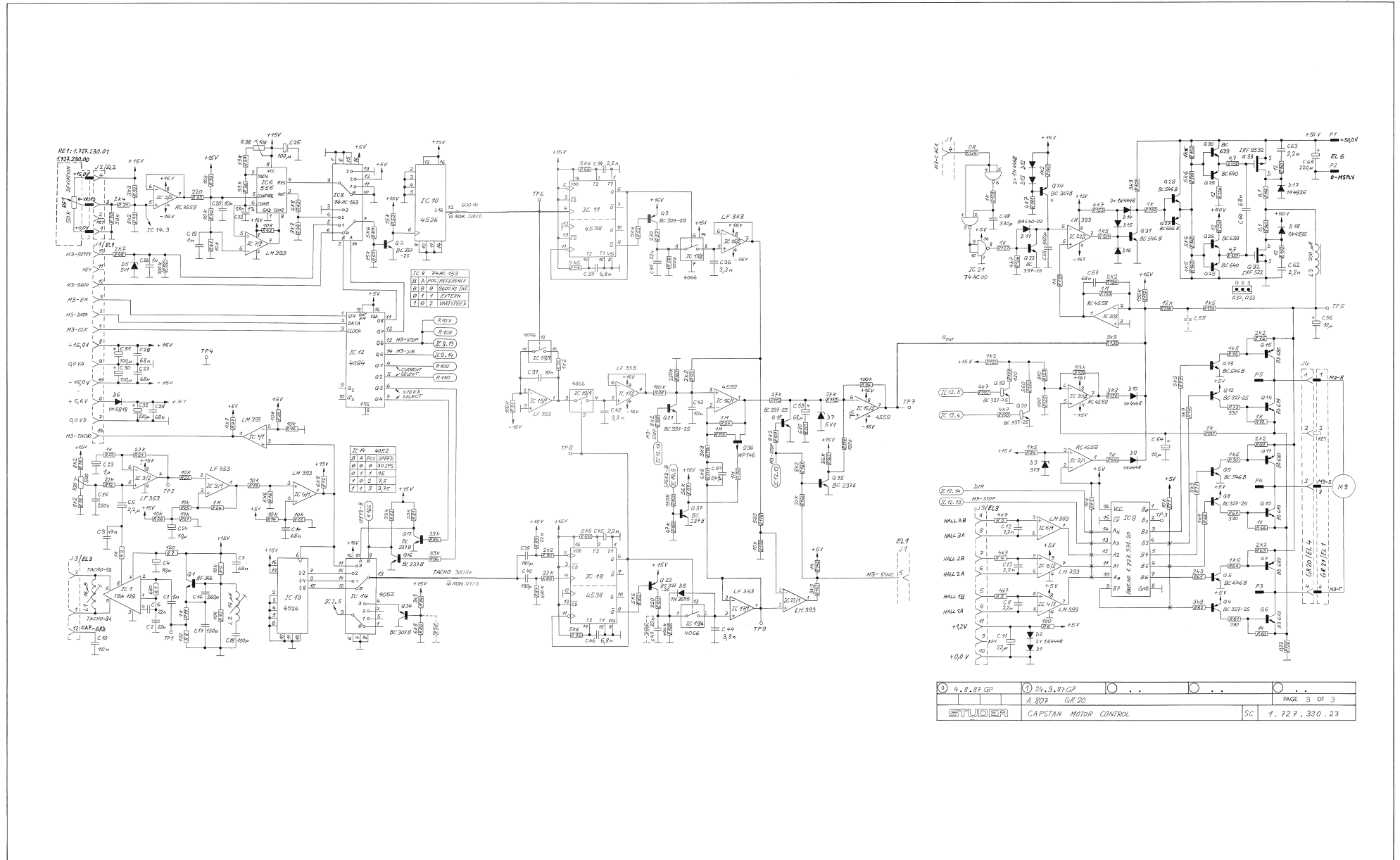

④ 4.8.81 GP	① 24.9.87 GP	○ . . . ○ . . .	○ . . . ○ . . .
STUDER	A 807 GR 20	PAGE 3 OF 3	
CAPSTAN MOTOR CONTROL		SC	1.727.330.23

CAPSTAN MOTOR CONTROL 1.727.330.23 GRP20

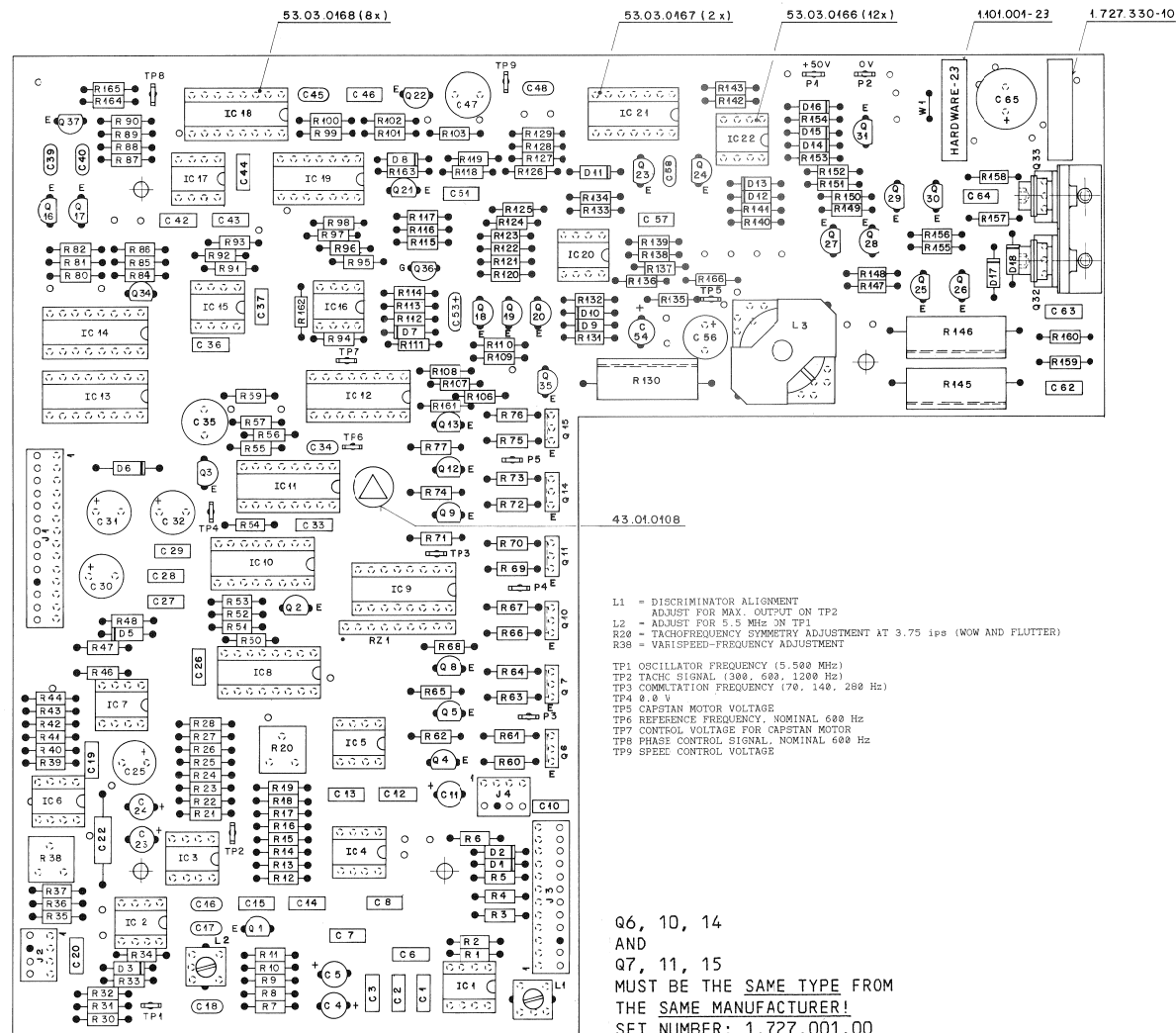

43.01.0108

- L1 = DISCRIMINATOR ALIGNMENT
ADJUST FOR MAX. OUTPUT ON TP2
- L2 = ADJUST FOR 5.5 MHz ON TP1
- R20 = TAGHOFREQUENCY SYMMETRY ADJUSTMENT AT 3.75 ips (WOW AND FLUTTER)
- R30 = VARI-SPEED-FREQUENCY ADJUSTMENT

- TP1 OSCILLATOR FREQUENCY (5.590 Mhz)
- TP2 TAPIC SIGNAL (300, 600, 1200 Hz)
- R20 TAGHOFREQUENCY SYMMETRY ADJUSTMENT AT 3.75 ips (WOW AND FLUTTER)
- R30 VARI-SPEED-FREQUENCY ADJUSTMENT
- TP1 OSCILLATOR FREQUENCY (5.590 Mhz)
- TP2 TAPIC SIGNAL (300, 600, 1200 Hz)
- TP3 COMMUTATION FREQUENCY (70, 140, 280 Hz)
- TP4 0.0 V
- TP5 CAPSTAN MOTOR VOLTAGE
- TP6 REFERENCE FREQUENCY, NOMINAL 600 Hz
- TP7 CONTROL VOLTAGE FOR CAPSTAN MOTOR
- TP8 PHASE CONTROL SIGNAL, NOMINAL 600 Hz
- TP9 SPEED CONTROL VOLTAGE

Q6, 10, 14
AND
Q7, 11, 15
MUST BE THE SAME TYPE FROM
THE SAME MANUFACTURER!
SET NUMBER: 1.727.001.00



CAPSTAN MOTOR CONTROL 1.727.330.23 GRP20

Table with columns: IND., POS.NO., PART NO., VALUE, SPECIFICATIONS / EQUIVALENT, MANUF., and a second set of the same columns. Contains parts list for CAPSTAN MOTOR CONTROL 1.727.330.23.

S T U D E R (01) 87/09/24 GP CAPSTAN MOTOR CONTROL 1.727.330.23 PAGE 1 S T U D E R (01) 87/09/24 GP CAPSTAN MOTOR CONTROL 1.727.330.23 PAGE 4

Table with columns: IND., POS.NO., PART NO., VALUE, SPECIFICATIONS / EQUIVALENT, MANUF., and a second set of the same columns. Contains parts list for CAPSTAN MOTOR CONTROL 1.727.330.23.

S T U D E R (01) 87/09/24 GP CAPSTAN MOTOR CONTROL 1.727.330.23 PAGE 2 S T U D E R (01) 87/09/24 GP CAPSTAN MOTOR CONTROL 1.727.330.23 PAGE 5

Table with columns: IND., POS.NO., PART NO., VALUE, SPECIFICATIONS / EQUIVALENT, MANUF., and a second set of the same columns. Contains parts list for CAPSTAN MOTOR CONTROL 1.727.330.23.

S T U D E R (01) 87/09/24 GP CAPSTAN MOTOR CONTROL 1.727.330.23 PAGE 3 S T U D E R (01) 87/09/24 GP CAPSTAN MOTOR CONTROL 1.727.330.23 PAGE 6

CAPSTAN MOTOR CONTROL 1.727.330.23 GRP20



IND.	POS.NO.	PART NO.	VALUE	SPECIFICATIONS / EQUIVALENT	MANUF.	IND.	POS.NO.	PART NO.	VALUE	SPECIFICATIONS / EQUIVALENT	MANUF.
R....63		57.11.4222	2.2 kOhm	2%, 0.25W, MF		W.....1		1.010.321.64		Wire Bridge	
R....64		57.11.4152	1.5 kOhm	2%, 0.25W, MF		XIC...1		53.03.0166	8 Pole	IC socket	
R....65		57.11.4332	3.3 kOhm	2%, 0.25W, MF		XIC...2		53.03.0166	8 Pole	IC socket	
R....66		57.11.4102	1 kOhm	2%, 0.25W, MF		XIC...3		53.03.0166	8 Pole	IC socket	
R....67		57.11.4392	3.9 kOhm	2%, 0.25W, MF		XIC...4		53.03.0166	8 Pole	IC socket	
R....68		57.11.4392	3.9 kOhm	2%, 0.25W, MF		XIC...5		53.03.0166	8 Pole	IC socket	
R....69		57.11.4222	2.2 kOhm	2%, 0.25W, MF		XIC...6		53.03.0166	8 Pole	IC socket	
R....70		57.11.4152	1.5 kOhm	2%, 0.25W, MF		XIC...7		53.03.0166	8 Pole	IC socket	
R....71		57.11.4332	3.3 kOhm	2%, 0.25W, MF		XIC...8		53.03.0168	16 Pole	IC socket	
R....72		57.11.4102	1 kOhm	2%, 0.25W, MF		XIC...9		53.03.0168	16 Pole	IC socket	
R....73		57.11.4331	330 Ohm	2%, 0.25W, MF		XIC...10		53.03.0168	16 Pole	IC socket	
R....74		57.11.4392	3.9 kOhm	2%, 0.25W, MF		XIC...11		53.03.0168	16 Pole	IC socket	
R....75		57.11.4222	2.2 kOhm	2%, 0.25W, MF		XIC...12		53.03.0168	16 Pole	IC socket	
R....76		57.11.4152	1.5 kOhm	2%, 0.25W, MF		XIC...13		53.03.0168	16 Pole	IC socket	
R....77		57.11.4332	3.3 kOhm	2%, 0.25W, MF		XIC...14		53.03.0168	16 Pole	IC socket	
R....80		57.11.4682	6.8 kOhm	2%, 0.25W, MF		XIC...15		53.03.0166	8 Pole	IC socket	
R....81		57.11.4333	33 kOhm	2%, 0.25W, MF		XIC...16		53.03.0166	8 Pole	IC socket	
R....82		57.11.4333	33 kOhm	2%, 0.25W, MF		XIC...17		53.03.0166	8 Pole	IC socket	
R....84		57.11.4332	3.3 kOhm	2%, 0.25W, MF		XIC...18		53.03.0168	16 Pole	IC socket	
R....85		57.11.4333	33 kOhm	2%, 0.25W, MF		XIC...19		53.03.0167	14 Pole	IC socket	
R....86		57.11.4333	33 kOhm	2%, 0.25W, MF		XIC...20		53.03.0166	8 Pole	IC socket	
R....87		57.11.4474	470 kOhm	2%, 0.25W, MF		XIC...21		53.03.0167	14 Pole	IC socket	
R....88		57.11.4223	22 kOhm	2%, 0.25W, MF		XIC...22		53.03.0166	8 Pole	IC socket	
R....89		57.11.4223	22 kOhm	2%, 0.25W, MF							
R....90		57.11.4222	2.2 kOhm	2%, 0.25W, MF							
R....91		57.11.4104	100 kOhm	2%, 0.25W, MF							
R....92		57.11.4122	1.2 kOhm	2%, 0.25W, MF							
R....93		57.11.4222	2.2 kOhm	2%, 0.25W, MF							
R....94		57.11.4104	100 kOhm	2%, 0.25W, MF							
R....95		57.11.4105	1 MOhm	2%, 0.25W, MF							
R....96		57.11.4105	1 MOhm	2%, 0.25W, MF							
R....97		57.11.4563	56 kOhm	2%, 0.25W, MF							
R....98		57.11.4104	100 kOhm	2%, 0.25W, MF							
R....99		57.11.4562	5.6 kOhm	2%, 0.25W, MF							
R....100		57.11.4562	5.6 kOhm	2%, 0.25W, MF							
R....101		57.11.4221	220 Ohm	2%, 0.25W, MF							
R....102		57.11.4562	5.6 kOhm	2%, 0.25W, MF							

S T U D E R (01) 87/09/24 GP CAPSTAN MOTOR CONTROL 1.727.330.23 PAGE 7 S T U D E R (01) 87/09/24 GP CAPSTAN MOTOR CONTROL 1.727.330.23 PAGE 10

IND.	POS.NO.	PART NO.	VALUE	SPECIFICATIONS / EQUIVALENT	MANUF.	IND.	POS.NO.	PART NO.	VALUE	SPECIFICATIONS / EQUIVALENT	MANUF.
R....103		57.11.43104	100 kOhm	1%, 0.25W, MF							
R....106		57.11.4102	1 kOhm	2%, 0.25W, MF							
R....107		57.11.4822	8.2 kOhm	2%, 0.25W, MF							
R....108		57.11.4822	8.2 kOhm	2%, 0.25W, MF							
R....109		57.11.4472	4.7 kOhm	2%, 0.25W, MF							
R....110		57.11.4472	4.7 kOhm	2%, 0.25W, MF							
R....111		57.11.4601	680 Ohm	2%, 0.25W, MF							
R....112		57.11.4273	27 kOhm	2%, 0.25W, MF							
R....113		57.11.4273	27 kOhm	2%, 0.25W, MF							
R....114		57.11.4124	120 kOhm	2%, 0.25W, MF							
R....115		57.11.4105	1 MOhm	2%, 0.25W, MF							
R....116		57.11.4332	3.3 kOhm	2%, 0.25W, MF							
R....117		57.11.4682	6.8 kOhm	2%, 0.25W, MF							
R....118		57.11.4561	560 Ohm	2%, 0.25W, MF							
R....119		57.11.4103	10 kOhm	2%, 0.25W, MF							
R....120		57.11.4561	560 Ohm	2%, 0.25W, MF							
R....121		57.11.4121	120 Ohm	2%, 0.25W, MF							
R....122		57.11.4122	1.2 kOhm	2%, 0.25W, MF							
R....123		57.11.3911	910 Ohm	2%, 0.25W, MF							
R....124		57.11.4333	33 kOhm	2%, 0.25W, MF							
R....125		57.11.4101	100 Ohm	2%, 0.25W, MF							
R....126		57.11.4472	4.7 kOhm	2%, 0.25W, MF							
R....127		57.11.4102	1 kOhm	2%, 0.25W, MF							
R....128		57.11.4102	1 kOhm	2%, 0.25W, MF							
R....129		57.11.4000	0 Ohm								
R....130		57.56.5228	0.22 Ohm	5%, 4.0 W, Wire							
R....131		57.11.4102	1 kOhm	2%, 0.25W, MF							
R....132		57.11.4332	3.3 kOhm	2%, 0.25W, MF							
R....133		57.11.4105	1 MOhm	2%, 0.25W, MF							
R....134		57.11.4222	2.2 kOhm	2%, 0.25W, MF							
R....135		57.11.4152	1.5 kOhm	2%, 0.25W, MF							
R....136		57.11.4332	3.3 kOhm	2%, 0.25W, MF							
R....137		57.11.4154	150 kOhm	2%, 0.25W, MF							
R....138		57.11.4123	12 kOhm	2%, 0.25W, MF							
R....139		57.11.4102	1 kOhm	2%, 0.25W, MF							
R....140		57.11.4122	1.2 kOhm	2%, 0.25W, MF							
R....141		57.11.4472	4.7 kOhm	2%, 0.25W, MF							

S T U D E R (01) 87/09/24 GP CAPSTAN MOTOR CONTROL 1.727.330.23 PAGE 8 S T U D E R (01) 87/09/24 GP CAPSTAN MOTOR CONTROL 1.727.330.23 PAGE 11

IND.	POS.NO.	PART NO.	VALUE	SPECIFICATIONS / EQUIVALENT	MANUF.	IND.	POS.NO.	PART NO.	VALUE	SPECIFICATIONS / EQUIVALENT	MANUF.
R....142		57.11.4102	1 kOhm	2%, 0.25W, MF							
R....143		57.11.4332	3.3 kOhm	2%, 0.25W, MF							
R....145		57.56.5108	0.1 Ohm	10%, 4.0 W, Wire							
R....146		57.56.5108	0.1 Ohm	10%, 4.0 W, Wire							
R....147		57.11.4152	1.5 kOhm	2%, 0.25W, MF							
R....148		57.11.4562	5.6 kOhm	2%, 0.25W, MF							
R....149		57.11.4562	5.6 kOhm	2%, 0.25W, MF							
R....150		57.11.4152	1.5 kOhm	2%, 0.25W, MF							
R....151		57.11.4392	3.9 kOhm	2%, 0.25W, MF							
R....152		57.11.4102	1 kOhm	2%, 0.25W, MF							
R....153		57.11.4472	4.7 kOhm	2%, 0.25W, MF							
R....154		57.11.4152	1.5 kOhm	2%, 0.25W, MF							
R....155		57.11.4120	12 Ohm	2%, 0.25W, MF							
R....156		57.11.4120	12 Ohm	2%, 0.25W, MF							
R....157		57.11.4479	4.7 Ohm	2%, 0.25W, MF							
R....158		57.11.4479	4.7 Ohm	2%, 0.25W, MF							
R....159		57.11.4120	12 Ohm	2%, 0.25W, MF							
R....160		57.11.4120	12 Ohm	2%, 0.25W, MF							
R....161		57.11.4822	8.2 kOhm	2%, 0.25W, MF							
R....162		57.11.4563	56 kOhm	2%, 0.25W, MF							
R....163		57.11.4224	220 kOhm	2%, 0.25W, MF							
R....164		57.11.4473	47 kOhm	2%, 0.25W, MF							
R....165		57.11.4154	150 kOhm	2%, 0.25W, MF							
R....166		57.11.4223	22 kOhm	2%, 0.25W, MF							
RZ....1		57.88.4103	8810 kOhm	5%, Single Line							
TP....1		54.02.0320	1 Pole	Tab							
TP....2		54.02.0320	1 Pole	Tab							
TP....3		54.02.0320	1 Pole	Tab							
TP....4		54.02.0320	1 Pole	Tab							
TP....5		54.02.0320	1 Pole	Tab							
TP....6		54.02.0320	1 Pole	Tab							
TP....7		54.02.0320	1 Pole	Tab							
TP....8		54.02.0320	1 Pole	Tab							
TP....9		54.02.0320	1 Pole	Tab							

S T U D E R (01) 87/09/24 GP CAPSTAN MOTOR CONTROL 1.727.330.23 PAGE 9

CAPSTAN MOTOR CONTROL 1.727.330.24 GRP20

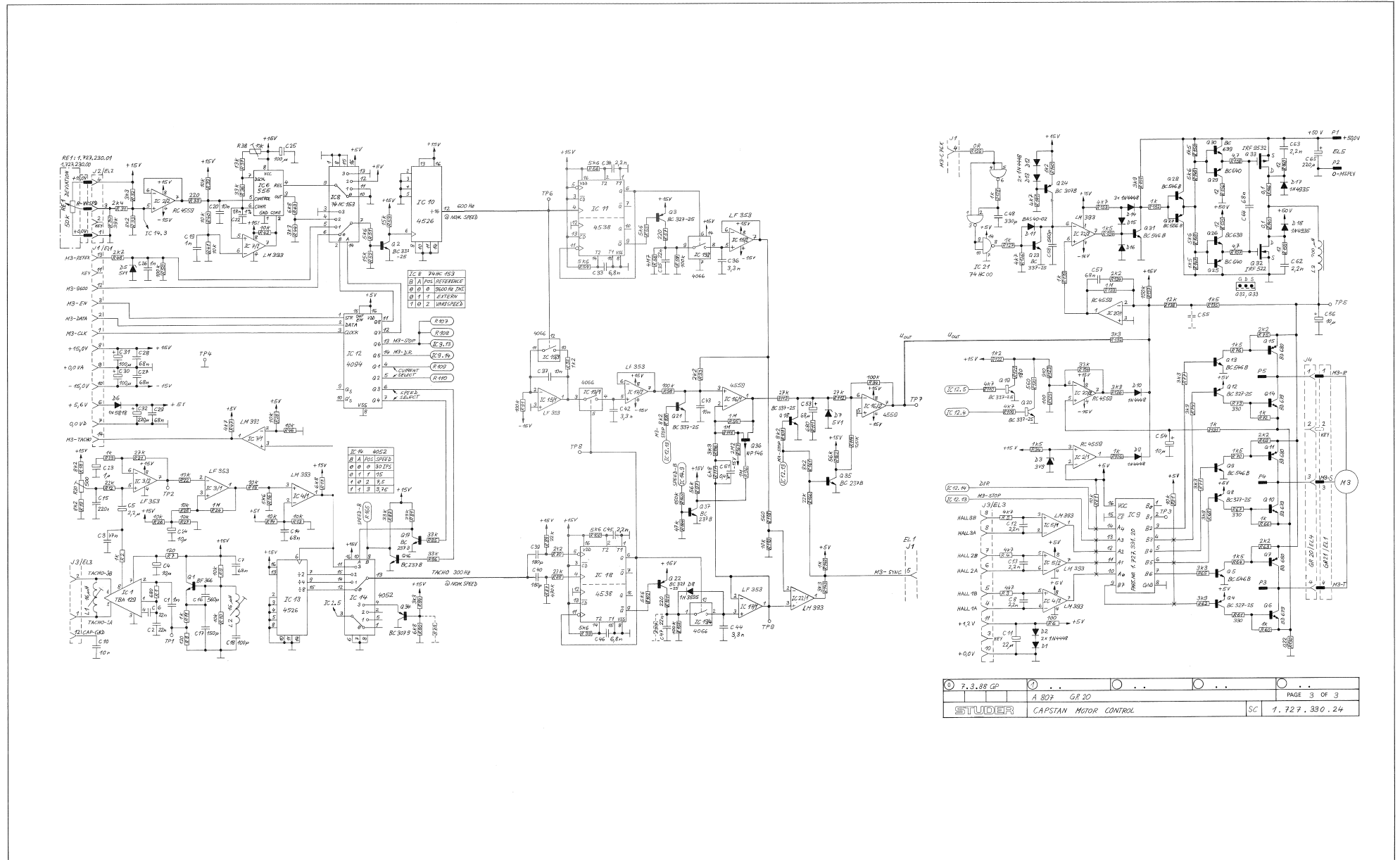

CAPSTAN MOTOR CONTROL 1.727.330.24 GRP20

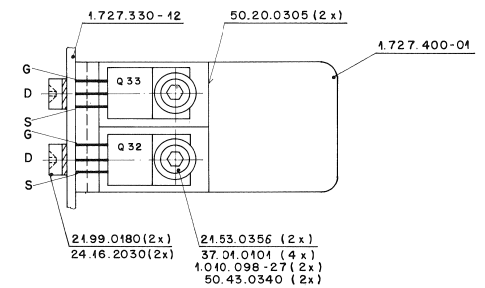
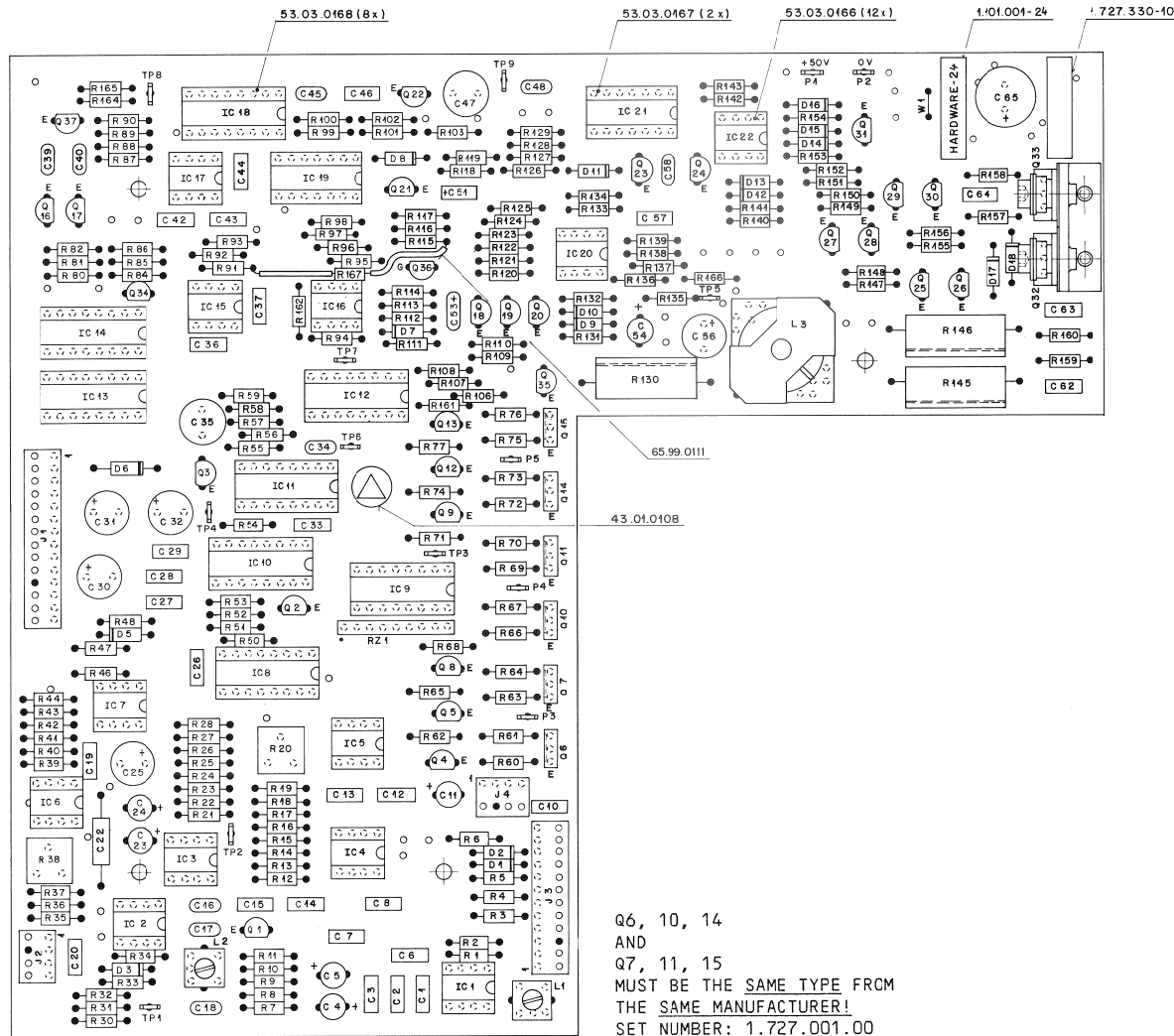

Q6, 10, 14
AND
Q7, 11, 15
MUST BE THE SAME TYPE FROM
THE SAME MANUFACTURER!
SET NUMBER: 1.727.001.00

CAPSTAN MOTOR CONTROL 1.727.330.24 GRP20



Table with 11 columns: IND., POS.-NO., PART NO., VALUE, SPECIFICATIONS / EQUIVALENT, MANUF., IND., POS.-NO., PART NO., VALUE, SPECIFICATIONS / EQUIVALENT, MANUF. Contains component lists for CAPSTAN MOTOR CONTROL 1.727.330.24 PAGE 1.

S T U D E R (00) 88/03/07 GP CAPSTAN MOTOR CONTROL 1.727.330.24 PAGE 1 S T U D E R (00) 88/03/07 GP CAPSTAN MOTOR CONTROL 1.727.330.24 PAGE 4

Table with 11 columns: IND., POS.-NO., PART NO., VALUE, SPECIFICATIONS / EQUIVALENT, MANUF., IND., POS.-NO., PART NO., VALUE, SPECIFICATIONS / EQUIVALENT, MANUF. Contains component lists for CAPSTAN MOTOR CONTROL 1.727.330.24 PAGE 2.

S T U D E R (00) 88/03/07 GP CAPSTAN MOTOR CONTROL 1.727.330.24 PAGE 2 S T U D E R (00) 88/03/07 GP CAPSTAN MOTOR CONTROL 1.727.330.24 PAGE 5

Table with 11 columns: IND., POS.-NO., PART NO., VALUE, SPECIFICATIONS / EQUIVALENT, MANUF., IND., POS.-NO., PART NO., VALUE, SPECIFICATIONS / EQUIVALENT, MANUF. Contains component lists for CAPSTAN MOTOR CONTROL 1.727.330.24 PAGE 3.

S T U D E R (00) 88/03/07 GP CAPSTAN MOTOR CONTROL 1.727.330.24 PAGE 3 S T U D E R (00) 88/03/07 GP CAPSTAN MOTOR CONTROL 1.727.330.24 PAGE 6

CAPSTAN MOTOR CONTROL 1.727.330.24 GRP20



IND.	POS.NO.	PART NO.	VALUE	SPECIFICATIONS / EQUIVALENT	MANUF.	IND.	POS.NO.	PART NO.	VALUE	SPECIFICATIONS / EQUIVALENT	MANUF.
R....63		57.11.3222	2.2 kOhm	1%, 0.25W, MF		W.....1		1.010.321.64		Wire Bridge	
R....64		57.11.3152	1.5 kOhm	1%, 0.25W, MF		XIC...1		53.03.0166	8 Pole	IC socket	
R....65		57.11.3332	3.3 kOhm	1%, 0.25W, MF		XIC...2		53.03.0166	8 Pole	IC socket	
R....66		57.11.3102	1 kOhm	1%, 0.25W, MF		XIC...3		53.03.0166	8 Pole	IC socket	
R....67		57.11.3331	330 Ohm	1%, 0.25W, MF		XIC...4		53.03.0166	8 Pole	IC socket	
R....68		57.11.3222	2.2 kOhm	1%, 0.25W, MF		XIC...5		53.03.0166	8 Pole	IC socket	
R....69		57.11.3222	2.2 kOhm	1%, 0.25W, MF		XIC...6		53.03.0166	8 Pole	IC socket	
R....70		57.11.3152	1.5 kOhm	1%, 0.25W, MF		XIC...7		53.03.0166	8 Pole	IC socket	
R....71		57.11.3332	3.3 kOhm	1%, 0.25W, MF		XIC...8		53.03.0168	16 Pole	IC socket	
R....72		57.11.3102	1 kOhm	1%, 0.25W, MF		XIC...9		53.03.0168	16 Pole	IC socket	
R....73		57.11.3331	330 Ohm	1%, 0.25W, MF		XIC...10		53.03.0168	16 Pole	IC socket	
R....74		57.11.3392	3.9 kOhm	1%, 0.25W, MF		XIC...11		53.03.0168	16 Pole	IC socket	
R....75		57.11.3222	2.2 kOhm	1%, 0.25W, MF		XIC...12		53.03.0168	16 Pole	IC socket	
R....76		57.11.3152	1.5 kOhm	1%, 0.25W, MF		XIC...13		53.03.0168	16 Pole	IC socket	
R....77		57.11.3332	3.3 kOhm	1%, 0.25W, MF		XIC...14		53.03.0168	16 Pole	IC socket	
R....80		57.11.3682	6.8 kOhm	1%, 0.25W, MF		XIC...15		53.03.0166	8 Pole	IC socket	
R....81		57.11.3333	33 kOhm	1%, 0.25W, MF		XIC...16		53.03.0166	8 Pole	IC socket	
R....82		57.11.3333	33 kOhm	1%, 0.25W, MF		XIC...17		53.03.0166	8 Pole	IC socket	
R....84		57.11.3332	3.3 kOhm	1%, 0.25W, MF		XIC...18		53.03.0168	16 Pole	IC socket	
R....85		57.11.3333	33 kOhm	1%, 0.25W, MF		XIC...19		53.03.0167	14 Pole	IC socket	
R....86		57.11.3333	33 kOhm	1%, 0.25W, MF		XIC...20		53.03.0166	8 Pole	IC socket	
R....87		57.11.3674	470 kOhm	1%, 0.25W, MF		XIC...21		53.03.0167	14 Pole	IC socket	
R....88		57.11.3223	22 kOhm	1%, 0.25W, MF		XIC...22		53.03.0166	8 Pole	IC socket	
R....89		57.11.3223	22 kOhm	1%, 0.25W, MF							
R....90		57.11.3222	2.2 kOhm	1%, 0.25W, MF							
R....91		57.11.3104	100 kOhm	1%, 0.25W, MF							
R....92		57.11.3122	1.2 kOhm	1%, 0.25W, MF							
R....93		57.11.3222	2.2 kOhm	1%, 0.25W, MF							
R....94		57.11.3104	100 kOhm	1%, 0.25W, MF							
R....95		57.11.3105	1 MOhm	1%, 0.25W, MF							
R....96		57.11.3105	1 MOhm	1%, 0.25W, MF							
R....97		57.11.3563	56 kOhm	1%, 0.25W, MF							
R....98		57.11.3104	100 kOhm	1%, 0.25W, MF							
R....99		57.11.3562	5.6 kOhm	1%, 0.25W, MF							
R....100		57.11.3562	5.6 kOhm	1%, 0.25W, MF							
R....101		57.11.3221	220 Ohm	1%, 0.25W, MF							
R....102		57.11.3562	5.6 kOhm	1%, 0.25W, MF							

S T U D E R (00) 88/03/07 GP CAPSTAN MOTOR CONTROL 1.727.330.24 PAGE 7 S T U D E R (00) 88/03/07 GP CAPSTAN MOTOR CONTROL 1.727.330.24 PAGE 10

IND.	POS.NO.	PART NO.	VALUE	SPECIFICATIONS / EQUIVALENT	MANUF.	IND.	POS.NO.	PART NO.	VALUE	SPECIFICATIONS / EQUIVALENT	MANUF.
R....103		57.11.3104	100 kOhm	1%, 0.25W, MF							
R....106		57.11.3102	1 kOhm	1%, 0.25W, MF							
R....107		57.11.3822	0.2 kOhm	1%, 0.25W, MF							
R....108		57.11.3822	0.2 kOhm	1%, 0.25W, MF							
R....109		57.11.3472	4.7 kOhm	1%, 0.25W, MF							
R....110		57.11.3472	4.7 kOhm	1%, 0.25W, MF							
R....111		57.11.3681	680 Ohm	1%, 0.25W, MF							
R....112		57.11.3273	27 kOhm	1%, 0.25W, MF							
R....113		57.11.3273	27 kOhm	1%, 0.25W, MF							
R....114		57.11.3124	120 kOhm	1%, 0.25W, MF							
R....115		57.11.3105	1 MOhm	1%, 0.25W, MF							
R....116		57.11.3332	3.3 kOhm	1%, 0.25W, MF							
R....117		57.11.3682	6.8 kOhm	1%, 0.25W, MF							
R....118		57.11.3561	560 Ohm	1%, 0.25W, MF							
R....119		57.11.3103	10 kOhm	1%, 0.25W, MF							
R....120		57.11.3561	560 Ohm	1%, 0.25W, MF							
R....121		57.11.3181	180 Ohm	1%, 0.25W, MF							
R....122		57.11.3122	1.2 kOhm	1%, 0.25W, MF							
R....123		57.11.3911	910 Ohm	1%, 0.25W, MF							
R....124		57.11.3333	33 kOhm	1%, 0.25W, MF							
R....125		57.11.3101	100 Ohm	1%, 0.25W, MF							
R....126		57.11.3472	4.7 kOhm	1%, 0.25W, MF							
R....127		57.11.3102	1 kOhm	1%, 0.25W, MF							
R....128		57.11.3102	1 kOhm	1%, 0.25W, MF							
R....129		57.11.4000	0 Ohm								
R....130		57.56.9228	0.22 Ohm	5%, 4.0 W, Wire							
R....131		57.11.3102	1 kOhm	1%, 0.25W, MF							
R....132		57.11.3332	3.3 kOhm	1%, 0.25W, MF							
R....133		57.11.3105	1 MOhm	1%, 0.25W, MF							
R....134		57.11.3222	2.2 kOhm	1%, 0.25W, MF							
R....135		57.11.3152	1.5 kOhm	1%, 0.25W, MF							
R....136		57.11.3332	3.3 kOhm	1%, 0.25W, MF							
R....137		57.11.3154	150 kOhm	1%, 0.25W, MF							
R....138		57.11.3123	12 kOhm	1%, 0.25W, MF							
R....139		57.11.3102	1 kOhm	1%, 0.25W, MF							
R....140		57.11.3122	1.2 kOhm	1%, 0.25W, MF							
R....141		57.11.3472	4.7 kOhm	1%, 0.25W, MF							

Note 1 - For excellent wow and flutter values at 3.75 ips the NPN - respective the PNP - Transistors should be from the same manufacturer.

MATERIALS: CER = Ceramic, EL = Electrolytic, MF = Metalfilm, PETP = Polyesterfoil, PS = Polystyrol, PP = Polypropylen

MANUFACTURER: AMP = AMP Incorporated, FC = Fairchild, GI = General Instruments, IR = International Rectifier, Mot = Motorola, NEC = Nippon Electric Corp., NS = National Semiconductor, Ph = Philips, Ra = Raytheon, SG5 = SG5/Atos, Sie = Siemens, Sig = Signetics, St = Studer, TI = Texas Instruments

ORIG 88/03/07

S T U D E R (00) 88/03/07 GP CAPSTAN MOTOR CONTROL 1.727.330.24 PAGE 8 S T U D E R (00) 88/03/07 GP CAPSTAN MOTOR CONTROL 1.727.330.24 PAGE 11

IND.	POS.NO.	PART NO.	VALUE	SPECIFICATIONS / EQUIVALENT	MANUF.
R....142		57.11.3102	1 kOhm	1%, 0.25W, MF	
R....143		57.11.3332	3.3 kOhm	1%, 0.25W, MF	
R....145		57.56.5108	0.1 Ohm	10%, 4.0 W, Wire	
R....146		57.56.5108	0.1 Ohm	10%, 4.0 W, Wire	
R....147		57.11.3152	1.5 kOhm	1%, 0.25W, MF	
R....148		57.11.3562	5.6 kOhm	1%, 0.25W, MF	
R....149		57.11.3562	5.6 kOhm	1%, 0.25W, MF	
R....150		57.11.3152	1.5 kOhm	1%, 0.25W, MF	
R....151		57.11.3392	3.9 kOhm	1%, 0.25W, MF	
R....152		57.11.3102	1 kOhm	1%, 0.25W, MF	
R....153		57.11.3472	4.7 kOhm	1%, 0.25W, MF	
R....154		57.11.3152	1.5 kOhm	1%, 0.25W, MF	
R....155		57.11.3120	12 Ohm	1%, 0.25W, MF	
R....156		57.11.3120	12 Ohm	1%, 0.25W, MF	
R....157		57.11.3479	4.7 Ohm	1%, 0.25W, MF	
R....158		57.11.3479	4.7 Ohm	1%, 0.25W, MF	
R....159		57.11.3120	12 Ohm	1%, 0.25W, MF	
R....160		57.11.3120	12 Ohm	1%, 0.25W, MF	
R....161		57.11.3822	0.2 kOhm	1%, 0.25W, MF	
R....162		57.11.3563	56 kOhm	1%, 0.25W, MF	
R....164		57.11.3473	47 kOhm	1%, 0.25W, MF	
R....165		57.11.3154	150 kOhm	1%, 0.25W, MF	
R....166		57.11.3223	22 kOhm	1%, 0.25W, MF	
R....167		57.11.5225	2.2 MOhm	5%, 0.25W, MF	
RZ....1		57.88.4103	8*10 kOhm	5%, Single Line	
TP....1		54.02.0320	1 Pole	Tab	
TP....2		54.02.0320	1 Pole	Tab	
TP....3		54.02.0320	1 Pole	Tab	
TP....4		54.02.0320	1 Pole	Tab	
TP....5		54.02.0320	1 Pole	Tab	
TP....6		54.02.0320	1 Pole	Tab	
TP....7		54.02.0320	1 Pole	Tab	
TP....8		54.02.0320	1 Pole	Tab	
TP....9		54.02.0320	1 Pole	Tab	

S T U D E R (00) 88/03/07 GP CAPSTAN MOTOR CONTROL 1.727.330.24 PAGE 9



CAPSTAN MOTOR CONTROL HS 1.727.335.20 GRP20

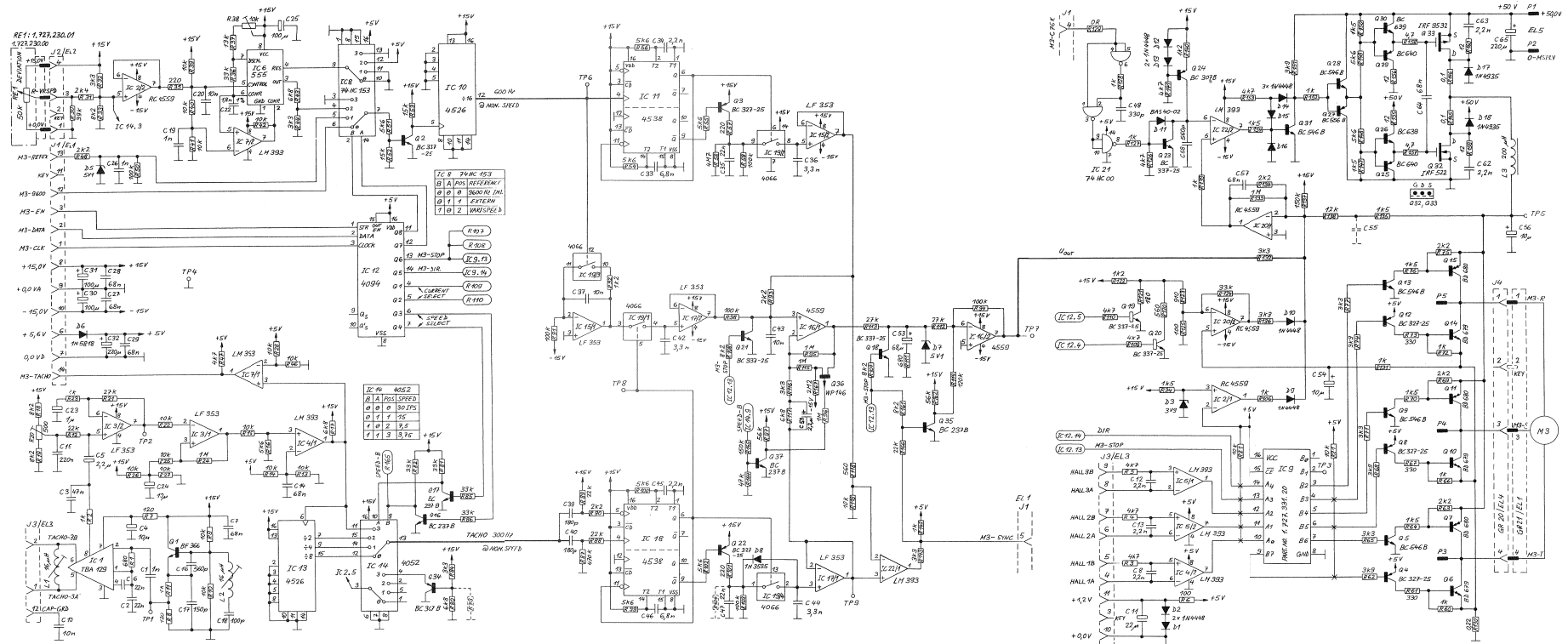

7.3.88 GP	A 807 GR 20	PAGE 3 OF 3
STUDER	CAPSTAN MOTOR CONTROL HS	SC 1.727.335.20

CAPSTAN MOTOR CONTROL HS 1.727.335.20 GRP20

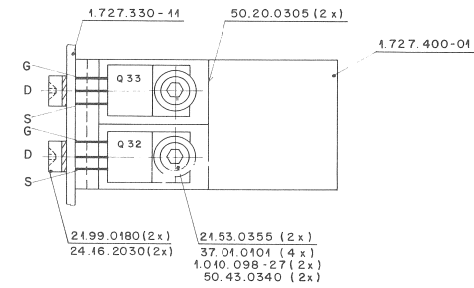
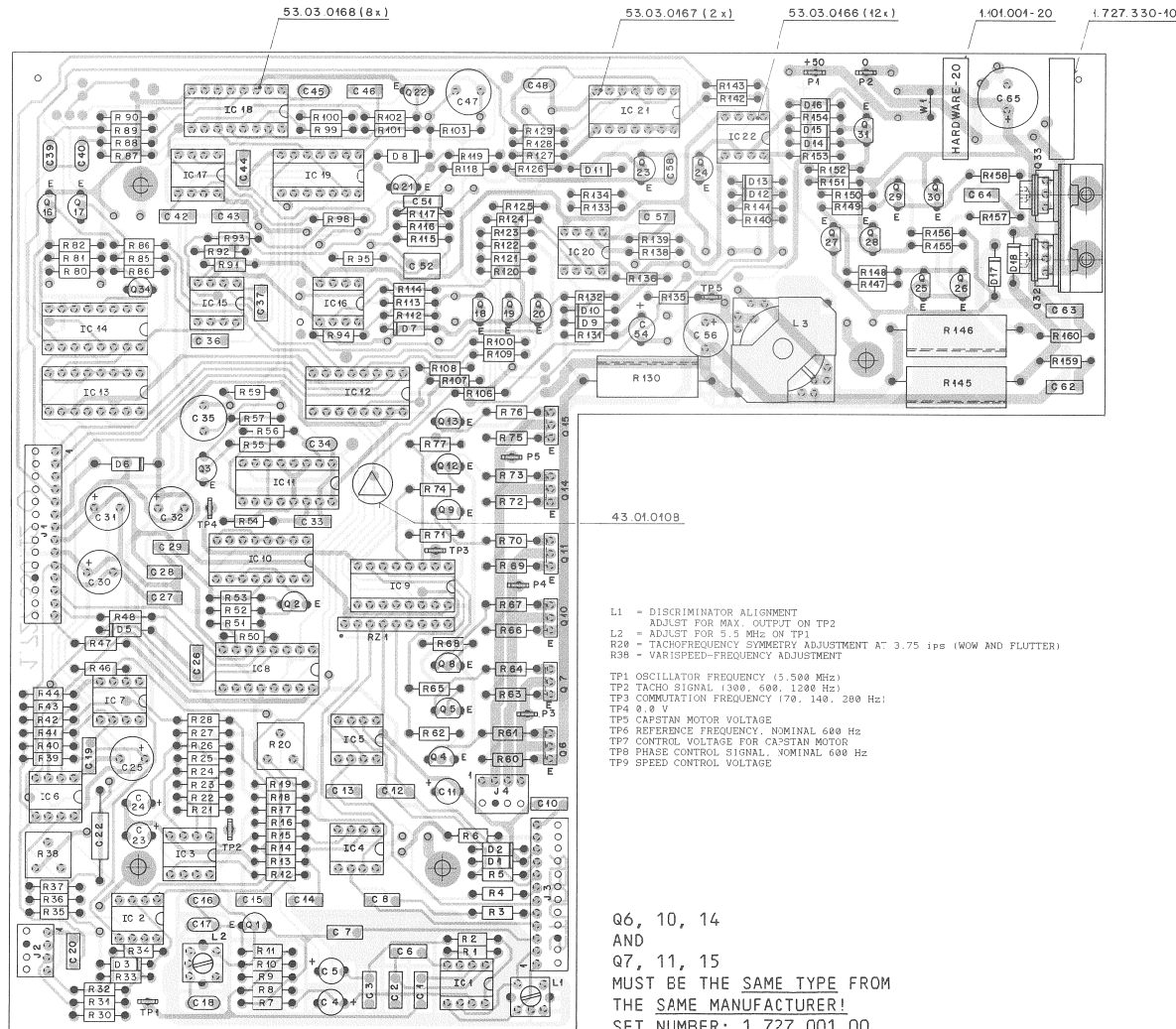

- L1 - DISCRIMINATOR ALIGNMENT
ADJUST FOR MAX. OUTPUT ON TP2
- L2 = ADJUST FOR 5.5 MHz ON TP1
- R38 - TACHOFREQUENCY SYMMETRY ADJUSTMENT AT 3.75 ips (WOW AND FLUTTER)
- R38 - VARISPEED-FREQUENCY ADJUSTMENT

- TP1 OSCILLATOR FREQUENCY (5.500 MHz)
- TP2 TACHO SIGNAL (300, 600, 1200 Hz)
- TP3 COMMUTATION FREQUENCY (70, 140, 280 Hz)
- TP4 0.9 V
- TP5 CAPSTAN MOTOR VOLTAGE
- TP6 REFERENCE FREQUENCY, NOMINAL 600 Hz
- TP7 CONTROL VOLTAGE FOR CAPSTAN MOTOR
- TP8 PHASE CONTROL SIGNAL, NOMINAL 600 Hz
- TP9 SPEED CONTROL VOLTAGE

Q6, 10, 14
AND
Q7, 11, 15
MUST BE THE SAME TYPE FROM
THE SAME MANUFACTURER!
SET NUMBER: 1.727.001.00



CAPSTAN MOTOR CONTROL HS 1.727.335.20 GRP20

Table with 10 columns: IND., POS.-NO., PART NO., VALUE, SPECIFICATIONS / EQUIVALENT, MANUF., IND., POS.-NO., PART NO., VALUE, SPECIFICATIONS / EQUIVALENT, MANUF. It lists various electronic components and their specifications for the CAPSTAN MOTOR CONTROL HS.

S T U D E R (00) 88/03/21 GP CAPSTAN MOTOR CONTROL HS 1.727.335.20 PAGE 1 S T U D E R (00) 88/03/21 GP CAPSTAN MOTOR CONTROL HS 1.727.335.20 PAGE 4

Table with 10 columns: IND., POS.-NO., PART NO., VALUE, SPECIFICATIONS / EQUIVALENT, MANUF., IND., POS.-NO., PART NO., VALUE, SPECIFICATIONS / EQUIVALENT, MANUF. It continues the list of components for the CAPSTAN MOTOR CONTROL HS.

S T U D E R (00) 88/03/21 GP CAPSTAN MOTOR CONTROL HS 1.727.335.20 PAGE 2 S T U D E R (00) 88/03/21 GP CAPSTAN MOTOR CONTROL HS 1.727.335.20 PAGE 5

Table with 10 columns: IND., POS.-NO., PART NO., VALUE, SPECIFICATIONS / EQUIVALENT, MANUF., IND., POS.-NO., PART NO., VALUE, SPECIFICATIONS / EQUIVALENT, MANUF. It lists components including ICs, resistors, capacitors, and other electronic parts.

S T U D E R (00) 88/03/21 GP CAPSTAN MOTOR CONTROL HS 1.727.335.20 PAGE 3 S T U D E R (00) 88/03/21 GP CAPSTAN MOTOR CONTROL HS 1.727.335.20 PAGE 6

CAPSTAN MOTOR CONTROL HS 1.727.335.20 GRP20



IND.	POS.NO.	PART NO.	VALUE	SPECIFICATIONS / EQUIVALENT	MANUF.	IND.	POS.NO.	PART NO.	VALUE	SPECIFICATIONS / EQUIVALENT	MANUF.
R....63	57.11.3222	2.2 kOhm	1%	0.25W, MF		W....1	1.010.321.64			Wire Bridge	
R....64	57.11.3152	1.5 kOhm	1%	0.25W, MF		XIC...1	53.03.0166	8 Pole		IC socket	
R....65	57.11.3332	3.3 kOhm	1%	0.25W, MF		XIC...2	53.03.0166	8 Pole		IC socket	
R....66	57.11.3102	1 kOhm	1%	0.25W, MF		XIC...3	53.03.0166	8 Pole		IC socket	
R....67	57.11.3331	330 Ohm	1%	0.25W, MF		XIC...4	53.03.0166	8 Pole		IC socket	
R....68	57.11.3392	3.9 kOhm	1%	0.25W, MF		XIC...5	53.03.0166	8 Pole		IC socket	
R....69	57.11.3222	2.2 kOhm	1%	0.25W, MF		XIC...6	53.03.0166	8 Pole		IC socket	
R....70	57.11.3152	1.5 kOhm	1%	0.25W, MF		XIC...7	53.03.0166	8 Pole		IC socket	
R....71	57.11.3332	3.3 kOhm	1%	0.25W, MF		XIC...8	53.03.0168	16 Pole		IC socket	
R....72	57.11.3102	1 kOhm	1%	0.25W, MF		XIC...9	53.03.0168	16 Pole		IC socket	
R....73	57.11.3331	330 Ohm	1%	0.25W, MF		XIC...10	53.03.0168	16 Pole		IC socket	
R....74	57.11.3392	3.9 kOhm	1%	0.25W, MF		XIC...11	53.03.0168	16 Pole		IC socket	
R....75	57.11.3222	2.2 kOhm	1%	0.25W, MF		XIC...12	53.03.0168	16 Pole		IC socket	
R....76	57.11.3152	1.5 kOhm	1%	0.25W, MF		XIC...13	53.03.0168	16 Pole		IC socket	
R....77	57.11.3332	3.3 kOhm	1%	0.25W, MF		XIC...14	53.03.0168	16 Pole		IC socket	
R....80	57.11.3682	6.8 kOhm	1%	0.25W, MF		XIC...15	53.03.0166	8 Pole		IC socket	
R....81	57.11.3333	33 kOhm	1%	0.25W, MF		XIC...16	53.03.0166	8 Pole		IC socket	
R....82	57.11.3333	33 kOhm	1%	0.25W, MF		XIC...17	53.03.0166	8 Pole		IC socket	
R....84	57.11.3332	3.3 kOhm	1%	0.25W, MF		XIC...18	53.03.0168	16 Pole		IC socket	
R....85	57.11.3333	33 kOhm	1%	0.25W, MF		XIC...19	53.03.0167	14 Pole		IC socket	
R....86	57.11.3333	33 kOhm	1%	0.25W, MF		XIC...20	53.03.0166	8 Pole		IC socket	
R....87	57.11.3474	470 kOhm	1%	0.25W, MF		XIC...21	53.03.0167	14 Pole		IC socket	
R....88	57.11.3223	22 kOhm	1%	0.25W, MF		XIC...22	53.03.0166	8 Pole		IC socket	
R....89	57.11.3223	22 kOhm	1%	0.25W, MF							
R....90	57.11.3222	2.2 kOhm	1%	0.25W, MF							
R....91	57.11.3104	100 kOhm	1%	0.25W, MF							
R....92	57.11.3122	1.2 kOhm	1%	0.25W, MF							
R....93	57.11.3222	2.2 kOhm	1%	0.25W, MF							
R....94	57.11.3104	100 kOhm	1%	0.25W, MF							
R....95	57.11.3105	1 MOhm	1%	0.25W, MF							
R....96	57.11.3105	1 MOhm	1%	0.25W, MF							
R....97	57.11.3563	56 kOhm	1%	0.25W, MF							
R....98	57.11.3104	100 kOhm	1%	0.25W, MF							
R....99	57.11.3562	5.6 kOhm	1%	0.25W, MF							
R....100	57.11.3562	5.6 kOhm	1%	0.25W, MF							
R....101	57.11.3221	220 Ohm	1%	0.25W, MF							
R....102	57.11.3562	5.6 kOhm	1%	0.25W, MF							
S T U D E R (00) 88/03/21 GP CAPSTAN MOTOR CONTROL HS 1.727.335.20 PAGE 7						S T U D E R (00) 88/03/21 GP CAPSTAN MOTOR CONTROL HS 1.727.335.20 PAGE 10					
IND.	POS.NO.	PART NO.	VALUE	SPECIFICATIONS / EQUIVALENT	MANUF.	IND.	POS.NO.	PART NO.	VALUE	SPECIFICATIONS / EQUIVALENT	MANUF.
R...103	57.11.3104	100 kOhm	1%	0.25W, MF		Note 1 - For excellent wow and flutter values at 3.75 ips the NPN respective the PNP - Transistors should be from the same manufacturer. MATERIALS: CER = Ceramic, EL = Electrolytic, MF = Metalfilm PETP = Polyesterfoil, PS = Polystyrol, PP = Polypropylen					
R...106	57.11.3102	1 kOhm	1%	0.25W, MF							
R...107	57.11.3822	8.2 kOhm	1%	0.25W, MF		MANUFACTURER: AMP = AMP Incorporated Ph = Philips Fc = Fairchild Ra = Raytheon GI = General Instruments SG5 = SGS/Ates IR = International Rectifier Sie = Siemens Mot = Motorola Sig = Signetics NEC = Nippon Electric Corp. St = Studer NS = National Semiconductor TI = Texas Instruments					
R...108	57.11.3222	8.2 kOhm	1%	0.25W, MF							
R...109	57.11.3472	4.7 kOhm	1%	0.25W, MF							
R...110	57.11.3472	4.7 kOhm	1%	0.25W, MF							
R...111	57.11.3681	680 Ohm	1%	0.25W, MF							
R...112	57.11.3273	27 kOhm	1%	0.25W, MF							
R...113	57.11.3273	27 kOhm	1%	0.25W, MF							
R...114	57.11.3124	120 kOhm	1%	0.25W, MF							
R...115	57.11.3105	1 MOhm	1%	0.25W, MF							
R...116	57.11.3332	3.3 kOhm	1%	0.25W, MF							
R...117	57.11.3682	6.8 kOhm	1%	0.25W, MF							
R...118	57.11.3561	560 Ohm	1%	0.25W, MF							
R...119	57.11.3103	10 kOhm	1%	0.25W, MF							
R...120	57.11.3561	560 Ohm	1%	0.25W, MF							
R...121	57.11.3181	180 Ohm	1%	0.25W, MF							
R...122	57.11.3122	1.2 kOhm	1%	0.25W, MF							
R...123	57.11.3111	910 Ohm	1%	0.25W, MF							
R...124	57.11.3333	33 kOhm	1%	0.25W, MF							
R...125	57.11.3101	100 Ohm	1%	0.25W, MF							
R...126	57.11.3472	4.7 kOhm	1%	0.25W, MF							
R...127	57.11.3102	1 kOhm	1%	0.25W, MF							
R...128	57.11.3102	1 kOhm	1%	0.25W, MF							
R...129	57.11.4000	0 Ohm									
R...130	57.56.5228	0.22 Ohm	5%	4.0 W, Wire							
R...131	57.11.3102	1 kOhm	1%	0.25W, MF							
R...132	57.11.3332	3.3 kOhm	1%	0.25W, MF							
R...133	57.11.3105	1 MOhm	1%	0.25W, MF							
R...134	57.11.3222	2.2 kOhm	1%	0.25W, MF							
R...135	57.11.3152	1.5 kOhm	1%	0.25W, MF							
R...136	57.11.3332	3.3 kOhm	1%	0.25W, MF							
R...137	57.11.3154	150 kOhm	1%	0.25W, MF							
R...138	57.11.3123	12 kOhm	1%	0.25W, MF							
R...139	57.11.3102	1 kOhm	1%	0.25W, MF							
R...140	57.11.3122	1.2 kOhm	1%	0.25W, MF							
R...141	57.11.3472	4.7 kOhm	1%	0.25W, MF							
S T U D E R (00) 88/03/21 GP CAPSTAN MOTOR CONTROL HS 1.727.335.20 PAGE 8						S T U D E R (00) 88/03/21 GP CAPSTAN MOTOR CONTROL HS 1.727.335.20 PAGE 11					
IND.	POS.NO.	PART NO.	VALUE	SPECIFICATIONS / EQUIVALENT	MANUF.	IND.	POS.NO.	PART NO.	VALUE	SPECIFICATIONS / EQUIVALENT	MANUF.
R...142	57.11.3102	1 kOhm	1%	0.25W, MF							
R...143	57.11.3332	3.3 kOhm	1%	0.25W, MF							
R...145	57.56.5108	0.1 Ohm	10%	4.0 W, Wire							
R...146	57.56.5108	0.1 Ohm	10%	4.0 W, Wire							
R...147	57.11.3152	1.5 kOhm	1%	0.25W, MF							
R...148	57.11.3562	5.6 kOhm	1%	0.25W, MF							
R...149	57.11.3562	5.6 kOhm	1%	0.25W, MF							
R...150	57.11.3152	1.5 kOhm	1%	0.25W, MF							
R...151	57.11.3392	3.9 kOhm	1%	0.25W, MF							
R...152	57.11.3102	1 kOhm	1%	0.25W, MF							
R...153	57.11.3472	4.7 kOhm	1%	0.25W, MF							
R...154	57.11.3152	1.5 kOhm	1%	0.25W, MF							
R...155	57.11.3120	12 Ohm	1%	0.25W, MF							
R...156	57.11.3120	12 Ohm	1%	0.25W, MF							
R...157	57.11.3479	4.7 Ohm	1%	0.25W, MF							
R...158	57.11.3479	4.7 Ohm	1%	0.25W, MF							
R...159	57.11.3120	12 Ohm	1%	0.25W, MF							
R...160	57.11.3120	12 Ohm	1%	0.25W, MF							
R...161	57.11.3822	8.2 kOhm	1%	0.25W, MF							
R...162	57.11.3563	56 kOhm	1%	0.25W, MF							
R...164	57.11.3473	47 kOhm	1%	0.25W, MF							
R...165	57.11.3154	150 kOhm	1%	0.25W, MF							
R...166	57.11.3223	22 kOhm	1%	0.25W, MF							
R...167	57.11.5225	2.2 MOhm	5%	0.25W, MF							
RZ....1	57.88.4103	8*10 kOhm	5%	Single Line							
TP....1	54.02.0320	1 Pole		Tab							
TP....2	54.02.0320	1 Pole		Tab							
TP....3	54.02.0320	1 Pole		Tab							
TP....4	54.02.0320	1 Pole		Tab							
TP....5	54.02.0320	1 Pole		Tab							
TP....6	54.02.0320	1 Pole		Tab							
TP....7	54.02.0320	1 Pole		Tab							
TP....8	54.02.0320	1 Pole		Tab							
TP....9	54.02.0320	1 Pole		Tab							
S T U D E R (00) 88/03/21 GP CAPSTAN MOTOR CONTROL HS 1.727.335.20 PAGE 9											

COMMAND PANEL (WITHOUT VU-METERS) 1.727.360.00 GRP30

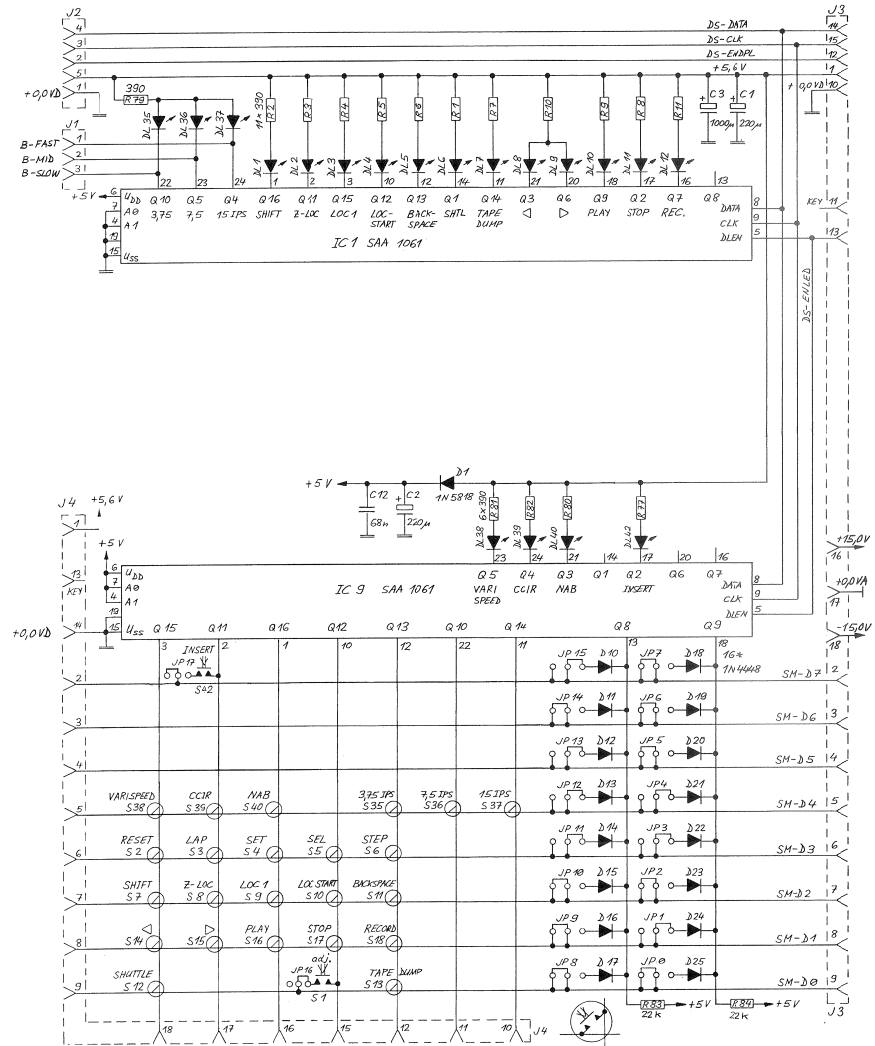

① 25.11.86 GP A 807 GR30 PAGE 1 OF 1
STUDER COMMAND PANEL BOARD 1.727.360.00

IND.	POS.ND.	PART NO.	VALUE	SPECIFICATIONS / EQUIVALENT	MANUF.	IND.	POS.ND.	PART NO.	VALUE	SPECIFICATIONS / EQUIVALENT	MANUF.
A.....1		1.727.370.00		Display Board		R.....80	57.11.4391	390 Ohm	2% 0.25W MF		
A.....2		1.727.180.00		Shuttle Control		R.....81	57.11.4391	390 Ohm	2% 0.25W MF		
C.....1		94.02.2221	222 uF	-20% 10 V EL		R.....82	57.11.4391	390 Ohm	2% 0.25W MF		
C.....2		94.02.2221	222 uF	-20% 10 V EL		R.....83	57.11.4223	22 kOhm	2% 0.25W MF		
C.....3		94.02.1007	1000 uF	-20% 10 V EL		R.....84	57.11.4223	22 kOhm	2% 0.25W MF		
C.....4		94.04.0083	68 uF	10% 50 V PEP		S.....1	55.15.0130		Push button Switch	ITT	
D.....1		50.04.0512		IN6818	30 V Schottky	XIC.....1	55.03.0169	24-Pole	IC Socket		
D.....2		50.04.0125		IN4448	50 V S1	XIC.....9	55.03.0169	24-Pole	IC Socket		
D.....3		50.04.0125		IN4448	50 V S1						
D.....4		50.04.0125		IN4448	50 V S1						
D.....5		50.04.0125		IN4448	50 V S1						
D.....6		50.04.0125		IN4448	50 V S1						
D.....7		50.04.0125		IN4448	50 V S1						
D.....8		50.04.0125		IN4448	50 V S1						
D.....9		50.04.0125		IN4448	50 V S1						
D.....10		50.04.0125		IN4448	50 V S1						
D.....11		50.04.0125		IN4448	50 V S1						
D.....12		50.04.0125		IN4448	50 V S1						
D.....13		50.04.0125		IN4448	50 V S1						
D.....14		50.04.0125		IN4448	50 V S1						
D.....15		50.04.0125		IN4448	50 V S1						
D.....16		50.04.0125		IN4448	50 V S1						
D.....17		50.04.0125		IN4448	50 V S1						
D.....18		50.04.0125		IN4448	50 V S1						
D.....19		50.04.0125		IN4448	50 V S1						
D.....20		50.04.0125		IN4448	50 V S1						
D.....21		50.04.0125		IN4448	50 V S1						
D.....22		50.04.0125		IN4448	50 V S1						
D.....23		50.04.0125		IN4448	50 V S1						
D.....24		50.04.0125		IN4448	50 V S1						
D.....25		50.04.0125		IN4448	50 V S1						
DL.....1		50.04.2501	MV5452	LED grn D=5 mm	GI						
DL.....2		50.04.2500	MV5352	LED yel D=5 mm	GI						
DL.....3		50.04.2500	MV5352	LED yel D=5 mm	GI						
DL.....4		50.04.2500	MV5352	LED yel D=5 mm	GI						
DL.....5		50.04.2500	MV5352	LED yel D=5 mm	GI						
DL.....6		50.04.2500	MV5352	LED yel D=5 mm	GI						
DL.....7		50.04.2500	MV5352	LED yel D=5 mm	GI						
DL.....8		50.04.2500	MV5352	LED yel D=5 mm	GI						
DL.....9		50.04.2500	MV5352	LED yel D=5 mm	GI						
DL.....10		50.04.2500	MV5352	LED yel D=5 mm	GI						
DL.....11		50.04.2500	MV5352	LED yel D=5 mm	GI						
DL.....12		50.04.2501	MV5452	LED grn D=5 mm	GI						
DL.....13		50.04.2500	MV5352	LED yel D=5 mm	GI						
DL.....14		50.04.2500	MV5352	LED yel D=5 mm	GI						
DL.....15		50.04.2500	MV5352	LED yel D=5 mm	GI						
DL.....16		50.04.2500	MV5352	LED yel D=5 mm	GI						
DL.....17		50.04.2500	MV5352	LED yel D=5 mm	GI						
DL.....18		50.04.2500	MV5352	LED yel D=5 mm	GI						
DL.....19		50.04.2500	MV5352	LED yel D=5 mm	GI						
DL.....20		50.04.2500	MV5352	LED yel D=5 mm	GI						
DL.....21		50.04.2500	MV5352	LED yel D=5 mm	GI						
DL.....22		50.04.2500	MV5352	LED yel D=5 mm	GI						
DL.....23		50.04.2500	MV5352	LED yel D=5 mm	GI						
DL.....24		50.04.2500	MV5352	LED yel D=5 mm	GI						
DL.....25		50.04.2500	MV5352	LED yel D=5 mm	GI						
IC.....1		50.13.0106	SAA 1061	Driver	PH						
IC.....2		50.13.0106	SAA 1061	Driver	PH						
J.....1		94.01.0287	3-Pole	CES Socket Strip	AMP						
J.....2		94.01.0288	1-Pole	CES Socket Strip	AMP						
J.....3		94.01.0228	18-Pole	CES Socket Strip	AMP						
J.....4		94.01.0228	18-Pole	CES Socket Strip	AMP						
J.....5		94.01.0021		RF-socket							
J.....6		94.01.0021		RF-socket							
J.....7		94.01.0021		RF-socket							
J.....8		94.01.0021		RF-socket							
J.....9		94.01.0021		RF-socket							
J.....10		94.01.0021		RF-socket							
J.....11		94.01.0021		RF-socket							
J.....12		94.01.0021		RF-socket							
J.....13		94.01.0021		RF-socket							
J.....14		94.01.0021		RF-socket							
J.....15		94.01.0021		RF-socket							
J.....16		94.01.0021		RF-socket							
J.....17		94.01.0021		RF-socket							
MP.....		94.01.0020	14 pcs	Contact Pin							

STUDER (00) 86/11/25 GP COMMAND PANEL BOARD 1.727.360.00 PAGE 1 STUDER (00) 86/11/25 GP COMMAND PANEL BOARD 1.727.360.00 PAGE 4

IND.	POS.ND.	PART NO.	VALUE	SPECIFICATIONS / EQUIVALENT	MANUF.
DL.....17		50.04.2115	MV5752	LED red D=5 mm	GI
DL.....18		50.04.2500	MV5352	LED yel D=5 mm	GI
DL.....19		50.04.2500	MV5352	LED yel D=5 mm	GI
DL.....20		50.04.2500	MV5352	LED yel D=5 mm	GI
DL.....21		50.04.2500	MV5352	LED yel D=5 mm	GI
DL.....22		50.04.2500	MV5352	LED yel D=5 mm	GI
DL.....23		50.04.2500	MV5352	LED yel D=5 mm	GI
DL.....24		50.04.2500	MV5352	LED yel D=5 mm	GI
DL.....25		50.04.2500	MV5352	LED yel D=5 mm	GI
DL.....26		50.04.2500	MV5352	LED yel D=5 mm	GI
DL.....27		50.04.2500	MV5352	LED yel D=5 mm	GI
DL.....28		50.04.2500	MV5352	LED yel D=5 mm	GI
DL.....29		50.04.2500	MV5352	LED yel D=5 mm	GI
DL.....30		50.04.2500	MV5352	LED yel D=5 mm	GI
DL.....31		50.04.2500	MV5352	LED yel D=5 mm	GI
DL.....32		50.04.2500	MV5352	LED yel D=5 mm	GI
DL.....33		50.04.2500	MV5352	LED yel D=5 mm	GI
DL.....34		50.04.2500	MV5352	LED yel D=5 mm	GI
DL.....35		50.04.2500	MV5352	LED yel D=5 mm	GI
DL.....36		50.04.2500	MV5352	LED yel D=5 mm	GI
DL.....37		50.04.2500	MV5352	LED yel D=5 mm	GI
DL.....38		50.04.2500	MV5352	LED yel D=5 mm	GI
DL.....39		50.04.2500	MV5352	LED yel D=5 mm	GI
DL.....40		50.04.2500	MV5352	LED yel D=5 mm	GI
DL.....41		50.04.2500	MV5352	LED yel D=5 mm	GI
DL.....42		50.04.2501	MV5452	LED grn D=5 mm	GI
IC.....1		50.13.0106	SAA 1061	Driver	PH
IC.....2		50.13.0106	SAA 1061	Driver	PH
J.....1		94.01.0287	3-Pole	CES Socket Strip	AMP
J.....2		94.01.0288	1-Pole	CES Socket Strip	AMP
J.....3		94.01.0228	18-Pole	CES Socket Strip	AMP
J.....4		94.01.0228	18-Pole	CES Socket Strip	AMP
J.....5		94.01.0021		RF-socket	
J.....6		94.01.0021		RF-socket	
J.....7		94.01.0021		RF-socket	
J.....8		94.01.0021		RF-socket	
J.....9		94.01.0021		RF-socket	
J.....10		94.01.0021		RF-socket	
J.....11		94.01.0021		RF-socket	
J.....12		94.01.0021		RF-socket	
J.....13		94.01.0021		RF-socket	
J.....14		94.01.0021		RF-socket	
J.....15		94.01.0021		RF-socket	

COMMAND PANEL (WITHOUT VU-METERS) 1.727.360.00 GRP30

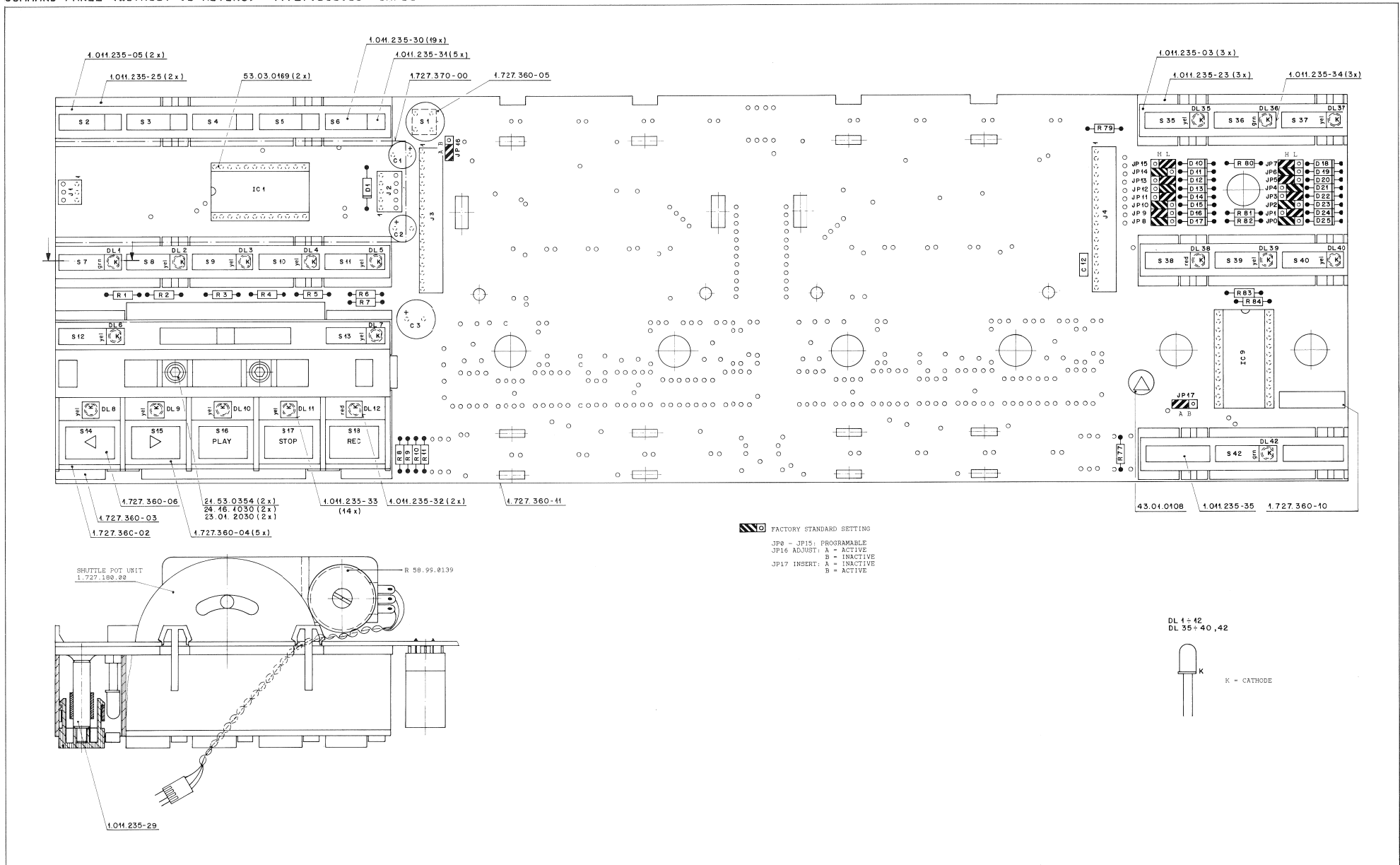

FACTORY STANDARD SETTING
 JP8 - JP15: PROGRAMMABLE
 JP16 ADJUST: A = ACTIVE
 B = INACTIVE
 JP17 INSERT: A = INACTIVE
 B = ACTIVE

DL 4 = 42
 DL 35 = 40, 42

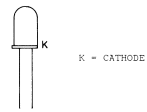



COMMAND PANEL (1 VU) 1.727.361.00 GRP30

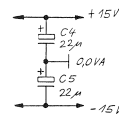
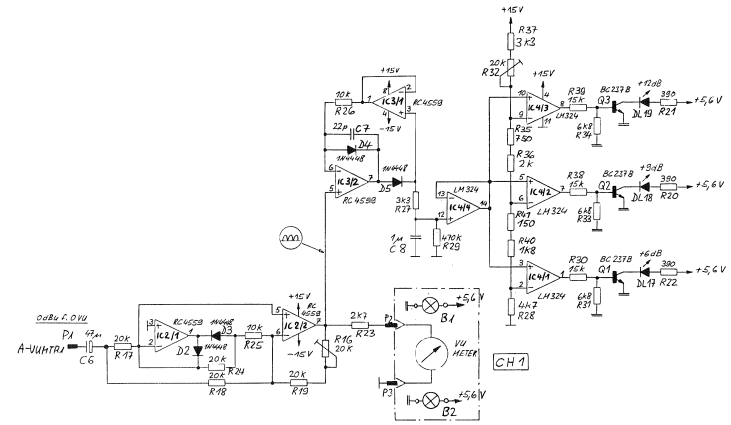
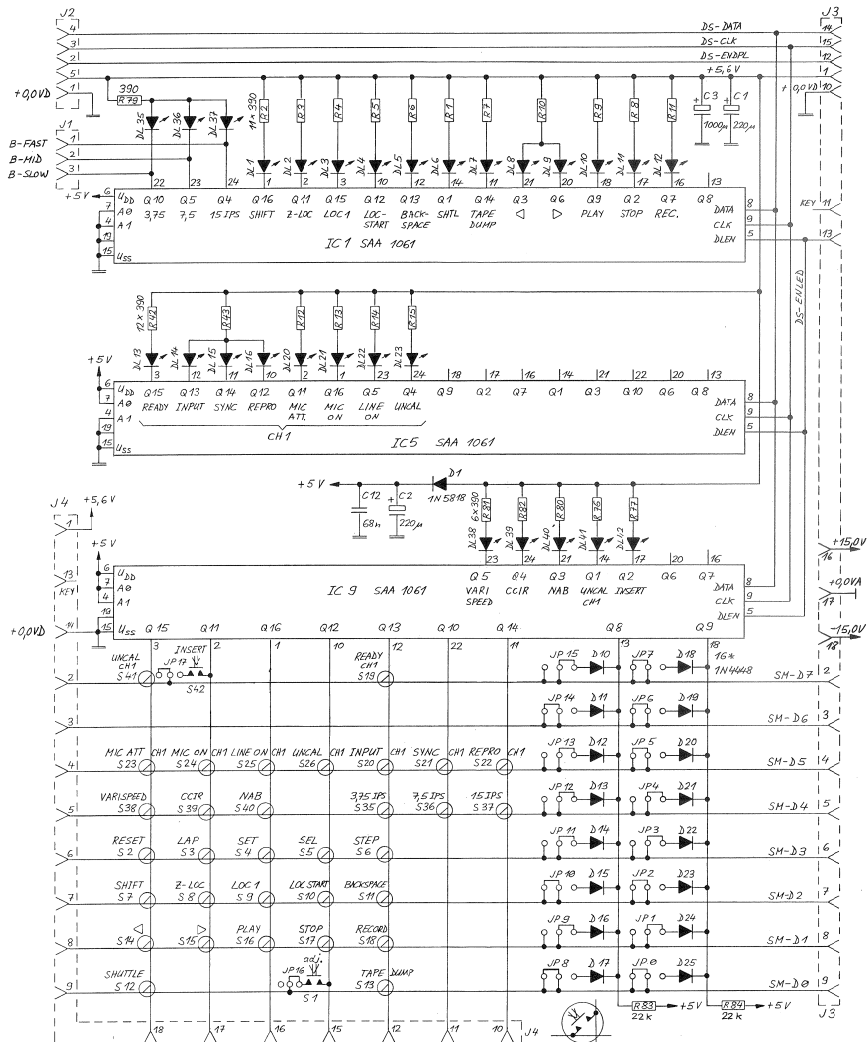

① 25.1.86 GP	○ . . ○ . . ○ . .	○ . . ○ . . ○ . .	○ . . ○ . . ○ . .
	A 807 GR 30		PAGE 2 OF 2
STUDER	COMMAND PANEL BOARD 1 VU	SC	1.727.361.00

COMMAND PANEL (1 VU) 1.727.361.00 GRP30

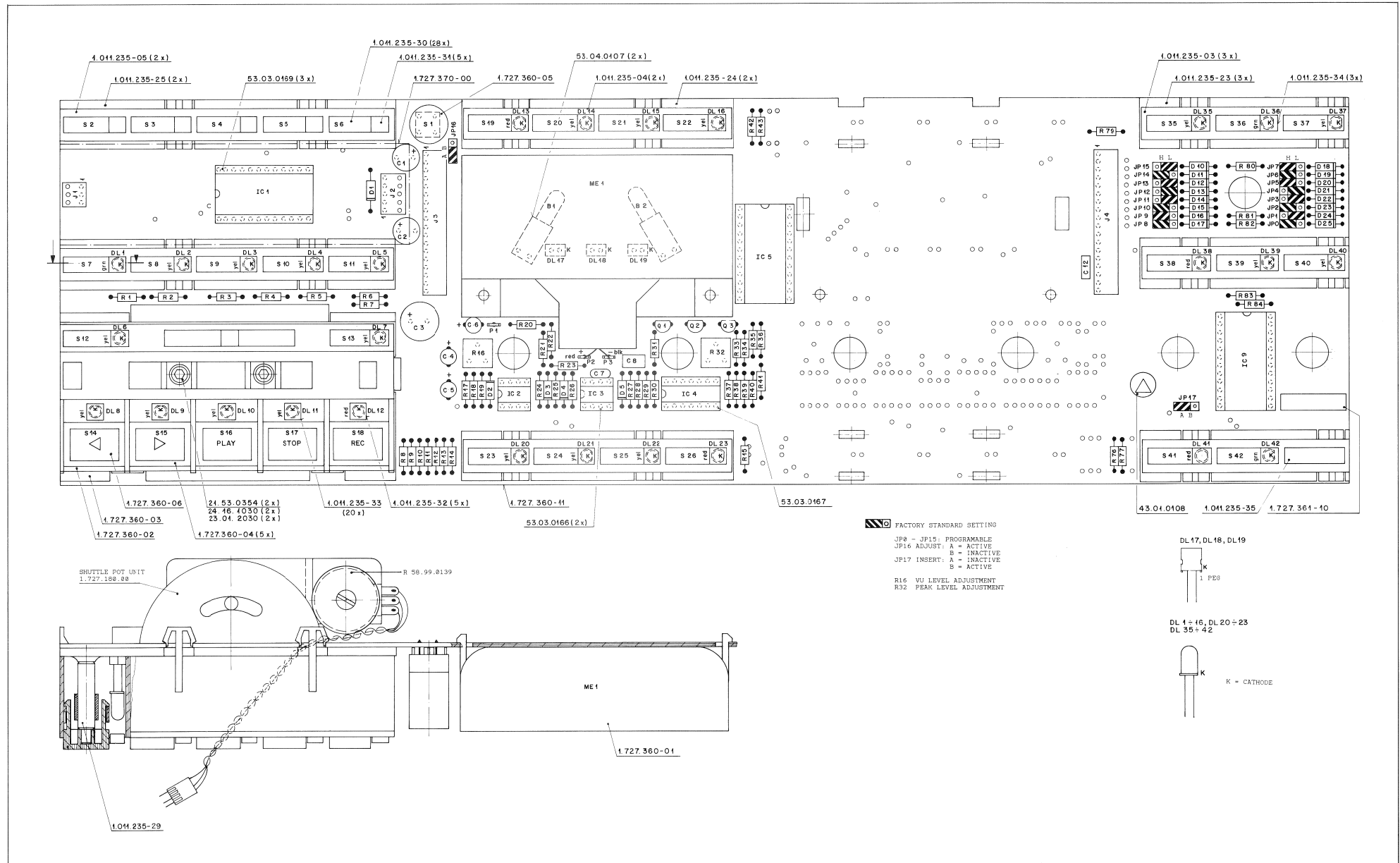



COMMAND PANEL (1 VU) 1.727.361.00 GRP30

IND.	POS.NO.	PART NO.	VALUE	SPECIFICATIONS / EQUIVALENT	MANUF.	IND.	POS.NO.	PART NO.	VALUE	SPECIFICATIONS / EQUIVALENT	MANUF.
A.....1	1.727.370.00			Display Board		MP...10	1.011.235.31		5 pcs	Dummy Calotte	
A.....2	1.727.180.00			Shuttle Control		MP...11	1.011.235.32		5 pcs	Calotte red	
B.....1	51.02.0144	6 V		0.03 A Lamp		MP...12	1.011.235.33		20 pcs	Calotte yel	
B.....2	51.02.0144	6 V		0.03 A Lamp		MP...13	1.011.235.34		3 pcs	Calotte grn	
C.....1	59.22.3221	220 uF	-20%	10 V EL		MP...14	1.727.360.02		1 pcs	Push button case with Shuttle	
C.....2	59.22.3221	220 uF	-20%	10 V EL		MP...15	1.727.360.03		1 pcs	Conductive rubber with Shuttle	
C.....3	59.22.3102	1000 uF	-20%	10 V EL		MP...16	1.727.360.04		5 pcs	Push button 19P14	
C.....4	59.22.5220	22 uF	-20%	25 V EL		MP...17	1.727.360.05		1 pcs	Push button Adj.	
C.....5	59.22.5220	22 uF	-20%	25 V EL		MP...18	1.727.361.10		1 pcs	No. Label	
C.....6	59.22.3470	47 uF	-20%	10 V EL		MP...19	1.727.360.11		1 pcs	Command Panel PCB	
C.....7	59.34.2220	22 pF	10%	50 V CER		MP...20	53.03.0221		31 pcs	2-pole LED Socket	
C.....8	59.06.0105	1 uF	10%	50 V PETP		MP...21	1.727.362.93		1 pcs	L-LSI Command Panel Board	
C.....12	59.06.0683	68 nF	10%	50 V PETP		MP...22	21.93.0354		2 pcs	Hexagon socket head cap screw M3*6	
D.....1	50.04.0512	1N5818		30 V Schottky		MP...23	23.01.2032		2 pcs	Washer	
D.....2	50.04.0125	1N4448		50 V SI		MP...24	26.16.1030		2 pcs	Fin washer	
D.....3	50.04.0125	1N4448		50 V SI		MP...25	43.01.0108		1 pcs	ESE Warning Label	
D.....4	50.04.0125	1N4448		50 V SI		MP...26	1.727.360.06		1 pcs	Push button labels (<>,<PLAY>,STOP,REC)	
D.....5	50.04.0125	1N4448		50 V SI		MP...27	1.011.235.35		1 pcs	Dummy push button 19*5	
D.....10	50.04.0125	1N4448		50 V SI		P.....1	54.02.0320			Plug 2.8*0.8	AMP
D.....11	50.04.0125	1N4448		50 V SI		P.....2	54.02.0320			Plug 2.8*0.8	AMP
D.....12	50.04.0125	1N4448		50 V SI		P.....3	54.02.0320			Plug 2.8*0.8	AMP
D.....13	50.04.0125	1N4448		50 V SI		Q.....1	50.03.0436	8C237B		BC547B, BC550B	NPN
D.....14	50.04.0125	1N4448		50 V SI		Q.....2	50.03.0436	8C237B		BC547B, BC550B	NPN
D.....15	50.04.0125	1N4448		50 V SI		Q.....3	50.03.0436	8C237B		BC547B, BC550B	NPN
D.....16	50.04.0125	1N4448		50 V SI		R.....1	57.11.4391	390 Ohm	2%	0.25W MF	
D.....17	50.04.0125	1N4448		50 V SI		R.....2	57.11.4391	390 Ohm	2%	0.25W MF	
D.....18	50.04.0125	1N4448		50 V SI		R.....3	57.11.4391	390 Ohm	2%	0.25W MF	
D.....19	50.04.0125	1N4448		50 V SI		R.....4	57.11.4391	390 Ohm	2%	0.25W MF	
D.....20	50.04.0125	1N4448		50 V SI		R.....5	57.11.4391	390 Ohm	2%	0.25W MF	
D.....21	50.04.0125	1N4448		50 V SI		R.....6	57.11.4391	390 Ohm	2%	0.25W MF	
D.....22	50.04.0125	1N4448		50 V SI		R.....7	57.11.4391	390 Ohm	2%	0.25W MF	
D.....23	50.04.0125	1N4448		50 V SI		R.....8	57.11.4391	390 Ohm	2%	0.25W MF	
D.....24	50.04.0125	1N4448		50 V SI		R.....9	57.11.4391	390 Ohm	2%	0.25W MF	
D.....25	50.04.0125	1N4448		50 V SI		R.....10	57.11.4391	390 Ohm	2%	0.25W MF	

S T U D E R (00) 86/09/23 GP COMMAND PANEL BOARD 1VU 1.727.361.00 PAGE 1 S T U D E R (00) 86/09/23 GP COMMAND PANEL BOARD 1VU 1.727.361.00 PAGE 4

IND.	POS.NO.	PART NO.	VALUE	SPECIFICATIONS / EQUIVALENT	MANUF.	IND.	POS.NO.	PART NO.	VALUE	SPECIFICATIONS / EQUIVALENT	MANUF.
DL.....1	50.04.2501	MV5452		LED grn D=5 mm	GI	R.....11	57.11.4391	390 Ohm	2%	0.25W MF	
DL.....2	50.04.2500	MV5352		LED yel D=5 mm	GI	R.....12	57.11.4391	390 Ohm	2%	0.25W MF	
DL.....3	50.04.2500	MV5352		LED yel D=5 mm	GI	R.....13	57.11.4391	390 Ohm	2%	0.25W MF	
DL.....4	50.04.2500	MV5352		LED yel D=5 mm	GI	R.....14	57.11.4391	390 Ohm	2%	0.25W MF	
DL.....5	50.04.2500	MV5352		LED yel D=5 mm	GI	R.....15	57.11.4391	390 Ohm	2%	0.25W MF	
DL.....6	50.04.2500	MV5352		LED yel D=5 mm	GI	R.....16	58.01.8203	20 kOhm	10%	0.5 W PCerm	
DL.....7	50.04.2500	MV5352		LED yel D=5 mm	GI	R.....17	57.11.3203	20 kOhm	2%	0.25W MF	
DL.....8	50.04.2500	MV5352		LED yel D=5 mm	GI	R.....18	57.11.3203	20 kOhm	2%	0.25W MF	
DL.....9	50.04.2500	MV5352		LED yel D=5 mm	GI	R.....19	57.11.3203	20 kOhm	2%	0.25W MF	
DL.....10	50.04.2500	MV5352		LED yel D=5 mm	GI	R.....20	57.11.4391	390 Ohm	2%	0.25W MF	
DL.....11	50.04.2500	MV5352		LED yel D=5 mm	GI	R.....21	57.11.4391	390 Ohm	2%	0.25W MF	
DL.....12	50.04.2115	MV5752		LED red D=5 mm	GI	R.....22	57.11.4391	390 Ohm	2%	0.25W MF	
DL.....13	50.04.2115	MV5752		LED red D=5 mm	GI	R.....23	57.11.4272	2.7 kOhm	2%	0.25W MF	
DL.....14	50.04.2500	MV5352		LED yel D=5 mm	GI	R.....24	57.11.3203	20 kOhm	2%	0.25W MF	
DL.....15	50.04.2500	MV5352		LED yel D=5 mm	GI	R.....25	57.11.4103	10 kOhm	2%	0.25W MF	
DL.....16	50.04.2500	MV5352		LED yel D=5 mm	GI	R.....26	57.11.4103	10 kOhm	2%	0.25W MF	
DL.....17	50.04.2119	MV57124		LED red 6.35*3.81	GI	R.....27	57.11.4332	3.3 kOhm	2%	0.25W MF	
DL.....18	50.04.2119	MV57124		LED red 6.35*3.81	GI	R.....28	57.11.3672	4.7 kOhm	1%	0.25W MF	
DL.....19	50.04.2119	MV57124		LED red 6.35*3.81	GI	R.....29	57.11.4474	470 kOhm	2%	0.25W MF	
DL.....20	50.04.2500	MV5352		LED yel D=5 mm	GI	R.....30	57.11.4153	15 kOhm	2%	0.25W MF	
DL.....21	50.04.2500	MV5352		LED yel D=5 mm	GI	R.....31	57.11.4682	6.8 kOhm	2%	0.25W MF	
DL.....22	50.04.2500	MV5352		LED yel D=5 mm	GI	R.....32	58.01.8203	20 kOhm	10%	0.5 W PCerm	
DL.....23	50.04.2115	MV5752		LED red D=5 mm	GI	R.....33	57.11.4682	6.8 kOhm	2%	0.25W MF	
DL.....35	50.04.2500	MV5352		LED yel D=5 mm	GI	R.....34	57.11.4682	6.8 kOhm	2%	0.25W MF	
DL.....36	50.04.2500	MV5352		LED yel D=5 mm	GI	R.....35	57.11.3751	750 Ohm	1%	0.25W MF	
DL.....37	50.04.2500	MV5352		LED yel D=5 mm	GI	R.....36	57.11.3202	2 kOhm	1%	0.25W MF	
DL.....38	50.04.2115	MV5752		LED red D=5 mm	GI	R.....37	57.11.4332	3.3 kOhm	2%	0.25W MF	
DL.....39	50.04.2500	MV5352		LED yel D=5 mm	GI	R.....38	57.11.4153	15 kOhm	2%	0.25W MF	
DL.....40	50.04.2500	MV5352		LED yel D=5 mm	GI	R.....39	57.11.4153	15 kOhm	2%	0.25W MF	
DL.....41	50.04.2115	MV5752		LED red D=5 mm	GI	R.....40	57.11.3182	1.8 kOhm	1%	0.25W MF	
DL.....42	50.04.2115	MV5452		LED grn D=5 mm	GI	R.....41	57.11.4151	150 Ohm	2%	0.25W MF	
IC.....1	50.13.0106	SAA 1061		Driver	Ph	R.....42	57.11.4391	390 Ohm	2%	0.25W MF	
IC.....2	50.09.0107	RC4559		Dual Op. Amp.	Ra	R.....43	57.11.4391	390 Ohm	2%	0.25W MF	
IC.....3	50.09.0107	RC4559		Dual Op. Amp.	Ra	R.....44	57.11.4391	390 Ohm	2%	0.25W MF	
IC.....4	50.09.0109	LK324		Quad Op. Amp.	NS+Mot	R.....45	57.11.4391	390 Ohm	2%	0.25W MF	
IC.....5	50.13.0106	SAA 1061		Driver	Ph	R.....46	57.11.4391	390 Ohm	2%	0.25W MF	

S T U D E R (00) 86/09/23 GP COMMAND PANEL BOARD 1VU 1.727.361.00 PAGE 2 S T U D E R (00) 86/09/23 GP COMMAND PANEL BOARD 1VU 1.727.361.00 PAGE 5

IND.	POS.NO.	PART NO.	VALUE	SPECIFICATIONS / EQUIVALENT	MANUF.	IND.	POS.NO.	PART NO.	VALUE	SPECIFICATIONS / EQUIVALENT	MANUF.
IC.....9	50.13.0106	SAA 1061		Driver	Ph	R.....81	57.11.4391	390 Ohm	2%	0.25W MF	
J.....1	54.01.0287	3-Pole		CIS Socket Strip	AMP	R.....82	57.11.4391	390 Ohm	2%	0.25W MF	
J.....2	54.01.0288	5-Pole		CIS Socket Strip	AMP	R.....83	57.11.4223	22 kOhm	2%	0.25W MF	
J.....3	54.01.0228	18-Pole		CIS Socket Strip	AMP	R.....84	57.11.4223	22 kOhm	2%	0.25W MF	
J.....4	54.01.0228	18-Pole		CIS Socket Strip	AMP	S.....1	55.15.0130			Push button Switch	ITT
JP.....0	54.01.0021			Bridge		XB.....1	53.04.0107			Lamp holder	
JP.....1	54.01.0021			Bridge		XB.....2	53.04.0107			Lamp holder	
JP.....2	54.01.0021			Bridge		XIC.....1	53.03.0169			24-Pole IC Socket	
JP.....3	54.01.0021			Bridge		XIC.....2	53.03.0166			8-Pole IC Socket	
JP.....4	54.01.0021			Bridge		XIC.....3	53.03.0166			8-Pole IC Socket	
JP.....5	54.01.0021			Bridge		XIC.....4	53.03.0167			14-Pole IC Socket	
JP.....6	54.01.0021			Bridge		XIC.....5	53.03.0169			24-Pole IC Socket	
JP.....7	54.01.0021			Bridge		XIC.....9	53.03.0169			24-Pole IC Socket	
JP.....8	54.01.0021			Bridge							
JP.....9	54.01.0021			Bridge							
JP.....10	54.01.0021			Bridge							
JP.....11	54.01.0021			Bridge							
JP.....12	54.01.0021			Bridge							
JP.....13	54.01.0021			Bridge							
JP.....14	54.01.0021			Bridge							
JP.....15	54.01.0021			Bridge							
JP.....16	54.01.0021			Bridge							
JP.....17	54.01.0021			Bridge							
ME.....1	1.727.360.01			VU Meter							
MP.....1	54.01.0020	54 pcs		Contact Pin							
MP.....2	1.011.235.03	3 pcs		Push button case 3							
MP.....3	1.011.235.04	2 pcs		Push button case 4							



COMMAND PANEL (2 VU) 1.727.362.00 GRP30

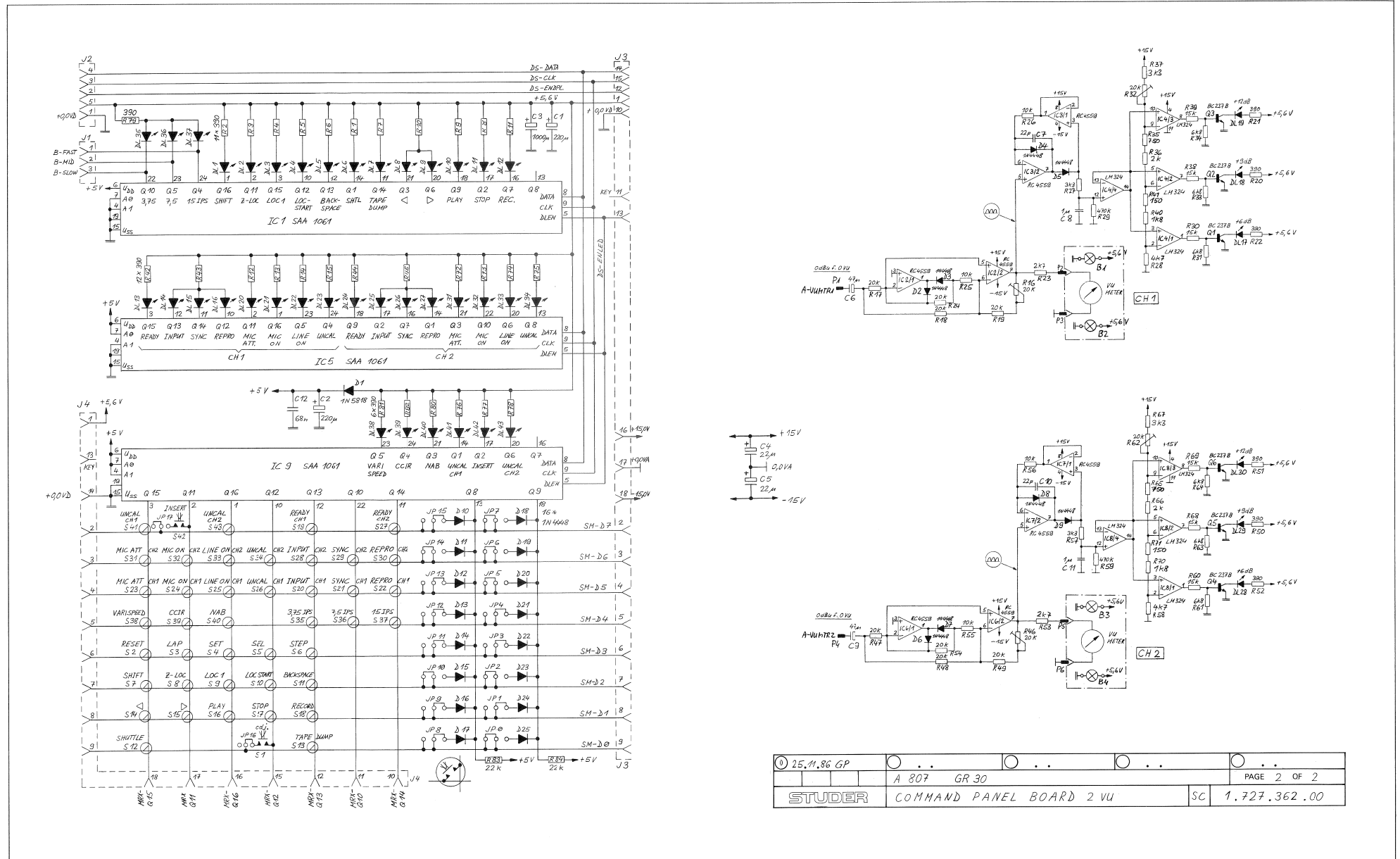

0 25.11.86 GP									
			A 807	GR 30					PAGE 2 OF 2
STUDER	COMMAND PANEL BOARD 2 VU						SC	1.727.362.00	

COMMAND PANEL (2 VU) 1.727.362.00 GRP30

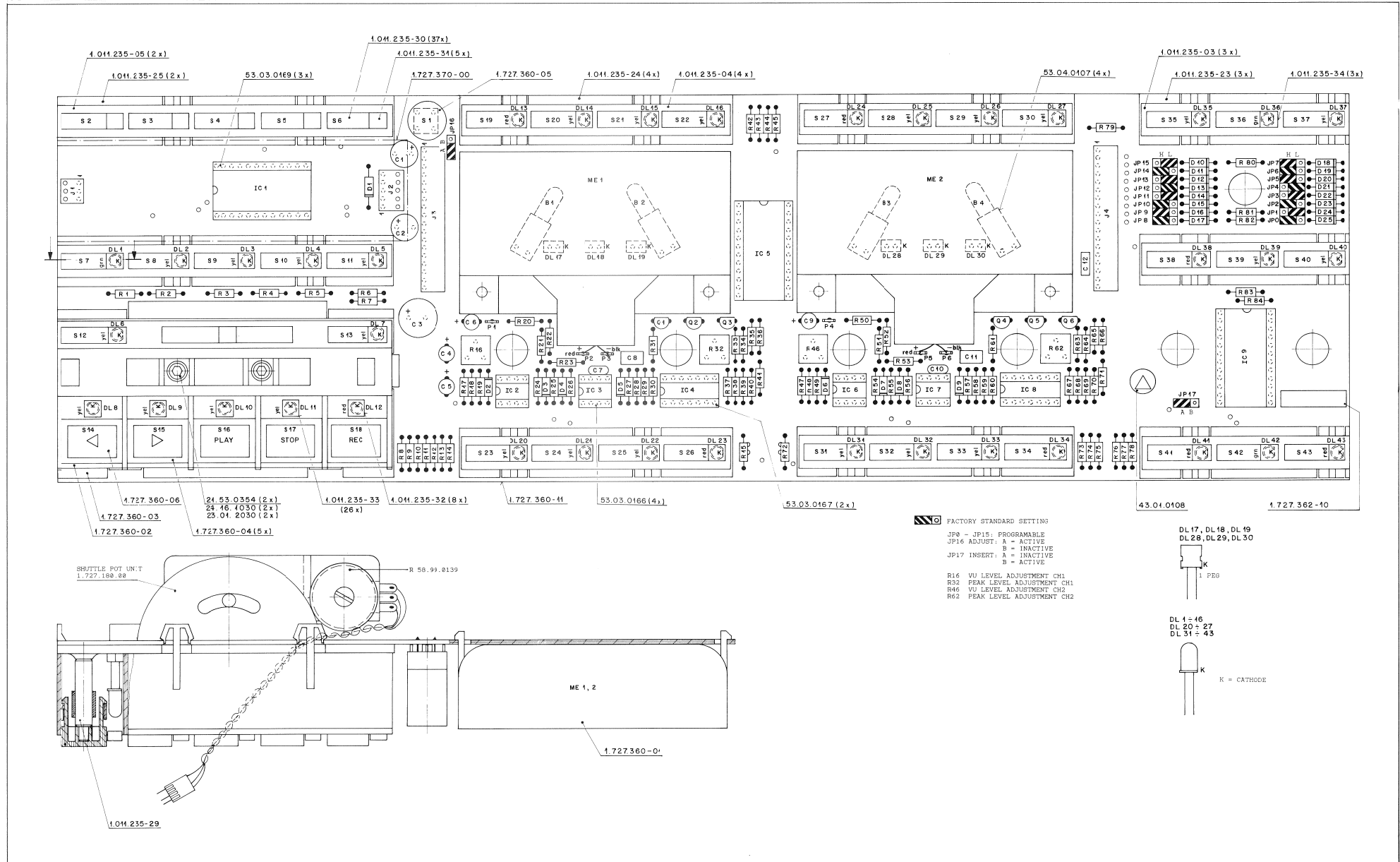



COMMAND PANEL (2 VU) 1.727.362.00 GRP30

IND.	POS.NO.	PART NO.	VALUE	SPECIFICATIONS / EQUIVALENT	MANUF.	IND.	POS.NO.	PART NO.	VALUE	SPECIFICATIONS / EQUIVALENT	MANUF.
A.....1	1.727.370.00			Display Board		JP.....5	54.01.0021			Bridge	
A.....2	1.727.180.00			Shuttle Control		JP.....6	54.01.0021			Bridge	
B.....1	51.02.0144	6 V		0-03 A Lamp		JP.....7	54.01.0021			Bridge	
B.....2	51.02.0144	6 V		0-03 A Lamp		JP.....8	54.01.0021			Bridge	
B.....3	51.02.0144	6 V		0-03 A Lamp		JP.....9	54.01.0021			Bridge	
B.....4	51.02.0144	6 V		0-03 A Lamp		JP.....10	54.01.0021			Bridge	
C.....1	59.22.3221	220 uF		-20% 10 V EL		JP.....11	54.01.0021			Bridge	
C.....2	59.22.3221	220 uF		-20% 10 V EL		JP.....12	54.01.0021			Bridge	
C.....3	59.22.3102	1000 uF		-20% 10 V EL		JP.....13	54.01.0021			Bridge	
C.....4	59.22.5220	22 uF		-20% 25 V EL		JP.....14	54.01.0021			Bridge	
C.....5	59.22.5220	22 uF		-20% 25 V EL		JP.....15	54.01.0021			Bridge	
C.....6	59.22.3470	47 uF		-20% 10 V EL		JP.....16	54.01.0021			Bridge	
C.....7	59.34.2220	22 pF		10% 50 V CER		JP.....17	54.01.0021			Bridge	
C.....8	59.06.0105	1 uF		10% 50 V PETP		ME.....1	1.727.360.01			VU Meter	
C.....9	59.22.3470	47 uF		-20% 10 V EL		ME.....2	1.727.360.01			VU Meter	
C.....10	59.34.2220	22 pF		10% 50 V CER		MP.....1	54.01.0020		54 pcs	Contact Pin	
C.....11	59.06.0105	1 uF		10% 50 V PETP		MP.....2	1.011.235.03		3 pcs	Push button case	38
C.....12	59.06.0683	68 nF		10% 50 V PETP		MP.....3	1.011.235.04		4 pcs	Push button case	48
D.....1	50.04.0512	1N5818		30 V Schottky		MP.....4	1.011.235.05		2 pcs	Push button case	58
D.....2	50.04.0125	1N4448		50 V SI		MP.....5	1.011.235.23		3 pcs	Conductive rubber	38
D.....3	50.04.0125	1N4448		50 V SI		MP.....6	1.011.235.24		4 pcs	Conductive rubber	48
D.....4	50.04.0125	1N4448		50 V SI		MP.....7	1.011.235.25		2 pcs	Conductive rubber	58
D.....5	50.04.0125	1N4448		50 V SI		MP.....8	1.011.235.29		42 pcs	Bolt	
D.....6	50.04.0125	1N4448		50 V SI		MP.....9	1.011.235.30		37 pcs	Push button 14*5	
D.....7	50.04.0125	1N4448		50 V SI		MP.....10	1.011.235.31		5 pcs	Dummy calotte	
D.....8	50.04.0125	1N4448		50 V SI		MP.....11	1.011.235.32		8 pcs	Calotte red	
D.....9	50.04.0125	1N4448		50 V SI		MP.....12	1.011.235.33		26 pcs	Calotte yellow	
D.....10	50.04.0125	1N4448		50 V SI		MP.....13	1.011.235.34		3 pcs	Calotte green	
D.....11	50.04.0125	1N4448		50 V SI		MP.....14	1.727.360.02		1 pcs	Push button case with Shuttle	
D.....12	50.04.0125	1N4448		50 V SI		MP.....15	1.727.360.04		5 pcs	Push button 10*14	
D.....13	50.04.0125	1N4448		50 V SI		MP.....16	1.727.360.05		1 pcs	Push button Adj.	
D.....14	50.04.0125	1N4448		50 V SI		MP.....17	1.727.360.10		1 pcs	No. Label	
D.....15	50.04.0125	1N4448		50 V SI		MP.....18	1.727.360.11		1 pcs	Command Panel PCB	
D.....16	50.04.0125	1N4448		50 V SI		MP.....19	1.727.360.11		1 pcs	Command Panel PCB	
D.....16	50.04.0125	1N4448		50 V SI		MP.....20	53.03.0221		43 pcs	2-pole LED Socket	

S T U D E R (00) 86/09/23 GP COMMAND PANEL BOARD 2VU 1.727.362.00 PAGE 1 S T U D E R (00) 86/09/23 GP COMMAND PANEL BOARD 2VU 1.727.362.00 PAGE 4

IND.	POS.NO.	PART NO.	VALUE	SPECIFICATIONS / EQUIVALENT	MANUF.	IND.	POS.NO.	PART NO.	VALUE	SPECIFICATIONS / EQUIVALENT	MANUF.
D.....17	50.04.0125	1N4448		50 V SI		MP.....21	1.727.362.93		2 pcs	L-List Command Panel Board	
D.....18	50.04.0125	1N4448		50 V SI		MP.....22	21.53.0354		2 pcs	Hexagon socket head cap screw M3*6	
D.....19	50.04.0125	1N4448		50 V SI		MP.....23	43.01.2032		2 pcs	Washer	
D.....20	50.04.0125	1N4448		50 V SI		MP.....24	24.16.1030		2 pcs	Fin washer	
D.....21	50.04.0125	1N4448		50 V SI		MP.....25	43.11.0108		1 pcs	ESE Warning label	
D.....22	50.04.0125	1N4448		50 V SI		MP.....26	1.727.360.06		1 pcs	Push button Labels (<->,PLAY,STOP,REC)	
D.....23	50.04.0125	1N4448		50 V SI		P.....1	54.02.0320			Plug 2*80*8	AMP
D.....24	50.04.0125	1N4448		50 V SI		P.....2	54.02.0320			Plug 2*80*8	AMP
D.....25	50.04.0125	1N4448		50 V SI		P.....3	54.02.0320			Plug 2*80*8	AMP
DL.....1	50.04.2501	MV5452		LED grn 0=5 mm	GI	P.....4	54.02.0320			Plug 2*80*8	AMP
DL.....2	50.04.2500	MV5352		LED yel 0=5 mm	GI	P.....5	54.02.0320			Plug 2*80*8	AMP
DL.....3	50.04.2500	MV5352		LED yel 0=5 mm	GI	P.....6	54.02.0320			Plug 2*80*8	AMP
DL.....4	50.04.2500	MV5352		LED yel 0=5 mm	GI	P.....6	54.02.0320			Plug 2*80*8	AMP
DL.....5	50.04.2500	MV5352		LED yel 0=5 mm	GI	Q.....1	50.03.0436	BC237B	BC547B, BC550B	NPN	
DL.....6	50.04.2500	MV5352		LED yel 0=5 mm	GI	Q.....2	50.03.0436	BC237B	BC547B, BC550B	NPN	
DL.....7	50.04.2500	MV5352		LED yel 0=5 mm	GI	Q.....3	50.03.0436	BC237B	BC547B, BC550B	NPN	
DL.....8	50.04.2500	MV5352		LED yel 0=5 mm	GI	Q.....4	50.03.0436	BC237B	BC547B, BC550B	NPN	
DL.....9	50.04.2500	MV5352		LED yel 0=5 mm	GI	Q.....5	50.03.0436	BC237B	BC547B, BC550B	NPN	
DL.....10	50.04.2500	MV5352		LED yel 0=5 mm	GI	Q.....6	50.03.0436	BC237B	BC547B, BC550B	NPN	
DL.....11	50.04.2500	MV5352		LED yel 0=5 mm	GI	R.....1	57.11.4391	390 Ohm	2% 0.25W	MF	
DL.....12	50.04.2115	MV5752		LED red 0=5 mm	GI	R.....2	57.11.4391	390 Ohm	2% 0.25W	MF	
DL.....13	50.04.2115	MV5752		LED red 0=5 mm	GI	R.....3	57.11.4391	390 Ohm	2% 0.25W	MF	
DL.....14	50.04.2500	MV5352		LED yel 0=5 mm	GI	R.....4	57.11.4391	390 Ohm	2% 0.25W	MF	
DL.....15	50.04.2500	MV5352		LED yel 0=5 mm	GI	R.....5	57.11.4391	390 Ohm	2% 0.25W	MF	
DL.....16	50.04.2500	MV5352		LED yel 0=5 mm	GI	R.....6	57.11.4391	390 Ohm	2% 0.25W	MF	
DL.....17	50.04.2119	MV57124		LED red 6.35*3.81	GI	R.....7	57.11.4391	390 Ohm	2% 0.25W	MF	
DL.....18	50.04.2119	MV57124		LED red 6.35*3.81	GI	R.....8	57.11.4391	390 Ohm	2% 0.25W	MF	
DL.....19	50.04.2119	MV57124		LED red 6.35*3.81	GI	R.....9	57.11.4391	390 Ohm	2% 0.25W	MF	
DL.....20	50.04.2500	MV5352		LED yel 0=5 mm	GI	R.....10	57.11.4391	390 Ohm	2% 0.25W	MF	
DL.....21	50.04.2500	MV5352		LED yel 0=5 mm	GI	R.....11	57.11.4391	390 Ohm	2% 0.25W	MF	
DL.....22	50.04.2500	MV5352		LED yel 0=5 mm	GI	R.....12	57.11.4391	390 Ohm	2% 0.25W	MF	
DL.....23	50.04.2115	MV5752		LED red 0=5 mm	GI	R.....13	57.11.4391	390 Ohm	2% 0.25W	MF	
DL.....24	50.04.2115	MV5752		LED red 0=5 mm	GI	R.....14	57.11.4391	390 Ohm	2% 0.25W	MF	
DL.....25	50.04.2500	MV5352		LED yel 0=5 mm	GI	R.....15	57.11.4391	390 Ohm	2% 0.25W	MF	
DL.....26	50.04.2500	MV5352		LED yel 0=5 mm	GI	R.....16	58.01.8203	20 kOhm	10% 0.5 W	PCterm	
DL.....27	50.04.2500	MV5352		LED yel 0=5 mm	GI						

S T U D E R (00) 86/09/23 GP COMMAND PANEL BOARD 2VU 1.727.362.00 PAGE 2 S T U D E R (00) 86/09/23 GP COMMAND PANEL BOARD 2VU 1.727.362.00 PAGE 5

IND.	POS.NO.	PART NO.	VALUE	SPECIFICATIONS / EQUIVALENT	MANUF.	IND.	POS.NO.	PART NO.	VALUE	SPECIFICATIONS / EQUIVALENT	MANUF.
DL.....28	50.04.2119	MV57124		LED red 6.35*3.81	GI	R.....17	57.11.3203	20 kOhm	2% 0.25W	MF	
DL.....29	50.04.2119	MV57124		LED red 6.35*3.81	GI	R.....18	57.11.3203	20 kOhm	2% 0.25W	MF	
DL.....30	50.04.2119	MV57124		LED red 6.35*3.81	GI	R.....19	57.11.3203	20 kOhm	2% 0.25W	MF	
DL.....31	50.04.2500	MV5352		LED yel 0=5 mm	GI	R.....20	57.11.4391	390 Ohm	2% 0.25W	MF	
DL.....32	50.04.2500	MV5352		LED yel 0=5 mm	GI	R.....21	57.11.4391	390 Ohm	2% 0.25W	MF	
DL.....33	50.04.2500	MV5352		LED yel 0=5 mm	GI	R.....22	57.11.4391	390 Ohm	2% 0.25W	MF	
DL.....34	50.04.2115	MV5752		LED red 0=5 mm	GI	R.....23	57.11.4272	2.7 kOhm	2% 0.25W	MF	
DL.....35	50.04.2500	MV5352		LED yel 0=5 mm	GI	R.....24	57.11.3203	20 kOhm	2% 0.25W	MF	
DL.....36	50.04.2501	MV5452		LED grn 0=5 mm	GI	R.....25	57.11.4103	10 kOhm	2% 0.25W	MF	
DL.....37	50.04.2500	MV5352		LED yel 0=5 mm	GI	R.....26	57.11.4103	10 kOhm	2% 0.25W	MF	
DL.....38	50.04.2115	MV5752		LED red 0=5 mm	GI	R.....27	57.11.4332	3.3 kOhm	2% 0.25W	MF	
DL.....39	50.04.2500	MV5352		LED yel 0=5 mm	GI	R.....28	57.11.3472	4.7 kOhm	1% 0.25W	MF	
DL.....40	50.04.2500	MV5352		LED yel 0=5 mm	GI	R.....29	57.11.4474	470 kOhm	2% 0.25W	MF	
DL.....41	50.04.2115	MV5752		LED red 0=5 mm	GI	R.....30	57.11.4153	15 kOhm	2% 0.25W	MF	
DL.....42	50.04.2501	MV5452		LED grn 0=5 mm	GI	R.....31	57.11.4682	6.8 kOhm	2% 0.25W	MF	
DL.....43	50.04.2115	MV5752		LED red 0=5 mm	GI	R.....32	58.01.8203	20 kOhm	10% 0.5 W	PCterm	
IC.....1	50.13.0106	SA4 1061		Driver	Ph	R.....33	57.11.4582	6.8 kOhm	2% 0.25W	MF	
IC.....2	50.09.0107	RC4559		Dual Op. Amp.	Ra	R.....34	57.11.3751	750 Ohm	1% 0.25W	MF	
IC.....3	50.09.0107	RC4559		Dual Op. Amp.	Ra	R.....35	57.11.3202	2 kOhm	1% 0.25W	MF	
IC.....4	50.05.0199	LM324		Quad Op. Amp.	NS/Mot	R.....36	57.11.4332	3.3 kOhm	2% 0.25W	MF	
IC.....5	50.13.0106	SA4 1061		Driver	Ph	R.....37	57.11.4332	3.3 kOhm	2% 0.25W	MF	
IC.....6	50.09.0107	RC4559		Dual Op. Amp.	Ra	R.....38	57.11.4153	15 kOhm	2% 0.25W	MF	
IC.....7	50.09.0107	RC4559		Dual Op. Amp.	Ra	R.....39	57.11.4153	15 kOhm			



COMMAND PANEL (2 VU) 1.727.362.00 GRP30

IND.	POS. NO.	PART NO.	VALUE	SPECIFICATIONS / EQUIVALENT	MANUF.
R....54	57.11.3203	20	KOhm	2%, 0.25W, MF	
R....55	57.11.4103	10	KOhm	2%, 0.25W, MF	
R....56	57.11.4103	10	KOhm	2%, 0.25W, MF	
R....57	57.11.4332	3.3	KOhm	2%, 0.25W, MF	
R....58	57.11.3472	4.7	KOhm	1%, 0.25W, MF	
R....59	57.11.4474	470	KOhm	2%, 0.25W, MF	
R....60	57.11.4153	15	KOhm	2%, 0.25W, MF	
R....61	57.11.4682	6.8	KOhm	2%, 0.25W, MF	
R....62	58.01.8203	20	KOhm	10%, 0.5 W, PTerm	
R....63	57.11.4682	6.8	KOhm	2%, 0.25W, MF	
R....64	57.11.4682	6.8	KOhm	2%, 0.25W, MF	
R....65	57.11.3751	750	Ohm	1%, 0.25W, MF	
R....66	57.11.3202	2	KOhm	1%, 0.25W, MF	
R....67	57.11.4332	3.3	KOhm	2%, 0.25W, MF	
R....68	57.11.4153	15	KOhm	2%, 0.25W, MF	
R....69	57.11.4153	15	KOhm	2%, 0.25W, MF	
R....70	57.11.3182	1.8	KOhm	1%, 0.25W, MF	
R....71	57.11.4151	150	Ohm	2%, 0.25W, MF	
R....72	57.11.4391	390	Ohm	2%, 0.25W, MF	
R....73	57.11.4391	390	Ohm	2%, 0.25W, MF	
R....74	57.11.4391	390	Ohm	2%, 0.25W, MF	
R....75	57.11.4391	390	Ohm	2%, 0.25W, MF	
R....76	57.11.4391	390	Ohm	2%, 0.25W, MF	
R....77	57.11.4391	390	Ohm	2%, 0.25W, MF	
R....78	57.11.4391	390	Ohm	2%, 0.25W, MF	
R....79	57.11.4391	390	Ohm	2%, 0.25W, MF	
R....80	57.11.4391	390	Ohm	2%, 0.25W, MF	
R....81	57.11.4391	390	Ohm	2%, 0.25W, MF	
R....82	57.11.4391	390	Ohm	2%, 0.25W, MF	
R....83	57.11.4223	22	KOhm	2%, 0.25W, MF	
R....84	57.11.4223	22	KOhm	2%, 0.25W, MF	
S.....1	55.15.0130			Push button Switch	ITT
XB....1	53.04.0107			Lamp holder	
XB....2	53.04.0107			Lamp holder	
XB....3	53.04.0107			Lamp holder	

S T U D E R (00) 86/09/23 GP COMMAND PANEL BOARD 2VU 1.727.362.00 PAGE 7

IND.	POS. NO.	PART NO.	VALUE	SPECIFICATIONS / EQUIVALENT	MANUF.
XB....4	53.04.0107			Lamp holder	
XIC...1	53.03.0169	24-Pole		IC Socket	
XIC...2	53.03.0166	8-Pole		IC Socket	
XIC...3	53.03.0166	8-Pole		IC Socket	
XIC...4	53.03.0167	14-Pole		IC Socket	
XIC...5	53.03.0169	24-Pole		IC Socket	
XIC...6	53.03.0166	8-Pole		IC Socket	
XIC...7	53.03.0166	8-Pole		IC Socket	
XIC...8	53.03.0167	14-Pole		IC Socket	
XIC...9	53.03.0169	24-Pole		IC Socket	

CER=Ceramic, LL=Electrolytic, PETP=Polyester, SI=Silicon,
 MF=Metal Film, PGerm=Pot. Cermet,
 MANUFACTURER: AMP, GI=General Instruments, ITT, Mot=Motorola,
 NS=National Semiconductor, Ph=Philips, Ra=Raytheon

ORIG 86/09/23

S T U D E R (00) 86/09/23 GP COMMAND PANEL BOARD 2VU 1.727.362.00 PAGE 8

COMMAND PANEL (2-2) 1.727.363.00 GRP30

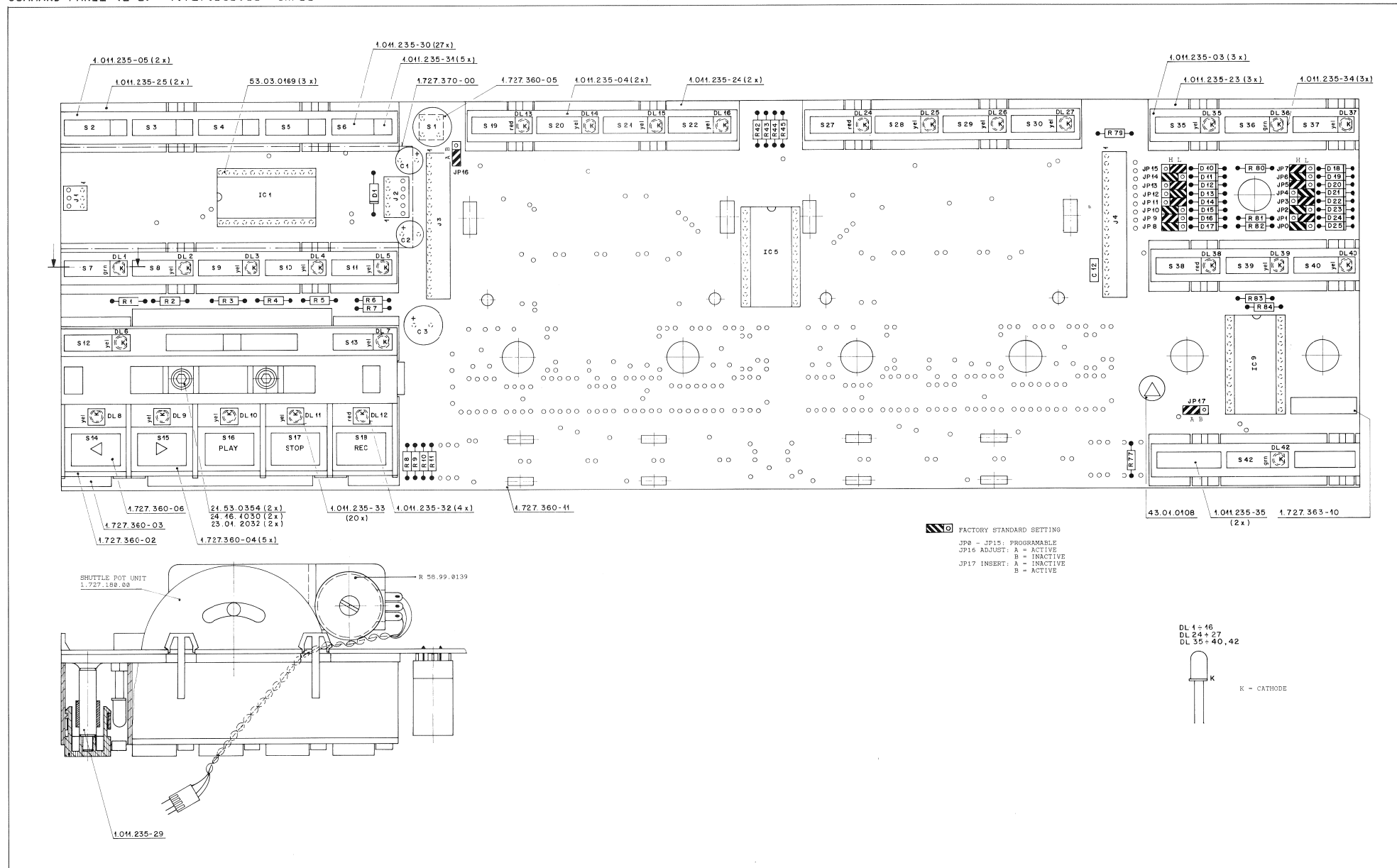

COMMAND PANEL (2 VU, REPRO ONLY) 1.727.364.00 GRP30

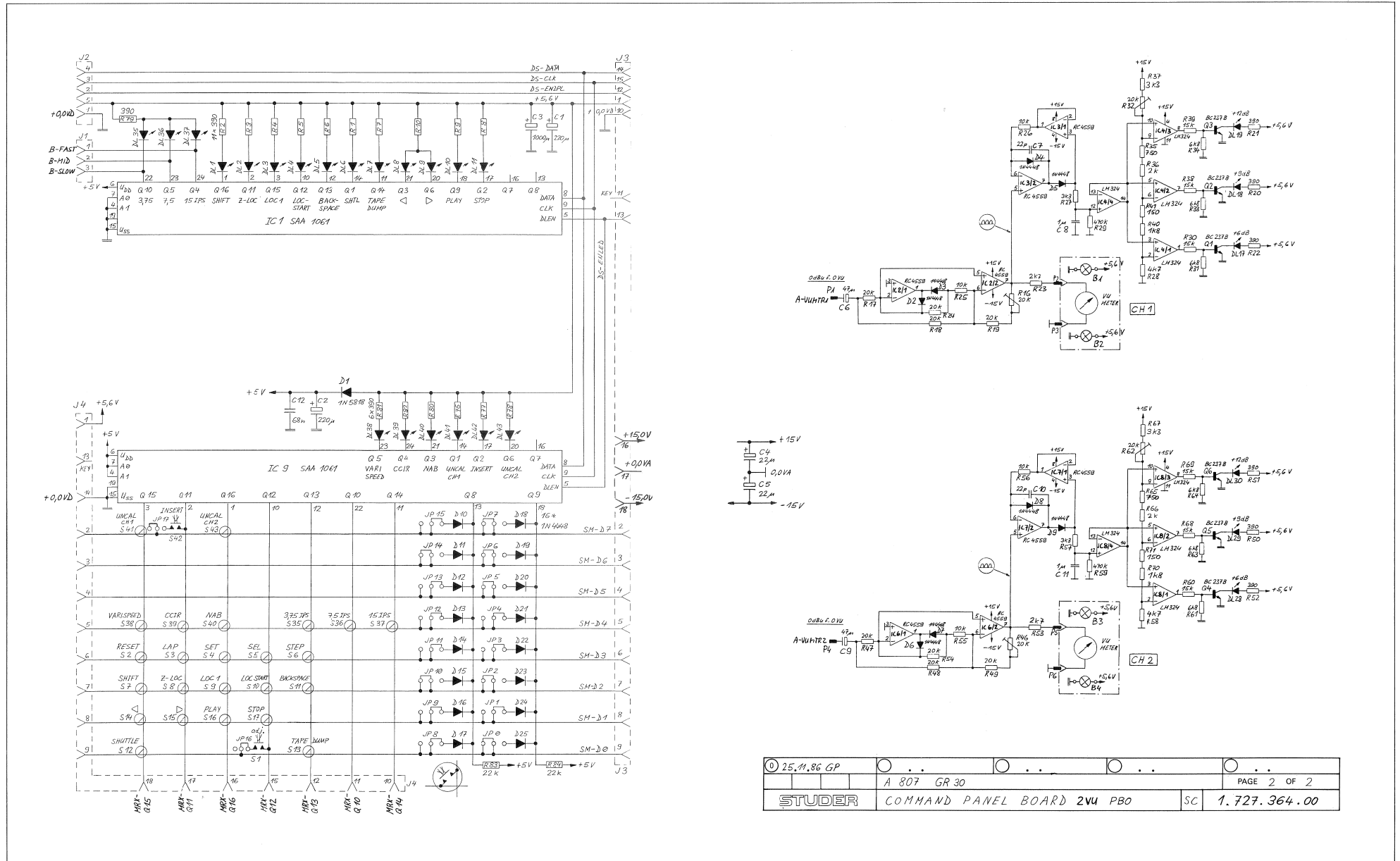

COMMAND PANEL (2 VU, REPRO ONLY) 1.727.364.00 GRP30

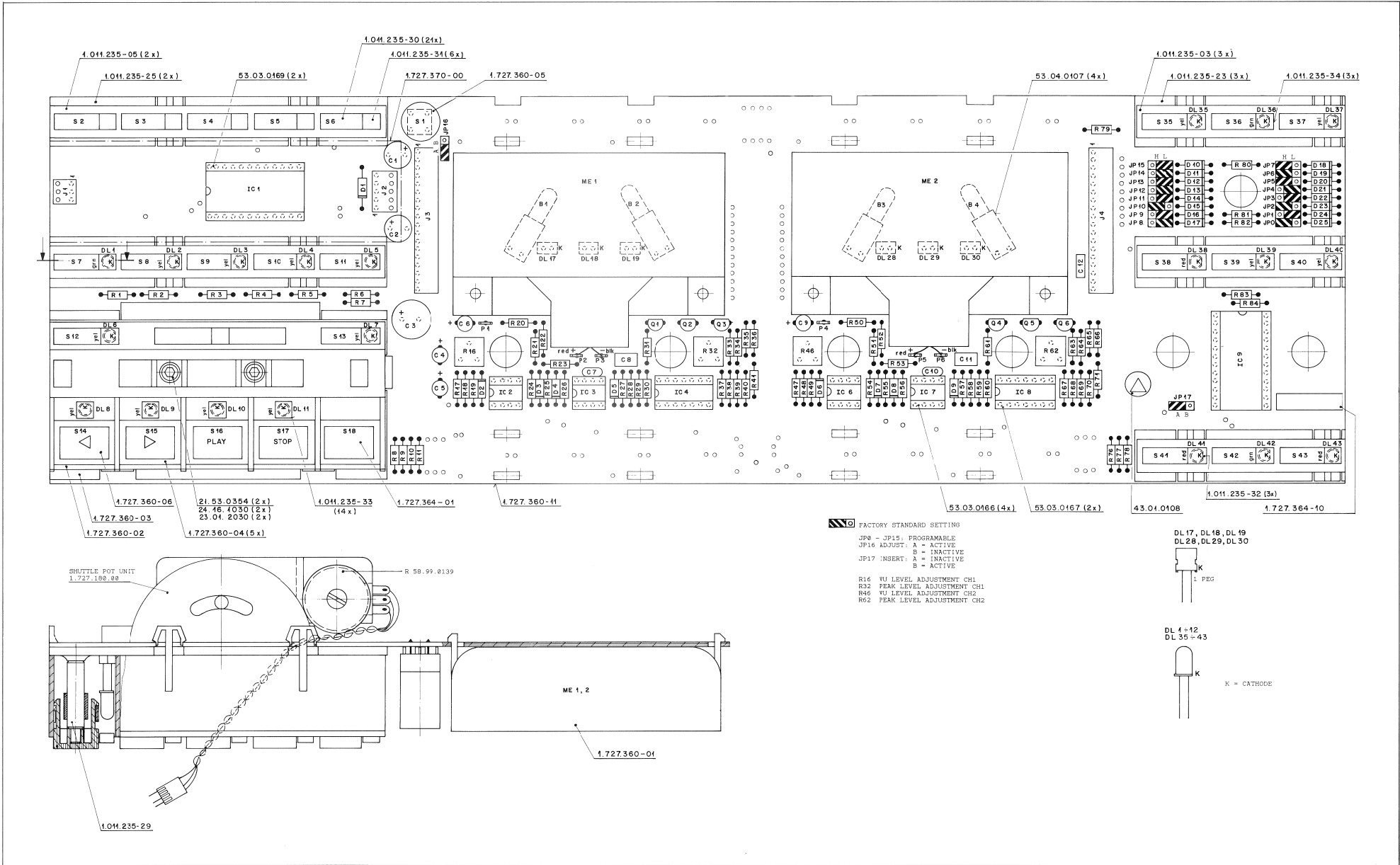



COMMAND PANEL (2 VU, REPRO ONLY) 1.727.364.00 GRP30

IND.	POS.NO.	PART NO.	VALUE	SPECIFICATIONS / EQUIVALENT	MANUF.	IND.	POS.NO.	PART NO.	VALUE	SPECIFICATIONS / EQUIVALENT	MANUF.
A.....1	1.727.370.00			Display Board		MP.....1	54.01.0020		54 pcs	Contact Pin	
A.....2	1.727.180.00			Shuttle Control		MP.....2	1.011.235.03		3 pcs	Push button case 3ø	
B.....1	51.02.0144	6 V	0.03 A	Lamp		MP.....4	1.011.235.05		2 pcs	Push button case 5ø	
B.....2	51.02.0144	6 V	0.03 A	Lamp		MP.....5	1.011.235.23		3 pcs	Conductive rubber 3ø	
B.....3	51.02.0144	6 V	0.03 A	Lamp		MP.....7	1.011.235.25		2 pcs	Conductive rubber 5ø	
B.....4	51.02.0144	6 V	0.03 A	Lamp		MP.....9	1.011.235.30		24 pcs	Callotette red	
C.....1	59.22.3221	220 uF	-20%	10 V EL		MP.....10	1.011.235.31		5 pcs	Push button 14x5	
C.....2	59.22.3221	220 uF	-20%	10 V EL		MP.....10	1.011.235.31		5 pcs	Dummy calotte	
C.....3	59.22.3102	1000 uF	-20%	10 V EL		MP.....11	1.011.235.32		3 pcs	Callotette red	
C.....4	59.22.5220	22 uF	-20%	25 V EL		MP.....12	1.011.235.33		14 pcs	Callotette yel	
C.....5	59.22.5220	22 uF	-20%	25 V EL		MP.....13	1.011.235.34		3 pcs	Callotette grn	
C.....6	59.22.3470	67 uF	-20%	10 V EL		MP.....14	1.727.360.02		1 pcs	Push button case with Shuttle	
C.....7	59.34.2220	22 pF	10%	50 V CER		MP.....15	1.727.360.03		1 pcs	Conductive rubber with Shuttle	
C.....8	59.06.0105	1 uF	10%	50 V PETP		MP.....16	1.727.360.04		5 pcs	Push button 19x14	
C.....9	59.22.3470	47 uF	-20%	10 V EL		MP.....17	1.727.360.05		1 pcs	Push button Adj.	
C.....10	59.34.2220	22 pF	10%	50 V CER		MP.....18	1.727.364.10		1 pcs	No. Label	
C.....11	59.06.0105	1 uF	10%	50 V PETP		MP.....19	1.727.360.11		1 pcs	Command Panel PCB	
C.....12	59.06.0683	68 nF	10%	50 V PETP		MP.....20	53.03.0221		27 pcs	2-pole LED Socket	
D.....1	50.04.0512	1N5818	30 V	Schottky		MP.....21	1.727.362.93		2 pcs	L-ST Command Panel Board	
D.....2	50.04.0125	1N4448	50 V	SI		MP.....22	21.53.0354		2 pcs	Hexagon socket head cap screw M3x6	
D.....3	50.04.0125	1N4448	50 V	SI		MP.....23	23.12.0320		2 pcs	Washer	
D.....4	50.04.0125	1N4448	50 V	SI		MP.....24	24.16.1030		2 pcs	Fin washer	
D.....5	50.04.0125	1N4448	50 V	SI		MP.....25	43.01.0108		1 pcs	ESE Warning label	
D.....6	50.04.0125	1N4448	50 V	SI		MP.....26	1.727.360.05		1 pcs	Push button labels (<+>PLAY,STOP,REC)	
D.....7	50.04.0125	1N4448	50 V	SI		MP.....27	1.727.364.01		1 pcs	Push button label blank (For 51ø)	
D.....8	50.04.0125	1N4448	50 V	SI		P.....1	54.02.0320			Plug 2.8x0.8	AMP
D.....9	50.04.0125	1N4448	50 V	SI		P.....2	54.02.0320			Plug 2.8x0.8	AMP
D.....10	50.04.0125	1N4448	50 V	SI		P.....3	54.02.0320			Plug 2.8x0.8	AMP
D.....11	50.04.0125	1N4448	50 V	SI		P.....4	54.02.0320			Plug 2.8x0.8	AMP
D.....12	50.04.0125	1N4448	50 V	SI		P.....5	54.02.0320			Plug 2.8x0.8	AMP
D.....13	50.04.0125	1N4448	50 V	SI		P.....6	54.02.0320			Plug 2.8x0.8	AMP
D.....14	50.04.0125	1N4448	50 V	SI		Q.....1	50.03.0436	BC237B	BC547B, BC550B	NPN	
D.....15	50.04.0125	1N4448	50 V	SI		Q.....2	50.03.0436	BC237B	BC547B, BC550B	NPN	
D.....16	50.04.0125	1N4448	50 V	SI		Q.....3	50.03.0436	BC237B	BC547B, BC550B	NPN	

S T U D E R (01) 87/05/08 GP COMMAND PANEL BOARD 2VU PBD 1.727.364.00 PAGE 1

IND.	POS.NO.	PART NO.	VALUE	SPECIFICATIONS / EQUIVALENT	MANUF.
D.....17	50.04.0125	1N4448	50 V	SI	
D.....18	50.04.0125	1N4448	50 V	SI	
D.....19	50.04.0125	1N4448	50 V	SI	
D.....20	50.04.0125	1N4448	50 V	SI	
D.....21	50.04.0125	1N4448	50 V	SI	
D.....22	50.04.0125	1N4448	50 V	SI	
D.....23	50.04.0125	1N4448	50 V	SI	
D.....24	50.04.0125	1N4448	50 V	SI	
D.....25	50.04.0125	1N4448	50 V	SI	
DL.....1	50.04.2501	MV5452	LED grn 0.5 mm	GI	
DL.....2	50.04.2500	MV5352	LED yel 0.5 mm	GI	
DL.....3	50.04.2500	MV5352	LED yel 0.5 mm	GI	
DL.....4	50.04.2500	MV5352	LED yel 0.5 mm	GI	
DL.....5	50.04.2500	MV5352	LED yel 0.5 mm	GI	
DL.....6	50.04.2500	MV5352	LED yel 0.5 mm	GI	
DL.....7	50.04.2500	MV5352	LED yel 0.5 mm	GI	
DL.....8	50.04.2500	MV5352	LED yel 0.5 mm	GI	
DL.....9	50.04.2500	MV5352	LED yel 0.5 mm	GI	
DL.....10	50.04.2500	MV5352	LED yel 0.5 mm	GI	
DL.....11	50.04.2500	MV5352	LED yel 0.5 mm	GI	
DL.....12	50.04.2115	MV5752	LED red 0.5 mm	GI	
(00) DL.....12			not used		
DL.....17	50.04.2119	MV57124	LED red 6.35x3.81	GI	
DL.....18	50.04.2119	MV57124	LED red 6.35x3.81	GI	
DL.....19	50.04.2119	MV57124	LED red 6.35x3.81	GI	
DL.....20	50.04.2119	MV57124	LED red 6.35x3.81	GI	
DL.....21	50.04.2119	MV57124	LED red 6.35x3.81	GI	
DL.....22	50.04.2119	MV57124	LED red 6.35x3.81	GI	
DL.....23	50.04.2119	MV57124	LED red 6.35x3.81	GI	
DL.....24	50.04.2501	MV5352	LED yel 0.5 mm	GI	
DL.....25	50.04.2501	MV5452	LED grn 0.5 mm	GI	
DL.....26	50.04.2500	MV5352	LED yel 0.5 mm	GI	
DL.....27	50.04.2500	MV5352	LED yel 0.5 mm	GI	
DL.....28	50.04.2115	MV5752	LED red 0.5 mm	GI	
DL.....29	50.04.2500	MV5352	LED yel 0.5 mm	GI	
DL.....30	50.04.2115	MV5752	LED red 0.5 mm	GI	
DL.....31	50.04.2501	MV5452	LED grn 0.5 mm	GI	
DL.....32	50.04.2500	MV5352	LED yel 0.5 mm	GI	
DL.....33	50.04.2500	MV5352	LED yel 0.5 mm	GI	
DL.....34	50.04.2115	MV5752	LED red 0.5 mm	GI	
DL.....35	50.04.2501	MV5452	LED grn 0.5 mm	GI	
DL.....36	50.04.2500	MV5352	LED yel 0.5 mm	GI	
DL.....37	50.04.2500	MV5352	LED yel 0.5 mm	GI	
DL.....38	50.04.2115	MV5752	LED red 0.5 mm	GI	
DL.....39	50.04.2500	MV5352	LED yel 0.5 mm	GI	
DL.....40	50.04.2500	MV5352	LED yel 0.5 mm	GI	
DL.....41	50.04.2115	MV5752	LED red 0.5 mm	GI	
DL.....42	50.04.2501	MV5452	LED grn 0.5 mm	GI	

S T U D E R (01) 87/05/08 GP COMMAND PANEL BOARD 2VU PBD 1.727.364.00 PAGE 2

IND.	POS.NO.	PART NO.	VALUE	SPECIFICATIONS / EQUIVALENT	MANUF.
DL.....43	50.04.2115	MV5752	LED red 0.5 mm	GI	
IC.....1	50.13.0106	SAA 1061	Driver	Ph	
IC.....2	50.09.0107	RC4559	Dual Op. Amp.	Ra	
IC.....3	50.09.0107	RC4559	Dual Op. Amp.	Ra	
IC.....4	50.05.0199	LK324	Quad Op. Amp.	Ns+Mot	
IC.....5	50.09.0107	RC4559	Dual Op. Amp.	Ra	
IC.....6	50.09.0107	RC4559	Dual Op. Amp.	Ra	
IC.....7	50.09.0107	RC4559	Dual Op. Amp.	Ra	
IC.....8	50.05.0199	LK324	Quad Op. Amp.	Ns+Mot	
IC.....9	50.13.0106	SAA 1061	Driver	Ph	
J.....1	54.01.0287	3-Pole	CIS Socket Strip	AMP	
J.....2	54.01.0288	5-Pole	CIS Socket Strip	AMP	
J.....3	54.01.0228	18-Pole	CIS Socket Strip	AMP	
J.....4	54.01.0228	18-Pole	CIS Socket Strip	AMP	

IND.	POS.NO.	PART NO.	VALUE	SPECIFICATIONS / EQUIVALENT	MANUF.
JP.....0	54.01.0021			Bridge	
JP.....1	54.01.0021			Bridge	
JP.....2	54.01.0021			Bridge	
JP.....3	54.01.0021			Bridge	
JP.....4	54.01.0021			Bridge	
JP.....5	54.01.0021			Bridge	
JP.....6	54.01.0021			Bridge	
JP.....7	54.01.0021			Bridge	
JP.....8	54.01.0021			Bridge	
JP.....9	54.01.0021			Bridge	
JP.....10	54.01.0021			Bridge	
JP.....11	54.01.0021			Bridge	
JP.....12	54.01.0021			Bridge	
JP.....13	54.01.0021			Bridge	
JP.....14	54.01.0021			Bridge	
JP.....15	54.01.0021			Bridge	
JP.....16	54.01.0021			Bridge	
JP.....17	54.01.0021			Bridge	

M.....1 1.727.360.01 VU Meter
M.....2 1.727.360.01 VU Meter

S T U D E R (01) 87/05/08 GP COMMAND PANEL BOARD 2VU PBD 1.727.364.00 PAGE 3

IND.	POS.NO.	PART NO.	VALUE	SPECIFICATIONS / EQUIVALENT	MANUF.
XB.....1	53.04.0107			Lamp holder	
XB.....2	53.04.0107			Lamp holder	
XB.....3	53.04.0107			Lamp holder	
XB.....4	53.04.0107			Lamp holder	
XIC.....1	53.03.0169			24-Pole IC Socket	
XIC.....2	53.03.0166			3-Pole IC Socket	
XIC.....3	53.03.0166			8-Pole IC Socket	
XIC.....4	53.03.0167			14-Pole IC Socket	
XIC.....5	53.03.0166			8-Pole IC Socket	
XIC.....6	53.03.0166			8-Pole IC Socket	
XIC.....7	53.03.0166			8-Pole IC Socket	
XIC.....8	53.03.0167			14-Pole IC Socket	
XIC.....9	53.03.0169			24-Pole IC Socket	

(01) 8.5-Ø Correction
CER=Ceramic, EL=Electrolytic, PETP=Polyester, SI=Silicon
MF=Metal Film, PCerm=Pot. Cermet.
MANUFACTURER: AMP, GI=General Instrument, ITT, Mot=Motorola,
NS=National Semiconductor, Ph=Philips, Ra=Raytheon

ORIG 87/01/23 (01) 87/05/08

S T U D E R (01) 87/05/08 GP COMMAND PANEL BOARD 2VU PBD 1.727.364.00 PAGE 7

ITT

COMMAND PANEL (1 VU, REPRO ONLY) 1.727.365.00 GRP30

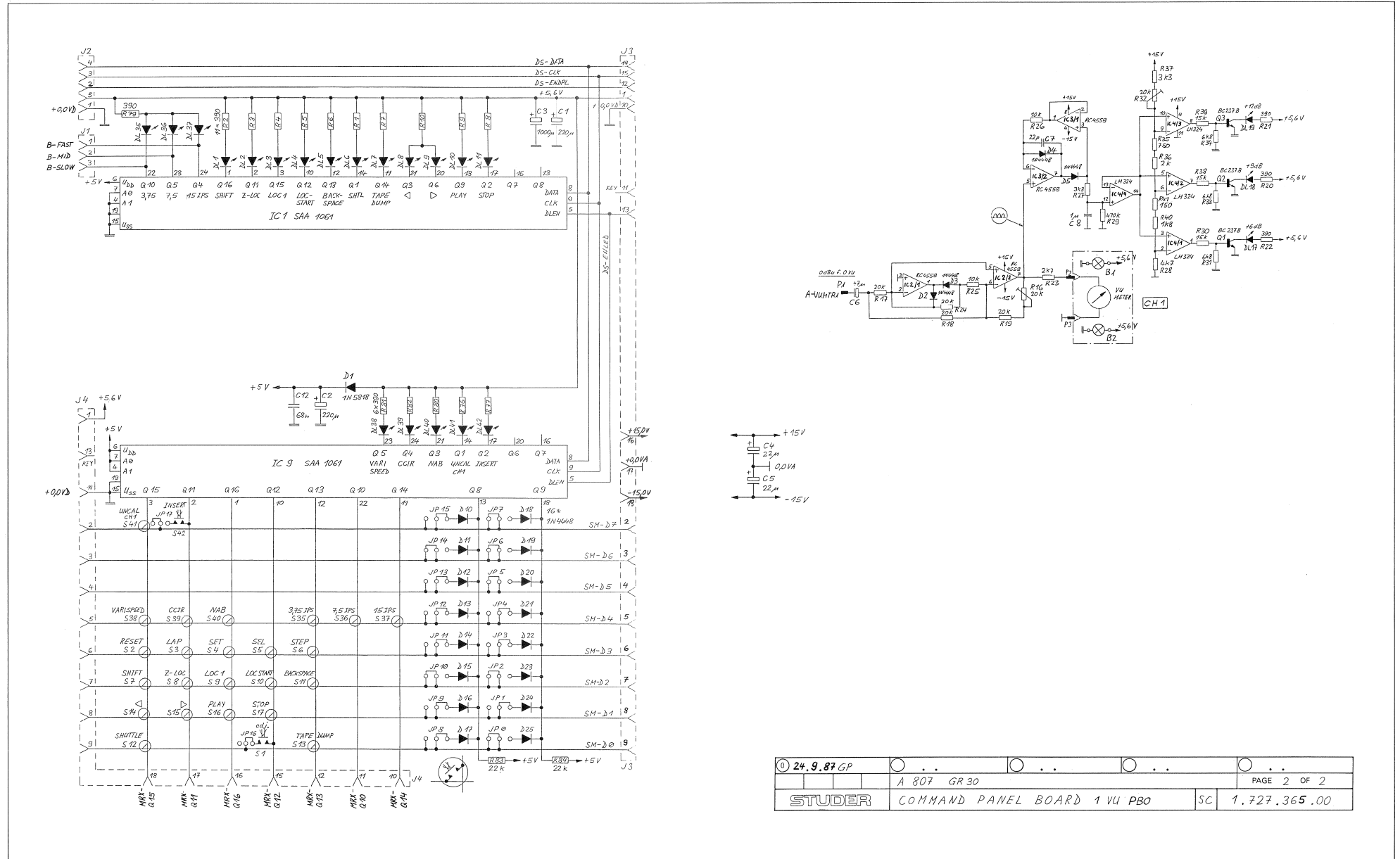

0 24.9.87 GP
A 807 GR 30				PAGE 2 OF 2
STUDER			COMMAND PANEL BOARD 1 VU PBO	SC 1.727.365.00

COMMAND PANEL (1 VU, REPRO ONLY) 1.727.365.00 GRP30

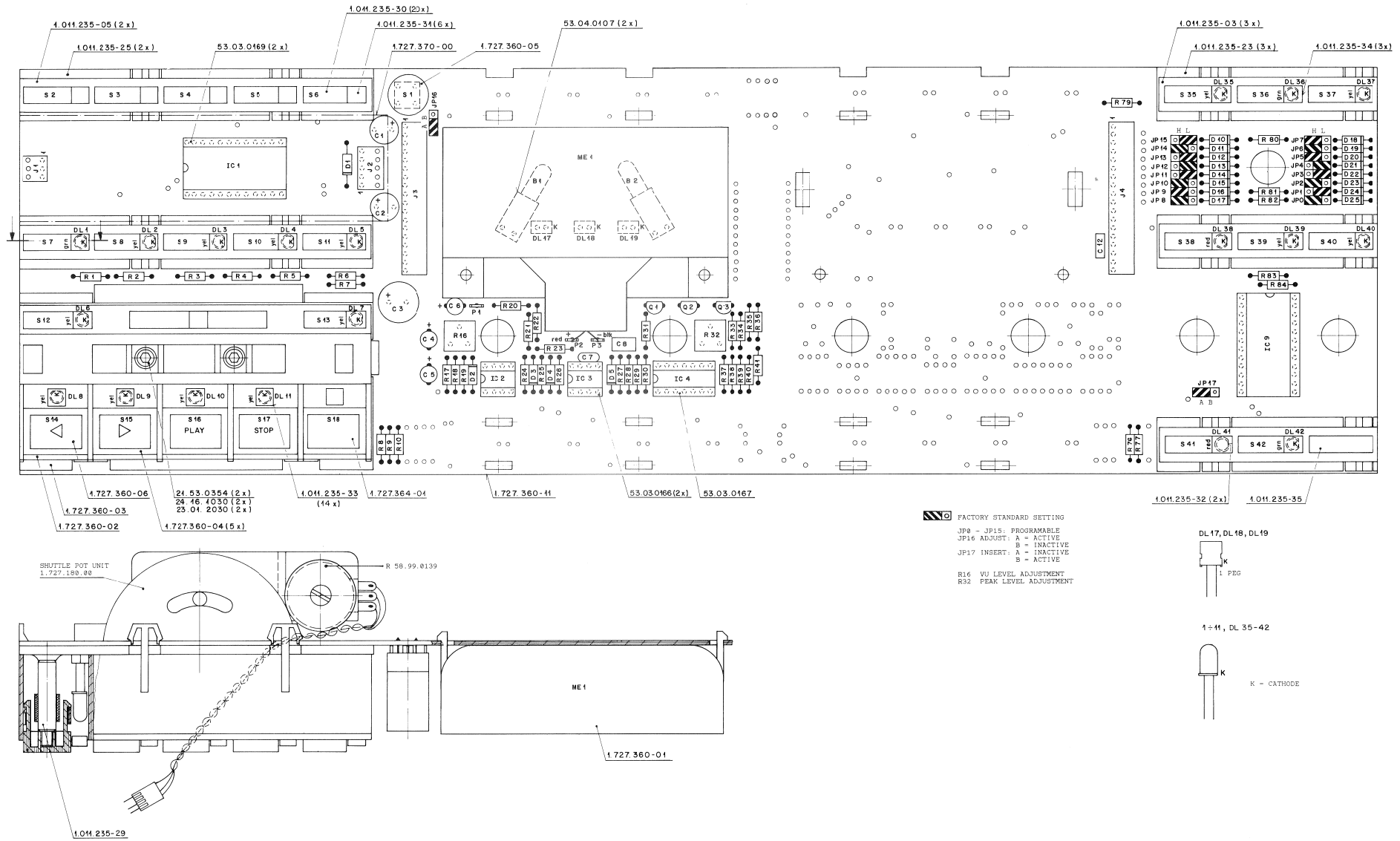

DISPLAY 1.727.370.00 GRP31

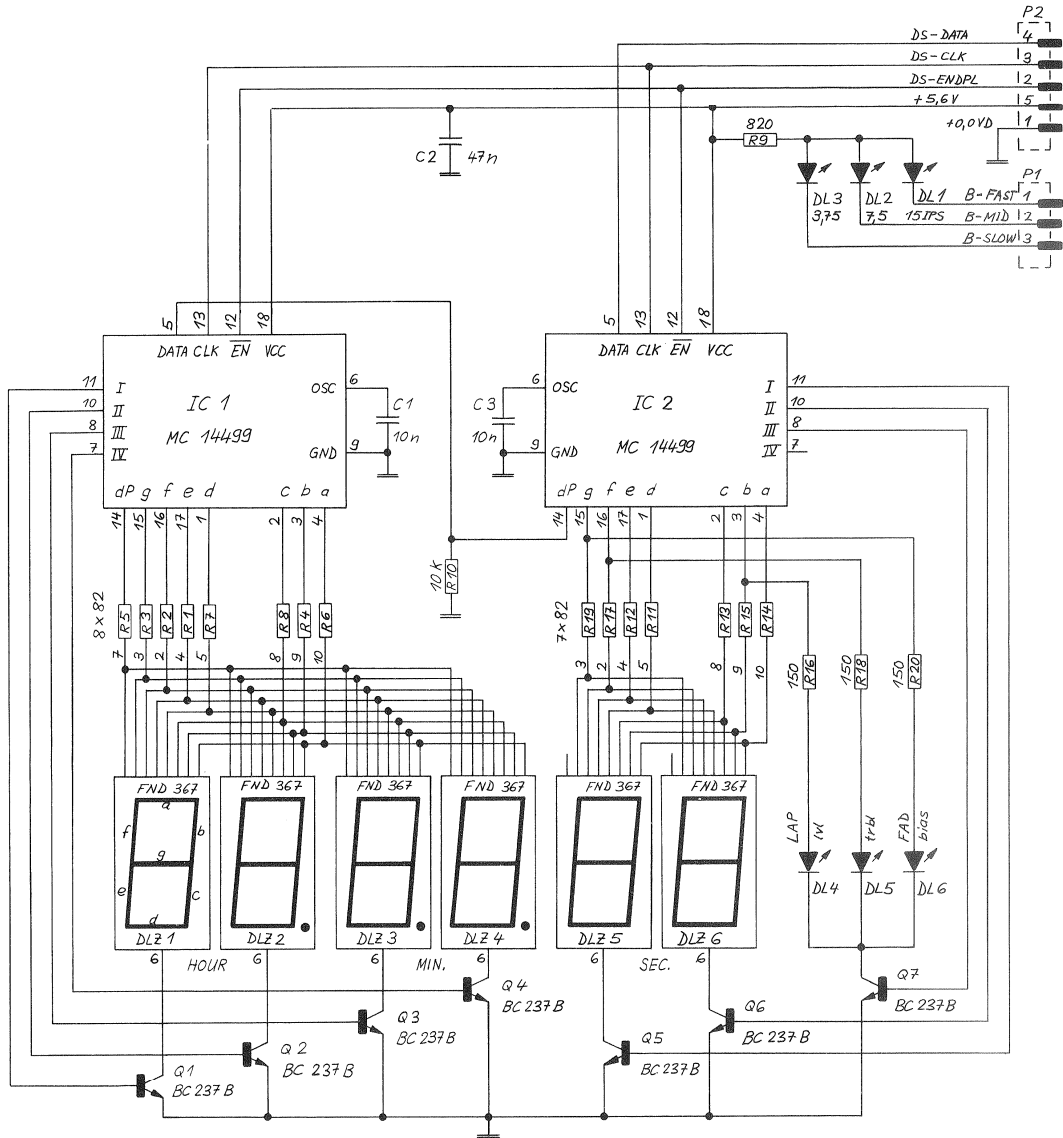

© 25.11.86 GP	○ . . .	○ . . .	○ . . .	○ . . .
	A 807	GRP31		PAGE 1 OF 1
STUDER	DISPLAY BOARD		SC	1.727.370.00



DISPLAY 1.727.370.00 GRP31

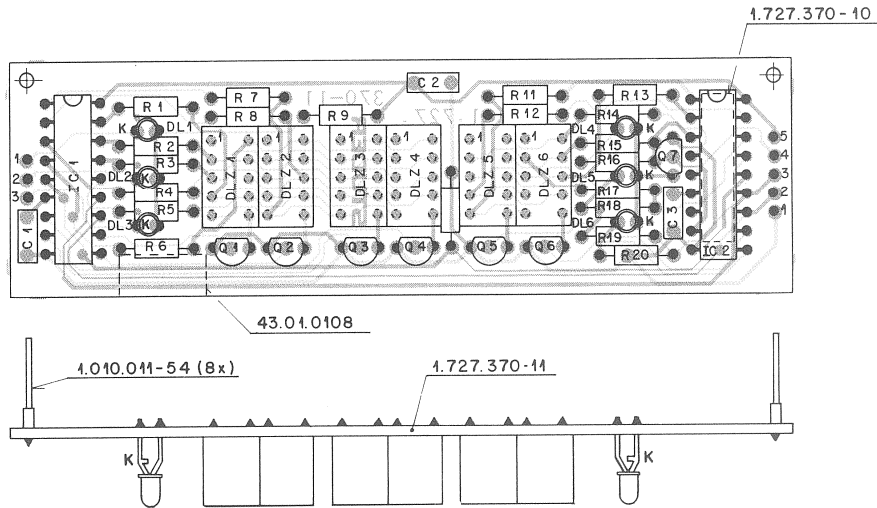

K = CATHODE

IND.	POS.-NO.	PART NO.	VALUE	SPECIFICATIONS / EQUIVALENT	MANUF.	IND.	POS.-NO.	PART NO.	VALUE	SPECIFICATIONS / EQUIVALENT	MANUF.
C.....1	59.06.0103	10 nF	10% 63 V, PETP			R.....4	57.11.4820	82 Ohm	2% 0.25W, MF		
C.....2	59.06.0473	47 nF	10% 63 V, PETP			R.....5	57.11.4820	82 Ohm	2% 0.25W, MF		
C.....3	59.06.0103	10 nF	10% 63 V, PETP			R.....6	57.11.4820	82 Ohm	2% 0.25W, MF		
DL.....1	50.04.2129	CQV11-7	LED red D=3 mm	Sie		R.....7	57.11.4820	82 Ohm	2% 0.25W, MF		
DL.....2	50.04.2129	CQV11-7	LED red D=3 mm	Sie		R.....8	57.11.4820	82 Ohm	2% 0.25W, MF		
DL.....3	50.04.2129	CQV11-7	LED red D=3 mm	Sie		R.....9	57.11.4821	820 Ohm	2% 0.25W, MF		
DL.....4	50.04.2129	CQV11-7	LED red D=3 mm	Sie		R.....10	57.11.4820	82 Ohm	2% 0.25W, MF		
DL.....5	50.04.2129	CQV11-7	LED red D=3 mm	Sie		R.....11	57.11.4820	82 Ohm	2% 0.25W, MF		
DL.....6	50.04.2129	CQV11-7	LED red D=3 mm	Sie		R.....12	57.11.4820	82 Ohm	2% 0.25W, MF		
DLZ.....1	73.01.0121	FND 367	Seven Segment Display	GI		R.....13	57.11.4820	82 Ohm	2% 0.25W, MF		
DLZ.....2	73.01.0121	FND 367	Seven Segment Display	GI		R.....14	57.11.4820	82 Ohm	2% 0.25W, MF		
DLZ.....3	73.01.0121	FND 367	Seven Segment Display	GI		R.....15	57.11.4820	82 Ohm	2% 0.25W, MF		
DLZ.....4	73.01.0121	FND 367	Seven Segment Display	GI		R.....16	57.11.4151	150 Ohm	2% 0.25W, MF		
DLZ.....5	73.01.0121	FND 367	Seven Segment Display	GI		R.....17	57.11.4820	82 Ohm	2% 0.25W, MF		
DLZ.....6	73.01.0121	FND 367	Seven Segment Display	GI		R.....18	57.11.4151	150 Ohm	2% 0.25W, MF		
IC.....1	50.07.0010	MC 14499	Display Decoder/Driver	Hot		R.....19	57.11.4820	82 Ohm	2% 0.25W, MF		
IC.....2	50.07.0010	MC 14499	Display Decoder/Driver	Hot		R.....20	57.11.4151	150 Ohm	2% 0.25W, MF		
MP.....1	1.727.370-11	1 pcs	DISPLAY PCB								
MP.....2	1.010.011-54	8 pcs	Contact pin								
MP.....3	1.727.370-10	1 pcs	No. Label								
MP.....4	43.01.0108	1 pcs	ESE Warning Label								
Q.....1	50.03.0436	BC237B	BC547B, BC550B	NPN							
Q.....2	50.03.0436	BC237B	BC547B, BC550B	NPN							
Q.....3	50.03.0436	BC237B	BC547B, BC550B	NPN							
Q.....4	50.03.0436	BC237B	BC547B, BC550B	NPN							
Q.....5	50.03.0436	BC237B	BC547B, BC550B	NPN							
Q.....6	50.03.0436	BC237B	BC547B, BC550B	NPN							
Q.....7	50.03.0436	BC237B	BC547B, BC550B	NPN							
R.....1	57.11.4820	82 Ohm	2% 0.25W, MF								
R.....2	57.11.4820	82 Ohm	2% 0.25W, MF								
R.....3	57.11.4820	82 Ohm	2% 0.25W, MF								

PETP=Polyester, MF=Metal Film
MANUFACTURER: GI=General Instruments, Mot=Motorola, Sie=Siemens

ORIG 86/08/08

7. AUDIO DIAGRAMS

CONTENTS

SECTION 7

	Page
CONTENTS OF DIAGRAM SECTIONS IN NUMERICAL ORDER	7/2
AUDIO BLOCK DIAGRAM	7/3
AUDIO WIRING DIAGRAM	7/4
AUDIO LEVEL DIAGRAMS	7/4
HEAD BLOCK ASSEMBLY	7/5
REPRODUCE PREAMPLIFIER	7/7
AUDIO CONTROL ■ .. 1.050.340.00	GRP39
AUDIO CONTROL ■ .. 1.727.430.00	GRP43
AUDIO CONTROL ■ .. 1.727.400.00	GRP40
AUDIO CONTROL ■ .. 1.727.400.81	GRP40
AUDIO CONTROL ■ .. 1.727.400.82	GRP40
AUDIO CONTROL HS ■ .. 1.727.401.00	GRP40
MONITOR INTERNAL	7/21
AUDIO ELECTRONICS (VU) ■ .. 1.727.120.00	GRP36/37
- LINE OUTPUT CONNECTOR	7/25
AUDIO ELECTRONICS (VU) ■ .. 1.727.420.00	GRP41/42
- LINE INPUT CONNECTOR	7/27
AUDIO ELECTRONICS (VU) ■ .. 1.727.240.00	GRP01 ELM09/10
- MIC INPUT CONNECTOR	7/32
AUDIO ELECTRONICS (VU) ■ .. 1.727.241.00	GRP01 ELM11/12
- AUDIO ELECTRONICS (VU)	7/33
AUDIO ELECTRONICS (VU) ■ .. 1.727.242.00	GRP01 ELM13/14
- AUDIO ELECTRONICS (VU)	7/34
AUDIO ELECTRONICS (VU) ■ .. 1.727.460.00	GRP41/42
AUDIO ELECTRONICS (VU) ■ .. 1.727.460.81	GRP41/42
- AUDIO ELECTRONICS (VU)	7/35
AUDIO ELECTRONICS (Ø VU) ■ .. 1.727.420.81	GRP41/42
AUDIO ELECTRONICS (Ø VU) ■ .. 1.727.421.00	GRP41/42
AUDIO ELECTRONICS (Ø VU) ■ .. 1.727.461.00	GRP41/42
AUDIO ELECTRONICS (Ø VU) ■ .. 1.727.461.81	GRP41/42
- AUDIO ELECTRONICS (Ø VU)	7/41
AUDIO ELECTRONICS VUK (2 VU) ■ .. 1.727.421.81	GRP41/42
AUDIO ELECTRONICS (2-2 WITH CH. SELECTORS ONLY) ■ .. 1.727.462.81	GRP41/42
AUDIO ELECTRONICS (2-2 WITH CH. SELECTORS ONLY) ■ .. 1.727.423.00	GRP41/42
AUDIO ELECTRONICS (2-2 WITH CH. SELECTORS ONLY) ■ .. 1.727.463.00	GRP41/42
AUDIO ELECTRONICS (2-2 WITH CH. SELECTORS ONLY) ■ .. 1.727.463.81	GRP41/42
- AUDIO ELECTRONICS (2-2 WITH CH. SELECTORS ONLY) ■ .. 1.727.423.81	GRP41/42
AUDIO ELECTRONICS (PBO) ■ .. 1.727.425.00	GRP41/42
AUDIO ELECTRONICS (PBO) ■ .. 1.727.465.00	GRP41/42
AUDIO ELECTRONICS (PBO) ■ .. 1.727.465.81	GRP41/42
- AUDIO ELECTRONICS (PBO) ■ .. 1.727.425.81	GRP41/42
AUDIO ELECTRONICS VUK (2 VU/HS) ■ .. 1.727.467.00	GRP41/42
MONO/STEREO SWITCH BLOCK DIAGRAM (WITH TEST GENERATOR)	7/109
MONO/STEREO SWITCH WIRING DIAGRAM	7/115
M/S INPUT AMPLIFIER WITH TEST GENERATOR ■ .. 1.727.441.00	GRP44
M/S OUTPUT AMPLIFIER WITH TEST GENERATOR ■ .. 1.727.442.00	GRP44
M/S ADJUSTMENT WITH TEST GENERATOR	7/117
MONO/STEREO SWITCH BLOCK DIAGRAM (WITHOUT TEST GENERATOR)	7/119
M/S INPUT AMPLIFIER ■ .. 1.727.443.00	GRP45
M/S OUTPUT AMPLIFIER PBO	7/121
M/S ADJUSTMENT	7/122
M/S ADJUSTMENT PBO	7/123
CONSOLE MONITOR PANEL WIRING DIAGRAM	7/125
CONSOLE MONITOR ■ .. 1.727.451.00	GRP45
CONSOLE MONITOR ■ .. 1.727.452.00	GRP45
EXT. VU-PANEL 2CH WIRING DIAGRAM	7/127
EXT. VU-PANEL MONO WIRING DIAGRAM	7/128
VU PANEL (2 VU) ■ .. 1.727.453.00	GRP46
VU PANEL (1 VU) ■ .. 1.727.454.00	GRP46
EXT. STEREO MONITOR VU-PANEL WIRING DIAGRAM	7/129
MONITOR WITH VU-METERS (STEREO) ■ .. 1.727.910.00	GRP90
LS AMPLIFIER (STEREO)	7/131
LS AMPLIFIER (STEREO)	7/135
LS AMPLIFIER (STEREO)	7/139
LS AMPLIFIER (STEREO)	7/143
LS AMPLIFIER (STEREO)	7/147
LS AMPLIFIER (STEREO)	7/149
LS AMPLIFIER (STEREO)	7/153

(■ = ELECTROSTATICALLY SENSITIVE ASSEMBLY)

CONTENTS OF DIAGRAM SECTIONS IN NUMERICAL ORDER

	Page	
1.050.340.00	HEAD BLOCK ASSEMBLY	7/5
1.727.120.00	MONITOR INTERNAL	7/25
1.727.180.00	SHUTTLE CONTROL	6/36
1.727.240.00	LINE OUTPUT CONNECTOR	7/32
1.727.241.00	LINE INPUT CONNECTOR	7/33
1.727.242.00	MIC INPUT CONNECTOR	7/34
1.727.300.00	POWER SUPPLY	6/7
1.727.310.00	RECTIFIER	6/7
1.727.315.00	SPOOLING MOTOR TACHO LEFT	6/21
1.727.316.00	SPOOLING MOTOR TACHO RIGHT	6/21
1.727.320.00	TAPE TENSION SENSOR	6/23
1.727.321.00	TAPE MOVE SENSOR	6/19
1.727.330.20/21	CAPSTAN MOTOR CONTROL	6/41
1.727.330.22	CAPSTAN MOTOR CONTROL	6/45
1.727.330.23	CAPSTAN MOTOR CONTROL	6/51
1.727.330.24	CAPSTAN MOTOR CONTROL	6/55
1.727.332.00	CAPSTAN START CONTROL	6/49
1.727.335.20	CAPSTAN MOTOR CONTROL HS	6/59
1.727.340.20	SPOOLING MOTOR CONTROL	6/27
1.727.340.21	SPOOLING MOTOR CONTROL	6/31
1.727.341.00	TAPE TENSION ADJUST	6/35
1.727.342.00	SPOOLING MOTOR FILTER	6/37
1.727.350.20/21/22	TAPE DECK ELECTRONICS	6/9
1.727.350.23	TAPE DECK ELECTRONICS	6/14
1.727.360.00	COMMAND PANEL (WITHOUT VU-METERS)	6/63
1.727.361.00	COMMAND PANEL (1 VU)	6/65
1.727.362.00	COMMAND PANEL (2 VU)	6/69
1.727.363.00	COMMAND PANEL (2-2)	6/73
1.727.364.00	COMMAND PANEL (2 VU, REPRO ONLY)	6/75
1.727.365.00	COMMAND PANEL (1 VU, REPRO ONLY)	6/79
1.727.370.00	DISPLAY	6/83
1.727.400.00	AUDIO CONTROL	7/9
1.727.400.81	AUDIO CONTROL	7/13
1.727.400.82	AUDIO CONTROL	7/17
1.727.401.00	AUDIO CONTROL HS	7/21
1.727.420.00	AUDIO ELECTRONICS (VU)	7/27
1.727.420.81	AUDIO ELECTRONICS (VU)	7/41
1.727.421.00	AUDIO ELECTRONICS (Ø VU)	7/49
1.727.421.81	AUDIO ELECTRONICS (Ø VU)	7/61
1.727.423.00	AUDIO ELECTRONICS (2-2 WITH CH. SELECTORS ONLY)	7/75
1.727.423.81	AUDIO ELECTRONICS (2-2 WITH CH. SELECTORS ONLY)	7/87
1.727.425.00	AUDIO ELECTRONICS (PBO)	7/95
1.727.425.81	AUDIO ELECTRONICS (PBO)	7/103
1.727.430.00	REPRODUCE PREAMPLIFIER	7/7
1.727.441.00	M/S INPUT AMPLIFIER WITH TEST GENERATOR	7/117
1.727.442.00	M/S OUTPUT AMPLIFIER WITH TEST GENERATOR	7/119
1.727.443.00	M/S ADJUSTMENT WITH TEST GENERATOR	7/121
1.727.451.00	M/S INPUT AMPLIFIER	7/123
1.727.452.00	M/S OUTPUT AMPLIFIER	7/125
1.727.453.00	M/S ADJUSTMENT	7/127
1.727.454.00	M/S ADJUSTMENT PBO	7/128
1.727.460.00	AUDIO ELECTRONICS (VU)	7/35
1.727.460.81	AUDIO ELECTRONICS (VU)	7/41
1.727.461.00	AUDIO ELECTRONICS (Ø VU)	7/55
1.727.461.81	AUDIO ELECTRONICS (Ø VU)	7/61
1.727.462.81	AUDIO ELECTRONICS VUK (2 VU)	7/69
1.727.463.00	AUDIO ELECTRONICS (2-2 WITH CH. SELECTORS ONLY)	7/81
1.727.463.81	AUDIO ELECTRONICS (2-2 WITH CH. SELECTORS ONLY)	7/87
1.727.465.00	AUDIO ELECTRONICS (PBO)	7/99
1.727.465.81	AUDIO ELECTRONICS (PBO)	7/103
1.727.467.00	AUDIO ELECTRONICS VUK (2 VU/HS)	7/109
1.727.910.00	CONSOLE MONITOR	7/131
1.727.910.81	CONSOLE MONITOR	7/135
1.727.925.00	VU PANEL (2 VU)	7/139
1.727.935.00	VU PANEL (1 VU)	7/143
1.727.965.00	MONITOR WITH VU-METERS (STEREO)	7/149
1.727.966.00	LS AMPLIFIER (STEREO)	7/153

AUDIO BLOCK DIAGRAM

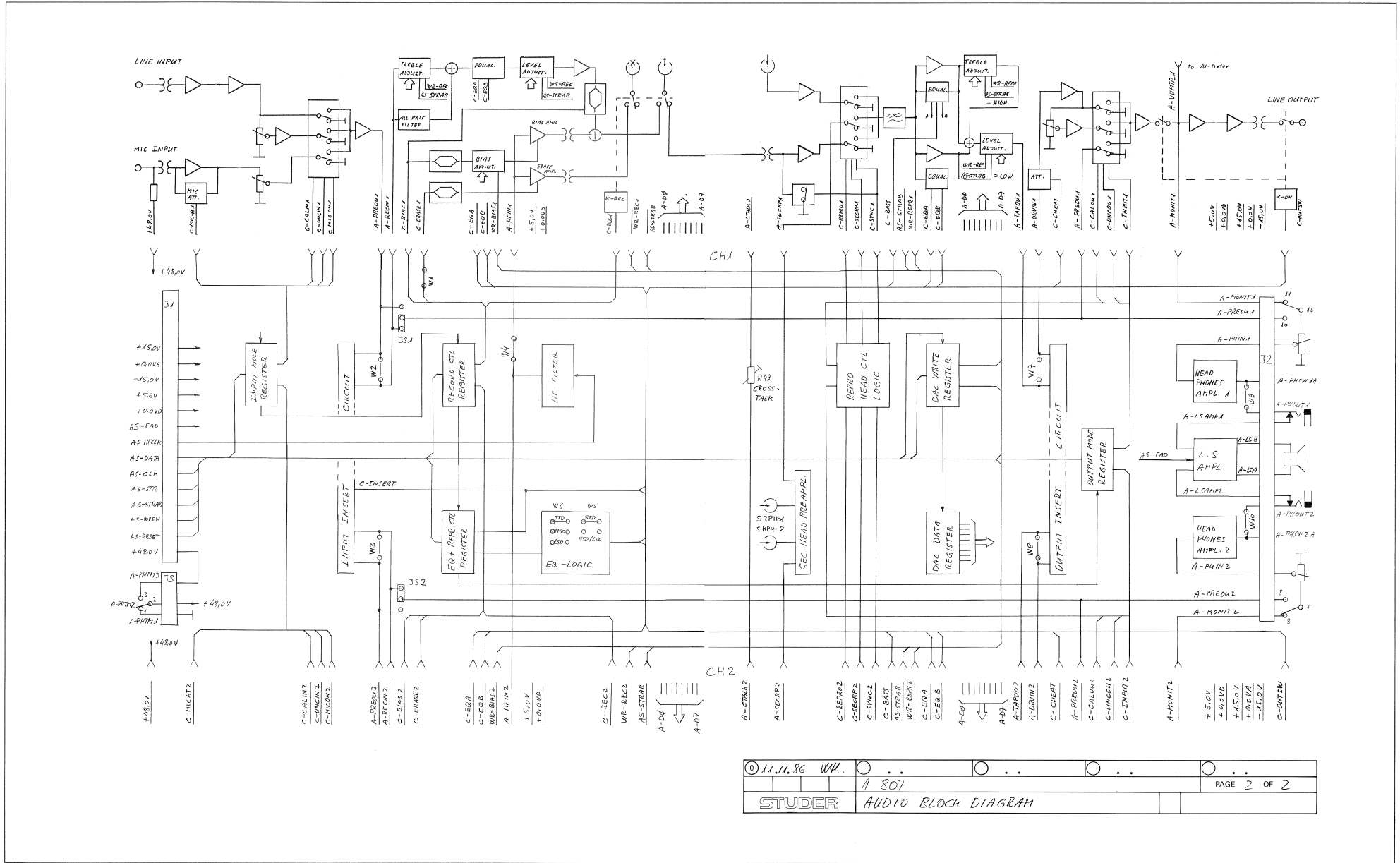

© 11.11.86 W.K.	A 807	PAGE 2 OF 2
STUDER AUDIO BLOCK DIAGRAM		

AUDIO WIRING DIAGRAM

AUDIO LEVEL DIAGRAMS

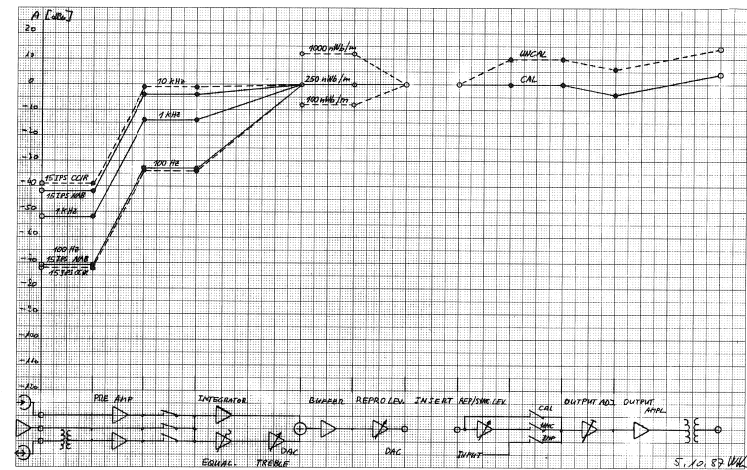
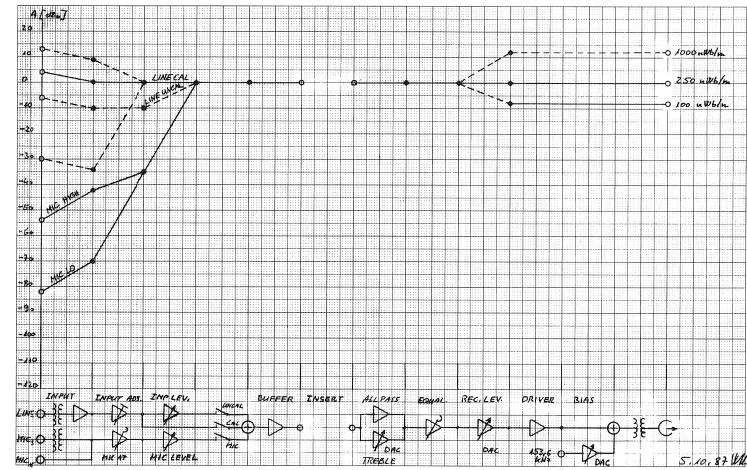
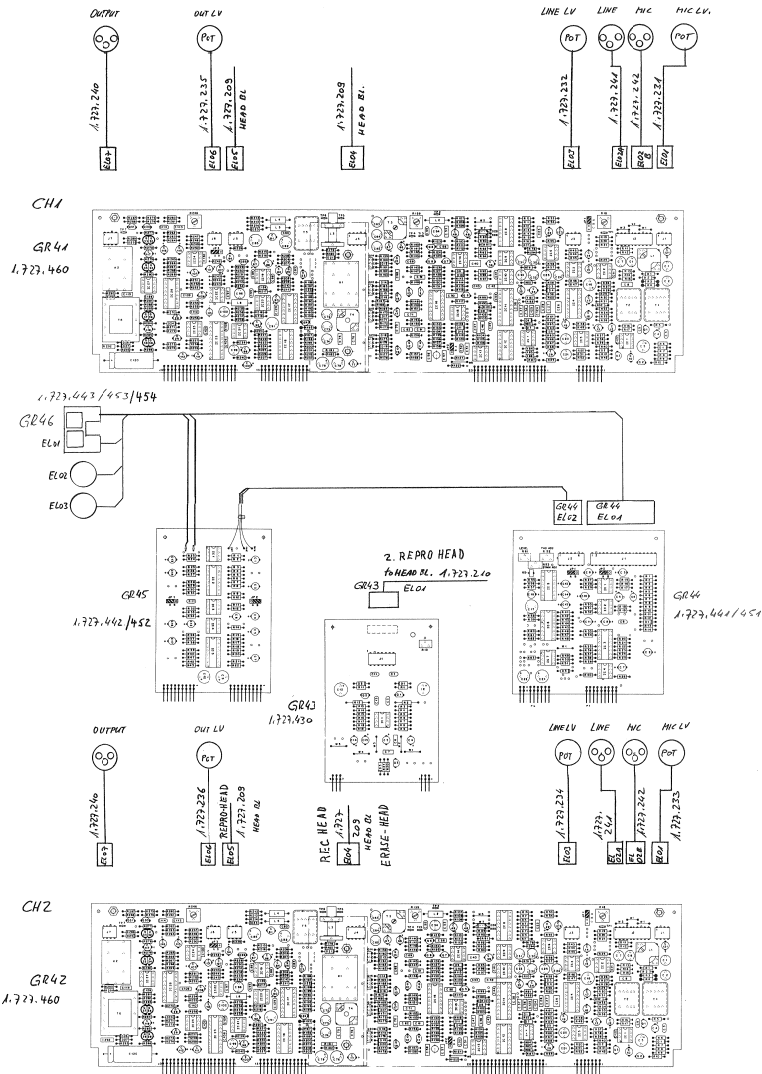

⑩ 10.12.86 WK	○ A.9.87 WK	○ . .	○ . .	○ . .	PAGE OF
STUDER			Verdrahtung, Audio		

HEAD BLOCK ASSEMBLY 1.050.340.00 GRP39

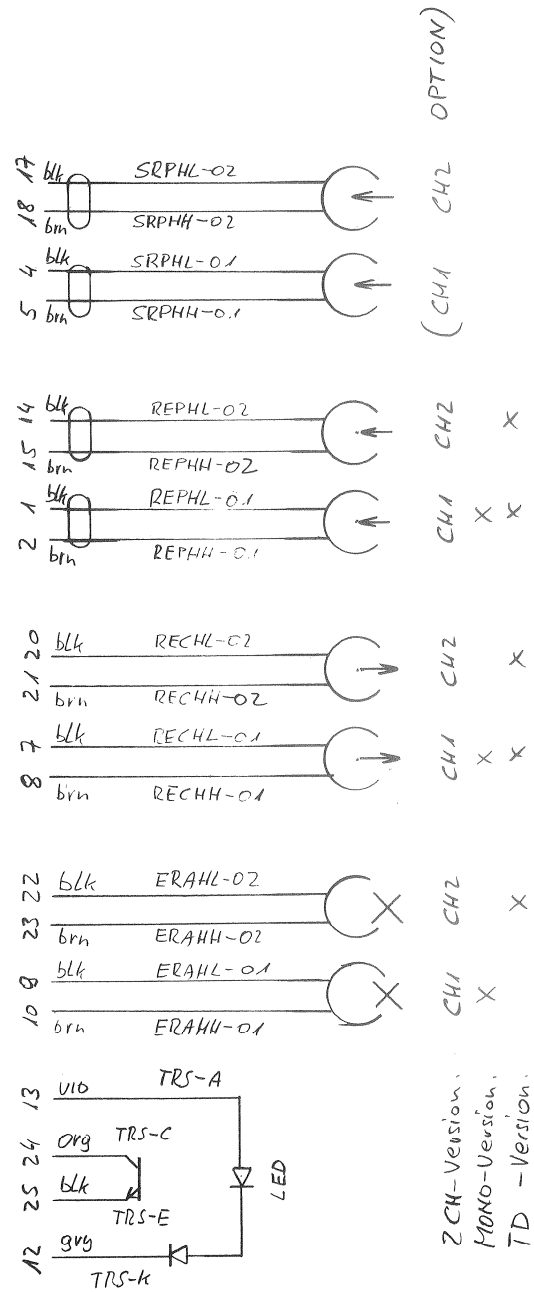
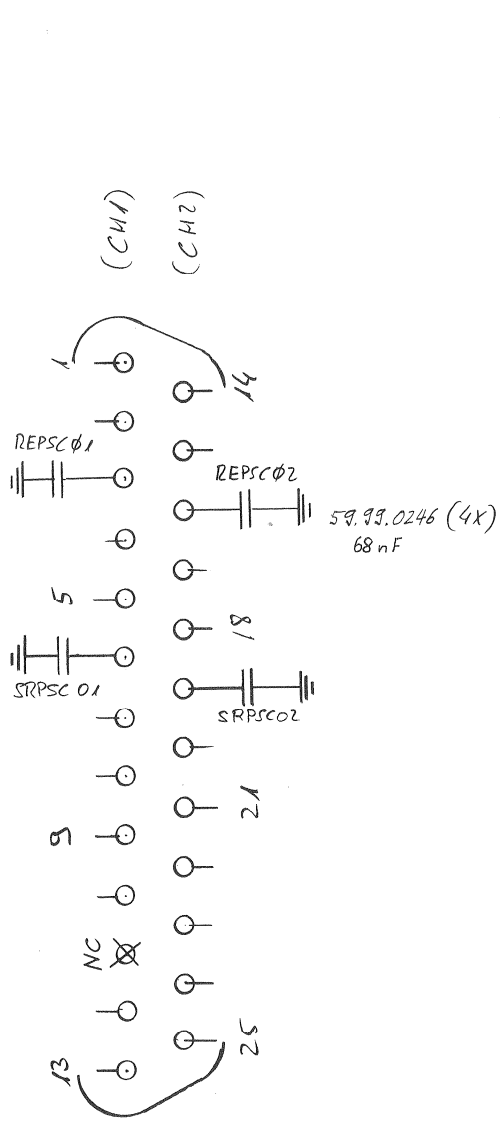

2 CH-Version
 MONO-Version
 TD -Version
 340,
 344, 345

© 1.9.86 W/H	○ ..	○ ..	○ ..	○ ..
	A 807		PAGE	OF
STUDER	HEAD BLOCK ASSEMBLY		1.050.343.00	



REPRODUCE PREAMPLIFIER 1.727.430.00 GRP43

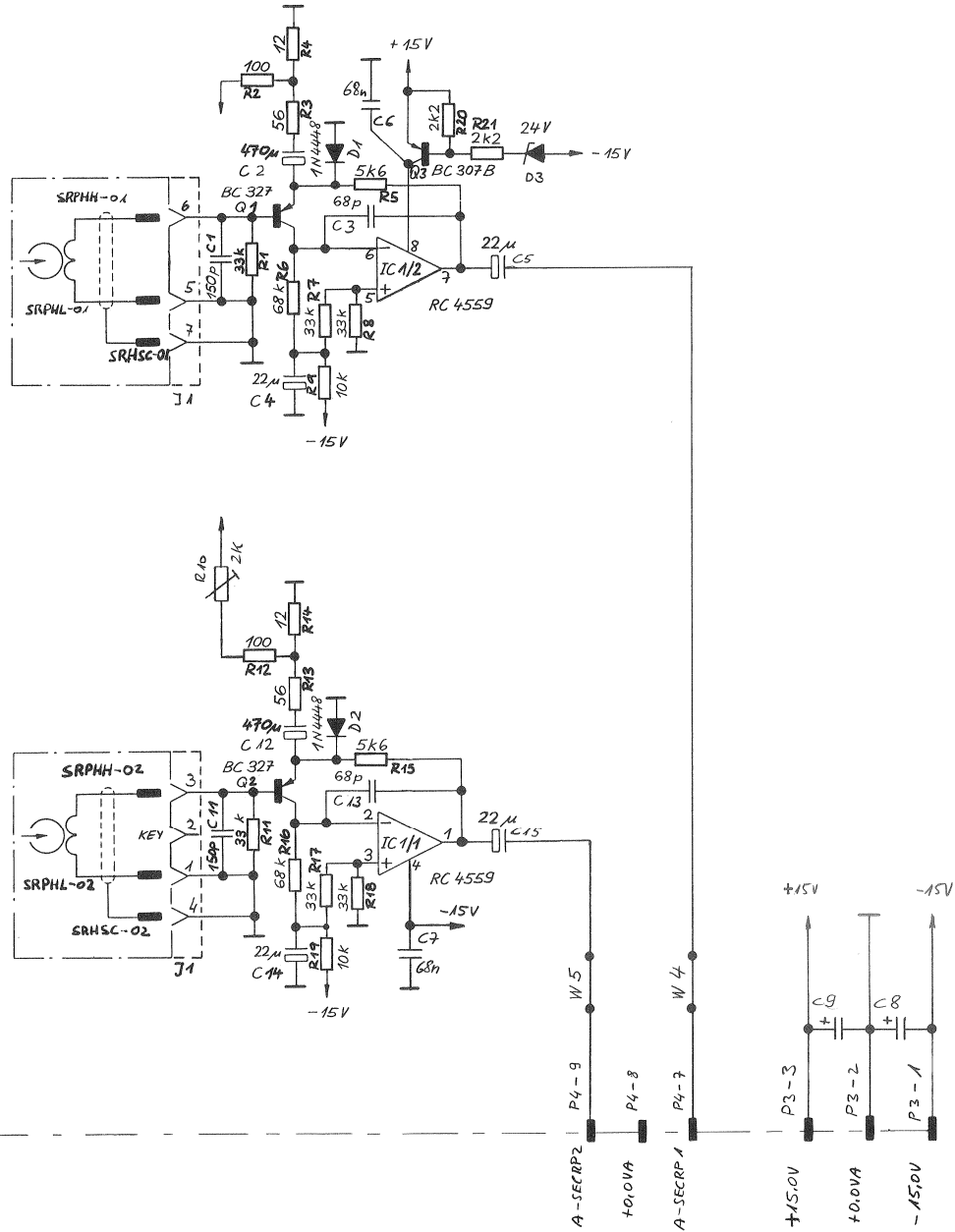

30.1.86	Wk.								
A 807 GR43								PAGE 1 OF 1	
STUDER						PREAMPLIFIER BOARD		1.727.430.00	

REPRODUCE PREAMPLIFIER 1.727.430.00 GRP43

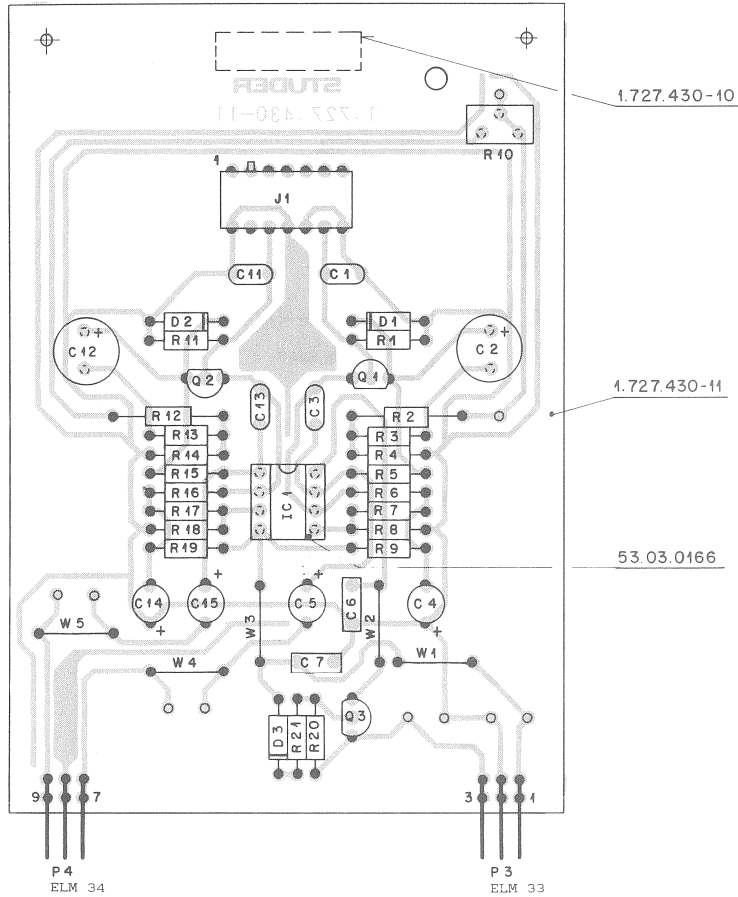

IND.	PDS-NO.	PART NO.	VALUE	SPELIF-ICATIUNS / EQUIVALENT	MANUF.	IND.	PDS-NO.	PART NO.	VALUE	SPECIFICATIONS / EQUIVALENT	MANUF.
C.....1	59-34-4151	150 pF	10%	50V Cer		R.....5	57-11-4562	5.6 kOhm	2%, 0.25W, MF		
C.....2	59-22-2471	470 uF	-20%	6.3V EL		R.....6	57-11-4683	68 kOhm	2%, 0.25W, MF		
C.....3	59-34-4680	68 pF	10%	50V Cer		R.....7	57-11-4333	33 kOhm	2%, 0.25W, MF		
C.....4	59-22-5220	22 uF	-20%	25V EL		R.....8	57-11-4333	33 kOhm	2%, 0.25W, MF		
C.....5	59-22-5220	22 uF	-20%	25V EL		R.....9	57-11-4103	10 kOhm	2%, 0.25W, MF		
C.....6	59-06-0683	68 nF	10%	63V PETP		R.....10	58-01-9202	2 kOhm	10%, 0.5 W, PMG		
C.....7	59-06-0683	68 nF	10%	63V PETP		R.....11	57-11-4333	33 kOhm	2%, 0.25W, MF		
C.....8				not used		R.....12	57-11-4101	100 Ohm	2%, 0.25W, MF		
C.....9				not used		R.....13	57-11-4560	56 Ohm	2%, 0.25W, MF		
C.....11	59-34-4151	150 pF	10%	50V Cer		R.....14	57-11-4120	12 Ohm	2%, 0.25W, MF		
C.....12	59-22-2471	470 uF	-20%	6.3V EL		R.....15	57-11-4562	5.6 kOhm	2%, 0.25W, MF		
C.....13	59-34-4680	68 pF	10%	50V Cer		R.....16	57-11-4683	68 kOhm	2%, 0.25W, MF		
C.....14	59-22-5220	22 uF	-20%	25V EL		R.....17	57-11-4333	33 kOhm	2%, 0.25W, MF		
C.....15	59-22-5220	22 uF	-20%	25V EL		R.....18	57-11-4333	33 kOhm	2%, 0.25W, MF		
D.....1	50-04-0125	1N4448		50V SI		R.....19	57-11-4103	10 kOhm	2%, 0.25W, MF		
D.....2	50-04-0125	1N4448		50V SI		R.....20	57-11-4222	2.2 kOhm	2%, 0.25W, MF		
D.....3	50-04-1121	24 V	5%	0.4W Zener		R.....21	57-11-4222	2.2 kOhm	2%, 0.25W, MF		
IC.....1	50-09-0107	RC 4559		Dual Op. Amp.	Ra	W.....1	64-01-0106		wire bridge		
J.....1	54-31-0244	7-Pole		CIS Socket Strip	AMP	W.....2	64-01-0106		wire bridge		
MP.....1	1-727-430-10	1 PCS		No. Label	St	W.....3	64-01-0106		wire bridge		
MP.....2	1-727-430-11	1 PCS		Preamplifier PCB	St	W.....4	64-01-0106		wire bridge		
Q.....1	50-03-0625	BC327		PNP		W.....5	64-01-0106		wire bridge		
Q.....2	50-03-0625	BC327		PNP		XIC....1	53-03-0166	8 POLE	IC Socket		
Q.....3	50-03-0515	BC307B		BC557B, BC560B							
P.....1	54-01-0227	3-Pole		CIS Plug Strip	AMP						
P.....2	54-01-0227	3-Pole		CIS Plug Strip	AMP						
R.....1	57-11-4333	33 kOhm	2%	0.25W, MF							
R.....2	57-11-4101	106 Ohm	2%	0.25W, MF							
R.....3	57-11-4560	56 Ohm	2%	0.25W, MF							
R.....4	57-11-4120	12 Ohm	2%	0.25W, MF							

AUDIO CONTROL 1.727.400.00 GRP40

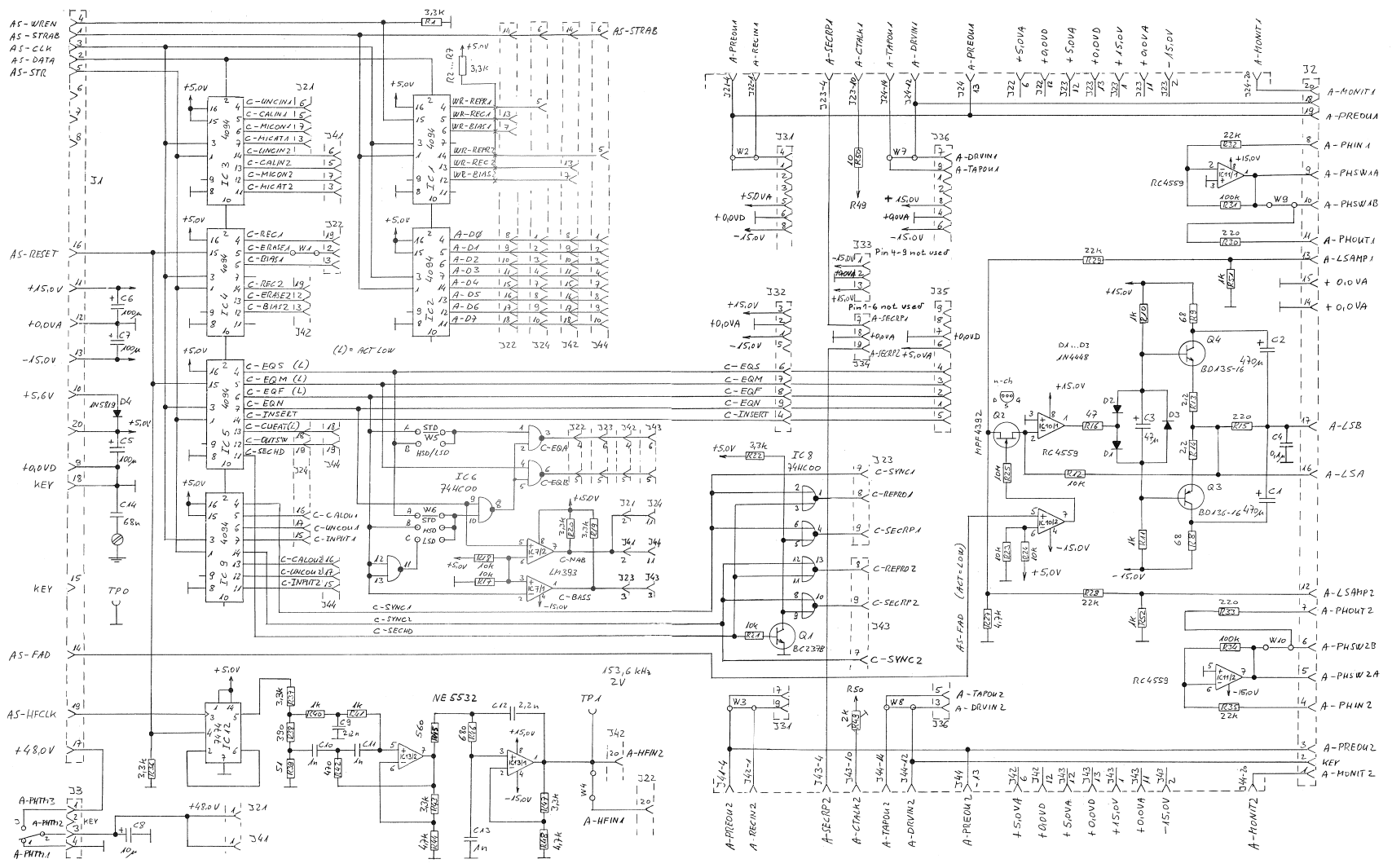

② 20.11.86 Wk.	① 08.01.87 Wk.	○ . . .	○ . . .	○ . . .
A 807 GR 40				
STUDER			AUDIO CONTROL BOARD	
				PAGE 2 OF 2
				1.727.400.00

AUDIO CONTROL 1.727.400.00 GRP40

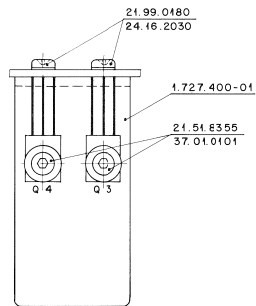
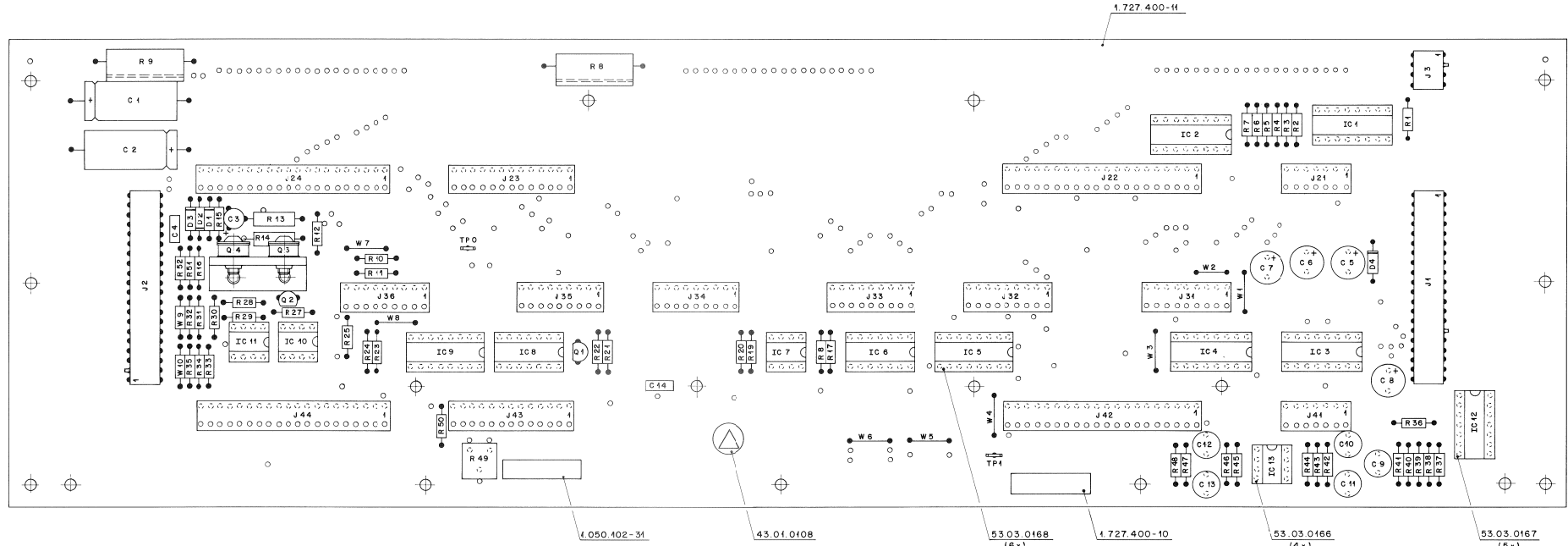

- R49 = CROSSTALK ADJUSTMENT
 - W1 = C-BRAGE1 (TO BE INTERRUPTED FOR 2CH VERSIONS WITH MONO-ERAHEAD)
 - W2 = LINK OF INPUT INSERT CH1 (INTERRUPT FOR ANY INPUT INSERTS)
 - W3 = LINK OF INPUT INSERT CH2 (INTERRUPT FOR ANY INPUT INSERTS)
 - W4 = -
 - W5 = SPEED SELECTOR LINK
 - W6 = SPEED SELECTOR LINK
 - W7 = LINK OF OUTPUT INSERT CH1 (INTERRUPT FOR ANY OUTPUT INSERTS)
 - W8 = LINK OF OUTPUT INSERT CH2 (INTERRUPT FOR ANY OUTPUT INSERTS)
- TP0 0 0 V
 TP1 HF SIGNAL 2.0 V/153.6 kHz

1.050.402-31 43.01.0108 53.03.0168 (6 x) 1.727.400-10 53.03.0166 (4 x) 53.03.0167 (5 x)



AUDIO CONTROL 1.727.400.00 GRP40

IND.	POS.-NO.	PART NO.	VALUE	SPECIFICATIONS / EQUIVALENT	MANUF.	IND.	POS.-NO.	PART NO.	VALUE	SPECIFICATIONS / EQUIVALENT	MANUF.
C.....1	59.25.3471	470 uF	-20%	16 V EL		R....34	57.11.4104	100 kOhm	2%	0.25W, MF	
C.....2	59.25.3471	470 uF	-20%	16 V EL		R....35	57.11.4223	22 kOhm	2%	0.25W, MF	
C.....3	59.22.3470	47 uF	-20%	10 V EL		R....36	57.11.4332	3.3 kOhm	2%	0.25W, MF	
C.....4	59.06.0104	0.1 uF	10%	63 V PETP		(00) R....37	57.11.4332	3.3 kOhm	2%	0.25W, MF	
C.....5	59.22.5101	100 uF	-20%	25 V EL		(01) R....37	57.11.4332	3.3 kOhm	2%	0.25W, MF	
C.....6	59.22.5101	100 uF	-20%	25 V EL		R....39	57.11.4310	31 Ohm	1%	0.25W, MF	
C.....7	59.22.5101	100 uF	-20%	25 V EL		R....40	57.11.4102	1 kOhm	2%	0.25W, MF	
C.....8	59.22.3100	10 uF	-20%	63 V EL		R....41	57.11.4102	1 kOhm	2%	0.25W, MF	
C.....9	59.09.1222	2.2 nF	1%	160 V PP		R....42	57.11.4471	470 Ohm	2%	0.25W, MF	
C.....10	59.05.1102	1 nF	1%	160 V PP		R....43	57.11.4332	3.3 kOhm	2%	0.25W, MF	
C.....11	59.05.1102	1 nF	1%	160 V PP		R....44	57.11.4472	4.7 kOhm	2%	0.25W, MF	
C.....12	59.05.1222	2.2 nF	1%	160 V PP		R....45	57.11.4561	560 Ohm	2%	0.25W, MF	
C.....13	59.05.1102	1 nF	1%	160 V PP		R....46	57.11.4591	680 Ohm	2%	0.25W, MF	
C.....14	59.06.0583	68 nF	10%	63 V PETP		R....47	57.11.4332	3.3 kOhm	2%	0.25W, MF	
D.....1	50.04.0125	1N4448		50V		R....48	57.11.4472	4.7 kOhm	2%	0.25W, MF	
D.....2	50.04.0125	1N4448		50V		R....49	58.01.8202	2 kOhm		Potmeter PMG	
D.....3	50.04.0125	1N4448		50V		R....50	57.11.4100	10 Ohm	2%	0.25W, MF	
D.....4	50.04.0512	1N5819		30V	Mot	R....51	57.11.4102	1 kOhm	2%	0.25W, MF	
IC....1	50.07.0018	MC14094		CMOS	Mot	R....52	57.11.4102	1 kOhm	2%	0.25W, MF	
IC....2	50.07.0019	MC14094		CMOS	Mot	TP....0	54.02.0320			PLUG 2.8x0.8	
IC....3	50.07.0018	MC14094		CMOS	Mot	TP....1	54.02.0320			PLUG 2.8x0.8	
IC....4	50.07.0018	MC14094		CMOS	Mot	W....1	64.01.0106			Wire Bridge	
IC....5	50.07.0018	MC14094		CMOS	Mot	W....2	64.01.0106			Wire Bridge	
IC....6	50.17.1000	74HC00		HCMOS		W....3	64.01.0106			Wire Bridge	
IC....7	50.05.0283	LM393		Dual Comparator		W....4	64.01.0106			Wire Bridge	
IC....8	50.17.1002	74HC02		HCMOS		W....5	64.01.0106			Wire Bridge	
IC....9	50.07.0018	MC14094		CMOS	Mot	W....6	64.01.0106			Wire Bridge	
IC....10	50.09.0107	RC4559		Dual Op. Amp.		W....7	64.01.0106			Wire Bridge	
IC....11	50.09.0107	RC4559		Dual Op. Amp.		W....8	64.01.0106			Wire Bridge	
IC....12	50.17.1074	74HC74		HCMOS		W....9	57.11.4000			Wire Bridge	
IC....13	50.09.0101	LF353		Dual Op. Amp.		W....10	57.11.4000			Wire Bridge	
(01) IC....13	50.09.0105	NE5532		Dual Op. Amp.		XIC...1	53.03.0168	16 pol		IC Socket	
J.....1	54.01.0248	20-POLE		CIS Socket Strip	AMP	XIC...2	53.03.0168	16 pol		IC Socket	
J.....2	54.01.0248	20-POLE		CIS Socket Strip	AMP						

S T U D E R (01) 87/01/08 Wth AUDIO CONTROL BOARD 1.727.400.00 PAGE 1 S T U D E R (01) 87/01/08 Wth AUDIO CONTROL BOARD 1.727.400.00 PAGE 4

IND.	POS.-NO.	PART NO.	VALUE	SPECIFICATIONS / EQUIVALENT	MANUF.	IND.	POS.-NO.	PART NO.	VALUE	SPECIFICATIONS / EQUIVALENT	MANUF.
J.....3	54.01.0304	4-POLE		CIS Socket Strip	AMP	XIC...3	53.03.0168	16 pol		IC Socket	
J.....11				not used		XIC...4	53.03.0168	16 pol		IC Socket	
J.....12				not used		XIC...5	53.03.0168	16 pol		IC Socket	
J.....13				not used		XIC...6	53.03.0167	14 pol		IC Socket	
J.....21	54.01.0219	7-POLE		CIS Socket Strip	AMP	XIC...7	53.03.0166	8 pol		IC Socket	
J.....22	54.01.0226	20-POLE		CIS Socket Strip	AMP	XIC...8	53.03.0167	14 pol		IC Socket	
J.....23	54.01.0292	13-POLE		CIS Socket Strip	AMP	XIC...9	53.03.0168	16 pol		IC Socket	
J.....24	54.01.0226	20-POLE		CIS Socket Strip	AMP	XIC...10	53.03.0166	8 pol		IC Socket	
J.....31	54.01.0217	9-POLE		CIS Socket Strip	AMP	XIC...11	53.03.0166	8 pol		IC Socket	
J.....32	54.01.0217	9-POLE		CIS Socket Strip	AMP	XIC...12	53.03.0167	14 pol		IC Socket	
J.....33	54.01.0217	9-POLE		CIS Socket Strip	AMP	XIC...13	53.03.0166	8 pol		IC Socket	
J.....34	54.01.0217	9-POLE		CIS Socket Strip	AMP						
J.....35	54.01.0217	9-POLE		CIS Socket Strip	AMP						
J.....36	54.01.0217	9-POLE		CIS Socket Strip	AMP						
J.....41	54.01.0218	7-POLE		CIS Socket Strip	AMP						
J.....42	54.01.0226	20-POLE		CIS Socket Strip	AMP						
J.....43	54.01.0292	13-POLE		CIS Socket Strip	AMP						
J.....44	54.01.0226	20-POLE		CIS Socket Strip	AMP						
NP....1	1.727.400.11	1 pce		Audio Control PCB	St						
NP....2	1.727.400.01	1 pce		Headsink	St						
NP....3	1.727.400.12	1 pce		Box Label	St						
NP....4	21.99.0180	2 pcs		Screw M3 x 5	St						
NP....5	1.727.170.00	2 pcs		Revited spring	St						
NP....6	1.727.400.02	1 pce		Frame	St						
NP....7	1.727.400.03	1 pce		Tin plate	St						
NP....8	1.727.400.04	1 pce		Isolating plate	St						
NP....9	21.53.0355	2 pcs		Screw M3 x 8	St						
NP....10	24.16.2030	2 pcs		Lock washer	St						
NP....11	21.53.0354	11 pcs		Screw M3 x 6	St						
NP....12	24.16.1030	11 pcs		Lock washer	St						
NP....13	23.01.1032	5 pcs		Flat washer	St						
NP....14	28.31.0004	4 pcs		Pop rivets	St						
NP....15	37.01.0101	4 pcs		Lock washer	St						
NP....16	43.01.0108	1 pce		ESE warning label	St						
Q.....1	50.03.0436	BC2378		BC547B, BC550B NPN							

S T U D E R (01) 87/01/08 Wth AUDIO CONTROL BOARD 1.727.400.00 PAGE 2 S T U D E R (01) 87/01/08 Wth AUDIO CONTROL BOARD 1.727.400.00 PAGE 5

IND.	POS.-NO.	PART NO.	VALUE	SPECIFICATIONS / EQUIVALENT	MANUF.
Q.....2	50.03.0350	MPF4392	J112	FET	Mot,Six
Q.....3	50.03.0510	BD136-16		PNP	
Q.....4	50.03.0495	BD135-16		NPN	
R....1	57.11.4332	3.3 kOhm	2%	0.25W, MF	
R....2	57.11.4332	3.3 kOhm	2%	0.25W, MF	
R....3	57.11.4332	3.3 kOhm	2%	0.25W, MF	
R....4	57.11.4332	3.3 kOhm	2%	0.25W, MF	
R....5	57.11.4332	3.3 kOhm	2%	0.25W, MF	
R....6	57.11.4332	3.3 kOhm	2%	0.25W, MF	
R....7	57.11.4332	3.3 kOhm	2%	0.25W, MF	
R....8	57.56.5680	68 Ohm	2%	4 W DR	
R....9	57.56.5680	68 Ohm	2%	4 W DR	
R....10	57.11.4102	1 kOhm	2%	0.25W, MF	
R....11	57.11.4102	1 kOhm	2%	0.25W, MF	
R....12	57.11.4103	10 kOhm	2%	0.25W, MF	
R....13	57.13.4229	2.2 Ohm	2%	0.5 W MF	
R....14	57.13.4229	2.2 Ohm	2%	0.5 W MF	
R....15	57.11.4621	220 Ohm	2%	0.25W, MF	
R....16	57.11.4670	47 Ohm	2%	0.25W, MF	
R....17	57.11.4103	10 kOhm	2%	0.25W, MF	
R....18	57.11.4103	10 kOhm	2%	0.25W, MF	
R....19	57.11.4332	3.3 kOhm	2%	0.25W, MF	
R....20	57.11.4332	3.3 kOhm	2%	0.25W, MF	
R....21	57.11.4103	10 kOhm	2%	0.25W, MF	
R....22	57.11.4332	3.3 kOhm	2%	0.25W, MF	
R....23	57.11.4103	10 kOhm	2%	0.25W, MF	
R....24	57.11.4103	10 kOhm	2%	0.25W, MF	
R....25	57.11.5106	10 kOhm	2%	0.25W, MF	
R....26				not used	
R....27	57.11.4472	4.7 kOhm	2%	0.25W, MF	
R....28	57.11.4223	22 kOhm	2%	0.25W, MF	
R....29	57.11.4223	22 kOhm	2%	0.25W, MF	
R....30	57.11.4221	220 Ohm	2%	0.25W, MF	
R....31	57.11.4104	100 kOhm	2%	0.25W, MF	
R....32	57.11.4223	22 kOhm	2%	0.25W, MF	
R....33	57.11.4221	220 Ohm	2%	0.25W, MF	

S T U D E R (01) 87/01/08 Wth AUDIO CONTROL BOARD 1.727.400.00 PAGE 3

AUDIO CONTROL 1.727.400.81 GRP40

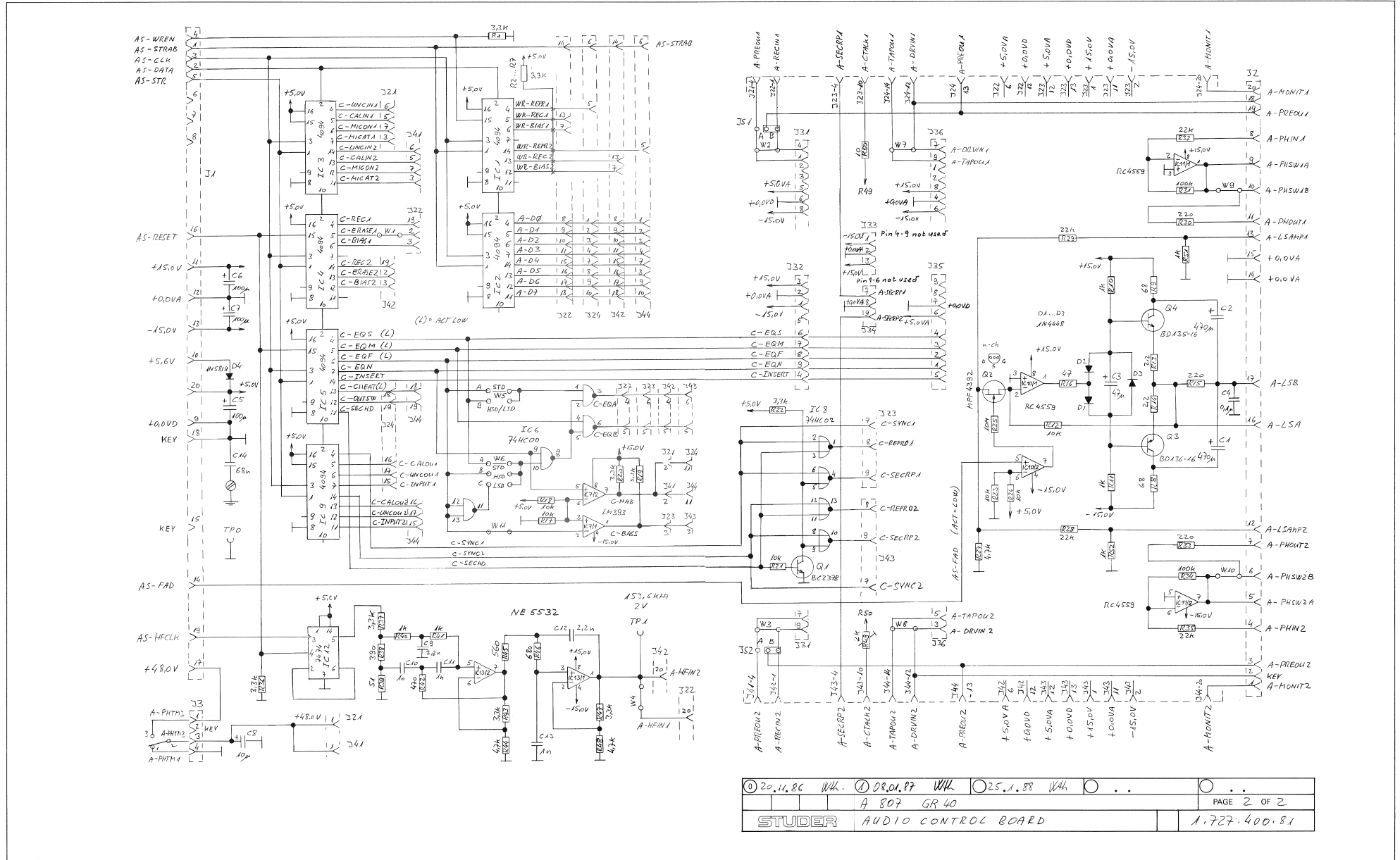

20.11.86 Wk.	08.01.87 Wk.	25.1.88 Wk.		
A 807 GR 40				
STUDER AUDIO CONTROL BOARD				
				PAGE 2 OF 2
				1.727.400.81



AUDIO CONTROL 1.727.400.81 GRP40

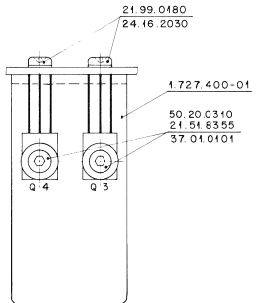
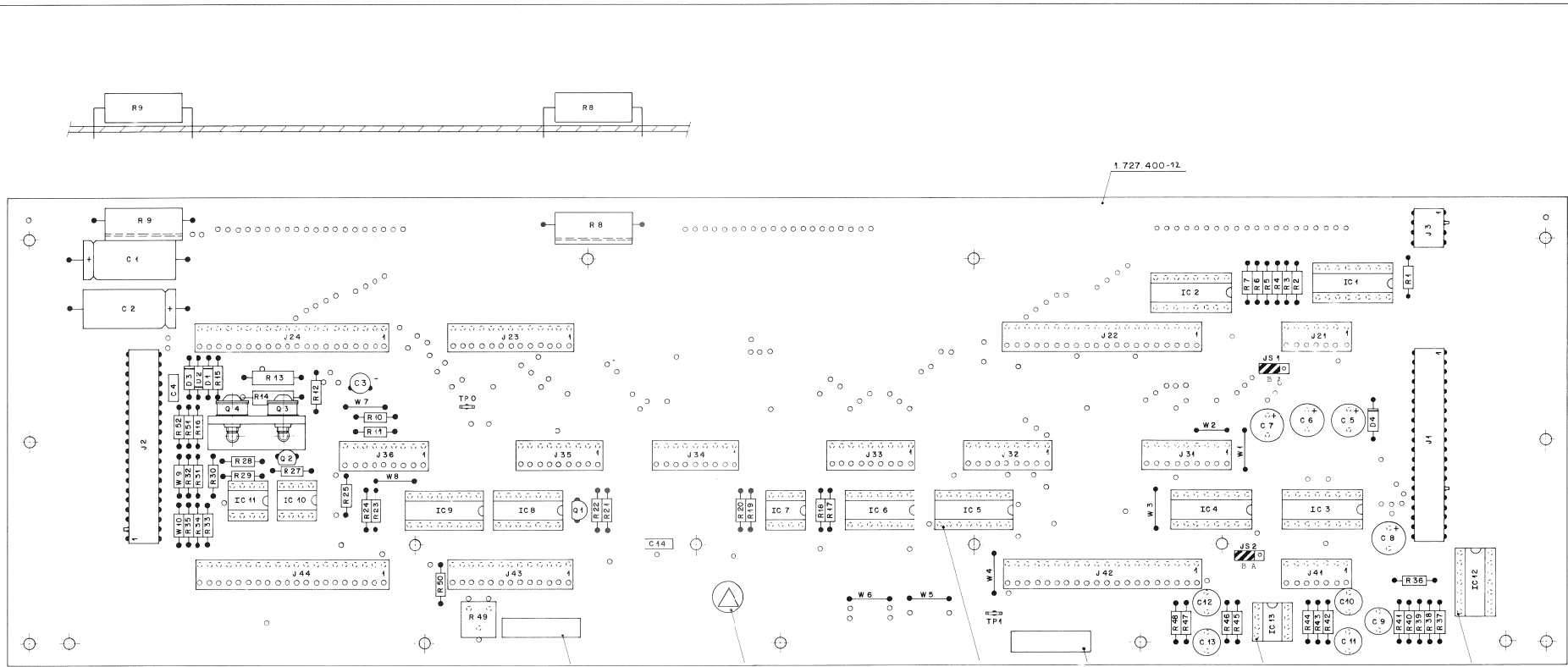

- R49 = CROSSTALK ADJUSTMENT
- W1 = C-ERASE: (TO BE INTERRUPTED FOR 2CH VERSIONS WITH MONO-ERASEHEAD)
- W2 = LINK OF INPUT INSERT CH1 (INTERRUPT FOR ANY INPUT INSERTS)
- W3 = LINK OF INPUT INSERT CH2 (INTERRUPT FOR ANY INPUT INSERTS)
- W4 = ---
- W5 = SPEED SELECTOR LINK
- W6 = SPEED SELECTOR LINK
- W7 = LINK OF OUTPUT INSERT CH1 (INTERRUPT FOR ANY OUTPUT INSERTS)
- W8 = LINK OF OUTPUT INSERT CH2 (INTERRUPT FOR ANY OUTPUT INSERTS)

- JS1 A = MONITORING BEFORE INPUT INSERT POINT CH1
- B = MONITORING AFTER INPUT INSERT POINT CH1
- JS2 A = MONITORING BEFORE INPUT INSERT POINT CH2
- B = MONITORING AFTER INPUT INSERT POINT CH2

TP8 0.0 V
 TP1 HF SIGNAL 2.0 V/153.6 kHz



AUDIO CONTROL 1.727.400.81 GRP40

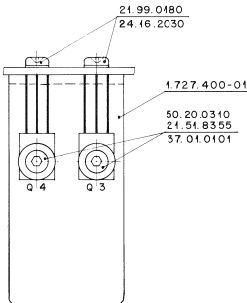
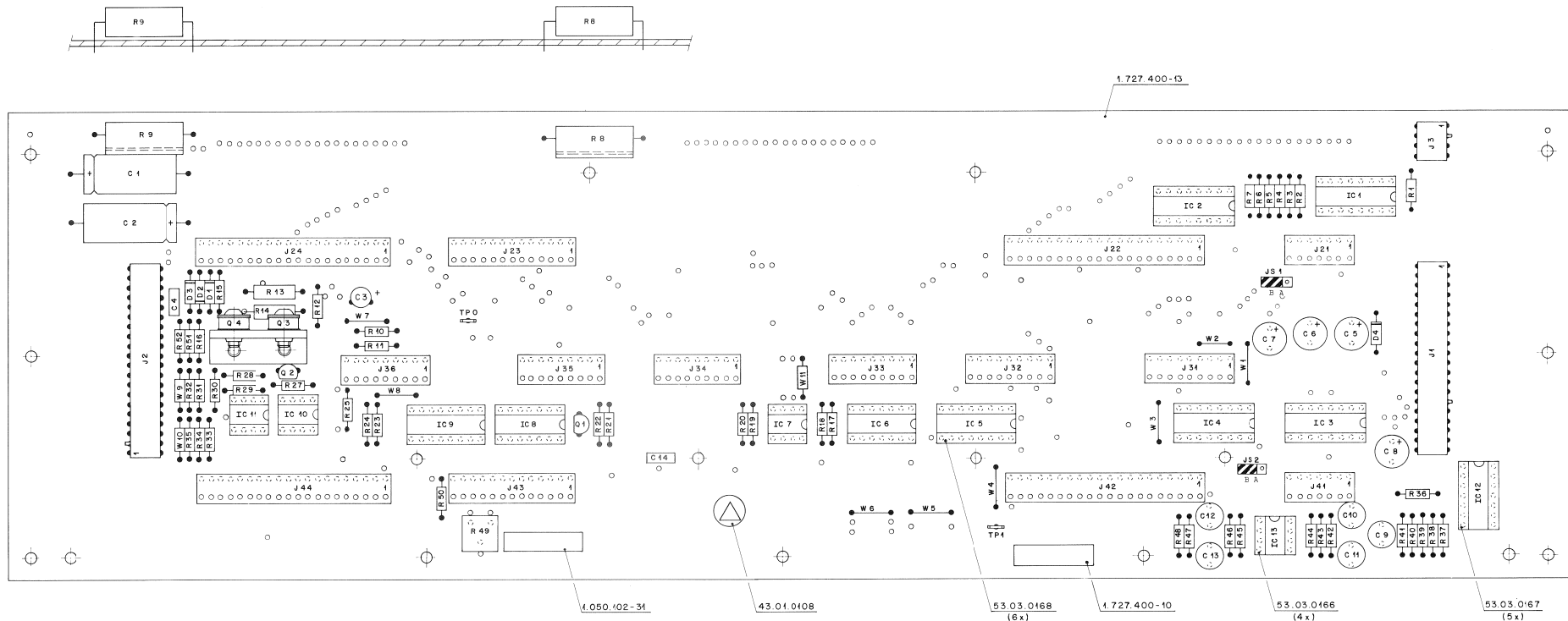

- R49 = CROSSTALK ADJUSTMENT
- W1 = C-RASEL (TO BE INTERRUPTED FOR 2CH VERSIONS WITH MONO-ERASEHEAD)
- W2 = LINK OF INPUT INSERT CH1 (INTERRUPT FOR ANY INPUT INSERTS)
- W3 = LINK OF INPUT INSERT CH2 (INTERRUPT FOR ANY INPUT INSERTS)
- W4 =
- W5 = SPEED SELECTOR LINK
- W6 = SPEED SELECTOR LINK
- W7 = LINK OF OUTPUT INSERT CH1 (INTERRUPT FOR ANY OUTPUT INSERTS)
- W8 = LINK OF OUTPUT INSERT CH2 (INTERRUPT FOR ANY OUTPUT INSERTS)
- TP0 0.0 V
- TP1 HF SIGNAL 2.0 V/153.6 kHz

- FACTORY STANDARD SETTING
- J31 A = MONITORING BEFORE INPUT INSERT POINT CH1
- B = MONITORING AFTER INPUT INSERT POINT CH1
- J32 A = MONITORING BEFORE INPUT INSERT POINT CH2
- B = MONITORING AFTER INPUT INSERT POINT CH2

AUDIO CONTROL 1.727.400.82 GRP40

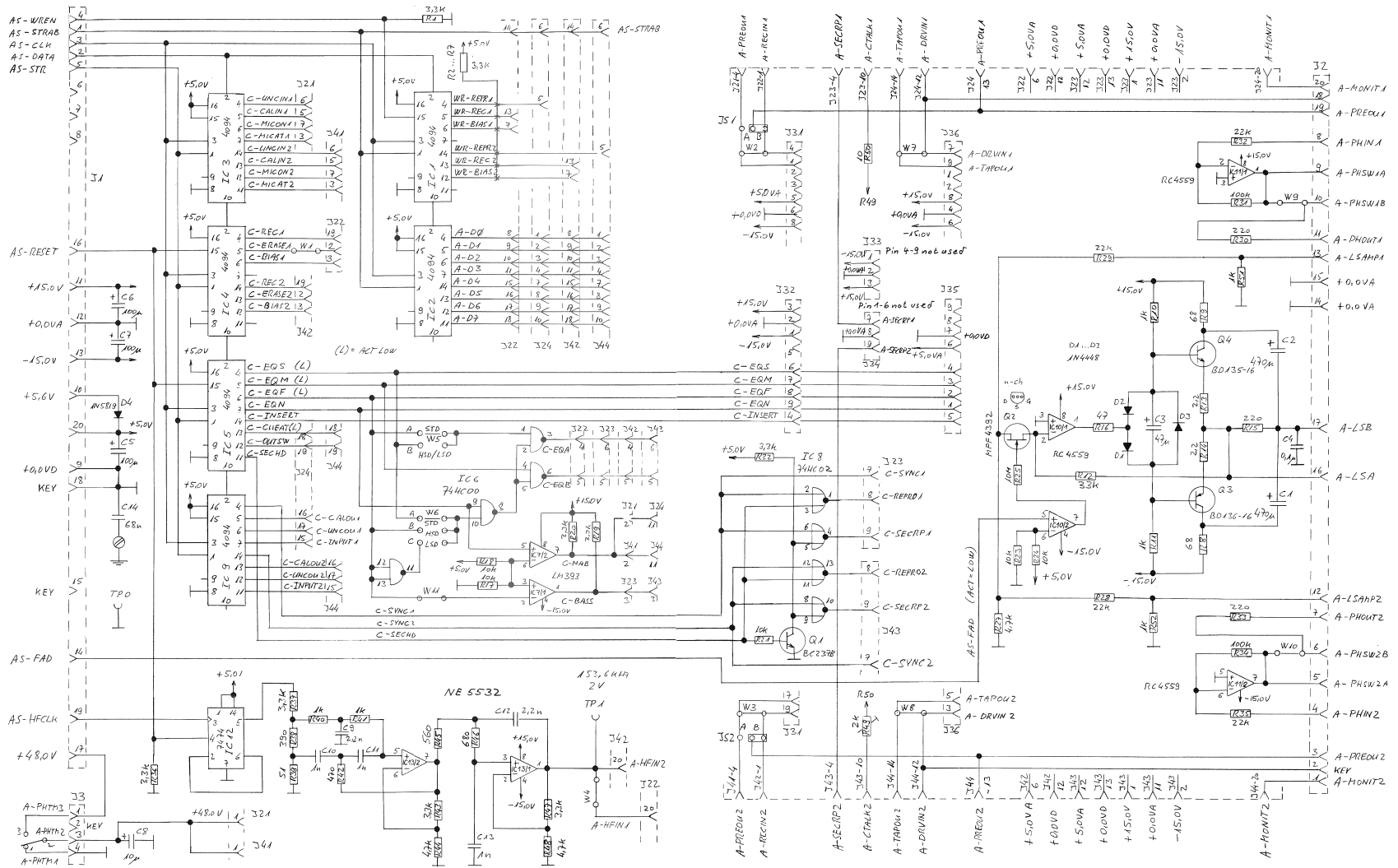

① 16.6.88	W.H.								
		A 807	GRP 40						PAGE 2 OF 2
STUDER									AUDIO CONTROL BOARD
									1.727.400.82

AUDIO CONTROL 1.727.400.82 GRP40

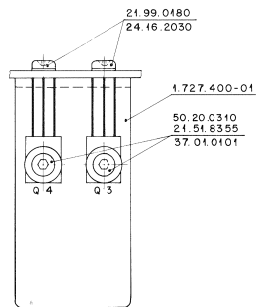
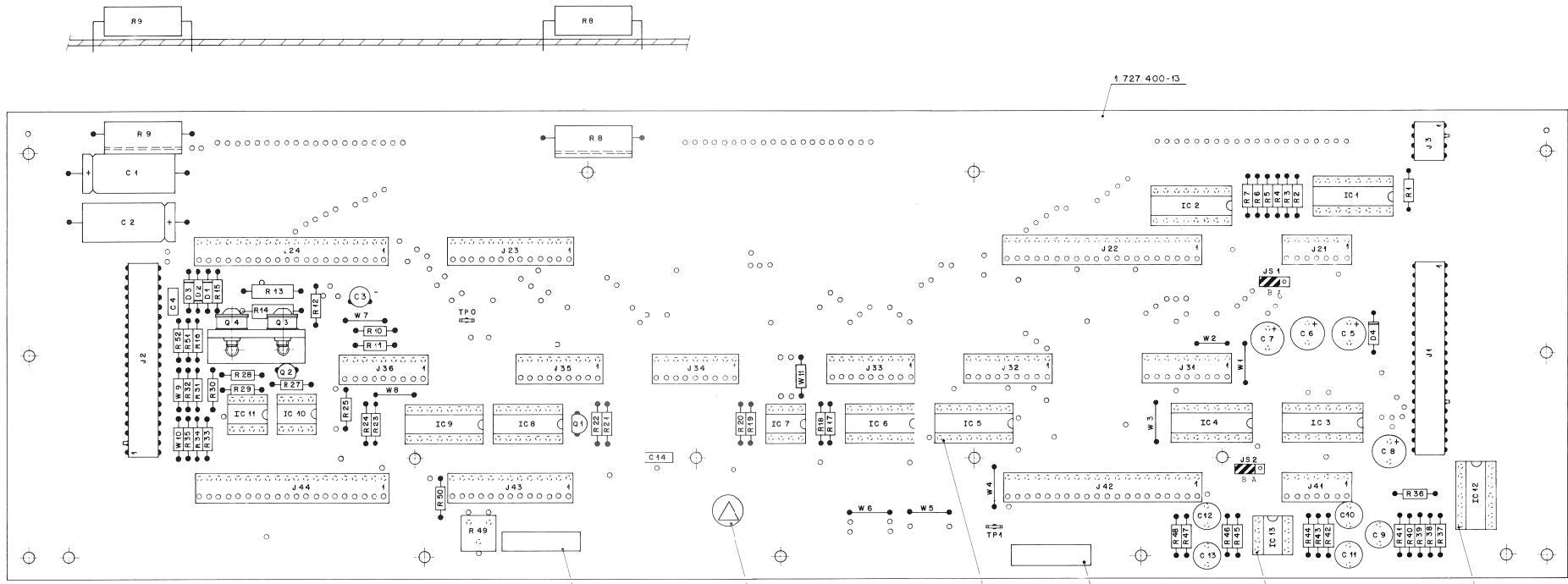

- 1.050.402-31
 - 43.01.0108
 - 53.03.0168 (6x)
 - 1.727.400-10
 - 53.03.0166 (4x)
 - 53.03.0167 (5x)
- R49** - CROSSTALK ADJUSTMENT
W1 = C-ERASE: (TO BE INTERRUPTED FOR 2CH VERSIONS WITH MONO-ERASEHEAD)
W2 = LINK OF INPUT INSERT CH1 (INTERRUPT FOR ANY INPUT INSERTS)
W3 = LINK OF INPUT INSERT CH2 (INTERRUPT FOR ANY INPUT INSERTS)
W4 =
W5 = SPEED SELECTOR LINK
W6 = SPEED SELECTOR LINK
W7 = LINK OF OUTPUT INSERT CH1 (INTERRUPT FOR ANY OUTPUT INSERTS)
W8 = LINK OF OUTPUT INSERT CH2 (INTERRUPT FOR ANY OUTPUT INSERTS)
- TP0** 0.0 V
TP1 HF SIGNAL 2.0 V/153.6 kHz
- NO** FACTORY STANDARD SETTING
JS1 A = MONITORING BEFORE INPUT INSERT POINT CH1
B = MONITORING AFTER INPUT INSERT POINT CH1
JS2 A = MONITORING BEFORE INPUT INSERT POINT CH2
B = MONITORING AFTER INPUT INSERT POINT CH2



AUDIO CONTROL 1.727.400.82 GRP40

IND.	POS.NO.	PART NO.	VALUE	SPECIFICATIONS / EQUIVALENT	MANUF.	IND.	POS.NO.	PART NO.	VALUE	SPECIFICATIONS / EQUIVALENT	MANUF.
C.....1	59.25.3471	470 uF	-20%	16 V EL		XIC...7	53.03.0166	8 pol		IC Socket	
C.....2	59.25.3471	470 uF	-20%	16 V EL		XIC...8	53.03.0167	16 pol		IC Socket	
C.....3	59.22.3470	47 uF	-20%	10 V EL		XIC...9	53.03.0168	16 pol		IC Socket	
C.....4	59.06.0104	0.1 uF	10%	63 V PETP		XIC...10	53.03.0166	8 pol		IC Socket	
C.....5	59.22.5101	100 uF	-20%	25 V EL		XIC...11	53.03.0166	8 pol		IC Socket	
C.....6	59.22.5101	100 uF	-20%	25 V EL		XIC...12	53.03.0167	16 pol		IC Socket	
C.....7	59.22.5101	100 uF	-20%	25 V EL		XIC...13	53.03.0166	8 pol		IC Socket	
C.....8	59.22.8100	10 uF	-20%	63 V EL							
C.....9	59.05.1222	2.2 nF	1%	160 V PP							
C.....10	59.05.1102	1 nF	1%	160 V PP							
C.....11	59.05.1102	1 nF	1%	160 V PP							
C.....12	59.05.1222	2.2 nF	1%	160 V PP							
C.....13	59.05.1102	1 nF	1%	160 V PP							
C.....14	59.06.0683	68 nF	10%	63 V PETP							
D.....1	50.04.0125	1N4448		50V							
D.....2	50.04.0125	1N4448		50V							
D.....3	50.04.0125	1N4448		50V							
D.....4	50.04.0512	1N5819		30V	Mot						
IC....1	50.07.0018	MC14094		CMOS	Mot						
IC....2	50.07.0018	MC14094		CMOS	Mot						
IC....3	50.07.0018	MC14094		CMOS	Mot						
IC....4	50.07.0018	MC14094		CMOS	Mot						
IC....5	50.07.0018	MC14094		CMOS	Mot						
IC....6	50.17.1000	74HC00		HCMOS							
IC....7	50.05.0283	LM393		Dual Comparator							
IC....8	50.17.1002	74HC02		HCMOS							
IC....9	50.07.0018	MC14094		CMOS	Mot						
IC....10	50.09.0107	RC4559		Dual Op. Amp.							
IC....11	50.09.0107	RC4559		Dual Op. Amp.							
IC....12	50.17.1074	74HC74		HCMOS							
IC....13	50.09.0105	NE5532		Dual Op. Amp.							
J.....1	54.01.0248	20-POLE		CIS Socket Strip	AMP						
J.....2	54.01.0248	20-POLE		CIS Socket Strip	AMP						
J.....3	54.01.0304	4-POLE		CIS Socket Strip	AMP						

EL=Electrolytic, PP=Polypropylen, SI=Silicon, MF=Metal Film
PETP=Polyester

MANUFACTURER:Mot=Motorola, St=Studer, Six=Siliconix

ORIG 88/03/28

S T U D E R (00) 88/03/28 Wth AUDIO CONTROL BOARD 1.727.400.82 PAGE 1 S T U D E R (00) 88/03/28 Wth AUDIO CONTROL BOARD 1.727.400.82 PAGE 5

IND.	POS.NO.	PART NO.	VALUE	SPECIFICATIONS / EQUIVALENT	MANUF.	IND.	POS.NO.	PART NO.	VALUE	SPECIFICATIONS / EQUIVALENT	MANUF.
J.....11				not used		R.....38	57.11.3391	390 Ohm	2%	0.25W	MF
J.....12				not used		R.....39	57.11.3510	51 Ohm	1%	0.25W	MF
J.....21				not used		R.....40	57.11.3102	1 kOhm	2%	0.25W	MF
J.....22	54.01.0218	7-POLE		CIS Socket Strip	AMP	R.....41	57.11.3102	1 kOhm	2%	0.25W	MF
J.....23	54.01.0226	20-POLE		CIS Socket Strip	AMP	R.....42	57.11.3471	470 Ohm	2%	0.25W	MF
J.....24	54.01.0292	13-POLE		CIS Socket Strip	AMP	R.....43	57.11.3332	3.3 kOhm	2%	0.25W	MF
J.....25	54.01.0226	20-POLE		CIS Socket Strip	AMP	R.....44	57.11.3472	4.7 kOhm	2%	0.25W	MF
J.....31	54.01.0217	9-POLE		CIS Socket Strip	AMP	R.....45	57.11.3561	560 Ohm	2%	0.25W	MF
J.....32	54.01.0217	9-POLE		CIS Socket Strip	AMP	R.....46	57.11.3681	680 Ohm	2%	0.25W	MF
J.....33	54.01.0217	9-POLE		CIS Socket Strip	AMP	R.....47	57.11.3332	3.3 kOhm	2%	0.25W	MF
J.....34	54.01.0217	9-POLE		CIS Socket Strip	AMP	R.....48	57.11.3472	4.7 kOhm	2%	0.25W	MF
J.....35	54.01.0217	9-POLE		CIS Socket Strip	AMP	R.....49	50.01.0202	2 kOhm			PMC
J.....36	54.01.0217	9-POLE		CIS Socket Strip	AMP	R.....50	57.11.3100	10 Ohm	2%	0.25W	MF
J.....41	54.01.0218	7-POLE		CIS Socket Strip	AMP	R.....51	57.11.3102	1 kOhm	2%	0.25W	MF
J.....42	54.01.0226	20-POLE		CIS Socket Strip	AMP	R.....52	57.11.3102	1 kOhm	2%	0.25W	MF
J.....43	54.01.0292	13-POLE		CIS Socket Strip	AMP	TP.....0	54.02.0320				PLUG 2.8#0.8
J.....44	54.01.0226	20-POLE		CIS Socket Strip	AMP	TP.....1	54.02.0320				PLUG 2.8#0.8
J.....1	54.01.0021			Bridge		W.....1	64.01.0106				Wire Bridge
J.....2	54.01.0021			Bridge		W.....2	64.01.0106				Wire Bridge
MP.....1	1.727.400.13	1 pce		Audio Control PCB	St	W.....3	64.01.0106				Wire Bridge
MP.....2	1.727.400.01	1 pce		Headring	St	W.....4	64.01.0106				Wire Bridge
MP.....3	1.727.400.10	1 pce		No. label	St	W.....5	64.01.0106				Wire Bridge
MP.....4	21.99.0180	2 pcs		Screw M3 x 5		W.....6	64.01.0106				Wire Bridge
MP.....5	21.53.0355	2 pcs		Screw M3 x 8		W.....7	64.01.0106				Wire Bridge
MP.....6	24.16.2030	2 pcs		Lock washer	St	W.....8	64.01.0106				Wire Bridge
MP.....7	37.01.0101	4 pcs		Lock washer	St	W.....9	57.11.4000				Wire Bridge
MP.....8	43.01.0108	1 pce		ESE warning label	St	W.....10	57.11.4000				Wire Bridge
MP.....9	54.01.0020	6 pcs		Contact pin	St	W.....11	57.11.4000				Wire Bridge
Q.....1	50.03.0436	BC237B		BC547B, BC550B	NPN	XIC...1	53.03.0168	16 pol		IC Socket	
Q.....2	50.03.0350	MPE4392		J112	FET	XIC...2	53.03.0168	16 pol		IC Socket	
Q.....3	50.03.0510	80136-10			PMP	XIC...3	53.03.0168	16 pol		IC Socket	
Q.....4	50.03.0495	80135-10			PMP	XIC...4	53.03.0168	16 pol		IC Socket	
R.....1	57.11.3332	3.3 kOhm	2%	0.25W	MF	XIC...5	53.03.0168	16 pol		IC Socket	
XIC...6	53.03.0167	14 pol		IC Socket							

S T U D E R (00) 88/03/28 Wth AUDIO CONTROL BOARD 1.727.400.82 PAGE 2 S T U D E R (00) 88/03/28 Wth AUDIO CONTROL BOARD 1.727.400.82 PAGE 4

IND.	POS.NO.	PART NO.	VALUE	SPECIFICATIONS / EQUIVALENT	MANUF.
R.....2	57.11.3332	3.3 kOhm	2%	0.25W	MF
R.....3	57.11.3332	3.3 kOhm	2%	0.25W	MF
R.....4	57.11.3332	3.3 kOhm	2%	0.25W	MF
R.....5	57.11.3332	3.3 kOhm	2%	0.25W	MF
R.....6	57.11.3332	3.3 kOhm	2%	0.25W	MF
R.....7	57.11.3332	3.3 kOhm	2%	0.25W	MF
R.....8	57.56.3680	68 Ohm	2%	4 W	DR
R.....9	57.56.3680	68 Ohm	2%	4 W	DR
R.....10	57.11.3102	1 kOhm	2%	0.25W	MF
R.....11	57.11.3102	1 kOhm	2%	0.25W	MF
R.....12	57.11.3333	33 kOhm	2%	0.25W	MF
R.....13	57.13.3229	2.2 Ohm	2%	0.5 W	MF
R.....14	57.13.3229	2.2 Ohm	2%	0.5 W	MF
R.....15	57.11.3221	220 Ohm	2%	0.25W	MF
R.....16	57.11.3470	47 Ohm	2%	0.25W	MF
R.....17	57.11.3103	10 kOhm	2%	0.25W	MF
R.....18	57.11.3103	10 kOhm	2%	0.25W	MF
R.....19	57.11.3332	3.3 kOhm	2%	0.25W	MF
R.....20	57.11.3332	3.3 kOhm	2%	0.25W	MF
R.....21	57.11.3103	10 kOhm	2%	0.25W	MF
R.....22	57.11.3332	3.3 kOhm	2%	0.25W	MF
R.....23	57.11.3103	10 kOhm	2%	0.25W	MF
R.....24	57.11.3103	10 kOhm	2%	0.25W	MF
R.....25	57.11.5106	10 MOhm	5%	0.25W	MF
R.....26				not used	
R.....27	57.11.3472	4.7 kOhm	2%	0.25W	MF
R.....28	57.11.3223	22 kOhm	2%	0.25W	MF
R.....29	57.11.3223	22 kOhm	2%	0.25W	MF
R.....30	57.11.3221	220 Ohm	2%	0.25W	MF
R.....31	57.11.3104	100 kOhm	2%	0.25W	MF
R.....32	57.11.3223	22 kOhm	2%	0.25W	MF
R.....33	57.11.3221	220 Ohm	2%	0.25W	MF
R.....34	57.11.3104	100 kOhm	2%	0.25W	MF
R.....35	57.11.3223	22 kOhm	2%	0.25W	MF
R.....36	57.11.3332	3.3 kOhm	2%	0.25W	MF
(00) R.....37	57.11.3392	3.9 kOhm	2%	0.25W	MF
R.....38	57.11.3332	3.3 kOhm	2%	0.25W	MF

S T U D E R (00) 88/03/28 Wth AUDIO CONTROL BOARD 1.727.400.82 PAGE 3

AUDIO CONTROL HS 1.727.401.00 GRP40

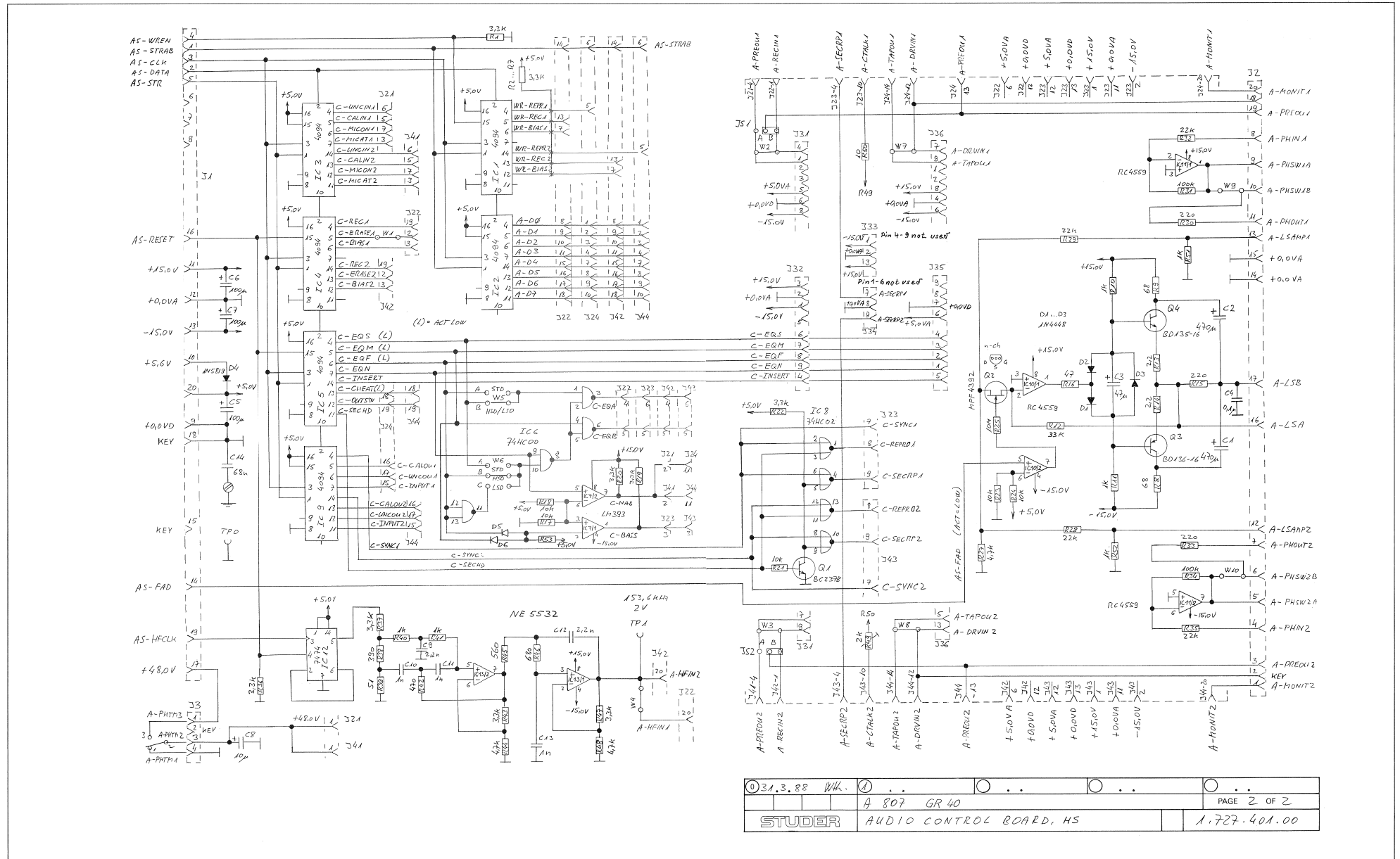

① 31.3.88 Wk.	②	③	④	⑤	⑥	⑦	⑧	⑨	⑩	⑪	⑫	⑬	⑭	⑮	⑯	⑰	⑱	⑲	⑳	㉑	㉒	㉓	㉔	㉕	㉖	㉗	㉘	㉙	㉚	㉛	㉜	㉝	㉞	㉟	㊱	㊲	㊳	㊴	㊵	㊶	㊷	㊸	㊹	㊺	㊻	㊼	㊽	㊾	㊿
A 807 GR 40															PAGE 2 OF 2																																		
STUDER															AUDIO CONTROL BOARD, HS										1.727.401.00																								

AUDIO CONTROL HS 1.727.401.00 GRP40

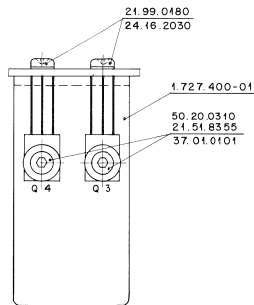
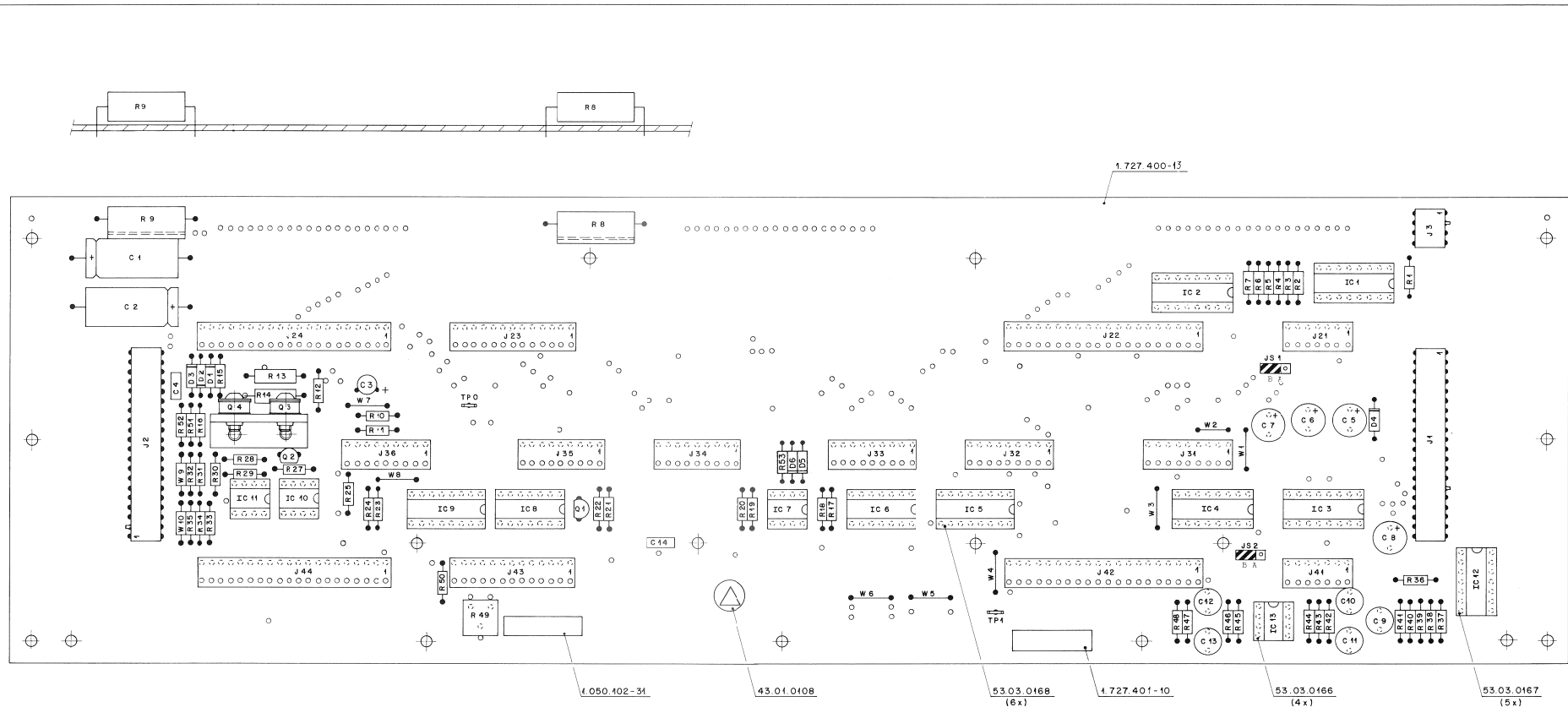

- R49 = CROSSTALK ADJUSTMENT
- W1 = C-ERASE1 (TO BE INTERRUPTED FOR 2CH VERSIONS WITH MONO-ERASEHEAD)
- W2 = LINK OF INPUT INSERT CH1 (INTERRUPT FOR ANY INPUT INSERTS)
- W3 = LINK OF INPUT INSERT CH2 (INTERRUPT FOR ANY INPUT INSERTS)
- W4 = SPEED SELECTOR LINK
- W5 = SPEED SELECTOR LINK
- W6 = SPEED SELECTOR LINK
- W7 = LINK OF OUTPUT INSERT CH1 (INTERRUPT FOR ANY OUTPUT INSERTS)
- W8 = LINK OF OUTPUT INSERT CH2 (INTERRUPT FOR ANY OUTPUT INSERTS)
- TP0 0.8 V
- TP1 HF SIGNAL 2.3 V/153.6 kHz

FACTORY STANDARD SETTING

- JS1 A = MONITORING BEFORE INPUT INSERT POINT CH1
- B = MONITORING AFTER INPUT INSERT POINT CH1
- JS2 A = MONITORING BEFORE INPUT INSERT POINT CH2
- B = MONITORING AFTER INPUT INSERT POINT CH2

1.050.402-31 43.01.0408 53.03.0168 (6x) 1.727.401-10 53.03.0166 (4x) 53.03.0167 (5x)



AUDIO CONTROL HS 1.727.401.00 GRP40

IND.	POS-NO.	PART NO.	VALUE	SPECIFICATIONS / EQUIVALENT	MANUF.	IND.	POS-NO.	PART NO.	VALUE	SPECIFICATIONS / EQUIVALENT	MANUF.
C.....1	59.25.3471	470 uF	-20%	16 V EL		R.....37	57.11.3332	3.3 kOhm	2%, 0.25W, MF		
C.....2	59.25.3471	470 uF	-20%	16 V EL		R.....38	57.11.3391	390 Ohm	2%, 0.25W, MF		
C.....3	59.22.3470	47 uF	-20%	10 V EL		R.....39	57.11.3510	51 Ohm	1%, 0.25W, MF		
C.....4	59.06.0104	0.1 uF	10%	63 V PETP		R.....40	57.11.3102	1 kOhm	2%, 0.25W, MF		
C.....5	59.22.5101	100 uF	-20%	25 V EL		R.....41	57.11.3102	1 kOhm	2%, 0.25W, MF		
C.....6	59.22.5101	100 uF	-20%	25 V EL		R.....42	57.11.3471	470 Ohm	2%, 0.25W, MF		
C.....7	59.22.5101	100 uF	-20%	25 V EL		R.....43	57.11.3332	3.3 kOhm	2%, 0.25W, MF		
C.....8	59.22.8100	10 uF	-20%	63 V EL		R.....44	57.11.3472	4.7 kOhm	2%, 0.25W, MF		
C.....9	59.05.1222	2.2 nF	1%	160 V PP		R.....45	57.11.3561	560 Ohm	2%, 0.25W, MF		
C.....10	59.05.1102	1 nF	1%	160 V PP		R.....46	57.11.3681	680 Ohm	2%, 0.25W, MF		
C.....11	59.05.1102	1 nF	1%	160 V PP		R.....47	57.11.3332	3.3 kOhm	2%, 0.25W, MF		
C.....12	59.05.1222	2.2 nF	1%	160 V PP		R.....48	57.11.3472	4.7 kOhm	2%, 0.25W, MF		
C.....13	59.05.1102	1 nF	1%	160 V PP		R.....49	58.01.8202	2 kOhm	Potmeter PMG		
C.....14	59.06.0683	68 nF	10%	63 V PETP		R.....50	57.11.3100	10 Ohm	2%, 0.25W, MF		
D.....1	50.04.0125	1N4448		50V		R.....51	57.11.3102	1 kOhm	2%, 0.25W, MF		
D.....2	50.04.0125	1N4448		50V		R.....52	57.11.3102	1 kOhm	2%, 0.25W, MF		
D.....3	50.04.0125	1N4448		50V		R.....53	57.11.3332	3.3 kOhm	2%, 0.25W, MF		
D.....4	50.04.0512	1N5819		30V	Mot	TP.....0	54.02.0320		PLUG 2.8x0.8		
D.....5	50.04.0125	1N4448		50V		TP.....1	54.02.0320		PLUG 2.8x0.8		
D.....6	50.04.0125	1N4448		50V							
IC.....1	50.07.0018	MC14094		CMOS	Mot	W.....1	64.01.0106		Wire Bridge		
IC.....2	50.07.0018	MC14094		CMOS	Mot	W.....2	64.01.0106		Wire Bridge		
IC.....3	50.07.0018	MC14094		CMOS	Mot	W.....3	64.01.0106		Wire Bridge		
IC.....4	50.07.0018	MC14094		CMOS	Mot	W.....4	64.01.0106		Wire Bridge		
IC.....5	50.07.0018	MC14094		CMOS	Mot	W.....5	64.01.0106		Wire Bridge		
IC.....6	50.17.1000	74HC00		HCMOS	Mot	W.....6	64.01.0106		Wire Bridge		
IC.....7	50.05.0283	LM393		Dual Comparator		W.....7	64.01.0106		Wire Bridge		
IC.....8	50.17.1002	74HC02		HCMOS		W.....8	64.01.0106		Wire Bridge		
IC.....9	50.07.0018	MC14094		CMOS	Mot	W.....9	57.11.4000		Wire Bridge		
IC.....10	50.09.0107	RC4559		Dual Op. Amp.		W.....10	57.11.4000		Wire Bridge		
IC.....11	50.09.0107	RC4559		Dual Op. Amp.		XIC.....1	53.03.0168	16 pol	IC Socket		
IC.....12	50.17.1074	74HC74		HCMOS		XIC.....2	53.03.0168	16 pol	IC Socket		
IC.....13	50.09.0105	NE5532		Dual Op. Amp.		XIC.....3	53.03.0168	16 pol	IC Socket		
J.....1	54.01.0248	20-POLE		CIS Socket Strip	AMP	XIC.....4	53.03.0168	16 pol	IC Socket		
XIC.....5						XIC.....5	53.03.0168	16 pol	IC Socket		

S T U D E R (01) 88/03/28 Wch AUDIO CONTROL BOARD HS 1.727.401.00 PAGE 1 S T U D E R (01) 88/03/28 Wch AUDIO CONTROL BOARD HS 1.727.401.00 PAGE 4

IND.	POS-NO.	PART NO.	VALUE	SPECIFICATIONS / EQUIVALENT	MANUF.	IND.	POS-NO.	PART NO.	VALUE	SPECIFICATIONS / EQUIVALENT	MANUF.
J.....2	54.01.0248	20-POLE		CIS Socket Strip	AMP	XIC.....6	53.03.0167	14 pol	IC Socket		
J.....3	54.01.0304	4-POLE		CIS Socket Strip	AMP	XIC.....7	53.03.0166	8 pol	IC Socket		
J.....11				not used		XIC.....8	53.03.0167	14 pol	IC Socket		
J.....12				not used		XIC.....9	53.03.0168	16 pol	IC Socket		
J.....13				not used		XIC.....10	53.03.0166	8 pol	IC Socket		
J.....21	54.01.0218	7-POLE		CIS Socket Strip	AMP	XIC.....11	53.03.0166	8 pol	IC Socket		
J.....22	54.01.0226	20-POLE		CIS Socket Strip	AMP	XIC.....12	53.03.0167	14 pol	IC Socket		
J.....23	54.01.0292	13-POLE		CIS Socket Strip	AMP	XIC.....13	53.03.0166	8 pol	IC Socket		
J.....24	54.01.0226	20-POLE		CIS Socket Strip	AMP						
J.....31	54.01.0217	9-POLE		CIS Socket Strip	AMP						
J.....32	54.01.0217	9-POLE		CIS Socket Strip	AMP						
J.....33	54.01.0217	9-POLE		CIS Socket Strip	AMP						
J.....34	54.01.0217	9-POLE		CIS Socket Strip	AMP						
J.....35	54.01.0217	9-POLE		CIS Socket Strip	AMP						
J.....36	54.01.0217	9-POLE		CIS Socket Strip	AMP						
J.....41	54.01.0218	7-POLE		CIS Socket Strip	AMP						
J.....42	54.01.0226	20-POLE		CIS Socket Strip	AMP						
J.....43	54.01.0292	13-POLE		CIS Socket Strip	AMP						
J.....44	54.01.0226	20-POLE		CIS Socket Strip	AMP						
J.....1	54.01.0021			Bridge							
J.....2	54.01.0021			Bridge							
MP.....1	1.727.400.13			1 pce Audio Control PCB	St						
MP.....2	1.727.400.01			1 pce Headsink	St						
MP.....3	1.727.401.10			1 pce No. label	St						
MP.....4	21.99.0180			2 pcs Screw M3 x 5							
MP.....5	21.53.0355			2 pcs Screw M3 x 8							
MP.....6	24.16.2030			2 pcs Lock washer							
MP.....7	37.01.0101			4 pcs Lock washer	St						
MP.....8	43.01.0108			1 pce ESC warning label	St						
MP.....9	54.01.0020			6 pcs Contact pin							
Q.....1	50.03.0436	8C237B		BC547B, BC550B NPN	Mot,Six						
Q.....2	50.01.0202	HPF92		J112							
Q.....3	50.03.0510	BD136-16		PNP							
Q.....4	50.03.0495	BD135-16		PNP							

(01) 28.03.1988 Sensibility extension

EL=Electrolytic, PP=Polypropylen, SI=Silicon, MF=Metal Film
PETP=Polyester,

MANUFACTURER:Mot=Motorola, St=Studer, Six=Siliconix

ORIG 87/11/30 (01) 88/03/28

S T U D E R (01) 88/03/28 Wch AUDIO CONTROL BOARD HS 1.727.401.00 PAGE 2 S T U D E R (01) 88/03/28 Wch AUDIO CONTROL BOARD HS 1.727.401.00 PAGE 5

IND.	POS-NO.	PART NO.	VALUE	SPECIFICATIONS / EQUIVALENT	MANUF.
R.....1	57.11.3332	3.3 kOhm	2%, 0.25W, MF		
R.....2	57.11.3332	3.3 kOhm	2%, 0.25W, MF		
R.....3	57.11.3332	3.3 kOhm	2%, 0.25W, MF		
R.....4	57.11.3332	3.3 kOhm	2%, 0.25W, MF		
R.....5	57.11.3332	3.3 kOhm	2%, 0.25W, MF		
R.....6	57.11.3332	3.3 kOhm	2%, 0.25W, MF		
R.....7	57.11.3332	3.3 kOhm	2%, 0.25W, MF		
R.....8	57.56.5680	68 Ohm	2%, 4 W, DR		
R.....9	57.56.5680	68 Ohm	2%, 4 W, DR		
R.....10	57.11.3102	1 kOhm	2%, 0.25W, MF		
R.....11	57.11.3102	1 kOhm	2%, 0.25W, MF		
R.....12	57.11.3103	10 kOhm	2%, 0.25W, MF		
R.....13	57.11.3333	33 kOhm	2%, 0.25W, MF		
R.....14	57.13.3229	2.2 Ohm	2%, 0.5 W, MF		
R.....15	57.13.3229	2.2 Ohm	2%, 0.5 W, MF		
R.....16	57.11.3221	220 Ohm	2%, 0.25W, MF		
R.....17	57.11.3470	47 Ohm	2%, 0.25W, MF		
R.....18	57.11.3103	10 kOhm	2%, 0.25W, MF		
R.....19	57.11.3103	10 kOhm	2%, 0.25W, MF		
R.....20	57.11.3332	3.3 kOhm	2%, 0.25W, MF		
R.....21	57.11.3332	3.3 kOhm	2%, 0.25W, MF		
R.....22	57.11.3332	3.3 kOhm	2%, 0.25W, MF		
R.....23	57.11.3103	10 kOhm	2%, 0.25W, MF		
R.....24	57.11.3103	10 kOhm	2%, 0.25W, MF		
R.....25	57.11.5106	10 MOhm	5%, 0.25W, MF		
R.....26			not used		
R.....27	57.11.3472	4.7 kOhm	2%, 0.25W, MF		
R.....28	57.11.3223	22 kOhm	2%, 0.25W, MF		
R.....29	57.11.3223	22 kOhm	2%, 0.25W, MF		
R.....30	57.11.3221	220 Ohm	2%, 0.25W, MF		
R.....31	57.11.3104	100 kOhm	2%, 0.25W, MF		
R.....32	57.11.3223	22 kOhm	2%, 0.25W, MF		
R.....33	57.11.3221	220 Ohm	2%, 0.25W, MF		
R.....34	57.11.3104	100 kOhm	2%, 0.25W, MF		
R.....35	57.11.3223	22 kOhm	2%, 0.25W, MF		
R.....36	57.11.3332	3.3 kOhm	2%, 0.25W, MF		

S T U D E R (01) 88/03/28 Wch AUDIO CONTROL BOARD HS 1.727.401.00 PAGE 3

MONITOR INTERNAL 1.727.120.00 GRP36/37

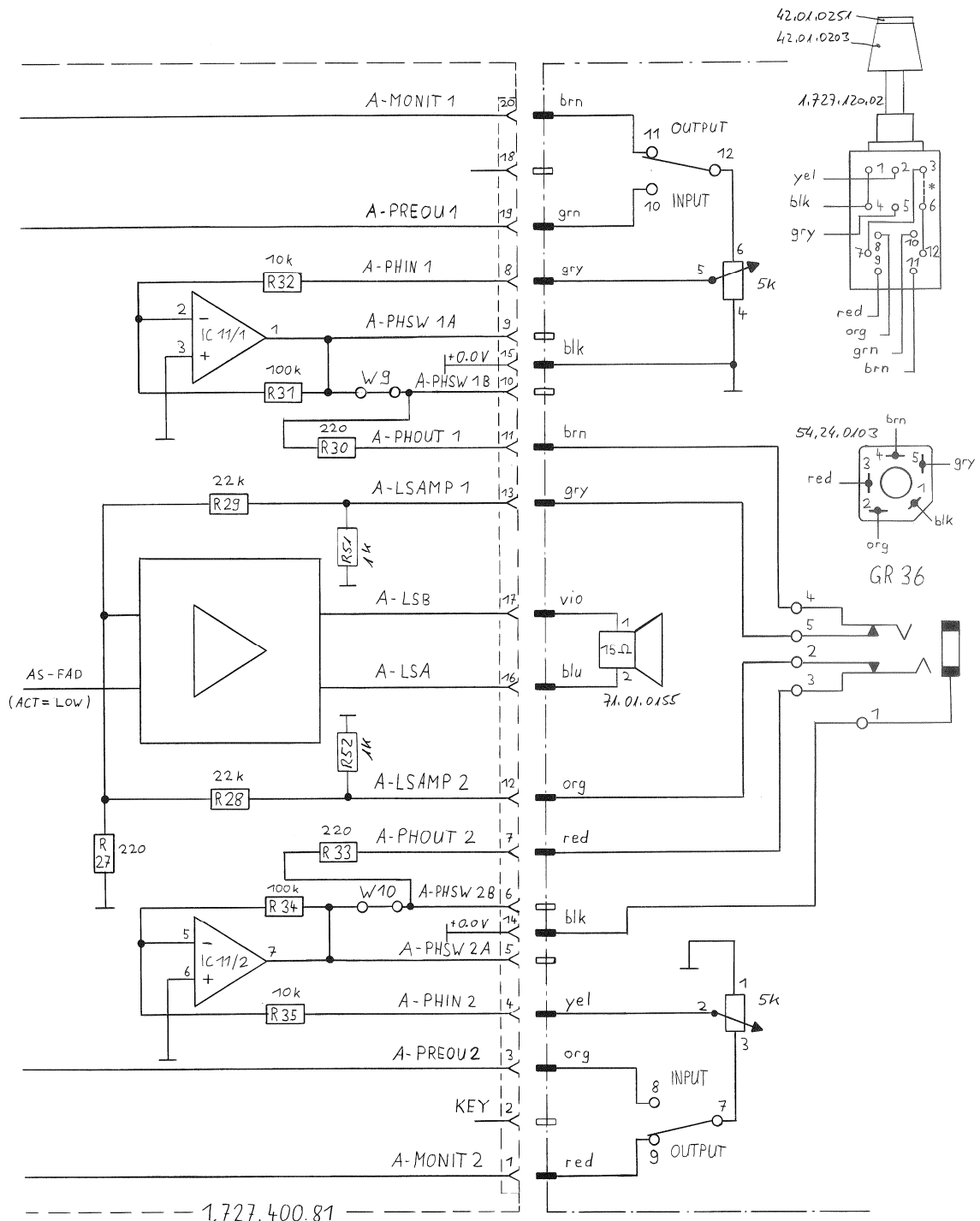

* FOR MONO-VERSION ONLY

© 2003.87 S10	○ ..	○ ..	○ ..	○ ..
A 807	GR 36, GR 37	PAGE 1 OF 1		
STUDER	MONITOR	1.727.120.00		

MONITOR INTERNAL 1.727.120.00 GRP36/37

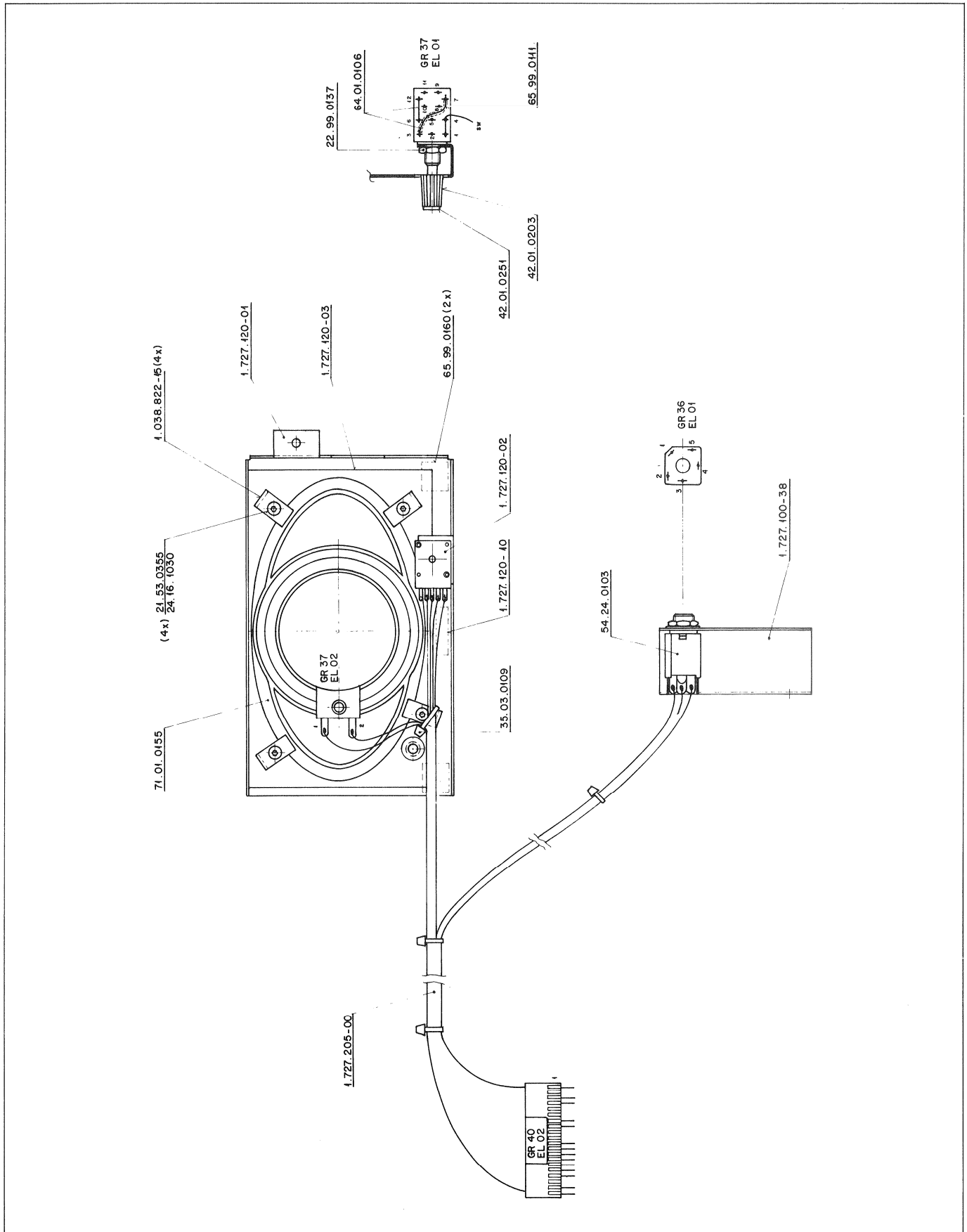

- AUDIO ELECTRONICS (VU) 1.727.420.00 GRP41/42
- LINE OUTPUT CONNECTOR 1.727.240.00 (SEE PAGE 7/32)
- LINE INPUT CONNECTOR 1.727.241.00 (SEE PAGE 7/33)
- MIC INPUT CONNECTOR 1.727.242.00 (SEE PAGE 7/34)

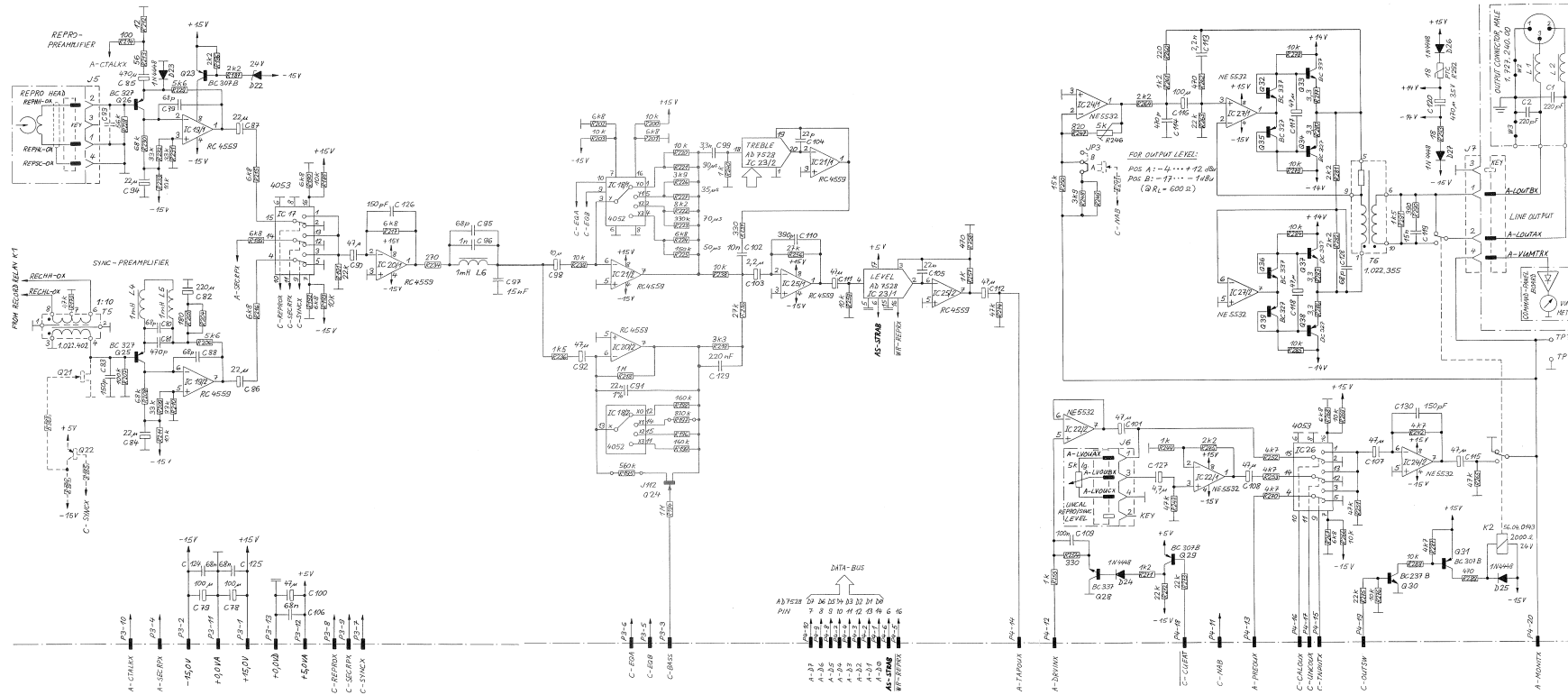

30.9.86 GP	28.7.87 GP	28.4.87 GP	
A 727 GR 41/42			PAGE 6 OF 6
STUDER AUDIO ELECTRONICS BOARD			SC 1.727.420.00

AUDIO ELECTRONICS (VU) 1.727.420.00 GRP41/42

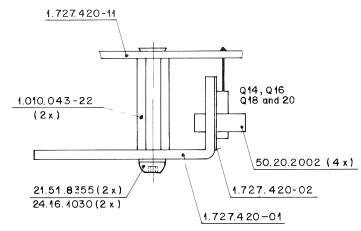
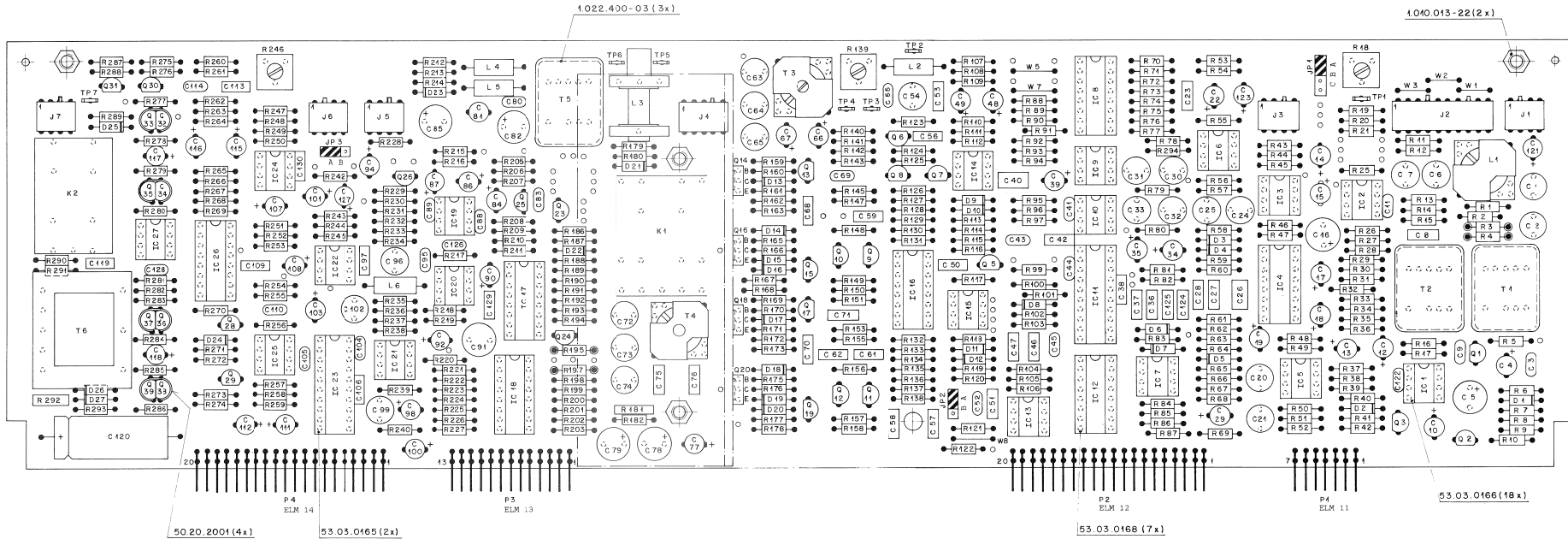

FACTORY STANDARD SETTING



AUDIO ELECTRONICS (VU) 1.727.420.00 GRP41/42

Table with 10 columns: IND., POS.ND., PART NO., VALUE, SPECIFICATIONS / EQUIVALENT, MANUF., and 5 additional columns. It lists various electronic components like resistors, capacitors, and diodes with their respective values and manufacturer part numbers.

S T U D E R (02) 87/04/28 GP AUDIO ELECTRONICS BOARD 1.727.420.00 PAGE 1 S T U D E R (02) 87/04/28 GP AUDIO ELECTRONICS BOARD 1.727.420.00 PAGE 4 S T U D E R (02) 87/04/28 GP AUDIO ELECTRONICS BOARD 1.727.420.00 PAGE 7 S T U D E R (02) 87/04/28 GP AUDIO ELECTRONICS BOARD 1.727.420.00 PAGE 10

Table with 10 columns: IND., POS.ND., PART NO., VALUE, SPECIFICATIONS / EQUIVALENT, MANUF., and 5 additional columns. It lists various electronic components like resistors, capacitors, and diodes with their respective values and manufacturer part numbers.

S T U D E R (02) 87/04/28 GP AUDIO ELECTRONICS BOARD 1.727.420.00 PAGE 2 S T U D E R (02) 87/04/28 GP AUDIO ELECTRONICS BOARD 1.727.420.00 PAGE 5 S T U D E R (02) 87/04/28 GP AUDIO ELECTRONICS BOARD 1.727.420.00 PAGE 8 S T U D E R (02) 87/04/28 GP AUDIO ELECTRONICS BOARD 1.727.420.00 PAGE 11

Table with 10 columns: IND., POS.ND., PART NO., VALUE, SPECIFICATIONS / EQUIVALENT, MANUF., and 5 additional columns. It lists various electronic components like resistors, capacitors, and diodes with their respective values and manufacturer part numbers.

S T U D E R (02) 87/04/28 GP AUDIO ELECTRONICS BOARD 1.727.420.00 PAGE 3 S T U D E R (02) 87/04/28 GP AUDIO ELECTRONICS BOARD 1.727.420.00 PAGE 6 S T U D E R (02) 87/04/28 GP AUDIO ELECTRONICS BOARD 1.727.420.00 PAGE 9 S T U D E R (02) 87/04/28 GP AUDIO ELECTRONICS BOARD 1.727.420.00 PAGE 12

LINE OUTPUT CONNECTOR 1.727.240.00 GRP01 ELM09/10
(DIAGRAM: AUDIO ELECTRONICS PCBs)

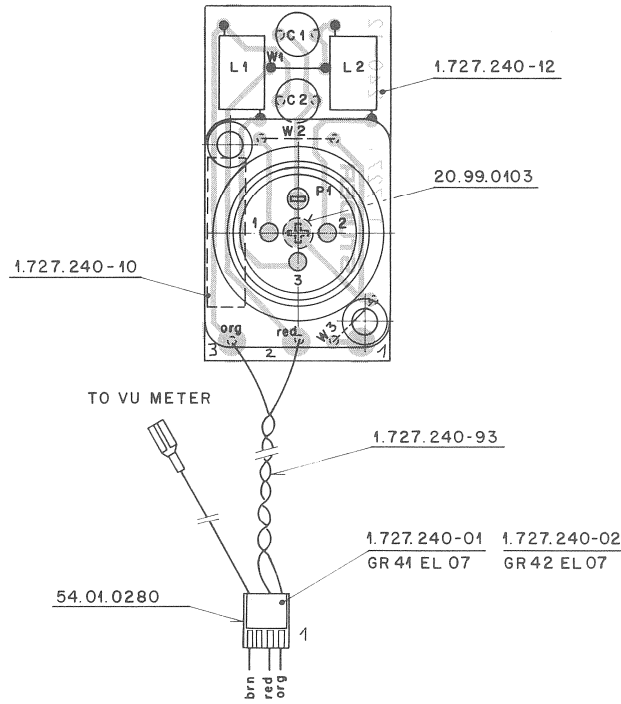

IND.	POS.NO.	PART NO.	VALUE	SPECIFICATIONS / EQUIVALENT	MANUF.
	C.....1	59.05.1221	220 pF	1 % 630V PP	
	C.....2	59.05.1221	220 pF	1 % 630V PP	
	L.....1	62.01.0115		Interference Coil, Note 1	Ph
	L.....2	62.01.0115		Interference Coil, Note 1	Ph
(00)	MP.....1	1.727.240.11	1 pcs	Output Connector PCB	St
(01)	MP.....1	1.727.240.12	1 pcs	Output Connector PCB	St
	MP.....2	1.727.240.93	1 pcs	Li-L Audio Connector	St
	MP.....3	20.99.0103	1 pcs	Screw Ø 2.2 x 5	
	MP.....4	54.01.0280	4 pcs	C15, Case	AMP
	MP.....5	1.727.240.10	1 pcs	Nr. Label	St
	P.....1	54.21.2001		XLR, Male	Neu
	W.....1	1.010.323.64		Wire Bridge	
	W.....2	1.010.324.64		Wire Bridge	
	W.....3	1.010.323.64		Wire Bridge	

Note 1: Philips 4312 020 36700

PP=Polypropylen

MANUFACTURER: AMP=AMP, Neu=Neutrik, Ph=Philips, St=Studer

ORIG 86/08/08 (01) 87/02/19

S T U D E R (01) 57/02/19 GP OUTPUT CONNECTOR, MALE 1.727.240.00 PAGE 1

LINE INPUT CONNECTOR 1.727.241.00 GRP01 ELM11/12
(DIAGRAM: AUDIO ELECTRONICS PCBs)

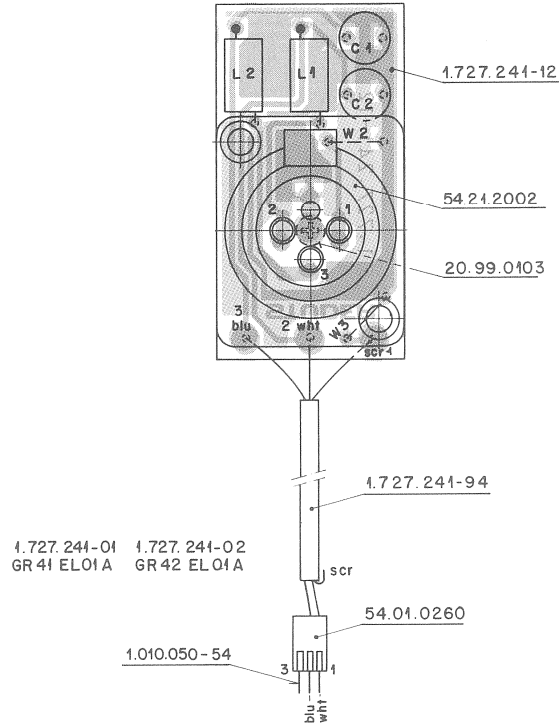

IND.	POS.-NO.	PART NO.	VALUE	SPECIFICATIONS / EQUIVALENT	MANUF.
	C.....1	59.05.1221	220 pF	1 % 630V PP	
	C.....2	59.05.1221	220 pF	1 % 630V PP	
	J.....1	54.21.2002		XLR, Female,	Neu
	L.....1	o2.01.0115		Interference Coil, Note 1	Ph
	L.....2	o2.01.0115		Interference Coil, Note 1	Ph
(00)	MP.....1	1.727.241.11	1 pcs	Line Connector PCB	St
(01)	MP.....1	1.727.241.12	1 pcs	Line Connector PCB	St
	MP.....2	1.727.241.94	1 pcs	KA-L Line Connector	St
	MP.....3	20.99.0103	1 pcs	Screw 0 2x2 9	
	MP.....4	54.01.0260	3 pcs	CIS, Case	AMP
	MP.....5	1.010.050.54	1 pcs	CIS, Plug	AMP
	MP.....6	1.727.241.10	1 pcs	Nr. Label	St
	W.....2	1.010.323.64		Wire Bridge	
	W.....3	1.010.323.64		Wire Bridge	
				

Note 1: Philips 4312 020 36700

PP=Polypropylen

MANUFACTURER: AMP=AMP, Neu=Neutrik, Ph=Philips, St=Studer

DRIG 86/08/08 (01) 87/02/19

S T U D E R (01) 87/02/19 GP LINE CONNECTOR, FEMALE 1.727.241.00 PAGE 1

MIC INPUT CONNECTOR 1.727.242.00 GRP01 ELM13/14
(DIAGRAM: AUDIO ELECTRONICS PCBs)

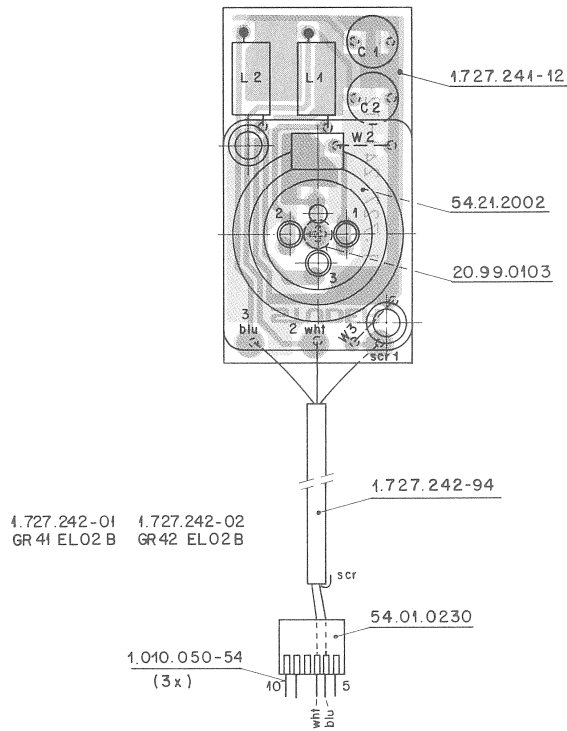

IND.	PDS-NO.	PART NO.	VALUE	SPECIFICATIONS / EQUIVALENT	MANUF.
C.....1		59.05.1221	220 pF	1 ± 630V PP	
C.....2		59.05.1221	220 pF	1 ± 630V PP	
J.....1		54.21.2002		XLR, Female,	Neu
L.....1		62.01.0115		Interference Coil, Note 1	Ph
L.....2		62.01.0115		Interference Coil, Note 1	Ph
(00) MP....1		1.727.241.11	1 pcs	Mic Connector PCB	St
(01) MP....1		1.727.241.12	1 pcs	Mic Connector PCB	St
MP....2		1.727.242.94	1 pcs	KA-L Mic Connector	St
MP....3		20.99.0103	1 pcs	Screw D 2.2 x 5	
MP....4		54.01.0230	6 pos	CIS, Case	AMP
MP....5		1.010.050.54	3 pcs	CIS, Plug	AMP
MP....6		1.727.242.10	1 pcs	Nr. Label	St
W.....2		1.010.323.64		Wire Bridge	
W.....3		1.010.323.64		Wire Bridge	

Note 1: Philips 4312 020 36700

PP=Polypropylen,

MANUFACTURER:AMP=AMP, Neu=Neutrik, Ph= Philips, St=Studer

ORIG 86/08/08 (01) 87/02/19

STUDER (01) 87/02/19 GP MIC CONNECTOR, FEMALE 1.727.242.00 PAGE 1

- AUDIO ELECTRONICS (VU) 1.727.460.00 GRP41/42
- LINE OUTPUT CONNECTOR 1.727.240.00 (SEE PAGE 7/32)
- LINE INPUT CONNECTOR 1.727.241.00 (SEE PAGE 7/33)
- MIC INPUT CONNECTOR 1.727.242.00 (SEE PAGE 7/34)

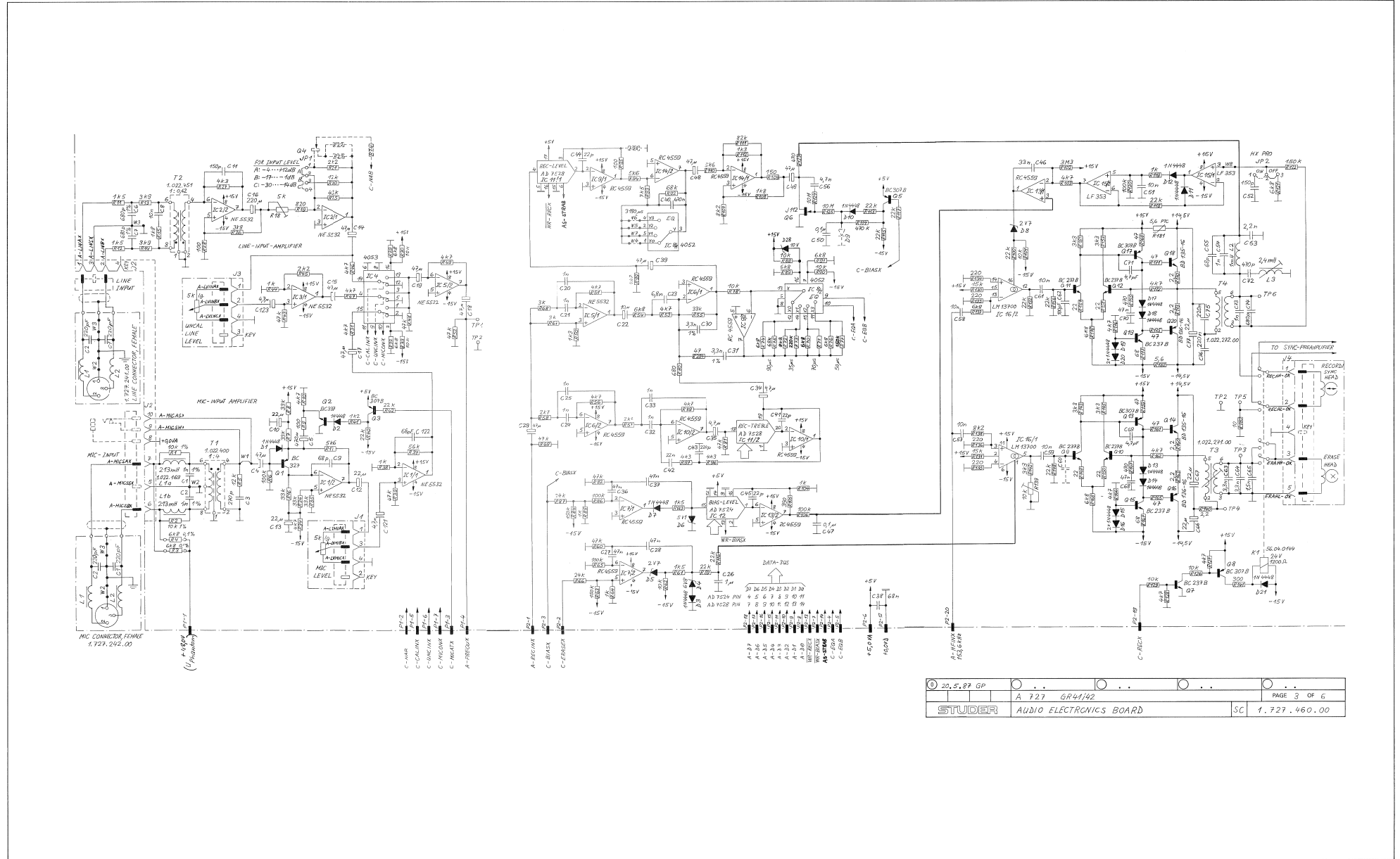

20.5.87 GP	A 727 GR41/42	PAGE 3 OF 6
STUDER	AUDIO ELECTRONICS BOARD	SC 1.727.460.00

AUDIO ELECTRONICS (VU) 1.727.460.00 GRP41/42

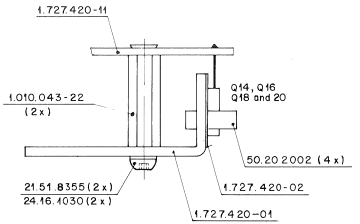
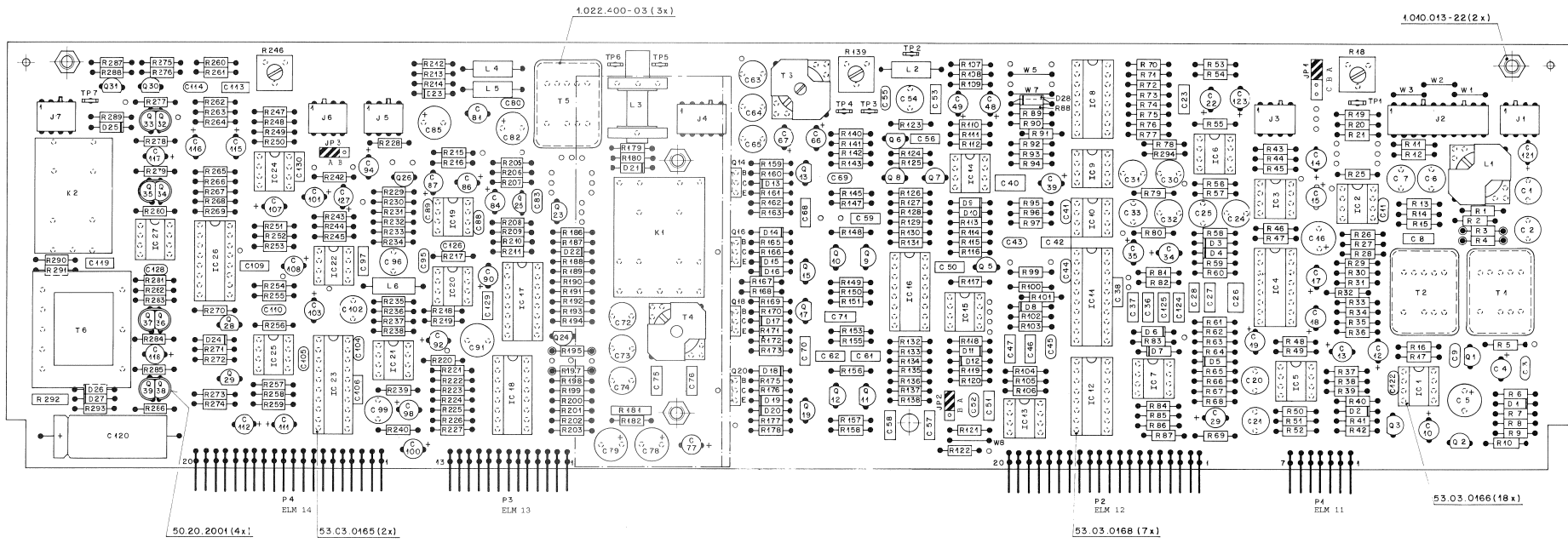



AUDIO ELECTRONICS (VU) 1.727.460.00 GRP41/24

Table with columns: IND., POS.ND., PART NO., VALUE, SPECIFICATIONS / EQUIVALENT, MANUF. Contains parts list for page 1 of the audio electronics board.

Table with columns: IND., POS.ND., PART NO., VALUE, SPECIFICATIONS / EQUIVALENT, MANUF. Contains parts list for page 2 of the audio electronics board.

S T U D E R (00) 87/05/20 GP AUDIO ELECTRONICS BOARD 1.727.460.00 PAGE 1

S T U D E R (00) 87/05/20 GP AUDIO ELECTRONICS BOARD 1.727.460.00 PAGE 4

Table with columns: IND., POS.ND., PART NO., VALUE, SPECIFICATIONS / EQUIVALENT, MANUF. Contains parts list for page 2 of the audio electronics board.

Table with columns: IND., POS.ND., PART NO., VALUE, SPECIFICATIONS / EQUIVALENT, MANUF. Contains parts list for page 3 of the audio electronics board.

S T U D E R (00) 87/05/20 GP AUDIO ELECTRONICS BOARD 1.727.460.00 PAGE 2

S T U D E R (00) 87/05/20 GP AUDIO ELECTRONICS BOARD 1.727.460.00 PAGE 3

Table with columns: IND., POS.ND., PART NO., VALUE, SPECIFICATIONS / EQUIVALENT, MANUF. Contains parts list for page 3 of the audio electronics board.

Table with columns: IND., POS.ND., PART NO., VALUE, SPECIFICATIONS / EQUIVALENT, MANUF. Contains parts list for page 4 of the audio electronics board.

S T U D E R (00) 87/05/20 GP AUDIO ELECTRONICS BOARD 1.727.460.00 PAGE 3

S T U D E R (00) 87/05/20 GP AUDIO ELECTRONICS BOARD 1.727.460.00 PAGE 4



AUDIO ELECTRONICS (VU) 1.727.460.00 GRP41/42

IND.	POS.NO.	PART NO.	VALUE	SPECIFICATIONS / EQUIVALENT	MANUF.	IND.	POS.NO.	PART NO.	VALUE	SPECIFICATIONS / EQUIVALENT	MANUF.
R...	180	57.11.4100	10 Ohm	2%, 0.25W, MF		R...	291	57.11.4152	1.5 KOhm	2%, 0.25W, MF	
R...	181	57.99.0209	5.6 Ohm	PTC		R...	292	57.92.1151	18 Ohm	150mA, PTC	
R...	182	57.11.4569	5.6 Ohm	2%, 0.25W, MF		R...	293	57.11.4180	18 Ohm	2%, 0.25W, MF	
R...	183			not used		R...	294	57.11.4470	47 Ohm	2%, 0.25W, MF	
R...	184			not used		T....	1	1.022.400.00	1:4	Mic Input Trafo	St
R...	185			not used		T....	2	1.022.451.00	1:0.62	Line Input Trafo	St
R...	186	57.11.4222	2.2 KOhm	2%, 0.25W, MF		T....	3	1.022.271.00		Erase Trafo	St
R...	187	57.11.4222	2.2 KOhm	2%, 0.25W, MF		T....	4	1.022.271.00		Bias Trafo	St
R...	188	57.11.4103	10 KOhm	2%, 0.25W, MF		T....	5	1.022.402.00	1:10	Sync Trafo	St
R...	189	57.11.4682	6.8 KOhm	2%, 0.25W, MF		T....	6	1.022.355.00		Line Output Trafo	St
R...	190	57.11.4682	6.8 KOhm	2%, 0.25W, MF		TP...	1	54.02.0320		Plug 2.80x0.8	AMP
R...	191	57.11.4223	22 KOhm	2%, 0.25W, MF		TP...	2	54.02.0320		Plug 2.80x0.8	AMP
R...	192	57.11.4682	6.8 KOhm	2%, 0.25W, MF		TP...	3	54.02.0320		Plug 2.80x0.8	AMP
R...	193	57.11.4103	10 KOhm	2%, 0.25W, MF		TP...	4	54.02.0320		Plug 2.80x0.8	AMP
R...	194	57.11.4105	10 KOhm	2%, 0.25W, MF		TP...	5	54.02.0320		Plug 2.80x0.8	AMP
R...	195	57.11.4684	680 KOhm	2%, 0.25W, MF, with socket		TP...	6	54.02.0320		Plug 2.80x0.8	AMP
R...	196			not used		TP...	7	54.02.0320		Plug 2.80x0.8	AMP
R...	197	57.11.4105	1 MOhm	2%, 0.25W, MF, with socket		W....	1	64.01.0106		Wire Bridge	
R...	198	57.11.3164	156 KOhm	2%, 0.25W, MF		W....	2	64.01.0106		Wire Bridge	
R...	199	57.11.3164	160 KOhm	2%, 0.25W, MF		W....	3	64.01.0106		Wire Bridge	
R...	200	57.11.4103	10 KOhm	2%, 0.25W, MF		W....	4	64.01.0106		Wire Bridge	
R...	201	57.11.4682	6.8 KOhm	2%, 0.25W, MF		W....	5	64.01.0106		Wire Bridge	
R...	202	57.11.4682	6.8 KOhm	2%, 0.25W, MF		W....	6	64.01.0106		Wire Bridge	
R...	203	57.11.4103	10 KOhm	2%, 0.25W, MF		W....	7	64.01.0106		Wire Bridge	
R...	204			not used		W....	8	64.01.0106		Wire Bridge	
R...	205	57.11.4191	180 Ohm	2%, 0.25W, MF		XIC...	9	53.03.0166	8-Pole	IC Socket	
R...	206	57.11.4562	5.6 KOhm	2%, 0.25W, MF		XIC...	10	53.03.0166	8-Pole	IC Socket	
R...	207	57.11.4104	100 KOhm	2%, 0.25W, MF		XIC...	11	53.03.0166	20-Pole	IC Socket	
R...	208	57.11.4683	68 KOhm	2%, 0.25W, MF		XIC...	12	53.03.0168	16-Pole	IC Socket	
R...	209	57.11.4333	33 KOhm	2%, 0.25W, MF		XIC...	13	53.03.0166	8-Pole	IC Socket	
R...	210	57.11.4333	33 KOhm	2%, 0.25W, MF		XIC...	14	53.03.0166	8-Pole	IC Socket	
R...	211	57.11.4103	10 KOhm	2%, 0.25W, MF		XIC...	15	53.03.0166	8-Pole	IC Socket	
R...	212	57.11.4120	12 Ohm	2%, 0.25W, MF		XIC...	16	53.03.0168	16-Pole	IC Socket	
R...	213	57.11.4560	5.6 Ohm	2%, 0.25W, MF		XIC...	17	53.03.0168	16-Pole	IC Socket	
R...	214	57.11.4101	100 Ohm	2%, 0.25W, MF		XIC...	18	53.03.0166	8-Pole	IC Socket	
R...	215	57.11.4682	6.8 KOhm	2%, 0.25W, MF		XIC...	19	53.03.0166	8-Pole	IC Socket	
R...	216	57.11.4682	6.8 KOhm	2%, 0.25W, MF		XIC...	20	53.03.0166	8-Pole	IC Socket	

S T U D E R (00) 87/05/20 GP AUDIO ELECTRONICS BOARD 1.727.460.00 PAGE 13 S T U D E R (00) 87/05/20 GP AUDIO ELECTRONICS BOARD 1.727.460.00 PAGE 16

IND.	POS.NO.	PART NO.	VALUE	SPECIFICATIONS / EQUIVALENT	MANUF.	IND.	POS.NO.	PART NO.	VALUE	SPECIFICATIONS / EQUIVALENT	MANUF.
R...	217	57.11.4682	6.8 KOhm	2%, 0.25W, MF		XIC...	9	53.03.0166	8-Pole	IC Socket	
R...	218	57.11.4105	1 MOhm	2%, 0.25W, MF		XIC...	10	53.03.0166	8-Pole	IC Socket	
R...	219	57.11.4152	1.5 KOhm	2%, 0.25W, MF		XIC...	11	53.03.0166	20-Pole	IC Socket	
R...	220	57.11.4103	10 KOhm	2%, 0.25W, MF		XIC...	12	53.03.0168	16-Pole	IC Socket	
R...	221			not used		XIC...	13	53.03.0166	8-Pole	IC Socket	
R...	222	57.11.4822	8.2 KOhm	2%, 0.25W, MF		XIC...	14	53.03.0166	8-Pole	IC Socket	
R...	223	57.11.4473	47 KOhm	2%, 0.25W, MF		XIC...	15	53.03.0166	8-Pole	IC Socket	
R...	224	57.11.4682	6.8 KOhm	2%, 0.25W, MF		XIC...	16	53.03.0168	16-Pole	IC Socket	
R...	225	57.11.4393	39 KOhm	2%, 0.25W, MF		XIC...	17	53.03.0168	16-Pole	IC Socket	
R...	226	57.11.4392	3.9 KOhm	2%, 0.25W, MF		XIC...	18	53.03.0168	16-Pole	IC Socket	
R...	227	57.11.4503	56 KOhm	2%, 0.25W, MF		XIC...	19	53.03.0166	8-Pole	IC Socket	
R...	228	57.11.4503	56 KOhm	2%, 0.25W, MF		XIC...	20	53.03.0166	8-Pole	IC Socket	
R...	229	57.11.4562	5.6 KOhm	2%, 0.25W, MF		XIC...	21	53.03.0166	8-Pole	IC Socket	
R...	230	57.11.4683	68 KOhm	2%, 0.25W, MF		XIC...	22	53.03.0166	8-Pole	IC Socket	
R...	231	57.11.4333	33 KOhm	2%, 0.25W, MF		XIC...	23	53.03.0166	20-Pole	IC Socket	
R...	232	57.11.4333	33 KOhm	2%, 0.25W, MF		XIC...	24	53.03.0166	8-Pole	IC Socket	
R...	233	57.11.4103	10 KOhm	2%, 0.25W, MF		XIC...	25	53.03.0166	8-Pole	IC Socket	
R...	234	57.11.4271	270 Ohm	2%, 0.25W, MF		XIC...	26	53.03.0168	16-Pole	IC Socket	
R...	235	57.11.4273	27 KOhm	2%, 0.25W, MF		XIC...	27	53.03.0166	8-Pole	IC Socket	
R...	236	57.11.4152	1.5 KOhm	2%, 0.25W, MF		XR...	3	53.03.0221	2-Pole	R3/R4 Socket	
R...	237	57.11.4331	330 Ohm	2%, 0.25W, MF		XR...	4	53.03.0221	2-Pole	R3/R4 Socket	
R...	238	57.11.4103	10 KOhm	2%, 0.25W, MF							
R...	239	57.11.4103	10 KOhm	2%, 0.25W, MF							
R...	240	57.11.4102	1 KOhm	2%, 0.25W, MF							
R...	241			not used							
R...	242	57.11.4472	4.7 KOhm	2%, 0.25W, MF							
R...	243	57.11.4473	47 KOhm	2%, 0.25W, MF							
R...	244	57.11.4102	1 KOhm	2%, 0.25W, MF							
R...	245	57.11.4222	2.2 KOhm	2%, 0.25W, MF							
R...	246	57.01.0502	5 KOhm	10%, 0.5 W, PMG							
R...	247	57.11.4821	820 Ohm	2%, 0.25W, MF							
R...	248	57.11.4392	3.9 KOhm	2%, 0.25W, MF							
R...	249			not used							
R...	250	57.11.4153	15 KOhm	2%, 0.25W, MF							
R...	251	57.11.4473	47 KOhm	2%, 0.25W, MF							
R...	252	57.11.4472	4.7 KOhm	2%, 0.25W, MF							
R...	253	57.11.4472	4.7 KOhm	2%, 0.25W, MF							

S T U D E R (00) 87/05/20 GP AUDIO ELECTRONICS BOARD 1.727.460.00 PAGE 14 S T U D E R (00) 87/05/20 GP AUDIO ELECTRONICS BOARD 1.727.460.00 PAGE 17

IND.	POS.NO.	PART NO.	VALUE	SPECIFICATIONS / EQUIVALENT	MANUF.	IND.	POS.NO.	PART NO.	VALUE	SPECIFICATIONS / EQUIVALENT	MANUF.
R...	254	57.11.4331	330 Ohm	2%, 0.25W, MF							
R...	255	57.11.4102	1 KOhm	2%, 0.25W, MF							
R...	256	57.11.4273	27 KOhm	2%, 0.25W, MF							
R...	257	57.11.4102	1 KOhm	2%, 0.25W, MF							
R...	258	57.11.4471	470 Ohm	2%, 0.25W, MF							
R...	259	57.11.4103	10 KOhm	2%, 0.25W, MF							
R...	260	57.11.4271	270 Ohm	2%, 0.25W, MF							
R...	261	57.11.4122	1.2 KOhm	2%, 0.25W, MF							
R...	262	57.11.4471	470 Ohm	2%, 0.25W, MF							
R...	263	57.11.4223	22 KOhm	2%, 0.25W, MF							
R...	264	57.11.4222	2.2 KOhm	2%, 0.25W, MF							
R...	265	57.11.4473	47 KOhm	2%, 0.25W, MF							
R...	266	57.11.4103	10 KOhm	2%, 0.25W, MF							
R...	267	57.11.4682	6.8 KOhm	2%, 0.25W, MF							
R...	268	57.11.4682	6.8 KOhm	2%, 0.25W, MF							
R...	269	57.11.4103	10 KOhm	2%, 0.25W, MF							
R...	270	57.11.4472	4.7 KOhm	2%, 0.25W, MF							
R...	271	57.11.4122	1.2 KOhm	2%, 0.25W, MF							
R...	272	57.11.4223	22 KOhm	2%, 0.25W, MF							
R...	273	57.11.4223	22 KOhm	2%, 0.25W, MF							
R...	274	57.11.4473	47 KOhm	2%, 0.25W, MF							
R...	275	57.11.4223	22 KOhm	2%, 0.25W, MF							
R...	276	57.11.4103	10 KOhm	2%, 0.25W, MF							
R...	277	57.11.4339	3.3 Ohm	2%, 0.25W, MF							
R...	278	57.11.4103	10 KOhm	2%, 0.25W, MF							
R...	279	57.11.4103	10 KOhm	2%, 0.25W, MF							
R...	280	57.11.4339	3.3 Ohm	2%, 0.25W, MF							
R...	281	57.11.4222	2.2 KOhm	2%, 0.25W, MF							
R...	282	57.11.4222	2.2 KOhm	2%, 0.25W, MF							
R...	283	57.11.4339	3.3 Ohm	2%, 0.25W, MF							
R...	284	57.11.4103	10 KOhm	2%, 0.25W, MF							
R...	285	57.11.4103	10 KOhm	2%, 0.25W, MF							
R...	286	57.11.4339	3.3 Ohm	2%, 0.25W, MF							
R...	287	57.11.4472	4.7 KOhm	2%, 0.25W, MF							
R...	288	57.11.4103	10 KOhm	2%, 0.25W, MF							
R...	289	57.11.4471	470 Ohm	2%, 0.25W, MF							
R...	290	57.11.4391	390 Ohm	2%, 0.25W, MF							

Note 1 Variable Phantom Supply

U (V)	POS.NO.	PART NO.	VALUE
48	R 3 / R 4	57990250	6.8 KOhm 0.1 % 0.25 W MF
24	R 3 / R 4		1 6.8 KOhm 0.1 % 0.25 W MF
12	R 3 / R 4	57990199	1 680 Ohm 0.1 % 0.25 W MF

Ger = Ceramic EL = Electrolytic PETP = Polyester
 PP = Polypropylen MF = Metal Film SI = Silicon
 MANUFACTURER: ADI = Analog Devices Inc. Mot = Motorola
 NS = National Semiconductors Ra = Raytheon
 Sig = Signetics St = Studer

ORIG 87/05/20 S T U D E R (00) 87/05/20 GP AUDIO ELECTRONICS BOARD 1.727.460.00 PAGE 18

- AUDIO ELECTRONICS (VU) 1.727.460.81 GRP41/42
- AUDIO ELECTRONICS (VU) 1.727.420.81 GRP41/42
- LINE OUTPUT CONNECTOR 1.727.240.00 (SEE PAGE 7/32)
- LINE INPUT CONNECTOR 1.727.241.00 (SEE PAGE 7/33)
- MIC INPUT CONNECTOR 1.727.242.00 (SEE PAGE 7/34)

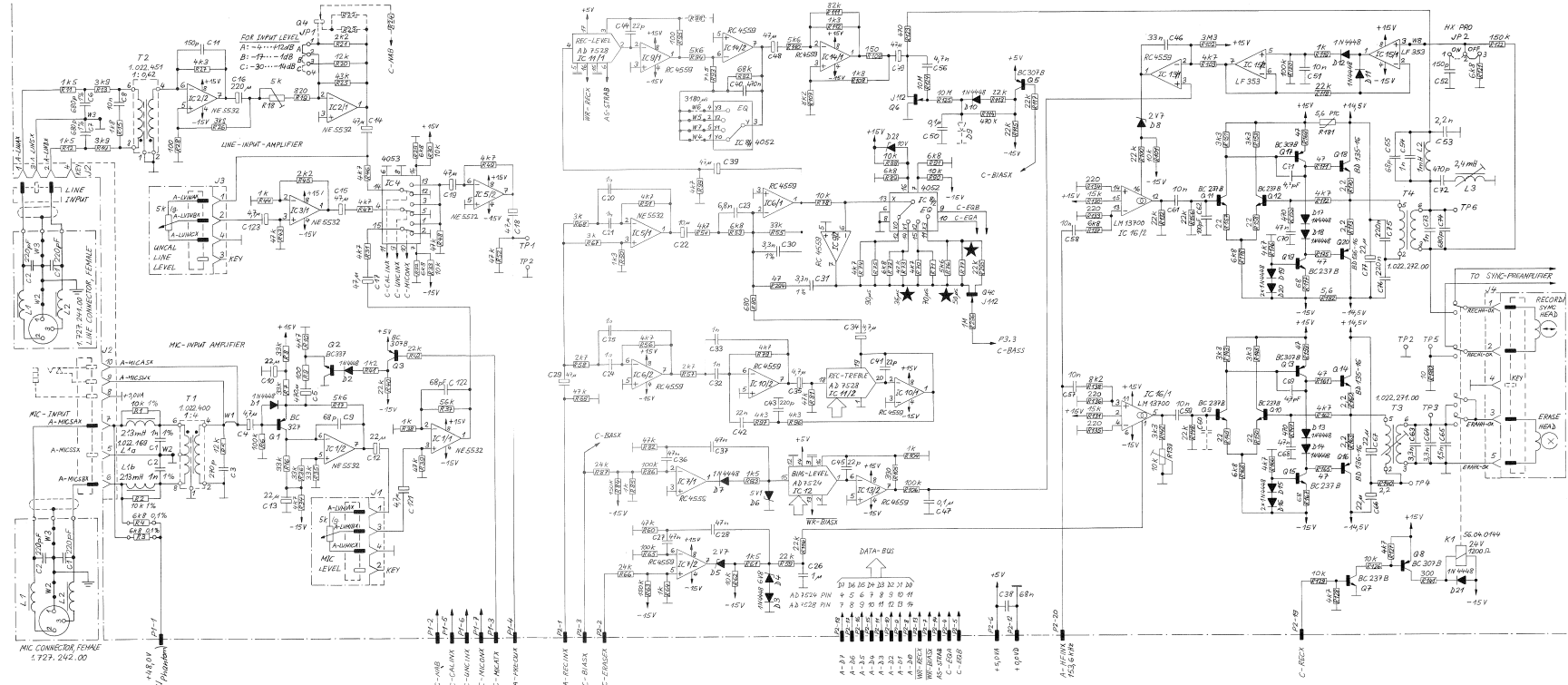

★ NOT THE SAME VALUES FOR 1.727.460.81 AND 1.727.420.81 !

5.7.87 GP	A 727 GR41/42	PAGE 3 OF 6
STUDER	AUDIO ELECTRONICS BOARD	SC 1.727.460.81

- AUDIO ELECTRONICS (VU) 1.727.460.81 GRP41/42
- AUDIO ELECTRONICS (VU) 1.727.420.81 GRP41/42
- LINE OUTPUT CONNECTOR 1.727.240.00 (SEE PAGE 7/32)
- LINE INPUT CONNECTOR 1.727.241.00 (SEE PAGE 7/33)
- MIC INPUT CONNECTOR 1.727.242.00 (SEE PAGE 7/34)

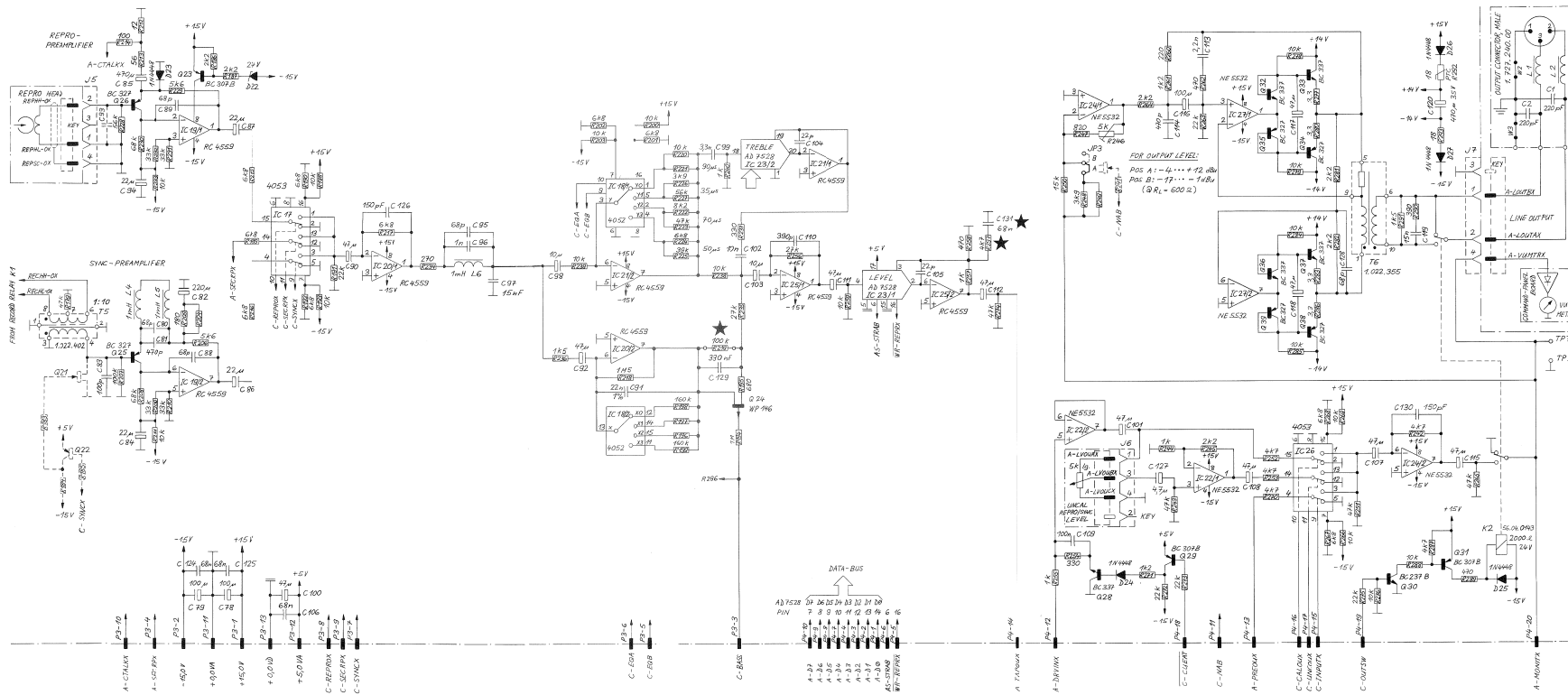

★NOT THE SAME VALUES FOR 1.727.460.81 AND 1.727.420.81 !

0	9.7.87GP			
A	727	GR 41/42		PAGE 6 OF 6
STUDER		AUDIO ELECTRONICS BOARD		SC 1.727.460.81

AUDIO ELECTRONICS (VU) 1.727.460.81 GRP41/42

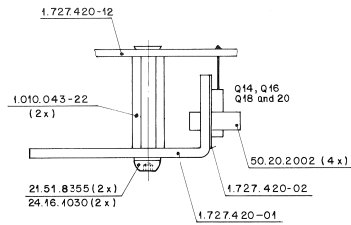
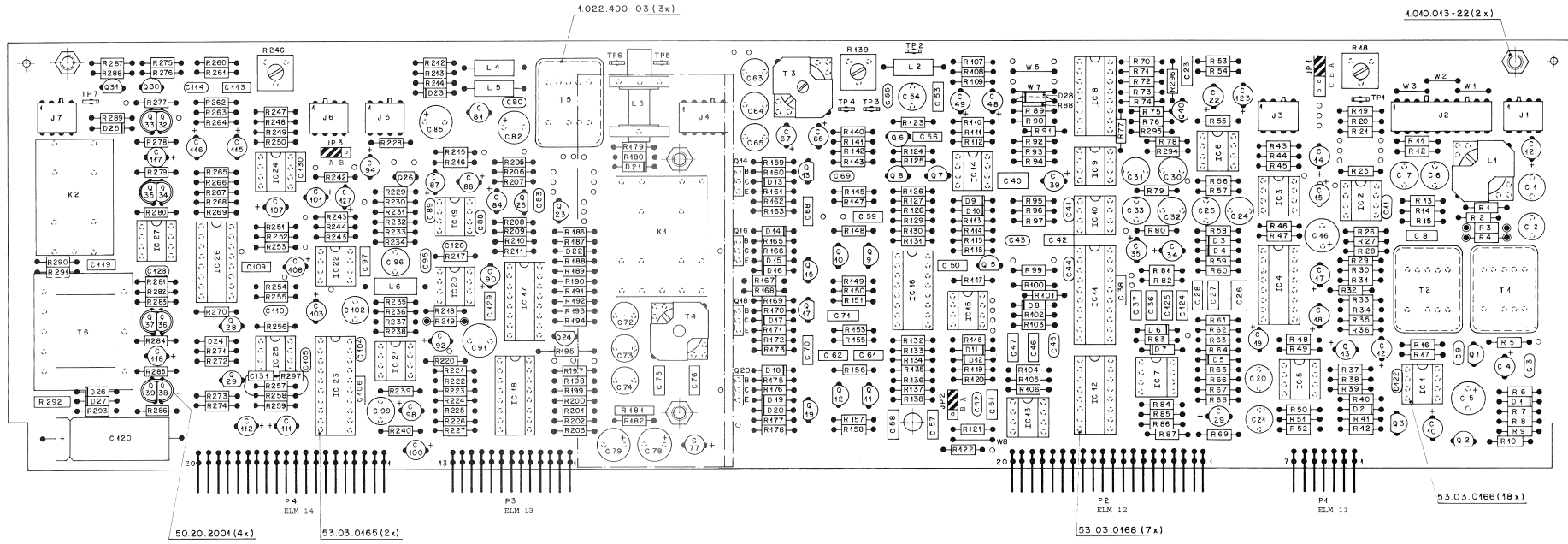



AUDIO ELECTRONICS (VU) 1.727.460.81 GRP41/42

Table with 4 columns: IND., POS.NO., PART NO., VALUE. It lists electronic components such as resistors, capacitors, and diodes for the AUDIO ELECTRONICS BOARD (VU) 1.727.460.81 GRP41/42. The table is divided into four sections corresponding to different board groups.

S T U D E R (00) 87/07/99 GP AUDIO ELECTRONICS BOARD 1.727.460.81 PAGE 1 S T U D E R (00) 87/07/99 GP AUDIO ELECTRONICS BOARD 1.727.460.81 PAGE 4 S T U D E R (00) 87/07/99 GP AUDIO ELECTRONICS BOARD 1.727.460.81 PAGE 7 S T U D E R (00) 87/07/99 GP AUDIO ELECTRONICS BOARD 1.727.460.81 PAGE 10

Table with 4 columns: IND., POS.NO., PART NO., VALUE. It lists electronic components such as resistors, capacitors, and diodes for the AUDIO ELECTRONICS BOARD (VU) 1.727.460.81 GRP41/42. The table is divided into four sections corresponding to different board groups.

S T U D E R (00) 87/07/99 GP AUDIO ELECTRONICS BOARD 1.727.460.81 PAGE 2 S T U D E R (00) 87/07/99 GP AUDIO ELECTRONICS BOARD 1.727.460.81 PAGE 5 S T U D E R (00) 87/07/99 GP AUDIO ELECTRONICS BOARD 1.727.460.81 PAGE 8 S T U D E R (00) 87/07/99 GP AUDIO ELECTRONICS BOARD 1.727.460.81 PAGE 11

Table with 4 columns: IND., POS.NO., PART NO., VALUE. It lists electronic components such as resistors, capacitors, and diodes for the AUDIO ELECTRONICS BOARD (VU) 1.727.460.81 GRP41/42. The table is divided into four sections corresponding to different board groups.

S T U D E R (00) 87/07/99 GP AUDIO ELECTRONICS BOARD 1.727.460.81 PAGE 3 S T U D E R (00) 87/07/99 GP AUDIO ELECTRONICS BOARD 1.727.460.81 PAGE 6 S T U D E R (00) 87/07/99 GP AUDIO ELECTRONICS BOARD 1.727.460.81 PAGE 9 S T U D E R (00) 87/07/99 GP AUDIO ELECTRONICS BOARD 1.727.460.81 PAGE 12



AUDIO ELECTRONICS (VU) 1.727.460.81 GRP41/42

IND.	POS.NO.	PART NO.	VALUE	SPECIFICATIONS / EQUIVALENT	MANUF.	IND.	POS.NO.	PART NO.	VALUE	SPECIFICATIONS / EQUIVALENT	MANUF.
R...	178	57.11.4692	6.8 kOhm	2%, 0.25W, MF		R...	289	57.11.4471	470 Ohm	2%, 0.25W, MF	
R...	179	57.11.4473	47 kOhm	2%, 0.25W, MF		R...	290	57.11.4391	390 Ohm	2%, 0.25W, MF	
R...	180	57.11.4102	10 Ohm	2%, 0.25W, MF		R...	291	57.11.4192	1.5 kOhm	2%, 0.25W, MF	
R...	181	57.99.0209	5.6 Ohm	PTC		R...	292	57.92.1151	18 Ohm	150mA, PTC	
R...	182	57.11.4567	5.6 Ohm	2%, 0.25W, MF		R...	293	57.11.4100	10 Ohm	2%, 0.25W, MF	
R...	183			not used		R...	294	57.11.4470	47 Ohm	2%, 0.25W, MF	
R...	184			not used		R...	295	57.11.4223	22 kOhm	2%, 0.25W, MF	
R...	185			not used		R...	296	57.11.4105	1 kOhm	2%, 0.25W, MF	
R...	186	57.11.4222	2.2 kOhm	2%, 0.25W, MF		R...	297	57.11.4472	4.7 kOhm	2%, 0.25W, MF	
R...	187	57.11.4222	2.2 kOhm	2%, 0.25W, MF		I...	1	1.022.400.00	1:4	Mic Input Trafo	St
R...	188	57.11.4103	10 kOhm	2%, 0.25W, MF		I...	2	1.022.451.00	150.62	Line Input Trafo	St
R...	189	57.11.4682	6.8 kOhm	2%, 0.25W, MF		I...	3	1.022.271.00		Erase Trafo	St
R...	190	57.11.4682	6.8 kOhm	2%, 0.25W, MF		I...	4	1.022.272.00		bias Trafo	St
R...	191	57.11.4223	22 kOhm	2%, 0.25W, MF		I...	5	1.022.402.00	1:10	Sync Trafo	St
R...	192	57.11.4682	6.8 kOhm	2%, 0.25W, MF		I...	6	1.022.355.00		Line Output Trafo	St
R...	193	57.11.4103	10 kOhm	2%, 0.25W, MF		TP...	1	54.02.0320		Plug 2.80x0.8	AMP
R...	194	57.11.4105	1 kOhm	2%, 0.25W, MF		TP...	2	54.02.0320		Plug 2.80x0.8	AMP
R...	195	57.11.4681	680 Ohm	2%, 0.25W, MF		TP...	3	54.02.0320		Plug 2.80x0.8	AMP
R...	196			not used		TP...	4	54.02.0320		Plug 2.80x0.8	AMP
R...	197			not used		TP...	5	54.02.0320		Plug 2.80x0.8	AMP
R...	198	57.11.3164	160 kOhm	2%, 0.25W, MF		TP...	6	54.02.0320		Plug 2.80x0.8	AMP
R...	199	57.11.3164	160 kOhm	2%, 0.25W, MF		TP...	7	54.02.0320		Plug 2.80x0.8	AMP
R...	200	57.11.4103	10 kOhm	2%, 0.25W, MF		W...	1	64.01.0106		Wire Bridge	
R...	201	57.11.4682	6.8 kOhm	2%, 0.25W, MF		W...	2	64.01.0106		Wire Bridge	
R...	202	57.11.4682	6.8 kOhm	2%, 0.25W, MF		W...	3	64.01.0106		Wire Bridge	
R...	203	57.11.4103	10 kOhm	2%, 0.25W, MF		W...	4	64.01.0106		Wire Bridge	
R...	204			not used		W...	5	64.01.0106		Wire Bridge	
R...	205	57.11.4181	180 Ohm	2%, 0.25W, MF		W...	6	64.01.0106		Wire Bridge	
R...	206	57.11.4562	5.6 kOhm	2%, 0.25W, MF		W...	7	64.01.0106		Wire Bridge	
R...	207	57.11.4104	100 kOhm	2%, 0.25W, MF		W...	8	64.01.0106		Wire Bridge	
R...	208	57.11.4683	68 kOhm	2%, 0.25W, MF		XIC...	1	53.03.0166	8-Pole	IC Socket	
R...	209	57.11.4333	33 kOhm	2%, 0.25W, MF		XIC...	2	53.03.0166	8-Pole	IC Socket	
R...	210	57.11.4333	33 kOhm	2%, 0.25W, MF		XIC...	3	53.03.0166	16-Pole	IC Socket	
R...	211	57.11.4103	10 kOhm	2%, 0.25W, MF							
R...	212	57.11.4193	12 Ohm	2%, 0.25W, MF							
R...	213	57.11.4560	56 Ohm	2%, 0.25W, MF							
R...	214	57.11.4101	100 Ohm	2%, 0.25W, MF							

S T U D E R (00) 87/07/09 GP AUDIO ELECTRONICS BOARD 1.727.460.81 PAGE 13 S T U D E R (00) 87/07/09 GP AUDIO ELECTRONICS BOARD 1.727.460.81 PAGE 16

IND.	POS.NO.	PART NO.	VALUE	SPECIFICATIONS / EQUIVALENT	MANUF.	IND.	POS.NO.	PART NO.	VALUE	SPECIFICATIONS / EQUIVALENT	MANUF.
R...	215	57.11.4682	6.8 kOhm	2%, 0.25W, MF		XIC...	4	53.03.0166	8-Pole	IC Socket	
R...	216	57.11.4682	6.8 kOhm	2%, 0.25W, MF		XIC...	5	53.03.0166	8-Pole	IC Socket	
R...	217	57.11.4682	6.8 kOhm	2%, 0.25W, MF		XIC...	6	53.03.0166	8-Pole	IC Socket	
R...	218	57.11.4195	1.5 MOhm	5%, 0.25W, MF		XIC...	7	53.03.0166	8-Pole	IC Socket	
R...	219	57.11.4104	100 kOhm	2%, 0.25W, MF, with socket		XIC...	8	53.03.0166	16-Pole	IC Socket	
R...	220	57.11.4103	10 kOhm	2%, 0.25W, MF		XIC...	9	53.03.0166	8-Pole	IC Socket	
R...	221			not used		XIC...	10	53.03.0166	8-Pole	IC Socket	
R...	222	57.11.4822	8.2 kOhm	2%, 0.25W, MF		XIC...	11	53.03.0166	20-Pole	IC Socket	
R...	223	57.11.4473	47 kOhm	2%, 0.25W, MF		XIC...	12	53.03.0166	16-Pole	IC Socket	
R...	224	57.11.4682	6.8 kOhm	2%, 0.25W, MF		XIC...	13	53.03.0166	8-Pole	IC Socket	
R...	225	57.11.4393	3.9 kOhm	2%, 0.25W, MF		XIC...	14	53.03.0166	8-Pole	IC Socket	
R...	226	57.11.4392	3.9 kOhm	2%, 0.25W, MF		XIC...	15	53.03.0166	8-Pole	IC Socket	
R...	227	57.11.4563	56 kOhm	2%, 0.25W, MF		XIC...	16	53.03.0166	16-Pole	IC Socket	
R...	228	57.11.4563	56 kOhm	2%, 0.25W, MF		XIC...	17	53.03.0166	16-Pole	IC Socket	
R...	229	57.11.4562	5.6 kOhm	2%, 0.25W, MF		XIC...	18	53.03.0166	16-Pole	IC Socket	
R...	230	57.11.4683	68 kOhm	2%, 0.25W, MF		XIC...	19	53.03.0166	8-Pole	IC Socket	
R...	231	57.11.4333	33 kOhm	2%, 0.25W, MF		XIC...	20	53.03.0166	8-Pole	IC Socket	
R...	232	57.11.4333	33 kOhm	2%, 0.25W, MF		XIC...	21	53.03.0166	8-Pole	IC Socket	
R...	233	57.11.4103	10 kOhm	2%, 0.25W, MF		XIC...	22	53.03.0166	8-Pole	IC Socket	
R...	234	57.11.4271	270 Ohm	2%, 0.25W, MF		XIC...	23	53.03.0166	20-Pole	IC Socket	
R...	235	57.11.4273	27 kOhm	2%, 0.25W, MF		XIC...	24	53.03.0166	8-Pole	IC Socket	
R...	236	57.11.4152	1.5 kOhm	2%, 0.25W, MF		XIC...	25	53.03.0166	8-Pole	IC Socket	
R...	237	57.11.4331	330 Ohm	2%, 0.25W, MF		XIC...	26	53.03.0166	16-Pole	IC Socket	
R...	238	57.11.4103	10 kOhm	2%, 0.25W, MF		XIC...	27	53.03.0166	8-Pole	IC Socket	
R...	239	57.11.4103	10 kOhm	2%, 0.25W, MF							
R...	240	57.11.4102	1 kOhm	2%, 0.25W, MF							
R...	241			not used							
R...	242	57.11.4472	4.7 kOhm	2%, 0.25W, MF							
R...	243	57.11.4473	47 kOhm	2%, 0.25W, MF							
R...	244	57.11.4102	1 kOhm	2%, 0.25W, MF							
R...	245	57.11.4222	2.2 kOhm	2%, 0.25W, MF							
R...	246	58.01.8502	5 kOhm	10%, 0.5 W, PMG							
R...	247	57.11.4821	820 Ohm	2%, 0.25W, MF							
R...	248	57.11.4392	3.9 kOhm	2%, 0.25W, MF							
R...	249			not used							
R...	250	57.11.4153	15 kOhm	2%, 0.25W, MF							
R...	251	57.11.4473	47 kOhm	2%, 0.25W, MF							

S T U D E R (00) 87/07/09 GP AUDIO ELECTRONICS BOARD 1.727.460.81 PAGE 14 S T U D E R (00) 87/07/09 GP AUDIO ELECTRONICS BOARD 1.727.460.81 PAGE 17

IND.	POS.NO.	PART NO.	VALUE	SPECIFICATIONS / EQUIVALENT	MANUF.	IND.	POS.NO.	PART NO.	VALUE	SPECIFICATIONS / EQUIVALENT	MANUF.
R...	252	57.11.4472	4.7 kOhm	2%, 0.25W, MF							
R...	253	57.11.4472	4.7 kOhm	2%, 0.25W, MF							
R...	254	57.11.4331	330 Ohm	2%, 0.25W, MF							
R...	255	57.11.4102	1 kOhm	2%, 0.25W, MF							
R...	256	57.11.4273	27 kOhm	2%, 0.25W, MF							
R...	257	57.11.4102	1 kOhm	2%, 0.25W, MF							
R...	258	57.11.4471	470 Ohm	2%, 0.25W, MF							
R...	259	57.11.4103	10 kOhm	2%, 0.25W, MF							
R...	260	57.11.4221	220 Ohm	2%, 0.25W, MF							
R...	261	57.11.4122	1.2 kOhm	2%, 0.25W, MF							
R...	262	57.11.4471	470 Ohm	2%, 0.25W, MF							
R...	263	57.11.4223	22 kOhm	2%, 0.25W, MF							
R...	264	57.11.4222	2.2 kOhm	2%, 0.25W, MF							
R...	265	57.11.4473	47 kOhm	2%, 0.25W, MF							
R...	266	57.11.4103	10 kOhm	2%, 0.25W, MF							
R...	267	57.11.4682	6.8 kOhm	2%, 0.25W, MF							
R...	268	57.11.4682	6.8 kOhm	2%, 0.25W, MF							
R...	269	57.11.4103	10 kOhm	2%, 0.25W, MF							
R...	270	57.11.4472	4.7 kOhm	2%, 0.25W, MF							
R...	271	57.11.4122	1.2 kOhm	2%, 0.25W, MF							
R...	272	57.11.4223	22 kOhm	2%, 0.25W, MF							
R...	273	57.11.4223	22 kOhm	2%, 0.25W, MF							
R...	274	57.11.4473	47 kOhm	2%, 0.25W, MF							
R...	275	57.11.4223	22 kOhm	2%, 0.25W, MF							
R...	276	57.11.4103	10 kOhm	2%, 0.25W, MF							
R...	277	57.11.4339	3.3 Ohm	2%, 0.25W, MF							
R...	278	57.11.4103	10 kOhm	2%, 0.25W, MF							
R...	279	57.11.4103	10 kOhm	2%, 0.25W, MF							
R...	280	57.11.4339	3.3 Ohm	2%, 0.25W, MF							
R...	281	57.11.4222	2.2 kOhm	2%, 0.25W, MF							
R...	282	57.11.4222	2.2 kOhm	2%, 0.25W, MF							
R...	283	57.11.4339	3.3 Ohm	2%, 0.25W, MF							
R...	284	57.11.4103	10 kOhm	2%, 0.25W, MF							
R...	285	57.11.4103	10 kOhm	2%, 0.25W, MF							
R...	286	57.11.4339	3.3 Ohm	2%, 0.25W, MF							
R...	287	57.11.4472	4.7 kOhm	2%, 0.25W, MF							
R...	288	57.11.4103	10 kOhm	2%, 0.25W, MF							

Note 1 Variable Phantom Supply

U (V)	POS.NO.	PART NO.	VALUE
48	R 3 / R 4	57990250	1 6.8 kOhm 0.1 % 0.25 W MF
24	R 3 / R 4	57990199	1 4.3 kOhm 0.1 % 0.25 W MF
12	R 3 / R 4	57990199	1 680 Ohm 0.1 % 0.25 W MF

Cer = Ceramic EL = Electrolytic PETP = Polyester
PP = Polypropylen MF = Metal Film SI = Silicon
MANUFACTURER: ADI = Analog Devices Inc. Mot = Motorola
NS = National Semiconductors Ra = Raytheon
Sig = Signetics St = Studer

DRIG 87/07/09 S T U D E R (00) 87/07/09 GP AUDIO ELECTRONICS BOARD 1.727.460.81 PAGE 18

AUDIO ELECTRONICS (VU) 1.727.420.81 GRP41/42

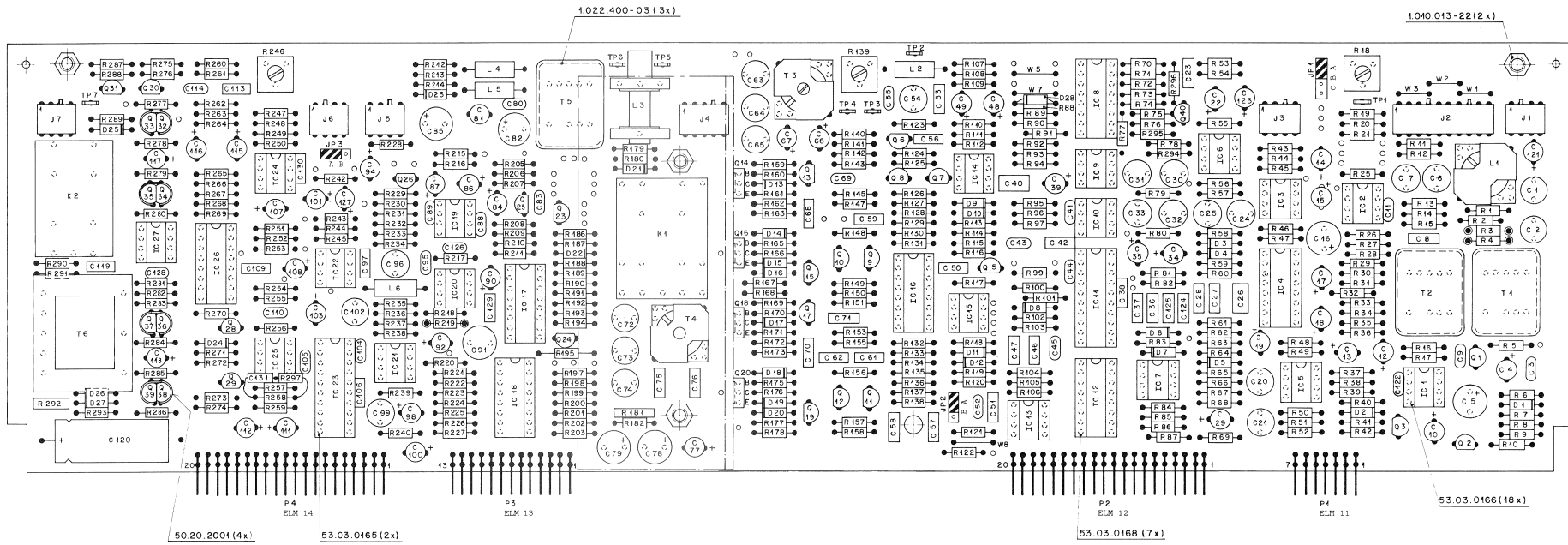

IND.	POS.IND.	PART NO.	VALUE	SPECIFICATIONS / EQUIVALENT	MANUF.
A.....1		1.727.420.81		AUDIO ELECTRONICS BOARD	
C.....131		59.06.0474	0.47uF	10%, 50V, PETP	
MP.....10		1.727.420.10		1 pcs No. Label	
R.....73		57.11.4124	1.0K OHM	2%, 0.25W, MF	
R.....76		57.11.4082	0.4K OHM	2%, 0.25W, MF	
R.....77		57.11.4563	5K OHM	2%, 0.25W, MF	
R.....78		57.11.4113	47 OHM	2%, 0.25W, MF with socket	
R.....79		57.11.4182	1.8K OHM	2%, 0.25W, MF	

Note 1 Variable Phantec Supply

U (V)	I (A)	R (ohm)	C (pF)	L (mH)	W (W)	M (M)	S (Si)	P (P)	
50	1.3	1.4	57990250	1	0.4	0.1	3	0.25	MF
24	1.3	1.4							MF
12	1.3	1.4	57990199	1	0.4	0.1	3	0.25	MF

Cer = Ceramic EL = Electrolytic PETP = Polyester
 PP = Polypropylene MF = Metal Film SI = Silicon
 MANUFACTURER: ADI = Analog Devices Inc. Mot = Motorola
 NS = National Semiconductors RA = Raytheon
 Sig = Signetics ST = Sturmer

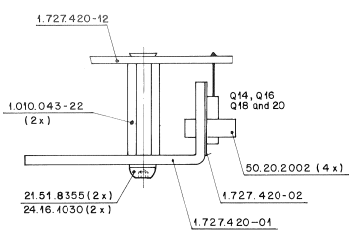

AUDIO ELECTRONICS (O VU) 1.727.421.00 GRP41/42
 - LINE OUTPUT CONNECTOR 1.727.240.00 (SEE PAGE 7/32)
 - LINE INPUT CONNECTOR 1.727.241.00 (SEE PAGE 7/33)

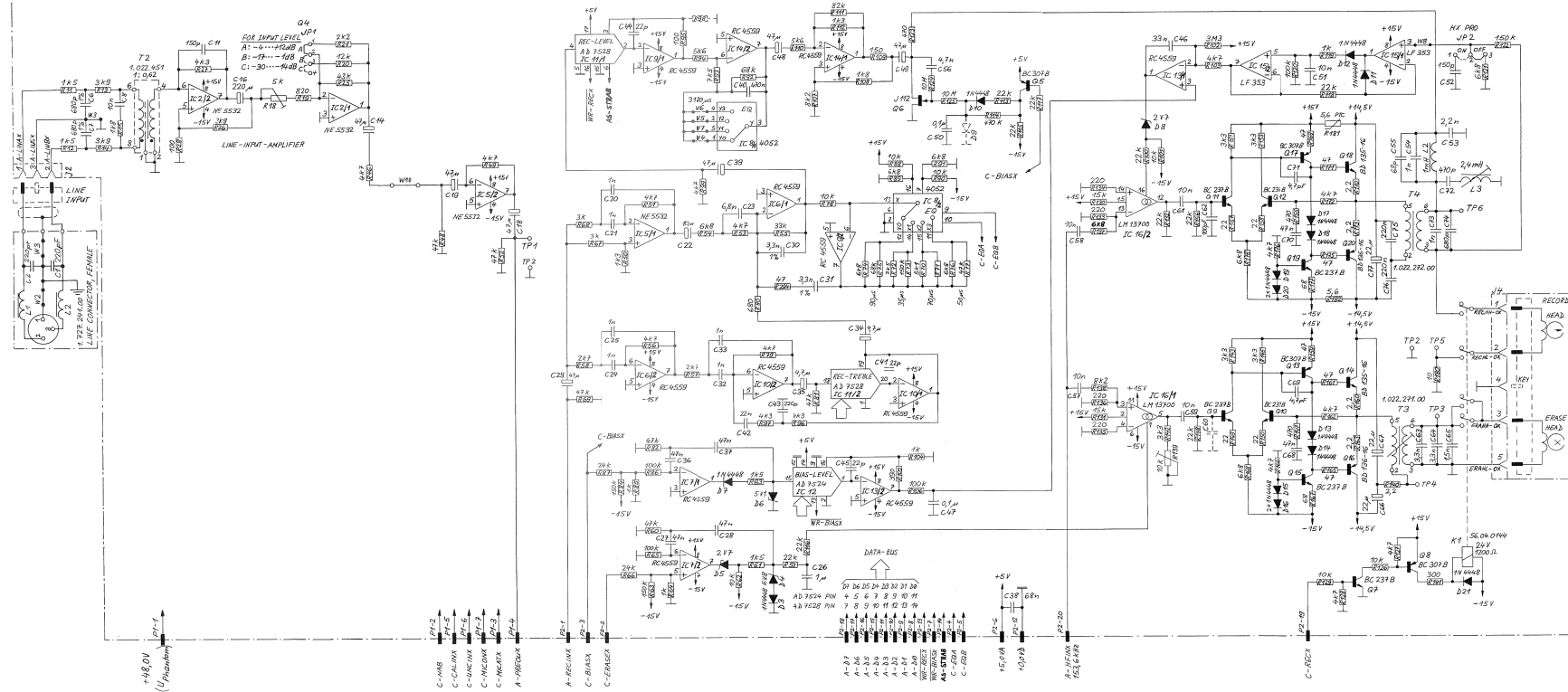

① 30.9.86 GP	② 28.1.87 GP	③ 28.9.87 GP	④ . . .
A 727 GR41/42			
STUDER		AUDIO ELECTRONICS BOARD TD	SC 1.727.421.00
			PAGE 3 OF 6

AUDIO ELECTRONICS (O VU) 1.727.421.00 GRP41/42
 - LINE OUTPUT CONNECTOR 1.727.240.00 (SEE PAGE 7/32)
 - LINE INPUT CONNECTOR 1.727.241.00 (SEE PAGE 7/33)

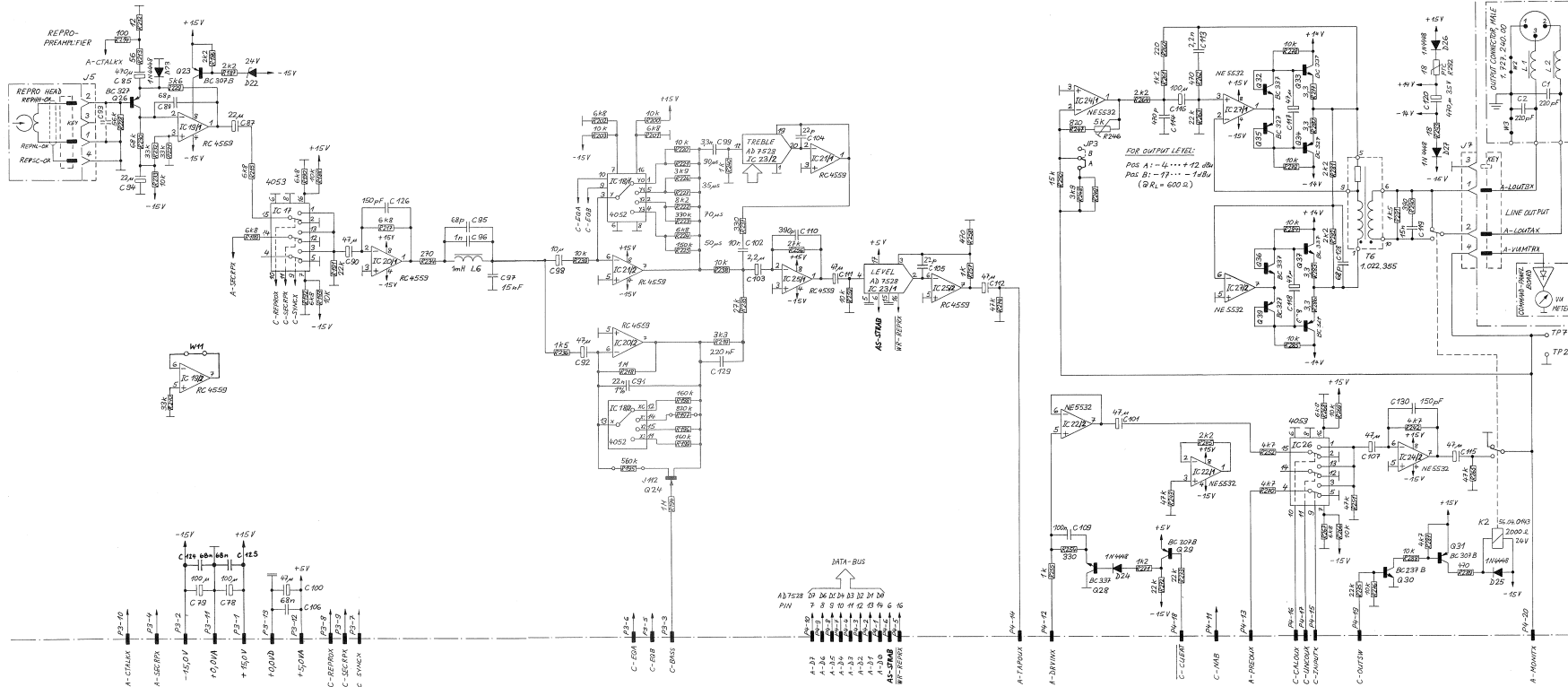

30.9.86 GP	28.1.87 GP	28.4.87 GP	
A 727	GR 41/42		PAGE 6 OF 6
STUDER AUDIO ELECTRONICS BOARD TD			SC 1.727.421.00

AUDIO ELECTRONICS (O VU) 1.727.421.00 GRP41/42

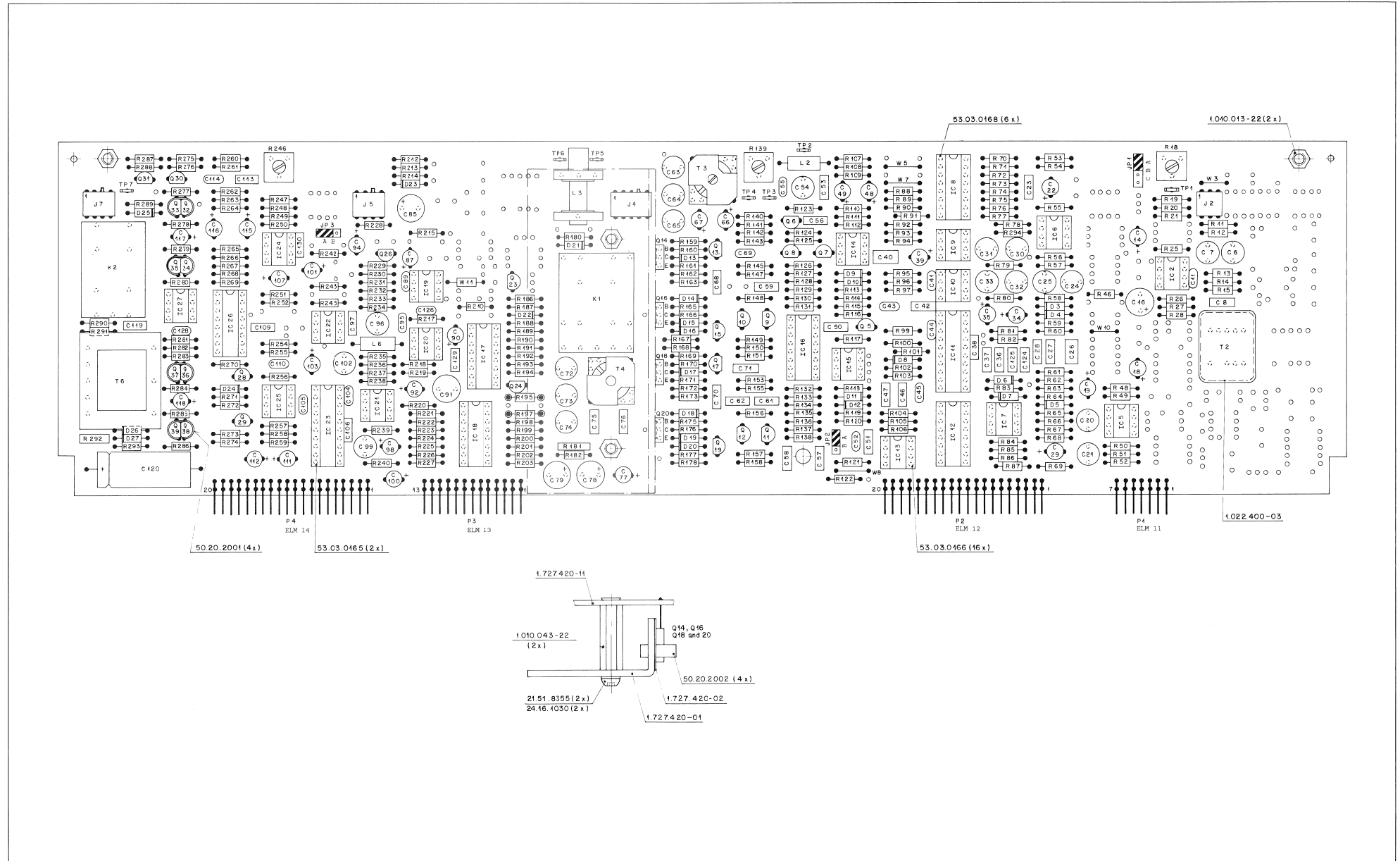



AUDIO ELECTRONICS (O VU) 1.727.421.00 GRP4/42

Table with 5 columns: IND., POS.ND., PART NO., VALUE, SPECIFICATIONS / EQUIVALENT, MANUF. It contains multiple rows of component data for AUDIO ELECTRONICS BOARD TO 1.727.421.00 PAGE 1.

S T U D E R (02) 87/04/28 GP AUDIO ELECTRONICS BOARD TO 1.727.421.00 PAGE 1

S T U D E R (02) 87/04/28 GP AUDIO ELECTRONICS BOARD TO 1.727.421.00 PAGE 4

S T U D E R (02) 87/04/28 GP AUDIO ELECTRONICS BOARD TO 1.727.421.00 PAGE 7

S T U D E R (02) 87/04/28 GP AUDIO ELECTRONICS BOARD TO 1.727.421.00 PAGE 10

Table with 5 columns: IND., POS.ND., PART NO., VALUE, SPECIFICATIONS / EQUIVALENT, MANUF. It contains multiple rows of component data for AUDIO ELECTRONICS BOARD TO 1.727.421.00 PAGE 2.

S T U D E R (02) 87/04/28 GP AUDIO ELECTRONICS BOARD TO 1.727.421.00 PAGE 2

S T U D E R (02) 87/04/28 GP AUDIO ELECTRONICS BOARD TO 1.727.421.00 PAGE 5

S T U D E R (02) 87/04/28 GP AUDIO ELECTRONICS BOARD TO 1.727.421.00 PAGE 8

S T U D E R (02) 87/04/28 GP AUDIO ELECTRONICS BOARD TO 1.727.421.00 PAGE 11

Table with 5 columns: IND., POS.ND., PART NO., VALUE, SPECIFICATIONS / EQUIVALENT, MANUF. It contains multiple rows of component data for AUDIO ELECTRONICS BOARD TO 1.727.421.00 PAGE 3.

S T U D E R (02) 87/04/28 GP AUDIO ELECTRONICS BOARD TO 1.727.421.00 PAGE 3

S T U D E R (02) 87/04/28 GP AUDIO ELECTRONICS BOARD TO 1.727.421.00 PAGE 6

S T U D E R (02) 87/04/28 GP AUDIO ELECTRONICS BOARD TO 1.727.421.00 PAGE 9

S T U D E R (02) 87/04/28 GP AUDIO ELECTRONICS BOARD TO 1.727.421.00 PAGE 12



AUDIO ELECTRONICS (O VU) 1.727.421.00 GRP41/42

IND.	POS.NO.	PART NO.	VALUE	SPECIFICATIONS / EQUIVALENT	MANUF.
R...	264	57.11.4222	2.2 kOhm	2%, 0.25W, MF	
R...	265	57.11.4473	47 kOhm	2%, 0.25W, MF	
R...	266	57.11.4103	10 kOhm	2%, 0.25W, MF	
R...	267	57.11.4682	6.8 kOhm	2%, 0.25W, MF	
R...	268	57.11.4682	6.8 kOhm	2%, 0.25W, MF	
R...	269	57.11.4103	10 kOhm	2%, 0.25W, MF	
R...	270	57.11.4472	4.7 kOhm	2%, 0.25W, MF	
R...	271	57.11.4122	1.2 kOhm	2%, 0.25W, MF	
R...	272	57.11.4223	22 kOhm	2%, 0.25W, MF	
R...	273	57.11.4223	22 kOhm	2%, 0.25W, MF	
R...	274	57.11.4473	47 kOhm	2%, 0.25W, MF	
R...	275	57.11.4223	22 kOhm	2%, 0.25W, MF	
R...	276	57.11.4103	10 kOhm	2%, 0.25W, MF	
R...	277	57.11.4339	3.3 Ohm	2%, 0.25W, MF	
R...	278	57.11.4103	10 kOhm	2%, 0.25W, MF	
R...	279	57.11.4103	10 kOhm	2%, 0.25W, MF	
R...	280	57.11.4339	3.3 Ohm	2%, 0.25W, MF	
R...	281	57.11.4222	2.2 kOhm	2%, 0.25W, MF	
R...	282	57.11.4222	2.2 kOhm	2%, 0.25W, MF	
R...	283	57.11.4339	3.3 Ohm	2%, 0.25W, MF	
R...	284	57.11.4103	10 kOhm	2%, 0.25W, MF	
R...	285	57.11.4103	10 kOhm	2%, 0.25W, MF	
R...	286	57.11.4339	3.3 Ohm	2%, 0.25W, MF	
R...	287	57.11.4472	4.7 kOhm	2%, 0.25W, MF	
R...	288	57.11.4103	10 kOhm	2%, 0.25W, MF	
R...	289	57.11.4471	470 Ohm	2%, 0.25W, MF	
R...	290	57.11.4391	390 Ohm	2%, 0.25W, MF	
R...	291	57.11.4152	1.5 kOhm	2%, 0.25W, MF	
R...	292	57.02.1151	18 Ohm	2%, 150m, DTC	
R...	293	57.11.4180	18 Ohm	2%, 0.25W, MF	
R...	294	57.11.4470	47 Ohm	2%, 0.25W, MF	
T.....	2	1.022.451.00	1:0.62	Line Input Trafo	St
T.....	3	1.022.271.00		Erase Trafo	St
T.....	4	1.022.272.00		Bias Trafo	St
T.....	6	1.022.355.00		Line Output Trafo	St

S T U D E R (02) 87/04/28 GP AUDIO ELECTRONICS BOARD TD 1.727.421.00 PAGE 13

IND.	POS.NO.	PART NO.	VALUE	SPECIFICATIONS / EQUIVALENT	MANUF.
TP....	1	54.02.0320		Plug 2.8*0.8	AMP
TP....	2	54.02.0320		Plug 2.8*0.8	AMP
TP....	3	54.02.0320		Plug 2.8*0.8	AMP
TP....	4	54.02.0320		Plug 2.8*0.8	AMP
TP....	5	54.02.0320		Plug 2.8*0.8	AMP
TP....	6	54.02.0320		Plug 2.8*0.8	AMP
TP....	7	54.02.0320		Plug 2.8*0.8	AMP
W.....	3	64.01.0106		Wire Bridge	
W.....	4			not used	
W.....	5	64.01.0106		Wire Bridge	
W.....	6			not used	
W.....	7	64.01.0106		Wire Bridge	
W.....	8	64.01.0106		Wire Bridge	
W.....	10	64.01.0106		Wire Bridge	
W.....	11	57.11.4000		Wire Bridge	
XIC....	2	53.03.0166	8-Pole	IC Socket	
XIC....	5	53.03.0166	8-Pole	IC Socket	
XIC....	6	53.03.0166	8-Pole	IC Socket	
XIC....	7	53.03.0166	8-Pole	IC Socket	
XIC....	8	53.03.0168	16-Pole	IC Socket	
XIC....	9	53.03.0166	8-Pole	IC Socket	
XIC....	10	53.03.0166	8-Pole	IC Socket	
XIC....	11	53.03.0165	20-Pole	IC Socket	
XIC....	12	53.03.0168	16-Pole	IC Socket	
XIC....	13	53.03.0166	8-Pole	IC Socket	
XIC....	14	53.03.0166	8-Pole	IC Socket	
XIC....	15	53.03.0166	8-Pole	IC Socket	
XIC....	16	53.03.0168	16-Pole	IC Socket	
XIC....	17	53.03.0168	16-Pole	IC Socket	
XIC....	18	53.03.0168	16-Pole	IC Socket	
XIC....	19	53.03.0166	8-Pole	IC Socket	
XIC....	20	53.03.0166	8-Pole	IC Socket	
XIC....	21	53.03.0166	8-Pole	IC Socket	
XIC....	22	53.03.0166	8-Pole	IC Socket	
XIC....	23	53.03.0165	20-Pole	IC Socket	

S T U D E R (02) 87/04/28 GP AUDIO ELECTRONICS BOARD TD 1.727.421.00 PAGE 14

IND.	POS.NO.	PART NO.	VALUE	SPECIFICATIONS / EQUIVALENT	MANUF.
XIC....	24	53.03.0166	8-Pole	IC Socket	
XIC....	25	53.03.0166	8-Pole	IC Socket	
XIC....	26	53.03.0168	16-Pole	IC Socket	
XIC....	27	53.03.0166	8-Pole	IC Socket	

(01) 87/01/28 better frequency response
 (02) 87/04/28 better S/N ratio
 Cer = Ceramic EL = Electrolytic PETP = Polyester
 PP = Polypropylen MF = Metal Film SI = Silicon
 MANUFACTURER: ADI = Analog Devices Inc. Mot = Motorola
 NS = National Semiconductors Ra = Raytheon
 Sig = Signetics St = Studer

ORIG 86/10/10 (01) 87/01/28 (02) 87/04/28
 S T U D E R (02) 87/04/28 GP AUDIO ELECTRONICS BOARD TD 1.727.421.00 PAGE 15

AUDIO ELECTRONICS (O VU) 1.727.461.00 GRP41/42
- LINE OUTPUT CONNECTOR 1.727.240.00 (SEE PAGE 7/32)
- LINE INPUT CONNECTOR 1.727.241.00 (SEE PAGE 7/33)

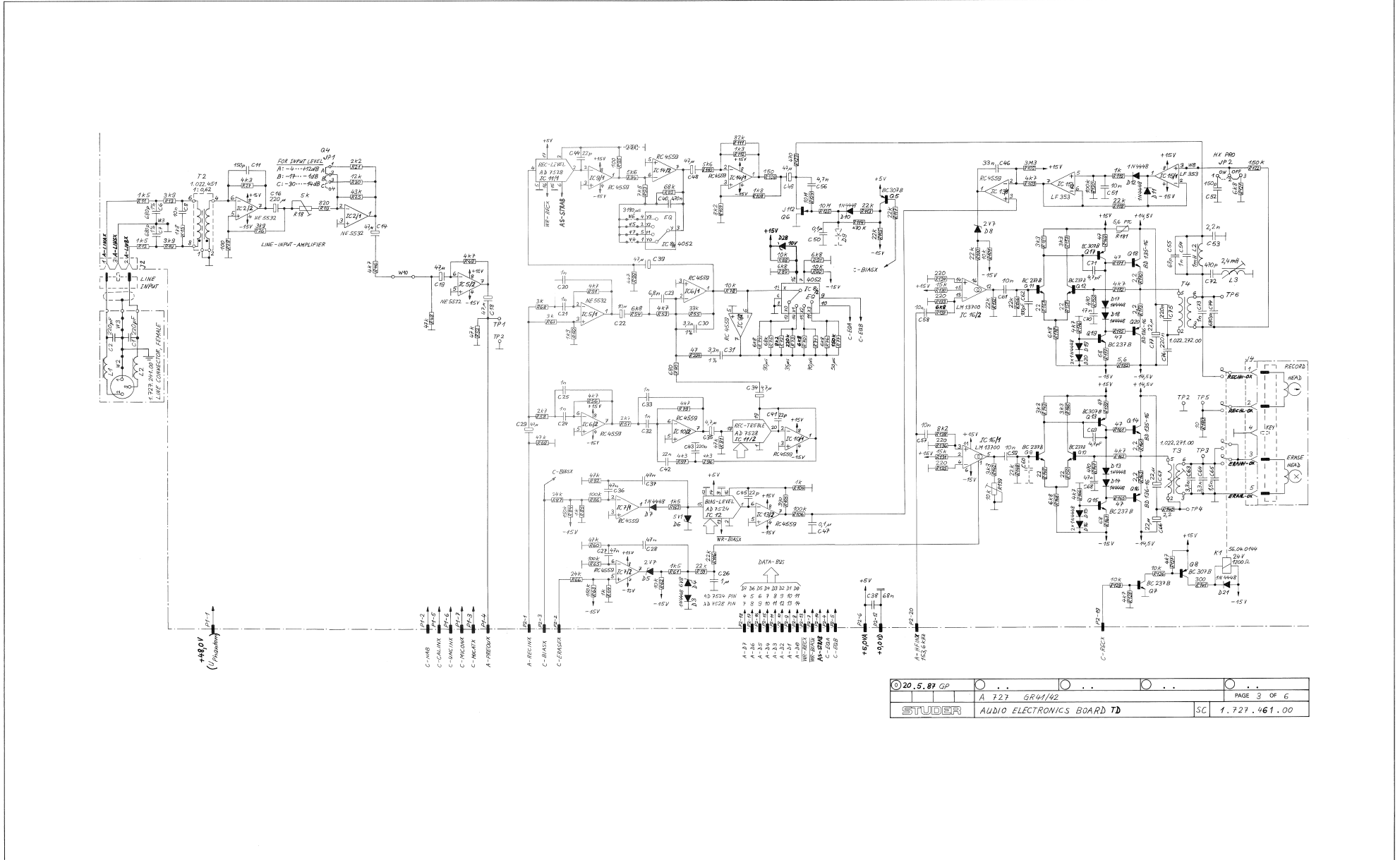

020,5.87 GP	A 727 GR41/42	PAGE 3 OF 6
STUDER AUDIO ELECTRONICS BOARD TD		SC 1.727.461.00

AUDIO ELECTRONICS (O VU) 1.727.461.00 GRP41/42
 - LINE OUTPUT CONNECTOR 1.727.240.00 (SEE PAGE 7/32)
 - LINE INPUT CONNECTOR 1.727.241.00 (SEE PAGE 7/33)

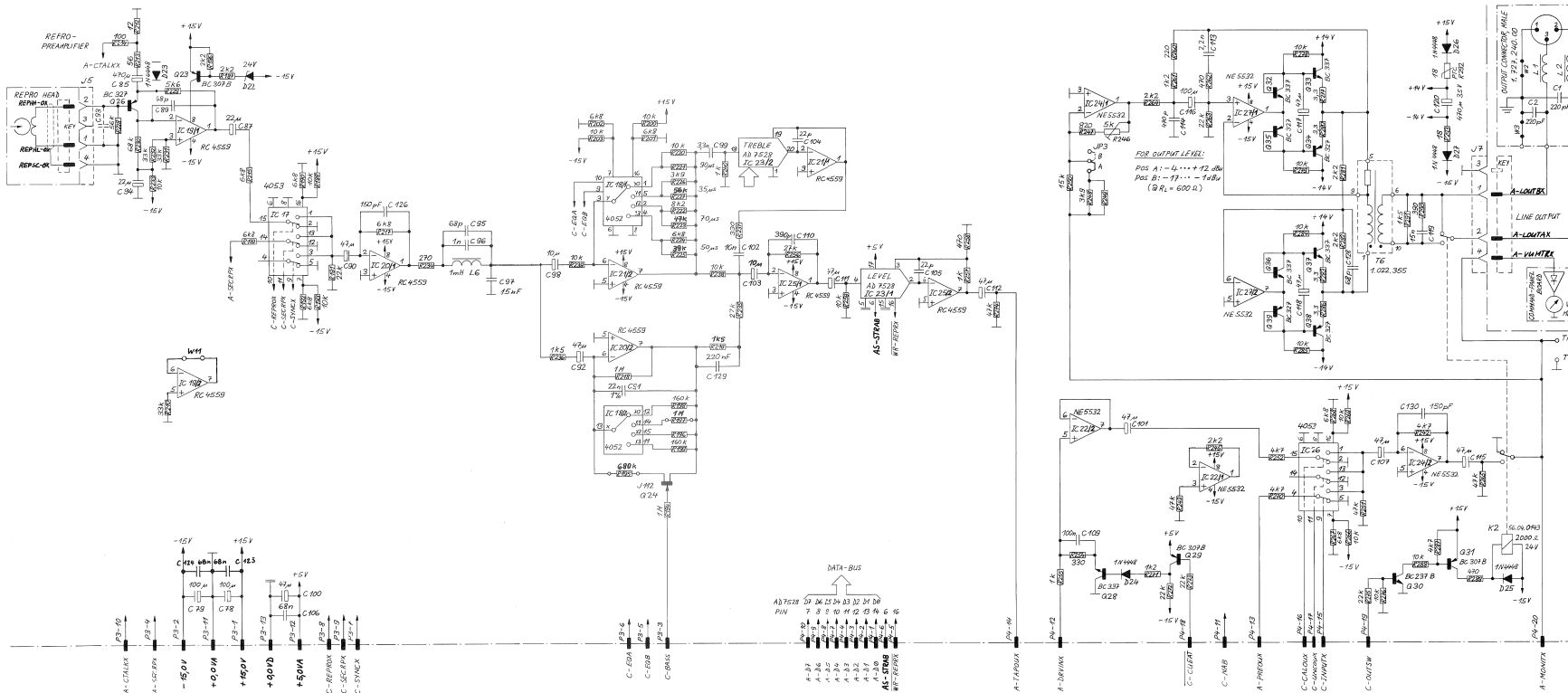

20.5.87 GP		A 727 GR 41/42		PAGE 6 OF 6	
STUDER		AUDIO ELECTRONICS BOARD TD		SC 1.727.461.00	

AUDIO ELECTRONICS (O VU) 1.727.461.00 GRP41/42

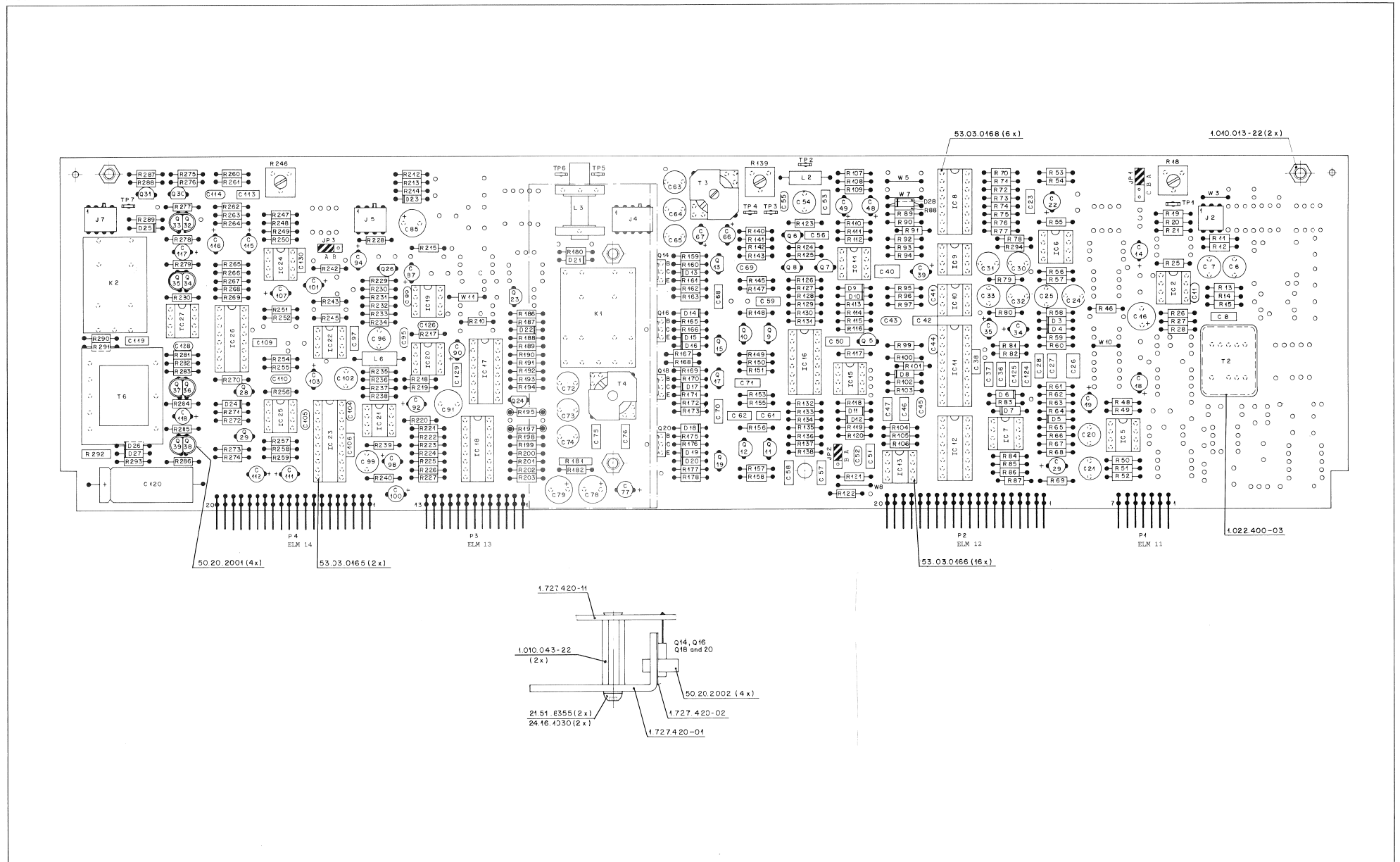



AUDIO ELECTRONICS (O VU) 1.727.461.00 GRP41/42

Table with columns: IND., POS.ND., PART NO., VALUE, SPECIFICATIONS / EQUIVALENT, MANUF. Contains component data for the first section of the board.

Table with columns: IND., POS.ND., PART NO., VALUE, SPECIFICATIONS / EQUIVALENT, MANUF. Contains component data for the second section of the board.

Table with columns: IND., POS.ND., PART NO., VALUE, SPECIFICATIONS / EQUIVALENT, MANUF. Contains component data for the third section of the board.

Table with columns: IND., POS.ND., PART NO., VALUE, SPECIFICATIONS / EQUIVALENT, MANUF. Contains component data for the fourth section of the board.

S T U D E R (00) 87/05/20 GP AUDIO ELECTRONICS BOARD TO 1.727.461.00 PAGE 1

S T U D E R (00) 87/05/20 GP AUDIO ELECTRONICS BOARD TO 1.727.461.00 PAGE 4

S T U D E R (00) 87/05/20 GP AUDIO ELECTRONICS BOARD TO 1.727.461.00 PAGE 7

S T U D E R (00) 87/05/20 GP AUDIO ELECTRONICS BOARD TO 1.727.461.00 PAGE 10

Table with columns: IND., POS.ND., PART NO., VALUE, SPECIFICATIONS / EQUIVALENT, MANUF. Contains component data for the first section of the board.

Table with columns: IND., POS.ND., PART NO., VALUE, SPECIFICATIONS / EQUIVALENT, MANUF. Contains component data for the second section of the board.

Table with columns: IND., POS.ND., PART NO., VALUE, SPECIFICATIONS / EQUIVALENT, MANUF. Contains component data for the third section of the board.

Table with columns: IND., POS.ND., PART NO., VALUE, SPECIFICATIONS / EQUIVALENT, MANUF. Contains component data for the fourth section of the board.

S T U D E R (00) 87/05/20 GP AUDIO ELECTRONICS BOARD TO 1.727.461.00 PAGE 2

S T U D E R (00) 87/05/20 GP AUDIO ELECTRONICS BOARD TO 1.727.461.00 PAGE 5

S T U D E R (00) 87/05/20 GP AUDIO ELECTRONICS BOARD TO 1.727.461.00 PAGE 8

S T U D E R (00) 87/05/20 GP AUDIO ELECTRONICS BOARD TO 1.727.461.00 PAGE 11

Table with columns: IND., POS.ND., PART NO., VALUE, SPECIFICATIONS / EQUIVALENT, MANUF. Contains component data for the first section of the board.

Table with columns: IND., POS.ND., PART NO., VALUE, SPECIFICATIONS / EQUIVALENT, MANUF. Contains component data for the second section of the board.

Table with columns: IND., POS.ND., PART NO., VALUE, SPECIFICATIONS / EQUIVALENT, MANUF. Contains component data for the third section of the board.

Table with columns: IND., POS.ND., PART NO., VALUE, SPECIFICATIONS / EQUIVALENT, MANUF. Contains component data for the fourth section of the board.

S T U D E R (00) 87/05/20 GP AUDIO ELECTRONICS BOARD TO 1.727.461.00 PAGE 3

S T U D E R (00) 87/05/20 GP AUDIO ELECTRONICS BOARD TO 1.727.461.00 PAGE 6

S T U D E R (00) 87/05/20 GP AUDIO ELECTRONICS BOARD TO 1.727.461.00 PAGE 9

S T U D E R (00) 87/05/20 GP AUDIO ELECTRONICS BOARD TO 1.727.461.00 PAGE 12



AUDIO ELECTRONICS (O VU) 1.727.461.00 GRP41/42

IND.	POS.NO.	PART NO.	VALUE	SPECIFICATIONS / EQUIVALENT	MANUF.
R...	268	57.11.4682	6.8 kOhm	2%, 0.25W, MF	
R...	269	57.11.4103	10 kOhm	2%, 0.25W, MF	
R...	270	57.11.4472	4.7 kOhm	2%, 0.25W, MF	
R...	271	57.11.4122	1.2 kOhm	2%, 0.25W, MF	
R...	272	57.11.4223	22 kOhm	2%, 0.25W, MF	
R...	273	57.11.4223	22 kOhm	2%, 0.25W, MF	
R...	274	57.11.4473	47 kOhm	2%, 0.25W, MF	
R...	275	57.11.4223	22 kOhm	2%, 0.25W, MF	
R...	276	57.11.4103	10 kOhm	2%, 0.25W, MF	
R...	277	57.11.4339	3.3 Ohm	2%, 0.25W, MF	
R...	278	57.11.4103	10 kOhm	2%, 0.25W, MF	
R...	279	57.11.4103	10 kOhm	2%, 0.25W, MF	
R...	280	57.11.4339	3.3 Ohm	2%, 0.25W, MF	
R...	281	57.11.4222	2.2 kOhm	2%, 0.25W, MF	
R...	282	57.11.4222	2.2 kOhm	2%, 0.25W, MF	
R...	283	57.11.4339	3.3 Ohm	2%, 0.25W, MF	
R...	284	57.11.4103	10 kOhm	2%, 0.25W, MF	
R...	285	57.11.4103	10 kOhm	2%, 0.25W, MF	
R...	286	57.11.4339	3.3 Ohm	2%, 0.25W, MF	
R...	287	57.11.4472	4.7 kOhm	2%, 0.25W, MF	
R...	288	57.11.4103	10 kOhm	2%, 0.25W, MF	
R...	289	57.11.4471	470 Ohm	2%, 0.25W, MF	
R...	290	57.11.4391	390 Ohm	2%, 0.25W, MF	
R...	291	57.11.4152	1.5 kOhm	2%, 0.25W, MF	
R...	292	57.92.1151	18 Ohm	150mA, PTC	
R...	293	57.11.4180	18 Ohm	2%, 0.25W, MF	
R...	294	57.11.4470	47 Ohm	2%, 0.25W, MF	
T.....	2	1.022.451.00	1:0.62	Line Input Trafo	St
T.....	3	1.022.271.00		Erase Trafo	St
T.....	4	1.022.272.00		Biast Trafo	St
T.....	6	1.022.355.00		Line Output Trafo	St
TP....	1	54.02.0320		Plug 2.8*0.8	AMP
TP....	2	54.02.0320		Plug 2.8*0.8	AMP
TP....	3	54.02.0320		Plug 2.8*0.8	AMP
TP....	4	54.02.0320		Plug 2.8*0.8	AMP

S T U D E R (00) 87/05/20 GP AUDIO ELECTRONICS BOARD TD 1.727.461.00 PAGE 13

IND.	POS.NO.	PART NO.	VALUE	SPECIFICATIONS / EQUIVALENT	MANUF.
TP....	5	54.02.0320		Plug 2.8*0.8	AMP
TP....	6	54.02.0320		Plug 2.8*0.8	AMP
TP....	7	54.02.0320		Plug 2.8*0.8	AMP
W.....	3	64.01.0106		Wire Bridge	
W.....	4			not used	
W.....	5	64.01.0106		Wire Bridge	
W.....	6			not used	
W.....	7	64.01.0106		Wire Bridge	
W.....	8	64.01.0106		Wire Bridge	
W.....	10	64.01.0106		Wire Bridge	
W.....	11	57.11.4000		Wire Bridge	
XIC....	2	53.03.0166	8-Pole	IC Socket	
XIC....	5	53.03.0166	8-Pole	IC Socket	
XIC....	6	53.03.0166	8-Pole	IC Socket	
XIC....	7	53.03.0166	8-Pole	IC Socket	
XIC....	8	53.03.0168	16-Pole	IC Socket	
XIC....	9	53.03.0166	8-Pole	IC Socket	
XIC....	10	53.03.0166	8-Pole	IC Socket	
XIC....	11	53.03.0166	20-Pole	IC Socket	
XIC....	12	53.03.0168	16-Pole	IC Socket	
XIC....	13	53.03.0166	8-Pole	IC Socket	
XIC....	14	53.03.0166	8-Pole	IC Socket	
XIC....	15	53.03.0166	8-Pole	IC Socket	
XIC....	16	53.03.0168	16-Pole	IC Socket	
XIC....	17	53.03.0168	16-Pole	IC Socket	
XIC....	18	53.03.0168	16-Pole	IC Socket	
XIC....	19	53.03.0166	8-Pole	IC Socket	
XIC....	20	53.03.0166	8-Pole	IC Socket	
XIC....	21	53.03.0166	8-Pole	IC Socket	
XIC....	22	53.03.0166	8-Pole	IC Socket	
XIC....	23	53.03.0166	20-Pole	IC Socket	
XIC....	24	53.03.0166	8-Pole	IC Socket	
XIC....	25	53.03.0166	8-Pole	IC Socket	
XIC....	26	53.03.0168	16-Pole	IC Socket	
XIC....	27	53.03.0166	8-Pole	IC Socket	

S T U D E R (00) 87/05/20 GP AUDIO ELECTRONICS BOARD TD 1.727.461.00 PAGE 14

IND.	POS.NO.	PART NO.	VALUE	SPECIFICATIONS / EQUIVALENT	MANUF.
Cer = Ceramic EL = Electrolytic PETP = Polyester PP = Polypropylen MF = Metal Film SI = Silicon					
MANUFACTURER: ADI = Analog Devices Inc. Mot = Motorola NS = National Semiconductors Ra = Raytheon Sig = Signetics St = Studer					

ORIG 87/05/20
S T U D E R (00) 87/05/20 GP AUDIO ELECTRONICS BOARD TD 1.727.461.00 PAGE 15

AUDIO ELECTRONICS (0 VU) 1.727.461.81 GRP41/42
AUDIO ELECTRONICS (0 VU) 1.727.421.81 GRP41/42
- LINE OUTPUT CONNECTOR 1.727.240.00 (SEE PAGE 7/32)
- LINE INPUT CONNECTOR 1.727.241.00 (SEE PAGE 7/33)

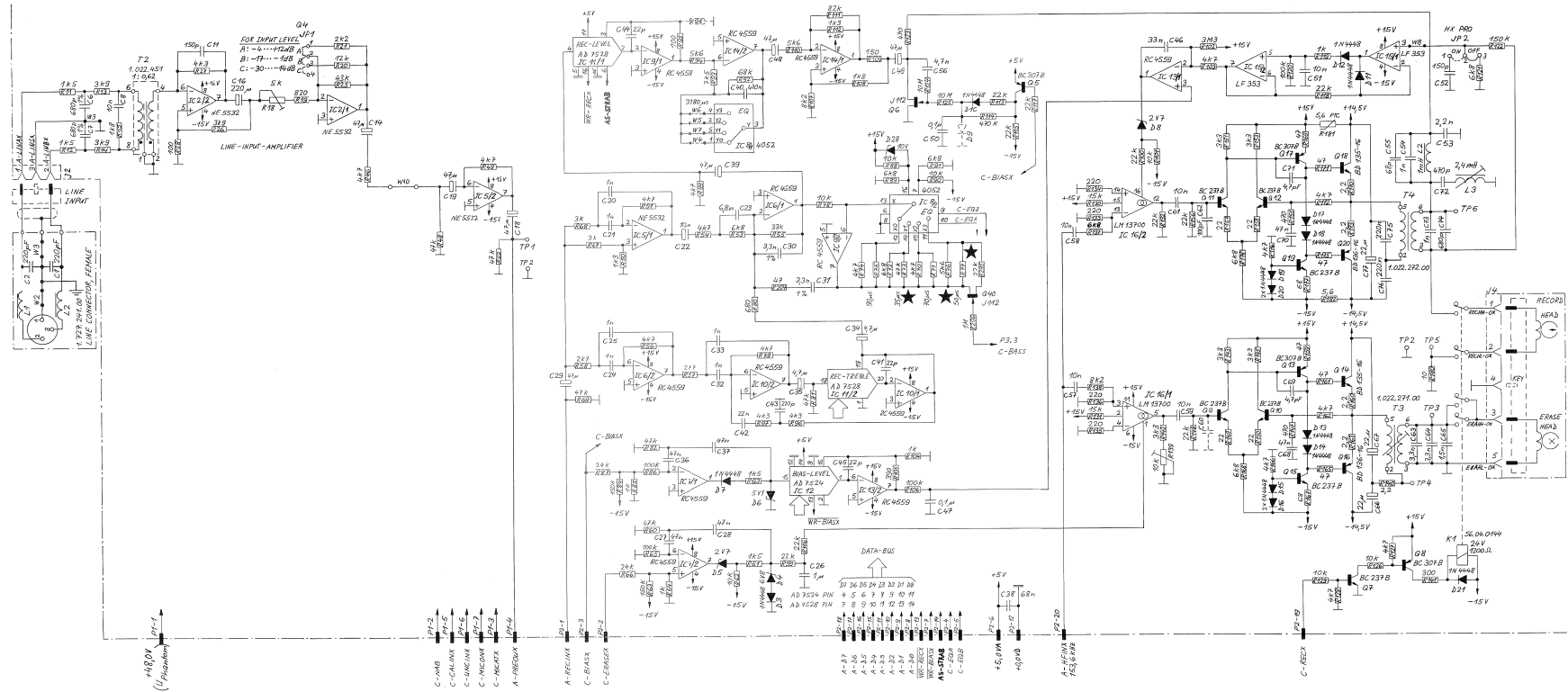

★NOT THE SAME VALUES FOR 1.727.461.81 AND 1.727.421.81 !

0 3 . 7 . 87 GP	A 127 GR41/42	PAGE 3 OF 6
STUDER	AUDIO ELECTRONICS BOARD TD	SC 1.727.461.81

AUDIO ELECTRONICS (O VU) 1.727.461.81 GRP41/42
 AUDIO ELECTRONICS (O VU) 1.727.421.81 GRP41/42
 - LINE OUTPUT CONNECTOR 1.727.240.00 (SEE PAGE 7/32)
 - LINE INPUT CONNECTOR 1.727.241.00 (SEE PAGE 7/33)

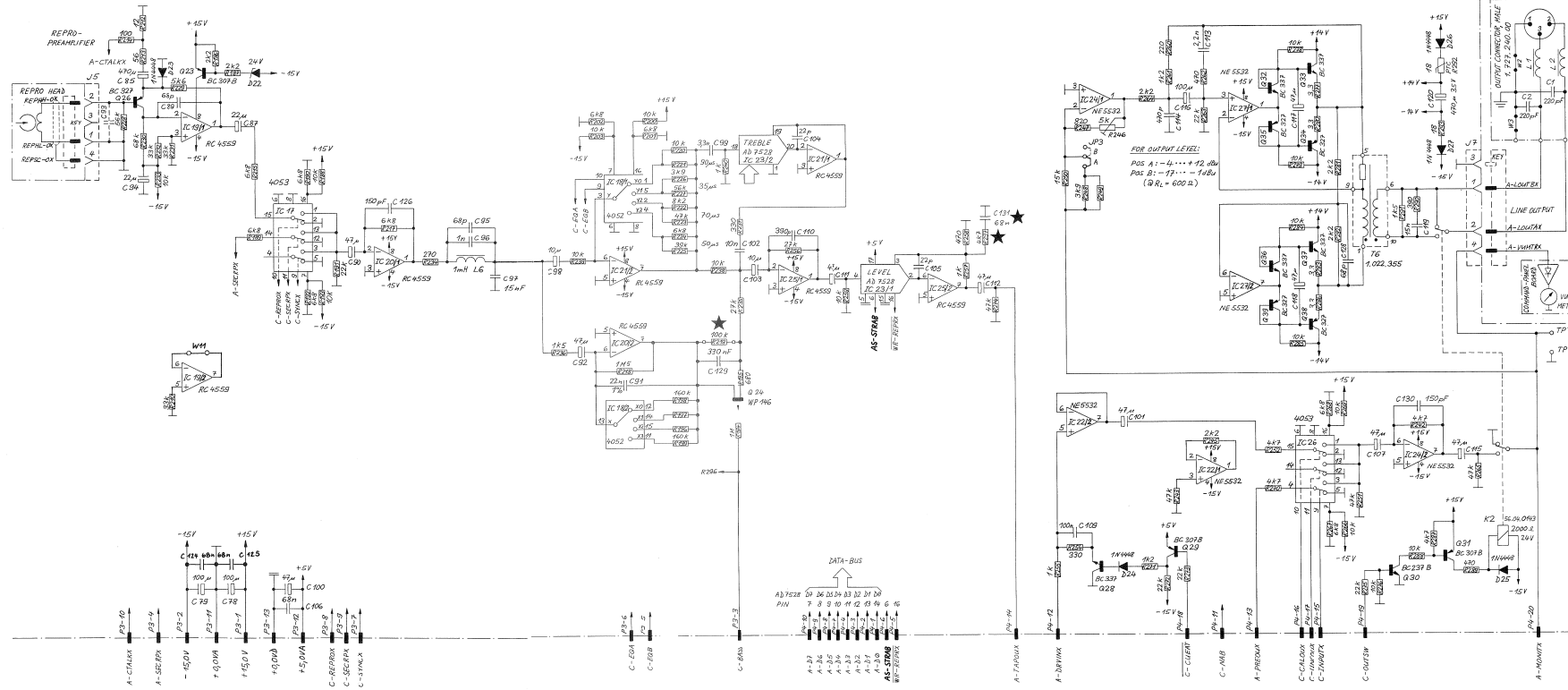

★NOT THE SAME VALUES FOR 1.727.461.81 AND 1.727.421.81 !

0	B	7	87	GP		
		A	727	GR	41	142
STUDER		AUDIO ELECTRONICS BOARD TD			SC	1.727.461.81
					PAGE	6 OF 6

AUDIO ELECTRONICS (O VU) 1.727.461.81 GRP41/42

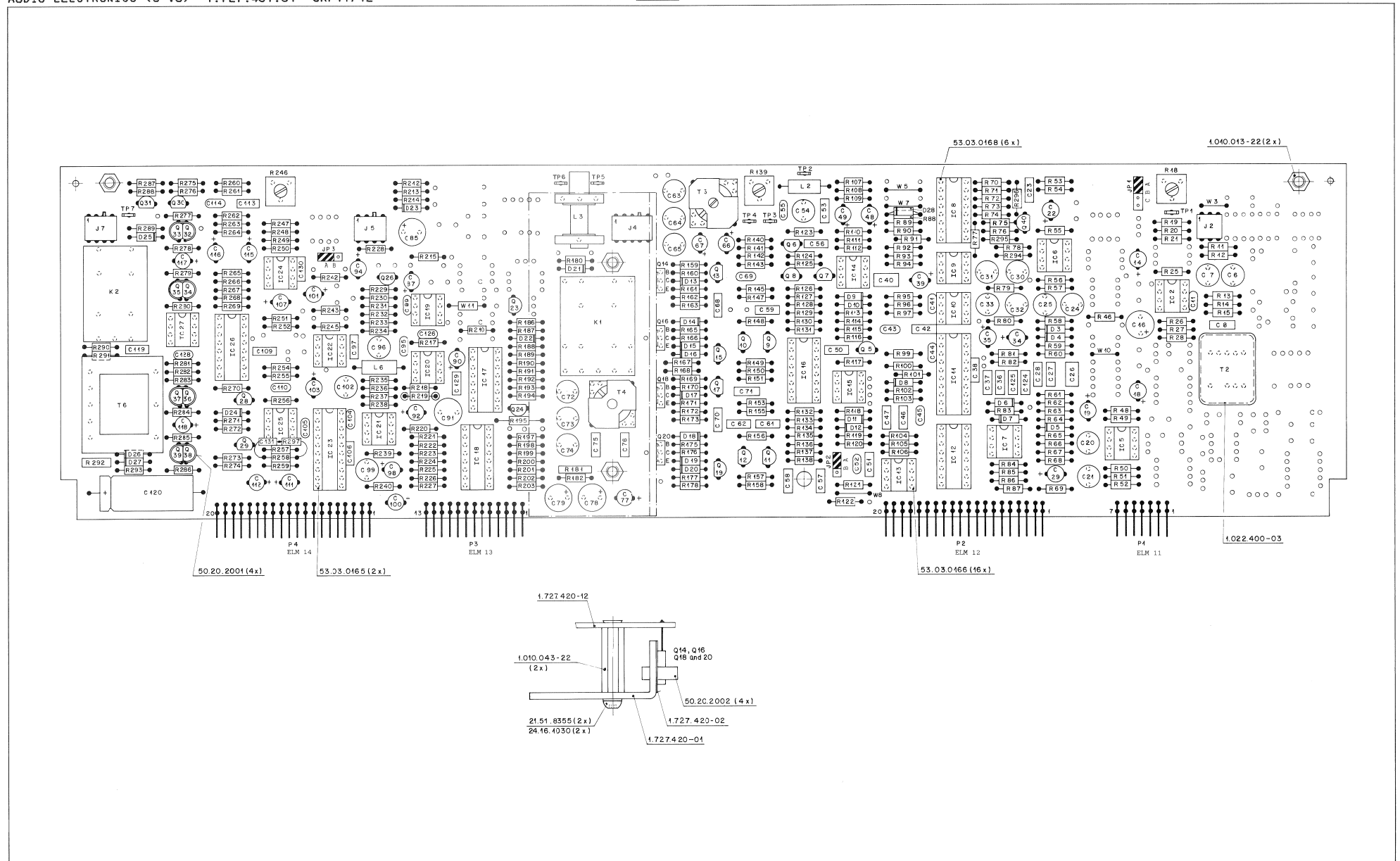



AUDIO ELECTRONICS (O VU) 1.727.461.81 GRP41/42

Table with 10 columns: IND., POS.ND., PART NO., VALUE, SPECIFICATIONS / EQUIVALENT, MANUF., IND., POS.ND., PART NO., VALUE, SPECIFICATIONS / EQUIVALENT, MANUF., IND., POS.ND., PART NO., VALUE, SPECIFICATIONS / EQUIVALENT, MANUF., IND., POS.ND., PART NO., VALUE, SPECIFICATIONS / EQUIVALENT, MANUF., IND., POS.ND., PART NO., VALUE, SPECIFICATIONS / EQUIVALENT, MANUF. This table lists various electronic components and their specifications across multiple pages.

S T U D E R (00) 87/07/09 GP AUDIO ELECTRONICS BOARD TO 1.727.461.81 PAGE 1

S T U D E R (00) 87/07/09 GP AUDIO ELECTRONICS BOARD TO 1.727.461.81 PAGE 1

S T U D E R (00) 87/07/09 GP AUDIO ELECTRONICS BOARD TO 1.727.461.81 PAGE 7

S T U D E R (00) 87/07/09 GP AUDIO ELECTRONICS BOARD TO 1.727.461.81 PAGE 10

Table with 10 columns: IND., POS.ND., PART NO., VALUE, SPECIFICATIONS / EQUIVALENT, MANUF., IND., POS.ND., PART NO., VALUE, SPECIFICATIONS / EQUIVALENT, MANUF., IND., POS.ND., PART NO., VALUE, SPECIFICATIONS / EQUIVALENT, MANUF., IND., POS.ND., PART NO., VALUE, SPECIFICATIONS / EQUIVALENT, MANUF., IND., POS.ND., PART NO., VALUE, SPECIFICATIONS / EQUIVALENT, MANUF. This table continues the list of electronic components and their specifications.

S T U D E R (00) 87/07/09 GP AUDIO ELECTRONICS BOARD TO 1.727.461.81 PAGE 2

S T U D E R (00) 87/07/09 GP AUDIO ELECTRONICS BOARD TO 1.727.461.81 PAGE 5

S T U D E R (00) 87/07/09 GP AUDIO ELECTRONICS BOARD TO 1.727.461.81 PAGE 8

S T U D E R (00) 87/07/09 GP AUDIO ELECTRONICS BOARD TO 1.727.461.81 PAGE 11

Table with 10 columns: IND., POS.ND., PART NO., VALUE, SPECIFICATIONS / EQUIVALENT, MANUF., IND., POS.ND., PART NO., VALUE, SPECIFICATIONS / EQUIVALENT, MANUF., IND., POS.ND., PART NO., VALUE, SPECIFICATIONS / EQUIVALENT, MANUF., IND., POS.ND., PART NO., VALUE, SPECIFICATIONS / EQUIVALENT, MANUF., IND., POS.ND., PART NO., VALUE, SPECIFICATIONS / EQUIVALENT, MANUF. This table continues the list of electronic components and their specifications.

S T U D E R (00) 87/07/09 GP AUDIO ELECTRONICS BOARD TO 1.727.461.81 PAGE 3

S T U D E R (00) 87/07/09 GP AUDIO ELECTRONICS BOARD TO 1.727.461.81 PAGE 4

S T U D E R (00) 87/07/09 GP AUDIO ELECTRONICS BOARD TO 1.727.461.81 PAGE 9

S T U D E R (00) 87/07/09 GP AUDIO ELECTRONICS BOARD TO 1.727.461.81 PAGE 12



AUDIO ELECTRONICS (O VU) 1.727.461.81 GRP41/42

IND.	POS.NO.	PART NO.	VALUE	SPECIFICATIONS / EQUIVALENT	MANUF.
R...	266	57.11.4103	10 kOhm	2% 0.25W MF	
R...	267	57.11.4582	6.8 kOhm	2% 0.25W MF	
R...	268	57.11.4682	6.8 kOhm	2% 0.25W MF	
R...	269	57.11.4103	10 kOhm	2% 0.25W MF	
R...	270	57.11.4472	4.7 kOhm	2% 0.25W MF	
R...	271	57.11.4122	1.2 kOhm	2% 0.25W MF	
R...	272	57.11.4223	22 kOhm	2% 0.25W MF	
R...	273	57.11.4223	22 kOhm	2% 0.25W MF	
R...	274	57.11.4473	4.7 kOhm	2% 0.25W MF	
R...	275	57.11.4223	22 kOhm	2% 0.25W MF	
R...	276	57.11.4103	10 kOhm	2% 0.25W MF	
R...	277	57.11.4339	3.3 Ohm	2% 0.25W MF	
R...	278	57.11.4103	10 kOhm	2% 0.25W MF	
R...	279	57.11.4103	10 kOhm	2% 0.25W MF	
R...	280	57.11.4339	3.3 Ohm	2% 0.25W MF	
R...	281	57.11.4222	2.2 kOhm	2% 0.25W MF	
R...	282	57.11.4222	2.2 kOhm	2% 0.25W MF	
R...	283	57.11.4339	3.3 Ohm	2% 0.25W MF	
R...	284	57.11.4103	10 kOhm	2% 0.25W MF	
R...	285	57.11.4103	10 kOhm	2% 0.25W MF	
R...	286	57.11.4339	3.3 Ohm	2% 0.25W MF	
R...	287	57.11.4472	4.7 kOhm	2% 0.25W MF	
R...	288	57.11.4103	10 kOhm	2% 0.25W MF	
R...	289	57.11.4471	4.7 Ohm	2% 0.25W MF	
R...	290	57.11.4391	390 Ohm	2% 0.25W MF	
R...	291	57.11.4152	1.5 kOhm	2% 0.25W MF	
R...	292	57.92.1151	18 Ohm	150mA PIC	
R...	293	57.11.4180	18 Ohm	2% 0.25W MF	
R...	294	57.11.4470	4.7 Ohm	2% 0.25W MF	
R...	295	57.11.4223	22 kOhm	2% 0.25W MF	
R...	296	57.11.4105	1 MOhm	2% 0.25W MF	
R...	297	57.11.4472	4.7 kOhm	2% 0.25W MF	
T...	2	1.022.451.00	1:0.62	Line Input Trafo	St
T...	3	1.022.271.00		Erase Trafo	St
T...	4	1.022.272.00		Bias Trafo	St
T...	6	1.022.355.00		Line Output Trafo	St

S T U D E R (00) 87/07/09 GP AUDIO ELECTRONICS BOARD TO 1.727.461.81 PAGE 13

IND.	POS.NO.	PART NO.	VALUE	SPECIFICATIONS / EQUIVALENT	MANUF.
TP...	1	54.02.0320		Plug 2.8*0.8	AMP
TP...	2	54.02.0320		Plug 2.8*0.8	AMP
TP...	3	54.02.0320		Plug 2.8*0.8	AMP
TP...	4	54.02.0320		Plug 2.8*0.8	AMP
TP...	5	54.02.0320		Plug 2.8*0.8	AMP
TP...	6	54.02.0320		Plug 2.8*0.8	AMP
TP...	7	54.02.0320		Plug 2.8*0.8	AMP
W.....	3	64.01.0106		Wire Bridge	
W.....	4			not used	
W.....	5	64.01.0106		Wire Bridge	
W.....	6			not used	
W.....	7	64.01.0106		Wire Bridge	
W.....	8	64.01.0106		Wire Bridge	
W.....	10	64.01.0106		Wire Bridge	
W.....	11	57.11.4000		Wire Bridge	
XIC...	2	53.03.0166	8-Pole	IC Socket	
XIC...	5	53.03.0166	8-Pole	IC Socket	
XIC...	6	53.03.0166	4-Pole	IC Socket	
XIC...	7	53.03.0166	8-Pole	IC Socket	
XIC...	8	53.03.0168	16-Pole	IC Socket	
XIC...	9	53.03.0166	8-Pole	IC Socket	
XIC...	10	53.03.0166	8-Pole	IC Socket	
XIC...	11	53.03.0165	20-Pole	IC Socket	
XIC...	12	53.03.0168	16-Pole	IC Socket	
XIC...	13	53.03.0166	8-Pole	IC Socket	
XIC...	14	53.03.0166	4-Pole	IC Socket	
XIC...	15	53.03.0166	8-Pole	IC Socket	
XIC...	16	53.03.0168	16-Pole	IC Socket	
XIC...	17	53.03.0168	16-Pole	IC Socket	
XIC...	18	53.03.0168	16-Pole	IC Socket	
XIC...	19	53.03.0166	8-Pole	IC Socket	
XIC...	20	53.03.0166	8-Pole	IC Socket	
XIC...	21	53.03.0166	8-Pole	IC Socket	
XIC...	22	53.03.0166	8-Pole	IC Socket	
XIC...	23	53.03.0165	20-Pole	IC Socket	

S T U D E R (00) 87/07/09 GP AUDIO ELECTRONICS BOARD TO 1.727.461.81 PAGE 14

IND.	POS.NO.	PART NO.	VALUE	SPECIFICATIONS / EQUIVALENT	MANUF.
XIC...	24	53.03.0166	8-Pole	IC Socket	
XIC...	25	53.03.0166	8-Pole	IC Socket	
XIC...	26	53.03.0168	16-Pole	IC Socket	
XIC...	27	53.03.0166	8-Pole	IC Socket	

Cer = Ceramic EL = Electrolytic PETP = Polyester
 PP = Polypropylen MF = Metal Film SI = Silicon
 MANUFACTURER: ADI = Analog Devices Inc. Mot = Motorola
 NS = National Semiconductors Ra = Raytheon
 Sig = Signetics St = Studer

ORIG 87/07/09

S T U D E R (00) 87/07/09 GP AUDIO ELECTRONICS BOARD TO 1.727.461.81 PAGE 15

AUDIO ELECTRONICS (O VU) 1.727.421.81 GRP41/42

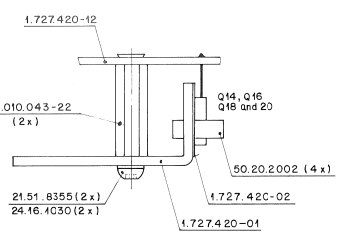
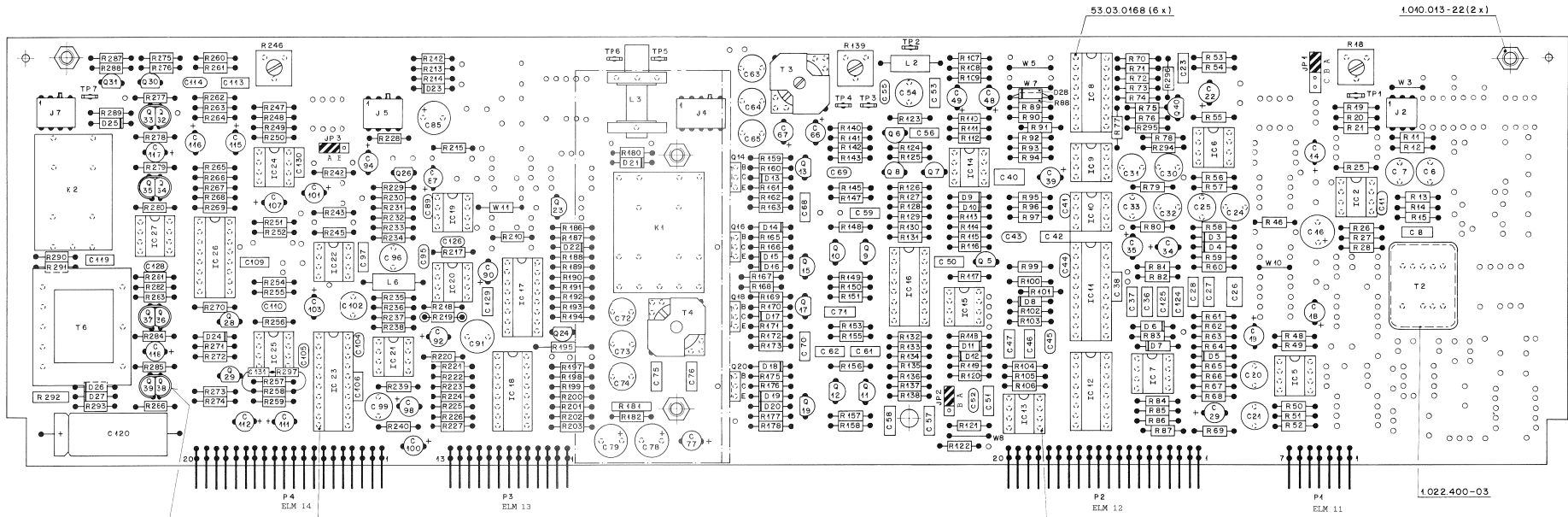

INO.	PDS-NO.	PART-NO.	VALUE	SPECIFICATIONS / EQUIVALENT	MANUF.
A.....1	1.727-421-81			AUDIO ELECTRONICS BOARD TO	
C.....131	59-06-0479		0.47uF	IGS 50V+ PEPP	
MP.....10	1.727-421-10		1 PCB	Bo. Labor	
R.....73	57-11-1104		100 kOhm	2% 0.25W MF	
R.....70	57-11-4402		6.8 kOhm	2% 0.25W MF	
R.....77	57-11-4563		96 kOhm	2% 0.25W MF	
R.....77	57-11-4473		47 kOhm	2% 0.25W MF with socket	
R.....82	57-11-4162		1.6 kOhm	2% 0.25W MF	

Note 1 Variable Phenom Supply

U [V]	PDS-NO.	PART-NO.	VALUE
48	1 R 3 / R 4	57990250	0.48 Ohm
24	1 R 3 / R 4	57990250	0.48 Ohm
12	1 R 3 / R 4	57990199	0.60 Ohm

Cer = Ceramic EL = Electrolytic PETP = Polyester
 PP = Polypropylen MF = Metal Film SI = Silicon
 MANUFACTURER: AD = Analog Devices Inc. Rot = Motorola
 NS = National Semiconductors Ro = Raytheon
 Sig = Signetics St = Studer

- AUDIO ELECTRONICS VUK (2 VU) 1.727.462.81 GRP41/42
- LINE OUTPUT CONNECTOR 1.727.240.00 (SEE PAGE 7/32)
- LINE INPUT CONNECTOR 1.727.241.00 (SEE PAGE 7/33)

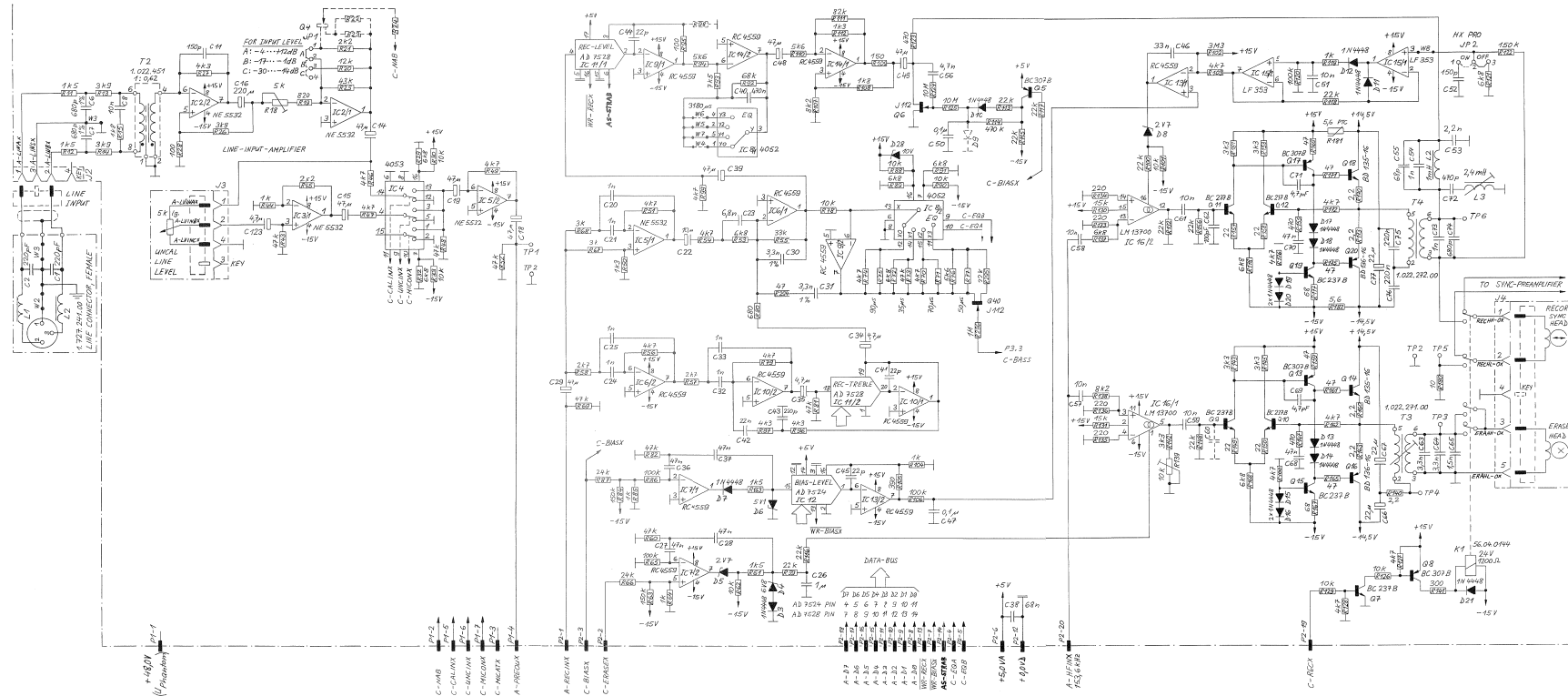

①	S. 2.87 GP	○	○	○	○	○	○	○	○	
	A 727 GRP41/42								PAGE 3 OF 6	
STUDER		AUDIO ELECTRONICS BOARD 212 VUK					SC	1.727.462.81		

AUDIO ELECTRONICS VUK (2 VU) 1.727.462.81 GRP41/42
 - LINE OUTPUT CONNECTOR 1.727.240.00 (SEE PAGE 7/32)
 - LINE INPUT CONNECTOR 1.727.241.00 (SEE PAGE 7/33)

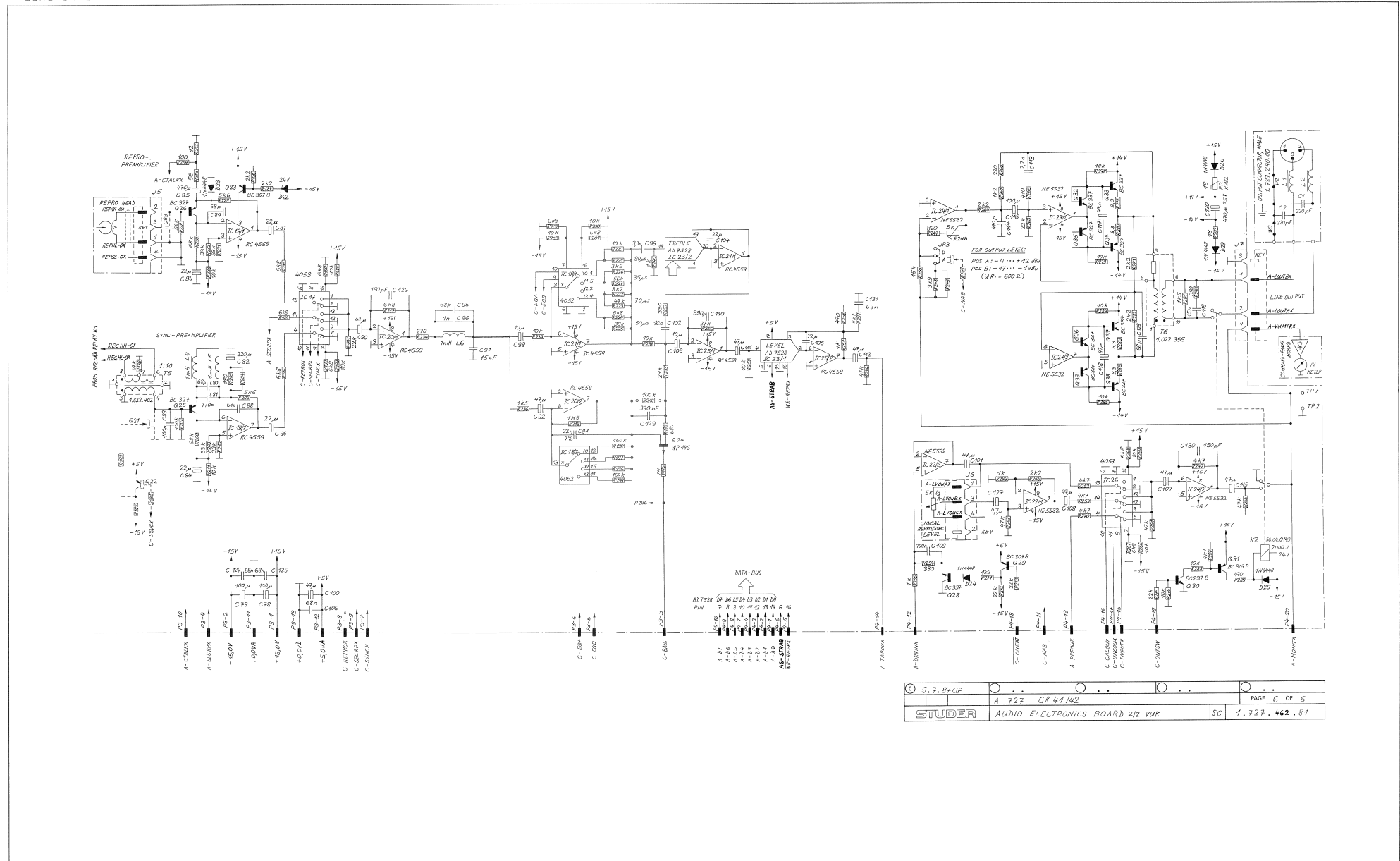

9.7.82 GP	A 727 GR 41/42	PAGE 6 OF 6
STUDER	AUDIO ELECTRONICS BOARD 212 VUK	SC 1.727.462.81

AUDIO ELECTRONICS VUK (2 VU) 1.727.462.81 GRP41/42

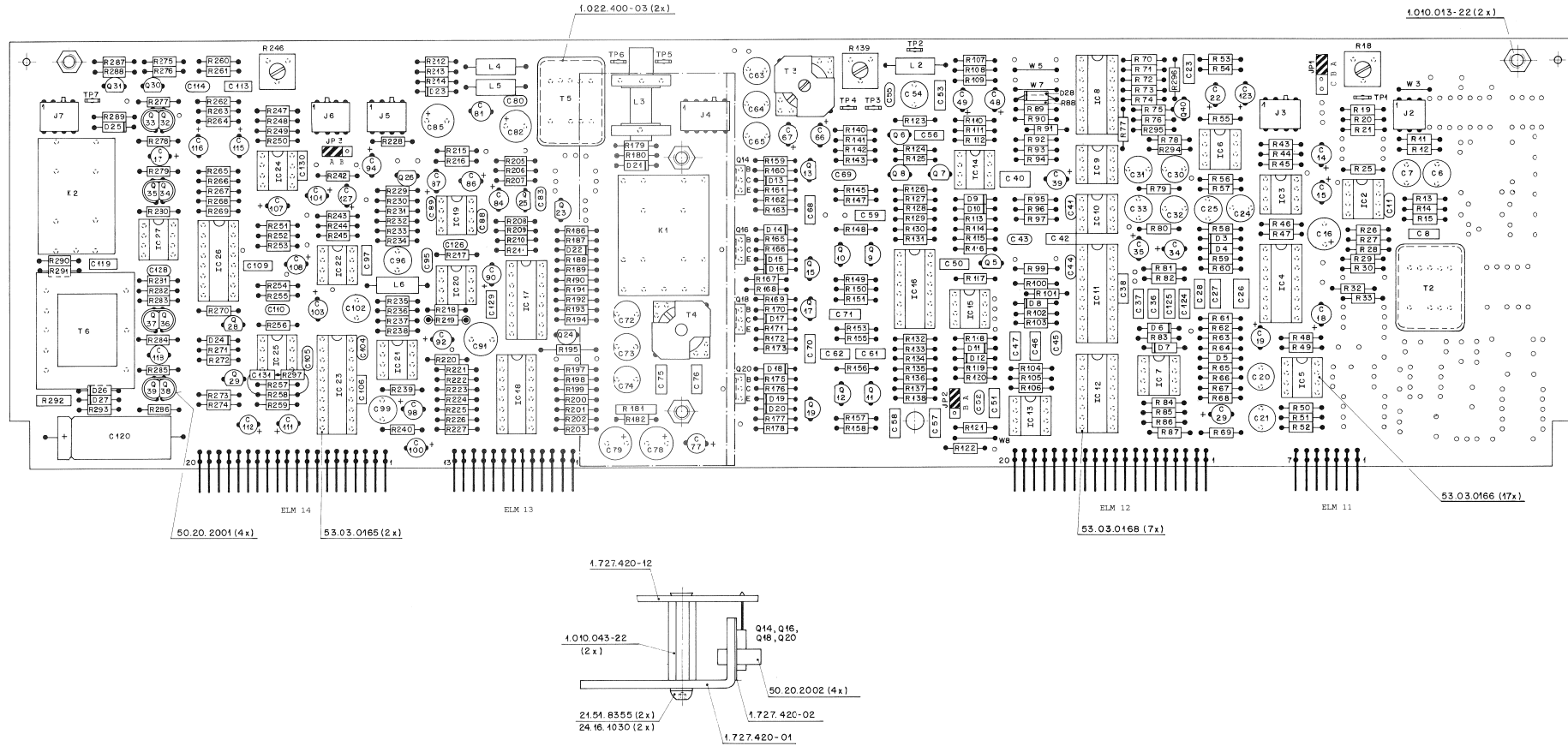



AUDIO ELECTRONICS VUK (2 VU) 1.727.462.81 GRP41/42

Table with columns: IND., POS.ND., PART NO., VALUE, SPECIFICATIONS / EQUIVALENT, MANUF. Contains component data for the first page of the bill of materials.

Table with columns: IND., POS.ND., PART NO., VALUE, SPECIFICATIONS / EQUIVALENT, MANUF. Contains component data for the second page of the bill of materials.

Table with columns: IND., POS.ND., PART NO., VALUE, SPECIFICATIONS / EQUIVALENT, MANUF. Contains component data for the third page of the bill of materials.

Table with columns: IND., POS.ND., PART NO., VALUE, SPECIFICATIONS / EQUIVALENT, MANUF. Contains component data for the fourth page of the bill of materials.

Table with columns: IND., POS.ND., PART NO., VALUE, SPECIFICATIONS / EQUIVALENT, MANUF. Contains component data for the fifth page of the bill of materials.

STUDER (00) 87/07/09 GP AUDIO ELECTRONICS BOARD Z2VUK 1.727.462.81 PAGE 1

STUDER (00) 87/07/09 GP AUDIO ELECTRONICS BOARD Z2VUK 1.727.462.81 PAGE 4

STUDER (00) 87/07/09 GP AUDIO ELECTRONICS BOARD Z2VUK 1.727.462.81 PAGE 7

STUDER (00) 87/07/09 GP AUDIO ELECTRONICS BOARD Z2VUK 1.727.462.81 PAGE 10

Table with columns: IND., POS.ND., PART NO., VALUE, SPECIFICATIONS / EQUIVALENT, MANUF. Contains component data for the sixth page of the bill of materials.

Table with columns: IND., POS.ND., PART NO., VALUE, SPECIFICATIONS / EQUIVALENT, MANUF. Contains component data for the seventh page of the bill of materials.

Table with columns: IND., POS.ND., PART NO., VALUE, SPECIFICATIONS / EQUIVALENT, MANUF. Contains component data for the eighth page of the bill of materials.

Table with columns: IND., POS.ND., PART NO., VALUE, SPECIFICATIONS / EQUIVALENT, MANUF. Contains component data for the ninth page of the bill of materials.

Table with columns: IND., POS.ND., PART NO., VALUE, SPECIFICATIONS / EQUIVALENT, MANUF. Contains component data for the tenth page of the bill of materials.

STUDER (00) 87/07/09 GP AUDIO ELECTRONICS BOARD Z2VUK 1.727.462.81 PAGE 2

STUDER (00) 87/07/09 GP AUDIO ELECTRONICS BOARD Z2VUK 1.727.462.81 PAGE 5

STUDER (00) 87/07/09 GP AUDIO ELECTRONICS BOARD Z2VUK 1.727.462.81 PAGE 8

STUDER (00) 87/07/09 GP AUDIO ELECTRONICS BOARD Z2VUK 1.727.462.81 PAGE 11

Table with columns: IND., POS.ND., PART NO., VALUE, SPECIFICATIONS / EQUIVALENT, MANUF. Contains component data for the eleventh page of the bill of materials.

Table with columns: IND., POS.ND., PART NO., VALUE, SPECIFICATIONS / EQUIVALENT, MANUF. Contains component data for the twelfth page of the bill of materials.

Table with columns: IND., POS.ND., PART NO., VALUE, SPECIFICATIONS / EQUIVALENT, MANUF. Contains component data for the thirteenth page of the bill of materials.

Table with columns: IND., POS.ND., PART NO., VALUE, SPECIFICATIONS / EQUIVALENT, MANUF. Contains component data for the fourteenth page of the bill of materials.

Table with columns: IND., POS.ND., PART NO., VALUE, SPECIFICATIONS / EQUIVALENT, MANUF. Contains component data for the fifteenth page of the bill of materials.

STUDER (00) 87/07/09 GP AUDIO ELECTRONICS BOARD Z2VUK 1.727.462.81 PAGE 3

STUDER (00) 87/07/09 GP AUDIO ELECTRONICS BOARD Z2VUK 1.727.462.81 PAGE 6

STUDER (00) 87/07/09 GP AUDIO ELECTRONICS BOARD Z2VUK 1.727.462.81 PAGE 9

STUDER (00) 87/07/09 GP AUDIO ELECTRONICS BOARD Z2VUK 1.727.462.81 PAGE 12



AUDIO ELECTRONICS VUK (2 VU) 1.727.462.81 GRP41/42

IND.	POS.NO.	PART NO.	VALUE	SPECIFICATIONS / EQUIVALENT	MANUF.	IND.	POS.NO.	PART NO.	VALUE	SPECIFICATIONS / EQUIVALENT	MANUF.
R...	220	57.11.4103	10 kOhm	2%, 0.25W, MF		XIC...	13	53.03.0166	8-Pole	IC Socket	
R...	221			not used		XIC...	14	53.03.0166	8-Pole	IC Socket	
R...	222	57.11.4822	8.2 kOhm	2%, 0.25W, MF		XIC...	15	53.03.0166	8-Pole	IC Socket	
R...	223	57.11.4473	47 kOhm	2%, 0.25W, MF		XIC...	16	53.03.0168	16-Pole	IC Socket	
R...	224	57.11.4682	6.8 kOhm	2%, 0.25W, MF		XIC...	17	53.03.0168	16-Pole	IC Socket	
R...	224	57.11.4393	30 kOhm	2%, 0.25W, MF		XIC...	18	53.03.0168	16-Pole	IC Socket	
R...	226	57.11.4392	3.9 kOhm	2%, 0.25W, MF		XIC...	19	53.03.0166	8-Pole	IC Socket	
R...	227	57.11.4563	56 kOhm	2%, 0.25W, MF		XIC...	20	53.03.0166	8-Pole	IC Socket	
R...	228	57.11.4563	56 kOhm	2%, 0.25W, MF		XIC...	21	53.03.0166	8-Pole	IC Socket	
R...	229	57.11.4562	5.6 kOhm	2%, 0.25W, MF		XIC...	22	53.03.0166	8-Pole	IC Socket	
R...	230	57.11.4683	68 kOhm	2%, 0.25W, MF		XIC...	23	53.03.0165	20-Pole	IC Socket	
R...	231	57.11.4333	33 kOhm	2%, 0.25W, MF		XIC...	24	53.03.0166	8-Pole	IC Socket	
R...	232	57.11.4333	33 kOhm	2%, 0.25W, MF		XIC...	25	53.03.0166	8-Pole	IC Socket	
R...	233	57.11.4103	10 kOhm	2%, 0.25W, MF		XIC...	26	53.03.0168	16-Pole	IC Socket	
R...	234	57.11.4271	270 Ohm	2%, 0.25W, MF		XIC...	27	53.03.0166	8-Pole	IC Socket	
R...	235	57.11.4273	27 kOhm	2%, 0.25W, MF							
R...	236	57.11.4152	1.5 kOhm	2%, 0.25W, MF							
R...	237	57.11.4331	330 Ohm	2%, 0.25W, MF							
R...	238	57.11.4103	10 kOhm	2%, 0.25W, MF							
R...	239	57.11.4103	10 kOhm	2%, 0.25W, MF							
R...	240	57.11.4102	1 kOhm	2%, 0.25W, MF							
R...	241			not used							
R...	242	57.11.4472	4.7 kOhm	2%, 0.25W, MF							
R...	243	57.11.4473	47 kOhm	2%, 0.25W, MF							
R...	244	57.11.4102	1 kOhm	2%, 0.25W, MF							
R...	245	57.11.4222	2.2 kOhm	2%, 0.25W, MF							
R...	246	58.01.8502	5 kOhm	10%, 0.5 W, PMG							
R...	247	57.11.4621	820 Ohm	2%, 0.25W, MF							
R...	248	57.11.4392	3.9 kOhm	2%, 0.25W, MF							
R...	249			not used							
R...	250	57.11.4153	15 kOhm	2%, 0.25W, MF							
R...	251	57.11.4473	47 kOhm	2%, 0.25W, MF							
R...	252	57.11.4472	4.7 kOhm	2%, 0.25W, MF							
R...	253	57.11.4472	4.7 kOhm	2%, 0.25W, MF							
R...	254	57.11.4331	330 Ohm	2%, 0.25W, MF							
R...	255	57.11.4102	1 kOhm	2%, 0.25W, MF							
R...	256	57.11.4273	27 kOhm	2%, 0.25W, MF							

Cer = Ceramic EL = Electrolytic PETP = Polyester
 PP = Polypropylen MF = Metal Film SI = Silicon
 MANUFACTURER: ADI = Analog Devices Inc. Mot = Motorola
 NS = National Semiconductors Ra = Raytheon
 Sig = Signetics St = Studer
 ORIG 87/07/09

S T U D E R (00) 87/07/09 GP AUDIO ELECTRONICS BOARD 2/2VUK 1.727.462.81 PAGE 13 S T U D E R (00) 87/07/09 GP AUDIO ELECTRONICS BOARD 2/2VUK 1.727.462.81 PAGE 16

IND.	POS.NO.	PART NO.	VALUE	SPECIFICATIONS / EQUIVALENT	MANUF.
R...	257	57.11.4102	1 kOhm	2%, 0.25W, MF	
R...	258	57.11.4471	470 Ohm	2%, 0.25W, MF	
R...	259	57.11.4103	10 kOhm	2%, 0.25W, MF	
R...	260	57.11.4221	220 Ohm	2%, 0.25W, MF	
R...	261	57.11.4122	1.2 kOhm	2%, 0.25W, MF	
R...	262	57.11.4471	470 Ohm	2%, 0.25W, MF	
R...	263	57.11.4223	22 kOhm	2%, 0.25W, MF	
R...	264	57.11.4222	2.2 kOhm	2%, 0.25W, MF	
R...	265	57.11.4473	47 kOhm	2%, 0.25W, MF	
R...	266	57.11.4103	10 kOhm	2%, 0.25W, MF	
R...	267	57.11.4682	6.8 kOhm	2%, 0.25W, MF	
R...	268	57.11.4682	6.8 kOhm	2%, 0.25W, MF	
R...	269	57.11.4103	10 kOhm	2%, 0.25W, MF	
R...	270	57.11.4472	4.7 kOhm	2%, 0.25W, MF	
R...	271	57.11.4122	1.2 kOhm	2%, 0.25W, MF	
R...	272	57.11.4223	22 kOhm	2%, 0.25W, MF	
R...	273	57.11.4223	22 kOhm	2%, 0.25W, MF	
R...	274	57.11.4473	47 kOhm	2%, 0.25W, MF	
R...	275	57.11.4223	22 kOhm	2%, 0.25W, MF	
R...	276	57.11.4103	10 kOhm	2%, 0.25W, MF	
R...	277	57.11.4339	3.3 Ohm	2%, 0.25W, MF	
R...	278	57.11.4103	10 kOhm	2%, 0.25W, MF	
R...	279	57.11.4103	10 kOhm	2%, 0.25W, MF	
R...	280	57.11.4339	3.3 Ohm	2%, 0.25W, MF	
R...	281	57.11.4222	2.2 kOhm	2%, 0.25W, MF	
R...	282	57.11.4222	2.2 kOhm	2%, 0.25W, MF	
R...	283	57.11.4339	3.3 Ohm	2%, 0.25W, MF	
R...	284	57.11.4103	10 kOhm	2%, 0.25W, MF	
R...	285	57.11.4103	10 kOhm	2%, 0.25W, MF	
R...	286	57.11.4339	3.3 Ohm	2%, 0.25W, MF	
R...	287	57.11.4472	4.7 kOhm	2%, 0.25W, MF	
R...	288	57.11.4103	10 kOhm	2%, 0.25W, MF	
R...	289	57.11.4471	470 Ohm	2%, 0.25W, MF	
R...	290	57.11.4391	390 Ohm	2%, 0.25W, MF	
R...	291	57.11.4152	1.5 kOhm	2%, 0.25W, MF	
R...	292	57.92.1151	18 Ohm	150mA, PTC	
R...	293	57.11.4180	18 Ohm	2%, 0.25W, MF	

S T U D E R (00) 87/07/09 GP AUDIO ELECTRONICS BOARD 2/2VUK 1.727.462.81 PAGE 14

IND.	POS.NO.	PART NO.	VALUE	SPECIFICATIONS / EQUIVALENT	MANUF.
R...	294	57.11.4470	47 Ohm	2%, 0.25W, MF	
R...	295	57.11.4223	22 kOhm	2%, 0.25W, MF	
R...	296	57.11.4105	1 MOhm	2%, 0.25W, MF	
R...	297	57.11.4472	4.7 kOhm	2%, 0.25W, MF	
T...	2	1.022.451.00	1:0.62	Line Input Trafo	St
T...	3	1.022.271.00		Erase Trafo	St
T...	4	1.022.272.00		Bias Trafo	St
T...	5	1.022.402.00	1:10	Sync Trafo	St
T...	6	1.022.355.00		Line Output Trafo	St
TP...	1	54.02.0320		Plug 2.8P0.8	AMP
TP...	2	54.02.0320		Plug 2.8P0.8	AMP
TP...	3	54.02.0320		Plug 2.8P0.8	AMP
TP...	4	54.02.0320		Plug 2.8P0.8	AMP
TP...	5	54.02.0320		Plug 2.8P0.8	AMP
TP...	6	54.02.0320		Plug 2.8P0.8	AMP
TP...	7	54.02.0320		Plug 2.8P0.8	AMP
W...	3	64.01.0106		Wire bridge	
W...	4			not used	
W...	5	64.01.0106		Wire Bridge	
W...	6			not used	
W...	7	64.01.0106		Wire Bridge	
W...	8	64.01.0106		Wire Bridge	
XIC...	2	53.03.0166	8-Pole	IC Socket	
XIC...	3	53.03.0168	16-Pole	IC Socket	
XIC...	4	53.03.0166	8-Pole	IC Socket	
XIC...	5	53.03.0166	8-Pole	IC Socket	
XIC...	6	53.03.0166	8-Pole	IC Socket	
XIC...	7	53.03.0166	8-Pole	IC Socket	
XIC...	8	53.03.0168	16-Pole	IC Socket	
XIC...	9	53.03.0166	8-Pole	IC Socket	
XIC...	10	53.03.0166	8-Pole	IC Socket	
XIC...	11	53.03.0165	20-Pole	IC Socket	
XIC...	12	53.03.0168	16-Pole	IC Socket	

S T U D E R (00) 87/07/09 GP AUDIO ELECTRONICS BOARD 2/2VUK 1.727.462.81 PAGE 15

AUDIO ELECTRONICS (2-2 WITH CHANNEL SELECTORS ONLY) 1.727.423.00 GRP41/42
 - LINE OUTPUT CONNECTOR 1.727.240.00 (SEE PAGE 7/32)
 - LINE INPUT CONNECTOR 1.727.241.00 (SEE PAGE 7/33)

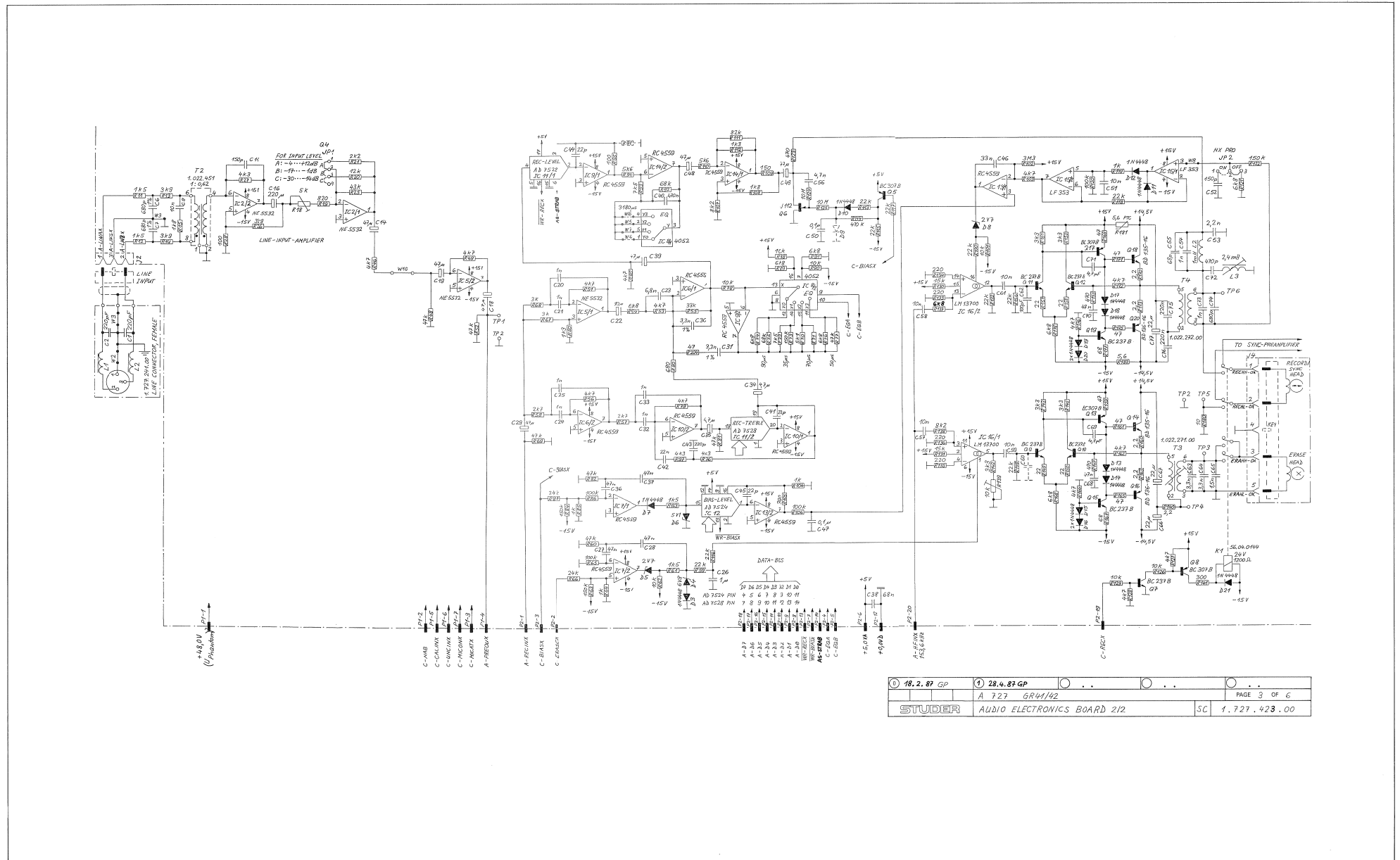

18.2.87 GP	28.4.87 GP				
A 727 GR41/42					
STUDER				AUDIO ELECTRONICS BOARD 2/2	
				SC	1.727.423.00
PAGE 3 OF 6					

AUDIO ELECTRONICS (2-2 WITH CHANNEL SELECTORS ONLY) 1.727.423.00 GRP41/42

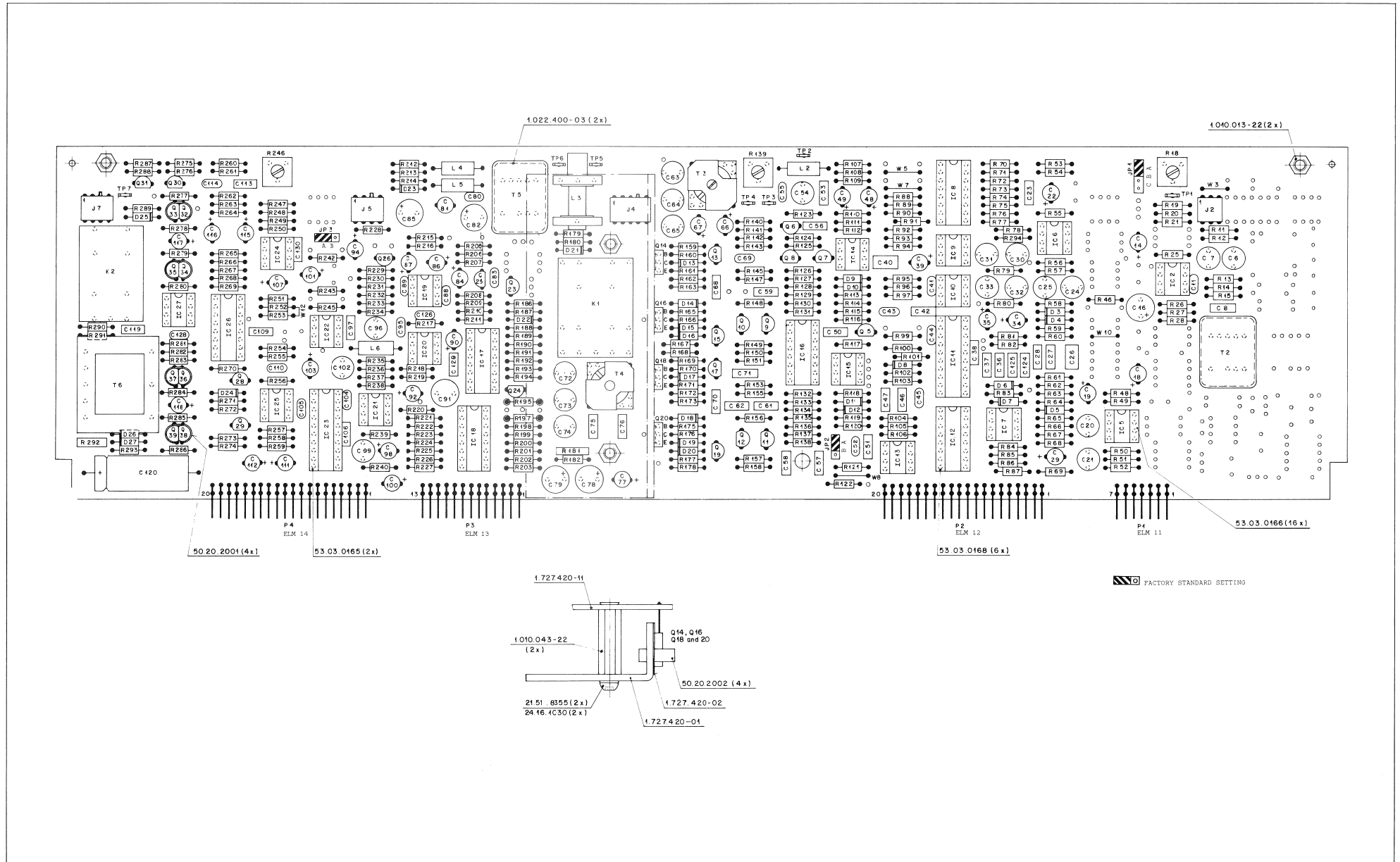



AUDIO ELECTRONICS (2-2 WITH CHANNEL SELECTORS ONLY) 1.727.423.00 GRP41/42

Table with columns: IND., POS.ND., PART NO., VALUE, SPECIFICATIONS / EQUIVALENT, MANUF. Contains component data for the first board.

Table with columns: IND., POS.ND., PART NO., VALUE, SPECIFICATIONS / EQUIVALENT, MANUF. Contains component data for the second board.

Table with columns: IND., POS.ND., PART NO., VALUE, SPECIFICATIONS / EQUIVALENT, MANUF. Contains component data for the third board.

Table with columns: IND., POS.ND., PART NO., VALUE, SPECIFICATIONS / EQUIVALENT, MANUF. Contains component data for the fourth board.

Table with columns: IND., POS.ND., PART NO., VALUE, SPECIFICATIONS / EQUIVALENT, MANUF. Contains component data for the fifth board.

S T U D E R (01) 87/04/28 GP AUDIO ELECTRONICS BOARD Z/2 1.727.423.00 PAGE 1

S T U D E R (01) 87/04/28 GP AUDIO ELECTRONICS BOARD Z/2 1.727.423.00 PAGE 4

S T U D E R (01) 87/04/28 GP AUDIO ELECTRONICS BOARD Z/2 1.727.423.00 PAGE 7

S T U D E R (01) 87/04/28 GP AUDIO ELECTRONICS BOARD Z/2 1.727.423.00 PAGE 10

Table with columns: IND., POS.ND., PART NO., VALUE, SPECIFICATIONS / EQUIVALENT, MANUF. Contains component data for the sixth board.

Table with columns: IND., POS.ND., PART NO., VALUE, SPECIFICATIONS / EQUIVALENT, MANUF. Contains component data for the seventh board.

Table with columns: IND., POS.ND., PART NO., VALUE, SPECIFICATIONS / EQUIVALENT, MANUF. Contains component data for the eighth board.

Table with columns: IND., POS.ND., PART NO., VALUE, SPECIFICATIONS / EQUIVALENT, MANUF. Contains component data for the ninth board.

Table with columns: IND., POS.ND., PART NO., VALUE, SPECIFICATIONS / EQUIVALENT, MANUF. Contains component data for the tenth board.

S T U D E R (01) 87/04/28 GP AUDIO ELECTRONICS BOARD Z/2 1.727.423.00 PAGE 2

S T U D E R (01) 87/04/28 GP AUDIO ELECTRONICS BOARD Z/2 1.727.423.00 PAGE 5

S T U D E R (01) 87/04/28 GP AUDIO ELECTRONICS BOARD Z/2 1.727.423.00 PAGE 8

S T U D E R (01) 87/04/28 GP AUDIO ELECTRONICS BOARD Z/2 1.727.423.00 PAGE 11

Table with columns: IND., POS.ND., PART NO., VALUE, SPECIFICATIONS / EQUIVALENT, MANUF. Contains component data for the eleventh board.

Table with columns: IND., POS.ND., PART NO., VALUE, SPECIFICATIONS / EQUIVALENT, MANUF. Contains component data for the twelfth board.

Table with columns: IND., POS.ND., PART NO., VALUE, SPECIFICATIONS / EQUIVALENT, MANUF. Contains component data for the thirteenth board.

Table with columns: IND., POS.ND., PART NO., VALUE, SPECIFICATIONS / EQUIVALENT, MANUF. Contains component data for the fourteenth board.

Table with columns: IND., POS.ND., PART NO., VALUE, SPECIFICATIONS / EQUIVALENT, MANUF. Contains component data for the fifteenth board.

S T U D E R (01) 87/04/28 GP AUDIO ELECTRONICS BOARD Z/2 1.727.423.00 PAGE 3

S T U D E R (01) 87/04/28 GP AUDIO ELECTRONICS BOARD Z/2 1.727.423.00 PAGE 6

S T U D E R (01) 87/04/28 GP AUDIO ELECTRONICS BOARD Z/2 1.727.423.00 PAGE 9

S T U D E R (01) 87/04/28 GP AUDIO ELECTRONICS BOARD Z/2 1.727.423.00 PAGE 12



AUDIO ELECTRONICS (2-2 WITH CHANNEL SELECTORS ONLY) 1.727.423.00 GRP41/42

IND.	POS. NO.	PART NO.	VALUE	SPECIFICATIONS / EQUIVALENT	MANUF.
R...	243	57.11.4473	47 kOhm	2%, 0.25W, MF	
R...	245	57.11.4222	2+2 kOhm	2%, 0.25W, MF	
R...	246	58.01.8502	5 kOhm	10%, 0.5 W, PMG	
R...	247	57.11.4821	820 Ohm	2%, 0.25W, MF	
R...	248	57.11.4372	3+3 kOhm	2%, 0.25W, MF	
R...	249			not used	
R...	250	57.11.4153	15 kOhm	2%, 0.25W, MF	
R...	251	57.11.4473	47 kOhm	2%, 0.25W, MF	
R...	252	57.11.4472	4.7 kOhm	2%, 0.25W, MF	
R...	253	57.11.4472	4.7 kOhm	2%, 0.25W, MF	
R...	254	57.11.4331	330 Ohm	2%, 0.25W, MF	
R...	255	57.11.4102	1 kOhm	2%, 0.25W, MF	
R...	256	57.11.4273	27 kOhm	2%, 0.25W, MF	
R...	257	57.11.4102	1 kOhm	2%, 0.25W, MF	
R...	258	57.11.4471	470 Ohm	2%, 0.25W, MF	
R...	259	57.11.4103	10 kOhm	2%, 0.25W, MF	
R...	260	57.11.4221	220 Ohm	2%, 0.25W, MF	
R...	261	57.11.4122	1.2 kOhm	2%, 0.25W, MF	
R...	262	57.11.4471	470 Ohm	2%, 0.25W, MF	
R...	263	57.11.4223	22 kOhm	2%, 0.25W, MF	
R...	264	57.11.4222	2.2 kOhm	2%, 0.25W, MF	
R...	265	57.11.4473	47 kOhm	2%, 0.25W, MF	
R...	266	57.11.4103	10 kOhm	2%, 0.25W, MF	
R...	267	57.11.4682	6.8 kOhm	2%, 0.25W, MF	
R...	268	57.11.4682	6.8 kOhm	2%, 0.25W, MF	
R...	269	57.11.4103	10 kOhm	2%, 0.25W, MF	
R...	270	57.11.4472	4.7 kOhm	2%, 0.25W, MF	
R...	271	57.11.4122	1.2 kOhm	2%, 0.25W, MF	
R...	272	57.11.4223	22 kOhm	2%, 0.25W, MF	
R...	273	57.11.4223	22 kOhm	2%, 0.25W, MF	
R...	274	57.11.4473	47 kOhm	2%, 0.25W, MF	
R...	275	57.11.4223	22 kOhm	2%, 0.25W, MF	
R...	276	57.11.4103	10 kOhm	2%, 0.25W, MF	
R...	277	57.11.4339	3+3 Ohm	2%, 0.25W, MF	
R...	278	57.11.4103	10 kOhm	2%, 0.25W, MF	
R...	279	57.11.4103	10 kOhm	2%, 0.25W, MF	
R...	280	57.11.4339	3+3 Ohm	2%, 0.25W, MF	

S T U D E R (01) 87/04/28 GP AUDIO ELECTRONICS BOARD 2/2 1.727.423.00 PAGE 13

IND.	POS. NO.	PART NO.	VALUE	SPECIFICATIONS / EQUIVALENT	MANUF.
R...	281	57.11.4222	2+2 kOhm	2%, 0.25W, MF	
R...	282	57.11.4222	2+2 kOhm	2%, 0.25W, MF	
R...	283	57.11.4339	3+3 Ohm	2%, 0.25W, MF	
R...	284	57.11.4103	10 kOhm	2%, 0.25W, MF	
R...	285	57.11.4103	10 kOhm	2%, 0.25W, MF	
R...	286	57.11.4339	3+3 Ohm	2%, 0.25W, MF	
R...	287	57.11.4472	4.7 kOhm	2%, 0.25W, MF	
R...	288	57.11.4103	10 kOhm	2%, 0.25W, MF	
R...	289	57.11.4471	470 Ohm	2%, 0.25W, MF	
R...	290	57.11.4391	390 Ohm	2%, 0.25W, MF	
R...	291	57.11.4152	1.5 kOhm	2%, 0.25W, MF	
R...	292	57.92.1151	18 Ohm	150mA, PTC	
R...	293	57.11.4180	18 Ohm	2%, 0.25W, MF	
R...	294	57.11.4470	47 Ohm	2%, 0.25W, MF	
T....	2	1.022.451.00	1:0.62	Line Input Trafo	St
T....	3	1.022.271.00		Erase Trafo	St
T....	4	1.022.272.00		Bias Trafo	St
T....	5	1.022.492.00	1:10	Sync Trafo	St
T....	6	1.022.355.00		Line Output Trafo	St
TP...	1	54.02.0320		Plug 2x80.8	AMP
TP...	2	54.02.0320		Plug 2x80.8	AMP
TP...	3	54.02.0320		Plug 2x80.8	AMP
TP...	4	54.02.0320		Plug 2x80.8	AMP
TP...	5	54.02.0320		Plug 2x80.8	AMP
TP...	6	54.02.0320		Plug 2x80.8	AMP
TP...	7	54.02.0320		Plug 2x80.8	AMP
W....	3	64.01.0106		Wire Bridge	
W....	4			not used	
W....	5	64.01.0106		Wire Bridge	
W....	6			not used	
W....	7	64.01.0106		Wire Bridge	
W....	8	64.01.0106		Wire Bridge	
W....	10	64.01.0106		Wire Bridge	
W....	12	64.01.0106		Wire Bridge	

S T U D E R (01) 87/04/28 GP AUDIO ELECTRONICS BOARD 2/2 1.727.423.00 PAGE 14

IND.	POS. NO.	PART NO.	VALUE	SPECIFICATIONS / EQUIVALENT	MANUF.
XIC...	2	53.03.0166	8-Pole	IC Socket	
XIC...	5	53.03.0166	8-Pole	IC Socket	
XIC...	6	53.03.0166	8-Pole	IC Socket	
XIC...	7	53.03.0166	8-Pole	IC Socket	
XIC...	8	53.03.0168	16-Pole	IC Socket	
XIC...	9	53.03.0166	8-Pole	IC Socket	
XIC...	10	53.03.0166	8-Pole	IC Socket	
XIC...	11	53.03.0165	20-Pole	IC Socket	
XIC...	12	53.03.0168	16-Pole	IC Socket	
XIC...	13	53.03.0166	8-Pole	IC Socket	
XIC...	14	53.03.0166	8-Pole	IC Socket	
XIC...	15	53.03.0166	8-Pole	IC Socket	
XIC...	16	53.03.0168	16-Pole	IC Socket	
XIC...	17	53.03.0168	16-Pole	IC Socket	
XIC...	18	53.03.0168	16-Pole	IC Socket	
XIC...	19	53.03.0166	8-Pole	IC Socket	
XIC...	20	53.03.0166	8-Pole	IC Socket	
XIC...	21	53.03.0166	8-Pole	IC Socket	
XIC...	22	53.03.0166	8-Pole	IC Socket	
XIC...	23	53.03.0165	20-Pole	IC Socket	
XIC...	24	53.03.0166	8-Pole	IC Socket	
XIC...	25	53.03.0166	8-Pole	IC Socket	
XIC...	26	53.03.0168	16-Pole	IC Socket	
XIC...	27	53.03.0166	8-Pole	IC Socket	

(01) 87/04/28 better S/N ratio
 Cer = Ceramic EL = Electrolytic PETP = Polyester
 PP = Polypropylen MF = Metal Film SI = Silicon
 MANUFACTURER: ADI = Analog Devices Inc. Mot = Motorola
 NS = National Semiconductors Ra = Raytheon
 Sig = Signetics St = Studer
 ORIG 87/02/18 (01) 87/04/28
 S T U D E R (01) 87/04/28 GP AUDIO ELECTRONICS BOARD 2/2 1.727.423.00 PAGE 15

AUDIO ELECTRONICS (2-2 WITH CHANNEL SELECTORS ONLY) 1.727.463.00 GRP41/42
 - LINE OUTPUT CONNECTOR 1.727.240.00 (SEE PAGE 7/32)
 - LINE INPUT CONNECTOR 1.727.241.00 (SEE PAGE 7/33)

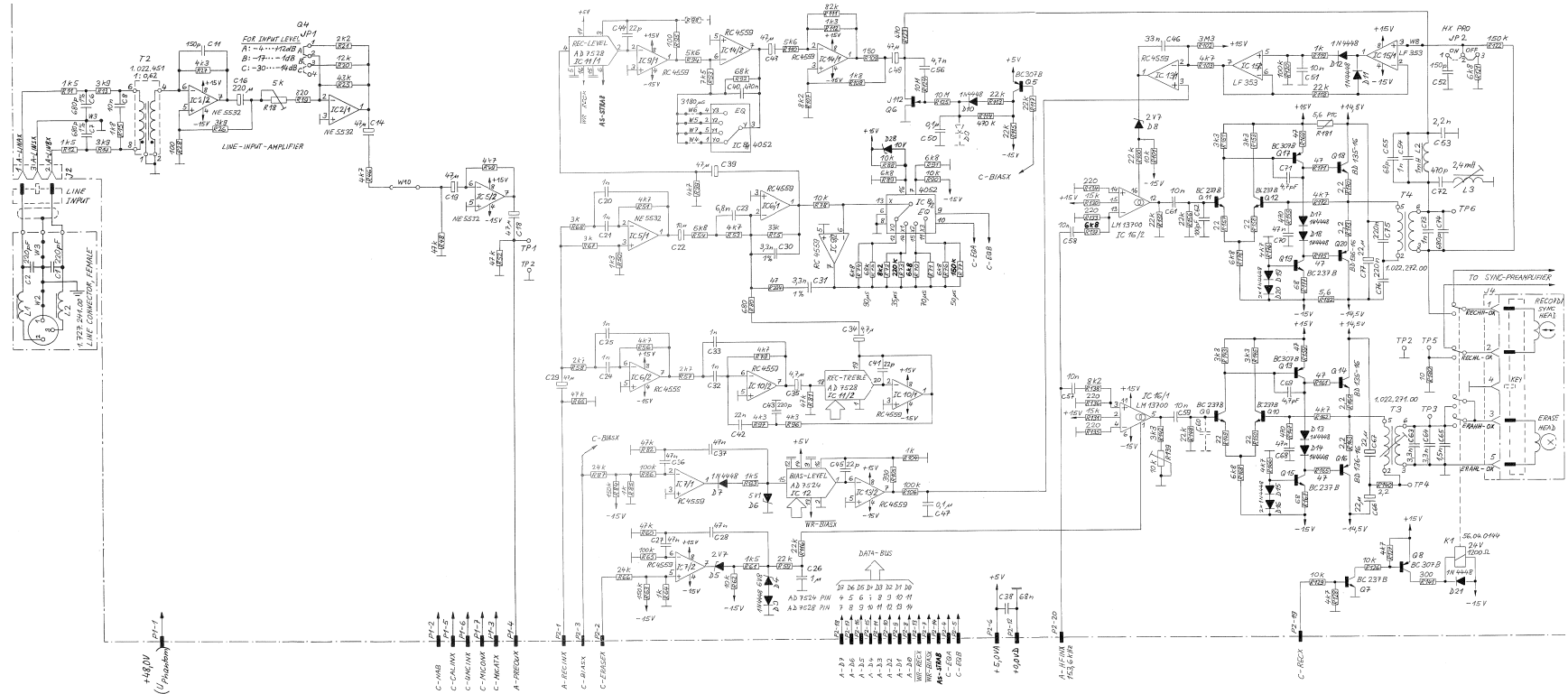

20.5.81	GP							
A 727	GRP41/42							PAGE 3 OF 6
STUDER	AUDIO ELECTRONICS BOARD 2/2						SC	1.727.463.00

AUDIO ELECTRONICS (2-2 WITH CHANNEL SELECTORS ONLY) 1.727.463.00 GRP41/42
 - LINE OUTPUT CONNECTOR 1.727.240.00 (SEE PAGE 7/32)
 - LINE INPUT CONNECTOR 1.727.241.00 (SEE PAGE 7/33)

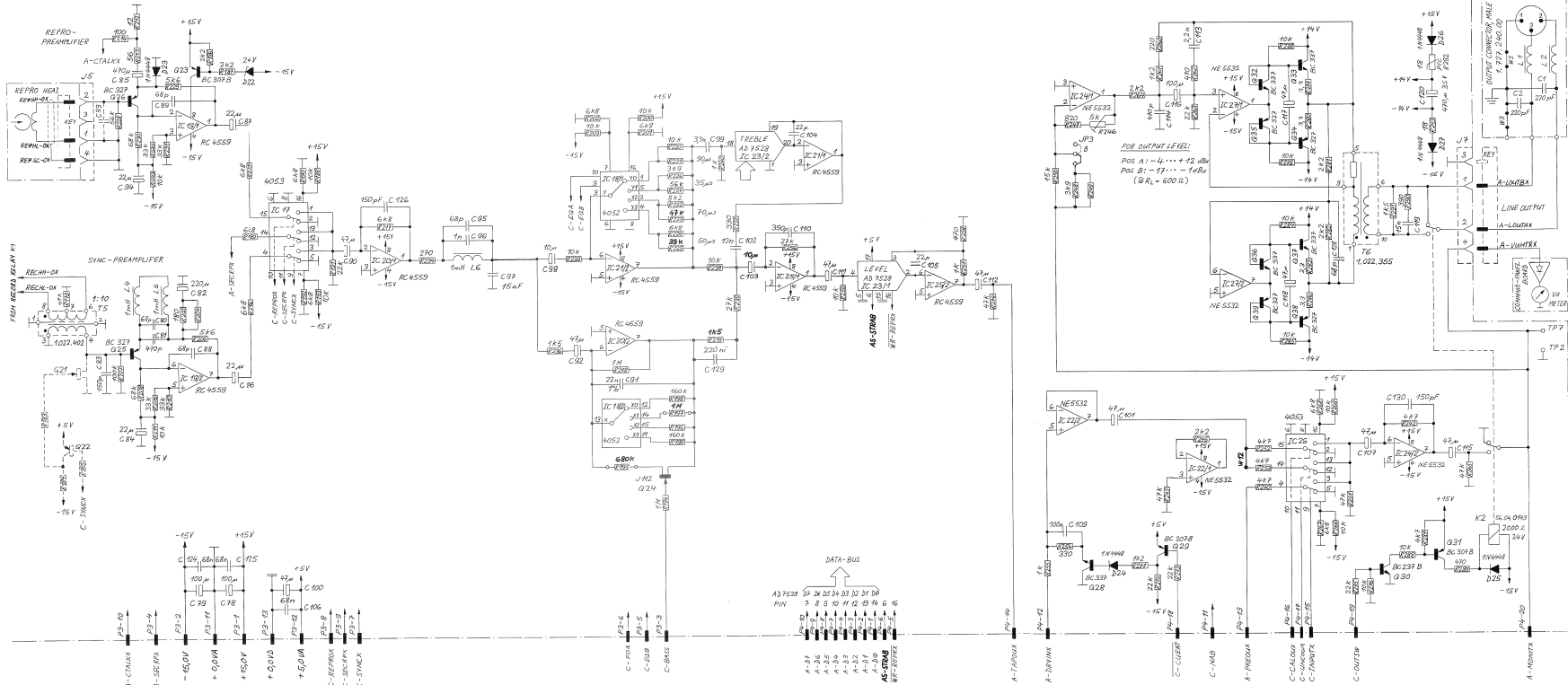

20.5.#	GP								
A 727	GR 41/42								PAGE 6 OF 6
STUDER		AUDIO ELECTRONICS BOARD 2/2				SC	1.727.463.00		

AUDIO ELECTRONICS (2-2 WITH CHANNEL SELECTORS ONLY) 1.727.463.00 GRP41/42

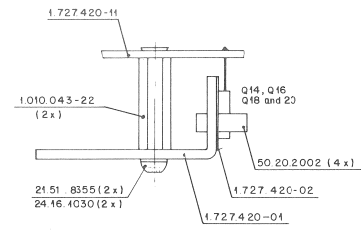
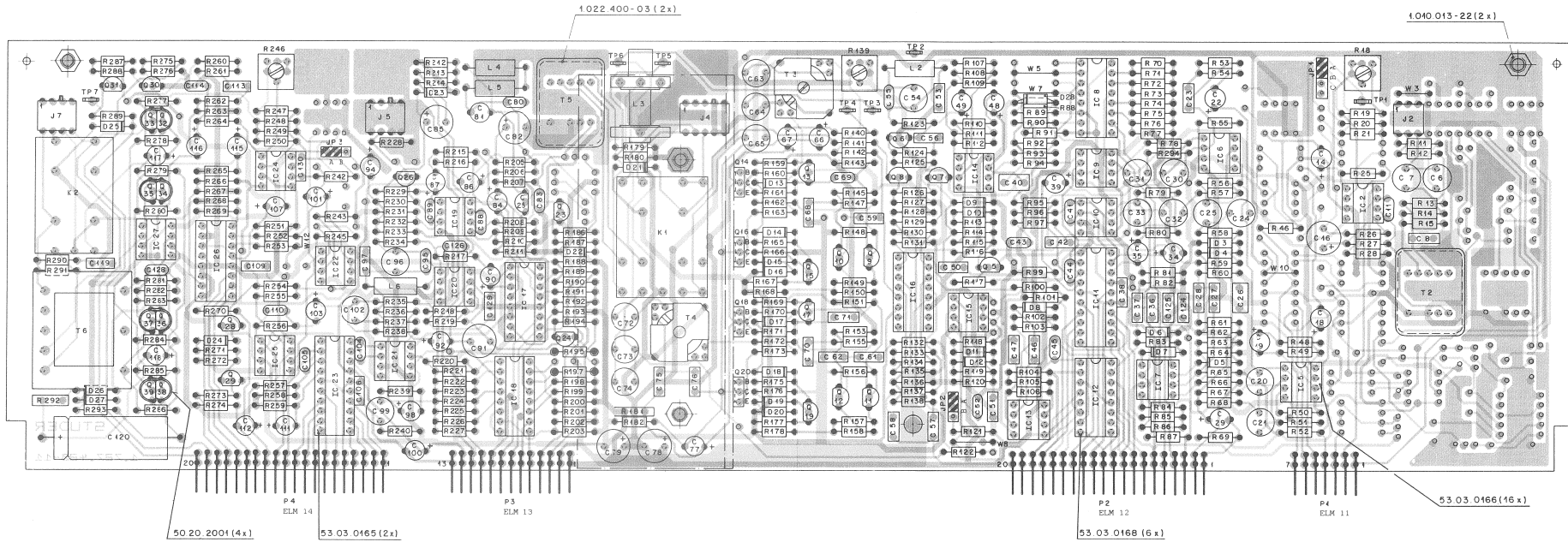

- R18 = INPUT LEVEL ADJUSTMENT
- R139 = ERASE VOLTAGE ADJUSTMENT
- R246 = OUTPUT LEVEL ADJUSTMENT
- L3 = BIAS TRAP
- T3 = ERASE HEAD CIRCUIT
- JP1 INPUT LEVEL SENSITIVITY
- JP2 HX PRO: A = ON, B = OFF
- JP3 OUTPUT LEVEL SENSITIVITY
- TP1 RECORD AMPLIFIER SIGNAL (0.775 V = 0 VU)
- TP2 0.0 V
- TP3 VOLTAGE ON ERASE HEAD
- TP4 PRIMARY CURRENT ON ERASE TRANSFORMER
- TP5 BIAS CURRENT ON 1.0 Ω
- TP6 REFLECTOR FILTER ADJUSTMENT
- TP7 VU METER SIGNAL (0.775 V = 0 VU)

FACTORY STANDARD SETTING



AUDIO ELECTRONICS (2-2 WITH CHANNEL SELECTORS ONLY) 1.727.463.00 GRP41/42

Table with 10 columns: IND., POS.ND., PART NO., VALUE, SPECIFICATIONS / EQUIVALENT, MANUF., IND., POS.ND., PART NO., VALUE, SPECIFICATIONS / EQUIVALENT, MANUF., IND., POS.ND., PART NO., VALUE, SPECIFICATIONS / EQUIVALENT, MANUF., IND., POS.ND., PART NO., VALUE, SPECIFICATIONS / EQUIVALENT, MANUF. This table lists electronic components for the first board (A807).

S T U D E R (00) 87/05/20 GP AUDIO ELECTRONICS BOARD 2/2 1.727.463.00 PAGE 1 S T U D E R (00) 87/05/20 GP AUDIO ELECTRONICS BOARD 2/2 1.727.463.00 PAGE 4 S T U D E R (00) 87/05/20 GP AUDIO ELECTRONICS BOARD 2/2 1.727.463.00 PAGE 7 S T U D E R (00) 87/05/20 GP AUDIO ELECTRONICS BOARD 2/2 1.727.463.00 PAGE 10

Table with 10 columns: IND., POS.ND., PART NO., VALUE, SPECIFICATIONS / EQUIVALENT, MANUF., IND., POS.ND., PART NO., VALUE, SPECIFICATIONS / EQUIVALENT, MANUF., IND., POS.ND., PART NO., VALUE, SPECIFICATIONS / EQUIVALENT, MANUF., IND., POS.ND., PART NO., VALUE, SPECIFICATIONS / EQUIVALENT, MANUF. This table lists electronic components for the second board (A808).

S T U D E R (00) 87/05/20 GP AUDIO ELECTRONICS BOARD 2/2 1.727.463.00 PAGE 2 S T U D E R (00) 87/05/20 GP AUDIO ELECTRONICS BOARD 2/2 1.727.463.00 PAGE 5 S T U D E R (00) 87/05/20 GP AUDIO ELECTRONICS BOARD 2/2 1.727.463.00 PAGE 8 S T U D E R (00) 87/05/20 GP AUDIO ELECTRONICS BOARD 2/2 1.727.463.00 PAGE 11

Table with 10 columns: IND., POS.ND., PART NO., VALUE, SPECIFICATIONS / EQUIVALENT, MANUF., IND., POS.ND., PART NO., VALUE, SPECIFICATIONS / EQUIVALENT, MANUF., IND., POS.ND., PART NO., VALUE, SPECIFICATIONS / EQUIVALENT, MANUF., IND., POS.ND., PART NO., VALUE, SPECIFICATIONS / EQUIVALENT, MANUF. This table lists electronic components for the third board (A809).

S T U D E R (00) 87/05/20 GP AUDIO ELECTRONICS BOARD 2/2 1.727.463.00 PAGE 3 S T U D E R (00) 87/05/20 GP AUDIO ELECTRONICS BOARD 2/2 1.727.463.00 PAGE 6 S T U D E R (00) 87/05/20 GP AUDIO ELECTRONICS BOARD 2/2 1.727.463.00 PAGE 9 S T U D E R (00) 87/05/20 GP AUDIO ELECTRONICS BOARD 2/2 1.727.463.00 PAGE 12



AUDIO ELECTRONICS (2-2 WITH CHANNEL SELECTORS ONLY) 1.727.463.00 GRP41/42

IND.	POS.NO.	PART NO.	VALUE	SPECIFICATIONS / EQUIVALENT	MANUF.
R...	243	57.11.4473	47 kOhm	2%, 0.25W, MF	
R...	245	57.11.4222	2.2 kOhm	2%, 0.25W, MF	
R...	246	58.01.8502	5 kOhm	10%, 0.5 W, PMG	
R...	247	57.11.4921	820 Ohm	2%, 0.25W, MF	
R...	248	57.11.4392	3.9 kOhm	2%, 0.25W, MF	
R...	249			not used	
R...	250	57.11.4153	15 kOhm	2%, 0.25W, MF	
R...	251	57.11.4473	47 kOhm	2%, 0.25W, MF	
R...	252	57.11.4472	4.7 kOhm	2%, 0.25W, MF	
R...	253	57.11.4472	4.7 kOhm	2%, 0.25W, MF	
R...	254	57.11.4331	330 Ohm	2%, 0.25W, MF	
R...	255	57.11.4102	1 kOhm	2%, 0.25W, MF	
R...	256	57.11.4273	27 kOhm	2%, 0.25W, MF	
R...	257	57.11.4102	1 kOhm	2%, 0.25W, MF	
R...	258	57.11.4971	470 Ohm	2%, 0.25W, MF	
R...	259	57.11.4103	10 kOhm	2%, 0.25W, MF	
R...	260	57.11.4221	220 Ohm	2%, 0.25W, MF	
R...	261	57.11.4122	1.2 kOhm	2%, 0.25W, MF	
R...	262	57.11.4471	470 Ohm	2%, 0.25W, MF	
R...	263	57.11.4223	22 kOhm	2%, 0.25W, MF	
R...	264	57.11.4222	2.2 kOhm	2%, 0.25W, MF	
R...	265	57.11.4473	47 kOhm	2%, 0.25W, MF	
R...	266	57.11.4103	10 kOhm	2%, 0.25W, MF	
R...	267	57.11.4682	6.8 kOhm	2%, 0.25W, MF	
R...	268	57.11.4682	6.8 kOhm	2%, 0.25W, MF	
R...	269	57.11.4103	10 kOhm	2%, 0.25W, MF	
R...	270	57.11.4472	4.7 kOhm	2%, 0.25W, MF	
R...	271	57.11.4122	1.2 kOhm	2%, 0.25W, MF	
R...	272	57.11.4223	22 kOhm	2%, 0.25W, MF	
R...	273	57.11.4223	22 kOhm	2%, 0.25W, MF	
R...	274	57.11.4473	47 kOhm	2%, 0.25W, MF	
R...	275	57.11.4223	22 kOhm	2%, 0.25W, MF	
R...	276	57.11.4103	10 kOhm	2%, 0.25W, MF	
R...	277	57.11.4339	3.3 Ohm	2%, 0.25W, MF	
R...	278	57.11.4103	10 kOhm	2%, 0.25W, MF	
R...	279	57.11.4103	10 kOhm	2%, 0.25W, MF	
R...	280	57.11.4339	3.3 Ohm	2%, 0.25W, MF	

S T U D E R (00) 87/05/20 GP AUDIO ELECTRONICS BOARD 2/2 1.727.463.00 PAGE 13

IND.	POS.NO.	PART NO.	VALUE	SPECIFICATIONS / EQUIVALENT	MANUF.
R...	281	57.11.4222	2.2 kOhm	2%, 0.25W, MF	
R...	282	57.11.4222	2.2 kOhm	2%, 0.25W, MF	
R...	283	57.11.4339	3.3 Ohm	2%, 0.25W, MF	
R...	284	57.11.4103	10 kOhm	2%, 0.25W, MF	
R...	285	57.11.4103	10 kOhm	2%, 0.25W, MF	
R...	286	57.11.4339	3.3 Ohm	2%, 0.25W, MF	
R...	287	57.11.4472	4.7 kOhm	2%, 0.25W, MF	
R...	288	57.11.4103	10 kOhm	2%, 0.25W, MF	
R...	289	57.11.4471	470 Ohm	2%, 0.25W, MF	
R...	290	57.11.4391	390 Ohm	2%, 0.25W, MF	
R...	291	57.11.4152	1.5 kOhm	2%, 0.25W, MF	
R...	292	57.92.1151	18 Ohm	150mA, PTC	
R...	293	57.11.4100	18 Ohm	2%, 0.25W, MF	
R...	294	57.11.4470	47 Ohm	2%, 0.25W, MF	

T.....2 1.022.451.00 1:0.62 Line Input Trafo
 T.....3 1.022.271.00 Erase Trafo
 T.....4 1.022.272.00 Bias Trafo
 T.....5 1.022.402.00 1:10 Sync Trafo
 T.....6 1.022.355.00 Line Output Trafo

TP....1	54.02.0320			Plug 2.8*0.8	AMP
TP....2	54.02.0320			Plug 2.8*0.8	AMP
TP....3	54.02.0320			Plug 2.8*0.8	AMP
TP....4	54.02.0320			Plug 2.8*0.8	AMP
TP....5	54.02.0320			Plug 2.8*0.8	AMP
TP....6	54.02.0320			Plug 2.8*0.8	AMP
TP....7	54.02.0320			Plug 2.8*0.8	AMP
W.....3	64.01.0106			Wire Bridge	
W.....4				not used	
W.....5	64.01.0106			Wire Bridge	
W.....6				not used	
W.....7	64.01.0106			Wire Bridge	
W.....8	64.01.0106			Wire Bridge	
W.....10	64.01.0106			Wire Bridge	
W.....12	64.01.0106			Wire Bridge	

S T U D E R (00) 87/05/20 GP AUDIO ELECTRONICS BOARD 2/2 1.727.463.00 PAGE 14

IND.	POS.NO.	PART NO.	VALUE	SPECIFICATIONS / EQUIVALENT	MANUF.
XIC...2	53.03.0166		8-Pole	IC Socket	
XIC...5	53.03.0166		8-Pole	IC Socket	
XIC...6	53.03.0166		8-Pole	IC Socket	
XIC...7	53.03.0166		8-Pole	IC Socket	
XIC...8	53.03.0168		16-Pole	IC Socket	
XIC...9	53.03.0166		8-Pole	IC Socket	
XIC...10	53.03.0166		8-Pole	IC Socket	
XIC...11	53.03.0165		20-Pole	IC Socket	
XIC...12	53.03.0168		16-Pole	IC Socket	
XIC...13	53.03.0166		8-Pole	IC Socket	
XIC...14	53.03.0166		8-Pole	IC Socket	
XIC...15	53.03.0165		8-Pole	IC Socket	
XIC...16	53.03.0168		16-Pole	IC Socket	
XIC...17	53.03.0168		16-Pole	IC Socket	
XIC...18	53.03.0168		16-Pole	IC Socket	
XIC...19	53.03.0166		8-Pole	IC Socket	
XIC...20	53.03.0166		8-Pole	IC Socket	
XIC...21	53.03.0166		8-Pole	IC Socket	
XIC...22	53.03.0166		8-Pole	IC Socket	
XIC...23	53.03.0165		20-Pole	IC Socket	
XIC...24	53.03.0166		8-Pole	IC Socket	
XIC...25	53.03.0166		8-Pole	IC Socket	
XIC...26	53.03.0168		16-Pole	IC Socket	
XIC...27	53.03.0166		8-Pole	IC Socket	

Cer = Ceramic EL = Electrolytic PETP = Polyester
 PP = Polypropylen MF = Metal Film SI = Silicon
 MANUFACTURER: ADI = Analog Devices Inc. Mot = Motorola
 NS = National Semiconductors Ra = Raytheon
 Sig = Signetics St = Studer

ORIG 87/05/20
 S T U D E R (00) 87/05/20 GP AUDIO ELECTRONICS BOARD 2/2 1.727.463.00 PAGE 15

AUDIO ELECTRONICS (2-2 WITH CHANNEL SELECTORS ONLY) 1.727.463.81 GRP41/42
 AUDIO ELECTRONICS (2-2 WITH CHANNEL SELECTORS ONLY) 1.727.423.81 GRP41/42
 - LINE OUTPUT CONNECTOR 1.727.240.00 (SEE PAGE 7/32)
 - LINE INPUT CONNECTOR 1.727.241.00 (SEE PAGE 7/33)

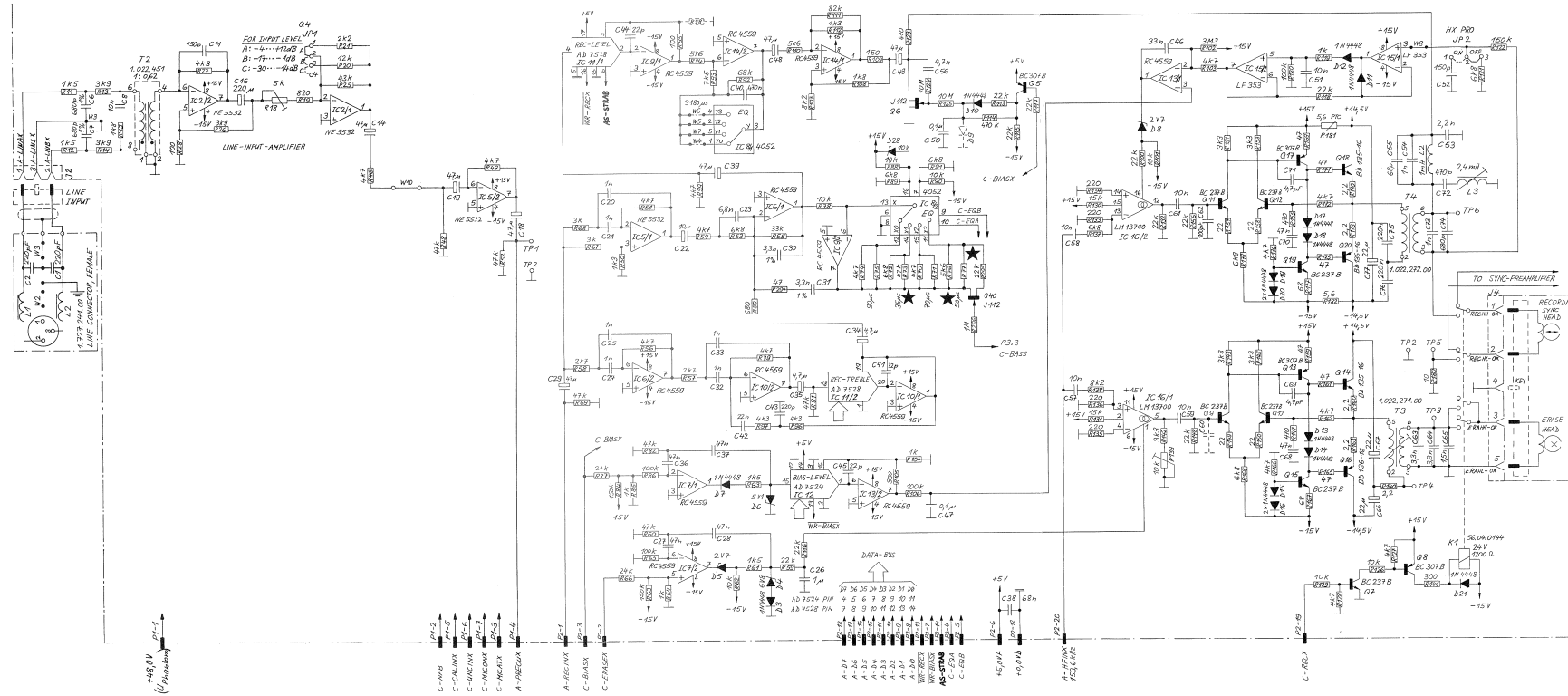

★NOT THE SAME VALUES FOR 1.727.463.81 AND 1.727.423.81 !

①	9.7.87 GP	○	○	○	○	○	○
A 727 GRP41/42		PAGE 3 OF 6					
STUDER AUDIO ELECTRONICS BOARD 212						SC	1.727.463.81

- AUDIO ELECTRONICS (2-2 WITH CHANNEL SELECTORS ONLY) 1.727.463.81 GRP41/42
- AUDIO ELECTRONICS (2-2 WITH CHANNEL SELECTORS ONLY) 1.727.423.81 GRP41/42
- LINE OUTPUT CONNECTOR 1.727.240.00 (SEE PAGE 7/32)
- LINE INPUT CONNECTOR 1.727.241.00 (SEE PAGE 7/33)

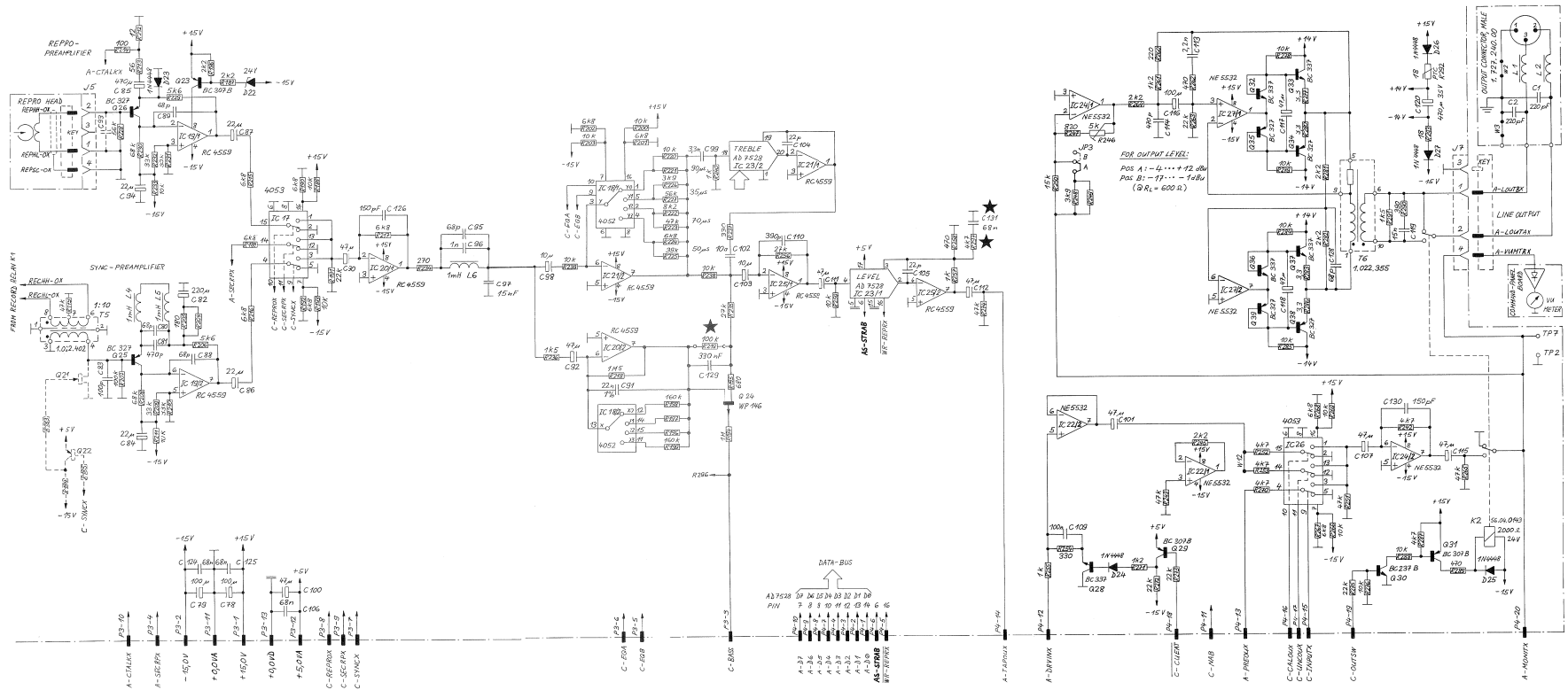

★NOT THE SAME VALUES FOR 1.727.463.81
AND 1.727.423.81 !

9 7 87 GP		
A 727 GR 41/42		PAGE 6 OF 6
STUDER	AUDIO ELECTRONICS BOARD 212	SC 1.727.463.81

AUDIO ELECTRONICS (2-2 WITH CHANNEL SELECTORS ONLY) 1.727.463.81 GRP41/42

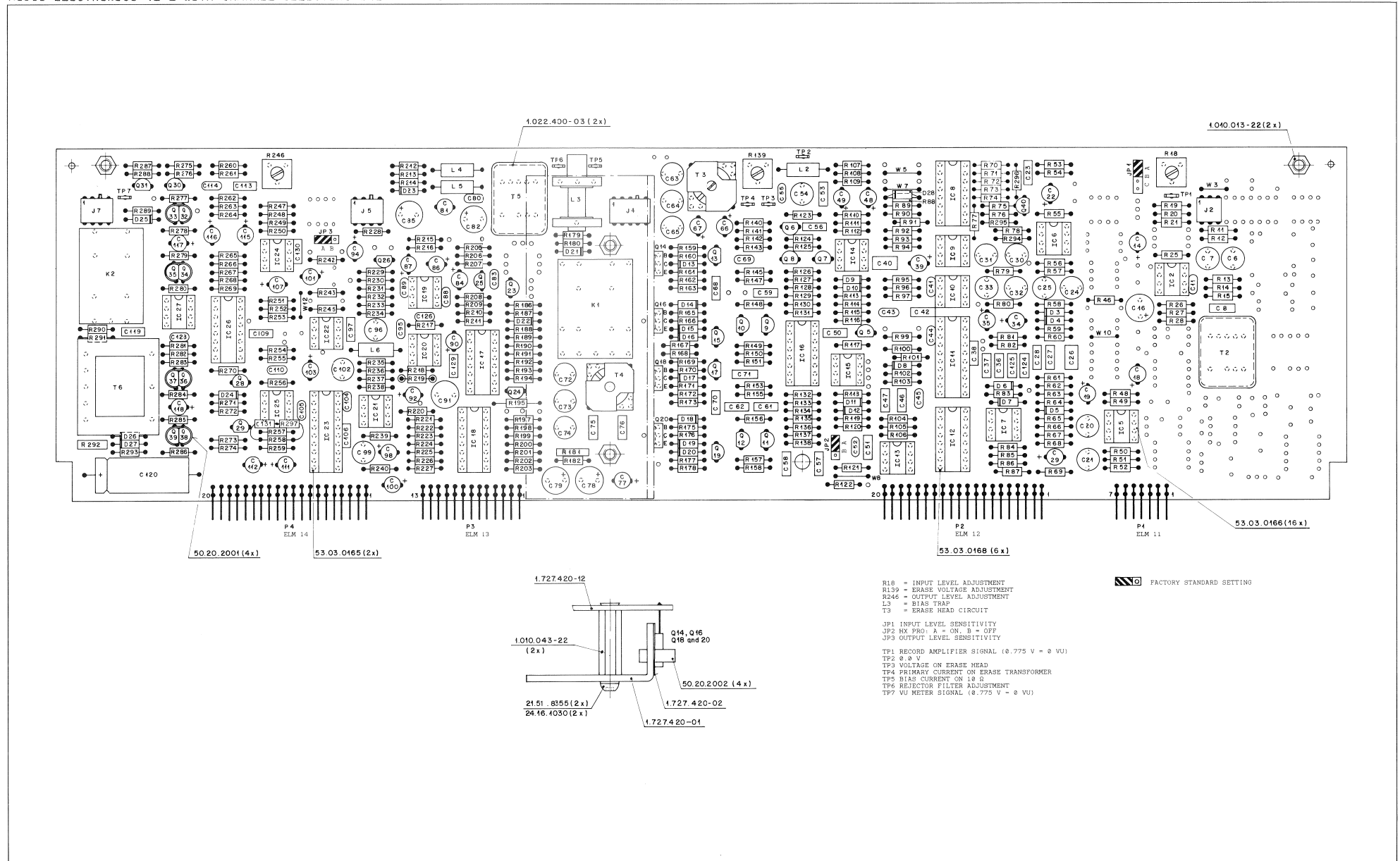

- R18 = INPUT LEVEL ADJUSTMENT
- R139 = ERASE VOLTAGE ADJUSTMENT
- R246 = OUTPUT LEVEL ADJUSTMENT
- L3 = BIAS TRAP
- T3 = ERASE HEAD CIRCUIT
- JP1 INPUT LEVEL SENSITIVITY
- JP2 HX PRO: A = ON, B = OFF
- JP3 OUTPUT LEVEL SENSITIVITY
- TP1 RECORD AMPLIFIER SIGNAL (0.775 V = 0 WU)
- TP2 0.0 V
- TP3 VOLTAGE ON ERASE HEAD
- TP4 PRIMARY CURRENT ON ERASE TRANSFORMER
- TP5 BIAS CURRENT ON L3
- TP6 REFLECTOR FILTER ADJUSTMENT
- TP7 WU METER SIGNAL (0.775 V = 0 WU)

FACTORY STANDARD SETTING



AUDIO ELECTRONICS (2-2 WITH CHANNEL SELECTORS ONLY) 1.727.463.81 GRP41/42

Table with 4 columns: IND., POS.ND., PART NO., VALUE. Specifications / EQUIVALENT MANUF. This table lists electronic components for the first section of the board, including various capacitors, resistors, and integrated circuits.

S T U D E R (00) 87/07/99 GP AUDIO ELECTRONICS BOARD 2/2 1.727.463.A1 PAGE 1 S T U D E R (00) 87/07/99 GP AUDIO ELECTRONICS BOARD 2/2 1.727.463.B1 PAGE 1 S T U D E R (00) 87/07/99 GP AUDIO ELECTRONICS BOARD 2/2 1.727.463.C1 PAGE 1 S T U D E R (00) 87/07/99 GP AUDIO ELECTRONICS BOARD 2/2 1.727.463.D1 PAGE 1

Table with 4 columns: IND., POS.ND., PART NO., VALUE. Specifications / EQUIVALENT MANUF. This table continues the list of components, including diodes, transistors, and various passive components.

S T U D E R (00) 87/07/99 GP AUDIO ELECTRONICS BOARD 2/2 1.727.463.A1 PAGE 2 S T U D E R (00) 87/07/99 GP AUDIO ELECTRONICS BOARD 2/2 1.727.463.B1 PAGE 2 S T U D E R (00) 87/07/99 GP AUDIO ELECTRONICS BOARD 2/2 1.727.463.C1 PAGE 2 S T U D E R (00) 87/07/99 GP AUDIO ELECTRONICS BOARD 2/2 1.727.463.D1 PAGE 2

Table with 4 columns: IND., POS.ND., PART NO., VALUE. Specifications / EQUIVALENT MANUF. This table lists components for the final section of the board, including connectors, relays, and other specialized parts.

S T U D E R (00) 87/07/99 GP AUDIO ELECTRONICS BOARD 2/2 1.727.463.A1 PAGE 3 S T U D E R (00) 87/07/99 GP AUDIO ELECTRONICS BOARD 2/2 1.727.463.B1 PAGE 3 S T U D E R (00) 87/07/99 GP AUDIO ELECTRONICS BOARD 2/2 1.727.463.C1 PAGE 3 S T U D E R (00) 87/07/99 GP AUDIO ELECTRONICS BOARD 2/2 1.727.463.D1 PAGE 3



AUDIO ELECTRONICS (2-2 WITH CHANNEL SELECTORS ONLY) 1.727.463.81 GRP41/42

IND.	POS.NO.	PART NO.	VALUE	SPECIFICATIONS / EQUIVALENT	MANUF.	IND.	POS.NO.	PART NO.	VALUE	SPECIFICATIONS / EQUIVALENT	MANUF.
R...	242	57.11.4472	4.7 KOhm	2%, 0.25W MF		Cer = Ceramic EL = Electrolytic PETP = Polyester PP = Polypropylen MF = Metal Film SI = Silicon MANUFACTURER: ADI = Analog Devices Inc. Mot = Motorola NS = National Semiconductors Ro = Raytheon Sig = Signetics St = Studer					
R...	243	57.11.4473	4.7 KOhm	2%, 0.25W MF		ORIG 87/07/09					
R...	245	57.11.4222	2.2 KOhm	2%, 0.25W MF		S T U D E R (00) 87/07/09 GP AUDIO ELECTRONICS BOARD 2/2 1.727.463.81 PAGE 13 S T U D E R (00) 87/07/09 GP AUDIO ELECTRONICS BOARD 2/2 1.727.463.81 PAGE 16					
R...	246	58.01.8502	5 KOhm	10%, 0.5 W PMG							
R...	247	57.11.4821	820 Ohm	2%, 0.25W MF							
R...	248	57.11.4392	3.9 KOhm	2%, 0.25W MF							
R...	249	57.11.4153	15 KOhm	not used							
R...	250	57.11.4473	4.7 KOhm	2%, 0.25W MF							
R...	251	57.11.4473	4.7 KOhm	2%, 0.25W MF							
R...	252	57.11.4472	4.7 KOhm	2%, 0.25W MF							
R...	253	57.11.4472	4.7 KOhm	2%, 0.25W MF							
R...	254	57.11.4331	330 Ohm	2%, 0.25W MF							
R...	255	57.11.4102	1 KOhm	2%, 0.25W MF							
R...	256	57.11.4273	27 KOhm	2%, 0.25W MF							
R...	257	57.11.4102	1 KOhm	2%, 0.25W MF							
R...	258	57.11.4471	470 Ohm	2%, 0.25W MF							
R...	259	57.11.4103	10 KOhm	2%, 0.25W MF							
R...	260	57.11.4221	220 Ohm	2%, 0.25W MF							
R...	261	57.11.4122	1.2 KOhm	2%, 0.25W MF							
R...	262	57.11.4471	470 Ohm	2%, 0.25W MF							
R...	263	57.11.4223	22 KOhm	2%, 0.25W MF							
R...	264	57.11.4222	2.2 KOhm	2%, 0.25W MF							
R...	265	57.11.4473	4.7 KOhm	2%, 0.25W MF							
R...	266	57.11.4103	10 KOhm	2%, 0.25W MF							
R...	267	57.11.4682	6.8 KOhm	2%, 0.25W MF							
R...	268	57.11.4682	6.8 KOhm	2%, 0.25W MF							
R...	269	57.11.4103	10 KOhm	2%, 0.25W MF							
R...	270	57.11.4472	4.7 KOhm	2%, 0.25W MF							
R...	271	57.11.4122	1.2 KOhm	2%, 0.25W MF							
R...	272	57.11.4223	22 KOhm	2%, 0.25W MF							
R...	273	57.11.4223	22 KOhm	2%, 0.25W MF							
R...	274	57.11.4473	4.7 KOhm	2%, 0.25W MF							
R...	275	57.11.4223	22 KOhm	2%, 0.25W MF							
R...	276	57.11.4103	10 KOhm	2%, 0.25W MF							
R...	277	57.11.4339	3.3 Ohm	2%, 0.25W MF							
R...	278	57.11.4103	10 KOhm	2%, 0.25W MF							
R...	279	57.11.4103	10 KOhm	2%, 0.25W MF							

IND.	POS.NO.	PART NO.	VALUE	SPECIFICATIONS / EQUIVALENT	MANUF.
R...	280	57.11.4339	3.3 Ohm	2%, 0.25W MF	
R...	281	57.11.4222	2.2 KOhm	2%, 0.25W MF	
R...	282	57.11.4222	2.2 KOhm	2%, 0.25W MF	
R...	283	57.11.4339	3.3 Ohm	2%, 0.25W MF	
R...	284	57.11.4103	10 KOhm	2%, 0.25W MF	
R...	285	57.11.4103	10 KOhm	2%, 0.25W MF	
R...	286	57.11.4339	3.3 Ohm	2%, 0.25W MF	
R...	287	57.11.4472	4.7 KOhm	2%, 0.25W MF	
R...	288	57.11.4103	10 KOhm	2%, 0.25W MF	
R...	289	57.11.4471	470 Ohm	2%, 0.25W MF	
R...	290	57.11.4391	390 Ohm	2%, 0.25W MF	
R...	291	57.11.4152	1.5 KOhm	2%, 0.25W MF	
R...	292	57.92.1151	16 Ohm	150mA PTC	
R...	293	57.11.4180	18 Ohm	2%, 0.25W MF	
R...	294	57.11.4470	47 Ohm	2%, 0.25W MF	
R...	295	57.11.4223	22 KOhm	2%, 0.25W MF	
R...	296	57.11.4105	1 MOhm	2%, 0.25W MF	
R...	297	57.11.4472	4.7 KOhm	2%, 0.25W MF	
T...	...	1.022.451.00	1:0.62	Line Input Trafo	St
T...	...	1.022.271.00		Erase Trafo	St
T...	...	1.022.272.00		Bias Trafo	St
T...	...	1.022.402.00	1:10	Sync Trafo	St
T...	...	1.022.355.00		Line Output Trafo	St
TP...	...	54.02.0320		Plug 2.8*0.8	AMP
TP...	...	54.02.0320		Plug 2.8*0.8	AMP
TP...	...	54.02.0320		Plug 2.8*0.8	AMP
TP...	...	54.02.0320		Plug 2.8*0.8	AMP
TP...	...	54.02.0320		Plug 2.8*0.8	AMP
TP...	...	54.02.0320		Plug 2.8*0.8	AMP
TP...	...	54.02.0320		Plug 2.8*0.8	AMP
W...	...	64.01.0106		Wire Bridge	
W...	...	64.01.0106		not used	
W...	...	64.01.0106		Wire Bridge	
W...	...	64.01.0106		not used	

IND.	POS.NO.	PART NO.	VALUE	SPECIFICATIONS / EQUIVALENT	MANUF.
W...	...	64.01.0106		Wire Bridge	
W...	...	64.01.0106		Wire Bridge	
W...	...	64.01.0106		Wire Bridge	
W...	...	64.01.0106		Wire Bridge	
XIC...	...	53.03.0166	8-Pole	IC Socket	
XIC...	...	53.03.0166	8-Pole	IC Socket	
XIC...	...	53.03.0166	8-Pole	IC Socket	
XIC...	...	53.03.0166	8-Pole	IC Socket	
XIC...	...	53.03.0168	16-Pole	IC Socket	
XIC...	...	53.03.0166	8-Pole	IC Socket	
XIC...	...	53.03.0166	8-Pole	IC Socket	
XIC...	...	53.03.0165	20-Pole	IC Socket	
XIC...	...	53.03.0168	16-Pole	IC Socket	
XIC...	...	53.03.0166	8-Pole	IC Socket	
XIC...	...	53.03.0166	8-Pole	IC Socket	
XIC...	...	53.03.0168	16-Pole	IC Socket	
XIC...	...	53.03.0168	16-Pole	IC Socket	
XIC...	...	53.03.0168	16-Pole	IC Socket	
XIC...	...	53.03.0166	8-Pole	IC Socket	
XIC...	...	53.03.0166	8-Pole	IC Socket	
XIC...	...	53.03.0166	8-Pole	IC Socket	
XIC...	...	53.03.0165	20-Pole	IC Socket	
XIC...	...	53.03.0166	8-Pole	IC Socket	
XIC...	...	53.03.0166	8-Pole	IC Socket	
XIC...	...	53.03.0168	16-Pole	IC Socket	
XIC...	...	53.03.0166	8-Pole	IC Socket	

AUDIO ELECTRONICS (2-2 WITH CHANNEL SELECTORS ONLY) 1.727.423.81 GRP41/42

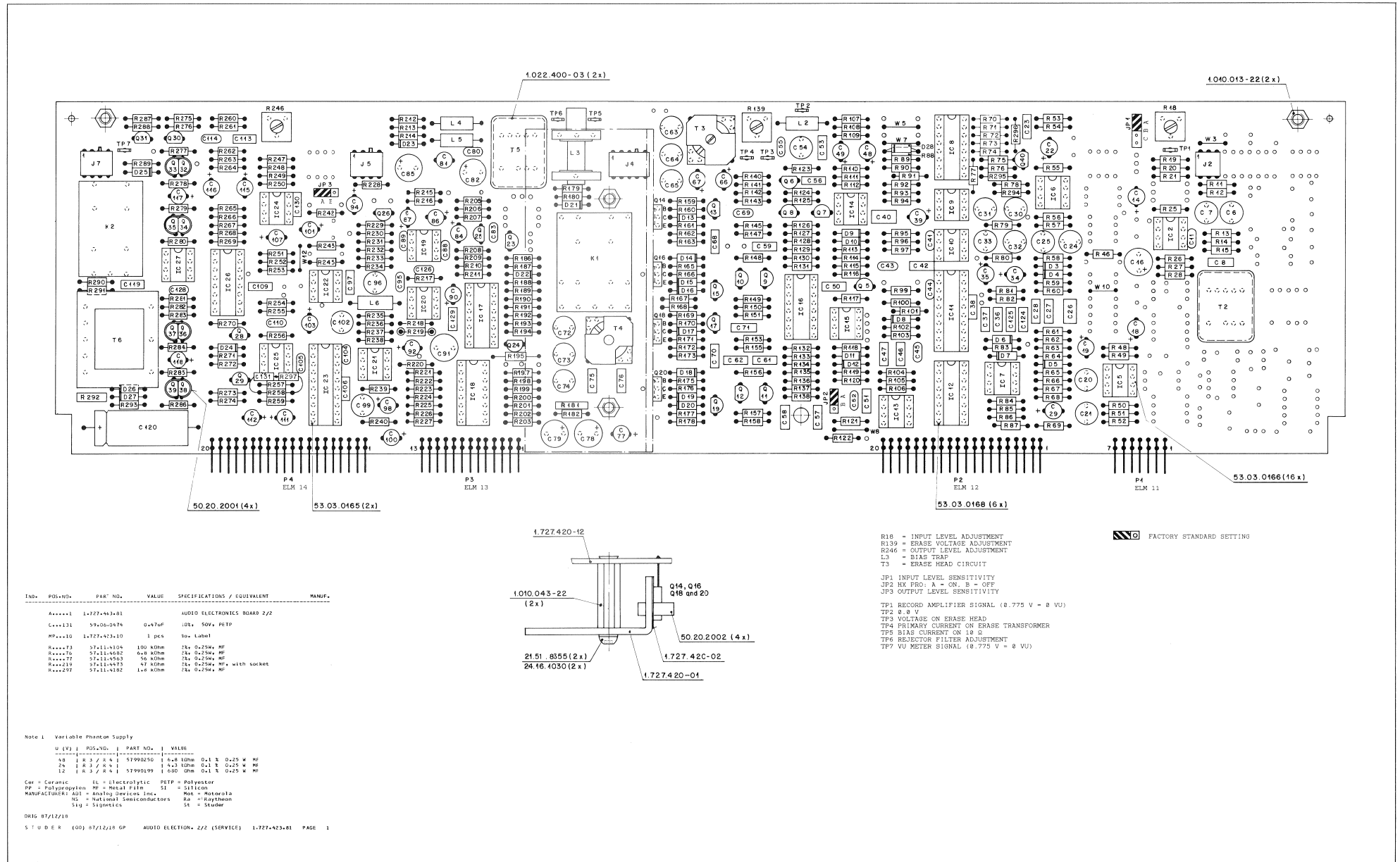

INS.	POS.ND.	PART NO.	VALUE	SPECIFICATIONS / EQUIVALENT	MANUF.
A	...	1.727.443-81		AUDIO ELECTRONICS BOARD 2/2	
C	...	59.06.0974	0.47uF	10%, 50V, PETP	
MP	...	1.727.431-10	1 pcs	50c Label	
R	...	57.11.1104	100 kOhm	2%, 0.25W, MF	
R	...	57.11.6602	6.8 kOhm	2%, 0.25W, MF	
R	...	57.11.0503	50 kOhm	2%, 0.25W, MF	
R	...	57.11.4473	47 kOhm	2%, 0.25W, MF with socket	
R	...	57.11.0102	100 kOhm	2%, 0.25W, MF	

Note 1 Variable Phantom Supply

U (V)	POS.ND.	PART NO.	VALUE
40	1	57990250	1.6x3 100m 0.1 ± 0.25 W MF
24	1	57990250	1.6x3 100m 0.1 ± 0.25 W MF
12	1	57990199	1.600 50m 0.1 ± 0.25 W MF

Car = Ceramic EL = Electrolytic PETP = Polyester
 PP = Polypropylene MF = Metal Film SI = Silicon
 MANUFACTURERS: ADJ = Analog Devices Inc. MO = Motorola
 NS = National Semiconductors RA = Raytheon
 S4 = Supertec SI = Studer

AUDIO ELECTRONICS (PBO) 1.727.425.00 GRP41/42
- LINE OUTPUT CONNECTOR 1.727.240.00 (SEE PAGE 7/32)

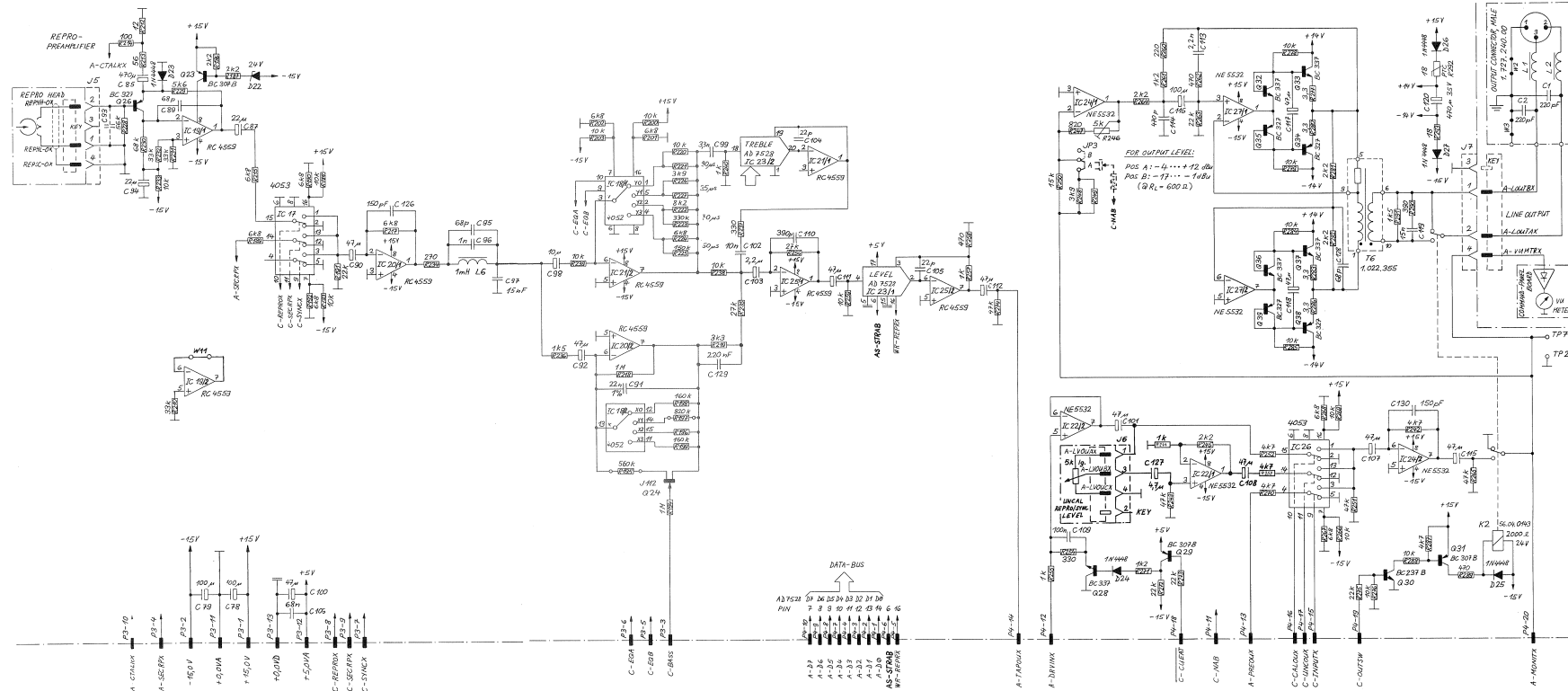

28.1.87 GP	A 727 GR 41/42	PAGE 3 OF 3
STUDER	AUDIO ELECTRONICS BOARD 780	SC 1.727.425.00

AUDIO ELECTRONICS (PBO) 1.727.425.00 GRP41/42

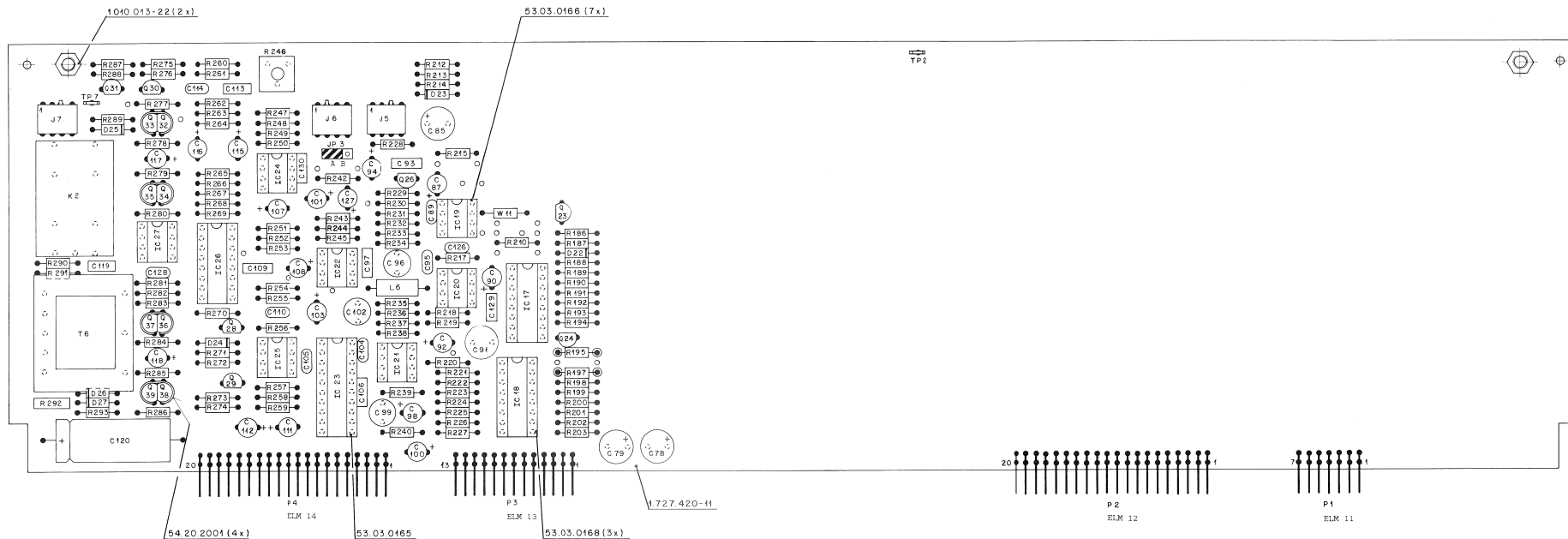

IND.	POS.ND.	PART NO.	VALUE	SPECIFICATIONS / EQUIVALENT	MANUF.	IND.	POS.ND.	PART NO.	VALUE	SPECIFICATIONS / EQUIVALENT	MANUF.	IND.	POS.ND.	PART NO.	VALUE	SPECIFICATIONS / EQUIVALENT	MANUF.	IND.	POS.ND.	PART NO.	VALUE	SPECIFICATIONS / EQUIVALENT	MANUF.	
C...	78	59.22.5101	100 uF	-20% 25V EL		C...	127	59.22.0877	4.7 uF	20% 35V EL		M...	11	1.727.425.11	1	pcs	Audio Electronics PCB	St	R...	197	57.11.4824	820 kOhm	2%, 0.25W, MF, with socket	
C...	79	59.22.5101	100 uF	-20% 25V EL		C...	128	59.22.0877	4.7 uF	20% 35V EL		M...	13	1.010.011.22	2	pcs	RAW, Not MMS		R...	198	57.11.3164	150 kOhm	2%, 0.25W, MF	
C...	85	59.22.2471	470 uF	-20% 50V EL		C...	129	59.06.0224	220 nF	10% 50V PEP		M...	15	43.01.0308	1	pcs	ESE Warning Label		R...	199	57.11.3164	150 kOhm	2%, 0.25W, MF	
C...	87	59.22.5100	22 uF	-20% 25V EL		C...	130	59.38.0131	150 nF	10% 50V Cer		M...	16	53.03.0228	4	pcs	1-Pole Socket (R195,R197)		R...	200	57.11.4103	10 kOhm	2%, 0.25W, MF	
C...	89	59.24.4680	68 pF	-10% 50V Cer		D...	22	50.04.1121	24 V	5% 0.44 Zener		P...	1	54.01.0223	7	PinStr	CIS Pin Strip		R...	201	57.11.4102	6.8 kOhm	2%, 0.25W, MF	
C...	90	59.22.3670	47 uF	-20% 18V EL		D...	23	50.04.0125	1N4448	50V SI		P...	2	54.01.0261	20	PinStr	CIS Pin Strip		R...	202	57.11.4103	10 kOhm	2%, 0.25W, MF	
C...	91	59.05.1223	22 nF	-1% 100 PP		D...	24	50.04.0125	1N4448	50V SI		P...	3	54.01.0273	13	PinStr	CIS Pin Strip		R...	203	57.11.4103	10 kOhm	2%, 0.25W, MF	
C...	92	59.22.3670	47 uF	-20% 18V EL		D...	25	50.04.0125	1N4448	50V SI		P...	4	54.01.0261	20	PinStr	CIS Pin Strip		R...	204	57.11.4120	12 Ohm	2%, 0.25W, MF	
C...	93	59.22.3670	47 uF	-20% 18V EL		D...	26	50.04.0125	1N4448	50V SI		G...	23	50.03.0515	RC3078	RC5570, RC5600	PNP	Not	R...	211	57.11.4120	50 Ohm	2%, 0.25W, MF	
C...	94	59.22.5220	22 uF	-20% 25V EL		D...	27	50.04.0125	1N4448	50V SI		G...	24	50.03.0500	1112		RET	R...	212	57.11.4101	100 Ohm	2%, 0.25W, MF		
C...	95	59.24.4680	68 pF	-10% 50V Cer		D...	28	50.04.0125	1N4448	50V SI		G...	25	50.03.0645	RC327		NPN	R...	213	57.11.4102	6.8 kOhm	2%, 0.25W, MF		
C...	96	59.05.1200	10 uF	±5% 50V PP		D...	29	50.04.0107	RC 14052	OMC Analog Switch	Not	G...	26	50.03.0515	RC327		NPN	R...	214	57.11.4102	6.8 kOhm	2%, 0.25W, MF		
C...	97	59.06.0153	15 nF	-10% 50V PEP		D...	30	50.04.0107	RC 14052	OMC Analog Switch	Not	G...	27	50.03.0515	RC327-25		NPN	R...	215	57.11.4102	6.8 kOhm	2%, 0.25W, MF		
C...	98	59.22.5100	22 uF	-20% 25V EL		D...	31	50.04.0107	RC 14052	OMC Analog Switch	Not	G...	28	50.03.0515	RC327	RC5570, RC5600	NPN	R...	216	57.11.4102	6.8 kOhm	2%, 0.25W, MF		
C...	99	59.05.2332	3.3 nF	±5% 50V PP		D...	32	50.04.0107	RC 14052	OMC Analog Switch	Not	G...	29	50.03.0516	RC327	RC5570, RC5600	NPN	R...	217	57.11.4332	3.3 kOhm	2%, 0.25W, MF		
C...	100	59.22.3670	47 uF	-20% 18V EL		D...	33	50.04.0107	RC 14052	OMC Analog Switch	Not	G...	30	50.03.0516	RC327	RC5570, RC5600	NPN	R...	218	57.11.4103	10 kOhm	2%, 0.25W, MF		
C...	101	59.22.3670	47 uF	-20% 18V EL		D...	34	50.04.0107	RC 14052	OMC Analog Switch	Not	G...	31	50.03.0515	RC327	RC5570, RC5600	NPN	R...	219	57.11.4103	10 kOhm	2%, 0.25W, MF		
C...	102	59.05.2332	3.3 nF	±5% 50V PP		D...	35	50.04.0107	RC 14052	OMC Analog Switch	Not	G...	32	50.03.0515	RC327	RC5570, RC5600	NPN	R...	220	57.11.4103	10 kOhm	2%, 0.25W, MF		
C...	103	59.22.3670	47 uF	-20% 18V EL		D...	36	50.04.0107	RC 14052	OMC Analog Switch	Not	G...	33	50.03.0516	RC327	RC5570, RC5600	NPN	R...	221	57.11.4103	10 kOhm	2%, 0.25W, MF		
C...	104	59.22.3670	47 uF	-20% 18V EL		D...	37	50.04.0107	RC 14052	OMC Analog Switch	Not	G...	34	50.03.0516	RC327	RC5570, RC5600	NPN	R...	222	57.11.4103	10 kOhm	2%, 0.25W, MF		
C...	105	59.22.3670	47 uF	-20% 18V EL		D...	38	50.04.0107	RC 14052	OMC Analog Switch	Not	G...	35	50.03.0516	RC327	RC5570, RC5600	NPN	R...	223	57.11.4103	10 kOhm	2%, 0.25W, MF		
C...	106	59.05.2332	3.3 nF	±5% 50V PP		D...	39	50.04.0107	RC 14052	OMC Analog Switch	Not	G...	36	50.03.0516	RC327	RC5570, RC5600	NPN	R...	224	57.11.4103	10 kOhm	2%, 0.25W, MF		
C...	107	59.22.3670	47 uF	-20% 18V EL		D...	40	50.04.0107	RC 14052	OMC Analog Switch	Not	G...	37	50.03.0516	RC327	RC5570, RC5600	NPN	R...	225	57.11.4103	10 kOhm	2%, 0.25W, MF		
C...	108	59.22.3670	47 uF	-20% 18V EL		D...	41	50.04.0107	RC 14052	OMC Analog Switch	Not	G...	38	50.03.0516	RC327	RC5570, RC5600	NPN	R...	226	57.11.4103	10 kOhm	2%, 0.25W, MF		
C...	109	59.06.0104	100 nF	-10% 50V PEP		D...	42	50.04.0107	RC 14052	OMC Analog Switch	Not	G...	39	50.03.0516	RC327	RC5570, RC5600	NPN	R...	227	57.11.4103	10 kOhm	2%, 0.25W, MF		
C...	110	59.24.4680	68 pF	-10% 50V Cer		J...	1	54.01.0304	4-Pole	CIS Socket Strip	AMP	R...	186	57.11.4222	2.2 kOhm	2%, 0.25W, MF		R...	228	57.11.4563	56 kOhm	2%, 0.25W, MF		
C...	111	59.22.3670	47 uF	-20% 18V EL		J...	2	54.01.0304	4-Pole	CIS Socket Strip	AMP	R...	187	57.11.4222	2.2 kOhm	2%, 0.25W, MF		R...	229	57.11.4562	56 kOhm	2%, 0.25W, MF		
C...	112	59.22.3670	47 uF	-20% 18V EL		J...	3	54.01.0304	4-Pole	CIS Socket Strip	AMP	R...	188	57.11.4103	10 kOhm	2%, 0.25W, MF		R...	230	57.11.4562	56 kOhm	2%, 0.25W, MF		
C...	113	59.06.0222	2.2 nF	-10% 50V PEP		J...	4	54.01.0304	4-Pole	CIS Socket Strip	AMP	R...	189	57.11.4103	10 kOhm	2%, 0.25W, MF		R...	231	57.11.4562	56 kOhm	2%, 0.25W, MF		
C...	114	59.24.4680	68 pF	-10% 50V Cer		J...	5	54.01.0304	4-Pole	CIS Socket Strip	AMP	R...	190	57.11.4103	10 kOhm	2%, 0.25W, MF		R...	232	57.11.4562	56 kOhm	2%, 0.25W, MF		
C...	115	59.22.3670	47 uF	-20% 18V EL		J...	6	54.01.0304	4-Pole	CIS Socket Strip	AMP	R...	191	57.11.4103	10 kOhm	2%, 0.25W, MF		R...	233	57.11.4562	56 kOhm	2%, 0.25W, MF		
C...	116	59.22.3670	47 uF	-20% 18V EL		J...	7	54.01.0304	4-Pole	CIS Socket Strip	AMP	R...	192	57.11.4103	10 kOhm	2%, 0.25W, MF		R...	234	57.11.4562	56 kOhm	2%, 0.25W, MF		
C...	117	59.22.3670	47 uF	-20% 18V EL		J...	8	54.01.0304	4-Pole	CIS Socket Strip	AMP	R...	193	57.11.4103	10 kOhm	2%, 0.25W, MF		R...	235	57.11.4562	56 kOhm	2%, 0.25W, MF		
C...	118	59.22.3670	47 uF	-20% 18V EL		J...	9	54.01.0304	4-Pole	CIS Socket Strip	AMP	R...	194	57.11.4103	10 kOhm	2%, 0.25W, MF		R...	236	57.11.4562	56 kOhm	2%, 0.25W, MF		
C...	119	59.06.0153	15 nF	-10% 50V PEP		J...	10	54.01.0304	4-Pole	CIS Socket Strip	AMP	R...	195	57.11.4103	10 kOhm	2%, 0.25W, MF		R...	237	57.11.4562	56 kOhm	2%, 0.25W, MF		
C...	120	59.22.3670	47 uF	-20% 18V EL		J...	11	54.01.0304	4-Pole	CIS Socket Strip	AMP	R...	196	57.11.4103	10 kOhm	2%, 0.25W, MF		R...	238	57.11.4562	56 kOhm	2%, 0.25W, MF		
C...	121	59.24.4680	68 pF	-10% 50V Cer		J...	12	54.01.0304	4-Pole	CIS Socket Strip	AMP	R...	197	57.11.4103	10 kOhm	2%, 0.25W, MF		R...	239	57.11.4562	56 kOhm	2%, 0.25W, MF		
C...	122	59.24.4680	68 pF	-10% 50V Cer		J...	13	54.01.0304	4-Pole	CIS Socket Strip	AMP	R...	198	57.11.4103	10 kOhm	2%, 0.25W, MF		R...	240	57.11.4562	56 kOhm	2%, 0.25W, MF		
C...	123	59.24.4680	68 pF	-10% 50V Cer		J...	14	54.01.0304	4-Pole	CIS Socket Strip	AMP	R...	199	57.11.4103	10 kOhm	2%, 0.25W, MF		R...	241	57.11.4562	56 kOhm	2%, 0.25W, MF		
C...	124	59.24.4680	68 pF	-10% 50V Cer		J...	15	54.01.0304	4-Pole	CIS Socket Strip	AMP	R...	200	57.11.4103	10 kOhm	2%, 0.25W, MF		R...	242	57.11.4562	56 kOhm	2%, 0.25W, MF		
C...	125	59.24.4680	68 pF	-10% 50V Cer		J...	16	54.01.0304	4-Pole	CIS Socket Strip	AMP	R...	201	57.11.4103	10 kOhm	2%, 0.25W, MF		R...	243	57.11.4562	56 kOhm	2%, 0.25W, MF		
C...	126	59.24.4680	68 pF	-10% 50V Cer		J...	17	54.01.0304	4-Pole	CIS Socket Strip	AMP	R...	202	57.11.4103	10 kOhm	2%, 0.25W, MF		R...	244	57.11.4562	56 kOhm	2%, 0.25W, MF		
C...	127	59.24.4680	68 pF	-10% 50V Cer		J...	18	54.01.0304	4-Pole	CIS Socket Strip	AMP	R...	203	57.11.4103	10 kOhm	2%, 0.25W, MF		R...	245	57.11.4562	56 kOhm	2%, 0.25W, MF		
C...	128	59.24.4680	68 pF	-10% 50V Cer		J...	19	54.01.0304	4-Pole	CIS Socket Strip	AMP	R...	204	57.11.4103	10 kOhm	2%, 0.25W, MF		R...	246	57.11.4562	56 kOhm	2%, 0.25W, MF		
C...	129	59.24.4680	68 pF	-10% 50V Cer		J...	20	54.01.0304	4-Pole	CIS Socket Strip	AMP	R...	205	57.11.4103	10 kOhm	2%, 0.25W, MF		R...	247	57.11.4562	56 kOhm	2%, 0.25W, MF		
C...	130	59.24.4680	68 pF	-10% 50V Cer		J...	21	54.01.0304	4-Pole	CIS Socket Strip	AMP	R...	206	57.11.4103	10 kOhm	2%, 0.25W, MF		R...	248	57.11.4562	56 kOhm	2%, 0.25W, MF		
C...	131	59.24.4680	68 pF	-10% 50V Cer		J...	22	54.01.0304	4-Pole	CIS Socket Strip	AMP	R...	207	57.11.4103	10 kOhm	2%, 0.25W, MF		R...	249	57.11.4562	56 kOhm	2%, 0.25W, MF		
C...	132	59.24.4680	68 pF	-10% 50V Cer		J...	23	5																



AUDIO ELECTRONICS (PBO) 1.727.425.00 GRP41/42

IND.	POS.NO.	PART NO.	VALUE	SPECIFICATIONS / EQUIVALENT	MANUF.
R...	243	57.11.4473	47 kOhm	2%, 0.25W, MF	
R...	244	57.11.4102	1 kOhm	2%, 0.25W, MF	
R...	245	57.11.4222	2+2 kOhm	2%, 0.25W, MF	
R...	246	58.01.8502	5 kOhm	10%, 0.5 W, PMG	
R...	247	57.11.4021	0.20 Ohm	2%, 0.25W, MF	
R...	248	57.11.4392	3+9 kOhm	2%, 0.25W, MF	
R...	249			not used	
R...	250	57.11.4153	15 kOhm	2%, 0.25W, MF	
R...	251	57.11.4473	47 kOhm	2%, 0.25W, MF	
R...	252	57.11.4472	4+7 kOhm	2%, 0.25W, MF	
R...	253	57.11.4472	4+7 kOhm	2%, 0.25W, MF	
R...	254	57.11.4331	330 Ohm	2%, 0.25W, MF	
R...	255	57.11.4102	1 kOhm	2%, 0.25W, MF	
R...	256	57.11.4273	27 kOhm	2%, 0.25W, MF	
R...	257	57.11.4102	1 kOhm	2%, 0.25W, MF	
R...	258	57.11.4471	470 Ohm	2%, 0.25W, MF	
R...	259	57.11.4103	10 kOhm	2%, 0.25W, MF	
R...	260	57.11.4221	220 Ohm	2%, 0.25W, MF	
R...	261	57.11.4122	1+2 kOhm	2%, 0.25W, MF	
R...	262	57.11.4471	470 Ohm	2%, 0.25W, MF	
R...	263	57.11.4223	22 kOhm	2%, 0.25W, MF	
R...	264	57.11.4222	2+2 kOhm	2%, 0.25W, MF	
R...	265	57.11.4473	47 kOhm	2%, 0.25W, MF	
R...	266	57.11.4103	10 kOhm	2%, 0.25W, MF	
R...	267	57.11.4682	6+8 kOhm	2%, 0.25W, MF	
R...	268	57.11.4682	6+8 kOhm	2%, 0.25W, MF	
R...	269	57.11.4103	10 kOhm	2%, 0.25W, MF	
R...	270	57.11.4472	4+7 kOhm	2%, 0.25W, MF	
R...	271	57.11.4122	1+2 kOhm	2%, 0.25W, MF	
R...	272	57.11.4223	22 kOhm	2%, 0.25W, MF	
R...	273	57.11.4223	22 kOhm	2%, 0.25W, MF	
R...	274	57.11.4472	4+7 kOhm	2%, 0.25W, MF	
R...	275	57.11.4223	22 kOhm	2%, 0.25W, MF	
R...	276	57.11.4103	10 kOhm	2%, 0.25W, MF	
R...	277	57.11.4339	3+3 Ohm	2%, 0.25W, MF	
R...	278	57.11.4103	10 kOhm	2%, 0.25W, MF	
R...	279	57.11.4103	10 kOhm	2%, 0.25W, MF	

S T U D E R (00) 87/02/17 GP AUDIO ELECTRONICS BOARD PBD 1.727.425.00 PAGE 5

IND.	POS.NO.	PART NO.	VALUE	SPECIFICATIONS / EQUIVALENT	MANUF.
R...	280	57.11.4339	3+3 Ohm	2%, 0.25W, MF	
R...	281	57.11.4222	2+2 kOhm	2%, 0.25W, MF	
R...	282	57.11.4222	2+2 kOhm	2%, 0.25W, MF	
R...	283	57.11.4339	3+3 Ohm	2%, 0.25W, MF	
R...	284	57.11.4103	10 kOhm	2%, 0.25W, MF	
R...	285	57.11.4103	10 kOhm	2%, 0.25W, MF	
R...	286	57.11.4339	3+3 Ohm	2%, 0.25W, MF	
R...	287	57.11.4472	4+7 kOhm	2%, 0.25W, MF	
R...	288	57.11.4103	10 kOhm	2%, 0.25W, MF	
R...	289	57.11.4471	470 Ohm	2%, 0.25W, MF	
R...	290	57.11.4391	390 Ohm	2%, 0.25W, MF	
R...	291	57.11.4152	1+5 kOhm	2%, 0.25W, MF	
R...	292	57.92.1151	18 Ohm	150mA, PTC	
R...	293	57.11.4180	18 Ohm	2%, 0.25W, MF	
T.....	6	1-022-355-00		Line Output Trafo	St
TP....	2	54.02.0320		Plug 2.8*0.8	AMP
TP....	7	54.02.0320		Plug 2.8*0.8	AMP
W.....	11	57.11.4000		Wire Bridge	
XIC..	17	53.03.0168	16-Pole	IC Socket	
XIC..	18	53.03.0168	16-Pole	IC Socket	
XIC..	19	53.03.0166	8-Pole	IC Socket	
XIC..	20	53.03.0166	8-Pole	IC Socket	
XIC..	21	53.03.0166	8-Pole	IC Socket	
XIC..	22	53.03.0166	8-Pole	IC Socket	
XIC..	23	53.03.0166	20-Pole	IC Socket	
XIC..	24	53.03.0166	8-Pole	IC Socket	
XIC..	25	53.03.0166	8-Pole	IC Socket	
XIC..	26	53.03.0168	16-Pole	IC Socket	
XIC..	27	53.03.0166	8-Pole	IC Socket	

S T U D E R (00) 87/02/17 GP AUDIO ELECTRONICS BOARD PBD 1.727.425.00 PAGE 6

IND.	POS.NO.	PART NO.	VALUE	SPECIFICATIONS / EQUIVALENT	MANUF.
Cer = Ceramic EL = Electrolytic PETP = Polyester PP = Polypropylen MF = Metal Film SI = Silicon					
MANUFACTURER: ADI = Analog Devices Inc. Mot = Motorola NS = National Semiconductors Ra = Raytheon Sig = Signetics St = Studer					

ORIG 87/02/17
S T U D E R (00) 87/02/17 GP AUDIO ELECTRONICS BOARD PBD 1.727.425.00 PAGE 7

AUDIO ELECTRONICS (PBO) 1.727.465.00 GRP41/42
- LINE OUTPUT CONNECTOR 1.727.240.00 (SEE PAGE 7/32)

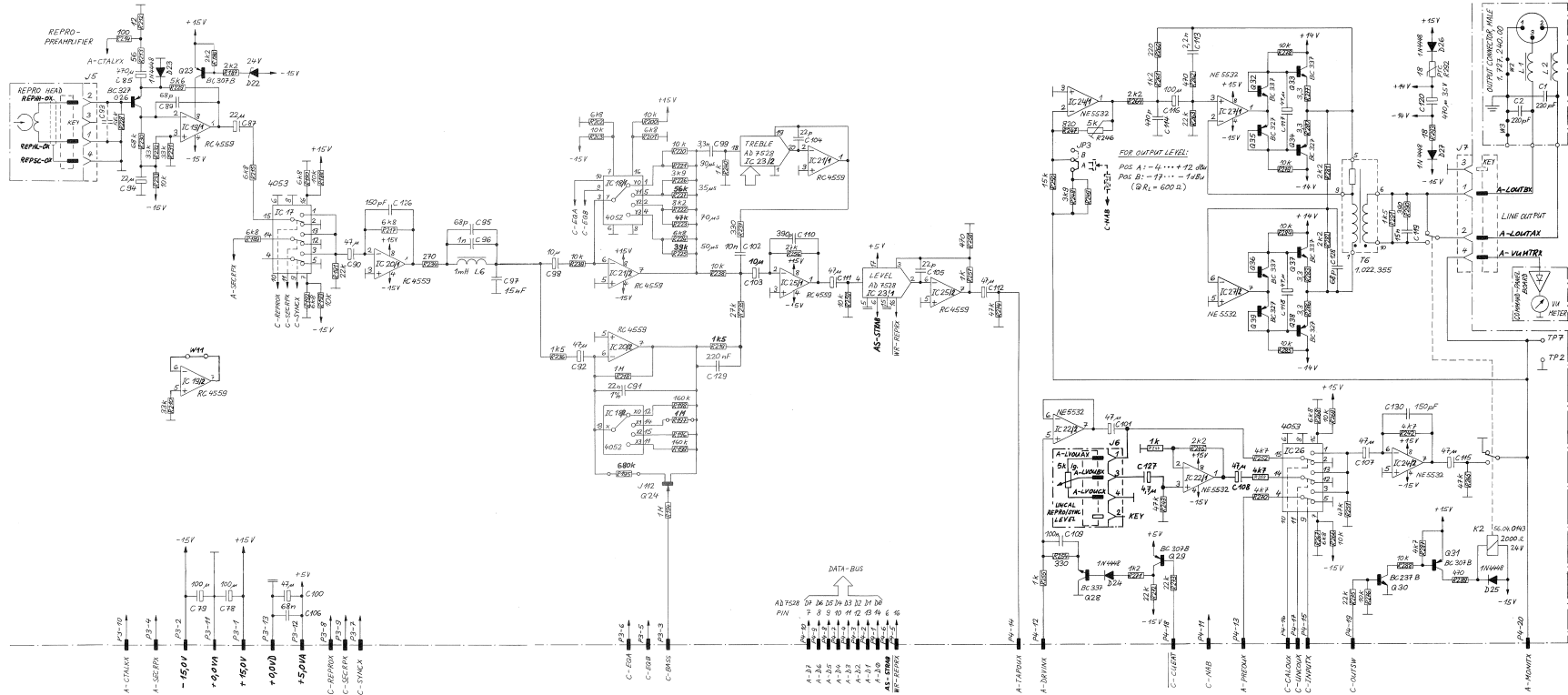

0 20.5.87 GP	A 727 GR 41/42	PAGE 3 OF 3
STUDER	AUDIO ELECTRONICS BOARD PBO	SC 1.727.465.00

AUDIO ELECTRONICS (PBO) 1.727.465.00 GRP41/42

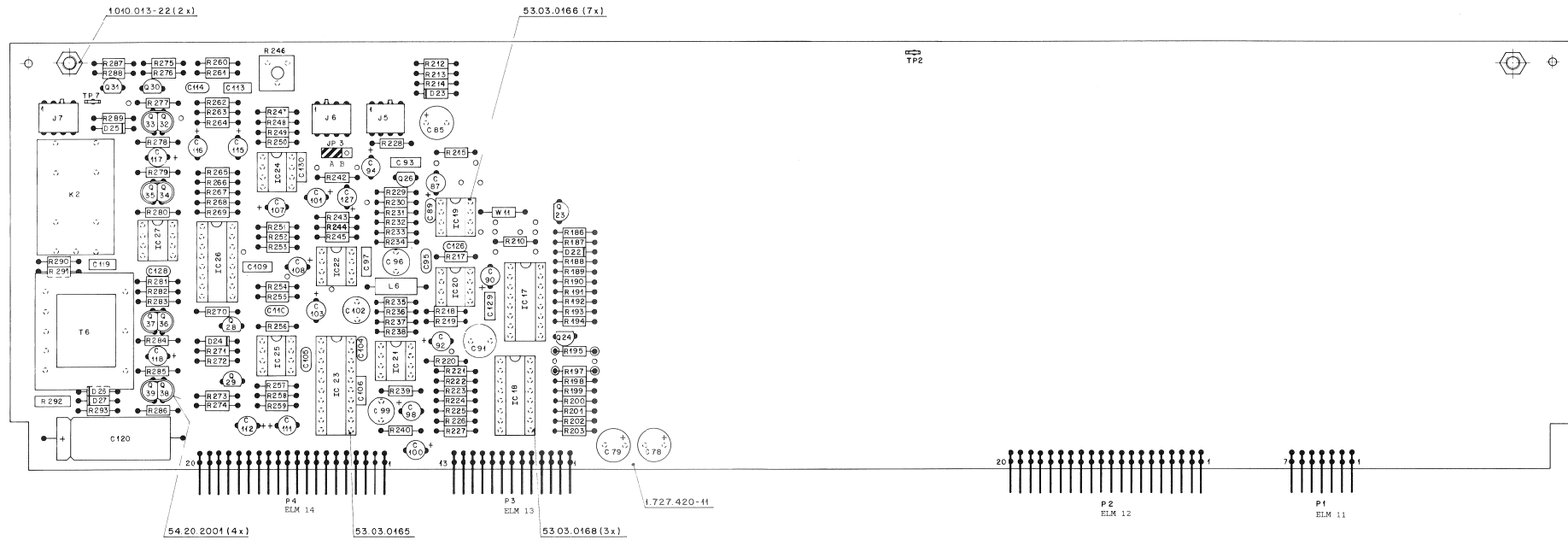

IND.	POS.ND.	PART NO.	VALUE	SPECIFICATIONS / EQUIVALENT	MANUF.	IND.	POS.ND.	PART NO.	VALUE	SPECIFICATIONS / EQUIVALENT	MANUF.	IND.	POS.ND.	PART NO.	VALUE	SPECIFICATIONS / EQUIVALENT	MANUF.	IND.	POS.ND.	PART NO.	VALUE	SPECIFICATIONS / EQUIVALENT	MANUF.	
...
S T U D E R	(05)	87/05/20 GP	AUDIO ELECTRONICS BOARD PBO	1.727.465.00	PAGE 1	S T U D E R	(05)	87/05/20 GP	AUDIO ELECTRONICS BOARD PBO	1.727.465.00	PAGE 2	S T U D E R	(05)	87/05/20 GP	AUDIO ELECTRONICS BOARD PBO	1.727.465.00	PAGE 3	S T U D E R	(05)	87/05/20 GP	AUDIO ELECTRONICS BOARD PBO	1.727.465.00	PAGE 4	



AUDIO ELECTRONICS (PBO) 1.727.465.00 GRP41/42

IND.	POS.NO.	PART NO.	VALUE	SPECIFICATIONS / EQUIVALENT	MANUF.
R...	243	57.11.4473	47 kOhm	2%, 0.25W, MF	
R...	244	57.11.4102	1 kOhm	2%, 0.25W, MF	
R...	245	57.11.4222	2+2 kOhm	2%, 0.25W, MF	
R...	246	56.01.8502	5 kOhm	10%, 0.5 W, PMG	
R...	247	57.11.4821	820 Ohm	2%, 0.25W, MF	
R...	248	57.11.4303	2.0 kOhm	2%, 0.25W, MF	
R...	249			not used	
R...	250	57.11.4153	15 kOhm	2%, 0.25W, MF	
R...	251	57.11.4473	47 kOhm	2%, 0.25W, MF	
R...	252	57.11.4472	4.7 kOhm	2%, 0.25W, MF	
R...	253	57.11.4472	4.7 kOhm	2%, 0.25W, MF	
R...	254	57.11.4331	330 Ohm	2%, 0.25W, MF	
R...	255	57.11.4102	1 kOhm	2%, 0.25W, MF	
R...	256	57.11.4273	27 kOhm	2%, 0.25W, MF	
R...	257	57.11.4102	1 kOhm	2%, 0.25W, MF	
R...	258	57.11.4471	470 Ohm	2%, 0.25W, MF	
R...	259	57.11.4103	10 kOhm	2%, 0.25W, MF	
R...	260	57.11.4621	220 Ohm	2%, 0.25W, MF	
R...	261	57.11.4122	1+2 kOhm	2%, 0.25W, MF	
R...	262	57.11.4471	470 Ohm	2%, 0.25W, MF	
R...	263	57.11.4223	22 kOhm	2%, 0.25W, MF	
R...	264	57.11.4222	2+2 kOhm	2%, 0.25W, MF	
R...	265	57.11.4473	47 kOhm	2%, 0.25W, MF	
R...	266	57.11.4103	10 kOhm	2%, 0.25W, MF	
R...	267	57.11.4682	6+8 kOhm	2%, 0.25W, MF	
R...	268	57.11.4682	6+8 kOhm	2%, 0.25W, MF	
R...	269	57.11.4103	10 kOhm	2%, 0.25W, MF	
R...	270	57.11.4472	4.7 kOhm	2%, 0.25W, MF	
R...	271	57.11.4122	1+2 kOhm	2%, 0.25W, MF	
R...	272	57.11.4223	22 kOhm	2%, 0.25W, MF	
R...	273	57.11.4223	22 kOhm	2%, 0.25W, MF	
R...	274	57.11.4473	47 kOhm	2%, 0.25W, MF	
R...	275	57.11.4223	22 kOhm	2%, 0.25W, MF	
R...	276	57.11.4103	10 kOhm	2%, 0.25W, MF	
R...	277	57.11.4339	3+3 Ohm	2%, 0.25W, MF	
R...	278	57.11.4103	10 kOhm	2%, 0.25W, MF	
R...	279	57.11.4103	10 kOhm	2%, 0.25W, MF	

S T U D E R (00) 87/05/20 GP AUDIO ELECTRONICS BOARD PBO 1.727.465.00 PAGE 5

IND.	POS.NO.	PART NO.	VALUE	SPECIFICATIONS / EQUIVALENT	MANUF.
R...	280	57.11.4339	3+3 Ohm	2%, 0.25W, MF	
R...	281	57.11.4222	2+2 kOhm	2%, 0.25W, MF	
R...	282	57.11.4222	2+2 kOhm	2%, 0.25W, MF	
R...	283	57.11.4339	3+3 Ohm	2%, 0.25W, MF	
R...	284	57.11.4103	10 kOhm	2%, 0.25W, MF	
R...	285	57.11.4103	10 kOhm	2%, 0.25W, MF	
R...	286	57.11.4339	3+3 Ohm	2%, 0.25W, MF	
R...	287	57.11.4472	4.7 kOhm	2%, 0.25W, MF	
R...	288	57.11.4103	10 kOhm	2%, 0.25W, MF	
R...	289	57.11.4471	470 Ohm	2%, 0.25W, MF	
R...	290	57.11.4391	390 Ohm	2%, 0.25W, MF	
R...	291	57.11.4152	1.5 kOhm	2%, 0.25W, MF	
R...	292	57.92.1151	18 Ohm	150mA, PTC	
R...	293	57.11.4180	18 Ohm	2%, 0.25W, MF	
T.....	6	1.022.355.00		Line Output Trafo	St
TP.....	2	54.02.0320		Plug 2.8*0.8	AMP
TP.....	7	54.02.0320		Plug 2.8*0.8	AMP
W.....	11	57.11.4000		Wire Bridge	
XIC...	17	53.03.0168	16-Pole	IC Socket	
XIC...	18	53.03.0168	16-Pole	IC Socket	
XIC...	19	53.03.0166	8-Pole	IC Socket	
XIC...	20	53.03.0166	8-Pole	IC Socket	
XIC...	21	53.03.0166	8-Pole	IC Socket	
XIC...	22	53.03.0166	8-Pole	IC Socket	
XIC...	23	53.03.0165	20-Pole	IC Socket	
XIC...	24	53.03.0166	8-Pole	IC Socket	
XIC...	25	53.03.0166	8-Pole	IC Socket	
XIC...	26	53.03.0168	16-Pole	IC Socket	
XIC...	27	53.03.0166	8-Pole	IC Socket	

S T U D E R (00) 87/05/20 GP AUDIO ELECTRONICS BOARD PBO 1.727.465.00 PAGE 6

IND.	POS.NO.	PART NO.	VALUE	SPECIFICATIONS / EQUIVALENT	MANUF.
Cer = Ceramic EL = Electrolytic PETP = Polyester PP = Polypropylen MF = Metal Film SI = Silicon					
MANUFACTURER: ADI = Analog Devices Inc. Mot = Motorola NS = National Semiconductors Ra = Raytheon Sig = Signetics St = Studer					

DRIG 87/05/20
S T U D E R (00) 87/05/20 GP AUDIO ELECTRONICS BOARD PBO 1.727.465.00 PAGE 7

AUDIO ELECTRONICS (PBO) 1.727.465.81 GRP41/42
 AUDIO ELECTRONICS (PBO) 1.727.425.81 GRP41/42
 - LINE OUTPUT CONNECTOR 1.727.240.00 (SEE PAGE 7/32)

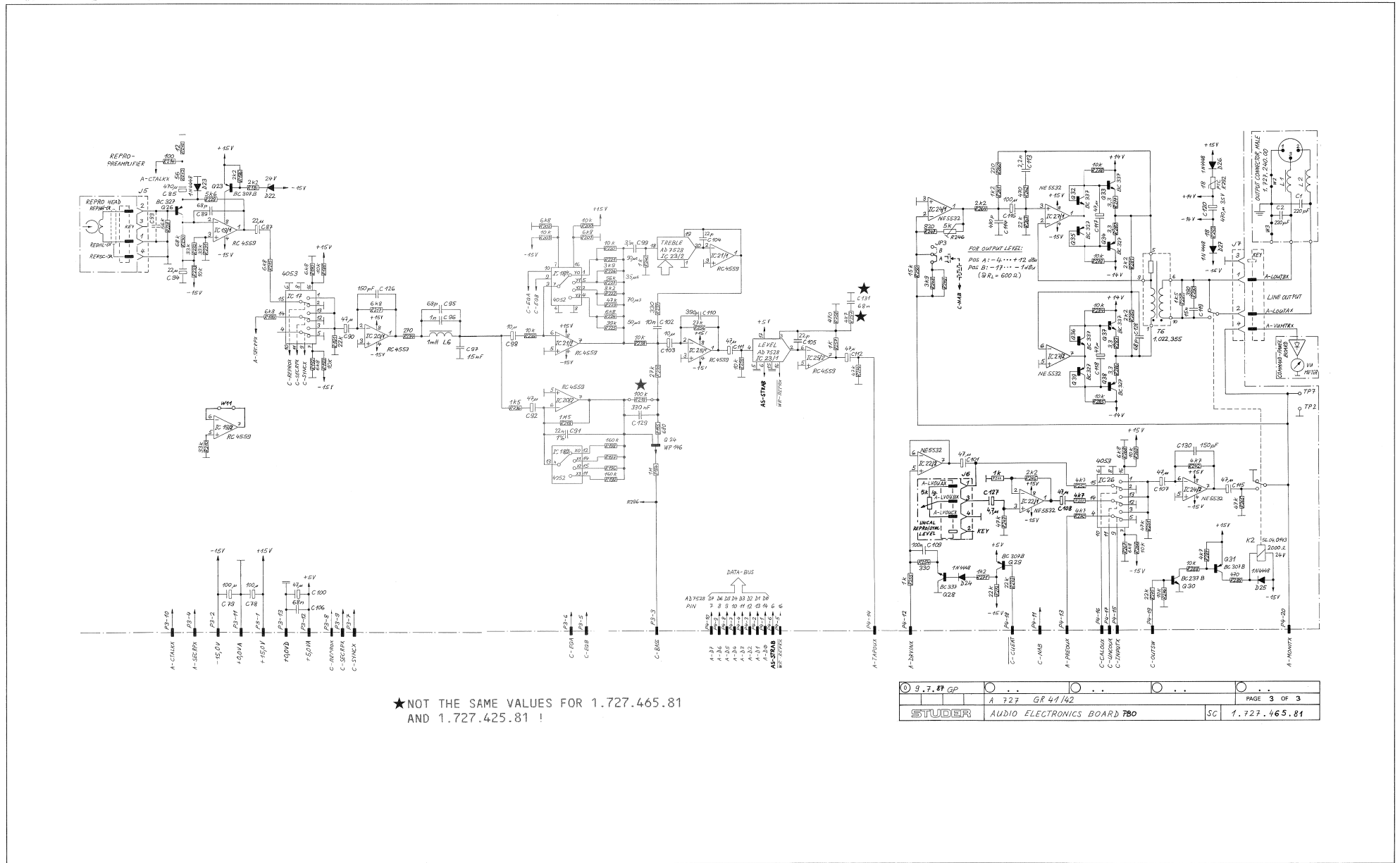

★NOT THE SAME VALUES FOR 1.727.465.81 AND 1.727.425.81 !

0	9	7	87	GP	0	0	0	0	0
A 727 GR 41/42					PAGE 3 OF 3				
STUDER AUDIO ELECTRONICS BOARD PBO					SC 1.727.465.81				



AUDIO ELECTRONICS (PBO) 1.727.465.81 GRP41/42

IND.	POS. NO.	PART NO.	VALUE	SPECIFICATIONS / EQUIVALENT	MANUF.
R...	242	57.11.4472	4.7 kOhm	2% 0.25W MF	
R...	243	57.11.4473	4.7 kOhm	2% 0.25W MF	
R...	244	57.11.4102	1 kOhm	2% 0.25W MF	
R...	245	57.11.4222	2.2 kOhm	2% 0.25W MF	
R...	246	88-01.8809	5 kOhm	10% 0.5 W PWC	
R...	247	57.11.4821	820 Ohm	2% 0.25W MF	
R...	248	57.11.4392	3.9 kOhm	2% 0.25W MF	
R...	249			not used	
R...	250	57.11.4153	15 kOhm	2% 0.25W MF	
R...	251	57.11.4473	4.7 kOhm	2% 0.25W MF	
R...	252	57.11.4472	4.7 kOhm	2% 0.25W MF	
R...	253	57.11.4472	4.7 kOhm	2% 0.25W MF	
R...	254	57.11.4391	390 Ohm	2% 0.25W MF	
R...	255	57.11.4102	1 kOhm	2% 0.25W MF	
R...	256	57.11.4273	27 kOhm	2% 0.25W MF	
R...	257	57.11.4102	1 kOhm	2% 0.25W MF	
R...	258	57.11.4471	470 Ohm	2% 0.25W MF	
R...	259	57.11.4103	10 kOhm	2% 0.25W MF	
R...	260	57.11.4221	220 Ohm	2% 0.25W MF	
R...	261	57.11.4122	1.2 kOhm	2% 0.25W MF	
R...	262	57.11.4471	470 Ohm	2% 0.25W MF	
R...	263	57.11.4223	22 kOhm	2% 0.25W MF	
R...	264	57.11.4222	2.2 kOhm	2% 0.25W MF	
R...	265	57.11.4473	4.7 kOhm	2% 0.25W MF	
R...	266	57.11.4103	10 kOhm	2% 0.25W MF	
R...	267	57.11.4682	6.8 kOhm	2% 0.25W MF	
R...	268	57.11.4682	6.8 kOhm	2% 0.25W MF	
R...	269	57.11.4103	10 kOhm	2% 0.25W MF	
R...	270	57.11.4472	4.7 kOhm	2% 0.25W MF	
R...	271	57.11.4122	1.2 kOhm	2% 0.25W MF	
R...	272	57.11.4223	22 kOhm	2% 0.25W MF	
R...	273	57.11.4223	22 kOhm	2% 0.25W MF	
R...	274	57.11.4473	4.7 kOhm	2% 0.25W MF	
R...	275	57.11.4223	22 kOhm	2% 0.25W MF	
R...	276	57.11.4103	10 kOhm	2% 0.25W MF	
R...	277	57.11.4399	3.3 Ohm	2% 0.25W MF	
R...	278	57.11.4103	10 kOhm	2% 0.25W MF	

S T U D E R (00) 87/07/09 GP AUDIO ELECTRONICS BOARD PBO 1.727.465.81 PAGE 5

IND.	POS. NO.	PART NO.	VALUE	SPECIFICATIONS / EQUIVALENT	MANUF.
R...	279	57.11.4103	10 kOhm	2% 0.25W MF	
R...	280	57.11.4339	3.3 Ohm	2% 0.25W MF	
R...	281	57.11.4222	2.2 kOhm	2% 0.25W MF	
R...	282	57.11.4222	2.2 kOhm	2% 0.25W MF	
R...	283	57.11.4339	3.3 Ohm	2% 0.25W MF	
R...	284	57.11.4103	10 kOhm	2% 0.25W MF	
R...	285	57.11.4103	10 kOhm	2% 0.25W MF	
R...	286	57.11.4399	3.3 Ohm	2% 0.25W MF	
R...	287	57.11.4472	4.7 kOhm	2% 0.25W MF	
R...	288	57.11.4103	10 kOhm	2% 0.25W MF	
R...	289	57.11.4471	470 Ohm	2% 0.25W MF	
R...	290	57.11.4391	390 Ohm	2% 0.25W MF	
R...	291	57.11.4152	1.5 kOhm	2% 0.25W MF	
R...	292	57.92.1151	18 Ohm	150mA PFC	
R...	293	57.11.4180	18 Ohm	2% 0.25W MF	
R...	297	57.11.4472	4.7 kOhm	2% 0.25W MF	
T.....	6	1.022.355.00		Line Output Trafo	St
TP....	2	54.02.0320		Plug 2.8*0.8	AMP
TP....	7	54.02.0320		Plug 2.8*0.8	AMP
W....	11	57.11.4000		Wire Bridge	
XIC..	17	53.03.0168	16-Pole	IC Socket	
XIC..	18	53.03.0168	16-Pole	IC Socket	
XIC..	19	53.03.0166	8-Pole	IC Socket	
XIC..	20	53.03.0166	8-Pole	IC Socket	
XIC..	21	53.03.0166	8-Pole	IC Socket	
XIC..	22	53.03.0166	8-Pole	IC Socket	
XIC..	23	53.03.0165	20-Pole	IC Socket	
XIC..	24	53.03.0166	8-Pole	IC Socket	
XIC..	25	53.03.0166	8-Pole	IC Socket	
XIC..	26	53.03.0168	16-Pole	IC Socket	
XIC..	27	53.03.0166	8-Pole	IC Socket	

S T U D E R (00) 87/07/09 GP AUDIO ELECTRONICS BOARD PBO 1.727.465.81 PAGE 6

IND.	POS. NO.	PART NO.	VALUE	SPECIFICATIONS / EQUIVALENT	MANUF.
Cer = Ceramic EL = Electrolytic PETP = Polyester PP = Polypropylen MF = Metal Film SI = Silicon					
MANUFACTURER: ADI = Analog Devices Inc. Mot = Motorola NS = National Semiconductors Ra = Raytheon Sig = Signetics St = Studer					

ORIG 87/07/09
S T U D E R (00) 87/07/09 GP AUDIO ELECTRONICS BOARD PBO 1.727.465.81 PAGE 7



AUDIO ELECTRONICS (PBO) 1.727.425.81 GRP41/42

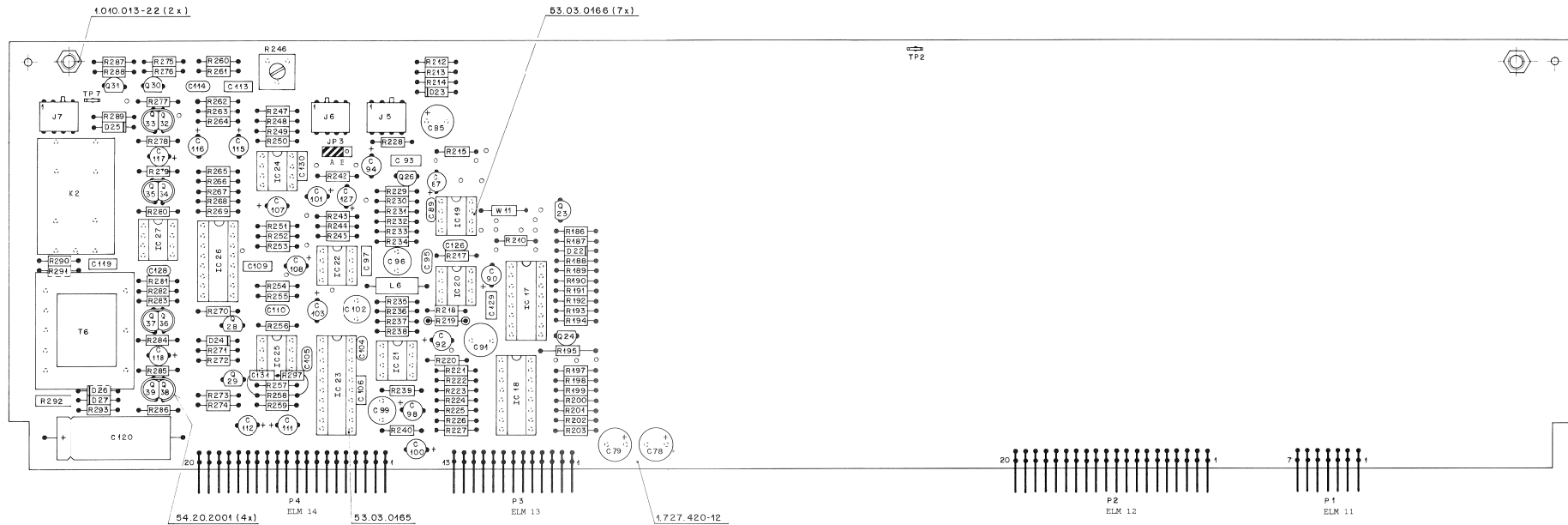

R246 = OUTPUT LEVEL ADJUSTMENT
 JP3 OUTPUT LEVEL SENSITIVITY
 TP2 0.6 V
 TP7 VU METER SIGNAL (0.775 V = 0 VU)

FACTORY STANDARD SETTING

INO.	PDS-NO.	PART NO.	VALUE	SPECIFICATIONS / EQUIVALENT	MANUF.
A.....1	1.727.425.81			AUDIO ELECTRONICS BOARD PBO	
C...131	59.96.0474	D+70P	101	90V PEP	
MP...10	1.727.425.10		1	pcs Ro. Label	
R...219	57.11.4473	47 KOhm	2x	0.25W. MF. with socket	
R...297	57.11.4182	1.8 KOhm	2x	0.25W. MF	

Cer = Ceramic EL = Electrolytic PETP = Polyester
 PP = Polypropylon ME = Metall Film SI = Silicon
 MANUFACTURER: ADI = Analog Devices Incc. Rot = Motorola
 NS = National Semiconductors Ro = Raytheon
 Sig = Signetics ST = Studer

ORIG 07/12/18
 S U D E R (00) 07/12/18 GP AUDIO ELECTRON. PBO (SERVICE) 1.727.425.81 PAGE 1



AUDIO ELECTRONICS VUK (2 VU/HS) 1.727.467.00 GRP41/42

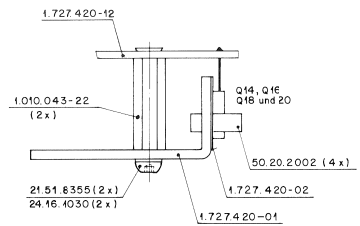
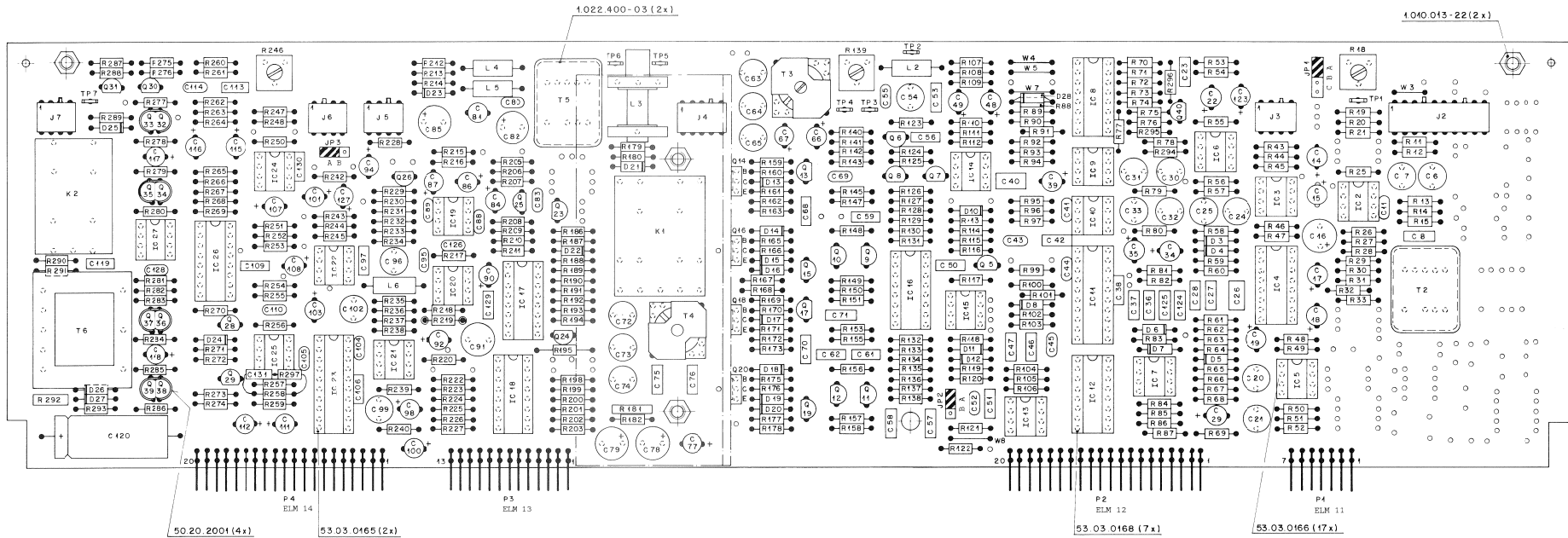

- R18 = INPUT LEVEL ADJUSTMENT
- R139 = ERASE VOLTAGE ADJUSTMENT
- R246 = OUTPUT LEVEL ADJUSTMENT
- L3 = BIAS TRAP
- T3 = ERASE HEAD CIRCUIT
- JP1 INPUT LEVEL SENSITIVITY
- JP2 HX PRO: A = ON, B = OFF
- JP3 OUTPUT LEVEL SENSITIVITY
- TP1 RECORD AMPLIFIER SIGNAL (0.775 V ± 0 VU)
- TP2 0.8 V
- TP3 VOLTAGE ON ERASE HEAD
- TP4 PRIMARY CURRENT ON ERASE TRANSFORMER
- TP5 BIAS TRAP
- TP6 REJECTOR FILTER ADJUSTMENT (0.775 V ± 0 VU)
- TP7 VU METER SIGNAL (0.775 V ± 0 VU)

FACTORY STANDARD SETTING



AUDIO ELECTRONICS VUK (2 VU/HS) 1.727.467.00 GRP41/24

Table with columns: IND., POS.ND., PART NO., VALUE, SPECIFICATIONS / EQUIVALENT, MANUF., and a partial view of the next column. It lists various electronic components like capacitors and resistors.

S T U D E R (00) 89/02/16 GP AUDIO ELECTR. BOARD 2/2 VUK HS 1.727.467.00 PAGE 1

Table with columns: IND., POS.ND., PART NO., VALUE, SPECIFICATIONS / EQUIVALENT, MANUF., and a partial view of the next column. It lists various electronic components like capacitors and resistors.

S T U D E R (00) 89/02/16 GP AUDIO ELECTR. BOARD 2/2 VUK HS 1.727.467.00 PAGE 2

Table with columns: IND., POS.ND., PART NO., VALUE, SPECIFICATIONS / EQUIVALENT, MANUF., and a partial view of the next column. It lists various electronic components like capacitors and resistors.

S T U D E R (00) 89/02/16 GP AUDIO ELECTR. BOARD 2/2 VUK HS 1.727.467.00 PAGE 3

Table with columns: IND., POS.ND., PART NO., VALUE, SPECIFICATIONS / EQUIVALENT, MANUF., and a partial view of the next column. It lists various electronic components like capacitors and resistors.

S T U D E R (00) 89/02/16 GP AUDIO ELECTR. BOARD 2/2 VUK HS 1.727.467.00 PAGE 4

Table with columns: IND., POS.ND., PART NO., VALUE, SPECIFICATIONS / EQUIVALENT, MANUF., and a partial view of the next column. It lists various electronic components like capacitors and resistors.

S T U D E R (00) 89/02/16 GP AUDIO ELECTR. BOARD 2/2 VUK HS 1.727.467.00 PAGE 5

Table with columns: IND., POS.ND., PART NO., VALUE, SPECIFICATIONS / EQUIVALENT, MANUF., and a partial view of the next column. It lists various electronic components like capacitors and resistors.

S T U D E R (00) 89/02/16 GP AUDIO ELECTR. BOARD 2/2 VUK HS 1.727.467.00 PAGE 6

Table with columns: IND., POS.ND., PART NO., VALUE, SPECIFICATIONS / EQUIVALENT, MANUF., and a partial view of the next column. It lists various electronic components like capacitors and resistors.

S T U D E R (00) 89/02/16 GP AUDIO ELECTR. BOARD 2/2 VUK HS 1.727.467.00 PAGE 7

Table with columns: IND., POS.ND., PART NO., VALUE, SPECIFICATIONS / EQUIVALENT, MANUF., and a partial view of the next column. It lists various electronic components like capacitors and resistors.

S T U D E R (00) 89/02/16 GP AUDIO ELECTR. BOARD 2/2 VUK HS 1.727.467.00 PAGE 8

Table with columns: IND., POS.ND., PART NO., VALUE, SPECIFICATIONS / EQUIVALENT, MANUF., and a partial view of the next column. It lists various electronic components like capacitors and resistors.

S T U D E R (00) 89/02/16 GP AUDIO ELECTR. BOARD 2/2 VUK HS 1.727.467.00 PAGE 9

Table with columns: IND., POS.ND., PART NO., VALUE, SPECIFICATIONS / EQUIVALENT, MANUF., and a partial view of the next column. It lists various electronic components like capacitors and resistors.

S T U D E R (00) 89/02/16 GP AUDIO ELECTR. BOARD 2/2 VUK HS 1.727.467.00 PAGE 10

Table with columns: IND., POS.ND., PART NO., VALUE, SPECIFICATIONS / EQUIVALENT, MANUF., and a partial view of the next column. It lists various electronic components like capacitors and resistors.

S T U D E R (00) 89/02/16 GP AUDIO ELECTR. BOARD 2/2 VUK HS 1.727.467.00 PAGE 11



AUDIO ELECTRONICS VUK (2 VU/HS) 1.727.467.00 GRP41/42

IND.	POS.NO.	PART NO.	VALUE	SPECIFICATIONS / EQUIVALENT	MANUF.	IND.	POS.NO.	PART NO.	VALUE	SPECIFICATIONS / EQUIVALENT	MANUF.
R...	220	57.11.3222	2.2 kOhm	1%, 0.25W, MF		XIC..	13	53.03.0166	8-Pole	IC Socket	
R...	221			not used		XIC..	14	53.03.0166	8-Pole	IC Socket	
R...	222	57.11.3392	3.9 kOhm	1%, 0.25W, MF		XIC..	15	53.03.0166	8-Pole	IC Socket	
R...	223	57.11.3563	56 kOhm	1%, 0.25W, MF		XIC..	16	53.03.0168	16-Pole	IC Socket	
R...	224	57.11.3642	6.8 kOhm	1%, 0.25W, MF		XIC..	17	53.03.0168	16-Pole	IC Socket	
R...	225	57.11.3393	39 kOhm	1%, 0.25W, MF		XIC..	18	53.03.0168	16-Pole	IC Socket	
R...	226	57.11.3822	8.2 kOhm	1%, 0.25W, MF		XIC..	19	53.03.0166	8-Pole	IC Socket	
R...	227	57.11.3473	47 kOhm	1%, 0.25W, MF		XIC..	20	53.03.0166	8-Pole	IC Socket	
R...	228	57.11.3565	56 kOhm	1%, 0.25W, MF		XIC..	21	53.03.0166	8-Pole	IC Socket	
R...	229	57.11.3562	5.6 kOhm	1%, 0.25W, MF		XIC..	22	53.03.0166	8-Pole	IC Socket	
R...	230	57.11.3683	68 kOhm	1%, 0.25W, MF		XIC..	23	53.03.0165	20-Pole	IC Socket	
R...	231	57.11.3333	33 kOhm	1%, 0.25W, MF		XIC..	24	53.03.0166	8-Pole	IC Socket	
R...	232	57.11.3333	33 kOhm	1%, 0.25W, MF		XIC..	25	53.03.0166	8-Pole	IC Socket	
R...	233	57.11.3103	10 kOhm	1%, 0.25W, MF		XIC..	26	53.03.0168	16-Pole	IC Socket	
R...	234	57.11.3271	270 Ohm	1%, 0.25W, MF		XIC..	27	53.03.0166	8-Pole	IC Socket	
R...	235	57.11.3273	27 kOhm	1%, 0.25W, MF							
R...	236	57.11.3152	1.5 kOhm	1%, 0.25W, MF							
R...	237	57.11.3331	330 Ohm	1%, 0.25W, MF							
R...	238	57.11.3103	10 kOhm	1%, 0.25W, MF							
R...	239	57.11.3103	10 kOhm	1%, 0.25W, MF							
R...	240	57.11.3102	1 kOhm	1%, 0.25W, MF							
R...	241			not used							
R...	242	57.11.3472	4.7 kOhm	1%, 0.25W, MF							
R...	243	57.11.3473	47 kOhm	1%, 0.25W, MF							
R...	244	57.11.3102	1 kOhm	1%, 0.25W, MF							
R...	245	57.11.3222	2.2 kOhm	1%, 0.25W, MF							
R...	246	56.01.8502	5 kOhm	10%, 0.5 W, PMG							
R...	247	57.11.3221	220 Ohm	1%, 0.25W, MF							
R...	248	57.11.3392	3.9 kOhm	1%, 0.25W, MF							
R...	249			not used							
R...	250	57.11.3153	15 kOhm	1%, 0.25W, MF							
R...	251	57.11.3473	47 kOhm	1%, 0.25W, MF							
R...	252	57.11.3472	4.7 kOhm	1%, 0.25W, MF							
R...	253	57.11.3472	4.7 kOhm	1%, 0.25W, MF							
R...	254	57.11.3331	330 Ohm	1%, 0.25W, MF							
R...	255	57.11.3102	1 kOhm	1%, 0.25W, MF							
R...	256	57.11.3273	27 kOhm	1%, 0.25W, MF							

Cer = Ceramic EL = Electrolytic PETP = Polyester
 PP = Polypropylen MF = Metal Film SI = Silicon
 MANUFACTURER: ADI = Analog Devices Inc. MoL = Motorola
 NS = National Semiconductors Ra = Raytheon
 Sig = Signetics St = Studer

ORIG 88/02/16

S T U D E R (00) 88/02/16 GP AUDIO ELECTR. BOARD 2/2 VUK HS 1.727.467.00 PAGE 13

S T U D E R (00) 88/02/16 GP AUDIO ELECTR. BOARD 2/2 VUK HS 1.727.467.00 PAGE 16

IND.	POS.NO.	PART NO.	VALUE	SPECIFICATIONS / EQUIVALENT	MANUF.
R...	257	57.11.3102	1 kOhm	1%, 0.25W, MF	
R...	258	57.11.3471	470 Ohm	1%, 0.25W, MF	
R...	259	57.11.3103	10 kOhm	1%, 0.25W, MF	
R...	260	57.11.3221	220 Ohm	1%, 0.25W, MF	
R...	261	57.11.3122	1.2 kOhm	1%, 0.25W, MF	
R...	262	57.11.3471	470 Ohm	1%, 0.25W, MF	
R...	263	57.11.3223	22 kOhm	1%, 0.25W, MF	
R...	264	57.11.3222	22 kOhm	1%, 0.25W, MF	
R...	265	57.11.3473	47 kOhm	1%, 0.25W, MF	
R...	266	57.11.3103	10 kOhm	1%, 0.25W, MF	
R...	267	57.11.3682	6.8 kOhm	1%, 0.25W, MF	
R...	268	57.11.3682	6.8 kOhm	1%, 0.25W, MF	
R...	269	57.11.3103	10 kOhm	1%, 0.25W, MF	
R...	270	57.11.3472	4.7 kOhm	1%, 0.25W, MF	
R...	271	57.11.3122	1.2 kOhm	1%, 0.25W, MF	
R...	272	57.11.3223	22 kOhm	1%, 0.25W, MF	
R...	273	57.11.3223	22 kOhm	1%, 0.25W, MF	
R...	274	57.11.3473	47 kOhm	1%, 0.25W, MF	
R...	275	57.11.3223	22 kOhm	1%, 0.25W, MF	
R...	276	57.11.3103	10 kOhm	1%, 0.25W, MF	
R...	277	57.11.3339	3.3 Ohm	1%, 0.25W, MF	
R...	278	57.11.3103	10 kOhm	1%, 0.25W, MF	
R...	279	57.11.3103	10 kOhm	1%, 0.25W, MF	
R...	280	57.11.3339	3.3 Ohm	1%, 0.25W, MF	
R...	281	57.11.3222	2.2 kOhm	1%, 0.25W, MF	
R...	282	57.11.3222	2.2 kOhm	1%, 0.25W, MF	
R...	283	57.11.3339	3.3 Ohm	1%, 0.25W, MF	
R...	284	57.11.3103	10 kOhm	1%, 0.25W, MF	
R...	285	57.11.3103	10 kOhm	1%, 0.25W, MF	
R...	286	57.11.3339	3.3 Ohm	1%, 0.25W, MF	
R...	287	57.11.3472	4.7 kOhm	1%, 0.25W, MF	
R...	288	57.11.3103	10 kOhm	1%, 0.25W, MF	
R...	289	57.11.3471	470 Ohm	1%, 0.25W, MF	
R...	290	57.11.3391	390 Ohm	1%, 0.25W, MF	
R...	291	57.11.3152	1.5 kOhm	1%, 0.25W, MF	
R...	292	57.92.1151	18 Ohm	150mA, PTC	
R...	293	57.11.3180	18 Ohm	1%, 0.25W, MF	

S T U D E R (00) 88/02/16 GP AUDIO ELECTR. BOARD 2/2 VUK HS 1.727.467.00 PAGE 14

IND.	POS.NO.	PART NO.	VALUE	SPECIFICATIONS / EQUIVALENT	MANUF.
R...	294	57.11.3470	47 Ohm	1%, 0.25W, MF	
R...	295	57.11.3223	22 kOhm	1%, 0.25W, MF	
R...	296	57.11.3105	1 MOhm	1%, 0.25W, MF	
R...	297	57.11.3472	4.7 kOhm	1%, 0.25W, MF	
T...	2	1.022.451.00	1:0.62	Line Input Trafo	St
T...	3	1.022.271.00		Erase Trafo	St
T...	4	1.022.272.00		Back Trafo	St
T...	5	1.022.402.00	1:10	Sync Trafo	St
T...	6	1.022.355.00		Line Output Trafo	St
TP...	1	54.02.0320		Plug 2.890.8	AMP
TP...	2	54.02.0320		Plug 2.890.8	AMP
TP...	3	54.02.0320		Plug 2.890.8	AMP
TP...	4	54.02.0320		Plug 2.890.8	AMP
TP...	5	54.02.0320		Plug 2.890.8	AMP
TP...	6	54.02.0320		Plug 2.890.8	AMP
TP...	7	54.02.0320		Plug 2.890.8	AMP
W...	3	64.01.0106		Wire Bridge	
W...	4	64.01.0106		Wire Bridge	
W...	5	64.01.0106		Wire Bridge	
W...	6			not used	
W...	7	64.01.0106		Wire Bridge	
W...	8	64.01.0106		Wire Bridge	
XIC...	2	53.03.0166		8-Pole IC Socket	
XIC...	3	53.03.0168		16-Pole IC Socket	
XIC...	4	53.03.0166		8-Pole IC Socket	
XIC...	5	53.03.0166		8-Pole IC Socket	
XIC...	6	53.03.0166		8-Pole IC Socket	
XIC...	7	53.03.0166		8-Pole IC Socket	
XIC...	8	53.03.0168		16-Pole IC Socket	
XIC...	9	53.03.0166		8-Pole IC Socket	
XIC...	10	53.03.0166		8-Pole IC Socket	
XIC...	11	53.03.0169		20-Pole IC Socket	
XIC...	12	53.03.0168		16-Pole IC Socket	

S T U D E R (00) 88/02/16 GP AUDIO ELECTR. BOARD 2/2 VUK HS 1.727.467.00 PAGE 15

MONO/STEREO SWITCH BLOCK DIAGRAM (WITH TEST GENERATOR)

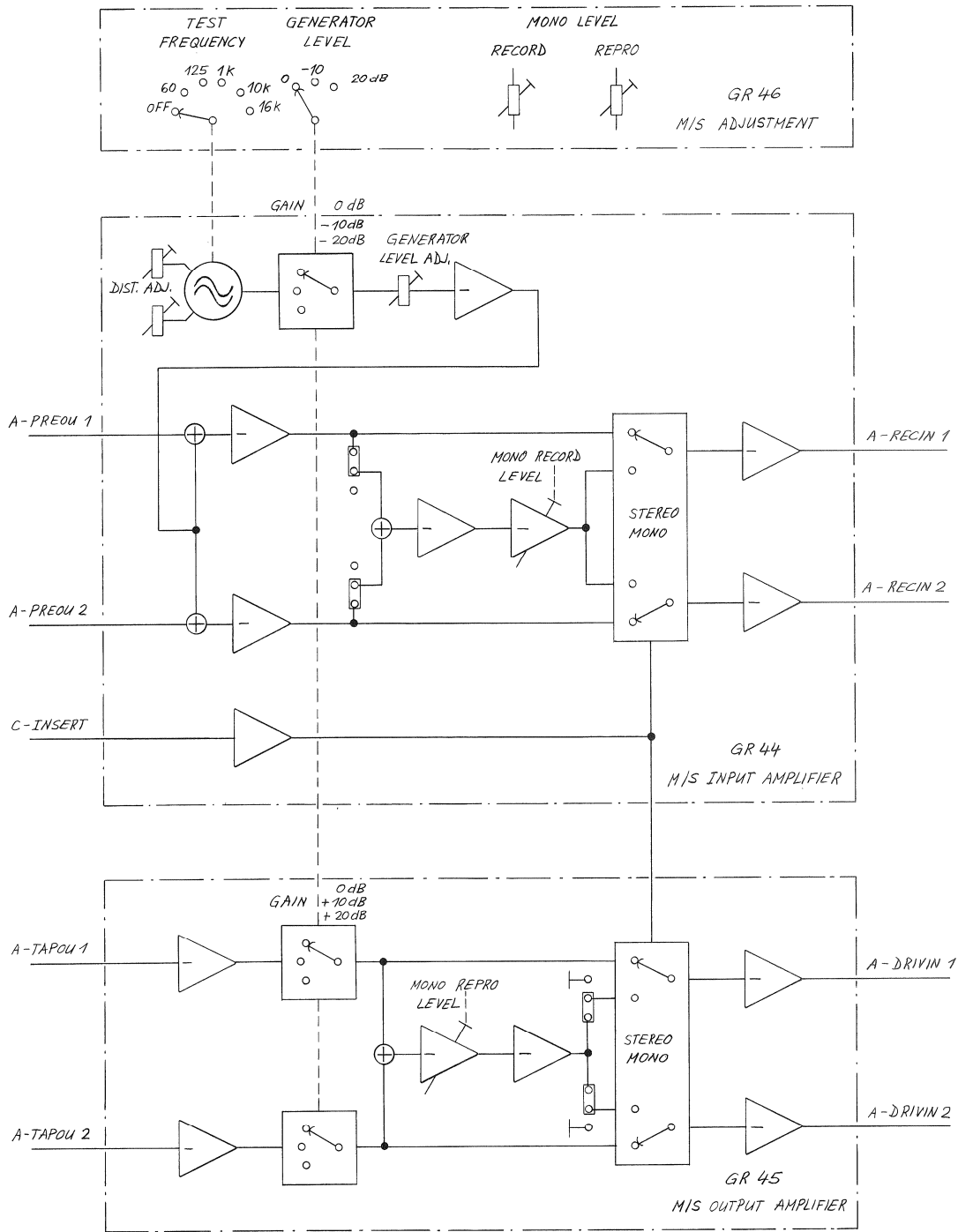

① 27.2.87 GP	○ ..	○ ..	○ ..	○ ..
	A 807			PAGE 1 OF 1
STUDER	MONO / STEREO SWITCH BLOCK DIAGRAM			1.727.440.00

MONO/STEREO SWITCH WIRING DIAGRAM

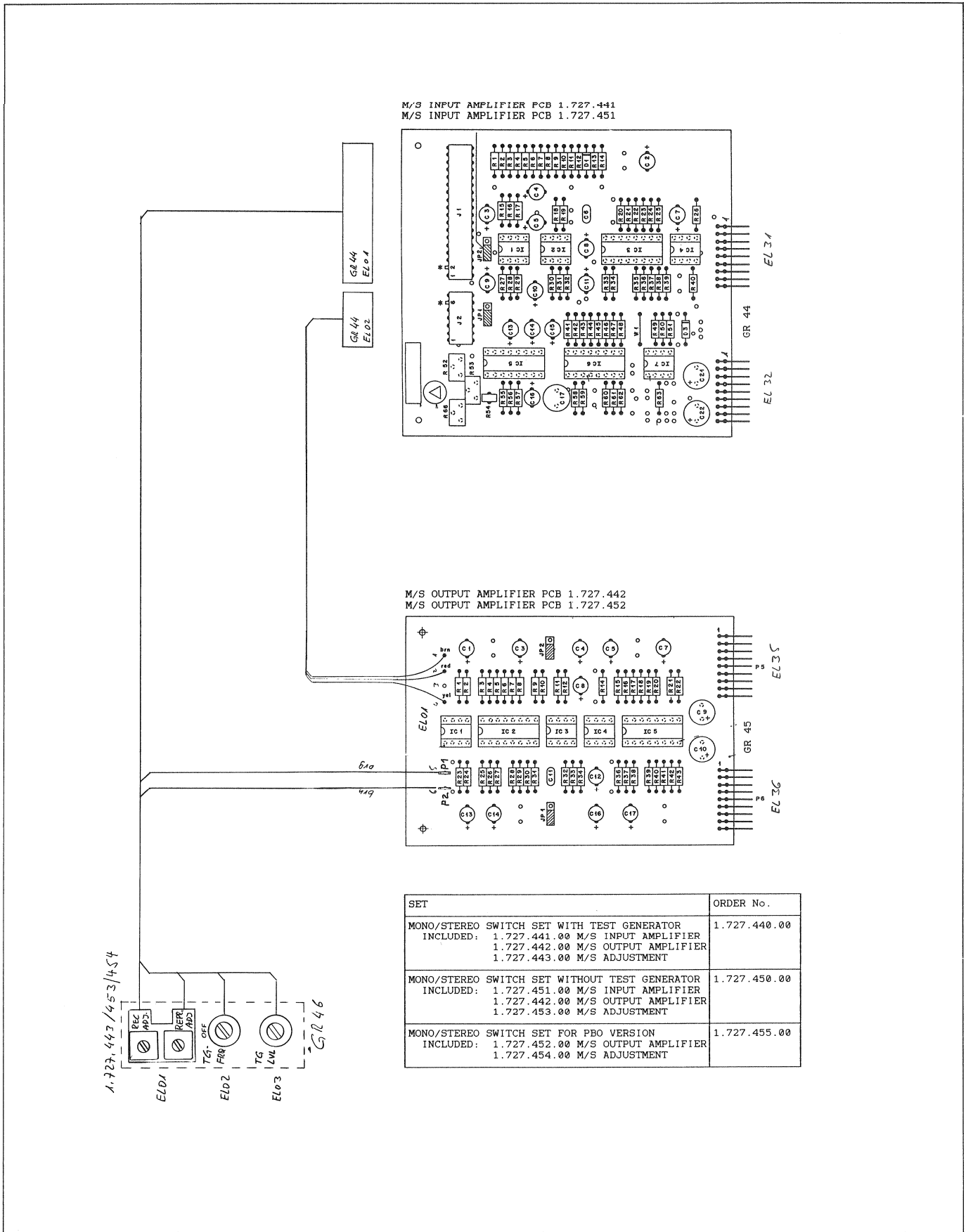

M/S INPUT AMPLIFIER PCB 1.727.441
M/S INPUT AMPLIFIER PCB 1.727.451

M/S OUTPUT AMPLIFIER PCB 1.727.442
M/S OUTPUT AMPLIFIER PCB 1.727.452

SET	ORDER No.
MONO/STEREO SWITCH SET WITH TEST GENERATOR INCLUDED: 1.727.441.00 M/S INPUT AMPLIFIER 1.727.442.00 M/S OUTPUT AMPLIFIER 1.727.443.00 M/S ADJUSTMENT	1.727.440.00
MONO/STEREO SWITCH SET WITHOUT TEST GENERATOR INCLUDED: 1.727.451.00 M/S INPUT AMPLIFIER 1.727.442.00 M/S OUTPUT AMPLIFIER 1.727.453.00 M/S ADJUSTMENT	1.727.450.00
MONO/STEREO SWITCH SET FOR PBO VERSION INCLUDED: 1.727.452.00 M/S OUTPUT AMPLIFIER 1.727.454.00 M/S ADJUSTMENT	1.727.455.00

1.727.443 / 453 / 454

M/S INPUT AMPLIFIER WITH TEST GENERATOR 1.727.441.00 GRP44

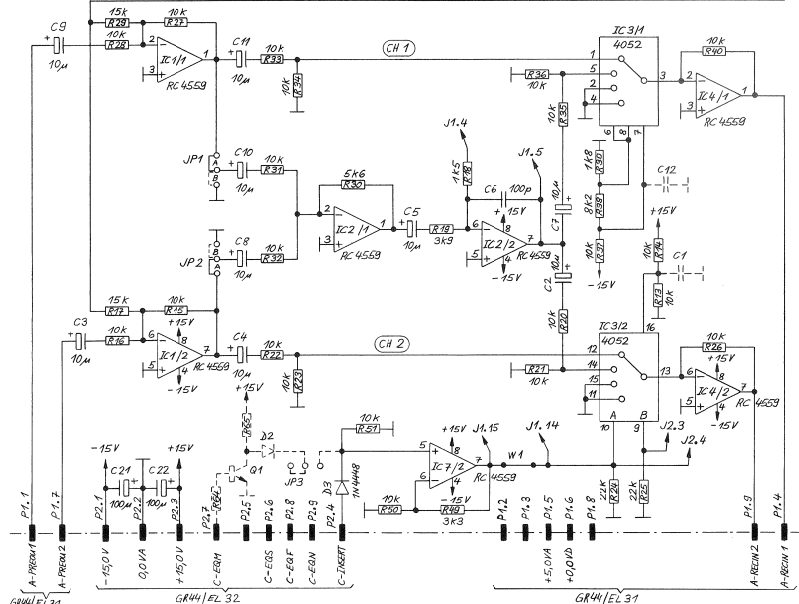
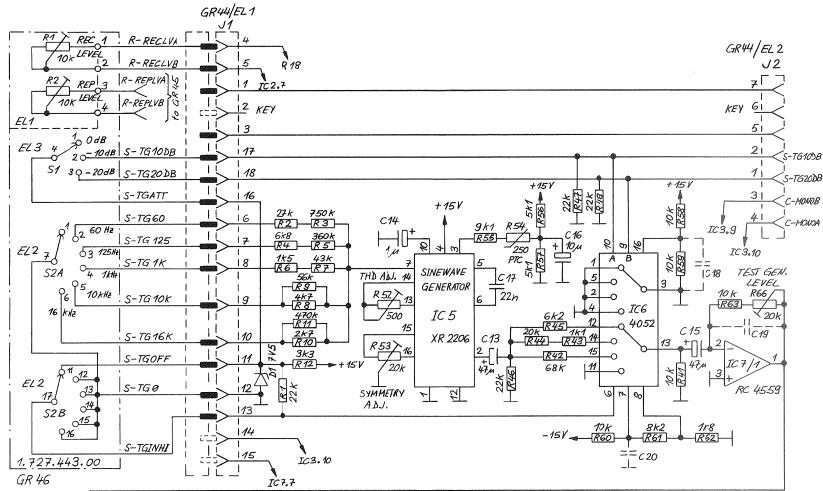

① 26.2.87 GP	① 26.3.87 GP	② 12.2.88 GP	○ . .	○ . .
A - 807 GR 44, GR 46				
PAGE 1 OF 1				
STUDER		M/S INPUT AMPL. BOARD WITH TEST GEN.		SC 1.727.441.00



M/S INPUT AMPLIFIER WITH TEST GENERATOR 1.727.441.00 GRP44

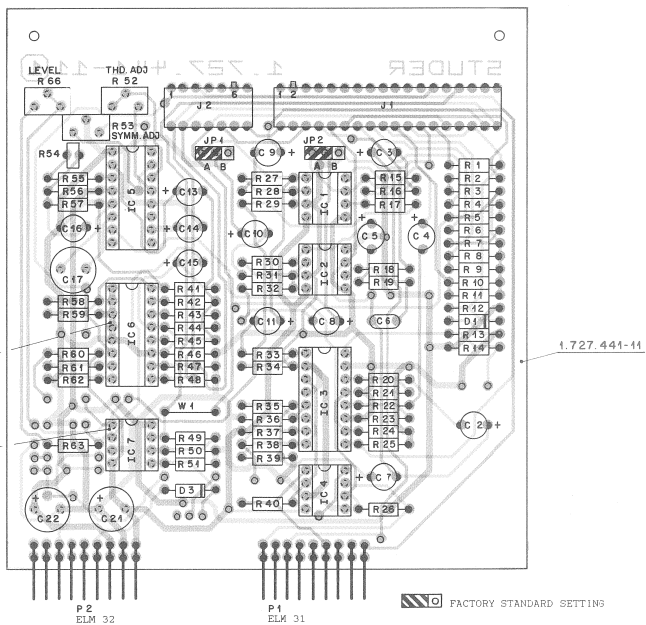

JP1: A = INPUT SIGNAL FROM CH1 ON
 B = INPUT SIGNAL FROM CH1 OFF
JP2: A = INPUT SIGNAL FROM CH2 ON
 B = INPUT SIGNAL FROM CH2 OFF
R52 = THD ADJUSTMENT
R53 = SYMMETRY ADJUSTMENT
R66 = TEST GENERATOR LEVEL

IND.	POS.ND.	PART NO.	VALUE	SPECIFICATIONS / EQUIVALENT	MANUF.
C****1				not used	
C****2	59-22-0400	10 uF	-20%	35V EL	
C****3	59-22-0400	10 uF	-20%	35V EL	
C****4	59-22-0400	10 uF	-20%	35V EL	
C****5	59-22-0400	10 uF	-20%	35V EL	
C****6	59-24-0101	100 uF	10%	50V Cor	
C****7	59-22-0400	10 uF	-20%	35V EL	
C****8	59-22-0400	10 uF	-20%	35V EL	
C****9	59-22-0400	10 uF	-20%	35V EL	
C****10	59-22-0400	10 uF	-20%	35V EL	
C****11	59-22-0400	10 uF	-20%	35V EL	
C****12				not used	
C****13	59-22-3470	47 uF	-20%	10V EL	
C****14	59-22-0409	1 uF	-20%	25V EL	
C****15	59-22-3470	47 uF	-20%	10V EL	
C****16	59-22-0400	10 uF	-20%	35V EL	
C****17	59-05-1223	22 nF	1%	50V PP	
C****18				not used	
C****19				not used	
C****20				not used	
C****21	59-22-5101	100 uF	-20%	25V EL	
C****22	59-22-5101	100 uF	-20%	25V EL	
D****1	50-04-1103	2-01060	7.5V	not used	
D****2				not used	
D****3	50-04-0025	18c444	75V	not used	
IC****1	50-09-0027	RC 4559		Dual Op. Amp.	
IC****2	50-09-0027	RC 4559		Dual Op. Amp.	
IC****3	50-07-0024	AC 14052		CM5 AMS	Not
IC****4	50-09-0027	RC 4559		Dual Op. Amp.	Ra
IC****5	50-11-0108	AS 2206CP		Function Gene.	Ra
IC****6	50-07-0024	AC 14052		CM5 AMS	Not
IC****7	50-09-0027	RC 4559		Dual Op. Amp.	
J****1	54-01-0207	18-Pole		CIS Socket Strip	AMP
J****2	54-01-0244	7-Pole		CIS Socket Strip	AMP

STUDER (01) 89/02/12 GP M/S INPUT AMPL. BOARD W.T.GEN. 1.727.441.00 PAGE 1

IND.	POS.ND.	PART NO.	VALUE	SPECIFICATIONS / EQUIVALENT	MANUF.
JP****1	54-01-0201			Bridge	
JP****2	54-01-0201			Bridge	
JP****3				not used	
MP****1	1.727.441-10	0 pcs		No. Label	St
MP****2	1.727.441-11	1 pcs		Input Ampl. PCB	St
MP****3	54-01-0200	3 pcs		Contact Pin JPI	
MP****4	54-01-0200	1 pcs		Contact Pin JPC	
MP****5	43-01-0108	1 pcs		ESE Warning Label	
P****1	54-01-0270	9-Pole		CIS Pin Strip	AMP
P****2	54-01-0220	9-Pole		CIS Pin Strip	AMP
Q****1				not used	
R****1	57-11-1223	22 kOhm	1%	0.25W MF	
R****2	57-11-1213	27 kOhm	1%	0.25W MF	
R****3	57-11-1754	750 kOhm	1%	0.25W MF	
R****4	57-11-1682	6.8 kOhm	1%	0.25W MF	
R****5	57-11-1764	360 kOhm	1%	0.25W MF	
R****6	57-11-1512	1.5 kOhm	1%	0.25W MF	
R****7	57-11-1613	4.3 kOhm	1%	0.25W MF	
R****8	57-11-1672	4.7 kOhm	1%	0.25W MF	
R****9	57-11-1613	4.3 kOhm	1%	0.25W MF	
R****10	57-11-1272	2.7 kOhm	1%	0.25W MF	
R****11	57-11-1474	470 kOhm	1%	0.25W MF	
R****12	57-11-1312	3.3 kOhm	1%	0.25W MF	
R****13	57-11-1303	10 kOhm	1%	0.25W MF	
R****14	57-11-1303	10 kOhm	1%	0.25W MF	
R****15	57-11-1303	10 kOhm	1%	0.25W MF	
R****16	57-11-1303	10 kOhm	1%	0.25W MF	
R****17	57-11-1303	10 kOhm	1%	0.25W MF	
R****18	57-11-1303	10 kOhm	1%	0.25W MF	
R****19	57-11-1302	2.2 kOhm	1%	0.25W MF	
R****20	57-11-1302	1.5 kOhm	1%	0.25W MF	
R****21	57-11-1302	3.9 kOhm	1%	0.25W MF	
R****22	57-11-1303	10 kOhm	1%	0.25W MF	

STUDER (01) 89/02/12 GP M/S INPUT AMPL. BOARD W.T.GEN. 1.727.441.00 PAGE 2

IND.	POS.ND.	PART NO.	VALUE	SPECIFICATIONS / EQUIVALENT	MANUF.
R****22	57-11-1303	10 kOhm	1%	0.25W MF	
R****23	57-11-1303	10 kOhm	1%	0.25W MF	
R****24	57-11-1223	22 kOhm	1%	0.25W MF	
R****25	57-11-1223	22 kOhm	1%	0.25W MF	
R****26	57-11-1303	10 kOhm	1%	0.25W MF	
R****27	57-11-1303	10 kOhm	1%	0.25W MF	
R****28	57-11-1303	10 kOhm	1%	0.25W MF	
R****29	57-11-1303	10 kOhm	1%	0.25W MF	
R****30	57-11-1562	5.6 kOhm	1%	0.25W MF	
R****31	57-11-1303	10 kOhm	1%	0.25W MF	
R****32	57-11-1303	10 kOhm	1%	0.25W MF	
R****33	57-11-1303	10 kOhm	1%	0.25W MF	
R****34	57-11-1303	10 kOhm	1%	0.25W MF	
R****35	57-11-1303	10 kOhm	1%	0.25W MF	
R****36	57-11-1303	10 kOhm	1%	0.25W MF	
R****37	57-11-1303	10 kOhm	1%	0.25W MF	
R****38	57-11-1622	8.2 kOhm	1%	0.25W MF	
R****39	57-11-1302	1.8 kOhm	1%	0.25W MF	
R****40	57-11-1303	10 kOhm	1%	0.25W MF	
R****41	57-11-1303	10 kOhm	1%	0.25W MF	
R****42	57-11-2683	68 kOhm	1%	0.25W MF	
R****43	57-11-1112	1.1 kOhm	1%	0.25W MF	
R****44	57-11-2003	20 kOhm	1%	0.25W MF	
R****45	57-11-2622	6.2 kOhm	1%	0.25W MF	
R****46	57-11-1223	22 kOhm	1%	0.25W MF	
R****47	57-11-1223	22 kOhm	1%	0.25W MF	
R****48	57-11-1223	22 kOhm	1%	0.25W MF	
R****49	57-11-1302	3.3 kOhm	1%	0.25W MF	
R****50	57-11-1303	10 kOhm	1%	0.25W MF	
R****51	57-11-1303	10 kOhm	1%	0.25W MF	
R****52	56-01-1901	500 Ohm	10%	0.5W Pccern	
R****53	50-04-0003	20 kOhm	10%	0.5W Pccern	
R****54	57-99-0216	25% Ohm		PTE Resistor	
R****55	57-11-1912	9.1 kOhm	1%	0.25W MF	
R****56	57-11-1512	5.1 kOhm	1%	0.25W MF	
R****57	57-11-1512	5.1 kOhm	1%	0.25W MF	
R****58	57-11-1303	10 kOhm	1%	0.25W MF	

STUDER (01) 89/02/12 GP M/S INPUT AMPL. BOARD W.T.GEN. 1.727.441.00 PAGE 3



M/S OUTPUT AMPLIFIER WITH TEST GENERATOR 1.727.442.00 GRP45

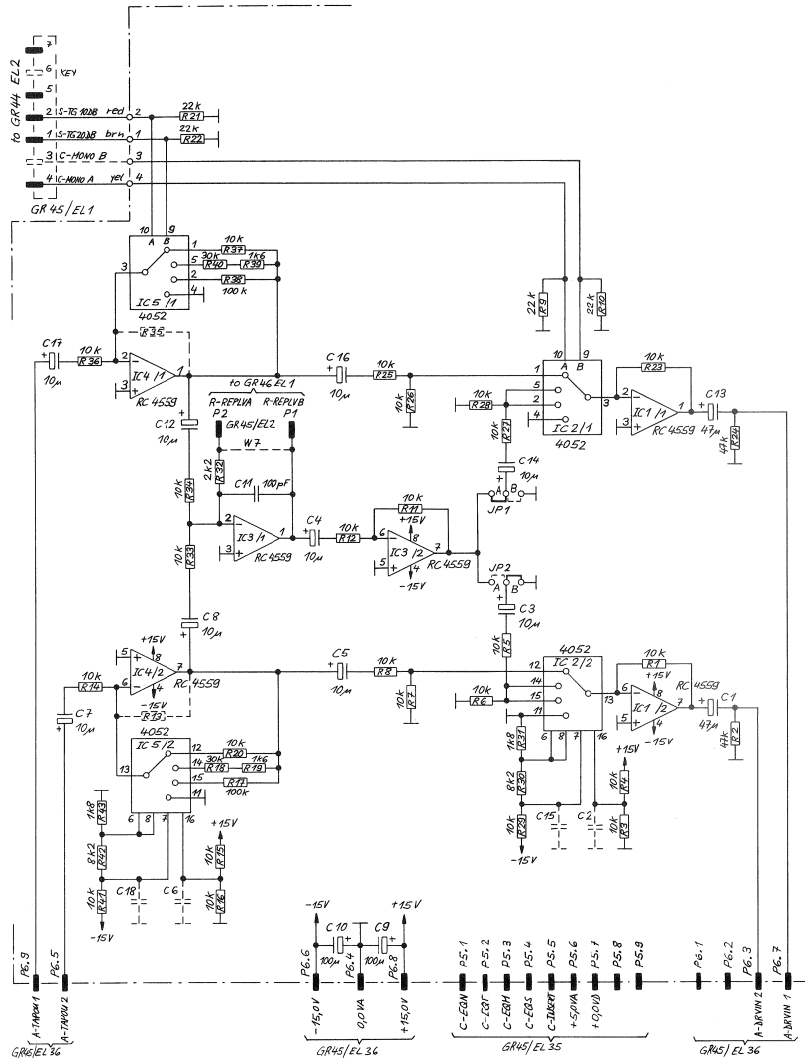

① 26.02.87 GP	① 26.3.87 GP		
A-807 GR 45		PAGE 1 OF 1	
STUDER	M/S OUTPUT AMPL. BOARD	SC	1.727.442.00

M/S ADJUSTMENT WITH TEST GENERATOR 1.727.443.00 GRP46

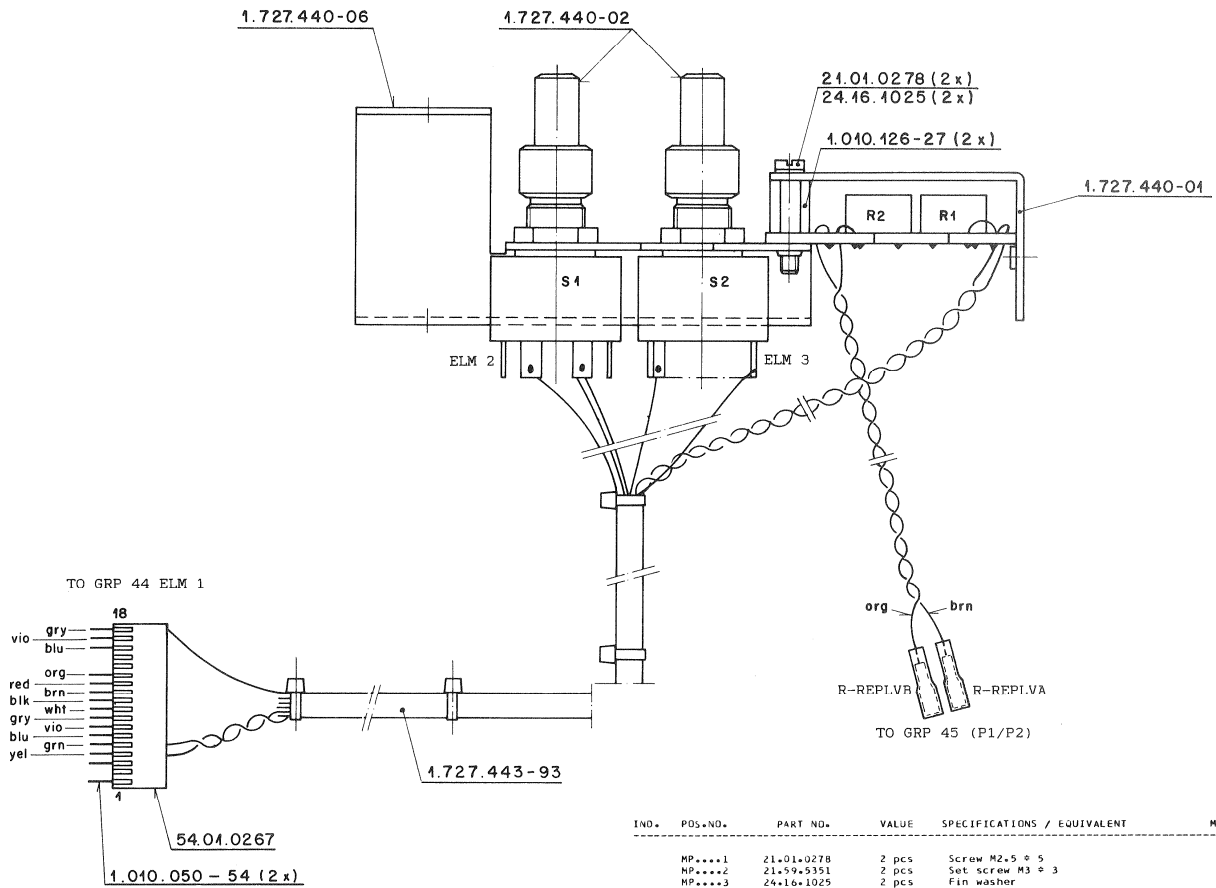
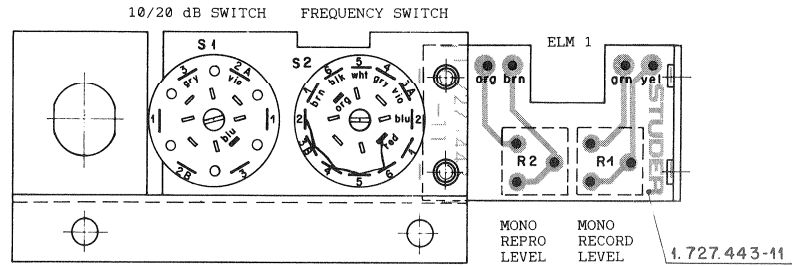

IND.	POS. NO.	PART NO.	VALUE	SPECIFICATIONS / EQUIVALENT	MANUF.
MP...	1	21-01.0278	2 pcs	Screw M2.5 x 5	
MP...	2	21-59.5351	2 pcs	Set screw M3 x 3	
MP...	3	24-16.1025	2 pcs	Fin washer	
MP...	4	54-01.0267	1 pcs	18-pole Cis Pin Case	AMP
MP...	5	1-010-126-27	2 pcs	Screw hole	St
MP...	6	1-727-440-01	1 pcs	Cover sheet	St
MP...	7	1-727-440-02	2 pcs	Button	St
MP...	8	1-727-440-03	0 pcs	Text label, RECORD LVL	St
MP...	9	1-727-440-04	0 pcs	Text label, REPROD. LVL	St
MP...	10	1-727-440-06	1 pcs	Jack chassis	St
MP...	11	1-727-443-01	0 pcs	Text label	St
MP...	12	1-727-443-10	0 pcs	No label	St
MP...	13	1-727-443-11	1 pcs	M/S Adjustment PCB	St
MP...	14	1-727-443-93	1 pcs	Wiring list	St
R.....	1	58-01.8103	10 kOhm	10% 0.5 W PPerm	
R.....	2	58-01.8103	10 kOhm	10% 0.5 W PPerm	
S.....	1	55-01.0220	2 x 3	Rotation switch	EL
S.....	2	55-13.0027	2 x 6	Rotation switch	EL

MANUFACTURER:AMP, EL=ELMA, St=Studer

ORIG 87/03/03

STUDER (00) 87/03/03 GP M/S ADJUSTMENT UNIT W.T.GEN. 1.727.443.00 PAGE 1

MONO/STEREO SWITCH BLOCK DIAGRAM (WITHOUT TEST GENERATOR)

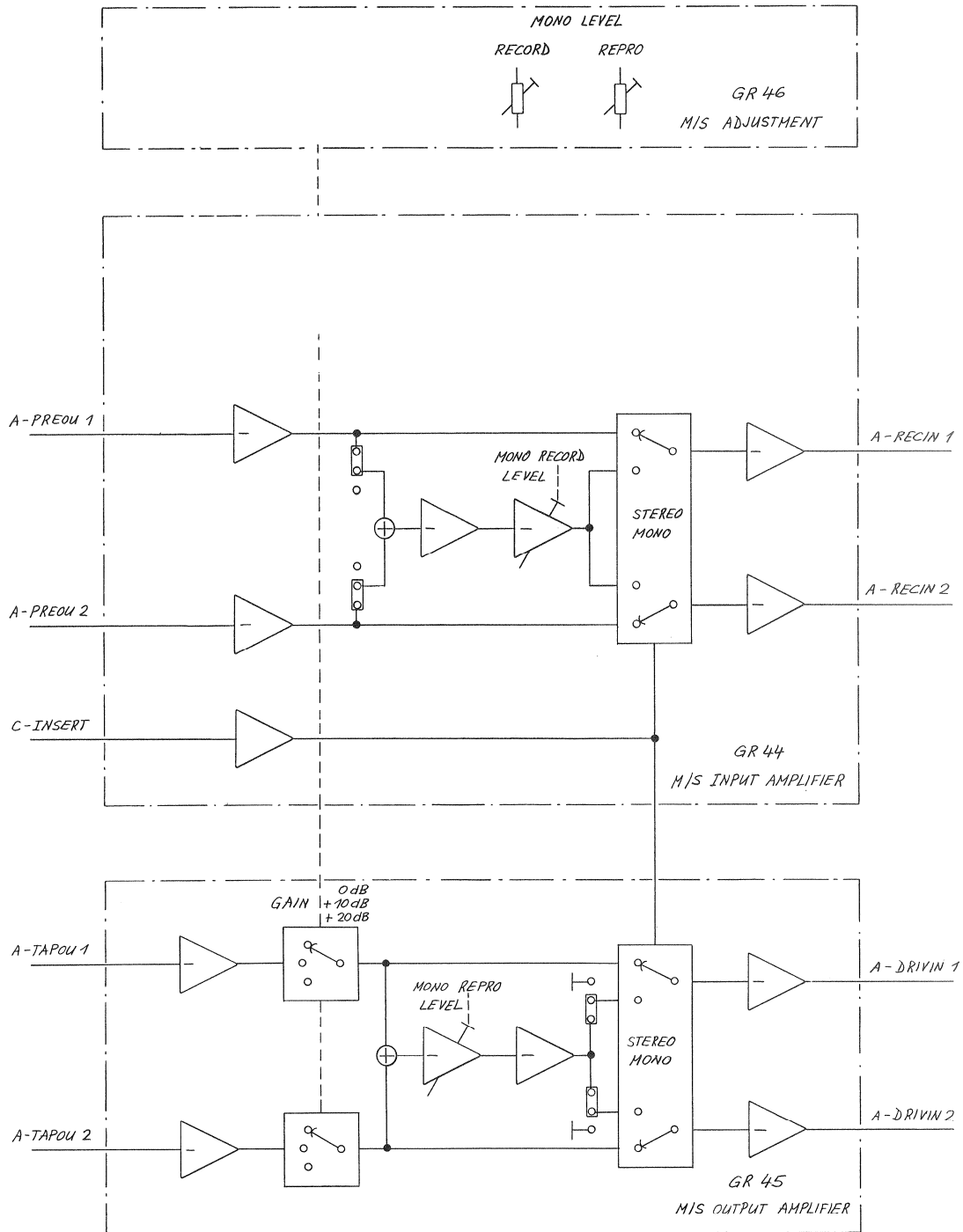

© 27.2.87 GP	○ . . .	○ . . .	○ . . .	○ . . .
	A 807			PAGE 1 OF 1
STUDER	MONO / STEREO SWITCH BLOCK DIAGRAM			1.727.450.00



M/S INPUT AMPLIFIER 1.727.451.00 GRP44

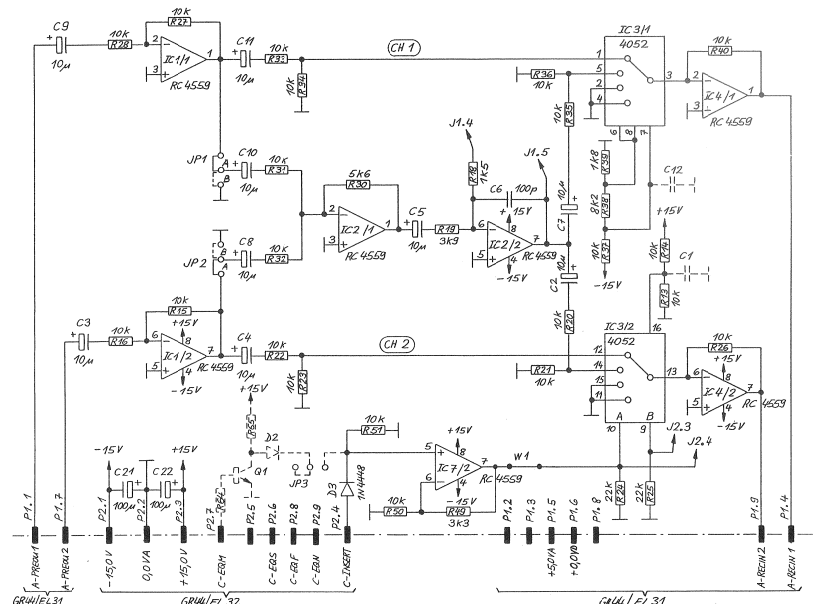
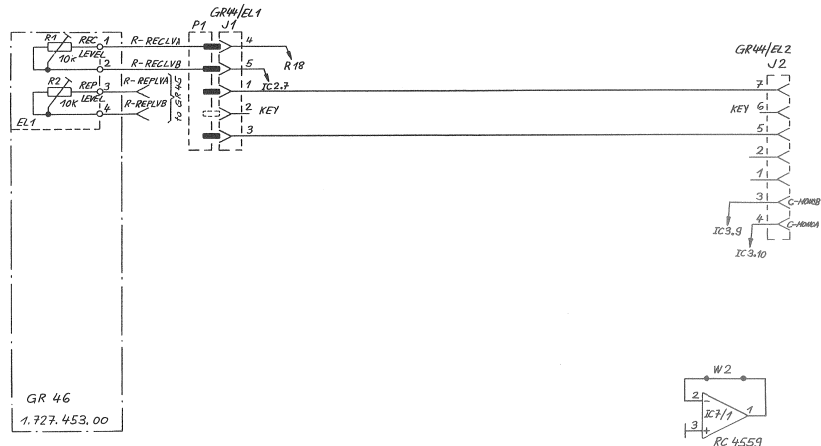

① 26.2.87 GP	② 26.3.87 GP	③ 12.2.88 GP	○ . .	○ . .
A 807 GR 44, GR 46				
PAGE 1 OF 1				
STUDER M/S INPUT AMPL. BOARD			SC	1.727.451.00



M/S INPUT AMPLIFIER 1.727.451.00 GRP44

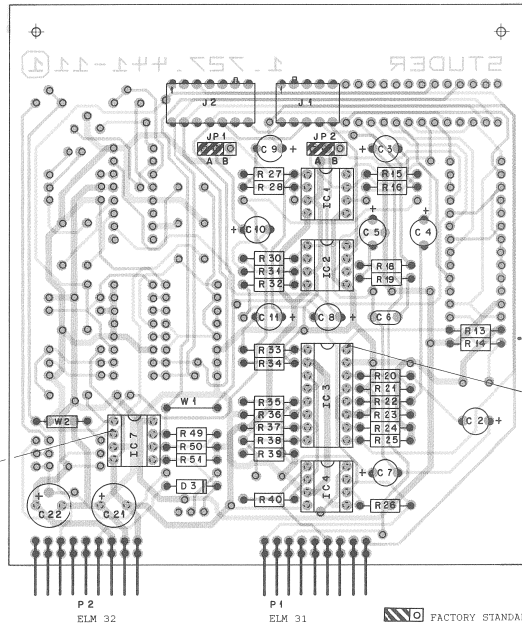

JP1: A = INPUT SIGNAL FROM CH1 ON
 B = INPUT SIGNAL FROM CH1 OFF
 JP2: A = INPUT SIGNAL FROM CH2 ON
 B = INPUT SIGNAL FROM CH2 OFF

IND.	POS.NO.	PART NO.	VALUE	SPECIFICATIONS / EQUIVALENT	MANUF.
C****2		59.22.4100	10 uF	-20% 35V EL	
C****3		59.22.4100	10 uF	-20% 35V EL	
C****4		59.22.4100	10 uF	-20% 35V EL	
C****5		59.22.4100	10 uF	-20% 35V EL	
C****6		59.24.4101	100 uF	10% 35V CER	
C****7		59.22.4100	10 uF	-20% 35V EL	
C****8		59.22.4100	10 uF	-20% 35V EL	
C****9		59.22.4100	10 uF	-20% 35V EL	
C****10		59.22.4100	10 uF	-20% 35V EL	
C****11		59.22.4100	10 uF	-20% 35V EL	
C****12		59.22.4101	100 uF	-20% 35V EL	
C****22		59.22.5101	100 uF	-20% 25V EL	
D****3		50.04.0125	1N4448	75V	
IC****1		50.09.0107	RC 4559	Dual Op. Amp.	
IC****2		50.09.0107	RC 4559	Dual Op. Amp.	
IC****3		50.07.0024	MC 14052	CMOS AMPL	Not
IC****4		50.09.0107	RC 4559	Dual Op. Amp.	Ra
IC****7		50.09.0107	RC 4559	Dual Op. Amp.	
J****1		54.01.0305	5-Pole	C15 Socket Strip	AMP
J****2		54.01.0294	7-Pole	C15 Socket Strip	AMP
JP****1		54.01.0021		Bridge	
JP****2		54.01.0021		Bridge	
MP****1		1.727.451.10	0 pcs	No. Label	St
MP****2		1.727.451.11	1 pcs	Input Ampl. PCB	St
MP****3		54.01.0020	3 pcs	Contact Pin JPI	
MP****4		54.01.0020	3 pcs	Contact Pin JPI	
MP****5		54.01.0108	1 pcs	ESV Warning Label	
P****1		54.01.0220	9-Pole	C15 Pin Strip	AMP
P****2		54.01.0220	7-Pole	C15 Pin Strip	AMP
R****13		57.11.3103	10 kOhm	1%, 0.25W, MF	

STUDER (01) 88/02/12 GP M/S INPUT AMPL. BOARD 1.727.451.00 PAGE 1

IND.	POS.NO.	PART NO.	VALUE	SPECIFICATIONS / EQUIVALENT	MANUF.
R****14		57.11.3103	10 kOhm	1%, 0.25W, MF	
R****15		57.11.3103	10 kOhm	1%, 0.25W, MF	
R****16		57.11.3103	10 kOhm	1%, 0.25W, MF	
R****18		57.11.3222	2.2 kOhm	1%, 0.25W, MF	
R****19		57.11.3102	1.5 kOhm	1%, 0.25W, MF	
R****19		57.11.3392	3.0 kOhm	1%, 0.25W, MF	
R****20		57.11.3103	10 kOhm	1%, 0.25W, MF	
R****21		57.11.3103	10 kOhm	1%, 0.25W, MF	
R****22		57.11.3103	10 kOhm	1%, 0.25W, MF	
R****23		57.11.3103	10 kOhm	1%, 0.25W, MF	
R****24		57.11.3223	22 kOhm	1%, 0.25W, MF	
R****25		57.11.3223	22 kOhm	1%, 0.25W, MF	
R****26		57.11.3103	10 kOhm	1%, 0.25W, MF	
R****27		57.11.3103	10 kOhm	1%, 0.25W, MF	
R****28		57.11.3103	10 kOhm	1%, 0.25W, MF	
R****30		57.11.3962	5.6 kOhm	1%, 0.25W, MF	
R****31		57.11.3103	10 kOhm	1%, 0.25W, MF	
R****32		57.11.3103	10 kOhm	1%, 0.25W, MF	
R****33		57.11.3103	10 kOhm	1%, 0.25W, MF	
R****34		57.11.3103	10 kOhm	1%, 0.25W, MF	
R****35		57.11.3103	10 kOhm	1%, 0.25W, MF	
R****36		57.11.3103	10 kOhm	1%, 0.25W, MF	
R****37		57.11.3103	10 kOhm	1%, 0.25W, MF	
R****38		57.11.3922	8.2 kOhm	1%, 0.25W, MF	
R****39		57.11.3102	1.0 kOhm	1%, 0.25W, MF	
R****40		57.11.3103	10 kOhm	1%, 0.25W, MF	
R****49		57.11.3102	3.0 kOhm	1%, 0.25W, MF	
R****50		57.11.3103	10 kOhm	1%, 0.25W, MF	
R****51		57.11.3103	10 kOhm	1%, 0.25W, MF	
W****1		64.71.0106		Wire bridge	
W****2		57.11.4000		Wire bridge	
X1C****1		53.03.0166	0-Pole	IC Socket	
X1C****2		53.03.0166	0-Pole	IC Socket	
X1C****3		53.03.0168	16-Pole	IC Socket	
X1C****4		53.03.0166	0-Pole	IC Socket	

STUDER (01) 88/02/12 GP M/S INPUT AMPL. BOARD 1.727.451.00 PAGE 2

IND.	POS.NO.	PART NO.	VALUE	SPECIFICATIONS / EQUIVALENT	MANUF.
X1C****7		53.03.0166	0-Pole	IC Socket	

(01) 12-02-03 Extended range of pins.
 Electronic Center-Ceramic-Ceramic-PCB-Metal-Film-PP-Polypropylen
 MANUFACTURE: M/S Input Amplifier Board - Studer
 041G 97/02/16 (01) 88/02/12
 STUDER (01) 88/02/12 GP M/S INPUT AMPL. BOARD 1.727.451.00 PAGE 3



M/S OUTPUT AMPLIFIER PB0 1.727.452.00 GRP45

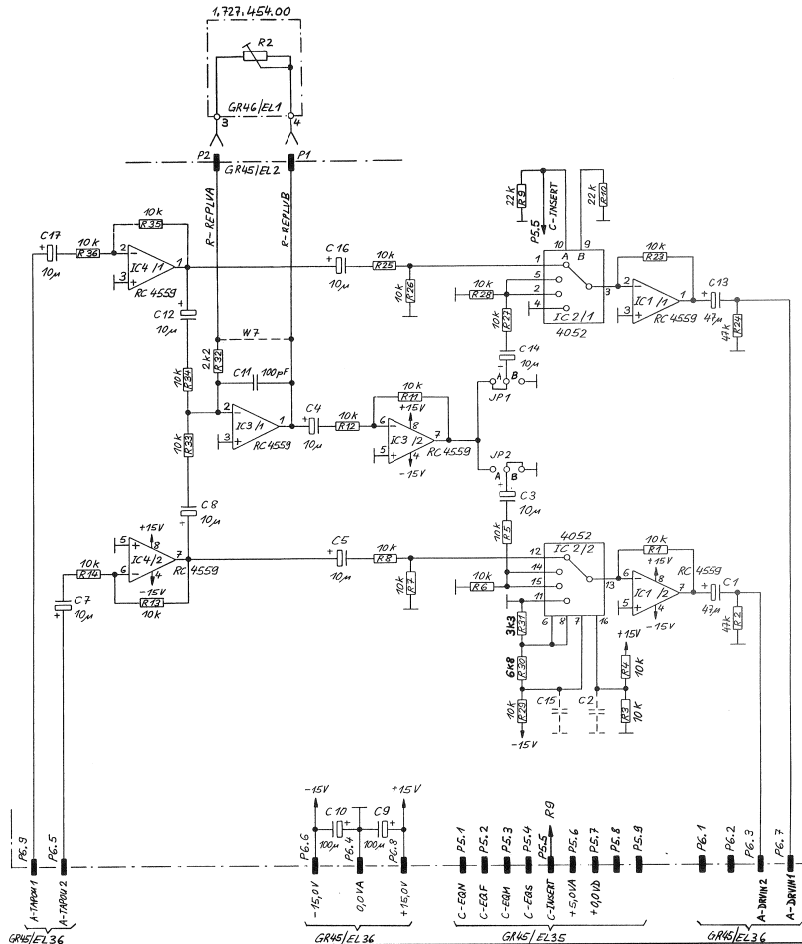

① 9.M.87 GP	①	①	①
A-807 GR45,GR46			
STUDER		M/S OUTPUT AMPL. BOARD	SC 1.727.452.00



M/S OUTPUT AMPLIFIER PBO 1.727.452.00 GRP45

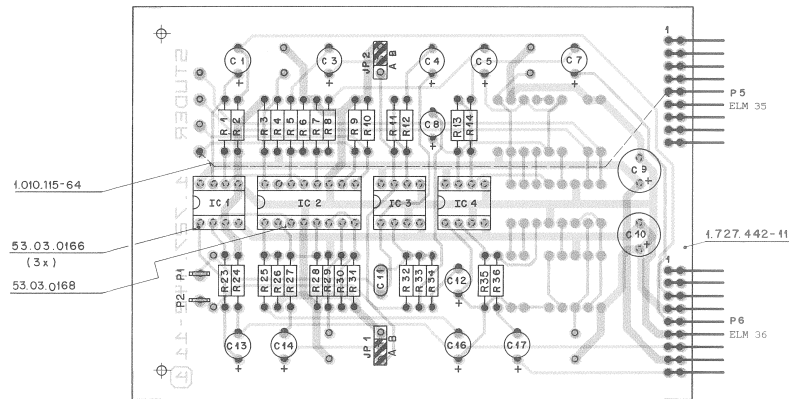

FACTORY STANDARD SETTING

JP1: A = MONO OUTPUT SIGNAL PRESENT ON CH1
B = NO MONO OUTPUT SIGNAL ON CH1
JP2: A = MONO OUTPUT SIGNAL PRESENT ON CH2
B = NO MONO OUTPUT SIGNAL ON CH2

IND.	POS.NO.	PART NO.	VALUE	SPECIFICATIONS / EQUIVALENT	MANUF.
C.....1	59.22+3470		47 uF	-20% 10V EL	
C.....2				not used	
C.....3	59.22+6109		10 uF	-20% 35V EL	
C.....4	59.22+6109		10 uF	-20% 35V EL	
C.....5	59.22+6109		10 uF	-20% 35V EL	
C.....6	59.22+6109		10 uF	-20% 35V EL	
C.....7	59.22+6109		10 uF	-20% 35V EL	
C.....8	59.22+6109		10 uF	-20% 35V EL	
C.....9	59.22+5101		100 uF	-20% 25V EL	
C.....10	59.22+5101		100 uF	-20% 25V EL	
C.....11	59.34+4101		100 pF	10% 50V Cer	
C.....12	59.22+6109		10 uF	-20% 35V EL	
C.....13	59.22+3470		47 uF	-20% 10V EL	
C.....14	59.22+6109		10 uF	-20% 35V EL	
C.....15				not used	
C.....16	59.22+6109		10 uF	-20% 35V EL	
C.....17	59.22+6109		10 uF	-20% 35V EL	
IC.....1	50.09+0107	RC 4559		Dual Op. Amp.	Not
IC.....2	50.07+0206	MC 14032		CMOS AMP	
IC.....3	50.09+0107	RC 4559		Dual Op. Amp.	
IC.....4	50.09+0107	RC 4559		Dual Op. Amp.	
JP.....1	54.01+0021			Bridge	
JP.....2	54.01+0021			Bridge	
MP.....1	1.727+452+10		0 pcs	Nov. Label	5t
MP.....2	1.4030+115+46		150 mm	Here	
MP.....3	1.727+442+11		1 pcs	Output Ampl. PCB	5t
MP.....4	54.01+0020		1 pcs	Contact Pin JP1	
MP.....5	54.01+0020		1 pcs	Contact Pin JP2	
MP.....6	4.30+10+08		1 pcs	ESC Material Label	
P.....1	54.02+0370	2-BPO-B		Contact pin	AMP
P.....2	54.02+0370	2-BPO-B		Contact pin	AMP
P.....3	54.01+0220	9-Pole		C15 Pin Strip	AMP
P.....4	54.01+0220	9-Pole		C15 Pin Strip	AMP

STUDER (08) 87/11/09 GP M/S OUTPUT AMPL. BOARD 1.727.452-00 PAGE 1

IND.	POS.NO.	PART NO.	VALUE	SPECIFICATIONS / EQUIVALENT	MANUF.
R.....1	97.11+4103		10 KOhm	2% 0.25W MF	
R.....2	97.11+4473		47 KOhm	2% 0.25W MF	
R.....3	97.11+4103		10 KOhm	2% 0.25W MF	
R.....4	97.11+4103		10 KOhm	2% 0.25W MF	
R.....5	97.11+4103		10 KOhm	2% 0.25W MF	
R.....6	97.11+4103		10 KOhm	2% 0.25W MF	
R.....7	97.11+4103		10 KOhm	2% 0.25W MF	
R.....8	97.11+4103		10 KOhm	2% 0.25W MF	
R.....9	97.11+4223		22 KOhm	2% 0.25W MF	
R.....10	97.11+4103		10 KOhm	2% 0.25W MF	
R.....11	97.11+4103		10 KOhm	2% 0.25W MF	
R.....12	97.11+4103		10 KOhm	2% 0.25W MF	
R.....13	97.11+4103		10 KOhm	2% 0.25W MF	
R.....14	97.11+4103		10 KOhm	2% 0.25W MF	
R.....15	97.11+4103		10 KOhm	2% 0.25W MF	
R.....16	97.11+4473		47 KOhm	2% 0.25W MF	
R.....17	97.11+4103		10 KOhm	2% 0.25W MF	
R.....18	97.11+4103		10 KOhm	2% 0.25W MF	
R.....19	97.11+4103		10 KOhm	2% 0.25W MF	
R.....20	97.11+4103		10 KOhm	2% 0.25W MF	
R.....21	97.11+4103		10 KOhm	2% 0.25W MF	
R.....22	97.11+4103		10 KOhm	2% 0.25W MF	
R.....23	97.11+4103		10 KOhm	2% 0.25W MF	
R.....24	97.11+4103		10 KOhm	2% 0.25W MF	
R.....25	97.11+4103		10 KOhm	2% 0.25W MF	
R.....26	97.11+4103		10 KOhm	2% 0.25W MF	
R.....27	97.11+4103		10 KOhm	2% 0.25W MF	
R.....28	97.11+4103		10 KOhm	2% 0.25W MF	
R.....29	97.11+4103		10 KOhm	2% 0.25W MF	
R.....30	97.11+4608		0.6 KOhm	2% 0.25W MF	
R.....31	97.11+4332		3.3 KOhm	2% 0.25W MF	
R.....32	97.11+4222		2.2 KOhm	2% 0.25W MF	
R.....33	97.11+4103		10 KOhm	2% 0.25W MF	
R.....34	97.11+4103		10 KOhm	2% 0.25W MF	
R.....35	97.11+4103		10 KOhm	2% 0.25W MF	
R.....36	97.11+4103		10 KOhm	2% 0.25W MF	
R.....37	97.11+4103		10 KOhm	2% 0.25W MF	
R.....38				not used	
XL.....1	91.73+0106		8-Pole	IC Socket	
XL.....2	91.73+0106		16-Pole	IC Socket	
XL.....3	91.73+0106		8-Pole	IC Socket	
XL.....4	91.73+0106		8-Pole	IC Socket	

STUDER (08) 87/11/09 GP M/S OUTPUT AMPL. BOARD 1.727.452-00 PAGE 2

IND.	POS.NO.	PART NO.	VALUE	SPECIFICATIONS / EQUIVALENT	MANUF.
ELN:Electrolytic;Cer:Ceramic;M-Metal Film					
MANUFACTURER:AMP;MOT:Motorola;ST:Studer					

0816 87/11/09
STUDER (08) 87/11/09 GP M/S OUTPUT AMPL. BOARD 1.727.452-00 PAGE 3

M/S ADJUSTMENT 1.727.453.00 GRP46

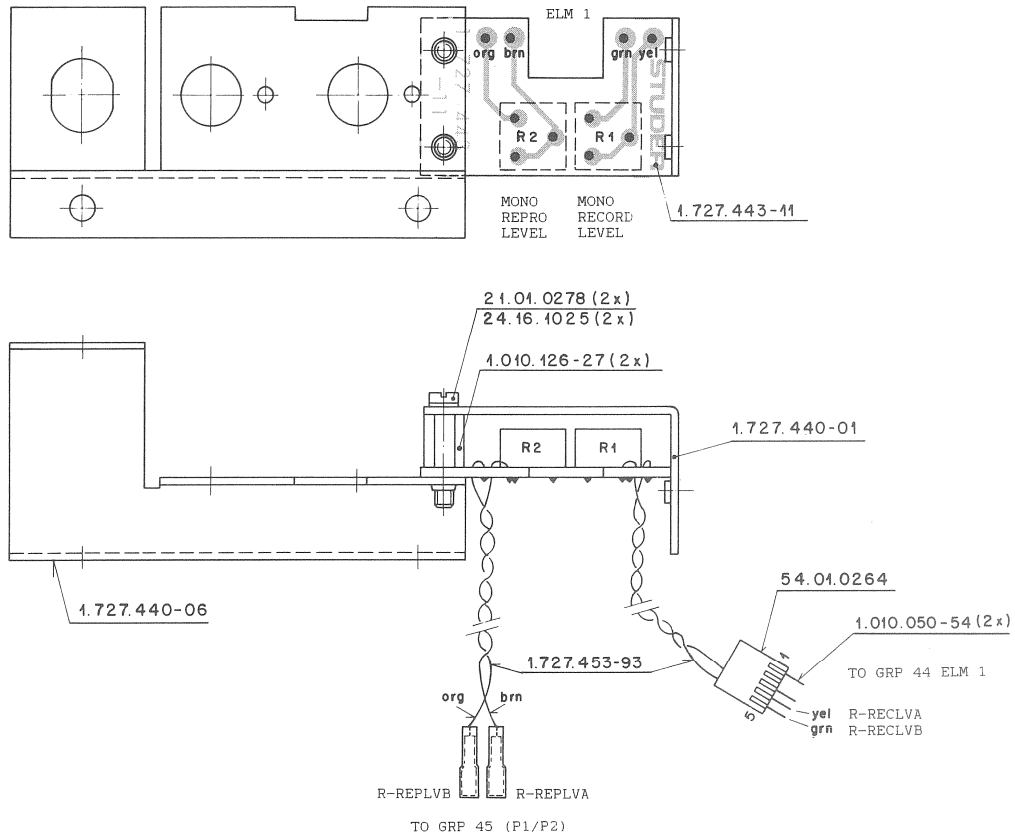

IND.	POS. NO.	PART NO.	VALUE	SPECIFICATIONS / EQUIVALENT	MANUF.
MP....1		21.01.0278	2 pcs	Screw M2.5 \varnothing 5	
MP....2		24.16.1025	2 pcs	Fin washer	
MP....3		54.01.0264	1 pcs	5-pole C15 Pin Case	AMP
MP....4		4.010.126-27	2 pcs	Screw bolt	St
MP....5		1.727.440-01	1 pcs	Cover sheet	St
MP....6		1.727.440-03	0 pcs	Text label, REPROD LVL	St
MP....7		1.727.440-04	0 pcs	Text label, REPROD LVL	St
MP....8		1.727.440-06	1 pcs	Jack chassis	St
MP....9		1.727.443-01	0 pcs	Text label	St
MP....10		1.727.453-11	1 pcs	M/S Adjustment PCB	St
MP....11		1.727.453-10	0 pcs	No. Label	St
MP....12		1.727.453-93	1 pcs	Wiring list	St
R.....1		58.01.8103	10 kOhm	10%, 0.5 W, PCerm	
R.....2		58.01.8103	10 kOhm	10%, 0.5 W, PCerm	

MANUFACTURER: AMP, St=Studer

ORIG 87/03/02

S T U D E R (00) 87/03/02 GP

M/S ADJUSTMENT UNIT

1.727.453.00 PAGE 1

M/S ADJUSTMENT PBO 1.727.454.00 GRP46

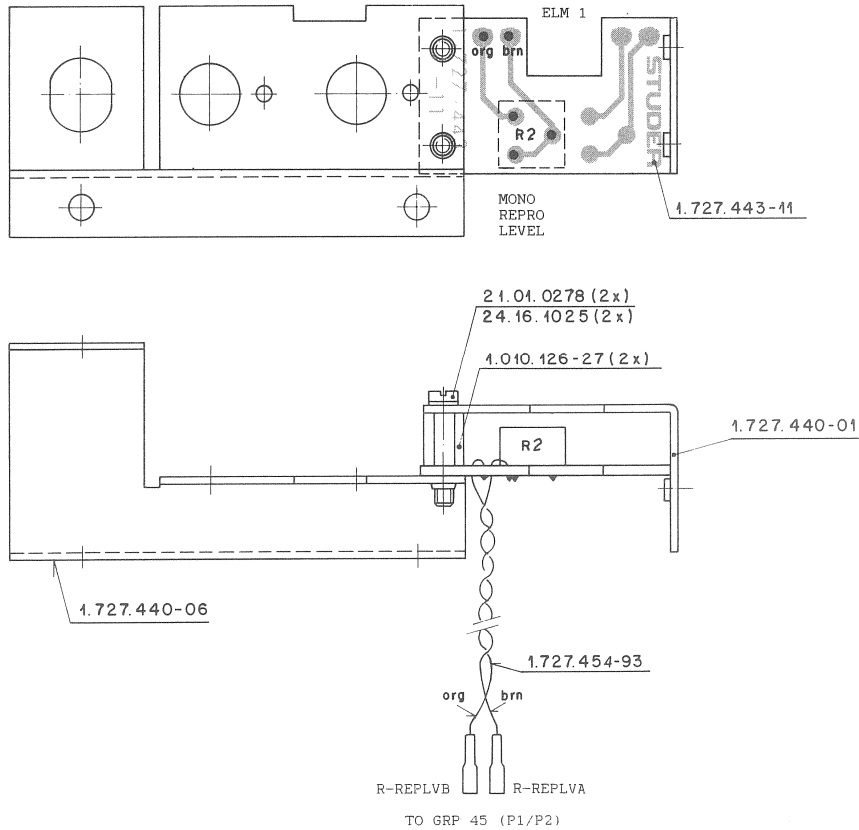

IND.	POS. NO.	PART NO.	VALUE	SPECIFICATIONS / EQUIVALENT	MANUF.
MP....1		21-01-0278	2 pcs	Screw M2.5 ø 5	
MP....2		24-16-1025	2 pcs	Fin washer	St
MP....4		4-010-126-27	2 pcs	Screw bolt	St
MP....5		1-727-440-01	1 pcs	Cover sheet	St
MP....7		1-727-440-04	0 pcs	Text label, REPROD.LVL	St
MP....8		1-727-440-06	1 pcs	Jack chassis	St
MP....10		1-727-443-11	1 pcs	M/S Adjustment PCB	St
MP....11		1-727-454-10	0 pcs	No. Label	St
MP....12		1-727-454-93	1 pcs	Wiring list	St
R.....2		58-01-0103	10 kOhm	10%, 0.5 W, P1erm	

MANUFACTURER:AMP,St=Studer

DRIG 07/11/12

S T U D E R (00) 07/11/12 With M/S ADJUSTMENT PBO UNIT 1.727.454.00 PAGE 1

CONSOLE MONITOR PANEL WIRING DIAGRAM

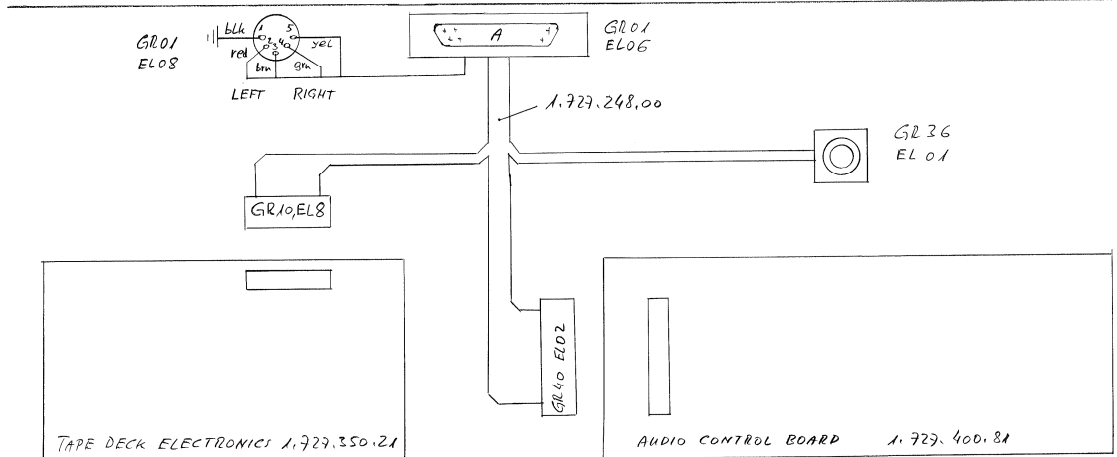
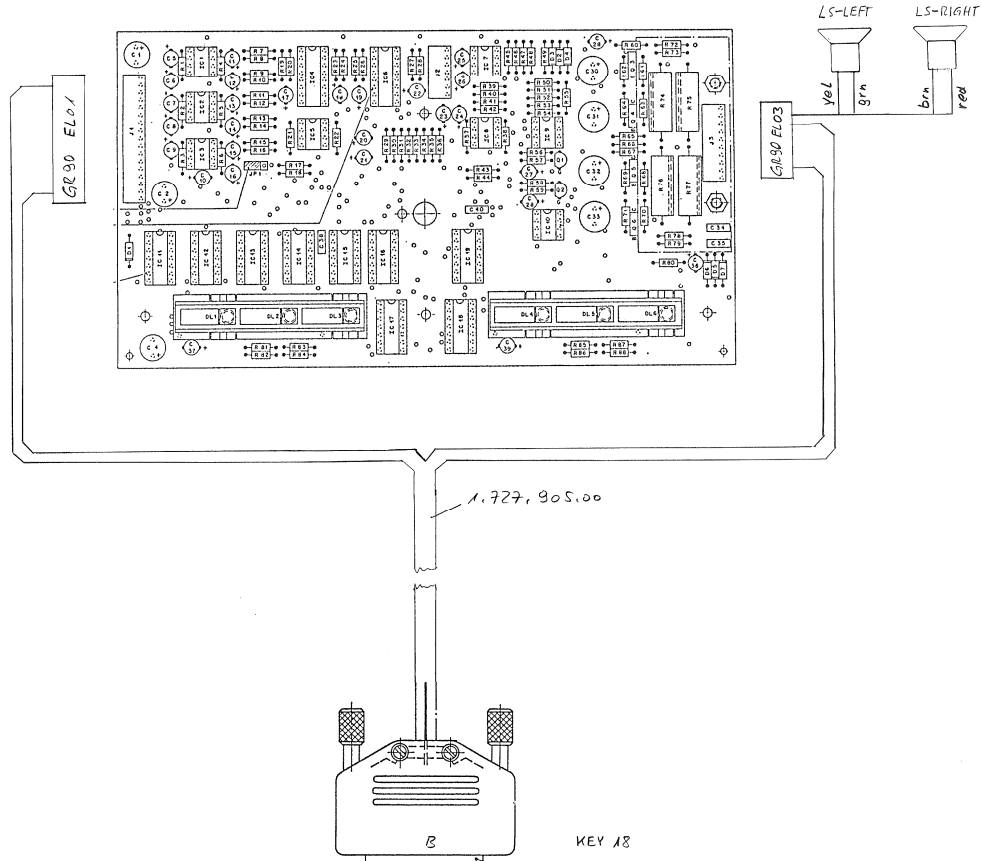

① 6.8.87 <i>WKR</i>	○ ..	○ ..	○ ..	○ ..
	A807		PAGE 1 OF 2	
STUDIER	WIRING DIAGRAM, MONITOR PANEL		1.727.091.00	

CONSOLE MONITOR PANEL WIRING DIAGRAM

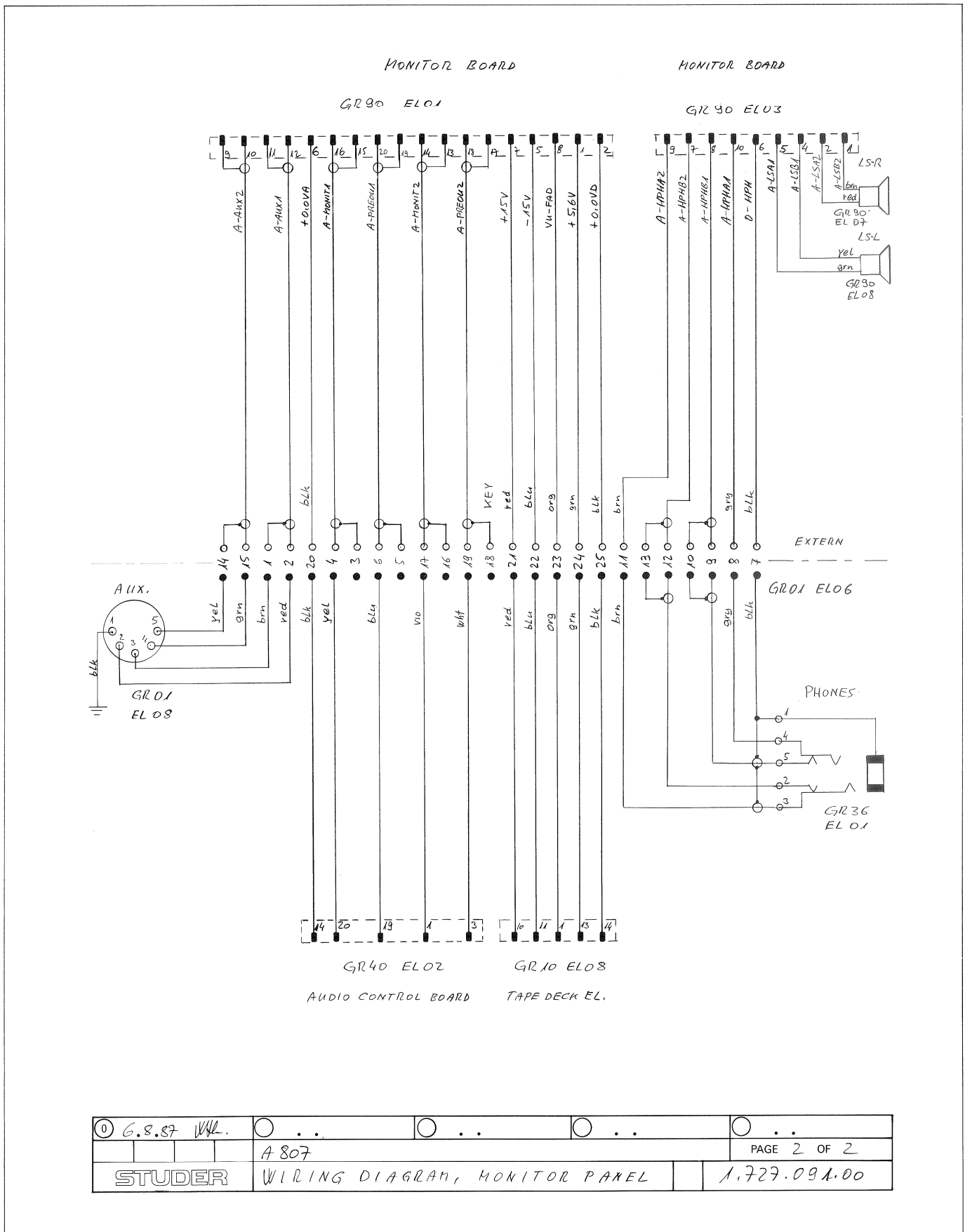

① G.8.87 W.H.	○ ..	○ ..	○ ..
A 807		PAGE 2 OF 2	
STUDER		WIRING DIAGRAM, MONITOR PANEL	1.727.09A.00



CONSOLE MONITOR 1.727.910.00 GRP90

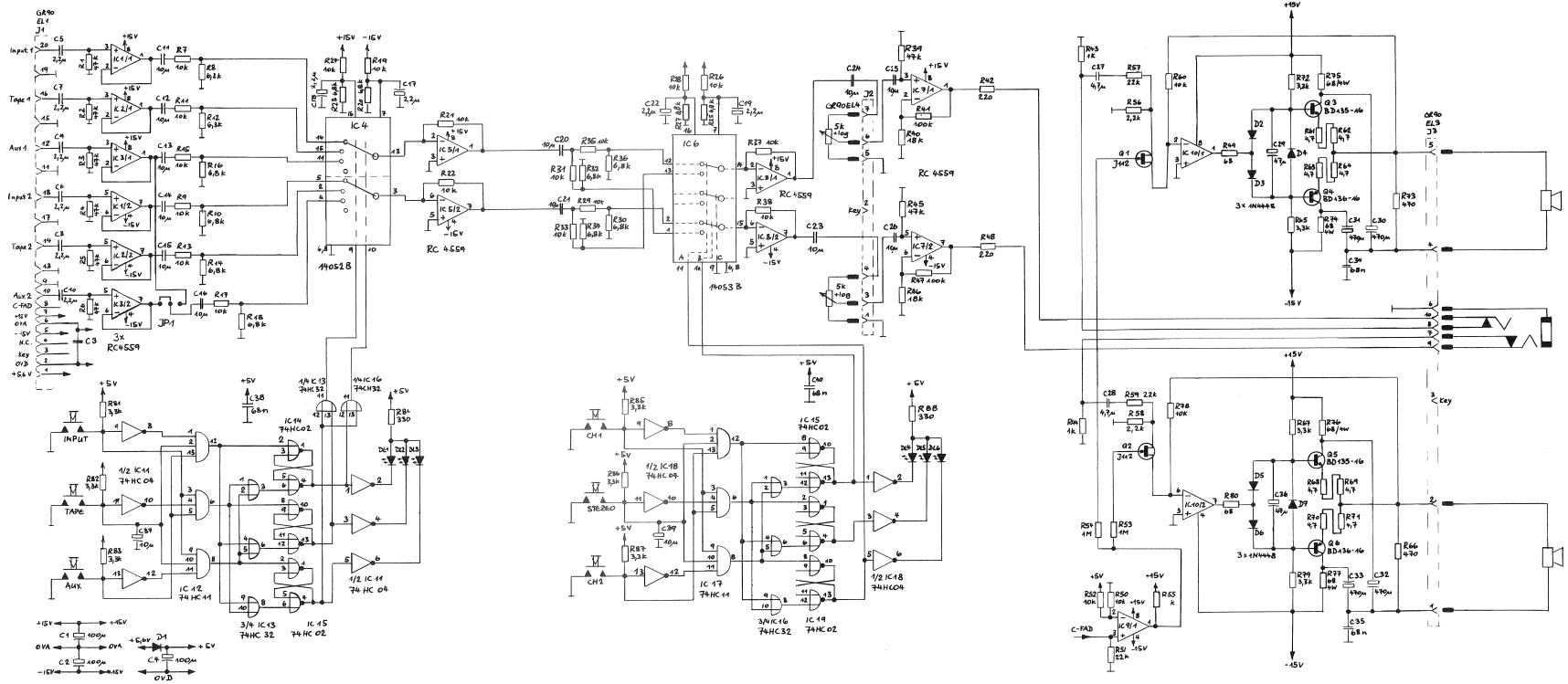

3.2.26	Rev.								
A807								PAGE 3 OF 3	
STUDER MONITOR BOARD								1.727.910.00	



CONSOLE MONITOR 1.727.910.00 GRP90

IND.	POS.-NO.	PART NO.	VALUE	SPECIFICATIONS / EQUIVALENT	MANUF.
R****7		57.11.4103	10 kOhm	2%, 0.25W, MF	
R****8		57.11.4682	6.8 kOhm	2%, 0.25W, MF	
R****9		57.11.4103	10 kOhm	2%, 0.25W, MF	
R****10		57.11.4682	6.8 kOhm	2%, 0.25W, MF	
R****11		57.11.4103	10 kOhm	2%, 0.25W, MF	
R****12		57.11.4682	6.8 kOhm	2%, 0.25W, MF	
R****13		57.11.4103	10 kOhm	2%, 0.25W, MF	
R****14		57.11.4682	6.8 kOhm	2%, 0.25W, MF	
R****15		57.11.4103	10 kOhm	2%, 0.25W, MF	
R****16		57.11.4682	6.8 kOhm	2%, 0.25W, MF	
R****17		57.11.4103	10 kOhm	2%, 0.25W, MF	
R****18		57.11.4682	6.8 kOhm	2%, 0.25W, MF	
R****19		57.11.4103	10 kOhm	2%, 0.25W, MF	
R****20		57.11.4682	6.8 kOhm	2%, 0.25W, MF	
R****21		57.11.4103	10 kOhm	2%, 0.25W, MF	
R****22		57.11.4103	10 kOhm	2%, 0.25W, MF	
R****23		57.11.4682	6.8 kOhm	2%, 0.25W, MF	
R****24		57.11.4103	10 kOhm	2%, 0.25W, MF	
R****25		57.11.4682	6.8 kOhm	2%, 0.25W, MF	
R****26		57.11.4103	10 kOhm	2%, 0.25W, MF	
R****27		57.11.4682	6.8 kOhm	2%, 0.25W, MF	
R****28		57.11.4103	10 kOhm	2%, 0.25W, MF	
R****29		57.11.4103	10 kOhm	2%, 0.25W, MF	
R****30		57.11.4682	6.8 kOhm	2%, 0.25W, MF	
R****31		57.11.4103	10 kOhm	2%, 0.25W, MF	
R****32		57.11.4682	6.8 kOhm	2%, 0.25W, MF	
R****33		57.11.4103	10 kOhm	2%, 0.25W, MF	
R****34		57.11.4682	6.8 kOhm	2%, 0.25W, MF	
R****35		57.11.3103	10 kOhm	2%, 0.25W, MF	
R****36		57.11.4682	6.8 kOhm	2%, 0.25W, MF	
R****37		57.11.4103	10 kOhm	2%, 0.25W, MF	
R****38		57.11.4103	10 kOhm	2%, 0.25W, MF	
R****39		57.11.4473	47 kOhm	2%, 0.25W, MF	
R****40		57.11.4183	18 kOhm	2%, 0.25W, MF	
R****41		57.11.4104	100 kOhm	2%, 0.25W, MF	
R****42		57.11.4221	220 Ohm	2%, 0.25W, MF	
R****43		57.11.4102	1 kOhm	2%, 0.25W, MF	

S T U D E R (00) 86/07/11 BEC MONITOR BOARD 1.727.910.00 PAGE 4

IND.	POS.-NO.	PART NO.	VALUE	SPECIFICATIONS / EQUIVALENT	MANUF.
R****44		57.11.4102	1 kOhm	2%, 0.25W, MF	
R****45		57.11.4473	47 kOhm	2%, 0.25W, MF	
R****46		57.11.4183	18 kOhm	2%, 0.25W, MF	
R****47		57.11.4104	100 kOhm	2%, 0.25W, MF	
R****48		57.11.4221	220 Ohm	2%, 0.25W, MF	
R****49		57.11.4680	68 Ohm	2%, 0.25W, MF	
R****50		57.11.4103	10 kOhm	2%, 0.25W, MF	
R****51		57.11.4223	22 kOhm	2%, 0.25W, MF	
R****52		57.11.4103	10 kOhm	2%, 0.25W, MF	
R****53		57.11.4105	1 MOhm	2%, 0.25W, MF	
R****54		57.11.4105	1 MOhm	2%, 0.25W, MF	
R****55		57.11.4223	22 kOhm	2%, 0.25W, MF	
R****56		57.11.4222	2.2 kOhm	2%, 0.25W, MF	
R****57		57.11.4223	22 kOhm	2%, 0.25W, MF	
R****58		57.11.4222	2.2 kOhm	2%, 0.25W, MF	
R****59		57.11.4223	22 kOhm	2%, 0.25W, MF	
R****60		57.11.4103	10 kOhm	2%, 0.25W, MF	
R****61		57.11.4479	4.7 Ohm	2%, 0.25W, MF	
R****62		57.11.4479	4.7 Ohm	2%, 0.25W, MF	
R****63		57.11.4479	4.7 Ohm	2%, 0.25W, MF	
R****64		57.11.4479	4.7 Ohm	2%, 0.25W, MF	
R****65		57.11.4332	3.3 kOhm	2%, 0.25W, MF	
R****66		57.11.4471	470 Ohm	2%, 0.25W, MF	
R****67		57.11.4332	3.3 kOhm	2%, 0.25W, MF	
R****68		57.11.4479	4.7 Ohm	2%, 0.25W, MF	
R****69		57.11.4479	4.7 Ohm	2%, 0.25W, MF	
R****70		57.11.4479	4.7 Ohm	2%, 0.25W, MF	
R****71		57.11.4479	4.7 Ohm	2%, 0.25W, MF	
R****72		57.11.4332	3.3 kOhm	2%, 0.25W, MF	
R****73		57.11.4471	470 Ohm	2%, 0.25W, MF	
R****74		57.56.5680	68 Ohm	2%, 4 W, DR	
R****75		57.56.5680	68 Ohm	2%, 4 W, DR	
R****76		57.56.5680	68 Ohm	2%, 4 W, DR	
R****77		57.56.5680	68 Ohm	2%, 4 W, DR	
R****78		57.11.4103	10 kOhm	2%, 0.25W, MF	
R****79		57.11.4332	3.3 kOhm	2%, 0.25W, MF	
R****80		57.11.4680	68 Ohm	2%, 0.25W, MF	

S T U D E R (00) 86/07/11 BEC MONITOR BOARD 1.727.910.00 PAGE 5

IND.	POS.-NO.	PART NO.	VALUE	SPECIFICATIONS / EQUIVALENT	MANUF.
R****81		57.11.4332	3.3 kOhm	2%, 0.25W, MF	
R****82		57.11.4332	3.3 kOhm	2%, 0.25W, MF	
R****83		57.11.4332	3.3 kOhm	2%, 0.25W, MF	
R****84		57.11.4331	330 Ohm	2%, 0.25W, MF	
R****85		57.11.4332	3.3 kOhm	2%, 0.25W, MF	
R****86		57.11.4332	3.3 kOhm	2%, 0.25W, MF	
R****87		57.11.4332	3.3 kOhm	2%, 0.25W, MF	
R****88		57.11.4331	330 Ohm	2%, 0.25W, MF	
XIC***1		54.03.0166	8 Pole	IC Socket	
XIC***2		54.03.0166	8 Pole	IC Socket	
XIC***3		54.03.0166	8 Pole	IC Socket	
XIC***4		54.03.0168	16 Pole	IC Socket	
XIC***5		54.03.0166	8 Pole	IC Socket	
XIC***6		54.03.0168	16 Pole	IC Socket	
XIC***7		54.03.0166	8 Pole	IC Socket	
XIC***8		54.03.0166	8 Pole	IC Socket	
XIC***9		54.03.0166	8 Pole	IC Socket	
XIC***10		54.03.0166	8 Pole	IC Socket	
XIC***11		54.03.0167	14 Pole	IC Socket	
XIC***12		54.03.0167	14 Pole	IC Socket	
XIC***13		54.03.0167	14 Pole	IC Socket	
XIC***14		54.03.0167	14 Pole	IC Socket	
XIC***15		54.03.0167	14 Pole	IC Socket	
XIC***16		54.03.0167	14 Pole	IC Socket	
XIC***17		54.03.0167	14 Pole	IC Socket	
XIC***18		54.03.0167	14 Pole	IC Socket	
XIC***19		54.03.0167	14 Pole	IC Socket	

EL=Electrolytic, PP=Polypropylen, SI=Silicon, MF=Metal Film
MANUFACTURER:

DRIG 86/07/11

S T U D E R (00) 86/07/11 BEC MONITOR BOARD 1.727.910.00 PAGE 6



CONSOLE MONITOR 1.727.910.81 GRP90

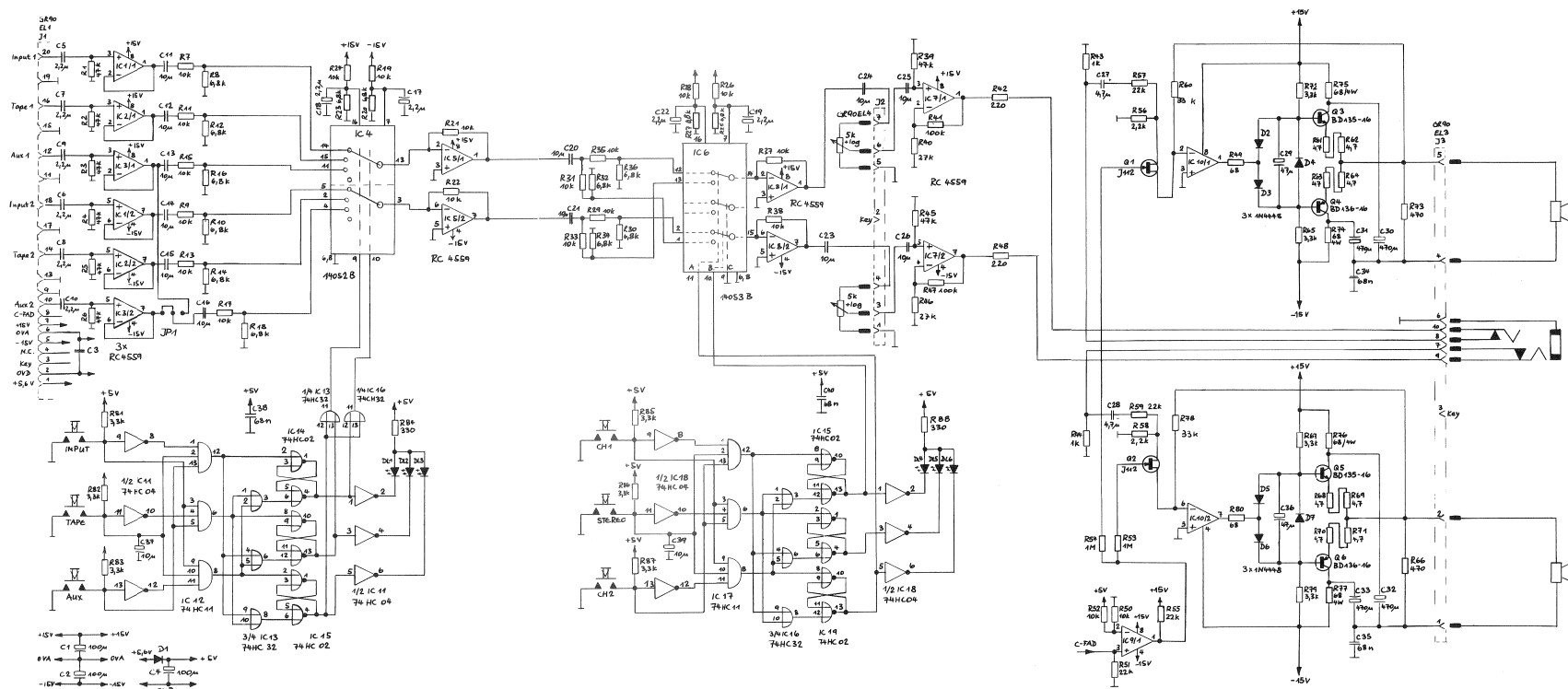

16.6.88	Boc								
		A807						PAGE 3 OF 3	
STUDER		MONITOR BOARD						1.727.910.81	

CONSOLE MONITOR 1.727.910.81 GRP90

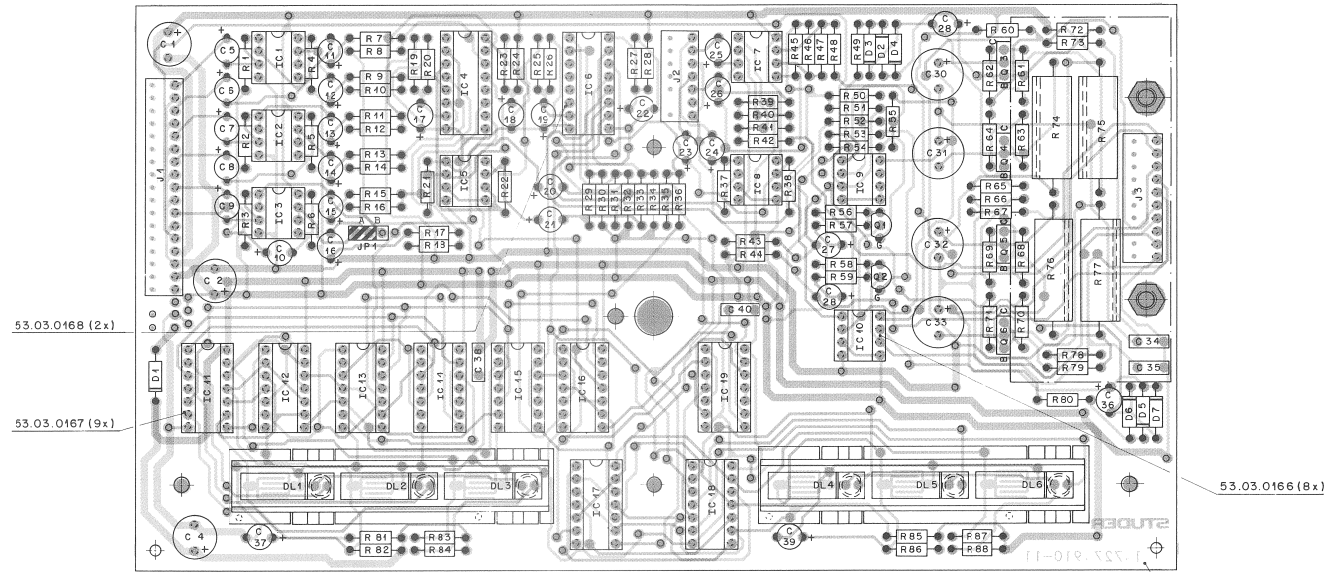

53.03.0168 (2x)

53.03.0167 (9x)

53.03.0166 (8x)

FACTORY STANDARD SETTING

JP1: A - AUX STEREO
B - AUX1 ONLY

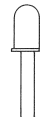

K = CATHODE

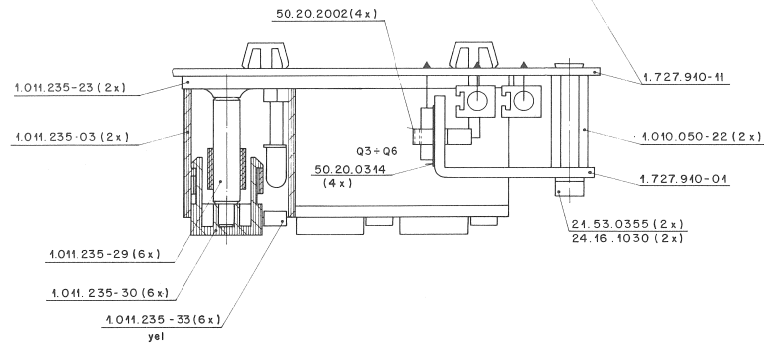



CONSOLE MONITOR 1.727.910.81 GRP90

IND.	POS.-NO.	PART NO.	VALUE	SPECIFICATIONS / EQUIVALENT	MANUF.	IND.	POS.-NO.	PART NO.	VALUE	SPECIFICATIONS / EQUIVALENT	MANUF.
C.....1	59.22.5101	100 uF	-20%	25 V EL		R.....7	57.11.3103	10 kOhm	2%	0.25W MF	
C.....2	59.22.5101	100 uF	-20%	25 V EL		R.....8	57.11.3682	6.8 kOhm	2%	0.25W MF	
C.....3		not used				R.....9	57.11.3103	10 kOhm	2%	0.25W MF	
C.....4	59.22.5101	100 uF	-20%	25 V EL		R.....10	57.11.3682	6.8 kOhm	2%	0.25W MF	
C.....5	59.22.8229	2.2 uF	-20%	50 V EL		R.....11	57.11.3103	10 kOhm	2%	0.25W MF	
C.....6	59.22.8229	2.2 uF	-20%	50 V EL		R.....12	57.11.3682	6.8 kOhm	2%	0.25W MF	
C.....7	59.22.8229	2.2 uF	-20%	50 V EL		R.....13	57.11.3103	10 kOhm	2%	0.25W MF	
C.....8	59.22.8229	2.2 uF	-20%	50 V EL		R.....14	57.11.3682	6.8 kOhm	2%	0.25W MF	
C.....9	59.22.8229	2.2 uF	-20%	50 V EL		R.....15	57.11.3103	10 kOhm	2%	0.25W MF	
C.....10	59.22.8229	2.2 uF	-20%	50 V EL		R.....16	57.11.3682	6.8 kOhm	2%	0.25W MF	
C.....11	59.22.6100	10 uF	-20%	35 V EL		R.....17	57.11.3103	10 kOhm	2%	0.25W MF	
C.....12	59.22.6100	10 uF	-20%	35 V EL		R.....18	57.11.3682	6.8 kOhm	2%	0.25W MF	
C.....13	59.22.6100	10 uF	-20%	35 V EL		R.....19	57.11.3103	10 kOhm	2%	0.25W MF	
C.....14	59.22.6100	10 uF	-20%	35 V EL		R.....20	57.11.3682	6.8 kOhm	2%	0.25W MF	
C.....15	59.22.6100	10 uF	-20%	35 V EL		R.....21	57.11.3103	10 kOhm	2%	0.25W MF	
C.....16	59.22.6100	10 uF	-20%	35 V EL		R.....22	57.11.3103	10 kOhm	2%	0.25W MF	
C.....17	59.22.8229	2.2 uF	-20%	50 V EL		R.....23	57.11.3682	6.8 kOhm	2%	0.25W MF	
C.....18	59.22.8229	2.2 uF	-20%	50 V EL		R.....24	57.11.3103	10 kOhm	2%	0.25W MF	
C.....19	59.22.8229	2.2 uF	-20%	50 V EL		R.....25	57.11.3682	6.8 kOhm	2%	0.25W MF	
C.....20	59.22.6100	10 uF	-20%	35 V EL		R.....26	57.11.3103	10 kOhm	2%	0.25W MF	
C.....21	59.22.6100	10 uF	-20%	35 V EL		R.....27	57.11.3682	6.8 kOhm	2%	0.25W MF	
C.....22	59.22.8229	2.2 uF	-20%	50 V EL		R.....28	57.11.3103	10 kOhm	2%	0.25W MF	
C.....23	59.22.6100	10 uF	-20%	35 V EL		R.....29	57.11.3103	10 kOhm	2%	0.25W MF	
C.....24	59.22.6100	10 uF	-20%	35 V EL		R.....30	57.11.3682	6.8 kOhm	2%	0.25W MF	
C.....25	59.22.6100	10 uF	-20%	35 V EL		R.....31	57.11.3103	10 kOhm	2%	0.25W MF	
C.....26	59.22.6100	10 uF	-20%	35 V EL		R.....32	57.11.3682	6.8 kOhm	2%	0.25W MF	
C.....27	59.22.8479	4.7 uF	-20%	50 V EL		R.....33	57.11.3103	10 kOhm	2%	0.25W MF	
C.....28	59.22.8479	4.7 uF	-20%	50 V EL		R.....34	57.11.3682	6.8 kOhm	2%	0.25W MF	
C.....29	59.22.3470	4.7 uF	-20%	10 V EL		R.....35	57.11.3103	10 kOhm	2%	0.25W MF	
C.....30	59.22.6100	10 uF	-20%	35 V EL		R.....36	57.11.3682	6.8 kOhm	2%	0.25W MF	
C.....31	59.22.4471	470 uF	-20%	16 V EL		R.....37	57.11.3103	10 kOhm	2%	0.25W MF	
C.....32	59.22.4471	470 uF	-20%	16 V EL		R.....38	57.11.3103	10 kOhm	2%	0.25W MF	
C.....33	59.22.4471	470 uF	-20%	16 V EL		R.....39	57.11.3473	4.7 kOhm	2%	0.25W MF	
C.....34	59.06.0683	68 nF	10%	63 V PE		R.....40	57.11.3273	27 kOhm	2%	0.25W MF	
C.....35	59.06.0683	68 nF	10%	63 V PE		R.....41	57.11.3104	100 kOhm	2%	0.25W MF	
C.....36	59.22.3470	4.7 uF	-20%	10 V EL		R.....42	57.11.3221	220 Ohm	2%	0.25W MF	
C.....37	59.22.6100	10 uF	-20%	35 V EL		R.....43	57.11.3102	1 kOhm	2%	0.25W MF	

S T U D E R (00) 88/03/28 Mth MONITOR BOARD 1.727.910.81 PAGE 1 S T U D E R (00) 88/03/28 Mth MONITOR BOARD 1.727.910.81 PAGE 4

IND.	POS.-NO.	PART NO.	VALUE	SPECIFICATIONS / EQUIVALENT	MANUF.	IND.	POS.-NO.	PART NO.	VALUE	SPECIFICATIONS / EQUIVALENT	MANUF.
C.....38	59.06.0683	68 nF	10%	63 V PE		R.....44	57.11.3102	1 kOhm	2%	0.25W MF	
C.....39	59.22.6100	10 uF	-20%	35 V EL		R.....45	57.11.3473	4.7 kOhm	2%	0.25W MF	
C.....40	59.06.0683	68 nF	10%	63 V PE		R.....46	57.11.3273	27 kOhm	2%	0.25W MF	
D.....1	50.04.0512	1N5818	30 V			R.....47	57.11.3104	100 kOhm	2%	0.25W MF	
D.....2	50.04.0125	1N4448	75 V			R.....48	57.11.3221	220 Ohm	2%	0.25W MF	
D.....3	50.04.0125	1N4448	75 V			R.....49	57.11.3680	6.8 Ohm	2%	0.25W MF	
D.....4	50.04.0125	1N4448	75 V			R.....50	57.11.3103	10 kOhm	2%	0.25W MF	
D.....5	50.04.0125	1N4448	75 V			R.....51	57.11.3223	22 kOhm	2%	0.25W MF	
D.....6	50.04.0125	1N4448	75 V			R.....52	57.11.3103	10 kOhm	2%	0.25W MF	
D.....7	50.04.0125	1N4448	75 V			R.....53	57.11.3105	1 MOhm	2%	0.25W MF	
DL.....1	50.04.2500	MV5352	LED	yel D=5mm	GI	R.....54	57.11.3105	1 MOhm	2%	0.25W MF	
DL.....2	50.04.2500	MV5352	LED	yel D=5mm	GI	R.....55	57.11.3223	22 kOhm	2%	0.25W MF	
DL.....3	50.04.2500	MV5352	LED	yel D=5mm	GI	R.....56	57.11.3222	2.2 kOhm	2%	0.25W MF	
DL.....4	50.04.2500	MV5352	LED	yel D=5mm	GI	R.....57	57.11.3223	22 kOhm	2%	0.25W MF	
DL.....5	50.04.2500	MV5352	LED	yel D=5mm	GI	R.....58	57.11.3222	2.2 kOhm	2%	0.25W MF	
DL.....6	50.04.2500	MV5352	LED	yel D=5mm	GI	R.....59	57.11.3223	22 kOhm	2%	0.25W MF	
IC.....1	50.09.0107	RC 4559	DUAL OP-AMP.			R.....60	57.11.3333	33 kOhm	2%	0.25W MF	
IC.....2	50.09.0107	RC 4559	DUAL OP-AMP.			R.....61	57.11.3479	4.7 Ohm	2%	0.25W MF	
IC.....3	50.09.0107	RC 4559	DUAL OP-AMP.			R.....62	57.11.3479	4.7 Ohm	2%	0.25W MF	
IC.....4	50.07.0024	MC14052	DUAL 4-CH AMUX			R.....63	57.11.3479	4.7 Ohm	2%	0.25W MF	
IC.....5	50.07.0017	MC14052	DUAL OP-AMP.			R.....64	57.11.3332	3.3 kOhm	2%	0.25W MF	
IC.....6	50.07.0015	MC14053	TRIPLE 2-CH AMUX			R.....65	57.11.3332	3.3 kOhm	2%	0.25W MF	
IC.....7	50.09.0107	RC 4559	DUAL OP-AMP.			R.....66	57.11.3471	4.7 Ohm	2%	0.25W MF	
IC.....8	50.09.0107	RC 4559	DUAL OP-AMP.			R.....67	57.11.3332	3.3 kOhm	2%	0.25W MF	
IC.....9	50.09.0107	RC 4559	DUAL OP-AMP.			R.....68	57.11.3479	4.7 Ohm	2%	0.25W MF	
IC.....10	50.09.0107	RC 4559	DUAL OP-AMP.			R.....69	57.11.3479	4.7 Ohm	2%	0.25W MF	
IC.....11	50.17.1004	74HC04	HEX INVERTER			R.....70	57.11.3479	4.7 Ohm	2%	0.25W MF	
IC.....12	50.17.1011	74HC11	TRIP 3-INPUT AND GATE			R.....71	57.11.3479	4.7 Ohm	2%	0.25W MF	
IC.....13	50.17.1032	74HC32	QUAD 2-INPUT OR GATE			R.....72	57.11.3332	3.3 kOhm	2%	0.25W MF	
IC.....14	50.17.1002	74HC02	QUAD 2-INPUT NOR GATE			R.....73	57.11.3471	4.7 Ohm	2%	0.25W MF	
IC.....15	50.17.1002	74HC02	QUAD 2-INPUT NOR GATE			R.....74	57.56.5680	68 Ohm	2%	4 Hs DR	
IC.....16	50.17.1002	74HC32	QUAD 2-INPUT OR GATE			R.....75	57.56.5680	68 Ohm	2%	4 Hs DR	
IC.....17	50.17.1011	74HC11	TRIP 3-INPUT AND GATE			R.....76	57.56.5680	68 Ohm	2%	4 Hs DR	
IC.....18	50.17.1004	74HC04	HEX INVERTER			R.....77	57.56.5680	68 Ohm	2%	4 Hs DR	
						R.....78	57.11.3333	33 kOhm	2%	0.25W MF	
						R.....79	57.11.3332	3.3 kOhm	2%	0.25W MF	
						R.....80	57.11.3680	6.8 Ohm	2%	0.25W MF	

S T U D E R (00) 88/03/28 Mth MONITOR BOARD 1.727.910.81 PAGE 2 S T U D E R (00) 88/03/28 Mth MONITOR BOARD 1.727.910.81 PAGE 5

IND.	POS.-NO.	PART NO.	VALUE	SPECIFICATIONS / EQUIVALENT	MANUF.	IND.	POS.-NO.	PART NO.	VALUE	SPECIFICATIONS / EQUIVALENT	MANUF.
IC.....19	50.17.1002	74HC02	QUAD 2-INPUT NOR GATE			R.....81	57.11.3332	3.3 kOhm	2%	0.25W MF	
J.....1	54.01.0237	20-PDLE	CIS Socket Strip		AMP	R.....82	57.11.3332	3.3 kOhm	2%	0.25W MF	
J.....2	54.01.0263	7-PDLE	CIS Socket Strip		AMP	R.....83	57.11.3332	3.3 kOhm	2%	0.25W MF	
J.....3	54.01.0242	10-PDLE	CIS Socket Strip		AMP	R.....84	57.11.3331	330 Ohm	2%	0.25W MF	
JP.....1	54.01.0021		Bridge			R.....85	57.11.3332	3.3 kOhm	2%	0.25W MF	
MP.....1	1.727.910.11	1 pcs	Monitor PCB			R.....86	57.11.3332	3.3 kOhm	2%	0.25W MF	
MP.....2	54.01.0020	3 pcs	Contact Pin			R.....87	57.11.3332	3.3 kOhm	2%	0.25W MF	
MP.....3	1.727.910.01	1 pcs	Kuehlblech			R.....88	57.11.3331	330 Ohm	2%	0.25W MF	
MP.....4	1.011.235.03	2 pcs	Taschengehaese 3er			XIC.....1	54.03.0166	8 Pole		IC Socket	
MP.....5	1.011.235.23	2 pcs	Schalttaette 3er			XIC.....2	54.03.0166	8 Pole		IC Socket	
MP.....6	1.011.235.29	6 pcs	Bolzen			XIC.....3	54.03.0168	16 Pole		IC Socket	
MP.....7	1.011.235.30	6 pcs	Drucktaette			XIC.....4	54.03.0168	16 Pole		IC Socket	
MP.....8	1.011.235.33	6 pcs	Kalotte gelb			XIC.....5	54.03.0166	8 Pole		IC Socket	
MP.....9	1.727.910.10	0 pcs	No.Schild			XIC.....6	54.03.0168	16 Pole		IC Socket	
MP.....10	53.03.0221	6 pcs	LED Socketen 18mm			XIC.....7	54.03.0166	8 Pole		IC Socket	
MP.....11	1.010.050.22	2 pcs	Disanzgehause 3er			XIC.....8	54.03.0166	8 Pole		IC Socket	
MP.....12	21.53.0355	2 pcs	Schrauben M3,8mm			XIC.....9	54.03.0166	8 Pole		IC Socket	
MP.....13	24.16.1030	2 pcs	Sicherungsscheiben			XIC.....10	54.03.0167	14 Pole		IC Socket	
MP.....14	50.20.2002	4 pcs	Transistorencaps			XIC.....11	54.03.0167	14 Pole		IC Socket	
MP.....											

EXT. VU-PANEL 2CH WIRING DIAGRAM
 EXT. VU-PANEL MONO WIRING DIAGRAM

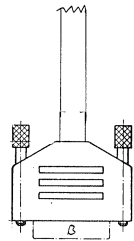
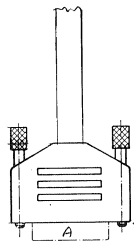
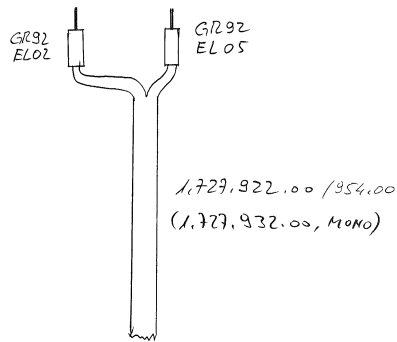
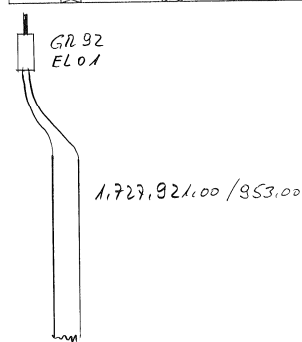
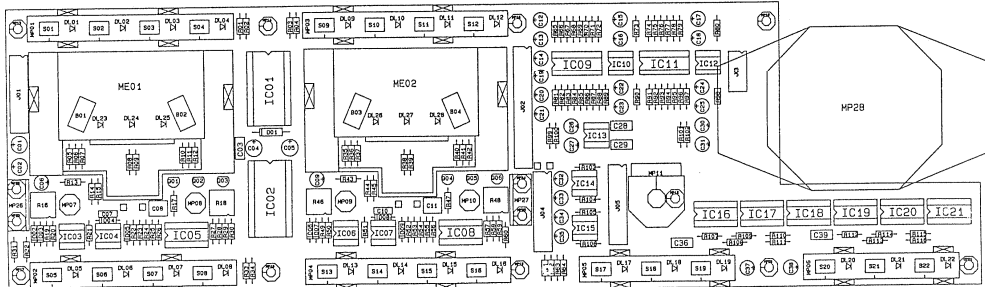

KEY 11

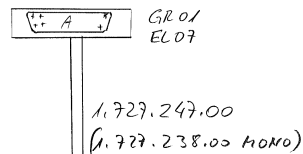
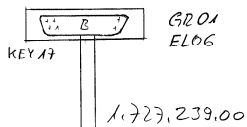

to GR10 EL08
 TAPE DECK ELECTRONICS

GR36
EL01

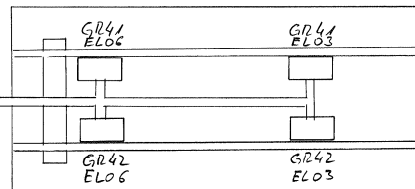

04.05.87 W.H.
A 807, VERSION VUK			PAGE	OF
STUDER		VERDRÄHTUNG, EXT. VU-PANEL		1.727.920.00



VU PANEL (2 VU) 1.727.925.00 GRP92

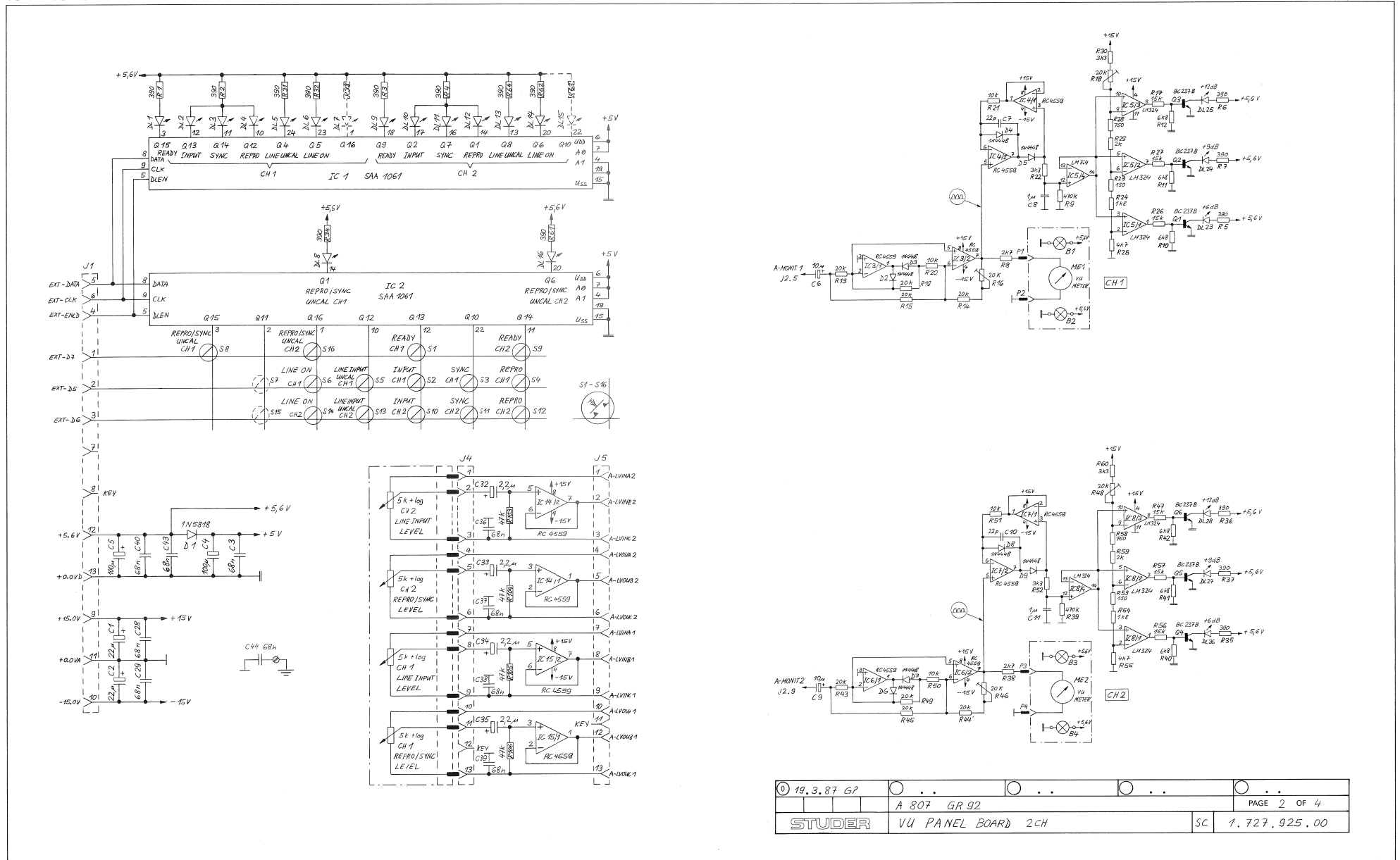



VU PANEL (2 VU) 1.727.925.00 GRP92

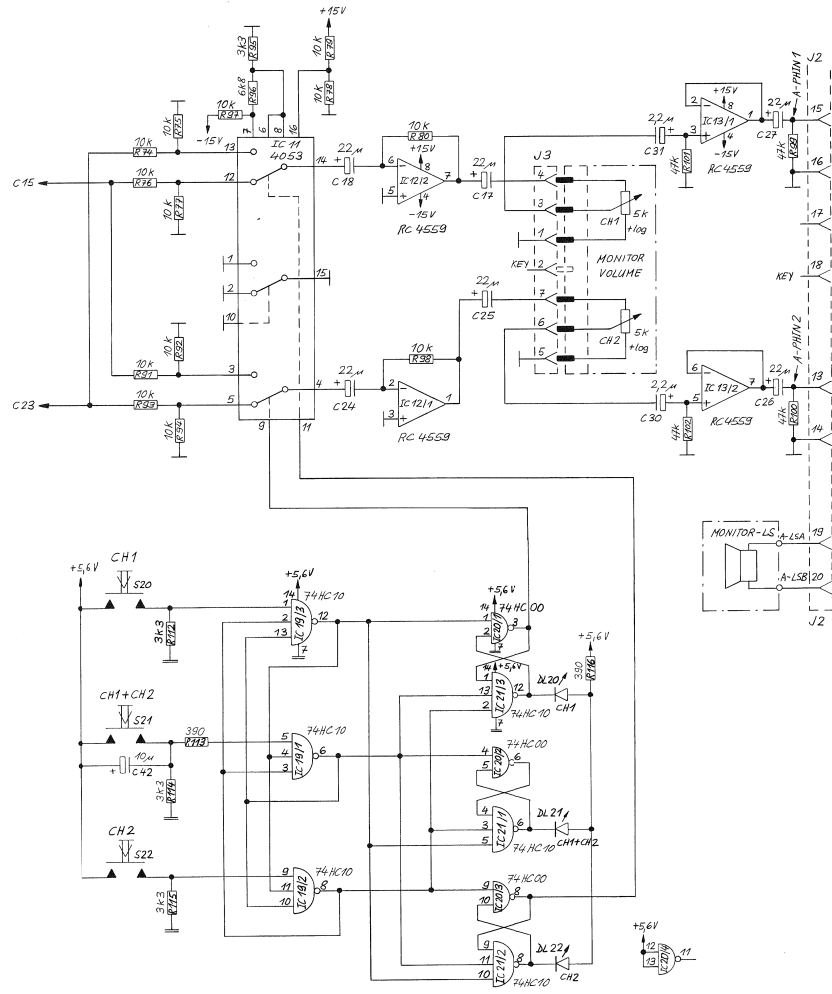
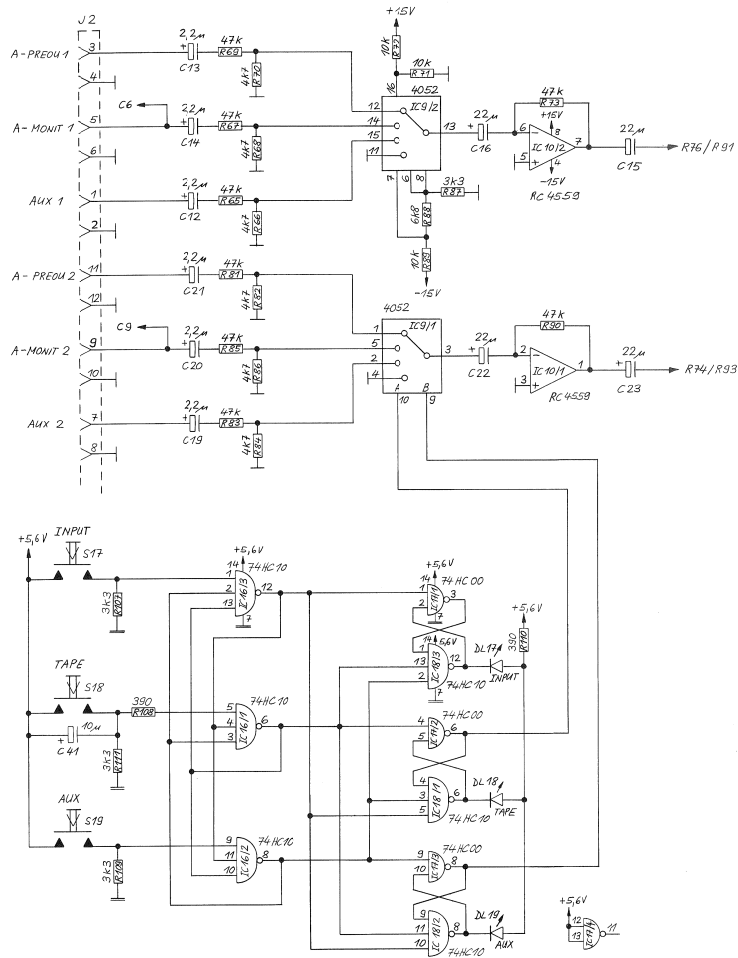

19.3.87 GP				
A 807 GR 92			PAGE 4 OF 4	
STUDER			VU PANEL BOARD 2CH	SC 1.727.925.00

VU PANEL (2 VU) 1.727.925.00 GRP92

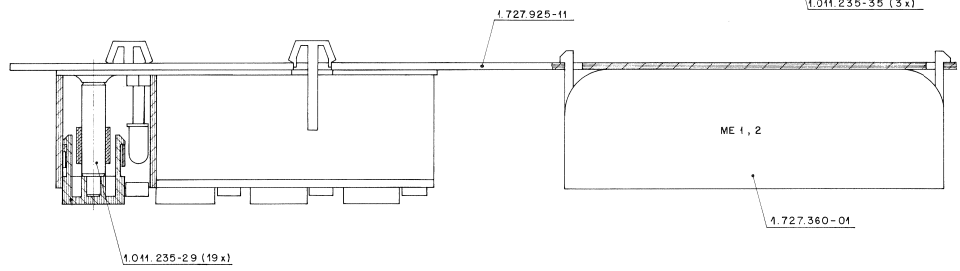
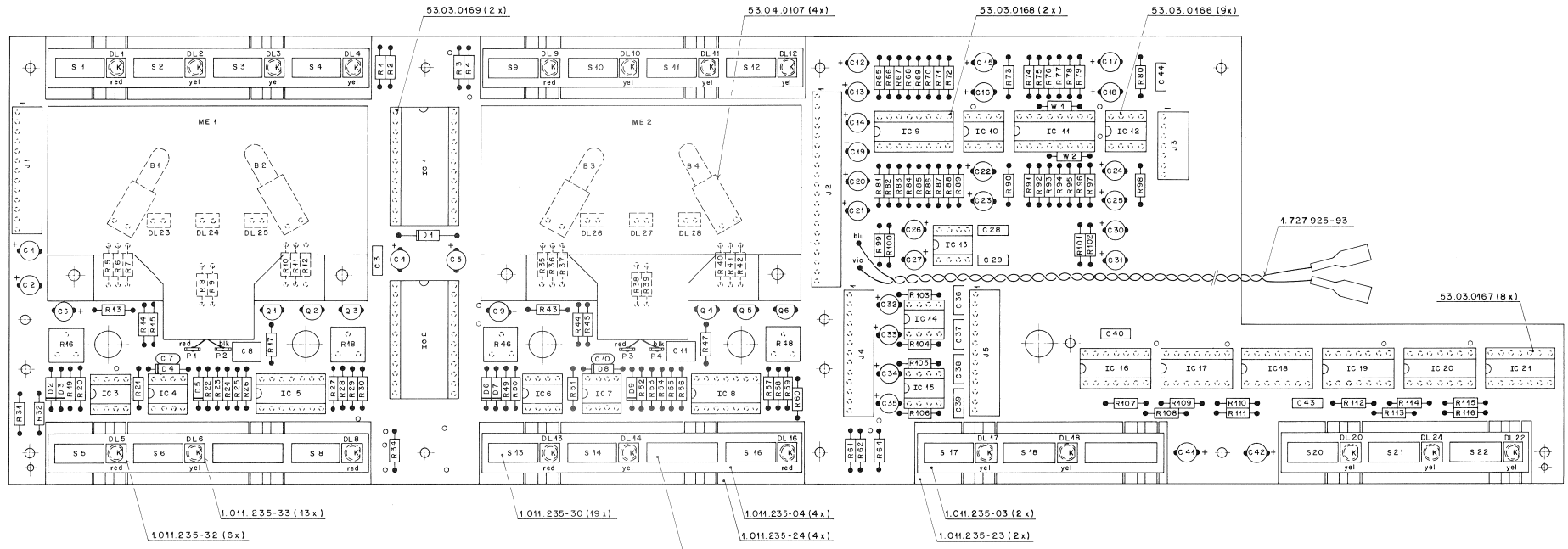

R16 = VU METER LEVEL CH1
 R18 = PEAK LEVEL CH1
 R46 = VU METER LEVEL CH2
 R48 = PEAK LEVEL CH2

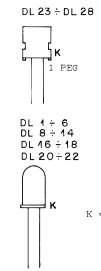



VU PANEL (2 VU) 1.727.925.00 GRP92

Table with columns: IND., POS.ND., PART NO., VALUE, SPECIFICATIONS / EQUIVALENT, MANUF. Contains parts list for VU PANEL BOARD ZCH, page 1.

S T U D E R (00) 87/06/01 GP VU PANEL BOARD ZCH 1.727.925.00 PAGE 1

Table with columns: IND., POS.ND., PART NO., VALUE, SPECIFICATIONS / EQUIVALENT, MANUF. Contains parts list for VU PANEL BOARD ZCH, page 2.

S T U D E R (00) 87/06/01 GP VU PANEL BOARD ZCH 1.727.925.00 PAGE 2

Table with columns: IND., POS.ND., PART NO., VALUE, SPECIFICATIONS / EQUIVALENT, MANUF. Contains parts list for VU PANEL BOARD ZCH, page 3.

S T U D E R (00) 87/06/01 GP VU PANEL BOARD ZCH 1.727.925.00 PAGE 3

Table with columns: IND., POS.ND., PART NO., VALUE, SPECIFICATIONS / EQUIVALENT, MANUF. Contains parts list for VU PANEL BOARD ZCH, page 4.

S T U D E R (00) 87/06/01 GP VU PANEL BOARD ZCH 1.727.925.00 PAGE 4

Table with columns: IND., POS.ND., PART NO., VALUE, SPECIFICATIONS / EQUIVALENT, MANUF. Contains parts list for VU PANEL BOARD ZCH, page 5.

S T U D E R (00) 87/06/01 GP VU PANEL BOARD ZCH 1.727.925.00 PAGE 5

Table with columns: IND., POS.ND., PART NO., VALUE, SPECIFICATIONS / EQUIVALENT, MANUF. Contains parts list for VU PANEL BOARD ZCH, page 6.

S T U D E R (00) 87/06/01 GP VU PANEL BOARD ZCH 1.727.925.00 PAGE 6

Table with columns: IND., POS.ND., PART NO., VALUE, SPECIFICATIONS / EQUIVALENT, MANUF. Contains parts list for VU PANEL BOARD ZCH, page 7.

S T U D E R (00) 87/06/01 GP VU PANEL BOARD ZCH 1.727.925.00 PAGE 7

Table with columns: IND., POS.ND., PART NO., VALUE, SPECIFICATIONS / EQUIVALENT, MANUF. Contains parts list for VU PANEL BOARD ZCH, page 8.

S T U D E R (00) 87/06/01 GP VU PANEL BOARD ZCH 1.727.925.00 PAGE 8

Table with columns: IND., POS.ND., PART NO., VALUE, SPECIFICATIONS / EQUIVALENT, MANUF. Contains parts list for VU PANEL BOARD ZCH, page 9.

S T U D E R (00) 87/06/01 GP VU PANEL BOARD ZCH 1.727.925.00 PAGE 9

Table with columns: IND., POS.ND., PART NO., VALUE, SPECIFICATIONS / EQUIVALENT, MANUF. Contains parts list for VU PANEL BOARD ZCH, page 10.

S T U D E R (00) 87/06/01 GP VU PANEL BOARD ZCH 1.727.925.00 PAGE 10

Table with columns: IND., POS.ND., PART NO., VALUE, SPECIFICATIONS / EQUIVALENT, MANUF. Contains parts list for VU PANEL BOARD ZCH, page 11.

S T U D E R (00) 87/06/01 GP VU PANEL BOARD ZCH 1.727.925.00 PAGE 11

Table with columns: IND., POS.ND., PART NO., VALUE, SPECIFICATIONS / EQUIVALENT, MANUF. Contains parts list for VU PANEL BOARD ZCH, page 12.

S T U D E R (00) 87/06/01 GP VU PANEL BOARD ZCH 1.727.925.00 PAGE 12



VU PANEL (1 VU) 1.727.935.00 GRP92

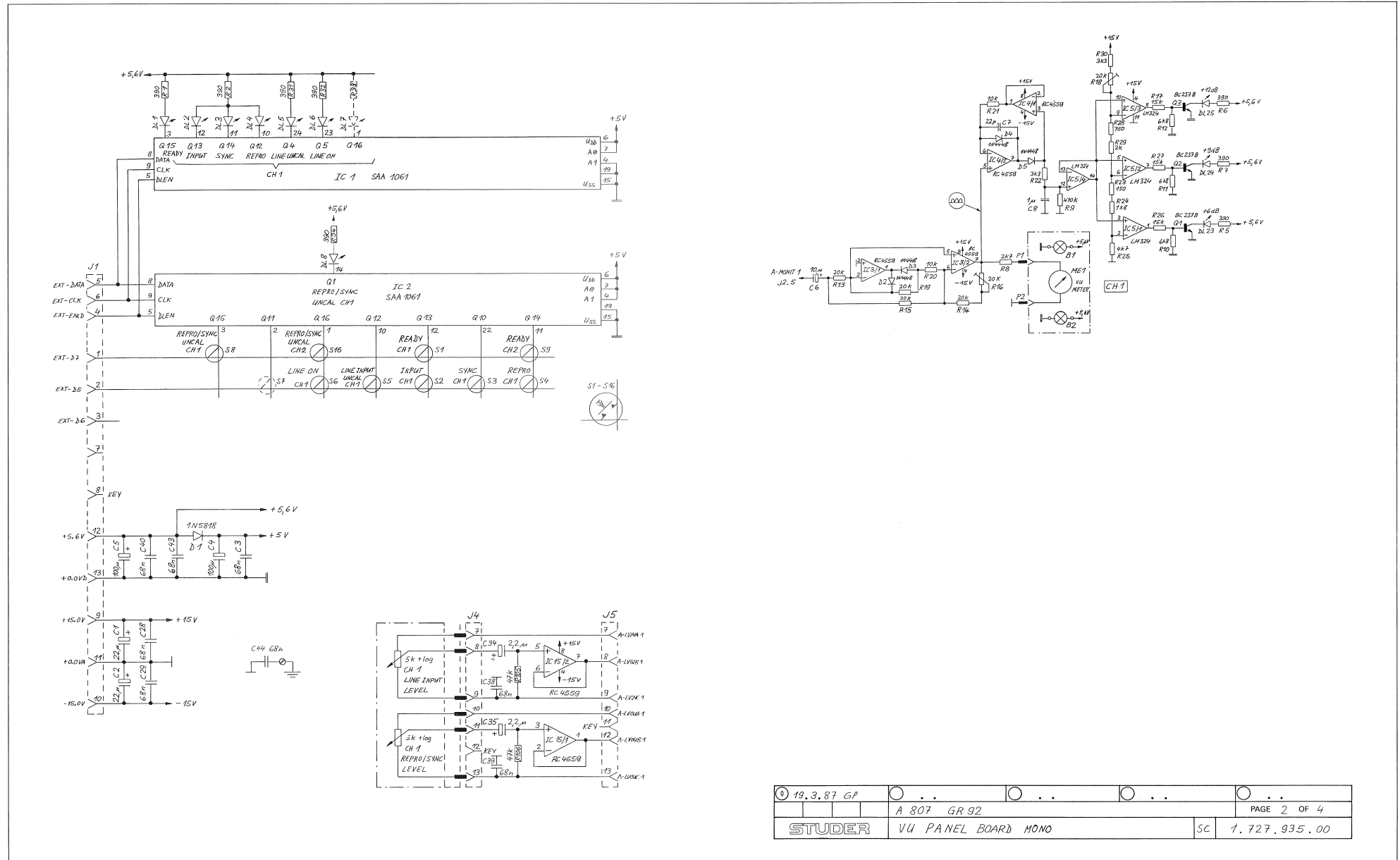

0	19.3.87 GP				
	A 807 GR 92				PAGE 2 OF 4
STUDER	VU PANEL BOARD MONO	SC	1.727.935.00		



VU PANEL (1 VU) 1.727.935.00 GRP92

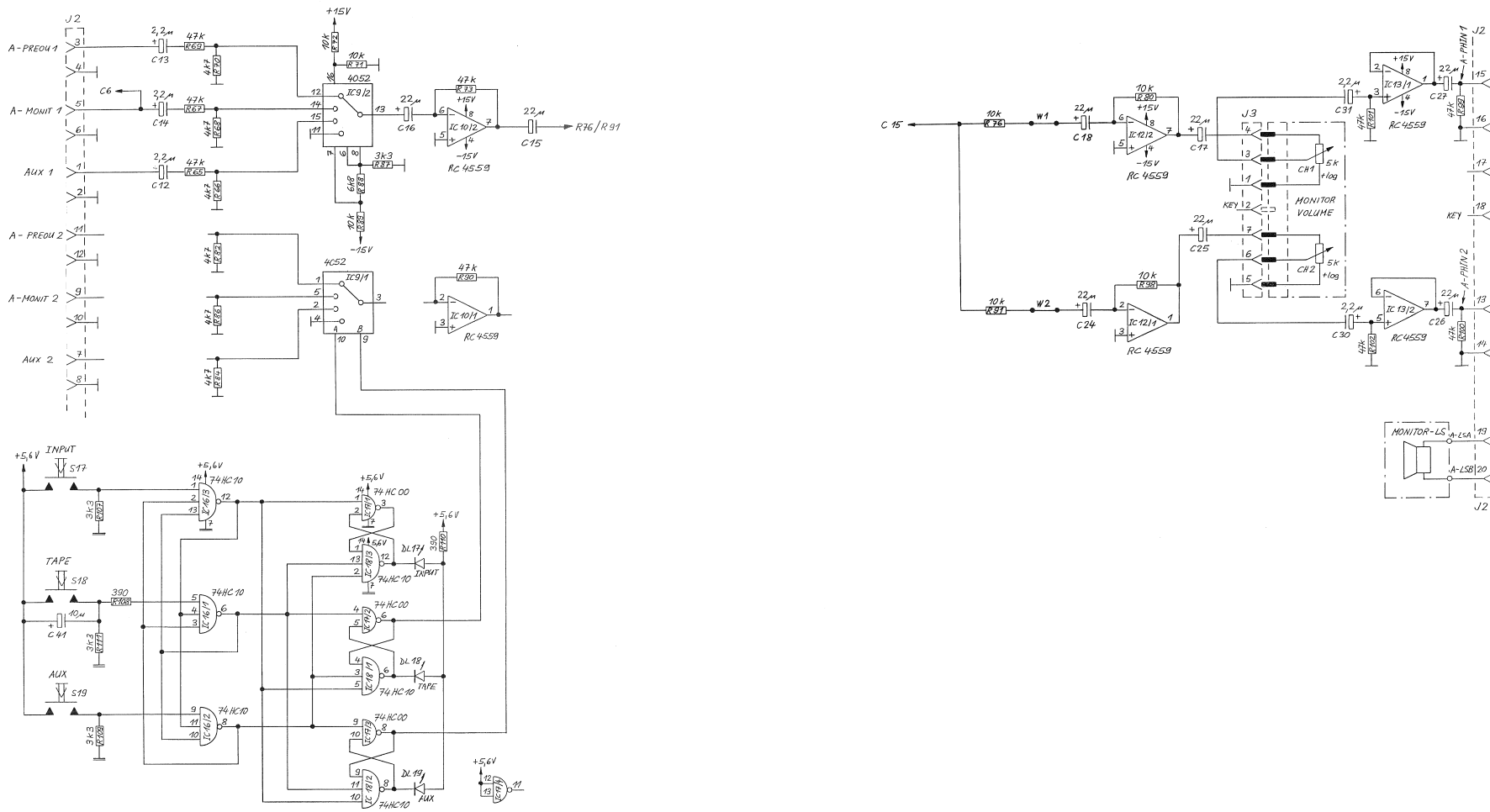

0	19.3.87 GP				
		A 807 GR 92			PAGE 4 OF 4
STUDER		VU PANEL BOARD MONO	SC		1.727.935.00



VU PANEL (1 VU) 1.727.935.00 GRP92

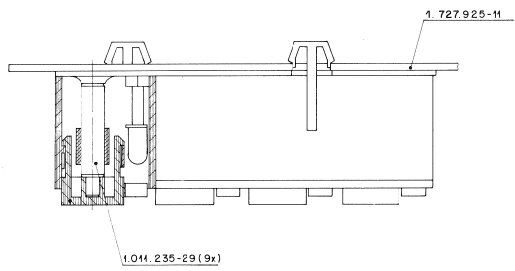
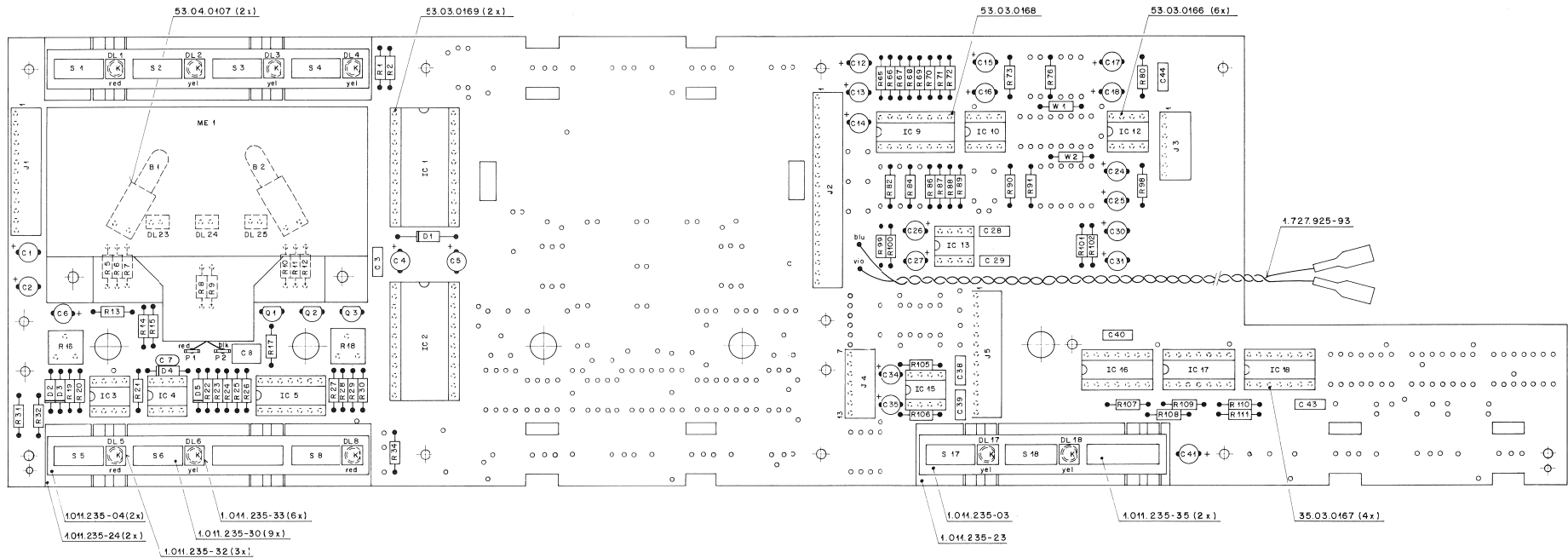

R16 = VU METER LEVEL
 R18 = PEAK LEVEL

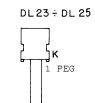

DL 1 = DL 6, DL 8
 DL 17, DL 18

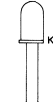

K = CATHODE

EXT. STEREO MONITOR VU-PANEL WIRING DIAGRAM

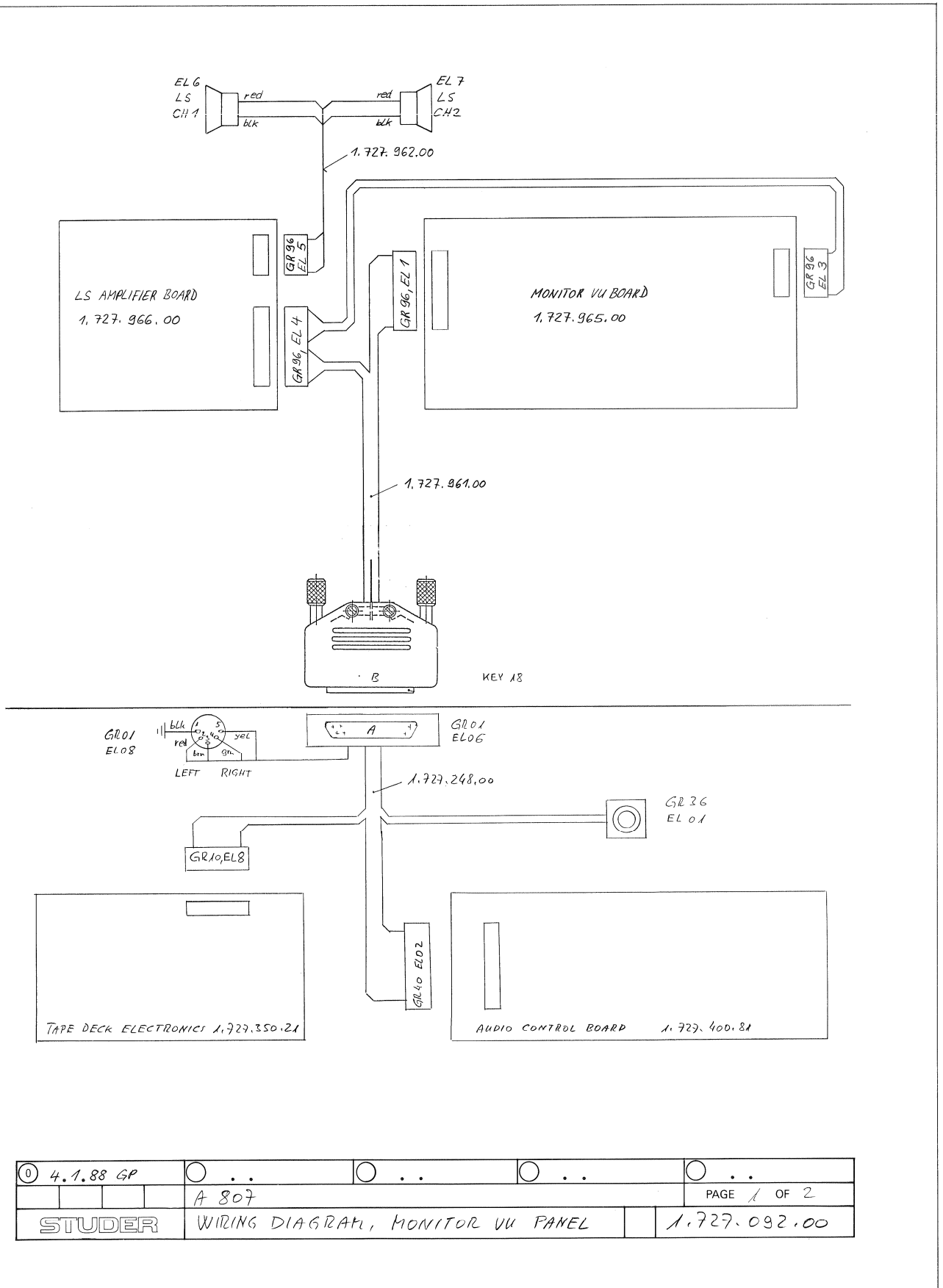

① 4.1.88 GP	○ ..	○ ..	○ ..	○ ..
	A 807			PAGE 1 OF 2
STUDER	WIRING DIAGRAM, MONITOR VU PANEL			1.727.092.00

EXT. STEREO MONITOR VU-PANEL WIRING DIAGRAM

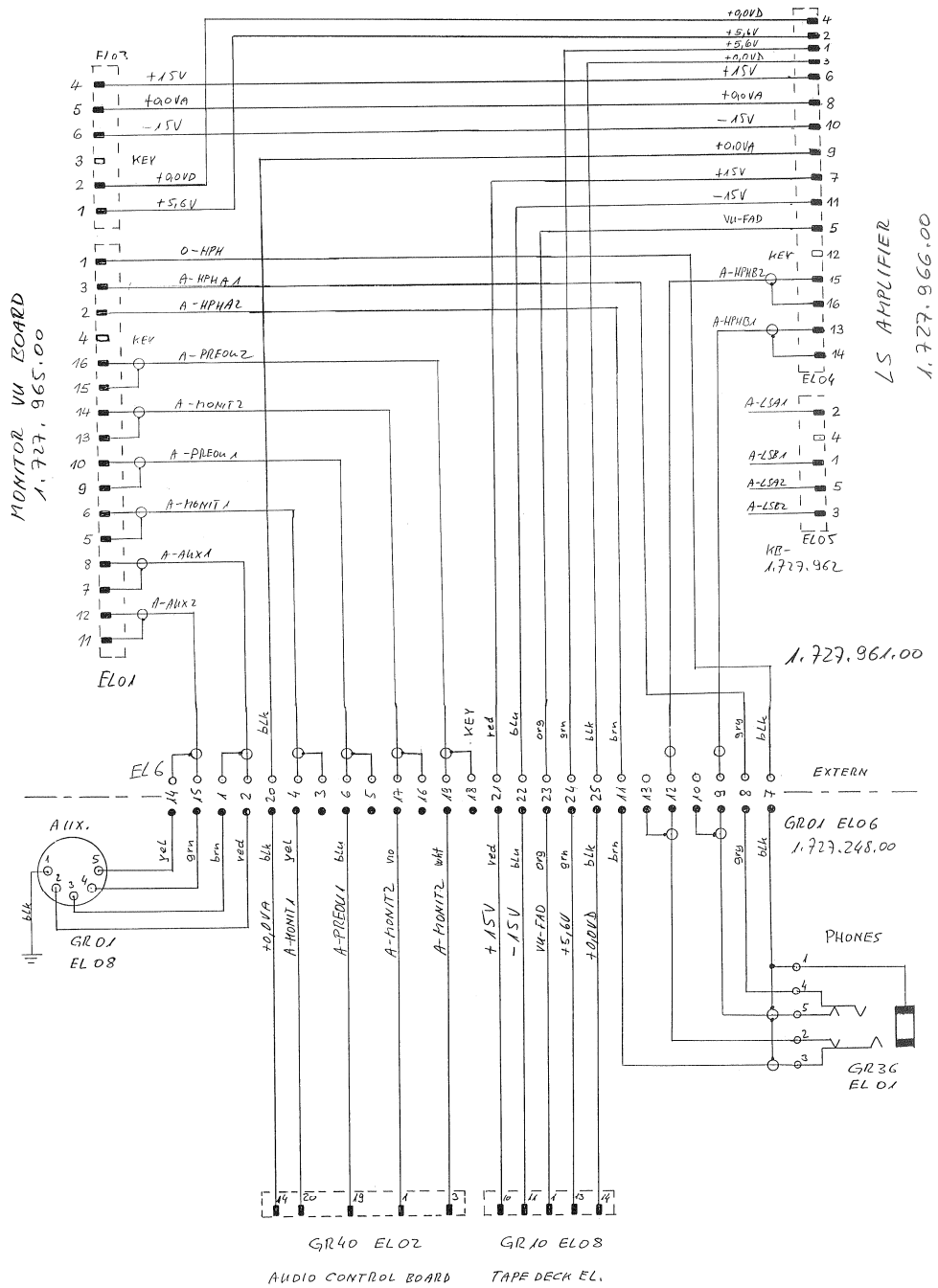

④ 4.1.88 WH.	○ ..	○ ..	○ ..	○ ..
	A 807			PAGE 2 OF 2
STUDER	WIRING DIAGRAM, MONITOR VU PANEL			1.727.092.00



MONITOR WITH VU-METERS (STEREO) 1.727.965.00

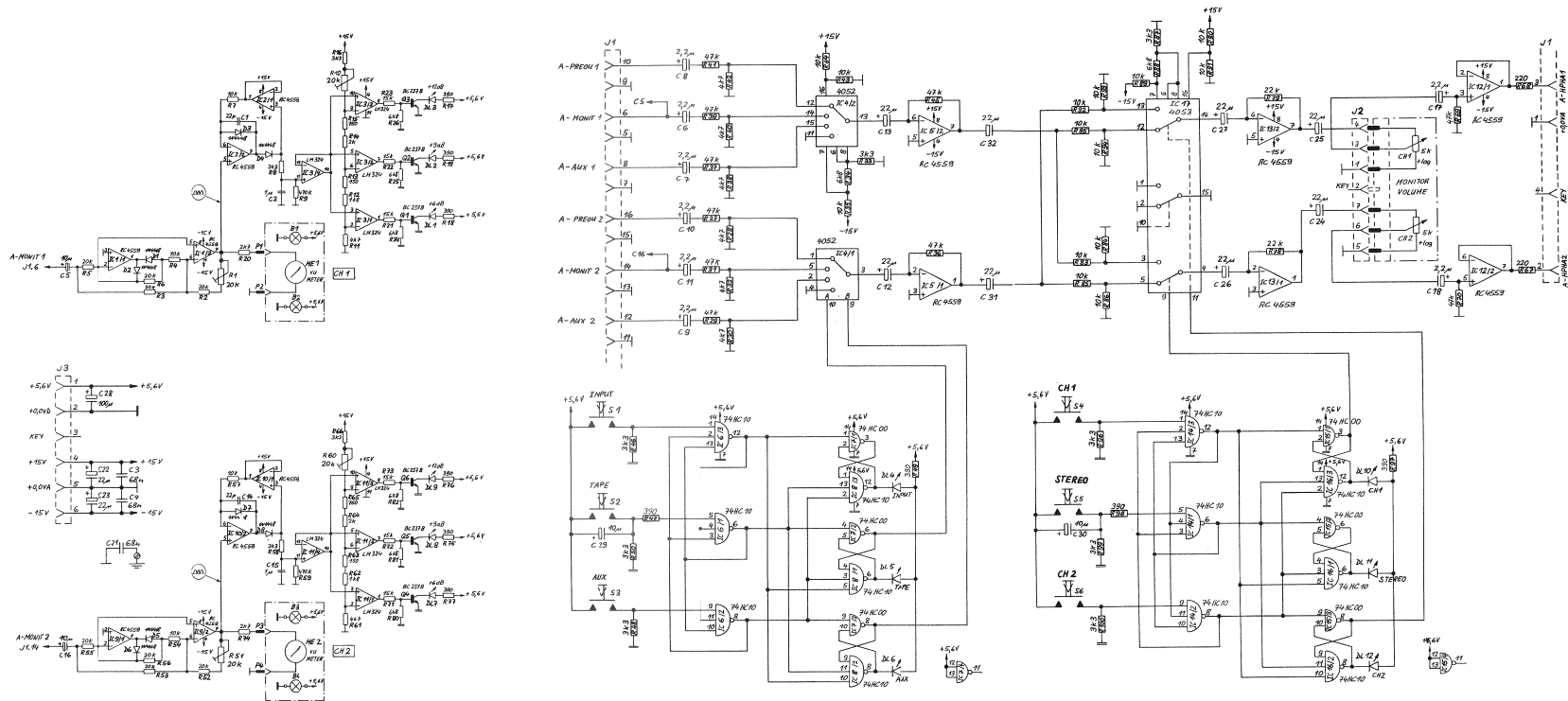

①	2.72.87 GP	○	○	○	○	○	○	○	○
	A 807 GR 96								PAGE 3 OF 3
STUDER	MONITOR VU BOARD							SC	1.727.965.00

MONITOR WITH VU-METERS (STEREO) 1.727.965.00

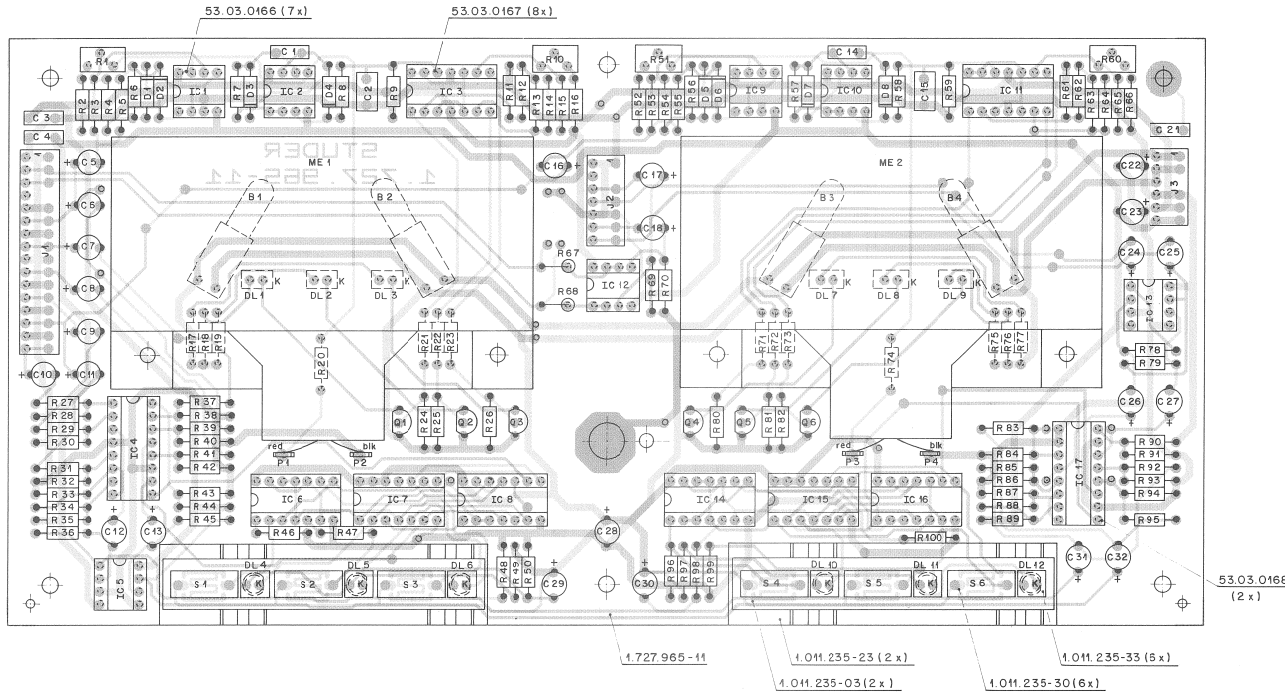

IND.	POS.+NO.	PART NO.	VALUE	SPECIFICATIONS / EQUIVALENT	MANUF.
B.....1	51.02.0144	6 V	B-03 A	Lamp	
B.....2	51.02.0144	6 V	B-03 A	Lamp	
B.....3	51.02.0144	6 V	B-03 A	Lamp	
B.....4	51.02.0144	6 V	B-03 A	Lamp	
C.....1	59.24.2220	22 uF	10% 50 V	CEP	
C.....2	59.04.0105	10 uF	10% 50 V	PETP	
C.....3	59.04.0083	47 uF	10% 50 V	PETP	
C.....4	59.22.0100	10 uF	-20% 25 V	EL	
C.....5	59.22.0229	2.2 uF	-20% 25 V	EL	
C.....6	59.22.0229	2.2 uF	-20% 25 V	EL	
C.....7	59.22.0229	2.2 uF	-20% 25 V	EL	
C.....8	59.22.0229	2.2 uF	-20% 25 V	EL	
C.....9	59.22.0229	2.2 uF	-20% 25 V	EL	
C.....10	59.22.0229	2.2 uF	-20% 25 V	EL	
C.....11	59.22.0229	2.2 uF	-20% 25 V	EL	
C.....12	59.22.0229	2.2 uF	-20% 25 V	EL	
C.....13	59.22.0229	2.2 uF	-20% 25 V	EL	
C.....14	59.22.0229	2.2 uF	-20% 25 V	EL	
C.....15	59.04.0105	10 uF	10% 50 V	PETP	
C.....16	59.22.0100	10 uF	-20% 25 V	EL	
C.....17	59.22.0229	2.2 uF	-20% 25 V	EL	
C.....18	59.04.0083	47 uF	10% 50 V	PETP	
C.....19	59.22.0229	2.2 uF	-20% 25 V	EL	
C.....20	59.22.0229	2.2 uF	-20% 25 V	EL	
C.....21	59.22.0229	2.2 uF	-20% 25 V	EL	
C.....22	59.22.0229	2.2 uF	-20% 25 V	EL	
C.....23	59.22.0229	2.2 uF	-20% 25 V	EL	
C.....24	59.22.0229	2.2 uF	-20% 25 V	EL	
C.....25	59.22.0229	2.2 uF	-20% 25 V	EL	
C.....26	59.22.0100	10 uF	-20% 25 V	EL	
C.....27	59.22.0100	10 uF	-20% 25 V	EL	
C.....28	59.22.0100	10 uF	-20% 25 V	EL	
C.....29	59.22.0100	10 uF	-20% 25 V	EL	
C.....30	59.22.0100	10 uF	-20% 25 V	EL	
D.....1	50.04.0125	IN4448	50 V SI		

STUDER (03) 88/01/05 GP MONITOR VU BOARD 1.727.965-00 PAGE 1

IND.	POS.+NO.	PART NO.	VALUE	SPECIFICATIONS / EQUIVALENT	MANUF.
D.....2	50.04.0125	IN4448	50 V SI		
D.....3	50.04.0125	IN4448	50 V SI		
D.....4	50.04.0125	IN4448	50 V SI		
D.....5	50.04.0125	IN4448	50 V SI		
D.....6	50.04.0125	IN4448	50 V SI		
D.....7	50.04.0125	IN4448	50 V SI		
D.....8	50.04.0125	IN4448	50 V SI		
UL.....1	50.04.2119	MY3124	LED red 6.35x1.61		G1
UL.....2	50.04.2119	MY3124	LED red 6.35x1.61		G1
UL.....3	50.04.2119	MY3124	LED red 6.35x1.61		G1
UL.....4	50.04.2500	MY352	LED yel 0.5 mm		G1
UL.....5	50.04.2500	MY352	LED yel 0.5 mm		G1
UL.....6	50.04.2500	MY352	LED yel 0.5 mm		G1
UL.....7	50.04.2500	MY352	LED yel 0.5 mm		G1
UL.....8	50.04.2500	MY352	LED yel 0.5 mm		G1
UL.....9	50.04.2500	MY352	LED yel 0.5 mm		G1
UL.....10	50.04.2500	MY352	LED yel 0.5 mm		G1
UL.....11	50.04.2500	MY352	LED yel 0.5 mm		G1
UL.....12	50.04.2500	MY352	LED yel 0.5 mm		G1
IC.....1	50.04.0107	IC 4559	Quard Op. Amp.		Ra
IC.....2	50.04.0107	IC 4559	Quard Op. Amp.		Ra
IC.....3	50.04.0107	IC 4559	Quard Op. Amp.		Ra
IC.....4	50.04.0107	IC 4559	Quard Op. Amp.		Ra
IC.....5	50.04.0107	IC 4559	Quard Op. Amp.		Ra
IC.....6	50.04.0107	IC 4559	Quard Op. Amp.		Ra
IC.....7	50.04.0107	IC 4559	Quard Op. Amp.		Ra
IC.....8	50.04.0107	IC 4559	Quard Op. Amp.		Ra
IC.....9	50.04.0107	IC 4559	Quard Op. Amp.		Ra
IC.....10	50.04.0107	IC 4559	Quard Op. Amp.		Ra
IC.....11	50.04.0107	IC 4559	Quard Op. Amp.		Ra
IC.....12	50.04.0107	IC 4559	Quard Op. Amp.		Ra
IC.....13	50.04.0107	IC 4559	Quard Op. Amp.		Ra
IC.....14	50.17.1000	74 HC 10	Triple 3-Input NAND Gate		Ra
IC.....15	50.17.1000	74 HC 10	Triple 3-Input NAND Gate		Ra
IC.....16	50.17.1000	74 HC 10	Triple 3-Input NAND Gate		Ra

STUDER (03) 88/01/05 GP MONITOR VU BOARD 1.727.965-00 PAGE 2

IND.	POS.+NO.	PART NO.	VALUE	SPECIFICATIONS / EQUIVALENT	MANUF.
IC.....17	50.07.0015	ME 14053	CMDS Analog Switch		Mot
J.....1	54.01.0301	16-Pole	CIS Socket Strip		AMP
J.....2	54.01.0263	7-Pole	CIS Socket Strip		AMP
J.....3	54.01.0238	6-Pole	CIS Socket Strip		AMP
ME.....1	1.727.965.01		VU Meter		St
ME.....2	1.727.965.01		VU Meter		St
MP.....1	51.21.0108	1 pcs	ESE Warning Label		St
MP.....2	51.03.0221	12 pcs	2-Pole LED Socket		St
MP.....3	1.011.235-03	2 pcs	Push Button Case 3p		St
MP.....4	1.011.235-23	2 pcs	Connective rubber 3p		St
MP.....5	1.011.235-29	6 pcs	ROF		St
MP.....6	1.011.235-30	6 pcs	Push button 1x55		St
MP.....7	1.011.235-33	6 pcs	Colored yel		St
MP.....8	1.727.965-10	2 pcs	1-LIT Command Panel Board		St
MP.....9	1.727.965-10	1 pcs	Rev Label		St
MP.....10	1.727.965-11	1 pcs	MONITOR VU PCB		St
P.....1	54.02.0320		Plug 2-BRD-B		AMP
P.....2	54.02.0320		Plug 2-BRD-B		AMP
P.....3	54.02.0320		Plug 2-BRD-B		AMP
P.....4	54.02.0320		Plug 2-BRD-B		AMP
S.....1	50.03.0436	HC2376	HC5476B RC5500 NPN		AMP
S.....2	50.03.0436	HC2376	HC5476B RC5500 NPN		AMP
S.....3	50.03.0436	HC2376	HC5476B RC5500 NPN		AMP
S.....4	50.03.0436	HC2376	HC5476B RC5500 NPN		AMP
S.....5	50.03.0436	HC2376	HC5476B RC5500 NPN		AMP
S.....6	50.03.0436	HC2376	HC5476B RC5500 NPN		AMP
S.....7	50.03.0436	HC2376	HC5476B RC5500 NPN		AMP
S.....8	50.03.0436	HC2376	HC5476B RC5500 NPN		AMP
S.....9	50.03.0436	HC2376	HC5476B RC5500 NPN		AMP
S.....10	50.03.0436	HC2376	HC5476B RC5500 NPN		AMP
S.....11	50.01.9203	20 kOhm	10% 0.5 W PCForm		AMP
S.....12	51.11.3203	20 kOhm	1% 0.25W HF		AMP
S.....13	51.11.3203	20 kOhm	1% 0.25W HF		AMP
S.....14	51.11.4103	10 kOhm	1% 0.25W HF		AMP
S.....15	51.11.3203	20 kOhm	1% 0.25W HF		AMP

STUDER (03) 88/01/05 GP MONITOR VU BOARD 1.727.965-00 PAGE 3

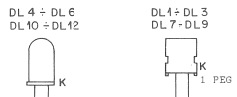
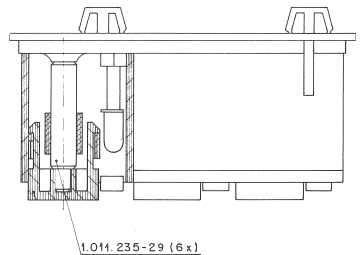

K - CATHODE

1.011.235-29 (6x)



MONITOR WITH VU-METERS (STEREO) 1.727.965.00

IND.	POS.-NO.	PART NO.	VALUE	SPECIFICATIONS / EQUIVALENT	MANUF.	IND.	POS.-NO.	PART NO.	VALUE	SPECIFICATIONS / EQUIVALENT	MANUF.
R.....6	57.11.3203	20	kOhm	1% 0.25W, MF		XIC...11	53.03.0167	14-Pole	IC Socket		
R.....7	57.11.4103	10	kOhm	2% 0.25W, MF		XIC...12	53.03.0166	8-Pole	IC Socket		
R.....8	57.11.4332	3.3	kOhm	2% 0.25W, MF		XIC...13	53.03.0166	8-Pole	IC Socket		
R.....9	57.11.4474	470	kOhm	2% 0.25W, MF		XIC...14	53.03.0167	14-Pole	IC Socket		
R.....10	58.01.9203	20	kOhm	10% 0.5 W, PCterm		XIC...15	53.03.0167	14-Pole	IC Socket		
R.....11	57.11.4472	4.7	kOhm	2% 0.25W, MF		XIC...16	53.03.0167	14-Pole	IC Socket		
R.....12	57.11.4102	1.9	kOhm	2% 0.25W, MF		XIC...17	53.03.0168	16-Pole	IC Socket		
R.....13	57.11.4151	150	Ohm	2% 0.25W, MF							
R.....14	57.11.3202	2	kOhm	1% 0.25W, MF							
R.....15	57.11.3751	750	Ohm	1% 0.25W, MF							
R.....16	57.11.4332	3.3	kOhm	2% 0.25W, MF							
R.....17	57.11.4391	390	Ohm	2% 0.25W, MF							
R.....18	57.11.4391	390	Ohm	2% 0.25W, MF							
R.....19	57.11.4391	390	Ohm	2% 0.25W, MF							
R.....20	57.11.4272	2.7	kOhm	2% 0.25W, MF							
R.....21	57.11.4153	15	kOhm	2% 0.25W, MF							
R.....22	57.11.4153	15	kOhm	2% 0.25W, MF							
R.....23	57.11.4153	15	kOhm	2% 0.25W, MF							
R.....24	57.11.4682	6.8	kOhm	2% 0.25W, MF							
R.....25	57.11.4682	6.8	kOhm	2% 0.25W, MF							
R.....26	57.11.4682	6.8	kOhm	2% 0.25W, MF							
R.....27	57.11.4473	4.7	kOhm	2% 0.25W, MF							
R.....28	57.11.4472	4.7	kOhm	2% 0.25W, MF							
R.....29	57.11.4473	4.7	kOhm	2% 0.25W, MF							
R.....30	57.11.4472	4.7	kOhm	2% 0.25W, MF							
R.....31	57.11.4473	4.7	kOhm	2% 0.25W, MF							
R.....32	57.11.4472	4.7	kOhm	2% 0.25W, MF							
R.....33	57.11.4332	3.3	kOhm	2% 0.25W, MF							
R.....34	57.11.4682	6.8	kOhm	2% 0.25W, MF							
R.....35	57.11.4103	10	kOhm	2% 0.25W, MF							
R.....36	57.11.4473	4.7	kOhm	2% 0.25W, MF							
R.....37	57.11.4473	4.7	kOhm	2% 0.25W, MF							
R.....38	57.11.4472	4.7	kOhm	2% 0.25W, MF							
R.....39	57.11.4473	4.7	kOhm	2% 0.25W, MF							
R.....40	57.11.4472	4.7	kOhm	2% 0.25W, MF							
R.....41	57.11.4473	4.7	kOhm	2% 0.25W, MF							
R.....42	57.11.4472	4.7	kOhm	2% 0.25W, MF							

CER=Ceramic; EL=Electrolytic; PCTP=Polyester; SI=Silicon;
 MF=Metal Film; PCterm=PC term; Cermet;
 MANUFACTURER: AMP=AMP, GI=General Instrument, IIT=Intermetall,
 Mot=Motorola; NS=National Semiconductors; Ph=Philips;
 Ra=Raytheon; St=Studer.

ORIG 88/01/05

S T U D E R (00) 88/01/05 GP MONITOR VU BOARD 1.727.965.00 PAGE 4 S T U D E R (00) 88/01/05 GP MONITOR VU BOARD 1.727.965.00 PAGE 7

IND.	POS.-NO.	PART NO.	VALUE	SPECIFICATIONS / EQUIVALENT	MANUF.
R.....43	57.11.4103	10	kOhm	2% 0.25W, MF	
R.....44	57.11.4103	10	kOhm	2% 0.25W, MF	
R.....45	57.11.4473	4.7	kOhm	2% 0.25W, MF	
R.....46	57.11.4332	3.3	kOhm	2% 0.25W, MF	
R.....47	57.11.4391	390	Ohm	2% 0.25W, MF	
R.....48	57.11.4332	3.3	kOhm	2% 0.25W, MF	
R.....49	57.11.4391	390	Ohm	2% 0.25W, MF	
R.....50	57.11.4332	3.3	kOhm	2% 0.25W, MF	
R.....51	58.01.9203	20	kOhm	10% 0.5 W, PCterm	
R.....52	57.11.3203	20	kOhm	1% 0.25W, MF	
R.....53	57.11.3203	20	kOhm	1% 0.25W, MF	
R.....54	57.11.4103	10	kOhm	2% 0.25W, MF	
R.....55	57.11.3203	20	kOhm	1% 0.25W, MF	
R.....56	57.11.3203	20	kOhm	1% 0.25W, MF	
R.....57	57.11.4103	10	kOhm	2% 0.25W, MF	
R.....58	57.11.4332	3.3	kOhm	2% 0.25W, MF	
R.....59	57.11.4474	470	kOhm	2% 0.25W, MF	
R.....60	58.01.9203	20	kOhm	10% 0.5 W, PCterm	
R.....61	57.11.4472	4.7	kOhm	2% 0.25W, MF	
R.....62	57.11.4102	1.9	kOhm	2% 0.25W, MF	
R.....63	57.11.4151	150	Ohm	2% 0.25W, MF	
R.....64	57.11.3202	2	kOhm	1% 0.25W, MF	
R.....65	57.11.3751	750	Ohm	1% 0.25W, MF	
R.....66	57.11.4332	3.3	kOhm	2% 0.25W, MF	
R.....67	57.11.4221	220	Ohm	2% 0.25W, MF	
R.....68	57.11.4221	220	Ohm	2% 0.25W, MF	
R.....69	57.11.4473	4.7	kOhm	2% 0.25W, MF	
R.....70	57.11.4473	4.7	kOhm	2% 0.25W, MF	
R.....71	57.11.4153	15	kOhm	2% 0.25W, MF	
R.....72	57.11.4153	15	kOhm	2% 0.25W, MF	
R.....73	57.11.4153	15	kOhm	2% 0.25W, MF	
R.....74	57.11.4272	2.7	kOhm	2% 0.25W, MF	
R.....75	57.11.4391	390	Ohm	2% 0.25W, MF	
R.....76	57.11.4391	390	Ohm	2% 0.25W, MF	
R.....77	57.11.4391	390	Ohm	2% 0.25W, MF	
R.....78	57.11.4223	22	kOhm	2% 0.25W, MF	
R.....79	57.11.4223	22	kOhm	2% 0.25W, MF	

S T U D E R (00) 88/01/05 GP MONITOR VU BOARD 1.727.965.00 PAGE 5

IND.	POS.-NO.	PART NO.	VALUE	SPECIFICATIONS / EQUIVALENT	MANUF.
R.....80	57.11.4682	6.8	kOhm	2% 0.25W, MF	
R.....81	57.11.4682	6.8	kOhm	2% 0.25W, MF	
R.....82	57.11.4682	6.8	kOhm	2% 0.25W, MF	
R.....83	57.11.4103	10	kOhm	2% 0.25W, MF	
R.....84	57.11.4103	10	kOhm	2% 0.25W, MF	
R.....85	57.11.4103	10	kOhm	2% 0.25W, MF	
R.....86	57.11.4103	10	kOhm	2% 0.25W, MF	
R.....87	57.11.4332	3.3	kOhm	2% 0.25W, MF	
R.....88	57.11.4682	6.8	kOhm	2% 0.25W, MF	
R.....89	57.11.4103	10	kOhm	2% 0.25W, MF	
R.....90	57.11.4103	10	kOhm	2% 0.25W, MF	
R.....91	57.11.4103	10	kOhm	2% 0.25W, MF	
R.....92	57.11.4103	10	kOhm	2% 0.25W, MF	
R.....93	57.11.4103	10	kOhm	2% 0.25W, MF	
R.....94	57.11.4103	10	kOhm	2% 0.25W, MF	
R.....95	57.11.4103	10	kOhm	2% 0.25W, MF	
R.....96	57.11.4332	3.3	kOhm	2% 0.25W, MF	
R.....97	57.11.4391	390	Ohm	2% 0.25W, MF	
R.....98	57.11.4391	390	Ohm	2% 0.25W, MF	
R.....99	57.11.4332	3.3	kOhm	2% 0.25W, MF	
R.....100	57.11.4332	3.3	kOhm	2% 0.25W, MF	
XB.....1	53.04.0107			Lamp holder	
XB.....2	53.04.0107			Lamp holder	
XB.....3	53.04.0107			Lamp holder	
XB.....4	53.04.0107			Lamp holder	
XIC...1	53.03.0166	8-Pole		IC Socket	
XIC...2	53.03.0166	8-Pole		IC Socket	
XIC...3	53.03.0167	14-Pole		IC Socket	
XIC...4	53.03.0168	16-Pole		IC Socket	
XIC...5	53.03.0166	8-Pole		IC Socket	
XIC...6	53.03.0167	14-Pole		IC Socket	
XIC...7	53.03.0167	14-Pole		IC Socket	
XIC...8	53.03.0167	14-Pole		IC Socket	
XIC...9	53.03.0166	8-Pole		IC Socket	
XIC...10	53.03.0166	8-Pole		IC Socket	

S T U D E R (00) 88/01/05 GP MONITOR VU BOARD 1.727.965.00 PAGE 6

LS AMPLIFIER (STEREO) 1.727.966.00

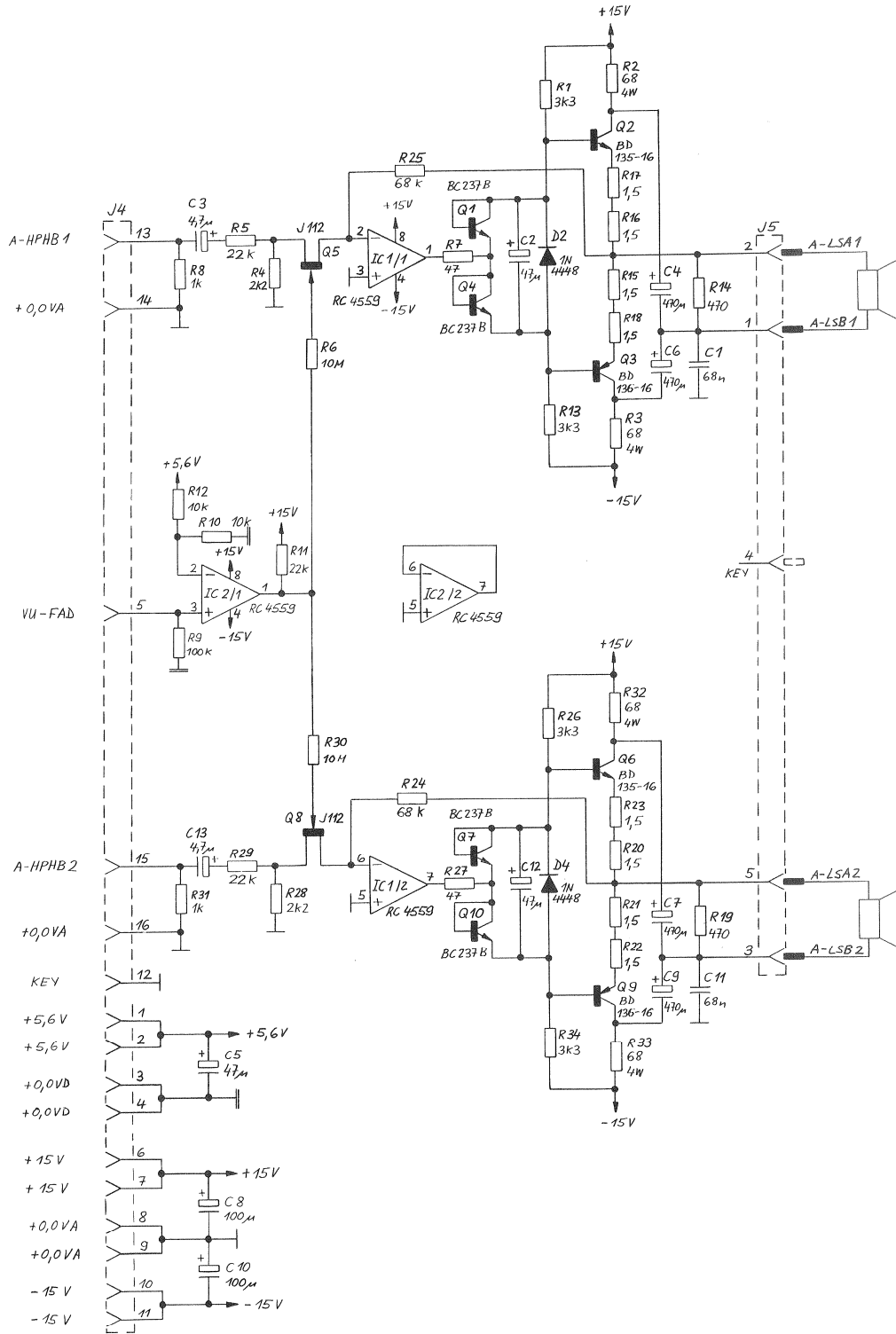

① 2.12.87 GP	① 21.1.88 GP	○ ..	○ ..	○ ..
A 807 GR 96			PAGE 1 OF 1	
STUDER LS AMPLIFIER BOARD			SC	1.727.966.00

LS AMPLIFIER (STEREO) 1.727.966.00

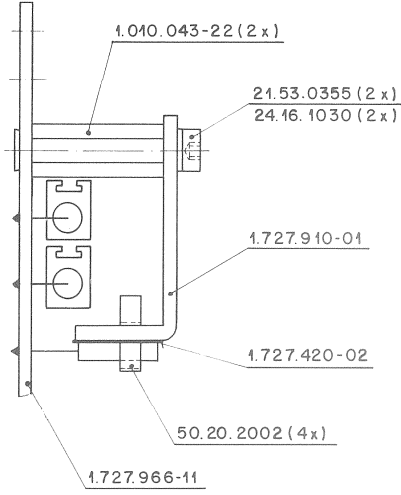
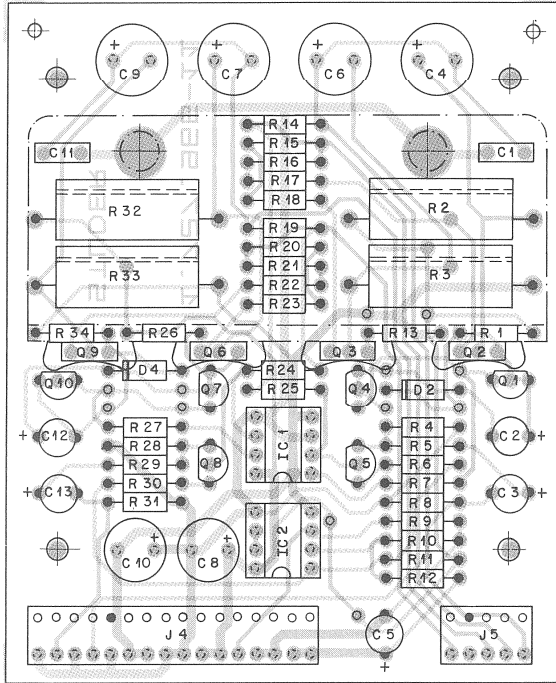

IND.	POS.-NO.	PART NO.	VALUE	SPECIFICATIONS / EQUIVALENT	MANUF.
C.....1		59-06-0683	68 nF	10% 63 V PETP	
C.....2		59-22-3670	47 uF	-20% 10 V EL	
C.....3		59-22-8679	4.7 uF	-20% 50 V EL	
C.....4		59-22-4471	470 uF	-20% 15 V EL	
C.....5		59-22-3670	47 uF	-20% 10 V EL	
C.....6		59-22-4471	470 uF	-20% 16 V EL	
C.....7		59-22-4471	470 uF	-20% 16 V EL	
C.....8		59-22-5101	100 uF	-20% 25 V EL	
C.....9		59-22-4471	470 uF	-20% 16 V EL	
C.....10		59-22-5101	100 uF	-20% 25 V EL	
C.....11		59-06-0583	68 nF	10% 63 V PETP	
C.....12		59-22-3670	47 uF	-20% 10 V EL	
C.....13		59-22-8679	4.7 uF	-20% 50 V EL	
D.....1				not used	
D.....2		50-04-0125	1N4448	50 V	SI
D.....3				not used	
D.....4		50-04-0125	1N4448	50 V	SI
D.....5				not used	
D.....6				not used	
IC.....1		50-09-0107	RE. 4559	DUAL OP-AMP.	Ra
IC.....2		50-09-0107	RE. 4559	DUAL OP-AMP.	Ra
J.....4		54-01-0294	16-POLE	CIS Socket Strip	AMP
J.....5		54-01-0288	5-POLE	CIS Socket Strip	AMP
HP.....1		21-53-0355	2 pcs	Screw M3x8mm	
HP.....2		24-16-1030	2 pcs	Washer	
HP.....3		50-10-2002	4 pcs	Chip: T0126	Ph
HP.....4		1-010-043-22	2 pcs	Rivet: Nut M3x20mm	St
HP.....5		1.727.420-02	1 pcs	Thermoplastic	St
HP.....6		1.727.910-01	1 pcs	HeatSink	St
MP.....7		1.727.966-10	0 pcs	No-Label	St
MP.....8		1.727.966-11	1 pcs	LS Amplifier PCB	St
Q.....1		50-03-0436	BC237B	BC547B	NPN

S T U D E R (01) 88/01/21 GP LS AMPLIFIER BOARD 1.727.966.00 PAGE 1

IND.	POS.-NO.	PART NO.	VALUE	SPECIFICATIONS / EQUIVALENT	MANUF.
Q.....2		50-03-0495	BD135-16		NPN
Q.....3		50-03-0510	BD136-16		PNP
Q.....4		50-03-0436	BC237B	BC547B	NPN
Q.....5		50-03-0350	MPP4392	J112	FET
Q.....6		50-03-0495	BD135-16		NPN
Q.....7		50-03-0436	BC237B	BC547B	NPN
Q.....8		50-03-0350	MPP4392	J112	FET
Q.....9		50-03-0510	BD136-16		PNP
Q.....10		50-03-0436	BC237B	BC547B	NPN
R.....1		57-11-3332	3.3 kOhm	1%, 0.25W, MF	
R.....2		57-56-5680	68 Ohm	5%, 4 W, Wire	
R.....3		57-56-5680	68 Ohm	5%, 4 W, Wire	
R.....4		57-11-3222	2.2 kOhm	1%, 0.25W, MF	
R.....5		57-11-3223	22 kOhm	1%, 0.25W, MF	
R.....6		57-11-5106	10 MOhm	5%, 0.25W, MF	
R.....7		57-11-3670	47 Ohm	1%, 0.25W, MF	
R.....8		57-11-3102	1 kOhm	1%, 0.25W, MF	
R.....9		57-11-3104	100 kOhm	1%, 0.25W, MF	
R.....10		57-11-3103	10 kOhm	1%, 0.25W, MF	
R.....11		57-11-3223	22 kOhm	1%, 0.25W, MF	
R.....12		57-11-3103	10 kOhm	1%, 0.25W, MF	
R.....13		57-11-3332	3.3 kOhm	1%, 0.25W, MF	
R.....14		57-11-3671	470 Ohm	1%, 0.25W, MF	
R.....15		57-11-3159	1.5 Ohm	1%, 0.25W, MF	
R.....16		57-11-3159	1.5 Ohm	1%, 0.25W, MF	
R.....17		57-11-3159	1.5 Ohm	1%, 0.25W, MF	
R.....18		57-11-3159	1.5 Ohm	1%, 0.25W, MF	
R.....19		57-11-3671	470 Ohm	1%, 0.25W, MF	
R.....20		57-11-3159	1.5 Ohm	1%, 0.25W, MF	
R.....21		57-11-3159	1.5 Ohm	1%, 0.25W, MF	
R.....22		57-11-3159	1.5 Ohm	1%, 0.25W, MF	
R.....23		57-11-3159	1.5 Ohm	1%, 0.25W, MF	
R.....24		57-11-3223	22 kOhm	1%, 0.25W, MF	
R.....25		57-11-3683	68 kOhm	1%, 0.25W, MF	
R.....25		57-11-3683	68 kOhm	1%, 0.25W, MF	

S T U D E R (01) 88/01/21 GP LS AMPLIFIER BOARD 1.727.966.00 PAGE 2

IND.	POS.-NO.	PART NO.	VALUE	SPECIFICATIONS / EQUIVALENT	MANUF.
R.....26		57-11-3332	3.3 kOhm	1%, 0.25W, MF	
R.....27		57-11-3670	47 Ohm	1%, 0.25W, MF	
R.....28		57-11-3222	2.2 kOhm	1%, 0.25W, MF	
R.....29		57-11-3223	22 kOhm	1%, 0.25W, MF	
R.....30		57-11-5106	10 MOhm	5%, 0.25W, MF	
R.....31		57-11-3102	1 kOhm	1%, 0.25W, MF	
R.....32		57-56-5680	68 Ohm	5%, 4 W, Wire	
R.....33		57-56-5680	68 Ohm	5%, 4 W, Wire	
R.....34		57-11-3332	3.3 kOhm	1%, 0.25W, MF	
XIC.....1		53-03-0166	8 Pole	IC Socket	
XIC.....2		53-03-0166	8 Pole	IC Socket	

(01) Erroress of gain.
 CER=Ceramic, EL=Electrolytic, PETP=Polyester, SI=Silicon,
 MF=Metal Film.
 MANUFACTURER: AMP=AMP, Mot=Motorola, Ph=Philips, Ra=Raytheon, St=Studer.

ORIG 87/11/30 (01) 88/01/21
 S T U D E R (01) 88/01/21 GP LS AMPLIFIER BOARD 1.727.966.00 PAGE 3

<u>INHALT/CONTENTS</u>	<u>SECTION 8</u>
8.1 VERKLEIDUNG UND ZUBEHOER COVERS AND ACCESSOIRES	1
8.2 LAUFWERK BEDIENPANEL TAPE DECK PANEL	2
8.3 ANDRUCKAGGREGAT UND BANDABHEBUNG ROLLER ASSEMBLY	4
8.4 BANDBREMSE BRAKE CHASSIS	6
8.5 BANDZUGWAAGE TAPE TENSION SENSOR	8
8.6 WICKELMOTOR SPOOLING MOTOR	10
8.7 SHUTTLE EINHEIT SHUTTLE UNIT	12
8.8 ANSCHLUSSFELD TERMINAL BOARD	(13)
8.9 KOPFTRAEGER HEAD BLOCK	14
8.10 KONSOLE OHNE PANEL-AUFBAU CONSOLE WITHOUT OVERBRIDGE	20
8.10.1 KONSOLE MIT PANEL-AUFBAU CONSOLE WITH OVERBRIDGE	22
8.11 PANEL-AUFBAU OVERBRIDGE	24
8.12 SCHILDER LABEL	(25)
8.13 KABELBUENDE LAUFWERK WIRE HARNESS TAPE TRANSPORT	26
8.14 VERDRAHTUNG, AUDIO AUDIO WIRING DIAGRAM	28
8.15 VERDRAHTUNG, EXT. VU-PANEL WIRING DIAGRAM, EXT. VU-PANEL	30
8.16 VERDRAHTUNG EXT. STEREO MONITOR PANEL CONSOLE EXT. STEREO MON. WIRING DIAGRAM	32
8.17 A807 VARIANTEN A807 VERSIONS	34

8.1
VERKLEIDUNG UND ZUBEHOER / COVERS AND ACCESSOIRES

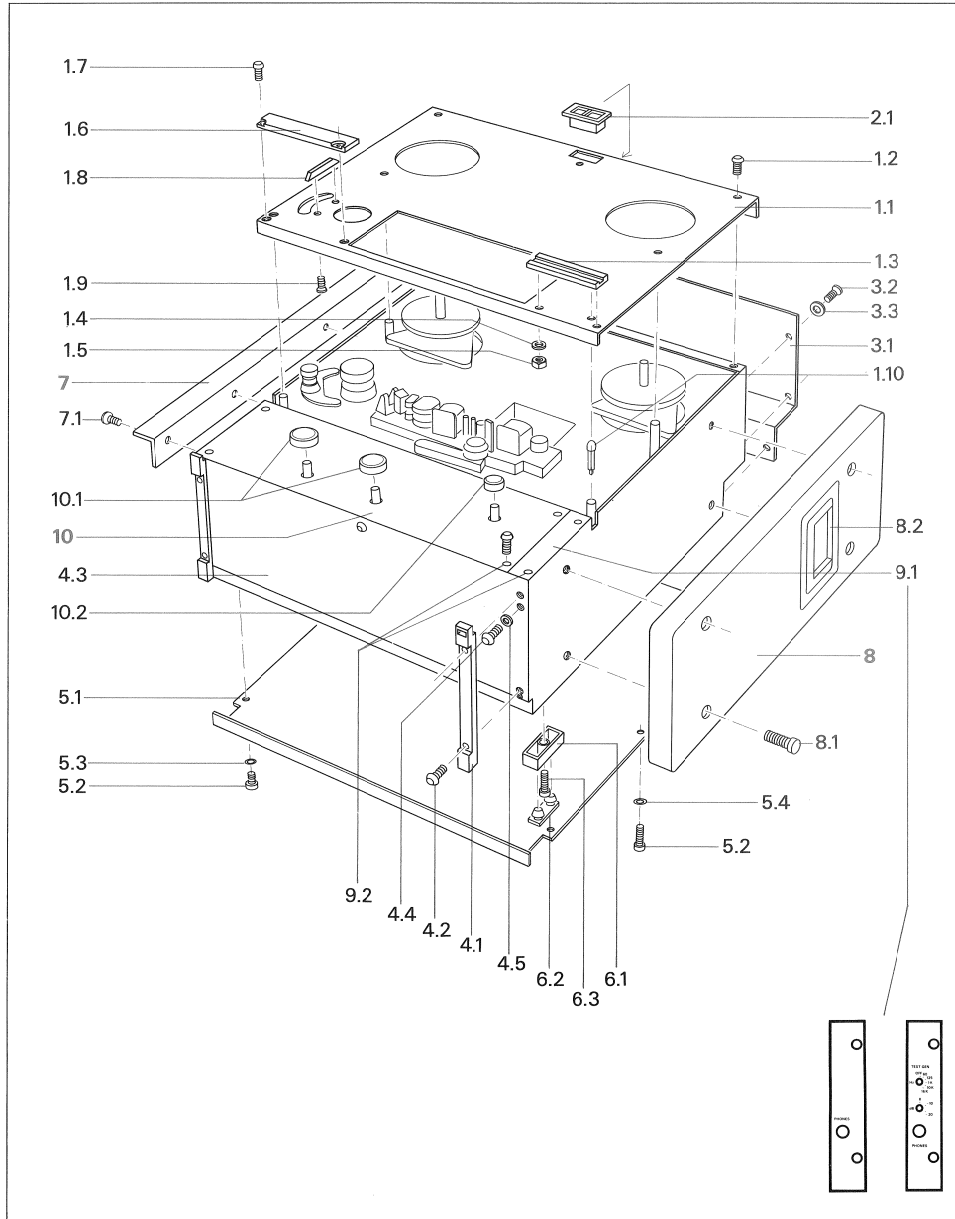

VERKLEIDUNG UND ZUBEHOER

POS	QTY	ORDERNUMMER	BEZEICHNUNG	SPEZIFIKATION
1.1		1.727.100.07	Laufwerkabd. mit Monitor	
		1.727.091.01	Laufwerkabd. ohne Monitor	
		1.727.120.00	Monitorlautsprecher kpl.	
1.2		21.51.8455	Lin-Schraube IS M4x8	
1.3		1.727.100.42	Klebeschiene	
1.4		24.16.1030	Sicherungsscheibe D3,2/5,5	
1.5		22.01.8030	6kt. Mutter M3	
1.6		1.727.100.37	Pot.- Meter Abdeckung mit Klebeschiene	
1.7		1.010.010.21	Lin-Schraube IS M4x8 spez.	
1.8		1.811.090.20	Bandanlauf	
1.9		20.01.2153	S-Blechschrabe D2,9x6,5	
1.10		1.077.100.20	Gummikappe	
2.1		55.12.0001	Netzschalter	
3.1		1.727.161.01	Rückwand / Anschlusschiene	
3.2		1.010.007.21	Lin.- Schraube IS M4x8 SW	
3.3		24.16.1030	Sicherungsscheibe D3,2/5,5	
4.1		1.727.100.10	Kunststofffüsse	
4.2		1.010.007.21	Lin.- Schraube IS M4x8 SW	
4.3		1.727.100.06	Abdeckblech audio	
4.4		1.010.042.21	Lin.- Schraube IS M4x6	
4.5		24.16.2040	Fächerscheibe D4,3	
5.1		1.727.100.05	Bodenblech	
5.2		1.010.007.21	Lin.- Schraube IS M4x8 SW	
5.3		24.16.1030	Sicherungsscheibe D3,2/5,5	
5.4		24.16.2040	Fächerscheibe D4,3	
6.1		1.177.930.08	Fuss	
6.2		1.067.010.08	Gummielnlage	
6.3		21.53.0356	Z-Schraube IS M3x10	
7		1.727.071.00	19" Rackwinkel Set (Option)	
7.1		21.51.2454	S-Schraube IS M4x6	
8		1.727.070.00	Holzseitenwand Set (Option)	
8.1		21.53.0511	Z-Schraube IS M5x22	
8.2		1.810.077.04	Klappgriffe kpl.	
9.1		1.727.011.01	Abdeckung Standard	
		1.727.440.05	Abdeckung Testgenerator	
9.2		1.010.047.21	Lin.- Schraube M4x8	
10			Audio-Frontabdeckung (Varianten-abhängig)	
			Best.Nr. siehe nächste Seite	
10.1		1.727.100.43	Drehknöpfe gross	
10.2		1.727.100.33	Drehknöpfe klein	

COVERS AND ACCESSOIRES

POS	QTY	ORDER NUMBER	PART NAME	SPECIFICATION
1.1		1.727.100.07	Tape transport cover with MONITOR	
		1.727.091.01	Tape transport cover without MONITOR	
		1.727.120.00	Monitor-loudspeaker compl.	
1.2		21.51.8455	Oval head screw IS M4x8	
1.3		1.727.100.42	Splicing block	
1.4		24.16.1030	Lock washer D3.2/5.5	
1.5		22.01.8030	Hexanut M3	
1.6		1.727.100.37	Cover plate w.splicing block	
1.7		1.010.010.21	Screw IS M4x8	
1.8		1.811.090.20	Threading guide	
1.9		20.01.2153	Screw D2.9x6.5	
1.10		1.077.100.20	Cap	
2.1		55.12.0001	Slide switch	
3.1		1.727.161.01	Top cover	
3.2		1.010.007.21	Screw IS M4x8	
3.3		24.16.1030	Lock washer D3.2/5.5	
4.1		1.727.100.10	Footrail	
4.2		1.010.007.21	Screw IS M4x8	
4.3		1.727.100.06	Bottom cover	
4.4		1.010.042.21	Screw IS M4x6	
4.5		24.16.2040	Lock washer D4.3	
5.1		1.727.100.05	Rear cover	
5.2		1.010.007.21	Screw IS M4x8	
5.3		24.16.1030	Lock washer D3.2/5.5	
5.4		24.16.2040	Lock washer D4.3	
6.1		1.177.930.08	Foot	
6.2		1.067.010.08	Foot insert grey	
6.3		21.53.0356	Z-Screw IS M3x10	
7		1.727.071.00	19" Rack rail set (option)	
7.1		21.51.2454	S-Screw IS M4x6	
8		1.727.070.00	Set of wooden side panels (option)	
8.1		21.53.0511	Z-Screw IS M5x22	
8.2		1.810.077.04	Handle compl.	
9.1		1.727.011.01	Jack socket cover (standard)	
		1.727.440.05	Jack socket cover with testgenerator	
9.2		1.010.047.21	Screw M4x8	
10			Audio-Frontpanel (according to different versions) / Order-Number following page	
10.1		1.727.100.43	Push button	
10.2		1.727.100.33	Rotary knob varispeed	

8.2
LAUFWERK BEDIENPANEL / TAPE DECK PANEL

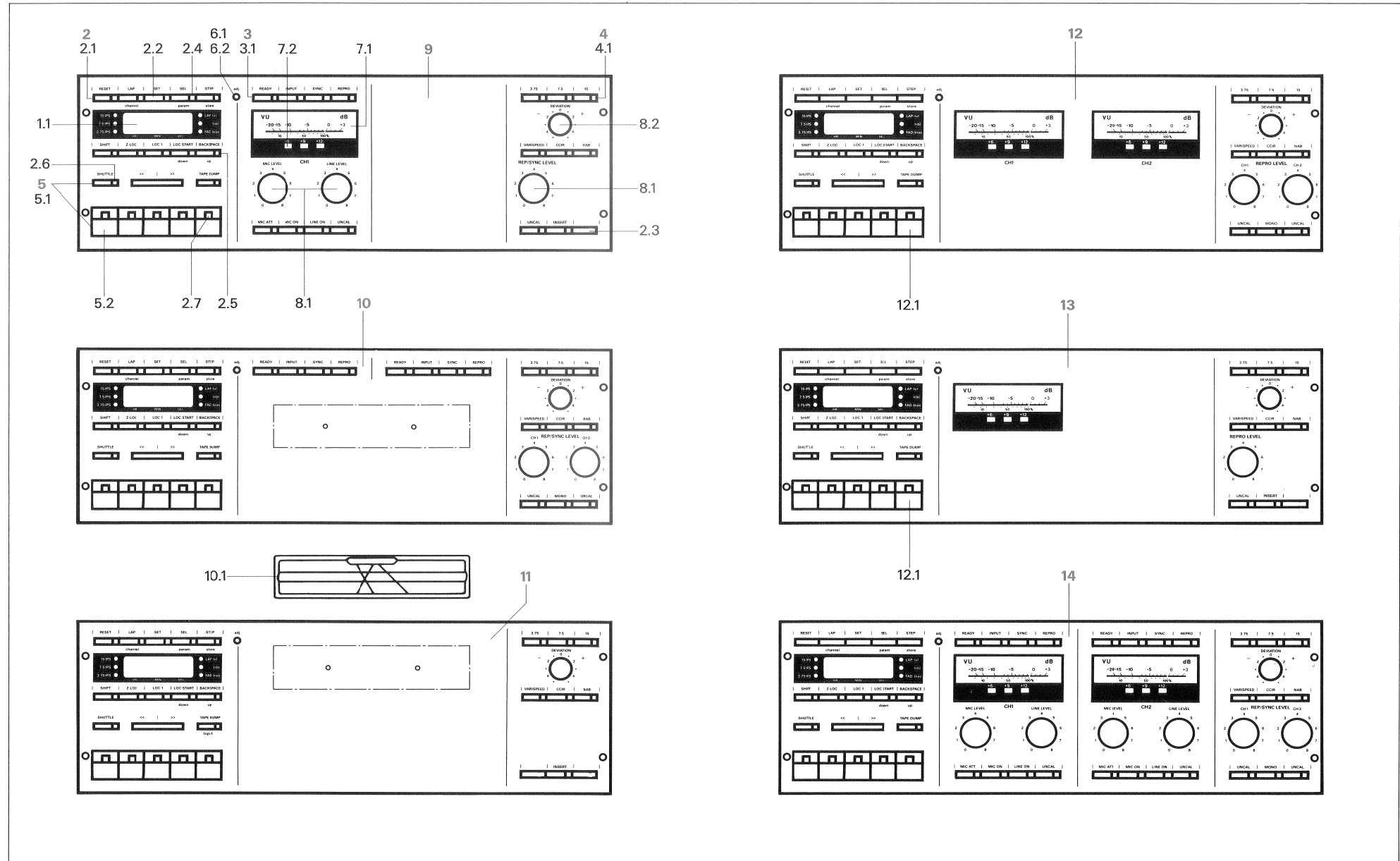

PANELS

POS	QTY	ORDERNUMMER	BEZEICHNUNG	SPEZIFIKATION
1.1		1.727.100.40 1.727.015.02	Anzeigefenster 3,75-15ips Anzeigefenster 7,5 -30ips	
2		1.011.235.05	Tastengehäuse (5-Tasten)	
2.1		1.011.235.25	Schaltmatte (5 Kontakte)	
2.2		1.011.235.30	Druck-Taste	
2.3		1.011.235.35	Blind-Taste	
2.4		1.011.235.31	Blind-Kalotte	
2.5		1.011.235.33	Kalotte gelb	
2.6		1.011.235.34	Kalotte grün	
2.7		1.011.235.32	Kalotte rot	
2.8		1.011.235.29	Bolzen	
3		1.011.235.04	Tastengehäuse (4 Tasten)	
3.1		1.011.235.24	Schaltmatte (4 Kontakte)	
4		1.011.235.03	Tastengehäuse (3 Tasten)	
4.1		1.011.235.23	Schaltmatte (3 Kontakte)	
5		1.727.360.02	Tastengehäuse	
5.1		1.727.360.03	Schaltmatte	
5.2		1.727.360.04 1.727.360.06	Drucktaste gross Schildersatz	
6.1		1.727.360.05	Adjust-Tastenverlängerung	
6.2		55.15.0130	Adjust-Schalter	
7		1.727.360.01	VU-meter	
7.1		51.02.0144	VU-meter-Beleuchtungs- lämpchen 6V/0,03A	
7.2		50.04.2119	Peak LED	
8.1		1.727.100.43	Drehkopf gross	
8.2		1.727.100.33	Drehknopf klein	
9		1.727.100.26	Bedienpanel Mono	
10		1.727.100.23	Bedienpanel 2/2	
10.1		1.820.110.18	Klebeschiene (Option)	
11		1.727.100.25 1.727.015.01	Bedienpanel OVU Bedienpanel OVU / HS	
12		1.727.100.27	Bedienpanel nur Wiedergabe	
12.1		1.727.364.01	Tastenschild unbeschriftet	
13		1.727.100.29	Bedienpanel nur Wieder- gabe Mono	
14		1.727.100.24 1.727.064.01	Bedienpanel 2VU Bedienpanel 2VU / HS	

PANELS

POS	QTY	ORDER NUMBER	PART NAME	SPEZIFIKATION
1.1		1.727.100.40 1.727.015.02	Display 3.75-15ips Display 7.5 -30ips	
2		1.011.235.05	Push button housing for 5 push button	
2.1		1.011.235.25	Switching rubber activater mat for 5 push button	
2.2		1.011.235.30	Push button	
2.3		1.011.235.35	Push button cover cap	
2.4		1.011.235.31	Filler cover	
2.5		1.011.235.33	Cover yellow	
2.6		1.011.235.34	Cover green	
2.7		1.011.235.32	Cover red	
2.8		1.011.235.29	Bolt	
3		1.011.235.04	Push button housing for 4 push buttons	
3.1		1.011.235.24	Switching rubber activater mat for 4 push button	
4		1.011.235.03	Push button housing for 3 push buttons	
4.1		1.011.235.23	Switching rubber activater mat for 3 push button	
5		1.727.360.02	Push button housing	
5.1		1.727.360.03	Switching rubber activater mat	
5.2		1.727.360.04 1.727.360.06	Push button large Label set	
6.1		1.727.360.05	Adjust-Extension	
6.2		55.15.0130	Adjust-push button switch	
7		1.727.360.01	VU-meter	
7.1		51.02.0144	Vu-meter-bulb 6V/0.03A	
7.2		50.04.2119	Peak LED	
8.1		1.727.100.43	Push button large	
8.2		1.727.100.33	Push button small	
9		1.727.100.26	Cover plate for operating panel mono	
10		1.727.100.23	Audio-frontcover plate	
10.1		1.820.110.18	Splicing block (Option)	
11		1.727.100.25 1.727.015.01	Cover plate for operating panel without VU-meter Frontcover plate OVU / HS	
12		1.727.100.27	Frontpanel-cover for playback only version	
12.1		1.727.364.01	Blanc label	
13		1.727.100.29	Frontpanel-cover for mono playback only version	
14		1.727.100.24 1.727.064.01	Frontcover plate 2VU Frontcover plate 2VU / HS	

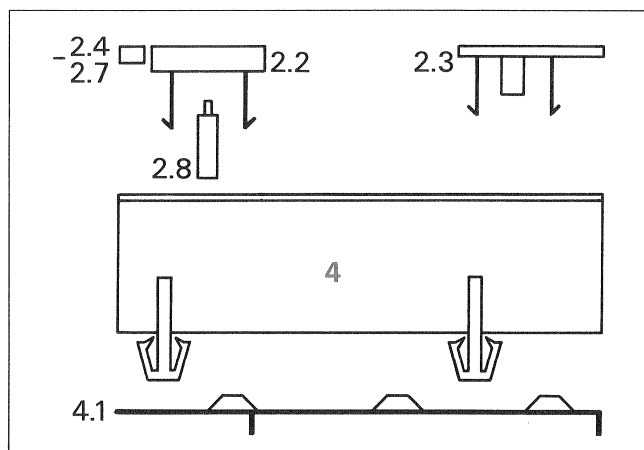

8.3
ANDRUCKAGGREGAT UND BANDABHEBUNG / ROLLER ASSEMBLY

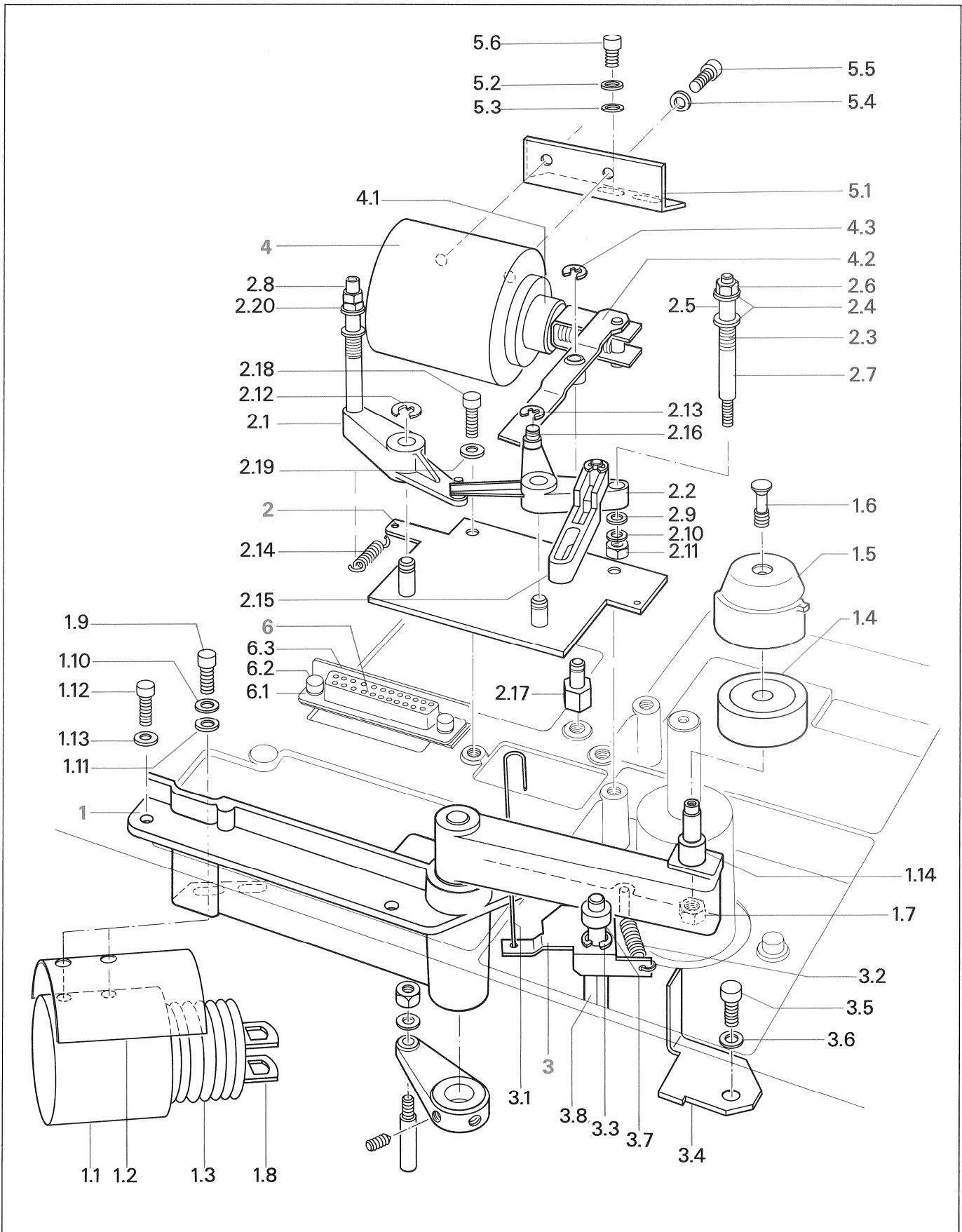

ANDRUCKAGGREGAT UND BANDABHEBUNG

POS	QTY	ORDERNUMMER	BEZEICHNUNG	SPEZIFIKATION
1		1.727.135.81	Andruckaggregat kpl.	
1.1		1.014.718.00	Andruckmagnet	
1.2		1.810.100.09	Abschirmung	
1.3		1.810.100.08	Gummibalg	
1.4		1.167.178.82	Andruckrolle	
1.5		1.727.136.00	Andruckrollendeckel kpl.	
1.6		1.010.048.21	S-Schraube IS	
1.7		22.01.5040	6kt.Mutter M4x0,5	
1.8		1.810.101.00	Anker kpl.	
1.9		21.53.0455	Schraube IS,ZN M4x8	
1.10		24.16.1040	Sicherungsscheibe D4,3/7	
1.11		23.01.2043	U-Scheibe D4,3/9x0,8	
1.12		21.53.0456	Schraube IS,ZN M4x10	
1.13		24.16.1040	Sicherungsscheibe D4,3/7	
1.14		1.727.135.01	Andruckachse	
2		1.727.115.00	Bandabhebung kpl.	
2.1		1.810.133.00	Lifterarm links kpl.	
2.2		1.810.132.00	Lifterarm rechts kpl.	
2.3		1.020.820.12	Druckfeder	
2.4		1.810.130.13	Bandführungsscheibe	
2.5		1.810.130.09	Distanzhülse	
2.6		22.99.0112	6Kt. Stop-Mutter M3	
2.7		1.810.130.10	Lifterbolzen	
2.8		1.727.115.02	Abschlussmutter	
2.9		23.01.1032	U-Scheibe D3,2/6	
2.10		24.16.1030	Sicherungsscheibe D3,2/5,5	
2.11		22.01.5030	6Kt. Mutter M3	
2.12		24.16.3040	Clip	
2.13		24.16.3019	Clip	
2.14		1.020.250.21	Zugfeder	
2.15		1.810.130.12	Lasche	
2.16		1.727.115.01	Rolle	
2.17		1.810.090.10	Bolzen	
2.18		21.53.0353	Schraube IS ZN M3x5	
2.19		24.16.1030	Sicherungsscheibe D3,2/5,5	
2.20		22.15.8030	6kt. Mutter M3	
3		1.727.130.00	Sperrklinke kpl.	
3.1		1.727.100.48	Auslöse-Gestänge	
3.2		1.077.100.13	Zugfeder	
3.3		24.16.3040	Seegerring D4	
3.4		1.727.100.59	Entriegelungswinkel für Andruckarm	
3.5		21.53.0454	Schraube IS ZN M4x6	
3.6		24.16.1040	Sicherungsscheibe D4,3/7	
3.7		1.067.170.14	Dämpfungsgummi	
3.8		1.727.100.47	Bolzen	
4		1.014.718.00	Liftermagnet kpl.	
4.1		1.810.136.00	Anker kpl.	
4.2		1.810.135.00	Hebel kpl.	
4.3		24.16.3032	Seegerring D3	
5.1		1.810.090.09	Befestigungswinkel	
5.2		24.16.1040	Sicherungsscheibe D4,3/7	
5.3		23.01.1043	Unterlagsscheibe D4,3/8	
5.4		24.16.1040	Sicherungsscheibe D4,3/7	
5.5		21.53.0453	Schraube M4x5	
5.6		21.51.8455	Z-Schraube IS M4x8	
6		1.727.211.00	Kabelbaum kpl. Mono	
		1.727.209.00	Kabelbaum kpl. Stereo	
		1.727.210.00	Kabelbaum kpl. Stereo mit 2.Repro-Kopf	
		54.02.0442	Kopfträger Steckergehäuse D-Type 25pol	
		54.02.0450	Crimp-Kontakte für 0,22 mm ² Draht	
		54.02.0454	Crimp-Kontakte für 0,56 mm ² Draht	
6.1		24.16.1030	Sicherungsscheibe D3,2/5,5	
6.2		21.51.8354	Schraube LS IS M3x6	
6.3		1.727.209.07	Zugentlastung	

ROLLER ASSEMBLY

POS	QTY	ORDER NUMBER	PART NAME	SPECIFICATION
1		1.727.135.81	Pressure aggregat compl.	
1.1		1.014.718.00	Solenoid	
1.2		1.810.100.09	Shield	
1.3		1.810.100.08	Rubber bellows	
1.4		1.167.178.82	Pinch roller	
1.5		1.727.136.00	Pressure roller cover compl.	
1.6		1.010.048.21	S-Screw IS	
1.7		22.01.5040	Hex nut M4x0,5	
1.8		1.810.101.00	Plunger compl.	
1.9		21.53.0455	Screw IS ZN M4x8	
1.10		24.16.1040	Lock washer D4,3/7	
1.11		23.01.2043	Washer D4,3/9 x0,8	
1.12		21.53.0456	Screw IS ZN M4x10	
1.13		24.16.1040	Lock washer D4,3/7	
1.14		1.727.135.01	Pressure roller shaft	
2		1.727.115.00	Tape lifting compl.	
2.1		1.810.133.00	Lifter lever left compl.	
2.2		1.810.132.00	Lifter lever right compl.	
2.3		1.020.820.12	Pressure spring	
2.4		1.810.130.13	Guide washer	
2.5		1.810.130.09	Guide bushing	
2.6		22.99.0112	Self locking nut M3	
2.7		1.810.130.10	Lifter bolt	
2.8		1.727.115.02	Hex nut	
2.9		23.01.1032	Washer D3,2/6	
2.10		24.16.1030	Lock washer D3,2/5,5	
2.11		22.01.5030	Hex nut M3	
2.12		24.16.3040	Circlip	
2.13		24.16.3019	Circlip	
2.14		1.020.250.21	Tension spring	
2.15		1.810.130.12	Fish plate	
2.16		1.727.115.01	Roller	
2.17		1.810.090.10	Bold	
2.18		21.53.0353	Screw IS ZN M3x5	
2.19		24.16.1030	Lock washer D3,2/5,5	
2.20		22.15.8030	Hexanut M3	
3		1.727.130.00	Stop pawl compl.	
3.1		1.727.100.48	Connecting rod	
3.2		1.077.100.13	Brake tension spring	
3.3		24.16.3040	Circlip D4	
3.4		1.727.100.59	Edit lever retainer	
3.5		21.53.0454	Screw IS ZN M4x6	
3.6		24.16.1040	Lock washer D4,3/7	
3.7		1.067.170.14	Rubber tube	
3.8		1.727.100.47	Bold	
4		1.014.718.00	Solenoid compl.	
4.1		1.810.136.00	Plunger compl.	
4.2		1.810.135.00	Lever compl.	
4.3		24.16.3032	Circlip D3	
5.1		1.810.090.09	Mounting bracket	
5.2		24.16.1040	Lock washer D4,3/7	
5.3		23.01.1043	Washer D4,3/8	
5.4		24.16.1040	Lock washer D4,3/7	
5.5		21.53.0453	Screw M4x5	
5.6		21.51.8455	Z-Screw IS M4x8	
6		1.727.211.00	Cable harness compl. mono	
		1.727.209.00	Cable harness compl. stereo	
		1.727.210.00	Cable harness compl. stereo with 2.Repro-head	
		54.02.0442	Chassis receptacle housing 25p	
		54.02.0450	Crimp-contact for 0,22 mm ² cable	
		54.02.0454	Crimp-contact for 0,56 mm ² cable	
6.1		24.16.1030	Lock washer D3,2/5,5	
6.2		21.51.8354	Screw LS IS M3x6	
6.3		1.727.209.07	Cable harness tie on bracket	

8.4
BANDBREMSE / BRAKE CHASSIS

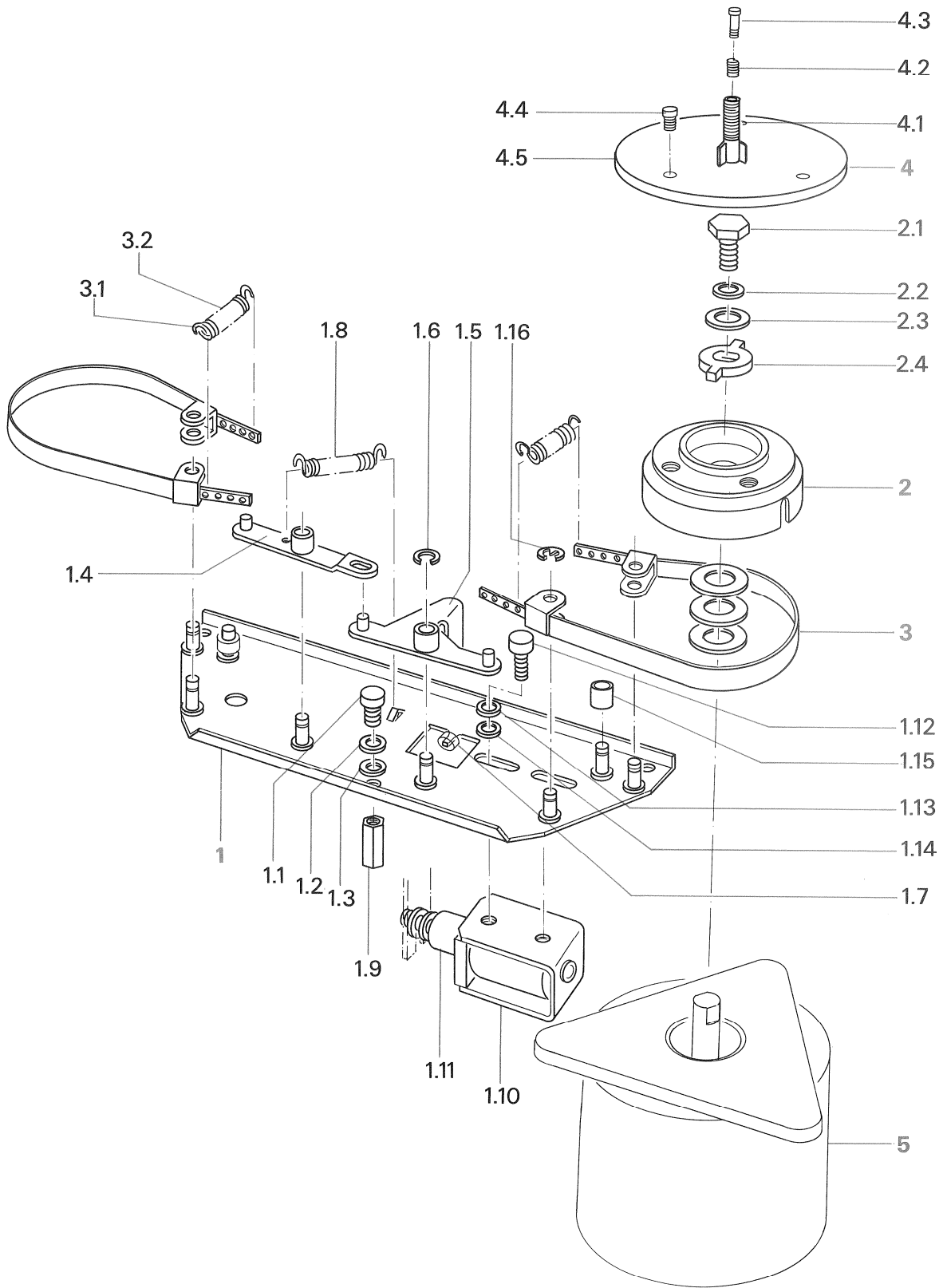

BANDBREMSE

POS	QTY	ORDERNUMMER	BEZEICHNUNG	SPEZIFIKATION
1		1.077.406.00	Bremsschassis kpl.	
1.1		21.53.0354	Z-Schraube IS M3x6	
1.2		24.16.1030	Sicherungsscheibe D3,2/5,5	
1.3		23.01.2032	U-Scheibe D3,2/7 x0,5	
1.4		1.077.415.00	Bremshebel links	
1.5		1.077.411.00	Bremshebel rechts	
1.6		24.16.3032	Clip	
1.7		1.067.100.36	Anschlagschlauch	
1.8		1.062.210.06	Feder Bremshebel links	
1.9		1.010.139.27	Befestigungsbolzen	
			Laufwerkchassis	
1.10		1.014.852.00	Bremsmagnet	
1.11		1.014.854.00	Anker kpl.	
1.12		21.53.0353	Z-Schraube IS M3x5	
1.13		24.16.3032	Sicherungsscheibe D3,2/5,5	
1.14		23.01.2032	U-Scheibe D3,2/7 x0,5	
1.15		1.067.170.14	Dämpfungsgummi	
1.16		24.16.3032	Seegerring 3,2	
2		1.067.242.00	Bremssrolle kpl.	
2.1		21.01.4455	Schraube 6kt. M4x8	
2.2		24.16.1040	Sicherungsscheibe D4,3/7	
2.3		23.01.3043	U-Scheibe D4,3/12 x1	
2.4		1.067.100.27	Mitnehmerscheibe	
3		1.167.866.00	Bremssband kpl.	
3.1		1.077.100.13	Bremssfeder	
3.2		1.727.100.90	Dämpfungsschlauch	
4		1.067.688.00	Wickelteller kpl.	
4.1		1.067.688.01	3 Zack-Hülse	
4.2		1.067.688.02	Druckfeder	
4.3		1.062.390.02	Schaftschraube	
4.4		21.51.0355	Z-Schraube IS M3x8	
4.5		1.077.567.01	Wickelteller	
5		1.021.250.00	Wickelmotor kpl.	

BRAKE CHASSIS

POS	QTY	ORDER NUMBER	PART NAME	SPECIFICATION
1		1.077.406.00	Brake chassis compl.	
1.1		21.53.0354	Z-Screw IS M3x6	
1.2		24.16.1030	Lock washer D3,2/5,5	
1.3		23.01.2032	Washer D3,2/7 x0,5	
1.4		1.077.415.00	Brake lever left	
1.5		1.077.411.00	Brake lever right	
1.6		24.16.3032	Circlip	
1.7		1.067.100.36	Stop tube	
1.8		1.062.210.06	Return spring	
1.9		1.010.139.27	Spacer bolt	
1.10		1.014.852.00	Brake solenoid	
1.11		1.014.854.00	Plunger compl.	
1.12		21.53.0353	Z-Screw IS M3x5	
1.13		24.16.3032	Circlip D3,2/5,5	
1.14		23.01.2032	Washer D3,2/7 x0,5	
1.15		1.067.170.14	Rubber tube	
1.16		24.16.3032	Circlip 3.2	
2		1.067.242.00	Brake drum compl.	
2.1		21.01.4455	Screw hex M4x8	
2.2		24.16.1040	Lock washer D4,3/7	
2.3		23.01.3043	Washer D4,3/12 x1	
2.4		1.067.100.27	Cam disc	
3		1.167.866.00	Brake band compl.	
3.1		1.077.100.13	Brake tension spring	
3.2		1.727.100.90	Rubber tube	
4		1.067.688.00	Spooling plate compl.	
4.1		1.067.688.01	Cine centre sleeve	
4.2		1.067.688.02	Cine centre spring	
4.3		1.062.390.02	Cine centre shaft screw	
4.4		21.51.0355	Z-Screw IS M3x8	
4.5		1.077.567.01	Spooling plate	
5		1.021.250.00	Spooling motor compl.	

8.5
BANDZUGWAAGE / TAPE TENSION SENSOR

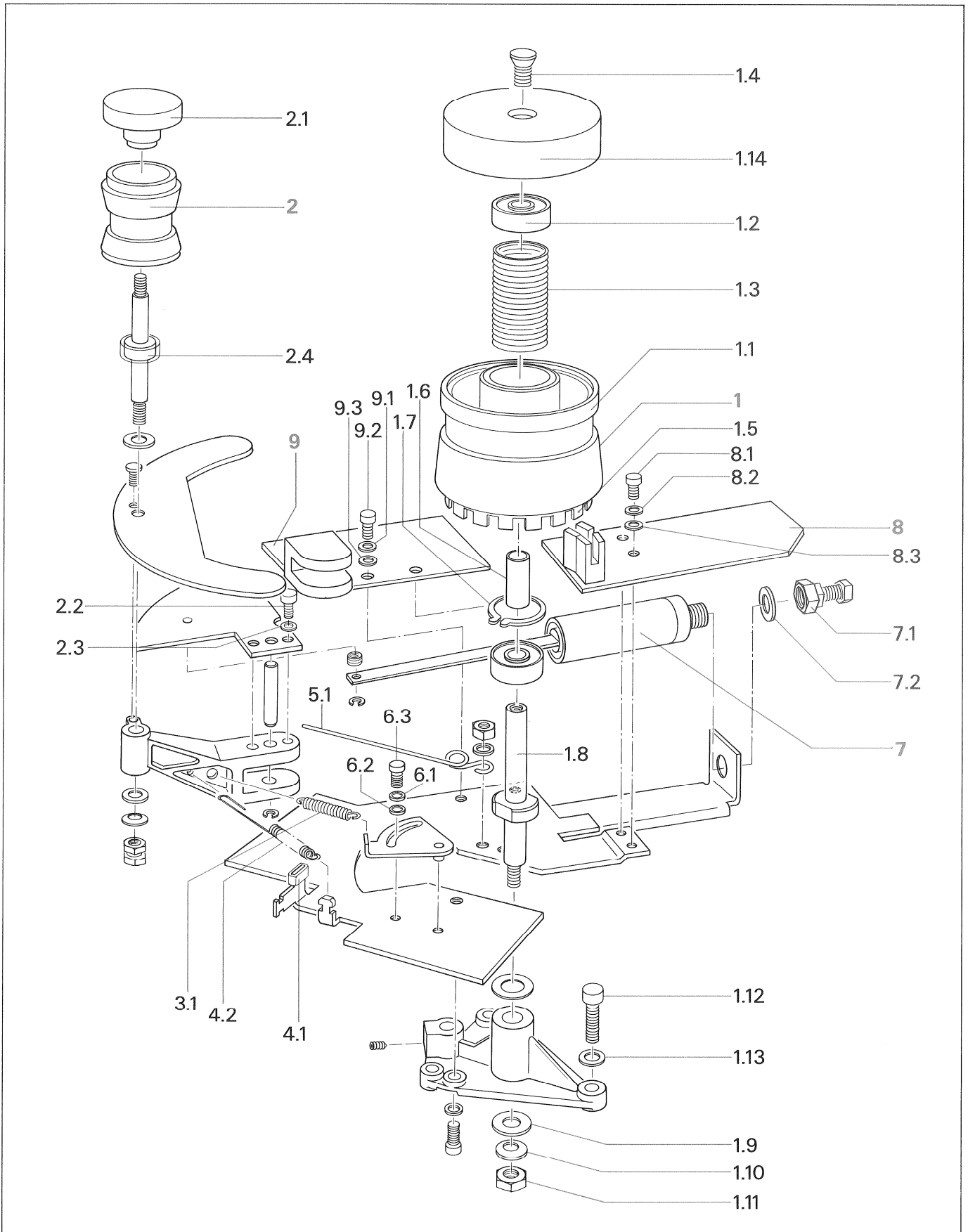

BANDZUGWAAGE

POS	QTY	ORDERNUMMER	BEZEICHNUNG	SPEZIFIKATION
1		1.727.110.81	Bandzugwaage kpl.	
1.1		1.727.112.81	Tachorolle kpl.	
1.2		1.810.150.08	Tachorolle	
1.3		41.99.0106	Kugellager	
1.4		1.010.091.37	Druckfeder	
1.5		21.51.2356	S-Schraube IS NI M3x10	
1.6		1.810.150.01	Tachoblende	
1.7		1.167.838.02	Distanzhülse	
1.8		24.16.4160	Clip	
1.9		1.811.111.06	Achse	
1.10		23.01.1064	U-Scheibe D6,4x11	
1.11		24.16.1060	Sicherungsscheibe D6,4x10	
1.12		22.01.8060	6kt. Mutter M6	
1.13		21.53.0357	Z-Schraube IS M3x12	
1.14		24.16.1030	Sicherungsscheibe D3,2x5,5	
		1.810.150.03	Tachorollendeckel	
2		1.727.113.00	Umlenkrolle kpl.	
2.1		1.167.831.00	Deckel	
2.2		21.01.0203	Z-Schraube M2x5	
2.3		24.16.1020	Sicherungsscheibe D2,2x4	
2.4		1.811.110.02	Anschlag-Gummiring	
3.1		1.010.032.37	Zugfeder kurz	
4.1		1.067.170.14	Dämpfungsgummi	
4.2		1.010.125.37	Zugfeder lang	
5.1		1.727.110.03	Anschlagfeder	
6.1		24.16.1030	Sicherungsscheibe D3,2x5,5	
6.2		23.01.2032	U-Scheibe D3,2x7	
6.3		21.53.0353	Z-Schraube IS M3x5	
7		1.727.114.00	Dämpfungspumpe kpl. eingest.	
7.1		22.01.5060	Mutter M6	
7.2		37.02.0101	Tellerfeder D6,2x9,8	
8		1.727.321.00	Move sensor BOARD kpl.	
8.1		21.53.0353	Z-Schraube IS M3x5	
8.2		24.16.1030	Sicherungsscheibe D3,2x5,5	
8.3		23.01.2032	Unterlagsscheibe D3,2x7	
9		1.727.320.00	Tape tension sensor BOARD kpl.	
9.1		24.16.1030	Sicherungsscheibe D3,2x5,5	
9.2		21.53.0353	Z-Schraube IS M3x5	
9.3		23.01.2032	Unterlagsscheibe D3,2x7	

TAPE TENSION SENSOR

POS	QTY	ORDER NUMBER	PART NAME	SPECIFICATION
1		1.727.110.81	Tacho tension sensor compl.	
1.1		1.727.112.81	Tacho roller compl.	
1.2		1.810.150.08	Tacho roller	
1.3		41.99.0106	Ball bearing D5/16x6	
1.4		1.010.091.37	Pressure spring	
1.5		21.51.2356	Screw IS M3x10	
1.6		1.810.150.01	Tacho mask	
1.7		1.167.838.02	Spacer	
1.8		24.16.4160	Internal retaining ring D16	
1.9		1.811.111.06	Shaft	
1.10		23.01.1064	Washer D6.4x11	
1.11		24.16.1060	Lock washer D6.4x10	
1.12		22.01.8060	Hexanut M6	
1.13		21.53.0357	Z-Screw IS M3x12	
1.14		24.16.1030	Lock washer D3.2x5.5	
		1.810.150.03	Cover	
2		1.727.113.00	Guide roller compl.	
2.1		1.167.831.00	Cover	
2.2		21.01.0203	Z-Screw M2x5	
2.3		24.16.1020	Lock washer D2.2x4	
2.4		1.811.110.02	Stop rubber	
3.1		1.010.032.37	Tension spring short	
4.1		1.067.170.14	Rubber tube	
4.2		1.010.125.37	Tension spring long	
5.1		1.727.110.03	Spring	
6.1		24.16.1030	Lock washer D3.2x5.5	
6.2		23.01.2032	Washer D3.2x7	
6.3		21.53.0353	Z-Screw IS M3x5	
7		1.727.114.00	Dashpot compl. adjusted	
7.1		22.01.5060	Nut M6	
7.2		37.02.0101	Spring washer D6.2x9.8	
8		1.727.321.00	Move sensor BOARD compl.	
8.1		21.53.0353	Z-Screw IS M3x5	
8.2		24.16.1030	Lock washer D3.2x5.5	
8.3		23.01.2032	Washer D3.2x7	
9		1.727.320.00	Tape tension sensor BOARD compl.	
9.1		24.16.1030	Lock washer D3.2x5.5	
9.2		21.53.0353	Z-Screw IS M3x5	
9.3		23.01.2032	Washer D3.2x7	

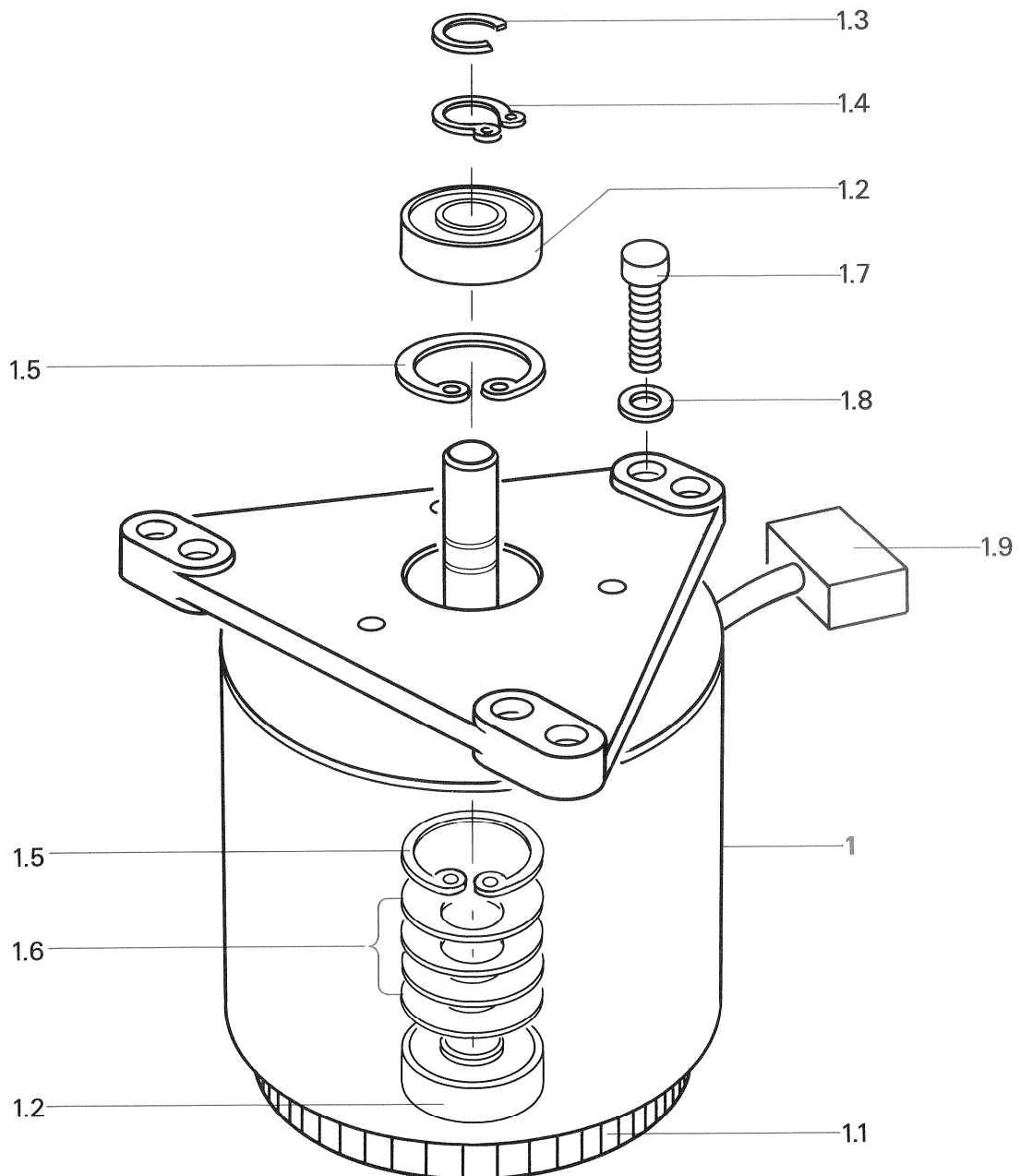
8.6
WICKELMOTOR / SPOOLING MOTOR

WICKELMOTOR

POS	QTY	ORDERNUMMER	BEZEICHNUNG	SPEZIFIKATION
1		1.021.250.00	Wickelmotor kpl.	
1.1		1.777.100.40	Tachoblende	
1.2		41.99.0105	Kugellager	
1.3		1.021.256.04	Clip geschliffen	
1.4		24.16.5080	Clip	
1.5		24.16.4220	Clip	
1.6		37.02.0206	Tellerfeder	
1.7		21.53.0457	Z-Schraube IS M4x12	
1.8		24.16.1040	Sicherungsschraube	
1.9		54.25.0303	Steckergehäuse 3pol/16A	
		54.01.0207	Kontaktstift	

SPOOLING MOTOR

POS	QTY	ORDER NUMBER	PART NAME	SPECIFICATION
1		1.021.250.00	Spooling motor compl.	
1.1		1.777.100.40	Tacho ring	
1.2		41.99.0105	Ball bearing	
1.3		1.021.256.04	Circlip	
1.4		24.16.5080	Circlip	
1.5		24.16.4220	Circlip	
1.6		37.02.0206	Spring washer	
1.7		21.53.0457	Z-Screw IS M4x12	
1.8		24.16.1040	Lock washer	
1.9		54.25.0303	Connector shell 3pol/16A	
		54.01.0207	Contact pin	

8.7
SHUTTLE EINHEIT / SHUTTLE UNIT

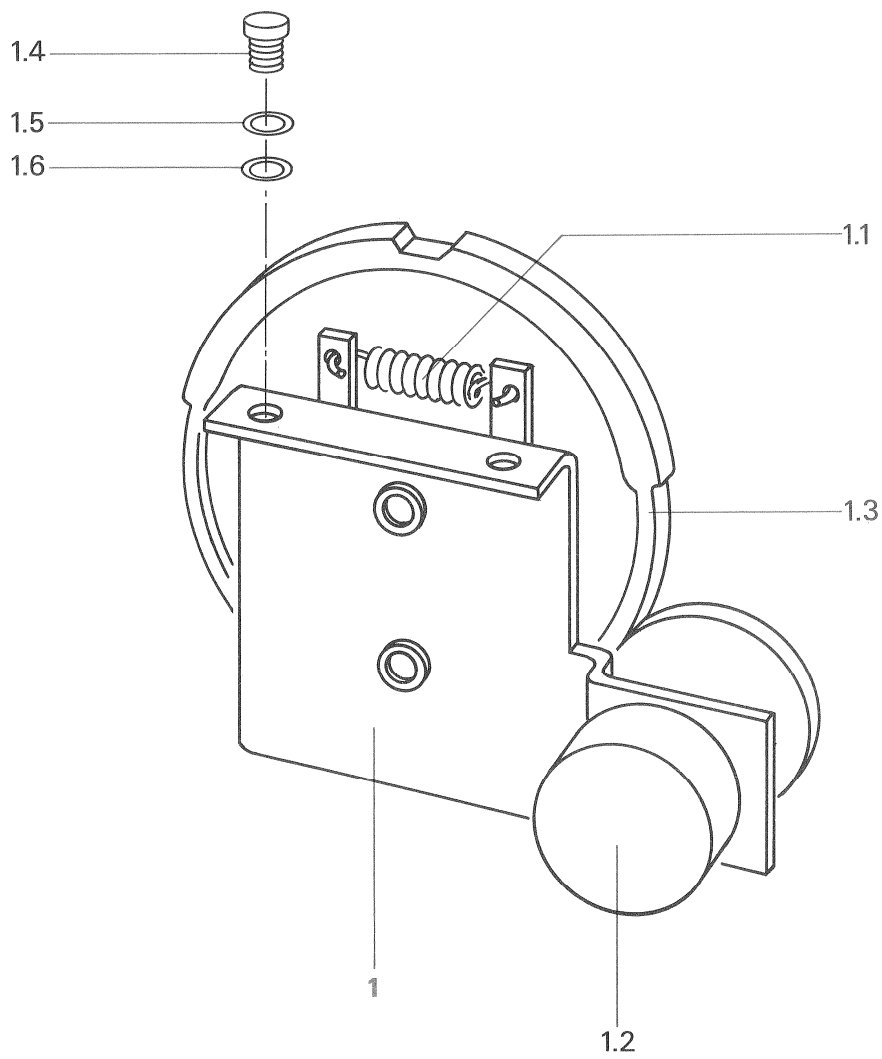

SHUTTLE EINHEIT

POS	QTY	ORDERNUMMER	BEZEICHNUNG	SPEZIFIKATION
1		1.727.180.00	Shuttle-Einheit kpl.	
1.1		1.010.101.37	Zugfeder	
1.2		58.99.0139	Shuttle-Potentiometer	5 kΩ/2 W
1.3		1.727.180.01	Shuttle-Rad	
1.4		21.53.0354	Z-Schraube IS M3x6	
1.5		24.16.1030	Sicherungsscheibe E3,2/5,5	
1.6		23.01.2032	U-Scheibe D3,2	

SHUTTLE UNIT

POS	QTY	ORDER NUMBER	PART NAME	SPECIFICATION
1		1.727.180.00	Shuttle-unit compl.	
1.1		1.010.101.37	Tension spring	
1.2		58.99.0139	Shuttle-potentiometer	5 kΩ/2 W
1.3		1.727.180.01	Shuttle-wheel	
1.4		21.53.0354	Z-Screw IS M3x6	
1.5		24.16.1030	Lock washer D3.2/5.5	
1.6		23.01.2032	Washer D3.2	

8.8 ANSCHLUSSFELD / TERMINAL BOARD

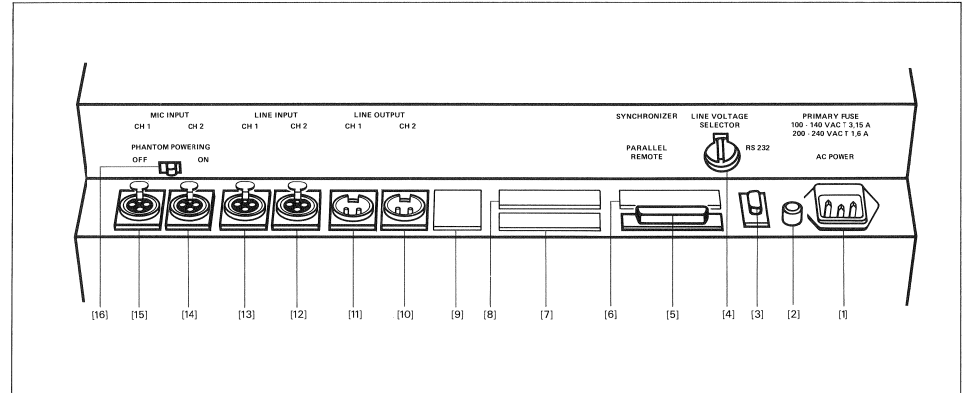

POS	QTY	ORDERNUMMER	BEZEICHNUNG	SPEZIFIKATION
1		54.42.0003	Netzsteckersockel	
		51.01.0119	Sicherung 1,6A (220V)	
		51.01.0122	Sicherung 3,15A (110V)	
2		1.010.001.53	Messbuchse 0 V	
3		1.727.245.00	Kabelbaum RS 232	
4		53.03.0128	Spannungswähler	
5		1.727.244.00	Kabelbaum Parallele Fernsteuerung	
6		1.820.560.06	Blindabdeckung oder Kabelbaum SYNCHRONIZER	
7		1.820.560.06	Blindabdeckung oder Kabelbaum Stereo-Monitor oder Kabelbaum VU-Panel	Schaltsignale
		1.727.248.00		
		1.727.239.00		
8		1.820.560.06	Blindabdeckung oder Kabelbaum VU-Panel	Audio Stereo oder Kabelbaum VU-Panel
		1.727.247.00		Audio Mono
		1.727.238.00		
9		1.820.560.11	Blindabdeckung oder Einbaubuchse	5-pol
		1.727.091.02		
10-11		1.727.240.00	XLR-Ausgang mit Kabel	
12-13		1.727.241.00	XLR-Eingang mit Kabel oder Blindabdeckung	
		1.820.560.11		
14-15		1.727.242.00	XLR-Mic. Eingang mit Kabel oder Blindabdeckung	
		1.820.560.11		
16		1.727.249.00	Phantom Ein/Ausschalter mit Kabel	
		55.12.0007	Schalter	
		1.820.560.05	oder Blindabdeckung	

POS	QTY	ORDER NUMBER	PART NAME	SPECIFICATION
1		54.42.0003	Power socket	
		51.01.0119	Fuse 1.6A (220V)	
		51.01.0122	Fuse 3.15A (110V)	
2		1.010.001.53	0 V Terminal	
3		1.727.245.00	Wire harness RS 232	
4		53.03.0128	Voltage selector	
5		1.727.244.00	Wire harness parallel remote control	
6		1.820.560.06	Cover plate or wire harness SYNCHRONIZER	
7		1.820.560.06	Cover plate or wire harn. Stereo monitor or wire harness VU-Panel	switching signals
		1.727.248.00		
		1.727.239.00		
8		1.820.560.06	Cover plate or wire harness VU-panel	audio stereo or wire harness VU-panel
		1.727.247.00		audio mono
		1.727.238.00		
9		1.820.560.11	Cover plate or 5-pin XLR socket	f
		1.727.091.02		
10-11		1.727.240.00	XLR output incl. wire harness	
12-13		1.727.241.00	XLR input incl. wire harness or cover plate	
		1.820.560.11		
14-15		1.727.242.00	XLR Mic-input incl. wire harn. or cover plate	
		1.820.560.11		
16		1.727.249.00	Phantom sw. incl. wire harness	
		55.12.0007	Phantom powering switch	
		1.820.560.05	or cover plate	

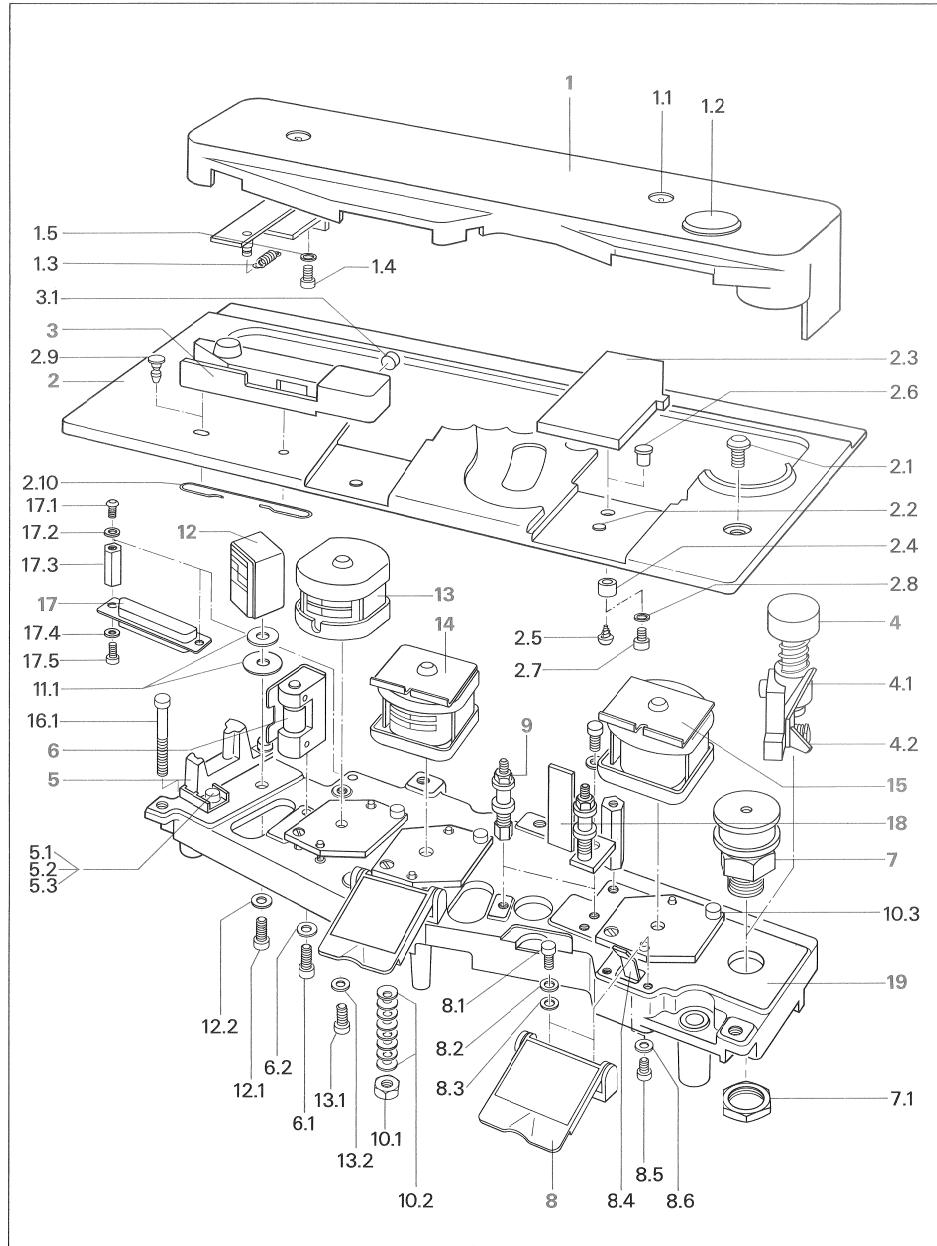
8.9
KOPFTRAEGER / HEAD BLOCK

KOPFTRAEGER

POS	QTY	ORDERNUMMER	BEZEICHNUNG	SPEZIFIKATION
1		1.727.125.00	Kopfabdeckung kpl.	
1.1		1.010.036.21	S-Schraube IS	
1.2		1.727.125.04	Abdeckkappe	
1.3		1.010.025.37	Zugfeder	
1.4		21.53.0354	Z-Schraube IS M3x6	
1.5		24.16.1030	Sicherungsscheibe D3,2x5,5	
2		1.727.126.00	Kopftragerabdeckung kpl.	
2.1		1.010.011.21	Lin.- Schraube IS	
2.2		1.179.143.03	Gummianschlag	
2.3		1.727.126.02	Abdeckung 2.Repro-Kopf	
2.4		1.727.126.03	Buchse	
2.5		20.23.7280	Schraube KS D2,5	
2.6		1.727.127.01	Gewindebuchse	
2.7		21.53.0353	Z-Schraube IS M3x5	
2.8		24.16.1030	Sicherungsscheibe D3,2x5,5	
2.9		1.810.186.02	Abdeckstopfen	
2.10		1.810.400.05	Feder	
3		1.810.402.81	Bandmarkierer kpl. (OPTION)	
3.1		1.337.958.05	Stempelsatz	
4		1.020.889.81	Bandschere kpl. (OPTION)	
4.1		1.020.861.07	Scherenblatt fest	
4.2		1.020.715.12	Scherenblatt beweglich	
5		1.050.314.00	Lichtschranke kpl.	
5.1		21.53.0354	Z-Schraube IS M3x6	
5.2		24.16.1030	Sicherungsscheibe D3,2/5,5	
5.3		23.01.1032	Unterlagsscheibe D3,2x6	
6		1.050.311.00	Beruhigungserolle kpl.	
6.1		21.53.0355	Z-Schraube IS M3x8	
6.2		24.16.1030	Sicherungsscheibe D3,2/5,5	
7		1.050.351.00	Umlenkrolle kpl.	
7.1		1.050.351.04	Mutter	
8		1.050.350.00	Abschirmklappe kpl.	
8.1		21.51.8355	Lin.- Schraube IS M3x8	
8.2		24.16.1030	Sicherungsscheibe D3,2x5,5	
8.3		23.01.1032	U-Scheibe D3,2x6/0,5	
8.4		1.050.340.03	Blattfeder	
8.5		21.53.0353	Z-Schraube IS M3x5	
8.6		24.16.1030	Sicherungsscheibe D3,2x5,5	
9		1.020.859.00	Bandfuhrungsbolzen kpl.	
10.1		22.01.8030	Mutter M3x0,8	
10.2		37.01.0101	Tellerfeder D3,2x8x0,3	
10.3		1.020.710.05	Azimuthinstellschraube	
11.1		1.020.500.01	Distanzscheibe D4,2/15,5x0,1	
12			Variabel siehe unter 19	
12.1		21.53.0456	Schraube	
12.2		24.16.1040	Sicherungsscheibe	
13			Variabel siehe unter 19	
13.1		21.53.0455	Schraube	
13.2		24.16.1040	Sicherungsscheibe	
14			Variabel siehe unter 19	
15			Variabel siehe unter 19	
16.1		21.53.0464	Schraube M4x30	
17		54.13.1003	Stecker D-Type 25pol	
17.1		21.51.8355	Lin.- Schraube IS M3x8	
17.2		24.16.1030	Sicherungsscheibe D3,2x5,5	
		29.26.1022	Lotse D3,2x5,5x10,5	
17.3		1.050.340.07	Distanzbolzen	
17.4		24.16.1020	Sicherungsscheibe D2,2x4	
17.5		21.01.0204	Z-Schraube M2x6	
18			Siehe Foto	

HEAD BLOCK

POS	QTY	ORDER NUMBER	PART NAME	SPECIFICATION
1		1.727.125.00	Head cover compl.	
1.1		1.010.036.21	S-Screw special	
1.2		1.727.125.04	Cover cap for scissors	
1.3		1.010.025.37	Tension spring shape B4x17	
1.4		21.53.0354	Z-Screw IS M3x6	
1.5		24.16.1030	Lock washer D3.2x5.5	
2		1.727.126.00	Head block cover compl.	
2.1		1.010.011.21	Lin.- Screw IS special	
2.2		1.179.143.03	Rubber bumper for head cover	
2.3		1.727.126.02	Cover plate for 2nd reprohead	
2.4		1.727.126.03	Socket	
2.5		20.23.7280	Screw KS D2.5	
2.6		1.727.127.01	Screw socket	
2.7		21.53.0353	Z-Screw IS M3x5	
2.8		24.16.1030	Lock washer D3.2x5.5	
2.9		1.810.186.02	Stopper	
2.10		1.810.400.05	Spring	
3		1.810.402.81	Marker compl. (OPTION)	
3.1		1.337.958.05	Rubber insert with ink	
4		1.020.889.81	Tape scissors compl. (OPTION)	
4.1		1.020.861.07	Scissor blade fixed	
4.2		1.020.715.12	Scissor blade movable	
5		1.050.314.00	Light barrier compl.	
5.1		21.53.0354	Z-Screw IS M3x6	
5.2		24.16.1030	Lock washer D3.2/5.5	
5.3		23.01.1032	Washer D3.2x6	
6		1.050.311.00	Damping pulley compl.	
6.1		21.53.0355	Z-Screw IS M3x8	
6.2		24.16.1030	Lock washer D3.2/5.5	
7		1.050.351.00	Tape guide roller compl.	
7.1		1.050.351.04	Nut	
8		1.050.350.00	Headshield compl.	
8.1		21.51.8355	Lin.- Screw IS M3x8	
8.2		24.16.1030	Lock washer D3.2x5.5	
8.3		23.01.1032	Washer D3.2x6/0.5	
8.4		1.050.340.03	Plate spring	
8.5		21.53.0353	Z-Screw IS M3x5	
8.6		24.16.1030	Lock washer D3.2x5.5	
9		1.020.859.00	Tape guide pin compl.	
10.1		22.01.8030	Nut M3x0.8	
10.2		37.01.0101	Spring washer D3.2x8.0.3	
10.3		1.020.710.05	Head adjustment screw	
11.1		1.020.500.01	Sleeve spacer	
12			Variable see 19	
12.1		21.53.0456	Screw	
12.2		24.16.1040	Lock washer	
13			Variable see 19	
13.1		21.53.0455	Screw	
13.2		24.16.1040	Lock washer	
14			Variable see 19	
15			Variable see 19	
16.1		21.53.0464	Screw M4x30	
17		54.13.1003	Connector D-Type 25pin	
17.1		21.51.8355	Lin.- Screw IS M3x8	
17.2		24.16.1030	Lock washer D3.2x5.5	
		29.26.1022	Soldering tab D3.2x5.5x10.5	
17.3		1.050.340.07	Bold	
17.4		24.16.1020	Lock washer D2.2x4	
17.5		21.01.0204	Z-Screw M2x6	
18			See picture	

KOPFTRAEGER VOLLSPUR (MONO)

POS	QTY	ORDERNUMMER	BEZEICHNUNG	SPEZIFIKATION
19		1.050.340.00	Kopfträger Vollspur kpl.	
12		1.116.097.81	Löschkopf Vollspur	
13		1.317.710.00	Aufnahmekopf Vollspur	
14		1.317.616.00	Wiedergabekopf Vollspur	

POS	QTY	ORDERNUMMER	BEZEICHNUNG	SPEZIFIKATION
19		1.050.390.00	Kopfträger Vollspur kpl.	
12		1.116.097.81	Löschkopf Vollspur	
13		1.318.710.00	Aufnahmekopf Vollspur	
14		1.318.616.00	Wiedergabekopf Vollspur	

POS	QTY	ORDERNUMMER	BEZEICHNUNG	SPEZIFIKATION
19		1.050.381.00	Kopfträger Vollspur nur Wiedergabe kpl.	
12		1.116.089.01	Löschkopfatrappe	
13		1.216.010.01	Aufnahmekopfatrappe	
14		1.318.616.00	Wiedergabekopf Vollspur	

KOPFTRAEGER 2-SPUR 2mm

POS	QTY	ORDERNUMMER	BEZEICHNUNG	SPEZIFIKATION
19		1.050.341.00	Kopfträger 2-Spur 2mm kpl.	
12		1.116.092.81	Löschkopf 2-Spur überlappend	
13		1.317.720.00	Aufnahmekopf 2-Spur 2mm	
14		1.317.626.00	Wiedergabekopf 2-Spur 2mm	

POS	QTY	ORDERNUMMER	BEZEICHNUNG	SPEZIFIKATION
19		1.050.391.00	Kopfträger 2-Spur 2mm kpl.	
12		1.116.092.81	Löschkopf 2-Spur überlappend	
13		1.318.720.00	Aufnahmekopf 2-Spur 2mm	
14		1.318.626.00	Wiedergabekopf 2-Spur 2mm	

POS	QTY	ORDERNUMMER	BEZEICHNUNG	SPEZIFIKATION
19		1.050.343.81	Kopfträger 2-Spur 2mm mit zusätzlichem ¼Spur 2CH Wiedergabekopf kpl.	
12		1.116.092.81	Löschkopf 2-Spur überlappend	
13		1.317.720.00	Aufnahmekopf 2-Spur 2mm	
14		1.317.626.00	Wiedergabekopf 2-Spur 2mm	
15		1.318.629.81	Wiedergabekopf ¼Spur 2CH	

POS	QTY	ORDERNUMMER	BEZEICHNUNG	SPEZIFIKATION
19		1.050.393.81	Kopfträger 2-Spur mit zusätzlichem ¼Spur 2CH Wiedergabekopf kpl.	
12		1.116.092.81	Löschkopf 2-Spur überlappend	
13		1.318.720.00	Aufnahmekopf 2-Spur 2mm	
14		1.318.626.00	Wiedergabekopf 2-Spur 2mm	
15		1.318.629.81	Wiedergabekopf ¼Spur 2CH	

HEAD BLOCK FULL-TRACK (MONO)

POS	QTY	ORDER NUMBER	PART NAME	SPECIFICATION
19		1.050.340.00	Head block full track compl.	
12		1.116.097.81	Erase head full track	
13		1.317.710.00	Record head full track	
14		1.317.616.00	Reproduce head full track	

POS	QTY	ORDER NUMBER	PART NAME	SPECIFICATION
19		1.050.390.00	Head block full track compl.	
12		1.116.097.81	Erase head full track	
13		1.318.710.00	Record head full track	
14		1.318.616.00	Reproduce head full track	

POS	QTY	ORDER NUMBER	PART NAME	SPECIFICATION
19		1.050.381.00	Head block full track repro-only compl.	
12		1.116.089.01	Dummy erase head	
13		1.216.010.01	Dummy record head	
14		1.318.616.00	Reproduce head full track	

HEAD BLOCK 2-TRACK 2mm

POS	QTY	ORDER NUMBER	PART NAME	SPECIFICATION
19		1.050.341.00	Head block 2-track 2mm compl.	
12		1.116.092.81	Erase head 2-track overlapp.	
13		1.317.720.00	Record head 2-track 2mm	
14		1.317.626.00	Reproduce head 2-track 2mm	

POS	QTY	ORDER NUMBER	PART NAME	SPECIFICATION
19		1.050.391.00	Head block 2-track 2mm compl.	
12		1.116.092.81	Erase head 2-track overlapp.	
13		1.318.720.00	Record head 2-track 2mm	
14		1.318.626.00	Reproduce head 2-track 2mm	

POS	QTY	ORDER NUMBER	PART NAME	SPECIFICATION
19		1.050.343.81	Head block 2-track 2mm with additional ¼track 2CH reproduce head compl.	
12		1.116.092.81	Erase head 2-track overlapp.	
13		1.317.720.00	Record head 2-track 2mm	
14		1.317.626.00	Reproduce head 2-track 2mm	
15		1.318.629.81	Reproduce head ¼track 2CH	

POS	QTY	ORDER NUMBER	PART NAME	SPECIFICATION
19		1.050.393.81	Head block 2-track with additional ¼track 2CH reproduce head compl.	
12		1.116.092.81	Erase head 2-track overlapp.	
13		1.318.720.00	Record head 2-track 2mm	
14		1.318.626.00	Reproduce head 2-track 2mm	
15		1.318.629.81	Reproduce head ¼track 2CH	

POS	QTY	ORDERNUMMER	BEZEICHNUNG	SPEZIFIKATION
19		1.050.345.00	Kopfträger 2-Spur 2mm mit Vollspur Löschkopf kpl.	
12		1.116.097.81	Löschkopf Vollspur	
13		1.317.720.00	Aufnahmekopf 2-Spur 2mm	
14		1.317.626.00	Wiedergabekopf 2-Spur 2mm	

POS	QTY	ORDER NUMBER	PART NAME	SPECIFICATION
19		1.050.345.00	Head block 2-track 2mm with full track erase head compl.	
12		1.116.097.81	Erase head full track	
13		1.317.720.00	Record head 2-track 2mm	
14		1.317.626.00	Reproduce head 2-track 2mm	

POS	QTY	ORDERNUMMER	BEZEICHNUNG	SPEZIFIKATION
19		1.050.395.00	Kopfträger 2-Spur 2mm mit Vollspur Löschkopf kpl.	
12		1.116.097.81	Löschkopf Vollspur	
13		1.318.720.00	Aufnahmekopf 2-Spur 2mm	
14		1.318.626.00	Wiedergabekopf 2-Spur 2mm	

POS	QTY	ORDER NUMBER	PART NAME	SPECIFICATION
19		1.050.395.00	Head block 2-track 2mm with full track erase head compl.	
12		1.116.097.81	Erase head full track	
13		1.318.720.00	Record head 2-track 2mm	
14		1.318.626.00	Reproduce head 2-track 2mm	

POS	QTY	ORDERNUMMER	BEZEICHNUNG	SPEZIFIKATION
19		1.050.347.00	Kopfträger 2-Spur 2mm, Löschkopf 0,8mm Trennspur kpl.	
12		1.116.814.00	Löschkopf mit 0,8mm Trennspur	
13		1.317.720.00	Aufnahmekopf 2-Spur 2mm	
14		1.317.626.00	Wiedergabekopf 2-Spur 2mm	

POS	QTY	ORDER NUMBER	PART NAME	SPECIFICATION
19		1.050.347.00	Head block 2-track 2mm, erase head 0.8mm sep. track compl.	
12		1.116.814.00	Erase head, 0.8mm sep. track	
13		1.317.720.00	Record head 2-track 2mm	
14		1.317.626.00	Reproduce head 2-track 2mm	

POS	QTY	ORDERNUMMER	BEZEICHNUNG	SPEZIFIKATION
19		1.050.397.00	Kopfträger 2-Spur 2mm, Löschkopf 0,8mm Trennspur kpl.	
12		1.116.814.00	Löschkopf mit 0,8mm Trennspur	
13		1.318.720.00	Aufnahmekopf 2-Spur 2mm	
14		1.318.626.00	Wiedergabekopf 2-Spur 2mm	

POS	QTY	ORDER NUMBER	PART NAME	SPECIFICATION
19		1.050.397.00	Head block 2-track 2mm, erase head, 0.8mm sep. track compl.	
12		1.116.814.00	Erase head, 0.8mm sep. track	
13		1.318.720.00	Record head 2-track 2mm	
14		1.318.626.00	Reproduce head 2-track 2mm	

POS	QTY	ORDERNUMMER	BEZEICHNUNG	SPEZIFIKATION
19		1.050.348.00	Kopfträger 2-Spur 2mm nur Wiedergabe kpl.	
12		1.116.089.01	Löschkopfattrappe	
13		1.216.010.01	Aufnahmekopfattrappe	
14		1.317.626.00	Wiedergabekopf 2-Spur 2mm	

POS	QTY	ORDER NUMBER	PART NAME	SPECIFICATION
19		1.050.348.00	Head block 2-track 2mm repro-only compl.	
12		1.116.089.01	Dummy erase head	
13		1.216.010.01	Dummy record head	
14		1.317.626.00	Reproduce head 2-track 2mm	

POS	QTY	ORDERNUMMER	BEZEICHNUNG	SPEZIFIKATION
19		1.050.398.00	Kopfträger 2-Spur 2mm nur Wiedergabe kpl.	
12		1.116.089.01	Löschkopfattrappe	
13		1.216.010.01	Aufnahmekopfattrappe	
14		1.318.626.00	Wiedergabekopf 2-Spur 2mm	

POS	QTY	ORDER NUMBER	PART NAME	SPECIFICATION
19		1.050.398.00	Head block 2-track 2mm repro-only compl.	
12		1.116.089.01	Dummy erase head	
13		1.216.010.01	Dummy record head	
14		1.318.626.00	Reproduce head 2-track 2mm	

KOPFTRAEGER STEREO 0,75mm

POS	QTY	ORDERNUMMER	BEZEICHNUNG	SPEZIFIKATION
19		1.050.342.00	Kopfträger 0,75 mit 2-Spur Löschkopf überlappend kpl.	
12		1.116.092.81	Löschkopf 2-Spur überlappend	
13		1.317.730.00	Aufnahmekopf 0,75	
14		1.317.636.00	Wiedergabekopf 0,75	

HEAD BLOCK STEREO 0,75mm

POS	QTY	ORDER NUMBER	PART NAME	SPECIFICATION
19		1.050.342.00	Head block 0.75 with 2-track overlapping erase head compl.	
12		1.116.092.81	Erase head 2-track overlapp.	
13		1.317.730.00	Record head 0.75	
14		1.317.636.00	Reproduce head 0.75	

POS	QTY	ORDERNUMMER	BEZEICHNUNG	SPEZIFIKATION
19		1.050.392.00	Kopfträger 0,75 mit 2-Spur Löschkopf überlappend kpl.	
12		1.116.092.81	Löschkopf 2-Spur überlappend	
13		1.318.730.00	Aufnahmekopf 0,75	
14		1.318.636.00	Wiedergabekopf 0,75	

POS	QTY	ORDER NUMBER	PART NAME	SPECIFICATION
19		1.050.392.00	Head block 0.75 with 2-track overlapping erase head compl.	
12		1.116.092.81	Erase head 2-track overlapp.	
13		1.318.730.00	Record head 0.75	
14		1.318.636.00	Reproduce head 0.75	

POS	QTY	ORDERNUMMER	BEZEICHNUNG	SPEZIFIKATION
19		1.050.344.00	Kopfträger 0,75 mit	
12		1.116.097.81	Vollspur Löschkopf kpl.	
13		1.317.730.00	Löschkopf Vollspur	
14		1.317.636.00	Aufnahmekopf 0,75	Wiedergabekopf 0,75

POS	QTY	ORDERNUMMER	BEZEICHNUNG	SPEZIFIKATION
19		1.050.394.00	Kopfträger 0,75 mit	
12		1.116.097.81	Vollspur Löschkopf kpl.	
13		1.318.730.00	Löschkopf Vollspur	
14		1.318.636.00	Aufnahmekopf 0,75	Wiedergabekopf 0,75

POS	QTY	ORDERNUMMER	BEZEICHNUNG	SPEZIFIKATION
19		1.050.346.81	Kopfträger 0,75 mit zusätzl.	
12		1.116.092.81	¼Spur 2CH Wiedergabekopf kpl.	
13		1.317.730.00	Löschkopf 2-Spur überlappend	
14		1.317.636.00	Aufnahmekopf 0,75	Wiedergabekopf 0,75
15		1.318.629.81	Wiedergabekopf ¼Spur 2CH	

POS	QTY	ORDERNUMMER	BEZEICHNUNG	SPEZIFIKATION
19		1.050.396.81	Kopfträger 0,75 mit zusätzl.	
12		1.116.092.81	¼Spur 2CH Wiedergabekopf kpl.	
13		1.318.730.00	Löschkopf 2-Spur überlappend	
14		1.318.636.00	Aufnahmekopf 0,75	Wiedergabekopf 0,75
15		1.318.629.81	Wiedergabekopf ¼Spur 2CH	

POS	QTY	ORDERNUMMER	BEZEICHNUNG	SPEZIFIKATION
19		1.050.349.00	Kopfträger 0,75 nur	
12		1.116.089.01	Wiedergabe kpl.	
13		1.216.010.01	Löschkopfattrappe	
14		1.317.636.00	Aufnahmekopfattrappe	Wiedergabekopf 0,75

POS	QTY	ORDERNUMMER	BEZEICHNUNG	SPEZIFIKATION
19		1.050.399.00	Kopfträger 0,75 nur	
12		1.116.089.01	Wiedergabe kpl.	
13		1.216.010.01	Löschkopfattrappe	
14		1.318.636.00	Aufnahmekopfattrappe	Wiedergabekopf 0,75

KOPFTRAEGER 1/4 SPUR 2 SPUR *

POS	QTY	ORDERNUMMER	BEZEICHNUNG	SPEZIFIKATION
19 *		1.050.380.81	Kopfträger ¼Spur 2CH kpl.	
12		1.116.099.81	Löschkopf ¼Spur 2CH	
13		1.318.724.00	Aufnahmekopf ¼Spur 2CH	
14		1.318.699.81	Wiedergabekopf ¼Spur 2CH	

* WIRD NICHT MEHR PRODUZIERT,
NUR NOCH ERSATZKOEPE ERHAELTLICH

POS	QTY	ORDER NUMBER	PART NAME	SPECIFICATION
19		1.050.344.00	Head block 0.75 with	
12		1.116.097.81	full track erase head compl.	
13		1.317.730.00	Erase head full track	
14		1.317.636.00	Record head 0.75	Reproduce head 0.75

POS	QTY	ORDER NUMBER	PART NAME	SPECIFICATION
19		1.050.394.00	Head block 0.75 with	
12		1.116.097.81	full track erase head compl.	
13		1.318.730.00	Erase head full track	
14		1.318.636.00	Record head 0.75	Reproduce head 0.75

POS	QTY	ORDER NUMBER	PART NAME	SPECIFICATION
19		1.050.346.81	Head block 0.75 with add.	
12		1.116.092.81	¼track 2CH repro-head compl.	
13		1.317.730.00	Erase head 2-track overlapp.	
14		1.317.636.00	Record head 0.75	Reproduce head 0.75
15		1.318.629.81	Reproduce head ¼track 2CH	

POS	QTY	ORDER NUMBER	PART NAME	SPECIFICATION
19		1.050.396.81	Head block 0.75 with add.	
12		1.116.092.81	¼track 2CH repro-head compl.	
13		1.318.730.00	Erase head 2-track overlapp.	
14		1.318.636.00	Record head 0.75	Reproduce head 0.75
15		1.318.629.81	Reproduce head ¼track 2CH	

POS	QTY	ORDER NUMBER	PART NAME	SPECIFICATION
19		1.050.349.00	Head block 0.75	
12		1.116.089.01	repro-only compl.	
13		1.216.010.01	Dummy erase head	
14		1.317.636.00	Dummy record head	Reproduce head 0.75

POS	QTY	ORDER NUMBER	PART NAME	SPECIFICATION
19		1.050.399.00	Head block 0.75	
12		1.116.089.01	repro-only compl.	
13		1.216.010.01	Dummy erase head	
14		1.318.636.00	Dummy record head	Reproduce head 0.75

HEAD BLOCK 1/4 TRACK 2 TRACK *

POS	QTY	ORDER NUMBER	PART NAME	SPECIFICATION
19 *		1.050.380.81	Head block ¼track 2CH compl.	
12		1.116.099.81	Erase head ¼track 2CH	
13		1.318.724.00	Record head ¼track 2CH	
14		1.318.699.81	Reproduce head ¼track 2CH	

* NO LONGER PRODUCED,
JUST REPLACEMENT HEADS AVAILABLE

KOPFTRAEGERBESTANDTEILE

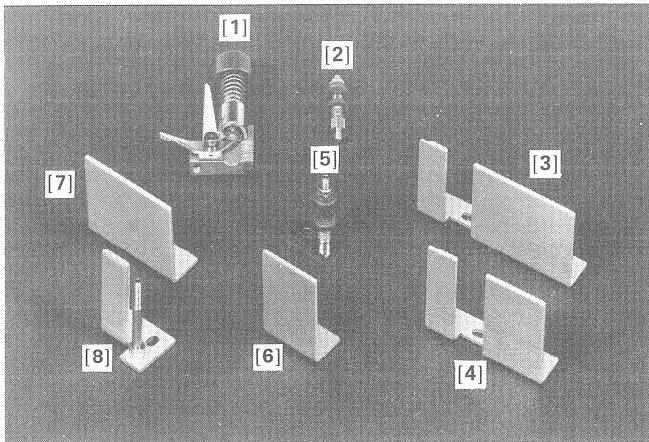

HEAD BLOCK PARTS

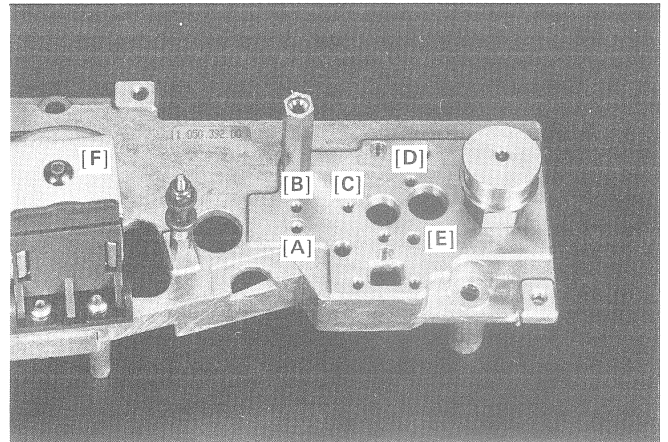

[1] = 1.020.889.81 Bandschere kpl. (Befest. mit Pass-Sitz in POS D und mit der Schraube in POS E).

Teile für Kopfträger von A807 mit Seriennummern über 2200 (POS A vorhanden) :

[2] = 1.020.859.00 Bandführungsbolzen kpl. (Befestigung in POS A)
 [3] = 1.050.390.01 Abschlusswinkel 56mm Version ohne Bandschere (Befest. in POS B und C)
 [4] = 1.050.390.02 Abschlusswinkel 41mm Version mit Bandschere (Befest. in POS B und C)

Teile für Kopfträger von A807 mit Seriennummern unter 2200 (Loch POS A fehlt) :

[5] = 1.050.352.00 Bandführungsbolzen (ohne Führungselemente) (Befestigung in POS B)
 [6] = 1.050.340.06 Abschlusswinkel 20mm Version mit Bandschere (Befestigung in POS C)
 [7] = 1.050.340.05 Abschlusswinkel 36mm Version ohne Bandschere (Befestigung in POS C)

Umbau: Verlängerte Abschlusswinkel für Kopfträger von A807 mit Seriennummern unter 2200 :

[8] = 1.050.353.00 Bandführungsbolzen (ohne Führungselemente) (Befest. in POS B) auch in Kopftr. mit 2.Reprokopf vorhanden
 - Führungselemente von Bandführung [5] verwenden
 - Abschlusswinkel [6] oder [7] bleiben eingebaut

[F] = 1.050.340.04 μ - Metall Anschlag siehe Zeichnung 8.9 Index 14/15

[1] = 1.020.889.81 Tape scissors complete (Fastening with dowel pin in POS D and mounting screw in POS E).

HEADBLOCKPARTS of A807 with Serialnumbers above 2200 (POS A existing) :

[2] = 1.020.859.00 Tape guide pin complete (Fastening in POS A)
 [3] = 1.050.390.01 Angle braket 56mm, version without tape scissors (Fastening in POS B and C)
 [4] = 1.050.390.02 Angle braket 41mm, version with tape scissors (Fastening in POS B and C)

HEADBLOCKPARTS of A807 with Serialnumbers below 2200 (hole POS A not existing) :

[5] = 1.050.352.00 Tape guide pin (without tape guide elements) (Fastening in POS B)
 [6] = 1.050.340.06 Angle braket 20mm, version with tape scissors (Fastening in POS C)
 [7] = 1.050.340.05 Angle braket 36mm, version without tape scissors (Fastening in POS C)

CONVERSION for extended angle braket for A807 headblock with Serialnumbers below 2200 :

[8] = 1.050.353.00 Tape guide pin (without tape guide elements) (Fastening in POS B)
 - Use tape guide elements of tape guide pin [5].
 - Remain angle braket [6] or [7] built - in.

[F] = 1.050.340.04 μ - metal stopper see drawing 8.9 Index 14/15

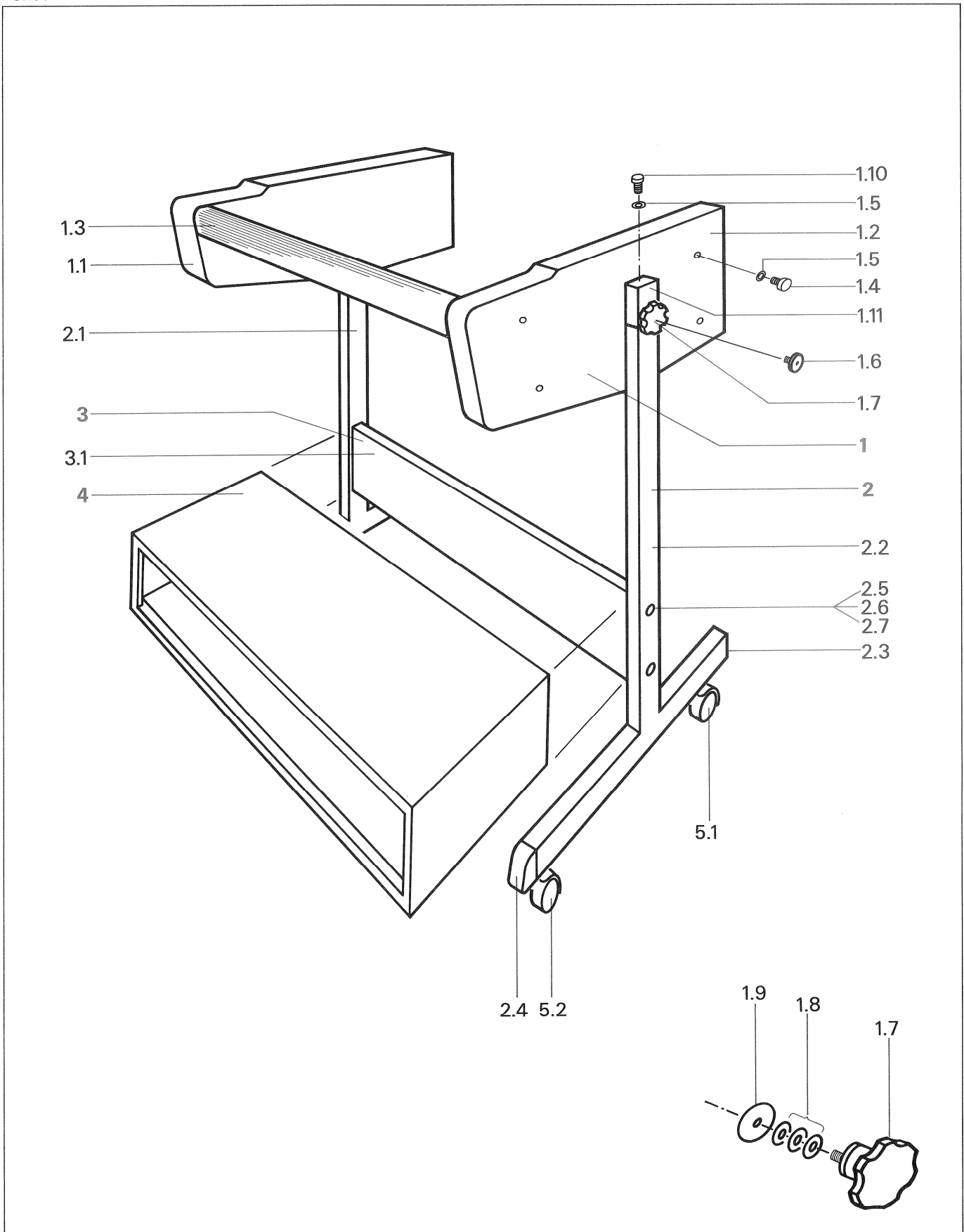
8.10
KONSOLE OHNE PANEL-AUFBAU / CONSOLE WITHOUT OVERBRIDGE

KONSOLE OHNE PANEL-AUFBAU

POS	QTY	ORDERNUMMER	BEZEICHNUNG	SPEZIFIKATION
1		20.020.205.25 20.020.205.35	Konsole kompl. mit Traver- se ohne Panelaufbau Konsole kompl. mit 19" Rack- unterbau ohne Panelaufbau	
1		1.058.055.00	Konsolenset ohne Panelaufbau	
1.1		1.058.055.01	Holzseitenwand links	
1.2		1.058.055.02	Holzseitenwand rechts	
1.3		1.058.071.00 21.53.0456	Handauflage Befestigungsschraube Z IS M4x10	
		24.16.1040	Rippenscheibe D 4,3/7	
1.4		1.010.037.21	IS-Schraube M5x30	
1.5		24.16.1050	Rippenscheibe D 5,3/9	
1.6		1.058.053.05	Spez. Schraube M10	
1.7		1.058.053.06	Handrad spez M10	
1.8		37.01.0128	Tellerfeder	
1.9		1.058.053.06	Anlaufscheibe	
1.10		1.010.052.21	Z-Schraube IS M5x50	
1.11		1.058.068.00	Lagerbock kompl.	
2		1.058.050.00	Beinset	
2.1		1.058.060.00	Bein links H=780/840	
2.2		1.058.061.00	Bein rechts H=780/840	
2.3		1.038.880.01	Abschlusspfropfen	
2.4		1.058.001.05	Rohrabschluss	
2.5		31.03.0106	Abdeckkappe	
2.6		21.53.0571	Z-Schraube IS M6x14	
2.7		26.16.1060	Rippenscheibe D 6,4/10	
3		1.058.101.00	Traversenset kompl.	
3.1		1.058.112.00	Traverse	
4		1.058.057.00	19" Rackunterbau	
5.1		33.04.0270	Rolle schwenkbar ohne Bremse	
5.2		33.04.0271	Rolle schwenkbar mit Bremse	

CONSOLE WITHOUT OVERBRIDGE

POS	QTY	ORDER NUMBER	PART NAME	SPECIFICATION
1		20.020.205.25 20.020.205.35	Console with traverse for machines without overbridge Console with pedestal rack 19" for machines without overbridge	
1		1.058.055.00	Console-set without overbridge	
1.1		1.058.055.01	Side panel left	
1.2		1.058.055.02	Side panel right	
1.3		1.058.071.00 21.53.0456	Leather hand rest Fixing screw Z IS M4x10	
		24.16.1040	Lock washer D 4.3/7	
1.4		1.010.037.21	Screw IS M5x30	
1.5		24.16.1050	Lock washer D 5.3/9	
1.6		1.058.053.05	Special screw M10	
1.7		1.058.053.06	Handwheel M10	
1.8		37.01.0128	Spring washer	
1.9		1.058.053.06	Thrust-ring	
1.10		1.010.052.21	Z-Screw IS M5x50	
1.11		1.058.068.00	Bearing bracket	
2		1.058.050.00	Set of legs	
2.1		1.058.060.00	Leg left H=780/840	
2.2		1.058.061.00	Leg right H=780/840	
2.3		1.038.880.01	Cover cap straight	
2.4		1.058.001.05	Plastic plug	
2.5		31.03.0106	Plastic cover	
2.6		21.53.0571	Z-Screw IS M6x14	
2.7		26.16.1060	Lock washer D 6,4/10	
3		1.058.101.00	Traverse compl.	
3.1		1.058.112.00	Traverse	
4		1.058.057.00	Pedestal rack 19"	
5.1		33.04.0270	Castor black without brake	
5.2		33.04.0271	Castor black with brake	

BLINDABDECKPLATTE FUER 19" RACKUNTERBAU

	FARBE	
	grau	eloxal
1 Einheit hoch	1.918.011.00	1.918.001.00
2 Einheiten hoch	1.918.012.00	1.918.002.00
3 Einheiten hoch	1.918.013.00	1.918.003.00
Schrauben für 19" Rackeinschub M6x12	21.99.0164	
Schrauben für 19" Rackeinschub M6x16	21.99.0167	
Unterlagsscheibe für Schrauben M6 für 19" Rackeinschub	23.99.0121	

FILLER PANELS FOR 19" PEDESTAL RACK

	FINISH	
	gray paint	anodized
1 unit width	1.918.011.00	1.918.001.00
2 units width	1.918.012.00	1.918.002.00
3 units width	1.918.013.00	1.918.003.00
Screw for 19" rack mounting M6x12	21.99.0164	
Screw for 19" rack mounting M6x16	21.99.0167	
Washer for 19" rack mounting M6	23.99.0121	

8.10.1
KONSOLE MIT AUFBAU / CONSOLE WITH OVERBRIDGE

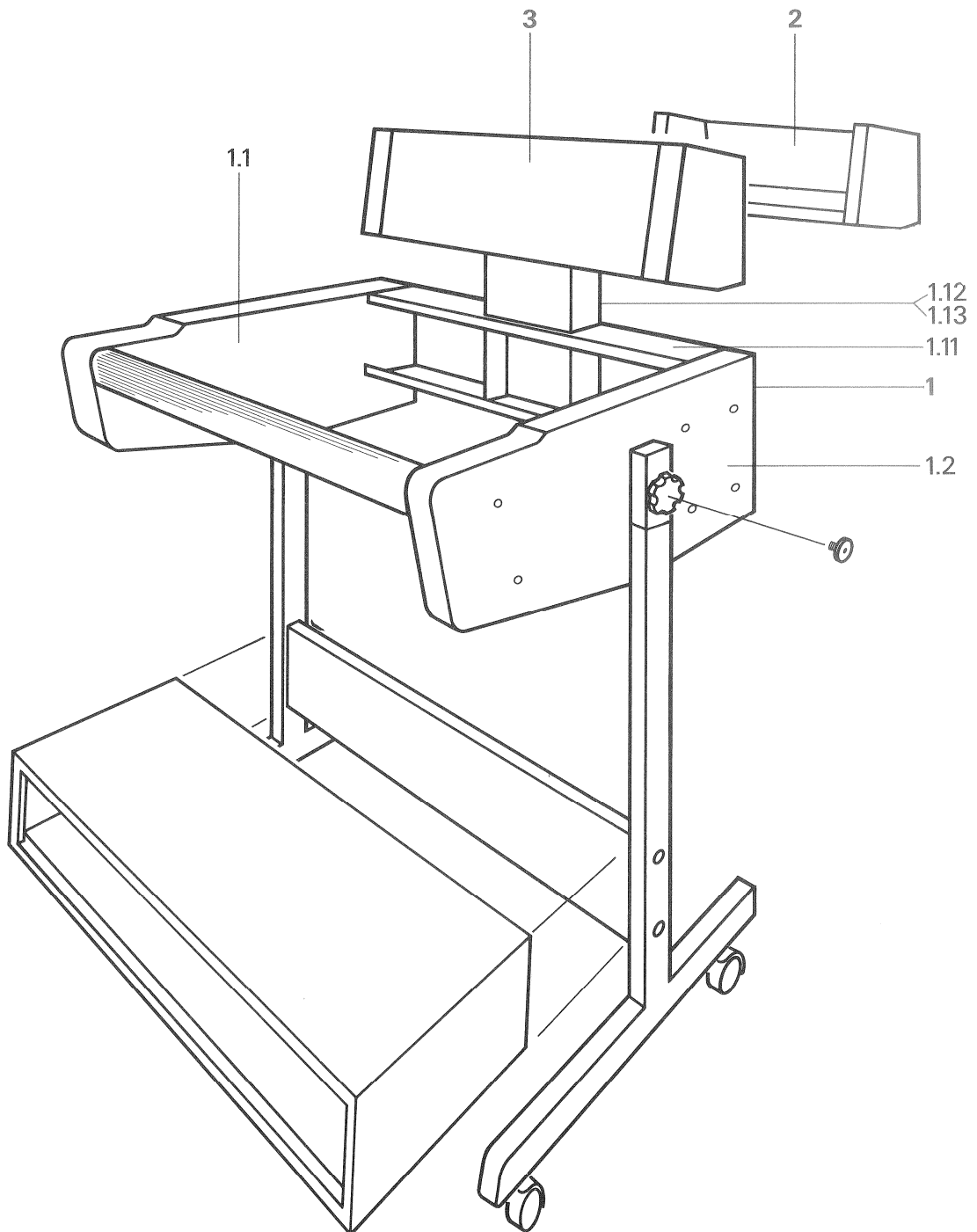

KONSOLE MIT PANELAUFBAU

POS	QTY	ORDERNUMMER	BEZEICHNUNG	SPEZIFIKATION
1		20.020.205.05	Konsole mit Panelaufbau und Traverse	
		20.020.205.15	Konsole mit Panelaufbau und 19" Rackunterbau	
1		1.058.056.00	Konsolenset mit Panelaufbau	
1.1		1.058.056.01	Holzseitenwand links	
1.2		1.058.056.02	Holzseitenwand rechts	
1.12		1.058.072.00	Konsolenrückwand mit Hals	
1.13		1.058.100.17	Deckblech Hals	
1.14		1.010.034.21	Schrauben für Deckblech Hals IS M4 x 8	
2		21.811.560.00	Tablar - Aufbau	
3			Panelaufbau Versionen siehe Paragraph 8.11	

CONSOLE WITH OVERBRIDGE

POS	QTY	ORDER NUMBER	PART NAME	SPECIFICATION
1		20.020.205.05	Console with overbridge and traverse	
		20.020.205.15	Console with overbridge and 19" pedestal rack	
1		1.058.056.00	Console-set with overbridge	
1.1		1.058.056.01	Lumber side panel left	
1.2		1.058.056.02	Lumber side panel right	
1.12		1.058.072.00	Console back panel with neck	
1.13		1.058.100.17	Plate cover neck	
1.14		1.010.034.21	Screw for plate cover neck IS M4 x 8	
2		21.811.560.00	Shelf	
3			Overbridge - Versions see paragraph 8.11	

8.11
PANEL-AUFBAU / OVERBRIDGE

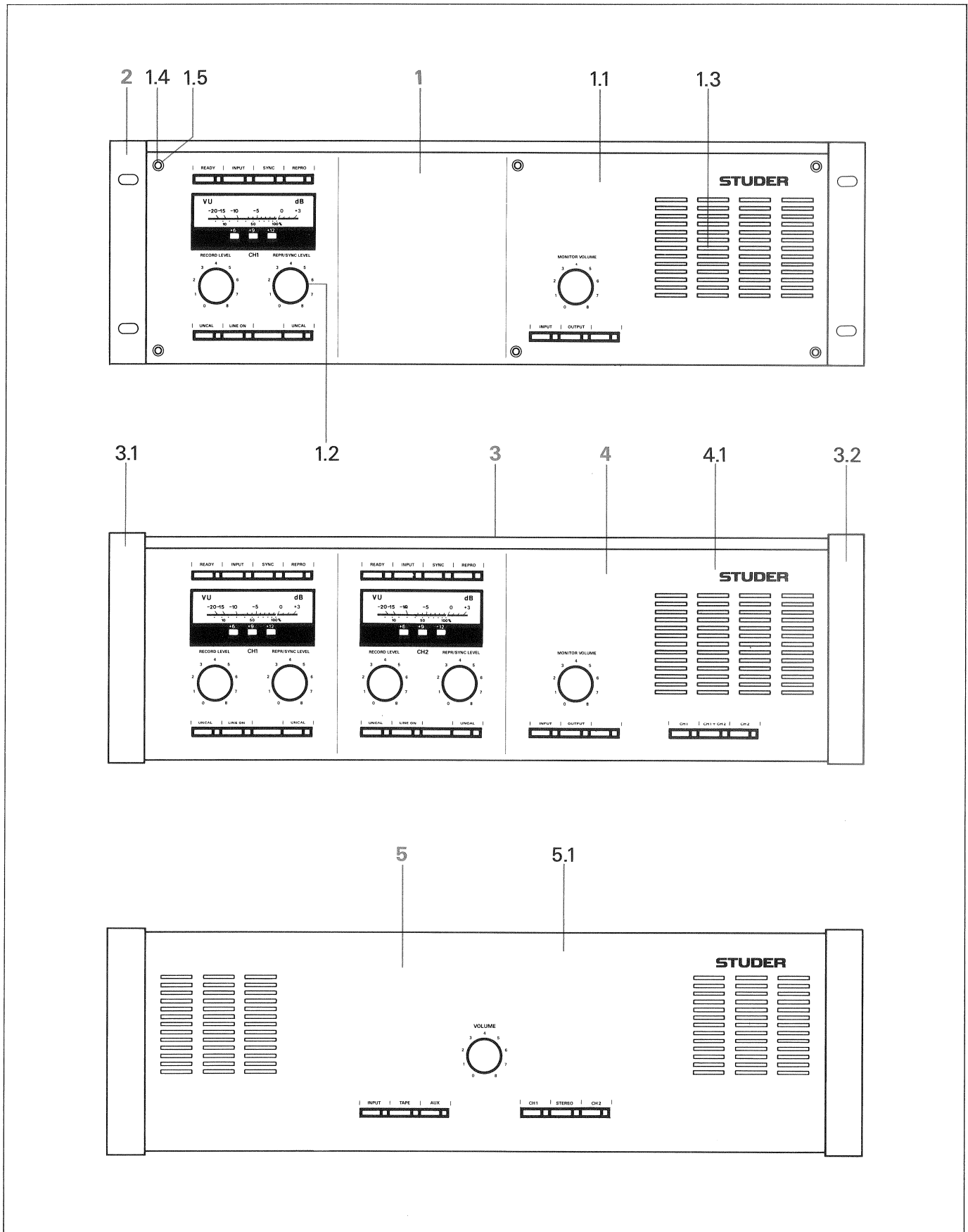

PANEL-AUFBAU / OVERBRIDGE

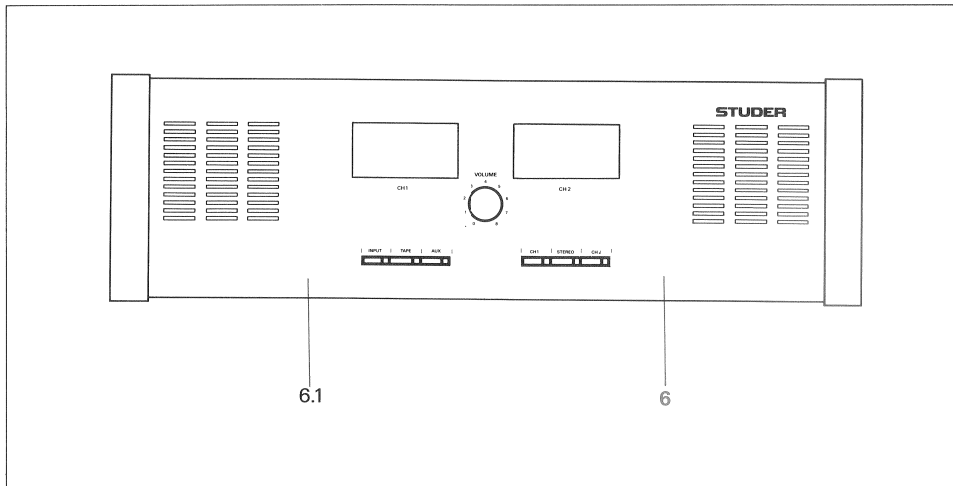

POS	QTY	ORDERNUMMER	BEZEICHNUNG	SPEZIFIKATION
1		1.727.930.81	Ext. Panel Mono kpl. mit Holzseitenwänden	
		1.727.951.81	Ext. Panel Mono kpl. mit 19" Rack-Winkeln	
1.1		1.727.930.01	Ext. Frontpanel Abd. Mono	
1.2		1.727.100.43	Drehknopf	
1.3		71.01.0159	Lautsprecher	
1.4		1.010.025.21	Schraube M3x6	
1.5		1.010.001.24	Spannscheibe M3	
2		1.727.952.00	19" Rackbox kompl.	
3		1.811.550.00	Panelaufbau mit Holzseitenwänden	
3.1		1.820.550.03	Holzseitenwand links	
3.2		1.820.550.04	Holzseitenwand rechts	
4		1.727.920.81	Ext. Panel stereo kpl. mit Holzseitenwänden	
		1.727.950.81	Ext. Panel stereo kpl. mit 19" Rack-Winkeln	
4.1		1.727.920.01	Ext. Frontpanel Abd. 2VU	
5		1.727.900.00	Ext. Monitor Panel stereo kpl. mit Holzseitenwänden	
5.1		1.727.900.01	Ext. Monitor Frontpanel Abdeckung	
6		1.727.960.00	Ext. Stereo-VU monitor Panel kpl. mit Holzseitenwänden	
6.1		1.727.960.01	Ext. Stereo-VU monitor Panel Abdeckung	

POS	QTY	ORDER NUMBER	PART NAME	SPECIFICATION
1		1.727.930.81	Ext. panel mono compl. with wooden side panels	
		1.727.951.81	Ext. monitor panel mono compl. with 19" rack rail set	
1.1		1.727.930.01	Ext. front panel cover mono	
1.2		1.727.100.43	Button	
1.3		71.01.0159	Loudspeaker	
1.4		1.010.025.21	Screw M3x6	
1.5		1.010.001.24	Washer M3	
2		1.727.952.00	19" rack box compl.	
3		1.811.550.00	Overbridge with wooden side panels	
3.1		1.820.550.03	Wooden side panel left	
3.2		1.820.550.04	Wooden side panel right	
4		1.727.920.81	Ext. panel stereo compl. with wooden side panels	
		1.727.950.81	Ext. panel stereo compl. with 19" rack rail set	
4.1		1.727.920.01	Ext. front panel cover 2VU	
5		1.727.900.00	Ext. monitor panel stereo compl. with wooden side panel	
5.1		1.727.900.01	Ext. monitor front panel cover	
6		1.727.960.00	Ext. Stereo-VU monitor panel compl. with wooden side panels	
6.1		1.727.960.01	Ext. Stereo-VU monitor front cover plate	

8.12 SCHILDER / LABEL



1.727.100.50

Audio Anschlussaufkleber
Audio connection destination plate, self adhesive



1.727.364.01

Tastenschild unbeschriftet
(für P80 - Versionen)
Designation plate blank for P80 - versions

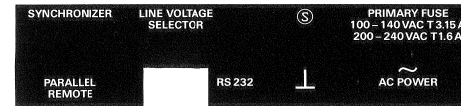

1.727.100.49

Schild - Netzteil, Fernsteuer - Anschlüsse
Power supply, remote control designation plate, self adhesive

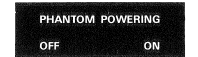

1.727.100.57

Schild Phantom - Speisungsschalter
Phantom powering switch designation plate, self adhesive



1.727.360.06

Schildersatz, Laufwerkstasten
Set of designation plates, tape transport keys



1.727.091.03

Monitor Panel - Anschlussaufkleber
Monitor panel designation plate, self adhesive

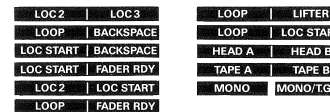

1.727.100.58

Schildersatz programmierbare Tasten
Set of designation plates, programmable keys



1.727.013.01

VU - Meter Panel - Anschlussaufkleber
VU - meter panel designation plate, self adhesive

8.13
KABELBUENDE LAUFWERK / WIRE HARNESS TAPE TRANSPORT

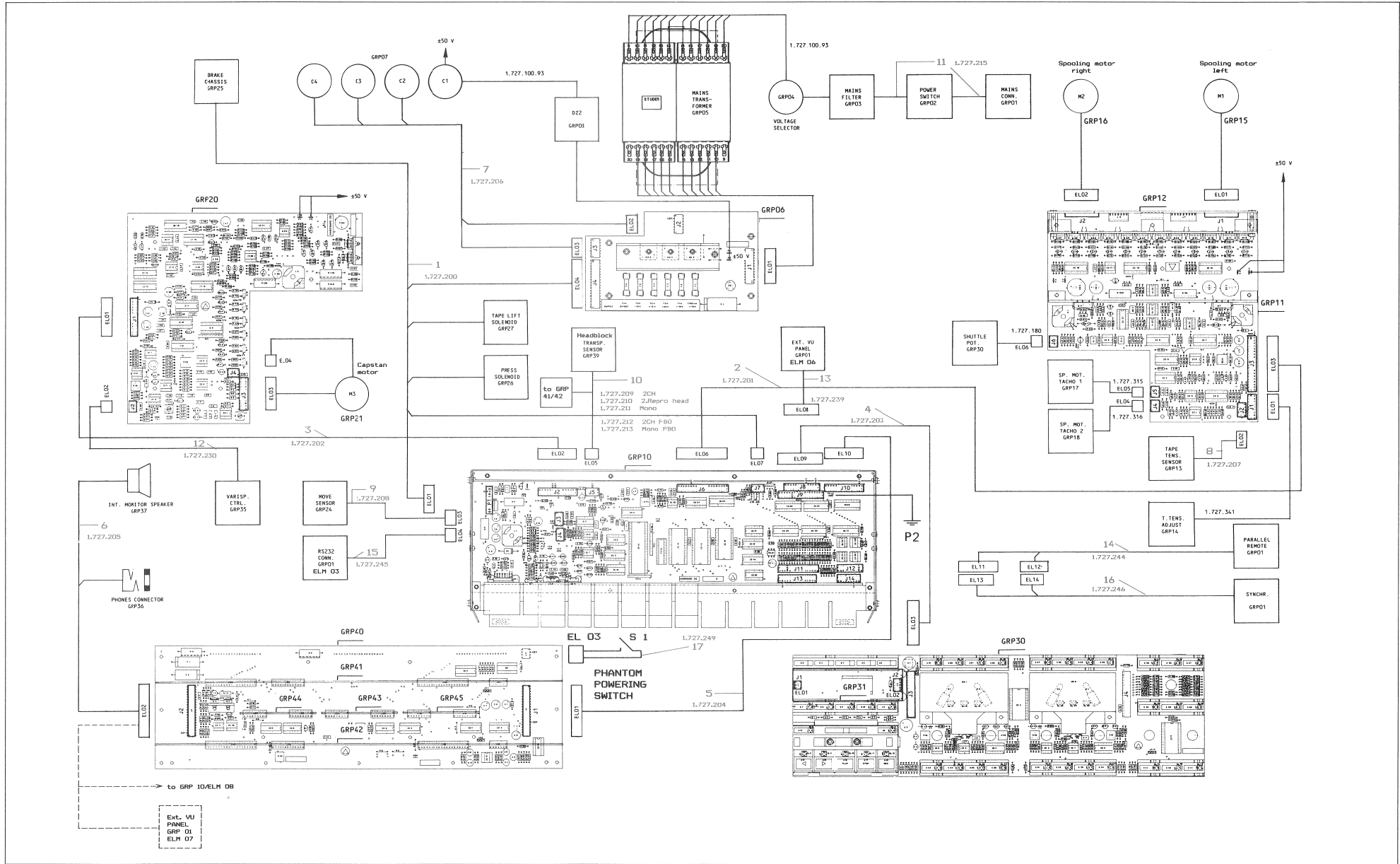

KABELBUENDE LAUFWERK

POS	QTY	ORDERNUMMER	BEZEICHNUNG	SPEZIFIKATION
1		1.727.200.00	Kabelbund Netzteil	
2		1.727.201.00	Kabelbund Laufwerk - Wickelmotorsteuerung	
3		1.727.202.00	Kabelbund Laufwerk - Capstanmotorsteuerung	
4		1.727.203.00	Kabelbund Laufwerk - Commandpanel	
5		1.727.204.00	Kabelbund Laufwerk - Audiocontrol-Print	
6		1.727.205.00	Kabelbund int. Monitor - Audio control print	
		1.727.238.00	Kabelbund ext. VU-Panel Audioanschluss MONO	oder anstelle von 1.727.205.:
		1.727.247.00	Kabelbund ext. VU-Panel Audioanschluss 2CH	
		1.727.248.00	Kabelbund ext. Monitoranschluss	
7		1.727.206.00	Kabelbund Kondensatoren, Gleichrichter - Print	
8		1.727.207.00	Kabelbund Bandzugsensor, Wickelmotorsteuerung	
9		1.727.208.00	Kabelbund Bewegungs- sensor - Laufwerk	
10		1.727.209.00	Kabelbund Kopfträger 2CH	
		1.727.210.00	Kabelbund Kopfträger 2CH + zusätzlicher Reprokopf	
		1.727.211.00	Kabelbund Kopfträger MONO (1CH)	
		1.727.212.00	Kabelbund Kopfträger 2CH nur Wiedergabe	
		1.727.213.00	Kabelbund Kopfträger MONO nur Wiedergabe	
11		1.727.215.00	Kabelbund Netzeingang	
12		1.727.230.00	Kabelbund Varispeed - Poti	
		1.727.230.01	Potentiometer 50k Ω lin	
13		1.727.239.00	Kabelbund ext. VU-Panel Control - Anschluss	
14		1.727.244.00	Kabelbund paralleler Fernsteuer - Anschluss	
15		1.727.245.00	Kabelbund serieller Fernsteuer - Anschluss	
16		1.727.246.00	Kabelbund paralleler Synchronisator - Anschluss	
17		1.727.249.00	Kabelbund Phantomschalter	
		55.12.0007	Phantom Schalter S1	

WIRE HARNESS TAPE TRANSPORT

POS	QTY	ORDER NUMBER	PART NAME	SPECIFICATION
1		1.727.200.00	Wire harness supply	
2		1.727.201.00	Wire harness tape transport - spooling motor control	
3		1.727.202.00	Wire harness tape transport - capstan motor control	
4		1.727.203.00	Wire harness tape transport - command panel	
5		1.727.204.00	Wire harness tape transport - audio control	
6		1.727.205.00	Wire harness int. Monitor - audio control PCB	
		1.727.238.00	Wire harness ext. VU-Panel audio connector MONO	or in place of 1.727.205.:
		1.727.247.00	Wire harness ext. VU-Panel audio connector 2CH	
		1.727.248.00	Wire harness ext. Monitor connector	
7		1.727.206.00	Wire harness capacitors - rectifier PCB	
8		1.727.207.00	Wire harness tape tension sensor, spooling motor contr.	
9		1.727.208.00	Wire harness move sensor - tape transport	
10		1.727.209.00	Wire harness headblock 2CH	
		1.727.210.00	Wire harness headblock 2CH + add. reprohead	
		1.727.211.00	Wire harness headblock MONO (1CH)	
		1.727.212.00	Wire harness headblock 2CH playback only	
		1.727.213.00	Wire harness headblock MONO playback only	
11		1.727.215.00	Wire harness mains input	
12		1.727.230.00	Wire harness varispeed - pot.	
		1.727.230.01	Potentiometer 50k Ω lin	
13		1.727.239.00	Wire harness ext. VU-Panel control connector	
14		1.727.244.00	Wire harness parallel remote control connector	
15		1.727.245.00	Wire harness serial remote control connector	
16		1.727.246.00	Wire harness parallel synchronizer connector	
17		1.727.249.00	Wire harness ph. pow. switch	
		55.12.0007	Phantom powering switch S1	

8.14
VERDRÄHTUNG, AUDIO / AUDIO WIRING DIAGRAM

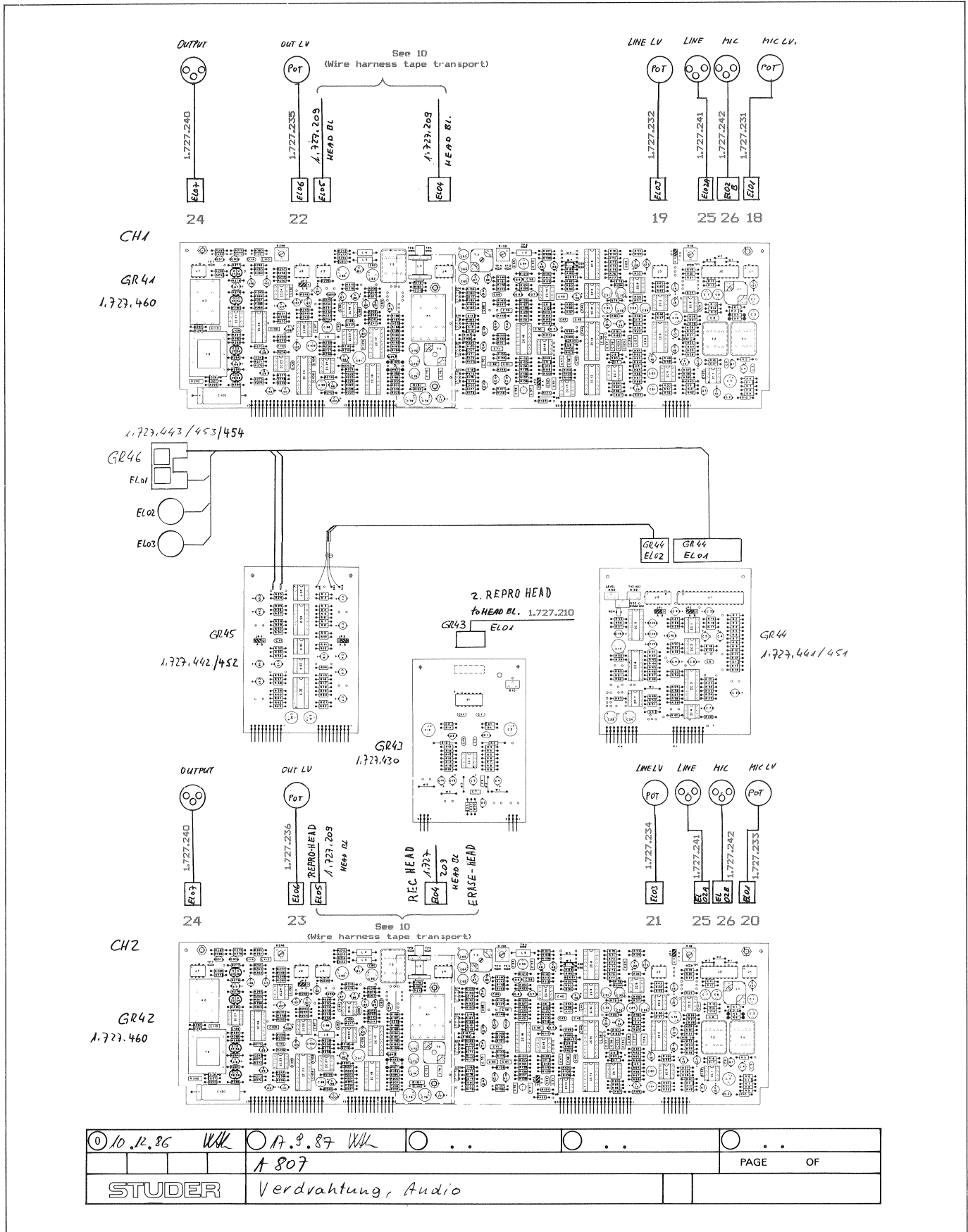

VERDRAHTUNG, AUDIO

POS	QTY	ORDER NUMBER	PART NAME	SPECIFICATION
18		1.727.231.00	Kabelbund Mic. Pegel	Pot. Meter CH1
19		1.727.232.00	Kabelbund Linien-Pegel	Pot. Meter CH1
20		1.727.233.00	Kabelbund Mic. Pegel	Pot. Meter CH2
21		1.727.234.00	Kabelbund Linien-Pegel	Pot. Meter CH2
22		1.727.235.00	Kabelbund Ausgangspegel	Pot. Meter CH1
23		1.727.236.00	Kabelbund Ausgangspegel	Pot. Meter CH2
18 - 23		1.727.230.01	Pot. Meter	50k Ω lin
24		1.727.240.00	XLR Ausgang kpl. (Stecker)	
25		1.727.241.00	XLR Linien-Eingang kpl. (Buchse)	
26		1.727.242.00	XLR Mic.-Eingang kpl. (Buchse)	

AUDIO WIRING DIAGRAM

POS	QTY	ORDERNUMMER	BEZEICHNUNG	SPEZIFIKATION
18		1.727.231.00	Wire harness Mic. Level	pot. meter CH1
19		1.727.232.00	Wire harness Line Level	pot. meter CH1
20		1.727.233.00	Wire harness Mic. Level	pot. meter CH2
21		1.727.234.00	Wire harness Line Level	pot. meter CH2
22		1.727.235.00	Wire harness Output Level	pot. meter CH1
23		1.727.236.00	Wire harness Output Level	pot. meter CH2
18 - 23		1.727.230.01	Pot. meter	50k Ω lin
24		1.727.240.00	XLR Output compl. (connector)	
25		1.727.241.00	XLR Line input compl. (jack)	
26		1.727.242.00	XLR Mic. input compl. (jack)	

8.15
 VERDRÄHTUNG, EXT. VU-PANEL / WIRING DIAGRAM, EXT. VU-PANEL

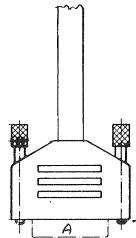
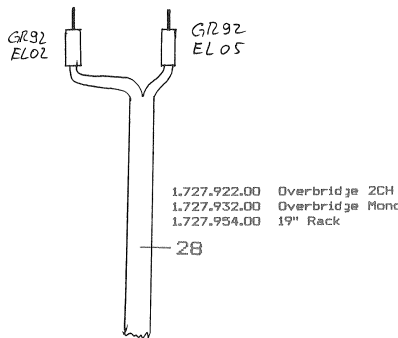
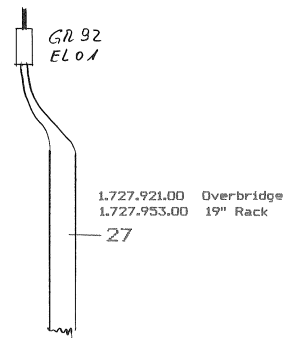
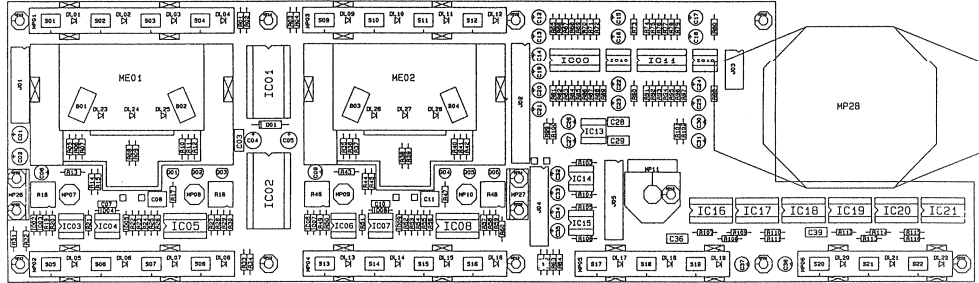

PANEL SECTION

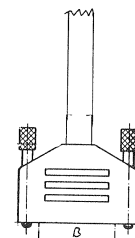

KEY A1

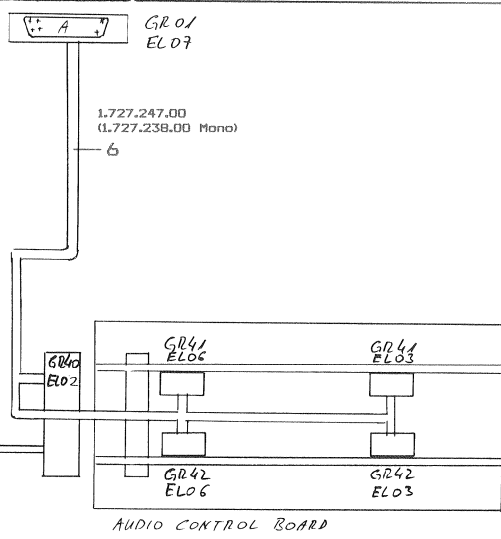
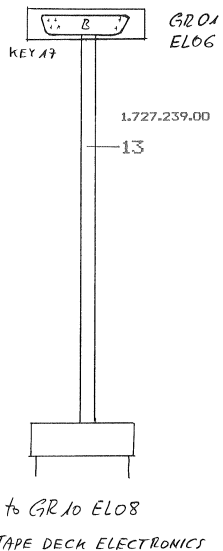

TAPE TRANSPORT SECTION

04.05.87 WAK
A 807, VERSION VUK				PAGE OF
STUDER		VERDRÄHTUNG, EXT. VU-PANEL		1.727.920.00

VERDRAHTUNG, EXT. VU-PANEL / WIRING DIAGRAM, EXT. VU-PANEL

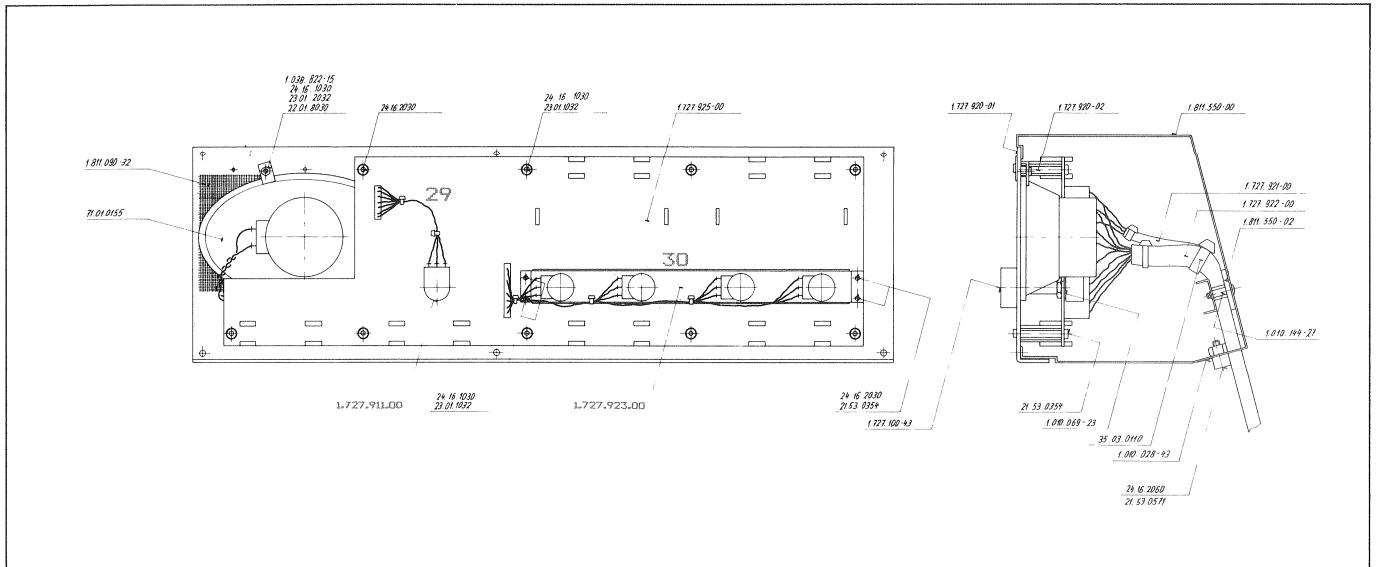

POS	QTY	ORDERNUMMER	BEZEICHNUNG	SPEZIFIKATION
27		1.727.921.00	Kabelbund VU-Meter Panel	Control
		1.727.953.00	Kabelbund 19" Rack VU-Meter Panel, Control	oder
28		1.727.922.00	Kabelbund VU-Meter Panel	Audio 2CH
		1.727.932.00	Kabelbund VU-Meter Panel	Audio Mono
		1.727.954.00	Kabelbund 19" Rack VU-Meter Panel	Audio
29		1.727.911.00	Kabelbund ext. Monitor	Pot. Meter
		1.727.911.01	Pot. Meter Monitor-	lautstärke
30		1.727.923.00	Kabelbund ext. Potmetergruppe	Pegel
		1.727.231.01	Pegel Pot. 5k Ω log	

POS	QTY	ORDER NUMBER	PART NAME	SPECIFICATION
27		1.727.921.00	Wire harness VU-Meter	panel control
		1.727.953.00	Wire harness 19"rack moun-	ting VU-Panel, control
28		1.727.922.00	Wire harness VU-Meter panel	Audio 2CH
		1.727.932.00	Wire harness VU-Meter panel	Audio mono
		1.727.954.00	Wire harness 19"rack VU-Meter	panel Audio
29		1.727.911.00	Wire harness ext. monitor	pot. meter
		1.727.911.01	Monitor volume control	pot. meter
30		1.727.923.00	Wire harness ext. Level	pot. meter unit
		1.727.231.01	Level pot. 5k Ω log	

8.16
 VERDRÄHTUNG EXT. STEREO MONITOR PANEL / CONSOLE EXT. STEREO MONITOR WIRING DIAGRAM

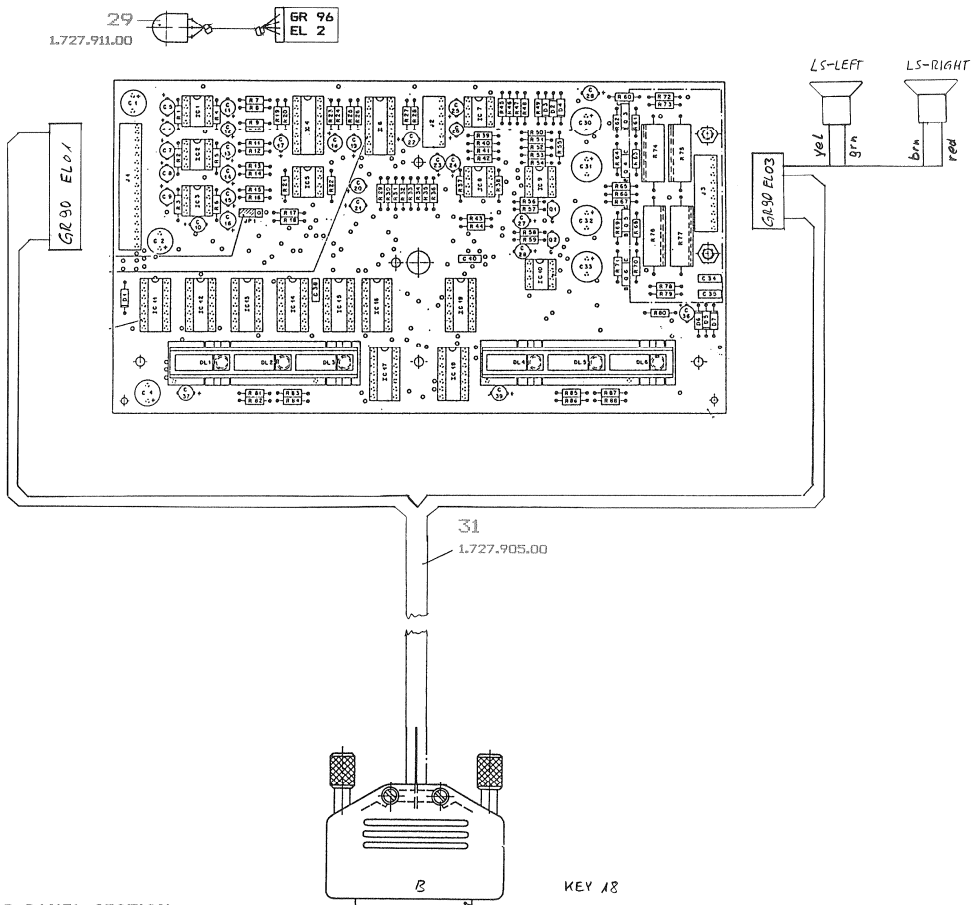

MONITOR PANEL SECTION

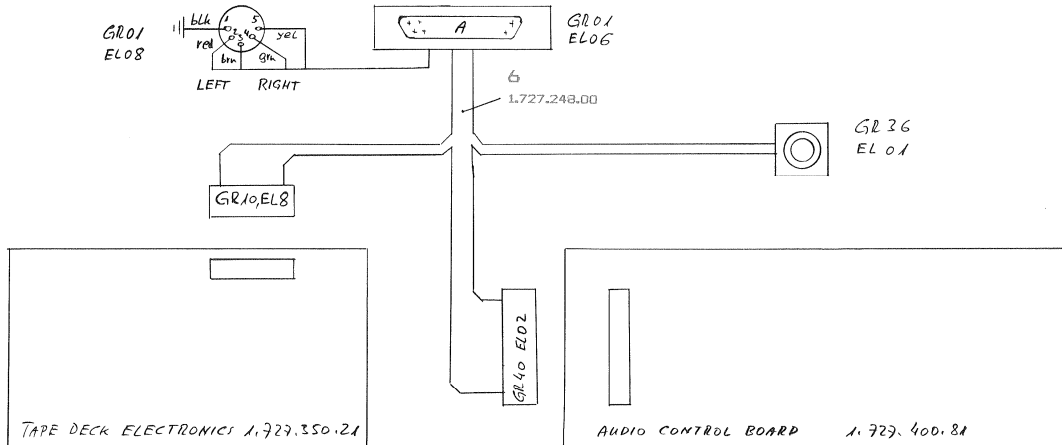

TAPE TRANSPORT SECTION

① 6.8.87	WJK	○ ..	○ ..	○ ..	○ ..
A807				PAGE 1 OF 2	
STUDER		WIRING DIAGRAM, MONITOR PANEL			1.727.091.00

VERDRAHTUNG EXT. STEREO MONITOR VU PANEL / CONSOLE EXT. STEREO MONITOR VU PANEL WIRING DIAGRAM

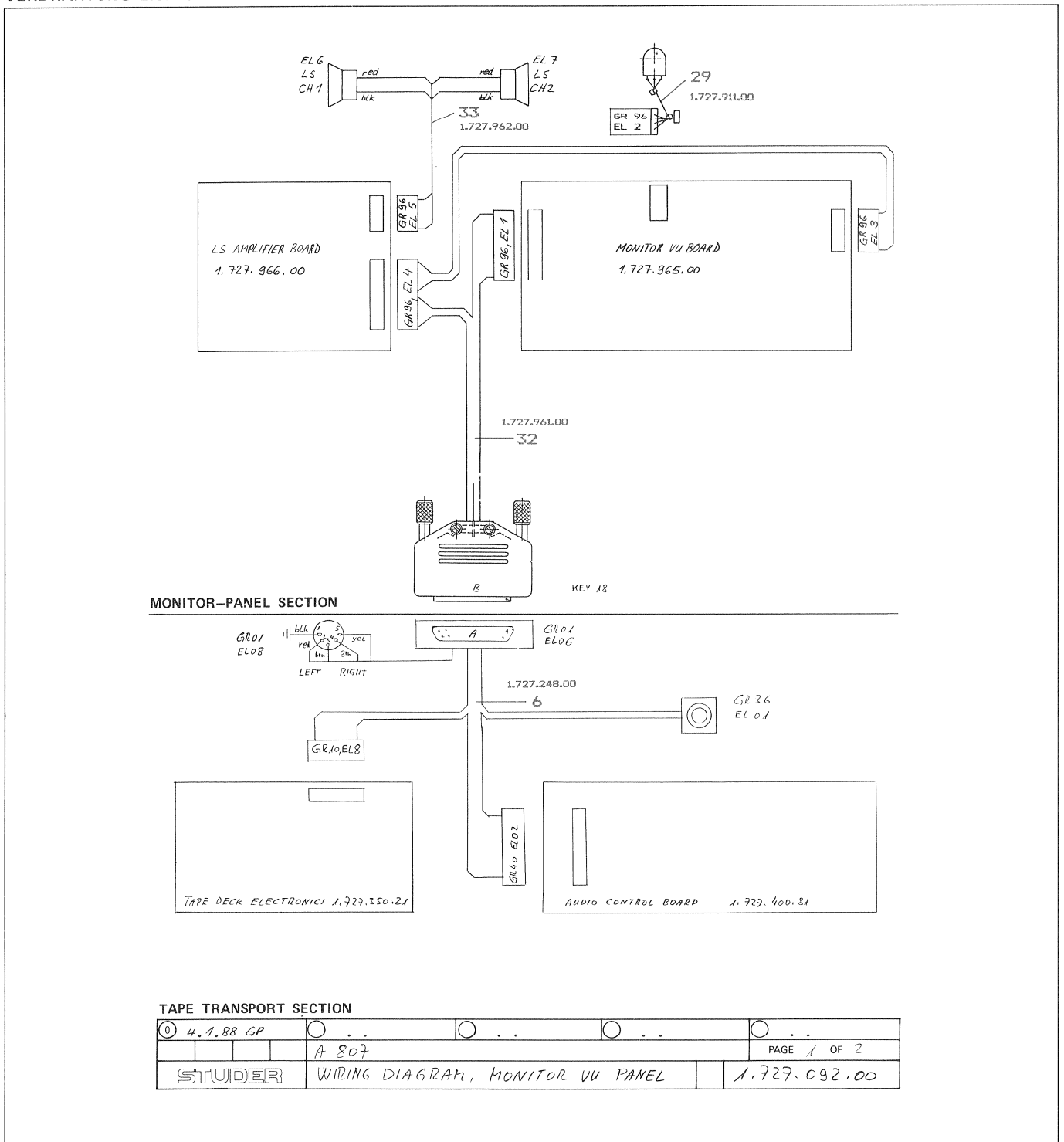

POS	QTY	ORDERNUMMER	BEZEICHUNG	SPEZIFIKATION
31		1.727.905.00	Kabelbund Stereo-Monitor Panel	
32		1.727.961.00	Kabelbund Stereo-Monitor Panel mit VU-Metern	
33		1.727.962.00	Kabelbund Lautsprecher Stereo-Monitor VU-Panel	

POS	QTY	ORDER NUMBER	PART NAME	SPECIFICATION
31		1.727.905.00	Wire harness Stereo-monitor panel	
32		1.727.961.00	Wire harness Stereo-monitor panel with VU-meters	
33		1.727.962.00	Wire harness Loudspeaker Stereo-monitor VU-panel	

8.17

A807 VARIANTEN / A807 VERSIONS

A 8 0 7 VERSIONS		Headblock	Capstan	Command	Audio	Audio
Number	Part Name	1.050.---.XX	Contr. 1.727.---.XX	Panel 1.727.---.XX	Contr. 1.727.---.XX	Electr.PCB 1.727.---.XX
60.116.07011	A807-1	.390	.330	.360	.400	.461
60.116.07012	A807-1 VU	.390	.330	.361	.400	.460
60.116.07013	A807-1 VUK	.390	.330	.360	.400	.462
60.116.07015	A807-1 VUK HS	.390	.335	.360	.401	.461
60.116.07016	A807-1 N.W.(PBO)	.381	.330	.360	.400	.465
60.116.07017	A807-1 VU N.W.(PBO)	.381	.330	.365	.400	.465
60.116.07021	A807-0.75	.394	.330	.360	.400	.461
60.116.07022	A807-0.75 VU	.392	.330	.362	.400	.460
60.116.07024	A807-0.75 VUK	.392	.330	.360	.400	.462
60.116.07025	A807-0.75 VUK HS	.392	.335	.360	.401	.467
60.116.07026	A807-0.75 N.W.(PBO)	.399	.330	.360	.400	.465
60.116.07027	A807-0.75 VU.N.W.(PBO)	.399	.330	.364	.400	.465
60.116.07030	A807-2 F	.395	.330	.360	.400	.461
60.116.07031	A807-2/2	.391	.330	.363	.400	.463
60.116.07032	A807-2/2 VU	.391	.330	.362	.400	.460
60.116.07033	A807-2	.397	.330	.360	.400	.461
60.116.07034	A807-2/2 VUK	.391	.330	.360	.400	.462
60.116.07036	A807-2/2 N.W.(PBO)	.398	.330	.360	.400	.465
60.116.07037	A807-2/2 VU.N.W.(PBO)	.398	.330	.364	.400	.465
60.116.07051	A807-2/4 VUK	.393	.330	.360	.400	.462
60.116.07052	A807-0.75/4 VUK	.396	.330	.360	.400	.462
60.116.07053	A807-2/4 VU	.393	.330	.362	.400	.460
60.116.07054	A807-0.75/4 VU	.396	.330	.362	.400	.460
60.116.07063	A807-0.75 VU/HS	.392	.335	.362	.401	.469
60.116.07064	A807-2/2 VU/HS	.391	.335	.362	.401	.469
60.116.07065	A807-2/2 VUK HS	.391	.335	.360	.401	.467
60.116.07066	A807-2/2 VUK NRS	.391	.330	.360	.402	.462

9 SPARE PARTS/DIAGRAMS ACCESSORIES

CONTENTS

TAPE DECK REMOTE CONTROL CABINET (PARALLEL)	1.328.250.00	9/1
-TAPE DECK REMOTE CONTROL PCB	1.328.251.00	9/3
LED PCB (2X).....	1.810.735.00.....	9/3
TAPE DECK REMOTE CONTROL MODULE (PARALLEL)	1.328.255.00	9/5
-PUSHBUTTON PCB	1.328.256.00	9/7
-CONNECTOR PCB.....	1.328.257.00.....	9/9
REMOTE TIMER	1.328.275.00	9/11
-CPU PCB	1.328.276.20	9/13
-DISPLAY BOARD.....	1.328.277.00.....	9/15
VARISPEED CONVERSION KIT (FOR PARALLEL REMOTE CONTROL ONLY)	1.328.253.00	9/17
VARISPEED CONTROL MODULE	1.328.290.00	9/19
-VARISPEED CONTROL PCB.....	1.810.762.82.....	9/20
VARISPEED CONTROL MODULE DE LUXE	1.328.280.00	9/21
-DISPLAY AND KEYBOARD PCB	1.328.281.00	9/23
-MAIN BOARD	1.328.282.20	9/25
-CONNECTORS BOARD.....	1.328.283.00.....	9/28

TAPE DECK REMOTE CONTROL CABINET (PARALLEL) 1.328.250

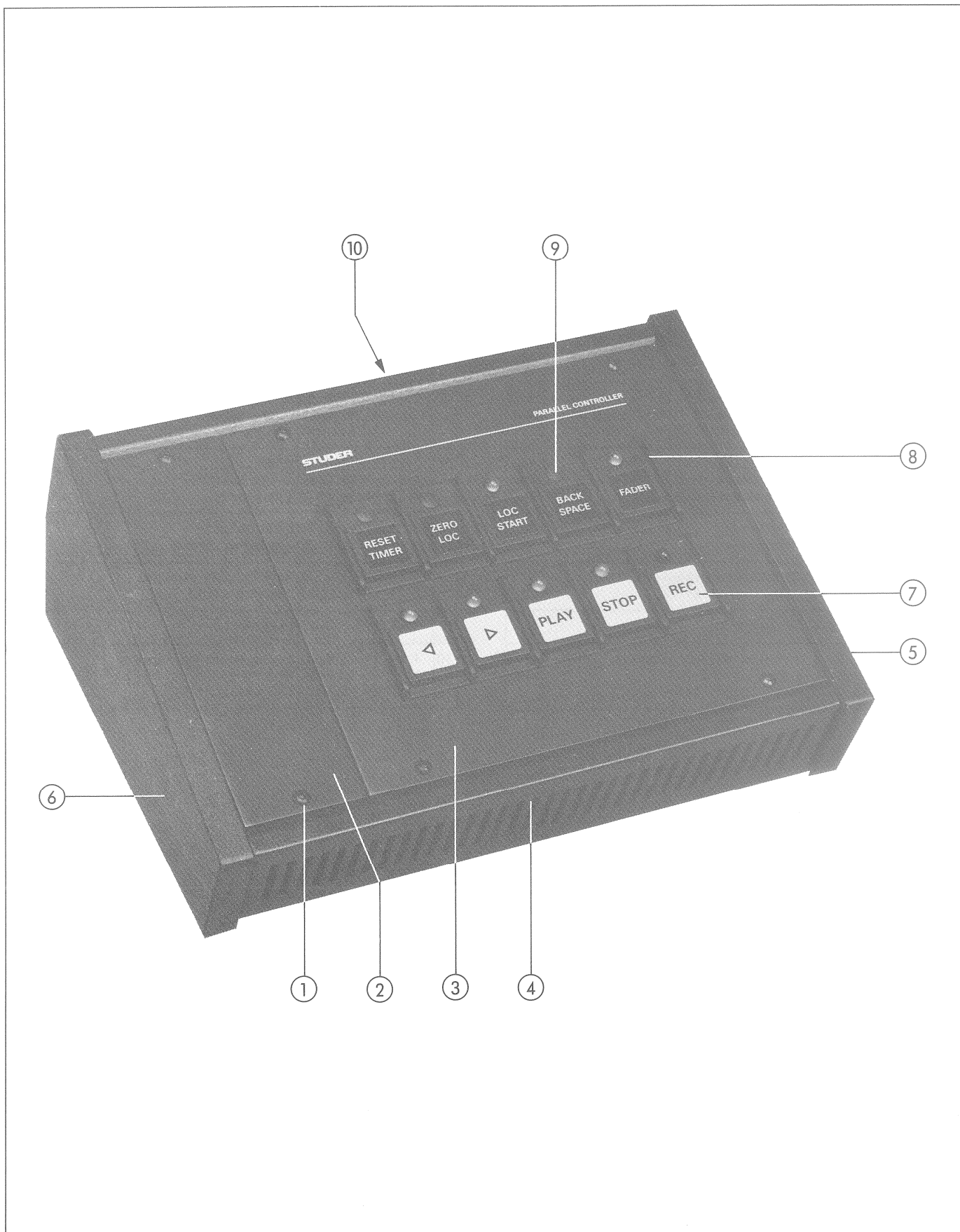

TAPE DECK REMOTE CONTROL CABINET (PARALLEL) 1.328.250

ANZ	BESTELLN.R.	BEZEICHNUNG	SPEZIFIKATION
1	1.328.250.00	Laufwerk-Fernsteuerung (parallel) (Klebeschilder: Paragraph 8.12)	
1	1.328.251.00	Laufwerk control Print	
4	1.328.250.08	Sechskantbolzen	
4	1.010.025.21	Linsenkopfschraube	M3x6
4	24.16.1030	Sicherungsscheibe	
4	23.01.1032	Unterlagsscheibe	
01	6	1.010.025.21	Linsenkopfschraube M3x6
02	1	1.328.250.05	Blindabdeckung
03	1	1.328.250.03	Frontblende
04	1	1.820.921.00	Gehäuse kompl. (mit Pos 5,6,10 und Füßen)
4	31.02.0211	Fuss	
05	1	1.328.250.02	Holzseitenwand rechts
4	21.53.0454	Z-Schraube IS	M4x6
4	24.16.1040	Unterlagsscheibe	
06	1	1.328.250.01	Holzseitenwand links
4	21.53.0454	Z-Schraube IS	M4x6
4	24.16.1040	Unterlagsscheibe	
07	10	1.011.210.01	Drucktaste
10	1.010.202.37	Druckfeder	
08	2	1.810.300.03	Drucktastengehäuse
2	1.810.300.06	Dämpfungstreifen	
09	3	1.810.300.21	Abdeckkappe
10	1	35.03.0120	Kabelbefestigungssockel
1	21.51.8454	LIN-Schraube IS	M4x6
1	24.16.1040	Sicherungsscheibe	

QTY	ORDER NUMBER	PART NAME	SPECIFICATION
1	1.328.250.00	Tape deck remote control cabinet (parallel) (self-adhesive Labels:Paragraph8.12)	
1	1.328.251.00	TAPE DECK REMOTE CONTROL PCB	
4	1.328.250.08	Hex stud bolt	
4	1.010.025.21	Round head allen screw	M3x6
4	24.16.1030	Fin washer	
4	23.01.1032	Washer	
01	6	1.010.025.21	Round head allen screw M3x6
02	1	1.328.250.05	Dummy plate
03	1	1.328.250.03	Front cover
04	1	1.820.921.00	Housing compl. (with pos.5, 6, 10 and feet)
4	31.02.0211	Foot	
05	1	1.328.250.02	Side panel right
4	21.53.0454	Allen screw	M4x6
4	24.16.1040	Fin washer	
06	1	1.328.250.01	Side panel left
4	21.53.0454	Allen screw	M4x6
4	24.16.1040	Fin washer	
07	10	1.011.210.01	Push button
10	1.010.202.37	Pressure spring	
08	2	1.810.300.03	Push button housing
2	1.810.300.06	Damping strip	
09	3	1.810.300.21	Plastic cover
10	1	35.03.0120	Cable mounting support
1	21.51.8454	Round head allen screw	M4x6
1	24.16.1040	Fin washer	

TAPE DECK REMOTE CONTROL CABINET (PARALLEL) 1.328.250.00
 - TAPE DECK REMOTE CONTROL PCB 1.328.251.00
 - LED PCB (2 x) 1.810.735.00

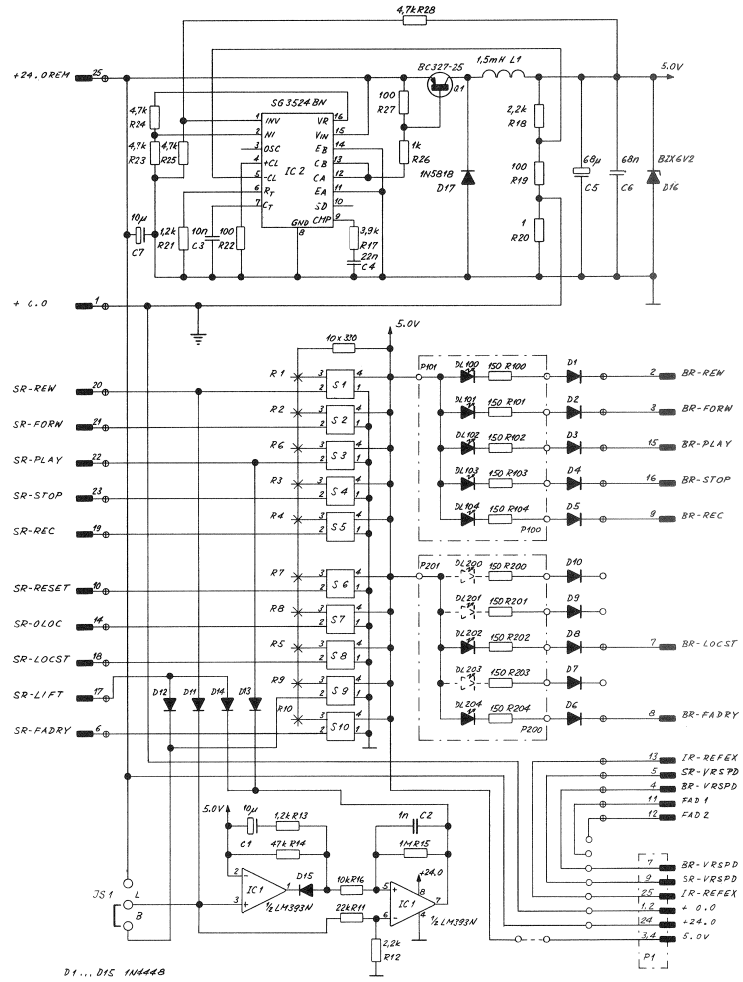

D1... D15 1H444B

1.3.85	PAGE 1 OF 1
STUDER	TAPE DECK REMOTE CONTROL SC 1.328.251-00

TAPE DECK REMOTE CONTROL MODULE (PARALLEL) 1.328.255

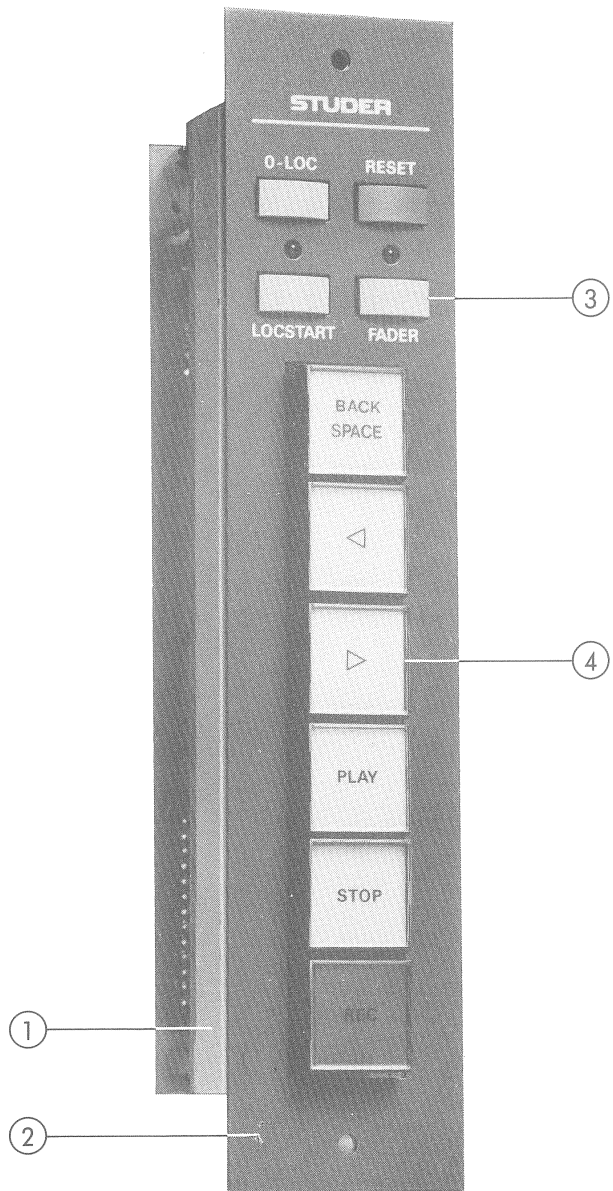

TAPE DECK REMOTE CONTROL MODULE (PARALLEL) 1.328.255

	ANZ	BESTELLNR.	BEZEICHNUNG	SPEZIFIKATION
	1	1.328.255.00	Parallele Laufwerksteuerung (Schilder: Paragraph 8.12)	
	1	1.328.256.00	Drucktasten Print	
	1	1.328.257.00	Connector Print	
	4	1.010.110.27	Sechskant-Gewinde-Bolzen	M3x6
	4	21.53.0354	Z-Schraube IS	
	4	24.16.1030	Sicherungsring	
	4	23.01.1032	Unterlagsscheibe	
01	1	1.328.255.01	Träger	
02	1	1.328.255.02	Frontplatte	
03	1	55.15.0122	Tasten	rot
	3	55.15.0128	Tasten	grau
04	1	55.15.0201	Tastenkopf-Abdeckung	konkav
	5	55.15.0202	Tastenkopf-Abdeckung	flach
	1	55.15.0212	Folie	rot
	5	55.15.0221	Folie	weiss
	6	55.15.0228	Tastenkopf-Rahmen	

	QTY	ORDER NUMBER	PART NAME	SPECIFICATION
	1	1.328.255.00	Tape deck remote control module (parallel) (Labels: Paragraph 8.12)	
	1	1.328.256.00	PUSH BUTTON PCB	
	1	1.328.257.00	CONNECTOR PCB	
	4	1.010.110.27	Hex stud bolt	M3x6
	4	21.53.0354	Allen screw	
	4	24.16.1030	Fin washer	
	4	23.01.1032	Washer	
01	1	1.328.255.01	Support	
02	1	1.328.255.02	Front plate	
03	1	55.15.0122	Push button knob	red
	3	55.15.0128	Push button knob	grey
04	1	55.15.0201	Push button cover	concave
	5	55.15.0202	Push button cover	flat
	1	55.15.0212	Diffusing screen	red
	5	55.15.0221	Diffusing screen	white
	6	55.15.0228	Push button frame	

TAPE DECK REMOTE CONTROL MODULE (PARALLEL) 1.328.255.00
 - PUSHBUTTON PCB 1.328.256.00

TO J 1 1.328.257-00

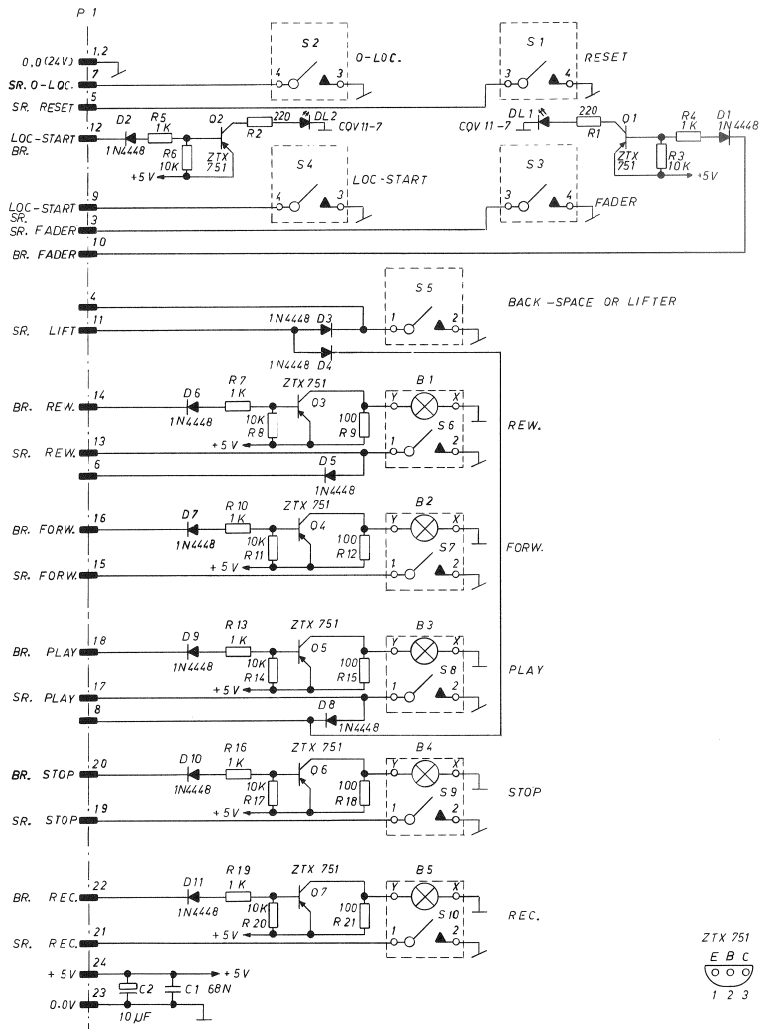

ZTX 751
 E B C
 (O O O) BOTTOM VIEW
 1 2 3

① 12,02,86 C. METZ	MODUL PARALLEL A727, A812, A820	PAGE 1 OF 1
STUDER	PUSHBUTTON BOARD	SC 1.328.256-00

TAPE DECK REMOTE CONTROL MODULE (PARALLEL) 1.328.255.00
 - PUSHBUTTON PCB 1.328.256.00

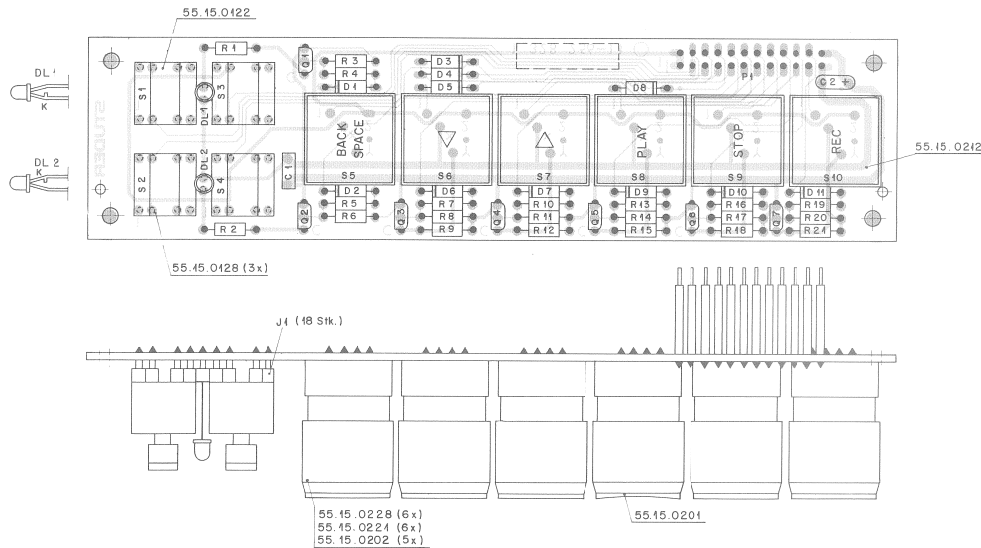

IND.	POS.ND.	PART NO.	VALUE	SPECIFICATIONS / EQUIVALENT	MANUF.
B****1		51-02-0155	5 V	0.060 A	
B****2		51-02-0155	5 V	0.060 A	
B****3		51-02-0155	5 V	0.060 A	
B****4		51-02-0155	5 V	0.060 A	
B****5		51-02-0155	5 V	0.060 A	
C****1		59-06-0683	+068 u	10%, 0.3V x PETP	
C****2		59-26-2110	10 u	20%, 10V x SAL	
D****1		50-04-0125	1 N 4448	75 V; 0.1 A; S1	
D****2		50-04-0125	1 N 4448	75 V; 0.1 A; S1	
D****3		50-04-0125	1 N 4448	75 V; 0.1 A; S1	
D****4		50-04-0125	1 N 4448	75 V; 0.1 A; S1	
D****5		50-04-0125	1 N 4448	75 V; 0.1 A; S1	
D****6		50-04-0125	1 N 4448	75 V; 0.1 A; S1	
D****7		50-04-0125	1 N 4448	75 V; 0.1 A; S1	
D****8		50-04-0125	1 N 4448	75 V; 0.1 A; S1	
D****9		50-04-0125	1 N 4448	75 V; 0.1 A; S1	
D****10		50-04-0125	1 N 4448	75 V; 0.1 A; S1	
D****11		50-04-0125	1 N 4448	75 V; 0.1 A; S1	
DL****1		50-04-2129	RED DIFF.	EQV 11-7	Sie
DL****2		50-04-2129	RED DIFF.	EQV 11-7	Sie
P****1		1-010-019-54	2 x 24 PIN	L = 20 MM	
Q****1		50-03-0352	ZTX 751 S	60 V; 2 A; PNP; SI	Fer
Q****2		50-03-0352	ZTX 751 S	60 V; 2 A; PNP; SI	Fer
Q****3		50-03-0352	ZTX 751 S	60 V; 2 A; PNP; SI	Fer
Q****4		50-03-0352	ZTX 751 S	60 V; 2 A; PNP; SI	Fer
Q****5		50-03-0352	ZTX 751 S	60 V; 2 A; PNP; SI	Fer
Q****6		50-03-0352	ZTX 751 S	60 V; 2 A; PNP; SI	Fer
Q****7		50-03-0352	ZTX 751 S	60 V; 2 A; PNP; SI	Fer
R****1		57-11-4221	220	2%, 0207 x MF	
R****2		57-11-4221	220	2%, 0207 x MF	
R****3		57-11-1003	10 k	2%, 0207 x MF	

STUDER (00) 86/02/13 CM PUSHBUTTON BOARD 1.328.256-00 PAGE 1

IND.	POS.ND.	PART NO.	VALUE	SPECIFICATIONS / EQUIVALENT	MANUF.
R****4		57-11-4102	140 k	2%, 0207 x MF	
R****5		57-11-4102	140 k	2%, 0207 x MF	
R****6		57-11-4103	10 k	2%, 0207 x MF	
R****7		57-11-4102	140 k	2%, 0207 x MF	
R****8		57-11-4103	10 k	2%, 0207 x MF	
R****9		57-11-4101	100	2%, 0207 x MF	
R****10		57-11-4102	140 k	2%, 0207 x MF	
R****11		57-11-4103	10 k	2%, 0207 x MF	
R****12		57-11-4101	100	2%, 0207 x MF	
R****13		57-11-4102	140 k	2%, 0207 x MF	
R****14		57-11-4103	10 k	2%, 0207 x MF	
R****15		57-11-4101	100	2%, 0207 x MF	
R****16		57-11-4102	140 k	2%, 0207 x MF	
R****17		57-11-4103	10 k	2%, 0207 x MF	
R****18		57-11-4101	100	2%, 0207 x MF	
R****19		57-11-4102	140 k	2%, 0207 x MF	
R****20		57-11-4103	10 k	2%, 0207 x MF	
R****21		57-11-4101	100	2%, 0207 x MF	
S****1		55-15-0112	MK II	MOMENTARY PUSHBUTTON SWITCH	MEK
S****2		55-15-0112	MK II	MOMENTARY PUSHBUTTON SWITCH	MEK
S****3		55-15-0112	MK II	MOMENTARY PUSHBUTTON SWITCH	MEK
S****4		55-15-0112	MK II	MOMENTARY PUSHBUTTON SWITCH	MEK
S****5		55-15-0231		MOMENTARY PUSHBUTTON SWITCH	EAD
S****6		55-15-0231		MOMENTARY PUSHBUTTON SWITCH	EAD
S****7		55-15-0231		MOMENTARY PUSHBUTTON SWITCH	EAD
S****8		55-15-0231		MOMENTARY PUSHBUTTON SWITCH	EAD
S****9		55-15-0231		MOMENTARY PUSHBUTTON SWITCH	EAD
S****10		55-15-0231		MOMENTARY PUSHBUTTON SWITCH	EAD

STUDER (00) 86/02/13 CM PUSHBUTTON BOARD 1.328.256-00 PAGE 2

IND.	POS.ND.	PART NO.	VALUE	SPECIFICATIONS / EQUIVALENT	MANUF.
------	---------	----------	-------	-----------------------------	--------

CEP=Ceramic, EL=Electrolytic, MP=Metallized Paper, MPC=Metallized Polycarbonate, MPEP=Metallized Polyester, PC=Polycarbonate, PET=Polyester, PPE=Polypropylene, PS=Polystyrol, SAL=Solid Aluminium, TA=Tantal, Ceram=Ceramic Metal, MF=Metol Film.

MANUFACTURERS :
 EAD = Elektro Apparaten Gfren
 Fe = Ferrarelle
 MEK = Mekonisk Elektrisk Compagni af 1975
 Sie = Siemens

08/02/13
 STUDER (00) 86/02/13 CM PUSHBUTTON BOARD 1.328.256-00 PAGE 3

TAPE DECK REMOTE CONTROL MODULE (PARALLEL) 1.328.255.00
 - CONNECTOR PCB 1.328.257.00

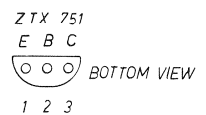
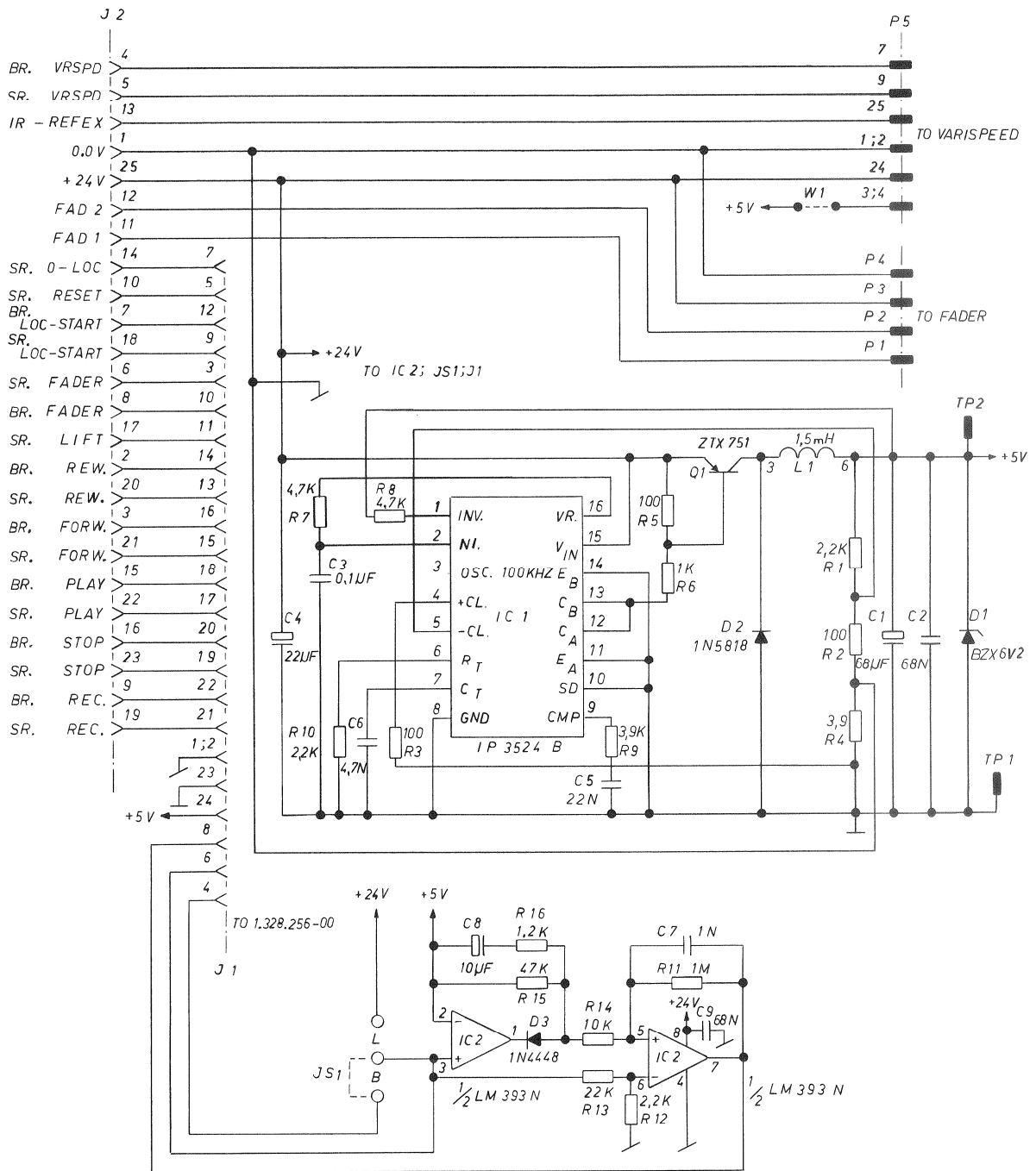

13,02,86 C. METZ	MODUL PARALLEL A727, A812, A820	PAGE 1 OF 1
STUDER	CONNECTORS BOARD	SC 1,328.257-00

TAPE DECK REMOTE CONTROL MODULE (PARALLEL) 1.328.255.00
 - CONNECTOR PCB 1.328.257.00

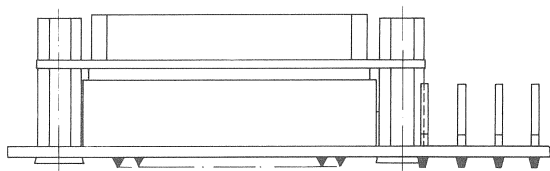
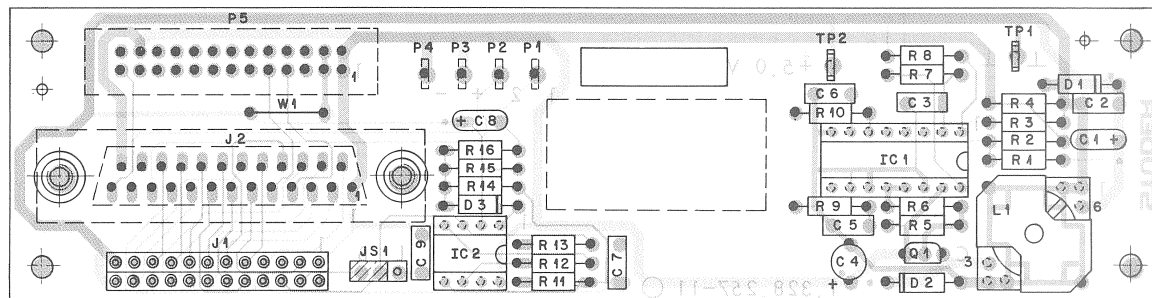

IND.	POS-NO.	PART NO.	VALUE	SPECIFICATIONS / EQUIVALENT	MANUF.
C.....1	59.26.0680	68 u	20%	6.3V * SAL	
C.....2	59.06.0683	+068 u	10%	6.3V * PETP	
C.....3	59.06.0106	.1 u	10%	6.3V * PETP	
C.....4	59.22.6220	22 u	-20%	35V * EL	
C.....5	59.06.0223	-022 u	10%	6.3V * PETP	
C.....6	59.06.0472	4700 p	10%	6.3V * PETP	
C.....7	59.06.0102	1000 p	10%	6.3V * PETP	
C.....8	59.26.2100	10 u	20%	16V * SAL	
C.....9	59.06.0683	+068 u	10%	6.3V * PETP	
D.....1	50.04.1118	BZX 6W2	5%	6.2 V; 0.40 A; Z;	
D.....2	50.04.0912	1 N 5818		SCHOTTKY	Mot.
D.....3	50.04.0125	1 N 4448		75 V; 100 mA; SI	
IC.....1	50.05.0279	IP 3524 B		REGULATING PULSE WIDTH MODULATOR	IPS.
IC.....2	50.05.0283	LM 393 N		DUAL LOW POWER COMPARATOR	TI.
J.....1	53.03.0212	2 12 PIN			
J.....2	54.13.0023			D-TYPE, 25 PIN PRINT FEMALE CONNECTOR	
JS.....1	54.01.0021	2 0.63		JUMPER	
L.....1	1.022.197.00	1.5 mH		CHOKE	St.
P.....1	54.02.0320	2.8 0.8		SOLDERING PIN	
P.....2	54.02.0320	2.8 0.8		SOLDERING PIN	
P.....3	54.02.0320	2.8 0.8		SOLDERING PIN	
P.....4	54.02.0320	2.8 0.8		SOLDERING PIN	
P.....5	54.14.2003			26 PIN PRINT MALE CONNECTOR	
Q.....1	50.03.0352	ZTX 751 S		60 V; 2 A; PNP SI	Fe.
R.....1	57.11.4222	2.2 k		2%, 0207 * MF	
R.....2	57.11.4101	100		2%, 0207 * MF	
R.....3	57.11.4101	100		2%, 0207 * MF	
R.....4	57.11.4399	3.9		2%, 0207 * MF	
R.....5	57.11.4101	100		2%, 0207 * MF	

IND.	POS-NO.	PART NO.	VALUE	SPECIFICATIONS / EQUIVALENT	MANUF.
R.....6	57.11.4102	1.0 k		2%, 0207 * MF	
R.....7	57.11.4472	4.7 k		2%, 0207 * MF	
R.....8	57.11.4472	4.7 k		2%, 0207 * MF	
R.....9	57.11.4392	3.9 k		2%, 0207 * MF	
R.....10	57.11.4222	2.2 k		2%, 0207 * MF	
R.....11	57.11.4105	1 M		2%, 0207 * MF	
R.....12	57.11.4222	2.2 k		2%, 0207 * MF	
R.....13	57.11.4223	22 k		2%, 0207 * MF	
R.....14	57.11.4103	10 k		2%, 0207 * MF	
R.....15	57.11.4473	47 k		2%, 0207 * MF	
R.....16	57.11.4122	1.2 k		2%, 0207 * MF	
TP.....1	54.02.0320	2.8 0.8		SOLDERING PIN	
TP.....2	54.02.0320	2.8 0.8		SOLDERING PIN	

CER=Ceramic; EL=Electrolytic; MP=Metallized Paper; MPC=Metallized Poly-carbonate; MPETP=Metallized Polyester; PC=Polycarbonate; PETP=Polyester
 PP=Polypropylene; PS=Polystyrol; SAL=Solid Aluminium; TA=Tantal
 Cermet=Ceramic Metal; MF=Metal Film.

MANUFACTURERS :
 Fe = Ferranti
 IPS = Integrated Power Semiconductors Limited
 Mot = Motorola
 St = Studer
 TI = Texas Instruments

ORIG 86/02/14

REMOTE TIMER (SERIAL) 1.328.275



REMOTE TIMER (SERIAL) 1.328.275

	BESTELLN.R.	BEZEICHNUNG	SPEZIFIKATION
1	1.010.045.21 21.51.2354	Schraube schwarz Schraube Ni	M3x6 M3x6
2	31.02.0211	Fuss schwarz	D16x6,5
3	1.328.275.01	Frontplatte	
4	1.810.253.00	Display-Gehäuse komplett	
5	1.810.303.01	Display-Gehäuse	
6	1.810.303.02	Filterglas	
7	1.011.210.14 1.011.210.01	Schild RESET TIMER Taste	
8	1.011.210.15 1.011.210.01	Schild ZERO LOC Taste	

	ORDER NUMBER	PART NAME	SPECIFICATION
1	1.010.045.21 21.51.2354	Screw black Screw Ni	M3x6 M3x5
2	31.02.0211	Foot black	D16x6,5
3	1.328.275.01	Front cover	
4	1.810.253.00	Display cover compl.	
5	1.810.303.01	Display cover	
6	1.810.303.02	Display window	
7	1.011.210.14 1.011.210.01	Label ZERO TIMER Push button	
8	1.011.210.15 1.011.210.01	Label ZERO LOC Push button	

ZUBEHÖR

ACCESSORIES

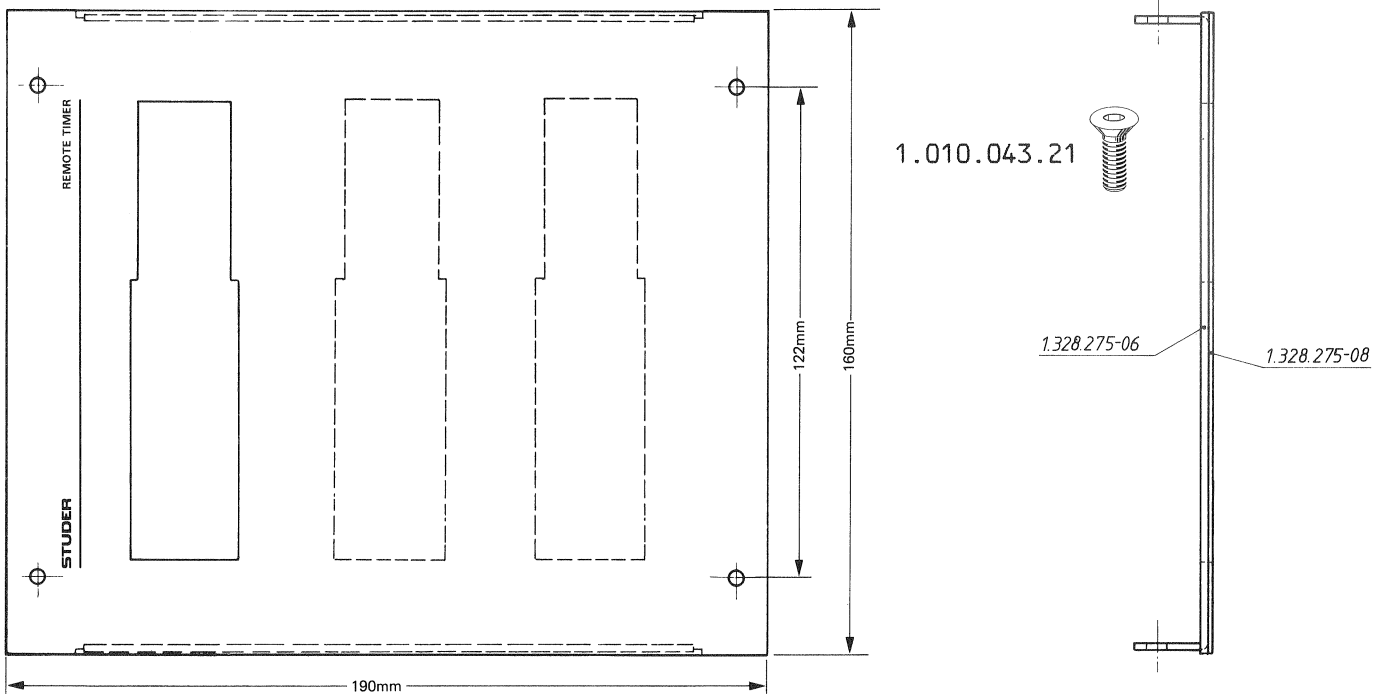

	BESTELLN.R.	BEZEICHNUNG
9	1.328.275.31	Befestigungsblende für 1 Zähler
10	1.328.275.32	Befestigungsblende für 2 Zähler
11	1.328.275.33	Befestigungsblende für 3 Zähler

	ORDER NUMBER	PART NAME	SPECIFICATION
9	1.328.275.31	Mounting frame for 1 counter	
10	1.328.275.32	Mounting frame for 2 counter	
11	1.328.275.33	Mounting frame for 3 counter	

CPU BOARD 1.328.276.00

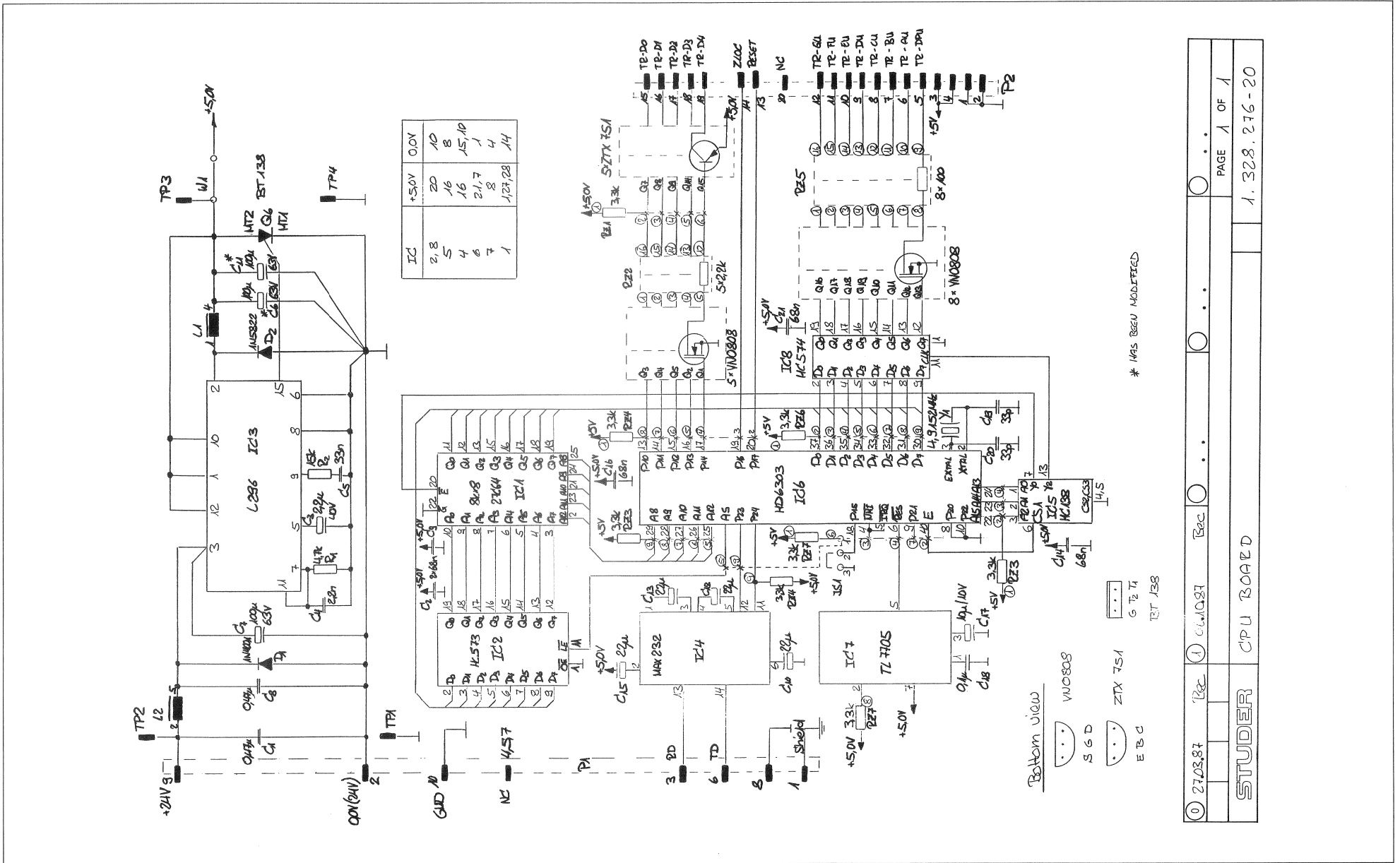

CPU BOARD 1.328.276.00

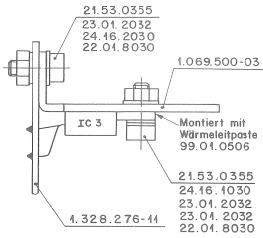
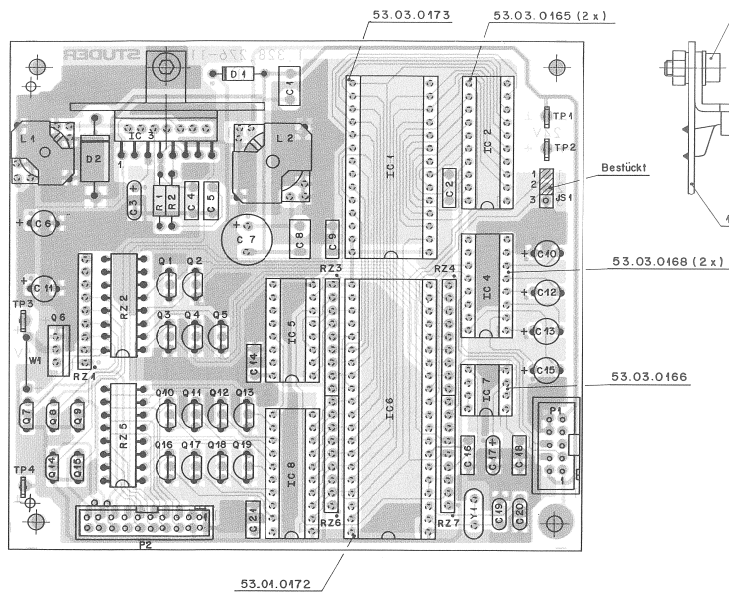

IND.	POS.-NO.	PART NO.	VALUE	SPECIFICATIONS / EQUIVALENT	MANUF.
C.....1	59-06-0679	+47 u	10K	63V + PETP	
C.....2	59-06-0683	+068 u	10K	63V + PETP	
C.....3	59-26-5229	2.2 u	20V	25V + SAL	
C.....4	59-06-0222	2200 u	10K	63V + PETP	
C.....5	59-06-0333	+033 u	10K	63V + PETP	
C.....6	59-22-3181	100 u	-20%	10V + EL	
C.....7	59-22-1101	100 u	-20%	10V + EL	
C.....8	59-06-0679	+47 u	10K	63V + PETP	
C.....9	59-06-0683	+068 u	10K	63V + PETP	
C.....10	59-22-0207	22 u	-20%	40V + EL	
C.....11	59-22-1101	100 u	-20%	10V + EL	
C.....12	59-22-0207	22 u	-20%	40V + EL	
C.....13	59-22-0207	22 u	-20%	40V + EL	
C.....14	59-06-0683	+068 u	10K	63V + PETP	
C.....15	59-22-0207	22 u	-20%	40V + EL	
C.....16	59-26-0603	+068 u	10K	63V + PETP	
C.....17	59-16-0100	10 u	20%	10V + SAL	
C.....18	59-26-0104	+1 u	10K	63V + PETP	
C.....19	59-16-2305	33 p	5%	N150 + CER	
C.....20	59-14-2330	33 p	5%	N150 + CER	
C.....21	59-26-0683	+068 u	10K	63V + PETP	
D.....1	50-34-0122	1N 4001	50 V 1 A 5i		
D.....2	50-04-0519	1N 5822	40 V 3 A Schottky		
IC.....1	1-328-982-27			54 50287 HCMTE Timer	St
IC.....2	52-17-1573	74 HC 573		3-State Octal D-Type Latch	St
IC.....3	50-10-0110	L 296		Switching Voltage Regulator	St
IC.....4	50-13-0120	MAX 232LPE		RS 232 Transceiver/Receiver	MAX
IC.....5	50-17-1138	74 HC 138		1-of-8 Decoder/Demultiplexer	St
IC.....6	50-16-0119	HD 63050BP		Microcomputer Unit CMOS 8 Bit, J Mhz	HD
IC.....7	50-11-0122	TL 77054CP		Waveform Generator	TL
IC.....8	50-17-0376	74 HC 574		3-State Non Inverting Octal D-Type Flip-Flop	St
JS.....1	54-31-0021	2 * 0x3		Jumper (bridging 2 of 3 pins 54-01-0020)	
L.....1	1-022-191-00			Inductor	St
S T U D E R (01) 87/10/06 CM CPU BOARD PL 1.328-276-20 PAGE 1					

IND.	POS.-NO.	PART NO.	VALUE	SPECIFICATIONS / EQUIVALENT	MANUF.
L.....2	1-022-252-00	0-32 uH		Filter Coil 0x4	St
P.....1	54-14-0001	2 * 9 Pin		Straight Print Male Connector	
P.....2	54-14-0008	2 * 10 Pin		Straight Print Male Connector	
VN.....1	50-03-1505	VN 0808 H	80 V 0.35 A	FEET 4-Channel	Six
VN.....2	50-03-1505	VN 0808 H	80 V 0.35 A	FEET 4-Channel	Six
VN.....3	50-03-1505	VN 0808 H	80 V 0.35 A	FEET 4-Channel	Six
VN.....4	50-03-1505	VN 0808 H	80 V 0.35 A	FEET 4-Channel	Six
VN.....5	50-03-1505	VN 0808 H	80 V 0.35 A	FEET 4-Channel	Six
VN.....6	50-03-1505	VN 0808 H	80 V 0.35 A	FEET 4-Channel	Six
ZTX.....1	50-03-0352	ZTX 751 S	60 V 2 A PNP Si		PH
ZTX.....2	50-03-0352	ZTX 751 S	60 V 2 A PNP Si		PH
ZTX.....3	50-03-0352	ZTX 751 S	60 V 2 A PNP Si		PH
ZTX.....4	50-03-0352	ZTX 751 S	60 V 2 A PNP Si		PH
ZTX.....5	50-03-0352	ZTX 751 S	60 V 2 A PNP Si		PH
ZTX.....6	50-03-0352	ZTX 751 S	60 V 2 A PNP Si		PH
ZTX.....7	50-03-0352	ZTX 751 S	60 V 2 A PNP Si		PH
ZTX.....8	50-03-0352	ZTX 751 S	60 V 2 A PNP Si		PH
ZTX.....9	50-03-0352	ZTX 751 S	60 V 2 A PNP Si		PH
ZTX.....10	50-03-0352	ZTX 751 S	60 V 2 A PNP Si		PH
ZTX.....11	50-03-1505	VN 0808 H	80 V 0.35 A	FEET 4-Channel	Fe
ZTX.....12	50-03-1505	VN 0808 H	80 V 0.35 A	FEET 4-Channel	Fe
ZTX.....13	50-03-1505	VN 0808 H	80 V 0.35 A	FEET 4-Channel	Fe
ZTX.....14	50-03-1505	VN 0808 H	80 V 0.35 A	FEET 4-Channel	Fe
ZTX.....15	50-03-1505	VN 0808 H	80 V 0.35 A	FEET 4-Channel	Fe
ZTX.....16	50-03-1505	VN 0808 H	80 V 0.35 A	FEET 4-Channel	Fe
ZTX.....17	50-03-1505	VN 0808 H	80 V 0.35 A	FEET 4-Channel	Fe
ZTX.....18	50-03-1505	VN 0808 H	80 V 0.35 A	FEET 4-Channel	Fe
ZTX.....19	50-03-1505	VN 0808 H	80 V 0.35 A	FEET 4-Channel	Six
ZTX.....20	50-03-1505	VN 0808 H	80 V 0.35 A	FEET 4-Channel	Six
ZTX.....21	57-11-4472	4.7 k	2%	0207 + 4F	
ZTX.....22	57-11-4133	15 k	2%	0207 + 4F	
ZTX.....23	57-08-4332	8 * 3.3 k	2%	SIP 9	
ZTX.....24	57-08-3222	8 * 2.2 k	2%	DIL 16	
ZTX.....25	57-08-4332	8 * 3.3 k	2%	SIP 9	
ZTX.....26	57-08-4332	8 * 3.3 k	2%	SIP 9	
ZTX.....27	57-08-4332	8 * 3.3 k	2%	DIL 16	
ZTX.....28	57-08-4332	8 * 3.3 k	2%	SIP 9	
ZTX.....29	57-08-4332	8 * 3.3 k	2%	SIP 9	
ZTX.....30	57-08-4332	8 * 3.3 k	2%	SIP 9	
ZTX.....31	57-08-4332	8 * 3.3 k	2%	SIP 9	
ZTX.....32	57-08-4332	8 * 3.3 k	2%	SIP 9	
ZTX.....33	57-08-4332	8 * 3.3 k	2%	SIP 9	
ZTX.....34	57-08-4332	8 * 3.3 k	2%	SIP 9	
ZTX.....35	57-08-4332	8 * 3.3 k	2%	SIP 9	
ZTX.....36	57-08-4332	8 * 3.3 k	2%	SIP 9	
ZTX.....37	57-08-4332	8 * 3.3 k	2%	SIP 9	
ZTX.....38	57-08-4332	8 * 3.3 k	2%	SIP 9	
ZTX.....39	57-08-4332	8 * 3.3 k	2%	SIP 9	
ZTX.....40	57-08-4332	8 * 3.3 k	2%	SIP 9	
ZTX.....41	57-08-4332	8 * 3.3 k	2%	SIP 9	
ZTX.....42	57-08-4332	8 * 3.3 k	2%	SIP 9	
ZTX.....43	57-08-4332	8 * 3.3 k	2%	SIP 9	
ZTX.....44	57-08-4332	8 * 3.3 k	2%	SIP 9	
ZTX.....45	57-08-4332	8 * 3.3 k	2%	SIP 9	
ZTX.....46	57-08-4332	8 * 3.3 k	2%	SIP 9	
ZTX.....47	57-08-4332	8 * 3.3 k	2%	SIP 9	
ZTX.....48	57-08-4332	8 * 3.3 k	2%	SIP 9	
ZTX.....49	57-08-4332	8 * 3.3 k	2%	SIP 9	
ZTX.....50	57-08-4332	8 * 3.3 k	2%	SIP 9	
ZTX.....51	57-08-4332	8 * 3.3 k	2%	SIP 9	
ZTX.....52	57-08-4332	8 * 3.3 k	2%	SIP 9	
ZTX.....53	57-08-4332	8 * 3.3 k	2%	SIP 9	
ZTX.....54	57-08-4332	8 * 3.3 k	2%	SIP 9	
ZTX.....55	57-08-4332	8 * 3.3 k	2%	SIP 9	
ZTX.....56	57-08-4332	8 * 3.3 k	2%	SIP 9	
ZTX.....57	57-08-4332	8 * 3.3 k	2%	SIP 9	
ZTX.....58	57-08-4332	8 * 3.3 k	2%	SIP 9	
ZTX.....59	57-08-4332	8 * 3.3 k	2%	SIP 9	
ZTX.....60	57-08-4332	8 * 3.3 k	2%	SIP 9	
ZTX.....61	57-08-4332	8 * 3.3 k	2%	SIP 9	
ZTX.....62	57-08-4332	8 * 3.3 k	2%	SIP 9	
ZTX.....63	57-08-4332	8 * 3.3 k	2%	SIP 9	
ZTX.....64	57-08-4332	8 * 3.3 k	2%	SIP 9	
ZTX.....65	57-08-4332	8 * 3.3 k	2%	SIP 9	
ZTX.....66	57-08-4332	8 * 3.3 k	2%	SIP 9	
ZTX.....67	57-08-4332	8 * 3.3 k	2%	SIP 9	
ZTX.....68	57-08-4332	8 * 3.3 k	2%	SIP 9	
ZTX.....69	57-08-4332	8 * 3.3 k	2%	SIP 9	
ZTX.....70	57-08-4332	8 * 3.3 k	2%	SIP 9	
ZTX.....71	57-08-4332	8 * 3.3 k	2%	SIP 9	
ZTX.....72	57-08-4332	8 * 3.3 k	2%	SIP 9	
ZTX.....73	57-08-4332	8 * 3.3 k	2%	SIP 9	
ZTX.....74	57-08-4332	8 * 3.3 k	2%	SIP 9	
ZTX.....75	57-08-4332	8 * 3.3 k	2%	SIP 9	
ZTX.....76	57-08-4332	8 * 3.3 k	2%	SIP 9	
ZTX.....77	57-08-4332	8 * 3.3 k	2%	SIP 9	
ZTX.....78	57-08-4332	8 * 3.3 k	2%	SIP 9	
ZTX.....79	57-08-4332	8 * 3.3 k	2%	SIP 9	
ZTX.....80	57-08-4332	8 * 3.3 k	2%	SIP 9	
ZTX.....81	57-08-4332	8 * 3.3 k	2%	SIP 9	
ZTX.....82	57-08-4332	8 * 3.3 k	2%	SIP 9	
ZTX.....83	57-08-4332	8 * 3.3 k	2%	SIP 9	
ZTX.....84	57-08-4332	8 * 3.3 k	2%	SIP 9	
ZTX.....85	57-08-4332	8 * 3.3 k	2%	SIP 9	
ZTX.....86	57-08-4332	8 * 3.3 k	2%	SIP 9	
ZTX.....87	57-08-4332	8 * 3.3 k	2%	SIP 9	
ZTX.....88	57-08-4332	8 * 3.3 k	2%	SIP 9	
ZTX.....89	57-08-4332	8 * 3.3 k	2%	SIP 9	
ZTX.....90	57-08-4332	8 * 3.3 k	2%	SIP 9	
ZTX.....91	57-08-4332	8 * 3.3 k	2%	SIP 9	
ZTX.....92	57-08-4332	8 * 3.3 k	2%	SIP 9	
ZTX.....93	57-08-4332	8 * 3.3 k	2%	SIP 9	
ZTX.....94	57-08-4332	8 * 3.3 k	2%	SIP 9	
ZTX.....95	57-08-4332	8 * 3.3 k	2%	SIP 9	
ZTX.....96	57-08-4332	8 * 3.3 k	2%	SIP 9	
ZTX.....97	57-08-4332	8 * 3.3 k	2%	SIP 9	
ZTX.....98	57-08-4332	8 * 3.3 k	2%	SIP 9	
ZTX.....99	57-08-4332	8 * 3.3 k	2%	SIP 9	
ZTX.....100	57-08-4332	8 * 3.3 k	2%	SIP 9	
ZTX.....101	57-08-4332	8 * 3.3 k	2%	SIP 9	
ZTX.....102	57-08-4332	8 * 3.3 k	2%	SIP 9	
ZTX.....103	57-08-4332	8 * 3.3 k	2%	SIP 9	
ZTX.....104	57-08-4332	8 * 3.3 k	2%	SIP 9	
ZTX.....105	57-08-4332	8 * 3.3 k	2%	SIP 9	
ZTX.....106	57-08-4332	8 * 3.3 k	2%	SIP 9	
ZTX.....107	57-08-4332	8 * 3.3 k	2%	SIP 9	
ZTX.....108	57-08-4332	8 * 3.3 k	2%	SIP 9	
ZTX.....109	57-08-4332	8 * 3.3 k	2%	SIP 9	
ZTX.....110	57-08-4332	8 * 3.3 k	2%	SIP 9	
ZTX.....111	57-08-4332	8 * 3.3 k	2%	SIP 9	
ZTX.....112	57-08-4332	8 * 3.3 k	2%	SIP 9	
ZTX.....113	57-08-4332	8 * 3.3 k	2%	SIP 9	
ZTX.....114	57-08-4332	8 * 3.3 k	2%	SIP 9	
ZTX.....115	57-08-4332	8 * 3.3 k	2%	SIP 9	
ZTX.....116	57-08-4332	8 * 3.3 k	2%	SIP 9	
ZTX.....117	57-08-4332	8 * 3.3 k	2%	SIP 9	
ZTX.....118	57-08-4332	8 * 3.3 k	2%	SIP 9	
ZTX.....119	57-08-4332	8 * 3.3 k	2%	SIP 9	
ZTX.....120	57-08-4332	8 * 3.3 k	2%	SIP 9	
ZTX.....121	57-08-4332	8 * 3.3 k	2%	SIP 9	
ZTX.....122	57-08-4332	8 * 3.3 k	2%	SIP 9	
ZTX.....123	57-08-4332	8 * 3.3 k	2%	SIP 9	
ZTX.....124	57-08-4332	8 * 3.3 k	2%	SIP 9	
ZTX.....125	57-08-4332	8 * 3.3 k	2%	SIP 9	
ZTX.....126	57-08-4332	8 * 3.3 k	2%	SIP 9	
ZTX.....127	57-08-4332	8 * 3.3 k	2%	SIP 9	
ZTX.....128	57-08-4332	8 * 3.3 k	2%	SIP 9	
ZTX.....129	57-08-4332	8 * 3.3 k	2%	SIP 9	
ZTX.....130	57-08-4332	8 * 3.3 k	2%	SIP 9	
ZTX.....131	57-08-4332	8 * 3.3 k	2%	SIP 9	
ZTX.....132	57-08-4332	8 * 3.3 k	2%	SIP 9	
ZTX.....133	57-08-4332	8 * 3.3 k	2%	SIP 9	
ZTX.....134	57-08-4332	8 * 3.3 k	2%	SIP 9	
ZTX.....135	57-08-4332	8 * 3.3 k	2%	SIP 9	
ZTX.....136	57-08-4332	8 * 3.3 k	2%	SIP 9	
ZTX.....137	57-08-4332	8 * 3.3 k	2%	SIP 9	
ZTX.....138	57-08-4332	8 * 3.3 k	2%	SIP 9	
ZTX.....139	57-08-4332	8 * 3.3 k	2%	SIP 9	
ZTX.....140	57-08-4332	8 * 3.3 k	2%	SIP 9	
ZTX.....141	57-08-4332	8 * 3.3 k	2%	SIP 9	
ZTX.....142	57-08-4332	8 * 3.3 k	2%	SIP 9	
ZTX.....143	57-08-4332	8 * 3.3 k	2%	SIP 9	
ZTX.....144	57-08-4332	8 * 3.3 k	2%	SIP 9	
ZTX.....145	57-08-4332	8 * 3.3 k	2%	SIP 9	
ZTX.....146	57-08-4332	8 * 3.3 k	2%	SIP 9	
ZTX.....147	57-08-4332	8 * 3.3 k	2%	SIP 9	
ZTX.....148	57-08-4332	8 * 3.3 k	2%	SIP 9	
ZTX.....149					

DISPLAY BOARD 1.328.277.00

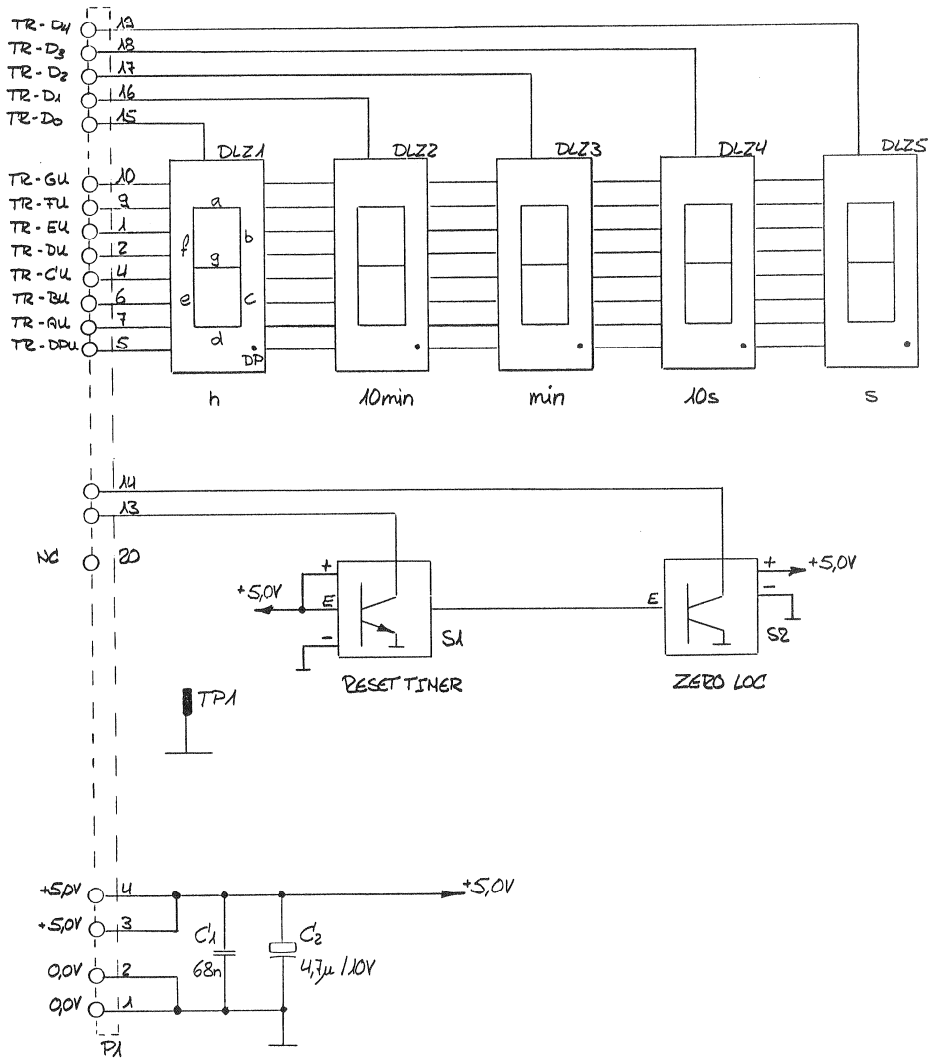

① 10.04.87	Bec	○ ..	○ ..	○ ..	○ ..
					PAGE 1 OF 1
STUDER		DISPLAY BOARD			1.328.277-00

DISPLAY BOARD 1.328.277.00

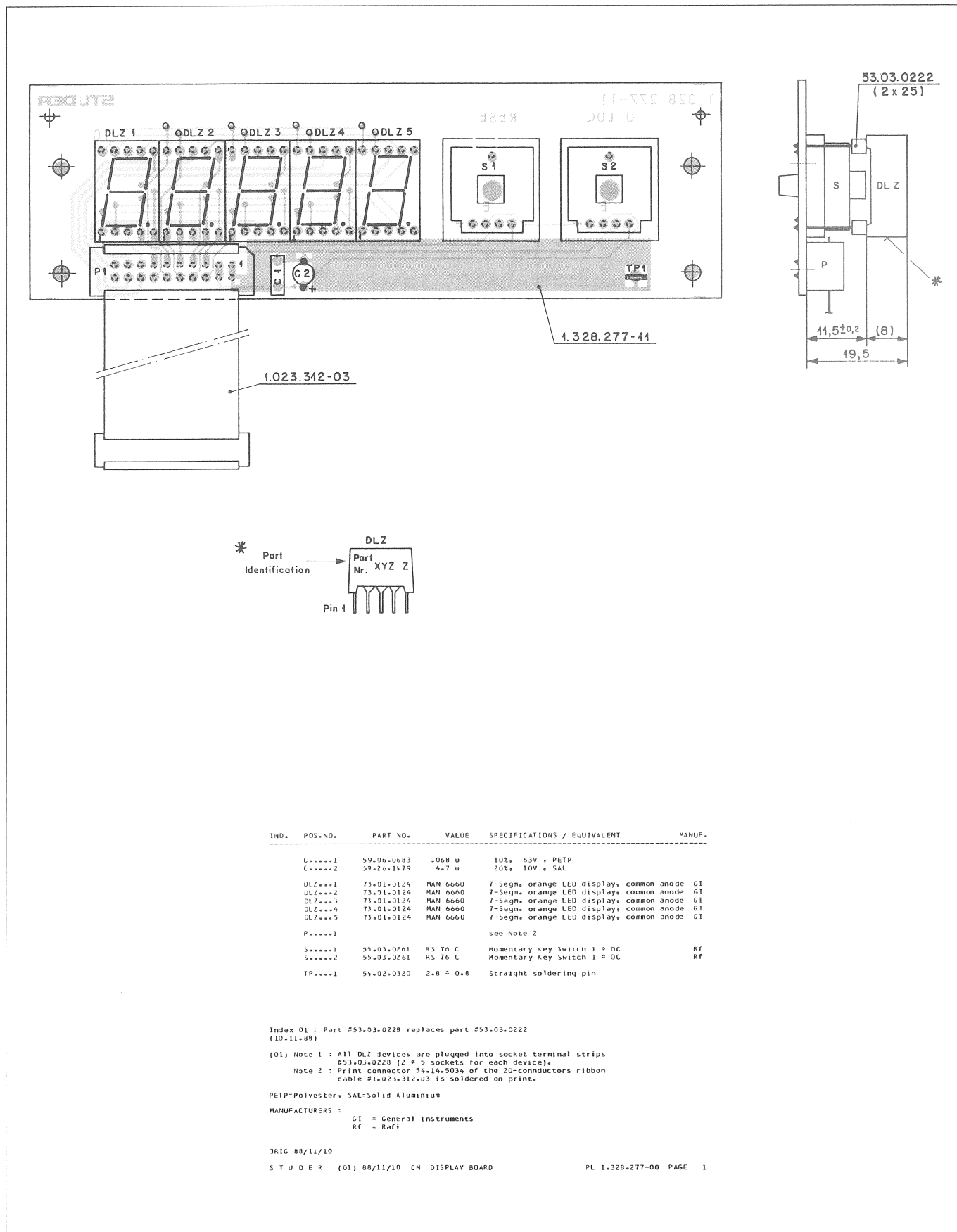

IND.	POS.NO.	PART NO.	VALUE	SPECIFICATIONS / EQUIVALENT	MANUF.
C.....1		59-06-0683	+068 u	10%, 63V, PETP	
C.....2		59-26-1179	4*7 u	20%, 10V, SAL	
DLZ...1		73-01-0124	MAN 6660	7-Segm. orange LED display, common anode	GI
DLZ...2		73-01-0124	MAN 6660	7-Segm. orange LED display, common anode	GI
DLZ...3		73-01-0124	MAN 6660	7-Segm. orange LED display, common anode	GI
DLZ...4		73-01-0124	MAN 6660	7-Segm. orange LED display, common anode	GI
DLZ...5		73-01-0124	MAN 6660	7-Segm. orange LED display, common anode	GI
P.....1				see Note 2	
S.....1		55-03-0261	RS 76 C	Momentary Key Switch 1 * DC	RF
S.....2		55-03-0261	RS 76 C	Momentary Key Switch 1 * DC	RF
TP.....1		54-02-0320	2*8 ± 0*8	Straight soldering pin	

Index 01 : Part #53.03.0228 replaces part #53.03.0222 (10.11.88)

(01) Note 1 : All DLZ devices are plugged into socket terminal strips #53.03.0228 (2 ± 5 sockets for each device)

Note 2 : Print connector 54.14.5034 of the 20-conductors ribbon cable #1.023.312.03 is soldered on print.

PETP=Polyester, SAL=Solid Aluminium

MANUFACTURERS :
GI = General Instruments
RF = Raft

ORIG 88/11/10

STUDER (01) 88/11/10 CM DISPLAY BOARD

PL 1.328.277-00 PAGE 1

VARISPEED CONVERSION KIT (FOR PAR. REMOTE CONTROL ONLY) 1.328.253.00
VARISPEED CONTROL MODULE 1.328.290.00
- VARISPEED CONTROL PCB 1.810.762.82

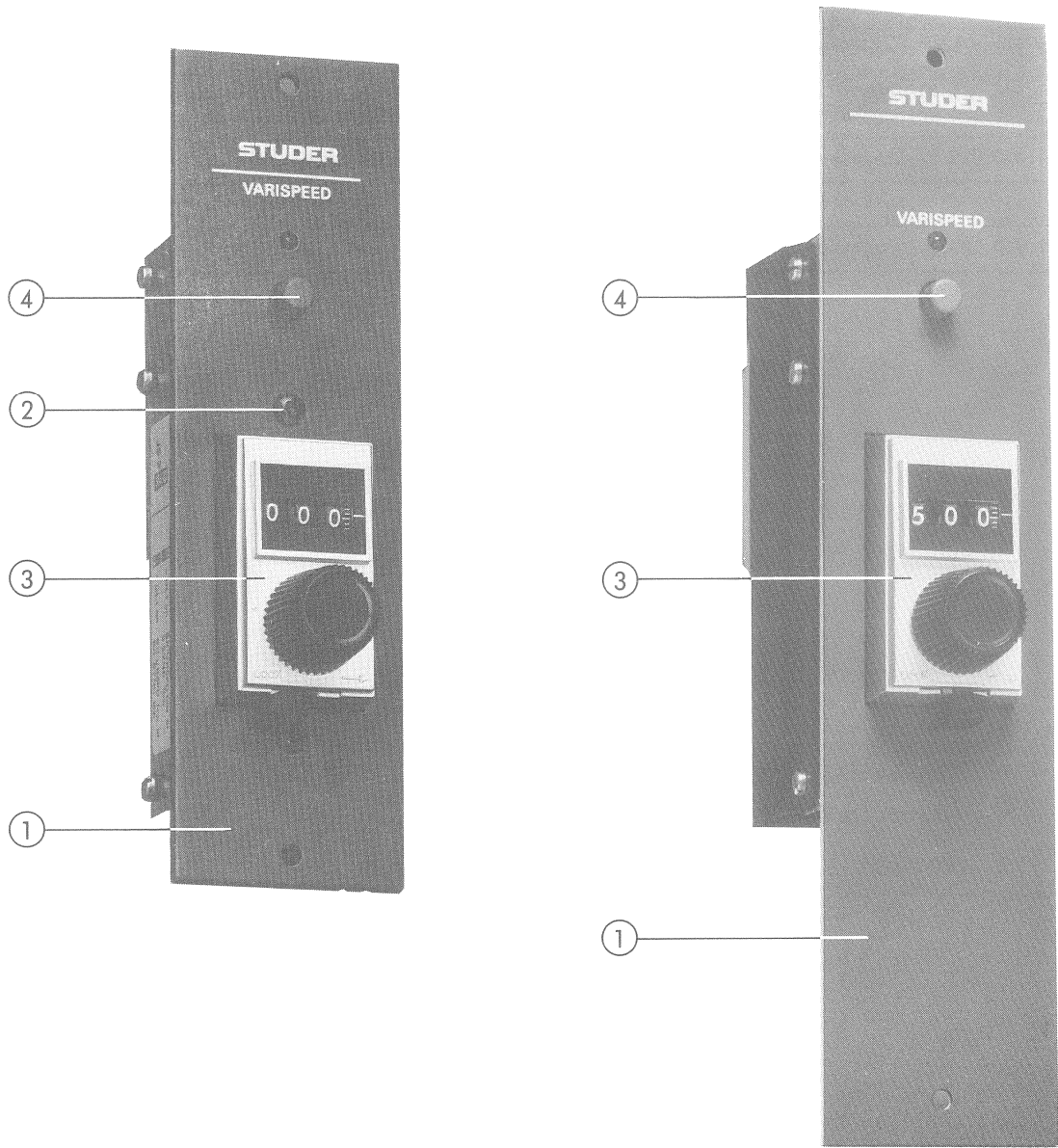

VARISPEED CONVERSION KIT (FOR PAR. REMOTE CONTROL ONLY) 1.328.253.00

VARISPEED CONTROL MODULE 1.328.290.00

- VARISPEED CONTROL PCB 1.810.762.82

	ANZ	BESTELLN.R.	BEZEICHNUNG	SPEZIFIKATION
	1	1.328.253.00	Nachrüstsatz Varispeed (nur für parallele Fernsteuerung)	
	1	1.328.290.00	Varispeed Einheit	
	1	1.810.762.82	Varispeed control Print	
	3	21.01.0279	Z-Schraube	M2,5x6
	3	24.16.1025	Sicherungsscheibe	
	1	1.328.290.04	Isolation	
01	1	1.328.250.10	Frontblende	
	1	1.810.330.02	Unterlage	
	1	1.328.290.01	Träger	
	1	1.328.290.02	Frontplatte	
01	2	1.010.025.21	Linsenkopfschraube	M3x6
03	1	58.99.0116	Feinantrieb mit Ableseskala	
04	1	1.810.320.07	Druckknopf, lang	rot

	QTY	ORDER NUMBER	PART NAME	SPECIFICATION
	1	1.328.253.00	Varispeed conversion kit (for parallel remote control only)	
	1	1.328.290.00	Varispeed control module	
	1	1.810.762.82	VARISPEED CONTROL PCB	
	3	21.01.0279	Slotted cheese head screw	M2.5x6
	3	24.16.1025	Fin washer	
	1	1.328.290.04	Insulation	
01	1	1.328.250.10	Front cover	
	1	1.810.330.02	Spacer	
	1	1.328.290.01	Support	
	1	1.328.290.02	Front plate	
02	2	1.010.025.21	Round head allen screw	M3x6
03	1	58.99.0116	Fine drive with reading scale	
04	1	1.810.320.07	Push button, long	red

VARI SPEED CONVERSION KIT (FOR PAR. REMOTE CONTROL ONLY) 1.328.253.00
 VARI SPEED CONTROL MODULE 1.328.290.00
 - VARI SPEED CONTROL PCB 1.810.762.82

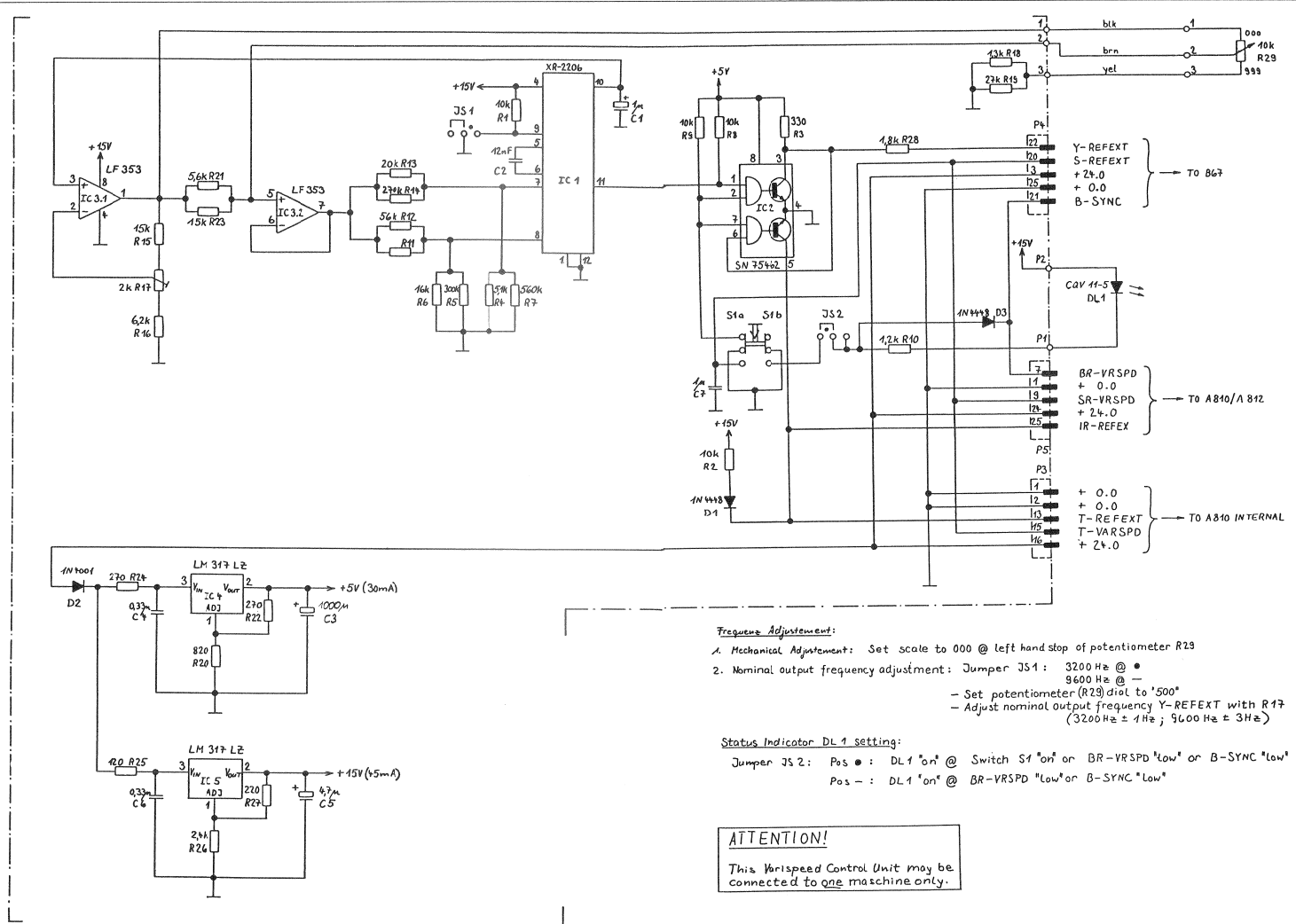

Frequency Adjustment:
 1. Mechanical Adjustment: Set scale to 000 @ left hand stop of potentiometer R23
 2. Nominal output frequency adjustment: Jumper JS1: 3200 Hz @ ●
 9600 Hz @ —
 - Set potentiometer (R23) dial to '500'
 - Adjust nominal output frequency Y-REFEXT with R17
 (3200 Hz ± 1 Hz; 9600 Hz ± 3 Hz)

Status Indicator DL1 setting:
 Jumper JS2: Pos ●: DL1 'on' @ Switch S1 'on' or BR-VRSPD 'low' or B-SYNC 'low'
 Pos —: DL1 'on' @ BR-VRSPD 'low' or B-SYNC 'low'

ATTENTION!
 This Vari speed Control Unit may be connected to one machine only.

07.02.84 LN				
STUDER			Varispeed Control Board	SC 1.810.762.82
				PAGE 1 OF 1

VARI SPEED CONVERSION KIT (FOR PAR. REMOTE CONTROL ONLY) 1.328.253.00
VARI SPEED CONTROL MODULE 1.328.290.00
- VARI SPEED CONTROL PCB 1.810.762.82

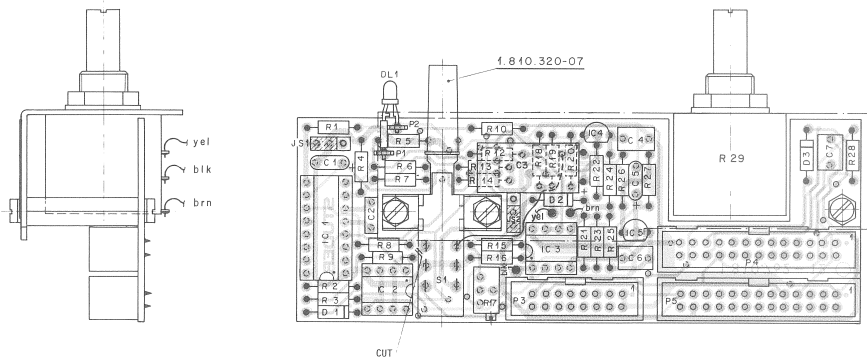

IND.	POS.ND.	PART ND.	VALUE	SPECIFICATIONS / EQUIVALENT	MANUF.
C..0001	59.26.9109		1 uF	201, 40V + Sul	Ph
C..0002	59.99.0220		1.2 uF	50V, 50V + Cer see note 1	
C..0003	59.99.1100		1000 uF	6.3V l. 25mm d x 10mm	
C..0004	59.06.033A		0.33uF	10%, 63V + Petp	Ph
C..0005	59.26.9170		6.7 uF	201, 50V + Sul	
C..0006	59.06.033A		0.33uF	10%, 63V + Petp	
C..0007	59.06.03105		1uF	10%, 50V + Petp	
O..0001	50.0w.0125		1W 6648		Ph+Soc, ITT, FC, FF
D..0002	50.0w.0122		1W 4001		Not in Sol
D..0003	50.0w.0125		1W 4448		Ph+Soc, ITT, FC, FF
DL-0001	50.0w.2129		CDV11-7		Sio
IC-0001	50.11.0108		KR2206CP	5G 2256	Ex
IC-0002	50.05.0227		SN7546CP		TI
IC-0003	50.09.0101		LF 3538	TL 07ZCP	TI+Soc, Mac
IC-0004	50.10.0108		LM317LZ		Not in Mac
IC-0005	50.10.0109		LM317LZ		Not in Mac
J5-0001	54.01.0020		Pin (35)	54-01-0021 Bridge (15) see note 2	
J5-0002	54.01.0020		Pin (38)	54-01-0021 Bridge (15) see note 2	
P..0001	54.02.0320			24PDB	
P..0002	54.02.0320			24PDB	
P..0003	54.14.2002			18-contacts see note 3	
P..0004	54.14.2003			20-contacts see note 4	
P..0005	54.14.2003			26-contacts see note 4	
R..0001	57.11.4103		10 kOhm	5%	
R..0002	57.11.4103		10 kOhm	5%	
R..0003	57.11.4331		330 Ohm	5%	
R..0004	57.11.4312		5.1 kOhm	1%	
R..0005	57.11.3304		300 kOhm	5%	
R..0006	57.11.4303		10 kOhm	1%	
R..0007	57.11.4304		500 kOhm	5%	
R..0008	57.11.4103		10 kOhm	5%	

STUDER (00) 05/07/09 LN VARI SPEED CONTROL BOARD 1.810.762.82 PAGE 1

IND.	POS.ND.	PART ND.	VALUE	SPECIFICATIONS / EQUIVALENT	MANUF.
R..0009	57.11.4103		10 kOhm	5%	
R..0010	57.11.4122		1.2 kOhm	5%	
R..0011				Not used	
R..0012	57.11.3503		56 kOhm	1%	
R..0013	57.11.3025		20 kOhm	1%	
R..0014	57.11.4274		270 kOhm	5%	
R..0015	57.11.3153		15 kOhm	5%	
R..0016	57.11.3622		6.2 kOhm	5%	
R..0017	50.05.0222		2 kOhm		25 turns
R..0018	57.11.3132		1.3 kOhm	1%	
R..0019	57.11.4272		27 kOhm	5%	
R..0020	57.11.3021		920 Ohm	1%	
R..0021	57.11.3022		5.6 kOhm	1%	
R..0022	57.11.3271		270 Ohm	1%	
R..0023	57.11.3153		15 kOhm	1%	
R..0024	57.11.3271		270 Ohm	5%	
R..0025	57.11.4121		1.2 kOhm	5%	
R..0026	57.11.3242		2.4 kOhm	1%	
R..0027	57.11.3221		2.2 kOhm	1%	
R..0028	57.11.4102		1.8 kOhm	5%	10 turns
R..0029	50.05.0123		10 kOhm		
S..0001	1.477.100.07			Switch	56

STUDER (00) 05/07/09 LN VARI SPEED CONTROL BOARD 1.810.762.82 PAGE 2

IND. POS.ND. PART ND. VALUE SPECIFICATIONS / EQUIVALENT MANUF.

Note 1: 12V±50V: General No. CA 40 6 123 J
Siemens No. 0 31 983 J - 5123 - J
Komet No. C 062 5 123 J 5 G 5 Ca

Note 2: Contact pin: Berg No. 75100-102-36
Philips No. 2422 024 8903
Orange: Berg No. 65474-001
AMP No. 141767-1
Philips No. 2422 024 8903

Note 3: 18-contacts: Yamachi No. FAP-16-08/4
Surdny No. BPH 9 B 16 800 GS

Note 4: 20-contacts: Yamachi No. FAP-26-08/4
Surdny No. BPH 9 B 26 800 GS

Manufacturers: Ex=Exar, FC=Fairchild, GI=General Instruments,
ITT=Intertec, J=Johannes, Mac=Motorola, Not=Not in Mac (Not in Mac),
NS=National Semiconductor, PH=Philips,
Soc=Siemens, Soc=Siemens, Sol=Soliton,
Soc=Siemens, Soc=Siemens, ITT=Intertec Instrument

DRG 05/07/09
STUDER (00) 05/07/09 LN VARI SPEED CONTROL BOARD 1.810.762.82 PAGE 3

VARISPEED CONTROLLER 1.328.280

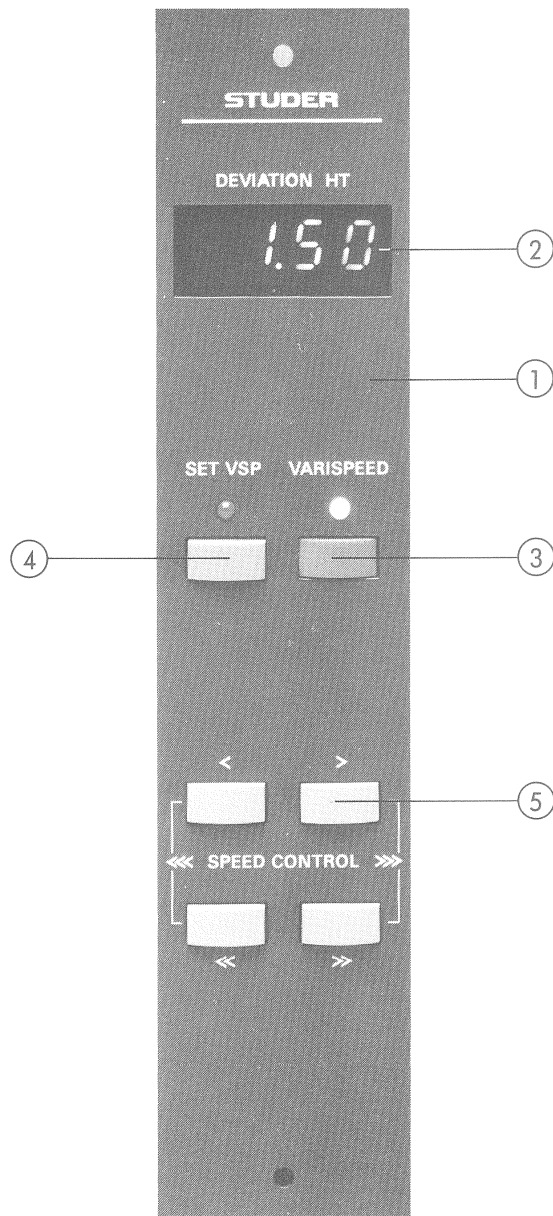

VARISPEED CONTROLLER 1.328.280

	BESTELNR.	BEZEICHNUNG
1	1.328.280.01	Frontblende
2	1.328.280.U3	Blende
3	55.15.0122	Tastenkopf rot
4	55.15.0123	Tastenkopf orange
5	55.15.0128	Tastenkopf grau

	ORDER NUMBER	PART NAME	SPECIFICATION
1	1.328.280.01	Front cover	
2	1.328.280.U3	Display cover	
3	55.15.0122	Push button red	
4	55.15.0123	Push button orange	
5	55.15.0128	push button grey	

VARISPEED DISPLAY AND KEYBOARD 1.328.281.00

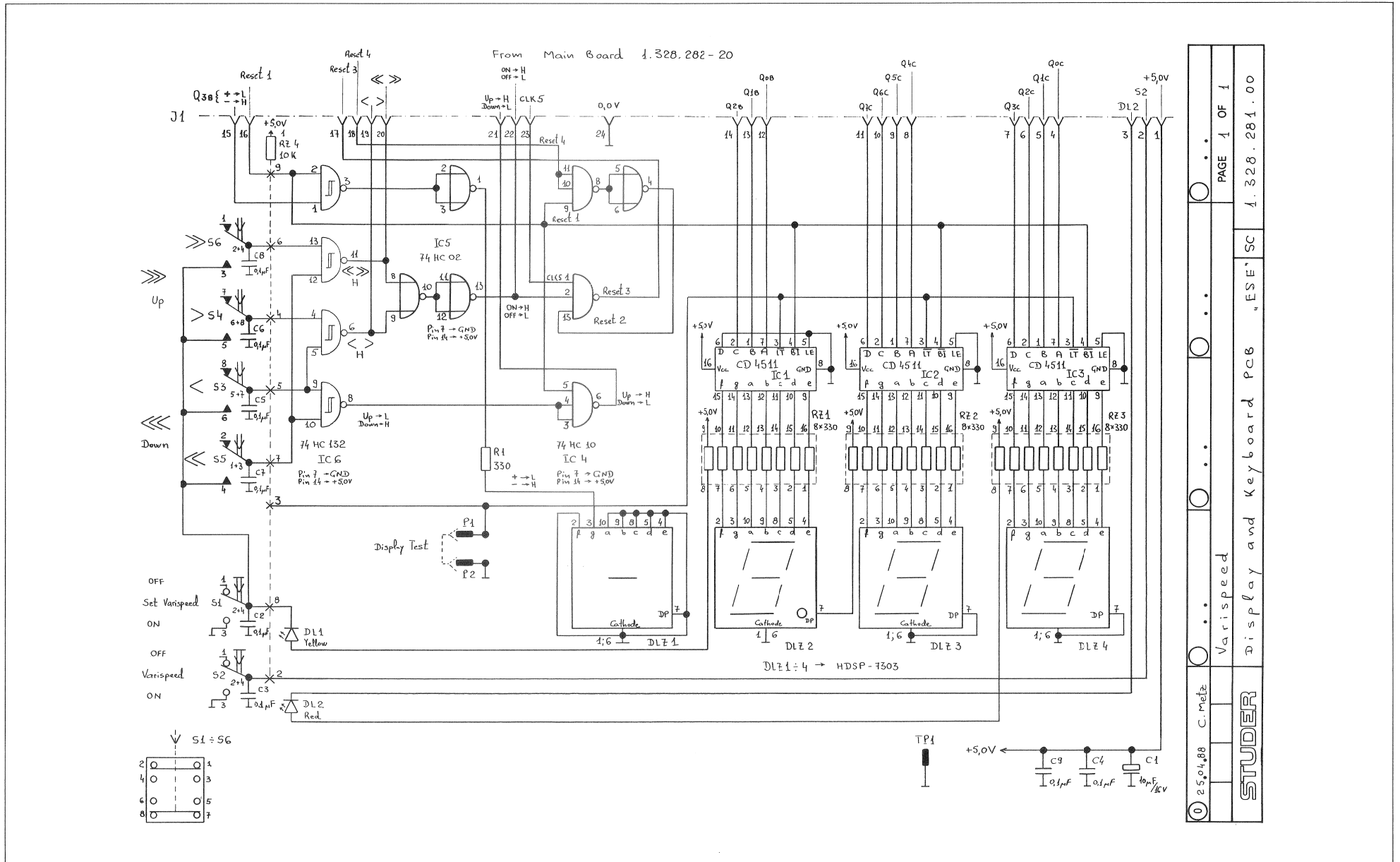

STUDER
 Varispeed
 Display and Keyboard PCB "ESE" SC 1.328.281.00
 PAGE 1 OF 1

VARISPEED DISPLAY AND KEYBOARD 1.328.281.00

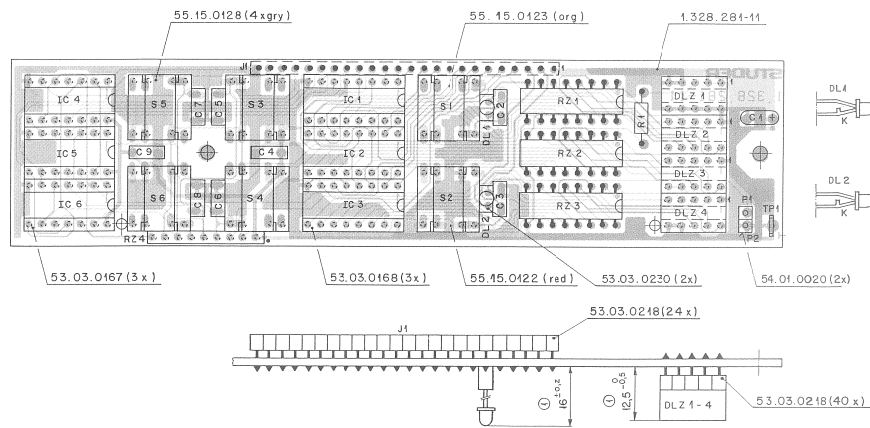

IND.	POS-NO.	PART NO.	VALUE	SPECIFICATIONS / EQUIVALENT	MANUF.
C	****1	59.24.2100	10 u	20%, 10V + SAL	
C	****2	59.24.0104	+1 u	10%, 63V + PETF	
C	****3	59.04.0104	+1 u	10%, 63V + PETF	
C	****4	59.04.0104	+1 u	10%, 63V + PETF	
C	****5	59.04.0104	+1 u	10%, 63V + PETF	
C	****6	59.24.0104	+1 u	10%, 63V + PETF	
C	****7	59.04.0104	+1 u	10%, 63V + PETF	
C	****8	59.04.0104	+1 u	10%, 63V + PETF	
C	****9	59.04.0104	+1 u	10%, 63V + PETF	
DL	****1	50.04.2130	LY 3160	Diffused yellow.	Sia.
DL	****2	50.04.2129	LS 3160	Diffused red.	Sia.
DLZ	****1	75.01.0128	H05P-7303	Red Micro-Bright 7 Seg. Display 7.6 mm HP.	
DLZ	****2	75.01.0128	H05P-7303	Red Micro-Bright 7 Seg. Display 7.6 mm HP.	
DLZ	****3	75.01.0128	H05P-7303	Red Micro-Bright 7 Seg. Display 7.6 mm HP.	
DLZ	****4	75.01.0128	H05P-7303	Red Micro-Bright 7 Seg. Display 7.6 mm HP.	
IC	****1	50.07.0511	CD 4511	BCD-to-7 Seg. Latch/Decoder/Driver.	
IC	****2	50.07.0511	CD 4511	BCD-to-7 Seg. Latch/Decoder/Driver.	
IC	****3	50.07.0511	CD 4511	BCD-to-7 Seg. Latch/Decoder/Driver.	
IC	****4	55.11.1010	74 HC 10	Triplet 3-Input NAND Gate.	
IC	****5	50.11.1002	74 HC 02	Quad 2-Input NOR Gate.	
IC	****6	50.11.1132	74 HC 132	Quad 2-Input Schmitt Trigger NAND Gate.	
J	****1	53.03.0218	24 * 1 pin	Straight socket strip (24 pcs.)	
P	****1	54.01.0020	0.63x0.63	Straight soldering male pin.	
P	****2	54.01.0020	0.63x0.63	Straight soldering male pin.	
R	****1	57.11.3331	330	1%, 0207 + MF	
R	****2	57.00.3331	0 ± 330	2%, 01L16	
R	****3	57.00.3331	0 ± 330	2%, 01L16	
R	****4	57.00.3331	0 ± 330	2%, 01L16	
R	****5	57.00.4123	0 ± 10 k	2%, SIP 9	

S T U D E R (100) 88/02/81 CM DISPLAY & KEYBOARD PCB PL 1.328-281-00 PAGE 1

IND.	POS-NO.	PART NO.	VALUE	SPECIFICATIONS / EQUIVALENT	MANUF.
S	****1	54.15.0113	2 * U	Push-Push Button Switch.	REC.
S	****2	54.15.0113	2 * U	Push-Push Button Switch.	REC.
S	****3	54.15.0112	2 * U	Momentary Push Button Switch.	REC.
S	****4	54.15.0112	2 * U	Momentary Push Button Switch.	REC.
S	****5	54.15.0112	2 * U	Momentary Push Button Switch.	REC.
S	****6	54.15.0112	2 * U	Momentary Push Button Switch.	REC.
TP	****1	54.02.0129	2.8 * 0.8	Straight soldering strip.	

Note : DL 1 and DL 2 are mounted on LED sockets 53.03.0230 (2 pcs.)
 whereas DL 3 and DL 4 are mounted on 2 * 5 pins 53.03.0218 pins.
 SAL=Solid Aluminium; PTFP=Polyester; MF=Metal Film.
 MANUFACTURERS :
 HP = Hewlett Packard
 REC = Munkwitz Elektrisk Compagny of 1975
 Sia = Siemens

DATE 88/02/81
 S T U D E R (100) 88/02/81 CM DISPLAY & KEYBOARD PCB PL 1.328-281-00 PAGE 2

VARISPEED MAIN BOARD 1.328.282.20

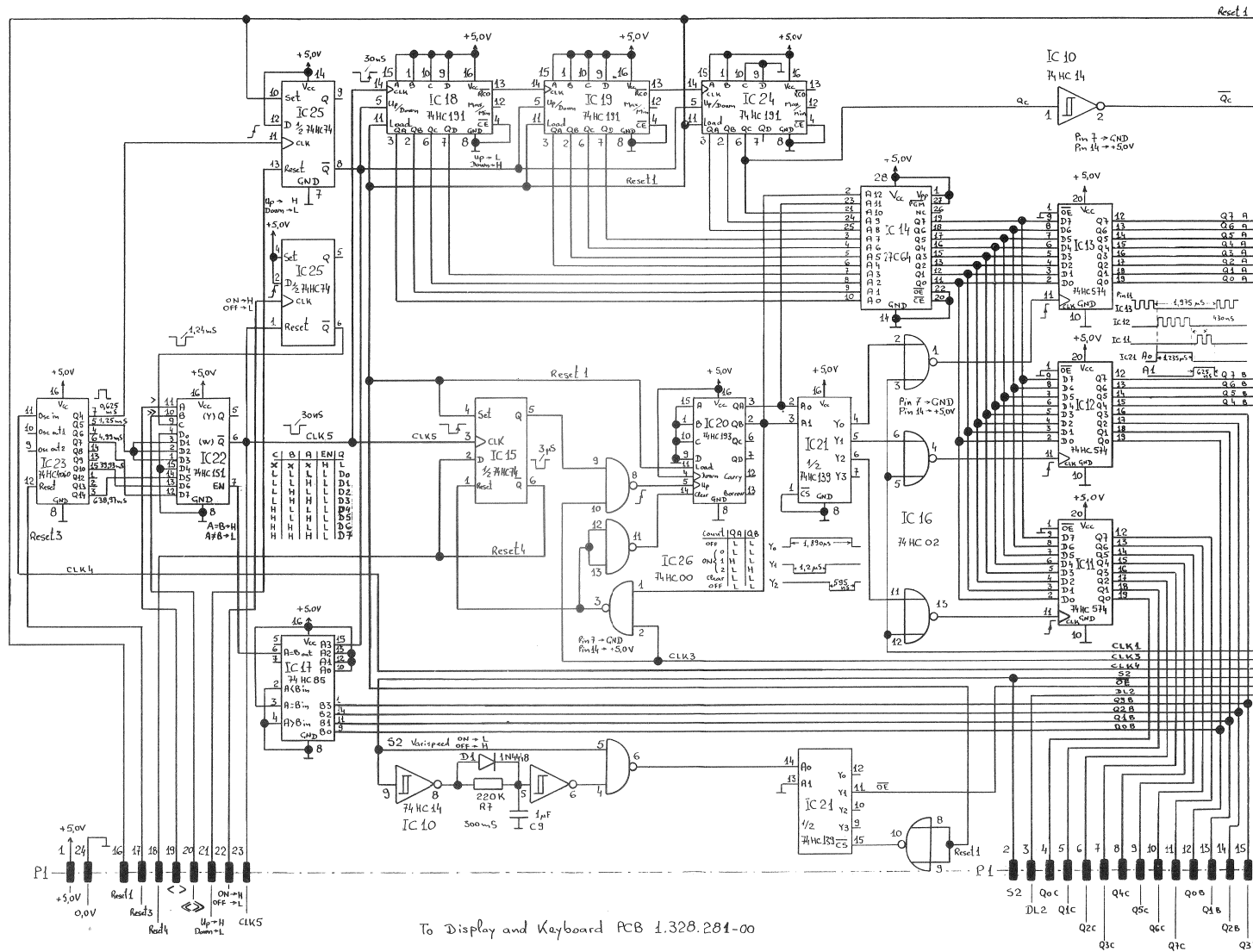

To Display and Keyboard PCB 1.328.281-00

0 14 04 88 C. Metz	Varispeed	STUDER	PAGE 1 OF 2
			ESE SC 1.328.282-20

VARISPEED MAIN BOARD 1.328.282.20

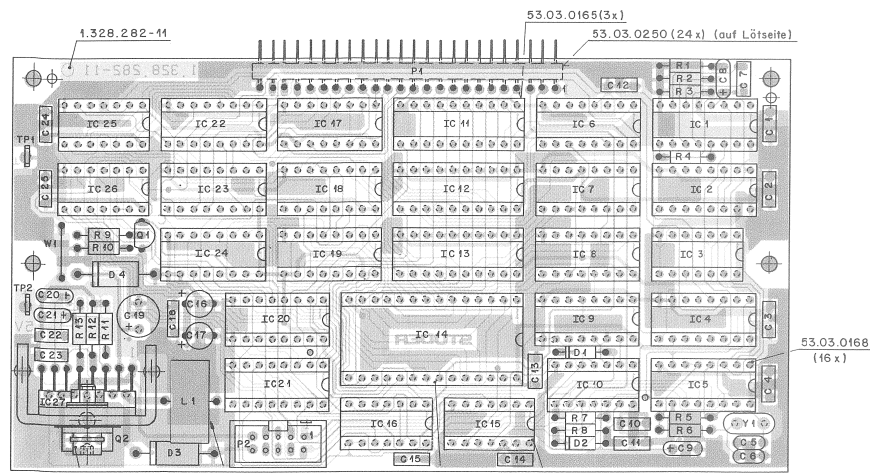

IND.	POS.ND.	PART NO.	VALUE	SPECIFICATIONS / EQUIVALENT	MANUF.
C****1		59.06.0104	-1 u	10%, 63V * PETP	
C****2		59.06.0104	-1 u	10%, 63V * PETP	
C****3		59.06.0104	-1 u	10%, 63V * PETP	
C****4		59.06.0104	-1 u	10%, 63V * PETP	
C****5		59.34.1100	10 p	5%, 100 p * CER	
C****6		59.34.2390	39 p	5%, HS50 * CER	
C****7		59.06.0102	1000 p	10%, 63V * PETP	
C****8		59.26.2339	3.3 u	20%, 16V * SAL	
C****9		59.26.3109	1 u	20%, 25V * SAL	
C****10		59.06.0104	-1 u	10%, 63V * PETP	
C****11		59.06.0102	1000 p	10%, 63V * PETP	
C****12		59.06.0104	-1 u	10%, 63V * PETP	
C****13		59.06.0104	-1 u	10%, 63V * PETP	
C****14		59.06.0104	-1 u	10%, 63V * PETP	
C****15		59.06.0104	-1 u	10%, 63V * PETP	
C****16		59.22.4101	100 u	-20%, 16V * EL	
C****17		59.22.4073	67 u	-20%, 16V * EL	
C****18		59.06.0104	-1 u	10%, 63V * PETP	
C****19		59.26.2229	2.2 u	20%, 16V * SAL	
C****20		59.26.2229	2.2 u	20%, 16V * SAL	
C****21		59.26.2229	2.2 u	20%, 16V * SAL	
C****22		59.26.0331	+033 u	10%, 63V * PETP	
C****23		59.06.0222	2200 p	10%, 63V * PETP	
C****24		59.06.0104	-1 u	10%, 63V * PETP	
C****25		59.06.0104	-1 u	10%, 63V * PETP	
D****1		50.24.0125	1N 4448	75 V, 0.1 A, 4 pos. Si	
D****2		50.24.0125	1N 4448	75 V, 0.1 A, 4 pos. Si	
D****3		50.24.0130	1 N 5822	40 V, 3 A, Schutzky.	Mot.
D****4		50.24.0921	MUR 410	100 V, 5 A, Si.	
IC****1		50.07.0006	MC 14046.0	Phase-Locked Loop.	Mot.
IC****2		50.17.1920	74 HC 4520	Dual 4-Bit Binary Counter.	
IC****3		50.17.1313	74 HC 113	Dual 2-Input NAND Gate.	
IC****4		50.17.1920	74 HC 4520	Dual 4-Bit Binary Counter.	
IC****5		50.17.1368	74 HC 168	Hex 3-State Inv. Buffer, 2-Bit & 4-Bit Sect.	
IC****6		50.17.1193	74 HC 193	Preset. 4-Bit Bin. Up/Down Count. with Reset	

S T U D E R (00) 88/03/08 CM MAIN BOARD PL 1.328.282-20 PAGE 1

IND.	POS.ND.	PART NO.	VALUE	SPECIFICATIONS / EQUIVALENT	MANUF.
IC****7		50.17.1193	74 HC 193	Preset. 4-Bit Bin. Up/Down Count. with Reset	
IC****8		50.17.1193	74 HC 193	Preset. 4-Bit Bin. Up/Down Count. with Reset	
IC****9		50.17.1193	74 HC 193	Preset. 4-Bit Bin. Up/Down Count. with Reset	
IC****10		50.17.1014	74 HC 14	Hex Schmitt-Trigger Inverter.	
IC****11		50.17.1574	74 HC 574	Dctal 3-State Noninverting 0-Type Flip-Flop.	
IC****12		50.17.1574	74 HC 574	Dctal 3-State Noninverting 0-Type Flip-Flop.	
IC****13		50.17.1574	74 HC 574	Dctal 3-State Noninverting 0-Type Flip-Flop.	
IC****14		1.328.981.20		SW 51/81 VARISPEED CONTROLLE	St.
IC****15		50.17.1007	74 HC 74	Dual 0-Type Flip-Flop with Set & Reset.	
IC****16		50.17.1002	74 HC 02	Dual 2-Input NOR Gate.	
IC****17		50.17.1005	74 HC 89	4-Bit Magnitude Comparator.	
IC****18		50.17.1191	74 HC 191	Presettable 4-Bit Binary Up/Down Counter.	
IC****19		50.17.1191	74 HC 191	Presettable 4-Bit Binary Up/Down Counter.	
IC****20		50.17.1193	74 HC 193	Preset. 4-Bit Bin. Up/Down Count. with Reset	
IC****21		50.17.1191	74 HC 191	Dual 4-Input Decoder/Multiplexer.	
IC****22		50.17.1151	74 HC 151	8 Input Data Selector/Multiplexer.	
IC****23		50.17.1005	74 HC 89	4-Input Binary Ripple Counter with Dec.	
IC****24		50.17.1191	74 HC 191	Presettable 4-Bit Binary Up/Down Counter.	
IC****25		50.17.1074	74 HC 74	Dual 0-Type Flip-Flop with Set & Reset.	
IC****26		50.17.1007	74 HC 02	Dual 2-Input NAND Gate.	
IC****27		50.10.0119	L 296	High Current Switching Voltage Regulator SGS	
L****1		42.73.0909	250 uH	1 A Toroidal Choke.	St.
P****1		53.03.0125	16 x 1.6 mm	Right Angle Male Contact Strip- (24 pcs-)	
P****2		53.03.2001	2 x 3.0 mm	Storage Print Male Connector.	
Q****1		50.03.0147	1C 337-25	45 V, 0.8 A, Si. NPN.	KCA.
Q****2		50.99.0106	T 2800 0	400 V, 8 A, Triac.	
R****1		57.11.3221	22 k	1%, 0207 * MF	
R****2		57.11.3193	39 k	1%, 0207 * MF	
R****3		57.11.3194	150 k	1%, 0207 * MF	
R****4		57.11.3193	39 k	1%, 0207 * MF	
R****5		57.11.3105	1 k	1%, 0207 * MF	
R****6		57.11.3193	39 k	1%, 0207 * MF	
R****7		57.11.3224	220 k	1%, 0207 * MF	

S T U D E R (00) 88/03/08 CM MAIN BOARD PL 1.328.282-20 PAGE 2

IND.	POS.ND.	PART NO.	VALUE	SPECIFICATIONS / EQUIVALENT	MANUF.
R****8		57.11.3222	2.2 k	1%, 0207 * MF	
R****9		57.11.3471	470	1%, 0207 * MF	
R****10		57.11.3193	39 k	1%, 0207 * MF	
R****11		57.11.3133	13 k	1%, 0207 * MF	
R****12		57.11.3472	4.7 k	1%, 0207 * MF	
R****13		57.11.3153	15 k	1%, 0207 * MF	
TP****1		54.02.0320	2.8 x 0.8	Straight Tolerating Strip.	
TP****2		54.02.0320	2.8 x 0.8	Straight Tolerating Strip.	
W****1		1-310-324-64	4.3 x 10-2	Bridge.	
Y****1		89-01-0376	3.2768 MHz	HC 10 U Ceramic Resonator.	

CER=Ceramic; EL=Electrolytic; PETP=Polyesters; SAL=Solid Aluminium.

MF=Metall Film.

MANUFACTURERS :
 Mot. = Motorola
 KCA = RCA Corporation
 SGS = SGS - Microelettronica Sp A
 St. = Studer

DRIG 88/03/08

S T U D E R (00) 88/03/08 CM MAIN BOARD PL 1.328.282-20 PAGE 3

VARISPEED CONNECTORS BOARD 1.328.283.00

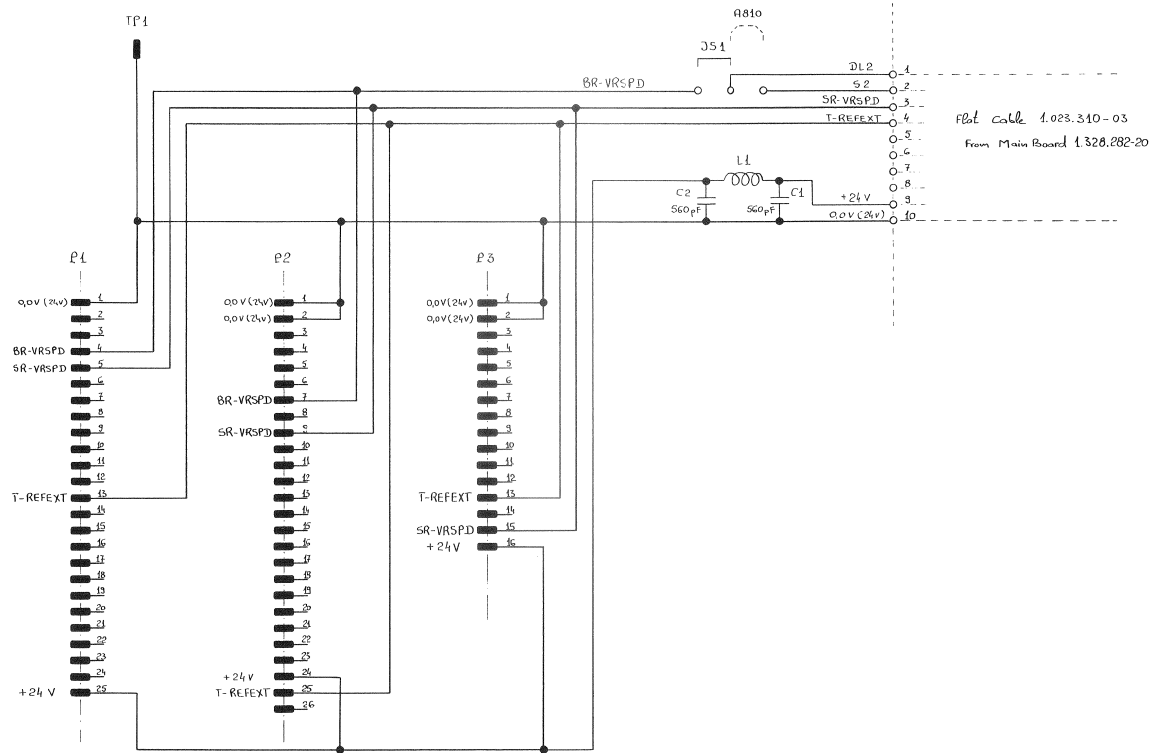

1.328.283.00 C. M. P. 1.328.283.00
Varispeed
Connectors Board
STUDER
PAGE 1 OF 1
SC 1.328.283.00