

# RCA GUIDE for TRANSMITTING TUBES

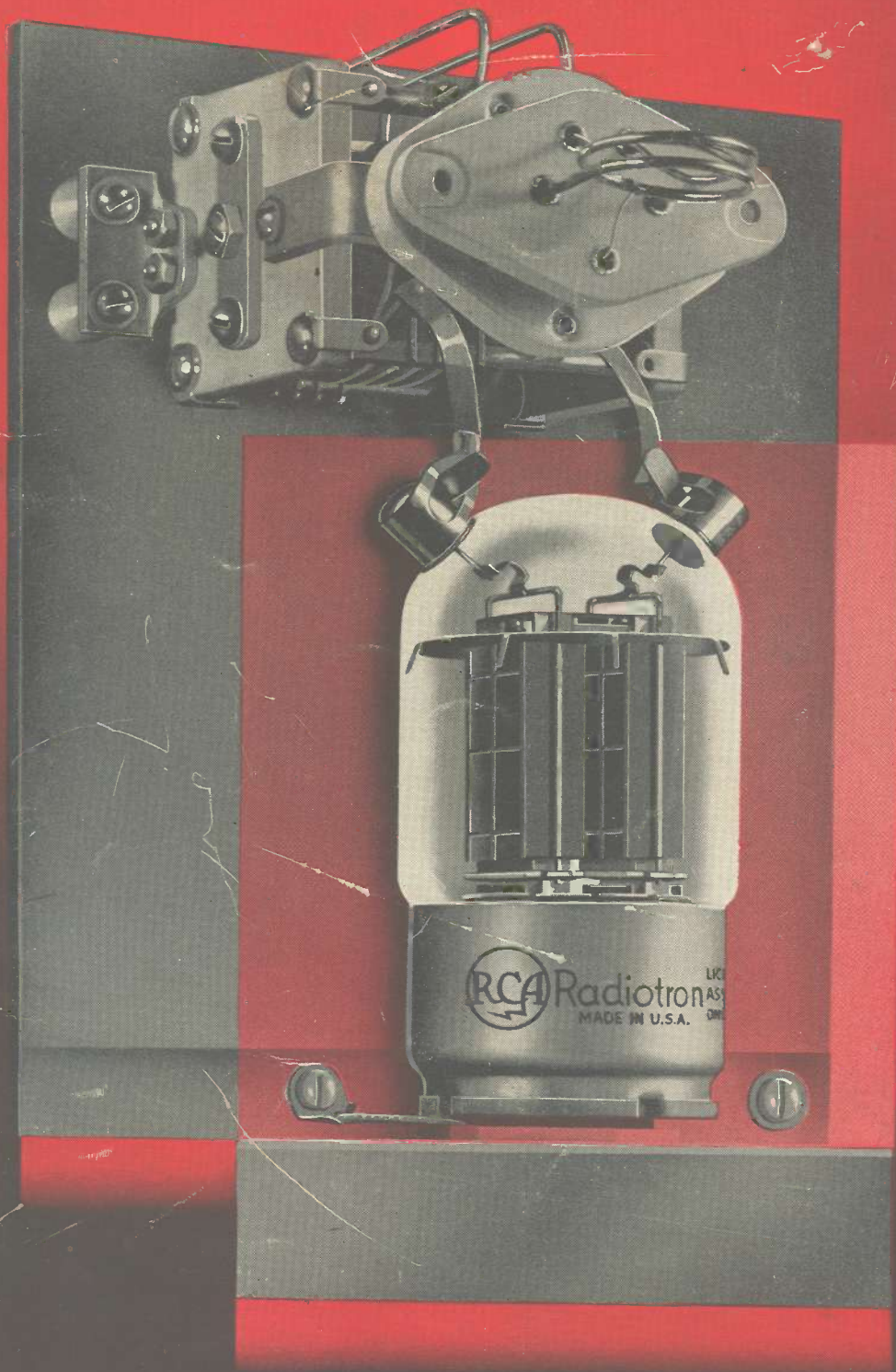

*For*  
**ENGINEERS  
EXPERIMENTERS**

*Includes*  
SPECIAL CHART FOR  
TRANSMITTING TUBES  
(Air- and Water-Cooled),  
CATHODE-RAY TUBES,  
SPECIAL-PURPOSE TUBES  
AND PHOTOTUBES

*Price 35 Cents*

RCA MANUFACTURING COMPANY, INC., CAMDEN, N. J., U. S. A.

# POWER

● WHEN YOU WANT IT

● AS MUCH AS YOU WANT

● FOR THE SERVICE YOU WANT

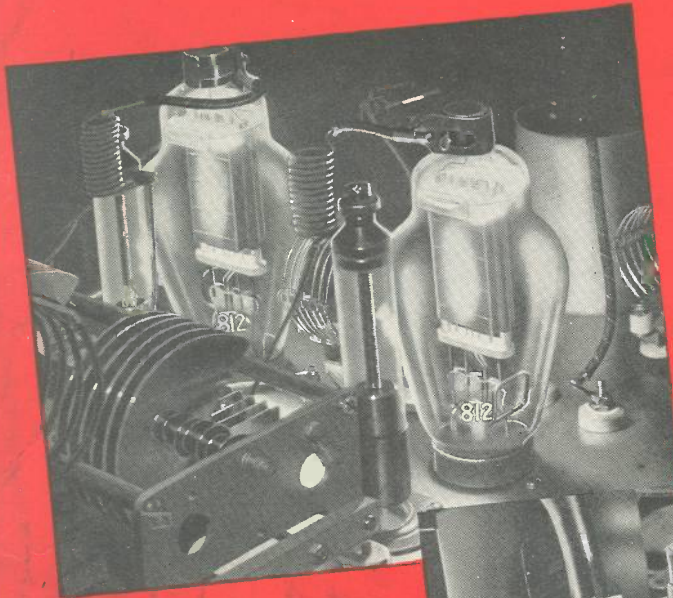

## 450 WATTS INPUT— TUBE COST, \$7.00

RCA-812 triodes in push-pull will take 450 watts input up to 60 Mc—an all-time high in tube economy with 64.3 watts input per dollar. RCA-812's and their high- $\mu$  companions, RCA-811's, are the only low-priced tubes with the Zirconium-coated anode. This anode, an RCA development, has very high heat dissipating qualities and functions as a highly effective getter.



## 360 WATTS INPUT—LESS THAN A WATT OF DRIVE!

The RCA-813 beam transmitting tube offers real power and circuit amplification. It makes possible efficient and flexible high-gain stages at a cost comparable with that of equipment using ordinary tube combinations.

## 6,360 VOLTS AT ½ AMPERE!

Single-phase full-wave bridge rectifier using long-life 866-A/866's delivers over three kilowatts of power to the load. RCA-866-A/866's handle high voltages at low initial cost, have tremendous emission reserve, and provide longer life. Reasons are that these tubes are designed with improved filaments, have dome bulbs and insulated plate caps.

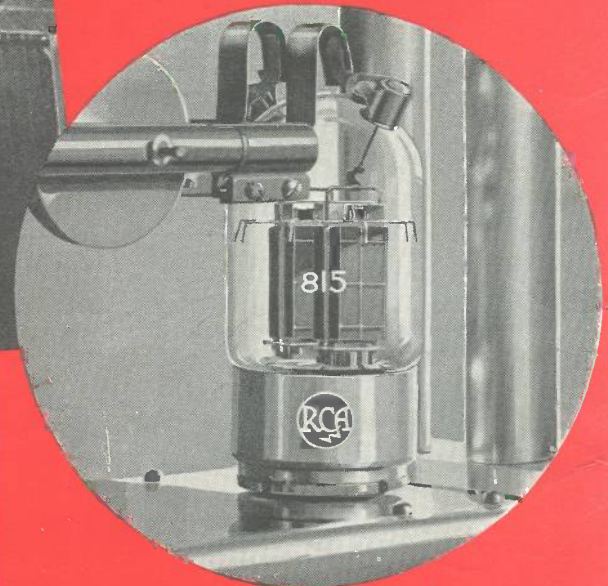

## PUSH-PULL-BEAM POWER ON 150 Mc

The 815 in this tuned-line r-f power amplifier delivers 50 watts output at 150 Mc—with a grid drive of less than one-half watt. It will operate satisfactorily at reduced input up to 225 Mc. For economical p-p beam power in modern UHF applications, this tube is a logical choice.

## 4,000 WATTS INPUT AT 20 Mc

The two RCA-833-A triodes shown at the left are operated in push-pull as an r-f power amplifier in push-pull at a plate voltage of 4,000 volts and a plate current of 1 ampere! Small and compact, the 833-A will handle several kilowatts of power in a tube less than 9 inches high and 4½" in diameter. It utilizes the famous RCA Zirconium-coated anode and has a maximum plate dissipation of 450 watts (ICAS). This ultra-modern triode is built to last.

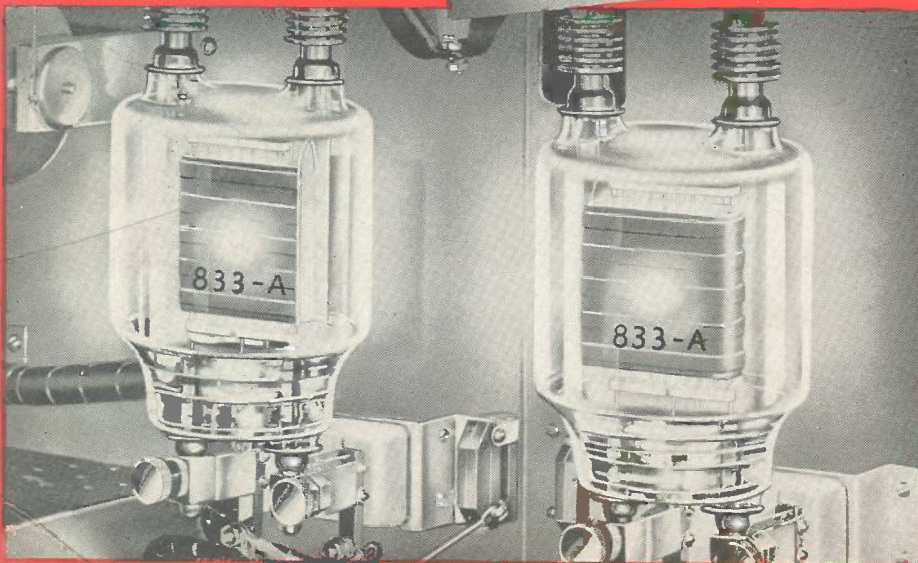

# FOREWORD

On radio communication rests man's destiny. Like the magic of Merlin, it controls airfleets, moves armies, guides convoys, dissolves horizons. It is the coordinator of fighting legions. It controls the destiny of nations.

Power Tubes make radio communication possible. Within their geometric confines evolves the phenomena of electronics on which hinges the complicated functioning of communication equipment. Small wonder then that the need for Power Tubes on the front line of battle is tremendous and that a supreme effort is needed to supply them in the quantities required. That means that Power Tubes for all other purposes may become even more difficult to replace. It is, therefore, a patriotic duty and sound business policy to operate tubes wisely.

We welcome the opportunity to cooperate in helping RCA Transmitting Tube users to extend tube life to the fullest by setting forth the following suggestions. Operate tubes conservatively. Avoid overloading. Follow carefully the instructions and published data outlined in the Instruction Book packed with each tube. Reduce grid, screen and plate dissipation. Use forced ventilation wherever possible. Use adequate fuse and overload-relay protection. Preheat mercury-vapor rectifiers—measure ambient temperatures. Operate tubes having coated cathodes and thoriated-tungsten filaments at rated cathode or filament voltages. Reduce filament voltage of pure tungsten-filament types wherever possible. (A 5% decrease will double tube life when the transmitter can be adjusted for operation closer to maximum permissible distortion). Operate spare tubes occasionally.

In presenting the 1942 RCA GUIDE to radio engineers and technicians in the Services and in the war industries, it is our belief that the up-to-date information contained in this volume will prove most helpful in choosing the right tube for the job and in getting the most from the tubes on the job. Should you desire additional information on any of the tubes described herein, or if you have special tube problems, we invite you to write to the Commercial Engineering Section, RCA Manufacturing Company, Inc., Harrison, N. J. Should you need sales information on RCA tubes or any other RCA product, we invite you to write to the Sales Department, RCA Manufacturing Company, Inc., Camden, N. J.

Prices in this book apply only in the United States of America and are subject to change or withdrawal without notice. Prices are those effective October 15, 1941.



#### LICENSE NOTICE FOR RCA TUBES

Licensed for all uses other than in apparatus and systems for use in the field of public service communication for hire or toll. The sale of this device does not convey any license under patent claims on combinations of the device with other devices or elements.

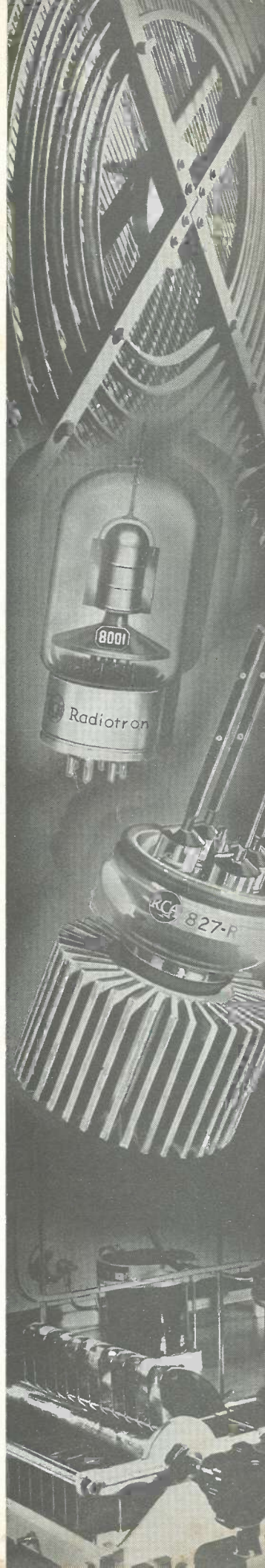



# 813

## OUTSTANDING CONSTRUCTIONAL FEATURES OF THE 813 BEAM TRANSMITTING TUBE

The 813 is RCA's largest glass air-cooled beam transmitting tube. It is designed for transmitters requiring exceptional overall efficiency. It is a logical choice for the ultra-modern final and intermediate r-f amplifier that needs no neutralizing adjustments and that can switch channels in a flash. Also, it meets the requirements for high-power transmitters having few tuning controls and a minimum of driver equipment. RCA-813 doubles, triples, and quadruples with unusually high efficiency and high harmonic output. In brief, this exceptional beam tube can handle a greater variety of big-time jobs than any other tube of its size or class.

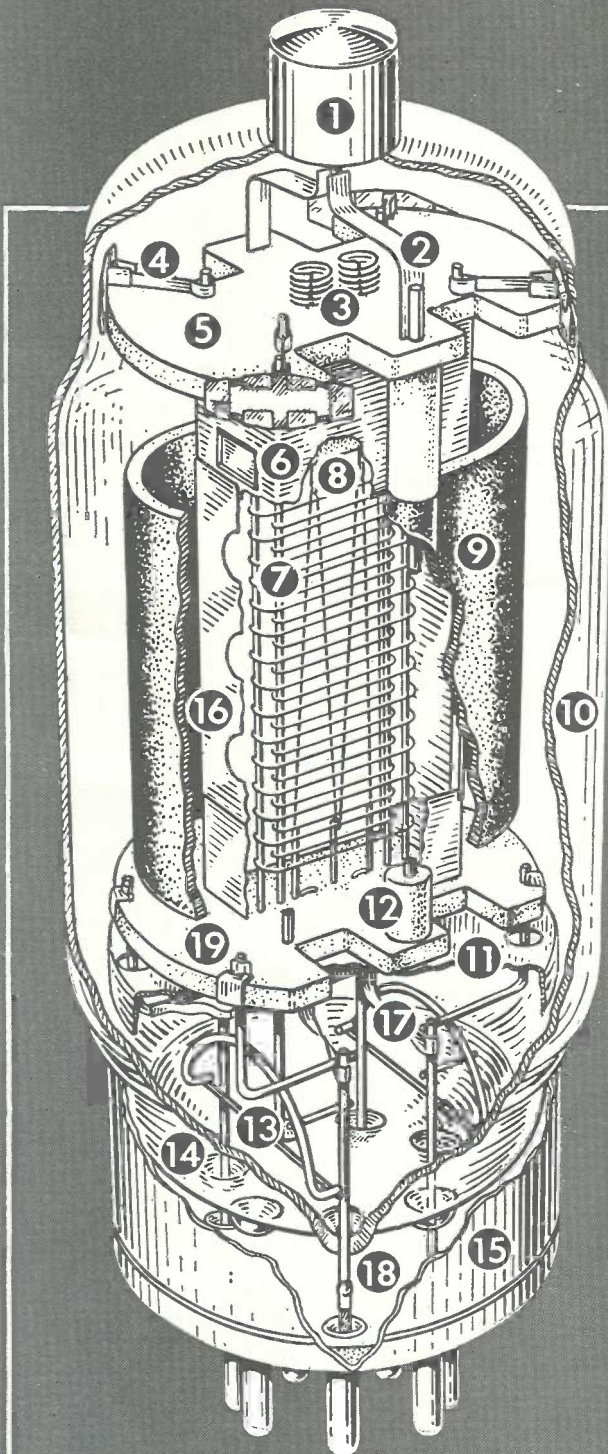

- 1 MEDIUM METAL CAP
- 2 SHORT RIBBON PLATE CONNECTOR
- 3 FILAMENT SUPPORT SPRINGS
- 4 MOUNT SUPPORT
- 5 TOP CERAMIC MOUNT SUPPORT
- 6 TOP SHIELD
- 7 ALIGNED-TURN CONTROL AND SCREEN GRIDS
- 8 HEAVY-DUTY FILAMENT
- 9 LARGE STURDY GRAPHITE PLATE
- 10 HARD-GLASS BULB
- 11 BOTTOM SHIELD DISC
- 12 CERAMIC PLATE-SUPPORT SPACER
- 13 DIRECTIVE-TYPE GETTER CONTAINER
- 14 DISH-TYPE STEM
- 15 CERAMIC-INSERT GIANT BASE
- 16 BEAM-FORMING PLATE
- 17 FILAMENT CONNECTOR
- 18 TUNGSTEN-TO-GLASS SEAL
- 19 BOTTOM CERAMIC MOUNT SUPPORT

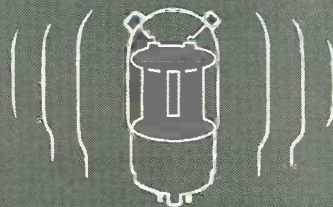

# CONTENTS

## TUBE DATA BY TYPES

	PAGE		PAGE		PAGE
2V3-G	43	857-B	43	1603	45
2X2/879	43	858	41	1608	42
12A6	45	860	41	1609	45
3AP1/906P1	43	862	41	1610	42
3AP4/906P4	43	864	45	1612	45
5AP4/1805P4	43	865	41	1613	42
5BP1/1802P1	43	866-A/866	20	1614	42
5BP4/1802P4	43	868	44	1619	42
7AP4	43	869-B	43	1621	45
9AP4/1804P4	43	870-B	43	1622	45
12AP4/1803P4	43	872	30	1623	10
VR75-30	44	872-A	30	1624	42
VR105-30	44	874	44	1625	42
VR150-30	44	878	43	1626	42
203-A	41	880	42	1629	45
204-A	41	884	31	1631	45
207	41	885	31	1632	45
211	41	887	42	1633	45
217-A	43	888	42	1634	45
217-C	43	889	42	1840	43
800	41	889-R	42	1847	43
801-A	41	891	42	1848	43
802	4	891-R	42	1849	43
803	5	892	42	1850	43
804	5	892-R	42	1851	45
805	6	893	42	1898	43
806	7	893-R	42	1899	43
807	8	898	42	2000	45
808	9	902	43	2050	31
809	10	904	43	2051	31
810	11	905	43	8000	33
811	13	907	43	8001	34
812	14	908	43	8003	35
813	15	913	43	8005	36
814	17	914	43	8012	38
815	18	917	44	8013	39
816	20	918	41	8016	39
825	21	919	44	9001	40
826	21	920	44	9002	40
827-R	22	921	44	9003	40
828	23	922	44		
829	25	923	44		
830-B	41	924	44		
832	25	925	44		
833-A	26	926	44		
834	28	927	44		
836	28	928	44		
837	29	929	44		
838	29	930	44		
841	41	931	44		
842	41	954	32		
843	41	955	32		
845	41	956	32		
846	41	957	32		
849	41	958	32		
850	41	959	32		
851	41	991	44		
852	41	1602	45		

### GENERAL INFORMATION

Constructional View of a Beam Transmitting Tube	2
Tube Data Charts	41
Transmitting Circuit Facts	46
Variable Frequency Oscillator	52
Economy Transmitter	57
UHF 815 Transmitter (2½ to 160 Meters)	59
Single-Control Transmitter Using 813	64
Plate-Modulated Transmitter	67
Filter Design Curves	72

For sales information regarding any RCA product, please write to

SALES DEPARTMENT  
RCA MANUFACTURING COMPANY, Inc.  
CAMDEN, N. J.

For technical information on RCA Tubes, please write to

COMMERCIAL ENGINEERING SECTION  
RCA MANUFACTURING COMPANY, Inc.  
HARRISON, N. J.





# TRANSMITTING TUBE DATA

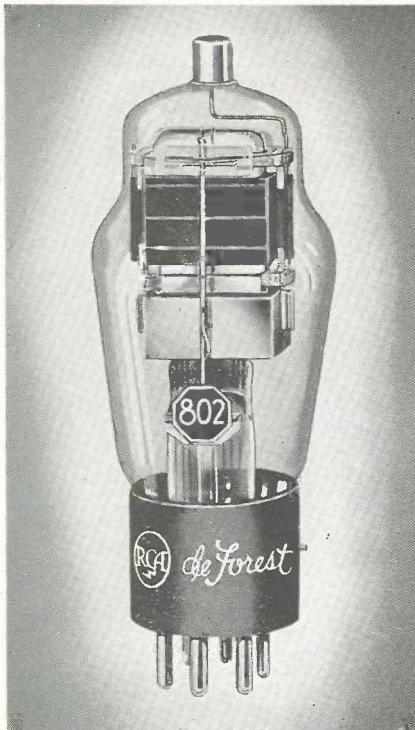

## TRANSMITTING PENTODE

SPECIAL INTERNAL SHIELD DESIGN

33 WATTS INPUT

List Price **\$3.50**

### Features

# 802

*E-C Oscillator*

- **EXCELLENT OSCILLATOR**  
Crystal current extremely low in straight pentode crystal-oscillator connection. Gives high output as electron-coupled oscillator.
- **EXCEPTIONALLY WELL-SHIELDED TUBE STRUCTURE**  
Tube contains special internal shield.
- **LOW DRIVING POWER**  
23 watts output with only 0.3 watt of grid drive.
- **NEUTRALIZATION UNNECESSARY**

RCA-802 is a highly versatile transmitting pentode having a maximum plate-dissipation rating of 13 watts (ICAS).

It is a handy tube to have around the station because of its adaptability to innumerable uses such as, for example, r-f amplifier, frequency multiplier, oscillator, and suppressor-, grid- or plate-modulated amplifier. It may also be used as a class A pentode amplifier or modulator. Neutralization is unnecessary in adequately shielded circuits. As a crystal oscillator, the 802 may be operated under the conditions shown for class C telegraph service. A small condenser of 2 to 3  $\mu\mu\text{f}$  should be connected between control grid and plate to introduce external feed-back. The plate of the tube shows no color at the maximum plate-dissipation rating of 13 watts. The screen should not be allowed to show more than a barely perceptible red color.

Max. Permissible Percentage of Max. Rated Plate Voltage and Plate Input for High-Frequency Operation

FREQUENCY	30	55	100	Mc
CLASS C TELEGRAPHY	100	77	55	Per Cent

### RATINGS

HEATER VOLTAGE (A.C. OR D.C.)	6.3	Volts
HEATER CURRENT	0.9	Ampere
TRANSCONDUCTANCE, FOR PLATE CUR. OF 20 MA.	2250	Micromhos
DIRECT INTERELECTRODE CAPACITANCES:		
Grid-Plate (With external shielding)	0.15 max.	$\mu\mu\text{f}$
Input	12	$\mu\mu\text{f}$
Output	8.5	$\mu\mu\text{f}$
MAXIMUM HEIGHT	5 3/4"	
MAXIMUM DIAMETER	2-1/16"	
SOCKET.....7-Contact (0.855" pin-circle dia), such as RCA type No. 9923		

	CCS	ICAS	
D-C GRID CURRENT	7.5 max.	7.5 max.	Ma.
PLATE INPUT	25 max.	33 max.	Watts
SUPPRESSOR INPUT	2 max.	2 max.	Watts
SCREEN INPUT	6 max.	6 max.	Watts
PLATE DISSIPATION	10 max.	13 max.	Watts

TYPICAL OPERATION:			
D-C Plate Voltage	500	600	Volts
D-C Suppressor Voltage	40	40	Volts
D-C Screen Voltage:*			
From a fixed supply of	250	250	Volts
or from a series resistor of	20800	22000	Ohms

D-C Grid Voltage:*			
From a fixed supply of	-100	-120	Volts
or from cathode resistor of	1700	1620	Ohms
or from a grid resistor of	50000	42000	Ohms
Peak R-F Grid Voltage	155	165	Volts

Internal Shield	Connected to cathode at socket		
D-C Plate Current	45	55	Ma.
D-C Screen Current	12	16	Ma.
D-C Grid Current (Approx.)	2	2.4	Ma.
Driving Power (Approx.)	0.25	0.3	Watt
Power Output (Approx.)	16	23	Watts

\* When a preceding stage is keyed, a fixed, low-voltage screen supply and a fixed grid bias supply should be used.

### MAXIMUM CCS and ICAS RATINGS with TYPICAL OPERATING CONDITIONS

As R-F Power Amplifier and Oscillator Pentode — Class C Telegraphy  
Key-down conditions per tube without modulation

	CCS	ICAS	
D-C PLATE VOLTAGE	500 max.	600 max.	Volts
D-C SUPPRESSOR VOLT. (GRID No. 3)	200 max.	200 max.	Volts
D-C SCREEN VOLT. (GRID No. 2)	250 max.	250 max.	Volts
D-C GRID VOLTAGE (GRID No. 1)	-200 max.	-200 max.	Volts
D-C PLATE CURRENT	60 max.	60 max.	Ma.

### 802-807 REINARTZ HARMONIC GENERATOR For harmonic output up to 8 times fundamental frequency

- C<sub>1</sub>=2 to 3  $\mu\mu\text{f}$  (max.), 600 v.
- C<sub>2</sub>=100  $\mu\mu\text{f}$ , mica
- C<sub>3</sub> C<sub>4</sub> C<sub>5</sub> C<sub>10</sub>=0.005  $\mu\text{f}$ , mica
- C<sub>6</sub> C<sub>7</sub>=1  $\mu\mu\text{f}$ /meter
- C<sub>7</sub>=50  $\mu\mu\text{f}$ , 600 volts
- C<sub>9</sub>=100  $\mu\mu\text{f}$ , 600 volts
- C<sub>11</sub> C<sub>12</sub> C<sub>13</sub>=0.005  $\mu\text{f}$ , mica
- R<sub>1</sub>=5000 ohms, wire wound
- R<sub>2</sub>=20000 ohms, 10 watts
- R<sub>3</sub>=15000 ohms, 10 watts
- R<sub>4</sub>=15000 ohms, 5 watts
- R<sub>5</sub>=10000 ohms, 1 watt
- R<sub>6</sub>=200 ohms, 5 watts
- L<sub>1</sub>=For 1/2 crystal freq., with C<sub>2</sub>
- L<sub>2</sub>=Tune to freq. "F"
- L<sub>3</sub>=Tune to output frequency
- L<sub>4</sub>=R-f choke
- X=Crystal, frequency "F"

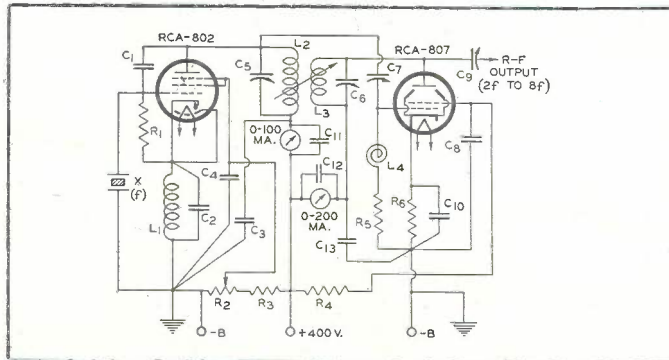

NOTE: Adjust coupling of L<sub>2</sub> and L<sub>3</sub> for maximum harmonic output.  
Correct polarization of L<sub>2</sub> and L<sub>3</sub> is essential.

Bottom View of Socket Connections

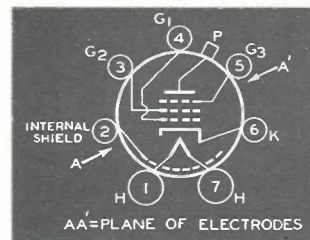

Tube Mounting Position  
VERTICAL or HORIZONTAL



# TRANSMITTING TUBE DATA

## 803 TRANSMITTING PENTODE

350 WATTS INPUT

RCA'S BIGGEST PENTODE

List Price **\$28.50**

RCA-803, with its maximum plate dissipation of 125 watts, is the largest of the RCA transmitting pentodes. It is particularly useful as an r-f amplifier, frequency multiplier, oscillator, and suppressor-, grid-, or plate-modulated amplifier. Neutralization of the tube is unnecessary in adequately shielded circuits. *Maximum plate input for suppressor modulation and grid modulation services is 180 watts. Maximum plate input for plate-modulated pentode and tetrode services is 250 watts. Maximum plate input for pentode and tetrode c-w service is 350 watts.*

The suppressor of the 803 is connected to a separate base-pin terminal. This permits operation of the suppressor at optimum d-c voltage for maximum power output of the tube. It also makes practical the use of the tube as a suppressor-modulated amplifier.

RCA-803 may be operated at maximum ratings at frequencies as high as 20-Mc. It employs a hard glass bulb, is equipped with a ceramic base, has a graphite anode, and contains a heavy-duty, thoriated-tungsten filament.

### RATINGS

FILAMENT VOLTAGE (A.C. or D.C.)	10.0	Volts
FILAMENT CURRENT	5	Amperes
TRANSCONDUCTANCE, for plate cur. of 62.5 ma.	4000	Micromhos
DIRECT INTERELECTRODE CAPACITANCES:		
Grid-Plate (with external shielding)	0.15 max.	$\mu\text{f}$
Input	17.5	$\mu\text{f}$
Output	29	$\mu\text{f}$
MAXIMUM HEIGHT	9 3/4"	
MAXIMUM DIAMETER	2 3/8"	
SOCKET	Giant 5-contact such as RCA type 9927	

### MAXIMUM CCS RATINGS

As Class C R-F Power Amplifier	Plate Modulation	C.W.	
D-C PLATE VOLTAGE	1600 max.	2000 max.	Volts
D-C SUPPRESSOR VOLTAGE (Grid No. 3)	500 max.	500 max.	Volts
D-C SCREEN VOLTAGE (Grid No. 2)	500 max.	600 max.	Volts
D-C GRID VOLTAGE (Grid No. 1)	-500 max.	-500 max.	Volts
D-C PLATE CURRENT	160 max.	175 max.	Ma.
D-C GRID CURRENT	50 max.	50 max.	Ma.
PLATE INPUT	250 max.	350 max.	Watts
SUPPRESSOR INPUT	10 max.	10 max.	Watts
SCREEN INPUT	20 max.	30 max.	Watts
PLATE DISSIPATION	85 max.	125 max.	Watts

### Maximum Permissible Percentage of Maximum Rated Plate Voltage and Plate Input for High-Frequency Operation

FREQUENCY	20	40	60	Mc	
CLASS C	Telegraphy	100	77	60	Per Cent
	Grid-Mod. Telegraphy	100	86	80	Per Cent
	Suppressor-Mod. Tel'y	100	86	80	Per Cent
	Plate-Mod. Telegraphy	100	77	60	Per Cent

## 804 TRANSMITTING PENTODE

150 WATTS INPUT

List Price **\$15.00**

RCA-804 is a pentode transmitting tube of the thoriated-tungsten filament type having a maximum plate-dissipation rating of 50 watts (ICAS). It is well suited for application as an r-f amplifier, frequency multiplier, oscillator, and suppressor-, grid- or plate-modulated amplifier. Neutralization of the tube is unnecessary in adequately shielded circuits. *Maximum plate input for suppressor modulation and grid modulation service is 75 watts (ICAS). Maximum plate input for plate-modulated pentode and tetrode services is 100 watts (ICAS). Maximum plate input for pentode and tetrode c-w service is 150 watts (ICAS).* As a pentode in any r-f service, RCA-804 requires less than 2 watts of driving power.

The suppressor of the 804 is connected to a separate base-pin terminal. This permits operation of the suppressor at optimum d-c voltage for maximum power output of the tube. It also makes practical the use of the tube as a suppressor-modulated amplifier. RCA-804 may be operated at maximum ratings at frequencies as high as 15 Mc. The tube is designed with a MICANOL base.

### RATINGS

FILAMENT VOLTAGE (A.C. or D.C.)	7.5	Volts
FILAMENT CURRENT	3	Amperes
TRANSCONDUCTANCE, for plate cur. of 32 ma.	3250	Micromhos
DIRECT INTERELECTRODE CAPACITANCES:		
Grid-Plate (with external shielding)	0.01 max.	$\mu\text{f}$
Input	16	$\mu\text{f}$
Output	14.5	$\mu\text{f}$
MAXIMUM HEIGHT	7 3/4"	
MAXIMUM DIAMETER	2-1/16"	
SOCKET	Standard 5-contact such as RCA type 9920	

### MAXIMUM CCS and ICAS RATINGS

As R-F Power Amplifier and Oscillator Pentode — Class C Telegraphy	CCS	ICAS	
D-C PLATE VOLTAGE	1250 max.	1500 max.	Volts
D-C SUPPRESSOR VOLTAGE (Grid No. 3)	200 max.	200 max.	Volts
D-C SCREEN VOLTAGE (Grid No. 2)	300 max.	300 max.	Volts
D-C GRID VOLTAGE (Grid No. 1)	-300 max.	-300 max.	Volts
D-C PLATE CURRENT	95 max.	100 max.	Ma.
D-C GRID CURRENT	15 max.	15 max.	Ma.
PLATE INPUT	120 max.	150 max.	Watts
SUPPRESSOR INPUT	5 max.	5 max.	Watts
SCREEN INPUT	15 max.	15 max.	Watts
PLATE DISSIPATION	40 max.	50 max.	Watts

### SUPPRESSOR-MODULATED PENTODE Power Output 21 Watts (Approx.)

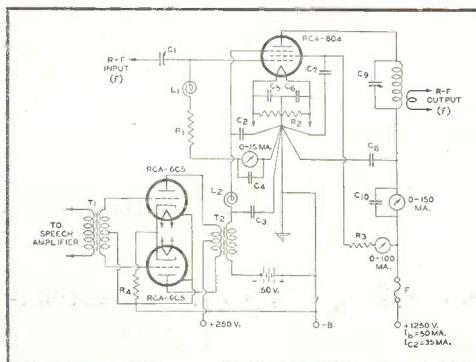

- C<sub>1</sub> = 100  $\mu\text{f}$ , midget
- C<sub>2</sub> C<sub>3</sub> = 0.001  $\mu\text{f}$ , mica
- C<sub>4</sub> C<sub>5</sub> C<sub>10</sub> = 0.005  $\mu\text{f}$ , mica
- C<sub>7</sub> = 0.002  $\mu\text{f}$ , 1500 volts
- C<sub>8</sub> = 0.005  $\mu\text{f}$ , 1500 volts
- C<sub>9</sub> = 0.5  $\mu\text{f}$  / meter
- R<sub>1</sub> = 15000 ohms, 2 watts
- R<sub>2</sub> = 50 ohms, c.t., wire-wound

- R<sub>3</sub> = 27000 ohms, 50 watts
- R<sub>4</sub> = 500 ohms, 0.5 watt
- L<sub>1</sub> L<sub>2</sub> = R-f choke
- T<sub>1</sub> = A-f transformer
- T<sub>2</sub> = Modulation transformer, ratio P/S = 3.0
- F = 1/2ga. high-voltage fuse

### Max. Permissible Percentage of Max. Rated Plate Voltage and Plate Input for High-Frequency Operation

FREQUENCY	15	35	80	Mc	
CLASS C	Telegraphy	100	75	50	Per Cent
	Grid-Mod. Telegraphy	100	88	76	Per Cent
	Sup.-Mod. Telegraphy	100	88	76	Per Cent
	Plate-Mod. Telegraphy	100	75	50	Per Cent

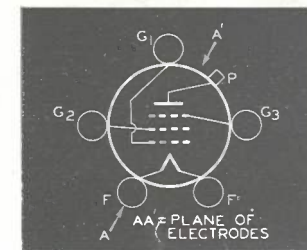
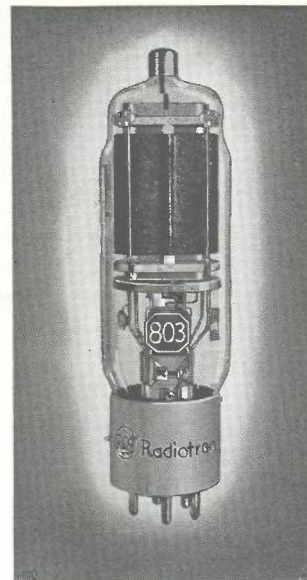

Bottom View of 803 Socket Connections

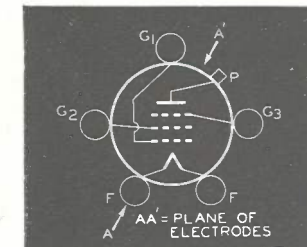
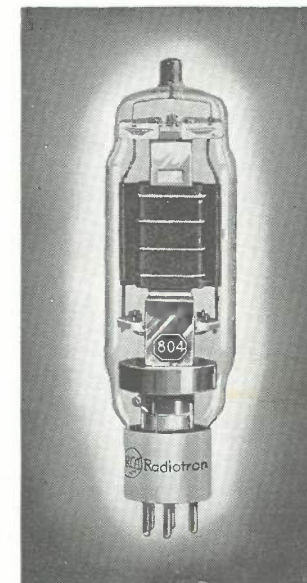

Bottom View of 804 Socket Connections



# TRANSMITTING TUBE DATA

## TRANSMITTING TRIODE

### LOW-DISTORTION CLASS B MODULATOR

315 WATTS INPUT

List Price **\$13.50**

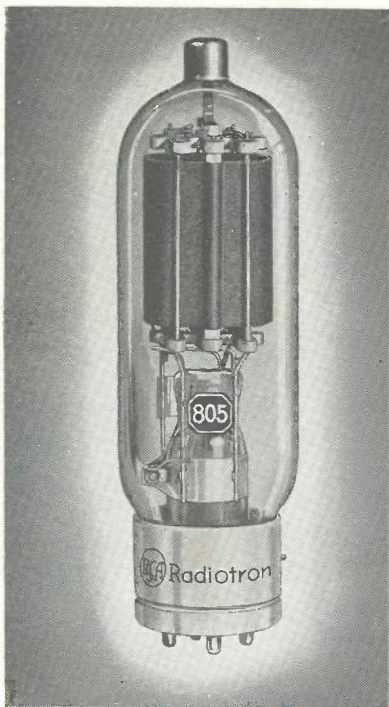

# 805

### Features

- HIGH-POWER OUTPUT WITH LOW PLATE VOLTAGE
- CLASS B A-F OUTPUT DISTORTION BELOW 3%
- 30-Mc OPERATION AT FULL RATINGS
- SPECIAL-PROCESSED GRAPHITE ANODE

RCA-805 is a husky high-mu transmitting triode of the thoriated-tungsten filament type with a maximum plate dissipation of 125 watts (CCS). It is designed both for class B modulator service and for r-f amplifier service. Grid-bias requirements of the tube are unusually low. For example, at the maximum plate-voltage rating of 1500 volts in class C telegraphy, a bias of only -10 volts is needed to protect the tube against loss of grid-excitation voltage.

The grid of the 805 is designed so that the amplification of the tube varies with the amplitude of the input signal. This feature facilitates the design of class B a-f amplifiers and modulators to give high output with low distortion.

RCA-805 contains a graphite plate that is processed to insure high thermal radiation and a minimum of gas. The plate lead is brought out to a rugged terminal at the top of the bulb. The small overall size of the tube lends itself to compact circuit layout. As an r-f power amplifier, RCA-805 may be operated at maximum ratings at frequencies as high as 30 Mc.

### RATINGS

FILAMENT VOLTAGE (A.C. or D.C.)	10.0	Volts
FILAMENT CURRENT	3.25	Ampères
DIRECT INTERELECTRODE CAPACITANCES:		
Grid-Plate	6.5	$\mu\text{f}$
Grid-Filament	8.5	$\mu\text{f}$
Plate-Filament	10.5	$\mu\text{f}$
MAXIMUM HEIGHT	8 1/2"	
MAXIMUM DIAMETER	2-5/16"	
SOCKET	Transmitting 4-contact, such as the RCA type 9936	

### MAXIMUM CCS RATINGS and TYPICAL OPERATING CONDITIONS

#### As A-F Power Amplifier and Modulator—Class B

D-C PLATE VOLTAGE	1500 max.	Volts
MAX-SIGNAL D-C PLATE CURRENT*	210 max.	Ma.
MAX-SIGNAL PLATE INPUT*	315 max.	Watts
PLATE DISSIPATION*	125 max.	Watts

#### TYPICAL OPERATION:

Unless otherwise specified, values are for 2 tubes

D-C Plate Voltage	1250	1500	Volts
D-C Grid Voltage	0	-16	Volts
Peak A-F Grid-to-Grid Voltage	235	280	Volts

Zero-Sig. D-C Plate Current	148	84	Ma.
Max.-S g. D-C Plate Current	400	400	Ma.
Load Resistance (per tube)	1675	2050	Ohms
Effective Load Res. (Plate-to-Plate)	6700	8200	Ohms
Max.-Sig. Driving Power (Approx.)	6	7	Watts
Max-Sig. Power Output (Approx.)	300†	370‡	Watts

#### As R-F Power Amplifier—Class C

	Plate Modulation	C.W.
D-C PLATE VOLTAGE	1250 max.	1500 max. Volts
D-C GRID VOLTAGE	-500 max.	-500 max. Volts
D-C PLATE CURRENT	175 max.	210 max. Ma.
D-C GRID CURRENT	70 max.	70 max. Ma.
PLATE INPUT	220 max.	315 max. Watts
PLATE DISSIPATION	85 max.	125 max. Watts

#### TYPICAL OPERATION:

D-C Plate Voltage	1250	1500	Volts
D-C Grid Voltage:			
From fixed supply of	-160	-105	Volts
From cathode resistor	—	440	Ohms
From grid resistor	2700	2600	Ohms
Peak R-F Grid Voltage	300	235	Volts
D-C Plate Current	160	200	Ma.
D-C Grid Current (Approx.)	60	40	Ma.
Driving Power (Approx.)	16	8.5	Watts
Power Output (Approx.)	140	215	Watts

- \* Averaged over any audio-frequency cycle of sine-wave form.
- † Approximately 4% harmonic distortion.
- ‡ Approximately 3% harmonic distortion.

### APPLICATION

In class B a-f amplifier and modulator service employing two 805's, it is practical to limit the a-f distortion in the output to less than 3% by using a small amount of grid-bias voltage at reduced plate voltage. Typical operating conditions are approximately the same as those for the 1250-volt conditions. The exceptions are: grid-bias voltage, -14 volts; peak a-f grid-to-grid voltage, 250 volts; and zero-signal d-c plate current, 60 milliamperes (two tubes).

#### GRID-MODULATED R-F AMPLIFIER Power Output 60 Watts (Approx.)

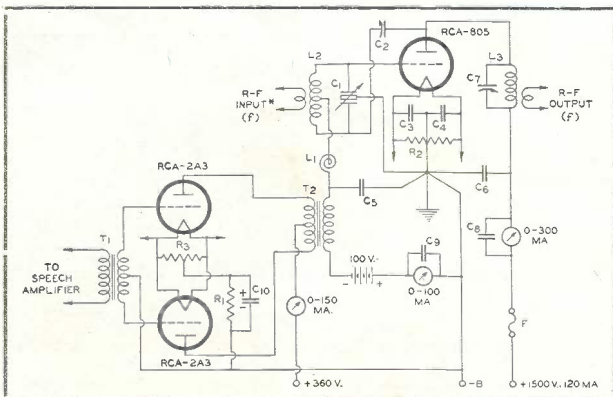

- C<sub>1</sub>=1.5  $\mu\text{f}$  /meter /section
- C<sub>2</sub>=6.5  $\mu\text{f}$  (approx.), 4000 v.
- C<sub>3</sub> C<sub>4</sub> C<sub>5</sub> C<sub>6</sub>=0.005  $\mu\text{f}$ , mica
- C<sub>7</sub>=0.0005  $\mu\text{f}$ , mica
- C<sub>8</sub>=0.005  $\mu\text{f}$ , 2000 v.
- C<sub>9</sub>=1.0  $\mu\text{f}$  /meter
- C<sub>10</sub>=25 to 50  $\mu\text{f}$ , 100 v.
- R<sub>1</sub>=775 ohms, 10 watts
- R<sub>2</sub>=50 ohms, c.t., wire-wound
- R<sub>3</sub>=20 ohms, c.t., wire-wound
- L<sub>1</sub>=R-f choke
- L<sub>2</sub> L<sub>3</sub>=Tune to frequency "f"
- T<sub>1</sub>=Interstage a-f transformer
- T<sub>2</sub>=Modulation transformer
- F=3/16 a. high-voltage fuse

\* The r-f driver should have good r-f voltage regulation under the varying load of the grid-modulated stage.

#### Max. Permissible Percentage of Max. Rated Plate Voltage and Plate Input for High-Frequency Operation

FREQUENCY	CLASS C			
	30	45	80	Mc
CLASS C { Telegraphy Plate-Mod. Telephony	100	82	55	Per Cent

#### Bottom View of Socket Connections

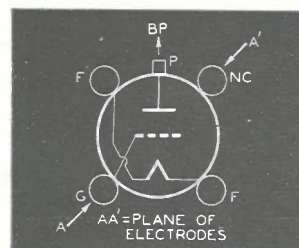

#### Tube Mounting Position

VERTICAL—Base down only.  
HORIZONTAL—Plane of electrodes vertical.





# TRANSMITTING TRIODE

WITH ENCLOSED ANODE

1000 WATTS INPUT

List Price **\$22.00**

## Features

- **TAKES 1000 WATTS (ICAS) ON C.W.**  
Two 806's take 1200 Watts on 'phone.
- **BIG ENCLOSED ANODE**  
This design, a development by RCA, provides more than 75 watts of extra power.
- **50-WATT THORIATED-TUNGSTEN FILAMENT**  
Insures great reserve of emission.
- **30-Mc OPERATION AT FULL RATINGS**  
Up to 100 Mc at reduced ratings.

# 806

*The  
1000 Watter*

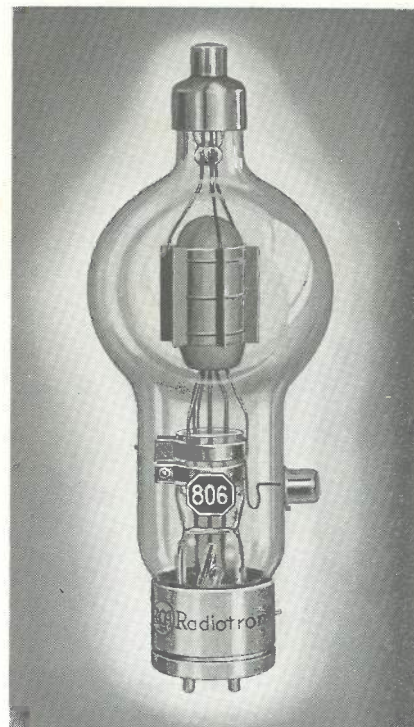

RCA-806 is designed for hard use as a high-power r-f amplifier and class B modulator. A single tube in class C telegraph service can take an input of 1000 watts and requires only 3/4 watts of driving power! Maximum plate dissipation of the tube is 225 watts (ICAS).

The plate of the RCA-806 shows an orange-red color at its maximum plate-dissipation ratings. It is normal for the plate to show some color, even at low loads. Forced ventilation is required for continuous key-down conditions in class C telegraph service and is recommended for all classes of service at frequencies of 30 Mc. or higher.

With a c-w carrier power of 780 watts and 460 watts for 'phone, the 806 is one of the most remarkable values ever offered in the "big-tube" class.

## RATINGS

FILAMENT VOLTAGE (A.C. OR D.C.)	5.0	Volts
FILAMENT CURRENT	9.5	Amperes
AMPLIFICATION FACTOR	12.6	
DIRECT INTERELECTRODE CAPACITANCES:		
Grid-Plate	4.0	$\mu\text{mf}$
Grid-Filament	5.6	$\mu\text{mf}$
Plate-Filament	0.4	$\mu\text{mf}$
MAXIMUM HEIGHT	10"	
MAXIMUM DIAMETER	3-13/16"	
SOCKET.....Standard 4-contact transmitting type, such as RCA type 9936		

	CCS	ICAS	
TYPICAL OPERATION:			
D-C Plate Voltage	2500	3000	Volts
D-C Grid Voltage of	-600	-670	Volts
From a grid resistor of	15000	25000	Ohms
Peak R-F Grid Voltage	890	970	Volts
D-C Plate Current	195	195	Ma.
D-C Grid Current (Approx.)	40	27	Ma.
Driving Power (Approx.)	32	24	Watts
Power Output (Approx.)	390	460	Watts

## MAXIMUM CCS and ICAS RATINGS with TYPICAL OPERATING CONDITIONS

As Plate-Modulated R-F Power Amplifier—Class C Telephony

Carrier conditions per tube for use with a max. modulation factor of 1.0

	CCS	ICAS	
D-C PLATE VOLTAGE	2500 max.	3000 max.	Volts
D-C GRID VOLTAGE	-1000 max.	-1000 max.	Volts
D-C PLATE CURRENT	200 max.	200 max.	Ma.
D-C GRID CURRENT	50 max.	50 max.	Ma.
PLATE INPUT	500 max.	600 max.	Watts
PLATE DISSIPATION	110 max.	150 max.	Watts

Max. Permissible Percentage of Max. Rated Plate Voltage and Plate Input for High-Frequency Operation

FREQUENCY	30	50	100	Mc
CLASS C { Telephony	100	80	50	Per Cent
CLASS C { Plate-Mod. Telephony				

Bottom View of Socket Connections

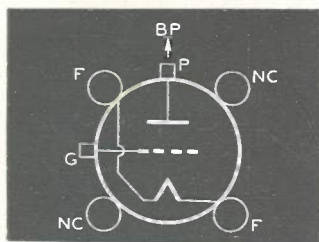

Tube Mounting Position  
VERTICAL—Base down only  
HORIZONTAL—Not recommended

- C<sub>1</sub>=0.7  $\mu\text{mf}$ /meter/section\*+
- C<sub>2</sub> C<sub>3</sub> C<sub>4</sub>=0.005  $\mu\text{f}$  mica
- C<sub>5</sub> C<sub>6</sub>=4.0  $\mu\text{mf}$ \*, high voltage
- C<sub>7</sub>=0.002  $\mu\text{f}$  mica, 7500 volts
- C<sub>8</sub>=1  $\mu\text{mf}$ /meter/section\*+
- R<sub>1</sub>=12500 ohms, 80 watts
- RFC=R-f choke, 500 ma.
- T<sub>1</sub>=Filament transformer
- T<sub>2</sub>=Modulation transformer, 600 watts
- L<sub>1</sub> L<sub>2</sub>=Tune to frequency "f"
- L<sub>3</sub>=D-c overload relay, 600 ma\*\*
- f=Operating frequency
- \*Approximate
- +Capacitance in actual use
- #Maximum value for plate-modulated telephony (ICAS)
- \*\*Contacts of L<sub>3</sub> should break the primary circuit of the high-voltage supply

NOTE: Rotor shaft of C<sub>5</sub> is at the d-c plate potential. An insulated coupling shaft must be inserted between the rotor shaft of C<sub>5</sub> and its control dial.

As R-F Power Amplifier and Oscillator—Class C Telephony  
Key-down conditions per tube without modulation

	CCS	ICAS	
D-C PLATE VOLTAGE	3000 max.	3300 max.	Volts
D-C GRID VOLTAGE	-1000 max.	-1000 max.	Volts
D-C PLATE CURRENT	200 max.	300 max.	Ma.
D-C GRID CURRENT	50 max.	50 max.	Ma.
PLATE INPUT	600 max.	1000 max.	Watts
PLATE DISSIPATION	150 max.	225 max.	Watts
TYPICAL OPERATION:			
D-C Plate Voltage	3000	3300	Volts
D-C Grid Voltage:			
From a fixed supply of	-600	-600	Volts
or from a grid resistor of	24000	15000	Ohms
or from a cathode resistor of	2700	1730	Ohms
Peak R-F Grid Voltage	870	930	Volts
D-C Plate Current	195	300	Ma.
D-C Grid Current (Approx.)	25	40	Ma.
Driving Power (Approx.)	20	34	Watts
Power Output (Approx.)	450	780	Watts

1200-WATT PLATE-MODULATED R-F AMPLIFIER  
Power Output 900 Watts (ICAS)\*

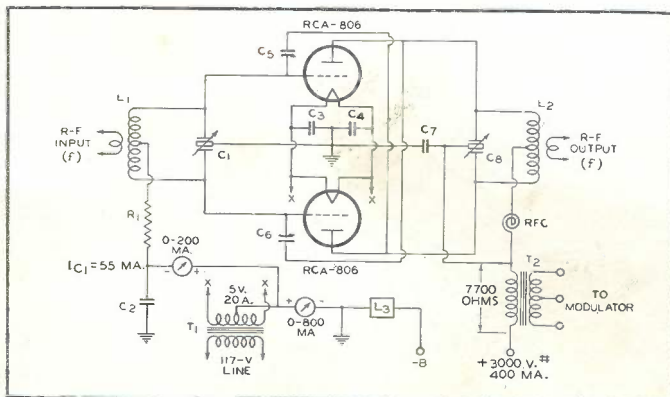



# TRANSMITTING TUBE DATA

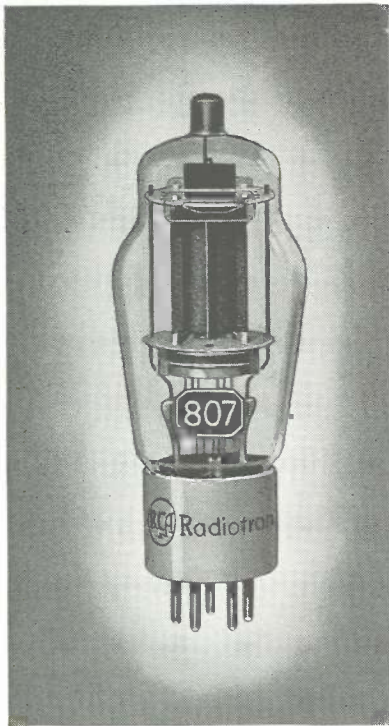

## TRANSMITTING BEAM POWER AMPLIFIER

"LOWEST GRID-DRIVING REQUIREMENT"

75 WATTS INPUT

List Price **\$2.50**

# 807

*The  
"Little Magician"*

### Features

- EXTREMELY LOW DRIVING POWER  
75 Watts input with only 0.2 watt grid drive.
- 60-Mc OPERATION AT FULL RATINGS
- MINIMIZES NUMBER OF DRIVER STAGES
- ELIMINATES NEED FOR NEUTRALIZATION
- 21.4 WATTS INPUT PER DOLLAR (ICAS)
- MICANOL BASE

RCA-807 is a beam power transmitting tube of the heater-cathode type having a maximum plate dissipation rating of 30 watts (ICAS). It is capable of giving full power output with very low driving power. For example, in class C telegraph service, two 807's will deliver 100 watts of power with the amazingly small driving power of less than one-half watt! It is well suited for use in a low-power, portable, storage-battery-operated transmitter; a single 6J5 crystal oscillator will drive it very nicely.

The high power sensitivity of the 807 makes it especially useful as a frequency multiplier where high harmonic output is essential. The tube is also well suited for use as a buffer amplifier in medium-power transmitters, and is ideal as a final amplifier in low-power transmitters. It is an excellent crystal oscillator. Neutralization is unnecessary in adequately shielded circuits. RCA-807 can be operated at maximum ratings at frequencies as high as 60 Mc and at reduced ratings up to 125 Mc. In class AB<sub>2</sub> service, two tubes are capable of modulating 100% an r-f amplifier having an input of nearly 250 watts.

### RATINGS

HEATER VOLTAGE (A.C. OR D.C.)	6.3	Volts
HEATER CURRENT	0.9	Ampere
TRANSCONDUCTANCE, for plate cur. of 72 Ma.	6000 approx.	Micromhos
DIRECT INTERELECTRODE CAPACITANCES:		
Grid-plate (With external shielding)	0.2 max.	$\mu\text{f}$
Input	11	$\mu\text{f}$
Output	7	$\mu\text{f}$
MAXIMUM HEIGHT	5-3/4"	
MAXIMUM DIAMETER	2-1/16"	
SOCKET	Standard 5-contact such as RCA type 9920	

### MAXIMUM CCS and ICAS RATINGS with TYPICAL OPERATING CONDITIONS

As R-F Power Amplifier and Oscillator — Class C Telegraphy  
Key-down conditions per tube without modulation

	CCS	ICAS
D-C PLATE VOLTAGE	600 max.	750 max.
D-C SCREEN VOLTAGE (GRID No. 2)	300 max.	300 max.
D-C GRID VOLTAGE (GRID No. 1)	-200 max.	-200 max.
D-C PLATE CURRENT	100 max.	100 max.
D-C GRID CURRENT	5 max.	5 max.
PLATE INPUT	60 max.	75 max.
SCREEN INPUT	3.5 max.	3.5 max.
PLATE DISSIPATION	25 max.	30 max.

### TYPICAL OPERATION:

D-C Plate Voltage	600	750	Volts
D-C Screen Voltage:			
From a fixed supply of	250	250	Volts
or from a series resistor of	50000	85000	Ohms
D-C Grid Voltage:*			
From a fixed supply of	-45	-45	Volts
or from a cathode resistor of	410	410	Ohms
or from a grid resistor of	12800	12800	Ohms
Peak R-F Grid Voltage	65	65	Volts
D-C Plate Current	100	100	Ma.
D-C Screen Current	7	6	Ma.
D-C Grid Current (Approx.)	3.5	3.5	Ma.
Driving Power (Approx.)	0.2	0.2	Watt
Power Output (Approx.)	40	50	Watts

\* The total effective grid-circuit resistance should not exceed 25000 ohms.

### Max. Permissible Percentage of Max. Rated Plate Voltage and Plate Input for High Frequency Operation

FREQUENCY	60	80	125	Mc
CLASS C { Telegraphy	100	80	55	Per Cent
{ Plate-Mod. Telephony				

### APPLICATION

An r-f amplifier circuit using the RCA-807 is shown on this page. It is capable of producing a power output of approximately 50 watts as an r-f amplifier and about 25 watts as a doubler, with ICAS ratings. The carrier power output in telephony service (ICAS) is approximately 42 watts.

(Continued on page 9)

Bottom View of Socket Connections

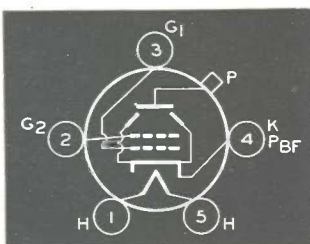

Tube Mounting Position VERTICAL or HORIZONTAL

- C<sub>1</sub>=50  $\mu\text{f}$  midget
- C<sub>2</sub> C<sub>3</sub> C<sub>4</sub> C<sub>6</sub>=0.005  $\mu\text{f}$  mica
- C<sub>5</sub>=2  $\mu\text{f}$ /meter, 1200 v.
- R<sub>1</sub>=6000 ohms, 1 watt
- R<sub>2</sub>=250 ohms, 5 watts
- R<sub>3</sub>=35000 ohms, 10 watts
- R<sub>4</sub>=20000 ohms, 10 watts
- L<sub>1</sub>=R-f choke
- F=1/8 a. high-voltage fuse

NOTE: For frequency doubling, tune C<sub>5</sub> L<sub>2</sub> to frequency "2f." A 50,000-ohm, 10-watt series screen resistor can be used in place of R<sub>3</sub> and R<sub>4</sub>.

### BEAM POWER R-F AMPLIFIER OR FREQUENCY DOUBLER

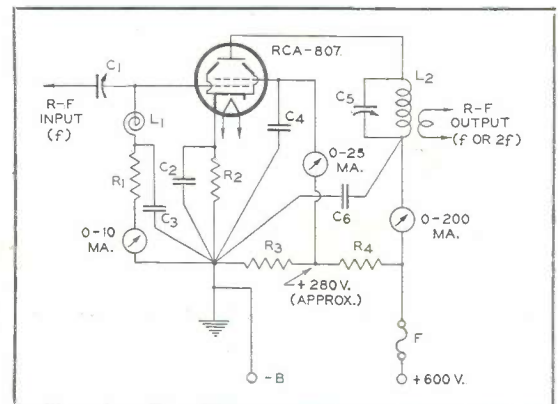

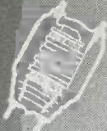

# TRANSMITTING TUBE DATA



## TRITET CRYSTAL OSCILLATOR

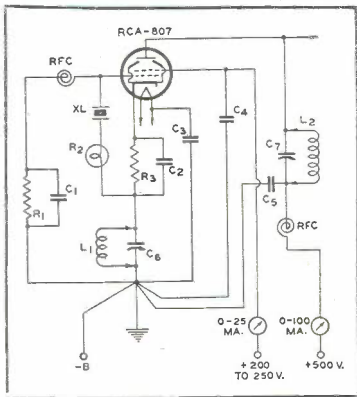

- C<sub>1</sub>=0.001  $\mu$ f, mica
- C<sub>2</sub> C<sub>3</sub> C<sub>4</sub> C<sub>5</sub>=0.01  $\mu$ f, mica
- C<sub>6</sub>=100  $\mu$ f midget
- C<sub>7</sub>=1.0  $\mu$ f/meter
- R<sub>1</sub>=75000 ohms, 1 watt
- R<sub>2</sub>=2.0-Volt, 60-ma. pilot lamp
- R<sub>3</sub>=400 Ohms, 5 watts
- XL=Crystal of frequency "f"
- L<sub>1</sub>=See Note\*
- L<sub>2</sub>=Tune for f, 2f, or 4f

\* See QST for April 1937, for data on Tritet oscillator design, as described by J. J. Lamb.

The "Tritet" crystal-oscillator circuit shown on this page has exceptional efficiency when properly designed and adjusted. The plate circuit may be used for "straight-through" operation, frequency doubling, or frequency quadrupling, whichever is desired. In each case, ample excitation is available to fully excite an 807 buffer amplifier. A guide for the cathode and plate coils may be obtained from those designed in Tables 5 and 6 for the Plate-Modulated Transmitter, page 68.

The push-pull 807 circuit shown on this page will deliver approximately 100 watts output. It provides medium output with minimum driver requirements. It is also useful as a buffer to drive a more powerful amplifier such as an 833-A, push-pull 806's, or push-pull 810's. The circuit is designed for cathode keying. If it is desired to key the oscillator stage for break-in operation, the screen voltage should be obtained from a 275-volt source having good regulation rather than from the series screen resistor. In addition, the grid leak (R<sub>1</sub>) should be replaced by a fixed bias source of about -25 to -30 volts. If no parasitics are encountered in the circuit, R<sub>2</sub>, R<sub>3</sub>, R<sub>4</sub>, and R<sub>5</sub> should be omitted. If it is desired

to use plate modulation, the following changes should be made: R<sub>1</sub>=7500 ohms, 1 watt; R<sub>6</sub>=130 ohms, 20 watts; R<sub>7</sub>=25,000 ohms, 20 watts; E<sub>b</sub>=600 volts, maximum; and a 0.01- $\mu$ f, 600-volt paper condenser should be shunted directly across R<sub>7</sub>, in order to compensate for the audio-frequency by-passing of the screen condensers, C<sub>5</sub> and C<sub>6</sub>. With these changes, the carrier-power output will be approximately 50 watts. The secondary impedance of the modulation transformer should be about 2700 ohms, allowing for modulation of both screen and plate circuits. 100% modulation with excellent linearity can be obtained with a modulator having an a-f power output of about 60 watts.

## PUSH-PULL BEAM POWER R-F AMPLIFIER

Power Output 100 Watts\*—For Class C Telegraph Service

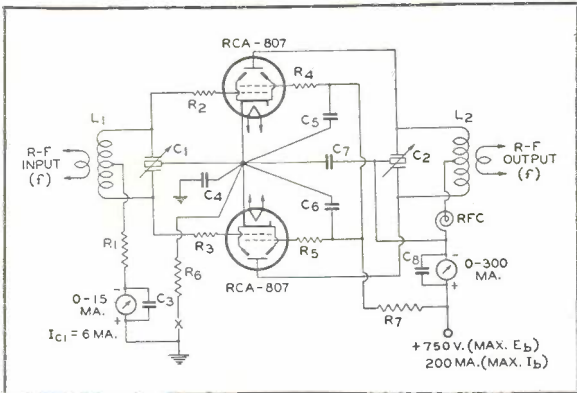

- C<sub>1</sub>=1.5  $\mu$ f/meter/section
- C<sub>2</sub>=2  $\mu$ f/meter/section†
- C<sub>3</sub> C<sub>5</sub>=0.002  $\mu$ f mica
- C<sub>4</sub> C<sub>6</sub> C<sub>7</sub>=0.005  $\mu$ f mica, 1000 V.
- R<sub>1</sub>=2900 ohms, 1 watt
- R<sub>2</sub> R<sub>3</sub> R<sub>4</sub> R<sub>5</sub>=50-ohm carbon, 0.5 watt parasitic suppressor
- R<sub>6</sub>=110 ohms, 20 watts
- R<sub>7</sub>=42500 ohms, 20 watts
- L<sub>1</sub> L<sub>2</sub>=For desired frequency
- RFC=R-f choke
- X=Keying relay
- \*Approximate
- †Capacitance in actual use

NOTES: (1) This circuit is not suitable for keying in the oscillator stage—see text.

(2) Rotor shaft of C<sub>2</sub> is at d-c plate potential; an insulated coupling must be used between rotor shaft and control dial.

# TRANSMITTING TRIODE 808

ENCLOSED ANODE

200 WATTS INPUT

List Price \$7.75

## Features

- ENCLOSED ANODE
- EXTREMELY HIGH VACUUM
- CONSERVATIVE MAXIMUM RATINGS

RCA-808 is a high- $\mu$  transmitting triode having a maximum plate-dissipation rating of 50 watts (CCS). It is excellent for use as an r-f amplifier, frequency multiplier, oscillator, and class B modulator. The anode of the tube almost completely encloses the grid and filament and thus conserves power by eliminating loss from bulb bombardment and stray electrons. No insulation is used within the tube between grid and plate. Wherever uninterrupted service and reliability are required, this rugged triode is a wise choice.

## RATINGS

FILAMENT VOLTAGE (A.C. or D.C.)	7.5	Volts
FILAMENT CURRENT	4	Ampères
AMPLIFICATION FACTOR	47	
DIRECT INTERELECTRODE CAPACITANCES:		
Grid-Plate	2.8	$\mu$ f
Grid-Filament	5.3	$\mu$ f
Plate-Filament	0.15	$\mu$ f
MAXIMUM HEIGHT	6-1/16"	
MAXIMUM DIAMETER	2-13/16"	
SOCKET	Standard 4-contact, such as RCA type 9937 or 9919	

## MAXIMUM RATINGS with TYPICAL OPERATING CONDITIONS

As R-F Power Amplifier and Oscillator—Class C Telegraphy

D-C PLATE VOLTAGE	1500 max. Volts
D-C GRID VOLTAGE	-400 max. Volts
D-C PLATE CURRENT	150 max. Ma.
D-C GRID CURRENT	35 max. Ma.
PLATE INPUT	200 max. Watts
PLATE DISSIPATION	50 max. Watts

## TYPICAL OPERATION:

D-C Plate Voltage	1500	Volts
D-C Grid Voltage:		
From a fixed supply of	-200	Volts
or from a grid resistor of	6700	Ohms
or from a cathode resistor of	1300	Ohms
Peak R-F Grid Voltage	350	Volts
D-C Plate Current	125	Ma.
D-C Grid Current (Approx.)	30	Ma.
Driving Power (Approx.)	9.5	Watts
Power Output (Approx.)	140	Watts

Max. Permissible Percentage of Max. Rated Plate Voltage and Plate Input for High-Frequency Operation

FREQUENCY		30	60	130	Mc
CLASS C	Telegraphy	100	75	50	Per Cent
	Plate-Mod. Telephony				





# TRANSMITTING TUBE DATA



## TRANSMITTING TRIODES

100 WATTS INPUT PER TUBE

List Price **\$250** Each

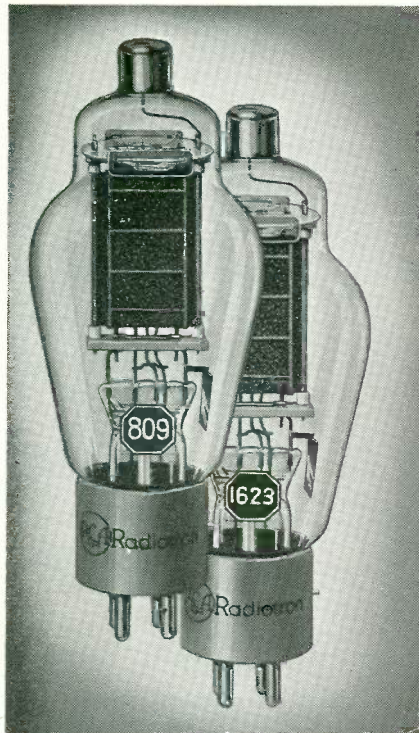

# 809 AND 1623

### 809 Features

- 40 WATTS INPUT PER DOLLAR
- HIGH EFFICIENCY WITH LOW-VOLTAGE POWER SUPPLY
- LOW DRIVING POWER
- 60-Mc OPERATION AT FULL RATINGS

### 1623 Features

- EXTREMELY STABLE OSCILLATOR
- HIGH EFFICIENCY WITH LOW-VOLTAGE POWER SUPPLY
- 75 WATTS OUTPUT WITH ONLY 3.1 WATTS OF GRID DRIVE
- 40 WATTS INPUT PER DOLLAR

RCA-809 and RCA-1623 are high permeance transmitting triodes having a maximum plate dissipation of 30 watts (ICAS) each. The 809 has a mu of 50; the 1623, a mu of 20. Both tubes are designed for use as an r-f power amplifier, frequency doubler, class B modulator, or oscillator. The 809 has the advantage of requiring low grid bias in all services. As a class B modulator it requires only -10 volts bias at a d-c plate voltage of 1000 volts (ICAS). Two 809's in class B a-f service are capable of modulating 100% an r-f stage having a d-c plate input up to 260 watts. As an r-f amplifier, either of these tubes will drive a single plate-modulated 806, or a p-p stage using 810's, 203-A's, or 838's. The 1623 is particularly well suited for self-excited oscillator circuits and performs nicely at 2½ meters. It is unaffected by ordinary plate-load variations and grid-excitation changes. Both types are equipped with the low-loss "Micanol" base.

### RATINGS for 809 and 1623

	Type 1623	Type 809	
FILAMENT VOLTAGE (A.C. or D.C.)	6.3	6.3	Volts
FILAMENT CURRENT	2.5	2.5	Amperes
AMPLIFICATION FACTOR	20	50	
DIRECT INTERELECTRODE CAPACITANCES:			
Grid-Plate	6.7	6.7	μmf
Grid-Filament	5.7	5.7	μmf
Plate-Filament	0.9	0.9	μmf
MAXIMUM LENGTH	6-9/16"		
MAXIMUM DIAMETER	2-7/16"		
SOCKET FOR 809 & 1623: Standard 4-Contact, such as RCA type 9937 or 9919			

### MAXIMUM ICAS RATINGS AND TYPICAL OPERATING CONDITIONS

	As A-F Power Amplifier and Modulator—Class B		
	1623 ICAS	809 ICAS	
D-C PLATE VOLTAGE	1000 max.	1000 max.	Volts
MAX.-SIGNAL D-C PLATE CURRENT*	100 max.	100 max.	Ma.
MAX.-SIGNAL PLATE INPUT*	100 max.	100 max.	Watts
PLATE DISSIPATION*	30 max.	30 max.	Watts
TYPICAL OPERATION: Unless otherwise specified, values are for two tubes			
D-C Plate Voltage	1000	1000	Volts
D-C Grid Voltage	-40	-10	Volts
Peak A-F Grid-to-Grid Voltage	230	156	Volts
Zero-Sig. D-C Plate Current	30	40	Ma.
Max.-Sig. D-C Plate Current	200	200	Ma.
Effective Load Res. (Plate-to-Plate)	12000	11600	Ohms
Max.-Sig. Driving Power	4.2	3.4	Watts
Max.-Sig. Power Output	145	145	Watts

\*Averaged over any audio-frequency cycle of sine-wave form.

### As Plate-Modulated R-F Power Amplifier—Class C Telephony

	Carrier conditions per tube for use with a max. modulation factor of 1.0		
	1623 ICAS	809 ICAS	
D-C GRID VOLTAGE	750 max.	750 max.	Volts
D-C PLATE VOLTAGE	200 max.	200 max.	Volts
D-C PLATE CURRENT	100 max.	100 max.	Ma.
D-C GRID CURRENT	25 max.	35 max.	Ma.
PLATE INPUT	75 max.	75 max.	Watts
PLATE DISSIPATION	25 max.	25 max.	Watts

### Max. Permissible Percentage of Max. Rated Plate Voltage and Plate Input for High-Frequency Operation

FREQUENCY	CLASS C			
	60	70	120	Mc
Teleg. (Plate-Mod. Telephony)	100	88	50	Per Cent

TYPICAL OPERATION:			
D-C Plate Voltage	750	750	Volts
D-C Grid Voltage:			
From a fixed supply of	-125	-60	Volts
or from a grid resistor of	6250	2000	Ohms
Peak R-F Grid Voltage	215	150	Volts
D-C Plate Current	100	100	Ma.
D-C Grid Current (Approx.)	20	32	Ma.
Driving Power (Approx.)	4	4.3	Watts
Power Output (Approx.)	55	55	Watts

### As R-F Power Amplifier and Oscillator—Class C Telegraphy

	1623 ICAS		809 ICAS		
	1000 max.	1000 max.	1000 max.	1000 max.	
D-C PLATE VOLTAGE	1000 max.	1000 max.	1000 max.	1000 max.	Volts
D-C GRID VOLTAGE	-200 max.	-200 max.	-200 max.	-200 max.	Volts
D-C PLATE CURRENT	100 max.	100 max.	100 max.	100 max.	Ma.
D-C GRID CURRENT	25 max.	35 max.	25 max.	35 max.	Ma.
PLATE INPUT	100 max.	100 max.	100 max.	100 max.	Watts
PLATE DISSIPATION	30 max.	30 max.	30 max.	30 max.	Watts
TYPICAL OPERATION:					
D-C Plate Voltage	1000	1000	1000	1000	Volts
D-C Grid Voltage:					
From a fixed supply of	-90	-75	-75	-75	Volts
or from a grid resistor of	4500	3000	3000	3000	Ohms
or from a cathode resistor of	750	600	600	600	Ohms
Peak R-F Grid Voltage	172	160	160	160	Volts
D-C Plate Current	100	100	100	100	Ma.
D-C Grid Current (Approx.)	20	25	25	25	Ma.
Driving Power (Approx.)	3.1	3.8	3.8	3.8	Watts
Power Output (Approx.)	75	75	75	75	Watts

### PUSH-PULL 2½-METER OSCILLATOR (Tuned-Plate, Tuned-Filament Circuit) Power Output 45 Watts

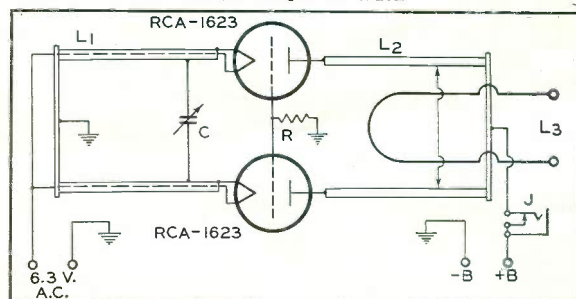

- C=15 μmf, approx.
- R=1000 ohms, 5 watts
- L1=Two 12-inch lengths of 1/2-inch dia. metal tubing spaced 1 inch between centers
- L2=Two 12-inch lengths of 5/8-inch dia. metal tubing spaced 1-1/8 inches between centers. Shorting bar 8-1/2 inches from plate end
- L3=Pick-up loop, 8 inches long
- J=Plate-current jack

### OPERATING CONDITIONS

	C.W.	Phone
PLATE VOLTAGE	500	375 V.
D-C PLATE CUR.	200	200 Ma.

### CLASS "B" MODULATOR (Output 145 Watts)

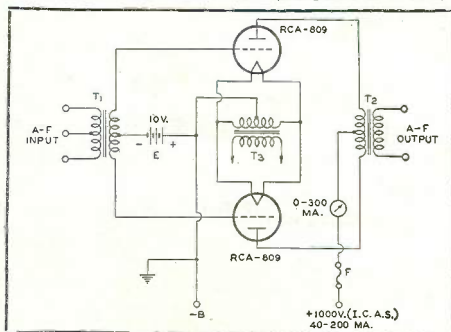

- T1=Input transformer
- T2=Output transformer; primary impedance 11600 ohms, plate-to-plate; 150-watt rating.
- T3=6.3 volt, 5.0 ampere, c.t., filament transformer
- F=¼ a. high-voltage fuse

### Bottom View of 809 and 1623 Socket Connections

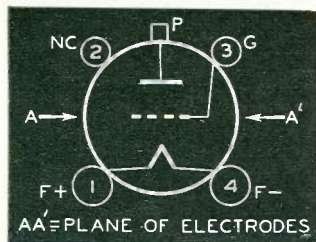

Tube Mounting Position  
 VERTICAL—Base down.  
 HORIZONTAL—Plane of electrodes vertical.



# TRANSMITTING TUBE DATA



## TRANSMITTING TRIODE

GRAPHITE ANODE, SHIELDED FILAMENT

620 WATTS INPUT

List Price **\$13.50**

### Features

- **HIGH POWER WITH RELATIVELY LOW PLATE VOLTAGE**  
High tube perveance permits c-w power input of 620 watts (ICAS) at a plate voltage of only 2250 volts.
- **LOW DRIVING POWER**  
475 watts output on c.w. with 12 watts of drive; 335 watts on 'phone with only 17 watts of drive!
- **BIG, SPECIAL-PROCESSED GRAPHITE PLATE**  
Assures high thermal radiation; gas-free.
- **CLASS B MODULATOR**  
Two tubes will modulate 100% nearly 1½ kilowatts of power.
- **SHIELDED, HEAVY-DUTY FILAMENT**  
End-shields eliminate bulb-bombardment and stray electrons.
- **30-Mc OPERATION AT FULL RATINGS**

# 810

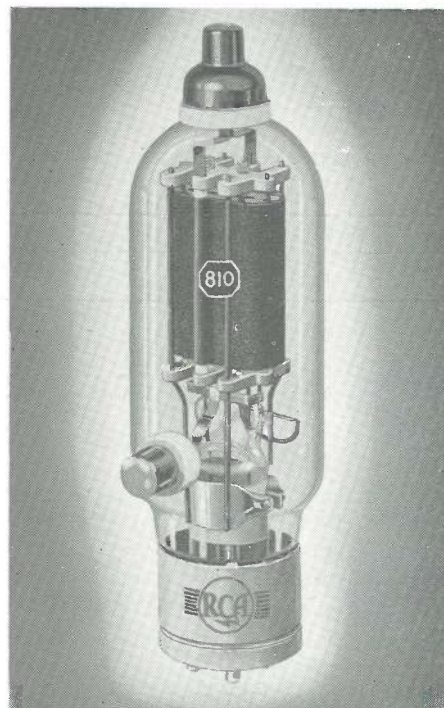

RCA-810 is a high-power transmitting triode with a maximum plate dissipation of 150 watts (ICAS) and a mu of 36. RCA-810 is designed for use as a radio-frequency amplifier and class B modulator. Because of its high perveance, it can be operated at high plate efficiency with low driving power and relatively low plate voltage. For example, two 810's in class C telegraph service (ICAS) will take a plate input of 1240 watts and require only 24 watts of driving power. In class B modulator service (ICAS) two tubes are capable of plate-modulating 100% an r-f amplifier having a power input of nearly one and one-half kilowatts! Grid-bias requirements are unusually low. At a plate voltage of 2000 volts, a grid bias of only -45 volts will protect the tube against overloading caused by loss of grid excitation.

The filament of the 810 is shielded at each end. This construction increases power output by eliminating losses from bulb bombardment and stray electrons. This tube has a graphite anode, specially processed to insure high thermal radiation and a minimum of gas. Plate and grid leads are brought out to rugged terminals at the top and side of the bulb, respectively. This design provides very low lead inductance and permits compact circuit layout for h-f installations. RCA-810 can be operated at frequencies as high as 30 Mc with maximum ratings.

### RATINGS for 810

	RCA-810	
FILAMENT VOLTAGE (A.C. or D.C.)	10.0	Volts
FILAMENT CURRENT	4.5	Amperes
AMPLIFICATION FACTOR	36	
DIRECT INTERELECTRODE CAPACITANCES:		
Grid-Plate	4.8	µuf
Grid-Filament	8.7	µuf
Plate-Filament	12	µuf
MAXIMUM HEIGHT	9-1/16"	
MAXIMUM RADIUS	2-9/16"	
SOCKET	Transmitting 4-contact, such as the RCA type 9936	

### MAXIMUM CCS and ICAS RATINGS with TYPICAL OPERATING CONDITIONS

As A-F Power Amplifier and Modulator—Class B

	CCS	ICAS
D-C PLATE VOLTAGE	2000 max.	2250 max. Volts
MAX.-SIGNAL D-C PLATE CURRENT*	250 max.	250 max. Ma.
MAX.-SIGNAL PLATE INPUT*	425 max.	510 max. Watts
PLATE DISSIPATION*	125 max.	150 max. Watts

TYPICAL OPERATION:

Unless otherwise specified, values are for 2 tubes

D-C Plate Voltage	2000	2250	Volts
D-C Grid Voltage†	-50	-60	Volts
Peak A-F Grid-to-Grid Voltage	345	380	Volts
Zero-Sig. D-C Plate Current	60	70	Ma.
Max.-Sig. D-C Plate Current	420	450	Ma.
Effective Load Resistance (Plate-to-Plate)	11000	11600	Ohms
Max.-Sig. Driving Power (Approx.)	10	13	Watts
Max.-Sig. Power Output (Approx.)	590	725	Watts

As Plate-Modulated R-F Power Amplifier—Class C Telephony

Carrier conditions per tube for use with a max. modulation factor of 1.0

	CCS	ICAS	
D-C PLATE VOLTAGE	1600 max.	1800 max. Volts	
D-C GRID VOLTAGE	-500 max.	-500 max. Volts	
D-C PLATE CURRENT	210 max.	250 max. Ma.	
D-C GRID CURRENT	70 max.	70 max. Ma.	
PLATE INPUT	335 max.	450 max. Watts	
PLATE DISSIPATION	85 max.	125 max. Watts	
TYPICAL OPERATION:			
D-C Plate Voltage	1600	1800	Volts
D-C Grid Voltage:			
From a fixed supply of	-200	-200	Volts

or from a grid resistor of	4000	4000	Ohms
Peak R-F Grid Voltage	370	370	Volts
D-C Plate Current	210	250	Ma.
D-C Grid Current (Approx.)	50	50	Ma.
Driving Power (Approx.)	17	17	Watts
Power Output (Approx.)	250	335	Watts

As R-F Power Amplifier and Oscillator—Class C Telegraphy

Key-down conditions per tube without modulation

	CCS	ICAS	
D-C PLATE VOLTAGE	2000 max.	2250 max. Volts	
D-C GRID VOLTAGE	-500 max.	-500 max. Volts	
D-C PLATE CURRENT	250 max.	275 max. Ma.	
D-C GRID CURRENT	70 max.	70 max. Ma.	
PLATE INPUT	500 max.	620 max. Watts	
PLATE DISSIPATION	125 max.	150 max. Watts	
TYPICAL OPERATION—Class B			
D-C Plate Voltage	2000	2250	Volts
D-C Grid Voltage:			
From a fixed supply of	-160	-160	Volts
or from a grid resistor of	4000	4000	Ohms
or from a cathode resistor of	550	510	Ohms
Peak R-F Grid Voltage	330	330	Volts
D-C Plate Current	250	275	Ma.
D-C Grid Current (Approx.)	40	40	Ma.
Driving Power (Approx.)	12	12	Watts
Power Output (Approx.)	375	475	Watts

\* Averaged over any audio-frequency cycle of sine-wave form.

† Grid voltages are given with respect to the mid-point of filament operated on a.c. If d.c. is used, each stated value of grid voltage should be decreased by one-half the rated filament voltage.

Bottom View of 810 Socket Connections

Tube Mounting Position

VERTICAL—Base down.  
HORIZONTAL—Plane of electrodes vertical.

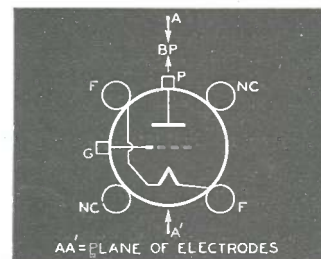



# TRANSMITTING TUBE DATA



† Grid bias may be obtained from a grid leak, or from a combination of grid leak and fixed supply, or grid leak and cathode resistor. The cathode resistor should be suitably by-passed for both a.f. and r.f. The combination method of grid leak and fixed supply has the advantage of not only protecting the tube from damage through loss of excitation but also of minimizing distortion by bias-supply compensation.

Max. Permissible Percentage of Max. Rated Plate Voltage and Plate Input for High-Frequency Operation

FREQUENCY		30	60	100	Mc
CLASS C	Telegraphy	100	70	50	Per Cent
	Plate-mod. Telephony				

## APPLICATION

A typical single-ended r-f amplifier circuit using the 810 or 1627 is shown below. Keying is shown in the filament-to-ground return lead. If it is desired to key the oscillator for break-in operation, a partial fixed bias of -45 volts should be used in conjunction with a grid leak ( $R_1$ ) of about 3000 ohms (10 watts). This amount of fixed bias will protect either tube against removal of grid excitation when the key is open. An RCA-809 operated at reduced ratings or an 807 is suitable for the driver stage. For 10-meter operation with an 80-meter crystal, a practical tube line up is an 807 or 6L6 "Tritet" crystal oscillator-quadrupler, an 807 buffer-amplifier and an 809 doubler. The 809 is needed only for 10-meter operation; it may be omitted for the other bands. With a 10-meter crystal and a 6J5 triode oscillator, an 807 can be used to drive the 810 or 1627 directly, thereby providing a 3-stage, 10-meter transmitter of respectable power output.

CLASS B MODULATOR  
CCS A-F Power Output 590 Watts\*

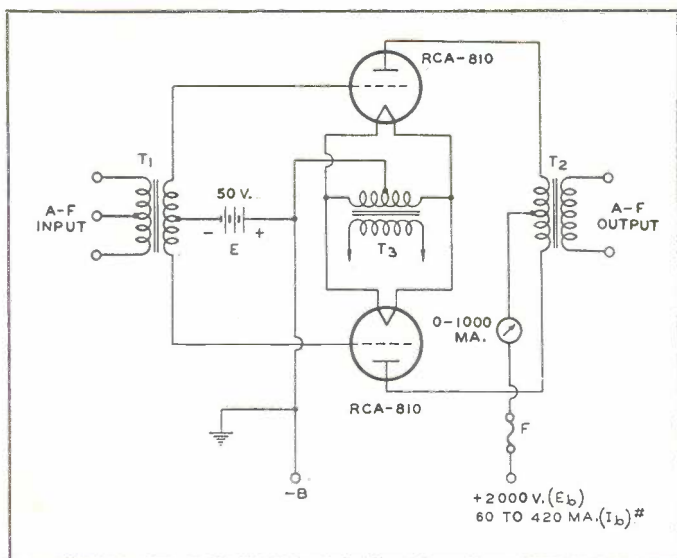

$T_1$ =Input transformer; plate-to-plate impedance, 1500 ohms (Note 2)

$T_2$ =c.t. filament transformer

$T_3$ =Output transformer,  $Z=11,000$  ohms plate-to-plate

$F=1/2$  A. high-voltage fuse

\* Approximately 725 watts for ICAS.

NOTE 1: With  $E_b=1500$  v.,  $E_c=-30$  v.,  $Z=6600$  ohms,  $I_b=80$  to 500 ma., and the power output is 510 watts.

NOTE 2: Four 2A3's in push-pull-parallel, Class AB<sub>1</sub>, operating at  $E_b=300$  v. and  $E_c=-62$  v. (fixed bias), are recommended for the driver stage.

The r-f amplifier circuit shown on this page may be plate modulated by reducing the d-c plate voltage to 1600 volts and the d-c plate current to 210 ma. The grid current should be increased to 50 ma. These are CCS values.

An important advantage of the RCA-810 or the RCA-1627 is its suitability in application now using tubes of the so-called "50-watt" class and where it is desired to increase power without completely re-building the transmitter. In general, these tubes can be used to replace a "50-watt" with only minor circuit changes, including re-neutralizing. If the existing plate supply delivers only 1250 volts, but has ample current capacity, the higher plate-current rating of these tubes can be used to increase the plate input from 220 to 310 watts. If the plate supply is changed so that it will deliver 2250 volts at 275 milliamperes, the power input can be increased from 220 to 620 watts in class C telegraphy service! At the higher voltages, some additional driving power will be needed, but this can usually be obtained without any radical changes in the exciter and driver stages.

A class B modulator employing two 810's or two 1627's is also shown on this page. A recommended driver stage for the modulator employs four 2A3's in class AB<sub>1</sub>, push-pull-parallel, operating at a plate voltage of 300 volts and at a fixed grid bias of -62 volts.

The plates of these tubes show a dull red color at their maximum ICAS plate-dissipation ratings. They show only a barely perceptible red color at their maximum CCS plate-dissipation ratings.

When considering an 810 or a 1627 for high power, you save not only on initial tube cost, but also on the cost of the final-stage tank condenser, on the high-voltage power supply, and on the number of exciter stages required.

R-F POWER AMPLIFIER  
CCS Power Output 375 Watts‡

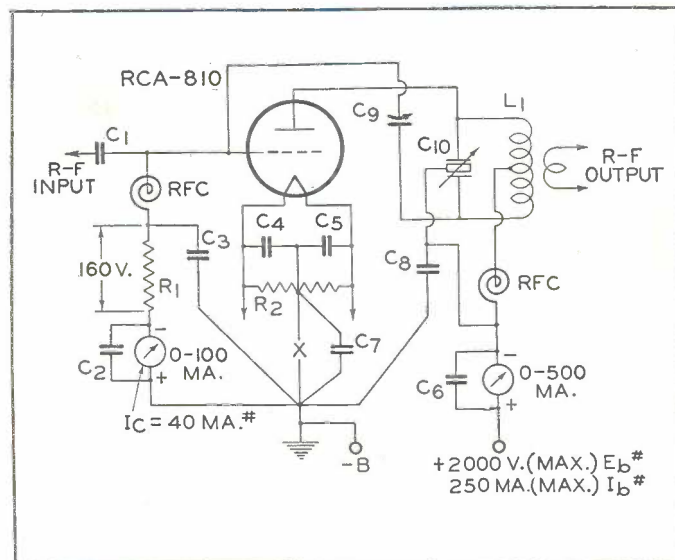

$C_1=0.0005$   $\mu$ f, mica, 1500 v.

$C_2$  to  $C_6=0.002$   $\mu$ f, mica

$C_7=0.002$   $\mu$ f, mica, 2500 v.

$C_8=0.002$   $\mu$ f, mica, 5000 v.

$C_9=4.8$   $\mu$ f (approx.), 7500 v.

$C_{10}=0.75$   $\mu$ f/meter/section†

$R_1=4000$  ohms, 20 watts

$R_2=50$  ohms, c.t., wire-wound

$L_1$ =Select for band desired

RFC=R-f choke

X=Insert keying relay here

‡ Approximately 475 watts for ICAS.

† Approximate capacitance in actual use at resonance.

# For CCS plate-modulated telephony service, reduce  $E_b$  to 1600 v.,  $I_b$  to 210 ma., and increase  $I_c$  to 50 ma. The power output is approximately 250 watts.



# TRANSMITTING TUBE DATA

## TRANSMITTING TRIODE

ZIRCONIUM-COATED ANODE

225 WATTS INPUT

List Price **\$3.50**

### Features

- ZIRCONIUM-COATED ANODE  
Has remarkable heat-dissipating qualities. Acts as an exceptionally effective getter.
- EXTREMELY HIGH MU OF 160  
Zero-bias operation as class B modulator up to 1250 volts.
- IDEAL FOR BREAK-IN OPERATION
- 60-Mc OPERATION AT FULL RATINGS

RCA-811 is a husky high-mu triode having a maximum plate-dissipation rating of 55 watts (ICAS). With a mu of 160, this tube requires no bias in class B modulator service up to a plate voltage of 1250 volts—and only -4.5 to -9 volts of bias up to 1500 volts.

The remarkable ability of the 811 to "take it" is due in a large measure to its Zirconium-coated plate, an RCA development. This type of anode has very high heat-dissipating qualities and in addition functions to keep the tube *hard* during its entire life. Thus, the 811 is capable of withstanding heavy temporary overloads without damage to its filament emission. The tube has a rugged, 25-watt, thoriated-tungsten filament which insures tremendous reserve of emission.

The features of zero-bias operation, 170 watts output on c.w., 120 watts output on 'phone, and 225 watts of audio in class B (2 tubes) make the 811 one of the finest values in transmitting triodes ever presented.

### RATINGS

FILAMENT VOLTAGE (A.C. or D.C.)	6.3	Volts
FILAMENT CURRENT	4	Amperes
AMPLIFICATION FACTOR	160	
DIRECT INTERELECTRODE CAPACITANCES:		
Grid-Plate	5.5	$\mu\text{uf}$
Grid-Filament	5.5	$\mu\text{uf}$
Plate-Filament	0.6	$\mu\text{uf}$
MAXIMUM HEIGHT	6-9/16"	
MAXIMUM DIAMETER	2-7/16"	
SOCKET	Standard 4-contact, such as RCA type 9937	

### MAXIMUM CCS and ICAS RATINGS with TYPICAL OPERATING CONDITIONS

As A-F Power Amplifier and Modulator—Class B

	CCS	ICAS	
D-C PLATE VOLTAGE	1250 max.	1500 max.	Volts
MAX.-SIGNAL D-C PLATE CURRENT*	125 max.	125 max.	Ma.
MAX.-SIGNAL PLATE INPUT*	125 max.	150 max.	Watts
PLATE DISSIPATION*	40 max.	50 max.	Watts

TYPICAL OPERATION: Unless otherwise specified values are for 2 tubes

D-C Plate Voltage	1250	1500	Volts
D-C Grid Voltage	0	-9	Volts
Peak A-F Grid-to-Grid Voltage	140	160	Volts
Zero-Sig. D-C Plate Current	48	20	Ma.
Max.-Sig. D-C Plate Current	200	200	Ma.
Effective Load Resistance (Plate-to-Plate)	15000	18000	Ohms
Max.-Sig. Driving Power (Approx.)	3.8	4.2	Watts
Max.-Sig. Power Output (Approx.)	175	225	Watts

As R-F Power Amplifier and Oscillator—Class C Telegraphy

	CCS	ICAS	
D-C PLATE VOLTAGE	1250 max.	1500 max.	Volts
D-C GRID VOLTAGE	-200 max.	-200 max.	Volts
D-C GRID CURRENT	125 max.	150 max.	Ma.
D-C GRID CURRENT	50 max.	50 max.	Ma.
PLATE INPUT	155 max.	225 max.	Watts
PLATE DISSIPATION	40 max.	55 max.	Watts

Bottom View of Socket Connections

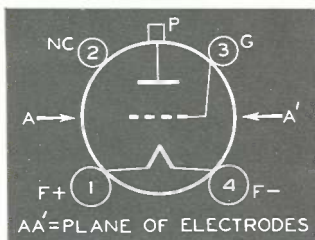

Tube Mounting Position

VERTICAL—Base down.

HORIZONTAL—Plane of plate vertical (on edge).

- C<sub>1</sub>=0.0005  $\mu\text{f}$  mica, 1000 v.
- C<sub>2</sub> C<sub>3</sub>=0.005  $\mu\text{f}$  mica
- C<sub>4</sub> C<sub>7</sub>=0.002  $\mu\text{f}$  mica, 5000 v.
- C<sub>6</sub>=5.5  $\mu\text{f}$ ,\* 6000 v.
- C<sub>8</sub>=0.6  $\mu\text{f}$ /meter/section, † 2000 v.
- R<sub>1</sub>=3500 ohms, 10 watts
- RFC=R-f choke
- T<sub>1</sub>=Filament transformer, 2000 v. insulation
- L<sub>1</sub>=Tune to frequency "f"
- f=Operating frequency

\* Approximate.

† Capacitance in actual use.

NOTE: Rotor shaft of C<sub>8</sub> is at the high d-c plate potential. An insulated coupling shaft must be inserted between the rotor shaft of C<sub>8</sub> and its control dial.

# 811

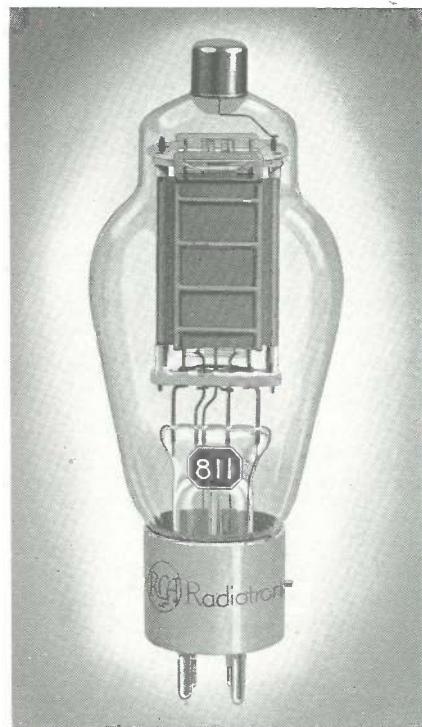

### TYPICAL OPERATION:

	CCS	ICAS	Volts
D-C Plate Voltage	1250	1500	
D-C Grid Voltage:			
From a fixed supply of	-87.5	-113	Volts
or from a grid resistor of	2500	3200	Ohms
or from a cathode resistor of	550	610	Ohms
Peak R-F Grid Voltage	180	225	Volts
D-C Plate Current	125	150	Ma.
D-C Grid Current (Approx.)	35	35	Ma.
Driving Power (Approx.)	7	8	Watts
Power Output (Approx.)	115	170	Watts

\* Averaged over any audio-frequency cycle of sine-wave form.

### Max. Permissible Percentage of Max. Rated Plate Voltage and Plate Input for High-Frequency Operation

CLASS C	FREQUENCY			
	60	80	100	Mc
{ Telegraphy Plate-Mod. Telephony	100	75	60	Per Cent

### APPLICATION

An r-f power amplifier circuit using a single 811 and designed particularly for c-w service is shown below. A single 6L6, 6L6-G, or 6V6-GT/G is suitable for the driver stage.

The plate of the 812 shows a dull red color at its maximum plate-dissipation ratings of 50 to 55 watts; it shows no color at a plate-dissipation of 40 watts. If, for any reason, the plate dissipation rises to approximately 150 watts or more (200% overload!) the excessive plate temperature causes the Zirconium coating to alloy with the plate. This action may produce a shiny spot on the plate which, once formed, remains permanently. It seldom affects the performance of the tube in subsequent normal operation.

### CW R-F POWER AMPLIFIER Class C Telegraphy Power Output 170 Watts\*

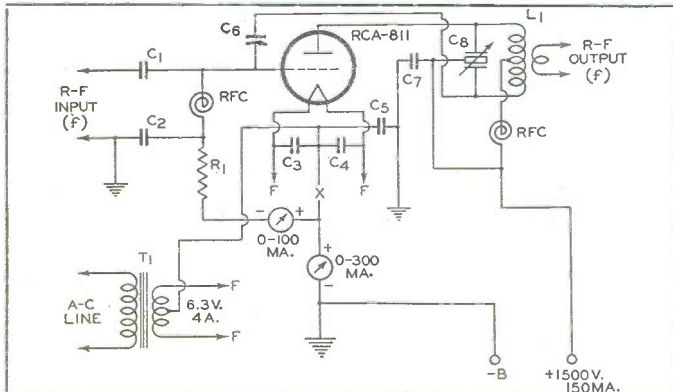

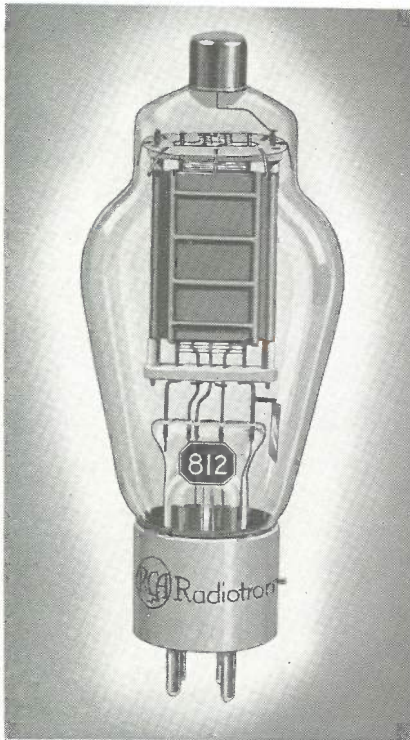

# TRANSMITTING TRIODE

ZIRCONIUM-COATED ANODE

225 WATTS INPUT

List Price **\$3.50**

# 812

### Features

- **ZIRCONIUM-COATED ANODE**  
Has remarkably high heat-dissipating qualities. Acts as an exceptionally effective getter.
- **LOW-LOSS MICANOL BASE**
- **LOW DRIVING POWER**  
170 watts output with only 6.5 watts of grid drive.
- **60-Mc OPERATION AT FULL RATINGS**  
Up to 100 Mc at reduced input.

RCA-812 is a high-perveance, easy-to-drive triode having a maximum plate-dissipation rating of 55 watts (ICAS). This tube, with a medium mu of 29, requires unusually low driving power for class C telegraph and telephone services. Two 812's in class C telegraph service will take a plate input up to 450 watts with the exceptionally low driving power of only 13 watts.

With a carrier power of 170 watts for c-w operation and 120 watts for 'phone operation, the RCA-812 is a transmitting triode that is hard to beat on a basis of performance versus cost.

### RATINGS

FILAMENT VOLTAGE (A.C. or D.C.)	6.3	Volts
FILAMENT CURRENT	4	Amperes
AMPLIFICATION FACTOR	29	
DIRECT INTERELECTRODE CAPACITANCES:		
Grid-Plate	5.3	$\mu\text{f}$
Grid-Filament	5.3	$\mu\text{f}$
Plate-Filament	0.8	$\mu\text{f}$
MAXIMUM HEIGHT	6-9/16"	
MAXIMUM DIAMETER	2-7/16"	
SOCKET	Standard 4-contact, such as RCA type 9937	

### MAXIMUM CCS and ICAS RATINGS with TYPICAL OPERATING CONDITIONS

As Plate-Modulated R-F Power Amplifier—Class C Telephony

Carrier conditions per tube for use with a max. modulation factor of 1.0

	CCS	ICAS
D-C PLATE VOLTAGE	1000 max.	1250 max.
D-C GRID VOLTAGE	-200 max.	-200 max.
D-C PLATE CURRENT	105 max.	125 max.
D-C GRID CURRENT	25 max.	25 max.
PLATE INPUT	105 max.	155 max.
PLATE DISSIPATION	27 max.	40 max.

### TYPICAL OPERATION:

D-C Plate Voltage	1000	1250	Volts
D-C Grid Voltage off	-100	-125	Volts
From a grid resistor of	4000	5000	Ohms
Peak R-F Grid Voltage	180	245	Volts
D-C Plate Current	105	125	Ma.
D-C Grid Current (Approx.)	25	25	Ma.
Driving Power (Approx.)	4.5	6	Watts
Power Output (Approx.)	82	120	Watts

As R-F Power Amplifier and Oscillator—Class C Telegraphy

	CCS	ICAS
D-C PLATE VOLTAGE	1250 max.	1500 max.
D-C GRID VOLTAGE	-200 max.	-200 max.
D-C PLATE CURRENT	125 max.	150 max.
D-C GRID CURRENT	35 max.	35 max.
PLATE INPUT	155 max.	225 max.
PLATE DISSIPATION	40 max.	55 max.

### TYPICAL OPERATION:

D-C Plate Voltage	1250	1500	Volts
D-C Grid Voltage:			
From a fixed supply of	-125	-175	Volts
or from a grid resistor of	5000	7000	Ohms
or from a cathode resistor of	835	1000	Ohms
Peak R-F Grid Voltage	215	285	Volts
D-C Plate Current	125	150	Ma.
D-C Grid Current (Approx.)	25	25	Ma.
Driving Power (Approx.)	5	6.5	Watts
Power Output (Approx.)	116	170	Watts

† Grid bias may be obtained from a grid leak or from a combination of grid leak and fixed supply, or grid leak and cathode resistor. The cathode resistor should be suitably by-passed for both a.f. and r.f. The combination method of grid leak and fixed supply has the advantage of not only protecting the tube from damage through loss of excitation but also of minimizing distortion by bias-supply compensation.

### Max. Permissible Percentage of Max. Rated Plate Voltage and Plate Input for High-Frequency Operation

CLASS C	FREQUENCY			
	60	80	100	Mc
{ Telegraphy	100	75	60	Per Cent
{ Plate-Mod. Telephony				

### CW R-F POWER AMPLIFIER Class C Telephony Power Output 170 Watts\*

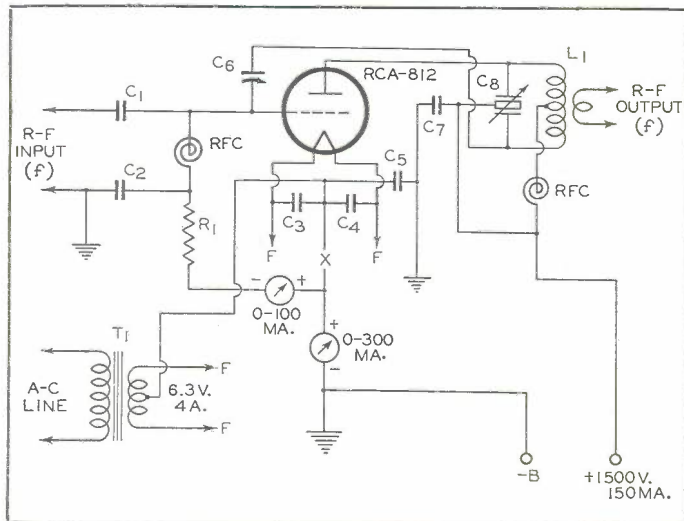

- C<sub>1</sub>=0.0005  $\mu\text{f}$  mica, 1000 v.
- C<sub>2</sub> C<sub>3</sub> C<sub>4</sub>=0.005  $\mu\text{f}$  mica
- C<sub>5</sub> C<sub>7</sub>=0.002  $\mu\text{f}$  mica, 5000 v.
- C<sub>6</sub>=5.3  $\mu\text{f}$ ,\* 6000 v.
- C<sub>8</sub>=0.6  $\mu\text{f}$ /meter/section, † 2000 v.
- R<sub>1</sub>=7000 ohms, 10 watts
- RFC=R-f choke
- T<sub>1</sub>=Filament transformer, 2000-v. insulation
- L<sub>1</sub>=Tune to frequency "f"
- f=Operating frequency

\* Approximate.  
† Capacitance in actual use.

NOTE: Rotor shaft of C<sub>8</sub> is at the high d-c plate potential. An insulated coupling shaft must be inserted between the rotor shaft of C<sub>8</sub> and its control dial.

### Bottom View of Socket Connections

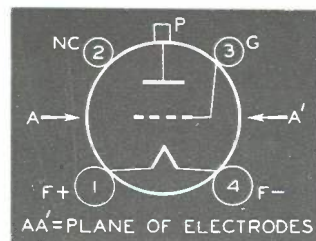

### Tube Mounting Position

VERTICAL—Base down.  
HORIZONTAL—Plane of plate vertical (on edge).



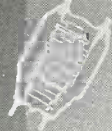

# TRANSMITTING TUBE DATA



## TRANSMITTING BEAM POWER AMPLIFIER

HIGH POWER SENSITIVITY

360 WATTS INPUT

List Price **\$22.00**

### Features

- **HIGH POWER WITH MINIMUM OF EQUIPMENT**  
260 watts output with less than one watt of r-f drive. Any crystal oscillator will drive it.
- **NEUTRALIZING UNNECESSARY**  
Ideal as a high-power final amplifier for quick band-change.
- **LOW SCREEN CURRENT**
- **NEW MOLDED GLASS-DISH TYPE STEM**  
Provides short, heavy leads and low lead inductance.
- **30-Mc OPERATION AT FULL RATINGS**
- **GIANT 7-PIN BASE**  
Has short shell and wide pin spacing.

# 813



RCA-813 is a beam power transmitting tube of extremely high power sensitivity with a maximum plate-dissipation rating of 100 watts. The tube actually requires less than 1 watt of driving power to give 260 watts output on c.w. Neutralization is unnecessary in adequately shielded circuits. RCA-813 makes an excellent power amplifier for the final stage of medium-power transmitters where quick frequency-change without neutralizing adjustments is desirable, and where a minimum of driver equipment is required. The tube requires a very low screen current. RCA-813 is also an excellent frequency multiplier capable of giving high harmonic output with unusually high efficiency.

RCA-813 employs the new Molded Glass-Dish type stem structure, which makes practical a compact but powerful tube—only 7½ inches high—having very short leads and low lead inductance. Other features of the tube include a heavy-duty (50-watt) thoriated-tungsten filament, over-size graphite plate, dome-top bulb with cushion-mounted supports, and a Giant 7-pin base having a short shell and wide pin spacings. As a result of its special construction, the 813 can be operated at maximum ratings at frequencies as high as 30 Mc and at reduced ratings as high as 60 Mc.

RCA-813 is conservatively rated at 360 watts input for class C c-w service and 240 watts for plate-modulated service.

### RATINGS

FILAMENT VOLTAGE (A.C. or D.C.)	10.0	Volts
FILAMENT CURRENT	5	Amperes
TRANSCONDUCTANCE, for Plate Cur. of 50 Ma.	3750 approx.	Micromhos
DIRECT INTERELECTRODE CAPACITANCES:		
Grid-Plate (with External Shielding)	0.2 max.	μuf
Input	16.3	μuf
Output	14	μuf
MAXIMUM HEIGHT	7-1/2"	
MAXIMUM DIAMETER	2-9/16"	
SOCKET	7-contact transmitting, such as the RCA type 9929	

Peak R-F Grid Voltage	195	210	Volts
Beam-Forming Plate Voltage†	0	0	Volts
D-C Plate Current	150	150	Ma.
D-C Screen Current	16	20	Ma.
D-C Grid Current (Approx.)	4	6	Ma.
Driving Power (Approx.)	0.7	1.2	Watts
Power Output (Approx.)	135	175	Watts

### As R-F Power Amplifier and Oscillator—Class C Telegraphy

Key-down conditions per tube without modulation

	CCS		
D-C PLATE VOLTAGE	2000 max.	Volts	
D-C SCREEN VOLTAGE	400 max.	Volts	
D-C GRID VOLTAGE	-300 max.	Volts	
D-C PLATE CURRENT	180 max.	Ma.	
D-C GRID CURRENT	25 max.	Ma.	
PLATE INPUT	360 max.	Watts	
SCREEN INPUT	22 max.	Watts	
PLATE DISSIPATION	100 max.	Watts	

#### TYPICAL OPERATION:

D-C Plate Voltage	1250	1500	2000	Volts
D-C Screen Voltage	300	300	400	Volts
From a series resistor of†	42000	60000	107000	Ohms
D-C Grid Voltage	-60	-70	-90	Volts
From a grid resistor*	8500	11700	30000	Ohms
Peak R-F Grid Voltage	145	150	160	Volts
Beam-Forming Plate Voltage‡	0	0	0	Volts
D-C Plate Current	180	180	180	Ma.
D-C Screen Current	23	20	15	Ma.
D-C Grid Current (Approx.)	7	6	3	Ma.
Driving Power (Approx.)	1	0.8	0.5	Watt
Power Output (Approx.)	155	190	260	Watts

† Series screen resistor should not be used except where the 813 is employed as a buffer amplifier and is not keyed.

‡ Beam-forming plates should be connected to the mid-point of filament circuit operated on a.c., or to the negative end of the filament when a d-c filament supply is used.

§ Supplied preferably from separate modulated screen-voltage source; voltage-dropping resistor in series with modulated plate-voltage supply may be used.

\* The total effective grid-circuit resistance should not exceed 30000 ohms.

### MAXIMUM RATINGS AND TYPICAL OPERATING CONDITIONS

As Plate-Modulated R-F Power Amplifier—Class C Telephony  
Carrier conditions per tube for use with a max. modulation factor of 1.0

	CCS		
D-C PLATE VOLTAGE	1600 max.	Volts	
D-C SCREEN VOLTAGE	400 max.	Volts	
D-C GRID VOLTAGE	-300 max.	Volts	
D-C PLATE CURRENT	150 max.	Ma.	
D-C GRID CURRENT	25 max.	Ma.	
PLATE INPUT	240 max.	Watts	
SCREEN INPUT	15 max.	Watts	
PLATE DISSIPATION	67 max.	Watts	
TYPICAL OPERATION:			
D-C Plate Voltage	1250	1600	Volts
D-C Screen Voltage †	400	400	Volts
From a series screen resistor	58000	60000	Ohms
D-C Grid Voltage*	-120	-130	Volts
From a grid resistor of	30000	21600	Ohms

### Bottom View of Socket Connections

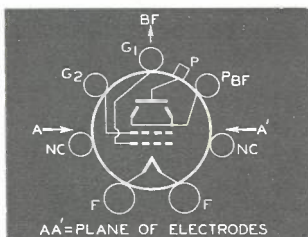

### Tube Mounting Position

VERTICAL—Base up or down.  
HORIZONTAL—Plate in vertical plane (on edge).

### Max. Permissible Percentage of Max. Rated Plate Voltage and Plate Input for High-Frequency Operation

	FREQUENCY	30	45	60	Mc
CLASS C	Telegraphy	100	87	75	Per Cent
	Plate-Mod. Telephony				



## APPLICATION

A circuit employing the 813 in plate-modulated telephony service is shown on this page. In this circuit it will be noted that the plate-circuit by-pass condenser  $C_6$  is connected to ground in series with screen by-pass  $C_5$ . This arrangement minimizes the by-passing effect of  $C_5$  at high audio frequencies and greatly improves the modulation of the screen voltage. Because the screen impedance of the 813 is about 20000 ohms and the series screen resistor required is 60000 ohms, the capacitance ratio of  $C_5$  to  $C_6$  should be about 3 to 1, as indicated in the legend. For operation at 3.5 Mc and lower frequencies, it may be desirable to increase the values of  $C_5$  and  $C_6$ , keeping their ratio the same.

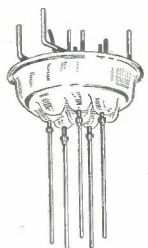

Moulded glass stem assembly showing individual lead seals.

In class C telegraph service, where the grid excitation or the cathode circuit of the 813 is to be keyed, it is important that the screen voltage be obtained from a separate, low-voltage source, or from a tap on a bleeder circuit across the plate supply. It should not be obtained through a series resistor as shown in the plate-modulated-telephony circuit. With the series-resistor method, the d-c screen voltage will rise to the plate potential when the space current is reduced to zero. This voltage, of course, greatly exceeds the maximum screen-voltage rating. When the d-c screen voltage is limited to approximately 400 volts under key-up conditions, a fixed grid bias of -45 or -50 volts is adequate to reduce the plate current to a safe value; partial fixed bias, therefore, is recommended in c-w transmitters where the oscillator stage is to be keyed for break-in operation. The remainder of the required grid bias can be conveniently obtained from a grid leak.

### 813 DESIGN FEATURES

1. Medium Metal Cap
2. Short Ribbon Plate Connector
3. Filament Support Springs
4. Mount Support
5. Top Ceramic Mount Support
6. Top Shield
7. Aligned-Turn Control and Screen Grids
8. Heavy-Duty Thoriated-Tungsten Filament
9. Large Sturdy Graphite Plate
10. Hard Glass Bulb with Mount-Aligning Dome
11. Bottom Shield Disc
12. Ceramic Plate-Support Spacer
13. Directive-Type Getter Container
14. Dish Type Stem
15. Ceramic-Insert Giant Base
16. Beam-Forming Plate
17. Filament Connector
18. Tungsten-to-Glass Seal
19. Bottom Ceramic Mount Support

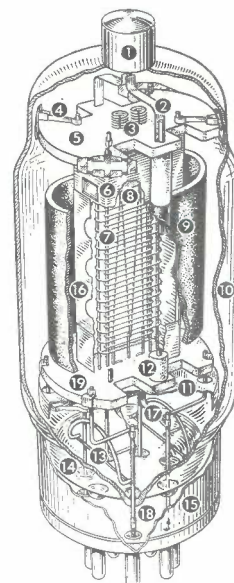

The RCA-813 may also be operated as a grid-modulated r-f power amplifier (class C). Typical operating conditions are: D-c plate voltage, 2000 volts; d-c screen voltage, 400 volts; d-c grid voltage, -120 volts; peak r-f grid voltage, 120 volts; peak a-f grid voltage, 60 volts; beam-forming plate voltage, 0; d-c plate current, 75 ma; and d-c screen current, 3 ma. Under these conditions, power output is approximately 50 watts. In grid-modulated service, the grid bias should be obtained from a fixed supply. Screen voltage should be obtained from a separate source or from a voltage divider connected across the plate-voltage supply. Driving power usually is negligible and never more than 2 watts. Audio driving power is generally never more than 1 watt.

**PUSH-PULL C-W AMPLIFIER**  
Power Output 520 Watts (Approx.)

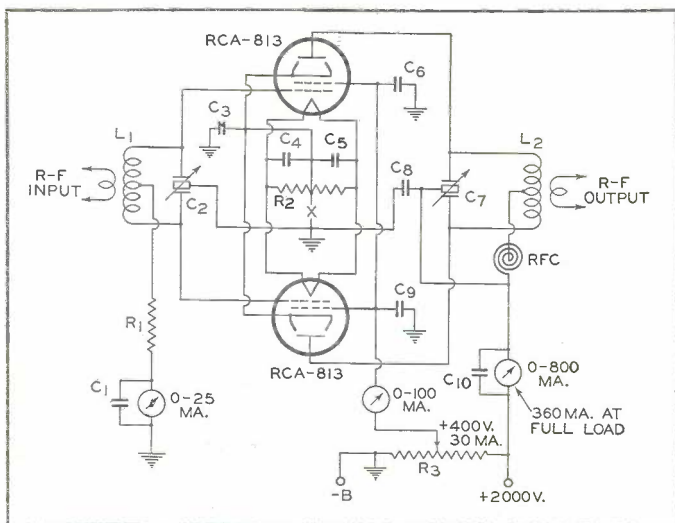

- $C_1$   $C_3$   $C_4$   $C_5$   $C_{10}$  = 0.002  $\mu$ f mica
- $C_2$  = 2  $\mu$ f/meter/section
- $C_6$   $C_9$  = 0.05  $\mu$ f mica, 1000 volts
- $C_7$  = 1.5  $\mu$ f/meter/section
- $C_8$  = 0.005  $\mu$ f mica, 2500 volts
- $L_1$   $L_2$  = Tune to operating frequency

- $R_1$  = 15000 ohms, 2 watts
- $R_2$  = 50 ohms, center-tapped
- $R_3$  = Bleeder Resistor (40000 ohms total or less)
- X = High-voltage keying relay, insulated for 2500 volts. Do not use an ordinary key in this position.

NOTE: Grid circuit should be shielded from plate circuit by metal chassis, or other means.

**PLATE-MODULATED CLASS C R-F POWER AMPLIFIER**  
Power Output 175 Watts (Approx.)

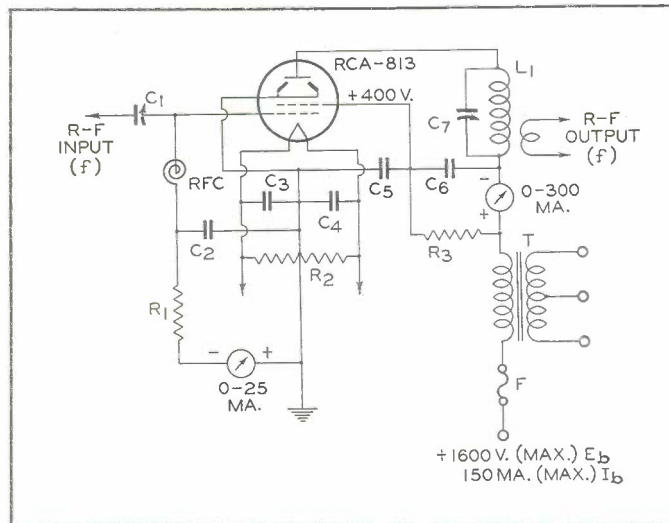

- $C_1$  = 2  $\mu$ f/meter
- $C_2$   $C_3$   $C_4$  = 0.002  $\mu$ f (or larger) mica
- $C_5$  = 0.006  $\mu$ f (or larger) mica, 2000 v.†
- $C_6$  = 0.002  $\mu$ f (or larger) mica, 5000 v.‡
- $C_7$  = 1.2  $\mu$ f/meter†
- $R_1$  = 22000 ohms, 2 watts

- $R_2$  = 50 ohms, c.t., wire-wound
- $R_3$  = 60000 ohms, 50 watts
- $L_1$  = For frequency "f"
- RFC = R-f choke
- T = Modulation transformer; secondary Z = 9500 ohms
- F = 1/4 a. high-voltage fuse

† Ratio of  $C_5$  to  $C_6$  should be kept approximately 3 to 1  
‡ Capacitance in actual use.



# TRANSMITTING TUBE DATA



## TRANSMITTING BEAM POWER AMPLIFIER

CARBONIZED NICKEL ANODE

225 WATTS INPUT

List Price **\$17.50**

### Features

- HIGH POWER SENSITIVITY
- NEUTRALIZING UNNECESSARY
- 30-Mc OPERATION AT FULL RATINGS
- CARBONIZED NICKEL ANODE; MICANOL BASE

# 814

RCA-814 is a beam transmitting tube of the thoriated-tungsten filament type with a maximum plate dissipation rating of 65 watts (ICAS). The high power sensitivity of the tube makes it specially suited for use as an r-f amplifier, frequency multiplier, oscillator, or grid or plate-modulated amplifier. For example, a single 814 is capable of giving a power output of 160 watts in class C telegraphy (ICAS) with a driving power of only 1.5 watts. The plate connection of the tube is brought out to a separate seal at the top of the bulb to maintain low grid-plate capacitance.

The 814 may be operated at maximum ratings in all classes of service at frequencies as high as 30 Mc and at reduced ratings as high as 75 Mc. Neutralization is unnecessary in adequately shielded circuits. For those who require moderately high power and desire a minimum number of transmitter stages, the 814 with its carbonized nickel anode and its Micanol base will be found unexcelled.

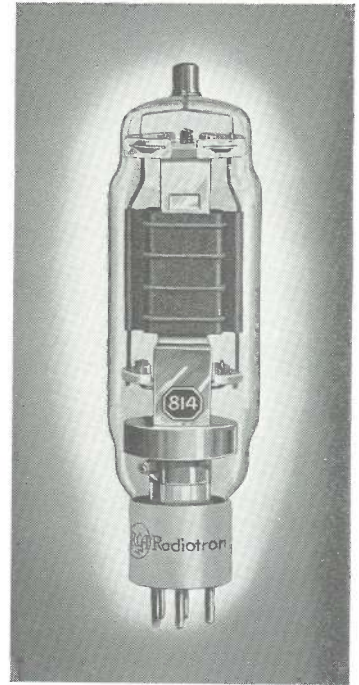

### RATINGS

FILAMENT VOLTAGE (A. C. OR D. C.)	10.0	Volts
FILAMENT CURRENT	3.25	Amperes
TRANSCONDUCTANCE, For plate cur. of 39 ma.	3300	Micromhos
DIRECT INTERELECTRODE CAPACITANCES:		
Grid-Plate (With external shielding)	0.1 max.	$\mu\mu\text{f}$
Input	13.5	$\mu\mu\text{f}$
Output	13.5	$\mu\mu\text{f}$
MAXIMUM HEIGHT	7-3/4"	
MAXIMUM DIAMETER	2-1/16"	
SOCKET	Standard 5-contact, such as the RCA type 9920	

#### As Plate-Modulated R-F Power Amplifier — Class C Telephony

	CCS	ICAS	
D-C PLATE VOLTAGE	1000 max.	1250 max.	Volts
D-C SCREEN VOLTAGE (Grid No. 2)	400 max.	400 max.	Volts
D-C GRID VOLTAGE (Grid No. 1)	-300 max.	-300 max.	Volts
D-C PLATE CURRENT	120 max.	150 max.	Ma.
D-C GRID CURRENT	15 max.	15 max.	Ma.
PLATE INPUT	120 max.	180 max.	Watts
SCREEN INPUT	6.7 max.	6.7 max.	Watts
PLATE DISSIPATION	34 max.	50 max.	Watts
TYPICAL OPERATION:			
D-C Plate Voltage	900	1000	1250
D-C Screen Voltage*			Volts
From a fixed supply of	300	300	300
From a series resistor of	40000	40000	48000
D-C Grid Voltage			Ohms
From a fixed supply of	-150	-150	-150
From a grid resistor of	15000	15000	15000
Beam-Forming Plate Voltage#	0	0	0
Peak R-F Grid Voltage..	215	222	222
D-C Plate Current	120	120	144
D-C Screen Current	15	17.5	20
D-C Grid Cur. (Approx.)	10	10	10
Driving Power (Approx.)	2	2	2
Power Output (Approx.)	76	87	130
			Watts

#### As R-F Power Amplifier and Oscillator — Class C Telegraphy

	1250 max.	1500 max.	
D-C PLATE VOLTAGE	1250 max.	1500 max.	Volts
D-C SCREEN VOLTAGE (Grid No. 2)	400 max.	400 max.	Volts
D-C GRID VOLTAGE (Grid No. 1)	-300 max.	-300 max.	Volts
D-C PLATE CURRENT	150 max.	150 max.	Ma.
D-C GRID CURRENT	15 max.	15 max.	Ma.

### GRID-MODULATED R-F AMPLIFIER

Power Output 29 Watts\* CCS

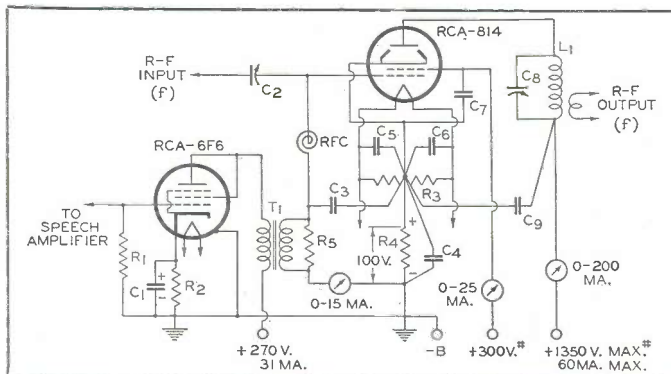

	CCS	ICAS	
PLATE INPUT	180 max.	225 max.	Watts
SCREEN INPUT	10 max.	10 max.	Watts
PLATE DISSIPATION	50 max.	65 max.	Watts

#### TYPICAL OPERATION:

	1250	1500	Volts
D-C Plate Voltage	1250	1500	Volts
D-C Screen Voltage**			Volts
From a fixed supply of	300	300	300
From a series resistor of	42000	50000	48000
D-C Grid Voltage			Ohms
From a fixed supply of	-80	-90	-90
From a cathode resistor of	450	490	490
From a grid resistor of	8000	9000	9000
Beam-Forming Plate Voltage#	0	0	0
Peak R-F Grid Voltage	165	170	170
D-C Plate Current	144	150	150
D-C Screen Current	22.5	24	24
D-C Grid Current (Approx.)	10	10	10
Driving Power (Approx.)	1.5	1.5	1.5
Power Output (Approx.)	130	160	160
			Watts

# Beam-forming plates should be connected to the mid-point of the filament circuit operated on a.c., or to the negative end of the filament when a d-c filament supply is used.

\* Screen voltage is preferably obtained from a fixed supply, modulated simultaneously with the plate voltage. Series voltage-dropping resistor connected to the modulated plate-voltage supply may also be used.

\*\* Series screen resistor should not be used except where the 814 is employed as a buffer amplifier and is not keyed.

#### Maximum Permissible Percentage of Maximum Rated Plate Voltage and Plate Input for High-Frequency Operation

FREQUENCY	CLASS C			
	30	50	75	Mc
Telegraphy				
Plate-Mod. Telephony	100	80	64	Per Cent

- C<sub>1</sub>=25  $\mu\text{f}$ , electrolytic, 50 volts
- C<sub>2</sub>=35  $\mu\text{f}$ , midget
- C<sub>3</sub>=0.002  $\mu\text{f}$ , mica
- C<sub>4</sub> C<sub>5</sub> C<sub>6</sub> C<sub>7</sub>=0.005  $\mu\text{f}$ , mica
- C<sub>8</sub>=0.6  $\mu\text{f}$ /meter
- C<sub>9</sub>=0.002  $\mu\text{f}$ , mica, 2000 volts
- R<sub>1</sub>=0.5 megohm, 0.5 watt
- R<sub>2</sub>=645 ohms, 2 watts
- R<sub>3</sub>=50 ohms, c.t., wire-wound
- R<sub>4</sub>=1560 ohms, 20 watts
- R<sub>5</sub>=8000 ohms, 1 watt
- RFC=R-F choke
- L<sub>1</sub>=Tune to frequency f
- T<sub>1</sub>=Modulation transformer, turns ratio, P/S=1.3; primary load impedance=4000 ohms

\* Approximate.

# The extra 100 volts is to compensate for the voltage drop across cathode resistor R<sub>4</sub>; grid, screen, and plate voltages are measured to the filament. The screen voltage should be obtained from a separate, fixed-voltage source, or from a voltage divider having good regulation—not from a series resistor.

#### Bottom View of Socket Connections

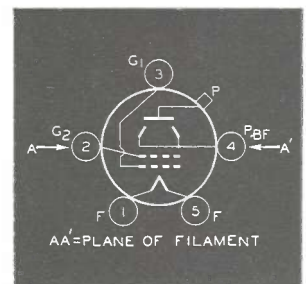

Tube Mounting Position  
VERTICAL—Base down.  
HORIZONTAL—Not recommended.



# TRANSMITTING TUBE DATA



## PUSH-PULL BEAM POWER AMPLIFIER

75 WATTS INPUT TO 2 METERS

List Price \$4.50



# 815

- OPERATES PUSH-PULL WITH 75 WATTS INPUT ON C.W. THROUGH ALL FREQUENCIES TO 150 Mc
- USES LESS THAN 1/2 WATT OF GRID DRIVE
- EXCELLENT FOR EXPERIMENTAL LOW-POWER FM AND TELEVISION TRANSMISSION
- ONLY 400 TO 500 PLATE VOLTS REQUIRED
- GLASS-BUTTON STEM STRUCTURE PROVIDES SHORT LEADS AND LOW LEAD INDUCTANCE

### Features

RCA-815 is the new, low-cost push-pull beam transmitting tube. It is designed particularly for use at wave lengths as low as 2 meters. It requires little driving power, a minimum of driver equipment, and provides full output on only 400 to 500 volts.

The exceptional efficiency of the 815 at the ultra high frequencies is made possible by the balanced and compact structure of the beam units, excellent internal shielding, and close electrode spacing. Internal leads are short in order to minimize lead inductance and resistance. A single 815 operating in push-pull c-w service is capable of handling 75 watts input (ICAS) with less than 0.2 watt of driving power—at frequencies as high as 150 Mc. It may be operated at reduced input up to 225 Mc (1-1/4 meters). Neutralizing of the tube is usually unnecessary.

RCA-815 is equipped with a big octal-type metal-shell base using low-loss Micanol insulation. The heaters of the tube may be operated either in parallel from a 6.3-volt supply or in series from a 12.6-volt supply.

Whether you buy for regular transmitter requirements or with an eye to your new u-h-f and television transmitter, you will find the RCA-815 just about the biggest value on the market. It provides push-pull operation and yet requires but one socket, one cathode resistor, and one screen resistor.

### CHARACTERISTICS and RATINGS

Unless otherwise specified, values are for both units

HEATER (A. C. OR D. C.):			
Voltage per Unit	6.3	Volts	
Current per Unit	0.8	Ampere	
TRANSCONDUCTANCE, for plate current of 25 ma.	4000	Micromhos	
GRID-SCREEN MU-FACTOR	6.5		
DIRECT INTERELECTRODE CAPACITANCES (EACH UNIT):			
Grid-Plate (With external shielding)	0.2 max.	μμf	
Input	13.3	μμf	
Output	8.5	μμf	
MAXIMUM HEIGHT	4-9/16"		
MAXIMUM DIAMETER	2-1/2"		
SOCKET	Standard Octal such as RCA type 9924		

### MAXIMUM CCS and ICAS RATINGS with TYPICAL OPERATING CONDITIONS

As Push-Pull A-F Amplifier and Modulator — Class AB<sub>2</sub>

	CCS	ICAS	
D-C PLATE VOLTAGE	400 max.	500 max.	Volts
D-C SCREEN VOLTAGE (Grid No. 2)	200 max.	200 max.	Volts
MAX.-SIGNAL D-C PLATE CURRENT	150 max.	150 max.	Ma.
MAX.-SIGNAL PLATE INPUT	60 max.	75 max.	Watts
MAX.-SIGNAL SCREEN INPUT	4 max.	4 max.	Watts
PLATE DISSIPATION	20 max.	25 max.	Watts

#### TYPICAL OPERATION:

D-C Plate Voltage	400	500	Volts
D-C Screen Voltage	125	125	Volts
D-C Grid Voltage (Grid No. 1)	-15	-15	Volts
Peak A-F Grid-to-Grid Voltage	60	60	Volts
Zero-Signal D-C Plate Current	20	22	Ma.
Max.-Signal D-C Plate Current	150	150	Ma.
Max.-Signal D-C Screen Current	32	32	Ma.
Load Resistance (Per Plate)	1550	2000	Ohms
Effective Load Resistance (Plate-to-Plate)	6200	8000	Ohms
Max.-Signal Driving Power (Approx.)*	0.36	0.36	Watt
Max.-Signal Power Output (Approx.)	42	54	Watts

As Grid-Modulated Push-Pull R-F Power Amplifier — Class C Telephony Carrier conditions per tube for use with a max. modulation factor of 1.0

	CCS	ICAS	
D-C PLATE VOLTAGE	400 max.	500 max.	Volts
D-C SCREEN VOLTAGE (Grid No. 2)	200 max.	200 max.	Volts
D-C GRID VOLTAGE (Grid No. 1)	-175 max.	-175 max.	Volts
D-C PLATE CURRENT	75 max.	75 max.	Ma.
PLATE INPUT	30 max.	37.5 max.	Watts
SCREEN INPUT	2.5 max.	2.5 max.	Watts
PLATE DISSIPATION	20 max.	25 max.	Watts

#### TYPICAL OPERATION:

D-C Plate Voltage	400	500	Volts
D-C Screen Voltage	125	125	Volts
D-C Grid Voltage	-40	-40	Volts
Peak R-F Grid-to-Grid Voltage	80	80	Volts
Peak A-F Grid Voltage	19	17	Volts
D-C Plate Current	75	75	Ma.
D-C Screen Current	3	3	Ma.
D-C Grid Current (Approx.)	0.4	0.4	Ma.
Driving Power (Approx.) <sup>o</sup>	0.32	0.28	Watt
Power Output (Approx.)	10.5	13	Watts

As Plate-Modulated Push-Pull R-F Power Amplifier — Class C Telephony Carrier conditions per tube for use with a max. modulation factor of 1.0

	CCS	ICAS	
D-C PLATE VOLTAGE	325 max.	400 max.	Volts
D-C SCREEN VOLTAGE (Grid No. 2)	200 max.	200 max.	Volts
D-C GRID VOLTAGE (Grid No. 1)	-175 max.	-175 max.	Volts
D-C PLATE CURRENT	125 max.	150 max.	Ma.
D-C GRID CURRENT	6 max.	6 max.	Ma.
PLATE INPUT	40 max.	60 max.	Watts
SCREEN INPUT	2.7 max.	2.7 max.	Watts
PLATE DISSIPATION	13.5 max.	20 max.	Watts

#### TYPICAL OPERATION:

D-C Plate Voltage	325	400	Volts
D-C Screen Voltage <sup>#</sup>			
From a fixed supply of	165	175	Volts



# TRANSMITTING TUBE DATA



	CCS	ICAS	
From a series resistor of	10000	15000	Ohms
D-C Grid Voltage of	-45	-45	Volts
From a grid resistor of**	11250	15000	Ohms
Peak R-F Grid-to-Grid Voltage	112	116	Volts
D-C Plate Current	123	150	Ma.
D-C Screen Current	16	15	Ma.
D-C Grid Current (Approx.)	4	3	Ma.
Driving Power (Approx.)	0.2	0.16	Watt
Power Output (Approx.)	30	45	Watts

	CCS	ICAS	
From a series resistor of	15000	17500	Ohms
D-C Grid Voltage			
From a fixed supply of	-45	-45	Volts
From a cathode resistor of	260	265	Ohms
From a grid resistor of**	10000	13000	Ohms
Peak R-F Grid-to-Grid Voltage	116	112	Volts
D-C Plate Current	150	150	Ma.
D-C Screen Current	17	17	Ma.
D-C Grid Current (Approx.)	4.5	3.5	Ma.
Driving Power (Approx.)	0.23	0.18	Watt
Power Output (Approx.)	44	56	Watts

### As Push-Pull R-F Power Amplifier and Oscillator — Class C Telegraphy

	CCS	ICAS	
D-C PLATE VOLTAGE	400 max.	500 max.	Volts
D-C SCREEN VOLTAGE (Grid No. 2)	200 max.	200 max.	Volts
D-C GRID VOLTAGE (Grid No. 1)	-175 max.	-175 max.	Volts
D-C PLATE CURRENT	150 max.	150 max.	Ma.
D-C GRID CURRENT	6 max.	6 max.	Ma.
PLATE INPUT	60 max.	75 max.	Watts
SCREEN INPUT	4 max.	4 max.	Watts
PLATE DISSIPATION	20 max.	25 max.	Watts

TYPICAL OPERATION:

D-C Plate Voltage	400	500	Volts
D-C Screen Voltage			
From a fixed supply of	145	200	Volts

### Max. Permissible Percentage of Max. Rated Plate Voltage and Plate Input for High-Frequency Operation

CLASS C	FREQUENCY	PERCENTAGE			
		150	200	225	Mc
}	Grid Mod. Telephony	100	85	75	Per Cent
	Telegraphy	100	80	70	Per Cent
	Plate Mod. Telephony	100	80	70	Per Cent

## APPLICATION

In class C r-f telegraph service, the 815 may be supplied with screen voltage from a separate source, from a voltage divider, or from the plate supply through a series resistor. When a series screen resistor is used, the regulation of the plate supply should be good enough so that the plate voltage will not exceed 600 volts under key-up conditions. Grid bias may be obtained by any convenient method, except when a preceding stage is keyed. In this case, sufficient fixed bias should be used to maintain the d-c plate current at a low value when the key is up.

In plate-modulated class C r-f amplifier service the screen voltage for the RCA-815 should preferably be obtained from a fixed supply modulated simultaneously with the plate voltage, although it may also be obtained from a voltage-dropping resistor connected to the modulated plate supply. In any case, the screen voltage must be modulated simultaneously with the plate voltage so that the ratio of screen voltage to plate voltage remains constant. Modulation of a fixed supply can be accomplished by connecting the screen lead to a separate winding on the modulation transformer.

In grid-modulated class C r-f service grid bias for the 815 should preferably be obtained from a fixed supply. The plates of the tube are supplied with unmodulated d-c voltage. The audio power required in this service is very small and need be sufficient only to meet the peak power requirement of the grids of the class C amplifier on the positive

crest of the input signal. The actual peak value is generally never more than 0.5 watt. The screen voltage should be obtained from a separate source or from a voltage divider connected across the plate supply.

A circuit illustrating an application of the 815 as an u-h-f plate-modulated amplifier is shown on this page. In this service the tube is capable of delivering approximately 45 watts output at a plate voltage of 400 volts. The stage requires about one watt of useful r-f power to insure ample grid excitation of the 815. D-c grid current adjustment may be made by varying the coupling between L1 and L2 and tuning C and C2. Amplifier loading is obtained by adjusting the coupling of the "hairpin" antenna coil to L3. L1 and L2 should be well shielded from L3 by a metal chassis or by a vertical metal baffle plate used to mount the 815. If desired, a small lumped inductance can be used in place of the grid lines. In this case, grid-circuit tuning is best obtained by varying the inductance of the grid coil rather than by tuning it with a variable condenser.

Additional circuit information on the 815 is given under TRANSMITTER CONSTRUCTION, page 59.

The plates of the 815 show no color when the tube is operated at its maximum plate-dissipation rating.

112-116-Mc PLATE-MODULATED R-F POWER AMPLIFIER  
Power Output 45 Watts (ICAS) \*

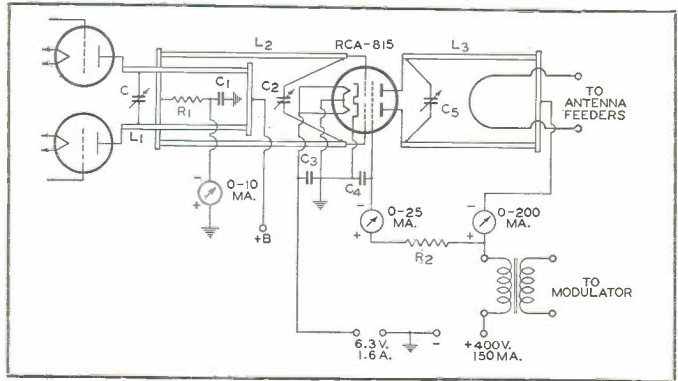

\* Approximate

Bottom View of Socket Connections

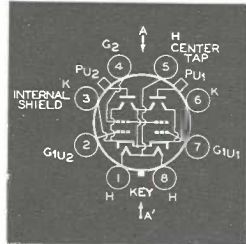

Note: Terminals 3 & 6 must be connected together. Plane of electrodes of each unit is parallel to plane through axis of tube and AA'

PIN 1=Heater  
PIN 2=Grid No. 1 of Unit No. 2  
PIN 3=Cathode, Internal Shield  
PIN 4=Screen  
PIN 5=Heater Center Tap  
PIN 6=Cathode  
PIN 7=Grid No. 1 of Unit No. 1  
PIN 8=Heater  
Pu1 AND Pu2=Plate Terminals of Units No. 1 and No. 2 respectively

- C=See L1
- C1 C3 C4=1" x 1 1/2" copper sheet insulated from chassis by mica sheet 0.002" thick, or 0.0005-μf "postage stamp" mica condensers soldered to chassis with shortest practicable leads
- C2 C5=Copper discs, 1/8" x 1 1/2". Solder discs to 10-32 brass screws 1" long. Drill and tap grid and plate lines for 10-32 screws
- R1=15000 ohms, 0.5 watt
- R2=15000 ohms, 25 watts, adjustable
- L1=1/2" dia. copper tubing. Length of tubing and capacitance of C depend upon driver tubes employed
- L2=1/2" dia. copper tubing, 12 1/2" long and spaced approx. 7/8" between centers
- L3=1/2" dia. copper tubing, 13" long and spaced approx. 7/8" between centers



# TRANSMITTING TUBE DATA

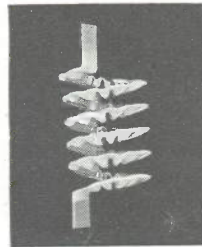

Unique filament design used in the 866-A/866 and its junior, the 816.

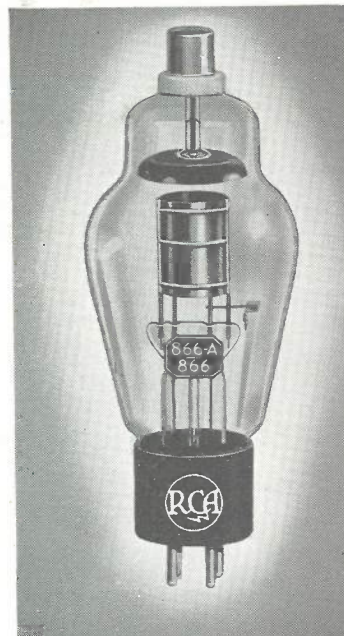

Bottom View of 816, 866A/866 Socket Connections

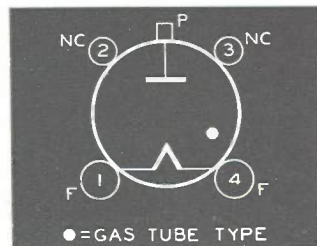

## HALF-WAVE MERCURY-VAPOR RECTIFIER

"JUNIOR OF THE 866-A/866"

List Price **\$1.00**

# 816

### Features

- **SMALL AS A RECEIVING TUBE**
- **TWO TUBES HANDLE TRANSMITTERS UP TO 400 WATTS INPUT (TOTAL).**
- **LONG LIFE**  
Assured by (1) 866-A/866 type filament construction and material, (2) plate lead through top of bulb.
- **HIGH RATINGS FOR SIZE OF TUBE**  
5000 volts, peak inverse voltage  
500 ma., peak plate current

RCA-816 is the junior transmitting-type rectifier for use particularly in medium power transmitters of 400 watts input (total) or less. Unlike ordinary small half-wave, mercury-vapor rectifiers of this type, the 816 is designed so that the plate lead is brought out through a separate seal at the top of the bulb, a construction which eliminates stem electrolysis and makes it possible for the tube to handle a maximum peak inverse voltage rating of 5000 volts. *Two 816's operating in a full-wave rectifier circuit are capable of delivering to the input of a choke-input type filter a rectified voltage of 1600 volts at 250 ma., with good regulation, with exceptional life—and at a total rectifier tube cost of only \$2.00!*

### RATINGS FOR RCA-816

FILAMENT VOLTAGE (A.C.)	2.5	Volts
FILAMENT CURRENT	2.0	Amperes
PEAK INVERSE VOLTAGE*	5000 max.	Volts
PEAK PLATE CURRENT	500 max.	Ma.
AVERAGE PLATE CURRENT	125 max.	Ma.
TUBE VOLTAGE DROP (Approx.)	15	Volts
MAXIMUM HEIGHT	4-11/16"	
MAXIMUM DIAMETER	1-9/16"	
SOCKET	Standard 4-contact, such as RCA type 9919	

\* For supply frequency up to 150 cycles and for a condensed-mercury temperature of 20 to 60° C.

## HALF-WAVE MERCURY-VAPOR RECTIFIER

"A RECTIFIER TUBE WITH A LONGER LIFE"

List Price **\$1.50**

# 866-A 866

### Features

- **LONGER LIFE**  
Assured by (1) radically new filament, (2) insulated plate cap
- **ENORMOUS EMISSION RESERVE**
- **HIGH RATINGS**  
10,000 volts, peak inverse voltage  
1,000 ma., peak plate current

RCA-866-A/866 is a half-wave, mercury-vapor rectifier, strikingly different in design and construction from ordinary 866 types. Secret of the 866-A/866 is its edgewise-wound coated ribbon filament, illustrated on this page. This filament has great mechanical strength and provides more emitting area for the same filament power rating. It utilizes a new alloy material that not only has tremendous electron-emitting capabilities but also holds the key to greater tube life.

RCA-866-A/866 supersedes the 866-A and 866 and may be used in equipment designed for the former types. It combines the ability of the 866-A to withstand high peak inverse voltages with the ability of the 866 to conduct at low plate voltage. *Thus, at the maximum peak inverse voltage rating of 10,000 volts and a maximum peak plate current rating of 1.0 ampere per tube, two 866-A/866's operating in a full-wave rectifier circuit are capable of delivering to the input of a choke-input filter a rectified voltage of 3200 volts at 500 ma. with good regulation and with exceptional life.*

RCA-866-A/866 not only handles more power at lower initial cost, but its long life provides great tube economies. When this type is installed in your equipment you can forget rectifier tube problems for a long time to come.

For circuit information, refer to page 30 under RCA-872 and 872-A. For design of filters, see page 72.

### RATINGS FOR RCA-866A/866

FILAMENT VOLTAGE (A.C.)	2.5	2.5	Volts
FILAMENT CURRENT	5.0	5.0	Amperes
PEAK INVERSE VOLTAGE*:			
(For supply frequencies up to 150 cycles)			
Cond. Mercury Temp. 25° to 60° C.	—	10000 max.	Volts
Cond. Mercury Temp. 25° to 70° C.	200 max.	—	Volts
(For supply frequencies up to 1000 cycles)			
Cond. Mercury Temp. 25° to 70° C.	—	5000 max.	Volts
Cond. Mercury Temp. 25° to 70° C.	2.0 max.	1.0 max.	Amperes
PEAK PLATE CURRENT	0.5 max.	0.25 max.	Ampere
AVERAGE PLATE CURRENT	15	15	Volts
TUBE VOLTAGE DROP (Approx.)			
MAXIMUM HEIGHT			6-5/8"
MAXIMUM DIAMETER			2-7/16"
SOCKET	Standard 4-contact, such as RCA type 9937 or 9919		

\* Operation of tube at 40°±5° C. is recommended



# TRANSMITTING TUBE DATA

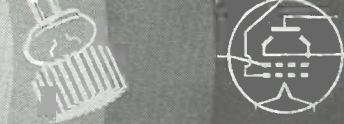

## INDUCTIVE-OUTPUT AMPLIFIER

60% EFFICIENCY AT 500 Mc!

# 825

100 WATTS INPUT

List Price \$34.50

RCA-825 is a multi-electrode transmitting tube designed for use as a power amplifier, particularly at frequencies above 300 Mc. It is capable of giving as much as 35 watts output at frequencies up to 500 Mc, depending on the bandwidth and service of the application.

As a result of a new principle employed wherein the electron stream is inductively coupled to the output circuit, the 825 is free from many of the ordinary tube limitations encountered in ultra high-frequency operations. Its high transconductance and its adaptability to tank circuits having low effective capacitance makes it especially suited for wideband services such as television and frequency-modulation. The 825 is also useful as an oscillator and harmonic generator in the same way as tubes of more conventional design.

The 825 is an RCA engineering achievement which suggests new possibilities for radio transmission at the ultra-high frequencies. Complete technical information on the tube is available on request.

### RATINGS

HEATER VOLTAGE (A.C. or D.C.)	6.3	Volts
HEATER CURRENT	0.75	Ampere
TRANSCONDUCTANCE for plate current of 50 ma.	5500	Micromhos
DIRECT INTERELECTRODE CAPACITANCES:		
Grid No. 1 to Grid No. 2	1.8 max.	$\mu\text{f}$
Grid No. 1 to Cathode	3.2	$\mu\text{f}$
Grid No. 2 to Cathode	0.9	$\mu\text{f}$
MAXIMUM LENGTH	8-3/4"	
MAXIMUM DIAMETER	2-1/16"	
SOCKET	RCA type 9918	

### MAXIMUM CCS RATINGS

As R-F Power Amplifier and Oscillator—Class C Telegraphy

D-C COLLECTOR VOLTAGE	2000 max.	Volts
D-C GRID No. 4 VOLTAGE	1500 max.	Volts
D-C GRID No. 3 VOLTAGE	3600 max.	Volts
D-C GRID No. 2 VOLTAGE	3600 max.	Volts
D-C GRID No. 1 VOLTAGE	-100 max.	Volts
D-C COLLECTOR CURRENT	50 max.	Ma.
D-C GRID No. 1 CURRENT	2.5 max.	Ma.
COLLECTOR INPUT	100 max.	Watts
GRID No. 4 INPUT	7 max.	Watts
GRID No. 3 INPUT	5 max.	Watts
GRID No. 2 INPUT	7 max.	Watts
COLLECTOR DISSIPATION	50 max.	Watts
GRID No. 1 DISSIPATION	0.15 max.	Watt



Bottom View of 825 Socket Connections

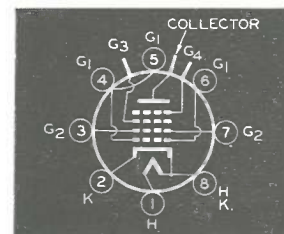

## U-H-F TRANSMITTING TRIODE

ZIRCONIUM-COATED ANODE; MOLDED GLASS DISH STEM

125 WATTS INPUT

# 826

List Price \$19.00

RCA-826 is a ruggedly built triode for use as an oscillator, r-f power amplifier, and frequency multiplier at the ultra-high frequencies. It has a maximum plate dissipation rating of 60 watts (CCS) and may be operated with unusual plate-circuit efficiency at frequencies as high as 250 Mc— at reduced ratings up to 300 Mc.

RCA-826 possesses many mechanical and electrical features. It contains zirconium-coated anode to insure gas-free operation at extremely high temperatures; its grid and plate are closely spaced to increase plate-circuit efficiency at the higher frequencies; it is designed with a double-helical thoriated-tungsten filament that is center-tapped within the tube to minimize effects of filament inductance; and it is constructed with a molded glass-dish stem which makes possible a compact but powerful tube having very short leads and low lead inductance. Terminal arrangement of the tube permits the use of short and separate leads for neutralizing.

RCA-826 fills that long need for a moderately priced triode that delivers the goods at the ultra highs.

When the 826 is operated at the ultra-high frequencies, push-pull operation is recommended. This connection has the advantage of simplifying the balancing of high-frequency circuits by providing symmetry of circuit layout. In oscillator service, it is desirable to connect the two grid terminals and the two plate terminals of each tube in parallel in order to reduce the respective lead inductances.

### RATINGS

FILAMENT VOLTAGE (A.C. or D.C.)	7.5	Volts
FILAMENT CURRENT	4	Ampere
AMPLIFICATION FACTOR	31	
DIRECT INTERELECTRODE CAPACITANCES:		
Grid-Plate	2.9	$\mu\text{f}$
Grid-Filament	3.7	$\mu\text{f}$
Plate-Filament	1.4	$\mu\text{f}$
MAXIMUM LENGTH	8-11/16"	
MAXIMUM DIAMETER	2-1/16"	
SOCKET	Special, such as RCA type 9934	

### MAXIMUM CCS RATINGS and TYPICAL OPERATING CONDITIONS

As Class C R-F Power Amplifier

	Plate Modulation	C.W.
D-C PLATE VOLTAGE	800 max.	1000 max. Volts
D-C GRID VOLTAGE	-500 max.	-500 max. Volts
D-C PLATE CURRENT	95 max.	125 max. Ma.
D-C GRID CURRENT	40 max.	35 max. Ma.
PLATE INPUT	75 max.	125 max. Watts
PLATE DISSIPATION	40 max.	60 max. Watts
TYPICAL OPERATION:		
D-C Plate Voltage	800	1000 Volts
D-C Grid Voltage:		
From a fixed supply of	-98	-70 Volts
or from a grid resistor of	2800	2000 Ohms
or from a cathode resistor of	—	440 Ohms
Peak R-F Grid Voltage	198	183 Volts
D-C Plate Current	94	125 Ma.
D-C Grid Current (Approx.)	35	35 Ma.
Driving Power (Approx.)	6.2	5.8 Watts
Power Output (Approx.)	53	86 Watts

Max. Permissible Percentage of Max. Rated Plate Voltage and Plate Input for High-Frequency Operation

FREQUENCY	250	300	Mc
CLASS C { Telegraphy	100	80	Per Cent
{ Plate-Mod. Telegraphy			

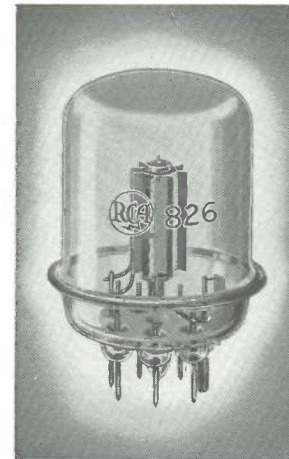

Bottom View of 826 Socket Connections

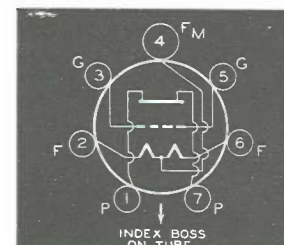

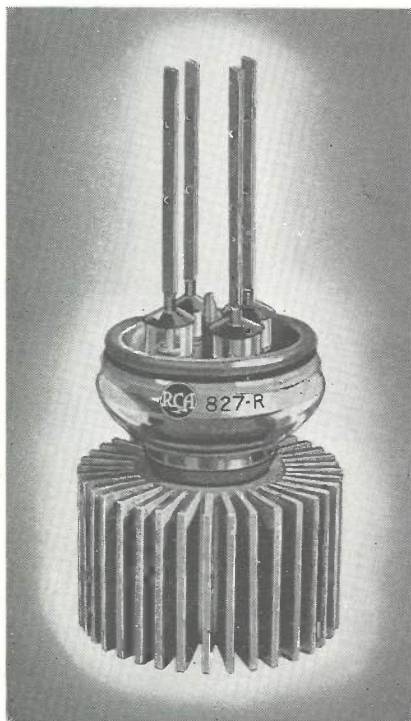

# TRANSMITTING TETRODE POWER AMPLIFIER

RCA'S MOST POWERFUL TETRODE

1500 WATTS INPUT

List Price **\$135.00**

## Features

# 827-R

- **GIANT IN POWER; LILLIPUT IN SIZE**  
800 watts plate dissipation. Tube size less than 5" x 6".
- **CONSERVATIVE MAXIMUM RATINGS**  
Two plate-modulated 827-R's take 2.4 kw. input.
- **FULL POWER TO 110 Mc**  
Ideal for F.M., Television, Standard Broadcasting, Communications
- **NEUTRALIZATION UNNECESSARY**  
Excellent internal shielding. Isolated input and output circuits.

RCA-827-R is a transmitting tetrode of the Air-Radiator type only 6 inches high and less than 5 inches in diameter—yet has a maximum plate dissipation of 800 watts! *One 827-R is capable of delivering its full power output of 1050 watts at frequencies as high as 110 Mc.* For this reason the tube is particularly well suited for use as an r-f power amplifier both in frequency-modulation and television, as well as in general broadcast and communication services.

Outstanding features of the 827-R include its use of (1) thoriated-tungsten filament with special low-resistance, multiple-ribbon leads that handle high current without heating, (2) two multiple-ribbon grid leads that minimize the effect of lead inductance and (3) an entrant metal header-type construction. The header-type design serves not only as a low-inductance terminal for the screen but facilitates isolation of the input and output circuits. As a result, neutralization of the tube is unnecessary except at the very highest frequencies. The plate of the 827-R is air-cooled by means of a highly efficient finned radiator which forms an integral part of the tube. This radiator must be cooled by means of a vertical flow of air from a properly installed air-cooling system.

RCA-827-R is a remarkable tetrode that opens the way for new economies of tube installation and application. It is the answer for dependability of high power at the ultra highs.

## RATINGS

FILAMENT VOLTAGE (A.C. or D.C.)	7.5	Volts
FILAMENT CURRENT	25	Amperes
GRID-SCREEN MU-FACTOR	16	
DIRECT INTERELECTRODE CAPACITANCES:		
Grid-Plate (with external shielding)	0.18 max.	$\mu\text{mf}$
Input	21	$\mu\text{mf}$
Output	13	$\mu\text{mf}$
MAXIMUM HEIGHT (less Multiple Ribbon Leads)	6"	
MAXIMUM DIAMETER	4-21/32"	

## MAXIMUM CCS RATINGS and TYPICAL OPERATING CONDITIONS

### As Plate-Modulated R-F Power Amplifier—Class C Telephony

D-C PLATE VOLTAGE	3000 max.	Volts
D-C SCREEN VOLTAGE (Grid No. 2)	800 max.	Volts
D-C GRID VOLTAGE (Grid No. 1)	-500 max.	Volts
D-C PLATE CURRENT	400 max.	Ma.
D-C GRID CURRENT	125 max.	Ma.
PLATE INPUT	1200 max.	Watts
SCREEN INPUT	100 max.	Watts
PLATE DISSIPATION	550 max.	Watts
RADIATOR TEMPERATURE	150 max.	°C
TYPICAL OPERATION:		
D-C Plate Voltage	2500	3000 Volts
D-C Screen Voltage:		
From a fixed supply of	700	750 Volts
From a series resistor of	13000	18000 Ohms
D-C Grid Voltage:		
From a fixed supply of	-350	-325 Volts
From a grid resistor of	2800	2600 Ohms
Peak R-F Grid Voltage	640	600 Volts
D-C Plate Current	400	400 Ma.
D-C Screen Current	140	125 Ma.
D-C Grid Current (Approx.)	125	125 Ma.
Driving Power (Approx.)	72	68 Watts
Power Output (Approx.)	670	825 Watts

- C<sub>1</sub>=35  $\mu\text{mf}$  /section, 0.070" spacing
- C<sub>2</sub> C<sub>3</sub> C<sub>5</sub> C<sub>6</sub>=500  $\mu\text{mf}$  mica (integral part of socket)
- C<sub>4</sub> C<sub>7</sub>=1000  $\mu\text{mf}$  mica (integral part of socket)
- C<sub>8</sub> C<sub>9</sub>=Neutralizing condensers, 3/8" dia. disk 1" from plate line
- C<sub>10</sub>=6  $\mu\text{mf}$  /section, 3/8" spacing
- C<sub>11</sub>=0.001  $\mu\text{mf}$  5000 volt mica
- C<sub>12</sub> C<sub>13</sub> C<sub>14</sub> C<sub>15</sub>=0.005  $\mu\text{f}$  mica
- R<sub>1</sub>=1000 ohms, 200 watts
- R<sub>2</sub>=50 ohms, 200 watts
- R<sub>3</sub>=10 ohms, 500 watts, adjustable
- R<sub>4</sub>=9000 ohms, 750 watts
- R<sub>5</sub>=50 ohms, 25 watts, non-inductive

- L<sub>1</sub>=1-turn coupling link
- L<sub>2</sub>=Tune to operating frequency
- L<sub>3</sub>=1" diameter copper tubing spaced 2 1/2" between centers. Approx. 35" long (for 60 Mc)
- L<sub>4</sub>=RFC 50 turns 1" dia. #14 wire spaced wire diameter
- M<sub>1</sub>=0-500 ma. D-C grid current meter
- M<sub>2</sub> M<sub>3</sub>=0-300 ma. D-C milliammeter
- M<sub>4</sub>=0-2.0 amp. D-C milliammeter
- M<sub>5</sub>=0-10 v. A-C filament voltmeter
- F<sub>1</sub>=0-500 ma. 5000-volt fuse
- P<sub>1</sub>=1.5 amp. overload relay
- S<sub>1</sub>=Mercury switch on air flow interlock
- T<sub>1</sub>=117-volt primary 15-volt secondary 0.5 kva filament transformer

### As R-F Power Amplifier—Class C Telegraphy

D-C PLATE VOLTAGE	3500 max.	Volts
D-C SCREEN VOLTAGE (Grid No. 2)	1000 max.	Volts
D-C GRID VOLTAGE (Grid No. 1)	-500 max.	Volts
D-C PLATE CURRENT	500 max.	Ma.
D-C GRID CURRENT	150 max.	Ma.
PLATE INPUT	1500 max.	Watts
SCREEN INPUT	150 max.	Watts
PLATE DISSIPATION	800 max.	Watts
RADIATOR TEMPERATURE	150 max.	°C
TYPICAL OPERATION:		
D-C Plate Voltage	3000	3500 Volts
D-C Screen Voltage:		
From a fixed supply of	900	700 Volts
From a series resistor of	12500	15100 Ohms
D-C Grid Voltage:		
From a fixed supply of	-350	-300 Volts
From a cathode resistor of	560	570 Ohms
From a grid resistor of	2800	3000 Ohms
Peak R-F Grid Voltage	590	520 Volts
D-C Plate Current	500	425 Ma.
D-C Screen Current	165	185 Ma.
D-C Grid Current (Approx.)	125	100 Ma.
Driving Power (Approx.)	66	50 Watts
Power Output (Approx.)	1000	1050 Watts

\* Obtained preferably from fixed supply, modulated simultaneously with the plate voltage. Series voltage-dropping resistor connected to modulated plate-voltage supply may also be used.

### PUSH-PULL CLASS C R-F POWER AMPLIFIER

Plate-Modulated Power Output Approximately 1650 Watts

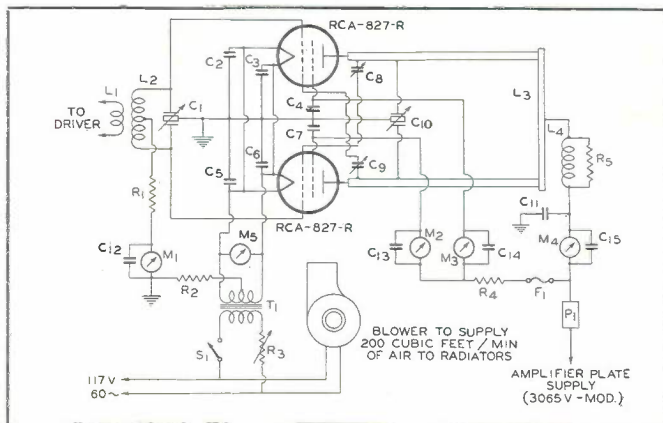





# TRANSMITTING BEAM POWER AMPLIFIER

270 WATTS INPUT

List Price **\$17.50**

## Features

- **HIGH POWER OUTPUT; LOW DRIVING POWER**  
270 watts input on c.w. with 2.2 watts grid drive.  
200 watts input on 'phone with 2.7 watts grid drive.
- **NEUTRALIZING UNNECESSARY**  
Makes frequency-shifting easy.
- **30-Mc OPERATION AT FULL RATINGS**  
75-Mc operation at reduced ratings.
- **LOW-DISTORTION CLASS AB<sub>1</sub> MODULATOR**  
Two 828's deliver 300 watts output with 1% distortion.
- **LOW-LOSS MICANOL BASE**

# 828

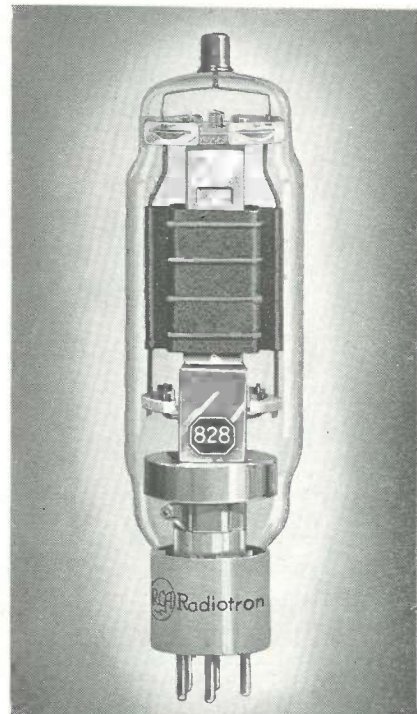

RCA-828 is a multi-electrode transmitting tube with a maximum plate-dissipation rating (ICAS) of 80 watts. The tube contains a suppressor and has beam power features. Because of its high power sensitivity, the 828 can be operated in r-f services to give full power output with very little driving power and, consequently, with a minimum of driver equipment. For example, *in class C telegraph service, the 828 is capable of delivering 200 watts (ICAS) with only 2.2 watts of driving power!* Neutralization is unnecessary in adequately shielded circuits. The tube is well suited for use in r-f applications as an r-f power amplifier, frequency multiplier, oscillator, and grid- or plate-modulated amplifier. It makes an excellent power amplifier for the final stage of medium-power transmitters where quick band-change without neutralizing adjustments is desirable. The 828 may be operated at maximum ratings at frequencies as high as 30 Mc and at reduced ratings up to 75 Mc.

RCA-828 is also well suited for use as a class AB<sub>1</sub> modulator and a-f power amplifier. Two tubes in class AB<sub>1</sub>, CCS, are capable of delivering 300 watts of audio power with only 1% distortion!

RCA-828 is equipped with the MICANOL base having excellent insulating qualities at high frequencies, together with a low moisture-absorption characteristic. The plate connection of the tube is brought out through a separate seal at the top of the bulb to provide high insulation. RCA-828 contains a husky 32.5-watt thoriated-tungsten filament which has a great reserve of filament emission.

## RATINGS

FILAMENT VOLTAGE (A.C. or D.C.).....	10.0	Volts
FILAMENT CURRENT .....	3.25	Amperes
TRANSCONDUCTANCE, for plate cur. of 43 ma.....	2800	Micromhos
DIRECT INTERELECTRODE CAPACITANCES:		
Grid-Plate (with external shield).....	0.05 max.	μf
Input .....	13.5	μf
Output .....	14.5	μf
MAXIMUM HEIGHT .....	7-3/4"	
MAXIMUM DIAMETER .....	2-1/16"	
SOCKET.....	Standard 5-contact such as RCA type 9920	

D-C Suppressor Current .....	9	9	Ma.
Zero-Signal D-C Screen Current.....	4	2	Ma.
Max.-Signal D-C Screen Current.....	43	60	Ma.
Effective Load Resistance (Plate-to-plate) .....	16200	18500	Ohms
Grid Input Power.....	0	0	Watt
Max.-Signal Power Output.....	300§	385	Watts

As Grid-Modulated R-F Power Amplifier—Class C Telephony  
Carrier conditions per tube for use with a max. modulation factor of 1.0

## MAXIMUM CCS and ICAS RATINGS with TYPICAL OPERATING CONDITIONS

As Push-Pull A-F Power Amplifier and Modulator—Class AB<sub>1</sub>

	CCS	ICAS	
D-C PLATE VOLTAGE .....	1750 max.	2000 max.	Volts
D-C SUPPRESSOR VOLTAGE (Grid No. 3) ..	100 max.	100 max.	Volts
D-C SCREEN VOLTAGE (Grid No. 2).....	750 max.	750 max.	Volts
MAX.-SIGNAL D-C PLATE CURRENT*.....	150 max.	150 max.	Ma.
MAX.-SIGNAL PLATE INPUT*.....	225 max.	270 max.	Watts
SCREEN INPUT* .....	16 max.	23 max.	Watts
PLATE DISSIPATION* .....	70 max.	80 max.	Watts

### TYPICAL OPERATION:

Unless otherwise specified, values are for 2 tubes

D-C Plate Voltage.....	1700	2000	Volts
D-C Suppressor Voltage .....	60	60	Volts
D-C Screen Voltage§ .....	750	750	Volts
D-C Grid Voltage (Grid No. 1) .....	-120	-120	Volts
Peak A-F Grid-to-Grid Voltage.....	240	240	Volts
Zero-Signal D-C Plate Current.....	50	50	Ma.
Max.-Signal D-C Plate Current.....	248	270	Ma.

	CCS	ICAS	
D-C PLATE VOLTAGE .....	1250 max.	1500 max.	Volts
D-C SUPPRESSOR VOLTAGE (Grid No. 3) ..	100 max.	100 max.	Volts
D-C SCREEN VOLTAGE (Grid No. 2).....	400 max.	400 max.	Volts
D-C GRID VOLTAGE (Grid No. 1).....	-300 max.	-300 max.	Volts
D-C PLATE CURRENT .....	100 max.	100 max.	Ma.
PLATE INPUT .....	105 max.	120 max.	Watts
SUPPRESSOR INPUT .....	5 max.	5 max.	Watts
SCREEN INPUT .....	11 max.	11 max.	Watts
PLATE DISSIPATION .....	70 max.	80 max.	Watts

### TYPICAL OPERATION:

D-C Plate Voltage .....	1250	1500	Volts
D-C Suppressor Voltage .....	75	75	Volts
D-C Screen Voltage .....	400	400	Volts
D-C Grid Voltage .....	-150	-150	Volts
Peak R-F Grid Voltage.....	165	165	Volts
Peak A-F Grid Voltage .....	94	94	Volts
D-C Plate Current .....	84	80	Ma.
D-C Suppressor Current .....	4	3.5	Ma.
D-C Screen Current .....	5	4	Ma.
D-C Grid Current (Approx.) .....	1.6	1.3	Ma.
Driving Power (Approx.)** .....	2.5	2.5	Watts
Power Output (Approx.) .....	36	41	Watts



# TRANSMITTING TUBE DATA



## As Plate-Modulated R-F Power Amplifier—Class C Telephony

Carrier conditions per tube for use with a max. modulation factor of 1.0

	CCS	ICAS	
D-C PLATE VOLTAGE	1000 max.	1250 max.	Volts
D-C SUPPRESSOR VOLTAGE (Grid No. 3)	100 max.	100 max.	Volts
D-C SCREEN VOLTAGE (Grid No. 2)	400 max.	400 max.	Volts
D-C GRID VOLTAGE (Grid No. 1)	-300 max.	-300 max.	Volts
D-C PLATE CURRENT	135 max.	160 max.	Ma.
D-C GRID CURRENT	15 max.	15 max.	Ma.
PLATE INPUT	135 max.	200 max.	Watts
SUPPRESSOR INPUT	5 max.	5 max.	Watts
SCREEN INPUT	11 max.	11 max.	Watts
PLATE DISSIPATION	47 max.	70 max.	Watts

### TYPICAL OPERATION:

D-C Plate Voltage	1000	1250	Volts
D-C Suppressor Voltage	75	75	Volts
D-C Screen Voltage	400	400	Volts
From a series resistor†	26000	30000	Ohms
D-C Grid Voltage‡	-140	-140	Volts
From a grid resistor of	14000	11700	Ohms
Peak R-F Grid Voltage	230	250	Volts
D-C Plate Current	135	160	Ma.
D-C Suppressor Current	13	15	Ma.
D-C Screen Current	23	28	Ma.
D-C Grid Current (Approx.)	10	12	Ma.
Driving Power (Approx.)	2.1	2.7	Watts
Power Output (Approx.)	100	150	Watts

## As R-F Power Amplifier and Oscillator—Class C Telephony

D-C PLATE VOLTAGE	1250 max.	1500 max.	Volts
D-C SUPPRESSOR VOLTAGE (Grid No. 3)	100 max.	100 max.	Volts
D-C SCREEN VOLTAGE (Grid No. 2)	400 max.	400 max.	Volts
D-C GRID VOLTAGE (Grid No. 1)	-300 max.	-300 max.	Volts
D-C PLATE CURRENT	160 max.	180 max.	Ma.
D-C GRID CURRENT	15 max.	15 max.	Ma.
PLATE INPUT	200 max.	270 max.	Watts
SUPPRESSOR INPUT	5 max.	5 max.	Watts
SCREEN INPUT	16 max.	16 max.	Watts
PLATE DISSIPATION	70 max.	80 max.	Watts

### TYPICAL OPERATION:

D-C Plate Voltage	1250	1500	Volts
D-C Suppressor Voltage	75	75	Volts
D-C Screen Voltage	400	400	Volts
D-C Grid Voltage:			
From a fixed supply	-95	-100	Volts
or from a grid resistor of	7900	8300	Ohms
or from a cathode resistor of	415	430	Ohms
Peak R-F Grid Voltage	195	205	Volts
D-C Plate Current	160	180	Ma.
D-C Suppressor Current	22	14	Ma.
D-C Screen Current	35	28	Ma.
D-C Grid Current (Approx.)	12	12	Ma.
Driving Power (Approx.)	2.1	2.2	Watts
Power Output (Approx.)	150	200	Watts

\* Averaged over any a-f cycle of sine-wave form.

\*\* At crest of audio-frequency cycle with modulation factor of 1.0.

† Zero-signal screen voltage must not exceed 775 volts.

‡ Connected to modulated plate-voltage supply.

§ Distortion only 1% with 20 DB of feedback to grid to driver.

¶ Grid bias may be obtained from a grid leak or from a combination of either grid leak and fixed supply or grid leak and cathode resistor. The combination method of grid leak and fixed supply has the advantage not only of protecting the tube from damage through loss of excitation but also of minimizing distortion, by means of bias-supply compensation.

## Max. Permissible Percentage of Max. Rated Plate Voltage and Plate Input for High-Frequency Operation

FREQUENCY	30	50	75	Mc
CLASS C { Telephony Plate-Mod. Telephony	100	80	65	Per Cent

Bottom View of Socket Connections

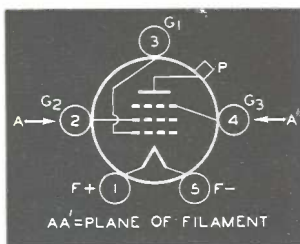

### Tube Mounting Position

VERTICAL—Base down.  
HORIZONTAL—Plane of filament vertical.

- C<sub>1</sub>=50 μmf midget
- C<sub>2</sub> C<sub>3</sub> C<sub>4</sub>=0.005 μf, mica
- C<sub>5</sub> C<sub>6</sub>=0.002 μf, mica, 5000 v.
- C<sub>6</sub> C<sub>7</sub>=0.01 μf, mica
- C<sub>8</sub>=1.5 μmf/meter\*
- R<sub>1</sub>=8300 ohms, 4 watts
- L<sub>1</sub>=Tune to frequency "f"
- RFC=R-f choke
- T<sub>1</sub>=Filament transformer, 2000-v. insulation
- f=Operating frequency
- X=Insert keying relay here

\* Capacitance in actual use. Minimum air-gap should be 0.07".

NOTE: Power output of driver stage should be about 5 watts.

## APPLICATION

In push-pull class AB<sub>1</sub> service, the 828 may be operated as shown under CHARACTERISTICS. The values are determined on the basis that no grid current flows during the most positive swing of the input signal and of cancellation of second-harmonic distortion by virtue of the push-pull circuit. Fixed bias of good voltage regulation is recommended in order to realize the maximum power-output capabilities of the class AB<sub>1</sub> stage. Two 828's are capable of providing power outputs of 300 to 385 watts with very low distortion when inverse feedback is used.

In grid-modulated class C telephony service, the 828 is supplied with unmodulated r-f grid voltage and with a d-c grid bias which is modulated at audio frequencies. Grid bias should preferably be obtained from a fixed supply. The suppressor voltage should be obtained from a battery or any other d-c source of good regulation. The screen voltage should be obtained from a separate source or from a voltage divider of good regulation. The audio power required in this service is very small, being sufficient only to meet the peak grid-power requirement of the class C amplifier on the positive crest of the a-f input signal. The actual a-f power is generally never more than 2 watts, depending on circuit conditions.

A circuit illustrating the application of the 828 in cw service is shown on this page. In this service the tube will deliver approximately 200 watts with a d-c plate voltage of 1500 volts. The power output of the driver should be about 5 watts. Thus, almost any small a-f or r-f power amplifier tube is suitable for the driver stage. A 6V6-GT/G or a 6L6 as a "Tritet" crystal oscillator will drive an 828 satisfactorily, even if frequency doubling is used in the oscillator plate circuit.

Although the 828 has a suppressor grid, this new tube is not recommended for suppressor-modulated telephony service. The reason is that the suppressor-voltage/power-output characteristic of the tube is not linear when the suppressor is operated with a negative bias.

In class C r-f telegraph service, the 828 should be supplied with screen voltage from a fixed, low-voltage source if the 828 or any preceding stage is keyed. The regulation of this source need only be good enough to prevent the screen voltage, under key-up conditions, from rising higher than twice the maximum screen-voltage rating. Grid bias may be obtained by any convenient method, except when a preceding stage is keyed; in this case, sufficient fixed bias should be used to maintain the d-c plate current at a low value when the key is up.

The plate of the 828 shows a barely perceptible red color at its maximum rated plate dissipation of 80 watts; it shows no color at a plate dissipation of 70 watts or less. The screen should not be allowed to attain a temperature corresponding to more than a barely perceptible red color.

## R-F POWER AMPLIFIER

Class C Telegraph Power Output 200 Watts

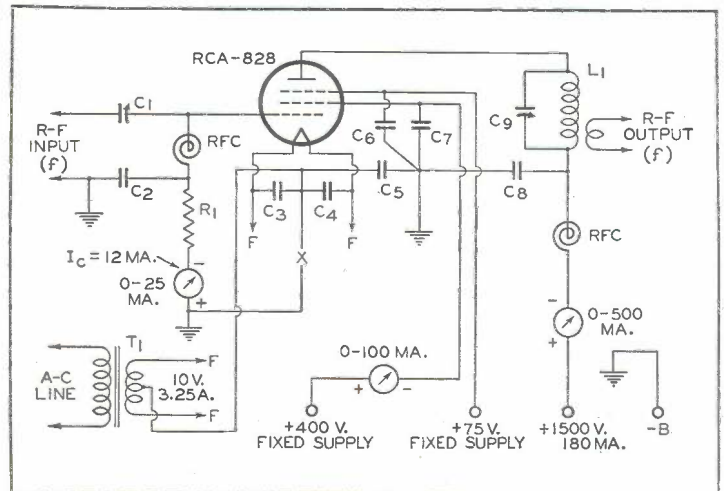



# TRANSMITTING TUBE DATA



## PUSH-PULL R-F BEAM POWER AMPLIFIERS

# 829

120 WATTS  
INPUT AT  
200 Mc

**\$19.50**  
List Price

# 832

36 WATTS  
INPUT AT  
150 Mc

**\$17.00**  
List Price

Small enough to lie comfortably in the palm of your hand, yet "big" enough to deliver unusually high outputs for their size, the 829 and 832 fill a long need by engineers and experimenters for a transmitting tube that will "deliver the goods" at the ultra highs without need for neutralization. These two beautifully constructed tubes contain two beam power units within one envelope. Total maximum plate dissipation of the 829 is 40 watts. Total maximum plate dissipation of the 832 is 15 watts.

A single 829 is capable of giving approximately 83 watts output with less than a watt of r-f grid drive, at frequencies as high as 200 Mc. Its smaller brother, the 832, is capable of giving approximately 22 watts at frequencies as high as 150 Mc. Both tubes may be operated at higher frequencies at reduced inputs.

The unusual efficiency of these tubes at the ultra-high frequencies is made possible by the balanced and compact structure of the beam power units, the excellent internal shielding, and the close electrode spacing. Both the 829 and 832 employ the molded glass dish stem which makes practical a compact but powerful tube having very short leads and low lead inductance. Their terminal arrangements provide excellent insulation and are designed to facilitate symmetry of circuit layout.

Both the 829 and 832 are of the heater-cathode type. Their heaters are arranged to permit operation from either a 12.6-volt or a 6.3-volt supply.

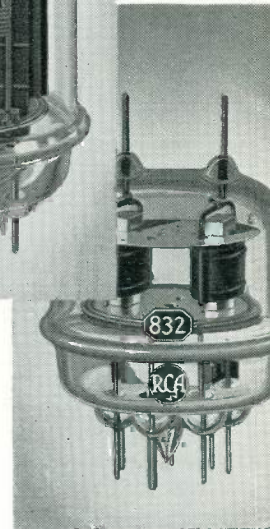
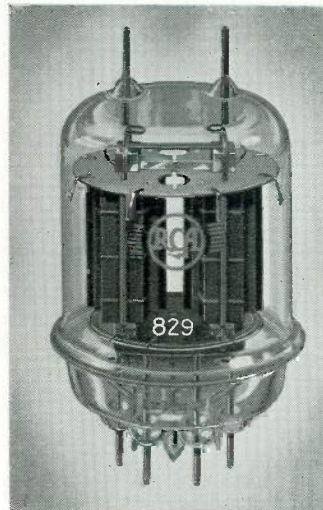

"A WHAL  
OF A TUB  
FOR ITS  
SIZE"

### RATINGS

HEATER (A.C. OR D.C.):	RCA-829	RCA-832	
Voltage per Unit.....	6.3	6.3	Volts
Current per Unit.....	1.125	0.8	Amperes
DIRECT INTERELECTRODE CAPACITANCES (Each Unit):			
Grid-Plate (with external shield).....	0.1 max.	0.05 max.	$\mu\text{f}$
Input .....	14.5	7.5	$\mu\text{f}$
Output .....	7.0	3.8	$\mu\text{f}$
MAXIMUM HEIGHT .....	4 1/2"	3 1/2"	
MAXIMUM DIAMETER .....	2 3/8"	2 3/8"	
SOCKET .....	Special, such as RCA type UT-106 below 60 Mc and UT-107 above 60 Mc		

D-C GRID CURRENT .....	15 max.	6 max.	Ma.
PLATE INPUT .....	120 max.	22 max.	Watts
SCREEN INPUT .....	7 max.	3.4 max.	Watts
PLATE DISSIPATION .....	40 max.	10 max.	Watts
TYPICAL OPERATION:			
D-C Plate Voltage .....	425	425	Volts
D-C Screen Voltage of.....	200	200	Volts
From a series resistor of.....	6400	14000	Ohms
D-C Grid Voltage of.....	-60	-60	Volts
From a grid resistor of.....	5500*	25000‡	Ohms
Peak R-F Grid-to-Grid Voltage.....	154	140	Volts
D-C Plate Current .....	212	52	Ma.
D-C Screen Current .....	35	16	Ma.
D-C Grid Current (Approx.) .....	11	2.4	Ma.
Driving Power (Approx.) .....	0.8	0.15	Watt
Power Output (Approx.) .....	63	16	Watts

### MAXIMUM RATINGS and TYPICAL OPERATING CONDITIONS

As Plate-Modulated Push-Pull R-F Power Amplifier—Class C Telephony  
Carrier conditions per tube for use with a max. modulation factor of 1.0

	RCA-829 CCS	RCA-832 CCS	
D-C PLATE VOLTAGE .....	425 max.	425 max.	Volts
D-C SCREEN VOLTAGE .....	225 max.	250 max.	Volts
D-C GRID VOLTAGE .....	-175 max.	-100 max.	Volts
D-C PLATE CURRENT .....	212 max.	68 max.	Ma.

\* The grid-circuit resistance should never exceed 15000 ohms (total) per tube, or 30000 ohms per unit. If additional bias is necessary, use a cathode resistor or a fixed supply.  
† Connected to modulated plate-voltage supply.  
‡ The grid-circuit resistance should never exceed 25000 ohms (total) per tube, or 50000 ohms per unit.

### Max. Permissible Percentage of Max. Rated Plate Voltage and Plate Input for High-Frequency Operation

RCA-829			
FREQUENCY	200	250	Mc
CLASS C { Telegraphy Plate-Mod. Telephony	100	89	Per Cent

RCA-832			
FREQUENCY	200	250	Mc
CLASS C { Telegraphy Plate-Mod. Telephony	93	82	Per Cent

R<sub>1</sub> R<sub>2</sub>=7500 to 15000 ohms, 1 watt  
R<sub>3</sub>=60 ohms, 10 watts  
R<sub>4</sub>=6400 ohms, 15 watts  
T<sub>1</sub>=Modulation Transformer.

C<sub>1</sub>=1.2 to 10  $\mu\text{f}$  per section  
C<sub>2</sub>=25  $\mu\text{f}$ , 200 volts  
C<sub>3</sub> C<sub>4</sub> C<sub>5</sub> C<sub>6</sub>=500  $\mu\text{f}$ , mica  
C<sub>7</sub>: C<sub>8</sub>=3 to 35  $\mu\text{f}$

Bottom View  
of 829 and 832 Socket Connections

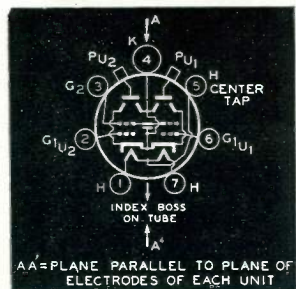

**Tube Mounting Position**  
VERTICAL—Plate terminals up or down.  
HORIZONTAL—Plane of each plate vertical (on edge).  
PIN 1=Heater  
PIN 2=Grid No. 1 of Unit No. 2  
PIN 3=Screen  
PIN 4=Cathode  
PIN 5=Heater center tap  
PIN 6=Grid No. 1 of Unit No. 1  
PIN 7=Heater  
P<sub>1</sub> AND P<sub>2</sub>=Plate terminals of Units

### ULTRA-HIGH-FREQUENCY PLATE-MODULATED PUSH-PULL R-F POWER AMPLIFIER

(Operating Frequency Approx. 200 Mc)

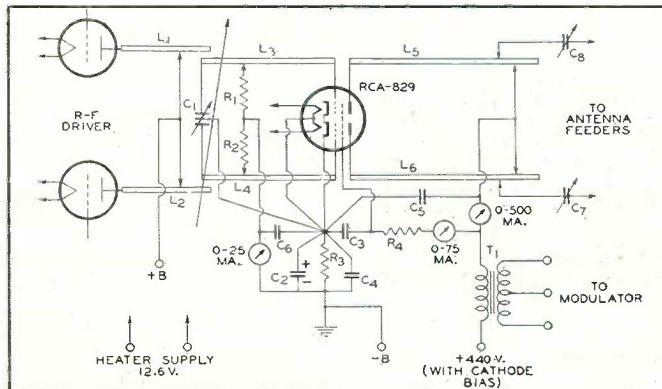

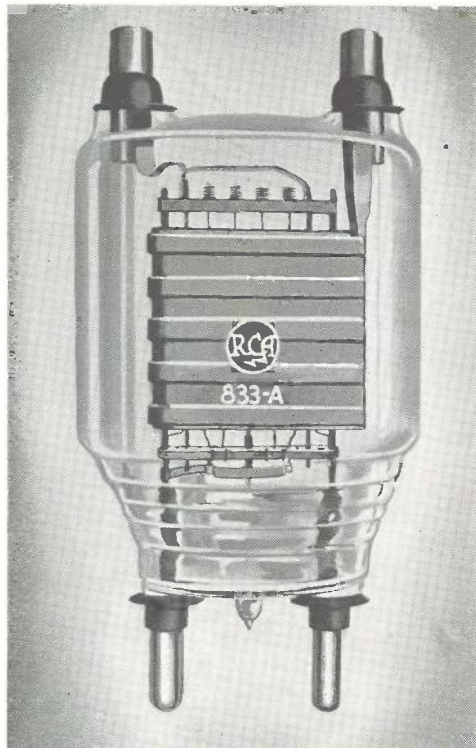

## ULTRA-MODERN TRANSMITTING TRIODE

2000 WATTS INPUT  
(FORCED-AIR-COOLING)

List Price **\$85.00**

# 833-A

### Features

- RCA'S MOST POWERFUL GLASS-TYPE TRIODE
- 2000 WATTS MAXIMUM INPUT ON C.W.  
1800 Watts Maximum on 'Phone
- DESIGNED FOR LONG DEPENDABLE SERVICE
- GIANT ZIRCONIUM-COATED ANODE  
Maximum dissipation, 450 Watts (with forced-air cooling)
- 100-WATT THORIATED-TUNGSTEN FILAMENT  
Filament end-shielding eliminates bulb bombardment.

inches in diameter. For example, with forced air cooling it will take maximum input of 1800 watts (ICAS) in plate-modulated service and 2,000 watts input (ICAS) on c.w.—at frequencies as high as 20 Mc. Under CCS ratings with natural cooling, the tube will take a maximum input of 1250 watts at frequencies as high as 30 megacycles!

RCA-833-A is designed with post terminals that provide a rugged structure and make bases unnecessary. The Zirconium-coated anode is supported direct from its post terminal at the top of the bulb. The 100-watt thoriated-tungsten filament of the 833-A has a tremendous reserve of emission. This filament is shielded by means of a special plate construction to conserve input power by eliminating bulb bombardment and stray electrons.

Designed to meet the specification requirements of commercial high-power, high-frequency applications, RCA-833-A is built to last.

RCA-833-A is the famous high-power, air-cooled triode with a maximum plate dissipation of 450 watts (ICAS). It is designed for use as an r-f amplifier, class B modulator, and oscillator. RCA-833-A is similar in appearance to its well known predecessor, the 833, but utilizes a Zirconium-coated anode and includes many other processing refinements. In existing equipment using the former 833, the RCA-833-A with forced air cooling can be used to boost power substantially.

Small and compact, the 833-A will handle several kilowatts of power in a tube less than 9 inches high and 4-5/8

### RATINGS

FILAMENT VOLTAGE (A.C. or D.C.)	10	Volts
FILAMENT CURRENT	10	Amperes
AMPLIFICATION FACTOR	35	
DIRECT INTERELECTRODE CAPACITANCES:		
Grid-Plate	6.3	$\mu\text{mf}$
Grid-Filament	12.3	$\mu\text{mf}$
Plate-Filament	8.5	$\mu\text{mf}$
MAXIMUM HEIGHT	8-5/8" $\pm 3/16$ "	
MAXIMUM DIAMETER	4-19/32"	
SOCKET	RCA type 9938	

	Natural Cooling	Forced-Air Cooling		
	CCS	CCS	ICAS	
Load Resistance (Per tube)	2375	3000	2750	Ohms
Effective Load Resistance (Plate to Plate)	9500	12000	11000	Ohms
Max.-Sig. Driving Power (Approx.)	20	29	38	Watts
Max.-Sig. Power Output (Approx.)	1650	2400	2700	Watts

### MAXIMUM CCS and ICAS RATINGS with TYPICAL OPERATING CONDITIONS

#### As A-F Power Amplifier and Modulator—Class B

	Natural Cooling	Forced-Air Cooling		
	CCS	CCS	ICAS	
D-C PLATE VOLTAGE	3000 max.	4000 max.	4000 max.	Volts
MAX.-SIG. D-C PLATE CUR.*	500 max.	500 max.	500 max.	Ma.
MAX.-SIG. PLATE INPUT*	1125 max.	1600 max.	1800 max.	Watts
PLATE DISSIPATION*	300 max.	400 max.	450 max.	Watts

Unless otherwise specified, values are for 2 tubes

D-C Plate Voltage	3000	4000	4000	Volts
D-C Grid Voltage	-70	-100	-100	Volts
Peak A-F Grid-to-Grid Voltage	400	480	510	Volts
Zero-Sig. D-C Plate Current	100	100	100	Ma.
Max.-Sig. D-C Plate Current	750	800	900	Ma.

#### As Plate-Modulated R-F Power Amplifier—Class C Telephony

	Natural Cooling	Forced-Air Cooling		
	CCS	CCS	ICAS	
D-C PLATE VOLTAGE	2500 max.	3000 max.	4000 max.	Volts
D-C GRID VOLTAGE	-500 max.	-500 max.	-500 max.	Volts
D-C PLATE CURRENT	400 max.	450 max.	450 max.	Ma.
D-C GRID CURRENT	75 max.	100 max.	100 max.	Ma.
PLATE INPUT	835 max.	1250 max.	1800 max.	Watts
PLATE DISSIPATION	200 max.	270 max.	350 max.	Watts

#### TYPICAL OPERATION:

D-C Plate Voltage	2500	3000	4000	Volts
D-C Grid Voltage	-300	-300	-325	Volts
From a fixed supply of	4000	3600	3600	Ohms
From a grid resistor of	460	490	520	Volts
Peak R-F Grid Voltage	335	415	450	Ma.
D-C Plate Current	75	85	90	Ma.
D-C Grid Cur. (Approx.)	30	37	42	Watts
Driving Power (Approx.)	635	1000	1500	Watts
Power Output (Approx.)				

\* Averaged over any audio-frequency cycle of sine-wave form.



# TRANSMITTING TUBE DATA



## As R-F Power Amplifier—Class C Telegraphy

	Natural Cooling		Forced-Air Cooling	
	CCS	ICAS	CCS	ICAS
D-C PLATE VOLTAGE	3000 max.	4000 max.	4000 max.	4000 max.
D-C GRID VOLTAGE	-500 max.	-500 max.	-500 max.	-500 max.
D-C PLATE CURRENT	500 max.	500 max.	500 max.	500 max.
D-C GRID CURRENT	75 max.	100 max.	100 max.	100 max.
PLATE INPUT	1250 max.	1809 max.	2000 max.	2000 max.
PLATE DISSIPATION	300 max.	400 max.	450 max.	450 max.

## TYPICAL OPERATION:

D-C Plate Voltage	3000	4000	4000	Volts
D-C Grid Voltage				
From a fixed supply of	-200	-200	-225	Volts
From a grid resistor of	3500	2650	2400	Ohms
From a cathode resistor of				
Peak R-F Grid Voltage	425	380	380	Ohms
D-C Plate Current	360	375	415	Volts
D-C Grid Cur. (Approx.)	415	450	500	Ma.
Driving Power (Approx.)	55	75	95	Ma.
Power Output (Approx.)	20	26	35	Watts
	1000	1440	1600	Watts

## PUSH-PULL CLASS C R-F AMPLIFIER—PLATE MODULATED

Power Output 2000\* Watts (CCS)

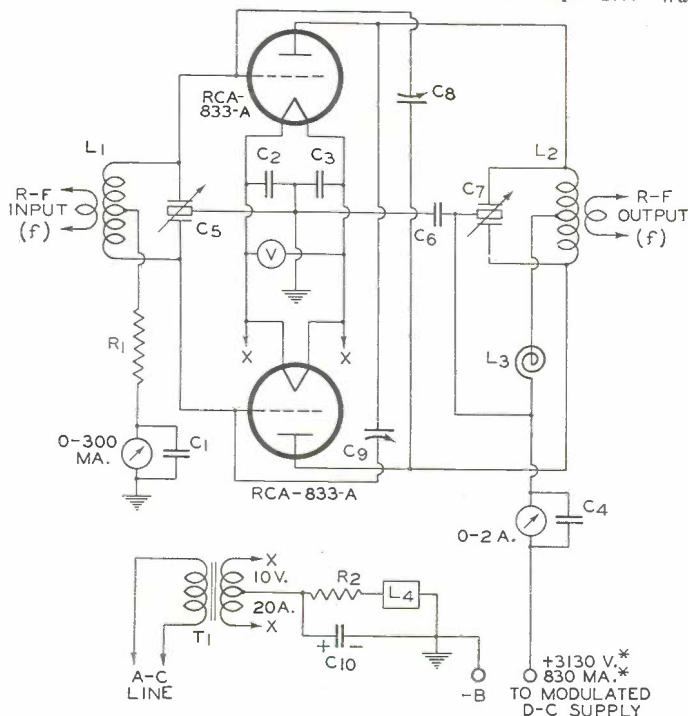

- C<sub>1</sub> to C<sub>4</sub>=0.005μf, mica
- C<sub>5</sub>=1μmf/meter/section
- C<sub>6</sub>=0.005μf, 7500 volts
- C<sub>7</sub>=1.7μmf/meter/section
- C<sub>8</sub> C<sub>9</sub>=6.3 μmf (approx.)
- C<sub>10</sub>=50μf, 250 volts
- R<sub>1</sub>=1000 ohms, 50 watts
- R<sub>2</sub>=130 ohms, 200 watts
- L<sub>1</sub> L<sub>2</sub>=Tune to frequency "f"
- L<sub>3</sub>=R-F choke, 1 ampere
- L<sub>4</sub>=See Note (1)
- T<sub>1</sub>=Filament transformer
- V=0-15v. A-C voltmeter

NOTE (1) L<sub>4</sub> is a 12-Ohm d-c overload relay set to open the primary circuit of the high-voltage transformer when the d-c cathode current reaches 1.2 amperes.

\* These ratings apply when forced-air cooling is used at the rate of 80 cu. ft. per minute and when maximum bulb surface temperature between grid and plate does not exceed 145°C.

The output transformer of the 833-A in class B modulator service should be designed so that the resistance load presented by the modulated class C amplifier is reflected as the correct plate-to-plate load in the class B a-f stage. For example, for the 3000-volt condition, a plate-to-plate load of 9500 ohms is required. If an output transformer efficiency of 90% is assumed, two 833-A's operated under conditions shown for a 3000-volt plate supply, are capable of modulating 100% an input of approximately 2970 watts to a class C r-f power amplifier. Since two 833-A's will modulate 2970 watts, a convenient class C amplifier would be one operating at 6000 volts and 495 milliamperes. These conditions represent a resistance of approximately 12120 ohms. The ratio of the output transformer is then 12120 ÷ 9500, or 1 to 1.13, step-up. Grid bias for class B modulator service should be obtained from a battery or other source of good regulation. It should not be obtained from a high-resistance supply

such as a grid resistor, nor from a rectifier, unless the latter has exceptionally good voltage regulation.

When the 833-A is used in the final amplifier or a preceding stage of a c-w transmitter designed for break-in operation and oscillator keying, a small amount of fixed bias must be used to maintain the plate current at a safe value. With plate voltage of 4000 volts, a fixed bias of at least -90 volts should be used.

The plate of the 833-A shows an orange-red color at the maximum plate-dissipation rating for each class of service.

Max. Permissible Percentage of Max. Rated Plate Voltage and Plate Input for High-Frequency Operation

FREQUENCY	NATURAL COOLING			FORCED-AIR COOLING			Mc
	30	50	75	20	50	75	
CLASS C { Plate-Mod. Telegraphy	100	90	72	100	83	65	Per Cent
	100	90	72	100	83	65	Per Cent

Tube Mounting Position  
VERTICAL—Up or down.  
HORIZONTAL—Plane of plate vertical.

### 833-A End Connections

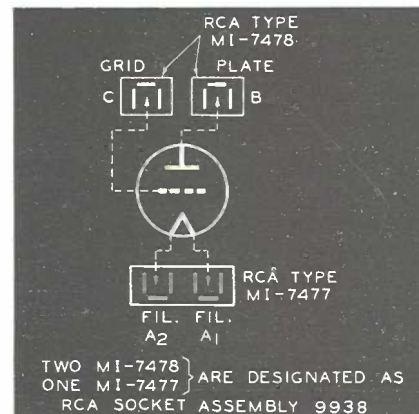



# TRANSMITTING TUBE DATA



## U - H - F TRANSMITTING TRIODE

MOLYBDENUM ANODE

125 WATTS INPUT

List Price **\$12.50**

# 834

- 100 Mc AT MAXIMUM RATINGS  
350 Mc at reduced input.
- MOLYBDENUM PLATE  
Operates gas-free at extremely high temperatures.

### Features

- TUNGSTEN GRID AND PLATE LEADS
- HARD-GLASS BULB

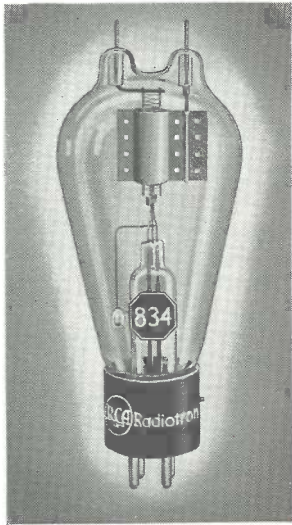

Max. Permissible Percentage of Max. Rated Plate Voltage and Plate Input for High-Frequency Operation

FREQUENCY	100	170	350	Mc
CLASS C { Telegraphy Plate-Mod. Telephony	100	80	53	Per Cent

RCA-834 is a transmitting triode designed particularly for use as an r-f amplifier and oscillator at the ultra-high frequencies. It has a maximum plate-dissipation rating of 50 watts (CCS) and can be used with maximum ratings at frequencies up to 100 Mc! It may be operated at reduced input up to 350 Mc! RCA-834 is conservatively rated at 125 watts input for class C telegraph service and 100 watts for plate-modulated service.

The grid and plate of the 834 are supported from the top of the glass bulb by individual tungsten leads which are brought out of the tube through separate seals. This construction minimizes lead inductance, eliminates need for internal insulation, and provides low interelectrode capacitances. The molybdenum plate insures gas-free operation at extremely high temperatures and functions to maintain a high vacuum during the life of the tube. The 834 has a husky, 25-watt, thoriated-tungsten filament which insures a tremendous reserve of emission.

### RATINGS

FILAMENT VOLTAGE (A.C. OR D.C.)	7.5	Volts
FILAMENT CURRENT	3.1	Amperes
AMPLIFICATION FACTOR	10.5	
DIRECT INTERELECTRODE CAPACITANCES:		
Grid-Plate	2.6	$\mu\mu\text{f}$
Grid-Filament	2.2	$\mu\mu\text{f}$
Plate-Filament	0.6	$\mu\mu\text{f}$
MAXIMUM HEIGHT	6-7/8"	
MAXIMUM DIAMETER	2-11/16"	
SOCKET	Standard 4-Contact, such as RCA type 9937 or 9919	

### MAXIMUM CCS RATINGS and TYPICAL OPERATING CONDITIONS

As Class C R-F Power Amplifier	C. W.	Plate Modulation
D-C PLATE VOLTAGE	1250 max.	1000 max. Volts
D-C GRID VOLTAGE	-400 max.	-400 max. Volts
D-C PLATE CURRENT	100 max.	100 max. Ma.
D-C GRID CURRENT	20 max.	20 max. Ma.
PLATE INPUT	125 max.	100 max. Watts
PLATE DISSIPATION	50 max.	35 max. Watts
TYPICAL OPERATION:		
D-C Plate Voltage	1250	1000 Volts
D-C Grid Voltage:		
From a fixed supply of	-225	-310 Volts
or from a grid-resistor of	15000	18000 Ohms
or from a cathode resistor of	2150	3000 Ohms
Peak R-F Grid Voltage	350	435 Volts
D-C Plate Current	90	90 Ma.
D-C Grid Current (Approx.)	15	17.5 Ma.
Driving Power (Approx.)	4.5	6.5 Watts
Power Output (Approx.)	75	58 Watts

Bottom View of 834 Socket Connections

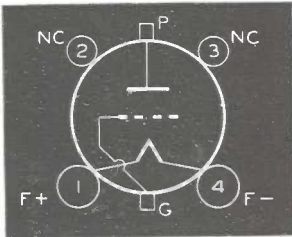

Tube Mounting Position  
VERTICAL—Base up or down  
HORIZONTAL—Not recommended



# 836

## HALF-WAVE HIGH-VACUUM RECTIFIER

THE HIGH-VOLTAGE RECTIFIER WITH A HEATER CATHODE

List Price **\$11.50**

RCA-836 is a half-wave, high-vacuum rectifier tube of the heater-cathode type for use in high-voltage rectifying devices where freedom from r-f disturbances in the output is an important factor. The excellent voltage characteristic of the 836 is due to the close spacing of the cathode and plate and to the use of double cathode construction. In single-phase circuits, full-wave rectification is accomplished by using two 836's.

### RATINGS

HEATER VOLTAGE*	2.5	Volts
HEATER CURRENT	5.0	Amperes
PEAK INVERSE VOLTAGE	5000 max.	Volts
PEAK PLATE CURRENT	1.0 max.	Ampere
AVERAGE PLATE CURRENT	0.25 max.	Ampere
SOCKET	Standard 4-contact such as RCA Type 9937 or 9919	

\* Heating time of heater is approximately 40 seconds.

The a-c input voltage (RMS) for two 836's, plate-to-plate in a full-wave, single-phase circuit must not exceed 3530 volts in order to limit the maximum peak inverse voltage to the rated value of 5000 volts. With a sine-wave input and the use of a suitable choke preceding any condenser in the filter circuit, the no-load d-c output voltage from the rectifier is 0.9 of the a-c input voltage per tube. On this basis, the maximum d-c output voltage is 1600 volts when the maximum a-c input voltage of 1765 volts is used. Under the above voltage and filter conditions, the regulation produced by the drop in the tube at full-load current will not be greater than 55 volts, approximately.

The cathode of the 836 is connected within the tube to one side of the heater. Therefore, the positive return lead to the filter and load circuit should be connected to the heater lead (Pin 4) to which the cathode is connected. When the heaters of two or more 836's are operated in parallel, the corresponding cathode leads must be connected together; likewise, the corresponding heater leads.

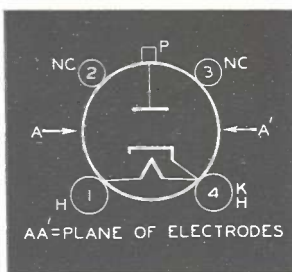

Bottom View of 836 Socket Connections



## DELUXE TRANSMITTING PENTODE 837

FOR EXACTING APPLICATIONS

List Price **\$7.50**

32 WATTS INPUT

RCA-837 is a pentode transmitting tube of the 12.6-volt heater-cathode type for use as an r-f amplifier, frequency-multiplier, oscillator, and suppressor, grid or plate-modulated amplifier, particularly in aircraft, police, commercial, and broadcast equipment. RCA-837 is conservatively rated at a maximum plate dissipation of 12 watts. It may be operated at maximum ratings at frequencies up to 20 Mc—at reduced ratings at frequencies up to 60 Mc.

The suppressor of the 837 is connected to an individual base pin to permit suppressor modulation of the tube as well as to provide for the use of a separate suppressor supply voltage for obtaining optimum power output from the tube. RCA-837 contains a special internal shield which also is connected to an individual base pin. Neutralization of the tube is unnecessary in adequately shielded circuits.

The 837 is equipped with a Micanol base.

### PENTODE R-F AMPLIFIER OR FREQUENCY MULTIPLIER Amplifier Power Output 22 Watts (Approx.)

HEATER VOLTAGE (A.C. OR D.C.)	12.6	Volts
HEATER CURRENT	0.7	Ampere
TRANSCONDUCTANCE, For plate cur. of 24 ma.	3400	Micromhos
DIRECT INTERELECTRODE CAPACITANCES:		
Grid-Plate (With external shielding)	0.20 max.	$\mu\text{mf}$
Input	16	$\mu\text{mf}$
Output	10	$\mu\text{mf}$
MAXIMUM HEIGHT	5-7/8"	
MAXIMUM DIAMETER	2-1/16"	
SOCKET...Medium 7-contact (0.855" pin-circle dia.), such as RCA type 9923		

### MAX. CCS RATINGS

As R-F Power Amplifier and Oscillator—  
Class C Telegraphy

D-C PLATE VOLTAGE	500 max.	Volts
D-C SUPPRESSOR VOLTAGE (Grid No. 3)	200 max.	Volts
D-C SCREEN VOLTAGE (Grid No. 2)	200 max.	Volts
D-C GRID VOLTAGE (Grid No. 1)	-200 max.	Volts
D-C PLATE CURRENT	80 max.	Ma.
D-C GRID CURRENT	8 max.	Ma.
PLATE INPUT	32 max.	Watts
SUPPRESSOR INPUT	5 max.	Watts
SCREEN INPUT	8 max.	Watts
PLATE DISSIPATION	12 max.	Watts

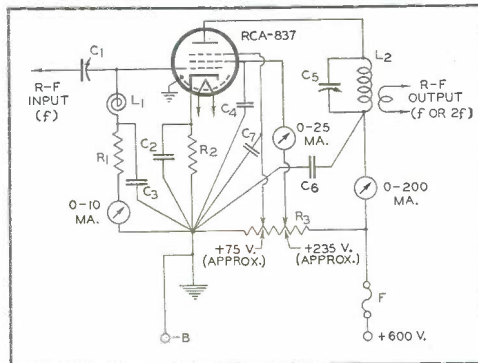

$C_1=50 \mu\text{mf}$  midget  
 $C_2, C_3, C_4, C_6, C_7=0.005 \mu\text{f}$ , mica  
 $C_5=2 \mu\text{mf}/\text{meter}$ , 1200 v.  
 $R_1=10000$  ohms, 1 watt  
 $R_2=450$  ohms, 5 watts  
 $R_3=35000$  ohms, 10 watts  
 $L_1=R-F$  choke  
 $F=1/2$  a. high-voltage fuse  
 NOTE: For frequency doubling, tune  $C_5, L_2$  to frequency "2f." A 20000-ohm, 10-watt series screen resistor can be used in place of  $R_3$ , and No. 3 grid connected to cathode.

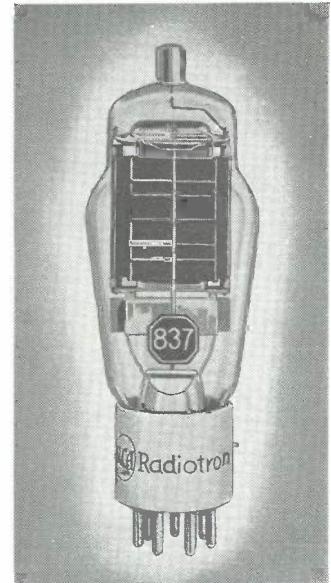

Bottom View of 837 Socket Connections

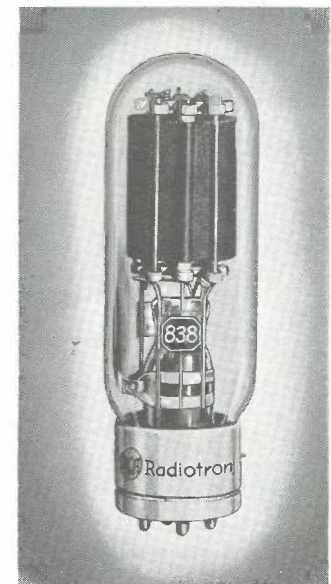
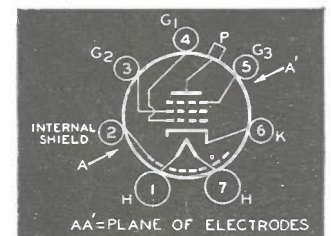

Bottom View of 838 Socket Connections

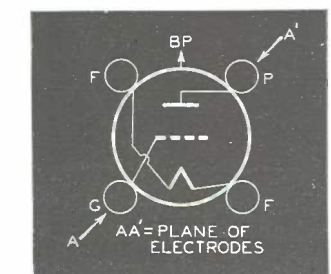

## TRANSMITTING TRIODE 838

ZERO-BIAS CLASS B MODULATOR

List Price **\$11.00**

220 WATTS INPUT

RCA-838 is a high-mu, 3 electrode transmitting tube particularly well suited for use as a zero-bias class B modulator or a-f power amplifier. Maximum plate dissipation is 100 watts. The grid of the 838 is designed so that the amplification factor of the tube varies with the amplitude of the input signal. This feature facilitates the design of class B amplifier to give high output with low distortion. In class B audio service, two 838's are capable of giving an output of 260 watts with less than 5% distortion! As an r-f power amplifier, the 838 may be used at maximum ratings at frequencies as high as 30 Mc.

### RATINGS

FILAMENT VOLTAGE (A.C. OR D.C.)	10.0	Volts
FILAMENT CURRENT	3.25	Ampere
DIRECT INTERELECTRODE CAPACITANCES:		
Grid-Plate	8	$\mu\text{mf}$
Grid-Filament	6.5	$\mu\text{mf}$
Plate-Filament	5	$\mu\text{mf}$
MAXIMUM HEIGHT	7-7/8"	
MAXIMUM DIAMETER	2-5/16"	
SOCKET.....Standard Transmitting, such as RCA type 9936		

### TYPICAL OPERATION:

Unless otherwise specified, values are for 2 tubes

D-C Plate Voltage	1250	Volts
D-C Grid Voltage	0	Volts
Peak A-F Grid-to-Grid Voltage	200	Volts
Zero-Sig. D-C Plate Current	148	Ma.
Max.-Sig. D-C Plate Current	320	Ma.
Load Resistance (Per tube)	2250	Ohms
Effective Load Res. (Plate-to-plate)	9000	Ohms
Max-Sig. Driving Power (Approx.)	7.5	Watts
Max.-Sig. Power Output (Approx.)#	260	Watts

\* Averaged over any audio-frequency cycle of sine-wave form.

# Approximately 4% harmonic distortion.

### MAXIMUM CCS RATINGS and TYPICAL OPERATING CONDITIONS

As A-F Power Amplifier and Modulator—Class B

D-C PLATE VOLTAGE	1250 max.	Volts
MAX.-SIGNAL D-C PLATE CUR.*	175 max.	Ma.
MAX.-SIGNAL PLATE INPUT*	220 max.	Watts
PLATE DISSIPATION*	100 max.	Watts

In special cases where it is desirable to keep the audio-frequency distortion of the class B a-f amplifier or modulator to a value lower than 4%, the use of a small amount of grid-bias voltage is advantageous. Typical operating conditions are approximately the same as those for zero-bias operation, with a plate supply voltage of 1250 volts. The exceptions are: grid-bias voltage, -15 volts; peak a-f grid-to-grid voltage, 210 volts; and zero-signal d-c plate current, 50 milliamperes (2 tubes).



# HALF-WAVE MERCURY-VAPOR RECTIFIERS

## 872

Heavy-Duty Type

Peak Inverse Voltage, 7500 Volts, Maximum  
Peak Plate Current, 5 Amperes, Maximum

List Price **\$9.00**

## 872-A

Heavy-Duty Type, with Shielded Filament

Peak Inverse Voltage, 10000 Volts, Maximum  
Peak Plate Current, 5 Amperes, Maximum

List Price **\$11.00**

FOR HIGHER VOLTAGES

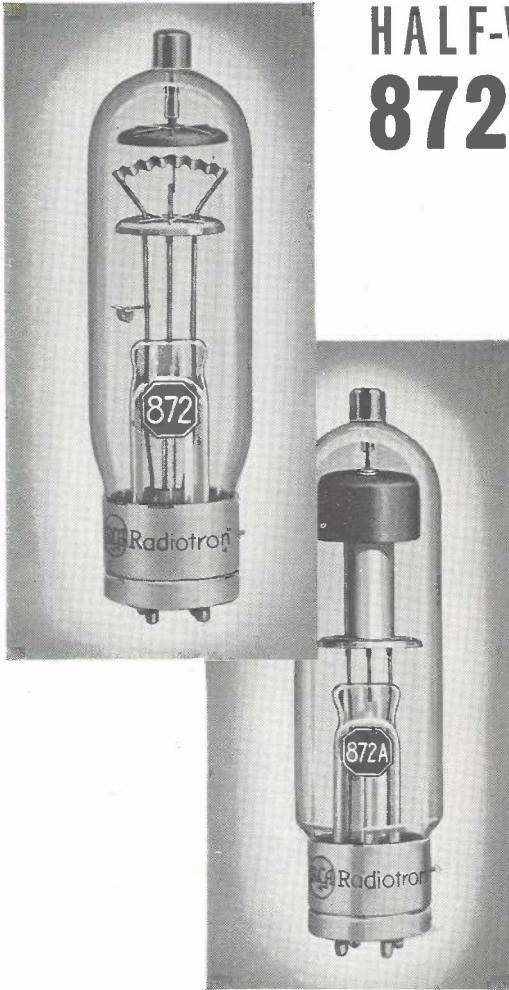

RCA-872 and RCA-872-A are high-voltage, half-wave, mercury-vapor rectifiers designed to handle heavy loads. They will give long, trouble-free service.

### RATINGS

	RCA-872	RCA-872-A	
FILAMENT VOLTAGE (A.C.)	5.0	5.0	Volts
FILAMENT CURRENT	10	6.75**	Amperes
PEAK INVERSE VOLTAGE:#			
Cond. Mercury Temp. of 10° to 60° C	7500 max.	—	Volts
Cond. Mercury Temp. of 20° to 60° C	—	10000 max.	Volts
Cond. Mercury Temp. of 20° to 70° C	—	5000 max.	Volts
PEAK PLATE CURRENT	5 max.	5 max.	Amperes
AVERAGE PLATE CURRENT*	1.25 max.	1.25 max.	Amperes
TUBE VOLTAGE DROP (APPROX.)	15	10	Volts
SOCKET	Standard transmitting 4-contact, such as RCA type 9936		

# For supply frequency up to 150 cycles. \* Averaged over 15 seconds  
\*\* Filament transformer should be designed for 10 amperes per tube

### RECTIFIER CIRCUITS

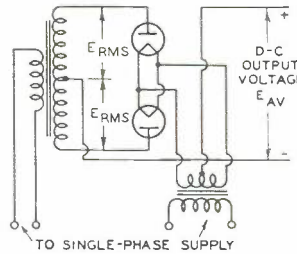

Fig. A

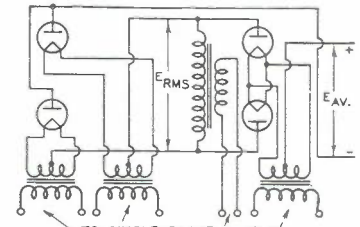

Fig. B

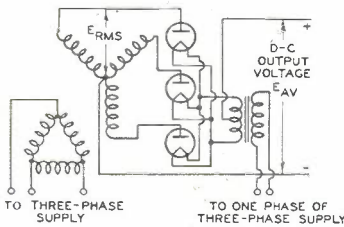

Fig. C

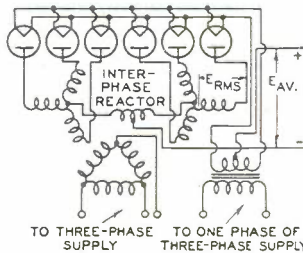

Fig. D

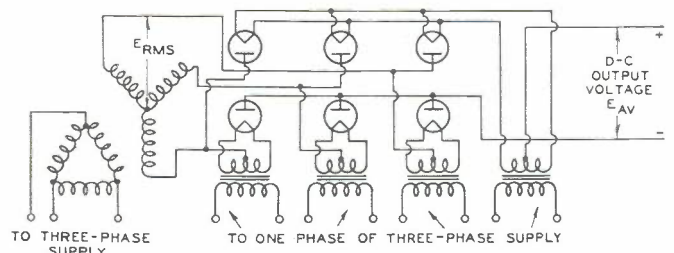

Fig. E

### SUMMARY OF CIRCUIT CONDITIONS\*

CIRCUIT	FIG.	TRANSFORMER SECONDARY VOLTAGE $E_{RMS}$	D-C OUTPUT VOLTAGE TO FILTER $E_{AV}$	PEAK INVERSE VOLTAGE $E_{INV}$	MAX. AVERAGE LOAD CURRENT PERMITTED
Single-Phase Full-Wave (2 Tubes)	A	(per tube) $0.353x E_{INV}$ or $1.11x E_{AV}$	$0.318x E_{INV}$ or $0.9x E_{RMS}$	$3.14x E_{AV}$ or $2.83x E_{RMS}$	$2x$ {Max. Average Plate-Current Rating per Rectifier Tube
Single-Phase Full-Wave Bridge (4 Tubes)	B	(total) $0.706x E_{INV}$ or $1.11x E_{AV}$	$0.636x E_{INV}$ or $0.9x E_{RMS}$	$1.57x E_{AV}$ or $1.41x E_{RMS}$	$2x$ {Max. Average Plate-Current Rating per Rectifier Tube
Three-Phase Half-Wave (3 Tubes)	C	(per leg) $0.408x E_{INV}$ or $0.855x E_{AV}$	$0.478x E_{INV}$ or $1.17x E_{RMS}$	$2.09x E_{AV}$ or $2.45x E_{RMS}$	$3x$ {Max. Average Plate-Current Rating per Rectifier Tube
Three-Phase Parallel Double Y (6 Tubes)	D	(per leg) $0.408x E_{INV}$ or $0.855x E_{AV}$	$0.478x E_{INV}$ or $1.17x E_{RMS}$	$2.09x E_{AV}$ or $2.45x E_{RMS}$	$6x$ {Max. Average Plate-Current Rating per Rectifier Tube
Three-Phase Full-Wave (6 Tubes)	E	(per leg) $0.408x E_{INV}$ or $0.428x E_{AV}$	$0.956x E_{INV}$ or $2.34x E_{RMS}$	$1.05x E_{AV}$ or $2.45x E_{RMS}$	$3x$ {Max. Average Plate-Current Rating per Rectifier Tube

\* Table is based on sine-wave input and the use of a suitable choke preceding any condenser in the filter circuit. It does not take into account the voltage drop in the power transformer, the rectifier tubes, nor the filter-choke windings under load conditions.

Bottom View of 872 and 872-A Socket Connections

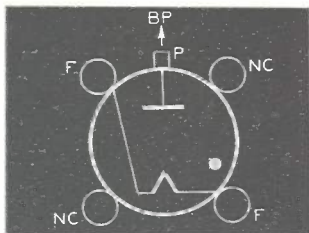

Tube Mounting Position

VERTICAL—Base down only.  
HORIZONTAL—Not recommended.





# HOT-CATHODE GAS TRIODE AND TETRODE DATA



## HOT-CATHODE GAS TRIODES

List Price **\$2.00** each

# 884

# 885

RCA-884 and RCA-885 are grid-controlled, gaseous-discharge tubes of the heater-cathode type. They are designed for use as sweep-circuit oscillators in cathode-ray tube circuits.

Operation of the 884 and 885 can be controlled by means of a condenser shunted across the plate circuit and charged through a resistor. When the plate voltage reaches breakdown potential, the condenser discharges through the tube, the plate voltage drops, the grid resumes control and a new cycle starts. This action results in a saw-tooth wave which is essentially linear, and which is especially suited for use as a time base in a cathode-ray oscillograph. The 884 and 885 are characterized by extremely low de-ionization time, the corresponding practicability of operation at high frequency, and stability of operation.

### LINEAR SWEEP-CIRCUIT OSCILLATOR AND AMPLIFIER

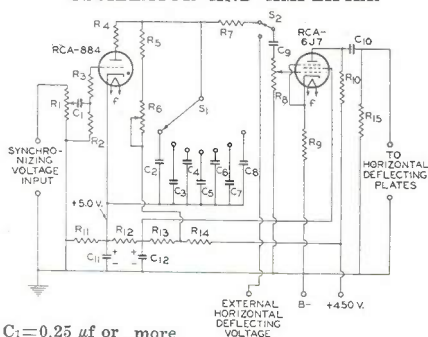

- C<sub>1</sub>=0.25 μf or more
- C<sub>2</sub>=0.25 μf, 500 v.
- C<sub>3</sub>=0.1 μf, 500 v.
- C<sub>4</sub>=0.04 μf, 500 v.
- C<sub>5</sub>=0.015 μf, 500 v.
- C<sub>6</sub>=0.005 μf, 500 v.
- C<sub>7</sub>=0.002 μf, 500 v.
- C<sub>8</sub>=0.0008 μf, 500 v.
- C<sub>9</sub>=0.5 μf, 250 v.
- C<sub>10</sub>=0.5 μf, 500 v.
- C<sub>11</sub>=25 μf, 15 v.

- C<sub>12</sub>=8 μf, 200 v.
- R<sub>1</sub>=5000 ohm (Max.) potentiometer
- R<sub>2</sub>=Not greater than 50000 ohms
- R<sub>3</sub>=2000-3000 ohms, 0.5 watt
- R<sub>4</sub>=350-500 ohms, 0.5 watt
- R<sub>5</sub>=0.3-0.5 megohm, 0.5 watt
- R<sub>6</sub>=1 megohm potentiometer
- R<sub>7</sub>=1 megohm, 0.5 watt
- R<sub>8</sub>=0.5 megohm potentiometer

- R<sub>9</sub>=850 ohms, 0.5 watt
- R<sub>10</sub>=0.1 megohm, 0.5 watt
- R<sub>11</sub>=1500 ohms, 0.5 watt
- R<sub>12</sub>=25000 ohms, 1.0 watt
- R<sub>13</sub>=60000 ohms, 1.0 watt
- R<sub>14</sub>=60000 ohms, 1.0 watt
- R<sub>15</sub>=2.0 megohms, 1.0 watt
- S<sub>1</sub>=7-contact S.P. switch
- S<sub>2</sub>=S.P.D.T. switch

### RATINGS FOR 884 AND 885

HEATER VOLTAGE...	884 6.3	885 2.5	Volts
HEATER CURRENT...	884 0.6	885 1.4	Amperes
TUBE VOLTAGE			
DROP (Approx.)	16	16	Volts
SOCKET...	RCA type 9924		

### As a Sweep-Circuit Oscillator

PLATE VOLT. (Instantaneous)	300 max. Volts
PEAK VOLT. BETWEEN ANY 2 ELECTRODES	350 max. Volts
PEAK PLATE CURRENT	300 max. Ma.
AVERAGE PLATE CURRENT:	
For freq. below 200 c./sec.	3 max. Ma.
For freq. above 200 c./sec.	2 max. Ma.
GRID RESISTOR:	
Should be not less than 1000 ohms per max. instantaneous volt applied to the grid. Values in excess of 0.5 megohm may cause circuit instability.	



### Approx. Frequency Range (Cycles/Sec.)

SWITCH (S <sub>1</sub> ) ON	C <sub>2</sub>	C <sub>3</sub>	C <sub>4</sub>	C <sub>5</sub>	C <sub>6</sub>	C <sub>7</sub>	C <sub>8</sub>
R <sub>6</sub> at Maximum.....	20	43	109	280	670	1500	3600
R <sub>6</sub> at Minimum.....	59	132	340	880	2180	4900	11400

## HOT-CATHODE GAS TETRODES

2050.....List Price **\$3.00**      2051.....List Price **\$2.50**

RCA-2050 and RCA-2051 are sensitive, gas-filled tetrodes of the heater-cathode type, designed for grid-controlled rectifier service. Both tubes have a steep control characteristic (high control ratio) which is independent of ambient temperature over a wide range. Because of the special electrode structure employed, the pre-conduction or gas-leakage currents to the anode are extremely small right up to the beginning of the conduction cycle. In addition, grid current is very low (less than 0.1 microampere), so that a high resistance may be used in the grid circuit. This characteristic provides tubes with a high sensitivity and permits their operation directly from a vacuum-type phototube.

# 2050

# 2051

### TYPICAL LIGHT-OPERATED RELAY CIRCUIT

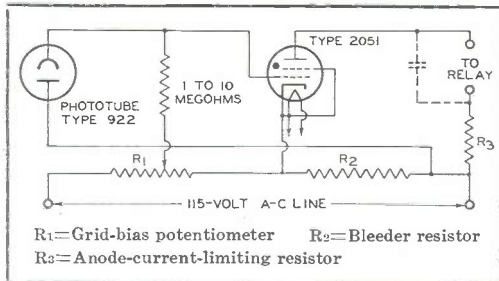

- R<sub>1</sub>=Grid-bias potentiometer
- R<sub>2</sub>=Bleeder resistor
- R<sub>3</sub>=Anode-current-limiting resistor

### RATINGS FOR 2050 AND 2051

HEATER VOLT. (A.C. or D.C.)	6.3	Volts
HEATER CURRENT	0.6	Amperes
GRID-ANODE CAPACITANCE	0.2	μf
SOCKET	Standard Octal (RCA type 9924)	

### As Grid-Controlled Rectifier

	Type 2050	Type 2051
PEAK FORWARD ANODE VOLTAGE	650 max.	350 max. Volts
PEAK INVERSE ANODE VOLTAGE	1300 max.	700 max. Volts
SHIELD GRID (Grid No. 2) VOLTAGE	0	0 Volts
PEAK ANODE CUR.	500 max.	375 max. Ma.
AVERAGE ANODE CURRENT#	100 max.	75 max. Ma.
TUBE VOLTAGE		
DROP (Approx)	8	14 Volts
GRID RESISTOR#	{ 0.01 min. 10 max.	{ 0.01 min. 10 max. Megohms



# Averaged over a period of not more than 30 seconds. When the tube is operated with an a-c anode voltage and a high value of grid resistance, the grid-anode capacitance should be made as small as possible by placing the grid resistor directly at the socket terminal, by connecting pins No. 4 and No. 8 together at the socket, and by using a close-fitting bulb shield connected to the cathode terminal.



# ACORN TUBE DATA



## U - H - F A C O R N T Y P E S

Type	List Prices	Type	List Prices	Type	List Prices
954	....\$5.00	956	....\$5.00	958	....\$3.00
955	.... 3.00	957	.... 3.00	959	.... 5.00



Tubes Shown Actual Size

The RCA Acorn tubes are designed for use by engineers and experimenters particularly at the ultra high frequencies. These remarkable short-wave tubes, assembled with the aid of a microscope, provide unusual r-f gain with remarkable efficiencies at wavelengths as low as 0.7 to 0.5 meter! Operation of the Acorn tubes at such short wavelengths is made possible by the use of an unconventional tube structure having extremely small size, close electrode spacing, and short terminal connections. Maximum height of the pentode types is only 1 7/8"; maximum height of the triode types is only 1 1/2".

RCA-954, 955, and 956 are the 6.3-volt heater-cathode types. The 954 is a pentode. As an r-f amplifier, this tube is capable of gains of three or more in circuits of conventional design. It is capable of working at wavelengths as short as 0.7 meter. The 955 is a triode well suited for use as a detector or r-f amplifier in u-h-f receivers. It is also well suited as an oscillator in "fly-power" transmitters operating at frequencies unreachable with ordinary tubes. RCA-955 is capable of giving an output of 1/2 watt at 5 meters and with only moderate reduction in this value for wavelengths as low as 1 meter. The 956 is a pentode of the remote cut-off type for use as a radio- and intermediate-frequency amplifier, or a mixer, in receivers operating at wavelengths as low as 0.7 meter. The 956 is capable of giving a gain of 4 or more when it is used as an r-f amplifier in circuits of conventional design.

RCA-957, 958, and 959 are a series of Acorn tubes having low-current filaments of the coated type. Their economy of filament and plate power and small sizes make them particularly useful in compact portable and other battery-operated equipment where minimum size and weight are important features. The filament of each of these three types can be operated without series resistance directly from a single flashlight dry cell. The 957 is a triode having a moderately high amplification factor. It may be used as a detector, amplifier, and oscillator. The 958 is a triode especially designed for transmitting service as an oscillator and r-f amplifier. It may also be used as an audio power output tube. Useful audio output for headphone operation may be obtained with plate voltage down to 45 volts, or lower. The 959 is a sharp cut-off pentode intended for use as an r-f amplifier and detector. It may also be used as a resistance-coupled a-f amplifier having moderate gain.

### 954 • 955 • 956 RATINGS and CHARACTERISTICS

As an Amplifier—Class A

	954	955	956	
HEATER VOLTAGE (A.C. or D.C.)	6.3	6.3	6.3	Volts
HEATER CURRENT	0.15	0.15	0.15	Ampere
MAX. PLATE VOLTAGE	250	250	250	Volts
SUPPRESSOR	†	—	†	Volts
MAX. SCREEN VOLTAGE	100	—	100	Volts
GRID VOLTAGE	-3 min.	-7	-3 min.	Volts
PLATE CURRENT	2	6.3	5	Ma.
SCREEN CURRENT	0.5	—	1.8	Ma.
PLATE RESIST. (APPROX.)	—	11400	700000	Ohms
AMPLIFICATION FACTOR	—	25	1440	
TRANSCONDUCTANCE	1400	2200	1800	Micromhos
DIRECT INTERELECTRODE CAPACITANCES:				
Grid-Plate	0.007‡	1.4	0.007‡	μμf
Grid-Cathode	—	1.0	—	μμf
Plate-Cathode	—	0.6	—	μμf
Input	3	—	3.4	μμf
Output	3.4	—	3	μμf

TERMINAL MOUNTING ..... RCA type 9925  
 † Connected to cathode at terminal mounting.  
 \* Greater than 1.5 megohms. ‡ Maximum with shield baffle.

### 957 • 958 • 959 RATINGS and CHARACTERISTICS

As an Amplifier—Class A

	957	958	959	
FILAMENT VOLTAGE (D.C.)	1.25	1.25	1.25	Volts
FILAMENT CURRENT	0.05	0.10	0.05	Ampere
PLATE VOLTAGE (Max.)	135	135	135	Volts
SUPPRESSOR	—	—	*	
SCREEN VOLTAGE (Max.)	—	—	67.5	Volts
GRID VOLTAGE†	-5	-7.5	-3	Volts
PLATE CURRENT	2	3	1.7	Ma.
SCREEN CURRENT	—	—	0.4	Ma.
PLATE RES. (APPROX.)	24600	10000	800000	Ohms
AMPLIFICATION FACTOR	16	12	480	
TRANSCONDUCTANCE	650	1200	600	Micromhos
DIRECT INTERELECTRODE CAPACITANCES:				
Grid-Plate	1.8	2.6	0.015‡	μμf
Grid-Filament	0.3	0.6	—	μμf
Plate-Filament	0.7	1.1	—	μμf
Input	—	—	1.8	μμf
Output	—	—	2.5	μμf

TERMINAL MOUNTING ..... RCA type 9925  
 \* Connected to minus filament at mounting.  
 † Maximum, with shield baffle.  
 ‡ Maximum resistance in grid circuit should not exceed 0.5 meg.

### ULTRA-HIGH-FREQUENCY HARTLEY OSCILLATOR

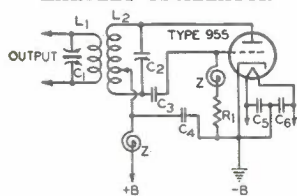

### PUSH-PULL OSCILLATOR TUNED-PLATE TUNED-GRID TYPE

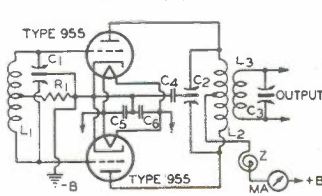

L1 C1, L2 C2=Depend on frequency range desired  
 C3=0.00005 μf  
 C4 C5 C6=0.0001 μf  
 R1=20000 to 25000 ohms, 1/2 watt  
 Z=R-F choke  
 L1 C1, L2 C2, L3 C3=Depend on frequency range desired  
 C4 C5 C6=0.0001 μf  
 R1=10000 to 12500 ohms, 1/2 watt

### TYPICAL R-F AMPLIFIER CIRCUIT

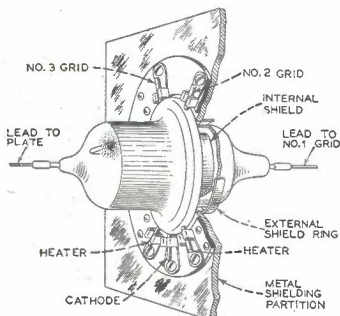
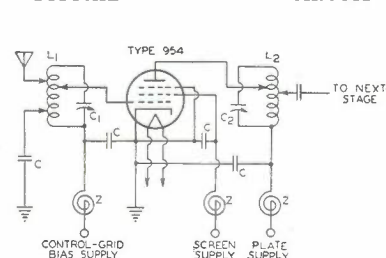

TYPICAL SHIELD CONSTRUCTION

\*B.C.=Bare Copper □S.L.=Single layer  
 Note: The above data are necessarily approximate. For ultra-high frequencies, coils L1 and L2 may be tapped at suitable points determined by test to reduce effect of tube loading on circuit impedances. Since electronic plate loading is not serious in a pentode, the use of coil L2 with tapped plate connection may not be necessary to give satisfactory results. The condensers should all be of high quality and be designed for u-h-f operation.

WAVE-LENGTH RANGE	2.75 TO 5.3 METERS APPROX.	1 TO 3 METERS APPROX.	0.8 METER APPROX.
L1, L2	10 TURNS WIRE N#16, B.C.* 3/8" 3/4"	4 TURNS WIRE N#16, B.C.* 2/8" 2/16"	5 TURNS WIRE N#30, B.C.* 1/8" 1/8"
C1, C2 (VARIABLE)	3 TO 25 μμf 100 TO 500 μμf	3 TO 25 μμf 100 TO 500 μμf	3 TO 4 μμf 100 TO 500 μμf
Z	15 TURNS WIRE N#30 1/4" S.L.□	15 TURNS WIRE N#30 1/4" S.L.□	15 TURNS WIRE N#30 1/4" S.L.□



# TRANSMITTING TRIODE

FOR HIGH PEAK-VOLTAGE REQUIREMENTS

620 WATTS INPUT

## Features

**\$13.50**

List Price

# 8000

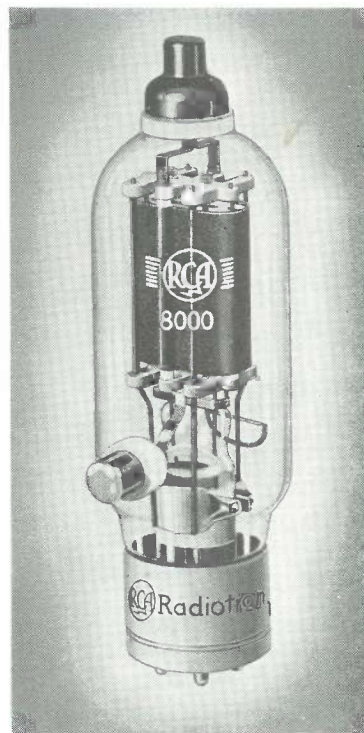

- **HIGH INSULATION RESISTANCE BETWEEN ELECTRODES**  
Enables tube to withstand high peak voltages.
- **HIGH POWER WITH RELATIVELY LOW PLATE VOLTAGE**
- **LOWER AMPLIFICATION FACTOR (16.5)**  
Lower driving power requirements. 475 watts output with 9 watts of grid drive.
- **BIG, SPECIAL-PROCESSED GRAPHITE ANODE**  
Assures high thermal radiation; gas free.
- **SHIELDED, HEAVY-DUTY 45-WATT FILAMENT**  
End-shields eliminate bulb bombardment and stray electrons.
- **30-Mc OPERATION AT FULL RATINGS**  
100-Mc Operation at reduced ratings.

RCA-8000 is a high-power transmitting triode with a low mu of 16.5 and a plate dissipation of 150 watts (ICAS). Special feature of the 8000 is its construction which provides high insulation resistance between electrodes. This enables the tube to withstand high peak voltages. RCA-8000 is particularly suitable for use as an r-f amplifier and class B modulator. *A single tube in class C telegraph service (ICAS) will take a plate input of 620 watts with a grid drive of only 9 watts.* In class B modulator service, two 8000's will modulate 100% nearly 1½ kilowatts of power!

In self-rectifying oscillator circuits, such as are used in therapeutic applications, two 8000's are capable of delivering a useful power output of 550 watts (85% circuit efficiency). In this application, as well as in general radio transmitter applications, the 8000 may be operated at maximum ratings at frequencies as high as 30 Mc and with reduced plate voltage and input as high as 100 Mc. The tube has a large graphite anode, specially processed, to insure high thermal radiation and a minimum of gas. The plate and grid leads are brought out to rugged terminals at the top and side of the bulb respectively.

Priced right, RCA-8000 offers economy not only in initial tube cost but also in substantial savings in final-stage tank condenser, high-voltage power supply, and the number of exciter stages required.

## RATINGS

FILAMENT VOLTAGE (A. C. OR D. C.)	10	Volts
FILAMENT CURRENT	4.5	Amperes
AMPLIFICATION FACTOR	16.5	
DIRECT INTERELECTRODE CAPACITANCES:		
Grid-Plate	6.4	μμf
Grid-Filament	5.0	μμf
Plate-Filament	3.3	μμf
MAXIMUM HEIGHT	9-1/16"	
MAXIMUM RADIUS	2-1/4"	
SOCKET	Transmitting 4-contact, such as RCA type 9936	

## MAXIMUM CCS and ICAS RATINGS with TYPICAL OPERATING CONDITIONS

As R-F Power Amplifier and Oscillator — Class C Telegraphy

	CCS	ICAS	
D-C PLATE VOLTAGE	2000 max.	2250 max.	Volts
D-C GRID VOLTAGE	-500 max.	-500 max.	Volts
D-C PLATE CURRENT	250 max.	275 max.	Ma.
D-C GRID CURRENT	40 max.	40 max.	Ma.
PLATE INPUT	500 max.	620 max.	Watts
PLATE DISSIPATION	125 max.	150 max.	Watts
TYPICAL OPERATION:			
D-C Plate Voltage	2000	2250	Volts
D-C Grid Voltage:			
From a fixed supply of	-195	-210	Volts
From a grid resistor of	8100	8400	Ohms
From a cathode resistor of	710	700	Ohms
PEAK R-F GRID VOLTAGE	370	400	Volts
D-C PLATE CURRENT	250	275	Ma.
D-C GRID CURRENT (Approx.)	24	25	Ma.
DRIVING POWER (Approx.)	8	9	Watts
POWER OUTPUT (Approx.)	375	475	Watts

As Self-Rectifying Oscillator—Class C

	CCS	
A-C PLATE VOLTAGE (RMS)	2500 max.	Volts
D-C GRID VOLTAGE	-200 max.	Volts
PEAK R-F GRID VOLTAGE	750 max.	Volts
D-C PLATE CURRENT	160 max.	Ma.
D-C GRID CURRENT	25 max.	Ma.
PLATE INPUT	450 max.	Watts
PLATE DISSIPATION	125 max.	Watts
TYPICAL OPERATION IN PUSH-PULL CIRCUIT AT 30 Mc:		
Unless otherwise specified, values are for 2 tubes		
A-C Plate Voltage (RMS)	2500	Volts
Grid Resistor	3500	Ohms
D-C Plate Current	320	Ma.
D-C Grid Current (Approx.)	30	Ma.
Power Output (Approx.)	650	Watts
Power Output from Tank Circuit (When circuit efficiency is 85%)	550	Watts

Max. Permissible Percentage of Max. Rated Plate Voltage and Plate Input for High-Frequency Operation

FREQUENCY	30	60	100	Mc
CLASS C/Telegraphy	100	70	50	Per Cent
Plate-Mod. Telephony				

R-F POWER AMPLIFIER USING RCA-8000  
Power Output 475 Watts, ICAS

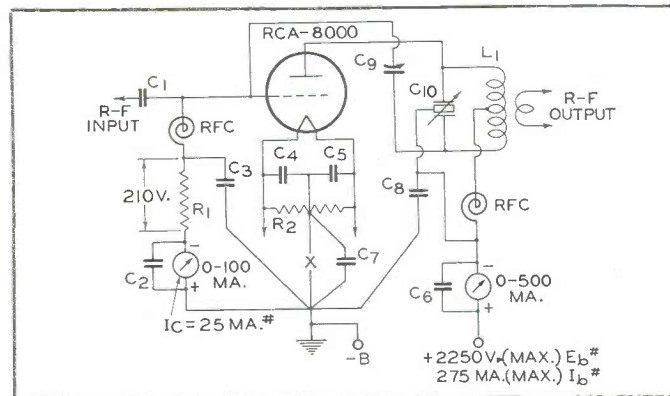

- C1=0.0005 μf, mica, 1500 v.
- C2 to C6=0.002 μf, mica
- C7=0.002 μf, mica, 2500 v.
- C8=0.002 μf, mica, 5000 v.
- C9=4.8μμf (approx.), 7500 v.
- C10=0.75 μμf/meter/section†

- R1=8400 ohms, 20 watts
- R2=50 ohms, c.t., wire-wound
- L1=Select for band desired
- RFC=R-f choke
- X=Insert keying relay here

† Approximate capacitance in actual use at resonance.  
# For ICAS plate-modulated telephony service, reduce Eb to 1800 v., Ib to 250 ma., and decrease Ic to 20 ma. The power output is approximately 335 watts.

Bottom View of Socket Connections

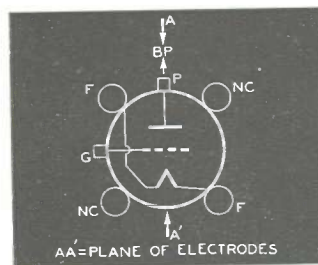

## Tube Mounting Position

VERTICAL—Base Down  
HORIZONTAL—Plane of electrodes vertical



# TRANSMITTING BEAM POWER AMPLIFIER

HIGH BEAM POWER FOR THE HIGHER FREQUENCIES

300 WATTS INPUT

List Price **\$27.50**

## Features

# 8001

- 75-MC OPERATION AT FULL RATINGS  
150-Mc Operation at Reduced Ratings
- HIGH POWER WITH MINIMUM DRIVER EQUIPMENT  
230 Watts Output—1½ Watts Drive
- HARD-GLASS BULB
- ENCLOSED TANTALUM ANODE  
Increases Power Output at High Frequencies
- GLASS DISH-TYPE STEM  
Provides Extremely Short Leads; Minimizes Internal Lead Inductance

RCA-8001 is a multi-electrode transmitting tube with a maximum plate dissipation rating of 75 watts. The tube contains a suppressor and has beam power features. RCA-8001 fills the need by engineers, experimenters, and amateurs for a beam tube that will deliver reasonably high power at the higher radio frequencies. For example, one 8001 will take a maximum plate input of 300 watts at frequencies as high as 75-Mc, with only 1.4 watts of driving power—and without neutralization. The tube is particularly well suited as an r-f amplifier, frequency multiplier, and suppressor-, grid-, or plate-modulated amplifier. It may also be used as a class A1 a-f power amplifier or modulator and in this service it is capable of delivering approximately 34 watts of audio power with very low distortion.

Other features of the 8001 are its dish-type stem which makes possible the use of unusually short internal leads, its hard-glass bulb to withstand extremely high temperatures, its enclosed tantalum anode to insure permanent gas-free operation and to eliminate loss of power from electron bombardment of the bulb, a giant 7-pin base having ceramic insulation and wide pin spacing, and a 37.5-watt thoriated-tungsten filament.

## RATINGS

FILAMENT VOLTAGE (A. C.)	5.0	Volts
FILAMENT CURRENT	7.5	Amperes
TRANSCONDUCTANCE, for plate current of 75 Ma.	2800	Micromhos
DIRECT INTERELECTRODE CAPACITANCES:		
Grid-Plate (With external shielding)	0.1 max.	μμf
Input	13.8	μμf
Output	6.7	μμf
MAXIMUM HEIGHT	6-7/8"	
MAXIMUM DIAMETER	2-11/16"	
SOCKET	7-contact transmitting, such as the RCA type 9929	

D-C Screen Voltage*	600	600	Volts
from a fixed supply of			
or from a series resistor of	82000	240000	Ohms
D-C Grid Voltage**			
from a fixed supply of	-200	-200	Volts
or from a grid resistor of	145000	330000	Ohms
or from combination of grid res. of	110000	250000	Ohms
and cathode resistor of	310	450	Ohms
Peak R-F Grid Voltage	255	220	Volts
D-C Plate Current	185	100	Ma.
D-C Suppressor Current	3	3	Ma.
D-C Screen Current	11	8	Ma.
D-C Grid Current (Approx.)	1.4	0.6	Ma.
Driving Power (Approx.)	0.4	0.1	Watts
Power Output (Approx.)	145	200	Watts

## MAXIMUM CCS RATINGS with TYPICAL OPERATING CONDITIONS

As Plate-Modulated R-F Power Amplifier—Class C Telephony

Carrier conditions per tube for use with a max. modulation factor of 1.0

D-C PLATE VOLTAGE	3000 max.	Volts
D-C SCREEN VOLTAGE (Grid No. 2)	600 max.	Volts
D-C GRID VOLTAGE (Grid No. 1)	-500 max.	Volts
D-C PLATE CURRENT	185 max.	Ma.
D-C GRID CURRENT	25 max.	Ma.
PLATE INPUT	250 max.	Watts
SCREEN INPUT	18 max.	Watts
PLATE DISSIPATION	65 max.	Watts

TYPICAL OPERATION:

D-C Plate Voltage	1500	2500	Volts
D-C Suppressor Voltage (Grid No. 3)	60	60	Volts

As R-F Power Amplifier—Class C Telegraphy

D-C PLATE VOLTAGE	4000 max.	Volts
D-C SCREEN VOLTAGE (Grid No. 2)	750 max.	Volts
D-C GRID VOLTAGE (Grid No. 1)	-500 max.	Volts
D-C PLATE CURRENT	150 max.	Ma.
D-C GRID CURRENT	25 max.	Ma.
PLATE INPUT	300 max.	Watts
SCREEN INPUT	225 max.	Watts
PLATE DISSIPATION	75 max.	Watts

TYPICAL OPERATION:

D-C Plate Voltage	2000	3000	Volts
D-C Supp. Voltage (Grid No. 3)	0	60	Volts
D-C Screen Voltage			
From a fixed supply of	750	750	Volts
From a series resistor of #	70000	280000	Ohms
D-C Grid Voltage**			
from a fixed supply of	-200	-200	Volts
or from a cathode resistor of	1200	1800	Ohms
or from a grid resistor of	300000	—	Ohms
Peak R-F Grid Voltage	225	170	Volts
D-C Plate Current	150	100	Ma.
Suppressor Current	0	3	Ma.
D-C Screen Current	18	8	Ma.
D-C Grid Current (Approx.)	0.7	0	Ma.
Driving Power (Approx.)	0.2	0	Watts
Power Output (Approx.)	230	235	Watts

\* Screen voltage should preferably be obtained from a fixed supply.

\*\* Total effective grid-circuit resistance should not exceed 50000 ohms.

# Series screen resistor should not be used except where the 8001 is employed as a buffer amplifier and is not keyed.

Bottom View of Socket Connections

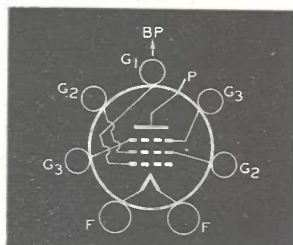

Tube Mounting Position VERTICAL—Base up or down HORIZONTAL—Not recommended

Max. Permissible Percentage of Max. Rated Plate Voltage and Plate Input for High-Frequency Operation

FREQUENCY	75	120	150	Mc
CLASS C { Telegraphy Plate-Mod. Telephony	100	75	50	Per Cent



# TRANSMITTING TRIODE

FOR HIGH PEAK VOLTAGE REQUIREMENTS

330 WATTS INPUT

List Price **\$12.00**

## Features

- WITHSTANDS HIGHER PEAK VOLTAGES THAN ORDINARY 100-WATTERS
- HIGH POWER OUTPUT WITH LOW PLATE VOLTAGE. 250 WATTS OUTPUT AT A PLATE VOLTAGE OF ONLY 1350 VOLTS
- EXCELLENT AS SELF-RECTIFIED OSCILLATOR SUCH AS USED IN THERAPEUTIC APPLICATIONS
- 30-Mc OPERATION AT FULL RATINGS

# 8003

RCA-8003 is a new transmitting triode with a maximum plate-dissipation rating of 100 watts and a low  $\mu$  of 12. RCA-8003 is suitable for use as an r-f power amplifier, class B modulator, and oscillator. In class C telegraph service, it will deliver a power output of 250 watts. In self-rectifying oscillator circuits such as are used in therapeutic applications, two 8003's are capable of delivering a useful power output of 380 watts when the circuit efficiency is 85%. The tube may be operated at maximum ratings at frequencies as high as 30 Mc—at reduced ratings to 50 Mc. RCA-8003 is designed with the standard 32.5 watt thoriated-tungsten filament.

For a thoroughly dependable triode either in standard transmitter installations or in the special application field, the 8003 is a logical choice. It is as rugged as they come.

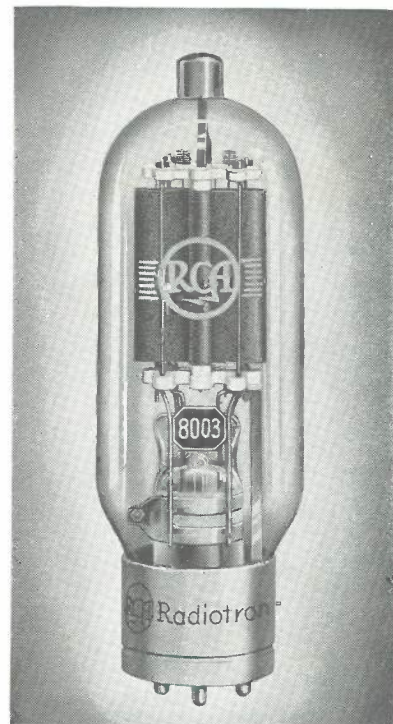

## RATINGS

FILAMENT VOLTAGE (A.C. OR D.C.)	10.0	Volts
FILAMENT CURRENT	3.25	Amperes
AMPLIFICATION FACTOR	12	
DIRECT INTERELECTRODE CAPACITANCES:		
Grid-Plate	11.7	$\mu\text{f}$
Grid-Filament	5.8	$\mu\text{f}$
Plate-Filament	3.4	$\mu\text{f}$
MAXIMUM HEIGHT	8-1/2"	
MAXIMUM DIAMETER	2-9/16"	
SOCKET	Transmitting 4-contact, such as the RCA type 9936	

## MAX. CCS RATINGS with TYPICAL OPERATING CONDITIONS

As R-F Power Amplifier — Class C Service

	Plate Modulation	C. W.	
D-C PLATE VOLTAGE	1100 max.	1350 max.	Volts
D-C GRID VOLTAGE	-400 max.	-400 max.	Volts
D-C PLATE CURRENT	200 max.	250 max.	Ma.
D-C GRID CURRENT	50 max.	50 max.	Ma.
PLATE INPUT	220 max.	330 max.	Watts
PLATE DISSIPATION	67 max.	100 max.	Watts

### TYPICAL OPERATION:

D-C Plate Voltage	1100	1350	Volts
D-C Grid Voltage			
From a fixed supply of	-260	-175	Volts
From a grid resistor of	6500	5000	Ohms
From a cathode resistor of		625	Ohms
Peak R-F Grid Voltage	430	350	Volts
D-C Plate Current	200	245	Ma.
D-C Grid Current (Approx.)	40	35	Ma.
Driving Power (Approx.)	15	11	Watts
Power Output (Approx.)	167	250	Watts

## As Self-Rectifying Oscillator—With Unfiltered Plate Supply

	Supply 1*	Supply 2**	
PLATE VOLTAGE	1200	1500 max.	Volts
D-C GRID VOLTAGE	-250	-200 max.	Volts
D-C PLATE CURRENT	225	200 max.	Ma.
D-C GRID CURRENT	45	30 max.	Ma.
PLATE INPUT	330	330 max.	Watts
PLATE DISSIPATION	100	100 max.	Watts

TYPICAL OPERATION in push-pull circuit at 25 Mc:

Unless otherwise specified, values are for 2 tubes

Plate Voltage	1200	1500 (RMS)	Volts
Grid Resistor	3000	2000	Ohms
D-C Plate Current	450	400	Ma.
D-C Grid Current	45	35	Ma.
Power Output (Approx.)	450	500	Watts
Circuit Power Output			
(When circuit efficiency is 85%)	380	425	Watts

\* Rectified but unfiltered single-phase full-wave supply. . . . .  
 \*\* Self-rectified a-c supply. Plate voltages are RMS values.

A typical single-ended r-f amplifier circuit using the 8003 is shown on this page. Keying is shown in the filament-to-ground return lead. If it is desired to key the oscillator for break-in operation, a fixed bias of approximately -100 volts should be used in conjunction with a grid leak  $R_1$  of about 2300 ohms (20 watts). This amount of fixed bias will protect the tube against removal of grid excitation when the key in the oscillator or buffer is open. This amplifier may also be plate modulated by reducing the d-c plate voltage to 1100 volts and the d-c plate current to 200 ma.

## Max. Permissible Percentage of Max. Rated Plate Voltage and Plate Input for High-Frequency Operation

CLASS C	FREQUENCY		Mc
	30	50	
Teleggraphy Plate-mod. Telephony	100	83	Per Cent

## R-F POWER AMPLIFIER USING RCA-8003 — Power Output 250 Watts (Class C Telegraphy)

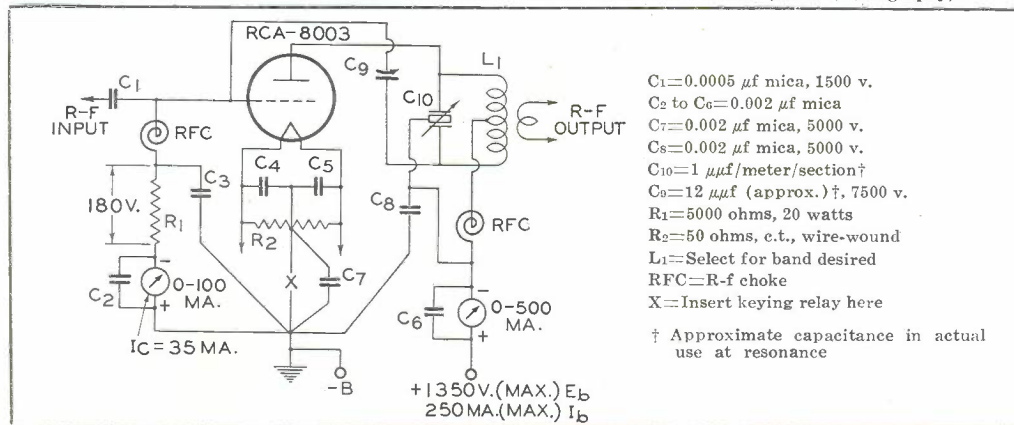

- C1=0.0005  $\mu\text{f}$  mica, 1500 v.
- C2 to C6=0.002  $\mu\text{f}$  mica
- C7=0.002  $\mu\text{f}$  mica, 5000 v.
- C8=0.002  $\mu\text{f}$  mica, 5000 v.
- C10=1  $\mu\text{f}$ /meter/section†
- C9=12  $\mu\text{f}$  (approx.)†, 7500 v.
- R1=5000 ohms, 20 watts
- R2=50 ohms, c.t., wire-wound
- L1=Select for band desired
- RfC=R-f choke
- X=Insert keying relay here

† Approximate capacitance in actual use at resonance

## Bottom View of Socket Connections

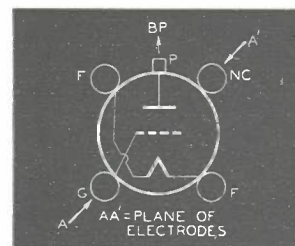

## Tube Mounting Position

VERTICAL—Base down.  
 HORIZONTAL—Plane of electrodes vertical (on edge).

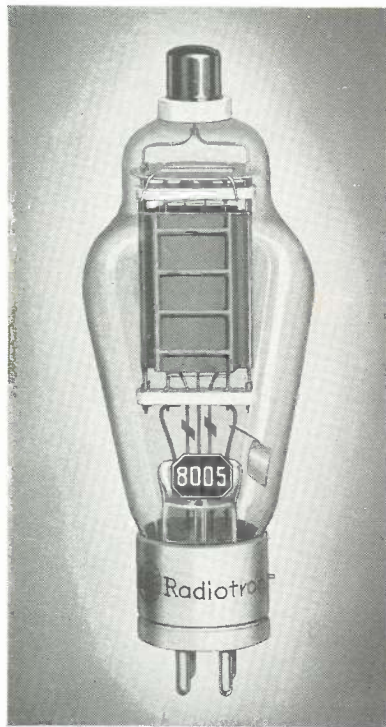

# TRANSMITTING TRIODE DELUXE

HARD-GLASS BULB; ZIRCONIUM-COATED ANODE

300 WATTS INPUT

List Price **\$7.00**

## 8005

"MINIATURE  
POWER  
HOUSE"

### Features

- **MOST POWERFUL OF THE SMALL TRIODES**  
Handles 300 watts input in a tube only 6<sup>1</sup>/<sub>4</sub>" high and 2<sup>7</sup>/<sub>8</sub>" in diameter.
- **LOW AMPLIFICATION FACTOR (20)**  
Low grid-drive requirements.
- **60-Mc OPERATION AT FULL RATINGS**  
100-Mc operation at reduced ratings.
- **EXCEPTIONAL DESIGN FEATURES**  
Zirconium-coated anode, 32.5 watt thoriated-tungsten filament, ceramic insulated plate cap, metal-shell base with ceramic insert.

RCA-8005 is a deluxe transmitting tube of the high-perveance type—most powerful of the small triodes. It has a maximum plate dissipation of 85 watts (ICAS) and a low mu of 20. RCA-8005 is designed for use as a radio-frequency amplifier and class B modulator. A single tube in class C telegraph service will handle 300 watts input (ICAS)—deliver about 220 watts of power—with less than 8 watts of grid drive. In plate-modulated service, it will take 240 watts (ICAS) with only 9 watts of grid drive. In self-rectifying oscillator circuits, such as are used in therapeutic applications, *two 8005's are capable of delivering an output of 280 watts when the circuit efficiency is 85%! In this application, as well as in general radio transmitter applications, the 8005 may be operated at maximum ratings at frequencies as high as 60 Mc and with reduced ratings up to 100 Mc.*

The remarkable power handling ability of the 8005 is a result of a number of outstanding features not usually

found together in a single tube of this size. First, the tube is designed with a hard-glass bulb which is capable of withstanding high temperatures without cracking or collapsing. Second, it contains the famous RCA Zirconium-coated anode having high heat-dissipating qualities and effective getter action that functions to keep the tube *hard during its entire life!* Third, it is constructed with a ceramic plate cap insulator to minimize corona discharge. Fourth, the metal-shell base of the tube employs ceramic insulation to withstand high temperatures, extreme climatic conditions, and to afford adequate grid-circuit insulation at the higher frequencies. Fifth, the tube contains an extra heavy-duty, 32.5-watt, thoriated-tungsten filament having enormous reserve of emission.

RCA-8005 is designed and built for RELIABILITY. It will deliver the goods under the most severe conditions of operation—in all classes of service. RCA-8005 handles more power than any other conventional tube of its size and class.

### RATINGS

FILAMENT VOLTAGE (A.C. or D.C.).....	10.0	Volts
FILAMENT CURRENT .....	3.25	Amperes
AMPLIFICATION FACTOR .....	20	
DIRECT INTERELECTRODE CAPACITANCES (Approx.):		
Grid-Plate .....	5.0	μf
Grid-Filament .....	6.4	μf
Plate-Filament .....	1.0	μf
MAXIMUM HEIGHT .....	6-11/16"	
MAXIMUM DIAMETER .....	2-7/16"	
SOCKET.....	Standard 4-contact, such as RCA type 9937	

### MAXIMUM CCS and ICAS RATINGS with TYPICAL OPERATING CONDITIONS

As A-F Power Amplifier and Modulator—Class B

	CCS	ICAS
D-C PLATE VOLTAGE.....	1250 max.	1500 max. Volts
MAX.-SIGNAL D-C PLATE CURRENT*... 200 max.		200 max. Ma.
MAX.-SIGNAL PLATE INPUT*..... 225 max.		250 max. Watts
PLATE DISSIPATION* .....	75 max.	85 max. Watts

### TYPICAL OPERATION:

Unless otherwise specified, values are for two tubes

	CCS	ICAS	
D-C Plate Voltage .....	1250	1500	Volts
D-C Grid Voltage .....	-55	-70	Volts
Peak A-F Grid-to-Grid Voltage.... 290		310	Volts
Zero-Signal D-C Plate Current.... 40		40	Ma.
Max.-Signal D-C Plate Current.... 320		310	Ma.
Load Resistance (per tube)..... 2000		2500	Ohms
Effective Load Resistance (Plate-to-Plate) .....	8000	10000	Ohms
Max.-Signal Driving Power (Approx.) .....	4	4	Watts
Max.-Signal Power Output (Approx.) .....	250	300	Watts

As Plate-Modulated R-F Power Amplifier—Class C Telephony

Carrier conditions per tube for use with a max. modulation factor of 1.0

	CCS	ICAS
D-C PLATE VOLTAGE .....	1000 max.	1250 max. Volts
D-C GRID VOLTAGE .....	-200 max.	-200 max. Volts
D-C PLATE CURRENT .....	160 max.	200 max. Ma.
D-C GRID CURRENT .....	45 max.	45 max. Ma.



# TRANSMITTING TUBE DATA



	CCS	ICAS	
PLATE INPUT	160 max.	240 max.	Watts
PLATE DISSIPATION	50 max.	75 max.	Watts
TYPICAL OPERATION:			
D-C Plate Voltage	1000	1250	Volts
D-C Grid Voltage:			
From a fixed supply of	-195	-195	Volts
From a grid resistor of	7000	7000	Ohms
Peak R-F Grid Voltage	350	350	Volts
D-C Plate Current	160	190	Ma.
D-C Grid Current (Approx.)	28	28	Ma.
Driving Power (Approx.)	9	9	Watts
Power Output (Approx.)	115	170	Watts

### As R-F Power Amplifier and Oscillator—Class C Telegraphy

	CCS	ICAS	
D-C PLATE VOLTAGE	1250 max.	1500 max.	Volts
D-C GRID VOLTAGE	-200 max.	-200 max.	Volts
D-C PLATE CURRENT	200 max.	200 max.	Ma.
D-C GRID CURRENT	45 max.	45 max.	Ma.
PLATE INPUT	240 max.	300 max.	Watts
PLATE DISSIPATION	75 max.	85 max.	Watts
TYPICAL OPERATION:			
D-C Plate Voltage	1250	1500	Volts
D-C Grid Voltage:			
From a fixed supply of	-115	-130	Volts
From a grid resistor of	3800	4000	Ohms
From a cathode resistor of	520	560	Ohms

	CCS	ICAS	
Peak R-F Grid Voltage	240	255	Volts
D-C Plate Current	190	200	Ma.
D-C Grid Current (Approx.)	30	32	Ma.
Driving Power (Approx.)	6.5	7.5	Watts
Power Output (Approx.)	170	220	Watts

### As Self-Rectifying Oscillator

	Supply 1#	Supply 2##	
PLATE VOLTAGE	1750 max.	1125 max.	Volts
D-C GRID VOLTAGE	-125 max.	-125 max.	Volts
D-C PLATE CURRENT	125 max.	180 max.	Ma.
D-C GRID CURRENT	25 max.	40 max.	Ma.
PLATE INPUT	240 max.	240 max.	Watts
PLATE DISSIPATION	75 max.	75 max.	Watts

TYPICAL OPERATION in push-pull circuit at 50 Mc:

Unless otherwise specified, values are for two tubes

Plate Voltage (RMS)	1750	1100	Volts
D-C Plate Current	250	360	Ma.
Grid Resistor	2000	2000	Ohms
D-C Grid Current (Approx.)	35	40	Ma.
Power Output (Approx.)	330	330	Watts
Circuit Power Output (Approx.)			
(When circuit efficiency is 85%)	280	280	Watts

\*Averaged over any audio-frequency cycle of sine-wave form.

# Self-rectified a-c supply. Plate voltages are RMS values.

## Rectified but unfiltered single-phase, full-wave supply.

### Max. Permissible Percentage of Max. Rated Plate Voltage and Plate Input for High-Frequency Operation

FREQUENCY	60	80	100	Mc
Class B R-F Telephony	100	90	83	Per Cent
Class C Plate-Mod. Telephony	100	75	60	Per Cent
Class C Telegraphy	100	75	60	Per Cent
Self-Rectifying Oscillator	100	75	60	Per Cent

## APPLICATION

A typical push-pull, plate-modulated r-f amplifier circuit using two 8005's is shown on this page. A single 807 operated as a straight amplifier at its CCS ratings of 600 plate volts is the logical choice for the driver, because it is capable of delivering the 18 watts driving power required for the 8005's, with power to spare.

For cw service, R<sub>1</sub> should be changed to 2000-ohms, T<sub>2</sub> should be left out of the circuit, and the plate voltage may be increased to 1500 volts, maximum. For oscillator keying, a fixed bias of approximately -70 volts should be used in conjunction with a 750-ohm, 20-watt grid resistor. This amount of fixed bias is sufficient to protect the 8005's when the key is up.

Bottom View of Socket Connections

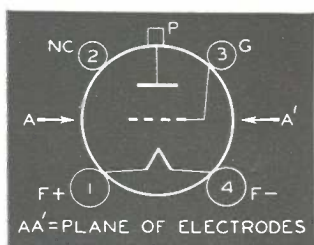

### Tube Mounting Position

VERTICAL—Base down.  
HORIZONTAL—Plane of plate vertical (on edge).

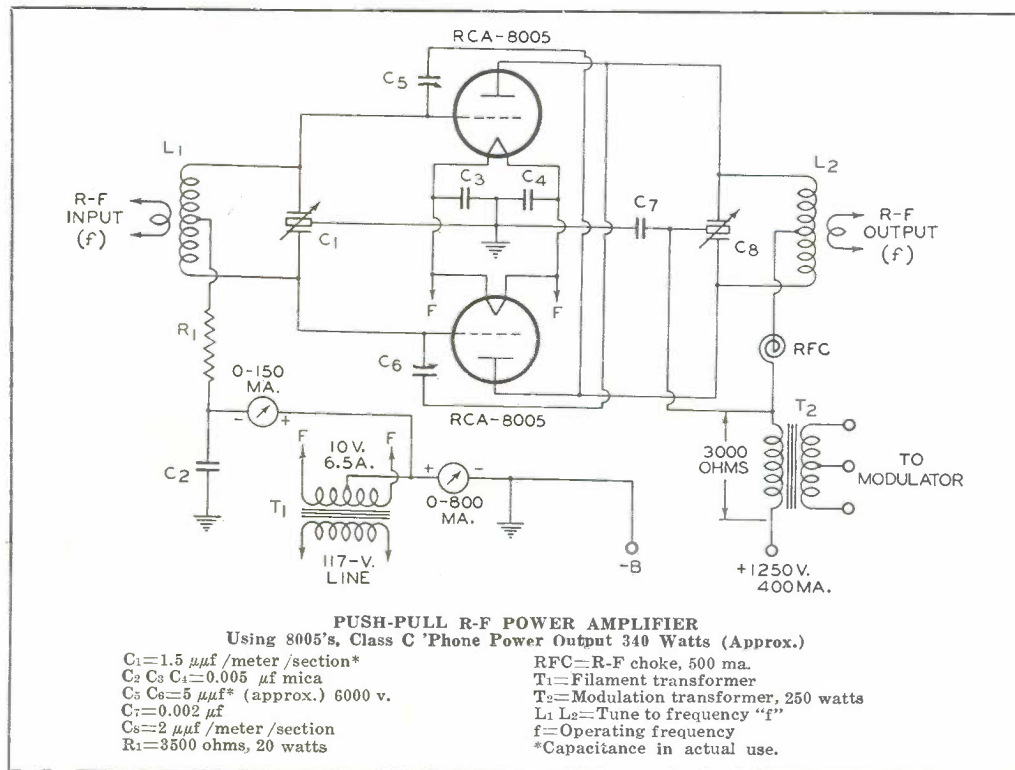



# TRANSMITTING TUBE DATA

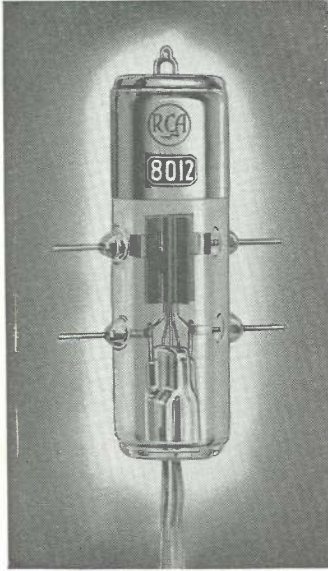

## IMPROVED U-H-F TRIODE

FULL POWER TO 500 Mc!

50 Watts Input

List Price **\$19.00**

# 8012

- IMPROVED PERFORMANCE AT LOWER COST
- 500 MC AT MAXIMUM RATINGS  
*600 Mc at reduced ratings*
- DOUBLE-HELICAL, CENTER-TAPPED FILAMENT  
*Minimizes effect of filament-lead inductance*

RCA-8012 is the new uhf triode. It is designed for use as an oscillator, r-f power amplifier, and frequency multiplier and supersedes the 1628. At a lower cost than the former type, this tube is capable of giving improved performance. *It takes full input to 500 Mc. It takes full input to 600 Mc with only a 63% decrease in plate voltage. At 600 Mc, a pair of 8012's is capable of delivering about 25 watts output with an efficiency of approximately 35%.*

Outstanding engineering features make the 8012 unexcelled in its class. It is designed with a zirconium-coated anode to insure gas-free operation at extremely high temperatures. Grid and plate are closely spaced to increase plate efficiency at the higher frequencies by decreasing electron transit time between filament and plate. The tube contains a thoriated-tungsten, double-helical filament having a center-tap lead that is brought out of the bulb through a separate seal. By connecting the three external filament leads in parallel through r-f by-pass condensers, RCA-8012 now makes it practical to minimize the effect of filament lead inductance at ultra-high frequencies. Double grid and plate leads, also brought out through separate seals, can be connected in parallel to reduce lead inductance. In grid-modulated service the tube is capable of delivering a power output of approximately 20 watts.

### RATINGS

FILAMENT VOLTAGE (A.C. OR D.C.)	6.3	Volts
FILAMENT CURRENT	2	Amperes
AMPLIFICATION FACTOR	18	
DIRECT INTERELECTRODE CAPACITANCES:		
Grid-Plate	2.8	$\mu\text{f}$
Grid-Filament	2.7	$\mu\text{f}$
Plate-Filament	0.35	$\mu\text{f}$
MAXIMUM HEIGHT	3-15/16"	
MAXIMUM RADIUS	1-1/8"	

### MAX. CCS RATINGS and TYPICAL OPERATING CONDITIONS

As R-F Power Amplifier—Class C.

	Plate Modulation	C.W. or Oscillator	
D-C PLATE VOLTAGE	800 max.	1000 max.	Volts
D-C GRID VOLTAGE	-200 max.	-200 max.	Volts

D-C PLATE CURRENT	65 max.	80 max.	Ma.
D-C GRID CURRENT	20 max.	20 max.	Ma.
PLATE INPUT	33 max.	50 max.	Watts
PLATE DISSIPATION	27 max.	40 max.	Watts
TYPICAL OPERATION:			
D-C Plate Voltage	800	1000	Volts
D-C Grid Voltage:			
from a fixed supply of	-105	-90	Volts
or from a grid resistor of	10000	6400	Ohms
or from a cathode resistor of	—	1400	Ohms
Peak R-F Grid Voltage	145	130	Volts
D-C Plate Current	40	50	Ma.
D-C Grid Current (Approx.)	10.5	14	Ma.
Driving Power (Approx.)	1.4	1.6	Watts
Power Output (Approx.)	22	35	Watts

### Max. Permissible Percentage of Max. Rated Voltage and Plate Input for High-Frequency Operation

CLASS C	FREQUENCY	Percentage		
		500	600	Mc
Telegraphy Plate-Modulation	100	63	Per Cent	

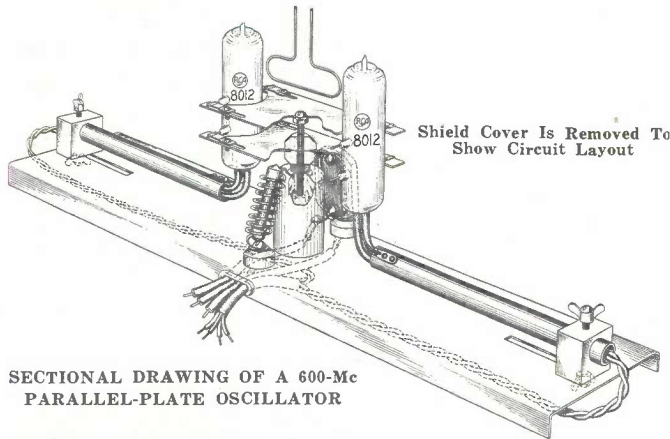

SECTIONAL DRAWING OF A 600-Mc PARALLEL-PLATE OSCILLATOR

In operation of the 8012 at the higher frequencies, the grid- and plate-return circuits of the tube should be by-passed for r.f. to the center lead of the filament. The returns should be made to this common connection in order to avoid r-f interaction through common return circuits. It may also be advisable to connect r-f chokes in these returns to form a filter network. All three filament leads should be connected in parallel through r-f by-pass condensers. The center lead of this parallel connection should be by-passed to the center-tap of the filament transformer or to ground. It should not be returned to these points directly.

A cutaway drawing and circuit for a 600-Mc oscillator employing two 8012's in push-pull are shown on this page. The structural arrangement permits unusual symmetry of construction. The oscillator makes use of two parallel plates, L<sub>3</sub> and L<sub>4</sub>, as frequency-determining elements.

The filaments of the tubes are maintained close to ground potential for r-f by means of the tuned filament lines, L<sub>1</sub> and L<sub>2</sub>. The shorting bars, S<sub>1</sub> and S<sub>2</sub> can be used to control excitation to the grids of the tubes. The slots in L<sub>3</sub> and L<sub>4</sub> are primarily for mechanical alignment of the tubes, although they can also be used to make minor tuning adjustments. The parallel plates, L<sub>3</sub> and L<sub>4</sub>, are supported at their geometric centers and d-c plate and grid connections are made to the plates at these points.

### 600-Mc PARALLEL-PLATE OSCILLATOR Useful Power Output, 25 Watts (Approx.)

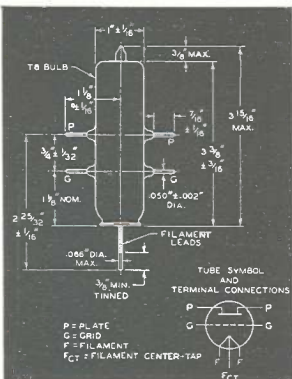
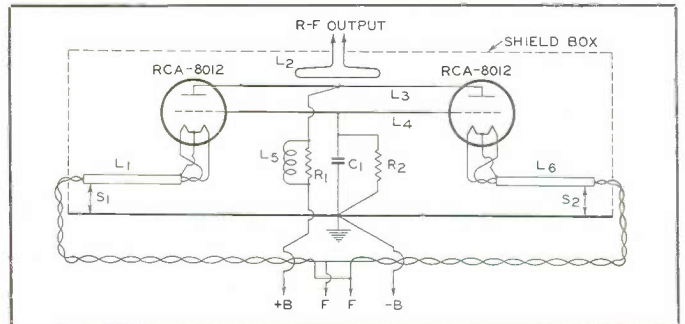

C<sub>1</sub>=0.001  $\mu\text{f}$  mica  
 L<sub>1</sub>, L<sub>2</sub>=Filament Lines; each 5/8" copper tubing, 6-1/2" long, approx.  
 L<sub>3</sub>=Pickup Loop; 1" high, 2" long, approx.  
 L<sub>4</sub>=Plate Line; 1/32" sheet copper, 4" by 2-5/16", with cut-outs to fit tube bulbs  
 L<sub>5</sub>=Grid Line; similar to L<sub>3</sub> and spaced approx. 3/4" from it  
 L<sub>6</sub>=8 turns of No. 12 copper wire 5/8" diameter wound around R<sub>1</sub>  
 R<sub>1</sub>=200 ohms, 2 watts  
 R<sub>2</sub>=1200 ohms, 2 watts  
 S<sub>1</sub>, S<sub>2</sub>=Shorting blocks  
 Typical Operating Conditions of Oscillator (values are given for both tubes):  
 Filament Voltage=6.3 volts  
 Filament Current=2 amperes  
 Plate Voltage=450 v. max.  
 Plate Current=150 ma. max.  
 Grid Current=32 ma. (approx.)





## HALF-WAVE, HIGH-VACUUM RECTIFIER

40,000 VOLTS, PEAK INVERSE RATING

List Price **\$12.00**

### Features

- D-C OUTPUT VOLTAGE 18,000 VOLTS AT 20 MA.
- SHIELDED STEM TO PREVENT ELECTRON BOMBARDMENT
- THORIATED-TUNGSTEN FILAMENT POSSESSES HIGH EMISSION CAPABILITIES

# 8013

RCA-8013 is a new high-voltage, half-wave rectifier tube of the high-vacuum type. It is designed particularly for use in rectifying systems to supply d-c currents up to 20 milliamperes per tube at very high d-c voltages. In properly designed equipment, voltages up to approximately 18,000 volts may be obtained at full output current. Outstanding features of the 8013 are its 12.5-watt, thoriated-tungsten filament with high emission capabilities, its shielded stem structure to prevent electron bombardment, its large skirted anode cap with rolled edges to prevent corona discharge and resultant heating and puncture of the bulb, and its highly polished and rolled-edge type anode to minimize cold emission and arc-backs. Smoothing filter requirements for high-voltage, low-current applications of the type requiring the use of 8013's can ordinarily be met by the use of a small condenser connected across the output of the rectifier.

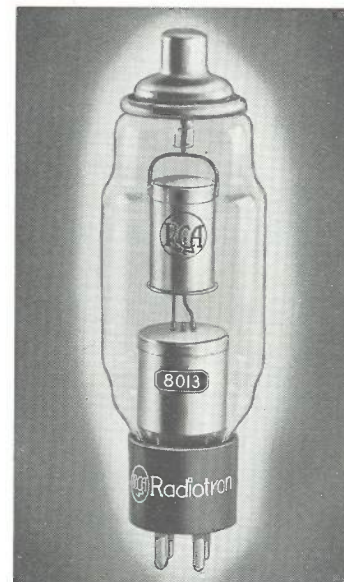

### RATINGS

FILAMENT VOLTAGE (A.C.)*	2.5	Volts
FILAMENT CURRENT	5	Amperes
PEAK INVERSE VOLTAGE	40000 <i>max.</i>	Volts
PEAK PLATE CURRENT	150 <i>max.</i>	Ma.
AVERAGE PLATE CURRENT	20 <i>max.</i>	Ma.
MAXIMUM HEIGHT	6-15/16"	
MAXIMUM DIAMETER	2-1/16"	
SOCKET	Standard 4-contact, such as RCA type 9919	

\* Voltage should be applied to the filament for a length of time sufficient for the filament to come up to normal operating temperature before plate current is drawn from the tube. For average conditions, the delay is approximately 5 seconds.

Bottom View of Socket Connections

Tube Mounting Position

- VERTICAL —Base down
- HORIZONTAL —Not recommended

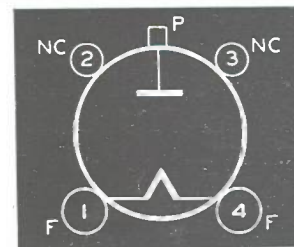

## HALF-WAVE, HIGH-VACUUM RECTIFIER

10,000 VOLTS, PEAK RATING

List Price **\$2.75**

### Features

- 0.25-WATT COATED TYPE FILAMENT PERMITS TRANSFORMER ECONOMY. USE OF R-F SOURCE
- D-C OUTPUT VOLTAGE 4500 VOLTS AT 2 MA.
- SHIELDED CONSTRUCTION PREVENTS ELECTRON BOMBARDMENT OF BULB AND STEM
- ANODE CONTAINS APERTURE FOR OBSERVING FILAMENT TEMPERATURE

# 8016

RCA-8016 is a new high-voltage, half-wave rectifier of the high-vacuum type. It is for use in rectifier systems designed to deliver high voltages at low current and in such applications can supply d-c voltages up to about 4500 volts at a current of 2 ma. Outstanding features of the 8016 are its shielded structure and its 0.25-watt filament, which together, make the tube suitable for supplying high-voltage rectified power from an r-f source. Other features of the tube are its highly polished rolled edge type anode to minimize cold emission and arc-backs, and its anode aperture to permit observation of the filament temperature. In voltage doubler service, two 8016's may be connected to deliver approximately twice the d-c output voltage obtainable with the half-wave or the full-wave method.



### RATINGS

FILAMENT VOLTAGE (A.C.)*	1.25	Volts
FILAMENT CURRENT	0.2	Ampere
PEAK INVERSE VOLTAGE	10000 <i>max.</i>	Volts
PEAK PLATE CURRENT	7.5 <i>max.</i>	Ma.
AVERAGE PLATE CURRENT	2 <i>max.</i>	Ma.
FREQUENCY OF SUPPLY VOLTAGE	500 <i>max.</i>	Kilocycles
PLATE-FILAMENT CAPACITANCE	1.3	$\mu\mu\text{f}$
MAXIMUM HEIGHT	4-3/8"	
MAXIMUM DIAMETER	1-5/16"	
SOCKET	Standard Octal, such as RCA type 9924	

\* Filament voltage should not vary more than  $\pm 10\%$  from the rated value. With an r-f supply, under any conditions, the filament must never be allowed to reach a temperature higher than that caused by operation on d.c. or low-frequency a.c. at 1.75 volts. Even momentary operation at higher temperatures is certain to cause damage to the tube.

Bottom View of Socket Connections

Tube Mounting Position

- VERTICAL —Base down
- HORIZONTAL —Not recommended

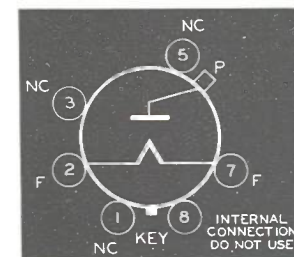



# MIDGET TUBE DATA



# 9001 9002 9003



TUBES  
ARE SHOWN  
ACTUAL  
SIZE

## THE U-H-F MIDGETS

9001 ..... List Price \$2.50      9002 ..... List Price \$2.00

9003 ..... List Price \$2.50

RCA-9001, 9002, and 9003 are the special Midget tubes designed for use by engineers and experimenters working in the ultra high frequencies. They are the answer to the need for economical tubes designed particularly for applications requiring high-efficiency, high-gain circuits at unusually high frequencies. Moreover, the tubes have mechanical advantages not to be overlooked since their conventional method of mounting means that they can be inserted and removed from their sockets with ease and that they can be made to fit into just about any space.

The 9001 is a sharp cut-off pentode, the 9002 is a triode, and the 9003 is a remote cut-off pentode. Static electrical characteristics are quite similar to the corresponding Acorn types, the 954, 955, and 956, respectively. In the Midget tubes, as in the Acorns, transit time loading effect is decreased by closely spacing the electrodes. Interelectrode capacitances are decreased by using small cathodes, grids, and plates. Short, internal leads and low lead inductance are insured through the use of the glass-button stem structure and the single-ended design. In order to reduce the common feedback inductance, each tube has two cathode leads which may be used either in parallel or as separate returns for input and output circuits. The 9002 triode also is designed with two plate leads.

### CHARACTERISTICS • RATINGS • TYPICAL OPERATING CONDITIONS

	9001 Sharp Cut-Off Pentode	9002 Triode	9003 Super- Control Pentode			
HEATER VOLTAGE (A.C. OR D.C.)	6.3	6.3	6.3	Volts		
HEATER CURRENT	0.15	0.15	0.15	Ampere		
DIRECT INTERELECTRODE CAPACITANCES:						
Grid-Plate	0.01 max.	1.4	0.01 max.	$\mu\text{mf}$		
Input	3.6	—	3.4	$\mu\text{mf}$		
Output	3.0	—	3.0	$\mu\text{mf}$		
Grid-Cathode	—	1.2	—	$\mu\text{mf}$		
Plate-Cathode	—	1.1	—	$\mu\text{mf}$		
MAXIMUM LENGTH	1-13/16"	1-13/16"	1-13/16"			
MAXIMUM DIAMETER	3/4"	3/4"	3/4"			
SOCKET	All three tubes use RCA type 9914					
PLATE VOLTAGE	250 max.	250 max.	250 max.	Volts		
SCREEN VOLTAGE	100 max.	—	100 max.	Volts		
GRID VOLTAGE	-3 min.	—	-3 min.	Volts		
TYPICAL OPERATION AS CLASS A1						
AMPLIFIER:						
Plate Voltage	90	250	90	250	Volts	
Screen Voltage	90	100	—	100	Volts	
Grid Voltage	-3*	-3*	2.5	-7	-3	Volts
Grid Voltage for Transconductance	—	—	—	—	-45	Volts
of 2 $\mu\text{mhos}$	1	**	14700	11400	0.7	Megohm
Plate Resistance	—	—	25	25	—	
Amplification Factor	—	—	1700	2200	1800	Micromhos
Transconductance	1100	1400	2.5	6.3	6.7	Ma.
Plate Current	1.2	2	—	—	2.7	Ma.
Screen Current	0.5	0.7	—	—	—	

\* 5 volts (approx.) is minimum for oscillator peak voltage of 4 volts. Value is optimum.

\*\* Greater than 1 megohm.

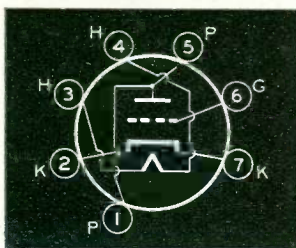

Bottom View  
of 9002 Socket Connections

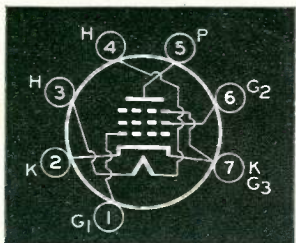

Bottom View  
of 9001 and 9003 Socket Connections

In application, the Midget tubes may be used in uhf equipment in much the same manner that ordinary tubes are used in standard broadcast receiver application. For example, a typical short-wave receiver might employ 9001's or 9003's as r-f amplifiers or mixers. The 9002 could be used as an oscillator. The 9001's or 9003's could also be used in the i-f stages when the i-f frequency is above 100 Mc. Midget tubes may also be used in other applications, such as resistance-coupled audio amplifiers and biased detectors, particularly where there are limits on space and weight. The circuit on this page shows the 9002 employed as an oscillator. Under the conditions given, the oscillator will perform smoothly at frequencies as high as 600 Mc with a plate input of 1.6 watts. The tuned grid and plate lines are each one-quarter wave long.

### 600-Mc OSCILLATOR USING MIDGET TRIODE 9002

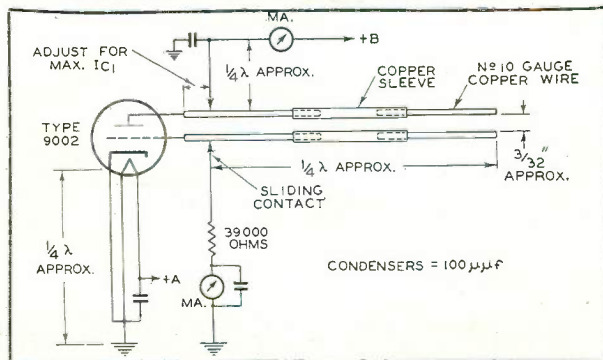

# OTHER PROVEN RCA TRANSMITTING AND SPECIAL-PURPOSE TUBES

## TRANSMITTING TYPES

Tube No.	Classification	Plate Dissipation (Watts)	DESCRIPTION	Tube List Price	Tube No.	Classification	Plate Dissipation (Watts)	DESCRIPTION	Tube List Price
<b>203-A</b>	Air-Cooled Triode	100	R-F Power Amplifier. Class B Modulator. Filament Voltage, 10 v. Max. D-C Plate Voltage, 1250 v. Class C c-w Output, 130 w. (approx.). Full Input to 15 Mc. $\mu=25$ . Uses RCA Socket, type 9936.	<b>\$10<sup>00</sup></b>	<b>845</b>	Air-Cooled Triode	100	A-F Power Amplifier. Filament Voltage, 10 v. Max. Filament Current, 3.25 a. Max. D-C Plate Voltage, 1250 v. Class AB <sub>2</sub> Output, 2 tubes, 115 w. Uses RCA Socket, type 9936.	<b>\$10<sup>00</sup></b>
<b>204-A</b>	Air-Cooled Triode	250	R-F Power Amplifier. Class B Modulator. Filament Voltage, 11 v. Max. D-C Plate Voltage, 2500 v. Class C c-w Output, 450 w. (approx.). Full Input to 3 Mc. $\mu=23$ . Uses RCA type 9938 Socket Assembly.	<b>\$85<sup>00</sup></b>	<b>846</b>	Water-Cooled Triode	2500	R-F Power Amplifier. Class B Modulator. Filament Voltage, 11 v. Max. Filament Current, 51 a. Max. D-C Plate Voltage, 7500 v. Class C c-w Output, 4250 w. (approx.). Full Input to 50 Mc. $\mu=40$ . Uses Special Water Jacket. Information Available on Request.	<b>\$260<sup>00</sup></b>
<b>207</b>	Water-Cooled Triode	10,000	R-F Power Amplifier. Class B Modulator. Filament Voltage, 22 v. Max. Filament Current, 52 a. Max. D-C Plate Voltage, 15,000 v. Class C c-w Output, 15,000 w. (approx.). Full Input to 1.5 Mc. $\mu=20$ . Uses RCA Water Jacket, type UT-1285-A.	<b>\$275<sup>00</sup></b>	<b>849</b>	Air-Cooled Triode	400	R-F Power Amplifier. Class A and B Modulator. Filament Voltage, 11 v. Max. D-C Plate Voltage, 2500 v. Class C c-w Output, 560 w. (approx.). Full Input to 3 Mc. $\mu=19$ . Uses RCA type 9938 Socket Assembly.	<b>\$120<sup>00</sup></b>
<b>211</b>	Air-Cooled Triode	100	R-F Power Amplifier. Class B Modulator. Filament Voltage, 10 v. Max. D-C Plate Voltage, 1250 v. Class C c-w Output, 130 w. (approx.). Full Input to 15 Mc. $\mu=12$ . Uses RCA Socket, type 9936.	<b>\$10<sup>00</sup></b>	<b>850</b>	Air-Cooled Tetrode	100	R-F Power Amplifier. Filament Voltage, 10 v. Max. D-C Plate Voltage, 1250 v. Class C c-w Output, 130 w. (approx.). Full Input to 15 Mc. Uses RCA Socket, type 9936.	<b>\$37<sup>50</sup></b>
<b>800</b>	Air-Cooled Triode	35	R-F Power Amplifier. Class B Modulator. Filament Voltage, 7.5 v. Max. D-C Plate Voltage, 1250 v. Class C c-w Output, 65 w. (approx.). Full Input to 60 Mc. $\mu=15$ . Uses RCA Socket, type 9937 or 9919.	<b>\$10<sup>00</sup></b>	<b>852</b>	Air-Cooled Triode	100	R-F Power Amplifier. Filament Voltage, 10 v. Max. D-C Plate Voltage, 3000 v. Class C c-w Output, 165 w. (approx.). Full Input to 30 Mc. $\mu=12$ . Uses RCA Socket, type 9937.	<b>\$16<sup>40</sup></b>
<b>801-A</b>	Air-Cooled Triode	20	R-F and A-F Power Amplifier. Class B Modulator. Filament Voltage, 7.5 v. Max. D-C Plate Voltage, 600 v. Class C c-w Output, 25 w. (approx.). Full Input to 60 Mc. $\mu=8$ . Uses RCA Socket, type 9937 or 9919.	<b>\$3<sup>45</sup></b>	<b>858</b>	Water-Cooled Triode	20,000	R-F Power Amplifier. Class B Modulator. Filament Voltage, 22 v. Max. Filament Current, 52 a. Max. D-C Plate Voltage, 20,000 v. Class C c-w Output, 22,400 w. (approx.). Full Input to 1.5 Mc. $\mu=42$ . Uses RCA Water Jacket, type UT-1290.	<b>\$400<sup>00</sup></b>
<b>830-B</b>	Air-Cooled Triode	60	R-F Power Amplifier. Class B Modulator. Filament Voltage, 10 v. Max. D-C Plate Voltage, 1000 v. Class C c-w Output, 90 w. (approx.). Full Input to 15 Mc. $\mu=25$ . Uses RCA Socket, type 9937 or 9919.	<b>\$10<sup>00</sup></b>	<b>860</b>	Air-Cooled Tetrode	100	R-F Power Amplifier. Filament Voltage, 10 v. Max. D-C Plate Voltage, 3000 v. Class C c-w Output, 165 w. (approx.). Full Input to 30 Mc. Uses RCA Socket, type 9937.	<b>\$32<sup>50</sup></b>
<b>841</b>	Air-Cooled Triode	15	R-F Power Amplifier. Class B Modulator. Filament Voltage, 7.5 v. Maximum D-C Plate Voltage, 450 v. Class C c-w Output, 15 w. (approx.). Full Input to 6 Mc. $\mu=30$ . Uses RCA Socket, type 9937 or 9919.	<b>\$3<sup>25</sup></b>	<b>861</b>	Air-Cooled Tetrode	400	R-F Power Amplifier. Filament Voltage, 11 v. Max. D-C Plate Voltage, 3500 v. Class C c-w Output, 700 w. (approx.). Full Input to 20 Mc. Uses RCA type 9938 Socket Assembly.	<b>\$195<sup>00</sup></b>
<b>842</b>	Air-Cooled Triode	12	Class A Modulator. Filament Voltage, 7.5 v. Maximum D-C Plate Voltage, 425 v. Undistorted Power Output, 3 w. $\mu=3$ . Uses RCA Socket, type 9937 or 9919.	<b>\$3<sup>25</sup></b>	<b>862</b>	Water-Cooled Triode	100,000	R-F Power Amplifier. Class B Modulator. Filament Voltage, 33 v. Max. Filament Current, 207 a. Max. D-C Plate Voltage, 20,000 v. Class C c-w Output, 100,000 w. (approx.). Full Input to 1.6 Mc. $\mu=48$ . Uses RCA Water Jacket, type UT-1289.	<b>\$1650<sup>00</sup></b>
<b>843</b>	Air-Cooled Triode	15	R-F Power Amplifier. Class A Modulator. Heater Voltage, 2½ v. Maximum D-C Plate Voltage, 450 v. Class C c-w Output, 7½ w. (approx.). Full Input up to 6 Mc. $\mu=7.7$ . Uses RCA Socket, type 9920.	<b>\$6<sup>75</sup></b>	<b>865</b>	Air-Cooled Tetrode	15	R-F Power Amplifier. Filament Voltage, 7.5 v. Max. D-C Plate Voltage, 750 v. Class C c-w Output, 16 w. (approx.). Uses RCA Socket, type 9937 or 9919.	<b>\$12<sup>75</sup></b>

TRANSMITTING TYPES (Continued)

Tube No.	Classification	Plate Dissipation (Watts)	DESCRIPTION	Tube List Price
880	Water-Cooled Triode	20,000	R-F Power Amplifier. Class B Modulator. Filament Voltage, 12.6 v. Filament Current, 320 a. Max. D-C Plate Voltage, 10,500 v. Class C c-w Output, 45,000 w. (approx.). Full Input to 25 Mc. $\mu=20$ . Uses RCA Water Jacket, type UT-4001.	\$850 <sup>00</sup>
887	Water-Cooled UHF Triode	1000	R-F Power Amplifier. Filament Voltage, 11 v. Filament Current, 24 a. Max. D-C Plate Voltage, 3000 v. Class C c-w Output, 800 w. (approx.). Full Input to 225 Mc. $\mu=10$ . Water Jacket is Integral Part of Tube.	\$150 <sup>00</sup>
888	Water-Cooled UHF Triode	1000	R-F Power Amplifier. Filament Voltage, 11 v. Filament Current, 24 a. Max. D-C Plate Voltage, 3000 v. Class C c-w Output, 800 w. (approx.). Full Input to 225 Mc. $\mu=30$ . Water Jacket is Integral Part of Tube.	\$150 <sup>00</sup>
889	Water-Cooled Triode	5000	R-F Power Amplifier. Class B Modulator. Filament Voltage, 11 v. Filament Current, 125 a. Max. D-C Plate Voltage, 7500 v. Class C c-w Output, 10,000 w. (approx.). Full Input to 50 Mc. $\mu=21$ . Uses RCA Water Jacket, type UT-4000.	\$275 <sup>00</sup>
889-R	Air-Radiator Triode	5000	R-F Power Amplifier. Class B Modulator. Filament Voltage 11 v. Filament Current, 125 a. Max. D-C Plate Voltage, 8500 v. Class C c-w Output, 10,000 w. (approx.) Full Input to 25 Mc. $\mu=21$ . Uses RCA Mounting, type UT-4394.	\$425 <sup>00</sup> (Incl. Radiator)
891	Water-Cooled Triode	6000	R-F Power Amplifier. Two-Phase Filament. (Voltage per Unit, 11 v; Current per Unit, 60 a.). Max. D-C Plate Voltage 12,000 v. Class C c-w Output, 10,000 w. (approx.). Full Input to 1.6 Mc. $\mu=8$ . Uses RCA Water Jacket, type UT-1285-A.	\$285 <sup>00</sup>
891-R	Air-Radiator Triode	4000	R-F Power Amplifier. Class B Modulator. Two-Phase Filament. (Voltage per Unit, 11 v; Current per Unit, 60 a.). Max. D-C Plate Voltage, 10,000 v. Class C c-w Output, 10,000 w. (approx.). Full Input to 1.6 Mc. $\mu=8$ . Uses Special Mounting. Information Available on Request.	\$410 <sup>00</sup> (Incl. Radiator)
892	Water-Cooled Triode	10,000	R-F Power Amplifier. Class B Modulator. Two-Phase Filament. (Voltage per Unit, 11 v; Current per Unit, 60 a.). Max. D-C Plate Voltage, 15,000 v. Class C c-w Output, 14,000 w. (approx.). Full Input to 1.6 Mc. $\mu=50$ . Uses RCA Water Jacket, type UT-1285-A.	\$285 <sup>00</sup>
892-R	Air-Radiator Triode	4000	R-F Power Amplifier. Class B Modulator. Two-Phase Filament. (Voltage per Unit, 11 v; Current per Unit, 60 a.). Max. D-C Plate Voltage, 12,500 v. Class C c-w Output, 10,000 w. (approx.). Full Input to 1.6 Mc. $\mu=50$ . Uses Special Mounting. Information Available on Request.	\$410 <sup>00</sup> (Incl. Radiator)
893	Water-Cooled Triode	20,000	R-F Power Amplifier. Class B Modulator. Three-Phase Filament. (Voltage per Strand, 10 v; Current per Terminal, 61 a.). Max. D-C Plate Voltage, 20,000 v. Class C c-w Output, 50,000 w. (approx.). Full Input to 5 Mc. $\mu=36$ . Uses RCA Water Jacket, type 1290-A.	\$750 <sup>00</sup>

\* ICAS Rating

Tube No.	Classification	Plate Dissipation (Watts)	DESCRIPTION	Tube List Price
893-R	Air-Radiator Triode	20,000	R-F Power Amplifier. Class B Modulator. Three-Phase Filament. (Voltage per Strand, 10 v; Current per Terminal, 61 a.). Max. D-C Plate Voltage, 20,000 v. Class C c-w Output 50,000 w. (approx.). Full Input to 5 Mc. $\mu=36$ . Uses Special Mounting. Information Available on Request.	\$1150 <sup>00</sup> (Incl. Radiator)
898	Water-Cooled Triode	100,000	R-F Power Amplifier. Class B Modulator. Three-Phase Filament. (Voltage per Strand, 17.3 v; Current per Terminal, 71.5 a.). Max. D-C Plate Voltage, 20,000 v. Class C c-w Output 100,000 w. (approx.). Full Input to 1.6 Mc. $\mu=44$ . Uses RCA Water Jacket, type UT-1289.	\$1650 <sup>00</sup>
1608	Air-Cooled Triode	20	R-F Power Amplifier. Class B Modulator. Filament Voltage, 2½v. Max. D-C Plate Voltage, 420 v. Class C c-w Output, 27 w. (approx.). Full Input to 45 Mc. $\mu=20$ . Uses RCA Socket, type 9937 or 9919.	\$40 <sup>00</sup>
1610	Air-Cooled Pentode	6	Crystal Oscillator. Frequency Multiplier. Filament Voltage, 2½ v. Max. D-C Plate Voltage, 400 v. Class C c-w Output, 5 w. (approx.). Full Input to 20 Mc. Uses RCA Socket, type 9920.	\$20 <sup>00</sup>
1613	Air-Cooled Pentode (Metal Type)	10	R-F Power Amplifier. Crystal Oscillator. Frequency Multiplier. Filament Voltage, 6.3 v. Max. D-C Plate Voltage, 350 v. Class C c-w Output, 9 w. (approx.). Full Input to 45 Mc. Uses RCA Socket, type 9924.	\$27 <sup>50</sup>
1614	Air-Cooled Beam Tube (Metal Type)	21	R-F Power Amplifier. Filament Voltage, 6.3 v. Max. D-C Plate Voltage, 375 v. Class C c-w Output, 17 w. (approx.). Full Input to 80 Mc. Uses RCA Socket, type 9924.	\$35 <sup>00</sup>
1619	Air-Cooled Beam Tube (Metal Type)	15	R-F Power Amplifier. Modulator. Filament Voltage, 2.5 v. Max. D-C Plate Voltage, 400 v. Class C c-w Output, 19.5 w. (approx.). Full Input to 45 Mc. Uses RCA Socket, type 9924. Quick Heating for Fast Off-On Operation.	\$47 <sup>50</sup>
1624	Air-Cooled Beam Tube	25	R-F Power Amplifier. Class AB <sub>2</sub> Modulator. Frequency Multiplier. Similar to 807 but has 2.5-v. Filament. Quick Heating for Fast Off-On Operation. Uses RCA Socket, type 9923.	\$35 <sup>00</sup>
1625	Air-Cooled Beam Tube	30*	R-F Power Amplifier. Class AB <sub>2</sub> Modulator. Frequency Multiplier. Similar to 807 but has 12.6-v. Heater. Uses RCA Socket, type 9923. Especially Useful in Aircraft Transmitters.	\$35 <sup>00</sup>
1626	Air-Cooled Triode	5	R-F Oscillator. Designed for applications requiring unusually stable characteristics. Heater voltage, 12.6 v. Max. D-C Plate Voltage, 250 v. R-F Power Output, 4 w. (approx.). Full Input to 30 Mc. $\mu=5$ . Uses RCA type Socket, 9924.	\$25 <sup>00</sup>

## HALF-WAVE TRANSMITTING AND TELEVISION RECTIFIERS

Tube No.	DESCRIPTION	Filament (or heater) Ratings	Max. Peak Inverse Volts #	Max. Peak Plate Amperes	Condensed Mercury Temp. Range °C	Max. D-C Output Amperes	RCA Socket No.	Tube List Price
<b>2V3-G</b>	High-Vacuum Type. For Cathode-Ray and Television Application	2.5 v. 5 a.	16,500	0.012 a.	.....	0.002 a. (2 ma.)	9924	<b>\$280</b>
<b>2X2/879</b>	High-Vacuum Type. For Cathode-Ray and Television Application	2.5 v. 1.75 a.	12,500	0.1 a.	.....	0.0075 a. (7.5 ma.)	9919	<b>\$230</b>
<b>217-A</b>	High-Vacuum Type	10 v., 3.25 a.	3,500	0.6 a.	.....	0.2 a.	9936	<b>\$2000</b>
<b>217-C</b>	High-Vacuum Type	10 v., 3.25 a.	7,500	0.6 a.	.....	0.15 a.	9936	<b>\$2000</b>
<b>857-B</b>	Mercury-Vapor Type. Forced Air-Cooling. Supersedes 857	5 v. 30 a.	22,000	40.0 a.	30-40°	10.0 a.	Special Mounting	<b>\$24000</b>
<b>869-B</b>	Mercury-Vapor Type. Supersedes 869-A	5 v. 18 a.	20,000	10.0 a.	30-40°	2.5 a.	9938 Assembly	<b>\$12500</b>
<b>870-B</b>	Mercury-Vapor Type. Forced Air-Cooling. Supersedes 870	5 v. 65 a.	16,000	450.0 a.	35-40°	75.0 a.	Special Mounting	<b>\$115000</b>
<b>878</b>	High-Vacuum Type. For Cathode-Ray and Television Application	2.5 v. 5 a.	20,000	0.02 a.	.....	0.005 a. (5 ma.)	9919	<b>\$1100</b>
<b>1616</b>	High-Vacuum Type	2.5 v., 5 a.	5,500	0.8	.....	0.13 a.	9937	<b>\$575</b>

# For d-c output voltage and other circuit conditions, see table page 30.

## CATHODE-RAY TYPES (OSCILLOSCOPES, KINESCOPES, ICONOSCOPES, MONOSCOPES, ORTHICON)

Tube No.	DESCRIPTION	Max. Anode Volts	Tube List Price	Tube No.	DESCRIPTION	Max. Anode Volts	Tube List Price
<b>3AP1/906-P1</b>	3-Inch Green-Phosphor-Screen Oscilloscope. Electrostatic deflection. Medium persistence. Sensitivity of deflecting electrodes near gun=0.23 mm/volt d.c. Uses RCA Socket type 9923.	1500	<b>\$1350</b>	<b>907</b>	5-Inch Blue-Phosphor-Screen Oscilloscope. Electrostatic deflection. Short persistence. Sensitivity of deflecting electrodes near gun=0.23 mm/volt d.c. Uses RCA Socket type 9920.	2000	<b>\$4875</b>
<b>3AP4/906-P4</b>	3-Inch White-Phosphor-Screen Picture Tube (Kinescope). Electrostatic deflection. Sensitivity of deflecting electrodes near gun=0.23 mm/volt d. c. Uses RCA Socket type 9923.	1500	<b>\$1825</b>	<b>908</b>	3-Inch Blue-Phosphor-Screen Oscilloscope. Electrostatic deflection. Short persistence. Sensitivity of deflecting electrodes near gun=0.23 mm/volt d.c. Uses RCA Socket type 9923.	1500	<b>\$1800</b>
<b>5AP4/1805-P4</b>	5-Inch White-Phosphor-Screen Picture Tube (Kinescope). Short bulb. Electrostatic deflection. Sensitivity of deflecting electrodes near gun=0.21 mm/volt d.c.	2000	<b>\$2750</b>	<b>913</b>	1-Inch Green-Phosphor-Screen Oscilloscope. Electrostatic deflection. Medium persistence. Sensitivity of deflecting electrodes near gun=0.10 mm/volt d.c. Uses RCA Socket type 9924.	500	<b>\$400</b>
<b>5BP1/1802-P1</b>	5-Inch Green-Phosphor-Screen Oscilloscope. Electrostatic deflection. Medium persistence. Sensitivity of deflecting electrodes near gun=0.33 mm/volt d.c.	2000	<b>\$2475</b>	<b>914</b>	9-Inch Green-Phosphor-Screen Oscilloscope. Electrostatic deflection. Medium persistence. Sensitivity of deflecting electrodes near gun=0.093 mm/volt d.c. Uses RCA type Socket 9921.	7000	<b>\$8500</b>
<b>5BP4/1802-P4</b>	5-Inch White-Phosphor-Screen Picture Tube (Kinescope). Electrostatic deflection. Sensitivity of deflecting electrodes near gun=0.33 mm/volt d.c.	2000	<b>\$2750</b>	<b>1840</b>	Orthicon for Direct and Film Pick-Up Camera. Electrostatic-Magnetic deflection. Magnetic focus. Uses RCA type Socket 9924.	300	<b>\$65000</b>
<b>7AP4</b>	7-Inch White-Phosphor-Screen Picture Tube (Kinescope). Magnetic deflection. Short bulb. Uses RCA Socket type 9920.	3500	<b>\$3600</b>	<b>1847</b>	Iconoscope for Experimental Use. Electrostatic deflection. Electrostatic focus. Uses RCA type Socket 9924.	600	<b>\$2450</b>
<b>9AP4/1804-P4</b>	9-Inch White-Phosphor-Screen Picture Tube (Kinescope). Magnetic deflection. Uses RCA Socket type 9921.	7000	<b>\$6250</b>	<b>1848</b>	Iconoscope for Portable Television Camera. Magnetic deflection. Electrostatic focus. Uses RCA type Socket 9924.	1200	<b>\$52500</b>
<b>12AP4/1803-P4</b>	12-Inch White-Phosphor-Screen Picture Tube. Largest RCA Kinescope. Magnetic deflection. Uses RCA Socket type 9921.	7000	<b>\$7500</b>	<b>1849</b>	Iconoscope for Film Pick-Up Camera. Magnetic deflection. Electrostatic focus. Uses RCA type Socket 9921.	1200	<b>\$65000</b>
<b>902</b>	2-Inch Green-Phosphor-Screen Oscilloscope. Electrostatic deflection. Medium persistence. Sensitivity of deflecting electrodes near gun=0.22 mm/volt d.c. Uses RCA Socket type 9924.	600	<b>\$750</b>	<b>1850</b>	Iconoscope for Direct Pick-Up Camera. Magnetic deflection. Electrostatic focus. Uses RCA type Socket 9921.	1200	<b>\$65000</b>
<b>904</b>	5-Inch Green-Phosphor-Screen Oscilloscope. Electrostatic-magnetic deflection. Medium persistence. Sensitivity of deflecting electrodes=0.09 mm/volt d.c. Uses RCA Socket type 9921.	4600	<b>\$5250</b>	<b>1898</b>	Monoscope for Generating Test Pattern. Three-inch size. Electrostatic deflection and focus. Uses RCA type Socket 9923.	1200	<b>\$2400</b>
<b>905</b>	5-Inch Green-Phosphor-Screen Oscilloscope. Electrostatic deflection. Medium persistence. Sensitivity of deflecting electrodes near gun=0.23 mm/volt d.c. Uses RCA Socket type 9920.	2000	<b>\$4500</b>	<b>1899</b>	Monoscope for Generating Test Pattern. Five-inch size. High resolution capability. Magnetic deflection. Electrostatic focus.	1500	<b>\$9500</b>

## PHOTOTUBES

Tube No.	DESCRIPTION	Luminous Sensitivity (Microamp./Lumen)**	Tube List Price
<b>868</b>	Gas type. For sound reproduction. Uses RCA type Socket 9919.	65	<b>\$370</b>
<b>917</b>	Vacuum type. For relays and measurements. Has anode cap. Uses RCA type Socket 9919.	20	<b>\$475</b>
<b>918</b>	Gas type. Has high sensitivity for sound reproduction. Uses RCA type Socket 9919.	110	<b>\$450</b>
<b>919</b>	Vacuum type. For relays and measurements. Has cathode cap. Uses RCA type Socket 9919.	20	<b>\$475</b>
<b>920</b>	Gas twin type. For sound reproduction. Uses RCA type Socket 9919.	75 (each unit)	<b>\$525</b>
<b>921</b>	Gas type. Cartridge design. For sound reproduction and relays. Uses RCA type Socket 9926.	100	<b>\$200</b>
<b>922</b>	Vacuum type. Cartridge design. For relays and measurements. Uses RCA type Socket 9926.	20	<b>\$200</b>
<b>923</b>	Gas type. Has high sensitivity. For sound reproduction and relays. For new equipment, the 930 is recommended. Uses RCA type Socket 9919.	100	<b>\$260</b>
<b>924</b>	Gas type. For use with relays. End style with intermediate lamp screw base.	55	<b>\$200</b>
<b>925</b>	Vacuum type. Short design. For use with relays. Uses RCA type Socket 9924.	15	<b>\$200</b>
<b>926</b>	Vacuum type. Cartridge design. For colorimetry. Uses RCA type Socket 9926.	6.5	<b>\$300</b>
<b>927</b>	Gas type. Miniature design. For sound reproduction. Requires special Pee-Wee base.	75	<b>\$370</b>
<b>928</b>	Gas type. Non-directional style. For relay applications. Uses RCA type Socket 9919.	65	<b>\$200</b>
<b>929</b>	Vacuum type. Has high sensitivity. For relays and measurements. Uses RCA type Socket 9924.	45	<b>\$300</b>
<b>930</b>	Gas type. Has high sensitivity. For sound reproduction and relays. Uses RCA type socket 9924.	100	<b>\$200</b>
<b>931</b>	Electron-multiplier type. Has 9 electrically focused stages. Enormous sensitivity. Low noise level. For relays, sound reproduction, and scientific research. Uses RCA type Socket 9915.	$2.3 \times 10^9$	<b>\$1200</b>

\*\* With incandescent light source at 2870° K.

## VOLTAGE REGULATORS

(All types are glow-discharge and have cold cathode.)

Tube No.	D-C Operating Voltage (approx.)	D-C Operating Current, Ma. (approx.)	D-C Starting Volts (min.)	RCA Socket No.	Tube List Price
<b>VR75-30</b>	75	5 to 30	105	9921	<b>\$125</b>
<b>VR105-30</b>	105	5 to 30	127	9924	<b>\$125</b>
<b>VR150-30</b>	150	5 to 30	180	9924	<b>\$125</b>
<b>874</b>	90	10 to 50	125	9919	<b>\$150</b>
<b>991</b>	67 to 48	0.4 to 2	87	##	<b>\$090</b>

## Tube is equipped with a standard bayonet candelabra, double-contact base.

## SPECIAL AMPLIFIER TUBES

Tube No.	DESCRIPTION	Tube List Price
<b>12A6</b>	A-F Beam Power Amplifier. Metal type. Designed particularly for aircraft applications. Heater voltage, 12.6 v. Max. plate voltage, 250 v. Power Output, 3.4 w. Uses RCA type Socket 9924.	<b>.70</b>
<b>864</b>	Low-Microphonic Amplifier Triode. Filament voltage, 1.1 v. Max. plate voltage, 135 v. Uses RCA type Socket 9919.	<b>\$100</b>
<b>1602</b>	Low-Microphonic Triode (special type 10). Useful in a-f and r-f services. Filament voltage, 7.5 v. Max. d-c plate voltage, 450 v. Power output, class A, 1.6 w. $\mu=8$ . Uses RCA type Socket 9919.	<b>\$275</b>
<b>1603</b>	Low-Microphonic Pentode. Low-hum, low-noise output. Heater voltage, 6.3 v. Max. plate voltage, 250 v. Uses RCA type Socket 9921.	<b>\$475</b>
<b>1609</b>	Low-Microphonic Pentode. Companion to 864. Filament voltage, 1.1 v. Max. plate voltage, 135 v. Uses RCA type Socket 9920.	<b>\$160</b>
<b>1612</b>	Low-Microphonic Pentagrid Amplifier. Similar to 6L7. Heater voltage, 6.3 v. Max. plate voltage, 250 v. Uses RCA type Socket 9924.	<b>\$325</b>
<b>1621</b>	A-F Power Amplifier Pentode. Metal type. For applications requiring continuity of service. Heater voltage, 6.3 v. In push-pull service, max. plate voltage is 300 v., a-f power output, 5 watts. Uses RCA type Socket 9924.	<b>\$250</b>
<b>1622</b>	A-F Beam Power Amplifier. Metal type. For applications requiring continuity of service. Heater voltage, 6.3 v. In push-pull service, max. plate voltage is 300 v., power output, 10 watts. Uses RCA type Socket 9924.	<b>\$275</b>
<b>1629</b>	Electron-Ray tube. Similar to 6E5 but has a 12.6-v. heater. Uses RCA type Socket 9924.	<b>\$125</b>
<b>1631</b>	A-F Beam Power Amplifier. Metal type. Similar to 6L6 but has 12.6-v. heater and is especially suited for applications requiring uniformity of characteristics. Uses RCA type Socket 9924.	<b>\$200</b>
<b>1632</b>	A-F Beam Power Amplifier. Metal type. Similar to 25L6 but has 12.6-v. heater and is especially suited for applications requiring uniformity of characteristics. Uses RCA type Socket 9924.	<b>\$200</b>
<b>1633</b>	Twin-Triode Amplifier. Similar to 6SN7-GT but has a 25-v. heater and is especially suited for applications requiring matched triode units. Uses RCA type Socket 9924.	<b>\$150</b>
<b>1634</b>	Twin-Triode Amplifier. Single-ended metal type. Similar to 12SC7 and is especially suited for applications requiring matched triode units. Uses RCA type Socket 9924.	<b>\$200</b>
<b>1851</b>	Amplifier Pentode. Metal type. Features high transconductance of 9000 micromhos. For new equipment, the 6AC7/1852 is recommended.	<b>\$210</b>
<b>MISCELLANEOUS</b>		
<b>2000</b>	Half-Wave Gas Rectifier. Excellent stability. Especially suited for supplying rectified current to exciter lamps in sound equipment. Max. ratings are: peak inverse volts, 350; d-c output volts, 90; d-c output amperes, 6. Filament ratings: 2.2 v; 18 a. Tube requires a Mogul screw socket.	<b>\$600</b>



# GENERAL TUBE AND TRANSMITTER DATA

In the following pages, information is given concerning a few fundamental subjects which are of primary interest to amateurs who are designing, building, adjusting, or operating a transmitter. More comprehensive information on these subjects as well as on many others of equal importance can be found in the RCA TRANSMITTING TUBE MANUAL. Additional references which few amateurs can afford to be without, whether they be newcomers or "old timers," are the following excellent handbooks:

**"The Radio Amateur's Handbook"**

Published by  
The A. R. R. L.  
WEST HARTFORD, CONN.

**"Radio Handbook"**

Published by  
The Editors of RADIO  
1300 KENWOOD ROAD,  
SANTA BARBARA, CALIF.

## CHOICE OF TUBE TYPES

In the design of a radio transmitter, the choice of the number and types of transmitting tubes is of paramount importance. Engineers, radio amateurs, and others interested in transmitter design are fortunate in having available a large variety of power tubes with which to work. The very number of tube types may even seem to be a source of confusion, but the problem, if approached logically, represents no great difficulty. The designer can, by the simple process of elimination, reduce the number of tube types suitable for a specific application to a small group from which a final choice can readily be made.

Most modern transmitters are of the crystal-oscillator-power-amplifier type. In almost every case, however, the ultimate design revolves around the final stage—the r-f power amplifier which develops useful r-f energy and supplies it to the radiating system. The following considerations are important in the choice of power tubes for the final amplifier stage: (1) power capability, (2) frequency capability, (3) design suitability, and (4) economic suitability.

**Power capability.** The tube or tubes used in the r-f power amplifier should be capable of delivering the desired power output when operated (with a practicable value of efficiency) within the maximum ratings. The efficiency of the final stage depends on a number of factors, chief of which are the class of amplification and the operating frequency. Typical efficiencies to be expected in the various classes of amplifier service are as follows:

Class C r-f amplifier .....	65-75%
Class C r-f frequency doubler .....	30-50%
Grid-modulated class C r-f amplifier .....	30-35%
Suppressor-modulated class C r-f amplifier .....	30-35%
Cathode-modulated class C r-f amplifier ..	45-60%
Class B linear r-f amplifier .....	30-35%
Class B a-f amplifier .....	60-70%

**Frequency capability.** The final amplifier tube or tubes should be capable of operating at the desired radio frequency with sufficient d-c plate input so that, with a practicable value of efficiency, the required power output can be obtained. Data for operating frequency versus tube ratings are usually given under each tube type. A tube which can be used at maximum ratings at 60 Mc is obviously a better high-frequency tube than one which can be used with maximum ratings only up to 30 Mc. As the frequency is increased, tube and circuit losses increase rapidly and plate-circuit efficiency

decreases. Almost any tube is capable of operating satisfactorily at frequencies up to 15 Mc. At 30 Mc and higher frequencies, however, a tube should be selected with special attention to its high-frequency capabilities.

**Design suitability.** Under this broad heading is included a large number of miscellaneous factors which the designer should consider. Some of these are:

(1) Power supply. This factor is important in the choice of tube types. In portable designs, it may be necessary to use tubes which can be operated economically from a heavy-duty, low-voltage battery supply. In fixed-station service, where a source of a-c power is available, the problem of d-c voltage supplies is greatly simplified through the use of suitable rectifiers and filters. Even here, however, one tube may be preferable to another because it is better suited for use with an available power-supply voltage and/or current.

(2) Power sensitivity. In those cases where the total number of stages in a transmitter must be kept to a minimum, tubes having high power sensitivity should be employed. Power pentodes and beam power tubes, such as the 804, 807, and 813, require very little driving power compared to triodes of equivalent power output. For low-power frequency multipliers and intermediate amplifier stages, the 802 pentode and the 807 beam power amplifier are very useful.

(3) Circuit flexibility. Where a transmitter must be capable of operating on a number of widely different frequencies with a minimum of time required for changing frequencies, the use of tetrodes or pentodes (in preference to triodes) is indicated. Because tetrode and pentode amplifiers do not, in general, require neutralization, the problems that are sometimes encountered with neutralized triode amplifiers are avoided.

(4) Mechanical considerations. The size and shape of the tube may be important in some transmitter designs because of space or weight requirements. The arrangement of the electrode terminals is sometimes of importance because it affects circuit wiring and the mounting of circuit components.

(5) Electrical considerations. It is frequently convenient to use certain tube types together because they can be operated from a common filament supply, from a common plate-voltage source, or because they make practical other simplifications in design and maintenance.

**Economic suitability.** This factor includes not only initial tube cost but also the costs of auxiliary equipment, maintenance, and operation. An analysis of these costs will often indicate that it is desirable to modify the design to meet the requirements of a particular installation.

### R-F Driving Power

An important problem in transmitter design is the choice of tube types for the intermediate amplifier, multiplier (if any), and oscillator stages. In practice, it is generally convenient to begin with the r-f power amplifier stage and work "backward," toward the master- or crystal-oscillator stage. The driving power necessary for the final tube (or tubes) can be obtained, for a specified class of service, from the tabulated tube data. This power, as shown for triodes and tetrodes in class B r-f service and in class C service, is subject to wide variations, depending on the impedance of the output or load circuit. High-impedance load circuits require more driving power to obtain the desired output. Low-impedance circuits need less driving power, but cause a sacrifice of plate-circuit efficiency.





The driver stage should have a tank circuit of good regulation and should be capable of delivering considerably more than the rated driving power of the final amplifier tube. For example, if the final amplifier has a rated driving power of 10 watts in class C telegraphy service, the driver stage may have to be capable of delivering 15 to 25 watts of r-f power in order to compensate for circuit losses and to have suitable regulation. The actual value will depend on several variable factors, so that some actual experience is frequently necessary before the designer of a transmitter can choose the most logical tube type for the driver stage. In general, however, it is advisable to have available some surplus driving power, because class C amplifiers do not operate efficiently when under-excited. An important advantage of pentodes and beam power tubes is that they require very little driving power, so that the choice of a suitable driver stage for such tubes usually presents no great problem. In most cases, the driver should be operated as an amplifier rather than as a plate-circuit frequency multiplier, because the efficiency and power output of the latter are relatively low.

The choice of tube types for the stages preceding the last intermediate amplifier depends, of course, on considerations of frequency and power. A typical arrangement for a high-frequency, multi-stage transmitter includes a crystal-controlled oscillator and one or more frequency-multiplier stages. Examples of such transmitters are shown in the TRANSMITTER CONSTRUCTION SECTION. The number of multiplier stages (usually frequency doublers) depends on the frequency of the crystal and on the desired operating frequency. In many cases, special oscillator circuits are used so that frequency multiplication initially takes place in the oscillator stage itself. These circuits usually reduce the number of multiplier stages necessary to reach a specified operating frequency with a crystal whose fundamental frequency is a sub-multiple of the operating frequency.

Pentodes and beam power tubes, such as the 802 and 807, respectively, are very useful as frequency multipliers and low-power intermediate amplifiers. These tubes, when used in properly designed and shielded circuits, ordinarily require no neutralization in r-f amplifier service. This advantage is very worthwhile in multi-stage transmitters which necessarily require numerous controls and adjustments. The intermediate amplifier is often driven by the last frequency-doubler stage. This arrangement is quite satisfactory provided the output of the doubler is sufficient to excite adequately the intermediate amplifier stage.

Fig. 1 illustrates the use of fixed bias in several types of r-f amplifier circuits. The voltage source may be a battery, or a power pack designed to have good regulation. An r-f choke and by-pass condenser serve to exclude the r-f grid voltage from the bias-voltage supply. Where a tuned grid circuit is employed, the r-f choke is often not essential and may sometimes even be detrimental to the operation of the circuit. An r-f choke of the wrong value in the grid circuit may cause trouble from parasitic oscillations, especially where a similar r-f choke is used in the plate circuit. A bias voltage from a fixed source serves to protect the tube against accidental removal of the r-f grid excitation, provided the bias is large enough to reduce the d-c plate current to cutoff, or to a low value.

The connections for a grid-leak-biased stage are the same as those shown in the circuits of Fig. 1, except that a suitable resistor is substituted for the bias battery in each case. The value of the grid leak is determined by Ohm's law,  $R = E/I$ , where R is in ohms, E is the negative grid bias (in volts) recommended for the particular class of service contemplated, and I is the value of d-c grid current (in amperes) shown under "typical operation" in the tabulated data. For example, the recommended grid bias for an RCA-812 at 1500 plate volts in class C telegraph service is -175 volts; the d-c grid current is 25 ma., or 0.025 ampere. The correct grid leak will have a resistance  $R = 175/0.025$ , or 7000 ohms. The power (P) dissipated by this resistor is equal to EI, or  $P = (175)(0.025) = 4.38$  watts. A 5-watt resistor would be operated near its maximum rating and might become quite hot. A 10-watt resistor would, therefore, be a logical choice. If two tubes are used in parallel or in push-pull, the d-c grid current of both tubes usually flows through a common grid leak. In this case, the resistance of the grid leak will be one-half that for a single tube.

## GRID-BIAS CONSIDERATIONS

There are three general methods of obtaining negative grid bias for vacuum-tube amplifiers. Not all of these methods are suitable for every class of service. The three methods

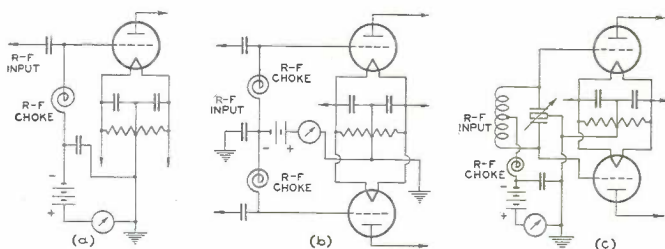

CONNECTIONS FOR FIXED BIAS SUPPLY

Fig. 1

are: (1) fixed source, (2) grid-leak resistor, and (3) cathode resistor (self-bias). In some applications it may be desirable to use a combination of two bias methods. Combinations of grid-leak and cathode-resistor and of grid-leak and fixed bias are frequently employed (see TRANSMITTER CONSTRUCTION SECTION).

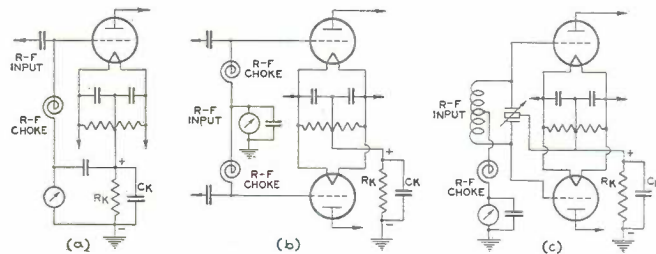

CONNECTIONS FOR CATHODE-RESISTOR BIAS SUPPLY

Fig. 2

The grid-leak bias method has the advantage of simplicity and of automatically biasing the grid in proportion to the excitation voltage available. Because of this automatic action, the bias voltage developed across a grid leak is not critically dependent on the value of the grid-leak resistance. Therefore, considerable variation in the resistance of the leak can usually be tolerated. Special care must be observed when grid-leak bias is used because accidental removal of the r-f grid excitation will cause the grid bias to fall to zero and (in the case of a tube having a low or medium amplification factor) the plate current to rise to an excessive value. The use of a protective device designed to remove the plate voltage (and screen voltage, in the case of tetrodes and pentodes) on excessive rises of plate current will minimize the danger of destructive overloads.

Fig. 2 illustrates the use of cathode-resistor bias. In these circuits, the cathode current flowing through  $R_k$  builds up a voltage drop which makes the cathode positive with respect to ground. Since the grid is at ground potential with respect to all d-c voltages, the grid is biased negatively with respect to the cathode. The cathode current for triodes is the sum of the d-c plate current and the d-c grid current. For tetrodes and pentodes, the screen current must also be added.



Cathode-resistor bias, or self-bias, is advantageous in that it tends to protect the tube against heavy d-c plate-current overloads; that is, when the plate current increases, the bias voltage across the cathode resistor also increases so that the rise in plate current is automatically opposed. A disadvantage of self-bias is that the effective d-c plate voltage is reduced by the amount of the bias voltage. Thus, the voltage output of the plate supply must equal the desired plate voltage plus the required bias voltage.

The value of cathode resistor  $R_k$  can be determined by Ohm's law,  $R=E/I$ , where  $R$  is in ohms,  $E$  is the required bias in volts, and  $I$  is the total cathode current in amperes. For example, assume that the total d-c plate current under normal load is 100 milliamperes (0.1 ampere), that the total d-c grid current is 20 milliamperes (0.02 ampere), and that the required bias is -240 volts. Then,  $R_k = 240/0.120 = 2000$  ohms. The power dissipated by  $R_k$  is equal to  $EI$ , or  $(240)(0.120) = 28.8$  watts. A 50-watt resistor is a logical choice.

Where a combination-bias method is used, such as grid-leak and cathode-resistor bias, the basic formulas used in determining the resistor values are the same as before. The total bias voltage required is divided into two parts (not necessarily equal parts). For example, an 807 requires a bias of -50 volts in class C r-f service. If we decide to get 20 volts of this bias from a cathode resistor and the remaining 30 volts from a grid leak, the values of 20 and 30 are substituted for "E" in the cathode-resistor and grid-leak formulas given above. In fact, we can see at a glance that the grid leak will be 30/50 or 0.6 of the value required if 100% grid-leak bias were to be employed. Thus, for a plate voltage of 500 volts, the grid leak is (0.6)(25000), or 15000 ohms (see 807 data). The cathode resistor ( $R_k$ ) will then have a value of  $20/(0.095+0.009+0.002) = 20/0.106 = 189$  ohms, where the full-load plate, screen, and grid currents are 95 ma., 9 ma., and 2 ma., respectively. A 200-ohm resistor is close enough and would be used. It must dissipate about (20)(0.1) or 2 watts; a 5-watt resistor is suitable.

## INDUCTANCE AND CAPACITANCE FOR TUNED CIRCUITS

The performance of a transmitting tube definitely depends on the characteristics of the circuit in which it is used. Because parallel-tuned circuits are almost universally

employed for the plate, or output, circuit of vacuum-tube r-f amplifiers, except at ultra-high radio frequencies, considerations involving inductance ( $L$ ) and capacitance ( $C$ ) are very important in transmitter design.

The resonant frequency of the parallel-tuned circuits used in transmitters is given by the relation,

$$f = \frac{1,000,000}{2\pi \sqrt{LC}} \quad (1)$$

where  $f$  is frequency in kilocycles per second (kc)  
 $L$  is inductance in microhenrys ( $\mu h$ )  
 $C$  is capacitance in micro-microfarads ( $\mu\mu f$ )

This relation can be further simplified, so that

$$f = \frac{159160}{\sqrt{LC}} \quad (\text{or}) \quad (2)$$

$$L = \frac{(159160)^2}{f^2 C} = \frac{25.33 \times 1,000,000,000}{f^2 C} \quad (3)$$

Equation (3) can be used to determine the inductance necessary to tune to a specified frequency "f" with a known value of capacitance "C." The product of  $L$  and  $C$  is a constant for a given frequency; the frequency of a resonant circuit varies inversely as the square root of the product of inductance and capacitance. Doubling both  $L$  and  $C$  halves the resonant frequency; reducing both  $L$  and  $C$  to one-half doubles the frequency. In actual circuits, of course, the effect of stray inductances and capacitances of the circuit wiring and of the tubes must be taken into account, especially at the higher radio frequencies.

The value of  $L$  and  $C$  should be chosen with considerable care. Because an r-f amplifier tube supplies power only during a fraction of each cycle, the tank circuit must function as a "fly-wheel" to carry on the oscillation to the next plate-current pulse. A measure of this fly-wheel effect is the ratio of volt-amperes in the tank circuit to the power delivered by the tube. This ratio is defined as the operating  $Q$ .

It is common practice to employ an operating  $Q$  of 10 to 15 for either telegraphy or telephony service. If the value of  $Q$  is much lower, there will be considerable distortion of the r-f waveform with resultant power output at harmonic frequencies. Harmonic output from the power amplifier is very undesirable because it represents wasted power and may lead to radiation at harmonic frequencies which will cause interference to other radio services. A value of  $Q$  which is too high will result in excessive losses in the tank circuit due to the large circulating r-f current in a high- $Q$  circuit. This condition is evidenced by high plate current even when the tank circuit is not loaded. Other factors being equal, the  $Q$  is proportional to the tuning capacitance in the tank circuit. The capacitance needed for the tuned circuit of an r-f amplifier can be determined approximately from the following relation:

$$C = \frac{300 Q I_b}{f E_b} \quad (4)$$

where  $Q$  is a constant (about 10 to 15)

$I_b$  is the total d-c plate current in milliamperes  
 $f$  is the frequency in megacycles  
 $E_b$  is the d-c plate voltage in volts  
 $C$  is the total capacitance, in micro-microfarads ( $\mu\mu f$ ), across the tank inductance

This value of  $C$  is for an amplifier of the single-ended type employing a tank circuit which is not split. It is the *capacitance in actual use* and not the maximum capacitance of the tank condenser. The value of  $C$  determined from equation (4) represents a *minimum* value; a slightly larger value can usually be used without appreciable reduction in power output.

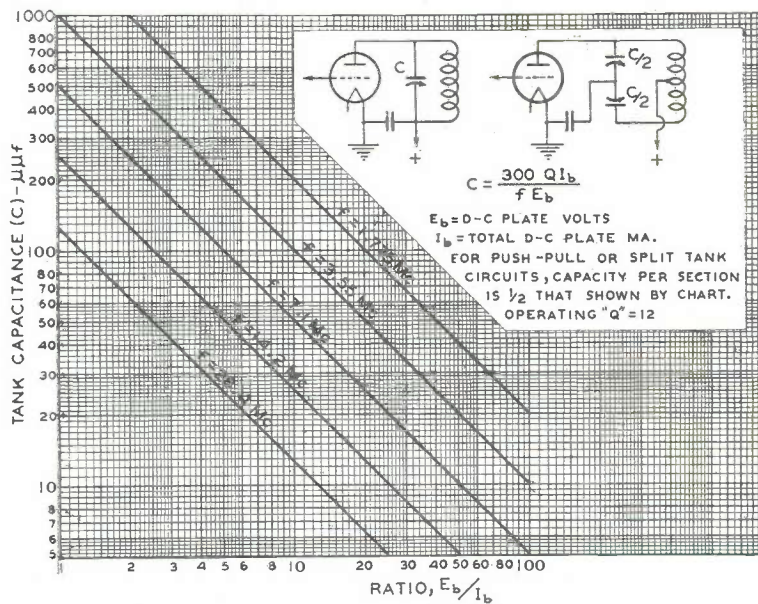
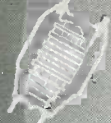

Fig. 3



# TRANSMITTING CIRCUIT FACTS



Where a single-ended stage is used with a split tank circuit, the value of C (the total capacitance across the inductance) should be one-fourth that given by equation (4). The corresponding tank inductance should be approximately four times that employed in a tank circuit which is not split, in order to keep the product of L and C the same. For a push-pull stage of the *same power input*, the value of C is also but one-fourth that given by the formula. Because the condenser used in a push-pull stage is generally of the split-stator type, each section of the condenser should have a capacitance equal to one-half that given by equation (4). The factor  $I_b$  used in the equation is the total d-c plate current of the amplifier stage, regardless of the number of tubes used in parallel or in push-pull.

For amateur-station design purposes, an operating Q of 12 is satisfactory for either telegraphy or plate-modulated telephony service. The chart shown in Fig. 3, based on a Q of 12, presents a simple method of determining the value of C.

Knowing the frequency and the capacitance required, the designer can quickly determine the proper value of inductance in microhenrys from equation (3). In order to determine the approximate design of a single-layer coil to give the desired inductance, the following formula can be used:

$$L = \frac{R^2 N^2}{9R + 10B} \quad (5)$$

where L is the inductance in microhenrys ( $\mu h$ ),  
 R is the mean radius of the coil in inches,  
 B is the length of the winding in inches,  
 N is the number of turns.

## NEUTRALIZING

A triode used as an r-f amplifier will oscillate because of r-f feedback through the grid-plate capacitance of the tube, unless the effect of this feedback is eliminated. In tetrodes and pentodes, the grid-plate capacitance is practically eliminated by means of a screen grid placed between the grid and the plate. Feedback between grid and plate in a triode is nullified by a circuit arrangement which takes some of the r-f voltage from one circuit and feeds it back into the other circuit so that it effectively cancels the r-f voltage operating through the grid-plate capacitance of the tube. This procedure, known as *neutralization*, permits a triode to operate as a stable r-f amplifier without self-excited oscillations. *Parasitic oscillations* may still occur, but they can be eliminated by proper circuit design and layout. For proper neutralization, the r-f neutralizing voltage must be opposite in phase and equal in amplitude to the feedback voltage between the grid and the plate.

Typical neutralizing circuits are shown in Figures 4, 5, and 6. Fig. 4 illustrates *grid neutralization*, where the neutralizing condenser CN is returned to the balanced grid circuit. Figures 5 and 6 illustrate *plate neutralization*, where CN is returned to the plate circuit. In balanced circuits of this type, neutralizing condenser CN theoretically should have a capacitance equal to the grid-plate capacitance ( $C_{gp}$ ) of the tube. Actually, however, CN may vary somewhat from the value of  $C_{gp}$ , due to the effects of stray capacitance in the circuit. The circuit from

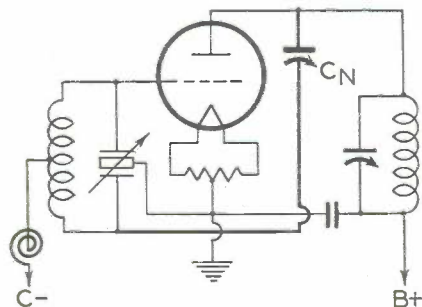

Fig. 4

which the neutralizing voltage is obtained is sometimes not of the balanced type. If the tap on the plate coil in Fig. 5 is placed more than half the total number of turns from the "tube end," the capacitance required at CN will increase about in proportion to the relative number of turns in the two portions of the coil. In most cases, it is desirable that CN should have a small range of capacitance which is adequate to extend beyond both sides of the required value, to take care of circuit and tube variations.

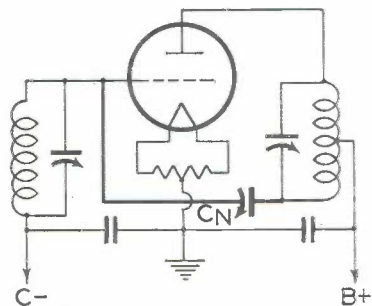

Fig. 5

Two triodes in a push-pull circuit are neutralized by means of two neutralizing condensers connected in the so-called "criss-cross" circuit. The grid of each tube is connected through a neutralizing condenser to the plate of the other tube. Two illustrations of this arrangement are given in the TRANSMITTER CONSTRUCTION SECTION.

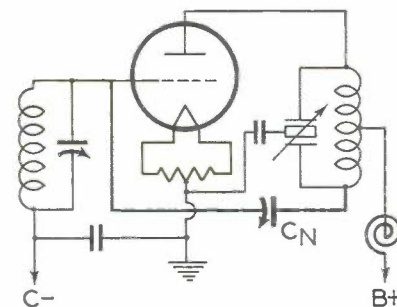

Fig. 6

The neutralizing circuits shown in Figs. 5 and 6 are the ones most commonly used in amateur transmitters employing single-tube amplifier stages. They are entirely satisfactory for most transmitting triodes operating at frequencies up to 15 or 20 Mc. These circuits may cause amplifier instability at higher frequencies,

however, especially when used with a tube having a relatively large plate-to-filament capacitance ( $C_{pf}$ ). The trouble is due to the fact that  $C_{pf}$  tends to upset the neutralizing action of CN, particularly when the operating frequency is changed in a multi-band transmitter. If such trouble is experienced, it is advisable to neutralize the plate-filament capacitance of the tube by means of an additional neutralizing condenser ( $C_r$ ), as shown in Fig. 7. Condenser  $C_r$  should have (in a balanced-type plate circuit) a capacitance approximately equal to the plate-filament capacitance of the tube and a peak voltage rating equal to that of the grid-plate neutralizing condenser.

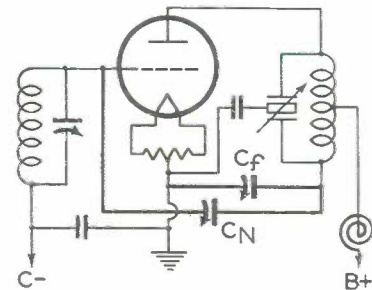

Fig. 7

### Neutralizing Procedure

The technique in neutralizing an r-f amplifier is essentially the same irrespective of the type of tube or circuit employed. As the first step, the positive high voltage should be removed from the amplifier. The filament of the tube should be lighted and the r-f grid excitation (from the driver stage) applied. Next, a fairly sensitive r-f indicator should be loosely coupled to the plate tank coil. Suitable r-f indicators are a neon bulb, a flashlight bulb or a thermogalvanometer connected in series with a one- or two-turn loop of insulated wire, a vacuum-tube voltmeter, or a cath-



ode-ray oscillograph. The simple indicators are usually more convenient to use than the more complicated instruments. The plate tank circuit of the amplifier should be tuned to resonance, which will be shown by a maximum "reading" on the r-f indicator. The neutralizing condenser is now adjusted until the r-f indicator shows a minimum reading. This operation may detune the plate tank of the driver stage slightly, so that the latter should be carefully retuned to resonance. The plate tank of the amplifier should again be tuned to resonance. The r-f indicator will usually show another maximum reading, but one of considerably less magnitude than the original reading. The neutralizing condenser is again adjusted for minimum (or zero) r-f indication. After this procedure has been repeated several times, a setting of the neutralizing condenser should have been found which shows no r-f voltage in the plate tank circuit of the amplifier. As the point of correct neutralization is more closely approached, the coupling of the r-f indicator will usually have to be tightened, because there is less r-f voltage available to operate the indicator. After each adjustment of the neutralizing condenser, the driver tank and the amplifier tank should be retuned to resonance. When the r-f indicator shows zero r-f voltage in the amplifier tank, the stage is properly neutralized.

If a push-pull stage is to be neutralized, both neutralizing condensers should be adjusted simultaneously, or alternately in small steps. They will not, however, always have exactly the same setting when neutralization is reached, because of slight differences in stray capacitances and because the tuned tank circuit may not be electrically symmetrical.

A very sensitive neutralizing indicator is a d-c milliammeter connected in the grid-return circuit of the amplifier which is being neutralized so as to measure rectified grid current. With the plate voltage off as before, the driver tank circuit is tuned until the d-c meter in the amplifier grid circuit shows a maximum reading. If the amplifier is not properly neutralized initially, tuning its plate tank circuit through resonance will cause the d-c grid current to vary. The neutralizing condenser should be adjusted slowly while the plate tank circuit of the amplifier is tuned gradually back and forth through resonance. As the point of correct neutralization is approached, the flicking of the needle of the d-c grid meter will gradually decrease in amplitude. If the amplifier is perfectly neutralized, tuning the plate circuit through resonance will not change the meter reading even slightly. During these adjustments, the driver plate circuit should occasionally be returned to resonance, as indicated by a dip in its d-c plate current or by a maximum in the d-c grid current of the amplifier.

Because the rectified d-c grid current is a measure of the r-f excitation applied to the amplifier, the use of a d-c grid meter is usually advisable. The grid meter is not only useful for neutralizing adjustments, but it also provides a continuous check on the operation of the amplifier and of the driver stage as well.

In some cases it may be found that, while a setting of the neutralizing condenser can be made which will give a definite minimum r-f indication, no adjustment will entirely eliminate r-f voltage from the plate tank circuit. This effect is sometimes due to stray coupling between the amplifier and driver plate tanks or to stray capacitances between various parts of the amplifier which tend to unbalance the neutralizing circuit. Adequate shielding between grid and plate circuits and between stages will often eliminate neutralizing difficulties. Shielding may actually cause trouble, however, if it is placed too close to the tuned circuits or to the neutralizing condensers. It is important that the ground lead from the rotor of a split-stator condenser be made direct (and as short as possible) to the filament circuit.

## TUNING A CLASS C R-F AMPLIFIER

In general, the same adjustments are made in tuning different class C r-f amplifiers, irrespective of the type of tube or circuit used. Although the tuning of a triode r-f amplifier is described in the following paragraphs, the procedure applies almost equally well to tetrode and pentode amplifiers. In the following discussion, it is assumed that the triode has been correctly neutralized.

The filament of the amplifier tube is lighted, the positive plate voltage is left off\*, and r-f excitation from the driver stage applied. The plate circuit of the driver is tuned to resonance, which is indicated by a dip in the *driver* plate current or by a maximum d-c grid-current reading in the *amplifier* stage. If the amplifier has a tuned grid circuit, the latter must also be tuned to resonance (indicated by the grid-current reading). The maximum amplifier grid current obtained by these tuning processes may be too low. In this case, the coupling between the driver and the amplifier may be adjusted to give more amplifier grid current, if this can be done without overloading the driver stage. The plate circuit of the driver should be retuned to resonance every time the coupling is changed, because of the interaction between the various circuits.

After the interstage-couplings adjustments have been made, the amplifier plate tank should be set as near resonance as possible. A protective resistance of adequate size should then be placed in series with the positive plate-supply lead. In the case of large, high-power tubes which are protected by d-c overload relays, this protective resistor can be omitted, especially in those installations where the d-c plate voltage can be reduced to about 50 per cent of its rated value by means of taps in the primary circuit of the plate-supply transformer. The plate voltage is now applied and the plate tank circuit *quickly* tuned to resonance (indicated by a sharp dip in the d-c plate current of the amplifier). The plate current at resonance will usually drop to a value between 10 and 20 per cent of the rated full-load value (see Fig. 8), if no load is coupled to the plate circuit. In case

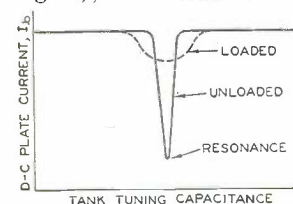
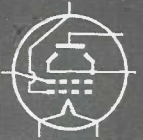

Fig. 8

the plate tank condenser does not have an adequate voltage rating, the high r-f voltage developed across the unloaded plate tank circuit may cause the condenser to flash over. This effect should not occur with the d-c plate voltage reduced 50 per cent when the condenser is suitable for the purpose. If it does occur, however, the load circuit can be coupled to the plate tank in order to reduce the r-f voltage developed.

If the plate tank can not be tuned to resonance, the reason will usually be found in improper tuned-circuit constants. Either the tank inductance L, or the tank capacitance C, or both, may have to be increased or reduced, depending on whether the circuit is found to tune higher or lower than the desired frequency. The "off-resonance" plate current of an amplifier may be quite high, even with a protective resistor in the plate-supply lead. For this reason, a tube *should not be operated with its plate circuit out of resonance*, except for the very short time required to make the proper tuning adjustment. If the plate current does not dip normally with the plate tank unloaded, the trouble may be due to insufficient r-f grid excitation, to excessive tank-circuit losses, or to improper neutralization. Because the minimum plate current under no-load conditions depends on the Q of the tank circuit, on the biasing method used, and on the excitation voltage, the minimum plate-current value

\* The screen voltage should also be left off, if the tube is a tetrode or a pentode.



should not be considered too definite an indication of the efficiency of an amplifier.

When the tuning procedure described has been completed, the load circuit may be coupled to the amplifier. The load may be an antenna, a dummy antenna (for test purposes), or the grid circuit of a following r-f amplifier stage. When the load is applied, the amplifier plate current will rise. The plate circuit of the amplifier should be retuned to resonance to guard against the possibility that the load has caused detuning. The plate current will still dip, but its minimum value will be considerably higher than under no-load conditions. Full plate voltage should now be applied and the coupling of the load made tighter, until the minimum plate current (at the dip) reaches the normal value given in the typical operating conditions tabulated under the tube type. Of course, if the required power output can be obtained with a lower value of plate current, the load-circuit coupling can be loosened or the d-c plate voltage reduced. In no case should the d-c plate input exceed the value given under **MAXIMUM RATINGS** for the particular class of service involved.

Pentodes and tetrodes are tuned in the same manner as triodes. Because neutralization is ordinarily not required for these screen-grid tubes, the circuits of these tubes are relatively simple and easy to adjust. It is quite important in a screen-grid r-f amplifier to prevent stray coupling between the input and output circuits. Although the use of a screen grid in a tube substantially eliminates internal feedback within the tube, self-oscillation and unstable operation may be caused by external feedback due to stray capacitances. Complete shielding of the input and output circuits from each other, and in some cases from the tube itself, is generally advisable.

The value of the d-c potential on the screen usually has an important effect on power output; adjustment of this voltage after the circuit has been tuned may result in better efficiency and more power output. Care should be observed, however, that the maximum rated d-c power input to the screen is not exceeded.

As the load on an r-f amplifier is increased, the d-c grid current will decrease. After the load has been adjusted to the desired value, the d-c grid current should be checked. If it has dropped substantially lower than the normal value, insufficient r-f grid excitation or excessive d-c grid bias may be the cause.

The methods of tuning other types of amplifiers will vary somewhat, depending on the class of service in which the tubes are used. Further information on the subject of tuning can be found in the two radio handbooks listed earlier in this chapter.

## HOW TUBE RATINGS ARE DETERMINED

During the development of an RCA tube, tentative designs are constructed to meet desired ratings. For these designs, the materials chosen, the dimensions used, and the structures employed are based on the chemical and physical properties of materials, our research work, and the experience of our engineers with other tube types, both in the laboratory and in the field. Sample tubes of the new designs are then checked for compliance with the desired ratings and characteristics. Destructive overload tests are made to determine if there is a reasonable margin of safety in the designs. Life tests, however, are most important of all in the selection of the final design and the determination of final ratings. Groups of tubes are placed on life-test racks and operated under maximum rated conditions. At intervals they are removed for electrical measurements, but life testing is continued until the tubes fail. When the life tests indicate that the design is satisfactory for good tube performance at the tentative maximum ratings, these ratings are established for the tube type.

## INTERPRETATION OF TUBE RATINGS

A thorough understanding of the significance of published ratings is necessary if optimum results are to be obtained. The following explanation is intended to clarify the meaning of the ratings tabulated under each individual tube type.

The filament or heater voltage given in the tabulations is a normal value unless otherwise stated. Transformers and resistances in the filament circuit should be designed to operate the filament or heater at the rated value for full-load operating conditions with an average line voltage. Variations from the rated value due to line-voltage fluctuations or other causes should not exceed plus or minus 5 per cent, unless otherwise stated under the tube type.

In general, the filament of a transmitting tube may be operated with either an a-c or d-c supply. An a-c source is usually employed because of its convenience and economy, unless a d-c source is necessary to avoid hum. With a-c operation, the grid return and the plate return should be connected to the mid-point of the filament circuit. This point may be the center tap of the filament winding or of a low resistance shunted across the filament circuit. When direct current is used, the return leads should be connected to the negative filament terminal.

Where it is found desirable to use d-c filament excitation on any filament-type tube for which data are given on an a-c basis, the grid-bias values as shown in the tabulated data should be decreased by an amount equal to approximately one-half the rated filament voltage. The grid-bias voltage should be measured from the negative filament terminal.

An entirely new system of ratings for many RCA Air-Cooled Transmitting Tubes is now in effect. Instead of one set of maximum ratings for a tube, two are available. These ratings are designated **CONTINUOUS COMMERCIAL SERVICE (CCS)** and **INTERMITTENT COMMERCIAL AND AMATEUR SERVICE (ICAS)**. CCS ratings are essentially the equivalent of former Maximum Ratings and are based on considerations of long tube life and maximum reliability of tube operation. ICAS ratings are considerably higher than CCS ratings. They permit the handling of much greater power, but tube life under these conditions, of course, is reduced. However, since there are innumerable applications where the design factors of minimum size, light weight, and maximum power output are far more important than extremely long tube life, the transmitter designer may very properly decide that a small tube operated with ICAS ratings better meets his requirements than a larger tube operated with CCS ratings. The choice of tube operating conditions best fitted for any particular application should be based on a careful consideration of all pertinent factors.

In the rating of RCA transmitting tubes, certain tabulated values are given as *maximum*. These are limiting values which should always be observed in each tube application.

Typical operating conditions are given in the tube data section on many of the types. These values should not be confused with *ratings*, because a tube can be used under any suitable conditions within its maximum ratings, according to the application. The output value for any operating condition is an approximate tube output—that is, plate input minus plate loss. Circuit losses must be subtracted from tube output in order to determine the useful output. Output values are approximate and should not be considered as being output ratings. The actual output in any case depends on a number of variable factors, important among which are circuit efficiency and operating frequency.



## RCA VARIABLE FREQUENCY OSCILLATOR

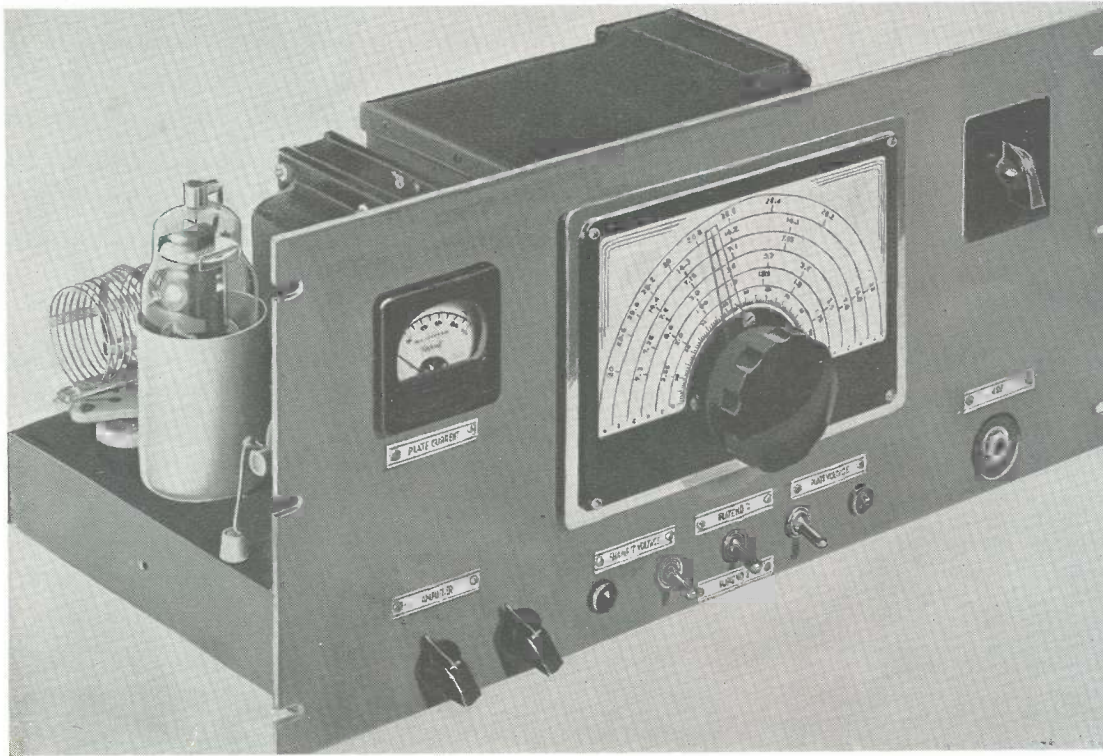

- LESS THAN 20-CYCLE DRIFT PER HOUR AFTER 40-MINUTE WARM-UP
- R-F POWER OUTPUT 10 TO 25 WATTS OVER FREQUENCY RANGE OF 1.75 TO 30 Mc
- CHIRPLESS KEYING AND BREAK-IN OPERATION
- HIGH RESET ACCURACY AND WIDE BANDSPREAD
- SELF-CONTAINED POWER SUPPLY

FIG. 9

This thoroughly engineered VFO is designed to meet modern requirements for a master control oscillator and frequency standard having exceptional frequency stability. It has 5-band coverage and high power output with a minimum of tubes. Bandspread extends from approximately 120° on 14 Mc and 3.5 Mc, to 145° on 7 and 30 Mc. Frequency drift of the instrument is less than 400 cycles up to 30 minutes following a cold start. Thereafter, drift is less than 20 cycles per hour! It is practical to reset frequency adjustment to within a few hundred cycles of a marked point (3.5-Mc band).

### *Uses 802 ECO at Reduced Ratings*

An 802 is used as a electron-coupled oscillator at greatly reduced ratings. Operation of this well-screened pentode at low ratings minimizes frequency drift caused by slightly changing interelectrode capacitances while the tube warms up.

Unquestionably, a receiving tube may also be operated as an oscillator to provide equally stable frequency characteristics, but by the time the input of the tube has been reduced sufficiently to obtain the desired stability, its useful output will have dropped nearly to the vanishing point. Then, extra amplifiers are required to make up the loss of power. The 802 in this VFO operates at a plate voltage of approximately 470 volts, at a screen voltage of 105 volts (regulated by a VR-105/30), and at a plate current of only 8 to 10 ma.! Even at these low ratings the tube furnishes enough power to drive an 807 operating as a buffer, doubler, or quadrupler to a fairly respectable output.

The circuit in Fig. 13 shows that a bandswitching arrangement is provided for the 802 grid circuit and that switch  $S_1$  cuts in three different sets of pre-tuned grid-coil, trimmer, and padder combinations for practical 5-band operation having exceptional bandspread. The lowest L/C ratio consistent with reasonable efficiency is used on all bands.

When 160- or 80-meter output is desired the 802 grid circuit is tuned to 160 meters (1750 to 2050 kc) by means of  $C_{10}$ ,  $C_{11}$ ,  $C_{12}$ ,  $C_{13}$ , and  $L_3$ .  $C_{11}$  and  $C_{12}$  are zero-temperature-coefficient condensers. The plate circuit (located beneath the chassis of the 802) is designed to resonate broadly on either 160 or 80 meters by means of a tapped coil  $L_5$ , which makes it possible to short out a portion of the inductance by means of switch  $S_2$  for 80-meter operation. A separate coil  $L_4$  is used for 20-meter output, which also is selected by means of  $S_2$ . Primary reason for using a broadly self-resonant plate circuit is to eliminate a tuning control. Secondary benefit is that it eliminates apparent reaction on the oscillator frequency caused by normal tuning adjustments in the oscillator plate circuit. While it is possible to use an ordinary r-f choke in the 802 plate circuit,  $L_4$  and  $L_5$  constructed in accordance with the specifications given in the legend of the circuit provide greater useful output and higher circuit efficiency. Output from the 802 is capacitatively coupled to the 807 stage. Power output from the 807 at the desired frequency is dependent on the resonant frequency of  $L_6$  and  $C_{15}$ .  $L_6$  is of the plug-in variety and dimensions are given in table 1, page 54.



# TRANSMITTER CONSTRUCTION



For 40-meter operation,  $S_1$  is set to include the 80-meter grid circuit of the 802. This circuit includes  $L_2$ ,  $C_2$ ,  $C_3$ ,  $C_7$ ,  $C_8$ ,  $C_9$  and  $C_{13}$ .  $C_2$  and  $C_3$  are series padding condensers, used for bandspread over the range of 10 to 90 on the dial.  $S_2$  is set to short out a portion of  $L_5$  so that 80-meter output will be obtained from the 802 plate circuit. The 807 is operated as a 40-meter doubler. Power sensitivity of the 807 is so high that nearly as much output is obtained at this frequency as is obtained on the two lower frequency bands.

For 20-meter operation,  $S_1$  and  $S_2$  are set the same as for 40-meter operation. The 807 is operated as a frequency quadrupler. Output is still sufficient to drive a pair of 812's in push-pull to full power output on 20 meters. Bandspread on this band is approximately  $2/3$  that on 40 meters.

For 10-meter output,  $S_1$  is set to include the 802 20-meter grid circuit  $C_1$ ,  $C_5$ ,  $C_6$ , and  $L_1$ .  $C_6$  is a zero-temperature-coefficient condenser.  $S_2$  is set to include  $L_4$ , tuned to resonate the 802 plate circuit broadly on 20 meters. The 807 is operated as a 10-meter doubler. Bandspread on the 10-meter band covers 10 to 90.

Sturdy mechanical construction, proper layout of components to minimize temperature rise in critical tuned circuits, high-quality parts, good voltage regulation, and the proper use of sufficient zero-temperature-coefficient condensers are the essentials of a well-performing ECO. If these important factors are considered from the start, the results are almost always bound to be satisfactory.

As can be noted from the general views of the VFO in Fig. 9, 10, and 11, chassis and panel design is conventional. Choice of dimensions may be left completely to individual needs. In this case the chassis is 17" long x 10" wide x 2" deep. The panel is 19" long x  $8\frac{3}{4}$ " high x  $\frac{1}{8}$ " thick. The combination provides the necessary solid foundation for the job.

## Frequency Stability Considerations

The effective temperature rise of the all-important grid-circuit components has been limited by grouping the grid-circuit components together in one shield box (as shown in Fig. 12) and by isolating this box as far as possible, from all high heat-dissipating units such as transformers, tubes, and bleeder resistors. The grid-circuit shield box is  $5\frac{1}{2}$ " x 6" x  $5\frac{1}{2}$ " in size. Only heat-dissipating element in this unit is the 802 grid leak  $R_1$  which may be considered negligible because the grid current flowing through the grid circuit is unusually small. The 802 itself is mounted to the left of the shield box so that the tube projects horizontally away from the box. It is well ventilated—and, what is more important, its heat does not affect the tuned circuits within the box.

As added precautions to minimize the amount of heat reaching the all-important oscillator grid circuit, the 807, power transformers, rectifier tube, and filter chokes are mounted along the rear and side edges of the chassis so that they are well ventilated and are as far removed from the grid-circuit shield box as is possible. The stability of the d-c screen voltage of an oscillator designed primarily for con-

stant frequency output is of great importance. The use of a voltage divider for supplying a fixed value of screen voltage is of help but is not sufficient for maximum stability. For this reason, a voltage-regulator tube is used in the screen-voltage supply of the 802. It irons out effects caused by line-voltage variation and reduces oscillator hum. It is particularly helpful in eliminating chirps in the output when the oscillator is keyed.

## Temperature Compensation

All of the foregoing features are vital to a smooth performing and stable VFO, but the final results are incomplete without the application of temperature compensation to offset the change in frequency caused by whatever heat does reach the vital 802 grid circuit. Judicious use of zero-temperature-coefficient capacitors in parallel with the three grid-tank circuits of the oscillator do much to give the oscillator its exceptionally low frequency drift. These capacitors are not a cure-all but they do come into their own where frequency drift is due to reasonably small amounts of heat. The capacitors are mounted within the grid shield box and their installation will be covered later on.

## Assembling the Vital Grid Circuit

The shield box has a removable top and bottom. The five air padders,  $C_1$ ,  $C_2$ ,  $C_5$ ,  $C_7$ , and  $C_{10}$ , and the three grid coils  $L_1$ ,  $L_2$ , and  $L_3$  are mounted on the left side of the box. Dimensions of  $L_1$ ,  $L_2$ , and  $L_3$  are given in the circuit legend under Fig. 13. The coils are mounted end-on by means of 6-32 spade lugs.  $C_{13}$ , the main tuning condenser, is held in place by three sets of mounting screws and studs furnished with it for front mounting. The back of  $C_{13}$  is held in place by a

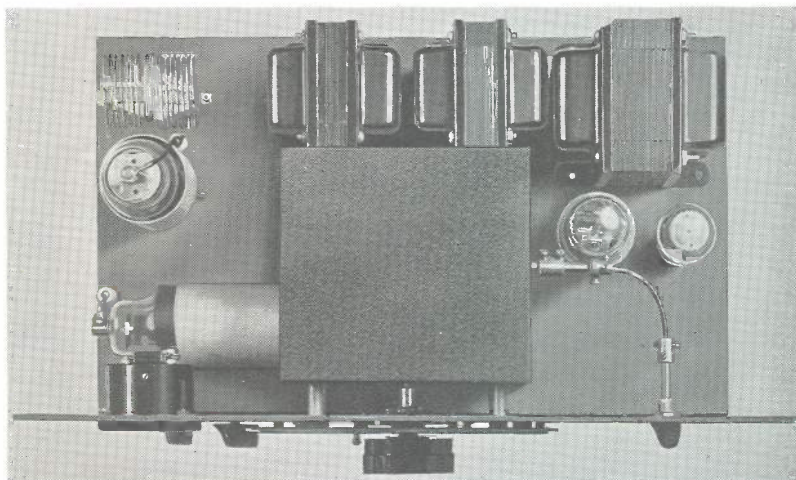

FIG. 10

strip of  $\frac{1}{2}$ " Bakelite,  $2\frac{1}{2}$ " wide and 6" long, solidly bolted to the opposite sides of the box. The zero-coefficient condensers are rigidly held between two additional Bakelite strips. These two strips should first be clamped together and drilled with holes large enough to accommodate the zero-coefficient condensers. The strips should then be separated and the condensers inserted. Since these condensers are in the form of



# TRANSMITTER CONSTRUCTION



rather fragile ceramic tubing it is suggested that they be wrapped with several turns of rubber tape to reduce the danger of cracking them. This cushioning also aids in damping any possible vibration. The Bakelite mounting strips are then clamped together and bolted to opposite sides of the grid box, as shown in figure 12. They serve a further purpose by acting as cross-braces to increase the rigidity of the box and of the parts mounted on it. Bandswitch  $S_1$  is mounted on the right side of the grid circuit shield box. It is held in place by means of a third Bakelite cross-brace.  $S_1$  selects the critical-tuned grid circuits and its importance cannot be overestimated. It should be of good quality and be designed with ceramic insulation.  $S_1$  is controlled from the front panel by means of a short, flexible shaft which must make a right-angle bend.

The entire shield-can assembly with the 802 on the side, is then mounted to the chassis by means of four shock-absorbing rubber washer assemblies. A National ACN was chosen for the tuning control and because it has remarkable freedom from backlash and includes a built-in, semi-flexible coupling device which compensates for minor mis-alignment of dial or condenser. The ACN dial permits mounting of the tuning control directly on the grid-circuit shield can so that the whole assembly including the dial is free to float. The white cardboard dial itself is fastened to a sheet-metal backing plate which in turn is mounted solidly to the shield can by means of four  $\frac{3}{8}$ " metal studs. These studs are made about 1" long to permit the dial to be placed about  $\frac{1}{4}$ " in front of the main VFO panel and the grid-circuit shield box about  $\frac{5}{8}$ " behind the VFO panel. Clearance holes are made in the VFO panel to allow for suitable clearance of the studs. The studs are drilled and tapped at each end for 6-32 or 8-32 screws. The dial-backing plate is fastened to the studs by means of countersunk screws to permit a snug fit of the dial against the plate. Four  $\frac{5}{8}$ " holes are drilled through the panel behind the dial to clear the mounting studs, and a  $2\frac{1}{2}$ " hole should be made around the condenser shaft center to clear the dial mechanism.

In the actual assembly and wiring of the grid shield box, the layout of the large parts should first be determined. Then the ACN dial and  $C_{13}$  should be mounted on the shield box and the positions of the panel holes behind the dial deter-

mined. The bottom cover of the can may be mounted by means of the four rubber washer assemblies. The dial and  $C_{13}$  should next be removed from the shield can and with both covers removed from the can, all holes should be drilled, all parts mounted, and all wiring completed. A small "pencil" type soldering iron will prove useful in the wiring of this unit.

Long, flexible leads should be soldered to the 802 socket while the shield can is out in the open. These leads can then be threaded through grommets in the bottom shield cover and the chassis before replacing the shield can of the tube. Several inches of slack should be left in these power leads so that the grid-circuit shield box can be tipped up on edge for servicing later. The 802 plate coils  $L_4$  and  $L_5$  and bandswitch  $S_2$  are mounted beneath the chassis for added shielding. Dimensions of  $L_4$  and  $L_5$  are given in the legend of the circuit.

## Laying Out the 807 Stage

As can be seen from the illustrations, layout of the 807 is comparatively simple. Plug-in plate coils are used in this stage. The socket for the plate coil,  $L_6$ , is mounted above the chassis for convenience in changing coils. Tuning condenser  $C_{10}$  is mounted on a bracket beneath the chassis and is connected by a long insulated extension shaft to a control knob on the front panel. The 807 operates at a d-c plate voltage of approximately 470 volts and a d-c plate current of 100 ma. at full load. D-c screen voltage is approximately 150 volts.

Table 1  
807 PLATE TANK COIL ( $L_6$ )

Output Band Meters	Diameter Inches	Length Inches	No. Turns	End Link Turns
160	1 $\frac{5}{8}$	1 $\frac{1}{2}$	45	3
80	1 $\frac{3}{8}$	1 $\frac{1}{4}$	32	3
40	1 $\frac{1}{8}$	1 $\frac{3}{4}$	18	2
20	1 $\frac{1}{4}$	2 $\frac{3}{8}$	13	2
10	1 $\frac{1}{4}$	2	8	2

## Power Supply Is Simple

An inexpensive 600-0-600 volt power transformer and an 83 mercury-vapor rectifier supply all voltages for the VFO. A double-section filter system is used.  $L_7$  is of the swinging type.  $L_8$  is a standard fixed type. Regulation of the power supply is excellent. The 83 with its low voltage drop,  $L_7$  and  $L_8$  with their reasonably low d-c resistance, and the swinging properties of  $L_7$  all tend to compensate for variations in load. Output ripple voltage of the supply is very low. This fact is important in any ECO.

At this point it should be called to the attention of the constructor that the extra 6.3-volt filament winding on the power transformer is connected in series with the primary of the transformer so that the high secondary voltage is reduced to 550-0-550. This is done to prevent application of excessive voltage to the 83.

A tap on bleeder resistor  $R_4$  permits adjustment of the VR-75-30 voltage regulator tube so that it draws about 25 ma. under key-up conditions. A d-c milliammeter may be inserted at "x" during this screen-circuit voltage adjustment. In actual tests, it has been found that use of a VR-75-30

FIG. 11

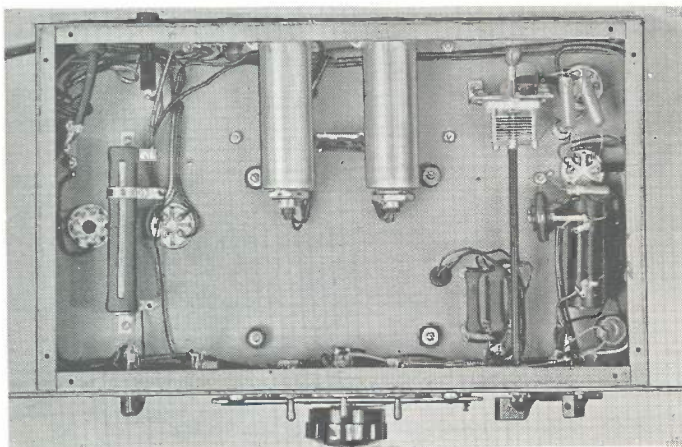





# TRANSMITTER CONSTRUCTION



gives more 807 output from 160 to 20 meters than when the 802 screen is operated at a higher voltage with a VR-105-30. Moreover, the use of the higher screen voltage doubles the 802 plate current and increases frequency drift during warm-up periods.

## Aligning and Calibrating

This VFO may be considered a precision instrument and as such is deserving of accurate calibration. A frequency standard is invaluable for aligning and calibrating it. First, the 802 grid circuit should be adjusted. Plate and screen voltage of the 807 should be removed by leaving  $S_3$  open. Set  $S_1$  to "160" and adjust  $C_{10}$  with a screwdriver so that the oscillator output tunes exactly to 1900 kc. with  $C_{13}$  set at "50" on the dial. If the band will not center, use a larger or smaller value of  $C_{11}$ . Should the dial not cover the complete range from 1750 to 2050 kc., remove one or two turns from  $L_3$  and add to  $C_{10}$ ,  $C_{11}$  or  $C_{12}$  as needed. This completes the calibration for 160 meters and since this grid tank circuit is also used on 80 meters by doubling in the plate circuit, the calibration is also completed for 80 meters.

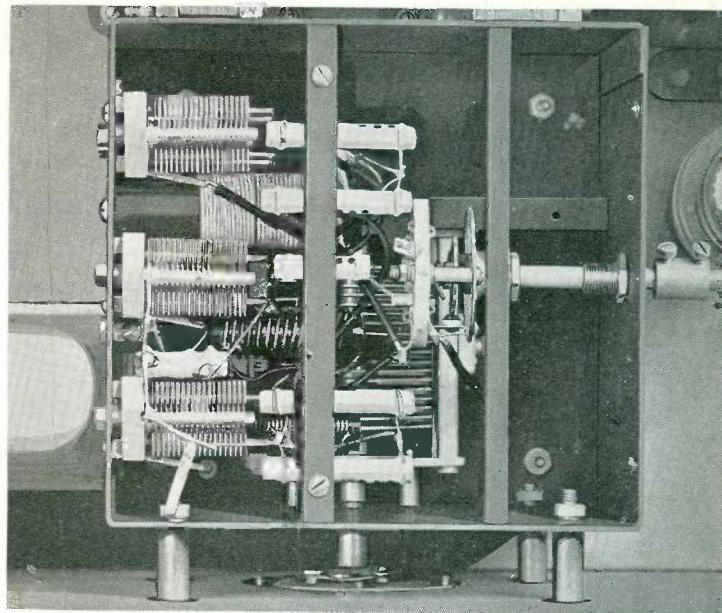

FIG. 12

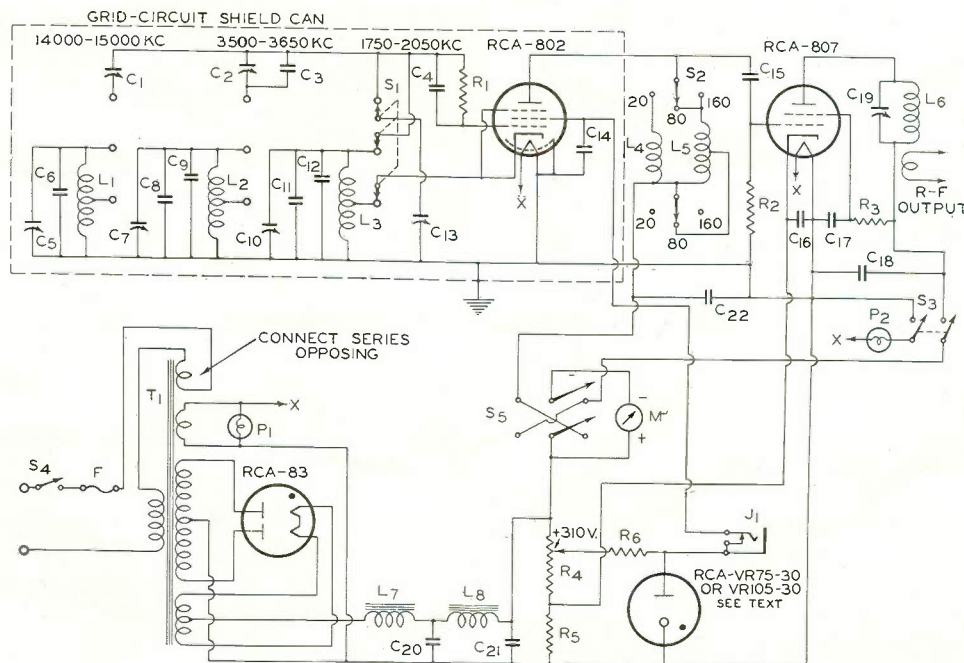

FIG. 13

- $C_1, C_2, C_5, C_7, C_{10}$  = 140  $\mu\text{mf}$  air trimmers (Hammarlund APC-140)
- $C_3, C_6$  = 150  $\mu\text{mf}$  zero-temperature coefficient (Centralab)
- $C_4, C_{15}$  = 250  $\mu\text{mf}$  mica
- $C_8, C_{11}$  = 350  $\mu\text{mf}$  zero-temperature coefficient
- $C_9$  = 250  $\mu\text{mf}$  zero-temperature coefficient
- $C_{12}$  = 300  $\mu\text{mf}$  zero-temperature coefficient
- $C_{13}$  = 40  $\mu\text{mf}$  (min.) to 395  $\mu\text{mf}$  (max.) main tuning condenser (Hammarlund APC-350-C)
- $C_{14}$  = 0.001  $\mu\text{f}$  mica
- $C_{16}, C_{17}, C_{18}$  = 0.01  $\mu\text{f}$  paper, 600 v.
- $C_{19}$  = 100  $\mu\text{mf}$  variable (Cardwell ZU-100-AS)
- $C_{20}, C_{21}$  = 8-8  $\mu\text{f}$  Replacement (Cornell-Dublier #PE-B)
- $J_1$  = Keying Jack

- $L_1$  = 6 turns of #16 en. wire on  $\frac{1}{2}$ " form, winding length  $\frac{5}{8}$ " in. Cathode tapped 3 turns from ground end
- $L_2$  = 23 t. #16 en. wire on  $\frac{1}{2}$ " form, close wound. Cathode tapped 8 turns from ground end
- $L_3$  = 33 t. #18 DCC wire on 1" form, close wound. Cathode tapped 15 turns from ground end
- $L_4$  = 7 t. #16 en. wire on  $\frac{3}{4}$ " form, winding  $\frac{3}{4}$ " long
- $L_5$  = 110 t. #30 en. wire on 1" form, tapped at 71 turns; close wound
- $L_6$  = B. & W. coils. (See table)
- $L_7$  = 8-35 henry. 200 ma. choke (Stancor C-1645)

- $L_8$  = 20 henry, 200-ma. choke (Stancor C-1646)
- $P_1, P_2$  = 6.3-volt pilot lights ( $\frac{1}{2}$  inch)
- $R_1, R_2$  = 25,000 ohms, 1 w.
- $R_3$  = 17,500 ohms, 2 watt
- $R_4$  = 15,000 ohms, 50 watt slider
- $R_5$  = 250 ohms, 10 watt
- $R_6$  = 10,000 ohms, 10 watt
- $S_1$  = TPTT rotary ceramic switch
- $S_2$  = DPST rotary switch
- $S_3$  = DPST toggle switch
- $S_4$  = SPST toggle switch
- $S_5$  = DPDT toggle switch
- $T_1$  = 600-0-600 volt, 200 ma. power transformer (Stancor P-6170)
- $M$  = 0-150 ma. 2" square meter (Triplitt or Simpson)



# TRANSMITTER CONSTRUCTION

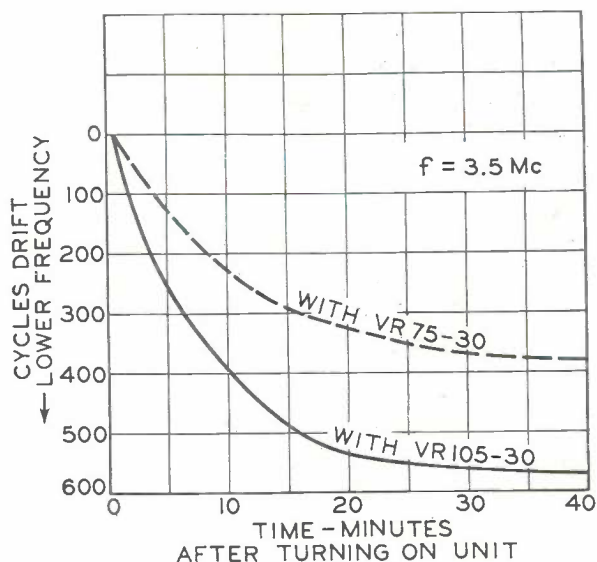

FIG. 14

Second operation is to calibrate the 802 grid circuit operation on 40 meters. Set  $S_2$  to the "80" position and adjust  $C_7$  so that the second harmonic of the oscillator tunes exactly to 7300kc. with  $C_{13}$  set at "10" (near minimum). Next, turn  $C_{13}$  to read "90" on the dial (near maximum) and adjust  $C_2$  so that the oscillator just hits 3500 kc. This completes the calibration for 7.0 Mc and since the 3.5 Mc grid tank circuit is also used by quadrupling in the plate circuit, the calibration is also completed for 14 Mc.

Third operation is to calibrate the 802 grid circuit for operation on 10 meters. Set  $S_2$  to "20" and adjust  $C_5$  so the second harmonic of the oscillator tunes exactly to 28,000 kc. with  $C_{13}$  set at "90." Output on 10 meters is obtained by doubling in the 802 plate circuit.

After the 802 grid circuit has been aligned, plate coil  $L_5$  should be adjusted to give 3 to 5 ma. grid current when  $S_1$  and  $S_2$  together are set at "80" or "160."  $L_1$  should then be adjusted to give 1 to 2 ma. when  $S_1$  and  $S_2$  together are set at "20." Grid current can be measured by opening the ground end of  $R_2$  and inserting an 0-5 or 0-10 d-c milliammeter in the 807 grid circuit. The opened end of  $R_2$  should be by-passed for r.f. to the chassis during the measurement to maintain a short r-f grid circuit return. As discussed earlier, the 807 is protected during key-up conditions by the semi-fixed bias voltage provided by the sum of the 807 cathode current and the bleeder current developed across  $R_5$ .

### Keying Is Crisp and Clean-Cut

Keying of this VFO is done in the oscillator circuit for break-in operation. Oscillation is completely cut off by keying the 802 screen voltage, between the 802 and the voltage-regulator tube. It is important to note that keying of the screen voltage should not be accomplished between the voltage-regulator tube and the negative side of the voltage supply as shown by "X" in the circuit for this method will produce very bad keying transients. With the circuit shown, keying is clean and crisp and any slight key clicks resulting from making and breaking this low-current circuit can readily be eliminated by means of a simple resistance-capacitance filter across the key contacts. To "spot" a desired station, close  $J_1$  and swing  $C_{13}$  to zero beat with the desired incoming signal. When flip  $S_3$  to "on" when ready to transmit.

### How VFO Performs

The curves in Fig. 14 show the number of cycles the 802 control grid circuit drifts from a cold start when operating

at 3.5 Mc. Note that, when using a VR-75-30 regulator in the screen circuit of the 802, the overall drift is less than 400 cycles and that practically all of this drift occurs within the first 30 minutes of operation. Moreover, after the first 10 minutes of operation, the oscillator drifts only about 150 cycles. When a VR-105-30 is used in place of the VR-75-30, the drift increases, but the results are still exceptional. Various tests were made to check mechanical and electrical stability. When the oscillator grid box was jarred, bumped or twisted, it was found that the signal always returned to within about  $\pm 5$  cycles of its original frequency. It was found that wrapping the bulb of the 802 bulb with several turns of rubber tape aided stability by preventing tube movement within its shield can. In a careful check of the stability and accuracy of the instrument, it was found that the oscillator could be reset to a few parts in a hundred thousand. Measured power output from the 807 was approximately 25 watts on 160 meters, 20 watts on 80 meters, 15 watts on 40 and 20 meters and 5 watts on 10 meters. If it is desired to drive a beam tube, such as an 828 or an 813, it is recommended that a potentiometer be used in place of the 807 screen series resistor in order to reduce the 807 output by controlling the 807 screen voltage.

### Appendix

Tuning-condenser values for an ECO designed to have approximately 100% bandwidth may be calculated as follows:

For a given total maximum capacitance ( $C_{max}$ ), the net capacitance variation ( $K$ ) required to give 100% coverage from a low-frequency limit ( $f_{low}$ ) to a high-frequency limit ( $f_{high}$ ) can be calculated from the following relation:

$$K = C_{max} \left[ 1 - \left( \frac{f_{low}}{f_{high}} \right)^2 \right]$$

As an example, for the "160" grid-circuit position, assume  $C_{max} = 1185 \mu\mu\text{f}$ ,  $f_{low} = 1750 \text{ kc.}$ , and  $f_{high} = 2050 \text{ kc.}$  Therefore,

$$K = 1185 \left[ 1 - \left( \frac{1750}{2050} \right)^2 \right] = 324 \mu\mu\text{f}$$

For a variable condenser having a total maximum capacitance of  $395 \mu\mu\text{f}$ , the total shunt padder capacitance should be  $1185 - 395 = 790 \mu\mu\text{f}$  which equals the sum of  $C_{10}$ ,  $C_{11}$ ,  $C_{12}$ , and stray capacitances.

If, for example, a tuning condenser having a maximum capacitance of (say)  $500 \mu\mu\text{f}$ , and a minimum capacitance of (say)  $50 \mu\mu\text{f}$  is used, the total  $K$  is  $500 - 50 \mu\mu = K$ . For calculation purposes,  $K$  can be treated approximately as a fixed capacitance. Using the well-known series-condenser relations we obtain:

$$\begin{aligned} \frac{1}{C_{series}} &= \frac{1}{C_{net}} - \frac{1}{C_{tuning}} \\ \frac{1}{C_{series}} &= \frac{1}{324} - \frac{1}{450} \\ C_{series} &= 1340 \mu\mu\text{f} \end{aligned}$$

This  $1010 \mu\mu\text{f}$  capacitance may be made up of several zero-coefficient condensers in parallel with each other and with a small adjustable padder.

The above calculations are, of course, complicated by the presence of stray tube and circuit capacitances. However, by carefully estimating and allowing for stray tube and circuit capacitances, it is possible to come out fairly closely. Use of partially adjustable padders will make up for reasonable errors. It should be mentioned in passing that, in practice, more error results from inaccurate coil-size calculations, than from inaccurate stray-capacitance allowances.

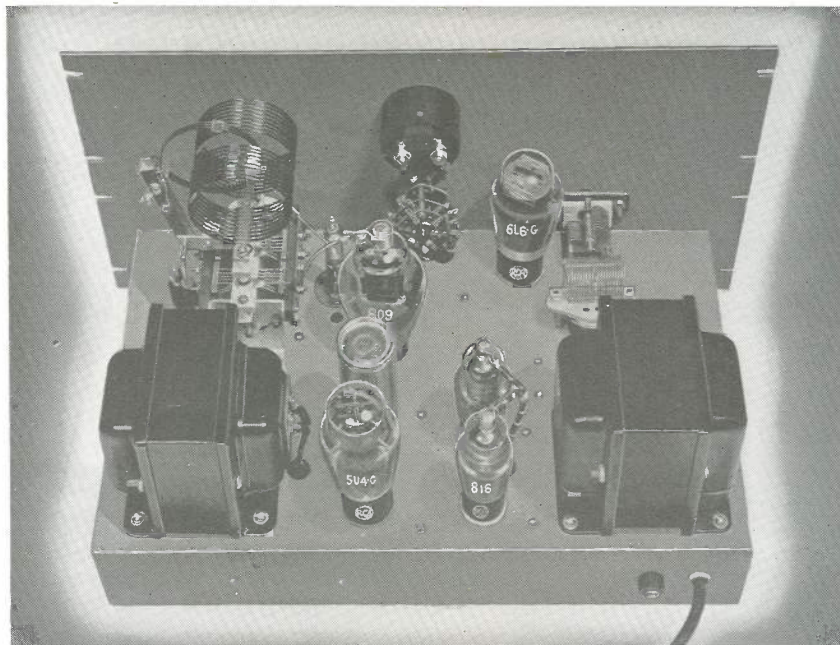

FIG. 15

## RCA ECONOMY TRANSMITTER

- 40- AND 80-METER C-W OPERATION
- OSCILLATOR KEYING
- 70-WATT C-W OUTPUT
- COMPLETELY SELF-CONTAINED

This transmitter is designed to meet the needs for a medium-power c-w transmitter stripped of non-essentials. Tube cost is kept low by using a 6L6-G crystal oscillator to drive an 809 to approximately 70 watts output on the 40- and 80-meter bands. Power-supply cost is kept low by using two 816 mercury-vapor rectifiers for the high-voltage supply.

Unusual simplicity of operation is obtained by limiting the transmitter to use only a small range of frequencies. Since the oscillator is always used for "straight-through" operation, the number of tuning adjustments are reduced to a minimum. Oscillator keying is employed so that all the well-known advantages of break-in operation can be realized. A meter-switching system enables measurement of grid and plate currents with a single 150-ma. meter.

### The Circuit

An excellent impedance match is obtained between the 6L6-G plate and the 809 grid by tapping the excitation lead half-way down the oscillator plate coil. This arrangement can be seen by reference to Fig. 17. Connecting the excitation lead directly to the 6L6-G plate actually has the effect of reducing rather than increasing the 809 grid current. The oscillator tube is afforded considerable protection during tune-up periods by the cathode resistor,  $R_2$ , which places a limit on out-of-resonance plate current. A small amount of bleeder current is run through  $R_1$  to furnish ample cut-off bias for the 809 under key-up conditions without resorting to cumbersome fixed bias supplies.

Either the oscillator plate current or 809 grid or plate current can be measured by flipping the selector switch,  $S_1$ , to the appropriate position. Closed circuits are maintained for grid and plate currents regardless of switch position by means of  $R_4$ ,  $R_5$ , and the upper section of  $R_7$ . The values of these resistances have been so chosen that they have negligible effect on meter readings, yet do not result in appreciable voltage drop.

Keying is accomplished in the cathode return of the 6L6-G crystal-oscillator tube. With this type of keying, the

cathode tends to approach the screen voltage when the key is up; therefore, the filament and cathode should be tied together to prevent insulation breakdown, and the filament wiring and transformer secondary should be insulated from ground. This arrangement requires an individual filament winding for the 6L6-G.

Plug-in coils are used in both plate-tank circuits to obtain a desirable value for "Q" on both bands. The use of a swinging link assembly for  $L_2$  facilitates output loading adjustments.

The high-voltage section of the power supply makes use of two 816's. These tubes are used because the voltage delivered by  $T_1$  is considerably in excess of the ratings of receiving-type rectifiers, but not high enough to require the use of the 866-A/866's. The 816's fit right into this transmitter design because they are low in cost, have low filament-power requirements, and take up so little space.

The low-voltage requirements of the transmitter are handled by a 5U4-G. A single, tapped high-voltage transformer and one filter choke is used to obtain a dual power supply which has good regulation combined with low hum output. In addition, it weighs less, occupies less space, and costs less than two separate supplies.

### Construction

By mounting the power-supply components along the rear half of the chassis, it is practical to place the r-f section next to the panel, so that tuning-condenser shafts are readily accessible. This arrangement is quite satisfactory with the 10" x 17" x 3" chassis bolted to the  $\frac{1}{8}$ " x 10 $\frac{1}{2}$ " x 19" steel panel. With lighter panels it may be necessary to install additional angle brackets to prevent sag, if relay-rack mounting is contemplated. Many details of the layout can be seen by reference to Figs. 15, 16, and 17. Therefore, only the less noticeable but nevertheless highly desirable features will be mentioned here.

The 809 plate-tank condenser,  $C_0$ , is mounted on four tiny feed-through insulators so that connections to the B+ (rotor) can conveniently be made underneath the chassis. A pi-wound r-f choke is mounted above the chassis and connected between the rotor of  $C_0$  and the centertap of  $L_2$ . The 809 socket is mounted approximately  $\frac{1}{2}$ " below the chassis



# TRANSMITTER CONSTRUCTION

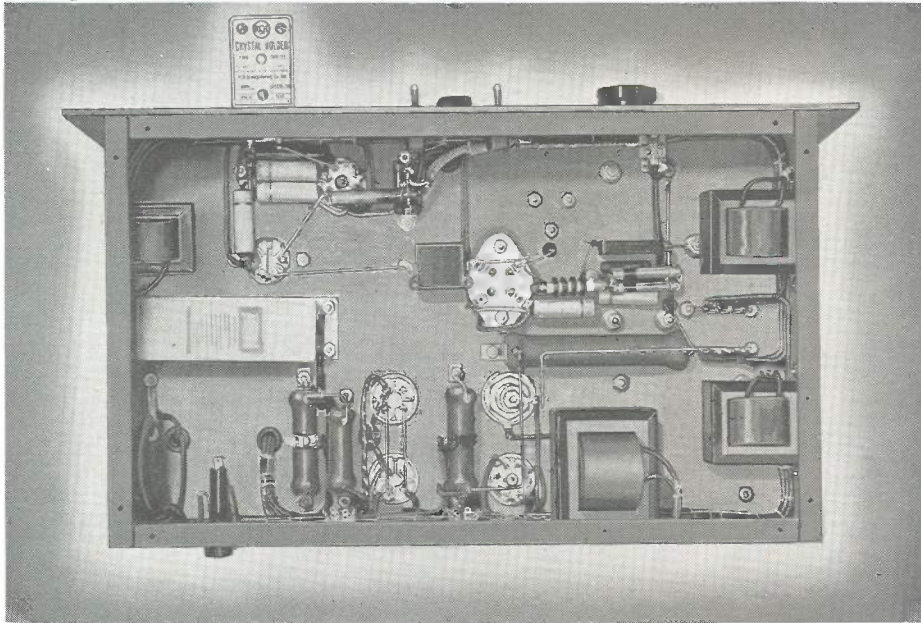

FIG. 16

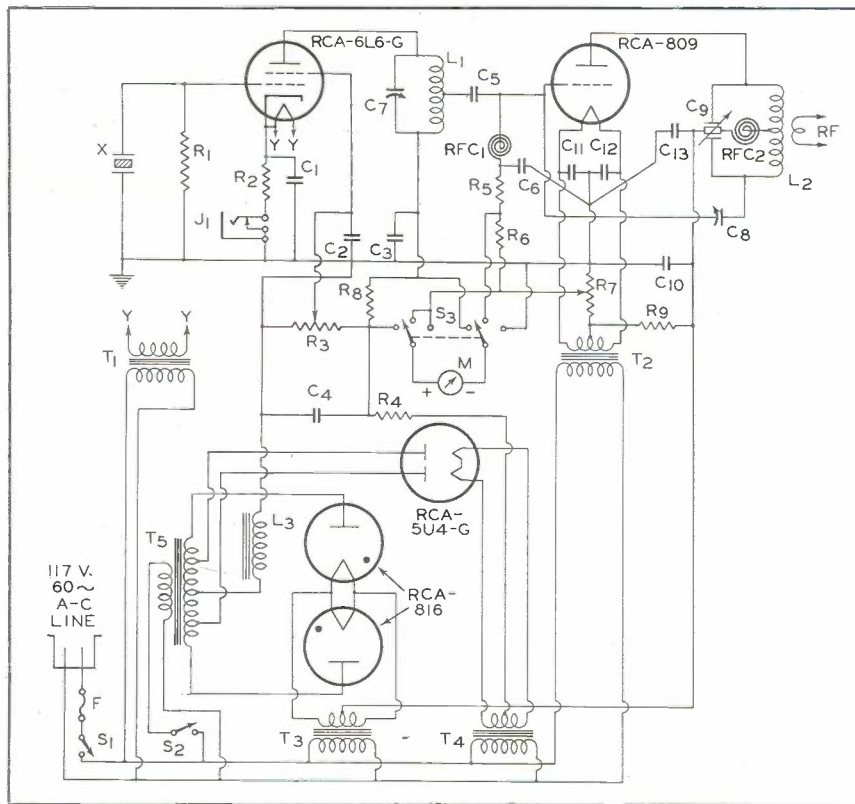

FIG. 17

### PARTS SHOWN IN FIG. 17

- C<sub>1</sub> C<sub>2</sub> C<sub>3</sub> C<sub>6</sub> C<sub>11</sub> C<sub>12</sub> = .005 μf mica, 1000 volts (Sangamo)
- C<sub>4</sub> = "8 μf Replacement" 600 volt paper condenser (Cornell-Dubilier #PE-CH)
- C<sub>5</sub> = .0001 μf mica, 1000 volts Sangamo
- C<sub>7</sub> = 100 μmf Cardwell ZU-100-AS
- C<sub>8</sub> = Neutralizing condenser Millen #15003 (1.5 to 8.3 μmf)
- C<sub>9</sub> = 100 μmf split stator condenser Cardwell MR-100-BD
- C<sub>10</sub> = 2 μf 1000 volt Cornell-Dubilier Type TLA
- C<sub>13</sub> = .001 μf 2500 volts mica Sangamo
- J<sub>1</sub> = Key jack

- R<sub>1</sub> = 20,000 ohms, 2 watts
- R<sub>2</sub> = 250 ohms, 2 watts
- R<sub>3</sub> = 25,000 ohms, 25 watts (IRC #DHA)
- R<sub>4</sub> = 3000 ohms, 20 watts (IRC DG)
- R<sub>5</sub> = 1500 ohms, 2 watts
- R<sub>6</sub> R<sub>8</sub> = 50 ohms, 1 watt
- R<sub>7</sub> = 500 ohms, 25 watts, adjustable
- R<sub>9</sub> = 40,000 ohms, 50 watts
- L<sub>1</sub> = B & W "Baby" Coils—40 and 80 meters
- L<sub>2</sub> = B & W BVL Coils—40 and 80 meters
- L<sub>3</sub> = 12-henry, 300-milliampere choke (Thordarson T-19C43)

- T<sub>1</sub> = 6.3-volt, 1-ampere filament transformer (Thordarson T19F80)
  - T<sub>2</sub> = 6.3-volt, 3-ampere filament transformer (Thordarson T19F97)
  - T<sub>3</sub> = 2.5-volt, 5.25-ampere filament transformer (Thordarson T19F88)
  - T<sub>4</sub> = 5-volt, 5-ampere filament transformer (Thordarson T19F83)
  - T<sub>5</sub> = { 1075-0-1075 volts at 125 ma. }  
       { 507-0-507 volts at 150 ma. }  
       (Thordarson T19P57)
  - M = 0-200 ma. meter Triplett 2" square
- NOTE: A 5000-ohm, 2-watt resistor may be shunted across RFC<sub>2</sub>, if necessary to prevent parasitics.

top by means of small metal pillars to lower the stray grid-ground capacitance. Short leads to C<sub>7</sub> are obtained by mounting the 6L6-G plate-coil socket above the chassis. A large hole is cut in the chassis below the coil socket to obtain ample clearance for "hot" r-f and d-c leads brought out beneath the chassis. A workman-like job is assured by cabling all power leads and tying small parts to Bakelite terminal strips. As can be seen in Fig. 16, the small filament transformers are mounted around the inside edges of the chassis wherever space is available near the tubes they serve.

### Tuning Adjustments

Initial tuning adjustments should be made with plate voltage removed from the 809. This can conveniently be done by temporarily removing the plate-cap connectors from the 816's, or better yet, by disconnecting the high-voltage d-c lead between C<sub>10</sub> and C<sub>13</sub>. The plate current of the 6L6-G, in resonance, should be about 30 ma., and the corresponding 809 grid current should be approximately 35 ma., with no plate voltage on the 809. The oscillator is exceptionally easy on the crystal, inasmuch as it is used only for straight-through operation. The conventional 60 ma. pilot bulb in series with the crystal is omitted, since it would not indicate excessive crystal current under any condition of tuning or mis-tuning.

After the 809 stage has been neutralized by one of the methods outlined in *Transmitting Circuit Facts*, plate voltage may be applied to the 809 through a 10000-ohm, 50-watt protective resistor. The 809 should now be tuned to resonance and a load applied before boosting plate voltage to the normal value. With 1000 volts on the 809, C<sub>9</sub> will arc over when tuned to resonance unless the tank circuit is kept loaded. For optimum output, the 809 should be loaded until its plate current is 100 ma. maximum at resonance. Grid current should then be approximately 25 ma.

After experience has been obtained in operating the transmitter, it should not be necessary to insert a protective resistor each time it is tuned. By very carefully tuning C<sub>7</sub> so that the 809 grid current is very low, it is possible to find the resonance point for C<sub>9</sub> without difficulty, and to keep the 809 out-of-resonance plate current within reason. Then, C<sub>7</sub> can be tuned for optimum output and C<sub>9</sub> "touched up".

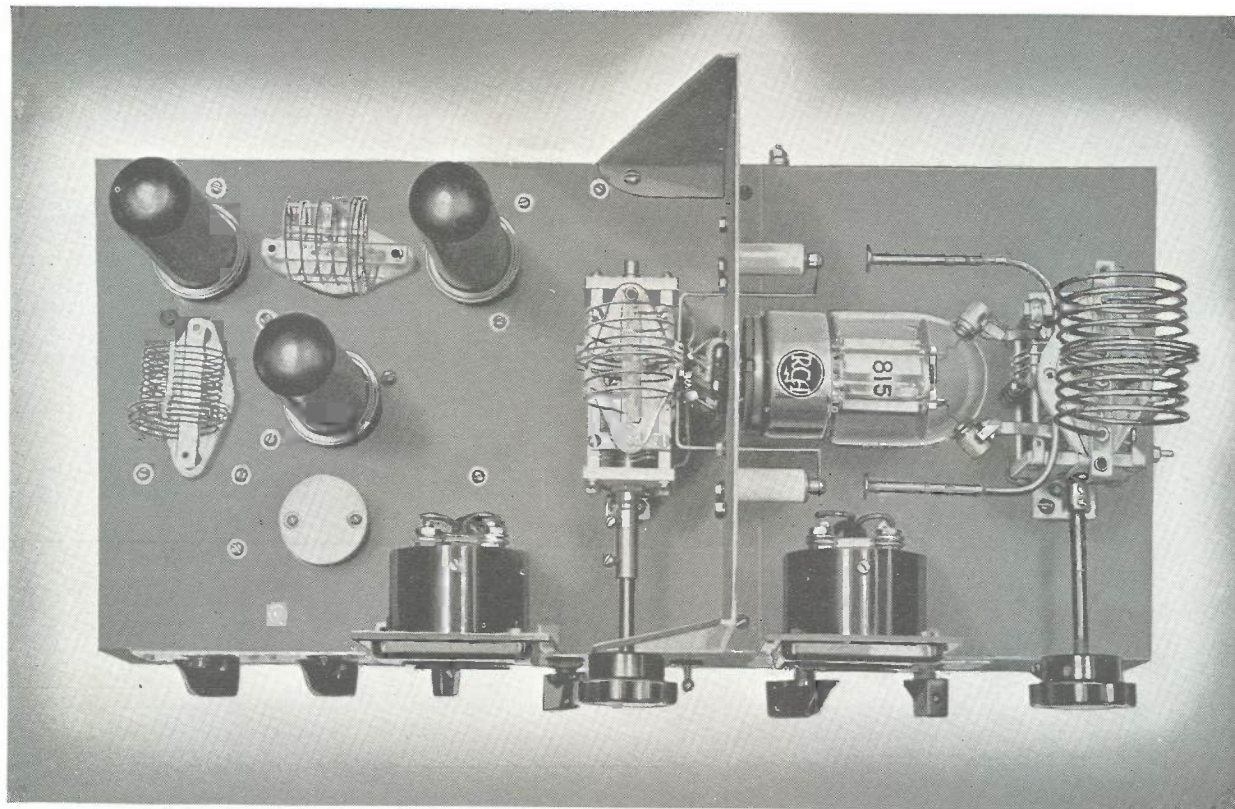

FIG. 18

## RCA - 815 U - H - F TRANSMITTER

**30 to 45 WATTS OUTPUT**  
**2½ to 20 METERS**

This transmitter has been designed to bridge a definite gap in modern transmitter equipment—the gap between the high and the ultra-high frequencies. It will deliver 30 to 45 watts from 2½ to 20 meters. It can be used to feed an antenna directly or to drive a separate, high-powered final on one or all of these bands. An 815 push-pull beam tube is employed in the final and the modulator and makes possible efficient u-h-f operation with small driver requirements and low cost.

### The Circuit

The 815 is employed as a straight push-pull modulated class C r-f amplifier on all four bands. The circuit is given in Fig. 20. The exciter starts out with a 6L6 tritet\* crystal oscillator and a 40-meter crystal. For 20-meter operation the oscillator doubles in its plate circuit to drive the 815 directly. Neither of the two 6L6 doublers is used for operation on this band. For 10 meters, one 6L6 doubler is added. For 5 meters, the oscillator quadruples in its plate circuit and drives the single 6L6 doubler, while for 2½ meters, an additional doubler tube is brought into the circuit. Two crystals are required to cover all four phone bands. One crystal will do for 20, 5 and 2½ meters, while a second crystal will provide harmonic output on 10, 5, and 2½ meters. Suitable crystal frequencies are listed in Table 3.

Conventional parallel-tuned circuits are used throughout, except in the 2½-meter doubler plate tank. In this tank, a so-called "series-tuned circuit" is used to make possible a larger physical size of L, and to permit tuning of the circuit without an increase in the total circuit capacitance.

Capacitance coupling is used between the oscillator and first doubler, and between the first and second doublers. The

\* The "tritet" type of oscillator circuit was originally described by Mr. J. J. Lamb in "QST."

815 grid circuit may be link coupled either to the oscillator or to one of the doublers, depending on the operating band, by means of switch S<sub>1</sub>. At the same time, S<sub>2</sub> removes filament voltage from any unneeded doubler tubes. This method is very convenient for effectively disconnecting a tube from the circuit, as only one switch contact is required. In addition, a tube with a cold cathode presents only a capacitive load to its driver, and therefore uses negligible r-f power. This method of switching also makes possible the use of very short r-f excitation leads. When the transmitter is switched from 20 to 10, or from 5 to 2½ meters, the 15 or 20 seconds required for filament heating should not unduly delay the band change.

A combination of grid-leak and cathode bias helps to protect the oscillator and doubler tubes during the tune-up periods by limiting both plate voltage and plate current. The 815 obtains its entire bias from a grid leak, however.

Each r-f tube has a separate voltage-dropping resistor for its screen supply to prevent screen-voltage shifts when a doubler is cut into or out of the circuit for band changes. The 815 series screen resistor performs an additional function as well; it permits modulation of the screen simultaneously with the plate without the need for a special, tapped modulation transformer. Modulation of both the screen and plate is necessary in order to obtain 100 per cent modulation with good linearity.

Provision is made for two meters in the circuit, one for the plate current of any tube, and the other for all grid currents except that of the oscillator. S<sub>3</sub> controls the grid meter, and S<sub>4</sub> the plate meter. The principle of the switching circuits is described under the heading RCA ECONOMY TRANSMITTER.



# TRANSMITTER CONSTRUCTION

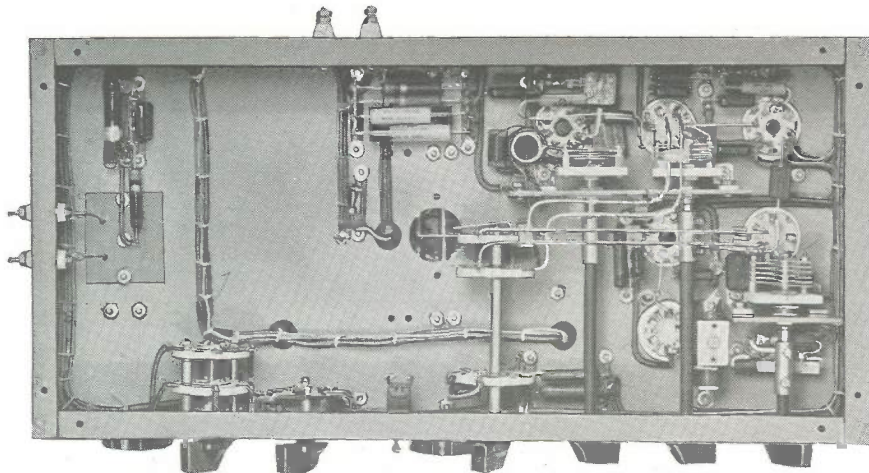

FIG. 19

## The Layout

A layout has been chosen that makes for very short r-f leads and simplified mechanical construction. The three 6L6 oscillator and doubler tubes are grouped closely together so that the r-f leads connecting these tubes can be as short as practicable. With this arrangement, the low-impedance lines connecting  $S_2$  to the plate circuit links of the 6L6's and the 815 grid circuit are also quite short. These low-impedance lines are made of two No. 14 copper wires spaced about  $\frac{1}{4}$ -inch and held apart by means of small pieces of polystyrene.

The 815 is the only tube in this transmitter that operates as a straight class C amplifier; each 6L6 either doubles or quadruples. Therefore, the 815 is the only tube that requires shielding to prevent oscillation. Shielding of the 815 is obtained by mounting its socket on a vertical baffle plate, with the tube horizontal. Additional shielding is furnished by the chassis itself.

The 815 final must be neutralized for stable operation with high-efficiency circuits on the 5 and  $2\frac{1}{2}$  meter bands. Construction of suitable neutralizing condensers is simple. The grid connections should be crossed over between  $C_{16}$  and the 815 socket to permit the neutralizing leads to be run directly between  $C_{16}$  and  $C_{20}$ . Two No. 14 copper wires are run from  $C_{16}$ , one on each side, through  $\frac{1}{4}$ -inch holes in the vertical shield plate. They are supported at their far ends by small standoff insulators. The metal top of each insulator serves as

one plate of each neutralizing condenser. Two No. 10 copper wires, each with a  $\frac{3}{8}$ -inch disc fastened to one end, may be soldered to  $C_{20}$ , one on each side, to complete the pair of neutralizing condensers. Each condenser is adjusted by bending the No. 10 wire to obtain the proper spacing between the  $\frac{3}{8}$ -inch disc and the metal top of the insulator. An alternative method of adjusting the condensers is shown in Fig 18. In this arrangement, the  $\frac{3}{8}$ -inch discs are soldered to short copper-tubing sleeves which are free to slide on the No. 10 wire. Since adjustment of  $C_{22}$  and  $C_{23}$  is not critical, this refinement is optional.

All of the tuning condensers except  $C_{15}$  and  $C_{20}$  are mounted below the chassis and supported on strips of Micarta.  $C_{16}$  and  $C_{20}$

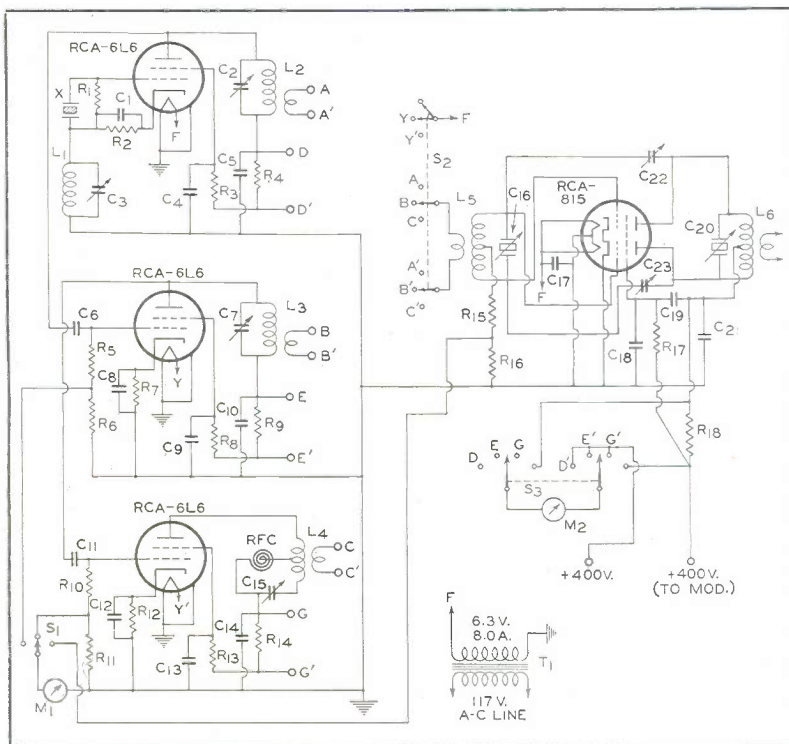

FIG. 20

## PARTS SHOWN IN FIG. 20

- $C_1$   $C_4$   $C_5$   $C_8$   $C_9$   $C_{10}$   $C_{12}$   $C_{13}$   $C_{14}$   $C_{17}$  = 0.001  $\mu$ f mica
- $C_2$  = 35  $\mu$ f variable (Cardwell No. ZR-35-AS)
- $C_3$  = 3-35  $\mu$ f mica trimmer (Hammarlund MEX)
- $C_6$  = 20  $\mu$ f mica
- $C_7$   $C_{11}$  = 25  $\mu$ f variable (Cardwell No. ZR-25-AS)
- $C_{15}$  = 15  $\mu$ f variable (Cardwell No. ZR-15-AS)
- $C_{16}$  = 75  $\mu$ f/section variable (Cardwell EU-75-AS)
- $C_{18}$  = 0.0015  $\mu$ f mica
- $C_{19}$  = 0.001  $\mu$ f mica
- $C_{20}$  = 35  $\mu$ f/section (Hammarlund No. HFBD-35-C)
- $C_{21}$  = 0.001  $\mu$ f mica, 1000 v.
- $R_1$   $R_5$   $R_{10}$  = 100,000 ohms, 0.5 watt
- $R_2$   $R_7$   $R_{12}$  = 200 ohms, 1 watt
- $R_3$   $R_8$   $R_{13}$  = 40,000 ohms, 1 watt
- $R_4$   $R_6$   $R_9$   $R_{11}$   $R_{14}$   $R_{16}$  = 50 ohms, 0.5 watt
- $R_{15}$  = 15,000 ohms, 1 watt
- $R_{17}$  = 9000 ohms, 10 watts
- $R_{18}$  = 50 ohms, 1 watt
- $L_1$  to  $L_6$  See Tables No. 2 and 4

- RFC = 25 Turns No. 28 enameled wire spaced one wire diameter on  $\frac{3}{8}$ " coil form
- $M_1$  = 0-10 ma. Grid current meter
- $M_2$  = 0-250 ma. Plate current meter
- $T_1$  = Filament transformer 6.3v. 8a (Kenyon T-387)
- $S_1$  = Single pole, 3 position rotary switch
- $S_2$  = Two sections of single pole, 3 position switch and 1 section of 2 pole, 3 position switch ganged on single switch assembly
- $S_3$  = Two pole, 4 position rotary switch
- \* This transformer is located on power supply chassis and supplies all filaments except rectifiers

## ADDITIONAL PARTS

- 1 Chassis 8" x 17" x 3" steel
- 1 Bracket  $5\frac{1}{2}$ " x 8" plus  $\frac{1}{2}$ " mounting ledge
- 4 Feed through insulators
- 6 Sockets, 5-contact, ceramic, RCA type 9920
- 4 Sockets, Octal, ceramic, RCA type 9924
- 2 Standoff ins. 1" long (National No. GS-1)
- 4 Standoff ins.  $\frac{3}{8}$ " long



# TRANSMITTER CONSTRUCTION

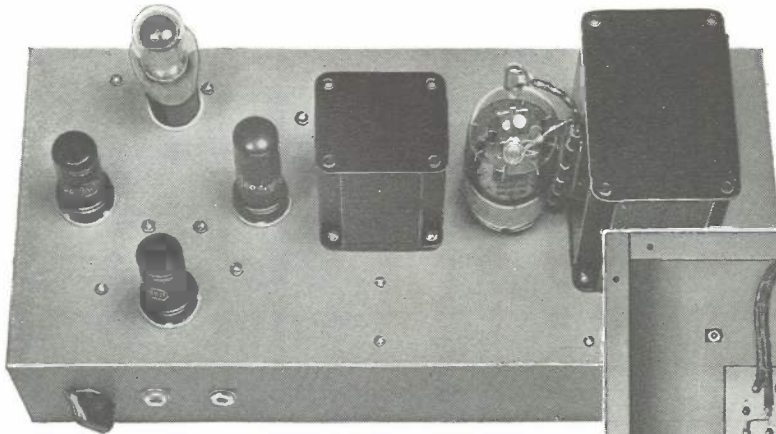

FIG. 21

are mounted on small standoff insulators above the chassis.

The 2½-meter doubler plate coil,  $L_4$ , is mounted directly on  $C_{15}$ , in order to obtain the shortest possible leads for this circuit.  $L_4$  is wired permanently into the circuit because it does not have to be changed when the band is changed. Each link is automatically changed with its coil, so it is not necessary to readjust the positions of the links for band changes, if the optimum positions have been determined at the outset.

### Tuning

This transmitter was found to be exceptionally easy to tune up, especially when one considers the high frequencies involved. No "bugs" were encountered in actual operation.

For the initial tuning adjustments, plate and screen voltage should be removed from the 815 by disconnecting the 815 +B lead.  $S_2$  should first be set to position A, to prevent overloading the doublers when the oscillator is being tuned. Ten-meter coils should be plugged in for  $L_2$  and  $L_5$ , and  $C_3$  adjusted for maximum crystal-oscillator output as indicated by the 815 grid current. Maximum output should occur when  $C_3$  is set about one turn less than its maximum capacitance. A lower setting than this may result in the crystal oscillator stage breaking into spurious oscillations. The adjustment of  $C_3$  is most critical when the oscillator is used to quadruple to 10 meters. The same setting is satisfactory when the oscillator is used to double to 20 meters.

After the optimum setting has been found for  $C_3$ , the transmitter should be tuned up for optimum performance on the 20-meter band. Switch  $S_2$  should be left at position A,

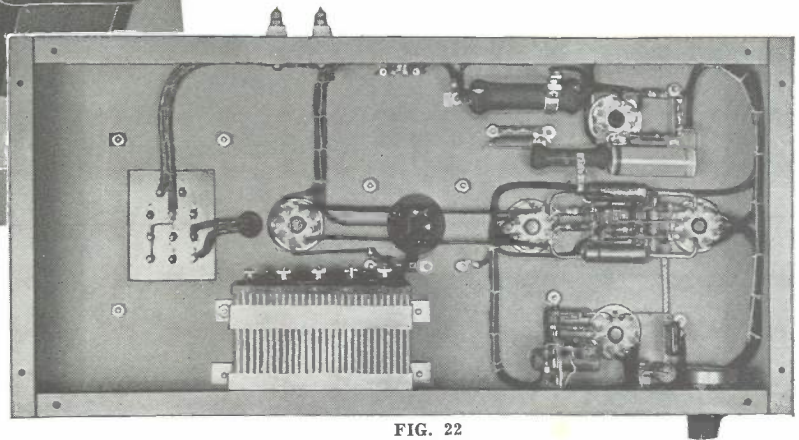

FIG. 22

and 20-meter coils inserted for  $L_2$ ,  $L_5$ , and  $L_6$ . Positions of  $S_2$  and coil numbers are given in Table 2, while coil dimensions are given in Table 4. The links mounted on  $L_2$  and  $L_5$  should be trimmed to one turn and bent away, if necessary, from the coils to limit the 815 grid current to 6 ma. or less. The 815 stage should now be neutralized by one of the methods described under TRANSMITTING CIRCUIT FACTS. The gap between the plates of each neutralizing condenser is about ½-inch for the neutralizing arrangement used in this transmitter; the spacing is not critical and can be the same for all bands.

Once the 815 has been neutralized, plate voltage can be applied and  $C_{20}$  quickly tuned to resonance. The no-load plate current of the 815 is about 10 to 20 ma. at resonance. Tuning without load may cause the screen dissipation to go as high as 6 watts, and should therefore be done for short periods of time only. An antenna may now be coupled to  $L_6$  and the loading increased until the 815 plate current is 150 ma., the rated maximum. The 815 grid current should be from 3-5 ma.

Tuning the transmitter for 10 and 5-meter operation is done in the same manner, except that the first doubler is cut into the circuit (See Tables 2 and 4). For 10 meters, the first doubler grid current should be 1 to 2 ma., and for 5

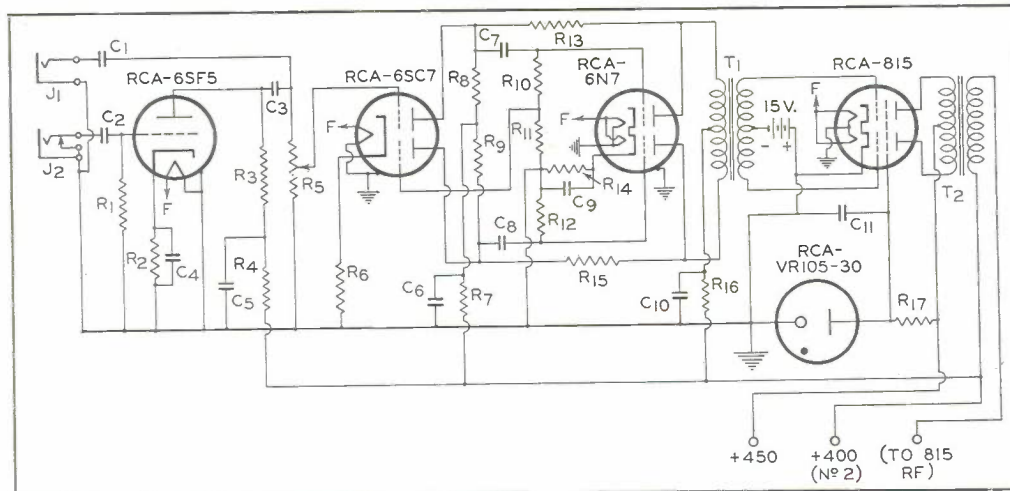

FIG. 23

### PARTS SHOWN IN FIG. 23

- $C_1$   $C_2$   $C_3$  = 0.004  $\mu$ f mica
- $C_4$  = 5  $\mu$ f electrolytic, 50 v.
- $C_5$   $C_6$   $C_{10}$   $C_{11}$  = 4  $\mu$ f electrolytic, 450 v.
- $C_7$   $C_8$  = 0.01  $\mu$ f paper, 600 v.
- $C_9$  = 10  $\mu$ f electrolytic, 25 v.
- $R_1$   $R_{12}$   $R_{15}$  = 1 megohm, 0.5 watt
- $R_2$  = 5000 ohms, 0.5 watt
- $R_3$   $R_4$   $R_{10}$   $R_{12}$  = 0.5 megohm, 0.5 watt
- $R_5$  = 1 megohm, a-f gain control potentiometer
- $R_6$  = 2000 ohms, 0.5 watt
- $R_7$  = 50,000 ohms, 0.5 watt
- $R_8$   $R_9$  = 250,000 ohms, 0.5 watt
- $R_{11}$  = 12,000 ohms, 0.5 watt
- $R_{14}$  = 750 ohms, 1 watt
- $R_{16}$  = 10,000 ohms, 10 watts
- $R_{17}$  = 11,000 ohms, 25 watts adjustable
- $T_1$  = Driver transformer (Kenyon T-255)
- $T_2$  = Output transformer (Kenyon T-493)
- $J_1$  = Open circuit input jack
- $J_2$  = Closed circuit input jack

### ADDITIONAL PARTS

- 1 Chassis 8" x 17" x 3" steel
- 4 Sockets 8-contact
- 1 Socket 5-contact
- 2 Insulators feed through



# TRANSMITTER CONSTRUCTION



and 2½ meters it should be 0.5 to 1 ma. These values are adequate for full output of this stage.

For 2½-meter operation the inductance of  $L_4$  should be adjusted until  $C_{15}$  tunes near minimum capacitance, for maximum output. The links on  $L_4$  and  $L_5$  should be adjusted to deliver 2 to 3 ma. grid current to the 815 when the final tank circuit is fully loaded.

The useful power output of the 815, measured into a lampload, was 46 watts on 10 and 20 meters with a plate input of 60 watts. With this same input the power output on 5 meters was 38 watts and on 2½ meters, 31 watts. The lowered values of measured power output on 5 and 2½ meters were largely the result of increased circuit losses at these frequencies. The tube operates within its plate dissipation ratings on all bands.

## Modulator Unit

Using the same plate-voltage supply as the 815 final, the 815 modulator delivers the required audio power output with nominal plate current and with low distortion.

The modulator is illustrated in Figs. 21 and 22. A single 6N7 with its two triode units connected in push-pull furnishes sufficient drive for the 815. A 6SC7 phase inverter driven by a 6SF5 high-mu triode completes the tube lineup. The circuit is given in Fig. 23.

Provision is made for either a low- or a high-level, high-impedance microphone. A low-level crystal microphone should be plugged into the "low" jack. If it is desired to utilize a carbon or other low-impedance microphone, an input transformer must be used between the mike and the appropriate input jack. Amplifier gain for either input jack is conveniently controlled by means of  $R_5$ , which is connected after the 6SF5. Placing  $R_5$  after the first voltage-amplifier tube, rather than before, helps to reduce undesired noises originating in the gain control. The maximum signal input to the low-level jack should not exceed 0.5 volt. Approximately 2 millivolts input to the "low" jack is required for 100 per cent modulation.

## Screen-Voltage Stabilization Necessary

It is perhaps not too well known that in order to obtain rated output from a class  $AB_2$  beam a-f power amplifier, the screen voltage must be held fixed independent of wide variations in the screen current. A voltage-regulator tube, such as a VR105-30, is the logical device for stabilizing the screen-supply voltage in this instance.

Plate voltage for the 6SC7, 6N7, and 6SF5 are obtained from the 450-volt supply through separate resistor-capacitor filters which effectively isolate the tubes, reduce hum to a very low value, and, in the case of the 6N7, reduce the plate-supply voltage to rated value.

Bias for the 815 is obtained from two midget 7½-volt "C" batteries strapped underneath the chassis, as shown in Fig. 22, while bias for the other tubes is furnished by conventional cathode resistors. A-f voltage for phase inversion is taken from the 6N7 grid circuit. In order to lower the effective internal impedance of the high-mu 6N7 driver, parallel inverse feedback from each 6N7 plate to the corresponding 6SC7 plate is used.

Optimum impedance match between the modulator and its class C amplifier load is obtained with a 6000-ohm primary and a 2500-ohm secondary. For transformer  $T_2$  specified in the modulator circuit legend (See Fig. 23), the 815 modulator plates are connected to terminals 1 and 6; "+450" to terminals 3 and 4; and "+400 (No. 2)" and "To 815 RF" to terminals A and D, respectively.

There is nothing tricky about the layout or construction of the modulator unit of this transmitter. Sufficient shielding for most purposes is furnished by the single-ended metal tubes and by the chassis. Shielding problems are greatly simplified by allowing plenty of space between the input and

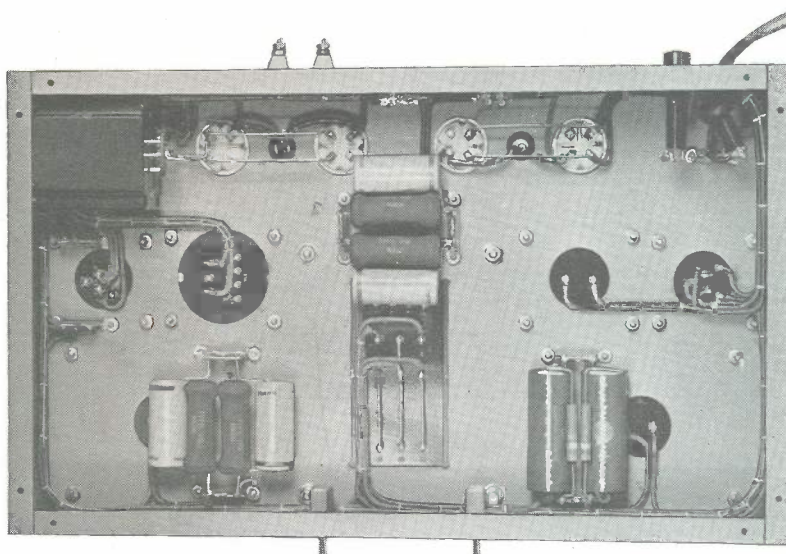

FIG. 24

output circuits of the amplifier unit. Both the modulator and the r-f units are built on 8 x 17 x 3 steel chassis.

## Power-Supply Unit

The total plate-current requirements of the r-f and modulator units is greater than 500 ma. at 400 to 450 volts. A heavy, three-winding power transformer feeding into two different rectifier and filter systems proves to be an economical design. The unit is illustrated in Figs. 24 and 25; the circuit is given in Fig. 26.

The use of two separate filter systems makes it practical to employ relatively low-cost filter chokes designed for low voltages. By using two separate full-wave rectifier systems, it is possible to avoid circuits involving paralleled rectifier tubes. The use of a three-winding transformer provides two windings in parallel to feed both 815's plus the speech amplifier tubes, and the third winding for the three 6L6's of the exciter. The two high-voltage windings that are paralleled must, of course, be connected with the same polarity in relation to each other. The windings should first be connected temporarily, and then 110 volts a.c. applied to the primary through a 100-watt lamp. If the lamp lights only dimly, the polarity is correct. If, on the other hand, the lamp lights to nearly full brilliancy, the polarity is incorrect and must be reversed.

Two 866-A/866's deliver a maximum of 350 ma. to the 815's and the speech tubes. A swinging choke  $L_3$ , helps to provide excellent regulation. Power for the modulator unit is taken off after  $T_2$  to improve regulation further and to relieve  $L_2$  of some of its load. A dropping resistor,  $R_7$ , is employed to reduce the 815 plate voltage to the rated maximum of 400 volts.

Two 816's handle the exciter current requirements. About 200 ma. is required for the three 6L6's for 2½-meter operation. For 5- and 10-meter operation, the drain is reduced to about 130 ma., since the 2½-meter doubler is out of the circuit. For 20 meters, with both doublers out, the drain of this section of the power supply is only about 60 ma.

The power transformer employed in this power supply is quite versatile; in addition to having three different windings, each winding has taps for three different voltages. While a receiving-type rectifier, such as a 5U4-G or 83 can satisfactorily handle the 400-volt, 200-ma. requirements of the three 6L6's of this transmitter, two 816 rectifiers have been employed to permit the use of one of the higher voltage taps for other equipment, if desired.

The power-supply unit is mounted on a 10" x 17" x 3" chassis. No panel is shown, although one can be added if desired.





# TRANSMITTER CONSTRUCTION

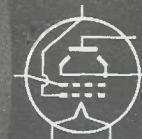

**Table 2—COIL NUMBER AND SWITCH POSITIONS**  
(40-meter Crystal for all bands)

Operating Band	L <sub>2</sub> No.	L <sub>3</sub> No.	L <sub>4</sub> No.	L <sub>5</sub> No.	L <sub>6</sub> No.	S <sub>2</sub> Position
20	(1)	—	—	(2)	(3)	A
10	(1)	(4)	—	(5)	(6)	B
5	(4)	(7)	—	(8)	(9)	B
2½	(4)	(7)	(10)	(11)	(12)	C

**Table 3—CRYSTAL FREQUENCY CHART**

Crystal Frequency KC.	Phone Band			
	20 Meters	10 Meters	5 Meters	2½ Meters
7000-7075	CW only	CW only	56000-56600	112000-113200
7075-7125	14150-14250	CW only	56600-57000	113200-114000
7125-7200	CW only	28500-28800	57000-57600	114000-115200
7200-7250	—	28800-29000	57600-58000	115200-116000
7250-7300	—	29000-29200	58000-58400	—
7300-7500	—	29200-30000	58400-60000	—

**Table 4—COIL DIMENSIONS**

Operating Band Meters	Coil No.	B & W Coil	Length Inches	Dia Inches	Number Turns	Link	
						Turns	Position
20	1	20 MEL*	1¼	1¼	13	1	End
20	2	20 MCL	1½	1¼	14	1	Center
20	3	20 JVL	2¾	1¾	14	3	Center
10	4	10 MEL	1¼	1¼	6	1	End
10	5	10 MCL	1¼	1¼	6	1	Center
10	6	10 JVL	2	1¾	8	3	Center
5	7	—	¾	¾	3	1	End
5	8	—	¾	¾	4	1	Center
5	9	—	1¾	1¾	4#	2	Center
2½	10	—	¾	¾	5	1	Center
2½	11	—	½	½	2	1	Center
2½	12	—	1	1½	2‡	1	Center
All	L <sub>1</sub>	—	¾	¾	12	—	—

\* Two turns removed from coil  
# No. 10 Copper Wire  
‡ ¼" Copper Tubing

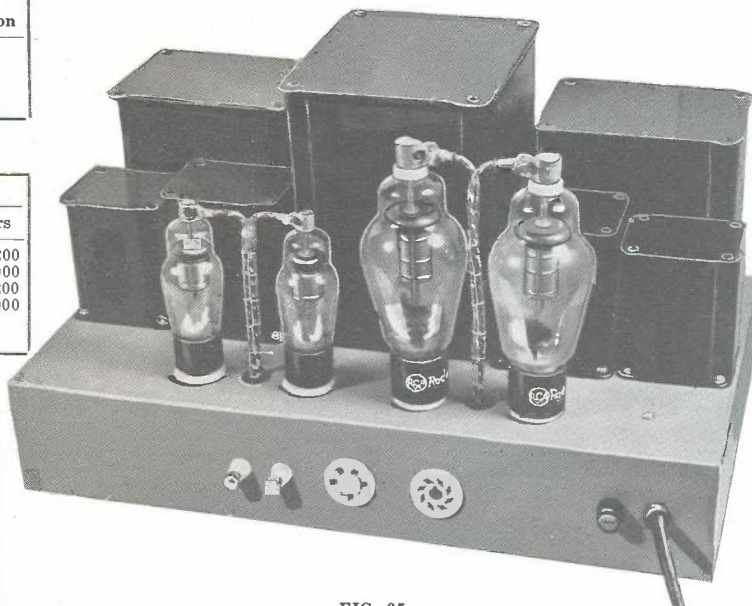

FIG. 25

**PARTS FOR FIG. 26**

- C<sub>1</sub> C<sub>2</sub> C<sub>3</sub> C<sub>4</sub>=16 μf electrolytic, 450 v.
- C<sub>5</sub> C<sub>6</sub>=16 μf electrolytic, 500 v.
- R<sub>1</sub> R<sub>2</sub>=8000 ohms, 20 watts
- R<sub>3</sub> R<sub>4</sub>=15,000 ohms, 20 watts
- R<sub>5</sub> R<sub>6</sub>=250,000 ohms 1 watt
- R<sub>7</sub>=100 ohms, 20 watts
- L<sub>1</sub> L<sub>2</sub>=Smoothing choke, 10 henrys, 200 ma. (Kenyon No. T-152)
- L<sub>3</sub>=Swinging choke, 6-19 henrys, 300-30 ma. (Kenyon No. T-510)
- T<sub>1</sub>=Filament transformer, 2.5 v., 5a (Kenyon No. T-379)
- T<sub>2</sub>=Plate transformer  
520-0-520 v. 175 ma.  
570-0-570 v. 175 ma.  
570-0-570 v. 175 ma. (Kenyon No. T-658)
- T<sub>3</sub>=Filament transformer, 2.5 v., 10a (Kenyon No. T-352)
- S<sub>1</sub> S<sub>2</sub>=S.P.S.T. toggle switch
- F=10a fuse

**ADDITIONAL PARTS**

- 1 Chassis 10" x 17" x 3" steel
- 4 Sockets 4-contact, RCA type 9919
- 1 Socket 5-contact, RCA type 9920
- 1 Socket 8-contact, RCA type 9924

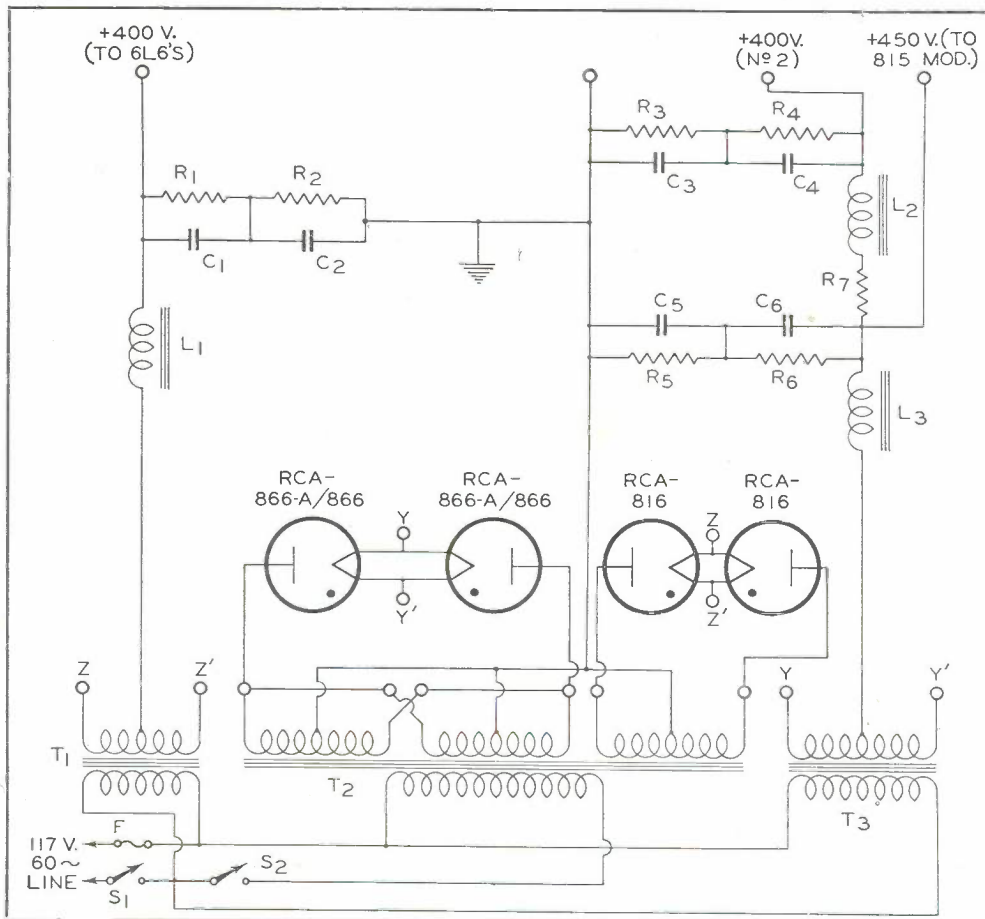

FIG. 26



## TRANSMITTER CONSTRUCTION



360 WATTS INPUT ON C. W.

•

240 WATTS INPUT ON PHONE

•

6V6-GT/G PIERCE OSCILLATOR

•

813 FINAL AMPLIFIER

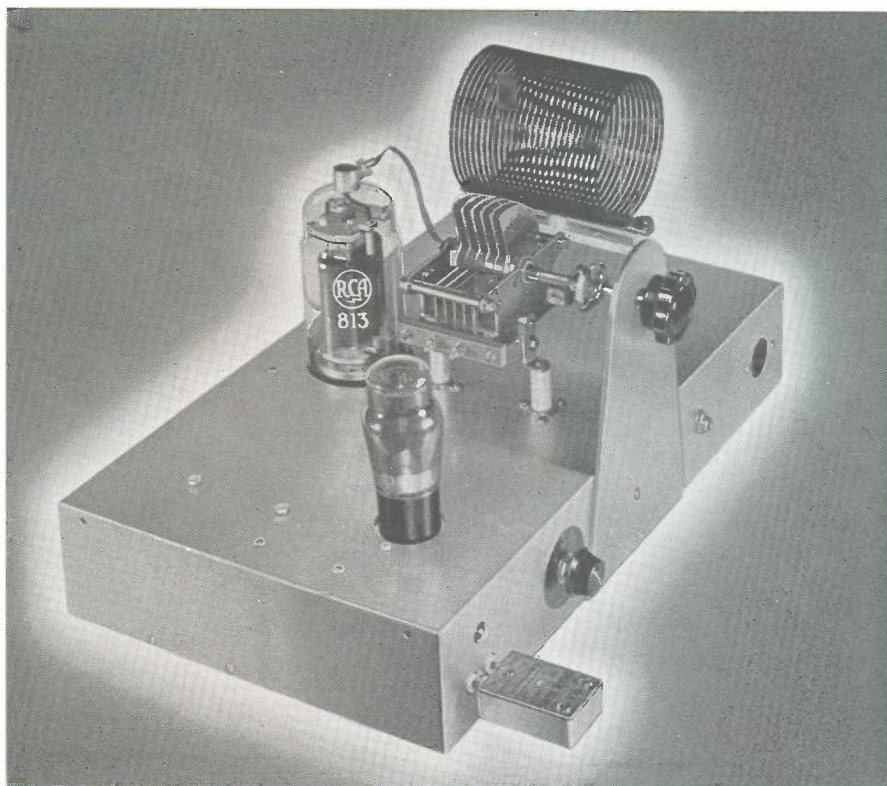

FIG. 27

# RCA SINGLE-CONTROL 360-WATT TRANSMITTER

Real power with simple one-chassis construction, a single tuning control, and high overall efficiency are the outstanding features of the 360-watt, two-tube transmitter shown in the top and bottom views of Figs. 27, 30, and 31.

This single-control transmitter employs a 6V6-GT/G as a Pierce crystal oscillator, and an RCA-813 final amplifier. The transmitter operates "straight-through" with either a 40-, 80-, or 160-meter crystal in the oscillator circuit and has a novel arrangement in which need for a low-voltage power supply is eliminated by obtaining the 6V6-GT/G plate and screen voltage through the 813 screen-dropping resistor.

The fixed-tuned, band-switching Pierce oscillator circuit shown in Fig. 29 makes it unnecessary to retune the oscillator when changing crystals. The equivalent d-c circuit showing how the voltage for the 6V6-GT/G is obtained is shown in Fig. 28. It will be noticed that the d-c resistance of the 6V6-GT/G plate circuit is used to replace part of the 813 series screen resistor. For technical reasons it is desirable to have the equivalent d-c resistance of the oscillator tube high and its plate current low. A 6V6-GT/G was chosen for the oscillator because it can operate on fairly low plate current and still furnish ample drive for the 813. The elimination of a separate low-voltage power supply reduces the cost of this transmitter. Furthermore, since a buffer stage is not required, this transmitter is simpler and can be built for no greater cost than one of the same power using triodes.

Ample shielding for the 813 is obtained by mounting the large 7-pin socket so that the chassis is flush with the internal shield plate of the tube. A 6V6-GT/G is used for the oscillator rather than a metal 6V6 because the shell of a 6V6 would have to be 400 volts above ground.

The location of the various parts on the chassis is not particularly critical; a convenient and practical layout is shown in the photographs.  $C_7$  is mounted on two sturdy, metal-base ceramic insulators each  $1\frac{3}{8}$  inches high;  $L_2$  is mounted on two inexpensive feed-through insulators equipped with G-R jacks. The 813 is placed immediately behind the tank condenser and has its socket mounted  $1\frac{1}{4}$  inches below the chassis top by means of four angle brackets. The oscillator tube is mounted near the front left corner of the chassis so that the crystal socket, 60-ma. pilot bulb, and band switch can conveniently be mounted on the front apron of the chassis. The 60-ma. pilot bulb is used to indicate r-f crystal current. Since it also acts as a fuse for the crystal, it should be left in the circuit at all times.

As a safety precaution, the 813 plate-current jack is mounted on a small strip of bakelite recessed  $1\frac{1}{2}$  inches behind the front chassis apron as shown in Fig. 31. Two long 6-32 screws make a rigid support for the bakelite strip. Addition of an insulated coupling between the shaft of  $C_7$  and the tuning knob is recommended to further reduce shock hazard. The power terminals, including a bakelite safety terminal for the high-voltage lead, a chassis-type 110-volt connector, and an ordinary binding post for ground, are all mounted on the rear of the chassis. The various circuit components which are listed by the manufacturer's trade name are the parts that were actually used in the construction of this transmitter. In many cases, equivalent parts of other manufacture can be utilized, if desired.

### *Pierce Oscillator Circuit*

By using an untuned Pierce oscillator for the driver, circuit adjustments for band and frequency shifting are reduced to a minimum. Tuning adjustments for the oscillator can be made once and then forgotten.



# TRANSMITTER CONSTRUCTION



A tapped, untuned plate coil  $L_1$  (see Fig. 29) is used in the oscillator so that high output can be obtained with low crystal current. The usual form of Pierce oscillator with a conventional pi-wound r-f choke for the plate tank circuit is quite satisfactory for 160-meter crystals. However, 40- and 80-meter crystals require critical adjustment of the feedback (grid-ground) capacitance  $C_{11}$  to avoid excessive r-f crystal current. Also, any appreciable reduction in crystal current obtained by reducing the value of the capacitance  $C_{11}$  has the effect of lowering the output of the oscillator. These disadvantages can largely be overcome by winding an untuned plate inductance of the proper value for a 160-meter crystal and shorting out portions of this coil for 80- or 40-meter crystals. The coil is illustrated in Fig. 29. When the optimum value for  $L_1$  is used, the oscillator output is at maximum, r-f crystal is at minimum, and the value of  $C_{11}$  is not critical. Specifications for  $L_1$  including the tap locations are given in the legend for Fig. 29. Different circuit layouts, coil-form sizes, or wire sizes may require a slight adjustment of the positions. If it is necessary to move one of the taps because of excessive crystal current, it is probable that the inductance of  $L_1$  is too large; if the crystal is hard to start,  $L_1$  is probably too small.

All preliminary adjustments to the oscillator should be made with the 813 plate disconnected and the supply voltage reduced to approximately 1000 volts, either by utilizing a different power supply or else by inserting a resistance of 50000 to 100000 ohms in series with  $R_5$ . With these adjustments, approximately 3 to 6 ma. of grid current can be obtained without the 60-ma. pilot bulb showing any color. The 813 plate can now be connected and  $C_7$  tuned to resonance. Then, a load can be coupled to  $L_2$  and the plate voltage boosted to the normal operating value. A 300-watt light bulb clipped across a portion of the plate tank gives a nice visual indication of the output, and is often much more satisfactory for testing purposes than an antenna load. With 2000 volts on the plate of the 813 and 180 ma. plate current, a 300-watt

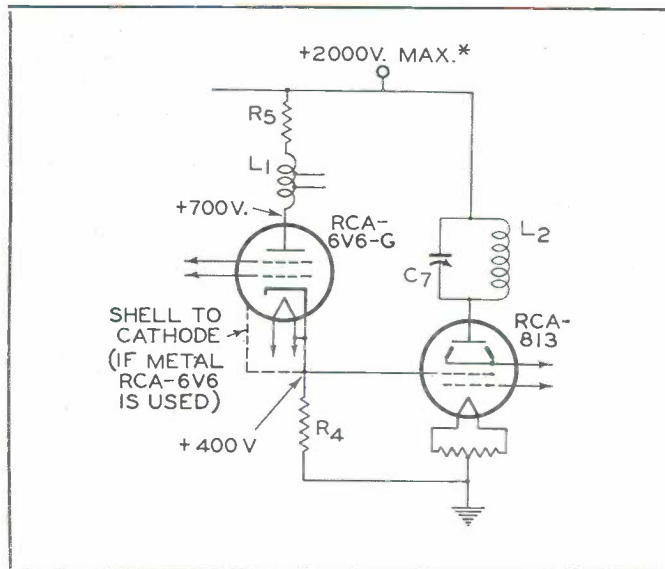
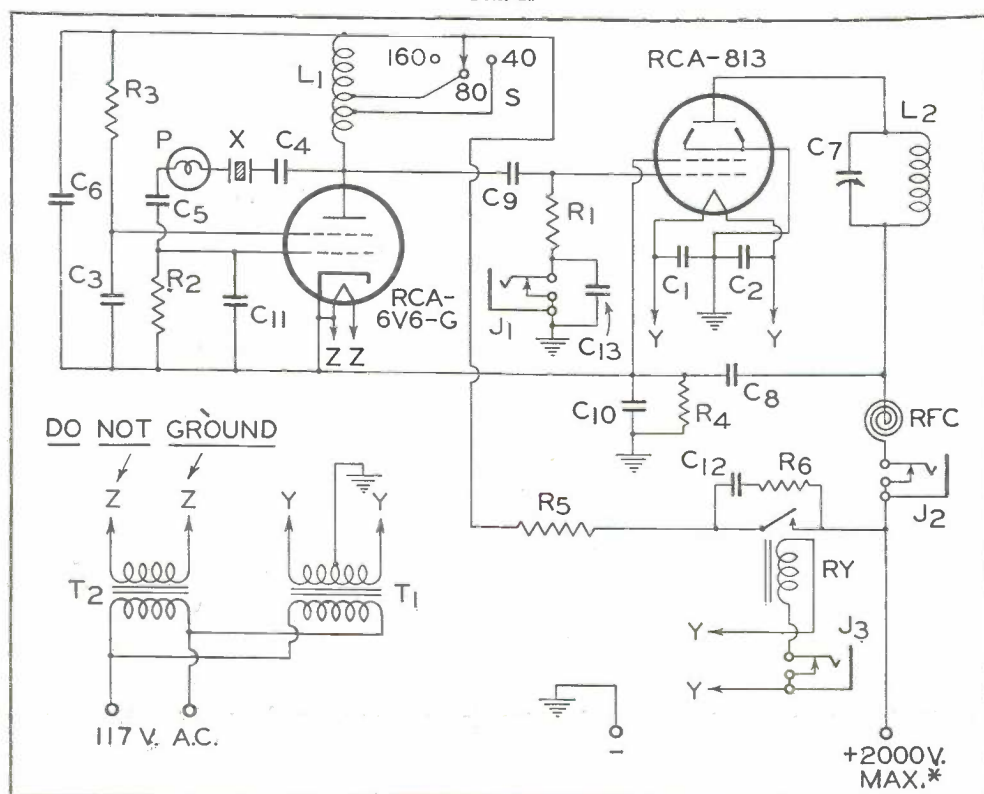

FIG. 28

bulb should light up to practically full brilliancy. After satisfactory output has been obtained, the dummy load can be removed and the antenna connected.

It should be noticed that when the 813 plate tank is tuned to resonance, the screen current rises as resonance is approached. The increasing screen current increases the power input to the oscillator because of the series arrangement which in turn increases the oscillator output, crystal current, and 813 grid current. These increases in grid and crystal currents are entirely normal and are not necessarily an indication of regeneration in the 813 stage. It is best to keep the 813 plate tank loaded at all times unless the voltage

FIG. 29



## RCA SINGLE-CONTROL 360-WATT TRANSMITTER

$C_1$   $C_2$   $C_3$   $C_4$   $C_5$   $C_6$   $C_{11}$  = 0.005 mica, 1000 v.

$C_7$  = 90  $\mu$ f, 0.084 in. #spacing (Cardwell XP-90-KS)

$C_8$  = 0.002  $\mu$ f mica, 5000 v.

$C_9$  = 0.00005  $\mu$ f mica, 1000 v.

$C_{10}$  = 0.006  $\mu$ f mica, 1000 v.

$C_{11}$  = 0.0001  $\mu$ f mica, 1000 v.

$C_{12}$  = 0.001  $\mu$ f, 2500 v.

$L_1$  = 155 turns #28 enamelled wire close-wound on  $1\frac{1}{8}$ " dia. form, tapped at 21 and 65 turns, for 40 and 80 meters respectively

$L_2$  = Bud "T" coils for crystal frequency

$R_1$  = 20000 ohms, 1 watt

$R_2$   $R_3$  = 50000 ohms, 1 watt

$R_4$  = 20000 ohms, 10 watts (omit for phone)

$R_5$  = 50000 ohms, 50 watts

$R_6$  = 1000 ohms, 1 watt

$R_7$  = Keying relay (Guardian K-100)

$T_1$  = 10-v. 5-a. filament transformer (Thordarson T-19F96)

$T_2$  = 6.3-v. 1-a. filament transformer (Thordarson T-19F80)

$J_1$   $J_2$  = Current jacks

$J_3$  = Key jack

X = Crystal

# 0.07 in. spacing is adequate for cw operation

\* Reduce to 1600 v. for PM-phone



# TRANSMITTER CONSTRUCTION



applied to the hot end of  $R_5$  is reduced to approximately 1000 volts, as mentioned earlier. When filament voltage is applied, sufficient time should be allowed for the 6VT-GT/G heater to warm up before applying high voltage. If this is not done, excessive voltage may appear across the 6VT-GT/G.

### Screen-Keying System

The screen-supply circuit is keyed because the small amount of current that must be handled makes it relatively easy to eliminate key-clicks. In addition, break-in operation becomes possible without the use of fixed bias, because the oscillator is keyed simultaneously with the 813. The filter  $C_{12}$   $R_6$  reduces key clicks considerably, and also serves to "blow out" arcs across the relay contacts. If the filter is omitted, the relay contact spacing must be nearly  $\frac{1}{4}$  inch to extinguish the arc. It is absolutely necessary to use a keying relay in this circuit because of the high voltage which is handled. Keying is positive and clean-cut and without clicks or chirps.

For the c-w conditions of 2000 volts on the plate of the 813, 180 ma. plate current, and 7 to 10 ma. grid current, a useful carrier power output of 275 watts was obtained with an efficiency of better than 75%, the total bleeder current (which is the oscillator plate current) being 25 ma. For 'phone or c-w operation at 1600 volts or less,  $R_4$  should be disconnected in order to supply the correct screen voltage to the 813.

### Arrangement for Modulation

With no change other than a reduction of plate voltage to 1600 volts and omission of  $R_4$ , the transmitter is ready for the modulator. With 1600 volts on the plate of the 813, 150 ma. plate current, and 7 ma. grid current, a useful carrier power output of 175 watts was obtained with an ef-

iciency of better than 70%. Since the screen-bleeder current was slightly less than 20 ma., the modulator must be able to handle  $150 + 20$ , or 170 ma. at 1600 volts. A pair of RCA-809's in class B would furnish the 135 watts of audio power required, but a separate 1000-volt supply would be needed for this combination. If the plate voltage of the 813 is reduced to 1500 volts, a pair of class-B 811's can be operated from the same power supply. A modulator using class-B 811's and an associated supply are described in SPECIAL RCA HAM BULLETIN No. 1. This publication can be obtained on request from the Commercial Engineering Section, RCA Manufacturing Co., Inc., Harrison, N. J.

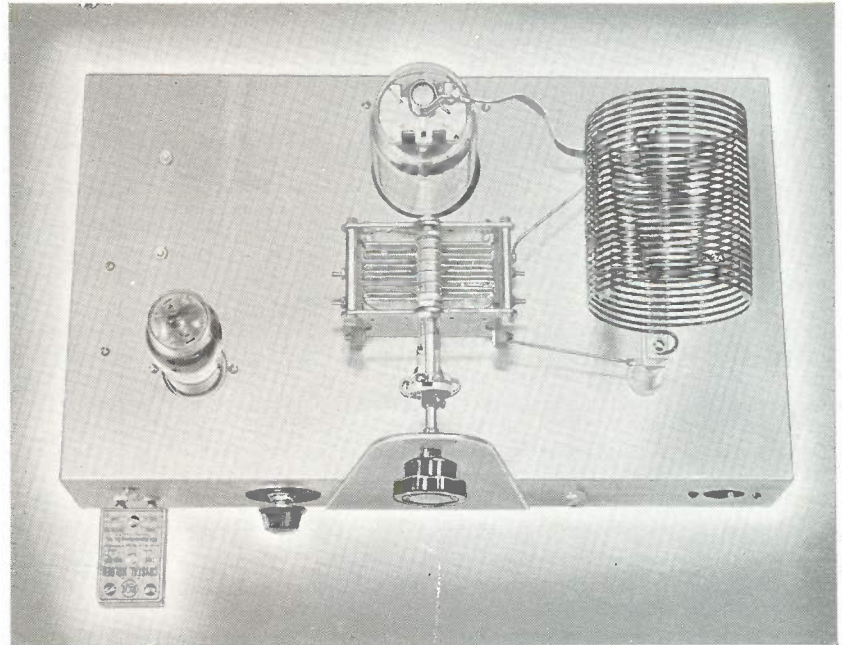

FIG. 30

FIG. 31

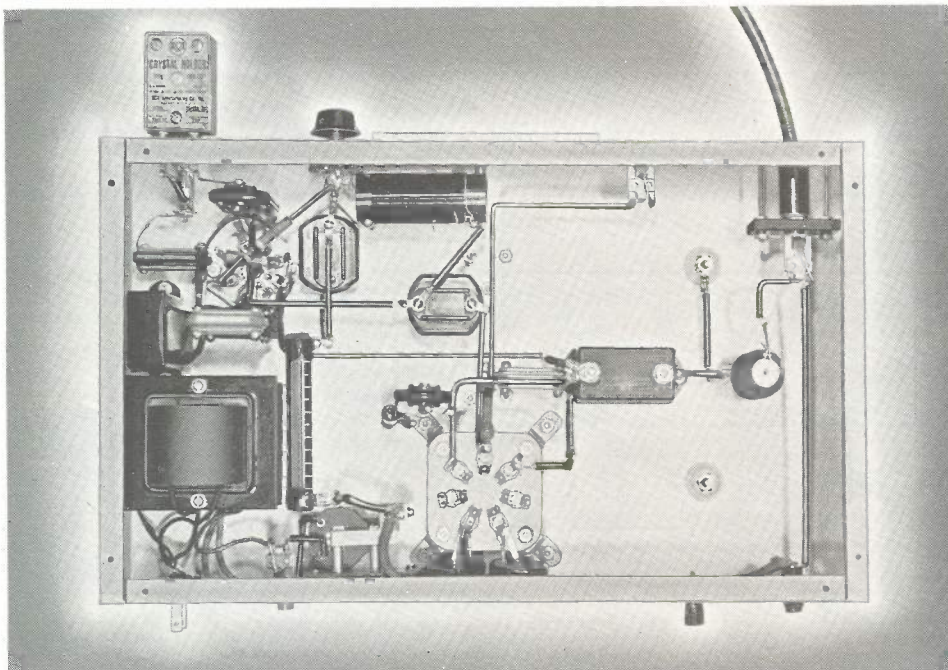
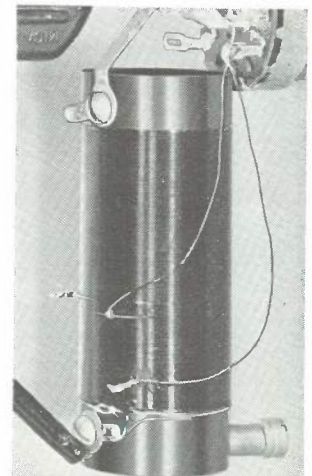

FIG. 32





## RCA 5-BAND PLATE-MODULATED 'PHONE C-W TRANSMITTER

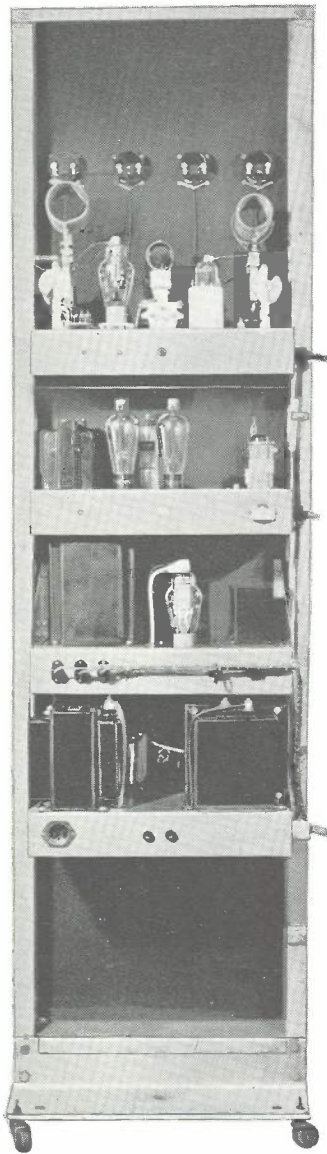

FIG. 33

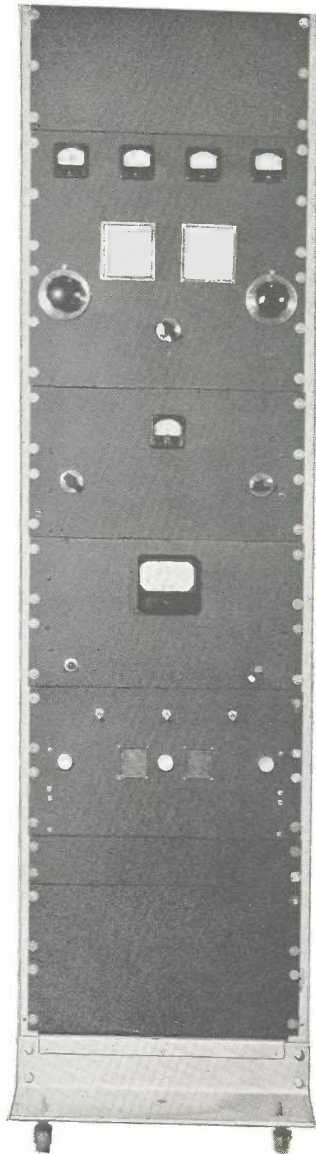

FIG. 34

- 10-160 METER OPERATION
- 310 WATTS INPUT ON PHONE
- 450 WATTS INPUT ON C.W.
- PUSH-PULL 812 FINAL
- CLASS B 811 MODULATOR

The 10- to 160-meter, three-stage transmitter illustrated above is designed for either c-w or plate-modulated-telephony operation. It has a power output of approximately 340 watts on c-w and 240 watts on 'phone.

Band changing can be accomplished conveniently and rapidly by means of plug-in coils. Because each oscillator cathode coil can be used on two or more bands, only four coils have to be changed in most cases.

The transmitter includes 4 separate chassis-panel units mounted on an open, 6-foot relay rack. These four units will be described in detail, and are as follows: High-voltage power supply, class B modulator, crystal oscillator plus low-voltage supply, and buffer amplifier plus push-pull 812 final amplifier. The transmitter is complete except for a speech-amplifier-and-driver chassis and an antenna-tuning network. A suitable circuit for the speech equipment is shown in Fig. 47 on page 71. The design of the antenna-tuning unit will, of course, depend on the type of antenna feeder system to be used.

### PM Transmitter; Exciter and Low-Voltage Supply Unit

The exciter unit (see Figs. 35, 36, and 37) consists of a standard "Tritet" crystal oscillator using an RCA-6L6. The plate circuit of the oscillator is used for "straight-through" operation, frequency doubling, or frequency quadrupling, which ever may be required. In each case, ample grid excitation is delivered to the 807 buffer stage located on the final-amplifier chassis.

The exciter unit employs a husky 600-volt power supply, which furnishes plate voltage both to the 6L6 oscillator (from a tap on a voltage divider) and to the 807 buffer. A pair of 816's are used in this supply because the 800 volts delivered by the power transformer is considerably in excess of the voltage rating of rectifiers such as the 83 and 5Z3.

The only trick in getting the "Tritet" oscillator to operate properly on the 2nd and 4th harmonics of the crystal is in the design and tuning of the *cathode tank* ( $L_c C_c$ ) shown in Fig. 36. The fourth-harmonic output is ample to drive the 807, and the second-harmonic output is several times larger than necessary. Data for the cathode coils and for the plate coils are given in tables 5, 6, and 7.

A number of variable factors influence the cathode tank capacitance, so that individual adjustment of  $C_c$  is recommended for each installation. If the tuning adjustment is not correct, the 6L6 may oscillate vigorously, self-excited. If the inductance of  $L_c$  is too far from the optimum value, any amount of adjustment on  $C_c$  will not produce satisfactory operation. Self-excited oscillation is highly undesirable; it can usually be detected on a receiver, and also by a *relatively broad, slow dip* in the oscillator plate current (nominally about 50 ma. when the plate circuit is out of resonance). A true crystal-controlled harmonic oscillation will produce a fast, sharp dip in plate current as  $C_c$  is passed through resonance. It will also produce, at exact resonance, a decided dip in r-f crystal current, as indicated by pilot bulb "P." Normally, this bulb should glow only a dull red,—never "white."

It is recommended that the oscillator plate voltage be limited to 320 volts and the screen voltage to about 150-200 volts to avoid danger of fracturing the crystal due to circuit misadjustment during tuning. Also, that the cathode tank coils be individually tuned by separate *fixed mica trimmers*, as indicated in table 5. Thus, once the correct adjustments are made, there is no danger that  $C_c$  will be mis-tuned. In addition, it is a definite advantage to be able to plug in a correctly tuned cathode tank for each desired operating band, instead of having to re-tune a variable-air condenser—and perhaps having its capacitance pass through a number of values definitely inimical to crystal longevity! One more precaution—do not mistake the 3rd harmonic for the 4th; for example, with a 10-meter plate coil, a plate-current dip can be obtained at 21 Mc as well as at 28 Mc.

The layout of the parts on the exciter chassis is shown in Figs. 35 and 37. The steel panel is  $\frac{1}{8}$ " x  $10\frac{1}{2}$ " x 19" and the cadmium-plated steel chassis is 3" x 10" x 17".



# TRANSMITTER CONSTRUCTION



**Table 5—OSCILLATOR CATHODE COIL DATA**  
(L<sub>2</sub>, FIG. 36)

Coil No.	Xtal Band	Turns	Wire	Form Diameter	Length	Shunt Capacitance*	Operating Bands
1	40	8	# 20 DCC	1½"	1"	10-70 μμf	40, 20 & 10
2	80	11	# 20 DCC	1½"	1"	10-70 μμf	80 & 40
3	160	22	# 28 DCC	1½"	1½"	25-100 μμf	160, 80 & 40

\*Use mica trimmers and adjust each one for optimum harmonic operation of the oscillator.

**Table 6—OSCILLATOR PLATE COIL DATA**  
(L<sub>3</sub>, FIG. 36)

Band	Turns	Wire	Mean Diameter	Length	Taps*
10	5	# 14 bare	1¾"	1"	A
20	10	# 14 bare	1¾"	1¾"	B
40	18	# 20 DCC	1½"	¾"	C
80	31	# 20 DCC	1½"	1½"	D
160	55	# 28 DCC	1½"	1½"	A

\*Taps as follows for 807 excitation lead:  
A = Center  
B = 6½ turns from plate end  
C = 7 turns from plate end  
D = 20 turns from plate end

**Table 7—BUFFER PLATE COIL DATA**  
(L<sub>1</sub>, FIG. 40)\*

Band	Turns	Wire	Mean Diameter	Length	(Or) B & W Type
10	7	⅜" C.T.	1½"	4½"	10 BL
20	9	⅜" C.T.	2¼"	4½"	20 BL
40	20	# 14 bare	2"	2½"	40 BL
80	28	# 16 bare	2½"	2½"	80 BL
160	45	# 18 bare	2½"	2½"	160 BL

\*All coils have a 2-turn link on "cold" end. C.T. indicates copper tubing.

**Table 8—FINAL AMPLIFIER GRID COIL DATA**  
(L<sub>1</sub>, FIG. 40)\*

Band	Turns	Wire	Mean Diameter	Length	(Or) Bud Type
10	6	# 14 bare	1½"	1¾"	OCL-10
20	12	# 14 bare	1½"	1¾"	OCL-20
40	20	# 16 bare	1½"	1¾"	OCL-40
80	32	# 18 bare	1¾"	1¾"	OCL-80
160	55	# 18 DCC	2"	2¼"	OCL-160

\*All coils are center tapped and center linked with a 2- or 3-turn link.

**Table 9—FINAL AMPLIFIER PLATE COIL DATA**  
(L<sub>5</sub>, FIG. 40)†

Band	Turns	Wire*	Mean Diameter	Length	(Or) B & W Type
10	6	⅜" C.T.	2¼"	3½"	10 TL
20	12	⅜" C.T.	2¼"	4¼"	20 TL
40	22	# 12 bare	2½"	4¾"	40 TL
80	28	# 12 bare	3½"	4¾"	80 TL
160‡	36	# 12 bare	5"	4¾"	160 TL

† All coils are center tapped and center linked with a 2-turn link.

‡ A 75-μμf padding condenser (not shown) must be shunted across the 160-meter coil, in addition to C<sub>10</sub>. A coil of slightly larger inductance can be used with C<sub>10</sub> alone, although the LC ratio will be somewhat larger than the value required for a "Q" of 12.

\* C.T. indicates copper tubing.

FIG. 35

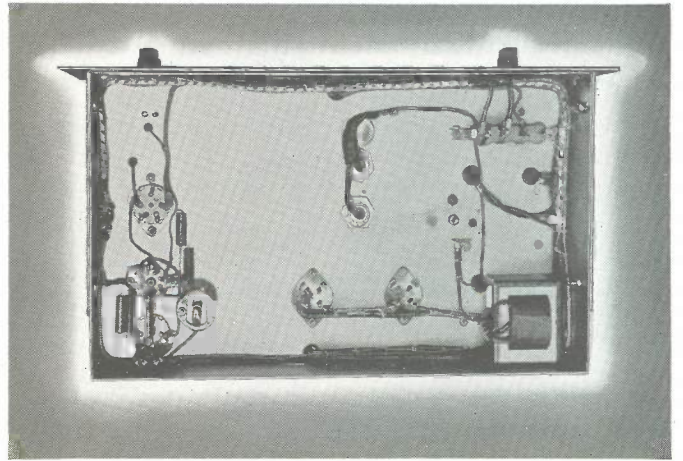

▲ FIG. 36

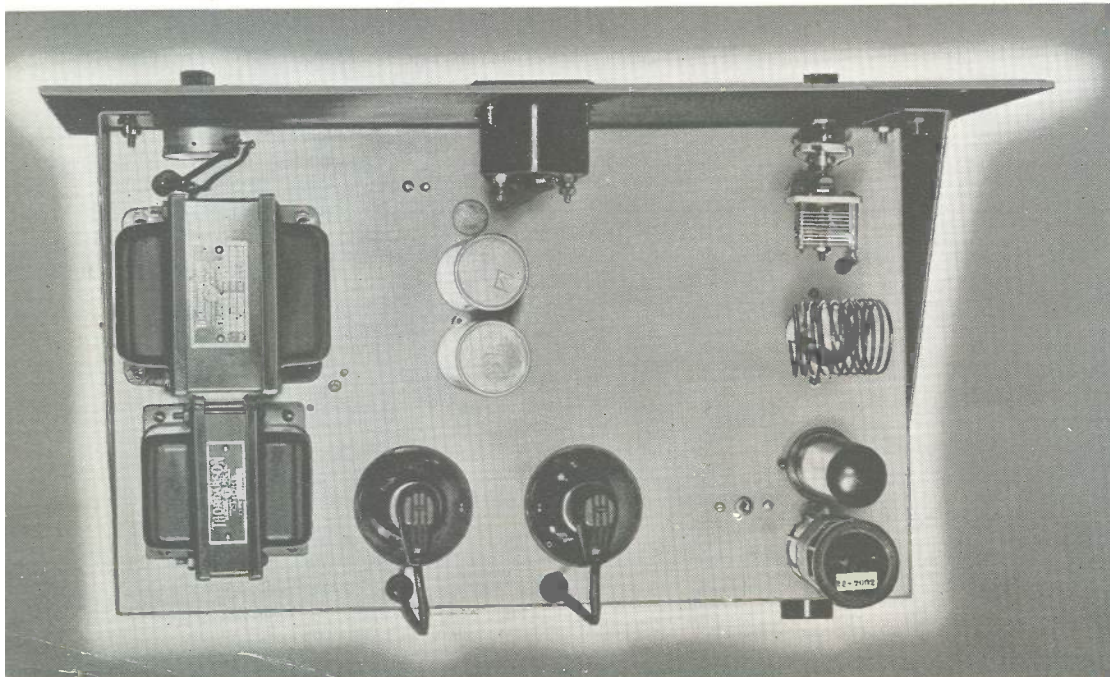
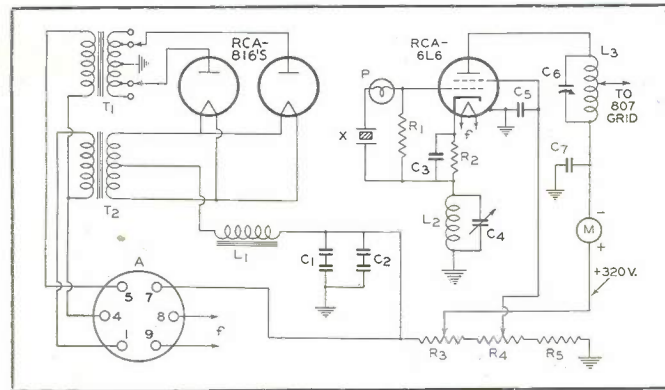

PARTS SHOWN IN FIG. 36

- R<sub>1</sub>=50000 ohms, 1 watt
- R<sub>2</sub>=300 ohms, 1 watt
- R<sub>3</sub>=15000 ohms, 25 watts; tap adjusted to 320 volts from ground
- R<sub>4</sub>=10000-ohm, 4-watt potentiometer
- R<sub>5</sub>=7500 ohms, 10 watts
- C<sub>1</sub> C<sub>2</sub>=8-8 μf dual-section paper, 600 v. (Cornell-Dubilier #PEB-6808)
- C<sub>3</sub> C<sub>5</sub> C<sub>7</sub>=0.005 μf mica
- C<sub>4</sub>=See text and Table 7
- C<sub>6</sub>=100 μμf variable (Cardwell #ZU100AS)
- L<sub>1</sub>=15 h., 150 ma. filter choke (Thordarson #T-74C29)
- L<sub>2</sub> L<sub>3</sub>=See Tables 6 and 7
- T<sub>1</sub>=Plate transformer, 900-800-0-800-900 v., 225 ma. (Thordarson #T-19P56)
- T<sub>2</sub>=Filament transformer, 2.5 v., 10 a. (Thordarson #T-19F90)
- P=Tan bead pilot bulb, 6.3 v., 150 ma. (Mazda #40)
- X=40, 80, or 160 meter crystal
- M=0-100 ma. plate meter, 2" square (Simpson #127)
- A=6-pin wafer socket

FIG. 37



# TRANSMITTER CONSTRUCTION



## PM Transmitter; Final Amplifier Unit

The r-f power amplifier employs two RCA-812's in push-pull, driven by an RCA-807 buffer mounted on the same chassis, as illustrated in Figs. 38, 39, and 40. Fig. 33 shows the rear view of the transmitter, mounted in a 6-foot relay rack. The 812 stage will deliver a power output of approximately 340 watts on cw and 240 watts on 'phone. Ample grid excitation is supplied by the 807 buffer on all 5 bands.

For cw operation, the final stage is directly keyed in the filament-return circuit by keying-relay  $L_7$ . When the key plug is removed from the key jack (J), the relay automatically closes the 812 filament-return circuit, so that the amplifier is ready for plate-modulated operation.

One additional S.P.S.T. switch, not shown in Fig. 40, might well be added to the amplifier panel. This switch should be inserted in series with the +600-volt lead coming from cable terminal No. 7, so that the plate-and-screen voltage supply to the 807 can be removed while the oscillator stage is being tuned; otherwise, the 807 is likely to be kept out of resonance too long with resultant overheating of the tube. One of the Yaxley ceramic "Hamband" rotary switches will satisfactorily handle the voltage involved.

The mechanical layout of the circuit components on the

chassis and panel is shown in Figs. 38 and 39. The  $\frac{1}{8}$ " x  $17\frac{1}{2}$ " x 19" steel panel is mounted on a cadmium-plated steel chassis 3" x 10" x 17".

The voltage leads to the amplifier unit are brought in through a cable (see Fig. 40) terminated with a 6-pin tube base. The tube-socket receptacle (P) has its 6 terminals marked 1-6-7-4-8-9. Each of these terminals must be connected to correspondingly numbered terminals on all of the other chassis. For example, amplifier terminal No. 1 is tied in with terminal No. 1 on the exciter, modulator, and high-voltage power-supply chassis. Amplifier terminal No. 7 is connected to exciter terminal No. 7, and so on. The same wiring system applies to all other cable connections.

D-c plate current of the 807 should never exceed 100 ma. The two 812's should not be run at more than 300 ma. on cw, or 250 ma. on 'phone. During the initial tuning of the 812's on each band, a 5000-ohm, 200-watt protective resistor should be inserted in the +1250-volt lead. This resistor can conveniently be connected in series with terminal No. 6 on the modulator chassis. This simple precaution will prevent the r-f tubes and the power supply from being heavily overloaded due to prolonged out-of-resonance operation of the final stage.

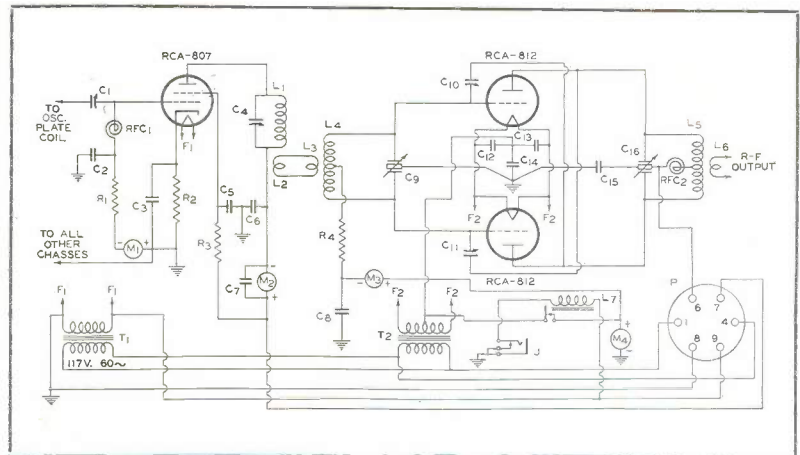
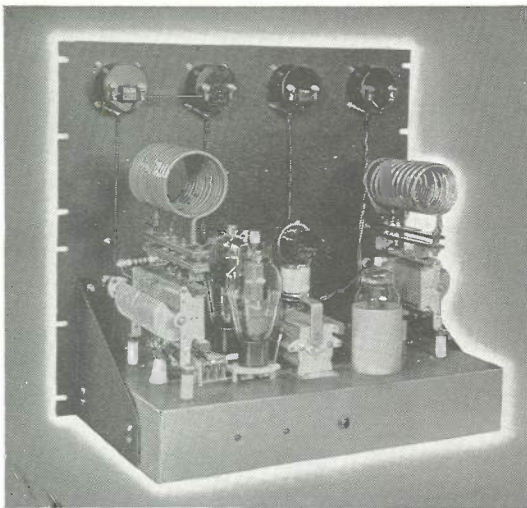

FIG. 38

FIG. 40

### PARTS SHOWN IN FIG. 40

- $C_1$ —8-30  $\mu\text{f}$  mica trimmer (Hammarlund #MEX)
- $C_2$   $C_3$   $C_5$   $C_6$   $C_7$   $C_8$   $C_{12}$   $C_{13}$ —0.005  $\mu\text{f}$  mica
- $C_4$ —165  $\mu\text{f}$ , 0.05" air gap (Cardwell #MO-165-BS)
- $C_{10}$ —260  $\mu\text{f}$ /section, 0.081" air gap (Cardwell #MR-260-BD)
- $C_{11}$ —4-7  $\mu\text{f}$ , 0.140" air gap (Cardwell #ZS7SS)
- $C_{14}$   $C_{15}$ —0.002  $\mu\text{f}$  mica, 5000 V. (Sangamo #A50)
- $C_{16}$ —100  $\mu\text{f}$ /section, 0.070" air gap (Cardwell #MT-100-GD)
- $R_1$ —10000 ohms, 1 watt
- $R_2$ —300 ohms, 10 watts
- $R_3$ —40000 ohms, 10 watts
- $R_4$ —3500 ohms, 25 watts\*

FIG. 39

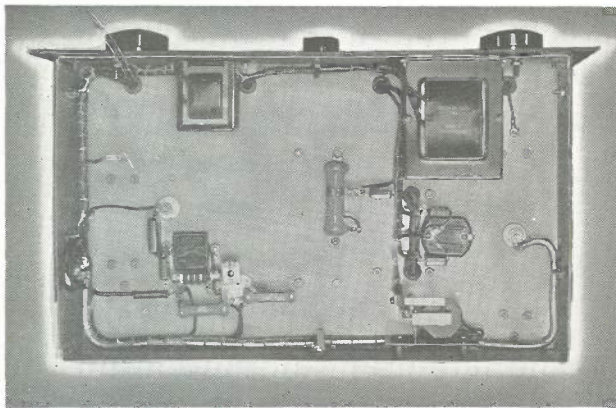

- RFC<sub>1</sub> RFC<sub>2</sub>—2.5-mh r-f choke (National #R-100)
- $L_1$   $L_2$   $L_3$   $L_4$   $L_5$   $L_6$ —See Tables 5, 6, and 7
- $T_1$ —Filament transformer; 6.3 v., 3 a. (Thordarson #T-19F97)
- $T_2$ —Filament transformer; 6.3 v., 10 a. (Thordarson #T-19F99)
- $M_1$ —0-10 ma. grid meter (Simpson #127)
- $M_2$ —0-200 ma. plate meter (Simpson #127)
- $M_3$ —0-150 ma. grid meter (Simpson #127)
- $M_4$ —0-500 ma. plate meter (Simpson #127)
- J—Key jack
- $L_7$ —Keying relay, 6.3 V. A.C. (Guardian #K-100)
- P—6-pin ceramic socket

\* Reduce  $R_4$  to 2500 ohms for plate-modulated telephony service, in order to obtain grid-bias voltage shown in tube data under "Typical Operation."

## PM Transmitter; Class B 811 Modulator Unit

The class B modulator unit employs two RCA-811's and is capable of delivering (with a plate voltage of 1250 volts) a useful audio power of 171 watts. Actually, only 155 watts are needed to modulate completely the 310-watt input to the push-pull 812 final amplifier. At 1250 plate volts, the 811 modulators operate with zero bias, so that no troublesome bias-supply problem is presented.

The modulator unit is illustrated in Figs. 41 and 42 and in Fig. 43. Filament switch  $S_1$  permits the tube filaments to be turned off when cw operation is desired. The d-c plate-current meter ( $M_1$ ) is connected in the filament-return lead so that it does not create a high-voltage

hazard on the panel. Resistor  $R_3$  affects the meter reading very little; its purpose is to keep  $T_1$  and  $T_2$  grounded in case the meter circuit should open accidentally. Otherwise,  $T_1$  and  $T_2$  would assume the high d-c plate potential.

One essential design feature of the modulator purposely has been left for the individual amateur to supply, because there are several designs which can be selected. This feature is the shorting mechanism for the secondary winding of  $T_2$ —the output transformer. It is absolutely essential, of course, that this winding be shorted for cw operation. The most simple method is to shunt a S.P.S.T. high-voltage switch (rated for about 2500 volts) directly across the secondary.



# TRANSMITTER CONSTRUCTION



This switch can be mounted on the panel without destroying panel symmetry.

An "elegant" solution is to employ a suitable relay (such as  $L_r$  in Fig. 40) across the secondary of the modulation transformer. Then, when keying-jack "J" (Fig. 40) is replaced with a suitable 2-circuit jack (1 "open" circuit and 1 "close" circuit), the shorting relay will automatically operate whenever the key plug is inserted in "J". This convenient arrangement relieves the operator of the necessity for remembering to short  $T_s$ . The voltage to operate the shorting relay can be obtained from the 807 filament transformer,  $T_1$  (Fig. 40). It should not be obtained from the 811 filament transformer or from the 812 filament supply.

Data for making cable connections to the modulator chassis are given in the Final Amplifier Section. For convenience in connecting the Kenyon input and output transformers, the following data should be used:

INPUT TRANSFORMER No. T-263		OUTPUT TRANSFORMER No. T-496	
Primary	Secondary	Primary (18000 ohms)	Secondary (5100 ohms)
Plate=2	Grid=C	Plate=1	Connect to I
Plate=2'	Grid=C'	Plate=13	Connect to J
B+=4 & 4'	C.T.=D & D'	Tie 2 & 3	
		Tie 4 & 5	
		Tie 6 & 14	
		Tie 17 & 7	
		B+=16	

(Turns ratio, P to  $\frac{1}{2}$  S=6:1)

In operation, the no-signal d-c plate current of the two 811's is about 50 ma.; the d-c plate voltage is about 1315 volts. With a sine-wave signal modulating the r-f carrier 100%, the modulator current and voltage are about 180 ma. and 1290 volts, respectively.

The steel panel on the modulator unit is  $\frac{1}{8}$ " x  $10\frac{1}{2}$ " x 19". The cadmium-plated steel chassis employed is 3" x 10" x 17".

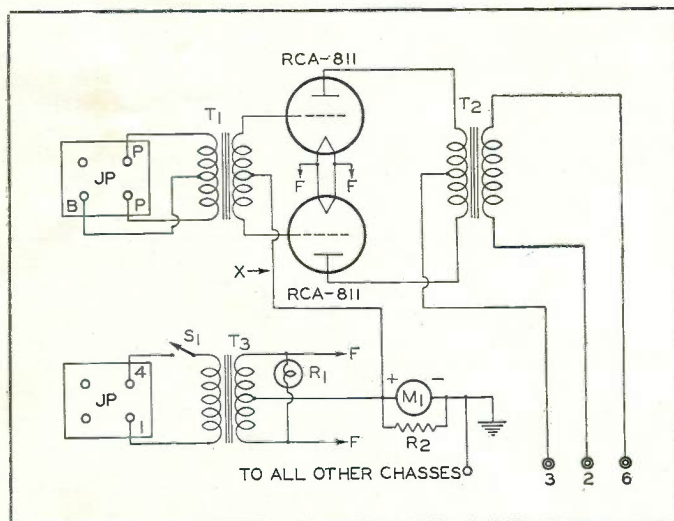

FIG. 43  
PARTS SHOWN IN FIG. 43

- $R_1$ =6.3-volt pilot light (green)
- $R_2$ =50 ohms, 25 watts
- $T_1$ =18-watt universal driver transformer (Kenyon #T-263)
- $T_2$ =300-watt universal output transformer (Kenyon #T-496)
- $T_3$ =6.3 v., 8 a. filament transformer (Kenyon #T-387)
- $M_1$ =0-300 ma. plate meter (Triplet #426)
- $S_1$ =S.P.S.T. toggle switch; 3 a., 250 v.
- JP=4-terminal chassis connectors (H. B. Jones #P-304-AB and #S-304-FHT)
- X=Insert 4.5-v. bias battery when d-c plate voltage is 1500 volts\*

\*The 811's in this transmitter do not need to be operated at more than 1250 volts.

## PM Transmitter; High-Voltage Power-Supply Unit

The 1250-volt, 500-ma. power supply unit is illustrated in Figs. 44 and 45. Safety features include placing of the high-voltage transformer terminals next to the panel, insulated plate connectors on the 866-A/866's, a female cable receptacle, and mounting of several high-voltage components under the chassis. Rubber safety caps (not shown) should

## Speech Amplifier and Driver

Although no speech amplifier and driver are shown mounted in the transmitter rack, a recommended design for this equipment is shown in Fig. 47. Two RCA-2A3 triodes, operated with self bias, supply sufficient driving power for the 811's, provided the power supply is carefully adjusted to the permissible maximum of 360 volts. Best operation under both ICAS and CCS conditions for the 811's will be obtained when the driver transformer is adjusted for a 5 to 1 or a 6 to 1 step-down turns ratio, from primary to one-half secondary.

The 6SJ7 speech amplifier and the 6N7 phase inverter are capable of driving the 2A3's to full output if a microphone having a peak output of 10 to 12 millivolts is employed. This output voltage (or more) is usually available from amateur-type crystal microphones. It is important, of course, to use a standard, shielded microphone cable to prevent r-f pick-up. Circuit details and a parts list for the complete speech amplifier and driver are shown in Fig. 47. The plate-to-plate impedance (5000 ohms) of the 2A3's is low enough so that a short, 3-wire, shielded line can be run a reasonable distance from their plate circuit to the Jones plug on the modulator chassis. For example, the 2A3's may be located on one side of the operating room and the transmitter rack on the other. A low-impedance line is *not* recommended, due to the extra driving power which is lost when two a-f coupling transformers are employed. A class B modulator of the type described is not only quite economical on a basis of audio-watts-output-per-dollar, but at the same time is capable of providing a modulating signal of high quality. The measured total harmonic distortion is only 5.8 per cent at a measured a-f power output of 171 watts.

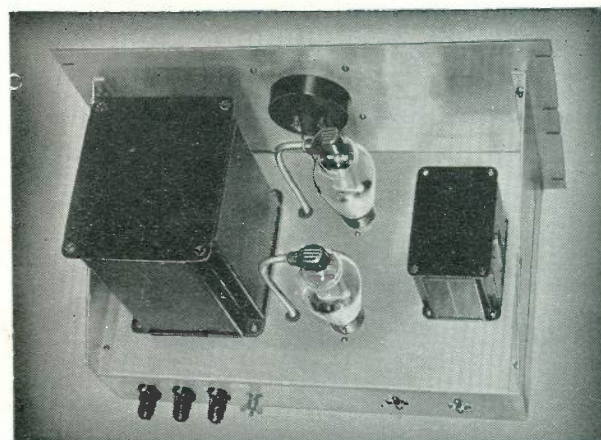

FIG. 41

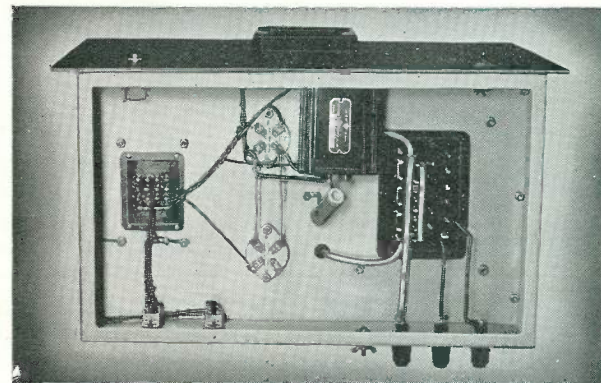

FIG. 42

be placed over the terminals of filter chokes  $L_1$  and  $L_2$ , as an additional precaution.

For 'phone operation, the Thordarson high-voltage transformer is used with the 1560-volt secondary taps. The d-c output voltage with the modulator "resting" is approximately 1250 volts when the usual a-c line-voltage regulation is taken





# TRANSMITTER CONSTRUCTION



into account. Under full load, the measured ripple in the 812 plate supply is 0.69 per cent (when the carrier is fully modulated).

For c-w operation, the 1875-volt transformer taps can be used. The key-up voltage is 1660 volts. Under a key-down load of 300 ma., the final-amplifier plate voltage is about 1500 volts.

The a-c line switches  $S_1$ ,  $S_2$  and  $S_3$  are wired in series.  $S_1$  controls the filaments of all the tubes in the transmitter;  $S_2$  controls the 600-volt power supply on the exciter chassis; and  $S_3$  controls the high-voltage power supply. Neither  $S_2$  nor  $S_3$  will operate unless filament switch  $S_1$  is turned on first. Likewise,  $S_3$  will not operate unless both  $S_1$  and  $S_2$  are closed. In normal operation of the rig,  $S_1$  and  $S_2$  are left on, so that  $S_3$  becomes the master plate-supply switch for both low- and high-voltage supplies.

The power-supply unit has fuses in both sides of the a-c line, in order to meet Underwriters' requirements. These fuses should be as small as the peak rectifier load will permit; a value of 15 amperes is satisfactory.

The two filter condensers, the rectifier filament transformer, and the 200-watt bleeder resistor are mounted beneath the chassis. The resistor is mounted about one inch below the chassis so as to allow free circulation of air. A series of  $\frac{3}{8}$ -inch vent holes (not shown) should also be drilled in the chassis, above the bleeder, in the clear space between the plate transformer and the filter chokes.

The steel panel on the power-supply unit is  $\frac{1}{8}$ " x  $10\frac{1}{2}$ " x 19". The cadmium-plated steel chassis is 3" x 12" x 17".

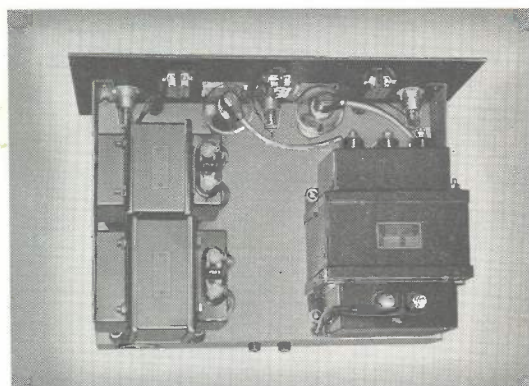

FIG. 44

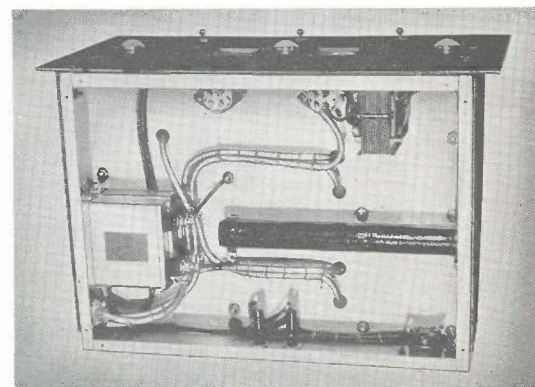

FIG. 45

- $C_1=6\text{-}\mu\text{f}$  electrolytic, 25 V.
- $C_2=0.05\ \mu\text{f}$ , 400 V.
- $C_3\ C_{11}=8\text{-}\mu\text{f}$  electrolytic, 450 V.
- $C_4=0.002\ \mu\text{f}$ , 400 V.
- $C_5=25\text{-}\mu\text{f}$  electrolytic, 25 V.
- $C_6\ C_7=0.01\ \mu\text{f}$ , 600 V.
- $C_8=40\text{-}\mu\text{f}$  electrolytic, 150 V.
- $C_9=1\text{-}\mu\text{f}$  paper, 600 V. working
- $C_{10}=16\text{-}\mu\text{f}$  electrolytic, 450 V.
- $R_1=2$  megohms, 0.5 watt
- $R_2=1400$  ohms, 0.5 watt
- $R_3=2.2$  megohms, 0.5 watt
- $R_4\ R_{12}=0.5$  megohm, 0.5 watt
- $R_5=75000$  ohms, 0.5 watt

- $R_6=1$ -megohm a-f gain-control potentiometer
- $R_7=3500$  ohms, 0.5 watt
- $R_8\ R_9=0.25$  megohm, 0.5 watt
- $R_{10}=480000$  ohms, 0.5 watt
- $R_{11}=20000$  ohms, 0.5 watt
- $R_{13}=780$  ohms, 10 watts
- $R_{14}=25000$  ohms, 10 watts
- $T_1$ =Power transformer, as indicated
- $L_1=12$ -henry, 120-ohm, 100-ma. smoothing choke
- $L_2=40$ -henry, 2000-ohm, 15-ma. smoothing choke
- $S_1$ =S.P.S.T. a-c line switch
- AA'=Input for crystal microphone

\* From 6SJ7 grid to 2A3 grids.

NOTE: The primary of  $T_1$  should be by-passed by two 0.1  $\mu\text{f}$  condensers in series, with the mid-point grounded to the chassis.

## PM TRANSMITTER; HIGH-VOLTAGE POWER-SUPPLY UNIT

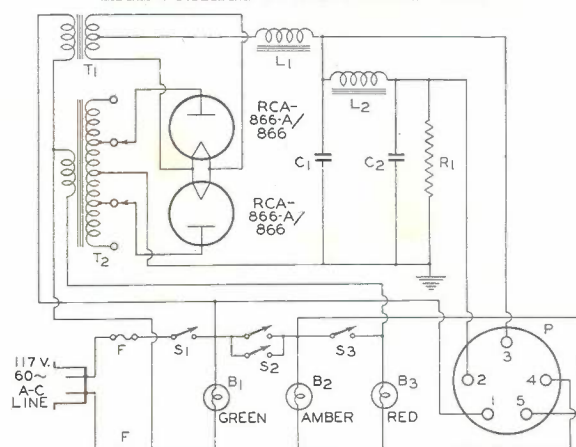

FIG. 46

- $C_1\ C_2=2\ \mu\text{f}$ , 2000 V. (Cornell-Dubilier #TJU-20020)
- $R_1=25000$  ohms, 200 watts (Ohmite "Dividohm" #1368)
- $L_1=5\text{-}20$  henry, 75-ohm, 500-ma. swinging choke (Thordarson #T-19C38)
- $L_2=12$ -henry, 90-ohm, 400-ma. smoothing choke (Thordarson #T-19C44)
- $T_1=2.5\text{-V.}$ , 10-A, filament transformer (Thordarson #T-19F90)
- $T_2=500\text{-ma.}$  high-voltage transformer, 1875-0-1875 and 1560-0-1560 volts RMS (Thordarson #T-19P64)
- $B_1\ B_2\ B_3=115\text{-V.}$  pilot lights, candelabra base (Drake No. 75; color as indicated)
- $S_1\ S_3$ =S.P.S.T., 250-V., 10-a. (Cutler-Hammer power toggle switch)
- $S_2$ =D.P.S.T., 250-V., 10-a. (Cutler-Hammer power toggle switch)
- F=A-c line fuses, 15 a. (Littelfuse #1075)
- P=5-pin ceramic tube socket

## SPEECH AMPLIFIER AND DRIVER FOR CLASS B 811's. VOLTAGE GAIN, 5700\*

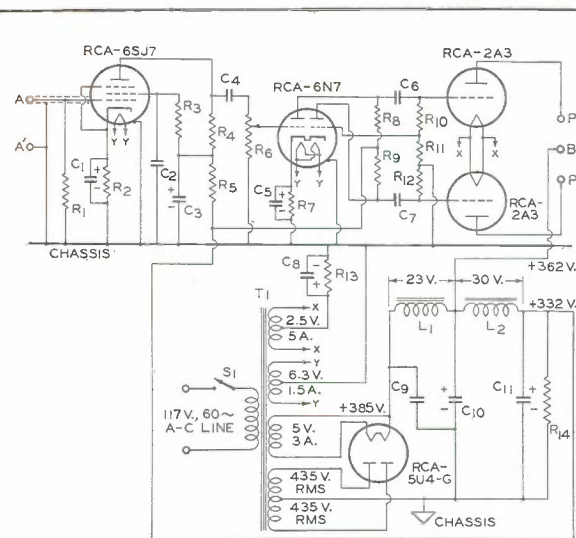

FIG. 47

The various components which have been mentioned by manufacturers' trade names in each of the units described in this book are the parts which were actually used. Other parts may be substituted with equally good results provided they have similar characteristics.



## FILTER DESIGN CURVES

FOR FULL-WAVE, SINGLE-PHASE CIRCUITS ONLY—60-CYCLE SINE-WAVE SUPPLY  
 (When the supply is a 50-cycle source, multiply the selected values of inductance and capacitance by 1.2.  
 When the supply is a 25-cycle source, multiply the filter values by 2.4.)

SINGLE-SECTION FILTER

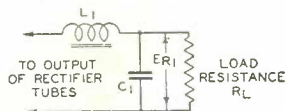

Fig. 48—Curves for choice of filter values for (1) the first section of a double-section filter, or (2) a single-section filter.

DOUBLE-SECTION FILTER

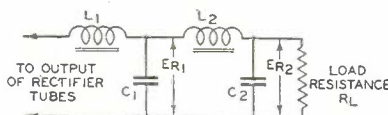

Fig. 49—Curves for choice of filter values for second section of a double-section filter.

ERMS=Maximum volts (RMS) per plate applied to rectifier tube.

RL=Load Resistance.

ER1=Per cent ripple in d-c output voltage from (1) the first section of a double-section filter, or (2) a single-section filter.

ER2=Per cent ripple in d-c output voltage from second section of a double-section filter.

### GENERAL RULES FOR SELECTION OF FILTER CONSTANTS

#### SINGLE-SECTION FILTER (FIG. 48)

Select Inductance Values

- (1) above proper RL Curve
- (2) to left of proper ERMS Curve
- (3) along desired ER1 Curve

For each selected inductance value, use corresponding value of filter capacitance.

#### DOUBLE-SECTION FILTER (FIG. 49)

- (1) Select desired percentage of output ripple voltage ER2 on appropriate curve of ER1
- (2) Read corresponding L2 C2 product
- (3) To satisfy this product, choose convenient values of L2 and C2
- (4) Check value of selected L2 to make sure that it is greater than  $3(C_1 + C_2) \div 2C_1 C_2$

#### EXAMPLE No. 1

**Problem:** Given a d-c output voltage of 3180 volts (corresponds to a peak inverse voltage of 10,000 volts) from a 60-cycle full-wave rectifier employing two 866-A/866's, design a single-section filter of the choke-input type which will limit the ripple voltage to 5% at a load current equal to the combined maximum d-c load-current rating of the tubes (500 ma.), and still prevent the peak plate current of either tube from rising higher than the maximum peak plate-current rating of the 866-A/866.

**Procedure:** ERMS is equal to  $3180 \times 1.11$ , or 3535 volts (see Summary of Rectifier Circuit Conditions, page 30). R1 is equal to  $3180/0.5$  ampere, or 6360 ohms. From Fig. 48, R1=6360 lies below curve ERMS=3535 (as shown for the 866-A/866). Hence, any combination of inductance and capacitance along the curve ER1=5% and to the left of the curve ERMS=3535 will satisfy the requirements. A suitable combination is a filter section employing a 25-henry choke and a 1- $\mu$ f condenser.

#### EXAMPLE No. 2

**Problem:** Given a d-c output voltage of 3180 volts (corresponds to a peak inverse voltage of 10,000 volts) from a 60-cycle full-wave rectifier employ-

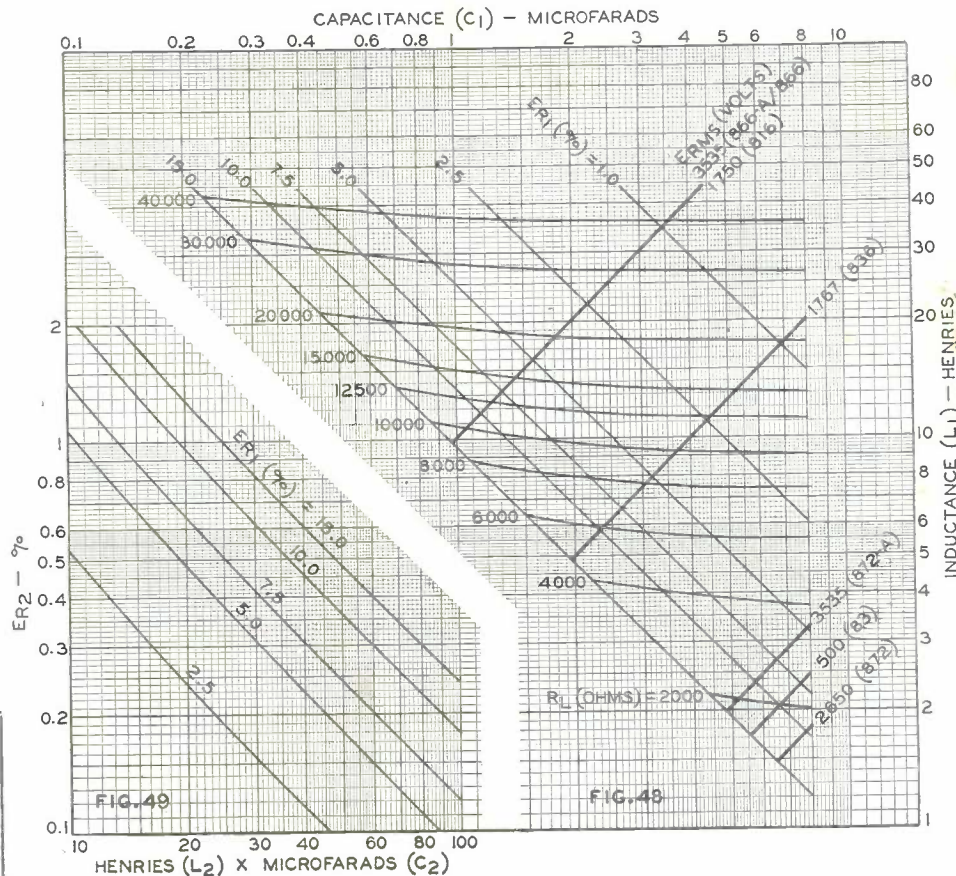

ing two type 866-A/866's, design a double-section filter which will limit the output ripple voltage to 0.5% at a load current equal to the combined maximum d-c load-current rating of the tubes (500 ma.) and still prevent the peak plate current of either tube from rising higher than its maximum peak plate-current rating. The input choke is to be of the swinging type and the voltage regulation is to be good from no-load to full load.

**Procedure:** ERMS is equal to  $3180 \times 1.11$ , or 3535 volts. At maximum load,  $R_1=3180/0.5$  ampere, or 6360 ohms. Therefore, any combination of inductance and capacitance along ER1 and to the left of ERMS=3535 will be suitable. A value of 10% ripple at the output of the first filter section will be assumed to be satisfactory. The minimum value of swinging-choke inductance and corresponding value of capacitance for the first-section filter condenser, therefore, may be selected along curve ER1=10% and to the left of curve ERMS=3535 volts (for 866-A/866). Suitable values are 13.5 henries and 1  $\mu$ f. The maximum value of swinging-choke inductance to be used with a condenser having a capacity of 1  $\mu$ f should be as high as practical. Assume that this value is 40 henries. Then, with a capacitance value of 1  $\mu$ f the maximum value of R1 is approximately 44,000 ohms. Therefore, a bleeder resistance of 44,000 ohms is required to keep the d-c output from "soaring" at transmitter no-load conditions. With a load resistance of 44,000 ohms, the bleeder current is  $2385/44000=0.073$  ampere, or 73 ma. The total useful d-c output current is then 500-73, or 427 ma.

The design of the second filter section should now be considered. It must be capable of reducing the ripple voltage from 10% in the first section to 0.5% in its own output. From Fig. 49, the value of the product L2 C2 is 37 as read on the curve ER1=10% when ER2=0.5%. If C2 is chosen to be 2  $\mu$ f,  $L_2=37/2$ , or 18.5 henries. This value of L2 is greater than  $3(C_1+C_2) \div 2C_1 C_2=3(1+2) \div 2(1 \times 2)$ , or 2.25, and therefore is of ample size to avoid resonance effects.

# POPULAR RCA TUBE PUBLICATIONS AND ENGINEERING HELPS

Available from RCA  
Transmitting-Tube Distributors  
or direct from the  
Commercial Engineering Section,  
RCA Manufacturing Co., Inc.,  
Harrison, New Jersey

## TECHNICAL INSTRUCTION BOOKLETS

These booklets are the authority on RCA Transmitting and Special-Purpose Tubes. They contain the technical information required to insure optimum performance and long life from each type. These are the days when it is essential to operate tubes with all possible care. If you do not have Instruction Booklets on the RCA tube types in your equipment, write to us for free copies. Be sure to mention the tube type numbers.

## RECEIVING-TUBE CHARACTERISTICS BOOKLET

The sixteen page Receiving-Tube Characteristics Booklet, known as the 1275-B, contains the salient characteristics, socket connections, and a special classification index of all RCA receiving tubes, including the important Miniature types. Available on request.

## PHOTOTUBE BOOKLET

This sixteen page Phototube booklet contains complete technical data on RCA's line of light-sensitive tubes. In it are included data charts, curves, phototube theory, and circuits for sound reproduction, light-measuring indicators, automatic counters, color discriminators, etc. Available on request.

## RADIOTRON DESIGNER'S HANDBOOK

This 356-page book has particular value to those engaged in circuit-design work and to those interested in the fundamental principles of practical radio-circuit design. It includes elaborate discussions on audio-frequency considerations, tests and measurements, tube data, general theory, many illustrations, reference charts, tables, etc. Edited by F. Langford Smith.

Price, \$1.00 each.

## TRANSMITTING AND SPECIAL-PURPOSE TUBE CHART BOOKLET

This beautifully illustrated booklet, known as the TT-100, lists the pertinent data on all RCA Transmitting and Special-Purpose Tubes, including the Acorn and Midget types, gas types, voltage regulators, phototubes, cathode-ray tubes, and television tubes. Charts on phototubes and transmitting tubes are provided to facilitate selection of a tube type for a particular service or application. Available on request.

## TUBE HANDBOOKS (All Types HB-3)

In wide use throughout the radio engineering and communication field is the RCA Tube Handbook. This loose-leaf publication, bound in flexible fabricoid binders, contains a wealth of data and engineering curves on all the various RCA tube types. In addition the HB-3 Handbook contains valuable general information, such as definitions of tube terms, base dimensions, types of cathodes, conversion-factor chart, outline drawings, resistance-coupled amplifier charts, etc. Available on subscription basis. Write to Commercial Engineering Section for complete descriptive folder and order form.

## RC-14 RECEIVING TUBE MANUAL

The RC-14 Manual is a virtual encyclopedia of receiving tubes. It contains 256 pages of technical data on 333 different types. It is brimful of tube theory, application, circuits, and charts. It is the most complete book of its kind ever published. This is the manual used in many schools and colleges to supplement their radio courses.

Price, 25 cents each.

## HAM TIPS from RCA

Although publication of HAM TIPS has been suspended for the duration, there is still a wealth of information on circuits and tubes contained in past issues. A complete set of these news publications is now available in binder form. Have a copy for ready reference.

Price, 25 cents per set with binder.

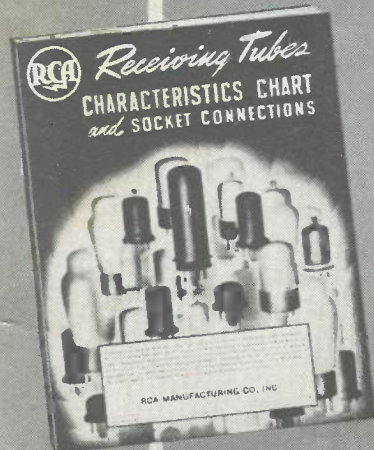
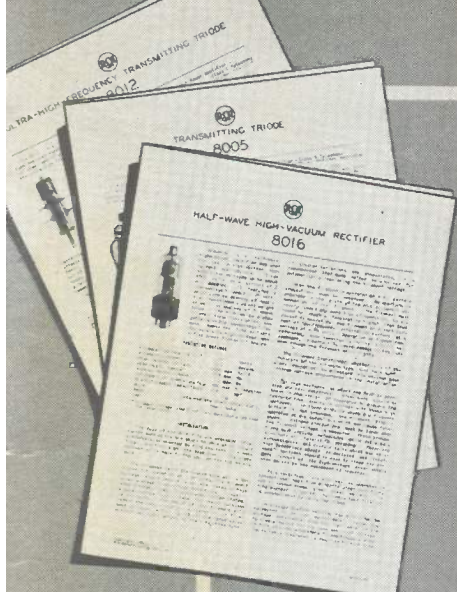
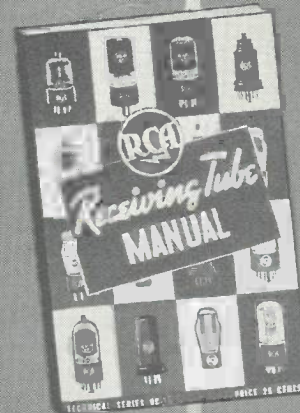
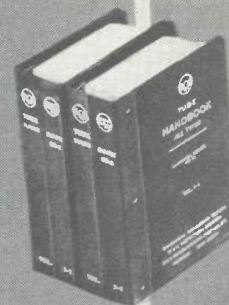



**TRANSMITTING TUBES**

*Proved in Communications' Most Exacting Services*