

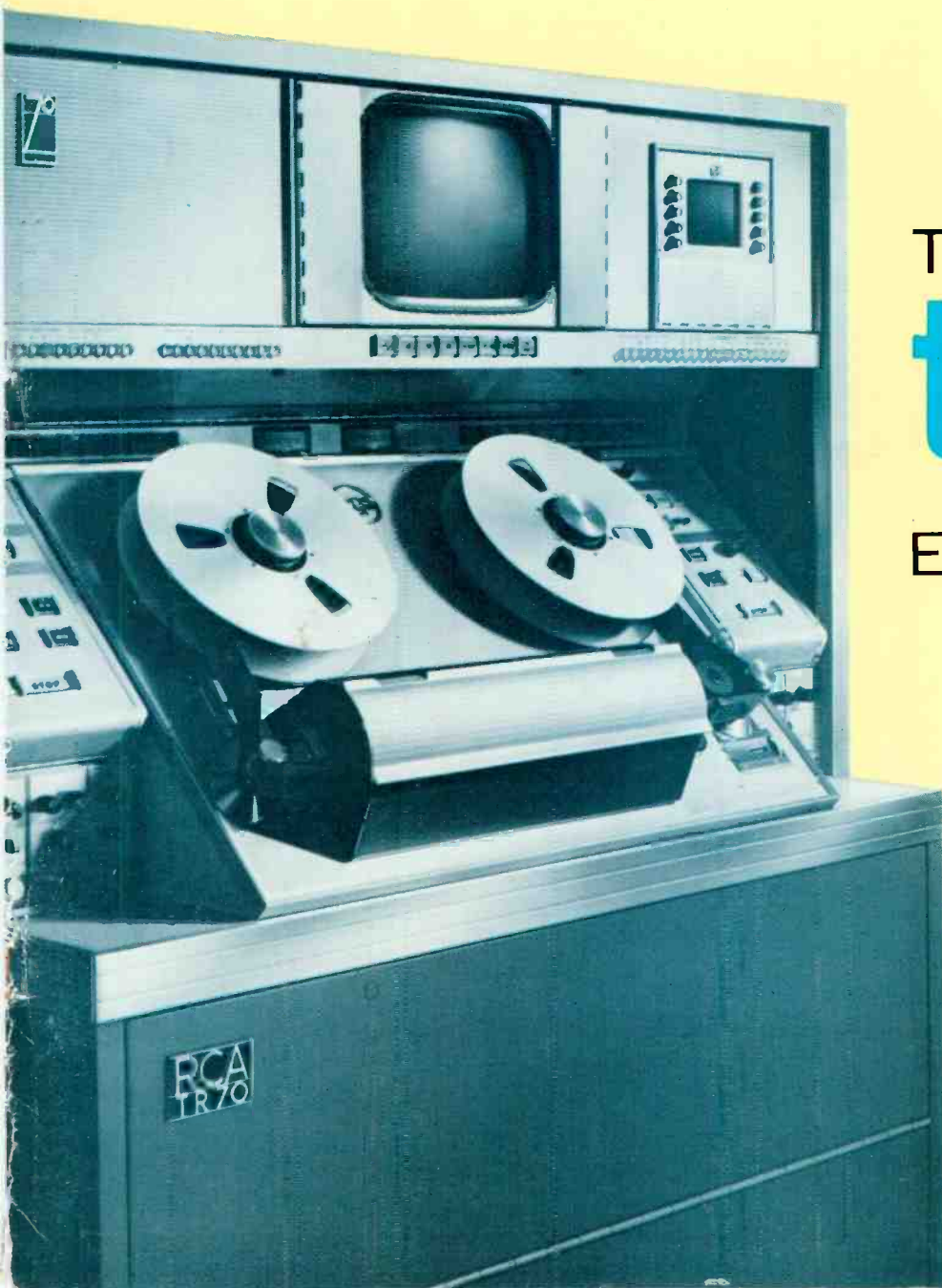

TV TAPE RECORDERS • TV TAPE ACCESSORIES • TV TAPE MOBILE UNITS



TELEVISION
tape
EQUIPMENT

**TELEVISION
TAPE EQUIPMENT
CATALOG**



THE MOST TRUSTED NAME IN TELEVISION

ABOUT THIS CATALOG

This catalog provides information on RCA Television Tape Equipment. Other RCA Broadcast Equipment Catalogs supply information on TV camera, TV film, Terminal and Switching, and Audio equipment; also on AM, FM, VHF, and UHF TV transmitters, antennas, and transmission line.

The information contained in this catalog is intended to serve as a buying guide for the user. Complete specifications and ordering information are supplied. Readers who desire more information or individual bulletins on particular equipment items are invited to write to their RCA Broadcast Representative.

OTHER RCA TECHNICAL PRODUCTS

RCA also manufactures many other electronic products, including: two-way radio and microwave relay communications equipment; optical and magnetic film recording equipment; sound systems of all types; 16mm projectors and magnetic recorders; industrial inspection and automation equipment; scientific instruments, such as the electron microscope; closed-circuit television systems; and many types of custom-built equipment for industry, the military, educational and medical services. Information describing these products may be obtained from RCA Sales Offices in the United States and Canada or internationally from local RCA Distributors or RCA International Division.

PRICES

Domestic prices of the equipment shown in this catalog are provided in a separate price list. Equipments are identified by type and MI (Master Item) numbers which are used to identify apparatus on invoices and packing slips. International prices for the various equipment items shown in this catalog are available from RCA Distributors or RCA International Division.

HOW TO ORDER

The RCA Television Tape Equipment shown in this catalog is sold through RCA Broadcast Representatives, who are familiar with broadcast equipment and related problems. These RCA Representatives are located in convenient offices throughout the United States. Domestic orders for equipment, or requests for additional information, should be directed to the nearest RCA Sales Office. International Readers are invited to contact their local RCA Distributor or the RCA International Division Office.

Contents

Page

TR-4 Compact TV Tape Recorder	5
TR-3 TV Tape Player	13
TR-5 Mobile TV Tape Recorder	21
TR-22D Deluxe TV Tape Recorder	29
TR-70 Super-Deluxe TV Tape Recorder	37
TV Tape Electronic Accessories	49
TV Tape Mechanical Accessories	57
TJ-72 TV Tape Mobile Unit	65
Index	69



Compact TV Tape Recorder, Type TR-4

- Quadruplex Recorder and Player for monochrome and color
- Compact machine with simplified controls
- Uses standard transistorized modules



Compact Recorder/Player

with quality features for color and monochrome

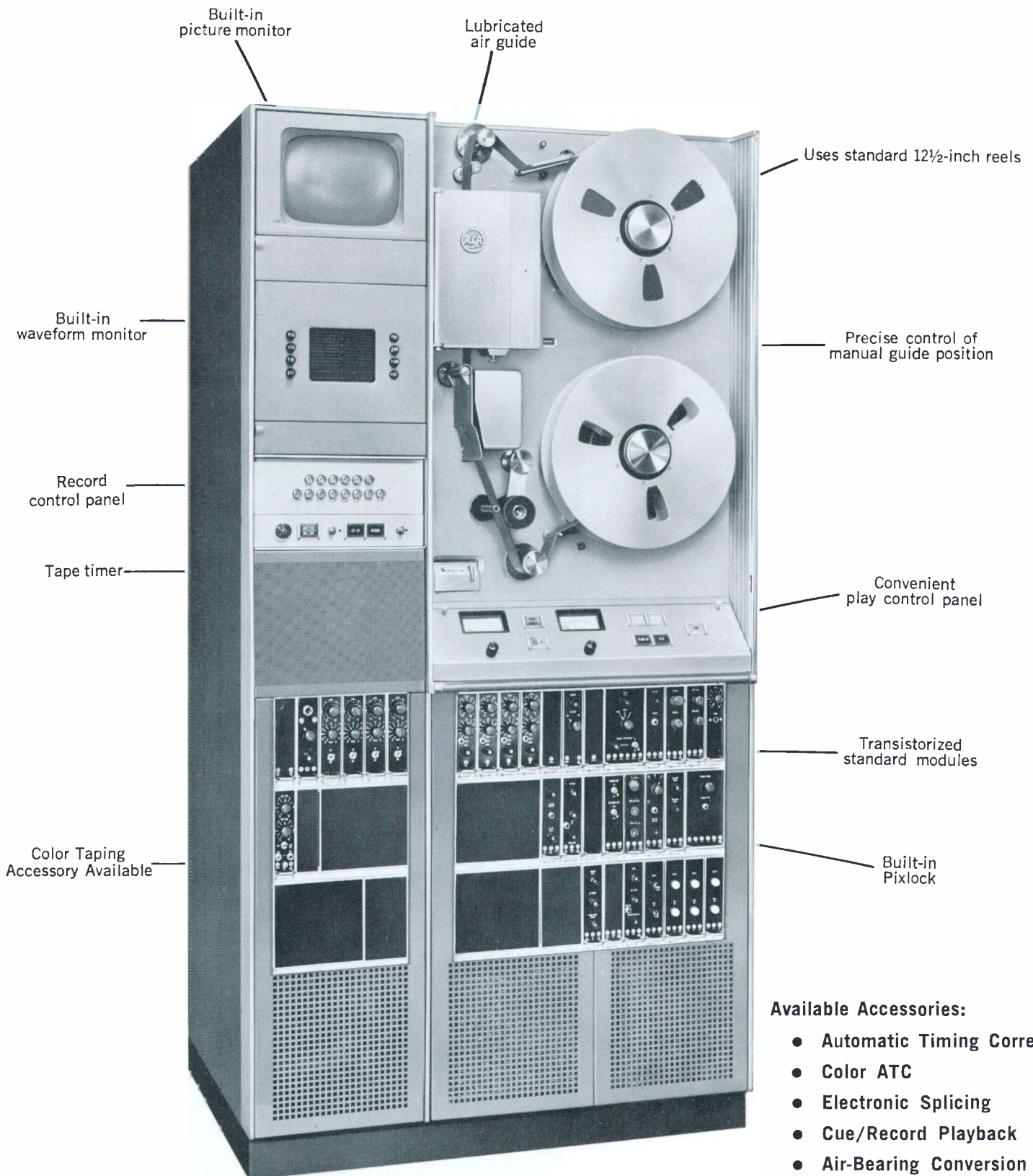

Available Accessories:

- Automatic Timing Corrector
- Color ATC
- Electronic Splicing
- Cue/Record Playback
- Air-Bearing Conversion
- Drop-out Compensator

Compact TV Tape Recorder, TR-4

The RCA TR-4 is a compact, completely transistorized TV Tape machine that performs both recording and playback functions. It is available as a color or monochrome equipment. It is de-

signed to reflect reduction in size, weight and power. It meets all professional broadcast standards of performance, and is compatible with all of today's quadruplex recorders.

Description

The TR-4 is a new generation TV Tape Recorder employing interchangeable transistorized modules. It is engineered to reproduce the finest quality pictures now provided by the latest television equipment. Broadcast standards for both monochrome and color are maintained.

"New Look" Emphasized

Transistorized circuits in modular form are used throughout the TR-4. Operational stability readily permits semi-automatic "pre-set" operation and remote control. This frees operators from constant attention and frequent adjustments. Many of the TR-4 modules are interchangeable with those of other RCA TV tape machines. Such standardization simplifies servicing, reduces the number of spares required, and lowers costs. Operation is simplified because arrangements and set ups are similar in all RCA machines.

Switchable Standards

The TR-4 is available in two basic models: (1) a 60-cycle, 525-line machine, and (2) a 50-cycle, switchable standards machine for 525/625/405-line operation. In an optional switchable standards model, 819-line operation may be specified as the third standard instead of 405-lines.

To change from one standard to another, the operator merely moves a single selector switch to the desired position. This master switch changes all circuitry including monitor and CRO to the desired standard.

Built-in Two-Speed Operation

Circuits are provided in the TR 4

allowing choice of operating speeds of 7½ or 15-inches per second. The use of a narrow track headwheel in place of the headwheel normally supplied permits twice as much information to be recorded on the same length of tape. Thus substantial savings in TV tape stock can be realized by switching to half-speed (7½ IPS). It is not recommended that 5 mil heads be used at 15 IPS for recording.

Pixlock

The Pixlock system accurately synchronizes vertical sync and horizontal sync pulses (derived from television tape signals) with the vertical and horizontal sync pulses provided by the station's local sync generator. This makes possible fades, wipes, dissolves and special effects. Only a single operating control is required and maximum lock-in time is 5 seconds.

Color Capability

The TR-4 can be adapted for color operation by the addition of a group of color modules plus the Automatic Timing Correction (ATC) modules. These transistorized units fit into spaces reserved in the module bank. Color recording thus becomes an automatic operation with the color ATC circuits offering precise stabilization and a high order of color performance.

Functional Styling

The TR-4 Recorder is completely self-contained in a compact, newly-styled cabinet that separates record from playback facilities for convenience and ease of servicing. The record functions in the left compartment include a picture and waveform monitor, push-button switcher,

the record control panel, speaker system and associated record electronics. The right portion of the cabinet houses the tape transport, playback control panel and the playback modules.

Simplified Controls

The record control panel groups all essential controls for easy operation. Two rows of pushbuttons are connected to the picture and waveform monitor to check key circuits and assure proper set-up of the machine. This panel also contains master record and set-up mode switches, record current and tracking meter switch, volume level control for the audio monitor, and one mode indicator.

On the playback control panel are functional pushbuttons for STOP, PLAY, FORWARD and REVERSE WIND, TAPE SPEED, and LOCAL/REMOTE. A 5-position record current/tracking switch is connected to a meter on the panel for measuring each of the four video head currents individually as well as FM level for accurate tracking. There is also a control for optimizing the control track phase. A 5-position switch is connected to the built-in meter that indicates the level of video, audio or cue.

Compact and Convenient

The TR-4 is compacted into a cabinet of vertical configuration that requires less than 6 square feet of floor space. The recorder measures only 33 inches wide, 24 inches deep and stands 66 inches high. It weighs approximately 800 pounds. The recorder is mounted on casters and may be moved readily through doorways to any desired location.

Playback control panel is model of efficiency.

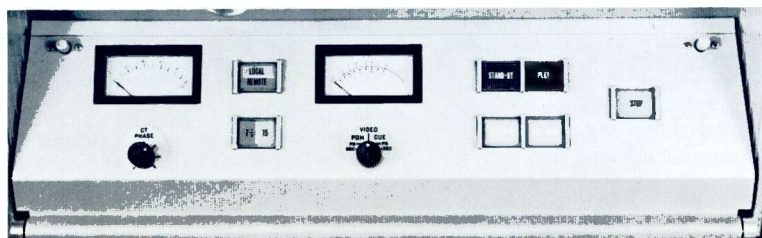

Record functions in TR-4 are grouped for convenience and ease of operation.

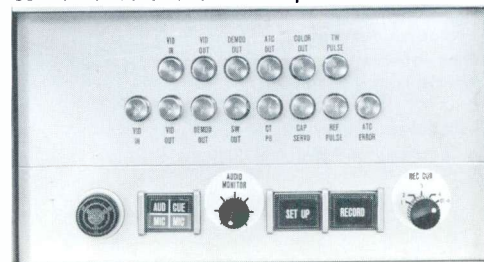

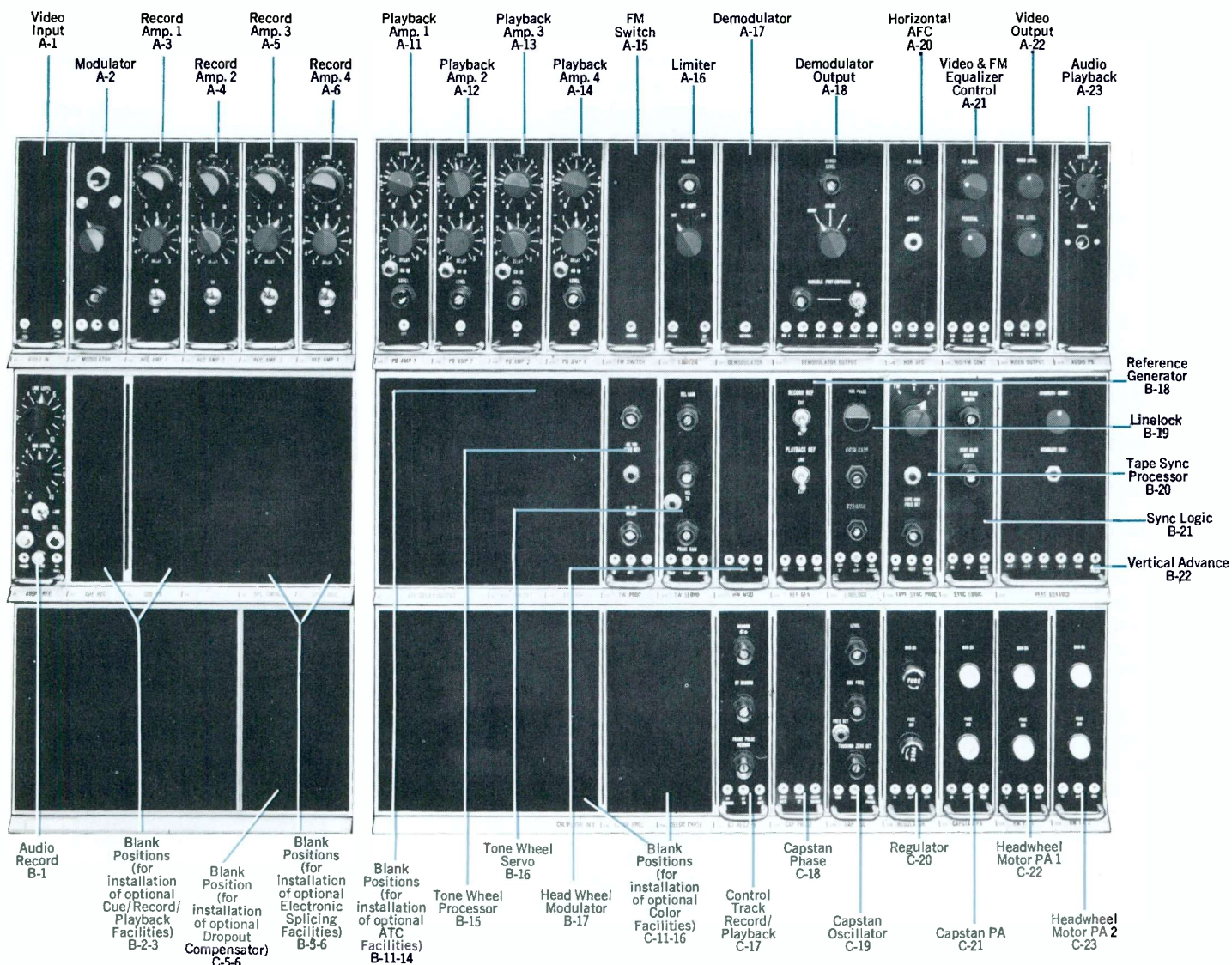

TR-4 Module Bank . . . Description of Functions

A1—Video Input

A distribution amplifier with two outputs, 1 for systems operation and one for monitoring. It has an external video gain control to adjust for varying input levels. Also provides sync separation of the input signal.

A2—Modulator

Clamps pre-emphasized video at the sync-tip level to modulate a capacity-diode-controlled heterodyne-type modulator. Circuitry included for rf copy facility.

A3—Record Amplifier #1

Provides variable delay and high level FM current for driving record head No. 1.

A4—Record Amplifier #2

Same function for head No. 2.

A5—Record Amplifier #3

Same function for head No. 3.

A6—Record Amplifier #4

Same function for head No. 4.

A11—Playback Amplifier #1

Provides gain, variable delay and equalization for channel No. 1.

A12—Playback Amplifier #2

Same function for channel No. 2.

A13—Playback Amplifier #3

Same function for channel No. 3.

A14—Playback Amplifier #4

Same function for channel No. 4.

A15—FM Switch

Switches between heads during playback, connecting the head scanning the tape to the output.

A16—Limiter

Provides approximately 55 db of limiting of the FM signal.

A17—Demodulator

Accepts signal from limiter. Contains demodulator delay line and output filter circuit.

A18—Demodulator Output

Separates tape sync from tape signal and provides line drivers to feed unprocessed video to monitoring circuits and to processing amplifier. It also contains post emphasis circuit.

A20—Horizontal AFC

Tape Sync from the demodulator output is used to control frequency and phase of a multivibrator.

This, in combination with other circuits, generates a new horizontal sync, front porch, and blanking.

A21—Video and FM Control

Clamps the video and provides new blanking. Permits adjustment of pedestal level in outgoing video signal and adjusts overall FM frequency response to compensate for video head frequency response.

A22—Video Output

One sending-end-terminated line driver distributes video within the machine. Three sending-end-terminated line drivers provide outputs from the machine.

A23—Audio Playback

Provides audio output to the program line and provides a jack for the headphone monitor.

B1—Audio Record

Provides the audio amplification, bias and erase current. A selector switch on the front permits selection of the microphone or the audio line input.

B2—Cue Record (Optional)

Space for this accessory equipment.

B3—Cue Playback (Optional)

Space for this accessory equipment.

B4—Spare Module Space

B5—Electronic Splicing

Space for this accessory equipment.

B11—ATC Delay and Output (Optional)

Space for this accessory equipment.

B13—ATC Error Detector (Optional)

Space for this accessory equipment.

B14—ATC Reference (Optional)

Space for this accessory equipment.

B15—Tone Wheel Processor

Shapes the tone wheel pulse and provides 960-cycle switcher drive.

B16—Tone Wheel Servo

Derives error signal controlling the headwheel motor in the tonewheel mode of operation.

B17—Headwheel Modulator

Amplitude-modulates the headwheel motor-drive sine waves. Gives wide-band, two-phase output for Scott-T transformer.

B18—Reference Generator

Processes local sync to produce horizontal-rate reference, field-rate reference, and frame-rate reference. The module also processes the 60-cycle power line reference.

B19—Linelock

Locks the machine to local horizontal and vertical sync signals to permit the use of special effects, fades, etc. Module includes automatic sensing to permit automatic drop-back to switchlock whenever the signal is interrupted.

B20—Tape Sync Processor

Processes tape sync to produce horizontal-rate reference, field-rate reference and frame-rate reference.

B21—Sync Logic

Generates horizontal and vertical blanking; combines them into composite blanking. Combines tape sync and regenerated horizontal sync into composite regenerated sync. Generates a start pulse which phases the counting of the vertical advance circuitry.

B22—Vertical Advance

Special circuitry counts out number of pulses in a field to accurately determine position for regenerated vertical blanking. It includes 3-position standards switch in switchable standards model.

C1 thru C4—Spare Modules

C5—Drop Out Compensator (Optional)

Space for this accessory equipment.

C11 thru C16—Color ATC (Optional)

Accommodate Color ATC Accessory.

C17—Control Track Record/Playback Amplifier

The 240-cycle control track signal is amplified, filtered to produce clean 240-cycle sine wave, clipped, and shaped into a pulse.

C18—Capstan Phase

The preceding pulse feeds a chain of binary counters which divide the pulse frequency by eight to produce a 30-cycle output pulse.

C19—Capstan Oscillator

A phase detector which compares incoming pulse to local frame pulse and produces a dc voltage proportional to magnitude of the phase error. DC error voltage controls frequency of the oscillator which supplies the drive frequency for the capstan motor. Tape speed is thereby synchronized to local reference.

C20—Regulator

Provides regulated voltages to operate the transistor circuitry of the machine.

C21—Capstan Power Amplifier

PA for the capstan motor.

C22—Headwheel Motor PA #1

Provides power to drive one phase of the Scott-T transformer which in turn drives the three phase headwheel motor.

C23—Headwheel Motor PA #2

Provides power to drive one phase of the Scott-T transformer which in turn drives the three phase headwheel motor.

FUNCTIONAL DIAGRAM

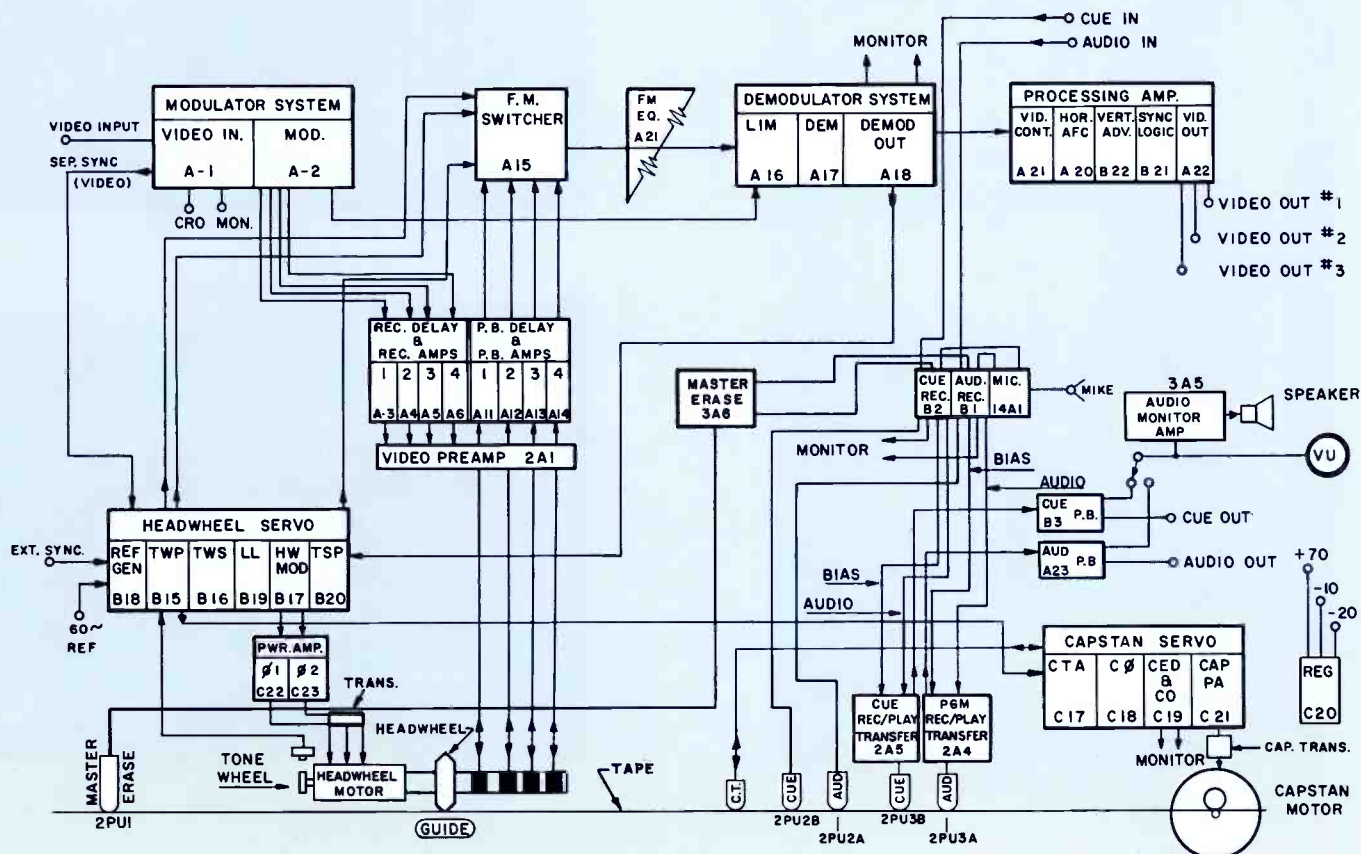

Modular Accessories for every taping need

Drop Out Compensator

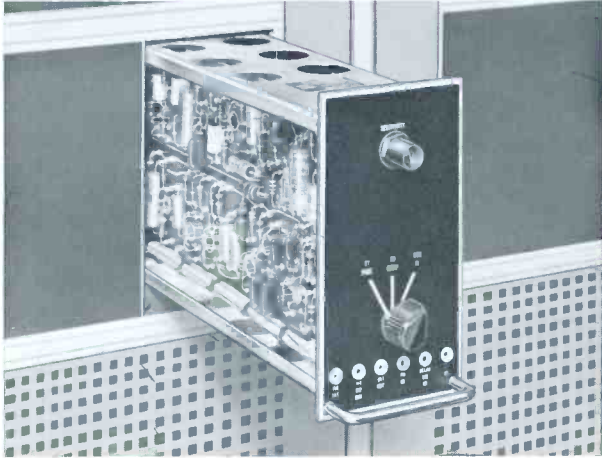

Monochrome ATC

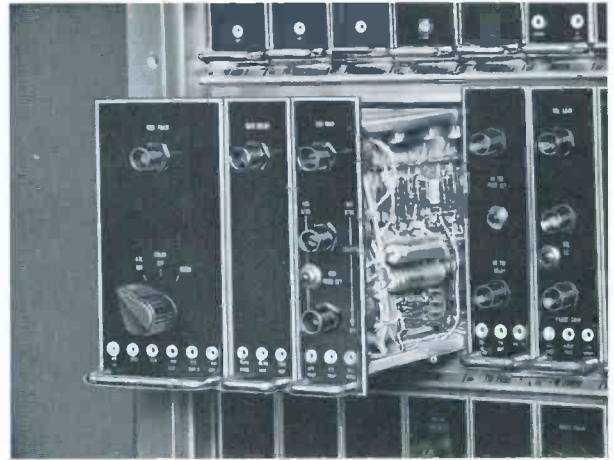

Color ATC

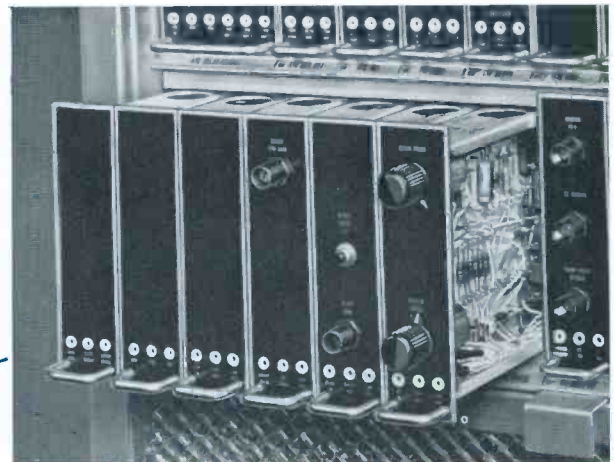

Electronic Splicing

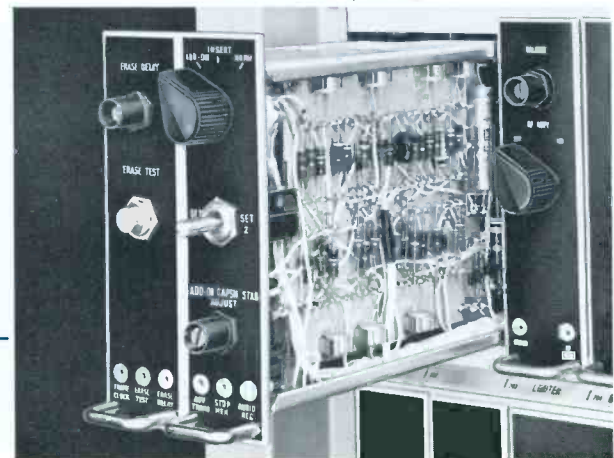

Major Accessories

Plug-in Modules

A full complement of accessories is available for use with the TR-4 TV Tape Recorder. These accessories are designed as transistorized plug-in modules. Space is provided for them in the Recorder.

ATC

The RCA Automatic Timing Corrector (ATC) is a transistorized video device that maintains near perfect picture geometry by automatically compensating for skewing, quadrature errors and scalloping. Its action is fully automatic. The ATC accessory operates with or without Pixlock. It thus serves as a continuous monitoring and correction device which automatically reduces the time delay errors occurring in the playback signal, thereby assuring the highest possible quality at all times.

The ATC equipment is supplied in kit form ready for installation in the TV Tape Recorder. The kit consists of a connector and cable assembly, three ATC plug-in circuit modules, a fixed delay line, ATC Relay Module and the parts required for installation. Installation of monochrome ATC includes most of the installation required for Color ATC.

Color ATC

The RCA Color Automatic Timing Corrector is designed to provide time base correction to the tape playback signal. It operates in conjunction with the monochrome ATC and pixlock servo system.

The Color ATC system comprises six transistorized modular units which plug into the module bank of the TR-4 and a plug-in fixed delay line.

Stabilization is accomplished by measuring the residual jitter in a signal that has been pre-stabilized by the pixlock and monochrome ATC systems and eliminates the timing errors or reduces them to a negligible value, utilizing a time-error correcting circuit whose major component is an electronically variable delay line. Its output signal, which is directed to the signal processing amplifier, has minimum jitter and geometric distortion. As an adjunct to this stabilization process, the Color ATC removes old burst and inserts regenerated burst.

Cue Record/Playback

The cue record/playback accessory head provides a means for recording cue information along one edge of the video tape. This can be in the form of voice, tone or digital information. A special feature of the program and cue channel is that recording can be done independent of video recording; in other words, sound may be dubbed in while playing back or previewing the video signal.

Electronic Splicing

Splicing and editing of TV tape by electronic means can be accomplished with the TR-4 by addition of an electronic splicer. It will permit program segments to be added to a recorded segment or inserted within it. It operates at either 7½ or 15 IPS tape speeds.

The equipment comprises three transistorized modular units (splice timing, splice control and splice logic modules), selective erase head, wiring harness, and auxiliary modification material.

The plug-in modular construction affords easy accessibility to all components. Furthermore, removal of any module automatically returns the tape recorder to normal operation. This by-pass feature is only one of several improvements in electronic splicing. Other features are two-speed operation, switchable standards, and pushbutton setup procedure.

Drop-Out Compensator

This module contains memory circuits that can reproduce a previous line of video information whenever the device senses a loss of RF. Use of this accessory promotes greater stability to the servo system, especially pixlock, and reduces video dropouts caused by tape imperfections. It can eliminate screening of tapes for such imperfections and prolongs the usefulness of old tapes.

High-Band Capability

The TR-4 provides the basic capability for later addition of high-band, an accessory that provides a new FM standard for improved quality when using color and dubs made through the video tape system. The conversion reduces moire "beats" and improves signal-to-noise ratio for color recording.

Other Accessories

In addition, remote operation of both record/playback mode and signal can easily be provided by remote control panels. Attention is also called to the advantages of Air Bearing Conversion of Headwheel, Narrow Track Recording, and the convenient Video Alignment Tapes.

COMPLETE LIST OF ACCESSORIES

Monochrome Automatic Timing Corrector.....	ES-43580-A	Headwheel Panel Assembly (Narrow Track Air Bearing).....	MI-40799
Color Automatic Timing Corrector.....	ES-43582	Headwheel Panel Assembly (Narrow Track Ball Bearing).....	MI-40791
(TR-4 Color Conversion requires the ES-43580-A ATC accessory.)		Guide Position Adjuster for Headwheel Panel.....	MI-43351
Cue Record/Playback	MI-43355	Video Preamplifier Module (spare).....	MI-40603-BS
Cue Preview Editing Accessory.....	MI-40698	Mechanical Tape Splicer (15 IPS).....	MI-40772
Electronic Splicing	ES-43578-A	Mechanical Tape Splicer (7½ IPS).....	MI-40748
Drop-Out Compensator	MI-43587	Test Module Extender.....	MI-40649
Remote Control Panel (Mode).....	MI-40691-A	Special Module Extender (44 terminals).....	MI-557301
Remote Control Panel (Signal).....	MI-40692-A	Monochrome Video Alignment Tape (525/60 Standard).....	MI-40793
Air Bearing Conversion Kit with Compressor, 117/230 volts, 50/60 cycles, internal mount.....	MI-43357	Monochrome Video Alignment Tapes (625 line, 60 cps).....	MI-40797
Air Bearing Conversion Kit with Compressor, 117/60, external mount.....	MI-43276	TM-27AC Color Monitor, 17".....	MI-40232-A
Air Bearing Conversion Kit with Compressor, 230/50, external mount.....	MI-43277	Magnetic Tape Head Degausser, 117/50 or 60.....	MI-11995
Headwheel Panel Assembly (Standard Track Air Bearing).....	MI-40790-A	Magnetic Tape Head Degausser, 220/50 or 60.....	MI-11996
Headwheel Panel Assembly (Standard Track Ball Bearing).....	MI-40760-B		

Specifications

General

Recording Medium.....Magnetic Tape 2" (5.08 cm) wide
 Reel Size.....Up to 14" (35.56 cm)

Tape Speed:	50 Cycle	60 Cycle
Normal Speed	15.6" (39.7 cm)	15" (38.2 cm)
Half Speed	7.8" (19.88 cm)	7.5" (19.1 cm)

Picture Sound Separation:

Normal Speed	14.8 frames sound leading	18.5 frames sound leading
Half Speed	29.6 frames sound leading	37 frames sound leading

Record/Playback Time:

Normal Speed	61 min. on a 12.5" reel (4800 ft.)	64 min. on a 12.5" reel (4800 ft.)
Half Speed	122 min. on a 12.5" reel (4800 ft.)	128 min. on a 12.5" reel (4800 ft.)

Rewind Time

Approx. 4 min. for 4800 ft.	Approx. 3 min. for 4800 ft.
-----------------------------	-----------------------------

Stopping Time.....Less than .2 seconds from record or play

Recording Time Reference.....To incoming video signal or local sync

Playback Time Reference.....To power line or local sync

Starting Time for Stabilized Picture and Sound:

Tone Wheel Mode.....Less than 5 seconds from stop, less than 3 seconds from setup or standby

Switchlock Mode.....Less than 5 seconds from stop

Tape Interchangeability.....Tapes made on any machine may be played back on any other machine providing they are made in accordance with all applicable proposed SMPTE recommended practices and proposed ASA standards.

Tape Timer.....Accumulated time measured in minutes and seconds at 15 in/sec tape speed on a 60 cycle machine and 15.6 in/sec (39.7 cm) on a 50 cycle machine. Repeatable within 3 seconds per hour.

Horizontal Displacement of Vertically Aligned Picture Elements.....Not to exceed 20 nsec. at junction points

RF Limiting.....Sufficient to allow RF signal level into the demodulator to be 55 db below nominal before video signal is affected by a 10 percent reduction in level.

Signal Levels

Input Signal Requirements:

VIDEO.....Input signal level may be between .5 volt p/p and 1.4 volts p/p composite signal. Signal may be looped through or terminated in 75 ohms.

AUDIO.....Line input level between -20 dbm and +18 dbm into a 10,000 ohms balanced bridging impedance

SYNC.....Negative polarity 3 to 5 volts p/p, loop through or terminated in 75 ohms

RF COPY.....0.8 to 1.2 volts, 75 ohm terminated

Output Signal Availability:

VIDEO-MONOCROME or COLOR (Processed):

Three Line Outputs.....Two composite—one composite or non-composite internally selected. Source impedance 75 ohms, load 75 ohms.

One additional composite line used internally for monitoring

Video Level.....5 to 1 volt p/p

Sync Level......2 to .4 volt p/p

Pedestal Level.....±20% of video level

AUDIO:

One line output: +18 dbm max. into 150/600 ohms balanced or unbalanced line

One phone jack output for high impedance phones

RF COPY.....1 volt p/p level, 75 ohms terminated

Electrical

Power Requirements:

60 cycle ±2 cycles.....115 volts a-c ±10% single phase, 2.0 kw

50 cycle ±2 cycles.....230 volts a-c ±10% single phase, 2.0 kw

Frequency Response:

Video Channel

Monochrome.....405/525 ±1.5 db 25 cycles to 4 mc

625/819 ±1.5 db 25 cycles to 4.5 mc; -3 db max. at 5 mc

Audio Channel:

Normal Speed.....±2 db 50 to 15,000 cycles

Half Speed.....±2 db 60 to 10,000 cycles

Signal-to-Noise Ratio (Video at 15 ips)

405/525 Line Monochrome.....Better than 40 db (37 db at 7½ ips) on an interchangeable tape basis with 4 db pre-emphasis

625/819 Line Monochrome.....Better than 37 db (34 db at 7½ ips) on an interchangeable tape basis with 4 db pre-emphasis

Audio.....Better than 50 db measured overall between a recorded level corresponding to 3% total rms distortion at 1000 cycles per second and noise present when playing back an erased unmodulated tape moving at standard speed.

Transient Response.....Rise time less than 150 nsec. Overshoot less than 12% on 62 nsec. sine-squared window test pattern

Wow and Flutter:

Total RMS wow and flutter 0.5 to 250 cps range:

Normal Speed, 0.2% rms; Half Speed, 0.25% rms

Ambient Temperature and Humidity.....Between 35° and 110°F (0° and 45°C) at 20 to 90% relative humidity

Mechanical

Dimensions: Width 33" (84 cm), Height (with built-in casters) 66" (168 cm), Depth 24" (61 cm)

Shipping Information: Width 38¾" (98.2 cm), Depth 29" (73.5 cm), Height 77" (195 cm), Volume 60.1 ft.³ (1.80 M³), Gross Weight 982 lbs. (444.4 kg)

Ordering Information

The Type TR-4 TV Tape Recorder is available for operation on 525, 625, 405 and 819 line tv standards. ... Can be supplied as color or monochrome equipment.

Two basic models are available:

- (1) a 525 line machine
- (2) a switchable machine for 525/625/405 or (optional 819) line operation

They may be ordered as follows:

- For 525 line operation, specify ES-43571
- For 525/625/405 line operation, 50 cycles, specify ES-43573-405
- For 525/625/819 line operation, 50 cycles, specify ES-43573-819

All models include the following equipment:

- 1 TV Tape Recorder (Cabinet Mounted) complete
- 1 Headwheel Panel Assembly (Ball Bearing, narrow track)
- 1 Kit of Maintenance Materials
- 1 Monochrome Video Alignment Tape
- 1 Mechanical Guide Adjustor

TV Tape Player, Type TR-3

- For on-air or closed circuit presentations
- Plays all standard quadruplex tapes . . . color and monochrome
- Expandable to include recording function



TV Tape Player

For All Standard Quadruplex Tapes

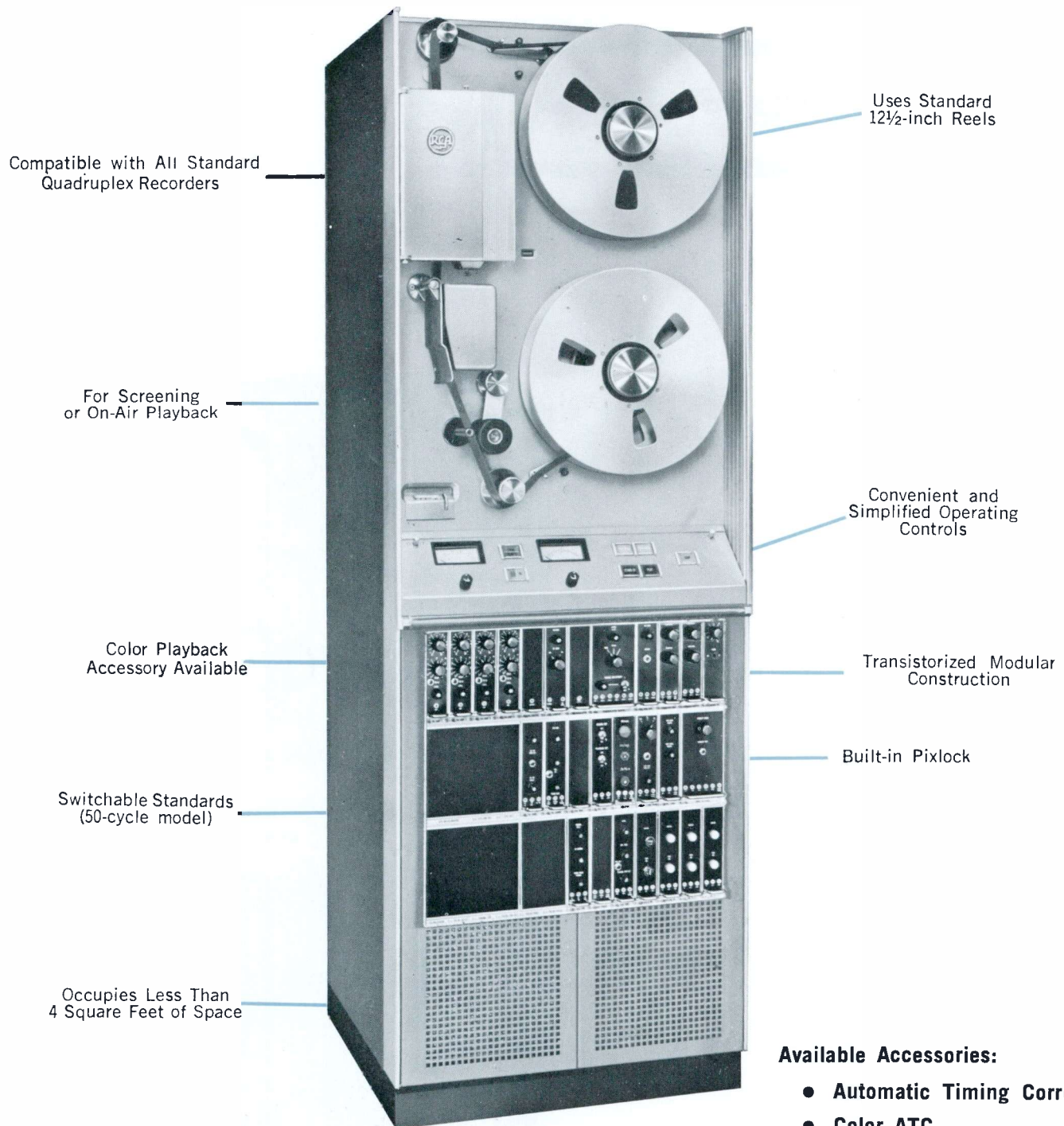

Available Accessories:

- Automatic Timing Corrector
- Color ATC
- High-Band Capability
- Air Bearing Conversion
- Monitor Accessory
- Record Accessory

TV Tape Player, Type TR-3

The RCA TR-3 Tape Player provides an economical means for playback of TV tapes. When equipped with color accessory, it plays both color and monochrome tapes for broadcast or closed circuit use. Operation is similar to a film projector. In the same way projectors are used to screen

films, this player is used to screen tapes. It is a compatible machine for playback of all TV tapes made on quadruplex recorders to broadcast standards. This player may be converted to a complete Record/Playback machine by adding an accessory cabinet.

Description

The TR-3 TV Tape Player is engineered to reproduce faithfully the fine quality pictures now provided by the latest television cameras and recorders. It conforms with industry standards for playback of monochrome or color video signals.

New Look Emphasized

The TR-3 is a "new look" equipment from RCA. Advanced design techniques including transistorization, modularization stabilization and standardization are achieved. Transistorized circuits in modular form are used throughout. Operational stability that readily permits semi-automatic "pre-set" operation and remote control frees operators from constant attention and frequent adjustments. Many of the modules of the TR-3 are interchangeable with those of other tape recorders. Such standardization reduces cost, makes quick replacement easy and operation less confusing because equipment arrangements and set ups are similar.

Quality Performance

Careful design has resulted in a self-contained player whose performance meets professional broadcast standards. It is compatible with all standard quadruplex television recorders. It meets rigid specifications to assure top performance. Features

include built-in two-speed, switch-lock and pixlock operation.

Switchable Standards

The TR-3 is available in 50 and 60-cycle models. The 50-cycle model is equipped for operation on international standards. To change from one standard to another, the operator merely moves the standards selector switch to the desired position. This master circuitry provides instantaneous switchover from 525 to 625 to 405 TV line standard.

Built-in Two-Speed Operation

Circuits to permit choice of operating speeds, 15 or 7½ inches per second, are built into the TR-3. Playback time of up to 60 minutes at 15 IPS or 120 minutes at 7½ IPS is possible with the 12¼-inch tape reels.

Pixlock

The Pixlock system accurately synchronizes vertical sync and horizontal sync pulses derived from television tape signals with the vertical and horizontal sync pulses provided by the station's local sync generator. This makes possible fades, wipes, dissolves and special effects. Only a single operating control is required and maximum lock-in time is 5 seconds.

Interchangeable Modules

The modular construction of the TR-3 player means that many of

the modules are interchangeable with the TR-4, TR-5 and TR-22 TV Tape machines. All modules are completely accessible and by means of a module extender it is possible to service the machine while in operation.

Advanced Styling

Advanced design techniques have resulted in significant reduction in size, weight and power consumption. The modern styled cabinet measures only 22 by 24 inches at the base and is 66 inches high. Weight is approximately 600 pounds. It can be readily moved on its built-in casters. Vertical construction requires less than 4 square feet of floor space.

Versatility

The TR-3 is a versatile supplement to the broadcaster's present TV taping facilities. Providing the same high quality as RCA de luxe machines, it is an additional source for on-air material. It may also be used for client previews and editing, relieving heavily scheduled recording equipment at relatively low cost. For agencies and station reps, the TR-3 provides a means for checking and presenting commercials to clients. It is a low-cost, highly-effective selling tool. For closed circuit users the TR-3 Player may be integrated into the system and used to present taped programs.

PLAYS BACK ALL QUADRUPLIX TAPES FOR A VARIETY OF APPLICATIONS

On-Air Broadcast

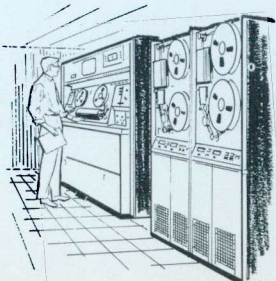

Educational TV

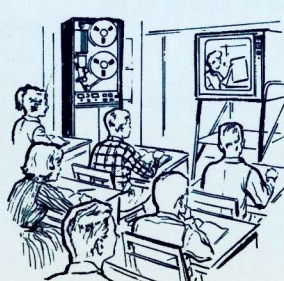

Previews and Presentations

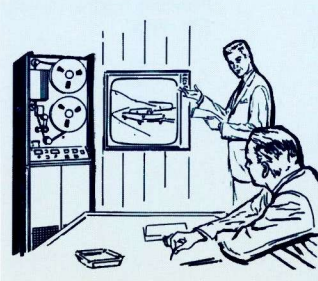

Editing and Splicing

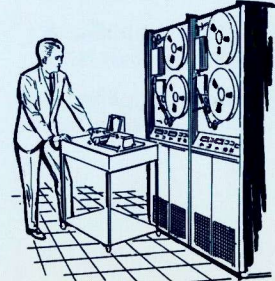

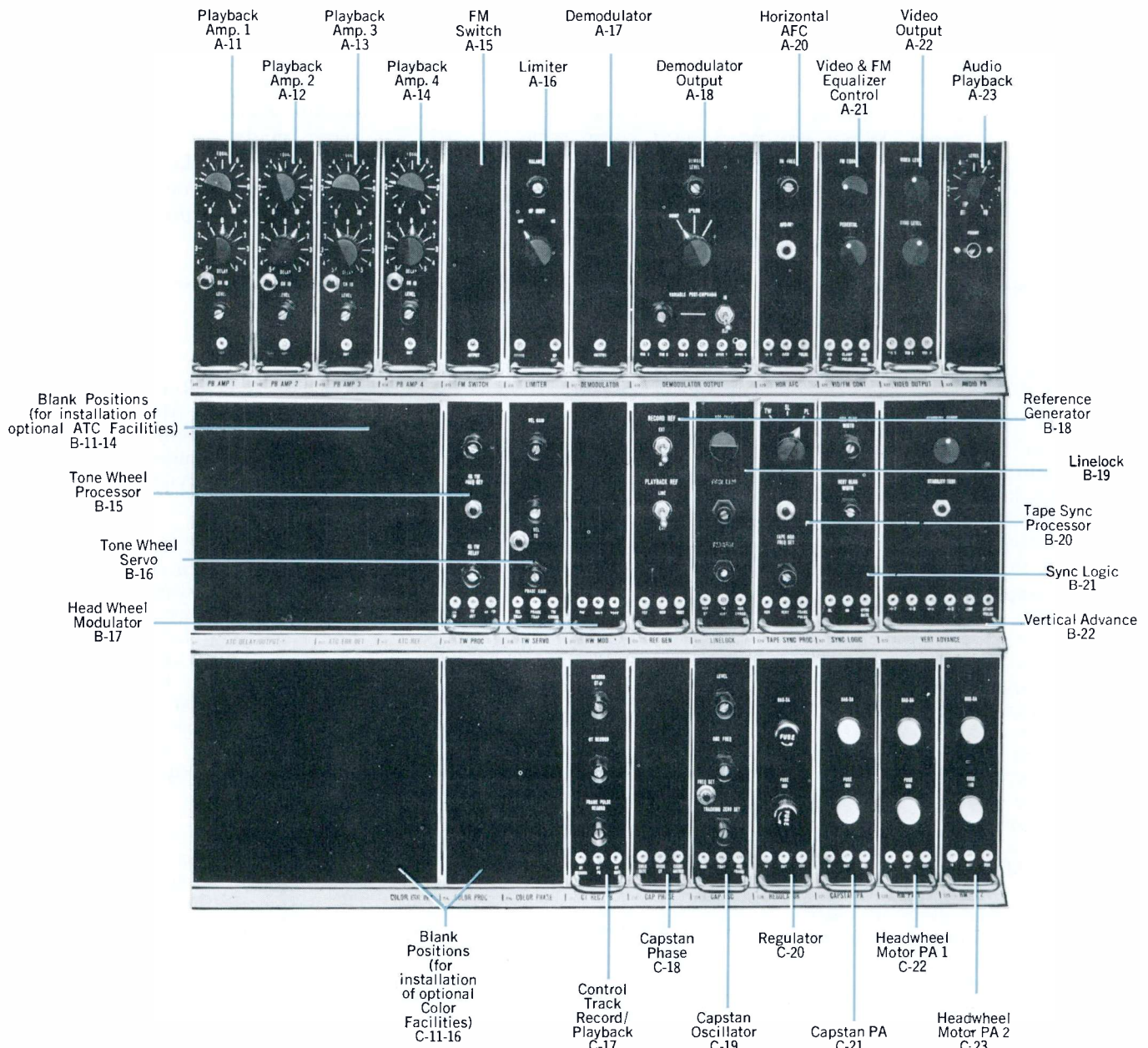

TR-3 Module Bank . . . Description of Functions

A11—Playback Amplifier #1

Provides gain, variable delay and equalization for channel No. 1.

A12—Playback Amplifier #2

Same function for channel No. 2.

A13—Playback Amplifier #3

Same function for channel No. 3.

A14—Playback Amplifier #4

Same function for channel No. 4.

A15—FM Switch

Switches between heads during playback, connecting the head scanning the tape to the output.

A16—Limiter

Provides approximately 55 db of limiting of the FM signal.

A17—Demodulator

Accepts signal from limiter. Contains output filter circuit.

A18 (A19)—Demodulator Output

Separates tape sync from tape signal and provides line drivers to feed unprocessed video to monitoring circuits and to processing amplifier. It also contains post emphasis circuit.

A20—Horizontal AFC

Tape Sync from the demodulator output is used to control frequency and phase of multivibrator. This, in combination with other circuits, generates a new horizontal sync, front porch, and blanking.

A21—Video and FM Control

Clamps the video and provides new blanking. Permits adjustment of pedestal level in outgoing video signal and adjusts overall FM frequency response to compensate for variations between video head assemblies.

A22—Video Output

One sending-end-terminated line driver distributes video within the machine. Three sending-end-terminated line drivers provide outputs from the machine.

A23—Audio Playback

Provides audio output to the program line and provides a jack for the headphone monitor.

B11 (B12)—ATC Delay and Output (Optional)

Space for this accessory equipment.

B13—ATC Error Detector (Optional)

Space for this accessory equipment.

B14—ATC Reference (Optional)

Space for this accessory equipment.

B15—Tone Wheel Processor

Shapes the tone wheel pulse and provides 960-cycle switcher drive.

B16—Tone Wheel Servo

Derives error signal controlling the headwheel motor in the tonewheel mode of operation.

B17—Headwheel Modulator

Amplitude-modulates the headwheel motor-drive sine waves. Gives wide-band, two-phase output for Scott-T transformer.

B18—Reference Generator

Processes local sync to produce horizontal-rate reference, field-rate reference, and frame-rate reference. The module also processes the 50/60-cycle power line reference.

B19—Linelock

Locks the machine to local horizontal and vertical sync signals to permit the use of special effects, fades, etc. Module includes automatic sensing to permit automatic drop-back to switchlock whenever the signal is interrupted.

B20—Tape Sync Processor

Processes tape sync to produce horizontal-rate reference, field-rate reference and frame-rate reference.

B21—Sync Logic

Generates horizontal and vertical blanking; combines them into composite blanking. Combines tape sync and regenerated horizontal sync into composite regenerated sync. Generates a start pulse which phases the counting of the vertical advance circuitry.

B22 (B23)—Vertical Advance

Special circuitry counts out number of pulses in a field to accurately determine position for regenerated vertical blanking. It includes 3-position standards switch in switchable standards model.

C11 thru C16—Color ATC (Optional)

Accommodate Color ATC Accessory.

C17—Control Track Record/Playback Amplifier

The 240-cycle control track signal is amplified, filtered to produce clean 240-cycle sine wave, clipped, and shaped into a pulse.

C18—Capstan Phase

The preceding pulse feeds a chain of binary counters which divide the pulse frequency by eight to produce a 30-cycle output pulse.

C19—Capstan Oscillator

A phase detector which compares incoming pulse to local frame pulse and produces a dc voltage proportional to magnitude of the phase error. DC error voltage controls frequency of the oscillator which supplies the drive frequency for the capstan motor. Tape speed is thereby synchronized to local reference.

C20—Regulator

Provides regulated voltages to operate the transistor circuitry of the machine.

C21—Capstan Power Amplifier

PA for the capstan motor.

C22—Headwheel Motor PA #1

Provides power to drive one phase of the Scott-T transformer which in turn drives the three phase headwheel motor.

C23—Headwheel Motor PA #2

Provides power to drive one phase of the Scott-T transformer which in turn drives the three phase headwheel motor.

FUNCTIONAL DIAGRAM

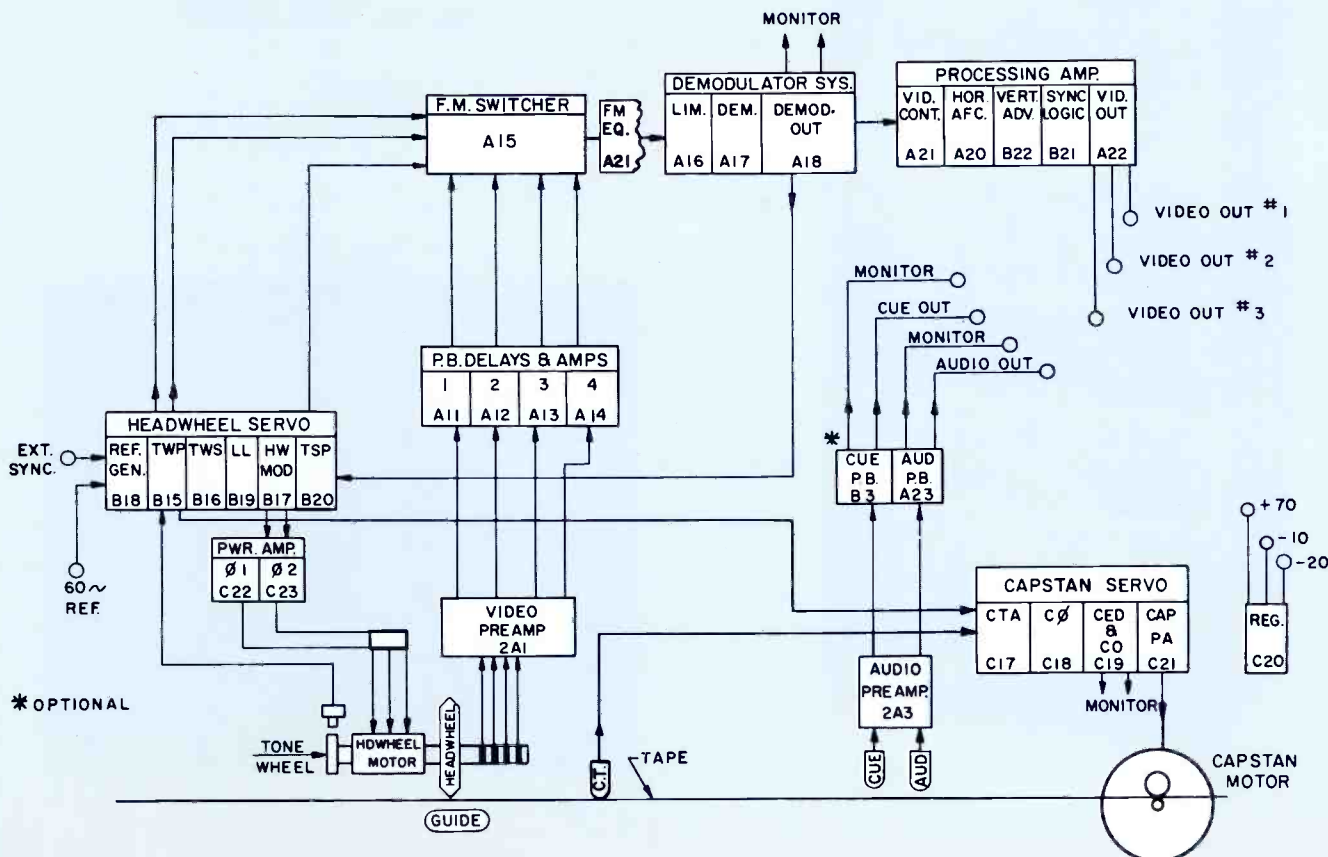

Plug-in Modular Accessories for every playback requirement

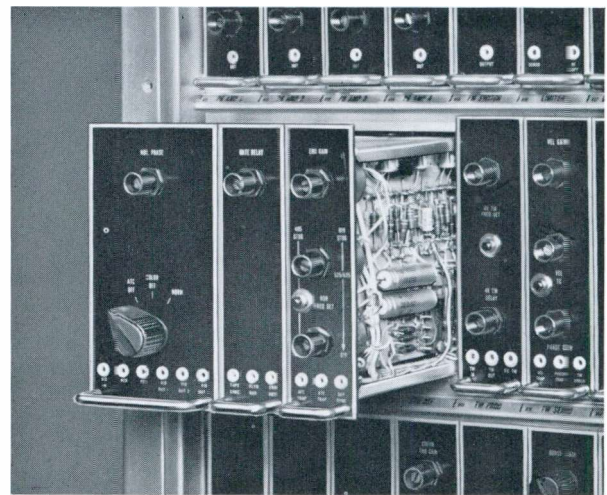

Automatic Timing Corrector

Color ATC

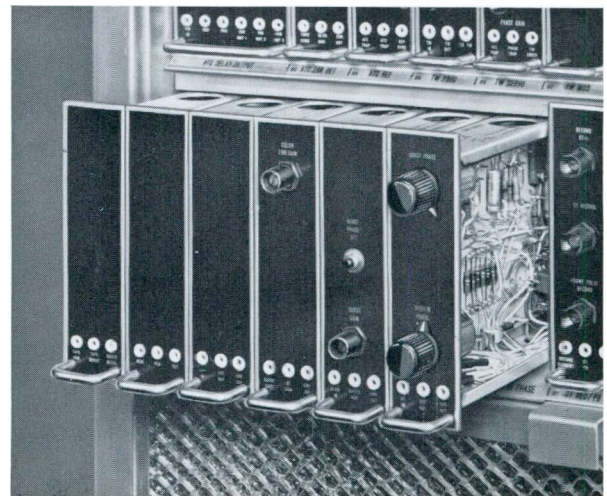

Major Accessories

Plug-In Modules

A full complement of Accessories is available for use with the TR-3 Player. These accessories are designed as transistorized plug-in modules. Space is provided for them in the Player.

ATC

The RCA Automatic Timing Corrector (ATC) is a transistorized video device that maintains near perfect picture geometry by automatically compensating for skewing, quadrature errors and scalloping. Its action is fully automatic. The ATC accessory operates with or without Pixlock. It thus serves as a continuous monitoring and correction device which automatically reduces the time delay errors occurring in the playback signal, thereby assuring the highest possible quality at all times.

The ATC equipment is supplied in kit form ready for installation in the TV Tape Player. The kit consists of a connector and cable assembly, three ATC plug-in circuit modules, a fixed delay line, ATC Relay Module and the parts required for installation. Installation of monochrome ATC allows color to be added by simply plugging in the Color ATC Modules.

Color ATC

The RCA Color Automatic Timing Corrector is designed to provide time base correction to the tape playback signal. It operates in conjunction with the monochrome ATC and pixlock servo system.

The Color ATC system comprises six transistorized modular units which plug into the module bank of the TR-3 and a plug in fixed delay line.

Stabilization is accomplished by measuring the residual jitter in a signal that has been pre-stabilized by the pixlock and monochrome ATC systems and eliminates the timing errors or reduces them to a negligible value, utilizing a time-error correcting circuit whose major component is an electronically variable delay line. Its output signal, which is directed to the signal processing amplifier, has less than ± 4 nanoseconds jitter and geometric distortion. As an adjunct to this stabilization process, the Color ATC removes old burst and inserts keyed local burst.

High-Band Capability

The TR-3 provides the basic capability for later addition of high-band,

an accessory that provides a new FM standard for improved quality when using color and dubs made through the video tape system. The conversion reduces moire "beats" and improves signal-to-noise ratio for color playback.

Record and Monitor Accessory

The addition of a MI-43361 Monitor Rack Assembly, and a MI-43360 Record Accessory will convert the TR-3 Tape Player into a complete TR-4 Compact Tape Recorder in a two step process that is easy on the budget, while allowing the continuous playback of video tape at a low initial cost. The MI-43361 Monitor Rack Assembly alone provides greater ease of maintenance as well as reduced setup time for refined servo adjustments.

Other Accessories

In addition, remote operation of both playback mode and signal can easily be provided by means of remote control panels. Attention is also called to the advantages of Air Bearing Conversion of Headwheel, Narrow Track Recording, and the convenient Video Alignment Tapes.

COMPLETE LIST OF ACCESSORIES

Monochrome Automatic Timing Corrector.....	ES-43580-A	Headwheel Panel Assembly (Narrow Track Ball Bearing).....	MI-40791
Color Automatic Timing Corrector.....	ES-43582	Headwheel Panel Assembly (Narrow Track Air Bearing).....	MI-40799
(TR-3 Color Conversion also requires the ES-43580-A ATC accessory.)		Guide Position Adjuster for Headwheel Panel.....	MI-43351
Audio/Cue Playback	MI-43369	Video Preamp Module (spare).....	MI-40603-BS
Monitor Rack Assembly.....	MI-43361	Mechanical Tape Splicer (15 IPS).....	MI-40772
Record Accessory	MI-43360	Mechanical Tape Splicer (7.5 IPS).....	MI-40748
(The TR-3 Record Conversion Requires Monitor Assembly MI-43361.)		Test Module Extender.....	MI-40649
Remote Control Panel (Mode).....	MI-40691-A	Special Module Extender (44 terminals).....	MI-557301
Remote Control Panel (Signal).....	MI-40692-A	Monochrome Video Alignment Tapes (525 line, 60 cps.).....	MI-40793
Air Bearing Conversion Kit with Compressor, 117/60, for external mounting.....	MI-43276	Monochrome Video Alignment Tapes (625 line, 50 cps.).....	MI-40797
Air Bearing Conversion Kit with Compressor, 230/50, for external mounting.....	MI-43277	TM-27AC Color Monitor, Cabinet 17".....	MI-40232-A
Headwheel Panel Assembly (Standard Track Air Bearing).....	MI-40790-A	Magnetic Tape Head Degausser.....	MI-11995
Headwheel Panel Assembly (Standard Track Ball Bearing).....	MI-40760-B		

Specifications

General

Storage Medium.....Magnetic tape 2" (5.08 cm) wide
 Reel Size.....Up to 14" (35.56 cm) reels
 Tape Speed: **50 Cycle** **60 Cycle**
 Normal Speed15.6" (39.7 cm) 15" (38.2 cm)
 Half Speed7.8" (19.8 cm) 7.5" (19.1 cm)

Picture-Sound Separation:
 Normal Speed14.8 frames sound leading 18.5 frames sound leading
 Half Speed29.6 frames sound leading 37 frames sound leading

Playback Time:
 Normal Speed61 min. on a 12.5" (31.75 cm) reel 64 min. on a 12.5" (31.75 cm) reel
 Half Speed122 min. on a 12.5" (31.75 cm) reel 128 min. on a 12.5" (31.75 cm) reel

Rewind TimeApprox. 4 min. for 4800 ft. of tape Approx. 3 min. for 4800 ft. of tape

Stopping Time.....Less than 0.2 seconds from play

Playback Time Reference.....To power line or local sync

Start Time for Stabilized Picture and Sound:
 Tone Wheel Mode.....Less than 5 seconds from Stop, Less than 3 seconds from Standby
 Switchlock Mode.....Less than 5 seconds from Stop

Tape Interchangeability...Tapes made on standard quadruplex machine may be played back on the TR-3 providing they are made in accordance with all applicable proposed SMPTE recommended practices and proposed ASA standards.

Tape Timer.....Accumulated time measured in minutes and seconds at 15 in./sec. tape speed on a 60 cycle machine and 15.6 in./sec. (39.7 cm) on a 50 cycle machine. Accuracy—Repeatable within 3 seconds per hour.

Horizontal Displacement of Vertical Aligned Picture Elements.....Not to exceed 20 nsec. at junction points

RF Limiting.....Sufficient to allow RF signal level into the demodulator to be 55 db below nominal before video signal is affected by a 10% reduction in level

Signal Levels

Input Signal Requirements:
 SYNC.....Negative polarity 3 to 5 volts p/p loop through or terminate in 75 ohms

Output Signal Availability:
 VIDEO-MONOCROME or COLOR
 (Processed).....Three line outputs—two composite—one composite or non-composite internally selected. Source impedance, 75 ohms. Load impedance, 75 ohms.

VIDEO-MONOCROME or COLOR

(Demodulator Output).....One line composite, 1 volt p/p nominal into 75 ohms
 Video Level.....0.5 to 1 volt p/p
 Sync Level.....0.2 to 0.4 volt p/p
 Pedestal Level.....±20% of video level

AUDIO:

One Line Output.....+18 dbm max. into 150/600 ohms balanced or unbalanced line
 One Phone Jack Output for High Impedance Phones
 RF COPY.....1 volt p/p level, 75 ohms terminated

Electrical

Power Requirements:
 60 cycles ±2 cycles.....115 volts a-c ±10% single phase 1.5 kw
 50 cycles ±2 cycles.....230 volts a-c ±10% single phase 1.5 kw

Frequency Response:
 Video Channel—Monochrome
 405/525 Lines.....±1.5 db 25 cycles to 4 mc
 625 Lines.....±1.5 db 25 cycles to 4.5 mc; -3 db max. at 5 mc
 Audio Channel:
 Normal Speed.....±2 db 50 to 15,000 cycles
 Half Speed.....±2 db 60 to 10,000 cycles

Signal-to-Noise Ratio:

Video on an interchangeable tape basis, 4 db pre-emphasis, 15 ips
 405/525 Line Monochrome.....Better than 40 db (37 db at 7½ ips)
 625 Line Monochrome.....Better than 37 db (34 db at 7½ ips)
 Audio.....Better than 50 db, measured overall between a recorded level corresponding to 3% total rms distortion at 1,000 cycles per second and noise present when playing back an erased unmodulated tape

Transient Response.....Rise time less than 150 nsec. Overshoot less than 12% on 60 nsec. sine-squared window test pattern

Ambient Temperature and Humidity.....Between 35° and 110°F (0° to 45°C) at 20 to 90% relative humidity

Wow and Flutter:

Total RMS Wow and Flutter—0.5 to 250 cps range:
 Normal Speed, 0.2% rms; Half Speed, 0.25% rms

Mechanical

Dimensions: Width 22" (56 cm), Height (with built-in casters) 66" (168 cm), Depth 24" (61 cm)

Shipping Information: Width 27¾" (70.5 cm), Depth 29" (73.5 cm), Height 77" (195 cm), Volume 43.0 ft.³ (1.29 M³), Gross Weight 720 lbs. (326.6 kg)

Ordering Information

The Type TR-3 Television Tape Player is available for operation on 525, 625 and 405 line tv standards. ... Can be supplied as color or monochrome equipment.

Two basic models are available:
 (1) a 525 line machine
 (2) a switchable machine for 525/625/405 (or optional 819) line operation

They may be ordered as follows:
 For 525 line operation, specify ES-43570
 For 525/625/405 line operation, 50 cycles, specify ES-43572-405
 For 525/625/819 line operation, 50 cycles, specify ES-43572-819

All models include the following equipment complement:

- 1 TV Tape Player (cabinet mounted) complete
- 1 Headwheel Panel Assembly (Ball Bearing)
- 1 Kit of Maintenance Materials
- 1 Monochrome Video Alignment Tape
- 1 Mechanical Guide Adjustor

Mobile TV Tape Recorder, Type TR-5

- **Compact, Quadruplex Recorder on Wheels**
- **Makes and Plays Tapes for Broadcast and Closed Circuit**
- **Records both Monochrome and Color Pictures**



Mobile TV Tape Recorder

for making quadruplex tapes in studio or field

Standard
1 1/2-inch Reels

Master
Erase Indicator

Built-in
Switchlock

Switchable
Standards

Fully
Transistorized

Two-speed
Operation

Built-in Playback
Reference

Interchangeable
Plug-in Modules

Compact...
Easily Transportable



Available Accessories:

- Electronic Splicer
- Audio Cue Record/Playback Channel
- Remote Control

COMPACT QUADRUPLEX RECORDER FOR A VARIETY OF APPLICATIONS

Mobile Recording

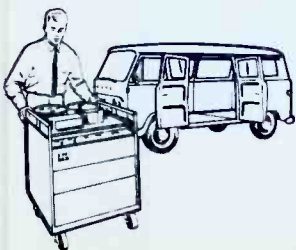

Educational TV Programming

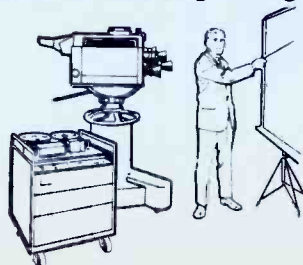

Tape Duplication

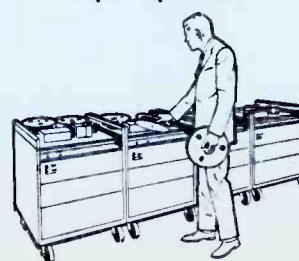

Client Presentations

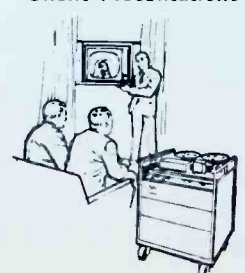

Mobile Tape Recorder, TR-5

The TR-5 TV Tape Recorder "on wheels" is an RCA "New Look" equipment especially designed for recording of video tapes, color and monochrome, at various locations in the plant or in the field. It is small in size and mounted on casters for easy movement from one location to another. The recorder con-

forms to highest broadcast standards. Tapes recorded on it are fully compatible with all standard broadcast quadruplex recorders. For closed circuit applications it comprises a complete recording and playback facility. It may also be used for on-air playback by adding a signal processing amplifier.

Description

The RCA Type TR-5 TV Tape Recorder is engineered to produce TV Tapes that faithfully reproduce the high quality monochrome and color pictures now provided by new, improved TV Cameras. It employs standard RCA transistorized, interchangeable modules. It accommodates cue record/playback and electronic splicer accessories.

Switchable Standards

The TR-5 is equipped for operation on international (switchable) or domestic standards. To change from one standard to another, an operator merely moves the standards selector switch to the desired position. This master circuitry provides instantaneous switchover from 525 to 625 to 405 TV line standard.

Built-In Two Speed Operation

Circuits to permit choice of operating speeds, 15 or 7½ inches per second, are built into the TR-5. Recording time of up to 60 minutes at 15 IPS and 120 minutes at 7½ IPS is possible with the 12½-inch tape reels.

Interchangeable Sub-Assemblies

The modular construction of the TR-5 mobile recorder means that many of the sub-assemblies are interchangeable with the TR-3/4 and TR-22 recorders. All modules are completely accessible and by means of a module extender it is possible to service the machine while in operation.

Transistorized for Reliability

Advanced transistorized modular circuits are used through the TR-5. These solid state circuits operate on lower voltages and require much less power and generate less heat. As a

result power supplies are small, efficient units, and air conditioning requirements are reduced. Transistors have proved extremely reliable and stable. All TR-5 circuits are conservatively rated, and permit semi-automatic "pre-set" type of operation. Warm-up time is greatly reduced, practically eliminated, since no warm-up cycle is required.

Record/Playback Circuitry

The record circuitry of the TR-5 includes a standard modulator and four standard record amplifiers. Each of the amplifiers provide quadrature delay as well as FM level control. Color or monochrome video signals are recorded with amazing realism.

The playback circuitry involved includes playback quadrature delay, four-channel equalization and head switching. Switchlock is also featured as part of the basic machine. For direct on-air broadcasts it is recommended that a signal processing amplifier be utilized. The equipment is designed with built-in audio playback for line drive as well as earphone level monitoring. Stable video playback of any properly recorded quadruplex tape is achieved.

Compact-Transportable

The Tape Recorder is contained in a small cabinet on casters measuring only 31 inches high (37 inches with casters), 33 inches wide and 24 inches deep. It weighs approximately 475 pounds. It may readily be moved from one studio to another or transported to remote locations.

Ease of Servicing

TR-5 modules can be easily removed for repair or replacement.

They may also be checked without removing through use of module extenders supplied with the equipment. Spares can be inserted as fast as one can pull out the module and plug in another. This standardization of modular circuits permits interchange of many modules between various RCA models in multiple equipment installations. Furthermore, complete modular spares can be stocked for emergency use.

Horizontal Tape Transport

The low contour of the TR-5, so essential for ease of transportation to remote locations has been achieved not only by the compact transistorized circuitry, but also by a horizontally mounted tape transport. This transport has all the conveniences and fine performance qualities of the TR-3 and TR-4 Tape Recorders. Air lubricated guide posts provide long tape life, while tapered guide post flanges aid tape threading. The transport panel is hinged for complete access to components.

Finger Tip Controls

Push-button operating controls are conveniently located. They afford complete mode control of play, record, fast forward, fast reverse, and stop. In addition there is a two-speed indicator, local and remote switch, audio/mike switch and (tone wheel/switchlock) indicator. A switchable audio-video VU meter and metering facilities for control track phasing can also be used for measuring sync tip frequency. Three front panels provide complete access to mode control modules, the module bank, and the base of the equipment where power supply and air system are located.

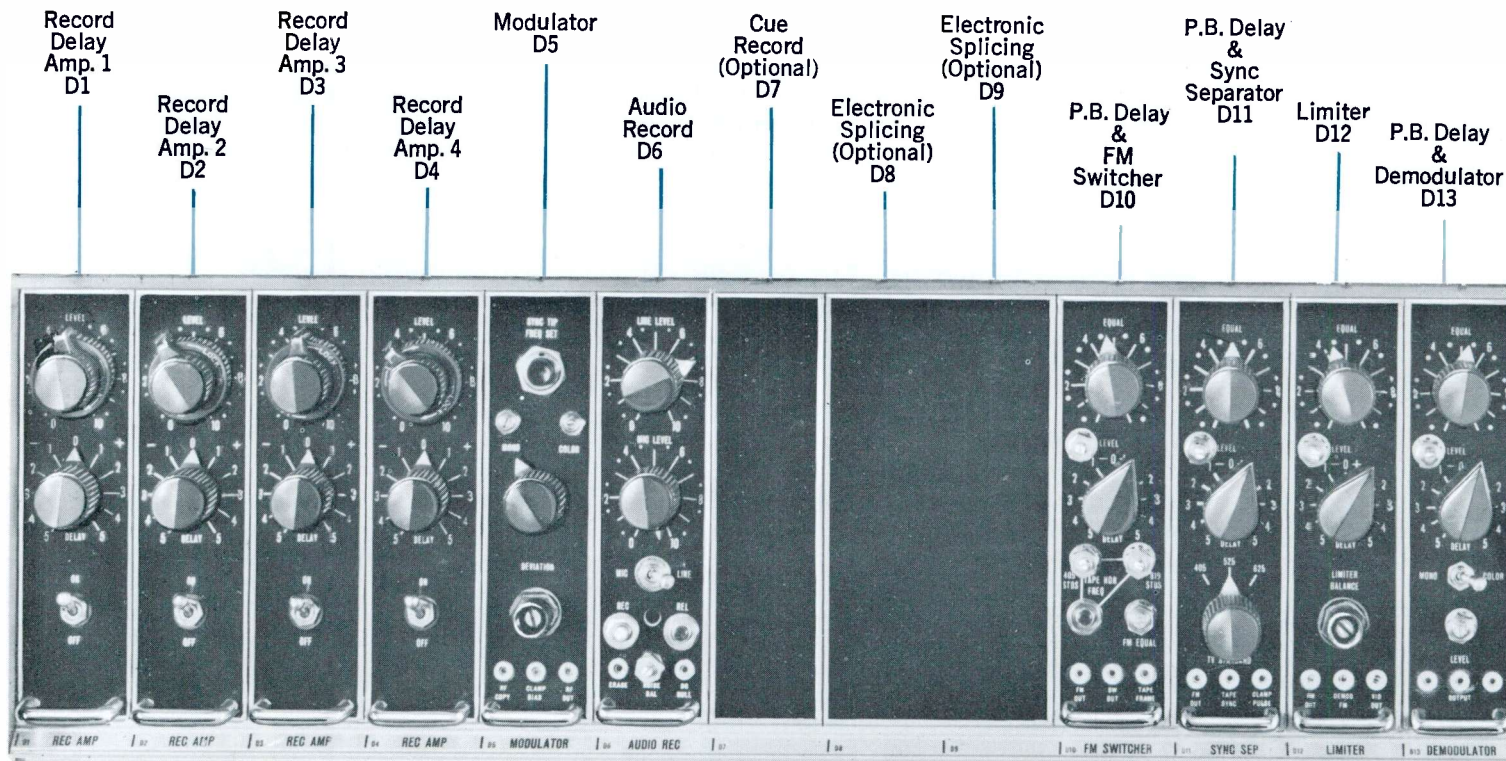

TR-5 Module Bank... Description of Functions

D1—Record Delay Amplifier #1

The Record FM signal is increased in level to a value sufficient for recording on tape and adjustable delays are introduced to compensate for head quadrature errors.

D2—Record Delay Amplifier #2

Same functions as D1.

D3—Record Delay Amplifier #3

Same functions as D1.

D4—Record Delay Amplifier #4

Same functions as D1.

D5—Modulator

Input video is pre-emphasized, clamped at the sync-tip level and used to modulate a capacity-diode-controlled heterodyne modulator. Circuitry is included for r-f copy facility.

D6—Audio Record

Provides audio record bias and erase currents. The microphone input control is included in the module.

D7—Cue Record (Optional)

Space is provided in the TR-5 for the accessory Cue Record Module.

D8—Electronic Splicing (Optional)

Space is provided for the accessory Splice Timing Module.

D9—Electronic Splicing (Optional)

Space is provided for the accessory Splice Logic Module.

D10—FM Switcher

This module includes a 2x1 switching circuit which alternately connects heads 1 and 3 and heads 2 and 4 to the output. Also included are tape sync processing circuits that produce horizontal-rate reference, field-rate reference and frame-rate reference. The playback delay amplifier, FM equalizer and FM level control for Head #1 are located in this module.

D11—Sync Separator

This module includes a sync separator and circuitry to provide the switching pushout pulse. The playback delay amplifier, FM equalizer and FM level control for Head #2 is included.

D12—Limiter

Module includes limiting circuits where the FM signal is converted to push-pull, passed through several stages until overall limiting character-

istic of at least 55 db is achieved. The playback delay amplifier, FM equalizer and FM level control for Head #3 is included.

D13—Demodulator

The Playback delay amplifier, FM equalizer and FM level control for Head #4 is included in this module which accepts signal from limiter and contains demodulator and output filter circuits. Provides output line driver.

D14—Control Track & Record/Playback

The 240-cycle control track signal is amplified, filtered to produce a clean 240-cycle sine wave, clipped, and shaped into a pulse. The pulse is then fed to a chain of binary counters that divide the pulse frequency by eight to produce a 30-cycle output pulse. Switchlock circuitry is also provided in this module.

D15—Capstan Oscillator

Acts as a phase detector which compares incoming pulse to the local frame pulse and produces a d-c voltage proportional to the magnitude of the phase error. The d-c error voltage controls the frequency of the oscillator which supplies the drive frequency for the capstan motor. Tape speed is thereby synchronized to local reference.

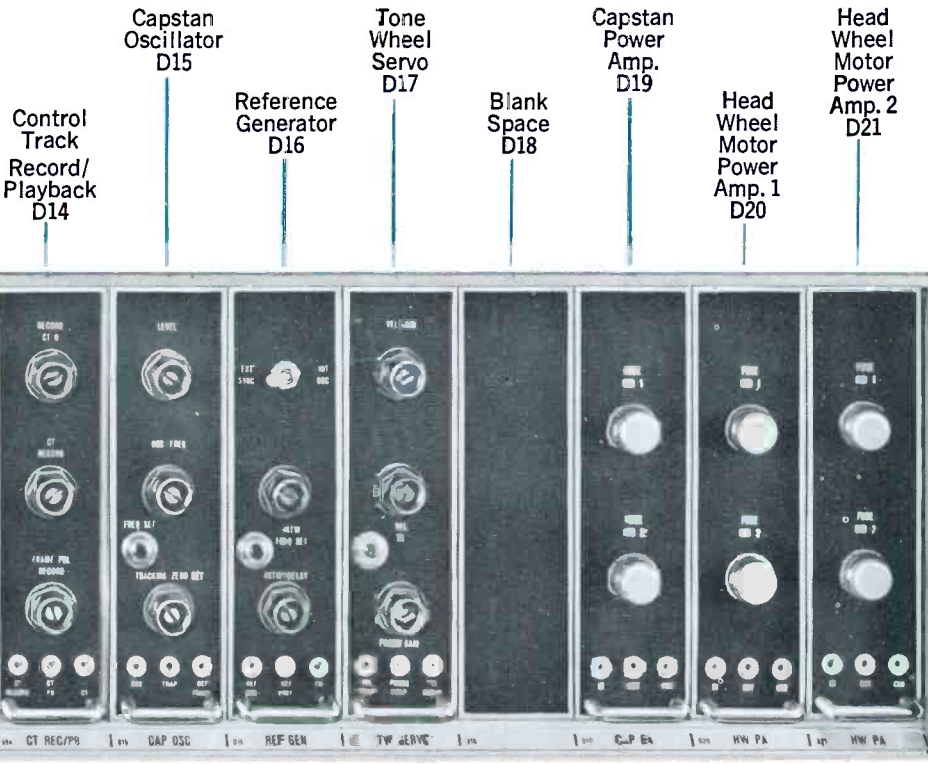

D16—Reference Generator

Processes local sync to produce horizontal-rate reference and field-rate reference. Provides playback reference from internal oscillator when local sync is not available. Module also includes the tone wheel pulse and provides 960-cycle switcher drive.

D17—Tone Wheel Servo

Derives error signal controlling the headwheel motor. Module includes circuits which amplitude-modulate the headwheel motor-drive sine waves. Gives wide band two-phase output.

D18—Blank Space

D19—Capstan Power Amplifier

Provides power amplification required by the capstan motor.

D20—Head Wheel Motor Power Amplifier #1

Power amplifier for one phase of the headwheel motor drive.

D21—Head Wheel Motor Power Amplifier #2

Power amplifier for one phase of the headwheel motor drive.

FUNCTIONAL DIAGRAM

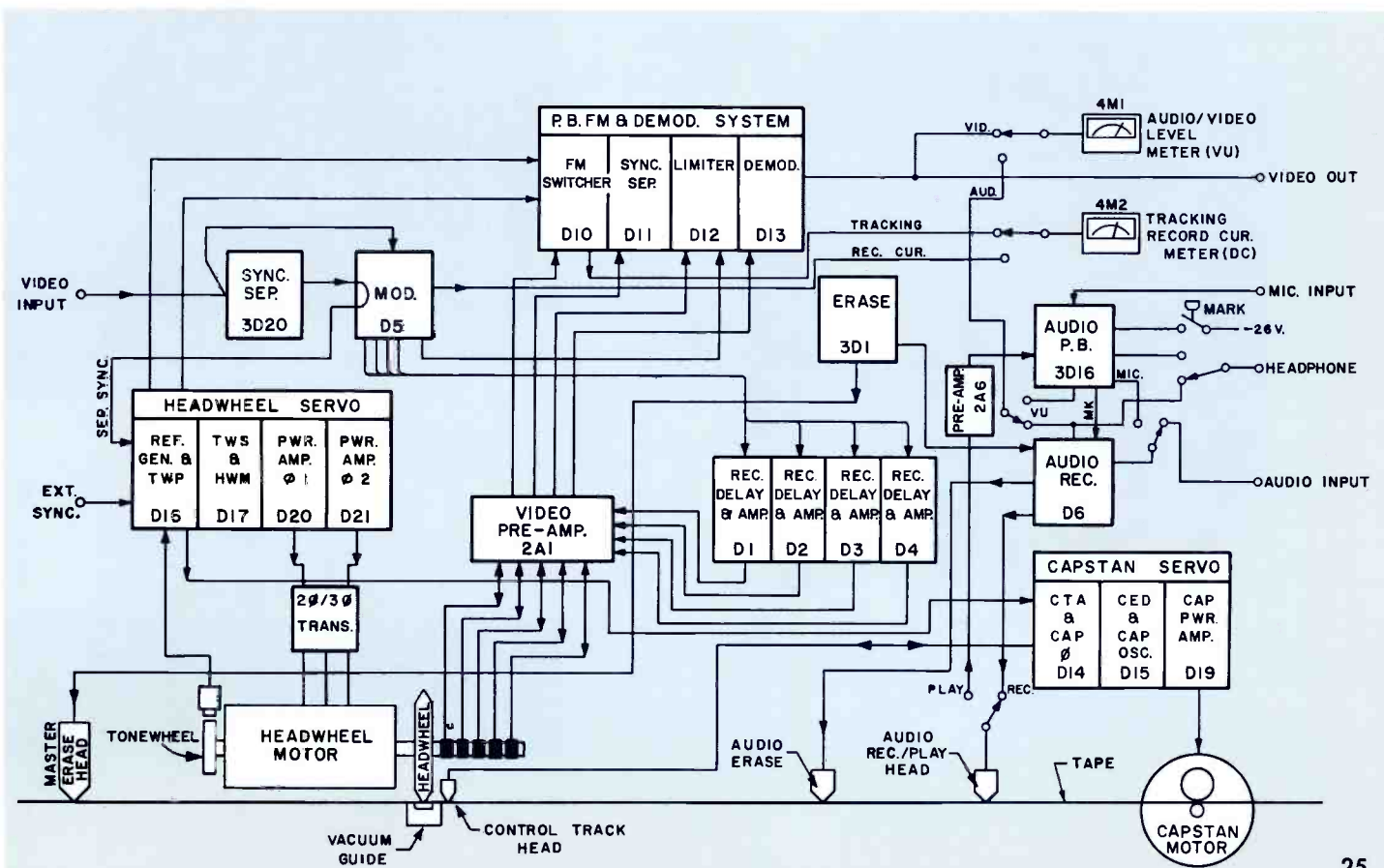

Modular Accessories increase recording capability

Audio Cue Record/Playback

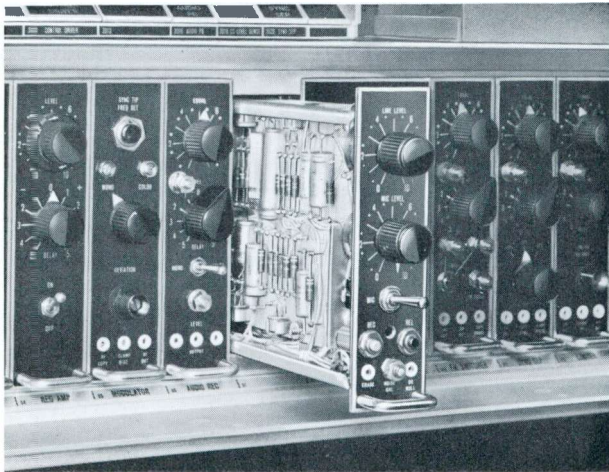

Electronic Splicer

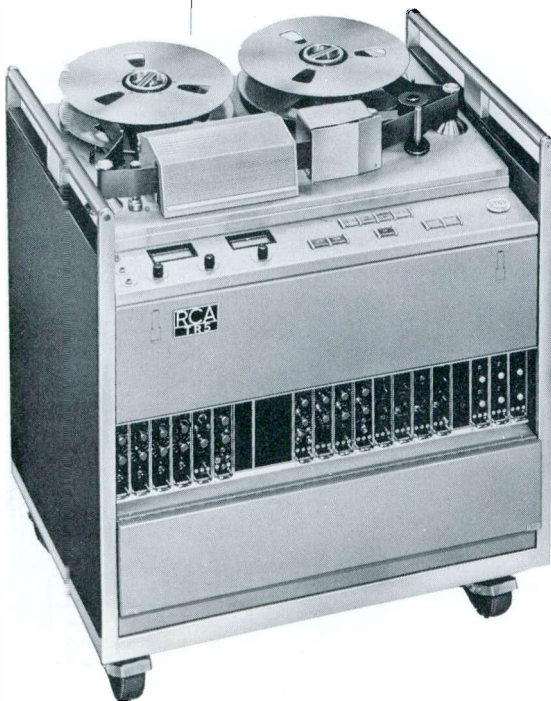

Remote Mode Control



Major Accessories

Space is provided in the TR-5 for the addition of two convenient accessory equipments—an audio cue channel and the electronic splicer.

Cue Record/Playback

The cue record/playback accessory head provides a means for recording cue information along one edge of the video tape. This can be in the form of voice, tone or digital information. A special feature of the program and cue channel is that recording can be done independent of video recording; in other words, sound may be dubbed in while playing back or previewing the video signal.

Electronic Splicing

Splicing and editing of TV tape by electronic means can be accomplished with the TR-5 by addition of an electronic splicer. It will permit program segments to be added to a recorded segment or inserted within it. It operates at either 7½ or 15 IPS tape speeds.

The equipment comprises three transistorized modular units (splice timing, splice control and splice logic modules), selective erase head, wiring harness and auxiliary modification material.

The modular construction affords

easy accessibility to all components. Furthermore, removal of any module automatically returns the tape recorder to normal operation. This by-pass feature is only one of several improvements in electronic splicing. Other features are two-speed operation, switchable standards, and push-button set-up procedure.

Remote Control

A Remote Mode Control Panel, MI-40691, enables the following functions to be performed: stop, fast forward wind, reverse wind, record and play. The control panel, can be operated from either an internal or external power source.

COMPLETE LIST OF ACCESSORIES

Electronic Splicing	ES-43566	Guide Position Adjuster for Headwheel Panel.....	MI-43351
Cue Record/Playback	MI-43348	Video Preampfier Module (spare).....	MI-40603-BS
Remote Control Panel (Mode).....	MI-40691-A	Mechanical Tape Splicer (15 IPS).....	MI-40772
Air Bearing Conversion Kit with Compressor, 117/60, external mount.....	MI-43344	Mechanical Tape Splicer (7½ IPS).....	MI-40748
Air Bearing Conversion Kit with Compressor, 230/50, external mount.....	MI-43345	Test Module Extender.....	MI-40649
Air Bearing Conversion Kit, Less Compressor, for systems using house air.....	MI-43342	Special Module Extender (44 terminals).....	MI-557301
Headwheel Panel Assembly (Standard Track Air Bearing).....	MI-40790-A	Ceramic Headset	MI-38028-2
Headwheel Panel Assembly (Standard Track Ball Bearing).....	MI-40760-B	Monochrome Video Alignment Tapes (525 line, 60 cps).....	MI-40793
Headwheel Panel Assembly (Narrow Track Air Bearing).....	MI-40799	Monochrome Video Alignment Tapes (625 line, 50 cps).....	MI-40797
Headwheel Panel Assembly (Narrow Track Ball Bearing).....	MI-40791	Magnetic Tape Head Degausser, 117/50 or 60.....	MI-11995
		Magnetic Tape Head Degausser, 220/50 or 60.....	MI-11996

Specifications

Record

Recording Medium.....Magnetic tape 2" wide

Tape Speed: **50 Cycle** **60 Cycle**

Normal Speed15.6" (39.7 cm) 15" (38.2 cm)

Half Speed7.8" (19.8 cm) 7.5" (19.1 cm)

Picture-Sound Separation:

Normal Speed14.8 frames sound leading 18.5 frames sound leading

Half Speed29.6 frames sound leading 37 frames sound leading

Recording Time:

Normal Speed61 min. on 12½" reel (4800 ft.) 64 min. on 12½" reel (4800 ft.)

Half Speed122 min. on 12½" reel (4800 ft.) 128 min. on 12½" reel (4800 ft.)

Rewind TimeApprox. 5 min. for 12½" reel Approx. 4 min. for 12½" reel

Stopping Time.....Less than 0.2 sec. from record or play mode

Recording Time Reference.....Composite video signal

Starting Time for Stabilized Picture and Sound.....5 secs. from stop; 3 secs. from set-up

Tape Interchangeability:

Record.....Tapes recorded on the TR-5 are made in accordance with all applicable proposed SMPTE recommended practices and proposed ASA standards and may be played back on any quadruplex machine.

Horizontal Displacement of Vertical Aligned

Picture Elements.....Not to exceed 0.02 microseconds when recordings from the TR-5 are played back on machines adjusted for correct playback of MI-40793 or 40797 alignment tape.

Input Signal Requirements:

VIDEO.....Input signal level may be between 0.8 and 1.2 volts p/p composite signal; signal may be looped through or terminated in 75 ohms.

AUDIO.....Line input level between -20 dbm and +18 dbm into a 10,000 ohms balanced bridging impedance

SYNC.....Negative polarity 3 to 5 volts p/p loop through or terminated in 75 ohms

Playback

Playback Time Reference.....To external sync or internal reference

Output Signal Availability:

Video (Unprocessed).....One composite line; video level 1.0 volt p/p into 75 ohms

Audio.....(1) One line output +18 dbm max. into 150/600 ohms balanced or unbalanced line. (2) One monitoring output for high impedance phones

Audio Mark.....A built-in audio mark oscillator is provided for insertion of a 400 cycle tone on the Audio Talk

Power Requirements.....115/230 volts a-c, ±10%, 48-62 cycles, single phase, 1.2 kw

Frequency Response:

Video Channel Monochrome.....405/525 ±1.5 db 25 cycles to 4 mc; 625/819 ±1.5 db 25 cycles to 4.5 mc; -3 db at 5 mc

Audio Channel:

Normal Speed.....±2 db 50 to 15,000 cycles

Half Speed.....±2 db 60 to 10,000 cycles

Signal-to-Noise Ratio:

Video at 15 ips
405/525 Line Monochrome.....Better than 40 db (37 db at 7½ ips)

625 Line Monochrome.....Better than 37 db (34 db at 7½ ips)

Audio.....Better than 50 db measured overall between a recorded level corresponding to 3% total rms distortion at 1000 cycles per second and noise present when playing back an erased unmodulated tape

Wow and Flutter:

Total RMS Wow and Flutter 0.5 to 250 cps range:

Normal Speed.....0.2% rms

Half Speed.....0.25% rms

Picture Jitter.....Recordings from the TR-5 may be played back on a TR-22 or equivalent machine in Pixlock mode with picture jitter less than ±0.1 microsecond

Ambient Temperature and Humidity.....Between 35° and 110°F (0° and 45°C) at 20 to 90% relative humidity

Mechanical

Dimensions:

Width.....32¾" (83 cm)

Height:

Overall with casters.....37" (94 cm)

Overall less casters.....31" (79 cm)

Depth.....24" (61 cm)

Shipping Information: Width 36⅝" (93 cm), Depth 28¼" (71.6 cm), Height 48" (122 cm), Volume 34.5 ft.³ (1.035 M³), Gross Weight 525 lbs. (238.16 kg)

Ordering Information

The Type TR-5 Mobile TV Tape Recorder operates on 525, 625, and 405 line tv standards.

Type TR-5 TV Tape Recorder, for 525/625/405 line, 50/60 cycles, switchableES-43565-405

Type TR-5 TV Tape Recorder, for 525/625/405 (or optional 819) line, 50/60 cycles, switchable.....ES-43565-819

All models include the following equipment:

- 1 TV Tape Recorder (Transportable Cabinet) complete
- 1 Headwheel Panel Assembly (Ball Bearing)
- 1 Kit of Maintenance MaterialsMI-43350
- 1 Monochrome Video Alignment Tape:
 - 525 LineMI-40793
 - 625 LineMI-40797

Deluxe TV Tape Recorder, Type TR-22D

- Fully transistorized for dependable performance
- Built-in Automatic Timing Correction
- Plug-in Color ATC accessory available

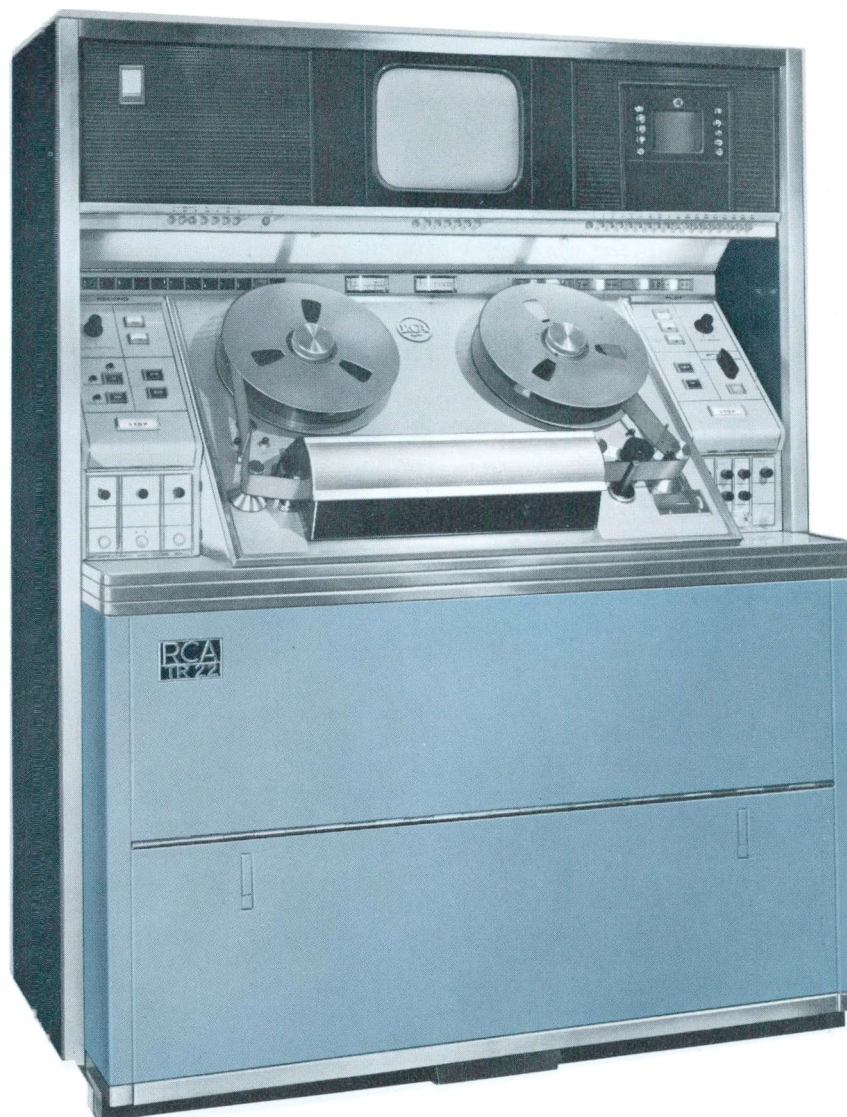

Deluxe TV Tape Recorder, Type TR-22D

This deluxe, transistorized tv tape recorder maintains a high measure of excellence in producing trouble-free, error-proof tape recordings and in obtaining high-quality reproduction from recorded tapes—both color and monochrome.

This new TR-22D model is designed for added facility in color taping operations. Accessory color modules merely plug into the space provided for them. Tape handling has been improved to increase color tape life. A number of technical innovations are included to fortify the reliability and repeatability of producing color tapes. The result is a machine on which good color tapes can be produced time after time—by semi-technical personnel.

Completely self-contained in a modern compact console, the TR-22D is functionally designed for utmost ease of operation. Included in the basic recorder are such quality features as automatic timing corrector (for monochrome operation), tape lifter, a tape motion sensor, and latest-design transistorized audio, picture and waveform monitors.

The TR-22D will accept a number of deluxe accessories that may be housed within the compact console. These accessories include automatic timing corrector (for color operation), dropout compensator, and electronic splicer. They are all transistorized, all modularized, all designed to plug into the spaces provided for them.

Description

Color Advantages

The TR-22D is designed to the exacting standards of color tv. It can be used for color taping by merely plugging in color ATC modules. This accessory fits into the planned space in the basic console. Addition of color ATC permits making and playing of color tapes with the same kind of reliability and repeatability experienced in monochrome taping.

A new headwheel servo system includes four high-performance modes of operation—tone wheel, switchlock, pixlock, and linelock. The fourth mode, linelock, is particularly valuable in playing color tapes. It will handle tapes made with a more than normal range of timing errors, thereby increasing the playability of color tapes from outside sources.

Transistorized for Reliability

The advanced circuitry of the TR-22D uses semiconductors to perform all circuit functions necessary to the recording and playing back of television tape. Use of long life transistors and other solid state components makes possible significant savings in size, weight, and power consumption. Transistor circuits provide reliability over long periods of time, reduce maintenance, and give dependable performance.

Stabilized for Uniform Quality

Uniform picture quality is a result of stabilized circuits in the

TR-22D. These circuits function to correct themselves, holding a high-level of performance over long periods of operation. They compensate for changes that may occur with component aging. Operators are freed from constant attention and frequent "touch-up" of controls.

Fully Instrumented Operation

Another significant contribution is a unique signalling system which indicates faulty operation during recording or playback. A series of indicator lights point out operational modes, warn operators of potential trouble, and help technicians quickly pinpoint and correct malfunctions, should they occur.

Automatic Timing Corrector

Transistorized circuits to provide electronic compensation for geometric distortions which may occur in some recorded tapes are built into the TR-22D. These distortions (skewing, quadrature or jitter) occur as timing delay errors and are virtually eliminated after passing through ATC. Serving as a continuous monitoring device, ATC automatically compensates for time delay errors, thereby assuring best possible playback quality.

Easy Handling Tape Path

The TR-22D is easier than ever to thread. This is made possible by using cone-shaped guide posts and a newly styled headwheel cover which

provides increased access to the video headwheel and audio heads.

A tape lifter is included in the tape path to remove the tape from the master erase head whenever the machine is in the wind mode. This device is air activated and is comprised of a sapphire rod on which the tape rides. Use of the tape lifter results in longer tape life, less tape scratching and also longer life for the master erase head.

Switchable Standards

In recognition of the increasing importance of international exchanges of television programs, the TR-22D is available in two basic models: (1) a 525-line machine, and (2) a switchable standards machine for 525/625/405 or 819-line operation. In the latter model, either 405 or 819 line operation may be specified as the third standard.

To change from one standard to another, an operator merely moves a selector switch to the desired position. This master switch changes all machine circuitry—i.e., monitors and CRO—to the desired standard.

Built-In Two-Speed Operation

Circuits to permit choice of operating speeds—7½ or 15 inches per second—are built into the TR-22D. By switchover to half-speed recording (7½ ips), substantial savings in tv tape stock can be realized. Use of a narrow track headwheel assem-

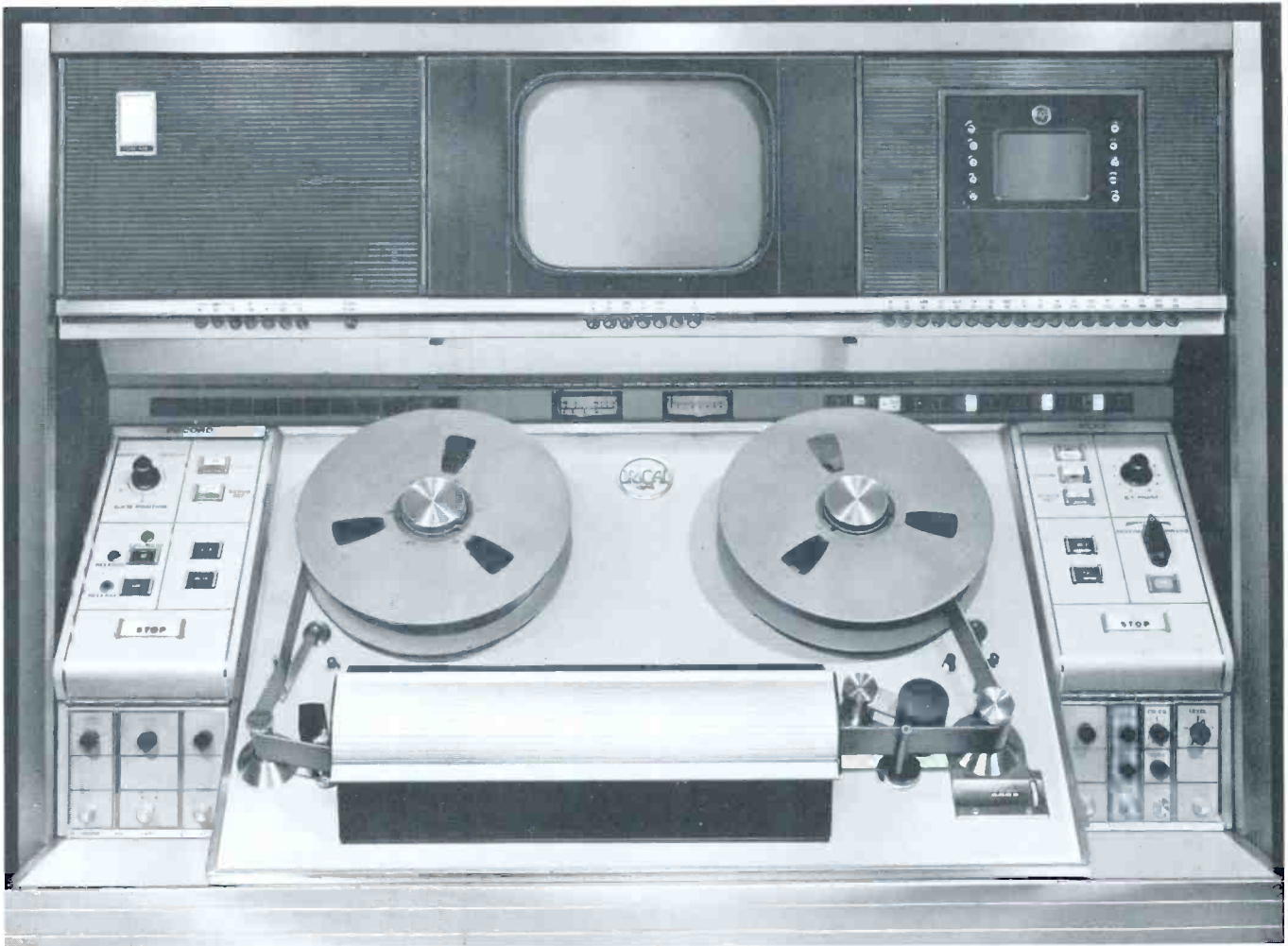

EASY THREADING FOR QUICK-ACTION TAPE HANDLING . . . Headwheel cover slides back against tape deck for easy threading . . . from natural, comfortable position. This expedites tape handling, splicing and editing.

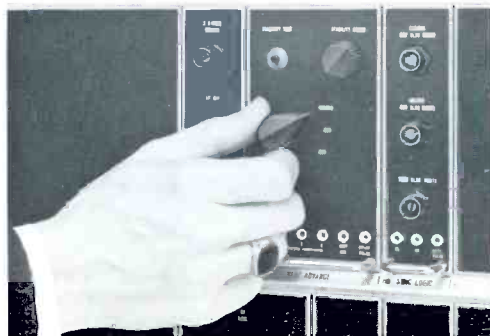

SWITCHABLE TV LINE STANDARDS FOR WORLD-WIDE USE . . . The TR-22D is available in a switchable standards model which provides instantaneous switchover from 525 to 625 to optional 405 or 819 tv line standards.

CONTROL CENTER . . . All operating functions of the TR-22D are centered at this modern tape deck—functionally styled to make operations easy and to encourage consistently high quality pictures with minimum effort. Recording and playback controls are built on separate panels arranged at either end of the tape deck to reduce the possibility of human errors. This is the quality control center—the “business” end of the TR-22D recorder.

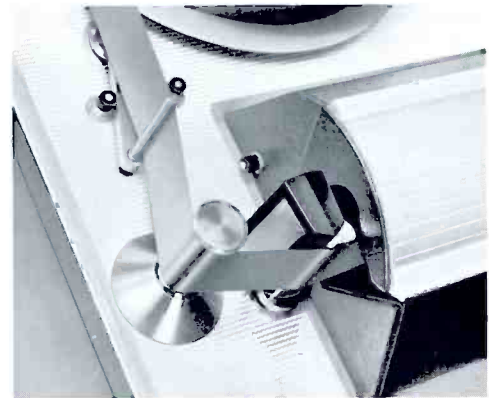

TAPE LIFTER AND CONE-SHAPED GUIDE . . . increase tape life and wear on erase head at same time reducing tape dropouts.

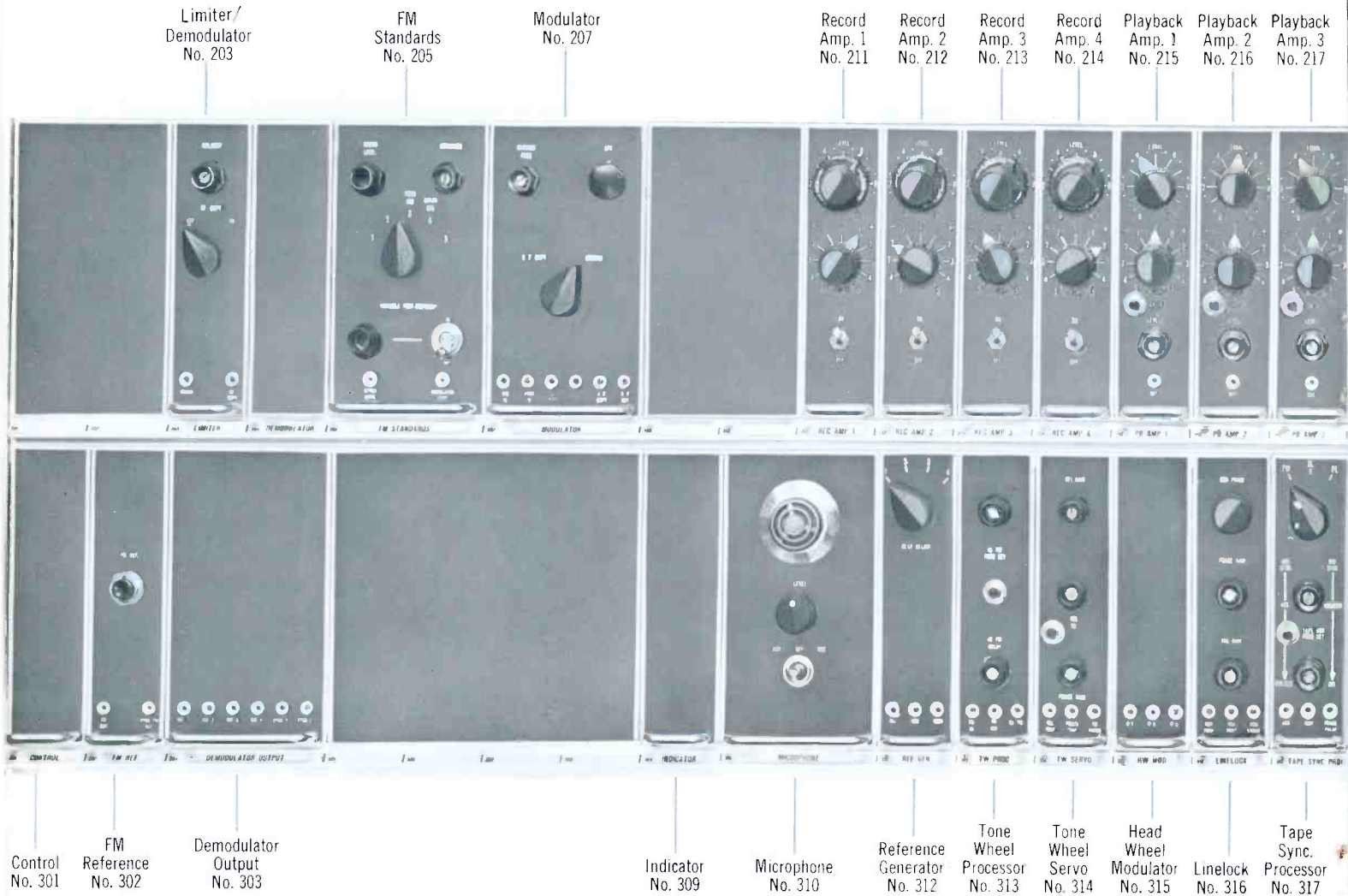

TR-22D Module Bank ..

Limiter/Demodulator—No. 203

FM signal is converted to push-pull, passed through several stages until overall limiting characteristic of at least 55 db is achieved. Contains demodulator and output filter circuits.

FM Standards—No. 205

Video input is pre-emphasized to make a standard recording. A five-position switch selects proper pre-emphasis for monochrome, color, or special standards. Post-emphasis for playback is also provided.

Modulator—No. 207

Clamps pre-emphasized video at the sync-tip level to modulate a capacity-diode-controlled heterodyne type modulator. Circuitry included for rf copy facility.

Record Amplifier 1—No. 211

Output from record delay amplifier No. 1 is increased in level to a value sufficient for recording on tape.

Record Amplifier 2—No. 212

Output from record delay amplifier No. 2 is increased in level to a value sufficient for recording on tape.

Record Amplifier 3—No. 213

Output from record delay amplifier No. 3 is increased in level to a value sufficient for recording on tape.

Record Amplifier 4—No. 214

Output from record delay amplifier No. 4 is increased in level to a value sufficient for recording on tape.

Playback Amplifier 1—No. 215

Gain circuit and equalizer amplifier for correcting variations of frequency response in Channel No. 1.

Playback Amplifier 2—No. 216

Gain circuit and equalizer amplifier for correcting variations of frequency response in Channel No. 2.

Playback Amplifier 3—No. 217

Gain circuit and equalizer amplifier for correcting variations of frequency response in Channel No. 3.

Playback Amplifier 4—No. 218

Gain circuit and equalizer amplifier for correcting variations of frequency response in Channel No. 4.

Guide Servo—No. 221

Control position of the guide to produce skew-free pictures. Functions in automatic, manual, record, and record-set modes of operation.

Delay/Output—No. 223

Delay video is time modulated line-by-line in the variable delay line. Output line drivers provide time corrected video signals for monitoring and processing.

ATC Error Detector—No. 225

Generates error signal which is amplified (non-linearly) and fed to two phase splitters. Four error outputs drive the variable delay line.

ATC Reference—No. 226

Contains AFC which may be locked to local sync signal or tape sync signal. ATC trapezoid is generated from ATC pulse. A clamp sync separator provides a time corrector sync output to the processing amplifier.

Horizontal AFC—No. 227

Tape sync from the demodulator output is used to control the frequency and phase of a multi-vibrator. This, in combination with other circuits, generates a new horizontal sync, front porch, and blanking.

Vertical Advance—No. 228

Special circuitry counts out the number of pulses in a field, to determine very accurately the position for regenerated vertical blanking. Includes 3-position standards switch in switchable standards model.

Sync Logic—No. 230

Generates horizontal and vertical blanking; combines them into composite blanking. Combines tape sync and regenerated horizontal sync into composite regenerated sync. Generates a start pulse which phases the counting of the vertical advance circuitry.

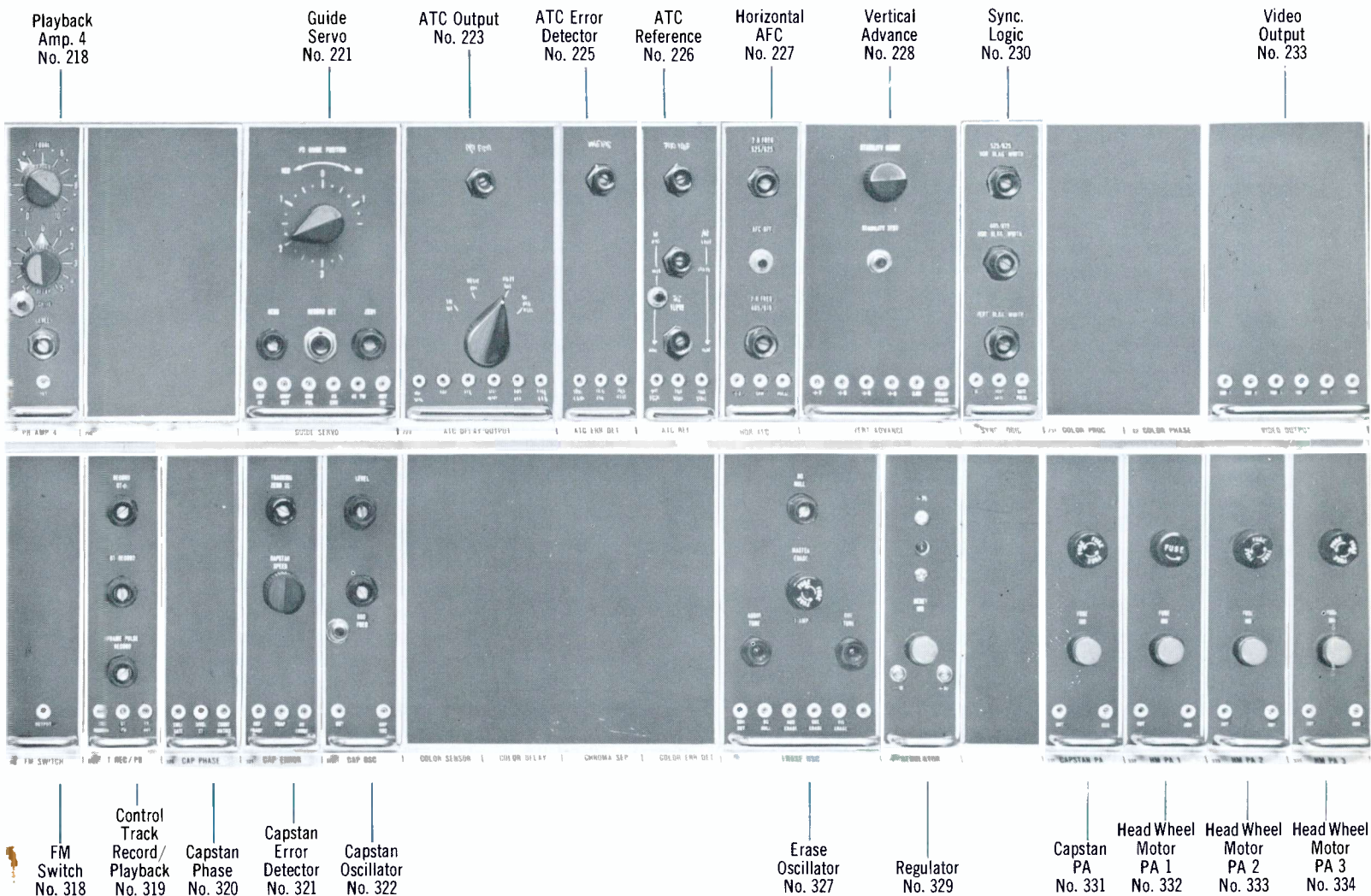

Description of Functions

Video Output—No. 233

Two sending-end-terminated line drivers distribute video within the machine. Three sending-end-terminated line drivers provide outputs from the machine.

Control—No. 301

Part of control system. Provides inhibit logic and time delays.

FM Reference—No. 302

Provides two reference frequencies keyed in from crystal oscillators. References are introduced on alternate vertical blanking intervals and represent precise sync-tip and peak-white frequencies.

Demodulator Output—No. 303

Separates tape sync from the tape signal. Provides line drivers to feed unprocessed video to monitoring circuits and to processing amplifier.

Indicator—No. 309

Senses machine performance and lights trouble indicator in the event of malfunction.

Microphone—No. 310

Houses microphone and mike-cable reel, with microphone amplifying circuits. Permits operator to record on either audio or cue tracks.

Reference Generator—No. 312

Processes local sync to produce horizontal-rate reference, field-rate reference and frame-rate reference.

Tonewheel Processor—No. 313

Shapes the tonewheel pulse and also provides 960-cycle switcher drive.

Tonewheel Servo—No. 314

Derives error signal controlling the headwheel motor in the tonewheel mode of operation.

Headwheel Modulator—No. 315

Amplitude-modulates the headwheel motor-drive sine waves. Gives wide-band three-phase output.

Linelock—No. 316

Provides line-by-line lock-up in the Pixlock mode.

Tape Sync Processor—No. 317

Processes tape sync to produce horizontal-rate reference, field-rate reference and frame-rate reference.

FM Switch—No. 318

Switches between heads during playback, connecting the head scanning the tape to the output.

Control Track Record/Playback—No. 319

The 240-cycle control track signal is amplified, filtered to produce a clean 240-cycle sine wave, clipped, and shaped into a pulse.

Capstan Phase—No. 320

The preceding pulse feeds a chain of binary counters which divide the pulse frequency by eight to produce a 30-cycle output pulse.

Capstan Error Detector—No. 321

A phase detector which compares incoming pulse to the local frame pulse and produces a d-c voltage proportional to the magnitude of the phase error.

Capstan Oscillator—No. 322

D-c error voltage controls the frequency of the oscillator which supplies the drive frequency for the capstan motor. Tape speed is thereby synchronized to local reference.

Erase Oscillator—No. 327

Supplies 87.5 kc erase and bias current to the audio and cue heads.

Regulator—No. 329

Provides regulated voltages to operate the transistor circuitry of the machine.

Capstan PA—No. 331

Power amplifier for the capstan motor.

Headwheel Motor PA 1—No. 332

Power amplifier for one of the three phases required by the headwheel motor.

Headwheel Motor PA 2—No. 333

Power amplifier for one of the three phases required by the headwheel motor.

Headwheel Motor PA 3—No. 334

Power amplifier for one of the three phases required by the headwheel motor.

bly (in place of the headwheel normally supplied) permits twice as many tracks to be recorded on the same length of tape—with full tape interchangeability with other machines, when operated at 15 ips.

Test and Set-Up Aids

Precision performance is standard with a TR-22D. All circuits, controls and monitors are fully instrumented so that technical personnel find it easy to maintain consistent quality. Complete checkout of recording or playback functions is at the operator's fingertips. A seven-position switcher permits monitoring of audio and cue channel information. The 14-inch picture monitor includes a 7-position switcher for checking picture information at various points in the recorder. Through a 20-position switcher, waveforms at key points in the TR-22D may be monitored.

Mode indicators show at a glance the mode of operation being employed while fault indicating lights point out to the operator areas which may be possible sources of circuit malfunction. A multi-meter used in conjunction with a 24-position module test switcher permits rapid checking of pertinent a-c and d-c voltages.

The Recording Process

The recording process centers at the tape deck and operational area. Before the tape gets to the headwheel, it passes over the master erase head which removes all previously recorded information. This clean tape then passes between the vacuum guide and headwheel where the FM modulated video signal is recorded. The tape next passes over the control track head where a 240-cycle signal is recorded. This signal will be used during playback to make sure that the video heads scan along their respective recorded tracks. A 30-cycle frame pulse superimposed on the control track is used to determine where the tape may be conveniently spliced.

Note: When operating with 50 cycle power, the control track frequency is 250 cycles, and the frame pulse rate is 25 cycles.

A program audio track is recorded along one edge of the tape, the area first having been erased by a separate erase head which is a little wider than the following record head. A simultaneous playback head, after

the record head, allows operator to monitor the audio signal as it is being recorded.

On the other edge of the tape, the cue channel record head provides a means for recording cue information. This can be in the form of voice, tone or digital information. A special feature of the program and cue channel is that recording can be done independently of video recording; in other words, sound may be dubbed in while playing back or previewing the video signal.

MAJOR ACCESSORIES

The complement of production accessories available for the TR-22D includes an Electronic Splicer, a Dropout Compensator, and Color ATC. The recorder is pre-wired to accept all of these by merely plugging them in the module spaces provided for them.

Electronic Splicing

Splicing of TV tape, electronically, is achieved in the TR-22D by inserting accessory plug-in modules into pre-wired receptacles. With the splicer installed, program segments in color or monochrome can be added to or inserted in recorded material without mechanically cutting the tape. The splicer operates at tape speeds of 7½ or 15 inches per second. The splicer modules afford easy access to all components. When any module is removed, a by-pass circuit automatically returns the recorder to normal operation. Other

This cue channel is of such high quality it can be used as a second program channel if desired.

Time-tested features of RCA's TV Tape Recorders are now standard in the TR-22D. These include electronic quadrature adjustment, continuously variable winding speed, separate guide position control for record and play, air lubricated tape guides, brake release switch, magnetic tone wheel, master erase head, simultaneous audio playback and complete cue facilities.

features of the splicer include switchable standards and pushbutton electronic setup procedure.

Dropout Compensator

The TR-22D is also pre-wired for insertion of a plug-in Dropout Compensator module. The purpose of this accessory is to eliminate video dropouts caused by tape imperfections. This preserves picture quality and prolongs the life of tapes. For color or monochrome operation, the device employs a delay line principle which inserts previous line video in the space occupied by the dropout.

Color ATC

Insertion of the plug-in color ATC modules converts the monochrome TR-22D for color without further modification. Color playbacks then become an automatic operation, with the color ATC circuits offering precise stabilization and a high order of color performance.

COMPLETE LIST OF ACCESSORIES

(supplied complete—order by MI-number)

Automatic Timing Corrector (color).....	ES-43581
Electronic Splicing Accessory.....	MI-40695-A
Dropout Compensator	MI-43309
Video Pre-Amplifier Module (spare).....	MI-40603-A
Remote Control Panel (mode).....	MI-40691-A
Remote Control Panel (signal).....	MI-40692-A
Narrow Track (7½-15) Headwheel Panel Assembly (air bearing)....	MI-40799
Headwheel Panel Assembly (air bearing).....	MI-40790-A
Tape Splicer (15 IPS) including Tape Developer.....	MI-40772
Tape Splicer (7½ IPS) including Tape Developer.....	MI-40748
Splicer Table	MI-40592
Dolly Assembly	MI-40668

HUMAN ENGINEERED

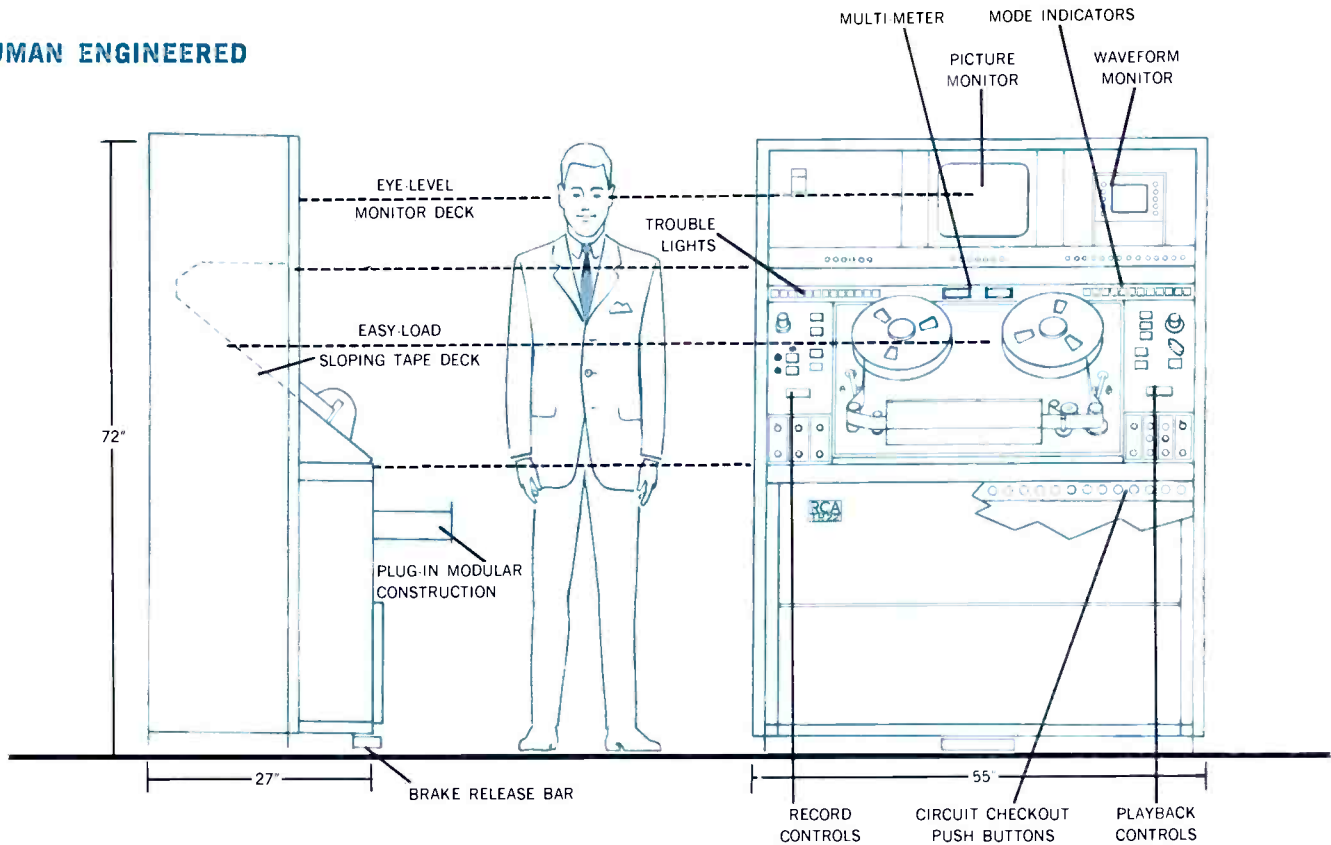

Among the human engineering features introduced in the TR-22D are a 45-degree angle tape deck set waist-high for ease in loading reels and threading tape. Recording and playback controls have been separated to minimize errors. Monitoring facilities are located at eye

and ear levels with the pushbuttons controlling their functions located immediately below each of the monitors. Also a series of warning lights, which operate continuously, prevent faulty recording. These features simplify the making and playing of quality color tv tapes.

FUNCTIONAL DIAGRAM

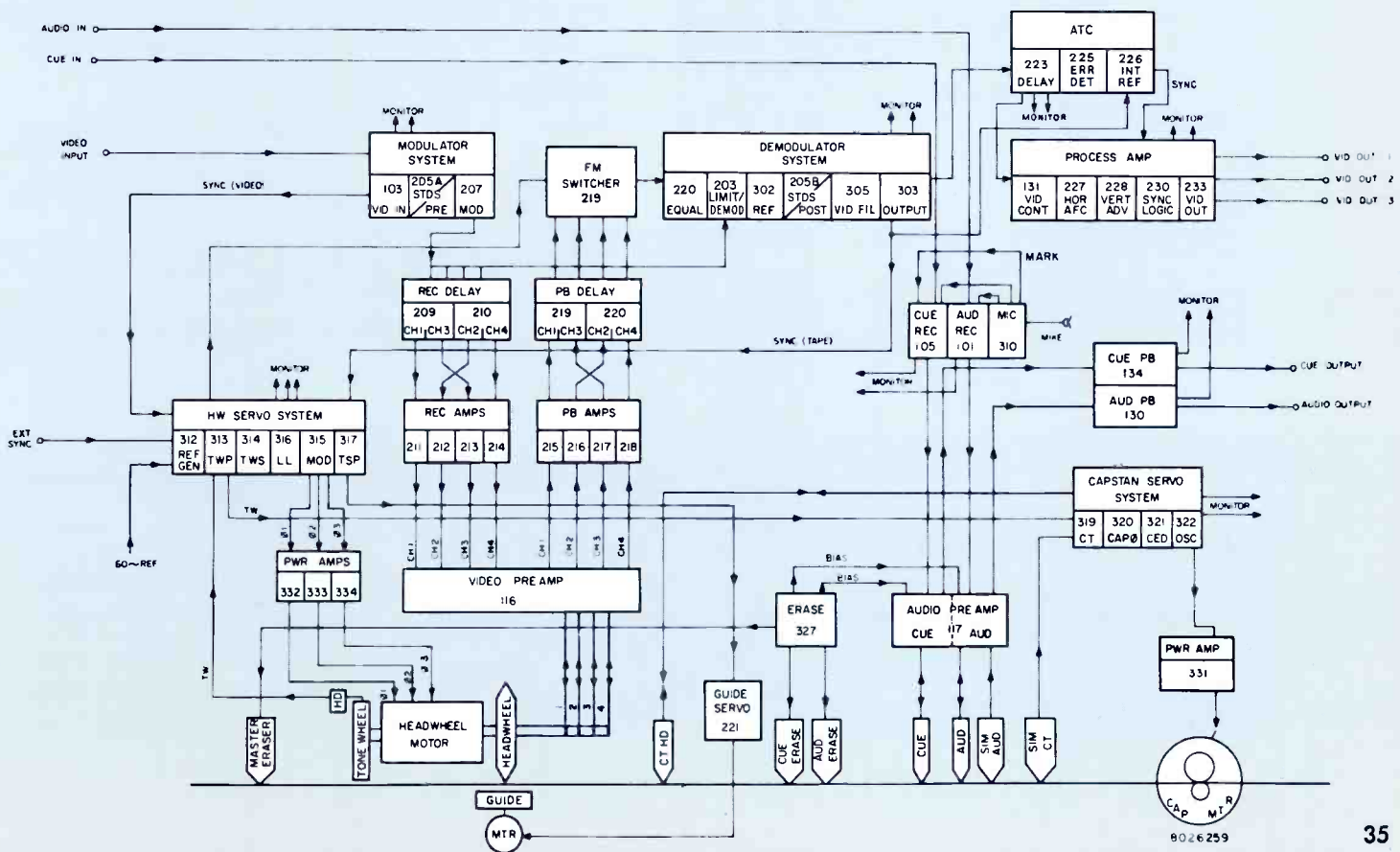

Specifications

General

Recording Medium.....	Magnetic tape 2" wide	
	50 Field	60 Field
Tape Speed	15.6 in. (39.7 cm)	15 in. (38.2 cm)
Picture-Sound Separation	14.8 frames sound leading	18.5 frames sound leading
Recording Time	92 min. on a 14 in. reel (7200 ft.)	96 min. on a 14 in. reel (7200 ft.)
Rewind Time	Approx. 5 min. for 7200 ft. reel	Approx. 4 min. for 7200 ft. reel
Recording Time Reference.....	To incoming video signal or an external reference	
Playback Time Reference.....	To the power line or to an external reference	
Stopping Time.....	Less than .2 seconds from Record or Play mode	
Start Time for Stabilized Picture and Sound (tone wheel mode).....	Less than 5 seconds from Stop, less than 3 seconds from Setup or Standby (Pix Lock mode).....	
	Less than 5 seconds from Stop	
Tape Interchangeability.....	Tapes made on any machine may be played back on any other machine providing they are made in accordance with all applicable proposed SMPTE recommended practices and proposed ASA standards.	
Tape Timer.....	Accumulated time measured in minutes and seconds. Accuracy within 3 seconds per hour	
Horizontal Displacement of Vertical Aligned Picture Elements.....	Not to exceed .02 microseconds at junction points	
RF Limiting.....	Sufficient to allow RF signal level into the demodulator to be 55 db below nominal before video signal is affected by a 10 percent reduction in level.	

Signal Levels

Input Signal Requirements:

VIDEO.....	Input signal level may be between .5 volt p/p and 1.4 volts p/p composite signal; signal may be looped through or terminated in 75 ohms.
AUDIO.....	Line input level between 0 and 36 dbm, 600 ohm balanced or unbalanced (Recorder may be wired for 150 ohm balanced or unbalanced or 5000 ohm bridging).
CUE.....	Same as Audio above
SYNC.....	Negative polarity 3 to 5 volts p/p
COLOR SUBCARRIER.....	1.5 to 2.5 volts p/p bridging or 75 ohm terminated
RF COPY.....	1 volt p/p nominal 75 ohm terminated

Output Signal Availability:

VIDEO (Monochrome or Color)	Three Line Outputs: one composite or non-composite
Two Monitor Outputs: composite	Video Level: .5 to 1 volt p/p; Sync Level: .2 to .4 volt p/p
Pedestal Level: ±20% of video level	Burst Level: .2 to .4 volt (color only)
Chroma Level: ±20% of nominal (color only)	

AUDIO.....	One Line output: ±18 dbm maximum into 150/600 ohms balanced or unbalanced line
	One Monitor output: +40 dbm maximum level into 8/16 ohm load (10 watts)
CUE.....	Same as Audio above
SYNC.....	3.5 to 5 volts p/p standard EIA sync signal
RF COPY.....	1 volt p/p level, 75 ohms terminated

Electrical

Power Requirements

60 cycle.....	117 volt a-c ±10% single phase 2 kw
50 cycle.....	234 volt ±10% single phase 2 kw

Frequency Response:

Video Channel.....	Monochrome—405/525 ±1.5 db 30 cycles to 4 mc; 625/819 ±1.5 db 25 cycles to 4.5 mc; -3 db at 5 mc
Audio Channel.....	(at 15 ips) ±2 db, 50 to 15,000 cycles (at 7½ ips) ±2 db, 60 to 10,000 cycles
Cue Channel*.....	(at 15 ips) ±2 db, 50-10,000 cps (at 7½ ips) ±3 db, 60-10,000 cps

Signal-to-Noise Ratio:

Video.....	On an interchangeable tape basis; 4 db pre-emphasis
405/525 line.....	Better than 40 db (37 db at 7½ ips)
625/809 line.....	Better than 37 db (34 db at 7½ ips)
Audio.....	Better than 55 db, measured overall between a recorded level corresponding to 3% total rms distortion at 1000 cycles per second and noise present when playing back an erased unmodulated tape
Cue.....	Better than 34 db, measured overall between a reference 5% record level and the noise present when playing back an erased, unmodulated tape
Transient Response.....	Rise time less than 0.15 µsec. overshoot less than 12% on 0.062 µsec. sine-squared window test pattern
Ambient Temperature and Humidity.....	Between 35° and 110° F. (0° to 45° C) at 20 to 90% relative humidity
Picture Jitter.....	With recorder in pixlock mode using air bearing headwheel assembly, picture jitter should not exceed ±.07 microseconds

Wow and Flutter.....	0.5 to 250 cps range (15 ips) 0.15% or less RMS (7½ ips) 0.25% or less RMS
----------------------	--

Mechanical

Transport.....	Centrally located at 45° angle and at a reel height of 48" (112 cm)
Dimensions: Width (overall) 55" (140 cm), Width (Less End Panel) 53" (134 cm), Height 71¼" (181 cm), Depth 26½" (67 cm)	
Shipping Information: Width 61¼" (155.5 cm), Depth 35" (88.8 cm), Height 84" (213 cm), Volume 125 ft. ³ (3.75 M ³), Gross Weight 1560 lbs. (708 kg)	

* Includes 36 db notch at 240 or 250 cps, automatically switchable for 50 or 60 cycle standards.

Ordering Information

The Type TR-22D TV Tape Recorder is available for operation on 525, 625, 405 and 819 line tv standards.

Two basic models are available:

- (1) a 525 line machine
- (2) a switchable machine for 525/625/405 or (optional 819) line operation

They may be ordered as follows:

- 525 line, 60 cycles, specify ES-43560
- 525/625/405 line, 50 cycles, specify ES-43561-405
- 525/625/819 line, 50 cycles, specify ES-43561-819

All models include the following equipment complement:

- 1 TV Tape Recorder (Console Mounted) complete
- 1 Headwheel Panel Assembly (Air-bearing)
- 2 End Panels
- 1 Kit of Maintenance Materials
- 1 Monochrome Video Alignment Tape

Color TV Tape Recorder, Type TR-70

- **Makes superb color tapes**
- **Makes finest multiple generation copies**
- **"Instant-Switching" standards, including highband**
- **High performance air bearing headwheel**
- **FM test facility**



Color Performance Features

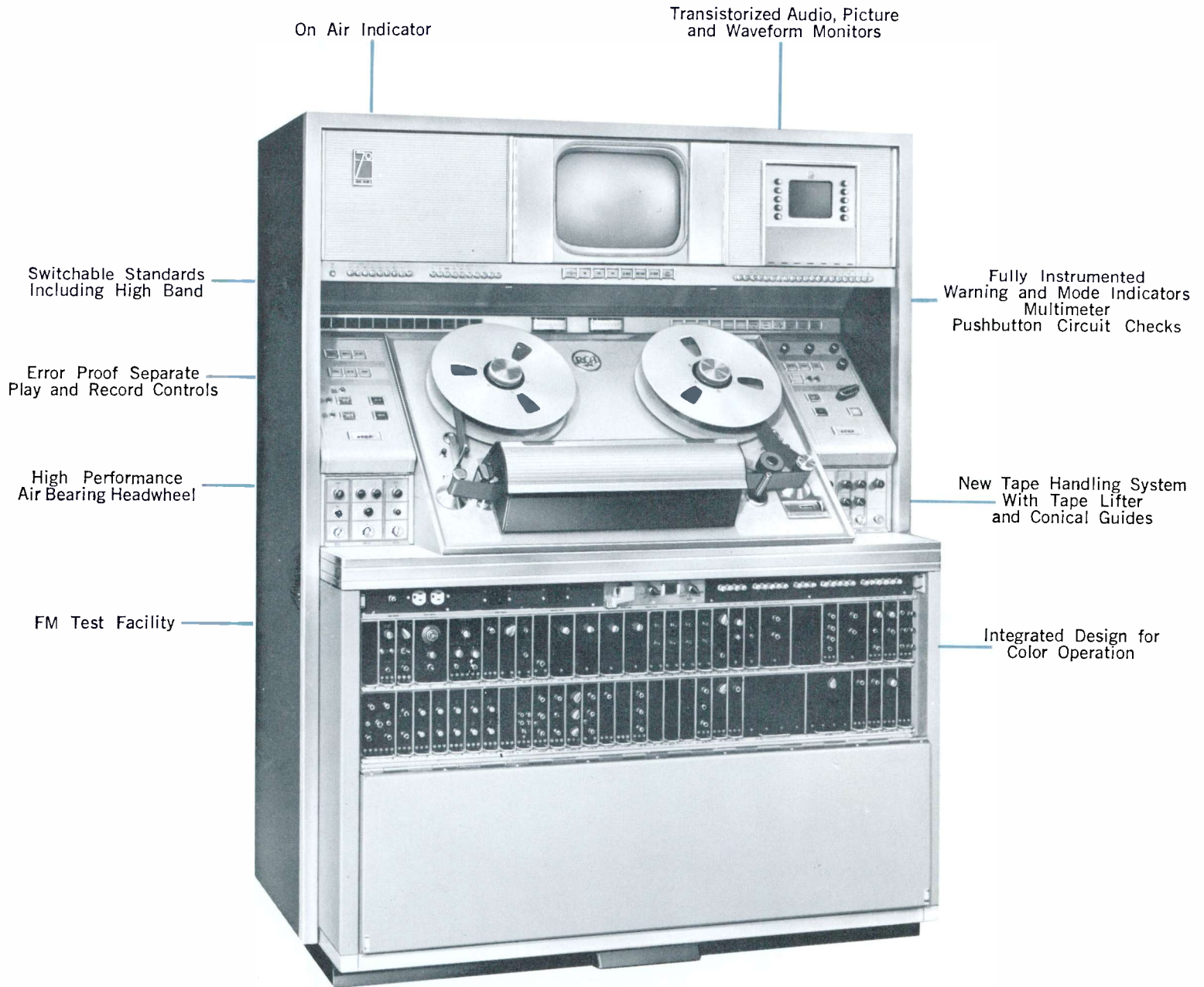

Color TV Tape Recorder, Type TR-70

The RCA Super-Deluxe TR-70 TV Tape Recorder makes possible a new level of performance in producing TV tapes of increased brilliance and realism—particularly in color. Multiple generation color tapes almost indistinguishable from original pictures are the result of new TR-70 engineering advances.

The TR-70 is a complete system within itself, designed for greatest reliability, operational convenience and picture performance in both monochrome and color

operation. There are no “extra” cost items to “add on” to obtain the color performance. Complete in a modern, beautifully styled console, the TR-70 is the ultimate in human engineering for easy, error-proof operation. The new highband air-bearing headwheel serves for all standards of operation—domestic or world wide. There is a choice of everything at the finger tips—highband, lowband, TV line standards, tape speeds, operating modes—all conveniently switchable.

Air bearing headwheel operates on all switchable tape standards—highband and lowband.

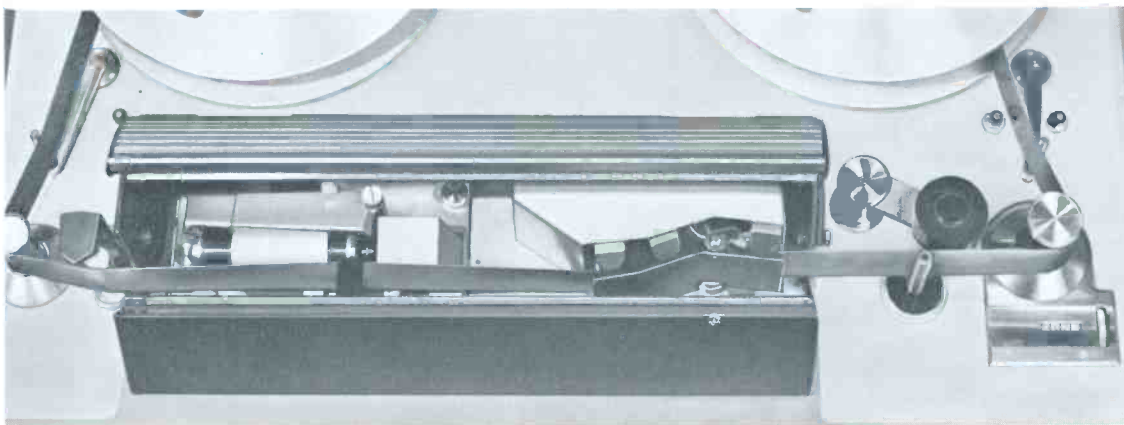

Switchable deviation standards for world wide use. International model provides choice of 405/525/625 (809 optional) line standards.

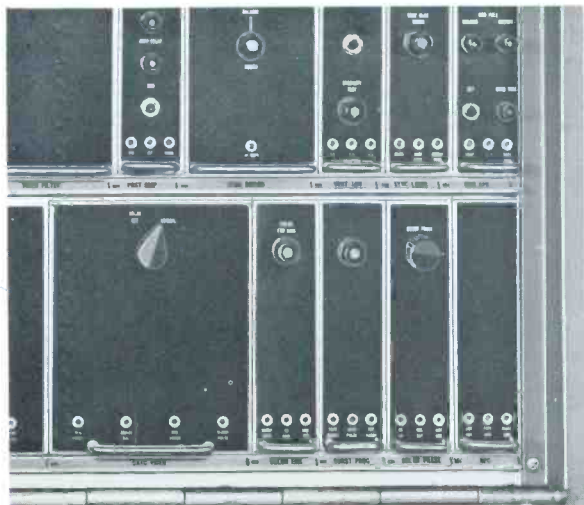

Color ATC modules (above) are pre-wired and tested at factory—an integral part of the TR-70 high band design.



TR-70 for Highband and Lowband

with built-in features for deluxe TV Taping

Description

Significant engineering advances designed to achieve superior pictures and multiple generation color copies are reflected in the TR-70. These improvements are to be noted in the s/n ratio, bandwidth, "K" factor (transient response rating), and differential phase and gain, greatly extending tape quality for both color and monochrome.

Uniform picture quality is a result of stabilized circuits in the equipment. These circuits function to correct themselves, holding a high level of performance over long periods of operation. They compensate for changes that may occur with component aging. Operators are freed from constant attention and frequent "touch up" of controls.

Switchable Standards

Highband, a new recording and playback mode that utilizes higher FM deviation frequencies for both color and monochrome, is a new development incorporated in the super-deluxe TR-70. Selection of monochrome or color FM standards (highband or lowband), TV line standards and tape speed is accomplished instantly on a push button basis. Inhibit circuits, which are incorporated in the switching logic, will not permit an incorrect selection of standards; for example, 625 line lowband color, or any other incompatible selection. All circuitry relating to the basic requirements of the system is built in. There are no

extra modules required to operate on different standards.

Faithful Multiple Copies

Advances in headwheel design coupled with new video and FM circuit techniques produce taped masters that are almost indistinguishable from the originating signals. Using the "highband" mode of operation multiple generation copies exhibit good color quality. The advance circuitry of the TR-70 is designed to complement the technical superiority of the highband technique, resulting in highest quality color reproduction over multiple generations.

Highband Headwheel

First introduced by RCA a few years ago, the air-bearing headwheel is standard equipment on the TR-22—however—in the TR-70 a new step forward results in a highband air-bearing headwheel. This headwheel operates on all switchable tape standards—highband and lowband.

New Tape Lifter

Also built into the TR-70 is a tape lifter, that permits the tape to contact a selective erase head only while actually recording. This simple method of lifting the tape away from the erase head bypasses problems arising from moving the erase head by an elaborate mechanical system. Tape life is increased and dropouts from tape wear are reduced. A further benefit is the reduction of wear to the selective erase head.

Selective Erase Head

The TR-70 includes a selective erase head, especially designed to fulfill the requirements of electronic splicing. When used with the electronic splicer, the selective erase feature permits erasure of existing video without disturbing the original recorded control track or audio track.

Pixlock Performance

Pixlock is standard on the TR-70. Long an important feature of the RCA solid state TV tape recorder system, Pixlock completely synchronizes switching between tapes, studio signals and other sources and permits fades, lap-dissolves, supers and other special effects.

Line Lock

Line Lock is a valuable feature of the TR-70 that enhances the color stability of the recorder. Locking on the horizontal line frequency, the unique circuit minimizes disturbances to color that might be caused by dropouts or poor electronic or mechanical splices.

Precision ATC

The high degree of stability in the TR-70 automatic timing circuits eliminates the requirement for front panel controls and the need to adjust. Picture geometry and burst correction is automatically achieved—freeing the operator from constant touch-up of controls.

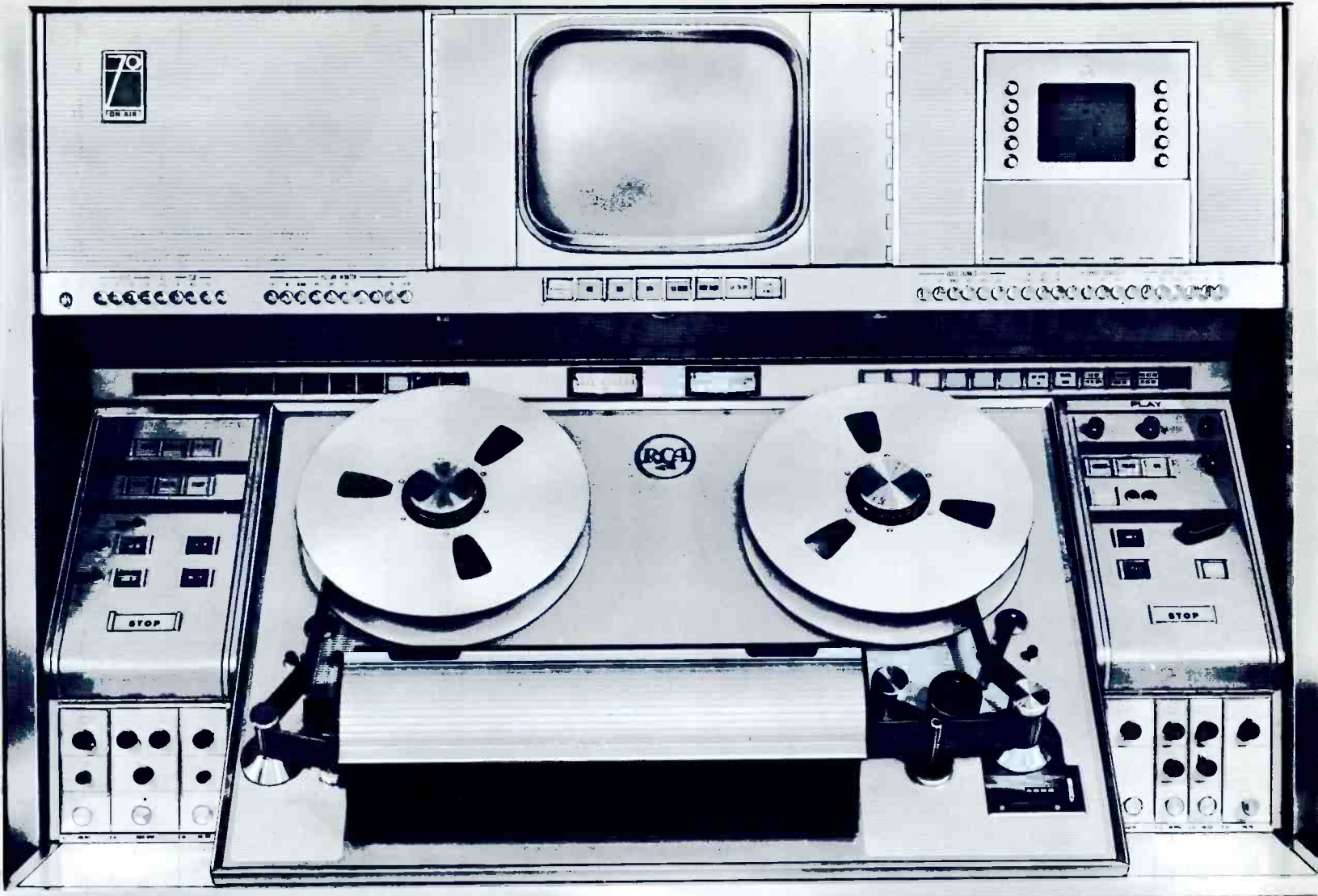

HERE, THE ULTIMATE IN QUALITY COMES EASY . . . All operating functions of the TR-70 are centered at this functional tape deck—designed to make it easy to produce consistently high quality pictures.

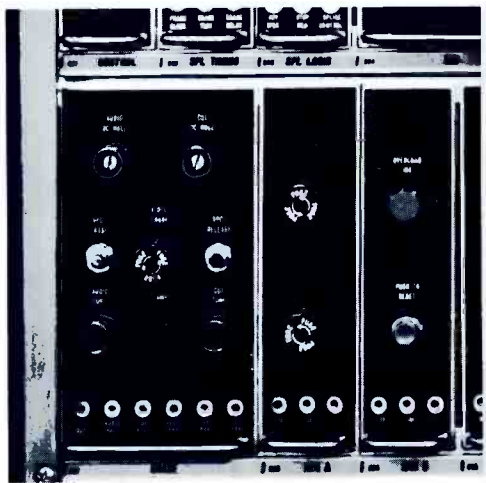

Spot erase—a new, quick audio editing feature.

Tape lifter and cone-shaped guide increase tape life and wear on erase head at same time reducing tape dropouts.



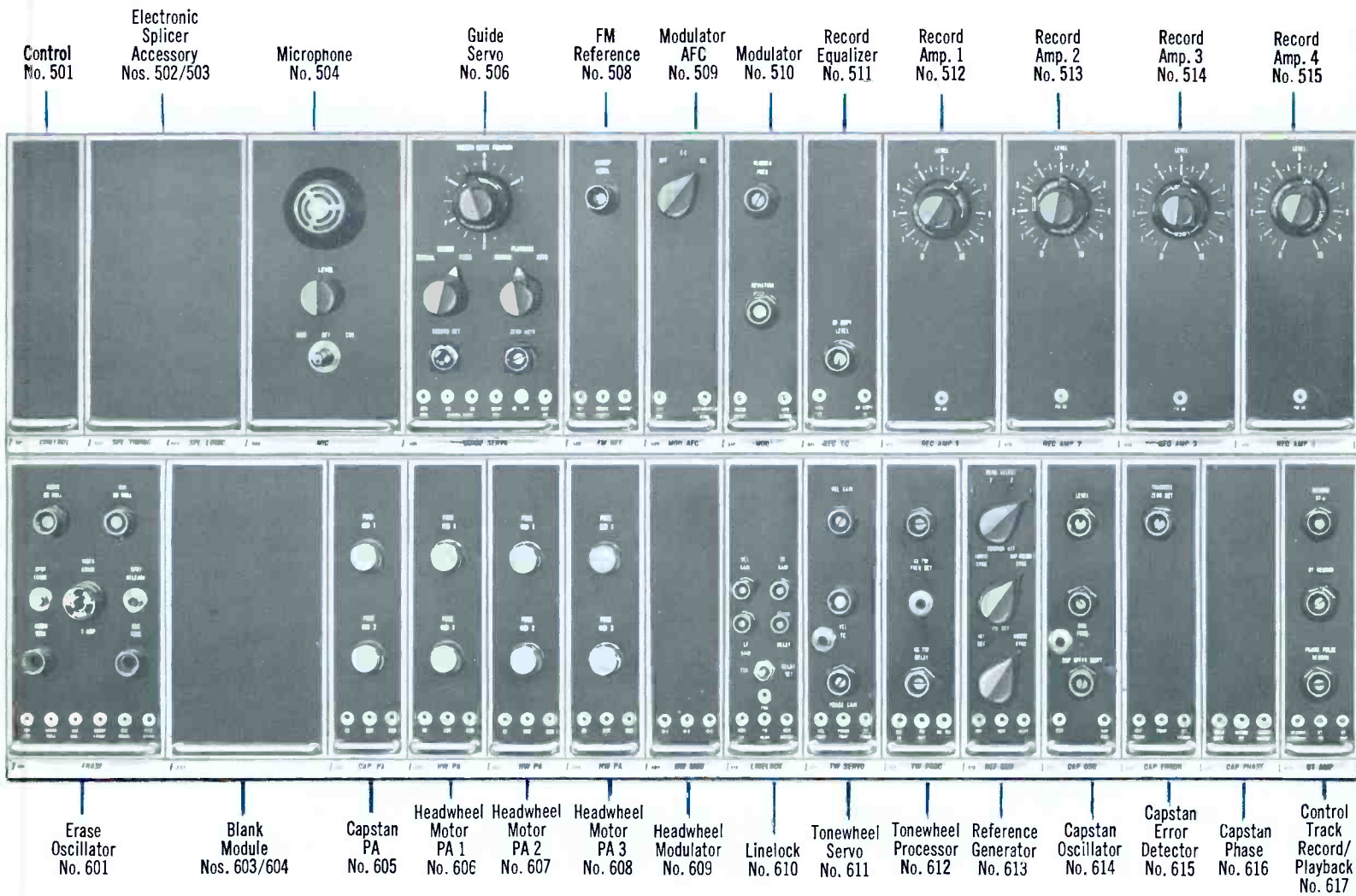

TR-70 Module Bank

501—Control

Part of control system. Provides inhibit logic and time delays.

502/503—Electronic Splicer Accessory

504—Microphone

Houses microphone and mike-cable reel, with microphone amplifying circuits. Permits operator to record on either audio or cue tracks.

506—Guide Servo

Control position of the guide to produce skew-free pictures. Functions in automatic, manual, record, and record-set modes of operation.

508—FM Reference

Provides a white reference frequency keyed into the vertical blanking interval of the signal for check of FM deviation. Also provides the crystal-controlled reference frequency for the modulator AFC.

509—Modulator AFC

Provides precise control of the FM modulator blank level frequency in accord with the crystal-controlled reference frequency from the FM reference module.

510—Modulator

Clamps pre-emphasized video at black level to modulate a capacity-diode-controlled heterodyne type modulator. Circuitry included for rf copy facility.

511—Record Equalizer

Provides compensation of the record drive signal so that constant current in the video head is maintained over the FM passband.

512—Record Amplifier 1

Output from record equalizer is increased in level to a value sufficient for recording on tape.

513—Record Amplifier 2

Output from record equalizer is increased in level to a value sufficient for recording on tape.

514—Record Amplifier 3

Output from record equalizer is increased in level to a value sufficient for recording on tape.

515—Record Amplifier 4

Output from record equalizer is increased in level to a value sufficient for recording on tape.

518/519/520/521—Playback Amplifier

Provides AGC control, head resonance compensation, and aperture compensation for correcting the playback characteristic of head channel No. 1-2-3-4.

522—FM Switcher

Switches between heads during playback, connecting the head scanning the tape to the output. Includes separate switching for two output channels, one for the picture and one for the sync.

523—FM Equalizer

Provides additional aperture compensation for the overall playback equalization characteristic. Also includes control circuits for the head resonance test mode.

524—FM Filter

Provides the precisely controlled overall response characteristic required for optimum signal-to-noise ratio and frequency response of the tape playback system.

525—Demodulator (video)

The FM signal is limited and demodulated to push-pull video.

527—Video Filter

Provides the low-pass filter characteristic after demodulation required for optimum noise, moire and frequency response. Appropriate filters are selected for each FM standard.

529—Post-Emphasis

Include the necessary post-emphasis characteristic for the demodulated video, and also provides switching transient suppression and video line output functions.

530—Demodulator (Sync)

The FM signal is limited and demodulated for the sync channel.

532—Vertical Advance

Special circuitry counts out the number of pulses in a field, to determine very accurately the position for regenerated vertical blanking.

533—Sync Logic

Generates horizontal and vertical blanking; combines them into composite blanking. Combines tape sync and regenerated horizontal sync into composite regenerated sync. Generates a start pulse which phases the counting of the vertical advance circuitry.

534—Horizontal AFC

Sync separated for the color corrected video signal is used to control the frequency and phase of a multi-vibrator. This, in combination with other circuits, generates a new horizontal sync, front porch, and blanking.

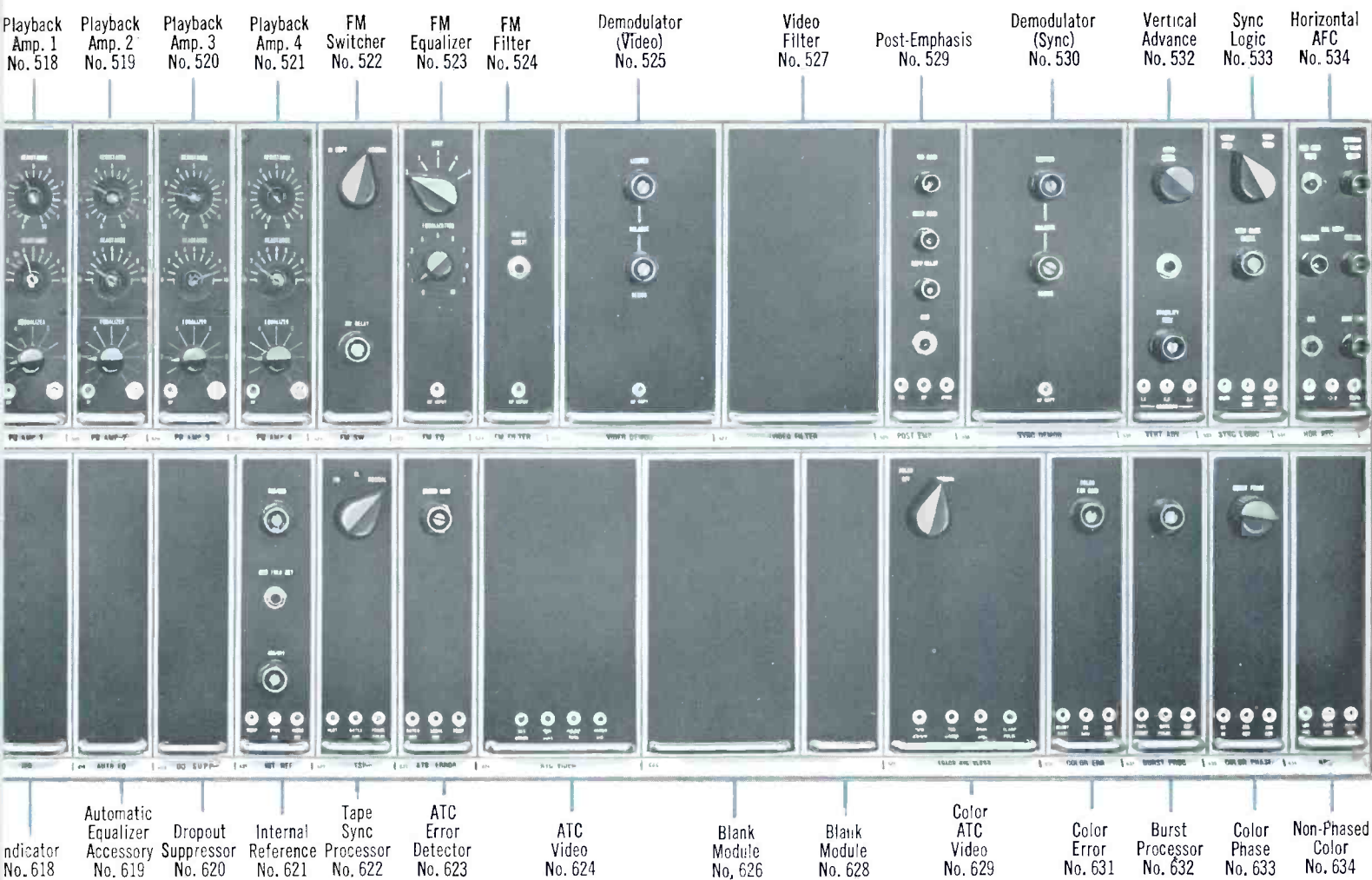

Description of Functions

601—Erase Oscillator

Supplies 87.5 kc erase and bias current to the audio, cue, and master erase heads. Also includes audio spot erase.

603/604—Blank

605—Capstan PA

Power amplifier for the capstan motor.

606—Headwheel Motor PA 1

Power amplifier for one of the three phases required by the headwheel motor.

607—Headwheel Motor PA 2

Power amplifier for one of the three phases required by the headwheel motor.

608—Headwheel Motor PA 3

Power amplifier for one of the three phases required by the headwheel motor.

609—Headwheel Modulator

Amplitude-modulates the headwheel motor-drive sine waves. Gives wide-band three-phase output.

610—Linelock

Provides line-by-line lock-up in the Pixlock and Linelock mode.

611—Tonewheel Servo

Derives error signal controlling the headwheel motor in the tonewheel mode of operation.

612—Tonewheel Processor

Shapes the tonewheel pulse and also provides 960-cycle switcher drive.

613—Reference Generator

Processes local sync to produce horizontal-rate reference, field-rate reference and frame-rate reference.

614—Capstan Oscillator

D-c error voltage controls the frequency of the oscillator which supplies the drive frequency for the capstan motor. Tape speed is thereby synchronized to local reference.

615—Capstan Error Detector

A phase detector which compares incoming pulse to the local frame pulse and produces a d-c voltage proportional to the magnitude of the phase error.

616—Capstan Phase

The control-track pulse feeds a chain of binary counters which divide the pulse frequency by eight to produce a 30-cycle output pulse.

617—Control Track Record/Playback

The 240-cycle control track signal is amplified, filtered to produce a clean 240-cycle sine wave, clipped, and shaped into a pulse.

618—Indicator

Senses machine performance and lights warning indicator in the event of malfunction.

619—Automatic Equalizer Accessory

620—Dropout Suppressor

Circuits in this module sense dropouts from the tape and automatically insert an average picture level to minimize the system disturbance.

621—Internal Reference

Provides AFC locked to the tape horizontal sync to provide precise timing of all switching, transient suppression, sync gating and ATC pulses.

622—Tape Sync Processor

Separates tape sync from the sync channel video and provides approximate noise immunity and transient gating for all sync functions.

623—ATC Error Detector

The time base error of the separated tape sync is measured and converted to the necessary control signal for ATC.

624—ATC Video

Contains the variable delay line and driver circuits for the ATC function.

626/627/628—Blank

629—Color ATC Video

Contains the variable delay line and driver circuits for the Color ATC function.

631—Color Error

Color time base errors are detected to provide the control signal for Color ATC.

632—Burst Processor

Provides separation for burst from the tape signal for the color error detector. Also includes circuits for shaping the new burst from local subcarrier.

633—Color Phase

Provides adjustment of regenerated burst phase and system subcarrier phase.

634—Non-Phased Color

Provides necessary pulse circuits for control of the non-phased color mode.

Human Engineering

for Trouble-Free, Error-Proof Operation

Layout and design of the TR-70 are based on studies made to achieve the highest degree of coupling between the machine and the operator. Features include a tape deck set waist high at an angle of 45 degrees for ease in loading reels and threading tape. Recording and playback controls are separated to minimize errors. A series of lights signal operating modes and warn of faulty recording. Plug-in electronics make the TR-70 the easiest-to-operate and to-maintain recorder ever produced.

Professional Design

Beautifully styled to enhance any surroundings and professionally designed to aid operator efficiency, the TR-70 presents four functional areas: the monitoring area, the tape deck and operations area, module electronics area, and console base power deck.

In the monitoring area at the top of the TR-70 are the transistorized audio monitor, picture, and waveform monitors. Under the picture monitor in the center is the tape transport panel with the RECORD control panel on the left side and the PLAYBACK control panel on the right. Directly below the tape transport behind the front panel is the bank of plug-in transistor modules containing the circuitry for video and FM processing and for all the servos required by the recorder. The console base contains the power supplies, vacuum and pressure pumps, air bearing pump and main cooling blower. Front accessibility for all

normal operation and maintenance is attained by centralized plug-in electronics modules and careful mechanical layout. The TR-70 is completely self contained. There are no external accessories.

Functional Control Clusters

The TR-70 operations center is a modern, well-lighted control center designed to assist the operator in trouble-free, error-proof recording and playback of the highest quality television tapes.

Record and play functions are separated to minimize the chance of accidental erasure. Controls and indicators for the record mode are grouped on one side of the tape deck, while those for the play mode are grouped on the other side. Tape threading is simple and is facilitated by cone shaped guide posts. Twelve or 14-inch tape reels are easily loaded on and slip off with ease—they do not interfere with any controls, covers or access panels. A tape timer featuring a clutch mechanism is built into the TR-70.

Fully Instrumented

Generous monitoring and metering facilities and a full complement of indicator lights signal assurance of good performance. They also signal warning of potential trouble or faulty operation. They help to quickly pin-point and correct malfunctions—should they occur. Lights just above the tape transport on the left side flash a red warning. White lights on the right side provide a

continuous indication of mode, such as the servo or FM deviation standard being used. This awareness by flicking the eyes across a row of lights is fast and foolproof.

FM Test Facility

The FM Test Facility, which is completely self-contained, can be programmed to perform several special tests in optimizing the TR-70. Up until now, it has been a difficult and tedious task to prepare a tape recorder for special tests; i.e., noise, moire, frequency, and headwheel record and playback optimization. The TR-70 can be programmed by the flick of a switch. Trial and error methods of matching the headwheel panel to the electronic system are eliminated in the TR-70. Now accurate headwheel optimization, in both monochrome and color, can be achieved in a few minutes with no guess work. The TR-70 generates its own special test signal in headwheel optimization mode, thus there is no need for external test equipment.

Operation-Tested Features

Time tested features of RCA TV tape recorders are standard in the TR-70. These include continuously variable winding speed, separate guide position control for record and play, air lubricated tape guide, brake release switch, magnetic tone wheel, selective erase head, simultaneous monitoring of servo control track, spot audio erase, simultaneous audio playback and complete cue facilities.

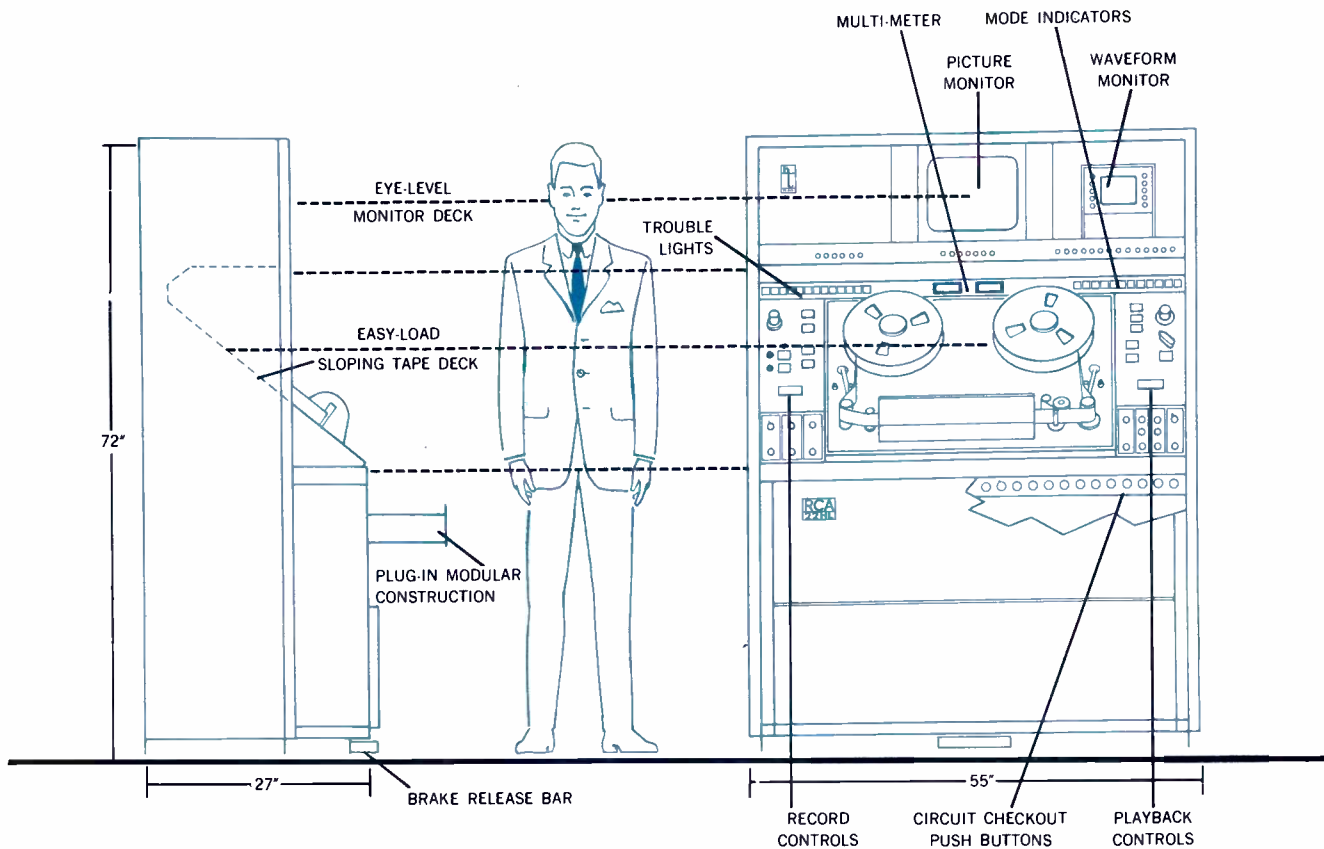

Among the human engineering features introduced in the TR-70 are a 45-degree angle tape deck set waist-high for ease in loading reels and threading tape. Recording and playback controls have been separated to minimize errors. Monitoring facilities are located at eye and ear levels

with the pushbuttons controlling their functions located immediately below each of the monitors. Also a series of warning lights, which operate continuously, prevent faulty recording. These features and others make premium performance standard in the TR-70.

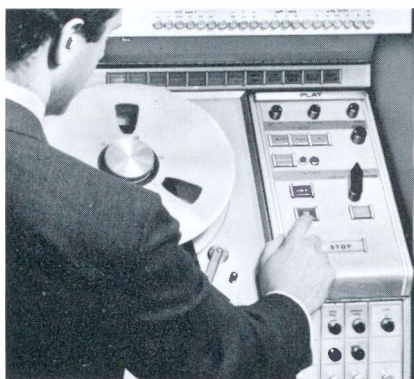

Separate play and record controls.



Easy load tape deck.

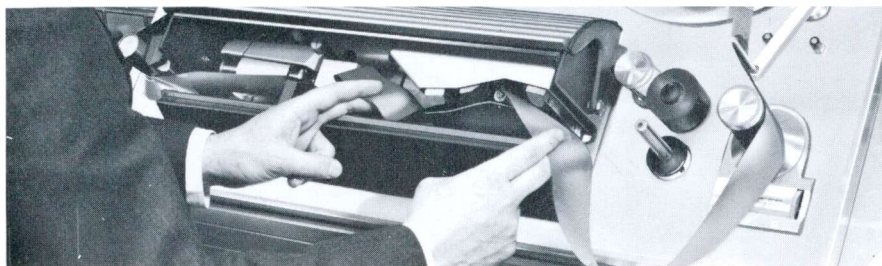

Fast uncomplicated threading.



Full instrumentation.

Fully Instrumented for Peak Performance

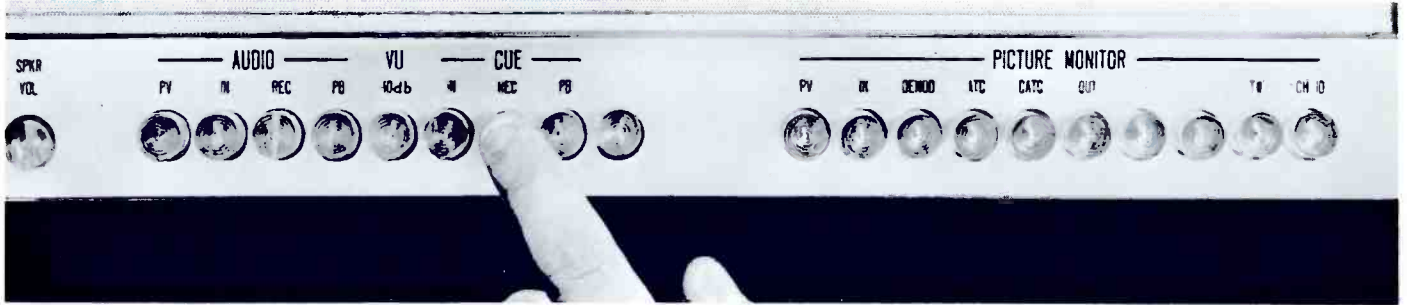

Multi-position switchers monitor important pictures and waveforms.

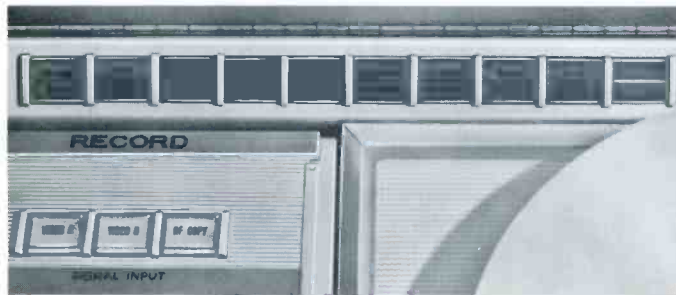
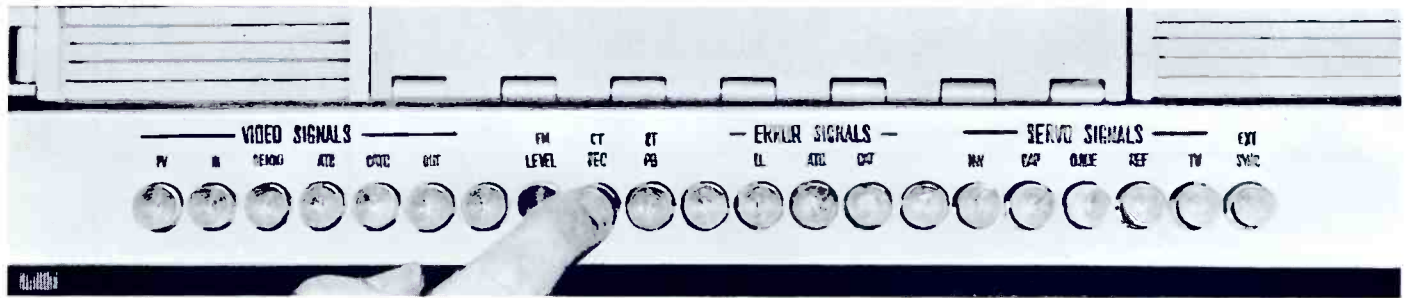

Expanding warning indicating system.



Non-standard mode indicator panel.

New FM Test Facility

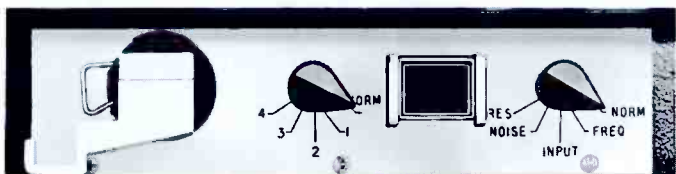

Integrated safety circuits while in test mode.

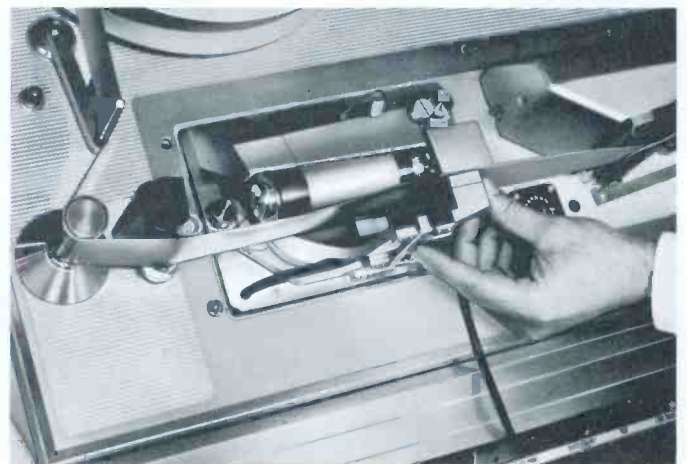

Test probe mounts on panel for quick and accurate set up of headwheel to system.

Accessibility for Preventive Maintenance

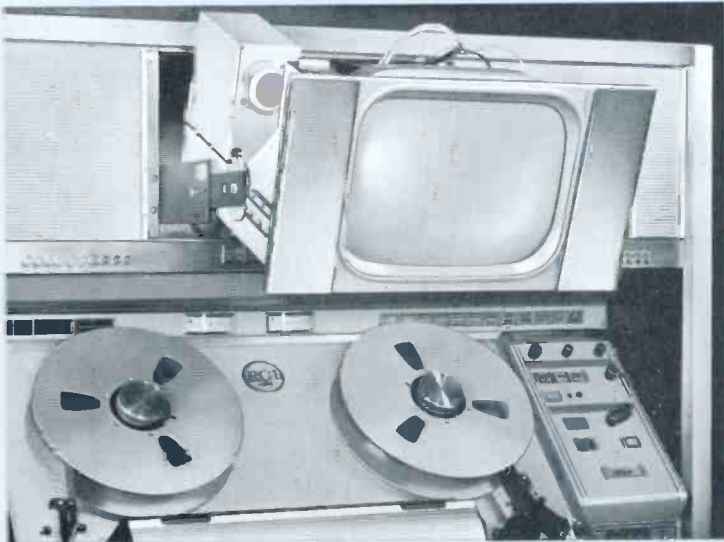

Slide and tilt mounted monitoring — accessibility plus.

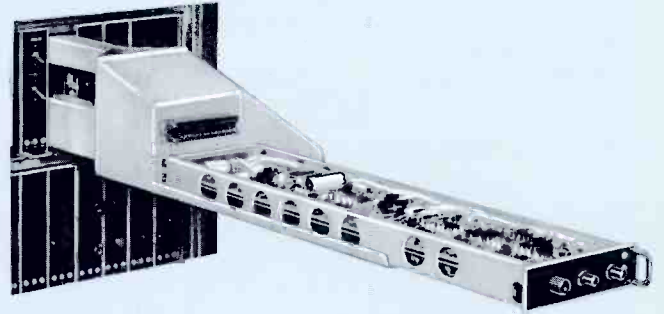

Similar module layout and construction — module extender for servicing — easy to maintain.



Slide-out switcher panel and components.

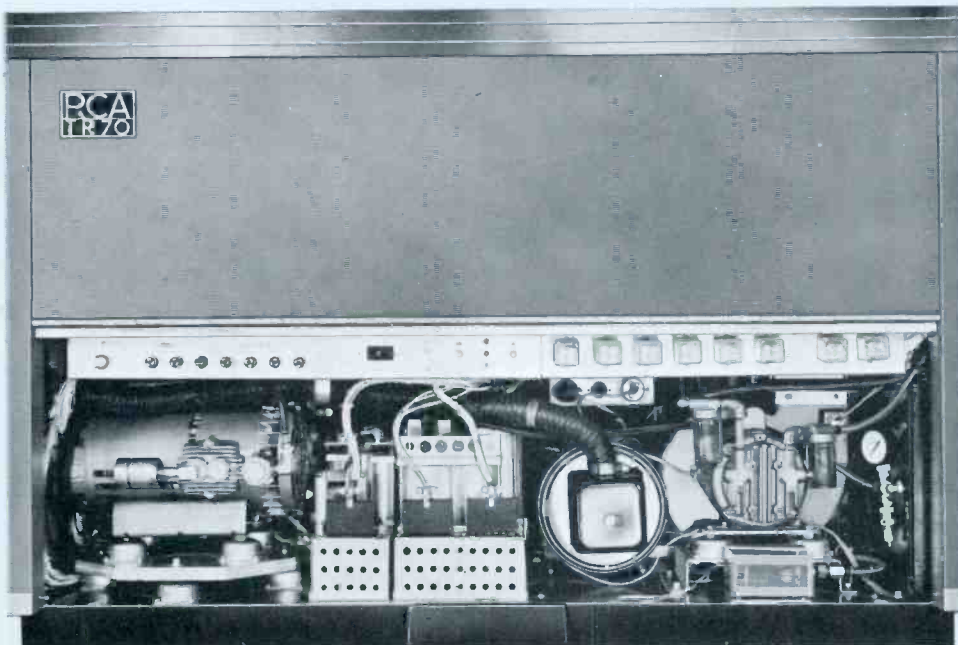

Cover removed to expose power deck and control panel. Air Bearing compressor is built in.

Specifications

General

Recording Medium	Magnetic tape 2" wide	
	50 Field	60 Field
Tape Speed	15.6 in. (39.7 cm) 7.8 in. (19.8 cm)	15 in. (38.2 cm) 7½ in. (19.1 cm)
Picture-Sound Separation	14.8 frames sound leading, 29.6 @ 7½ in.	18.5 frames sound leading, 37 @ 7½ in.
Recording Time	92 min. on a 14 in. reel (7200 ft.) 184 @ 7½ in.	96 min. on a 14 in. reel (7200 ft.) 192 @ 7½ in.
Rewind Time	Approx. 5 min. for 7200 ft. reel	Approx. 4 min. for 7200 ft. reel
Recording Time Reference	To incoming video signal or an external reference	
Playback Time Reference	To an external reference or an internal precision oscillator	
Stopping Time	Less than .2 seconds from Record or Play mode	

Start time for stabilized sound and picture (color):	5 seconds from standby mode; 6 seconds from stop mode
Tape Interchangeability	Tapes made on any machine may be played back on any other machine providing they are made in accordance with all applicable proposed SMPTE recommended practices and proposed ASA standards.
Tape Timer	Accumulated time measured in minutes and seconds. Accuracy within 3 seconds per hour.
Stability (with ATC) Total jitter and geometric distortion, including drift over a 30 second period	50 ns peak-to-peak
Temperature	0°C to 45°C
Relative Humidity	20%-90%
Lock Up Time from Stop Mode for Stable Audio and Video; Color Mode	Less than 6 seconds, normal or half speed
Lock Up Time from Stand-by or Set-up for Stable Operation	Less than 5 seconds, normal or half speed

Video (Color System Characteristics)

	Lowband		Highband	
	525/60	625/50	525/60	625/50
Frequency Response (100 kHz ref.)	±1 dB 30 Hz—3.8 MHz -3 dB max. at 4.2 MHz	±1 dB 25 cps—4.5 Mc -3 dB max. at 5.0 Mc	±0.5 dB 30 Hz —4.1 MHz -3 dB max. at 4.5 MHz	±0.5 dB 25 Hz —5.5 MHz -3 dB max. at 6.0 MHz
Signal-to-Noise—(Normal Speed) (Peak-to-peak Video/RMS Noise)	43 dB (Mono) 40 dB (Color)	42 dB (Mono) (Color) not applicable	46 dB	43 dB
Transient Response (2 T sine ² input)	2%	2%	Less than 1.5%	Less than 1.5%
Rise Time or Fall Time (20 ns or less on input)	120 ns max.	100 ns max.	120 ns	80 ns
Low Frequency Linearity (Blanking to White)	2% max.	2% max.	1% max.	1% max.
Differential Gain (Blanking to White)	Less than 4%	not applicable	Less than 4%	Less than 5%
Differential Phase	5° at 3.58 MHz	not applicable	Less than 5° at 3.58 MHz	Less than 5° at 4.43 MHz
Moire (Color bars, 75% modulation)	24 dB	not applicable	40 dB or better	34 dB or better

Audio

50/60 Hertz	Program	Cue
Frequency Response	±2 dB 50 Hz, 15 kHz	±2 dB, 50 Hz, 12 kHz except 20 dB notch at 240/250 Hz
Flutter and WOW	0.2% RMS (For components from 0.5 to 250 Hz)	0.2% RMS
Signal-to-Noise	55 dB	40 dB or better

Mechanical

Transport	Centrally located at 45 deg. angle and at a reel height of 48" (122 cm)
Cooling	Filtered, forced air
Dimensions: Width (overall) 55" (140 cm), Width (Less End Panels) 53" (134 cm), Height 71¼" (181 cm), Depth 26½" (67 cm)	
Shipping Information: Width 61¼" (155.5 cm), Depth 35" (88.8 cm), Height 84" (213 cm), Volume 125 ft. ³ (3.75 M ³), Gross Weight 1800 lbs. (816 kg)	

Ordering Information

The Type TR-70 Tape Recorder is available for operation on 525, 625, 405 and 819 line tv standards.

Two basic models are available:
 (1) a 525 line machine
 (2) a switchable machine for 525/625/405 or (optional 819) line operation
 They may be ordered as follows:
 For 525 line operation, specify ES-43583
 For 525/625/405 line operation, 50 Hertz, specify ES-43585-405
 For 525/625/819 line operation, 50 Hertz, specify ES-43585-819

All models include the following equipment complement:

- 1 TV Tape Recorder (Console Mounted) complete
- 1 Headwheel Panel Assembly (Air-bearing)
- 2 End Panels
- 1 Kit of Maintenance Materials
- 1 Monochrome Video Alignment Tape

TV Tape Electronic Accessories

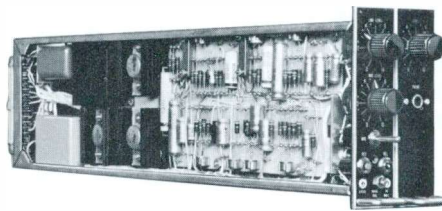

Cue Record

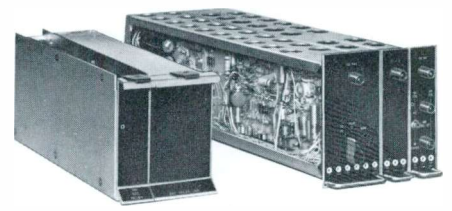

Automatic Timing Corrector (ATC)

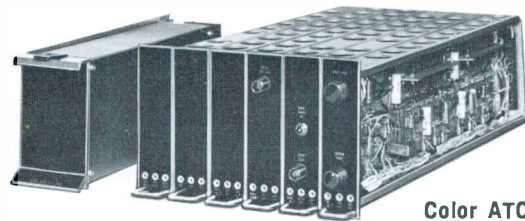

Color ATC



Electronic Splicer

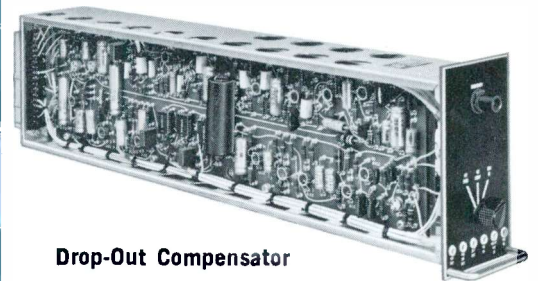

Drop-Out Compensator

Monochrome ATC Equipment

- Maintains near perfect picture geometry by automatically compensating for skewing, quadrature errors, and jitter
- Fully automatic—no operating controls
- Automatic error correction factor of 35 to 1 over total delay range of one microsecond

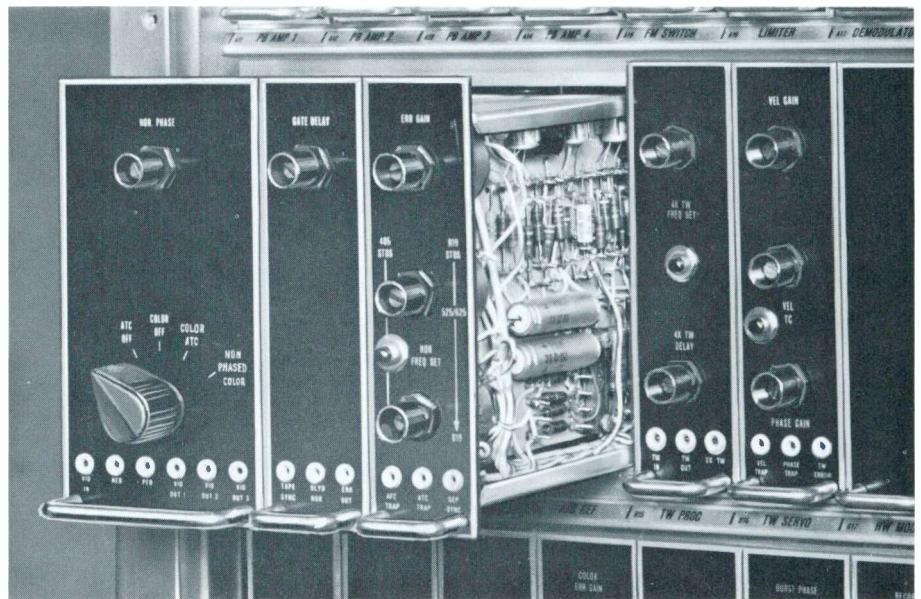

Description

The RCA Automatic Timing Corrector (ATC) is a transistorized video device providing electronic compensation for geometric distortion in the reproduced TV monochrome or color tape signal. Distortion, whether due to quadrature, skewing, or jitter is virtually eliminated when time delay errors are passed through ATC. It thus serves as a continuous monitoring and correction device which automatically reduces the time delay errors occurring in the playback signal, thereby assuring the highest possible quality at all times. It is a pre-requisite for color ATC.

The ATC circuit operates in either of two modes . . . "internal" or "external". The internal mode is used when the machine is in the tonewheel or switchlock modes. While in the internal mode, ATC

corrects geometric distortion but does not synchronize horizontal sync pulses from the tape recorder with the corresponding sync pulses from the local sync generator.

The external mode is used when the headwheel servo is in Pixlock. In the external mode, ATC, in addition to correcting geometric distortion, greatly reduces residual Pixlock jitter and results in an extremely stable output. The ATC circuits sense whether the machine is in Tonewheel or Pixlock and automatically switch to the internal or external modes.

If ATC is not desired, a switch on the ATC delay/output module permits manual bypassing of ATC circuits. In the bypass condition, the ATC modules can be tested or removed while normal playback con-

tinues, since the ATC circuits are completely removed from the signal path. Input signals are still provided to the ATC so that it can be checked while out of the signal path. All modules are interlocked so that removal of any module during ATC operation will cause automatic bypassing.

The equipment is supplied in kit form, ready for installation in the RCA TR-3, TR-4 and TR-22A/B/C TV Tape Recorders. The kit consists of a connector and cable assembly, three ATC plug-in circuit modules, a new demodulator output module, a fixed delay line, and the required hardware and electrical parts required for installation. Installation of monochrome ATC includes the harness assembly required for Color ATC.

Specifications

ELECTRICAL

Video Input.....From demod. output module
1 volt peak-to-peak

Video Output:

TR-22/TR-3/TR-4.....4 outputs (1 to oscilloscope,
1 to picture monitor, 1 Proc. Amp., 1 color ATC) 1 volt
peak-to-peak

Delay Control Range:

TR-22/TR-3/TR-4.....Minimum error reduction factor 35 to 1
for input errors up to 1 microsecond peak-to-peak

Frequency Response:

TR-22/TR-3/TR-4.....30 cycles to 6 mc ± 1 db over total
delay range ($\frac{1}{2}$ db variation at 3.58 mc and 4.43 mc)

Low Frequency Tilt......5% on 60 cycle square wave

Differential Gain......3% (50% APL, delay at mid-range,
standard level)

Differential Phase......3° (50% APL, delay at mid-range,
standard level)

Total Residual Jitter......80 nanoseconds peak-to-peak

Power Requirements.....Obtained from TR-3/4/22 tape systems

MECHANICAL

Dimensions (overall)......3 modules which fit into spaces
provided in basic TR-3, TR-4, and TR-22-A/B/C

Weight......15 lbs. (6.8 kg)

Ordering Information

Automatic Timing Corrector:

For TR-3/4 ES-43580-A
For TR-22-A/B ES-43579-A
For TR-22C MI-43391-A

Color ATC Equipment

- **Automatic operation—no operating controls**
- **Direct recovery of color information**
- **Plug-in facilities with no circuit modifications required**
- **Provision for playback of color "dubs"**

Description

The RCA Color Automatic Timing Corrector is designed to provide time base correction to the tape playback signal. It operates in conjunction with the monochrome ATC and pixlock servo system, both of which are required.

The color ATC system comprises six transistorized modular units which plug into the module bank of the RCA TR-3, TR-4 and TR-22 TV Tape Recorders, and a fixed delay line which mounts in the console. Circuitwise, it is inserted into the video path between the monochrome ATC and the signal processing amplifier during tape playback. The resultant color signal is of the highest quality and requires no further processing.

Stabilization is accomplished by measuring the residual timing errors in a signal that has been pre-stabilized by the pixlock and monochrome ATC systems and eliminates these errors or reduces them to a negligible value, utilizing a time-error correcting circuit whose major com-

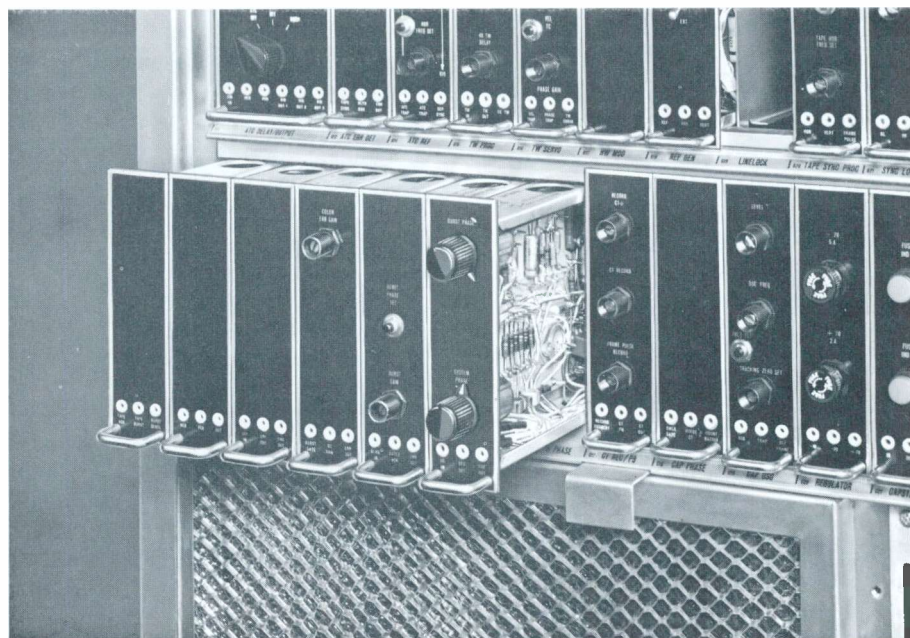

ponent is an electronically variable delay line.

The Color ATC output signal is directed to the signal processing amplifier. As an adjunct to this stabilization process, the Color ATC also cleans the blanking interval and inserts regenerated burst.

The Color ATC has two modes of operation. In the first mode, the device is used to stabilize a normal color recording. In the second mode, the color ATC is capable of stabilizing the chroma content of a second-generation color "dub" made by a heterodyne process.

Operation of the color ATC system is completely automatic; i.e., it is inserted into the video path by the selection of color deviation FM standards, and its correcting action commences immediately after the machine has achieved "lock-up" in the pixlock servo mode. The relatively few set-up adjustments need not be touched for long periods of time once they have been properly set. The Color ATC modules are

interlocked so that when any color module is disconnected from its receptacle the color ATC system is automatically bypassed.

The Color ATC system contains only two set-up controls. These are the "burst phase" and "system phase" controls located on the color phase module. The burst phase control is utilized in adjusting the system to obtain a proper color picture containing natural flesh tones, etc., as observed on the color monitor, while the system phase control is utilized as a cable length compensating device to insure that when mixing various color signal sources the phase of each is identical with respect to a reference.

The equipment is supplied in kit form, ready for immediate installation in the tape machine. The kit consists of six color ATC plug-in circuit modules, a fixed delay line and the required hardware and electrical parts required for installation. All of the necessary connectors and cable assemblies are supplied as part of the monochrome ATC kit.

Specifications

Differential Phase	3°
Differential Gain	2%
Correction Range.....	360° of subcarrier
Video Input.....	Receives signal from monochrome ATC
Power Requirements.....	Obtained from TR-3/4/22 tape systems

Ordering Information

Color ATC Equipment (for TR-22).....	ES-43581*
Color ATC Equipment (for TR-3/4).....	ES-43582*

* Applies to domestic and international equipment. Color ATC is dependent upon TR-3/4/22 machines having available monochrome ATC and pixlock modules.

Electronic Splicing Accessory

- Color or mono splicing
- Pushbutton setup
- Switchable standards
- Audio/cue retain
- Splice at 7½ or 15 IPS

Description

The RCA Electronic Splicing Accessory, provides a fast, accurate means of adding or replacing a sequence electronically in recorded color or mono video tape program material without mechanically cutting and rejoining tape. The electronic splice is achieved by the addition of three transistorized modular units included in Electronic Splicing Kit for the TR-4/5 and 22 TV Tape Recorders.

Electronic Splicing

The Electronic Splicer provides facilities in TV tape recorders for two new modes of operation—"ADD-ON" and "INSERT" that can often prove a more effective substitute for the former mechanical splicer. With electronic splicing, video tape is not cut or damaged, hence, the tape is not weakened at the splice nor is tape life shortened. The operation is fast, accurate, requires little or no skill on the part of the operator, yet every splice is consistently good. Mechanical splicing was slow, tedious, and required considerable skill to obtain consistently good splices.

Installation

The equipment comprises three transistorized modular units (splice timing, splice control and splice

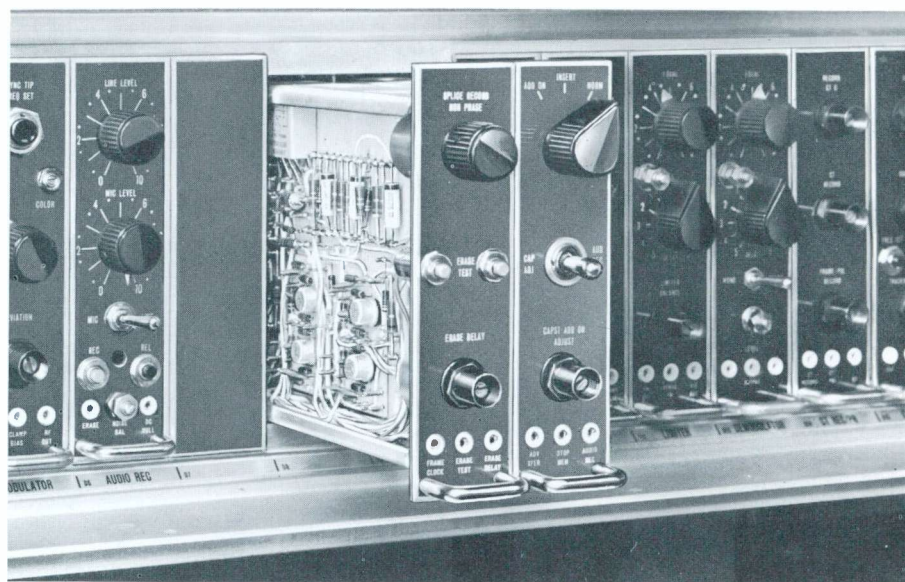

logic modules), new selective erase head, wiring harness and auxiliary modification material. The addition of Electronic Splicer in the TR-4/5 and 22 is accomplished by installing the new selective erase head, module sockets, wiring harness, and minor modification to other modules in the recorder.

Audio Cue Retain

An audio/cue retain feature permits recording video information while not disturbing previously recorded audio or cue information. The audio retain feature is activated only in the splice mode, allowing normal operation of audio record in the non-splice mode.

Operational Features

The plug-in modular construction affords easy accessibility to all components. Furthermore, removal of any module automatically returns the tape recorder to normal operation. This by-pass feature is only one of several improvements in electronic splicing. Other features are two-speed operation, switchable standards, and pushbutton setup procedure. When used on TV tape recorders equipped with the two-speed accessory, the splicer automatically switches to provide correct

operation at either tape speed. When used on switchable TV standards recorders, the splicer automatically provides correct operation on all TV standards. Momentary pushbuttons are provided for quick check of splicer adjustment using normal machine monitoring facilities for observation.

Operation Controls

There is one operating control which permits a choice of "ADD-ON", "INSERT" or "NORMAL" (non-splicing mode) operation. There are two set up controls. In the ADD ON mode, the recorder is capable of adding a new recording on to a previous recording with erasing and recording functions controlled so that the new material is spliced on to the old material with a transition similar to a clean video switch transfer. The INSERT mode provides a similar facility, except that the new recording may be inserted in the center of an old recording. Both ingoing and outgoing splices are accurately timed to ensure complete continuity. All splicing is done in the SWITCHLOCK servo mode. The splicer operates in color or monochrome, and provision is made for remote control of the splicer mode selector switch.

Specifications

Delay:

Into Splice.....	0.5 sec at 15 IPS; 1.0 sec at 7½ IPS
Out of Insert Splice.....	0.5 sec at 15 IPS; 1.0 sec at 7½ IPS
Out of Add-On Splice.....	Zero sec
Minimum Splice Time.....	0.5 sec at 15 IPS; 1.0 sec at 7½ IPS
Weight.....	15 lbs. approx. (6.8 kg.)

Ordering Information

Electronic Splicing Accessory for TR-22HL.....	MI-40695-A
Electronic Splicing Accessory for TR-22-A/B/C.....	ES-40922-A
Electronic Splicing Accessory for TR-4.....	ES-43578-A
Electronic Splicing Accessory for TR-5.....	ES-43566

Drop-Out Compensator

- Extends useful life of TV tapes
- Overcomes "drop-outs" by repeating video information from previous scan line
- Completely transistorized
- Plug-in modular construction

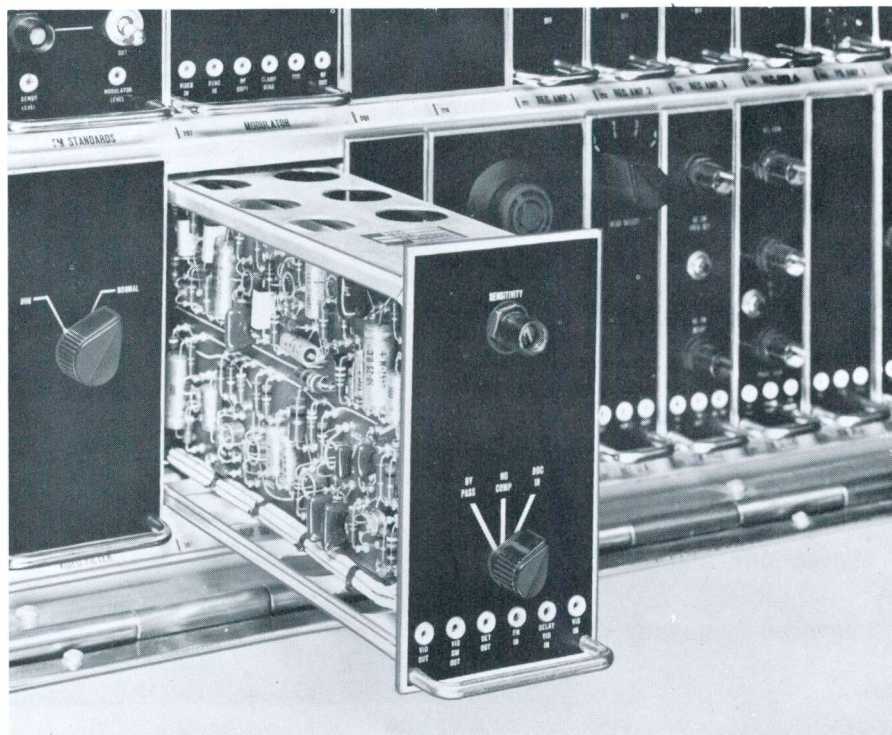

Description

Drop-Out Compensator

The Drop-Out Compensator eliminates or greatly reduces the effects of dropouts in tape recorded television signals. It consists of an electronic storage unit and associated harness designed to fit the various RCA TV Tape recorders.

Irregularities in video tape surfaces cause a brief reduction of rf carrier amplitude that appears as a distracting streak on the TV screen. These streaks, or dropouts can severely degrade the signal display when appearing in rapid succession. The Drop-Out Compensator is able

to store the video signal train for an interval equal to one scan line. During a dropout, the delay line supplies the video signal by substituting the stored information from the previous scan line. The viewer will not be aware of the substituted signal because of the similarity between successive scan lines. The stored video is supplied on demand through a fast-acting diode switch. A sensing circuit in the compensator continuously monitors the reproduced rf and actuates the switch whenever a dropout occurs.

The Drop-Out Compensator operates on either 525/625 line standards.

Specifications

Operating Levels.....FM loop-through—0.2 volt to 1.0 volt, 750 ohms; Video—2.0 volts peak-to-peak, unity gain

Frequency Response.....±1.0 db to 8 mc, 3.58 differential phase 1° maximum; 3.58 differential gain 2% maximum

Tilt.....3% maximum, 60 cps square wave

Dropout Length.....Minimum detectable—0.1 microsecond

Dropout Threshold.....Minimum detectable—4.0 db

Video Switching Transients..... Maximum duration—0.25 microsecond; (+) amplitude 0.25 volt; (-) amplitude 0.5 volt

Television Standards.....In standard module configuration—525/30 and 625/25; automatically selected by standards switch (vertical adv module)

Power.....—20 volts 500 ma

Impedance.....Video—300 ohms input/output
FM loop through—1500 ohms Linear Load

Weight.....15 lbs. approx. (6.8 kg)

Ordering Information

Drop-Out Compensator (for TR-22A/B/C)..... ES-43536

Drop-Out Compensator (for TR-4)..... ES-43587

Cue Record / Playback

- Adds voice, tone or pulse information
- Provisions for preview
- Plug-in modular construction
- Microphone and line inputs
- Improved frequency response

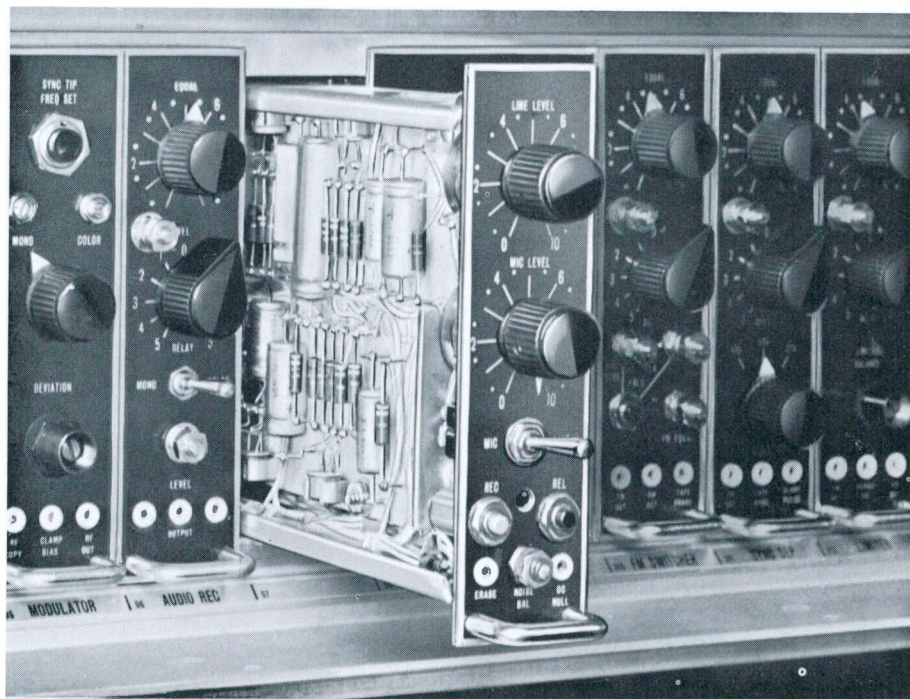

Description

Cue Record/Playback

Cue Record/Playback, a standard feature of RCA TR-22 Tape Recorders, can be provided for the TR-4 and TR-5 machines as accessory equipments. Space is provided in the module bank to accommodate this accessory. An audio/cue playback accessory kit for external mounting is available for use with the TR-3 Player.

Voice, Tone, or Pulse Cue

The Cue Record/Playback accessory head provides a means for recording cue information along one edge of the video tape. This can be in the form of voice, tone or pulse

information. A special feature of the program and cue channel is that recording can be done independent of video recording; in other words, sound may be dubbed in while playing back or previewing the video signal.

Accessory Kit

The TR-3 Cue Playback Accessory enables the cue track to be monitored for any special instructions or for program start information. The kit consists of a preamplifier, audio/cue playback head, audio amplifier and speaker, for external mounting. A harness is included to connect the cue preamplifier to the mounting system.

Specifications

Line Input Level.....0 dbm to 18 dbm into a 10,000 ohm balanced bridging impedance; may be reconnected for -20 dbm to 0 dbm matching input, 600 or 150 ohm, balanced or unbalanced.

Microphone Input.....Recordings may be made from built-in microphone and pre-amplifier simultaneously with or separately from audio channel.

Line Output Level.....18 dbm max. into 600 ohm balanced or unbalanced line; may be reconnected for a 150 ohm line

Phone Jack Output.....600 ohm or high impedance microphone

Frequency Response:
At 15 IPS..... ± 2 db, 50 to 190 cps and 310 to 10,000 cps

At $7\frac{1}{2}$ IPS..... ± 3 db, 60 to 190 cps and 310 to 10,000 cps (A 240/250 cps notch filter removes crosstalk from the control track. Effect of this filter on tonal balance of speech and music is imperceptible.)

Signal-to-noise Ratio.....Better than 34 db measured between a reference signal recorded at 1000 cps and 5% third harmonic distortion and none present when playing back on erased, unmodulated tape.

Ordering Information

Cue Record/Playback (for TR-4).....MI-43355
Cue Record/Playback (for TR-5).....MI-43348
Audio/Cue Playback (for TR-3).....MI-43369

Monitor/Record Assemblies

The TR-3 TV Tape Player upon addition of a Monitor Rack Assembly (MI-43361) and Record Accessory (MI-43360) provides the same record-playback versatility as the RCA TR-4 TV Tape Recorder. In addition, space is provided for the addition of Electronic Splice, Cue Record/Playback, Drop-out Compensator and future accessories. The Monitor/Record Assemblies thus allow stations presently requiring only playback facilities, to expand the TR-3 at any time more recording facilities are needed.

Monitor Rack Assembly, MI-43361

The monitor rack lends the TR-3 greater ease of maintenance as well as reduced setup time for refined servo adjustments. The picture monitor switcher is capable of selecting any one of the following: demodulator out, video out, mono ATC out, color out, and one position for an external video signal. In addition, tone wheel dots, representative of headwheel servo stability, may be superimposed on any of the previous displays.

The CRO Monitor can be switched to observe any of the following waveforms: demodulator out, video out, FM switcher out, control track playback, capstan servo, reference pulse, and monochrome ATC error.

The monitors are assembled in a compact rack cabinet, that also contains the monitor switchers and an audio monitoring system. It has a prewired harness that connects with the various servo and video signals in the TR-3. The cabinet has space for addition of the record electronics

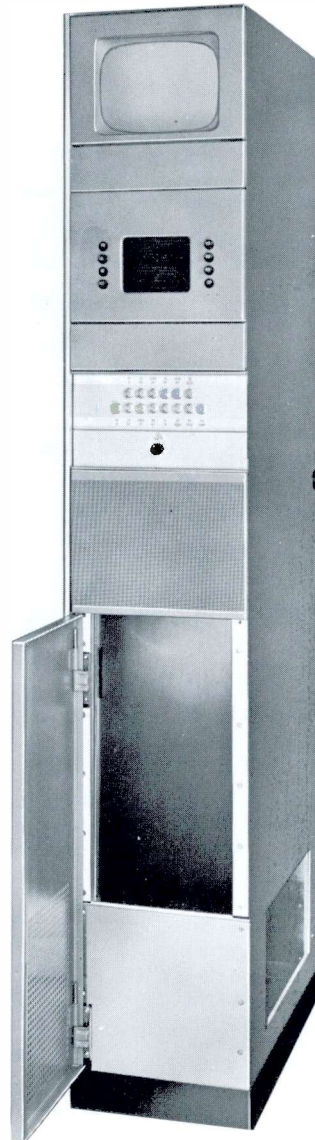

Monitor Rack

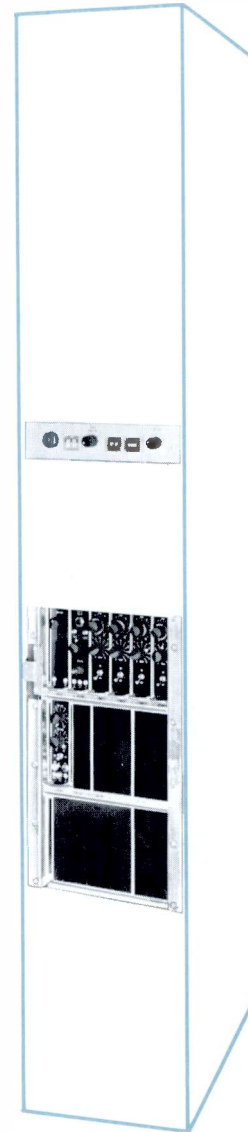

Record Accessory

and internal mounted air-bearing compressor kit.

Record Accessory, MI-43360

The Record Accessory requires the MI-43361 Monitor Assembly as a prerequisite. The Record Accessory is provided with the prewired harness and a module frame, designed to bolt into the monitor assembly

cabinet, and a record control panel, erase head, erase transformer, and an audio record head post.

The addition of the MI-43361 Monitor Assembly and the MI-43360 Record Accessory increase the versatility of the TR-3 in a two step process that is easy on the budget, while allowing the continuous playback of video tape at a low initial cost.

Specifications

TR-3 Monitor Rack, MI-43361

Power Requirements.....115 volts, AC, 60 cycles, 50 cps single phase, 300 watts max.; 230 volts, AC, single phase, 300 watts max.
Overall Dimensions.....66" high, 11" wide, 23½" deep (167.64 cm, 27.94 cm, 59.69 cm)
Weight.....165 lbs. (75 kg) approx.

Record Assembly, MI-43360

Overall Dimensions.....TR-3 Monitor rack assembly is pre-requisite. This accessory fits into above equipment physically and remains same size overall.

Weight.....50 lbs. (23 kg) approx.

Addition of this accessory and the MI-43361 will convert the TR-3 to a complete TR-4 Tape Recorder and all specifications of the TR-4 apply (see TR-4 Catalog).

Ordering Information

Monitor Rack Assembly.....MI-43361
Record AccessoryMI-43360

TO-4 Video Waveform Monitor

The TO-4 is a precision video waveform monitor featuring completely solid state circuit design and a self-contained well regulated power supply. It is intended for optimum performance for color and monochrome camera control, TV tape, transmitter, and line monitor applications.

Operating simplicity is achieved by reducing the operating controls to a set of pushbutton switches arranged vertically on each side of the cathode ray tube. Precision time base and vertical amplifier circuits result in accurately calibrated monitoring of the television waveform. A wide variety of mounting schemes adapts the TO-4 to almost any console or rack layout and the plug-in feature makes the monitor easy to install and remove.



Specifications

Input Circuits:

Input Video Signal Level, Volts:	Min.	Nominal	Max.
Peak-to-Peak, composite	0.3	1.0	2.0
Peak-to-Peak non-composite	0.25	0.7	1.4

Input Impedance, Video.....15,000 ohms minimum to 8 mc compensated for 75 ohm bridging circuit or termination
 External Sync Input.....1.75 to 9 volts peak, negative
 Tone Wheel Sweep Sync Input
 from TR-22 TV Tape Machine.....240 or 250 hertz
 negative, 4 volts peak, 325 microseconds duration
 Calibration Input, External.....1.0 volt peak-to-peak square wave

Remote Control Signals:

Internal-External Sync...Ground supplied at remote point
 120 or 125 hertz External Sync.....24 volts from TV Tape Machine

Remote Control Switching of

Scanning Standards.....24 volts from TV Tape Machine

Input Circuit Protection.....No damage with up to ± 300 volts at video and sync inputs

Output Signal:

Line Selector Brightening Pulse.....2.0 volts, peak-to-peak positive, 500 ohms source impedance, 1000 ohms load impedance

Vertical Amplifier:

Frequency Response, FLAT..... ± 0.25 db from 15 hertz to 5 mh, smooth roll off within -3 , -10 db at 8 mh
 Frequency Response, IEEE.....Conforms to IEEE roll off Standard #23S-1, 1958

Frequency Response, Color Calibration.....Response at 3.58 mh matches response within 0.1 db at 15.75 kh (4.43 mh and 15.625 kh for 625 lines, 50 fields)

Vertical Amplifier and Deflection Linearity.....Within $\pm 1.0\%$ of full 7 cm deflection for input signal of any duty cycle between 10% to 90%

DC Setter.....Back porch keyed clamp

Hum Level.....At least 46 db below full scale deflection

Horizontal Sweep Amplifier:

Sweep Trigger Rates, $\frac{1}{2}$ Vertical.....25 hertz and 30 hertz

Sweep Trigger Rates

$\frac{1}{2}$ Horizontal.....7812.5 hertz and 7875 hertz

Quadrature Display Rate.....125 hertz and 120 hertz

Sweep Linearity.....Within $\pm 2.0\%$ of full 10 cm deflection

Sweep Displays.....Two complete Vertical or two complete Horizontal blanking intervals. Sweep starts during active scanning time

Sweep Stabilization Time.....Less than 0.5 seconds

Expanded Vert. Sweep Rate.....200 microseconds per cm

Expanded Hor. Sweep Rate.....1.4 microseconds per cm

AC Power Input.....98 to 130 volts or 196 to 260 volts at 47 to 62 cycles, 100 watts

Operating Temperature Range..... -20°C to $+55^{\circ}\text{C}$ at altitudes to 10,000 ft.

Cooling.....Free air convection

Cathode Ray Tube.....5" rectangular

Overall Dimensions.....8 $\frac{3}{4}$ " high, 8 $\frac{3}{8}$ " wide, 17 $\frac{1}{2}$ " deep (22.2 cm, 21.9 cm, 44.5 cm)

Weight.....Approx. 43 lbs. (19.5 kg.)

Ordering Information

Type TO-4 Waveform Monitor.....ES-556904
 To include the following:

- 1 TO-4 Waveform Monitor Chassis
- 1 Connector Plate Assembly
- 1 Composite Signal Graticule
- 1 Percentage Modulation Graticule
- 1 Camera Control Graticule

TV Tape Mechanical Accessories

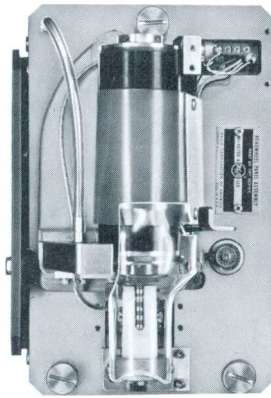

Headwheel Panel Assemblies



Automatic Magnetic Tape Eraser

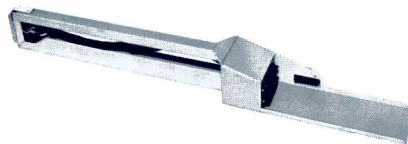

Test Module Extenders



Magnetic Tape Head Degausser



Video Tape Storage Cabinets



Alignment Tapes

Headwheel Panel Assemblies

- Choice of ball bearing or air bearing
- Full track or narrow track
- Long life

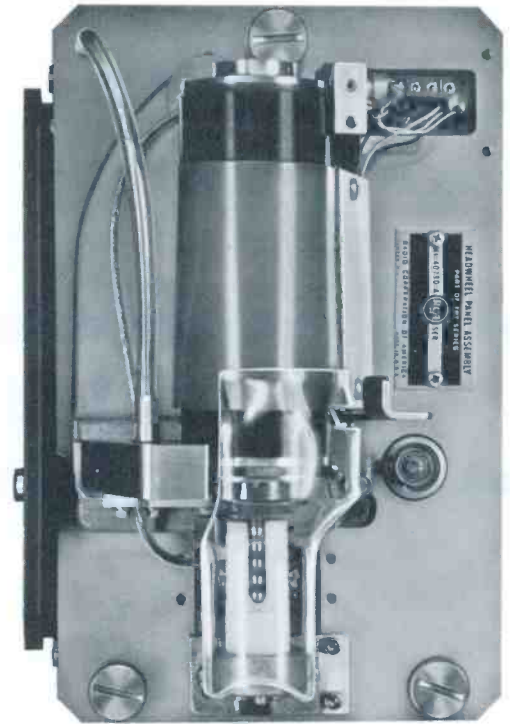

Standard Ball-bearing Headwheel Assemblies (provided on RCA TR-3, TR-4 and TR-5 TV Tape machines) and Air Bearing Headwheel Assemblies (provided on RCA TR-22 models) are readily interchangeable on all RCA video tape equipment. Either full-track (10 mil) to narrow-track (5 mil) headwheels are available for use as spares or to exploit the advantages of air as a lubricant to provide high quality in television tape recording and reproduction.

The headwheel panel assembly is easily inserted in the tape transport panel and held by three captive thumb screws. It consists principally of the headwheel, headwheel motor, brush and slip-ring assembly, control-track head, tone-wheel, tone-wheel head, and vacuum guide assembly.

The Air-Bearing Headwheel Assemblies are similar to the ball-bearing types. By substituting a thin layer of air under pressure for stand-

ard ball bearings, the motor shaft of the headwheel panel literally rides on a cushion of air. Metal friction is eliminated. Near perfect rotational concentricity is maintained throughout the life of the recording heads. Improved headwheel servo lock-up and reduced jitter materially improves the overall quality of performance. Tape guides on the transport are similarly air lubricated to save wear on tape. The panels are interchangeable on the TR-22, or on other model TV Tape Machines after the installation of an Air Bearing Conversion Kit.

The Conversion Kit contains an air pump in a soundproof housing, necessary gauges, relays and interconnecting hose. The air-bearing panel utilizes a pneumatic bearing for both the radial and axial positioning of the headwheel. The air compressor supplied is an oilless unit and includes a reservoir tank. A regulator to maintain 35 PSIG air pres-

sure and a filter-moisture separator are supplied to provide clean, dry air at the headwheel panel. The air line is equipped with a safety pressure switch. The safety switch prevents operation of the air bearing panel until adequate air pressure is available. In the event of an air supply failure, the safety switch will turn off the tape recorder and allow the headwheel to coast to a stop without damaging the air bearing surfaces.

Headwheel Panel Assemblies are shipped in a carrying case equipped with a shock mount support. They should be kept in the case at all times except when in actual use.

ORDERING INFORMATION

Ball-Bearing Headwheel Panel Assembly	MI-40760-B
Air-Bearing Headwheel Panel Assembly	MI-40790-A
Narrow Track Ball-Bearing Headwheel Panel Assembly.....	MI-40791
Narrow Track Air-Bearing Headwheel Panel Assembly.....	MI-40799

LIST OF ACCESSORIES

Air Bearing Conversion Kits	
With compressor for TR-5, 117 volts, 60 cycles, external mount.....	MI-43344
With compressor for TR-5, 230 volts, 50 cycles, external mount.....	MI-43345
With compressor for TR-4, 117/230 volts, 50/60 cycles, internal mount.....	MI-43357
With compressor for TR-3/4, 117 volts, 60 cycles, external mount.....	MI-43276
With compressor for TR-3/4, 230 volts, 50 cycles, external mount.....	MI-43277
Less compressor for TR-5, using house air system.....	MI-43342
Less compressor for TR-3/4 using house air system.....	MI-43364
Headwheel Brush (min. quantity order 10).....	#219748
Tip Protrusion Indicator	MI-43261

Remote Control Facilities



Remote Control Panel (Mode), MI-40691-A

The Remote Control Panel (Mode), MI-40691-A, provides a means for remotely controlling the mechanical functions of any RCA TV Tape Recorder and Player. It is equipped with controls that enable the following operational modes to be performed: stop, fast reverse wind, fast forward wind, record and play. Two tally lights, local and remote, indicate the method of control under which the machine is being operated.



Remote Control Panel (Signal), MI-40692-A

The RCA Remote Control Panel (Signal), MI-40692-A, contains controls that make it possible to remotely adjust the level of the video, sync and pedestal components of the output video signal. A pilot light indicates when the panel is in use.

Both types of remote control panels are $11\frac{1}{16}$ inches (6.76 cm) wide by $22\frac{1}{32}$ inches (28.1 cm) high. Either panel can be mounted in the stand-

ard console housing mounting adaptor, MI-26252, or in the rack mounting adaptor, MI-26254.

ORDERING INFORMATION

Remote Control Panel Kit (for TR-22/3/4/5)	MI-40691-A
Remote Video Control Panel (for TR-22/3/4/5)	MI-40692-A
Console Housing Mounting Adaptor (for MI-40691/40692).....	MI-26252
Rack Mounting Adaptor (for MI-40691/40692)	MI-26254

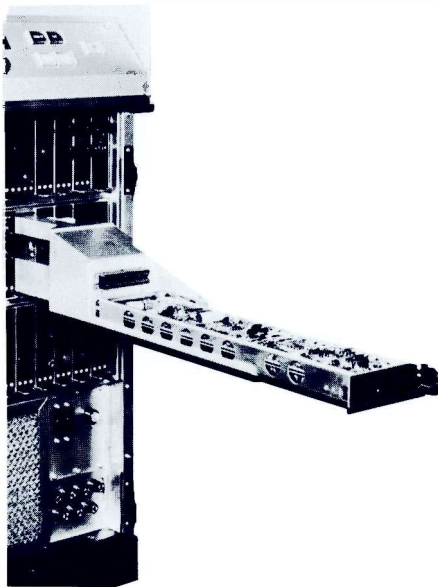

Test Module Extenders

A Test Module Extender, MI-40649, enables any one of the many modules which comprise the TR-22/3/4 or 5 processing amplifier, Pixlock, and ATC (with the exception of the modules located behind the control panel) to be withdrawn and service checks performed with the equipment in operation. The module extender is inserted in the TV Tape Recorders in place of the module to be tested and the module is then inserted on its side in the extender. The module is held firmly in a horizontal position by the extender greatly simplifying checkout of all circuits. With spare module

extenders, it is possible to check two or more modules simultaneously.

A Test Module Extender, MI-557301 is required for the modules located behind the play panel of the TR-3 and TR-4 and directly below the tape transport panel of the TR-5 Video Tape Machines. These modules, including record, playback and driver modules, etc., employ a 44-terminal connector plug.

ORDERING INFORMATION

Test Module Extender (spare).....	MI-40649
Special Module Extender (44 terminals)	MI-557301

Improved Headwheel Panel Cover

A new Headwheel Panel Cover, MI-40678, can be provided for earlier model TR-22 Tape Recorders that affords greater accessibility for threading, cleaning or inspecting the machine. Operational ease is realized by hinging the lower part of the new headwheel cover assembly. The audio post shield is also hinged and can be dropped down by a push-button release at the top of the audio head lockup post. Closing the headwheel cover will also close the audio head shield by means of an actuator attached to the hinged part of the headwheel cover.

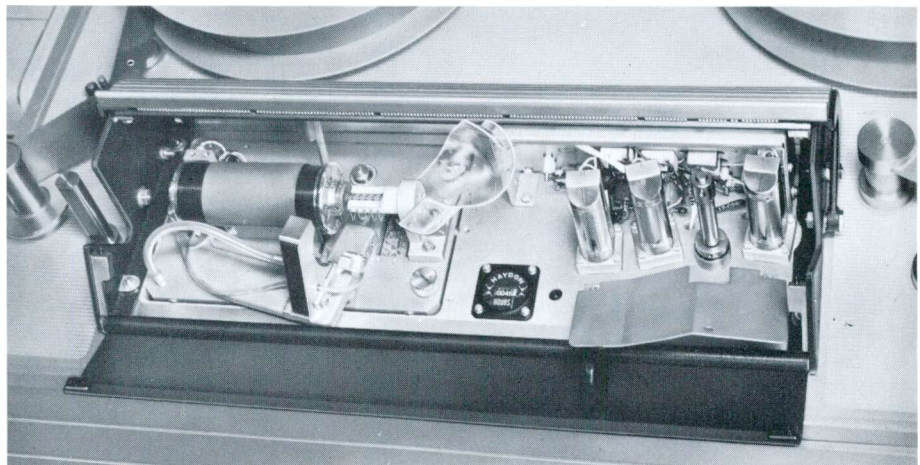

ORDERING INFORMATION

Headwheel Panel Cover.....	MI-40678
----------------------------	----------

Alignment Tool for Vacuum Guide Lead Screw

An Alignment Tool for Vacuum Guide Lead Screw, MI-40665, is a valuable accessory whose chief function is to standardize the tape transport panel of the TR-22 to permit rapid headwheel panel interchangeability. It consists of an aluminum jig with a critical Go/No-Go gauge that is used in adjusting the head screw protrusion of the TR-22 Recorder or the older RCA Type TRT-1 machines.

ORDERING INFORMATION

Alignment Tool for Vacuum Guide
Lead ScrewMI-40665

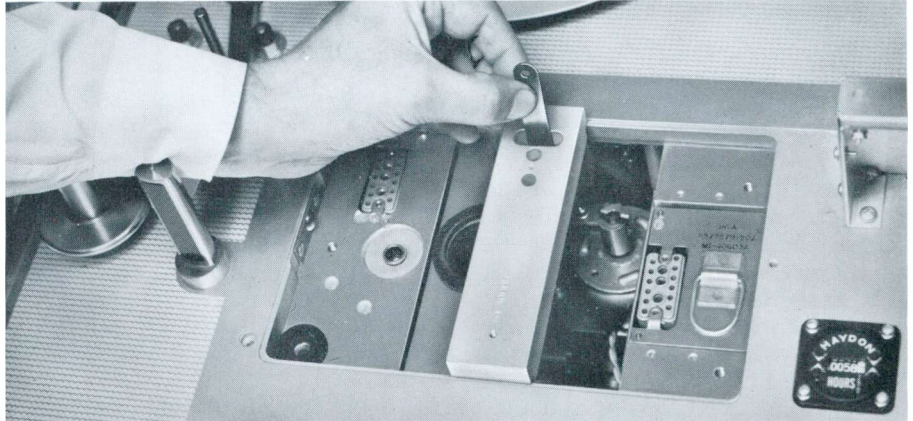

Guide Position Adjustor for Headwheel Panel

The vacuum Guide Adjusting Mechanism, MI-43351, is a mechanical accessory that enables video tape operators to accurately adjust the vacuum guide position on TR-3, TR-4 and TR-5 tape machines. It is designed to be used with the 525-line (MI-40793) or 625-line (MI-40779) Standard Video Alignment Tapes.

If penetrations other than the standard are desired, rapid manual adjustments can be affected during playback of a tape, by means of a knurled adjusting screw. The unit is provided with a direct reading dial

indicating the actual position of the vacuum guide. Dial readings of up to $+1\frac{1}{2}$ mils and as low as $-3\frac{1}{2}$ mils may be read directly. The dial may be returned to the zero reading even during operation to secure a standard recording.

In order to actuate this adjustment without opening the headwheel cover, a special rim drive disc is provided for use on the TR-3/4 and 5 headwheel panel cover.

ORDERING INFORMATION

Guide Position Adjustor.....MI-43351

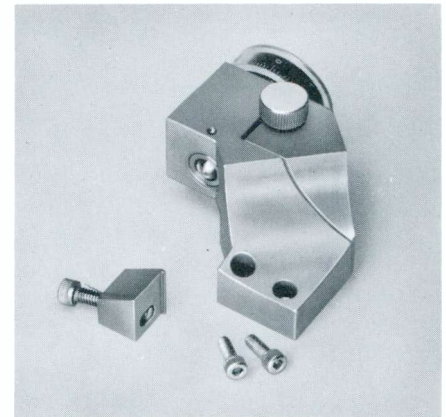

Magnetic Tape Head Degausser

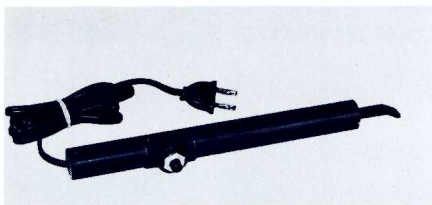

The Magnetic Tape Head Degausser, MI-11995, is designed to de-

magnetize the video, tone wheel, control track and audio heads of television tape recorders should they become magnetized. The unit is housed in a lightweight hand-grip case $9\frac{7}{8}$ inches (25 cm) long by $\frac{7}{8}$ inches (2.22 cm) in diameter. It has a $1\frac{3}{8}$ -inch (3.6 cm) demagnetizing tip that can be conveniently inserted amid the head assemblies. A momen-

tary-contact ON-OFF push-button safety switch energizes the unit. The line cord is 5 feet (1.52 cm) long and the tool operates on 117 volt, a-c, 50/60 cycles power line. It weighs approximately 9 ounces (28.3 gr.).

ORDERING INFORMATION

Magnetic Tape Head Degausser
(117 volt, 50/60 cps).....MI-11995
Magnetic Tape Head Degausser
(220 volt, 50/60 cps).....MI-11996

TR-22 Dolly Assembly

Studios desiring to mobilize their TR-22 TV Tape Recorders can readily attach Dolly Kit, MI-40668, to their machines. The assembly consists of two sturdy metal dollies each supported by four 2-inch heavy-duty casters and mounting hardware. The dollies perfectly fit and attach to the base of the TR-22 Re-

recorder by means of four $\frac{3}{4}$ -inch machine screws, spring lock-washers and hex nuts. Dollies are $26\frac{1}{2}$ inches (67 cm) deep by $10\frac{1}{4}$ inches (26 cm) wide and elevate the TR-22 approximately 3 inches (7.6 cm). Shipping weight is 60 pounds (27.2 kg).

ORDERING INFORMATION

Dolly Kit for TR-22.....MI-40668

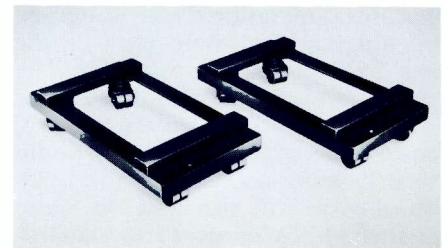

Automatic Magnetic Tape Eraser

- Complete audio and video signal erasure
- Automatic erase cycle
- Air core coil for uniform erasure
- Accommodates up to 2-inch tape on 15-inch reels



The new RCA Automatic Magnetic Tape Eraser is a self-contained unit mounted in a metal cabinet of table height requiring a floor space 22 inches square (.56 m sq.). The unit is designed to erase full reels of magnetic film tape and will accommodate up to 15-inch (38.1 cm) reels.

Audio and video signals are erased down to the noise level of the magnetic medium in an automatic 18

second cycle. The erase cycle is fully automatic and controlled by a motor operated mechanism. Once the reel of tape is placed on the carriage and pushed into the operating position the erase cycle is set in motion without manual operation of any controls.

The use of an air core coil eliminates the possibility of "erasure spokes" so common in erasing with

an iron core coil. Power factor correction with the air core coil provides a very high field strength from a nominal 12 ampere 220 volt input.

ORDERING INFORMATION

- Automatic Magnetic Tape Eraser,
Video Coil, 60 cycle.....ES-29975
- Automatic Magnetic Tape Eraser,
Video Coil, 50 cycle.....ES-29977

Alignment Tape

RCA Alignment Tapes are designed to speed set-up of new headwheel assemblies and assure proper head to tape spacing. The tapes are a very convenient servicing aid in preparing the physical or mechanical alignments of TV tape recorders so that proper quadrature adjustment results. Use of these test tapes helps the operator to make tapes that will be interchangeable for playback on other machines or headwheel assemblies.



The composite signal contained on the alignment tapes consists of (a) Stair-Step, (b) Multi-Burst, (c) Window, and (d) Sine-Squared Pulses. The sine-squared pulses form a vertical stripe pattern of narrow lines that are convenient for skewing, scalloping and quadrature error observation. Use of the standard alignment tapes when placing a new headwheel assembly into operation, plus periodic use throughout the life of a headwheel assembly, will enable the operator to readily check the following conditions:

1. Head quadrature
2. Vacuum guide position
3. Video Levels
4. Video amplitude vs frequency response
5. Video transient response
6. Low frequency tilt

7. Video amplitude linearity
8. Video head playback sensitivity
9. Relative noise banding
10. Carrier deviation frequencies
11. Program and cue audio level
12. Control track level and phase

Through standardization of these many operating parameters intersplicing of tapes is now readily accomplished.

Two tapes are available: MI-40793 for use on tape recorders operating 525 lines/60 cycles and MI-40797 for those operating at 625 lines/50 cycles. Both contain a minimum of 400 feet of specially recorded tape made in accordance with rigid RCA specifications and wound on an 8-inch (20.32 cm) diameter reel. The alignment tapes come in special plastic cases.

Stock Identification	Line Standard	Playing time at 15 inch/sec.	O.D.
MI-40793	525 line/60 cycle	6 min.	8.000" (20.32 cm)
MI-40797	625 line/50 cycle	6 min.	8.000" (20.32 cm)

Video Tape Storage Cabinets

- Protects and extends life of video tapes
- Sturdy, all steel construction—fire proof
- Enables fully indexed, orderly storage
- Wide choice of styles, capacity, and finishes
- Can be equipped with security bars



Neumade all-steel cabinets provide maximum video tape storage facilities in a minimum of space. Telecasters will find these clean and orderly compartmentalized storage cabinets an invaluable addition to any recording studio. This filing equipment also protects costly video tapes against damage from fire, dust and other hazards.

The Model VT Neumade cabinets are designed to house video tape reels ranging in size from 6 inches to 14 inches. Each reel has its own

double walled fireproof compartment of heavy gauge steel with safety air chambers completely surrounding it—door, sides, top, bottom and back. Individual doors are self-closing with semi-enclosed reel carriages especially designed to prevent reels from “catching.” A full grip handle and changeable index tab are provided on each door.

The video tape cabinets are available as complete floor model units housing from 30 to 50 reels accord-

ing to reel size or as separate ten compartment fireproof cabinets complete for use anywhere. On order, all cabinets can be equipped with approved security bars and combination locks. Neumade cabinets are supplied with standard olive-gray baked-on enamel finish but, when specified, will be supplied to match other manufacturers' finish in satin smooth baked-on enamel. Modern handles with brush chrome finish add to the streamline styling and beauty.

Ordering Information

Floor Cabinets:

For 6", 6½" or 8" Reels:

Files 50 reels in 5 ten compartment fireproof cabinet in outer steel cabinet 72" high, 39" wide, 15" deep.....Model VT-8-50

For 6" Reels Only:

Individual fireproof compartments for 50 fifteen minute reels, same as above but only 60" high.....Model VT-6-50

For 12½" Reels:

Individual fireproof compartments for 30 one hour reels in 3 ten compartment cabinets in outer steel cabinet 60" high, 39" wide and 15" deep.....Model VT-12-30

For 14" Reels:

Same as above but for 30 of the 14" reels. Size 67" high, 39" wide, 17" deep.....Model VT-14-30

Single 10 Compartment Fireproof Cabinets:

Ten 6-inch reels per cabinet.....Model VT-6-10
 Ten 6½-inch or 8-inch reels per cabinet.....Model VT-8-10
 Ten 12½-inch reels per cabinet.....Model VT-12-10
 Ten 14-inch reels per cabinet.....Model VT-14-10

Video Tape Storage Racks

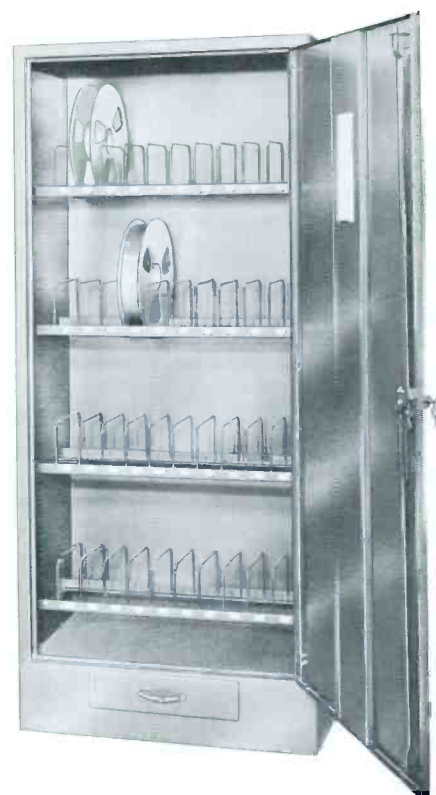
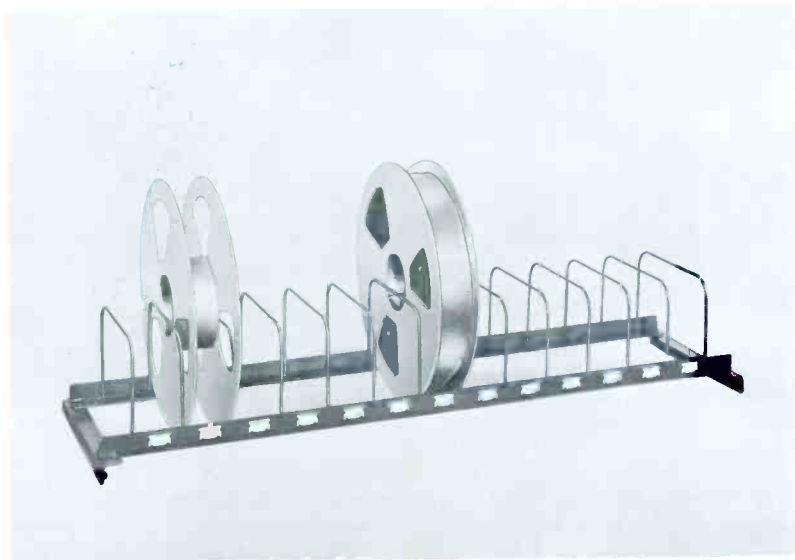

Although fully fireproof cabinets are recommended for storage of video tapes, these all steel single wall fire-resistant cabinet storage racks prove adequate under certain conditions. The interiors are fitted with steel separator racks with individualized storage and indexing for each reel plus a master index.

The steel cabinet is of sturdy design. The door has a three-point latch and key lock and a utility drawer is provided in the base. The cabinet is 70 inches high, 30 inches wide and 16 inches deep overall. Neumade olive-gray enamel baked-on is standard finish but a finish matching RCA is available on special order.

Open storage racks are also available to store video tapes. These all steel equipments are fully indexed, with steel rod separators welded to steel angles. Closed steel ends have cast iron feet drilled for floor mounting as are ends and back supports for mounting to wall or other units. Individual tape rack lengths of any size and length, cut to your needs and ready for use, are also available. These racks are supplied complete with end brackets and have an approximate capacity of 4 reels per foot of rack.

Ordering Information

Cabinet Racks:

- For 6" Reels:
Files 80 reels in fire resistant cabinet 70" high, 30" wide and 16" deep.....Model VT-806
- For 6½" and 8" Reels:
Files 70 reels in cabinet, same as above.....Model VT-708
- For 12½" Reels:
Files 40 reels in cabinet, same as above.....Model VT-402
- For 14" Reels:
Files 30 reels in cabinet, same as above.....Model VT-304

Tape Racks:

- For 6", 6½" and 8" Reels:
Files 125 reels on 7 tiers. Size 75" high, 48" wide, 10" deep.....Model RVT-125-68
- For 6", 6½" and 8" Reels:
Files 144 reels on 8 tiers, same rack as aboveModel RVT-144-68
- For 12½" and 14" Reels:
Files 90 reels on 5 heavy duty separator racks. Size 75" high, 48" wide and 16" deepModel RVT-90-124
- For All Size Reels:
Files 54 of the 6", 6½" or 8" reels and 54 of the 12½" or 14" reels. Size 75" high, 48" wide. 16" deep.....Model RVT-614

Tape Rack Lengths:

- For 6", 6½" and 8" Reels:
Files approximately 4 reels per ft. (specify length desired).....Model RVT-8
- For 12½" and 14" Reels:
Files approximately 4 reels per ft. (specify length desired).....Model RVT-14

Note: FOR REELS IN BOXES:

Racks listed above are for reels only. Supplied for reels in boxes when specified at same prices but capacities are less.

TV Tape Splicer

- Sheer type cutter—machined cutting surfaces accurate to 500 micro inches
- Precision mounted 40-power optical system
- Slide-in splicing tape dispenser
- Fold-a-way light

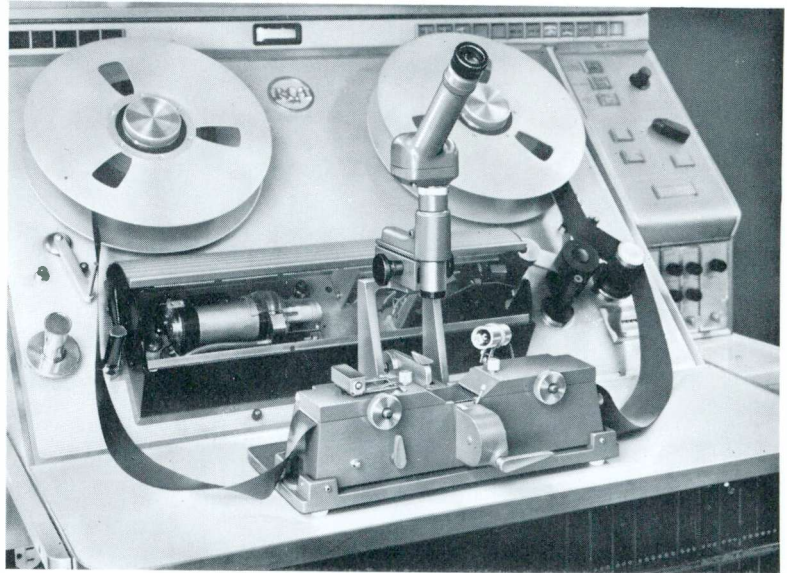

TV Tape Splicers are available in two models, a precision Mechanical Tape Splicer, MI-40772 for 15 ips, and another, MI-40748 for 7½ ips. Both Splicers are precision instruments for professional splicing of magnetic tape, required in television tape recording operations. They feature a shear-type cutter offering machined cutting surfaces accurate to 500 micro inches, a 40-power microscope for easy location and precise alignment of frame pulses. A slide-in splicing tape dispenser measures just the right amount of splicing tape and permits neat, secure splices free of creases and bulges.

The tape splicer has a number of lock-in adjustments which afford all the means for forming clean, solid, square butt-splices. With a minimum of time and effort operators can make perfect splices thus eliminating roll-over and other "splice-faults" of television tape programming.

The splicer consists of a sturdy base plate upon which an optical system and splicing components are mounted. The splicer body has a precision tape guide measuring 2 inches (5.08 cm) wide by ⅛-inch (.32 cm) deep in which the tape is placed during the splicing operations. Two hinged hold-down doors secure the tape in the tape guide. Two Vernier tape advanced knobs control tape movement in the guides and allow the operator to align the tape under the cutting shear. When properly

positioned for the cut, the tape may be secured by means of tape locks.

A light assembly containing a 6.3 volt screw-base lamp is hinged to the top of the left hand tape hold-down door. It is swung into position to light the splicing area while the optical alignment is being made and swung back to the "rest" position while the splice is being made. Another feature of the splicer is the saddlebar which slides through the ways in the splicer body at right angles to the tape guide. It carries the shear into position for cutting and the splicing tape into position for the splicing operations. The tape shear is mounted on the back end of the saddlebar assembly, and is made of a special alloy, hardened and precision ground. The splicing tape magazine is located on the

front-end of the saddlebar and contains a spring-loaded spool which holds the reel of splicing tape. The saddlebar can be locked into position to prevent the bar being moved during cutting or splicing operations.

Splicing Table

Splicing Table to accommodate the 15-ips Magnetic Tape Splicer, MI-40772, and the 7½-IPS Magnetic Tape Splicer, MI-40748, is available for use with the TR-22 Video Tape Recorder. The table is a one-piece shelf measuring 36 inches (91.44 cm) wide by 12 inches (30.48 cm) deep. A bar at each end hooks into studs mounted on the TR-22. The table is a great convenience when editing video tapes. It's rapid slip-on/off design does not impair normal operation of the tape recorder.

SPECIFICATIONS

Optical System.....	Magnification 40x
Alignment	500 micro-inches
Optical Assembly.....	6-8 volt lamp
Power Requirements.....	110 volts, single phase, 60 cycle
Power Cord.....	68 inches (1.73 m)
Overall Dimensions.....	15" wide, 15½" high, 13" deep, max. (38.1 cm, 39.27 cm, 33 cm)
Weight (Shipping).....	29 lbs. (13.15 kg)
Splicing Tape	
(aluminized low cold flow).....	Spool 66 ft. No. 41-VR ¼"
Finish.....	Dark umber gray

ORDERING INFORMATION

Mechanical Tape Splicer, 15 ips.....	MI-40772
Mechanical Tape Splicer, 7½ ips.....	MI-40748
Table for Tape Splicers.....	MI-40592
Tape Developer, 7 oz. bottle.....	#222408

TV Tape Mobile Unit, Type TJ-72

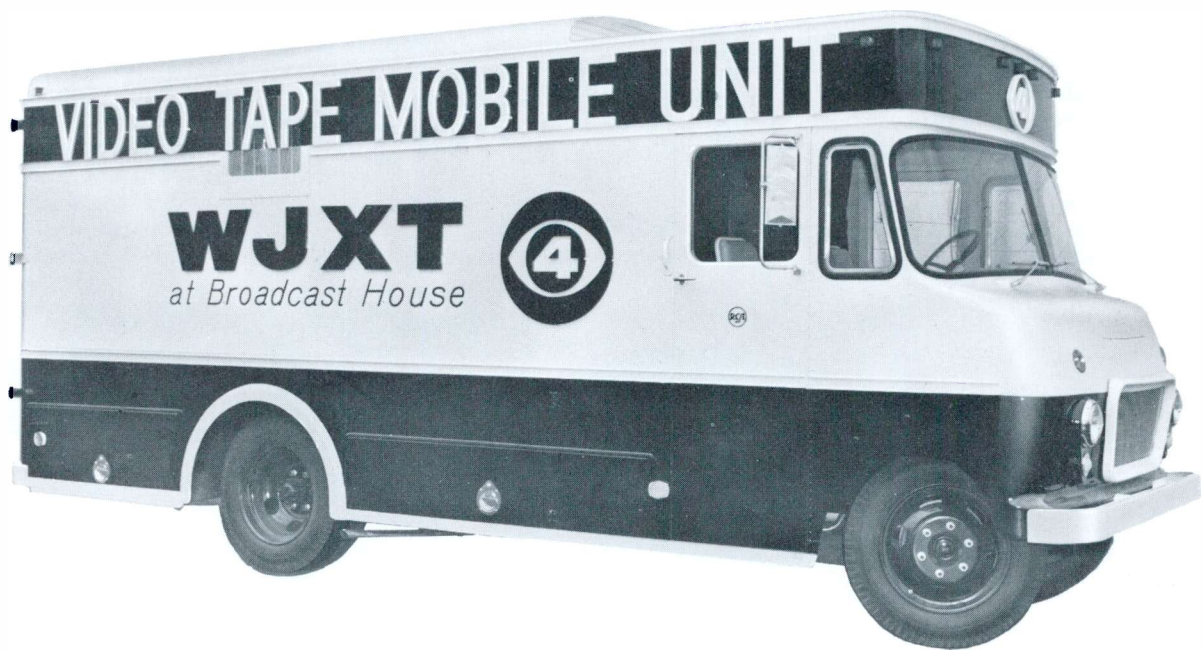

- Custom designed to hold "New Look" TV tape equipment
- For on-location television tape productions

Application

The Type TJ-72 Television Tape Mobile Unit is a traveling television tape studio affording ample space for operation, maintenance, tape editing and tape storage. It is unexcelled for producing programs and commercials. The RCA mobile unit is supplied completely equipped with monochrome or color tape recorder equipment for on-location recording of remote pickup events and effective commercials that capture the product story.

The TJ-72 Mobile Unit is designed to suit customer's requirements. It will house a variety of tape recording systems including deluxe 22HL's, and various combinations of TR-4 and TR-5 recorders along with the TR-3 tape player. Where requirements demand, a smaller bus or a larger trailer chassis can be supplied to carry the desired TV tape system. All equipment is installed and system tested, ready for use on delivery.

Description

The TJ-72 TV Tape Mobile Unit consists essentially of a standard 1½ ton chassis on which is constructed a custom two-level body attractively styled and well-engineered for practical application of remote video tape recording. The layout is planned for efficiency of operation and maintenance. The roomy interior provides 16 feet (4.88 m) of operation room behind the driver. The body interior measures 7 feet 6 inches (2.29 m) wide by 6 feet 9 inches (2.06 m) high. The equipment space is ample for any RCA Tape Recorder and associated facilities with space provided for extra color and test items.

Maximum Storage Space

Racks are provided to house audio facilities as well as cabinets and compartments for tape storage and areas for tape editing facilities, scopes, spare tape headwheel panel assembly, module extender and splicer. The custom body has a distinctive front design, complete trench system under the floor, three underside storage compartments, recessed locks and storage cabinets for accessory items including three cable reels.

Power Facilities

AC Power for the tape recorder is

supplied from a 7.5 KVA isolation transformer. A 6.0 KVA electro-mechanical voltage regulator is also supplied. The power distribution panel is conveniently located in the operating section. The body allows more than 5½ feet (1.68 m) of extra space at the rear for carrying cameras for a small remote pick-up of on-spot recording of a commercial. The tape equipment is securely and safely mounted. Screw clamps are used to secure removable equipment such as monitors. Wedges are press fitted under the blower and compressor shock mounts of the equipment while in transit.

AMPLE STORAGE FACILITIES—View showing one of three underside storage compartments revealing one of three cable reels, audio/video entrance panel, and power panel with weather-proof flap.

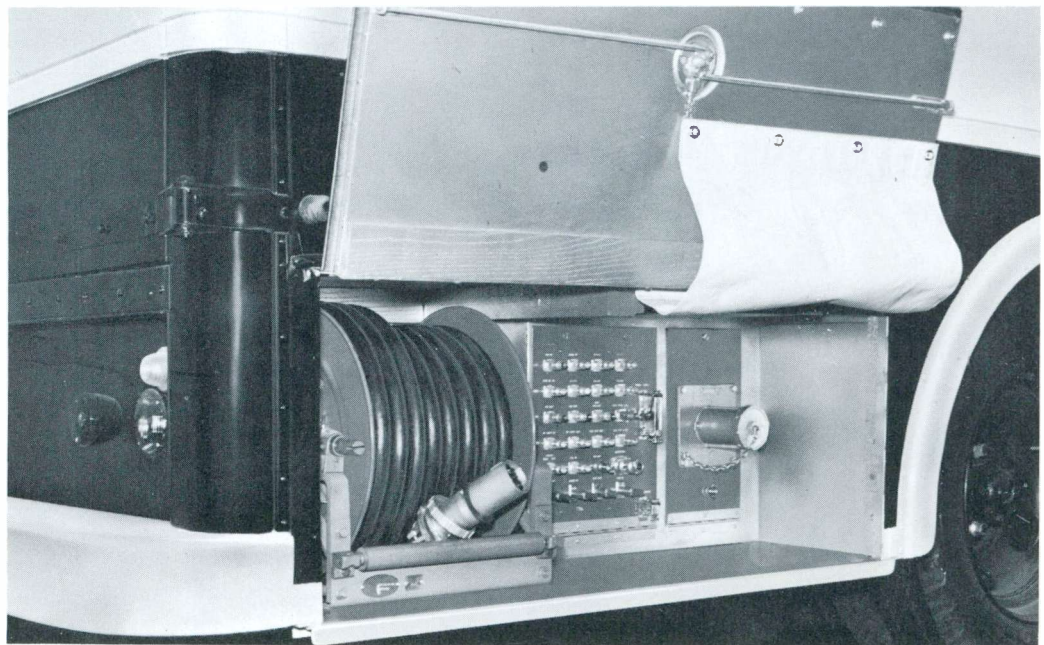



MOBILE TV TAPE RECORDING CENTER—Interior view of TJ-72 showing roomy interior with mounted TR-22 Tape Recorder together with audio facilities, cabinets, and compartments for tape storage, etc. More than 5½ feet of extra space at rear can accommodate field camera chain or other needed equipment for on-location tape recordings.

OPERATING CONVENIENCE — TJ-72 TV Tape Mobile Units are planned for efficiency of operation and maintenance. Operator is shown above at formica covered work bench. Air conditioning unit, power control panel, transistorized voltage regulator are installed in immediate area.



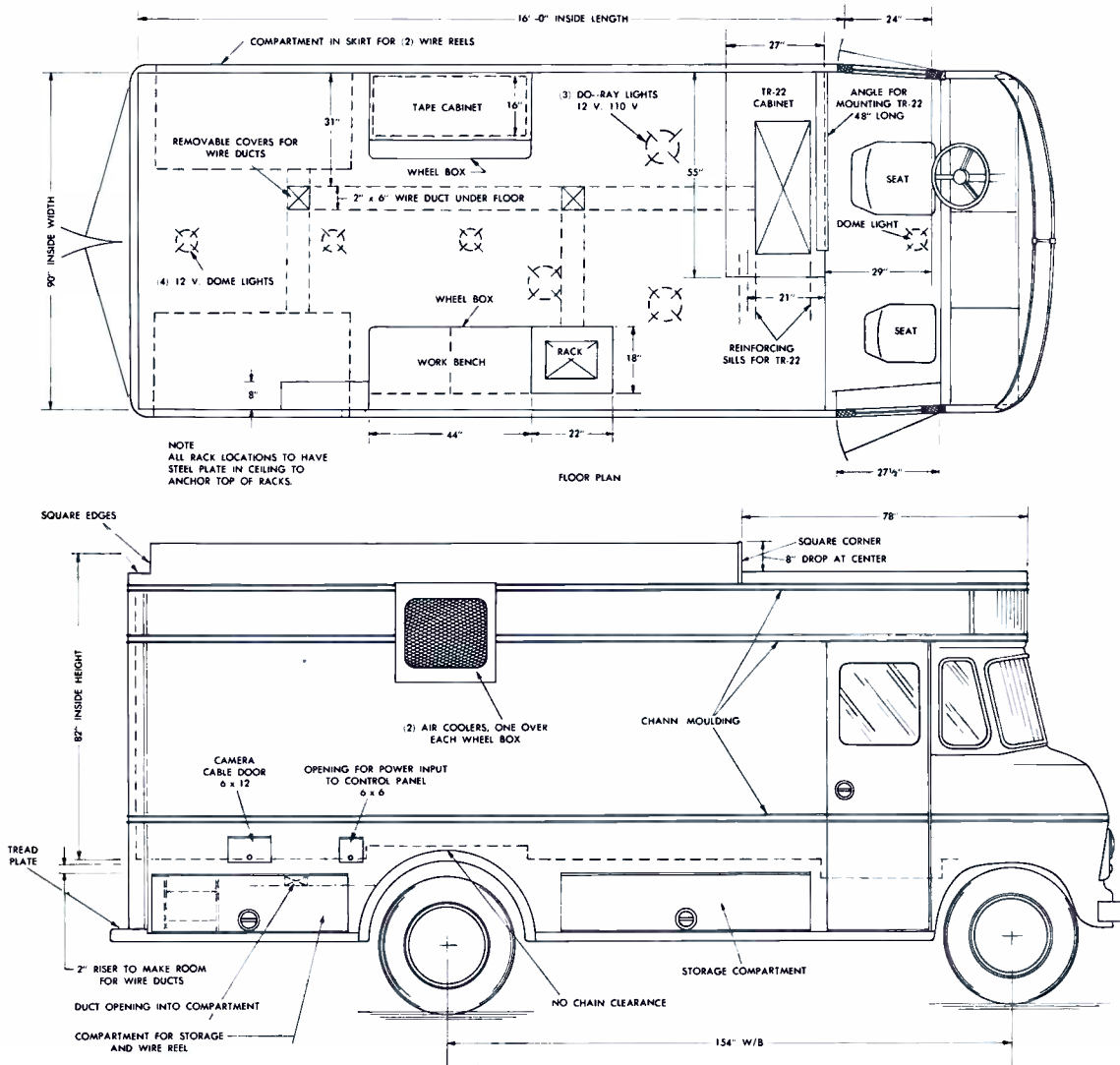

EFFICIENT SPACE UTILIZATION—Floor plan and elevation of a typical TJ-72 Mobile Unit showing provisions made for accommodating complete TV Tape Recording Equipment.

Specifications

Chassis.....	Standard 1½ ton truck with heavy duty springs and shocks
Tires.....	8:25-20, 10 ply. Dual rear wheels
Outside Dimensions:	
Length.....	23' 6" (8.05 m)
Width.....	7' 11½" (2.43 m)
Height.....	10' 6" (3.20 m)
Inside Dimensions:	
Length (back of driver seat).....	16' (4.88 m)
Width.....	7' 6" (2.29 m)
Height.....	6' 9" (2.06 m)
Outside Finish.....	To customer specification
Total Weight (with equipment).....	Approx. 14,000 lbs. (6350 kg)
Body.....	Custom built with 3 underside storage compartments, short racks with formica work surface, and tape storage cabinet

Ordering Information

Specify choice of TV Tape equipment and accessories.

The TJ-72A Mobile Tape Unit includes the following:

- 2 Air Conditioners, 28,000 BTU per air output
- 1 Stabiline Voltage Regulator, 6 KVA
- 1 Power Isolation Transformer, 7.5 KVA
- 1 Power Control Panel with a-c meter
- 1 Power Cable, 75 foot
- 1 A-c Power and conduit installed
- 3 Cable reels, manual
- 1 Fire extinguisher
- 1 Set of wiring, cables and connectors installed
- 1 Entrance connection panel for Audio, Video, Control and Power Cables

Index

	MI No.	Page
Adaptor, Control Panel:		
Console Housing Mounting.....	26252	59
Rack Mounting.....	26254	59
Air Bearing Headwheel Conversion Kit:		
With compressor for TR-5, 117/60, external mount.....	43344	58
With compressor for TR-5, 230/50, external mount.....	43345	58
With compressor for TR-4, 117/230 volts, 50/60 cycles, internal mount.....	43357	58
With compressor for TR-3/4, 117/60, external mount.....	43276	58
With compressor for TR-3/4, 230/50, external mount.....	43277	58
Less compressor for TR-5, using house air system.....	43342	58
Less compressor for TR-3/4 using house air system.....	43364	58
Air Bearing Headwheel Panel Assembly (10 mil).....	40790-A	58
Air Bearing Headwheel Panel Assembly (5 mil).....	40799	58
Alignment Tape:		
525 line, 60 cycle, monochrome.....	40793	61
625 line, 50 cycle, monochrome.....	40797	61
Alignment Tool for Vacuum Guide Lead Screw.....	40665	60
Audio/Cue Playback for TR-3.....	43369	54
Automatic Timing Corrector:		
Monochrome for TR-3/4 Series.....	ES-43580-A	50
Monochrome for TR-22A/B.....	ES-43579-A	50
Monochrome for TR-22C.....	43391-A	50
Color for TR-3/4 Series.....	ES-43582	51
Color for TR-22 A/B/C.....	ES-43581	51
Color for TR-22D.....	ES-43598	51
Ball Bearing Headwheel Panel Assembly (10 mil).....	40760-B	58
Ball Bearing Headwheel Panel Assembly (5 mil).....	40791	58
Brush, Headwheel (10 per package).....	#219748	58
Cabinets:		
Cabinet, holds 50—6/6½/8-inch reels.....	VT-8-50	62
Cabinet, holds 50—6-inch reels (15 min.).....	VT-6-50	62
Cabinet, holds 10—14-inch reels.....	VT-14-10	62
Cabinet, holds 10—12½-inch reels.....	VT-12-10	62
Cabinet, holds 10—8/6½-inch reels.....	VT-8-10	62
Cabinet, holds 10—6-inch reels.....	VT-6-10	62
Cabinet, holds 30—12½-inch reels (1 hour).....	VT-12-30	62
Cabinet, holds 30—14-inch reels (1 hour).....	VT-14-30	62
Cabinet with door, holds 30—14-inch reels.....	VT-304	63
Cabinet with door, holds 40—12½-inch reels.....	VT-402	63
Cabinet with door, holds 70—8/6½-inch reels.....	VT-708	63
Cabinet with door, holds 80—6-inch reels.....	VT-806	63
Ceramic Headset with Ear Cushions and Dynamic Microphone (for TR-5).....	38028-2	27
Color Automatic Timing Control:		
For TR-22 A/B/C.....	ES-43581	51
For TR-22D.....	ES-43598	51
For TR-3/4 Series.....	ES-43582	51
Combination Tape Rack, holds 54—14/12½-inch reels plus 54—8/6½/6-inch reels.....	RVT-614	63
Console Housing Mounting Adaptor (for MI-40691-A/40692-A).....	26252	59

	MI No.	Page
Cover for TR-22 (Headwheel Cover Assembly).....	40678	59
Cue Record/Playback:		
For TR-4 Series	43355	54
For TR-5.....	43348	54
Degausser, Magnetic Tape Head:		
For 110 volt, 50/60 cycle.....	11995	60
For 220 volt, 50/60 cycle.....	11996	60
Dolly Assembly for TR-22 Series (2 dollies and hardware).....	40668	60
Dropout Compensator (625/525 line):		
For TR-22 A/B/C.....	ES-43586	53
For TR-22D.....	43309	
For TR-4 Series.....	ES-43587	53
For TR-70.....	35959	
Electronic Splicing Accessory:		
For TR-70/TR-22D.....	40695-A	52
For TR-22 A/B/C	ES-40922-A	52
For TR-4.....	ES-43578-A	52
For TR-4A.....	ES-43569	
For TR-5.....	ES-43566	52
Erasers, Automatic Magnetic Tape:		
Video Coil, 60 cycles.....	ES-29975	61
Video Coil, 50 cycles.....	ES-29977	61
Guide Position Adjuster for Headwheel Panel (for TR-3/4/5).....	43351	60
Headset, Ceramic with ear cushions and microphone (for TR-5).....	38028-2	27
Headwheel Brush (minimum quantity—order 10).....	#219748	58
Headwheel Cover Assembly (for TR-22 Series).....	40678	59
Headwheel Panel Assembly:		
Air Bearing (10 mil).....	40790-A	58
Air Bearing, Narrow Track (5 mil).....	40799	58
Ball Bearing (10 mil).....	40760-B	58
Ball Bearing, Narrow Track (5 mil).....	40791	58
Indicator, Tip Protrusion.....	43261	58
Magnetic Tape Erasers:		
Video Coil, 60 cycles (automatic).....	ES-29975	61
Video Coil, 50 cycles (automatic).....	ES-29977	61
Magnetic Tape Head Degausser:		
110 volt, 50/60 cycles.....	11995	60
220 volt, 50/60 cycles.....	11996	60
Mobile Unit for TV Recorders/Players, Type TJ-72.....	Custom	65
Module Extender (spare for TR-22/3/4/5).....	40649	59
Module Extender, 44 terminal (spare for TR-3/4/5).....	557301	59
Monitor Rack Assembly (525/625 line, 50/60 cycles, switchable for TR-3).....	43361	55
Monochrome Automatic Timing Corrector for TR-3/4.....	ES-43580-A	50
Monitor, Waveform, Type TO-4, Including Front Panel and Connector Assembly.....	ES-556904	56
Narrow Track Air Bearing Headwheel Panel Assembly (5 mil).....	40799	58
Narrow Track Ball Bearing Headwheel Panel Assembly (5 mil).....	40791	58

	MI No.	Page
Panel:		
Air Bearing Headwheel Assembly (10 mil).....	40790-A	58
Ball Bearing Headwheel Assembly (10 mil).....	40760-B	58
Narrow Track Air Bearing Headwheel Assembly (5 mil).....	40799	58
Narrow Track Ball Bearing Headwheel Assembly (5 mil).....	40791	58
Remote Control (mode) for TR-22/3/4/5.....	40691-A	59
Remote Control (signal) for TR-22/3/4.....	40692-A	59
Player, Type TR-3A TV Tape (525 line, 60 cycle).....	ES-43570-A	13
Player, Type TR-3A TV Tape (525/625/405 line, 50 cycle, switchable).....	ES-43572-A-405	13
Player, Type TR-3A TV Tape (525/625/819 line, 50 cycle, switchable).....	ES-43572-A-819	13
Rack:		
Tape Storage, holds 125—6/6½/8-inch reels.....	RVT-125-68	63
Tape Storage, holds 144—6/6½/8-inch reels.....	RVT-144-68	63
Tape Storage, holds 90—12½/14-inch reels.....	RVT-90-124	63
Tape Storage, combination, holds 54—6/6½/8-inch and 54—12½/14-inch reels.....	RVT-614	63
Tape Storage, lengths cut to order, complete with end brackets (approx. 4 reels per ft.) for 6/6½/8-inch reels.....	RVT-8	63
Tape Storage, lengths cut to order, complete with end brackets (approx. 4 reels per ft.) for 12½/14-inch reels.....	RVT-14	63
Rack Mounting Adaptor (for MI-40691/40692).....	26254	59
Record Accessory (for use with MI-43361).....	43360	55
Recorder:		
TR-70 Color TV Tape (525 line, 60 cycle).....	ES-35977	37
TR-70 Color TV Tape (525/625/405 line, 50 cycle, switchable).....	ES-35979-405	37
TR-70 Color TV Tape (525/625/819 line, 50 cycle, switchable).....	ES-35979-819	37
TR-4A Compact TV Tape (525 line, 60 cycle).....	ES-43571-A	5
TR-4A Compact TV Tape (525/625/405 line, 50 cycle, switchable).....	ES-43573-A-405	5
TR-4A Compact TV Tape (525/625/819 line, 50/60 cycle, switchable).....	ES-43573-A-819	5
TR-5 Transportable TV Tape (525/625/405 line, 50/60 cycles).....	ES-43565	21
TR-22D TV Tape (525 line, 60 cycle).....	ES-43560	29
TR-22D TV Tape (525/625/405 line, 50 cycle).....	ES-43561-405	29
TR-22D TV Tape (525/625/819 line, 50 cycle).....	ES-43561-819	29
Remote Control Panel:		
Mode (for TR-22/3/4/5).....	40691-A	59
Signal (for TR-22/3/4).....	40692-A	59
Special Module Extender, 44 terminal (for TR-3/4/5).....	557301	59
Table for Mechanical Tape Splicer (for use with TR-22 Series).....	40592	64
Tape Splicer, Mechanical:		
Magnetic Tape 15 IPS.....	40772	64
Magnetic Tape 7½ IPS.....	40748	64
Tape Developer, 7 oz. bottle.....	#222408	64
Test Module Extender:		
For TR-22/3/4/5 (Spare).....	40649	59
Special for TR-3/4/5 with 44 terminals (Spare).....	557301	59
Tip Protrusion Indicator.....	43261	58
Tool, for Vacuum Guide Lead Screw of TR-22.....	40665	60
Transportable TV Tape Recorder, TR-5 (525/625/405 line, 50/60 cycles).....	ES-43565	21
Video Alignment Tape:		
Monochrome (525 line, 60 cycle).....	40793	61
Monochrome (625 line, 50 cycle).....	40797	61
Waveform Monitor, Type TO-4, Including Front Panel and Connector Assembly.....	ES-556904	56



PRICE
LIST
FOR

TELEVISION

tape

EQUIPMENT

Prices Effective March 1, 1966



The Most Trusted Name in Television

Ordering Information

RCA broadcast equipment is sold directly to broadcast stations through the Broadcast Sales Representatives operating out of the convenient sales offices listed below. These Broadcast specialists are available to assist you in discussing the application of broadcast equipment.

In ordering equipment, please indicate the Master Item (MI) number for each equipment. This will help us to speed the shipment to you. You will find the Master Item (MI) numbers are used to identify the equipment on the invoices and packing slips.

The Purchaser shall be responsible for all transportation charges, and shipments will normally be forwarded with shipping charges "collect." However, shipping charges can be prepaid and added to the billing invoice if your purchase order authorizes this method. We suggest that you consider the latter procedure since it eliminates the necessity of having petty cash on hand at the time of delivery. Your purchase order should specify the method of transportation desired, otherwise RCA will use its best judgment. The cheapest method of transportation is not always used as this may not always result in the most rapid delivery. Certain items, such as vacuum tubes, are usually shipped by Express because of the design of carrying container, insurance, etc.

RCA Broadcast Sales Offices

Atlanta, Ga.	30303	Dallas, Texas	75235	St. Louis, Mo.	63105
1121 Rhodes-Haverty Bldg.		210-C Court Terrace		7710 Carondelet Ave.	
Tel. 524-7703		Exchange Park, North		Tel. 862-3660	
Austin, Texas	78756	Denver, Colo.	80211	San Francisco, Calif.	94102
Northwest Professional Bldg.		Suite 223, 2785 N. Speer Blvd.		420 Taylor St.	
5425-B Burnet Rd.		Tel. 477-6832		Tel. 673-8027	
Tel. 453-8233		Indianapolis, Ind.	46201	Seattle, Wash.	98134
Birmingham, Ala.	35223	501 N. LaSalle St.		2246 First Ave., S.	
Office Park Circle Bldg. #10		Tel. 635-9000		Tel. 622-8350	
Tel. 871-1155		Kansas City, Mo.	64114	Southfield, (Detroit) Mich.	48076
Burbank, Calif.	91505	7711 State Line Rd.		17000 W. 8-Mile Rd., Rm. A3-300	
2700 W. Olive Ave.		Tel. 363-6770		Tel. 357-0080	
Tel. 849-6741		Meadow Lands,		Washington, D.C.	20006
Camden, N. J.	08102	(Pittsburgh) Penna.	15347	1725 "K" St., N.W.	
Front & Cooper Sts.		Washington County		Tel. 337-8500	
Tel. 963-8000 Ext. PC-3592		Tel. 341-5294		West Newton, (Boston) Mass.	
Charlotte, N. C.	28204	Memphis, Tenn.	38114	950 Watertown Street	02165
330 Charlottetown Center		2110 Airways Blvd.		Tel. 969-6010	
Tel. 333-3996		Tel. 324-4434		West Palm Beach, Fla.	33401
Chicago, Ill.	60654	Minneapolis, Minn.	55416	645 S. Military Trail	
2000 Merchandise Mart Plaza		4522 Excelsior Blvd.		Tel. 683-2219	
Tel. 467-5900		Tel. 929-3303		RCA International Div.	07066
Cleveland, Ohio	44115	New York, N. Y.	10020	Central & Terminal Avenues	
1600 Keith Bldg.		Rm. 1219, 30 Rockefeller Plaza		Clark, N. J.	
Tel. 241-3450		Tel. 689-7200		Tel. 382-1000	

Price List

	MI No.	Price
Adaptor, Control Panel:		
Console Housing Mounting.....	26252	\$ 40.00
Rack Mounting.....	26254	25.00
Air Bearing Headwheel Conversion Kit:		
With compressor for TR-5, 117/60, external mount.....	43344	1,050.00
With compressor for TR-5, 230/50, external mount.....	43345	1,050.00
With compressor for TR-4, 117/230 volts, 50/60 cycles, internal mount.....	43357	1,050.00
With compressor for TR-3/4, 117/60, external mount.....	43276	1,050.00
With compressor for TR-3/4, 230/50, external mount.....	43277	1,050.00
Less compressor for TR-5, using house air system.....	43342	595.00
Less compressor for TR-3/4 using house air system.....	43364	595.00
Air Bearing Headwheel Panel Assembly (10 mil).....	40790-A	1,950.00
Air Bearing Headwheel Panel Assembly (5 mil).....	40799	1,950.00
Alignment Tape:		
525 line, 60 cycle, monochrome.....	40793	200.00
625 line, 50 cycle, monochrome.....	40797	200.00
Alignment Tool for Vacuum Guide Lead Screw.....	40665	25.00
Audio/Cue Playback for TR-3.....	43369	995.00
Automatic Timing Corrector:		
Monochrome for TR-3/4 Series.....	ES-43580-A	7,900.00
Monochrome for TR-22A/B.....	ES-43579-A	7,900.00
Monochrome for TR-22C.....	43391-A	6,200.00
Color for TR-3/4 Series.....	ES-43582	9,950.00
Color for TR-22 A/B/C.....	ES-43581	9,950.00
Color for TR-22D.....	ES-43598	9,950.00
Ball Bearing Headwheel Panel Assembly (10 mil).....	40760-B	1,950.00
Ball Bearing Headwheel Panel Assembly (5 mil).....	40791	1,950.00
Brush, Headwheel (10 per package).....	#219748	3.80
Cabinets:		
Cabinet, holds 50—6/6½/8-inch reels.....	VT-8-50	595.00
Cabinet, holds 50—6-inch reels (15 min.).....	VT-6-50	537.00
Cabinet, holds 10—14-inch reels.....	VT-14-10	137.00
Cabinet, holds 10—12½-inch reels.....	VT-12-10	126.00
Cabinet, holds 10—8/6½-inch reels.....	VT-8-10	100.00
Cabinet, holds 10—6-inch reels.....	VT-6-10	89.00
Cabinet, holds 30—12½-inch reels (1 hour).....	VT-12-30	448.00
Cabinet, holds 30—14-inch reels (1 hour).....	VT-14-30	484.00
Cabinet with door, holds 30—14-inch reels.....	VT-304	258.00
Cabinet with door, holds 40—12½-inch reels.....	VT-402	253.00
Cabinet with door, holds 70—8/6½-inch reels.....	VT-708	263.00
Cabinet with door, holds 80—6-inch reels.....	VT-806	274.00
Ceramic Headset with Ear Cushions and Dynamic Microphone (for TR-5).....	38028-2	45.50
Color Automatic Timing Control:		
For TR-22 A/B/C.....	ES-43581	9,950.00
For TR-22D.....	ES-43598	9,950.00
For TR-3/4 Series.....	ES-43582	9,950.00
Combination Tape Rack, holds 54—14/12½-inch reels plus 54—8/6½/6-inch reels.....	RVT-614	179.00
Console Housing Mounting Adaptor (for MI-40691-A/40692-A).....	26252	40.00

	MI No.	Price
Cover for TR-22 (Headwheel Cover Assembly).....	40678	\$ 250.00
Cue Record/Playback:		
For TR-4 Series	43355	1,950.00
For TR-5.....	43348	2,250.00
Degausser, Magnetic Tape Head:		
For 110 volt, 50/60 cycle.....	11995	22.50
For 220 volt, 50/60 cycle.....	11996	On Request
Dolly Assembly for TR-22 Series (2 dollies and hardware).....	40668	175.00
Dropout Compensator (625/525 line):		
For TR-22 A/B/C.....	ES-43586	3,300.00
For TR-22D.....	43309	3,300.00
For TR-4 Series.....	ES-43587	3,300.00
For TR-70.....	35959	On Request
Electronic Splicing Accessory:		
For TR-70/TR-22D.....	40695-A	4,900.00
For TR-22 A/B/C	ES-40922-A	5,900.00
For TR-4.....	ES-43578-A	5,900.00
For TR-4A.....	ES-43569	5,900.00
For TR-5.....	ES-43566	5,900.00
Erasers, Automatic Magnetic Tape:		
Video Coil, 60 cycles.....	ES-29975	1,360.00
Video Coil, 50 cycles.....	ES-29977	1,360.00
Guide Position Adjuster for Headwheel Panel (for TR-3/4/5).....	43351	200.00
Headset, Ceramic with ear cushions and microphone (for TR-5).....	38028-2	45.50
Headwheel Brush (minimum quantity—order 10).....	#219748	3.80
Headwheel Cover Assembly (for TR-22 Series).....	40678	250.00
Headwheel Panel Assembly:		
Air Bearing (10 mil).....	40790-A	1,950.00
Air Bearing, Narrow Track (5 mil).....	40799	1,950.00
Ball Bearing (10 mil).....	40760-B	1,950.00
Ball Bearing, Narrow Track (5 mil).....	40791	1,950.00
Indicator, Tip Protrusion.....	43261	135.00
Magnetic Tape Erasers:		
Video Coil, 60 cycles (automatic).....	ES-29975	1,360.00
Video Coil, 50 cycles (automatic).....	ES-29977	1,360.00
Magnetic Tape Head Degausser:		
110 volt, 50/60 cycles.....	11995	22.50
220 volt, 50/60 cycles.....	11996	On Request
Mobile Unit for TV Recorders/Players, Type TJ-72.....	Custom	On Request
Module Extender (spare for TR-22/3/4/5).....	40649	175.00
Module Extender, 44 terminal (spare for TR-3/4/5).....	557301	90.00
Monitor Rack Assembly (525/625 line, 50/60 cycles, switchable for TR-3).....	43361	4,800.00
Monochrome Automatic Timing Corrector for TR-3/4.....	ES-43580-A	7,900.00
Monitor, Waveform, Type TO-4, Including Front Panel and Connector Assembly.....	ES-556904	1,803.00
Narrow Track Air Bearing Headwheel Panel Assembly (5 mil).....	40799	1,950.00
Narrow Track Ball Bearing Headwheel Panel Assembly (5 mil).....	40791	1,950.00

	MI No.	Price
Panel:		
Air Bearing Headwheel Assembly (10 mil).....	40790-A	\$ 1,950.00
Ball Bearing Headwheel Assembly (10 mil).....	40760-B	1,950.00
Narrow Track Air Bearing Headwheel Assembly (5 mil).....	40799	1,950.00
Narrow Track Ball Bearing Headwheel Assembly (5 mil).....	40791	1,950.00
Remote Control (mode) for TR-22/3/4/5.....	40691-A	325.00
Remote Control (signal) for TR-22/3/4.....	40692-A	125.00
Player, Type TR-3A TV Tape (525 line, 60 cycle).....	ES-43570-A	22,500.00
Player, Type TR-3A TV Tape (525/625/405 line, 50 cycle, switchable).....	ES-43572-A-405	On Request
Player, Type TR-3A TV Tape (525/625/819 line, 50 cycle, switchable).....	ES-43572-A-819	On Request
Rack:		
Tape Storage, holds 125—6/6½/8-inch reels.....	RVT-125-68	168.00
Tape Storage, holds 144—6/6½/8-inch reels.....	RVT-144-68	184.00
Tape Storage, holds 90—12½/14-inch reels.....	RVT-90-124	165.00
Tape Storage, combination, holds 54—6/6½/8-inch and 54—12½/14-inch reels.....	RVT-614	179.00
Tape Storage, lengths cut to order, complete with end brackets (approx. 4 reels per ft.) for 6/6½/8-inch reels.....	RVT-8	4.10 per ft.
Tape Storage, lengths cut to order, complete with end brackets (approx. 4 reels per ft.) for 12½/14-inch reels.....	RVT-14	5.00 per ft.
Rack Mounting Adaptor (for MI-40691/40692).....	26254	28.00
Record Accessory (for use with MI-43361).....	43360	9,000.00
Recorder:		
TR-70 Color TV Tape (525 line, 60 cycle).....	ES-35977	82,500.00
TR-70 Color TV Tape (525/625/405 line, 50 cycle, switchable).....	ES-35979-405	On Request
TR-70 Color TV Tape (525/625/819 line, 50 cycle, switchable).....	ES-35979-819	On Request
TR-4A Compact TV Tape (525 line, 60 cycle).....	ES-43571-A	34,900.00
TR-4A Compact TV Tape (525/625/405 line, 50 cycle, switchable).....	ES-43573-A-405	On Request
TR-4A Compact TV Tape (525/625/819 line, 50/60 cycle, switchable).....	ES-43573-A-819	On Request
TR-5 Transportable TV Tape (525/625/405 line, 50/60 cycles).....	ES-43565	20,950.00
TR-22D TV Tape (525 line, 60 cycle).....	ES-43560	59,500.00
TR-22D TV Tape (525/625/405 line, 50 cycle).....	ES-43561-405	On Request
TR-22D TV Tape (525/625/819 line, 50 cycle).....	ES-43561-819	On Request
Remote Control Panel:		
Mode (for TR-22/3/4/5).....	40691-A	325.00
Signal (for TR-22/3/4).....	40692-A	125.00
Special Module Extender, 44 terminal (for TR-3/4/5).....	557301	90.00
Table for Mechanical Tape Splicer (for use with TR-22 Series).....	40592	195.00
Tape Splicer, Mechanical:		
Magnetic Tape 15 IPS.....	40772	1,250.00
Magnetic Tape 7½ IPS.....	40748	1,250.00
Tape Developer, 7 oz. bottle.....	#222408	4.26
Test Module Extender:		
For TR-22/3/4/5 (Spare).....	40649	175.00
Special for TR-3/4/5 with 44 terminals (Spare).....	557301	90.00
Tip Protrusion Indicator.....	43261	135.00
Tool, for Vacuum Guide Lead Screw of TR-22.....	40665	25.00
Transportable TV Tape Recorder, TR-5 (525/625/405 line, 50/60 cycles).....	ES-43565	20,950.00
Video Alignment Tape:		
Monochrome (525 line, 60 cycle).....	40793	200.00
Monochrome (625 line, 50 cycle).....	40797	200.00
Waveform Monitor, Type TO-4, Including Front Panel and Connector Assembly.....	ES-556904	1,803.00

Broadcast Equipment Sales Policy

FOREWORD

The present statement sets forth basic conditions under which RCA sells broadcast equipment as described in our catalog, and notes certain supplemental information. This statement does not apply to the sale of tubes or sound film recording equipment, for which separate standard sales and lease policies are in effect.

RCA broadcast equipment is sold directly through RCA Sales representatives, who are familiar with broadcast equipment.

CONTRACT PROCEDURE

All Sales based on orders for transmitters, antennas and custom built or special apparatus and on orders over \$5,000 are made in accordance with the conditions of the RCA Standard Proposal Form for the sale of broadcast equipment and with any agreement stipulated thereon for individual customers.

PRICES

RCA broadcast equipment domestic prices are net f.o.b. factory or warehouse, which is Camden, New Jersey, for most items. These prices do not include any federal, state or local taxes based upon use or measured by sale or use and unless otherwise noted do not include federal excise tax. Any such taxes in effect at the time of shipment will be billed separately or will be included in the prices when required and will be due and payable upon delivery.

RCA's prices do not include installation or installation supervision unless specifically mentioned in a written condition or proposal. Purchaser assumes responsibility for installation and operation of the equipment as well as for obtaining all necessary licenses, permits, etc.

NOTE: The service of factory trained personnel who are specialists in the supervision of the installation of broadcast equipment and its maintenance and repair may be obtained through an order placed with the RCA Service Company, Inc. It is recommended that the advantages of this service be considered at the time of purchase of any major broadcast equipment.

In the case of orders under the Standard Proposal Form the billing prices are based on those prices effective at the date of the order to the extent indicated in the final contract. In the case of orders not under the Standard Proposal Form the billing prices are those prices in effect on the date of shipment.

RCA endeavors to keep its published prices current; however, all published prices are subject to change without notice.

Prices for items marked with a symbol (e) are estimates only and are subject to adjustment to those in effect on the date of shipment.

In the event the estimated prices quoted herein are exceeded by more than 10% and the billing price cannot be established by mutual agreement prior to shipment, such items may be cancelled without liability to RCA or Purchaser by either party giving written notice to the other.

PAYMENT

Terms of payment are subject to approval of RCA's Credit Department at Camden, New Jersey.

DELIVERY

RCA's delivery of broadcast equipment will be f.o.b. factory or warehouse, which is Camden, New Jersey for most items. The Purchaser shall be responsible for all transportation charges, and shipments will normally be forwarded with shipping charges "collect." As an accommodation, when specifically requested to do so by the Purchaser's order, RCA will prepay transportation charges and invoice them to the Purchaser as a separate item.

Delivery will be made to a carrier specified by the Purchaser, unless none is specified, in which event it will be to a common carrier selected by RCA. In the absence of specific

routing instructions from the purchaser, RCA's judgment with respect to the selection of a route will be final.

As a special service with respect to shipments overland, by inland waterways or by air we carry All Risk Transportation Insurance for the benefit of our Broadcast Equipment customers, and your interests will be amply protected in all shipments of equipment while in transit by the methods indicated above, at no additional expense to you, provided that you inspect all shipments within 15 days after receipt and report within that time in writing any shortages or damages to the carrier and to RCA.

RCA will endeavor to meet delivery schedules but it assumes no liability for damages of whatever kind for delays in delivery. No delays in delivery shall relieve the purchaser of his obligation of performance.

PATENT LICENSES

RCA broadcast equipment is licensed for radio telephone or television broadcast transmission under United States patents owned by RCA or under United States patents under which RCA is licensed.

PATENT PROTECTION

RCA, at its own expense, will defend any suit which may be brought against purchaser for infringement of United States patents by the equipment furnished when sold or used for radio telephone or television broadcast transmission, and in any such suit will satisfy any final award for such infringement. This is upon the condition that purchaser gives RCA prompt notice of such suit and full right and opportunity to conduct the defense thereof, together with full information and all reasonable cooperation, and upon the further condition that the claimed infringement does not result from the combination of the equipment furnished with other equipment, apparatus, or devices not furnished by RCA. No costs or expenses shall be incurred for the account of RCA without its written consent. If purchaser's sale or use of such equipment for radio telephone or television broadcast transmission shall be prevented by permanent injunction, RCA shall substitute for the infringing equipment or parts other equally suitable equipment or parts, or at RCA's option obtain for purchaser the right to sell or continue the use of such equipment, or at RCA's option take back such equipment and refund any sums purchaser has paid RCA therefor, less a reasonable amount for use, damage and obsolescence.

WARRANTY

Except for electronic tubes, which bear their own warranty which accompanies them at the time of their sale, RCA warrants its broadcast equipment to be free from defects in material and workmanship under normal use and service for a period of one year from the date of delivery. RCA's obligations under this warranty are limited to the repair or replacement of defective parts and the shipment of such repaired or replacement parts to the purchaser f.o.b. factory. Equipment furnished by RCA but listed as manufactured by another bears only the warranty given by such other manufacturer. No warranties other than those set forth herein are given or are to be implied with respect to broadcast equipment. In no event is RCA liable for consequential damages.

REPAIRED AND RETURNED APPARATUS

Before an apparatus is returned to RCA for repairs or adjustments, shipping instructions and an identifying number should be obtained from the nearest RCA Sales Office. RCA assumes no responsibility for unauthorized returns.

EQUIPMENT MODIFICATIONS AND WITHDRAWALS

RCA reserves the right to make, without notice, modifications of the equipment described in this catalog without affecting its right to sell such equipment under orders based on the catalog description, provided, however, that the modifications shall not materially affect performance. These modifications of equipment may be made by RCA or its suppliers from time to time for reasons such as improvement in performance, simplification in design, or availability of material. RCA also reserves the right to withdraw from sale, without notice, any equipment described in our catalog.

ACCEPTANCE OF ORDER

No order shall be binding upon RCA until accepted by it in writing at Camden, New Jersey, and the banking, negotiation or other use of the down payment shall not constitute an acceptance by RCA. Orders received by Sales Offices will be forwarded promptly to RCA's Camden Office.



RADIO CORPORATION OF AMERICA

BROADCAST & COMMUNICATIONS PRODUCTS DIVISION • CAMDEN, N. J. 08102

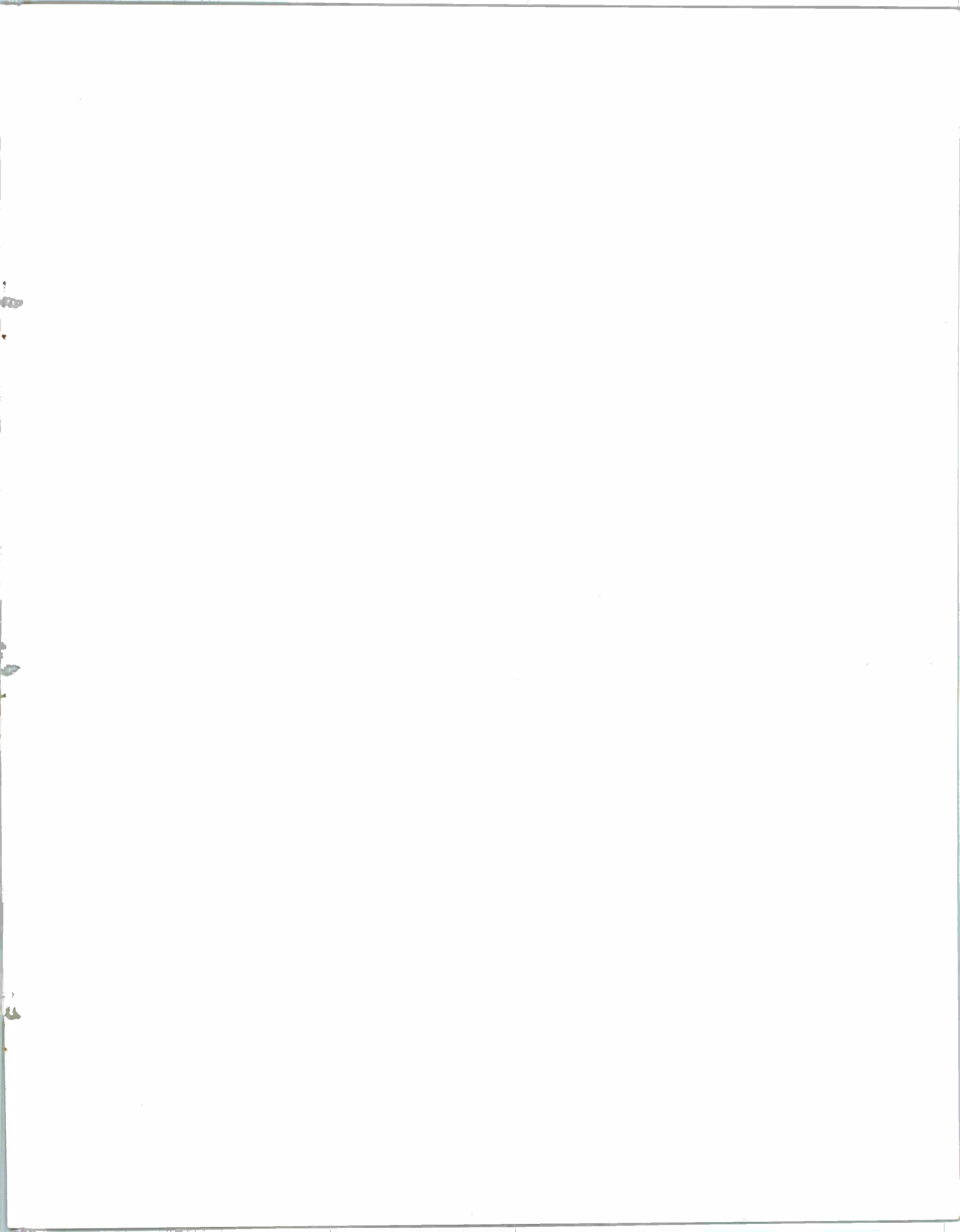



The Most Trusted Name in Television

RADIO CORPORATION OF AMERICA

BROADCAST AND COMMUNICATIONS PRODUCTS DIVISION, CAMDEN, N. J. 08102 • RCA INTERNATIONAL DIVISION, CENTRAL and TERMINAL AVENUES, CLARK, NEW JERSEY, U.S.A. 07066