



BROADCAST

6570
27
R52

14

audio

EQUIPMENT

INDEX

	PAGE		PAGE
A. MICROPHONES		Recording Amplifiers	29
General Information	3-4	Remote Pickup Amplifiers.....	30-32
Studio Microphones	5-9	D. RACKS AND PANELS	
Remote Microphones.....	8-9	Cabinet Racks	34-35
Economy Microphones	10	Blank Panels	35
Microphone Stands	11-13	Wall Cabinets	36
Microphone Plugs and Receptacles	14	Panel and Shelves.....	37
Microphone Cable	14	Meter Panels	38
B. ASSEMBLIES		Switch and Fuse Panels.....	38
Custom-Built Installations	16-17	Jack Panels	39
Studio Consolettes	18-19	Patch Cords	39
Transmitter Consoles	20	VU Meters	40
Transmitter Monitor Racks.....	21	Sound Effects Filters	41
C. AMPLIFIERS		Equalizers	42-44
Technical Data Summary.....	22	E. TRANSFORMERS—	
Preamplifiers	24-25	POWER SUPPLIES	
Program and Line Amplifiers.....	26-28	Audio Transformers	46
Monitoring Amplifiers	29	Preamplifier Power Supplies.....	47
		Interconnecting Cable	47
		Relay Power Supplies.....	48
		F. TURNTABLES—RECORDERS	
		Transcription Turntables	50-51
		Recording Installations	52
		Technical Data Summary.....	53
		Recording Attachments	55
		Professional Recorders	56-57
		Portable Recorders	58-59
		Recording Accessories	60-62
		G. LOUDSPEAKERS	
		Monitoring Loudspeakers	64
		Cueing and Talkback Speakers.....	65
		H. DATA SECTION	
		Charts and Curves.....	66-71, 74
		Typical Studio Layouts.....	72-73
		Recommended Equipment Lists.....	75-77

INDEX BY TYPE NUMBERS

TYPE	DESCRIPTION	PAGE	TYPE	DESCRIPTION	PAGE
BA-1A	Preamplifier	24	44-BX	Velocity Microphone	5
BA-2A	Booster Amplifier	25	56-C	Line Equalizer	43
BA-3A	Program Amplifier	28	56-E	Line Equalizer	43
BE-1A	Line Equalizer	42	57-C	Switch and Fuse Panel.....	38
BX-1A	Power Supply	47	59-B	Microphone Stand	12
9AX	Cabinet Rack	34-35	64-B	Monitoring Loudspeaker ...	64
15-D	Meter Panel	38	70-C1	Transcription Turntable ...	50-51
33-A	Jack Panel	39	72-D/72-DX	Recording Attachment	55
33-B	Jack Panel	39	73-B	Professional Recorder	56-57
36-B	Panel and Shelf.....	37	74-B	Jr. Velocity Microphone.....	9
			76-B2	Consolette	18-19
			77-D	Polydirectional Microphone	6-7
			82-C1	Monitoring Rec. Amp.	29
			86-A1	Limiting Amplifier	26-27
			88-A	Microphone	8
			90-A	Microphone Stand	11
			90-C	Microphone Stand	11
			91-A	Microphone Stand	12
			91-B	Microphone Stand	12
			OP-6	Remote Amplifier	30-31
			OP-7	Mixer Preamplifier	30-32
			OR-1A	Portable Recorder	58-59

INDEX BY MASTER ITEM NUMBERS

NOTE: When using this index, disregard any letters following MI numbers and refer to basic MI numbers shown above.

MI	DESCRIPTION	PAGE	MI	DESCRIPTION	PAGE
41	Cable	14	4646	Jack Panel	39
42	Cable	14	4652	Patch Cords	39
43	Cable	14	4682	Panel and Shelf	37
62	Cable	14	4842	Sapphire Stylus	62
63	Cable	47	4871	Turntable	50-51
64	Cable	47	4872	Turntable	50-51
65	Cable	47	4875	Pickup Kit	60
4027	Microphone	5	4878	Sapphire Stylus	62
4036	Microphone	9	4879	Steel Styli	62
4045	Microphone	6	4887	Recorder Head	61
4048	Microphone	8	4900	Transformer	46
4058	Stand	12	4901	Transformer	46
4068	Stand	13	4902	Transformer	46
4085	Carrying Case	12	4910	Conversion Kit	55
4089	Cable Hook	11	4916	Recording Filter	62
4090	Stand	11	4917	Sound Effects Filter.....	41
4092	Stand	12	4922	Suction Pump	60
4093	Stand	12	4923	Hose Kit	60
4094	Stand	11	4925	Compensator	43
4095	Stand	12	4928	Microscope	60
4096	Stand	13	6203	Microphone	10
4162	Line Equalizer	43	6206	Microphone	10
4168	Line Equalizer	43	6208	Stand	13
4196	Line Equalizer	42	6222	Console Cabinet	65
4388	Meter Panel	38	6223	Wall Cabinet	65
4395	Switch and Fuse Panel.....	38	6224	Baffle Assembly	65
4400	Speaker Cabinet	64	6226	Microphone	10
4405	Cabinet Base	64	6229	Adaptor	14
4410	Unmounted Speaker	64	6232	Microphone Stand	13
4519	Cabinet Rack	34-35	6234	Speaker	65
4525	"U" Strip	35	6329	Speaker	65
4534	Jack Panel	39	6425	Adaptor	14
4536	Jack Panel	39	6427	Stand	13
4537	"J" Strip	35	11100	Automatic Equalizer	57
4568	Terminal Strip	35	11101	Automatic Equalizer	55
4569	Terminal Strip	35	11202	Remote Amplifier	30-31
4570	Bracket	35	11209	Amplifier	29
4571	Cable Support	35	11210	Recorder	58-59
4589	} Blank Panels	35	11211	Turntable	59
4599			to	11212	Amplifier
4603	Transformer	46	11213	Preamplifier	32
4620	Connector	14	11214	Battery Box	30
4624	Receptacle	14	11216	Amplifier	26-27
4630	Plug	14	11218	Preamplifier	24
4645	Jack Panel	39	11224	Amplifier	28
			11226	Amplifier	25
			11250	Tube Kit	26
			11251	Meter Kit	40
			11252	Tube Kit	19
			11253	Tube Kit	31
			11254	Tube Kit	32
			11255	Battery Kit	30
			11256	Fabric Cover	31
			11257	Fabric Cover	32
			11258	Fabric Cover	30
			11259	Tube Kit	59
			11265	VU Meter	40
			11266	Tube Kit	28
			11280	Regulator	21
			11282	Tube Kit	29
			11285	Tube Kit	24
			11286	Tube Kit	26
			11287	Tube Kit	25
			11301	Power Supply	19
			11303	Power Supply	48
			11304	Power Supply	48
			11305	Power Supply	47
			11500	Cabinet	36
			11501	} Jack Mats	39
			to		
			11504		
			11606	Filament Transformer	47
			11613	Consolette	18-19
			11616	Transmitter Console	20
			11620	Monitor Rack	21
			11702	Relay	19
			11703	Relay	19
			11825	Recorder	56-57
			11826	Recorder	56-57
			11850	Recorder Head	61
			11851	Advance Ball Kit	62
			11852	Attachment	55
			11853	Recorder Head	61
			11854	Base Kit	55
			11901	Recorder	55
			12051	Adaptor	14
			12055	Adaptor	14
			12057	Adaptor	14
			12414	Speaker	65
			STOCK NUMBERS		
			32212	Adaptor	14
			33543	Adaptor	14
			43504	Meter	20

BROADCAST AUDIO (Speech Input) EQUIPMENT

FOR AM, FM AND TELEVISION

SEPTEMBER • 1945

Price . . . Fifty Cents



**BROADCAST EQUIPMENT
SECTION**

RADIO CORPORATION OF AMERICA

RCA VICTOR DIVISION

CAMDEN, N. J.

MICROPHONES A

ASSEMBLIES B

AMPLIFIERS C

RACKS & PANELS D

POWER SUPPLIES E

**TURNTABLES
RECORDERS F**

LOUDSPEAKERS G

DATA SECTION H

FOREWORD

This Broadcast Audio Section of the Broadcast Equipment Catalogue is intended to serve as a buying guide to the user of this type of equipment. An attempt has been made to present a clear and concise picture covering: uses, description, features, and specifications for each item of speech input equipment.

RCA manufactures a complete line of broadcast equipment from microphone to antenna inclusive—for FM, AM and Television. This line includes not only the operating units but also such necessary accessories as monitoring and test equipment. RCA is equipped to furnish custom built studio equipment and antenna phasing equipments. RCA designs and manufactures the components for its broadcast equipment whenever necessary or desirable to insure maximum performance and reliability. Major items of such components are tubes, inductance coils, mica capacitors, crystals and transformers.

RCA is the leader in the field of broadcast equipment which is evidenced by the fact that for ten years RCA equipment has outsold all other makes. This record includes large and small stations—among them a large proportion of the most notable installations made during this period. RCA has been and will continue to be an active leader in FM development. RCA pioneered the development of electronic television. Twenty-five years of progress in the radio field plus vast wartime experience has given RCA an engineering background for the production of the most advanced and highest quality broadcasting apparatus.

Readers of this catalogue are invited to communicate with our Main Office at 745 Fifth Avenue, New York, or to our Subsidiary, indicated on the back cover, regarding additional information or individual bulletins on the equipment shown herein. Separate catalogues or descriptive bulletins are available on other lines of RCA equipment such as Sound, Photophone, Aviation, Emergency Communications and Police, Electronic Heating, Electron Microscope, Records and Radio Receivers.

Engin. Lib.
Wahr
9-21-46
56190

MICROPHONES

SECTION

A

GENERAL INFORMATION

STUDIO MICROPHONES

REMOTE MICROPHONES

ECONOMY MICROPHONES

MICROPHONE STANDS

MICROPHONE PLUGS AND RECEPTACLES

MICROPHONE CABLE

W. L. ADE



Microphones General Information

RCA Microphones are the product of years of intensive research and development by outstanding engineers. Several types of microphones are available and each type has its own field of usefulness.

High Quality Broadcast Microphones

Broadcast Type Microphones, such as the Types 44-BX, 77-D and 88-A have characteristics which suit them for high quality pickup work. They have good frequency response curves, well shielded output transformers to prevent hum pickup, and are very well shock mounted to reduce low frequency noises caused by building rumble. The 44-BX and 77-D Microphones are particularly suitable for high quality indoor pickups while the 88-A is recommended for outside pickups where rough handling and wind may be experienced.

Public Address Microphones for Broadcast Use

Public address types of microphones such as the Type 74-B Velocity Microphone, and the MI-6203 Varacoustic Microphones have been designed as economy microphones for public address and industrial sound use. These microphones, however, are suitable for use in broadcast applications within their limitations. The 74-B may be used in place of the 44-BX in applications where the frequency response, shielding and shock mounting of the 44-BX is not required. Likewise the MI-6203 may be used in place of the 77-D for pickups where the frequency response, transformer shielding and shock mounting of the 77-D are not required.

Unloaded Transformer Input

RCA Broadcast Microphones are designed to work into a microphone preamplifier whose input transformer is unloaded. Under this condition of operation the full generated voltage of the microphone appears at the grid of the first tube resulting

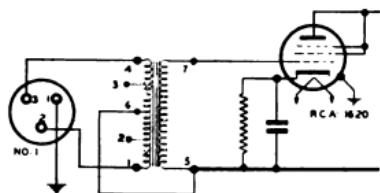

No. 1 Input Channel of OP-7 Portable Preamplifier showing unloaded transformer input

in a gain in signal to noise ratio of between 3 and 6 db depending on whether the major source of noise is in the microphone amplifier or in the input resistance of the microphone.

Microphones which are relatively inefficient or in which there is a great deal of damping associated with the moving system will in general have their frequency response characteristics little changed by loading. The 88-A and 77-D (in the pressure position) are examples of this.

Microphone Resistance Loading

Highly efficient microphones, particularly those in which the moving system is mass controlled usually show impedance vari-

ations for a constant generated voltage. Such microphones will have their response characteristics adversely affected by resistance loading because the mechanical constants of the moving system will be disturbed by the reflected resistance load. The Type 44-BX, and 77-D (in the bi-directional and uni-directional positions) are examples of this.

The frequency response curves for all microphones listed in this catalogue were taken with the microphone working into an unloaded input transformer of a preamplifier and it is recommended that the microphones be so operated in practice.

Effective Output Level

When a microphone is effectively working into an open circuit its output cannot be expressed in terms of db power level as no appreciable power is consumed by the open circuit termination. As a result of this condition the microphone output ratings are given as *Effective Output Level*. The effective level is so calculated that when the amplifier gain in db is added to the microphone output level in db the correct output level from the amplifier will be obtained. To do this the effective output level rating is based upon the assumption that the microphone works into a load impedance which is equal to its own rated output impedance. The voltage corresponding to this effective output level is actually 6 decibels below that which is obtained when the microphone is worked into an "open circuit" preamplifier input. This 6 db difference is brought about by the fact that the high input impedance of a preamplifier does not offer a load to the output of the microphone. Thus the 6 db apparent increase in gain is a function of the preamplifier input termination and not of the microphone itself. The "gain" ratings of preamplifiers takes into account this 6 db increase in gain so that it becomes necessary to rate the microphone output at its effective level for purposes of computing the overall gain of the system as noted above.

Microphones Shipped Less Plug

RCA Microphones are supplied less microphone plugs. Although Cannon Type "P" plugs and receptacles are recommended, and stocked by RCA, many stations use other types of plugs and prefer to supply their own. For this reason, we supply the microphone with cord and, if the Cannon Plug is desired, it should be ordered as an accessory.

Why 1/2" Pipe Thread

RCA has standardized on the rugged 1/2" pipe thread for microphone mounting. A recent questionnaire which we sent to broadcasting stations indicated that the 1/2" pipe thread was by far the most popular microphone thread size. This size pipe thread makes it easy to add microphone stand extensions, booms, etc. for they may be easily made up locally from standard 1/2" pipe and fittings.

Suitable microphone stands and adapters are available and shown in this catalogue for all RCA Microphones.

RCA Microphones

<i>Type No.</i>	<i>Directional Characteristic</i>	<i>Use</i>	<i>Effective Output Level db*</i>	<i>Output Impedance Ohms</i>	<i>Frequency Response cps</i>	<i>Finish</i>	<i>Fitting</i>
44-BX	Bi-directional	Studio	-55	50/250	30-15,000	Chromium and Black	1/2" Pipe Thread
77-D	Poly-directional	Studio or Stage	-59	50/250 600	50-10,000	Chromium and Black	1/2" Pipe Thread
88-A	Non-directional	Remotes	-56	50/250	60-10,000	Chromium and Black	1/2" Pipe Thread
74-B	Bi-directional	Studio	-56	50/250 15,000	50-9000	Chromium and UMBER Grey	1/2" Pipe Thread
MI-6203	Poly-directional	Economy Stage or Studio	-58	50/250	80-8000	Grey Wrinkle	1/8" Pipe Thread
MI-6206	Non-directional	Talkback	-56	250	80-8000	Black and Chromium	1/8" Pipe Thread
MI-6226-H	Non-directional	Talkback	-63	250	100-8000	Polished Chromium	1/8" Pipe Thread

* See "Microphones General." Reference level is one milliwatt for a sound pressure of 10 dynes/cm².

Velocity Microphone Type 44-BX

Uses

The 44-BX is primarily intended for studio use where a microphone of the highest quality of reproduction is desired. It can be used with practically any audio facilities system and lends itself readily to unusual or difficult studio problems. The 44-BX is also well suited for high quality remote work. The 44-BX is found in almost all of the leading studios in the country and has become a recognized symbol of broadcasting.

Description

The bi-directional pattern of the Type 44-BX Microphone is of the familiar "figure eight" type. Unlike other types of microphones, it has no diaphragm—the moving element being, instead, a thin metallic ribbon so suspended as to be able to vibrate freely between the poles of a permanent magnet. Because of its lightness, the motion of this ribbon corresponds exactly to the velocity of the air particles and the voltage generated in it is, therefore, an exact reproduction of the sound waves which traverse it. Moreover, since it has no diaphragm and is open in construction so that air flows freely through it, the Type 44-BX Velocity Microphone is free from the effects of cavity resonance, diaphragm resonance and pressure doubling, which cause undesirable peaks in the response of all pressure type microphones.

The 44-BX is attractively designed in chromium and black to harmonize with practically any modern studio interior. The yoke mounting provides added flexibility in that, tilting the microphone may suppress or emphasize portions of a program. It may be mounted on a variety of stands to widen its field of usefulness.

Features

- Sensitive ribbon element for faithful reproduction.
- Free from cavity or diaphragm resonance and pressure doubling.
- Uniform and smooth reproduction over the entire audio range.
- Response adjustment to provide the best possible frequency characteristics for either vocal or musical pickup.
- Bi-directional "figure eight" type pattern which allows placing of artists on both sides of the microphone and greatly reduces reflection pickup from side walls.
- Unaffected by temperature, humidity or changes in air pressure.
- Ruggedly built for hard usage.
- Shock mounted.
- Attractive in appearance.

Specifications

Directional Characteristic.....Bi-directional
 Output Impedances (tapped transformer).....50/250 ohms
 Effective Output Level.....-55 db*
 Frequency Response (see curves).....30-15,000 cycles
 Finish.....Polished black and chromium
 Mounting..... $\frac{1}{2}$ " pipe thread

Dimensions, overall

Height (including cushion mounting).....12"
 Width.....4 $\frac{3}{4}$ "
 Depth.....3 $\frac{3}{8}$ "
 Weight (unpacked, including mountings).....8 $\frac{1}{2}$ lbs.
 Cable (2 conductor, shielded).....30' less plug
 Stock Identification.....MI-4027-B

* Referred to one milliwatt and a sound pressure of 10 dynes/cm².

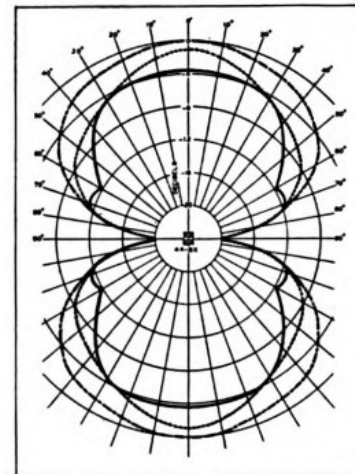

Directional characteristic of a typical 44-BX Velocity Microphone

————— 10,000 cps
 - - - - - 6,000 cps
 - · - · - 1,000 cps

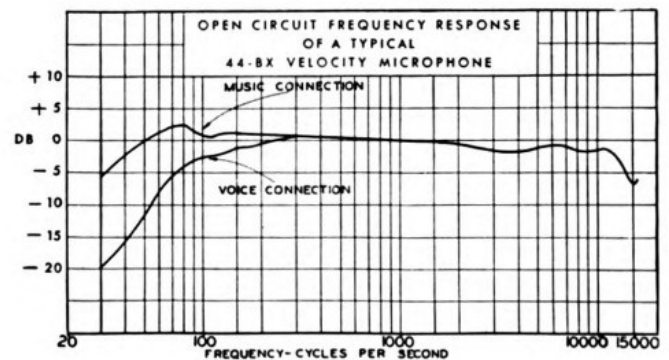

Polydirectional Microphone Type 77-D

MI-4045

Uses

Broadcasters will acclaim the new RCA 77-D Microphone with its continuously variable directional characteristic and smooth frequency response. With this one microphone a variety of non-directional, uni-directional and bi-directional characteristic patterns may be obtained by operating a screw-driver adjustment which is conveniently located on the back of the microphone. The 77-D combines the best features of the velocity and pressure microphones. The polydirectional characteristics of this microphone aid materially in obtaining a better balance, clarity, naturalness and selectivity in studio pickups. It is also of considerable value where difficulties are encountered in reverberant locations since the undesired sound reflections may be reduced by a choice of the proper directional pattern.

Description

The 77-D consists of a single ribbon placed in the air gap formed by the pole pieces of a permanent magnet, a variable acoustic network, a well-shielded matching transformer with low hum pickup and a perforated metal case housing. Effective shock-mounting is used between the microphone and stand to reduce building rumble.

One side of the microphone ribbon is completely closed by a connector tube which in turn is coupled to a damped pipe or labyrinth. An aperture, placed in the connector tube directly behind the ribbon, is made variable in size by a "damper" or valve control. The directional characteristics of the microphone are controlled by varying the area of the aperture in the labyrinth connector. When the aperture is so large that the back of the ribbon is effectively open to the atmosphere, as with a velocity microphone, the acoustic impedance is zero and a bi-directional characteristic pattern is obtained. When the aperture is completely closed, the acoustic impedance is infinite and the characteristic pattern is non-directional which is typical of a pressure operated microphone. By varying the area of the aperture a variety of characteristic patterns between bi-directional and non-directional may be obtained.

On the back side of the 77-D wind screen (upper shell) is a slotted shaft control adjustment which is brought out flush with a designation plate mounted on the screen. The plate is marked "U", "N", and "B", as designations for the uni-directional, non-directional and bi-directional response curves. Three additional markings are used as reference points for other patterns which may be obtained with the continuously variable control.

The lower half of the case contains the acoustical labyrinth, output transformer and a selector switch for voice or music. This switch will attenuate the low frequencies below 300 cycles for voice pickup and has three positions designated as "M", "V₁" and "V₂". The switch is operated by a screw driver and is accessible from the bottom of the lower cylindrical shell.

Features

- High fidelity.
- Adjustable directional characteristic, continuously variable, provides non-directional, bi-directional or uni-directional operation.
- Three position "voice-music" switch allows selection of best operating characteristic for voice or music.
- Well shielded output transformer assures low hum pick-up.
- Reduced reverberation pick-up through selection of proper directional characteristic.
- Efficient shock mounting reduces building vibrations.
- Small size—light weight.
- Attractive appearance.

Specifications

Directional Characteristic (adjustable)	Bi-directional, uni-directional and non-directional
Output Impedances (tapped transformer)	50/250/600 ohms
Effective Output Level	-59 db*
Frequency Response	See curves
Finish	Two-tone umber grey
Mounting	1/2" pipe thread
Dimensions, overall	
Height	11 1/2"
Width	3 3/4"
Depth	2 1/2"
Weight (unpacked including mountings)	3 lbs.
Cable (3 conductor shielded)	30' less plug
Stock Identification	MI-4045
Accessory Item	
Cannon Microphone Plug	MI-4630-B

* Referred to one milliwatt and a sound pressure of 10 dynes/cm².



Directional Response Patterns

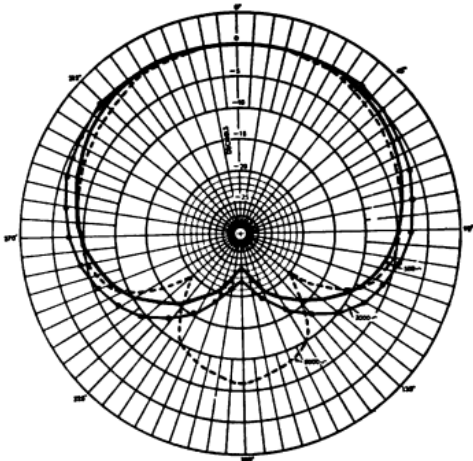

Uni-Directional Position

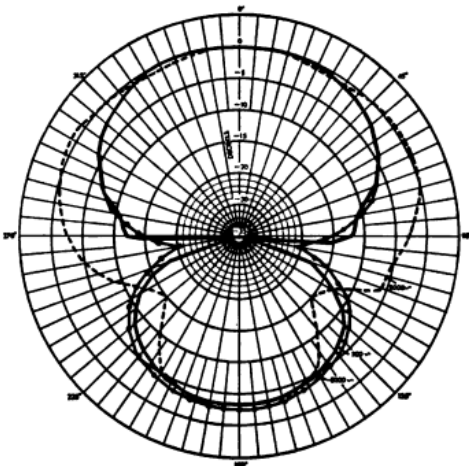

Bi-Directional Position

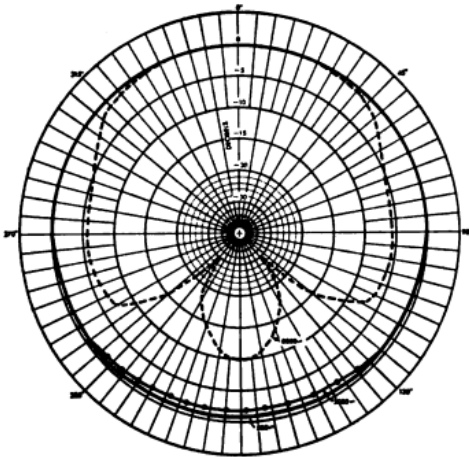

Non-Directional Position

Frequency Response Curves

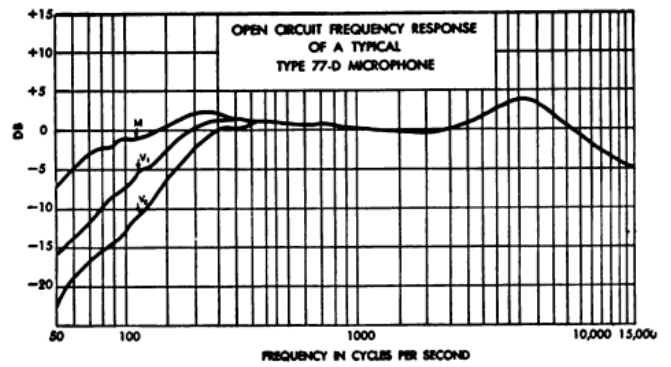

Uni-Directional Position

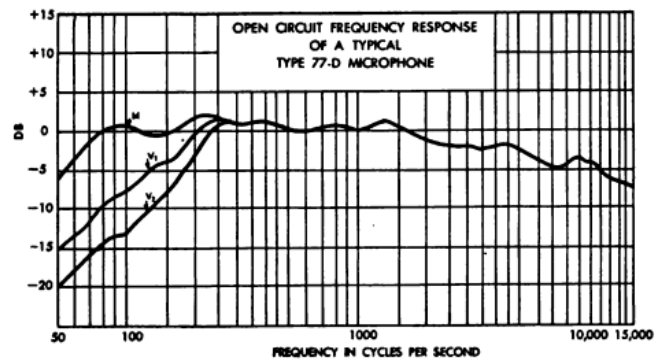

Bi-Directional Position

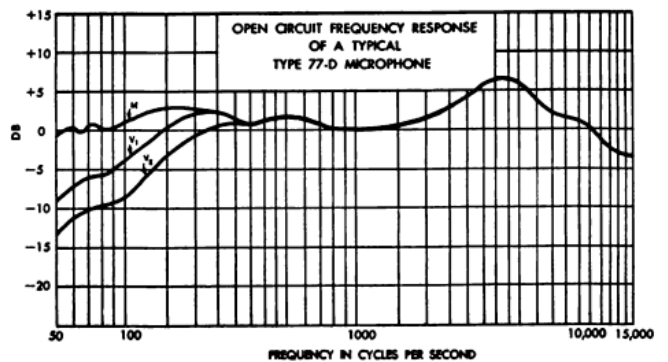

Non-Directional Position

Pressure Microphone Type 88-A

MI-4048-C

Uses

The Type 88-A is the ideal microphone for general remote pickup use. It has been specially designed to provide small size, light weight, good frequency response and relative freedom from the effects of wind and moisture. In spite of its light weight and small size, it is extremely rugged and well-suited to stand the hard usage to which a remote microphone is put. The characteristics of the 88-A also make it adaptable for many types of studio use where a non-directional microphone is desired.

Description

The Type 88-A Microphone is of the pressure-actuated type. The moving system consists of a thin molded diaphragm to which an annular coil assembly is attached. Coupled to the diaphragm is an acoustic circuit so proportioned that the diaphragm velocity will remain essentially constant for a constant sound pressure over the frequency range of 60-10,000 cycles. The coil is placed in the air gap of a magnetic structure and the ends connected to a transformer which provides output impedances of 50 or 250 ohms.

This microphone is styled and finished in black and chrome to present a very pleasing appearance. A ball and socket joint with a thumbscrew clamp permits operation in either a vertical or horizontal position.

Features

- Good frequency response.
- Light weight.
- Small size.
- Sturdy construction.
- Low cost.
- Minimum effects from wind and moisture.
- High output providing unusually good signal-to-noise ratio.
- Adaptable for use with any stand or may be carried in the hand for street interview programs.
- Output cord protected by spring.

Specifications

Directional Characteristics _____ Non-directional
 Output Impedances (tapped transformer) _____ 50/250 ohms
 Effective Output Level _____ -56 db*
 Frequency Response (see curves) _____ 60-10,000 cycles
 Finish _____ Polished black and chromium
 Mounting _____ 1/2" pipe thread

Dimensions, overall

Height (including mounting) _____ 4 1/2"
 Diameter _____ 2 1/8"
 Length _____ 3 3/8"
 Weight (unpacked) _____ 1 lb.
 Cable (2 conductor shielded) _____ 30' less plug
 Stock Identification _____ MI-4048-C

* Referred to one milliwatt and a sound pressure of 10 dynes/cm².

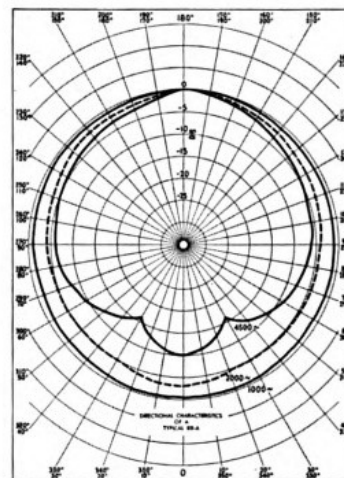

Directional characteristic of a typical 88-A Pressure Microphone

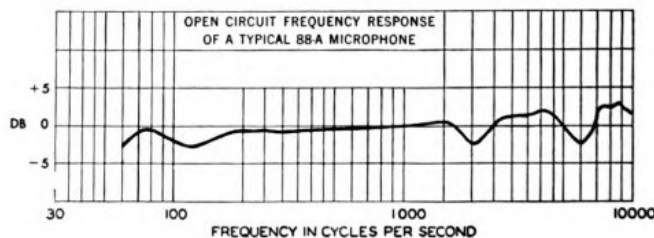

Junior Velocity Microphone Type 74-B

MI-4036-K

Uses

The 74-B has been widely used for years. It offers the smooth bi-directional response of a Velocity Microphone in an inexpensive, small and light-weight model. The 74-B is particularly recommended for applications where excellent quality is required. It is, therefore, a very useful microphone for audition studios, announce positions, talk back and for stage work. It may also be used for remote pickups where the frequency response is limited by lines and other factors. While the 74-B is particularly useful for pickups from inside remote points, the RCA dynamic types are more suited for general remote use. They are designed to give the greatest freedom from the effects of wind, shock and moisture.

Description

The transformer output impedance taps are for 50, 250 and 15,000 ohms. The die-punched case is finished in chromium and the base is black. Attached to the base is a ball and socket joint which permits rotation or tilting at any desired angle.

Features

- Free from objectional peaks or dips from 70 to 8,000 cycles.
- Bi-directional "figure eight" type pattern which allows placing of artists on both sides of the microphone and greatly reduces reflection pickup from side walls.
- Light weight, small size.
- Attractive appearance.

Specifications

Directional Characteristics _____ Bi-directional
 Output Impedances (tapped transformer) _____ 50/250/15,000 ohms
 Effective Output Level _____ -56 db*
 Frequency Response (see curves) _____ 50-9,000 cycles
 Finish _____ Polished black and chromium

Dimensions (overall)

Length _____ 7¾"
 Width _____ 2¾"
 Depth _____ 2½"
 Weight (unpacked) _____ 2½ lbs.
 Mounting _____ ½" pipe thread
 Cable (2 conductor, shielded) _____ 30' less plug
 Stock Identification _____ MI-4036-K

* Referred to one milliwatt and a sound pressure of 10 dynes/cm².

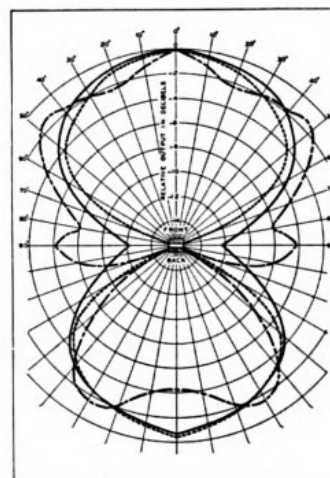

Directional characteristic of a typical 74-B Junior Velocity Microphone.

— 1000 cps
 - - - 300 cps
 - · - 8000 cps

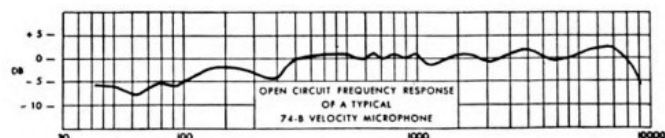

Frequency in Cycles per Second

Microphones MI-6203, MI-6206, MI-6226-H

Varacoustic MI-6203

Uses

The Varacoustic Microphone is ideally suited for public address use under high reverberatory conditions and for stage pickups where auditorium noises are to be kept to a minimum. As an economy microphone it may also be used for similar broadcast applications when shock mounting is not required and when it may be kept away from fluorescent lighting fixtures or other hum producing sources.

Description

This microphone is of entirely new design. A slide adjustment which changes the physical characteristics of the labyrinth permits a choice of non-directional, bi-directional or uni-directional operation. In addition, three variations between the uni-directional and bi-directional pattern may be obtained.



Features

- Low cost.
- Good frequency response.
- Reduced reverberation pickup.
- Adjustable directional characteristics to provide non-directional, bi-directional or directional pickup patterns.
- Attractive appearance.

Specifications

Directional Characteristics	Adjustable for non-directional, bi-directional or uni-directional
Output Impedance	250 ohms
Effective Output Level	-58 db*
Frequency Response	80-8,000 cycles
Finish	Grey wrinkle
Mounting	1/8" pipe thread (Supplied with adaptor 1/8" to 5/8"-27 fixture thread, MI-12501 Adaptor required for 1/2" pipe thread.)
Dimensions, overall	
Length	6 7/8"
Width	2 1/2"
Depth	6 7/8"
Weight (unpacked)	3 1/2 lbs.
Cable (two conductor shielded)	30' less plug
Stock Identification	MI-6203

Aeropressure MI-6206

Uses

The MI-6206 offers outstanding performance as a public address microphone. Its relatively wide frequency response, high sensitivity and attractive appearance also readily adapt it for use as a "talk back" microphone in broadcast studios. It is well suited to the requirements of a program director's microphone or it may be used for emergency announce purposes.

Description

Like other pressure operated microphones, the MI-6206 is relatively non-directional at the lower frequencies and directional at the higher frequencies. The reversible paracoustic baffle supplied with this microphone will change the high frequency directional characteristics. This baffle either sharpens or broadens the directional characteristic, depending upon whether its concave surface faces toward or away from the microphone grille. This microphone is supplied with a clevis mounting bracket.



Features

- Low cost.
- Good frequency response.
- Baffle for directional or non-directional application.
- Attractive appearance.

Specifications

Directional Characteristics	Non-directional (Baffle makes instrument more directional at higher frequencies.)
Output Impedance	250 ohms
Effective Output Level	-56 db*
Frequency Response	80-8,000 cycles
Finish	Black and chromium
Mounting	1/8" pipe thread (MI-12051 Adaptor required for 1/2" pipe thread.)
Dimensions, overall	
Length	5"
Diameter	2 1/8"
Weight (unpacked)	2 1/4 lbs.
Cable (two conductor shielded)	30' less plug
Stock Identification	MI-6206

Aerodynamic Pressure MI-6226-H

Uses

The Aerodynamic Microphone is an inexpensive unit which is especially well suited for broadcast "talk-back" purposes. It meets all the requirements for a close talking microphone.

Description

The Type MI-6226-H Aerodynamic Microphone is relatively insensitive to mechanical shock and is ruggedly constructed to give years of satisfactory service. The unit can be supplied with a special stand (MI-6227) to match the streamlined chromium plated microphone case.

Features

- Low cost.
- Frequency response sufficient for pleasing voice transmission.
- Especially suited for close talking.
- Rugged construction.
- Attractive appearance. Streamlined styling.



Specifications

Directional Characteristics	Non-directional
Output Impedance	250 ohms
Effective Output Level	-63 db*
Frequency Response	100-8,000 cycles
Finish	Polished chromium
Mounting	1/8" pipe thread (Supplied with adaptor 1/8" to 5/8"-27 fixture thread. MI-12051 Adaptor required for 1/2" pipe thread.)
Dimensions, overall	
Length	3"
Width	2 5/8"
Depth	3 3/4"
Weight (unpacked)	2 1/4 lbs.
Cable (two conductor shielded)	30' less plug
Stock Identification	MI-6226-H

* Referred to one milliwatt and a sound pressure of 10 dynes/cm².

Microphone Stands

Program Stand • Type 90-A

Uses

The 90-A Program Stand is the standard unit at leading Station and Network Studios. With its attractive finish and sturdy construction this stand will improve the appearance and operation of any studio set-up. It may be used with all RCA Broadcast Type microphones or with any other microphone which may be adapted to a 1/2 inch pipe thread mounting.

Description

The 90-A floor stand is equipped with a simple clamping device which permits height adjustments to be made easily and quietly *without operating any release mechanism*. The up and down operation is smooth and the locking operation positive. The patented clamp is mechanically simple and is ruggedly constructed to give years of service. The weighted base of the 90-A is equipped with equalizing projections to assure a firm position on an uneven floor. The stand is finished in satin chrome to harmonize with any studio decoration. Cable guides are included to hold the microphone cord in proper position.

Features

- Hundreds giving excellent performance in leading broadcast studios.
- Suitable for use with all RCA Microphones.
- Large heavy base with equalizing projections assure sturdy support of microphone.
- Simple non-slide, trouble free clamping device.
- Attractively finished in satin chrome.

Specifications

Height of Stand _____ Adjustable from 3'8" to 6'2"
 Microphone Mounting _____ Standard 1/2" pipe thread
 Diameter of Base _____ 12 1/4"
 Weight (unpacked) _____ 33 lbs.
 Finish _____ Satin Chrome
 Stock Identification _____ MI-4090A
 Accessory Item—Cable Hook _____ MI-4089



Boom Stand • Type 90-C

Uses

The 90-C is a studio type stand which is especially suited for piano pickups and arrangements where it is desirable to locate a microphone close to the source of sound. It is also ideal for picking up large orchestra groups where the microphone must be elevated above the height attained with a Type 90-A Stand.

Description

The 90-C Boom Stand has been designed to cover a number of adjustments. The horizontal arm is adjustable from 4'11" to 7'6" and may be swung through an angle of 150 degrees which permits a wide range of use. In addition, the stand itself may be raised from 4 1/2 ft to 8 ft. Adjustments are easily made with large knurled and polished handwheels. The boom is adjustable and counterbalanced. Smooth-rolling, rubber-tired casters eliminate noise and facilitate movement. The boom stand is finished in satin aluminum and black. Cable supports are provided for the microphone cord.

Features

- Sturdy construction, strong tubing and casting.
- Large base with rubber tired casters.
- Easily adjusted over wide range of heights and boom length.
- Positive locking adjustments.
- Attractively finished in satin aluminum and black.

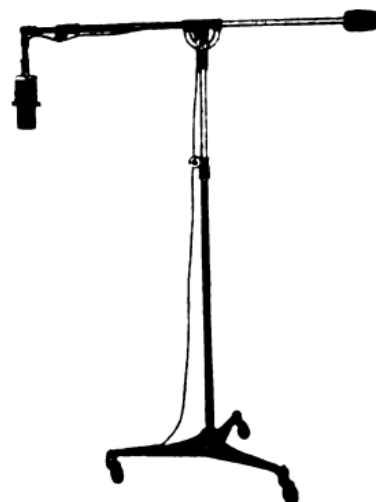

Specifications

Height of Stand _____ Adjustable from 4 1/2' to 8'
 Horizontal Arm Adjustment _____ 4'11" to 7'6"
 Microphone Mounting _____ Standard 1/2" pipe thread
 Weight (unpacked) _____ 62 lbs.
 Finish _____ Satin Aluminum and Black
 Stock Identification _____ MI-4094A

Cable Hook MI-4089

Uses

Attached to the 90-A stand the MI-4089 provides a convenient method of holding the cable when it is not in use.

Description

The MI-4089 is finished in satin chrome to match the stand and prevent tarnish or rust from frequent handling. It is extremely simple to install; merely tightening a recessed set screw holds it in position.



Features

- Can be attached or removed in a few seconds.
- Saves wear on the cable.
- Keeps cable out of the way when not in use.

Specifications

Weight _____ 17 oz.
 Finish _____ Chromium

Microphone Stands

Announce Stand Type 91-A

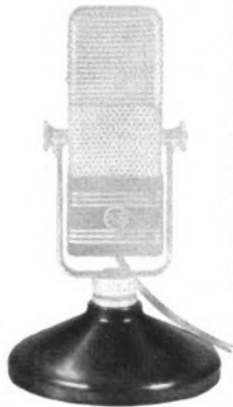

The 91-A is a simple but attractive desk stand for 44BX Microphones. It is finished in dark amber grey metalure and its base rests on three felt buttons. Height of the 44-BX Center above desk is $8\frac{3}{8}$ ". Base diameter, 7". The microphone mounting is for $\frac{1}{2}$ " pipe thread.

Weight (unpacked) _____ $3\frac{1}{2}$ lbs.
Stock Identification _____ MI-4058-C

Desk Stand Type 91-B

This is an attractively styled black and chromium base with a felt-covered bottom. Two fittings $\frac{3}{4}$ " and $1\frac{3}{4}$ " in length are provided for using the stand with 88-A, 77-D or 74-B Microphones. Base size $4\frac{1}{4}$ ". Height $1\frac{5}{8}$ " with $\frac{3}{4}$ " extension or $2\frac{5}{8}$ " with $1\frac{3}{4}$ " extension. The microphone mounting is for $\frac{1}{2}$ " pipe thread.

Weight (unpacked) _____ 4 lbs.
Stock Identification _____ MI-4092



Banquet Stand MI-4095

Uses

This newly designed stand is the ultimate for banquets or other occasions where a sturdy, attractive and truly portable stand is required.

Description

The MI-4095 is of novel construction in that its base forms a compact carrying case for the entire stand. The hollow under side of the base casting accommodates the stand's three telescoping tubular sections and its two fin type legs fold into the base sides. When unfolded the legs extend $5\frac{1}{4}$ " from center of the vertical rod. The bottom of the base is covered with felt.

Features

- Compact and convenient for portable use.
- Rugged construction.
- Easy to assemble or take apart.
- Attractive finish.

Specifications

Height—Adjustable $10\frac{3}{4}$ " to $24\frac{3}{4}$ "
Base Dimensions $3\frac{5}{8}$ " x $10\frac{1}{2}$ " x $1\frac{5}{8}$ "
Microphone Mounting
 $\frac{1}{2}$ " pipe thread
Weight _____ 5 lbs.
Finish
Black wrinkle and chromium
Stock Identification _____ MI-4095



Portable Stand Type 59-B

The 59-B is a collapsible, lightweight and rugged stand which is unexcelled for field use. It features a tripod base and a patented clutch arrangement which permits height adjustments to be quickly made without the operation of a mechanical release. The height is adjustable from 3' to 5'. Overall length, collapsed, 3'. Weight (unpacked $3\frac{1}{2}$ lbs. Finish—Satin chrome. The microphone mounting is for a standard $\frac{1}{2}$ " pipe thread.

Stock Identification _____ MI-4093-B

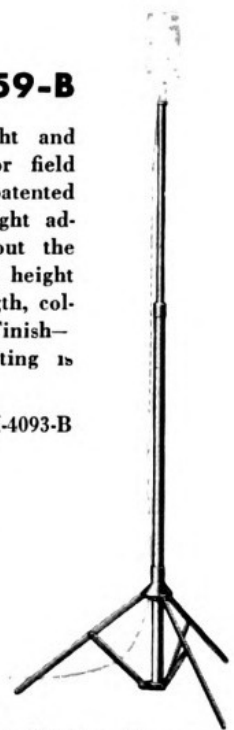

Microphone Carrying Case MI-4085

The MI-4085 is a very useful carrying case for the remote man. It has been designed to carry four (4) microphones such as Types 88-A, 77-D, 74-B, three (3) Type 59-B Collapsible Stands or equivalent and all necessary miscellaneous items such as cords, wire, and tools.

The MI-4085 is ruggedly constructed and reinforced to give long wear under hard usage. The case and its partitions are built of $\frac{3}{8}$ " veneer. The outer cover material is tough granite fiber and the corners are metal braced for additional strength and rigidity. An inner cover material of soft felt provides cushioning and prevents scratching of the microphones during transportation. The case opens up into two sections and has an inner lid which separates the microphone and stand compartments. It will carry a total of 35 lbs.

Dimensions

Height _____ $9\frac{1}{2}$ "
Width _____ $39\frac{1}{2}$ "
Depth _____ 11"
Weight (unpacked) _____ 26 lbs.
Stock Identification _____ MI-4085

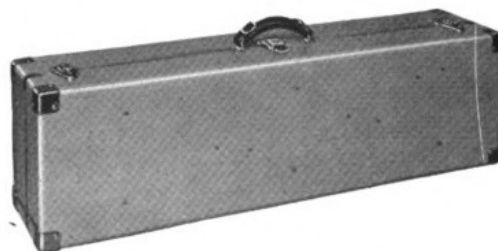

Microphone Stands

Three-section Microphone Stand MI-6208

Uses and Description

The MI-6208 is a convenient and attractive stand for floor or banquet use. It is especially suitable for portable use since it may be taken apart into three sections for easy packing or carrying. The stand has a heavy ten-inch grey crackle base which is trimmed with satin-silver stripes. The stand finish is chromium.

Features

- Utility stand for floor or banquet use.
- Three sections for easy packaging or carrying.
- Heavy ten-inch base.
- Attractive appearance.

Specifications

Height (for floor use—3 sections)
Adjustable from 3' 11" to 5'
Height (for banquet use—2 sections)
Adjustable from 1' 6" to 2' 7"
Microphone Mounting— $\frac{1}{2}$ " pipe thread
Finish
Stand _____ Polished chromium
Base _____ Gun metal crackle with
satin-silver stripes
Weight (unpacked) _____ 11 lbs.
Stock Identification _____ MI-6208

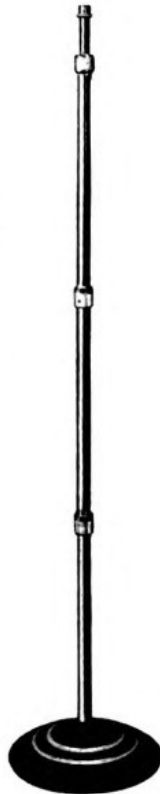

Desk Stand MI-6232-A

The MI-6232-A is a special 6" desk stand with a $\frac{1}{8}$ " pipe thread fitting. It is especially suited for use with the RCA Aero-pressure and Aerodynamic Microphones. It is attractively finished in chrome with black trimming and has a heavy 6" felted base.

Weight (unpacked) _____ $1\frac{1}{4}$ lbs.
Stock Identification _____ MI-6232A



Pushmike Stand MI-6427

This smartly designed table stand features a built-in microphone switch and is suitable for use with all RCA pressure type microphones. The switch is of the D.P.D.T. long leaf anti-capacity type and permits turning the microphone on and off right at the microphone stand.

The stand is $4\frac{3}{4}$ " high with $5\frac{3}{4}$ " base and is attractively finished in chromium. The microphone mounting is for a $\frac{5}{8}$ "—27 male or female thread. Stock #33543 Adaptor is available on separate order for microphone with $\frac{1}{2}$ " pipe thread.



Weight (unpacked) _____ $1\frac{1}{8}$ lbs.
Stock Identification _____ MI-6427

Floor Stand MI-4068-D

Uses and Description

The MI-4068D is a lightweight microphone floor stand with a twelve-inch base. It may be used with any RCA Microphone where a stand of heavier structure is not required.

Features

- Heavy twelve-inch base.
 - Modern appearance.
 - Finish harmonizes with all colors.
- Height _____ Adjustable from 2' 11" to 5' 7"

Description

Microphone Mounting— $\frac{5}{8}$ "—27 pipe thread fitted with $\frac{1}{2}$ " pipe thread adaptor. (For microphones with $\frac{1}{8}$ " pipe thread use MI-6229 Adaptor.)
Finish _____ Chromium and black
Weight (unpacked) _____ $14\frac{1}{2}$ lbs.
Stock Identification _____ MI-4068D



Announce Stand MI-4096

This attractively-designed announce stand is adjustable from 8 to $10\frac{1}{2}$ ", making it ideal for use on a desk or table. It is finished in chromium and black and features a $7\frac{1}{2}$ " heavy base. The microphone mounting is for a standard $\frac{1}{2}$ " pipe thread.

Weight (unpacked) _____ 4 lbs.
Stock Identification _____ MI-4096



Microphone Plugs and Receptacles

Most RCA Microphones are sold without plugs in order that the purchaser may use any type desired. However, Cannon fittings are recommended for their reliability and freedom from noise. For convenience to broadcasting stations, a number of these fittings are stocked by RCA. Provision is made in plugs and receptacles for three connections. All fittings are finished in satin chrome.

Description	Cannon Stock No.	RCA Stock Identification
Male plug for microphones (locking)	P3-CG-12S	MI-4630-B
Wall receptacle for above plug	P3-35	MI-4624-A
Note: The MI-4624-A Receptacle will fit in a Sprague No. SP-5800 Outlet Box.		
Extension cord—female connector	P3-CG-11S	MI-4620-B

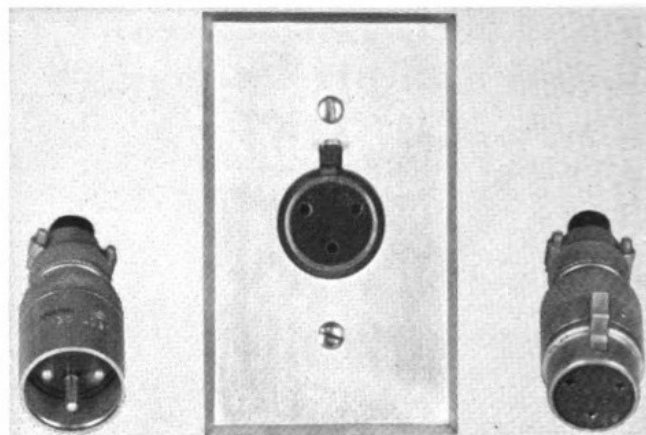

MI-4630-B
Microphone
Plug

MI-4624-A
Wall
Receptacle

MI-4620-B
Cord
Connector

Microphone Adaptors

Stand Thread	Microphone Thread	Stock Identification
1/8" pipe thread	1/2" pipe thread	Stock No. 32212
1/2" pipe thread	1/8" pipe thread	MI-12051
1/2" pipe thread	5/8"—24 (W.E.)	MI-12057
1/2" pipe thread	5/8"—27	MI-12055
5/8"—24 (W.E.)	1/2" pipe thread	MI-12057-A
5/8"—27	1/8" pipe thread	MI-6229
5/8"—27	1/2" pipe thread	Stock No. 33543

Pushmike Adaptor MI-6425

An adaptor with a built-in microphone switch of the D.P.D.T. long leaf anti-capacity type. The switch permits "push-to-talk" operation and may be used with any floor or table stand having 5/8"—27 fixture threads. The adaptor is an extremely light compact unit finished in chromium. It is 4 3/4" long, 1 3/8" in diameter and weight is 3/4 lbs. unpacked.

Fitting _____ Bottom 5/8"—27 fixture thread (female)
 Top _____ 5/8"—27 fixture thread (female) with added
 5/8"—27 thread, male nipple

Stock Identification _____ MI-6425

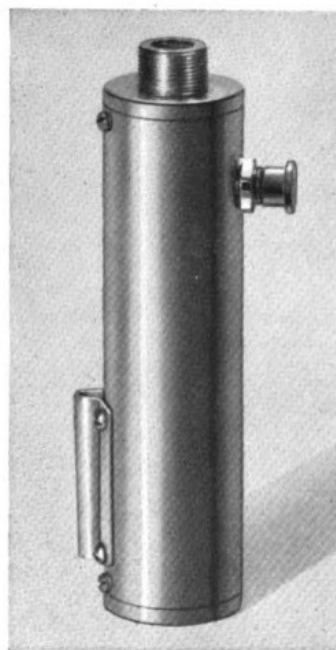

Microphone Cables

Cable MI-41

Use _____ High impedance microphone cable
 Type _____ Single conductor stranded equiv. #25 AWG
 Insulation _____ Special rubber compound
 Shield _____ Tinned Copper
 Outer Covering _____ Special durable black rubber compound
 Overall Diameter _____ Approximately 0.245"
 Capacity _____ Does not exceed 26 mmf per ft. at 1000 cycles
 Stock Identification (specify length in feet) _____ MI-41

Cable MI-42

Use _____ Low impedance microphone cable
 Type _____ Stranded two-conductor shielded equiv. #20 AWG
 Insulation _____ Special rubber compound
 Shield _____ Tinned Copper
 Outer Covering _____ Special durable black rubber compound
 Overall Diameter _____ Approximately 0.280"
 Stock Identification (specify length in feet) _____ MI-42

Cable MI-43

Use _____ Low impedance microphone cable
 Type _____ Stranded three-conductor shielded equiv. #20 AWG
 Insulation _____ Special rubber compound
 Shield _____ Tinned Copper
 Outer Covering _____ Special durable black rubber compound
 Overall Diameter _____ Approximately 0.280"
 Stock Identification (specify length in feet) _____ MI-43

Cable MI-62

Use _____ Low impedance microphone cable
 (Extra flexible lightweight construction for portable use)
 Type _____ Twisted two-conductor shielded, 41 strands #34 wire
 _____ Equiv. #18 AWG
 Insulation _____ Special rubber compound
 Shield _____ Tinned Copper
 Outer Covering _____ Special durable black rubber compound
 Overall Diameter _____ Approximately 0.285"
 Stock Identification (specify length in feet) _____ MI-62

ASSEMBLIES

SECTION

B

CUSTOM-BUILT INSTALLATIONS

STUDIO CONSOLETTES

TRANSMITTER CONSOLES

TRANSMITTER MONITOR RACKS

Custom Built Installations

RCA "Custom-Built" equipments are complete speech input systems designed according to the requirements and specifications of individual stations. RCA engineers have worked closely with the country's leading broadcast and network engineers in the design, production and installation of many such equipments, a few of which are shown in the accompanying photographs.

No two broadcast studio layouts are just alike, and never, except perhaps in the smallest stations, are the equipment requirements exactly the same. Moreover, the bigger the installation, the more specialized the equipment problem. But, however large, or however modern, may be the requirements, RCA "Custom-Built" equipments can be furnished to meet them.

Moreover, the "Custom-Built" service means more than just so many racks or pieces of equipment,—it includes, in fact, the services of the whole RCA engineering organization. In some cases, for instance, the station or network engineers may wish to lay out the system themselves, complete with specifications. In such instances, RCA engineers will assemble standard units and, where necessary, specially-built units to meet these specifications in every detail. On the other hand, where stations so desire, RCA engineers will study the requirements of the station, make overall and detailed layouts, and draw up specifications for the needed equipment.

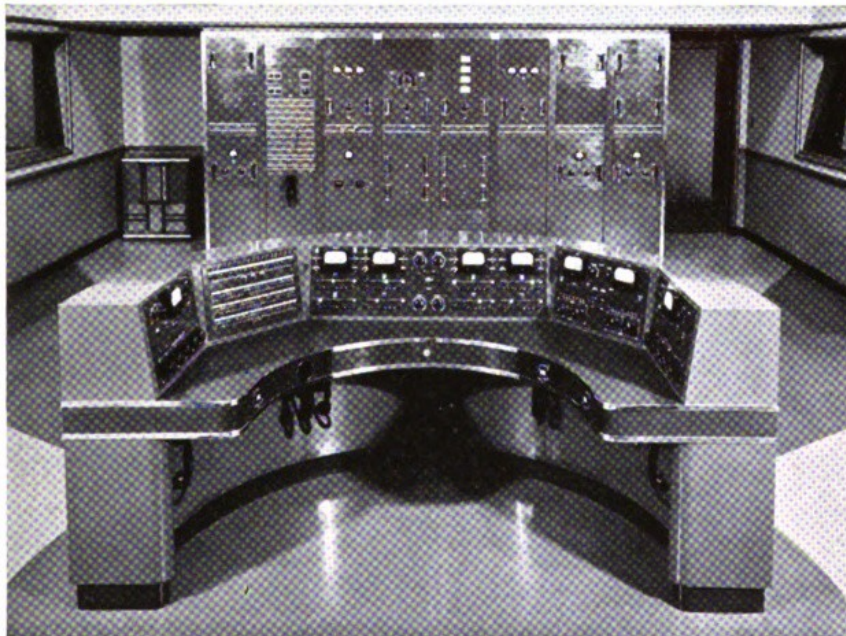

Speech Input Master Control Desk, Racks and Monitoring Loudspeaker installed at WFBR, Baltimore, Md.

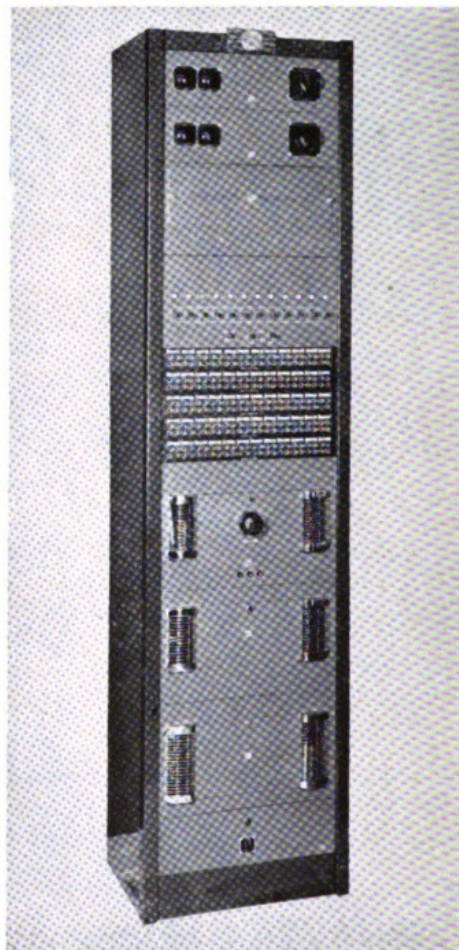

Line Terminating Rack at WHBC, Canton, Ohio.



A Studio Control Console and Rack built for WFBR, Baltimore, Md.

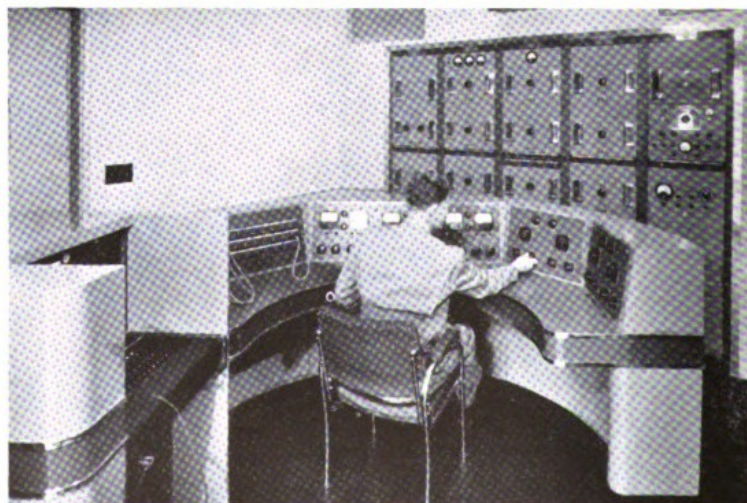

Speech Input Master Control Desk and Racks employed at the Golden Gate Exposition.

A few of the many RCA Custom Built Installations

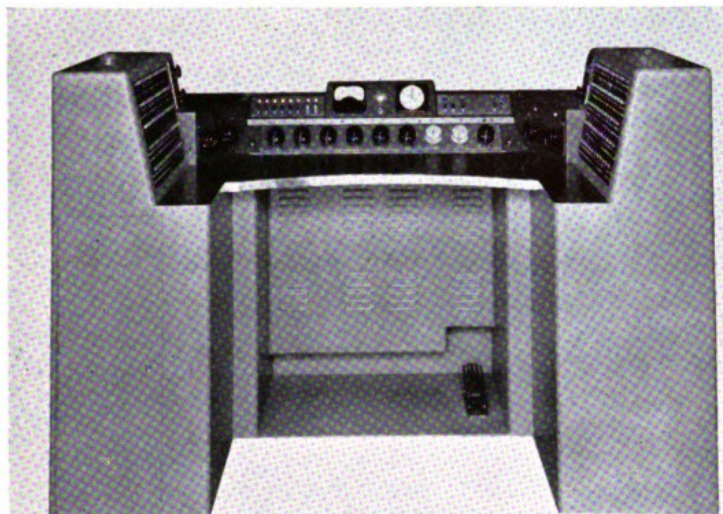

◀ *Type 2-A Desk built for CBS with view directly below it showing front and side open.*

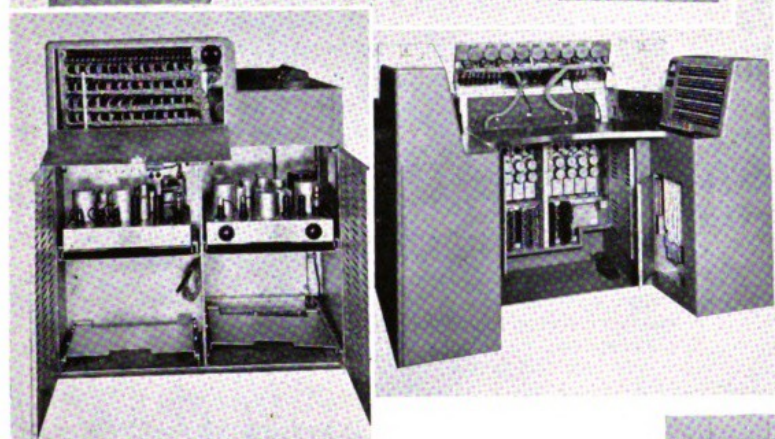

▲ *Custom Control Desk at WIRE*

Panels on left and right wings contain mixing facilities for remote lines and studios which are located adjacent to the control room. The center panel contains master control switching facilities for three outgoing channels.



Control Console at W/WNC.



Master Control Room Speech Input of WLS.

Speech Input Console Type 76-B2

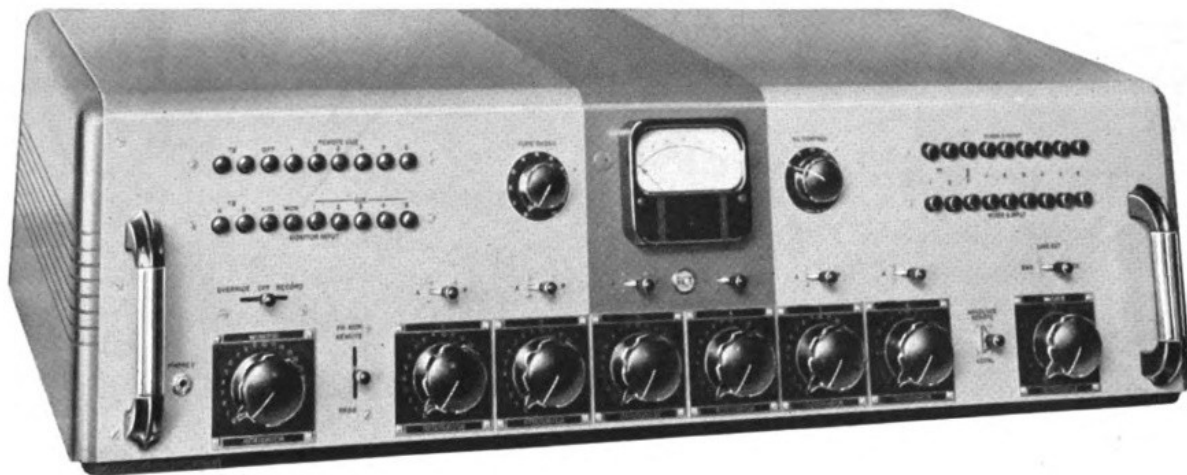

Uses

The 76-B2 provides a complete, flexible and high quality speech input system for FM as well as standard broadcasting. It is similar to the 76-B and 76-B1 Consolettes now giving highly satisfactory service in more than 100 broadcasting stations. The new design differs mainly in that its frequency response has been extended to 15,000 cycles.

The 76-B2 provides all the amplifying control and monitoring equipment required to handle successfully two studios, an announce booth microphone, a control-room announce microphone, two transcription turntables and six remote lines. Full facilities are provided for simultaneously auditioning and broadcasting from any combination of the studios, turntables or remote lines.

Description

All the amplifying and control equipment is mounted in a single metal console and the power supplies are located in a metal box designed for wall mounting.

The standardized, illuminated volume indicator meter is furnished calibrated in "vu's." This meter is also used to measure the plate current of all the tubes in the program channel. The meter is switched to the various tubes by means of the rotary switch which is mounted to the left of the meter. An adjustable attenuator at the right of the meter allows the 100% mark on the scale to be calibrated for +4, +8, +12, and +16 vu.

The console contains four pre-amplifiers, one high-gain program amplifier and one high-gain 8-watt monitoring amplifier. A six position mixer is utilized with the pre-amplifiers connected to four of the mixers and banks of mechanically interlocked push-keys connected to the remaining two. The output of each mixer connects to lever keys so it may be switched to the input of the program amplifier for broadcasting or to the monitor amplifier for auditioning. These key switches are interlocked to disconnect the studio loudspeakers and operate "On Air" light relays. A three position key switch in the input of the fourth pre-amplifier permits it to operate from a microphone in the studio, announce booth, or local control room. The push-keys on the fifth and sixth mixer positions allow any one of six remote lines and two turntables to be instantly connected to the input of either of the two mixers. Additional push-key sets provide circuits for feeding cue to remote lines and for bringing in monitoring circuits such as transmitter or master control outputs. A monitoring headset jack is supplied and the headphones may be connected to the output of the program channel, the remote line push-keys, or the incoming network by means of a three-position lever switch. Lever-keys permit using monitoring amplifier for program amplifier

in emergencies. Talkback facilities are included and separate push-keys permit talking back to either of the two studios or to the remote lines. The talk-back circuits are interlocked to prevent feed-back or program interruption.

An "Over-ride-Record" switch is provided which permits the remote operator to call in on any of the six remote lines and over-ride the program on the control room speaker. The "Record" position of the switch furnishes a signal source for an external recording amplifier. Two remote line repeating coils and attenuator pads are provided.

The console is constructed of metal with wooden style plates on each end. A lid is provided for access to tubes, etc. from the top and is equipped with sturdy concealed hinges. The entire console chassis is hinged across the back to permit quick and easy access to every component and all the wiring. Handles on the front panel facilitate opening the chassis for inspection. When the chassis is opened, all the mixers are made accessible for servicing.

The metal power supply box is equipped with a hinged front door and a hinged chassis. Two separate rectifier and filter units provide power for the program amplifier—pre-amplifiers, monitoring amplifier, three speaker interlocking relays and up to 4 external 12 volt relays for studio signal lights. A switch permits feeding the pre-amplifiers from the monitor supply in emergencies.

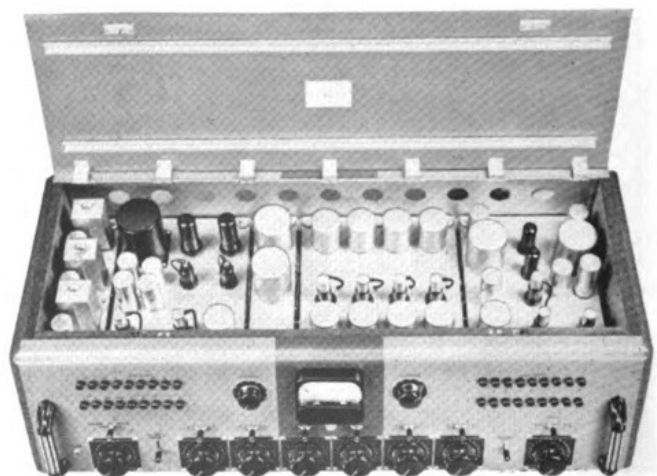

76-B2 with top raised.

Features

- Complete high fidelity speech input system for two studios, announce booth, turntables and remotes.
- Excellent frequency response—low distortion for FM or AM.
- No broadcast time lost from amplifier or power supply failures. Duplicate equipment may be quickly connected by means of switches.
- 8-watt monitoring and audition amplifier with interlocked relay circuits for three loudspeakers.
- Full facilities for simultaneous audition and broadcast.
- Push button selector switches—six channel mixer.
- Large vu meter connected to rotary selector switch permits accurate program monitoring and checks plate currents of all tubes in program channel.
- Talk-back system independent of program channel—interlocked switching prevents feed-back.
- Easy access for maintenance.
- Heavy duty power supply for external mounting allows space for full-sized components in small sized console.

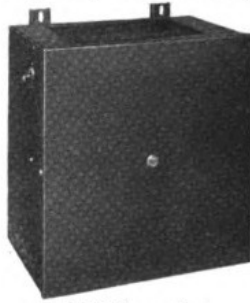

Wall Mounting
Power Supply

Specifications

Input (source) Impedance

Microphones	30/50 or 250 ohms
Remote Lines	300 or 600 ohms
Turntables	250 ohms
Monitor Cue	20,000 ohms

Output (load) Impedance

Line	500/600 ohms
Speaker (total of four speakers)	each 15 ohms

OUTPUT LEVEL

Line (distortion less than 0.5% 50-7000 cycles)	+16 VU
Maximum Line Output Level	+26 VU
(With 1.0% rms distortion at frequencies 50-7,000 cycles)	
Speaker (distortion less than 3% 50-7000 cycles)	8 watts

Gain (maximum microphone to line)	110 db
Frequency Response (to line or speaker)	± 2 db 30-15,000 cycles
Noise Level (72 db gain, +16 db output)	-60 db
Power Input: 105/125 volts, 50/60 cycles	225 watts
Dimensions	Console Power Supply
Length	39" 15"
Height	10 $\frac{1}{2}$ " 15"
Depth	17" 8"

Finish _____ Two-tone Umber Grey Dark Umber Grey

Weight, unpacked (less tubes) _____ 135 lbs. 60 lbs.

Stock Identification _____ MI-11613-A1 MI-11301-B

Accessory Equipment _____ Stock Identification

BA-2A Booster Amplifier (one required for each

70-C1 turntable) _____ MI-11226

Tube Kit (complete tube complement for 76-B2) _____ MI-11252

11 RCA-1620 1 RCA-5U4G

2 RCA-1621 2 RCA-1622 1 RCA-5Y4G

Emergency Tube Kit (complete tube complement) _____ MI-11252-A

11 RCA-6J7 1 RCA-5U4G

2 RCA-6F6 2 RCA-6L6 1 RCA-5Y4G

On-Air Light Relay (one required for each

studio on air or audition light) _____ MI-11702

Speaker Relay (not required unless an inter-
locked speaker is desired in Announce Booth) _____ MI-11703

Components Easily
Accessible with this
Hinged Feature

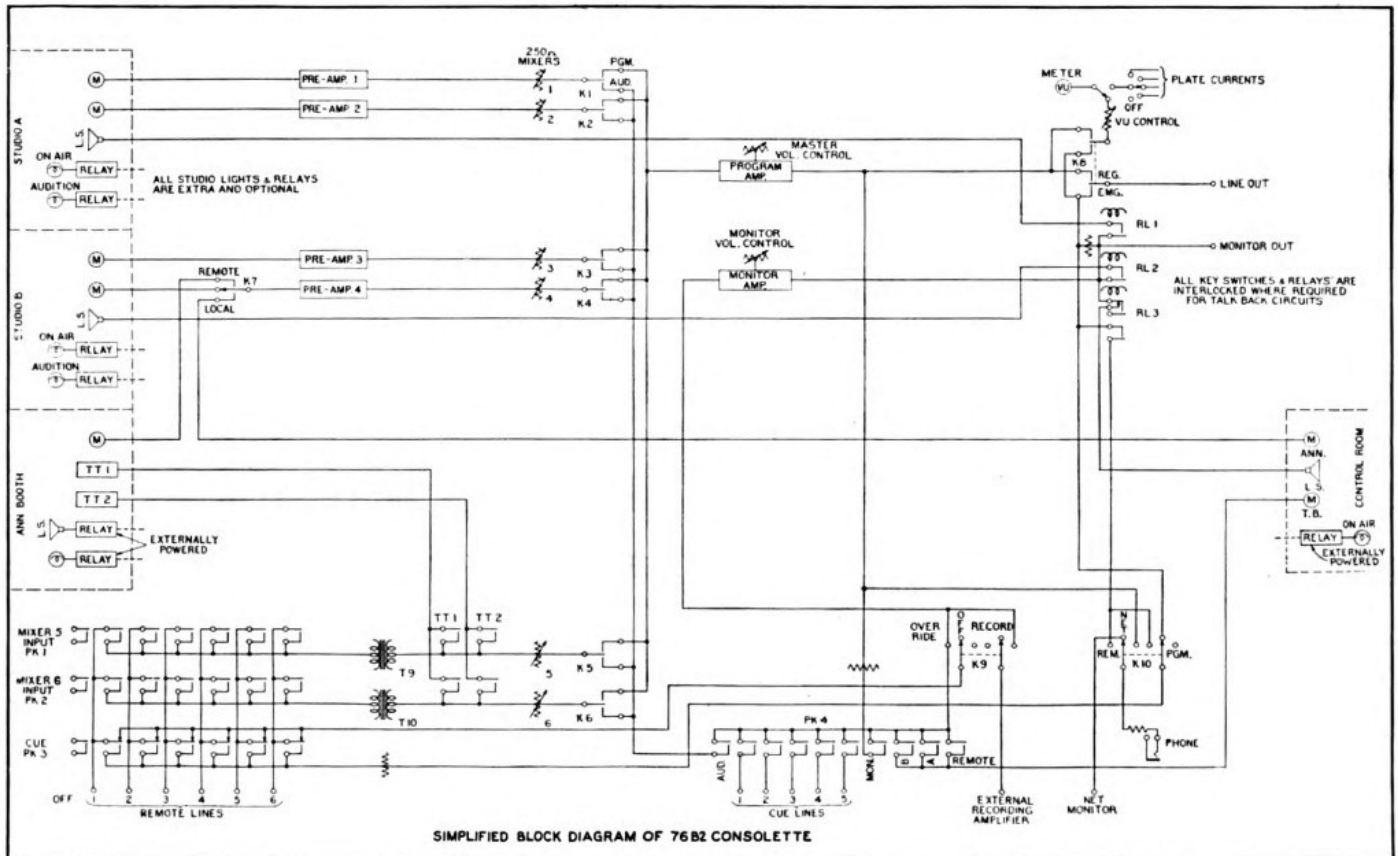
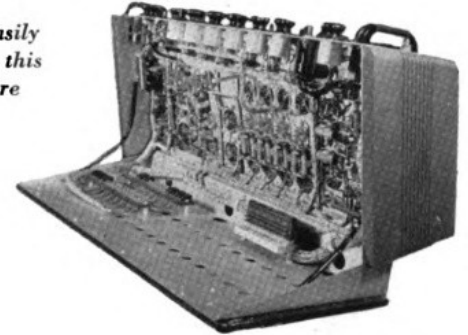

Transmitter Control Console MI-11616



Uses

The MI-11616 Transmitter Control Console is an attractive desk type console containing all the mixing and switching facilities required at the transmitter plant. It is equipped with a standardized vu meter, extension modulation monitor meter and antenna current meters. Designed primarily for use with the RCA 5-F and 10-F Broadcast Transmitter, it may be combined with the MI-11620 Transmitter Monitor and Amplifier Rack to provide a most flexible and complete system of controls and monitors.

Description

All controls, switches and meters are mounted on three panels which are assembled in the turret mounted on a metal desk. Each panel is hinged at the bottom so that it may be opened for easy servicing and the entire rear cover of the turret may be removed to facilitate installation or basic changes. Desk and turret are of metal construction throughout. The left hand pedestal contains a typewriter shelf and the right pedestal contains two convenient drawers. A third drawer is located in the center between the pedestals. A cylinder lock on this drawer also locks the drawers in the pedestal. Skirts have been provided below the pedestals to conceal the wiring conduits and all wiring is carried inside the desk. The desk top is covered with black linoleum with rounded corners and metal trim.

Mechanically interlocked push-keys permit instant selection of the circuit to be monitored by the vu meter or by the monitoring amplifier. By means of these keys, the monitoring speaker may be used to check (1) transmitter audio input, (2) transmitter audio output, (3 and 4) two incoming lines and (5) turntable output.

Balanced, high quality, step-by-step mixers are provided for the (1) incoming line, (2) announce microphone and (3) turntable. A master or transmitter input control and a monitor amplifier volume control are also furnished. Key switches in the outputs of the microphone and turntable mixers are equipped with indicating lamps. The microphone key is interlocked with the monitoring speaker through a relay and disconnects the speaker whenever the microphone is on. A line transfer key permits ready selection of two incoming lines and transfers the telephone set to the line not being used for the program. A three position key switch selects the studio line or the local microphone and turntable. Chromium plated guards prevent accidental operation of the important keys. A spare

D. P. D. T. lever key is furnished for the convenience of station personnel. The center panel contains a standardized vu meter, with a step-by-step control making it possible to read levels of +4 vu to +40 vu; a modulation meter intended to operate as an extension for a type 66A modulation monitor and an antenna current indicator consisting of a 0.50 ma, d-c movement with a scale of 50 divisions calibrated linearly from 0 to 10 amperes r-f (other scales are available) and intended to be connected into the rectified carrier circuit. Cutouts are provided for two additional meters such as an extension db compression meter for the limiting amplifier; an extension meter from a frequency monitor or additional antenna current indicators where required. The attenuator controls are located below the meters on the center panel.

A 12 volt, 1 ampere, d-c power supply furnishes power to the speaker interlocking relay and to the audio circuit indicating lamps. The power supply utilizes a copper sulphide dry rectifier and capacity filter.

The power control switches are mounted on the left hand panel and are designed for 230 volt operation. Associated lamps are furnished and may be arranged for operation on 115 volt for audio power and 230 volt for transmitter power. Switches and lamps are provided for (1) transmitter filaments, (2) transmitter plate, (3) overload reset, (4) transmitter high-low power transfer, (5) tower lights, (6) audio equipment and (7) spare.

Features

- Simplifies transmitter installation.
- Major control functions are at engineer's fingertips and important meters are within easy viewing distance.
- Contains all required mixing and switching facilities.
- Standardized vu meter plus extension modulation monitor and antenna current indication.
- All necessary controls for transmitter operations plus visual indicating lamps.

Specifications

Input Impedances

Lines 1 and 2, Studio, Master and Monitor Controls	600 ohms
Telephone Set	600 ohms
Microphone and Turntables	250 ohms
Monitor—Transmitter in and out (Bridging)	20,000 ohms
Monitor—Lines 1 and 2	20,000 ohms

Output Impedances

Lines 1 and 2, Lever Key; Microphone and Turntable Mixer;	
Studio, Master and Monitor Control	600 ohms
Microphone and Turntable Controls	250 ohms
Frequency Response (30 to 15,000 cycles)	± 0.1 db

Insertion Losses

(microphone and turntable mixer circuit) 7 db

Noise Level: Circuits are isolated so that residual noise level will not exceed the aggregate noise level of the associated amplifiers.

A-c Power Input for Lamps and Relays

(105-125 volts, 50-60 cycles) 25 watts

Dimensions, overall—Width 60", depth 34½", height 41½"

Note—Turret extends approximately 11" above desk top

Weight (unpacked) 393 lbs.

Stock Identification MI-11616

Accessories

Transmitter Monitor and Amplifier Rack MI-11620

Extension Meter for 86-A1 Amplifier Stock No. 43504

Transmitter Monitor and Amplifier Rack MI-11620

Uses

This rack with its associated equipment simplifies the installation of a broadcast transmitter. One factory-wired 9-AX Cabinet Rack houses all required items of transmitter speech input equipment, modulation and frequency monitors and power change panel. This rack may be used with the MI-11616 Control Console to provide a flexible and complete system of controls and monitors.

Description

The MI-11620-F Transmitter Monitor and Amplifier Rack consists of one Type 9-AX cabinet rack in which are mounted one Type 66-D modulation monitor, one Type 86-A1 limiting amplifier, one Type 82-C1 monitoring amplifier, two Type 33-A jack strips with mat and one Type 57-C switch and fuse panel.

Mountings and all wiring are provided for the following: one Type 311-AB frequency monitor, three Type BA-1A pre-amplifiers, three MI-4900-A line coils, one BX-1A power supply, one MI-4309 power change panel, two Type 56-C line equalizers, one MI-11265 VU meter panel, one MI-11280 Sola voltage regulator and one MI-11606 filament transformer. These are not furnished as a part of the rack, but are available separately. The voltage regulator may be desired for controlling the a-c supply to the limiting amplifier if the power supply voltage is subject to erratic variations.

Three Type 36-B panel and shelf assemblies are supplied, two of which are used to hold the limiting and monitoring amplifiers and the third is wired for mounting three Type BA-1A pre-amplifiers and one BX-1A power supply should these be required. One blank panel with mounting studs and wiring provides for three MI-4900-A line coils and two Type 56-C equalizers if these are used. Two 5¼" blank panels MI-4569 are supplied to complete the rack.

The two Type 33-A jack panels, in addition to providing flexibility in all described audio circuits, furnish seven spare double jacks for utility use according to local requirements. One complete set of tubes is furnished with the MI-11620-F Monitor and Amplifier Rack.

Features

- Simplifies transmitter installations.
- Provides complete monitor and amplifier facilities in one attractive rack.
- Provides extreme flexibility through termination of all audio units in jack strips.
- Wiring and monitoring facilities furnished for addition of optional equipment.

Specifications

Frequency Response (30 to 15,000 cycles)
line in to transmitter out _____ ± 2 db
 Noise Level (below +10 VU output, 28 db gain) _____ -60 db
 Distortion: see distortion curves for individual amplifiers listed in the Broadcast Audio section of this catalogue
 A-c Power Input (105-125 volts, 50-60 cycles) _____ 450 watts
 Dimensions, overall
 Width _____ 20 $\frac{5}{8}$ "
 Depth _____ 14 $\frac{3}{8}$ "
 Height _____ 82 $\frac{7}{8}$ "
 Weight (unpacked) _____ 383 lbs.
 Stock Identification
 (including one complete set of tubes) _____ MI-11620-F
 Stock

Accessories	Identification
Type 311-AB Frequency Monitor	MI-8211F
Type BA-1A Pre-Amplifier	MI-11218-A
Tube Kit for BA-1A Pre-amplifier	MI-11288
BX-1A Power Supply for Pre-Amplifiers	MI-11305
Tube Kit for BX-1A Power Supply	MI-11262

Power Change Panel (for 5F and 10F Transmitter)	MI-4309
Line Transformers	MI-4900-A
Type 56-C Line Equalizers (semi-fixed)	MI-4168
VU Meter Panel	MI-11265
MI-11606 Filament Transformer for VU Meter Lamp	MI-11606
Sola Voltage Regulator—60 Cycles	MI-11280
50 Cycles	MI-11280-A

Spare Tube Kits for Component Amplifiers	
Type 82-C1 Monitoring Amplifier Kit	MI-11282
(complete tube complement) 4 RCA-1620, 2 RCA-1622, 1 RCA-5U4G	
Spare Type 82-C1 Monitoring Amplifier Emergency Tube Kit	MI-11282-A
(complete tube complement) 4 RCA-6J7, 2 RCA-6L6, 1 RCA-5U4G	
Spare Type 86-A1 Limiting Amplifier Tube Kit	MI-11286
(complete tube complement) 2 RCA-6K7, 1 RCA-6N7, 2 RCA-1621, 1 RCA-6R7, 1 RCA-5T4	
Spare Set of Two Matched 6K7 Tubes only for 86-A1	MI-11250
Note: Type 66-D Modulation Monitor Tube Complement consists of 1 RCA-1V, 3 RCA-76, 1 RCA-84, 1 RCA-885.	



MI-11620-F Transmitter Monitor and Amplifier Rack with Type 311-AB Frequency Monitor and other accessories.



MI-11620-F Transmitter Monitor and Amplifier Rack as shipped.

RCA Broadcast Amplifiers

The RCA line of high fidelity Speech Input Amplifiers has been designed to provide stations with studio, recording and portable remote amplifiers which will offer the maximum in fidelity, flexibility, convenience and reliability. All amplifiers are suitable for FM having a uniform response to 15,000 cycles. Distortion and noise levels have been reduced to a very low value through careful engineering design and construction.

While the apparatus is tops in performance and appearance, it is very economical considering the many features which are offered. The amplifiers have been designed to give unsurpassed service and nothing has been omitted which would contribute to their usefulness and reliability. Plug-in electrolytic capacitors, which prevent loss of broadcast time caused by capacitor failures, are now featured in all RCA newly designed amplifier units.

Summary of RCA Broadcast Amplifier Characteristics

Type	Usage	Max. Gain db	Max. Input db*	Max. Output db*	Input Source Impedance Ohms	Output Load Impedance in Ohms	Type Mounting
BA-1A	Preamplifier	40	-30	+10	30/250	250/600	Chassis or Rack
BA-2A	Mic. Preamp. or Turntable Preamplifier	50	-25	-2	30/250	250/600	Chassis or Rack
BA-3A	Program Amp. Line Amp. Isolation Amp.	Match. 60 Bridg. 22	Match. -30 Bridg. +15	33 2 Watts	600/250	600/150/15 7.5 and 5	Chassis or Rack
85-X	Isolation Amplifier	Match. 20 Bridg. 4	Match. +3 Bridg. +18	14	600 (20,000 ohms amp. input bridging)	600	Chassis or Rack
86-A1	Limiting Amplifier	60	At lim. verge +10	+30	600/250	600/250	Chassis or Rack
82-C1	Monitoring or Recording Amplifier	105 70 with rem. v.c.	-25	+40.8 12 watts	30/250 (10,000 ohms amp. input rem. v.c.)	600/250/15 7.5 and 5	Chassis or Rack
76-B2	Speech Input Console	110	-30	+26	30/50/250 300/600	600 Pgm. 15 Mon.	Console
OP-7	Portable Pre-amp. Mixer	8	-27	-24	30/250	30/250	Port. Carry Case
OP-6	Portable Pickup Amp.	90	-24	+19	50/250	600/150	Port. Carry Case

* Reference level one milliwatt.

AMPLIFIERS

SECTION

C

TECHNICAL DATA SUMMARY

PREAMPLIFIERS

PROGRAM AND LINE AMPLIFIERS

MONITORING AMPLIFIERS

RECORDING AMPLIFIERS

REMOTE PICKUP AMPLIFIERS

Two Stage Preamp Type BA-1A

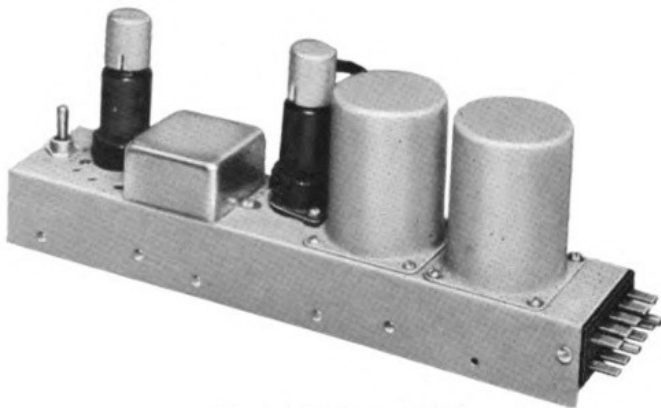

Type BA-1A Amplifier

Uses

The BA-1A is a compact, two stage high fidelity preamplifier. Its high gain (40 db), extremely low noise level and low distortion makes it an ideal unit for use as a microphone pre-amplifier, turntable preamplifier or booster amplifier. It may also be used as a low level isolation amplifier operating from a zero db* feeder bus. The BA-1A has a plug-in type chassis using multi-conductor plugs. The small size of the BA-1A gives it a great deal of mounting flexibility. It may be placed directly in a control console, control desk or transcription turntable cabinet. Where cabinet rack mounting is desired, one to six of these units may be installed in a single 36-B Panel and Shelf Assembly.

Description

The BA-1A has been designed to obtain the maximum gain from two pentode-connected RCA 1620 low noise tubes. The tubes are mounted vertically and are shock mounted to prevent microphonics. The circuit is conventional with unloaded transformer input, resistance-capacitance coupling between stages and transformer output. The distortion and hum level has been reduced to a very low value through proper circuit design and through the use of stabilized feedback. 11.5 decibels of feedback is provided from the plate of the second tube to the cathode of the first tube. Cross talk between units is -75 db*, 50 to 15,000 cycles when mounted side by side and operated from the BX-1A Power Supply.

As supplied the BA-1A has an essentially flat frequency response from 30 to 15,000 cycles. However, if desired to help compensate for deficient frequency response of other components of the system, a change can be made in one or both of two capacitors to provide either a 1 db boost at 30 cycles, a 1 db boost at 15,000 cycles or a 1 db boost at both 30 and 15,000 cycles. When used as an isolation amplifier the MI-11274 Volume Control Kit is used with the BA-1A to provide a 10,000 ohm bridging input. The volume control may be mounted in any convenient position on the control desk, control panel or at positions remote from the amplifier. When used as an isolation amplifier the BA-1A has 7 db gain and provides an isolation of approximately 80 db. A switch is provided for metering a portion of the cathode voltage of each tube when connected to a high resistance voltmeter such as the Type 15-D. The switch is off in the center position. The unit is designed to operate from the BX-1A Power Supply or its equivalent. The power requirements are 6.3 volts a-c or d-c at 0.6 amperes and 250 volts d-c at 3.4 ma.

Features

- Excellent frequency response ± 1 db 30 to 15,000 cycles.
- Two stages. Ample gain for any preamplifier application.
- May be used as an isolation amplifier providing 80 db isolation.
- Low distortion and hum level.
- Compact. Six units may be mounted in a single 36-B Panel and Shelf Assembly.
- Hermetically sealed output transformer.

Specifications

Input Source Impedance (unloaded input transformer)	30/250 ohms
Output Load Impedance (balanced)	600/250 ohms
Maximum Input Level (less than 0.5 rms dist. 50-7500 cps)	
(a) Matching	-30 db*
(b) Bridging (MI-11274 control at min. loss)	+3 db**
Normal Output Level	-15 db*
Distortion (at +10 db* output measured at frequencies 50-7500 cycles)	0.5% rms
Maximum Output Level	+10 db
Frequency Response	± 1 db 30 to 15,000 cycles
Gain, Maximum	
(a) Matching (250 ohm source to 250 ohm load)	40 db
(b) Bridging (MI-11274 control)	7 db
Noise Level	
(+10 db*, output full gain) below full output	-90 db
Plate Power Supply	250 volts d-c at 3.4 ma
Filament Supply	6.3 volts a-c or d-c at 0.6 amps
Dimensions, overall	Length 11 $\frac{3}{4}$ ", width 2 $\frac{1}{8}$ ", height 4 $\frac{3}{8}$ "
Finish	Silver grey opalescent
Weight (unpacked)	4 $\frac{1}{2}$ lbs.
Stock Identification (less tubes)	MI-11218-A

Accessories

Tube Kit #1 (complete tube complement)	
Two RCA 1620	MI-11288
Tube Kit #2 (emergency tube complement)	
Two RCA 6J7	MI-11288-A
NOTE: 6J7 may be used when maximum uniformity of characteristics and minimum of microphonics, hum and distortion are not required.	
Filament Transformer	MI-11606
Preamplifier Power Supply (furnishes filament and plate power for 1 to 6 BA-1A Preamplifiers)	MI-11305
Type 15-D Meter Panel (Black MI-4388)—U/G	MI-4388-A
36-B Panel and Shelf Assembly	
(required when cabinet rack mounting is desired)	
Umber Grey	MI-4682-H
Black	MI-4682-J

* Reference level one milliwatt.

** Maximum input level increases for increasing loss settings of MI-11274 control.

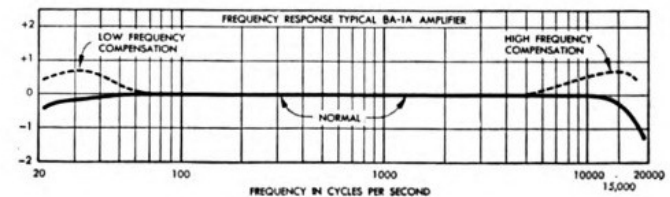

Booster Amplifier Type BA-2A



BA-2A Amplifier—Front View

Uses

The RCA BA-2A Amplifier is a high fidelity two stage unit for use as a microphone preamplifier, a booster amplifier for transcription turntables or as an isolation amplifier when used with suitable bridging resistors. It is also useful at transmitter installations where a high gain amplifier is required between the announce microphone and the limiting amplifier. When used as a transcription pickup amplifier, the BA-2A may be mounted inside the turntable cabinet. For rack mounting, two BA-2A Amplifiers may be mounted on one 36-B Panel and Shelf Assembly.

Description

The BA-2A differs from the 87-A only in its use of plug-in chassis and plug-in electrolytic capacitors. The circuit is conventional and utilizes two RCA 1620 tubes as triodes. Both amplifier tubes are mounted in shockproof sockets to reduce microphonic noises. An interstage gain control, which is a continuously variable potentiometer with a logarithmic taper, is provided for adjusting the output level. The amplifier is designed to work into a balanced load of 600/250 ohms. It will operate satisfactorily into amplifiers such as the type 86-A1 Limiting Amplifier, Type 82-B, 82-C or 82-C1 Monitoring Amplifiers or, if desired, into a Type 84-A, 84-B, or BA-3A Program Amplifier.

The amplifier is complete with built in a-c power supply which eliminates the need for external rectifiers. The hum and noise level has been kept to a very low value through the use of specially shielded power and audio transformers. Plug-in capacitors are used to simplify servicing the equipment and thus prevent loss of service from capacitor failures. Connections are provided from each cathode circuit to terminals on the male plug at the rear of the chassis. Corresponding terminals on the receptacle permit metering of tube condition when connected to a high resistance voltmeter such as the Type 15-D. Input, output and a-c connections are also brought out to the male plug. The unit is equipped with a power switch and fuse and is provided with a base cover plate for shielding when used in turntable installations. A mating receptacle is supplied for the male chassis plug.

Features

- High gain — Two stages — Self contained power supply.
- Excellent frequency response — Low distortion.
- Low noise level. Specially shielded transformers.
- Plug-in chassis — Plug-in electrolytic capacitors.
- Compact — two BA-2A's may be mounted on one 36-B Panel.
- May be mounted inside turntable cabinet.
- Provision for tube plate current check.
- Economically priced.

Specifications

Input Source Impedance	250 or 30 ohms	
Output Load Impedances (tapped transformer)	250 or 600 ohms	
Normal Output Level	-15 db*	
Distortion (at normal output level of -15 db* measured at any frequency between 40 and 15,000 cycles)	less than 0.75% rms	
Maximum Input Level (less than 1% distortion)	40-15,000 cycles) -25 db*	
Maximum Output Level (less than 1% distortion)	40-15,000 cycles) -2 db*	
Frequency Response (see curve)	±1.5 db 30 to 15,000 cycles	
Gain (250 or 30 ohm source to 600 or 250 ohm load)	50 db	
Noise Level (below +2 db* output, maximum gain)	-70 db	
A-c Power Input 105/125 volts, 50/60 cycles	13 watts	
Dimension	Overall	Chassis
Height	6½"	2½"
Width	8"	8"
Length	14"	11¾"
Weight (unpacked)		11 lbs.
Finish		Silver grey opalescent
Stock Identification (less tubes)		MI-11226

Accessory Items

- Tube Kit (complete tube complement)
2 RCA 1620, 1 RCA 6X5GT/G MI-11287
- Emergency Tube Kit (complete tube complement)
2 RCA 6J7, 1 RCA 6X5GT/G MI-11287-A
- Note: 6J7's may be used when maximum uniformity of characteristics and minimum of microphonics, hum and distortion are not required.
- 36-B Shelf and Panel Assembly, Umber-grey MI-4682-H

* Reference level one milliwatt.



BA-2A Amplifier—Rear view. Plug-in chassis permits easy removal of amplifier for servicing

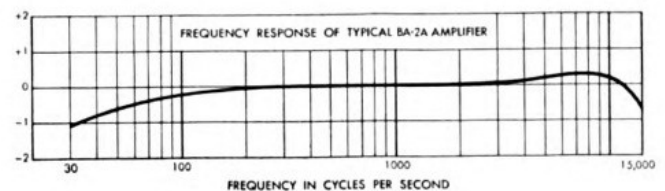

Limiting Amplifier - Type 86-A1

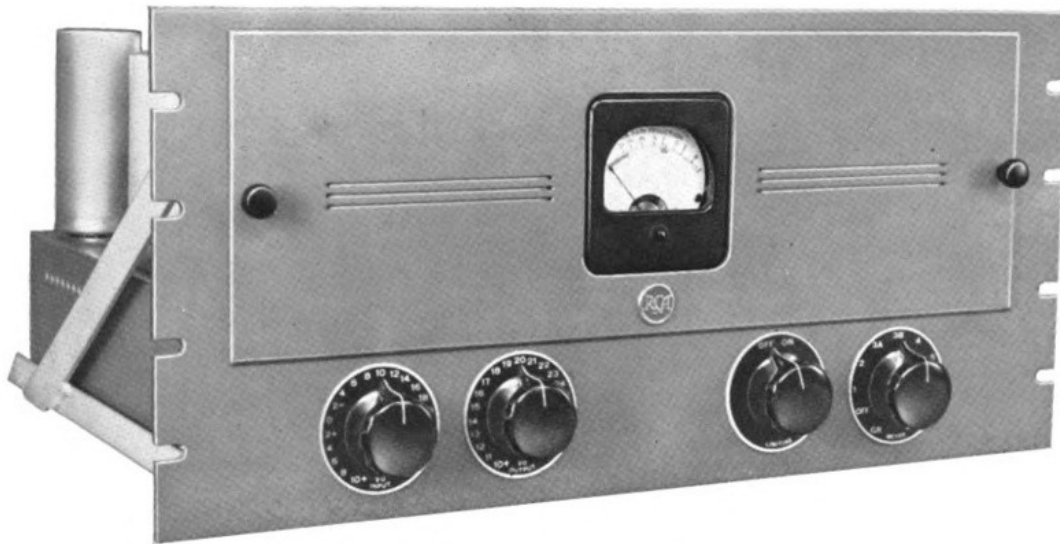

86-A1 Mounted on 36-B Shelf

Uses

The 86-A1 Limiting Amplifier has been designed for use in the speech input channels of FM and AM broadcast transmitters. It serves to limit the audio signal peaks to a certain pre-determined level thereby preventing over modulation with its consequent distortion and adjacent channel interference. This amplifier also provides for a more effective use of transmitter power by raising the average percentage modulation level several db without appreciably increasing the harmonic distortion. The limiting characteristics of the 86-A1 also readily adapt it for use in recording applications. For this use, it prevents over-cutting of the recording disc on heavy passages of music or speech and permits a marked improvement in the signal to noise ratio.

The 86-A1 Limiting Amplifier uses push-pull vacuum tubes (RCA 6K7) in the variable-gain stage. The design is such that a uniform frequency response and a remarkably low distortion is maintained with large compression ratios as much as 18 db. Moreover, low distortion is maintained at all modulating frequencies in the normal audio band.

There are no audible "thumps" even though a large compression is suddenly applied. Compression timing constants have been chosen which have proved most desirable in actual broadcast service. The fast pick-up time of one millisecond restricts over-modulation surges which might cause transmitter outages. The return time is slow enough to prevent distorting low frequency times, but fast enough to prevent noticeable level reduction after loud volume peaks.

The circuit of the 86-A1 is straight forward and push-pull stages are used throughout. The a-c power supply is self contained and utilizes one RCA 5T4 rectifier tube. New plug-in type electrolytic capacitors are used to simplify servicing the equipment. The hum and noise level is maintained to a low value through special transformer shielding. When used in conjunction with a two stage pre-amplifier, the 86-A1 has sufficient maximum gain (60 db) for making local announce-

Features

- Excellent frequency response—suitable for FM.
- High compression with low distortion.
- Low noise level.
- Prevents distortion and adjacent channel interference caused by overmodulation of transmitters.
- Provides for a more effective use of transmitter power by raising the average modulation percentage.
- Meter with rotary selector switch shows gain reduction, checks plate current of all tubes, and checks overall voltage supply.
- Economical in price.

Description

The push-pull output stage and efficient circuit design provide a maximum power output of 1 watt (+30 VU) with less than 0.75% total rms distortion measured at 400 cycles with a compression of 18 db. The distortion is less than 1.8% rms when measured at any frequency between 50 and 7500 cycles.

All the components are mounted on a single metal chassis. A meter is provided for (1) indicating gain reduction directly in db, (2) dynamic match indicator for input tubes, (3) measurement of all tube plate currents, and (4) measurement of plate voltage. A switch on the front of the chassis selects the desired meter function.

Step-by-step input and output volume controls are provided. These controls are equipped with "vu" scales to indicate input and output levels at the verge of compression. Auxiliary adjustable controls are (1) hum balance, (2) zero adjustment of gain reduction meter scale, (3) vernier control for close adjustment of level at which limiting action takes place, and (4) switch (on front) which makes limiter function inoperative. A power switch and fuse are provided. For rack mounting the Type 36-B Shelf should be used. A special umber-grey 36-B door panel with meter cut-out is supplied with the 86-A1 Amplifier.

Specifications

Input Source Impedance _____ 600 or 250 ohms
 Output Load Impedance _____ 600 or 250 ohms
 Frequency Response _____ ± 2 db 30-15,000 cycles
 (At any setting of gain controls—with or without compression)
Input Level
 Maximum (at limiting verge) _____ +10 VU
 Maximum (with 18 db gain reduction) _____ +30 VU
 Minimum (at limiting verge) _____ -30 VU
Output Level _____ +30 VU
 (Less than 1.8% rms distortion with 18 db compression at any frequency between 50 and 7500 cycles.)
Gain (with maximum volume control setting and signal below limiting level) _____ 60 db
Noise Level: below +30 vu output _____ -85 db
 below +10 vu output _____ -77 db
Power Output (with 18 db gain reduction and 0.75% total rms harmonic distortion at 400 cycles) _____ +30 VU
 (with no gain reduction and a 0.4% total rms harmonic distortion at 400 cycles) _____ +10 VU
Output Range (at verge of limiting) _____ +10 VU to +30 VU
Time Constants
 Seconds for complete action of gain reduction _____ 0.001
 Seconds for 90% recovery of gain after signal drops below limiting level (when connected as furnished) _____ 2.0
 Note: may be varied from .26 sec. to 5.2 sec. by changing one resistor.
Power Input (105-125 volts, 50-60 cycles) _____ 70 watts
Dimensions _____ Width 16", depth 13", height 7½"
Weight (unpacked) _____ 30 lbs.
Stock Identification: Umber grey _____ MI-11216-C
 Black _____ MI-11216-B
 Complete with one set of tubes and special 36-B door panel but less 36-B shelf.
Accessories
Tube Kit (complete tube complement) _____ MI-11286
 2 RCA-6K7, 1 RCA-6N7, 2 RCA-1621, 1 RCA-6R7,
 1 RCA-5T4
Tube Kit (set of two matched 6K7 tubes only) _____ MI-11250
Voltage Regulating Transformer _____ 60 cycles MI-11280
 _____ 50 cycles MI-11280-A
 (Not required unless line voltage variation exceeds 5%)
36-B Panel and Shelf Assembly: Umber grey _____ MI-4682-H
 Black _____ MI-4682-J

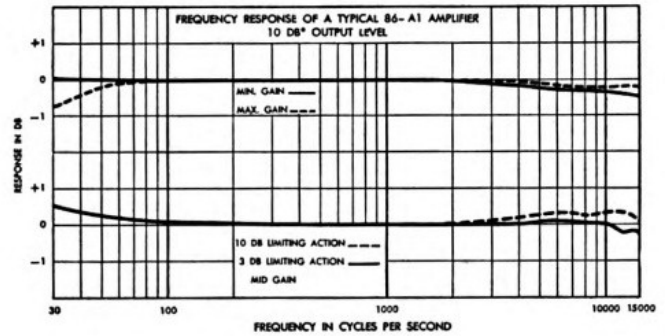
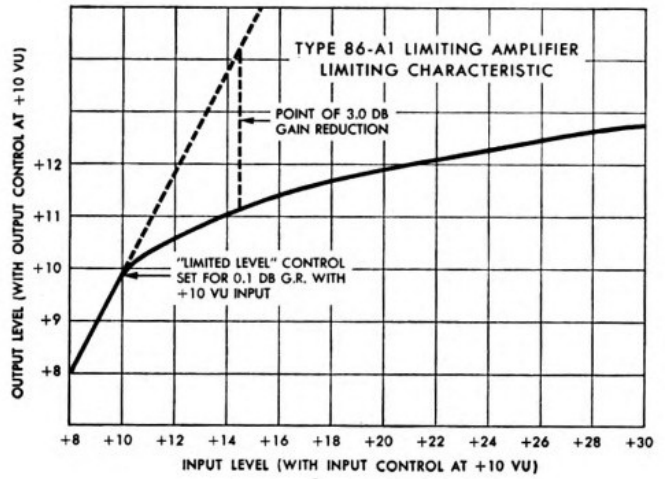

* Reference level one milliwatt.

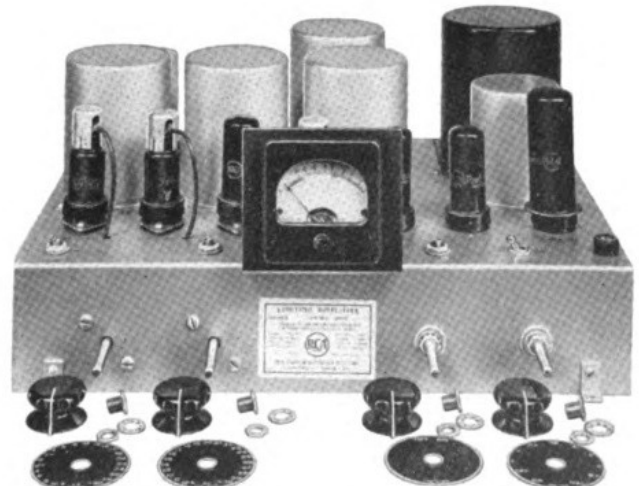
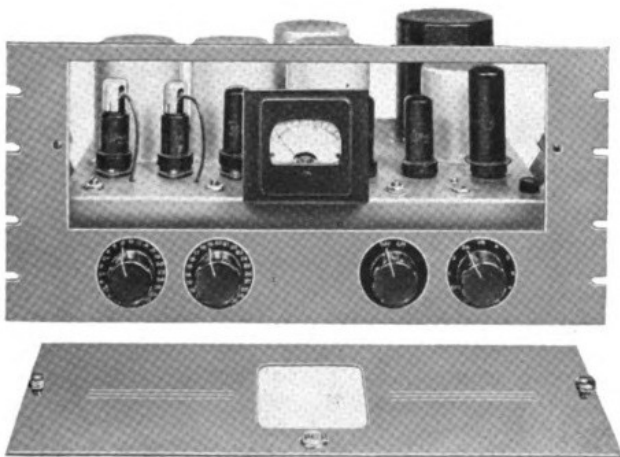

The 86-A1, as shipped, includes the Amplifier and small accessories as shown at right plus the special door panel shown in photograph at left

Program Amplifier Type BA-3A



Uses

The BA-3A is one of the most versatile high fidelity speech input amplifiers available. Its high gain and low distortion makes it an ideal studio or program amplifier to boost the output of preamplifiers or mixers to a level suitable for feeding broadcast telephone lines or radio transmitter inputs. It may be used as a bridging amplifier for isolation or other applications where a 22,000 ohm amplifier input is desirable. In addition to the above mentioned uses, the BA-3A may also be used as an emergency monitoring amplifier of approximately 2 watts output. This feature is made possible through conservative operation of the output tube and through the provision of suitable low impedance taps on the amplifier output transformer. The BA-3A features a plug-in type of base construction which allows quick and easy removal for servicing or interchanging units. It may be mounted in a console cabinet or in a 36-B Panel and Shelf Assembly which will accommodate two units.

Description

The BA-3A is a three stage amplifier employing one RCA-1620 pentode first stage, one RCA-1620 pentode second stage and one RCA-1622 beam power output tube. Excellent frequency response, high gain and low distortion have been provided in the design of this amplifier by use of resistance-capacitance interstage coupling and two feedback loops. Approximately 22 decibels of feedback is used in the driver and output stages and 15 decibels in the feedback loop around the first stage.

The gain of the BA-3A is 60 db for matching input, 22 db for 22,000 ohm bridging-input and 35 db for bridging-input with the remote volume control. When used as a bridging input, isolation will be considerably in excess of 100 db. The remote volume control is a potentiometer and resistance network which is used when the BA-3A input is to be bridged across a 600/250 ohm line. This control provides for a bridging input impedance of 10,000 ohms and may be placed on a console panel, or at any other point within two or three hundred feet of the amplifier.

A carbon potentiometer gain control is located in the grid circuit of the second stage. However, when required, a Daven Pad Type CP-350-T may be installed in place of the carbon control without additional panel drilling.

Where the normal flat frequency response is not desired by the user, a boost of the low, the high, or the low and high frequencies may be made by connecting additional resistors and capacitors. Up to 4 db (approx.) boost at 15,000 cycles

may be obtained by changing the value of one resistor and one capacitor. Up to 3 db (approx.) boost at 30 cycles may be obtained by changing two resistors and adding two capacitors. All external connections to the BA-3A are made through two ten prong Jones plugs which engage with two mating sockets supplied with the amplifier. Connections are provided from each cathode circuit to separate terminals on the Jones plug in the back of the amplifier. These connections permit metering of tube condition by means of a high resistance voltmeter such as the 15-D.

The amplifier is complete with built-in a-c power supply. The rectifier used is 1 RCA-5Y3GT/G. Plug-in capacitors are used to simplify servicing the equipment thus prevent loss of service from capacitor failures.

Features

- Variety of uses—program amplifier, line amplifier, bridging line or isolation amplifier, or emergency monitoring amplifier.
- Excellent frequency response—suitable for FM.
- High gain—low distortion—low noise level.
- Provision for connecting metering switch.
- Plug-in electrolytic capacitors.
- May be mounted in cabinet or in 36-B Panel and Shelf.
- Economical in price.

Specifications

Input Source Impedance (matching) _____ 600/250 ohms
 Bridging Input Impedance (balanced, center tap grounded)
 (a) 22,000 ohms with furnished resistors.
 (b) 10,000 ohms with remote volume control.

Maximum Input Level

- (a) Bridging (less than 0.5% rms distortion 30 to 15,000 cycles) _____ +15 db*
- (b) Matching (with less than 0.5% rms distortion 30 to 15,000 cycles) _____ -30 db*

NOTE: When the 20 db input pad provided is used, the input level may be correspondingly increased.

Output Load Impedance (tapped transformer)

600/150/15/7.5 and 5 ohms

Output Level

- Less than 0.5% rms distortion 30-15,000 cycles _____ +25 db*
- Less than 1% rms distortion 30-15,000 cycles _____ +30 db*
- Less than 1% rms distortion 50-15,000 cycles _____ +33 db*

Gain Maximum

- (a) Matching Input (600 ohm line to 600 ohm load) _____ 60 db
- (b) Bridging Input (600 ohm terminated line to 600 ohm load) _____ 22 db
- (c) Bridging Input (with remote volume control) 600 ohm terminated line to 600 ohm load _____ 35 db

Frequency Response _____ ±1 db 30 to 15,000 cycles

Noise Level (below rated output of +30 db*) _____ -86 db

A-c Power Input, 100 to 130 volts, 50/60 cycles _____ 55 watts

Dimensions, overall _____ Length 12"; width 8"; height 2 3/8"

Finish _____ Silver grey opalescent

Weight (unpacked) _____ 17 1/2 lbs.

Stock Identification _____ MI-11224-A

Accessories

Tube Kit (complete tube complement)
 2 RCA-1620, 1 RCA-1622, 1 RCA-5Y3GT/G _____ MI-11266

Emergency Tube Kit
 2 RCA-6J7, 1 RCA-6L6, 1 RCA-5Y3GT/G _____ MI-11266-A

36-B Panel and Shelf Assembly
 (Black MI-4682-J) U/G _____ MI-4682-H

Type 15-D Meter Panel (Black MI-4388) U/G _____ MI-4388-A

* Reference level one milliwatt.

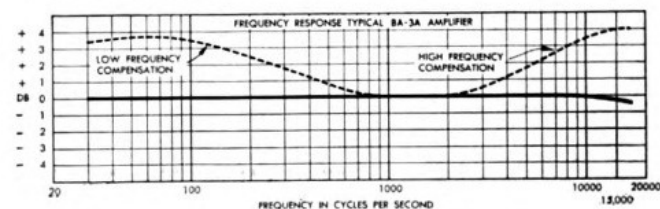

Monitoring Amplifier - Type 82-C1

Uses

The 82-C1 is a high fidelity, high gain flexible 12 watt amplifier suitable for monitoring, audition, recording, and talk back applications or it may be used in emergencies as a program or line amplifier. It is ideal for transcription playback booths since its 105 db gain is sufficient to operate a 64-B Speaker directly from the output of a 70-C1 Turntable. The high gain feature also allows its use directly in studio talk back circuits without an intervening preamplifier. The 82-C1 is an excellent recording amplifier being suitable for both high quality recording and playback applications. It may be mounted in a cabinet such as the 64-B Speaker Base Cabinet or may be mounted in a 36-B Panel and Shelf Assembly for rack mounting.

Description

Employing metal tubes in the audio circuits, this amplifier has four stages consisting of: (1) RCA-1620 single stage, (2) RCA-1620 single stage, (3) single stage with RCA-1620 phase inverter, and (4) 2 RCA-1622's in push-pull. Feedback is used around the phase inverter and output tubes to reduce noise and distortion. Gain adjustment is provided through the use of an interstage control in the grid circuit of the second RCA-1620 tube and through an additional remote volume control. The remote volume control is a potentiometer and resistance network which is used when the 82-C1 input is to be bridged across a 600/250 ohm line. This control provides for a bridging input impedance of 10,000 ohms and may be placed on the side of the 64-B Cabinet, on a console panel, or at any other point within two or three hundred feet of the amplifier. Where the normal flat frequency response is not desired by the customer, a boost of the low and high frequencies may be made by connecting additional resistors and capacitors which are supplied with the amplifier. A +5.0 db boost at 60 cycles is accomplished by adding a resistance capacity network into the plate circuit of the second stage. A +6.0 db boost at 15,000 cycles is accomplished by adding a resistance capacity network into the cathode circuit of the third stage.

The amplifier is complete with a heavy-duty built-in power supply. The hum level has been kept to a low value through the use of a multiple-case shielded input transformer. Plug-in electrolytic capacitors are used to simplify servicing the equipment and thus prevent loss of service from capacitor failures.

The amplifier is designed to supply a nominal low-distortion output of 12 watts.

Features

- Excellent frequency response to 15,000 cycles.
- 12 watts output with low distortion—uses feedback.
- Suitable for emergency use as program amplifier.
- Ideal for recording and playback applications.
- Sufficient gain for direct operation of 64-B Speaker from 70-C1 turntable output.
- High gain—Used directly in talk back circuits, without preamplifier.
- Heavy-duty components. Will operate continuous duty with ambients up to 120° F.
- Plug-in electrolytic capacitors.
- Suitable for cabinet or panel mounting.
- Compensator Kit supplied for boosting response at 60 and 15,000 cycles.
- Economical in price.

Specifications

Input Source Impedance (unloaded transformer input)	250/30 ohms
Input Bridging Impedance (when used with remote volume control)	10,000 ohms
Output Load Impedance	600/250/15/7.5/5 ohms
Audio Power Output (rated output with less than 3% total rms distortion 50-7500 cycles)	12 watts +40.8 db*
Maximum Gain	
Overall from 250 ohm source to a 15 ohm load	105 ±2 db
With bridging volume control 600 ohm terminated line to 15 ohm load	70 db
Frequency Response (see curve) 250 ohm source to 15 ohm load	±2 db
Noise Level (for +40.8 db output, maximum gain)	-59 db
A-c Power Input (105-125 volts, 50-60 cycles)	110 watts

Dimensions, overall

Width	16"
Depth	11"
Height	8"
Weight (unpacked)	26 lbs.
Mounting	may be mounted in cabinet or in 36-B Panel and Shelf Assembly
Stock Identification	MI-11209-B

Accessories

36-B Panel and Shelf Assembly (required for rack mounting)	MI-4682-H
Tube Kit (complete tube complement)	
4 RCA-1620, 2 RCA-1622, 1 RCA-5U4G	MI-11282
Emergency Tube Kit (complete tube complement)	
4 RCA-6J7, 2 RCA-6L6, 1 RCA-5U4G	MI-11282-A

Note: 6J7's may be substituted for RCA-1620's and 6L6's for RCA-1622's when maximum uniformity of characteristics and minimum of microphonics, hum and distortion are not required.

* Reference level one milliwatt.

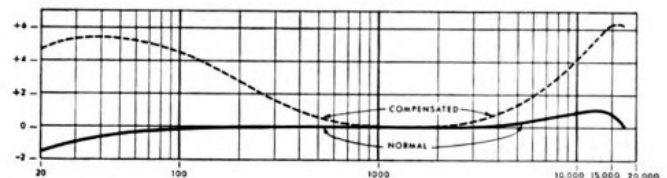

Frequency in Cycles per Second



Remote Pickup Equipment OP-6/OP-7

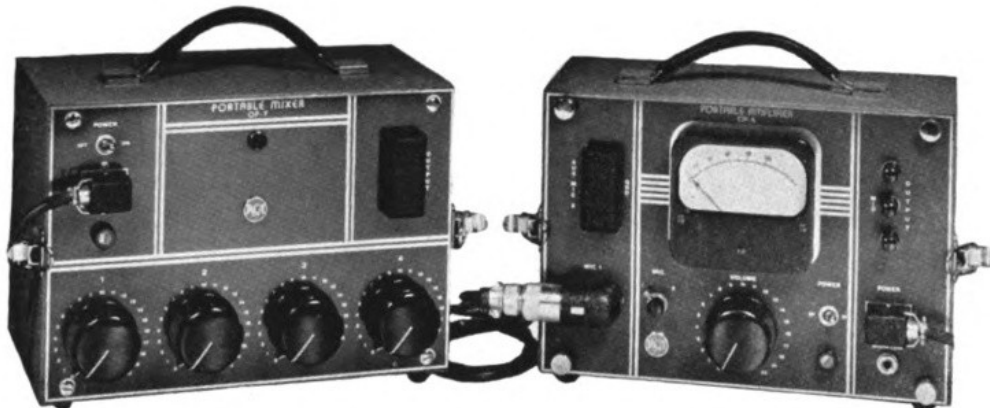

Uses

The OP-6/OP-7 is a high quality, light weight portable pickup equipment providing four microphone inputs with high level mixing and separate preamplifiers, built in a-c power supply and full sized vu meter. Small sized cases furnished with shoulder straps provide a maximum of convenience in carrying these units. Battery operation may be used at any time by plugging in the cord of the MI-11214 Battery Box. No circuit changes are required. The mixer and amplifier units may be used side by side or the amplifier may be mounted on top of the mixer. An outstanding value at an economical price, the OP-6/OP-7 combination provides the broadcaster with a field pickup equipment having studio quality performance.

Description

The OP-7 Mixer Preamplifier comprises four unloaded transformer input circuits each working into an RCA-1620 triode connected tube. Its input source impedance is for 30 or 250 ohm microphones and the output impedance is 250 ohms. While primarily designed for use with the OP-6 Amplifier, the OP-7 may be operated with any amplifier having a 250 ohm input and a gain of 80 db or more. A more complete de-

scription as well as features and specifications will be found on the OP-7 Mixer Preamplifier catalogue sheet.

The OP-6, companion unit to the OP-7, is a high quality, high gain, three stage resistance coupled amplifier using three RCA 1620 Pentode-Connected tubes. A more complete description as well as features and specifications will be found on the catalogue sheet for the OP-6 Amplifier.

Stock Identification _____ MI-11202-A/11213

Complete as shown in photograph but less tubes, vu meter and microphone plug. Complete listing for accessories will be found under the catalogue listing for the individual OP-6/OP-7 units.

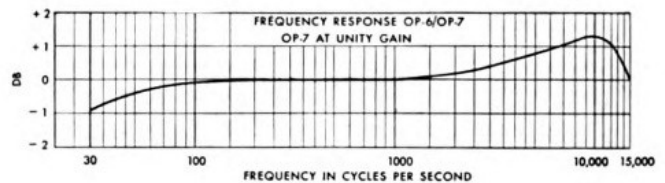

Battery Box MI-11214

The MI-11214 Battery Box has been designed especially for use with the OP-6 and OP-7 Remote Amplifiers. It is equipped with two interconnection cords so that it can be used with both amplifiers simultaneously if desired. The box is constructed of steel with durable grey wrinkle finish and is equipped with a large steel reinforced handle and rubber feet. The cables are stored in the cover when not in use.

Approximate Battery Life in hours for average amplifier operation six hours per day.

Burgess Type No.	Type OP-6 3 RCA 1620	Type OP-6 1 RCA 1620 2 RCA 6W7G	Type OP-7	Type OP-6 and Type OP-7
15 #4F "A"	34	50	26	7.5
*10 #4F "A"	16	24	12	3.5
* 6 #B-30 "B"	270	270	240	95

* RCA Kit. Stock Identification MI-11255.

Specifications

Finish (matches OP-6/OP-7) _____ Grey wrinkle

Dimensions

Height _____ 12½"

Width _____ 13½"

Depth _____ 8¾"

Weight (unpacked) _____ 15½ lbs.

Weight (including batteries) _____ 44 lbs.

Stock Identification _____ MI-11214

Accessory

Weather proof cover, MI-11258



Remote Pickup Amplifier Type OP-6

Description

The OP-6 is a three stage resistance coupled amplifier using RCA 1620 low noise, non microphonic tubes. The three stages afford a gain of 90 db which is more than ample for any required application. One RCA 6X5GT/G is used in the rectifier. Since only two tube types are used, the stocking of spares is simplified. The amplifier circuit is unique in that it utilizes two feedback loops. One loop is around the first stage and is varied with the main gain control thus maintaining a maximum feedback consistent with required gain. This arrangement prevents overloading the first tube by high output microphones. The gain control is located between the first and second stage and is a high quality step by step device equipped with a large knob. The second feedback loop is fixed and is connected around the second and third stages. Two inputs are provided and either may be selected by means of a turn key switch. One input is brought to shielded screw terminals and the other to a standard Cannon microphone receptacle. The output terminates on insulated binding posts which are located on the front panel for greater accessibility. The power input receptacle has a number of contacts which are used for altering the circuit for a-c or battery operation. An a-c power cord is furnished with the amplifier and the d-c battery cord is supplied with the MI-11214 Battery Box. Located on the front panel are the power switch, fuse and monitoring headset jack.

The complete amplifier and power supply is enclosed in a steel case which has removable cover, rubber feet, and steel reinforced handle. The handle lies flat when not in use. A leather shoulder strap facilitates transporting the unit and leaves the hands free to carry microphones, etc. The chassis and front panel may be easily slipped from the case by removing four thumb-screws. The unit is furnished less meter, thereby avoiding additional expense for those applications where a meter is unnecessary.

Features

- Excellent frequency response.
- High maximum output level with low distortion.
- Low noise and hum level.
- High overall gain permits use with high quality microphones under adverse conditions.
- Small size and light weight.
- A-c power supply built in. No external supply required.
- Two input positions and transfer key.
- Tapped input transformer accommodates any type of microphone.
- Ruggedly built with high quality components.
- Economically priced.

Specifications

Input Source Impedance	30/250 ohms
Output Load Impedance	150/600 ohms
Normal Output Level	+8 db*
Distortion (+8 db* output, 50-7500 cycles)	Less than 0.5% rms
Maximum Output Level (less than 1% rms distortion between 50 and 7500 cycles)	+19 db*
Frequency Response	±2 db 30 to 15,000 cycles ±1 db 40 to 10,000 cycles
Noise Level (+8 db* output, 70 db gain)	-65 db*
Dimensions, overall	
Height	9 1/2"
Width	12 3/8"
Depth	7 1/4"
Finish	Grey wrinkle
Weight (unpacked but including 8' power cord)	20 1/2 lbs.
A-c Power Input, 105-125 volts, 50 to 60 cycles	18 watts
Stock Identification (shipped less tubes)	MI-11202-A

* Reference level one milliwatt.

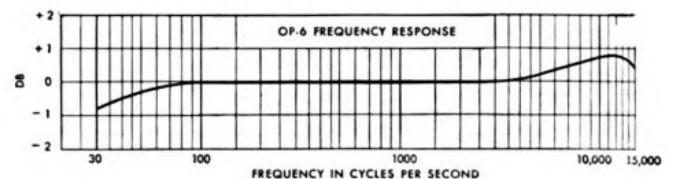

Accessories

Tube Kit (complete tube complement)	
Three RCA 1620 and one RCA 6X5GT/G	MI-11253
Emergency Tube Kit (complete tube complement)	
Three RCA 6J7 and one RCA 6X5GT/G	MI-11253-A
VU Meter and Attenuator Kit	MI-11251
Weatherproof Fabric Cover	MI-11256
Battery Box	MI-11214
Kit of Batteries	MI-11255
Cannon Microphone Plug	MI-4630-B
OP-7 Four Channel Mixer	MI-11213

Mixer Preamplifier Type OP-7

Description

The OP-7 is a high fidelity, compact and lightweight portable unit. It provides unloaded transformer input and high level mixing for as many as four microphones. It may be used with the OP-6 Portable Amplifier or with any other program amplifier which has a gain of at least 80 db.

The front panel contains the power receptacle, "on-off" power switch, a-c fuse, four mixer knobs and shielded output terminals. A front panel cover held by two snap type clasps protects the equipment and provides space for carrying cables. Four Cannon Type "P" Microphone Receptacles are assembled on the rear of the amplifier chassis. A fifth receptacle, with male contacts, provides a cable output connection.

The OP-7 comes equipped with long life carbon type mixing controls, however space is provided so that step type attenuators may be installed by the user if desired. The OP-7 is complete with built-in power supply or it may be operated from the MI-11214 Battery Box without circuit changes. A suitable OP-6 interconnection cable, equipped with Cannon plugs, is furnished with the OP-7.

Features

- Excellent frequency response to 15,000 cycles.
- High level mixing reduces noise to a minimum.
- Provides unloaded transformer input and high level mixing for one to four microphones.
- Completely self contained with a-c power supply or may be battery operated.
- May be used with any program amplifier having a gain of 80 db.
- Small size and light weight.
- Economical in price.

Specifications

Input Source Impedance	30/250 ohms
Output Load Impedance	30/250 ohms
Normal Output Level	-55 db*
Distortion (-55 db* output, 50-7500 cycles)	less than 0.5% rms
Maximum Output Level (less than 1% rms distortion measured at any frequency between 50 and 7500 cycles)	-24 db*
Gain (maximum, 250 ohm source to 250 ohm load)	8 db
Frequency Response	± 2 db 30 to 15,000 cycles ± 1 db 40 to 10,000 cycles
Noise Level (8 db gain, -24 db* output)	-87 db
Dimensions	
Height	9 1/2"
Width	12 3/4"
Depth	9"
Finish	Grey wrinkle
Weight (unpacked but with cables)	23 lbs.
A-c Power Input, 105-125 volts, 50 to 60 cycles	20 watts
Stock Identification	MI-11213

Accessories

Tube Kit (complete tube complement)	
4 RCA 1620, 1 RCA 6X5GT/G	MI-11254
Emergency Tube Kit (complete complement)	
4 RCA 6J7, 1 RCA 6X5GT/G	MI-11254-A
Weatherproof Fabric Cover*	MI-11257
Battery Box	MI-11214
Kit of Batteries	MI-11255
Cannon Microphone Plugs	MI-4630-B
OP-6 Amplifier	MI-11202-A

* Reference level one milliwatt.

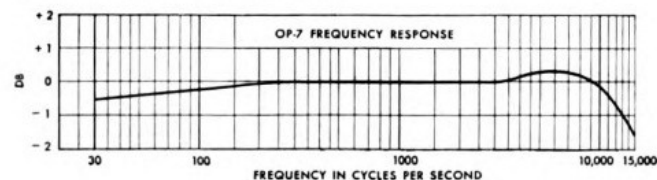

OP-7 with front panel cover removed. Covers of OP-7 and OP-6 provide space for carrying interconnecting cables.

MI-11257 Fabric Cover for OP-7. Similar covers, listed as accessories, are available for OP-6 and for the MI-11214 Battery Box.

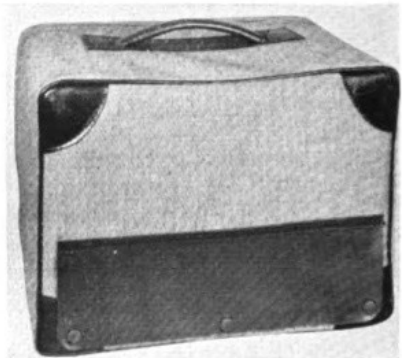

OP-7 chassis, rear view. Four microphone receptacles and output receptacle are provided.



RACKS AND PANELS

SECTION

D

CABINET RACKS

BLANK PANELS

WALL CABINETS

PANEL AND SHELVES

METER PANELS

SWITCH AND FUSE PANELS

JACK PANELS

PATCH CORDS

VU METERS

SOUND EFFECTS FILTERS

EQUALIZERS

Cabinet Rack Type 9-AX

Uses

The Type 9-AX is a heavy-duty Speech Input Cabinet Rack which is widely used in control room and transmitter installations. It provides 77" of panel space for mounting amplifiers, jack panels, switch panels, oscillators, measuring equipment or other panel-mounted equipment of standard 19" width. The 9-AX completely shields and protects all the equipment on the rack, while at the same time, largely dispensing with individual shield covers.

Description

This rack is of sheet metal construction with an open front and a hinged ventilated door on the rear. A metal plate placed approximately one inch below a rectangular opening in the cabinet top provides complete ventilation, but protects equipment from falling articles and dust. The plate may be removed completely, if desired. The rack is drilled and tapped, as shown on the Dimension Drawing, for standard 19" panels and has an overall height of 6' 10⁷/₈". It is shipped with supporting rods to insure accurate alignment.

Accessories for the Type 9-AX Rack include "J" Strips, "U" Strips, Terminal Block Mounting Brackets, A-C Terminal Blocks, Audio Terminal Blocks and Cable Supports. "J" Strips are used with the 9-AX Cabinet Racks to give them a finished appearance when the equipment is assembled on the racks. These strips, which mount along the side of the cabinet and cover the panel slots and mounting screws, are easily installed by means of clips and screws which are supplied with the strips. "U" Strips are used to dress up an assembly of cabinet racks when they are mounted side by side. Angle strips 8" long are mounted inside cabinet (see dimension drawing) as a support for the terminal block mounting bracket.

The bracket will accommodate as many as three W.E. 100-B (RCA Stock Identification, MI-4569) Audio Terminal Blocks and two General Electric 16EB1B3 (RCA Stock Identification, MI-4568) A-C Terminal Strips. The cable supports provide a convenient means for holding the cabling in place. They are mounted by means of the same screws which hold the front panels.

Included with each 9-AX Cabinet Rack is a quantity of 90 12-24 x 1/2" round head machine screws for mounting the panels.

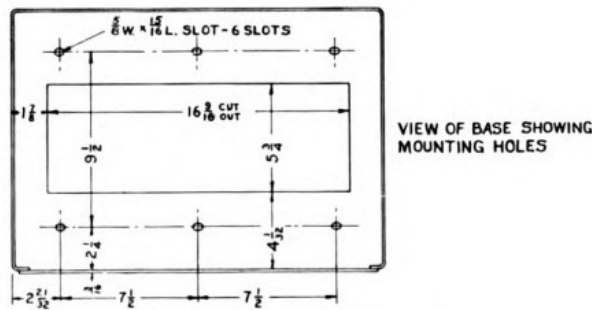
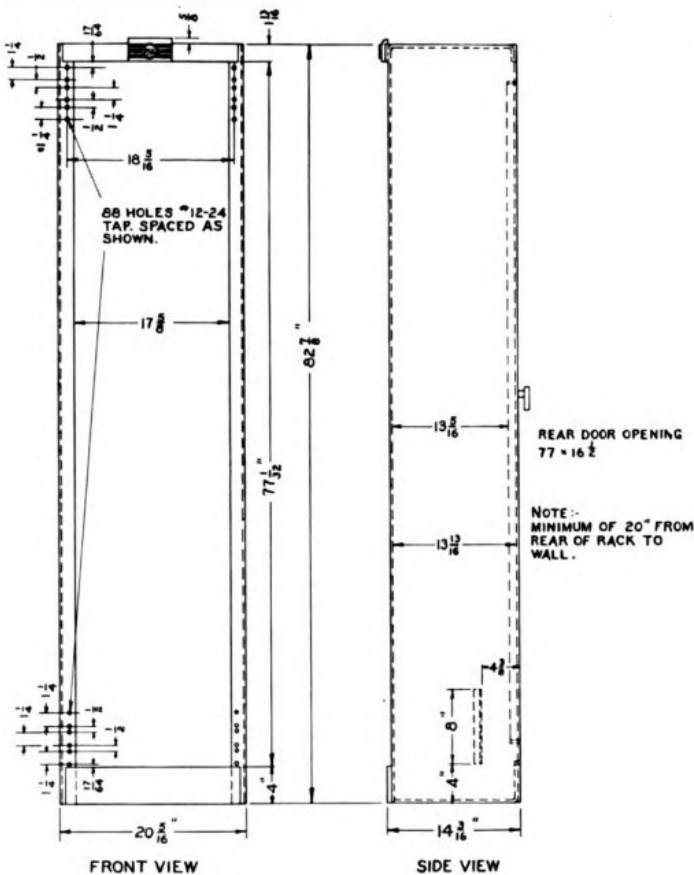

OUTLINE DIMENSIONS OF 9AX CABINET RACK

Outline Dimensions of 9-AX Cabinet Rack

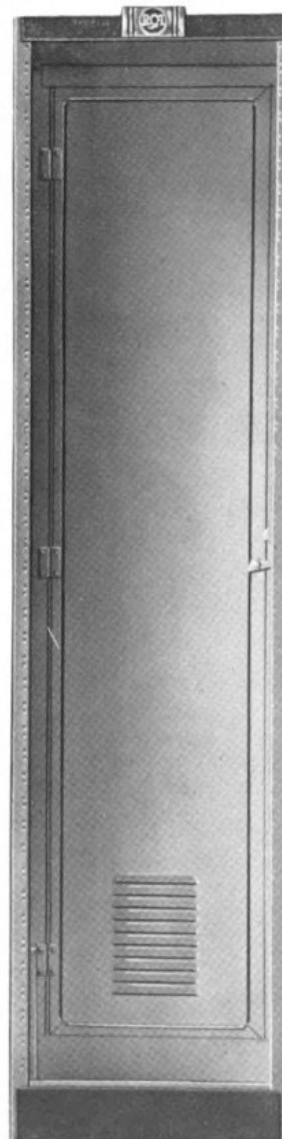

Front View Type 9-AX Cabinet Rack

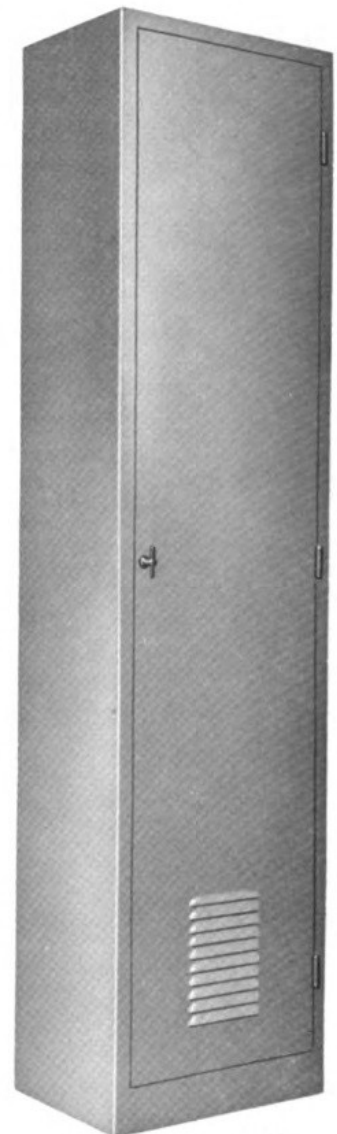

Rear View Type 9-AX Cabinet Rack

Cabinet Rack Type 9-AX

Specifications

Dimensions, overall	
Height	82 $\frac{7}{8}$ "
Width	20 $\frac{5}{16}$ "
Depth	14 $\frac{3}{16}$ "
Panel Size	19"
Mounting Space	77"
Weight (unpacked)	190 lbs.
Stock Identification	
Black	MI-4519-C
Light Umber Grey	MI-4519-E

Accessories

"J" Strip	
Black	MI-4537-A
Dark Umber Grey	MI-4537-D
"U" Strip	
Black	MI-4524-A
Dark Umber Grey	MI-4524-D
Terminal Block Mounting Bracket	MI-4570
W.E. 100-B, 80 Terminal (4 rows of 20 each) Block	MI-4569
G.E. A-C Terminal Strip (12 terminals)	MI-4568
Cable Support	MI-4571

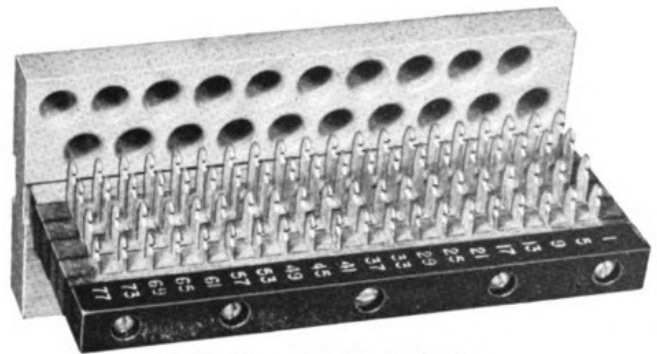

Audio Terminal Block MI-4569

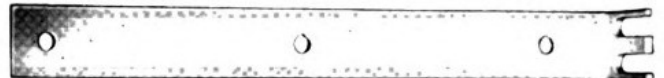

Cable Support MI-4571

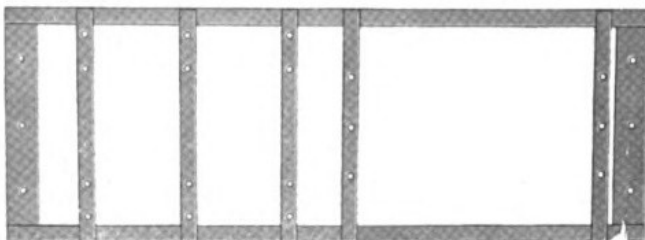

Terminal Block Mounting Bracket MI-4570

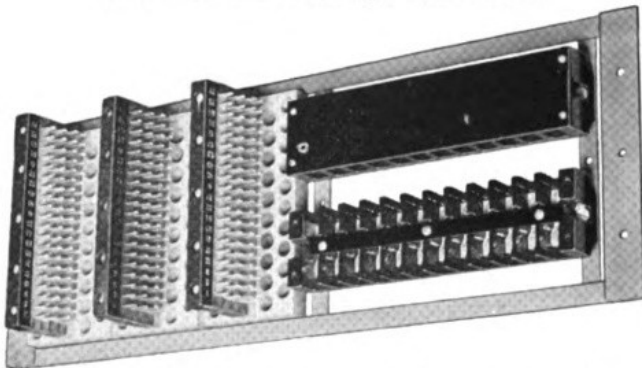

Terminal Block Mounting Bracket with Terminal Blocks in Position

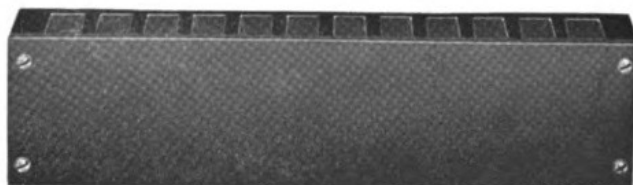
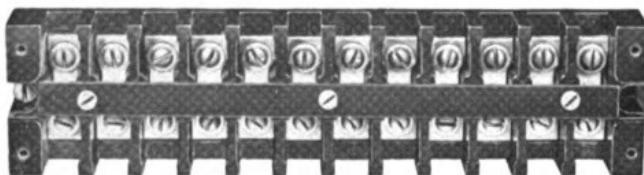

Power Terminal Block MI-4568

Blank Panels

A complete line of 19" blank panels are carried in stock for filling spaces on racks not occupied by equipment panels. These blanks are also suitable for applications where equalizers, transformers, switches or other items must be panel mounted by the user. The stock of panels includes all standard widths from 1 $\frac{3}{4}$ " to 13 $\frac{31}{32}$ ". They are $\frac{3}{16}$ " sheet steel and are finished and drilled to match the standard equipment panels.

The 33-A and 33-B Jack Panel heights are not standard multiples of 1 $\frac{3}{4}$ ". Therefore when these jack panels are mounted in a Type 9-AX Rack it is often necessary to use either a 2 $\frac{1}{8}$ " or 2 $\frac{3}{8}$ " blank panel so that the summation of all panel heights will equal 77".

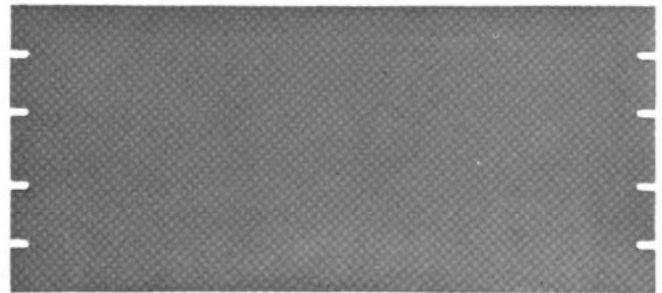

Panel Width

1 $\frac{23}{32}$ "	Blank Panel, Black	MI-4590
	Umber Grey	MI-4590-A
2 $\frac{1}{8}$ "	Black	MI-4598
	Umber Grey	MI-4598-A
2 $\frac{3}{8}$ "	Black	MI-4599
	Umber Grey	MI-4599-A
3 $\frac{3}{32}$ "	Black	MI-4589
	Umber Grey	MI-4589-A
3 $\frac{15}{32}$ "	Black	MI-4591
	Umber Grey	MI-4591-B
5 $\frac{7}{32}$ "	Black	MI-4592
	Umber Grey	MI-4592-B
6 $\frac{31}{32}$ "	Black	MI-4593
	Umber Grey	MI-4593-A
8 $\frac{23}{32}$ "	Black	MI-4594
	Umber Grey	MI-4594-B
10 $\frac{15}{32}$ "	Black	MI-4595
	Umber Grey	MI-4595-B
12 $\frac{7}{32}$ "	Black	MI-4596
	Umber Grey	MI-4596-A
13 $\frac{31}{32}$ "	Black	MI-4597
	Umber Grey	MI-4597-A

Wall Mounting Cabinet MI-11500

Uses

The MI-11500 Cabinet has been designed especially to mount a combination of line equalizers (Type 56-B, 56-D or 56-E) and jack panels (Type 33-A or 33-B). It will be found particularly useful for terminating remote lines in installations using the 76-B2 Console. Sample combinations for this cabinet are given below:

1. 1—56-E Equalizer and 4—33-A Jack Strips.
2. 1—56-E Equalizer, 3—33-A Jack Strips, 1—MI-4590 (1 $\frac{3}{4}$ " blank panel and 1—MI-11503 (7") Jack Mat.
3. 1—56-E Equalizer, 2—33-A Jack Strips, 1—MI-4591 (3 $\frac{1}{2}$ " blank panel and 1 MI-11502 (5 $\frac{1}{4}$ " Jack Mat.
4. 1—56-E Equalizer, 1—33-A Jack Strips, 2—MI-4598 (2 $\frac{1}{8}$ " blank panels and 1—MI-4599 (2 $\frac{3}{8}$ " blank panel.
5. 1—56-E Equalizer, 1—33-A Jack Strip, 1—MI-11501 (3 $\frac{1}{2}$ " Jack Mat and 1—MI-4592 (5 $\frac{1}{4}$ " blank panel.
6. 2—56-E Equalizers, 2—33-A Jack Strips and 1—MI-11502 (5 $\frac{1}{4}$ " Jack Mat.
7. 1—56-D Equalizer, 1—33-A Jack Strip and 1—MI-11501 (3 $\frac{1}{2}$ " Jack Mat.
8. 1—56B Equalizer, 3—33-A Jack Strip and 1—MI-11503 (7") Jack Mat.

Description

The cabinet is constructed of steel and is equipped with a hinged door on which the panels may be mounted. Drilling and tapping has been provided for standard 19" panels which are attached by means of the machine screws supplied. A left-hand and a right-hand "J" strip are furnished to cover the mounting screws. Five knockouts are provided in the bottom of the cabinet, and five in the top, for conduit connections. Five terminal blocks may be mounted inside the cabinet on the brackets provided. Mats are available for improving the appearance of the jack strips.

Features

- Provides mounting space for equalizer and jack panels.
- May be mounted at any convenient wall location.
- Sturdy steel construction.
- Hinged door permits easy access for servicing.
- Drilled and tapped for standard 19" panels.
- Attractive appearance.

Specifications

Dimensions Overall _____ 21" wide, 19 $\frac{1}{4}$ " high, 10 $\frac{3}{8}$ " deep
 Weight (unpacked, less panels) _____ 36 lbs.
 Finish _____ Dark Umber-Grey
 Panel Mounting Space _____ 19" wide, 12 $\frac{1}{4}$ " high
 Terminal Mounting Space _____ Maximum-five Standard W.E.
 Cat. No. 100-B, 80 terminal (4 rows of 20 each)
 blocks which are 2 $\frac{1}{8}$ " wide by 6 $\frac{1}{16}$ " long
 Stock Identification _____ MI-11500

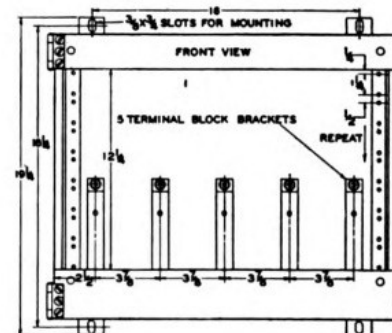
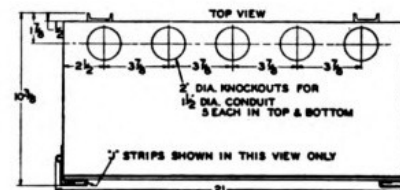
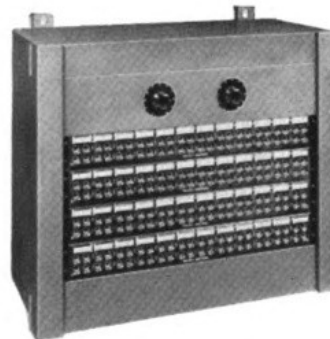
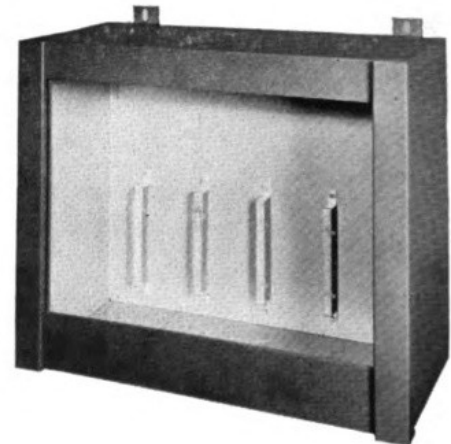

Panel and Shelf Assembly Type 36-B

Uses

The 36-B Panel and Shelf Assembly has been designed to provide a high quality, low cost unit of neat appearance for mounting amplifiers or other equipment of the chassis type construction on standard 19" racks and cabinets. Some of the units which may be mounted on one 36-B are:

- 6—BA-1A Preamplifiers
- 6—85-X Isolation Amplifiers
- 2—BA-3A Program Amplifiers
- 1—82-C1 Monitoring Amplifier
- 1—86-A1 Limiting Amplifier
- 2—BA-2A Booster Amplifiers
- 2—BX-1A Power Supplies

Description

The Panel and Shelf Assembly consists of a standard size 19" x 8 $\frac{3}{4}$ " panel and a 16 $\frac{3}{4}$ " x 13" horizontal shelf which is securely fastened to the rear of the panel. The panel and shelf is provided with a removable door in the panel through which the tubes of the units mounted within are available for inspection and servicing. It maintains a vertical mounting for all the tubes thereby insuring quieter operation and longer life. Four holes are provided in the panel for volume controls and meter switches. One metering switch is supplied with each panel and is used to read plate currents of various tubes. Mounting holes are provided in the horizontal shelf for the amplifier chassis.

Features

- Provides a high quality panel mounting for chassis type units.
- Removable door allows quick access to tubes for servicing.
- Maintains a vertical mounting for tubes insuring longer tube life.
- Metering switch supplied for providing plate current indication.
- Neat appearance.
- Low cost.

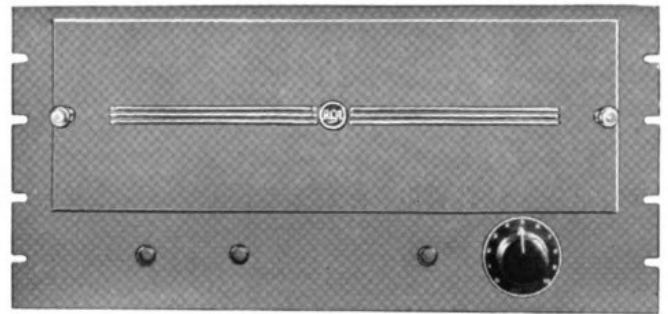

Type 36-B Panel and Shelf Assembly (Front View)

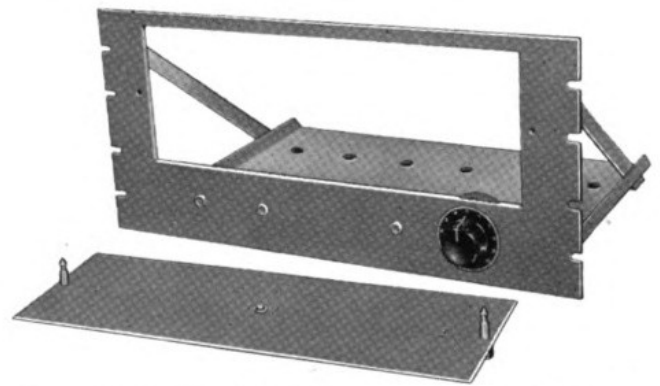

Type 36-B Panel and Shelf Assembly with Door Removed

Specifications

Dimensions, overall

Width _____ 19"
Height _____ 8 $\frac{3}{4}$ "
Depth _____ 13"

Weight (unpacked) _____ 14 $\frac{1}{2}$ lbs.

Finish _____ Black or Umber Grey

Stock Identification—Umber Grey _____ MI-4682-H

Black _____ MI-4682-J

Meter Panel Type 15-D



Uses

The 15-D Meter Panel provides a convenient means for checking the cathode bias voltages of amplifier tubes and thereby furnishes an indication of the operating conditions of amplifier tubes and circuits. Metering terminals are provided on the 84-C, 85-C, 85-X, 86-A1 and 87-A1 Amplifiers for use with this panel. The mounting is for a standard 19" cabinet rack.

Description

The 15-D consists essentially of a meter and switch mounted on a standard 3 15/32", 3/16" thick steel panel. The meter is a 7.5 volt dc voltmeter having a resistance of 20,000 ohms per volt. The double section switch has eleven positions including the "off" position and the switch arms are connected to the meter terminals. All connections to the panel are made to the switch contacts.

Features

- Provides meter and switch for measuring cathode voltage of amplifier tubes.
- Gives plate current indication of operating condition of tubes and circuits.
- Up to 10 circuits may be metered by rotary selector switch.
- Designed for cabinet rack mounting.

Specifications

D-c Voltmeter	0-7.5 volts, 20,000 ohm per volt
Metering Switch	10 position and "off," double pole
Dimensions (overall)	
Height	3 15/32"
Width	19"
Depth	2 1/4"
Weight (unpacked)	4 1/2 lbs.
Stock Identification	
Light Umber Grey	MI-4388-A
Black	MI-4388

Switch and Fuse Panel Type 57-C

Uses

The Type 57-C Switch and Fuse Panel is designed for use as a master input control of the a-c power supply. Ordinarily one such panel is used with each rack or channel of speech input units. The mounting is for a standard 19" relay cabinet rack.

Description

On this panel are mounted and wired an indicator lamp with red cap, two single fuse blocks of the screw-plug type and a double-pole single-throw power switch. In addition there is a subpanel which is drilled to provide a mounting for six of the standard MI-11606 Filament Transformers (two RT-262 isolation and two filament, or one isolation and four filament) used with the various amplifier units. This panel is ordinarily located near the bottom of the rack to keep the transformers well away from low-level amplifier circuits. A removable door permits front panel access to fuses and pilot lamp.

Features

- Provides master switch and fuses for rack-mounted equipment.
- Subpanel drilled and tapped for mounting 6 MI-11606 Filament Transformers.
- Pilot lamp shows when equipment is on.
- Removable door permits front panel access to fuses and pilot lamp.

Specifications

Switch	D.P.S.T., 250 volts, 30 amperes
Fuses	Screw-plug type (rating depends upon equipment to be protected)
Dimensions, overall (panel thickness 3/8")	
Height	5 7/32"
Width	19"
Depth	3 1/2"
Weight (unpacked)	8 1/2 lbs.
Stock Identification	
Black	MI-4395-A
Light Umber Grey	MI-4395-B



Front View

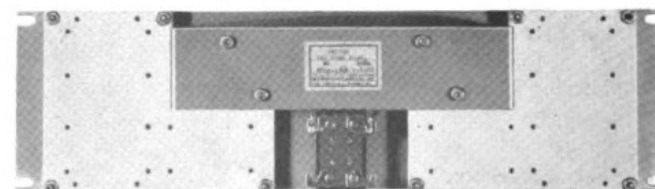

Rear View

Jack Panels Types 33-A and 33-B

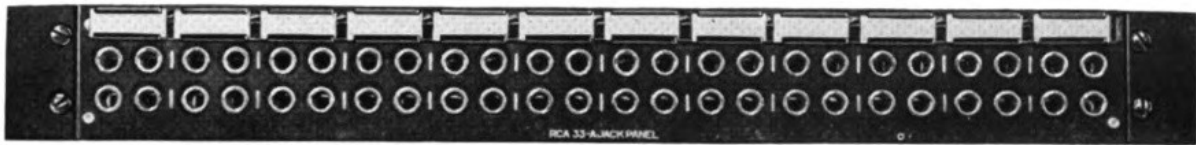

33-A Jack Panel

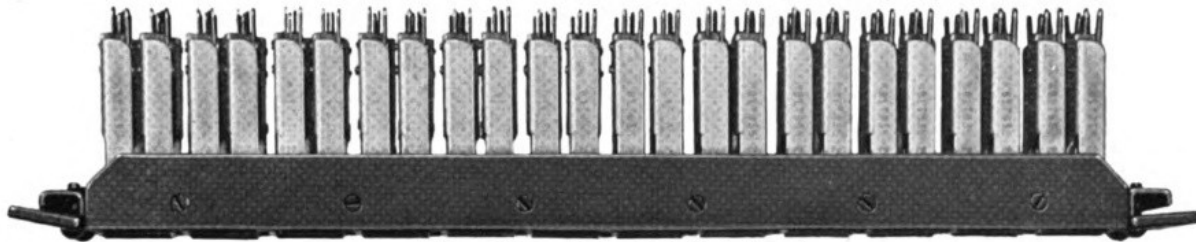

A Rear View of the 33-A Jack Panel

Jack Panels, with their associated patch cords, are used with broadcast speech input systems to improve the overall operating flexibility. In addition to providing a convenient termination for program and order wire telephone circuits, closed-circuit jacks may be connected to provide "patch cord" access to the input and output circuits of individual units of the speech assembly. When connected for this purpose, the regular circuits are continuous through the jacks until a patch cord is inserted to make an external connection. With properly connected jacks, patch cords may be freely used in emergencies or for test purposes to interchange or transfer telephone lines, amplifiers, mixers, microphones, or other equipment items.

The 33-A consists of two rows of twelve double jacks mounted on thick black bakelite and furnished with designation card holders. The 33-B is similar to the 33-A but has only one row of twelve double jacks. The jack sleeves are chromium plated.

Specifications

Number of Jack Pairs		
33-A	_____	24
33-B	_____	12
Type of Jacks	Double jacks of standard closed circuit type	
Dimensions		
33-A	2 1/8" x 19"	33-B 1 1/4" x 19"
Weight (unpacked)		
33-A	5 1/2 lbs.	33-B 3 lbs.
Stock Identification		
33-A (Yaxley Jacks)	_____	MI-4645
33-AW (W. E. Jacks)	_____	MI-4536-A
33-B (Yaxley Jacks)	_____	MI-4646
33-BW (W. E. Jacks)	_____	MI-4534-A



33-B Jack Panel

Jack Mats

Jack Mats are available for covering 1, 2, 3, or 4 type 33-A Double Jack Strips. When ordering specify finish desired.

Specifications

Single 33-A Jack Strip Mat, overall size	_____	19" x 3 15/32"
U/G	_____	MI-11501-A
Black	_____	MI-11501-B
Double 33-A Jack Strip Mat, overall size	_____	19" x 5 7/32"
U/G	_____	MI-11502-A
Black	_____	MI-11502-B
Triple 33-A Jack Strip Mat, overall size	_____	19" x 6 31/32"
U/G	_____	MI-11503
Black	_____	MI-11503-A
Quadruple 33-A Jack Strip Mat, overall size	_____	19" x 8 23/32"
U/G	_____	MI-11504
Black	_____	MI-11504-A

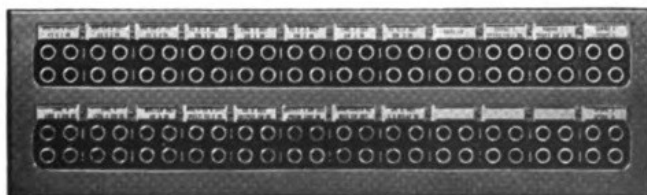

Patch Cords

RCA maintains a stock of patch cords for the convenience of broadcasting stations. The W.E. Cord is the standard telephone type using two W.E. 241-A Double Plugs. The Audio Development Co. Cord is shielded and uses two of their Type PJ-1 Plugs which are interchangeable with the W.E. Type 241-A Plug. Three sizes of patch cords are available as listed below:

	<i>Western Electric Co.</i>	<i>Audio Development Co.</i>
Two Foot Cord Length	MI-4652-2A	MI-4652-2B
Four Foot Cord Length	MI-4652-4A	MI-4652-4B
Six Foot Cord Length	MI-4652-6A	MI-4652-6B



Western Electric Telephone
Type Patch Cord



Audio Development Co.
Shielded Type Patch Cord

Volume Indicator Type MI-11265

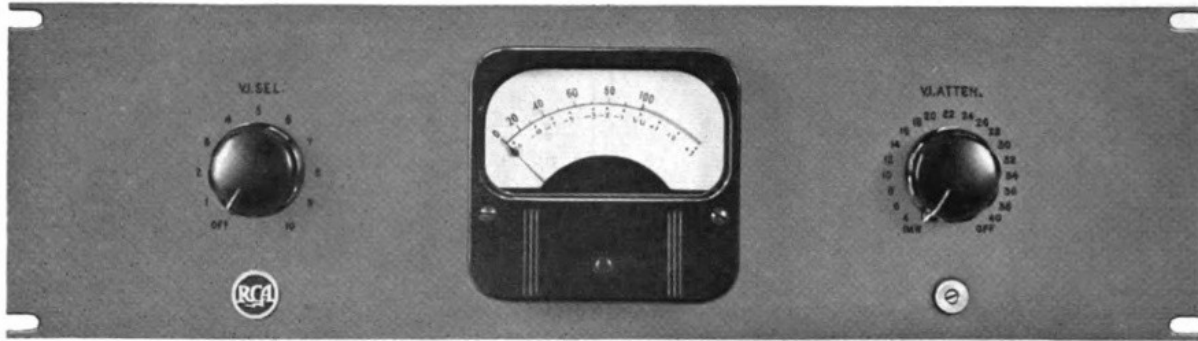

Uses

The MI-11265 employs the industry standardized Weston Type 30 VU Meter which embodies closely controlled electrical and dynamic characteristics combined with deliberate pointer action, moderate pointer speed, and small pointer overswing. It is intended as an audio level indicator for broadcasting, recording or wherever it is desired to read the level of one or more audio circuits with a rack mounting type of instrument.

Description

The volume indicator panel assembly includes the vu meter, a two circuit ten point selector switch, a variable step-by-step attenuator (4 to 40 db attenuation), and a vernier control for making a fine adjustment of the level reading over a range of ± 0.5 db. The attenuator has a 1 milliwatt reference position which enables a level reading of zero vu.

The vu meter scale is arranged with percent volts in black figures from "0" to "100" as the principal scale above the arc, and "vu" levels from "-20" to "0" to "+3" as supplementary figures in red below the arc.

The meter and attenuator are calibrated for use with a 600 ohm line, however, a calibration correction curve furnished with the instrument permits its use with loads other than 600 ohms. The ten point selector switch may be connected to any ten lines (or circuits). If one or more switch positions are connected to a jack strip, the number of circuits that may be monitored is unlimited.

Features

- Measures audio volume levels from +4 to +40 db.
- Ten point selector switch permits rapid connection to any number of circuits up to ten.
- Calibration curve supplied for loads other than 600 ohms.
- Large vu meter lessens eye strain and fatigue.

Specifications

Input Impedance (except on 1 milliwatt step)	_____	7500 ohms
Attenuator steps	_____	1 milliwatt position, +4 to +40 db in 2db steps and off position
No. of lines that may be measured	_____	1 to 10 inclusive
Mounting	_____	Standard Cabinet Rack
Dimensions		
Height	_____	5 1/4"
Width	_____	19"
Depth	_____	3 3/4"
Finish	_____	Light Umber Grey
Weight (unpacked)	_____	7 1/2 lbs.
Stock Identification		
Umber Grey	_____	MI-11265
Black	_____	MI-11265-D

VU Meter and Attenuator Kit MI-11251

The MI-11251 Meter and Attenuator Kit is used for indicating audio volume levels when installed in the OP-6 Portable Amplifier or the OR-1A Portable Recorder. It uses a Weston Type 30 VU Meter whose scale reads in percent voltage and in vu's. The meter has an impedance of 3900 ohms and is designed to be used in series with the furnished resistance of approximately 3600 ohms to effect the required ballistic characteristics. The circuit of the MI-11251 Kit employs the Type 30 Meter connected first to a 3900/3900 ohm constant impedance pad and then in series with 3200 ohm and tapped 800 ohm resistors across the amplifier's output. The 3900/3900 ohm pad has solder type terminals which permit attenuation adjustments for any value between 1 and 27 db in one db steps, while vernier adjustments in steps of 0.1 db, if required, are provided by the tapped 800 ohm resistor which is normally connected for 400 ohms. By changing the pad or resistor tap connections the "0" vu setting of the meter may be made to indicate any value from +4 to +31 db in steps of 1 db or 0.1 db.

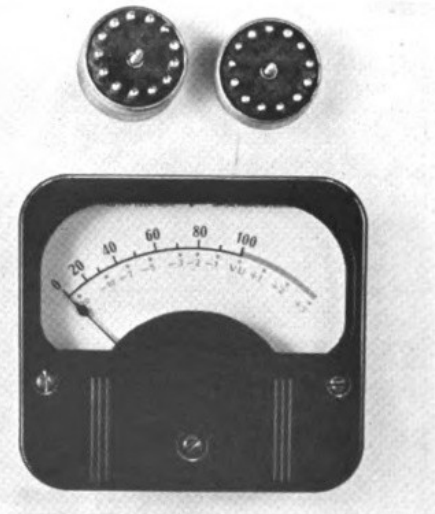

Variable Sound Effects Filter MI-4917-A

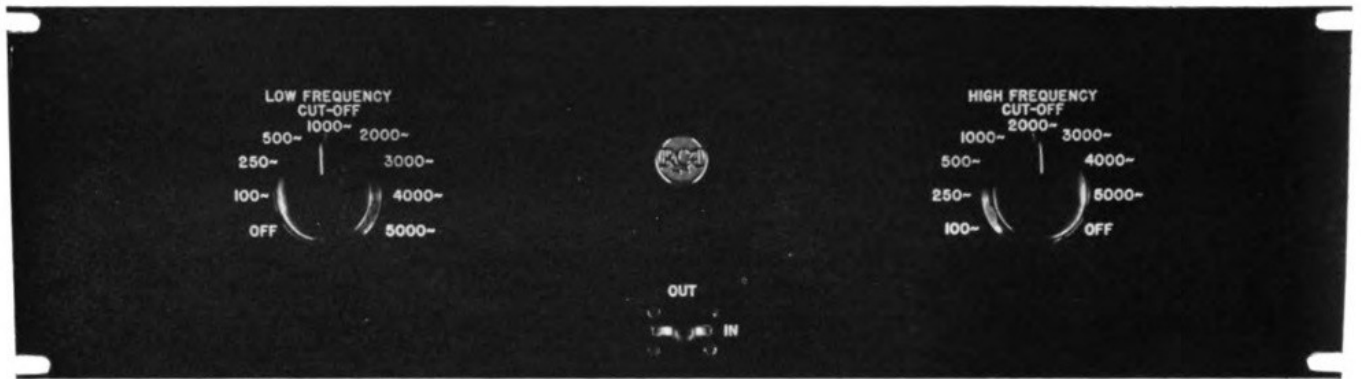

Uses

The MI-4917-A furnishes a desirable means for producing a variety of special or unusual sound effects through control of the audio bandwidth of the transmitted program. It is especially useful in the production of dramatic plays for making programs sound "bassy" or "tinny" or for simulating the sound of telephone conversations, short wave radio communications or midget radios.

Description

The MI-4917-A consists of high and low pass filters assembled on a panel with two selector panel switches. The switches have nine positions each and are calibrated for high and low cut-off frequencies of 100, 250, 500, 1,000, 2,000, 3,000, 4,000, and 5,000 cycles. There is also an "off" position on each switch. A key switch is provided for removing the filter from the circuit thus making it possible to preset the filter for the desired characteristics and insert it in the circuit instantly when required.

The 600 ohm input and output impedances of the filter enables it to be connected in any 600 ohm circuit or it may be used in a 250 ohm circuit with only a slight change in response characteristics.

Features

- Permits control of audio bandwidth to permit a variety of sound effects.
- Two front panel selector switches permit easy and quick change to desired sound effect.

Specifications

Input Source Impedance (unbalanced)	600 ohms
Output Load Impedance	600 ohms
Input Level	-60 to +23 db*
Output Level (maximum)	+23 db*
Frequency Response	see curves
Insertion Loss	1 db or less at frequencies remote from cut-off
Dimensions, overall	
Height	5 1/4"
Width	19"
Depth	5"
Weight (unpacked)	15 lbs.
Stock Identification—Black	MI-4917
Light Umber Grey	MI-4917-A

* Reference level one milliwatt.

MI-4917 VARIABLE SOUND EFFECTS FILTER (600Ω)

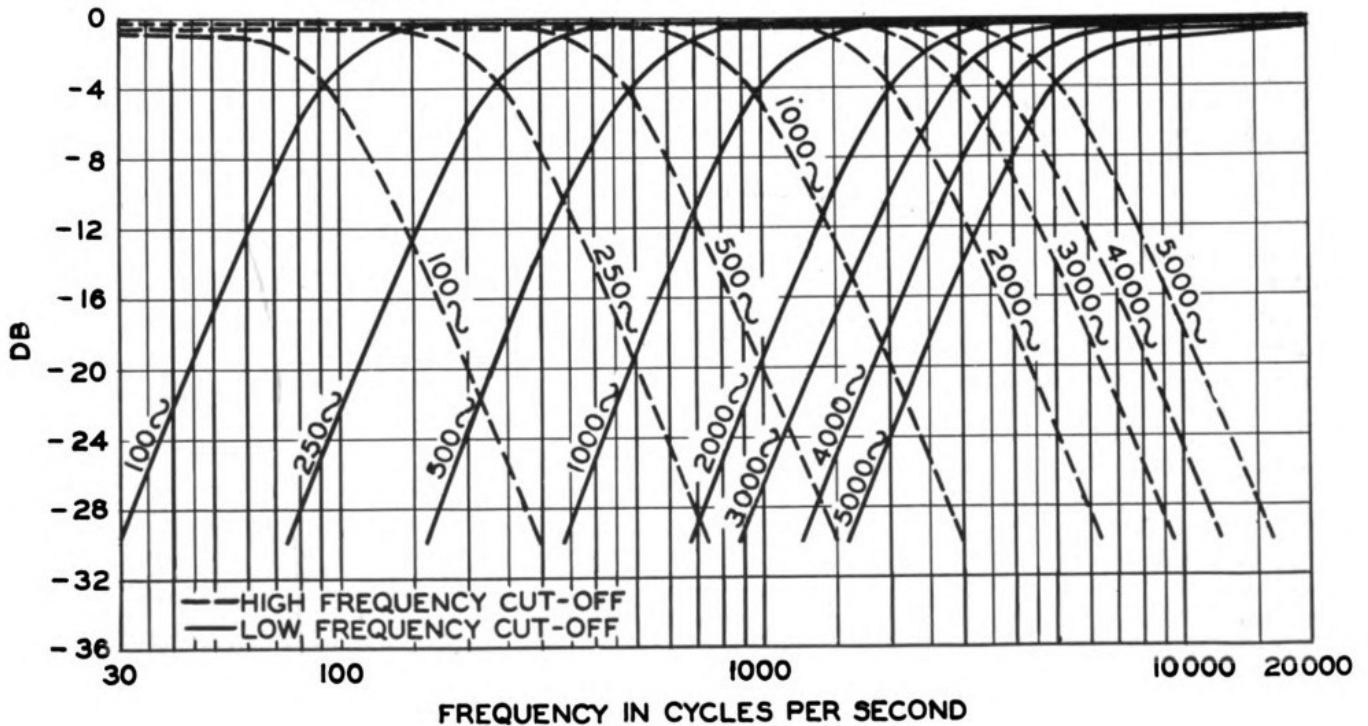

Variable Line Equalizer Type BE-1A

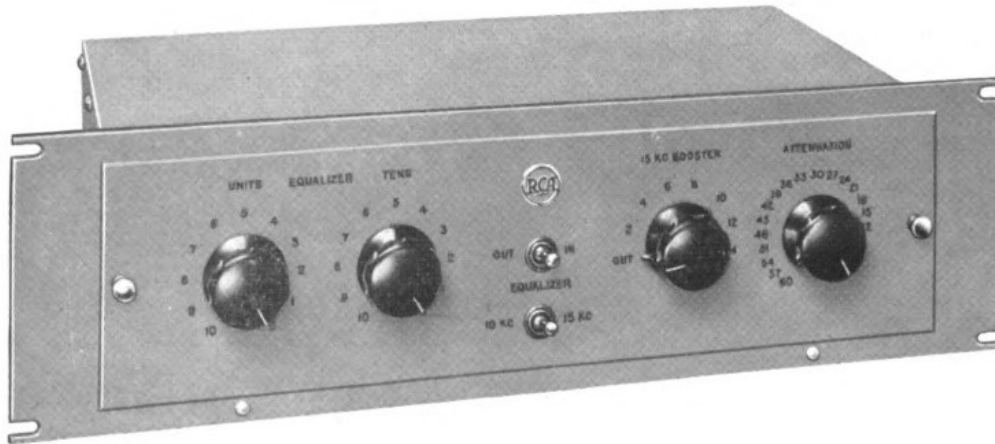

Uses

The BE-1A is an ideal FM unit for equalizing unloaded telephone lines up to ten miles in length to a frequency response within ± 1 db, 30 to 15,000 cycles. In addition to the conventional parallel resonant circuits this equalizer has additional tuned networks providing a variable frequency boost of 2 to 14 decibels (2 db steps) at 15,000 cycles. This feature aids materially in obtaining an overall flat frequency response to 15,000 cycles. More than 1,000 different attenuation vs frequency curves are available through adjustment of the front panel controls.

Description

The BE-1A consists of a tuned equalizing circuit, isolating transformer, attenuating pad, 15,000 cycle booster circuit and another isolating transformer in the output.

A single pole double throw switch is provided for putting the equalization in and out of the circuit. A similar switch selects the equalization up to 10,000 or up to 15,000 cycles. A 20 step (3 db per step, last step infinite) attenuator is inserted in the circuit to permit control of the output level. The 15,000 cycle booster circuit is controlled by an 8 position switch which will vary the boost from 0 to 14 db in 2 db steps. Attenuation vs Frequency curves are shown for extreme boost control settings of "Boost out" and "14 db boost." Intermediate attenuation values will be obtained for intermediate settings of the boost control.

The BE-1A is built on a standard 19" panel and is supplied with a dust cover. A hinged door on the front panel permits easy access for cleaning or servicing the equipment. A terminal strip, mounted on the rear of the unit, has five screw-type terminals for input, output and ground connections.

Features

- Provides line equalization to 15,000 cycles for FM.
- Frequency boost circuit permits up to 14 db boost at 15,000 cycles.
- Toggle switch permits 10 kc or 15 kc cut-off.
- 20 step attenuator affords variable output control.
- Line and Isolation transformers built in.
- Rack mounting panel—easy installation.

Specifications

Source Impedance (balanced or unbalanced) _____ 600 ohms
 Equalization Frequency Limit _____ 15,000 cycles
 Insertion Loss (attenuator at zero)

For 15 kc equalization _____ Min. 6.5 db; Max. 59 db
 For 10 kc equalization _____ Min. 3.5 db; Max. 42.5 db

Note: With equalization and boost out the minimum loss at 1000 cycles is 1.5 db.

Equalization Range _____ (See attenuation characteristic curves)
 Mounting _____ Standard 19" panel

Dimensions

Height _____ 5 $\frac{3}{16}$ "
 Width _____ 19"
 Depth behind panel _____ 8"
 Overall including knobs _____ 9 $\frac{1}{4}$ "

Weight (unpacked) _____ 7 lbs.

Stock Identification

Light Umber Grey _____ MI-4196
 Black _____ MI-4196-A

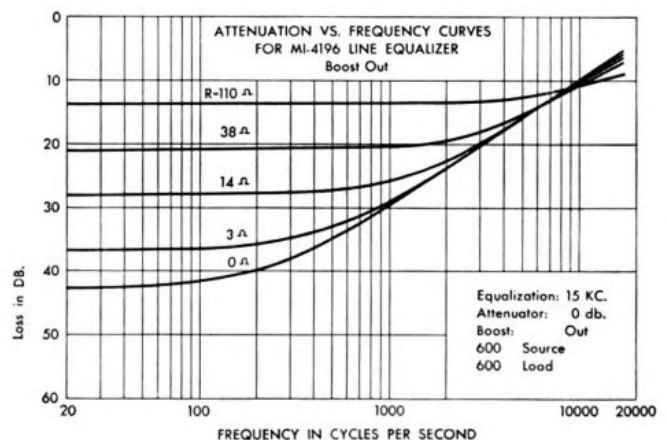
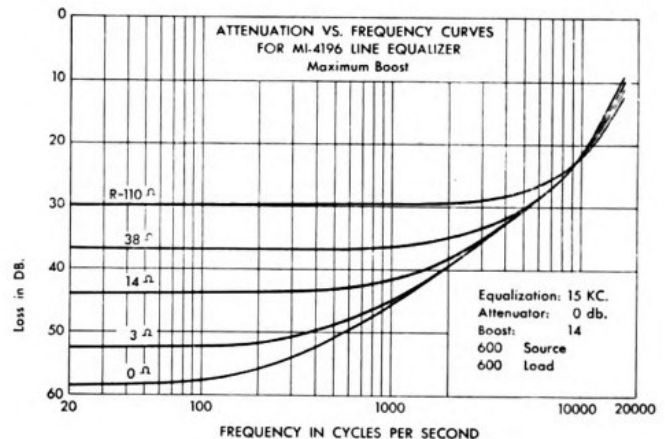

Dual Line Equalizer Type 56-E

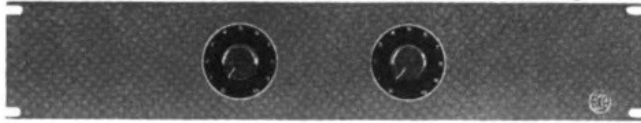

Uses

The 56-E has been designed to equalize the non-linear frequency characteristics of either one or two non-loaded telephone lines up to ten miles in length. It consists of two separate and complete variable equalizers mounted on a single panel. The 56-E is suitable for 15,000 cycle FM applications when used with the RCA MI-4925-A High Frequency Compensator. Without this compensator the cut-off frequency is 10,000 cycles.

Description

Parallel resonant circuits are used in the two equalizers. Each unit consists of a capacitor, a reactor, a series of resistors and a rotary selector switch for selecting different resistance values. Varying amounts of equalization may be obtained in steps of 3 db by rotation of the selector switch to the proper position. The 56-E does not include line transformers or master attenuators.

Features

- Provides line equalization to 10,000 cycles or to 15,000 cycles when used with MI-4925-A Compensator.
- Equalization variable in steps of 3 db.
- Facilities for equalizing two lines.
- Rack mounting panel—easy installation.

Specifications

Source Impedance	600 ohms
Equalization Frequency Limit	10,000 cycles
with MI-4925-A Compensator	15,000 cycles
Insertion Loss (minimum at 1000 cycles)	7 db
Equalization Range (see attenuation characteristic curve)	1.5 to 40 db
Mounting	Standard 19" panel
Dimensions	
Width	19"
Height	3 1/2"
Depth	4 3/4"
Weight (unpacked)	7 lbs.
Stock Identification	
Black	MI-4162
Umber Grey	MI-4162-A
Accessory	
High Frequency Compensator (2 units required if 56-E is to be converted for 15,000 cycle use)	MI-4925-A
Line Transformer	MI-4900-A

Equalizer Type 56-C

The 56-C Equalizer is a semi-fixed unit which is particularly useful in connection with permanent lines. Its applications are similar to those of the Type 56-E described elsewhere on this page. It is a single unit with reactor, capacitor and all necessary resistors mounted in a metal case to reduce space requirements. The resistance terminals are brought out to soldering lugs on the top of the case where connections may be made for obtaining any resistance value between 1 and 111 ohms in 1 ohm steps.

Specifications

Source Impedance	600 ohms
Equalization Frequency Limit	10,000 cycles
with MI-4925-A Compensator	15,000 cycles
Insertion Loss (minimum at 1000 cycles)	11.5 db

Equalization Range (see attenuation characteristic curves)
1.5 to 40 db

Dimensions
Width 3 5/8"
Height 3 3/4"
Depth 2 1/2"

Weight (unpacked) 7 lbs.

Stock Identification MI-4168

Accessory High Frequency Compensator

(one only required if 56-C is to be converted for 15,000 cycle use) MI-4925-A

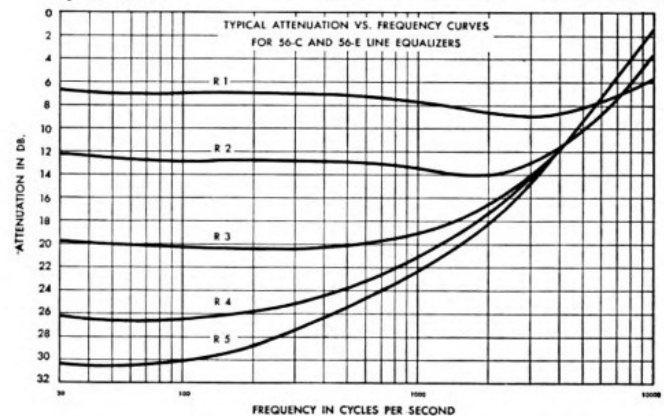

High Frequency Compensator MI-4925-A

The MI-4925-A is a constant impedance bridged "T" type compensator network to extend the range of the 56-C or 56-E Equalizers to 15,000 cycles. The necessary reactors and condensers are mounted inside a round metal can, on the side of which is mounted a terminal board and two groups of resistors. Compensation can be varied by shifting the resistor connections which are connected by means of solder type terminals.

Specifications

Source Impedance	600 ohms
Equalization Frequency Limit	15,000 cycles
Insertion Loss (minimum at 1000 cycles)	4.8 db
Equalization Range (see curves)	1.7 to 17.4 db
Mounting	Four-hole flange mounting
Dimensions	
Width	4 3/8"
Height	4 3/4"
Depth	3 3/4"
Weight (unpacked)	2 3/4 lbs.
Stock Identification	MI-4925-A

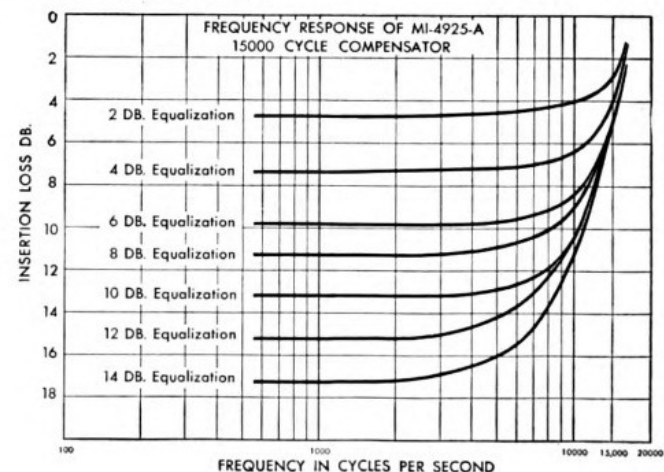

Line Equalization

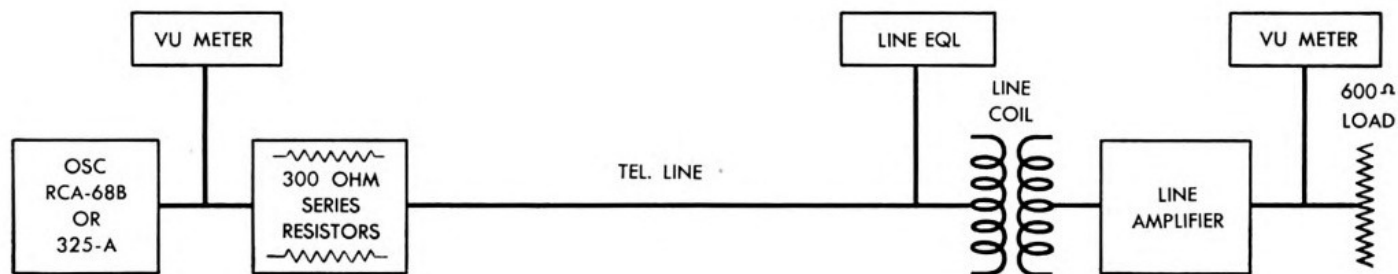

TYPICAL SET-UP FOR EQUALIZING TELEPHONE LINES

The above block diagram shows a typical setup for equalizing telephone lines.

The Type 68-B oscillator is desirable for use with studio-transmitter lines or for remote program lines where two lines are available making it unnecessary to transport the oscillator to the remote point.

The Type 325-A Portable Audio Frequency oscillator has been designed especially for use in remote line equalization. It is an economical, compact, portable audio oscillator for general use where an audio frequency voltage source is required.



Weighing but $6\frac{1}{2}$ pounds less batteries, it provides push button selection of 12 frequencies in the range of 50 to 15,000 cps. It has a built-in output level indicator and may be operated either from its built-in power supply or batteries.

With equipment set-up as shown in the block diagram above, a telephone line may be equalized by the following procedure:

- a. Have the operator at the remote point set the oscillator at 1000 cps (the reference frequency) and adjust and maintain the proper level.
- b. With the equalizer disconnected read the output of the line amplifier as indicated on the vu meter at the receiving location.
- c. Repeat this procedure for interval frequencies between 30 and 10,000 cps, or up to 15,000 cps if applicable and record the output level of the line for each frequency.
- d. From the recorded readings and reference to the frequency characteristic curves of the equalizer in use, determine the proper amount of equalization to be used.
- e. Connect the equalizer across the line, and after the equalizer settings have been made, run a complete frequency characteristic check over the entire frequency range holding a constant input to the line.
- f. If necessary make a further adjustment of the equalizer and make a re-check of the line frequency characteristics.
- g. If necessary make further adjustments on the equalizer with additional frequency checks until the line meets the required frequency tolerance.

**TRANSFORMERS
POWER SUPPLIES**

SECTION

E

AUDIO TRANSFORMERS

PREAMPLIFIER POWER SUPPLIES

INTERCONNECTING CABLE

RELAY POWER SUPPLIES

Line, Mixing and Bridging Transformers

The following standard RCA transformers are stocked as a convenience to broadcasting stations. These transformers are of the highest quality design having a frequency response which is within ± 1 db, from 30 to 15,000 cycles. They are provided with electrostatic shields between primary and secondary and are furnished with heavily shielded cases. Cores are of special high permeability steel. Terminals are at the top and diagrams of the connections are stenciled on the side of the case. Broadcasting stations may employ the RCA terminal transformers between units with assurance that the overall fidelity of the system will be maintained.

Specifications General for MI-4900-A MI-4901 and MI-4902

Frequency Response
 ± 1 db, 30 to 15,000 cycles

Dimensions, overall for cases
Height _____ $4\frac{3}{8}$ "
Diameter _____ 3"
Baseplate _____ $3\frac{1}{4}$ " x $3\frac{1}{4}$ "
Mounting _____ Four holes with center lines $2\frac{3}{4}$ " x $2\frac{3}{4}$ "
Weight _____ 2 lbs. 14 ozs.
Finish _____ Aluminum grey

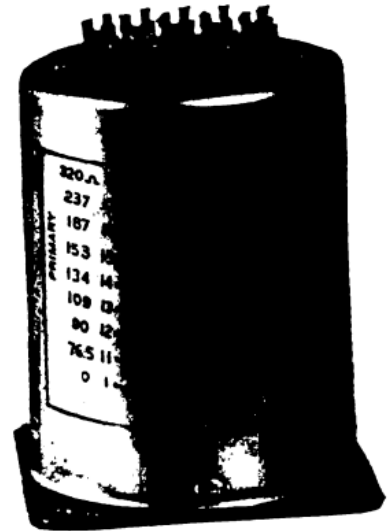

Line Transformer MI-4900-A

The core structure, frequency characteristics and shielding of this transformer makes it an ideal unit for isolating line circuits. Its large number of taps provide several combinations of available impedances. One to two of these transformers are very useful items to have around any broadcast station. The impedance combinations are:

Primary Impedances	Secondary Impedances
ohms	ohms
125	125
250	250
300	300
600	600

Stock Identification _____ MI-4900-A

Bridging Transformer MI-4901

The MI-4901 transformer may be used as an input transformer for a bridging line amplifier or a monitoring amplifier. It may also be satisfactorily used where it is desired to bridge a program line to feed programs to other mixing or outgoing circuits such as normally employed in a master control room line distribution system. The impedance combinations are:

Primary Impedances	Secondary Impedances
ohms	ohms
600	600
20,000	50,000

Stock Identification _____ MI-4901

Mixing Transformer MI-4902

Those contemplating the design of their own, or special microphone mixing circuits, will find this transformer ideal for a large number of mixer combinations. The impedance combinations are:

Primary Impedances	Secondary Impedances
ohms	ohms
76.5	153
90	187
109	237
134	

Stock Identification _____ MI-4902

Speaker Matching Transformer MI-4603

MI-4603 SPEAKER MATCHING TRANSFORMER					
2500 IMPED.	TERMS	IMPED.	TERMS	IMPED.	TERMS
	7.5	0-7.5	250	0-250	
	15	0-15	340	15-500	
500	34	100-250	385	7.5-500	
250	37.5	15-100	500	0-500	
	43	250-500	760	500-2500	
100	53	7.5-100	1165	250-2500	
	100	0-100	1600	100-2500	
15	143	15-250	2130	15-2500	
7.5	155	100-500	2250	7.5-2500	
0	170	7.5-250	2500	0-2500	

Specifications

Frequency Response
 ± 2 db, 30 to 15,000 cycles

Maximum Audio Power _____ 40 watts

Dimensions _____ $5\frac{3}{4}$ " x $5\frac{1}{8}$ " x 5"

Finish _____ Black

Weight (unpacked) _____ 9 lbs.

Stock Identification _____ MI-4603

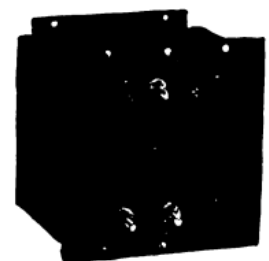

Pre-amplifier Power Supply BX-1A

The BX-1A Power Supply has a plug in chassis and has been designed to furnish plate and filament voltages to a maximum of six Type BA-1A Preamplifiers, ten Type 85-B1 Pre-amplifiers or ten Type 85-X Isolation Amplifiers. It contains a hum control potentiometer across the filament supply and an output voltage regulating potentiometer. Plug-in electrolytic capacitors are used as an aid to servicing and to prevent loss of operating time from capacitor failures. A power switch and a 1 ampere glass enclosed fuse is provided. Two BX-1A power supplies may be mounted on one 36-B Panel.

Specifications

Output
 Filament _____ 6.4 volts a-c, 3 amperes
 Plate _____ 180 to 250 volts d-c, 50 ma. max.
 Note: d-c voltage is adjustable through above limits by means of output voltage control.
 A-c Input, 100 to 130 volts a-c, 50/60 cycles _____ 65 watts max.
 Hum Level, approx. (below 250 volts at 50 ma) _____ 133 db
 Dimensions, overall
 Length _____ 11 $\frac{3}{4}$ "
 Width _____ 7 $\frac{1}{2}$ "
 Height _____ 7"
 Weight (unpacked) _____ 18 lbs.



Stock Identification (shipped less tube) _____ MI-11305
 Accessories
 One RCA-5Y3GT/G _____ MI-11262
 36-B Panel _____ Umber grey MI-4682-H
 Black MI-4682

Filament Transformer MI-11606

The MI-11606 Filament Transformer furnishes filament voltage to a maximum of three 85-C Pre-amplifiers, six 85-B1 Pre-amplifiers or six 85-X Isolation Amplifiers. It has primary taps for 110 and 120 volts a-c 50/60 cycles. A variable potentiometer is connected across the secondary and is screw driver operated for obtaining a hum minimum.

Specifications

Output _____ 6.3 volts, a-c, 1.8 amperes max.
 Dimensions, overall
 Height _____ 4"
 Base _____ 2 $\frac{1}{8}$ " x 2 $\frac{3}{8}$ "
 Mounting _____ Four .199" mounting holes are located on 2 $\frac{5}{8}$ " x 1 $\frac{1}{4}$ " center line
 Weight (unpacked) _____ 2 lbs.
 Stock Identification _____ MI-11606

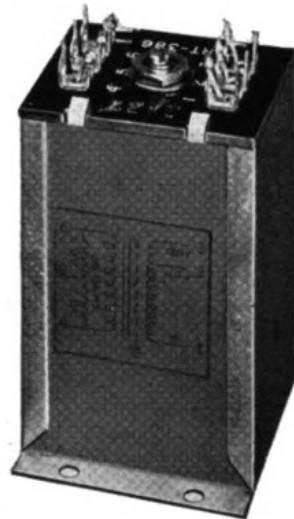

Speech Input Interconnecting Cable

The majority of wires required to interconnect the various components of a speech input assembly are of a special type and cannot be readily purchased from the local electrical dealer. In order to avoid unnecessary installation delays, RCA carries in stock three of the generally used special type wires.

Solid Conductor Cable MI-63-A

Use _____ General purpose audio transmission line
 Type _____ Twisted two-conductor, solid copper, shielded, tinned #19 AWG
 Insulation _____ Varnished cambric covered with a serving of cotton
 Shield _____ Tinned copper braid
 Color Code _____ Red and black
 Rating _____ 600 volts
 Stock Identification (stocked in 1000' rolls) _____ MI-63-A

Stranded Conductor Cable MI-64

Use _____ Recommended for power circuits particularly where extra flexibility is required

Type _____ Shielded, twisted pair, stranded. Composed of 10 .010 tinned copper conductors equivalent to #19 AWG
 Insulation _____ Varnished cambric covered with a serving of cotton
 Shield _____ Tinned copper braid
 Color Code _____ Red and black
 Rating _____ 600 volts
 Stock Identification (stocked in 1000' rolls) _____ MI-64

Stranded Conductor Cable MI-65

Use _____ Especially recommended for 110 volt supply and filament circuits
 Type _____ Shielded, twisted pair, stranded, composed of 26 .010 tinned copper conductors equivalent to #16 AWG
 Insulation _____ Varnished cambric covered with a serving of cotton
 Shield _____ Tinned copper braid
 Color Code _____ Red and black
 Rating _____ 600 volts
 Stock Identification (stocked in 1000' rolls) _____ MI-65

Relay Power Supply MI-11303

Uses

The MI-11303 Relay Power Supply is a complete unit capable of supplying filtered d-c power to a number of relays and pilot lights if the total load current at 12 volts does not exceed one ampere.

Description

The power supply is built in an attractive wall-mounting box. The electrical circuit consists of a power transformer, copper-sulfide magnesium full wave rectifier, and a resistance-capacity filter system with three 1000 mfd. electrolytic plug-in capacitors. The power transformer primary is tapped at 105, 115, and 125 volts to provide line voltage adjustment. The secondary of the power transformer is tapped and connected to a six position rotary switch which permits a variation in output voltage of approximately 1/2 volt per step.

The chassis is bolted in the enclosure with a snap-off cover. The chassis, inside of the mounting box and the terminal board cover are finished in silver grey. The outside of the box is finished in light umber grey with a 4 inch dark umber grey stripe through the middle of the cover.

Features

- Supplies 12 volts filtered d-c at 1 ampere.
- Rotary switch permits varying output voltage in 1/2 volt steps.
- Long life full wave copper sulphide magnesium rectifier.
- Housed in an attractive wall mounting cabinet with hinged door.

Specifications

Output (adjustable for loads from 0.2 to 1.0 ampere)
maximum 12 volts 1 amp.

Ripple Voltage (at maximum output of 1 amp.) 0.4 volts rms

Ac Power Input, 105 to 125 volts, 60 cycles
(maximum at rated output) 34 watts

Rectifier Copper-Sulphide magnesium full wave type

Dimensions

Height 9"

Width 9 5/8"

Depth 6"

Mounting Wall mounted by four mounting slots

Finish Two tone umber grey

Weight (unpacked) 14.5 lbs.

Stock Identification MI-11303

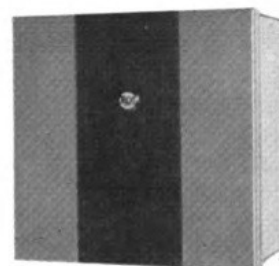

Heavy Duty Relay Power Supply MI-11304

Uses

The MI-11304 Relay Power Supply is a complete unit capable of supplying filtered d-c power to a number of relays and pilot lights if the total load current at 12 volts does not exceed 5 amperes.

Description

The power supply is built into an attractive cabinet for wall mounting. The electrical circuit consists of a power transformer, line and load voltage regulating and shunt reactors, full wave selenium rectifier, filter reactors and capacitors, variable resistors, and terminal board and fuses. Regulation of the d-c output voltage is accomplished by use of a saturable reactor which maintains the output voltage substantially constant from no-load to full-load output.

Features

- Supplies 12 volts filtered d-c at 5 amperes.
- Output voltage substantially constant from no-load to full-load output.
- Full wave Selenium Type Rectifier.
- Housed in an attractive wall-mounting box.

Specifications

Output (substantially constant from no-load to full-load output) maximum, 12 volts 5 amps.

Ripple Voltage (at full load) 0.1 volt rms

Ac Power Input, 105 to 125 volts, 60 cycles
(maximum at rated output) 165 watts

Rectifier full wave Selenium type

Dimensions

Height 16 3/8"

Width 15 1/4"

Depth 8 1/2"

Mounting Wall mounted by four mounting slots

Finish light umber grey

Weight (unpacked) 80 lbs.

Stock Identification MI-11304

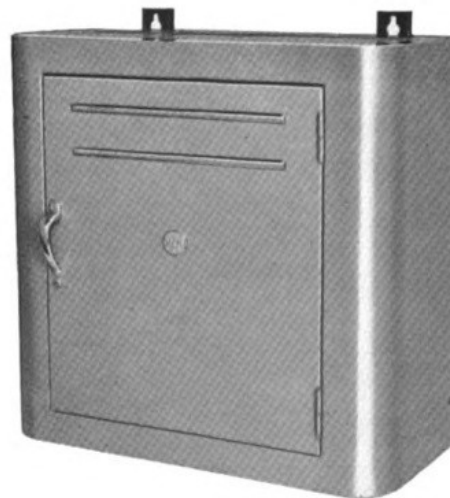

**TURNTABLES
RECORDERS**

SECTION

F

TRANSCRIPTION TURNTABLES

RECORDING INSTALLATIONS

TECHNICAL DATA SUMMARY

RECORDING ATTACHMENTS

PROFESSIONAL RECORDERS

PORTABLE RECORDERS

RECORDING ACCESSORIES

Transcription Turntable Type 70-C1

Uses

The Type 70-C1 Transcription Turntable has been developed to meet the continued demand for higher and higher quality in the reproduction of broadcast transcriptions. It is the latest edition to the popular 70 SERIES of transcription equipments, of which more than 1,500 are now in use. It has all the exclusive features of the former models, plus the newly designed universal pickup head and adjustable filter unit. The 70-C1 provides high fidelity reproduction of *all* vertical or lateral cut records.

Description

The complete equipment is housed in a cabinet of modern design. The cabinet is finished in two tones of umber grey and trimmed in chromium. A large removable door is located on the front of the cabinet so as to permit ready access to the motor and filter circuits. All filters are securely mounted within the cabinet and arranged for minimum hum pickup. There is also sufficient space within the cabinet for a booster amplifier (such as the RCA BA-2A) where additional output level is required. Terminal boards are provided for a-c and the audio connections and are accessible from the front of the cabinet. Mounted on top of the 70-C1 cabinet are the tone arm, tone arm rest and filter selector switch. The tone arm is of the counter weight balance type and provisions are made for accurately setting the stylus for one ounce pressure on a record. Possible damage to the pickup stylus is prevented by adjustable horizontal and vertical tone arm stops. The horizontal stop prevents the pickup stylus from reaching the small diameter on which the record driving holes are placed. The vertical stop can be adjusted so that the stylus just touches the top of the record platter.

The filter selector switch has six positions to provide various degrees of frequency compensation. Typical switch position settings for some commonly used types of recordings are given below:

LATERAL

1. Transcriptions, Orthacoustic, Columbia.
2. Home Records and Worn Transcriptions.
3. Home Records, World, Decca and AMP.
4. Test Records and Special Recordings. (Wide open at high frequencies.)

VERTICAL

1. World and AMP Transcriptions.
2. Worn Transcriptions.

Two vacant positions are available on the switch to permit additional filters or compensators to be added if so required.

The motor is a high torque synchronous type, cushion-mounted on the bottom shelf of the equipment, thus isolating motor noise from the cabinet. In order to insure the faithful reproduction of high fidelity records, the turntable platter has associated with it a separate specially designed flywheel. This flywheel is approximately 12" in diameter and is located within the cabinet itself. The turntable platter and flywheel assembly is completely isolated from the motor through a series of mechanical filters and a spring clutch arrangement. The combination insures excellent speed regulation and, with the cushion mounting of the motor, prevents noise and vibration

from being transmitted to the tone arm, a feature which is highly important when attempting to reproduce high fidelity records satisfactorily.

A silent type of power switch, located on top of the machine, permits the turntable to be operated near a microphone.

The RCA Type 72-D Recording Attachment is available for use with the 70-C1 Turntable. Mounting holes are provided for easy and quick installation.

Features

- High fidelity reproduction of all recordings.
- Combination lightweight pickup with long wear diamond point stylus.
- Heavy duty constant speed synchronous motor with ample driving power for recording or reproducing.
- Provision for RCA Recording Attachment.
- Quiet operation. Cushion-mounted motor with silent on-off switch.
- Speed change lever in rim of turntable permits change without removing record.
- Ruggedly built to give years of satisfactory service.

Specifications

Pickup Impedance	250 ohms
Load Impedance	Output of compensator should be connected to the unloaded input transformer of an amplifier designed to operate from a 250 ohm source such as RCA 85-A, 85-B, 85-B1, BA-1A, 87-A or BA-2A.
Output Level	-63 db (.001 watt reference) L1 position at 1,000 cycles T-2483-2 test record -68 db (.001 watt reference) V1 position at 1,000 cycles—TRV-102 test record
Frequency Response (see curves)	50-10,000 cycles
Transmission Loss of Filter	24 db at 1,000 cycles at each of the 6 switch positions
Stylus	Polished diamond
Turntable Diameter	16" (Will handle records up to 18" in diameter)
Turntable Speed	33 $\frac{1}{3}$ -78 rpm
Speed Regulation (wows)	0.2% rms at 33 $\frac{1}{3}$ rpm 0.09% rms at 78 rpm
Dimensions, overall	
Height	32 $\frac{1}{2}$ "
Width	25 $\frac{1}{4}$ "
Depth	24 $\frac{1}{4}$ "
Finish	Two tone umber grey with chromium trim
Weight (unpacked)	155 lbs.
Power Supply	105-125 volts, 50 or 60 cycles
Power Consumption	35 watts
Stock Identification	60 cycles, MI-4871-C 50 cycles, MI-4872-C

Accessories

BA-2A Booster Amplifier	MI-11226
72-D/72-DX Recording Attachment	MI-11901 or MI-11900



70-C1 Turntable complete with universal pickup head.

Outline photo of the Type 70-C1 showing its outstanding mechanical features, simplicity of design and ruggedness.

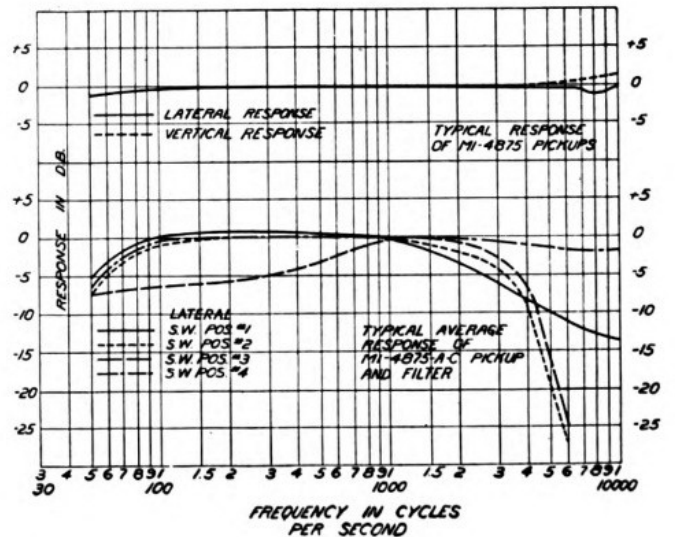
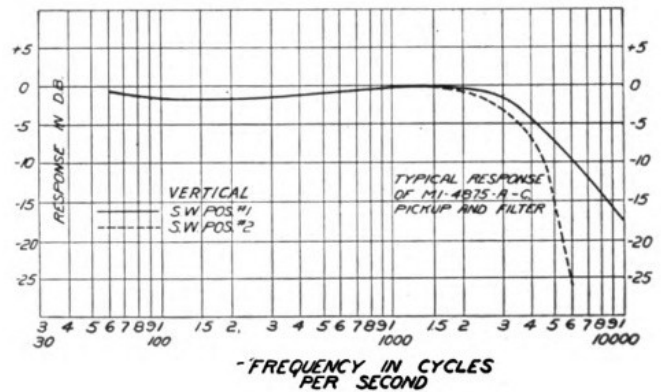
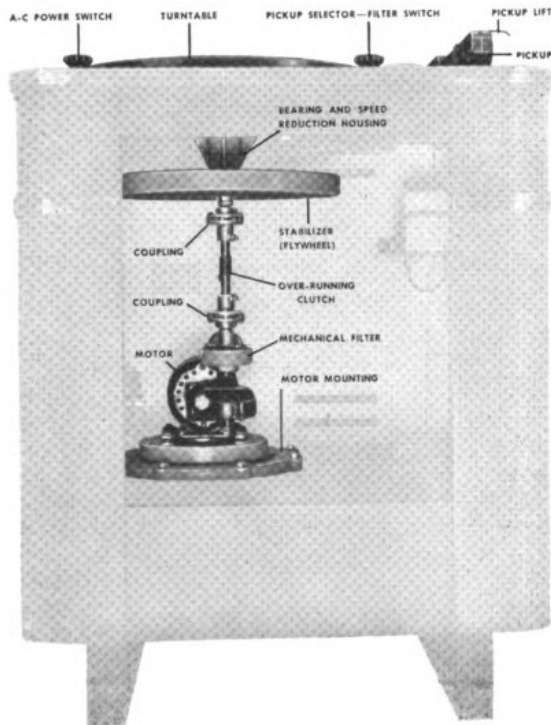

RCA Recording Installations

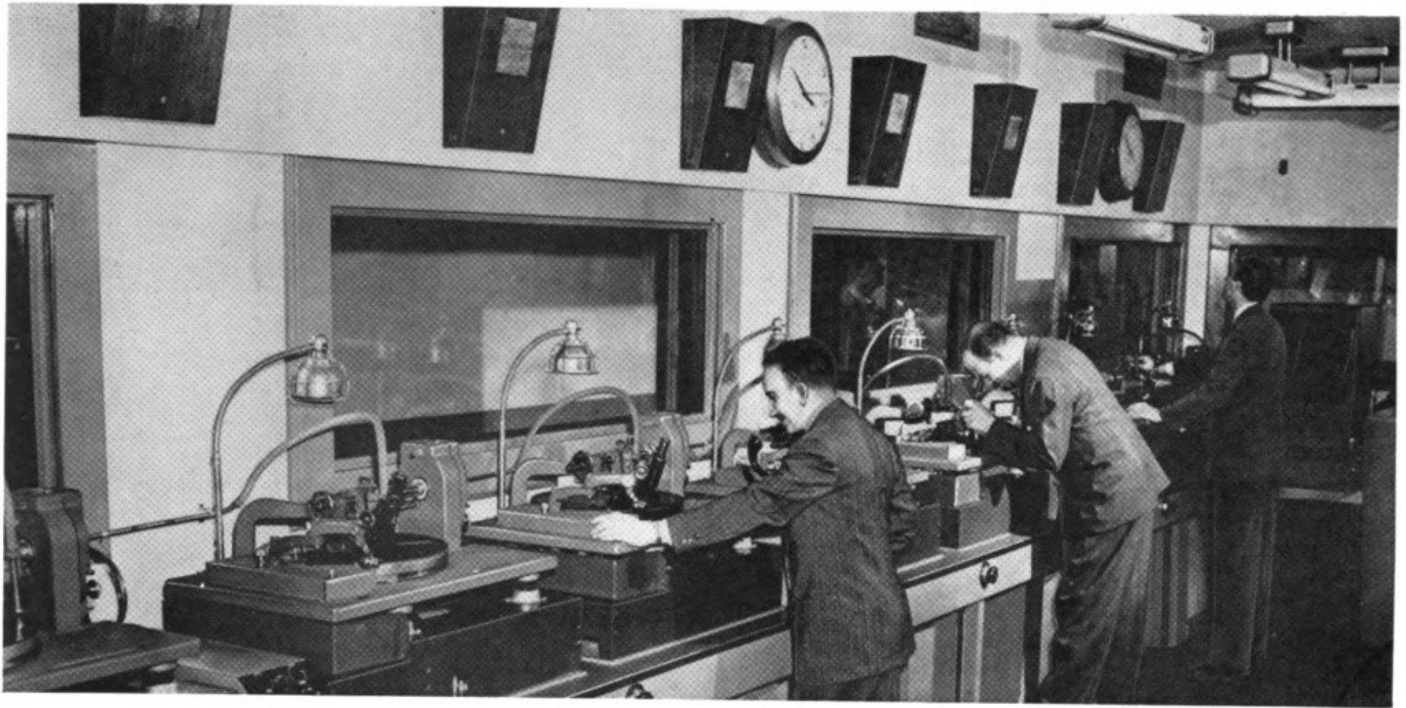

▲ *RCA Professional Recorder Installation at OWI, New York*

▼ *Recording Layout at WREC, Memphis*

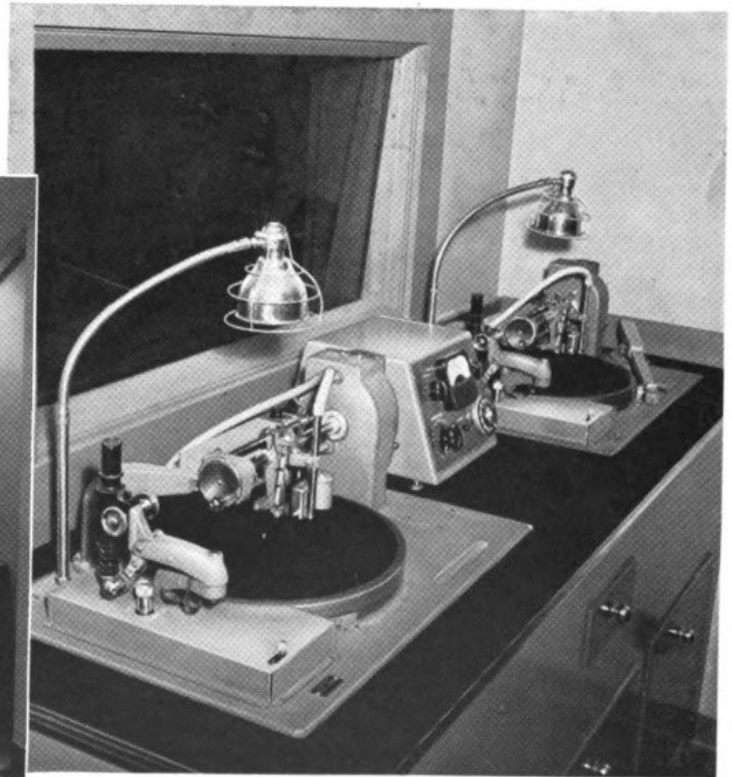
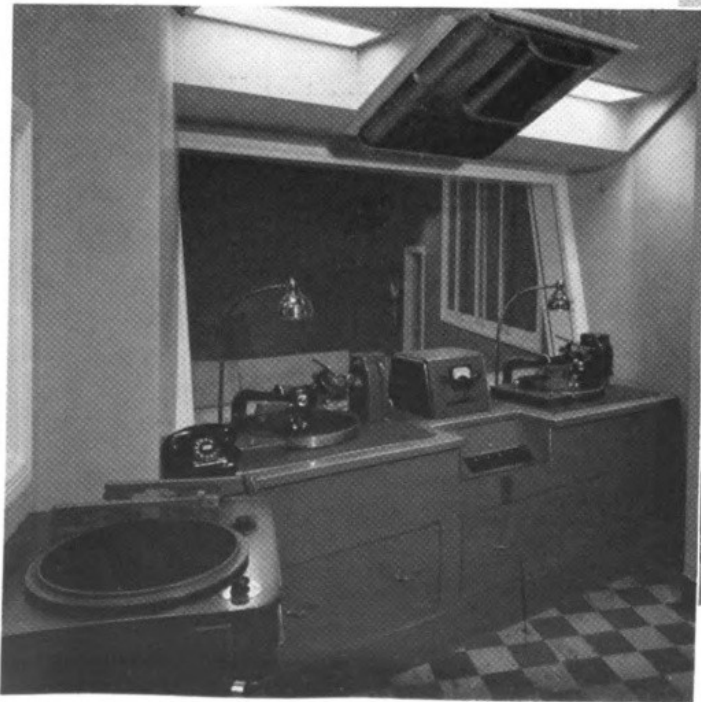

▲ *Professional Recorder Installation at the studios of KGLO, Mason City, Iowa*

Recording Equipment

RCA offers a complete line of high fidelity recording equipment featuring outstanding performance characteristics, simplicity of operation and many other exclusive features which are described on the following pages. For professional recording studios, broadcasting stations, educational institutions or wherever high quality discs are to be cut, these recorders are unexcelled.

CHART No. 1

Type	Usage	Recording Speed rpm	Recording Pitch Lines per Inch— Inside out or Outside in	Max. Dia. Blank	Frequency Response cps	Required Audio Power	Accessories See Chart 2
73-B	Professional FM-AM Broadcast Studios Educational	33½ or 78	Con. Var. 96 to 152	18¼"	±2 db 50-10,000	Approx. 3 Watts*	2-3-4-5-6-7-8-11-12
72-DX	FM-AM Broadcast Studios Educational	With 70 Ser. Turntables 33½ or 78	96,112,136	18¼"	±2 db 50-10,000	Approx. 3 Watts*	1-3-4-5-6-7-8-11-12-16
72-D	FM-AM Broadcast Studios Educational	With 70 Ser. Turntables 33½ or 78	96,112,136	18¼"	±4 db 50-7,500	Approx. 3 Watts*	1-3-4-5-6-7-8-11-12-16
OR-1A	Portable FM-AM Broadcast Studios Educational	33½ or 78	96,112,136	16"	±4 db 50-7,500	Approx. 3 Watts*	1-3-4-5-6-7-11-12-13-14-15-16
OR-1AX	Portable FM-AM Broadcast Studios	33½ or 78	96,112,136	16"	±2 db 50-10,000	Approx. 3 Watts*	1-3-4-5-6-7-11-12-13-14-15-16

* For 5 cm/sec stylus velocity at 1000 cps.

Recording Equipment Accessories

CHART No. 2

Item	Type	Description
1	MI-11101	Automatic Recording Equalizer
2	MI-11100	Automatic Recording Equalizer
3	MI-4916	Orthacoustic Equalizer
4	MI-4922	Suction Pump (less hose)
5	MI-4923	Hose and Coupling Kit (for suction pump)
6	MI-4878-C	90° Sapphire Stylus
7	MI-4842	70° Sapphire Stylus
8	82-C1	Recording Amplifier
9	MI-11850-B	High Fidelity Cutter Head
10	MI-11853	Standard Cutter Head
11	MI-11851	Advance Ball Kit
12	MI-11251	VU Meter Kit
13	44-BX, 77-D, 74-B or 88-A	Microphones
14	MI-11259	Tube Kit for OR-1A
15	MI-11259-A	Tube Kit for OR-1A (emergency)
16	MI-4928	Microscope

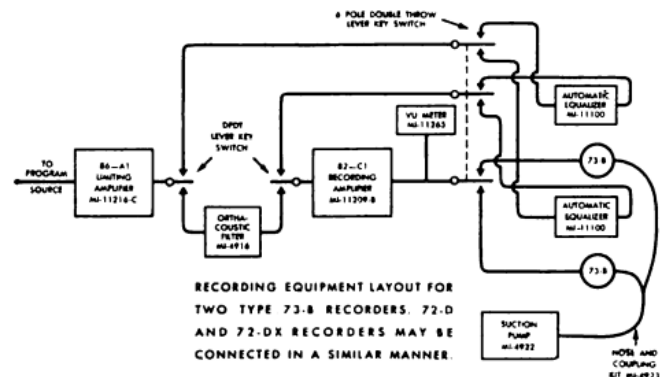

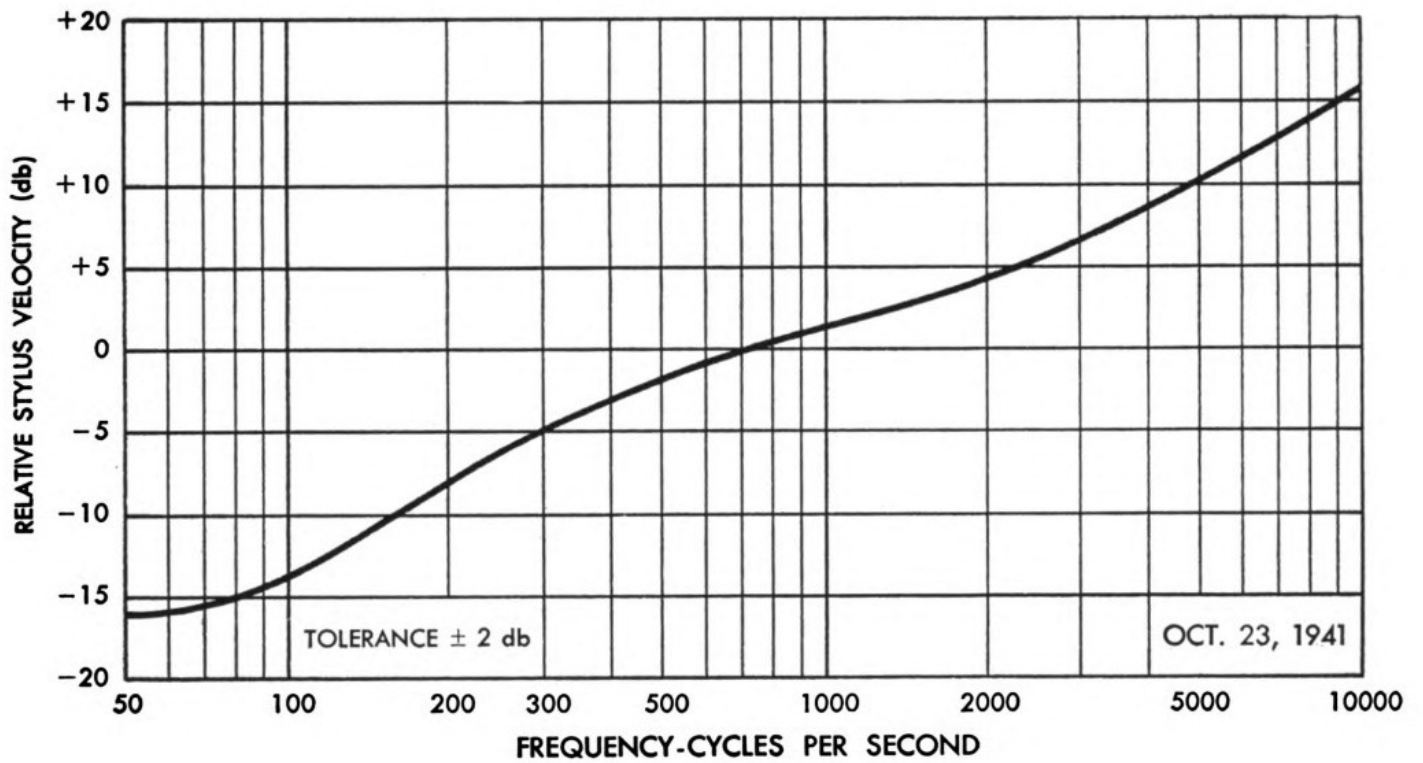

Reproducing characteristics for Lateral Transcriptions as set forth by the Recording and Reproducing Standards Committee of the National Association of Broadcasters.

Recording Attachment Type 72-D/72-DX

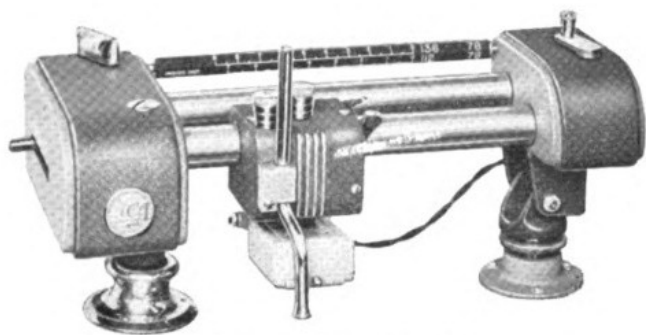

Type 72-D Recording Attachment

Uses

The 72-D Recording Attachment may be easily and quickly installed on any of the RCA 70-Series Turntables to provide an unusually high quality instantaneous recording equipment at an economical price. It is a newly designed and much improved version of the widely used Type 72-C. Broadcast stations will find many uses for this item such as recording rehearsals and controversial broadcasts, making records for use by the time salesmen and recording programs for delayed broadcasts. It may also be satisfactorily used for making masters for processing.

Description

The 72-D is equipped with a sturdy frame containing a screw mechanism for driving the cutter carriage across a record blank. Power coupling is made to the center of the turntable by means of a vertical shaft spiral gear and loosely coupled three pin driving flange which eliminates slippage and "knocks." Precision leveling adjustments are made by a swivel support with an accurate vertical adjustment. The mechanism is made so that it will swing clear when not in use or it may be easily removed from the transcription turntable if desired.

An improved lowering device permits the operator to gently lower the cutter on to the record, thus avoiding stylus breakage or deep cuts from sudden dropping. The angle of the stylus and the depth of cut may be conveniently adjusted even during operation. A spiralling hand crank permits spacing between musical selections without breaking the continuity of the groove. It is useful also for making starting and finishing spirals. The 72-D will record at either 33 $\frac{1}{3}$ or 78 rpm outside-in or inside-out at 96, 112 and 136 lines per inch. Selection of direction and pitch is made easily and quickly without changing lead screws or gears. Two interchangeable spring released hexagon timing scales are provided for giving an accurate indication of the remaining recording time. The scales are calibrated to cover all combinations of turntable speed and groove spacing. The cutter carriage does not ride on the feedscrew, but is supported on a metal tube in which the feedscrew is enclosed and is guided on another tube which is designed to house an automatic equalizer. This feature eliminates "grouping" of grooves, increases the life of the feedscrew and protects the feedscrew from dust. A lip has been turned on the driving spindle to catch the threads and prevent their climbing into the gears or bearings.

The 72-D is furnished complete with standard recorder head, MI-11853, mounting base and rest post. If higher fidelity response is required, the Type 72-DX with MI-11850-B recorder head is available. The MI-11854 base attachment kit is furnished for mounting the 72-D on all 70-series turntables. Additional mounting base kits are available if the recorder is to be used on more than one turntable. An MI-4910 conversion platter is available for use when the 72-D attachment is to be used with the 70-A or 70-B Turntables.

Features

- Makes high quality recordings on any 70-Series Turntable.
- Records at 33 $\frac{1}{3}$ or 78 rpm at 96, 112 and 136 lines per inch. *Outside-in or inside-out* recording is accomplished *without changing feedscrews or gears.*
- Timing scales indicate remaining recording time.
- Improved lowering device avoids stylus or record damage.
- Convenient adjustment of stylus angle and depth of cut.
- Hand crank for spiralling grooves.
- Convenient adjustment for horizontal alignment.
- Lead screw protected by cylindrical tube housing.
- Provision made for installing automatic equalizer.

Specifications

Input Impedance to Cutter	_____	15 ohms nominal
Audio Power Required (for 5 cm per sec. stylus velocity at 1000 cps)	_____	Approx. 3 watts
Frequency Response	_____	
Type 72-D	_____	± 4 db 50 to 7,500 cycles
Type 72-DX	_____	± 2 db 50 to 10,000 cycles
Recording Direction (adjustable)	_____	Inside-out and outside-in
Recording Pitch (adjustable)	_____	96, 112, and 136 lines per inch
Drive	_____	Platter of an RCA 70-C, 70-C1 or OR-1A Turntable (MI-4910 conversion required for 70-A or 70-B Turntables)
Dimensions, overall	_____	
Height	_____	6 $\frac{1}{2}$ "
Length	_____	15 $\frac{1}{4}$ "
Depth	_____	6 $\frac{1}{2}$ "
Weight (unpacked)	_____	9 $\frac{1}{2}$ lbs
Finish	_____	Two tone umber-grey, wrinkle
Stock Identification (as normally shipped)	_____	MI-11901 (Includes MI-11852 Attachment, MI-11853 Recorder Head, and MI-11854 Mounting Base)
Stock Identification (Type 72-DX)	_____	MI-11900 (Includes MI-11852 Attachment, MI-11850-B High Fidelity Recorder Head, and MI-11854 Mounting Base)
Accessories	_____	
Automatic Equalizer	_____	MI-11101
Fixed Orthacoustic Equalizer	_____	MI-4916
High Fidelity Cutter Head	_____	MI-11850-B
Recording Suction Equipment (less hose)	_____	MI-4922
Hose and Coupling Kit (for suction equipment)	_____	MI-4923
82-C1 Recording Amplifier	_____	MI-11209-B
Conversion Platter for 70-A or 70-B Turntables	_____	MI-4910
Sapphire Stylus	_____	90° MI-4878-C 70° MI-4842
Steel Stylus, package of 6	_____	MI-4879-A
Additional Mounting Base Kit	_____	MI-11854



Type 72-D Recorder Mounted on a Type 70-C1 Turntable

Professional Recorder Type 73-B



Uses

The 73-B Recorder is an outstanding professional type unit which has been designed to include almost every known device for making high quality recordings. Recording studios will acclaim the 73-B as the ideal recorder for making masters from which any number of pressings may be made. Broadcasting stations will find it unsurpassed for recording programs for use on delayed broadcasts, commercial accounts, rehearsals, auditions or the reference file.

The 73-B has all the exclusive features of the previous Type 73-A Recorder plus an improved cutter head, greatly improved carriage and feed screw assembly, automatic spiraling and an improved rim drive assembly. Its new lathe type construction insures continued perfect alignment of the carriage and permits quick record changing without removing the feed screw mechanism. Recordings may be made at 78 or 33½ rpm, either inside-out or outside-in, without changing feed screws or gears. A variable adjustment permits cutting from 96 to 152 lines per inch in steps of eight lines.

Description

The 73-B Recording Equipment consists of a high fidelity MI-11850-C cutting head with its associated carriage and lead screw mechanism, a turntable assembly which includes a dual motor with rim drive mechanism, a turntable platter with rubber mat, a microscope and microscope lamp and a suction nozzle (less the suction generating and hose connecting equipment) for removing acetate shavings from the record.

The MI-11850-C Recording Head is a high quality, precision built, magnetic type unit with a frequency response which does not depart from an ideal response curve by more than two decibels between 50 and 10,000 cycles per second. Its flat type mechanical construction eliminates flutter without the use of special damping mechanisms. The recorder head rides on a

smooth metal tube which encloses the feed screw and is guided on another tube which is designed to house an MI-11100 automatic equalizer. This arrangement eliminates "grouping" of grooves, increases the life of the feed screw and protects the feed screw from dust and dirt particles.

An improved cam-operated lowering device permits the head to be lowered gently with decreasing acceleration as the head approaches the record. This feature prevents stylus breakage or deep cuts from sudden dropping of the recorder head. The angle of the stylus, the depth of the cut and the number of lines per inch may be conveniently adjusted even while recording.

The turntable platter accommodates all standard discs for lacquer playback, lacquer masters for processing and wax masters for processing. Blanks up to 18¼ inches in diameter may be used. The platter is equipped with one driving pin which may be depressed into the platter for blanks without holes. A removable rubber mat on the platter provides a good record base and may be readily cleaned.

The turntable is rim driven through rubber idler rollers from two hysteresis type synchronous motors. These motors were chosen because of their quiet operation and accurate speed. The two motors and turntable drive wheels are both controlled by one "on-off" switch and both mechanisms are controlled by one "speed-change" switch. When the motor switch is turned "off", the driving rollers are disengaged and a brake is applied to the rim of the turntable, bringing it quickly to a stop. The motors are doubly rubber shock-mounted from the motor board to avoid motor rumble in the recordings.

The feed screw is driven by a planetary-drive mechanism using a rubber-tired roller on a vertical shaft and a flat driving-disc on the end of the horizontally mounted feed screw. The

Professional Recorder Type 73-B

driving roller may be adjusted to various vertical positions across the driving disc, the speed and direction of rotation of the feed screw being determined by the roller's position with respect to the center of the drive disc. The roller is automatically disengaged from the driving disc whenever the cutter head carriage is raised to the rest position. The number of cutting lines per inch is indicated by an illuminated scale in the drive housing. Four spring-released interchangeable time scales are provided to cover all combinations of turntable speed and groove spacings.

A separate motor, controlled by a push button on the recorder base, is used for motor driven spiralling, overdriving the lead screw to provide start and finishing spirals. The spiralling pitch is 4 lines per inch when the recorder is set for 96 lines per inch and the turntable speed is 78 rpm. For a turntable speed of 33 1/3 rpm, the spiralling pitch will be reduced in proportion to the speed change.

A high quality, 36 power, Spencer microscope is furnished for observing the grooves. The microscope has a calibrated eyepiece having 50 divisions of .001 inch and is mounted on an adjustable arm which permits it to be moved to any part of the record. On the same arm is mounted a small shielded lamp which is independently adjustable so as to illuminate the grooves under observation.

The 73-B is equipped with a heavy cast base and is well shock-mounted. The entire recording mechanism is isolated from room vibration by rubber mounts. The driver pulleys, using thick tires of special rubber, are unusually quiet in operation and give long and uniform life. A removable plate, placed over the pulleys on the left side of the machine, permits ready access to the driver pulleys and driver motors for servicing. Terminal boards are provided on the front and on the rear of the recorder base for a-c and audio connections respectively. The entire mechanism is furnished in an attractive and substantial wooden mounting cabinet but may be installed in a desk or bench by the user, if desired.

The 73-B is supplied with an adjustable suction nozzle attached to the carriage mechanism. A suction pump (MI-4922) and coupling hose (MI-4923) are available on separate order. Also available is the advance ball kit (MI-11851) for use with the MI-11850-C cutting head when making wax recordings.

Provision has been made for convenient installation of the MI-11100 Automatic Equalizer. A plug, wired to a terminal board, is supplied for the MI-11100 and knock-outs are provided for mounting its compensator switch.

Features

- Accommodates all sizes of recording discs for playback and processing.
- Complete shock mounting and special motors reduce vibration and rumble to a minimum.
- High fidelity cutter head handles full power with low distortion.
- Provisions made for attaching automatic equalizer.
- Two motor drive. Each motor has its own rubber idler wheel providing high torque and excellent regulation.
- Off-on switch releases rubber idler wheels to prevent "flats", and applies brake to turntable rim.
- Operates on either 33 1/3 or 78 rpm by turning a knob.
- Can be adjusted, while recording, for 96 to 152 lines per inch *inside-out or outside-in cut without changing lead screw or gears.*
- Large platter with rubber mat takes blanks up to 18 1/4 inches.
- One driving pin enables any type blank to be used. Pin is held up by spring and sinks into platter if record without driving holes is used.
- Cutter angle and depth of cut can be easily adjusted while recording.

- Spiralling motor, push button controlled, provides start and finishing spirals and spacing, between selections if desired.
- Dropping mechanism can be operated with one hand; lowers cutter on record slowly to prevent stylus damage.
- Lathe type construction insures accurate alignment and permits rapid record changing.
- Equipped with high grade microscope and illuminating lamp for accurately checking grooves on any portion of record.
- Furnished in attractive cabinet mounting—may be mounted in desk or on a bench.

Specifications

Recorder Head Impedance (MI-11850-B High Fidelity Head)	15 ohms nominal	
Audio Power Required (for 5 cm per sec. stylus velocity at 1000 cps)	Approximately 3 watts	
Frequency Response	±2 db 50 to 10,000 cycles	
Stylus	Sapphire or steel	
Turntable Diameter (handles blanks up to 18 1/4" dia. and up to 3/8" thick)	17 1/2"	
Turntable Drive	Rim driven through rubber idler rollers from two hysteresis synchronous motors	
Turntable Speed (accuracy ± 1/2%)	33 1/3 or 78 rpm	
Speed Regulation (wows)	0.14% rms at 33 1/3 rpm 0.07% rms at 78 rpm	
Recording Direction (adjustable)	Inside-out and Outside-in	
Recording Pitch	Continuously variable 96 to 152 lines per inch with detents provided in steps of 8 lines per inch	
Dimensions, overall	<i>With Cabinet</i>	<i>Less Cabinet</i>
Height	20"	20"
Width	31 3/4"	30"
Depth	22 1/4"	20 1/2"
Weight (unpacked, with cabinet)	289 lbs.	
Finish	Light umber grey wrinkle with dark umber grey trim. Cabinet finished with smooth dark umber grey. All control knobs and levers are polished nickel.	
A-c Power Supply, 115 volts 50-60 cycles—		
Turntable drive motors	80 watts	
Pilot Light	5 watts	
Spiralling Motor (when operating)	145 watts	
Stock Identification	60 cycles, MI-11825 50 cycles, MI-11826	
Accessories		
Automatic Equalizer	MI-11100	
Othacoustic Equalizer	MI-4916	
Suction Pump (less hose)	MI-4922	
Hose and Coupling Kit (for suction pump)	MI-4923	
Sapphire Stylus	90°	MI-4878-C
	70°	MI-4842
Steel Stylus	MI-4879-A	
Amplifier (Type 82-C1)	MI-11209-B	
Additional High Fidelity Cutter Head	MI-11850-C	
Standard Cutter Head	MI-11853	
Advance Ball Kit for MI-11850-B Cutter Head	MI-11851	

Portable Recording Equipment OR-1A

The Type OR-1 Portable Recorder with Type 72-C Recording Attachment. The OR-1A is similar in appearance but features the new and improved Type 72-D Recording Attachment shown elsewhere in this catalogue.

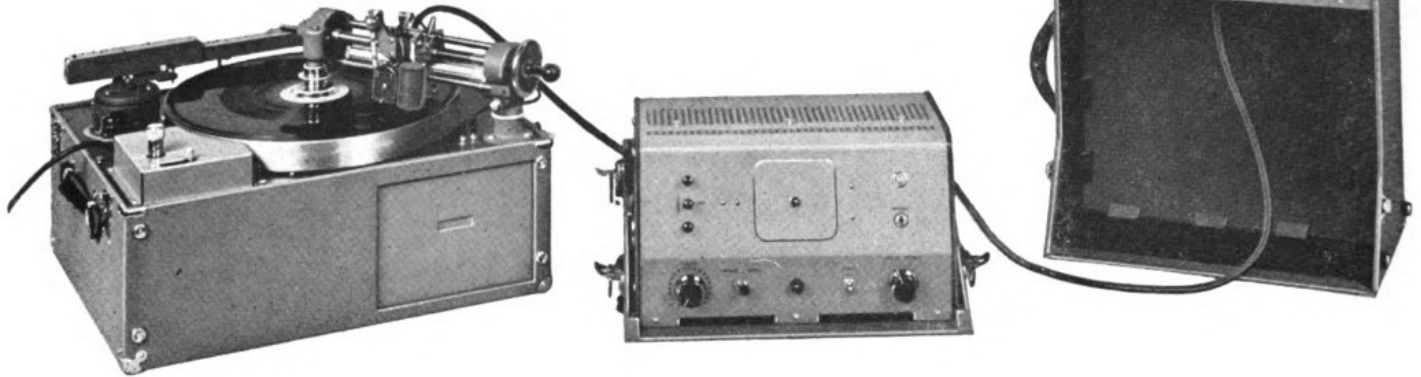

Uses

The OR-1A Portable Recording Equipment is a high quality reasonably priced assembly which includes all the equipment necessary for cutting high quality instantaneous recordings in the studio or at remote locations. It is a complete recording channel, less microphone, and will record at either 78 or 33 $\frac{1}{2}$ rpm at 96, 112 or 136 lines per inch. The turntable will accommodate any sized record up to 16 inches and the playback apparatus will reproduce all types of lateral and vertical records with a uniform frequency response between 30 and 10,000 cycles.

When required the turntable, amplifier and speaker units may be used, less the recording attachment, as a high fidelity record player for demonstration and sales purposes or, with a microphone, as a 12 watt P. A. system. The amplifier, turntable and speaker units may be ordered separately for this purpose. If desired, for a permanent installation, the turntable motor board may be removed from the carrying case and mounted in a desk or console.

Description

The OR-1A consists of a 16" Type MI-11212 Turntable, a Type 72-D Recording Attachment, Type MI-4875-B Combination Pickup and Arm Assembly, a 12 watt amplifier Type MI-11212 with dual loudspeaker unit.

The Recording mechanism (Type 72-D Attachment) meets all the requirements for making high quality recordings. A complete description and specifications of the Type 72-D will be found on the catalogue page featuring this unit. High fidelity reproduction of both lateral and vertical cut records is accomplished by use of the MI-4875-B Combination Pickup, which is essentially the same as that used on the 70-C1 Turntables.

The MI-11212 Amplifier has an overall gain of approximately 110 db. This gain remains approximately the same when the MI-11212 is used with the Orthacoustic Recording Filter or with the Automatic Recording Equalizer since a compensating pad is removed when either of these units is connected to the amplifier. The amplifier includes a built-in a-c rectifier, has a frequency response of ± 2 db from 30 to 15,000 cycles, a low noise level, and a distortion content of less than 3% rms at full output when measured at any frequency between 50 and 7500 cycles. A complete single stage preamplifier with input and output transformers is included as a part of the amplifier. This provides a 250 ohm circuit following the preamplifier for the insertion of equalizers, if desired.

A "playback-record" switch is mounted on the front panel and transfers both the input and output circuits of the amplifier. When thrown to the "playback" position, the input of the amplifier is connected to the pickup and the output to the loudspeakers. When the switch is in the "record" position, the input of the amplifier is connected to the input selector switch and the output to the recorder head. Two external input terminals are provided; one is a Cannon microphone receptacle for a 30 to 250 ohm microphone and the other is on insulated binding posts for bridging a 600 ohm line. The gain control is a high quality step-by-step potentiometer. A cut-out is provided in the front panel for the installation of an MI-11251 VU Meter Kit for monitoring the recording level, if desired. A monitoring headphone jack, a power switch and a fuse are also located on the front panel for ready accessibility. Mounted in the removable lid of the amplifier are two RCA "Accordion Cone" Speaker Units which are enclosed in a sealed compartment for proper cone loading and low frequency response. The unit is furnished with an a-c power cord and with a turntable interconnecting cable which is equipped with a Cannon plug to fit the receptacle in the MI-11211B Turntable.

Portable Recording Equipment OR-1A

Features

- Complete high quality portable recording and reproducing system.
- Records at 33 $\frac{1}{3}$ or 78 rpm at 96, 112 and 136 lines per inch outside-in or inside-out.
- All exclusive features of the 72-D Recorder such as three pin drive, inside-out or outside-in recording without changing feed screws or gears, spiralling hand crank and timing scales.
- High quality shock-mounted hysteresis type motor and two rubber-tired driver wheels provides minimum slippage and eliminates wows.
- High fidelity combination pickup with long wear diamond point reproduces all lateral or vertical cut records.
- High fidelity amplifier (± 2 db 30 to 15,000 cycles) with bridging and matching inputs provides 110 db gain and 12 watts rated output ample for any recording or reproducing requirement.
- Amplifier includes "playback-record" switch, two external input terminations, monitoring headphone jack, power switch and fuse.
- Low control panel includes necessary switches and controls while permitting good visibility of subject being recorded. Sloping mounting panel for installation of large volume meter.
- Two "accordion cone" speaker units mounted in carrying case with removable lid provide a total output of 6 watts.

Specifications

RECORDING MECHANISM TYPE 72-D

Type Cutter (MI-11850-B Recorder Head available) MI-11853
 Frequency Response ± 4 db 50 to 7500 cycles
 Recording Direction (adjustable) Inside-out or outside-in
 Recording Pitch Adjustable, 96, 112, or 136 lines per inch
 Finish Two tone umber grey wrinkle

PORTABLE TURNTABLE (60 cycles) MI-11211-B

Turntable Diameter (for 12", 14" or 16" records) 16"
 Turntable Speeds 33 $\frac{1}{3}$ — 78 rpm
 Turntable Drive Rim driven through rubber idler rollers by heavy duty synchronous motor
 Speed Regulation (wows) 0.15% rms max. at 33 $\frac{1}{3}$ rpm
 0.1% rms max. at 78 rpm
 Power Supply (105-125 volts, 50-60 cycles) 120 watts
 Dimensions Overall for Turntable Carrying Case
 Height 12 $\frac{3}{8}$ "
 Width 24"
 Depth 21"
 Weight (unpacked, but including 72-D Attachment) 56 lbs.

AMPLIFIER AND SPEAKER ASSEMBLY MI-11212

Input Source Impedance (unloaded transformer input) 250 ohms
 Input Bridging Impedance 20,000 ohms
 Output Load Impedance
 Cutter Head Terminals 15 ohms
 Speaker Terminals 7.5 ohms
 Preamplifier Output (to external filters) 250 ohms
 Audio Power Output (less than 3% rms distortion 50 to 7500 cycles) (40.8 db*) 12 watts
 Frequency Response (250 ohm source to 15 ohm load) ± 2 db 30 to 15,000 cycles
 Maximum Gain
 Overall from 250 ohm Microphone to 15 ohm cutter 110 db ± 2.0 db
 Overall from 250 ohm Pickup to 7.5 ohm Speakers 110 db ± 2.0 db
 Bridging 20,000 ohms Input 500 ohm line to 7.5 or 15 ohm load approximately 30 db
 Noise Level (40.8 db* output, maximum gain) 52 db*
 A-c Power Supply (105-125 volts, 50-60 cycles) 120 watts

Dimensions, Overall for Amplifier-Speaker Carrying Case
 Height 14"
 Width 18 $\frac{1}{2}$ "
 Depth 23 $\frac{1}{2}$ "
 Weight (unpacked—for Amplifier and Speakers) 63 lbs.
 Finish Two tone umber grey

Stock Identification

Complete Recorder, less tubes with MI-11853 Recorder Head MI-11210-E
 Complete Recorder, less tubes with High Fidelity Recorder Head Type MI-11850-B MI-11210-D

Accessories

Tube Kit (complete tube complement)
 5 RCA 1620, 2 RCA 1622, 1 RCA 5U4G MI-11259
 Emergency Tube Kit (complete tube complement)
 5 RCA 6J7's, 2 RCA 6L6's, 1 RCA 5U4G MI-11259-A
 VU Meter and Attenuator Kit MI-11251
 Orthacoustic Recording Filter MI-4916
 Automatic Recording Equalizer MI-11101
 Microphones RCA 44-BX, 77-D, 74-B, or 88-A
 Sapphire Stylus 90° MI-4878-C
 70° MI-4842
 Steel Styli, Package of 6 MI-4879-A

* Reference level one milliwatt.

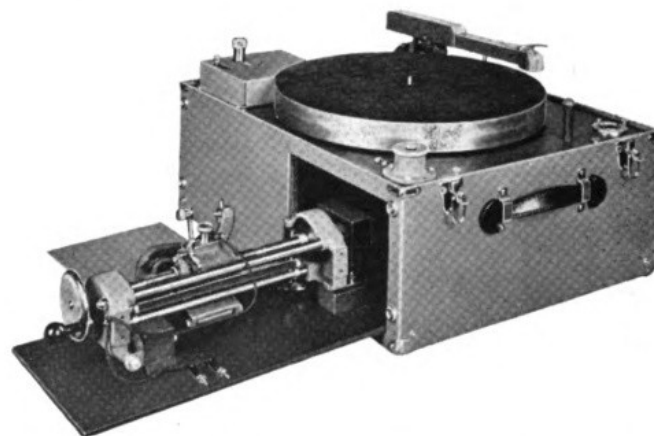

Showing method of Mounting Recording Attachment while transporting unit.



The complete OR-1A Equipment ready for transporting.

Recording Suction Equipment Type MI-4922 and Hose Kit Type MI-4923

The RCA MI-4922 and MI-4923 equipments are used for the removal of acetate shavings from the record surface during the cutting of records. The MI-4922 consists of the equipment used to create the vacuum, or suction. The MI-4923 consists of the necessary hose, tubing and couplings for connecting the suction equipment to the suction nozzles of either the 72 or 73 Series Recorders.

Specifications Type MI-4922 Suction Equipment

Power Supply _____ 105 to 125 volts, 25-60 cycles or d-c—
approx. 650 watts

Dimensions, overall
 Height _____ 19"
 Outside Diameter _____ 10 3/4"
 Weight (unpacked) _____ 25 lbs.
 Stock Identification _____ MI-4922

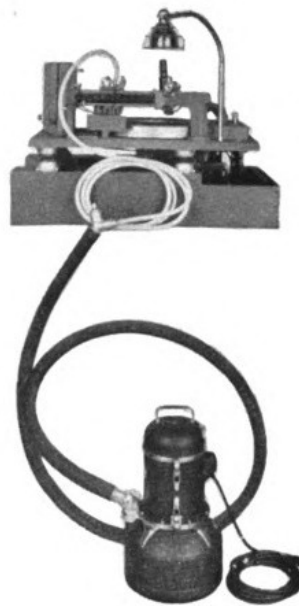

Recording Suction and Hose Equipment Attached to Type 73-A Recorder

Specifications Type MI-4923 Hose and Coupling Kit

It consists of:

- 1—10 foot length of 1 1/4" Black Hose for use between the MI-4922 suction equipment and the "Y" branch.
- 1—12 foot length of 3/8" White Rubber Tubing for use between the "Y" branch and the recorder nozzle.
- 1—90 degree "Y" branch and two reducing bushings for 1/4" to 3/8" outlets.

Universal Pickup Kit Type MI-4875-C

The RCA MI-4875-C Universal Pickup Kit has been designed to replace lateral and vertical pickups with one pickup which will reproduce the various kinds of records (orthacoustic, Victor, Columbia, World, etc.) with a response characteristic which is considered an ideal playback response. The filter unit is designed so that this may be accomplished by simply turning a switch to any one of six positions.

The MI-4875-C consists of one universal pickup and arm assembly and one reproducing switch and filter assembly. The pickup and arm assembly and the accessories provided are for use on the Types 70-A, 70-B or 70-C Transcription Turntables. For a more complete description, refer to the catalog page for the 70-C1 Turntable which features the Universal Pickup.

Weight (unpacked) _____ 15 lbs.
 Stock Identification _____ MI-4875-C

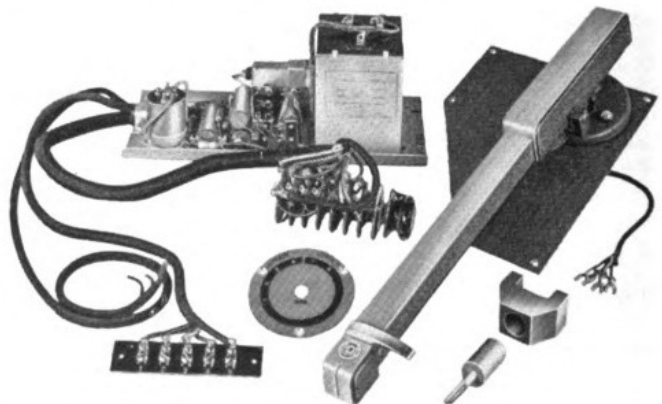

Microscope Type MI-4928

The MI-4928 is a high quality, 36 power Spencer Microscope and Arm Attachment for recorders. It permits close examination of the cutting needle to determine its condition and allows inspection of individual recording grooves for determining the nose level, quality and depth of cut.

The microscope has a calibrated eyepiece having 50 divisions of .001 inch and is mounted on an adjustable arm which permits it to be moved to any part of the record. On the same arm is mounted a small shielded lamp which is independently adjustable so as to illuminate the grooves under observation. The microscope is shipped complete with lens tube assembly, transformer for the microscope lamp, necessary mounting screws and installation instructions.

Specifications

Dimensions	Microscope Unmounted	Overall with Microscope Mounted on Arm	Microscope Light Transformer
Height _____	7 3/4"	9"	2 7/16"
Width _____	3"	3"	2 5/16"
Depth _____	2 5/8"	2 5/8"	2 7/32"

Finish
 Microscope _____ Finished instrument black
 Arm _____ Light umber grey

Weight (unpacked less transformer) _____ 7 1/2 lbs.
 Transformer _____ 1 lb.
 Stock Identification MI-4928

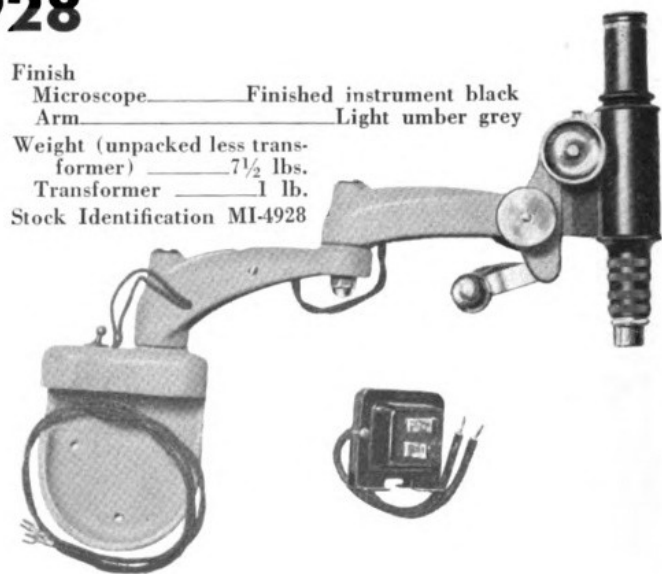

High Fidelity Recording Heads

Type MI-11850-C

The MI-11850-C High Fidelity Low Distortion Recording Head has been designed for use with the RCA 72-DX Recording Attachment, the 73-B Professional Recorder and the OR-1A Portable Recorder. It is a high quality, precision built, accurately adjusted unit of the magnetic type. Its flat type mechanical construction eliminates flutter without the need for special damping mechanism. Each unit is held within close frequency limits and does not depart from an ideal response curve by more than 2 decibels between 50 and 10,000 cycles per second.

Physically the MI-11850-C Recording Head consists of a laminated magnetic field structure with a driving coil and permanent magnet, an armature with damping material, a case to which the field structure is attached, and a bottom cover plate. The armature is mounted on the field structure and is located and held centrally with respect to the magnetic air gap by means of knife edge bearings and a steel centering spring. The damping material is carefully adjusted to obtain the ideal response curve.

Specifications

Input Impedance to Cutter _____ 15 ohms nominal
 Frequency Response—does not depart from an ideal response curve by more than _____ ± 2 db 50 to 10,000 cycles
 Audio Power Required (for 5 cm per sec. stylus velocity at 1000 cps) _____ Approx. 3 watts
 Stylus _____ Sapphire or steel
 Means of External Connections _____ Two single conductors 24" long with pin type plugs

Dimensions

Height _____ $1\frac{3}{8}$ "
 Width _____ 2"
 Length _____ $2\frac{3}{4}$ "
 Weight _____ 12 oz.
 Finish—
 Light umber grey

Stock Identification
 MI-11850-C

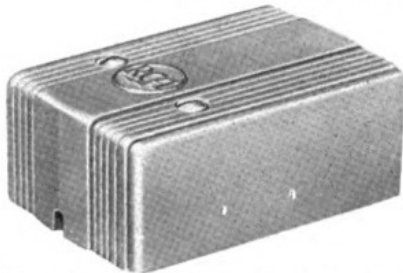

MI-11850-C High Fidelity Recorder Head

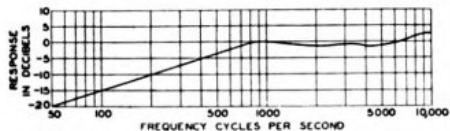

Typical frequency response of MI-11850-C and MI-4887 based upon optical measurements of the stylus tip motion for constant input

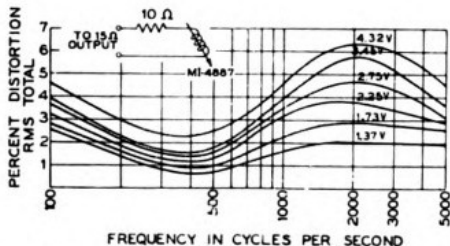

Typical distortion measurements for MI-11850-C and MI-4887 Recording Head

Type MI-4887

The MI-4887 High Fidelity Recording Head has been designed for use with the RCA Types 72-B, 72-C and 73-A Recording Equipments. The MI-4887 has a uniform frequency response from 30 to 10,000 cycles and distortion in records made with it is extremely low.

An impedance compensating network is furnished with the MI-4887 Head and the total input impedance remains sufficiently close to 15 ohms throughout the frequency range. Approximately 3 watts audio driving power is required for 5 cm per sec. stylus velocity at 1000 cps.

Stock Identification MI-4887



MI-4887 High Fidelity Recorder Head

Standard Recorder Head Type MI-11853

The MI-11853 Recording Head is supplied as the standard cutter for the 72-D Recording Attachment and the OR-1A Portable Recorder. It may also be used with the 73-B Professional Recorder for applications where the high fidelity response of the MI-11850-C Recording Head is not required. It is a high quality cutting head which does not depart from an ideal response curve by more than plus or minus 2 db from 50 to 7500 cycles.

The physical construction of the MI-11853 is similar to that of the MI-11850-C Cutting Head. Its flat type mechanical construction eliminates flutter without the need for special damping mechanism.

Specifications

Input Impedance _____ 15 ohms nominal
 Frequency Response _____ ± 4 db 50 to 7500 cycles
 Audio Power Required (for 5 cm per sec. stylus velocity at 1000 cps) _____ Approx. 3 watts

Stylus—
 Sapphire or steel
 Means of External Connections—
 Two single conductors 24" long with pin type plugs

Dimensions, overall
 Height _____ $1\frac{1}{8}$ "
 Width _____ 2"
 Length _____ $2\frac{7}{8}$ "
 Finish—
 Dark umber grey
 Weight _____ $7\frac{1}{2}$ oz.



MI-11853 Standard Recorder Head

Recording Filter Type MI-4916 (Orthacoustic)

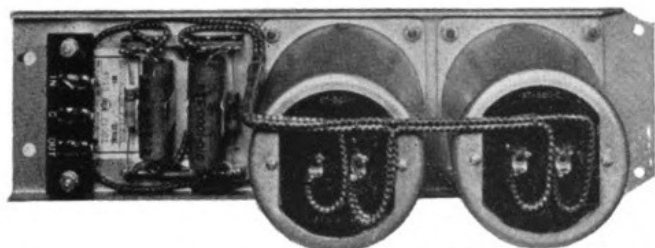

The MI-4916 Recording Filter has been designed to provide the most desirable reproduction characteristic for transcriptions as set forth by NAB standards for lateral transcriptions.

When used with the MI-11850-B or the MI-4887 High Fidelity Recording Heads, the MI-4916 Filter produces a recording frequency characteristic which is approximately 14 db below the 500 cycle level at 100 cycles and approximately 15 db above the 1000 cycle level at 10,000 cycles. The response is uniform between 500 and 1000 cycles. This filter may also be employed with the MI-11853 Recording Head with reduced frequency response above 7500 cycles. Such a frequency has been chosen as the most desirable for best reproduction of transcriptions.

Holes are provided for mounting the unit on a 36-B Shelf Assembly.

Specifications

Input Source Impedance..... 600 ohms
 Output Load Impedance..... 600 ohms
 Insertion Loss (at 1000 cycles)..... 17 db
 Maximum Input Level..... + 20 db*
 Hum Pickup Level (when placed 6" or more from a power transformer)..... -120 db*

Dimensions, overall

Height..... 4 $\frac{3}{4}$ "
 Width..... 3 $\frac{9}{16}$ "
 Length..... 12 $\frac{5}{8}$ "

Weight (unpacked)..... 6 $\frac{1}{2}$ lbs.

Stock Identification..... MI-4916

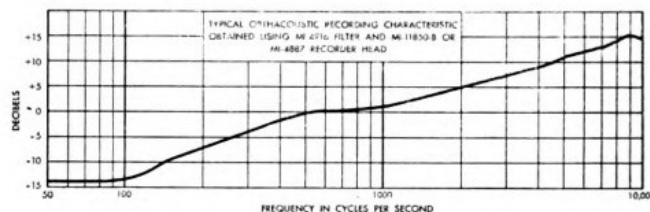

Advance Ball Kit Type MI-11851

The MI-11851 Advance Ball Kit has been designed to work with the MI-11850-B Recorder Head. It serves to control accurately the depth of groove when the Cutter Head is used with soft recording materials. The Advance Ball is essential when recording on wax and some operators find it convenient for use with lacquer recordings.

The Advance Ball is a sapphire cylinder with a tip that has been highly polished to a spherical shape and mounted in a Duralumin shank. The Ball rests on the unrecorded portion of the record surface, supporting the head at a constant height above the record, so that the depth and width of the groove will remain constant. An adjusting knob on top of the head adjusts the vertical position of the Advance Ball to regulate the depth of cut. Provision is made for moving the Advance Ball to either side of the stylus to accommodate outside-in or inside-out cuts as desired.

Specifications

Dimensions, overall, approximate

Height..... 1 $\frac{1}{4}$ "
 Width..... 1 $\frac{1}{2}$ "
 Depth..... 1"

Weight, approximate..... 10 grams

Finish..... White nickel

Stock Identification..... MI-11851



Cutting Styli

The MI-4842 Sapphire Stylus with 70° angle and short shank is recommended for use with RCA recorders for cutting lacquer blanks for immediate playback and for cutting masters for processing. The 90° stylus is recommended only for use in cutting masters from which 10" and 12" commercial pressings are to be made. Long shank styli are no longer stocked by RCA since their use impairs the recorder frequency response beyond 8000 c.p.s. and a rather severe peak may develop in this region.

The use of a sapphire stylus is recommended for all recordings except unimportant tests. Initial cost is reasonable and the moderate charge for sharpening brings the cost per minute

of recording equal to or below that for steel cutting points. Steel cutting points may be used with RCA recorders for unimportant tests or for cuttings being made by inexperienced personnel. In general, steel cutters are not recommended for high fidelity work because they may produce a higher noise level, a reduced frequency range and their life is relatively short. Both sapphire and steel cutting needles are carried in stock by RCA.

Stock Identification

70° Sapphire Stylus (short shank)..... MI-4842
 90° Sapphire Stylus (short shank)..... MI-4878-C
 Steel Styli (package of 6)..... MI-4879-A

LOUDSPEAKERS

SECTION

G

MONITORING LOUDSPEAKERS

CUEING AND TALKBACK SPEAKERS

Monitoring Speaker Type 64-B

Uses

The 64-B has been developed to meet the exacting demands of broadcasting stations for a high fidelity monitoring speaker. Its superior reproducing qualities make it ideally suited for use as a monitor in control rooms, audition booths, offices, lobbies or at any other place where high quality is of prime importance. The Type 64-B Monitoring Loudspeaker supersedes the Type 64-A—64AX Speaker which has proved to be a very popular unit. It differs from the 64-AX in that an improved cabinet styling and a new permanent magnet mechanism are employed.

Description

The speaker consists essentially of three items: namely, the cabinet, the speaker mechanism and the high frequency diffuser.

The cabinet houses a series of acoustic filter chambers of increasing size which open into the large grill at the bottom of the unit. This arrangement provides the equivalent of an 8-foot baffle. The cabinet is rigidly braced to eliminate tone distortion caused by vibrating members, walls or back. The closed back makes it possible to locate the unit at any distance from a wall without affecting the frequency response.

The speaker mechanism is a six inch, double-voice, coil unit employing a permanent magnet for field excitation. (A 6-inch 110 volt, 110 ma. electro-magnet double voice coil speaker, MI-4411, is also available for use with this cabinet.) The speaker itself is mounted behind the top grill in the small opening of the acoustic filter chamber.

Directly in front of the cone is a four vane high frequency diffuser which provides a wide angle distribution of the high frequencies. Thus the combination of a double-voice coil speaker plus the horn and high frequency diffusing vanes provides a high quality speaker with a wide frequency range. The 64-B Monitoring Loudspeaker can be operated from the Type 82-C1 Monitoring Amplifier. This amplifier has sufficient output capacity to operate three Type 64-B Speakers. If desired, the 82-C1 remote volume control may be mounted on the left side of the 64-B speaker cabinet where a "knock-out" is provided. This mounting hole may also be used for mounting a low impedance voice coil control.

A matching base-cabinet is available for use with the 64-B Speaker. This base is designed so that, when combined with the 64-B cabinet, the two cabinets appear as a single unit. The base may be used to house a monitoring amplifier.

Features

- Good frequency response.
- Wide angle sound distribution.
- Low distortion.
- Double voice coil.
- High sensitivity, low-driving power.
- Attractive cabinet design.

Specifications

Input Impedance	15 ohms nominal	
Frequency Response (see curve)	60-10,000 cycles	
Audio Power Input	10 watts, maximum	
Dimensions, overall	Cabinet	Base
Height	33"	14"
Width	29"	29½"
Depth	19"	19½"
Weight (unpacked)		
Cabinet	78½ lbs.	
Base	27 lbs.	
Permanent Magnet Speaker (MI-4410)	11 lbs.	
Finish	Umber Grey or Walnut	
Stock Identification		
Cabinet and PM Speaker, umber grey	MI-4400/4410	
Cabinet and PM Speaker, walnut	MI-4400-C/4410	
Base, umber grey	MI-4405	
Base, walnut	MI-4405-C	



64-B Monitoring Speaker

and

64-B Speaker Mounted on MI-4405 Base

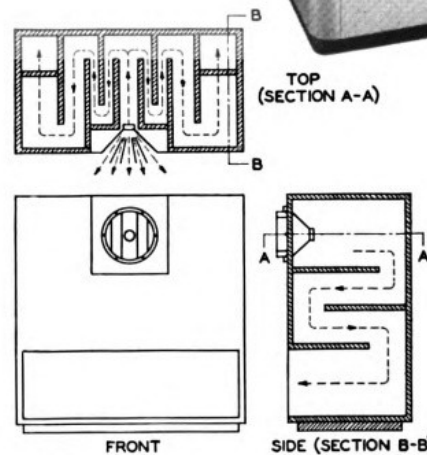
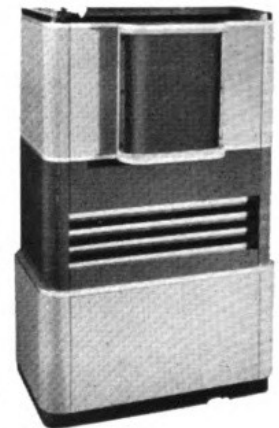

FRONT AND CROSS-SECTIONAL VIEWS SHOWING FOLDED HORN CONSTRUCTION IN RCA 64-B LOUDSPEAKER CABINET. DOTTED LINES INDICATE PATH OF SOUND WAVES.

AVERAGED FREQUENCY RESPONSE OF TYPICAL 64-B LOUD SPEAKER

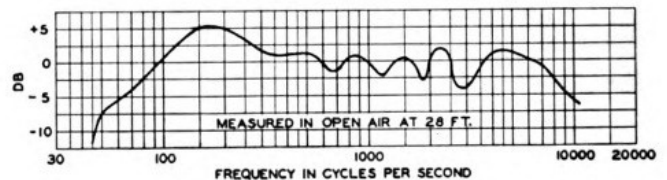

Floor Console Speaker MI-6222 / 6224 / 4-6234-A

The MI-6222 Console, with MI-6224 Baffle and Transformer Assembly and four MI-6234-A Speaker Mechanisms, may be used where the high fidelity response of the 64-B is not required. An acoustic phase inverter is built into the cabinet to extend the low frequency response. The appearance and size of this unit makes it an economical unit to use for office monitoring.

Specifications

Audio Power Input (maximum for the four speaker units) _____ 12 watts
 Frequency Response _____ 50 to 8000 cycles
 Speaker Mechanism _____ Four Type MI-6234-A Units (see MI-6234-A)
 Voice Coil Impedance _____ 15 ohms nominal
 Dimensions of Cabinet, overall
 Height _____ 32"
 Width _____ 24"
 Depth _____ 14 1/8"
 Weight
 Cabinet only (unpacked) _____ 30 lbs.
 Cabinet plus Speaker Assembly _____ 47 lbs.

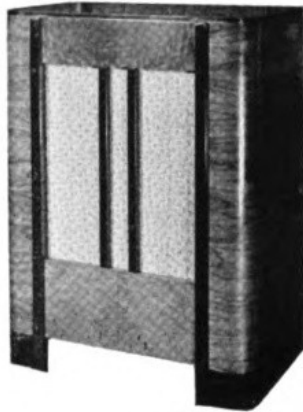

Finish _____ Polished walnut
 Stock Identification _____ MI-6222 / 6224 / 4-6234-A
 (Complete with four speakers, mounting baffle and matching transformer)

Console Speaker Cabinet MI-6222 with MI-6329 Speaker

The MI-6222 / 6329 employs a 15 inch Permanent Field Dynamic Speaker housed in the MI-6222 Floor Console pictured elsewhere on this page. This speaker has a felted cone and a large Alnico magnet assuring good bass response for high quality music reproduction. Large power handling capacity and sturdy construction permit normal operation at conservative power with huge reserve power available.

Specifications

Audio Power Input (maximum) _____ 15 watts
 Frequency Response _____ 60 to 4000 cycles
 Speaker Mechanism _____ One MI-6329 (see MI-6329 for details)
 Dimensions _____ See MI-6222 Console above
 Weight
 Cabinet only (unpacked) _____ 30 lbs.
 Cabinet plus Speaker (unpacked) _____ 43 1/4 lbs.
 Finish _____ See MI-6222 Console above
 Stock Identification _____ MI-6222 / 6329

Auditorium Wall Speaker Equipment MI-6223 / 6329

The MI-6223 / 6329 Speaker Equipment can be used to advantage in large theatre studios for cueing and talkback purposes. The cabinet houses one MI-6329 15 inch Permanent Field Dynamic Speaker which has excellent low frequency response.

Specifications

(See MI-6329 Speaker for description of speaker unit)
 Frequency Response _____ 60 to 4000 cycles
 Dimensions of Cabinet, overall
 Height _____ 28"
 Width _____ 18 7/8"
 Depth _____ 13"
 Weight
 Cabinet (unpacked) _____ 20 1/2 lbs.
 Cabinet plus Speaker (unpacked) _____ 33 3/4 lbs.
 Finish _____ Umber grey
 Stock Identification
 Complete with Speaker MI-6223 / 6329
 Wall Cabinet only MI-6223

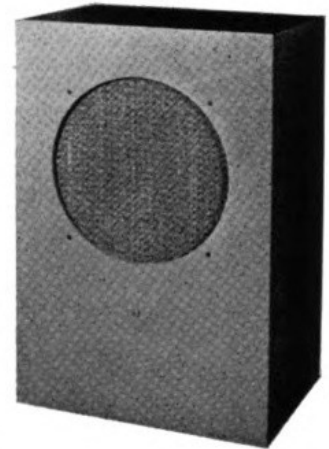

Wall Housing-Speaker MI-12414

The MI-12414 Assembly consists of one MI-6234-A Speaker mounted in an acoustically matched, sloping front wooden wall cabinet and an efficient auto type speaker matching transformer, MI-12315.

The entirely closed housing makes this speaker independent of changes in quality of reproduction resulting from differences in wall materials or air gaps between wall and housing. Line connections are made to an external screw type terminal board.

Specifications

Speaker Characteristics
 See MI-6234-A elsewhere on this page
 Frequency Response (speaker in cabinet) _____ 60 to 7000 cycles
 Dimensions, overall
 Height _____ 18"
 Width _____ 12"
 Depth _____ 6 3/4"
 Finish _____ Walnut
 Weight (unpacked) _____ 8 1/2 lbs.
 Stock Identification _____ MI-12414



MI-6329

The MI-6329 is suitable for use in the MI-6222 Console Cabinet, the MI-6223 Wall Cabinet or for flat baffle use. This heavy 15 inch permanent field speaker has a felted cone and large Alnico magnet to assure good bass response. Large power handling capacity and sturdy construction permit normal operation at conservative power with huge reserve power available.



Specifications

Audio Power Input _____ 15 watts
 Voice Coil Impedance _____ 8 ohms
 Cone Diameter _____ 15"
 Weight (unpacked) _____ 13 1/4 lbs.

Permanent Field Dynamic Speaker Units

The MI-6234-A is a radically different permanent field dynamic speaker unit with the revolutionary RCA accordion cone.

Specifications

Audio Power Input (maximum) _____ 3 watts
 Voice Coil Impedance _____ 6 ohms
 Dimensions, overall
 Diameter _____ 7"
 Depth _____ 4"
 Weight (unpacked) _____ 2 1/4 lbs.
 Finish _____ Grey
 Stock Identification _____ MI-6234-A

MI-6234-A



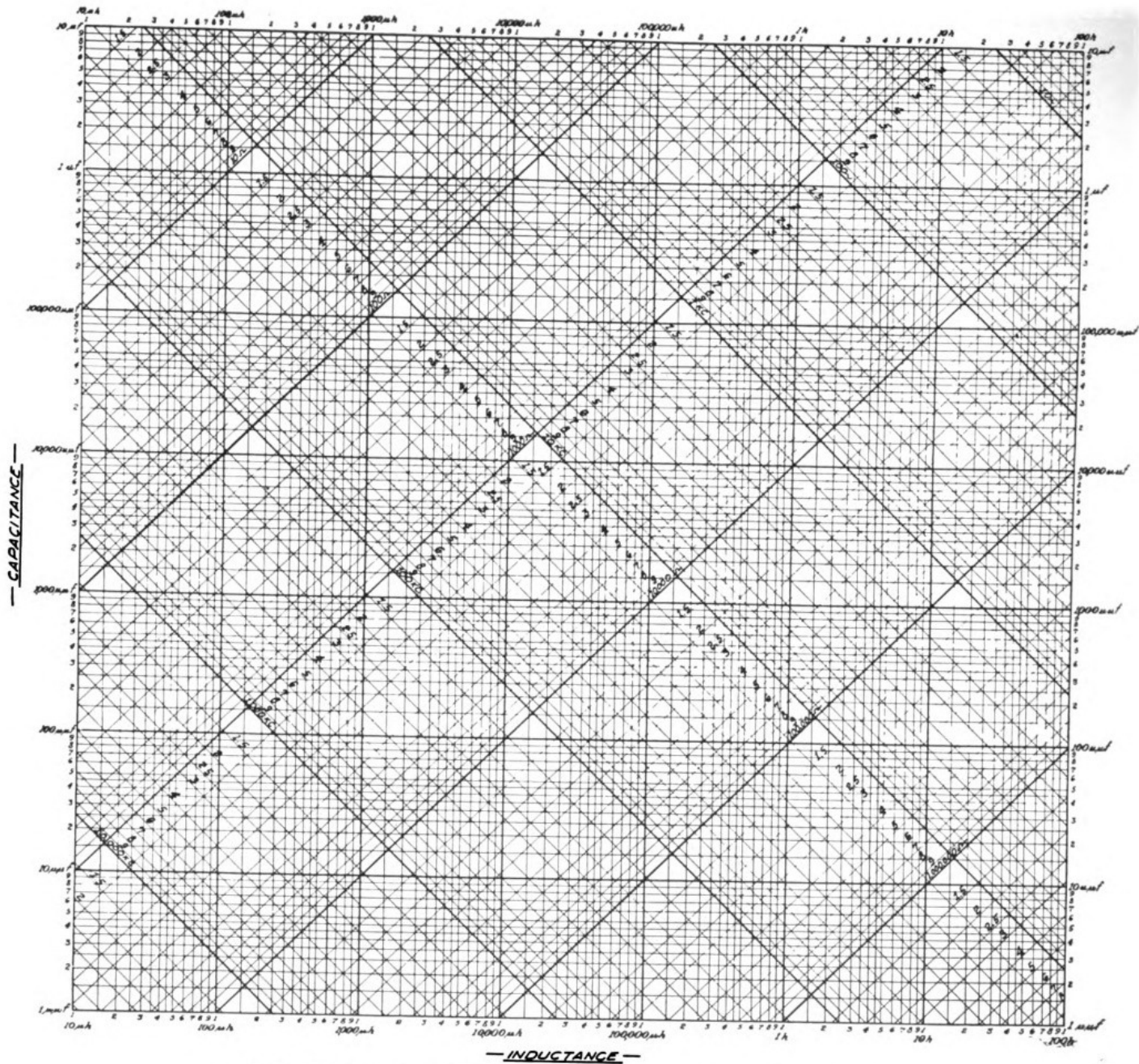

~ CHART OF FREQUENCY OR IMPEDANCE ~
 ~ VS ~
 ~ INDUCTANCE AND CAPACITANCE ~

DATA SECTION

SECTION

H

CHARTS AND CURVES

TYPICAL STUDIO LAYOUTS

RECOMMENDED EQUIPMENT LISTS

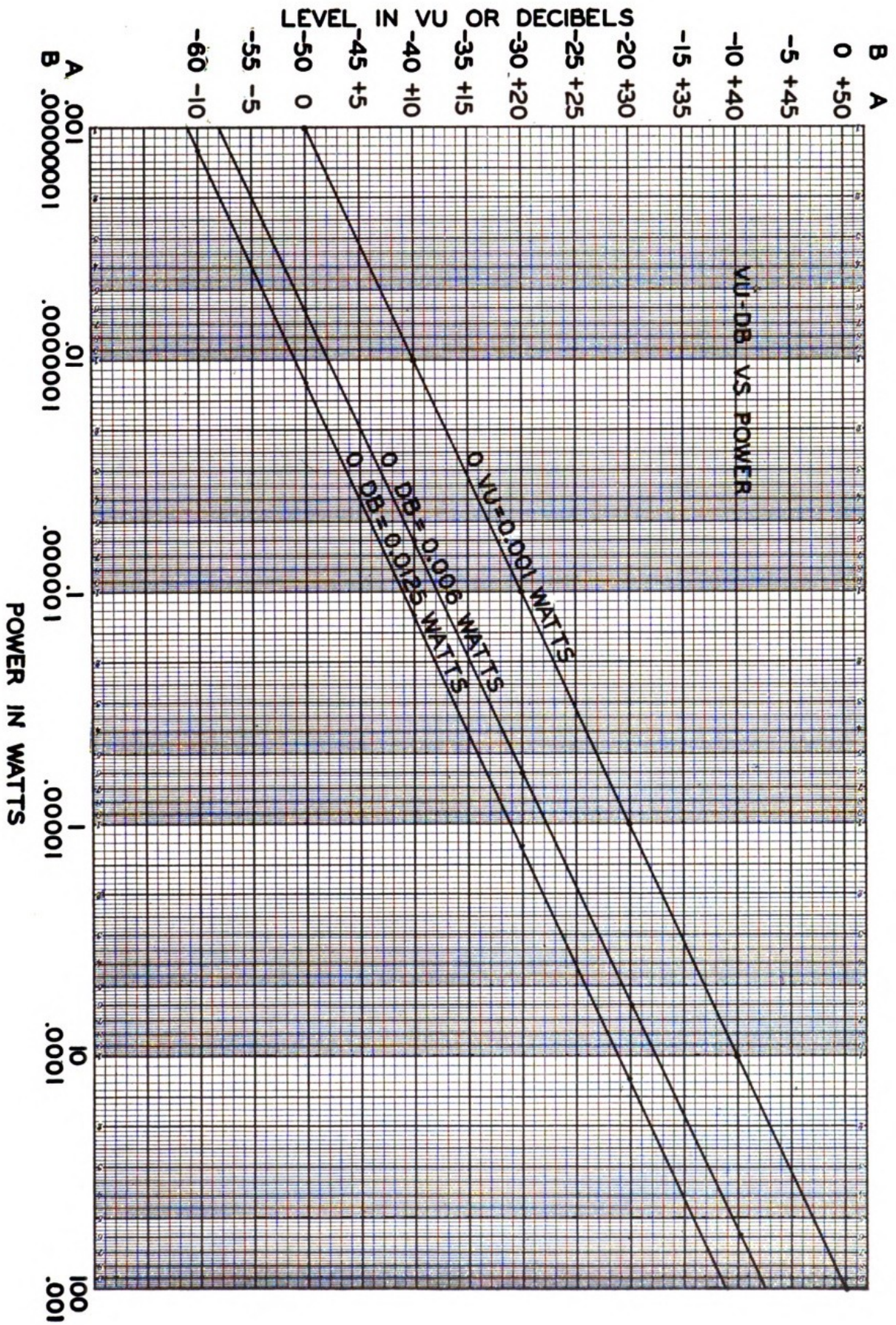

TO EXTEND RANGE MULTIPLY 'VOLTAGE RATIO'
BY 1000 AND ADD 60 TO DB

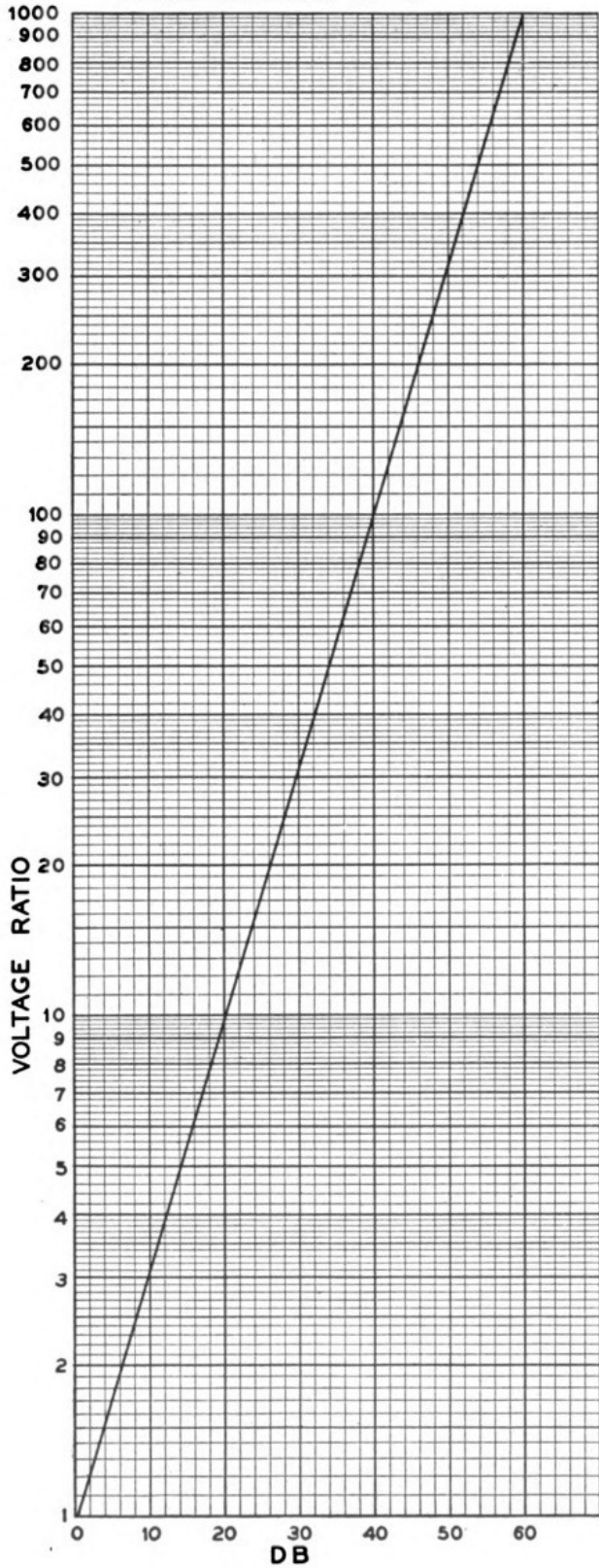

Voltage Ratio 1 DB

TO EXTEND RANGE MULTIPLY 'IMPEDANCE RATIO'
BY 1000 AND ADD 30 TO DB

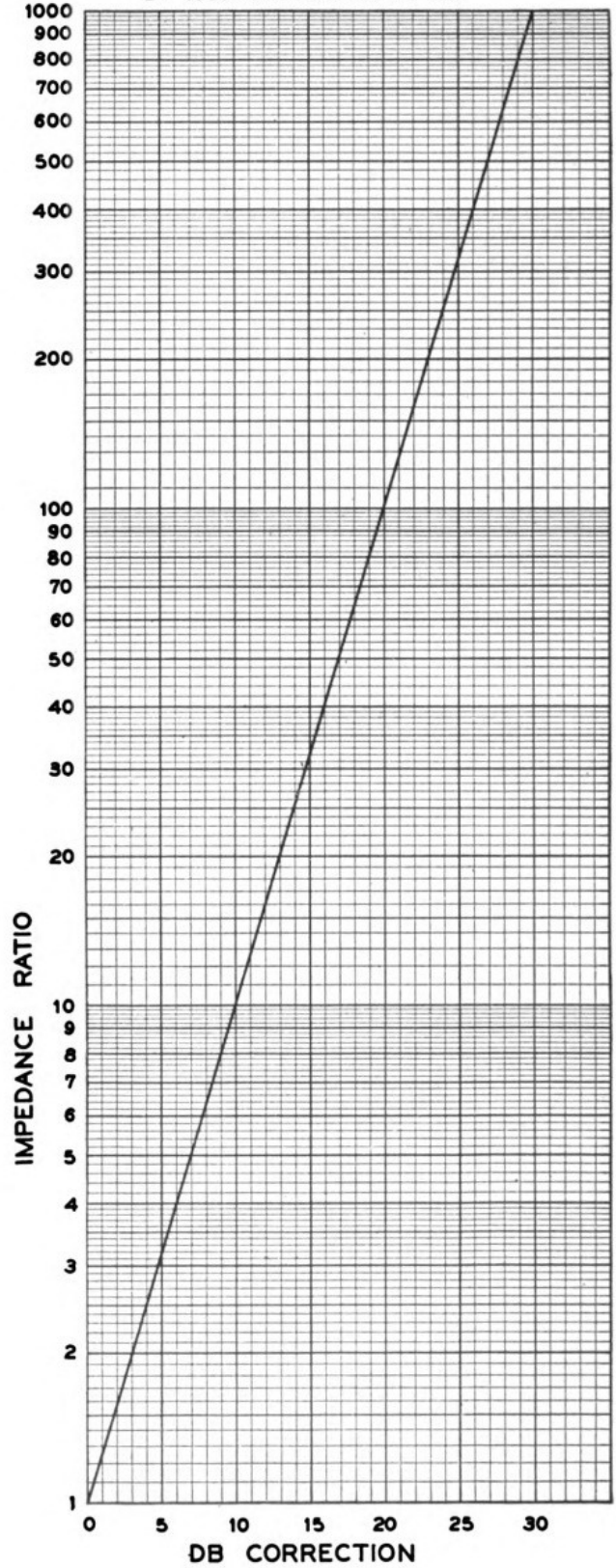

Impedance Ratio 1 DB Correction

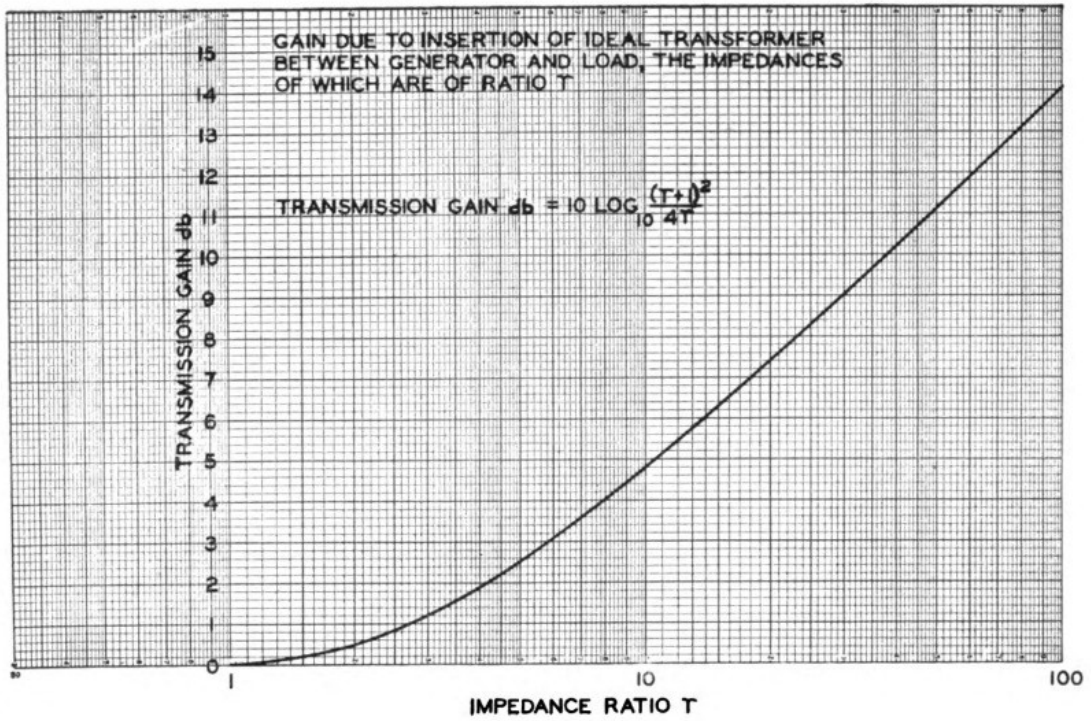

BRIDGING LOSS

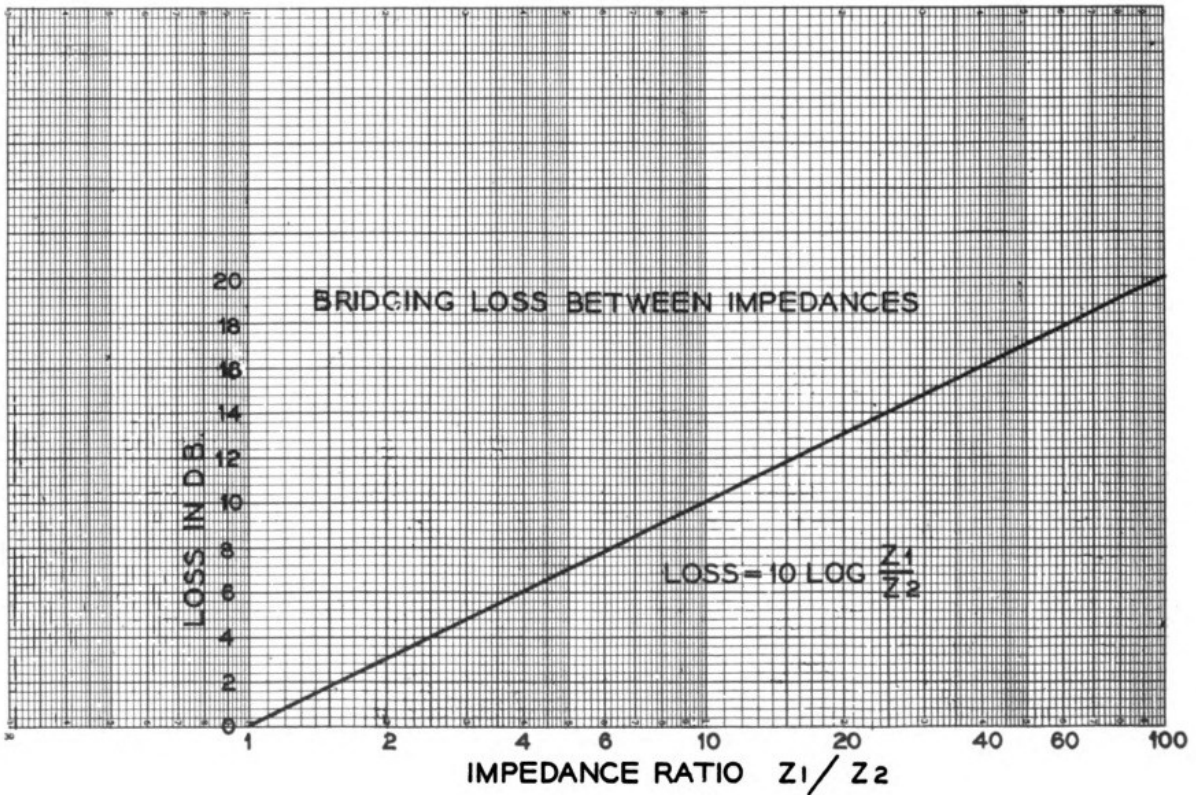

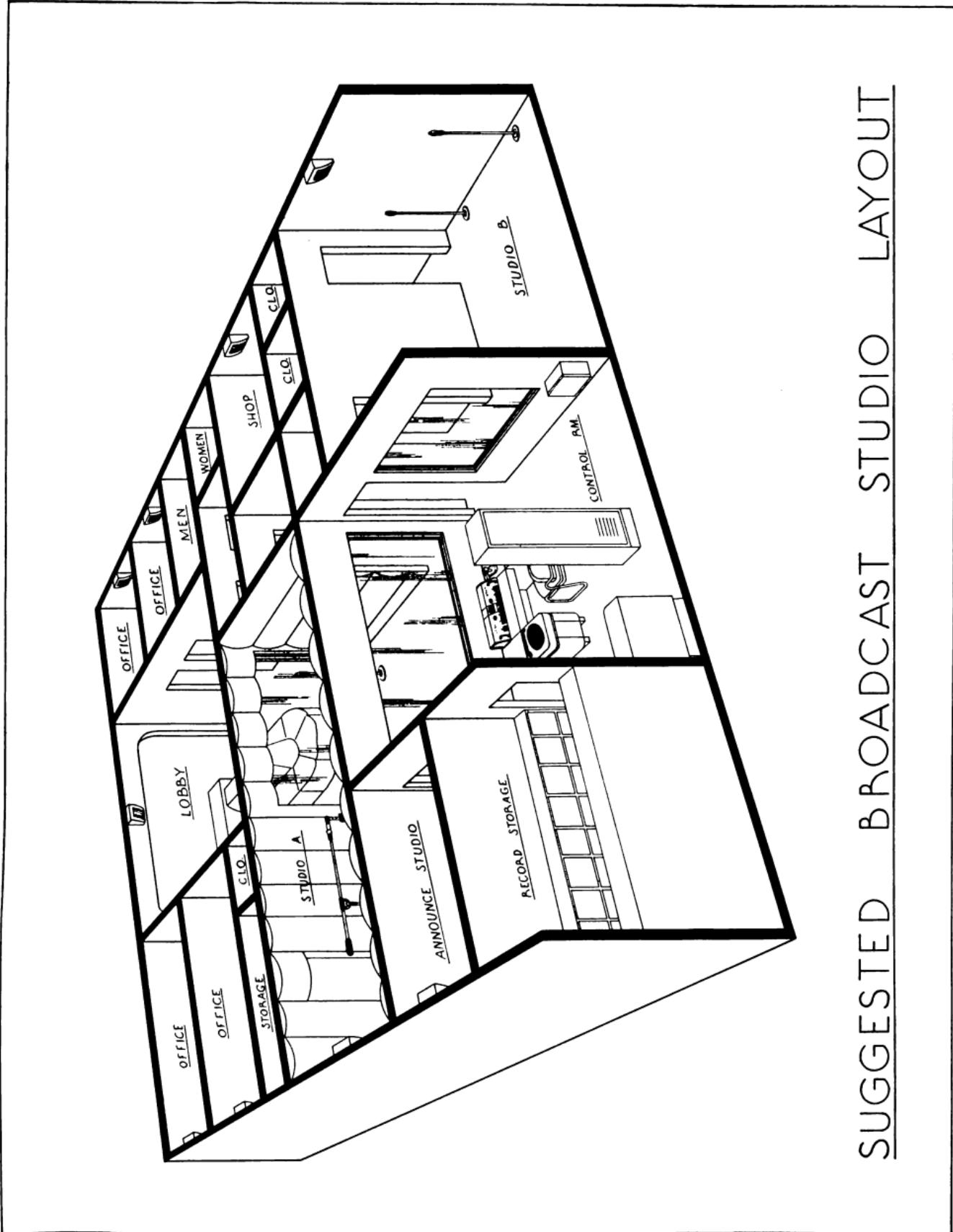

SUGGESTED BROADCAST STUDIO LAYOUT

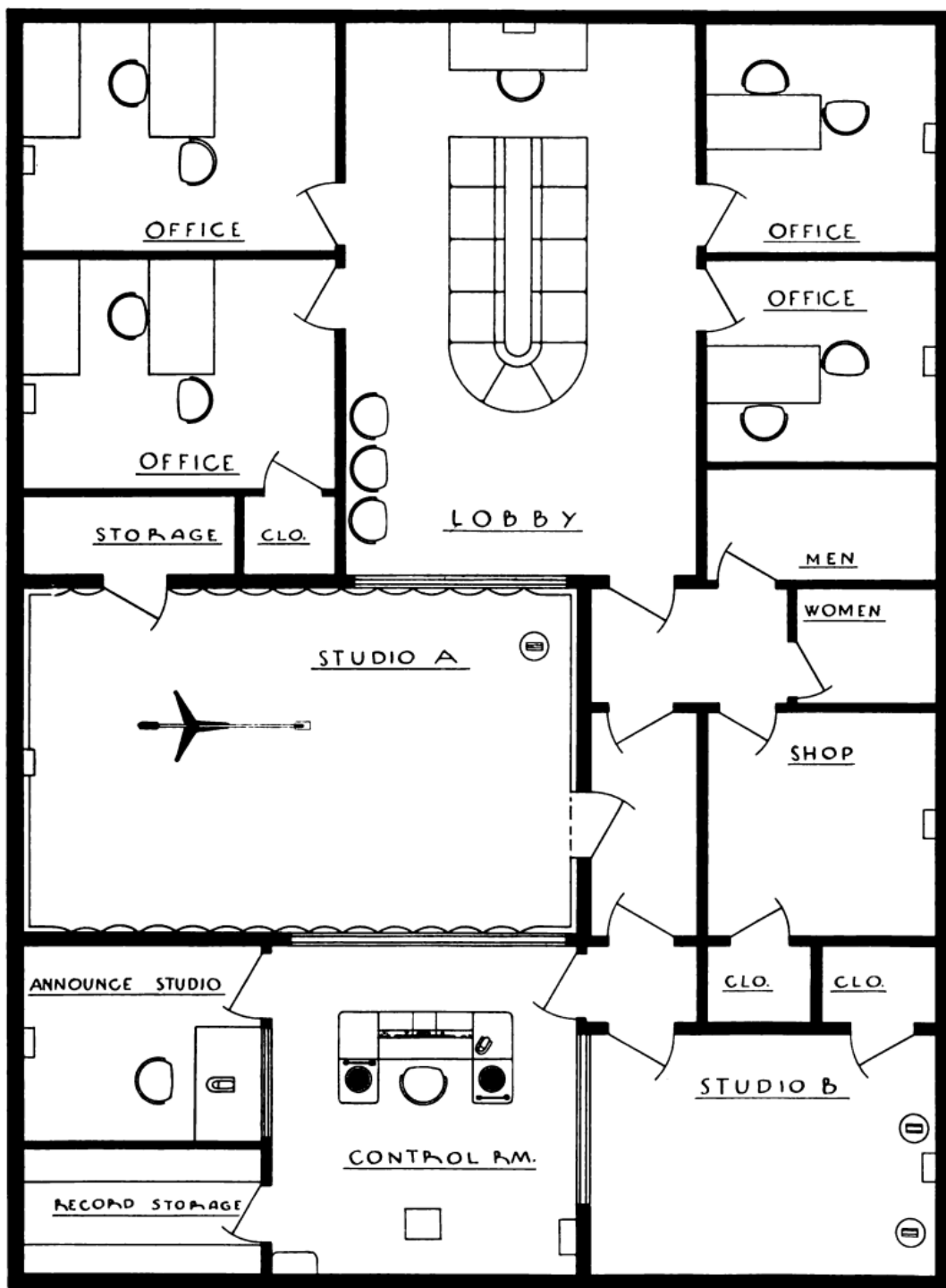

SUGGESTED BROADCAST STUDIO LAYOUT

Preferred Studio Dimensions

Based on $\sqrt[3]{2}$ Ratio Permissible Deviation $\pm 5\%$

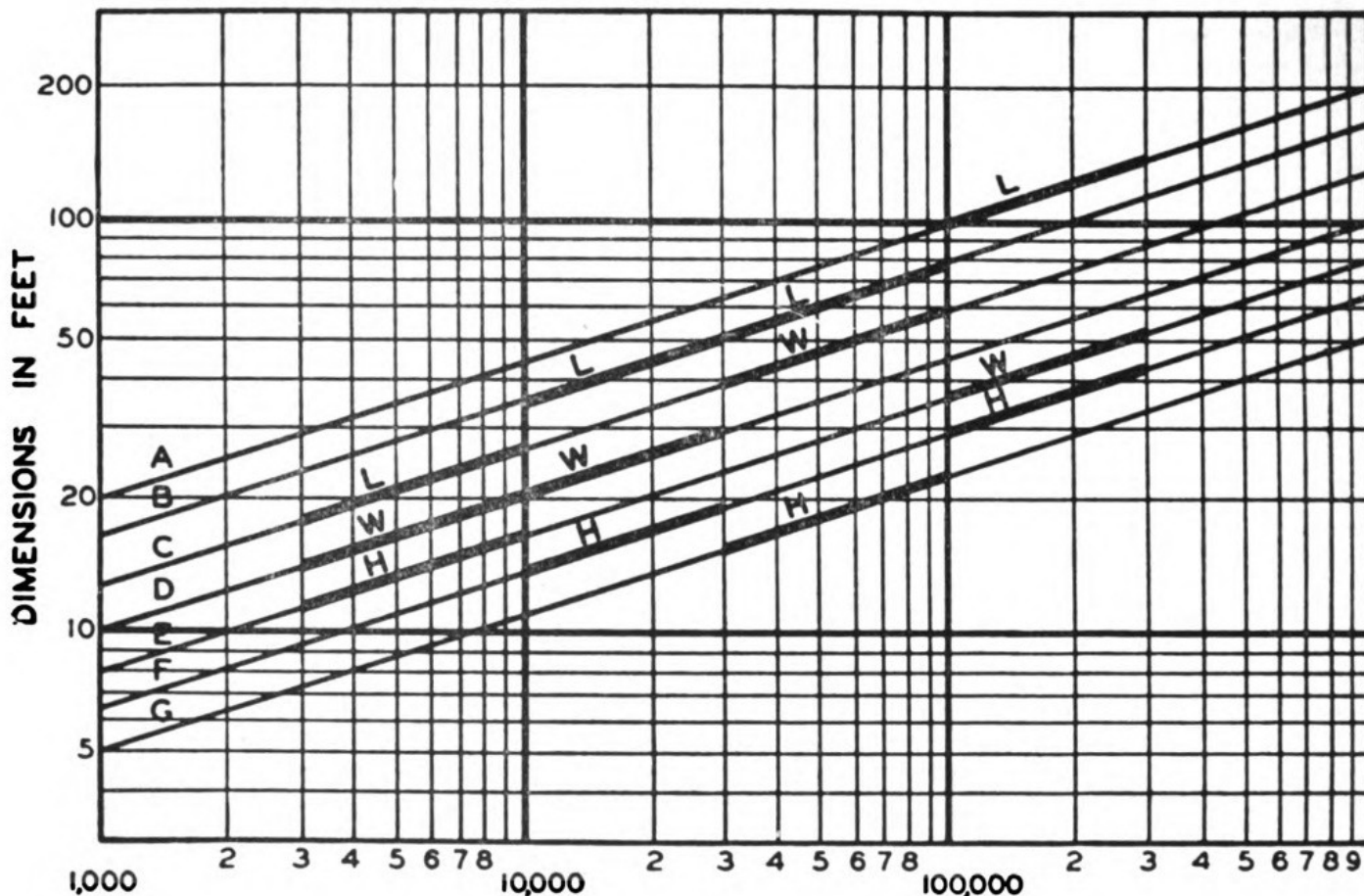

VOLUME IN CUBIC FEET

Small Rooms	_____	H:W:L = 1:1.25:1.6 = E:D:C
Average Shape Rooms	_____	H:W:L = 1:1.6:2.5 = F:D:B
Low Ceiling Rooms	_____	H:W:L = 1:2.5:3.2 = G:C:B
Long Rooms	_____	H:W:L = 1:1.25:3.2 = F:E:A

The above chart and accompanying explanation was taken from John E. Volkmann's article "Polycylindrical Diffusers in Room Acoustic Design" which appeared in Broadcast News for January 1945. The chart gives preferred dimensions versus room size for various types of studios. If a room is very small and nearly cubical in shape the direct ratio of the cube root of two would be preferred (see Curves C: D: E). For average studio sizes the ratio should be near the cube root of four

(see Curves B: D: F). This approximates the frequent practice in the broadcast field of using a ratio of 2: 3: 5. If a low ceiling is necessitated then the ratio given by Curves B: C: G would be preferred. In all cases the dimensions shown are derived from the ratio of the $\sqrt[3]{2}$. Stating it another way, the major dimensions should be separated 1/3 octave with respect to each other, or, other ratios derived from this fundamental ratio by shifting any or all of the dimensions by one or more integral octaves may be used.

Recommended Equipment Lists

The following equipment lists have been prepared as an aid to the selection of broadcast audio equipment required for an average studio installation and for audio and monitoring equipment required for use with a transmitter at the transmitter location. These lists should be used only as a guide in the selection of equipment since the individual requirements of each station must be considered carefully before the proper equipment selection can be made.

Equipment listed for the studio will successfully handle an average installation where not more than two studios are required. For more than two studios consideration should be given to the more extensive equipment requirements such as master control switching with individual studio control. RCA speech input engineers will gladly assist in planning master control installations when these are required.

Transmitter monitoring equipment lists suggest typical equipment for use when the transmitter is located at a point remote from the studio and for use when the transmitter and studio are at the same location. An equipment list is given also for use with control desks which are supplied as standard equipment with RCA 5-F, 10-F and BTA-50F AM Transmitters.

The equipment lists include:

- 1 Studio Equipment
 - 2 Remote Equipment
 - 3 Professional Type Recording Equipment
 - 4 Standard Type Recording Equipment
 - 5 Transmitter Monitoring Equipment
 - A Transmitter and Studio at Same Location
 - B Transmitter at Location Remote from Studio
 - C Transmitter at Location Remote from Studio
- MI-11620 Rack for use with Control Desk.

1 AM and FM Studio Equipment

Suggested apparatus for handling two studios, an announce booth, control room microphone, two transcription turntables and equalization for remote lines.

Item	Qty.	Description	MI- Number
1	1	76-B2 Console and Power Supply	11613-A1/ 11301-B
2	1	Set of Tubes for Item 1, 76-B2 and Power Supply	11252
3	6	Relays for Studio lights	11702
4	1	Relay for announce booth speaker	11703

Item	Qty.	Description	MI- Number
5	1	Wall Cabinet for mounting Items 6, 7, 8, 9, 10 and 11	11500
6	1	56-E Double Line Equalizer	4162
7	1	33-A Double Jack Panel	4645
8	1	Mat for Item 7, U/G	11501-A
9	1	5¼" Blank Panel, U/G	4592-B
10	1	6 db Pad, 600 ohms	4171-29
11	2	Audio Terminal Block	4569
12	4	Patch Cords	4652-2A
13	2	70-C1 Turntables, U/G (may be used in control room or in announce booth)	4871-C
14	2	BA-2A Booster Amplifiers (for Item 13)	11226
15	2	Sets of Tubes for Item 14, one each for BA-2A's	11287
16	2	44-BX Velocity Microphones (one for each studio)	4027-D
17	2	77-D Directional Microphones (one for each studio)	4045
18	2	88-A Pressure Microphones (for control room and announce booth)	4048-C
19	1	74-B Jr. Velocity Microphone (for general utility use)	4036-W
20	1	90-C Boom Stand (for larger studio)	4094-A
21	3	90-A Floor Stands (one for larger studio and two for smaller studios)	4090-A
22	3	91-B Desk Stands (one for announce booth, one for control room and one for general utility use)	4092
23	7	Microphone Cord Plugs	4630-B
24	6	Microphone Wall Receptacles (two for each studio, one for announce booth and one for control room)	4624-A
25	3	Wall Speakers (for studios and announce booth)	12414
26	1	64-B Monitoring Speaker, U/G (for control room)	4400/ 4410
27	1000'	Interconnecting Cable	63-A
28	1000'	Interconnecting Cable	64
29	1000'	Interconnecting Cable	65

Note: In addition to the above, the user will need to obtain items of wall outlet boxes, on-air lamps, conduit, etc., in accordance with instructions furnished with the 76-B2 Console. These may be purchased locally

2 AM and FM Remote Equipment

Suggested equipment for handling average remote requirements.

Item	Qty.	Description	MI- Number
1	2	Type OP-6 Remote Amplifiers	11202-A
2	2	Tube Kits for OP-6 (one each)	11253
3	2	VU Meter Kits for OP-6 (one each)	11251
4	1	OP-7 Portable Mixer-Preamplifier	11213
5	1	Tube Kit for OP-7	11254
6	1	Battery Box for OP-6 and/or OP-7	11214
7	3	Type 88-A Microphones	4048-C
8	5	Cannon Microphone Plugs	4630-B
9	2	59-B Portable Microphone Stands	4093-B
10	1	Collapsible Banquet Stand	4095
11	2	Microphone Carrying Cases	4085
12	100'	Microphone Extension Cable	42
13	2	Extension Cable Plugs	4620-A

3 Professional Type Recording Equipment

Suggested apparatus for making high quality recordings using Type 73-B Professional Recording Equipment.

Item	Qty.	Description	MI- Number
1	2	73-B Professional Recorder (with High Fidelity cutting heads)	11825/ 11850-B
2	3	Sapphire Cutting Styli	4842
3	1	Orthacoustic Recording Filter	4916
4	1	82-C1 Recording Amplifier	11209-B
5	1	Set of Tubes for 82-C1	11282
6	1	36-B Panel and Shelf for Item 4	4682-H
7	1	33-A Jack Strip	4645
8	1	Mat for Item 7	11501-A
9	1	VU Meter Panel	11265-B
10	3	Blank Panels 8 $\frac{3}{4}$ "	4594-B
11	1	Blank Panel 7"	4593-A
12	1	Blank Panel 3 $\frac{1}{2}$ "	4591-B
13	1	57-C Switch and Fuse Panel	4395-B
14	1	9-AX Cabinet Rack (for mounting Items 3 to 13, inclusive, and 15 to 19, inclusive)	4519-E
15	2	"J" Trim Strips	4537-D
16	1	Terminal Block (Audio)	4569
17	1	Terminal Block (Power)	4568
18	1	Terminal Block Mounting Bracket	4570
19	6	Cable Supports	4571
20	4	Patch Cords	4652-2A

Note 1: When used with the suggested studio equipment listed in Section I, the MI-11500 Wall Cabinet, Item 5, may be omitted from that section and Items 6, 7, 8, 9, 10 and 11 of Section I may be mounted in the 9-AX Cabinet Rack, Item 14 of this section. In such case, omit blank panels—one of Item 10 and Item 12 from this list.

Also, if desired, the BA-2A Booster Amplifiers, Item 14 of Section I, may be mounted in the 9-AX Cabinet Rack of this section, instead of in the turntable cabinets. In such case, increase Item 6 of this section, 36-B Panel, to a quantity of 2 and omit one of Item 10, Blank Panel.

Note 2: Some users also desire automatic recording equalizers for each recorder. For the 73-B Recorder, the MI-11100 automatic equalizer should be specified. If outside-in recordings are to be made, we recommend use of the MI-4922/4923 Recording Suction Equipment and Hose Kit.

4 Standard Type Recording Equipment

Suggested apparatus for making high quality recordings by using attachments for the 70-C1 Transcription Turntables.

Item	Qty.	Description	MI- Number
1	2	72-D Recording Attachment (with standard cutting heads)	11901
2	3	Sapphire Cutting Styli	4878-C
3	1	Orthacoustic Recording Filter	4916
4	1	82-C1 Recording Amplifier	11209-B
5	1	Set of Tubes for 82-C1	11282
6	1	36-B Panel and Shelf for Item 4	4682-H
7	1	33-A Jack Strip	4645
8	1	Mat for Item 7	11501-A
9	1	VU Meter Panel	11265-B
10	3	Blank Panels 8 $\frac{3}{4}$ "	4594-B
11	1	Blank Panel 7"	4593-A
12	1	Blank Panel 3 $\frac{1}{2}$ "	4591-B
13	1	57-C Switch and Fuse Panel	4395-B
14	1	9-AX Cabinet Rack (for mounting Items 3 to 13, inclusive, and 15 to 19, inclusive)	4519-E
15	2	"J" Trim Strips	4537-D
16	1	Terminal Block (Audio)	4569
17	1	Terminal Block (Power)	4568
18	1	Terminal Block Mounting Bracket	4570
19	6	Cable Supports	4571
20	4	Patch Cords	4652-2A

Note 1: When used with the suggested studio equipment listed in Section I, the MI-11500 Wall Cabinet, Item 5, may be omitted from that section and Items 6, 7, 8, 9, 10 and 11 of Section I may be mounted in the 9-AX Cabinet Rack, Item 14 of this section. In such case, omit blank panels—one of Item 10 and Item 12 from this list.

Also, if desired, the BA-2A Booster Amplifiers, Item 14 of Section I, may be mounted in the 9-AX Cabinet Rack of this section, instead of in the turntable cabinets. In such case, increase Item 6 of this section, 36-B Panel, to a quantity of 2 and omit one of Item 10, Blank Panel.

Note 2: Some users also desire automatic recording equalizers for each recording attachment. For the 72-D Attachment, the MI-11101, automatic equalizer should be specified. If outside-in recordings are to be made, we recommend use of the MI-4922/4923 Recording Suction Equipment and Hose Kit.

5 AM and FM Transmitter Audio and Monitoring Equipment

A—TRANSMITTER AND STUDIO AT SAME LOCATION

Item	Qty.	Description	MI- Number
1	1	9-AX Cabinet Rack, U/G	4519-E
2	2	"J" Trim Strips for Item 1	4537-D
*3	1	311-AB Frequency Monitor with one set of tubes	8211-G
*4	1	66-D Modulation Monitor with one set of tubes	7502-E
5	1	86-A1 Limiting Amplifier with one set of tubes	11216-C
6	1	36-B Panel for Item 5	4682-H
7	1	33-A Jack Panel	4645
8	1	Mat for Item 7, U/G	11501-A
9	2	Blank Panels 8 $\frac{3}{4}$ "	4594-B
10	2	Blank Panels 5 $\frac{1}{4}$ "	4592-B
11	2	Blank Panels 3 $\frac{1}{2}$ "	4591-B
12	1	57-C Switch and Fuse Panel	4395-B
13	1	Terminal Block (Audio)	4569
14	1	Terminal Block (Power)	4568
15	1	Terminal Block Mounting Bracket	4570
16	6	Cable Supports	4571
17	1000'	Interconnecting Cable	63-A
18	1000'	Interconnecting Cable	65

Note: When used with the suggested studio equipment listed in Section I, the MI-11500 Wall Cabinet, Item 5, should be omitted from that section. Items 6, 7, 8, 9, 10 and 11 of Section I should be mounted in the 9-AX Cabinet Rack, Item 1, of this section. For such case, omit blank panels—one of Item 9 and one of Item 11.

* For FM Stations delete Items 3 and 4. For Item 3, substitute RCA Type 336-A FM Frequency Monitor. For Item 4 substitute RCA Type 322-A FM Modulation Monitor.

B—TRANSMITTER AT LOCATION REMOTE FROM STUDIO

Item	Qty.	Description	MI- Number
1	1	9-AX Cabinet Rack, U/G	4519-E
2	2	"J" Trim Strips for Item 1	4537-D
*3	1	311-AB Frequency Monitor with one set of tubes	8211-G
*4	1	66-D Modulation Monitor with one set of tubes	7502-E
5	1	86-A1 Line Amplifier with one set of tubes	11216-C
6	1	82-C1 Monitoring Amplifier	11209-B
7	1	Set of Tubes for 82-C1	11282
8	2	BA-2A Booster Amplifier (for microphone and turntable)	11226
9	2	Sets of Tubes for BA-2A's (one each)	11287
10	3	36-B Panels for Items 5, 6 and 7	4682-H
11	1	33-A Jack Panel	4645
12	1	Mat for Item 11, U/G	11501-A
13	1	BE-1A Equalizer	4196
14	1	VU Meter Panel	11265-B
15	1	Blank Panel 7"	4593-A
16	1	Terminal Block Mounting Bracket	4570

Item	Qty.	Description	MI- Number
17	2	Terminal Blocks (Audio)	4569
18	1	Terminal Block (Power)	4568
19	6	Cable Support Brackets	4571
20	1	57-C Switch and Fuse Panel	4395-B
21	1	6.3 Volt Transformer for Lamp in Item 14	11606
22	3	2' Patch Cords	4652-2A
23	1	88-A Microphone	4048-C
24	1	91-B Desk Stand	4092
25	1	Microphone Cable Plug	4630-B
26	1	Microphone Wall Receptacle	4624-A
27	1	70-C1 Turntable, U/G	4871-C
28	1	64-B Monitor Speaker, U/G	4400/4410
29	1000'	Interconnecting Cable	63-A
30	1000'	Interconnecting Cable	65

* For FM Stations delete Items 3 and 4. For Item 3, substitute RCA Type 336-A FM Frequency Monitor. For Item 4 substitute RCA Type 322-A FM Modulation Monitor.

C—TRANSMITTER AT LOCATION REMOTE FROM STUDIO

MI-11620 RACK FOR USE WITH CONTROL DESK (SUPPLIED WITH RCA 5F, 10F AND BTA-50F TRANSMITTERS)

Item	Qty.	Description	MI- Number
1	1	Speech Input and Control Rack	11620
		This Rack is shipped with the following equipment:	
	1	Type 66-D Modulation Monitor	
	2	Type 33-A Jack Panels	
	1	MI-11502-A Mat for Above Jack Panel	
	1	Type 86-A1 Limiting Amplifier	
	1	Type 82-C1 Monitoring Amplifier	
	3	Type 36-B Panel and Shelf Assemblies	
	1	Type 57-C Switch and Fuse Panel	
	2	MI-4537-D "J" Strips	

Note: Wiring and provision for mounting is also included for MI-4309 Power Change Panel which is supplied with RCA transmitters when required.

The Rack is wired for the following items which are recommended for use with the MI-11620 Rack:

2	1	311-AB Frequency Monitor	8211-C
3	3	BA-1A Amplifiers	11218-A
4	3	Tube Kits for BA-1A Amplifiers (one each)	11285
5	1	BX-1A Preamplifier Power Supply	11305
6	3	Line Coils	4900-A
7	2	56-C Line Equalizers	4168
8	1	VU Meter Panel	11265-B
9	1	Sola Voltage Regulator	11280
10	1	Filament Transformer for VU Meter Lamp	11606

Note: For complete audio and monitoring facilities add Items 22 to 30 inclusive of Section 5-B.

POLICIES AND INFORMATION

Covering the Direct Sale of

BROADCAST EQUIPMENT

Foreword

RCA Broadcast Equipment is sold directly to the station through RCA's regional offices. Regional representatives are conveniently located to render service to broadcast stations and are familiar with broadcast equipment and broadcast problems.

The following outline is intended to convey to the purchaser the policies applicable to the sale of RCA broadcast equipment. Policies for the sale of tubes and other RCA products are described on separate sheets. RCA is setting forth this statement so that all purchasers will clearly understand the terms and conditions of our sales so that transactions may be carried forward fairly and promptly.

Contracts

RCA transmitters and all custom built or special apparatus is sold by means of a standard agreement form.

Prices

All prices are subject to change or withdrawal without notice. Prices are net, f.o.b. factory or warehouse. Prices do not include Federal Manufacturer's Tax nor any other state or local taxes based upon or measured by sales or use. Such taxes, when applicable, will be added to the price of the equipment.

Terms

Terms of payment are subject to approval of RCA's Credit Department.

Delivery

RCA will furnish an estimate of delivery but assumes no responsibility for delays in delivery. Shipment will be made by carrier specified or if no carrier is specified, RCA will use its best judgment in the selection of a carrier.

Warranty

RCA will repair or replace, at its expense, f.o.b. factory, any parts of equipment manufactured by RCA or sold under RCA's name, which parts show defects of workmanship or material when used in the normal manner under normal conditions, and when used for the intended purposes. This is provided that, at RCA's option, such parts are returned to RCA's factory for inspection, properly packed and all expenses prepaid, within one year from date of delivery, and providing that inspection indicates the defects to RCA's reasonable satisfaction. Equipment manufactured by others and listed in this catalog as products of other manufacturers shall bear only the guarantee as may be given by the manufacturer. Electron tubes are covered by a separate warranty.

RCA makes no warranties other than those above described.

Patent Protection

RCA agrees to defend any suit which may be brought against purchaser for infringement of United States patents arising out of purchaser's use of the equipment for the purposes and in the manner contemplated by this agreement, and to pay any judgment for damages or costs which may be finally awarded in such suit against the purchaser by a court of last resort. This is upon the condition that the purchaser will give RCA prompt notice of any such suit and full right and opportunity to conduct its defense, together with full information and all reasonable cooperation. The purchaser agrees that this does not apply to any infringement arising by reason of combination of the equipment with other apparatus. The purchaser also agrees that RCA shall have the right to substitute for the equipment or any parts of it which are claimed to infringe the patent rights of others, other equally suitable apparatus or parts, without altering the conditions of the sale, or obtain for the purchaser the right to continue to use such parts, or in the event RCA is unable to do so, take back the equipment, refunding any sums the purchaser has paid, less a reasonable allowance for use.

Installation

RCA's prices do not include installation, unless specifically mentioned in a letter of quotation. Purchaser assumes responsibility for installation and operation of the equipment as well as the obtaining of all necessary licenses, permits, etc.

Changes

RCA reserves the right to modify the specifications of equipment described in this catalog, without notice and to supply such equipment providing that the modifications will not materially affect the performance.

Acceptance of Orders

It is requested that all orders be forwarded to RCA's regional offices. Regional offices will forward orders promptly to RCA's Camden, N. J. office for acceptance.

Repairs and Returned Apparatus

Write to the nearest regional office for shipping instructions and identifying number before returning apparatus for repair or adjustment. This will enable RCA to render you better service. RCA receives many shipments daily and without proper identification, delays may occur. RCA can assume no responsibility for unauthorized returns.

RCA FIELD OFFICES

All orders or inquiries should be directed to one of the field offices listed below. At each location you will find a broadcast specialist who is anxious to help you with your problems.

411 Fifth Ave.
New York 16, N. Y.



718 Keith Bldg.
Cleveland 15, Ohio



445 N. Lake Shore Drive
Chicago 11, Ill.



530 Citizens & Southern Bank Bldg.
Atlanta, Ga.



2010 Jackson St.
Dallas 1, Texas



621 S. Hope St.
Los Angeles 14, Calif.