



*Instruction Book*

# BTA-250L

**BROADCAST TRANSMITTER**

**POWER - 250, 100/250 OR 100 WATTS**



# WARNING

THE VOLTAGES EMPLOYED IN THIS EQUIPMENT ARE SUFFICIENTLY HIGH TO ENDANGER HUMAN LIFE AND EVERY REASONABLE PRECAUTION HAS BEEN OBSERVED IN DESIGN TO SAFEGUARD THE OPERATING PERSONNEL. AN IMPORTANT PART OF THE PROTECTIVE SYSTEM IS THE SERIES OF DOOR INTERLOCK SWITCHES AND ANY TAMPERING WITH THESE SWITCHES SHOULD BE PROHIBITED. THE POWER SHOULD BE REMOVED COMPLETELY BEFORE CHANGING TUBES OR MAKING INTERNAL ADJUSTMENTS.

## FIRST AID IN CASE OF ELECTRIC SHOCK

1. PROTECT YOURSELF with dry insulating material.
2. BREAK THE CIRCUIT by opening the power switch or by pulling the victim free of the live conductor.

DON'T TOUCH VICTIM WITH YOUR BARE HANDS until the circuit is broken.

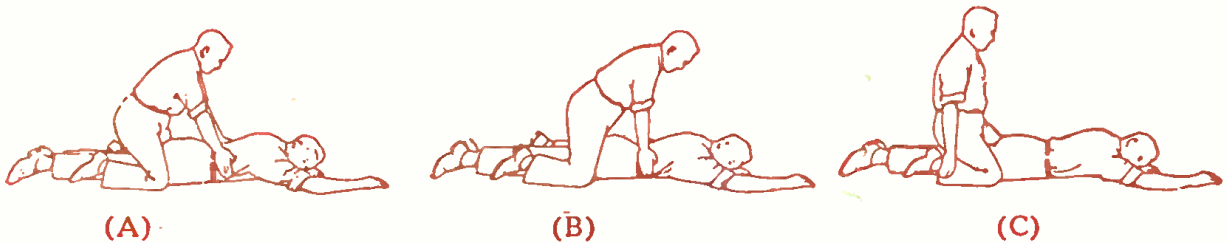

3. LAY PATIENT ON STOMACH, one arm extended, the other arm bent at elbow. Turn face outward resting on hand or forearm.
4. REMOVE FALSE TEETH, TOBACCO OR GUM from patient's mouth.
5. KNEEL STRADDLING PATIENT'S THIGHS. See (A).
6. PLACE PALMS OF YOUR HANDS ON PATIENT'S BACK with little fingers just touching the lowest ribs.
7. WITH ARMS STRAIGHT, SWING FORWARD gradually bringing the weight of your body to bear upon the patient. See (B).
8. SWING BACKWARD IMMEDIATELY to relieve the pressure. See (C).
9. AFTER TWO SECONDS, SWING FORWARD AGAIN. Repeat twelve to fifteen times per minute.
10. WHILE ARTIFICIAL RESPIRATION IS CONTINUED, HAVE SOMEONE ELSE:
  - (a) Loosen patient's clothing.
  - (b) Send for doctor.
  - (c) Keep patient warm.
11. IF PATIENT STOPS BREATHING, CONTINUE ARTIFICIAL RESPIRATION. Four hours or more may be required.
12. DO NOT GIVE LIQUIDS UNTIL PATIENT IS CONSCIOUS.

SUPPLEMENT  
TO  
INSTRUCTION BOOK  
FOR  
BTA-250L BROADCAST TRANSMITTER

Disposition: To be inserted in IB-30116

The following additions should be made to the instruction book text for the Type BTA-250L Broadcast Transmitter (IB-30116).

Page 13 - Under "Maintenance" add the following:

It is imperative that inductors (rotary coils) L5, L7, L9, L10, and L11 be kept clean at all times. This involves not only the removal of all dirt and dust but also cleaning of the electrical contact surfaces where oxidation may be present.

Deposits of dirt on the inductor slide shaft and wheel assembly will create a high-resistance joint which may cause heating and resultant damage to the spring and wheel contacts. It is particularly important that the slide shaft be kept clean and smooth. Use a clean, fine brush or a hand blower to remove all loose material. If a film or cake of dirt has formed, remove with a clean, soft cloth dipped in carbon tetrachloride. It is unnecessary to use a lubricant of any kind on the slide shaft or wheel assembly.

The ceramic coil form should also be treated as described in the preceding paragraph. If foreign deposits are present on the form between coil turns, clean with a cloth dipped in carbon tetrachloride.

To maintain the proper contact between the coil and slider, it is necessary to keep the coil contact surfaces clean. If a hand blower or a clean cloth dipped in carbon tetrachloride does not clean the surface properly, polish with crocus cloth applied lightly to avoid removal of the plating. NEVER USE SANDPAPER NOR EMERY CLOTH FOR THIS PURPOSE.

RADIC CORPORATION OF AMERICA  
ENGINEERING PRODUCTS DEPARTMENT  
Camden, New Jersey, U.S.A.

Printed in U.S.A.

IB-30116-b  
11-20-46

ERRATA  
IN INSTRUCTION BOOK  
FOR  
BTA-250L BROADCAST TRANSMITTER

Disposition: To be inserted in IB-30116

The following changes should be made in the instruction book text, parts list, and drawings for the Type BTA-250L Broadcast Transmitter (IB-30116).

- Page 4 - Under heading "ELECTRICAL CHARACTERISTICS" change "Permissible Voltage Deviation" to " $\pm 5\%$ " (plus or minus 5 percent).
- Page 6 - Text, right-hand column. Change first sentence of last paragraph under "DESCRIPTION" to read: "A level of approximately  $\frac{1}{3}$  dbm is available at the monitoring terminal (4B) on the transmitter."
- Page 6 - Text, right-hand column. In second paragraph under "Wiring," delete first sentence reading: "When a four-wire, 230-ohm transmission line is employed, it should be terminated at the terminals on the top of the transmitter unit."
- Page 7 - Text, left-hand column. Change last sentence of first paragraph to read: "Connections should then be completed as indicated on the wiring diagram, Figure 8."
- Page 14 - Parts List, right-hand column. Change description of LL4 to read, "Reactor, modulation."
- Page 23 - Figure 9. At upper left-hand corner, change designation of inductor near output coil and bushing to "L10" instead of "L11."

(over)

RADIO CORPORATION OF AMERICA  
ENGINEERING PRODUCTS DEPARTMENT  
Camden, New Jersey, U.S.A.

Page 8 - Text. To supplement "Buffer-Amplifier" column in "CAPACITOR CHART" tabulation, substitute following two columns for first column in tabulation.

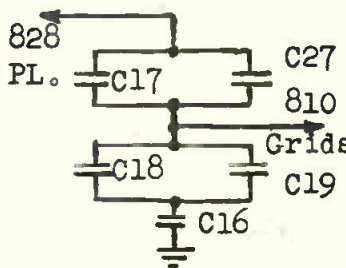
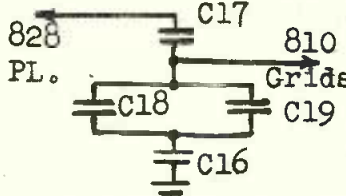
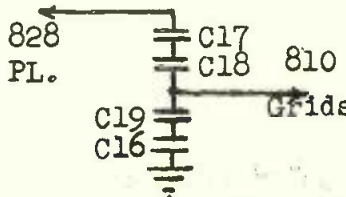
FREQUENCY (kc)	BUFFER-AMPLIFIER C17, C18, C19, C27
540-650	
650-750	SAME AS 540-650
750-850	
850-1050	SAME AS 750-850
1050-1300	
1300-1600	SAME AS 1050-1300

**BROADCAST TRANSMITTER  
TYPE BTA-250L  
MI-7242-C**

**INSTRUCTIONS**

Manufactured by  
**RADIO CORPORATION OF AMERICA**  
ENGINEERING PRODUCTS DEPARTMENT  
Camden, New Jersey, U. S. A.

Printed in U. S. A.

IB-30116  
4-18-46

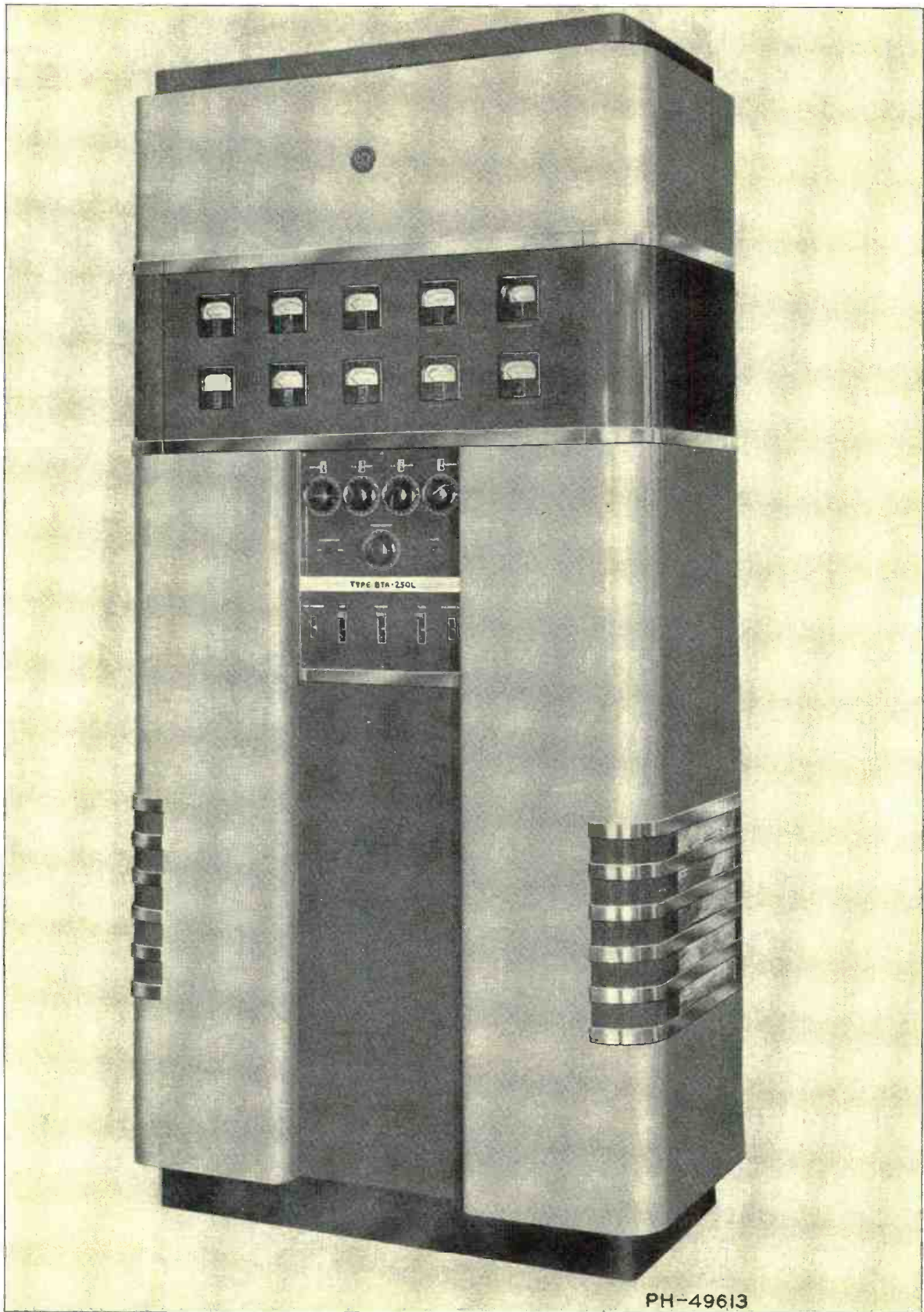

*Figure 1—Type BTA-250L Broadcast Transmitter*

## TABLE OF CONTENTS

Subject	Page
Warning .....	Inside Front Cover
Technical Summary .....	4
Electrical Characteristics .....	4
Tube Complement .....	4
Mechanical Specifications .....	4
Equipment .....	4
Description .....	5
Construction .....	5
Circuit Design .....	5
Installation .....	6
Location .....	6
Assembly .....	6
Wiring .....	6
Preliminary Adjustments .....	7
Tuning .....	7
Modulation Adjustment .....	9
Output Circuit Adjustment .....	9
Output Circuit Calculations .....	11
Typical Meter Readings .....	13
Operation .....	13
Maintenance .....	13
Parts List .....	14

## LIST OF ILLUSTRATIONS

Figure		Page
1	Type BTA-250L Broadcast Transmitter .....	2
2	Test Circuit (K-849842—sub 0) .....	10
3	Transmitter (Front View; Meter Panel Open) .....	16
4	Transmitter Chassis (Rear View) .....	17
5	Transmitter Chassis (Rear View) .....	18
6	Transmitter (Schematic, T-613868—sub 1) .....	19
7	Crystal Oscillator Unit (Wiring M-429907) .....	20
8	Transmitter (Wiring, WW-303933—sub 1) .....	21
9	Transmitter (External Connections, M-428531) .....	23
10	Transmitter (Outline, P-717504) .....	24
11	"P.A. NEUT." and "BUFFER" Dials (Tuning Chart S-853809) .....	25
12	"P.A. PLATE" Tank Circuit Dial (Tuning Chart S-853811) .....	26
13	Antenna "LOADING" Dial (Tuning Chart S-853810) .....	27
14	"P.A. PLATE" and "LOADING" Dials, 20-ohm Line (Tuning Chart S-853812) .....	28



## TECHNICAL SUMMARY

### ELECTRICAL CHARACTERISTICS

Power Output (20 to 250 ohms, unbalanced load) .....	250 watts
Frequency Range .....	540 to 1600 kc
Frequency Stability .....	±10 cycles
Type of Modulation .....	High level, Class B
Modulation Capability .....	Up to 100%
A-F Input (approximate)	
For 100% Modulation (sine wave) .....	+16 dbm
For Average Program Level .....	+8 vu
A-F Response .....	Deviation not more than ±1.5% db between 30 and 10,000 cycles
A-F Distortion .....	Less than 3% r-m-s (50 to 7500 cycles)
Hum and Noise Level .....	60 db below 100% modulation
R-F Harmonics .....	Less than 0.05%
Carrier Shift .....	Less than 5% from 0 to 100% modulation (50 to 7500 cycles)
Power Supply Requirements .....	
Permissible Voltage Deviation .....	105 to 115 volts, 50/60 cycles, single phase +5% v <sub>r</sub> - - 3%
Power Consumption (approximate)	
At Average Program Level .....	1625 watts
At 100% Modulation .....	1825 watts

### TUBE COMPLEMENT

Crystal Oscillator .....	1 RCA-807
Buffer .....	1 RCA-828
Power-Amplifier .....	2 RCA-810
First Audio .....	2 RCA-6J7
Modulator .....	2 RCA-828
High-Voltage Rectifier .....	2 RCA-8008
Bias Rectifier .....	1 RCA-5Y3-GT

### MECHANICAL SPECIFICATIONS

Dimensions (overall)	
Height .....	84 <sup>7</sup> / <sub>8</sub> inches
Width .....	40 <sup>1</sup> / <sub>2</sub> inches
Depth .....	21 <sup>1</sup> / <sub>16</sub> inches
Weight (net) .....	1360 pounds

### EQUIPMENT

The MI-7242-C Transmitter Equipment is comprised of the following items:

Quantity	Item	
1	Transmitter Unit .....	MI-7243-C
2	Crystal Units, Type TMV-129B, complete with crystals .....	MI-7467
1	Touch-Up Enamel Kit .....	MI-7443
2 sets	RCA Tubes (see "Tube Complement") .....	MI-7245-B
2	Instruction Books .....	IB-30116
1	Crystal Oscillator Unit .....	MI-19458
1	Ammeter, R-F Output .....	MI-7157-F

## DESCRIPTION

The Type BTA-250L Broadcast Transmitter is a complete, self-contained unit that will provide reliable, high-fidelity operation at any frequency within the range between 540 and 1600 kc. Excellent frequency stability is attained by the use of a crystal contained in a temperature-controlled chamber in the oscillator circuit. No greater deviation than  $\pm 10$  cycles from the assigned operating frequency is permitted.

**CONSTRUCTION** — The cabinet is designed to present a distinctive appearance as shown by the frontispiece illustration, Figure 1. All controls necessary to produce the required adjustments are conveniently grouped on the front of the unit. Such adjustments are further facilitated by the liberal provision of meters, which are mounted on a hinged panel directly above the tuning controls. The meter panel is conveniently located at eye level and the illuminated control panel is situated immediately below.

To raise the meter panel for access to its rear, it is necessary first to release the catches which secure this panel in place. These catches are operated by means of a handle which is accessible from the rear of the unit through a hand hole in the vertical transmitter chassis. Manipulation of this handle also actuates an interlock switch, which insures the removal of high voltage while the panel is raised. When the panel is open, it is held in the raised position by stay joints.

All internal apparatus is mounted on the vertical chassis and each component is readily accessible from the rear. Bevel gears and shafts are used to drive the variable tuning elements. The edges of the wire holes are rounded and the holes are of sufficient size to permit wires to be connected or replaced from the rear of the unit. In making repairs or replacements, it is unnecessary to remove the chassis from the cabinet.

**CIRCUIT DESIGN**—The radio-frequency portion of this transmitter consists of three stages, the oscillator, buffer, and power-amplifier.

The oscillator frequency is determined by the crystal, which is connected in the control grid circuit of the RCA-807 tube. The crystal is maintained at its operating temperature in the electrically heated crystal chamber by means of a thermostatically-controlled heater element. Vernier regulation of frequency is obtainable by adjustment of capacitor C1, which is connected across the crystal. An RCA-828 tube is used in the buffer stage, which feeds the Class "C" power-amplifier. The power-amplifier employs two RCA-810 tubes in parallel.

The audio-frequency portion of this transmitter employs two RCA-6J7 tubes in the first stage and two RCA-828 tubes in the Class "B" modulator

stage. The output of the latter is fed to the plate circuit of the power-amplifier. A 6 db pad (A8) is included in the audio circuit across the input transformer primary. This serves two purposes: (1) it presents a 600 ohm impedance to any audio frequency supplied to the input terminals, and (2), it effectively reduces the noise level to 6 db below the level that would be present if no such pad were included between the speech amplifier output and the transmitter audio input.

Approximately 20 db of feedback over the audio system is employed. Distortion is thus held to an extremely low value without the use of complex audio circuits. The entire audio system is designed in such a manner that it is inherently stable.

The five magnetically operated circuit-breakers, which provide overload protection for the equipment, are located on the control panel of the transmitter. These breakers also serve as control switches. When the main "LINE" breaker (S1) is opened, all power, except that supplied to the crystal heating circuit, is removed from the transmitter. With this breaker closed, the panel illuminating lamp (A7) is lighted. The "FILAMENT" breaker (S2) protects all filament circuits and in addition serves as a filament switch. When this breaker is closed, and S1 also is closed, filament power is made available to all tubes, and bias is applied to the modulator tubes.

Under this latter condition, a buzz should be heard from within the transmitter. This buzz originates at the holding coil of the "PLATE" breaker (S3), and is an indication that the time delay relay (E4) has not completed its cycle. The "PLATE" breaker cannot be closed until this time delay relay, which protects the rectifier tube filaments, has operated.

The time delay relay (E4) is a plunger type, mercury-filled unit. A glass tube, containing two electrodes, is partially filled with mercury, on which floats an iron plunger. The tube is encircled by a solenoid which is so positioned, that when energized, it pulls the iron plunger down. The mercury displaced by the plunger rises and contacts the electrodes, thus closing that circuit. The velocity of rise of the mercury, or "delay," is controlled by the rate of gas seepage through the porous wall of a gas chamber. For this relay, the design is such that an interval of about 30 seconds elapses before the electrode circuit is closed. The circuit is opened, however, about 2 seconds after the relay coil is de-energized.

When the time delay relay contacts are closed the coil of the auxiliary relay (E5) is energized. This latter relay de-energizes the holding coil of the "PLATE" breaker (S3), permitting S3 to be closed (by operation of the front panel lever), thus causing application of the plate voltage.

If a power interruption of greater duration than 2 seconds occurs, the auxiliary relay (E5) will close and lock the "PLATE" breaker open. If the duration is less than 2 seconds, power will be applied to the equipment immediately after the interruption, since the time delay relay (E4) will not have had time to open. Relay E5 will close momentarily when the power fails but since it is considerably faster than the "PLATE" breaker S3, the latter will not drop out when power is restored.

The three interlock switches (S4, S8, S9) are connected directly in the primary circuit of the plate transformer, T5. The "PLATE" indicator lamp, A4, located on the control panel, is connected directly across the primary terminals of

the plate transformer. This lamp is illuminated when voltage is applied to the primary of the transformer. All plate potentials are supplied by a rectifier which employs two RCA-8008 tubes. Taps are provided on the high voltage bleeder resistors, so that the potentials applied to the low level tubes may be brought to within the required limits. Bias voltage for the modulator tube is supplied by a separate rectifier, which employs an RCA-5Y3-GT tube.

A level of approximately +3 vu is available at the monitoring terminal (4B) on the transmitter. This level is sufficient to obtain full output from any of the monitoring amplifiers manufactured by RCA. The monitoring amplifier should be connected in the **bridging** position.

## INSTALLATION

**LOCATION** — The location of the transmitter should be carefully selected, and provision should be made for external connections before the unit is set in place. The outline drawing, Figure 10, and the external connection diagram, Figure 9, at the rear of these instructions, will facilitate this preliminary work. It is of the utmost importance that the transmitter frame be securely grounded by short connections. There should be an adequate circulation of air to prevent the room temperature from ever exceeding 113°F. (45°C.) under the most severe conditions. Ample working space should be allowed at the rear as well as at the front of the unit. A generous allowance of space around the transmitter will not only facilitate inspection and servicing but will also improve the general appearance of the installation.

**ASSEMBLY**—The entire transmitter is delivered to the station site as completely assembled and wired as is consistent with safe transportation. The control panel illuminating lamp, the lens for the control panel illuminating lamp, and the bushings for the transmission line are removed from the unit and packed in a separate case. Items such as tubes, crystals, etc., are grouped for safe and convenient handling in transportation. A kit of touch-up enamel is included.

The transmitter unit is mounted on wooden skids and is packed in a strong wooden box. After this box has been removed, and the unit is set in an upright position, it should be moved near its final location. Then it should be blocked up in such a manner that the four bolts which fasten the skids to the frame may be removed from under the unit. When those bolts have been taken out, the blocks should be removed and the unit slid from the skids into position. After the unit has been set in place, the parts that were removed and packed separately for safety in shipment should be replaced.

**WIRING**—The external connection diagram, Figure 9, supplies sufficient information to enable the selection of the proper conduits required for

any particular installation. In order that the wires may be brought through the wire holes and fanned out in such a manner that the cover plates may later be screwed in place, these conduits should be terminated so as to clear the bottom plate in the transmitter. The outline drawing, Figure 10, should be consulted when the locating and terminating of the conduits under the transmitter unit are being planned.

When a four-wire, 230-ohm transmission line is employed, it should be terminated at the terminals on the top of the transmitter unit. Copper tubing is usually used for connections between these terminals and the bushings in the wall of the transmitter house. When a concentric transmission line is used, it is usually desirable to bring it into the transmitter through the bottom of the unit. A hole is provided in the bottom plate of the transmitter for this purpose. The plug which normally is supplied in this hole should be removed before the transmitter unit is set in an upright position, otherwise it will be necessary to tilt the unit in order to perform this operation. Then, when the transmitter unit is set in place, the concentric line may be passed up through an opening in the floor. This opening in the floor also should be provided before the transmitter is set in place. The line should be terminated at a point slightly above the chassis, and the center conductor connected to the output terminal of L10. The outer conductor should be grounded and fastened at some point near its upper end to the chassis.

A "T" section network is provided in the output circuit for harmonic attenuation when the transmitter feeds an antenna directly. When the transmitter is fed into a transmission line, this section is not employed, since the usual antenna matching network consists of a harmonic filter. In this latter case, L11 and its associated capacitors are not used.

When the transmitter feeds an antenna directly, the antenna current meter is mounted on an in-

sulated panel and is located behind the window of the front-panel dummy meter case. The thermocouple is mounted behind the chassis. When the transmitter feeds a transmission line and the RCA Type BPA-1 (MI-7423-A) antenna tuner is purchased, a remote metering kit, MI-19404, is supplied in place of the r-f ammeter just mentioned. In this case, the dummy meter case is removed from the meter panel and the remote meter is mounted directly on the meter panel. The insulated meter plate and associated insulators are removed, and the ten-ohm adjustable resistor (supplied for calibrating the meter) is mounted on the chassis. Two tapped holes located near the thermocouple mounting holes are provided for this purpose. Connections should then be completed as indicated on the wiring diagram, Figure 7.

The power supply for the crystal heaters should be obtained from an external source, since power must be supplied continuously to the heaters, in order that the crystals may be maintained at the proper operating temperature.

**CAUTION**—Before proceeding with the adjustments of this transmitter read the notice on the inside front cover of this book.

**PRELIMINARY ADJUSTMENTS**—All breakers should be opened before power is applied to the transmitter. It should be noted that when the "P.A. OVERLOAD" and "MOD. OVERLOAD" (cathode) breakers, S5 and S6, respectively, are open and high voltage is applied to the transmitter, the cathodes of these tubes are at a high potential with respect to the ground.

**CAUTION**—Do not apply screen voltages to the RCA-828 tubes if their plate caps are not connected.

When the main "LINE" breaker (S1) is closed, the panel illuminating lamp (A7) should light and the "LINE VOLTMETER" (M12) should indicate the line voltage. Open the "LINE" breaker and connect the power leads to the taps of all transformers that most nearly correspond to the indicated line voltage. Then, with all tubes in their sockets, the "LINE" and "FILAMENT" breakers may both be closed. All filament voltages should then be adjusted to within 2 per cent of their rated value by means of the rheostats, R23 and R27, which are located on the back of the rectifier shelf.

A voltage of approximately 150 volts should be available at the output of the bias rectifier. This voltage may be measured by connecting a high resistance (not less than 1000 ohms per volt) d-c voltmeter across the terminals of capacitor C61. The modulator bias voltage should now be set to a maximum by adjusting potentiometers R22 and R54, which are located on the back of the rectifier shelf. This voltage may be measured by connecting a high-resistance d-c voltmeter between the grid terminal of each modulator tube and ground.

Insert the crystal holders in their proper sockets, and, making certain that the fuses (F1 and F2) are in their respective holders, connect a 115-volt (nominal) power supply line to terminals "17B" and "18B". The crystal holders should reach their maximum temperature in about 30 minutes.

This 30-minute interval also may be used as the initial warm-up period for the rectifier tubes if the filament power is kept on.

**NOTE**—When an 8008 is first placed in service, a "warm-up" period of at least 15 minutes should be allowed, during which normal filament voltage, but no plate voltage, should be applied to the tube. This will properly distribute the mercury throughout the tube. The procedure need not be repeated unless, during subsequent handling, mercury is splattered on the tube elements.

Before power is applied to the modulator tubes, the setting of the safety gaps on the primary of the modulation transformer (T6) should be checked. Each of these gaps should be set to a spacing of 25 mils (0.025 inch).

**TUNING**—A tapped coil is used in the plate circuit of the crystal oscillator stage, each tap covering a certain frequency range as follows:

Band Coverage (kc)	Tap No.
540-700 .....	1
700-1000 .....	2
1000-1300 .....	3
1300-1600 .....	4

Taps 5, 6, 7 and 8, which cover frequencies from 1600 to 3000 kc, are not used with the BTA-250L.

The proper tap, as indicated by the preceding tabulation, should be connected in the oscillator plate circuit before plate voltage is applied. If the oscillator should be sluggish in starting, however, the tap indicated for the next higher frequency band should be employed.

Three sets of tuning curves (Figures 11, 12 and 13) are included at the back of this book. These may be used to obtain approximate settings of the four tuning controls. Settings of the "P.A. PLATE" and "LOADING" controls for both 70 and 230-ohm loads have been included.

After the above mentioned approximate adjustments have been made, each circuit should be brought into exact adjustment as described in the following paragraphs.

After the initial warm-up period, the "PLATE" breaker may be closed, thus applying high voltage to the plate rectifier tubes. The control circuit should then be checked to see that all elements in that circuit operate properly. The "PLATE" breaker should be checked to ascertain that the holding coil functions properly during the thirty-second delay period, and the auxiliary relay (E5) should be checked for proper operation. Each of the rear doors and the meter

panel should be opened, in turn, in order to make sure that the associated interlock switches remove the plate voltage from the main rectifier.

When the plate voltage is applied, three ammeters should indicate current. They are, the "OSCILLATOR PLATE", the "1st AUDIO PLATE" and the "BUFFER PLATE", current meters. Meter readings close to those tabulated in the chart "Typical Meter Readings" should be obtained for the oscillator and first audio stages. The oscillator may be checked for oscillation by removing the crystal holder from its socket. When this is done, the oscillator plate current should increase.

Measurement of plate current and plate voltages of the first audio stage serves as a good check on the circuit elements in this stage. The plate volt-

ages to this stage should be read with a high-resistance voltmeter, i.e., one having at least 1000 ohms per volt. Refer to the table of "Typical Meter Readings" for the proper values. Taps are provided on the bleeder resistor (R64) in order that the supply voltage to this stage may be adjusted when necessary.

Refer to the following "CAPACITOR CHART" and connect capacitors in the plate-tank circuit of the buffer stage as indicated for the particular frequency. This stage should be tuned for minimum plate current by means of the control marked "BUFFER". After the power-amplifier stage has been adjusted, the plate circuit of the buffer stage should be readjusted to the point which causes maximum grid current in the power-amplifier. Minimum plate current to the buffer

### CAPACITOR CHART

Frequency (kc)	Buffer-Amplifier C17, 18, 19, 27	P.A. Neutralizing C20, C21, C42	P.A. Tank C48, C49, C50, C51	Line Matching C52, 53, 54, 63		
				20 ohms	70 ohms	230 ohms
*540- 650	C17 connected in parallel with C27, the combination in series with the parallel combination of C18 and C19. C18 and C19 connected from pa grid to C16.	C20, C21 and C42 connected in parallel	C48, C49, C50 and C51 connected in parallel	C52, C54 and C63 in parallel	C52, C53 and C54 connected in parallel	C52 and C54 connected in parallel
650- 750	Same as 540-650	Same as 540-650	C48 and C51 connected in parallel	Same as 540-650	C53 and C54 connected in parallel	C54
750- 850	C17 connected in series with the parallel combination of C18 and C19. C18 and C19 connected from pa grid to C16.	C20 and C42 connected in parallel	C49 and C50 connected in parallel	Same as 540-650	C52 and C53 connected in parallel	C53
850-1050	Same as 750-850	Same as 750-850	C49 and C51 connected in parallel	C52 and C63 in parallel	C54	C52
1050-1300	C17, C18 and C19 connected in series. C19 connected from pa grid to C16.	C21 connected in series with the parallel combination of C20 and C42	C-48 connected in series with parallel combination of C49 and C51	Same as 850-1050	C53	C52 connected in series with parallel combination of C53 and C54
1300-1600	Same as 1050-1300	Same as 1050-1300	C48 and C49 connected in series	Same as 850-1050	C52	C52 and C53 connected in series

\* For 540 kc. operation interchange C24 and C25 electrically and physically.

should be obtained at approximately this same point. It will be noted that the tank capacitors are arranged to form a capacitance voltage-divider in such a manner that, when the values designated are used, the proper excitation is supplied to the power-amplifier grids. Links are provided for capacitor connections in all tank circuits in order that connections may be changed readily. When the proper capacitors, as indicated in the "CAPACITOR CHART," have been connected in the neutralizing and power-amplifier tank circuits, the power-amplifier may be tuned as follows:

Adjust "P.A. NEUT" and "P.A. PLATE" controls as indicated in the tuning charts (Figures 11, 12 and 14). These adjustments are close enough to the final tuning that plate voltage may be applied.

Later, when the transmitter is being modulated, the neutralization should be checked by observing the output wave form on a cathode-ray oscilloscope. To obtain such a check it is necessary only to increase the level of the input signal at 1000 cycles to a value above 100 per cent modulation and then to observe the form of the negative peak on the oscilloscope screen. The "P.A. NEUT." control should be adjusted until the negative peaks form a thin, single line.

After these final neutralizing adjustments have been made, the "P.A. NEUT." control should be locked in position by means of the clamp provided on the bearing casting which is located on the rear of the control panel. This will prevent accidental movement of the control.

**MODULATION ADJUSTMENT** — Close the "MOD. OVERLOAD" breaker (S6). With plate voltage thus applied, the modulator tubes should not draw plate current with the grid bias potentiometers (R22 and R54) set as previously indicated. These potentiometers should now be readjusted so that the sum of the plate and screen-grid currents (as indicated on the plate current meters) for each of the modulator tubes is 25 milliamperes. The designations "LEFT" and "RIGHT" at the plate current meters refer to the tubes as viewed from the front of the transmitter. Taps are provided on the bleeder resistors R79, R80 and R84, in order that the screen and suppressor voltages supplied to the modulator tubes may be dropped to the proper values.

**OUTPUT CIRCUIT ADJUSTMENT**—When the transmitter is to be loaded into either a 70-ohm or 230-ohm transmission line, the adjustments of the output circuit should be made as follows:

L11 and its associated condensers, C55 to C58, are removed from the circuit and the transmission line is connected to the output terminal of L10. Proper capacitor combinations for line impedances of 70 and 230 ohms are shown in the "CAPACITOR CHART".

With the proper line-matching capacitors (C52, C53, C54, C63) connected in the circuit by means of the links supplied, as indicated in the "CAPACITOR CHART", the series line coil (L10) should be adjusted for maximum inductance by means of the "LOADING" control. Then, with the transmission line terminated in its proper impedance at the antenna, plate voltage should be applied.

The inductance of L10 should then be decreased by manipulation of the tuning control marked "LOADING" until the proper loading is obtained. While this adjustment is being made, the "POWER OUTPUT" control (R15) should be set so as to insert about half of the resistance (of R15) in the circuit. This will permit future compensation for ordinary line voltage variations.

When the proper loading has been obtained, and when the "P.A. PLATE" variable inductor (L9) has been adjusted for minimum power-amplifier plate current, the power-amplifier should be adjusted for maximum efficiency. This does not occur at the point of minimum plate current but is obtained by making the plate-tank circuit slightly capacitive by turning the control clockwise from resonance, and then adjusting the loading for the proper output. A few such adjustments will be required to arrive at the point of maximum efficiency. These adjustments should be made at average line voltage conditions. Compensation may be made for line voltage fluctuation during the normal course of operation by means of the "POWER OUTPUT" control.

If the transmitter is to feed the antenna directly, the shunt capacity required in the harmonic tank circuit should be computed for an impedance of  $230 + j\omega$  ohms as outlined under the section entitled "Output Circuit Calculations". Then the antenna should be connected to the output terminals of L11. If a radio-frequency bridge is available, it should be between the input ter-

minal to L10 and ground, and, with the plate circuit of the power-amplifier disconnected, the two inductors in the harmonic tank circuit should be adjusted so that the impedance looking into the harmonic tank is  $230 + j\omega$  ohms. When this adjustment is obtained, it should be found that only a portion of L10 is in use. This coil should now be adjusted for maximum inductance and the loading on the output stage adjusted as previously described. L10 then performs two functions: (1) Part of L10 acts as the input arm of a matching network having an input impedance of  $230 + j\omega$  ohms; (2) the remainder of L10 transforms this impedance to a suitable value for loading the transmitter, similar to the transmission line case above.

The harmonic tank circuit may be adjusted by the substitution method in cases where a radio-frequency bridge is not available. This method requires the use of a test circuit equivalent to that shown in Figure 2.

Referring to Figure 2, the coil, L, should be coupled to a low power source of radio frequency of the operating frequency. Very loose coupling should be employed. Only sufficient power to afford a readable deflection of an r-f milliammeter or thermo-galvanometer, is necessary. It is desirable that the test circuit be shielded and wired in such a manner that stray capacities are reduced to a minimum. The test resistor, R, should be a non-inductive, 230-ohm resistor (or 70 ohms, for the 70-ohm network) capable of dissipating approximately five watts.

After the proper shunt capacity, C55-C58, has been connected in the circuit, the adjustments are made as follows:

First throw the switch to the downward (resistor) position and vary the capacitor C until

the reading of the meter G is at a maximum. If the maximum reading is too low on the scale for accurate observation, increase the coupling to the source of excitation until a suitable deflection is produced. Note the capacitor dial and current meter indications.

Shift the switch to the upper (antenna) position and retune capacitor C for maximum deflection of meter G. If the capacitance value is now greater than before, the load is capacitively reactive; if less, it is inductively reactive; if unchanged, it is purely resistive. Similarly, if the current reading is now greater than before, the load resistance is less than 230 ohms; if less than before, the load resistance is greater than 230 ohms; if unchanged, the load resistance is 230 ohms.

When the adjustment which requires no change in C for maximum current in meter G, and which results in the same current through meter G with the switch in either position is obtained, the harmonic tank circuit is correctly adjusted, and the power-amplifier should be loaded as previously described; i.e., by increasing L10 to maximum and then reducing from this value until sufficient loading is obtained.

Excitation for the frequency monitor is obtained from a potentiometer (R14) connected across a capacitor (C16) in the ground side of the buffer-tank circuit. This potentiometer is provided in order that the excitation may be varied as required. After the frequency monitor has been adjusted, the frequency of the oscillator should be adjusted to zero beat with the monitor by means of the vernier capacitor, C1, which is connected across the crystal. A screw-driver slot in a bakelite shaft, accessible from the rear of the oscillator unit, is provided for this adjustment. The spare crystal should also be checked against the frequency monitor after inserting it in the socket provided in the oscillator unit.

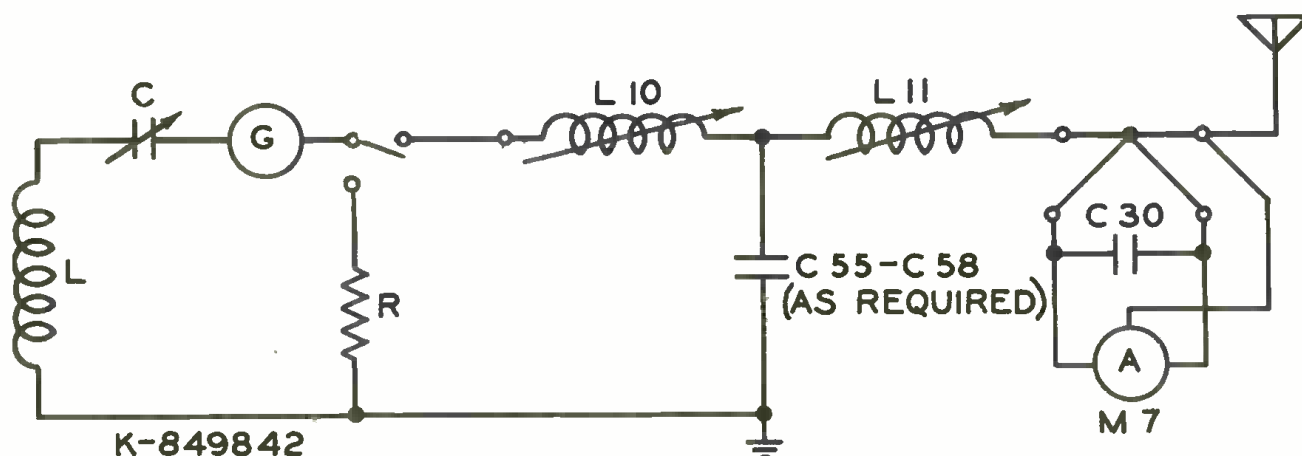

Figure 2—Test Circuit (K-849842—sub 0)

Individual plate current meters are not provided in the power-amplifier stage. However, tube balance may and should be checked in this stage. This check should be made as follows:

Remove the jumper between terminals 7-B and 8-B. With the transmitter modulated 100 per cent by means of a steady tone of approximately 1000 cycles, measure the voltage drop across one of the cathode resistors, R46, R47. Then interchange the two power-amplifier tubes and measure the voltage drop across the same cathode resistor under the same conditions. The tube unbalance in per cent may then be calculated from the following formula:

$$\text{Per cent unbalance} = \frac{(E-E')}{E} 100$$

where E = larger cathode resistor voltage drop and E' = smaller cathode resistor voltage drop

This unbalance should not exceed 5 per cent with new tubes. If this check is repeated at frequent intervals, such as once a month, and the date recorded, tube failures may be anticipated. When the unbalance has increased 5 per cent as compared to the original condition, the weak tube (or both tubes) should be discarded. This is an indication that restricted emission is limiting the peak power output of the tube, which results in a decrease in the voltage drop across the cathode resistor. Except when this check is being made, the jumper connected between terminals 7-B and 8-B should be in place in order that the plate voltmeter will indicate the true plate voltage of the output stage.

The pick-up coil, L13, which supplies excitation to the modulation indicator, is coupled to the tank coil, L9. It will be found necessary to remove turns from this coil, in most cases, to obtain sufficient excitation to the modulation indicator. This adjustment is rather critical and turns should be removed from the coil one at a time. While this adjustment is being made, the coil should be in the position for maximum coupling. After maximum output is obtained, the coupling may be adjusted to the value desired by rotating this coil.

**OUTPUT CIRCUIT CALCULATIONS**—The output circuit of the power-amplifier consisting of C52, C53, C54, C63 and a portion of L10 is designed in such a manner that it always works into a load of 70 or 230 ohms at some point on the variable "LOADING" inductor, L10. When the transmitter feeds the antenna directly, sufficient inductance is available in L10 so that one portion may be used to terminate the power amplifier tank circuit into 230 + jo ohms and another portion used as the input arm of the "T" network. It is necessary to adjust the "T" network to match this input impedance (230 + jo ohms) and the load impedance. When transmission lines having impedances other than those given in the "CAPACITOR CHART" are to be

used the "T" network may be employed to match impedances in the same manner as above.

Electrically, the "T" network consists of a low-pass filter in which the series arms (a portion of L10, and L11) are inductive and the parallel section (C55 to C58) is capacitive. The portion of each coil to be utilized and the selection of the capacitors (C55 to C58) will depend upon the resistance and reactance of the antenna (or the impedance of the transmission line) and upon the operating frequency. The correct values may be obtained from the following simple calculations.

Let  $R_0$  = input impedance of network (approximately 230 ohms)

$R_A$  = total resistance of antenna or impedance of transmission line

$X_A$  = total reactance (either inductive or capacitive) of antenna or transmission line. (For a transmission line,  $X_A$  is assumed to be zero.)

These three quantities have known values. The three quantities to be determined are:

- (1)  $X_G$  = required inductive reactance of input branch of network, (coil L10)
- (2)  $X_L$  = required inductive reactance of output branch of network, (coil L11)
- (3)  $X_C$  = required capacitive reactance of shunt capacitance, (capacitors C55 to C58)

Starting with the load conditions, and assuming that the transmitter feeds the antenna directly, the antenna reactance may be highly inductive, only slightly inductive, or capacitive. The algebraic sum of  $X_L$  and  $X_A$  (hereinafter called  $X_{AN}$ ) must always be inductive. If the antenna is only slightly inductive, having from 0 to approximately 100 ohms inductive reactance, a portion of coil L11 should be used to give the output circuit a definite inductive reactance ( $X_{AN}$ ). A good assumed value of  $X_L$  for this purpose is an inductive reactance corresponding to about one-fourth of the total inductance available in the coil; i.e., corresponding to 25 microhenries. The inductive reactance ( $X_L$ ) for this value depends upon the operating frequency. Some values of  $X_L$  are given in the following table:

Frequency (kc)	$X_L$ (ohms)
500	78
750	117
1000	156
1250	195
1500	234
1750	274
2000	313

If the antenna reactance is capacitive, sufficient turns of coil L11 must be used to make the sum of  $X_L$  and  $X_A$  ( $X_{AN}$ ) inductive, and of a value just large enough to provide a definite assurance



that the output branch ( $X_{AN}$ ) will never become capacitive due to climatic or other variations. When  $R_0$  is greater than  $R_A$ , the minimum permissible value of  $X_{AN}$  is given by:

$$X_{AN} \text{ (min.)} = \sqrt{R_A (R_0 - R_A)} \text{ ohms}$$

Assuming that:

$Z_{AN}^2 = R_A^2 + X_{AN}^2$  (algebraic values), then the values of  $X_0$  and  $X_C$  for an impedance match may be computed from the following formulas:

$$(1) X_0 = \sqrt{\frac{R_0}{R_A} (Z_{AN}^2 - R_A R_0)} \text{ ohms}$$

$$(2) X_C = \frac{Z_{AN}^2}{X_{AN} + \frac{R_A}{R_0} X_0} \text{ ohms}$$

The inductive reactance corresponding to the value of  $X_0$  thus obtained should not exceed 60 microhenries, which is approximately half of the inductive reactance ( $X_L$ ) of coil L10. The inductive reactance for this value of inductance varies with the operating frequency as is shown in the following table:

Frequency (kc)	$X_L$ — for 60 microhenries (ohms)
500	192
750	288
1000	383
1250	475
1500	580
1750	670
2000	780

The value of total shunt capacitance (C55 to C58) may be calculated from the equation:

$$C = \frac{10^3 \text{ microfarads}}{6.28 \times f \times X_C}$$

Where  $C$  = capacitance in microfarads  
and  $f$  = operating frequency in kilocycles.

The fixed capacitors have values and current ratings as follows:

Capacitors	Capacity (mmfd)	Current Rating		
		300 kc	1000 kc	300 kc
C55	1000	2.75 amp.	4.5 amp.	7.0 amp.
C56	1500	3.5 amp.	6.0 amp.	9.0 amp.
C57	2000	4.0 amp.	6.5 amp.	8.5 amp.
C58	3000	5.0 amp.	8.0 amp.	10.0 amp.

Parallel, series, or series-parallel combinations of capacitors may be used as required to obtain the proper total shunt capacitance as determined above. The values available will be between the limits of 7500 and 400 mmfd.

A check should be made in order to determine that none of the capacitors are operated in excess of their current rating. The total current

in the shunt capacitance branch may be determined from the following equation:

$$I_C = \left( \frac{R_A}{R_0} X_0 + X_{AN} \right) \frac{I_A \times 1.225}{Z_{AN}}$$

Where  $I_C$  = Total shunt capacitance current at 100 per cent sinusoidal modulation.

The antenna or transmission line current ( $I_A$ ) may be determined from the following equation:

$$I_A = \sqrt{\frac{W}{R_A}} \text{ amperes}$$

Where  $W$  = power output in watts,  
and  $R_A$  = antenna resistance or transmission line impedance in ohms

The voltage developed across the shunt capacitance branch may be computed from the equation:

$$E_C = I_C X_C$$

Where  $E_C$  = voltage across  $X_C$

From  $E_C$ , the current flowing through the capacitors for any particular combination may be computed. The current ratings for the capacitors supplied in the transmitter are shown in the foregoing tabulation. When the adjustments have been completed, the current through each of the capacitors should be checked with an r-f ammeter.

As an illustrative example of the proceeding calculations, it is assumed that the power output ( $W$ ) is 250 watts, and is loaded into an antenna whose characteristics ( $R_A + jX_A$ ) are  $25 + j34$ . The operating frequency ( $f$ ) is assumed to be 1250 kc.

The known values are:

$R_0$ (network input impedance)	=	230 ohms
$R_A$ (antenna resistance)	=	25 ohms
$X_A$ (antenna reactance)	=	+j34 ohms

Since the antenna is only slightly inductive, about one-eighth of the inductance of coil L11 should be used as a trial value. Assuming that the inductive reactance ( $X_L$ ) is equal to +j120 ohms:

$$\text{Then } X_{AN} = X_L + X_A = 120 + 34 = 154 \text{ ohms}$$

The minimum permissible value of  $X_{AN}$  is:

$$X_{AN} \text{ (min.)} = \sqrt{25 (230 - 25)} = \sqrt{5125} = 71.6 \text{ ohms}$$

This indicates that the above selection of  $X_L$  is amply large and probably should be reduced if a recalculation becomes necessary. Proceeding to determine  $X_0$  and  $X_C$ , we have:

$$Z_{AN}^2 = (25)^2 + (154)^2 = 24341$$

$$Z_{AN} = 156.0 \text{ ohms}$$

$$\text{Then, } X_0 = \sqrt{\frac{230}{25} [24341 - (25 \times 230)]} = 413.5 \text{ ohms}$$

Checking this value against the inductance available (half of L10), it may be seen in the tabulation that the maximum inductive reactance at 1250 kc is 475 ohms. Therefore, the value above of 413.5 ohms is satisfactory for  $X_0$ .

$$\text{Then, } X_c = \frac{24341}{154 + \left( \frac{25}{230} \times 413.5 \right)} = 122.4 \text{ ohms}$$

$$\text{hence, } C = \frac{10^3}{6.28 \times 1250 \times 122.4} = 1040 \text{ mmfd}$$

$$\text{and since, } I_A = \sqrt{\frac{250}{25}} = 3.16 \text{ amperes}$$

the current through this capacitance will be:

$$I_c = \left( \frac{25 \times 413.5}{230} + 154 \right) \frac{1.225 \times 3.16}{156} = 4.96 \text{ amperes}$$

Capacitor C55 is the nearest available to the calculated capacity but it has insufficient current carrying capacity. The combination with a resultant capacity nearest the value desired consists of C56 and C58 in series which is equivalent to 1000 mmfd. Both items have sufficient current capacity. If it is desired to obtain a solution for the exact capacity selected, it is necessary to assume several values for  $X_{AN}$  and to then compute the corresponding values of  $X_c$  and C.

A rough plot of C versus  $X_{AN}$  and an extrapolation for the current value of  $X_{AN}$  will minimize the number of approximations necessary for the desired solution.

### TYPICAL METER READINGS

Line Voltage (volts) . . . . .	110
Crystal Oscillator Plate Voltage (volts)	210
Crystal Oscillator Plate Current (ma) ..	28
* Buffer Plate Voltage (volts) . . . . .	1200
Buffer Plate Current (ma) . . . . .	95
* Buffer Screen Voltage (volts) . . . . .	285
* Buffer Suppressor Voltage (volts) ...	60
Power Amplifier Plate Voltage (volts) .	1500
Power Amplifier Plate Current (total ma) . . . . .	250
Power Amplifier Grid Current (ma) ..	85
* First Audio Plate Voltage (volts) . . . .	220
First Audio Plate Current (ma) . . . . .	7
Modulator Plate Current "Left" and "Right" . . . . .	
0% Modulation (includes screen current) ma . . . . .	20
100% Modulation (includes screen current) ma . . . . .	130
* Modulator Plate Voltage (volts) . . . .	1650
* Modulator Grid Voltage (volts) . . . .	-120
* Modulator Suppressor Voltage (volts) .	60
* Modulator Screen Voltage (volts) . . . .	
0% Modulation (maximum volts) .	825
100% Modulation (maximum volts) .	750

\* Must be measured with an external meter.

### OPERATION

After the transmitter has been tuned to the operating frequency, it may be placed in operation. To do this the following procedure should be followed:

1. Make sure that all cabinet doors are closed, that all switches are in the "OFF" position, and that the "P.A. OVERLOAD" and "MOD. OVERLOAD" circuit breakers are closed.

2. Close the "LINE" circuit breaker.
3. Close the "FILAMENT" circuit breaker.
4. After the time delay relay (E4) has operated, close the "PLATE" circuit breaker. When the transmission has been concluded, the transmitter should be shut down by opening the "LINE" switch, S1.

### MAINTENANCE

To secure continuous and reliable operation it is recommended that a definite maintenance schedule be arranged. It is important that the entire transmitter be kept free from dust and excessive moisture. Special care should be observed in the case of all insulators to avoid high resistance leaks. A small electric hand blower may be used advantageously to blow dust from inaccessible places.

The transmitter should be inspected periodically for poor contacts and loosened connections. At such time each contact of every relay and the door interlock switches should be inspected and cleaned. A small amount of vaseline should be

applied to the contacts of the door interlock switches after they have been cleaned. All r-f and ground connections should be tightened as required. The safety gaps on the modulation transformer should also be inspected and kept in a polished condition.

So far as possible, tube failures should be anticipated by keeping a log of tube life at least for each of the larger tubes employed. The appearance of the transmitter and its components may be kept like new by the judicious application of matching lacquers which are included as a part of this equipment.

## REPLACEMENT PARTS LIST

When ordering replacement parts, please give Symbol, Description, and Stock Number of each item ordered. The part which will be supplied against an order for a replacement item may not be an exact duplicate of the original part, however, it will be a satisfactory replacement, differing only in minor mechanical or electrical characteristics. Such differences will in no way impair the operation of the equipment.

Symbol No.	DESCRIPTION	Stock No.	Symbol No.	DESCRIPTION	Stock No.
A4	Lamp, plate indicator	23216	C56	Capacitor, antenna matching, same as C53	
A7	Lamp, control panel, illumination, 40 watt	47044	C57	Capacitor, antenna matching, same as C54	
A8	Attenuator, audio input, 6 db.	19651	C58	Capacitor, antenna matching, 3000 mmfd.	52422
C1	Capacitor, crystal tuning, 4.5-20 mmfd.	16890	C59	Capacitor, filter, 8 mfd., 1000 volts d-c	19341
C2, C3	Capacitor, bypass, .01 mfd.		C60, C61	Capacitor, bias rectifier filter, 4 mfd., 600 volts	19464
C4	Capacitor, output coupling, 47 mmfd.	50358	C62	Capacitor, monitor blocking, .5 mfd., 600 volts	60029
C5	Capacitor, filter, .002 mfd.	50359	C63	Capacitor, line matching, 1000 mmfd.	52415
C12, C13	Capacitor, buffer filament bypass, 10,000 mmfd.	69857	C64	Capacitor, power output control bypass, 1 mfd., 600 volts d-c	19465
C14	Capacitor, buffer screen bypass, same as C12		C65	Capacitor, P.A. grid resistor bypass, 30,000 mmfd.	52423
C15	Capacitor, buffer plate bypass, 20,000 mmfd.	69862	C68	Capacitor, neutralizing series, 150 mmfd.	69865
C16	Capacitor, freq. monitor bypass, 10,000 mmfd.	52410	C69, C70, C71, C72, C73, C74	Capacitor, modulator filament bypass, 3900 mmfd.	52413
C17	Capacitor, buffer plate tank, 620 mmfd.	52411	C76	Capacitor, feedback divider, 620 mmfd.	52416
C18, C19	Capacitor, buffer plate tank, 300 mmfd.	52412	C80	Capacitor, suppressor bypass, 10,000 mmfd.	52410
C20	Capacitor, neutralizing tank, 100 mmfd.	69863	C84, C85	Capacitor, i.f. compensation, 20,000 mmfd.	69674
C21, C24	Capacitor, neutralizing tank, 200 mmfd.	69864	C86	Capacitor, compensating, 390 mmfd.	52424
C22, C23	Capacitor, P.A. filament bypass, 3900 mmfd.	52413	E4	Capacitor, compensating, .001 mfd.	52415
C25	Capacitor, P.A. plate blocking, 5100 mmfd.	52414	E5	Relay, plate time relay; coil, 115 volts, 50/60 cycle	48197
C26	Capacitor, P.A. plate bypass, 1000 mmfd.	52415	F1, F2	Relay, time interlock, D.P.D.T., 115 volts, 50/60 cycle	46117
C27	Capacitor, buffer plate tank, 100 mmfd.	52417	J1	Fuse, crystal heater, 1 ampere	19335
C28, C29	Capacitor, crystal heater bypass, .01 mfd.	69857	J2	Plug, power, 8-prong	47317
C30	Capacitor, meter bypass, 0.01 mfd.	62055	J3, J4	Socket, oscillator	19656
C31, C32	Capacitor, modulator blocking, 0.25 mfd.	15943	L1	Connector, male	19568
C33, C36	Capacitor, feedback divider, 620 mmfd.	52416	L5	Inductor, oscillator plate tank	50360
C34, C35	Capacitor, feedback divider, 30,000 mmfd.	50787	L6	Inductor, buffer plate tank	50491
C37	Capacitor, P.A. filament bypass, 3900 mmfd.	52413	L7	Inductor, P.A. grid choke	16892
C39, C40	Capacitor, high voltage filter, 12 mfd., 2000 v.	19178	L8	Inductor, neutralizing tank	50491
C41	Capacitor, low-power audio filter, 2 mfd., 1000 volts	19652	L9	Inductor, P.A. plate choke	19185
C42	Capacitor, neutralizing tank, 100 mmfd.	69863	L10	Inductor, P.A. plate tank	50492
C43	Capacitor, P.A. filament bypass, 3900 mmfd.	52413	L11	Inductor, P.A. loading	50493
C44	Capacitor, thermostat bypass, 5100 mmfd.	52418	L12	Inductor, transmission line series, same as L10	
C45, C46	Capacitor, 270 mmfd.	65401	L13	Inductor, low-pass filter, 0.10 H	17906
C48	Capacitor, P.A. tank, 390 mmfd.	52419	L14	Inductor, modulation monitor, pick-up	19337
C49	Capacitor, P.A. tank, 200 mmfd.	52413	L15	Reactor, high voltage filter	16928
C50	Capacitor, P.A. tank, 150 mmfd.	69865	L16, L17	Reactor, high voltage filter	19201
C51	Capacitor, P.A. tank, 100 mmfd.	69863	M1	Reactor, bias rectifier filter	19343
C52	Capacitor, line matching, 1000 mmfd.	52415	M2	Milliammeter, oscillator plate, 0-50 ma. d-c	19188
C53	Capacitor, line matching, 1500 mmfd.	52420	M3	Milliammeter, buffer plate, 0-250 ma. d-c	19189
C54	Capacitor, line matching, 2000 mmfd.	52421	M4	Milliammeter, P.A. plate, 0-500 ma. d-c	19193
C55	Capacitor, antenna matching, same as C52		M5	Milliammeter, P.A. grid, same as M2	
			M9	Voltmeter, P.A. plate, 0-2 kv. d-c., 1000 ohms per volt, complete with external multiplier (R36)	19190
				Milliammeter, 1st Audio plate, 0-10 ma. d-c	44514

Symbol No.	DESCRIPTION	Stock No.	Symbol No.	DESCRIPTION	Stock No.
M10, M11	Milliammeter, modulator plate, same as M2	19189	R75	Resistor, feedback divider, 22,000 ohms, 2 watts	19206
M12	Voltmeter, line voltage, 0-150 volts, a-c	19194	R79, R80	Resistor, voltage divider, 1000 ohms, taps at 200 and 400 ohms	46118
P1, P2	Connector, female	19569	R81	Resistor, voltage divider, 800 ohms	19210
R1	Resistor, grid leak, 150,000 ohms, 1 watt	31895	R82, R83	Resistor, voltage divider, 1000 ohms	19870
R2	Resistor, cathode, 680 ohms, 2 watts	38325	R84	Resistor, 800 ohms, tap at 240 ohms	46119
R12	Resistor, buffer grid, 22,000 ohms, 2 watts	19081	R85	Resistor, 65,000 ohms, taps at 25,000 ohms, 40,000 ohms, section rated at 100 watts	52242
R13	Resistor, buffer series, 100 ohms, 2 watts	14162	R86, R87	Resistor, compensating, 27,000 ohms, 4 watts	
R14	Potentiometer, frequency monitor, 1000 ohms	19203	S1	Switch, breaker line, 30 amps.	19195
R15	Rheostat, power output control, 750 ohms	19204	S2	Switch, breaker filament, 5 amps.	19196
R16	Resistor, audio monitor, 10 ohms	19658	S3	Switch, breaker plate, 20 amps.	19339
R17	Resistor, P.A. grid, 4000 ohms	43140	S4, S8, S9	Switch, door interlock	18110
R18, R19	Resistor, parasitic suppressor, 68 ohms, 1 watt	52213	S5, S6	Switch, breaker, P.A. plate	19338
R22	Pctentiometer, bias bleeder, 5000 ohms	19206	S7	Switch, power change	20790
R23	Rheostat, r-f filament control, 10 ohms	17290	T1	Transformer, audio filament	19197
R24	Resistor, overload coil, 33 ohms, 1 watt	52293	T3	Transformer, r-f filament	19199
R26	Resistor, overload coil, 56 ohms, 2 watts	52230	T4	Transformer, rectifier filament	19200
R27	Rheostat, audio filament control, 15 ohms	19209	T5	Transformer, rectifier plate	19336
R28	Rheostat, rectifier filament control, 10 ohms, same as R23	17290	T6	Transformer, modulation	15516
R29, R30	Resistor, grid load, 33,000 ohms, 1 watt	60291	T7	Transformer, bias rectifier plate	19342
R32	Resistor, first audio bleeder, 39,000 ohms, 1 watt	45420	T8	Transformer, audio input	46109
R33, R34, R35	Resistor, first audio screen dropping, 27,000 ohms, 2 watts	44213	X1	Socket, tube	18724
R36	Resistor, multiplier, part of M5	28738	X2	Socket, crystal unit	16889
R41, R42	Resistor, 0.10 megohm, 2 watts	43018	X3	Socket, 6 contact, square	18724
R43, R44	Resistor, modulator grid, 0.22 megohm, 1 watt	43018	X4, X10, X11	Socket, buffer	18724
R45	Resistor, first audio cathode, 5600 ohms, 2 watts	51777	X5, X6	Socket, P.A., 4 contact, lock-in type	45684
R46, R47	Resistor, P.A. cathode, 50 ohms	19659	X7	Socket, bias rectifier	31319
R48	Resistor, bias bleeder, 5000 ohms, 10 watts	19206	X8, X9	Socket, first audio	18007
R54	Potentiometer, bias bleeder, 5000 ohms	19206	X12, X13	Socket, rectifier	44765
R64	Resistor. l.p. audio bleeder, 80,000 ohms, taps at 34,000—38,000—42,000 ohms	43311	X14, X15	Socket, fuse	19334
R65, R66	Resistor, modulator grid suppressor, 10 ohms, 2 watts	43008	X16	Socket, plate indicator lamp	19026
R72, R73, R77, R78	Resistor, feedback divider, 2.2 megohms, 2 watts	46350	X17	Socket, control panel, illuminating lamp	50506
R74, R76	Resistor, feedback divider, 3900 ohms, 1 watt	45420			
				<b>MISCELLANEOUS</b>	
				Mercury Unit, 3 section closing 2 section opening	44688
				Coil, mercury unit, 115 volts, 50/60 cycle	50504
				Counter, less coupling and gear	50508
				Jewel, pilot lamp, red, with nut	32805
				Relay, time interlock, D.P.D.T., 115 volts	46117
				Spring, tension, for L5, L7	50495
				Universal Joint, for gear bracket and knob shaft assemblies	47190

41-55-11

Woodlawn 38000

DAY PF 634-635

NIGHT DF 567

RCA  
Emergency  
Service  
PR 234  
PR 318

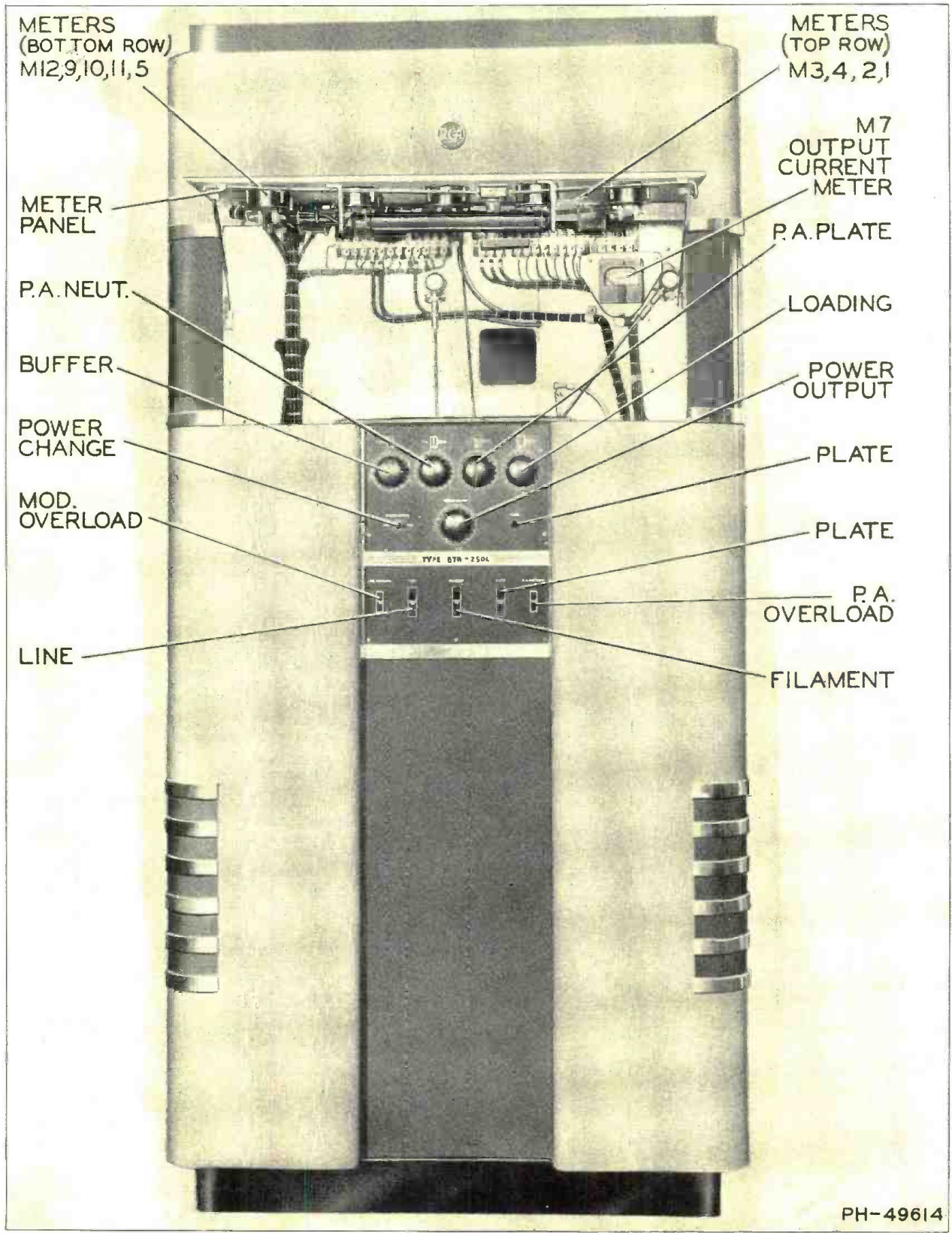

*Figure 3—Transmitter  
(Front View, Meter Panel Open)*

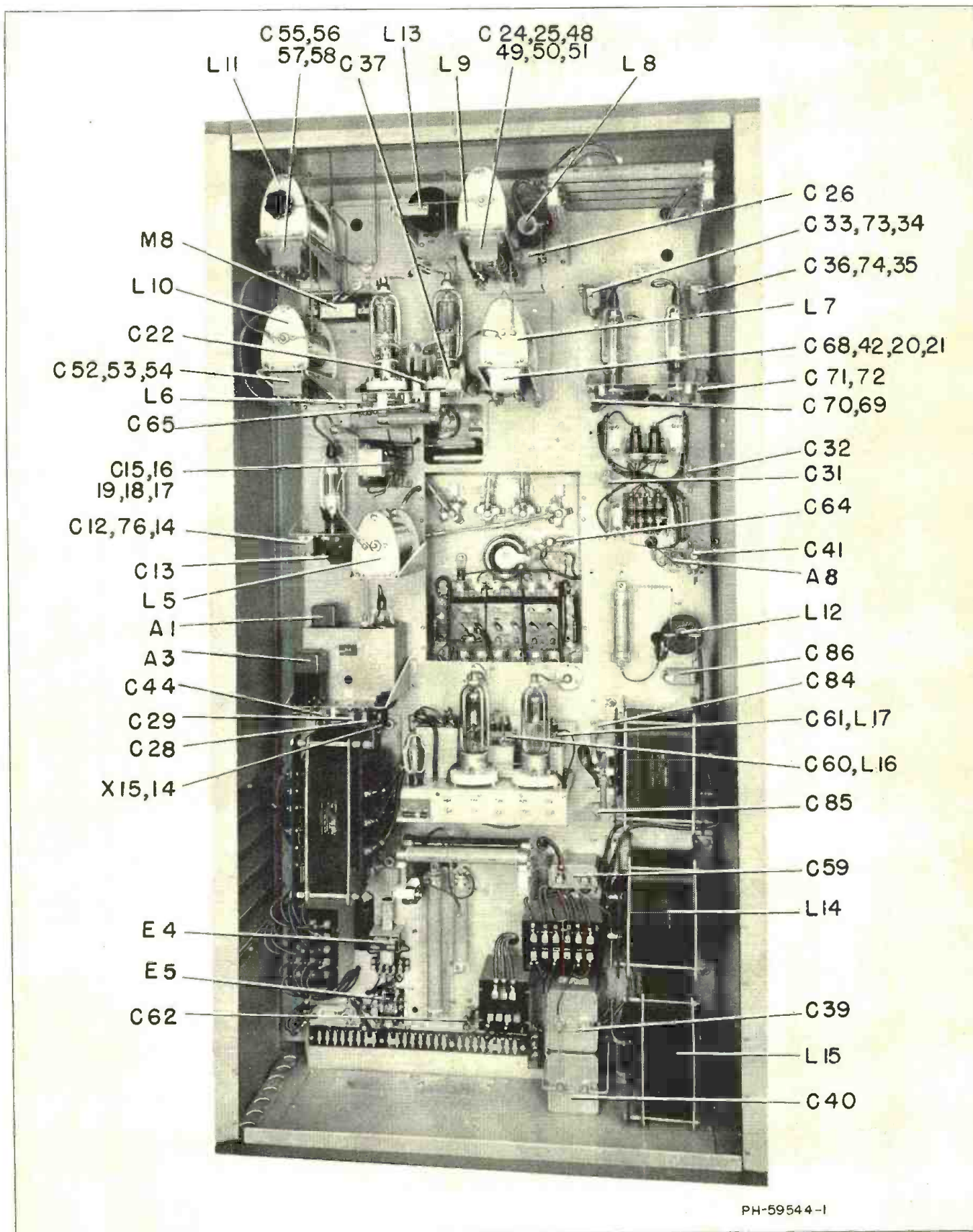
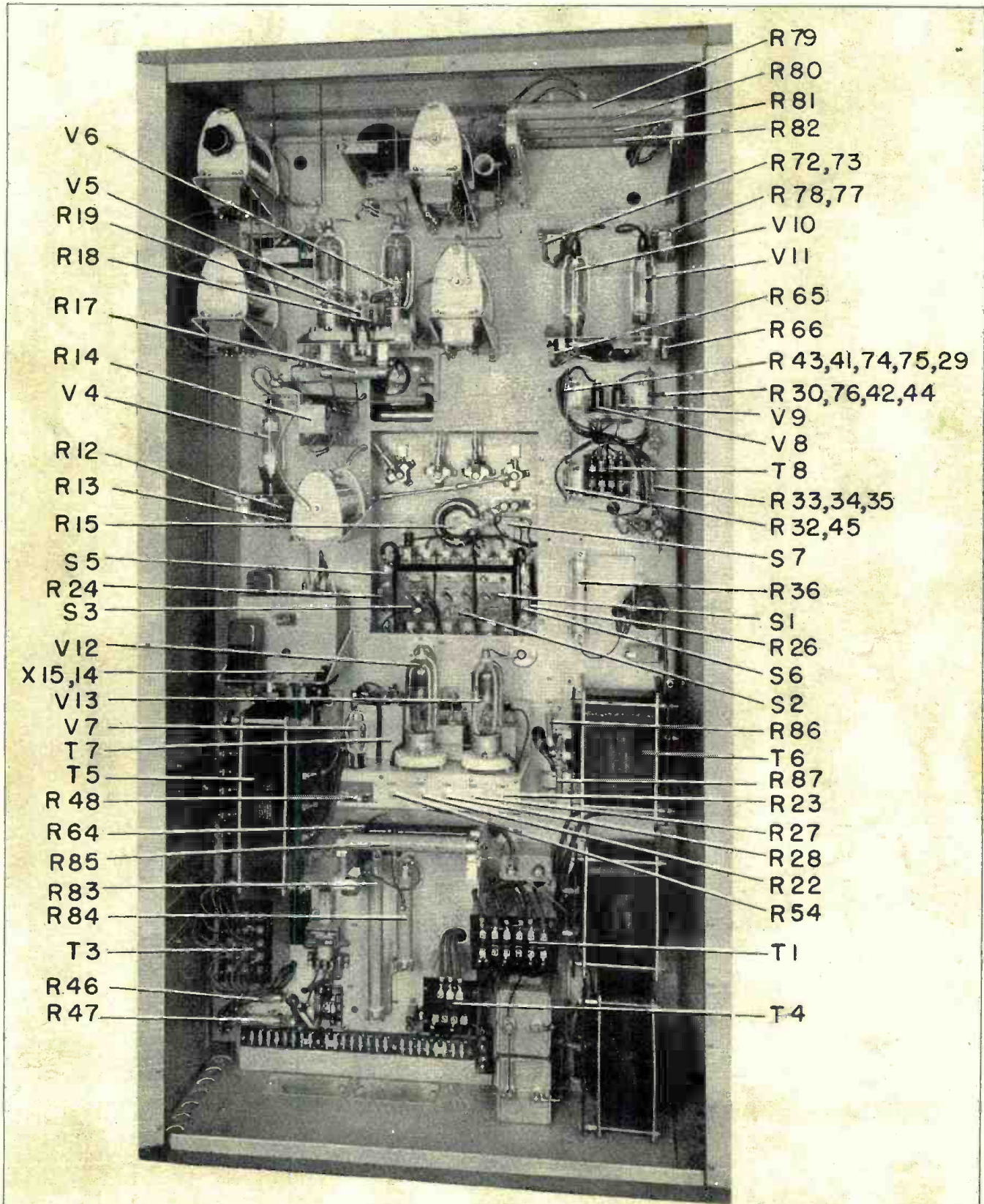

Figure 4—Transmitter Chassis (Rear View)



PH-59544-2

Figure 5—Transmitter Chassis  
(Rear View)

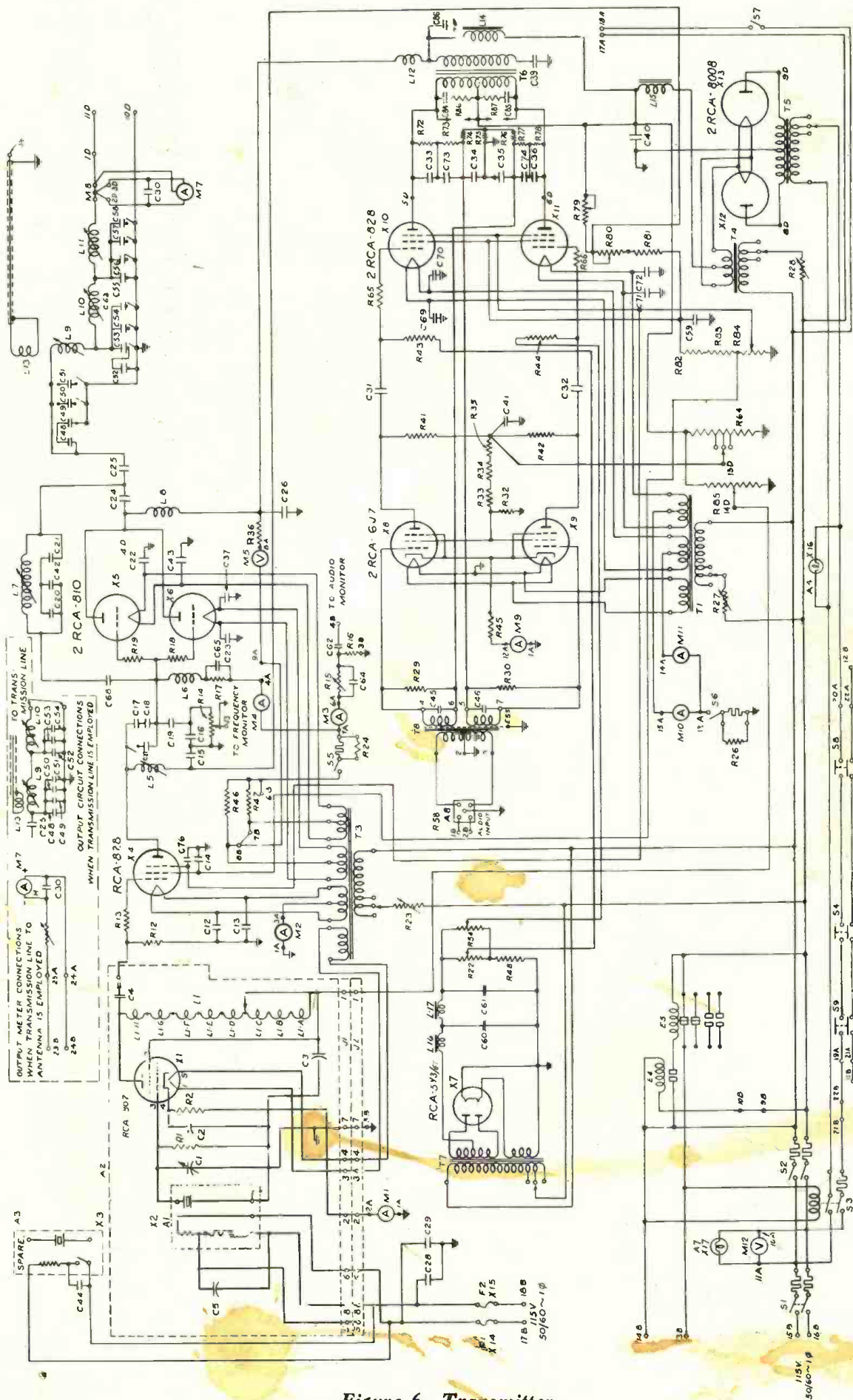

Figure 6—Transmitter  
(Schematic, T-613868—sub 1)





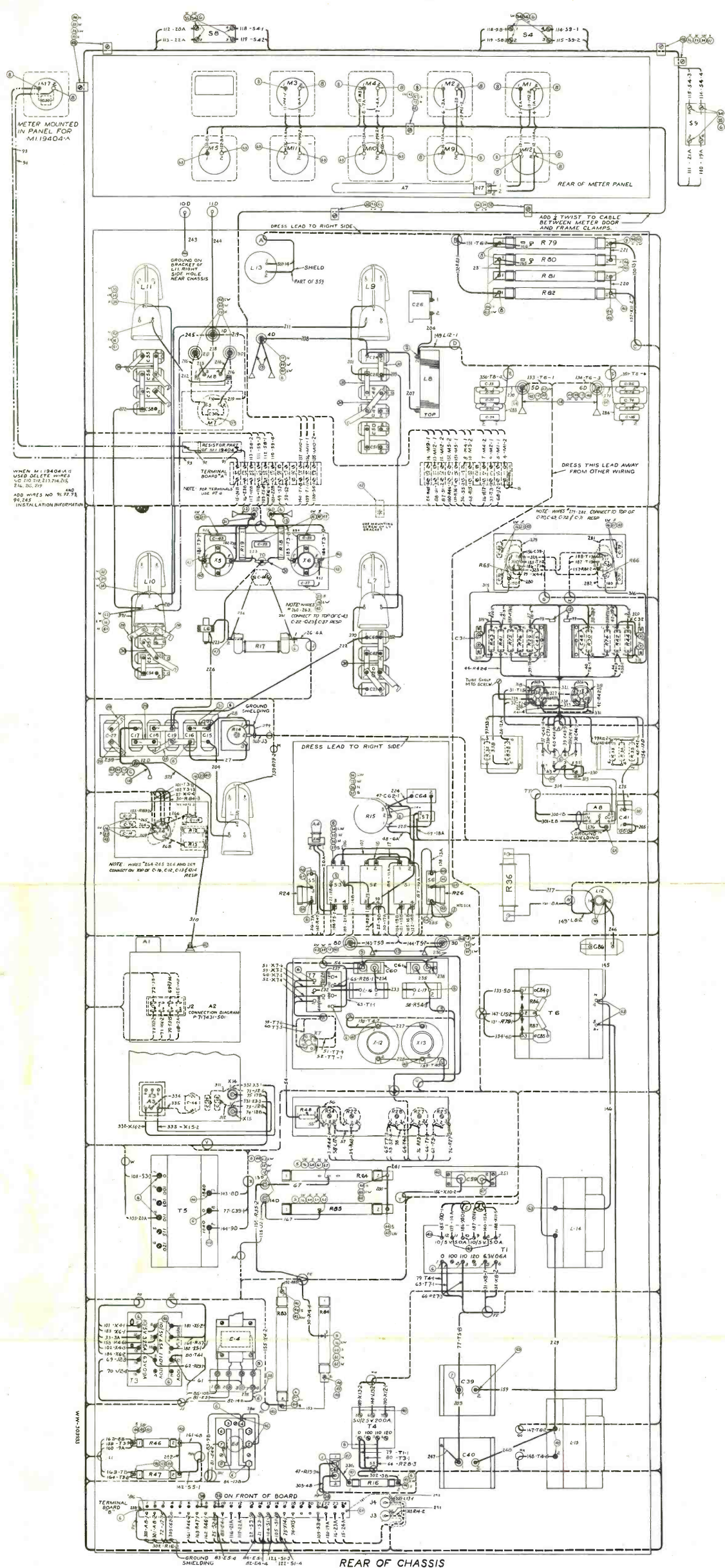
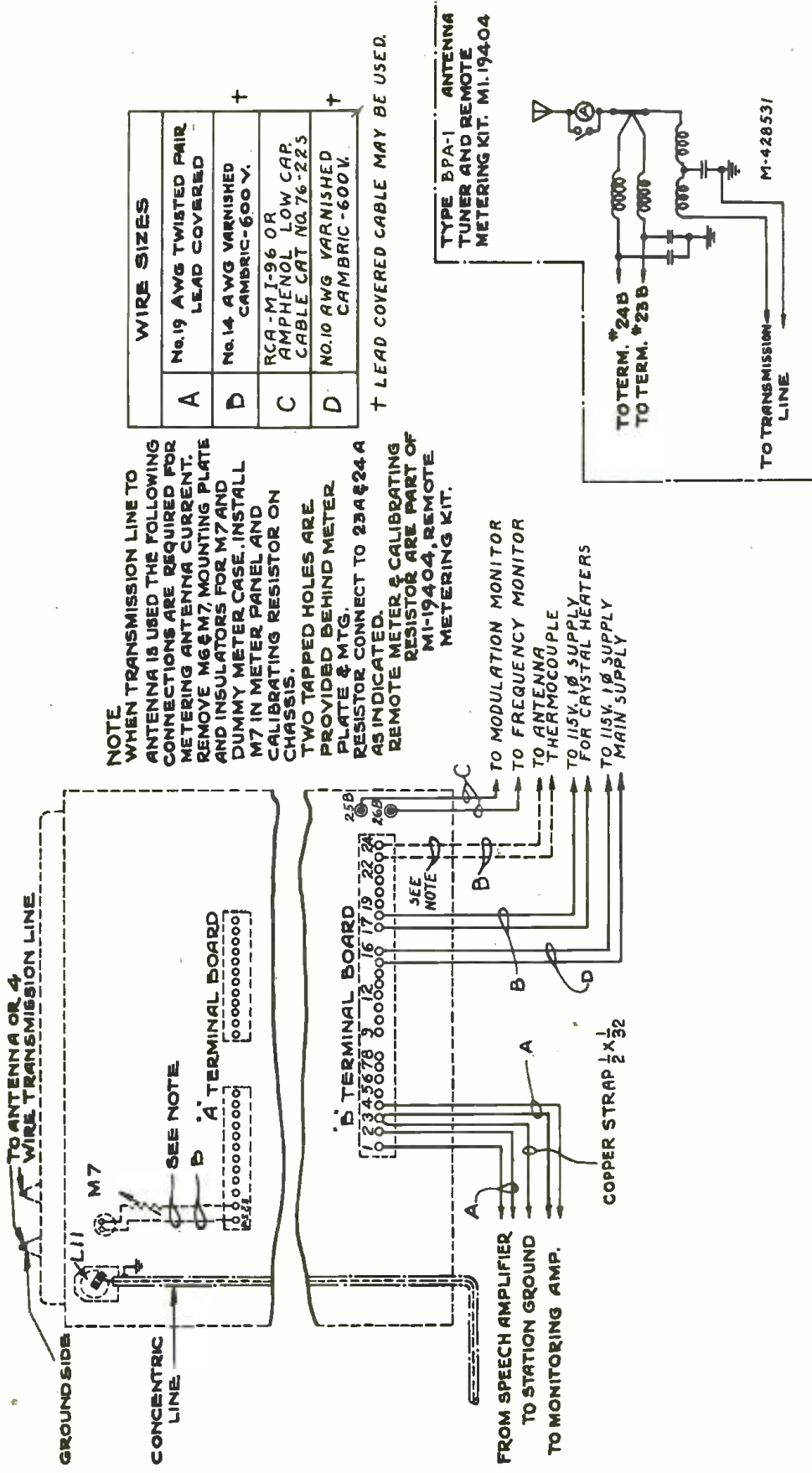

Figure 8—Transmitter  
 Wiring, W/W-303933—sub (0)



**NOTE**  
 WHEN TRANSMISSION LINE TO ANTENNA IS USED THE FOLLOWING CONNECTIONS ARE REQUIRED FOR METERING ANTENNA CURRENT. REMOVE M6 & M7, MOUNTING PLATE AND INSULATORS FOR M7 AND DUMMY METER CASE. INSTALL M7 IN METER PANEL AND CALIBRATING RESISTOR ON CHASSIS.  
 TWO TAPPED HOLES ARE PROVIDED BEHIND METER PLATE & MTG.  
 RESISTOR CONNECT TO 23A & 24A AS INDICATED.  
 REMOTE METER & CALIBRATING RESISTOR ARE PART OF MI-19404, REMOTE METERING KIT.

WIRE SIZES	
A	No. 19 AWG TWISTED PAIR LEAD COVERED
D	No. 14 AWG VARNISHED CAMBRIC-600 V.
C	RCA-MI-96 OR AMPHENOL LOW CAP CABLE CAT NO. 76-223
D	NO. 10 AWG VARNISHED CAMBRIC-600 V.

† LEAD COVERED CABLE MAY BE USED.

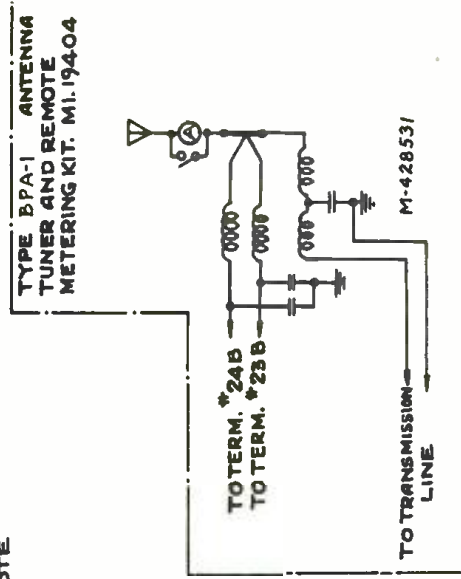

Figure 9—Transmitter  
 (External Connections, M-428531)

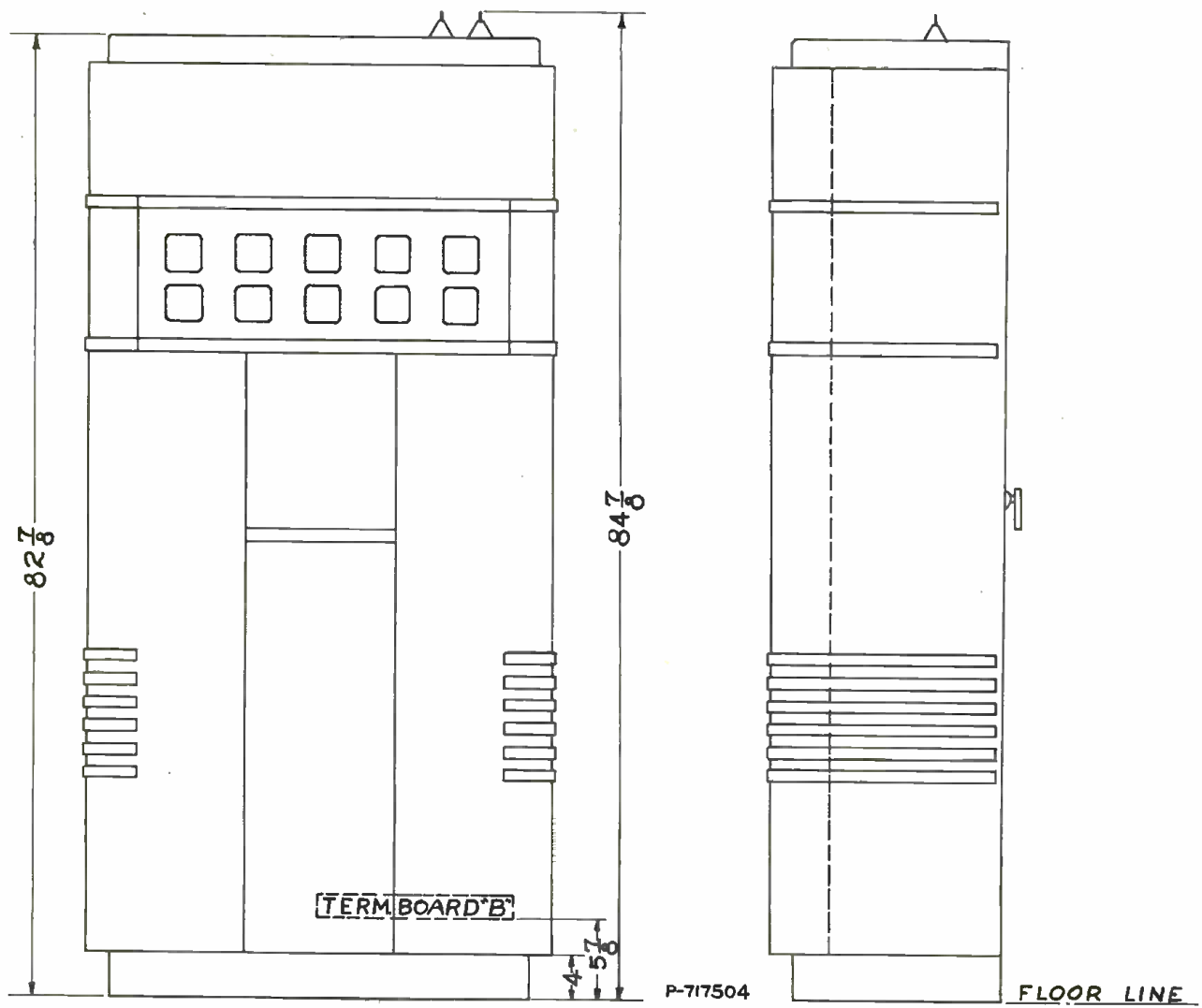
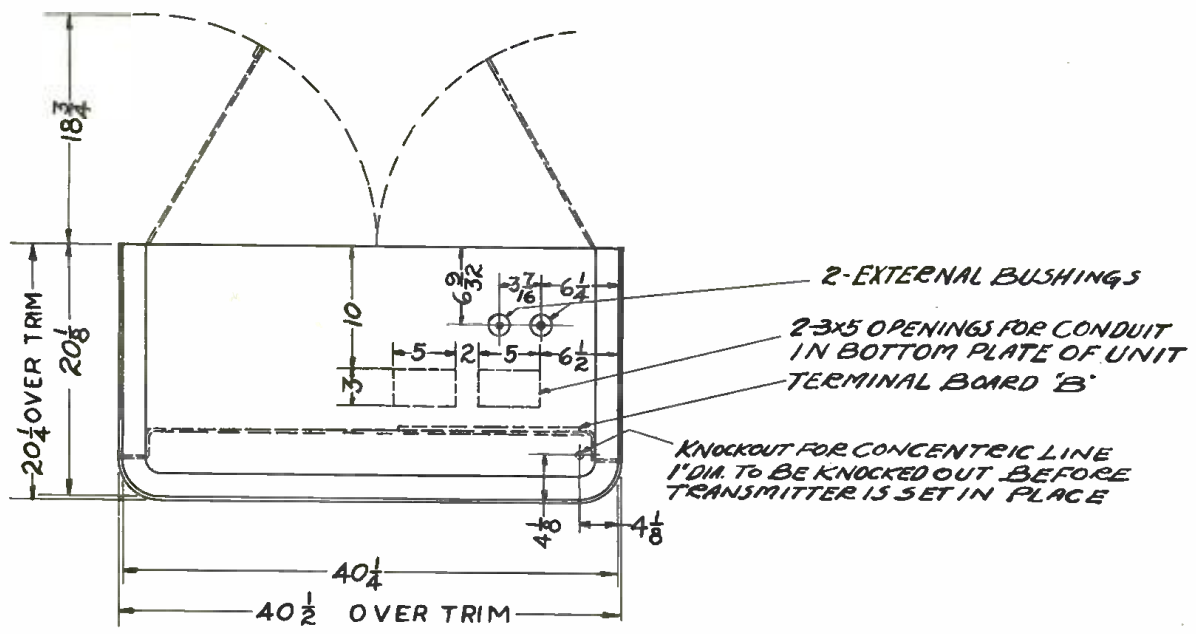

Figure 10—Transmitter  
(Outline, P-717504)

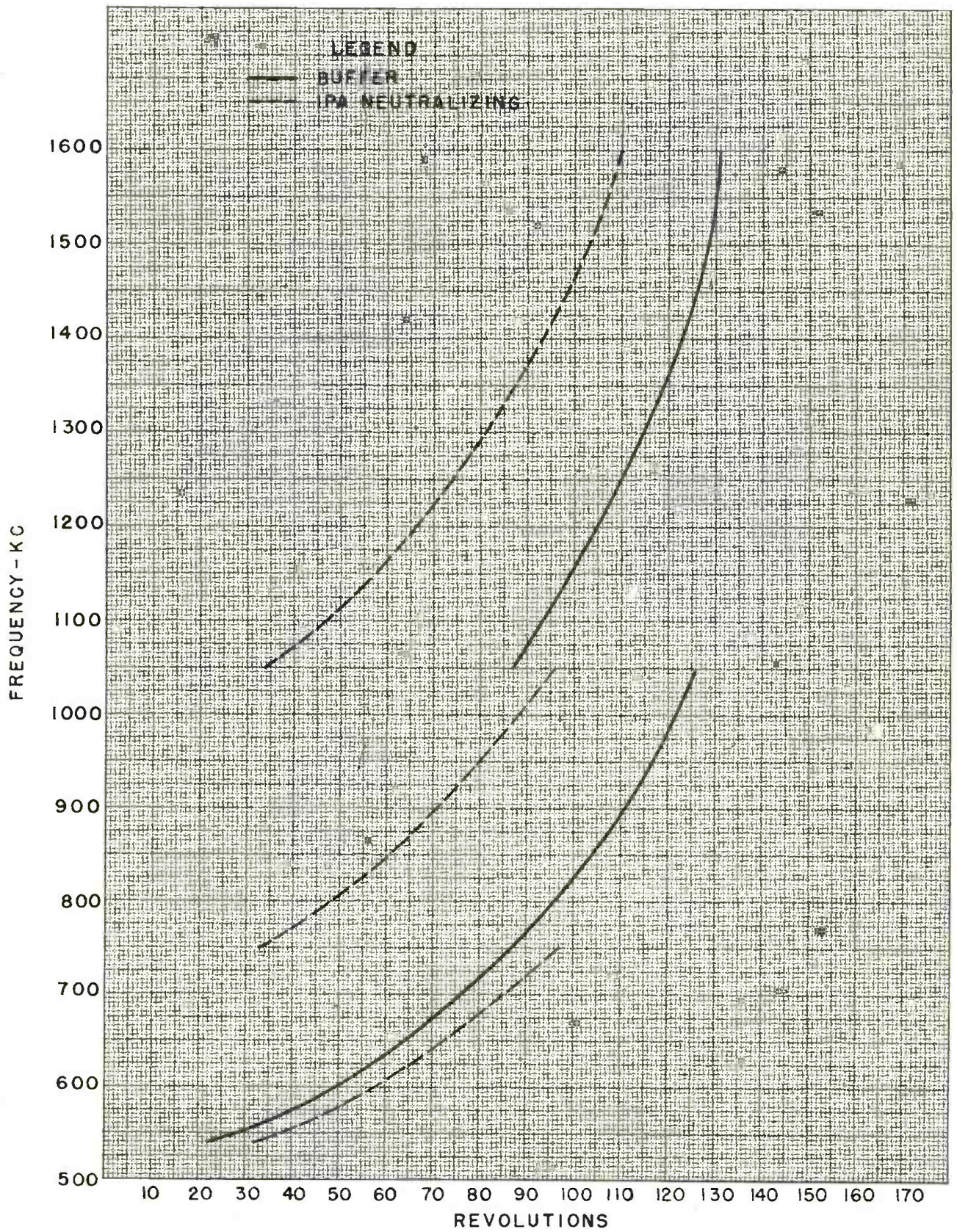

Figure 11—"P.A. NEUT." and "BUFFER"  
 Dials (Tuning Chart, S-853809)

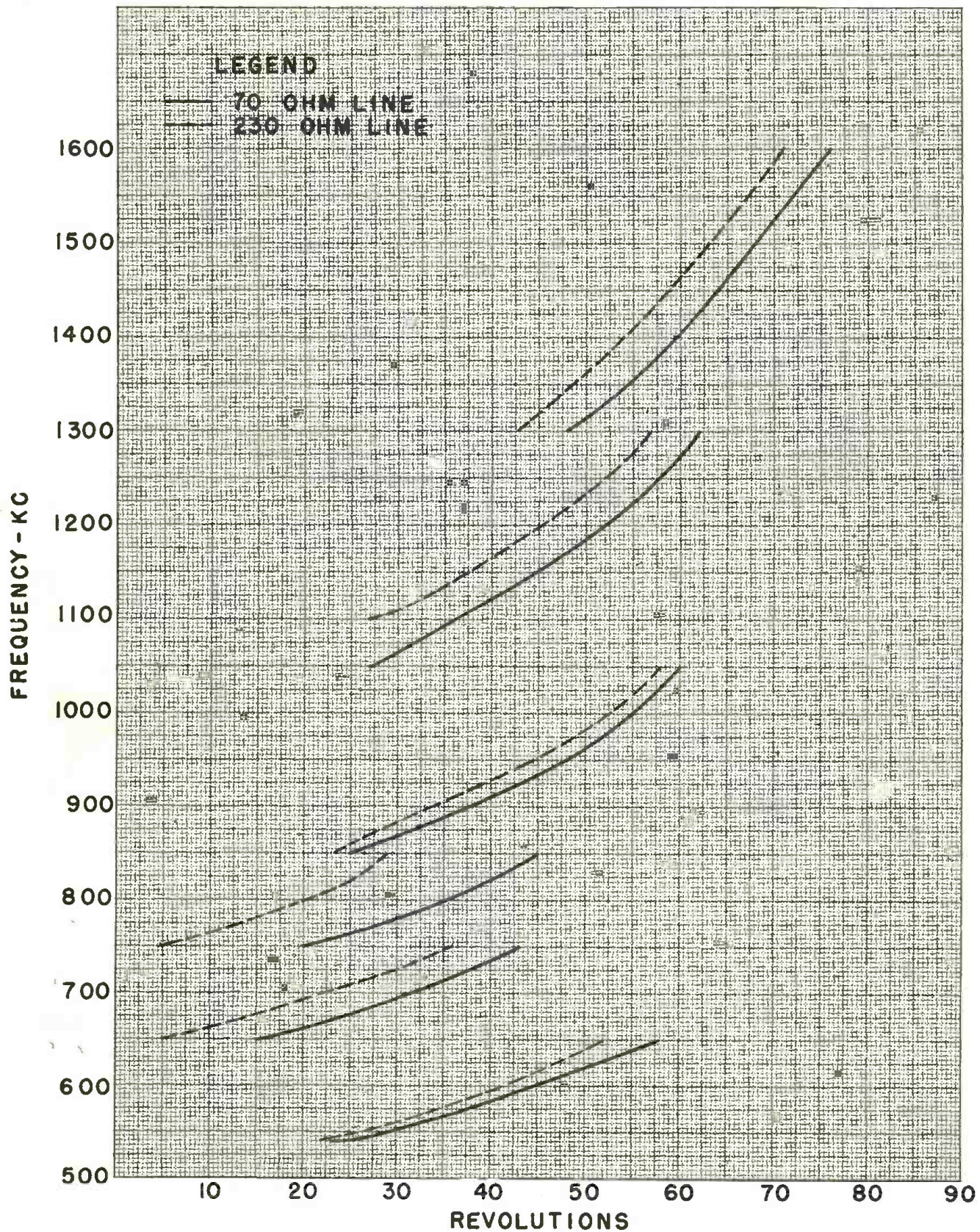

Figure 12—"P.A. PLATE" Tank Circuit Dial  
(Tuning Chart, S-853811)

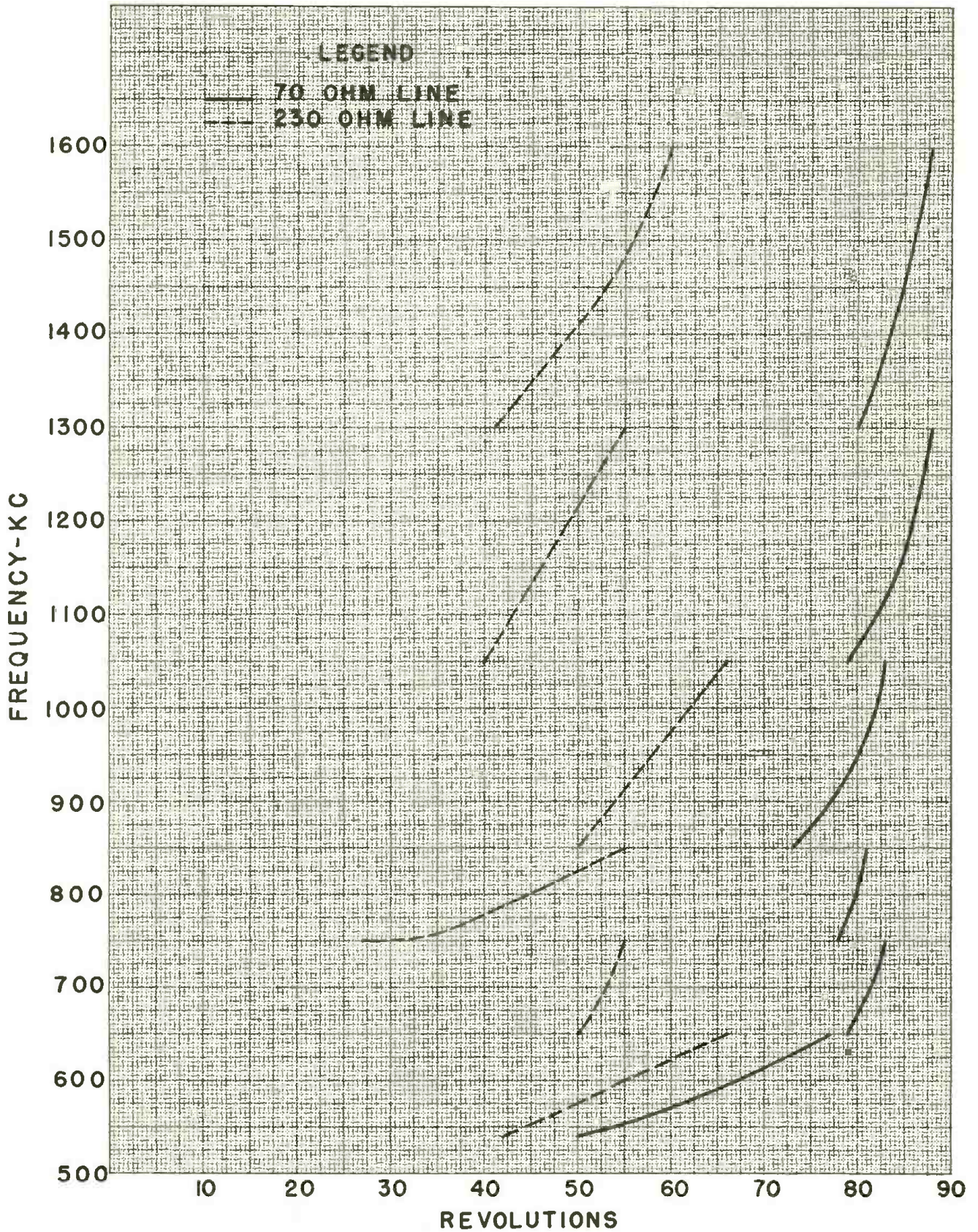
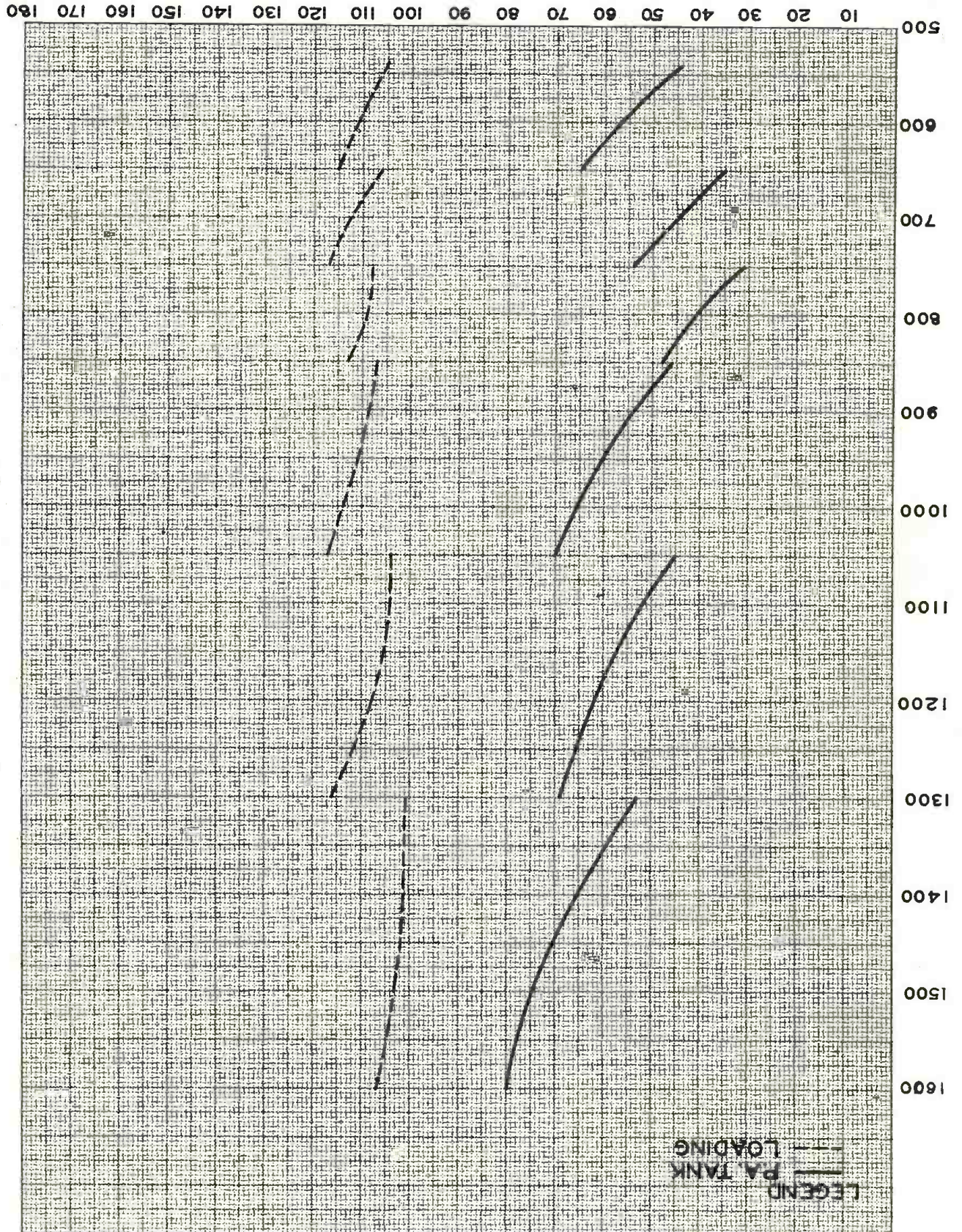

Figure 13—Antenna "LOADING" Dial  
 (Tuning Chart, S-853810)

Figure 14—"P.A. PLATE" and "LOADING"  
Dials, 20-ohm Line (Tuning Chart S-853812)







Manufactured by  
**RADIO CORPORATION OF AMERICA**  
*Engineering Products Department*  
**CAMDEN, NEW JERSEY, U. S. A.**

*Instruction Book*

**BTA-250L**

**BROADCAST TRANSMITTER**

**POWER - 250, 100/250 OR 100 WATTS**

