

Our

catalog RA.1011A

(Replaces B.6004)

RCA

One-Kilowatt AM Transmitter, Type BTA-1S

- Excellent frequency response, low distortion
- Low operating costs
- Circuit breaker overload protection
- Positive peak modulation capability: 125%



The RCA Type BTA-1S, 1-kilowatt AM Broadcast Transmitter is designed for reliability, outstanding fidelity, and economical operation. It provides a high quality amplitude modulated signal at any frequency in the 535 to 1620 kilohertz band and is capable of producing a maximum of 1100 watts.

Highly perfected audio circuits together with a large, high-quality modulation transformer and reactor provide 125-percent positive-peak modulation capability and unusually high fidelity sound. Stable, long-life tubes and solid-state devices have been used throughout the transmitter. Circuit breakers, *not fuses*, provide complete overload protection.

Provision for remote control and simplified power cutback are reflected in the BTA-1S design. Front panel or remote control selection of any two power levels of 1000, 500 or 250 watts is available. No unnecessarily complicated circuitry or superfluous parts have been included and all components are easily accessible for maintenance and inspection.

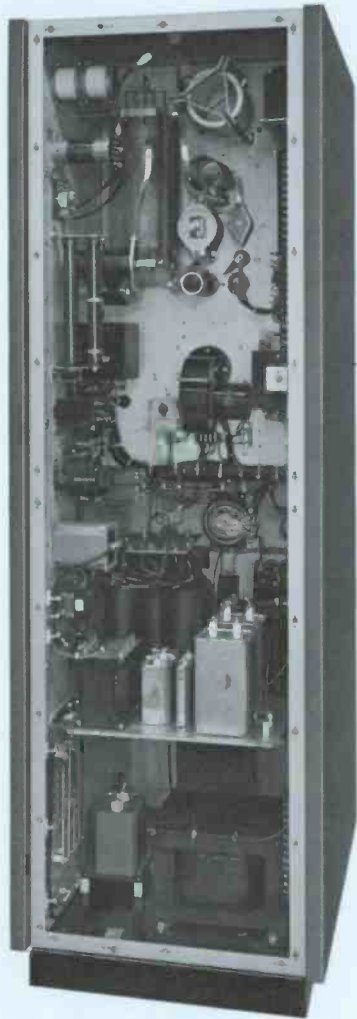

Unimpeded rear access to the transmitter is afforded by the full length door and the well laid out, vertical construction. Power supply components at bottom; r-f components at top.

Type BTA-1S Transmitter with outer and inner door open to display accessibility to the tubes. Power amplifier and modulator tubes are near top while the lower chassis carries the audio-amplifier and intermediate stages.



Functional Design

Improved functional design includes RCA's new color combination. Square construction permits locating the transmitter against the wall, or it can be installed against other equipment. The vertical construction makes it accessible from both front and rear for ease of maintenance. A single front panel tuning control provides simplified operation. Remote control provisions permit unattended operation of the transmitter.

Simplified Power Cutback

The BTA-1S easily fits into operations where power reduction at night is required. For "day-night" operation an optional Power Cutback Kit may be incorporated in the transmitter. By pressing a button on the front or at a remote panel, the transmitter can be cut back in power to either 500 or 250 watts. Efficient operation at the low power levels is achieved by reducing the high voltage by primary taps on the plate transformer.

Complete Accessibility

The entire transmitter is housed in a single steel cabinet that is mounted on a sturdy welded steel base. Control components are conveniently located on the panel above the front door and all meters are at eye level. Easy access is provided by a hinged front door and two interlocked removable rear panels. Most BTA-1S components are mounted on a vertical center chassis. Tubes and overload relays are mounted on the front and the other components are mounted on the rear. Larger power components are mounted on the base.

Solid State Power Supplies

Three power supplies are used: a low voltage supply for plate and screen voltages of all low voltage tubes, a bias supply for the modulator tubes, and a high voltage supply for the modulator and power amplifier tubes. All power supplies use silicon diodes which results in low power drain, cool operation and reliable performance. Automatic relays protect the transmitter against overload. These, in turn, are backed up with automatic circuit breakers. The design avoids the use of fuses anywhere in the unit.

Power Requirements

The transmitter operates from a 208-240-volt, 50/60-hertz, single-phase power source for the main power. In addition, the crystal heaters require 115-volt power source.

Solid-State Oscillator and Buffer Stages

Adding an extra measure of transmitter stability, the BTA-1S combines its oscillator and buffer amplifier into a single, solid-state subassembly. The combination of transistorized electronics and temperature-controlled crystals make for an adjustment-free facility which, in turn, reduces routine maintenance. The oscillator is equipped with two temperature-controlled crystals arranged through a front-panel selector switch so that a "hot" spare is always at hand, even via remote control.

Simple, Straightforward Circuitry

The buffer feeds a single 6146A driver tube which in turn feeds the power amplifier which consists of two 4-400A tubes connected in parallel. Tetrodes have been utilized throughout the RF section of the transmitter reducing the required stages and the power consumption. Tetrodes also eliminate the need for neutralization.

The modulator comprises two 2E26 tubes in push-pull, resistance coupled to two 4-400A modulator tubes. The modulator tubes operate as a class AB₁ ampli-

fier without grid current which results in an overall distortion of less than 2 percent up to 10,000 Hz.

Parallel/Redundant System

The BTA-1S is available also as a parallel/redundant transmitter system. This system consists of two identical BTA-1S transmitters and a combiner. In the "parallel" mode, the twin one-kilowatt outputs are combined to provide two kilowatts of power to the antenna system; in the "redundant" mode, the system operates one of the two transmitters as a hot standby while the other feeds the antenna system.

In either operational mode, the parallel/redundant system assures greater on-air dependability. For example, an outage in one transmitter or the other automatically switches the troubled transmitter to a dummy load while the operable one feeds a full kilowatt to the antenna system. This action is the result of a special-design combiner with essentially zero insertion loss. Further details of the BTA-1S parallel/redundant transmitter system are available from Aural Broadcast Equipment Marketing, RCA Building 2-5, Camden, N. J. 08102, U.S.A.

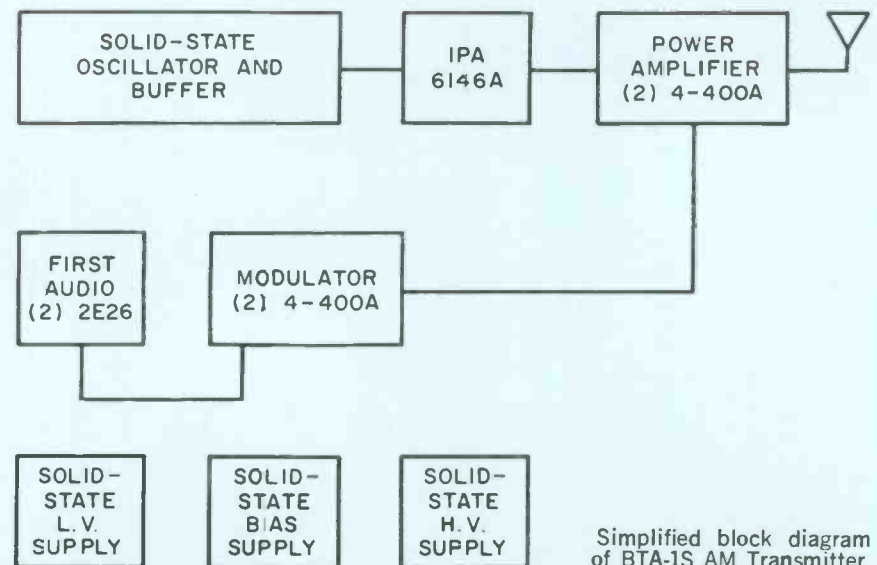

Specifications

Performance

AF Input Impedance	150/600 ohms
AF Input Level (100% modulation)	+10 ±2 dBm
AF Response:	
50-7500 Hz	±1 dB
30-10,000 Hz	±1.5 dB
AF Distortion (95% modulation):	
50-10,000 Hz	2%
50-12,000 Hz	3%
Noise (below 100% modulation)	60 dB
Frequency Range	535-1620 kHz
Frequency Stability	±2 Hz
Type of Output	Single ended
Carrier Shift (0-100% modulation)	3%
Output Impedance	40-250 ohms

Electrical

RF Voltage (for frequency monitoring)	6/10 V rms 75 ohms
RF Voltage (for modulation monitoring)	6/10 V rms 75 ohms
Power Output (nominal)	1000 watts
Power Output Capability	1100 watts
Power Supply	208/240 volts
Line Frequency	50/60 Hz
Phase	Single
Power Consumption (Approx.):	
0% modulation	2900 watts
100% modulation	3900 watts
Average program modulation	3200 watts
Power Factor	90%
Permissible combined line voltage variation and regulation	±5%
Crystal Heater Power Supply	115 volts 50/60 Hz

Tube Complement

1	6146A	Intermediate Power Amplifier
2	2E26	Audio Frequency Amplifier
2	4-400A	Modulator
2	4-400A	Power Amplifier

Mechanical

Height	77" (1955 mm)
Width	26" (660 mm)
Depth	30" (762 mm)
Weight (net)	900 pounds (408 kg) (approx.)
Altitude Range	0-5000 ft.* (0-1254 m)
Ambient Operating Temperature	-20 to 45°C (-4 - 113°F)
Shipping Data	1200 lbs (544 kg); 79 ft ³ (2.23 m ³)

Accessories

Operating Spare Tube Kit	ES-560655
Recommended Minimum Spare Tube Kit	ES-560656
Frequency and Modulation Monitor, Type BW-50	MI-560767
RF Amplifier (for BW-50)	MI-560762
Thirty-Function Remote Control, Type BTR-15	MI-561150
Sixty-Function Remote Control, Type BTR-30	MI-561440
High-Altitude Blower Kit	MI-34309-8
Spare Crystal Unit, Type TMV-130 (Specify Freq.)	MI-27493
RF Ammeters	MI-7157-F Series
Remote RF Pickup Unit (less meter)	MI-27966-B
Power Cutback Kit (Two Level)	MI-560657
Remote Power Adjust Kit	MI-560658
Oscillator-Buffer (Solid-State)	MI-27592

Ordering Information

One-Kilowatt AM Transmitter, Type BTA-1S	ES-560650
250- or 500-Watt AM Transmitter, Type BTA-1S (Specify power level)	ES-560947

*To 10,000 ft. (3048 m) with optional blower (MI-34309-8).



5 kW Ampliphase Transmitter, Type BTA-5L2

- High Fidelity Modulation (HFM)
- Low-distortion audio
- Solid-state exciter/modulator
- Extra modulation capability
- Designed for remote control
- Only two tube types in entire unit
- No modulation transformer

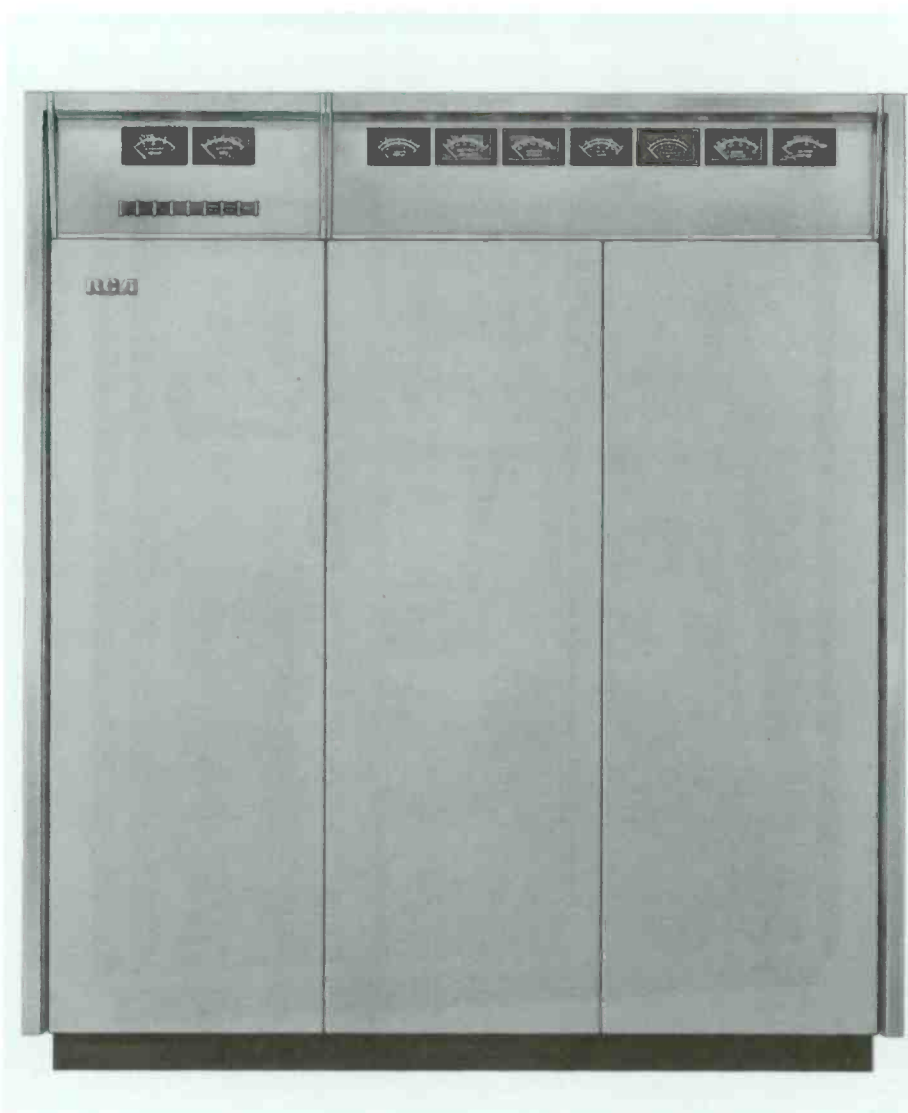

The BTA-5L2 is an Ampliphase transmitter for the AM-broadcast (medium-wave) band which delivers 5 kW to the antenna transmission line. The system offers superior audio quality, outstanding reliability and excellent efficiency.

As a result of the Ampliphase system, the BTA-5L2 Transmitter delivers extended audio-frequency response at distortion levels well below average perception at enviable operating economy and dependability.

The BTA-5L2 is available also in dual-unit systems for parallel or alternate-main operation.

In the "parallel" arrangement, the outputs of the two transmitters in the system are combined for a 10-kilowatt power output; in the alternate-main system, one transmitter serves the load while the second operates in hot standby mode. In this configuration, an outage in one transmitter or the other automatically connects the operable unit to the load.

A special feature of the parallel system is that, in the event of outage in one transmitter, the other transmitter delivers a full five-kilowatt output to the load.

Outstanding Audio Quality

Of particular interest to broadcasters who take pride in station "sound", the BTA-5L2 Transmitter offers outstandingly good audio quality. One reason for this is that the *Ampliphase* system eliminates iron-core high-level modulation components—and their inherent distortions—without adding the instabilities of separate "carrier" and "peak" power amplifiers. Even on ordinary AM radios, the outstanding audio quality of an *Ampliphase* transmitter is immediately apparent.

Extended Frequency Response

As evidence of the frequency-response characteristics the BTA-5L2 offers, it can put 30 kHz on-the-air—at full power—without strain. At the low-frequency end of the spectrum, frequencies down to 30 Hz go on-the-air at full level and low distortion. Transformer-equipped transmitters usually cut off below 50 Hz and above 15 kHz.

Extra Modulation Capability— "Superphase"

An advantage unique to the *Ampliphase* system is its capability for full modulation, even for extended periods, without overload. This is particularly important to stations programming music of high average level and low dynamics. Positive modulation peaks can go as high as 125 percent without transmitter overload. Another unique feature in *Ampliphase* is that it overmodulates without the "splatter" so common to other AM transmitter forms.

Provision for Spare Exciter

For those who prefer redundant exciters, the BTA-5L2 Transmitter provides rack space for a spare exciter. Offered as an option, the spare exciter includes switching gear for fast exciter substitution. A spare exciter is particularly valuable to the full-time station in that exciter maintenance is independent of transmitter operation.

Ready for Remote Control

Because the BTA-5L2 is built for the modern broadcaster it is engineered with remote control in mind. This manifests itself in extra components, wiring and connections fully compatible with remote control equipment carrying the RCA trademark. As a result, operating a BTA-5L2 via remote control requires investment only in control equipment and not in transmitter modification.

Two Tube Types

Being entirely solid-state at power levels below the IPA stage, the BTA-5L2 Transmitter uses a total of only four power tubes: two in each channel. Since



Front view, doors open. Note exciter unit.

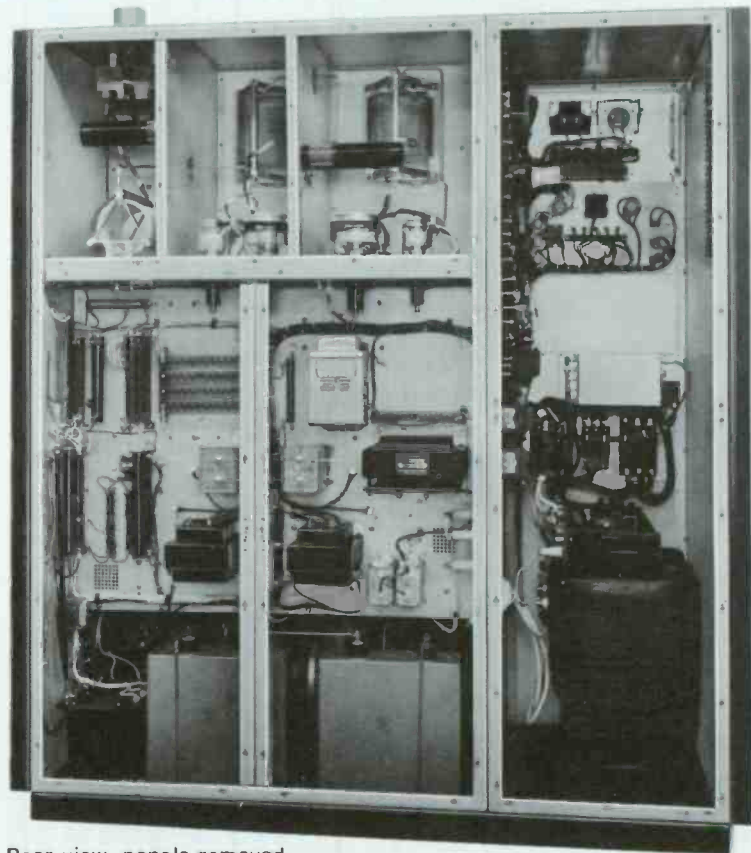

Rear view, panels removed.

these are of only two types, spares inventory need only be two tubes: one of each type. This reduces capital investment in spares and periodic rotation.

No Modulation Transformer

Using two identical R-F amplifier chains, the BTA-5L2 Transmitter uses *phase* modulation, at a low level, in such a manner that two phase-modulated carriers mix at the transmitter output to form an amplitude-modulated carrier. Since this system eliminates the modulation transformer and "carrier-peak" amplifiers, it eliminates the most-troublesome stages. This reflects itself in transmitter dependability that virtually eliminates unscheduled transmitter shutdown.

Faster Troubleshooting

A feature unique to *Ampliphase* makes routine repair easier. In a sense, a 5-kW *Ampliphase* transmitter is two identical 2.5-kW facilities in a single cabinet. Consequently, one amplifier chain is an excellent troubleshooting model for the other. Because the operating parameters of the two class-C amplifiers (operating as CW stages) can be quickly compared, the trouble can be isolated easily. Then, it's a simple matter of component replacement.

Ceramic Insulated PA Tubes

Ceramic power tubes have earned an enviable reputation among broadcasters

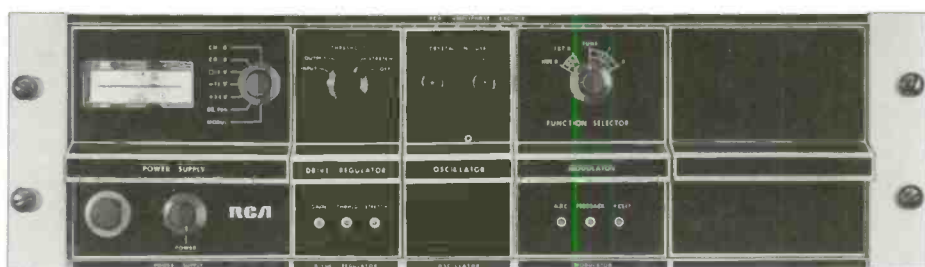

Ampliphase exciter unit. Completely solid-state, this unit is used in all RCA Ampliphase transmitters. Available separately for use as a spare. See Accessories.

for dependability and long life. The tube types selected for the BTA-5L2 operate well below ratings to take full advantage of their performance capabilities and built-in expected life. This pays dividends in low transmitter-operating expenses.

Fully Self-Contained

As the result of transistorization, the entire transmitter—including the power supply—fits within a single cabinet that occupies less than 14 square feet (1.3 m²) of floor space (see floor plan). This, of course, frees plant area for other productive purposes; office, studio or storage.

Parallel/Alternate-Main

The BTA-5L2 transmitter is available also as a parallel system. This arrangement uses two BTA-5L2 transmitters and a

combiner. In the "parallel" system, both transmitter outputs are combined to provide ten kilowatts to the load. Should one transmitter or the other have trouble, the operable transmitter continues to supply the load while the troubled transmitter is automatically switched from the antenna to a built-in dummy load.

In the alternate-main arrangement, one transmitter ordinarily feeds the antenna system while the other operates as a hot standby into a dummy load. Should the "air" unit fail, the system automatically connects the standby unit to the load and the troubled transmitter to the dummy load.

Further details are available from Aural Broadcast Marketing, RCA Building 2-5, Camden, N. J., 08102, U.S.A.

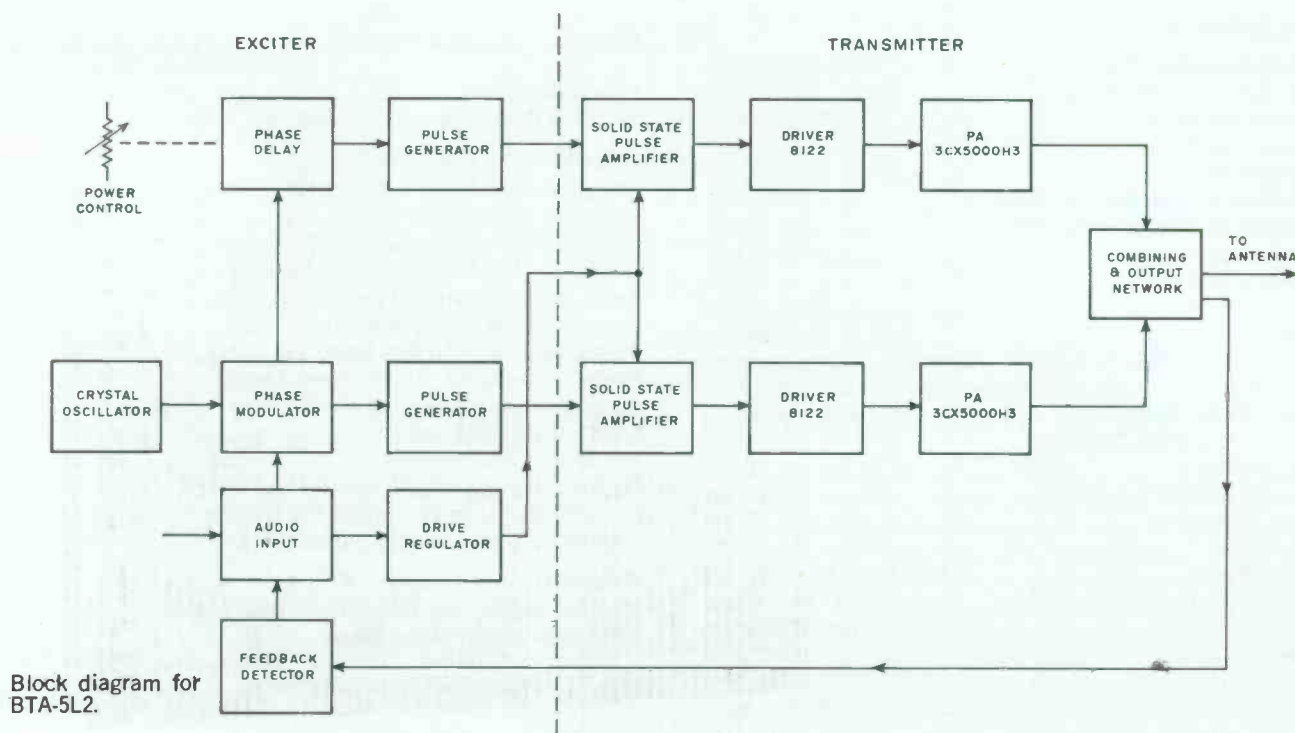

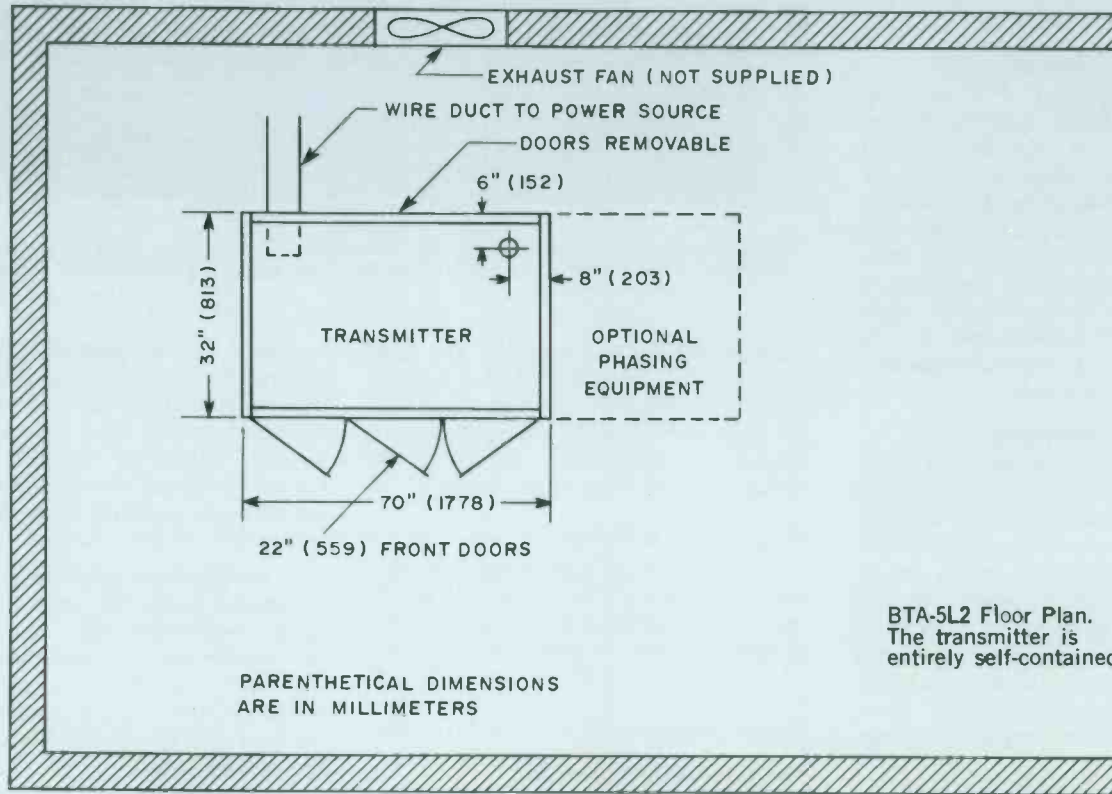

Specifications

Power Output (Nominal)	5,000 watts
Power Output Capability	5,500 watts
AF Input Impedance	150/600 ohms
AF Input Level	+10 ± 2 dBm
AF Response	±1.5 dB 30-15,000 Hz
AF Distortion (95% Mod. 30-10,000 Hz)	2.0% max.
Noise (Below 100% Modulation)60 dB
Frequency Range	535-1620 kHz
Frequency Stability	±2 Hz
Type of Output	Unbalanced
Output Impedance	40 to 250 ohms
Carrier Shift (0-100% Modulation, 400 Hz)	3% max.
Power Source	208/240 volts, 3-phase, ±11 volts 50/60 Hz
Crystal Heater Power	117 volts, 50/60 Hz
Power Consumption (Approx.):	
0% Modulation	10 kW
Average Modulation (30%)	12 kW
100% Modulation	17 kW
Power Factor90%
Altitude Range	0-7500 Ft. AMSL (2286 m)
Ambient Operating Temperature	-20° to +45° C.
Tube Complement	Two 8122; Two 3CX5000H3
Height	77" (1955 mm)
Width	70" (1778 mm)
Depth	32" (813 mm)

Finish	RCA charcoal grey and shadow blue textured Aluminum baked enamel
Weight (Approx.)	2500 lbs. (1134 kg)
Shipping Data (Approx.)	3000 lbs.; 180 ft ³ (1361 kg; 5.1 m ³)

Accessories and Options

Recommended Spare Tubes (Set)	ES-560682
Complete Spare Tubes (Set)	ES-560680
Spare Crystal Unit, Type TMV-130 (Specify freq.)	MI-27493
Conversion Kit, 10 kW Power Output	ES-560946
Spare Exciter System, Type BTE-20	ES-560752
Manual Exciter Changeover Panel	ES-560965
Power Cutback Kit (Two Power Levels)	ES-561009A
Power Cutback Kit (Three Power Levels)	ES-561009B
Frequency and Modulation Monitor, Type BW-50	MI-560767
BW-51 Modulation Meter	MI-561042
BW-52 Modulation Meter	MI-563472
RF Amplifier (For BW-50, above), Type BW-60	MI-560762
Transmission Line Protection Kit (VSWR)	ES-560961
Suggested Semiconductor Spares (BTE-20B)	RO-456

Ordering Information

Five-kW Ampliphase Transmitter, Type BTA-5L2	ES-560676
Dual-Unit Ten-kW Ampliphase Transmitter System	Built to Order
Alternate-Main Five-kW Ampliphase Transmitter System	Built to Order

Out



10 kW Ampliphase AM Transmitter, Type BTA-10L2

- High Fidelity Modulation (HFM)
- Low-distortion audio
- Solid-state exciter/modulator
- Extra modulation capability
- Designed for remote control
- Only two tube types in entire unit
- No modulation transformer

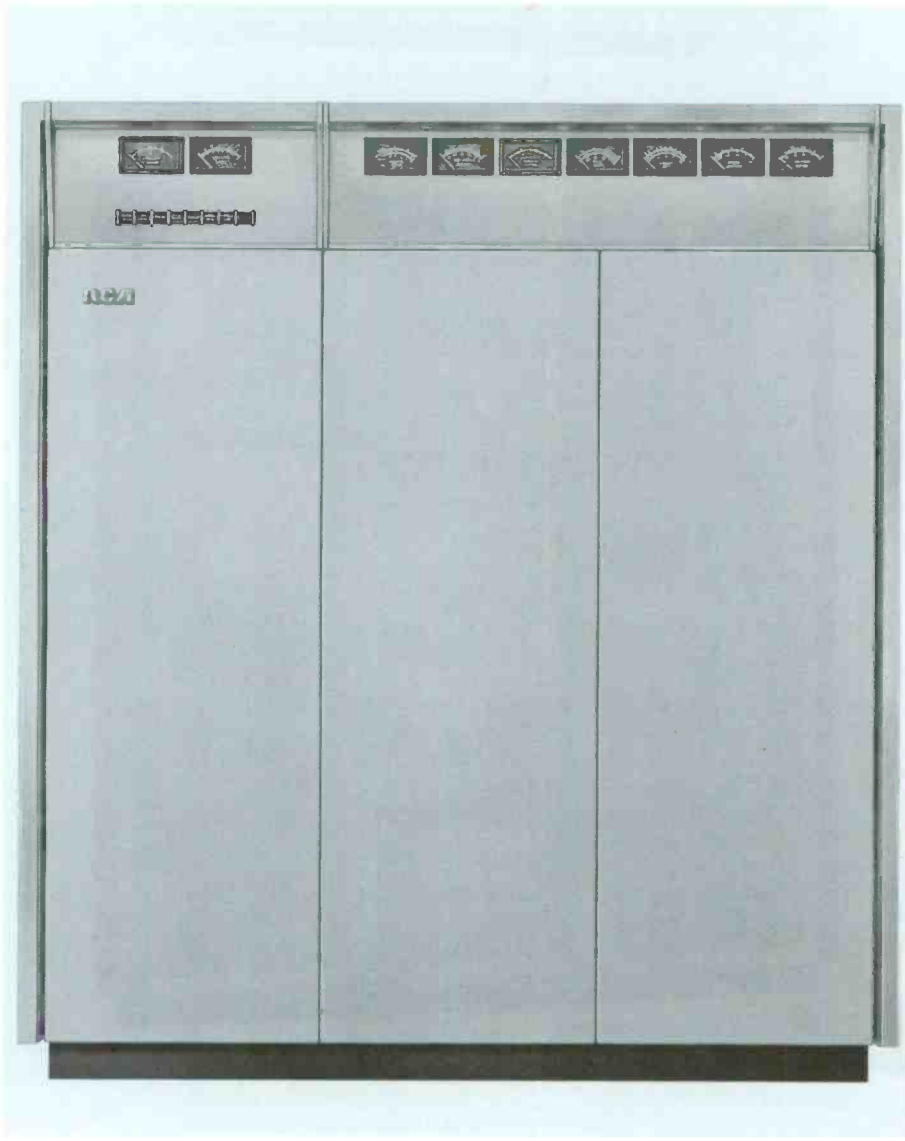

Offering superior audio quality, outstanding reliability and excellent efficiency, the BTA-10L2 is an Ampliphase transmitter for the AM-broadcast (medium-wave) band. The BTA-10L2 delivers 10 kW to the antenna transmission line.

As a result of the Ampliphase system, the BTA-10L2 Transmitter offers extended audio-frequency response at distortion levels well below average perception at enviable operating economy and dependability.

The BTA-10L2 is available also in dual-unit systems for parallel or alternate-main operation.

In the "parallel" arrangement, the outputs of the two transmitters in the system are combined for a 20-kilowatt power output; in the alternate-main system, one transmitter serves the load while the second operates in hot standby mode. In this configuration, an outage in one transmitter or the other automatically connects the operable unit to the load.

A special feature of the parallel system is that, in the event of outage in one transmitter, the other transmitter delivers a full ten-kilowatt output to the load.

Outstanding Audio Quality

Of particular interest to broadcasters who take pride in station "sound", the BTA-10L2 Transmitter offers outstandingly good audio quality. One reason for this is that the *Ampliphase* system eliminates iron-core high-level modulation components—and their inherent distortions—without adding the instabilities of separate "carrier" and "peak" power amplifiers. Even on ordinary AM radios, the outstanding audio quality of an *Ampliphase* transmitter is immediately apparent.

Extended Frequency Response

As evidence of the frequency-response characteristics the BTA-10L2 offers, it can put 30 kHz "on-the-air"—at full power—without strain. At the low-frequency end of the spectrum, frequencies down to 30 Hz go on-the-air at full level and low distortion. Transformer-equipped transmitters usually cut off below 50 Hz and above 15 kHz.

Extra Modulation Capability— "Superphase"

An advantage unique to the *Ampliphase* system is its capability for full modulation, even for extended periods, without overload. This is particularly important to stations programming music of high average level and low dynamics. Positive modulation peaks can go as high as 125 percent without transmitter overload. Another unique feature in *Ampliphase* is that it overmodulates without the "splatter" so common to other AM transmitter forms.

Provision for Spare Exciter

For those who prefer redundant exciters, the BTA-10L2 Transmitter provides rack space for a spare exciter. Offered as an option, the spare exciter includes switching gear for fast exciter substitution. A spare exciter is particularly valuable to the full-time station in that exciter maintenance is independent of transmitter operation.

Ready for Remote Control

Because the BTA-10L2 is built for the modern broadcaster it is engineered with remote control in mind. This manifests itself in extra components, wiring and connections fully compatible with remote control equipment carrying the RCA trademark. As a result, operating a BTA-10L2 via remote control requires investment only in control equipment and not in transmitter modification.

Two Tube Types

Being entirely solid-state at power levels below the IPA stage, the BTA-10L2 Transmitter uses a total of only six power



Front view, doors open. Note exciter unit.

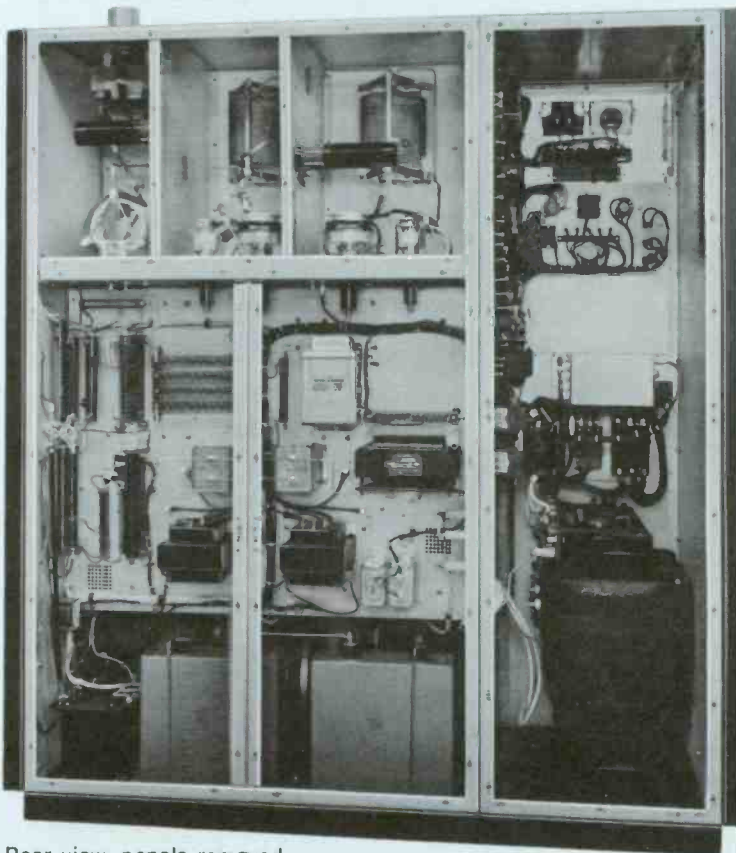

Rear view, panels removed.

tubes: three in each channel. Since these are of only two types, spares inventory need only be two tubes: one of each type. This reduces capital investment in spares and periodic spares rotation.

No Modulation Transformer

Using two identical R-F amplifier chains, the BTA-10L2 Transmitter uses *phase modulation*, at a low level, in such a manner that two phase-modulated carriers mix at the transmitter output to form an amplitude-modulated carrier. Since this system eliminates the modulation transformer and "carrier-peak" amplifiers, it eliminates the most-troublesome stages. This reflects itself in transmitter dependability that virtually eliminates unscheduled transmitter shutdown.

Faster Troubleshooting

A feature unique to *Ampliphase* makes routine repair easier. In a sense, a 10-kW *Ampliphase* transmitter is two identical 5-kW facilities in a single cabinet. Consequently, one amplifier chain is an excellent troubleshooting model for the other. Because the operating parameters of the two class-C amplifiers (operating as CW stages) can be quickly compared, the trouble can be easily isolated. Then, it's a simple matter of component replacement.

Ceramic Insulated PA Tubes

Ceramic power tubes have earned an enviable reputation among broadcasters

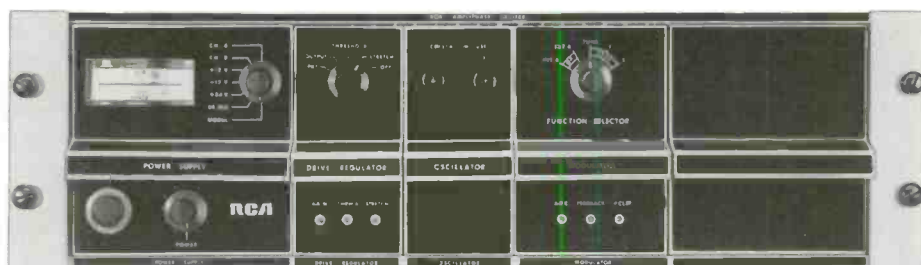

Ampliphase exciter unit. Completely solid-state, this unit is used in all RCA Ampliphase transmitters. Available separately for use as a spare. See Accessories.

for dependability and long life. The tube types selected for the BTA-10L2 operate well below ratings to take full advantage of their performance capabilities and built-in expected life. This pays dividends in low transmitter-operating expenses.

Fully Self-Contained

As the result of transistorization, the entire transmitter—including the power supply—fits within a single cabinet that occupies less than 14 square feet (1.3 m²) of floor space (see floor plan). This, of course, frees plant area for other productive purposes; office, studio or storage.

Parallel Systems

The BTA-10L2 transmitter is available also as a parallel system. This arrangement uses two BTA-10L2 transmitters and a

combiner. In the "parallel" system, both transmitter outputs are combined to provide 20 kilowatts to the load. Should one transmitter or the other have trouble, the operable transmitter continues to supply the load while the troubled transmitter is automatically switched from the antenna to a built-in dummy load.

In the alternate-main arrangement, one transmitter ordinarily feeds the antenna system while the other operates as a hot standby into a dummy load. Should the "air" unit fail, the system automatically connects the standby unit to the load and the troubled transmitter to the dummy load.

Further details are available from Aural Broadcast Marketing, RCA Building 2-5, Camden, N. J., 08102, U.S.A.

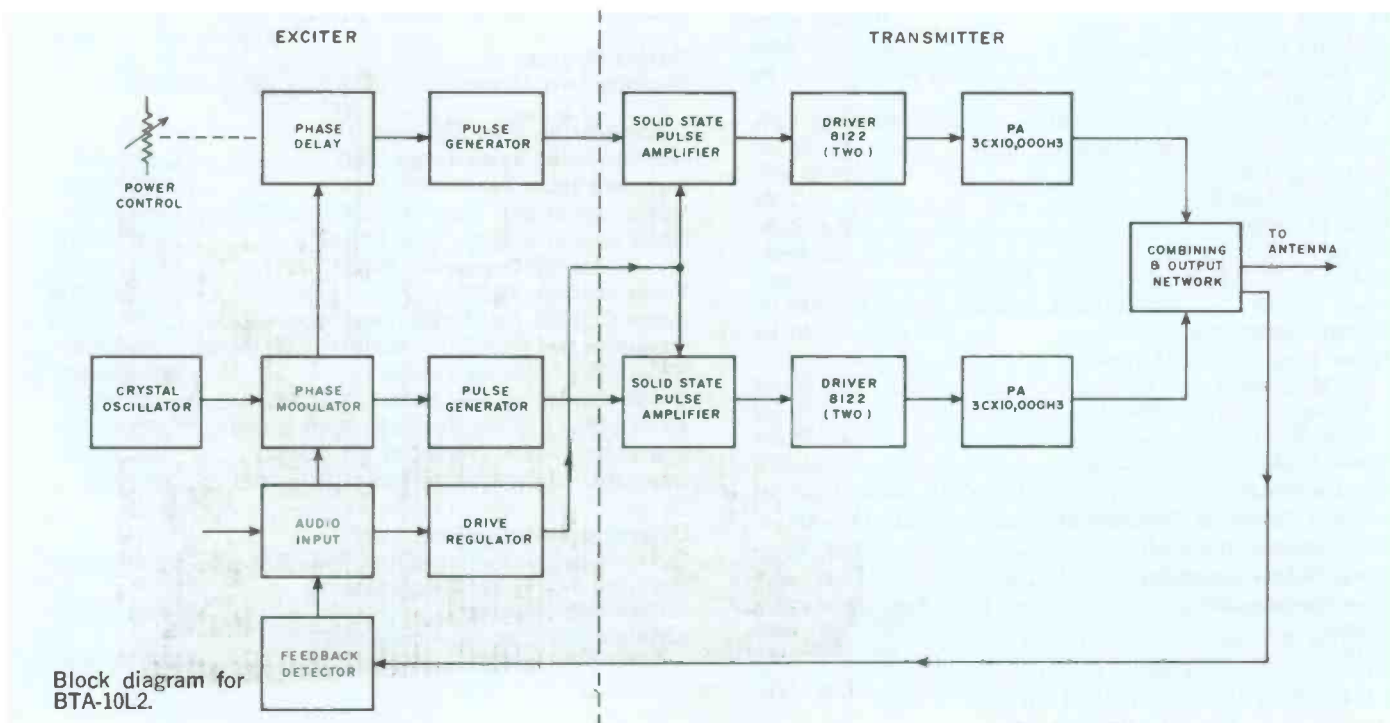

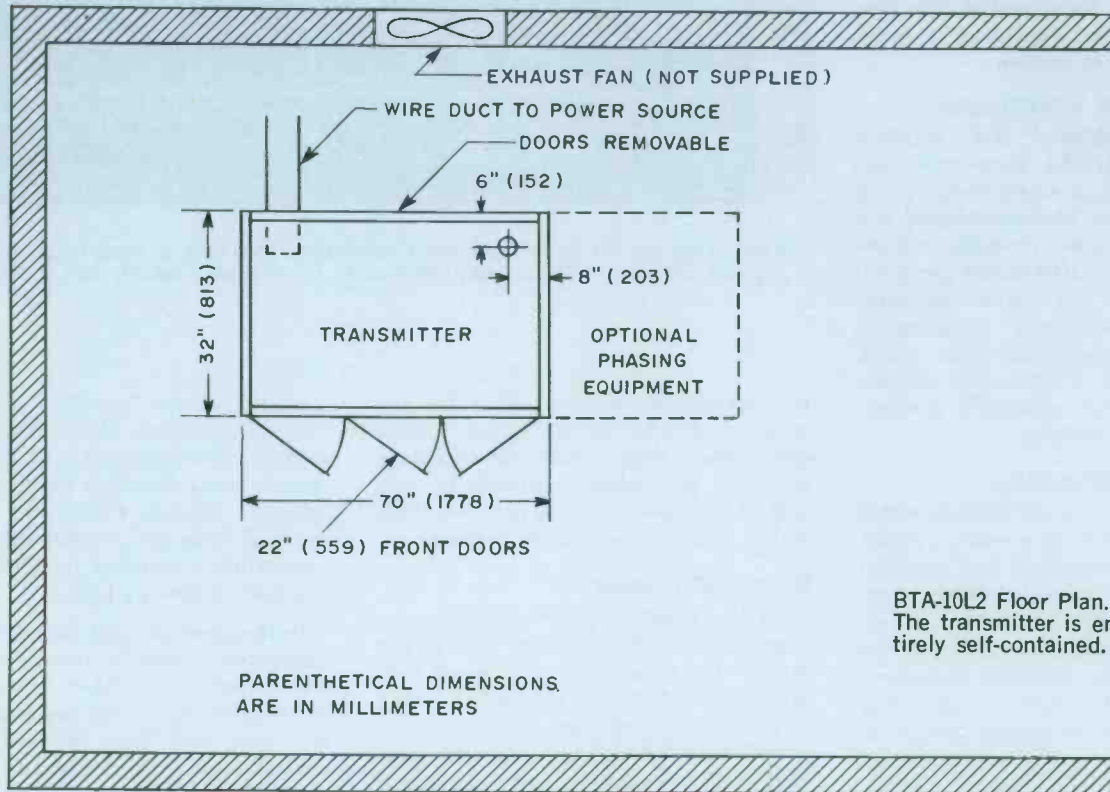

BTA-10L2 Floor Plan.
The transmitter is entirely self-contained.

PARENTHETICAL DIMENSIONS ARE IN MILLIMETERS

Specifications

AF Input Impedance	150/600 ohms
AF Input Level	+10 ±2 dBm
AF Response	±1.5 dB 30-15,000 Hz
AF Distortion	
(95% Modulation 30-10,000 Hz)	Less than 2.0%
Noise (Below 100% Modulation)60 dB
Frequency Range	535-1620 kHz
Frequency Stability	±2 Hz
Type of Output	Unbalanced
Output Impedance	40 to 250 ohms
Carrier Shift (0-100% Modulation, 400 Hz)3% max.
Power Source	208/240 volts, 3-phase, ±11 volts 50/60 Hz
Crystal Heater Power	117 volts, 50/60 Hz
Power Consumption (Approx.):	
0% Modulation	17 kW
Average Modulation (30%)	21 kW
100% Modulation	29 kW
Power Factor90%
Altitude Range	0-7500 Ft. AMSL (2286 m)
Ambient Operating Temperature	-20° to +45° C.
Power Output (Nominal)	10,000 watts
Power Output Capability	11,000 watts
Tube Complement	Four 8122; Two 3CX10,000H3
Height	77" (1955 mm)
Width	70" (1778 mm)

Depth	32" (813 mm)
Finish	RCA charcoal grey and shadow blue textured Aluminum baked enamel
Weight (Approx.)	2700 lbs. (1224 kg)
Shipping Data (Approx.)	3200 lbs.; 180 ft ³ (1452 kg; 5.1 m ³)

Accessories and Options

Recommended Spare Tubes (Set)	ES-560681
Complete Spare Tubes (Set)	ES-560679
Spare Crystal Unit, Type TMV-130 (Specify freq.)	MI-27493
Spare Exciter System, Type BTE-20	ES-560752
Manual Exciter Changeover Panel	ES-560965
Power Cutback Kit (Two Power Levels)	ES-561009A
Power Cutback Kit (Three Power Levels)	ES-561009B
Frequency and Modulation Monitor, Type BW-50	MI-560767
BW-51 Modulation only Meter	MI-561042
BW-52 Modulation only Meter	MI-563472
RF Amplifier (For BW-50, above), Type BW-60	MI-560762
Transmission Line Protection Kit (VSWR)	ES-560961
Suggested Semiconductor Spares (BTE-20B)	RO-456

Ordering Information

Ten-kW Ampliphase Transmitter, Type BTA-10L2	ES-560677
Dual-Unit Twenty-kW Ampliphase Transmitter System	Built to Order
Alternate-Main Ten-kW Ampliphase Transmitter System	Built to Order



catalog RA.1061A

(Replaces B.6050)

50 kW "Ampliphase" AM Transmitter, Type BTA-50J

- Excellent audio quality
- All solid-state exciter
- Only six tubes, three types
- High modulation capability

An AM transmitter with FM quality, the Type BTA-50J uses phase modulation in a way that results in high quality AM. The transmitter includes a fully solid-state exciter and modulator. "Ampliphase" applies modulation at a low level and uses Class C power amplifiers to provide the 50-kW output.



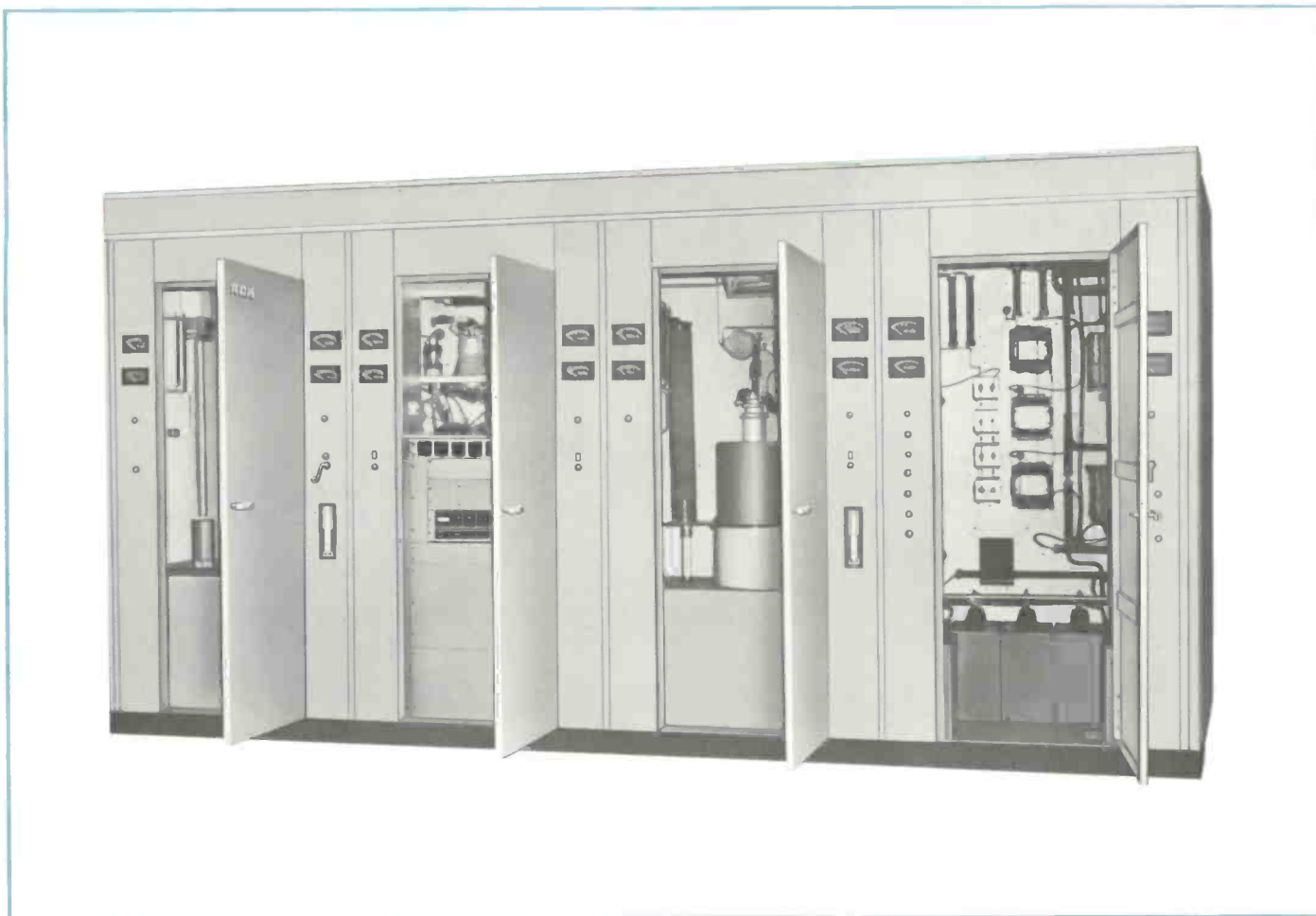

Compact in-line construction of BTA-50J showing left to right, left hand power amplifier, exciter, right hand power amplifier, and rectifier-control cubicle.

The RCA Type BTA-50J AM Broadcast Transmitter is a completely air-cooled, 50-kW phase-to-phase amplitude modulated transmitter designed for high fidelity transmission in the standard broadcast band (535 kHz to 1620 kHz). It provides a signal of exceptionally low distortion and extended frequency response. Measured response is flat within ± 3 dB from 35 Hz to 25,000 Hz. The equipment is capable of being modulated over the frequency range of 10 Hz to 30,000 Hz. Frequency response has been extended largely through the elimination of unnecessary transformers in the audio system as well as improved circuitry.

Low harmonic distortion with negligible carrier shift at maximum signal output has been achieved in the BTA-50J by selection of adequate power tube types and advanced solid state circuits in the exciter-modulator-drive regulator de-

sign throughout the entire equipment. The design features an inherently linear system capable of continuous high modulation levels impervious to inadvertent overmodulation. For example, the transmitter may be modulated 100 percent at any frequency between 30 and 15,000 Hz continuously for many hours without detrimental effects to any of the component parts. A small amount of overall feedback is incorporated to provide the exceptional performance. With the feedback circuit removed, the BTA-50J still meets FCC specifications for audio frequency response, harmonic distortion and noise.

Lowest Operating Cost in 50-kW Transmitters

A number of new refinements as well as time tested features which have proven their worth are incorporated in this modern 50-kW transmitter. Power requirements are moderate for the equipment.

Power amplifier plate efficiency of the order of 75 to 80 percent is obtained.

Fewer major components, as compared to those required by many 50-kW transmitters, are used in the BTA-50J. In addition to the low cost of operation of the transmitter a power-cutback kit can be added which permits operation at 10 kW. (Other power levels available on special order.)

Dual RF Chains

Two identical RF chains, each developing 25 kW, are incorporated in this equipment. Since they are identical, servicing is made easy by comparison of the two chains. Components are directly interchangeable, which allows substitution for comparison purposes. All components are easily accessible which results in a minimum schedule for maintenance. In addition, fewer replacement parts are required for adequate protection against lost air

time should a failure occur. Low power consumption, fewer major components and a reduced maintenance schedule make the BTA-50J operation cost the lowest.

Ready for Remote Control

Designed with unattended remote control in mind, the BTA-50J includes the components, wiring and connections to make it completely compatible with either of two RCA remote control systems (see *Accessories*). Such components as meter shunts, motorized controls and switching devices make remote control more efficient and dependable.

Lightweight Type 6697 Tubes in Final PA

One Type 6697 power amplifier tube is used in each of the two RF chains. Each amplifier tube is capable of delivering in excess of the normal 25 kW of modulated power to the common load. The Type 6697 is rated at 35 kW dissipation and under average modulation conditions it is only required to dissipate approximately 14 kW. Operation of the PA tubes so far below their maximum ratings assures long tube life. In addition, the 6697 is physically small in size and weighs only 43 pounds. One person, without the aid of mechanical assistance, can quickly and easily replace any tube in the transmitter.

One Type 4CX5000A tube is used in each of the driver stages in the two RF chains. The 4CX5000A is also operated well below its maximum ratings and gives long trouble free service. The only other tubes used in the transmitter are the two Type 4-250A intermediate power-amplifier tubes. Solid-state design extends into the monitor circuitry as well. Tube complement is such that inventory cost for required spares is kept at a minimum while adequate outage protection is maintained.

Solid State Rectifiers Used Throughout

All power supplies utilize solid state rectifiers. The plate supplies, bias supply and low-voltage supply use silicon units, very conservatively rated to assure long life. The current rating of the units is such that any conceivable load fault is cleared without jeopardizing the diode units. The use of solid state rectifiers permit the transmitter to operate in ambient temperatures as low as -20 degrees centigrade.

FCC and CCIR Harmonic Suppression

A completely shielded two section low pass filter is incorporated in the BTA-

50J. It consists of one π (π) section and one T section and each inductive series element is completely shielded. Two series-tuned, shunt-connected traps are used to provide added attenuation of the second harmonic.

Transmitter Equipment

Type BTA-50J AM Broadcast Transmitter consists of four equipment cabinets, two of which house the power amplifiers, one the exciter unit and the fourth cabinet the rectifier and control unit. The high-voltage reactor is housed in the lower rear compartment of the exciter cabinet, with the IHV plate transformer in the lower rear compartment of the rectifier and control cabinet.

Each of the four transmitter cabinets measure 44 inches wide by 60 inches deep by 84 inches high, and consists of an all aluminum cubicle erected on a welded steel base. This cubicle consists of a series of panels fabricated and assembled to form a rigid structure. The use of aluminum eliminates unnecessary weight and provides excellent shielding to assure effective confinement of spurious energy. Maximum accessibility to all transmitter components are afforded by 28-inch wide, six-foot front doors, while rear access is through two covers attached with quick-disconnect fasteners for easy removal.

A center vertical panel separates the cabinet into a front compartment and rear compartment which is further divided by a rear horizontal shelf into upper and lower compartments, giving each cabinet three basic totally shielded compartments in which to mount the electrical components. The eye-level meters, pilot lights and interlocks, mounted on eight-inch wide panels flanking each of the front doors, are also shielded.

In the rear at the top of each cabinet is a built-in wire duct. It joins similar ducts of adjacent cabinets to form a continuous duct on the four cabinets. This duct has a divider down the center on which the interconnection terminal boards are mounted. The rear half of the duct is used for interconnection wiring while the front half is used for internal cabinet wiring from the terminal boards. The internal wiring is carried through conduits to its destination in the cabinet thus shielding all power and control wiring from RF fields. Provision is also made at the top of the cabinets for the addition of an exhaust air duct.

Power Amplifiers

The first cabinet and the third cabinet from the left end are identical and

contain the final power amplifier stages. The 6697 tube and its grid circuits and part of the plate circuits are contained in the front portion of the cabinet. The upper rear section contains the plate tank coil, filament transformer and grid leak resistors. The lower rear section contains a low-noise blower which cools the 6697 tube and its cabinet and the adjacent half of the exciter cabinet. The two 6697 power amplifiers are designed to supply equal amounts of power to the output network. Because of the balanced dissipation in the two 6697 PA tubes, less air pressure with resultant lower air flow is required for adequate cooling of the power amplifier cubicles. The lower rear panel contains an impingement type air filter for the blower. The PA cabinets are constructed so that the blowers and filters can be mounted externally to the cabinets, if so desired.

The PA output circuit is a conventional pi-network type of tank circuit. Each tube has its own tank circuit, with a common output shunt element. Each network is adjusted to provide the proper load to the power amplifiers.

Solid-State Exciter-Modulator, Drive Regulator

Packaged in a series of four plug-in modules, the Ampliphase exciter-modulator uses a crystal-controlled, field-effect-transistor oscillator, a solid-state drive regulator, modulator and power supply. The entire assembly occupies only 5¼ inches (133 mm) of rack space in the left-of-center cabinet (see photo, facing page). As a result of untuned, digital-integrated circuits, the exciter-modulator is set up with but three trimmer adjustments. The RF chains in the exciter operate without tuned circuits.

The drive regulator circuitry uses entirely solid-state electronic devices; the regulator samples the audio, amplifies the sample and applies it to the grid circuits of the twin driver stages so as to adjust final amplifier drive in step with the level of the modulating audio. This system contributes significantly to the exceptional linearity of the *Ampliphase* system.

Solid-State Reflectometer

The far-right module in the exciter-modulator unit is a solid-state reflectometer that protects the transmitter from transmission line and/or antenna irregularities. The reflectometer senses changes in the voltage/current ratio on the load.

A large change in load characteristics causes the reflectometer system to momentarily interrupt the drive (to let the fault clear, if transient). If the fault persists

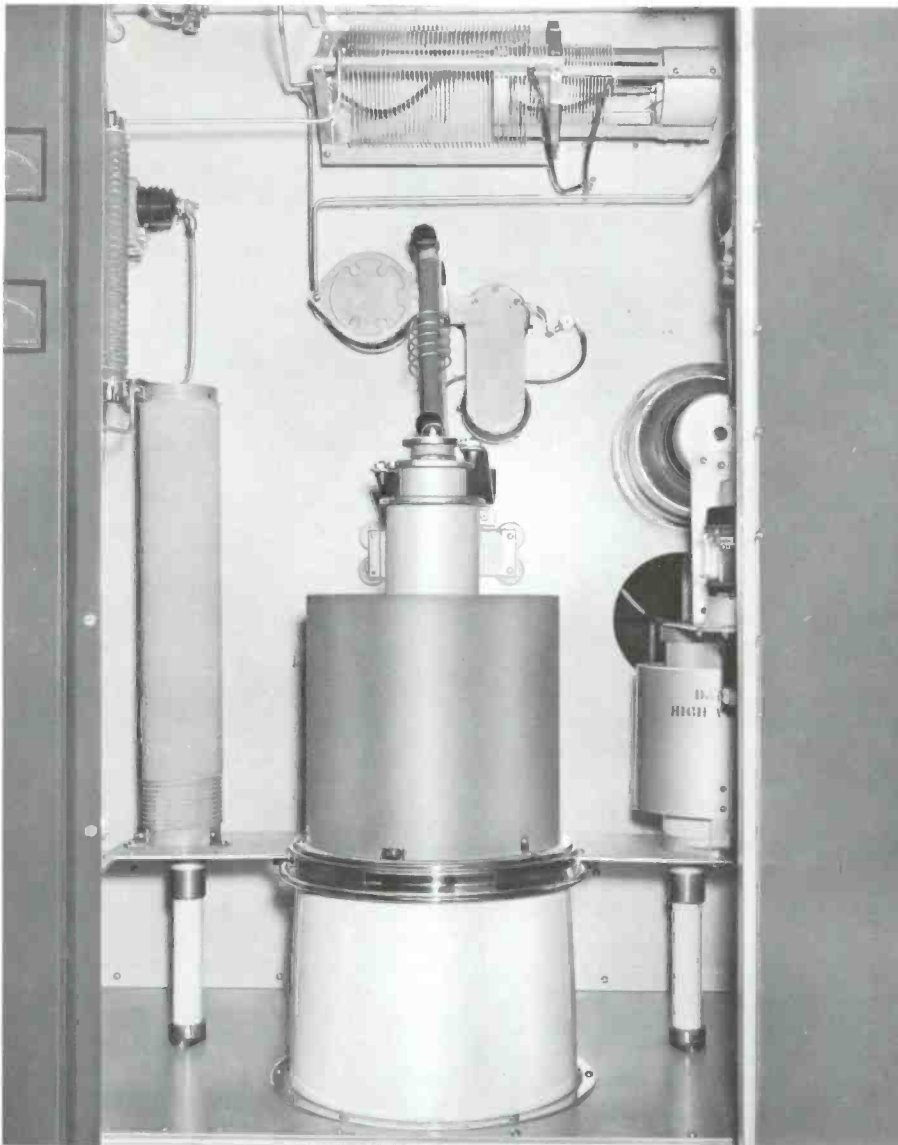

Close-up view of one of the dual final power amplifier stages. The new type 6697 tube together with grid circuits and part of the plate circuits are readily accessible from the front of the transmitter.

after several cycles, the reflectometer shuts down the transmitter thereby reducing the possibility of chain-reaction damage to any part of the system.

Above the exciter-modulator are two vertical sub-compartments, behind interlocked doors, which contain the 4CX5000A driver stages. A meter panel for these stages is located beneath the sub-compartments.

The common output capacitors of the two PA tanks and the harmonic filter are located in the upper rear of the cabinet. Sub-partitions are so arranged in this section that complete isolation and shielding is effected between the various sections of the filter and the output capacitor. The lower rear section of this cabinet contains high voltage filter reactor and driver dc filament supplies.

Provisions for Standby Operation

Space is provided in the exciter cabinet for the mounting of a second exciter-modulator unit. Each of the modulator-exciter units are complete and arranged so that either may be selected instantly by means of cutover switches. Thus, while one modulator is in operation, the other modulator is in standby condition. These provisions, with the extreme reliability designed into the high-power stages, essentially provide a second 50-kW transmitter for standby service.

Rectifier and Control Unit

The far right cabinet contains the high power rectifiers, low power distribution components, and the majority of the control components. The front portion of the cab-

inet contains the solid state 15-kV, 5-kV plate supplies and the low-voltage bias supplies. Also included here are the high-voltage grounding switches and the 15-kV filter capacitors. The top rear section of the cabinet contains control relays, overload relays, distribution contactors, and low-power distribution circuit breakers. The distribution breakers and overload relays are readily accessible, recessed so that they will not be damaged or improperly operated. The bottom rear of the cabinet contains the 5-kV rectifier components including plate transformer.

Solid-State Power Supplies

During periods of 100 percent modulation, the 6697 power amplifier tubes require 15-kV dc at 7.5 amperes, which is obtained from a three-phase, full-wave rectifier circuit. Two other plate voltages, 5-kV and 1-kV, are provided by separate supplies. Bias voltages for all tubes are supplied by an additional supply. The high-power distribution equipment for the transmitter consists of an electrically operated air circuit breaker, and a manually operated delta-wye switch for the 15-kV rectifier. The remaining transmitter power is distributed through a manually operated distribution circuit breaker to a 460- to 230-volt distribution transformer to voltage regulators and thence to the various low power distribution circuit breakers.

Transmitter Control

Control circuits in the BTA-50J contain a number of features which are designed to provide maximum flexibility in control, protection and operation. Among these are choice of single-button or step-by-step starting, automatic timing and sequencing of starting operations, and location of transmitter faults by a system of indicators. Protection of the operator is achieved by a system of interlocking grounding devices; protection of the equipment by conventional relays and circuit breakers.

Control of the transmitter is accomplished from the front of the rectifier and control cabinet. All necessary wiring to allow control from a remote location or console has been provided. Lamps, which show the status of the transmitter control circuits, are also mounted on the front of this cabinet. The control ladder is arranged and interlocked so that the BTA-50J can either be turned on by operating the control switches in sequence or by leaving all control switches in the "on" position with the exception of the start switch which, when operated to the "on"



Upper rear of exciter cabinet showing the combining and output networks.

position, allows the transmitter to come on automatically.

The two types of overload circuits used in this transmitter are the current type, instantaneous or time delay, that are connected directly in the tube circuit and rectifier ground leads, and the thermal magnetic circuit breakers connected in the a-c power leads used as back up protection and disconnect switches. The transmitter circuitry is arranged so that an overload either locks out the plate circuit or allows a single reclosure that resets if there are no further overloads. In either case, when a lockout position is reached, the transmitter resets by means of an Overload Reset control. The principal overload relays have indicating flags so that, even after the overload has cleared, there is a record of which overload relay operated. Another feature of the control circuit is the indicator lamps on each cabinet that indicate the interlock status in that particular cabinet.

Installation and Layout

Outstanding features of the BTA-50J are the small floor space requirements

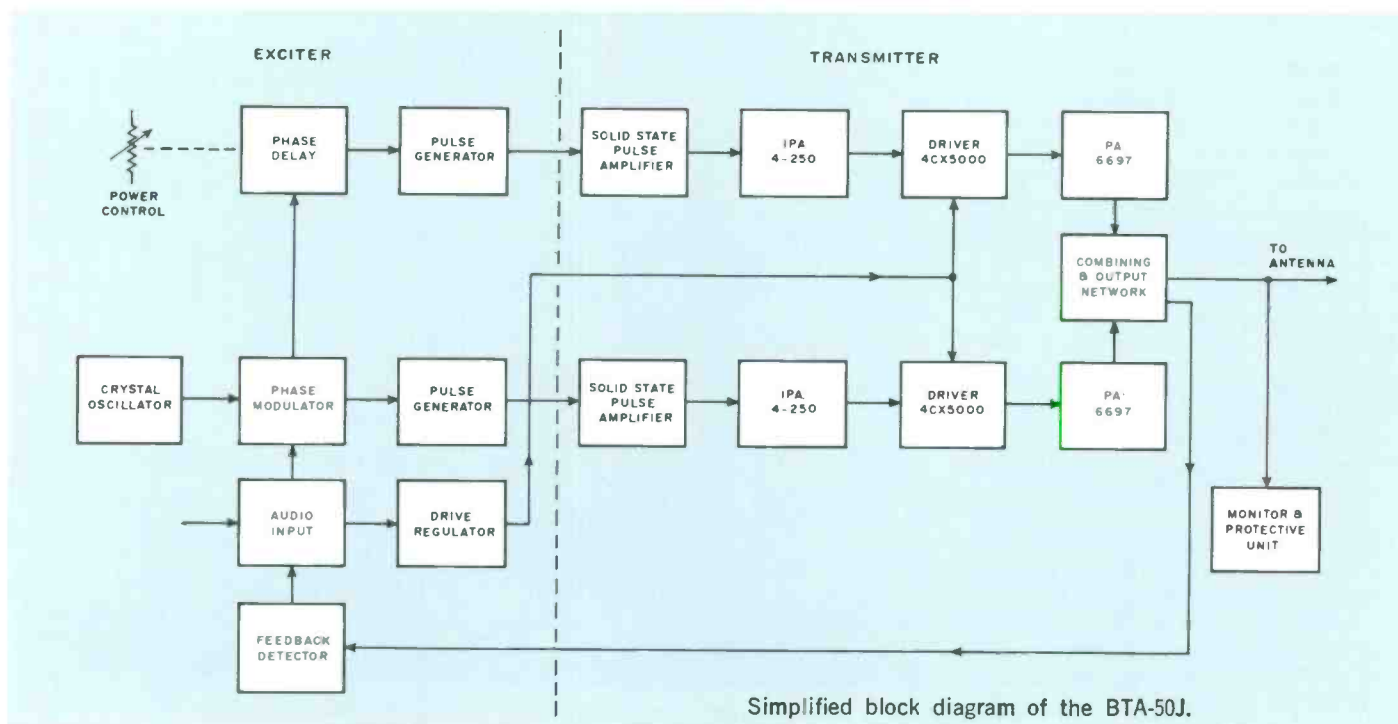

Simplified block diagram of the BTA-50J.

and ease of installation. In general, the transmitter layout consists of three basic units: the four, in-line cabinets which contain the major part of the transmitter; the wall-mounted switchgear components and the main plate transformers. The floor plan illustrates a typical layout of the complete equipment. Elimination of the need for under-floor cable trenches and considerable reduction in external air ducts, simplifies installation and reduces costs.

As shown in the layout, it is desirable to leave a passageway at the right end of the frontline cabinets since the circuit breakers and overload relays are most accessible from this end of the transmitter. The layout of the front line cabinets is such that a common exhaust duct can be used to carry off heated air from the transmitter.

Wall mounting of the switchgear as shown on the overall floor plan is suggested to make the BTA-50J most adaptable to existing transmitter buildings. The mounting of these components, however, is not critical as to location. They can be mounted in existing power distribution areas if desired. These components include the main plate circuit breaker, a delta-wye switch, a distribution circuit breaker, a 460- to 230-volt bank of distribution transformers, and two single-phase open delta connected regulators with their control panels. These components are wired through conduit and overhead ductwork to the main plate transformers and the transmitter cabinets.

Parallel/Redundant System

The BTA-50J is available also as a parallel/redundant transmitter system. This system consists of two identical BTA-50J transmitters and a combiner. In the "parallel" mode, the twin fifty-kilowatt outputs are combined to provide 100 kilowatts of power to the antenna system; in the "redundant" mode, the system operates one of the two transmitters as a hot standby while the other feeds the antenna system.

In either operational mode, the parallel/redundant system assures greater on-air dependability. For example, an outage in one transmitter or the other automatically switches the troubled transmitter to a dummy load while the operable one feeds a full fifty kilowatts to the antenna system. This action is the result of a special-design combiner with essentially zero insertion loss. Further details of the BTA-50J parallel/redundant transmitter system are available from Aural Broadcast Equipment Marketing, RCA Building 2-2, Camden, N. J. 08102, U.S.A.

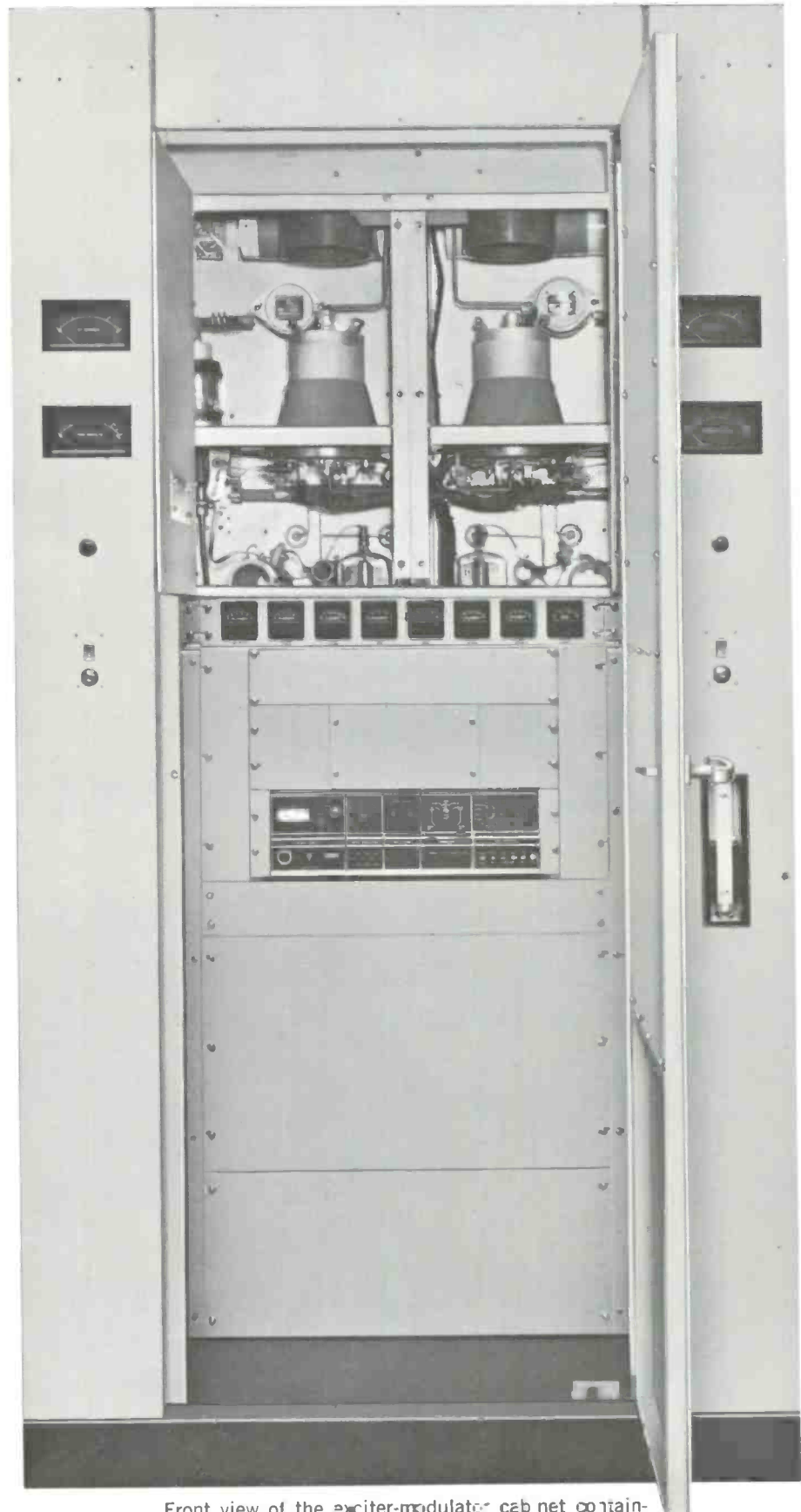

Front view of the exciter-modulator cabinet containing all sections from oscillator through driver stages.

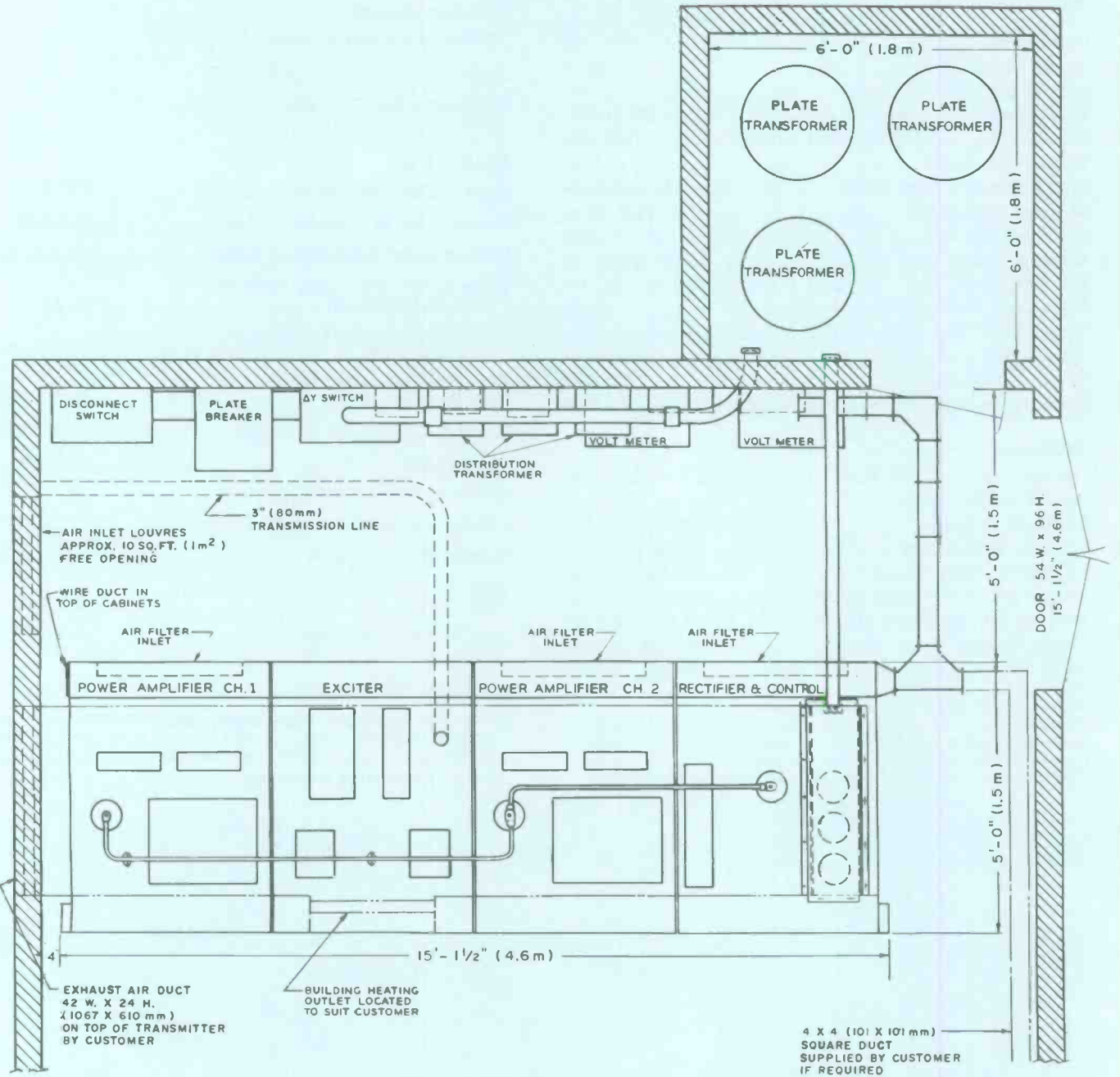

Typical floor plan for the BTA-50J Transmitter.

Specifications

General

Power Line Requirements:

Line	460 V, 50/60 Hz, 3 phase ¹
Combined Regulation and Variation	Not more than $\pm 5\%$
Power Consumption	.96 kW (approx.) at zero modulation; 100 kW (approx.) at average modulation
Power Factor	.90% min.
Crystal Heater Power	110 V
Type of Emission	A3
Power Output (at transmitter terminals)	56 kW (max.) ²
Frequency	Any specified between 535 and 1620 kHz
Frequency Stability	± 2 Hz
Type Modulation (High Level)	Phase to amplitude
AF Input Impedance	150/600 ohms
Audio Input Level	+10 ± 2 dBm
Audio Response	± 1.5 dB 30–10,000 Hz
AF Distortion	Less than 3% RMS 50–7500 Hz
Noise Level (Below 100% modulation)	60 dB
Carrier Shift (Neg. 100% modulation)	5% max.
Type Output	Unbalanced
Output Impedance	50 ohms ²
Spurious Emission (2nd Harmonic and above)	-83 dB

Mechanical

Cabinet Size	44" W, 84" H, 63" D (1118, 2134, 1600 mm)
Overall Weight (approx.)	11,500 lbs. (5216 kg) ³
Maximum Altitude	7500 ft. (2286 m)
Ambient Temperature	-20°C +45°C
PA Cabinet Weights (each) (approx.)	953 lbs. (432 kg)
Plate Transformer Weight (each) (approx.)	820 lbs. (372 kg)
Rectifier Cabinet Weight (approx.)	3,093 lbs. (1403 kg)
Exciter Cabinet Weight (approx.)	1,041 lbs. (472 kg)
Filter Reactor Weight (approx.)	570 lbs. (259 kg)

¹ Other line voltages available on request.

² Other output impedances available on request.

³ Operation at higher altitude available on request.

⁴ Cutback to other power levels available on request.

* Available in 100- and 200-kW systems as Types BTA-100J and BTA-200J.

Shipping Data

Weight, Domestic Packing (approx.)	13,500 lbs. (6124 kg)
Weight, Export Packing (approx.)	14,000 lbs. (6350 kg)

Tube Complement

Intermediate Power Amplifier: Type 4-250A
Driver Amplifier: Type 4CX5000A
Power Amplifier: Type 6697

Accessories

Spare Solid-State Exciter-Modulator	ES-560752
Complete Set of Operating Tubes	ES-27222E
Recommended Spare Set of Tubes	ES-27223D
Spare Crystal Unit, Type TMV-130B (Specify Frequency)	MI-27493
Type BTR-30 Remote Control (30 Functions)	MI-561446
Type BTR-15 Remote Control (15 Functions)	MI-561157/58
50/10-kW Cutback Kit	MI-27688C ⁴
Dummy Load	ES-34234
BPA-50 Antenna Tuner (230 ohms)	ES-28903
BPA-50 Antenna Tuner (70/51.5 ohms)	ES-28903
Remote RF Pickup Unit	MI-28027
Type BW-50 Frequency and Modulation Monitor	MI-560767
Type BW-60 RF Amplifier	MI-560762

Ordering Information

50-kW AM Broadcast Transmitter, Type BTA-50J, with two crystals, remote meter, one set of operating tubes, silicon rectifiers, and one exciter. Antenna tuning unit not included. (Specify operating frequency)	ES-272221D
--	------------



100 kW "Ampliphase" Medium-Wave, AM Transmitter, Type BTA-100J

- Excellent audio quality
- All solid-state exciter
- Only eight tubes, three types
- High modulation capability

An AM transmitter with FM quality, the Type BTA-100J uses phase modulation in a way that results in high fidelity AM. The transmitter includes a fully solid-state exciter and modulator. "Ampliphase" applies modulation at a low level and uses Class C, continuous-wave power amplifiers to provide the 100-kW output.

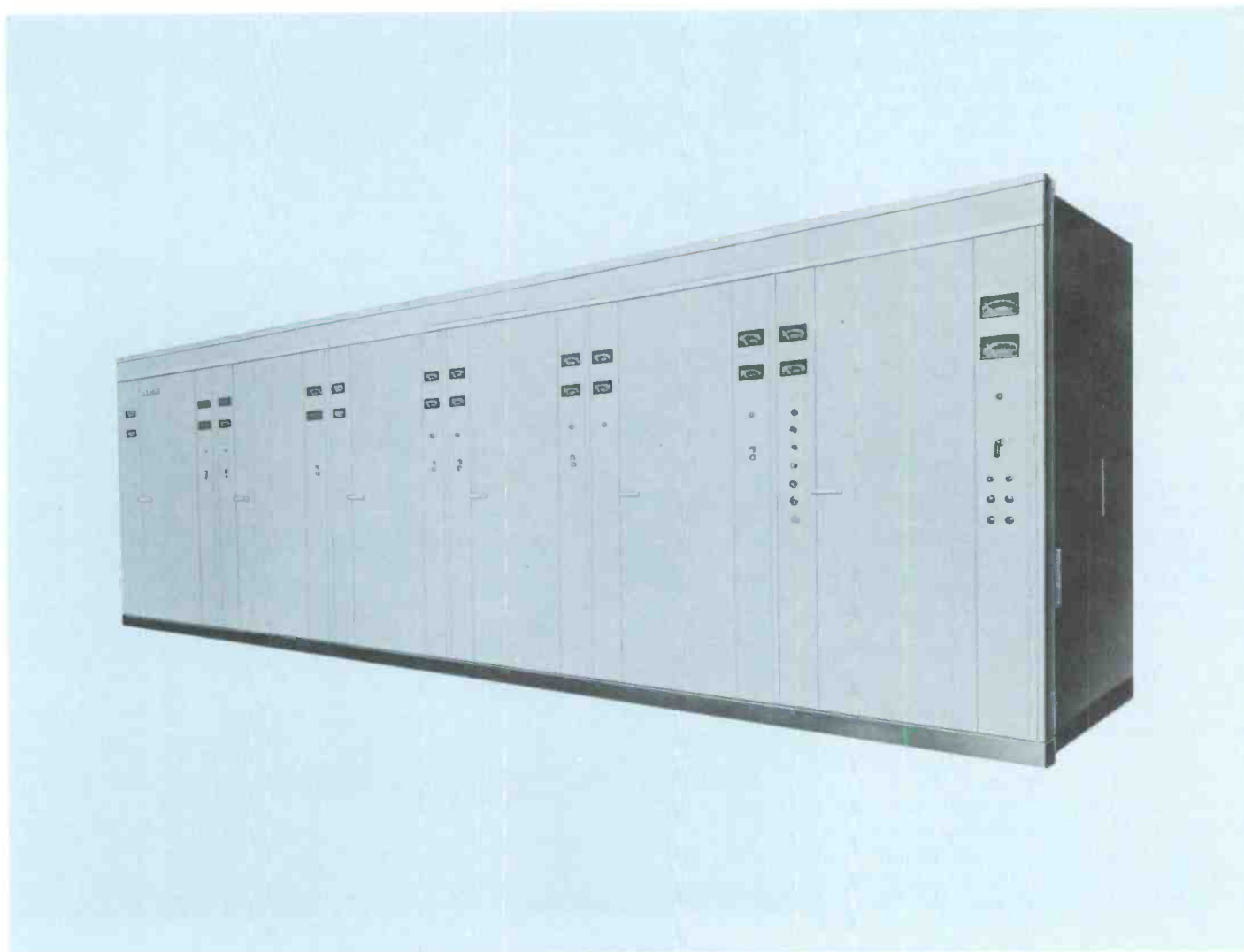

The RCA Type BTA-100J AM Broadcast Transmitter is a completely air-cooled, 100-kW phase-to-amplitude modulated transmitter designed for high fidelity transmission in the standard broadcast band (535 kHz to 1620 kHz). It provides a signal of exceptionally low distortion and extended frequency response. Measured response is flat within ± 3 dB from 35 Hz to 25,000 Hz. The equipment is capable of being modulated over the frequency range of 10 Hz to 30,000 Hz. Frequency response has been extended largely through the elimination of unnecessary transformers in the audio system as well as improved circuitry.

Low harmonic distortion with negligible carrier shift at maximum signal output has been achieved in the BTA-100J by selection of adequate power tube types and advanced solid state circuits in the exciter-modulator-drive regulator design throughout the entire equipment. The design features an inherently linear system capable of continuous high modulation levels impervious to inadvertent overmodulation. For example, the transmitter may be modulated 100 percent at any frequency between 30 and 15,000 Hz continuously for many hours without detrimental effects to any of the component parts. A small amount of overall feedback is incorporated to provide the exceptional performance.

Lowest Operating Cost in 100-kW Transmitters

A number of new refinements as well as time tested features which have proven their worth are incorporated in this modern 100-kW transmitter. Power requirements are moderate for the equipment. Power amplifier plate efficiency in the order of 75 to 80 percent is obtained.

Fewer major components, as compared to those required by many 100-kW transmitters, are used in the BTA-100J. In addition to the low cost of operation of the transmitter a power-cutback kit can be added which permits operation at 50 kW. (Other power levels available on special order).

Dual RF Chains

Two identical RF chains, each developing 50 kW, are incorporated in this equipment. Since they are identical, servicing is made easy by comparison of the two chains. Components are directly interchangeable, which allows substitution for comparison purposes. All components are easily accessible which results in a minimum schedule for maintenance. In addition,

fewer replacement parts are required for adequate protection against lost air time should a failure occur. Low power consumption, fewer major components and a reduced maintenance schedule make the BTA-100J operation cost the lowest.

Ready for Remote Control

Designed with unattended remote control in mind, the BTA-100J includes the components, wiring and connections to make it completely compatible with either of two RCA remote control systems (see *Accessories*). Such components as meter shunts, motorized controls and switching devices make remote control more efficient and dependable.

Lightweight Type 6697 Tubes in Final PA

Two Type 6697 power amplifier tubes are used in each of the two RF chains.

Each final amplifier is capable of delivering in excess of the normal 50 kW of modulated power to the common load. The Type 6697 is rated at 35 kW dissipation and, under average modulation conditions, is only required to dissipate approximately 14 kW. Operation of the PA tubes so far below their maximum ratings assures long tube life. In addition, the 6697 is physically small in size and weighs only 43 pounds (20 kg). One person, without the aid of mechanical assistance, can quickly and easily replace any tube in the transmitter.

One Type 4CX5000A tube is used in each of the driver stages in the two RF chains. The 4CX5000A is also operated well below its maximum rating and gives long trouble free service. The only other tubes used in the transmitter are the two Type 4-250A intermediate power-amplifier tubes. Solid-state design extends into the monitor circuitry as well. Tube

Close-up view of one of the dual final power amplifier stages. The new type 6697 tube together with grid circuits and part of the plate circuits are readily accessible from the front of the transmitter.

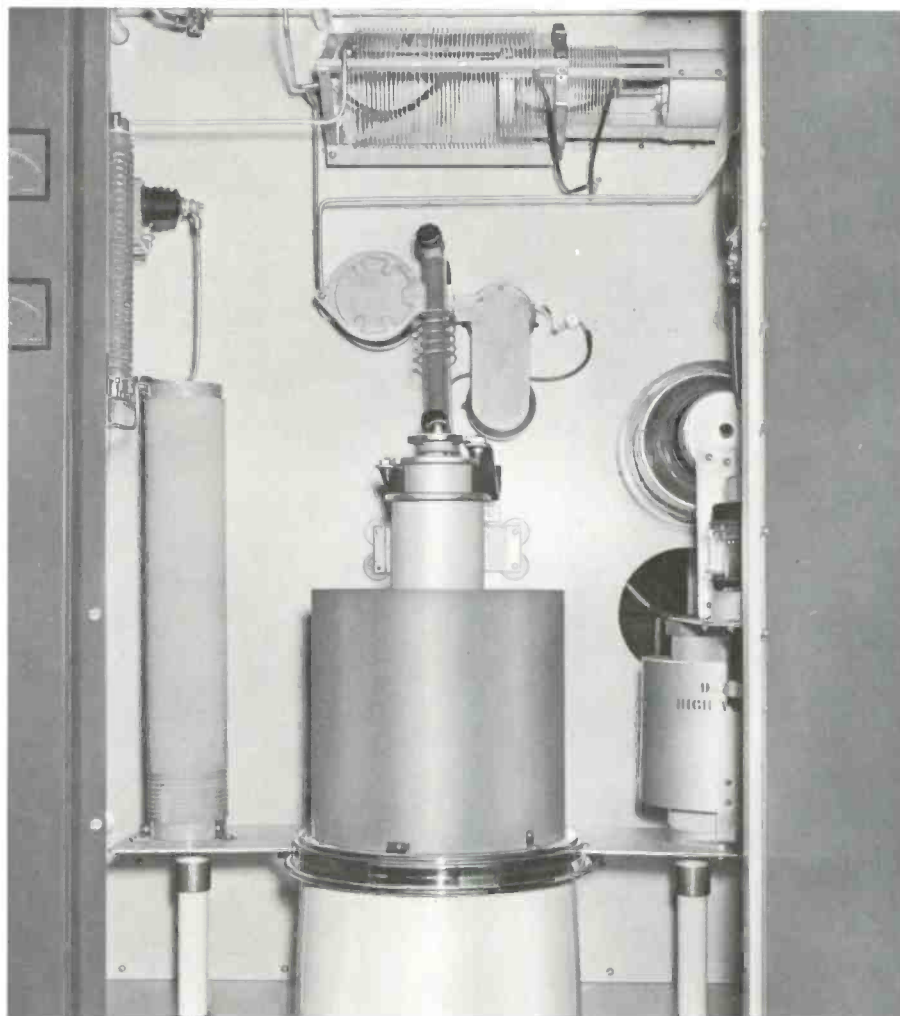

complement is such that inventory cost for spares is kept at a minimum while adequate outage protection is maintained.

Solid State Rectifiers Used Throughout

All power supplies utilize solid state rectifiers. The plate supplies, bias supply and low-voltage supply use silicon units, very conservatively rated to assure long life. The current rating of the units is such that any conceivable load fault is cleared without jeopardizing the diode units. The use of solid state rectifiers permit the transmitter to operate in ambient temperatures as low as -20 degrees centigrade.

FCC and CCIR Harmonic Suppression

A completely shielded two section low pass filter is incorporated in the BTA-100J. It consists of one π section and one T section and each inductive series element is completely shielded. Two series-tuned, shunt-connected traps are used to provide added attenuation of the second harmonic.

Operated in Parallel

Type BTA-100J Medium-Wave Transmitter consists of six equipment cabinets, four of which house the power amplifiers, one the exciter unit and the sixth cabinet, the rectifier and control unit.

Each of the six transmitter cabinets measure 44 inches wide by 60 inches deep by 84 inches high, (1118, 1524, 2133 mm) and consists of an all aluminum cubicle erected on a welded steel base. This cubicle consists of a series of panels fabricated and assembled to form a rigid structure. The use of aluminum eliminates unnecessary weight and provides excellent shielding to assure effective confinement of spurious energy. Accessibility to all transmitter components is through 28-inch (711 mm) wide, six-foot (1.8 m) front doors, while rear access is through two covers attached with quick-disconnect fasteners for easy removal.

A center vertical panel separates the cabinet into a front compartment and rear compartment which is further divided by a rear horizontal shelf into upper and lower compartments, giving each cabinet three basic totally shielded compartments in which to mount the electrical components. The eye-level meters, pilot lights and interlocks, mounted on eight-inch wide panels flanking each of the front doors, are also shielded.

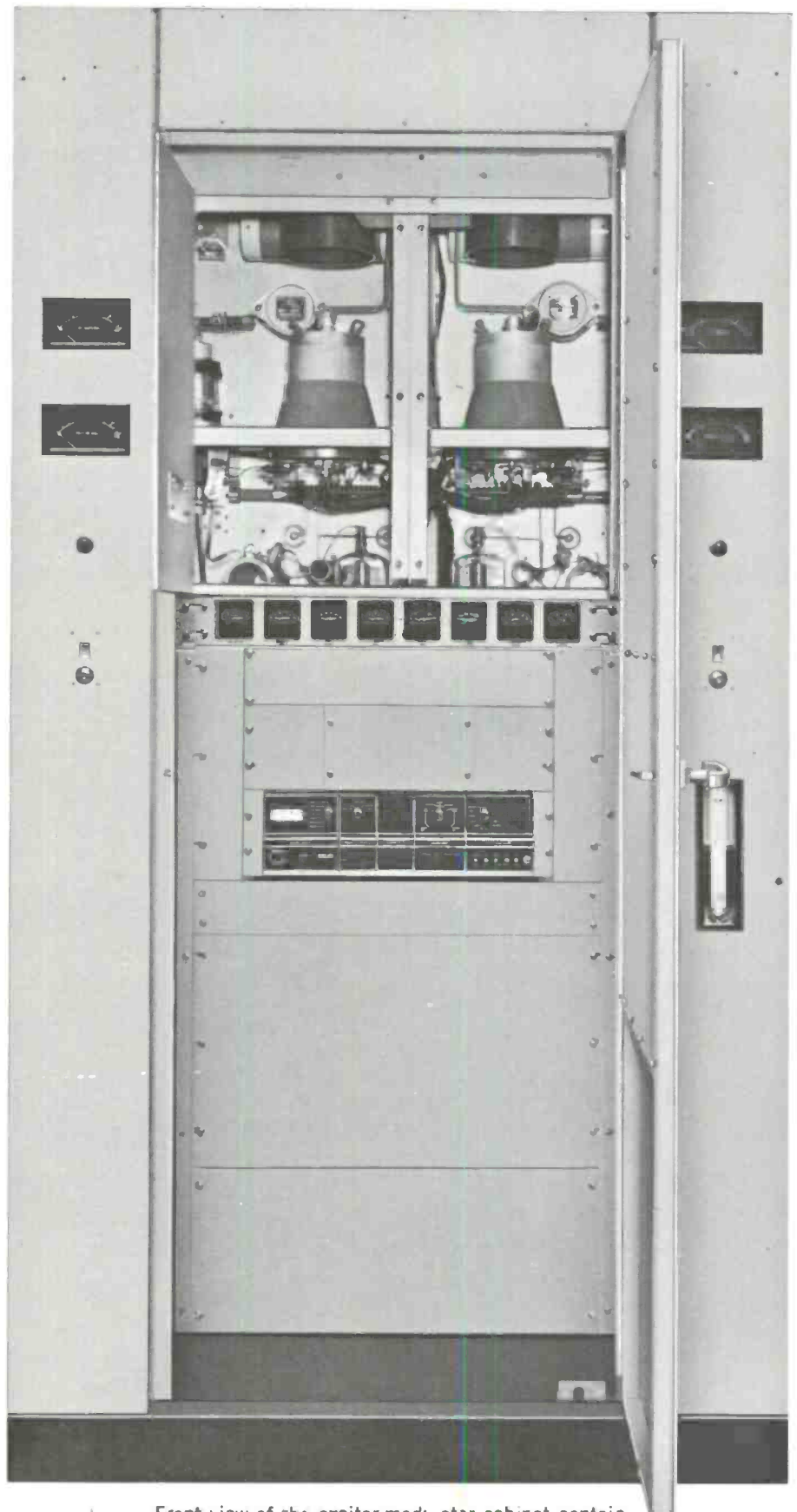

Front view of the exciter-modulator cabinet containing all sections from oscillator through driver stages.

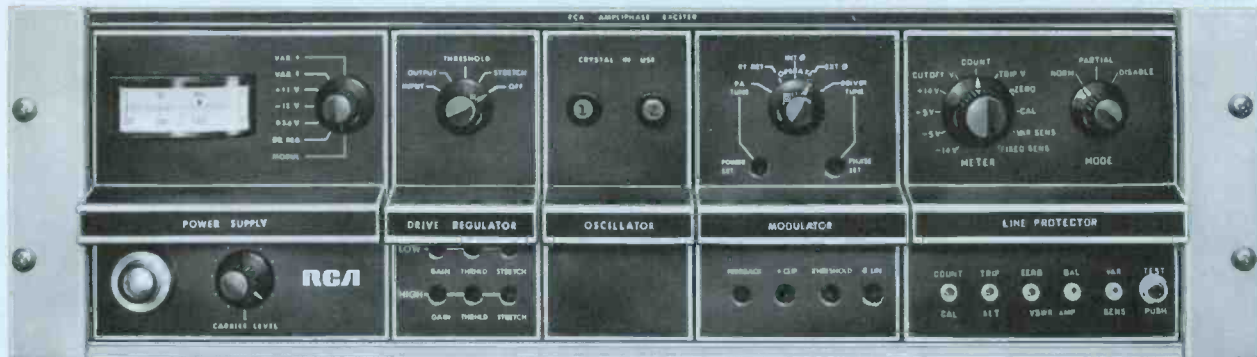

Exciter/modulator unit. Completely solid-state, this unit is used in all RCA Amplitude transmitters. Available separately for use as a spare. See Accessories.

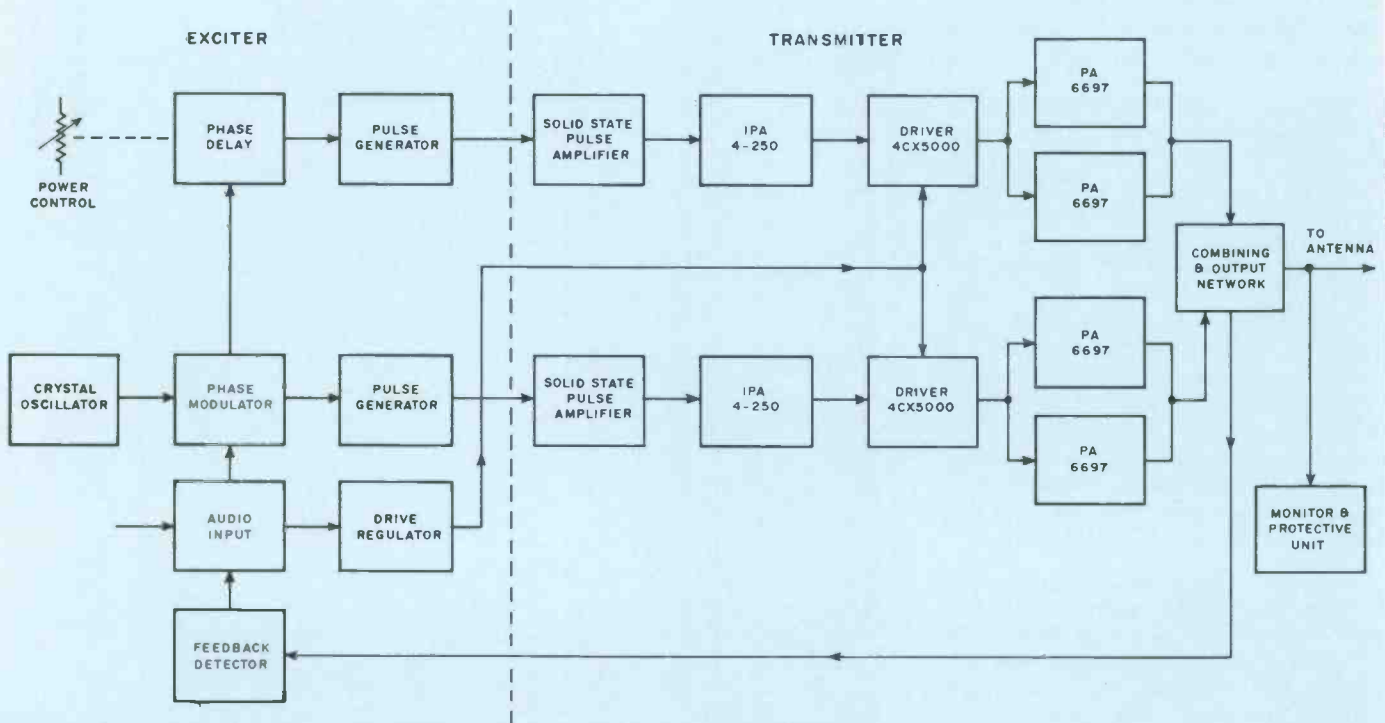

Simplified block diagram of the BTA-100J.

In the rear at the top of each cabinet is a built-in wire duct. It joins similar ducts of adjacent cabinets to form a continuous duct on the four cabinets. This duct has a divider down the center on which the interconnection terminal boards are mounted. The rear half of the duct is used for interconnection wiring while the front half is used for internal cabinet wiring from the terminal boards. The internal wiring is carried through conduits to its destination in the cabinet thus shielding all power and control wiring from RF fields. Provision is also made at the top of the cabinets for the addition of an exhaust air duct.

Power Amplifiers

The first and second cabinets and the fourth and fifth cabinets from the left end are identical and contain the final power amplifier stages. The 6697 tube and its grid circuits and part of the plate circuits are contained in the front portion of the cabinet. The upper rear section contains the plate tank coil, filament transformer and grid leak resistors. The lower rear section contains a low-noise blower which cools the 6697 tube and its cabinet. The blowers in cabinets two and four are arranged to cool the exciter cabinet. The two power amplifiers are designed to supply equal amounts of power to the output network. Because of the balanced dissipation in the PA tubes, less air pressure with resultant lower air flow is required for adequate cooling of the power amplifier cubicles. The lower rear panel contains an impingement type air filter for the blower. The PA cabinets are constructed so that the blowers and filters can be mounted externally to the cabinets, if so desired.

The PA output circuit is a conventional pi-network type of tank circuit. Each tube has its own tank circuit, with a common output shunt element. Each network is adjusted to provide the proper load to the power amplifiers.

Solid-State Exciter-Modulator, Drive Regulator

Packaged in a series of four plug-in modules, the *Ampliphase* exciter-modulator uses a crystal-controlled, field-effect-transistor oscillator, a solid-state drive regulator, modulator and power supply. The entire assembly occupies only 5¼ inches (133 mm) of rack space in the left-of-center cabinet (see photo). As a result of untuned, digital-integrated circuits, the exciter-modulator is set up with but three trimmer adjustments. The RF chains in the exciter operate with-out tuned circuits.

The drive regulator circuitry uses entirely solid-state electronic devices; the regulator samples the audio, amplifies the sample and applies it to the grid circuits of the twin driver stages so as to adjust final amplifier drive in step with the level of the modulating audio. This system contributes significantly to the exceptional linearity of the *Ampliphase* system.

Solid-State Reflectometer

The far-right module in the exciter-modulator unit is a solid-state reflectometer that protects the transmitter from transmission line and/or antenna irregularities. The reflectometer senses changes in the voltage/current ratio on the load.

A large change in load characteristics causes the reflectometer system to momentarily interrupt the drive (to let the fault clear, if transient). If the fault persists after several cycles, the reflectometer shuts down the transmitter thereby reducing the possibility of chain-reaction damage to any part of the system.

Above the exciter-modulator are two vertical sub-compartments, behind interlocked doors, which contain the 4CX-5000A driver stages. A meter panel for these stages is located beneath the sub-compartments.

The common output capacitors of the two PA tanks and the harmonic filter are located in the upper rear of the cabinet. Sub-partitions are so arranged in this section that complete isolation and shielding is effected between the various sections of the filter and the output capacitor. The lower rear section of this cabinet contains high voltage filter reactor and driver dc filament supplies.

Provisions for Standby Operation

Space is provided in the exciter cabinet for the mounting of a second exciter-modulator unit. Each of the exciter-modulator units are complete and arranged so that either may be selected instantly by means of an accessory cutover panel. Thus, while one modulator is in operation, the other modulator is in standby condi-

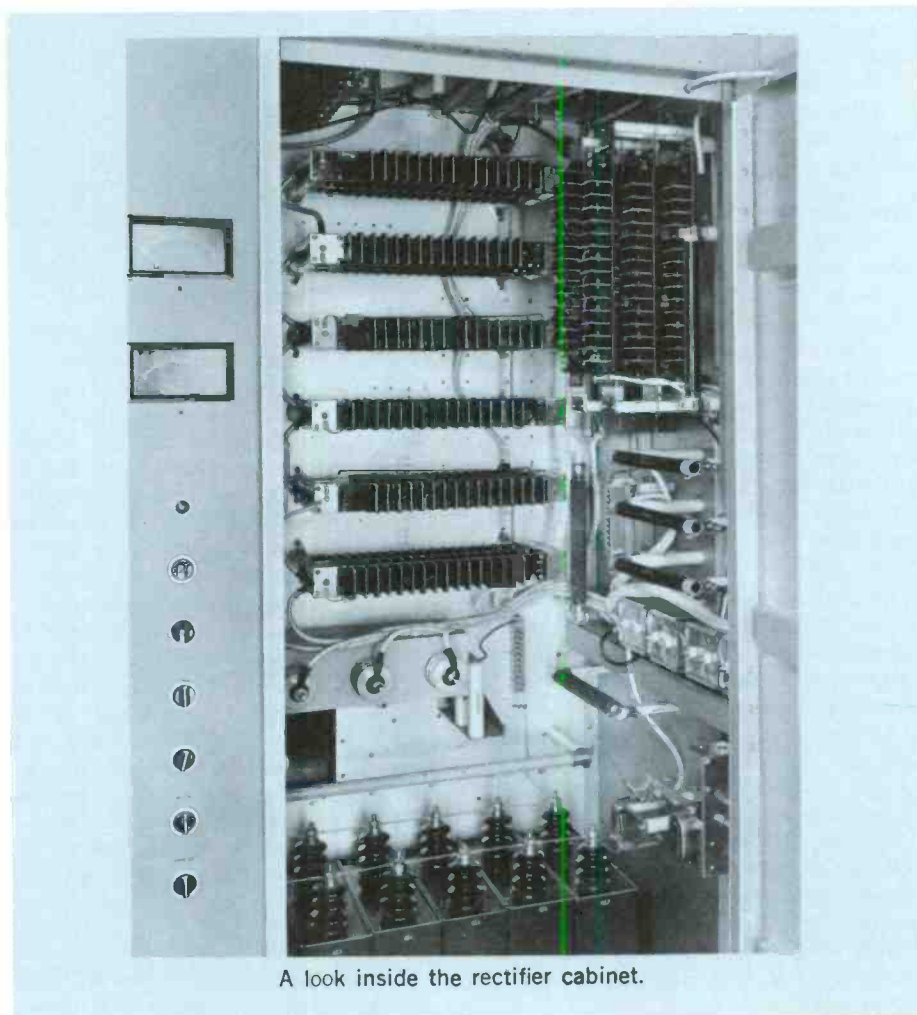

A look inside the rectifier cabinet.

tion. These provisions, with the extreme reliability designed into the high-power stages, essentially provide a second 100-kW transmitter for standby service.

Rectifier and Control Unit

The far right cabinet contains the high power rectifiers, low power distribution components, and the majority of the control components. The high-voltage and low-voltage transformers, filter capacitors and reactors are mounted externally to the transmitter cabinetry (see floor layout).

Solid-State Power Supplies

During periods of 100 percent modulation, each 6697 power amplifier tube requires 15kVdc at 7.5A, which is obtained from a three-phase, full-wave rectifier circuit. Two other plate voltages, 5kV and 1kV, are provided by separate supplies. Bias voltages for all tubes are supplied by an additional supply. The high-power distribution equipment for the transmitter consists of an electrically operated air circuit breaker, and a manually operated delta-wye switch for the 15-kV rectifier. The remaining transmitter power is distributed through a manually operated distribution circuit breaker to a 460- to 230-volt distribution transformer to voltage regulators and thence to the various low power distribution circuit breakers.

Transmitter Control

Control circuits in the BTA-100J contain a number of features which are designed to provide maximum flexibility in control, protection and operation. Among these are choice of single-button or step-by-step starting, automatic timing and sequencing of starting operations, and location of transmitter faults by a system of indicators. Protection of the operator is achieved by a system of interlocking grounding device, protection of the equipment by conventional relays and circuit breakers.

Control of the transmitter is accomplished from the front of the rectifier and control cabinet. All necessary wiring to allow control from a remote location or console has been provided. Lamps, which show the status of the transmitter control circuits, are also mounted on the front of this cabinet. The control ladder is arranged and interlocked so that the BTA-100J can either be turned on by operating the control switches in sequence or by leaving all control switches in the "on" position with the exception of the start switch which, when operated to the "on" position, allows the transmitter to come on automatically.

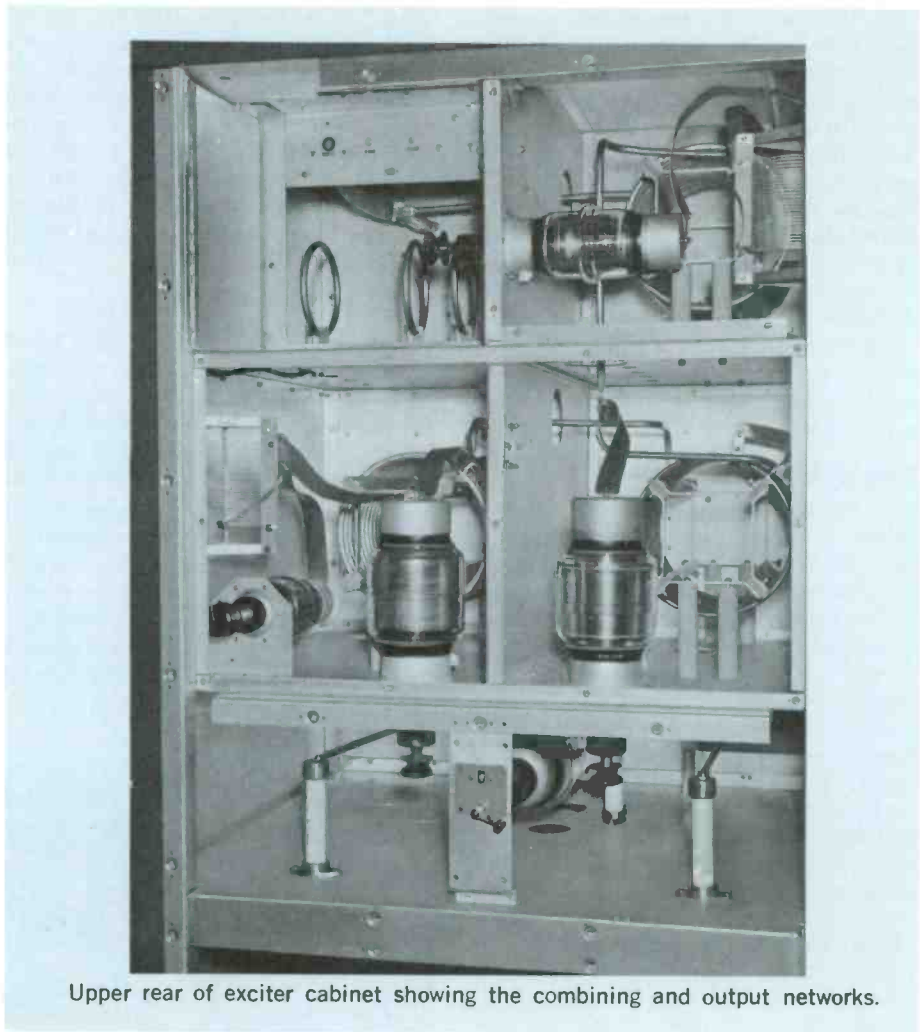

Upper rear of exciter cabinet showing the combining and output networks.

The two types of overload circuits used in this transmitter are the current type, instantaneous or time delay, that are connected directly in the tube circuit and rectifier ground leads, and the thermal magnetic circuit breakers connected in the a-c power leads used as back up protection and disconnect switches. The transmitter circuitry is arranged so that an overload either locks out the plate circuit or allows a single reclosure that resets if there are no further overloads. In either case, when a lockout position is reached, the transmitter resets by means of an Overload Reset control. The principal overload relays have indicating flags so that, even after the overload has cleared, there is a record of which overload relay operated. Another feature of the control circuit is the indicator lamps on each cabinet that indicate the interlock status in that particular cabinet.

Installation and Layout

Outstanding features of the BTA-100J are the small floor space requirements

and ease of installation. In general, the transmitter layout consists of three basic units: the six, in-line cabinets which contain the major part of the transmitter; the wall-mounted switchgear components, the main plate transformers, the HV filter capacitors and reactors and the LV power transformers. The floor plan illustrates a typical layout of the complete equipment. Elimination of the need for under-floor cable trenches and considerable reduction in external air ducts, simplifies installation and reduces costs.

As shown in the layout, it is desirable to leave a passageway at the right end of the frontline cabinets since the circuit breakers and overload relays are most accessible from this end of the transmitter. The layout of the front line cabinets is such that a common exhaust duct can be used to carry off heated air from the transmitter.

Wall mounting of the switchgear as shown on the overall floor plan is suggested to make the BTA-100J most adapt-

able to existing transmitter buildings. The mounting of these components, however, is not critical as to location. They can be mounted in existing power distribution areas if desired. These components include the main plate circuit breaker, a delta-wye switch, a distribution circuit breaker, a 460- to 230-volt bank of distribution transformers, and two single-phase open delta connected regulators with their control panels. These components are wired through conduit and overhead ductwork to the main plate transformers and the transmitter cabinets.

Parallel/Redundant System

The BTA-100J is available also as a parallel/redundant transmitter system. This system consists of two identical BTA-100J transmitters and a combiner. In the "parallel" mode, the twin 100-kilowatt outputs are combined to provide 200 kilowatts of power to the antenna system; in the "redundant" mode, the system operates one of the two transmitters as a hot standby while the other feeds the antenna system.

In either operational mode, the parallel/

redundant system assures greater on-air dependability. For example, an outage in one transmitter or the other automatically switches the troubled transmitter to a dummy load while the operable one feeds a full hundred kilowatts to the antenna system. This action is the result of a special-design combiner with essentially zero insertion loss. Further details of the BTA-100J parallel/redundant transmitter system are available from Aural Broadcast Equipment Marketing, RCA Building 2-7, Camden, N. J. 08102, U.S.A.

Typical floor plan for the BTA-100J Transmitter.

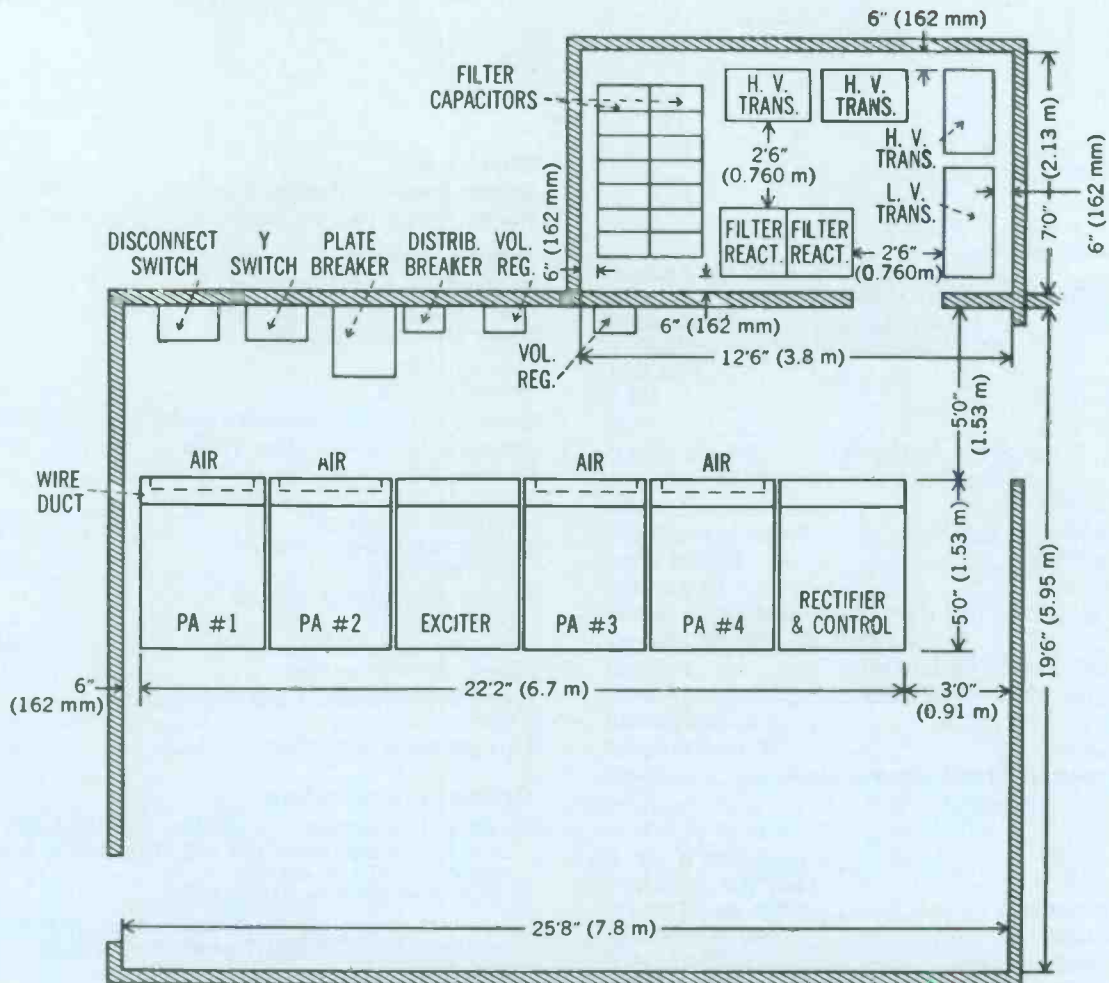

(All measurements in metric system are approximations... measurements in feet and inches are accurate)

Specifications

General

Power Line Requirements:	
Line	460/380 V, 50/60 Hz, 3 phase ¹
Combined Regulation and Variation	Not more than $\pm 5\%$
Power Consumption	180 kW (approx.) at zero modulation; 200 kW (approx.) at average modulation
Power Factor	90% min.
Crystal Heater Power	110 V
Type of Emission	A3
Power Output (at transmitter terminals)	110 kW (max.)*
Frequency	Any specified between 535 and 1620 kHz
Frequency Stability	± 2 Hz
Type Modulation (High Level)	Phase to amplitude
AF Input Impedance	150/600 ohms
Audio Input Level	+10 ± 2 dBm
Audio Response	30-10,000 Hz ± 1.5 dB; 30-15,000 Hz ± 3 dB
AF Distortion	Less than 3% RMS 50-7500 Hz
Noise Level (Below 100% modulation)	60 dB
Carrier Shift (Neg. 100% modulation)	5% max.
Type Output	Unbalanced
Output Impedance	50 or 230 ohms ²
Spurious Emission (2nd Harmonic and above)	-83 dB

Mechanical

Cabinet Size (each)	44" W, 84" H, 63" D (1118, 2134, 1600 mm)
Overall Weight (approx.)	17000 lbs. (7700 kg)
Maximum Altitude	7500 ft. (2286 m) ³
Ambient Temperature	-20°C +45°C
PA Cabinet Weights (each) (approx.)	1000 lbs. (454 kg)
Plate Transformer Weight (each) (approx.)	1500 lbs. (680 kg)
Rectifier Cabinet Weight (approx.)	2000 lbs. (907 kg)
Exciter Cabinet Weight (approx.)	1200 lbs. (544 kg)
Filter Reactor Weight (approx.)	1500 lbs. (680 kg)

Shipping Data

Weight, Domestic Packing (approx.)	19,000 lbs. (8618 kg)
Weight, Export Packing (approx.)	20,000 lbs. (9072 kg)

Tube Complement

Intermediate Power Amplifier:	Type 4-250A (Two used)
Driver Amplifier:	Type 4CX5000A (Two used)
Power Amplifier:	Type 6697 (Four used)

Accessories

Spare Solid-State Exciter-Modulator	ES-560752
Complete Set of Operating Tubes	ES-27222FX
Recommended Spare Set of Tubes	ES-27223EX
Spare Crystal Unit, Type TMV-130B (Specify Frequency)	MI-27493
Type BTR-30 Remote Control (30 Functions)	ES-561446
Type BTR-15 Remote Control (15 Functions)	ES-561157/58
100/50-kW Cutback Kit	MI-27688CX ⁴
Remote RF Pickup Unit	MI-28027
Type BW-50 Frequency and Modulation Monitor	MI-560767
Type BW-60 RF Amplifier	MI-560762

Ordering Information

100-kW AM Broadcast Transmitter, Type BTA-100J, with two crystals, remote meter, one set of operating tubes, silicon rectifiers, and one exciter. (Specify operating frequency)	ES-34100CX
200-kW AM Broadcast Transmitter, Type BTA-200J (Custom built from two BTA-100J Transmitters) (Please specify operating frequency)	ES-34100DX

¹ Other line voltages available on request.

² Other output impedances available on request.

³ Operation at higher altitude available on request.

⁴ Cutback to other power levels available on request.

* Available in 200-kW systems as Type BTA-200J.