



AM/FM RADIO

EQUIPMENT

1967 FIRST EDITION



RADIO CORPORATION OF AMERICA

AM/FM Radio Equipment Catalog Supplement

1967 FIRST EDITION

This is the first in a series of AM/FM Catalog Supplements designed to help you keep up-to-date with the latest developments in the RCA "Matched Line" of Broadcast Equipment.

The catalog folders found herein are not currently included in any of your RCA Broadcast Catalogs. They represent new equipments, and they have been assembled especially for the AM and FM Broadcaster.

We are taking this means to get new information to you just as soon as possible. As complete bound catalogs are available, you will be receiving them as well.



For assistance in selecting "Matched"
color equipment... see your
RCA Broadcast Representative

Atlanta, Ga. 30303
1121 Rhodes Haverly Bldg.
134 Peach Tree St., N.W. 404-524-7703
P. G. Walters

Austin, Texas 78756
Northwest Professional Bldg.
5425-B Burnet Rd. 512-453-8233
J. N. Barclay

Birmingham, Ala. 35223
Office Park Bldg. #10
Office Park Circle 205-871-1155
J. Smith

Boston: West Newton, Mass. 02165
950 Watertown St. 617-969-6010
E. H. Herlihy

Burbank, Calif. 91505
2700 W. Olive Ave. 213-849-6741
E. J. Frost • M. Ellison

Camden, N. J. 08102
Front & Cooper Sts. 609-963-8000
J. A. Gimbel

Charlotte, N. C. 28204
330 Charottetown Center 704-333-3996
R. M. Williams

Chicago, Ill. 60654
Merchandise Mart Plaza,
Rm. 200C 312-467-5900
D. C. Borchert • F. A. Timberlake

Cincinnati, Ohio 45224
8234 Winton Rd. 513-522-8810
C. E. Raasch

Cleveland, Ohio 44115
1600 Keith Bldg. 216-241-3450
W. C. Wiseman

Dallas, Texas 75235
210-C Court Terrace
Exchange Park, N. 214-351-5361
G. McClanathan • E. H. Hoff

Denver, Colo. 80211
2785 N. Speer Blvd.,
Suite 223 303-477-6832
R. F. Goodspeed

Detroit: Scuthfield, Mich. 48076
20830 Rutland Ave. 313-357-0080
W. P. Happel

Indianapolis, Ind. 46201
501 N. LaSalle St. 317-635-9000
R. Mele

Kansas City, Mo. 64114
7711 State Line Rd.
Suite 112 816-363-6770
V. S. Mattison

Memphis, Tenn. 38114
2110 Airways Blvd. 901-743-9442
B. E. Fincher

Minneapolis, Minn. 55416
4522 Excelsior Blvd. 612-922-3303
W. G. Eberhart

New York, N. Y. 10020
30 Rockefeller Plaza
Rm. 1219 212-689-7200
O. E. Wagner • R. F. Varda
J. R. Sims

Pittsburgh: Meadow Lands, Pa. 15347
Washington County 412-341-5294
D. P. Allen

San Francisco, Calif. 94104
343 Sansome St.
7th Floor 415-956-4818
M. M. Corbett • R. J. Newman

Seattle, Wash. 98134
2246 First Ave., S. 206-622-8350
R. Harding

St. Louis, Mo. 63105
7710 Carondelet Ave. 314-862-3560
D. B. Freeman

Washington, D. C. 20006
1725 "K" St., N.W. 202-337-8500
O. J. McReynolds

West Palm Beach, Fla. 33403
3900 Monet Rd.
Palm Beach Gardens
305-844-7351, Ext. 2891
R. E. Giles

RCA BROADCAST AND TELEVISION EQUIPMENT
BUILDING 15-5, CAMDEN, NEW JERSEY



The Most Trusted Name in Electronics

Table of Contents

Catalog Number	Type Number	Description
---------------------------	------------------------	--------------------

AUDIO

B.1025	BK-12A	Subminiature Dynamic Microphone
B.1027	SK-30/31	All Purpose Dynamic Microphone
B.1102	BC-3C	Standard Audio Console
B.1115	BC-7A	Dual-Channel Audio Console
B.1118	BC-8A	Studio Console
B.1119	BC-9A	Audio Console
B.1129	BC-19A	Stereo Console
B.1137	-----	Interphone Equipment
B.1140	EDC-12	Headset
B.1402	BA-8B	Transistor Cue Amplifier
B.1416	BA-28A	AGC Program Amplifier
B.1438	BN-16B	Four-Channel Remote Amplifier
B.1445	-----	Regulated Power Supply
B.1476	SA-202	20 Watt Sound Amplifier
B.1508	-----	Jack Panels, Mats and Cords
B.1512	-----	Audio Relay Switcher Module
B.1610	BQ-51B	12-Inch Dual Speed Turntable
B.1704	RT-21B	Professional Audio Tape Recorder
B.1732	RT-8A	Multicartridge Tape System
B.1736	RT-17A	Cartridge Tape Recorder
B.1738	RT-37A	Cartridge Tape Recorder
B.1756	BCA-15A	Audio Tape Programmer
B.1808	SL-12B	Dioplex 12-Inch Speaker
B.1810	LC-9A	Auditorium Loudspeaker
B.1812	-----	8-Inch Speakers
B.1823	-----	High Frequency Speaker Mechanism

TRANSMITTERS

B.6001	BTA-1R2	1 KW AM Broadcast Transmitter
B.6005	BTA-5T1	5 KW AM Broadcast Transmitter
B.6007	BTA-5U1/10U1	5-10 KW AM Broadcast Transmitter
B.6050	BTA-50H1	50 KW "Ampliphase" AM Transmitter
B.6310	-----	"Power Max" Negative Peak Limiter
B.6400	-----	AM Field Intensity Meter
B.6412	BW-11A/11AT	Frequency Monitors





Features

- **Lightweight subminiature design**
- **Easily concealed**
- **Non-directional pickup**
- **Improved efficiency**
- **Withstands rough usage**
- **Cartridge replacement eliminates factory repair**



Subminiature Dynamic Microphone, Type BK-12A

The BK-12A Subminiature Dynamic Microphone is RCA's "new look" in very small, extra lightweight mikes with excellent speech balance for use in television and public address applications. The BK-12's small bulk and neutral color make it

inconspicuous when worn around the neck on a lanyard, clipped to the clothing, or concealed in the hand. Due to its small size, the BK-12A is essentially non-directional to 6,000 Hertz, thus ordinary errors in orientation are inconsequential.

Description

The 20-gram mike has a wide range frequency response of 60 to 18,000 Hz which has been tailored for proper speech balance. Other notable features include a line impedance voice coil that permits use with 30 to 250 ohm unloaded inputs without changing the microphone's impedance. Through elimination of the output transformer, magnetic hum sensitivity is lower than comparable microphones that employ a

voice coil to line matching transformer. The micron-mesh acoustical filter provides dirt and moisture protection as well as an excellent appearance. Through careful design and the availability of improved magnetic materials, an extremely high acoustical to electrical power efficiency has been achieved in the BK-12A despite its small diaphragm area.

The user need never send the BK-12A back for factory repairs. A complete replacement cartridge can be installed in a few minutes. The cartridge may be roughly handled with little risk of damage. The cable is also easily replaced. Since the microphone is designed to withstand repeated drops and the cable is made of long-flex life cadmium copper, indefinitely long service can be expected with normal use.

Specifications

Output Impedance.....Low—for use with 30 to 250 ohm unloaded inputs
 Frequency Response.....60 to 18,000 Hz, shaped for lavalier use (see curve)
 Direction CharacteristicsNon-directional
 Output Level (1000 Hz):
 Effective (10 dynes/cm²).....-60 dbm (150 ohms)
 EIA—G₃₁.....-154 db (150 ohms)
 Effective Output Level @ 1000 Hz.....-60 dbm (150 ohms referred to a sound pressure of 10 dynes/cm²)
 EIA Sensitivity Rating.....-159 db (150 ohms)
 Output Voltage (open circuit).....75 mv/d/cm²
 Hum Pickup (0.001 gauss, 60 cps).....-120 dbm max.
 Cable (attached).....30 ft. 2-conductor shielded, highly flexible, beige PVC jacket
 Mounting.....Lavalier and tie clip holders supplied
 Overall Dimensions.....¾" dia. x 1½" long
 Weight......20 grams, less cable
 Finish.....Bronze epoxy and matte gold

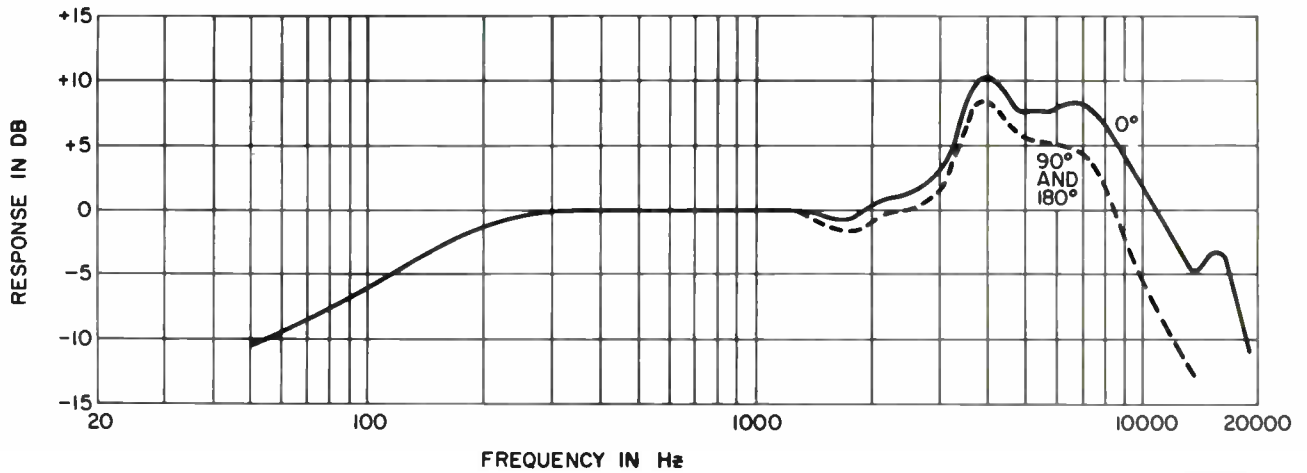
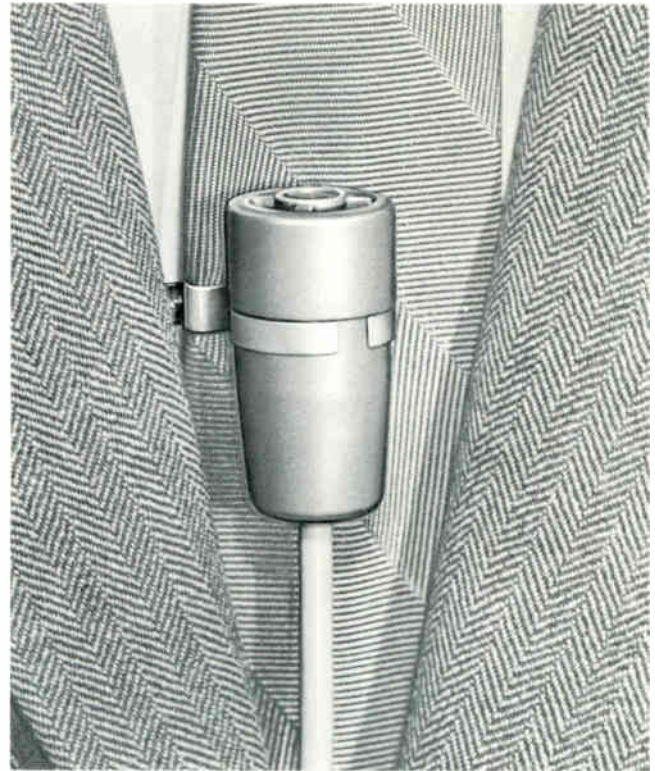

3322148

Ordering Information

Type BK-12A Subminiature Dynamic Microphone, complete with accessory Lavalier Holder, Tie Clip Holder and Cable Clip.....MI-11024



RADIO CORPORATION OF AMERICA

BROADCAST AND COMMUNICATIONS PRODUCTS DIVISION, CAMDEN, N. J. 08102 • RCA INTERNATIONAL DIVISION, CENTRAL and TERMINAL AVENUES, CLARK, NEW JERSEY, U.S.A. 07066

TRADEMARK(S) & REGISTERED MARCA(S) REGISTRADA(S)

PRINTED IN U.S.A.



- Economical General Purpose Units
- Compact and Lightweight
- Versatile—May be Hand-Held or Swivel Mounted
- High and Low Impedance Types



All Purpose Dynamic Microphone, Type SK-30/31



Description

This compact, attractive-looking unit is an ideal general purpose dynamic microphone for public address and paging applications.

It is omnidirectional, and available as a low impedance (SK-30) or high impedance (SK-31) unit. This is a rugged, lightweight microphone with good response to voice and music. In addition to being hand held, it may be used as either a lavalier microphone, or can be swivel-mounted on a desk or floor stand.

Specifications

Directional Characteristics	Omnidirectional
Frequency Response.....	60 to 12,000 cps
Output Impedance:	
SK-30.....	Matches 50-250 ohm input
SK-31	30,000 ohms
Effective Output Level (1000 cps)	
(10 dynes/cm ²).....	-56 dbm
EIA—G ₃₁	-150 db
Cable (Attached):	
SK-30.....	20 ft. two conductor shielded, no plug
SK-31	20 ft. single conductor shielded, no plug
Mounting	5/8—27 thread
Dimensions (overall).....	1½" diameter by 4½" long
Weight	5 oz.
Finish	Midnight blue

Connection Information

	Signal	Ground
SK-30.....	Black and White	Shield
SK-31.....	White	Shield

Ordering Information

Type SK-30 General Purpose Dynamic Microphone	
(Low Impedance)	MI-11030-1
Type SK-31 General Purpose Dynamic Microphone	
(High Impedance)	MI-11031-1

Accessory

5/8—27 Swivel Adaptor (Fits Conventional Floor and Desk Stands).....	MI-11032
--	----------

3PB



RADIO CORPORATION OF AMERICA

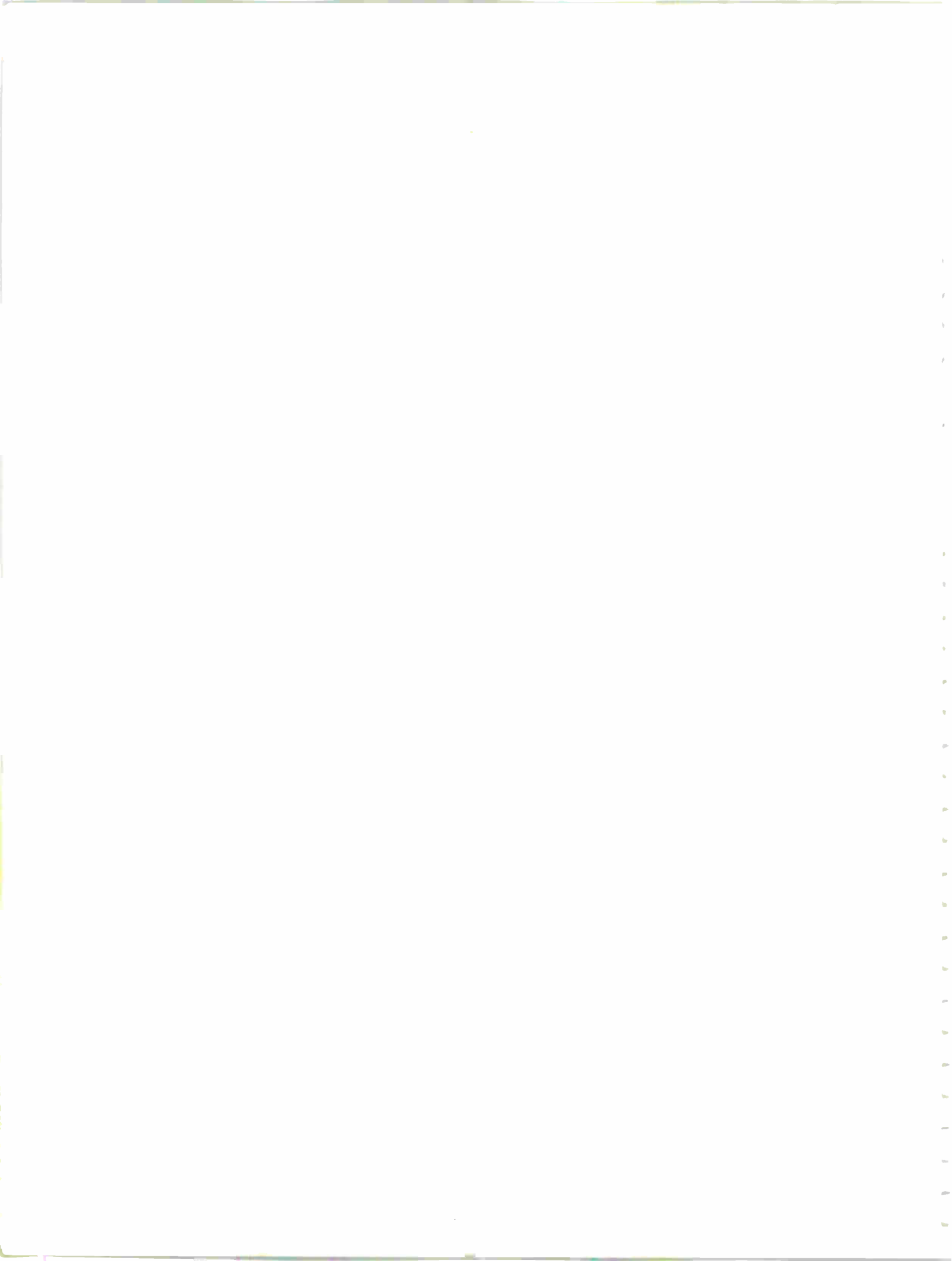



- Complete high-fidelity speech input system
- Headphone selection of network, remote, and program line
- Compact modular construction
- Easy operation



Standard Audio Console, Type BC-3C

Description

The RCA Type BC-3C Standard Audio Console is a compact, self-contained, high-fidelity speech-input system providing audio amplification, switching, control and monitoring facilities essential to the operation of medium size radio or television broadcast stations. This model incorporates eight mixer positions, which control thirteen inputs. The console is sufficiently flexible to accommodate two studios, announce booth, control room, transcription turntables and auxiliary input circuitry.

Convenient Operating Controls

The Type BC-3C Standard Audio Console is a convenient audio control equipment mounted in a smartly styled housing of all-metal construction. A hinged front panel and removable cover provide access to tubes, switches, gain controls and

other interior components. An etched panel contains all operating controls, an illuminated volume indicator calibrated in VU's, and a rack designed to hold script. The mixer controls are assigned so as to offer the greatest flexibility and operating ease.

Facilities for 13 Inputs

The BC-3C will handle thirteen separate inputs with provisions for simultaneously mixing of any eight inputs. There is provision for feeding program cue or talkback to remote lines. Headset switching is provided for network, program and remote line monitoring. Cue positions are incorporated on high level and turntable mixers. A separate audition channel is provided for maximum flexibility. The monitoring amplifier may be switched from the cue position, program line, audi-

tion bus, or external input. The output of an off-air receiver or modulation monitor can be connected to this external position. All inputs are terminated when the switches are in the off position.

Entirely Self-Contained

The BC-3C is of modular construction with etched wiring on durable glass-epoxy sub-assemblies. It has self-contained amplifiers and power supply. Three amplifiers are utilized in the design plus monitoring and booster equipment. Recommended operating practice is for the inclusion of separate BA-26 pre-amplifiers mounted in each turntable cabinet. The control circuits include two 24 volt relays for control room and studio speaker muting. The muting relays may be used to actuate "on air" light relays when such accessories are used.

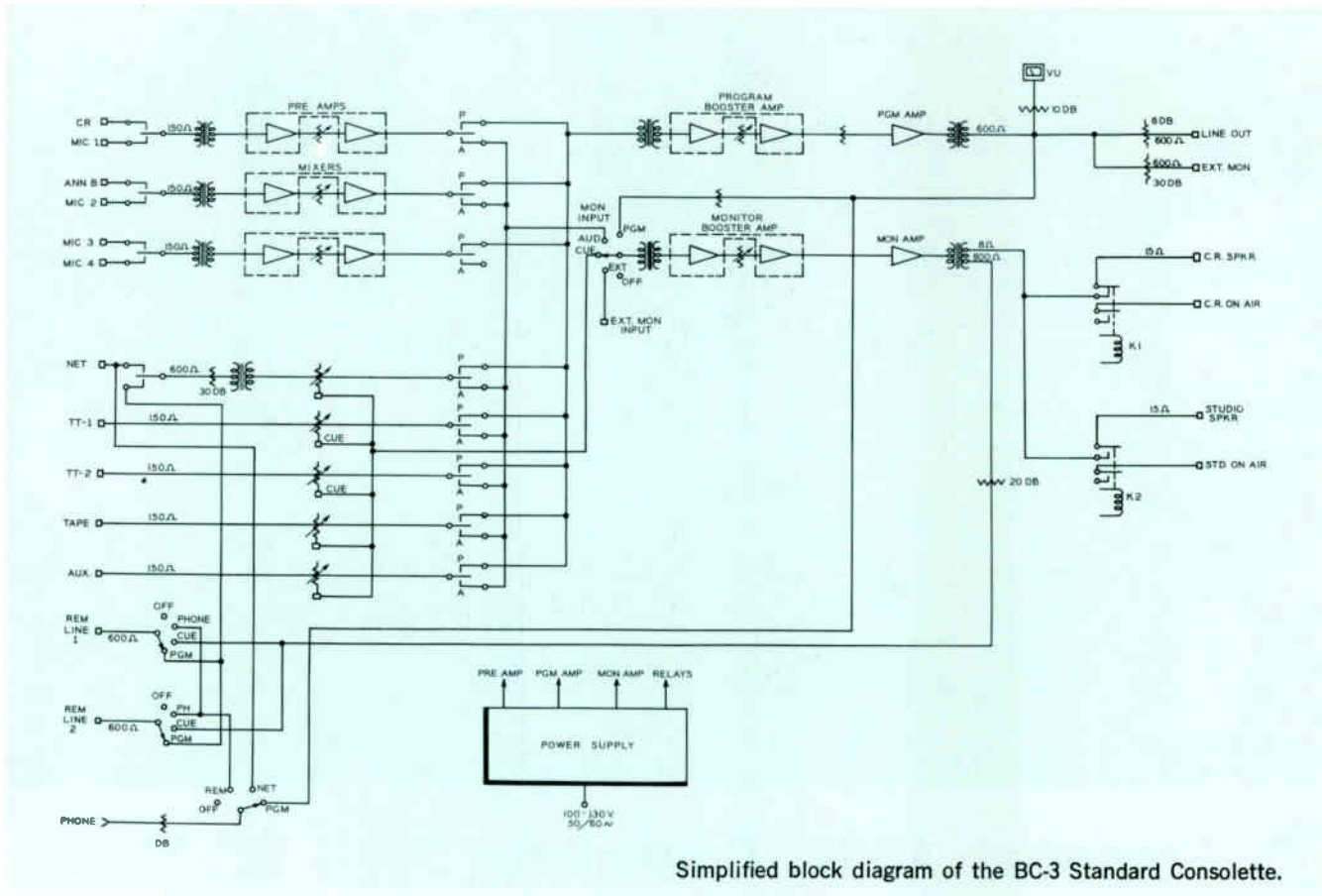

Simplified block diagram of the BC-3 Standard Console.

Specifications

Inputs:

- 6 Microphones (4 Studio, 1 Control Room and 1 Announce Booth).....37.5/150/600 ohms
- 2 Turntable, 1 Tape, and 1 Auxiliary Inputs.....150 ohms
- 2 Remote Lines,
1 Network and 1 External Monitor.....600 ohms

Outputs:

- 1 Program Line & 2 Remote
Lines Cue 600 ohms +18 dbm
- 2 Monitor Speakers 16 ohms 3 W each
- 1 External Monitor 600 ohms -6 dbm
- 1 Turntable Cue 150 ohms 1 V rms

Gain:

- Microphone to Program Line.....108 db
- Network or Remote to Program Line..... 32 db
- Turntable, Tape or Auxiliary to Program Line..... 64 db
- Microphone to Audition Speaker.....124 db
- Microphone to Program Speaker.....144 db
- Microphone to External Monitor..... 84 db
- Microphone to Remote Line (Cue).....106 db
- Network to Audition Speaker..... 48 db
- Network to Program Speaker..... 68 db

Frequency Response:

- Program ±1.5 db.....30-15,000 Hz
- Monitor ±2.5 db.....30-15,000 Hz

Harmonic Distortion:

- Program 18 dbm Output.....1% at 30 Hz; .75% at 50 Hz;
0.5% at 100-15,000 Hz
- Monitor 6 W Total.....1.5% at 50-10,000 Hz

Signal to Noise Ratio:

- Program Channel, Mixer and Master Gain
controls set for 68 db Gain.....68 db below 18 dbm output

Tube Complement:

- 2—6V6-GT, 2—12AU7, 2—12AX7, 1—5R4GY, 5—12AY7,
5—MI-11299 (selected 12AY7)

Power Requirements:

- 100-130 volts a-c, 50/60 Hz, 155 watts
- Dimensions.....33" wide, 11¼" high, 21¼" deep
(83.82 cm, 28.58 cm, 53.98 cm)

Weight:

- 88 lbs. (36.9 kg.)

Accessories

- Tube KitMI-11486-A
- On-Air Light Relay.....MI-11702-A
- Warning LightsMI-11706-Series
- BA-26A Equalized Preamplifier.....MI-11436
- Announce Booth Speaker Relay.....MI-11748
- Selected 12AY7 Tube.....MI-11299
- Cue Type Fader for BC-3C High Level Inputs...MI-94136

Ordering Information

- BC-3C Standard Console (less tubes).....MI-11641-A
- BC-3C Standard Console (complete with tubes)....ES-11103-A



RCA RADIO CORPORATION OF AMERICA

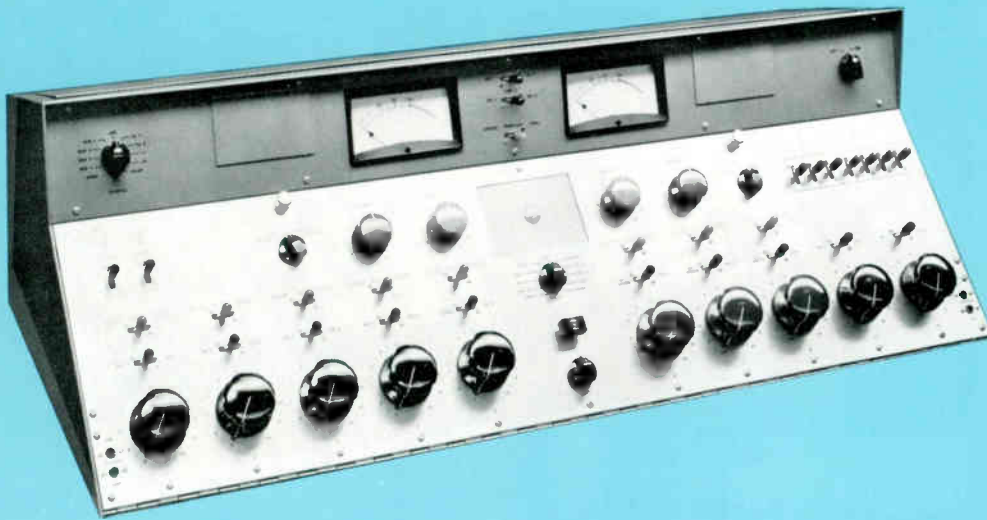

- Unmatched flexibility
- Ease of operation
- All transistor design
- Utmost reliability



Dual-Channel Audio Consolette, Type BC-7A

Description

The BC-7A Dual Channel Audio Consolette is a completely self-contained unit providing the broadcaster with both stereo or monaural mixing, switching, and monitoring facilities, plus dependable plug-in transistor amplifiers, low impedance mixing circuits, self-contained power supply and built-in cue/intercom amplifier. Provisions are included for installation of optional AGC meters so the gain reduction of an external amplifier may be observed while controlling program gain.

Stereo/Dual Channel Operation

The BC-7A is normally supplied with five preamplifiers, two program amplifiers, one cue/intercom amplifier and one monitor amplifier. With an additional preamplifier and a second monitor amplifier, complete stereo monitoring is available. For stereo broadcasting the program

master gain controls of the BC-7A are ganged together as are the monitor gain controls by placing the mode switch in the stereo position. A unique, smooth action, dual mixer control is used in all stereo positions.

Ten Preselected Program Inputs

The BC-7A consolette contains a total of ten mixer positions; five low level, each switchable to one of three inputs; three high level, each switchable to one of three inputs; and two line level, of which one is switchable to three, the other to four inputs. All amplifier inputs and outputs are brought out to terminal connections within the consolette, so that wiring to jack fields may easily be accomplished.

Functional Design

The BC-7A Dual Channel Consolette is designed not only for

greater operating convenience and ease of servicing, but for aesthetic value as well. The double slope front panel, pleasing functional design, large illuminated VU meters and completely uncluttered control panel highlight the simplicity and beauty of the unit. The finish of the main control panel is anodized, brushed aluminum while the housing and upper panel is finished in harmonizing blue color. The console is intended for flat top desk mounting.

Compact Control Arrangement

All switching, mixing, and operational controls are contained on the main control panel and are grouped and color coded for fast identification thus minimizing operator error. Permanent panel designations are etched in black whereas designations which are most subject to change, depending on individual

BC-7A with front panel lowered to show internal plug-in units, including left to right, preamplifiers, high-level isolation units, program amplifiers, cue amplifier and power supply.

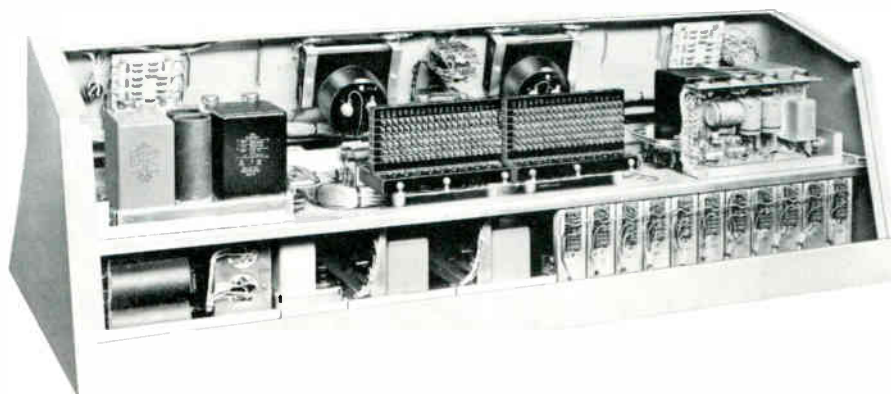
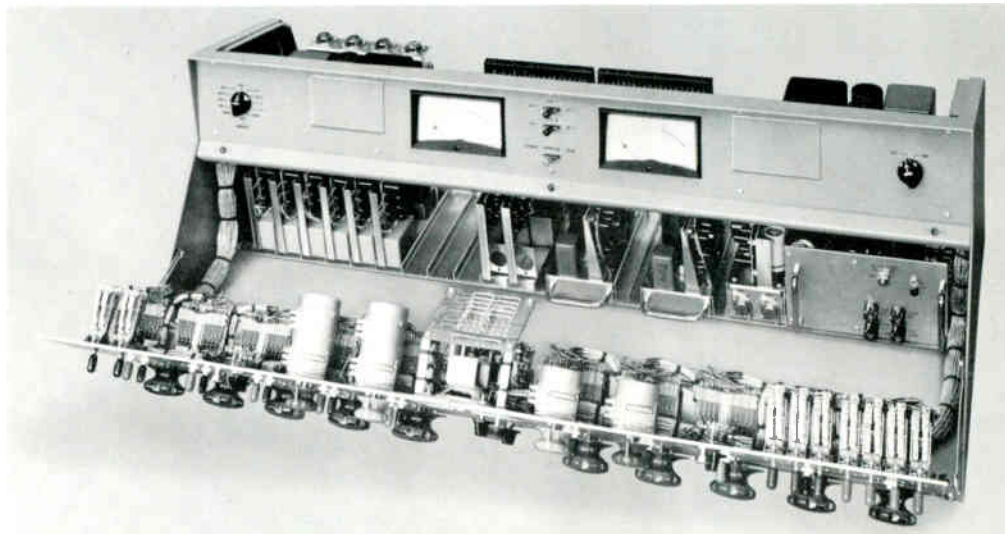

Rear of BC-7A with cover removed showing plug-in monitoring amplifiers and accessibility to external plug-in connection terminals.

needs, are left blank. Uniform panel depressions, provided at these locations, accept a wide assortment of pressure sensitive labels supplied with each unit. The labels provide a neat, permanent appearance to the console, yet can easily be changed when necessary.

Unitized Construction

Plug-in, unitized construction is the key to the flexibility of the BC-7A to meet the varying needs of TV and AM broadcasters as well as recording studio applications. Six plug-in unit types are used in the BC-7A: the preamplifier, program amplifier, monitor amplifier, cue/intercom amplifier, power supply and high level isolation unit.

Optional AGC Meters

The basic console consists of a wired housing including all operating controls, five dust-protected speaker muting relays, two VU meters, with provisions for adding

two optional gain reduction meters, and guide assemblies for accepting plug-in units.

All Solder Input Connectors

One feature of the design is the availability of the input and output circuits and all amplifiers and input plug-in units on terminals. This facilitates ease in wiring to external sound effects equipment, compensating networks or jack panels. Another feature is the muting relay strapping panel, conveniently located behind the main control panel at the top, center. Any of the five muting relays may be strapped so as to be controlled by any combination of source selection lever keys associated with mixers 1 thru 8.

Self-Contained Power Supply

The power supply provides operating power for up to ten preamplifiers, two program amplifiers, five speaker muting relays as well as reserve power for operation of five

additional optional warning light relays. The ten watt monitor amplifier and the cue/intercom amplifier are self-powered.

Mixing Facilities

Each of the ten, low impedance mixing positions will accept one of three plug-in units: the preamplifier for low level sources; the high level isolation unit for balanced high level sources or a simple jumper plug for direct unbalanced input to the mixer. The standard console housing is supplied with dual attenuators in mixer positions 5, 6, 7 and 8.

Auxiliary Mixer

The BCM-2A Auxiliary Mixer is designed as a companion piece to increase the number of available mixers by 5. One or more of the BCM-2A Auxiliary Mixer Units may be added. Convenient terminals are provided in the BC-7A console to extend the mixer bus to the BCM-2A.

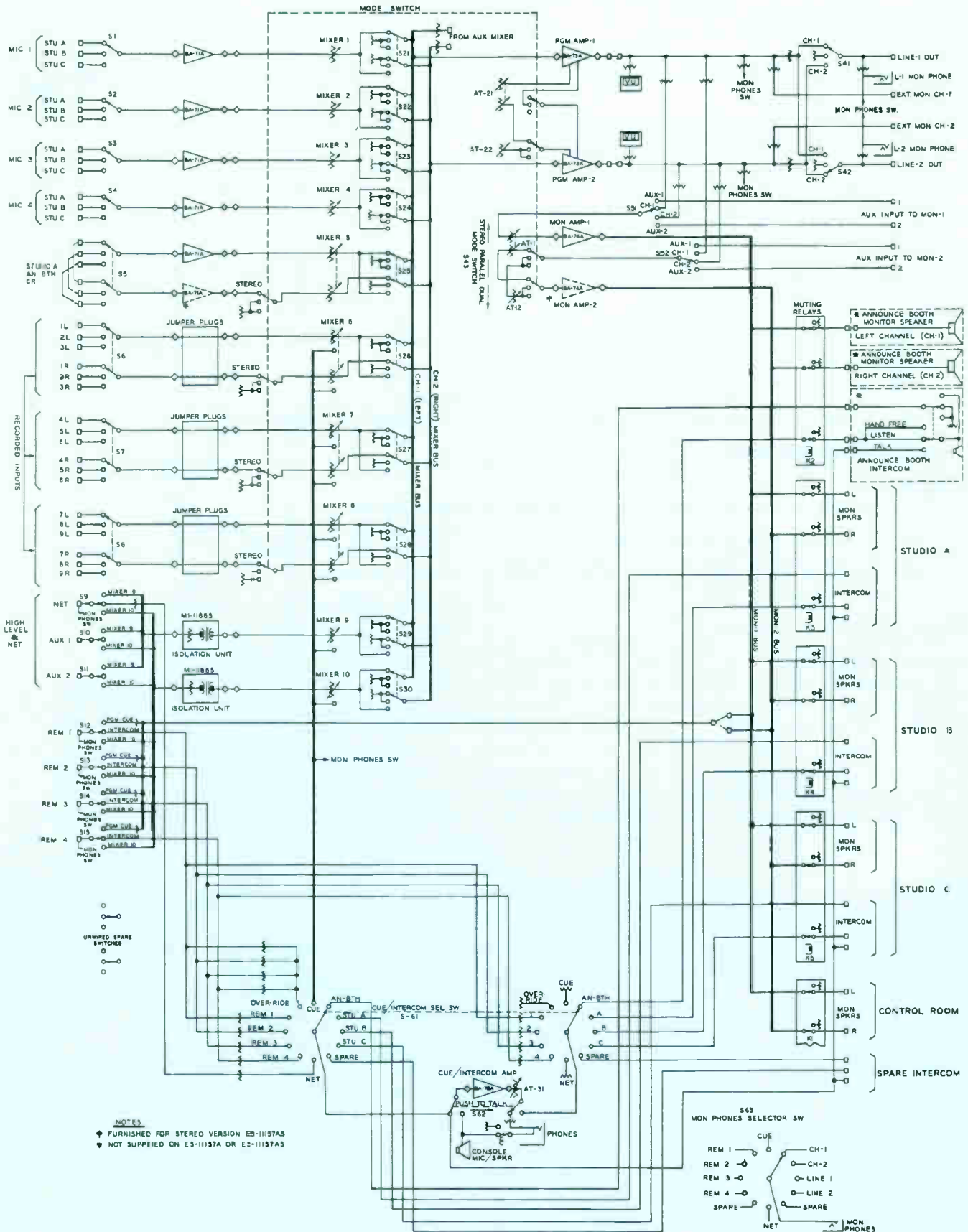

Simplified functional drawing of the BC-7A Dual Channel Audio Console.

Specifications

Mixers:

- 10 Selectable by lever key to either program channel.

Inputs:

- 15 Microphones switchable to five preamplifiers (microphone on mixer 5 may be split to feed both channels for stereo operation by addition of accessory preamplifier).
- 9 Turntable, tape or film, switchable to three high level mixers. (All three may be stereo operated.)
- 3 Network or high level, each switchable to either mixer No. 9 or mixer No. 10.
- 4 Remote lines, switchable to mixer No. 10, intercom, and program cue.
- 2 Spare monitor positions each channel.

Amplifiers:

- 5 Plug-in transistor preamplifiers (with provisions for five additional accessory preamplifiers).
- 2 Plug-in transistor program amplifiers with individual master gain controls. (Gain controls, ganged for stereo.)
- 1 Plug-in transistor cue/intercom amplifier.
- 1 Plug-in transistor monitor amplifier. Provisions are included for a second accessory monitor amplifier. Gain controls ganged for stereo.

Outputs:

- 2 Program lines (either channel may feed either or both lines).
- 2 External monitors (one for each channel).
- 5 Speakers per channel (provisions for 10 speakers, two per location for stereo operation when using optional second monitoring amplifier).

Source Impedance:

Microphones	37.5/150/600 ohms
Net and Remote Lines.....	600 ohms
Turntables	600 ohms
Tape	600 ohms
Film	600 ohms

Load Impedance:

Line	600 ohms
Speaker	16 ohms
Headphone	High Impedance

Output Level:

Program Channel.....	+18 dbm after 6 dbm isolation pad (each channel)
Monitor Amplifier.....	+40 dbm

Input Level:

Microphone Inputs (maximum).....	-22 dbm
Turntable Input (maximum).....	+18 dbm
Net or Remote Line (maximum).....	+18 dbm

Gain:

Microphone Input to Program Line.....	105 db, can be increased to 111 db
Turntable or Remote Line to Program Line.....	64 db

Frequency Response.....±1.5 db, 30 to 15,000 Hz

Distortion:

Program Channel.....	Less than .5%, 50-15,000 Hz Less than .75%, 30 Hz
Monitor Amplifier.....	Less than 1%, 50-15,000 Hz

Signal to Noise Ratio:

Microphone to Program Line (68 db gain, +18 dbm output).....	68 db
---	-------

Dimensions.....39¼" wide, 12½" high, 20" deep
(99.7 cm, 31.75 cm, 50.8 cm)

Accessories

Auxiliary Mixer Housing, Type BCM-2A (less all plug-in modules).....	MI-11656
On-Air Light Relay.....	MI-11702-A
Warning Lights	MI-11706-Series
Type BA-71A Preamplifier (less guide assembly).....	MI-11658
Type BA-73A Program Amplifiers (less guide assembly).....	MI-11659
Type BA-74A Monitor Amplifiers (less guide assembly).....	MI-11661-A
Type BA-78A Cue/Intercom Amplifiers (less guide assembly).....	MI-11662
Type BX-71 Power Supply (less guide assembly).....	MI-11663-A

Ordering Information

BC-7A Console Housing (less all plug-in modules).....	MI-11657
BC-7A Console (for monaural programming).....	ES-11157-A
Including the following:	
1 BC-7A Console Housing	MI-11657
5 Preamplifiers, Type BA-71	MI-11658
2 Program Amplifiers, Type BA-73.....	MI-11659
1 Monitor Amplifier, Type BA-74.....	MI-11661-A
1 Cue/Intercom Amplifier, Type BA-78.....	MI-11662

2 High Level Isolation Units.....	MI-11665
1 Power Supply, Type BX-71.....	MI-11663-A
BC-7A Console (for stereo programming).....	ES-11157-AS
Including the following:	
1 BC-7A Console Housing.....	MI-11657
6 Preamplifiers, Type BA-71.....	MI-11658
2 Program Amplifiers, Type BA-73.....	MI-11659
2 Monitor Amplifiers, Type BA-74.....	MI-11661-A
1 Cue/Intercom Amplifier, Type BA-78.....	MI-11662
2 High Level Isolation Units.....	MI-11665
1 Power Supply, Type BX-71.....	MI-11663-A



RADIO CORPORATION OF AMERICA



- Complete high-fidelity audio system designed for dual channel operation
- Compact self-contained
- Solid state design
- Provision for optional second VU meter
- Built-in cue monitor and intercom amplifier completely independent of program circuits
- Optional BCM-2A Auxiliary Mixer



Studio Console, Type BC-8A

Description

Possessing great flexibility and featuring simplified operation, the BC-8A Studio Console provides a high-fidelity audio input system for AM, FM and TV broadcast stations. Designed for operating convenience and ease of servicing, the Console offers two channel mixing and switching with monitoring facilities, plus dependable plug-in transistor amplifiers, low impedance mixing circuits, self-contained power supply and built-in cue/intercom amplifier. Provisions are included for

installation of a second VU meter so that simultaneous, visual monitoring of both program channels may be accomplished if desired.

Field installation of a third program channel is possible. This is useful for pre-testing microphone circuits for quality and level before switching to TV program or preview channels.

Plug-In Unitized Construction

Plug-in unitized construction is

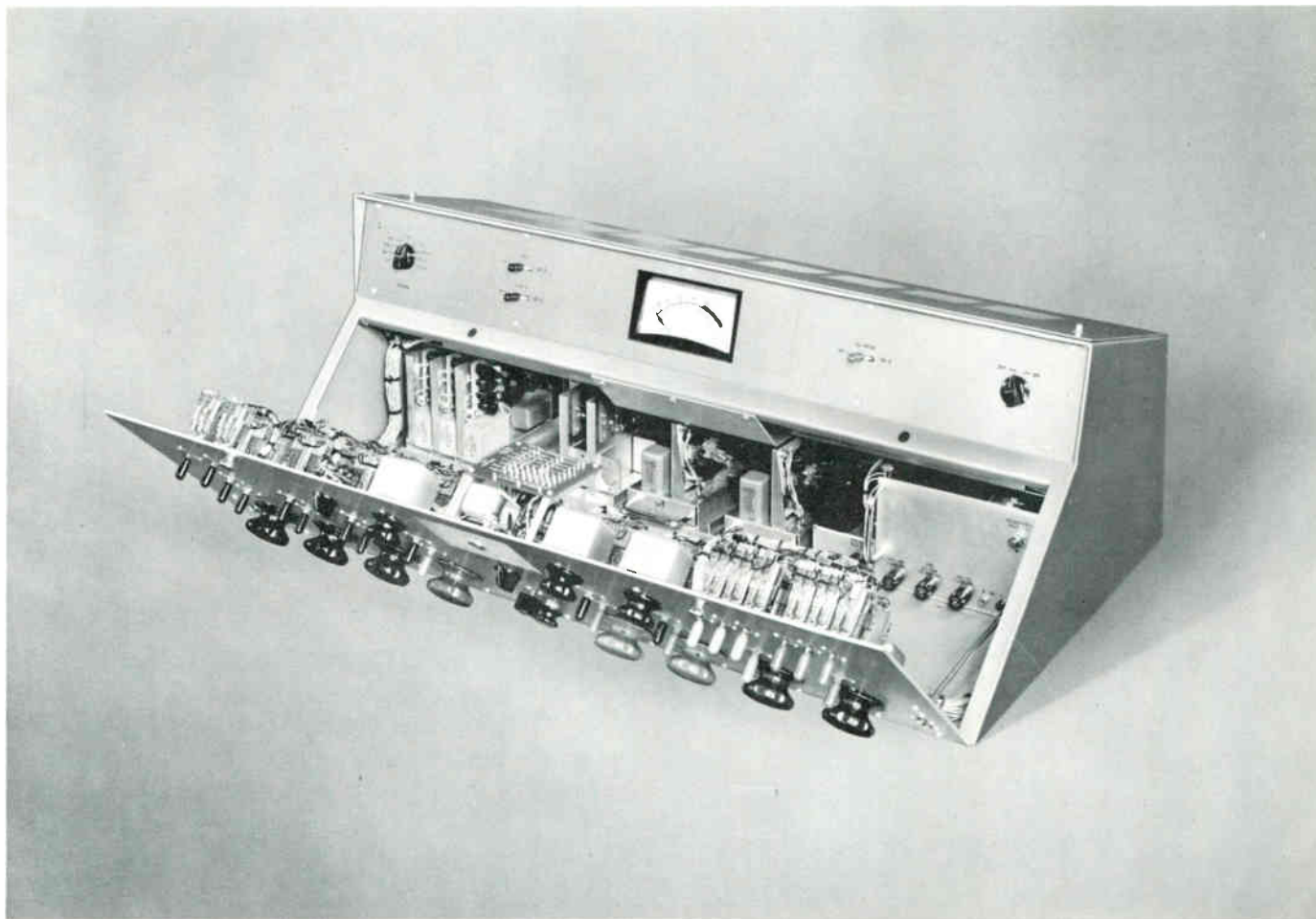

BC-8A with front panel lowered to show internal plug-in modules, pre-amplifiers, high-level isolation units, program amplifiers, cue amplifier and power supply.

the key to the flexibility of the BC-8A. The basic console consists of a wired housing including all operating controls, three dust-protected speaker muting relays, one VU meter, with provisions for adding an optional second VU meter, and guide assemblies for accepting plug-in transistor modules. These comprise three preamplifiers, two program amplifiers, one cue/intercom amplifier, one monitor amplifier, one power supply, and two high level isolation units. Plug-in units used are identical with those of the BC-7 Console and BCM-2A Auxiliary Mixer.

8 Low Impedance Mixers With Cue Positions

The BC-8A Studio Console contains a total of eight mixer positions; three low level, each switchable to one of three inputs; three high level, each switchable to one of three inputs; and two line level, each switchable to one of three inputs. All amplifier inputs and outputs are brought out to terminal connections within the console, so that wiring to external jack fields may be easily accomplished.

Ease of Operation

All switching, mixing, and operational controls are contained on the main control panel and are grouped

and color coded for fast identification. The double slope front panel, pleasing functional design, large illuminated VU meter and completely uncluttered control panel highlight the simplicity and beauty of the unit. The finish of the main control panel is anodized, brushed aluminum, while the housing and upper panel are finished in a harmonizing blue color. The console is intended for flat desk top mounting. The BCM-2A Auxiliary Mixer may be used with the BC-8A to increase the number of available mixers by five. Convenient terminals are provided in the BC-8A to extend the mixer bus to the BCM-2A.

FUNCTIONAL DRAWING OF THE BC-8A STUDIO CONSOLE

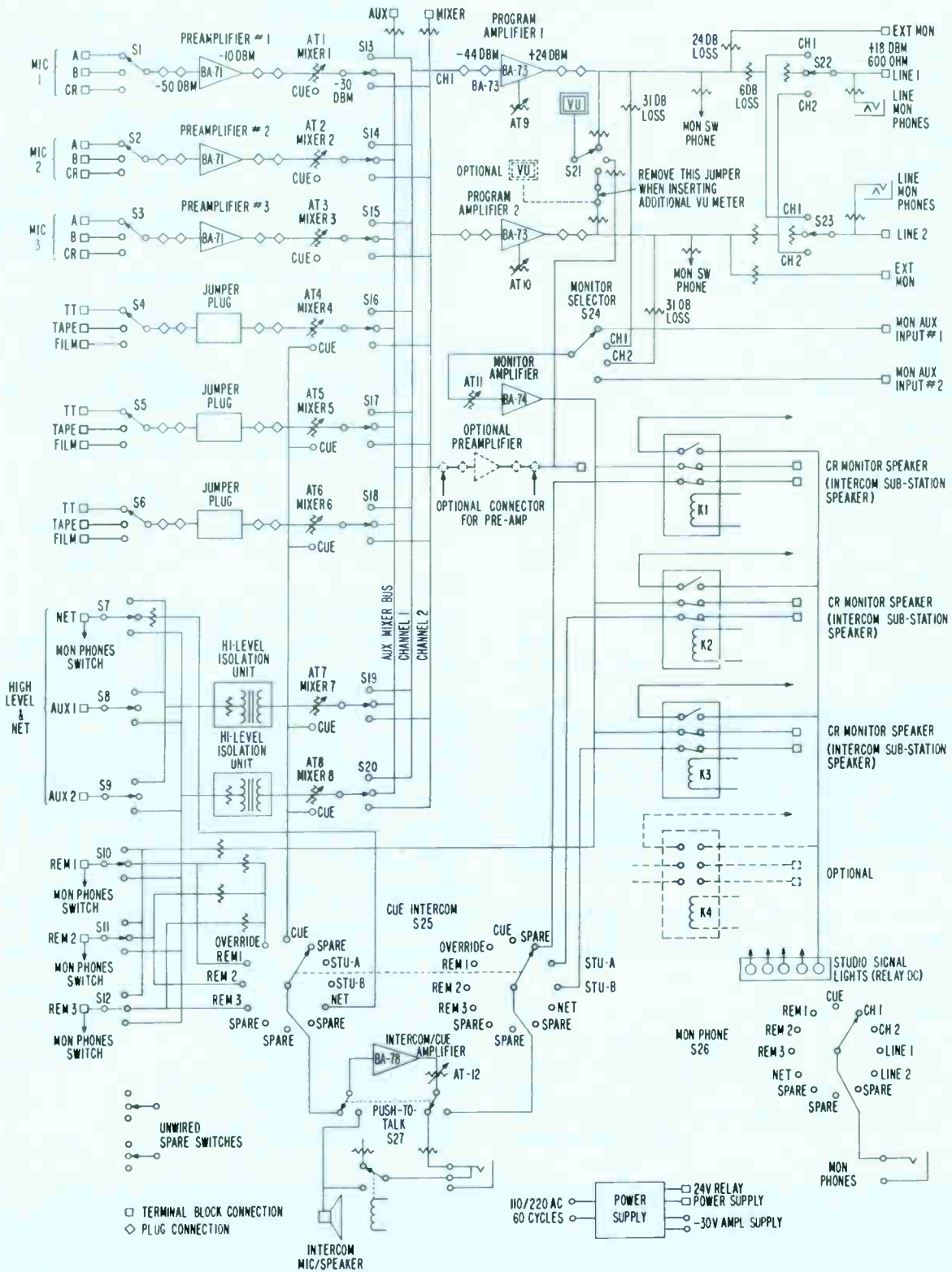

Specifications

Mixers.....8 (selectable by level key to either program channel)

Inputs:

- 9 Microphones switchable to 3 preamplifiers
- 9 Turntable, tape or film, switchable to 3 high level mixers
- 3 Network or high level, each switchable to Mixer No. 7 or No. 8
- 3 Remote lines, switchable to mixer No. 8, intercom, and program cue

Plug-in Components:

- 3 Plug-in transistor preamplifiers (with provisions for 3 additional accessory preamplifiers)
- 2 Plug-in transistor program amplifiers with individual master gain controls
- 1 Plug-in transistor cue/intercom amplifier
- 1 Plug-in transistor monitor amplifier with provisions for a second accessory monitor bus
- 1 Plug-in transistor power supply
- 2 High level isolation units

Outputs:

- 2 Program lines (either channel may feed either or both lines)
- 2 External monitor (one for each channel)
- 3 Speakers

Source Impedance:

- Microphones37.5/150/600 ohms
- Net and Remote Lines.....600 ohms balanced
- Turntables, tape and film.....600 ohms unbalanced (may be balanced by use of MI-11665 high level isolation units)

Load Impedance:

- Line.....600 ohms balanced from 6 db pad
- Speaker16 ohms
- HeadphoneHigh Impedance

Input Level:

- Microphone Inputs (maximum).....-22 dbm
- Turntable Input (maximum).....+18 dbm
- Net or Remote Line (maximum).....+18 dbm

Gain:

- Microphone Input to Program Line.....105 db (can be increased to 111 db)
- Turntable or Remote Line to Program Line.....64 db

Frequency Response.....±1.5 db, 30 to 15,000 Hz

Distortion:

- Program Channel.....Less than .5%, 50-15,000 Hz; less than .75% at 30 Hz
- Monitor Amplifier.....Less than 1%, 50-15,000 Hz

Signal-to-Noise Ratio:

- Microphone to Program Line (68 db gain, +18 dbm output).....68 db

Dimensions (overall).....34¾" wide, 12½" high, 20" deep (88.26 cm, 31.75 cm, 50.8 cm)

Weight.....Approximately 125 lbs. (57.7 kg) (with plug-in units)

Finish.....Blue, brushed aluminum panel, color coded controls

Power Requirements.....115/230 V, 50-60 Hz, 120 watt maximum

BA-71A PREAMPLIFIER, MI-11658

Power Requirements.....30 V, 45 ma (each) from BX-71A
 Maximum Ambient Temperature.....55°C (131°F)
 Mounting.....Plug-in for BC-8A Console
 Dimensions Overall.....13¾" wide, 4½" high, 7½" long (deep)
 (3.49 cm, 11.75 cm, 19.37 cm)
 Weight.....2¼ lbs. (1 kg)

BA-73A PROGRAM AMPLIFIER, MI-11659-A

Power Requirements.....30 V, 300 ma (each) from BX-71A
 Ambient Temperature.....55°C (131°F)
 Mounting.....Plug-in for BC-8A Console
 Dimensions Overall.....3¾" wide, 4½" high, 9" long (deep)
 (9.52 cm, 11.75 cm, 22.86 cm)
 Weight.....4 lbs. (1.8 kg)

BA-74A MONITOR AMPLIFIER, MI-11661-A

Power Requirements.....100-130 V, a-c, 50/60 Hz, 30 watts (with taps for 105, 115 and 125 volts)
 Ambient Temperature.....50°C (131°F)
 Mounting.....Plug-in for BC-8A Console
 Dimensions Overall.....5" wide, 4½" high, 9¾" long (deep)
 (12.7 cm, 11.75 cm, 25.08 cm)
 Weight.....11 lbs. (5 kg)

BA-78A CUE/INTERCOM AMPLIFIER, MI-11662

Power Requirements.....115/230 V, a-c, 50/60 Hz, 3-5 watts full program, 2 watts standby
 8 watts max. sine wave output
 Maximum Ambient Temperature.....50°C (131°F)
 Dimensions Overall.....3" wide, 4½" high, 8¾" long (deep)
 (7.62 cm, 11.75 cm, 21.27 cm)
 Weight.....3 lbs. (1.36 kg)

BX-71A POWER SUPPLY, MI-11663-A

Power Requirements.....100-130, or 200-260 V, a-c, 50/60 Hz, with taps at 105, 115, 125, 210, 230 and 250 V
 Power Output.....-30 V at 1 amp., regulated; 24 V at .56 amp., unregulated; 6 V a-c at 1.5 amp.
 Regulation.....0.35% no load to full load
 Ripple.....0.15 mV max. on 30 V supply
 Fuse.....1.5 and 1 ampere, slo-blow
 Mounting.....Plug-in for BC-8A Console
 Dimensions Overall.....7½" wide, 4½" high, 8¾" long (deep)
 (19.05 cm, 11.75 cm, 22.54 cm)
 Weight.....14 lbs. (6.35 kg)

Accessories

Auxiliary Mixer Housing, Type BCM-2A (less all plug-in modules).....MI-11656
 On-Air Light Relay.....MI-11702-A
 Warning Lights.....MI-11706-Series
 Type BA-71A Preamplifier (less guide assembly).....MI-11658
 Type BA-73A Program Amplifier (less guide assembly).....MI-11659-A
 Type BA-74A Monitor Amplifier (less guide assembly).....MI-11661-A
 Type BA-78A Cue/Intercom Amplifier (less guide assembly).....MI-11662
 Type BX-71 Power Supply (less guide assembly).....MI-11663-A

Ordering Information

BC-8A Studio Console, complete.....ES-11167-A



RADIO CORPORATION OF AMERICA



- Fully transistorized
- Pushbutton selection of high level sources
- Self-contained relay switching permits remote operation
- Plug-in modules interchangeable with other consolettes
- Built-in intercom



Audio Consolette, Type BC-9A

Description

The BC-9A is a monaural consolette which has just been added to the RCA family of transistorized audio mixing equipments. This compact consolette packs a lot of versatility and convenience. Multiple pushbuttons permit easy selection of high level sources (such as tape recorders, cartridge tape, turntable, etc.) to each of two mixer controls. The BC-9A may be operated remotely, since the sources are switched by self-contained relays. Two additional mixers are provided for use with microphones.

The modular plug-in amplifiers and power supply used in the BC-9A are identical with those incorporated in several other RCA audio consolettes (BC-19A, BC-7A, BC-8A). The advantages of this interchangeability are obvious.

Communications between control room and studio or remote locations is facilitated by the intercom facilities built into the BC-9A.

Specifications

Mixers	4 mono
Inputs:	
Low Level (Microphone).....	6
High Level.....	14 (7 to each of 2 mixers)
Outputs:	
Program	1
Audition	1
Monitor Speaker Relays.....	2
Source Impedances:	
Microphones	3.75/150/600 ohms
Turntables/Tape	600 ohms
Input Levels:	
Microphone.....	-22 dbm maximum
Turntables/Tape/Remote	-10 dbm
Maximum Gain.....	105 db
Frequency Response.....	±1.5 db 30-15,000 cps
Distortion:	
Program Channel.....	Less than .5% 50-15,000 cps Less than .75% 30 cps
Monitor Amplifier.....	Less than 1% 50-15,000 cps
Signal-to-Noise Ratio.....	68 db
Dimensions.....	19½" wide, 12½" high, 24" deep

Ordering Information

Type BC-9A Monaural Consolette.....	ES-11153-A
consisting of:	
2 Type BA-71B Preamplifiers	MI-11658-A
1 Type BA-73A Program Amplifier.....	MI-11659-A
1 Type BA-74A Monitor Amplifier.....	MI-11661-B
1 Type BX-71A Power Supply.....	MI-11663-A
1 Type BA-78A Cue Amplifier.....	MI-11662-A
1 High Level Isolation Unit.....	MI-11665
1 Console Housing	MI-11670-A

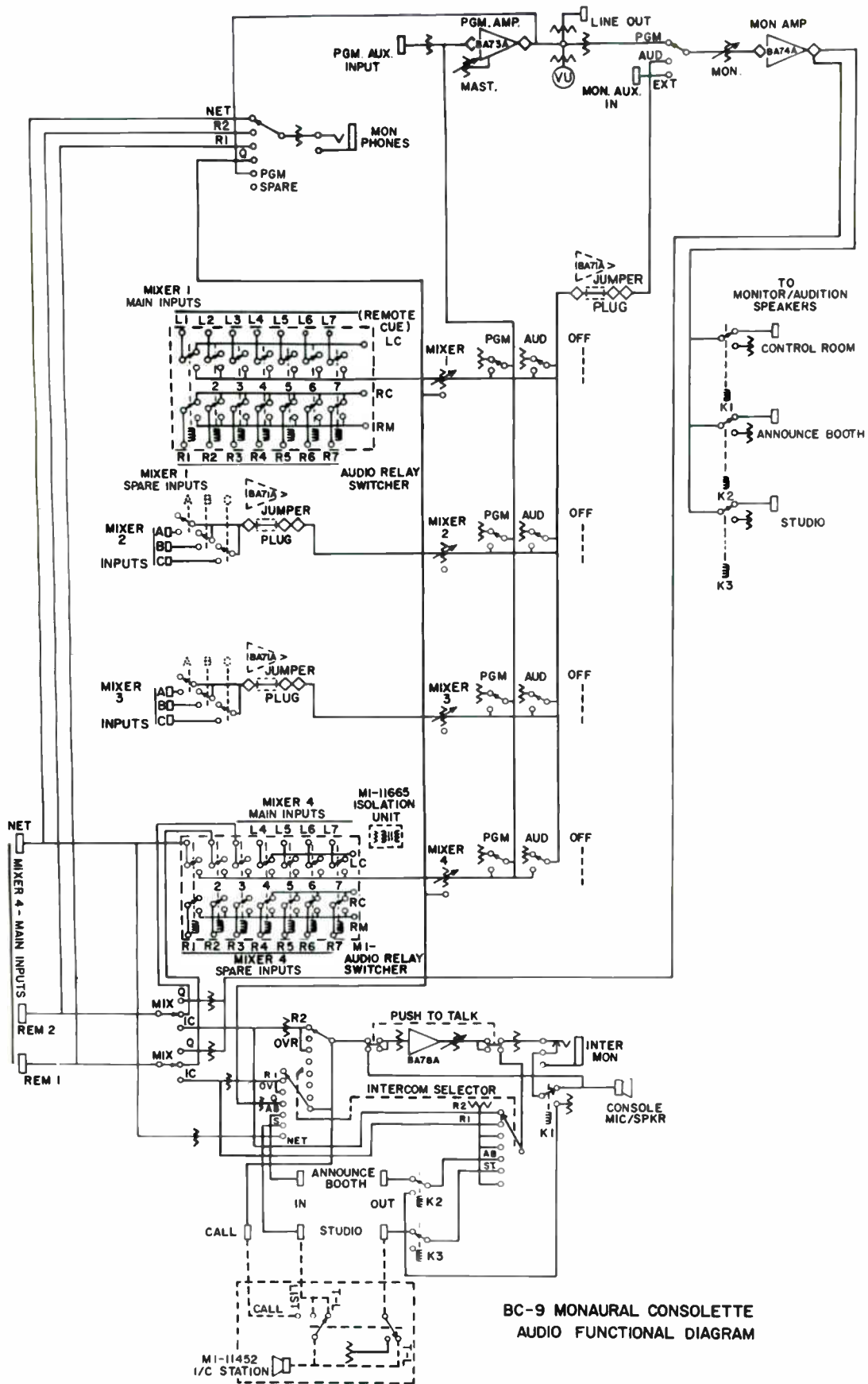

BC-9 MONAURAL CONSOLETT
AUDIO FUNCTIONAL DIAGRAM



RADIO CORPORATION OF AMERICA

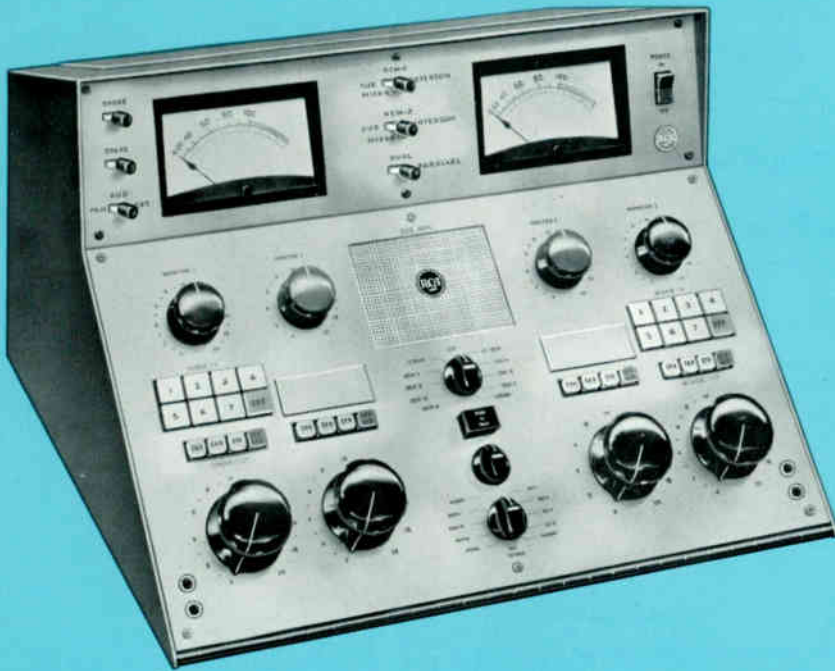

- Fully transistorized
- Pushbutton selection of high level sources
- Self-contained relay switching permits remote operation
- Plug-in modules interchangeable with other consolettes
- Built-in intercom



Stereo Consolette, Type BC-19A

Description

The BC-19A stereo consolette is a new addition to the growing RCA line of transistorized audio mixing equipments. It is a compact package which offers ample versatility and performance features.

Multiple pushbuttons permit easy selection of high level sources (such as tape recorders, cartridge tape, turntable, etc.) to each of two stereo mixer controls. Self-contained relays switch the sources, permitting remote operation of the BC-19A. Two additional stereo mixers are provided for use with microphones.

Interchangeability is another feature of the BC-19A. The modular plug-in amplifiers and power supply used in this unit are identical with those incorporated in several other RCA audio consolettes, including the BC-7A, BC-8A, BC-9A. Intercom facilities built into the BC-19A facilitate communications between control room and studio or remote locations.

For applications where stereo operation is not required, this versatile consolette can be used to provide two program channels and a separate intercom channel.

Mixers	4 stereo
Inputs:	
Low Level (Microphone).....	2 stereo
High Level.....	14 stereo (7 to each of 2 mixers)
Outputs:	
Program.....	2 mono, 1 stereo
Monitor Speaker Relays.....	2
Source Impedances:	
Microphones	3.75/150/600 ohms
Turntables/Tape	600 ohms
Input Levels:	
Microphone.....	-22 dbm maximum
Turntables/Tape/Remote	-10 dbm
Maximum Gain.....	105 db
Frequency Response.....	±1.5 db 30-15,000 cps
Distortion:	
Program Channel.....	Less than .5% 50-15,000 cps Less than .75% 30 cps
Monitor Amplifier.....	Less than 1% 50-15,000 cps
Signal-to-Noise Ratio.....	68 db
Dimensions.....	19½" wide, 12½" high, 24" deep

Ordering Information

Type BC-19A Stereo Consolette.....	ES-11154-A
consisting of:	
3 Type BA-71B Preamplifiers	MI-11658-A
2 Type BA-73A Program Amplifiers	MI-11659-A
2 Type BA-74B Monitor Amplifiers	MI-11661-B
1 Type BX-71-A Power Supply.....	MI-11663-A
1 Type BA-78A Cue Amplifier.....	MI-11662-A
1 High Level Isolation Unit.....	MI-11665
1 Console Housing	MI-11671-A

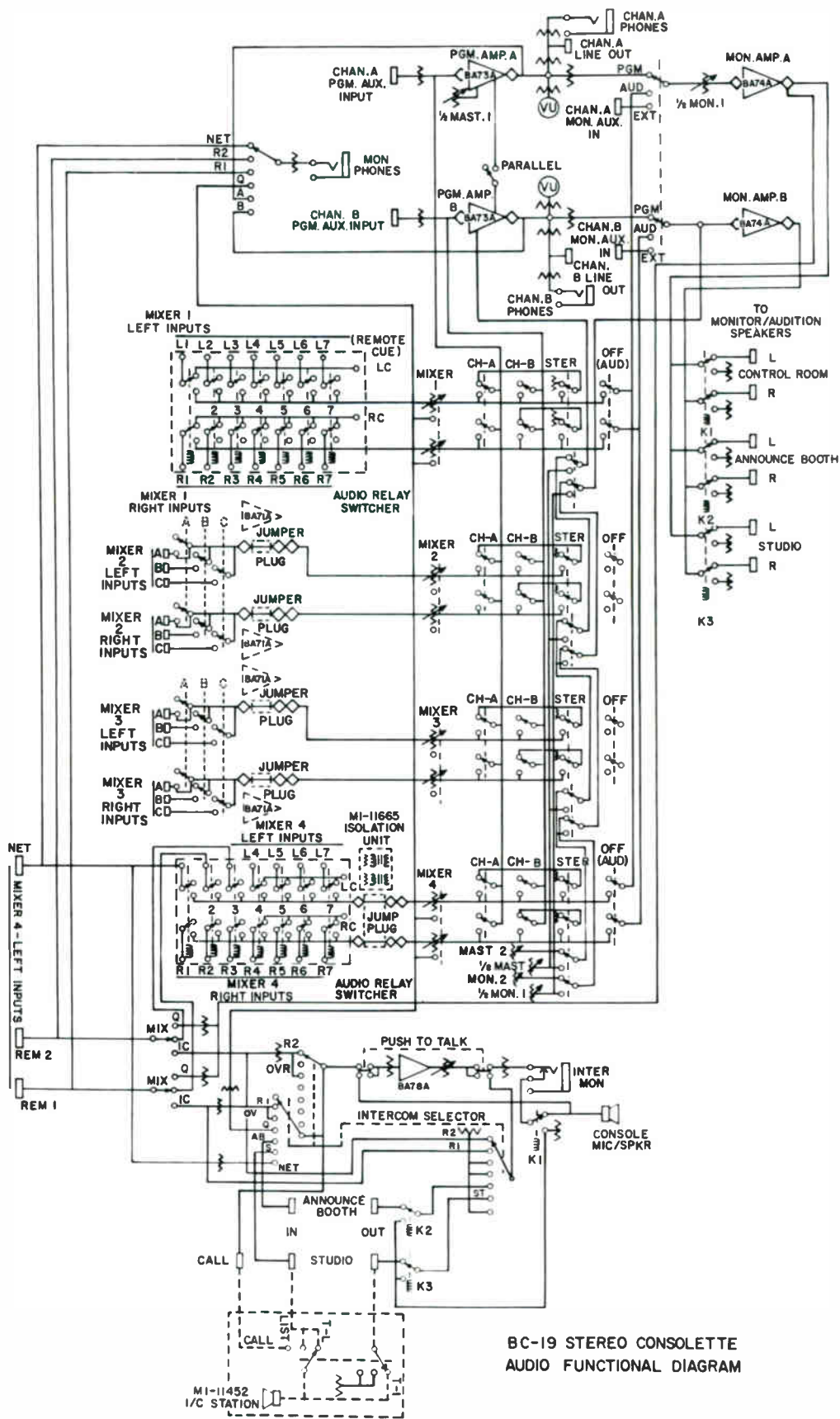

BC-19 STEREO CONSOLE
AUDIO FUNCTIONAL DIAGRAM



RCA RADIO CORPORATION OF AMERICA

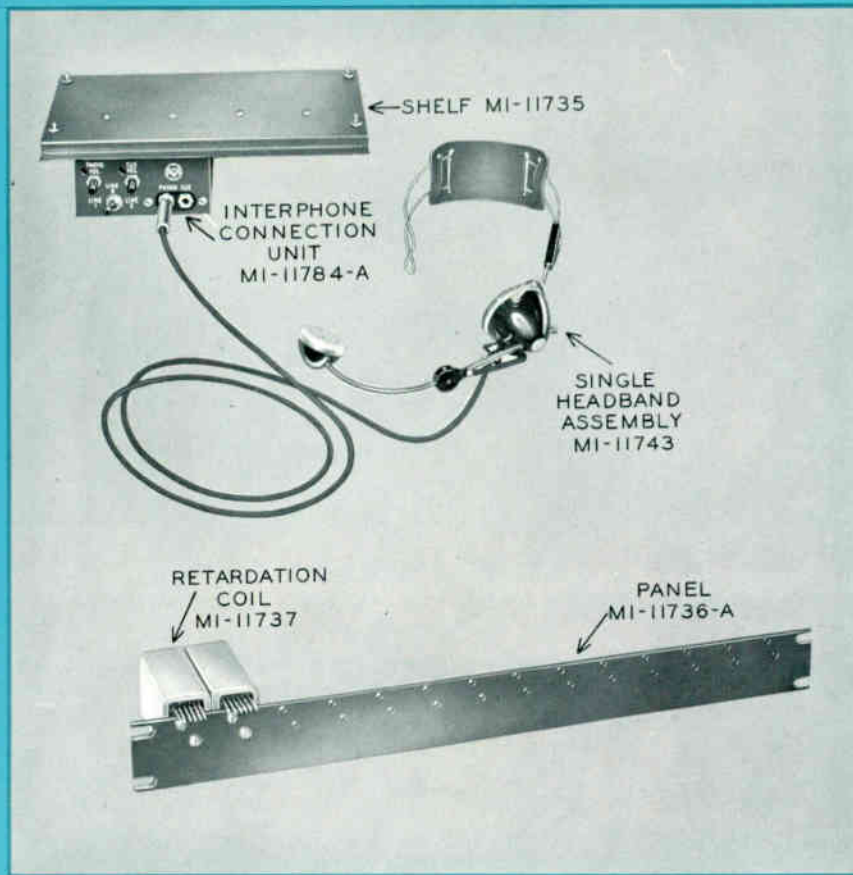

- Production intercom with studio personnel or remote line as desired
- Can mount to console, desk, or wall
- Compatible with RCA TV equipment
- Transistor amplifier or induction coil type interconnection units available
- Regulated power supply



Interphone Equipment

Description

RCA Interphone Equipment is designed to provide convenient line switching and headset connection facilities for a TV camera and studio communication system.

Heart of the RCA Interphone System is the Interphone Connection Unit. Two types of connection units are available. The MI-11784-A Transistor Interconnection Unit must be used with RCA TK-60 and other late model Cameras having transistorized intercommunication systems built into the camera. The MI-11734 Intercom Interconnection unit is designed for use with early RCA studio and field type cameras. The two interconnection units can not be intermixed in a system.

The MI-11784-A unit includes a single stage transistor amplifier, with

bridge rectifier and sidetone compensation network with level control to adjust volume. Each person on the talking bus can adjust the volume to suit his individual requirement. On the front is a three-way switch for selection of three intercom lines, and the separate volume controls for "phone" and "cue" adjustment. The box also contains two jacks to accommodate single or double headsets. A 9-pin and a 12-pin cable connector plug on the rear are used for external connection. The entire unit is housed in a box $4\frac{5}{8}$ inches wide, $2\frac{1}{2}$ inches high and $6\frac{3}{4}$ inches deep overall.

Operating power for the MI-11784-A interphone unit is derived from the common-battery interphone circuit to which the interphone unit

is connected. A bridge-rectifier is interposed in the line to the amplifier to maintain correct polarity at the amplifier regardless of the polarity of the interphone battery voltage. The sidetone compensation bridge is designed to hold the sidetone level to within 2 db of the received level for any number of connected stations up to 32.

The Transistor Interphone Connection Unit, MI-11784-A can replace the MI-11734 unit where it is designed to modernize the system since the unit physically replaces the MI-11734 Connection Unit and will operate with virtually all commercially available TV headsets using carbon microphones. The substitution can be made only if the camera is modified by substituting an MI-



Double Headband Assembly, MI-11744



Transistor Interphone Unit, MI-11784-A

11757 Transistor Amplifier for the induction coil in the interphone circuit. Other circuit changes as outlined in the instruction book are also required.

The Interphone Connection Unit, MI-11734, consists of a simple circuit having an induction coil and capacitor to provide an anti-sidetone feature. The circuit is housed in a compact box having two phone jacks for use either with a single or double headset as required, and a two-position toggle switch for selecting a local circuit or a remote line. A cable plug is mounted in the rear. It is designed to work in early intercom systems employing induction coils throughout.

All other components of the Interphone System are designed for operation with either Interconnection Unit.

The Retardation Coil, MI-11737, permits simultaneous use of four carbon microphones such as one interphone connection unit and three camera headsets on a common battery or power supply. The coil permits a d-c power voltage to be imposed upon the two-wire telephone talking line. The MI-11737 is an audio frequency choke which isolates the power supply from the telephone line at voice frequencies.

The MI-11736-A Mounting Panel is recommended for mounting retardation coils. The panels have

standard mounting dimensions for use in the RCA BR-84 Series Racks.

The accessory, MI-11735 Shelf, is available for mounting the interphone connection units under the countertops of console housings on which switching units or camera controls are housed. The plate will accommodate one or two Interphone Connection Units.

Either a single or double headset identified as Single Headband Assembly, MI-11743 and Double Headband Assembly, MI-11744 can be used with RCA Interphone Equipment. One earphone unit of the double headband assembly is used for "cue" reception. Either type can be used in the same system.

Front and rear view of Induction Coil Interphone Unit, MI-11734

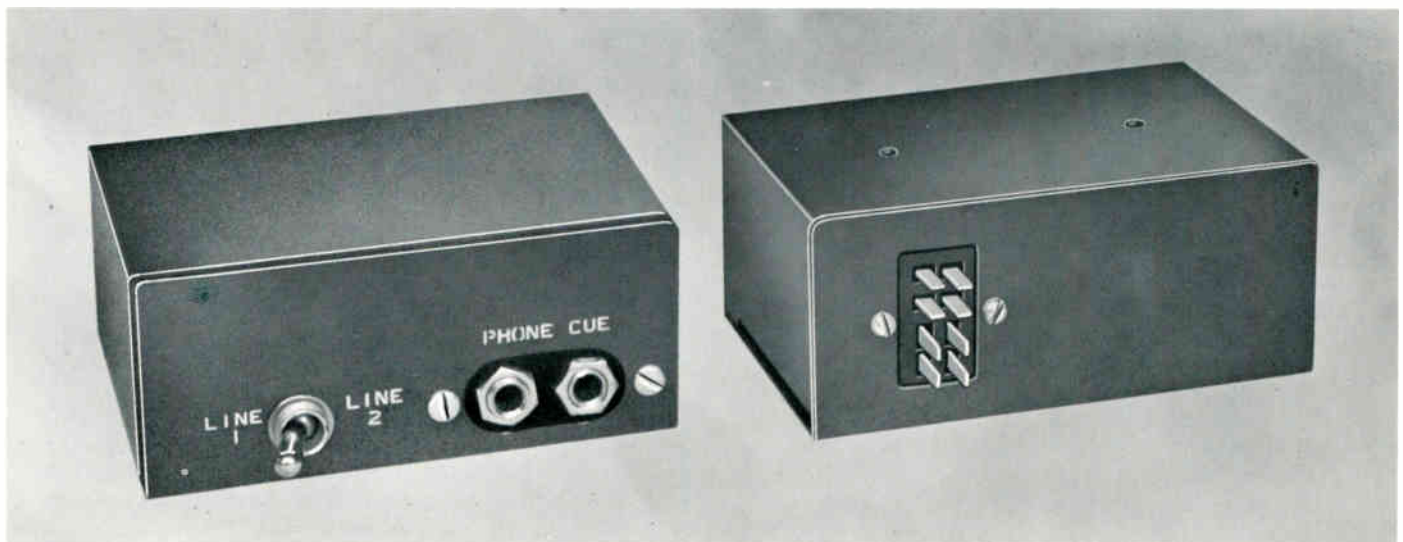

SCHEMATIC DIAGRAM FOR TRANSISTOR INTERPHONE SYSTEM

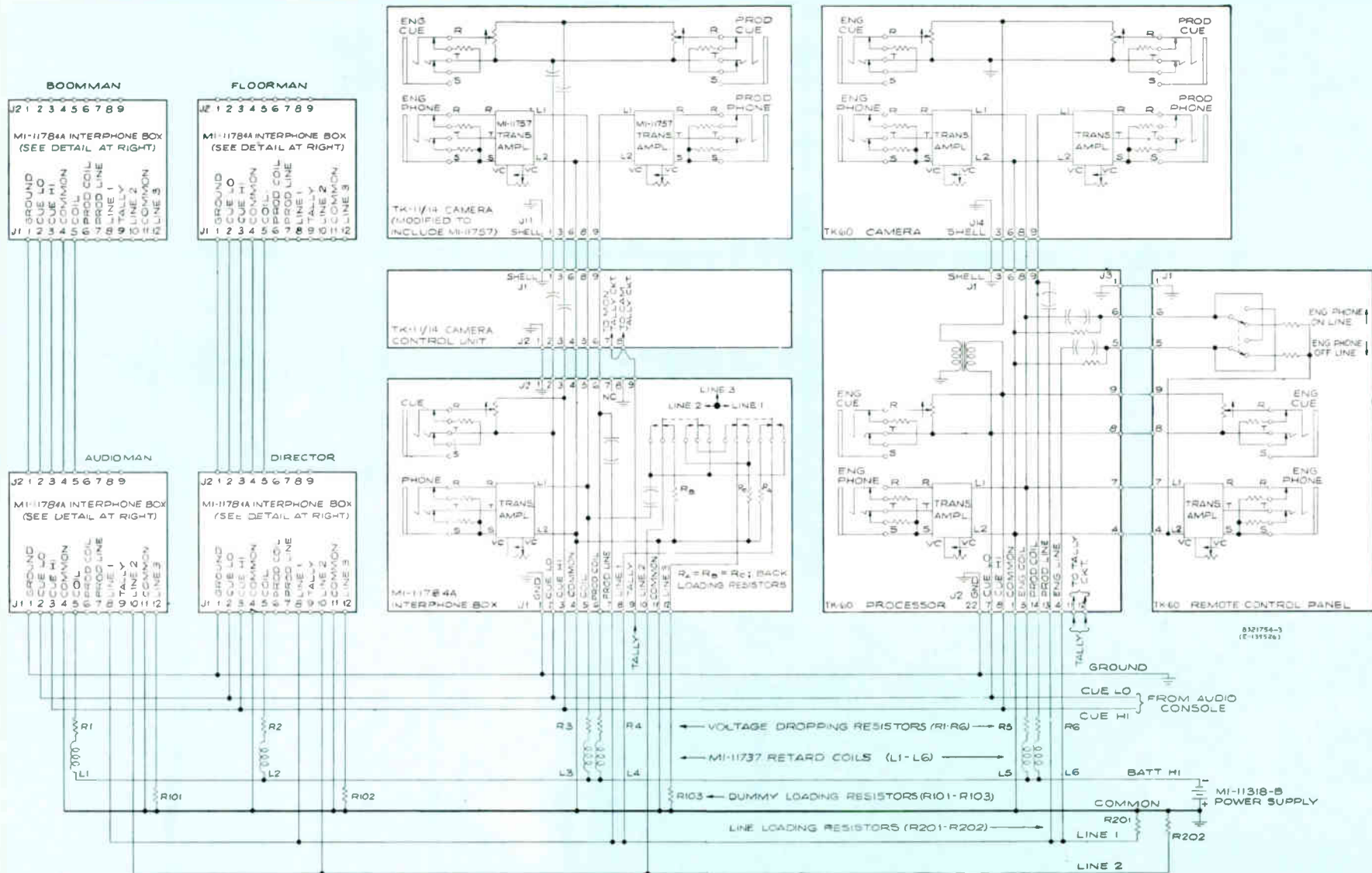

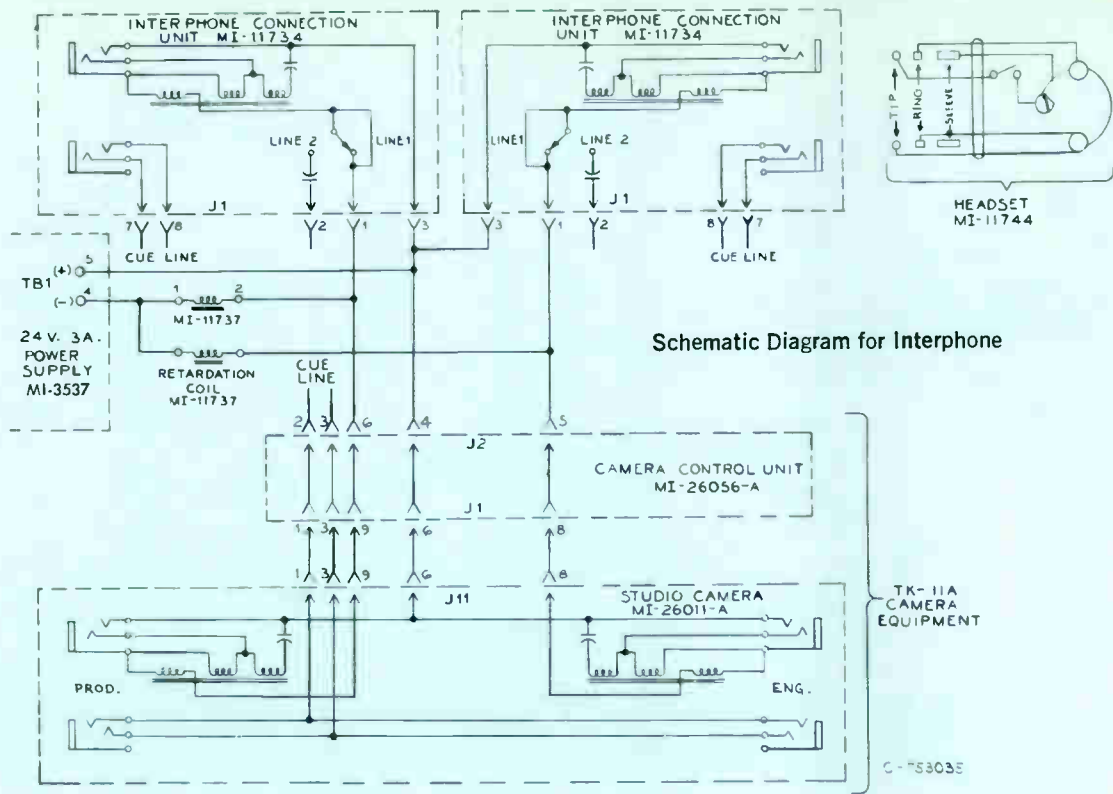

Specifications

Single or Double Headset

DC Resistance:	
Microphone Switch On.....	70 ohms approx.
Microphone Switch Off.....	Infinite
Inductance at 1000 Cycles:	
Microphone Switch On.....	70 millihenries approx.
Microphone Switch Off.....	245 millihenries
Weight:	
Single Headband Assembly.....	6 ozs. (less cord)
Double Headband Assembly.....	9 ozs. (less cord)

Transistor Interphone Connection Unit, MI-11784-A

Impedance.....	120 ohms
DC Voltage.....	8.5 volts (nominal)
DC Current.....	95 ma. (approx.)
Dimensions Overall.....	4 5/8" wide, 2 1/2" high, 6 3/4" deep
Weight.....	3 lbs.

Interphone Connection Unit, MI-11734

Dimensions Overall.....	4 5/8" wide, 2 3/8" high, 4 1/4" deep
Weight.....	1 lb., 11 ozs.

Retardation Coil, MI-11737

DC Resistance.....	165 ohms
Inductance.....	3.4 millihenries

Maximum Recommended Load Current.....	125 ma d-c
Dimensions Overall.....	1 1/8" wide, 1-45/64" high, 4 5/8" deep
Weight.....	16 ozs.

Power Supply, MI-3537

Input.....	115/230 volts \pm 10%, 50/60 cps
Output.....	Regulated 24 volts, 4 amps. d-c
Dimensions Overall.....	8 3/8" wide, 4 5/8" high, 11 1/8" deep
Weight.....	25 lbs.

Power Supply

Input:	
MI-11318.....	100-130 volts, a-c, 60 cps, single phase, 144 watts
MI-591318.....	200-260 volts, a-c, 50 cps, single phase, 144 watts
Output.....	Regulated 24 volts, 6 amps. d-c
Dimensions Overall.....	19" wide, 5 1/4" high, 9 3/4" deep
Weight.....	25 lbs.

Mounting Shelf

Capacity.....	Mounts one or two Interphone Connection Units
Dimensions.....	11" long, 6 3/8" wide
Weight.....	2 lbs. (approx.)

Retardation Coil Panel

Capacity.....	Mounts up to 14 retardation coils
Dimensions.....	19" wide, 1 3/4" high
Weight.....	18 ozs.

Ordering Information

Transistor Interphone Connection.....	MI-11784-A
Interphone Connection Unit.....	MI-11734
Retardation Coil.....	MI-11737
Shelf for Mounting MI-11734.....	MI-11735
Panel (accommodating 14 Retardation Coils).....	MI-11736-A
Single Headband Assembly.....	MI-11743

Double Headband Assembly.....	MI-11744
Regulated Power Supply (24 volts, d-c, 4 amps) 110 volts, a-c.....	MI-3537
Regulated Power Supply (24 volts, d-c, 6 amps) 110 volts, a-c.....	MI-11318
Regulated Power Supply (24 volts, d-c, 6 amps) 220 volts, a-c.....	MI-591318
Transistor Amplifier (Replacement for Induction Coil).....	MI-11757



RADIO CORPORATION OF AMERICA



- High impedance, ceramic type
- Lightweight for better comfort
- Comfortable ear cushions shield out noise
- Impact resistant
- Uses strong, flexible cadmium bronze cable

 Headset, Type EDC-12

Description

Rugged, Comfortable Ceramic Headset

The EDC-12 is a lightweight high impedance headset with an extended frequency range. It uses sensitive ceramic elements which are resistant to impact, vibration, heat and humidity. The earphones are made of Implex and equipped with removable vinyl covered plastic foam ear cushions. Light in weight and shaped to fit snugly the EDC-12 Headset can be worn comfortably for extended periods of time. Ear-phones and cushions effectively seal out noise and actually improve frequency response. A four foot cable terminating in a telephone plug is provided. The cable is made of cadmium bronze, an exceptionally strong and flexible material, and is covered in vinyl.

Specifications

Type	Ceramic
Impedance.....	8000 ohm @ 1000 cps
Frequency Response.....	20-11,000 cps \pm 5 db
Input Voltage for 0.5% distortion at 1 kc.....	14 volts
Sound Level for 0.5% distortion at 1 kc.....	113 db
Sound Level at maximum operating level (7 volts).....	109 db
Cord.....	Vinyl covered cadmium bronze cable, 4 ft. or 6 ft. long
Cord Termination.....	.206" diameter telephone plug
Weight	11 oz. (312 gr.)

Ordering Information

Type EDC-12 Ceramic Headset,
including cord and plug.....MI-38029-2

8PB



RADIO CORPORATION OF AMERICA





- Frequency response peaked for high intelligibility
- Input selector switch for ten inputs
- Speaker muting provisions
- Panel available for rack mounting



Transistor Cue Amplifier, Type BA-8B

Description

The RCA Type BA-8B Transistor Cue Amplifier is a compact, low-cost monitoring amplifier designed to provide high intelligibility whether used as a remote line, turntable cue or remote amplifier monitor. It provides an ideal monitor in the announce lounge, program director's office, news rooms, executive office, TV studio prop area, etc. Muting provisions are included in the amplifier so that when the unit is used in the control room or any location where a microphone will also be used, the muting terminals on the rear terminal board may be connected to a set of normally closed contacts on an external muting relay. The completely encased amplifier and loudspeaker may be placed on the consolette or desk near the operator.

Although the BA-8B is attractively styled for table-top installation, an aluminum epoxy mounting panel, MI-11449-A, is also available for rack mounting. The front panel of the BA-8B contains the volume and input selector switch controls plus a neon on-off indicator. A perforated metal grill serves as a protector for the 3 by 5-inch speaker.

Up to ten inputs may be selected by the self-contained input selector switch. Connections to the amplifier are made at a

rear terminal board where a plastic cable clamp is also provided for holding cables neatly in place. The number one input is wired for bridging a 600 ohm line, the other nine are matching inputs, but may be made bridging inputs by customer installation of the proper resistor network within the unit.

Specifications

Power Requirements.....	117/235 volt a-c, 50/60 cycles, single phase, 13 watts
Frequency Response.....	Compensated for high intelligibility
Number of Inputs.....	9 matching, 1 bridging
Input Impedance:	
Matching.....	600 ohms when shipped; may be connected for 150 ohms
Bridging	10,000 ohms
Input Level:	
Matching.....	-23 dbm \pm 2 dbm, minimum for +30 dbm (1 watt) output
Bridging.....	+8 dbm \pm 2 dbm, minimum for +30 dbm (1 watt) output
Gain.....	53 dbm (approx.)
Maximum Output Level.....	+30 dbm (1 watt)
Distortion.....	Less than 2% (measured with 1 watt output at 1 kc)
Muting Provision.....	Strapping on rear terminals marked MUTE
Loudspeaker Impedance.....	3.2 ohms
Loudspeaker Dimensions.....	3 by 5 inches elliptical, permanent magnet
Transistor and Diode Complement:	
	1—2N109, 1—2N404, 1—2N652, 1—2N456, 1—1N2069
Dimensions (Overall).....	7 $\frac{1}{4}$ " wide, 3 $\frac{1}{2}$ " high, 8 $\frac{1}{8}$ " deep (18.42 cm, 8.89 cm, 20.48 cm)
Weight.....	6 $\frac{1}{2}$ lbs. (2.95 kg)
Finish.....	Midnight blue, etched aluminum panel

7PB

Ordering Information

BA-8B Transistor Cue Amplifier (includes transistors)	MI-11450-A
Accessory Rack Mounting Panel (for BA-8B).....	MI-11449-A



RADIO CORPORATION OF AMERICA





- Three AGC modes available
- Small, compact, plug-in construction
- Self-contained power supply
- Metering switch provides quick tube check



AGC Program Amplifier, Type BA-28A

Description

The BA-28A Automatic-Gain-Controlled Program Amplifier is designed to automatically control variations in audio program level. The unit is capable of maintaining a nearly constant average output level over wide variations in input level. It provides expansion for input signal levels between the threshold of expansion and the threshold of compression. The advantage of this arrangement is a reduction in background noise level during low level passages.

The amplifier may be used with an external bias source for remote gain control or automatic fading, permitting unattended remote opera-

tion. It is also used for a program line compressor or master gain control for program line. Other uses include a microwave input audio control, and automatic fader control. It serves as a straight program amplifier, without level control, by removing one tube to disable the automatic level control circuit.

By simple strap connection, the user may select one of three AGC operating modes; straight compression, expansion/compression or fixed range compression. This feature of the BA-28A is especially important in providing proper gain control requirements in various program circuit applications.

The new BA-28A is a small compact amplifier mounted on a plug-in chassis for easy maintenance and replacement. Two amplifiers can be mounted on a BR-22 Shelf. A metering switch measures the cathode current of the amplifier tubes to obtain a quick indication of the tube conditions. Other controls, all located on the front panel include: a hum control for adjusting the hum level to a minimum, a power switch, an input level adjustment control, and controls for expansion range, expansion and compression threshold. An external attenuator may be used for adjusting the output level where necessary.

Transfer characteristics of BA-28A Program Amplifier.

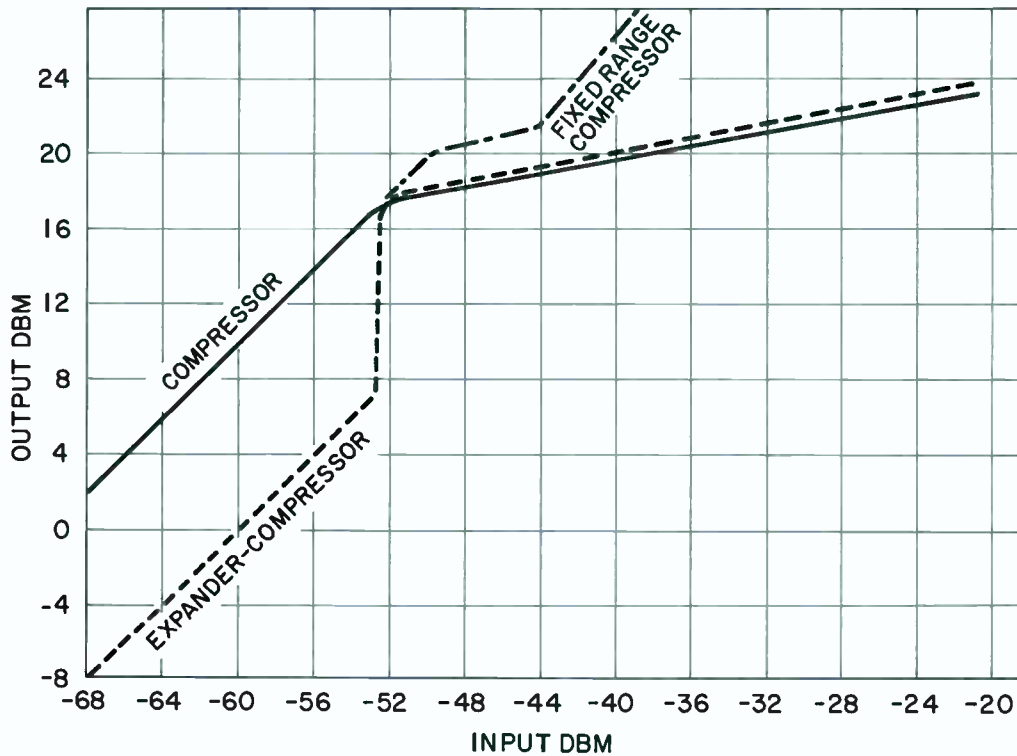

Specifications

Input Impedance.....	150/600 ohms
Source Impedance.....	150/600 ohms
Output Impedance.....	.30/120 ohms
Load Impedance.....	150/600 ohms
Maximum Input Level.....	-25 dbm
Maximum Output Level.....	+30 dbm
Maximum Noise Level, Output.....	Less than -46 dbm at 70 db gain
Frequency Response.....	±1 db from 30-15,000 cps
Harmonic Distortion.....	Less than 1% total RMS at 20 dbm output 30 to 15,000 cps

Gain, Maximum Below Verge of Compression.....	70 db ±1 db
Compression Ratio.....	5 to 1
Threshold of Expansion.....	8 dbm (adjustable)
Threshold of Compression.....	18 dbm (adjustable)
Attack Time Constant.....	12.5 milliseconds
Recovery Time Constant.....	1 sec.
Tube Complement:	
	1—OB2, 2—12AU7, 1—12AX7, 1—7025, 1—6386
Power Requirements.....	117/234 volts, 50/60 cycles, 40 watts
Dimensions, Overall.....	12½" long, 8¾" wide, 4-21/32" high (31.75 cm, 21.27 cm, 11.9 cm)
Finish.....	Aluminum epoxy
Weight.....	15 lbs. (6.804 kg.)

Ordering Information

BA-28A AGC Program Amplifier (less tubes).....	MI-11448
BA-28A AGC Program Amplifier (with tubes).....	ES-11125-A

ACCESSORIES

Tube Kit (Complete tube complement).....	MI-11487-A
Type BR-22 Mounting Shelf (mounts 2 BA-28A's).....	MI-11597-B
Type BI-1B Meter Panel.....	MI-11388



RADIO CORPORATION OF AMERICA



Features

- Completely Transistorized
- High Level Mixing
- Full 8 vu Output to Line
- Self-Contained AC and Battery Power Supplies



Four-Channel Remote Amplifier, Type BN-16B

Description

The Type BN-16B Portable Remote Amplifier is a four-channel transistor amplifier especially designed for remote broadcast use. Its small size and low power dissipation makes it equally useful in other applications requiring additional or auxiliary mixing facilities. AC or battery operation is available at the flip of a switch. Ten, single type silicon transistors employed in the amplifier contribute materially to its dependability and excellent performance characteristics. Four separate balanced input channels are provided as well as cueing, monitoring and mixer bus paralleling facilities.

Self-Contained AC and Battery Power Supplies

The BN-16B is completely self-contained for 115 or 230-volt, 50 or 60-cycle power line or battery operation. Other features include microphone input transformers for all channels, earphone monitoring and line cueing facilities and a PA gain control. Up to eight microphones may be mixed by paralleling the

mixer buses of two BN-16B amplifiers by means of receptacles made available for this purpose. This arrangement also provides a dual line feed and dual PA feed.

Simplified Controls— Full 8 VU Output to Line

All controls are located on the front panel including an illuminated VU meter, power switch, PA gain control, cue switch, four mixer controls, the master control, and monitoring phone jack. The VU meter is used to monitor the output level and to test the battery voltage. Five long-life mercury batteries may be used as a battery power supply for the BN-16B. A separate type D, dry cell battery will provide illumination for the VU meter. The generous power output capability of the amplifier allows a full +8 VU delivered to the line after the 6 db line isolation pad.

Functional Styling

The amplifier is a functionally styled unit in which an etched wir-

ing board including amplifier components and transistors, controls, batteries and alternate a-c power supply are all contained in a portable carrying case. The steel case, finished in midnite blue, is provided with a soft leather handle. An 8-foot power cord is clipped inside the cover of the carrying case. The cover is easily removed from the hinges and may be used as a tilt-rest for the amplifier. A recess in the bottom of the case protects the a-c power connector, fuse holder, microphone connectors, mixer bus receptacle and line binding posts. A weather-proof canvas carrying case, MI-11377-A is available as an accessory.

High Level Mixing

High level mixing on all four channels is afforded by the BN-16B Amplifier as shown in the block diagram. Each channel follows a similar path through its corresponding transformer, transistor and attenuator to the gain stage except that Microphone 1 input is fed through the CUE-Mic 1 switch. When this

switch is operated in the CUE position the telephone line from the output of the amplifier is connected to the microphone 1 input. Cue signals from the studio are then amplified through the BN-16B to the headphones. A pad in the cue circuit reduces the cue signal to proper preamplifier input level.

PA Gain Control

The PA gain control bridges the output of the amplifier and allows the operator to conveniently control the level fed to external PA equipment. Five convenient binding posts are mounted on the rear panel of the amplifier. Two are used for feeding the PA equipment, two for line output, and one for ground.

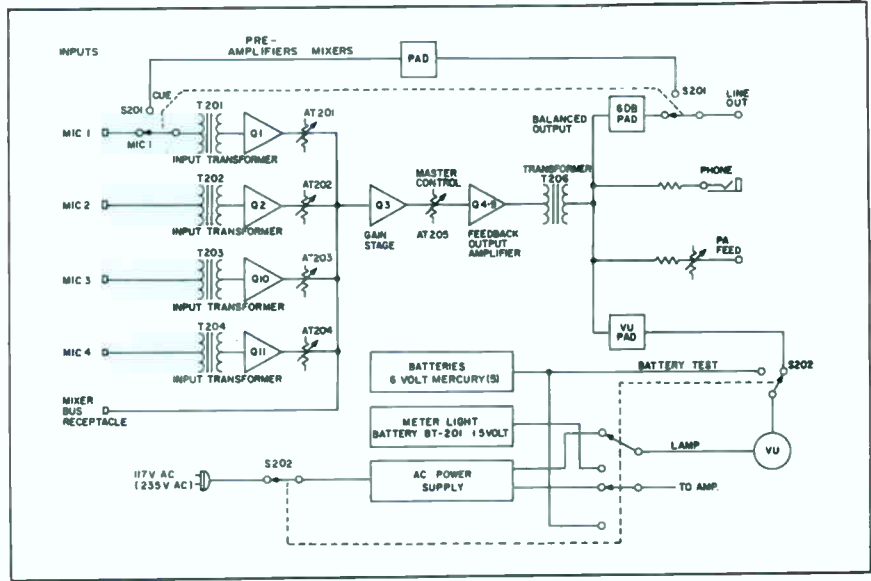

Specifications

Power Required:

AC Power.....117 volts/235 volts, 50-60 cps, 5 watts
 DC Power.....5—Mallory TR-135R, 6.5 volt (not supplied)
 1—RCA VS 306, 1.5 Volt, D Size (not supplied)

Inputs:

4 Microphone Inputs 37.5/150-250 ohms, balanced transformer (as shipped, strapped for 150-250 ohms)
 1 Mixer Bus receptacle (permits paralleling mixer buses of two BN-16B Amplifiers)

Output Level.....+18 dbm at 600/150 ohms, balanced (6 db isolation provided) (as shipped, strapped for 600 ohms)

PA Feed Output.....-7 dbm maximum, 600 ohms balanced, with adjustable attenuator

Gain.....90 db \pm 2 db

Frequency Response..... \pm 1 db from 30 to 15,000 cps

Harmonic Distortion.....Less than 1% with +18 dbm output master at step 14 and mixer control set for 68 db gain

Noise Level.....-120 dbm referred to input; equivalent to 70 db S/N with -50 db input and +18 dbm output 30 to 15,000 cps

Input Connections.....Type XLR (space available to mount P type or UA type connectors in place of the XLR type)

Transistor and Diode Complement:
 10—2N2270, 1—2N398A, 2—1N3253

Dimensions Overall.....16½" wide, 5½" high, 10½" deep (42 cm wide, 14.3 cm high, 26.7 cm deep)

Weight.....20.5 lbs. (9.2 kg), less batteries

Ordering Information

BN-16B Four-Channel Portable Remote Amplifier, complete with transistors and diodes (less batteries), MI-11221-D

LIST OF ACCESSORIES

Step Type Attenuator for Master Control.....	MI-11751-3
Step Type Attenuator for Mixer Controls.....	MI-11751-4
Weather-proof Canvas Carrying Case.....	MI-11377-A
XLR-4-12C Cable Connector (for combining two units, 2 required).....	Stock Number 219546
XLR-3-12C Input Cable Connector.....	MI-11089-A
2N2270 Transistor	Stock Number 226685
2N398A Transistor	Stock Number 258995
1N3253 Diode	Stock Number 225592



RADIO CORPORATION OF AMERICA

PRINTED IN U.S.A.



- Simplified design—low cost maintenance
- Constant DC voltage with variable loads
- Silicon diode rectifiers
- Low ripple voltage
- Self-regulating power transformer



Regulated Power Supply

Description

The MI-11318-C Heavy Duty Regulated Power Supply provides up to 6 amperes d-c at 24 volts to inductive, capacitive or resistive loads. This power supply therefore is widely used in audio and video relay switching systems, tally light circuits, and other equipments requiring a constant d-c source with varying current loads. High reliability and low cost maintenance makes the RCA MI-11318-C Power Supply an excellent choice. Also available, with identical specifications for 220 volt 50 cycle operation, is Regulated Power Supply, MI-591318.

Specifications

Input:	
60 Cycle Unit.....	100-130 volts a-c, 60 cps, single phase, 144 watts
50 Cycle Unit.....	200-260 volts a-c, 50 cps, single phase, 144 watts
Output.....	6 amperes, 24 volts d-c
Regulation.....	7.5% no load to full load, 2.5% 1/2 load to full load
Ripple Voltage.....	0.2 volt RMS maximum
Ambient Temperature.....	65°C max.
Finish.....	Aluminum epoxy
Dimensions Overall.....	19" wide, 5 1/4" high, 9 3/4" deep (48.26 cm, 13.34 cm, 24.76 cm)
Weight.....	Approx. 25 lbs. (11.3 kg)

Ordering Information

110 volt, 60 cycle Regulated Power Supply.....	MI-11318-C
220 volt, 50 cycle Regulated Power Supply.....	MI-591318

10PB



RADIO CORPORATION OF AMERICA



- High efficiency—low power consumption
- Two microphone, one auxiliary input
- Provision for low impedance inputs
- Volume controls for each input



20 Watt Sound Amplifier, Type SA-202

Description

The RCA MI-38182, 20-watt power amplifier provides outstanding performance at moderate cost. It is suitable for all but the most critical public address applications, and was designed with these purposes in mind. It is rugged both electrically and mechanically, providing long maintenance free operation.

This 20 watt amplifier contains separate controls for two microphone inputs, one auxiliary input, a bass and treble control, as well as a master gain control. The master gain control allows the operator to raise or lower the volume of the system at the same time. All input and output connections are located on the rear apron of the chassis, placing the system wiring out of the operator's way. Knock-outs are provided on the microphone input connectors supplied, so that the user may install a cannon plug. It is also possible to mount the MI-12377 (250 to 50,000 ohms) input transformer on the chassis, if low impedance microphones are desired. Ample choice of output impedances is available: 4, 8, 16 ohms, and 25 volt and 70 volt taps are provided.

Specifications

Power Required.....117 volts, 60 cps, 90 watts
 Power Output... 20 watts at less than 2% distortion at 400 cps;
 20 watts at less than 5% distortion 100-10,000 cps
 Gain at 1000 cps.....Microphone, 118 db; Auxiliary 82 db
 Frequency Response..... ± 3 db, 20-20,000 cps
 Inputs:
 Microphone (2).....500K ohms impedance
 Voltage Received for Full Output.....1.8 millivolts
 Auxiliary (1).....200K ohms impedance
 Voltage Received for Full Output.....1.3 volts
 Output Impedances.....4, 8, 16 ohms; 25-volt and 70-volt line
 Output Regulation, No Load to Full Load......5 db
 Number of Stages.....Five
 Controls.....Six: (2) mic, (1) aux., bass, treble, master gain
 Tube Complement:
 2—12AX7-A, 1—6AV6, 2—7868, 2—1N3195 Rect.
 Connections.....(2) Amphenol mic connector; (1) phono
 pin connector; output is screw type terminal board
 Dimensions.....With Cord: 14 $\frac{1}{4}$ " long, 5 $\frac{3}{4}$ " wide, 5 $\frac{3}{4}$ " high
 Weight12 $\frac{1}{2}$ lbs.

ORDERING INFORMATION

Type SA-202, 20 Watt Sound Amplifier.....MI-38182

ACCESSORIES

Chassis Mounted Microphone Input Transformer.....MI-12377
 High Impedance Lavalier Microphone.....MI-38020
 Carrying Case with two 8-inch Loudspeakers.....MI-38938

7PB



RADIO CORPORATION OF AMERICA

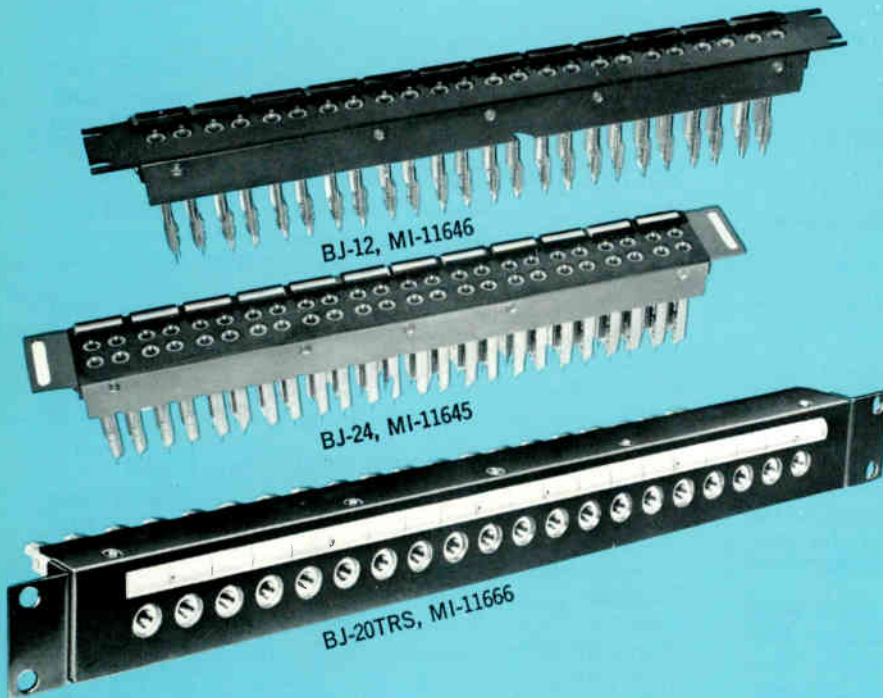

- Offset ground lugs—easy to wire
- Spacing of jack pairs prevents cross-circuit patching
- Bakelite strip reinforced to prevent warping or breakage



Jack Panels, Mats and Cords

Description

Jack Panels, with their associated patch cords, are used with broadcast speech input systems to improve the overall operating flexibility. In addition to providing a convenient termination for program and other wire telephone circuits, closed-circuit jacks may be connected to provide "patch cord" access to the input and output circuits of individual units of the audio system. When connected for this purpose, the regular circuits are continuous through the jacks until a patch cord is inserted to make an external connection. With properly connected jacks, patch cords may be freely used in emergencies or for test purposes to interchange or transfer telephone lines, amplifiers, mixers, microphones, or other equipment items.

The BJ-24 consists of two rows of twelve double jacks mounted on thick black bakelite and furnished with designation card holders. The BJ-12 is similar to the BJ-24 but has only one row of twelve double jacks.

The jack sleeves of the BJ-24 and BJ-12 are chromium plated. Tip-ring-sleeve jack panels are also available as MI-11666.

Jack Mats are available for covering 1 or 2 type BJ-24 Double Jack Strips.

RCA maintains a stock of patch cords for the convenience of broadcasting stations. The cord is shielded and uses two Type PJ-1 Plugs which are interchangeable with the W.E. Type 241-A Plug. A choice of black

or gray colored cord is available in three sizes. A two-foot black tip-ring-sleeve patch cord is also stocked.

Interconnection Cable

The majority of cables required to interconnect the various components of a broadcast audio assembly are of a special type and cannot be readily purchased from the local electrical dealer. In order to avoid unnecessary installation delays, RCA carries in stock the generally used special type cables.

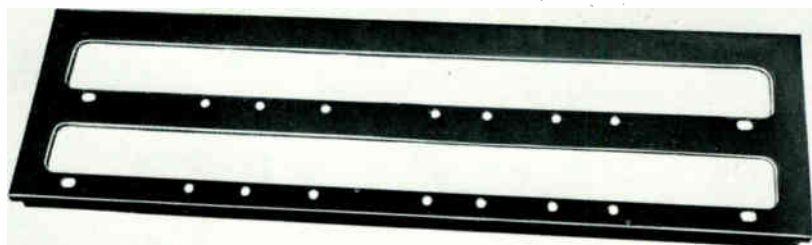

Double BJ-24 Jack Mat, MI-11647-2.

Specifications

Jack Panels	BJ-24	BJ-12	BJ-20TRS
Number of Jacks.....	24 pair	12 pair	20*
Dimensions	2 1/8" x 19"	1 3/4" x 19"	1 3/4" x 19"
Weight (unpacked)	5 1/2 lbs.	3 lbs.	3 lbs. (approx.)

Jack Mats

Dimensions (Overall):

Single BJ-24 Jack Strip Mat.....	17 7/8" x 3-5/32"
Double BJ-24 Jack Strip Mats.....	17 7/8" x 5-7/32"

Patch Cord

Overall Length..... Available in two, four, or six foot lengths

* BJ-20TRS Jacks spaced 3/4" on centers.

SOLID CONDUCTOR CABLE, MI-33

Use..... General purpose Audio Transmission Line

Type..... Shielded twisted pair, each conductor solid #20 tinned copper wire, with Vinyl resin insulation covered with lacquered rayon braid.

Shield..... Tinned copper braid

Overall Diameter..... Approximately .170"

Color Code..... Red and black

Rating..... 300 volts

STRANDED CONDUCTOR CABLE, MI-34

Use..... Recommended for audio circuits where extra flexibility is required

Type..... Shielded; twisted pair, stranded, composed of 7—.010 tinned copper conductors equivalent to #22 AWG

Insulation..... Vinyl resin insulated with lacquered rayon braid

Shield..... Tinned copper braid

Overall Diameter..... Approximately .166"

Color Code..... Red and black

Rating..... 300 volts

STRANDED CONDUCTOR CABLE, MI-35

Use..... Especially recommended for 110 volt supply and filament circuits

Type..... Shielded; twisted pair, stranded, composed of 16—.010 tinned copper conductors equivalent to #18 AWG

Insulation..... Vinyl resin insulated with lacquered rayon braid

Shield..... Tinned copper braid

Overall Diameter..... Approximately .236"

Color Code..... Red and black

Rating..... 300 volts

SOLID CONDUCTOR CABLE, MI-13342-1

Use..... General purpose Audio Transmission Line

Type..... Shielded twisted pair, tinned copper drain wire each conductor #22 tinned copper wire, cabled, with black vinyl jacket

Insulation..... Vinyl

Shield..... Tinned copper braid

Overall Diameter..... Approx. .200"

Color Code..... Red and black

Rating..... 200 volts

STRANDED CONDUCTOR CABLE, MI-13342-2

Use..... General purpose Audio Transmission Line

Type..... Shielded pair, each conductor #22 AWG (16 x 34) tinned copper wire, cabled, tinned copper drain wire, with black vinyl jacket

Insulation..... Vinyl insulated

Shield..... Tinned copper braid

Overall Diameter..... Approx. .210"

Color Code..... Red and black

Rating..... 200 volts

STRANDED CONDUCTOR CABLE, MI-13342-A

Use..... Miniature Broadcast Audio Cable

Type..... Tinned copper, polypropylene insulated #22 AWG (7 x 30) conductors, cabled. Stranded tinned copper ground drain wire, combination foil, aluminum, mylar, shield paper wrap

Insulation Thickness..... .008"

Jacket Thickness..... .020"

Outside Diameter (O.D.)..... .135"

Color Coding..... Black and red

Percent Shield Coverage..... 100%

Working Voltage..... 200 volts

CABLE LACING CORD, MI-11719

Lacing cord is available for general cable lacing and dressing uses. Cord is of strong material such as linen or nylon and thoroughly impregnated with a wax or paraffin. Supplied on spools.

Ordering Information

Type BJ-24 (RCA Standard) Jack Panel.....	MI-11645
Type BJ-12 (RCA Standard) Jack Panel.....	MI-11646
Single BJ-24 Jack Mat.....	MI-11647-1
Double BJ-24 Jack Mat.....	MI-11647-2
Type BJ-20TRS (Tip-Ring-Sleeve) Jack Panel.....	MI-11666
	Black Gray
Two-foot Patch Cord.....	MI-4652-B 4652-20
Four-foot Patch Cord.....	MI-4652-4B 4652-40
Six-foot Patch Cord.....	MI-4652-6B 4652-60
Two-foot Tip-Ring-Sleeve Patch Cord.....	MI-4652-D2
*Solid Conductor Cable, #20 AWG.....	MI-33

*Stranded Conductor Cable, #22 AWG.....	MI-34
*Stranded Conductor Cable, #18 AWG.....	MI-35
*Solid Conductor Cable, #22 AWG.....	MI-13342-1
*Stranded Conductor Cable, #22 AWG.....	MI-13342-2
*Stranded Conductor Cable, #22 AWG.....	MI-13342-A
Cable Lacing Cord:	
Black Linen, No. 6 med., 4 ply, 580 yds/lb., 30 lb. strength.....	MI-11719-A
Natural Nylon, .085" x .016", 500 yds, 50 lb. strength.....	MI-11719-C
Natural Nylon, .090" x .0125", 500 yds, 50 lb. strength.....	MI-11719-D

* Order in 100 ft. multiples only.



RADIO CORPORATION OF AMERICA

PRINTED IN U.S.A.

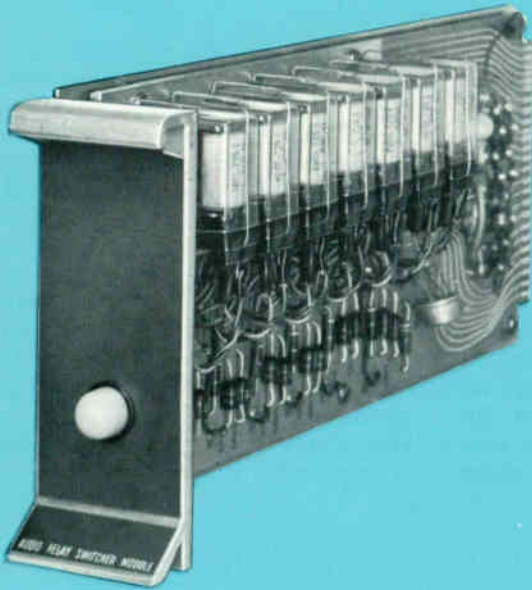

- "Custom" Switcher for Finest Audio Installations
- Solid State Modules Form Unlimited Switcher Configurations
- Seven Inputs, One Output Per Module
- Plug-in, Unitized Construction
- Switching Level 0 to +18 dbm in 600 Ohms



Audio Relay Switcher Module, MI-11787-A

Description

The Audio Relay Switcher Module is a primary component for use in custom relay switching systems. The basic module is a 7-input by 1-output switcher and offers the user a true building block in the development of unlimited audio switcher configurations.

Electronic Expansion

The MI-11787-A Module may be combined in numerous combinations to fit the needs of individual systems. A typical switcher (shown in the diagram) has 21 inputs each switchable to either or both of two outputs, such as preview and program bus. Such a switcher utilizes six modules mounted in an MI-557300 Standard Frame Assembly. Up to nine Audio Switcher Modules can be mounted in the frame to provide combinations such as the following: 2 modules for 14 x 1 or 7 x 2; 3 modules for 21 x 1 or 7 x 3; 4 modules for 28 x 1, 14 x 2 or 7 x 4; 5 modules for 35 x 1, or 7 x 5; 6 modules for 42 x 1, 21 x 2, 14 x 3 or 7 x 6; 7 modules for 49 x 1 or 7 x 7; 8 modules for 56 x 1, 28 x 2, 14 x 4 or 7 x 8;

9 modules for 63 x 1, 21 x 3 or 7 x 9. Systems beyond these configurations may be assembled by using additional frames and modules.

The use of standard plug-in modules greatly reduces the cost of custom-built switching systems, provides reliable performance and allows for future expansion requirements. The switcher may be controlled either by a custom-designed bank of individual push buttons or by pulses generated in automation or preset switching equipment.

DC Power Supply

A 24-volt DC power source such as an MI-11316 or MI-11318 power supply is required. Two module connector units are available as accessory items, the MI-11790 connector assembly and the MI-11789 connector kit.

The MI-11790 consists of an assembly of three connectors wired for use with three relay modules in a 7 x 3 switcher configuration. The assembly, if desired, can be reconnected for a 21 x 1 switcher. All

audio, tally and control circuits are wired to an audio terminal block on the assembly. Also included are three transformer mounting plates and hardware for securing the MI-11790 to the rear of the MI-557300 frame assembly. Numerous MI-11790 connector assemblies may be cross-connected to obtain any desired switcher configuration.

Mounting Accessories

The MI-11789 mating connector kit includes one connector housing, solder type terminals, one transformer mounting plate, and all hardware required for securing the connector and mounting plate to the rear of the MI-557300 frame assembly. One MI-11789 connector kit is required when installing a single MI-11787-A relay module.

Gap Switching

The Audio Relay Switcher Module utilizes a transistor latch circuit. The circuit design and relay characteristics are chosen so that relay drop-out is faster than pickup, hence gap switching is assured. Each Mod-

Description Continued

ule contains a pilot light to indicate presence of control voltage and fuse continuity. The lamp is operated at reduced voltage for greatly extended life.

Printed Circuitry

The latest printed circuitry techniques are employed including two-sided printed wiring on glass epoxy boards. The board contacts as well as the contacts of the mating receptacle are gold plated for maximum reliability. All audio circuits are wired with two conductor twisted pair cable, individually shielded and

insulated to minimize crosstalk as well as hum and noise pickup. Each module contains seven plug-in relays held in place by spring retaining clips. Each relay is equipped with gold contacts and a clear plastic dust cover to assure long life and quiet operation.

The MI-11787-A Switcher is designed for switching balanced audio circuits at levels of 0 dbm (up to +18 dbm) in 600 ohms, or equivalent levels at other impedances. An external bridging transformer is normally used to provide 20,000 ohms

impedance at the switcher crosspoints, with a choice of either 150 or 600 ohms output bus impedance. The MI-11791-A Bridging Transformer may be mounted on either the MI-11789 Connector Kit or MI-11790 Connector Assembly. Back loading of the input source is not required when using a bridging output, unless many outputs are simultaneously connected to one input. However, each relay crosspoint has "C" contacts, and the terminals are arranged so that back loading resistors may be conveniently installed if required.

Specifications

- Input/Output Impedance.....Dependent upon associated circuit (usually 600 or 150 ohms)
- Insertion Loss.....Essentially zero in the module (Normal loss through external bridging transformer 20 db)
- Crosspoint Activation.....Pulse or continuous voltage
- Switching Level.....0 to +18 dbm, 600 ohms
- Switching Time.....Break before make approx. 5 milliseconds
- Signal-to-Noise.....Better than 60 db; with 0 dbm, 600 ohm input
- Relay Contacts.....Gold plated; 2 form C and 3 form A (each relay)
- Maximum Length of Control Cable.....300 ft. using #22 wire

- Power Requirements.....24 volts, dc; 135 ma (including pilot lamp but excluding tally lamps)
- Fuse.....½ amp, 3 AG
- Pilot Lamp#327
- Dimensions (Overall).....4¾" high, 1¾" wide, 13" deep (12 cm, 4.5 cm, 33 cm)
- Weight.....2½ lbs. (1.13 kg)

Transistor and Diode Complement:
1—2N1183B, 14—1N2070, 1—1N746

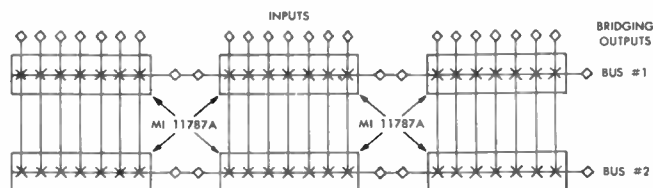

Ordering Information

Audio Relay Switcher Module, MI-11787-A

Optional and Accessory Equipment

- Standard Frame Assembly (holds up to 9 Modules).....MI-557300
- 24 Volts DC Power Supply.....MI-11316/11318
- Mating Connector Kit.....MI-11789
- 7 x 3 Connector Assembly.....MI-11790
- Bridging Transformer (mounts on MI-11790).....MI-11791-A



RADIO CORPORATION OF AMERICA



- Precision, 2-speed rim-drive mechanism for 33 $\frac{1}{3}$ and 45 rpm records
- Compact cabinet accepts BA-36 Equalizer Preamplifier
- Provision for mounting two tone arms for greater versatility
- Smooth and rapid starts



12-Inch Dual Speed Turntable, Type BQ-51B

Description

The RCA BQ-51B Dual Speed Turntable fulfills the broadcaster's need for a high-quality turntable mechanism to accommodate commercial disc recordings up to 12 inches in diameter at speeds of 33 $\frac{1}{3}$ and 45 r/min. The BQ-51B is available as a mechanism for mounting in custom-built arrangements. It may also be obtained as a complete assembly with a styled cabinet, MI-11809-A.

Space is provided on the top panel of the BQ-51B for mounting one or two standard low impedance, reluctance-type pickups that con-

form to EIA standards. The RCA 12-inch (MI-11894-A) or the RCA 16-inch (MI-11895-A) Tone Arm are recommended. Both arms accommodate the RCA Universal Pickup Cartridge, MI-11865 and associated styli, MI-11866 series, for playing stereo or monaural recordings.

The BQ-51B Dual Speed 12-inch Turntable is a 2-speed rim-drive mechanism, utilizing a hysteresis synchronous motor. It is available for 60 hertz or 50 hertz operation and a 2-position speed selector switch is provided on the turntable assembly. An "Off-On" selector control oper-

ates a mercury motor switch and simultaneously engages or disengages the rubber idler wheels. This feature relieves the idlers from pressure when set to the "Off" position.

The metal cabinet assembly, MI-11809-A of functional design, affords a simplified mounting for the drive assembly mechanism. A hinged door is located on the front of the cabinet to permit ready access to the interior. A sloped bracket is provided within the cabinet to mount the BA-36 Series Equalizer Preamplifier.



The BQ-51B turntable platter is a sturdy aluminum casting. The platter and spindle assembly is held in the main support casting by oilite bushings and the thrust is supported by a single ball at the bottom end of the spindle. A foam rubber belt on the outside rim of the platter eliminates resonance effects. The drive motor is mounted on a separate plate, supported by vibration mounts to eliminate rumble. A rubber cushioning frame reduces extraneous vibrations by isolating the motor board assembly from the mounting frame. All posts and shafts which provide bearings for cams and arms are assembled to a common plate to insure proper alignment.

Specifications

Performance Specifications

Turntable Speed.....	33 $\frac{1}{3}$ and 45 r/min. \pm 0.3%
Rumble.....	40 db down (ref. level 1.4 cm/s at 100 Hz)
Wow or Flutter:	
At 33 $\frac{1}{3}$ r/min.....	0.1% of mean speed
At 45 r/min.....	0.1% of mean speed
Motor.....	1/100 h.p., 1800 r/min. at 60 Hz or 1/125 h.p., 1500 r/min. at 50 Hz
Power Supply.....	105-125 V, 50/60 Hz single phase
Power Consumption.....	40 W
Power Cord.....	8 ft. long (2.44 m)
Turntable Diameter.....	12" (30.48 cm)
Hub and Spindle Diameter:	
Hub for 45 r/min. records.....	1.5" (4.31 cm)
Spindle for 33 $\frac{1}{3}$ records.....	0.2835" (72 mm)
Overall Dimensions:	
Turntable Drive Unit.....	22" wide, 18 $\frac{1}{16}$ " deep (55.9 cm x 45.9 cm)—height below top surface motor board, 9" (22.86 cm)—height above surface motor board, 1 $\frac{1}{2}$ " (3.81 cm)
Cabinet.....	23 $\frac{1}{16}$ " wide, 19 $\frac{1}{8}$ " deep and 29" high (58.5 cm x 46 cm x 73.66 cm)

Weight:	
Turntable Drive Unit.....	31 lbs. (14.06 kg)
Cabinet.....	47 lbs. (21.32 kg)
Finish.....	Shadow blue with aluminum trim

Accessories

Cabinet assembly to house turntable mechanism.....	MI-11809-A
12" Tone Arm (less pickup head).....	MI-11894-A
16" Tone Arm (less pickup head).....	MI-11895-A
Universal Cartridge (less stylus).....	MI-11865
0.7 Mil Diamond Stylus (for use with Universal Cartridge).....	MI-11866-7
1.0 Mil Diamond Stylus (for use with Universal Cartridge).....	MI-11866-10
2.5 Mil Diamond Stylus (for use with Universal Cartridge).....	MI-11866-25
BA-26B Pickup Equalizer-Preamplifier.....	MI-11436-B
BA-36A Stereo Pickup Equalizer-Preamplifier.....	MI-11441-A/-B
220 Volt Transformer Kit.....	MI-41605

Ordering Information

BQ-51B Dual Speed Turntable Mechanism for 60 hertz operation (less Cabinet, Tone Arm and Pickup Heads).....	MI-11810-B
BQ-51B Dual Speed Turntable Mechanism for 50 hertz operation (less Cabinet, Tone Arm and Pickup Heads).....	MI-11810-C



RADIO CORPORATION OF AMERICA

BROADCAST AND COMMUNICATIONS PRODUCTS DIVISION, CAMDEN, N. J. 08102 • RCA INTERNATIONAL DIVISION, CENTRAL and TERMINAL AVENUES, CLARK, NEW JERSEY, U.S.A. 07066

TRADEMARKS REGISTERED

©ARCA'S REGISTRACIÓ

PRINTED
IN
U.S.A.



- Solid state design
- Monaural or stereo recording
- 7½ and 15 or 3¾ and 7½ IPS tape speed models
- Rack, console or portable mounting
- Plug-in record equalizer



Professional Audio Tape Recorder, Type RT-21B

Description

The RCA Type RT-21B Professional Tape recorder is designed to meet rigid specifications and requirements set forth by broadcast and studio engineers for magnetic monaural or stereo tape operations. Utmost flexibility is provided in this complete transistor design, permitting programs to be recorded with greater ease.

Solid state circuitry accounts for the low power consumption, cool operation and small size of the RT-21B. Improved circuitry allows a wide range of record input levels, high playback output levels, and facilitates stereo performance. A master bias oscillator system is employed. The oscillator, located in the control module, drives power amplifiers in each amplifier module—an important feature where synchronous bias voltage is required such as in the stereo model of the RT-21B.

The RT-21B basic recorder is supplied in two sections: a tape transport and a control panel which includes one amplifier. These components readily enable either a custom or standard installation to be made. The equipment is normally supplied for rack mounting. Console cabinet and portable carrying case are optional equipment.

Ease of Operation

The control panel of the RT-21B is divided into three sections. The center contains the monaural record/playback module, the left area contains provisions for a duplicate module (used for stereo recording) and the right side of the control panel contains operating controls in a convenient grouping. When recording in stereo it is possible to record both tracks simultaneously in a normal manner or either of the two half-tracks by means of the A/B selector switch.

Front Panel Controls

The record/playback modules are identical and are directly interchangeable. Front panel controls consist of the following: a record level control, playback level control, headset jack, bias adjustment and meter function selector to monitor, playback, record, bias and erase signals. A record indicator light is associated with each amplifier so that when recording in stereo it is possible to quickly ascertain whether normal stereo or half track recording mode is selected.

Continuously Variable Speed Control and Interlocked Record Operation

The operating controls consist of the following: variable cue speed and related cue delegate button, record, record delegate, start, stop, fast forward and fast reverse. The control panel features an interlocked record operation. This means that to place



Portable carrying case with stereophonic RT-21B system.



Console cabinet with stereophonic RT-21B system.

the machine in the record mode, the record button must first be depressed and then the start button to begin operation. This interlock feature may be defeated by simple internal strapping so that the record button may be depressed at any time for editing purposes, etc.

All controls are d-c relay operated. The necessary 24 volt d-c control voltages are generated within the recorder and are also available for remote control purposes.

Tape Transport

The RT-21B Tape Transport Panel accommodates either 10½-inch or 7-inch EIA reels. NAB 10½-inch reels and NAB hubs are available as accessory items. Proper tape tension for 10½ or 7-inch reels is provided by means of a toggle switch at the lower right of the panel. Also located in this same area are the main power on-off switch and a switch for selecting either high or low tape speeds. Proper tape equalization is automatically selected by the speed change switch. 7½/15 IPS and 3¾/7½ IPS models are available. Each RT-21B is supplied with the proper plug-in record equalizer depending upon speed and track width ordered.

Velocity Brake System

The smooth acting "Velocity sensing brake system" providing velvet smooth action is achieved in the RT-21B by use of large surface area brake hubs which are integral parts of the reel motors. A microswitch, controlled by the tape brake arm, cuts power to the capstan motor and releases the control relays when the arm is in the down position. This safety feature stops the transport mechanism in the event of tape breakage. Power to the electronics is not controlled by this switch.

Threading of tape is simple and can be done without removal or movement of the head cover.

DC Solenoid Operated Tape Lifters

These are employed to lift the tape away from all magnetic heads whenever the machine is in the fast forward or fast reverse mode of operation. When the cue mode is selected, tape is then lifted from all heads except the playback head. This permits the operator to listen to the audio as he jockeys the tape for final

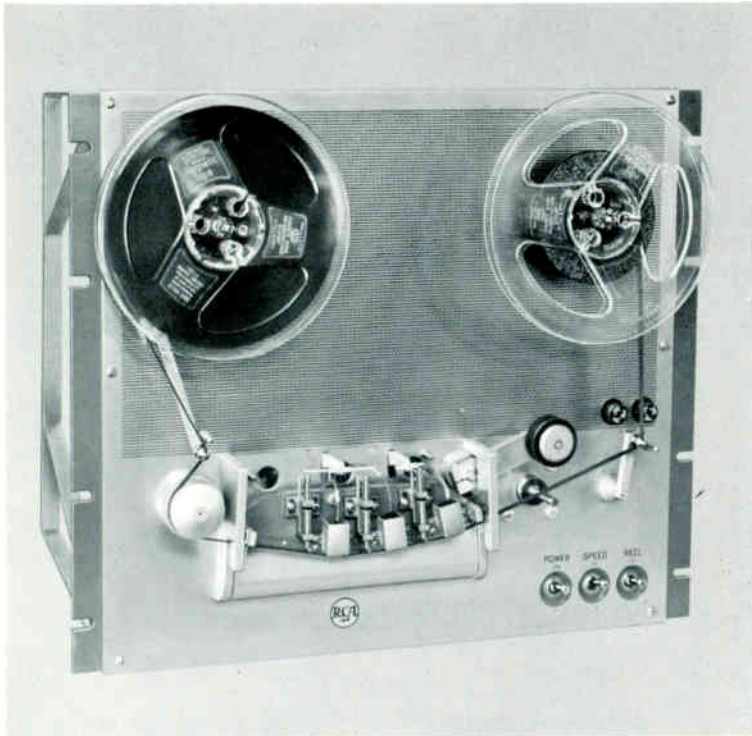

RT-21B Tape Transport with cover removed to reveal magnetic heads. Note cut-out provision on left for optional fourth head kit for playing pre-recorded stereo tapes.

cueing via the continuously variable speed control.

Full Track or Dual Half-Track

A total of four magnetic head positions are available. The three heads normally supplied with the equipment provide full or dual half-track recording, erase and playback (depending on model ordered). An optional fourth head may be used for time delay broadcast and other special applications. A switchable dual quarter-track fourth head kit is available for playing pre-recorded stereo tapes. All azimuth head adjustments are available from the front panel by simply removing the snap-on protective cover.

Remote Control Panel

A Remote Control Panel for the RT-21B Tape Recorder is available as an optional equipment. The panel affords remote operation of all front panel operations except variable speed cue, including the A/B record facilities. The remote panel, however, has facilities for defeating the tape lifter on all heads, so that tape cueing can be accomplished by using the fast forward and fast reverse pushbuttons.

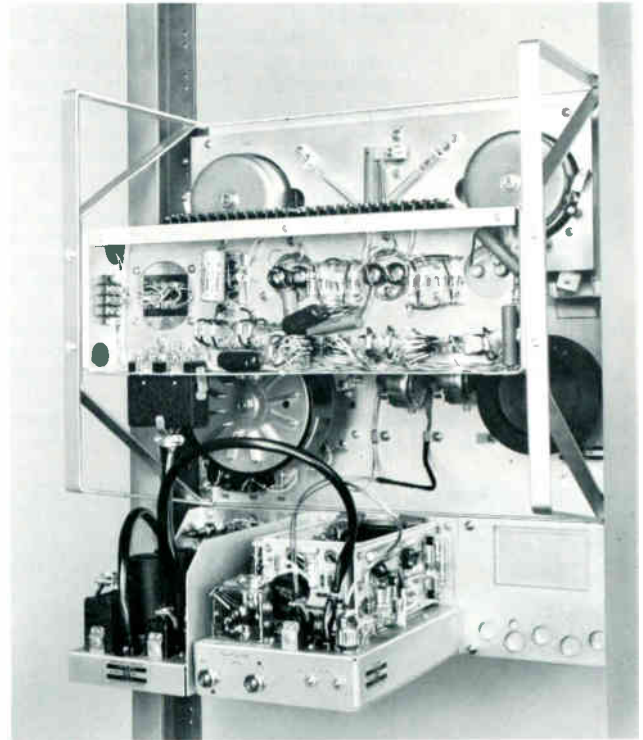
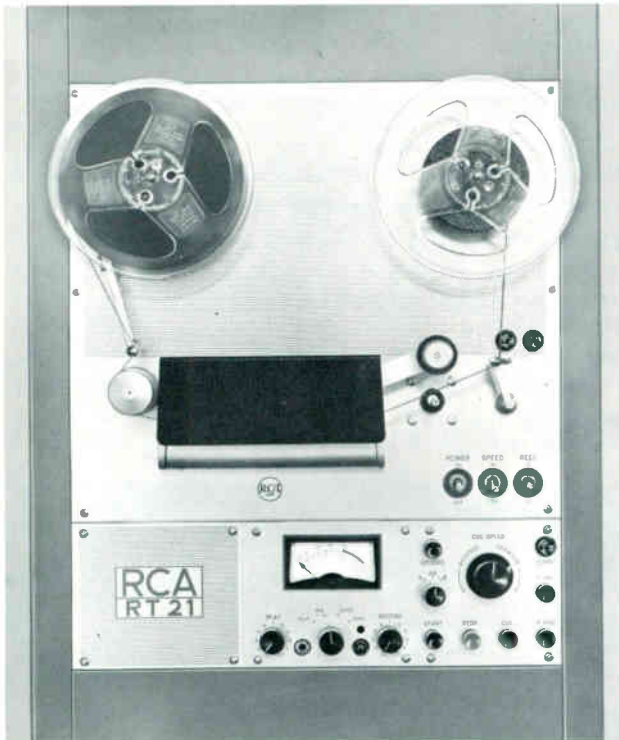

Front and rear views of RT-21B Tape Recorder showing tape transport at top, and control panel below. In rear view the modular control unit is shown at left and amplifier module in center. Space at right supports a second amplifier module for stereo tape operation.

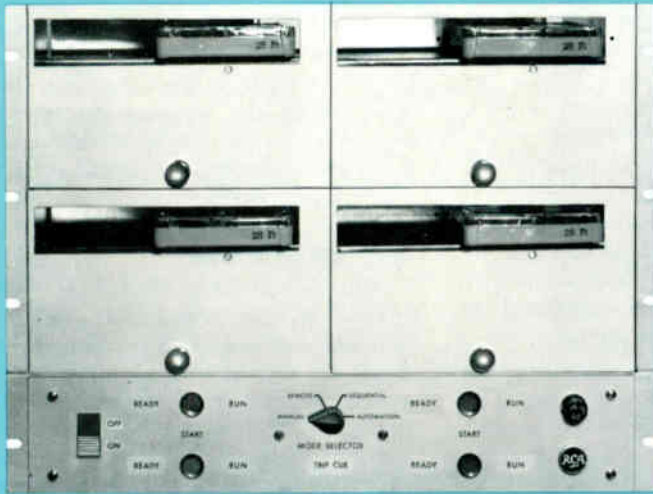

- Facilitates Continuous Broadcast Programming
- Any one of four Cartridges Available for Immediate Playback
- Four Modes of Operation: Manual, Remote, Sequential, Automation
- Plug-in Relays and Circuit Breaker
- Heavy Duty Tape Transports
- Self-Contained Relay Power Supply



Multicartridge Tape System, Type RT-8A

Description

The RCA Type RT-8A Multiple Cartridge Tape System (either monaural or stereo) is a single compact unit designed for instant playback of four pre-recorded tape cartridges singly or in random sequence. A mode selection switch allows four modes of operation: manually, remotely, sequentially, or by pulses supplied from an automation system. The RT-8A meets all NAB standards and plays either of the three NAB size of cartridge, with playback time varying from a few seconds to 31 minutes.

The RT-8A Multicartridge is available for use with cartridges recorded on the RT-7A/B cartridge tape units. An alternate model is designed for operation with cartridges recorded on the RT-17 tape cartridge unit. There is also an RT-8A designed for stereo operation, available with stereo transports and dual program amplifiers.

Tandem Operation

The RT-8A Multicartridge playback units may be connected in tandem to give systems of 4-8-12-16 or more units in an operating system.

Use of multiple RT-8A units could provide enough cartridge storage capacity to give continuous broadcast programming for long time periods.

The Multicartridge system consists primarily of four independent, roll-out tape transports, plug-in transistor circuit boards and control relays, a mode selector switch and separate start switches for each of the tape transports. These are housed in a rack-mounting cabinet. Adequate ventilation has been provided in the design of chassis and cabinet to allow two or more RT-8A's to be stack mounted in a standard rack.

Tape Transport

The rugged 10-pound tape transport is identical to those used in the Monaural RT-17A or Stereo RT-37A Single Cartridge Playback Units. The drive system for the transport consists of a heavy duty, hysteresis, synchronous motor, coupled by "O" ring belts to a precision-ground capstan and flywheel assembly. The mechanism meets latest NAB standards (tape speed $7\frac{1}{2}$ IPS with a speed accuracy of ± 0.4 percent; machine tape pulling force, minimum $1\frac{1}{2}$

pounds; flutter not to exceed 0.2 percent RMS.)

Fast, Quiet Operation

Insertion of a cartridge cocks the RT-8A mechanical system by swinging the pressure roller up to within a fraction of an inch of the capstan, assuring fast starts and quiet operation upon playback. Mechanical release of the cartridge is accomplished by merely lifting up the edge of the cartridge before removing it from the slot in the transport. All electrical connections to the transport are made through two, quick disconnect cable connectors, one for power and the other for the heads.

Relays

A set of six plug-in relays is associated with each individual transport system. They control the ready, start, run and play control functions of the transport as well as the cue and trip (end of message cue) functions. A mute relay and an audio switch relay are the two final relays in the system. The former mutes the audio output during initial starting of the playback process to prevent operational noises entering pro-

Description (continued)

gram circuits; the audio switch relay provides automatic audio switching to a single program channel when two or more RT-8A's are connected in tandem. The relays are protected from dirt and dust by individual plastic covers. Each is rigidly held in place by an overall metal cover.

Relay Power Supply

The RT-8A is completely self-contained including a 24 volt power supply for relay operation. Tally lamps indicate cartridge "ready" and "run". An individual cue and trip cue circuit board is associated with each tape transport. A common output audio amplifier is provided with each RT-8A.

Four Position Mode Switch

A four position mode switch selects the play mode desired. These are as follows:

- a. Manual—The operator can select the cartridge play sequence by operating "start" buttons on the RT-8A Control Panel. The deck that has been placed in operation will run until it is automatically "cued up." The second or following deck must be started manually.
- b. Remote Control—This is basically the same as manual. It allows for manual control from a remote position. Custom remote "trip cue" delegation panels may also be employed to vary cartridge sequence.
- c. Sequential—Any deck may be used to start a sequence. The sequence continues automatically within the RT-8A thru as many decks as there are cartridges inserted. The play se-

quence may be started locally or remotely.

- d. Automation—This mode permits external pulses to activate individual cartridge decks and "trip cue" pulses from the active deck to start the next device in the automation system. When the mode switch is in automation all manual control is removed.

Random Trip Cue

The MI-11973-2 8000-Cycle Random Trip Cue Board is an optional accessory. Random Trip Cue tones must be recorded in an RT-17/37 system during preparation of a cartridge. A "random trip cue" may be used to activate a slide projector or other device during play of a cartridge.

Specifications

Frequency Response.....	±2 db 50 to 12,000 cycles ±4 db 50 to 15,000 cycles
Distortion.....	2% or less at normal recording level
Signal-to-noise Ratio:	
Monaural.....	45 db at standard NAB reference level (53 db below 3% total harmonic distortion)
Stereo.....	42 db at standard NAB reference level (50 db below 3% total harmonic distortion)
Crosstalk, Cue Tone to Program Channel:	
Monaural.....	Better than 55 db
Stereo.....	Better than 50 db
Wow and Flutter.....	Less than 0.2% RMS
Tape Speed.....	7.5 IPS
Power.....	115/230 V, AC, *50/60 cycles, single phase
Playing Time.....	1 second to 31 minutes in 3 basic cartridge sizes
Cueing Accuracy.....	Within 0.1 second
Starting Time.....	0.05 second or less
Output Level.....	+18 dbm, 150/600 ohms, balanced
Finish.....	Aluminum Epoxy

Dimensions.....	19" wide, 14" high, 16" deep (48.25 cm, 35.5 cm, 31.25 cm)
Weight:	
Chassis, less decks.....	112 lbs. (50.8 kg.)
Chassis including four 10 lb. decks.....	152 lbs. (68.9 kg.)
Cartridge Transports.....	4 plug-in type
Mounting.....	Standard Relay Rack

Optional and Accessory Equipment

Remote Control Panel (for any RT-8A Multicartridge Tape System).....	MI-11968-1
150-Cycle End-of-Message Cue Board.....	MI-11973-1
8,000-Cycle Random Trip Cue Board (for use only with ES-11169 and MI-11961-AS Systems only).....	MI-11973-2
18,000-Cycle Trip Cue Board.....	MI-11973-3
Playback Amplifier.....	MI-11974-4
Power Supply.....	MI-11974-1
50-Cycle Modification Kit (4 required).....	MI-11494

* By use of MI-11494 Conversion Kits

Ordering Information

RT-8A Mono Multicartridge Tape System (for use with RT-7 Pre-Recorded Cartridges).....	ES-11168
Consisting of:	
1 RT-8A Multicartridge Unit including 4 mono transports, but less trip cue board.....	MI-11961-A
4 18,000-Cycle Trip Cue Circuit Board.....	MI-11973-3
RT-8A Mono Multicartridge Tape System (for use with RT-17 Pre-Recorded Cartridges).....	ES-11169
Consisting of:	
1 RT-8A Multicartridge Unit including 4 mono transports, but less random cue and end- of-message cue boards.....	MI-11961-A
4 150-Cycle End-of-Message Cue Boards.....	MI-11973-1
RT-8A Stereo Multicartridge Tape System (for use with RT-37 Pre-Recorded Cartridges).....	MI-11961-AS
Including 4 stereo transports and 4—150-cycle end-of-message cue boards for use with RT-37/BA-37 recorded cartridges	



RADIO CORPORATION OF AMERICA



- Monaural Program Record and Playback
- Pull-out Tape Transport
- Separate Record and Playback Heads
- Plug-in Circuit Boards
- Three Cue Frequencies
- Silicon Transistors



Cartridge Tape Recorder, Type RT-17A

Description

RCA Deluxe Cartridge Tape Recorders are ideal studio equipments for recording program material that is later available for instant selection and playback. The Monaural Type RT-17A with its automatic, silent operation, compact modern styling, and high quality reproduction adds a new realism to broadcast material from "quickie" spot announcements to complete programs.

With tape cartridges, cueing and threading of tape is unnecessary. The desired cartridge is selected, placed in the playback unit until "on air" time when it is instantly available for playback at the touch of the start button. Remote control permits program record or playback from any desired location. Through a trip cue tone which may be placed anywhere on the tape, the RT-17A can automatically trigger slide projectors, or other equipment capable of being remotely started. The end-of-message cue is used to instantly start RT-17's tape recorders, or other program units on completion of a message.

Compact, Modern Styling

The RT-17A Monaural Tape Cartridge System consists of two separate units, the RT-17A Playback

Unit and the BA-17A Cartridge Recorder. Both units are designed for standard rack or console mounting and require but 5¼ inches of rack space. Remote control panels, tape cartridges, cabinet stands, cartridge storage racks, etc. are optional accessories.

30 Minute Continuous Play

The RT-17A Playback Unit reproduces tape cartridges varying in length from 40 seconds to 31 minutes. Delayed broadcast, spot announcement campaigns, production aids, themes, station breaks—all can be handled by the unit with a minimum of effort.

Transistor Circuitry

Compact transistor design is displayed in the Deluxe Cartridge Tape System. Plug-in circuit boards and plug-in power supply circuit board together with the new roll-out transport mechanism permit quick access to the equipment for easy service. The 24-volt control relays are plug-in types.

The Playback Unit consists of tape deck, power supply, playback amplifier and cue circuitry all designed for continuous use, economical power consumption, and reliable operation.

The unit is housed in a shielded chassis with functional front panel of heavy gage aluminum. The panel contains the slot for insertion of the tape cartridge, an ON-OFF switch, and all operating controls.

Simplicity of Operation

The Cartridge playback unit is ready to go at the flick of a button. A red pilot light shows when the equipment is on. After insertion of the cartridge, an amber ready light located beside the start button will light. Upon depressing the start button, the tape will run and a green run light will show. At the end of the tape run the equipment will automatically stop, the green run light will go out and the amber light again appear. Indicator lights show presence of trip cue and end of message cues.

Three Cue Frequencies

Three cue frequencies—stop cue—end of message cue—and trip cue—are provided in the RT-17A. The tape may be stopped at any time by pressing the stop button. Relays control the start and stop functions of the unit through impulses generated by a cue tone control circuit. These cue tone bursts are

DESCRIPTION (Continued)

inserted automatically each time the tape is started during recording so that taped announcements always are properly recued and ready for reuse. A special feature is the use of two additional cue circuits which are independent of the cue-tone circuit. This feature allows the broadcaster to record the second, or "end of message" cue tone, immediately at the conclusion of the program material. It is used to "trigger" start following program devices or automation systems. The third, or trip-cue tone, may be recorded at any time. This tone, when reproduced during playback, can be used to activate associated program devices such as TV slide projectors with split-second accuracy.

Individual Record Level Controls

The BA-17A Record Amplifier is similar to the RT-17A Playback Unit in chassis construction and appearance

to provide an integrated appearance. The front panel contains the RECORD button and red supervisory light to indicate the recording mode. Cut buttons grouped at the right of the panel by themselves minimize accidental operation.

Microphone and Bridging Inputs

The BA-17 Amplifier has sufficient gain to permit microphone recording and a bridging pad may be connected for recording at line level. The record amplifier, bias and cue oscillators are mounted on glass epoxy laminate plug-in boards which can easily be removed for servicing. The unit is designed and shielded to minimize pick-up of hum and r-f fields. The recorder connects to the playback with a light, flexible cable and plug arrangement. Operating voltage for the amplifier are supplied by the Playback Unit. Operation at 115 or 230 volts is optional.

Continuous Playback

Careful consideration has been given to prevention of accidental recording. The recorder must be intentionally placed in the record mode before a recording can be made, and drops out of the mode whenever a tape is stopped. Convenient terminals are available for addition of a "stop cue" defeat switch that would permit start-stop recording of a series of separate messages. This will eliminate the intervening stop cues so as to permit continuous playback. Operation of the record button during playback will not accidentally place the system in the record mode.

Record-Playback Heads

Separate playback and record heads permit simultaneous playback or monitoring while recording. The RT-17 system employs two track heads for program and cue.

Specifications

Frequency Response.....	±2 db 50-12,000 cps at 7½ ips ±4 db 50-15,000 cps at 7½ ips
Distortion.....	Less than 2% at normal recording level
Signal-to-noise Ratio.....	45 db at standard NAB Reference level
Cross Talk Between Channels.....	Better than 55 db
Wow and Flutter.....	Less than 0.2% RMS
Bias Frequency.....	75 kc
Tape Speed.....	7.5 ips ±0.4%
Equalization.....	NAB
Playback Time.....	1 second to 31 minutes in 3 basic cartridge sizes
Cueing Accuracy.....	Within 0.1 second
Starting Time.....	0.05 second or less
Output Level.....	+18 dbm, 150/600 ohms, balanced
Recording Input Level.....	Microphone -70 dbm (minimum) Matching -20 dbm (maximum) Bridging ±18 dbm (maximum)
Input Impedance.....	Unloaded input transformer for 37/150/250 ohm microphones, or 20,000 ohm bridging input
Cue Signal.....	1 kc automatically recorded at start of recording
Auxiliary Cue Signals:	
End of Message.....	150 cps tone may be recorded manually or automatically
Trip Cue.....	.8 kc may be recorded at any time

Meters.....	Two 3" illuminated, rectangular VU
Indicator Lights:	
RT-17A.....	"Ready," "Run," "Trip Cue," and "End Cue"
BA-17A.....	"Record"
Heads.....	Two tracks, separate record and playback heads permit simultaneous monitoring while recording
Transistor and Diode Complement:	
RT-17A.....	17—2N2270, 1—2N301, 4—1N4140, 1—1N721A, 4—1N3253
BA-17A.....	11—2N2270, 4—1N34A, 6—1N3253
Power Requirements.....	115/230 volts, a-c, 60 cps
Power Consumption.....	Record, 80 watts; Playback, 69 watts; Ready, 54 watts; Standby, 8 watts
Ambient Temperature.....	55°C max.
Finish.....	Silver Gray epoxy
Dimensions (overall):	
	Wide High Deep
RT-17A.....	19" 5¼" 16¼" 48.26 cm 13.34 cm 41.28 cm
BA-17A.....	19" 5¼" 11⅝" 48.26 cm 13.34 cm 29.53 cm
Weight:	
RT-17A.....	52 lbs. (23.59 kg.)
BA-17A.....	25 lbs. (11.34 kg.)

Ordering Information

Other RT-17 System Components and spares including remote control panels, console cabinets, cartridges and cartridge storage racks, etc. are described in RCA Catalog B.1725.

RT-17A Cartridge Playback Unit (Monaural).....	MI-11965-A
BA-17A Cartridge Recorder (Monaural).....	MI-11966-A
50 Cycle Conversion Kit.....	MI-11494



RADIO CORPORATION OF AMERICA

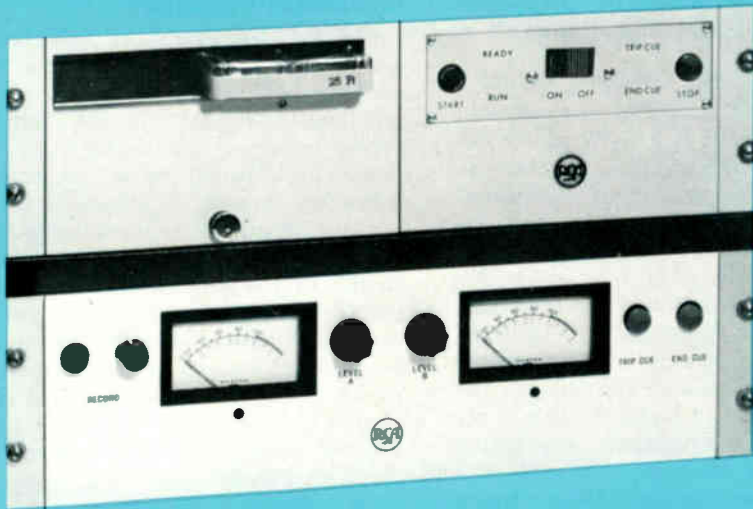

- Stereo Program Record and Playback
- Pull-out Tape Transport
- Separate Record and Playback Heads
- Plug-in Circuit Boards
- Three Cue Frequencies
- Silicon Transistors



Cartridge Tape Recorder, Type RT-37A

Description

RCA Deluxe Cartridge Tape Recorders are ideal studio equipments for recording program material that is later available for instant selection and playback. The Stereo Type RT-37A with its automatic, silent operation, compact modern styling, and high quality reproduction adds that third dimension to broadcast material from "quickie" spot announcements to complete programs.

With tape cartridges, cueing and threading of tape is unnecessary. The desired cartridge is selected, placed in the playback unit until "on air" time when it is instantly available for playback at the touch of the start button. Remote control permits program record or playback from any desired location. Through a trip cue tone which may be placed anywhere on the tape, the RT-37A can automatically trigger slide projectors, or other equipment capable of being remotely started. The end of message cue is used to instantly start RT-37's, tape recorders, or other program units on completion of a message.

Compact, Modern Styling

The RT-37A Stereo Tape Cartridge System consist of two separate units, the RT-37A Playback Unit

and the BA-37A Cartridge Recorder. Both units are designed for standard rack or console mounting and require but 5¼ inches of rack space. Remote control panels, tape cartridges, cartridge storage racks, etc. are optional accessories.

30 Minute Continuous Play

The RT-37A Playback Unit reproduces tape cartridges loaded with lubricated tape varying in length from 40 seconds to 31 minutes. Delayed broadcast, spot announcement campaigns, production aids, themes, station breaks—all can be handled by the unit with a minimum of effort.

Transistor Circuitry

Compact transistor design is displayed in the Deluxe Cartridge Tape System. The Playback unit consists of tape deck, power supply, playback amplifier and cue circuitry all designed for continuous use, economical power consumption, and reliable operation. The unit is housed in a shielded chassis with functional front panel of heavy gage aluminum. The panel contains the slot for insertion of the tape cartridge, an ON-OFF switch, and all operating controls.

Simplicity of Operation

The Cartridge playback unit is ready to go at the flick of a button. A red pilot light shows when the equipment is on. After insertion of the cartridge, an amber ready light located beside the start button will light. Upon depressing the start button, the tape will run and a green run light will show. At the end of the tape run the equipment will automatically stop, the green run light will go out and the amber light again appear. Indicator lights show presence of trip cue and end of message cues.

Three Cue Frequencies

Three cue frequencies—stop cue—end of message cue—and trip cue—are provided in the RT-37A. The tape may be stopped at any time by pressing the stop button. Relays control the start and stop functions of the unit through impluses generated by a cue tone control circuit. These cue tone bursts are inserted automatically each time the tape is started during recording so that taped announcements always are properly recued and ready for reuse. A special feature is the use of two additional cue circuits which are independent of the cue-tone circuit. This feature allows the broad-

DESCRIPTION (Continued)

caster to record the second, or "end of message" cue tone, immediately at the conclusion of the program material. It is used to "trigger" start following program devices or automation systems. The third, or trip-cue tone, may be recorded at any time. This tone, when reproduced during playback, can be used to activate associated program devices such as TV siled projectors with split-second accuracy.

Individual Record Level Controls

The BA-37A Record Amplifier is similar to the RT-37A Playback Unit in chassis construction and appearance to provide an integrated appearance. The front panel contains the RECORD button and red supervisory light to indicate the recording mode. The BA-37 Stereo Record Amplifiers have individual gain controls for level balancing and two front panel illuminated meters to monitor both channels simultaneously. Cue buttons grouped at the

right of the panel by themselves minimize accidental operation.

Microphone and Bridging Inputs

The BA-17 Amplifier has sufficient gain to permit microphone recording and a bridging pad may be connected for recording at line level. The record amplifier, bias and cue oscillators are mounted on glass epoxy laminate plug-in boards which can easily be removed for servicing. The unit is designed and shielded to minimize pick-up of hum and r-f fields. The recorder connects to the playback with a light, flexible cable and plug arrangement. Operating voltage for the amplifier are supplied by the Playback Unit. Operation at 115 or 230 volts is optional. The Stereo Amplifier has two microphone inputs for each channel with provision for monitoring the tone and bias levels. The dual circuitry of record amplifiers, bias and cue oscillators are mounted on three plug-in boards.

Continuous Playback

Careful consideration has been given to prevention of accidental recording. The recorder must be intentionally placed in the record mode before a recording can be made, and drops out of the mode whenever a tape is stopped. Convenient terminals are available for addition of a "stop cue" defeat switch that would permit start-stop recording of a series of separate messages. This will eliminate the intervening stop cues so as to permit continuous playback. Operation of the record button during playback will not accidentally place the system in the record mode.

Record-Playback Heads

Separate playback and record heads permit simultaneous playback or monitoring while recording. The RT-37 system has three track heads for stereo operation in which two tracks are used for program and one track for cue signals.

Specifications

Frequency Response.....	±2 db 50-12,000 cps at 7½ ips ±4 db 50-15,000 cps at 7½ ips
Distortion.....	Less than 2% at normal recording level
Signal-to-noise Ratio.....	42 db at NAB Standard Reference Level
Cross Talk Between Channels.....	Better than 50 db
Wow and Flutter.....	Less than 0.2% RMS
Bias Frequency.....	75 kc
Tape Speed.....	7.5 ips ±0.4%
Equalization.....	NAB
Playback Time.....	1 second to 31 minutes in 3 basic cartridge sizes
Cueing Accuracy.....	Within 0.1 second
Starting Time.....	0.05 second or less
Output Level.....	+18 dbm, 150/600 ohms, normally +8 v _μ
Recording Input Level.....	Microphone -70 dbm (minimum) Matching -20 dbm (maximum) Bridging +18 dbm (maximum)
Input Impedance.....	Unloaded input transformer for 37/150/250 ohm microphones, or 20,000 ohm bridging input
Transistor and Diode Complement:	
RT-37A.....	22—2N2270, 1—2N301, 4—1N4140, 1—1N721A, 4—1N3253
BA-37A.....	4—1N34A, 6—1N3253, 17—2N2270
Cue Signal.....	1 kc automatically recorded at start of recording

Auxiliary Cue Signals:	
End of Message.....	150 cps tone may be recorded manually or automatically
Trip Cue.....	.8 kc may be recorded at any time
Meters.....	Two 3" illuminated, rectangular VU
Indicator Lights:	
RT-37A.....	"Ready," "Run," "Trip Cue," and "End Cue"
BA-37A.....	"Record"
Heads.....	Three track, separate record and playback heads permit simultaneous monitoring while recording
Power Requirements.....	115/230 volts, a-c, 60 cps (50 cps optional by use of MI-11494 Conversion Kit)
Power Consumption.....	Record, 80 watts; Playback, 69 watts; Ready, 54 watts, Standby, 8 watts
Finish.....	Silver Gray epoxy
Ambient Temperature.....	55°C max.
Dimensions (overall):	

	Wide	High	Deep
RT-37A	19"	5¼"	16¼"
	48.26 cm	13.34 cm	41.28 cm
BA-37A	19"	5¼"	11½"
	48.26 cm	13.34 cm	29.53 cm
Weight:			
RT-37A.....	52 lbs. (23.59 kg.)		
BA-37A.....	25 lbs. (11.34 kg.)		

Ordering Information

Other RT-37 System Components and spares including remote control panels, console cabinets, cartridges and cartridge storage racks, etc. are described in RCA Catalog B.1725.

RT-37A Cartridge Playback Unit (Stereo).....	MI-11962-A
BA-37A Cartridge Recorder (Stereo).....	MI-11963-A
50 Cycle Conversion Kit.....	MI-11494



RADIO CORPORATION OF AMERICA

PRINTED
IN
U.S.A.

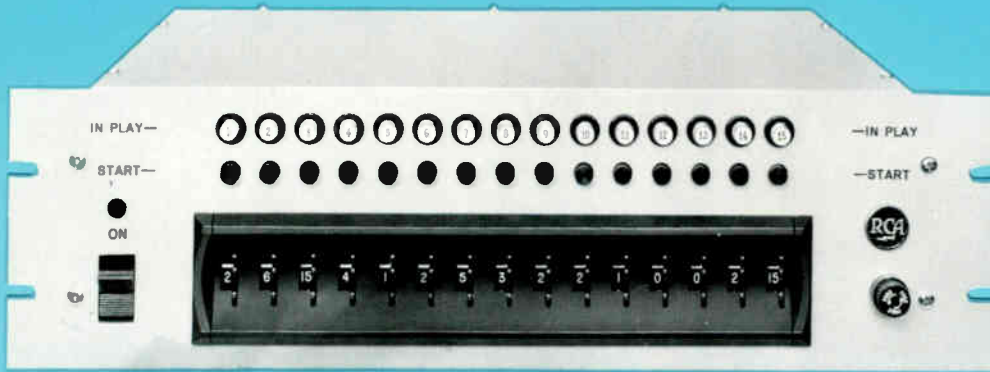

- Fifteen events, eighteen sources
- Solid state logic
- Plug-in relays used
- Quiet operation
- Provision for "skip" or "stop" events



Audio Tape Programmer, Type BCA-15A

Description

The Audio Tape Programmer, RCA Type BCA-15A, is designed to program fifteen events from any of 18 program sources. These sources can be derived from RCA Type RT-8, RT-17, RT-22 or RT-37 tape recorders. In addition, any source may be used if it can be started by a contact closure and provides a contact closure to signal the end of program material. Each of the 15 events is programmed by means of a thumbwheel switch which selects any of the 18 program sources. In addition, the switch permits an event to be skipped or the program sequence stopped. The program recycles to the first event upon completion of event 15.

The number of events may be increased easily by adding Audio Tape Programmer units either in series or as sub-programs to a particular event in a main program. Numbered lights indicate the event being played and a push button permits any particular event to be selected. Relays and solid state logic circuits are used to permit fast operation with so little noise that the BCA-15A may be used in announce positions with open microphones.

Specifications

Events	15
Program Sources	18
Source Selector.....	Thumbwheel switch
Source Relay Switching.....	+24 volts dc
Power.....	115/230 volts, a-c, 50/60 cps, 6.25 watts
Panel Size.....	5¼" high, 19" wide, 15½" deep (13.34 cm, 48.26 cm, 39.70 cm)
Weight.....	16 lbs. (7.25 kg.)
Terminals.....	Screw type barrier terminal strips

Ordering Information

Type BCA-15A Audio Tape Programmer.....MI-11365-A

10PB



RADIO CORPORATION OF AMERICA





- High sensitivity
- Smooth frequency response 50 to 16,000 cps
- Balanced listening characteristic
- Indox (ceramic) permanent magnet
- Excellent power handling capability
- Curvilinear cone plus a mechanically coupled high frequency cone



Dioplex 12-Inch Speaker, Type SL-12B

Description

The Type SL-12B is one of the finest High Fidelity speakers available for reproduction of voice or music. It easily handles 10 watts with excellent efficiency and reproduces the audio spectrum with full clarity and fidelity even when handling sharp "bursts and transients." This quality loudspeaker may be used with any standard 12-inch baffle, but it is recommended that for quality reproduction a minimum enclosure size of 5 cubic feet be used.

The smooth frequency response of the SL-12B Speaker is the result of extensive research by Dr. H. F. Olson and his associates at the Acoustical Laboratories of the David Sarnoff Research Center. A special shape has been used for the curvilinear cone, and, in addition, the material for the cone has received particular attention. These two factors play important roles in giving a broad pat-

tern to the speaker. A further refinement is the damping ring in the outer suspension of the cone which provides optimum acoustical impedance to effectively eliminate stand-

ing waves in the suspension and cone. This gives improved efficiency at the bass end and relatively smooth response at the high end of the spectrum.

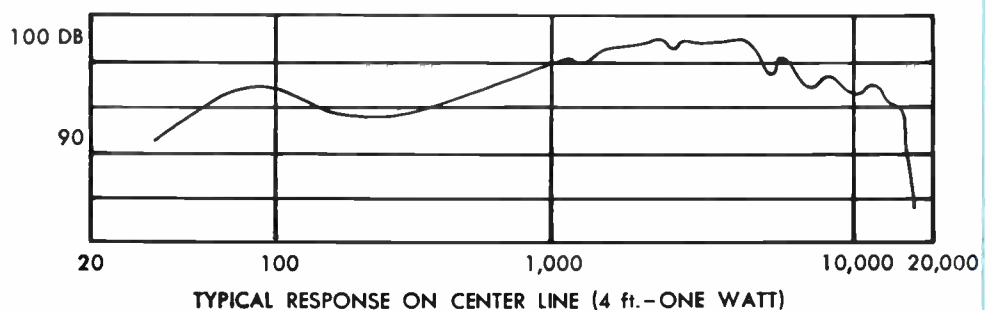

Specifications

Frequency Response.....	50 to 16,000 cycles
Power Handling Capacity.....	10 watts
Magnet Indox Weight.....	20 ounces
Input Impedance.....	8 ohms
Overall Diameter	12-7/32"
Depth	5-5/32"
Weight	4 lbs.
Axial Sensitivity at 4 ft. 1 watt, see curve.....	95 db
Cone Resonance (6½ cubic ft. cabinet).....	60-70 cps
Mounting Data (EIA).....	4 equally spaced slots on an 11¼" bolt circle
Voice Coil Diameter.....	1"
Flux Density.....	11,500 gauss

Architects' and Engineers' Specifications

The speaker shall be a permanent magnet field type using 20 oz. of Indox ceramic. It shall be capable of handling up to 10 watts of audio power, and capable of producing an audible frequency response over a range of 50 to 16,000 cycles per second and shall have a nominal axial sensitivity of 95 db at 4 feet with 1 watt input. The voice coil impedance shall be 8 ohms at 400 cycles. It shall have a one piece stamped steel frame with an outside diameter of 12-7/32 inches and shall have 4 equally spaced slots on a 11¼-inch bolt circle for mounting purposes. The overall depth shall be 5-5/32 inches. All ferrous metal parts shall be made rust resistant by plating.

Ordering Information

Type SL-12B Twelve-Inch Speaker.....MI-38315-A



RADIO CORPORATION OF AMERICA



- Excellent frequency response—
35 to 22,000 Hz
- 50 watts program input
- Wide angle sound radiation
of all frequencies
- Matching H.F. and L.F. wavefront
- 500 hertz crossover



Auditorium Loudspeaker, Type LC-9A

Description

The LC-9A Loudspeaker system is designed for applications where high acoustical level, wide dispersion angle, and extended frequency response are required. The frequency range is covered by separate low and high frequency horns with a cross-over point at 500 Hz. A feature of the LC-9A is the particular care with which the high and low frequency horns have been designed to provide matched acoustical wavefronts for smooth response over the entire frequency range at all listening angles.

Specifications

Power Input	50 Watts
Frequency Response	35-22,000 Hz
High Frequency:	
Horn	120° horizontal, 45° vertical dispersion
Driver	16 ohms, 1¾" diaphragm
Low Frequency:	
Horn	120° horizontal, 60° vertical dispersion
Driver	16 ohms, 15" speaker
Dividing Network	16 ohms, 500 Hz crossover frequency, 12 dB per octave
Overall Size	44" high, 36" wide, 27" deep (17" deep less flair)
	111.76 cm, 91.44 cm, 68.58 cm (43.18 cm less flair)
Weight	175 lbs. (79.4 kg.)
Finish	Shadow blue and midnight blue

Ordering Information

Type LC-9A Studio Loudspeaker.....MI-11423

1QB



RADIO CORPORATION OF AMERICA





- Improved frequency response—50-18,000 cps
- Indox (ceramic) magnet—shallow depth
- Acoustically designed for RCA wall baffles
- No soldering required—lower installation cost
- Edge damped—no “peaks” or “holes” in response
- Handles 15 watts of program material



8-Inch Speakers

Description

The MI-12454-C is an excellent quality 8-inch speaker which incorporates a high frequency cone mechanically coupled to the voice coil. It is also equipped with a 70 volt line matching transformer.

This extended range speaker has a power handling capacity of 15 watts and frequency response of 50-18,000 cycles. The speaker cone has been edge damped to eliminate “holes” or “peaks” in the response, resulting in a flat response.

Installation of the MI-12454-C is easily accomplished without soldering, by attaching the furnished transformer lead between the speaker terminal and to the desired tap on the transformer. Tap can be readily changed if necessary. Connections can be made to supply lines by means of screw caps.

For best reproduction, a minimum enclosure size of 2½ cubic feet is recommended for this speaker.

MI-38304-A

This speaker is excellent and economical for general applications such as background music systems where quality reproduction of voice

and music are required. Equipped with a high frequency cone mechanically coupled to the voice coil, it provides extended high frequency response to beyond the capability of most listeners. This speaker mechanism is ideally suited to high performance systems which require a response range to 18,000 cps. The

speaker cone has been treated to provide essentially flat response, without “peaks” or “holes.”

Any standard 8-inch baffle may be used with the MI-38304-A speaker, but for quality reproduction, a minimum enclosure size of 2½ cubic feet is recommended.

Specifications

Frequency Response.....	50-18,000 cps
Sensitivity (4 ft. at 1 watt).....	96 db
Voice Coil Impedance.....	8 ohms
Power Handling Capacity.....	15 watts program
Magnet (Indox) Weight.....	5 oz.
Transformer Taps.....	¼ watt; ½ watt; 1 watt
Overall Diameter.....	8⅞" (20.64 cm)
Mounting Data (EIA).....	4 equally spaced holes on 7⅝" bolt circle

MI-12454-C

Depth.....	2⅝" (6.67 cm)
Shipping Weight (with transformer).....	2½ lbs. (1.13 kg)

MI-38304-A

Depth.....	2⅝" (6.67 cm)
Shipping Weight.....	2¼ lbs. (1.02 kg)

Ordering Information

8-Inch Speaker	MI-38304-A
8-Inch Speaker, with 70 volt transformer.....	MI-12454-C

2QB



RADIO CORPORATION OF AMERICA

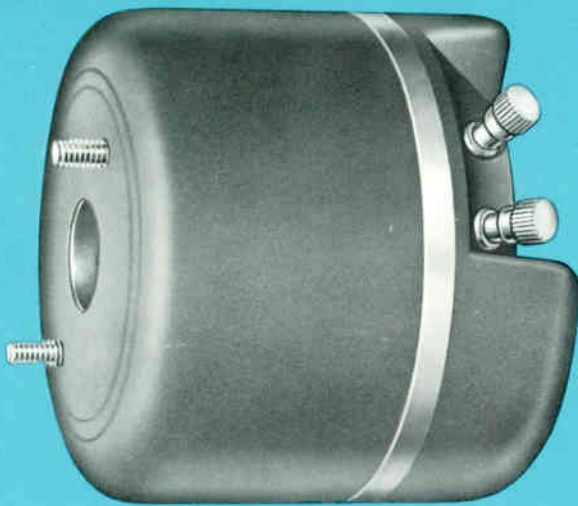

- Smooth response from 500 to 15,000 cps
- Aluminum voice coil and diaphragm
- High intensity permanent magnet
- Heavy duty construction



High Frequency Speaker Mechanism, MI-11419

Description

The MI-11419 High Frequency Speaker Mechanism is designed for professional audio use as a component in auditorium/studio type loudspeaker systems. Throat adapter MI-9575 may be used to couple it to RCA Radial Horns such as MI-9594 (60°) or MI-9595 (90°). It may be used with other horns having a suit-

able throat acoustic impedance and cross-over network.

The H.F. speaker mechanism attaches to the MI-9573 throat by means of two $\frac{1}{4}$ —20 threaded studs $2\frac{1}{4}$ inches apart. The throat is $2\frac{5}{16}$ inches front to back and adapts the H.F. speaker mechanism to the radial horn.



Throat Adaptor, MI-9575

Specifications

Nominal Voice Coil Impedance.....	16 ohms
Crossover Frequency	500 cycles
Power Handling Capacity.....	40 watts of program material when used in system with a suitable horn and cross-over network
Frequency Response.....	500 to 15,000 cps
Gap Flux Density.....	16,500 gauss
Voice Coil Diameter.....	1 $\frac{3}{4}$ " (4.45 cm)
Horn Throat Diameter.....	1" (2.54 cm)

Overall Diameter.....	4 $\frac{1}{2}$ " (11.47 cm)
Overall Depth.....	3 $\frac{7}{8}$ " (8.84 cm)
Mounting.....	Two $\frac{1}{4}$ —20 threaded studs, $2\frac{1}{4}$ " apart
Shipping Weight.....	10 lbs. (4.54 kg.)

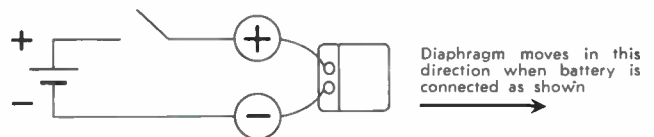

Ordering Information

High Frequency Speaker Mechanism.....	MI-11419
---------------------------------------	----------

ACCESSORIES

Throat (for use with RCA Horns MI-9594 or MI-9595).....	MI-9573
60° Radial Horn	MI-9594
90° Radial Horn	MI-9595
Diaphragm Assembly (Replacement).....	#234776

6PB



RADIO CORPORATION OF AMERICA

PRINTED IN U.S.A.



1 KW AM Broadcast Transmitter, Type BTA-1R2

- Excellent frequency response
- Low distortion
- Circuit breaker overload protection
- Low operating costs



BTA-1R2 Transmitter with front door open showing accessibility of tubes and components. Power amplifier and Modulator tubes are shown on top chassis; below is exciter chassis. All normal operating controls are on two side panels.



Rear view of BTA-1R2, with rear panels removed, showing vertical construction and accessibility of component parts.

View of oscillator chassis. The terminal strip on right contains all of the oscillator connections. The three crystals are switchable from a front panel control.

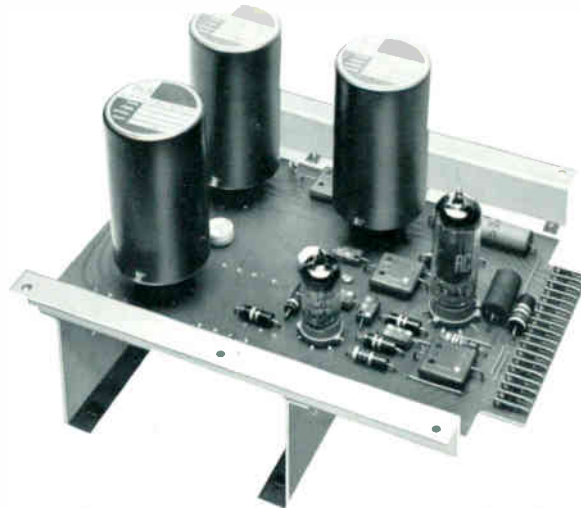

Description

The RCA Type BTA-1R2, 1-kilowatt AM Broadcast Transmitter is designed for reliability, outstanding fidelity, and economical operation. It provides a high quality amplitude modulated signal at any frequency in the 535 to 1620 kilohertz band and is capable of producing a maximum of 1100 watts.

Highly perfected audio circuits together with a large, high-quality transformer and reactor provide tremendous modulation capability and unusually High Fidelity sound. Stable, long-life tubes and silicon rectifiers have been used throughout the transmitter. Circuit breakers—not fuses—provide complete overload protection.

Provision for remote control and simplified power cutback are reflected in the BTA-1R2 design. Front panel or remote control selection of any two power levels of 1000, 500 or 250 watts is available. No unnecessarily complicated circuitry or superfluous parts have been included and all components are easily accessible for maintenance and inspection. The transmitter is designed for 208 or 240 volt operation.

Functional Design

Improved functional design includes RCA's new color combination. Square construction permits locating the transmitter against the wall, or it can be installed against other equipment. The vertical construction makes it accessible from both front and rear for ease of maintenance. A single front panel tuning control provides simplified operation. Remote control provisions permit unattended operation of the transmitter.

Simplified Power Cutback

The BTA-1R2 easily fits into operations where power reduction at night is required. For "day-night" operation the transmitter incorporates a built-in power cutback system. By pressing a switch on the front or at a remote panel, the transmitter can be cut back in power to either 500 or 250 watts. Efficient operation at the low power levels is achieved by reducing the high voltage by primary taps on the plate transformer.

Complete Accessibility

The entire transmitter is housed in a single steel cabinet that is mounted on a sturdy welded steel base. Control components are conveniently located on the control panels on both sides of the front door and all meters are at eye level. Easy access is provided by a hinged front door and two interlocked removable panels. Most BTA-1R2 components are mounted on a vertical center chassis. Tubes and overload relays are mounted on the front and the other components are mounted on the rear. Larger power components are mounted on the base.

Solid State Power Supplies

Three power supplies are used: a low voltage supply for plate and screen voltages of all low voltage tubes, a bias supply for the modulator tubes, and a high voltage supply for the modulator and power amplifier tubes. All power supplies use silicon diodes which results in lower power drain, cooler operation and more reliable performance.

Power Requirements

The transmitter operates from a 208-240 volt, 60 hertz single phase power source for the main power. In addition, the crystal heaters require an additional 115 volt power input. The transmitter can be modified for operation on 50 hertz a-c current if desired.

Switchable Crystal Oscillators

The BTA-1R2 uses an MI-27632-A Crystal Oscillator which has provisions for three switchable TVM-130B temperature controlled crystal units. These units maintain the frequency constant to within plus or minus five hertz. Selection of the desired crystal is by means of front panel switches and latching relays. The oscillator employs a broadband circuit with no adjustments, and uses a 6AK5 oscillator tube and a 5763 buffer tube.

Simple, Straightforward Circuitry

The buffer feeds a single 6146A driver tube which in turn feeds the power amplifier which consists of two 4-400A tubes connected in parallel. Tetrodes have been utilized throughout the r-f section of the transmitter reducing the required stages and the power consumption. Tetrodes also eliminate the need of neutralization.

The modulator comprises two 2E26 tubes in push-pull resistance coupled to two 4-400A modulator tubes. The modulator tubes operate as a class AB₁ amplifier without grid current which results in an overall distortion of less than 2 percent up to 10,000 hertz.

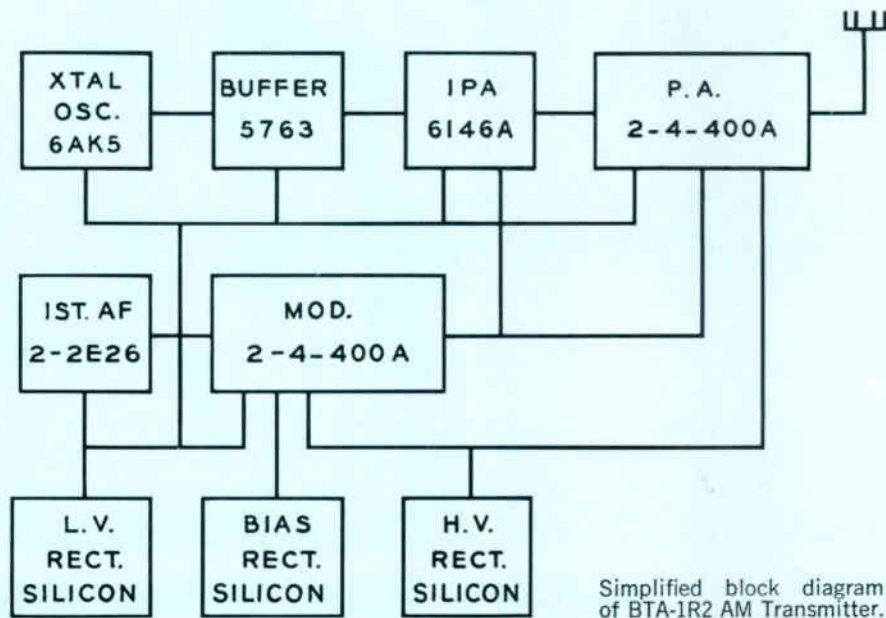

Specifications

Performance

AF Input Impedance.....	150/600 ohms
AF Input Level (100% modulation).....	+10 ±2 dbm
AF Response:	
50-7500 Hz.....	±1 db
30-10,000 Hz.....	±1.5 db
30-15,000 Hz.....	±3 db
AF Distortion (95% modulation):	
50-10,000 Hz.....	2%
50-12,000 Hz.....	3%
Noise (below 100% modulation).....	60 db
Frequency Range.....	535-1620 kHz
Frequency Stability.....	±5 Hz
Type of Output.....	Single ended
Carrier Shift (0-100% modulation).....	3%
Output Impedance.....	40-250 ohms

Electrical

RF Voltage (for frequency monitoring).....	10 V RMS 75 ohms
RF Voltage (for modulation monitoring).....	10 V RMS 75 ohms
Power Output (nominal).....	1000 watts
Power Output Capability.....	1100 watts
Power Supply.....	208/240 volts
Line Frequency.....	60 Hz
Phase.....	1
Power Consumption:	
(0% modulation).....	2900 watts (approx.)
(1000% modulation).....	3900 watts (approx.)
(average program modulation).....	3200 watts (approx.)
Power Factor.....	90%
Permissible combined line voltage variation and regulation.....	±5%
Crystal Heater Power Supply.....	115 volts 50/60 Hz

Tube Complement

1	6AK5	Crystal Oscillator
1	5763	Buffer
1	6146A	Intermediate Power Amplifier
2	2E26	Audio Frequency Amplifier
2	4-400A	Modulator
2	4-400A	Power Amplifier

Mechanical

Height.....	84" (213.4 cm)
Width.....	34" (86.4 cm)
Depth.....	32½" (82.6 cm) (less door handle)
Weight (net).....	1700 pounds (772 kg) (approx.)
Altitude Range.....	0-5000 ft. (0-1524 m)
Ambient Operating Temperature:	
(min.).....	-20°C (-4°F)
(max.).....	+45°C (113°F)

Accessories

Operating Spare Tube Kit.....	MI-27696-A
Recommended Minimum Spare Tube Kit.....	MI-27695-A
Type BTR-11B Remote Control System.....	ES-34280
Type BW-11A Frequency Monitor (Specify frequency).....	ES-34042
Type BW-66F Frequency Monitor.....	MI-30066-B
Power Max (Negative Peak Limiter).....	MI-34654
RF Ammeters.....	MI-7157-F Series
Ammeter Mounting Panel.....	MI-34656
Remote RF Pickup Unit (less meter).....	MI-27966-B
Remote Antenna Meter.....	MI-27644 Series
Automatic Logging Equipment.....	On Application

Ordering Information

Type BTA-1R2 1000-Watt AM Broadcast Transmitter complete.....	ES-27238-C
--	------------



RADIO CORPORATION OF AMERICA



5 KW AM Broadcast Transmitter, Type BTA-5T1

- Outstanding performance
- Only two tuning controls
- Power economy
- Built-in remote control provisions



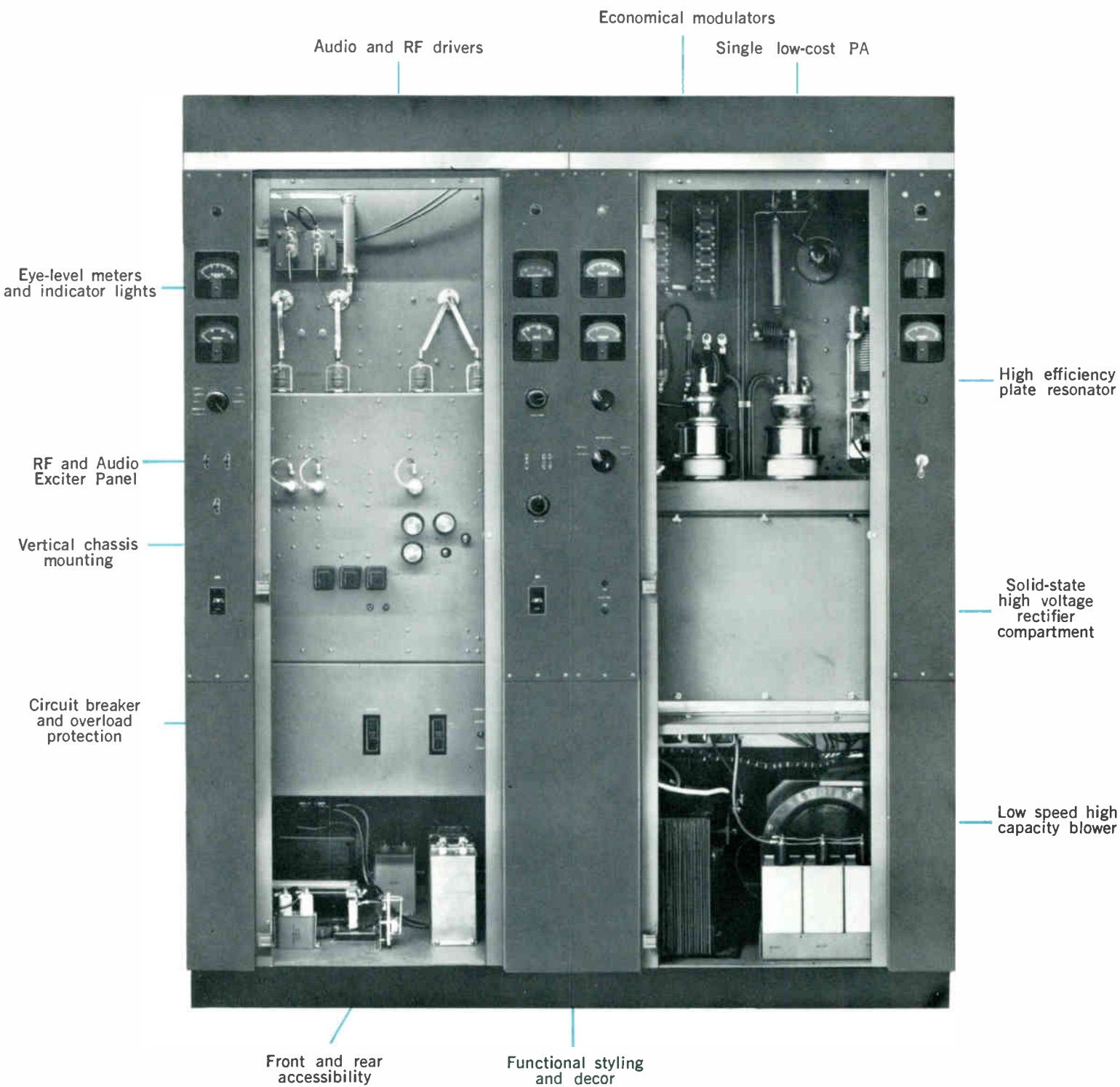

Audio and RF drivers

Economical modulators

Single low-cost PA

Eye-level meters and indicator lights

RF and Audio Exciter Panel

Vertical chassis mounting

Circuit breaker and overload protection

High efficiency plate resonator

Solid-state high voltage rectifier compartment

Low speed high capacity blower

Front and rear accessibility

Functional styling and decor

Description

The Type BTA-5T1 is RCA's high-efficiency 5-kilowatt AM Transmitter that has proved a popular choice for its reliable and economical operation. It has been restyled for even greater operating convenience.

The transmitter is designed to provide an amplitude modulated signal at any frequency in the standard broadcast band between 535 and 1620 kilohertz. The nominal power output rating is 5000 watts; however, it is capable of producing 5500 watts to compensate for losses in the antenna tuning equipment.

New High Efficiency PA

The BTA-5T1 Transmitter is an air-cooled transmitter featuring a number of RCA's finest developments, including an important refinement in Class C amplifier design. The high efficiency plate modulated power amplifier permits a single long-life 5762 tube to deliver the nominal 5 kW with 5.5 kW power output capability because the plate efficiency exceeds that of a conventional class C amplifier by 15 percent. As a result, considerable power savings can be realized. The amplifier is the only worthwhile development in class C amplifier design in 25 years. The high-voltage, low-voltage and bias supplies employ silicon type rectifiers throughout.

Built-in Features

Provisions for increased power, remote control and simplified power cutback are reflected in the RCA Type BTA-5T1. Improved functional design includes RCA's new color combinations to harmonize with the new studio color schemes. All doors and panels are interlocked and grounding switches provide utmost safety for operating personnel. The variable vacuum capacitor used for tuning the PA is operated from the front panel. A delay relay is employed to keep the blower system in operation for one minute after operation has been terminated. This refinement is used to improve tube life.

Improved Mechanical Design

The entire transmitter, except for the plate transformer, is housed in two attractively styled cabinets made of aluminized steel to provide improved magnetic and electrostatic shielding. Each cabinet consists of end panels with wrap-around front edges formed to provide control panels, mounted on a sturdy, welded steel base. Vertical center chassis are fastened between the end panels to form a basic "H" cross section. Hinged, front



IPA and modulator driver stages of the BTA-5T1 can be seen at top of open cabinet. The exciter is at the center of the cabinet, and control equipment is placed just below the exciter



Front view of the Silicon Rectifier Chassis of the BTA-5T1. The silicon cells offer improved performance since they are particularly resistant to aging, moisture and wide temperature variations.

of these chassis, while the larger power components are situated in the base of the cabinet. This type of construction provides greater ease in preventive maintenance and faster corrective maintenance.

Compact Size

The left hand cabinet contains the BTA-5T1 exciter-driver, while the right hand cabinet houses the amplifier, modulator and high voltage rectifier portions of the transmitter. The cabinets require less than 16 square feet of floor space. A plate transformer occupies only an additional 3 square feet.

Stable Circuit Design

The BTA-5T1 Transmitter incorporates RCA's MI-27632-A Crystal Oscillator with switchable temperature-controlled crystals. Each crystal will remain constant within plus or minus five Hertz. The desired crystal can be selected by means of a front panel switch or

doors are located between the control panels. Rear access to each cabinet is provided by two removable, interlocked panels. Control components are conveniently located on the panels on both sides of the front doors. All meters are at eye level to facilitate readings.

Functional Styling

Vertical construction provides complete accessibility to all components. It also permits installation of the transmitter against a side wall, or allows other equipment to be placed on either side of the cabinet.

The front doors of the transmitter give immediate access to the front of the vertical panels on which circuit components such as tubes, feedback ladders and overload relays are mounted. Other components are mounted on the rear

Rear view of high efficiency PA. Removal of the rear panel provides complete access to circuit components for ease of maintenance.

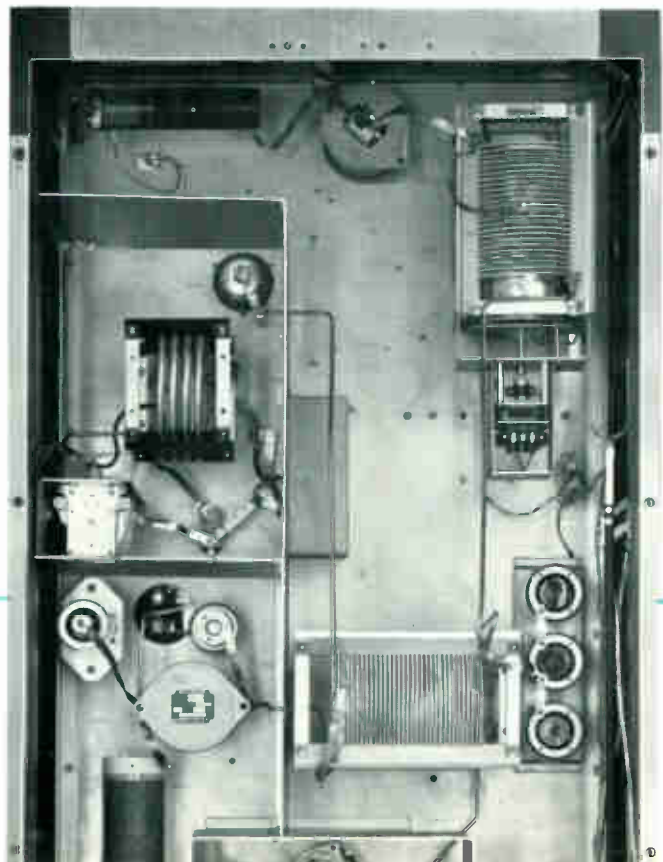

by means of a remote-control switch since relays are built into the exciter. The oscillator employs broadband circuits that require no adjustments. A 6AK5 is used as an oscillator tube with a 5763 as the buffer. This unit is built on an etched circuit panel easily accessible for service by removing the cover. The entire oscillator unit can be removed by disconnecting a cable, plug and retaining screws. Also a part of the basic exciter is the 6146 IPA stage which is operated very conservatively and a pair of 2E26 tubes used as the first a-f stage of the modulator circuit.

Broadband Circuits

The output of the 6146 IPA stage is broadband and requires no tuning. It drives a pair of 4-125A tubes used as the driver for the 5762 final r-f amplifier. A front panel control of a vacuum variable capacitor tunes the plate circuit.

The modulator of the transmitter consists of a pair of 2E26 tubes located in the exciter portion, resistance coupled to drive a pair of 6155/4-125A second audio frequency amplifiers which, in turn, are resistance coupled to drive a pair of 3X3000F1 modulators. These modulator tubes are low mu triodes, drawing no grid current. They are capable of excellent response and fidelity. Due to the high efficiency of the new power amplifier system, the power input of the modulator is also reduced affording appreciable power economies.

Dependable Semiconductor Power Supply

The BTA-5T1 incorporates 120 silicon rectifiers in the high-voltage power and supply. This rectifier is ideal not only in a combined operation, but even more so in a remote-control application.

The rectifiers are hermetically sealed so they will not be adverse-

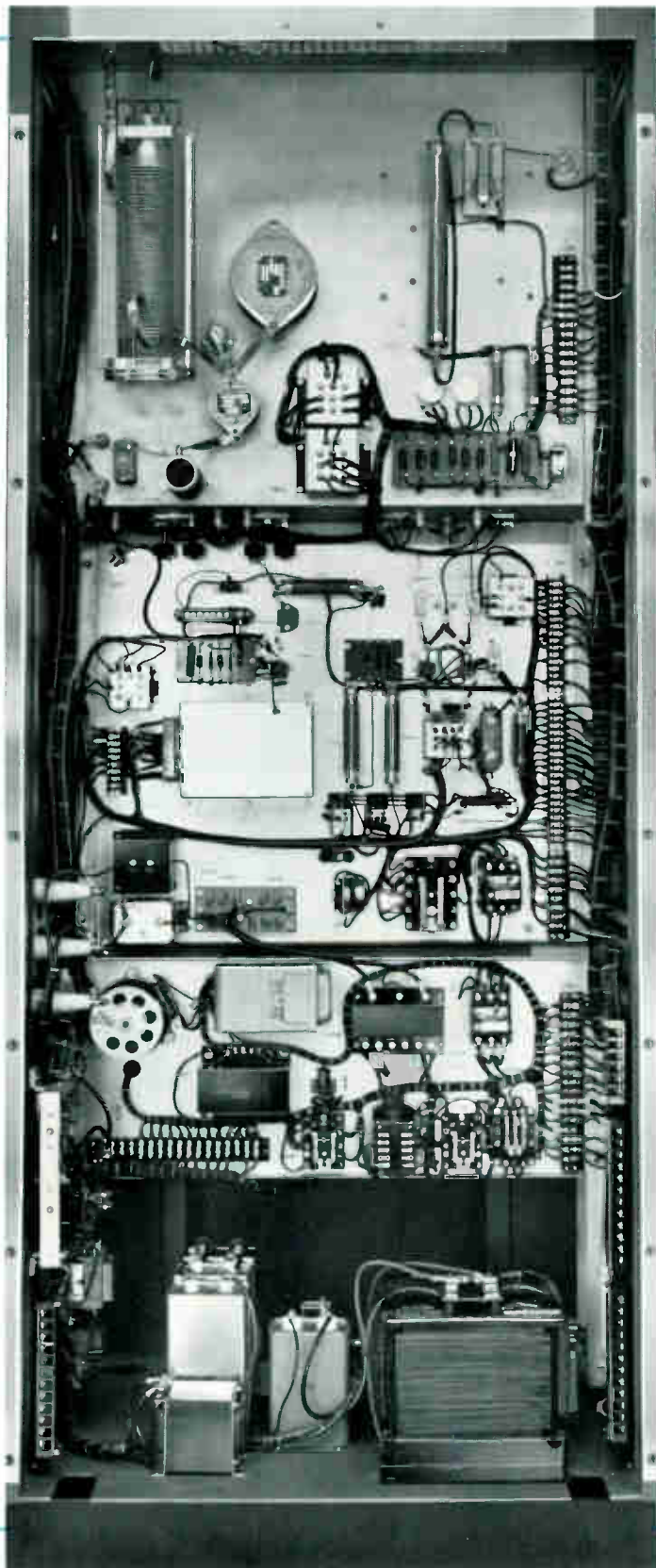

Rear of the BTA-5T1 exciter-driver cabinet.

ly affected by weather conditions. They can operate at ambient temperatures ranging from -20 degrees C to $+45$ degrees C and at altitudes up to 7500 feet above sea level. There is no significant aging of the forward drop characteristics. RCA specifications have been set higher than EIA standards by adding an additional 30 percent peak inverse voltage safety factor.

The bias and low-voltage rectifiers are sealed silicon units providing reliable operation.

Overload Protection

To provide additional reliability, improvements were made in the control and protective circuitry of the BTA-5T1 Transmitter. All primary lines are protected by means

of circuit breakers with instantaneous overload trip protection. Line and high-voltage plate circuit breakers have additional built-in thermal protection. The 3-phase blower is protected by a contactor with the thermal cutoff in each phase. Relay switching is sequential so that filaments will not come on unless the blower is operating. Low voltage is delayed to allow proper filament heating. The high voltage is interlocked with the low-voltage and the bias supply so that it will come on only after the low-voltage and bias potential is present. Overload protection is also provided in the low-voltage supply, the second AF stage, the IPA stages, the modulator, the PA stages and the high-voltage rectifier. They are instantaneous in action and each overload relay carries

a spare set of contacts wired to terminals that may be connected to an external indicator unit. A two cycle plate overload relay also permits the transmitter to return to the air automatically after one interruption has occurred.

Starting surges in the plate transformer, high voltage rectifier, and the filter capacitor are eliminated by the use of a step-start and damping circuit. This at one time was only available in the higher-power transmitters, but now longer life and added reliability are provided in the BTA-5T1 with the incorporation of this circuit for the suppression of starting transients. The damping circuit and the primary line reactors afford continuous protection against possible operational transients.

Simplified block diagram of BTA-5T1 Transmitter.

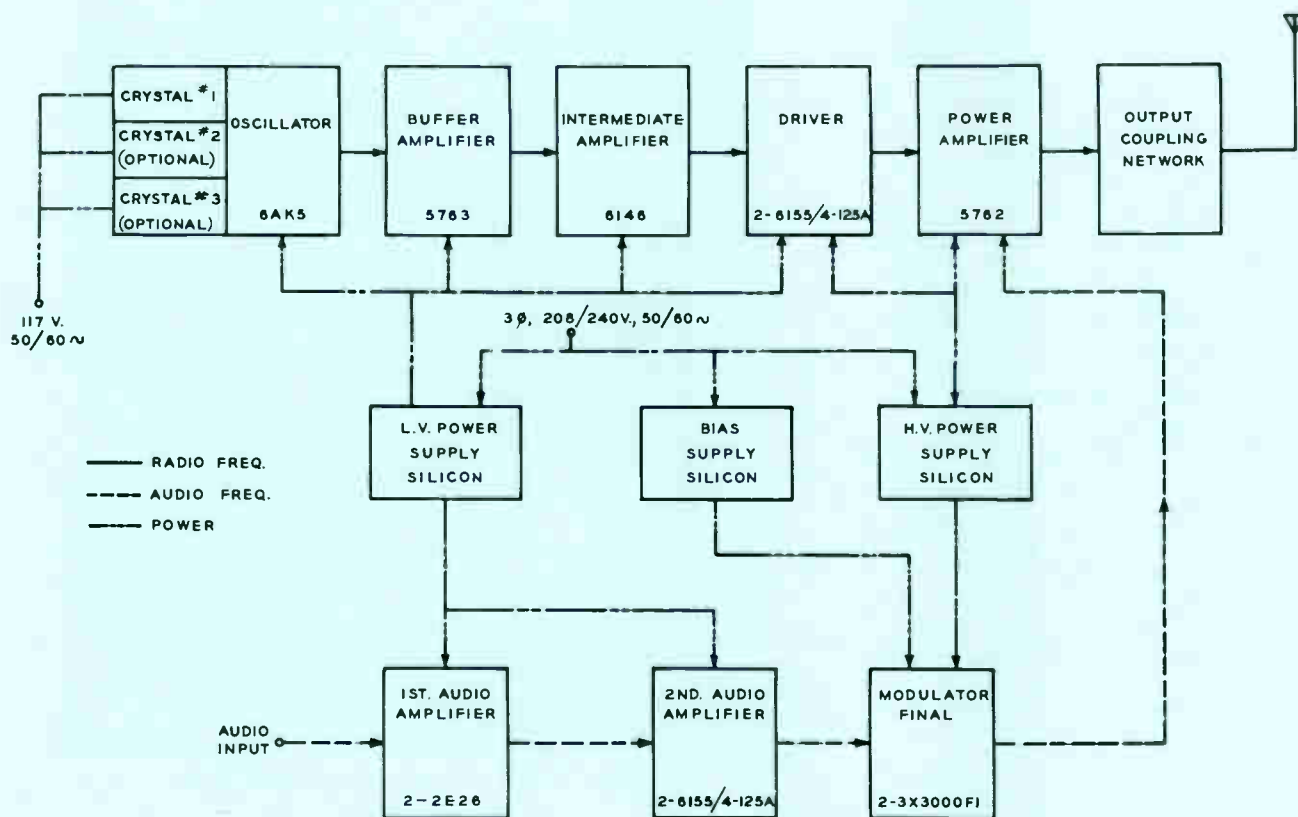

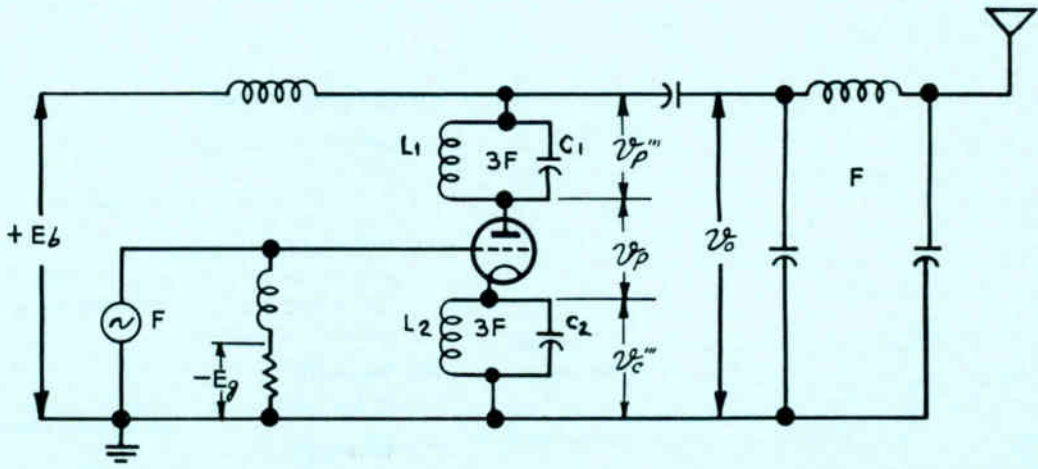

Simplified schematic of the new high efficiency PA stage. The adjustment of the circuit differs from a conventional class "C" only in that the coils L_1 and L_2 are resonated for maximum efficiency.

Audio Frequency Response for BTA-5T1 Transmitter.

TYPICAL FREQ RESPONSE

DECIBELS

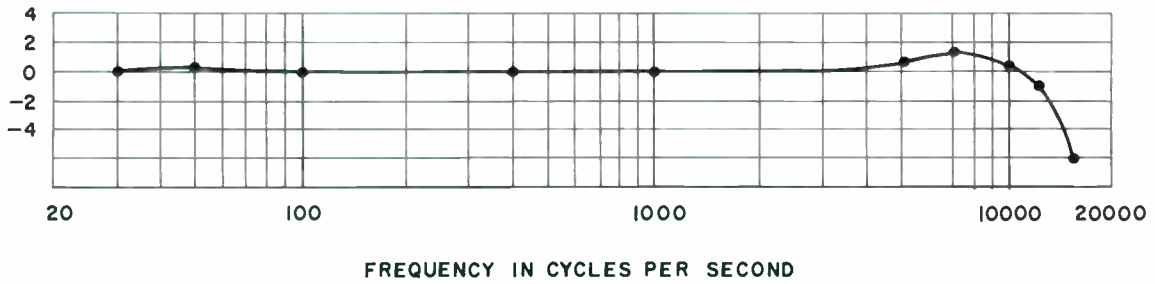

TYPICAL DISTORTION

PERCENT

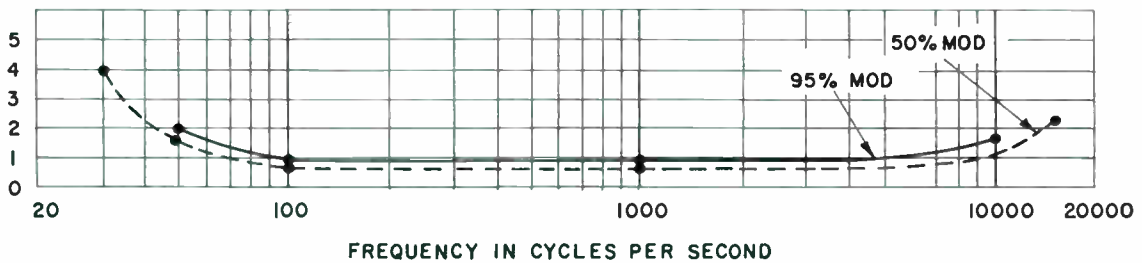

Specifications

Performance

AF Input Impedance.....	150/600 ohms
AF Input Level (100% modulation).....	+10 ±2 dBm
AF Response:	
50-7500 Hz.....	±1 dB
30-10,000 Hz.....	±1.5 dB
AF Distortion (95% modulation):	
50-10,000 Hz.....	2.5%
Noise (below 100% modulation).....	60 dB
Frequency Range.....	535-1620 Hz
Frequency Stability.....	±5 Hz
Type of Output.....	Single ended
Carrier Shift (0-100% modulation, 400 Hz).....	3% at constant line voltage 5% at normal line voltage regulation
Output Impedance.....	40-250 ohms

Electrical

RF Voltage (for frequency monitoring).....	10 V RMS 75 ohms
RF Voltage (for modulation monitoring).....	10 V, 75 ohms
Power Output (nominal).....	5000 watts
Power Output Capability.....	5500 watts
Power Supply.....	208/240 volts ±11 volts
Line Frequency.....	60 Hz (50 Hz kit available)
Phase.....	3
Power Consumption:	
(0% modulation).....	10.0 kW
(100% modulation).....	14.5 kW
(Average program modulation).....	11.0 kW
Power Factor.....	90%
Permissible Combined Line Voltage Variation and Regulation.....	±5%
Crystal Heater Power Supply.....	117 Volts 50/60 Hz

Tube Complement

- 1 6AK5 Crystal Oscillator
- 1 5763 Buffer
- 1 6146 Intermediate Power Amplifier
- 2 6155/4-125A Driver
- 1 5762 Power Amplifier
- 2 2E26 1st Audio Frequency Amplifier
- 2 6155/4-125A 2nd Frequency Audio Amplifier
- 2 3X3000F1 Modulator

Mechanical

Overall Height.....	.88" (223.5 cm)
	(84" or 213.4 cm less floor channels)
Cabinet Height.....	.84" (213.4 cm)
	(80" or 203.2 cm less floor channels)
Width.....	.69" (175.3 cm)
Depth.....	.32½" (82.6 cm) (less door handles)
Overall Depth.....	.55" (139.7 cm) (with door open)
Net Weight:	
Transmitter.....	3800 lbs. (1724 kg) (approx.)
Plate Transformer.....	420 lbs. (190.5 kg) (approx.)
Altitude Range.....	0-7500 ft. (0-2286 m)
Ambient Operating Temperature:	
BTA-5T1.....	-20°C (40°F) min.; +45°C (113°F) max.

Accessories

Complete Set of Tubes for BTA-5T1.....	ES-34230
Recommended Minimum Set of Spare Tubes.....	ES-34208
BTR-11B Remote Control System.....	ES-34280
BTR-20C Remote Control System.....	ES-34274
BW-11A AM Frequency Monitor.....	ES-34042
BW-66F AM Modulation Monitor.....	MI-30066-B
R-F Ammeter.....	MI-7157-F Series
Ammeter Mounting Panel.....	MI-34656
Antenna Tuning Equipment.....	ES-27256
R-F Meter Mounting Panel.....	MI-34656
Power Cutback Kit (1000/500 Watts).....	MI-34646-A
Remote R-F Pickup Unit (less meter).....	MI-27966-B
Remote Antenna Meter.....	MI-27644-Series
Automatic Logging Equipment.....	On Application

Ordering Information

Type BTA-5T1 5000-Watt Broadcast Transmitter (high-efficiency) including one set of tubes and crystal (Silicon Rectifier). Specify operating frequency and output impedance..... ES-34229



RADIO CORPORATION OF AMERICA



5-10 KW AM Broadcast Transmitter, Type BTA-5U1/10U1



- Outstanding sound
- High efficiency circuits
- High reliability
- Great overall economy

High Efficiency 5/10 Kilowatt Transmitter

Only Two
Tuning Controls

Dependable
Semi-Conductor
Power Supply

High
Efficiency
Cathode
and Plate
Resonators

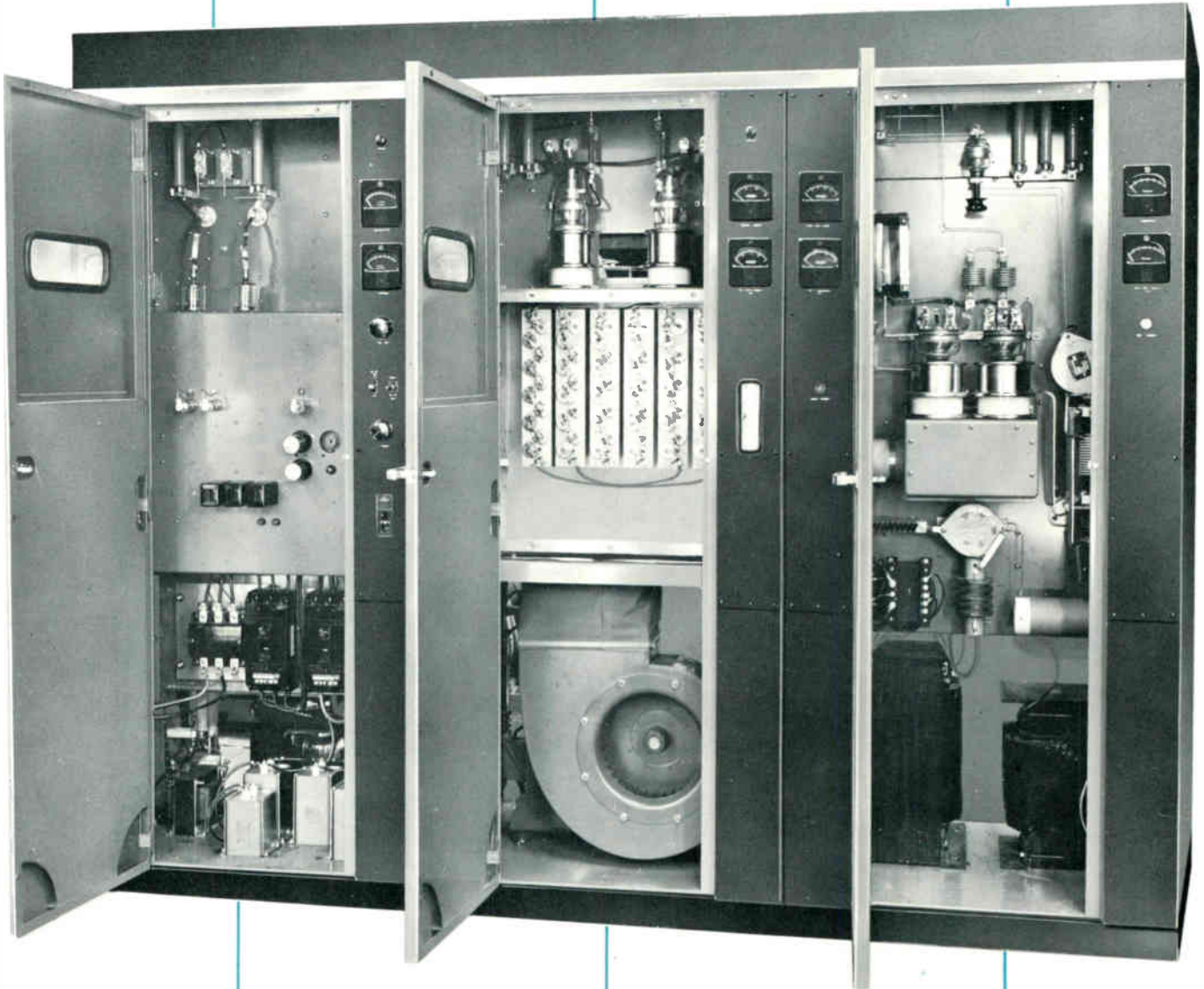

Built-in Remote
Control Provisions

Completely
Air Cooled

Self-contained 5-kW
Plate Transformer

5/10 KW AM Broadcast Transmitter, Type BTA-5U1/10U1

The BTA-5U1 is a 5 kilowatt amplitude modulated, high fidelity, broadcast transmitter for operation in the standard band between 535 and 1620 kilohertz. It is essentially the same as RCA's popular BTA-5T1 model with advanced provisions for power increase to 10 kilowatts.

The RCA BTA-10U1 AM Broadcast Transmitter is the fully converted deluxe BTA-5U1 with a second 5762 Amplifier tube to provide 10 kilowatt output. Both transmitters are outstanding in appearance and reliability, and meet requirements of the FCC and EIA.

The BTA-5U1/10U1 operates from a 208/240 volt, 50/60 hertz, three-phase

power source for the main power. The crystal heaters require an additional 115-volt 50/60 hertz single phase a-c power input. Both transmitters exceed nominal power output rating to compensate for losses in the antenna tuning equipment.

The spacious cabinet of the BTA-5U1 Transmitter permits internal mounting of the 5 kilowatt plate transformer. There are provisions for easy conversion to higher power at a later date. The transmitter allows simplified power change to 1 kilowatt or 500 watts, if desired, by installing an optional Power Cutback Kit, MI-34646-A. Similarly, the BTA-10U1 can be operated at 5 kilowatts, or at 1 kilowatt.

Description

The BTA-5U1/10U1 is an air-cooled transmitter featuring a number of design developments, including an important development in Class C amplifier design. The new high efficiency, plate modulated power amplifier permits one or two long-life 5762 tubes to deliver the nominal 5 or 10 kilowatt with 5.5 or 10.6 kilowatt power output capability. The plate efficiency appreciably exceeds that of a conventional class C amplifier. As a result, considerable power savings can be realized. Referring to the simplified schematic, the circuit arrangement is very similar to a conventional class C amplifier, except for the presence of two high efficiency resonators. The amplifier is stable and easy to adjust. The high-voltage, low-voltage and bias supplies employ silicon rectifiers throughout.

Other new design techniques of the transmitter provide simplified tuning, increased safety, longer tube life and improved performance. After initial adjustments, the transmitter can be tuned from the front panel. This is accomplished by only two controls. Provisions for manual or remote control operation are incorporated in the transmitter. For safety, all doors and panels are interlocked and grounding switches protect operating personnel. The transmitter is air-cooled by a single blower housed in the center cabinet.

Improved Mechanical Design

The BTA-5U1/10U1 Transmitter is housed in three attractively styled cabinets made of anodized aluminum steel to provide improved magnetic and electrostatic shielding. The left cabinet, or cubicle, contains the Transmitter Driver including exciter and control panel. The center cabinet houses the Modulator and High Voltage Rectifier, and the Blower. In the right hand cabinet is located the Power Amplifier, and the 5-kW Plate Transformer. The plate transformer of the BTA-10U1 is an external unit which can be mounted near the cabinets.

Accessible Vertical Panel Construction

Each cabinet consists of end panels with wrap-around front edges formed to provide control panels, mounted on a sturdy, welded steel base. Vertical center chassis are fastened between the end panels to form a basic "H" cross section. Reach-in accessibility to transmitter components is afforded by hinged front doors located between the control panels. Rear access to each cabinet is provided by two removable, interlocked panels. Control components are conveniently located on the panels on both sides of the front doors where all meters are situated at eye level.

The matched cabinets are designed to combine an attractive ap-

pearance with the utmost in utility. Vertical construction permits easier maintenance and service. It also permits installation of the transmitter against a side wall, or allows other equipment to be placed on either side of the cabinet. The front doors of the transmitter give immediate access to the front of the vertical panels on which circuit components such as tubes and overload relays are mounted. Remaining small components are mounted on the rear of these chassis, while the larger power components are situated in the base of the cabinet.

Efficient Circuit Design

The BTA-5U1/10U1 Transmitter incorporates RCA MI-27632-A Crystal Oscillator with three, switchable, temperature-controlled crystal positions. Crystal stability is plus or minus five cycles. The desired crystal can be selected by means of a front panel switch or by means of a remote-control switch since relays are built into the exciter. The oscillator employs broadband circuits that require no adjustments. A 6AK5 is used as an oscillator tube with a 5763 as the buffer. This unit is built on an etched circuit panel easily accessible for service by removing the cover. The entire oscillator unit can be removed by disconnecting a cable-plug and retaining screws. Also a part of the basic exciter is the 6146 IPA stage which is operated

Select Features

REACH-IN ACCESSIBILITY



Rear view of transmitter showing vertical construction permitting complete accessibility to all transmitter facilities. The modulation transformer and final PA tank circuitry are seen in foreground, rear of modulator and blower in center cabinet, while heavier components of driver are shown mounted on floor of third cabinet.

BUILT-IN REMOTE CONTROL

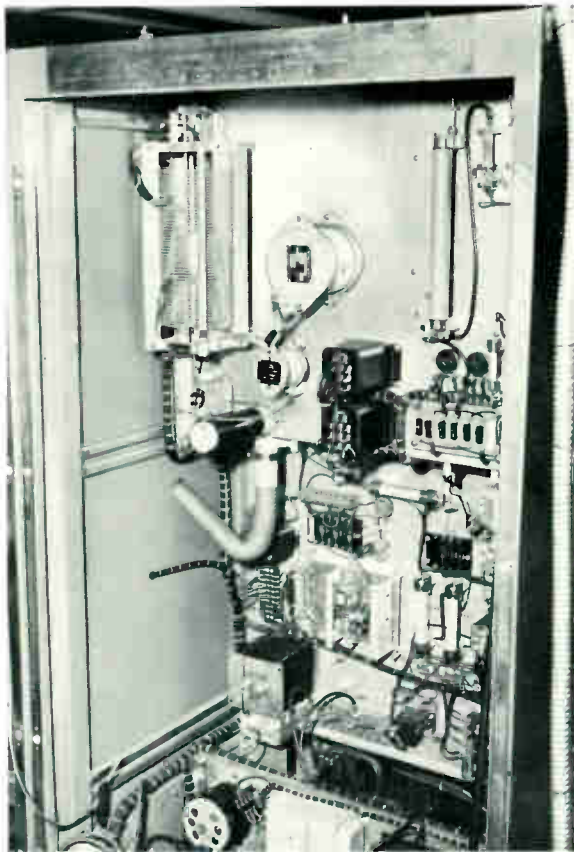

Rear view of BTA-10U1 exciter and control cabinet.

POWER ECONOMY

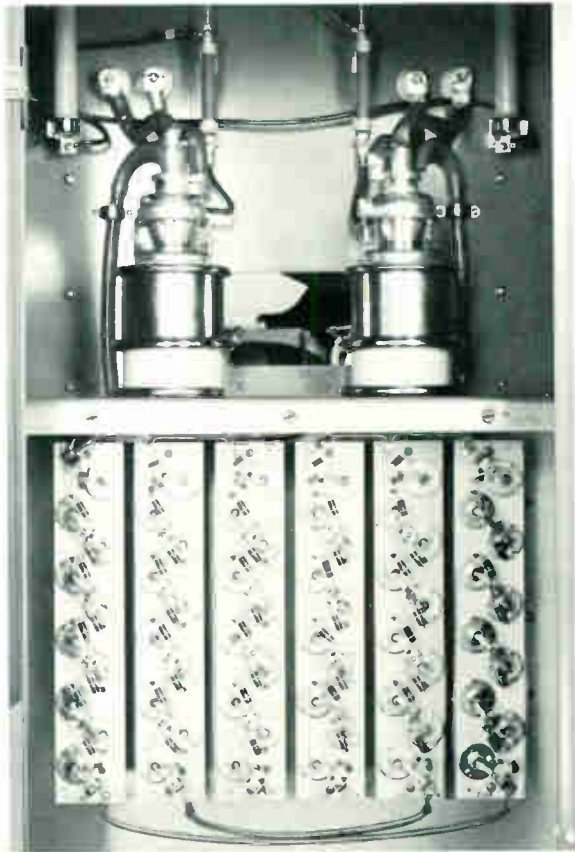

Modulator tubes and silicon high voltage rectifiers with cover removed.

STABLE CIRCUIT DESIGN

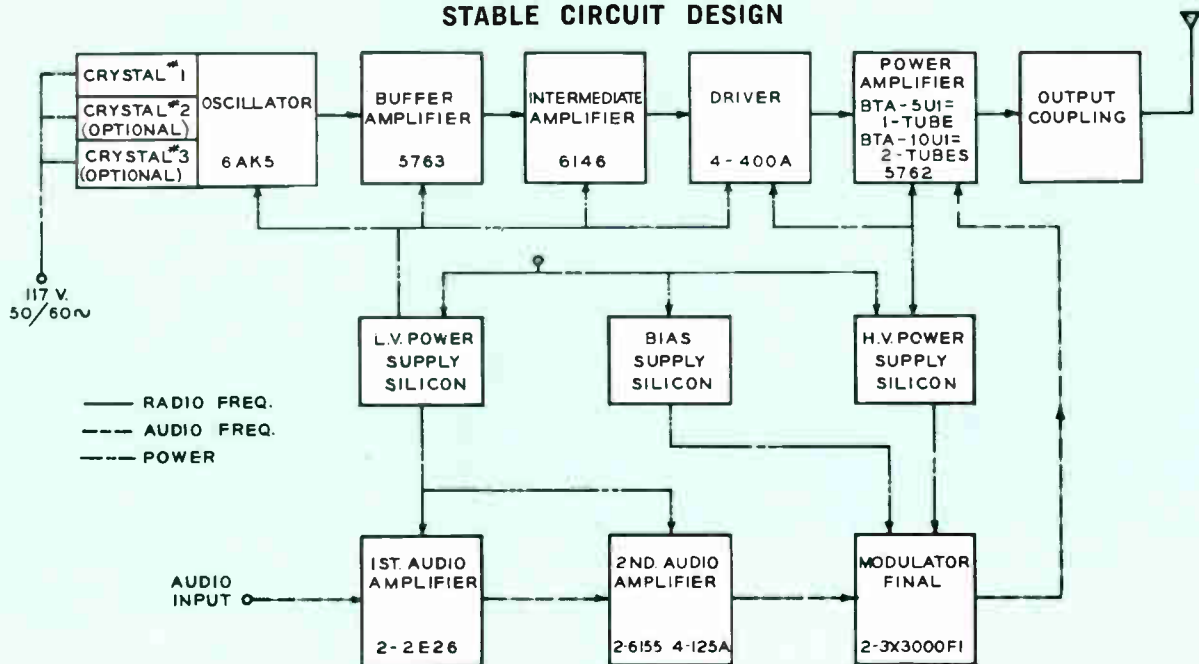

Block diagram of Type BTA-5U1 and BTA-10U1 Transmitters.

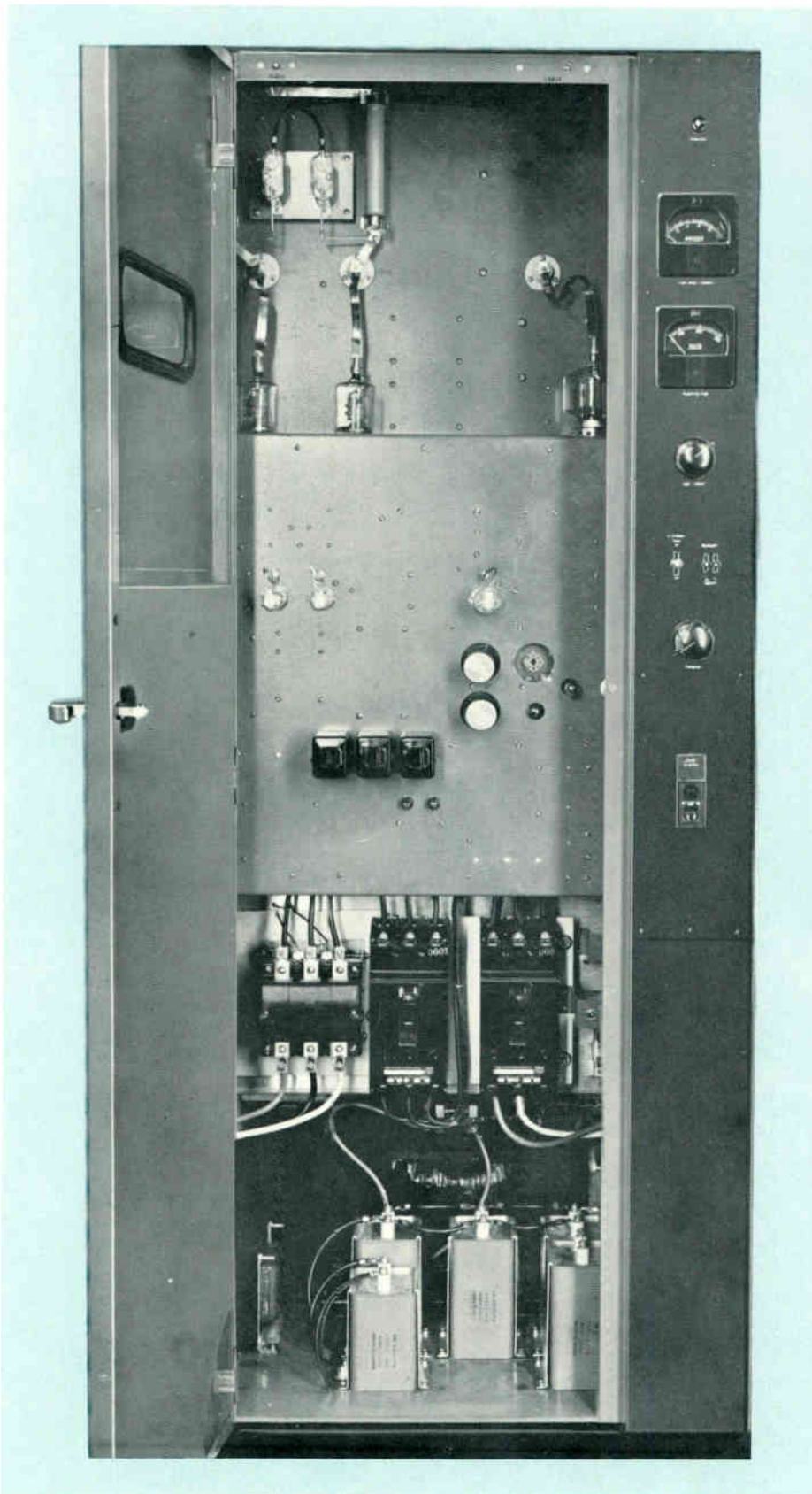

Driver cabinet including exciter and control panel.

very conservatively and a pair of 2E26 tubes used as the first a-f stage of the modulator circuit.

The output of the 6146 IPA stage is broadband and requires no tuning. It drives a single 4-400A tube where tuning is accomplished by using a slug-tuned coil controlled from the front panel. This tube, in turn, drives one or two high-efficiency, long life 5762 output triodes. A front panel control of a vacuum variable capacitor tunes the plate circuit.

Broadband Neutralization

A new slug-tuned coil was developed for the power output adjustment and it is driven by a reversible motor. The motor is actuated at the front panel or by remote control. The second harmonic trap uses a slug-tuned coil, thus eliminating the possibility of contact pitting from high RF currents. Neutralization of the PA is achieved by a broadband transformer and a variable vacuum capacitor.

The modulator of the transmitter consists of a pair of 2E26 tubes located in the exciter portion, resistance coupled to drive two 4-125A second audio frequency amplifiers which, in turn, are resistance coupled to drive a pair of 3X3000F1 modulators. These modulator tubes are low mu triodes, drawing no grid current. They are capable of excellent response and fidelity. Due to the low plate dissipation of the new PA system, the power input of the modulator is also reduced affording appreciable power economies.

Dependable Semiconductor Power Supply

The BTA-5U1/10U1 incorporates silicon rectifiers in the high-voltage circuits. This rectifier is ideal not only in a combined operation, but even more so in a remote-control application.

The rectifiers are hermetically sealed so they will not be adversely affected by weather conditions. They can operate at ambient temperatures ranging from -20 degrees to $+45$ degrees C and at altitudes up to 7500 feet above sea level. There is no significant aging of the forward drop characteristics. Across each of the individual silicon cells a resistor has been shunted so that they will all share equally the peak inverse voltage. RCA specifications have been set higher than EIA standards by adding an additional 30 percent peak inverse voltage safety factor.

Cooling System

The transmitter is completely air-cooled. Added refinements such as a delay relay have been built-in to keep the blower system in operation for one minute after the transmitter has been shut down. The continued supply of air extends tube life. The exciter cabinet employs convection cooling. A louvered lower back panel and top grill panel provide good ventilation. In the second cabinet a blower air system distributes air to the modulator as well as to the Power Amplifier tubes in cabinet three.

Overload Protection

To provide additional reliability, improvements were made in the control and protective circuitry of the transmitter. All primary lines are

protected by means of circuit breakers with instantaneous overload trip protection. Line and high-voltage plate circuit breakers have additional built-in thermal protection. The 3-phase blower is protected by a contactor with a thermal cutoff in each phase. Relay switching is sequential so that filaments will not come on unless the blower is operating. Low voltage is delayed to allow proper filament heating. The high voltage is interlocked with the low-voltage and the bias supply so that it will come on only after the low-voltage and bias potentials are present. Overload protection is also provided in the low-voltage supply, the second AF stage, the IPA stage, the modulator, the PA stage and the high-voltage rectifier. They are instantaneous in action and each

overload relay carries a spare set of contacts wired to terminals that may be connected to an external indicator. A two cycle plate overload relay also permits the transmitter to return to the air automatically after one interruption has occurred.

Starting surges in the plate transformer, high voltage rectifier, and the filter capacitor are eliminated by the use of a step-start and damping circuit. This at one time was only available in the higher-power transmitters, but now longer life and added reliability are provided in the BTA-5U1/10U1 with the incorporation of these circuits for the suppression of starting transients. The damping circuits and the primary line reactors afford continuous protection against possible operational transients.

Typical floor plan for BTA-5U1 and BTA-10U1 transmitters. External plate transformers are required only for the BTA-10U1 transmitter since the transformer for the BTA-5U1 can be mounted in the PA cabinet.

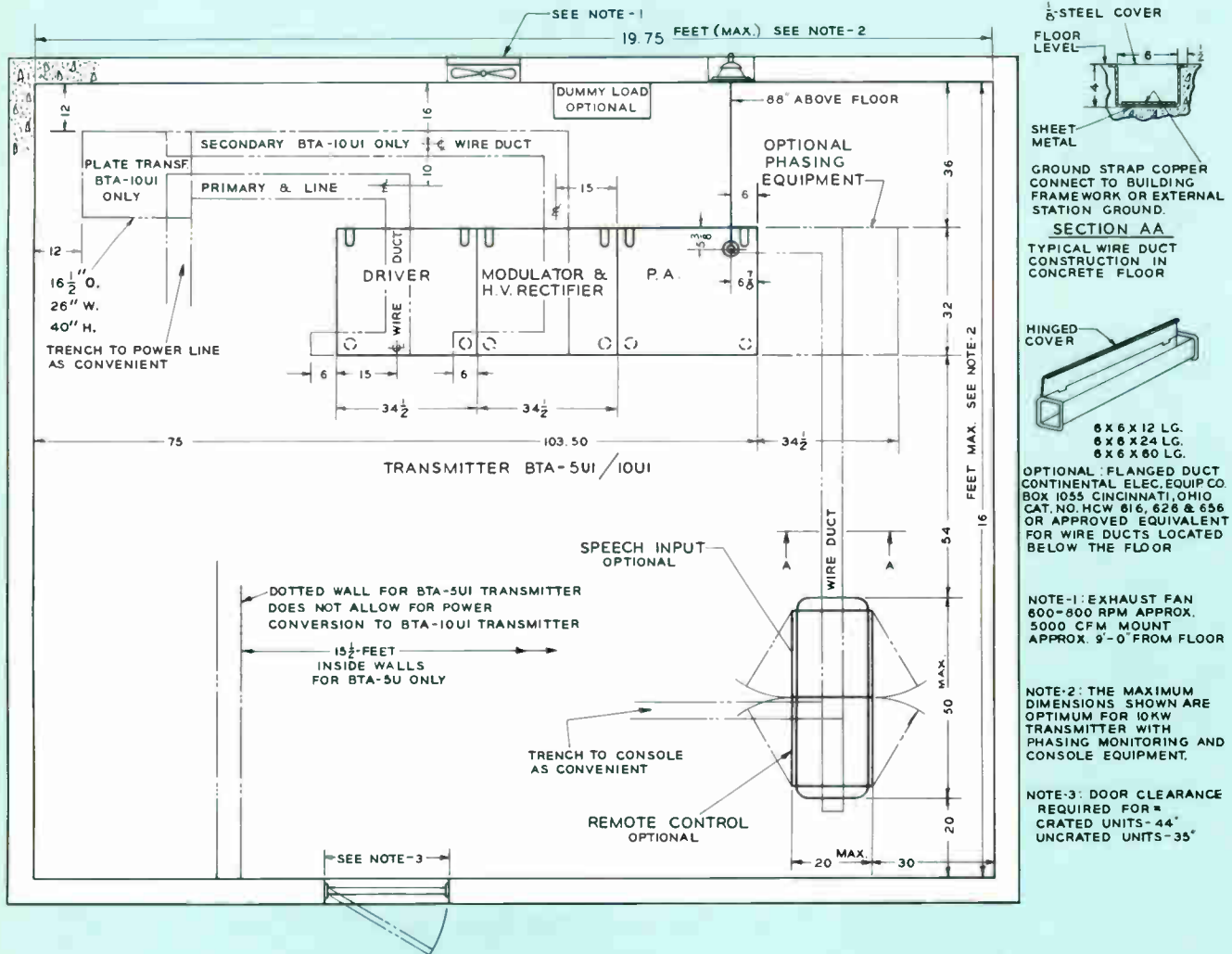

Specifications

Performance

AF Input Impedance	150/600 ohms
AF Input Level (100% modulation)	+10 ±2 dBm
AF Response:	
50—7500 Hz	±1 dB
30—10,000 Hz	±1.5 dB
AF Distortion (95% modulation):	
50—10,000 Hz	2.5%
Noise (below 100% modulation)	60 dB
Frequency Range	535—1620 kHz
Frequency Stability	±5 Hz
Type of Output	Single Ended
Carrier Shift (0—100% modulation, 400 Hz	3% at constant line voltage 5% at normal line voltage regulation
Output Impedance	40—250 ohms

Electrical

RF Voltage (for Frequency Monitoring) 10 volts RMS 75 ohms	
RF Voltage (for Modulation Monitoring)	10 volts 75 ohms
Power Output (nominal):	
BTA-5U1	5000 Watts
BTA-10U1	10,000 Watts
Power Output Capability:	
BTA-5U1	5500 Watts
BTA-10U1	10,600 Watts
Power Source Required	208/240 Volts ±11 Volts
Line Frequency	50/60 Hz
Phase	3
Power Consumption:	
(0% modulation)	BTA-5U1 10.0 kW BTA-10U1 17.5 kW
(100% modulation)	14.5 kW 26.0 kW
(Average program modulation)	11.0 kW 21.0 kW
Power Factor	90% 90%
Permissible Combined Line Voltage Variation and Regulation	±5% ±5%
Crystal Heater Power	117 volts 50/60 Hz
Tube Complement:	
1 6AK5 Crystal Oscillator	
1 5763 Buffer	
1 6146 Intermediate Power Amplifier	
1 4-400A Driver	
2 2E26 1st Audio Frequency Amplifier	
2 6155/4-125A 2nd Audio Frequency Amplifier	
2 3X3000F1 Modulator	
1 5762 Power Amplifier for BTA-5U1	
2 5762 Power Amplifier for BTA-10U1	

Mechanical

Overall Height	88" or 223.5 cm (84" or 213.4 cm less floor channels)
Cabinet Height	84" or 213.4 cm (80" or 203.2 cm less floor channels)
Width	103½" or 262.9 cm
Depth	32" or 81.3 cm (less door handle)
Overall Depth	55" or 139.7 cm (with door open)
Net Weight:	
BTA-10U1 Transmitter	4700 lbs. or 2132 kg. (approx.)
Plate Transformer	600 lbs. or 272 kg. (approx.)
BTA-5U1 Transmitter including Plate Transformer	4850 lbs. or 2200 kg. (approx.)
Altitude Range	0—7500 ft. (0—2286 m)
Ambient Operating Temperature	-20°C (-4°F) min., +45°C (113°F) max.

Accessories

Complete Set of Operating Tubes (for BTA-5U1)	ES-34233
Complete Set of Operating Tubes (for BTA-10U1)	ES-27290
Filament Hours, Elapsed Time Indicator*	MI-34614*
Type BTR-11B Remote Control System	ES-34280
Type BTR-20C Remote Control System	ES-34274
Antenna Tuning Equipment	ES-27256
Recommended Spare Tubes for BTA-5U1 and BTA-10U1	ES-27291
Type BW-11A AM Frequency Monitor	ES-34042
Type BW-66F AM Modulation Monitor	MI-30066-B
Alarm Indicator	MI-27567
Power Conversion Kit (BTA-5U1 to BTA-10U1)	ES-34279
Power Cutback Kit 5 kW to 500/1000 W	MI-34646-A
Power Cutback Kit 10 kW to 500/1000 W	ES-34287
Power Cutback Kit 10 kW to 5 kW	ES-34286
Remote RF Pick-up Unit for powers up to 5-kW (less meter)	MI-27966
Remote RF Pick-up Unit for higher powers (less meter)	MI-28027-B
Remote Antenna Meter	MI-27644-Series
Automatic Logging Equipment	On Application

*The 5U1/10U1 transmitter has a blank meter bezel which may be replaced with an elapsed time indicator, MI-34614. Specify 50 or 60 hertz.

Ordering Information

Type BTA-5U1 Transmitter (including 1 set of tubes and 1 crystal)	ES-27285
Type BTA-10U1 Transmitter (including 1 set of tubes and 1 crystal)	ES-27286
(specify operating frequency and output impedance)	



RADIO CORPORATION OF AMERICA

BROADCAST AND COMMUNICATIONS PRODUCTS DIVISION, CAMDEN, N. J. 08102 • RCA INTERNATIONAL DIVISION, CENTRAL and TERMINAL AVENUES, CLARK, NEW JERSEY, U.S.A. 07066

TRADEMARK(S) • REGISTERED

MARKA(S) • REGISTRADA(S)

PRINTED
IN
U.S.A.



50 KW "Ampliphase" AM Transmitter, Type BTA-50H1



- Excellent audio quality
- Wide range frequency response
- Solid state rectifiers used throughout
- Proven stability
- Designed for remote control
- Over 110 percent positive modulation capability



Compact in-line construction of BTA-50H1 showing left to right, left hand power amplifier, exciter, right hand power amplifier, and rectifier-control cubicle.

Description

The RCA Type BTA-50H1 AM Broadcast Transmitter is a completely air-cooled, 50-kW phase-to-amplitude modulated transmitter designed for high fidelity transmission in the standard broadcast band (535 kHz to 1620 kHz). It provides a signal containing exceptionally low distortion and extended frequency response. Measured response is flat within ± 3 dB from 35 hertz to 25,000 hertz. The equipment is capable of being modulated over the frequency range of 10 hertz to 30,000 hertz. Frequency response has been extended largely through the elimination of unnecessary transformers in the audio system as well as improved circuitry.

Low harmonic distortion with negligible carrier shift at maximum signal output has been achieved in the BTA-50H1 by selection of adequate new tube types and ad-

vanced design throughout the entire equipment. The design features an inherently linear system capable of continuous high modulation levels impervious to inadvertent over-modulation. For example, the transmitter may be modulated 100 percent at any frequency between 30 and 15,000 hertz continuously for many hours without detrimental effects to any of the component parts. A small amount of overall feedback is incorporated to provide the exceptional performance. With the feedback circuit removed, the BTA-50H1 will still meet the FCC specifications for audio frequency response, harmonic distortion and noise.

Lowest Operating Cost in 50-KW Transmitters

A number of new refinements as well as time tested features which

have proven their worth are incorporated in RCA's latest 50-kW transmitter. Power requirements are moderate for the equipment. Power amplifier plate efficiency of the order of 76 to 80 percent is obtained. Total power consumption for 50-kW carrier power will run approximately 94 kW, approximately 100 kW will be required for average levels of modulation, and approximately 130 kW will be required for 100 percent modulation.

Fewer major components, as compared to those required by many 50-kW transmitters, are used in the BTA-50H1. In addition to the low cost of operation of the transmitter a Power Cutback Kit, MI-27688-A can be added which will permit operation at 10 kW.

Two identical r-f chains, each developing a power of 25 kW, are incorporated in this equipment.

Since they are identical, servicing is made easy by comparison of the two chains. Components are directly interchangeable, which allows substitution for comparison purposes. All components are easily accessible which results in a minimum schedule for maintenance. In addition, fewer replacement parts are required for adequate protection against lost air time should a failure occur. Low power consumption, fewer major components and a reduced maintenance schedule make the BTA-50H1 operation cost the lowest in the 50-kW field.

Remote Control Operation

The BTA-50H1 AM Transmitter has been designed with remote control operation in mind. Ready for use with standard RCA remote control equipment, all transmitter components and wiring are standard in the equipment for FCC required metering and control facilities. In addition, other optional metering and control facilities may be incorporated by utilizing components and wiring that is supplied with the equipment. Details relative to incorporating remote switching to an auxiliary transmitter, dummy load and auxiliary power supplies can be supplied according to the needs of the individual customer.

Lightweight Type 6697 Tubes in Final PA

One Type 6697 power amplifier tube is used in each of the two r-f chains. Each amplifier tube is capable of delivering in excess of the normal 25 kW of modulated power to the common load. The Type 6697 is rated at 35 kW dissipation and under average modulation conditions it is only required to dissipate approximately 14 kW. Operation of the PA tubes so far below their maximum ratings assures the user of long tube life. In addition to providing long life, the 6697 is physically small in size and weighs only 29 pounds. One person, without the aid of mechanical assistance can quickly and easily replace any tube in the transmitter.

One Type 4CX5000A tube is used in each of the driver stages in the two r-f chains. The 4CX5000A is also operated well below its maximum ratings and will give long trouble free service. Other tubes

used in this equipment are of the small, low cost variety. Tube complement is such that inventory cost for required spares is kept at a minimum while adequate protection to the broadcaster is maintained.

Solid State Rectifiers Used Throughout

All power supplies utilize solid state rectifiers. The plate supplies, bias supply and low voltage supply use silicon units which are very conservatively rated to assure long life. The current rating of the units is such that any conceivable load fault is cleared without jeopardizing the diode units. The use of solid state rectifiers permit the transmitter to operate in ambient temperatures as low as -20 degrees centigrade.

Meets FCC Harmonic Suppression

A completely shielded two section low pass filter is incorporated in the BTA-50H1. It consists of one pi (π) section and one T section and each inductive series element is completely shielded. Two series-tuned, shunt-connected traps are used to provide added attenuation of the second harmonic.

Transmitter Equipment

Type BTA-50H1 AM Broadcast Transmitter consists of four equipment cabinets, two of which house the power amplifiers, one the exciter unit and the fourth cabinet the rectifier and control unit. The high-voltage reactor is housed in the lower rear compartment of the exciter cabinet, and the IHV plate transformer in the lower rear compartment of the rectifier and control cabinet.

Each of the four transmitter cabinets measure 44 inches wide by 60 inches deep by 84 inches high, and consists of an all aluminum cubicle erected on a welded steel base. This cubicle consists of a series of panels fabricated and assembled to form a rigid structure. The use of aluminum eliminates unnecessary weight and provides excellent shielding to assure effective confinement of spurious energy. Maximum accessibility to all transmitter components are afforded by 28-inch wide, full-length front doors, while rear access is through two covers

attached with quick-disconnect fasteners for easy removal.

A center vertical panel separates the cabinet into a front compartment and rear compartment which is further divided by a rear horizontal shelf into upper and lower compartments, giving each cabinet three basic totally shielded compartments in which to mount the electrical components. The eye-level meters, pilot lights and interlocks, mounted on eight-inch wide panels flanking each of the front doors, are also shielded.

In the rear at the top of each cabinet there is a built-in wire duct which joins similar ducts of the adjacent cabinets to form a continuous duct on the four cabinets. This duct has a divider down the center on which the interconnection terminal boards are mounted. The rear half of the duct is used for interconnection wiring while the front half is used for internal cabinet wiring from the terminal boards. The internal wiring is carried through conduits to its destination in the cabinet thus shielding all power and control wiring from r-f fields. Provision is also made at the top of the cabinets for the addition of an exhaust air duct.

Power Amplifiers

The left end cabinet and the third cabinet from the left end are identical and contain the final power amplifier stages. The 6697 tube and its grid circuits and part of the plate circuits are contained in the front portion of the cabinet. The upper rear section contains the plate tank coil, filament transformer and grid leak resistors. The lower rear section contains a low noise blower which cools the 6697 tube and its cabinet and the adjacent half of the exciter cabinet. The two 6697 power amplifiers are designed to supply equal amounts of power to the output network. Because of the balanced dissipation in the two 6697 PA tubes, less air pressure with resultant lower air flow is required for adequate cooling of the power amplifier cubicles. The lower rear panel contains an impingement type air filter for the blower. The PA cabinets are constructed so that the blowers and filters can be mounted externally to the cabinets, if so desired.

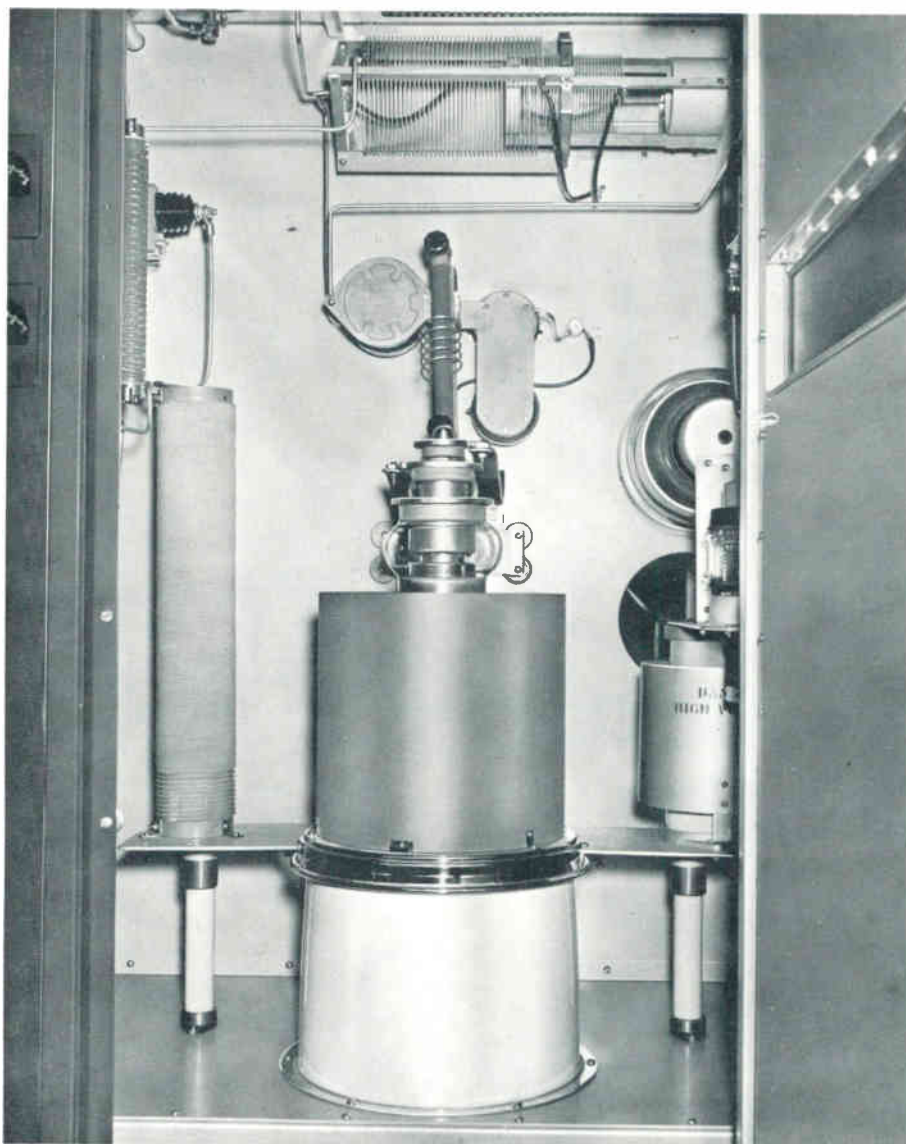

Close-up view of one of the dual final power amplifier stages. The new type 6697 tube together with grid circuits and part of the plate circuits are readily accessible from the front of the transmitter.

Exciter-Modulator

Located directly between the two power amplifier units is a cabinet that houses in its front section all the components from the oscillator through the driver stages. The separate branches are assembled as mirror images for symmetrical feed to the PA units at left and right. The rear cabinet section contains the 50 kW common output circuit, harmonic filter, and reflectometer protective circuits.

Two 807 crystal oscillators are located at the bottom front of the cabinet. The exciter-modulator unit is mounted on sliding rails directly above the drive regulator. It is a

self-contained unit with the r-f and a-f components mounted on a vertical hinged panel which in turn is mounted on a horizontal chassis containing the power components for the exciter-modulator. Above are two vertical sub-compartments behind interlocked doors which contain the 4-250 and 4CX5000A stages. A meter panel for these stages is located at the bottom of these sub-compartments.

The common output capacitors of the two PA tanks and the harmonic filter are located in the upper rear of the cabinet. Sub-partitions are so arranged in this section that complete isolation and shielding is effected between the

various sections of the filter and the output capacitor. The lower rear section of this cabinet contains high voltage filter reactor and driver d-filament supplies.

Provisions for Standby Operation

Space is provided in the exciter-modulator cabinet for the mounting of a second exciter-modulator unit. It is mounted on sliding rails like the first unit directly above the drive regulator. Each of the modulator-exciter units are complete and arranged so that either may be selected instantly by means of cut-over switches. Thus while modulator #1 is in operation, modulator #2 is in standby condition. Either of the 807 oscillators in the BTA-50H1 can be instantly switched to either modulator. These provisions with the extreme reliability designed into the high power stages essentially provides a second 50-kW transmitter for standby service. The spare modulator is supplied in the form of an optional kit (ES-34264).

Rectifier and Control Unit

The right hand cabinet contains the high power rectifiers, low power distribution components, and the majority of the control components. The front of the cabinet contains the solid state 15-kV, 5-kV, and low-voltage bias supplies. Also included here are the high voltage grounding switches and the 15-kV filter capacitors. The top rear section of the cabinet contains the control relays, overload relays, distribution contactors, and the low power distribution circuit breakers. The distribution breakers and overload relays are readily accessible, even though recessed so that they will not be damaged or improperly operated. The bottom rear of the cabinet contains the 5-kV rectifier components including plate transformer.

Circuit Description

R-F is generated in the BTA-50H1 by an 807 crystal controlled oscillator operating at carrier frequency. This signal is amplified and then separated into two channels differing in phase by 180 degrees. Each signal is then passed through d-c modulator stages adjusted so that a phase difference of approximately 135 degrees exists between the two signals. Modulation is applied at this point to each r-f channel by a variable resistance type of phase modulator.

The modulation process consists of the injection of a variable resistance into the plate tank circuit of the 5693 modulated stage in accordance with the modulation intelligence. This variable resistance is obtained through the use of cathode follower stages utilizing 5692 triodes. The outputs of the modulated stages are then fed through the 1614 amplifier stages. The power level after the 1614 amplifiers is in the order of 5 Watts, sufficient to adequately drive the following class "C" amplifier stages. These stages use 4-250 tetrodes that in turn drive 4CX5000 ceramic, air-cooled, tetrode amplifiers.

The PA output circuit is a conventional pi-network type of tank circuit. Each tube has its own tank circuit, with a common output shunt element. Each network is adjusted to provide the proper load to the power amplifiers.

Drive Regulator

The drive regulator samples the audio signal, amplifies it, and applies a desired value to the grids of the second IPA, providing adequate drive to the final amplifiers

as required by the level of audio input applied to the equipment. This technique contributes considerably to the overall linearity during modulation.

The drive regulator, consisting of three audio amplifiers (two 6AG7's and an 807) driving three 807 cathode followers, is used to control the grid operation conditions of the final power amplifier tubes to assure maximum plate efficiency over the complete audio cycle. During the trough of modulation when zero or very little output is required from the final stage, the drive regulator reduces the drive to the final stages; and, conversely, at the peak of modulation when maximum power is required from the final stage, the drive is increased over that at carrier condition.

During periods of 100 percent modulation, the 6697 power amplifier tubes require 15-kV d-c at 7.5 amperes, which is obtained by using RCA silicon power rectifiers in a three phase full wave rectifier circuit. Two other plate voltages, 5-kV and 1-kV, are provided by separate silicon supplies. Bias voltages for all tubes are supplied by an additional supply. The high power distribution equipment for the transmitter consists of an electrically operated air circuit breaker, and a manually operated delta-wye switch for the 15-kV rectifier. The remaining transmitter power is distributed through a manually operated distribution circuit breaker to a 460 to 230-volt distribution transformer to voltage regulators and thence to the various low power distribution circuit breakers.

Front section of the exciter-modulator containing all components from oscillator through the driver stages.

Upper rear of exciter portion of the BTA-50H1 showing the combining and output networks.

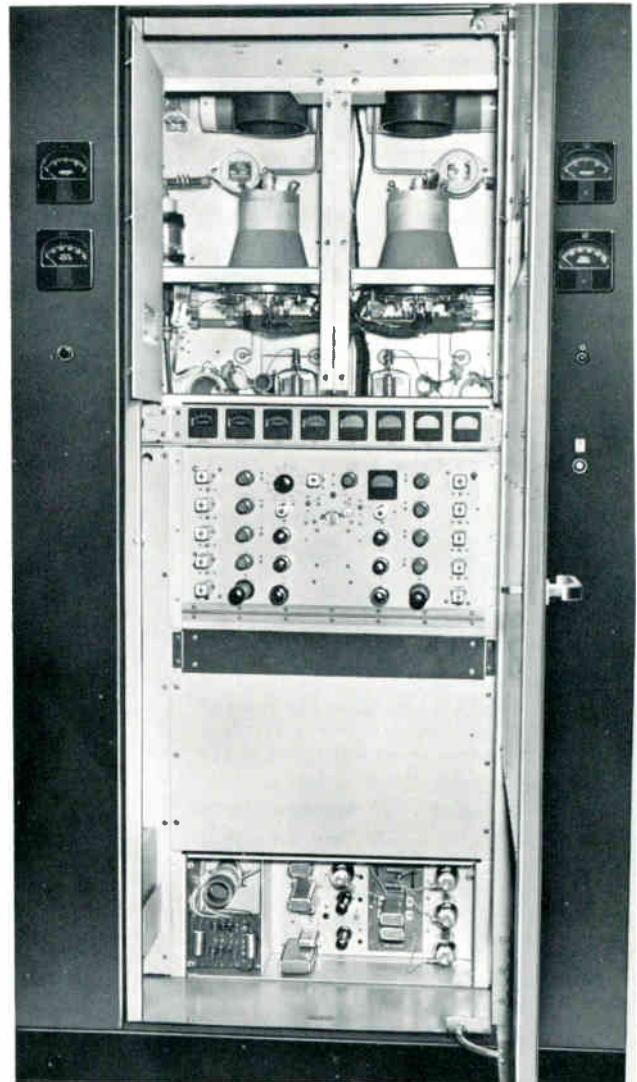
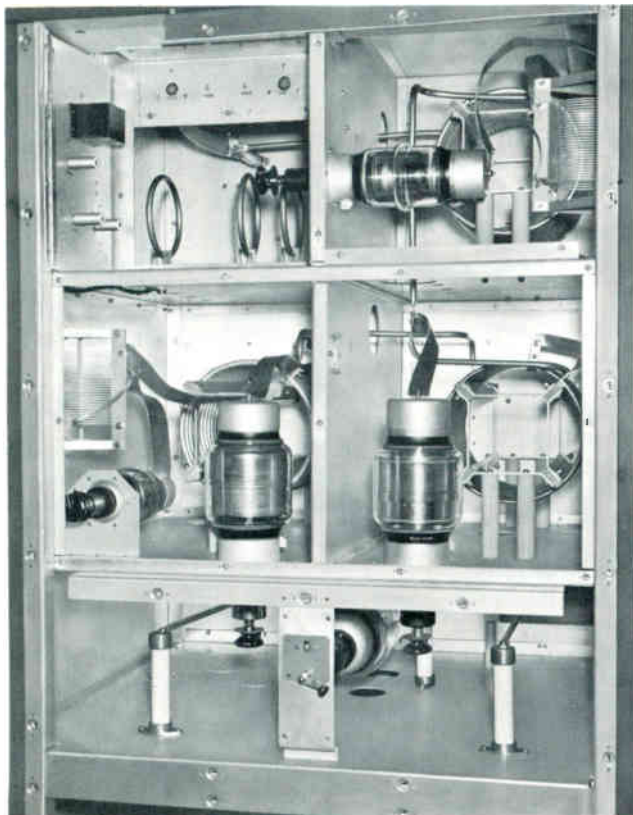

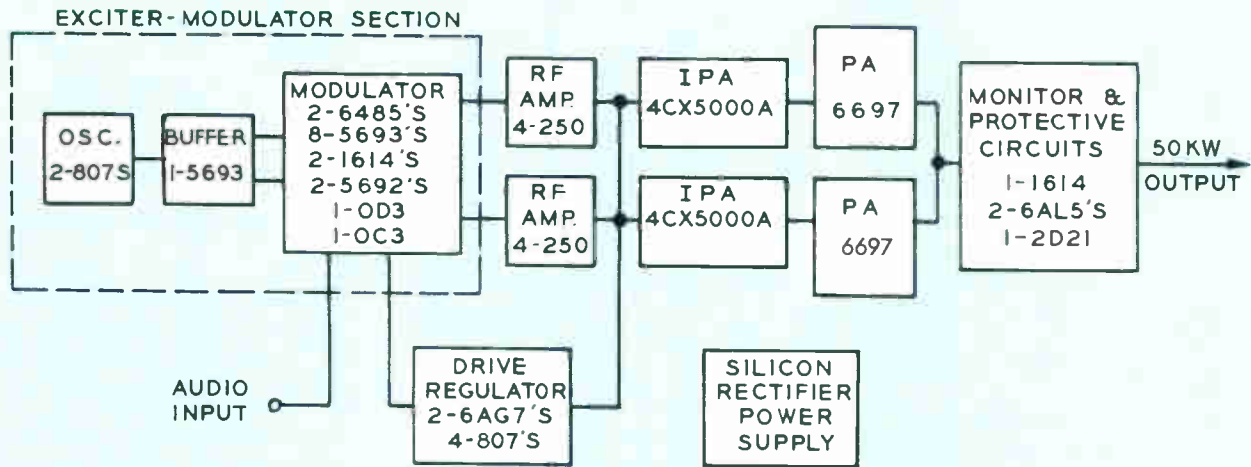

Simplified block diagram of the BTA-50H.

Simplified block diagram of the BTA-50H1.

Transmitter Control

Control circuits in the BTA-50H1 contain a number of features which are designed to provide maximum flexibility in control, protection and operation. Among these are choice of single-button or step-by-step starting, automatic timing and sequencing of starting operations, and location of transmitter faults by a system of indicators. Protection of the operator is achieved by a system of interlocking grounding devices; protection of the equipment by conventional relays and circuit breakers. There are provisions for the protection of the equipment against transmission line irregularities and air failure. A reflectometer is incorporated in the BTA-50H1 that is sensitive to the changes in voltage to current ratio on the output transmission line to the antenna. A great change in transmitter load acts to remove the carrier by removing drive momentarily to allow any r-f fault to clear. If, however, the fault persists after removing carrier several times, the plate power is automatically removed.

Control of the transmitter is accomplished from the front of the rectifier and control cabinet. All

necessary wiring to allow control from a remote location or console has been provided. Lamps which show the status of the transmitter control circuits are also mounted on the front of this cabinet. The control ladder is arranged and interlocked so that the BTA-50H1 can either be turned on by operating the control switches in sequence or by leaving all control switches in the ON position with the exception of the start switch, which when operated to the ON position allows the transmitter to automatically come on.

The two types of overload circuits used in this transmitter are the current type, instantaneous or time delay, that are connected directly in the tube circuit and rectifier ground leads, and the thermal magnetic circuit breakers connected in the a-c power leads used as back up protection and disconnect switches. The transmitter circuitry is arranged so that an overload will either lock out the plate circuit or allow a single reclosure that will reset if there are no further overloads. In either case, when a lockout position has been reached, the transmitter can be reset by means of an overload

reset control. The principal overload relays have indicating flags so that even after the overload has been cleared there is a record of which overload has operated. Another feature of the control circuit is provision of indication lamps on each cabinet that indicate the status of the interlock in that particular cabinet.

Installation and Layout

Outstanding features of the BTA-50H1 are the small floor space requirements and ease of installation of the transmitter. In general, the transmitter layout consists of three basic parts: the four in-line cabinets which contain the major part of the transmitter; the wall mounted switch-gear components; and the main plate transformers. The floor plan illustrates a typical layout of the complete equipment. Elimination of the need for under-floor cable trenches and considerable reduction in external air ducts, simplifies installation and reduces costs.

As shown in the layout, it is desirable to leave a passageway at the right end of the frontline cabinets since the circuit breakers and overload relays are most accessible from

this end of the transmitter. The layout of the front line cabinets is such that a common exhaust duct can be used to carry off heated air from the transmitter.

Wall mounting as shown on the overall floor plan is suggested to make the BTA-50H1 most adaptable

to existing transmitter buildings. The mounting of these components, however, is not critical as to location. They can be mounted in existing power distribution areas if desired. These components include the main plate circuit breaker, a delta-wye switch, a distribution cir-

cuit breaker, a 460 to 230-Volt bank of distribution transformers, and two single phase open delta connected regulators with their control panels. These components are wired through conduit and overhead ductwork to the main plate transformers and the transmitter cabinets.

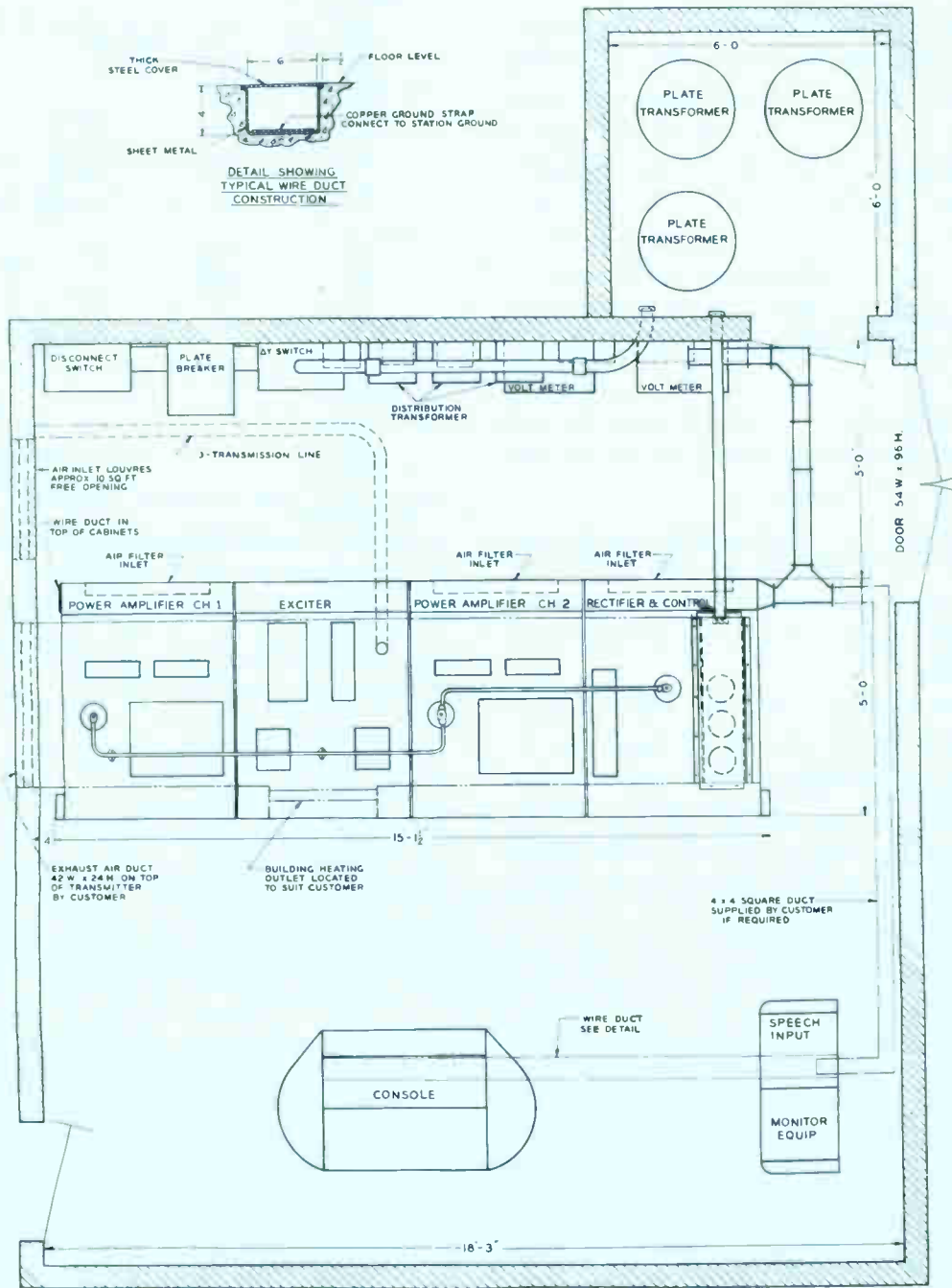

Typical floor plan for the BTA-50H1 Transmitter.

Specifications

General

Power Line Requirements:
 Line 460 Volts, 50/60 hertz, 3 phase
 Combined Regulation and VariationNot more than $\pm 5\%$

Power Consumption94 kW (approx.) at zero modulation

Power Consumption100 kW (approx.) at average modulation

Power FactorBetter than 90%

Crystal Heaters110 Volts

Type of EmissionA3

Power Output (at transmitter terminals)56 kW (max.)

FrequencyAny specified between 535 and 1620 kHz

Frequency StabilityAssigned frequency ± 5 hertz

Type ModulationPhase to amplitude

AF Input Impedance150/600 Ω

Audio Input Level+10 ± 2 dbm

Audio Response ± 1.5 dB 30–10,000 Hz

AF DistortionLess than 3% RMS 50–7500 Hz

Noise Level60 dB below 100% modulation

Carrier ShiftLess than 5% neg. 100% modulation

Type OutputUnbalanced

Output Impedance51.5 Ω or others specified

Spurious Emission (2nd Harmonic and above)83 dB down

Mechanical

Cabinet Size44" wide, 84" high, 63" deep
 (111.8 cm wide, 213.4 cm high, 160 cm deep)

Overall Weight12,000 lbs. approx. (545 kg)

Maximum Altitude7500 ft. (2286 m)

Ambient Temperature-20°C +45°C

Maximum Cabinet Weight3,093 lbs., approx. (1403 kg)

PA Cabinet Weights (each)953 lbs., approx. (432 kg)

Plate Transformer Weight (total)820 lbs., approx. (372 kg)

Rectifier Weight3,093 lbs., approx. (1403 kg)

Exciter Weight1,241 lbs., approx. (563 kg)

Filter Reactor570 lbs., approx. (259 kg)

Tube Complement

Exciter-Modulator Section:

2	807	Oscillator Tubes
1	5693	Buffer Amplifier
2	5693	DC Modulator
6	5693	Modulated Amplifier
2	1614	R-F Amplifier
2	6485	1st Audio Amplifier
4	5692	Phase Modulator
1	OD3	Low Voltage Regulator
1	OC3	Low Voltage Regulator

R-F Amplifier Section:

2	4-250A	Intermediate Power Amplifier
2	4CX5000A	Driver Amplifier
2	6697	Power Amplifier

Drive Regulator Section:

1	6AG7	1st Audio Amplifier
1	807	Intermediate Audio Amplifier
1	6AG7	Intermediate Audio Amplifier with Linearity Control
3	807	Cathode Follower Output Amplifier

Monitor Circuits:

1	1614	Frequency Monitor Amplifier
2	6AL5	Reflectometer
1	2D21	Thyratron Control

Accessories

Complete Set of Operating Tubes	ES-27222-C
Recommended Spare Set of Tubes	ES-27223-C
Spare Modulator Kit	ES-34264
Type BTR-11B Remote Control Equipment (10 Functions)	ES-34280
Type BTR-20C Remote Control Equipment (20 Functions)	ES-34274
BTRX-40A—20 Position Extension for BTR-20C	MI-27556
50/10-kW Cutback Kit for BTA-50H1 Transmitter	MI-27688-A
Dummy Load Schedule of Parts and Instructions	ES-34234
BPA-50 Antenna Tuning Unit	MI-28903-A/B
BPA-50 Antenna Tuner (230 ohms)	ES-28903-A
BPA-50 Antenna Tuner (70/51.5 ohms)	ES-28903-B
RF Ammeter (for BPA-50)	MI-7147-Series
Remote RF Pickup Unit (less Meter)	MI-28027-B
Remote Antenna Meter	MI-7157-Series
Type BW-11A Frequency Monitor	ES-34042
Type BW-66F Modulation Monitor	MI-30066-B
AM Carrier-Off Monitor	ES-34251
Automatic Logging Equipment	On Application

Ordering Information

Type BTA-50H1 50-kW AM Broadcast Transmitter with two crystals, remote meter, one set of operating tubes, silicon rectifiers, and one exciter. Does not include antenna tuning unit. (Specify operating frequency and output impedance)ES-27221-C



RADIO CORPORATION OF AMERICA



- Extends AM radio coverage
- Increased positive peak modulation
- Meets FCC rules
- Only two adjustments to install



"Power Max" Negative Peak Limiter

Description

The RCA "Power Max", MI-34654, is a non-linear limiter designed to extend area coverage of AM broadcast transmitters. With "Power Max" it is possible to modulate the positive peaks as much as 110 to 115 percent, limited only by transmitter capability without exceeding the FCC maximum 100 percent negative peak modulation. The "Power Max" does not clip the negative peaks; it limits the negative peak by rounding off the signal beyond a predetermined point. Many stations can achieve new maximum coverage from present transmitting equipment with "Power Max."

The equipment is completely housed in a rack-mounting chassis requiring only seven inches of rack space. It is quickly installed in the input of any AM transmitter; and for optimum performance it should be used following an RCA Limiting Amplifier. Only two adjustments are necessary upon installation. The equipment is easy to operate. It contains no tubes, transistors or other active circuits, and has a very small power drain. The gain of the overall system is not changed when the "Power Max" is switched in or out.

The MI-34654, "Power Max", is essentially a non-linear limiter which rounds off the negative peak modulation envelope so as to prevent overmodulation of the negative peaks in conformity with established FCC operating rules. The unit consists essentially of a 6 db attenuator pad followed by a non-linear shunt impedance, the impedance of which is a function of voltage amplitude. Thus the effective shunt impedance is reduced with increasing amplitude resulting in lower output at the higher amplitudes. The shunt element is polarized so as to be effective only on negative swings.

Circuit components which include no tubes, transistors or other active circuits, are mounted on a rack mounting chassis measuring 19 inches wide, 5½ inches deep and 7 inches high. All controls are mounted on the 7-inch high front panel. These include: two set-up screw driver adjustments for compression and threshold (use of an oscilloscope for initial set-up is recommended), a power switch, an indicator lamp, and a phase reversal switch. Provision is made to bypass the unit without changing the insertion loss. This permits the "Power Max" to be removed electrically from the circuit whenever desired.

Specifications

Input Level.....	+16 dbm ±2 db
Insertion Loss.....	.6 db
Power Requirement.....	115 volts, a-c, 60 Hz, 5 watts
Dimensions Overall.....	19" wide, 5½" deep, 7" high (48.26 cm, 13.97 cm, 17.78 cm)
Weight.....	Approx. 18 lbs. (8.2 kg)
Finish	Silver gray

Ordering Information

"Power Max" Negative Peak Limiter.....MI-34654

1QB



RADIO CORPORATION OF AMERICA





- **Stable in operation—calibrates readily in presence of strong fields**
- **Reads directly in microvolts per meter—no correction factor charts are needed**
- **Wide sensitivity range—10 microvolt/meter to 10 volts/meter**



AM Field Intensity Meter

Description

The Type 120E AM Field Intensity Meter is a lightweight portable instrument, especially adapted for field intensity measurements by Broadcast Station Engineers and Consultants. Designed for battery operation, it provides for a wide range of measurement (10 $\mu\text{v}/\text{meter}$ to 10 v/meter) in conducting broadcast band (540 to 1600 kHz) field intensity surveys. It makes possible close-in measurements on high-powered directional arrays, as well as interference studies where very low signal strengths are encountered.

The AM Field Intensity Meter is direct reading in microvolts per meter without the aid or necessity of charts, curves, correction factors, or computations of any kind. A statically shielded, unbalanced loop is used as an integral part of the instrument cover. The loop has only a few turns, thus the natural resonant frequency is very much higher than the highest frequency in the operating range. The high side of the loop is loaded with a high "Q" coil to provide the total inductance required for the operating range. Injection of the calibrating voltage into the loop circuit is by means of a small toroidal-wound inductance. The "Q" of the loop circuit is ap-

proximately 100 at one megahertz. This high "Q", plus the use of a stage of radio frequency amplification, results in a very high order of image rejection. This feature is desirable since the large increase in the number of stations in some localities has made impractical the use of field intensity meters having insufficient front-end selectivity. By careful design, other spurious responses, such

as i-f harmonics, have been greatly reduced. The use of crystal diodes for metering purposes eliminates the meter errors due to varying cathode voltages on thermionic rectifiers. The crystals are used in special circuits which swamp out variations due to temperature, etc. The meter will indicate accurately with filament voltages as low as one volt and plate voltages as low as 45 volts.

Specifications

Performance Specifications

Frequency Range.....	540-1600 kHz
Sensitivity.....	10 $\mu\text{v}/\text{m}$ to 10 v/m (all frequencies)
Power Supply (not supplied with equipment).....	2 67½ VB—5 1½ volt dry cells (RCA VS016)—(RCA VS036A)
Antenna.....	Built in loop with electro-static shield
Dimensions.....	9" high, 13" wide, 5¾" deep (22.86 cm, 33.02 cm, 14.61 cm)
Weight (including batteries).....	12½ lbs. (5.7 kg)
Tube Complement.....	4—1T4, 2—1R5

Accessories

Double Headset, 24,000 ohms impedance.....	MI-11750
67½ volt "B" battery.....	RCA VS016
1½ volt dry cell.....	RCA VS036A

Ordering Information

AM Field Intensity Meter, including electron tubes in place, but less battery power supply..... Nems Clarke Type 120E

11PB



RADIO CORPORATION OF AMERICA

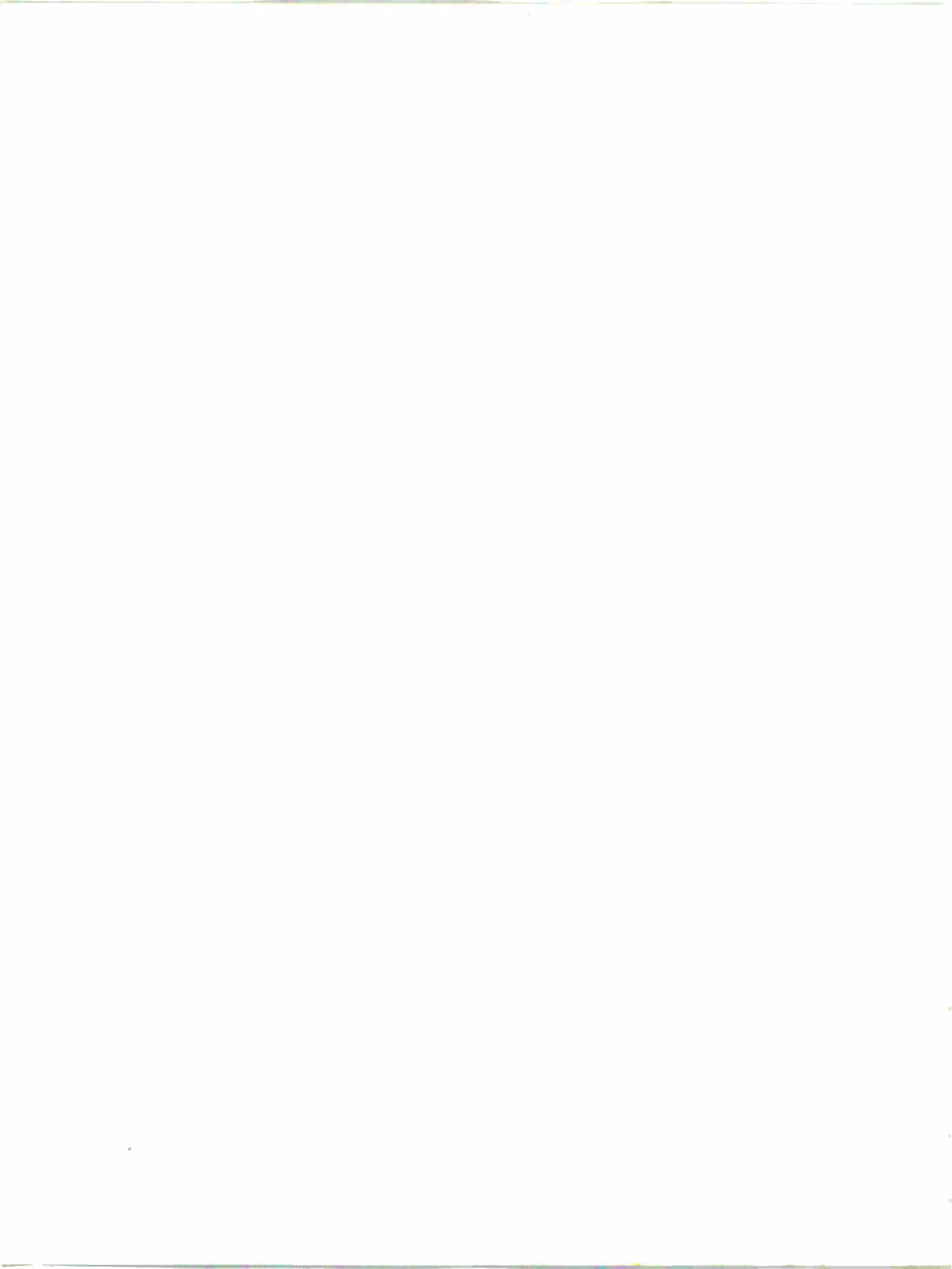

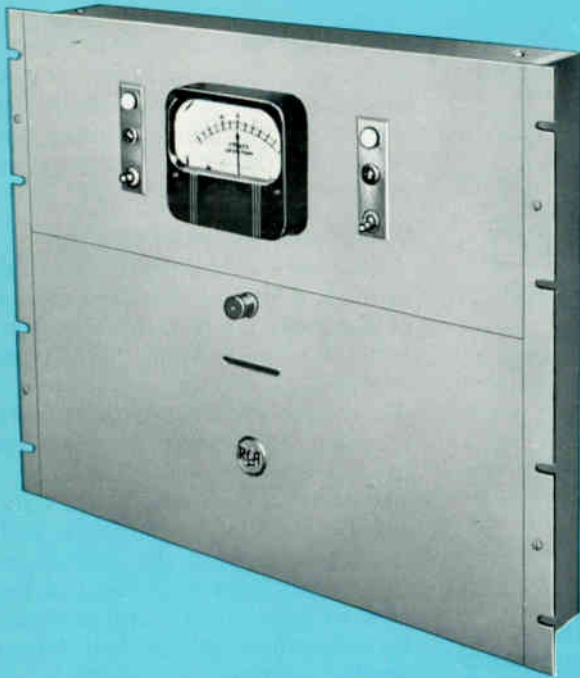

- Continuous reading deviation meter
- Wide input range
- Minimum accuracy at subcarrier frequency ± 5 hertz for 1 year
- Protected trimmer adjustments for frequency calibration
- Warning lamp indicates failure of transmitter carrier or monitor crystal oscillator
- Provision for simultaneous operation of remote indicating or recording meter



Frequency Monitors, Types BW-11A/11AT

Description

The RCA Frequency Deviation Monitors BW-11A and BW-11AT indicate continuously, and directly in hertz-per-second the magnitude and direction of any departure of the carrier signal from its proper frequency. The two models are used as follows:

1. Type BW-11A for AM broadcast stations to measure departure of the carrier from its assigned channel frequency.
2. Type BW-11AT for TV broadcast stations to measure departure of the color subcarrier from 3.579545 MHz standard frequency.

The BW-11A monitor bears FCC approval for use in standard broadcast stations. The BW-11AT more than meets FCC requirement for subcarrier accuracy of ± 10 hertz

maximum and will provide an accurate and convenient method of calibrating and monitoring the color frequency standard now used by stations originating color programs.

Monitoring Provisions

The monitor is a-c operated and is mounted on a single relay rack panel. Coupling of the BW-11A Monitor to the transmitter is obtained from a short length of wire attached to the input terminals to act as an antenna. The BW-11AT Monitor's input voltage is obtained by "looping through" a coaxial cable circuit carrying a subcarrier signal.

One Tuning Adjustment

The oscillator crystal is maintained at a constant temperature by means of a mercury thermostat-controlled oven. Additional isolation

against external influences is effected by the use of low heat conductivity wire to the crystal circuits and thermal cutout. No tuning adjustments are required other than the setting of a single capacitor. A wideband amplifier increases the crystal signal uniformly over the frequency range.

Heavy Duty Features

Since the equipment is designed to operate continuously without adjustment, only two switches are provided on the front panel, the monitor toggle switch, and the check push-button switch. The monitor switch controls power for all circuits except the oven heater which is thermostatically controlled and functions whenever the power cable is connected to the a-c power source. The check pushbutton switch permits a

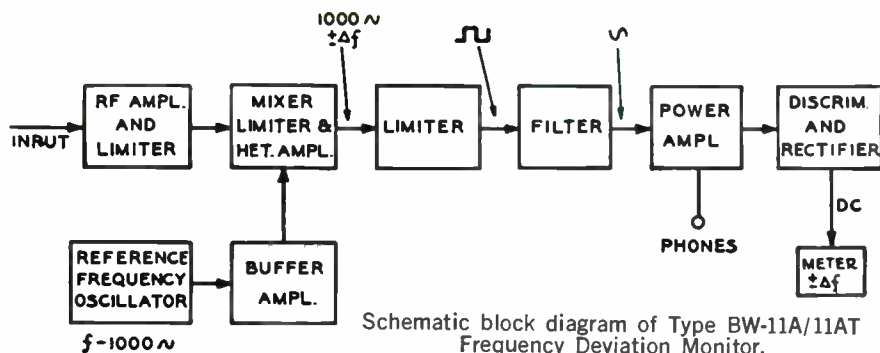

Schematic block diagram of Type BW-11A/11AT Frequency Deviation Monitor.

quick check on all circuits. When the monitor is working normally and this button is pressed, the meter deflection increases by approximately 5 Hz. A change appreciably different from 5 Hz indicates a defective circuit.

Circuit Description

The circuit arrangement of the BW-11A/11AT is shown in the accompanying block diagram. Voltage from a temperature-controlled piezoelectric oscillator (frequency $f - 1000$ Hz) and the carrier to be monitored (frequency $f \pm \Delta f$) are amplified and fed to a converter tube from which their difference frequency ($1000 \pm \Delta f$) is obtained. This audio-frequency is converted to a constant

amplitude square wave by means of a limiter amplifier and then restored to a constant amplitude sine wave of frequency ($1000 \text{ Hz} \pm \Delta f$) by a filter stage. After power amplification the audio frequency is applied to a discriminator and rectifier circuit, from which d-c is obtained. The amplitude and polarity of the d-c is determined by the deviation from 1000 Hz. Deviation is indicated on a linearly calibrated zero-center meter with a scale calibration of ± 30 Hz. A jack is provided for a remote indicating or recording meter, which can be operated simultaneously with the panel meter.

Circuits are designed so that wide variations in tube characteristics and

line voltage cause negligible error in deviation indications. Negative feedback is used on the power amplifier, and in other circuits, limiting and voltage regulation are employed to minimize these effects.

Operational Convenience

The oven thermometer is visible through a slot in the lower section of the front panel and it is illuminated for easy reading. Tubes and crystal oven, located on the back of the chassis, are easily accessible for servicing. The monitor is contained in a single unit which occupies a $15\frac{3}{4}$ -inch vertical space in a standard 19-inch cabinet rack. To facilitate maintenance, the bottom section of the front panel may be lowered to expose the monitor circuits for continuity checks, and all the routine maintenance controls. An MI-7982-B Crystal Unit specially ground to 1000 hertz below the transmitter frequency is provided for the BW-11A, and MI-7962-C Crystal Unit especially ground for the sub-carrier frequency is specified for the BW-11AT Monitor.

Specifications

	Model BW-11A	Model BW-11AT
Frequency Range	500 to 2000 kHz	3.579545
Frequency Deviation Range (readable to 1 cycle)	± 30 Hz	± 30 Hz
Accuracy	± 10 parts per million	± 1 Hz for 30 days ± 5 Hz for 1 year
R-F Input Voltage	Approx. 10 mV to 25 Volts	Approx. 0.15 to 25 Volts
Power Supply	105-130 Volts, 50/60 Hz, single phase	
Power Input		120 watts

Dimensions	19" wide, $15\frac{3}{4}$ " high, $9\frac{5}{8}$ " deep (48.26 cm, 40 cm, 24.45 cm)
Weight	60 lbs. (27.2 kg)
Finish	Silver gray
FCC Approval Number for BW-11A	1471
Tube Complement:	5-6AU6, 1-6BE6, 1-6V6-GT, 3-6AL5, 2-2D21, 1-5Y3-GT, 2-OC3/VR105

Accessories

Remote Meter (order from Replacement Parts)	SN-93688
Tube Kit for BW-11A/AT	MI-8295
Crystal Unit for BW-11A (specify frequency)	MI-34070
Crystal Unit for BW-11AT (frequency 1192.848 kHz)	MI-7962-C

Ordering Information

BW-11A AM Broadcast Frequency Monitor complete including Crystal Unit MI-34070.
(Specify operating frequency).....ES-34042

BW-11AT Color TV Sub-Carrier Frequency Monitor complete including Crystal Unit, MI-34075.
(Specify operating frequency).....ES-34040-A



RADIO CORPORATION OF AMERICA

