

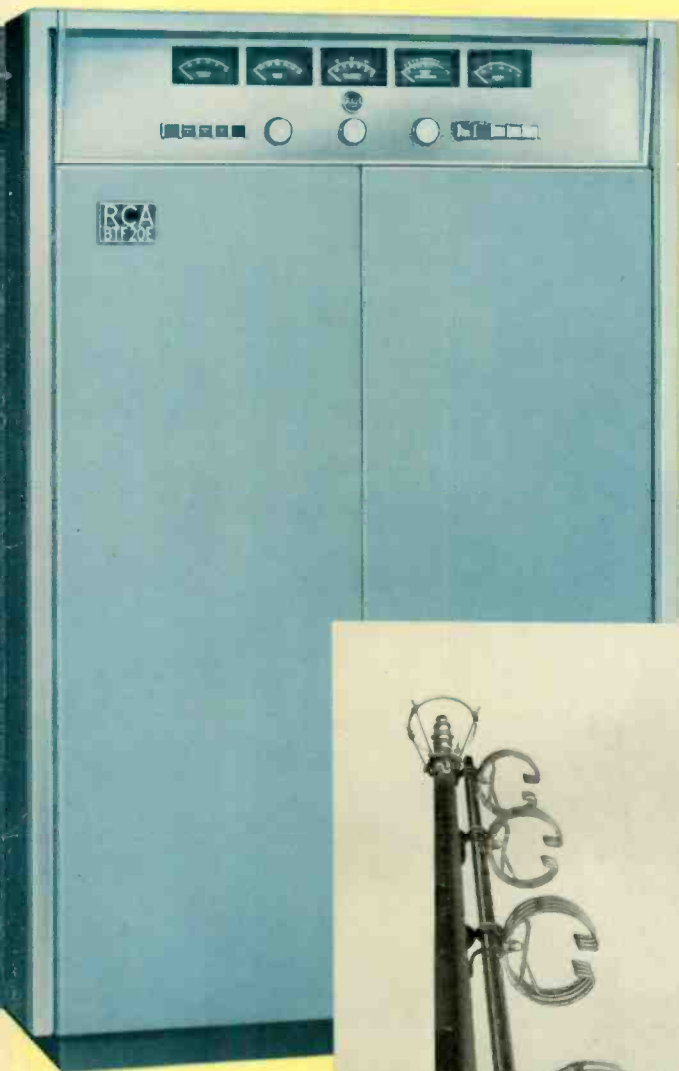

TRANSMITTERS • MULTIPLEX • ANTENNAS • TRANSMISSION LINE

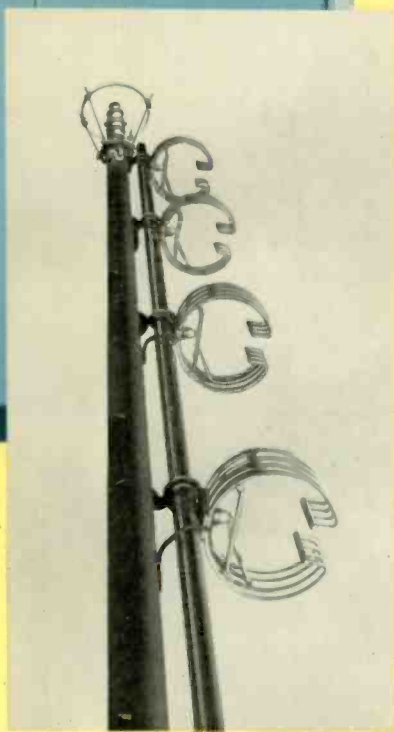

TRANSMITTING  
**fm-radio**  
EQUIPMENT



**TRANSMITTING  
FM RADIO  
EQUIPMENT  
CATALOG**



**THE MOST TRUSTED NAME IN TELEVISION**

## ABOUT THIS CATALOG

This catalog provides information on RCA FM Radio Transmitting Equipment. Other RCA Broadcast Equipment Catalogs supply information on TV camera, TV film, TV tape, Terminal and Switching, and Audio equipment; also on AM, VHF, and UHF TV transmitters, antennas, and transmission line.

The information contained in this catalog is intended to serve as a buying guide for the user. Complete specifications and ordering information are supplied. Readers who desire more information or individual bulletins on particular equipment items are invited to write to their RCA Broadcast Representative.

## OTHER RCA TECHNICAL PRODUCTS

RCA also manufactures many other electronic products, including: two-way radio and microwave relay communications equipment; optical and magnetic film recording equipment; sound systems of all types; 16mm projectors and magnetic recorders; industrial inspection and automation equipment; scientific instruments, such as the electron microscope; closed-circuit television systems; and many types of custom-built equipment for industry, the military, educational and medical services. Information describing these products may be obtained from RCA Sales Offices in the United States and Canada or internationally from local RCA Distributors or RCA International Division.

## PRICES

Domestic prices of the equipment shown in this catalog are provided in a separate price list. Equipments are identified by type and MI (Master Item) numbers which are used to identify apparatus on invoices and packing slips. International prices for the various equipment items shown in this catalog are available from RCA Distributors or RCA International Division.

## HOW TO ORDER

The RCA FM Radio Transmitting Equipment shown in this catalog is sold through RCA Broadcast Representatives, who are familiar with broadcast equipment and related problems. These RCA Representatives are located in convenient offices throughout the United States. Domestic orders for equipment, or requests for additional information, should be directed to the nearest RCA Sales Office. International Readers are invited to contact their local RCA Distributor or the RCA International Division Office.

# Contents

	Page
<b>BTF-1E1 FM Transmitter</b>	<b>5</b>
<b>BTF-5E FM Transmitter</b>	<b>9</b>
<b>BTF-10E FM Transmitter</b>	<b>17</b>
<b>BTF-20E FM Transmitter</b>	<b>25</b>
<b>BTF-40E FM Transmitter</b>	<b>33</b>
<b>BTE-10CT FM Transmitter</b>	<b>41</b>
<b>Stereo &amp; SCA Equipment</b>	<b>43</b>
<b>Remote Control &amp; Automatic Logging</b>	<b>49</b>
<b>Monitoring Equipment</b>	<b>59</b>
<b>AM-FM Transmission Line</b>	<b>67</b>
<b>AM-FM Antenna Towers</b>	<b>91</b>
<b>FM Antennas</b>	<b>95</b>
<b>Index</b>	<b>103</b>



# 1-KW FM Broadcast Transmitter, Type BTF-1E1

- "Direct FM" exciter
- High quality stereo with optional BTS-1A Generator
- Designed for remote control
- Silicon power supplies
- Voltage regulating filament transformer



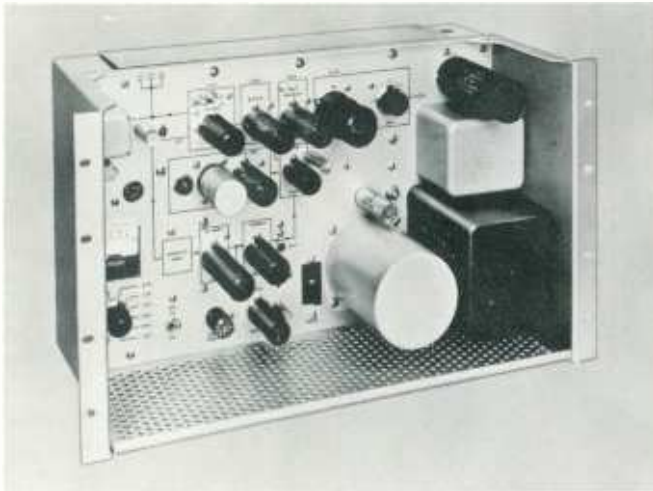

RCA "Direct FM" Multiplex Exciter is extremely stable.

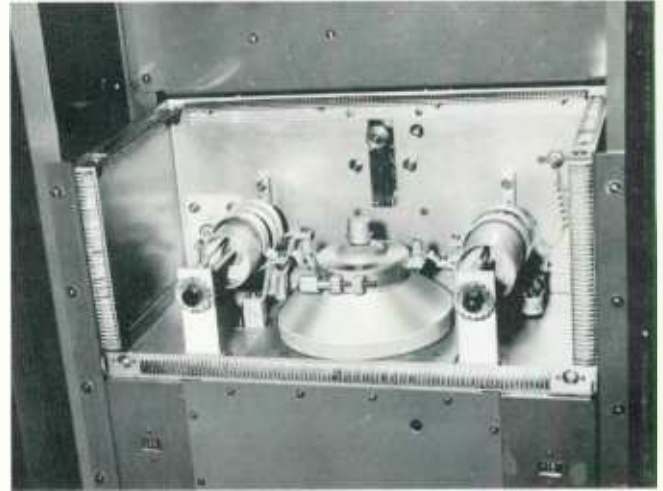

RF cavity with shielded cover removed.

## Description

RCA's Type BTF-1E1 FM Transmitter provides 1,000 Watts output for stations operating in the 88 to 108 MHz band. It is designed to provide the finest possible performance and reliability, and is specifically built to meet the stringent requirements of multiplex and stereo service transmission. It is a simple and compact unit easy to install.

The BTF-1E1 Transmitter supplies the latest in FM broadcast techniques. Only one tube beyond the exciter is required to supply 1000 Watts output. No IPA stage is required. The transmitter is extremely stable because it incorporates RCA's time-proven "Direct FM" Exciter. This exciter requires no special tuning or setting up for standard or for multiplex operations. It also reduces the number of components and tubes required. All circuits are single tuned. Cross-talk and noise are kept to an absolute minimum.

### Easy to Install and Operate

Other features incorporated in the BTF-1E1 include silicon rectifiers which provide long life with a minimum of maintenance. Accessibility is assured both front and rear by vertical chassis construction, surface mounting of components, and hinged mounting of the exciter. Mechanical and electrical overload protection is provided. All tubes operate at conservative rating for

long life. The BTF-1E1 is also designed so that a minimum number of tubes and components are required in the transmitter. To assure performance in accordance with FCC requirements, the transmitter is supplied with harmonic filter. Provisions for remote control have been provided in the transmitter.

High quality FM stereo transmission can be obtained by the addition of an RCA BTS-1A Stereo Generator. SCA programming may be transmitted simultaneously with stereo by the use of the optional BTX-1A subcarrier generator. The BTF-1E1 is type accepted for such simultaneous program transmission.

### Single Cabinet

The Type BTF-1E1 FM Transmitter is completely housed in one cabinet with total floor dimensions of only 26 by 21 inches. The cabinet is functionally styled to present a pleasing appearance. All meters and operating controls are conveniently located. Front and rear hinged doors give easy access to all portions of the transmitter.

Located at the front are the overload relays, the 1 kw amplifier and RF box containing tuning dials for the amplifier. A control panel and screen supply are located next, followed by the hinged mounted exciter. Concealed in the bottom of the transmitter are the high voltage rec-

tifier and power transformer. The rear of the transmitter gives access to the bias resistors, metering circuitry and blower, followed by the rear of the control panel and screen supply. A voltage regulating filament transformer is mounted on the control panel.

### Multiplex Exciter

The Type BTE-10C FM Exciter, which is the heart of RCA's new line of FM transmitters, is the simplest ever offered. The direct RF circuitry consists of the FM oscillator and buffer followed by a doubler stage and the final PA stage which provides a 10 Watt output. A built-in meter is provided for reading the plate current of the final amplifier. The self-contained power supply for the BTE-10C employs semiconductor rectifiers throughout. An AFC on-off toggle switch and simplified controls including the power on-off switch are all easily accessible on the chassis of the exciter.

### Frequency Modulated Oscillator

The frequency modulated oscillator operates from 44 to 54 MHz at one half the final frequency. This frequency is sampled after the buffer amplifier and fed into a mixer. A second frequency, 130 Hz higher, is obtained from a highly stable crystal oscillator as shown in the block diagram. Thus an output frequency of 130 Hz is obtained. Any variation

in frequency of the FM oscillator will immediately cause a corresponding change of the 130 Hz beat frequency. The 130 Hz frequency is applied to the input of a Schmitt trigger circuit that transforms the 130 kHz sine wave input signal into a square wave signal to make the following counter-type detector independent of possible amplitude variations of the 130 Hz beat frequency. The counter-type detector has a 130 Hz crossover frequency. An opposite polarity error signal will be obtained with opposite frequency departures of the 130 Hz square wave. This error voltage is amplified by a magnetic amplifier causing a total open-loop gain of the AFC loop of about 40 dB. The error signal, a DC voltage depending on its magnitude and polarity on the FM oscillators frequency, is then fed back into a capacitive diode which controls the frequency of the FM oscillator. This closes the AFC loop.

### Frequency Stability

Frequency stability of the counter-type detector is better than  $\pm 250$  Hz over a temperature range from  $-20$  to  $+15$  degrees Centigrade. This amount, multiplied by two (due to subsequent doubling of the RF portion of the BTE-10C) represents the major amount of possible carrier shift. High loop gain and excellent initial stability of the FM oscillator reduces the carrier frequency shift from these sources to not more than 25 percent of the contribution of the counter-discriminator. These variations are well within FCC requirements.

With the AFC operating, the center frequency can be adjusted manually over a range of approximately  $\pm 20$  kHz by a calibrated 10 turn potentiometer. Thus calibration tolerances of the reference crystal can be compensated and the carrier frequency can be adjusted to agree exactly with the assigned frequency.

### Power Amplifier

The output of the exciter is fed to the input of the ceramic 4CX-1000A amplifier tube. The amplifier input circuit is a simple parallel resonant circuit, tuned by a variable inductance with resistance swamping for stability of operation. This stage is neutralized by varying inductance in series with the screen. The output circuit is a modified pi network, having a variable inductance across the tube capacity—which is used to adjust the loading. All capacitors in the final stage are of the fixed ceramic type. A blower mounted on the back of the RF compartment provides sufficient filtered air for cooling at stations operating below 7500 feet. The filament transformer is of the automatic regulator type and keeps filament voltage constant within one percent.

The power amplifier is new in many respects. The variable inductors use no sliding contacts. There are no variable capacitors in the power amplifier. A single tube, the 4CX1000A, is used in the BTF-1E1 power amplifier and it is driven directly by the output of the exciter in an exclusive RCA circuit. Consequently, the transmitter can be oper-

ated with only eight tubes if there should be a failure in the AFC circuit of the exciter.

### Neutralizing Probe

A neutralizing probe is furnished with the transmitter. It utilizes the multimeter to indicate correct neutralization of the power amplifier.

The high voltage and screen power supplies make use of silicon rectifiers in a bridge circuit. This combined with choke input and adequate filtering results in an excellent well-regulated power source. A variable transformer is used in the primary of the screen power supply to control power output of the transmitter. Filament voltage regulation is provided for the 4CX1000A power amplifier tube.

### Harmonic Filter

The harmonic filter supplied with all RCA FM transmitters is not a simple harmonic trap. The filter consists of an M-derived half-T section, several low-pass filter sections, and a constant-K, half-T section. The M-derived section provides rapid cut-off in the second harmonic region, and a termination impedance at one end of the filter of 50 Ohms. Attenuation of the harmonics is accomplished by the low-pass filter sections, while the constant-K, half-T section serves to give a termination impedance of 50 Ohms at the other end of the unit. The use of such a filter assures compliance with FCC requirements regarding spurious radiation, as all harmonics through the seventh are effectively attenuated.

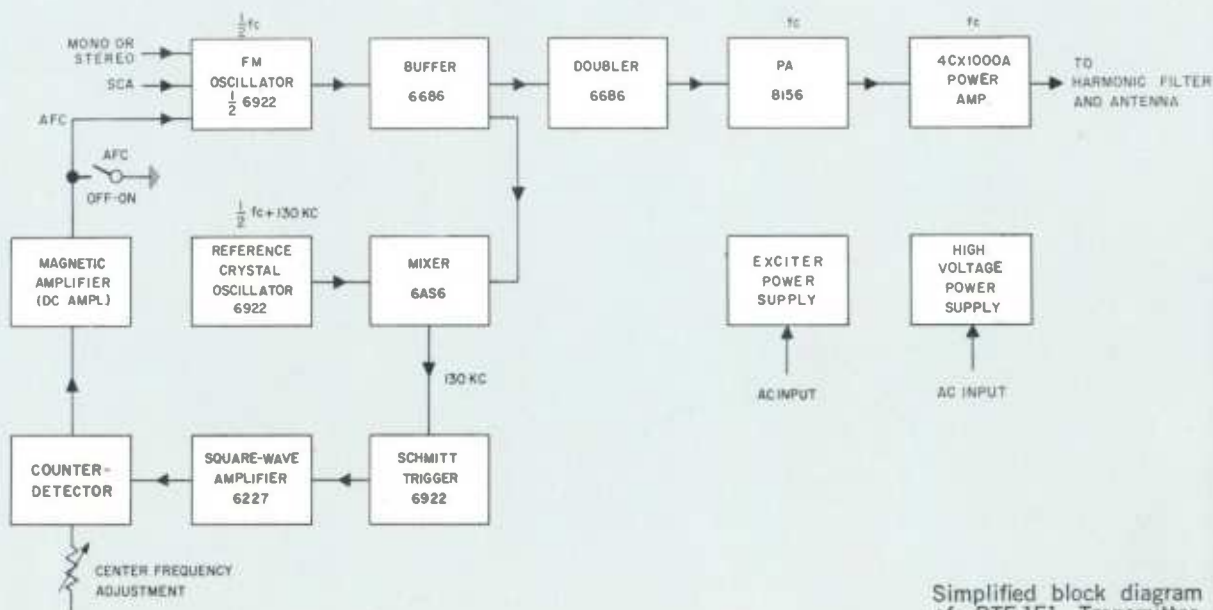

Simplified block diagram of BTF-1E1 Transmitter.



## Protective Circuits

Power circuits are protected by magnetically tripped circuit breakers as well as overload relays. An interlock relay prevents application of plate power until the 4CX1000A filament has heated and the exciter has reached a stable operating condition. Overload relays are used in the high voltage and screen power supplies. There is also an interlock in the air blower circuit. If the blower should fail or air flow be reduced below the proper level, the transmitter is taken off the air thus avoiding possible damage.

The overload relays are reset remotely or by means of an instantaneous key switch on the front panel. An overload indicator lamp signals when an overload has taken

place. All relays are easily accessible. Access to high voltage areas is protected by built-in high voltage shorting devices.

## Control Features

The BTE-10C exciter has a self-contained multimeter. It is used to read modulator cathode current, second and third multiplier grid current, PA cathode and plate current, AFC control voltage and plate voltage. In the amplifier of the transmitter, provision is made for metering PA plate current, plate voltage, output power and VSWR; a probe is furnished for neutralizing the transmitter and is used in connection with the multimeter. All tuning controls are located on the front panel for easy accessibility. They include key switches for fila-

ment on-off, plate on-off, and overload reset. The variable power control is also mounted on the front as are the overload indicator and plate power-on lights. The use of latching relays make it possible to control the transmitter with one button.

## Remote Control Provisions

The BTF-1E1 transmitter incorporates connections for remote control and remote meter reading when combined with a remote control system such as the BTR-11B or BTR-20C. Terminals for transmitter on-off, plate on-off, overload reset, plate voltage, cathode current, and power output are provided. To control transmitter power output remotely, an accessory motor drive may be connected to the screen supply control.

## Specifications

### Performance

Type of Emission.....	F3 and F9
Frequency Range.....	.88 to 108 MHz
Power Output.....	250-1000 Watts
Output Impedance (1 1/2" O.D. Line).....	50/51.5 Ohms
Frequency Deviation, 100% modulation.....	±75 kHz
Modulation Capability.....	±100 kHz
Carrier Frequency Stability.....	±1000 Hz max.
Audio Input Impedance.....	600/150 Ohms
Audio Input Level— <sup>1</sup> (100% mod.).....	+10±2 dBm
Audio Frequency Response— <sup>2</sup> (30 Hz-15 kHz).....	±1 dB max.
Harmonic Distortion— <sup>3</sup> (30 Hz-15 kHz).....	0.5% or less
FM Noise Level (referred to 100% FM mod.).....	-65 dB max.
AM Noise Level (referred to 100% AM mod.).....	-50 dB max.
Subcarrier Input Level (30% mod. of Carrier).....	.5 Volt max.
Subcarrier Input Impedance.....	10,000 Ohms
Subcarrier Frequency.....	30-67 kHz

### Electrical

Main-to-Subchannel Crosstalk.....	-53 dB referred to ±7.5 kHz deviation of the subcarrier by a 400 Hz tone. Main channel modulation 70% by 30-15,000 Hz tones.
Sub-to-Main-Channel Crosstalk.....	-65 dB referred to ±7.5 kHz deviation of the main carrier by a 400 Hz tone. Subchannel modulated 100% (±7.5 kHz/s) by 30-6000 Hz tones. Subcarrier modulated 30% on main carrier.
Power Line Requirements:	
Line.....	240/208 Volts, single phase, 60 Hz <sup>4</sup>
Slow Voltage Variation.....	±5%
Power Consumption.....	2800 Watts (approx.)
Power Factor (approx.).....	80%

<sup>1</sup> Level measured at input to pre-emphasis network.

<sup>2</sup> Audio Frequency response referred to 75 or 50 micro-second pre-emphasis curve.

<sup>3</sup> Distortion includes all harmonics up to 30 kHz and is measured following a standard 75 or 50 micro-second de-emphasis network.

<sup>4</sup> 50-Hz operation requires MI-34316-20 regulator.

### Crystal Heaters:

Line.....	117 Volts, single phase, 50/60 Hz
Power Consumption.....	7.5 Watts

### Tube Complement

#### Exciter:

1/2 6922 Frequency Modulated Oscillator	1 6922 Crystal Oscillator	1 6AS6 Mixer
1/2 6922 Cathode Follower	1 6922 Schmitt Trigger	1 6227 Square Wave Amplifier
1 6686 Buffer Amplifier	1 6686 Doubler	1 OG3 Reference Voltage Regulator
1 8156 Final Amplifier		

#### Power Amplifier:

1—4CX1000A

### Mechanical

Dimensions (overall).....	26" wide, 77" high, 20 1/8" deep (66.04 cm, 195.58 cm, 52.23 cm)
Weight.....	790 lbs. (3.58 kg.)
Finish.....	Textured vinyl in midnight blue and shadow blue, satin aluminum trim
Altitude.....	7500 ft. max. (2290 m)
Ambient Temperature Range.....	-20° to +45°C

### Accessories

Set of Spare Tubes for BTE-10C Exciter.....	MI-560301
Spare Amplifier Tube for BTF-1E1.....	MI-34709
Remote Power Control.....	MI-27558
Type BTR-11B Remote Control System.....	ES-34280
Type BTS-1A Stereo Subcarrier Generator.....	ES-560202
Type BTX-1A Subcarrier Generator.....	ES-27295
Filter for BTX-1A, if used during stereo transmissions.....	MI-560003
BW-73A Modulation and Multiplex Monitor.....	ES-560200-A
Frequency Monitor.....	TBM-3000

## Ordering Information

Type BTF-1E1 1-kw FM Broadcast Transmitter.....ES-27279-A

Please specify assigned frequency, power-line frequency and altitude of installation.

## 5-KW FM Transmitter, Type BTF-5E

- Ultra stable—easy to tune
- High quality stereo with SCA
- Power increase with minimum change
- Ready for remote control



# 5-KW FM Broadcast Transmitter

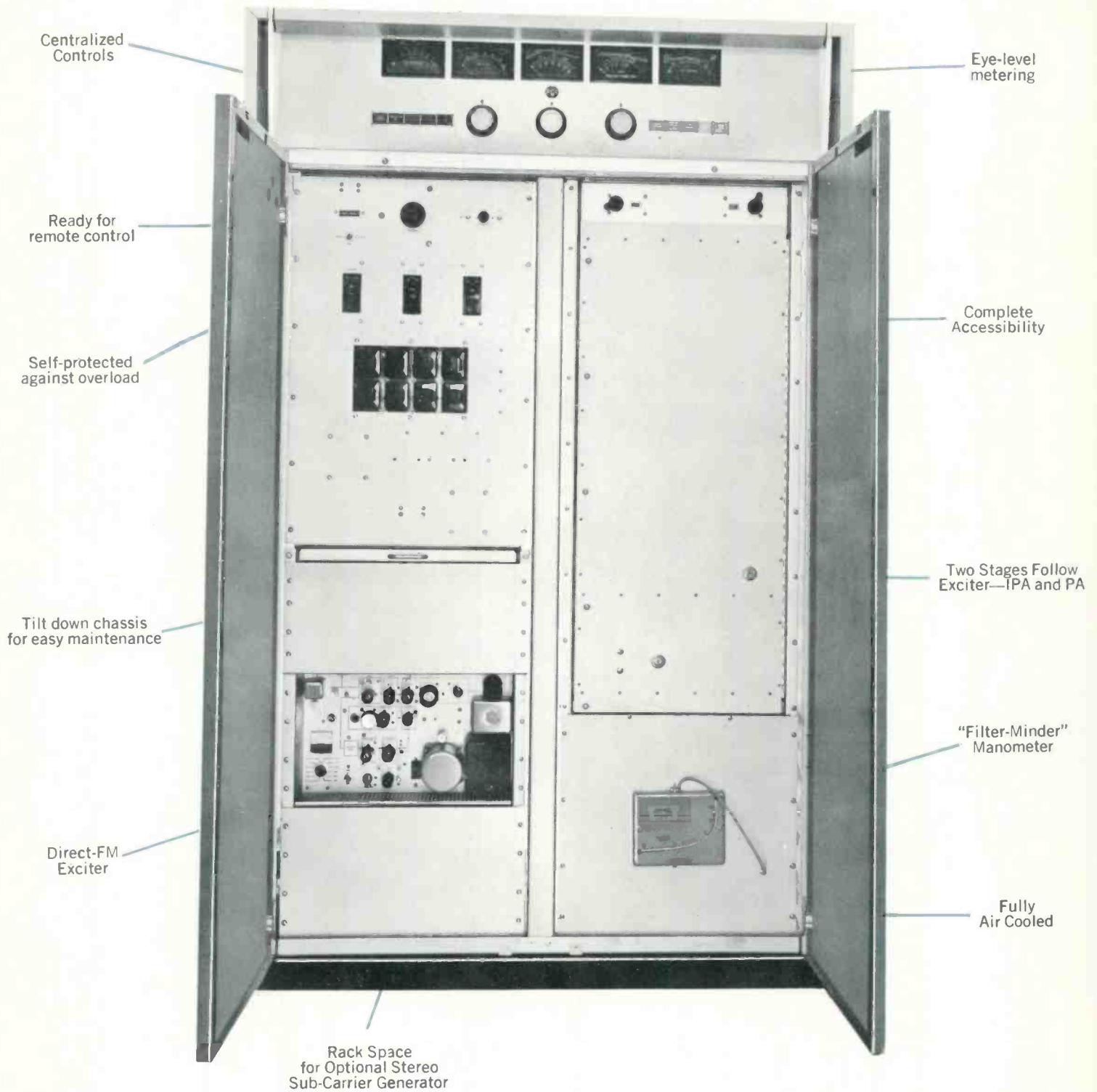

# Full-Fidelity FM Transmitter, Type BTF-5E

RCA's Type BTF-5E FM Broadcast Transmitter provides 5,000 Watts output for stations operating in the 88 to 108 MHz band. It is designed to provide the finest possible performance and reliability, and is specifically built to meet or exceed the stringent requirements of multiplex service transmission. The equipment is FCC type accepted and meets all requirements for harmonic and spurious emission.

The BTF-5E employs a new exciter that uses the time-tested and field-proven *direct-FM* system. The circuit uses capacitive diodes as modulators of an oscillator to produce *direct FM*. Automatic frequency-control maintains oscillator frequency to close tolerances under virtually all operating conditions.

Because of its wide frequency response and extreme stability, the exciter (and

the transmitter) is ideally suited for multiplex and stereo programming.

The exciter in the BTF-5E uses built-in silicon-rectifier power supplies for long life and great dependability. For ease of tuning, the exciter has a built-in multimeter and highly-accessible test points permitting convenient metering and checking while operating. All RF circuits are single tuned for utmost tuning simplicity.

Frequency response of the transmitter's main channel is 30 to 15,000 Hertz ( $\pm 1$  dB maximum) and the distortion over the same bandwidth is less than one-half of one percent.

The BTF-5E is designed specifically to be field-expandable to a 10- or 20-kW transmitter. It is noteworthy that this expansion is substantially electrical and there is virtually no increase in floor-space requirements.

## Description

### Mono or Stereo

The transmitter features a new exciter designed for stereo and multiplex. The exciter, including its self-contained semiconductor-equipped power supply, is mounted on a single vertical chassis.

### Two Stages Follow Exciter

From the 10-Watt output of the exciter, only two tubes generate the full 5-kW signal. A harmonic filter is included to reduce spurious radiation. Vacuum capacitors are used to tune the IPA plate and the PA grid.

### Ready for Remote Control

The transmitter is designed and built for remotely-controlled operation. Internal wiring and terminals are provided for remote control of these transmitter functions: transmitter on/off; raise/lower output power and overload reset. Remote metering facilities for the PA include: cathode current; plate voltage and power output.

### New Styling

Functional styling combined with fewer tubes permits the BTF-5E to

be housed in a single, double-door cabinet in a new midnight blue and shadow blue vinyl finish. For contrast, the meter panel is in bright aluminum and the cabinet is trimmed in satin-finished aluminum. The swing-out doors in the front and rear afford the excellent accessibility for which RCA transmitters are famous.

All operating controls and meters are mounted on a panel above the front doors.

### "Direct FM" Exciter

The RCA Type BTE-10C Exciter is a compact, self-contained unit which provides a modulated r-f output of ten watts at any specified frequency in the FM-broadcast band. Its simplified design provides superior performance under stereophonic, monophonic and subcarrier conditions.

The design employs the *direct-FM* modulation system with particular design emphasis placed on adjustment ease and reliable operation. All RF stages use simplified single-tuned circuits. A built-in multimeter and easily-accessible test points permit convenient metering and checking during air time.

Premium tubes designed for long

life, are used to extend reliability. The exciter is particularly well suited to unattended, remote-from-the studio duty.

### Simplified Circuitry

The FM exciter consists of only nine tubes, four of which are r-f, and four in the AFC loop. The ninth tube is a voltage-regulator type. A master oscillator, operating at one-half the carrier frequency, is frequency-modulated by a capacitive diode. A buffer amplifier, a frequency doubler and a power amplifier raise the power level to 10 Watts.

The four-tube AFC section maintains precision control of the master oscillator to within tight tolerances. Since the exciter applies modulation at one-half carrier frequency, the system avoids the critical adjustment tedium of cascaded modulators.

### Precision AFC

The frequency-modulated oscillator operates at a frequency between 44 and 54 MHz (one half the carrier frequency). Its accuracy is precisely controlled through an AFC system that uses a counter-detector and a magnetic amplifier. The noteworthy point is that the AFC system oper-

## Select Features

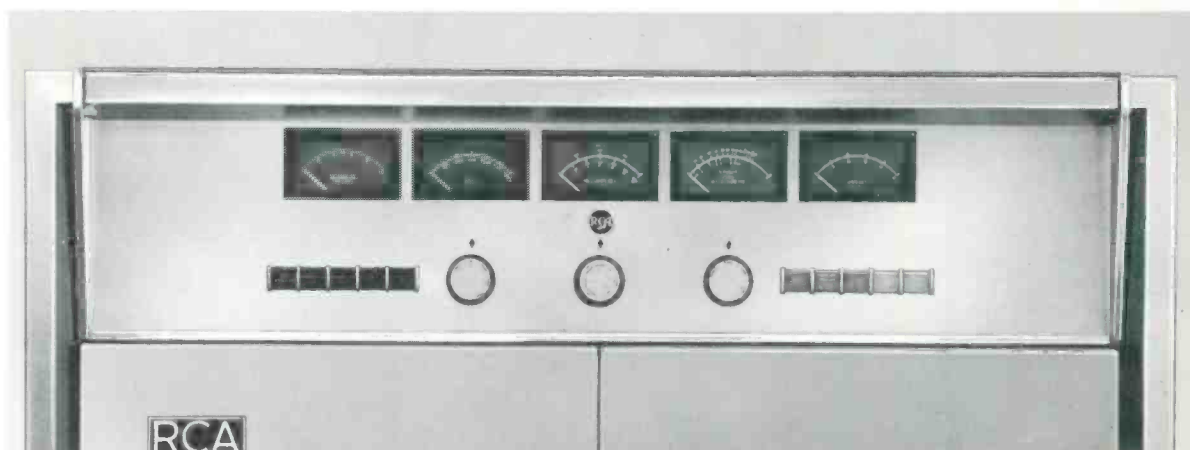

BTF-5E Control Panel. Tally lights and push-button controls simplify operation.

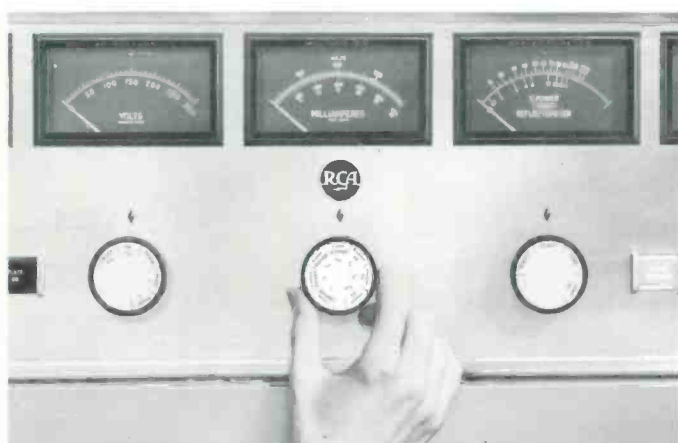

The large-diameter multimeter knobs speed log-keeping and minimize error.

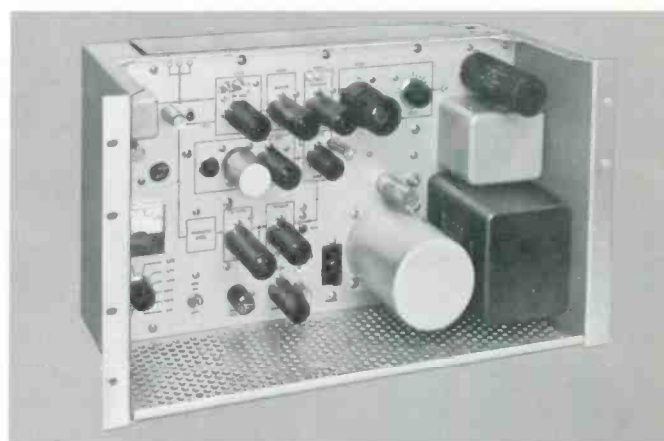

Nine-tube, direct-FM exciter provides unparalleled multiplex performance.

ates entirely without tuned circuits. This results in exceptional long-term stability.

The master oscillator offers excellent frequency stability even when "free-running." This stability permits manual control of center frequency in the rare event of AFC failure.

### Magnetic-Amplifier AFC

The "error" signal developed in the AFC counter-detector is amplified through the use of a magnetic

amplifier. This device provides a DC voltage gain of approximately 40 dB. This amplified "error" signal (DC) pulls (or pushes) the oscillator frequency to within tolerances.

### Class "C" Power Amplifiers

Two simplified, single-ended amplifiers operating class "C" follow the exciter. The 250-Watt driver stage uses a Type 7203/4CX250B tube, and the final power amplifier uses a Type 4CX5000A (ceramic tetrode). The driver stage is tuned by pi-network input-and-output cir-

cuits. Vacuum-dielectric variable capacitors tune the pi networks. The power amplifier, too, uses pi-network circuitry and tuning is accomplished by variable inductors operating at ground potential.

### 5-kW Class "C" Final Amplifier

The output tube, a ceramic tetrode, 4CX5000A, offers very high power-gain with little drive. Using this tube, only two stages of amplification are required between the exciter and the antenna for the 5,000-Watt output. Fewer compo-

nents result in improved reliability. Actual operating records have shown that the 4CX5000A gives excellent performance and long life.

### Motor-Driven Power-Output Control

Power output is controlled by means of a motor-driven variable transformer which controls the low-voltage power supply. This supply controls the driver-plate and the screen voltages of both stages simultaneously. A separate grid bias supply increases transmitter stability and reliability. The use of semiconductor (silicon) rectifiers reduces operating and maintenance costs.

### Harmonic Filter Standard Equipment

To keep spurious emission to a minimum, a harmonic filter is standard equipment with the BTF-5E. The filter consists of an "M"-derived "half-T" section, several low-pass

filter sections, and a constant-"K", "half-T" section. Attenuation of the harmonics through the seventh is accomplished by the passband of the low-pass filter sections, while the constant-"K", "half-T" section serves as a 50-Ohm termination impedance.

### Self-Protected Against Overload

Power circuits are protected by magnetically-tripped circuit breakers in addition to overload relays. An interlock system prevents turn-on of plate power until all filaments have heated and the exciter has reached a proper operating condition. In addition, a latching relay automatically re-applies power to the transmitter once before locking-out in the event of brief overloads or power interruptions. The overload relays are reset by illuminated push button switches on the front panel. Separate tally-light indicators are provided for overloads in the driver, power amplifier and low-voltage rectifier circuits.

### Fully Air-Cooled

Cooling air for the BTF-5E is supplied by a blower mounted below the amplifier stages. Heavy sound insulation reduces blower noise to a minimum. The blower supplies forced air to both the IPA and PA stages.

### Simplified Control

The transmitter has all operating controls and meters located on a panel just above the front doors. The push-button controls include: transmitter on/off, plate on/off, overload reset and power raise/lower. A cabinet disconnect switch, low-voltage circuit breaker, and filament control circuit breakers are located behind the left-hand door. The main- and low-power circuit breakers are located in the unitized rectifier cabinet. When servicing the BTE-5E, operation of the disconnect switch removes all voltages from the transmitter cabinet. Personnel are also protected by fully interlocked rear

Simplified Block Diagram of the BTF-5E Transmitter.

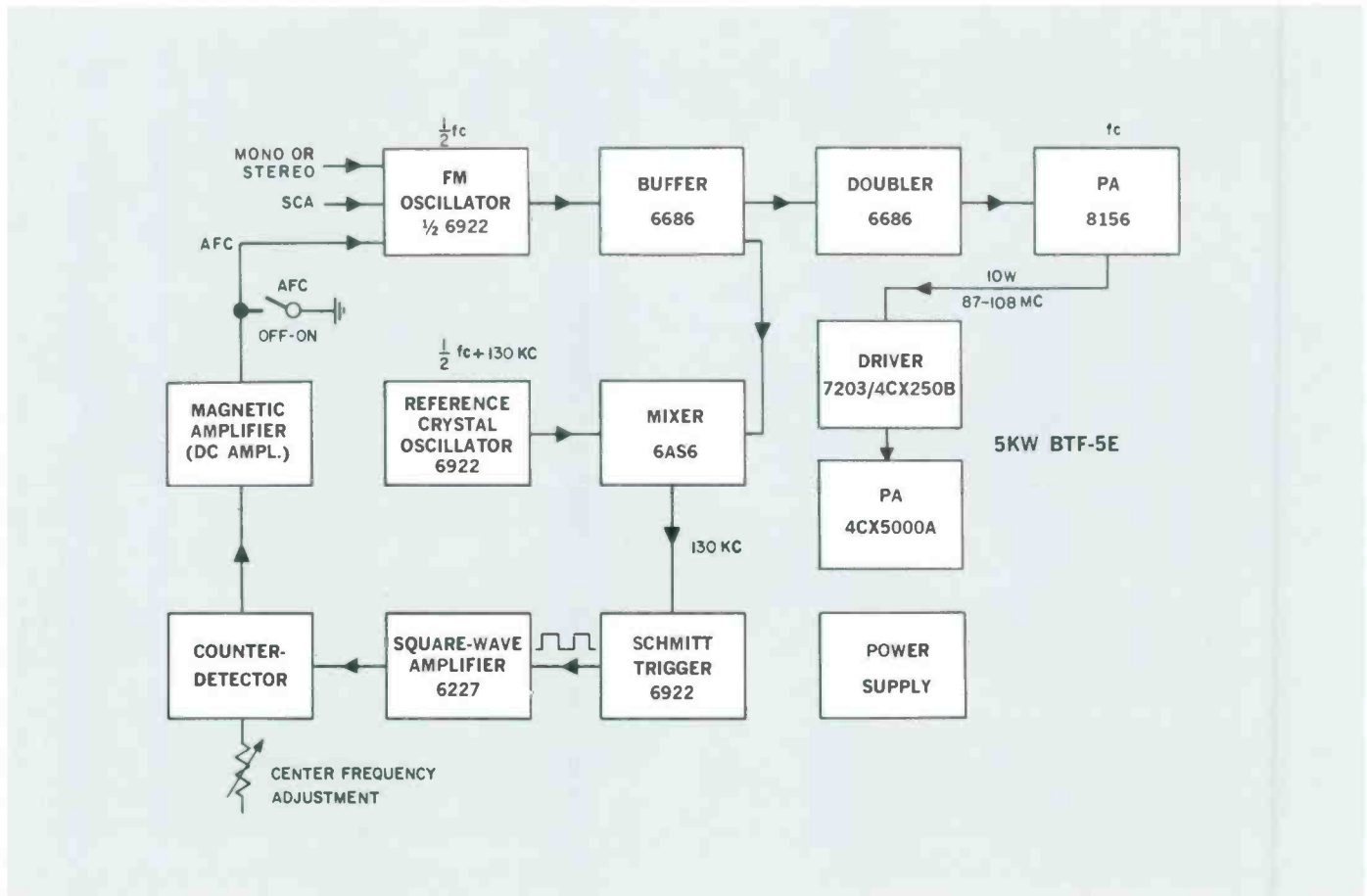

doors in addition to interlocked doors on the PA cubicle.

#### Full Metering

Five easy-to-read front-panel meters are provided. One for PA-plate voltage, another for PA-plate current, and a third for AC line and filament voltage. The remaining two are a reflectometer and a multimeter. The reflectometer measures the forward power or VSWR. The multimeter reads grid current, screen current and screen voltage of both power tubes. In addition the exciter has its own self-contained multimeter. This one provides complete information on operating conditions in the exciter.

#### Ready for Remote Control

Remote control provisions are included in the transmitter, and terminals are provided for use with remote control units such as the Type BTR-11B or BTR-20C and Automatic Logging Equipment. Additional terminals are provided for remote control of transmitter on/off, plate on/off, raise/lower power, and overload reset. Remote metering connections in the final amplifier for plate current, plate voltage, and power output are also provided.

#### High-Voltage Power Supply

The high-voltage power supply is housed in a unitized cabinet meas-

uring 27 inches wide, 23 inches deep and 43 inches high. It can be installed at any convenient site in the station. The cabinet houses the high-voltage-plate transformer, a bank of plug-in semiconductor rectifiers, a line-circuit breaker, a high-voltage circuit breaker, and the plate contactor. Personnel are fully protected from shock through interlock and grounding switches.

The rectifier section comprises silicon-junction diodes (with equalizing resistors and capacitors) in a three-phase, full-wave-bridge circuit. Circuit breakers are used instead of fuses in the transmitter adding to the dependability, particularly when operating remote control.

**ONLY TWO TUBES BETWEEN EXCITER AND OUTPUT**—View showing interior of PA and IPA cabinet with the 4CX5000A ceramic tetrode and one 7203/4CX250B IPA tube below shelf.



**COMPLETE ACCESSIBILITY**—Rear view of the BTF-5E revealing the clean, vertical construction of PA cavity to left and control panel to right.

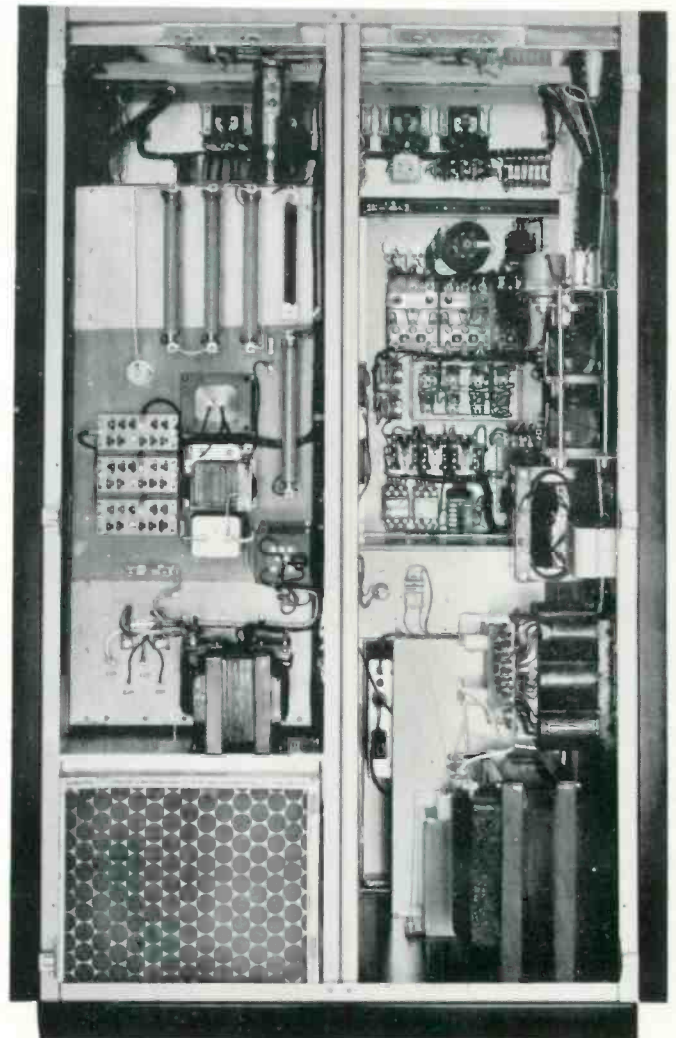

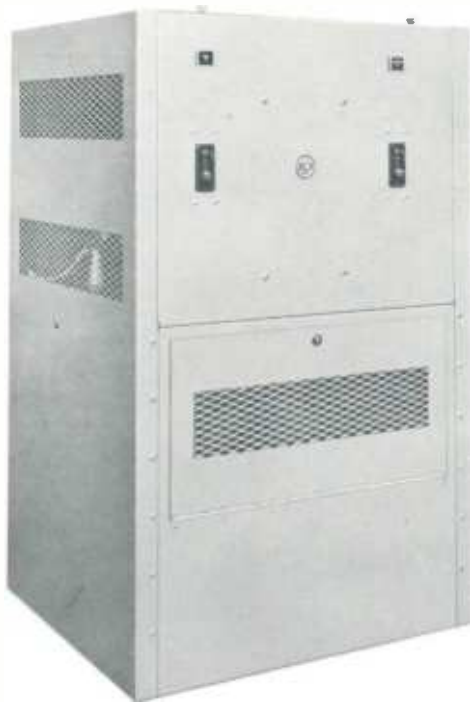

**UNITIZED HIGH VOLTAGE POWER SUPPLY**—With location not tied to the transmitter, the unitized power supply affords many installation and operating economies.

**MODULAR SILICON RECTIFIERS**—Quality components such as this plug-in silicon high-voltage rectifier are important elements in the BTF-5E's superior performance.

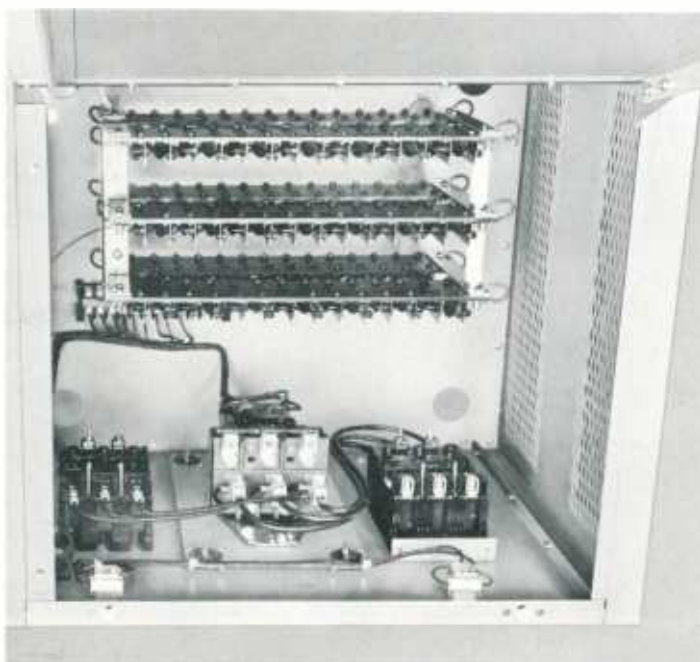

## Specifications

### Performance

Type of Emission.....	F3 and F9
Frequency Range.....	88 to 108 MHz
Power Output .....	5 kW
Output Impedance .....	50 Ohms
Frequency Deviation 100% modulation .....	±75 kHz
Modulation Capability .....	±100 kHz
Carrier Frequency Stability .....	±1000 Hz max.
Audio Input Impedance .....	600/150 Ohms
Audio Input Level—*(100% mod.).....	+10 ±2 dBm
Audio Frequency Response—**(30-15,000 Hz).....	±1 dB max.
Harmonic Distortion—**(30-15,000 Hz).....	0.5% or less
FM Noise Level (referred to 100% FM mod.).....	-65 dB max.
AM Noise Level (referred to 100% AM mod.).....	-50 dB max.
Subcarrier Input Level (30% mod. of Carrier).....	5 Volts max.
Subcarrier Input Impedance.....	10,000 Ohms
Pre-emphasis Network Time Constant.....	75 or 50 μs, as desired

### Electrical

Main-to-Subchannel Crosstalk...-55 dB referred to ±7.5 kHz deviation of the subcarrier by a 400 Hz tone. Main channel modulation 70% by 30-15,000 Hz tones.

Sub-to-Main-Channel Crosstalk...-65 dB referred to ±7.5 kHz deviation of the main carrier by a 400 Hz tone. Subchannel modulation 100% (±7.5 kHz) by 30-6000 Hz tones. Subcarrier modulated 30% on main carrier.

#### Power Line Requirements:

Line.....	240/208 Volts, 3 phase, 50/60 Hz
Combined Line Voltage Variation and Regulation.....	±5%
Power Consumption.....	10,000 Watts (approx.)
Power Factor (approx.).....	90%

#### Crystal Heater:

Line .....	117 Volts, single phase, 50/60 Hz
Power Consumption.....	7½ Watts

### Tube Complement

Exciter:	3—6922 or E88CC	1—8156	1—6227 or E80L
	2—6686 or E81L	1—6AS6	1—0G3 or 85A2

Driver:  
1—7203/4CX250B

Power Amplifier:  
1—4CX5000A

### Mechanical

Dimensions (overall):	Transmitter	High-Voltage Power Supply
Width .....	48½" (123 cm)	27" (68.6 cm)
Height .....	77" (195.6 cm)	43" (109.2 cm)
Depth .....	32½" (82.5 cm)	23" (58.5 cm)
Weight (approx.) .....	1250 lbs. (567 kg.)	590 lbs. (267.6 kg.)
Finish .....	Textured Vinyl in midnight blue and shadow blue, satin-aluminum trim.	
Altitude .....	7500 ft.† (2290 M)	
Ambient Temperature Range.....	-20° to +45°C	

\* Level measured at input terminal J1.

\*\* Audio Frequency response referred to 50- or 75-microsecond pre-emphasis curve.

\*\*\* Distortion includes all harmonics up to 30 kHz and is measured following a standard 50- or 75-microsecond de-emphasis network.

† Blowers can be provided for operation at higher altitudes.



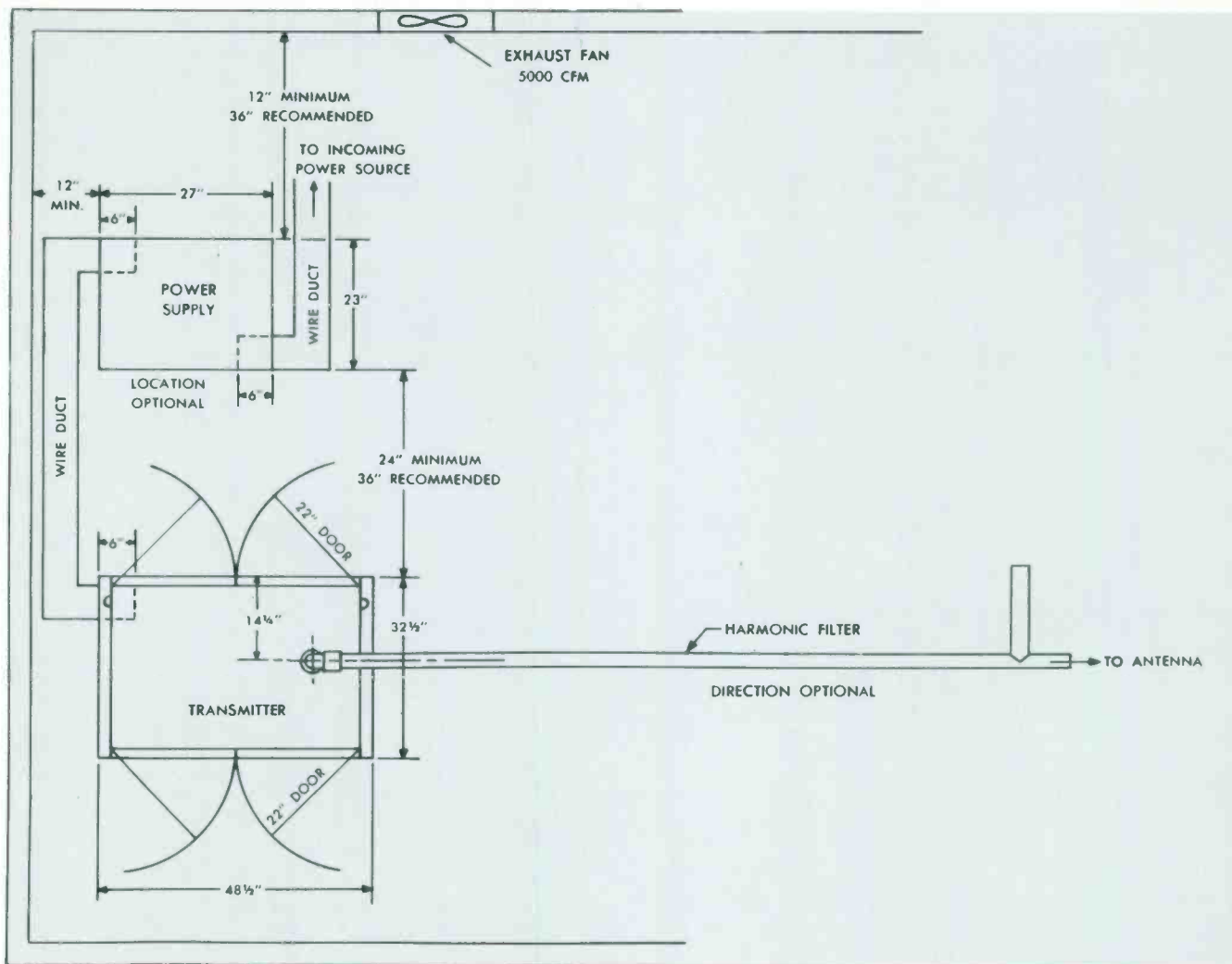

Space-saving floor plan of the BTF-5E. The separate, unitized power supply may be installed in the basement, attic, closet, or other convenient place. (Wire duct and fan shown are not furnished.)

### Optional Accessory Equipment

Set of Spare Amplifier Tubes for BTF-5E.....	ES-560226
Set of Spare Tubes for BTE-10C Exciter.....	MI-560301
Spare Crystal for BTE-10C Exciter.....	MI-560302
* (Specify channel frequency)	
Type BTS-1A Stereo Generator (Silver Gray finish).....	ES-560202
Spare Set of Tubes for BTS-1A.....	MI-560005

Type BTX-1A Subcarrier Generator (for SCA).....	ES-27295
Complete Set of Spare Tubes for BTX-1A.....	MI-34514
Recommended Minimum Spare Tubes for BTX-1A.....	MI-34519
53-kHz Filter (required when transmitting stereo and SCA).....	MI-560003
Type BTR-11B Remote Control System.....	MI-27537/27538-A
Type BW-73A FM Multiplex Monitor.....	ES-560200-A

## Ordering Information

Complete BTF-5E FM Broadcast Transmitter..... ES-560223  
 (Please specify assigned frequency, power-line frequency and altitude of installation)

## 10-KW FM Transmitter, Type BTF-10E

- Ultra stable—easy to tune
- High quality stereo with SCA
- Power increase with minimum change
- Ready for remote control



# 10-KW FM Broadcast Transmitter

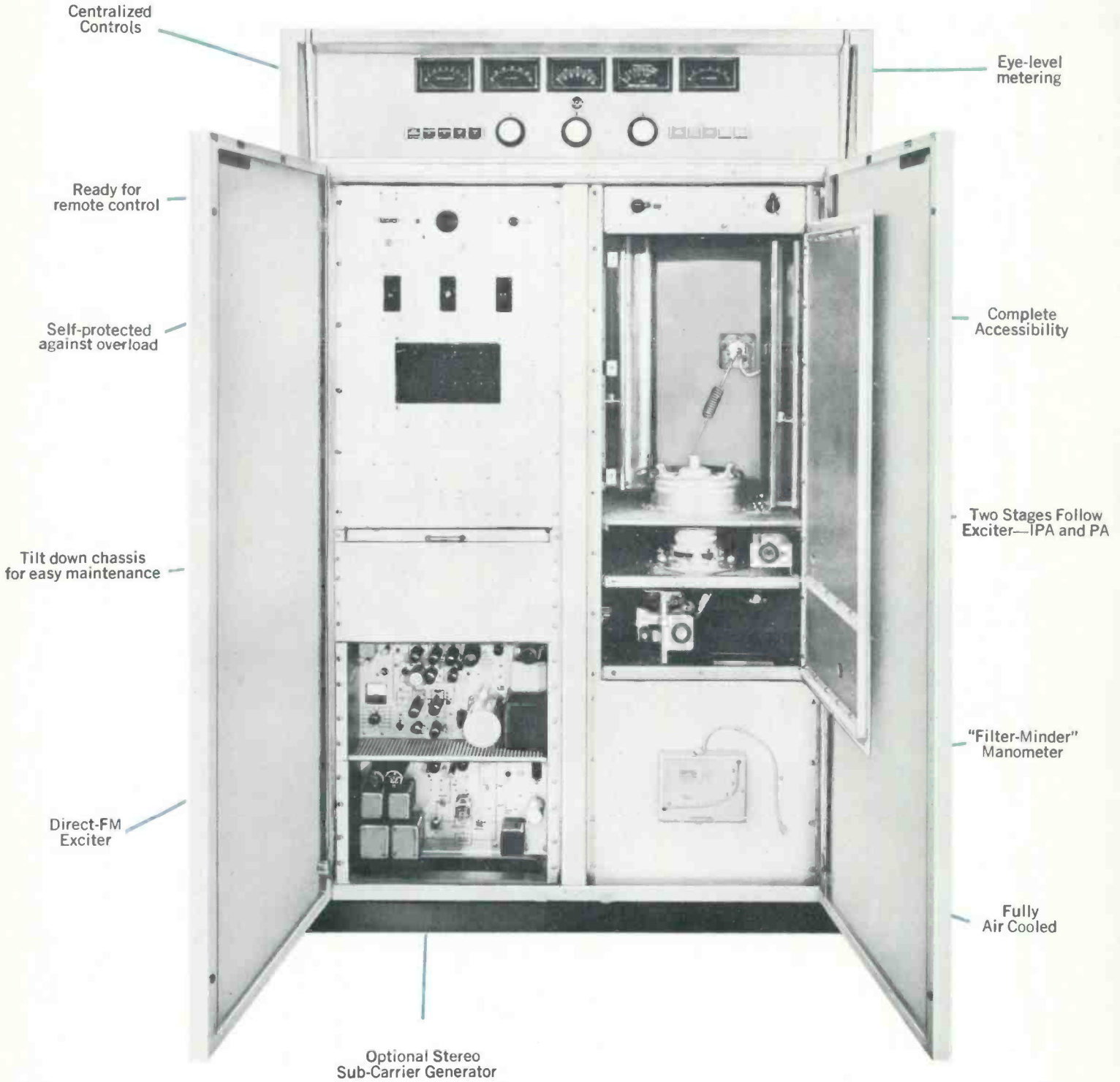

# Full-Fidelity FM Transmitter, Type BTF-10E

RCA's Type BTF-10E FM Broadcast Transmitter provides 10,000 Watts output for stations operating in the 88-to-108 MHz band. It is designed to provide the finest possible performance and reliability, and is specifically built to meet or exceed the stringent requirements of multiplex service transmission. The equipment is FCC type accepted and meets all requirements for harmonic and spurious emission.

The BTF-10E employs a new exciter that uses the time-tested and field-proven *direct-FM* system. The circuit uses capacitive diodes as modulators of an oscillator to produce *direct FM*. Automatic-frequency-control (AFC) maintains oscillator frequency to close tolerances under virtually all operating conditions.

The BTF-10E exciter uses a built-in silicon-rectifier power supply for long life and great dependability. For ease of tun-

ing, the exciter has a built-in multimeter and highly-accessible test points permitting convenient metering and checking while operating. All RF circuits are single tuned for utmost tuning simplicity.

Frequency response of the transmitter's main channel is 30 to 15,000 Hertz ( $\pm 1$  dB maximum) and the distortion over the same bandwidth is less than one-half of one percent.

A new feature of the transmitter is the built-in manometer. This device indicates air-filter efficiency and warns of reduced cooling-air supply over the power tubes. Properly used, the manometer can add hundreds of hours to power-tube life.

The BTF-10E is designed specifically to be field-expandable to a 20-kw transmitter. It is noteworthy that this expansion is substantially electrical and there is no increase in floor-space requirement.

## Description

### Mono or Stereo

The transmitter features a new exciter designed for stereo and multiplex. The exciter, including its self-contained semiconductor-equipped power supply, is mounted on a single vertical chassis. Coaxial connectors simplify connection of the appropriate accessory gear for stereo and SCA subcarrier.

### Two Stages Follow Exciter

From the 10-Watt output of the exciter, only two tubes are required for full 10-kW output. A harmonic filter is included to reduce spurious radiation. Vacuum capacitors are used to tune the IPA plate and the PA grid. In the power amplifiers, all adjustments are at ground potential.

### Ready for Remote Control

The transmitter is designed and built for remotely-controlled operation. Internal wiring and terminals are provided for remote control of these transmitter functions: transmitter on/off; output power raise/lower and overload reset. Remote metering facilities for the PA include: cathode current; plate voltage and power output.

### New Styling

Functional styling combined with fewer tubes permits the BTF-10E to be housed in a single, double-door cabinet in a new midnight blue and shadow blue textured vinyl finish. For contrast, the meter panel is in bright aluminum and the cabinet is trimmed in satin-finished aluminum. The swing-out doors in the front and rear afford the excellent accessibility for which RCA transmitters are famous.

All operating controls and meters are mounted on a panel above the front doors.

### Field Expandable to 20 kW

Since the BTF-10E is, basically, a 20-kW transmitter operating at 10 kilowatts, it is readily modified, after installation, to a 20-kW output. It is noteworthy that this expansion in power capability requires no additional floor space.

Expansion of the power output is particularly valuable if the station using a BTF-10E decides to combine horizontally- and vertically-polarized signals. This feature avoids any change in floor plan as a result of the power increase.

### "Direct FM" Exciter

The RCA Type BTE-10C Exciter is a compact, self-contained unit which provides a frequency-modulated RF output at any specified frequency in the FM-broadcast band. Its simplified design provides superior performance under stereophonic, monophonic and subcarrier conditions.

The design employs the *direct-FM* modulation system with particular design emphasis placed on adjustment ease and reliable operation. All RF stages use simplified single-tuned circuits. A built-in multimeter and easily-accessible test points permit convenient metering and checking during air time.

A self-contained, silicon-rectifier-equipped power supply provides all filament and plate power for the exciter.

Premium tubes, designed for long life, are used to extend reliability. The exciter is particularly well suited to unattended, remote-from-the-studio duty.

### Simplified Circuitry

The FM exciter consists of only nine tubes, four of which are RF,

## Select Features

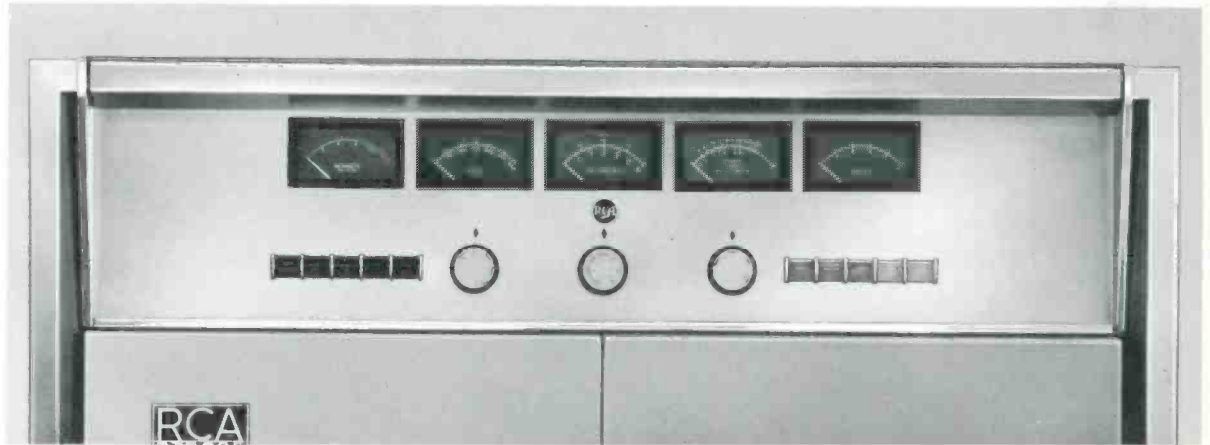

BTf-10E Control Panel. Tally lights and push-button controls simplify operation.

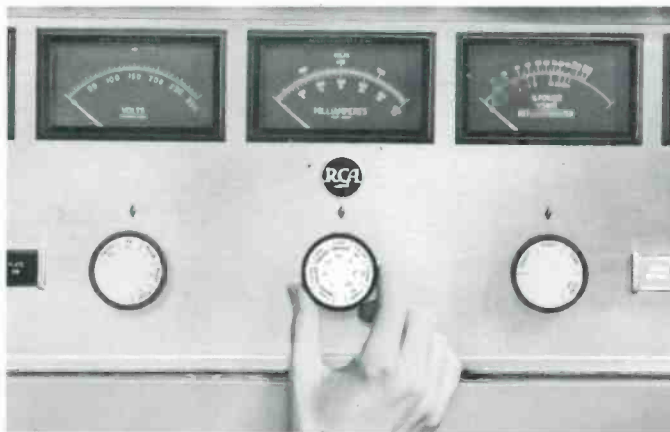

The large-diameter multimeter knobs speed log-keeping and minimize error.

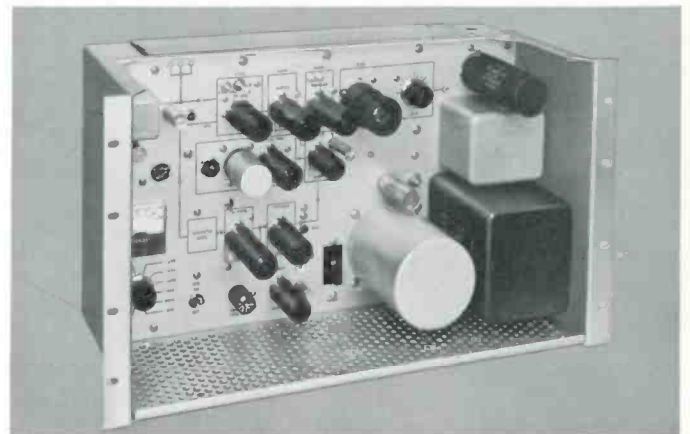

Nine-tube, direct-FM exciter provides unparalleled multiplex performance.

and four in the AFC loop. The ninth tube is a voltage-regulator type. A master oscillator, operating at one-half the carrier frequency, is frequency-modulated by a capacitive diode. A buffer amplifier, a frequency doubler and a power amplifier raise the power level to 10 Watts.

### Precision AFC

The four-tube AFC section maintains precision control of the master oscillator to within tight tolerances. Since the exciter applies modulation at one-half carrier frequency, the system avoids the critical adjustment tedium of frequency multiplier stages. In addition, the design avoids critical modulation-level adjustment.

The frequency-modulated oscil-

lator operates at a frequency between 44 and 54 MHz (one half the carrier-frequency). Its accuracy is precisely controlled through an AFC system that uses a counter-detector and a magnetic amplifier. The noteworthy point is that the AFC system operates entirely without tuned circuits. This results in exceptionally good long-term stability.

The master oscillator offers excellent frequency stability even when "free-running." This stability permits manual control of center frequency in the rare event of AFC failure.

### Magnetic-Amplifier AFC

The "error" signal developed in the AFC counter-detector is ampli-

fied through the use of a magnetic amplifier. This device provides a DC voltage gain of approximately 40 dB. This amplified "error" signal (DC) pulls (or pushes) the oscillator frequency to within tolerances.

Since the magnetic amplifier is a transformer-like device, it offers extremely long life. This, of course, simplifies the circuitry in the AFC system and sets a new level of dependability.

### Class "C" Power Amplifiers

Two simplified, single-ended amplifiers, operating in class "C", follow the exciter. The 250-Watt IPA stage uses a Type 7203/4CX250B tube, and the final power amplifier

uses a Type 4CX10000A (ceramic) tetrode. The driver stage is tuned by pi-network input-and-output circuits. Vacuum-dielectric variable capacitors tune these pi networks. The power amplifier, too, uses pi-network circuitry and tuning is accomplished by variable inductors operating at ground potential.

### 10-kW Class "C" Final Amplifier

The output tube, a ceramic tetrode, 4CX10000A, offers very high power-gain with little drive. Using this tube, only two stages of amplification are required between the exciter output and the antenna for the 10,000-Watt output. Fewer components result in improved reliability and less tuning error. Actual operating records have shown that the 4CX10000A gives excellent performance and long life.

### Motor-Driven Power-Output Control

Power output is controlled by means of a motor-driven variable transformer which controls the low-

voltage power supply. This supply controls the driver-plate and the screen voltages of both stages simultaneously. A separate grid bias supply increases transmitter stability and reliability. The use of semiconductor (silicon) rectifiers reduces operating and maintenance costs.

### Harmonic Filter Standard Equipment

To keep spurious emission to a minimum, a harmonic filter is standard equipment, with the BTF-10E. The filter consists of an "M"-derived "half-T" sections, several low-pass filter sections, and a constant-"K", "half-T" section. Attenuation of all harmonics through the seventh is accomplished by the passband of the low-pass filter sections, while the constant-"K", "half-T" section serves as a 50-Ohm termination impedance.

### Self-Protected Against Overload

Power circuits are protected by magnetically-tripped circuit breakers in addition to overload relays.

An interlock system prevents turn-on of plate power until all filaments have heated and the exciter has reached a proper operating condition. In addition, a latching relay automatically re-applies power to the transmitter once before locking-out in the event of transient overloads or power interruptions. The overload relays are reset by illuminated push button switches on the front panel. Separate tally-light indicators are provided for overloads in the driver, power amplifier and low voltage rectifier circuits.

### Fully Air-Cooled

Cooling air for the BTF-10E is supplied by a squirrel-cage blower mounted below the amplifier stages. Heavy sound insulation reduces blower noise to a minimum. The blower supplies forced air to both the IPA and PA stages.

Since the "drag" of a clogged air filter can reduce power-tube life, the transmitter monitors this drag with

Simplified block diagram of BTF-10E.

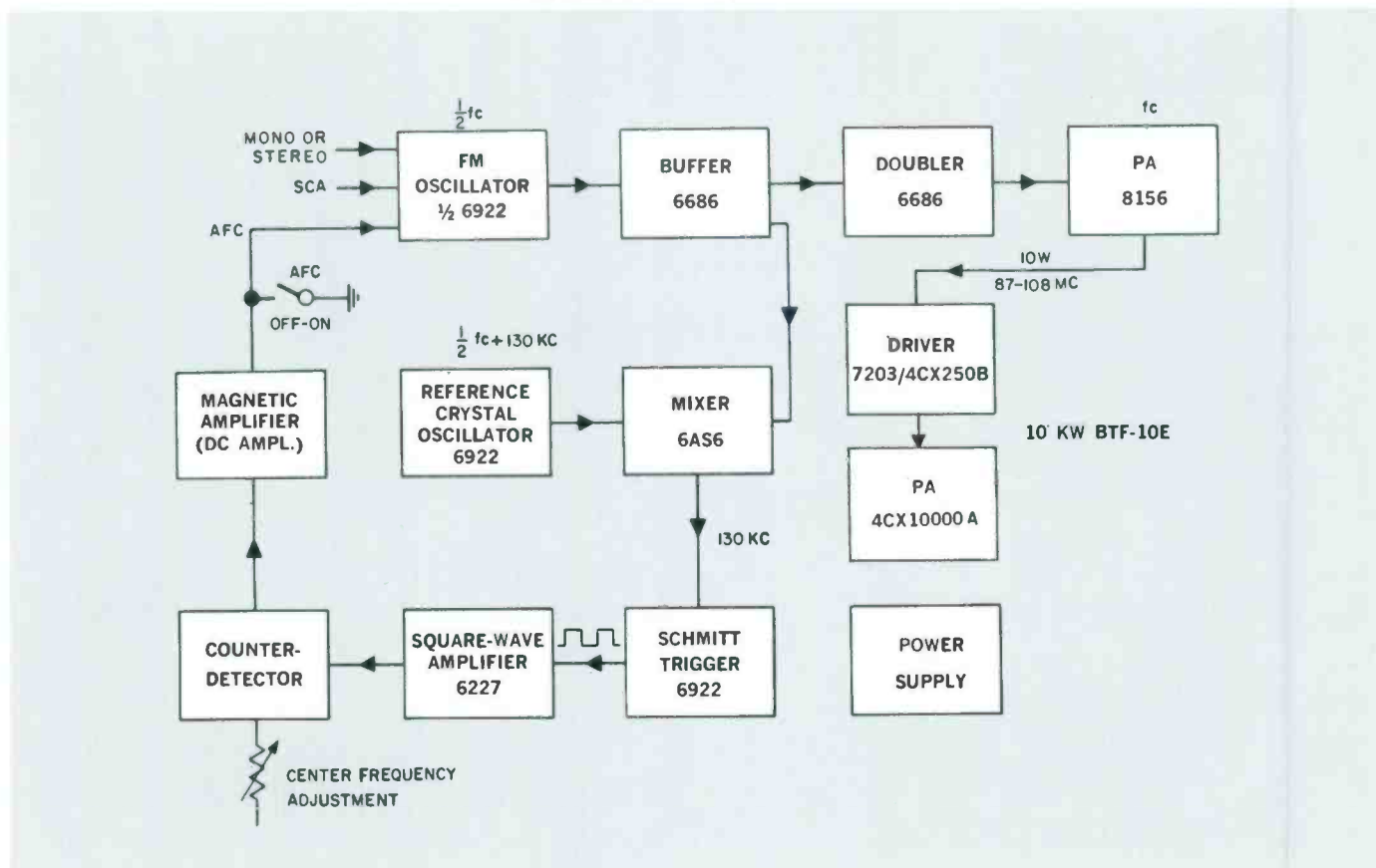

a high-resolution manometer. This device senses the relative air pressure at the fan "side" of the glass-fiber filter in inches of water. Properly monitored, the manometer indicates when filter clog has reduced the volume of cooling air supplied to the power tubes. Maintenance of filter efficiency is very important in realization of the potential life of the power tubes.

### Simplified Control

The transmitter has all operating controls and meters located on a panel just above the front doors. The

push-button controls include: transmitter on/off, plate on/off, overload reset and power raise/lower. A cabinet disconnect switch, low-voltage circuit breaker, and filament control circuit breakers are located behind the left-hand door. The main- and low-power circuit breakers are located in the unitized rectifier cabinet. When servicing the BTE-10E, operation of the disconnect switch removes all voltages from the transmitter cabinet. Personnel are also protected by fully interlocked rear doors in addition to interlocked doors on the PA cubicle.

### Full Metering

Five easy-to-read front-panel meters are provided. One for PA-plate voltage, another for PA-plate current, and a third for AC line and filament voltage. The remaining two are a reflectometer and a multimeter. The reflectometer measures the forward power or VSWR. The multimeter reads grid current, screen current and screen voltage of both power tubes. In addition to this metering, the exciter has its own self-contained multimeter. This one provides complete information on operating conditions in the exciter.



**ONLY TWO TUBES BETWEEN EXCITER AND OUTPUT**—View showing interior of PA and IPA cabinet with the 4CX10000A ceramic tetrode and one 7203/4CX250B IPA tube below shelf. These supply the necessary power for the full fidelity BTF-10E.

**COMPLETE ACCESSIBILITY**—Rear view of the BTF-20E revealing the clean, vertical construction of PA cavity to left and control panel to right.

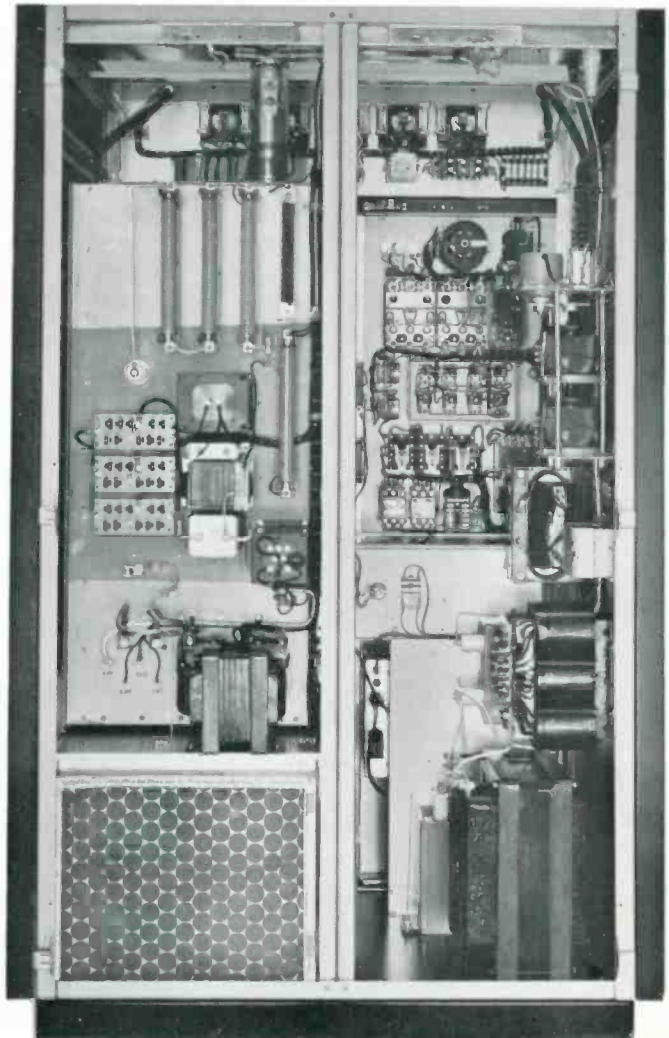

# Specifications



**UNITIZED HIGH VOLTAGE POWER SUPPLY**—With location not tied to the transmitter, the unitized power supply affords many installation and operating economies.

**MODULAR SILICON RECTIFIERS**—Quality components such as this plug-in silicon high voltage rectifier are important elements in the BTF-10E's superior performance.

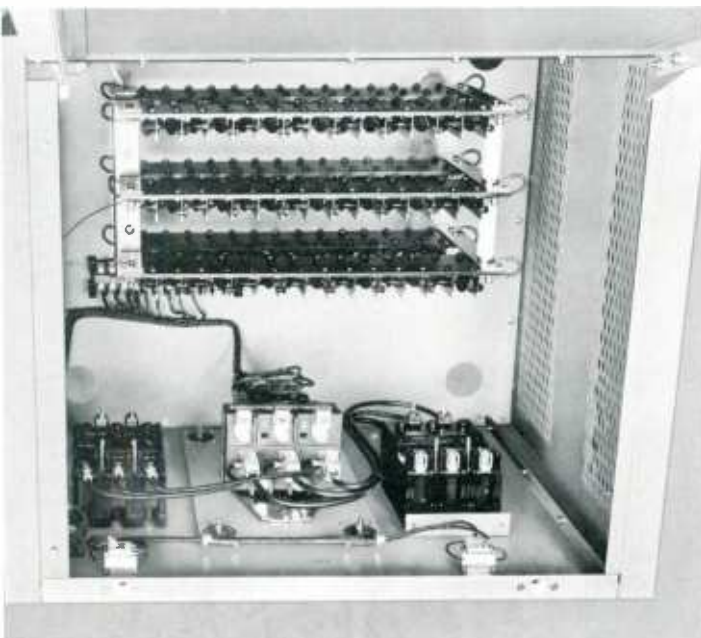

## Performance

Type of Emission.....	F3 and F9
Frequency Range.....	.88 to 108 MHz
Power Output .....	.10 kW
Output Impedance.....	50 Ohms
Frequency Deviation 100% modulation.....	±75 kHz
Modulation Capability .....	±100 kHz
Carrier Frequency Stability.....	±1000 Hz max.
Audio Input Impedance.....	600/150 Ohms
Audio Input Level—*(100% mod.).....	+10 ±2 dBm
Audio Frequency Response—**(30-15,000 Hz).....	±1 dB max.
Harmonic Distortion—**(30-15,000 Hz).....	0.5% or less
FM Noise Level (referred to 100% FM mod.).....	–65 dB max.
AM Noise Level (referred to 100% AM mod.).....	–50 dB max.
Subcarrier Input Level (30% mod. of Carrier).....	5 Volt max.
Subcarrier Input Impedance.....	10,000 Ohms
Pre-emphasis Network Time Constant.....	75 or 50 μs, as desired

## Electrical

Main-to-Subchannel Crosstalk....–55 dB referred to ±7.5 kHz deviation of the subcarrier by a 400 Hz tone. Main channel modulation 70% by 30-15,000 Hz tones.

Sub-to-Main-Channel Crosstalk....–65 dB referred to ±7.5 kHz deviation of the main carrier by a 400 Hz tone. Subchannel modulation 100% (±7.5 kHz) by 30-6000 Hz tones. Subcarrier modulated 30% on main carrier.

### Power Line Requirements:

Line.....	240/208 Volt, 3 phase, 50/60 Hz
Combined Line Voltage Variation and Regulation.....	±5%
Power Consumption.....	19,000 Watts (approx.)
Power Factor (approx.).....	90%

### Crystal Heater:

Line.....	117 Volt, single phase, 50/60 Hz
Power Consumption.....	7½ Watts

## Tube Complement

### Exciter:

3—6922 or E88CC	1—8156	1—6227 or E80L
2—6686 or E81L	1—6AS6	1—0G3 or 85A2

### Driver:

1—7203/4CX250B

### Power Amplifier:

1—4CX10000A

## Mechanical

Dimensions (overall):	Transmitter	High-Voltage Power Supply
Width .....	48½" (123 cm)	27" (68.6 cm)
Height .....	77" (195.6 cm)	43" (109.2 cm)
Depth .....	32½" (82.5 cm)	23" (58.5 cm)
Weight (approx.) .....	1300 lbs. (589.7 kg.)	840 lbs. (381 kg.)

Finish .....Textured Vinyl in midnight blue and shadow blue, satin-aluminum trim.

Altitude .....7500 ft.† (2290 M)

Ambient Temperature Range.....–20° to +45°C

\* Level measured at input terminal J1.

\*\* Audio Frequency response referred to 50- or 75-microsecond pre-emphasis curve.

\*\*\* Distortion includes all harmonics up to 30 kHz and is measured following a standard 50- or 75-microsecond de-emphasis network.

† Blowers can be provided for operation at higher altitudes.

Specifications subject to change without notice.



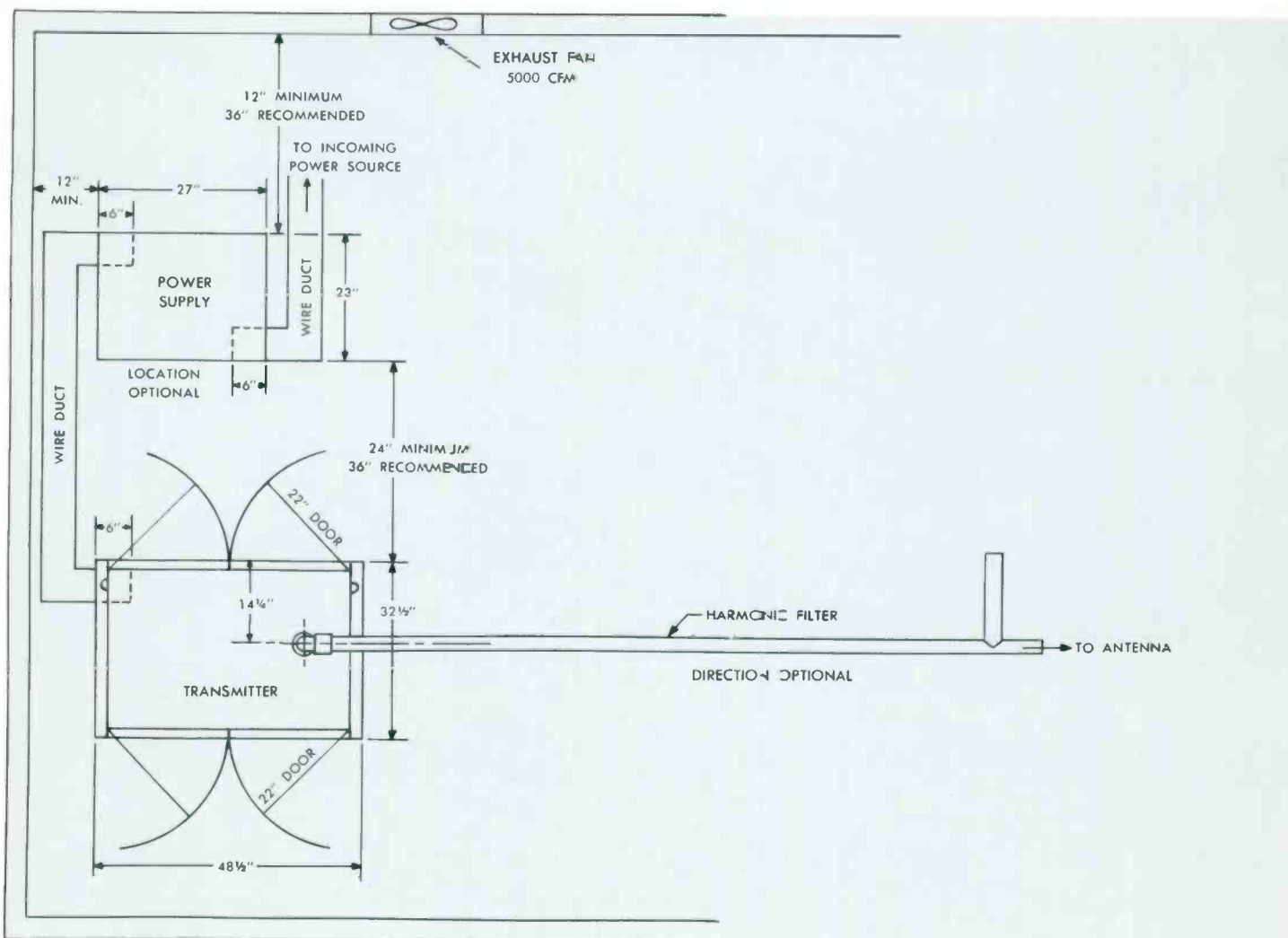

Space-saving floor plan of the BTF-10E. The separate, unitized power supply may be installed in a basement, attic, closet or other convenient place. (Wire duct and fan shown are not furnished.)

### Accessories

Set of Spare Amplifier Tubes for BTF-10E.....	ES-560227
Set of Spare Tubes for BTE-10C Exciter.....	MI-560301
Spare Crystal for BTE-10C Exciter.....	MI-560302
(Specify channel frequency)	
Type BTS-1A Stereo Generator (Silver Gray finish).....	ES-560202
Spare Set of Tubes for BTS-1A.....	MI-560305

Type BTX-1A Subcarrier Generator (for SCA).....	ES-27295
Complete Set of Spare Tubes for BTX-1A.....	MI-34514
Recommended Minimum Spare Tubes for BTX-1A.....	MI-34519
53-kHz Filter (required when transmitting both stereo and SCA).....	MI-560003
Type BTP-11B Remote Control System.....	MI-27537/27538-A
Type BW 73A FM Multiplex Monitor.....	ES-560200-A

## Ordering Information

Complete BTF-10E FM Broadcast Transmitter..... ES-560224  
(Please specify assigned frequency, power-line frequency  
and altitude of installation)

---

## 20-KW FM Transmitter, Type BTF-20E

---

- Ultra stable—easy to tune
- High quality stereo with SCA
- 100 KW ERP with 6-section antenna
- Ready for remote control

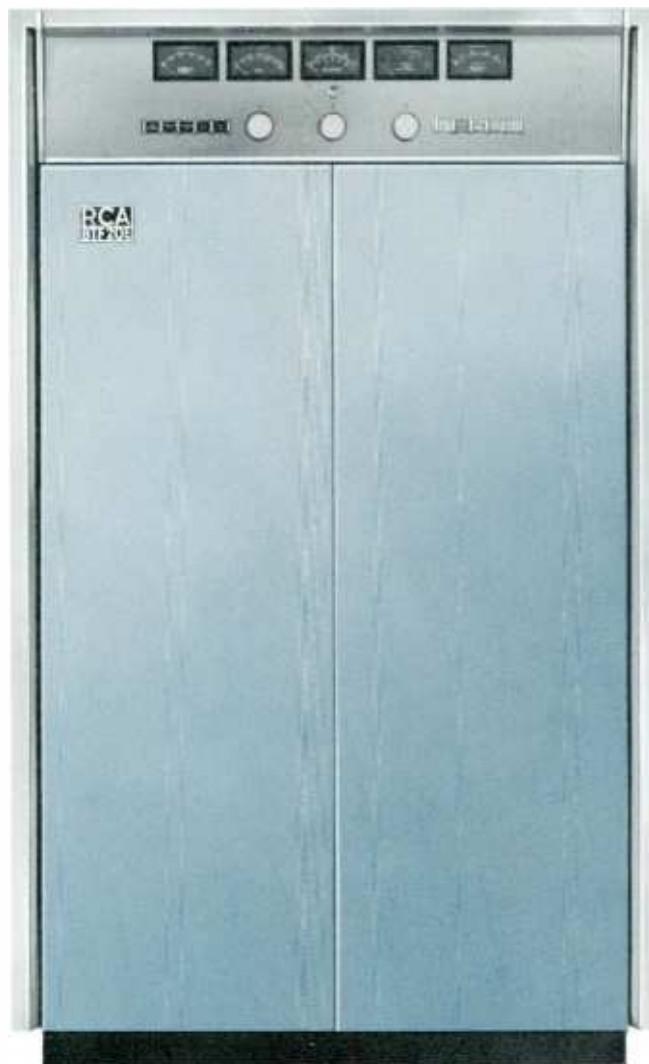

# 20-KW FM Broadcast Transmitter

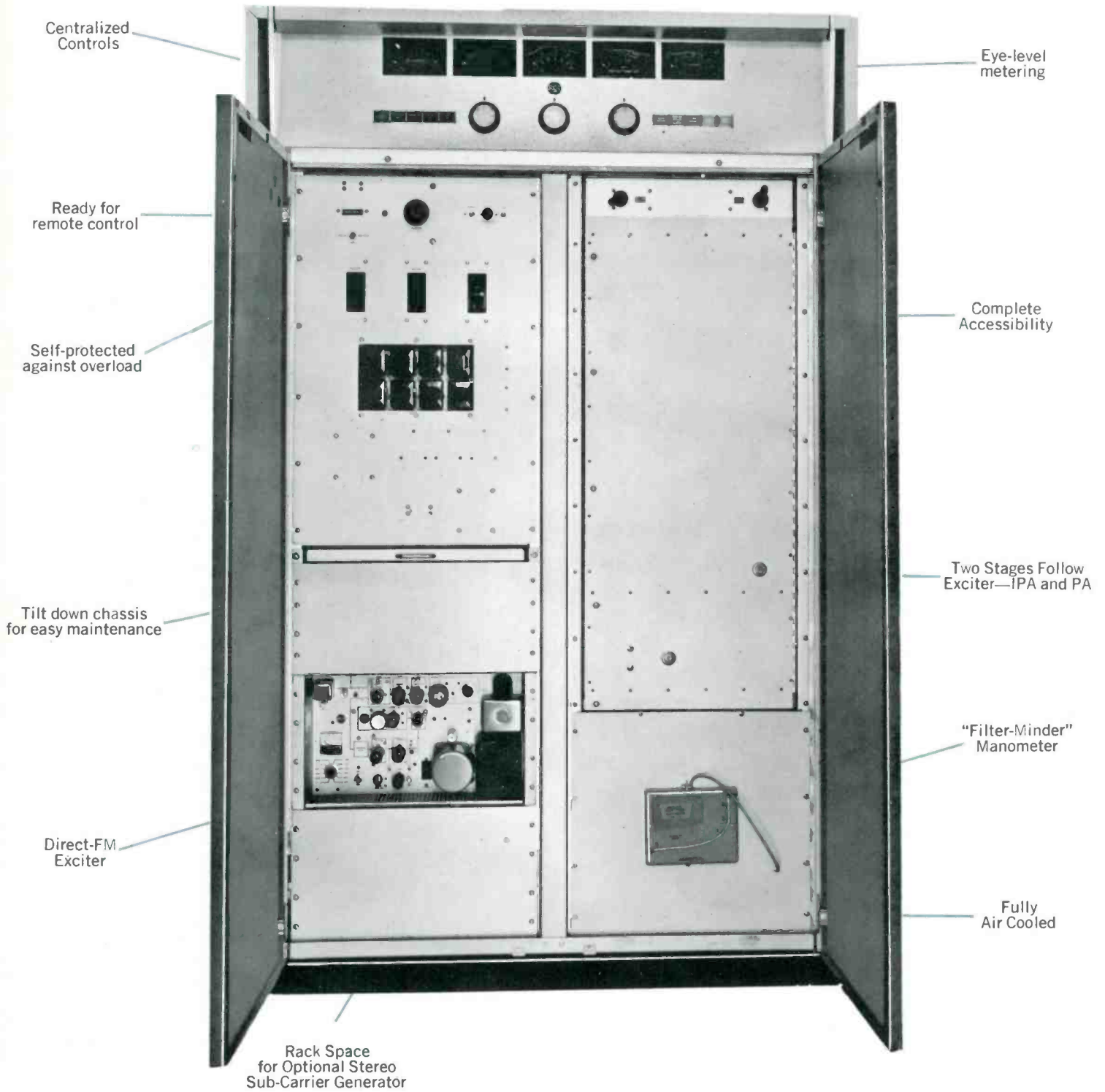

# Full-Fidelity FM Transmitter, Type BTF-20E

The RCA Type BTF-20E 20-kW FM Broadcast Transmitter is designed for high-power operation in the standard FM band, 88-108 MHz, and is specifically engineered to meet and exceed the stringent requirements of multiplex service transmission. The transmitter features a Type 4CX-15000A power amplifier driven by two 7203/4CX250B tubes in the IPA stage. In all, there are only three tubes between the exciter output and the antenna feed, and only a total of 7 in the RF chain. Except for the high voltage power supply, the transmitter is housed in a single, modern-styled, two-door cabinet.

The BTF-20E employs a new exciter that uses the time-tested and field-proven *direct FM* system. The circuit uses capacitive diodes as modulators of an oscillator to produce *direct FM*. Automatic frequency control (AFC) maintains oscillator frequency to close tolerance under virtually all operating conditions.

Because of its wide frequency response and extreme stability, the exciter is ideally suited for multiplex and stereo programming as specified by the FCC.

The BTF-20E uses silicon-rectifier power supplies for long life and great dependability. For ease of tuning, the exciter has a built-in multimeter and accessible test points permitting metering and checking during operation. All RF circuits are single tuned for utmost tuning simplicity.

Frequency response of the transmitter's main channel is 30 to 15,000 hertz ( $\pm 1$  dB maximum) and distortion over the same range is 0.5 percent or less.

A new feature of the transmitter is the built-in manometer. This device indicates air filter efficiency and warns of reduced cooling-air supply over the power tubes. Properly used, this device can add hundreds of hours to tube life.

## Description

### Mono or Stereo

The transmitter features a new exciter designed for stereo and multiplex. The exciter, including its self-contained, semiconductor-equipped power supply, is mounted on a single vertical chassis.

### Two Stages Follow Exciter

From the 10-Watt output of the exciter, only three tubes, two in the IPA and a ceramic-tetrode 4CX-15000A PA generate the full 20-kW signal. A harmonic filter is furnished to reduce spurious radiation.

Vacuum capacitors are used to tune the IPA plate and PA grid. In the power amplifier, all adjustments are at ground potential.

### Ready for Remote Control

The transmitter has been designed and built for remote controlled operation. Terminals are provided for remote control of transmitter on/off, raise/lower power and overload reset, while remote metering connections for the PA include cathode current, plate voltage and power output.

### New Styling

Functional styling together with fewer tubes and components has permitted the new BTF-20E transmitter to be housed in a single, double-door cabinet, in a new midnight blue and shadow blue finish, set off with aluminum meter panel and trim. Maximum accessibility is afforded by swing-out doors on the front and rear of the cabinet. All operating controls and meters used for rapid check of transmitter functions are located on a panel above the front doors. A separate unitized high-voltage power supply may be located anywhere in the FM station.

### "Direct FM" Exciter

The RCA Type BTE-10C FM Multiplex Exciter is a compact, self-contained unit which provides a modulated RF output of ten Watts at any specified frequency in the FM broadcast band. Its simplified design provides superior performance under stereophonic, monophonic, and SCA conditions.

The design employs the *direct-FM*

modulation system with particular design emphasis being placed on adjustment ease and reliable operation. All RF stages use simplified single-tuned circuits. A built-in multimeter and easily accessible test points allow convenient metering and checking during operation.

A self-contained silicon-rectifier-equipped power supply is used.

Premium tubes designed for long life are used for extended reliability. The BTE-10C lends itself particularly well to unattended, remote operation.

### Simplified Circuitry

The BTE-10C FM Multiplex Exciter is the simplest ever offered. It has nine tubes of which only four are required to give full performance with a dependable on-air signal (four are in the AFC system and the ninth is a voltage-regulator type). There are no series or cascaded modulators to adjust for low frequency response, nor are there critical modulation-level adjustments.

## Select Features

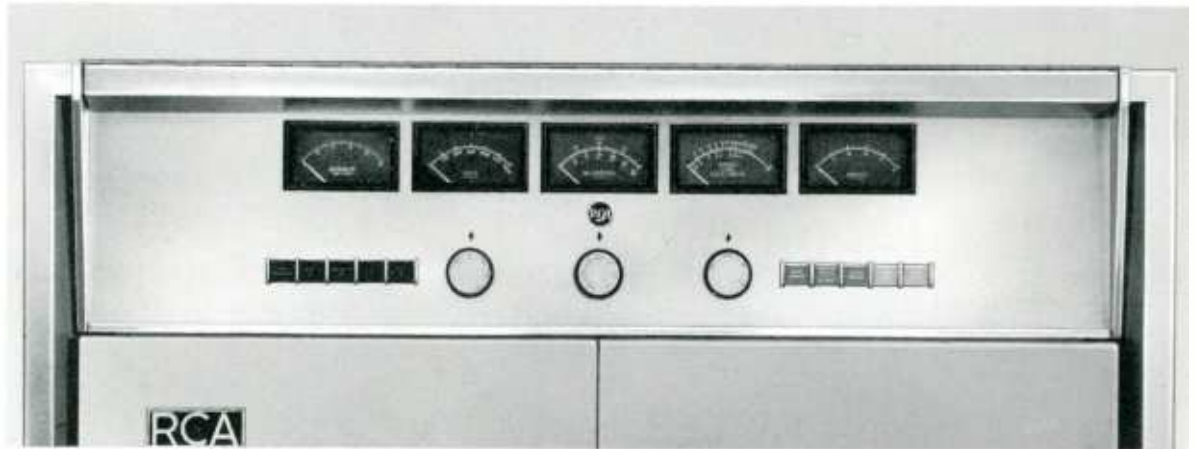

BTF-20E Control Panel. Tally lights and push-button controls simplify operation.

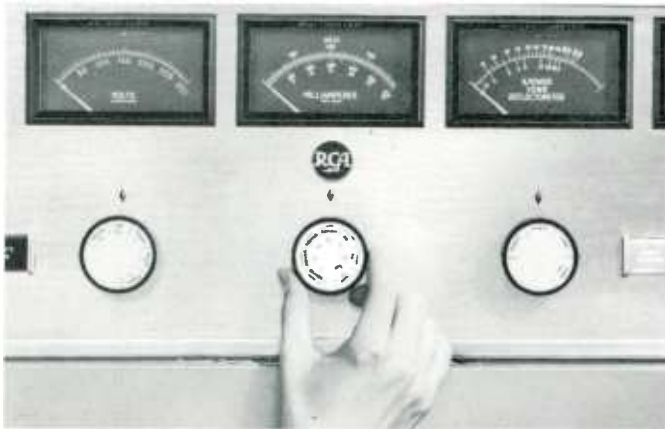

The large-diameter multimeter knobs speed log-keeping and minimize error.

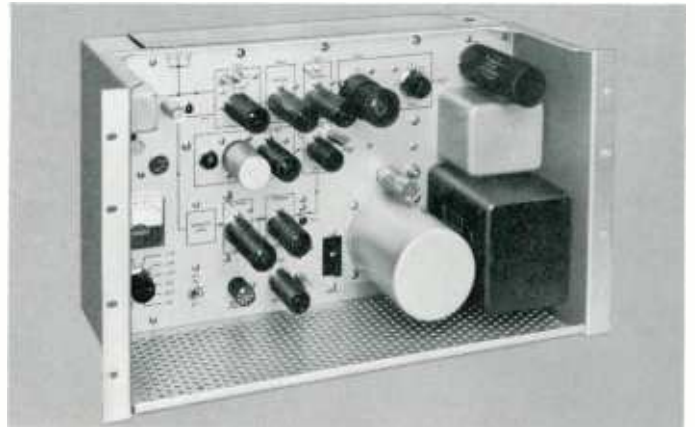

Nine-tube, direct-FM exciter provides unparalleled multiplex performance.

### Precision AFC

The frequency modulated oscillator operates at a frequency between 44 and 54 MHz (one-half final frequency). Its accuracy is precisely controlled through an AFC system that uses a DC discriminator and a magnetic amplifier. The noteworthy point is that the AFC system operates entirely without tuned circuits. This results in long-term stability.

### Magnetic-Amplifier AFC

The error signal developed in the AFC counter-detector is amplified through the use of a magnetic ampli-

fier that provides a voltage gain of approximately 40 dB. This amplified "error" signal (DC) pulls the oscillator frequency to within tolerance.

### Single-Ended Driver Amplifier

Two simplified, single-ended amplifiers (operating Class "C") follow the exciter. The IPA stage consists of two ceramic 7203/4CX250B tetrodes operating in parallel, and the final power amplifier is Type 4CX-15000A tube. The IPA stage is tuned by pi-network input and output circuits. Variable vacuum capacitors are used to tune the interstage network.

### 20-kW Class "C" Final Amplifier

The power amplifier also uses pi-network circuitry, however, the tuning of this stage is accomplished by variable inductors operating at ground potential. The output tube is designed for very high power gain with little drive. Power output is controlled by means of a motor-driven variable transformer connected in the primary of the low voltage power supply for the driver amplifier. This controls the IPA-plate and the PA-screen voltages simultaneously.

For increased transmitter stability

and reliability, a separate grid bias supply is incorporated in the BTF-20E. This supply, too, uses semiconductor rectifiers.

### Harmonic Filter Standard Equipment

To keep spurious emission at a minimum, the BTF-20E is furnished with a 6 1/8-inch harmonic filter as standard equipment. The filter consists of a series of transmission line elements with a uniform outer diameter conductor, a stepped inner conductor, and a shunt stub. The conductors are fabricated of a high-grade copper alloy. Attenuation of all harmonic radiation above channel limits is accomplished in an "M-derived" section, and a series of "constant-K" T-sections. This design provides a broad passband with a sharp high-frequency cut-off and excellent attenuation of frequencies above the passband.

### Self-Protected Against Overload

Power circuits are protected by magnetically-tripped circuit breakers in addition to overload relays. An interlocked system prevents turn-on of plate power until all filaments have heated and the exciter has reached a proper operating condition. In addition, a latching relay automatically re-applies power to the transmitter once before locking-out in the event of brief overloads or power interruptions. The overload relays are reset by illuminated push-button switches on the front panel. Separate tally-light indicators are provided for overloads in the driver, power amplifier and low voltage rectifier circuits.

### Fully Air-Cooled

Cooling air for the BTF-20E is supplied by means of a blower mounted below the amplifier stages.

A manometer indicates the efficiency of the fiber glass filter at the inlet and heavy sound insulation reduces blower noise to a minimum. The blower supplies forced air to both the IPA and PA stages.

### Simplified Control

The transmitter has all operating controls and meters located on a panel just above the front doors. The push-button controls include: transmitter on/off, plate on/off, overload reset and power raise/lower. A cabinet disconnect switch, low-voltage circuit-breaker, and filament- and control-circuit breakers are located behind the left-hand door. The main- and low-power circuit breakers are located in the rectifier unitized cabinet. When servicing the BTF-20E, operation of the "disconnect" switch removes all voltages from the transmitter cabinet. Personnel are

Simplified Block Diagram of BTF-20E FM Transmitter.

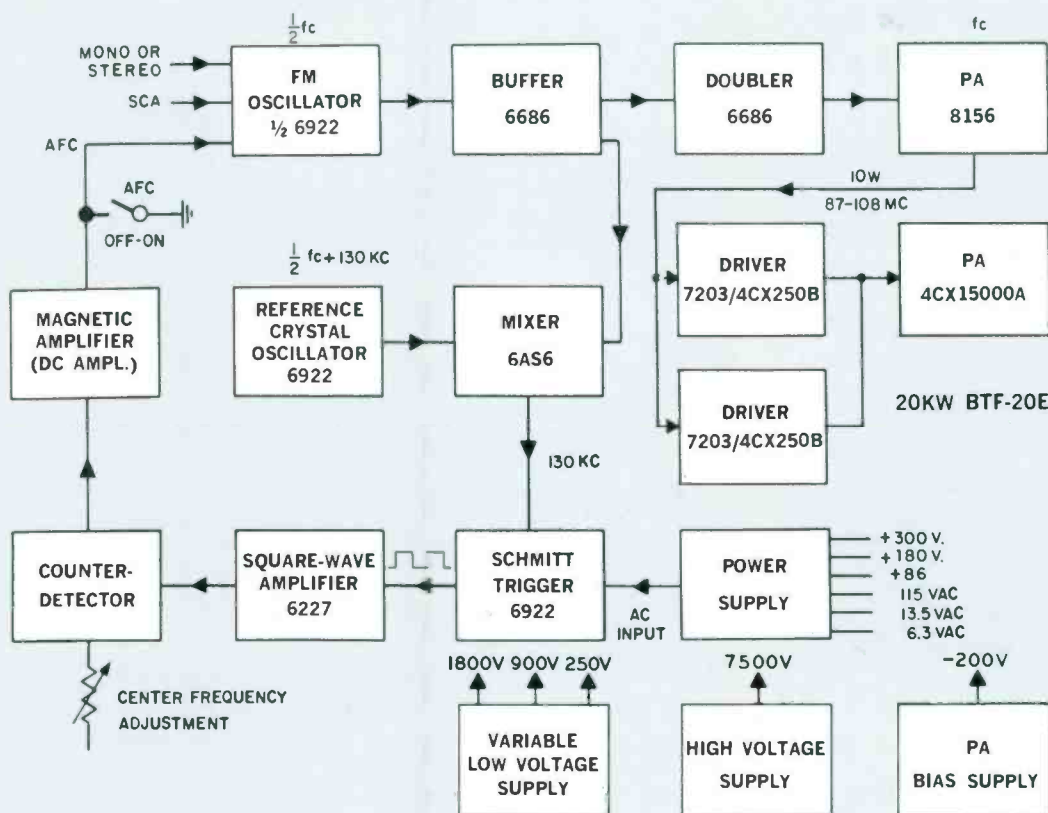

protected by fully interlocked rear doors, in addition to interlocked doors on the RF PA cubicle.

### Full Metering

Five easy-to-read front-panel meters are provided. One for PA-plate voltage, another for PA-plate current, and a third for ac-line and filament voltage. The remaining two are a reflectometer and a multimeter. The reflectometer measures either the forward power or VSWR. The multimeter reads the grid current, the screen current and the screen voltage of both power tubes. In addition, the exciter has its own self-contained multimeter. This one provides complete information on operating conditions in the exciter.

### Ready for Remote Control

Remote control provisions are included in the transmitter and terminals are provided for use with remote control units such as the Type BTR-11B (or BTR-20E) and Automatic Logging Equipment. Additional terminals are provided for remote control of transmitter on/off, plate on/off, raise/lower power, and overload reset. Remote metering connections in the final amplifier for plate current, plate voltage, and power output are also provided.

### High-Voltage Power Supply

The high-voltage power supply is housed in a unitized cabinet measur-

ing 32 inches wide, 23 inches deep and 49 inches high. It can be installed at any convenient place in the station. The cabinet houses the high-voltage-plate transformer, a bank of plug-in semiconductor rectifiers, a line-circuit breaker, a low-power circuit breaker, and the plate contactor. Personnel are fully protected from shock through interlock and grounding switches.

The rectifier section comprises silicon-junction diodes (with equalizing resistors and capacitors) in a three-phase, full-wave-bridge circuit. Circuit breakers are used instead of fuses in the transmitter adding to the dependability particularly when operating by remote control.

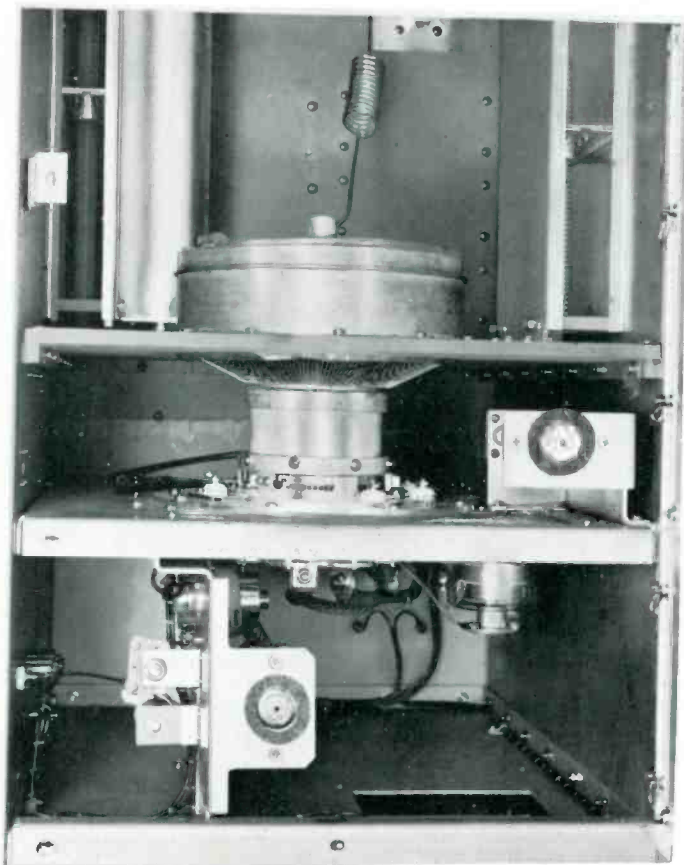

**ONLY THREE TUBES BETWEEN EXCITER AND OUTPUT**—View showing interior of PA and IPA cabinet with the 4CX15000A ceramic tetrode and two IPA tubes below shelf.

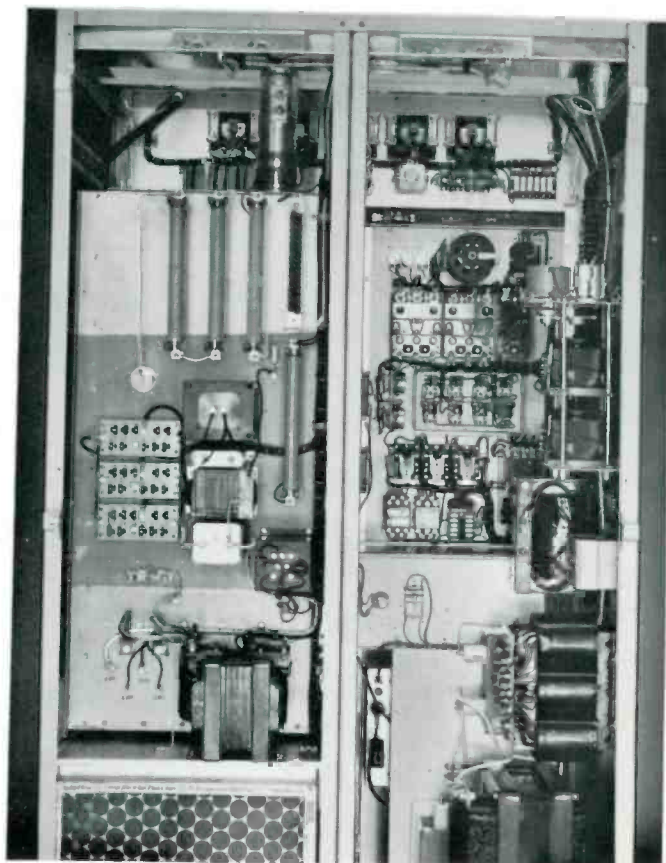

**COMPLETE ACCESSIBILITY**—Rear view of the BTF-20E revealing the clean, vertical construction of PA cavity to left and control panel to right.



**UNITIZED HIGH VOLTAGE POWER SUPPLY**—With location not tied to the transmitter, the unitized power supply affords many installation and operating economies.

## Specifications

### Performance

Type of Emission.....F3 and F9  
 Frequency Range.....88 to 108 MHz  
 Power Output......20 kW  
 Output Impedance.....50 Ohms  
 Frequency Deviation 100% modulation.....±75 kHz  
 Modulation Capability.....±100 kHz  
 Carrier Frequency Stability.....±1000 Hz max.  
 Audio Input Impedance.....600/150 Ohms  
 Audio Input Level—\*(100% mod.).....+10 ±2 dBm  
 Audio Frequency Response—\*\*(30-15,000 Hz).....±1 dB max.  
 Harmonic Distortion—\*\*\*(30-15,000 Hz).....0.5% or less  
 FM Noise Level (referred to 100% FM mod.).....-65 dB max.  
 AM Noise Level (referred to 100% AM mod.).....-50 dB max.  
 Subcarrier Input Level (30% mod. of Carrier).....5 Volt max.  
 Subcarrier Input Impedance.....10,000 Ohms  
 Pre-emphasis Network Time Constant.....75 or 50 μs, as desired

### Electrical

Main-to-Subchannel Crosstalk.....-55 dB referred to ±7.5 kHz deviation of the subcarrier by a 400 Hz tone. Main channel modulation 70% by 30-15,000 Hz tones.

Sub-to-Main-Channel Crosstalk.....-65 dB referred to ±75 kHz deviation of the main carrier by a 400 Hz tone. Subchannel modulation 100% (±7.5 kHz) by 30-6000 Hz tones. Subcarrier modulated 30% on main carrier.

#### Power Line Requirements:

Line.....240/208 Volt, 3 phase, 50/60 Hz  
 Combined Line Voltage Variation and Regulation.....±5%  
 Power Consumption.....36,000 Watts (approx.)  
 Power Factor (approx.).....90%

#### Crystal Heater:

Line.....117 Volt, single phase, 50/60 Hz  
 Power Consumption.....7½ Watts

### Tube Complement

Exciter:  
 3—6922 or E88CC      1—8156      1—6227 or E80L  
 2—6686 or E81L      1—6AS6      1—0G3 or 85A2

Driver:  
 2—7203/4CX250B

Power Amplifier:  
 1—4CX15000A

### Mechanical

	Transmitter	High-Voltage Power Supply
Dimensions (overall):		
Width .....	48½" (123 cm)	32" (81.3 cm)
Height .....	77" (195.6 cm)	49" (124.5 cm)
Depth .....	32½" (82.5 cm)	23" (58.5 cm)
Weight (approx.) .....	1425 lbs. (646.4 kg.)	1025 lbs. (164.9 kg.)
Finish .....	Textured Vinyl in midnight blue and shadow blue, satin-aluminum trim.	
Altitude .....	7500 ft.† (2290 M)	
Ambient Temperature Range.....	-20° to +45°C	

\* Level measured at input terminal J1.

\*\* Audio Frequency response referred to 50- or 75-microsecond pre-emphasis curve.

\*\*\* Distortion includes all harmonics up to 30 kHz and is measured following a standard 50- or 75-microsecond de-emphasis network.

† Blowers can be provided for operation at higher altitudes.

Specifications subject to change without notice.



**EASE OF MAINTENANCE**—Full access to all transmitter sections is an important feature in the mechanical design of the BTF-20E.



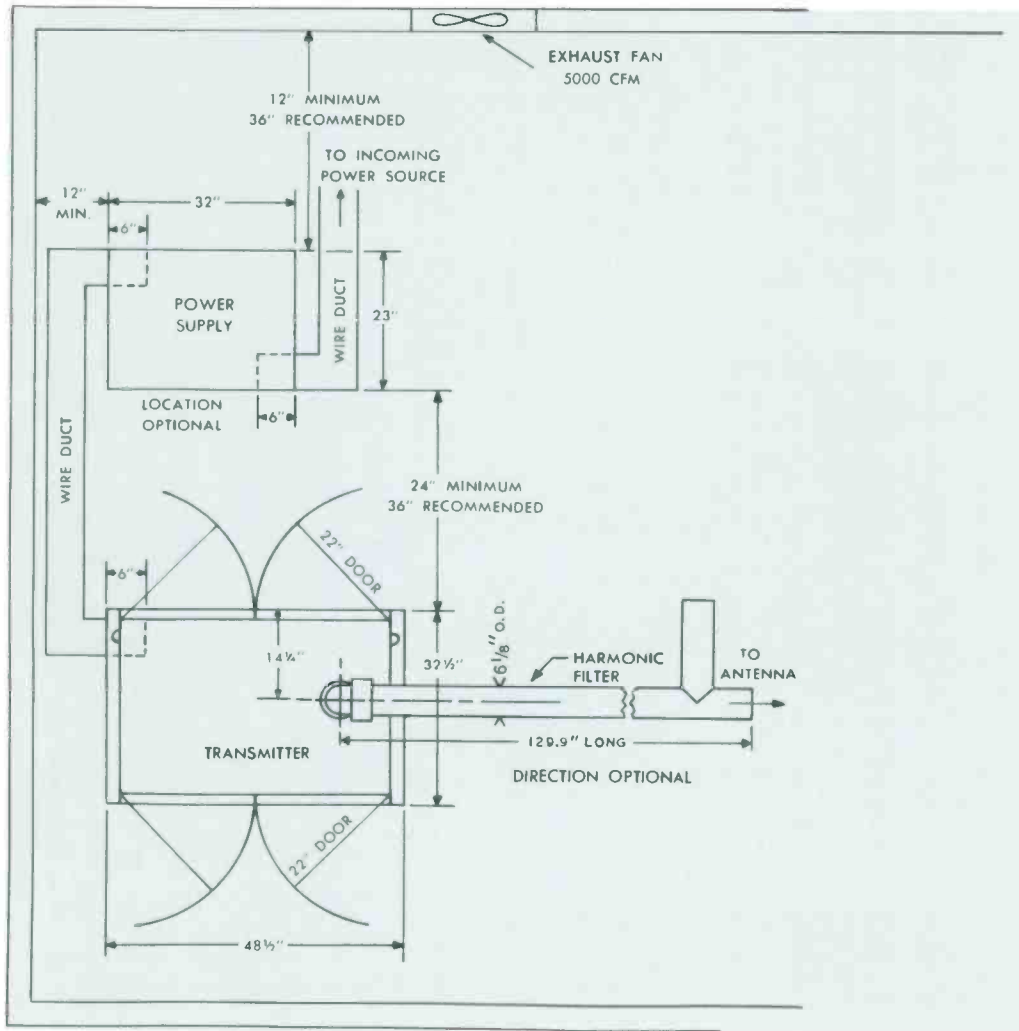

Space-saving floor plan of the BTF-20E. The separate, unitized power supply may be installed in a basement, attic, closet or other convenient place. (Wire duct and fan shown are not furnished.)

### Accessories

Set of Spare Amplifier Tubes for BTF-20E.....	ES-560228
Set of Spare Tubes for BTE-10C Exciter.....	MI-560301
Spare Crystal for BTE-10C Exciter.....	MI-560302
(Specify channel frequency)	
Type BTS-1A Stereo Generator (Silver Gray finish).....	ES-560202
Spare Set of Tubes for BTS-1A.....	MI-560005

Type BTX-1A Subcarrier Generator (for SCA).....	ES-27295
Complete Set of Spare Tubes for BTX-1A.....	MI-34514
Recommended Minimum Spare Tubes for BTX-1A.....	MI-34519
53-kHz Filter (required when transmitting both stereo and SCA).....	MI-560003
Type BTR-11B Remote Control System.....	MI-27537/27538-A
Type BW-73A FM Multiplex Monitor.....	ES-560200-A

## Ordering Information

Complete BTF-20E FM Broadcast Transmitter ..... ES-560225  
(Please specify assigned frequency, power-line frequency  
and altitude of installation)

## 40-KW FM Transmitter, Type BTF-40E

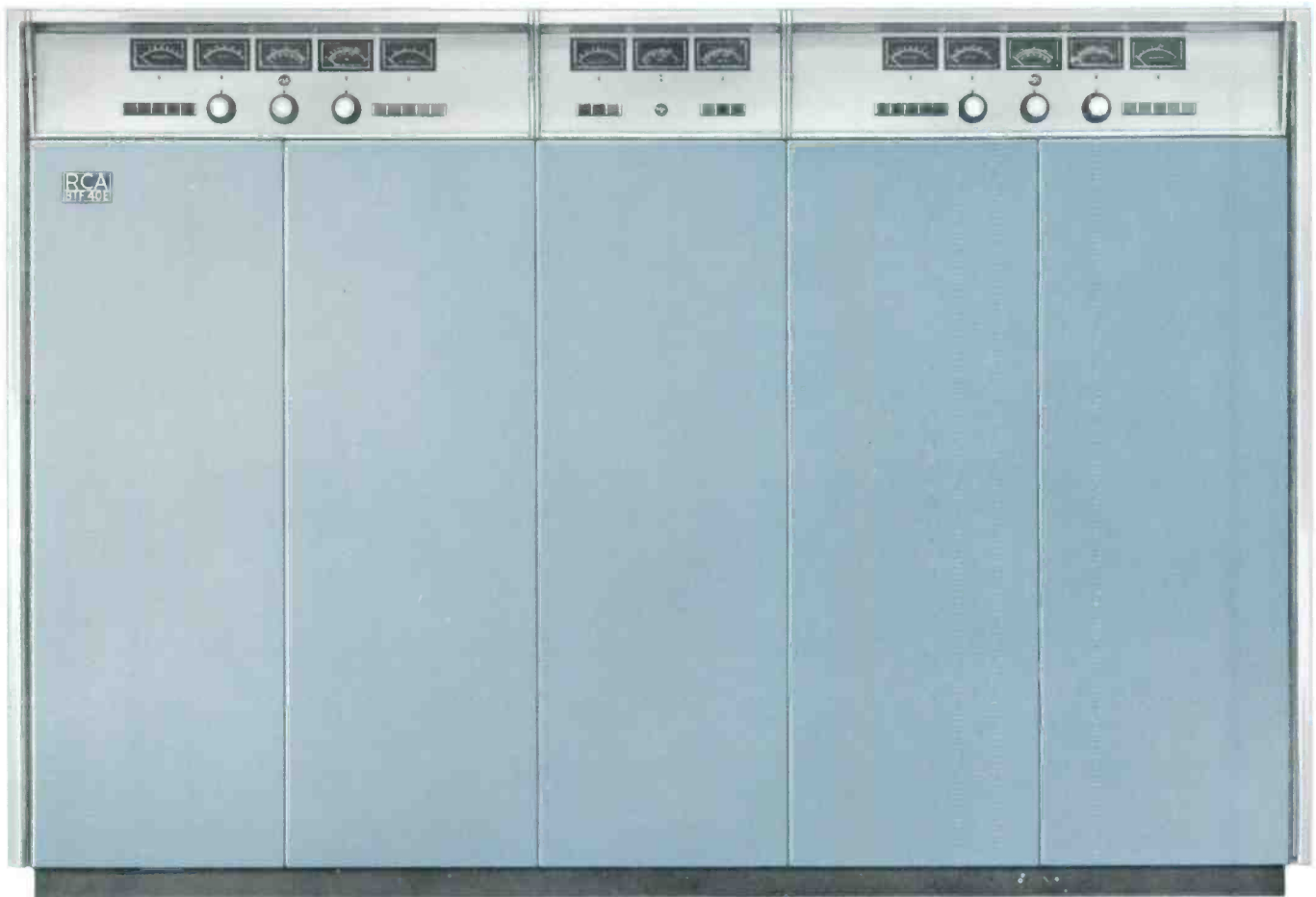

- Ultra stable—easy to tune
- High quality stereo with SCA
- Reliable dual RF amplifiers
- Ready for remote control

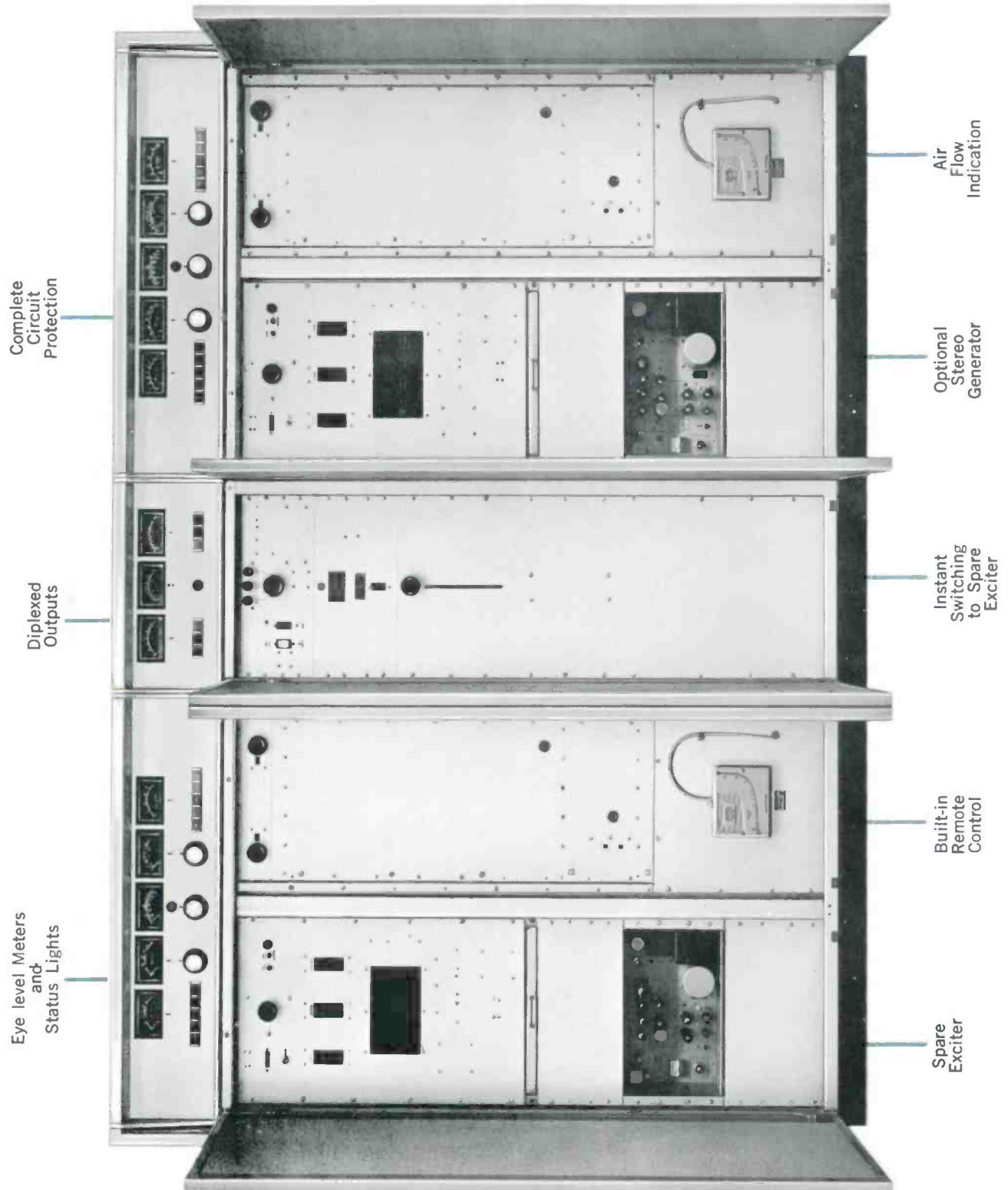

Eye level Meters  
and  
Status Lights

Diplexed  
Outputs

Complete  
Circuit  
Protection

Spare  
Exciter

Built-in  
Remote  
Control

Instant  
Switching  
to Spare  
Exciter

Optional  
Stereo  
Generator

Air  
Flow  
Indication

## 40-KW Full-Fidelity FM Transmitter, Type BTF-40E

The RCA Type BTF-40E, 40 kilowatt FM Broadcast Transmitter is designed for high-power operation in the standard FM band, 88-108 megahertz and is specifically engineered to meet and exceed the requirements of multiplex service transmission.

The transmitter consists of two twenty kilowatt units driven from a single exciter. The use of exciter switching and an output diplexing system assures continuous operation even when one power amplifier or exciter is removed from service for maintenance or repair. The transmitter is housed in two cabinets separated by a control panel and the diplex assembly.

The BTF-40E employs exciters that use the time-tested and field-proven *direct FM* system. *Direct FM* is produced in a circuit that uses capacitive diodes as modulators of an oscillator. Automatic frequency control (AFC) maintains oscillator frequency

to tolerance under virtually all operating conditions.

Because of its wide frequency response and extreme stability, the exciter is ideally suited for multiplex and stereo programming, as specified by the FCC.

The BTF-40E uses silicon-rectifier power supplies for long life and dependability. For ease of tuning, the exciter has a built-in multimeter and accessible test points permitting metering and checking during operation. All RF circuits are single tuned for utmost tuning simplicity. Built-in manometers can add hundreds of hours to tube life by indicating air filter efficiency and warning of reduced cooling-air supply over the power tubes.

Frequency response of the transmitter's main channel is 30 to 15,000 hertz ( $\pm 1$  dB maximum) and distortion over the same range is 0.5 percent or less.

### Description

The BTF-40E is a diplexed transmitter consisting of two 20E transmitters united by a mid-combining panel. The diplexed output combiner, a 3 dB Hybrid Coupler, MI-560309, and one 6 $\frac{1}{8}$ -inch Harmonic Filter, MI-561506, are external to the cabinets of the 40E.

The combining panel consists of five sections, the first of which contains the following control and metering functions: six illuminated pushbuttons for operating the combined unit on, off, plate on, plate off, and to indicate transmitter overload, and output line VSWR overload. Also located here are three meters essential for operation of the 40E. A "Reject Power" meter is used to indicate power into the two 5-kilowatt air cooled reject loads. The second, a "Reflected Output Power Meter," serves to indicate reflected power and to protect the transmitter from an unusually high value in case of a line or antenna fault. The control can be adjusted to any value of VSWR. The third meter indicates "Power Output."

The second section in the combining panel is used to mount the set point module of the meter-control and to mount the reflectometer adjustments and controls. Below this, a third section contains illuminated switches for Exciter 1 or 2, control circuit line breaker, and a meter indicating reject power in the input balun. The fourth section has a control for adjustment of the line stretcher used for phasing the input circuits of the combined 20E units. The last section is a blank panel.

On the top of the combiner unit is a blower, thermostatically controlled, so that in case of failure of either of the 20-kilowatt transmitters, the heat from the 10-kilowatt reject loads will be removed from the cabinet. Each air cooled 5-kilowatt load is also equipped with a thermo controlled fan for cooling.

The transmitter can be controlled as a 40-kilowatt unit from the combining cabinet panel, or as individual 20-kilowatt transmitters from their own control positions. If sufficient controls on a remote system are available, the whole transmitter, or the individual 20-kilowatt sections can be operated separately.

Relays automatically switch all inputs, that is, stereo and two SCA channels from one exciter to the other. The primary power to each exciter is always fed from the transmitter that is not shut down. The exciters are modified to eliminate the doubler, and the IPA stage of two 4CX250B's are operated as doublers. This results in sufficient drive to saturate all stages with some margin, and permits stable operation without driver neutralization.

#### Mono or Stereo

The transmitter features a new exciter designed for stereo and multiplex. The exciter, including its self-contained, semiconductor-equipped power supply, is mounted on a single vertical chassis.

#### Two Stages Follow Exciter

From the 10-Watt output of the exciter, only three tubes, two in the IPA and a ceramic-tetrode 4CX-15000A PA, generate the full 20-kW signal from each amplifier. A harmonic filter reduces spurious radiation. Vacuum capacitors tune the IPA plate and PA grid. All PA adjustments are at ground potential.

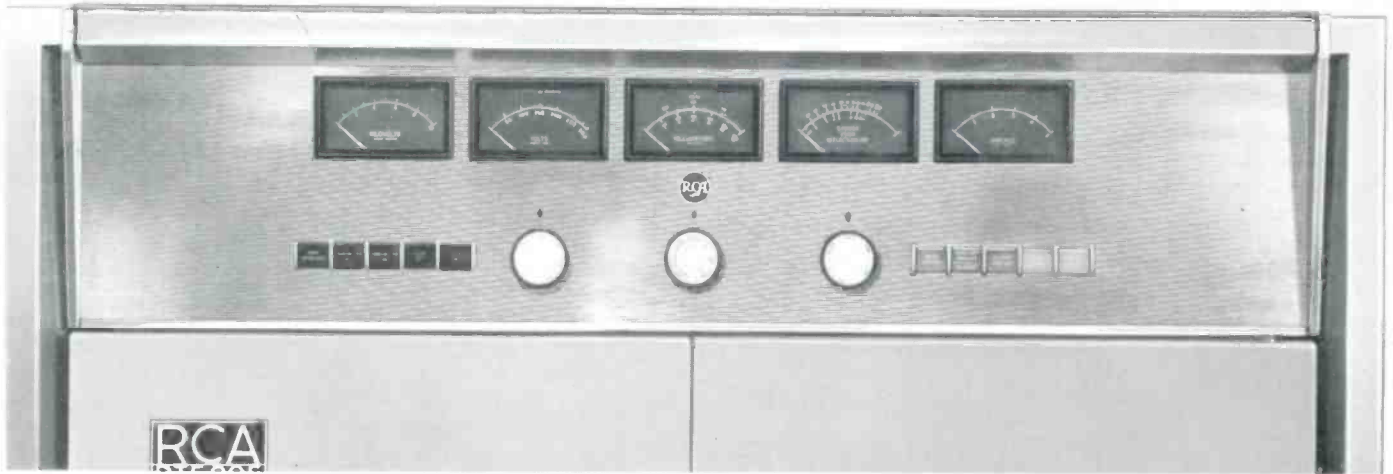

Control Panel of one of the diplexed 20-kW transmitter units. Tally lights and pushbutton controls permit operation of BTF-40E even when one power amplifier or exciter is removed from service. The large diameter multimeter knobs speed log keeping and minimize error.

### New Styling

Functional styling together with fewer tubes and components has permitted the new BTF-40E transmitter and a control panel to be housed in two double-door cabinets. They employ the new midnight blue and shadow blue finish, set off with aluminum meter panel and trim. Swing-out doors on the front and rear of the cabinet give maximum accessibility. Two separate unitized high-voltage supplies may be located anywhere in the FM station.

### "Direct FM" Exciter

The RCA Type BTE-10C FM Multiplex Exciter is a compact, self-contained unit which provides a modulated RF output of ten watts at any specified frequency in the FM broadcast band. Its simplified design provides superior performance under stereophonic, monophonic, and SCA conditions.

The design employs the *direct-FM* modulation system with particular design emphasis being placed on ad-

justment ease and reliable operation. All RF stages use simplified single-tuned circuits. A built-in multimeter and easily accessible test points allow convenient metering and checking during operation.

A self-contained, silicon-rectifier-equipped power supply is used. Long life premium tubes provide extended reliability. The BTE-10C has been particularly designed for unattended, remote operation.

Block diagram of the BTF-40E FM Transmitter.

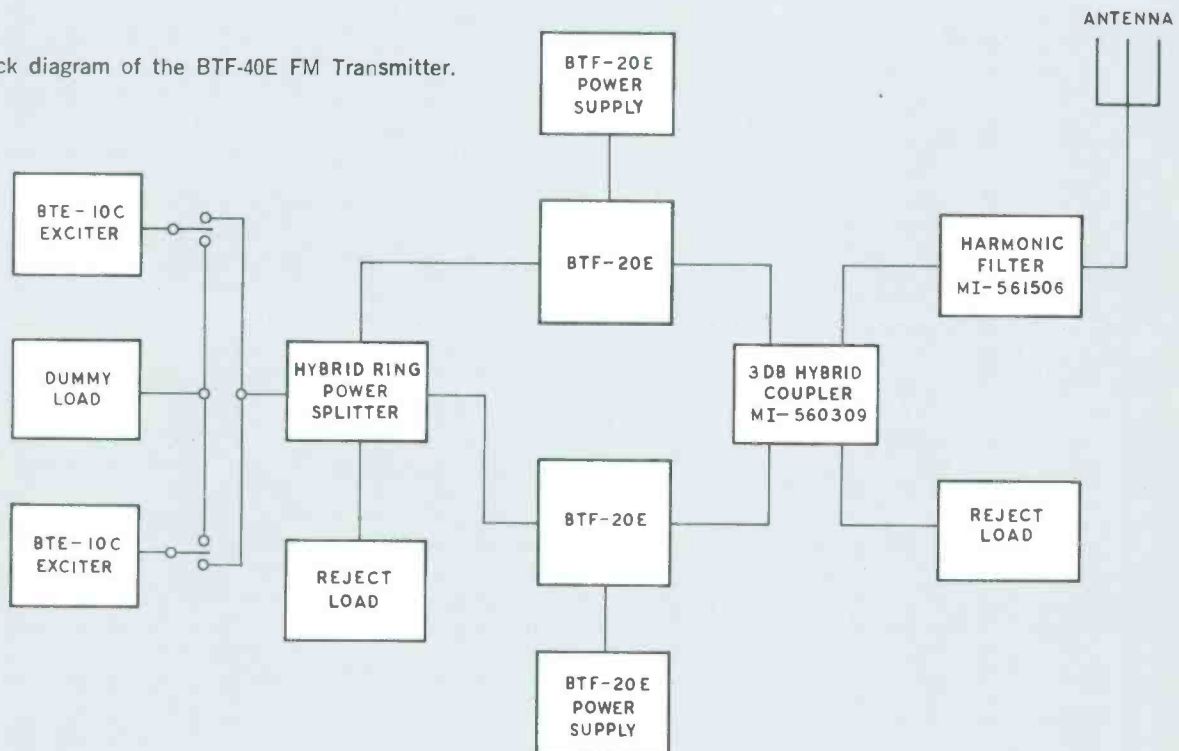

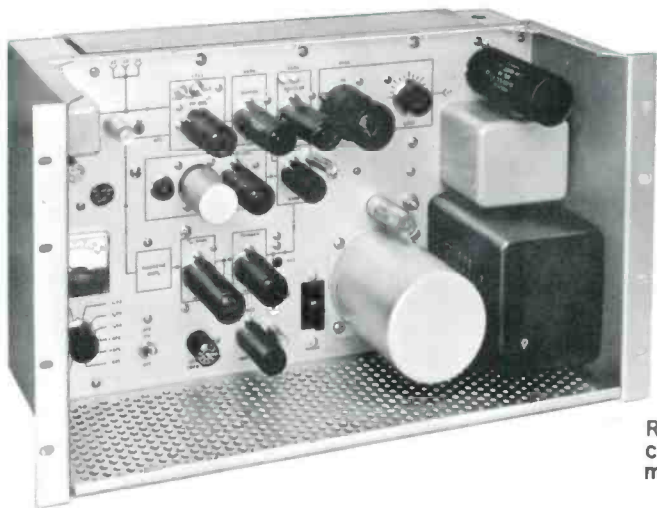
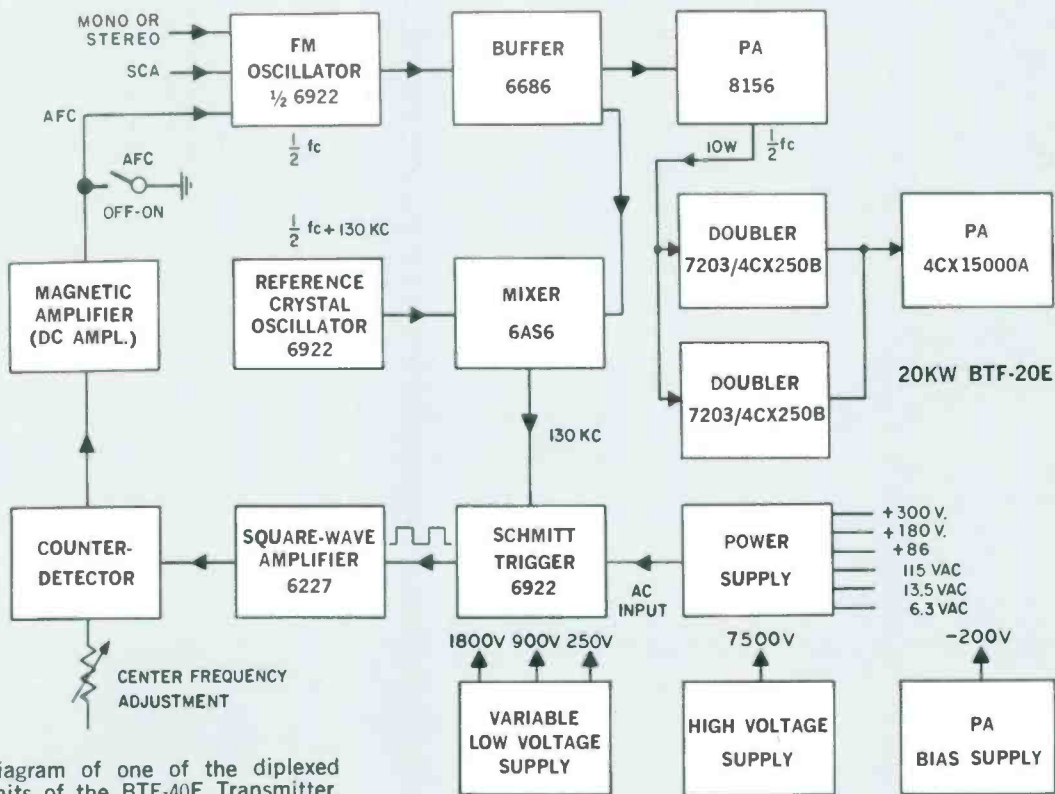

RCA's "direct FM" exciter provides excellent multiplex performance.

### Simplified Circuitry

The BTE-10C FM Multiplex Exciter is the simplest ever offered. It has eight tubes of which only three are required to give full performance with a dependable on-air signal. Four are in the AFC system and the eighth is a voltage-regulator type. There are no series or cascaded modulators to adjust for low frequency response, nor are there critical modulation-level adjustments.

### Precision AFC

The frequency modulated oscillator operates at a frequency between 44 and 54 megahertz (one-half final frequency). Its accuracy is precisely controlled through an AFC system that uses a DC discriminator and a magnetic amplifier. The noteworthy point is that the AFC system operates entirely without tuned circuits. This results in long-term stability. In the event the AFC sys-

tem cannot control the oscillator frequency to within tolerance, it immediately moves the frequency to beyond the passband of the buffer amplifier and, thus, removes the carrier from the air.

### Magnetic-Amplifier AFC

The error signal developed in the AFC counter-detector is amplified through the use of a magnetic amplifier that provides a voltage gain of approximately 40 decibels. This amplified "error" signal (DC) pulls the oscillator frequency to within tolerance.

### Single-Ended Driver Amplifier

Two simplified, single-ended amplifiers (operating Class "C") follow the exciter in each 20-kW unit. The IPA stages consist of two ceramic 7203/4CX250B tetrodes operating in parallel, and both final power amplifiers are Type 4CX15000A tubes. The IPA stages are tuned by pi-network input and output circuits. Variable vacuum capacitors are used to tune the interstage network.

### 20-kW Class "C" Final Amplifier

The power amplifiers also use pi-network circuitry, however, the tuning of these stages is accomplished by variable inductors operating at ground potential. The output tubes are designed for very high power gain with little drive. Power output is controlled by means of motor-driven variable transformers connected in the primary of the low voltage power supply for the driver amplifiers. This controls the IPA-plate and the PA-screen voltages simultaneously.

For increased transmitter stability and reliability, separate grid bias supplies are incorporated in the BTF-40E. These supplies also use semi-conductor rectifiers.

### Harmonic Filter is Standard Equipment

To keep spurious emission at a minimum, the transmitter is furnished with a 6 $\frac{1}{8}$ -inch harmonic filter. The filter consists of a series of transmission line elements with a uniform outer diameter conductor, a stepped inner conductor, and a shunt stub. The conductors are fabricated of a high-grade copper alloy. Attenuation of all harmonic radiation above channel limits is accomplished in an "M-derived" section, and a series of "constant-K" T-sections. This design provides a broad passband with a sharp high-frequency cut-off and excellent attenuation of frequencies above the passband.

### Self-Protected Against Overload

Power circuits are protected by magnetically-tripped circuit breakers in addition to overload relays. An interlocked system prevents turn-on of plate power until all filaments have heated and the exciter has reached a proper operating condition. In addition, a latching relay automatically re-applies power to the transmitter once before locking-out in the event of brief overloads or power interruptions. The overload relays are reset by illuminated push-button switches on the front panel. Separate tally-light indicators are provided for overloads in the driver, power amplifier and low voltage rectifier circuits.

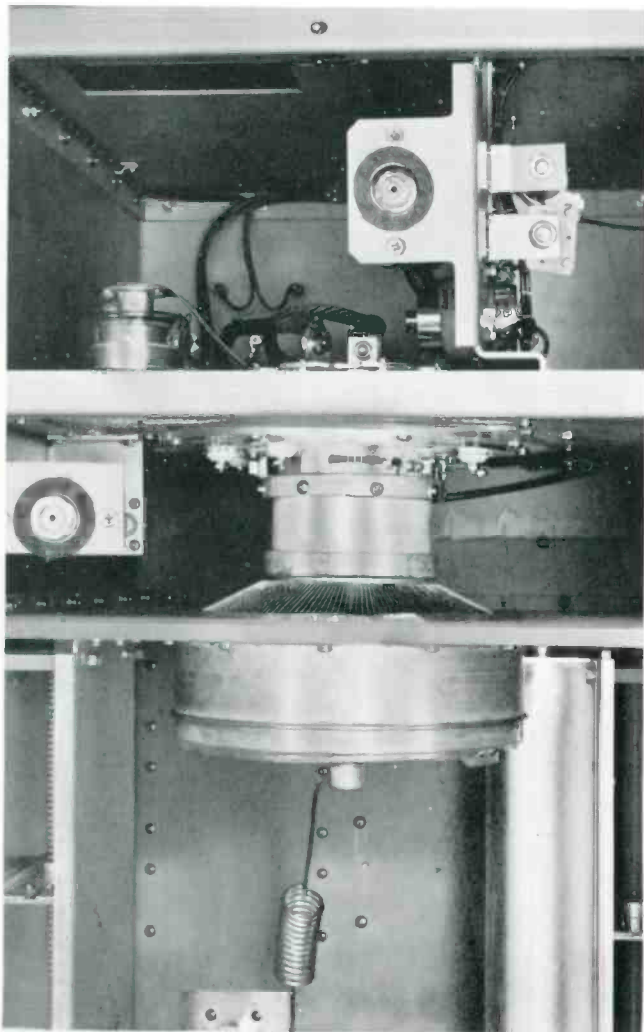

View showing interior of one of the two identical PA and IPA cabinets with the 4CX15000A ceramic tetrode and two IPA tubes below shelf.

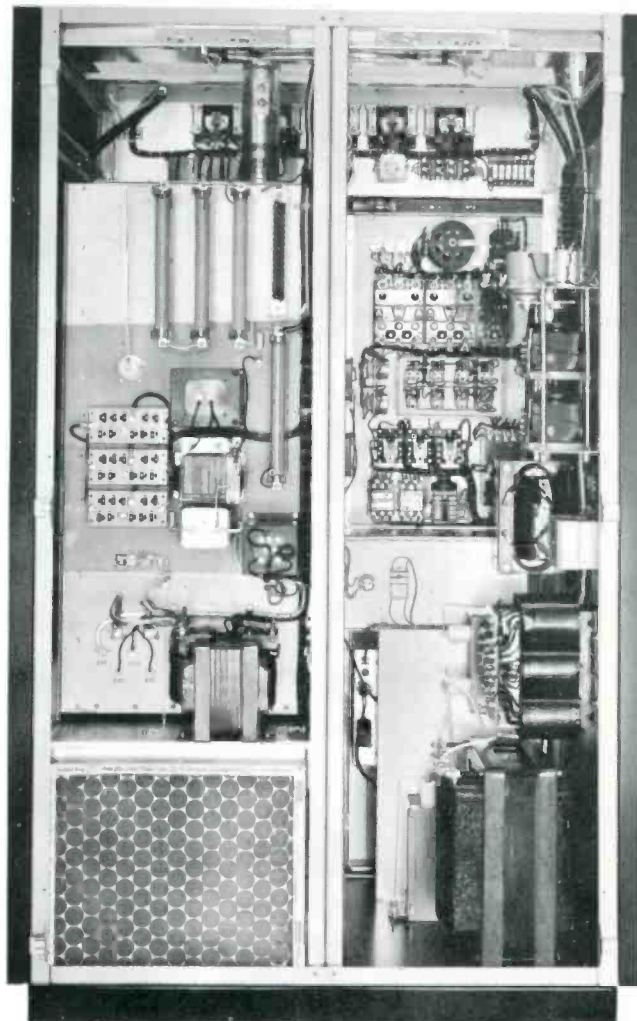

Complete accessibility. Rear view showing one of the amplifiers of the BTF-40E revealing the clean, vertical construction of PA cavity to left and control panel to right.

## Fully Air-Cooled

Cooling air for the BTF-40E is supplied by the use of two blowers mounted below the amplifier stages. Manometers indicate the efficiency of the fiber glass filter at the inlet and heavy sound insulation reduces blower noise to a minimum. The blowers supply forced air to all IPA and PA stages.

## Simplified Control

In addition to the combining control panel already described, each 20-kilowatt unit has operating controls and meters located on a panel just above the front doors. The push-button controls include: transmitter on/off, plate on/off, overload reset and power raise/lower. A cabinet disconnect switch, low-voltage circuit-breaker, and filament- and control-circuit breakers are located behind the left-hand door. The main- and low-power circuit breakers are located in the rectifier unitized cabinet. When servicing the BTF-40E, operation of the "disconnect" switch removes all voltages from the trans-

mitter cabinet. Personnel are protected by fully interlocked rear doors, in addition to interlocked doors on the RF PA cubicles.

## Full Metering

Five easy-to-read front-panel meters are provided for each amplifier. One for PA-plate voltage, another for PA-plate current, and a third for AC line and filament voltage. The remaining two are a reflectometer and a multimeter. The reflectometer measures either the forward power or VSWR. The multimeter reads the grid current, the screen current and the screen voltage of both power tubes. In addition, the exciter has its own self-contained multimeter, that provide complete information on operating conditions in the exciter.

## Ready for Remote Control

Remote control provisions are included in the transmitter. Terminals are provided for use with remote control units such as the Type BTR-20C and BTG Series Automatic Logging Equipment. Addi-

tional terminals are supplied for remote control of transmitter on/off, plate on/off, raise/lower power, and overload reset. Remote metering connections in the final amplifier for plate current, plate voltage, and power output are also provided.

## High-Voltage Power Supply

The high-voltage power supplies are housed in unitized cabinets each measuring 32 inches wide, 23 inches deep and 49 inches high. They can be installed at any convenient place in the station. The cabinets house the high-voltage-plate transformers, a bank of plug-in semiconductor rectifiers, a line-circuit breaker, a low-power circuit breaker, and the plate contactor. Personnel are fully protected from shock through interlock and grounding switches.

The rectifier section comprises silicon-junction diodes (with equalizing resistors and capacitors) in a three-phase, full-wave-bridge circuit. Circuit breakers are used instead of fuses in the transmitter adding to the dependability, particularly when operating by remote control.

# Specifications

## Performance

Type of Emission .....	F3 and F9
Frequency Range .....	88 to 108 MHz
Power Output .....	40 kW
Output Impedance .....	50 Ohms
Frequency Deviation 100% modulation .....	±75 kHz
Modulation Capability .....	±100 kHz
Carrier Frequency Stability .....	±1000 Hz max.
Audio Input Impedance .....	600/150 Ohms
Audio Input Level—*(100% mod.) .....	+10 ±2 dBm
Audio Frequency Response—**(30-15,000 Hz) .....	±1 dB max.
Harmonic Distortion—*** (30-15,000 Hz) .....	0.5% or less
FM Noise Level (referred to 100% FM mod.) .....	-65 dB max.
AM Noise Level (referred to 100% AM mod.) .....	-50 dB max.
Subcarrier Input Level (30% mod. of Carrier) .....	5 Volt max.
Subcarrier Input Impedance .....	10,000 Ohms
Pre-emphasis Network Time Constant.....	75 or 50 µs, as desired

## Tube Complement

Exciter:		
6—6922 or E88CC	2—8156	2—6227 or EO80L
4—6686 or E81L	2—6AS6	2—0G3 or 85A2
Driver:		
4—7203/4CX250B		
Power Amplifier:		
2—4CX15000A		

## Electrical

Power Line Requirements:	
Line .....	240/208 Volt, 3 phase, 50/60 Hz
Combined Line Voltage Variation and Regulation .....	±5%
Power Consumption .....	72,000 Watts (approx.)
Power Factor (approx.) .....	90%
Crystal Heater:	
Line .....	117 Volt, single phase, 50/60 Hz
Power Consumption .....	15 Watts

## Mechanical

Dimensions (overall):	Transmitter	High-Voltage Power Supply
Width .....	114¼" (288.2 cm)	64" (162.6 cm)
Height .....	77" (195.6 cm)	49" (124.5 cm)
Depth .....	32½" (82.5 cm)	23" (58.5 cm)
Weight (approx.) .....	2950 lbs. (1336.4 kg)	2050 lbs. (329.8 kg.)
Finish .....	Textured Vinyl in midnight blue and shadow blue, satin-aluminum trim.	
Altitude .....	7500 ft. (2290 m)†	
Ambient Temperature Range .....	-20° to +45°C	

\* Level measured at input to pre-emphasis network.

\*\* Audio Frequency response referred to 50- or 75-microsecond pre-emphasis curve.

\*\*\* Distortion includes all harmonics up to 30 kHz and is measured following a standard 50- or 75-microsecond de-emphasis network.

† Blowers can be provided for operation at higher altitudes.

Specifications subject to change without notice.



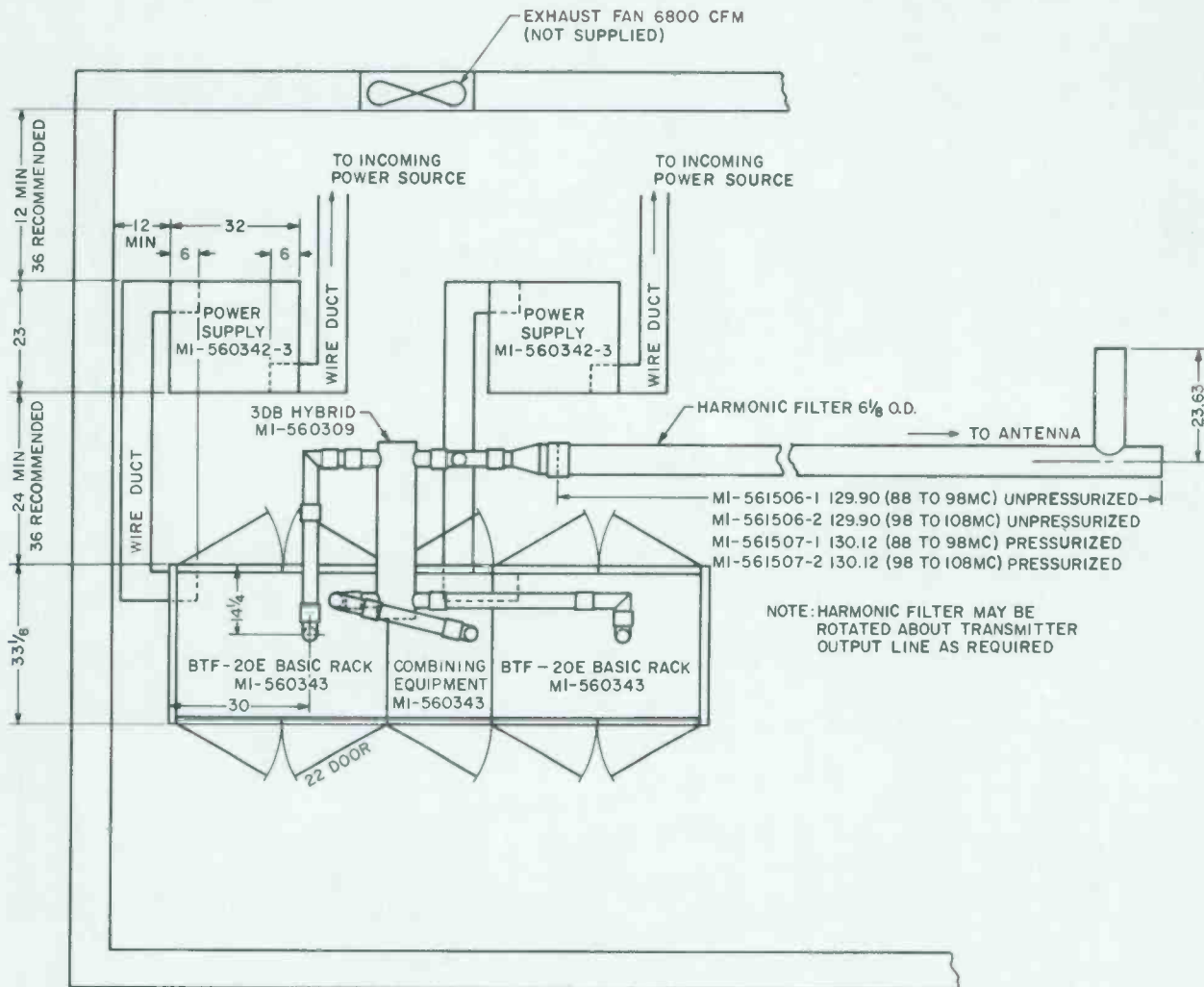

Space-saving floor plan of the BTF-40E. The separate, unitized power supply may be installed in a basement, attic, closet or other convenient place. (Wire duct and fan shown are not furnished.)

### Accessories

- Set of Spare Amplifier Tubes for BTF-40E ..... ES-560233
- Set of Spare Tubes for BTE-10C Exciter ..... MI-560301
- Spare Crystal for BTE-10C Exciter ..... MI-560302  
(Specify channel frequency)
- Type BTS-1A Stereo Generator (Silver Gray finish) ES-560202
- Spare Set of Tubes for BTS-1A ..... MI-560005

- Type BTX-1A Subcarrier Generator (for SCA) ..... ES-27295
- Complete Set of Spare Tubes for BTX-1A ..... MI-34514
- Recommended Minimum Spare Tubes for BTX-1A MI-34519
- 53-kHz Filter (required when transmitting both  
stereo and SCA) ..... MI-560003
- Type BTR-11B Remote Control System ..... MI-27537/27538-A
- Type BW-73A FM Multiplex Monitor ..... ES-560200-A

## Ordering Information

- Complete BTF-40E FM Broadcast Transmitter ..... ES-560229  
(Please specify assigned frequency, power-line frequency  
and altitude of installation)



- Ideal transmitter for educational stations
- Incorporates "Direct FM" exciter requiring minimum of tubes and parts
- Easy to install and operate
- Extremely stable
- Meets all FCC requirements

## 10-Watt FM Transmitter, Type BTE-10CT

### Description

The BTE-10CT 10-Watt FM Broadcast Transmitter conforms to FCC requirements for educational transmitters providing 10 Watts output for stations operating in the 88 to 108 MHz band. It is designed to provide the finest possible performance and reliability, and will meet the stringent requirements of stereo and multiplex service transmission. Low distortion, wide frequency response, ease of adjustment and reliable operation are characteristic of the transmitter.

The BTE-10CT consists of a BTE-10C Exciter and a Meter Panel. A specially styled cabinet, MI-560304 is an accessory for mounting the exciter and panel, or they may be mounted in standard broadcast equipment racks. For stereo operation the transmitter may be used

with the BTS-10A Stereo Subcarrier Generator. If, in addition, SCA operation is desired, the BTX-1A Subcarrier Generator may be specified.

The BTE-10CT Transmitter is a simplified "Direct FM" design, with nine tubes. Only four tubes are used to generate the RF signal, thus tuning and reliability is vastly improved. The RF chain uses only one frequency multiplier. Frequency divider, and tuned circuits have been avoided in the AFC (automatic frequency control) system. The BTE-10CT requires only 150 Watts power and the simplified circuitry provides ease of maintenance as well as more economical operation.

The transmitter can be tuned without additional or external equipment. A built-in meter serves as indicator and the crystal oscil-

lator as a frequency reference source. The unit is extremely simple to tune since only six adjustments are required for the five steps involved. Premium, long-life tubes used in the transmitter can be expected to give long time reliability and require a minimum of servicing.

The Meter Panel, MI-560303, includes a plate voltage meter, a calibrated program level meter, and a plate current meter, in accordance with FCC requirements. The plate voltage meter indicates the plate voltage of the final stage; the program meter (or VU meter) indicates degree of modulation; and the plate current meter reads current in the plate circuit of the voltage output stage of the transmitter. These meters are in addition to the built-in multimeter.

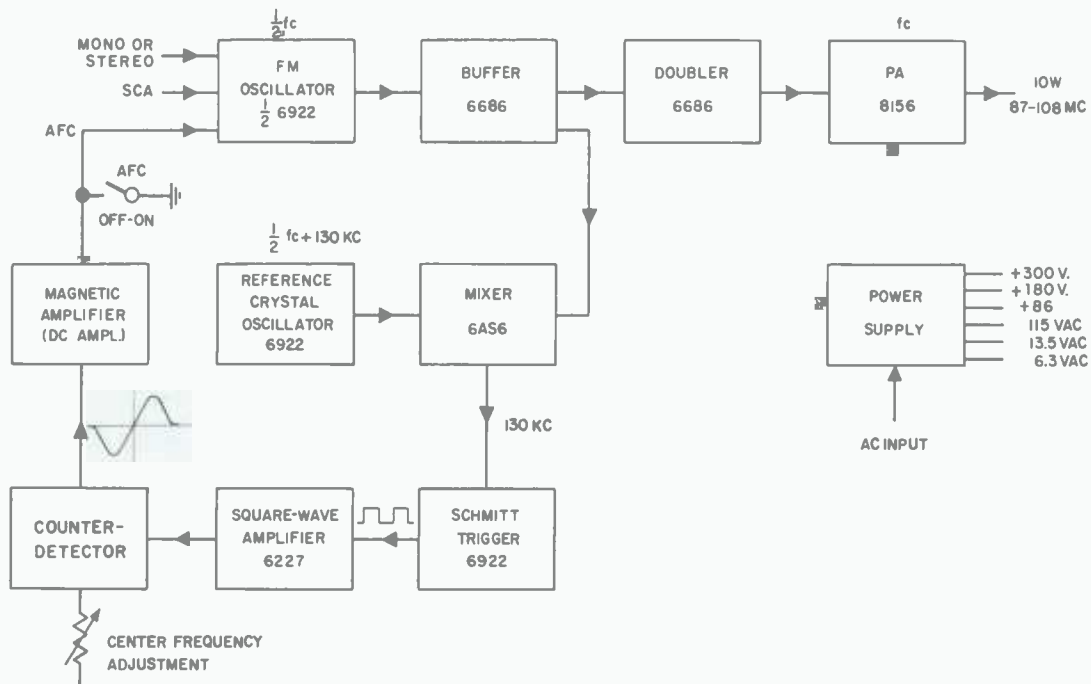

Block diagram of the BTE-10CT FM Transmitter.

## Specifications

### Electrical

Type of Emission.....	F3—F9
Frequency Range .....	88-108 MHz
Power Output .....	10 Watts
Output Impedance .....	50 Ohms
Modulation Capability.....	±100 kHz
Carrier Frequency Stability.....	±1000 Hz max.
Audio Input Impedance.....	600/150 Ohms (pre-emphasis 75 μs) (50 microseconds if desired)
Audio Input Level (100% Mod.) .....	+10 ±2 dBm (400 Hz tone applied J1)
Audio Frequency Response (30-15,000 Hz) .....	±1 dB max. (referred to 75 μs pre-emphasis curve)
Harmonic Distortion (30-15,000 Hz).....	1% max. (includes all harmonics up to 30kHz and is measured following standard 75 μs de-emphasis network)
FM Noise Level (referred to 100% FM Mod.) .....	-65 dB
AM Noise Level (referred to carrier voltage) .....	-50 dB
SCA Sub-Carrier Input Level (30% Mod. of carrier) .....	5 Volts max.
SCA Sub-Carrier Input Impedance .....	15,000 Ohms
Main-Channel to Sub-Channel Crosstalk .....	-55 dB (relative to 400 Hz per second tone deviating sub-carrier by ±7.5 kHz main channel modulated 70% by 30 to 15,000 Hz tones)
Sub-to-Main-Channel Crosstalk .....	-65 dB (relative to 400 Hz per second tone deviating main-carrier ±75 kHz, sub-carrier modulated ±7.5 kHz by 30 to 6000 Hz tones, main-carrier modulated 30% by sub-carrier.)
Power Line Requirements .....	240/208 or 117 Volts, single phase, 50/60 Hz
Slow Voltage Variations.....	±5%
Power Consumption .....	150 Watts (approx.)
Altitude.....	7500 ft. max. (2290 m)
Ambient Temperature Range.....	-20° to +45°C

### Mechanical

Overall Dimensions:	
BTE-10CT Chassis.....	19" wide, 14" high, 9" deep (48.5 cm wide, 35.5 cm high, 23 cm deep)
MI-560304 Optional Cabinet.....	24" wide, 14¾" high, 15" deep (61 cm wide, 37.5 cm high, 38 cm deep)
Weight.....	40 lbs. (18 kg)
Finish.....	Blue and Silver

### STEREOPHONIC OPERATION

All applicable requirements of Section 3.322 of the FCC Rules and Regulations will be met when used in conjunction with the BTS-1A Stereo Subcarrier Generator. Simultaneous stereo and SCA requires the use of 67 kHz for the SCA channel.

### Accessories

Complete Set of Spare Tubes for FM Broadcast Exciter, MI-560300-A.....	MI-560301
Cabinet for BTE-10CT FM Broadcast Exciter .....	MI-560304
Type BTS-1A Stereo Subcarrier Generator.....	ES-560202
Set of Spare Tubes for BTS-1A.....	MI-560005
BTX-1A Subcarrier Generator.....	ES-27295
Spare Tubes for BTX-1A.....	MI-34514
53 kHz Filter for use with BTS-1A when transmitting stereo and SCA service.....	MI-560003

## Ordering Information

BTE-10CT 10-Watt FM Broadcast Transmitter.....	ES-560236
comprising the following:	
1 Type BTE-10C FM Broadcast Exciter.....	MI-560300-A
1 Crystal Unit .....	MI-560302*
(*Crystal Unit to be ordered to suit customers assigned frequency)	
1 Meter Panel .....	MI-560303

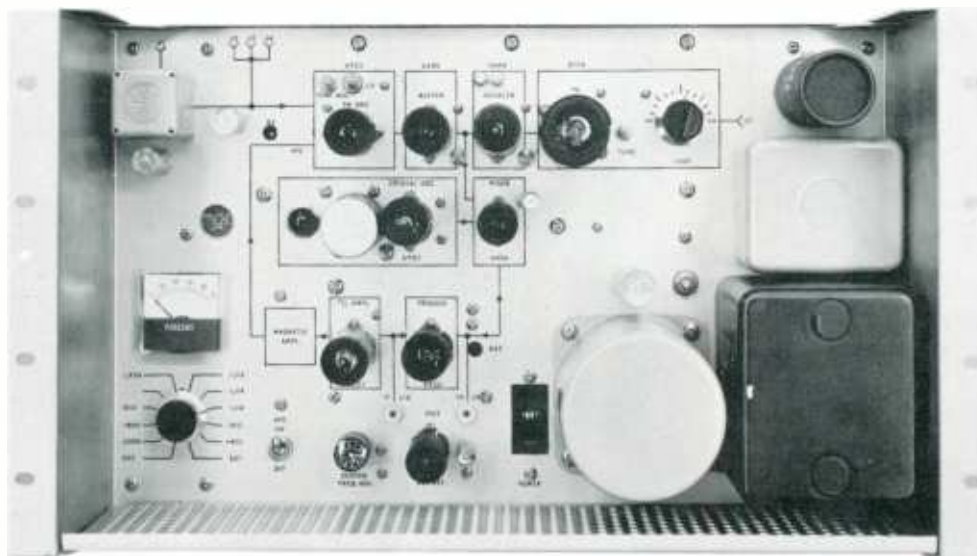

BTE-10C  
Multiplex Exciter

- "Direct FM" modulation
- Exciter requires no special tuning when setting up for Multiplex
- No spurious frequencies generated by modulation process
- Self-contained silicon power supply

## FM Multiplex Equipment

### Description

RCA FM Multiplex Equipment provides on-air FM stations with an inexpensive means of broadcasting two or more services simultaneously over their regularly assigned broadcast channel. With this equipment stations can offer background music services while retaining presently scheduled FM broadcast programming. The use of the equipment for subsidiary communications and stereo is type accepted by the FCC.

Multiplexing is the simultaneous transmission of two or more separate program channels on the same RF carrier. By employing the RCA BTE-10C Multiplex Exciter and one or two Type BTX-1A Subcarrier Generators, one or two additional program channels can be transmitted along with the regular FM program channel. This is accom-

plished by transferring the subchannel programs into the supersonic frequency range and frequency modulating the subchannel programs on 30-67 kHz subcarriers. The FM supersonic carriers are then used to modulate the RF carrier.

Stereophonic programming requires the use of an optional Stereo Generator, Type BTS-1A. It can be used simultaneously with one SCA Generator, Type BTX-1A.

#### BTE-10C Multiplex Exciter

The RCA Type BTE-10C FM Multiplex Exciter, ES-560217, is a compact self-contained unit which provides an RF output of ten Watts at any specified frequency in the FM broadcast band. Its new, simplified design provides superior performance under stereophonic, monophonic, and SCA conditions.

The design retains RCA's *Direct-FM* modulation with particular emphasis being placed on ease of adjustment and reliable operation. All RF stages use single-tuned circuits. A built-in meter, and easily accessible test points allow metering and checking during operation. A self-contained silicon power supply is used. Premium tubes, carrying a 10,000 hour guarantee, have been used for reliability and long life. The BTE-10C lends itself particularly well to unattended and remote operation. The unit is designed for mounting in a standard 19-inch rack.

#### Circuits

The BTE-10C FM Multiplex Exciter, which is the heart of RCA's new line of FM transmitters, is the simplest ever offered. It has nine tubes of which only four are re-

quired to give full performance with a dependable on-air signal. There are five total RF circuits, of which only four single-tuned RF circuits can effect the performance of the signal. There are no series or cascaded modulators to adjust for low frequency response, and the unit can be overmodulated without breakup.

The frequency modulated oscillator operates from 44 to 54 MHz at one half the final frequency. This frequency is sampled after the buffer amplifier and fed into a mixer. A second frequency, 130 kHz higher, is obtained from a highly stable crystal oscillator as shown in the block diagram. Thus an output frequency of 130 kHz is obtained. Any variation in frequency of the FM oscillator will immediately cause a corresponding change of the 130 kHz beat frequency. The 130 kHz frequency is applied to the input of a Schmitt trigger circuit that transforms the 130 kHz sine wave input signal into a square wave signal to make the following counter-detector independent of possible amplitude variations of the 130 kHz beat frequency input.

The counter-detector has a 130 kHz crossover frequency. An opposite polarity error signal will be obtained with opposite frequency departures of the 130 kHz square wave. This error voltage is amplified by a magnetic amplifier causing a total open-loop gain of the AFC loop of about 40 dB. The error signal, a DC voltage depending on its magnitude and polarity on the FM oscillators frequency, is then fed back into a capacitive diode which controls the frequency of the FM oscillator. This closes the AFC loop.

Frequency stability of the counter-detector is better than  $\pm 250$  Hz over a temperature range from  $-20$  to  $+15$  degrees Centigrade. This amount, multiplied by two (due to subsequent doubling of the RF portion of the BTE-10C) represents the major amount of possible carrier shift. High loop gain and excellent initial stability of the FM oscillator reduces the carrier frequency shift from these sources to not more than 25 percent of the contribution of the counter-detector. These variations are well within FCC requirements.

Muting and cut-off protective circuits provide built-in protection of

the exciter since, should a failure occur in the AFC loop the resulting unbalance of the input of the magnetic amplifier will saturate the magnetic amplifier. This will detune the FM oscillator to such a large degree that no RF signal output will be present at the output terminal. This action provides for an automatic off-frequency protection. Failure of the stages which are not connected directly with the AFC automatically remove the carrier.

With the AFC operating, the center frequency can be adjusted manually over a range of approximately  $\pm 20$  kHz by a calibrated 10 turn potentiometer. Thus calibration tolerances of the reference crystal can be compensated and the carrier frequency can be adjusted to agree exactly with the assigned frequency.

The direct RF circuitry consists of the FM oscillator and buffer mentioned before followed by a doubler stage and the final PA stage which provides a 10 Watt output. A built-in meter is provided for reading the plate current of the final amplifier. The self-contained power supply for the BTE-10C employs semiconductor rectifiers throughout. An AFC on-off toggle switch and simplified controls including the power on-off switch are all easily accessible on the chassis of the exciter.

#### **BTX-1A Subcarrier Generator**

The BTX-1A Subcarrier Generator is designed to provide a frequency modulated RF signal having a center frequency in the range of 30 to 67 kHz. When used in conjunction with the RCA BTE-10C FM Exciter, an FM station can multiplex up to two channels in addition to the regular program channel on a single RF carrier. Crystal units providing a center frequency of 32.5, 42, 59, and 67 kHz are currently available for use in the generator.

All components of the BTX-1A are mounted on a vertical chassis designed for standard rack mounting. The equipment employs miniature tubes in all stages except in the power supply which utilizes an OD3 voltage regulator and germanium rectifiers in a bridge circuit. Other features include a built-in monitor oscilloscope which permits instantaneous check and adjustment of all five AFC frequency dividers, and check and adjustment of the phase detector control action.

The BTX-1A circuitry consists of a master oscillator, push-pull reactance modulators, crystal oscillator, automatic frequency control, subcarrier muting stage, mixer, cathode follower output stage, alignment oscilloscope and a power supply. Two reactance modulators are connected to the oscillator plate, and the push-pull grids are inductively coupled to the plate tank. RF voltages on the two modulator grids are 180 degrees out of phase with respect to each other, and each is 90 degrees out of phase with the oscillator plate. Thus one tube appears as a capacitive reactance and the other appears as an inductive reactance across the oscillator tank. The magnitude of the reactive component presented to the tank coil varies with the audio voltage applied to the modulator grids. The frequency of the oscillator is varied accordingly. The mean frequency is controlled by the bias voltage applied to one grid by the automatic frequency control circuit.

The modulated output from the master oscillator and the RF output from a 12AT7 crystal oscillator are then fed into a mixer. This stage supplies the modulated beat frequency in the range of 30 to 67 kHz, which is connected to the cathode follower. A subcarrier muting stage is used to disable the mixer and thus suppress subcarrier output when no audio voltage is present at the audio input terminals of the generator. Operation of this stage is such that with no audio voltage present at the input, the plate of the second half of the 12AX7 tube clamps the grid voltage of the mixer to a very low value, reducing output of the mixer to zero. Audio applied to the input of the muting stage, however, is amplified in the first half of the 12AX7, rectified by a 1N38A crystal diode and applied as bias to disable the clamping section of the tube. A five-position switch is provided for switching the muting stage in and out of the circuit, and also selection of three different values of time delay before muting takes place. The push-pull modulation of the BTX-1A is similar to that in the BTE-10C and has the same features as previously outlined. The automatic frequency control circuitry used in the BTX-1A is also very similar to that in the BTE-10B Exciter, and it performs the same function.

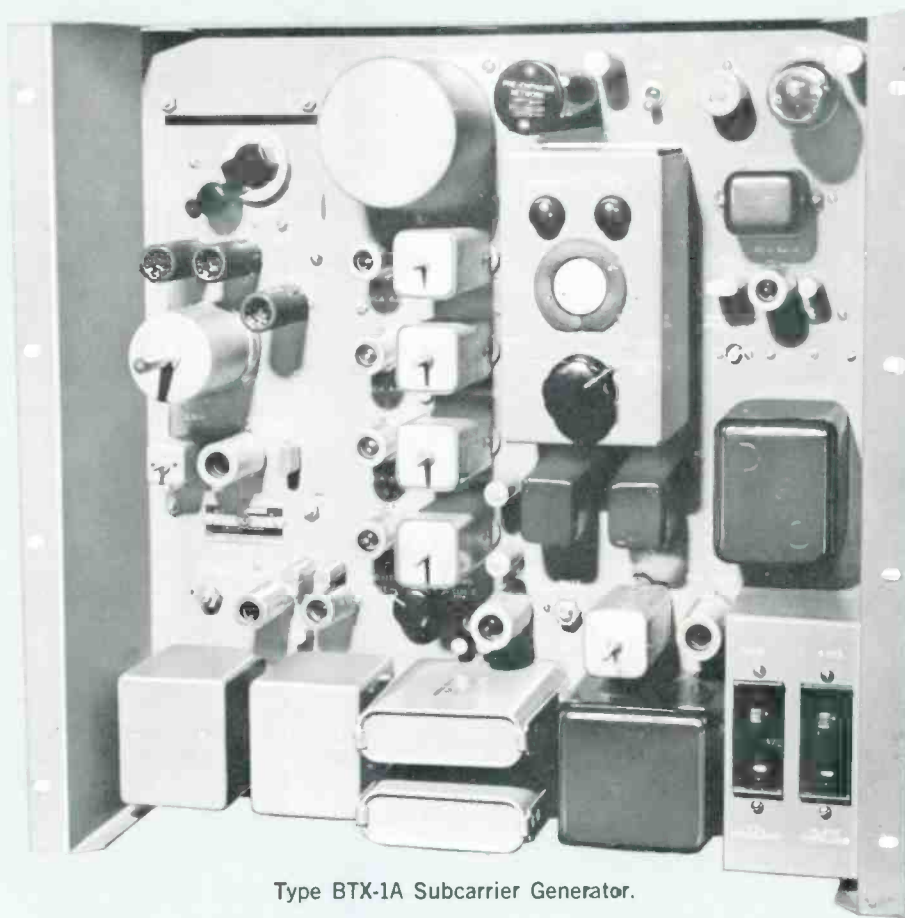

Type BTX-1A Subcarrier Generator.

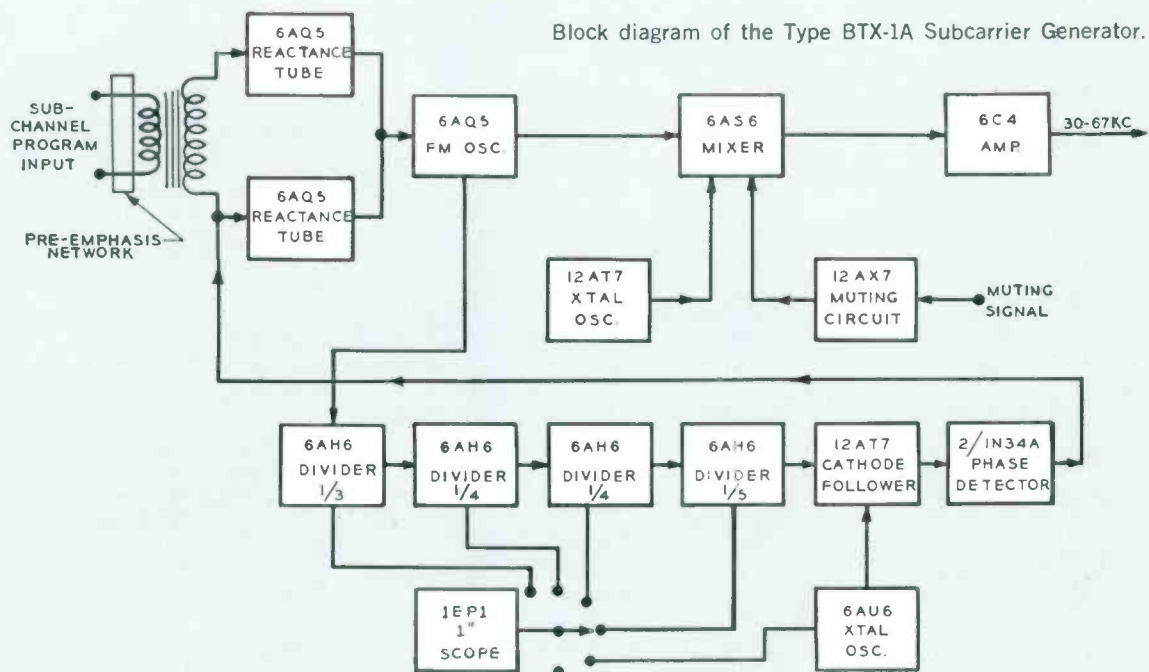

# Specifications

## TYPE BTE-10C EXCITER

### Performance

Type of Emission.....	F3-F9
Frequency Range .....	87-108 MHz <sup>6</sup>
Power Output .....	10 Watts
Output Impedance .....	50 Ohms
Frequency Deviation for 100% modulation.....	±75 kHz
Modulation Capability.....	±100 kHz min.
Carrier Frequency Stability.....	±1000 Hz max.
Audio Input Impedance (pre-emphasis 75μs).....	600/150 Ohms
Audio Input Level (100% mod.) .....	+10 ±2 dBm <sup>1</sup>
Audio Frequency Response (30 Hz-15 kHz) .....	±1.0 dB max. <sup>2</sup>
Harmonic Distortion (30 Hz-15 kHz).....	0.5% max. <sup>3</sup>
FM Noise Level (referred to 100% FM mod.) .....	-65 dB max.
AM Noise Level (referred to carrier voltage) .....	-50 dB max.
Subcarrier Input Level (30% mod. of carrier max.) .....	5 Volts max.
Subcarrier Input Impedance .....	10,000 Ohms
Subcarrier Center Frequency Range.....	30-67 kHz
Main-to-Sub Channel Crosstalk .....	-55 dB <sup>4</sup>
Sub-to-Main Channel Crosstalk .....	-65 dB <sup>5</sup>

### Electrical

#### Power Line Requirements:

##### Transmitter:

Line .....	240/208 or 117 V, AC, 50/60 Hz, single phase
Slow Voltage Variations.....	±5%
Power Consumption .....	150 Volts

##### Crystal Heaters:

Line .....	117 V, AC, 50/60 Hz, single phase
Power Consumption .....	28 Watts

### Tube Complement

½ 6922	Frequency Modulated Oscillator	1 6AS6	Mixer
½ 6922	Cathode Follower	1 6922	Schmitt Trigger
1 6686	Buffer Amplifier	1 6227	Square Wave Amplifier
1 6686	Doubler	1 OG3	Reference Voltage Regulator
1 8156	Final Amplifier		
1 6922	Crystal Oscillator		

### Mechanical

Overall Dimensions.....	19" wide, 10½" high, 11" deep (48.3 cm, 26.7 cm, 28.9 cm)
Weight.....	80 lbs. (36.29 kg.)
Maximum Altitude.....	7500 ft. (2290 m)
Ambient Temperature Range.....	20-45° C
Finish .....	Silver gray

<sup>1</sup> Level measured at input to pre-emphasis network using 400 Hz tone.

<sup>2</sup> Audio frequency response referred to 75 or 50 μsec pre-emphasis curve.

<sup>3</sup> Distortion includes all harmonics up to 30 kHz/s and is measured following a standard 75 or 50 μsec de-emphasis network.

<sup>4</sup> Reference shall be ±7.5 kHz deviation of the subcarrier by a 400 Hz tone. Main-channel modulated 75% by 30-15,000 Hz tones.

## Ordering Information

Type BTE-10C FM Exciter.....	ES-560217
Comprising the following:	
1 FM Exciter Unit (silver gray finish).....	MI-560300-A <sup>7</sup>
1 Crystal Unit .....	MI-560302*
(*Sales Order must specify crystal frequency)	

## TYPE BTX-1A SUB-CARRIER GENERATOR

### Performance

Type of Modulation.....	FM
Center Frequency Range of Sub-carrier.....	30-67 kHz
Output Voltage .....	5 Volts min.
Source Resistance.....	Approx. 400 Ohms, cathode follower
Frequency Deviation (100% subcarrier mod.).....	±7.5 kHz
Modulation Capability.....	±25 kHz
Carrier Frequency Stability.....	±500 Hz
Audio Input Impedance .....	600/150 Ohms
Audio Input Level (100% mod.) .....	+10 ±2 dBm <sup>1</sup>
Audio Frequency Response (30 Hz-60 Hz) .....	±1 dB max. <sup>2</sup>
Harmonic Distortion (30 Hz-60 kHz).....	0.75% <sup>3</sup>
FM Noise Level (referred to 100% mod.) .....	-60 dB max.
AM Noise Level (referred to carrier) .....	-50 dB max.

### Electrical

#### Power Line Requirements:

Line .....	240/208 V, AC, 50/60 Hz, single phase
Slow Voltage Variation.....	±5%
Power Consumption .....	100 Watts

### Tube Complement

2 6AQ5	Reactance Modulator	2 6AH6	Frequency Divider (¼)
1 6AQ5	Master Oscillator	1 6AH6	Frequency Divider (1/5)
1 12AT7	Crystal Oscillator #1	1 6AU6	Crystal Oscillator #2
1 6AS6	Mixer	1 12AT7	Cathode Follower
1 6C4	Cathode Follower	1 12AX7	Subcarrier Muting
1 6AH6	Frequency Divider (½)	1 OD3	Voltage Regulator
		1 1EP1	Cathode Ray Tube

### Mechanical

Overall Dimensions.....	19" wide, 17½" high, 10" deep (48.3 cm, 44.5 cm, 25.4 cm)
Weight.....	40 lbs. (18.64 kg.)
Maximum Altitude.....	7500 ft. (2290 m)
Ambient Temperature Range.....	0-45° C
Finish .....	Silver gray

### Accessories

BTS-1A Stereo Generator.....	ES-560202
Spare Set of Tubes for BTS-1A.....	MI-560005
53 kHz Filter (required if transmitting Stereo) .....	MI-560003
Spare Set of Operating Tubes for BTE-10C Exciter.....	MI-560301
Cabinet for BTE-10C FM Broadcast Exciter.....	MI-560304
Spare Set of Operating Tubes for BTX-1A Subcarrier Generator .....	MI-34514
Spare Crystal for BTE-10C Exciter.....	MI-560302*
(*Sales order must specify channel frequency.)	

<sup>1</sup> Reference shall be ±7.5 kHz deviation of the main-carrier by a 400 Hz tone. Sub-channel modulated 100% (±7.5 kHz/s) by 30 Hz-60 kHz tones.

<sup>2</sup> Coil furnished for 44 to 54 MHz for use where a doubler follows the exciter.

<sup>3</sup> To order an exciter with amber gray finish specify MI-560300.

## Ordering Information

Type BTX-1A Subcarrier Generator.....	ES-27295
Comprising the following:	
1 Subcarrier Generator Unit.....	MI-34500
1 Set of Operating Tubes.....	MI-34514
1 Crystal Unit, Type CR-18U.....	MI-34520*
(*Order must specify frequency of 67, 58, 42, or 32.5 kHz)	
1 Instruction Book .....	IB-30262

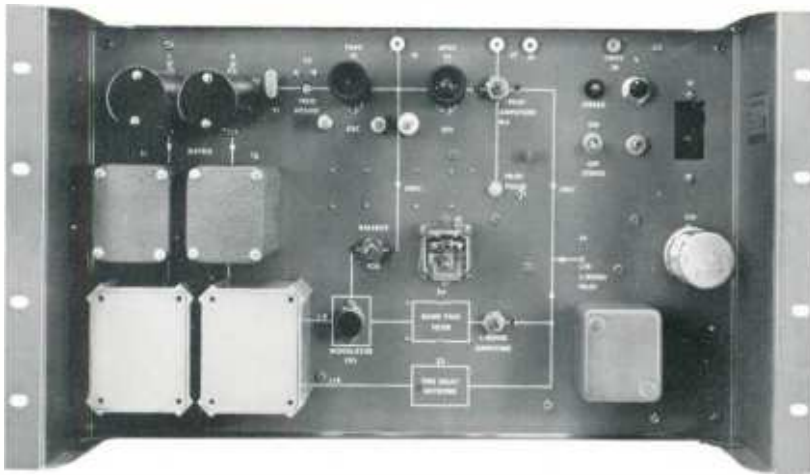

- High quality FM Stereo performance
- Plug-in pre-emphasis units
- Hermetically sealed silicon diode power supply
- Temperature stability  
−20 to +45 degrees C
- Mono-stereo relay and indicator included

## Stereo Subcarrier Generator, Type BTS-1A

### Description

The RCA Type BTS-1A Stereo Subcarrier Generator, MI-560001, is an all new improved unit, designed for high quality FM stereo operation. The generator produces a composite signal which is fed into the *Direct FM* exciter, BTE-10C, or its predecessor, BTE-10B.

All RCA FM transmitters incorporating the BTE-10B/C Exciter can be used for simultaneous stereo and SCA transmission using the BTS-1A Stereo Subcarrier Generator in conjunction with a BTX-1A SCA Subcarrier Generator. If, however, stereo and SCA service are transmitted simultaneously, a filter, MI-560003, will be required at the output of the BTX-1A to make certain all spurious signals are attenuated at

least 60 db at 53 kHz and below. Earlier RCA FM transmitters incorporating the MI-7016 Exciter may be used for stereo transmission using the BTS-1A. Simultaneous SCA service is not feasible, however, if the MI-7016 Exciter is used.

#### Minimum Adjustments

The BTS-1A incorporates a simple, easy-to-follow circuit with a minimum of adjustments resulting in continued reliability and stability. It is designed for remote control operation, and in many instances can be mounted in the transmitter cabinet or in any adjacent 19-inch rack.

Only two long life (10,000 hours) premium tubes, a 7643 and a 6922, are used. Frequency stability is maintained with a 38 kHz oscillator hav-

ing an accuracy of  $\pm 2$  Hz. The power supply consists of hermetically sealed silicon diodes. All parts are designed for conservative operation for maximum reliability. Plate voltage on the tubes is only 100 Volts.

#### Built-in Matrix

A matrix and time delay circuit are incorporated in the BTS-1A. The two stereo signals from the studio, L (left) and R (right), are fed into the matrix to obtain sum and difference signals. The difference signal is amplitude, suppressed carrier modulated. L+R and L-R (DSB) and pilot signals are added to form the composite signal which will frequency modulate the exciter (BTE-10B/C or MI-7016). The double side-band signal (DSB) is generated in a



ring modulator, which consists of four matched germanium diodes in one assembly. The diodes all have identical electrical characteristics regardless of temperature. The signal-to-noise ratio and distortion levels are the same for monophonic and stereophonic transmission. The L-R Signal at the output of the ring modulator is fed through a bandpass filter and added to the L+R signal.

The BTS-1A has a frequency response of 30 Hz-150 kHz,  $\pm 1.5$  dB. Distortion (90 percent main channel modulation by a L-R signal) is 1 percent or less. The signal-to-noise ratio under the same conditions as above is a maximum of  $-60$  dB. Total distortion of a composite signal (45 percent L+R and 45 percent L-R) (DSB) modulation will not exceed 0.75 percent.

#### Standard Rack Mounting

The BTS-1A Stereo Subcarrier Generator is designed to fit a standard 19-inch rack, and is only 10½ inches high. It offers utmost accessibility. To get at the back, all that is required is to remove a dust cover. There are four test points on the front panel for ease of servicing. There are only four screwdriver adjustments in the BTS-1A: ring modulator balance, L-R (DSB) amplitude, pilot amplitude, and pilot phase. There is one additional adjustment for matrix balance, that is set once at the factory for better than 50 dB balance (the unwanted channel rejected 50 dB or more).

#### Mono and Stereo Modes

The BTS-1A incorporates a switch for monophonic or stereophonic op-

erating modes (local or remote operation). There is an indicator lamp on the BTS-1A to show when it is in the stereo mode. When operating remote control, the monitor or receiver at the studio will indicate the unit is operating by reception of the 19 kHz pilot tone. When remote control over telephone lines is desired, the BTR-11 or BTR-20 remote control equipment should be used.

#### Solid State Power Supply

Power supply requirements for the generator are 117 or 208-240,  $\pm 11$  Volts, 50/60 Hz. Ambient temperature range is  $-20$  to  $\pm 45$  degrees, Centigrade (same wide ambient specifications as for any current RCA FM transmitter), which means that no special heating or cooling requirements are necessary for the transmitter area.

## Specifications

### Electrical

Pilot Carrier Stability.....	19 kHz $\pm 1$ Hz
Subcarrier Suppression.....	1% or better
Frequency Response, 30-15,000 Hz .....	$\pm 1.5$ dB <sup>1</sup>
Pre-emphasis.....	75 or 50 $\mu$ sec.
Left-Right Channel Separation.....	30 dB or better
Crosstalk—Stereophonic (main channel to subchannel).....	50 dB or better
Crosstalk (Subchannel to main channel).....	50 dB or better
Harmonic Distortion (100% modulation by composite stereo).....	1% or less
Line Voltage Requirements....	117 or 208-240 $\pm 11$ Volts, 50/60 Hz
Power Consumption.....	10 Watts

### Mechanical

Temperature Range.....	$-20$ to $+45$ degrees C.
Altitude.....	7,500 feet (2290 M)
Finish .....	Silver gray
Dimensions.....	10½" high, 19" wide, 8¾" deep (excluding plugs) (26.67 cm, 48.26 cm, 20.80 cm)
Weight.....	25 lbs. (11.4 kg)

### Accessories

Set Spare Tubes for BTS-1A.....	MI-560005
53 kHz filter for use with BTS-1A when transmitting stereo and SCA service.....	MI-560003
Input Adaptor for BTE-10B.....	MI-560004

<sup>1</sup> Audio frequency response referred to 75 or 50  $\mu$ sec pre-emphasis curve.

## Ordering Information

Type BTS-1A Stereo Subcarrier Generator complete with pre-emphasis network, connectors, plugs and electrolytic capacitor ..... ES-560202



Studio Control Unit

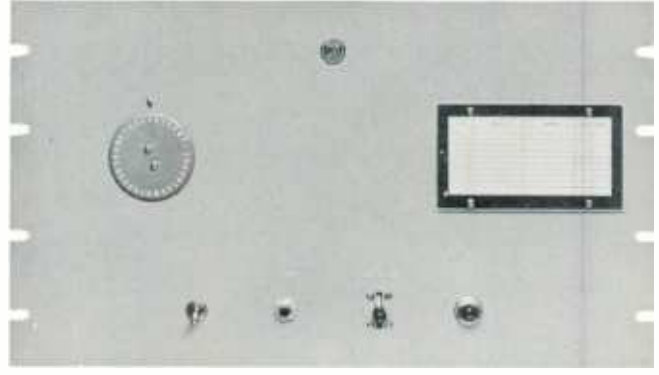

Transmitter Control Unit

- For AM, FM or TV transmitters
- Provides fail-safe circuit
- Lowest power consumption
- Home-step provision—rapid homing
- DC system operates on proven dial telephone principles

## Remote Control System, Type BTR-11B

### Description

The RCA Type BTR-11B Remote Control System is designed for use with AM, FM or TV broadcast transmitter equipment to remotely control the operation of the station transmitter and associated equipment. With this equipment, AM and FM stations now can be operated entirely from the broadcast studio or other remote point without an engineer at the transmitter site.

The Type BTR-11B Remote Control System provides control or measurement facilities of all essential transmitter functions. Up to ten functions such as transmitter on-off, plate on-off, overload reset, power output, tower lights, etc. may be controlled. Metering of filament voltage,

plate voltage, plate current, antenna current from a common point or base points, tower light current, modulation monitor, and frequency monitor may be read by means of the system.

The radio broadcast transmitter remote control equipment consists essentially of a Studio Control Unit, a Transmitter Control Unit, and a number of auxiliary units, the exact number depending on the functions to be controlled.

It is possible to control and/or measure the operation of up to 10 transmitter functions with the Type BTR-11B Remote Control System.

The Typical Metering and Control Functions Table contains a sample list of the transmitter circuits that can be measured and the opera-

tions that can be controlled by the Studio Control Unit at the remote location via two telephone lines with a loop resistance of up to 5000 Ohms. The Studio Control Unit is designed for rack mounting at the studio, while the Transmitter Control Unit and most auxiliary equipment is housed at the transmitter site.

### Studio Control Unit

The Studio Control Unit has the following front panel controls: "home-step" switch, "on-raise—off-lower" switch, power switch, indicator lamp, meter, and function indicator dial. The Transmitter Control Unit has a power switch, indicator lamp, function indicator dial, step switch, and "on-raise—off-lower" switch to facilitate local set-up or test operations.

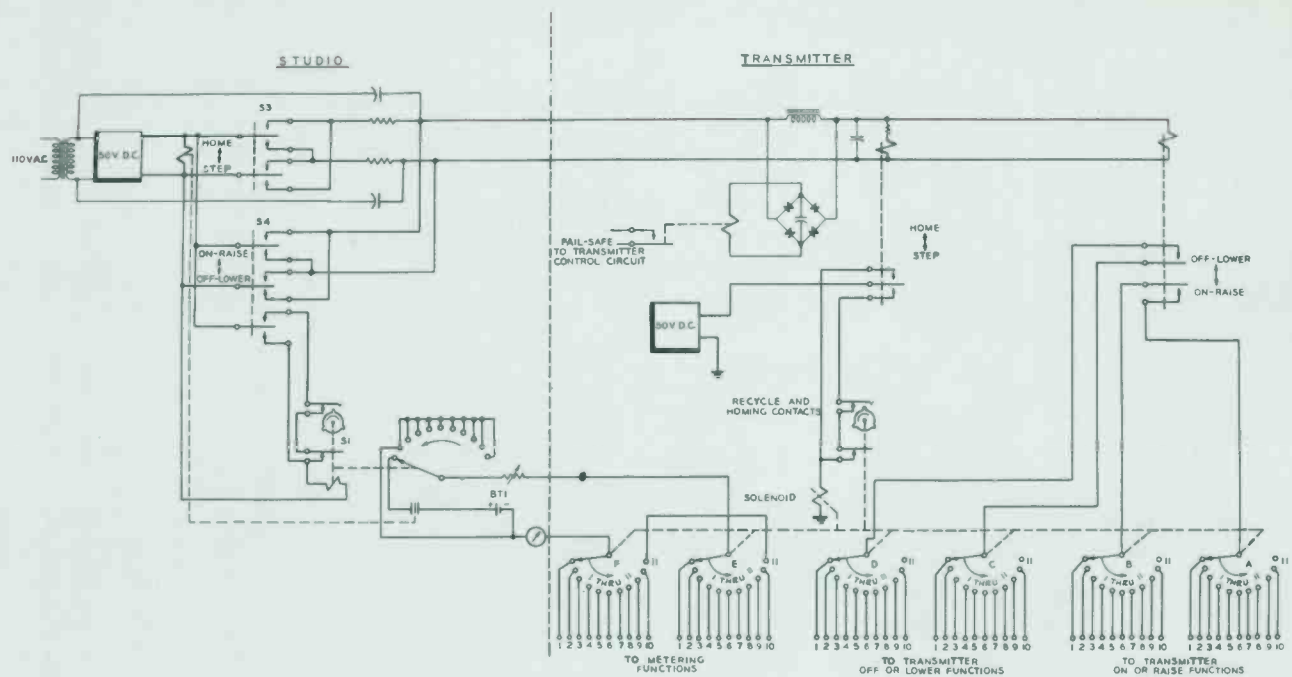

Simplified Schematic of BTR-11B Remote Control System.

**Typical Control and Metering Functions  
for BTA-5T AM Transmitter Controlled by  
BTR-11B Remote Control Unit (1 tower)**

Dial	Control	Metering
1	Transmitter On-Off	Filament Line
2	Plate On-off	Plate Volts
3	Output Raise-Lower	Antenna Current
4	Overload Resel	Plate Current
5	Tower Lights On-Off	Tower Lighting Current
6		Frequency Deviation
7		% Modulation
8	Spare	
9	Spare	
10	Spare	
11	Home	Calibrate

## Specifications

Control Functions .....	10
Power Requirements .....	117 Volts, AC, 50/60 Hz
Power Consumption and/or metering .....	25 Watts maximum
Calibration .....	Standard cell
Meter .....	0 to 150 percent (200 microamps)
Telephone Line .....	Special DC; 5000 Ohms loop resistance max.
Fail Safe Control .....	Meets FCC requirements
Dimensions (overall):	
BTR-11B Transmitter Control Unit.....	19" wide, 10½" high, 11" deep (48.26 cm, 26.67 cm, 27.94 cm)
BTR-11B Studio Control Unit.....	19" wide, 10½" high, 6" deep (48.26 cm, 26.67 cm, 15.25 cm)

Weight (approx.):

BTR-11B Transmitter Control Unit.....	18 lbs. (8.17 kg.)
BTR-11B Studio Control Unit.....	18 lbs. (8.17 kg.)

### Accessories

2-Meter Panels (AM Monitoring).....	ES-27220
AC Voltage Pickup .....	MI-27516
Tower Lighting Monitoring and Control Unit.....	MI-27519
Tower Light Monitoring Unit.....	MI-27544
Weatherproof Enclosure for MI-27544.....	MI-27543
Latching Relay Panel (including two relays).....	MI-27509-A
Latching Relay, DPST, 6 amperes.....	MI-27524-1
Latching Relay, DPST, 30 amperes.....	MI-27524-2
Latching Relay, 4DPT, 0.5 ampere.....	MI-27524-3
RF Relay, 12.5 amperes .....	MI-27545-1
Momentary Relay, DPDT, 15-20 amperes.....	MI-27545-2
RF Contactor, Latching Type SPDT, 25 amperes .....	MI-27755-1
RF Contactor, DPDT, 25 amperes .....	MI-27755-2
Remote RF Pickup (rated up to 50 kW) .....	MI-28027-B
Remote RF Pickup (rated up to 5 kW) .....	MI-27966-B
Meter Commutator .....	MI-27555
Remote Control Accessory Kit for BTA-50G.....	MI-27687
Remote Output Control for BTA-5/10H.....	MI-27517
Remote Filament Control for BTA-5/10H.....	MI-27518
Remote Power Cutback Kit for BTA-5/10H.....	MI-27520
Miscellaneous Resistors and Parts for BTA-5/10H.....	MI-27540
Temperature Indicator, Indoor -30°F to +150°F.....	MI-27550-1
Temperature Indicator, Outdoor -30°F to +150°F.....	MI-27550-2
FM Monitor Preamp, McMartin .....	TBM-2500

## Ordering Information

BTR-11B Remote Control System (10 functions).....	ES-34280
Consisting of:	
1 Studio Control Unit.....	MI-27537
1 Transmitter Control Unit.....	MI-27538-A

- Pushbutton selection of function position from studio position
- Provisions for checking metering circuit calibration at control point
- Operates without vacuum tubes amplifiers, oscillators or tuned circuits
- Easy accessibility to all terminal connections and components

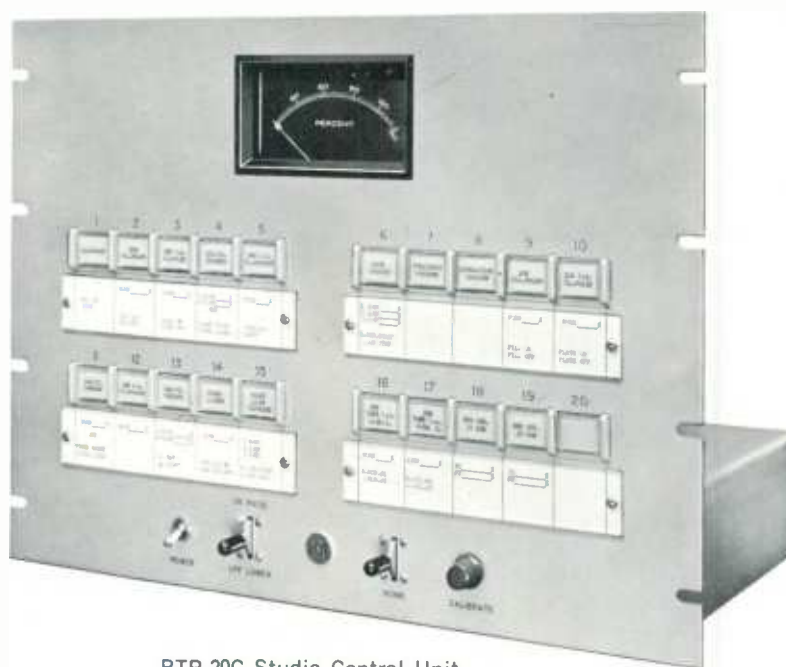

BTR-20C Studio Control Unit

## Remote Control System, Type BTR-20C

### Description

The RCA Type BTR-20C Remote Control System is designed for use with AM, FM or TV broadcast transmitter equipment to remotely control the operation of the station transmitter and associated equipment. With this unit AM and FM stations now can be operated entirely from the broadcast studio or other remote point without the presence of an engineer at the transmitter site.

The Type BTR-20C Remote Control System provides control or measurement facilities of all essential transmitter functions. Up to nineteen functions such as transmitter on-off, plate on-off, overload reset, power output, tower lights, etc., may be controlled. Metering of filament voltage, plate voltage, plate current, antenna current from a common point or base points, tower light current, modulation monitor, and frequency monitor may be read by means of the system. Spare control and metering accommodations are provided. This unit may be used to control a second or standby transmitter if desired.

The radio broadcast transmitter remote control equipment consists

essentially of a Studio Control Unit, a Transmitter Control Unit, and a number of auxiliary units, the exact number depending on the functions to be controlled. With this equipment it is possible to control and/or measure the operation of up to 19 functions with the BTR-20C Remote Control System.

#### Studio Control Unit

The Typical Metering and Control Functions Table contains a sample list of the transmitter circuits that can be measured and the operations that can be controlled by the Studio Control Unit at the remote location via two telephone lines with a loop resistance up to 5000 Ohms. The Studio Control Unit is designed for rack mounting at the studio location; while the Transmitter Control Unit and most of the auxiliary equipment is housed at the transmitter site.

The Studio Control Unit provides the following front-panel controls: "home" switch; "on raise/off lower" switch; twenty illuminated, push-button, function-selector switches; calibration control; and a power switch. On the Transmitter Control Unit of the BTR-20C there is a power switch, step switch, "on raise/off

lower" switch, indicator lamp, and an aperture behind which the number of the function being metered or controlled appears. This facilitates local set up or test operation.

#### Home-Step Provision

Stepping switches located in both studio and transmitter units can be rotated to the desired position by depressing the related switch-indicator. The push button for the position the stepping switch is in lights up. A "home" switch is provided in the studio unit to place the stepping switches in the two units in synchronization. The "home" switch moves both units to position 20.

A pulser is incorporated in the studio unit to operate both steppers. By depressing the push-button of the desired position, the stepping switches in the two units will move to that position and stop. It requires a maximum of four seconds for the units to move from any position to any other position. Illuminated switches indicate operating mode or position of the stepping switches. The mode to which the stepping switch is set can be read at the Transmitter unit by an indicating dial attached to the shaft.

A blank sheet of drafting film is provided on which can be typed any desired legend to be cut out and inserted in the push-buttons. A chart cover is provided below each push-button on which may be indicated normal meter readings and switch functions.

### Fail-Safe Circuit

It is possible to read on the studio meter any desired transmitter meter reading in any position of the stepping switches. With the addition of the accessory, MI-27555 Meter Commutator, up to twelve readings can be made on any one position of the BTR-20C. Means are provided for calibrating the line resistance by means of a standard cell. A fail-safe circuit is provided in the equipment system to meet all FCC requirements. In the event of a failure of the remote control system or the control telephone lines, the transmitter is automatically shut down. Both studio and transmitter units have self-contained power supplies. The remote control system requires the use of two "signal service" telephone

pairs. In-as-much as these lines carry only DC they can be rented at a minimum rate.

A number of auxiliary equipments are available to expand the facilities or to make more flexible the operation of RCA Remote Control Systems.

### Remote RF Pickup

Remote RF Pickup, MI-28027-B, provides the means of observing the antenna current at the studio control unit. The pickup coil is coupled to the antenna lead where it absorbs a sample of the transmitter RF output. A diode rectifier provides DC to operate the meter in the Studio Control Unit. A pickup can be installed at a common point to register the combined current of all the antennas. It can also be installed at the individual antennas to register the current of each antenna. It is satisfactory for use with all transmitters up to and including 50 kW. Remote RF Pick-up, MI-27966, is similar to the above but is rated only for 5 kW transmitters or a total current of 20 amperes.

### Accessory Meter Panel

Meter Panel (AM Monitoring), ES-27220, provides the means of monitoring the output frequency and modulation of an AM transmitter from the remote location. The studio control unit has provisions for connecting the meter panel to the meter circuit of the stepping switch. The unit contains a separate frequency meter and modulation meter mounted on a standard 19-inch panel. It includes a step-down transformer to supply voltage for illuminating the meter lamps.

### AC Voltage Pickup

AC Voltage Pickup, MI-27516, is installed at the transmitter and is connected to the transmitter control unit metering section. It provides an indication of the transmitter filament bus or line voltage on the studio control meter.

### Tower Lighting Equipment

Tower Lighting Monitoring and Control Unit, MI-27519, may be connected to the transmitter antenna tower lighting circuit to provide both the metering and control con-

Simplified Schematic of Remote Control System.

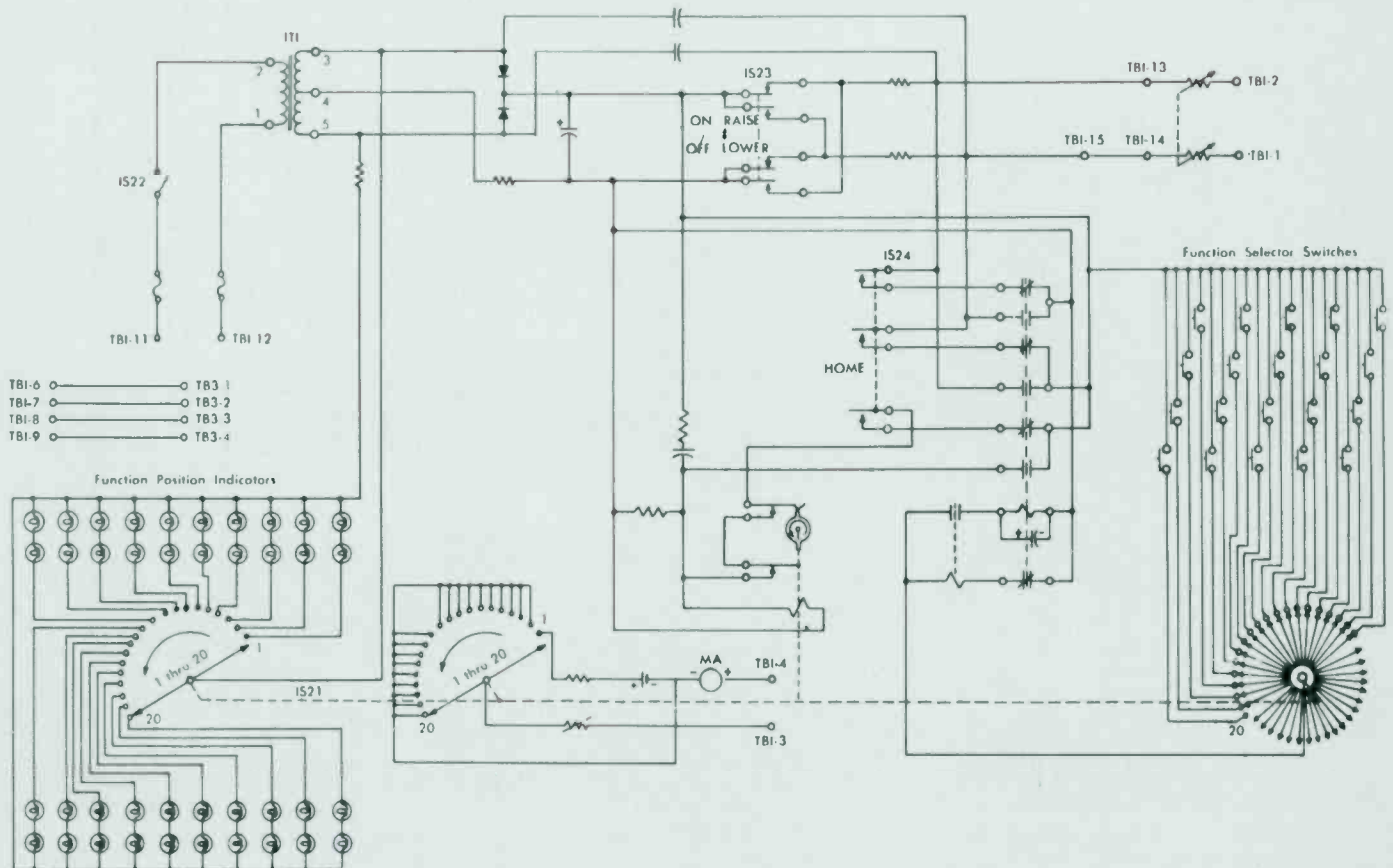

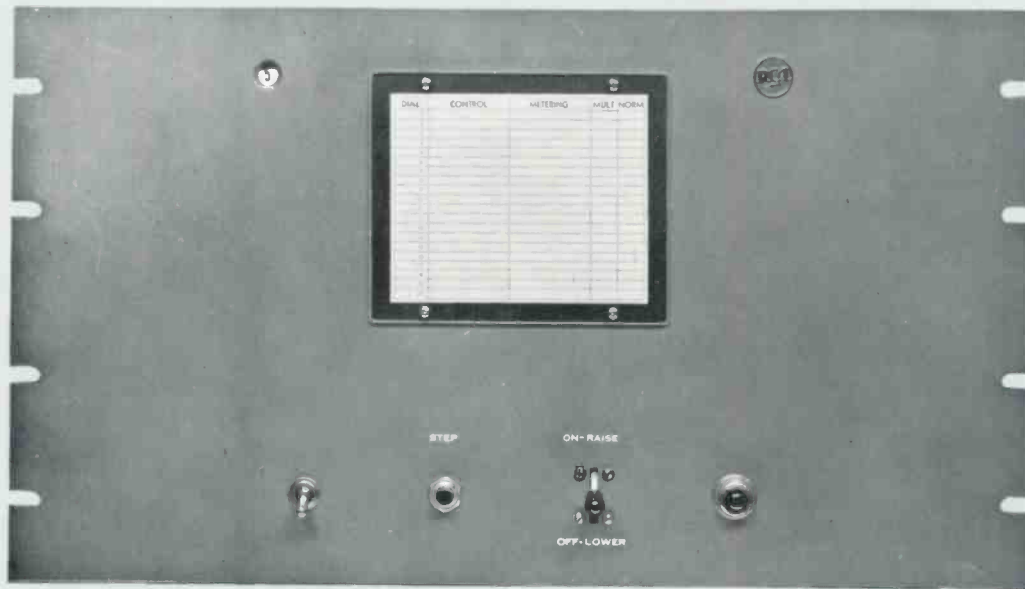

Front view of BTR-20C Transmitter Control Unit.

nections to the transmitter control unit. It provides DC voltage to the studio control meter for indicating tower light current and has a relay control circuit which enables the antenna tower lights to be turned on and off from the studio control unit.

Tower Lighting Unit, MI-27544, is similar to the above in that it will measure antenna lighting current up to 20 amperes. It does not incorporate switching for control purposes and is recommended in instances where a photo-cell or other means are used to control the lighting circuits. Temperature Indicators, MI-27550-1 and MI-27550-2, permit temperature readings from  $-30$  to  $+150$  degrees F over the remote control system. The MI-27550-1 is designed for indoor use and the MI-27550-2 for outdoor use.

#### Latching Relay Panel

Latching Relay Panel, MI-27509-A, is installed in the transmitting equipment where its function is to turn the transmitter on and off, or other similar function. It contains two relays which perform this control function when activated by the studio control unit. One relay turns the filament supply on or off and the other relay turns the plate voltage on or off.

#### Typical Control and Metering Function for AM BTA-1R AM Transmitter (3 towers) and BTF-5E FM Transmitter Controlled by BTR-20C Remote Control

Dial	Control	Metering
1	AM Transmitter On-Off	Filament Line
2	AM Plate On-Off	Plate Volts
3	AM Output Raise-Lower	Common Point Current
4	Overload Reset	Plate Current
5	AM Day-Night	Common Point Current
6		Base Current 1
7		Base Current 2
8		Base Current 3
9		AM Frequency Deviation
10		AM % Modulation
11	Spare	
12	Spare	
13	FM Transmitter On-Off	Filament Line
14	FM Plate On-Off	Plate Volts
15	FM Output Raise-Lower	Reflectometer
16	FM Overload Reset	FM Frequency Deviation
17		
18		
19	Tower Lights On-Off	Lighting Current
20	Home	Calibrate

## Specifications

Control Functions .....	19
Power Requirements.....	117 Volts, AC, 50/60 Hz
Power Consumption and/or metering.....	25 Watts maximum
Calibration .....	Standard cell
Meter.....	0 to 150 percent (200 microamps)
Telephone Line.....	Special DC; 500 Ohms loops resistance max.
Fail Safe.....	Meets FCC requirements
Dimensions (overall):	
BTR-20C Transmitter Control Unit.....	19" wide, 10" high, 12 <sup>7</sup> / <sub>8</sub> " deep (48 cm wide, 25 cm high, 33 cm deep)
BTR-20 Studio Control Unit.....	19" wide, 10" high, 8 <sup>7</sup> / <sub>8</sub> " deep (48 cm wide, 25 cm high, 22 cm deep)
Weight (approx.):	
BTR-20C Transmitter Control Unit.....	20 lbs. (9.07 kg.)
BTR-20C Studio Control Unit.....	20 lbs. (9.07 kg.)

### Accessories

Type BTRX-40A Extension Unit (19 functions).....	MI-27556
2-Meter Panels (AM Monitoring).....	ES-27220
AC Voltage Pickup, 115/230 Volt .....	MI-27516
Tower Lighting Monitoring and Control Unit.....	MI-27519
Tower Light Monitoring Unit.....	MI-27544
Weatherproof Enclosure for MI-27544.....	MI-27543
Latching Relay Panel (including two relays).....	MI-27509-A
Latching Relay, DPST, 6 amperes.....	MI-27524-1
Latching Relay, DPST, 30 amperes.....	MI-27524-2
Latching Relay, 4D <sup>+</sup> T, 0.5 ampere.....	MI-27524-3
RF Relay, 12.5 amperes.....	MI-27545-2
Momentary Relay, DPDT, 15-20 amperes.....	MI-27545-2
RF Contactor, Latching Type, SPDT, 25 amperes.....	MI-27755-1
RF Contactor, DPDT, 25 amperes .....	MI-27755-2
Remote RF Pickup (rated up to 50 kW).....	MI-28027-B
Remote RF Pickup (rated up to 5 kW).....	MI-27966-B
12 Function Meter Commutator.....	MI-27555
Remote Control Accessory Kit for BTA-50G.....	MI-27687
Remote Output Control for BTA-5/10H.....	MI-27517
Remote Filament Control for BTA-5/10H.....	MI-27518
Remote Power Cutback Kit for BTA-5/10H.....	MI-27520
Miscellaneous Resistors and Parts for BTA-5/10H.....	MI-27540
Temperature Indicator, Indoor -30°F to +150°F.....	MI-27550-1
Temperature Indicator, Outdoor -30°F to +150°F.....	MI-27550-2
FM Monitor Preamplifier, McMartin.....	TBM-2500

## Ordering Information

BTR-20C Remote Control System (19 functions).....	ES-34274
Consisting of:	
1 Studio Control Unit.....	MI-27539-B
1 Transmitter Control Unit.....	MI-27526-A



Meter Panel, ES-27220 for AM Monitoring.

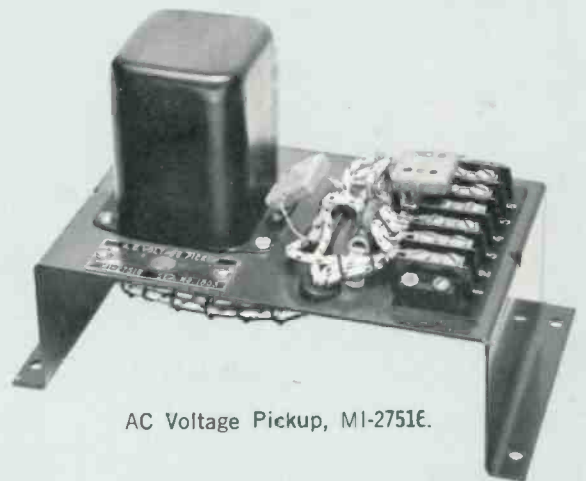

AC Voltage Pickup, MI-2751E.

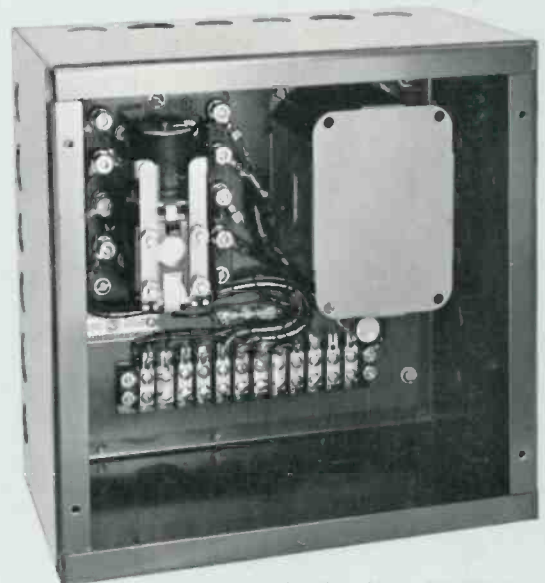

Tower Lighting Unit, MI-27519.

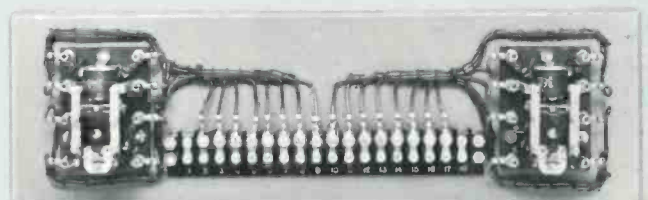

Latching Relay Panel, MI-27509-A.



- Maintains proper transmitter output power
- Requires only 5¼ inches in standard rack
- Extended scale meter relay
- Manual—Automatic switch

## Automatic Output Control

### Description

The Automatic Output Control, MI-27564, is designed to stabilize and control transmitter output power within FCC allowed limits or to shut down transmitter operation in case of serious failure. It is easily installed at the output of the transmitter.

In the case of AM transmitters, automatic power control is achieved by sampling the common point current and automatically maintaining it at the value corresponding to the licensed power within a tolerance plus 5 percent and minus 10 percent. This is accomplished by the use of an RCA MI-27966 or MI-28027-A Remote Pick-up Unit connected at the common-point and operating as an RF to DC current transducer. The output of the transducer is a function of carrier current only and does not respond to the modulation. FM or TV Transmitters are controlled by connecting the output of a reflectometer to the input of the automatic output control. In the case of television transmitters two control units are required to maintain the aural and visual outputs within required limits.

The output of the transducer is then fed to the input of the Automatic Output Control which constantly samples this input from the transducer. If it varies beyond the above tolerance, it acts to correct the transmitter output power by operating a motorized transmitter power output control. In the event that the automatic power output control cannot correct the transmitter to proper output level within a selected period (about 1½ minutes) the power control will lock out and sound an alarm at the studio. Provision has been made in the existing remote control system to take manual control and/or to reset the automatic power con-

trol. The unit may be automatically disabled while the carrier is being interrupted for a Conelrad test alarm or when the transmitter is shifted to Conelrad operation.

The Automatic Output Control is contained on a panel mounting chassis, 19 inches wide, 5¼ inches high and 9½ inches deep overall. The panel contains a manual-automatic switch, power-on indicator light and two lights designed to indicate increasing or decreasing power output. A meter relay with contacts that are fixed at upper and lower tolerances is also mounted on the same panel.

### Specifications

Power Requirement.....	117 Volts, AC, 50/60 Hz, 25 Watts
Fuse .....	½ amp.
Meter.....	Extended scale, 70 $\mu$ a to 130 $\mu$ a with fixed contacts
Dimensions Overall.....	19" wide, 5¼" high, 9½" deep (48.26 cm, 13.34 cm, 24.13 cm)
Weight.....	10 lbs. approx. (4.5 kg.)

### Ordering Information

Automatic Output Control.....MI-27564





Studio Unit, MI-27553

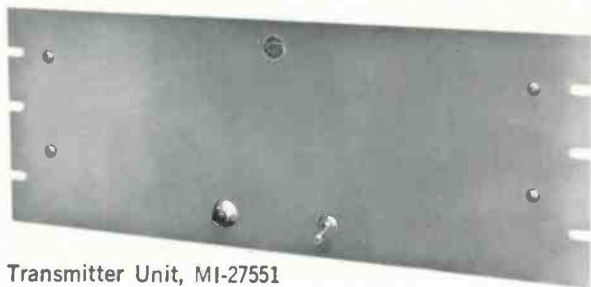

Transmitter Unit, MI-27551

- Basic unit provides up to 4 simultaneous alarm/status functions, and can be expanded to 8 functions
- Reserve battery supply for fail-safe operation
- Occupies 7 inches in standard rack
- Standard transformer components

## Tone Alarm Equipment, Type BTRA-5B

### Description

The RCA Type BTRA-5B Tone Alarm Equipment is an automatic system based on a series of tone generators that can provide up to four simultaneous alarm or status functions when installed at studio and transmitter locations. The system is comprised of the MI-27551 BTRA-5B Transmitter Unit and the MI-27553 BTRA-5B Studio Unit which are connected by an inexpensive low frequency telephone line. When used in conjunction with the BTR-11B or BTR-20B Remote Control Equipment, an additional telephone line is not required.

The alarm system consists of a series of tone generators located at the transmitter. Should trouble develop, the tone generator trips out and a selective detector in the studio then flashes an alarm. The tone alarm system may be used to indicate such varied functions as transmitter overload, out of tolerance operation, burglar alarm, standby generator status, over temperature conditions and many other applications.

Both transmitter and studio units are mounted on panel-mounting chassis 19 inches wide, 7 inches high and 8 $\frac{3}{8}$  inches deep overall. The

transmitter panel includes an indicator light indicating when power is on, and a power switch. It operates from a 115 Volt, 50/60 Hz AC line and power consumption is approximately 6 Watts. A storage battery is provided for fail-safe operation. The battery is constantly being charged while the equipment is in operation for instantaneous operation if power fails. The oscillator units operating at four different frequencies are epoxy encapsulated.

The alarm tones are transmitted from the transmitter over the telephone line to the studio and fed into

a resonant reed relay with reeds tuned to the approximate frequencies. Each of these detectors will flash an alarm if the tone to which it is tuned is removed. The studio unit panel has provisions for four lighted display screens to indicate the fault. There is also a power switch, power-on indicator lamp, and reset button. There is a gain control on both studio and transmitter chassis to regulate the telephone line, and transistor amplifier with input and output transformer and gain control. A fuse and fuse supply is located on the rear of both studio and transmitter units.

### Specifications

Number of Alarm/Status Functions..... Basic unit 4, 8 max.  
 Power Requirements..... 115 Volts, AC, 50/60 Hz, 6 Watts  
 Dimensions (overall—both units)... 19" wide, 7" high, 8 $\frac{3}{8}$ " deep  
 (48.26 cm, 17.78 cm, 21.27 cm)

#### Weight:

Transmitter Unit, MI-27551..... Approx. 10 lbs. (4.5 kg.)  
 Receiver Unit, MI-27553..... Approx. 10 lbs. (4.5 kg.)

### Ordering Information

BTRA-5B Tone Alarm Equipment..... ES-34281  
 Including the following:  
 1 Transmitter Unit ..... MI-27551  
 1 Studio Unit complete with four clear caps, four red and four green bases for display screens, sheet of 8 $\frac{1}{2}$  by 11-inch Mylar Film and lamp changing tool ..... MI-27553

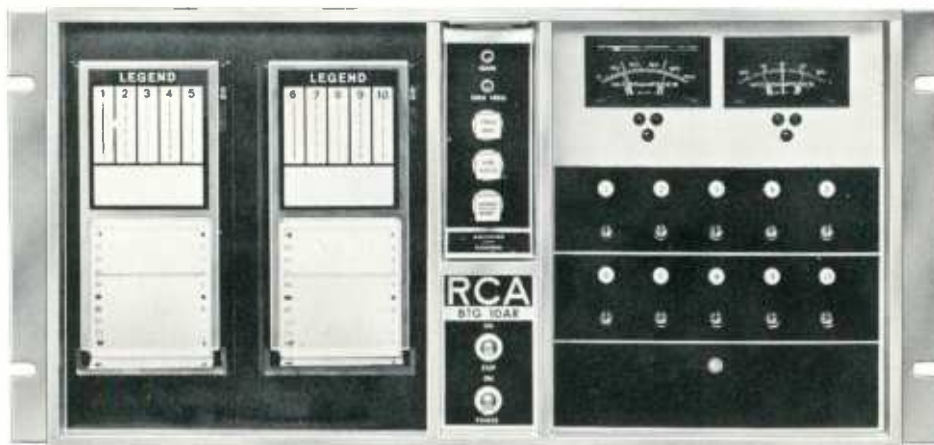

- Reliable logging of 5, 10 or 20 functions
- Suitable for AM, FM and TV
- Compatible with BTR-11B and BTR-20C Remote Control Equipment
- Three built-in alarms
- Solid state electronic switching
- Automatic synchronization in remote systems

## Automatic Logging Equipment, Type BTG-Series

### Description

RCA Automatic Logging Equipment supporting 5, 10 or 20 functions is available for local or remote operation by AM, FM and TV broadcast stations. The system is completely automatic and designed to record all operating parameters required by FCC regulations as well as other crucial or important functions. Each meter reading is scanned at approximately 2-second intervals for a permanent record.

Six Automatic Logging Systems are available. The BTG-5AL (local) or BTG-5AR (remote) systems are designed to measure all required functions for the small AM or FM station. These include such functions as plate voltage, plate current, frequency deviation, power output, and tower light current.

The BTG-10AL/AR 10 function systems will measure the required basic functions for the visual and aural transmitters of the VHF or UHF Television station. It also provides a more flexible logging system for the AM or FM station desiring to record more than basic operating parameters.

The BTG-20AL/AR 20-function logging systems are available for the AM-FM-TV broadcaster desiring flexibility in automatic logging.

A single record alarm unit comprises the BTG-5AL/10AL system. The BTG-5AR/10AR have a single record alarm unit and also an additional remote transmitter unit. The BTG-20AL/AR systems require an extension record unit to mount above a BTG-10AL/AR Record Alarm Unit.

The BTG Record-Alarm units are rack-mounted chassis that contain one or two strip recorders, a centrally located plug-in amplifier-control module and operating control panel; and on the right, two adjustable contact making microammeters and five or ten tally lights indicating the function being logged and associated calibration controls. The unit requires 8¾ inches of rack space. The extension record unit for the BTG-20AL/AR systems is similar and occupies an additional 8¾ inches.

The Remote Transmitter Logging Unit is self-contained on a similar

rack-mounted chassis. A single on-off power switch and a tally light that indicates operating mode occupy the front panel. The studio and transmitter units are connected by a single DC telephone line. The recorder has a high input impedance which makes the accuracy independent of telephone line variations.

In the BTG-systems, easily read recorders automatically log up to five operating parameters each. It is a single point strip chart recorder which operates at a speed of one inch per hour and contains paper for over two weeks of operation. The parameters to be recorded are sequentially selected by a stepping switch. Each function is recorded within a two second period. The chart paper is the inkless pressure sensitive type and, therefore, requires a minimum of attention. Voltage applied to the line for maximum recorder deflection is one volt. The recorder accuracy is within the FCC requirement of two percent. Each recorder is supplied with a legend on which the operator can identify and provide an appropriate scale for each reading.

The BTG Amplifier-Control module is self-contained, solid state, plug-in containing most of the important circuits of the system such as: recorder pulse generator, stepping pulse generator, alarm circuits, removable plug-in operational amplifiers and zener regulated power supplies. Stabilization of the operational amplifier is accomplished by the use of approximately 80 dB of feedback.

The Automatic Logging System may be expanded to include the BTRA-5B Tone Alarm System (ES-34281). The systems may be expanded for complete remote control by the addition of the BTR-11B Remote Control Equipment (10 functions) or the larger BTR-20C Remote Control Equipment (19 functions). Logging of FM and TV stations require the MI-27568-1 or

MI-27568-2 DC Amplifier unit for use with the frequency modulation monitors.

For automatic AM logging, base and common point currents are monitored via RF pickup units installed at the towers and phasor. These RF samples are fed to transducers which have been calibrated against the station's RF ammeter. The DC variation of the transducer

is recorded on the chart recorder. Frequency deviation signal is obtained from a frequency monitor. Tower lights and flasher are also monitored for proper operation. Various types of transducers are available to provide the standard one Volt DC (full scale) for all readings. Other important optional and accessory equipment is listed below under specifications.

Remote Transmitter Logging Unit



## Specifications

Logging Functions .....	5, 10 or 20
Record Method .....	Inkless, separate calibration for each function on strip chart
Measuring Circuit .....	Galvanometer Movement
Accuracy .....	2% max.
Input Impedance .....	100,000 Ohms
Chart Speed .....	1" (2.54 cm) per hour
Chart Size .....	30 ft. long, 2" wide (9.14 M x 5.08 cm)
Chart Life .....	360 hours (15 days)
Frequency Deviation Alarm .....	Contact making Microammeter 10-0-10 $\mu$ A
Power Output Alarm...Contact making Microammeter 0-20 $\mu$ A	
Alarm Limits .....	Adjustable
Operating Controls .....	Power On-Off, Stepping On-Off, and Alarm Reset
Adjustments .....	Two: Frequency Deviation Zero Adjust, Amplifier Gain
Power Requirements:	
Studio or Local .....	115 V, AC, 60 Hz, 50 Watts
Transmitter .....	115 V, AC, 60 Hz, 25 Watts
Finish:	
Studio or Local .....	Black and Silver Gray
Transmitter .....	Silver Gray

### Dimensions Overall:

Studio or Local .....	19" wide, 8 $\frac{3}{4}$ " high, 8 $\frac{1}{2}$ " deep (48.26 cm, 22.22 cm, 21.59 cm)
Transmitter .....	19" wide, 8 $\frac{3}{4}$ " high, 12 $\frac{1}{2}$ " deep (48.26 cm, 22.22 cm, 31.75 cm)
Extension (BTG-20AL/AR Only) .....	19" wide, 8 $\frac{3}{4}$ " high (48.26 cm, 22.22 cm)

### Weight:

Studio or Local .....	15 lbs. (approx.) 6.8 kg.
Transmitter .....	10 lbs. (approx.) 4.5 kg.
Extension Unit for BTG-20AL/AR Only .....	5 lbs. (approx.) 2.3 kg.

### Accessories

30-Foot Roll Strip Chart .....	MI-561430
Spare Amplifier-Control Module .....	MI-561433
BTR-11B Remote Control Equipment .....	ES-34280
BTR-20C Remote Control Equipment .....	ES-34274
BTRA-5B Tone Alarm System .....	ES-34281
BW-11A AM Frequency Monitor .....	ES-34042
BW-66F AM Modulation Monitor .....	MI-30066-B
BW-73A FM Multiplex Monitor .....	ES-560200-A
TBM-3000 McMartin FM Frequency Monitor .....	MI-560315
Power Max (Negative Peak Limiter) .....	MI-34654
Tower Light Monitor .....	MI-27544
Tower Light Monitoring and Control Unit .....	MI-27519
Monitor Amplifier Unit (FM) .....	MI-27568-1
Monitor Amplifier Unit (TV) .....	MI-27568-2
RF Pickup Unit .....	MI-27666-B
RF Pickup Unit .....	MI-28027-B

## Ordering Information

BTG-5AL 5-Function Local Automatic Logging Equipment .....	ES-561485
BTG-10AL 10-Function Local Automatic Logging Equipment .....	ES-561486
BTG-20AL 20-Function Local Automatic Logging Equipment .....	ES-561487

BTG-5AR 5-Function Remote Automatic Logging Equipment .....	ES-561488
BTG-10AR 10-Function Remote Automatic Logging Equipment .....	ES-561489
BTG-20AR 20-Function Remote Automatic Logging Equipment .....	ES-561490



- Continuous indication of broadcast frequency and modulation
- Simplified operation, no adjustments necessary during operation
- External meters may be remotely located
- Compact size, requires minimum rack space

## Frequency Monitor and Modulation Meter

### Description

The Type 335-BR Frequency and Modulation Meter monitors FM transmitters reliably, accurately, over long periods of time. No adjustments are necessary during operation, and because the instrument does not depend on a tuned circuit, it is not necessary to re-set the carrier level or re-align circuits. The instrument is specifically designed to operate without adjustment week after week. It

gives continuous indication of broadcast frequency and of modulation level at all times, and has FCC type approval. Simple to install, compact in size, the 335-BR FM monitor can be cabinet or rack mounted.

A low-temperature coefficient crystal, oscillating inside a temperature-controlled oven, provides the reference standard. To check the accuracy

of the counter circuits, a crystal-controlled oscillator at 200 kHz is provided. This check is operated by a front-panel switch.

The 335-BR includes provision for operation of a console modulation meter, as well as remote peak modulation indicator lamp. The percentage modulation at which the lamp flashes is adjusted on the front panel.

### Specifications

#### Frequency Monitor:

Frequency Range .....Any frequency, 88 MHz to 108 MHz  
Supplied with crystal frequency matching customer's transmitter.

Deviation Range.....+3 kHz to -3 kHz  
mean frequency deviation

Accuracy.....Deviation indicator accuracy  
better than  $\pm 1000$  Hz ( $\pm 0.01\%$ )

Power Required .....Approximately 2 Watts. Operates  
satisfactorily at levels above and below 2 Watts

#### Modulation Meter:

Modulation Range.....Meter reads full scale on modulation  
swing of 100 kHz. Scale calibrated to 100% at 75 kHz;  
133% at 100 kHz.

Accuracy.....Within 5% modulation percentage  
over entire scale

Meter Characteristics.....Meter damped in accordance  
with FCC requirements. Reads peak value of modulation  
peak of duration between 40 and 90 milliseconds. Meter  
returns from full reading to 10% of full value within 500  
to 800 milliseconds.

Frequency Response .....Flat within  $\pm 1/2$  dB  
from 50 to 15,000 Hz

External Meters.....Provision is made for installation of  
remote meter having full scale sensitivity of 400 micro-  
amperes. Scale should indicate 100% modulation at 300  
microamperes. Extra meters can be supplied with unit.

#### Peak Limit Indicator:

Peak Limit Range.....From 50% to 120% modulation  
(75 kHz = 100%). Provision for external peak limit in-  
dicators.

#### Audio Output:

Frequency Range.....20 Hz to 20 kHz. Response flat within  
 $\pm 1/2$  dB. Equipped with standard 75 microsecond de-  
emphasis circuit.

Distortion.....Less than 0.25% at 100% modulation

Output Voltage .....10 Volts into 20,000 Ohms,  
at low frequencies (at 100% modulation)

Noise .....At least 75 dB below audio output level  
resulting from 100% modulation at low frequencies

Monitoring Output .....4.0 mW into 600 Ohms, balanced,  
at 100% modulation (at low frequencies)

Tube Complement: 2-6AC7, 1-7F8, 6-6V6, 1-6SL7-GT,  
1-2050, 1-5R4GY, 2-VR-75, 1-6Y6G, 1-6SJ7

Dimensions (overall).....10 1/2" high, 19" wide, 14 1/2" deep  
(26.67 cm, 48.26 cm, 36.83 cm)

Weight.....45 lbs. (20.4 kg)

Power .....115 Volts,  $\pm 10$  Volts, 60 Hz, 165 Watts

Accessory Remote Modulation Meter.....HP-112-13

### Ordering Information

Hewlett-Packard FM Frequency Deviation and  
Modulation Monitor (specify frequency).....Model 335-BR



- Separate frequency monitor
- Frequency range 88 to 108 MHz
- Stable, accurate, trouble-free performance
- Provisions for external meter

## FM Frequency Monitor

### Description

The McMartin Model TBM-3000 FM Frequency Monitor is designed to meet FCC requirements for measuring the frequency deviation of an FM broadcast transmitter from its assigned frequency in the range of 88 to 108 MHz. The TBM-3000 Monitor provides a separate means of monitoring the frequency of an FM station, thus permitting its use in combination with modulation and deviation monitors of recent design for stereo and SCA use. The RCA BW-73A FM Multiplex Monitor, when used with the TBM-3000 provides a complete FCC approved station monitoring combination.

The TBM-3000 monitors the transmitter frequency by heterodyning the sample of the transmitter output to a standard frequency for measurement.

Provisions are made for substituting a precise crystal controlled 200 kilohertz signal in place of the heterodyned transmitter signal to make possible the exact calibration of the frequency counter circuit and meter for zero indication. Then when the heterodyning oscillator is injected, the frequency indicating meter will show the deviation of the transmit-

ter center frequency from zero or the assigned frequency.

The power supply is doubly regulated for stability of operation, and accuracy of measurements. The main power transformer furnishes the filament voltages and high voltages. It is a constant voltage type self-regulating transformer to protect against

power line voltage changes affecting either the tube heaters or the high voltage. The high voltage rectifier is of the silicon diode type to obtain trouble-free long life. A single section LC type filter is followed by an electronic gas tube voltage regulator which further stabilizes the high voltages, and attenuates hum and noise from this source.

### Specifications

Frequency Range .....	88 to 108 MHz, fixed
Deviation Range.....	+4 kHz to -4 kHz of specified frequency
Accuracy.....	Better than 1000 Hz at any frequency
Stability.....	.75 to 150 Hz within 24 hours
RF Input .....	1 to 5 Volts at 50 Ohms, 1/2 Watt max.
Front Panel Indicators.....	Modulation meter, AC power (neon), Crystal oven (6 V. incandescent)
Outputs.....	Provisions for external remote meter optionally available
Tubes and Diodes:	
	3-6201, 2-6265, 1-5814A, 1-OB2, 1-OA2, 4-1N56
Rectifiers .....	4 silicon 750 ma at 600 Volts
Power Requirements .....	100-130 Volts, AC, 60 Hz, 55 Watts
Dimensions Overall.....	19" wide, 8 3/4" high, 7 1/2" deep (48.26 cm, 22.22 cm, 19.05 cm)
Weight.....	18 lbs. (8.2 kg)

### Ordering Information

FM Frequency Monitor (McMartin Type TBM-3000).....MI-560315



- Fully "plug-in" modular design
- All metering function on one switch
- Direct meter reading of separation and crosstalk
- All silicon solid state

## Stereo Monitor

### Description

The McMartin TBM-4500A all silicon solid state stereo monitor is a self-contained unit for measurement of all modulation characteristics of FM stereo. Three modulation meters feature simultaneous readings of left, right and total modulation. All meter functions are controlled by one switch. The meters conform to FCC requirements and are protected against severe overload. When no stereo is broadcast, all meters will read identically. Pilot injection can be monitored at any time without affecting modulation metering. A pilot light indicator on the front panel indicates when the 19 kHz pilot is on. An adjustable high speed peak indicating light is also located on the front panel. Remote metering can be provided.

### Specifications

**RF Input:**  
 Impedance ..... 50 Ohms unbalanced  
 Sensitivity ..... 0.1 to 1 Watt

**Composite Input:**  
 Impedance ..... 50 K Ohms  
 Sensitivity ..... 0.1 to 1.5 Volts Peak-to-Peak

**Left or Right Modulation Meters:**  
 Accuracy ..... ±0.5 dB  
 Frequency Response ..... 30 to 15,000 Hz ±0.5 dB

**Total Modulation Meter:**  
 Accuracy ..... ±0.5 dB  
 Frequency Response ..... 30 to 75,000 Hz

**Left and Right Audio Output for Monitoring Circuits:**  
 Source Impedance ..... 600 Ohm balanced  
 Level ..... +5 dBm @100% modulation at 400 Hz  
 Distortion ..... Less than 1% (50 to 15,000 Hz)

**Left and Right Audio Output for Distortion Measurement:**  
 Impedance ..... 10 K or greater

Level ..... 8 Volts @ 100% modulation at 400 Hz  
 Frequency Response ..... 30 to 15,000 Hz ±0.5 dB

**Distortion:**  
 Monaural ..... 0.25% (30 to 15,000 Hz)  
 Stereo ..... 0.5% (30 to 15,000 Hz)  
 Noise Level ..... -66 dB below 100% modulation at 400 Hz

**Stereo Phones Output:**  
 Impedance ..... 20 K Ohms  
 Level ..... 2.0 Volts

**Composite Output:**  
 Source Impedance ..... 300 Ohms  
 Level ..... 0.30 Volt Peak-to-Peak  
 Frequency Response ..... 50 to 100,000 Hz ±0.2 dB

**Pilot Injection Circuit:**  
 Accuracy ..... ±0.5%  
 Meter Indication ..... 6 to 12%  
 Indicator ..... Pilot Lamp  
 (operates at 6% injection or higher)  
 Peak Flasher ..... Peak light adjustable to read positive or negative peaks from 50% to 100% modulation

**Separation:**  
 Left into Right ..... 50-15,000 Hz, 35 dB or better  
 Right into Left ..... 50-15,000 Hz, 35 dB or better  
 67 kHz into either channel ..... -60 dB or better

**Measurement of suppressed 38 kHz carrier:**  
 Modulated 100% with frequencies  
 above 5 kHz ..... Better than 46 dB  
 No Modulation ..... Better than 55 dB

**Cross Talk:**  
 Main to stereo Sub ..... 46 dB or better  
 Stereo Sub Channel to Main ..... 46 dB or Better  
 67 kHz into Main or Stereo ..... 66 dB or better

**Power Requirements** ..... 105-125 Volts, AC, 50/60 Hz, 45 Watts  
**Dimensions (Overall)** ..... 19" wide, 8 1/4" high, 14" deep  
 (48.26 cm, 20.96 cm, 35.56 cm)

**Weight** ..... 25 lbs. (11.34 kg.)  
**Finish** ..... Blue and brushed aluminum

### Ordering Information

Solid State Stereo Monitor ..... McMartin Model TBM-4500A



- Complete alignment from front panel
- Relative signal level meter
- Carrier failure relay for alarm circuit
- Stable, non-critical design
- Complete circuit shielding

## RF Amplifier

### Description

The McM Martin TBM-2500 RF Amplifier is designed for use with the McM Martin TBM Series of station monitors when remote operation is necessary. It also serves other monitors which require a higher input power level, and will feed a combination of high and low input level monitors.

The equipment operates over the full 88-108 MHz range. RF Sensitivity is in the order of 300  $\mu$ V for  $\frac{1}{2}$  Watt output or 1000  $\mu$ V input for 2 Watts output. The equipment is designed for standard rack mounting. Complete alignment is made from the front panel. The amplifier circuits are stable and of non-critical design and are completely shielded. The design affords exceptionally long tube life.

### Specifications

Operating range .....	88-108 MHz
RF Sensitivity .....	300 $\mu$ V input for $\frac{1}{2}$ Watt output 1000 $\mu$ V input for 2 Watts output
Input .....	50 Ohms coaxial
Outputs .....	(2) 50 Ohms coaxial
Dimensions .....	19" wide, 5 $\frac{1}{4}$ " high, 7" deep
Finish .....	Natural gray panel
Power .....	120 V AC, 50-60 Hz, 45 Watts

### Ordering Information

McM Martin RF Amplifier .....Type TBM-2500



- Modulation meter indicates total modulation of stereo and SCA program material
- Positive and negative peak flasher indication
- Output for stereo adaptor provided
- Measures subcarrier deviation
- Complete station monitoring by addition of accessory frequency meter

## FM Multiplex Monitor, Type BW-73A

### Description

The Type BW-73A FM Multiplex Monitor is an RCA engineered test instrument capable of supplying the necessary information to assure the multiplex broadcaster of high quality transmission. The instrument is type approved as an FM Broadcast Modulation Monitor by the FCC (Approval Number 3-118). When used with the McMartin Model TBM-3000 Frequency Monitor, it provides a complete station monitor.

#### Monitoring Functions

Specifically, the BW-73A will perform the following functions: indicate total modulation on the main carrier, the subcarrier(s) modulation of the main carrier, per cent program modulation on each subcarrier, beep tone modulation of main carrier, the swing on any external subcarrier, and will measure the RF input level to assure proper operating conditions in the monitor. A front panel flasher lamp with adjustable threshold will indicate modulation

peaks in any of the above services. In addition, outputs are available for aural monitoring of the above through phones or station lines. The Monitor will give continuous indication directly in per cent of main carrier deviation by the subcarrier.

#### Remote Metering Terminals

Terminals are provided for the connection of external meters for remote monitoring of all metered functions. A separate output is provided for interconnection of the station's distortion and noise meter. With this set-up, accurate measurements may quickly be made of signal-to-noise, distortion and frequency response. Similarly, the BW-73A will measure main-to-subcarrier as well as subcarrier-to-subcarrier crosstalk.

#### Rack Mounting Unit

The Type BW-73A FM Multiplex Monitor is designed to mount in a standard relay rack. The equipment is a self-contained unit mounted on

a vertical chassis. All circuits are mounted on the chassis behind a hinged front panel which greatly facilitates maintenance and servicing. Tubes are accessible from the rear. The two meters (modulation and deviation), peak indicator lamp and operating controls are located on the front panel for ease of operation and monitoring.

#### Circuit Features

The RF input signal is injected on a 50 ohm line and the level adjusted according to meter indication. The input level chosen was such that the monitor would be capable of making overall transmitter measurements and yet be relatively insensitive to spurious or unwanted signals. The oscillator is crystal controlled and operates at 10.7 MHz above the station channel. The mixer stage is followed by broadband I.F. and discriminator circuitry. The succeeding amplifier output is switch selected for choice of monitoring



mode. The subcarrier filters are plug-in units allowing fast convenient changes or additions of subcarriers should the need arise.

The subcarrier chain employs two double anode zener diodes in cascade guaranteeing the stability of the limiting level. At this point, the FM wave is applied to the pulse-counter detector where it is demodulated. Residual subcarrier is removed in the low pass filter and the remaining audio signal drives two separate stages. The first of these de-emphasizes the modulation, and it is this output which may be used for aural monitoring and distortion measurements in conjunction with an auxiliary distortion and noise meter.

### Self-Contained Power Supply

The second stage is an amplifier for driving the peak modulation indicator stage and the vacuum tube voltmeter-type modulation meter. The VTVM stage is compensated against zero drift. The ballistics characteristics of the meter meet the requirements of the FCC. The electronically regulated power supply is self-contained.

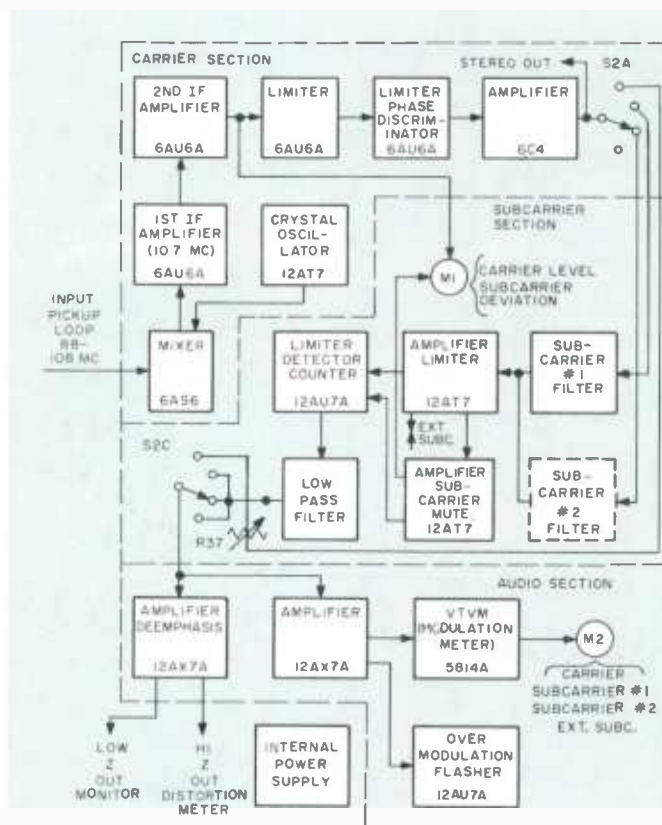

## Specifications

### Electrical

RF Input:	
Frequency Range .....	88-108 MHz
Impedance .....	50 Ohms unbalanced
Sensitivity .....	2 to 14 Volts
Main Carrier:	
Frequency Response (30-15,000 Hz) .....	±0.5 dB max. <sup>1</sup>
Harmonic Distortion (30-15,000 Hz) .....	0.5% max.
Noise Level .....	-65 dB max. <sup>2</sup>
Frequency Deviation for 100% Mod. ....	±75 kHz
Subcarrier: <sup>3</sup>	
Frequency Response (30-6,000 Hz) .....	±0.5 dB max. <sup>1</sup>
Harmonic Distortion .....	1% max.
Noise Level .....	-65 dB max. <sup>4</sup>
Center Frequency Range .....	30 to 67 kHz
Frequency Deviation for 100% Mod. ....	±7.5 kHz
Outputs:	
Audio Monitoring Circuit:	
Source Impedance .....	150 Ohms balanced/ 600 Ohms balanced
Level .....	1 Volt
Audio Distortion Meter Circuit:	
Source Impedance .....	20,000 Ohms
Level (at 100% Mod.) .....	4 Volts
Subcarrier Source Impedance .....	680 Ohms
Subcarrier Level .....	0.2 Volt <sup>5</sup>
Stereo Source Impedance .....	600 Ohms
Power—DC .....	250 Volts regulated, 75 ma
Power—AC .....	6.3 Volts, 3 amps

<sup>1</sup> Audio Frequency response referred to 75 microsecond de-emphasis curve.  
<sup>2</sup> Referred to ±75 kHz deviation, 100% modulation, at 400 Hz.  
<sup>3</sup> For precise measurement of frequency response and distortion above 400 Hz, the shorting plug should be in the socket (XZ1 or XZ2) corresponding to the subcarrier under measurement.  
<sup>4</sup> Referred to ±7.5 kHz deviation, 100% modulation, at 400 Hz.  
<sup>5</sup> Subcarrier modulated 15% on main carrier.

Modulation Indication:	
Accuracy .....	±0.5%
Frequency Response (30 Hz to 65 kHz) .....	±1.0 dB
Range .....	0 to 133%; -10 to +2 dB (0 dB equal to 100%)
Deviation Indication:	
Accuracy .....	±2%
Range .....	0 to 30%
Power Requirements .....	105-125 Volts AC, 50/60 Hz single phase, 140 Watts
Fuse .....	3 amps, 3AG
Tube Complement:	
1—6AS6, 5—6AU6A, 1—6C4, 3—12AT7, 1—OB2, 2—12AU7A, 2—12AX7A, 1—5814A, 1—5R4GY, 1—6AS7G	

### Mechanical

Dimensions .....	19" wide, 14" high, 10" deep (48.26 cm, 35.56 cm, 25.40 cm)
Weight .....	45 lbs. (20.4 kg)
Finish .....	Silver gray

### Accessories

Frequency Monitor.....McMartin Model TBM-3000

## Ordering Information

Type BW-73A FM Multiplex Monitor Complete.....	ES-560200-A
Including the following:	
FM Multiplex Monitor.....	MI-560310-A
Crystal Unit .....	MI-560311*
Subcarrier Filter .....	MI-560312*

(\* Sales order to specify customer's main channel and SCA frequency. Additional subcarrier filter may be ordered separately. Add "S" for stereophonic operation.)

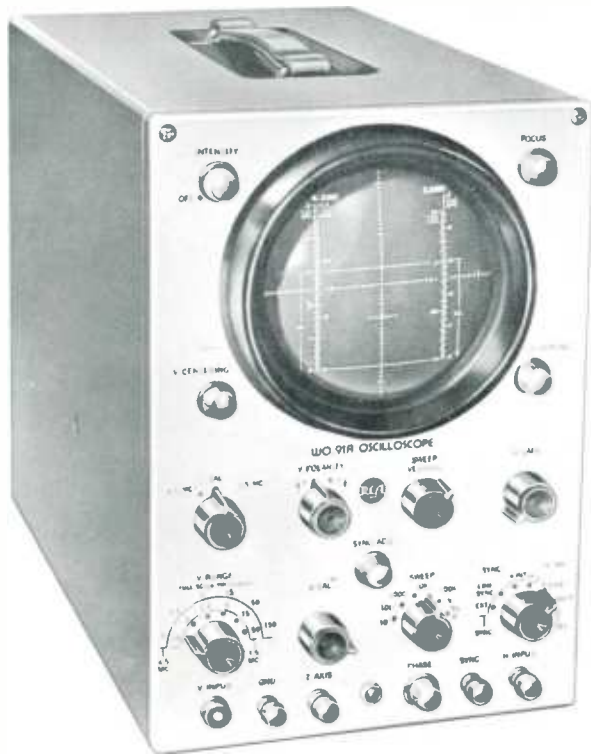

- Preset “V” and “H” sweep positions
- Calibrated, frequency-compensated, 3-to-1 step attenuator for vertical amplifier
- Simplified, semi-automatic voltage calibration for simultaneous voltage measurement and waveshape display
- Vertical-polarity reversal switch
- Z-Axis input facilities permit direct modulation of the cathode-ray-tube grid

## 5-Inch Cathode-Ray Oscilloscope, Type WO-91B

### Description

The RCA WO-91B 5-inch Cathode-Ray Oscilloscope is a precision instrument for use in general servicing of both monochrome and color television equipment. The WO-91B is a portable instrument, useful in such applications as studio maintenance and trouble-shooting, general waveform analysis, adjustments of radio receivers and transmitters, square-wave and general testing of audio equipment, peak-to-peak voltage measurements and observation of vacuum-tube characteristics.

The WO-91B incorporates several circuit and operational features which greatly increase its versatility. A primary feature is a front-panel bandwidth selector switch which changes the bandpass of the vertical-amplifier section from wide-band to narrow-band (high-sensitivity) opera-

tion. A voltage-calibrated, frequency-compensated vertical-input attenuator, an internal calibrating-voltage source, and a graph screen scaled directly in volts make it possible to use the WO-91B as a visual voltmeter. The unique system of calibrating the graph screen provides for scaling voltages directly from the screen. The measurement procedure is similar to that employed with a vacuum-tube voltmeter.

The WO-91B allows pre-setting of the sweep positions to provide automatic lock-in on vertical- and horizontal-frequency signals. The sweep-frequency control also is continuously adjustable from 10 Hz to 100 kHz. The sweep oscillator has excellent stability at high sweep rates, a fast retrace, and adequate

linearity throughout its frequency range. The overall frequency range of the oscillator is divided into four basic ranges; a vernier adjustment, which overlaps the basic sweep ranges, provides exact adjustment of the sweep frequency. The amount of sync signal fed to the sweep oscillator may be adjusted. Sweep synchronization is exceptionally stable throughout the sweep range of the oscillator.

A Z-axis input terminal permits direct modulation of the control grid of the CR tube. This is useful in special applications requiring trace blanking and time calibration of the sweep trace. A control switch is also provided for reversing the vertical polarity of the trace. By means of this control, the trace may

be displayed in an upright or inverted position.

The oscilloscope is equipped with a specially designed single-unit probe and input cable. This WG-300B Direct/Low-Capacitance Probe and Cable is provided with 48-inch long cable completely shielded from

microphone connector to probe tip to minimize hum and stray field pick-up. A built-in switch provides instant selection of direct or low-capacitance operation. The probe has an input characteristic of 10 megohms resistance, less than 12.5 pF capacitance in the low capacitance position. It

comes complete with ground lead and clip. A convenient "slip-on" type high-frequency probe is available for use with the WG-300B Probe to permit visual signal tracing for rapid isolation of trouble in RF, IF and VF stages. It is the WG-302A RF/IF/VF Signal Tracing Probe.

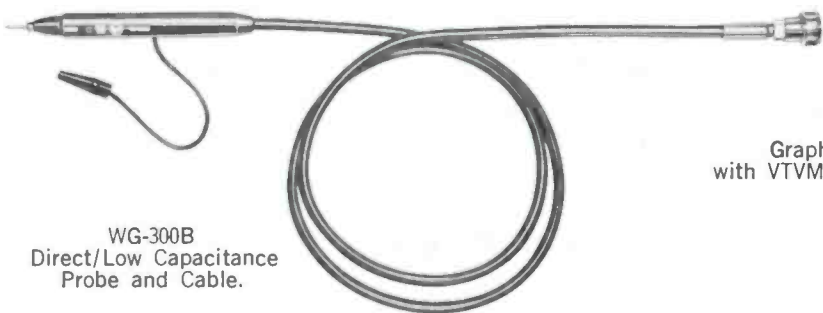

WG-300B  
Direct/Low Capacitance  
Probe and Cable.

Graph Screen  
with VTVM Type Scales.

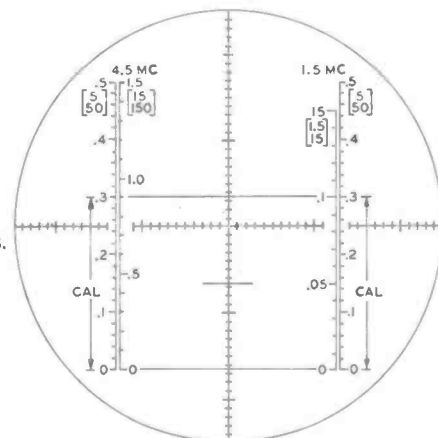

## Specifications

### Performance Specifications

Frequency Response (reference frequency 10 kHz):

Vertical Amplifier:

Wide-Band Positions  
(10 Hz to 4.5 MHz) ..... Flat within  $\pm 1$  dB

Narrow-Band (High-Sensitivity) Positions:

10 Hz to 0.5 MHz ..... Flat within  $\pm 1$  dB

10 Hz to 1.5 MHz ..... Flat within  $-6$  dB

Horizontal Amplifier (10 Hz to 500 kHz)..... Flat within  $-6$  dB

Deflection Sensitivity:

Vertical Amplifier:

Wide-Band  
Positions

High-Sensitivity  
Positions

at V INPUT Connector rms p/p 0.053 0.15 0.018 0.05 Volt/in

With WG-300B set to "DIRECT" ..... 0.053 0.15 0.018 0.05 Volt/in

With WG-300B set to "LOW CAP" ..... 0.53 1.5 0.18 0.5 Volt/in

Horizontal Amplifier at H INPUT terminal ..... 0.18 rms Volt/in

Vertical Deflection Plate Terminals ..... Approx. 40 Volts p-p/in

Average Rise Time (Vertical Amplifier):

4.5 MHz Positions ..... 0.1  $\mu$ sec

1.5 MHz Positions ..... 0.5  $\mu$ sec

Input Resistance and Capacitance:

Vertical Amplifier:

At V INPUT Connector ..... 1 megohm shunted by 40 pF

With WG-300B set to "DIRECT" ..... 1 megohm shunted by 75 pF

With WG-300B set to "LOW CAP" ..... 10 megohms shunted by 11 pF

Horizontal Amplifier:

(at H INPUT terminal)..... 10 megohms shunted by 30 pF

Sync Input Terminal ..... 0.5 megohm shunted by 35 pF

Sweep Oscillator:

Frequency Range (continuously adjustable)..... 10 Hz to 100 kHz

Preset Positions ..... 30 Hz (TV "V"); 7875 Hz (TV "H")

Z-Axis Input:

Minimum Input Voltage for Blanking ..... 12 rms Volts

Frequency Response ..... 3 Hz to 500 kHz

Tube Complement:

1—12AT7, 1—6CB6, 1—5UP1, 1—12AX7A, 1—6BQ7A,

2—12AU7A, 1—1V2, 1—6AX5GT, 2—6J6

Power Supply ..... 105-125 Volts, 50/60 Hz

Power Input ..... 70 Watts

Dimensions ..... 13½" high, 9" wide, 16½" deep  
(34.29 cm, 22.86 cm, 41.91 cm)

Weight ..... 30 lbs. (13.6 kg)

Finish ..... Blue-gray hammeroid case, brushed-aluminum panel

### Accessories

RF-IF-VF Signal-Tracing Probe for WO-91B ..... WG-302A

Voltage Divider Probe ..... WG-354A

## Ordering Information

Type WO-91B 5" Cathode-Ray Oscilloscope, including tubes in place, WG-300B direct/low-capacitance probe, and cable, alligator clip, clip insulator, ground cable, green graph screen, and instruction book ..... MI-40439



RIGID COPPER



FLEXIBLE RG/U

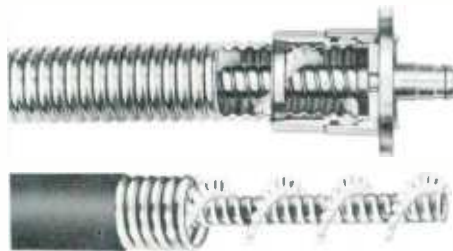

FLEXIBLE HELIAX

- Wide Choice of Styles and Sizes
- High Efficiency and Minimum VSWR
- Precision Mated Rigid Line Flanges
- Ease of Assembly
- Durable Construction

## AM-FM Coaxial Transmission Line

### Description

RCA coaxial transmission line provides an efficient means for transferring RF power to AM and FM antennas. Featuring economy, high efficiency and time saving installation, RCA line is manufactured in various sizes and types to accommodate a wide range of power and frequency requirements. RCA transmission line equipment includes the adapters, hangers and line dehydrators necessary to complete an installation.

#### Rigid 1½ and 3¼-Inch Line

Installation of outdoor rigid 1½-inch or 3¼-inch line is made easy

by the RCA developed flange line now used in all types of RF transmitting systems. This line is supplied in convenient 20-foot lengths with flanges already heliarc welded to the ends. Line sections are easily bolted together, with gasketed mating flanges automatically sealing the line for pressure. No special tools, torches or soldering are necessary. Lengths shorter than the standard 20 feet may be obtained by ordering the desired lengths with flanges welded on at the factory. Or, 20 foot sections may be cut, and flanged-to-unflanged line adapters used, if desired.

RCA rigid lines have a rolled groove at one end of the outer conductor. This allows the inner conductor to move in only one direction. The rolled groove supports the end insulator, and also supports the inner conductor when the line is in a vertical position. The opposite end is free to permit removal of the inner conductor for inspection.

#### Heliac® and RG Cable

Semi-rigid Heliac is specified for many installations, particularly where odd bends or curves are re-

© Andrew Corporation

**QUICK REFERENCE CHART  
RCA TRANSMISSION LINE EQUIPMENT**

Order Reference Number	Size (Inches)	Description	Power (KW @ 1 MHz)	Z (OHMS)	Dielectric	Class of Service And Notes
<b>RIGID COPPER LINE</b>						
MI-19112	1 $\frac{5}{8}$	Flanged, Steatite, 20' Lengths	25	51.5	Air	} AM-FM. Moderate installation cost. Line sections replaceable. Requires gassing.
MI-19113	3 $\frac{1}{8}$	Flanged, Steatite, 20' Lengths	94	51.5	Air	
<b>FLEXIBLE HELIAX LINE</b>						
(See Heliax Section for Types and Description)	1/4-5	Coaxial Copper Conductors, Polyethylene Insulation	(See Power Curves for Each Type)	50, 75	Air	} Low installation cost. Accommodates odd-shaped towers. Difficult to repair or replace. Foam type not recommended for FM.
	1/4-3	Coaxial Copper Conductors, Polyethylene Insulation		50, 75	Polyethylene Foam	
<b>FLEXIBLE RG CABLES</b>						
RG-8U	.405	Bare Copper Inner Conductor, Tinned Outer Braid		52	Polyethylene	} Low cost for AM use only.
RG-11U	.405	Tinned Copper Inner Conductor and Outer Braid		75	Polyethylene	
RG-17U	.870	Bare Copper Inner Conductor, Tinned Outer Braid		52	Polyethylene	
For information on rigid line mounting accessories, refer to section on "Hangers."						

quired. The line is quickly installed and the foam dielectric type requires no gassing. If the foam type is used for FM systems, however, a special gas line must be installed along with the Heliac, since the FM antenna feed line must be gassed. Repair of a damaged Heliac transmission line usually requires replacement of the entire line, since splicing of line sections on the tower is difficult. RG cables are inexpensive and convenient for low power AM installations.

**Complete Accessories**

RCA offers a complete line of adapters and hangers to meet every installation requirement. Special adapters and reducers permit joining lines of different types and sizes. Hangers include insulated

types for base insulated towers, spring suspended expansion hangers, lateral braces and direct mounting anchors. There are types for mounting to round, flat or angular tower members. A complete line of special hanger kits simplifies the indoor part of the installation. Line dehydrators are available in both automatic and manual types with capacities of up to three cubic feet per minute.

**Selecting Type of Line**

Choice of line depends mainly upon frequency and power to be handled. Selection of the proper line will provide the most economical and efficient installation.

The Quick Reference Chart presents the broad characteristics

of RCA transmission line, and identifies each type with the service recommended. Before ordering transmission line or fittings, a dimensional layout should be made of the transmission line run from the transmitter, up the tower to the antenna. This and other planning and installation procedures are described briefly in later pages of this catalog.

**Other RCA Transmission Line**

This catalog presents the characteristics and specifications of RCA Steatite insulated AM and FM transmission lines. RCA Teflon insulated lines, widely used in VHF and UHF television systems are described in the RCA TV transmission line catalog.

# 1 5/8-Inch 51.5 Ohm Rigid Copper Line

## Description

RCA 1 5/8-inch transmission line, MI-19112, is a hard tempered copper line with a nominal impedance of 51.5 ohms. Because of its low impedance and high efficiency, this type line is widely used in AM and FM installations.





The line is supplied in 20 foot lengths with flanges welded to the ends. The inner conductor is 5/8-inch diameter and uses low loss Steatite wafer insulators spaced 12 inches apart. The outer conductor is designed to allow for removal of the inner conductor for inspection. Line may be ordered in lengths less than 20 feet. When ordering special lengths, specify length and the MI-number designating the flange configuration desired.

## SPECIFICATIONS

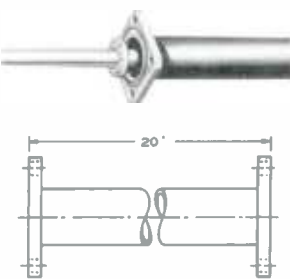
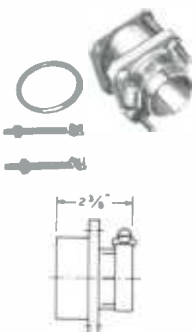
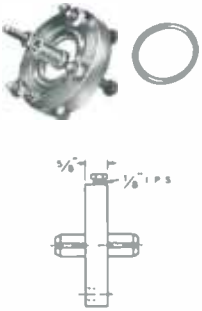
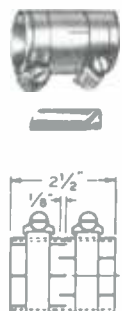
Stock Identification .....	MI-19112
Size .....	1 5/8 inches
Insulator Type and Spacing .....	Steatite Wafer, 12 inches
Impedance .....	51.5 ohms
AM Power Rating, Based on 100% modulation and Unity VSWR* (at 1.0 MHz) .....	25 kW
FM Power Rating (at 100 MHz) .....	10 kW
Voltage RMS 60 Hz .....	11 kV
Attenuation, dB/100 ft. @ 1 MHz .....	.0204 dB
Attenuation, dB/100 ft. @ 100 MHz .....	.234 dB
Velocity .....	96.3%
O. D. — Outer Conductor .....	1.527 inches
I. D. — Outer Conductor .....	1.429 inches
O. D. — Inner Conductor .....	.625 inches
I. D. — Inner Conductor .....	.569 inches

\* Power ratings for other values of VSWR are obtained by dividing the rated power by the VSWR.

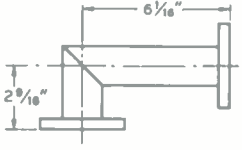
<p style="text-align: center;"><b>TRANSMISSION LINE</b></p>  <p>Supplied in standard 20 foot lengths or special lengths less than 20 feet. Includes solderless inner connector, O-ring and hardware, flanges attached MI-19112-1</p> <p>Same as MI-19112-1 but with only one flange .... MI-19112-1-F Same as MI-19112-1 but with no flanges ..... MI-19112-1-NF</p> <p style="text-align: center;">MI-19112-1, MI-19112-1-F, MI-19112-1-NF</p>	<p style="text-align: center;"><b>ADAPTER (GASSED)</b></p>  <p>Couples flanged to unflanged line. Complete with inner connector, O-ring and hardware.</p> <p style="text-align: center;">MI-19112-4</p>
<p style="text-align: center;"><b>GAS STOP</b></p>  <p>Seals gassed section from un-gassed section of line. Inserted between two flanged sections of line.</p> <p style="text-align: center;">MI-19112-5</p>	<p style="text-align: center;"><b>STRAIGHT COUPLING (UNGASSED)</b></p>  <p>Couples 1 5/8 unflanged line (not for gassed line). Outer and inner connectors and clamps.</p> <p style="text-align: center;">MI-19112-8</p>

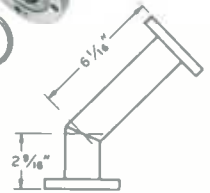
<p align="center"><b>SPECIAL INNER CONDUCTOR</b></p> <p>For splicing lengths of line cut at points between support insulators. As supplied is 0.645 O. D. x 0.569 I. D. x 12 feet long. Fits inner connector MI-19112-11.</p> <p align="center">MI-19112-9</p>	<p align="center"><b>O-RING GASKET</b></p> <p>Synthetic gasket for use between pressure tight flanges.</p> <p align="center">MI-19112-10</p>
<p align="center"><b>INNER CONNECTOR</b></p> <p>Solderless inner connector for joining inner conductors of 1<math>\frac{1}{8}</math>-inch 51.5 ohm line.</p> <p align="center">MI-19112-11</p>	<p align="center"><b>ADAPTER (UNGASSED)</b></p>  <p>Couples flanged to unflanged line. Complete with inner connector, hardware and clamp.</p>
<p align="center"><b>90° ELBOW</b></p>  <p>Full 360° swivel flanges, Teflon insulated. Supplied with two connectors, O-ring, hardware.</p> <p align="center">MI-19112-18</p>  <p>Same as MI-19112-18 but flange on long leg omitted.</p> <p align="center">MI-19112-18-IF</p> <p>Same as MI-19112-18 but both flanges omitted MI-19112-18-NF</p> <p align="center">MI-19112-18, MI-19112-18-IF, MI-19112-18-NF</p>	 <p align="center">MI-19112-16</p>
<p align="center"><b>SWIVEL FLANGE</b></p> <p>Similar to MI-19112-20 but flange rotates 360°.</p> <p align="center">MI-19112-21</p>	<p align="center"><b>FIXED FLANGE</b></p> <p>Same as used with transmission line. Adapts end of field cut line. Installed by silver soldering.</p> <p align="center">MI-19112-20</p>
<p align="center"><b>REDUCER (UNGASSED)</b></p> <p>Special built in connector at one end and type "N" 51.5 ohm jack at other. Supplied with integral outer connector and special clamp.</p> <p align="center">MI-19112-58</p>	<p align="center"><b>45° ELBOW</b></p>  <p>Same as MI-19112-18, -18-IF, -18-NF, but 45°.</p>  <p align="center">MI-19112-22, MI-19112-22-IF, MI-19112-22-NF</p>
<p align="center"><b>REDUCER (GASSED)</b></p> <p>Similar to MI-19112-58 but with flange and O-ring for use on gassed line.</p> <p align="center">MI-19112-59</p>	<p align="center"><b>ADAPTER (UNGASSED)</b></p> <p>Serves purpose similar to MI-19112-4 except installed by soft soldering. Made in one piece. Bolts not included.</p> <p align="center">MI-19112-60</p>
<p align="center"><b>ADAPTER</b></p> <p>Six inches long, adapts 50-ohm EIA flange to 51.5 ohm unflanged (no connectors). For FM use.</p> <p align="center">MI-19112-61</p>	<p align="center"><b>ADAPTER</b></p> <p>Six inches long, adapts 50-ohm EIA flange male to 51.5-ohm flange male (no connectors).</p> <p align="center">MI-19112-62</p>

# 3/8-Inch 51.5 Ohm Rigid Copper Line

## DESCRIPTION



RCA 3/8-inch transmission line, MI-19113, is a hard tempered copper line designed for efficient transfer of RF power in AM and FM installations.

The line is supplied in 20 foot lengths with flanges heliarc welded to the ends. Components are ruggedly and precisely constructed. Mitre elbows are fabricated with thick wall tubing and Teflon dielectric inner conductor supports. The inner conductor is 1.2-inch diameter and is supported by Steatite insulators. The outer conductor is designed to permit removal of the inner conductor for inspection. Line may be ordered in lengths less than 20 feet. When ordering special lengths, specify length and the MI- number that designates the flange configuration desired.





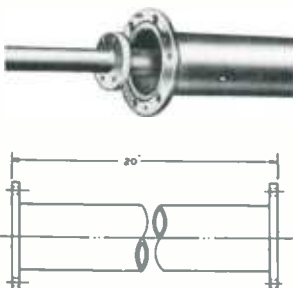

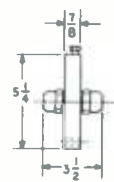
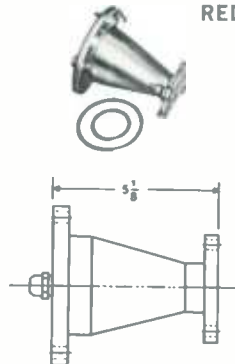
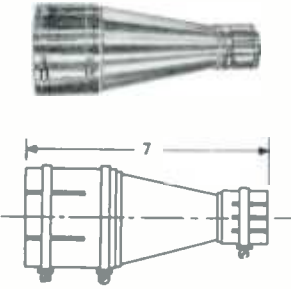

## SPECIFICATIONS

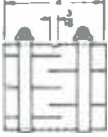
Stock Identification .....	MI-19113
Size .....	3/8 inches
Insulator Type and Spacing .....	Steatite Wafer, 12 inches
Impedance .....	51.5 ohms
AM Power Rating, based on 100% modulation and unity VSWR* (at 1.0 MHz) .....	94 kW
FM Power Rating (at 100 MHz) .....	42 kW
Voltage RMS 60 Hz .....	18 kV
Attenuation, dB/100 ft. @ 1 MHz .....	.0104 dB
Attenuation, dB/100 ft. @ 100 MHz .....	145 dB
Velocity .....	93%
Outer Conductor O. D. ....	3.125 inches
Outer Conductor I. D. ....	3.027 inches
Inner Conductor O. D. ....	1.200 inches
Inner Conductor I. D. ....	1.136 inches

\* Power ratings for other values of VSWR are obtained by dividing the rated power by the VSWR.

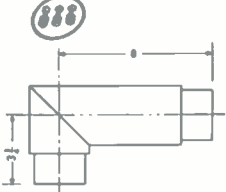
<p style="text-align: center;"><b>TRANSMISSION LINE</b></p>  <p>Supplied in standard 20 foot lengths or special lengths less than 20 feet. Includes solderless inner connector, O-ring and hardware, flanges attached MI-19113-C-1</p> <p>Same as MI-19113 but with only one flange .....MI-19113-C-1-F</p> <p>Same as MI-19113-1 but with no flanges .....MI-19113-C-1-NF</p> <p>Same as MI-19113-C-1 but one of the two flanges is a swivel flange. (For replacement only — not to be ordered for new installations) ..MI-19113-C-1-SF</p> <p style="text-align: center;"><b>MI-19113-C-1, MI-19113-C-1-F, MI-19113-C-1-NF, MI-19113-C-1-SF</b></p>	<p style="text-align: center;"><b>GAS STOP</b></p>  <p>Inserted between two flanged sections of line to seal gassed section from ungassed section.</p>  <p style="text-align: center;"><b>MI-19113-C-5</b></p>
<p style="text-align: center;"><b>REDUCER (GASSED)</b></p>  <p>Flanged coupling for reducing from 3/8-inch 51.5 ohm line. Supplied with inner conductor and connectors, O-ring gaskets and hardware.</p> <p style="text-align: center;"><b>MI-19113-C-6</b></p>	<p style="text-align: center;"><b>REDUCER (UNGASSED)</b></p>  <p>Couples 3/8-inch 51.5 ohm to 1 5/8-inch 51.5 ohm unflanged lines. Includes outer and inner conductors and connectors, clamps.</p> <p style="text-align: center;"><b>MI-19113-C-7</b></p>

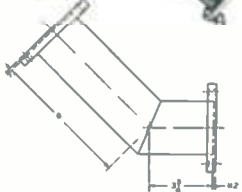

<p><b>STRAIGHT COUPLING (UNGASSED)</b></p>  <p>Couples unflanged lines (not for gassed line). Consists of sleeve, inner connectors and two 3/8-inch adjustable clamps. ....MI-19113-C-8</p> <p>Same as MI-19113-C-8, less inner connector MI-19113-C-8NB</p>  <p><b>MI-19113-C-8, MI-19113-C-8NB</b></p>	<p><b>SPECIAL INNER CONDUCTOR</b></p> <p>For splicing lengths of line cut at points between support insulators. As supplied is 1.282 O. D. x 1.136 I. D. x 12 feet long. Fits inner connector, MI-19113-C-11.</p> <p><b>MI-19113-C-9</b></p>
<p><b>INNER CONNECTOR</b></p>  <p>Solderless inner connector for joining inner conductors of 3/8-inch 51.5 ohm line.</p> <p><b>MI-19113-C-11</b></p>	<p><b>O-RING GASKET</b></p> <p>Synthetic gasket for use between pressure tight flanges.</p> <p><b>MI-19113-C-10</b></p>
<p><b>END SEAL</b></p> <p>Steatite insulated, 1/8" I. P. S. port for gas admission or bleeding the line. Overall length 4 1/2 inches. Furnished with solderless inner conductor, O-ring gasket and hardware.</p> <p><b>MI-19113-C-17</b></p>	<p><b>COVER PLATE</b></p>  <p>Used to cap end of 3/8-inch line to keep moisture out during installation or for other temporary capping of line.</p> <p><b>MI-19113-C-13</b></p>
<p><b>HARDWARE KIT</b></p> <p>Kit consisting of six bolts, nuts and lockwashers for 3/8-inch line.</p> <p><b>MI-19113-C-19</b></p>	<p><b>90° ELBOW</b></p>  <p>Full 360° swivel flanges. Teflon insulated. Supplied with two connectors, O-ring gasket, hardware. ....MI-19113-C-18</p>  <p>Same as MI-19113-C-18, but flange is omitted from short leg. ....MI-19113-C-18-F</p> <p>Same as MI-19113-C-18, but both flanges are omitted. MI-19113-C-18-NF</p> <p><b>MI-19113-C-18, MI-19113-C-18-F, MI-19113-C-18-NF</b></p>
<p><b>FIXED FLANGE</b></p> <p>Same as supplied on transmission line. Adapts ends of field cut line. Installed by silver soldering.</p> <p><b>MI-19113-C-20</b></p>	<p><b>SWIVEL FLANGE</b></p> <p>Similar to MI-19113-C-20 but flange is free to rotate.</p> <p><b>MI-19113-C-21</b></p>
<p><b>45° ELBOW</b></p>  <p>Same as MI-19113-C-18 except 45° .....MI-19113-C-22</p> <p>Same as MI-19113-C-22 except flange is omitted from short leg .....MI-19113-C-22-F</p> <p>Same as MI-19113-C-22 except both flanges are omitted. MI-19113-C-22-NF</p>  <p><b>MI-19113-C-22, MI-19113-C-22-F, MI-19113-C-22-NF</b></p>	<p><b>CUT-OFF GAUGE</b></p> <p>Special tool for cutting and dressing end of 1.282 O. D. inner conductor to insure precision cut .....MI-19113-C-51</p> <p>Similar to MI-19113-C-51, but for use on 1.200 O. D. inner conductor .....MI-19113-C-54</p> <p><b>MI-19113-C-51, MI-19113-C-54</b></p>
<p><b>ADAPTER, SOFT SOLDER</b></p>   <p>Adapts unflanged to flanged line. Made in one piece. Bolts not included.</p> <p><b>MI-19113-C-55</b></p>	

## 3 1/8-Inch Rigid Line (Continued)

<p style="text-align: center;"><b>ADAPTER, FLANGED</b></p> <p>Adapts unflanged to flanged line. Not pressure tight. For ungasged line. Adapter two inches long.</p> <p style="text-align: center;"><b>MI-19113-C-60</b></p>	<p style="text-align: center;"><b>REDUCER (UNGASSED)</b></p> <p>Cone reducer with special built in connector at one end and type "N" 51.5-ohm jack at other. Supplied with integral outer connector and special clamp.</p> <p style="text-align: center;"><b>MI-19113-C-58</b></p>
	<p style="text-align: center;"><b>REDUCER</b></p> <p>Flanged coupling for reducing 3 1/8-inch ungasged line to 1 5/8-inch flanged line. Complete with inner conductor, connectors, O-ring gaskets, hardware.</p> <p style="text-align: center;"><b>MI-19113-C-61</b></p>

## Special Adapters

<p style="text-align: center;"><b>INNER CONNECTOR ADAPTERS</b></p> <p>Adapter used between 3/8-inch EIA 50-ohm female flange and MI-19113 (Steatite) female flange. <span style="float: right;">MI-27988-4A</span> For adapting EIA 3/8-inch to MI-19313 (Teflon) ...MI-27988-4B</p> <p style="text-align: center;"><b>MI-27988-4A, MI-27988-4B</b></p>	<p style="text-align: center;"><b>ADAPTER FLANGE (UNGASSED)</b></p> <p>Adapts unflanged 3/8-inch 50-ohm (MI-27791-K) to 3/8-inch EIA flanged components.</p> <p style="text-align: center;"><b>MI-27988-4C</b></p>
<p style="text-align: center;"><b>QUICK STEP REDUCER (3/8 to 7/8)</b></p> <p>Used between flanged 3/8-inch 51.5 ohm and 7/8-inch EIA flanged components.</p> <p style="text-align: center;"><b>MI-27988-5A</b></p>	<p style="text-align: center;"><b>QUICK STEP REDUCER (3/8 to 1 1/8)</b></p> <p>Used between flanged 3/8-inch 51.5 ohm and 1 1/8-inch 50-ohm EIA flanged components.</p> <p style="text-align: center;"><b>MI-27988-5B</b></p>
<p style="text-align: center;"><b>QUICK STEP REDUCER (EIA 3/8 to 1 1/8)</b></p> <p>Used between flanged EIA 3/8-inch and flanged EIA 1 1/8-inch components.</p> <p style="text-align: center;"><b>MI-27988-5C</b></p>	<p style="text-align: center;"><b>QUICK STEP REDUCER (EIA 3/8 to 7/8)</b></p> <p>Used between flanged 3/8-inch 50-ohm EIA and 7/8-inch 50-ohm flanged components.</p> <p style="text-align: center;"><b>MI-27988-5D</b></p>
<p style="text-align: center;"><b>QUICK STEP REDUCER (EIA 1 1/8 to 7/8)</b></p> <p>Used between flanged 1 1/8-inch 50-ohm EIA and flanged 7/8-inch 50-ohm EIA components.</p> <p style="text-align: center;"><b>MI-27988-5E</b></p>	<p style="text-align: center;"><b>ADAPTER SECTION (3/8 to 3/8)</b></p> <p>Six inches long. Used to connect 3/8-inch 51.5 ohm flanged to 3/8-inch 50 ohm flanged EIA components.</p> <p style="text-align: center;"><b>MI-27988-7A</b></p>
<p style="text-align: center;"><b>ADAPTER SECTION (3/8 to MI-27791-K)</b></p> <p>Six inches long. Used to connect 3/8 inch 51.5 ohm flanged to MI-27791-K universal male components.</p> <p style="text-align: center;"><b>MI-27988-7B</b></p>	<p style="text-align: center;"><b>MALE TO MALE ADAPTERS (EIA)</b></p> <p>Six inches long. Used between flanged components, having integral inner conductor connectors.</p> <p>To connect 7/8-inch components <span style="float: right;">MI-27988-7C</span> To connect 1 1/8-inch components <span style="float: right;">MI-27988-7D</span> To connect 3/8-inch components <span style="float: right;">MI-27988-7E</span></p> <p style="text-align: center;"><b>MI-27988-7C, MI-27988-7D, MI-27988-7E</b></p>

# ATTENUATION AND POWER CURVES FOR 50-OHM AIR DIELECTRIC HELIAX AT UNITY VSWR

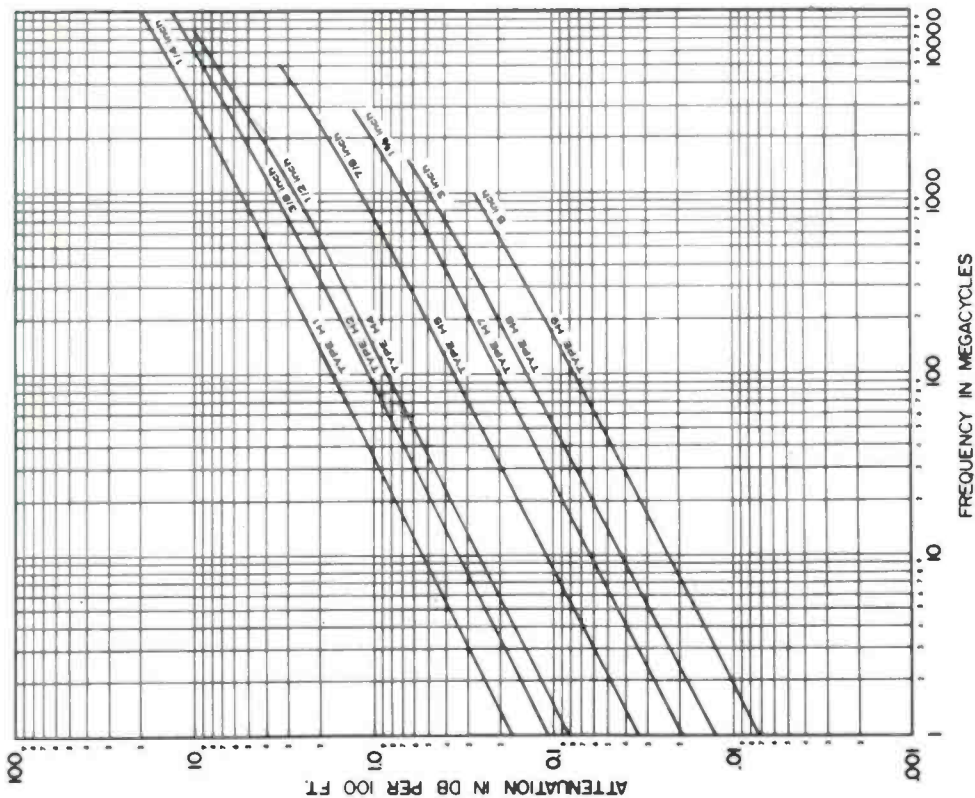
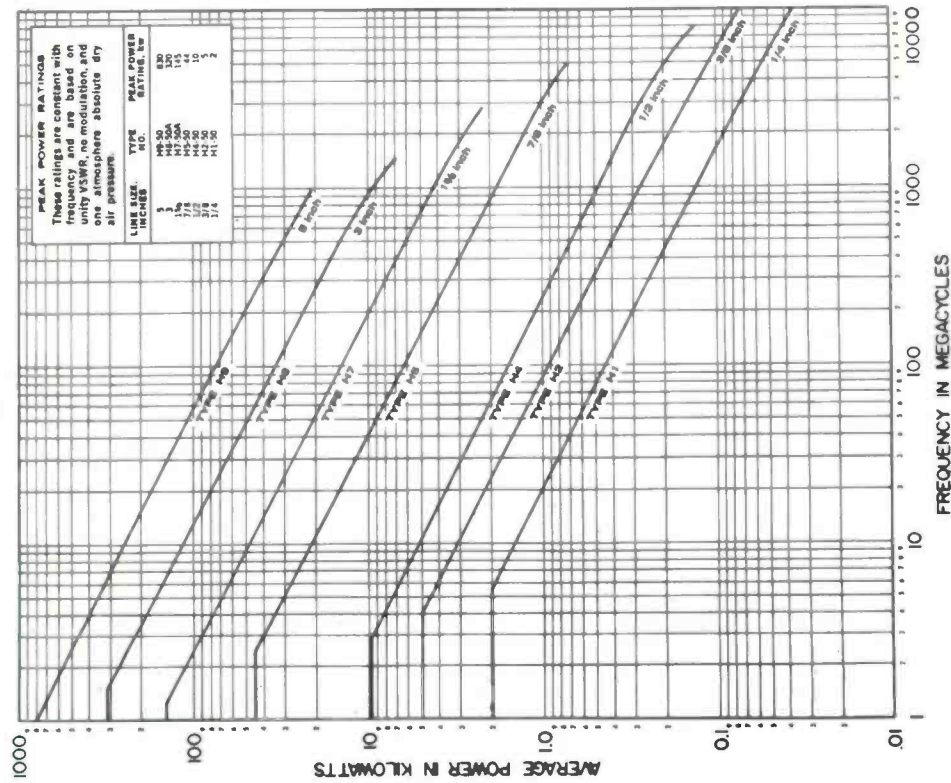

POWER CURVE

ATTENUATION CURVE

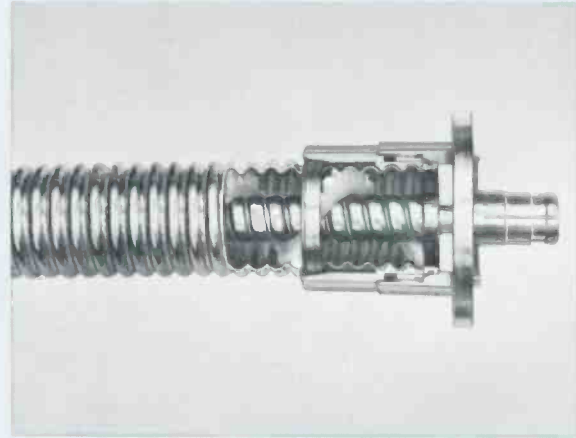
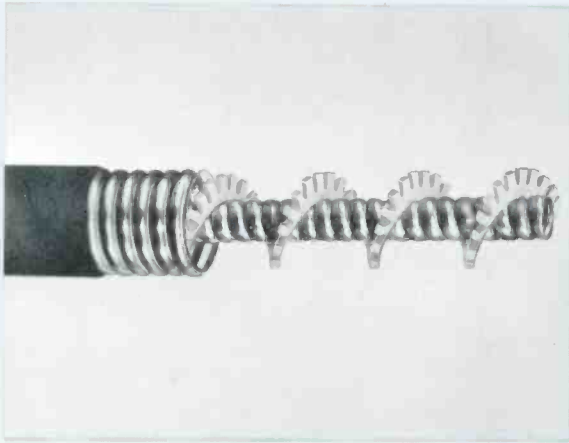

## Flexible Heliax Air Dielectric Line

### DESCRIPTION

Heliax is a flexible coaxial cable designed for both AM and FM installations. For maximum flexibility, it employs high conductivity corrugated copper outer conductors and is available with either 50- or 75-ohm

impedances. Supplied with or without a polyethylene jacket, Heliax is lighter weight and possibly less susceptible to damage than rigid copper line of comparable size. There are two types, air dielectric or polyethylene foam dielectric types. Sizes

range from instrumentation type 1/4-inch diameter cable to five-inch cable for high power. Complete data on types are given in the table. Included are complete accessories such as hangers, connectors, gas fittings and dehydrating equipment.

### SPECIFICATIONS AND ORDERING INFORMATION

#### Description

Heliax Cable, without jacket.....	H1-50	H2-50	H4-50	H5-50	H5-75	H7-50A	H7-75A	H8-50A	H8-75A	H9-50
Heliax Cable with Polyethylene Jacket.....	HJ1-50	HJ2-50	HJ4-50	HJ5-50	HJ5-75	HJ7-50A	HJ7-75A	HJ8-50A	HJ8-75A	HJ9-50
Nominal size, inch.....	1/4	3/8	1/2	7/8	7/8	1 1/8	1 1/8	3 1/8	3 1/8	5
Characteristic impedance, ohms.....	50	50	50	50	75	50	75	50	75	50
Velocity, percent.....	85	85.0	91.4	91.6	90.0	92.1	92.4	93.3	93.6	93.0
Peak power rating, kW.....	2	10.0	9.8	44.0	29.0	145	98.0	320.0	210.0	830.0
Attenuation (see curve).....	—	—	—	—	—	—	—	—	—	—
Insulation .....	Poly-ethylene spiral	Poly-ethylene spiral	Poly-ethylene spiral	Poly-ethylene spiral	Poly-ethylene spiral	Poly-ethylene spiral	Poly-ethylene spiral	Poly-ethylene spiral	Poly-ethylene spiral	Poly-ethylene spiral
Copper Outer Conductor,										
Major diameter .....	.250	0.375	.500	1.005	1.005	1.830	1.830	3.75	3.75	5.00
Outside diameter over jacket.....	.290	.435	.580	1.115	1.115	2.0	2.0	3.02	3.02	5.20
Minimum Bending Radius, inches.....	2.5	3.75	5.0	10.0	10.0	20.0	20.0	30.0	30.0	50.00
Weight, pounds per foot, unjacketed.....	.06	0.12	.21	0.43	0.410	0.72	0.718	1.21	1.20	3.08
Weight, pounds per foot, jacketed.....	.07	0.14	.27	0.53	0.51	1.04	1.04	1.78	1.78	4.59

## Accessories For Flexible Heliax Air Dielectric Line

### H1 — H2 — H4 HELIAX ACCESSORIES

Description	Ordering Information		
	H1 Line (1/4-inch)	H2 Line (3/8-inch)	H3 Line (1/2-inch)
Type N Jack (female) .....	71N	72N	74N
Type N Plug (male) .....	71W	72W	74W
Splice .....	71N/71W*	72N/72W*	74Z
End Terminal .....	13212-2**	13212-2**	74T
Grounding Kit, unjacketed .....	26892-1	26892-1	26891-1
Grounding Kit, jacketed .....	26892-2	26892-2	26892-2
Insulated Rigid Hanger .....	11662-3	11662-3	11662-3
Stainless Steel Wraplock .....	12395-1	12395-1	12395-1

\* Splice made with mating jack and plug.

\*\* Used with type N Plug for selected line size.

### H5 — H7 — H8 HELIAX ACCESSORIES

Description	Ordering Information		
	H5 Line (7/8-inch)	H7 Line (1 1/8-inch)	H8 Line (3-inch)
EIA Flange Connector, 50 ohm .....	75R	77R	22R
EIA Flange Connector, 75 ohm .....	75R-75	77R-75	22R-75
EIA Flange Connector, 100 ohm .....	—	77R-100	—
Type N Jack, 50 ohm .....	75N	77N	—
Type N Jack, 100 ohm .....	75N-100	—	—
UHF Jack, 50 ohm .....	75U	77U	—
UHF Jack, 75 ohm .....	75U-75	—	—
End Terminal, 50 ohm .....	75T	2061	2062
End Terminal, 75 ohm .....	75T-75	2071	2072
End Terminal, 100 ohm .....	75T-100	80799	—
Miter Elbow, 50 ohm .....	1060	1061	1062
Miter Elbow, 75 ohm .....	1070	1071	1072
Gas Barrier, 50 ohm .....	1260A	1261B	1262A
Gas Barrier, 75 ohm .....	—	1271	1272
Reducer Connector, 50 ohm .....	1860	77S	1862
Reducer Connector, 75 ohm .....	—	—	1861
Inner Connector, 50 ohm .....	18275	15069	23817
Inner Connector, 75 ohm .....	25385	24259	24530
Inner Connector Adapter, 50 to 51.5 ohm .....	4850	4851	—
Inner Connector Adapter, 50 to 75 ohm .....	25388	—	—
Hoisting Kit .....	19256A	24312	23146
Grounding Kit .....	24810	24811	23145
Hanger .....	—	—	22417
Insulated Hanger .....	11662-2	24622	22418
Wraplock .....	12395-1	12395-1	—
Automatic Dehydrator .....	1910A	1910A	1910A
Drv Air Pump .....	878A	878A	878A
Nitrogen Tank Fittings .....	858	858	858

# Flexible Heliac Foam Dielectric Line



## DESCRIPTION

Heliac foam dielectric cables are similar in construction and application to the air dielectric types, except that they employ a foamed polyethylene dielectric which completely fills the space between the inner and outer conductors. These cables are well suited to AM installations

where line pressurization is not required. Sizes range from 1/4-inch to three inches diameter. All types are available either plain or with polyethylene jacket. 50 or 75 ohm types are available for two line sizes. The table lists the types, sizes and characteristics.

## SPECIFICATIONS AND ORDERING INFORMATION

### Description

Description	FH1-50	FH2-50	FH4-50A	FH4-75	FH5-50	FH5-75	FH7-50	FH8-50
Foam Heliac, without jacket .....	FH1-50	FH2-50	FH4-50A	FH4-75	FH5-50	FH5-75	FH7-50	FH8-50
Foam Heliac, with jacket .....	FHJ1-50	FHJ2-50	FHJ4-50A	FHJ4-75	FHJ5-50	FHJ5-75	FHJ7-50	FHJ8-50
Nominal size, inches .....	1/4	3/8	1/2	1/2	7/8	7/8	1 1/2	3
Characteristic Impedance, ohms .....	50	50	50	75	50	75	50	50
Velocity, percent .....	79	79	79	79	79	79	79	92
Peak power rating, kW .....	5.0	8.0	19	12.7	44	29	145	320
Attenuation, see curve .....	—	—	—	—	—	—	—	—
Copper out conductor major diameter, inches .....	.250	.375	.540	.540	.980	.980	1.830	2.85
Outside diameter over jacket, inches .....	.290	.435	.620	.620	1.09	1.09	2.0	3.02
Minimum bending radius, inches .....	2.5	3.75	5.0	5.0	10.0	10.0	20	50
Weight, pounds per ft. unjacketed .....	.05	.10	.20	.20	.32	.32	1.03	1.21
Weight, pounds per ft. jacketed .....	.06	.12	.24	.24	.42	.42	1.35	1.78

### FH1 AND FH2 FOAM HELIAX ACCESSORIES

Description	Ordering Information	
	FH1 Line (1/4")	FH2 Line (3/8")
Type UHF Jack (female) .....	41U	42U
Type UHF Plug (male) .....	41P	42P
Type N Jack (female) .....	41N	42N
Type N Plug (male) .....	41W	42W
End Terminal Adaptor .....	13212-2*	13212-2*
Stainless Steel Wraplock .....	12395-1	12395-1
Copperweld Tie Wires .....	27290	27290
Insulated Mounting Clamp .....	11662-3**	11662-3**

\* Use with type N Plug.

\*\* For 1/2-inch cable, shim for smaller sizes.

### FH4, FH5, FH7, FH8 (50 ohm) FOAM HELIAX ACCESSORIES

Description	Ordering Information			
	FH4 (1/2")	FH5 (3/4")	FH7 (1 1/2")	FH8 (3")
EIA Flange .....	44AR	45AR	47R	48R
Splice .....	44AZ	45AZ	47Z	48Z
Type LC Plug (male) .....	44AM	45AM	—	—
Type LC Jack (female) .....	44AL	45AL	47L	—
Type UHF Plug (male) .....	44AP	45AP	—	—
Type UHF Jack (female) .....	44AU	45AU	—	—
Type N Plug (male) .....	44AN	45AN	47W	—
Type N Plug (female) .....	44AW	45AW	47N	—
End Terminal .....	44AT	45AT	2061	—
Grounding Kit, unjacketed .....	26892-1	24810-1	24811-1	—
Grounding Kit, jacketed .....	26892-2	24810-2	24811-2	—
Stainless Steel Wraplock .....	12395-1	12395-1	12395-1	—
Insulated Mounting Clamp .....	11662-3	11662-2	24622	—

# ATTENUATION AND POWER CURVES FOR 50-OHM FOAM HELIAX AT UNITY VSWR

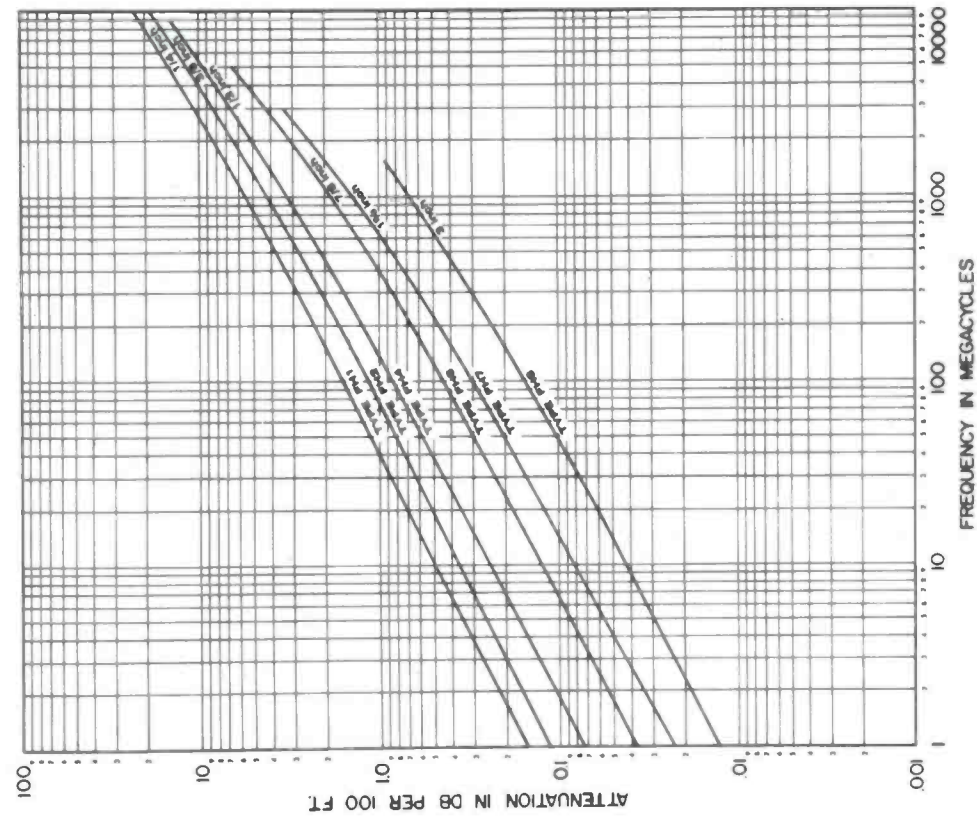

ATTENUATION CURVES

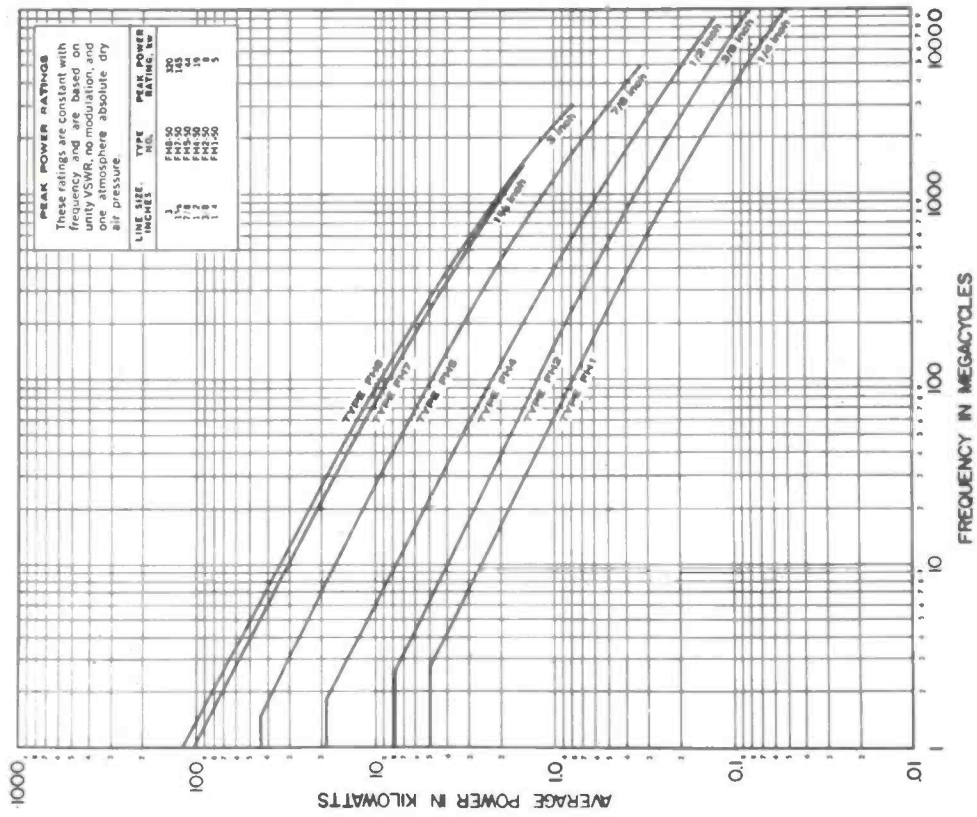

POWER CURVES

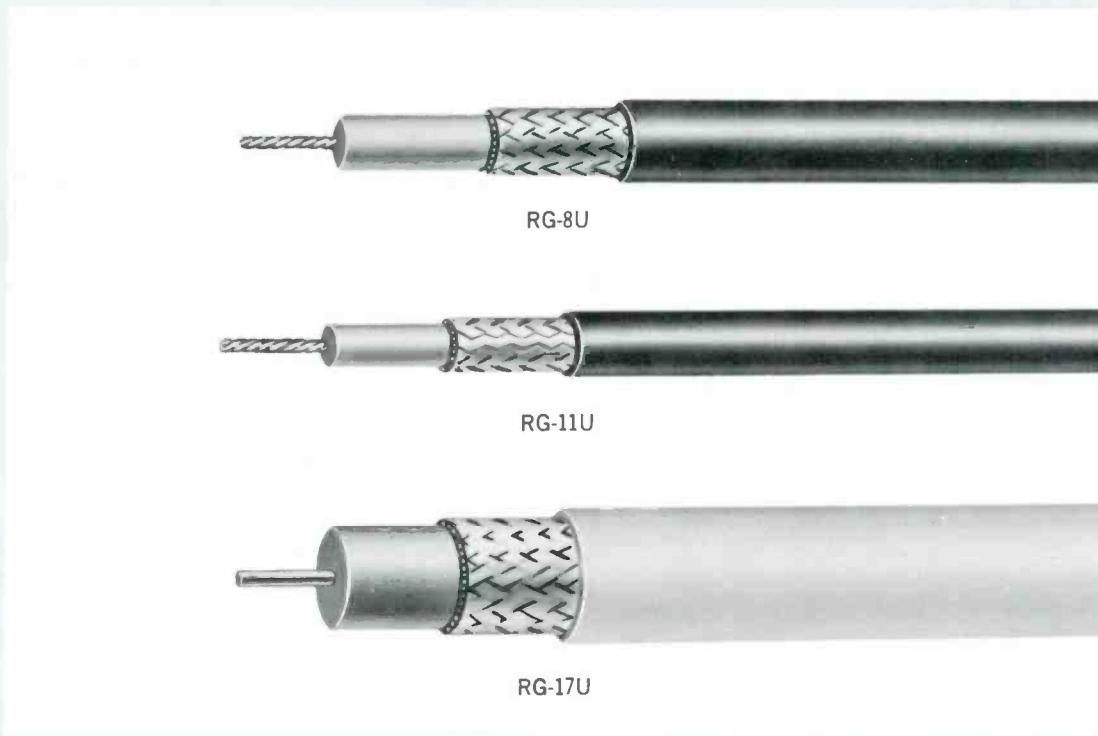

## Flexible RG/U Type Coaxial Cable

### DESCRIPTION

RG/U cables are solid dielectric types suitable for low power AM installations. These cables employ the maximum dielectric qualities of polyethylene with its flexibility and low moisture absorption qualities. The bending radius of these cables is ten times the outside cable diameter and is maintained over a large temperature range.

RG/U types are available in three sizes and with impedances of 52 or 75 ohms. Available types with their sizes and electrical characteristics are given in the accompanying table.

### SPECIFICATIONS

Type	O. D. Inches	Description	Power Rating*	Z Ohms	Attenuation DB/100 Ft. @ 1 MHz
RG-8U	.405	Tinned outer braid	1,320W	52	.16
RG-11U	.405	Tinned inner and outer conductors	920W	75	.18
RG-17U	.870	Tinned outer braid	5,150W	52	.060

\* For 100% modulation at 1 MHz and unity VSWR.



# Expansion Hangers, 1 5/8-Inch Rigid Line

## GROUNDING, CLAMP ON ROUND MEMBERS

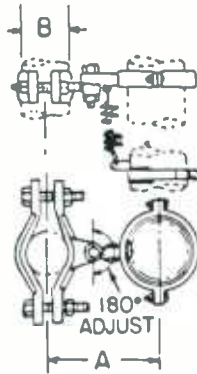

Spring Hanger for single line. Complete with clamps and pivot bolt to compensate for line misalignment. Spring must be preloaded at installation.

### Dimensions (Inches)

A	B	Ref. No.
4 3/8 - 5	1 - 2 1/4	MI-19312-23
7 7/8 - 8 1/2	1 - 2 1/4	MI-19312-24
5 1/6 - 6 1/6	2 1/4 - 5	MI-19312-26
8 1/6 - 9 1/6	2 1/4 - 5	MI-19312-27

MI-19312-23, MI-19312-24, MI-19312-26, MI-19312-27

## GROUNDING, MOUNT THROUGH HOLE

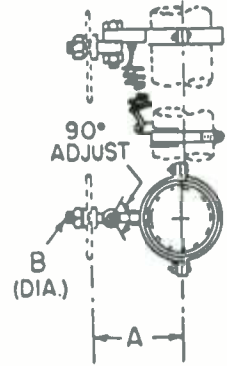

Spring hanger for single line. Complete with clamps and pivot bolt to compensate for line misalignment. Spring must be preloaded at installation.

### Dimensions (Inches)

A	B	Ref. No.
4 1/4	1/2	MI-19312-32
7 3/4	1/2	MI-19312-33

MI-19312-32, MI-19312-33

## GROUNDING, CLAMP ON ANGLE MEMBERS

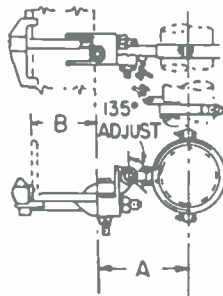

Spring hanger for single line. Complete with clamp and pivot bolt to compensate for line misalignment. Spring must be preloaded at installation.

### Dimensions (Inches)

A	B	Ref. No.
4 3/4	7 (max.)	MI-19312-29
8 1/4	7 (max.)	MI-19312-30

MI-19312-29, MI-19312-30

## INSULATED, CLAMP ON ROUND MEMBERS

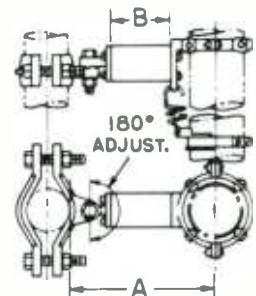



Spring hanger for single line. Complete with clamps and pivot bolt to compensate for line misalignment. Spring must be preloaded at installation.

### Dimensions (Inches)

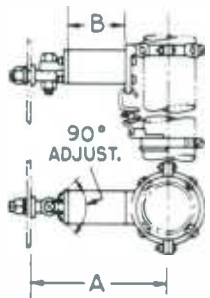

A	B	Ref. No.
8 1/6 - 9 5/6	1 - 2 1/4	MI-19312-25
8 5/6 - 9 5/6	2 1/4 - 5	MI-19312-28

MI-19312-25, MI-19312-28

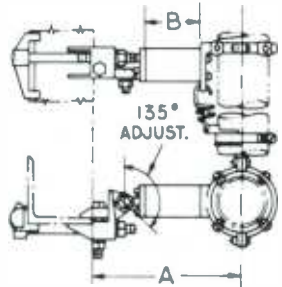
## Expansion Hangers, 1 $\frac{5}{8}$ -Inch Rigid Line (Continued)

INSULATED, MOUNT THROUGH HOLE		INSULATED, CLAMP ON ANGLE MEMBERS	
			
Spring hanger for single line. Complete with clamps and pivot bolt to compensate for line misalignment. Spring must be preloaded at installation.		Spring hanger for single line. Complete with clamp and pivot bolt to compensate for line misalignment. Spring must be preloaded at installation.	
<b>Dimensions (Inches)</b> A: 7 $\frac{3}{4}$ B: $\frac{1}{2}$ <b>MI-19312-34</b>		<b>Dimensions (Inches)</b> A: 8 $\frac{1}{4}$ B: 7 (Max.) <b>MI-19312-31</b>	
Ref. No. MI-19312-34		Ref. No. MI-19312-31	

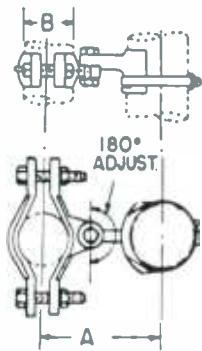
## Fixed Hangers, 1 $\frac{5}{8}$ -Inch Rigid Line

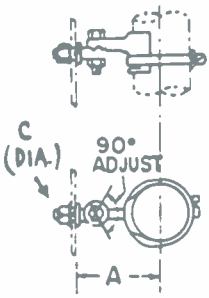
GROUNDED, CLAMP ON ROUND MEMBERS		GROUNDED, MOUNT THROUGH HOLE	
			
Fixed hanger for single line. Complete with clamp and pivot bolt to compensate for line misalignment.		Fixed hanger for single line. Requires mounting hole. Complete with clamp and pivot bolt to compensate for line misalignment.	
<b>Dimensions (Inches)</b> A: 4 $\frac{3}{8}$ - 5 B: 1 - 2 $\frac{1}{4}$ <b>MI-19312-41, MI-19312-42</b>		<b>Dimensions (Inches)</b> A: 3 $\frac{1}{6}$ - 7 $\frac{3}{4}$ B: $\frac{3}{8}$ - $\frac{1}{2}$ <b>MI-19312-44, MI-19312-47</b>	
Ref. No. MI-19312-41, MI-19312-42		Ref. No. MI-19312-44, MI-19312-47	

Fixed Hangers,  
 1 $\frac{5}{8}$ -Inch Rigid Line  
 (Continued)

**ROUNDED, CLAMP ON ANGLE MEMBERS**

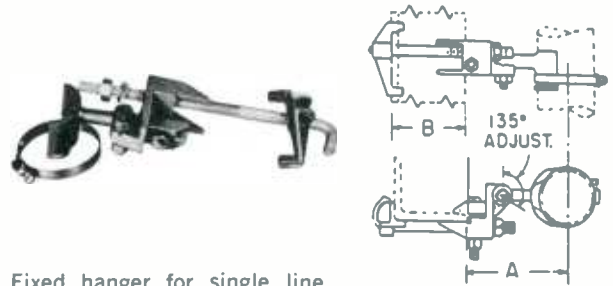

Fixed hanger for single line. Complete with clamp and pivot bolt to compensate for line misalignment.

**Dimensions (Inches)**

A	B
4 $\frac{3}{4}$	1-7

**Ref. No.**  
 MI-19312-43

MI-19312-43

Miscellaneous 1 $\frac{5}{8}$ -Inch Rigid Line Hanger Accessories

**ROUNDED HORIZONTAL ANCHOR**

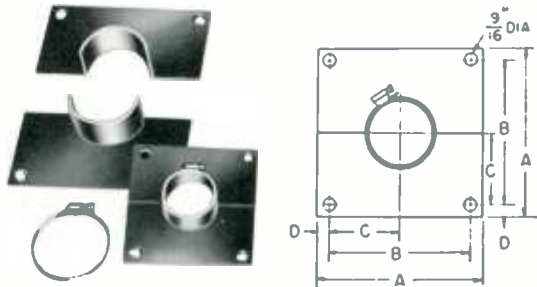

Supports single line at point of wall entry. One required on each side of wall. Furnished split in two pieces with clamp. Mounting bolts not supplied.

**Dimensions (Inches)**

A	B	C	D	Ref. No.
6	4 $\frac{7}{8}$	3	$\frac{1}{16}$	MI-119312-17

MI-19312-17

**ROUNDED HORIZONTAL ROLLER ASSEMBLY**

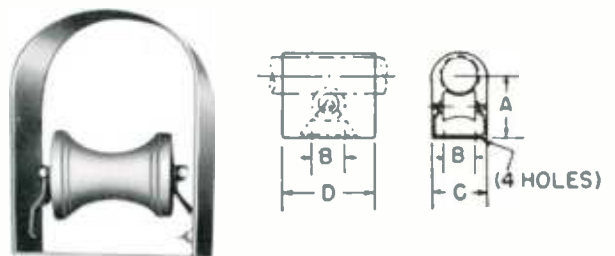

Supports single line. Roller permits line expansion. Hood protects roller. Mounting bolts not supplied.

**Dimensions (Inches)**

A	B	C	D	Ref. No.
2 $\frac{1}{16}$	1 $\frac{1}{16}$	3 $\frac{1}{16}$	6	MI-19312-35

MI-19312-35

### GROUNDING LATERAL BRACE

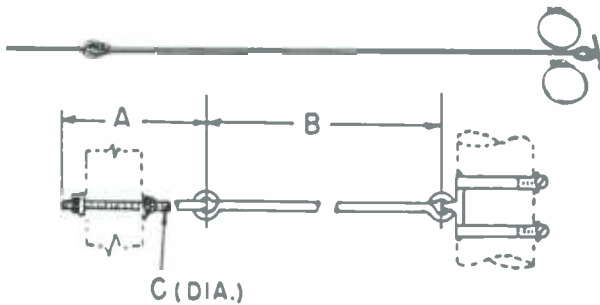

Maintains single line at fixed distance from tower or building. Mounts through single hole. Complete with two clamps.

Dimensions (Inches)			Ref. No.
A	B	C	
8	38½	½	MI-19312-36

MI-19312-36

### GROUNDING SWIVEL HANGER

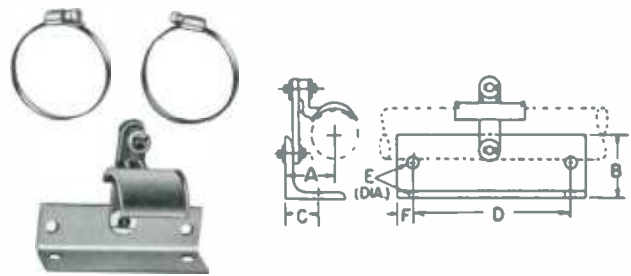

For single line, horizontal run, accommodates uneven terrain. Also compensates for some line expansion and misalignment. Angle support may be mounted horizontally or vertically. Complete with clamps.

Dimensions (Inches)					Ref. No.
B	C	D	E	F	
2 17/32	1½	5	9/32	½	MI-19312-37

MI-19312-37

## Expansion Hangers, 3/8-Inch Rigid Line

### GROUNDING, CLAMP ON ROUND MEMBERS



Spring hanger for single line. Complete with clamps and pivot bolt to compensate for line misalignment. Spring must be preloaded at installation.

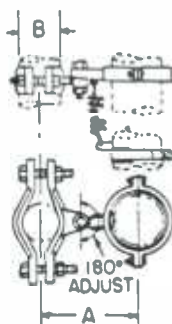

Dimensions (Inches)		Ref. No.
A	B	
5½ - 5¾	1 - 2¼	MI-19313-23
8½ - 9¾	1 - 2¼	MI-19313-24
5½ - 7¾	2¼ - 5	MI-19313-26
9¾ - 10¾	2¼ - 5	MI-19313-27

MI-19313-23, MI-19313-24, MI-19313-26, MI-19313-27

### GROUNDING, MOUNT THROUGH HOLE



Spring hanger for single line. Requires mounting hole. Complete with clamps and pivot bolt to compensate for line misalignment. Spring must be preloaded at installation.

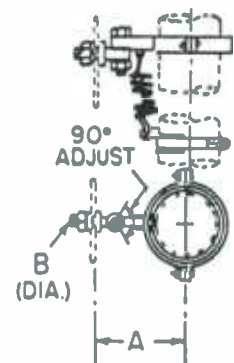

Dimensions (Inches)		Ref. No.
A	B	
5	½	MI-19313-32
8¾	½	MI-19313-33

MI-19313-32, MI-19313-33

# Expansion Hangers, 3/8-Inch Rigid Line (Continued)

## GROUNDING, CLAMP ON ANGLE MEMBERS

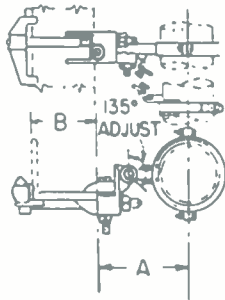

Spring hanger for single line. Complete with clamp and pivot bolt to compensate for line misalignment. Spring must be preloaded at installation.

Dimensions (Inches)		Ref. No.
A	B	
5 1/2	7 (Max.)	MI-19313-29
9 1/6	7 (Max.)	MI-19313-30

MI-19313-29, MI-19313-30

## INSULATED, CLAMP ON ROUND MEMBERS

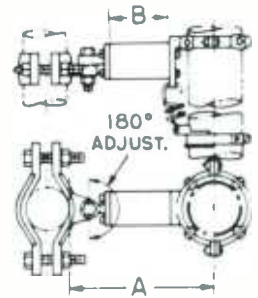

Spring hanger for single line. Complete with clamps and pivot bolt to compensate for line misalignment. Spring must be preloaded at installation.

Dimensions (Inches)		Ref. No.
A	B	
8 1/6 - 9 1/6	1 - 2 1/4	MI-19313-25
9 3/8 - 10 3/4	2 1/4 - 5	MI-19313-28

MI-19313-25, MI-19313-28

## INSULATED, MOUNT THROUGH HOLE

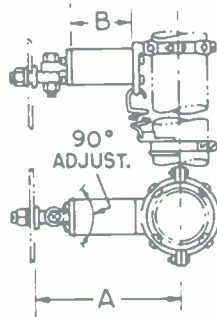

Spring hanger for single line. Mounting hole required. Complete with clamps and pivot bolt to compensate for line misalignment. Spring must be preloaded at installation.

Dimensions (Inches)		Ref. No.
A	B	
8 1/6	1/2	MI-19313-34

MI-19313-34

## INSULATED, CLAMP ON ANGLE MEMBERS

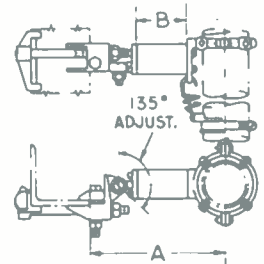

Spring hanger for single line. Complete with clamp and pivot bolt to compensate for line misalignment. Spring must be preloaded at installation.

Dimensions (Inches)		Ref. No.
A	B	
9 1/6	7 (Max.)	MI-19313-31

MI-19313-31

# Fixed Hangers, 3/8-Inch Rigid Line

## GROUNDING, CLAMP ON ROUND MEMBERS

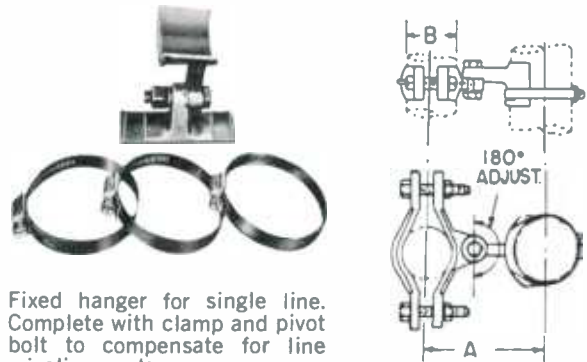

Fixed hanger for single line. Complete with clamp and pivot bolt to compensate for line misalignment:

Dimensions (Inches)		Ref. No.
A	B	
5 1/8 - 5 3/4	1 - 2 1/4	MI-19313-41
5 3/8 - 7 3/8	2 1/4 - 5	MI-19313-42

MI-19313-41, MI-19313-42

## GROUNDING, MOUNT THROUGH HOLE

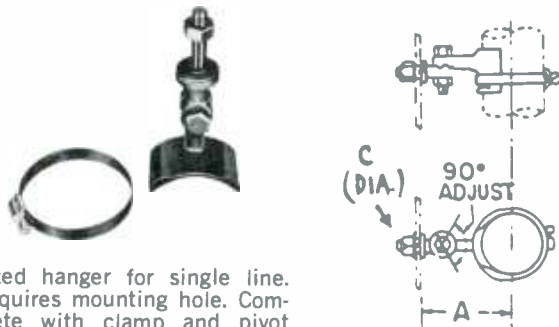

Fixed hanger for single line. Requires mounting hole. Complete with clamp and pivot bolt to compensate for line misalignment.

Dimensions (Inches)		Ref. No.
A	B	
5	1/2	MI-19313-44
8 1/8	1/2	MI-19313-47

MI-19313-44, MI-19313-47

## GROUNDING, CLAMP ON ANGLE MEMBERS

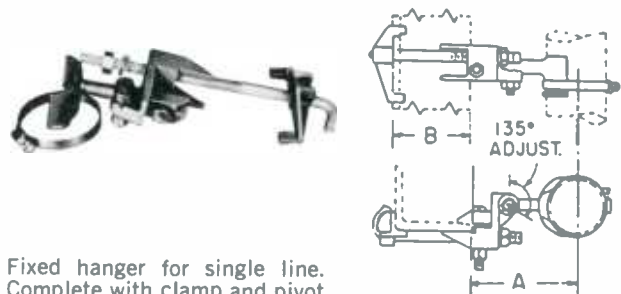

Fixed hanger for single line. Complete with clamp and pivot bolt to compensate for line misalignment.

Dimensions (Inches)		Ref. No.
A	B	
5 1/2	1 - 7	MI-19313-43

MI-19313-43

Miscellaneous  $3\frac{1}{8}$ -Inch  
Rigid Line Hanger  
Accessories

**GROUNDING HORIZONTAL ROLLER ASSEMBLY**

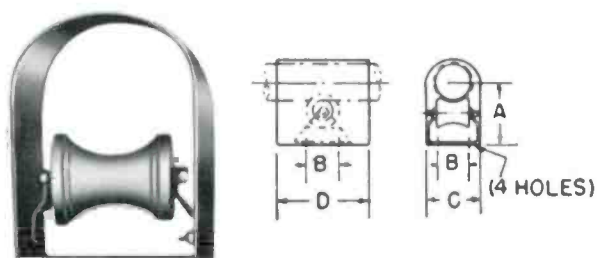

Supports single line. Roller permits line expansion. Hood protects roller. Mounting bolts not supplied.

**Dimensions (Inches)**

A	B	C	D	Ref. No.
$5\frac{3}{8}$	3	$4\frac{3}{4}$	8	MI-19313-35

MI-19313-35

**GROUNDING HORIZONTAL ANCHOR**

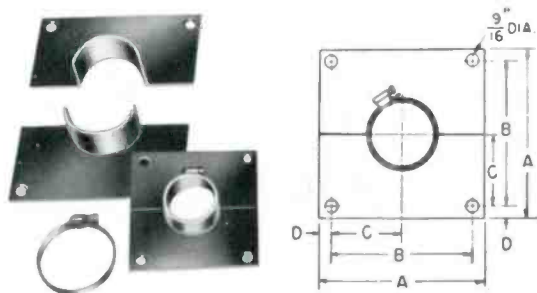

Supports single line at point of wall entry. One required on each side of wall. Furnished in two pieces with clamp. Mounting bolts not supplied.

**Dimensions (Inches)**

A	B	C	D	Ref. No.
8	$6\frac{7}{8}$	4	$\frac{5}{16}$	MI-19313-17

MI-19313-17

### GROUNDING LATERAL BRACE



Maintains single line at fixed distance from tower or building. Mounts through single hole. Complete with two clamps.

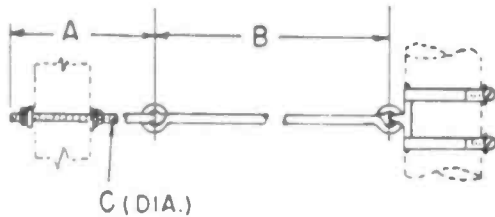

#### Dimensions (Inches)

A	B	C	Ref. No.
8	38½	½	MI-19313-36

MI-19313-36

### GROUNDING SWIVEL HANGER

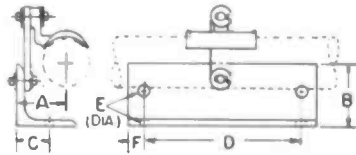

For single line, horizontal run. Accommodates uneven terrain. Also compensates for some line expansion and misalignment. Angle support may be mounted horizontally or vertically. Complete with clamps.

#### Dimensions (Inches)

B	C	D	E	F	Ref. No.
2 17/32	1 1/8	5	3/16	1/2	MI-19313-37

MI-19313-37

### GROUNDING 3-POINT HANGER

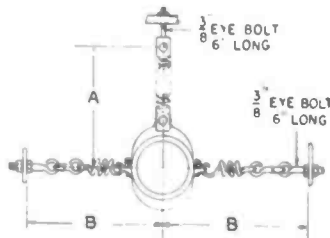
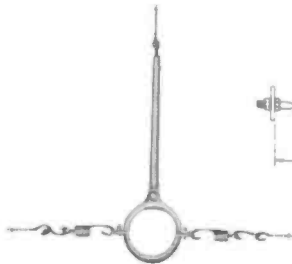

Spring hanger for horizontal suspension of single line. Anchored at three points. Complete with eye bolts and springs.

#### Dimensions (Inches)

A	B	Ref. No.
20¾	15	MI-19313-50

MI-19313-50



# Indoor Hanger Kits, 1 $\frac{5}{8}$ -, 3 $\frac{1}{8}$ -, 6 $\frac{1}{8}$ -Inch Rigid Line

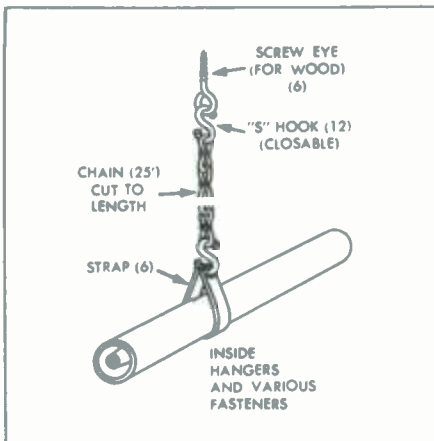

## HANGER AND FASTENER KIT

Attaches to line for ceiling support. Consists of stainless steel straps, 25 feet of chain and hardware for supporting line at six points. Chain tensile strength 260 pounds.

3 $\frac{1}{8}$ -Inch Line: MI-27700

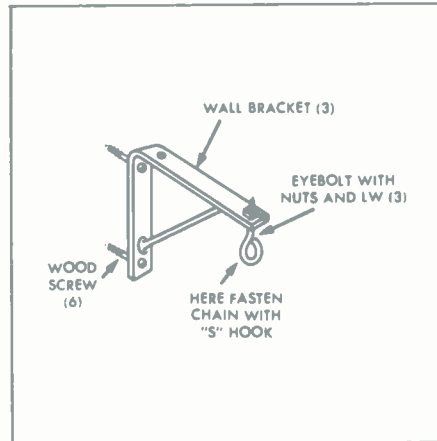

## WALL BRACKET KIT

For supporting line from wall of building. Consists of three heavy duty brackets 1 $\frac{1}{2}$  inches wide with 7 $\frac{1}{2}$  inch arms and mounting hardware for supporting line at three points.

3 $\frac{1}{8}$ -Inch Line: MI-27702

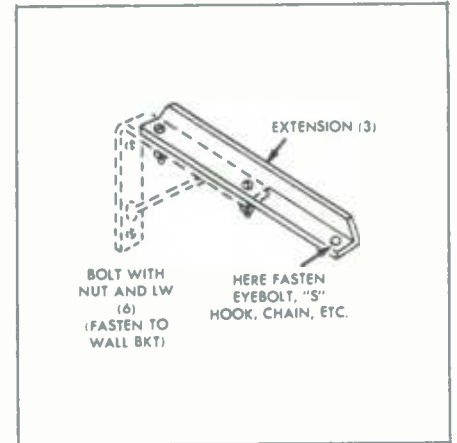

## WALL BRACKET EXTENSION KIT

For use with Wall Bracket Kit to extend line out from wall of building. Consists of three heavy duty angle extensions and hardware. Extension angles are 12 inches long,  $\frac{1}{8}$  inch thick and 1 $\frac{1}{4}$  inch each side.

3 $\frac{1}{8}$ -Inch Line: MI-27703

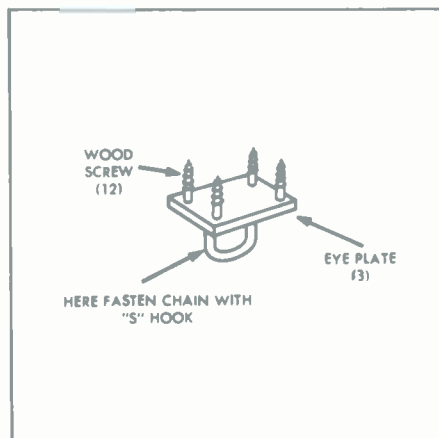

## HANGER PLATE MOUNTING KIT

For attaching Hanger and Fastener Kit to plaster or wood surfaces. Consists of three steel eye plates and mounting hardware.

MI-27704

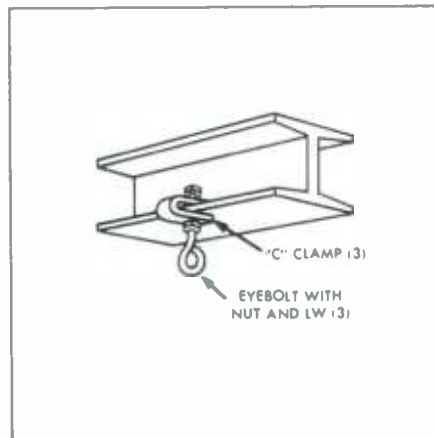

## "1" BEAM MOUNTING KIT

Special hanger for attaching Hanger and Fastener Kit to "1" beam. Consists of three clamps, eye bolts and hardware for three supporting points.

MI-27705

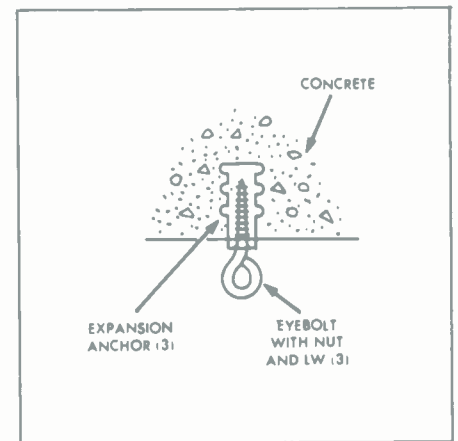

## CONCRETE MOUNTING KIT

For attaching Hanger and Fastener Kit to concrete wall or ceiling. Consists of eye bolts and expansion anchors for three supporting points.

MI-27706

# Layout and Installation of Rigid Transmission Line

A dimensioned layout of the entire transmission line run is helpful in ordering line and fittings. FM lines usually require a horizontal run from the transmitter, and a vertical run up the tower to the antenna feed line; while AM lines may terminate in a tuning house at the base of the tower. If the AM tower is base insulated and is to be used also as an FM antenna support, it is necessary to quarter-wave insulate the FM line from the tower and use insulated hangers. The rolled groove at one end of the RCA line supports the end insulator and keeps the inner conductor in place. This end should always be placed downward when the line is in a vertical position. For horizontal runs, the groove is placed at alternate joints, opposing grooves locking the line in position. Note that expansion hangers are used for the vertical length except the top hanger which is a fixed hanger (two are used in illustration because of change in tower shape). The fixed hanger forces thermal expansion toward opposite end of line to avoid damage to FM antenna. Assembly normally starts from this hanger. Observe maximum line bending radii.

Outdoor runs should use flanged type line and fittings which are pressure sealed by O-rings. Unflanged lines may be used inside where gassing may not be necessary. Gas stops are used between flanged and unflanged lines. Additional O-rings and flange bolts should be ordered to replace damage and loss during installation.

Make installations only during dry weather. If it is necessary to stop work, use cover plates at both ends of the line to keep moisture out. When completed, dry gas or dry air is applied through a bleeder valve at the antenna end until the line shows a resistance of 80 megohms or more.

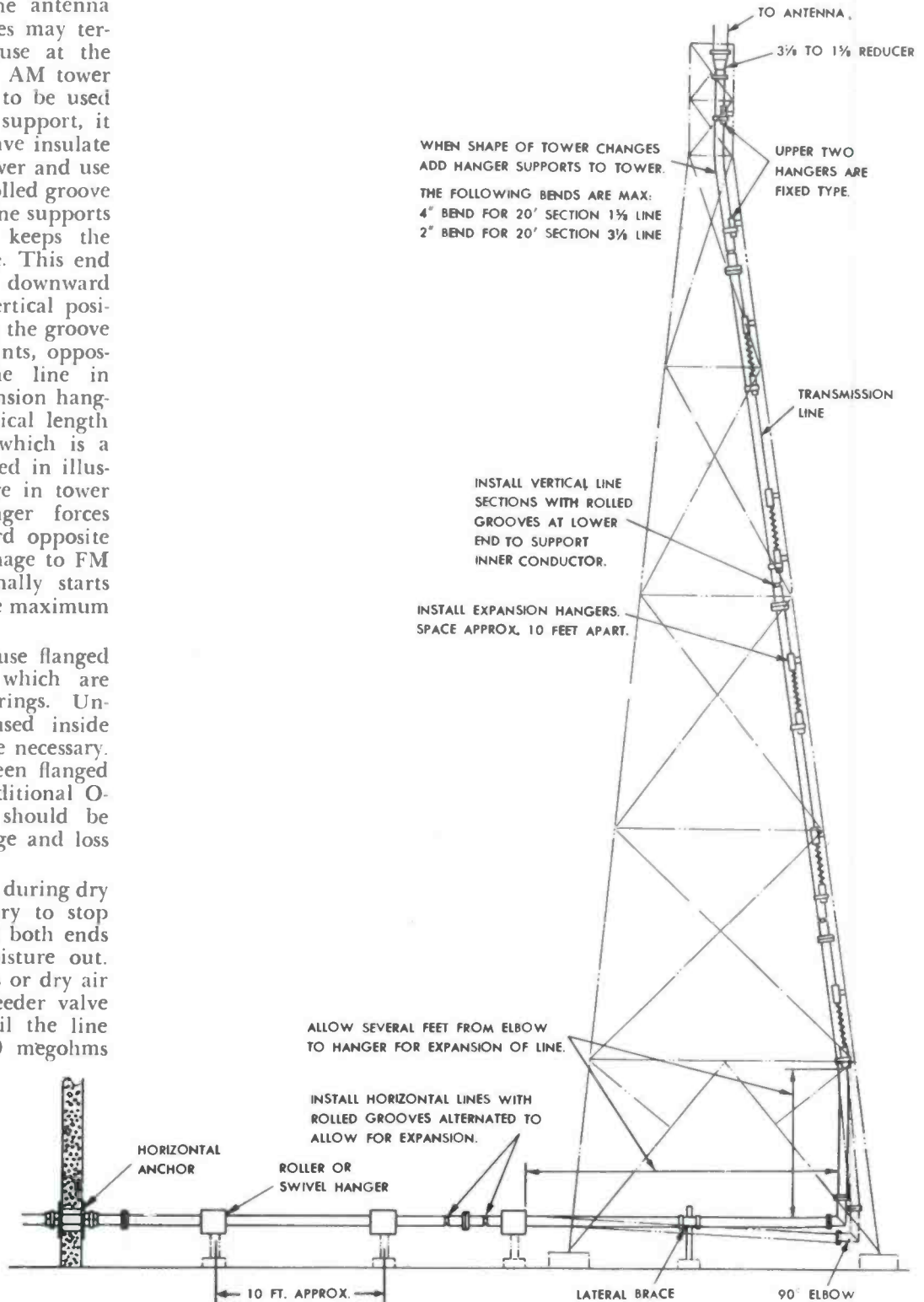

# Dehydrators For Coaxial Line, MI-563170 Series

The MI-563170-1/2/3 Dehydrator is designed to maintain transmission lines feeding broadcast antennas free of moisture. Each model provides a continuous supply of dry air at the rate of one standard cubic foot per minute. The Dew Point, or temperature at which moisture will condense out of the delivered air, is less than -40 degrees Fahrenheit when referred to a standard atmosphere.

All units will deliver their maximum

SCF capacity continuously for normal operation. During initial charging of cable systems or during emergency periods, the units are capable of delivering more than the specified SCFD. Operation is fully automatic. Only three connections are necessary for simple installation.

The complete Dehydrator system with alarm facilities is housed in a single cabinet which occupies a minimum of floor space.



MI-563170-1



MI-563170-3



MI-563170-2

## Accessories

**Water Dump Trap**—Used in areas with unusually high temperatures and high relative humidity for increased efficiency and longer life.

**Pressure Regulator**—Can be supplied in place of the pressure switch.

**Storage Tank**—A 2-gallon dry air reserve tank, which prevents rapid cycling.

**High and Low Pressure Alarm**—It operates when the delivered air pressure is too high or too low.

**Humidity Alarm**—To warn when relative humidity rises above a preset value.

## Specifications and Ordering Information

Ordering Information	MI-563170-1	MI-563170-2	MI-563170-3
<b>Output;</b>			
Flow Rate .....	1 SCFM	2 SCFM	3 SCFM
Dew Point .....	-40°F	-40°F	-40°F
Pressure (Adjustable) .....	1-15 lbf/in <sup>2</sup>	1-15 lbf/in <sup>2</sup>	1-15 lbf/in <sup>2</sup>
<b>Input;</b>			
Max. Temperature .....	125°F	125°F	125°F
Humidity .....	100%	100%	100%
Internal Operating Pressure ....	55-70	55-70	55-70
Motor Size .....	½ hp	¾ hp	1½ hp
Electrical Requirements .....	115 Volts, single phase, 60 Hz, 50 Hz*	115 Volts, single phase, 60 Hz, 50 Hz*	115 Volts, single phase, 60 Hz, 50 Hz*
<b>Dimensions;</b>			
Height .....	20" (51 cm)	28" (71 cm)	42" (107 cm)
Width .....	22" (56 cm)	22" (56 cm)	22" (56 cm)
Depth .....	15" (38 cm)	15" (38 cm)	18" (46 cm)
Weight .....	95 lbs. (43 kg.)	117 lbs. (53 kg.)	200 lbs. (91 kg.)

\* Available on special order. Requires 50 Hz motor.

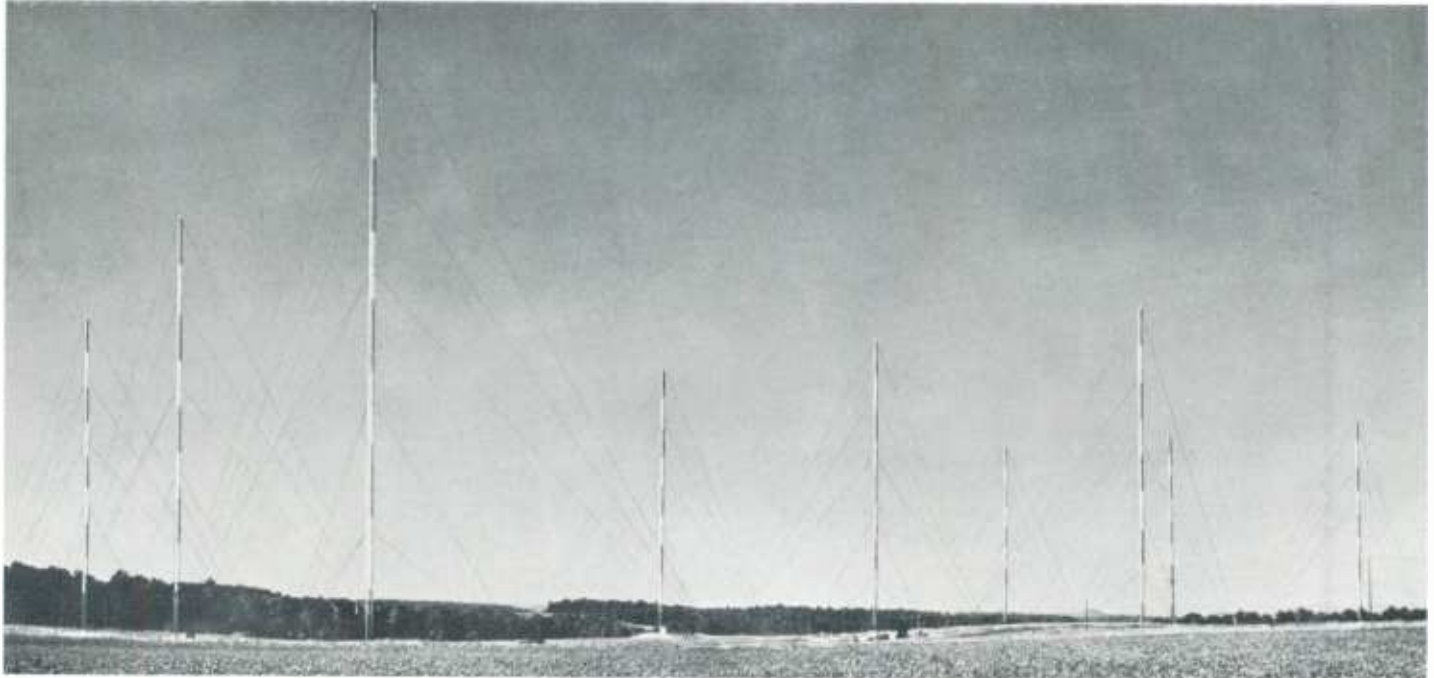

- Wide selection of AM or FM Antenna Towers
- Complete line of tower accessories
- Self-supporting or guyed types of standard or custom-made designs

## AM-FM Antenna Towers

### Description

RCA is well-qualified to assist in the planning and selection of proper AM towers and a qualified erector to complete the installation. A wide selection is available for all AM and FM applications . . . including standard self-supporting, guyed, and custom designs.

#### Guyed Towers

Where land area permits, towers are usually guyed and the usual cross sectional shape is triangular so that three point guying can be used. Guyed tower costs are normally lower than for self-supporting structures because less steel is used. A useful method for estimating the land required for a guyed structure is to consider the distance to the farthest guy anchorage as being about 80 percent the tower height.

#### Self-Supporting Towers

Self-supporting towers are especially advantageous in city and con-

gested districts where land is expensive. For estimating required space for a self-supporting tower, the distance between tower legs can normally be considered as 10 percent the height of the structure.

#### Wind Load

Towers must be designed and installed to safely withstand the maximum wind velocities that may be encountered. Experienced tower builders rarely design for less than a 30/20-pound loading. This means that the tower members are designed to resist a horizontal wind pressure of 30 pounds per square foot of projected area on all flat surfaces and 20 pounds on round surfaces. This is the equivalent of an actual wind velocity of 86.6 miles per hour. Towers with higher wind load ratings are, of course, available. Towers are designed in accordance with EIA specifications RS-222.

#### Tower Accessory Equipment

A number of accessories to complete various AM and FM broadcast towers are available. Most of them are fully described in specialized catalogs for these products. They include: FM antennas; FM transmission line, hangers and dehydrators; FM/AM isolation unit; material for ground systems; AM transmission line and hangers; antenna tuners; AM phasing systems (including power dividing networks, phase sampling loops, phase sampling lines and isolation coils); and tower lighting equipment (including tower lighting kits and photo electric control, lighting chokes and air core lighting transformers).

#### FM Antenna Equipment

RCA has a complete line of FM antennas and accessories; both horizontally and vertically polarized antennas are available. Coaxial transmission line which may be either

of the rigid or flexible type is used to conduct power from the transmitter to the antenna. Lines which use air as a dielectric will require pressurization using nitrogen or dry air to prevent condensation from accumulating inside the line. Various sized dehydrators and specialized hardware are available.

If the tower upon which the antenna is mounted is an insulated AM radiator, some means of isolating the effect of grounded transmission line where it crosses the base insulator must be provided. Using insulated hangers, a quarter wave balun at the AM frequency may be constructed or, under some circumstances, a Type BAF-14A FM/AM isolation unit, may be used.

In order to facilitate selection of the tower most suitable, and as an aid to the station in determining specific requirements, a sample questionnaire is included here.

**Material for Ground Systems**

In order to obtain reasonable radiation efficiency and, in the case of directional arrays, to stabilize the radiation pattern a system of buried radial copper wires extending outward from the tower base must be installed. RCA can supply the wire, copper strap, and ground mats required to meet the consultant's ground system specifications. Ground system installation may be included with the tower contract.

**Antenna Tuners**

In most cases the impedance of the transmission line and the base impedance of the tower are not alike and it is necessary to install

an antenna tuner at the base of the tower to transform the antenna impedance to the transmission line impedance. RCA markets a standard group of antenna tuners for low and medium power use. In the higher power range antenna tuning units are custom built.

**AM Phasing Equipment**

Multiple tower AM arrays are used to achieve specific horizontal and vertical radiation patterns as required by allocation or economic factors related to coverage. Varying amounts of power at various phase angles are fed to the various towers. RCA is in a position to supply all of the elements of phasing, power dividing, and antenna tuning units.

Antenna Tower Questionnaire		
LOCATION		
City	.....	
State	.....	
QUOTATIONS TO BE FURNISHED		
(Check those required)		
Number of Towers	..... ( )	
Ground System	..... ( )	
Tower	Guyed	..... ( )
	Self-Supporting	..... ( )
Tower Lighting Equipment	..... ( )	
Tower Erection:		
	Tower Installation	..... ( )
	Transmission Line Installation (FM)	..... ( )
SPECIFICATIONS		
Tower Height:		
	Ground to top of tower	.....
	Ground to top of base insulator	.....
Tower Use:		
	AM Radiator	.....
	Antenna support (when used for FM or TV)	.....
Channel or Frequency.....		
FM or TV Antenna: Type.....		
	Description	.....
Transmission Lines:		
Design Load:	Size	No.
	B-1 Open Country	.....
	B-2 Congested Area	.....
Remarks:		
	(Special requirements, site accessibility, etc.)	

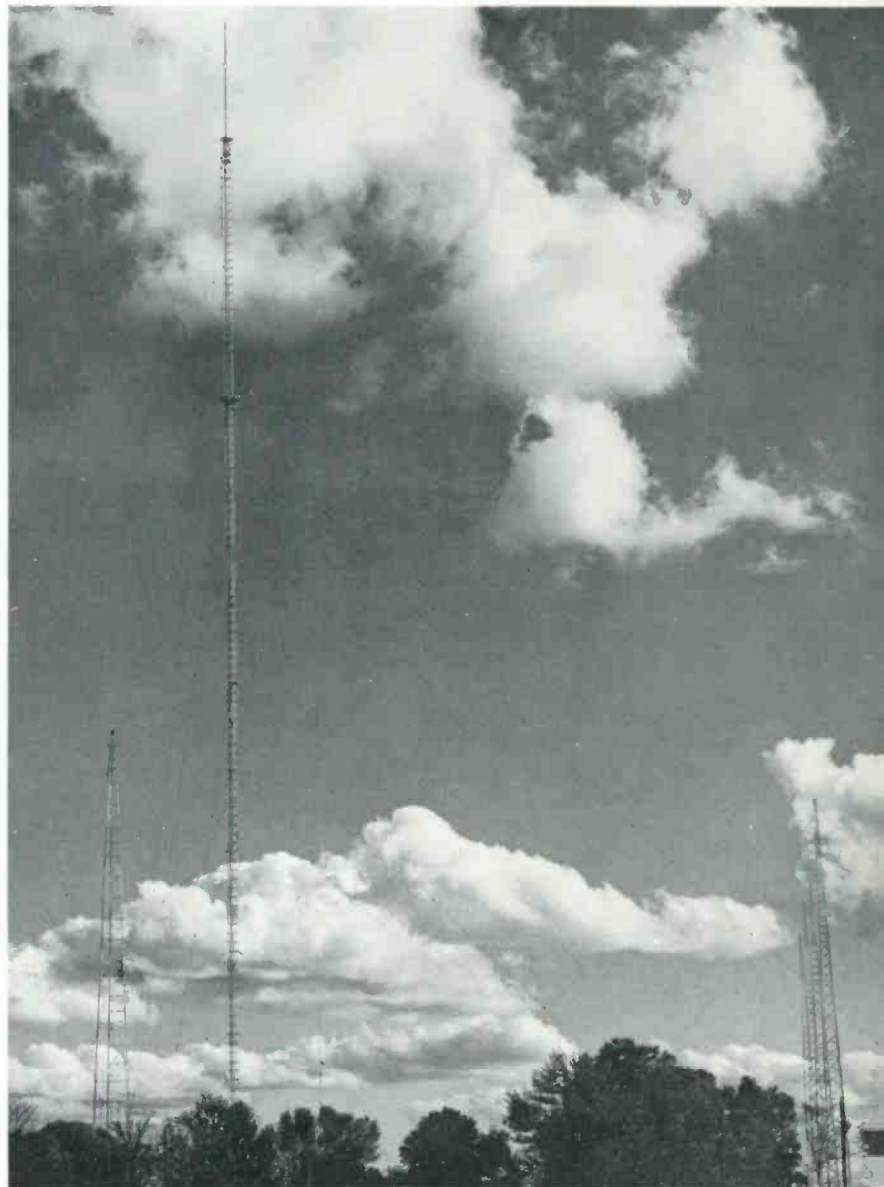

In these multi-tower arrays, methods for sampling the phase and amplitude of the rf voltage in each tower and conveying this sample to the phase measuring equipment located in the transmitter house are required. Accessory phase sampling loops, which are normally mounted on the individual towers, phase sampling lines to connect the loops to the measuring device, and means for isolating the grounded sampling lines where they cross the tower base insulator are also available.

### Antenna Feed Bus

The antenna tuning unit output should be connected to the tower by means of copper tubing which

is not normally supplied with the antenna or transmitting equipment. The tubing may be obtained from local sources and should be flattened and drilled at the ends so that it may be connected to the antenna tuning unit output feedthrough insulator and attached to the tower by bolt or brazing. At a point between the tower and the feedthrough insulator the line should be formed into a one or two turn coil, 12 to 18 inches in diameter. This coil can be self-supporting and is intended to retard lightning and aid in the breakdown at the ball or horn gap provided at the tower base thus keeping lightning discharges from damaging the radio equipment.

### Tower Lighting

The configuration of tower lights and the lighting equipment must conform to applicable government specifications. The AC power required to operate the lights may be conducted on wires which are buried in the ground or carried on the same poles which carry the transmission line from the transmitter house to the antenna tuning unit. The AC power lines will have to be isolated from the rf power where they cross the base insulator. This isolation can be provided either through the use of an antenna lighting choke and appropriate bypass condensers or by the use of an air core lighting transformer.

WIND VELOCITY AND CORRESPONDING WIND PRESSURE ON TOWERS—EIA STANDARD SPECIFICATION

Actual Wind Velocity MPH	Wind Pressure on Flat Surfaces $P = .004 V^2$	Wind Pressure on Round Surfaces	Estimated Survival Velocities F. S. 1.65
10	.4	.266	12.9
20	1.6	1.067	25.8
30	3.6	2.4	38.6
40	6.4	4.27	51.5
50	10.0	6.67	64.4
60	14.4	9.6	77.3
70.7	20.0	13.33	91.1
80	25.6	17.1	103.0
86.6	30.0	20.0	111.5
90	32.4	21.6	115.9
100	40.0	26.7	128.8
110	48.4	32.3	141.7
111.8	50.0	33.3	144.0
120	57.6	38.5	154.6
122.5	60.0	40.0	157.8
130	67.6	45.0	167.4
132.3	70.0	46.67	170.4
140	78.4	52.33	180.3
141.4	80.0	53.33	182.1
150	90.0	60.0	193.2
160	102.2	68.2	206.1
170	115.6	77.0	219.0
180	129.6	86.6	231.8
190	144.4	96.3	244.7
200	160.0	106.66	257.6

WSBT-AM/FM/TV's antenna farm showing first WSBT-TV television tower and new high-rise guyed TV tower for increased power at left. At the far right are the four towers used in the WSBT-AM directional array.

## Ordering Information

### Tower Accessories

- 8 ft. by 24 ft. Section Expanded Copper Ground Screen .....MI-27765
- No. 10 Copper Wire.....MI-28405-8
- 3" by .020 Ground Strap.....MI-28405-A4
- Double RF Antenna Lighting Choke.....MI-7112-C
- Triple RF Antenna Lighting Choke.....MI-27726
- Capacitor for Lighting Chokes.....MI-27728-1
- Weatherproof Housing .....MI-27741
- 1750 Watt Hughey and Phillips Transformer.....MI-28215-A1
- 3500 Watt Hughey and Phillips Transformer.....MI-28215-A2
- 3000 Watt Fisher Pierce Photo-Cell
- 6000 Watt Fisher Pierce Photo-Cell
- Fisher Pierce Light Control Relays .....251-A
- Hazard Markers (Set of 3 including installation material)
- "Hot Dip" Galvanizing of Angle Frame Work for Individual Markers

### Tower Lighting Kits

Tower Height	No. Beacons	No. Obstruction Lights	Order No.
21' - 150'	0	1 double	A-1
151' - 300'	1	2	A-2
301' - 450'	1	4	A-3
451' - 600'	2	6	A-4

(Lighting Kits include all materials required to light and wire a tower of heights specified, such as original and 100 percent spare lamps, beacon flasher, photo-electric control, color coded wire, stainless steel wraplock tape condulets, locknuts, supporting arms, unions, pipe compound, installation print, and bill of materials in accordance with FCC, CAA and National Electric Code Requirements.)

For other Antenna Accessories See appropriate RCA Catalogs.



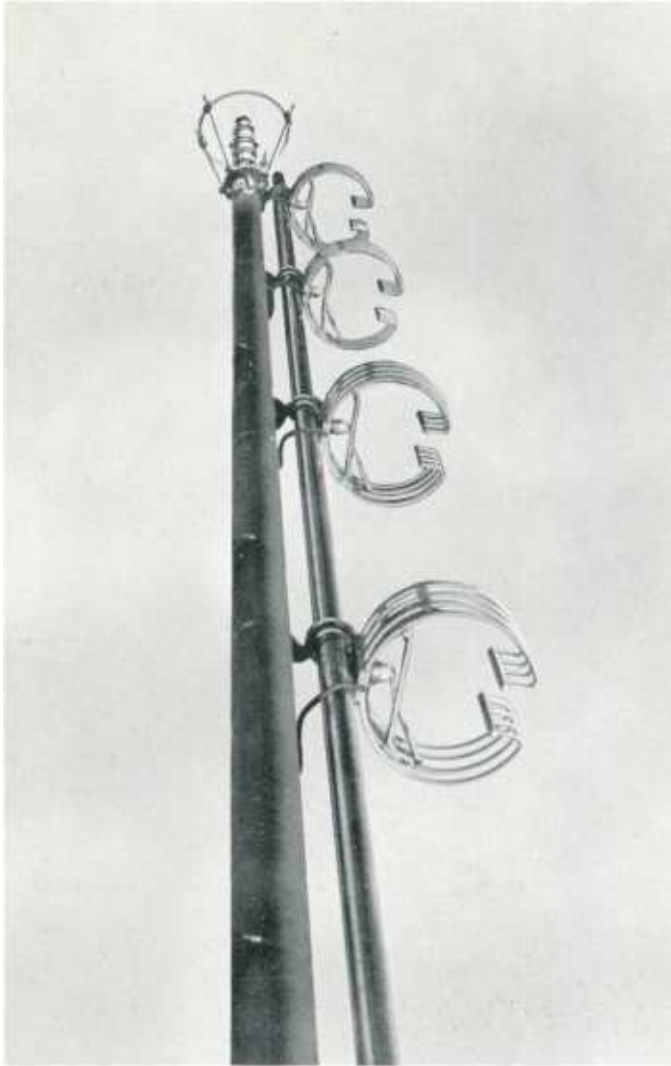

- Designed for both standard and multiplex FM broadcast service
- Low VSWR over entire 200 kHz band (1.1/1 ratio achieved with field trimming)
- Highest gain at low weight and windloading
- Can be side mounted on existing towers
- Provisions for de-icing if desired
- Easy to install—minimum maintenance

## Broadband FM Antenna, BFA Series

### Description

The RCA BFA Series of Broadband FM Antennas is designed for use in standard, stereo and multiplex broadcast service. These antennas provide a low-standing wave ratio over a 200 kilohertz channel providing optimum conditions for multiplex operation.

An improved "B-series" of the BFA Antenna offers higher power

rating, increased bandwidth and reduced effects from icing as well as many other mechanical improvements. Proven features such as sectionalized construction, high-low power for deicing, common  $3\frac{1}{8}$ -inch transmission line feed, and approximate wave length spacing between radiators have been retained from the former "A-series" antennas.

### Power Gain

This new antenna features sectionalized construction and can be erected with as many sections as are required for a given application. Power gain is approximately equal to the number of sections. The spacing of sections is approximately one wavelength. The antennas are designated BFA-1B, BFA-2B, BFA-3B,



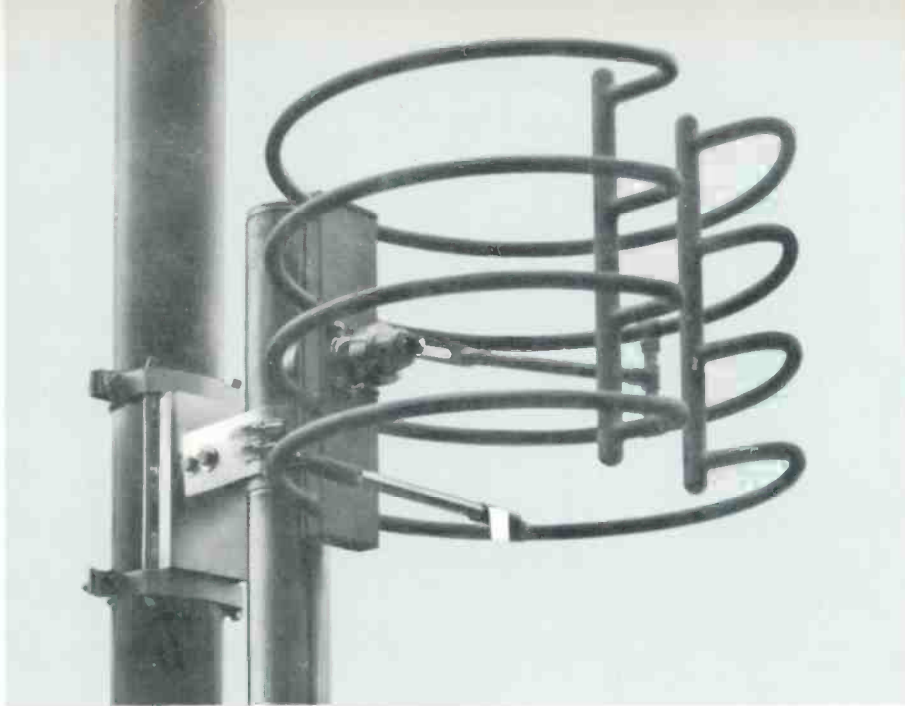

Single Section of BFA Broadband FM Antenna.

etc., depending upon the number of stacked sections provided.

### Rugged Construction

Mechanically, the antenna is designed for rugged service in all types of weather conditions, and will withstand wind velocities up to 110 miles per hour. Radiating elements are made of durable stainless steel that eliminates electrolysis and corrosion when bolted to the copper feed system. The design is flexible and permits ease of installation on the side of an existing tower, or pole mounting on top of towers or buildings. Mounting brackets are supplied with antennas for standard or conventional installations at no extra cost. Custom brackets can be supplied at extra cost for special or unusual types of installations. The antenna can be supplied with standard poles using either pedestal or socket mounts.

### De-icing Provisions

Deicing equipment is an accessory item and must be ordered with the antennas. The deicing system is recommended for most areas and especially where icing and sleet conditions are common.

### Sectionalized Construction

The RCA Type BFA Broadband FM Antenna is of sectionalized construction; each section consisting basically of four radiating rings attached to a supporting frame. An insulated feed assembly and a section of  $3\frac{1}{8}$ -inch transmission line is provided with flanges to fit  $3\frac{1}{8}$ -inch

coaxial feedlines. Adaptors are available for other size lines. Standard antennas have power gains from 0.9 to 16.5. Special designs are available on application. All BFA Antennas are factory tuned to any channel in the frequency range of 88 to 108 megahertz. In standard and multiplexing operations, a voltage standing wave ratio of 1.1 to 1 can be achieved with a minimum of field trimming. A transformer section is located near the input fitting.

### Radiation Pattern

The horizontal radiation pattern of the BFA is essentially omnidirectional for top mounting. The horizontal pattern in free space is within 1 dB of circular. The extent of deviation from a circular pattern for a side mounted array is dependent on type and size of the tower. It is recommended that the array be mounted, if possible, above the top set of guys on a guyed tower. Where this is not possible the guys in the immediate area of the antenna should be broken by insulators every  $3\frac{1}{2}$  feet for a distance of at least 14 feet. In addition, each guy in the vicinity of the antenna should be insulated at the point where it connects to the tower.

### Mechanical Features

Mechanically, each section consists of four stainless steel rings stacked and equally spaced to form a height dimension of 12 inches. The sections are mounted on  $3\frac{1}{8}$ -inch coaxial line with an insulated feed stud energizing each radiating sec-

tion. Only one coaxial transmission line is used to feed all sections of the antenna, and the individual radiating sections are identical mechanically and electrically. The radiators are both shunt fed and mechanically supported by this interconnecting feed-line which consists of modified lengths of RCA  $3\frac{1}{8}$ -inch rigid coaxial transmission line. The BFA-1B through BFA-8B Antennas terminate mechanically in a pressurized top cap with bleed valve and a bottom input flange for coupling the antenna to the desired type of transmission line. Type BFA-10B through BFA-16B antennas are center fed through a matching tee and lower and top radiators terminate mechanically in pressurized caps.

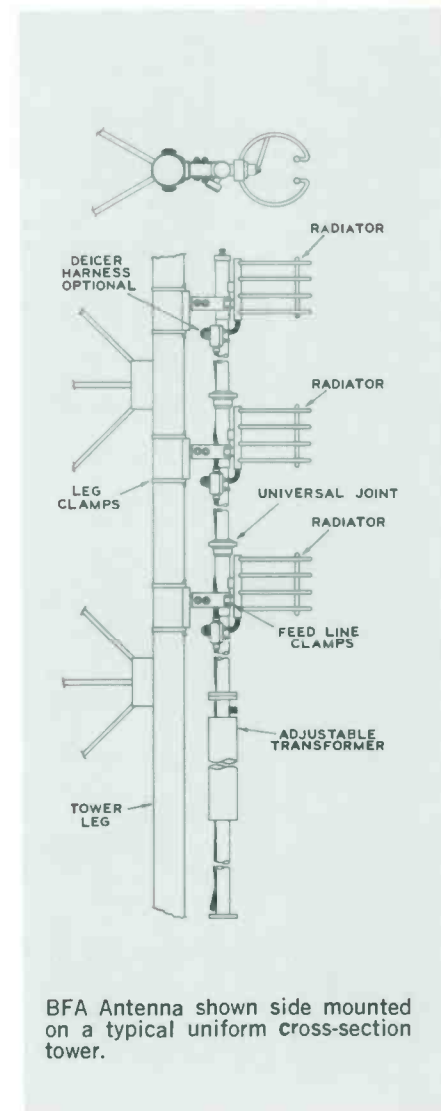

BFA Antenna shown side mounted on a typical uniform cross-section tower.

# Specifications

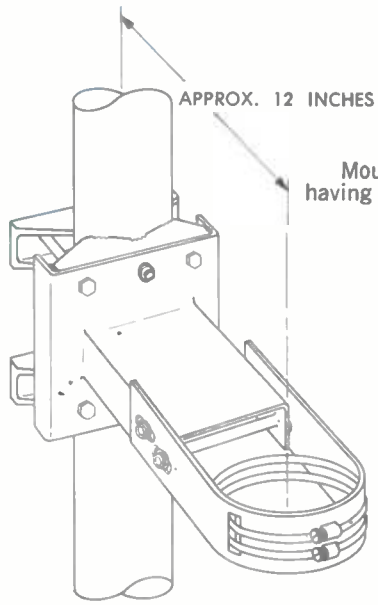

**TYPICAL LEG**  
Mounting bracket for towers having leg diameter of 2" to 3 3/4".

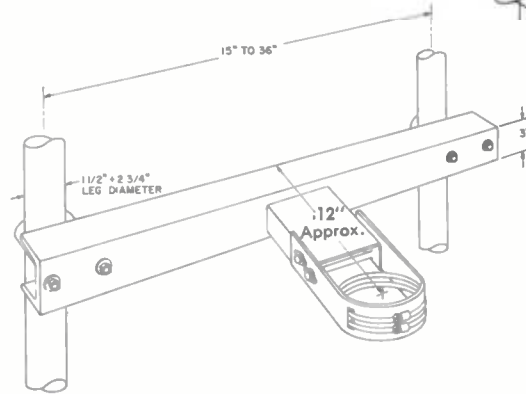
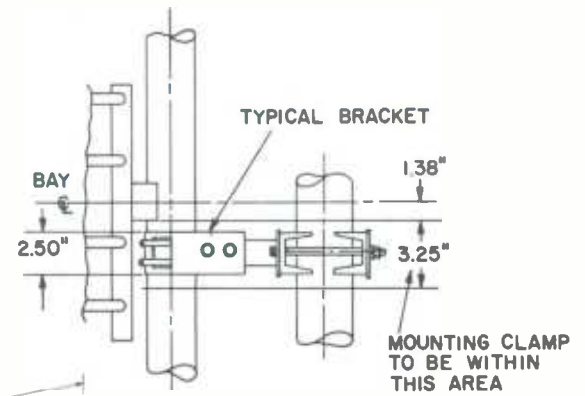

**TYPICAL FACE MOUNT BFA Mounting Details.**

RCA Type	Electrical Data				Freq. Mc	Dimensions in Feet†				Horizontal Windload*			
	Gain		Power Rating			HC Top	HC Side	H Top	H Side	Less De-Icers	With De-Icers		
	Power	dB	kW	dBk									
BFA-1B	0.9	-0.5	5	7.0	Interpolate for In-Between Frequencies						58	70	
					88	5.0	0.50	8.0	1.0	58			70
					98	5.0	0.50	8.0	1.0	58			70
BFA-2B	1.9	2.8	10	10.0	88	10.0	5.55	18.1	11.1	221	267		
					98	9.5	5.00	17.0	10.0	212	256		
					108	9.1	4.60	16.2	9.2	206	248		
BFA-3B	3.0	4.8	15	11.7	88	15.1	10.55	28.1	21.1	319	385		
					98	14.0	9.55	26.1	19.1	303	365		
					108	13.2	8.70	24.4	17.4	289	348		
BFA-4B	4.0	6.0	20	13.01	88	20.1	15.60	38.2	31.2	416	502		
					98	18.6	14.05	35.1	28.1	391	471		
					108	17.3	12.80	32.6	25.6	371	446		
BFA-5B	5.1	7.1	25	13.98	88	25.2	20.65	48.3	41.3	514	620		
					98	23.1	18.60	44.2	37.2	481	579		
					108	21.4	16.90	40.8	33.8	454	545		
BFA-6B	6.3	8.0	30	14.77	88	31.6	27.10	61.2	54.2	635	767		
					98	28.9	24.40	55.8	48.8	591	713		
					108	26.7	22.20	51.4	44.4	556	669		
BFA-7B	7.3	8.6	35	15.44	88	36.8	32.35	71.7	64.7	736	889		
					98	33.6	29.15	65.3	58.3	684	825		
					108	31.0	26.50	60.0	53.0	642	772		
BFA-8B	8.4	9.2	40	16.02	88	42.2	37.70	82.4	75.4	839	1014		
					98	38.4	33.90	74.8	67.8	778	938		
					108	35.3	30.80	68.6	61.6	729	876		
BFA-10B	10.5	10.2	50	16.99	88	52.7	48.25	103.5	96.5	1431	1649		
					98	47.9	43.45	93.9	86.9	1318	1516		
					108	44.0	39.50	86.0	79.0	1225	1407		
BFA-12B	12.5	11.0	60	17.78	88	63.4	58.90	124.8	117.8	1712	1972		
					98	57.5	53.00	113.0	106.0	1591	1817		
					108	52.6	48.10	103.2	96.2	1464	1681		
BFA-14B	14.5	11.62	80	19.03	88	74.1	69.55	146.1	139.1	1993	2295		
					98	67.1	62.55	132.1	125.1	1844	2118		
					108	61.2	56.70	120.4	113.4	1703	1955		
BFA-16B	16.5	12.18	80	19.03	88	84.8	80.20	167.4	160.4	2273	2607		
					98	76.7	72.10	151.2	144.2	2106	2418		
					108	69.8	65.3	137.6	130.6	1941	2228		

† "Hc" (Top Mounting) Height of radiation center above top of tower.  
 "Hc" (Side Mounting) Height of radiation center above lowest part of bottom radiator.  
 "H" (Top Mounting) overall height of antenna above top of tower, not including obstruction lighting.

"H" (Side Mounting) Overall height of antenna measured from top of radiator section to lowest part of bottom radiator section.  
 \* Pounds based on 30 lb./ft.<sup>2</sup> on projected areas of round surfaces.

# Specifications

## Electrical

Frequency Range.....	Factory tuned to any channel in 88-108 MHz band
Power Gain.....	Approximately equal to number of sections stacked (see table)
Polarization.....	Horizontal (Vertical Component is negligible)
Horizontal Pattern .....	Circularity $\pm 1$ dB in free space
VSWR at Input (without field trimming):	
Top Mounting.....	1.2/1 or better
Side Mounting.....	1.5/1 or better
VSWR at Input (with field trimming):	
Top or Side Mounting.....	1.1/1 can be achieved over entire 200 kHz channel
Input Connection .....	$3\frac{1}{8}$ " , 50 Ohms EIA flange
Power Input Rating .....	Approx. 5 kW per section (see table)

## Mechanical

Windload.....	50 psf for flat surfaces; 30 psf for cylindrical surfaces (based on true "extreme" velocity of 110 miles per hour. (see table of specific antenna windloads)
Section Dimensions:	
Height.....	12" (30.48 cm)
Ring Diameter:	
88-98 MHz .....	18" (45.72 cm)
98-108 MHz .....	16" (40.64 cm)
Gap:	
18" Ring.....	5" (12.70 cm)
16" Ring.....	4 $\frac{1}{2}$ " (11.43 cm)
Overall heights and radiation centers.—See Table	
Weight	
Each Four-Ring Radiating Section:	
18".....	22 lbs. (10 kg)
16".....	19 $\frac{1}{2}$ lbs. (9 kg)
Supporting $3\frac{1}{8}$ " Feedline.....	3.0 lbs. per foot (average) (1.36 kg per 30.48 cm)

## Approximate deadweight of antennas:

	Weight—lbs.		Weight—lbs.	
	$6\frac{1}{8}$ "	$3\frac{1}{8}$ "	$6\frac{1}{8}$ "	$3\frac{1}{8}$ "
BFA-1B.....	—	86	BFA-7B.....	596
BFA-2B.....	—	140	BFA-8B.....	648
BFA-3B.....	—	192	*BFA-10B.....	1088
BFA-4B.....	—	245	*BFA-12B.....	1148
BFA-5B.....	—	298	*BFA-14B.....	1221
BFA-6B.....	—	351	*BFA-16B.....	1284

\* Tee input center fed.

## Accessories

De-Icers .....	MI-27986*
Sleetmelter Control Unit.....	MI-27369-A
Transmission Line as required	
BAF-14A FM/AM Isolation Unit:	
88 to 92 MHz .....	MI-28227-1
92 to 108 MHz .....	MI-28227-2
Adaptors—Inner Conductor Only:	
To connect MI-19113 to MI-19089.....	MI-27988-4A
To connect MI-19313 to MI-19089.....	MI-27988-4B
Adaptor (Inner to outer conductor):	
MI-19113— $3\frac{1}{8}$ " 51.5 Ohm to MI-19089— $3\frac{1}{8}$ " 50 Ohm EIA—No transformer, length 6" .....	MI-27988-7A
MI-19113— $3\frac{1}{8}$ " 51.5 Ohm to MI-27791-D Universal Male Flange—No transformer, length 6".....	MI-27988-7B
Quick Step Reducers—Gassed:	
MI-19113 to $\frac{7}{8}$ " 50 Ohm EIA .....	MI-27988-5A
MI-19113/MI-19313 to $1\frac{1}{8}$ " 50 Ohm EIA .....	MI-27988-5B
MI-19089 to $1\frac{1}{8}$ " 50 Ohm EIA .....	MI-27988-5C
MI-19089 to $\frac{7}{8}$ " 50 Ohm EIA .....	MI-27988-5D
$1\frac{1}{8}$ " 50 Ohm EIA to $\frac{7}{8}$ " 50 Ohm EIA .....	MI-27988-5E

\*De-Icers must be factory installed.

# Ordering Information

BFA Type Broadband FM Antenna complete with standard support brackets for side mounting on conventional towers. Order by stock number as follows:

BFA-1B, single section FM antenna.....	MI-27985-1
BFA-2B, two-section FM antenna.....	MI-27985-2
BFA-3B, three-section FM antenna.....	MI-27985-3
BFA-4B, four-section FM antenna.....	MI-27985-4
BFA-5B, five-section FM antenna.....	MI-27985-5

BFA-6B, six-section FM antenna.....	MI-27985-6
BFA-7B, seven-section FM antenna.....	MI-27985-7
BFA-8B, eight-section FM antenna.....	MI-27985-8
BFA-10B, ten-section center-fed, FM antenna.....	MI-27985-10
BFA-12B, twelve-section center-fed, FM antenna .....	MI-27985-12
BFA-14B, fourteen-section center-fed, FM antenna .....	MI-27985-14
BFA-16B, sixteen-section center-fed, FM antenna .....	MI-27985-16

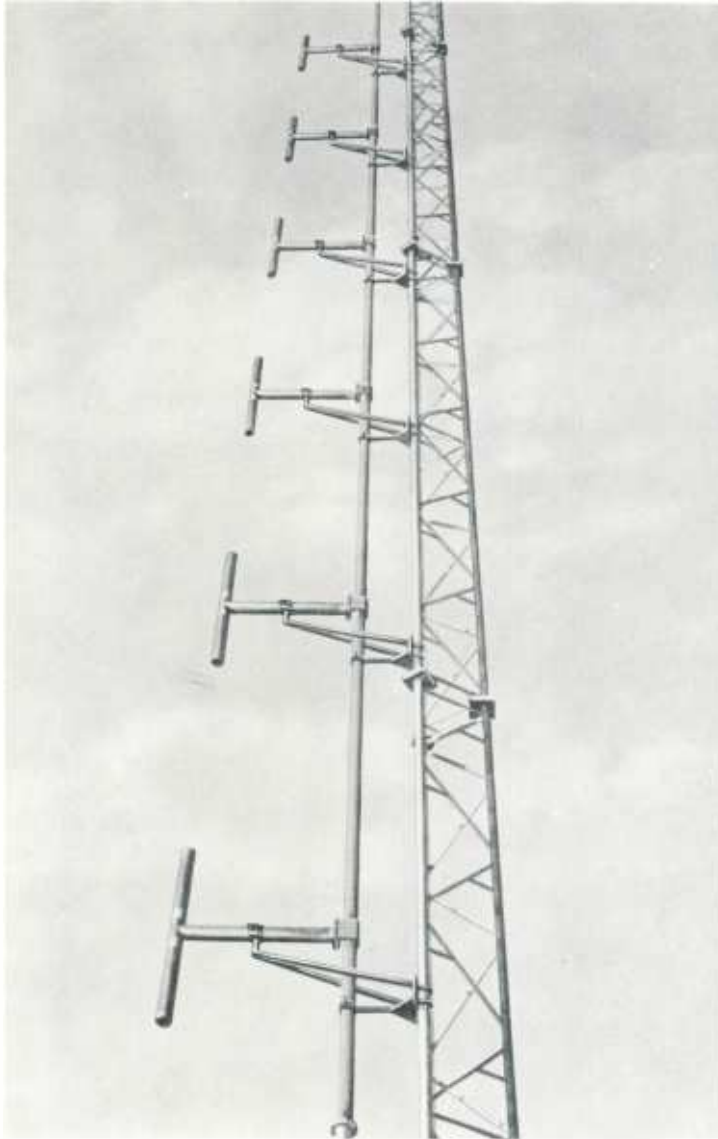

- More signal in auto receivers
- May be used with existing horizontal antennas
- Easy installation—minimum maintenance
- Custom brackets supplied
- Sturdy construction
- High gain—low VSWR
- Light weight—low windload
- Proven field performance

## Vertically Polarized FM Antennas, Type 300-V

### Description

The Type 300 Vertically Polarized FM Dipole Antenna enables an FM station to transmit a supplemental vertically polarized signal to achieve elliptical or circular polarization as authorized in the FCC Rules and Regulations. It can be readily added to an existing horizontally polarized antenna system. Any number of dipoles—from 1 to 16—may be utilized, providing maximum flexibility in the selection of power gain for a particular installation. Power

gain ranges from 0.95 to 17.48, and is approximately equal to the number of dipoles. Antenna arrays are capable of handling transmitter powers up to 48 kilowatts. Deicers are not required.

Special antennas can be provided with null fill or beam tilt for unusual applications.

The antenna consists of two basic parts: (1) radiating dipoles and (2) interconnecting transmission line sections. The dipoles in any array are all identical electrically and mechanically. The Type 300 dipole

is a product of straight-forward electrical and mechanical design. It has low Q which results in a broadband antenna that minimizes cross-coupling between main and subcarrier channels. Although rugged, it is light weight and presents a low windload, thus reducing the cost of supporting structures. It is mainly fabricated of copper tubing which is durable, weather-resistant, and has excellent electrical properties.

Antenna elements are normally spaced one wavelength apart with interconnecting transmission line sec-

tions, and fed through a common system input terminating in a 50 Ohm EIA flange. A typical antenna might consist of several dipoles fed through a power divider to apportion the transmitter power between separate horizontally and vertically polarized antennas.

### Mounting

The antenna is mounted on its supporting structure as a unit using brackets specially fabricated to match the tower and mounting arrangement specified by the purchaser. Antennas are usually side mounted on either guyed or self-supporting towers. Pole or top mounting is available on special order.

The selection of the most appropriate method of mounting a

vertical antenna for use with an existing horizontal polarized antenna is best determined by the station's consulting engineer, taking into account the requirements of coverage, tower loading considerations, feed system requirements, and construction permit requirements.

If there are guy wires in close proximity to the antenna, it is recommended that they be insulated from the tower and broken by insulators every 3 feet for a minimum of 15 feet from the tower to minimize detuning and distortion of the radiation pattern. Antennas of 9 bays or less are fed at the base through a 6 foot transmission line section. Ten or more elements are usually center fed through a 6-foot transmission line section and using a coaxial "T" connector.

### Circularity

Good horizontal pattern depends largely on the inherent circularity of the antenna element. The horizontal radiation pattern of the Type 300 dipole is omnidirectional within  $\pm 1$  dB in free space. When side mounted, the antenna pattern will be affected by the supporting structure. The extent of deviation from a circular pattern will vary with the type and size of the supporting structure.

### Bandwidth and VSWR

The voltage standing wave ratio of the Type 300 antenna can be field adjusted to better than 1.1 to 1. Substantial bandwidth virtually eliminates detuning effects caused by changes in atmospheric conditions. Antennas are carefully tuned to the customer's operating frequency before they are shipped, thus assuring the most efficient installation. Normally no adjustment is required in the field.

### Combining Networks

RCA offers custom combining networks to achieve proper feed of the vertically and horizontally polarized antennas. The custom combining network includes a power divider having the proper splitting ratio for the specific application, a variable matching transformer for use with the type 300-V Vertically Polarized Antenna, all necessary elbows, hangers, and pre-cut sections of rigid transmission line. The combining network is engineered to fit the customer's specific requirement and engineering drawings and layouts are provided to enable the rigger to install the Type 300-V Vertically Polarized Antenna and combining network with a minimum of installation difficulty.

The VSWR of a combined antenna system can be expected to be better than 1.8:1 upon installation and without field trim.

The variable transformers supplied with the combining network and with all RCA Type BFA Series Antennas permits field adjustment of a combined antenna system to provide a VSWR of 1.18:1 or better and assures proper division of power between the vertically and horizontally polarized antennas.



# Specifications

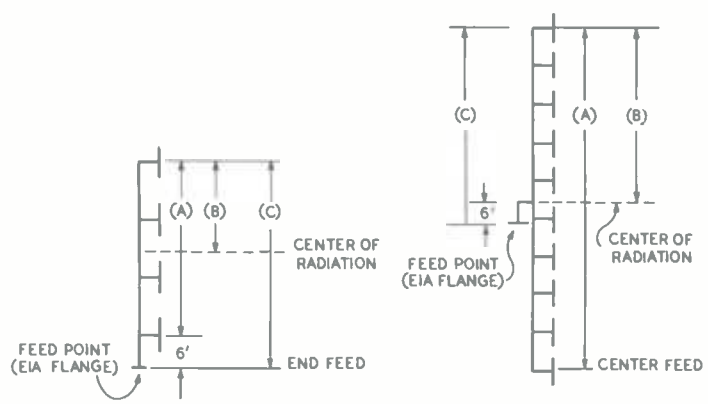
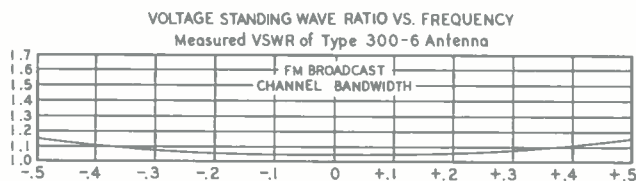

Type	No. of Sections	Gain <sup>1</sup>		Power Rating		Freq. Mc.	Length (Ft) (A)	Dist. (Ft) From Top To Radiation Center (B)	Dist. (Ft) From Top To Feed Point (C)	Weight (lbs) Dipoles & Coax Lines	Wind Load <sup>2</sup>		
		Kw	Db	Kw	Dbk						In Direction Toward Tower	In Direction Across Tower	
300-1	1 <sup>3</sup>	.95	-22	3	4.8	88	0	0	0	57	107	92	
							98	0	0	57	107	92	
							108	0	0	57	107	92	
300-2	2	1.97	2.94	6	7.8	88	11.1	5.6	17.1	164	390	422	
							98	10.0	5.0	16.0	161	378	411
							108	9.1	4.5	15.1	158	368	401
300-3	3	3.12	4.94	9	9.5	88	22.3	11.1	28.3	251	609	689	
							98	20.0	10.0	26.0	246	586	666
							108	18.1	9.1	24.1	241	566	647
300-4	4	4.20	6.23	12	10.8	88	33.4	16.7	39.4	339	829	957	
							98	30.0	15.0	36.0	331	794	922
							108	27.2	13.6	33.2	323	764	892
300-5	5	5.31	7.25	15	11.8	88	44.5	22.3	50.5	427	1048	1224	
							98	40.0	20.0	46.0	416	1002	1178
							108	36.3	18.1	42.3	406	962	1138
300-6	6	6.39	8.06	18	12.6	88	55.7	27.8	61.7	515	1268	1491	
							98	50.0	25.0	56.0	501	1210	1433
							108	45.4	22.7	51.4	489	1161	1384
300-7	7	7.50	8.75	21	13.2	88	66.8	33.4	72.8	603	1487	1758	
							98	60.0	30.0	66.0	586	1417	1689
							108	54.4	27.2	60.4	571	1359	1630
300-8	8	8.57	9.33	24	13.8	88	77.9	39.0	83.9	691	1707	2026	
							98	70.0	35.0	76.0	671	1625	1944
							108	63.5	31.7	69.5	654	1557	1876
300-9	9	9.76	9.89	27	14.3	88	89.0	44.5	95.0	779	1926	2293	
							98	80.0	40.0	86.0	756	1833	2200
							108	72.6	36.3	78.6	737	1755	2122
300-10 <sup>4</sup>	10	10.96	10.40	30	14.8	88	100.2	50.1	56.1	927	2151	2519	
							98	90.0	45.0	51.0	897	2046	2415
							108	81.6	40.8	46.8	873	1958	2326
300-11 <sup>4</sup>	11	11.87	10.74	33	15.2	88	111.3	55.7	67.2	1015	2370	2786	
							98	100.0	50.0	61.0	982	2254	2670
							108	90.7	45.4	55.9	956	2156	2572
300-12 <sup>4</sup>	12	13.20	11.20	36	15.6	88	122.4	61.2	67.2	1102	2590	3053	
							98	110.0	55.0	61.0	1067	2462	2926
							108	99.8	49.9	55.9	1039	2354	2818
300-13 <sup>4</sup>	13	14.03	11.47	39	15.9	88	133.6	66.8	78.3	1190	2809	3321	
							98	120.0	60.0	71.0	1152	2670	3182
							108	108.8	54.4	65.0	1121	2552	3064
300-14 <sup>4</sup>	14	15.29	11.84	42	16.2	88	144.8	72.3	78.3	1278	3029	3588	
							98	130.0	65.0	71.0	1238	2878	3437
							108	117.9	59.0	65.0	1204	2750	3310
300-15 <sup>4</sup>	15	16.30	12.12	45	16.5	88	155.9	77.9	89.5	1366	3248	3855	
							98	140.0	70.0	81.0	1323	3086	3693
							108	127.0	63.5	74.0	1286	2948	3556
300-16 <sup>4</sup>	16	17.48	12.43	48	16.8	88	167.0	83.5	89.5	1454	3468	4122	
							98	150.0	75.0	81.0	1408	3294	3948
							108	136.1	68.0	74.0	1369	3147	3801

<sup>1</sup> Referred to half-wave dipole in free space, assuming antenna radiates 95% of its input power.  
<sup>2</sup> 60 psf wind pressure on flat surfaces, 40 psf on cylindrical surfaces (123 mph actual wind velocity).

<sup>3</sup> 6 ft. transmission line not furnished with 1-section antennas.  
<sup>4</sup> Antennas of 10 bays and over are normally center fed if an even number of bays, or at a point one-half bay below center if an odd number of bays.

## Specifications (Cont.)

### Electrical

Frequency Range ..... Factory tuned to specified frequency  
in 88-108 MHz band.  
Power Gain ..... Approximately equal to number of dipoles.  
(See table)  
Polarization ..... Vertical  
Horizontal Linearity ..... Dipole circular  $\pm 1$  dB in free space  
VSWR ..... Tuned at factory to 1.1:1 or less; less than  
1.5:1 upon initial installation on tower.\*  
Input Impedance ..... 50 Ohms on  $3/8$ " coax.  
Power Input Rating ..... 3 kW per dipole

### Mechanical

Windload ..... 60 psf on flat surfaces, 40 psf on cylindrical  
surfaces (123 mph actual wind velocity)  
Dimensions ..... Length of dipole—3.75 ft. from center of  
transmission line to center of dipole—2.83 ft.  
Weight .....  $3/8$ " dipole—34.0 lbs.  
Typical mounting bracket—22.0 lbs.  
Deicers ..... Not required

\* With the addition of variable input transformer and its adjustment  
1.1:1 VSWR may be obtained for this antenna alone.

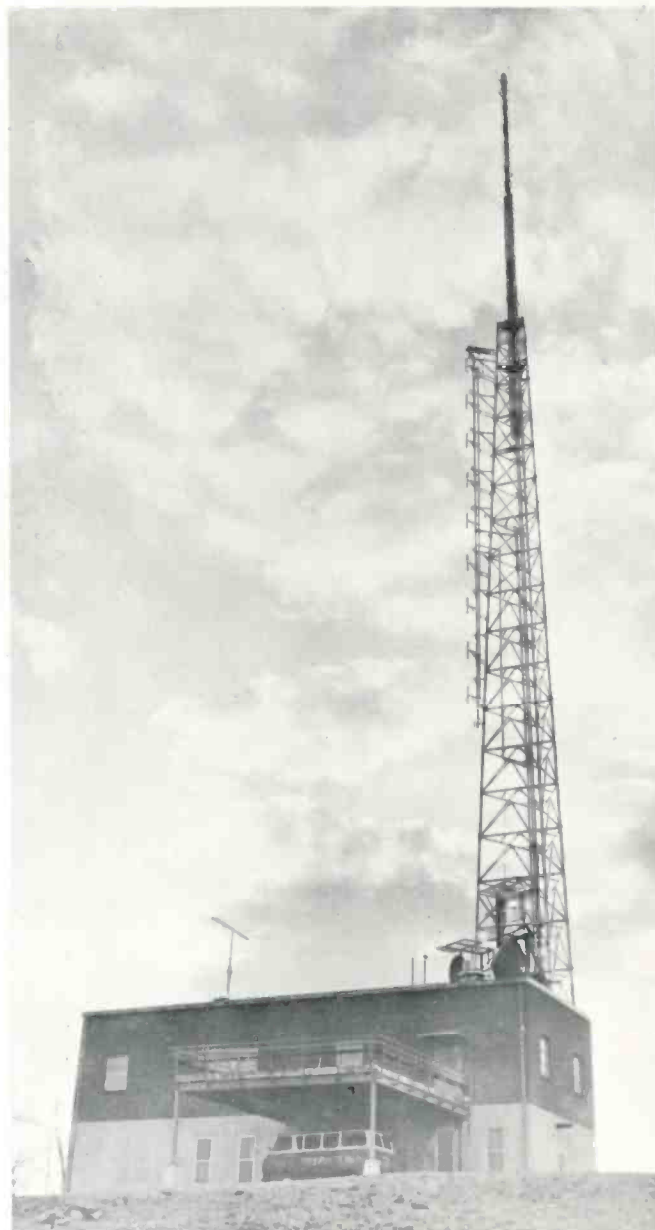

Vertical Polarized Antenna array.

## Ordering Information

Vertically Polarized FM Antenna Dipoles, custom mounting  
brackets,  $3/8$ " interconnecting rigid coax, and  $3/8$ " stand-  
ard EIA flange ..... Type 300-V

# Index

	MI No.	Page
AC Voltage Pickup .....	27516	50
Alarm System, Tone, Type BTRA-5B .....	ES-34281	56
Amplifier Control Module (For BTG Automatic Logging Equipment) .....	561433	58
Amplifier, RF, Type TBM-2500 .....	—	62
Antennas — FM Broadband:		
BFA-1B, Power Gain 0.9 .....	27985-1	95
BFA-2B, Power Gain 1.9 .....	27985-2	95
BFA-3B, Power Gain 3.0 .....	27985-3	95
BFA-4B, Power Gain 4.0 .....	27985-4	95
BFA-5B, Power Gain 5.1 .....	27985-5	95
BFA-6B, Power Gain 6.3 .....	27985-6	95
BFA-7B, Power Gain 7.3 .....	27985-7	95
BFA-8B, Power Gain 8.4 .....	27985-8	95
BFA-10B, Power Gain 10.5 .....	27985-10	95
BFA-12B, Power Gain 12.5 .....	27985-12	95
BFA-14B, Power Gain 14.5 .....	27985-14	95
BFA-16B, Power Gain 16.5 .....	27985-16	95
Antennas—FM Vertically Polarized .....	300-V	99
Antenna Lighting Choke:		
Capacitor for .....	27728-1	93
Double RF .....	7112-C	93
Triple RF .....	27726-A	93
Automatic Logging Equipment:		
BTG-5AL Five Function, Local Use .....	ES-561485	57
BTG-10AL Ten Function, Local Use .....	ES-561486	57
BTG-20AL Twenty Function, Local Use .....	ES-561487	57
BTG-5AR Five Function, Remote Use .....	ES-561488	57
BTG-10AR Ten Function, Local Use .....	ES-561489	57
BTG-20AR Twenty Function, Remote Use .....	ES-561490	57
Automatic Output Control .....	27564	55
Cabinet (For BTE-10C FM Exciter) .....	560304	42
Capacitor for Antenna Lighting Choke .....	27728-1	93
Chart, 6 Rolls, 30-foot each .....	561430	58
Commutator, Meter 12-Function .....	27555	50
Contactors:		
RF, DPDT, 25 Amp. ....	27755-2	54
RF Latching, Type SPDT, 25 Amp. ....	27755-1	54
Control, Automatic Output .....	27564	55
Control Module, Spare Amplifier (For BTG Automatic Logging Equipment) .....	561433	58
Crystal:		
For BTX-1A Sub-Carrier Generator .....	34520	46
For Oven (For BTE-10C Exciter) .....	560302	42
Exciter, FM Type BTE-10C .....	ES-560217	43
Filter:		
53 kHz (For use with Stereo and BTX-1A) .....	560003	48
Plug-In Sub-Carrier, tuned to SCA frequency .....	560312	63
5-Inch Cathode-Ray Oscilloscope, WO-91B .....	40439	65
Frequency Monitor, McMartin TBM-3000 .....	560315	60
Frequency Monitor & Modulation Meter, Model 335-BR .....	—	59



	MI No.	Page
<b>Generator:</b>		
BTS-1A Stereo Subcarrier .....	ES-560202	47
BTX-1A Subcarrier .....	ES-27295	43
Ground Screen, Expanded Copper, 8' x 24' .....	27765	93
Ground Strap 3" by .020 .....	28405-A4	93
Hazard Markers .....	—	93
Hot Dip Galvanizing of Angle Frame Work for Markers .....	—	93
Housing, Weatherproof .....	27741	93
<b>Indicator:</b>		
Temperature, Indoor .....	27550-1	50
Temperature, Outdoor .....	27550-2	50
<b>Latching Relay:</b>		
DPST .....	27524-2	50
DPST, 6 Amp. ....	27524-1	50
4 PDT .....	27524-3	50
Panel (Including two relays) .....	27509-A	50
Latching RF Contactor, Type SPDT, 25 Amp. ....	27755-1	54
Light Control Relays, Fisher Pierce .....	251-A	93
<b>Lighting Choke:</b>		
Double RF Antenna .....	7112-C	93
Triple RF Antenna .....	27726-A	93
Limiter, Power Max Negative Peak .....	34654	58
Meter Commutator, 12-Function .....	27555	50
Meter, Remote Modulation .....	HP-112-13	59
Momentary Relay Unmounted DPDT .....	27545-2	50
<b>Monitor:</b>		
Frequency, McMartin TBM-3000 .....	560315	60
Frequency & Modulation Meter, 335-BR .....	—	59
Multiplex, BW-73A .....	ES-560200-A	63
Stereo Modulation, McMartin, TBM-4500A .....	—	61
Monitoring & Control Unit, Tower Light .....	27519	50
Monitoring Unit (For Tower Light) .....	27544	50
<b>Multiplex Modulation Monitor:</b>		
Type BW-73A .....	ES-560200-A	63
Oscilloscope, 5-Inch Cathode-Ray, WO-91B .....	40439	65
Output Control, Automatic .....	27564	55
<b>Panel:</b>		
Latching Relay (Including two relays) .....	27509-A	50
2-Meter .....	ES-27220	50
<b>Photo-Cell:</b>		
3000 W Fisher Pierce .....	—	93
6000 W Fisher Pierce .....	—	93
<b>Pickup Unit:</b>		
Remote RF, 5 kW .....	27966-B	50
Remote RF, 50 kW .....	28027-B	50
Power Control, Remote (For BTF-1E) .....	27558	8
Power Cutback Kit, Remote .....	27520	50
Power Max Negative Peak Limiter .....	34654	58
<b>Probe:</b>		
RF-IF-VF Signal-Tracing, WG-302A .....	—	65
Voltage Divider, WG-354A .....	—	65

	MI No.	Page
<b>Relay:</b>		
Latching DPST, 6 Amp. ....	27524-1	50
Latching DPST .....	27524-2	50
Latching 4 PDT .....	27524-3	50
Latching Panel (Including two relays) .....	27509-A	50
Light Control (Fisher Pierce) .....	251-A	93
Momentary Unmounted DPDT .....	27545-2	50
RF 12.5 Amp. ....	27545-1	50
<b>Remote Control Equipment:</b>		
Type BTR-11B .....	ES-34280	49
Type BTR-20C .....	ES-34274	51
Type BTRX-40A .....	27556	54
Type BTF-1D/1E Power .....	27558	8
Remote Modulation Meter .....	HP-112-13	59
<b>Remote RF Pickup Unit:</b>		
5 kW .....	27966-B	50
50 kW .....	28027-B	50
RF Amplifier, Type TBM-2500 .....	—	62
<b>RF Contactor:</b>		
DPDT, 25 Amp. ....	27755-2	54
Latching Type SPDT, 25 Amp. ....	27755-1	54
RF-IF-VF Signal-Tracing Probe, WG-302A .....	—	65
RF Relay, 12.5 Amp. ....	27545-1	50
Screen, Expanded Copper Ground, 8' x 24' .....	27765	93
Stereo Modulation Monitor, McMartin TBM-4500A .....	—	61
Stereo Subcarrier Generator, BTS-1A .....	ES-560202	57
Strap, Ground 3" by .020 .....	28405-A4	93
Strip Chart for Logging, 6 Rolls, 30-foot each .....	561430	58
Subcarrier Filter, Plug-in, Tuned to SCA Frequency .....	560312	63
Subcarrier Generator (SCA), Type BTX-1A .....	ES-27295	43
<b>Temperature Indicator:</b>		
Indoor .....	27550-1	50
Outdoor .....	27550-2	50
Tone Alarm System, Type BTRA-5B .....	ES-34281	56
Tower Light Monitoring Unit .....	27544	50
Tower Light Monitoring & Control Unit .....	27519	50
<b>Tower Lighting Kits:</b>		
Heights up to 150 ft. ....	A-1	93
Heights of 151 ft. to 300 ft. ....	A-2	93
Heights of 301 ft. to 450 ft. ....	A-3	93
<b>Transformer:</b>		
1750 Watts (Hughey & Phillips) .....	TI-2017	93
3500 Watts (Hughey & Phillips) .....	TI-2035	93
<b>Transmission Line:</b>		
1½", 51.5 Ohm Rigid Copper Line;		
20' Length, Flanged .....	19112-1	69
20' Length, One Flange .....	19112-1-F	69
20' Length, No Flange .....	19112-1-NF	69
Adapter Plain to Flange Line .....	19112-4	69
Gas Stop .....	19112-5	69
Straight Coupling (Includes Bullet) .....	19112-8	69
Special size innerconductor for TV splicing .....	19112-9	70

	MI No.	Page
"O" Ring Gasket .....	19112-10	70
Innerconnector .....	19112-11	70
Cover Plate .....	19112-13	70
Adapter Flanged to Unflanged Line, Clamp Type .....	19112-16	70
End Seal .....	19112-17	70
90 Degree Miter Elbow .....	19112-18	70
90 Degree Miter Elbow (One Flange) .....	19112-18-1F	70
90 Degree Miter Elbow (No Flange) .....	19112-18-NF	70
Hardware Kit .....	19112-19	70
1½" Fixed Flange .....	19112-20	70
1½" Swivel Flange .....	19112-21	70
45 Degree Miter Elbow .....	19112-22	70
45 Degree Miter Elbow (One Flange) .....	19112-22-1F	70
45 Degree Miter Elbow (No Flange) .....	19112-22-NF	70
1½" Hose Clamp .....	19112-39	70
Reducer 1½" Type "N" (Ungassed) No Flange .....	19112-58	70
1½" Reducer to Type "N" (Gassed) Flanged .....	19112-59	70
Field Flange .....	19112-60	70
Adapter 1½" 51.5 Ohm Unflanged to 1½" 50 Ohm EIA Flange (No bullets) 6" long .....	19112-61	70
Adapter 1½" 51.5 Ohm Flange male to 1½" 50 Ohm Flange male (No bullets) 6" long .....	19112-62	70
<b>3½" 51.5 Ohm Rigid Copper Line;</b>		
20' Length, Flanged .....	19113-C-1	71
20' Length, One Flange .....	19113-C-1F	71
20' Length, No Flange .....	19113-C-1NF	71
20' Length, One Fixed Flange, One Swivel Flange .....	19113-C-1SF	71
Gas Stop .....	19113-C-5	71
Reducer (Gassed) .....	19113-C-6	71
Reducer (Ungassed) .....	19113-C-7	71
Straight Coupling (Includes Bullet and 2 Hose Clamps) .....	19113-C-8	71
Straight Coupling (less Bullet but including 2 Hose Clamps) .....	19113-C-8NB	71
Tube (Inner conductor for TV Splicing) .....	19113-C-9	71
O-Ring Gasket .....	19113-C-10	72
Innerconnector .....	19113-C-11	72
Cover Plate .....	19113-C-13	72
End Seal .....	19113-C-17	72
90 Degree Miter Elbow, Flanged .....	19113-C-18	72
90 Degree Miter Elbow, One Flange .....	19113-C-18F	72
90 Degree Miter Elbow, No Flange .....	19113-C-18NF	72
Hardware Kit .....	19113-C-19	72
Fixed Flange .....	19113-C-20	72
Swivel Flange .....	19113-C-21	72
45 Degree Miter Elbow, Flanged .....	19113-C-22	72
45 Degree Miter Elbow, One Flange .....	19113-C-22F	72
45 Degree Miter Elbow, No Flange .....	19113-C-22NF	72
Cut-Off Gauge .....	19113-C-51	72
Cut-Off Gauge .....	19113-C-54	72
Adapter, Soft Solder .....	19113-C-55	72
Reducer (Ungassed) .....	19113-C-58	73
Flanged to Unflanged Coupling (Ungassed Mechanical) .....	19113-C-60	73
Reducer .....	19113-C-61	73
<b>Special Adapters;</b>		
Inner connector Adapters .....	27988-4A	73
Inner connector Adapter .....	27988-4B	73
Adapter Flange (Ungassed) .....	27988-4C	73
Quick Step Reducer (3½" to 7/8") .....	27988-5A	73

	MI No.	Page
Quick Step Reducer (3½" to 1½") .....	27988-5B	73
Quick Step Reducer (EIA 3½" to 1½") .....	27988-5C	73
Quick Step Reducer (EIA 3½" to 7⁄8") .....	27988-5D	73
Quick Step Reducer (EIA 1½" to 7⁄8") .....	27988-5E	73
Adapter Section (¾" to 3½") .....	27988-7A	72
Adapter Section (3½" to MI-27791-K) .....	27988-7B	73
Male to Male Adapters (7⁄8") .....	27988-7C	73
Male to Male Adapters (1½") .....	27988-7D	73
Male to Male Adapters (3½") .....	27988-7E	73
Flexible Helix Air Dielectric Line .....	—	75
Accessories for Flexible Helix Air Dielectric Line .....	—	77
Flexible Helix Foam Dielectric Line .....	—	77
Accessories for Flexible Helix Foam Dielectric Line .....	—	77
Flexible RG/U Type Coaxial Cable,		
RG-8AU, 52 Ohms, Low Temp. Jacket .....	74A	70
RG-11AU, 75 Ohms, Low Temp. Jacket .....	83A	79
RG-17AU, 52 Ohms, Low Temp. Jacket .....	47A	79
Hangers;		
Expansion Type, 1½" Single Line,		
Pivot, Grounded Clamp on Round Members, 1" to 2¼" Short .....	19312-23	80
Pivot, Grounded Clamp on Round Members, 1" to 2¼" Long .....	19312-24	80
Pivot, Grounded Clamp on Round Members, 2¼" to 5" Short .....	19312-26	80
Pivot, Grounded Clamp on Round Members, 2¼" to 5" Long .....	19312-27	80
Pivot, Insulated Clamp on Round Members, 1" to 2¼" .....	19312-25	80
Pivot, Insulated Clamp on Round Members, 2¼" to 5" .....	19312-28	80
Grounded, Clamp on Angle Members .....	19312-29	80
Grounded, Clamp on Angle Member .....	19312-30	80
Pivot, Grounded Mount Through Hole, Short .....	19312-32	80
Pivot, Grounded Mount Through Hole, Long .....	19312-33	80
Pivot, Insulated Mount Through Hole .....	19312-34	81
Pivot, Insulated Clamp on Angle Member, Long .....	19312-31	81
Fixed, 1½" Rigid Line,		
Grounded, Clamp on Round Members .....	19312-41	81
Grounded, Clamp on Round Members .....	19312-42	81
Grounded, Mount Through Hole .....	19312-44	81
Grounded, Mount Through Hole .....	19312-47	81
Grounded, Clamp on Angle Members .....	19312-43	82
Miscellaneous 1½" Rigid Line Hanger Accessories,		
Grounded Horizontal Anchor .....	19312-17	82
Grounded Horizontal Roller Assembly .....	19312-35	82
Grounded Lateral Brace .....	19312-36	83
Grounded Swivel Hanger .....	19312-37	83
Expansion, 3⁄8" Rigid Line,		
Grounded, Clamp on Round Members (1" to 2¼" Short) .....	19313-23	83
Grounded Clamp on Round Members (1" to 2¼" Long) .....	19313-24	83
Grounded, Clamp on Round Members (2¼" to 5" Short) .....	19313-26	83
Grounded, Clamp on Round Members (2¼" to 5" Long) .....	19313-27	83
Grounded, Mount Through Hole, Short .....	19313-32	83
Grounded, Mount Through Hole, Long .....	19313-33	83
Grounded, Clamp on Angle Members, Short .....	19313-29	84
Grounded, Clamp on Angle Members, Long .....	19313-30	84
Insulated, Clamp on Round Members (1" to 2¼" Long) .....	19313-25	84
Insulated, Clamp on Round Members (2¼" to 5" Long) .....	19313-28	84
Insulated, Mount Through Hole .....	19313-34	84
Insulated, Clamp on Angle Members .....	19313-31	84

	MI No.	Page
Fixed, 3/8" Rigid Line,		
Pivot, Grounded Clamp on Round Members, (1" to 2 1/4" Short) .....	19313-41	85
Pivot, Grounded Clamp on Round Members, (2 1/4" to 5" Short) .....	19313-42	85
Pivot, Grounded Mount Through Hole, Short .....	19313-44	85
Pivot, Grounded Mount Through Hole, Long .....	19313-47	85
Pivot, Grounded Clamp on Angle Members, Short .....	19313-43	85
Miscellaneous 3/8" Rigid Line Accessories,		
Grounded Horizontal Roller Assembly .....	19313-35	86
Grounded Horizontal Anchor .....	19313-17	86
Grounded Lateral Brace .....	19313-36	87
Grounded Swivel Hanger .....	19313-37	87
Grounded 3-Point Hanger .....	19313-50	87
Indoor Hanger Kits;		
Hanger & Fastener Kit for 3/8" Line .....	27700	88
Wall Bracket Kit .....	27702	88
Wall Bracket Extension Kit .....	27703	88
Hanger Plate Mounting Kit .....	27704	88
"I" Beam Mounting Kit .....	27705	88
Concrete Mounting Kit .....	27706	88
Transmitters:		
BTE-10CT, 10-Watt FM Transmitter .....	ES-560236	41
BTF-1E1, 1-kW FM Transmitter .....	ES-27279-A	5
BTF-5E, 5-kW FM Transmitter .....	ES-560223	9
BTF-10E, 10-kW FM Transmitter .....	ES-560224	17
BTF-20E, 20-kW FM Transmitter .....	ES-560225	25
BTF-40E 40-kW FM Transmitters .....	ES-560229	33
Tubes:		
Complete Sets;		
For BTE-10CT .....	560301	42
For BTF-1E1 .....	560301/34709	8
For BTF-5E .....	560301/ES-560226	16
For BTF-10E .....	560301/ES-560227	24
For BTF-20E .....	560301/ES-560228	32
For BTF-40E .....	560301/ES-560233	40
Spare Sets;		
For BTE-10CT .....	560301	42
For BTF-1E1 Amplifier .....	34709	8
For BTF-5E Amplifier .....	ES-560226	16
For BTF-20E Amplifier .....	ES-560228	32
For BTF-10E Amplifier .....	ES-560227	24
For BTF-40E Amplifier .....	ES-560233	40
For BTS-1A .....	560005	48
For BTX-1A .....	34514	46
2-Meter Panel .....	ES-27220	50
Voltage Divider Probe, WG-354A .....	—	65
Voltage Pickup, AC .....	27516	50
Weatherproof Enclosure (For MI-27544) .....	27543	50
Weatherproof Housing .....	27741	93
Wire, No. 10 Copper .....	28405-8	93





**The Most Trusted Name in Electronics**

**RADIO CORPORATION OF AMERICA**

BROADCAST AND COMMUNICATIONS PRODUCTS DIVISION, CAMDEN, N. J. 08102 • RCA INTERNATIONAL DIVISION, CENTRAL and TERMINAL AVENUES, CLARK, NEW JERSEY, U.S.A. 07066