

# TABLE OF CONTENTS

ABOUT SPARTA	2
AUDIO SECTION	3
SPARTAMATION SECTION	45
TRANSMITTER SECTION	59
ANTENNAS AND ACCESSORIES	81
TRANSMITTER ACCESSORIES	89
GRAPHS AND SYMBOLS	101
SALES INFORMATION	103
INDEX	104



5851 FLORIN-PERKINS ROAD, SACRAMENTO, CALIFORNIA 95828 (916) 383-5353.

TELEX 377-488. CABLE: SPARTA

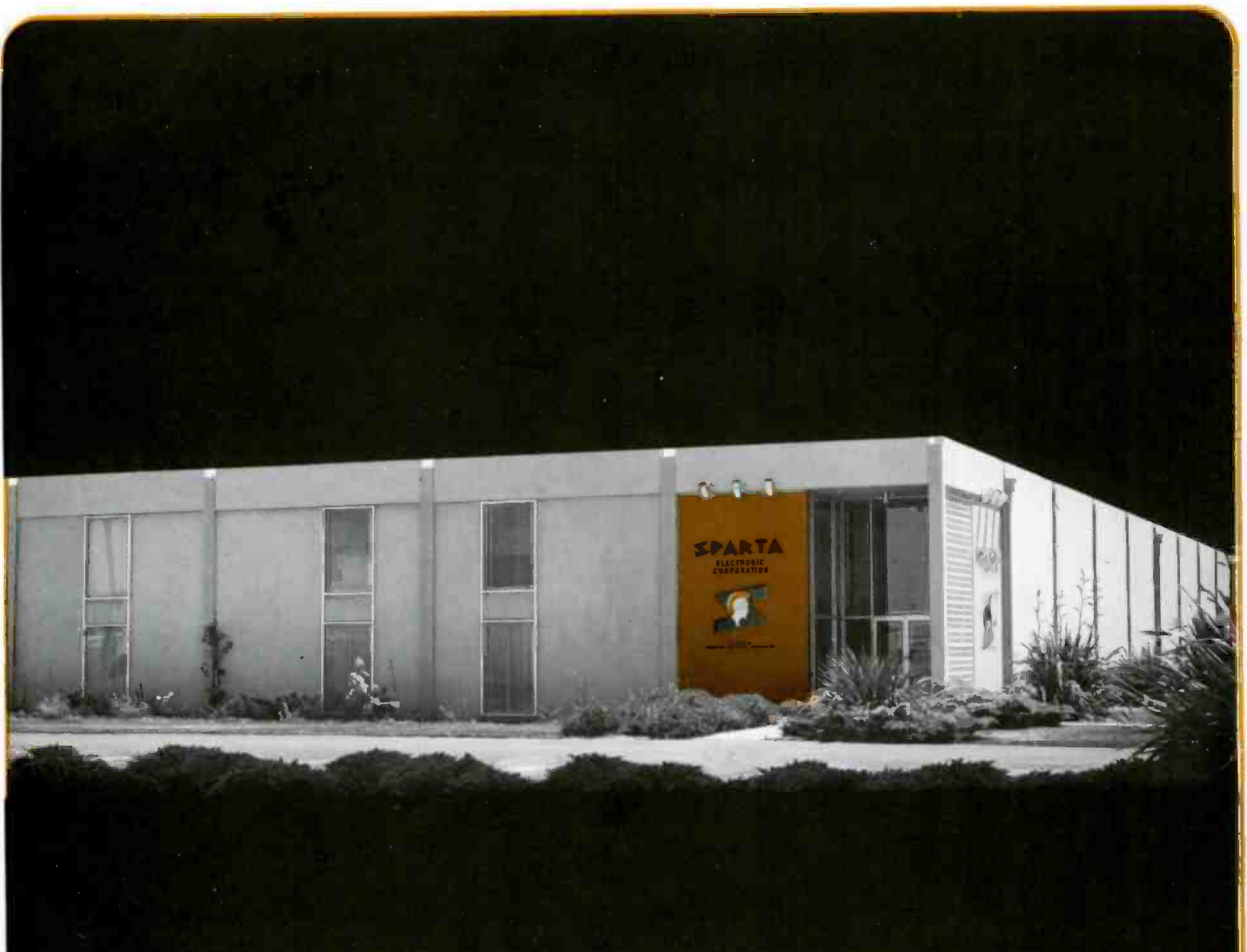

The world-wide marketing activities of Sparta Electronic Corporation originate at this facility in Sacramento, California. Both Audio and Transmitter products leave this building for broadcast, audio-visual, and cable TV use in every state of the union and most countries around the globe.

Yet in spite of its international business commitments, Sparta continues to offer broadcasters the type of service usually available only from a small company still in the process of building its reputation. It is Sparta's belief that sheer **BIGNESS** is not necessarily **PROGRESS**, and that more can be accomplished (and with greater satisfaction) by continuing to deal with its customers on a personalized basis. This is accomplished while giving nothing away in research and development, or technological knowhow.

The effort is worth the results, we believe, and the great and growing number of people who insist on doing business with Sparta is not only indicative of engineering excellence, but also of our personal service.

Sparta is not only buildings. Not only products. Not only an idea.

Sparta is **PEOPLE** . . . designing, fabricating, testing. Sparta is people . . . serving **YOU**.

# AUDIO

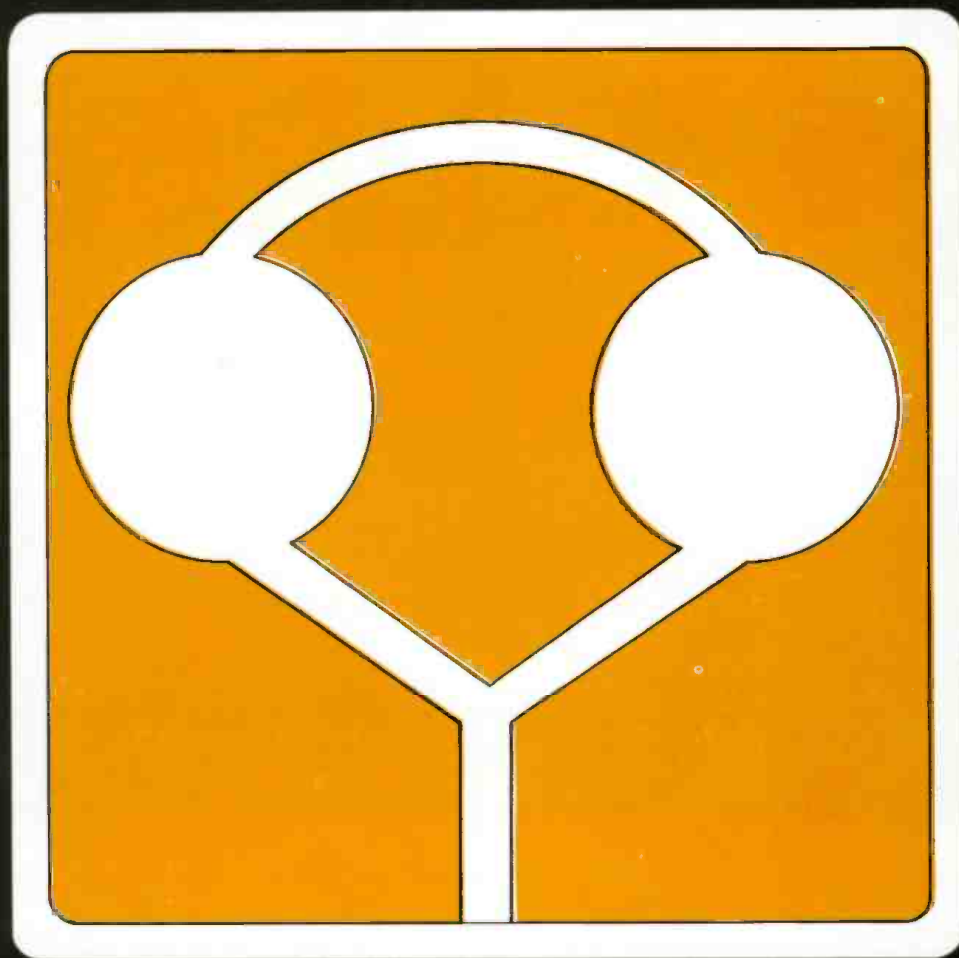



It's a DJ's delight! A *beautiful* place to work. It's the Sparta Showcase control room cabinetry series.

Each piece features rugged construction. The designs include extra heavy material, modular construction and special leveling devices. All surfaces are made of hard, mar-resistant plastic laminate.

The finish is color-coordinated in a rich walnut grain brown, offset by a light decorator beige.

Equipment and cabinetry are available individually or in several different groups at discounts. Your control room can now have the custom look of richness and quality without the custom cost.

## SHOWCASE PACKAGE

Save money over the single unit price by choosing one of several packages. Groups include equipment and furniture (except chair) in choice of monaural or stereo versions.

### GROUP 1

A-20B Console (monaural) or AS-40B-1 (stereo) with 101-1 Console Desk, 101-1-3 Console Hood Monitor/Cue Speaker, professional MIC-5 omnidirectional microphone with gooseneck mounting hardware, 101-3-4 Dual Turntable Return with 2 GT-12-4 Custom Turntable Systems.

### GROUP 2

All of Group 1, plus 101-3-5 Dual Utility Return Pedestal with 101-6 Cartridge Hutch.

### GROUP 3

All of Group 1 and 2, plus a SPARTA Century Series Tape Cartridge System of two playbacks and one record/playback.

A. The Dual Turntable Return (101-3-4) displays 2 new SPARTA GT-12 Custom Turntable Systems. An area directly below the top surface is for cables and accessories. Behind the sliding doors, a full set of metal record dividers is supplied. Optional Rack Brackets (101-3-1) provide 28" of standard 19" rack space. Dimensions: 30" high with level-adjusting feet, 40 7/8" wide, 20 1/8" deep.

B. The Single Turntable Return (101-7) has the same features as the Dual Return. It can be ordered without the turntable cut-out to serve as a utility cabinet. Dimensions: 30" high with level-adjusting feet, 20 3/4" wide, 20 1/8" deep.

C. The Console Desk (101-1A) with stainless steel legs, is designed for the A-20B Consoles and Console Hood (101-1-3). This unit is also available to fit any console. Dimensions: 82 1/4" long, 24 1/4" deep and 28 1/2" high to the work surface.

D. The Dual Utility Return (101-3-5) is shown with the Tape Cartridge Hutch (101-6). The Hutch stores 96 model 300 cartridges. The area beneath the top is for rack mount equipment as is the area behind the sliding doors. Optional Rack Brackets (101-3-1) provide 28" of standard 19" rack space. Dimensions: Dual Return and Hutch, 50" high with level-adjusting feet, 40 7/8" wide, 20 1/8" deep.



A.



B.



C.



D.



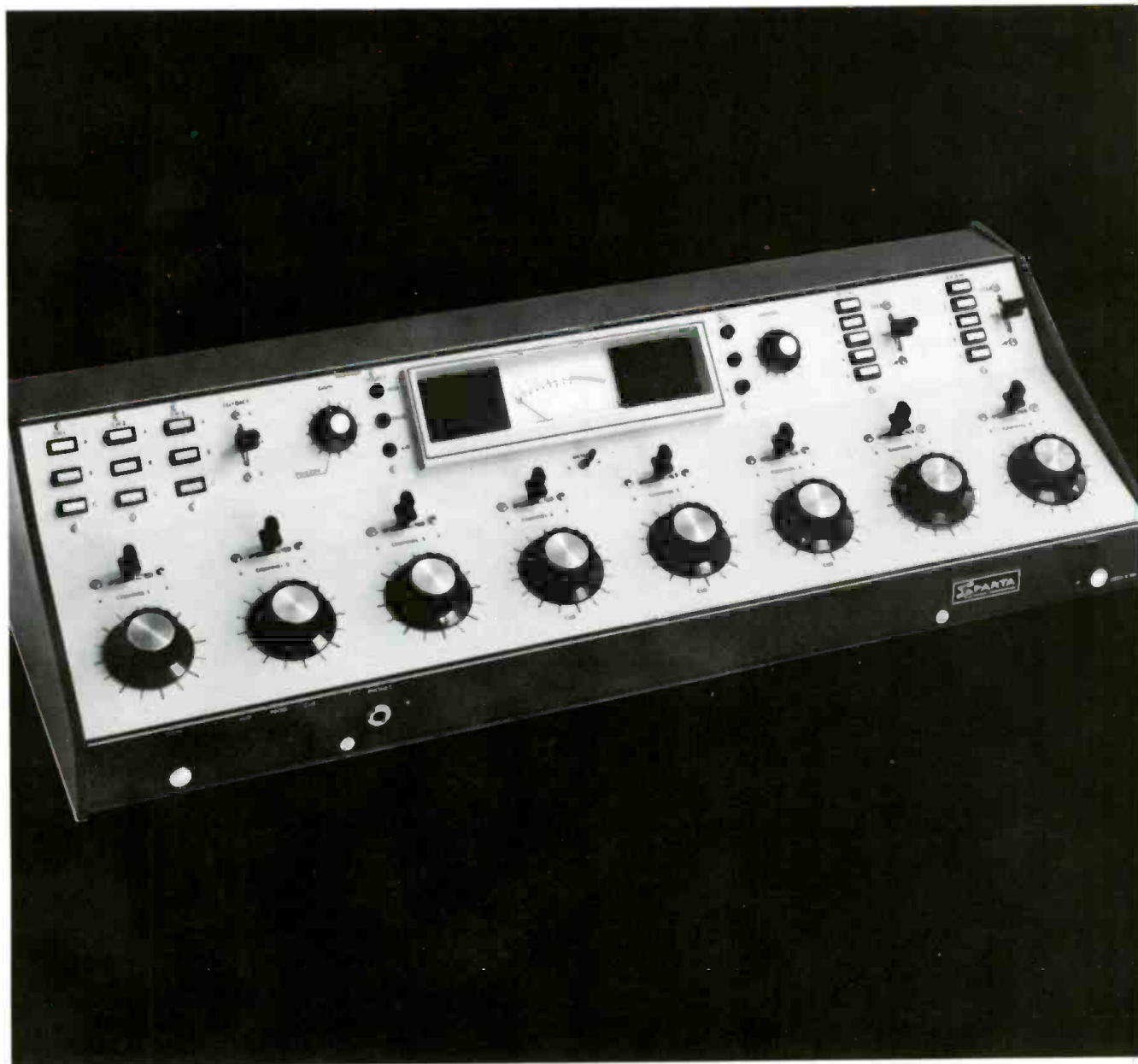

It's beautiful! And *functional*. The A-20B is today's newest 8-mixer, full facility monaural audio console. Contemporary styling and advanced solid-state design have made the A-20B more compact than any other comparable console in its class. Yet it does the job of consoles twice its size and price. Give your control room an uncluttered look, more room for other equipment, and still have plenty of operator work space.

The A-20B is feature loaded! Fast push-button se-

lection makes for a tight board operation. The 2 position meter switch provides dual monitoring capability for separate program outputs. Lasting quality of the A-20B is emphasized by its rugged and well shielded metal cabinet, tough textured vinyl finish, and its cast metal end plates and meter bezel.

The A-20B will do the job you want. And do it in style.

Full-facility operation of the A-20B is illustrated by the console functional diagram. The eight mixer controls are the preferred rotary attenuators with a counter-clockwise cue function. The cue position is present on all mixers. A lever switch above each mixer, with a center "off" position, directs the audio source to either the program or audition channels.

Mixers 1, 2 and 3 are provided as standard equipment with low-level preamplifiers for microphone mixing. A three-station push-button source selector switch for each of these mixers allows choice of three sources each, for a total of nine low-level inputs. If additional low-level channels are needed, preamplifiers may be installed.

Three muting relays are supplied which can function with any of the first three mixing channels in any combination, or alternately can be connected by the user to operate with other mixing channels. Each relay provides muted monitor-audio output plus an isolated contact-pair for control of external equipment.

A talk-back selector switch allows the output of the mixer 1 preamplifier to be diverted to either A or B terminals on the rear panel. These outputs may be fed to a small amplifier/speaker combination of the user's choice, to provide studio talk-back facilities.

Inputs to mixers 4, 5 and 6 are normally high-level and are fed to the channel selector without additional switching. Mixers 7 and 8 are each provided with a five station, push-button source selector switch for maximum flexibility, for a total of ten high-level inputs to these two mixers. A three-position lever switch associated with the push-button source-selector switch of mixer 7 and 8 extend the flexibility of the SPARTA A-20B even further by adding provisions for Mix, Cue and Feed. In the Mix position, the audio chosen by the source selector switch is fed to the bus for normal mixing. In the Cue position, the source selected is fed to the cue system so the incoming signal may be monitored. When in the Feed position, the audio chosen by the monitor selector switch, Audition, Program, or Air (Air is an external input), may be fed down a remote line.

The Program and Audition channels are identical in all respects and a front-panel switch is provided to allow the VU meter to monitor either one. The monitor amplifier is also provided with a switch to allow it to monitor either the program channel, audition channel or an external input such as "Air". To further increase flexibility of the A-20B, an auxiliary three-station push-button switch is provided plus a group of spare terminals on the rear panel. These items may be connected, at user discretion, to provide additional features. The headphone station has its own gain control and three-position source selector switch.

A unique feature of the A-20B Console is the use of high-impedance bridging inputs on all high-level channels. This allows the console to be used with high-impedance sources while in no way limiting its performance from normal 600 ohm line. High-level inputs may be terminated, either singly or collectively, (if required) by the simple addition of 620 ohm resistors.

MIXERS.....	Eight.
INPUTS.....	Twenty-two: Three each, mixers 1 to 3; one each, mixers 4 to 6; five each, mixers 7 and 8. Plus external monitor and headphones.
INPUT LEVELS.....	Low-level: -55 dbm from 50/150/250 ohms. Preamplifiers standard on mixers 1 to 3; optional for mixers 4 to 8. High-level: -10 dbm nominal, standard on mixers 4 to 8. External monitor; 1 volt rms. External headphones; 1 mw. rms.
INPUT IMPEDANCE.....	Balanced bridging; 600 ohm, see note 1.
OUTPUTS.....	Two identical (Audition and Program), cue, monitor, headphones.
OUTPUT LEVELS.....	Program and Audition: 8 dbm at $\phi$ vu. 20 dbm maximum. 600 ohms, bridging. Cue; 0.5 watts into 3.2 or 4 ohms. Monitor; 8 watts into 8 ohms.
RESPONSE.....	Program and Audition; $\pm 2$ db, 20 Hz to 20 kHz. Monitor and cue; $\pm 2$ db, 20 Hz to 20 kHz.
NOISE.....	Below 65 db at $\phi$ vu out with -55 db low-level input. Below 75 db at $\phi$ vu out with -10 dbm hi-level input.
DISTORTION.....	Program and Audition: Less than 0.5% THD at 8 dbm output; 1% maximum. Monitor and Cue: Less than 1% THD at rated output.
CROSSTALK.....	Within 6db of noise.
POWER.....	115/230 vac., 50/60 Hz.
SIZE.....	28 $\frac{3}{8}$ " long, 6 $\frac{1}{2}$ " high, 10" deep.
WEIGHT.....	35 lbs.
MUTING.....	Three internal relays operate from mixers 1, 2 or 3 in any combination via internal patch-panel. Each relay provides independent muted monitor out plus isolated closure for control of external equipment (115 vac., 5A max.)
NOTE 1.....	High level inputs are 10 K ohm balanced bridging, allowing individual termination of input lines at rear panel, if required.

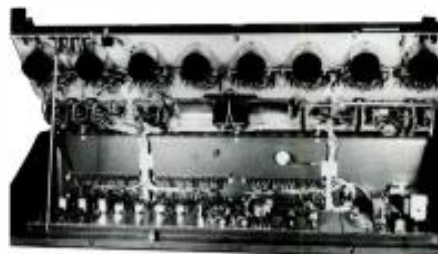

Front panel lifts for easy access to circuit modules.

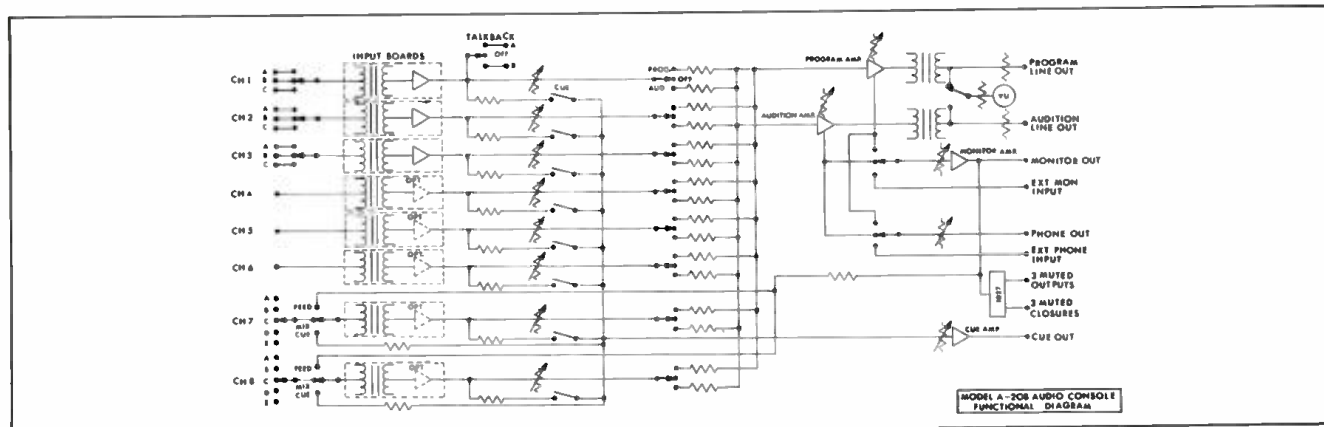





The new A-15B monaural audio console does the job better than any 5-mixer console. The A-15B can handle 14 audio source inputs with any combination of high or low-level you desire. It has a big 8-watt monitor amplifier with built-in relay muting and a 1-watt cue amplifier. Input switching is super-fast with quiet lever switching and 5-station push-button banks. Its top assignment is usually in the production room of a broadcast station. But it is equally efficient in radio or TV mobile vans, small main studios, CATV audio controls, school

and college broadcast facilities, newsrooms, and in many more audio requirements.

All this, and styling too. Its low silhouette is emphasized by a compact layout between thick cast metal end plates. The gleam of spun aluminum is softly offset by a textured beige field and deep smoke colored trim.

For the most capable, versatile and styling console, at a realistic price, nothing beats the A-15B.

The SPARTA A-15B is a compact audio console featuring five mixing channels with selection of A or B inputs on all mixers. A five-station push-button pre-selector is provided for the mixer five-B input. The microphone preamplifier is standard in mixer 1. However, high-level and low level cards may be installed in any combination in all five mixers.

High-level inputs are 10K ohm balanced bridging. This avoids source loading and greatly increases console flexibility by allowing it to be used with sources which cannot drive the usual 600 ohm load. Where a terminated line is required, it is terminated simply by adding a resistor across the line at either the source or console ends.

The muting relay system is quite flexible in that each relay controls an independent muted speaker output terminal, while a fourth terminal allows uninterrupted monitoring. Relay operation is determined by connections on the relay board and may be operated in a variety of combinations from the first three mixer positions. Each relay also provides an isolated closure by a separate connector for control of external AC operated equipment such as "on-the-air" lights, turntables or cartridge equipment. The contacts are rated at 300v and 5 amps.

The cue and monitor amplifiers may be operated with speakers of 4 to 16 ohms impedance, either singly or in combination. The cue amplifier operates from the cue position of each mixer pot while the monitor amplifier operates continuously through its own level-control from the program line amplifier. This provides constant assurance of program output quality. On the rear panel a P.A. output is also provided. It has a separate gain control for use with an external power amplifier for driving remote, multiple-speaker loads. All rear-panel input and output connections are clearly marked by function and the terminal strips will accept bare or stranded wire, with or without terminals, plus the standard fanning-strip.

An added feature is a front-panel, five-station push-button assembly for user-installed custom switching functions. Suggested uses are expansion of input capability for a particular mixer, or directing the line output to various external loads.

MIXERS .....	Five
INPUTS .....	Fourteen Total: Two each, mixers 1 to 4; six for mixer 5.
INPUT LEVELS .....	Low-level: -55 db nominal from 50 or 150/250 ohms. Low-level preamps standard on mixer 1; optional for mixers 2 thru 5. Low-level preamps standard on mixer 1; High level: -10 dbm nominal, standard on mixers 2 thru 5; optional for mixer 1.
INPUT IMPEDANCE .....	Balanced bridging; 600 ohm, see Note 1.
OUTPUTS .....	Program, monitor, cue, headphones and P.A.
OUTPUT LEVELS .....	Program: 8 dbm/600 ohms at 0 vu. 22 dbm max. Monitor: 8 w/8 ohms (4-16 ohms). Cue: 1 w/3.2 or 4 ohms. P.A.: 1 v. nominal into 10,000 ohm.
RESPONSE .....	All outputs: ±2 db, 20 Hz to 20 kHz.
NOISE .....	Below 65 db at 0 vu out with -55 db low level input. Below 75 db at 0 vu out with -10 dbm hi-level input.
DISTORTION .....	Program and Audition: Less than 0.5% THD at 8 dbm output. Monitor and Cue: Less than 1% THD at rated output.
CROSSTALK .....	Within 6db of noise.
POWER .....	115/230 vac., 50/60 Hz.
SIZE .....	15½" long, 6½" high, 10" deep.
WEIGHT .....	26 lbs.
MUTING .....	Three internal relays operate from mixers 1, 2 or 3 in any combination via internal patch-panel. Each relay provides independent muted monitor out plus isolated closure for control of external equipment (115 vac, 5A max).
NOTE 1 .....	High level inputs are 10 K ohm balanced bridging, allowing individual termination of input lines at rear panel, if required.



Front panel lifts for easy access to individual circuit modules. A convenient quarter-turn fastener securely locks the panel in place.

Installation is simple because of XLR microphone fittings. All terminals are clearly marked. No reference to a schematic is necessary.

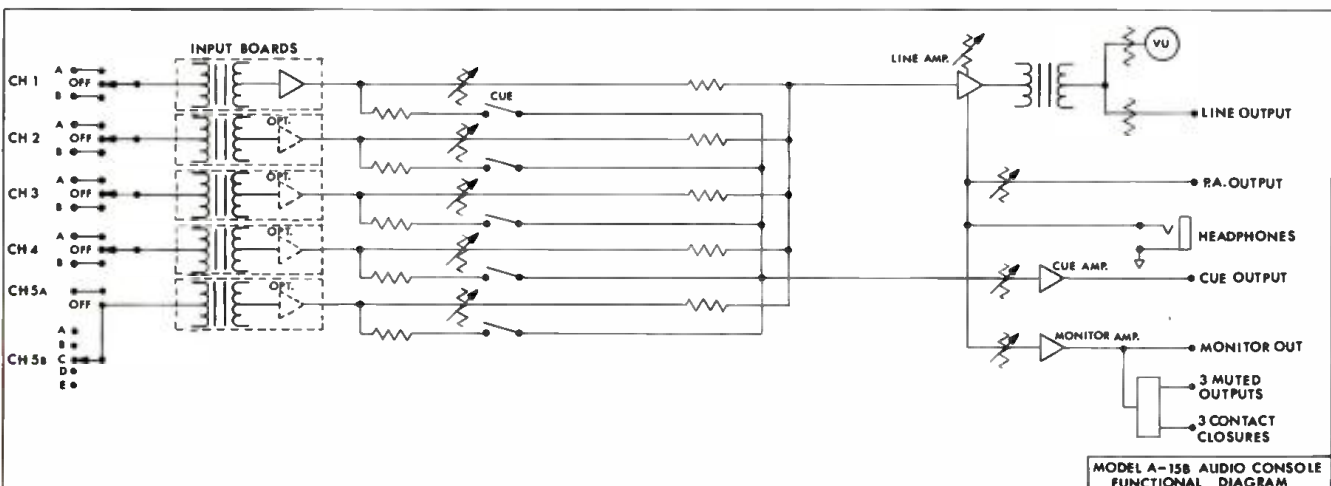

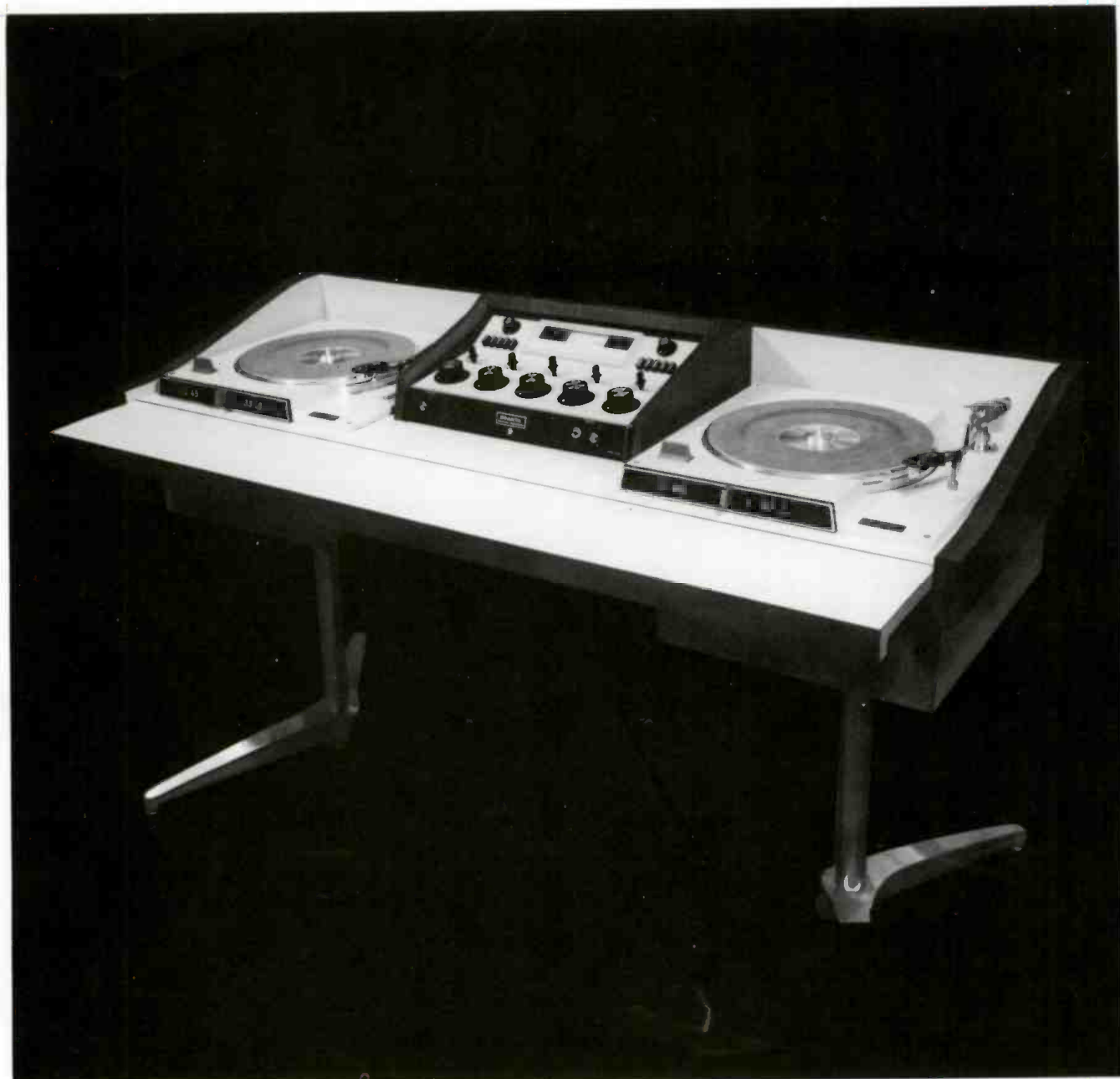

Remotes add spice to your daily programming. With the all new AC-155B, your remotes are done in style and convenience. This Studio Control and Remote Unit is right at home in a neighborhood supermarket, department store, or in the back of a mobile van. It's also extremely comfortable in your

production room. And the price fits nicely too!

All this and styling! A beautifully designed one-piece cabinet in rich walnut woodgrain and contrasting beige finish make the AC-155B an attractive display . . . anywhere!

Professional in every respect, the new Model AC-155B is unmatched in its diversified application as well as value. Here is a complete audio control center of professional quality that employs outstanding operational flexibility to serve as a permanent installation. At the same time it has the versatile portability that is required for remote broadcasts, mobile vans, and temporary setups. The AC-155B features two SPARTA GT-12 CUSTOM Turntables complete with tone arms, phono cartridges, equalized preamplifiers, plus the all-transistorized A-15B Audio Console.

The A-15B, the heart of the AC-155B Audio Console, is of modular construction. A total of fourteen inputs are available through the console's channels. As normally supplied, the A-15B accommodates low-level microphone inputs to channels 1A and 1B, with left and right turntables in channel 2A and 3A. Channels 2B and 3B are available for added high-level inputs, as are 4A, 4B, 5A and 5B. Channel 4 or 5 may be changed to accept low-level sources by the simple addition of a microphone preamplifier. Program monitor and separate cue functions are provided for with 2 speakers mounted in the AC-155B cabinet. A dual equalized preamplifier and console power supply are also contained in the AC-155B cabinet. The A-15B Console may be used separately from the AC-155B cabinet by simply removing the connections from the rear panel. The console can be battery operated or used with the power supply from the AC-155B.

The input impedance of the high-level mixing channels is 10K ohm transformer-coupled balanced, which avoids loading the source and greatly increases the flexibility of the console. This also permits the console to be driven from sources that are not designed to work into a 600 ohm load. If a 600 ohm termination is required, it is a simple matter to add a 620 ohm resistor across the line at either the source or the console end.

Three separate relays are provided in the A-15B console for muting. Each relay may be connected so as to close from any combination of pre-selected inputs on mixers one through three.

Common to all SPARTA Consoles is a "cue" position on each mixer potentiometer. In the AC-155B, program material from each mixer, through the cue switches and isolation resistors, is delivered to the internal amplifier and speaker

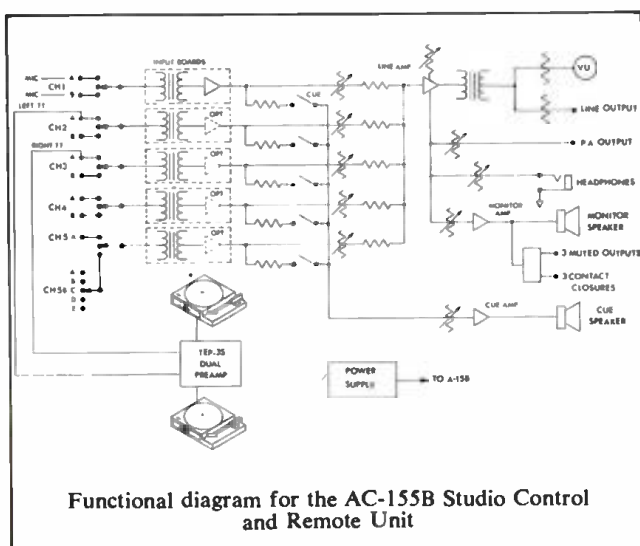

## MODEL A-15B Console

MIXERS .....	Five
INPUTS .....	Fourteen total: Two each for mixers 1 to 4, six for mixer 5.
INPUT LEVELS .....	Low-level; -55 db nominal for 50 or 150/250 ohms. Low-level preamp standard on mixer one. Optional for mixers four and five. High-level; -10 dbm nominal. Standard on mixers two thru five.
OUTPUTS .....	Program, monitor, cue, phones, P.A.
OUTPUT LEVELS .....	Program; 8 dbm/600 ohms at 0 VU. 22 dbm max. Monitor; 8 w/8 ohms (4-16 ohms). Cue; 1 w/3.2 or 4 ohms. P.A. 1v. nominal into 10,000 ohms.
RESPONSE .....	All outputs; ±2 db, 20 Hz to 20 kHz.
NOISE .....	Below 65 db at 0 VU out with -55 db low-level input. Below 75 db at 0 VU out with -10 dbm high-level input.
DISTORTION .....	Program and audition: Less than 0.5% THD at 8 dbm out. Monitor and cue: Less than 1% THD at rated output.
CROSSTALK .....	Within 6db of noise. incls and modes.
POWER .....	115/230 vac, 50/60 Hz.
MUTING .....	Three internal relays operate from mixers 1, 2, or 3 in any combination via internal patch-panel. Each relay provides independent muted Monitor Out plus isolated closure for control of external equipment (117 vac. 5A max).

## MODEL GT-12-4P Turntable System

Professional 2 speed (33 1/3 and 45 RPM); spring loaded paddle switch for one-hand cueing; speed indicator lamps. Instant start; 4 pole motor; Model ST-220 tone arm with stereo/mono phono cartridge and diamond stylus. 115 vac, 60 Hz. (Other power requirements upon request.)



Optional accessories for the versatile AC-155B include the accessory shelf shown installed and below, a dynamic cardioid microphone, the MIC-5B, with uniform pick-up about the axis at all frequencies, producing a remarkably faithful reproduction of voice. It is complete with wind "pop" filter, gooseneck and mounting hardware. The bench/lid provides added protection during transit and seating convenience on location.





Crystal clarity, trouble-free performance and rugged built-in value are things of today in stereo broadcasting with the new AS-40B!

The AS-40B, incorporating the latest solid-state equipment design, is built for reliability that you

can depend on! And it's big enough to handle ANY stereo broadcasting assignment! At a price far less than you would expect.

If you're serious about your stereo operation, you **MUST** consider the AS-40B Stereo Audio Console.

The all-new AS-40B Stereo Audio Console provides superb sound with rugged performance. SPARTA's advanced equipment design, results in eight mixing channels with pushbutton preselectors allowing 3 additional inputs each for mixers one, seven and eight, making a total of 14 stereo inputs. An auxiliary 3 station pushbutton bank is also included for custom purposes. Low-level preamplifiers for microphone operation are supplied as standard in mixing channels one and two, and the card-mounted high-level input transformers in mixing channel three can be replaced with an additional pair of microphone preamplifiers if desired. A microphone "pan pot," included in mixing channel one, plus the microphone mode switch, allows either the left or right microphone to be panned between the two channels. The "pan pot" also functions, in stereo mode, as an added balance control to compensate for variances in microphone levels. A selection of up to 6 microphone inputs is available through mixer one with the use of the microphone mode switch plus the 3 station pushbutton, input preselector.

Source loading of the high-level inputs in the AS-40B is optional due to the use of 10K ohm bridging transformers. This greatly increases the flexibility of the console by permitting operation from sources intended for single-ended, high impedance loads. However, in the instance when termination is required, it's a simple matter to add the appropriate value resistor across the line, at either the source or console end.

The audition and program amplifier modules, the line and meter pads and the output transformers in the AS-40B are identical and interchangeable, which permits standby operation from the audition side of the console. A two position switch under the VU meters provides the capability of visually monitoring either the program or audition outputs.

Both the program and audition output channels are provided with balance controls. These controls serve two purposes: One, to compensate for minor component imbalances within the console, and the other is to allow quick correction of any program source unbalance. These functions are carried out without significantly changing the total program output level.

All mixing channels have a cue position which is fed to the self-contained cue amplifier. A cue gain control as well as terminals for an external cue speaker are provided.

A headphone station with separate gain control is used to monitor program, audition and one other source of the user's choice, such as cue or air monitor.

The basic model AS-40B Stereo Console includes an external power supply to insure optimum performance. The SPARTA MAS-50, 50 Watt Stereo Power Monitor Amplifier and plug-in SM-3 Muting Relay System are complimentary accessories for the AS-40B.

MIXERS .....	Eight.
INPUTS .....	Fourteen stereo pairs; Mixer one; 3 low-level. Mixer 2; one low-level. Mixer 3; one high-level with low-level option. Mixers 4, 5, & 6; one each high-level. Mixers 7 & 8; three high-level.
INPUT LEVELS .....	Low-Level: -55 db nominal from 30/50 or 150/250 ohm sources. High-level; -10 dbm nominal from 600 ohm sources. AIR and EXT.; 1 volt nominal into 10k ohms (see Note 1.)
OUTPUTS .....	Program, Audition, Monitor, Cue and Headphones.
OUTPUT LEVELS .....	Program and Audition: 8 dbm into 600 ohms at $\phi$ vu. 22 dbm max. (14 db headroom). Monitor: 1 volt nominal into high -z load. Cue: 1 watt mixed-mono into external 3.2 to 8 ohm speaker. Headphones: 1 mw nominal into 10K ohms
RESPONSE .....	All outputs: Less than 1 db down, 30 Hz to 15kHz; less than 2 db down, 20 Hz to 20kHz.
NOISE .....	65 db or more below $\phi$ vu out (8 dbm) with -55 db low-level input. 75 db or more below $\phi$ vu out (8 dbm) with -10 dbm high-level input.
DISTORTION .....	All outputs: Less than 0.5% THD at normal operating levels. Less than 1% THD at maximum output.
CROSSTALK .....	Within 6db of noise at normal operating levels.
POWER .....	115/230 vac, 50/60 Hz.
SIZE .....	AS-40B Console; 29"x11 1/2"x6 3/4". PS-7 Power Supply; 5"x4"x2", 35 lbs total.
SHIPPING WEIGHT .....	35 lbs total.
MUTING .....	Switch closure on Audition and Program for mixers 1, 2 and 3 (for control of external relays.)
NOTE 1 .....	High-level inputs 10k bridging. Optional 150/600 resistive terminations.

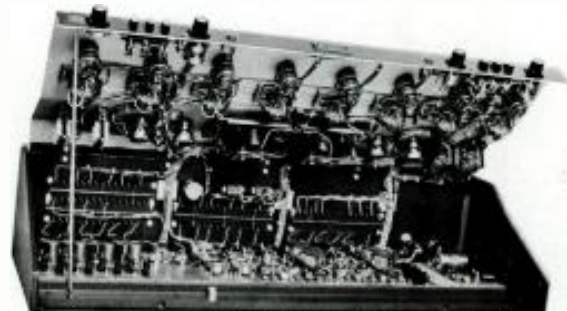

Front panel lifts for easy access to circuit modules.

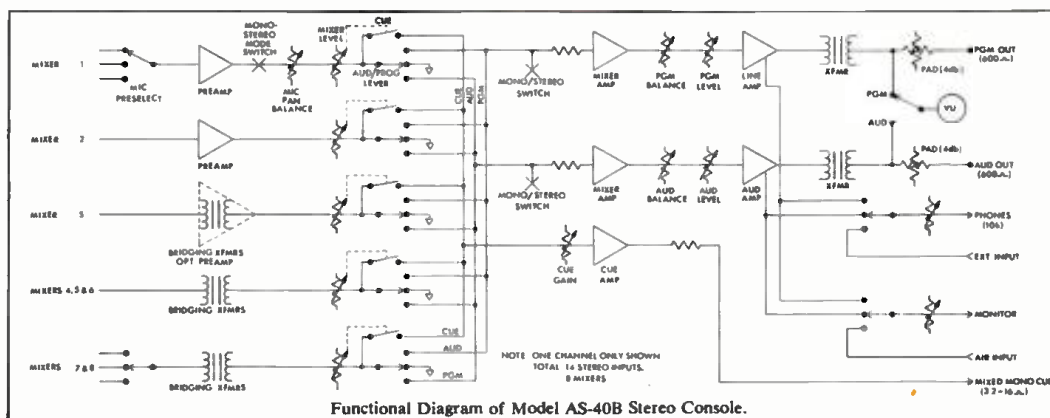

Functional Diagram of Model AS-40B Stereo Console.



Announcing the beautiful third dimension in stereo. Crystal clarity, trouble-free performance, *reasonable price* – that's the new Sparta stereo audio console.

The AS-30B is ideal for most stereo mixing needs. It's compact and versatile. The audition and pro-

gram channels have identical stereo line amplifiers, ideal for simultaneous recording and on-air use. Five mixers and 9 stereo inputs add up to the best value ever, in a stereo console.

Quality-packed and feature-loaded, the AS-30B gives you beautiful stereo in style.

The AS-30B is a compact desk-type stereo audio console featuring five mixing channels with push-button selected multiple inputs for Mixer 5. The first mixer includes low-level preamplifiers. The remaining four are supplied with high-level balanced input transformers. Input transformers for Mixer 2 are located on cards to allow replacement with a second pair of low-level microphone preamplifiers. The microphone preamplifiers are supplied ready to operate with 150 to 250 ohm microphones; 50 ohm microphones are accommodated by relocating a jumper on the individual preamplifier cards.

All high-level inputs are balanced bridging, which greatly increases the flexibility of the console by allowing operation with semi-professional tape decks, tuners or similar sources made for high-impedance loads. For single-ended sources, the minus input terminals of the console are simply connected to the shield to provide a single-ended input. In both balanced and single-ended applications, the input impedance is 10K. Where 600 ohm termination is required, simply add a pair of 620 ohm resistors across the lines at either the source or load end.

The Audition and Program amplifiers in the AS-30B are identical and interchangeable. Master Program Gain is set by the Master Gain Control. The gain of the Audition amplifiers is set by internal resistors to provide approximately the same level output as the program side. The Audition output terminals are fed directly from the audition line amplifiers from a single-ended source impedance of 60 ohms. The Audition output therefore is capable of driving multiple loads with little if any attenuation. The input source selector for Mixer 5 is a five station, multiple input push-button assembly.

The AS-30B console is intended to be used with external monitor and cue amplifiers such as the Sparta MAS-50 series. The stereo monitor output signal is controlled from a front panel monitor gain control. It delivers more than 1 volt of output signal. A push-button monitor-source selector switch is provided to allow monitoring of either the program or audition material, plus an external input. There are two unused push-button stations for user option. A front-panel selector permits the Mixer 1 microphones, either left or right, to drive both output lines monaurally. A rear-panel switch allows both program line amplifiers to be connected so that all mono or stereo sources will provide dual mono output to the program amplifiers. This latter feature provides a quick, easy check of proper phasing for stereo sources.

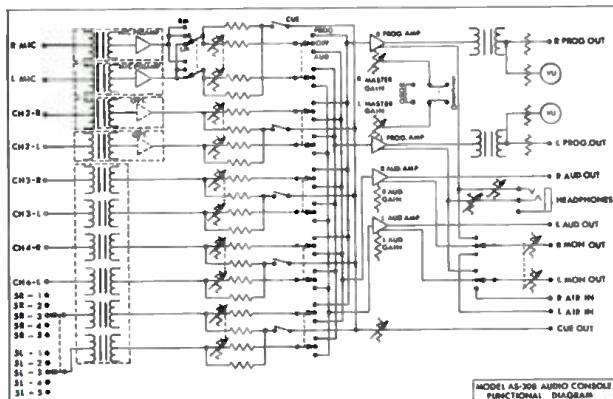

MIXERS.....	Five.
INPUTS.....	<i>Nine stereo pairs:</i> One each for Mixers 1 through 4 and five for Mixer 5, plus external AIR input.
INPUT LEVELS.....	<i>Low-level:</i> -55 db nominal from 150/250 ohms (50 ohm selected by jumper), standard on Mixer 1 (optional for Mixer 2). <i>Hi-level:</i> -10 dbm nominal from 600 ohm source, standard on Mixers 2 through 5. See Note 1. <i>AIR:</i> Depends upon external monitor-amp.
INPUT IMPEDANCE.....	<i>Balanced bridging:</i> 600 ohm, see Note 1.
OUTPUTS.....	Program, Audition, Monitor, Cue and Headphones.
OUTPUT LEVELS.....	<i>Program:</i> 8 dbm/600 ohms at 0 vu. 22 dbm. max. <i>Audition:</i> 8 dbm nominal/600 ohms (single-ended, 60 ohm source). See Note 2. <i>Monitor:</i> 1v nominal into hi-Z load. <i>Cue:</i> 0. 1v nominal into hi-Z load. <i>Headphones:</i> 1 mw nominal into 10K ohms.
RESPONSE.....	<i>All outputs:</i> ± 2 db, 20 Hz to 20 kHz.
NOISE.....	Below 65 db at 0 vu out with -55 db low level input. Below 75 db at 0 vu out with -10 dbm hi-level input.
DISTORTION.....	<i>All outputs:</i> Less than 0.5% THD at normal operating levels. Less than 1% THD at max outputs.
CROSSTALK.....	Within 6db of noise.
POWER.....	115/230 vac, 50/60 Hz.
SIZE.....	15 3/8" wide, 6 1/2" high, 10" deep.
SHIPPING WT.....	24 lbs. (incl. pwr. supply)
MUTING.....	Switch closure to rear-panel terminals from Mixers 1 to 3, closed in Aud. & Prog. modes for control of external DC relays.
NOTE 1.....	Hi-level inputs are balanced-bridging to allow individual termination of input lines at rear panel, if required. Permits constant line load plus use of high-impedance sources.
NOTE 2.....	Identical line amplifiers for Program and Audition.

Front panel lifts showing the clean and functional design. Notice the easy access to individual circuit modules. A convenient quarter-turn fastener securely locks the panel in the closed position.





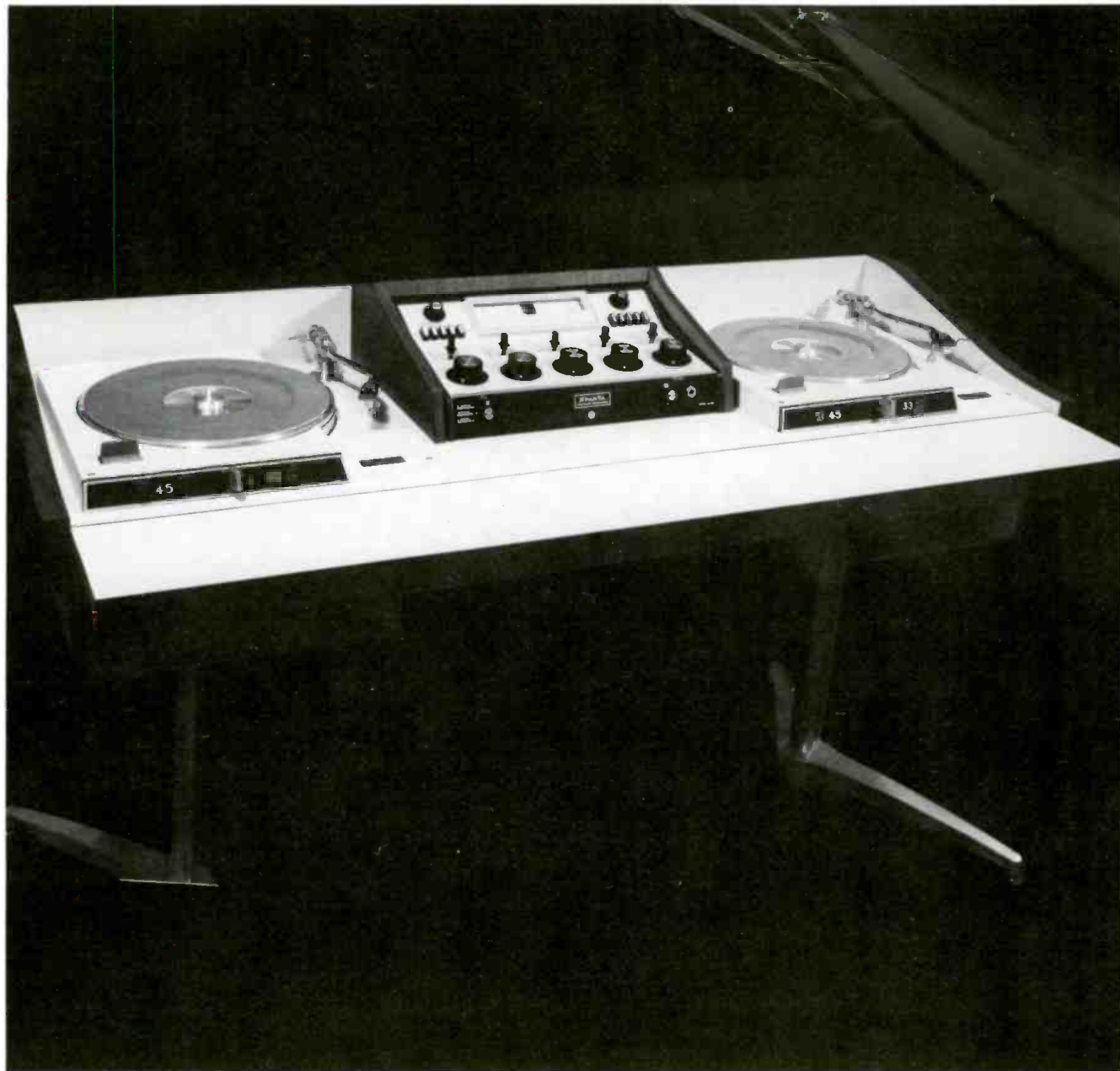

Stereo in style! This is the *HEART* of your stereo production center . . . this is *YOUR IMAGE* on remotes . . . this is the ASC-305B. It features everything you need for stereo studio control and remotes. An integral unit of beauty and performance

with a very modest price! It's rugged, mobile and stylish! The rich walnut woodgrain is offset by a soft beige in a distinctive one-piece design. You'll be broadcasting stereo in style with the ASC-305B . . . wherever you use it!

A neatly packaged all purpose, professional quality, stereo broadcast facility is embodied in the SPARTA Model ASC-305B. Its application is as varied as the imagination of a resourceful broadcaster. Because of its professional quality and all-purpose flexibility, the ASC-305B offers the stereo broadcaster a permanent integrated studio audio control as well as a hard working remote broadcasting unit. The ASC-305B features the all-transistorized AS-30B Stereo Console, plus two SPARTA GT-12 CUSTOM Turntables complete with tone arms, phono cartridges and stereo equalized preamplifiers.

At the center of the console is the extremely versatile SPARTA AS-30B Stereo Audio Console featuring five mixing channels with push-button-selected multiple inputs for mixer five. The first mixer includes low-level preamplifiers for 50 to 150 ohm microphones and the remaining are supplied with high-level balanced input transformers. The high-level inputs are balanced bridging, which avoids the source loading of the typical 600 ohm input and greatly increases the flexibility of the console. In the instance where a 600 ohm termination is required, it is a simple matter to add a pair of 620 ohm resistors across the line at either the source or load end. The audition and program amplifiers in the AS-30B are identical and interchangeable. In the audition side, the line amplifier gain is determined by internal resistors and is set to provide the same level output as the program side with normal gain control settings. The input source selector for mixer five is via a push-button assembly.

Each mixer potentiometer in the AS-30B Console has a "cue" position. Program material from each mixer, through the cue switches and isolation resistors, is delivered to the monitor/cue system.

The ASC-305B cabinet is of exceptionally fine construction and distinctive design. Thoughtful consideration has been made for operator legroom, lift-leaf work surface and an optional bench/lid arrangement. The tubular steel leg supports provide a solid jar-proof foundation and can be quickly removed for the convenience of portable setups. The cabinet finish is a very durable and rugged plastic laminate to provide years of lasting beauty and protection. The walnut woodgrain and contrasting beige color scheme make the ASC-305B an attractive display in the studio or on location.

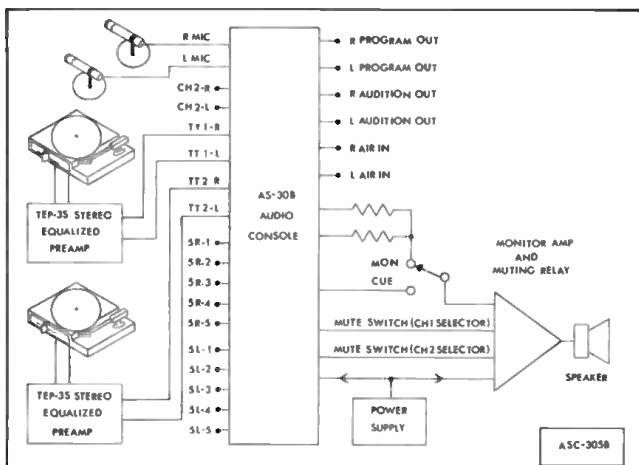

Functional Diagram for the ASC-305B Stereo Studio Control and Remote Unit

## Model AS-30B Stereo Console

MIXERS .....	Five
INPUTS .....	Nine Stereo pairs: One each for mixers 1 through 4 and five for mixer five, plus external AIR input.
INPUT LEVELS .....	Low-level; -55 dbm nominal from 150/250 ohms (50 ohm selected by jumper), standard on mixer 1 (optional for mixer 2). High level; -10 dbm nominal from 600 ohm source, standard on mixers 2 through 5. See Note 1. AIR: Depends upon external monitor-amp.
OUTPUTS .....	Program, Audition, Monitor, Cue and Headphones.
OUTPUT LEVELS .....	Program; 8 dbm balanced 600 ohms at 0 VU, 22 dbm max. Audition; 8 dbm nominal into 600 ohms single-ended. (from 60 ohm source). See Note 2. Monitor; 1 v nominal into high-Z load. Cue; 0.1 v nominal into high-Z load. Headphones; 1 mv nominal into 10K ohm.
RESPONSE .....	All outputs; ±2 db, 20 Hz to 20 kHz.
NOISE .....	Below 65 db at 0 VU out with -55 db low-level input. Below 75 db at 0 VU out with -10 dbm high-level input.
DISTORTION .....	All outputs: Less than 0.5% THD at normal operating levels. Less than 1% THD at max. outputs.
CROSSTALK .....	Below noise in all channels and modes.
POWER .....	115/230 vac. 50/60 Hz.
MUTING .....	Switch closure to rear panel terminals from mixers 1 to 3, closed in Audition and Program modes for control of external DC relays.
NOTE 1 .....	High-level inputs are balanced-bridging to allow individual termination of input lines at rear panel, if required. Permits constant line-load plus use of high impedance sources.
NOTE 2 .....	Identical line amplifiers for Program and Audition outputs.

## MODEL GT-12-4P Turntable System

Professional 2-speed (33 1/3 and 45 RPM); spring loaded power paddle switch for one hand cueing; speed indicator lamps; instant start; 4 pole motor; Model ST-220 tone arm with stereo/mono phono cartridge and diamond stylus. 115 vac. 60 Hz (Other power requirements available upon request).

## MODEL ASC-305B Cabinet.

HEIGHT .....	28" to work surface; 34" overall.
WIDTH .....	54"
DEPTH .....	25 3/4" with 6 3/4" lift-leaf work surface extenders; 5 inch monitor speaker.
SHIPPING WEIGHT .....	185 lbs.



Optional accessories for the versatile ASC-305B include the accessory shelf shown installed and the bench/lid providing added protection during transit and seating convenience on location.



With you in mind, and a thought toward your expanding operation, SPARTA engineers have developed the EP Series Extender Panels. They're designed for you, the users of the versatile A-15B, A-20B, AS-30B and AS-40B Consoles. And the nice thing about it, is that they make your expansion

inexpensive and convenient with that original factory look. The special customizing and high cost days of console expansion are gone for good with your use of the EP Series extender Panels. The Extender Panels will add to any job you're doing . . . and they will add a lot!

Five additional high-level mixing positions can be added to the SPARTA A-15B, 20B, 30B and 40B Consoles by adding one of the Extender Panel Series. The Extender Panel units are designed to be a perfect match to the SPARTA Consoles. The attractive cabinet, because of its functional design, can be added to either the left or right side of the main console. All holes are pre-drilled in the Extender Panel for the wiring harness and screws. Installation of the Extender Panel is the same for both right and left hand applications. In either case, the end panels supplied with the units are to be fastened together with screws provided and used as a joining section between the console and the Extender. The end panel removed from the main console is then attached to the open end of the Extender Panel. Internal connections are made to the appropriate console busses through the pre-drilled holes provided by the joining section. The process of adding the Extender Panel is a simple field modification and requires no factory assistance.

The input configurations of the EP-15B, 20B, 30B and 40B Extender Panels are identical to the Consoles for which they are designed. The inputs are via transformer cards that may be subsequently replaced with microphone preamplifiers. Adequate space is available in all of the Extender Panels for four additional transformer cards to meet specific customer installed applications. In addition to this, the front panel of the Extenders allow plenty of room for custom field modifications.

All input connectors from the Extender Panels to the console are made through barrier strips on the rear panel through the internal harness provided.

Voltage from the SPARTA Consoles power supply buss is not provided in the Extender Panel wiring harness. If active circuitry is desired by the user, it can be done as a customer option. SPARTA will provide recommendations and/or assistance.

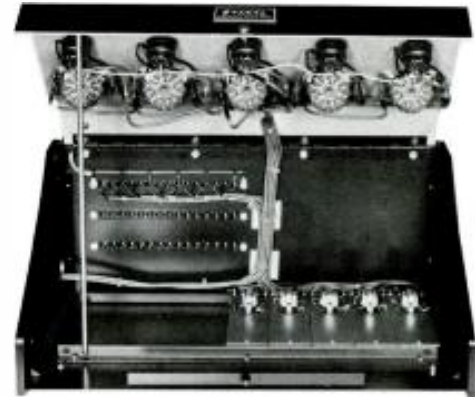

Front Panel lifts for easy access to circuit modules. This unit is for monaural applications.

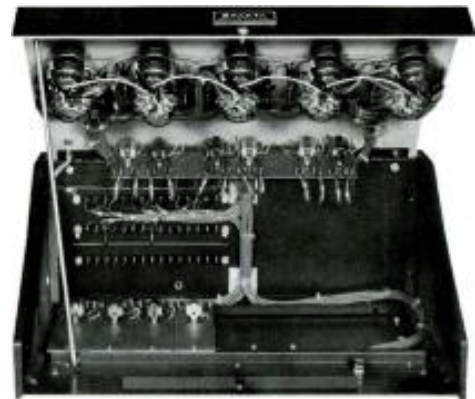

All units have ample room for additional custom electronics. This unit is for stereo applications.

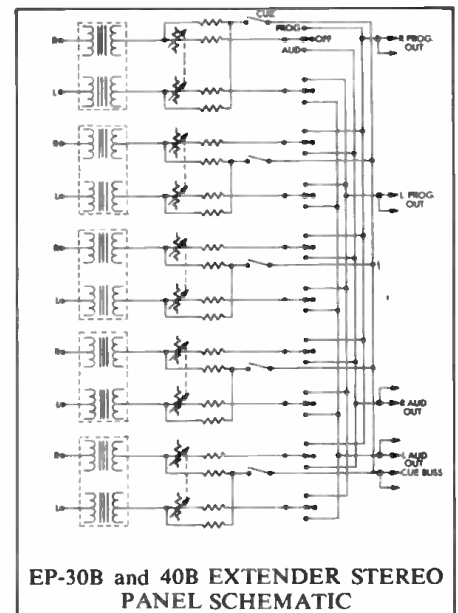
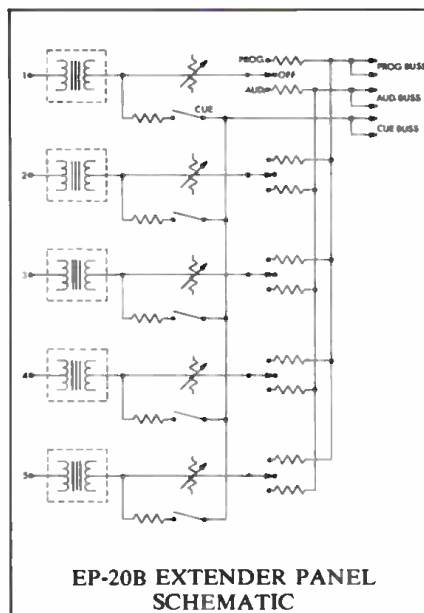
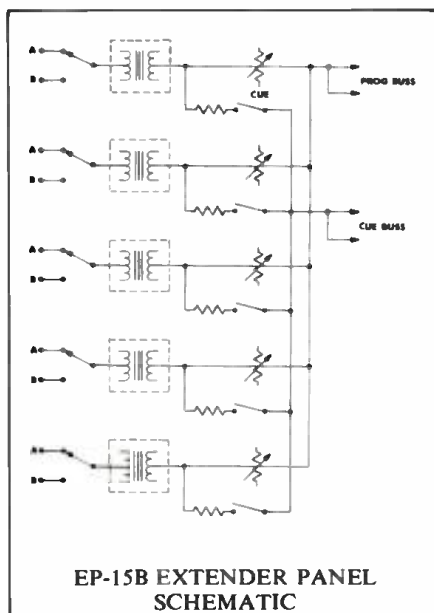

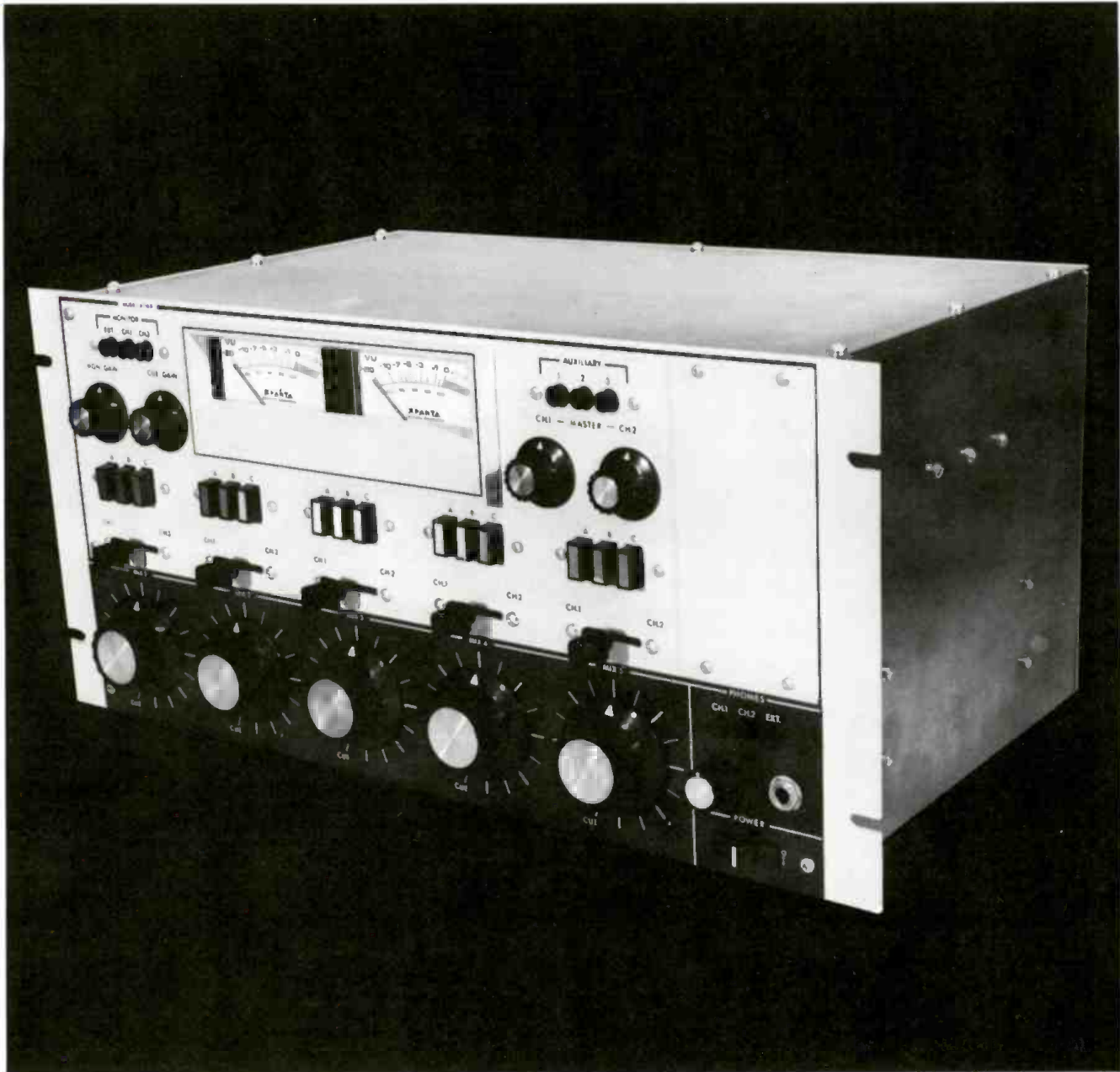

Fifteen inputs with two separate output channels! That's capability. And the new A-16R has it. It's a dual channel audio console. The A-16R easily handles several studios at once. Or with its independent VU meters you can air your program while doing production work. TV, CCTV and CATV stations are using the A-16R.

The A-16R gives you exceptional flexibility. A

spare removable front panel, spare controls and a spare terminal strip are available for custom needs. The A-16R uses only 8 3/4" standard rack space or comes with a handsome custom cabinet as an optional accessory.

For doing two jobs at once, with custom flexibility at a modest price, the A-16R will prove a wise investment.

The SPARTA A-16R Audio Console is a 19" rack-mounted unit featuring five mixing channels with three separate push-button selected inputs for each channel, permitting a total of fifteen program sources to be used. Mixer 1 includes a low-level preamplifier for operation from standard 150/250 ohm microphones. The preamplifier may also be strapped for 50 ohm operation. The input cards are identical in size for all five channels, so high-level and low-level cards may be intermixed in any combination.

The high-level input transformers are 10 k ohm balanced, permitting the user to bridge or terminate any high-level source independently as he chooses, thereby greatly increasing the flexibility of the console. This is particularly useful when operating from sources such as portable tape units which cannot feed a 600 ohm terminated load. High-level inputs may be individually and selectively terminated, as required, simply by adding an appropriate terminating resistor.

Two program-line amplifiers and VU meters are provided, and selected by individual 3-position lever switches for each mixing channel. In addition, an uncommitted 3-station push-button switch is provided for auxiliary use, such as feed-line selection between the two output channels. A removable utility panel is provided for custom features of the user's option.

The muting system of the A-16R is made quite flexible by including three separate relays which are factory wired to provide muted audio output to the monitor speakers. The rear panel has four separate monitor speaker terminals, three which are muted by the individual relays, and a fourth which is not muted. In addition, each relay provides an isolated contact closure to a separate connector for direct control of external equipment, such as turntables or On-the-Air lights. The contacts are capable of switching five ampere loads at 300 v. rms. Control for each relay is determined by patch-panel connections made on the relay board. Each relay can be connected to close from any combination of pre-selected inputs on mixers 1 through 3, either together or individually. (In each case, the relays will activate from the appropriate Channel 1 — Off — Channel 2 lever switch in either active position and release in the center Off position. This can be altered if required by simple changes to the lever-switch wiring.)

A number of spare rear-panel barrier-strip terminals are provided to accommodate added custom features such as another relay board if expanded control facilities are needed, or other functions which might be installed on the accessory panel. The power supply is "hard-regulated" and features remote-sensing for minimum crosstalk. It is capable of supplying steady state currents approaching half an ampere and can be used to supply reasonable accessory loads.

The all solid-state design coupled with the choice of quality components assures long life and trouble-free operation. The rugged construction and steel enclosure assures the shielding rigidity necessary for mobile applications as well as fixed station use.

MIXERS.....	Five: with push-button selected inputs.
INPUTS.....	Fifteen total: Three per mixing channel (push-button selected), plus external monitor and external headphone.
INPUT LEVELS.....	Low-level: -55 db nominal from 150/250 ohm source (50 ohm source standard option). Low-level preamplifier standard for mixer 1. Optional for mixers 2 thru 5. High-level: -10 dbm nominal from 600 ohm source. Standard on mixers 2 thru 5. See note 1. External monitor: 1 volt rms. into 5 K ohm. External headphones: 1 mw. rms. into 10 K ohm.
OUTPUTS.....	Two program (CH-1, CH-2), cue, monitor, headphones.
OUTPUT LEVELS.....	Program: 8 dbm/600 ohms at 0 vu. 22 dbm. max. Cue: 1 watt, 3.2 ohms. Monitor: 8 watts, 8 ohms (4-16 ohms).
RESPONSE.....	Program, Monitor and Cue: within 2 db, 20 Hz to 20 kHz.
NOISE.....	Below 65 db at 0 vu out with -55 db low-level input. Below 75 db at 0 vu out with -10 dbm high-level input.
DISTORTION.....	Program: Less than 0.5% THD at 8 dbm out. Less than 1% THD at 22 dbm out. Monitor and Cue: Less than 1% THD at rated output.
CROSSTALK.....	Within 6db of noise.
POWER.....	115/230 vac., 50/60 Hz.
SIZE.....	19" long, 8 3/4" high, 12" deep.
MUTING.....	Three internal relays operate from mixers 1, 2 or 3 in any combination via internal patch-panel. Each relay provides independent muted monitor out plus isolated closure for control of external equipment (115 vac., 5A max.).
NOTE 1.....	High-level inputs are 10 K ohm balanced bridging, allowing individual termination of input lines at rear-panel if required.

Above the master gain controls there are three auxiliary push-button switches for custom wiring. And for added flexibility, a removable utility panel is provided. It accommodates custom features of the user's option.

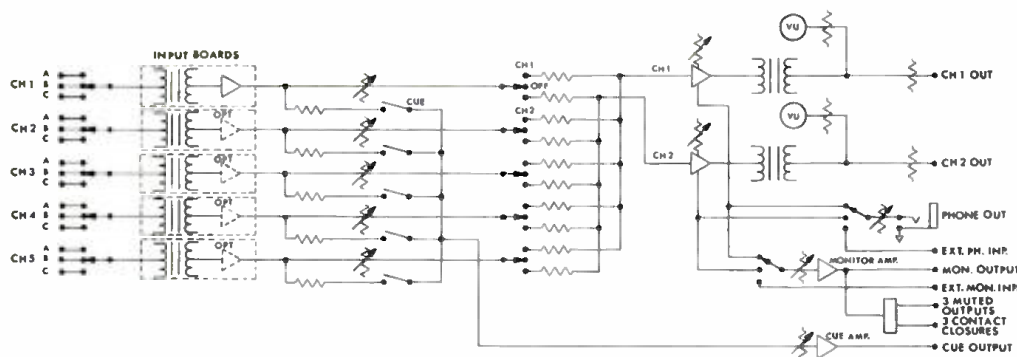

MODEL A-16R AUDIO CONSOLE FUNCTIONAL DIAGRAM



The RA-1 is a general purpose amplifier for use as a microphone preamplifier, a line booster amplifier or a remote station amplifier. As a microphone preamplifier, up to 65 db of gain is provided; as a line amplifier it will furnish up to 30 db of gain. In both applications, the output level is 10 dbm nominal into 600 ohms with a minimum of 12 db additional head-room.

Separate input connectors are provided for the microphone and line modes. The transient-free switching feature of the RA-1 Utility Amplifier allows "On-the-air" switching operations to be carried out in complete electronic silence. Portable tape recorders and similar sources can be operated through the high-impedance, balanced bridging input.

The RA-1 features a fully integrated-circuit design, and a unique line amplifier section with extremely low current drain for a lifetime of quiet, dependable and trouble-free operation.

MICROPHONE .....	50 or 150/250 ohms, selected by jumper. Factory wired for 150/250 ohms.
LINE .....	20K ohms balanced bridging. 10K ohms for single-ended inputs. 150 or 600 ohm termination optional.
GAINS .....	<i>Microphone:</i> 65 db max. <i>Line:</i> 30 db max.
OUTPUT LEVEL .....	10 dbm nominal into 600 ohms balanced. 22 dbm max. Adjustable to zero.
NOISE .....	More than 65 db below 10 dbm output level. (70-75 db typical).
DISTORTION .....	Less than 1% THD at all levels (Less than 05% typical)
RESPONSE .....	Within 2 db from 20 Hz to 20 kHz.
POWER .....	115 vac, 50/60 Hz, 3 watts max.
SIZE .....	2½"x4½"x7"
WEIGHT .....	2½ lbs. (Shipping).

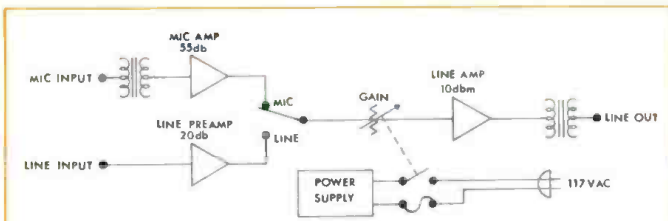

Functional Diagram of RA-1.





For sporting events, religious services and the other profit-building remote broadcasts your station may be considering, SPARTA's RA Series amplifiers will get your job done! They are attractive, functional and at a price so reasonable you can leave them on location!

The RA-4 is a four channel remote mixer providing a choice of either low-level microphone, or high-level program input to each channel. A 10 dbm nominal program level is delivered into a 600 ohm line through the program line amplifier. The low-level inputs will accommodate either 150-250 or 50 ohm microphones. The high-level inputs can be either 600 ohm terminated or high impedance bridging. The terminating resistors may be removed allowing the RA-4 to be operated with "semi-pro" tape units, tuners, or similar high impedance, single-ended sources.

AC line and DC battery supplies are internal, with automatic battery operation in the event of AC line failure. During AC operation there is no load on the batteries. Extremely long battery life results from a line amplifier operating at very high efficiency: the no-signal drain is very low.

Both program and/or "studio talk-back" material may be monitored through a novel headphone circuit. The RA-4 Remote Amplifier can be "stacked" for multiple mixing applications and multiple line feed due to the accessibility of its mixer buss.



- MIXING CHANNELS .....Four, with switch-selected low-level inputs (150-250 or 50 ohm microphones) or high-level inputs (balanced; choice of 600 ohm terminated or high-Z bridging).
- INPUT LEVELS .....-55 db nominal (low-level) or - $\phi$  db nominal (high-level).
- OUTPUT LEVELS .....10 dbm at  $\phi$  VU into 600 ohms. 24 dbm max., AC line: 18 dbm max., battery.
- FREQUENCY RESPONSE .....Within 2 db from 20 Hz to 29 kHz at all operating levels.
- DISTORTION .....Less than 0.5% THD at all operating levels. Typically 0.2%.
- NOISE LEVELS .....-125 dbm or better, referred to input.
- GAINS .....Low-level, 95 db; high-level, 50 db.
- MISC .....Test-tone oscillator; 700 Hz sets output level ( $\phi$  vu at 10 dbm) via Master gain control.

*Headphone monitor* for program or talkback; high Z phones. Monitor output for external monitor power amplifier. Mixer buss access for stacking two or more units.

*Battery test switch*, spring loaded for automatic return to line VU.

*Size*, 12x9x2½ inches, plus handle. *Weight*, approximately 7 lbs. Rack-mount option (handle removable).

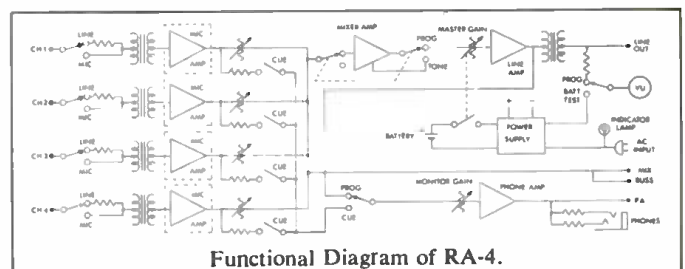

Functional Diagram of RA-4.





Now, the Custom GT-12 – a professional turntable that's much faster in two ways. Its jet speed acceleration gives you top speed immediately. And, its extra large power paddle with spring-loaded action, gives you quicker and easier start/cue convenience.

Dependability and ruggedness are foremost – from the thick cast metal control facing and one-piece

cast frame to the heavy platter and beefy hysteresis synchronous motor.

GT appointments couple beauty with convenience. From the special sure-grip felt to the handy speed reminder lights, you'll find the GT your best buy in a high performance turntable.



(Left) Large, functional "Power Paddle" switch in "off" position. Plastic guard on cartridge and stylus in ST-220 tonearm.

(Below) The solidity of the GT-12 is shown in this view of the sturdy die-cast chassis. Hysteresis synchronous motor shown: 4-pole also available (GT-12-4P).

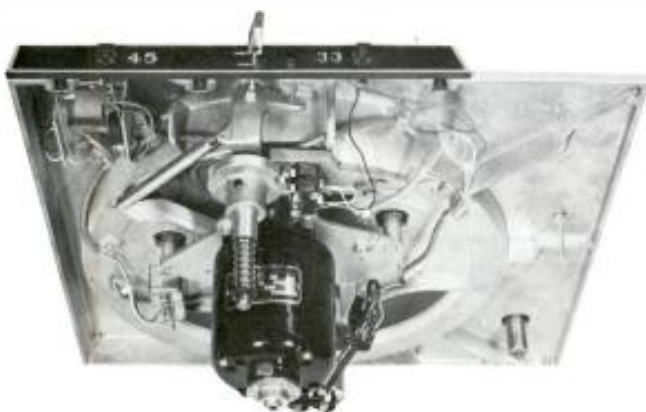

SPARTA AC-155B showing GT-12 Turntable with ST-220 Tone arm. Century Series Playback on accessory shelf.

- Rugged one-piece cast aluminum ribbed frame
- 3 vibration isolators and neoprene idler wheel
- Plays 45's without an adapter
- Heavy duty hysteresis synchronous motor (4-pole motor also available)



Dual Turntable Return (101-34) with two GT-12 Turntable Systems. Available separately or as part of "Showcase" Custom Cabinetry (pages 4 and 5).

## SPECIFICATIONS

BASE.....	16" wide, 15½" deep
BOTTOM CLEARANCE.....	5½" w/4-pole motor; 7" w/synchronous motor
TOP CLEARANCE.....	2" (without tone arm)
PLATTER SIZE.....	12"
ACCELERATION.....	Less than 1/16th turn @ 33½ RPM Less than 1/10th turn @ 45 RPM
RUMBLE.....	45 db @ 33½ RPM 40 db @ 45 RPM
WOW & FLUTTER.....	0.1% @ 33½ RPM
MOTOR.....	Hysteresis synchronous: GT-12-SY 4-pole: GT-12-4P
POWER.....	115 volt 60 cps (50 Hz available)
CONSTRUCTION.....	Chassis: One piece cast aluminum alloy Platter: Machined aluminum alloy
FINISH.....	Base: Light smoke gray baked enamel, orange peel texture Platter: Burnt orange felt Front control: Brushed aluminum Other base & felt colors available on special order
SHIPPING WEIGHT.....	27 lbs.

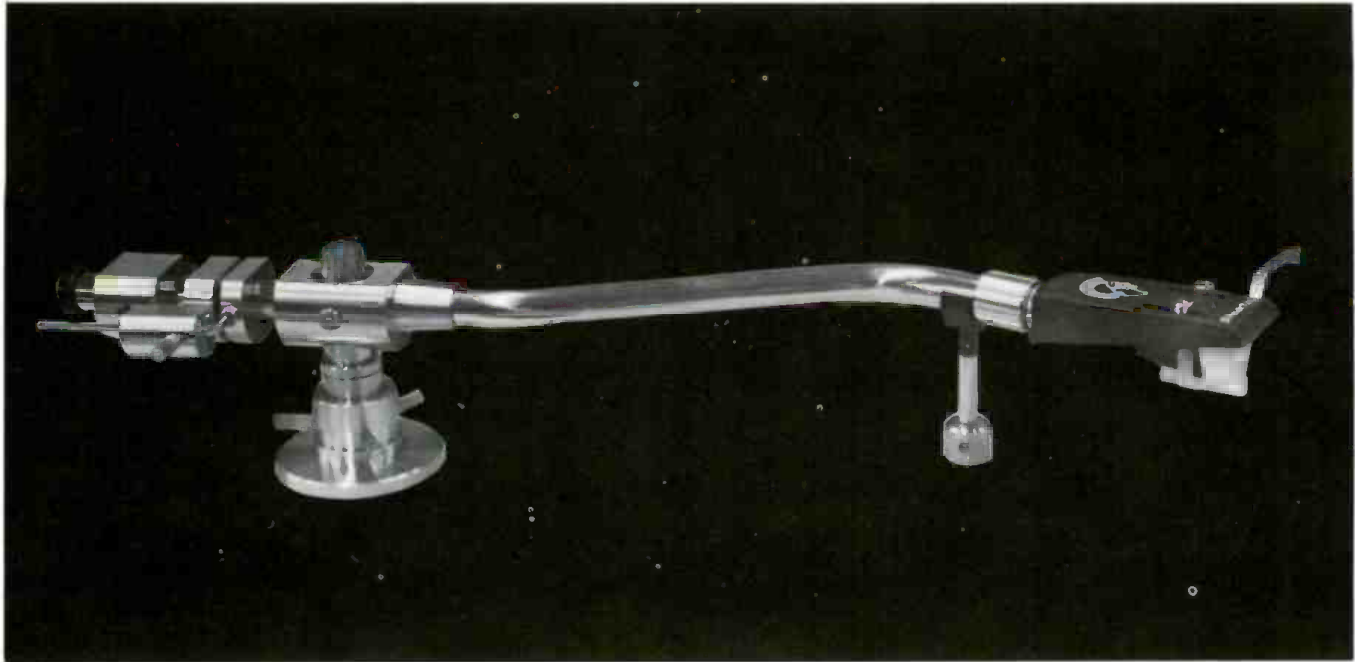

**ST-220 PROFESSIONAL STEREO TONE ARM**

The ST-220 Tonearm from SPARTA gives you either monaural or stereo operation, use of any cartridge and stylus of your choice, and a full range of adjustment including lateral balance. With the ST-220 you realize the full potential of your cartridge and every record.

**SPECIFICATIONS**

- TOTAL LENGTH . . . . . 310mm (12-13/32")
- EFFECTIVE LENGTH . . . . . 220 mm (8-21/32")
- OVERHANG . . . . . 15 mm (19/32")
- OFFSET ANGLE . . . . . 20°
- LATERAL BALANCE . . . Adjustable, all cartridges
- STYLUS PRESSURE . . . Adjustable, 1-6 grams recommended, depending on cartridge
- TRACKING ERROR . . . +4°, -1°

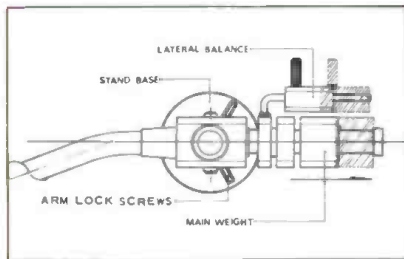

**STANTON 500 BROADCAST SERIES**

Great sound with little maintenance can be built into any broadcast operation with this rugged cartridge series. Stanton 500's have been designed to overcome operational problems caused by roughly handled cartridges and styli, without sacrificing quality performance and sound.

**500A**

For all-around broadcast application the 500A is widely recognized. It satisfies the most stringent requirements of the control room. Frequency response and separation meet or exceed broadcast standards.

**500A SPECIFICATIONS**

- FREQUENCY RESPONSE . . . . . 20 Hz to 10 kHz ± 1 dB
- 10 kHz to 20 kHz ± 2 dB
- OUTPUT . . . . . 1.0mV/cm/sec. ± 2 dB
- CHANNEL SEPARATION . . . . . 35 dB
- LOAD RESISTANCE . . . . . 47,000 ohms
- CABLE CAPACITANCE . . . . . 275 pF
- DC RESISTANCE . . . . . 800 ohms/channel
- INDUCTANCE . . . . . 550 millihenries/channel
- CHANNEL BALANCE . . . . . Within 2 dB
- STYLUS TIP . . . . . 0.7 mil Spherical Diamond
- TRACKING FORCE . . . . . 2.5 grams
- CARTRIDGE WEIGHT . . . . . 5 grams
- MOUNTING DIMENSIONS . . . . . 1/4" Mounting centers

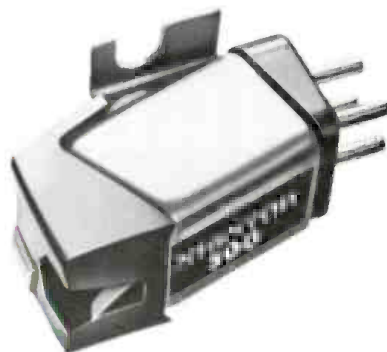

**SHURE M44 BROADCAST SERIES**

With their unusual combination of excellent performance, ruggedness, and inexpensive price, the Shure Standard Series cartridges are the most widely used pickups in stereo and stereo compatible monophonic broadcasting.

They feature exceptionally good sound, unusual uniformity and stand up best under hard usage. Wide choice of models, including spherical or elliptical styli; light or heavy tracking; special 78 RPM stylus is available.

**SPECIFICATIONS**

- FREQUENCY RESPONSE . . . From 20 to 20,000 Hz
- OUTPUT VOLTAGE . . . . . At 1,000 Hz at 5 CM/SEC, Model M44C, 9.3 millivolts per channel.
- CHANNEL SEPARATION . . . More than 25 db at 1,000 Hz
- STYLUS M44C . . . . . Weight: Heavy
- Stylus: Spherical .0007"



ALL M-44, SUPER TRACK AND HI-TRACK MODELS ALSO AVAILABLE.



### TEP-3S (STEREO) & TEP-3M (MONO) TURNTABLE PREAMPLIFIERS

These are high quality professional preamplifiers, equalized for the RIAA standard curve. They are designed for use with all modern hi-Z cartridges with added gain for the newer low output cartridges without compromising any other performance feature.

The basic design features integrated-circuit preamplifiers which have extremely high open-loop gain (typ. 20,000). This allows the operating gain and equalization to depend solely on the characteristics of simple passive components for long-term stability and reliability.

FREQ. RESPONSE.....	RIAA (NAB) within typical $\pm 0.5$ db ( $\pm 1$ db max)
OUTPUT LEVEL, PROGRAM.....	0 dbm into 600 ohms balanced, adjustable to below -20 dbm
OUTPUT LEVEL, MAX.....	10 dbm
DISTORTION.....	Less than 0.5% (0.15% Typical) THD
INPUT IMPEDANCE.....	47K ohms
SENSITIVITY.....	5 millivolts for 0 dbm output at 1 kHz

NOISE.....	.70 db below Program Level. More than 80 db below max. output.
HUM.....	Inaudible and virtually un-measurable. (Below noise)
SEPARATION.....	Stereo: 70 db typical (65 db min.)
SIZE.....	4½" high, 2¾" wide, 6½" deep.
WEIGHT.....	1 lb. 6 oz.
POWER.....	115 to 130 VAC, 50-60 Hz., 0.25A
MOUNTING.....	Rubber feet plus two single-hole "Z" clamps





The SPARTA MA Series of monitor amplifiers incorporates the latest solid state design and components to provide high-quality audio amplifiers to drive the wide-range, compact "linear-excursion" type speakers which are so popular for studio monitoring. The power amplifier is an individual plug-in module constructed with integral heat-sinks. The Glass-Melamine circuit board can be easily removed for maintenance or inspection. Careful design consideration of the power supply built into the MA Series allows the amplifier to provide instantaneous peak power far in excess of rated sine-wave power. Instantaneous program peaks approaching 70 watts will be faithfully reproduced. See price list for models available.

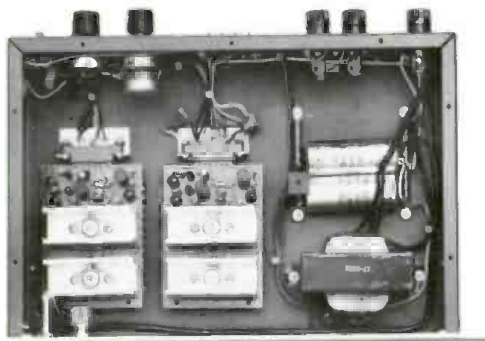

### SPECIFICATIONS

POWER OUTPUT \_\_\_\_\_ Cont. sine-wave output to 8 ohms:  
25 watts per channel  
MUSIC POWER OUTPUT \_\_\_\_\_ 40 watts per channel  
PEAK POWER OUTPUT \_\_\_\_\_ 50 watts per channel  
FUSED \_\_\_\_\_ 1A per channel



FREQUENCY RESPONSE \_\_\_\_\_  $\pm 1$ db 25-25KHz  
DISTORTION \_\_\_\_\_ Less than .5%THD @ 25 watts  
CHANNEL SEPARATION \_\_\_\_\_ 40 db (stereo only)  
HUM & NOISE \_\_\_\_\_ 80 db below rated output (cont.)  
INPUT IMPEDANCE \_\_\_\_\_ 25,000 ohms  
LOAD IMPEDANCE \_\_\_\_\_ 8 ohms  
INPUT \_\_\_\_\_ Less than 1 volt rms at rated output  
SWITCHABLE CONTOUR \_\_\_\_\_ +12 db @ 50 Hz  
FRONT PANEL CONTROLS \_\_\_\_\_ Power on/off and pilot light  
REAR CONTROLS \_\_\_\_\_ Gain: Contour (Ganged for stereo plus balance control)  
TRANSISTORS \_\_\_\_\_ All silicon  
POWER REQUIREMENTS \_\_\_\_\_ 120 volts - 50/60 Hz (220 volts available with no additional charge-please specify)  
DIMENSIONS \_\_\_\_\_ 19" rack; vertical rack space 3 1/4 in: 9" d.  
FINISH \_\_\_\_\_ Baked enamel with Smoke front panel  
SIZE \_\_\_\_\_ Desk Model; 12" w x 3 1/4" h x 9" d. Separate cue amplifier mounted within chassis (1/2 watt) SM-3 muting and relay accessory.



The CENTURY SERIES by SPARTA is a modular line of tape cartridge equipment uniquely styled and engineered to set new standards of excellence. The compactness of the modules enables three to be mounted side-by-side in standard rack cabinets. There are also single, dual, and 'quad' housings for table-top use. The entire Record/Playback system occupies only 11½x15" of desk space, and stands a

fraction over 6" high. The Century Series line is ultra-compact, giving the user full control of his available space . . . ultra-modern to keep its design advantage for years to come . . . feature-loaded for ease and convenience of operation . . . and priced so reasonably that every radio station can enjoy EVERYTHING expected of the finest tape cartridge handling system.



The record amplifier module, here in a monaural Record/Playback system, shows the care with which CENTURY SERIES was designed for user flexibility. The record preset button is also the EOM auxiliary cue tone control. The 'Touchbar' flashes when the EOM tone is read on playback, verifying that it was recorded. At the End-of-Message optional auxiliary cue tone, the red side of the 'Touchbar' control flashes while the green light remains on during runout. This gives the operator a highly visible signal even without taking his eye from copy or clock. The same features are standard in either monaural or stereo models. The standard function of the VU meter is to monitor record level; by pushbutton selection it ALSO tests bias and cue tone level. Note the pushbutton selection of THREE audio sources, designed to multiply the capability of any system in which CENTURY SERIES IS USED.



The compactness of the CENTURY SERIES design pays off handsomely in this 'quad' configuration. It accommodates four playbacks as shown, or a Record/Playback system plus two independent playbacks. Both playbacks may be wired back to the record amplifier audio source inputs for cart-to-cart dubbing. CENTURY SERIES does not achieve its compactness through any common-castan drive system; each module contains its own motor, which enables the user to dismount a module from any configuration and replace it with another. Modules slide out smoothly from the 'quad' or triple rack mounts for full and easy access to maintenance or adjustment points. In desk-top single or dual configurations the same easy access is provided simply by tilting up the Flip-top cover. The handsome cabinet is a complete container, finished in remarkably tough walnut-grain laminated plastic which complements the CENTURY SERIES colors and matches Sparta "Showcase" cabinetry. The handsome module face plates and blank panels are finished in Leatherette Brown and Light Smoke.

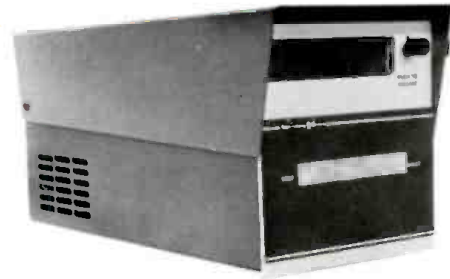

The compact CENTURY SERIES playback module is shown here with its single Flip-top cover for table-top use. The Stop/Start 'Touchbar' control is illuminated for positive control room identification. A soft but definite rose-red glow lights the left side of the bar when the module is at standby or ready. When running, the right side glows lime-green and the red light is out. Flip-top covers have a non-glare 'orange peel' textured Bittersweet Orange finish.



The triple rack mount illustrates the sturdy steel construction of the CENTURY SERIES system. This configuration houses playback modules as shown, or a Record/Playback system with another independent playback module which can be wired to one of the three audio source inputs of the record amplifiers. Used in that fashion, the operator controls a complete Record/Playback system with cart-to-cart dubbing, as well as having two playbacks for on-air use. The rack matches CENTURY SERIES colors. Stereo and monaural playback modules are externally identical in appearance.



Both record and playback modules of the CENTURY SERIES have single plug-in Printed Circuit Boards. Integrated Circuits are also plug-in. IC use in both program and cue amplifiers reduces the number of components substantially, while giving absolutely reliable cue detection.

## OUTSTANDING CENTURY SERIES FEATURES IN BRIEF:

New mechanical design produces almost noiseless operation of the CENTURY SERIES playback, while eliminating the need for complex or expensive damping mechanisms. The pinch roller is raised to within less than 1/8" of the capstan upon insertion of a cartridge, thereby positioning the cartridge positively and correctly for play. With such a short distance to travel, the pinch roller makes virtually no noise in contacting the capstan.

Play of NAB Standard 'A' cartridges (up to 10½ minute capacity) is accomplished by the CENTURY SERIES with unsurpassed wow and flutter characteristics. A high-speed motor is coupled to the non-magnetic capstan flywheel by a dual 'flutter-filter' belt system. The drive system, INDEPENDENT in EACH playback module, runs cooler, costs less and is less likely to vary from motor to motor than even the most expensive direct-drive system.

The CENTURY SERIES provides a dual cartridge release. A 'Tilt-up' release is coupled with a pushbutton release so operators used to either type will not be inconvenienced.

Sparta's 'True Tangent' precision head mount adjusts for height, zenith and azimuth (the latter without affecting head height). It is of non-magnetic construction with long-wearing stainless steel tape guides. The record head (see page 3) is offset slightly; this Sparta innovation results in more consistent high frequency recording characteristics.

The nominal audio output is a husky +6dbm, with a maximum output of over +16dbm. A built-in audio switcher eliminates 'pops' on tape starts, and also facilitates sending the output of several playback modules into a single audio console channel without separate isolation equipment.

The cue channel output of the CENTURY SERIES playback is brought out to the rear panel for ease of checking cue tones and for connection to automatic logging systems.

Field conversion of monaural CENTURY SERIES systems to stereo is made possible through simply replacing or adding a few components.

## SPECIFICATIONS

FREQUENCY RESPONSE	.. 50-15,000 Hz ±2db
NOISE	..... 55db or more below saturation recording (mono) 52db or more below saturation recording (stereo)
DISTORTION	..... 2% or less
WOW & FLUTTER	..... 0.2% or less
EQUALIZATION	..... NAB (adjustable)
AUDIO OUTPUT	..... 600 ohms balanced, +6dbm nominal, +16dbm maximum
METERING	..... Audio record level, cue record level, bias
RECORD INPUTS	..... 3 selected by pushbuttons. Balanced bridging -10 to +8dbm
CUE SIGNALS	..... NAB primary cue (stop 1 KHz standard; secondary cue (EOM) 150Hz optional; EOM signal provided as Form A contact closure.
TAPE SPEED	..... 7.5 ips; shielded hysteresis synchronous motor; non-magnetic dynamically balanced flywheel; dual belt flutter-filter drive system.
PLAYING TIME	..... 2 seconds to 10½ minutes, NAB size A cartridge
REMOTE CONTROL	..... All functions available
MOUNTING	..... Single desk, dual desk, 7" rack mount adapter for 3 modules, custom walnut grain cabinet for 4 modules (15"H x 14"W x 15½" D)
DIMENSIONS	..... Playback module and record amplifier module each, 6"H x 5¾"W x 14"D for interchangeable mounting.
POWER	..... 117 volts, 60 Hz (available for other power line standards on special order)

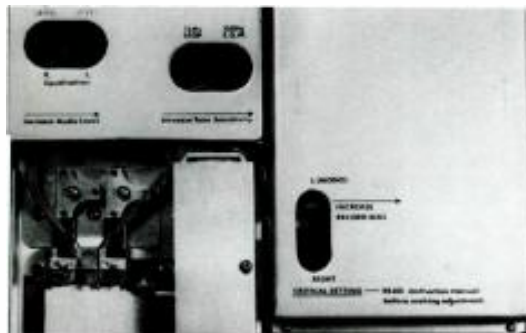

All critical adjustments are made on CENTURY SERIES modules through these convenient fingertip access ports. Printed Circuit Board covers are identical in monaural or stereo models, since mono modules can be field-converted later to stereo at the user's convenience. The Sparta improved 'True Tangent' head mount (HM-2) gives full adjustments plus spring-loaded lock to insure against drift. You are looking down at a Record/Playback system just as if you had raised the Fliptop cover of a desk unit, or slid the unit from a rack mount or custom cabinet.



The Record/Playback system ties together with utmost economy of wiring. All playback modules are prewired to become part of a Record/Playback system. AC can be fed from the outlet on the playback module to another playback or to the record amplifier. The record control plugs into its receptacle on the playback module as shown. Barrier strip wiring and absolutely clear labeling of the rear panels assures full use of the CENTURY SERIES flexibility. This is a desk-top system with dual Fliptop cover.





The CD-15 is providing many radio stations with a quick and convenient solution to the requirement of censoring live, extemporaneous talk programming before it is broadcast. With this precision unit, a program delay from three seconds to as much as 31 minutes can be accomplished simply by selecting a tape cartridge that is wound to the desired length of time delay. Using the continuous-loop principle of the tape cartridge, it is now possible to record any audio material as it is being monitored, and still have ample time to delete what might be considered objectionable material prior to its being broadcast. In this way, the CD-15 gives protection to the Broadcaster against violation of FCC Regulation.

Technical advances by SPARTA, and the use of highest quality components account for the outstanding performance given by this precision Record/Playback unit. Audio quality of the CD-15 surpasses even the most critical industry standards. The all solid state electronics are constructed on individual epoxy-glass circuit boards conveniently located for rapid inspection and normal maintenance. They include a transistorized playback amplifier, record amplifier, bias oscillator and the transistorized regulated power supply. Plug-in head cables for the erase, record and playback circuits lead to the Micro-adjusting head mount, which incorporates three combination erase/program heads. These heads are a high quality, premium series with metal facing to assure long-lasting, dependable performance. Each head plugs into a precision threaded holder that allows quick and positive azimuth and vertical position alignment.

For a time delay function, the CD-15 head

cables are arranged so as to use one combination erase/program head for erasing and recording, and another head (to the left of the first head) for playback. With the time delay cartridge inserted and running, the tape is erased, recorded, delayed and played back, in that order. The cartridge transport is designed for continuous duty and is manually engaged to start and stop the tape cartridge. As an added feature, a variety of special reverberation effects may be produced by the CD-15. Feedbacks of 160, 165 and 330 milli-seconds are available and governed by the fixed distances between the tape heads. Therefore, the head cables of the CD-15 may be set up so as to use one combination head for erasing and recording, and another head (to the right of the first head) for playback. The recorded audio may be taken immediately from the playback head, through the playback amplifier, and fed back into the recording source input. This procedure will produce an audio echo or reverberation effect creating an exciting audible-presence to both voice and music programming. Both playback gain and record level controls employ an on/off switch. When the record amplifier and erase bias are turned off, the CD-15 may be used as a continuous playback unit for background audio effects such as baseball re-creations, etc. One preloaded special SPARTA-MATIC time delay cartridge is supplied with the CD-15.

**SPECIFICATIONS**

TAPE SPEED . . . . . 7.5 ips  
 FREQUENCY RESPONSE  
     50 to 15,000 Hz ± 2 db  
 WOW AND FLUTTER . . . less than 0.2%  
 NOISE 55 db below saturation recording  
 DISTORTION  
     Total distortion less than 2%

**PLAYBACK OUTPUT**

+4 dbm into 600 ohms balanced  
**RECORDING INPUT**  
 -10 to +8 dbm 600 ohms balanced  
**METERING** . . . . . Audio Record Level  
**EQUALIZATION**  
     NAV Record and Playback  
**POWER** . . . . . 117 volts, 60 Hz standard  
     (others available)  
**HEIGHT** . . . . . 5½ inches  
**WIDTH** . . . . . 10¾ inches  
**DEPTH** . . . . . 14 inches  
**FRONT PANEL** . . . . Charcoal & Smoke  
**CABINET** . . . . . Heavy gauge steel—  
     ARMORSOL brown enamel  
**SHIPPING WEIGHT** . . . . . 27 pounds



The hinged top cover of the CD-15 provides immediate access to the head mount and cartridge engage lever. Input and output terminals are located on the rear panel. The cabinet housing and transport deck are of heavy gauge steel with a baked enamel finish. A precision VU meter is mounted in the front panel.

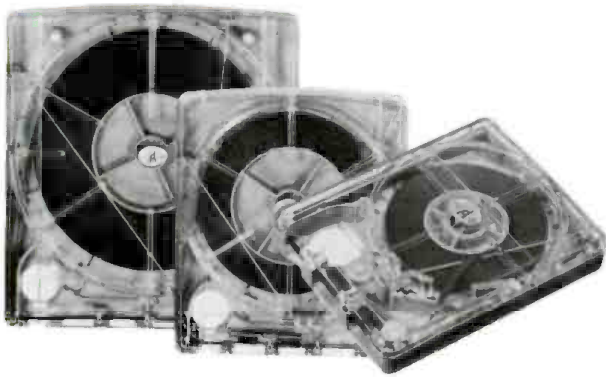

### NEW SPARTA FIDELIPAC NAB STANDARD CARTRIDGES

These tape cartridges are precision manufactured to rigid NAB standards. Each is factory loaded with only the finest quality lubricated tape, spliced exactly to minimize playback audio drop-out, fitted with special polyurethane pressure pads to insure perfect tape-to-head contact. After it meets demanding quality control tests, it is shipped to you in specially-designed containers to assure your receipt in best condition.

**M300:** available empty, or loaded with 20 seconds to 10½ minutes of tape.

**M600:** available empty or loaded with 16 minutes of tape

**M1200:** available empty or loaded with 31 minutes of tape

**AL-1 HEAD ALIGNMENT TEST TAPE** cartridge

**NAB APPROVED** frequency response (mono) cartridge

### SPARTA FIDELIPAC 350

The Model 350 cartridge is offered for service in applications requiring extreme accuracy of tape guidance at the Corner Post. The user may easily adjust the Corner Post Guide height to suit specific needs. Smooth vernier action is provided in a rugged mechanical assembly. Range of adjustment goes well beyond expected usage to cover extreme cases. As supplied, the Model 350 is preset to the industry standard height of .562 ± .002" above the deck so that the cartridge may be safely used in normal service without additional adjustment.

**Corner Post Body** – Precision molded of anti-friction plastic. Rigidly mounted in the cartridge base. Tape path remains vertical under all conditions of adjustment.

**Guide Arm** – Hard brass for long-life. Critically smoothed and polished.

**Adjustment Screw** – Tri-lobed thread-rolling design for smooth, backlash-free operation. Uses 56 threads per inch for maximum vernier action.

**Spring** – Designed for firm support of the Guide Arm without excessive force during adjustment.

**Range of Adjustment** – Plus or minus .020 inch, centered around the NAB standard height of .562 inch above the deck.

**Pressure Pad** – Beryllium copper spine faced with coated felt pads. The Pressure Pad is designed to fit all head and tape guide assemblies presently in use.

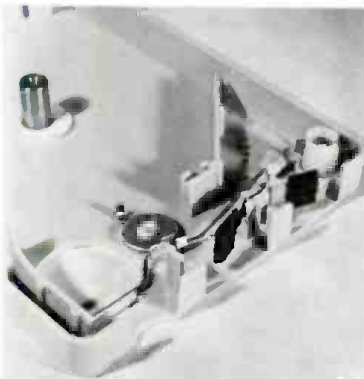

*The Model 350 is a modification of the standard Fidelipac Professional Cartridge. It includes a Corner Post which uses a cross-arm to guide the tape vertically. Turning the adjusting screw raises or lowers the arm as required. Access to the screw is through a hole in the cartridge cover.*

### TAPE CARTRIDGE FACTORY RECONDITIONING

Sparta factory reconditioning of your tape cartridges is a carefully controlled process. It begins with disassembly of the cartridge, inspection and discarding of those parts which are either automatically replaced, or show excessive wear. Then the cartridge is carefully cleaned with special solvents and buffing, parts are replaced where necessary, and the cartridge is loaded to your specifications and reassembled. The process is carried out by Sparta factory-trained reconditioning specialists, from initial inspection to final packing. These specialists have no other job than to send your cartridges back looking and operating like new. Minor parts are replaced as a matter of course, and their cost is included in the service charge. Fatigued or malfunctioning parts of major importance are replaced as necessary, and are charged for at a standard rate.



*The reconditioning process begins by dipping cartridge bodies and salvageable parts in special cleaner. Buffing will restore factory-new look to plastic.*



*Cleaned spools are reloaded with fine lubricated tape to customer's exact timing order, then completed cartridge is tape spliced and reassembled before final inspection, testing and packing.*



*Precision splicing guards against audio playback drop-out. The cartridge reconditioning service is a fulltime production unit at Sparta; the technicians are selected and factory-trained.*



### BULK REEL & CARTRIDGE ERASER

**MODEL CE-3** A professional device for heavy-duty use in broadcast stations where the assurance of the best possible tape erasure is required. Handles all cartridge sizes and tape reels up to 10½". Line voltage: 90-135 VAC/50 or 60 Hz. Current: 8.9 AMPS (900 watts). Erasure Level: below typical system noise. Duty Cycle: One minute On, three minutes Off. Weight: 9 pounds. Construction: Epoxy Fiberglass with plastic case. No-scratch rubber pad bottom. Removable reel center pin. 6-foot cord.



### ALIGNMENT GAUGE

**MODEL AG-2** Tape head alignment and cartridge rejections cease to be problems with the AG-2 Alignment Gauge. Allows for exact adjustment of all tape heads.



### CARTRIDGE RACKS

**MODEL CR-100** For wall-mount storage of up to 100 M-300 size tape cartridges. Furniture grade cabinet construction with surfaces finished in a woodgrain laminate, mar-proof plastic. Width: 25", Height: 27½", Depth: 5". Other sizes and finishes available on custom order.



**MODEL CR-120** Gives a generous cartridge storage facility using a minimum amount of space. Holds 120 M-300 size cartridges. Requires only an 18" square area to revolve. Height: 29", Width: 15¼". Comes in standard finish with other colors available on custom order.

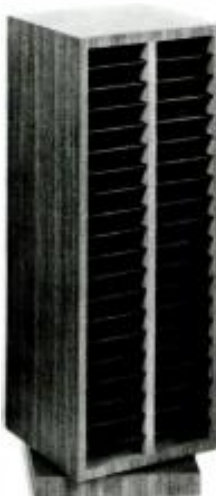

**MODEL CR-80** A revolving "lazy-susan" tape cartridge storage facility with a capacity of 80 M-300 size cartridges. Only requires an area 14" square to revolve. Height: 29", Width: 10½". Mar-proof woodgrain finish. Other finishes available on custom order.



### SM60 OMNIDIRECTIONAL DYNAMIC

It has smooth, natural wide-range response for both voice and music. The SM60 is equally at home in the studio or for remote pickups. Can actually be dropped on its nose without damage to internal structure.  
**FREQ. RESPONSE:** 45 to 15,000 Hz.  
**IMPEDANCE:** Matches any input from 50 to 250 ohms.  
**OUTPUT LEVEL:** -60.5 db (0 db = 1 nW with 10 microbars).



### SM53 UNIDIRECTIONAL DYNAMIC CARDIOID

Delivers a wide-range, natural flat response without strident peaks or false coloration. Extremely broad front working angle holds tonal quality constant despite user movement. Built-in shock mount reduces noise often associated with unidirectional microphones.  
**FREQUENCY RESPONSE:** 70-16,000 Hz.  
**IMPEDANCE:** Matches any input from 50 to 150 ohms.  
**OUTPUT LEVEL:** -58.5 db (0 db = 1 mW with 10 microbars).

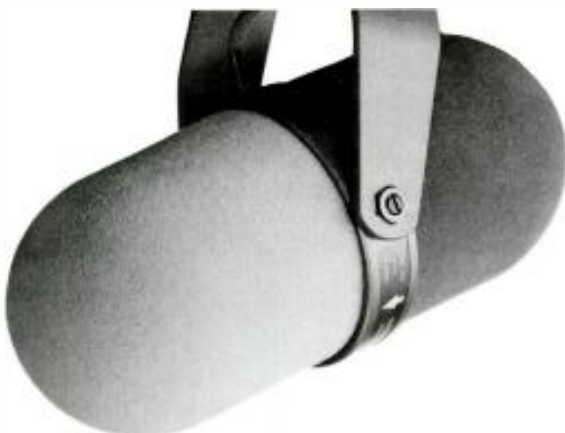

### SM5 UNIDIRECTIONAL DYNAMIC

A superb, close-working "DJ" microphone. Unusually effec-

tive cardioid pattern is completely symmetrical about the axis. This characteristic assures excellent rejection of unwanted sound and maintains presence over very wide working distance range. Effective integral windscreen.  
**FREQUENCY RESPONSE:** 10-15,000 Hz.  
**IMPEDANCE:** 50 or 150 ohms.  
**OUTPUT LEVEL:** -57 db (0 db = 1 mW with 10 microbars).



### C-37P VARIABLE-DIRECTIVITY CONDENSER STUDIO MICROPHONE

An up-dated version of the famous C-37A. Combines proven excellence in sound quality and the very latest in semiconductor technology. (Requires Sony AC-148A Phantom Power Supply.)

### AC-148A DC PHANTOM POWER SUPPLY

The AC-148A is specifically designed to power Sony Condenser Microphones, but is equally suited for use with others. Handles up to ten additional microphones.

### ECM-22P CARDIOID CONDENSER MICROPHONE

Used regularly in professional recording studios from coast to coast, the exceptional ECM-22P has gained a reputation for recordings which rival the original performance. The ECM-22P operates on either an internal battery or an external phantom power supply (Sony AC-148A power supply is recommended).



# AUDIO



## MODEL 635A

Most popular professional quality performers' microphone. Smooth, carefully shaped response yields "flat effect" when used close up. Built-in four-stage pop and breath blast filter.

RESPONSE: 80 to 13,000 Hz.

IMPEDANCE: 150 ohms.

OUTPUT LEVEL: -55 db.



## MODEL 1751 CARDIOID ELECTRET CONDENSER MICROPHONE

Cardioid pickup pattern reduces sound pickup from sides and rear to eliminate unwanted noise and reverberation and reduce feedback. Contains small FET impedance circuit requiring AA battery. May be used with low, medium or high impedance inputs.

RESPONSE: 60-15,000 Hz.

IMPEDANCE: 150 ohms, balanced.

OUTPUT: -43 db.

## MODEL RE16 SUPER CARDIOID

Most uniform polar pattern at all frequencies ever offered in a cardioid microphone. For close-up vocal use on stand or hand-held. Virtually eliminates pickup of breath noises. Strong metal screen prevents damage.

RESPONSE: 80 to 15,000 Hz.

ACCEPTANCE ANGLE: 150°.



IMPEDANCE: 150 ohms.

OUTPUT LEVEL: -56 db.



## VEGA 55/56 "PRO" WIRELESS

The transmitter weighs five ounces and is small enough to fit into a shirt pocket. It accepts high or low impedance microphones. The receiver has meter and a 3-position selector switch for monitoring audio level, R.F. carrier level, and primary power (self-contained battery or AC line).

FREQUENCY RESPONSE:  $\pm 2$  db, 40 to 15,000 Hz.

SIGNAL-TO-NOISE-RATIO: >60 db

HARMONIC DISTORTION: <1%

RF CARRIER: 70-200 MHz standard; 40-50 MHz and 200-220 MHz on special order.

FREQUENCY STABILITY: 0.005% (crystal controlled).

MODULATION:  $\pm 12$  kHz deviation

RANGE: 50-1000 ft.

## MODEL 55 TRANSMITTER

RF POWER: 15-20 mW

RF OUTPUT IMPEDANCE: 50 ohms.

MODULATION LIMITER: compression limiter activates at 100% modulation with 300 microsecond attack time.

AUDIO INPUTS: Two inputs. (1) -40 to -65 db, 150 ohms microphone; (2) high impedance (10 kohms) pickup.

DIMENSIONS: 3½" L. 2¾" W. .85" D. 5 oz.

## MODEL 56 RECEIVER

RF SENSITIVITY: 0.5  $\mu$ V for 20 db quieting.

IMAGE & SPURIOUS RESPONSE: Less than -60 db.

AUDIO OUTPUTS: -52 dbm, 150 ohms balanced (mike level); or 0 dbm, 600 ohms, balanced. At monitor plug, ¼ W, 8 ohms, unbalanced; pr 1 mW, 600 ohms, unbalanced.

POWER SOURCE: 115/230 VAC, 50/60 Hz or external 12 VDC battery.

DIMENSIONS: 9" L. 6.8" W. 3.7" D. 4 lbs.

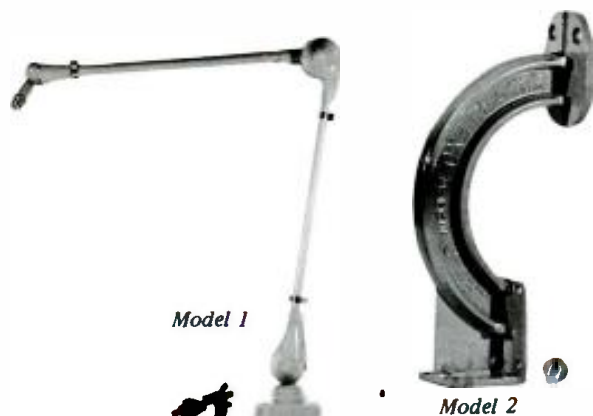

Model 1

Model 2

### FLEXO MIKESTER

Flexo Mikester is as flexible as the hand itself. Here is the ideal stand that permits you to instantly position mike exactly where needed to exactly fit the speaker or any other application desired, for greater comfort and sufficiency.

Swings out 36" in any direction when fully extended. The New Flexo Mikester will handle any mike up to 4 lbs. in weight.

**MODEL NO. 1** - Clamps or screws to any horizontal or angular position. Tow bolts clamp base firmly to surface up to 3" thick assuring greater stability. Bolts removable to allow for screw fastening.

**BRACKET MODEL NO. 2** - Same except with bracket for wall or vertical screw mounting.

**FLOOR MODEL NO. 3** - Additional 40" floor stand. Large, heavy 13½" base. (not pictured).



### FLOOR MICROPHONE STANDS

**MS-20** - Heavy duty professional stand. Grip-action clutch. Extra height. Tube assembly, same as MS-25. Low contour base. Height: 37"-66". Base: 12" dia., charcoal.

**MS-25** - (pictured) Stage and studio floor stand. Has integral air suspension system to counter-balance microphone weight. Extra heavy triangular base. Extra height, 1-1/8" dia. tube assembly with 5/8"-27 thread top adaptor. Height: 38"-67". Base: 17" dia., charcoal with chrome cover.



### MODEL S39A VIBRATION ISOLATION STAND

Isolates microphone from even extreme mechanical vibration. For tables, desks, footlight areas, remotes (particularly sporting events), etc. Designed for use with any Shure microphone or swivel adapter assembly. Heavy duty "non-fatigue" foam rubber internal isolation element. Low-silhouette, black high-impact non-glare plastic housing.

### A-40 SPEAKER SYSTEM

This enclosure is equal to the performance of the finest speaker systems and is priced well within the reach of every radio station usage.

With a power handling capability of 30 watts, (E.K.A.), and a frequency range of 35 Hz to 20,000 Hz, the system performs superbly when coupled to any audio electronic equipment, and gives unequalled sound reproduction in any listening environment.

The bass speaker is a 10-inch woofer, with a high compliance, specially treated cloth surround; and a 1½", 4-layered, long-throw voice coil. The midrange unit with a low resonance design. The high frequency unit is also a 3½" cone unit, closed back, flush mounted in front for excellent dispersion characteristics. The result is outstanding, full bass to crisp and sparkling highs. Crossover frequencies at 4,000 Hz and 10,000 Hz ensure the optimum performance from each speaker unit.



### SPECIFICATIONS

POWER HANDLING .....	30 watts E.I.A.
IMPEDANCE .....	8 ohms
DIMENSIONS .....	22" x 11¼" x 9½" deep
FREQUENCY RANGE.....	35 Hz. to 20,000 Hz.
BASS SPEAKER .....	10-inch high compliance, long throw woofer, 4-layer 1½" voice coil
MID RANGE SPEAKER .....	3½", flush mounted
CROSSOVER FREQUENCY ..	4,000 Hz. and 10,000 Hz.

### IMPROVED "THINLINE" SPEAKER SYSTEMS NOW WITH HEAVIER CONSTRUCTION

"THINLINE" Slanting corner speaker baffle combination - Heavy-duty performance in a thin, slanting corner baffle. Bass reflex, acoustic padding. Efficient slant-front, corner design aids performance because it aims sound down and corner location increases effective air mass. Transformers and L pads, installed and wired, available on request. Wood-grained vinyl, walnut or blond. Cane grille.

**SCB-208S** - Baffle with 8" speaker. 6 oz. ceramic magnet, 15 watts, 8 ohms.

Now the sleek "Thinline" series has been ruggedized to provide a heavy-duty product for every installation requirement. Choose from either Low Level 8", Dual Cone 8", or the Heavy-Duty 12" series. Each is designed to do a superior job in its own category and price range. And, each is clad in heavy wood-grained vinyl in either walnut or blond, matching cane grille. Extremely durable, and takes paint readily.

**WB-208C-8"** Thinline Baffle only. Max. speaker depth 3".  
**WB-212C-12"** baffle only. Maximum speaker depth 4-5/8".

THE ENTIRE ARGOS SPEAKER AND BAFFLE LINE IS AVAILABLE FROM SPARTA.



SCB-208S



WB-212C

## MODELS 1230/1250

**Record Pause Control:** Interrupt a recording and still have the recording amplifiers in the "ready" state. Releasing the pause lever immediately places the recorder back in the recording mode.

**Built-In MIC-LINE Mixer:** Allows signals from two sources to be blended together and fed simultaneously onto a tape at the proper level and balance. Separate and independent input control for Line and Mic.

### SPECIFICATIONS:

HEADS .....	Three, 4 track channel, stereo or mono 1230: erase, record, fwd. playback. 1250: erase, record, fwd. playback, rev. playback.
REEL SIZE .....	7" and 5"
TAPE SPEED .....	7½ ips and 3¾ ips (±0.5%)
MOTORS .....	1 dual speed hysteresis synchronous capstan motor. 2 eddy current induction reel motors.
WOW & FLUTTER .....	7½ ips 0.8%
FREQUENCY RESPONSE .....	30-22,000Hz (±3dB 40 to 18,000Hz) at 7½ ips. 30-16,000Hz (±3dB 40 to 12,000Hz) at 3¾ ips
SIGNAL TO NOISE RATIO .....	55dB
HARMONIC DISTORTION .....	1% at 1,000Hz
CROSSTALK .....	60dB
INPUTS .....	Microphone: 0.25 mV/-72 dB (600-10,000 ohms). Line: 0.1V, 50,000 ohms or more.
OUTPUTS .....	Line: 0.3V for load impedance of 10,000 ohms or more.

## 3300 SERIES

Model 3300-Series (-10, -11, -12) features include extended play 10½" reels, record pause control, fast operation (one-hand feather touch control system), easy editing, manual cueing, line and mike mixing, monitoring, independent record and playback preamplifiers, low noise/high output performance, hyperbolic heads, tape lifters, three motors, heavy duty diecast frame and rigid 11/64 aluminum front panel, faced with satin finished-brushed stainless steel.

### 3300-10 SPECIFICATIONS

HEADS .....	Three, 4 track 2 channel, stereo or mono erase, record and playback 10½" and 7"
REEL SIZE .....	7½ ips and 3¾ ips (±0.5%)
TAPE SPEED .....	7½ ips and 3¾ ips (±0.5%)
MOTORS .....	Same as 1230/1250
WOW & FLUTTER .....	0.06% at 7½ ips
FREQUENCY RESPONSE .....	25-24,000Hz (±3dB, 30-13,000 Hz) at 7½ ips. 25-16,000 Hz (±3 dB, 30-13,000 Hz) at 3¾ ips
SIGNAL TO NOISE RATIO .....	58 dB
HARMONIC DISTORTION .....	1% at 1,000 Hz
CROSSTALK .....	60 dB at 1,000 Hz
INPUTS & OUTPUTS .....	Same as 1230/1250

### 3300-11 SPECIFICATIONS

HEADS .....	Three, 2 track 2 channel, stereo or mono erase, record and playback.
TAPE SPEED .....	15 ips and 7½ ips (± 0.5%)
WOW & FLUTTER .....	0.04% at 15 ips
FREQUENCY RESPONSE .....	25-26,000Hz (± 3dB, 30-22,000 Hz) at 15 ips, 25-24,000 Hz (± 3dB, 30-20,000 Hz) at 7½ ips

SIGNAL TO NOISE RATIO .... 60 dB  
(ALL OTHERS SAME AS 3300-10)

### 3300-12 SPECIFICATIONS

HEADS .....	Same as 3300-11
SIGNAL TO NOISE RATIO .....	Same as 3300-11

(ALL OTHERS SAME AS 3300-10)

### 3300-10, 3300-11 and 3300-12 SPECIFICATIONS

3300-10 -	Standard 4-track stereo record and playback functions. 3¾ and 7½ ips.
3300-11 -	Half track record and playback with 7½ ips and 15 ips operation.
3300-12 -	Half track record and playback with 3¾ and 7½ ips operation.



## GSL-SERIES (6010, 7010, 7030GSL)

The TEAC GSL Series uses a separate motor for capstan drive and for each reel table. The rugged precision "dual speed hysteresis synchronous motor" drives the capstan thus allowing electrical rather than mechanical speed change.

Electronic automatic reverse. Automatic delay circuit - The 6010GSL and 7010GSL employ two methods of automatic reverse. The first is the TEAC Phase Sensing Signal system. This operates by placing a 50 or 60 Hz signal on the tape at the desired reverse point. With the AUTO REVERSE button in the "ON" position, the tape will change direction as this signal passes the record head. The second method uses conventional sensing foil placed on the tape backing.

The 7030GSL incorporates automatic rewind or stop functions.

Dual monitoring capability - the use of monitor switch allows instant comparison of the signal input and the actual recording being made.

The 7030GSL is a professional tape deck with operating speeds of 7½ and 15 ips. Since it is designed primarily for 2-track operation, it does not incorporate the automatic reverse features as found in the 6010GSL/7010GSL. Its normal head configuration is three 2-track stereo, and a fourth 4-track playback head for playing back pre-recorded 4-track stereo tapes. Selection of 2 or 4-track playback is accomplished by push button. The 7030GSL also has a cueing facility for precision cueing and editing.

The 6010GSL is identical to the 7010GSL in all respects, except that it accepts up to 7 inch reels only.

TEAC "HD" HEADS, standard on all "GSL" machines, are formed from High Density Ferrite, a material virtually impervious to wear. Each High Density Ferrite head bears a lifetime warranty.

Its high permeability permits a much higher bias level without increasing bias current. High Density Ferrite is very difficult to magnetize which means that it will retain less residual magnetism than previous materials.

The extreme hardness and crystalline structure of the material permits a degree of mechanical precision not possible with ordinary laminar construction techniques.



## MODEL 270

Designed to run for long periods, reliably and with trouble-free performance, the 270 is an extra-rugged, heavy duty reproducer designed and built with excellent craftsmanship.

### SPECIFICATIONS

HEAD CONFIGURATIONS .....	Monophonic Half or Full-Track; Stereo 2 or quarter-track
TAPE SPEED .....	3¾–7½ ips; 7½–15 ips
REEL SIZE .....	Up to 14"
START TIME .....	Play speed in 0.1 seconds
REWIND TIME .....	Approx. 105 seconds/4800 feet
TIMING ACCURACY .....	Better than 99.8% for 30 minute tape
POWER REQUIREMENTS .....	117Vac, 60/60 Hz, 275 Watts
CONTROL SYSTEM .....	All relays and solenoids 24 Vdc; plug-in relays.
FREQUENCY RESPONSE .....	±2 dB, 50–7,500 Hz at 3¾ ips; +2 dB, –3 dB, 50–15,000 Hz at 7½ ips; ±2 dB, 35–15,000 Hz at 15 ips.
SIGNAL TO NOISE RATIO .....	Mono Full-Track, 65 dB minimum at 7½ and 15 ips; Stereo 2-Track, 60 dB minimum at 7½ and 15 ips.
FLUTTER & WOW .....	3¾ ips, 0.2% rms or better; 7½ ips, 0.1% rms or better; 15 ips, 0.08% rms or better.
DISTORTION .....	Less than 0.5% total harmonic distortion at +18 dBm.
OUTPUT .....	+18 dBm from 600 ohm balanced line (normally supplied +4 dBm = zero VU).
SIZE .....	19" x 24½" x 8¾"

## MODEL 280

Famous smooth action tape lifters (with instant access to manual override), and new Motion Sensing, keeps the 280 heads above all others in its class.

### SPECIFICATIONS

CONFIGURATIONS .....	¼"–1 or 2 channels; ½"–3 or 4 channels
TAPE SPEED .....	3¾–7½ ips; 7½–15 ips. Others at special request
POWER REQUIREMENTS .....	117 Vac, 50/60 Hz, 275 Watts
CONTROL SYSTEM .....	All relays and solenoids 24 Vdc; plug-in relays.
TIMING ACCURACY .....	99.9% ±1.5 secs. for 30 min. tape.
REWIND TIME .....	Approx. 75 sec./2400 feet
FREQUENCY RESPONSE .....	+2 dB, 30 Hz to 15,000 Hz @ 15 ips; +2, –3 dB, 50 Hz to 15,000 Hz @ 7½ ips; +2, –3 dB, 50 Hz to 7,500 Hz @ 3¾ ips.
SIGNAL TO NOISE RATIO .....	Peak record level to noise using 3M 202 or equal, at 7½ and 15 ips. Measurements made relative to 6 dB above normal operating level. Measurements unweighted (dB min.) (30 Hz–18,000 Hz band). Full Track, ¼" ..... 65 2-Track, ½" ..... 63 4-Track, ½" ..... 63 8-Track, 1" ..... 63 12-Track, 1" ..... 56
FLUTTER & WOW .....	15 ips, 0.08% or better; 7½ ips, 0.1% or better; 3¾ ips, 0.2% or better
EQUALIZATION .....	Transport Speed Switch controls equalization NAB curve.
OUTPUT .....	+4 or +8 dBm (+18 dBm peak) 600 ohm balanced line.
INPUT .....	Bridging (600 ohm balanced or unbalanced) line level; Microphone
MONITORING .....	Separate record and playback amplifiers permit tape monitoring while recording.
PLAYBACK AMPLIFIER DISTORTION .....	Less than 0.5% THD at +18 dBm.



## MODEL 280

### ADDED FEATURES

Added control center features include Edit Control Switch, sweep loading tape path and hum shield lock.

Patented disc brakes. Selective Synchronization, for multi-channel over dub effects available (optional). Patented Linearity Control, for low distortion performance. Scrape filter for recording excellence. Tapped transformers for lowest operating temperatures.



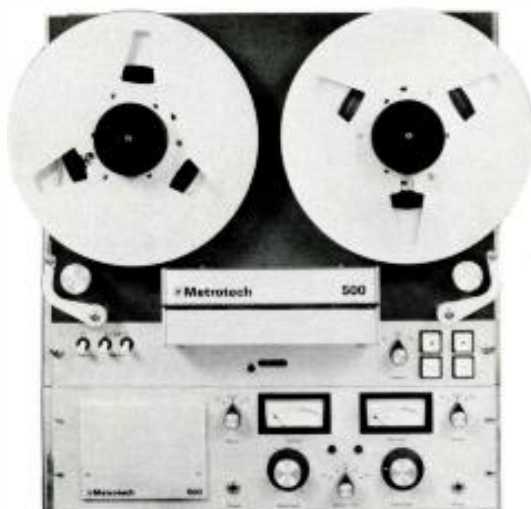

## 500 SERIES – RECORDERS: FEATURES

Choice of Six Tape Formats – full track mono; half and quarter track mono and stereo; quarter track fully sequenced mono. Dual Speed Operation – can be ordered to operate at any two adjacent speeds – 15, 7½, 3¾, and 1 7/8 ps. Selectable Motor Torque – provide the proper tension for either 10½” or 7” reels.

Automatic Equalization Switching – whenever tape speed is changed. Edit and Cue Control – makes it easy to add, delete and locate material. Hinged cover provides full access to tape. Rack or Optional Console Mounting.

## REPRODUCERS

The 500-Series Reproducers meet or exceed all NAB specifications, and are designed especially for the playback of tapes in broadcast automation systems. Their outstanding reliability makes them ideally suited to these applications, where day-in and day-out trouble-free operation is essential. In addition they offer three manually selectable speeds, and great compactness. 500-Series Reproducers are available in full track mono, half and quarter track mono and stereo, and quarter track fully sequenced mono.

## SPECIFICATIONS

<b>FREQUENCY RESPONSE</b> .....	15 ips: ±2 db, 30 Hz to 18KHz
	7½ ips: ±2 db, 40 Hz to 12 KHz;
	+2-4db, 30Hz to 15 KHz
	3¾ ips: ±2 db, 40 Hz to 8 KHz
	+2-6db, 30Hz to 10 KHz (12KHz with “HF” heads)
	1-7/8 ips: ±3 db, 30 Hz to 8 KHz (10KHz with “HF” heads)
	(Note: all parameters adjustable)
<b>SIGNAL-TO-NOISE RATIO</b> .....	15 ips: 65 db, full track
	7½ ips: 65 db, full track
	3¾ ips: 55 db, half track;
	51 db, quarter track
	1-7/8 ips: 53 db, half track;
	50 db, quarter track
<b>FLUTTER AND WOW</b> .....	15 ips: 0.6%
	7½ ips: 0.8%
	3¾ ips: .12%
	1-7/8 ips: .22%
	(RMS max. ASA Z57.1 1954 std.)

## MODEL A77 MARK III

The new A77 MK III is the best recorder that REVOX has ever made.

Operating element systematically laid out and functionally grouped. Feather-touch push buttons (relay controlled) for all transport functions. Professional three-head design for on/off tape monitoring as well as provision for mixing, multi-track and echo effects. Reel motor defeat switch for manual reel handling during editing. Exceptionally smooth fast forward and rewind speeds thanks to professional three motor design and servo braking system.



## SPECIFICATIONS

<b>TAPE SPEED</b> .....	3¾ and 7½ ips, max. deviation from nominal ± 0.2%
<b>WOW AND FLUTTER</b> .....	total rms, weighted 0.04% at 7½ ips and 0.05% at 3¾ ips. Weighted peak to peak flutter as per DIN 0.08% at 7½ ips and 0.1% at 3¾ ips
<b>FREQUENCY RESPONSE</b> .....	Via tape: at 7½ ips: 30 Hz to kHz + 2/-3 dB; 50 Hz to 15 kHz ± 1.5 dB. At 3¾ ips: 30 Hz to 16 kHz + 2/-3 dB; 50 Hz to 10 kHz ± 1.5 dB.
<b>DISTORTION</b> .....	measured via tape at 1 kHz peak level and at 0 VU respectively. 7½ ips less than 2% or 0.6% resp. 3¾ ips less than 3% or 1.0% resp.
<b>SIGNAL TO NOISE RATIO</b> .....	weighted readings via tape 7½ ips better than 61 dB (4-track 57 dB) 3¾ ips better than 58 dB (4-track 54 dB)
<b>INPUTS PER CHANNEL</b> .....	Microphone, low impedance 50 to 600 ohms 0.15 mV, high impedance up to 100 k ohms 2.5 mV – Radio 2.5 mV – Auxiliary 35 mV. All inputs have an overload margin of 40 dB (1:100)
<b>OUTPUTS PER CHANNEL</b> .....	Amplifier max. 2.5V, internal impedance 600 ohms – Radio max. 1.2 V, internal impedance 2.5 k ohms
<b>POWER REQUIREMENTS</b> .....	voltage selector for 110 to 250 V 50 to 60 Hz operation without need for conversion, consumption 70 . . . 100 watts
<b>DIMENSIONS</b> .....	in carrying case 20-5/8 x 15 x 8¾ inches



### CBS 4100-4110 VOLUMAX

CBS Laboratories new FM Volumax solves the FM Broadcaster's dilemma once and for all by using precise quadruple action control. Low, middle, and high frequency portions of the program energy are processed by independent functions, and overall instantaneous final limiting assures that no overmodulation will occur.

At low levels, where pre-emphasis can cause no overmodulation, the frequency response is flat over the entire range. At maximum peak levels, the response is the inverse of the pre-emphasis slope.

#### SPECIFICATIONS

Monophonic Model 4100

#### INPUT & OUTPUT

IMPEDANCE..... 600 Ohms balanced or unbalanced,  
 INPUT LEVEL..... -22 dBm to + 8 dBm  
 MAXIMUM PEAK  
 OUTPUT LEVEL..... + 28 dBm

FREQUENCY RESPONSE..... Flat  $\pm 1$  dB below the limiting threshold. Variable as a function of level above limiting threshold reaching the 75 microsecond de-emphasis characteristic  $\pm 1$  dB at maximum level.

HARMONIC DISTORTION..... Less than 1%, below threshold of limiting, 50-15,000 Hz.

ATTACK TIME..... Less than 1 microsecond or 2 milliseconds depending on program wave form.

RECOVERY TIME..... 200 milliseconds (low frequencies), 5 milliseconds (mid frequencies) 1 microsecond (high frequencies).

DIMENSIONS..... Standard 19" rack, 1 1/4" high, 18 3/4" deep.

Stereo Model 4110

Meets all Model 4100 specifications



### CBS 4440/4450 AUDIMAX

The new stereo AUDIMAX 4450 gives the broadcaster maximum latitude in original programming where the left and right channels are used separately to create special effects.

Audimax solid state logic circuitry monitors the incoming signal and compares it with its memory of average program content over a preceding period of time. This is a four-dimensional activity (input level, output level, memory, time). With explosive sounds such as pistol shots and sudden audience reaction, Audimax adapts the gain without leaving "holes". It is this ability to maintain stable gain at changing reference levels that makes Audimax unique.

Whenever standby conditions occur, Audimax waits about 10 seconds while keeping the gain steady at the last correct setting. Then, when its memory unit is convinced that the program has ended, it slowly returns to normal gain.

The monaural Audimax Model 4440 offers for the first time the ability to convert in the field to stereo, inexpensively and easily with no change in unit dimensions.

#### SPECIFICATIONS

FREQUENCY RESPONSE..... Flat within .5 dB from 50 to 15,000 Hz.

HARMONIC DISTORTION..... Less than .5% from 50 to 15,000 Hz.

SIGNAL-TO-NOISE RATIO..... 70 dB minimum.

CONTROL CHARACTERISTIC..... +10 dB of gain control

GATED GAIN STABILIZER..... threshold adjustable from -20dB to normal input

RETURN-TO-ZERO FUNCTION returns gain to normal during pauses greater than 10 seconds.

MAXIMUM GAIN..... 40 dB (for complete Audimax action)

#### INPUT & OUTPUT

IMPEDANCE..... 600 ohms, balanced or unbalanced

NORMAL OUTPUT LEVEL..... +14vu program, 18dBm sine wave

MAXIMUM OUTPUT..... +26 dBm

MINIMUM INPUT LEVEL..... -29vu program, -25dBm sine wave

PHYSICAL DIMENSIONS..... standard 19" rack mounting, 1 1/4" high, 16" deep

### CBS VOLUMAX 4000

The unit is capable of symmetrical or asymmetrical Peak Limiting by operation of a front panel switch. Two degrees of asymmetry are selectable. Relative to a transmitter, these positions are "120%" and "300%". The latter represents uncontrolled positive peaks.

#### SPECIFICATIONS

Maximum gain, 50 dB; signal to noise ratio, 70 dB minimum Input levels. from -24 dBm peak output.

Frequency response  $\pm .5$  dB (THD less than 1% between 50 and 15,000 Hz.)

Protection attack time less than 1 microsecond, release time 150 milliseconds.

Power requirements 12 watts 105-105/230 VAC 230 VAC, 50-60 Hz.

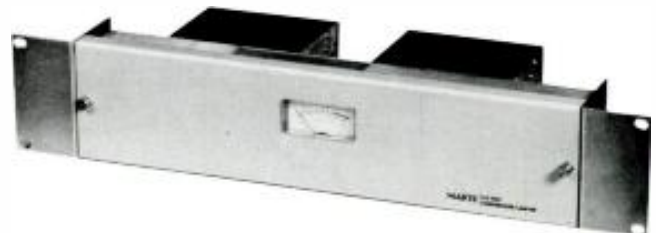

### MARTI CLA-40/A COMPRESSOR LIMITER

Fully accessible controls, permit its use as a Compressor, Compressor/Limiter or as a "Straight Through" amplifier for Proof of Performance measurements. The CLA-40/A is supplied with a meter reading in Gain Reduction, +4 VU and +10 VU

#### SPECIFICATIONS

APPLICATION..... AM or FM. Strap two together for stereo.

#### INPUT & OUTPUT

IMPEDANCES..... 600 ohms balanced or unbalanced.

INPUT LEVEL..... -15 to +20 DBM.

MAXIMUM OUTPUT LEVEL..... +20 DBM RMS.

FREQUENCY RESPONSE..... 50 Hz to 15 kHz flat within 0.5 DB in AM or FM mode.

MAXIMUM GAIN..... 40 DB.

NOISE LEVEL..... -66 DB Ref. +10 DBM output (FM Mode).

DISTORTION..... Less than 1% THD at all compression levels.

#### AUTOMATIC GAIN

CONTROL RANGE..... 40 DB dynamic.

RELEASE TIME..... Adjustable 800 milliseconds, 2 sec, 5 sec. approx.

ATTACK TIME..... Less than 1 microsecond in compress-limit mode.

PHYSICAL DIMENSIONS..... 3 1/2" x 19" rack panel.

## RPL-2T

Modularized circuitry using state-of-the-art devices and special attention to serviceability make the RPL-2T remote pickup link small-sized but not densely constructed. The RPL-2T Transmitter utilizes direct frequency modulation enabling outstanding audio frequency response and low distortion for the complete link. Modulation occurs in a voltage-controlled crystal oscillator (VCSO) which is multiplied to the operating frequency. Three final RF amplifier transistors operate in a parallel configuration to provide further reliability.

For 450 MHz operation, a varactor tripler assembly is added to the 160 MHz Transmitter output stage. All RPL-2 Transmitters and Receivers have provision for conversion from 160 MHz to 450 MHz operation. Slide-out drawer construction giving full front-panel accessibility is used in the RPL-2R Receiver. The RPL-2R is of the superheterodyne design. The 160 MHz Receiver is double-conversion. Triple-conversion is used in the 450 MHz Receiver.

### SYSTEM SPECIFICATIONS

AUDIO RESPONSE .....  $\pm 1.5$  db, 30 Hz–12,000 Hz  
 DISTORTION ..... Less than 1.3%, 30–12,000 Hz  
 SIGNAL-TO-NOISE-RATIO .... 55 db below 100% (58 db typical)  
 FREQUENCY RANGE ..... 148 MHz–174 MHz or 450 MHz–470 MHz, as ordered.

### TRANSMITTER SPECIFICATIONS

RF OUTPUT ..... 148–174 MHz: Minimum 30 watts continuous into 50 ohm load, 36 watts maximum. 450–470 MHz: Minimum 19 watts continuous into 50 ohm load, 22 watts maximum.  
 EMISSION ..... 148–174 MHz: 30F3 ( $\pm 5$  kHz for 100% modulation). 450–470 MHz: 50F3 ( $\pm 15$  kHz for 100% modulation)

### RECEIVER SPECIFICATIONS

SENSITIVITY (160 MHz & 450 MHz) ..... 0.7 microvolt for 20 db SNR, 75 microseconds de-3mphasis. 3 microvolts for 20 db SNR.  
 SELECTIVITY ..... -6 db at  $\pm 15$  kHz. -80 db at  $\pm 60$  kHz.



MODEL RPL-2

### RPT-40 REMOTE PICK UP TRANSMITTER SPECIFICATIONS

FREQUENCY STABILITY ....  $\pm .005\%$  – 30deg.C to +60deg. C.  
 DUAL FREQUENCY OPERATION ..... Available at extra cost  
 SPURIOUS EMISSION ..... Attenuated 60 DB+ below carrier level.  
 RF OUTPUT ..... Maximum 40 watts, nominal 36 watts.  
 MODULATION ..... 30 F3; normally adjusted for  $\pm 6$  kHz deviation. Plug-in direct FM modulator.  
 AUDIO INPUTS ..... Four microphone inputs standard (one push-to-talk)

### R-30/150 RECEIVER SPECIFICATIONS

CARRIER FREQUENCY RANGE ..... 150-172 Mhz.  
 DUAL FREQUENCY OPERATION ..... Provisions are the second crystal adjusted to frequency and switch assembly are optional.  
 SENSITIVITY ..... 0.5 microvolt for 20 db quieting.  
 INPUT IMPEDANCE ..... 50 ohms.  
 FREQUENCY STABILITY ....  $\pm .0005\%$ –30 deg.C. to + 60deg.C.  
 SELECTIVITY ..... 10.7/F30 filter module band width: 6 DB at  $\pm 17.5$  KHz, 60 DB at  $\pm 22.0$  KHz, 90 DB at  $\pm 23.5$  KHz, 100 DB + ultimate.  
 SPURIOUS RESPONSE ..... At least -95 DB.  
 AUDIO OUTPUT ..... Balanced 600 ohms. + 10 DBM.  
 FREQUENCY RESPONSE.....  $\pm 1$  DB 50 Hz to 8000 HZ when used with RPT-40 transmitter.  
 POWER REQUIREMENTS .... 115/230VAC, 50/60 HZ, 30 watts.  
 AC POWER SUPPLY ..... Precision, electronically regulated 2C. Plug-in module.  
 METERING ..... Precision taut-band meter with front panel test selector switch.

### SYSTEM SPECIFICATIONS

150 – 172 MHz RPT – 40 Transmitter with R-30/150 Receiver  
 AUDIO RESPONSE.....  $\pm 1.5$  DB 30 HZ-7500 HZ with 10.7/F30 Receiver I.F. Filter. The 10.7/F30 Filter is recommended because reduced bandwidth minimizes interference.  
 DISTORTION ..... Less than 2% THD within receiver Filter Bandwidth.  
 SIGNAL-TO-NOISE-RATIO .... Better than 50 DB below 100% modulation. (High Level Input).



MODEL RPT-40

### RPT-25 RPU TRANSMITTER SPECIFICATIONS

FREQUENCY ..... 450–470MHz  
 RF OUTPUT ..... 50 ohms

### R-50/450 RPU RECEIVER SPECIFICATIONS

CARRIER FREQUENCY RANGE ..... 450–470MHz

### SYSTEM SPECIFICATIONS

450-470 MHz RPT – 25 Transmitter with R-50/450 Receiver  
 AUDIO RESPONSE .....  $\pm 1.5$  DB 30 HZ-12000 HZ with 10.7/F100 Receiver I.F. Filter.  $\pm 1.5$  DB 30 Hz-10500 Hz with 10.7/F50 Receiver.I.F. Filter. The 10.7/F50 Filter is recommended because reduced bandwidth minimizes interference.  
 DISTORTION ..... Less than 2% THD within receiver Filter Bandwidth.  
 SIGNAL-TO-NOISE-RATIO .... Better than 50 DB below 100% modulation.

M30BT is the 30 watt, tube-type equivalent of the RPT-40. M20BT is the 20 watt, tube-type equivalent of the RPT-25.



**NORTRONICS  
TAPE HEADS**

NORTRONICS magnetic tape heads are designed to offer highest quality performance and long dependable service. As the foremost manufacturer of laminated-core magnetic heads, NORTRONICS offers a complete line of heads, available in a wide selection of track styles, function, and sizes.

The PREMIUM series of professional heads gives unsurpassed performance for broadcast, industrial, recording studio, and other exacting applications. Long life and extended high frequency response, particularly at the slower tape speeds, are major benefits in addition to:

- Fine laminated, precision-lapped, low loss core structures.
- Deposited quartz gaps result in exceptionally clean, sharp gap edges for optimum high frequency resolution. Gaps are from 50 to 500 micro-inches in length; shorter gaps down to 200 micro-inches available.
- Hyperbolic face contour gives intimate tape-to-gap contact without need for pressure pads, but allows use with pressure pads as well.
- Highly polished all-metal faces greatly reduce oxide buildup and the need for frequent cleaning.
- Superbly shielded against external magnetic fields.



**SPARTA HM-2  
DIE-CAST  
HEADMOUNT**

The precision HM-2 die-cast "True Tangent" headmount is of non-magnetic construction, with long wearing stainless steel tape guides. It has complete adjustments; height, azimuth, and zenith. Azimuth adjustment does not affect head height, and spring-loaded locks assure that adjustments will not drift. Note that the recording head is slightly offset. This Sparta innovation results in more consistent high frequency recording characteristics, and earns the HM-2 the designation of "True Tangent."

The HM-2 is the standard headmount in Century Series modular tape cartridge equipment, and readily replaces earlier Sparta, Nortronics, Viking and other head stacks. It will replace other manufacturers' equipment with only minor adaption. The HM-2RP is illustrated.



## CAB-61 MODULAR ELECTRONIC HOUSINGS

The "modular approach to housing equipment" allows the user to develop his own enclosure package by starting with the basic frame module, then creating the final design by selecting other components from a wide variety of doors, side panels, work or writing desks, etc. It combines all of the necessary functional characteristics with beauty in styling. Factory tests indicate over one-and-a-half-ton capacity for a single CAB-61 rack frame. Painted parts are vapor-degreased, primed, and baked enamels of the customer's choice are applied. A feature of the modular approach is that it provides either bolted or easily removable side panels. "Heliarc" welded frames are assembled of 11, 14 and 16 gauge prime steel.

## CALIFORNIA CHASSIS RACK CABINETS

Since 1947 Cal Chassis has supplied the West with complete design, production and service of sheet metal products. Their rack cabinets are fabricated of 16 gauge steel, and all standard panels will fit these racks. Cabinets are delivered knocked down, with all required hardware included. Rear doors (on slip pin hinges) and sides are ventilated top and bottom. Front corners are rounded, and fronts decorated with trim strips. Stock finish is grey hammertone. Cal Chassis models are available for most radio station uses.

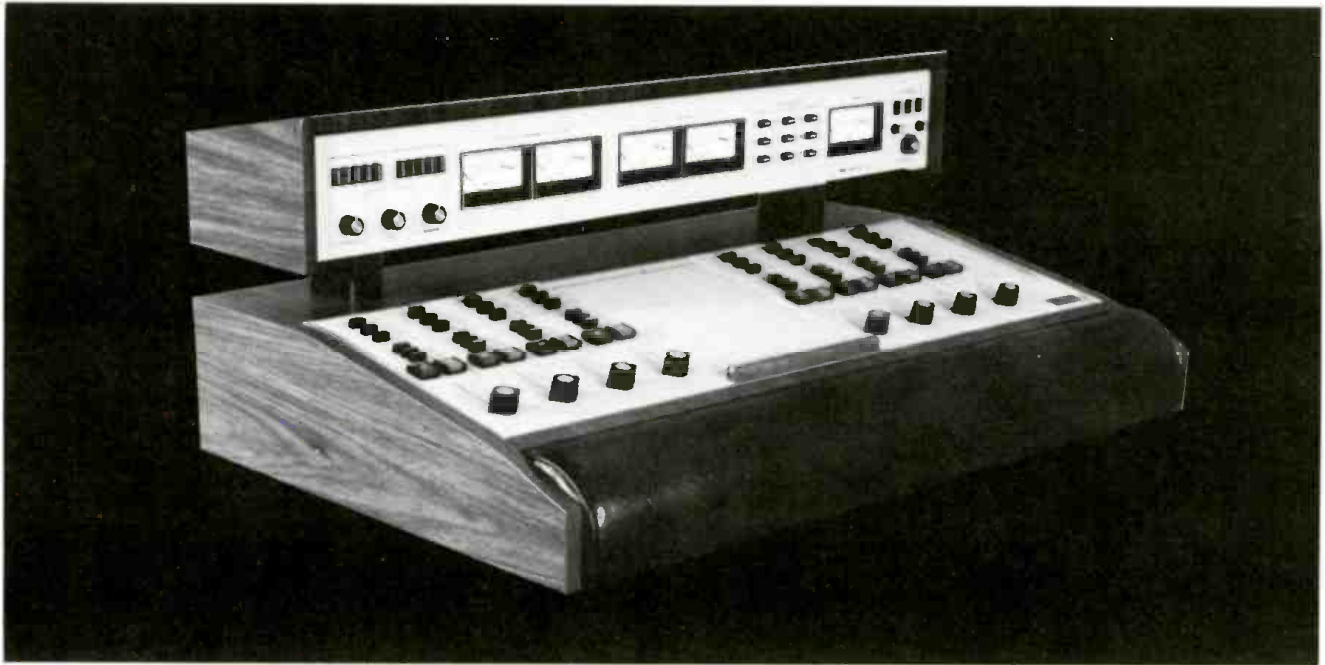

Enjoy the flexibility and convenience of a custom console, but at a production price. CENTURION I (mono) and CENTURION II (stereo, quad capable) have standard features to suit most broadcasters' conceivable needs. Options can be added at any time to meet changing requirements.

### STANDARD FEATURES

Electronic switching makes operation noiseless, and provides 2-way, in/out control: the CENTURION mixer module can either start or stop tape decks or turntables . . . or be turned on or off from an external signal such as a TV video switcher.

Mixer modules, supplied with either slide or rotary attenuators, are interchangeable. All high level amplifiers are identical. The self-contained plug in mixer modules are internally selectable for high or low level inputs. The basic 8-channel CENTURION I or II gives 24 inputs; 3 inputs per channel are standard in any capacity CENTURION console.

Quadraphonic operation is possible by gang-ing adjacent mixers of the CENTURION II STEREO console; the Program and Audition channels are separately metered for this purpose.

Extensive use of motherboards and ground plane p.c. techniques eliminate most cable harness required on less modern consoles.

### OPTIONS

Expanding CENTURION to nine, ten, eleven or twelve channels is simply a matter of adding the desired interchangeable mixer modules. A separate, matching 6-channel extender is also available for expansion to 18 channels. Reverberation and Equalization controls are also available.

### OPERATIONS

The CENTURION uses three inputs per channel, and three metered signal lines (Program, Audition and Utility). The Utility line can feed a separate program or be used to set the level of an incoming signal, independent

of either Program or Audition line content. In the CENTURION II any of the three lines can originate a Mono Feed output, which is metered. Power supply is dual. Push-buttons are illuminated. The monitor amplifier supplied is 25 watts per channel RMS, and cue speaker is internal.

### PRELIMINARY SPECIFICATIONS

MIXERS ..... 12 (8 standard).  
 INPUTS ..... 36 inputs (24 standard).  
 INPUT LEVELS -55 to 0 dbm, any input.  
 Gain of input amplifier is switch selected for 50 db, 20 db, or unity.

### INPUT

IMPEDANCE ... 150/600 ohms, switch selected on mixer amplifier board.

### OUTPUTS

..... Program; Audition; Utility; (Also Mono Feed on Centurion II); 8 dbm into 600 ohms for 0 VU indication. 22 dbm maximum output. Monitor; 25 watts per channel RMS. Cue; 1 watt to internal speaker. Phone; 1 watt per channel to 4 ohm headset. Also useable with high impedance phones.

### RESPONSE

..... All amplifiers within 1 db, 20-20,000 Hz, at rated output.

### SIGNAL-TO-NOISE

..... 65 db below + 8 dbm output, referenced to -50 dbm input.

### MUTING

..... Mixers 1-12 (1-8 standard).  
 SIZE ..... 41 W x 23½ D x 14 H.  
 Power supply 5¼" rack-mount.

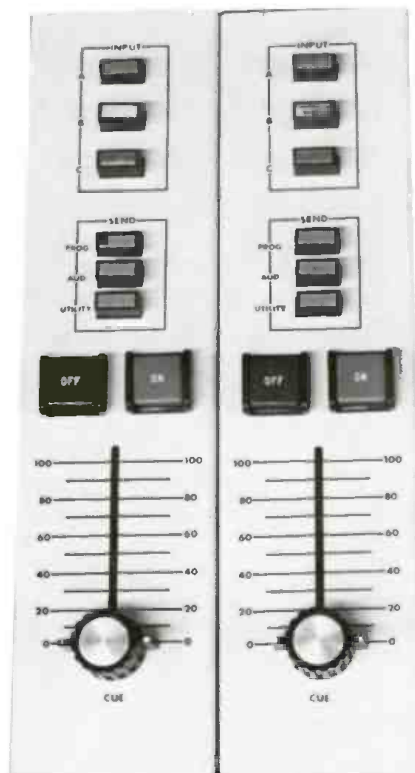

# SPARTAMATION

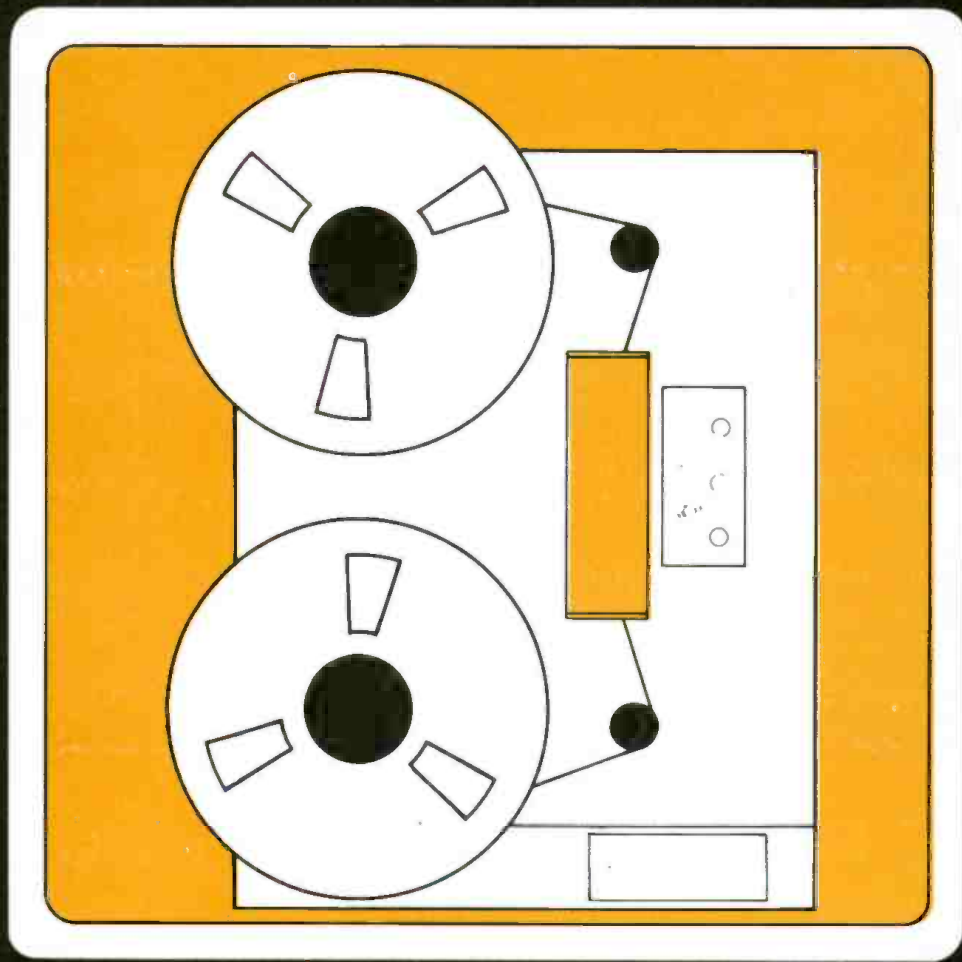

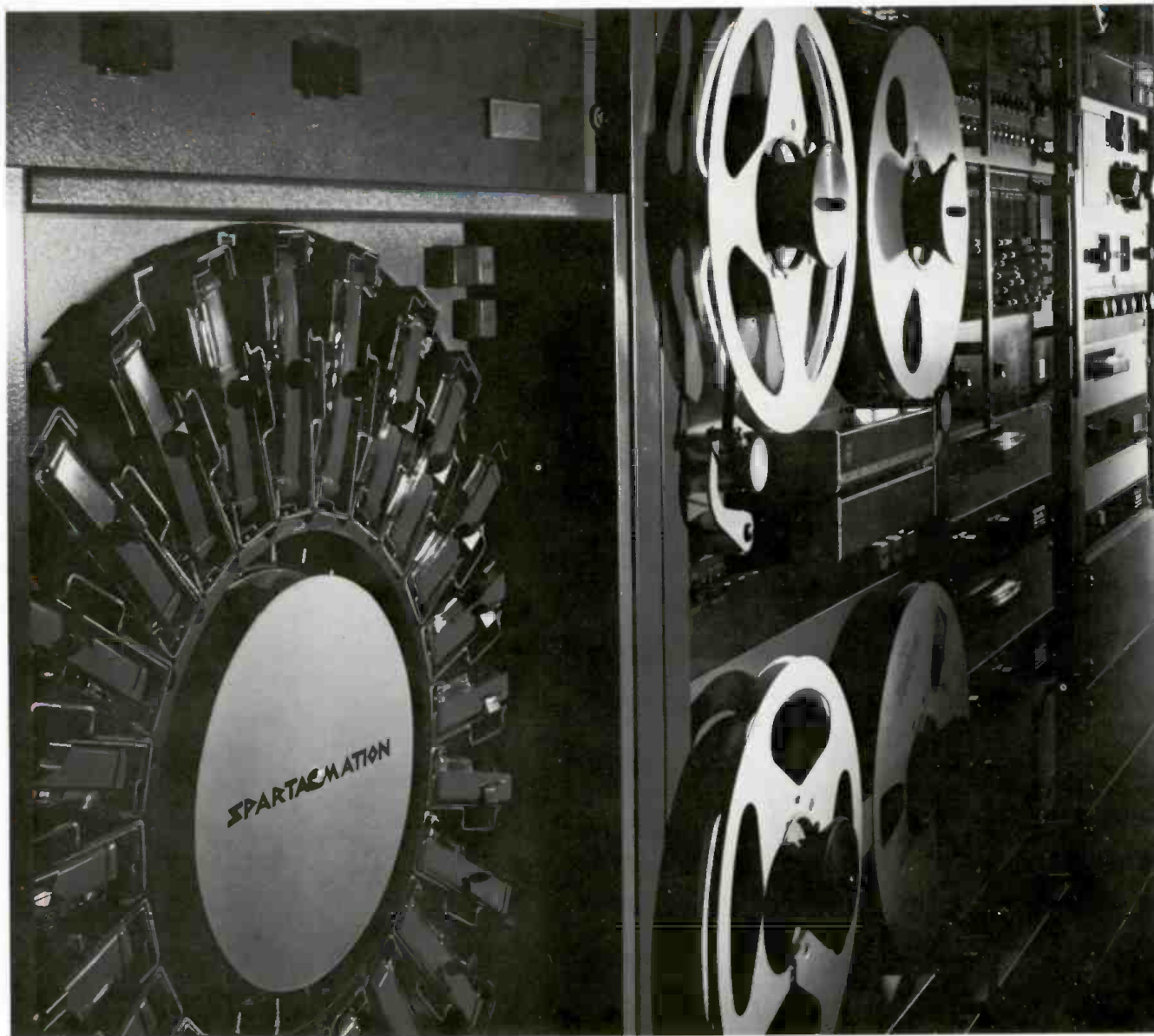

It really isn't as complicated as it looks! A Sparta-mation system consists mostly of audio tape reproducers. Usually they're multi-cartridge types for commercials, and either reel or multi-cartridge reproducers for music. One or more single cartridge playbacks are used for ID's and repetitive format material. A cartridge Random Access can be added—a series of 24 position slider switches to select the order in which commercial cartridges will play.

All the tape devices plug into our 1052 Automatic Program Controller. Removable pegs on the front

panel of the 1052 establish the format, the order in which the various music decks and commercial sources will be played. The 1052 has an internal clock to keep the format "on time" and to assure legal station ID times. The flick of a switch changes format. Also, you can add 52 event extender panels.

Each Sparta-mation system is custom-built, according to the station's size and needs. Often, existing equipment can be incorporated into the system to reduce the cost.

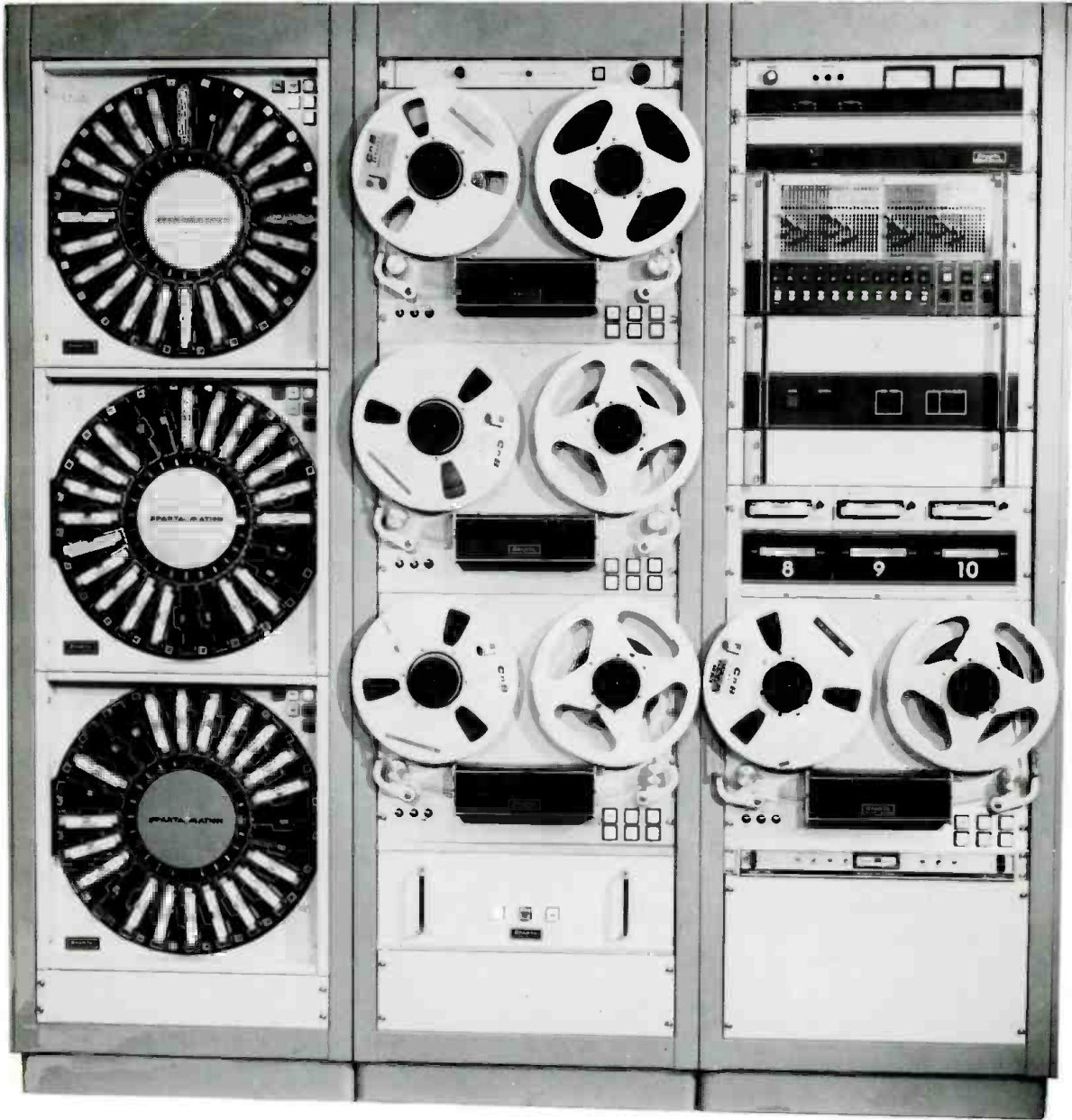

**COMMERCIALS:** RS-124 or 224 Carousels™ assure quality playback of stereo or mono announcements. Each Carousel holds 24 cartridges. Each cartridge can hold several spots that play in rotation – up to 10½ minutes per cartridge. Each time a cartridge is played, the next announcement is readied by the Cartridge Random Access.

**MUSIC:** Three reversing reel reproducers provide nine hours of music in three distinct categories. 14-inch music transports are also available, as well as economy transports for limited duty systems. A dual cartridge TA-581 Time Announcer is near the bottom of the rack. Time signals enhance the smooth, live sound of SPARTAMATION. A

silence-actuated alarm panel at the top of the rack flashes and beeps a warning if audio is temporarily interrupted.

**CONTROL:** The 1052 Automatic Program Controller is the “brain” of the system, controlling the format, or sequence of programming. A LAM-1 Stereo Line Amplifier is at the top of the rack and includes an optional eight watt/channel monitor amplifier. Below the 1052 Programmer is the RS-4100 Cartridge Random Access. Commercial cartridges are selected by slide switches in the drawer below the digital readouts. Three Century Series cartridge playbacks are available for ID’s, weather, format tapes, etc. in mono or stereo. A logging recorder is near the bottom of the rack.



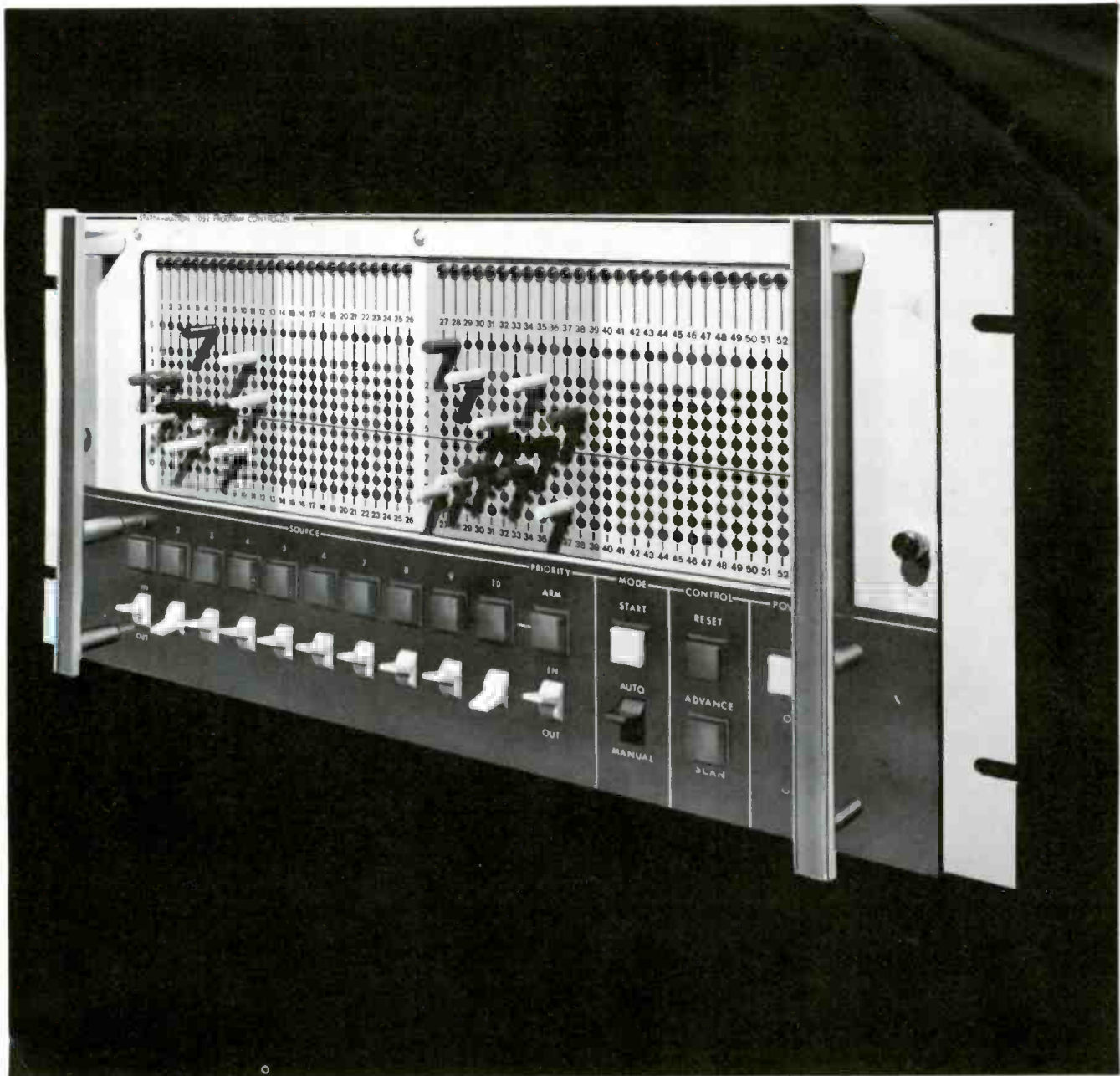

Broadcast Automation begins with the 1052 Automatic Program Controller. Just plug in the cartridge and/or reel tape reproducer of your choice and you're in business! No pops, clicks or embarrassing pauses. You'll get the *smoothest programming possible* — with tight segues, absolute format control and complete reliability.

Need automatic format changes? Add one or more FX-52 Format Expanders. Network joining? Sim-

ply plug-in a low-cost module. The 1052 is pre-wired to accept network audio. Maintenance? Please dust it now and then. All active circuits are on plug-in p.c. boards. The use of integrated circuits has reduced rack space to 8¾". But, if you'd prefer having it on your Program Director's desk, we'll supply a handsome walnut grain enclosure at no additional cost. Either way, the 1052 is the only way to go!

# SPARTAMATION

The 1052 provides fully automatic start/stop control and overlap audio switching for 10 channels of broadcast audio sources, *plus* two special channels for network audio and fill music. The basic model has a 52 event format capacity, with a Priority Interrupt feature which provides time-controlled insertion of additional events. One or more FX-52 Format Expanders can be added to the 1052, each providing an additional 52 event format.

An 11 x 52 matrix board contains the format information. The board is programmed with removable diode pins. A "skip" bus provides for skipping any undesired event. Front panel switches delete any audio source from the format, without reprogramming the board. Controls are provided for manual operation of all 10 audio sources; arming Priority and Reset; advancing to the next event; "scanning" the Controller ahead to another event location without affecting the event in progress. There is also an "auto/manual" switch. A row of indicators at the top of the matrix board indicates the event in progress. The 10 "manual start" switches are illuminated to show which audio source is active.

The 52 event matrix board is divided into 4 quadrants. Events 1, 14, 27 and 40 are the first events of the quadrants. Sub-miniature toggle switches on the 1052 chassis designate which of these 4 events will be valid reset points (approximate time correction intervals). Four additional sub-miniature toggles designate the reset times of 15, 30, 45 and 60 minutes. This enables a wide variation in possible formats, including a 13 event format, repeating each 60 minutes and a 52 format, repeating each 15 minutes. A chassis mounted clock provides the necessary timing signals.

Audio source 10 is controlled by a Priority Interrupt circuit, and also from the matrix board. The Priority circuit can be armed by depressing the front panel switch or by an external clock signal.

Each of the 10 audio control circuits has a "skip/play" connection. This feature is useful for programming uneven spot loads without altering the format on the 1052 matrix board. The SPARTAMATION RS-100B Random Cartridge Access provides for programming "skips" to delete commercial announcement availabilities previously allocated on the 1052 matrix board format.

The SPARTAMATION 1052 Automatic Program Controller is intended for use with any combination of broadcast quality reel or cartridge tape reproducers, capable of providing an audio level of 0 dbm into a 600 ohm load. It is preferable that cartridge reproducers be equipped with 150 Hz auxiliary tone detectors. If reel reproducers are used with the 1052, a 25-SEN 25 Hz Sensor/Filter will be required. A single 25-SEN connected to the 1052 Program Output will suffice for the entire system. However, individual 25-SEN's can be used with each reel transport if desired.

AUDIO INPUTS .....	10 regular audio inputs, Stereo or Monaural, <i>plus</i> fill music and network audio channels.
AUDIO LEVELS .....	-10 to 0 dbm input required. 1052 mixing amplifier provides unity gain, 600 ohm balanced output.
AUDITION OUTPUT .....	All inactive audio sources are bridged to a rear panel connector through a passive combining network.
PROGRAM METHOD .....	11 x 52 Matrix Board, using diode pins, expandable in 11 x 52 increments using optional FX-52 Format Expanders.
PRIORITY INTERRUPT .....	Front panel or external clock override of program board. Inserts audio source 10.
FORMAT LENGTH .....	52 events, divided into 4 format fields, individually switch selected. Expandable to any length.
TIME CORRECTION .....	Automatic time correction at end of each format segment, which can be 15/30/45/60 minutes.
SEQUENCING .....	Requires a single Model 25-SEN 25 Hz Sensor/Filter for reel systems, end-of-message contact closure from each deck in cartridge systems.
ACTIVE CIRCUITS .....	Silicon Integrated Circuits, transistors and diodes of highest quality.
RELAYS .....	Plug-in, clear plastic housing, gold-flashed silver contacts.
SPECIAL FEATURES .....	Logger output. Transistor regulated power supply, Silence Sensor — with output for remote alarm, Mixer/Line Amplifier, all on plug-in cards. Pre-wired for network joining, it requires only low-cost plug-in module, and timing source. Cannon and Switchcraft Audio Connectors.
POWER .....	110-125 volts, 50-60 Hz.
MOUNTING .....	Rack Mounting steel cabinet with chassis on sliders.
DIMENSIONS .....	8¾" high, 19" wide, 11¼" deep.
WEIGHT .....	.38 pounds.

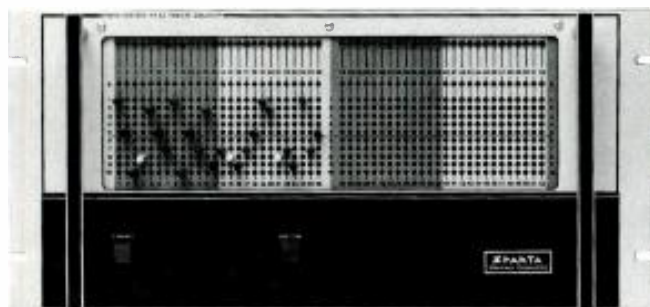

FX-52 FORMAT EXPANDER



REM-1052 REMOTE CONTROL

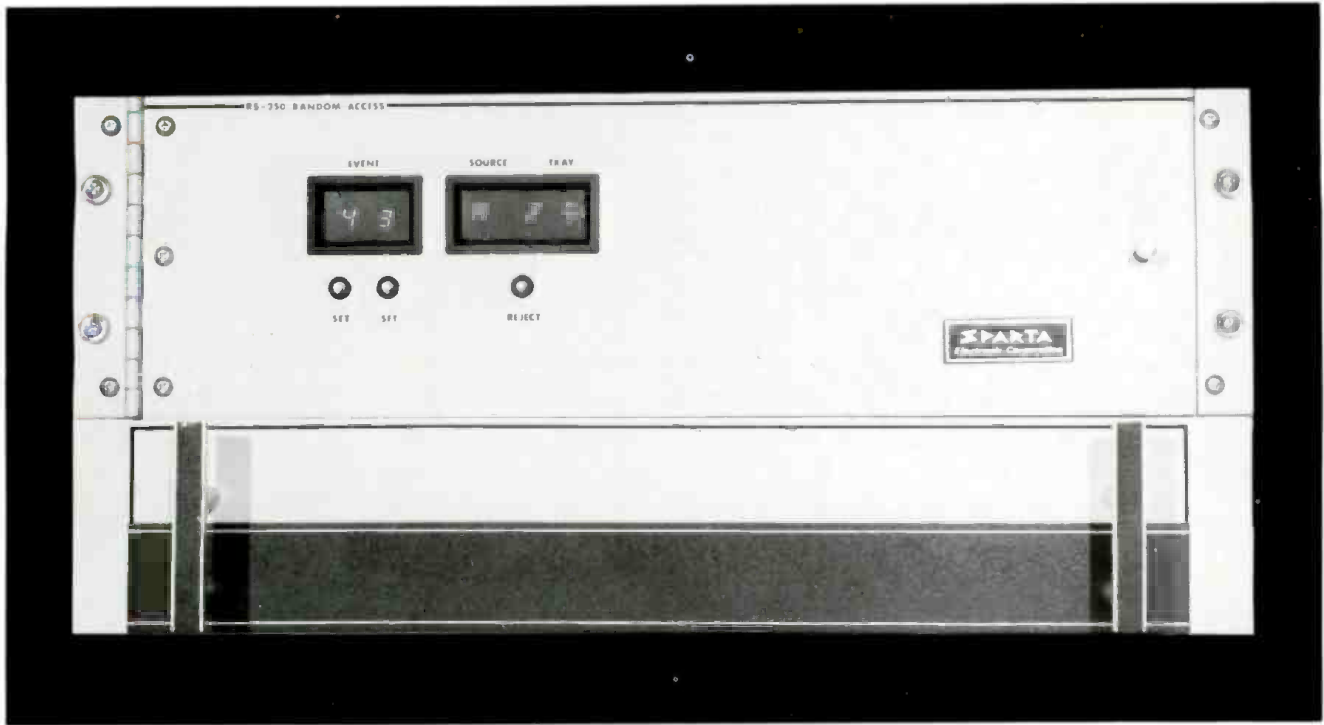

The Sparta RS250 Random Access was designed as an integral sub-programmer for SPARTAMATION systems, but works with and modernizes most other automation systems as well. Audio switching is built in, so that the two Carousels® (48 tape cartridges) are presented to the Model 1052 Program Controller as a single audio source. In this way, the RS250 determines which tape cartridge(s) will play or be skipped, and in what order, without reprogramming the 1052. When there is no announcement scheduled for an availability programmed on the 1052, the 'skip' setting on the RS250 causes the Controller to ignore the 'play' commercial' instruction, and the next scheduled event is aired instead. The 'skip' feature gives maximum flexibility in handling uneven commercial loads, and the RS250's search-ahead cueing readies both Carousels for back-to-back play without any access time lapse. In addition, adjacent announcements can be overlapped as desired for tight segues. The RS250 instantly upgrades any Carousel tape cartridge playback system which lacks search-ahead cueing. Electro-

nic are contained on plug in circuit boards with LED read-outs showing Carousel and tray number to play next. Event position is not lost in case of a power failure. Slide switches are placed in a drawer, which insures compactness of design, and is also a practical safety measure assuring that selection is not accidentally changed through a switch being bumped.



One RS250 and two RS124 Carousels are most commonly supplied with interconnecting cables cut for mounting the Random Access directly above adjacent Carousels. This combination, unmounted, is available as the SPARTAMATE "SPOT BANK" package for addition to existing SPARTAMATION or other automation systems. The RS250 takes 8¾" of rack space.

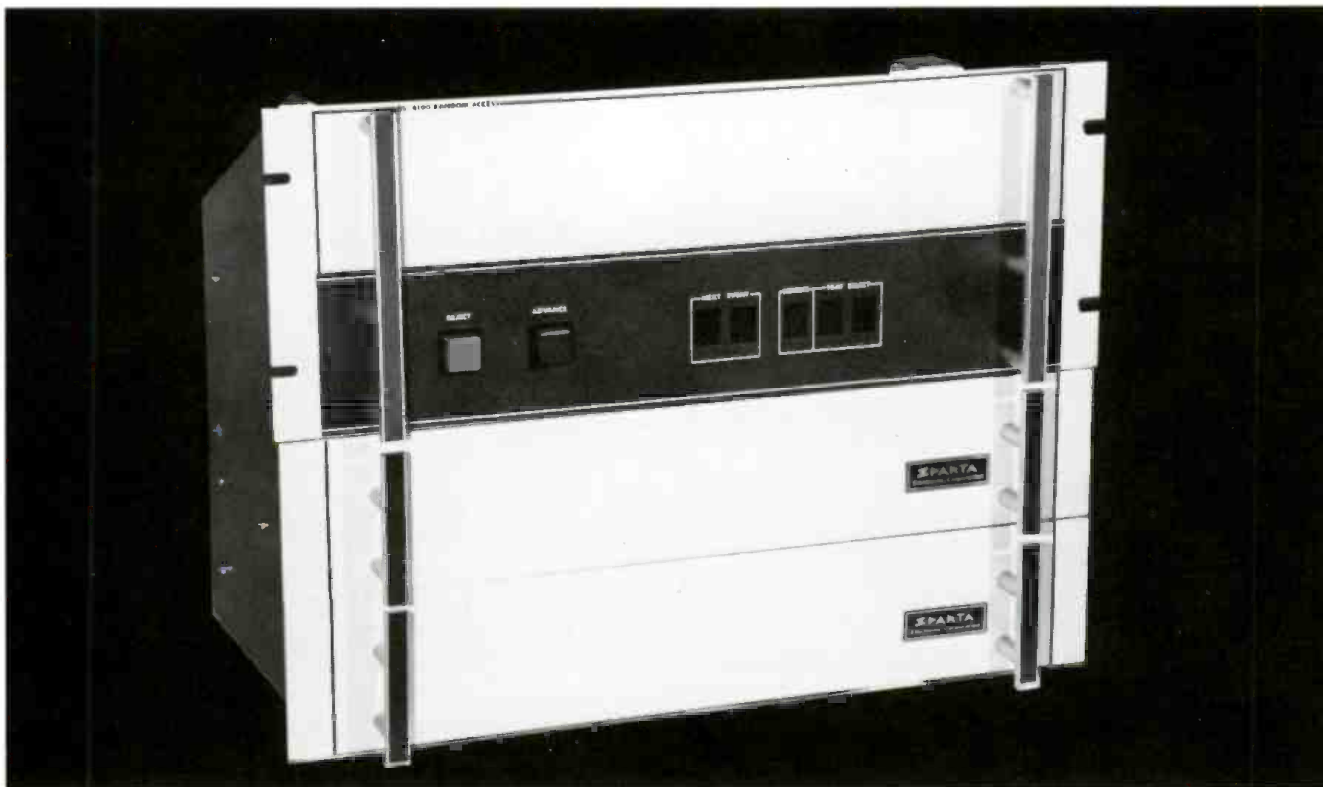

The RS4100 Random Access differs in some fundamentals from the RS250, but basically accomplishes double the work in less than double the space. The RS4100 controls four Carousels (96 tape cartridges) or a total of 100 events. Like the RS250, the 4100 presents the 96 tape cartridges it can control as a single audio source to the Model 1052 Program Controller. Besides being used with Models RS124 or 224 Carousels in systems using the Model 1052, it can be added to an existing system to upgrade it.

Programming switches are out of sight and harm's way in a drawer. The 'skip' feature allows the station with a heavy and uneven spot load to make utmost use of the RS4100's flexibility. Front panel readouts tell the number and address of the next cartridge to play. Multiple spots can be sub-pro-

grammed from the RS4100, as a single event schedule on the Program Controller, and adjacent spot overlapping can be done.

The RS4100 can also be supplied as a SPARTAMATE "SPOT-BANK" package for SPARTAMATION or other existing systems. When future necessity dictates, then, the RS4100's control capability will allow expansion from two to three or four Carousels. The RS4100 takes 14" of rack space.

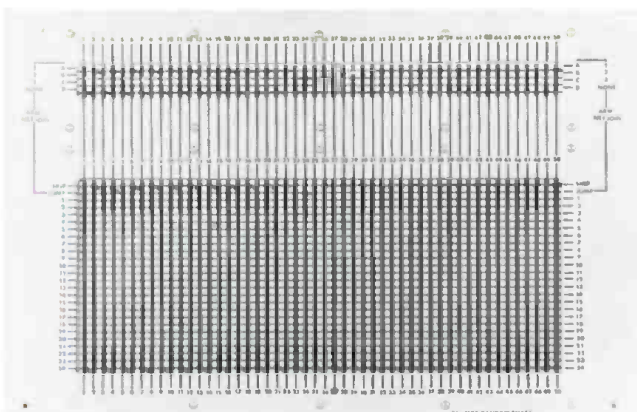

# SPARTAMATION DIGITAL CLOCK & NET JOIN

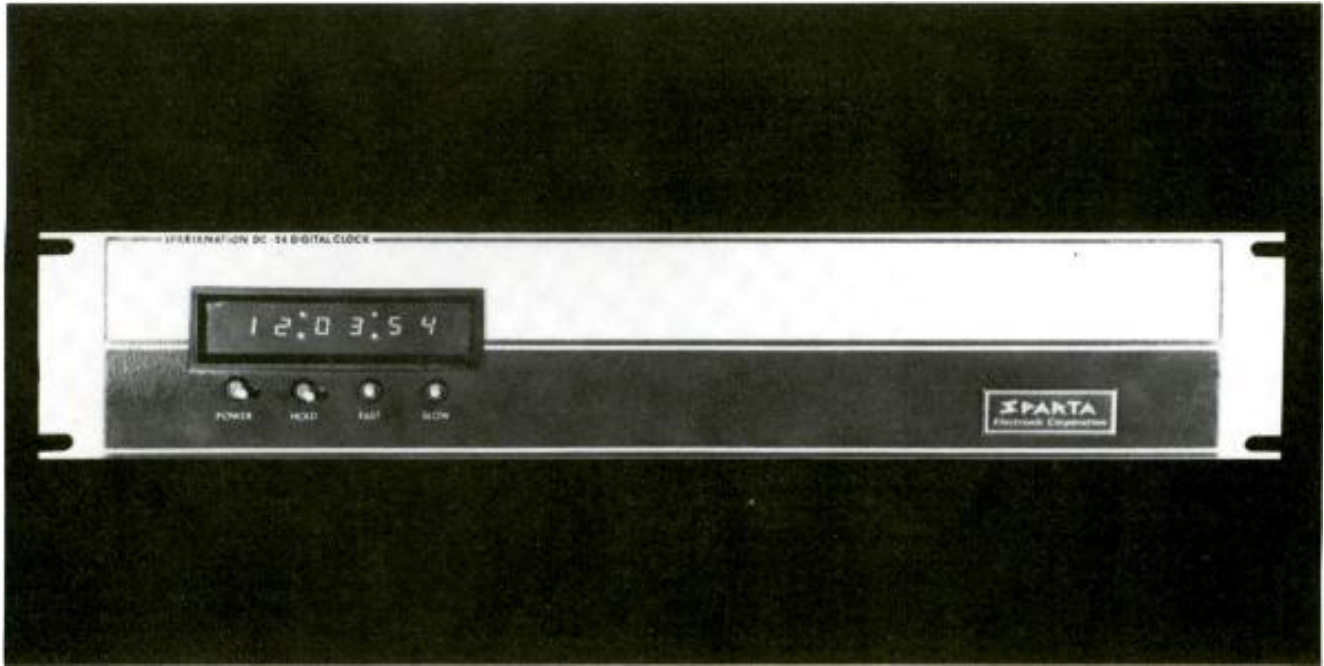

The DC-24 Digital Clock is the timing source for SPARTAMATION program and verification systems. Readout is from a bright, easy-to-read LED display, in 12 or 24 hour time. A series of digital comparator circuits provide a Form C contact closure to the Program Controller for arming the Reset function up to four times an hour. The times of the resets (approximate time corrections) are :13, :28, :43, and :58 minutes past the hour. Switches on the rear of the clock select which of the available times are to be used. The clock can also be supplied with additional digital comparators to supply logic outputs or contact closures for automatic network joining. Plug in time cards or thumbwheel switches are available for selecting network times.

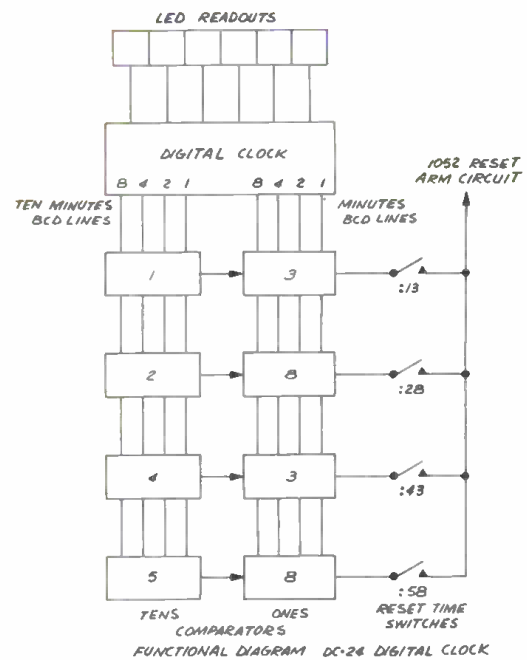

*Digital Clock with thumbwheel switches for control of automatic network joining.*

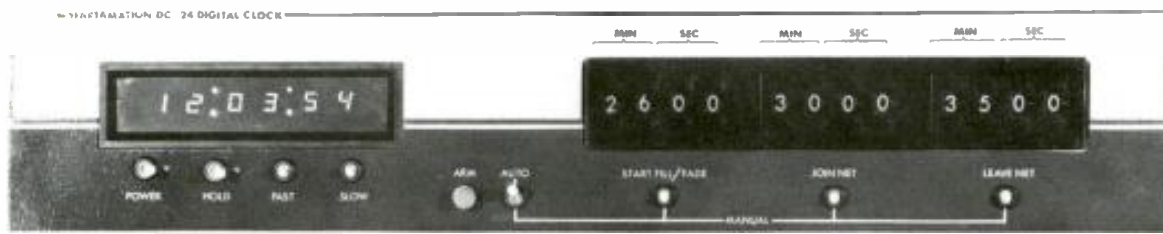

# RS-124 & 224 CAROUSELS™ SPARTAMATION



Spartamation RS-124 monaural and RS-224 stereo Carousels are the ultimate in multi-cartridge reproducers. They feature a 24 cartridge capacity, all plug-in solid state logic, new tray design, teletype logger output, and random selection.

The RS-124 and RS-224 will provide the highest quality music and commercial reproduction for both AM and FM operations.

Spartamation Carousels have fewer moving parts, and years of proven reliability at a much lower cost than other multi-cartridge reproducers. The RS-124/224 Carousels and RS-250 Random Cartridge Access are widely used for expanding any existing automation system.

## SPECIFICATIONS

MOTOR .....	Hysteresis synchronous
OUTPUT .....	+ 10 dbm into 600 ohms
FREQUENCY RESPONSE	.50 – 15 kHz, +1, –3 db (at –10 dbm)
SIGNAL TO NOISE .....	–48 db Typ. mono, –44 db Typ. stereo (NAB "0" level reference)
	–55 db Typ. mono, –50 db Typ. stereo (3% THD @ 400 Hz)
STOP CUE FREQUENCY	. 1,000 Hz
END OF MESSAGE FREQ	. 150 Hz

CAPACITY .....	24 series 300 cartridges
SHIFT TIME .....	4 Sec. from cartridge stop to next ready.
DRUM ROTATION .....	Maximum time 22 Sec.
SIZE .....	19½" high, 19" wide, 16" deep
WEIGHT .....	90 pounds

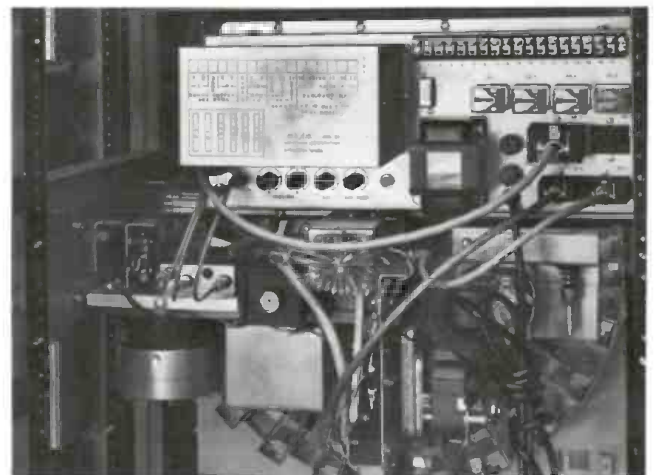

The Carousel is mounted on brackets which connect to the front and rear vertical rails of Sparta CAB-61 racks. The entire electronic section can be disconnected and removed in 2 minutes. All active circuits are on plug-in printed circuit boards.

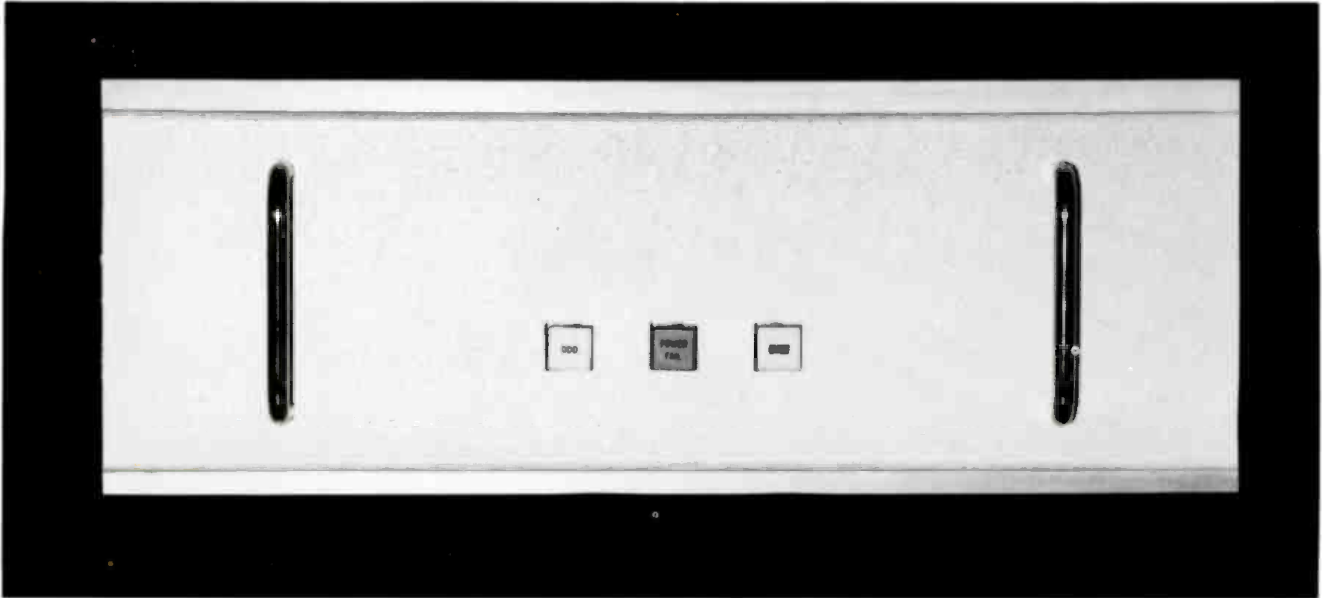

### Model TA-581 "ALWAYS READY" TIME ANNOUNCER

One of the most discussed aspects of automating a radio station is the complaint that it will lose a certain "live" sound. With advances in automation technology, however, companies such as Sparta recognize the complaint as valid at one time, but have now offset it with new devices and techniques.

One of the easiest ways to convince the listener that he is hearing live programming is to provide accurate time announcements. These can be prepared for the TA581 by your own station's announcers, or a prerecorded set of tapes may be welcome for other reasons.

The Sparta TA581 injects accurate time announcements into your automated program *whenever* the Model 1052 Program Controller directs it to. One of the two cartridges containing the messages is *always* ready on an 'odd and even' schedule, controlled by a self-contained synchronous clock. A 150 Hz tone follows each recorded time announcement, on the cue track, telling the 1052 to order the next event. The unit is disabled until reset in event of power interruption, so inaccurate time checks are never aired.

The Model TA581 is supplied with sliders. It requires a rack with front and rear rails. It takes 7" of rack space.

### SPECIFICATIONS

OUTPUT LEVEL (600-ohm transformer) .....	+10 dmb max.
HARMONIC DISTORTION .....	0.75% max.
FREQUENCY RESPONSE (at -10 dmb level) .....	50Hz to 12 KHz. +1 -2 db 50Hz to 15 KHz. +1 -3 db
SIGNAL/NOISE RATIO .....	48 DB typ.
CUE FREQUENCY .....	1 KHz ±75 Hz
SECONDARY CUE .....	150 Hz ±30 Hz
TAPE SPEED .....	7.5 IPS STD.
WOW & FLUTTER .....	Less than 0.2%
CARTRIDGES .....	Fidelepac type A-B-C
SIZE .....	7" H. x 19" W. 19½"
WEIGHT .....	50 lbs.

(Overall system Record/Playback) 55 db typ. (from 3% THD Level 400 Hz)

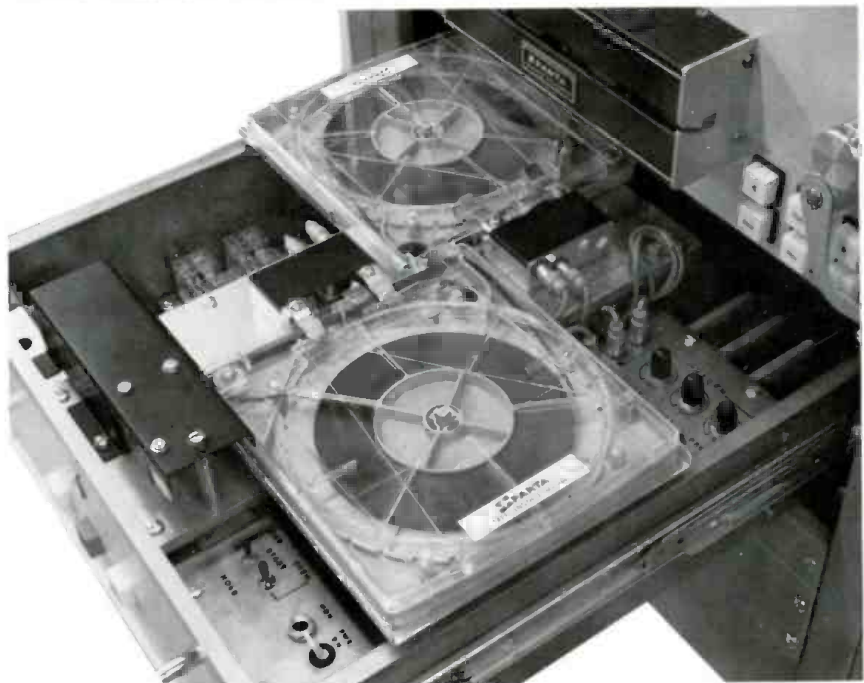

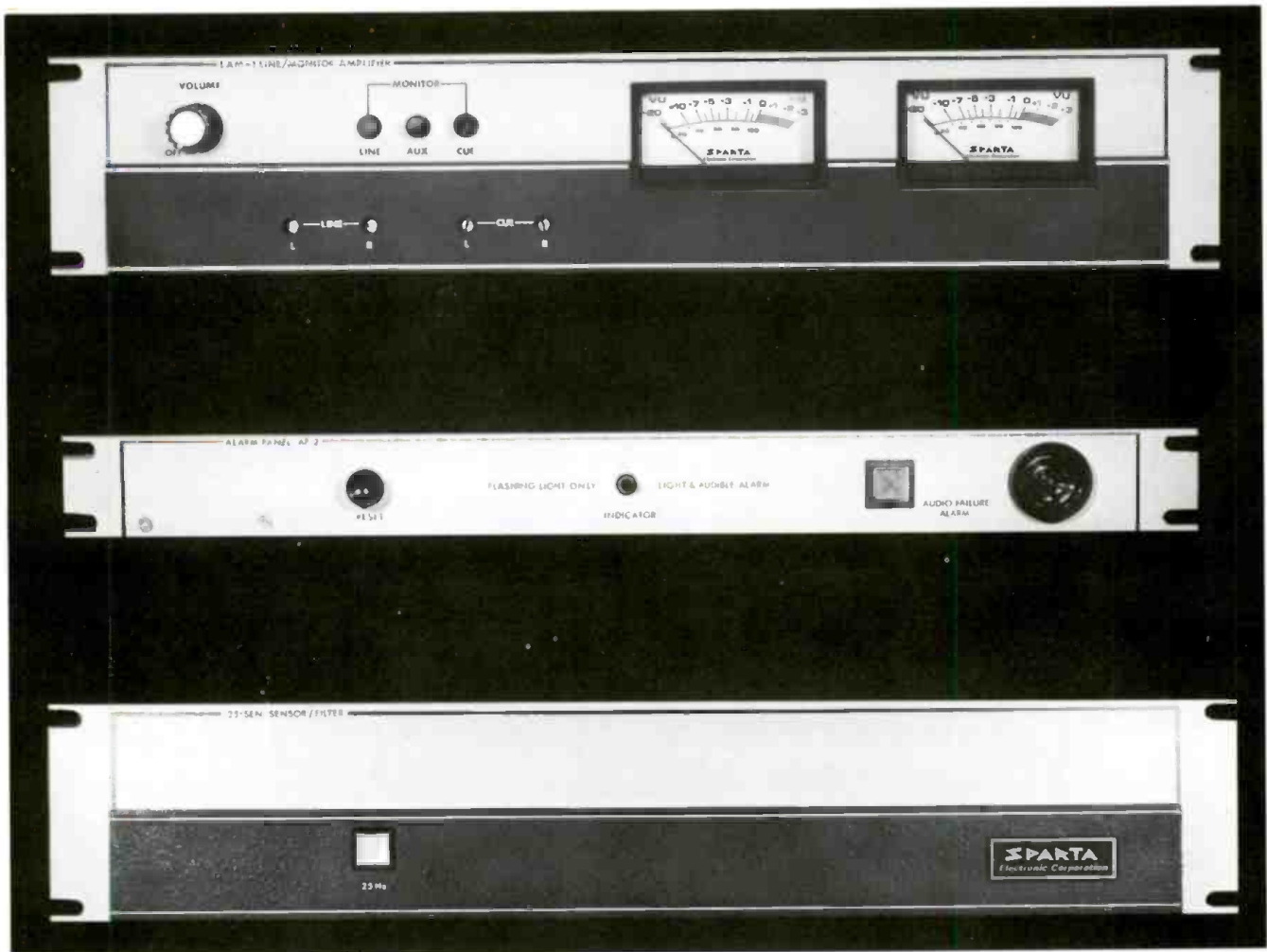
**LAM-1 (top photo)**

The Sparta LAM-1 Line Amplifier/Monitor Panel forms the audio output control station for your SPARTAMATION system. Program output is +8 dbm nominal to +23 dbm maximum. Both VU meter and audio monitoring of program and cue levels are provided, and are pushbutton selectable. (Stereo LAM-1S is shown.) A separate, regulated power supply is standard. Options include Model 1025 8 Watt Monitor Amplifiers (two required for stereo) installed. HP-40 High Pass Filters (two needed for stereo) are also available to mount in the LAM-1. The HP-40 has a 40 Hz cutoff to remove 25 Hz EOM tones from program output. The LAM-1 rack mounts in 3½" of space, including all options mentioned.

**AP-2 (middle photo)**

The AP-2 Alarm Panel emits a strident high pitched audible signal, and displays a blinking yellow warning light simultaneously, when the Auto Restart circuit of your SPARTAMATION system has operated. The Auto Restart advances the Program Controller by one event when a silent period is sensed by built in circuitry. The alarms inform the operator that tapes should be checked, or program corrections made.

**25-SEN (bottom photo)**

Twenty-five Hz tones are detected by the 25-SEN Sensor/Filter. Active high pass filters remove such tones, while the 25-SEN functions also as a super selective amplifier and relay driver. The 25-SEN is all solid state, and contains its own regulated power supply. Rack mount, 3½" panel.





**REM 25**

Many stations prefer to record their own music tapes so as to maintain total control over format and overall "sound" of the station. The REM-25 provides the necessary controls and convenient automatic timing circuits to precisely prepare music tapes using a reel-to-reel tape recorder which has provision for remote control, such as the Sparta 4400-Series. The REM-25 is intended for use with the 25 OSC oscillator/filter which generates the precision 25Hz switching tones and removes 25Hz components from program material.

**CONTROLS**

The REM-25 has remote control push buttons for all operational modes of the transport used for recording program tapes. The other control provided is a "mode" switch. The position of this switch determines whether the REM-25 will function as a remote control for the transport, or as an automatic makeup unit.



**TAPE RECORDER/REPRODUCER 500A**



**25-OSC 25 HZ OSCILLATOR/FILTER**

Generates accurate 25 Hz tones for recording end cues on tape selections. Includes filters to remove low frequency components from program material. Oscillator can be keyed by a remote switch. 3 1/2" rack panel. Mono or stereo.

**TYPICAL APPLICATION OF REM-25**

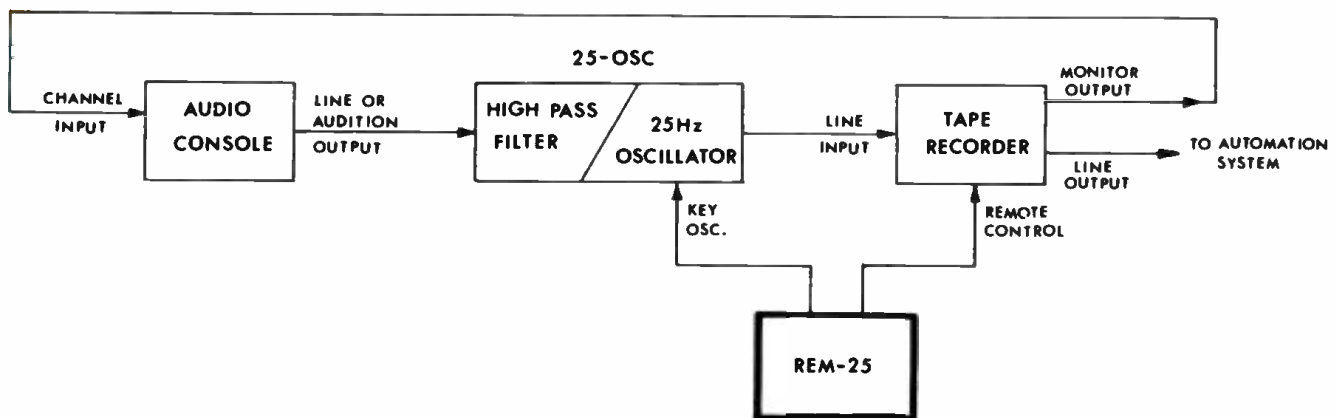

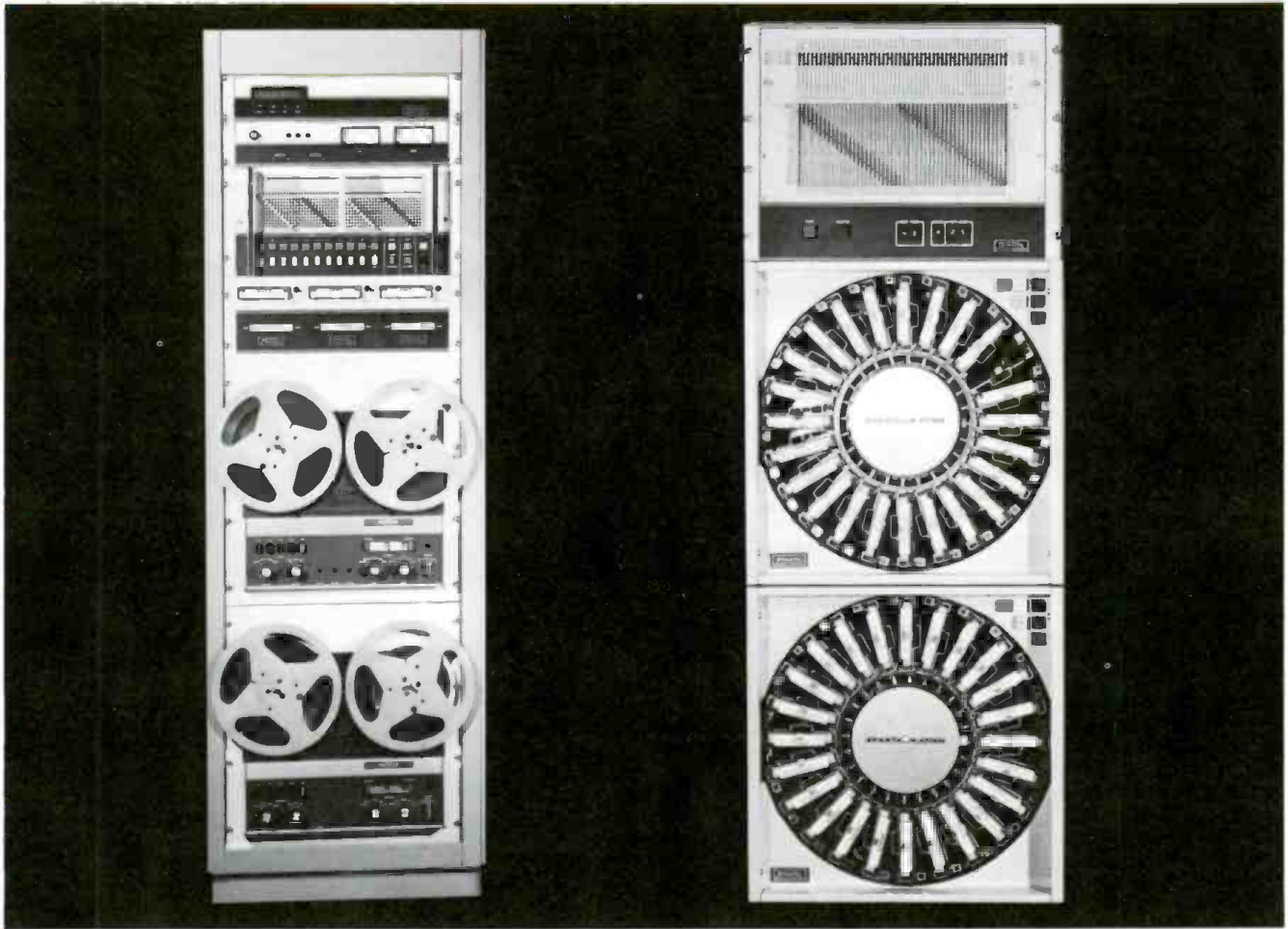

SPARTAMATE I basic system consists of the single rack above left. From top to bottom: DC24 DIGITAL CLOCK; provides timing signals for program time correction, LED readouts. LAMIS STEREO LINE AMPLIFIER & MONITOR PANEL; +8 dbM out, 8 Watts per channel monitor, switchable to audition buss of Controller for cueing tapes. 1052 AUTOMATIC PROGRAM CONTROLLER; ten audio channels, 52 overlapping events, priority interrupt, built-in silence sensor and 25 Hz tone detector. (THREE) CENTURY SERIES TAPE CARTRIDGE PLAYBACKS; (TWO) REVOX A77 MARK III TAPE RECORDER/PLAYBACKS; stereo, 10½" reel capacity, 3¾ and 7½ ips speeds. (Other popular tape transports available). Stereo music tapes and monaural cartridge announcements.

THE SPARTAMATE "SPOT BANK" (above right) is an entire sub-system of the SPARTAMATE concept, but also serves to interface with an existing system of another manufacturer for added flexibility. The components of the SPARTAMATE "SPOT BANK" are: RS250 RANDOM ACCESS; with all the features described under SPARTAMATE II. RS124 MONAURAL CAROUSELS; two in the subsystem as described under SPARTAMATE II. The components are supplied with interconnecting cables cut for mounting as shown.

SPARTAMATE II (right) extends the usefulness of SPARTAMATE I with the addition of 48 10-minute tape cartridges, playable in any order you choose by selection with the Sparta RS250 Random Access. Basically SPARTAMATE II is SPARTAMATE I complete as described above. The second rack adds, from top to bottom:

AP-2 ALARM PANEL; gives a visual and audible signal when auto restart circuit is operated by a period of silence. RS250 RANDOM ACCESS; selects 50 cartridge 'events' from two random Carousels®, overlap audio switching plays selection into single audio input, has skip and search ahead features. RS124 MONAURAL CAROUSELS; two in system, each with 24-cartridge capacity. TAS81 TIME ANNOUNCER; dual cartridge for odd/even announcements, one cartridge always ready so time announcement can be programmed for any period. Stereo music tapes and monaural cartridge announcements.

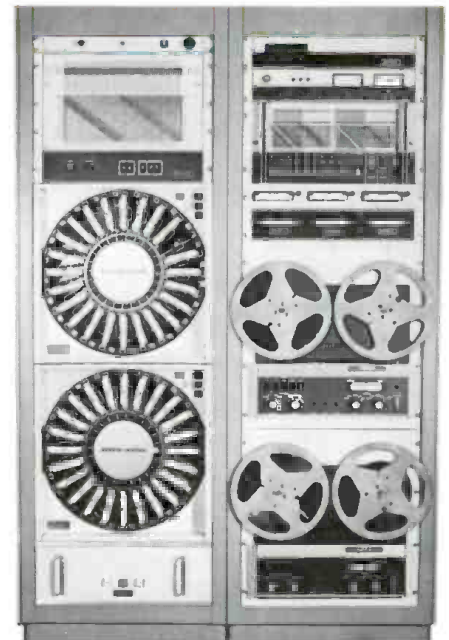

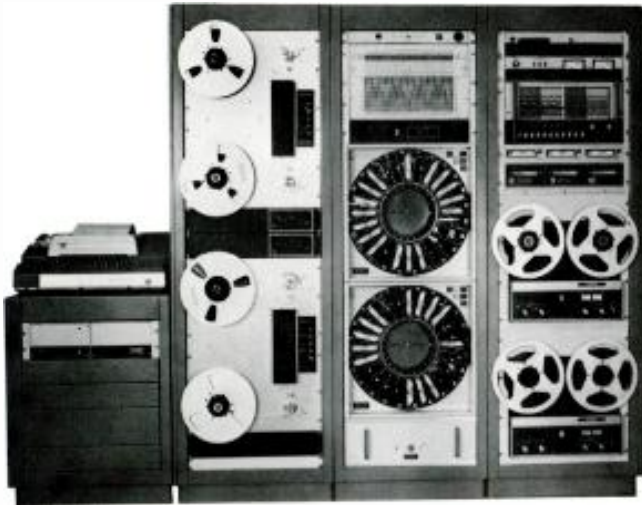

This system represents one possible expansion of the SPARTAMATE concept. To the full SPARTAMATE II have been added twin CORINTHIAN tape reproducers (see below) for increased music selection, and complete Alphameric Teletype logging. Further expansion might include a Sparta RS4100 Random Access in place of the RS250, with two additional Carousels for 100-cartridge flexibility. The FX52 Format Expander could be added to the Model 1052 Program Controller visible, and a considerably greater unattended operation time be provided through addition of reel/reel tape reproducers and tape cartridge chains.



The Corinthian deck provides long periods of unattended SPARTAMATION operation. Foil reversing ensures maximum use of tapes. The capstan is direct drive with dual speed hysteresis synchronous motor. A front panel level control is screwdriver adjusted. Amplifiers are plug-in.

### SPECIFICATIONS

HEAD CONFIGURATION	Half and full-track monaural, half and quarter-track stereo
TAPE SPEED	3.75 and 7.5 ips
REEL SIZE	Up to 16"
REEL HUBS	NAB and EIA
STARTING TIME	1/10 second
REWIND TIME	120 seconds for a 4800' reel
PLAYING TIME (14" reel, 1.0 mil tape @ 7.5 ips)	6 hours
WOW & FLUTTER	0.13% RMS @ 7.5 ips
TIMING ACCURACY	99.8%
SIZE (TRANSPORT)	19 w x 24.5 h x 5 3/4" d
SIZE (ELECTRONICS)	19 w x 3.5 h x 7 3/4" d



Complete alphameric printout logging is optional with SPARTAMATION systems of any type. Information encoded on tape cartridge cue tracks is coupled with the DC24 Digital Clock time printout for each item logged. Models 33RO and 33ASR teletypes (below left), Century Series Record/Playback with Encoder (below right), DC24 Digital Clock (page 52) and necessary wiring are provided for the system chosen. Half-rack stand for teletype printer, containing necessary electronics, is optional: depending on the system chosen, the teletype may be mounted on a stand as shown below, and electronics fitted into the system rack cabinets.



# TRANSMITTERS

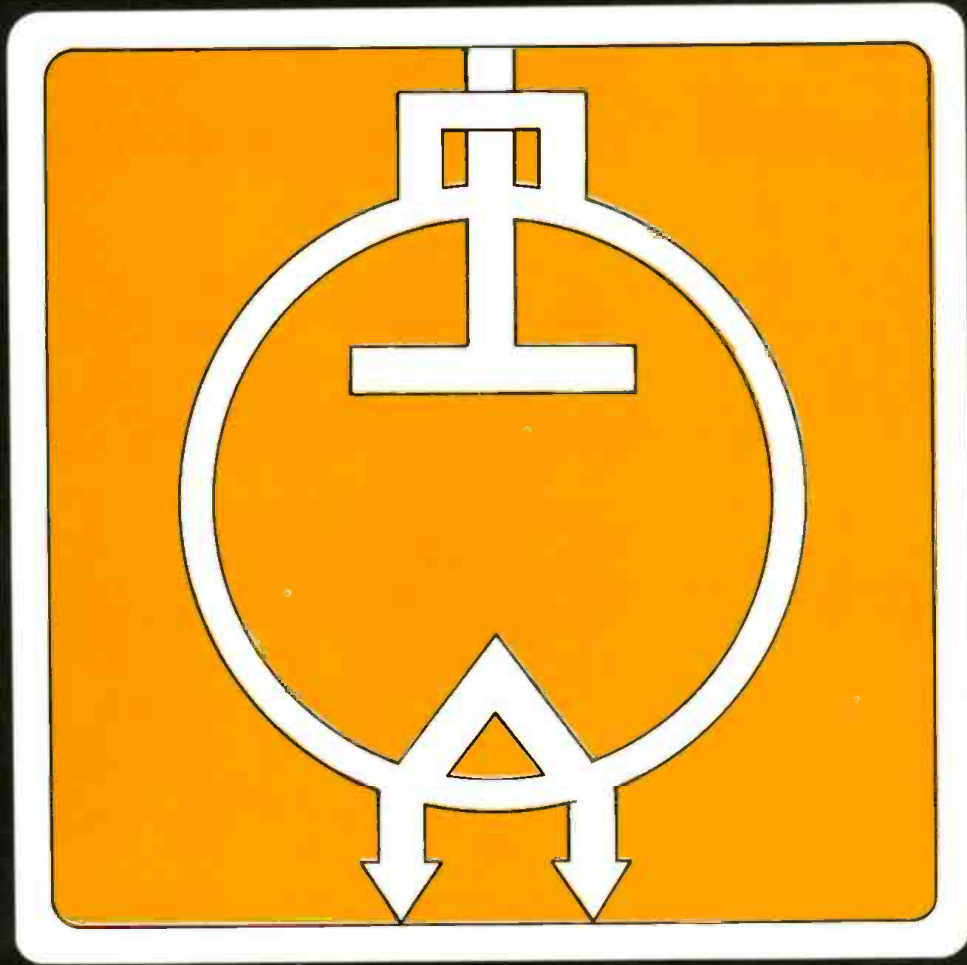

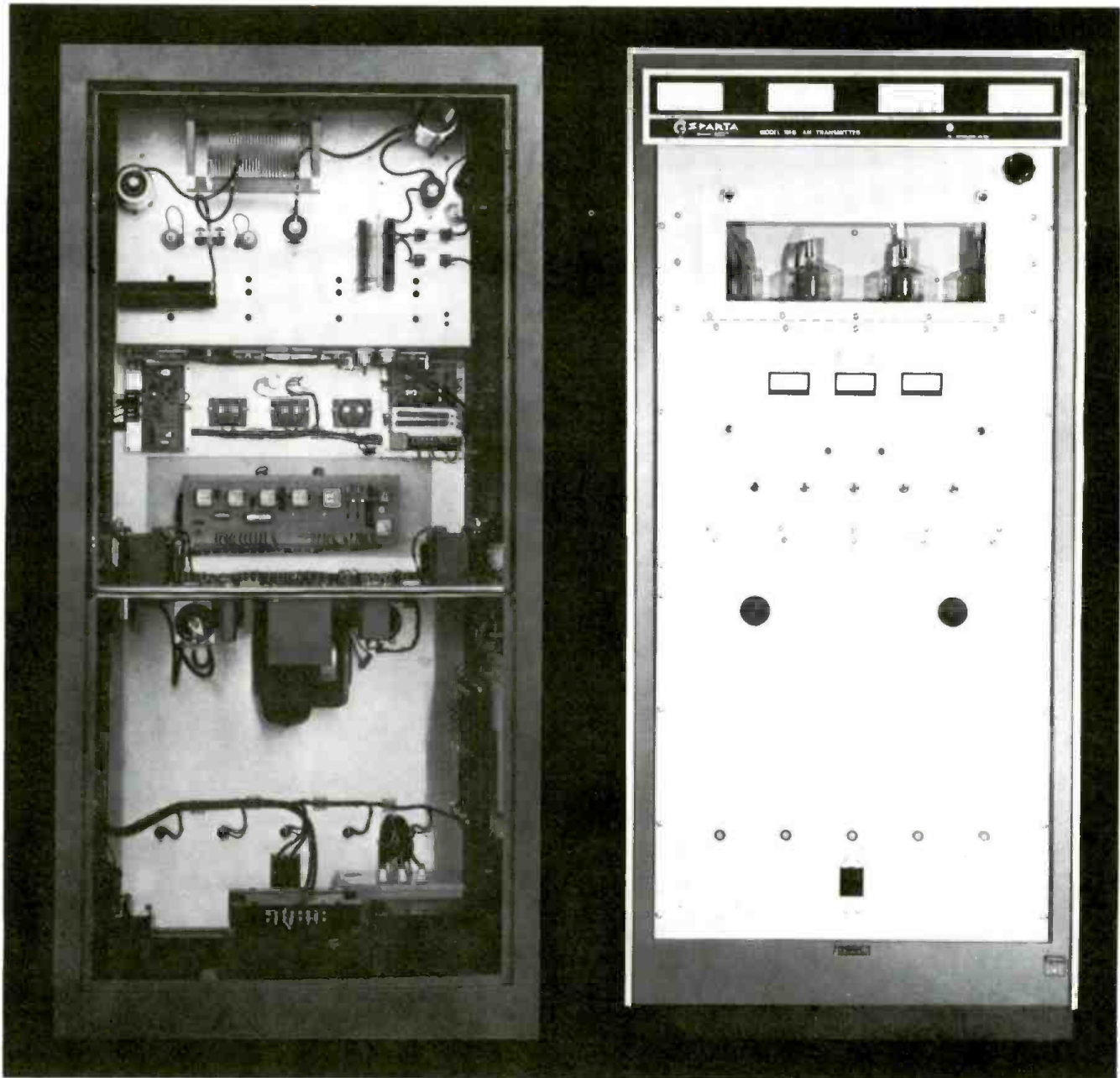

The simple straightforward engineering design of the new Model 701B is illustrated even in the classically simple layout of the front panel. The panel below the tubes and meters drops down for easy access. On its face are the "tally lights," which tell the engineer at a glance where his overload problem may have occurred, even though the automatic reset has returned the transmitter to the air.

The blower which supplies air to the pressurized upper case is actually adequate to cool a 5 kw transmitter! And notice the room for maintenance ease, which was an integral part of the design concept.

The big oil-filled modulation transformer is in the lower right hand corner of the transmitter case.

# TRANSMITTERS

The SPARTA Model 701B AM Transmitter replaces the 707, which was one of the most successful transmitters in broadcast history. More Model 707's are in service throughout the world than any other transmitter of its type.

The 701B retains proven features of its illustrious predecessor, and boasts improvements in three major areas:

**POWER TUBES . . .** The 701B is the only broadcast transmitter using the new Eimac 4-500A Tetrode. By using the 4-500A's, SPARTA's 701B will deliver full power easier, thus requiring less maintenance. And will produce 125% positive modulation peaks if you want it to.

**COOLING SYSTEM . . .** The larger blower (the same type used on SPARTA's 5kw transmitters) increases air circulation in a semi-pressurized lower case, allowing tremendously greater operating efficiency and longer component life.

All solid state right up to the 4-500A tubes. The oscillator generates a signal at four times carrier, which is then counted down for greater stability using modern binary techniques. The audio driver consists of only 2 silicon transistors.

All of the time tested features of the Model 707 have been retained in the new 701B: compactness . . . simultaneous full meter display of all important transmitter functions . . . circuit simplicity . . . variable vacuum capacitor for final plate tuning (no air capacitors to arc, or roller coils to freeze) . . . built-in dummy antenna . . . and oil filled modulation transformer to give dependable, long term service. Among innovations added to the newer model: the nuisance of momentary outages is eliminated by an automatic reset device, which also triggers a "tally light" overload indicator. A glance at the "tally light" which is left burning tells the engineer at what point the overload occurred within the transmitter, shortening his inspection and maintenance time.

The Model 701B is offered in the broadcaster's choice of switchable power combinations of 1000/250, 1000/500, or 500/250 watts.

## MODEL 701B - 1000/250 Watt-AM TRANSMITTER

AF INPUT IMPEDANCE	600 ohms
AF INPUT LEVEL	+ 10 DBM ± 2 DBM (100% Modulation)
AF RESPONSE	50-10,000 Hz (95% Modulation) ± 1.5 DB (typical - ±1DB)
AF DISTORTION	50-10,000 Hz (95% Modulation) less than 3% (typical - 1.5%)
NOISE	(below 100% Modulation) 1000 Watts - 55 DB 250 Watts - 52 DB
FREQUENCY RANGE	540-1600 KHz
FREQUENCY STABILITY	± 10 Hz 0-50° C
OUTPUT IMPEDANCE	50 Ohms unbalanced - others available on special order
CARRIER SHIFT	3% or less (0-100% Modulation)
DUMMY ANTENNA	50 Ohms - Capable full time operation 100% Program Modulation
POWER OUTPUT	1000/500/250 Watts - Any combination of two power levels (capable 1100 Watts)
POWER SUPPLY	208-240 volts ± 5%, 50/60 Hz, Single Phase
POWER CONSUMPTION	(1000 Watts output - 90% PF) Approx 0% Modulation 2950 Watts 30% Modulation 3400 Watts 100% Modulation 4150 Watts
AMBIENT OPERATING TEMPERATURE	To 113°F
ALTITUDE RANGE	To 7500 - Higher Altitudes on special order
SIZE	75" High, 34" Wide, 25½" Deep
WEIGHT	1000 lbs. NET

### OPTIONAL EQUIPMENT: (factory installed)

RMK-1-Remote Control Kit, including control relay assembly and motor rheostat.

CVT - Constant Voltage Transformer to maintain filament and low voltage supplies within ± 1%. 60 Hz,

### ORDERING INFORMATION:

The Model 701B is supplied in 1000/250 watts complete with tubes, transistors and crystal tuned and tested on frequency. If 1000/500 or 500/250 watt power levels are desired SO SPECIFY.

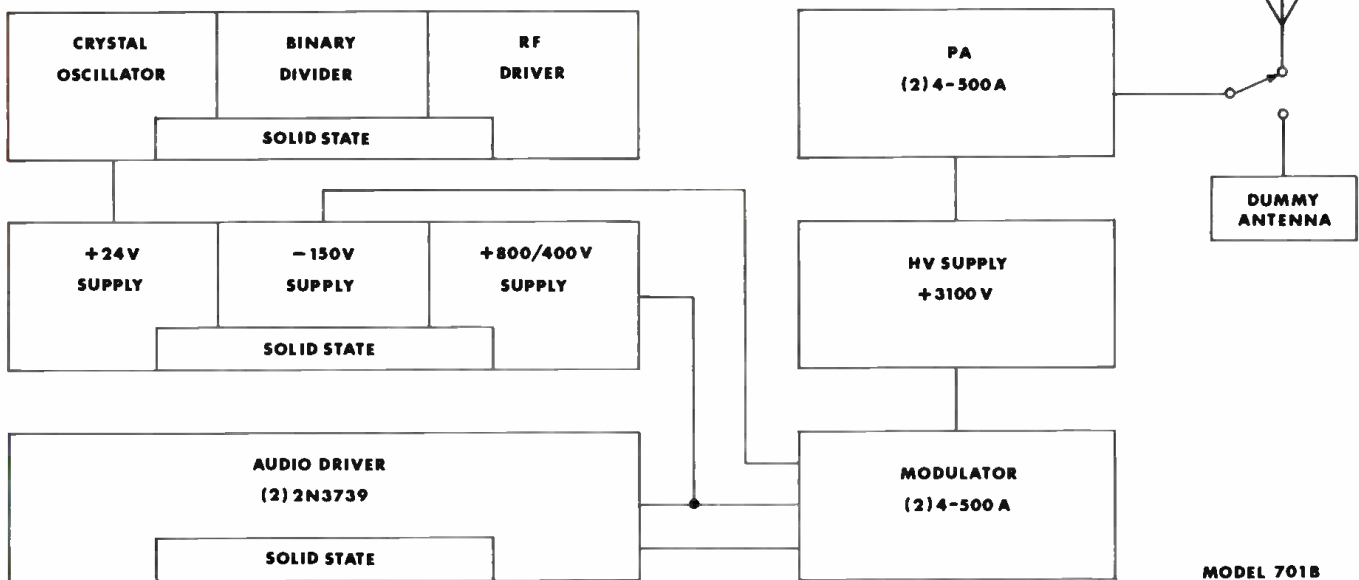

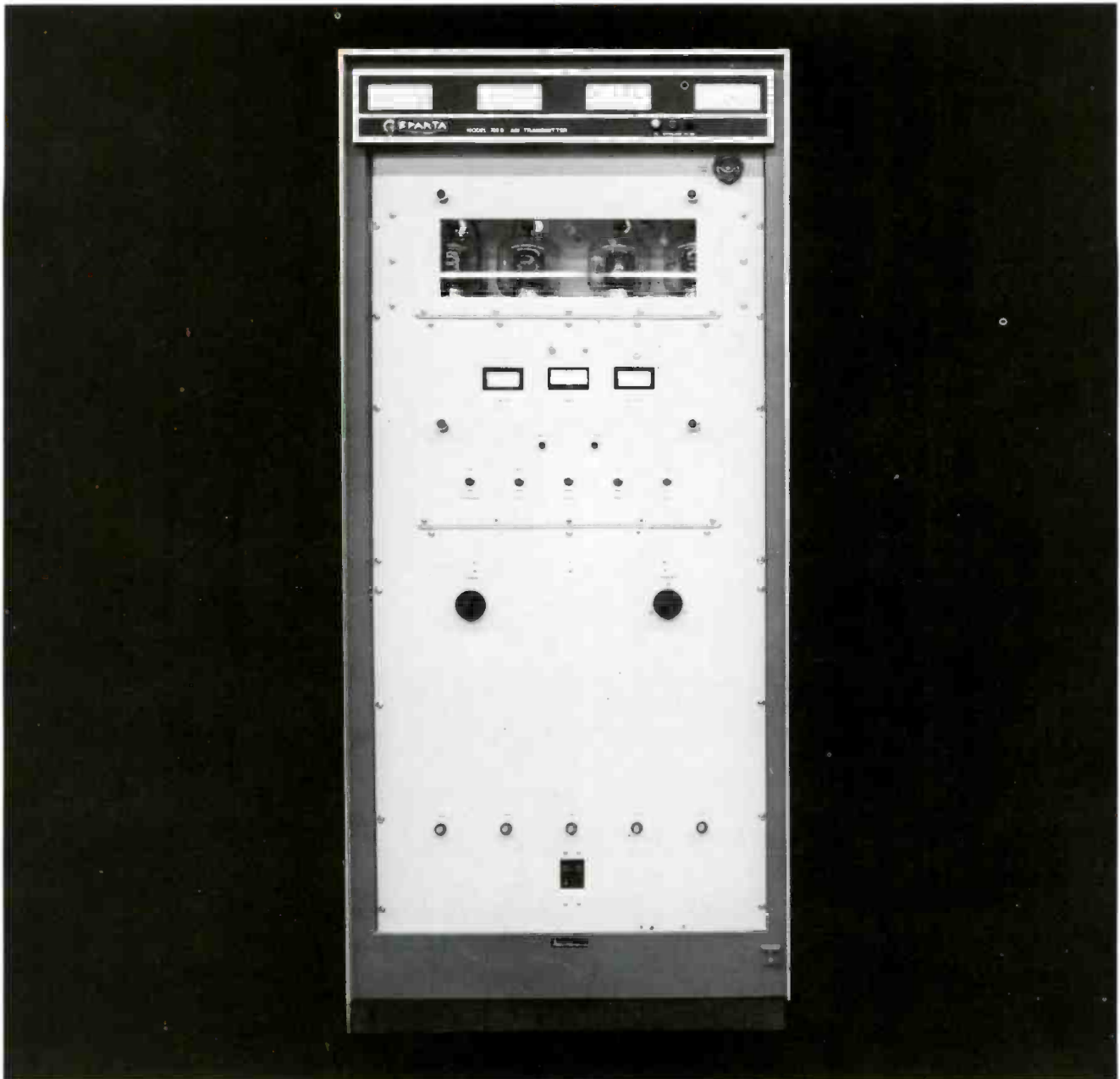

In response to requests by many Latin-American broadcasters, SPARTA has rounded out its AM transmitter line with the 3,000-watt Model 703B. In many areas of the world this power level is the most attractive in terms of resultant coverage and investment.

The Model 703B has many outstanding features — only four economical tubes, all high power components in oil, vacuum capacitor tuning of the final tank circuit, solid state RF and audio drivers, excellent specifications.

# TRANSMITTERS

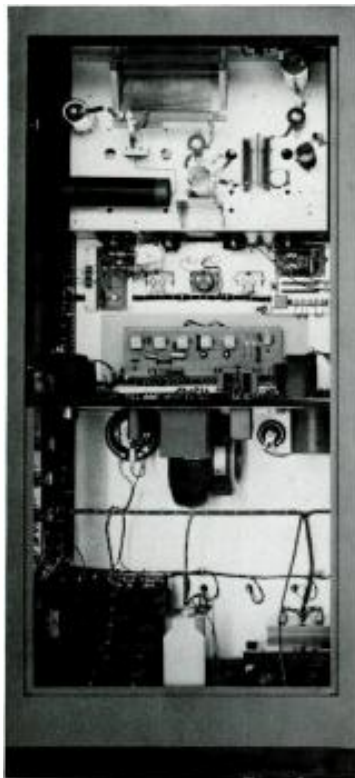
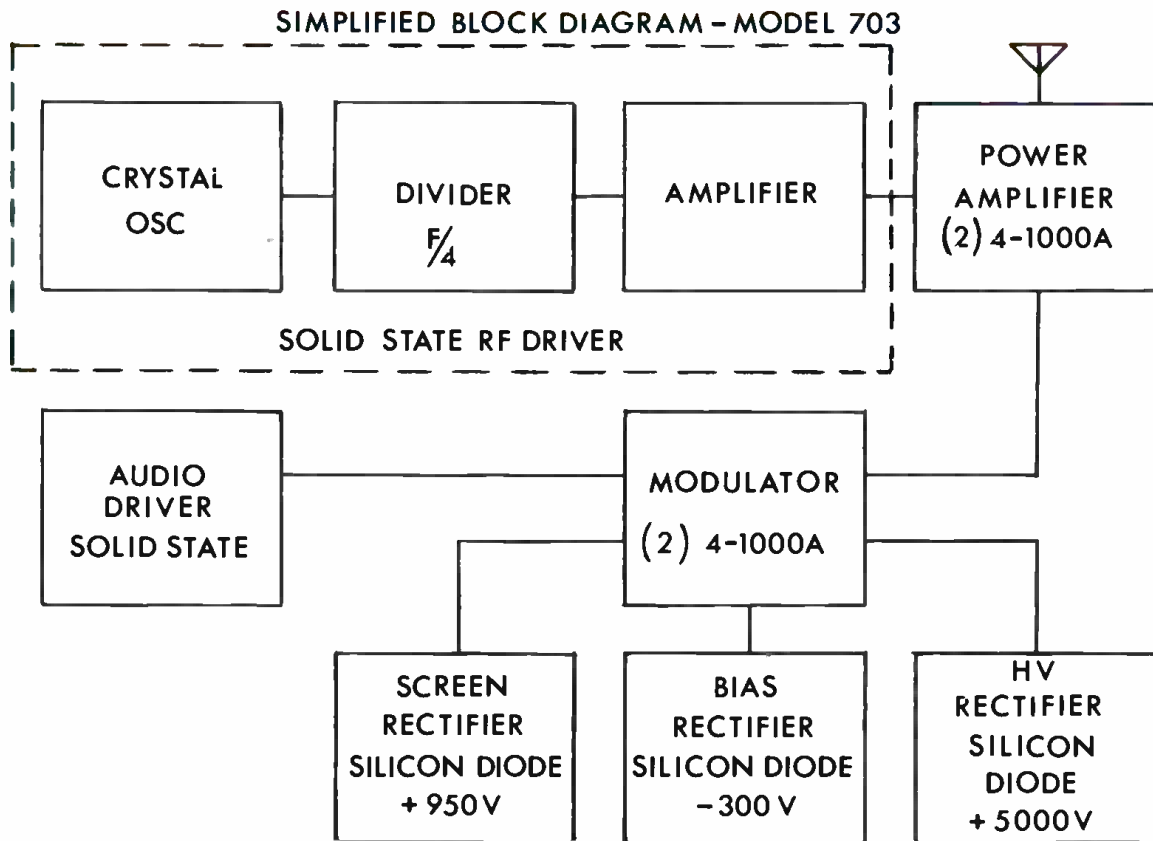

## MODEL 703 AM TRANSMITTER SPECIFICATIONS

POWER OUTPUT NOMINAL	2,500 W
POWER OUTPUT CAPABILITY	3,000 W
POWER SUPPLY	208/240 volts, 50/60 Hz 1 $\phi$
POWER CONSUMPTION	0% modulation - 8.5 kw Aver. modulation 8.9 kw 100% modulation 11.3 kw
POWER FACTOR	90%
TUBE COMPLEMENT	2 4-1000A power amplifier 2 4-1000A modulator
AF INPUT IMPEDANCE	600 ohms
AF INPUT LEVEL	10 dbm (100% modulation)
AF RESPONSE	$\pm 1$ db (30-12KHz)
AF DISTORTION	Less than 3% (95% modulation, 50-10 KHz)
NOISE	55 db or better (below 100% modulation)
FREQUENCY STABILITY	$\pm 10$ Hz 0-50 $^{\circ}$ C
RF OUTPUT	50/70 ohms, unbalanced
CARRIER SHIFT	Less than 3% (100% modulation)
HEIGHT	75"
WIDTH	34"
DEPTH	28"
WEIGHT	1,200 pounds
ALTITUDE RANGE	To 8,000 feet
AMBIENT TEMPERATURE	To 113 $^{\circ}$ F

## ORDERING INFORMATION

SPARTA MODEL 703 AM TRANSMITTER: 3,000 watts, complete with tubes and two crystals, tuned and tested on frequency.



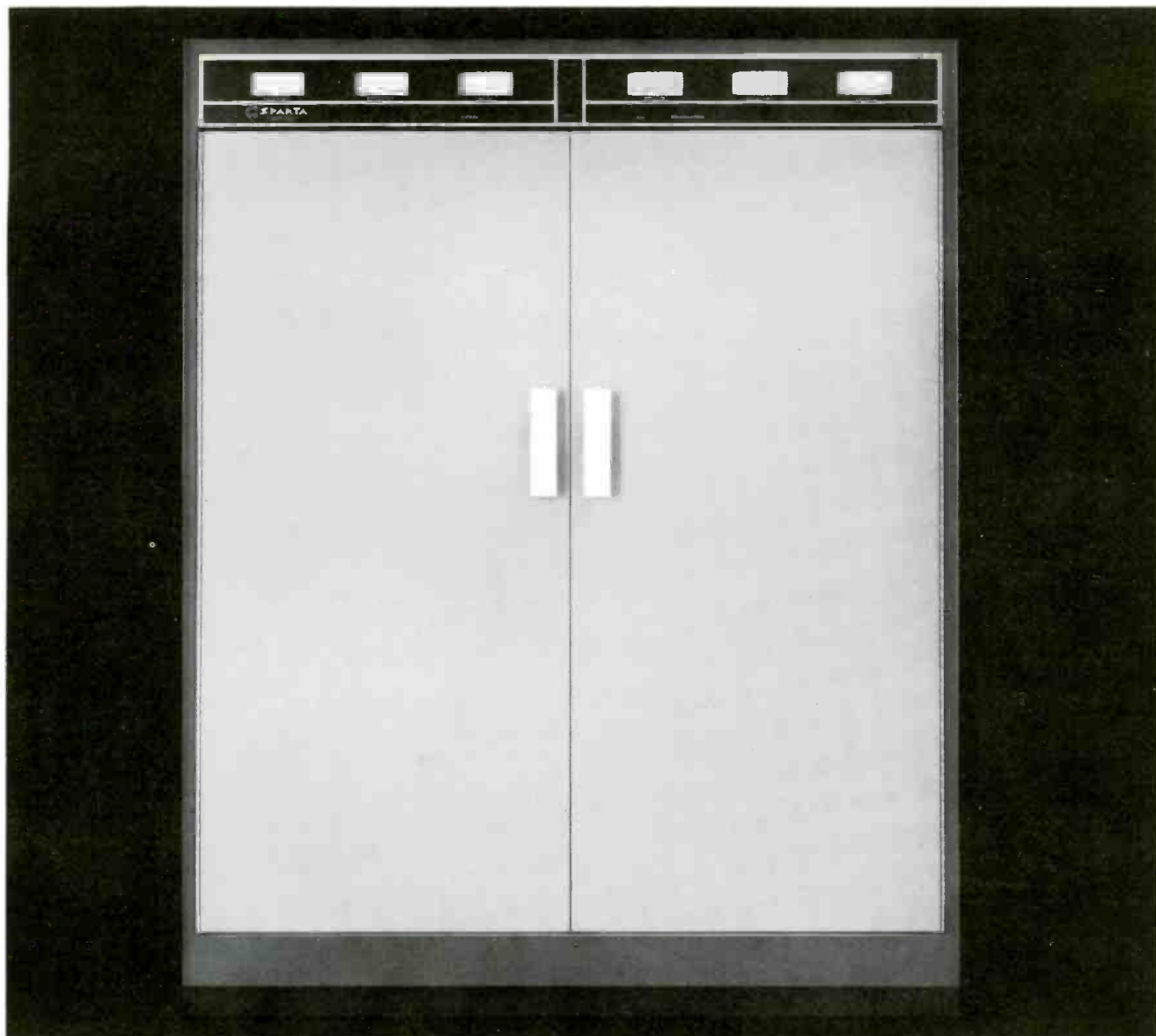

The Model 705 and 710AM Transmitters incorporate every modern development in transmitter technology that is genuinely useful and does not represent a complicated answer to a simple problem. The straightforward circuitry is easy to understand and service.

These transmitters offer benefits that must be considered by every broadcaster! Compact, space-saving size, 60" wide, 29" deep. Full metering in which all functions are displayed simultaneously. A tally-light fault locating system. Should there be a momentary overload, the transmitter will automatically recycle and the tally light system will tell you where the

overload occurred. Oil-filled modulation transformers for dependable long-term service. Top quality modulators – square wave tested, low distortion, outstanding transient response. 1% ripple power supply – simple, reliable design uses no filter chokes – improves low frequency modulating characteristics.

The 5000 watt Model 705 has a 6000 watt capability, the 10,000 watt Model 710 can deliver 12,000 watts with ease! This SPARTA extra margin in design means longer tube life, ample reserve for asymmetrical modulation, easier full power operation and less maintenance.

# TRANSMITTERS

## MODEL 705 AND 710 AM TRANSMITTERS

These SPARTA transmitters are type accepted for broadcast operation under Part 73 of the FCC rules.

### TRANSMITTER SPECIFICATIONS:

POWER OUTPUT NOMINAL	Model 705 - 5,000 watts/1,000 or 500 watts Model 710 - 10,000 watts
POWER OUTPUT CAPABILITY	Model 705 - 6,000 watts Model 710 - 12,500 watts
POWER SUPPLY	208/240 volts, 50/60 Hz 3 phase
POWER CONSUMPTION	Model 705 0% modulation - 10.6 kw Average modulation - 12.0 kw 100% modulation - 15.5 kw Model 710 0% modulation - 19 kw Average modulation - 22 kw 100% modulation - 27 kw
POWER FACTOR	90%
TUBE COMPLEMENT	Model 705 2-12BY7A buffers; 1 6DQ5 driver; 1 4CX5000A power amplifier; 2 EL-34/6CA7 audio driver; 2 4CX5000A modulator Model 710 2 12BY7A buffers; 2 6DQ5 drivers; 1 4CX 15,000A power amplifier; 2 EL-34/6CA7 audio driver; 2 4CX5000A modulator
AF INPUT IMPEDANCE	600 ohms
AF INPUT LEVEL	10 dbm (100% modulation)
AF RESPONSE	Model 705 and 710 ± 1 db (30-12KHz)
AF DISTORTION	Less than 3% (95% mod., 50-10 KHz)
NOISE	60 db or better (Below 100% modulation.)
FREQUENCY STABILITY	± 2 Hz
RF OUTPUT	50/70 ohms, unbalanced
CARRIER SHIFT	Less than 3% (100% modulation)
HEIGHT, 705 & 710	75 inches
WIDTH, 705 & 710	60 inches
DEPTH, 705 & 710	29 inches
WEIGHT	Model 705, 2,400 lbs. Model 710, 2,900 lbs.
ALTITUDE RANGE	To 8,000 ft.
AMBIENT OPERATING TEMPERATURE	To 113° F

### ORDERING INFORMATION:

#### MODEL 705

SPARTA Model 705 AM Transmitter, 5000/1000 or 500 watts, complete with tubes, two crystals, tuned and tested on frequency.

#### MODEL 710

SPARTA Model 710 AM Transmitter, 10,000 watts, complete with tubes, two crystals, tuned and tested on frequency.

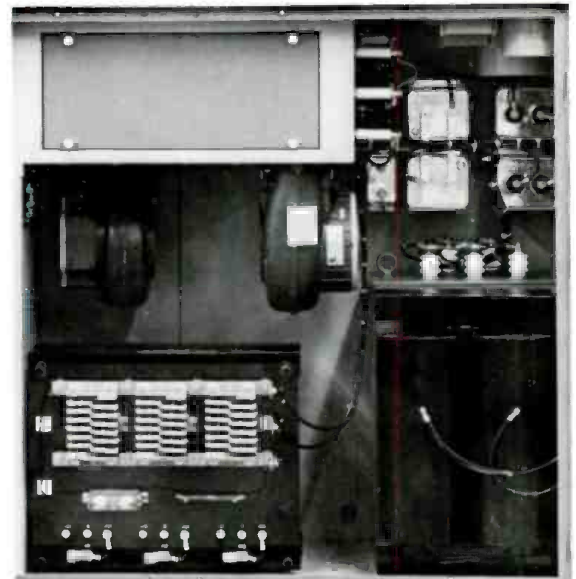
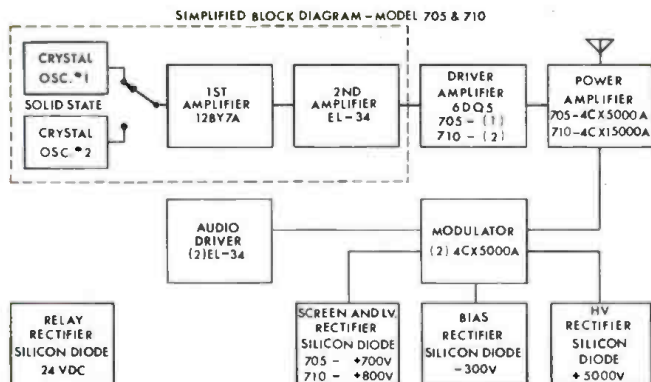

The outward appearance of both the Model 705 and 710 AM Transmitters is very similar. The metering and control functions in the 705 and 710 are identical. The difference is shown directly above. The power supply, modulation transformer and reactor are larger in the 710.

# TRANSMITTERS

# 700 AM & 720B AM



## MODEL 720B 50 WATT AM TRANSMITTER

The Sparta Model 720B is a completely self-contained 50 watt AM broadcast transmitter. Its simplicity, compactness and excellent performance characteristics make it ideal for service in any low power broadcast service . . . for presunrise or test site operation.

The Model 720B uses the same standard solid state oscillator circuitry used in higher power Sparta transmitters. The RF section is simple and straightforward and contains an output coupling network that is capable of matching a wide range of load impedances.

Every important parameter is metered to simplify tuning and adjustment. A built in modulation meter gives a continual display of audio level. Overload relay protection of the final stage is standard equipment.

## MODEL 720B SPECIFICATIONS

TYPE OF EMISSION .....	A3
RATED POWER OUTPUT .....	50 watts
RF OUTPUT IMPEDANCE .....	Adjustable, 10-1000 ohms
FREQUENCY RANGE .....	540-1700 kHz
FREQUENCY STABILITY .....	± 5 Hz
AUDIO INPUT LEVEL .....	Adjustable, -10 to +10 dBm
AUDIO INPUT IMPEDANCE .....	600/150 ohms
FREQUENCY RESPONSE .....	±2 dB, 0-95% modulation, 50-10,000 Hz
DISTORTION .....	3% max., 0-85% modulation, 50-10,000 Hz
NOISE LEVEL .....	-50 dB, below 100% modulation.
EFFICIENCY FACTOR (F) .....	0.65%
POWER CONSUMPTION .....	265 watts (50 watts out), 100% modulation.
POWER REQUIREMENTS .....	110 volts, 50/60 Hz, 90% power factor.
DIMENSIONS IN CABINET .....	15 5/8" H. x 20 7/8" W. x 23 1/8" D.
AMBIENT TEMP. RANGE .....	-20 to + 110° F.
ALTITUDE RANGE .....	0-8000 feet
CARRIER SHIFT .....	Less than 5%

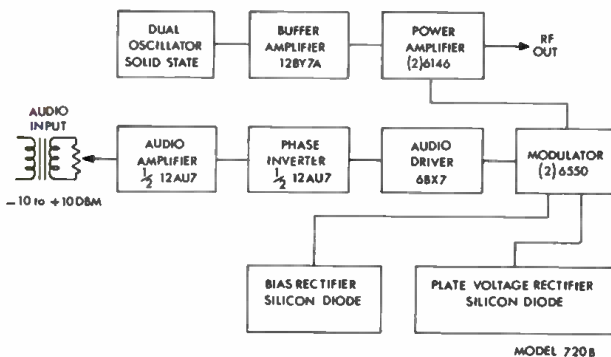

## MODEL 700 10 WATT AM TRANSMITTER

Fully solid state, the Model 700 provides the most modern approach to low power broadcasting. The frequency generating circuitry used is identical to that found in the higher power Sparta AM transmitters. Built in tuning and modulation indicators simplify operation by inexperienced personnel.

The unique output circuit of the Model 700 will match a variety of loads and provides a system free of 60Hz interference when used in a carrier current system.

## MODEL 700 SPECIFICATIONS

### OPERATING FREQUENCY

## MODEL 700 SPECIFICATIONS

OPERATING FREQUENCY .....	535 to 2100 kHz
POWER OUTPUT .....	10 Watts Nominal into 50 ohms
OUTPUT IMPEDANCE .....	2 to 525 ohms, ± j 600 (power output may vary at ends of range)
AUDIO INPUT LEVEL .....	± 10 dbm nominal (adjustable)
AUDIO INPUT IMPEDANCE .....	0 to 5K (5K bridging, bal.)
MODULATION CAPABILITY .....	95% neg., 135% pos.
FREQUENCY RESPONSE .....	+ or - 1db 30 Hz to 7.5 kHz, 95% Mod. 1% or less 20 Hz to 12.5 kHz, 50% Mod.
HARMONIC DISTORTION .....	2% or less 50Hz to 7.5 kHz, 95% Mod. 1% or less 20 Hz to 12.5 kHz, 50% Mod.
AMPLITUDE .....	
MODULATION NOISE .....	-60db below 95% Mod.
POWER INPUT .....	117 VAC 60 HZ 45 Watts nom.
CONTROLS .....	(a) Output tuning (b) Carrier on/off (c) Audio level
METERING .....	None. Panel lamps operate as an antenna current indicator for tune-up, and modulation peaks in excess of 94% for adjustment of audio input level.
SIZE .....	3 1/2" H. x 6" D. x 19" W.
WEIGHT .....	12 lbs.

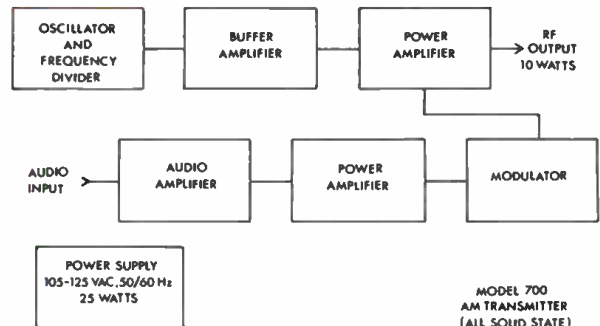
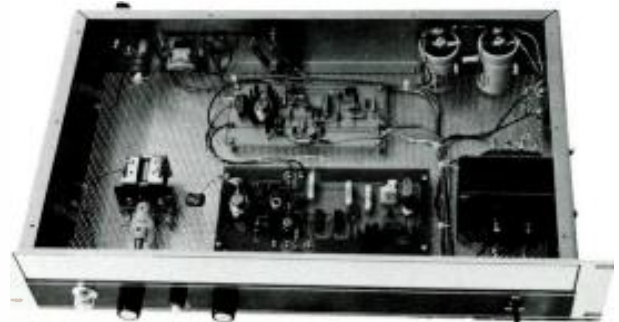

MODEL 700  
AM TRANSMITTER  
(ALL SOLID STATE)

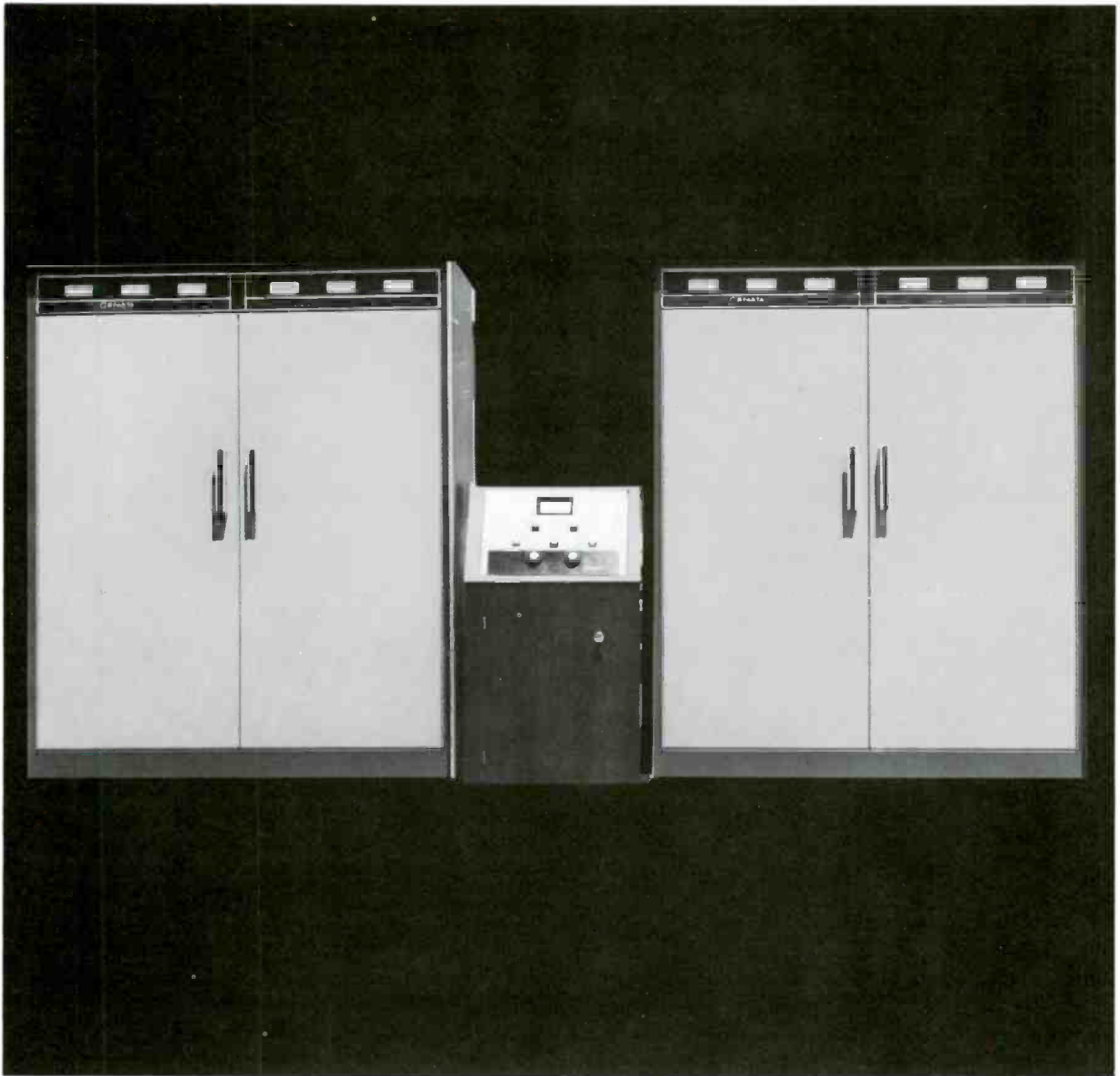

The Sparta Model 725 utilizes a unique ferrite combiner to parallel the outputs of two 12.5 kw transmitters for a power output of 25 kw. Except for a common RF drive unit, each transmitter maintains its individuality and can be operated independently of the other ... either into the built-in load or the antenna system. Automatic operation of the changeover is available, if desired.

Because of the broad band characteristics of the

ferrite combiner each transmitter sees a flat load whether the other unit is on or not. In normal operation the oscillators of each transmitter are phase locked with the regular buffer stage tuning control used to maintain phase between the two units. Operation is simple and straightforward. The combiner control panel, ferrite combiner and associated dummy loads are all located in a single matching cabinet measuring 75" high by 34" wide by 25½" deep. The transmitters are Model 715's.

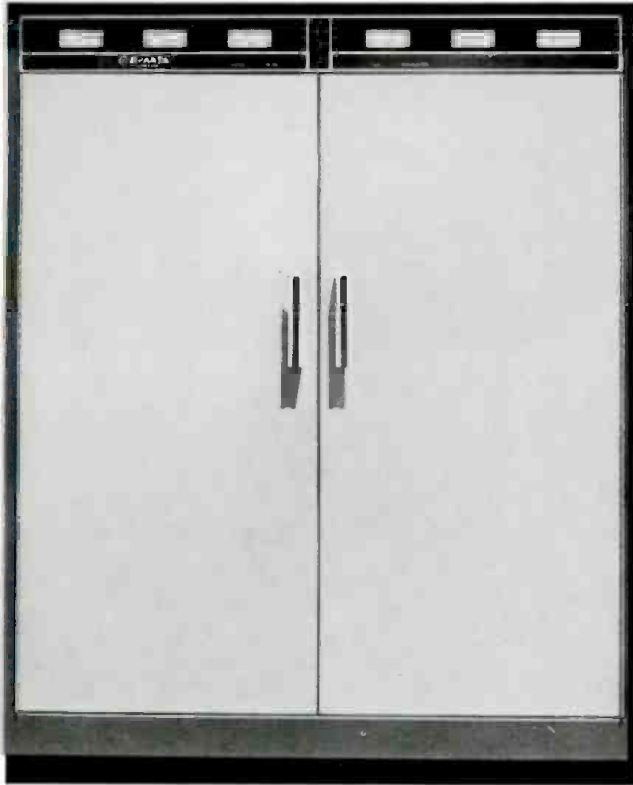

## 715 TRANSMITTER FEATURES

- TALLY LIGHT FAULT LOCATOR SYSTEM – tells you where overload occurred, even after transmitter has recycled.
- 1% ripple power supply improves low frequency modulation
- Oil-filled modulation transformers

### PASSPORT TO HIGH POWER

Full utilization of the tube capabilities is made in the Sparta 15,000-watt Model 715. In areas of the world where such power levels are usable, the 715 provides an economical step to high power. The Model 715 uses an external high voltage power supply to reach the higher power level – in all other ways it is identical to the Model 710.

## Model 725 Dummy Loads

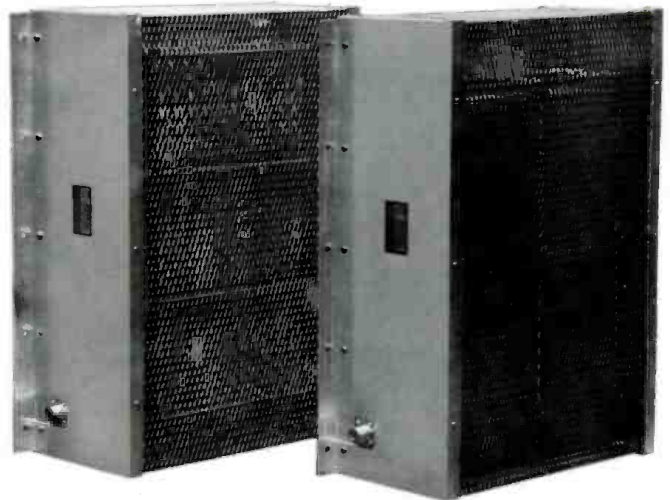

## Model 725 Ferrite Combiner



## Transformers

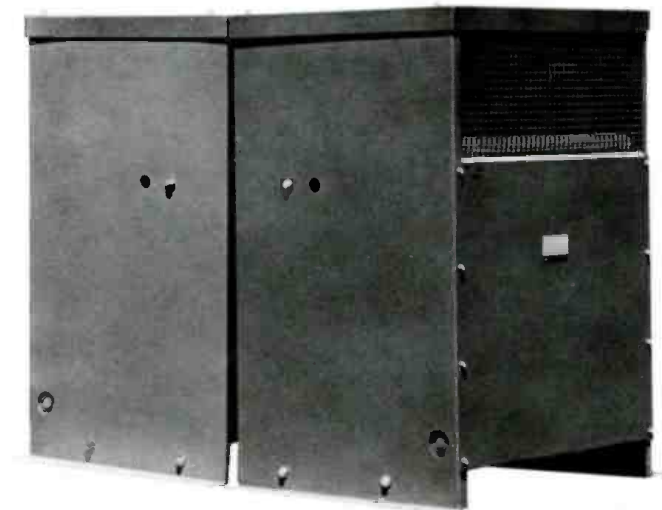

# TRANSMITTERS

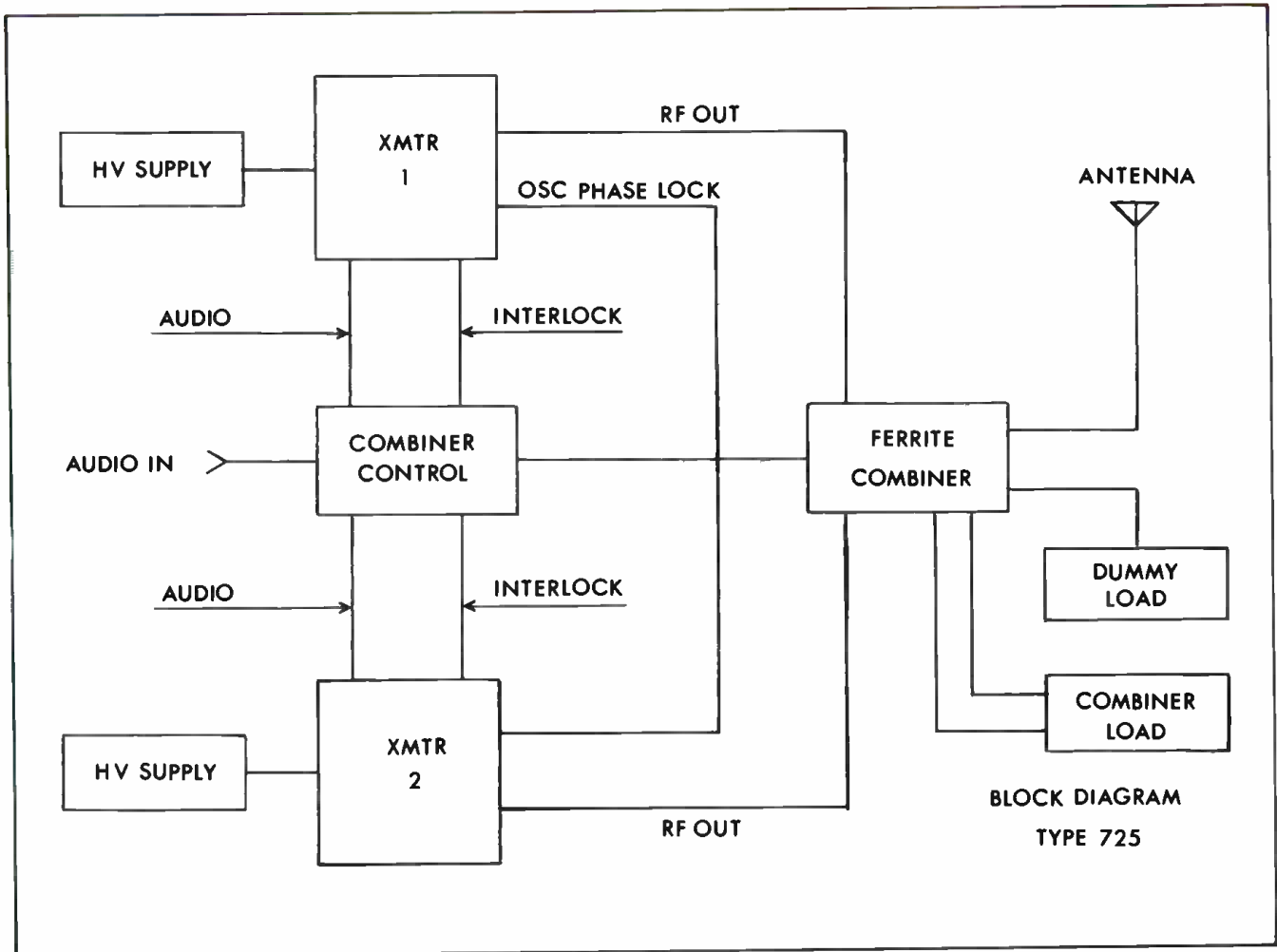

“XMTR No. 1” and “XMTR NO. 2” Above are model 715’s

Model 715: H.V. supply is external. All other details of block diagram are identical to Model 710.

## MODEL 715 AND 725 AM TRANSMITTER SPECIFICATIONS

POWER OUTPUT NOMINAL .. MODEL 715 14,000 W  
 MODEL 725 25,000 W  
 POWER OUTPUT CAPABILITY. MODEL 715 15,000 W  
 MODEL 725 27,500 W  
 POWER SUPPLY ..... 208/240 volts, 50/60 Hz 3 phase  
 POWER CONSUMPTION ..... MODEL 715  
 0% modulation – 28 kw  
 Aver modulation 33 kw  
 100% modulation 40.5 kw  
 MODEL 725  
 0% modulation – 48 kw  
 Aver modulation 55 kw  
 100% modulation 68 kw  
 POWER FACTOR ..... 90%  
 TUBE COMPLEMENT ..... MODEL 715  
 1 4CX15000A7 power amplifier  
 2 4CX5000A modulator  
 MODEL 725  
 2 4CX15000A power amplifier  
 4 4CX5000A modulator  
 AF INPUT IMEDANCE ..... 600 ohms  
 AF INPUT LEVEL ..... 10dbm (100% modulation)  
 AF RESPONSE .....  $\pm 1$  db (30-12KHz)

AF DISTORTION ..... Less than 3% (95% modulation, 50-10KHz)  
 NOISE ..... 60 db or better (below 100% modulation)  
 FREQUENCY STABILITY .....  $\pm 5$  Hz  
 RF OUTPUT ..... 50 ohms, unbalanced  
 CARRIER SHIFT ..... Less than 3% (100% modulation)  
 HEIGHT ..... 75 inches  
 WIDTH ..... MODEL 715 60 inches  
 MODEL 725 154 inches  
 DEPTH ..... 29 inches  
 WEIGHT ..... MODEL 715 3,000 pounds  
 MODEL 725 7,000 pounds  
 ALTITUDE RANGE ..... To 8,000 feet  
 AMBIENT TEMPERATURE ... To 113° F.

### ORDERING INFORMATION:

SPARTA MODEL 715 AM TRANSMITTER: 15,000 watts, complete with tubes, two crystals, tuned and tested on frequency.  
 SPARTA MODEL 725 AM TRANSMITTER: 25,000 watts, complete with tubes, four crystals, tuned and tested on frequency.

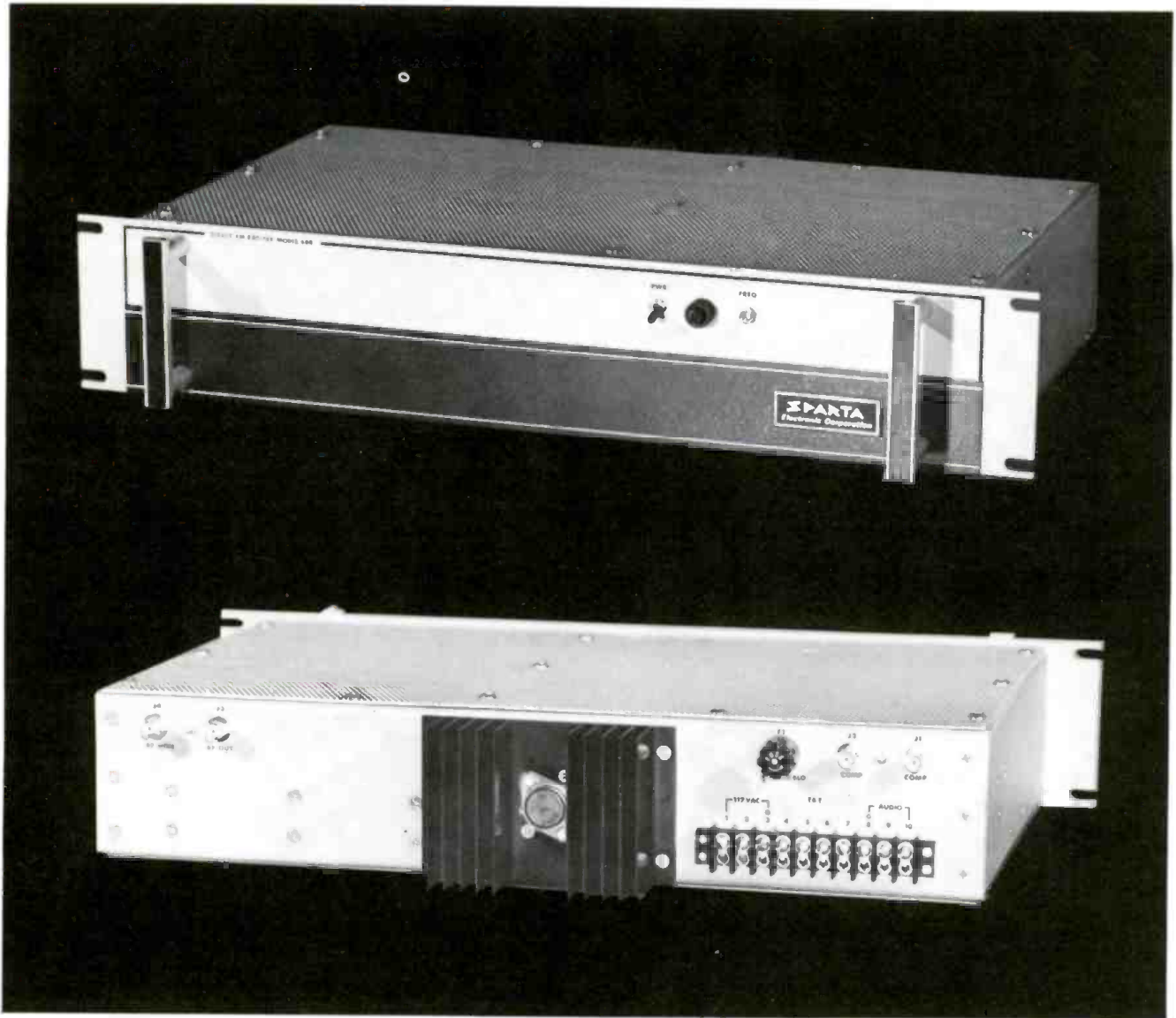

The Model 680 Direct FM Exciter is so simple and foolproof that NO field adjustment is EVER needed. In fact, there is no user-adjustment control except for the center-frequency adjustment. The Model 682 Stereo Generator companion to the Model 680

can also be used to drive any type accepted direct FM exciter. The 680 is capable of full Stereo and SCA operation, using the Models 682 Stereo and 683 SCA Generators, or other approved units.

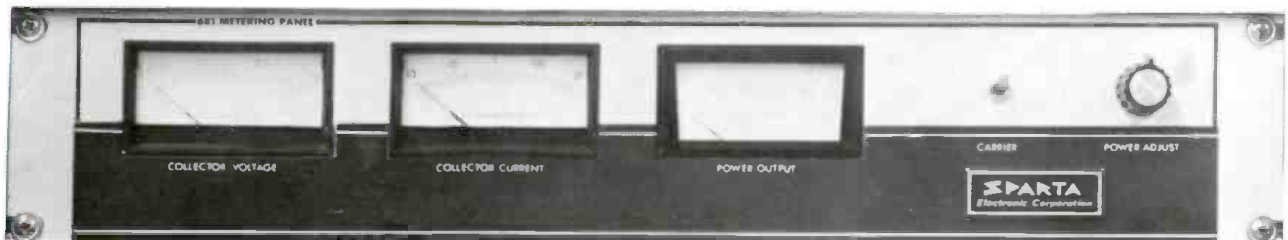

# TRANSMITTERS

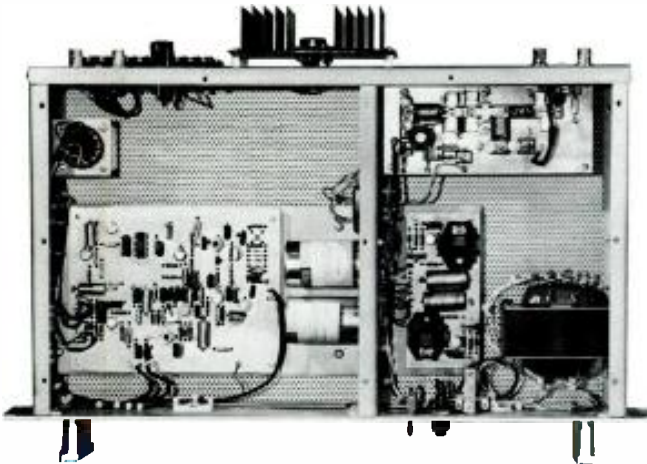

The Model 680 FM Exciter uses the most recent advances known in RF design. Its features include Strip Line Circuitry, Automatic Carrier Balance and an ovenless Digital AFC control circuit;

The 682 Stereo Generator provides a composite baseband signal, with only one user-adjustable control; overall gain is set with a front panel control for 8, 9, or 10% pilot injection. Remote control is possible through a simple contact closure, with terminals on the rear of the unit. Internal 682 circuitry uses integrated circuits sparingly, and only where they best perform. Bipolar transistors are used elsewhere. Circuitry in both the Models 680 and 682 is short circuit proof, with fold-back current limiting power supplies which prevent failure from misuse of the equipment.

When the Model 681 Metering Panel is added to the basic 680 Exciter, the resulting 10 Watt FM Transmitter takes on all the failure-proof characteristics of the basic Exciter. A more dependable FM transmitter for educational broadcasting cannot be found.

Simplicity, and through simplicity utmost dependability, has been the hallmark of design in the 680 FM Exciter and its component equipment.



## MODEL 680 DIRECT FM EXCITER SPECIFICATIONS

POWER REQUIREMENT	95-135 VAC, 50 to 60 Hz, single phase, 28 watts nominal
FREQUENCY RANGE	85-125 MHz
POWER OUTPUT	5-12.5 Watts (adj.)
OUTPUT IMPEDANCE	35.5 to 91 ohms resistance, 50 ohms nominal
LOAD VSWR	0 to infinity at all phase angles
MODULATION	F 3 and F9
MODULATION CAPABILITY	± 95 KHz
HARMONIC ATTENUATION	- 43 db below carrier
FREQUENCY STABILITY	± 1 KHz
FREQUENCY RESPONSE	
MONAURAL	±0.25 to -0.5 db from 75 US curve
WIDE BAND	±1.0 db 20 Hz to 250 KHz
WIDE BAND PHASE RESPONSE	±0.25° from phase linearity
FM NOISE	75 db below 100% mod. at 400 Hz
AM NOISE	At least - 60 db below carrier level
DISTORTION	0.5 or less all frequencies
INPUT IMPEDANCE	
MONAURAL AUDIO	600 ohms (± 10%) balanced
WIDE BAND	1 K unbalanced
INPUT LEVELS	
MONAURAL AUDIO	+ 10 db ± 2 db
SPURIOUS SIDEBANDS	- 65 db below carrier to 2.5 MHz
RF BANDWIDTH	2.5 MHz at -3 db power points
DIMENSIONS	3½" h. 10" d. 19" w.
AMBIENT TEMP. RANGE	0°C to + 45°C (+ 32°F to 113°F)
ALTITUDE RANGE	To 12,500'

## MODEL 682 STEREO GENERATOR SPECIFICATIONS

POWER REQUIREMENTS	105-125 VAC, 50/60 Hz, 1 Ø, 15 W
PILOT FREQ. STABILITY	± 1 Hz maximum
AUDIO INPUT IMPEDANCE	600 Ohms, balanced
AUDIO INPUT LEVEL	+ 10 dbm ± 2 DB at 400 Hz for 90% modulation
FREQUENCY RESPONSE	+ 0.25 to - 0.5 db from 50 Hz to 15,000 Hz (referred to 75-usec preemphasis)
DISTORTION	0.1% of composite waveform or less
NOISE	-65 db below 100% modulation
CROSSTALK	-50 db or better (-60 db typical)
SEPARATION	40 db, 50 to 15,000 Hz or better.
DIMENSIONS	3½" h. 6" d. 19" w
AMBIENT TEMP. RANGE	0° F to 120° F
MAXIMUM ALTITUDE	To 12,500 feet

## MODEL 683 SCA GENERATOR SPECIFICATIONS

CENTER FREQUENCY	
RANGE OF SUBCARRIER	Standard 41 or 67 KHz
OUTPUT VOLTAGE	At least 2 volts peak to peak into 10,000 ohms
FREQUENCY DEVIATION	+ 10% of center frequency (100% subcarrier modulation)
MODULATION CAPABILITY	± 15%
CARRIER FREQ. STABILITY	2,500 Hz over temperature range
AUDIO INPUT IMPEDANCE	600 ohms balanced
AUDIO INPUT LEVEL	+ 10 dbm at 400 Hz (100% modulation)
AUDIO FREQ. RESPONSE	± 2 db ref. 75 usec. pre-emphasis (30 Hz to 7.5 KHz) (convertible to 50 or 150 usec. pre-emphasis)
HARMONIC DISTORTION	Less than 1.5% (50 Hz to 7.5 KHz)
FM NOISE LEVEL	-65 db maximum (ref. to 15% deviation)
AMBIENT TEMP. LIMITS	+5° C to +50° C





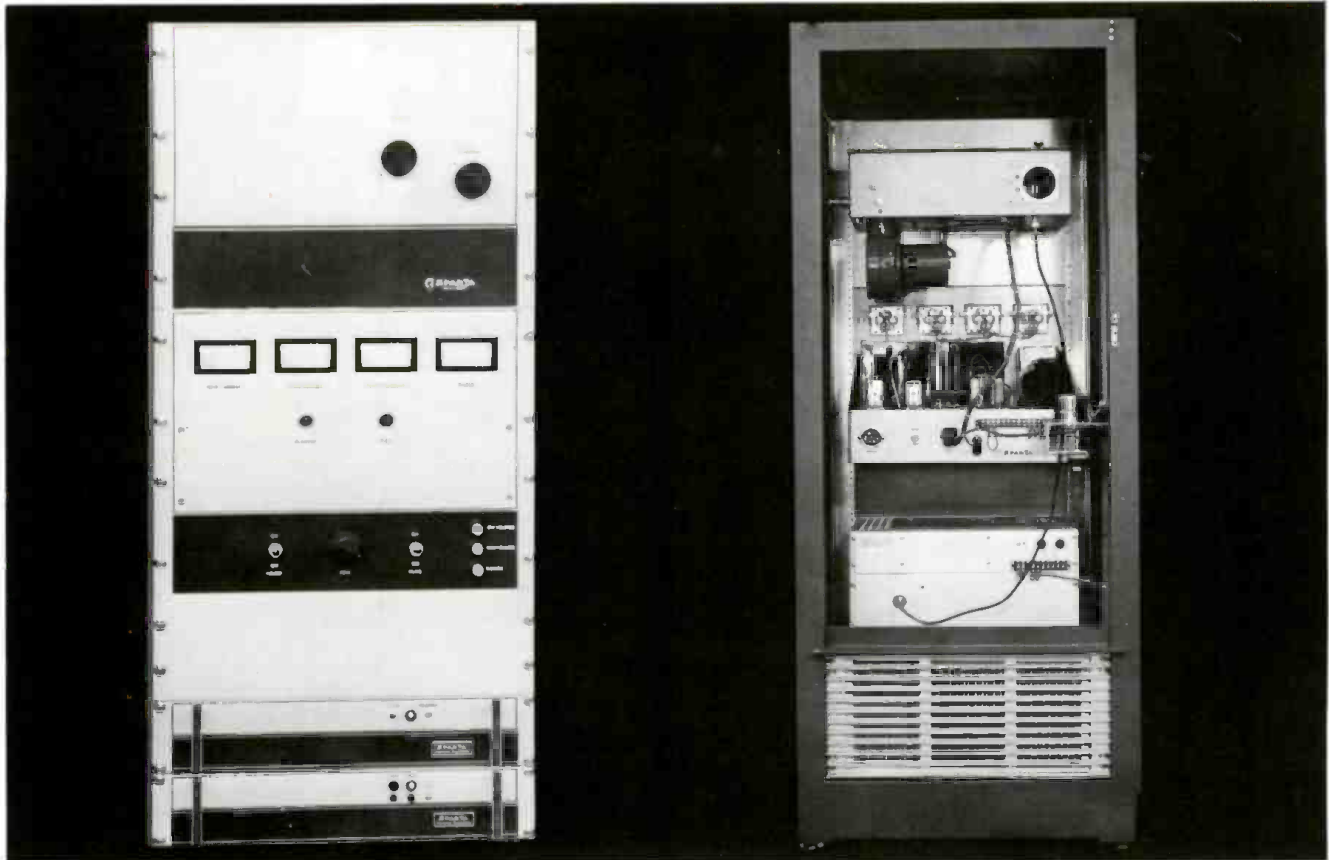

Sparta's Model 600A FM Transmitter for standby or low power operation offers the buyer a choice of space saving cabinet housings. All components of the Model 600A are a standard 19" rack size and due to their compactness can be consolidated into a single rack with monitors, remote control and STL equipment.

The solid state Model 680 Exciter is followed by a single 4CX250B tetrode, accomplishing a top quality FM signal with minimum cost in space, maintenance, complexity or dollars. All power supplies are solid state.

### SPECIFICATIONS

TYPE OF MODULATION.....	F3, F9 direct frequency modulation of mono, stereo and SCA audio inputs.
POWER OUTPUT CAPABILITY.....	250 W
FREQUENCY RANGE.....	88 to 108 MHz
FREQUENCY STABILITY.....	± 1 kHz
RF OUTPUT IMPEDANCE.....	50 ohms nominal
MODULATION CAPABILITY.....	±95 kHz
FM NOISE.....	Better than 65 dB below 100% modulation at 400 Hz
AM NOISE.....	Better than 50 dB below equivalent 100% AM
HARMONICS.....	Exceeds all FCC requirements
LINE POWER SUPPLY.....	115 volts, AC, single phase, 50-60 Hz.
LINE POWER CONSUMPTION.....	950 watts at 0.9 power factor
ALL AUDIO INPUTS.....	600 ohms ±10% balanced, +10 dBm ±2 dB for 100% modulation referred to 400 Hz.
POWER TUBE COMPLEMENT.....	1 ea. 4CX250B (Exciter and power supplies are completely solid state)

EQUIPMENT SIZE.....	Requires 3 1/2" of rack space
CABINET SIZE, STANDARD.....	55" high x 24" wide x 26" deep
CABINET SIZE, OPTIONAL.....	75" high x 24" wide x 26" deep
WEIGHT.....	350 pounds
ALTITUDE.....	to 7,500 feet
AMBIENT TEMPERATURE.....	to 113°F (45°C)

MONAURAL OPERATION FREQUENCY RESPONSE.....	Within 1 dB, 50-15,000 Hz (referred to 75µsec pre-emphasis)
DISTORTION.....	Less than 0.5%, 50-15,000 Hz
STEREOPHONIC OPERATION FREQUENCY RESPONSE.....	Within 1 dB, 50-15,000 Hz (referred to 75µsec pre-emphasis)
DISTORTION.....	Less than 0.5%, all frequencies

### ORDERING INFORMATION:

The Model 600A is supplied complete with harmonic filter and Model 680 Exciter in standard 55" cabinet, tuned and tested on frequency.

### OPTIONAL EQUIPMENT:

Tall Cabinet (75") for additional equipment mounting  
 500 watt Constant Voltage Transformer (CVS-2)  
 Stereo Generator (682)  
 SCA Generator (683)

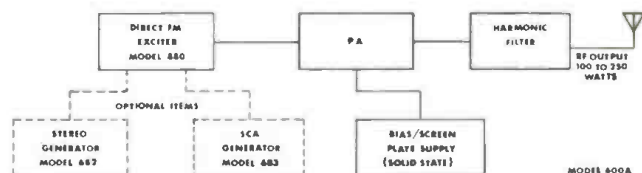

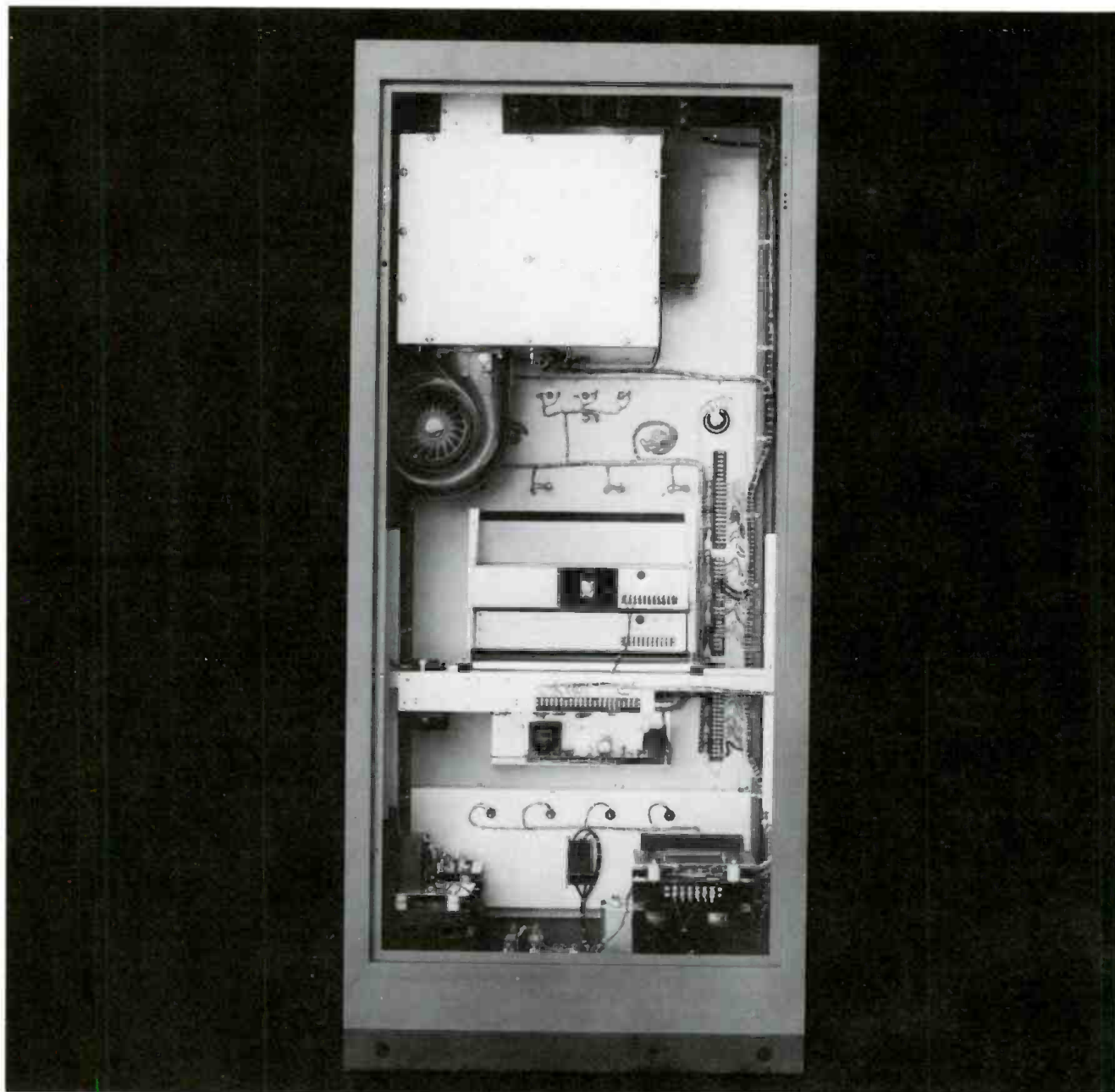

The Model 601A 1,000 watt FM Transmitter is identical to the Model 602A described on page 74, with the exception of the high voltage power supply which operates at 3 KV. The Model 601A is type accepted for operation from 700 to 1,500 watts.

Power Output . . . . . 1500 watts  
 Line Power Supply . . . . . 200-245 volts AC  
   Single Phase, 50/60 Hz  
 Line Power Consumption . . . . . 2,500 watts at  
   0.9 Power Factor (1500 watts out)

**SEE MODEL 602A FOR FURTHER SPECIFICATIONS**

**ORDERING INFORMATION:**

The Model 601A is supplied complete with the Model 680 Exciter, tubes and harmonic filter, factory tuned and tested on frequency. For stereo option specify Model 682 Stereo Generator. For SCA order Model 683 SCA Generator (specify sub-carrier frequency).

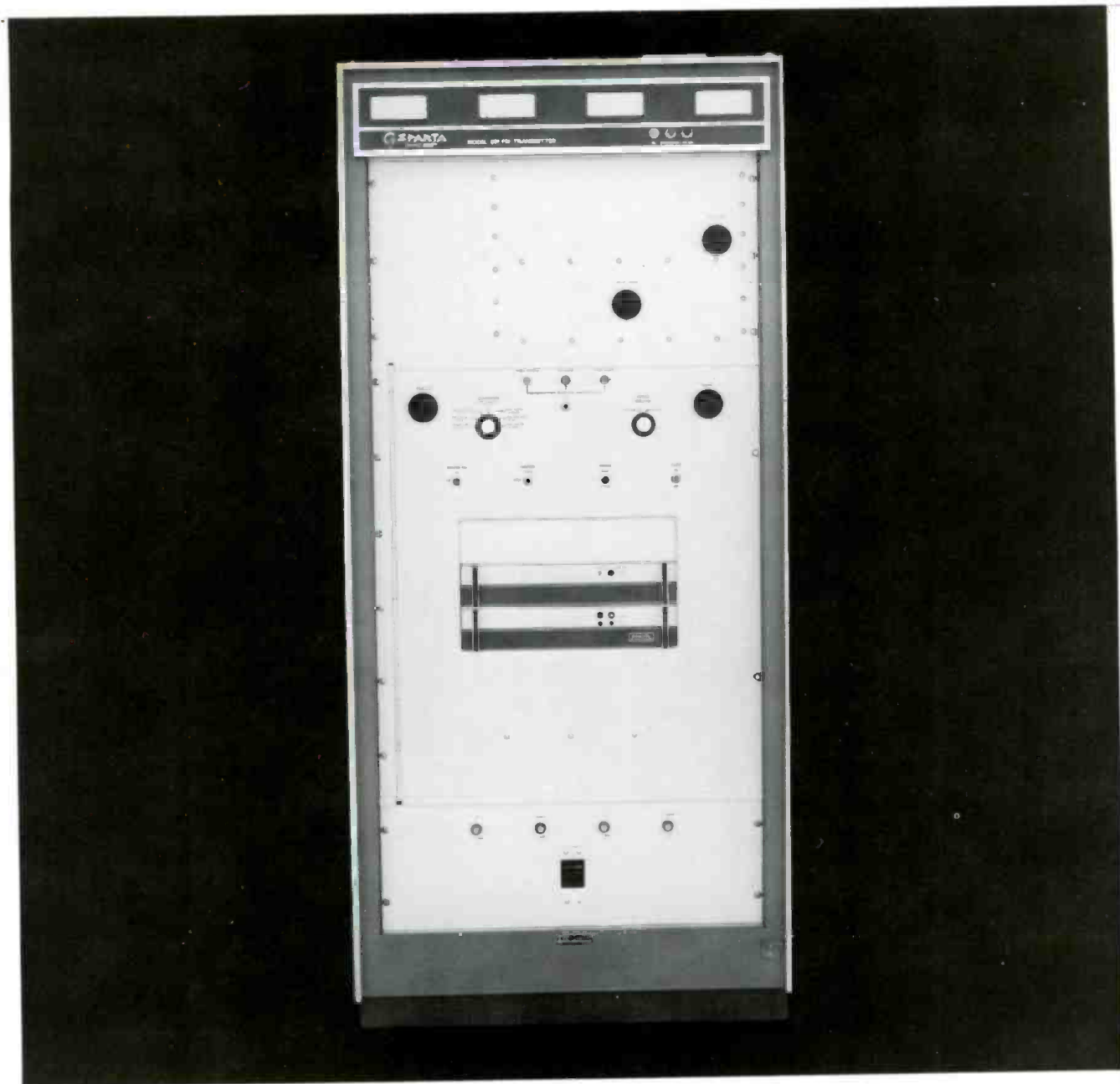

The SPARTA 602A Transmitter with a three bay circularly polarized antenna makes up the most economical package for full power Class A broadcasting. Its 2500 watts along with the standard 1.5 gain of a 3 bay circularly polarized antenna easily delivers the maximum 3000 watts ERP. Competitive transmitters require four bays to accomplish the same thing.

Reliability of the 602A FM Transmitter is highly emphasized by straightforward engineering design and an uncluttered layout. The front view, above indicated the placement of the model 680 FM Exciter within the transmitter. The front panel surrounding the 680 swings out for easy accessibility.

Ease and economy of installation is facilitated through the use of a single phase power supply.

## PERFORMANCE SPECIFICATIONS MODEL 602A

TYPE OF MODULATION .....	F3, F9 direct frequency modulation of mono, stereo, and SCA audio inputs.	PRE-EMPHASIS .....	75 usec - convertible to 50 usec
POWER OUTPUT CAPABILITY .....	1,000 to 2,500 w.	LEFT-RIGHT CHANNEL SEPARATION .....	40 db or better, 50 Hz to 15 KHz
FREQUENCY RANGE .....	88 to 108 MHz.	CROSSTALK-STEREOPHONIC .....	50 db or better below 100% mod., (main channel to subchannel) 50 Hz to 15 KHz
FREQUENCY STABILITY .....	± 1 kHz after initial warmup.	CROSSTALK .....	42 db or better below 100% mod., (subchannel to main channel) 50 Hz to 15 KHz
RF OUTPUT IMPEDANCE .....	50 ohms nominal.	DISTORTION .....	0.1% or less distortion of composite wave form (100% modulation by composite stereo)
MODULATION CAPABILITY .....	± 95 kHz		
FM NOISE .....	Better than 65 db below 100% modulation (Mono, Stereo, and SCA) referred to 400Hz.		
AM NOISE .....	Better than 50 db below equivalent 100% AM.	<b>SCA OPERATION</b>	
HARMONICS .....	At least 80 db below fundamental.	AMBIENT TEMPERATURE LIMITS .....	+5° C to +50° C
LINE POWER SUPPLY .....	200-245 volts AC, single phase, 50/60 Hz.	TYPE OF MODULATION .....	FM
LINE POWER CONSUMPTION .....	6,000 watts at 0.9 power factor (2,500 watts out)	CENTER FREQUENCY .....	
ALL AUDIO INPUTS .....	600 ohms balanced, +10 dbm ± 2 db for 100% modulation (referred to 400 Hz)	RANGE OF SUBCARRIER .....	Standard 41 or 67 KHz
POWER TUBE COMPLEMENT .....	1 ea 4X150 driver, 1 ea 5CX-1500A Power Amplifier (Exciter and power supplies are completely solid state)	OUTPUT VOLTAGE .....	At least 2 volts peak to peak into 10,000 ohms
CABINET SIZE .....	75" high x 34" wide x 25½" deep (101 x 86 x 65 cm) (low pass filter included)	FREQUENCY DEVIATION .....	± 10% of center frequency (100% subcarrier modulation)
WEIGHT .....	1000 pounds (453.6 Kg).	MODULATION CAPABILITY .....	± 15%
ALTITUDE .....	to 7,500 feet	CARRIER FREQUENCY STABILITY .....	2,500 Hz over temperature range
AMBIENT TEMPERATURE .....	to 113° F (45° C)	AUDIO INPUT IMPEDANCE .....	600 ohms balanced
<b>MONAURAL OPERATION</b>		AUDIO INPUT LEVEL .....	+10 dbm at 400 Hz (100% modulation)
Frequency response within 1 db 50-15,000 Hz (referred to 75 usec pre-emphasis).		AUDIO FREQUENCY RESPONSE .....	± 2 db ref. 75 usec. pre-emphasis (convertible to 50 or 150 usec. pre-emphasis)
Distortion less than 0.5% 50-15,000 Hz.		HARMONIC DISTORTION .....	Less than 1.5% (50 Hz to 7.5 KHz)
<b>STEREOPHONIC OPERATION</b>		FM NOISE LEVEL .....	-65 db maximum (ref. to 15% deviation)
PILOT CARRIER STABILITY .....	19 KHz ± 1 Hz		
SUBCARRIER SUPPRESSION .....	-45 db or better		
FREQUENCY RESPONSE .....	to .25 to -0.5 db from 50-15,000 Hz (referred to 75 usec pre-emphasis.)		

### ORDERING INFORMATION

The Model 602A is supplied complete with the Model 680 exciter, crystal and oven, tubes and harmonic filter - factory tuned and tested on frequency. For stereo option specify Model 682 stereo generator - for SCA Model 683 SCA generator (specify sub-carrier frequency).

SIMPLIFIED BLOCK DIAGRAM - MODEL 602A

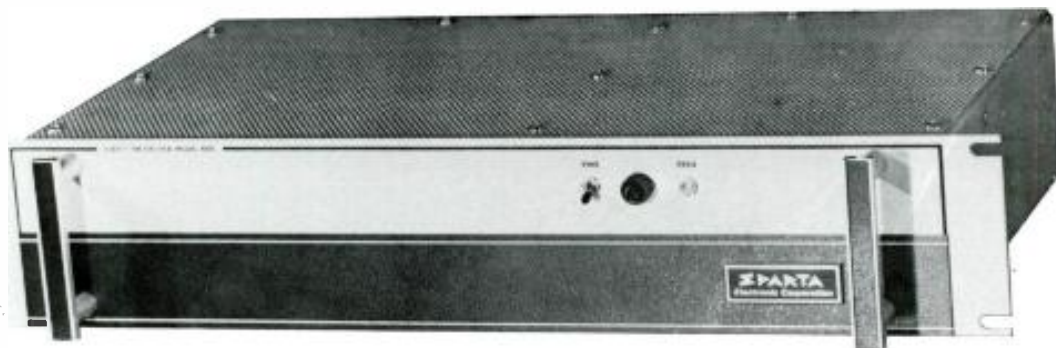
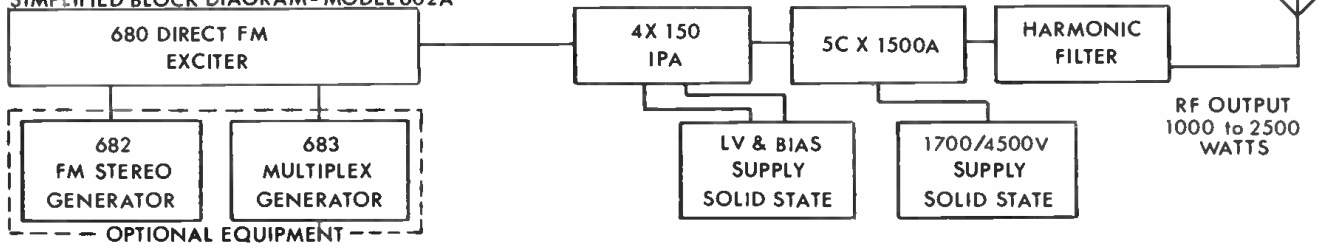

680 Exciter

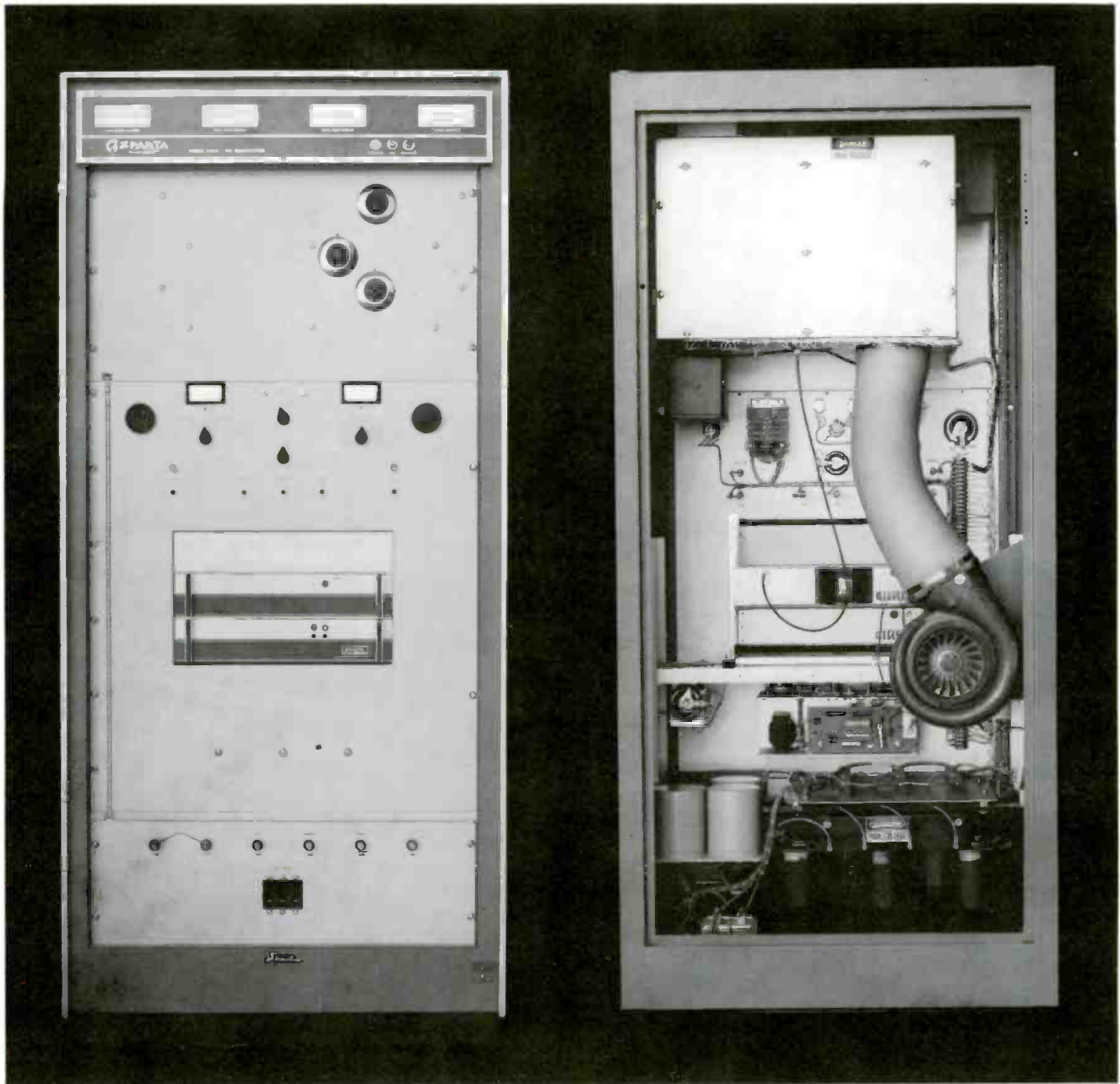

The SPARTA Model 605A is the only FM transmitter designed for primary operation at 5,000 watts! It's tube type, cabinet size and circuitry were designed to perform most economically at this power. And it's the smallest self-contained 5 kw FM available!

Reliability of the 605A FM Transmitter is highly

emphasized by straightforward engineering design and an uncluttered layout. Even through the swing-out front panel you can reach most of the components.

The rear view shows the final amplifier in the transmitter's upper portion. The front view shows the Model 680 Exciter.

# TRANSMITTERS

## MODEL 605A

This Sparta transmitter is type accepted for Broadcast operation under Part 73 of the FCC rules.

## PROVEN FM EXCITER

The Sparta Model 680 FM exciter features all-solid-state construction . . . built-in power supply . . . 10 watt out-put . . .

## TRANSMITTER SPECIFICATIONS

TYPE OF MODULATION	F3, F9 direct frequency modulation of mono, stereo, and SCA Audio inputs
POWER OUTPUT CAPABILITY	3,000 to 5,200 watts
FREQUENCY RANGE	88 to 108 MHz
FREQUENCY STABILITY	± 1 kHz after initial warmup
RF OUTPUT IMPEDANCE	50 ohms nominal
MODULATION CAPABILITY	± 95 kHz
FM NOISE	Better than 65 db below 100% modulation (Mono, Stereo, and SCA) referred to 400 Hz
AM NOISE	Better than 50 db below equivalent 100% AM
HARMONICS	At least 80 db below fundamental
LINE POWER SUPPLY	205-250 volts AC, three phases, 4-wire, 60/60 Hz
LINE POWER CONSUMPTION	11,000 watts at 0.9 power factor (5,200 watts output)
ALL AUDIO INPUTS	600 ohms balanced, +10 dbm ±2 db for 100% modulation (referred to 400 Hz)
POWER TUBE COMPLEMENT	1 ea. 4CX350 driver, 2 ea. 5CX1500A Power Amplifiers (Exciter and power supplies are completely solid state)
CABINET SIZE	75" high x 34" wide x 25½" deep (191 x 86 x 65 cm)
WEIGHT	1050 pounds (476 kg)
ALTITUDE	To 7,500 feet
AMBIENT TEMPERATURE	To 113°F (45°C)

## MONAURAL OPERATION

Frequency response within 1 db 50-15,000 Hz (referred to 75 usec pre-emphasis)  
Distortion less than 0.5% 50-15,000 Hz

## STEREOPHONIC OPERATION

PILOT CARRIER STABILITY	19 kHz — 1 Hz
SUBCARRIER SUPPRESSION	—45 db or better
FREQUENCY RESPONSE,	+0.25 to -0.5 db from 50-15,000 Hz (referred to 75 usec pre-emphasis).
PRE-EMPHASIS	75 usec — convertible to 50 usec
LEFT-RIGHT CHANNEL SEPARATION	40db or better, 50 Hz to 15 kHz
CROSSTALK-STEREOPHONIC	50 db or better below 100% mod., 50 Hz to 15 kHz (Main channel to subchannel)
CROSSTALK	50 db or better below 100% mod., 50 Hz to 15 kHz (subchannel to main channel)

DISTORTION ..... 0.1% or less distortion of composite wave form (100% modulation by composite stereo)

## SCA OPERATION

AMBIENT TEMPERATURE LIMITS	+5°C to +50°C
TYPE OF MODULATION	FM
CENTER FREQUENCY	Standard 41 or 67 kHz
RANGE OF SUBCARRIER	Standard 41 or 67 kHz
OUTPUT VOLTAGE	At least 2 volts peak to peak into 10,000 ohms
FREQUENCY DEVIATION	±10% of center frequency (100% subcarrier modulation)
MODULATION CAPABILITY	±15%
CARRIER FREQUENCY STABILITY	±500 Hz over temperature range
AUDIO INPUT IMPEDANCE	600 ohms balanced
AUDIO INPUT LEVEL	+10 dbm at 400 Hz (100% modulation)
AUDIO FREQUENCY RESPONSE	±2 db ref. 75 usec. pre-emphasis (30 Hz to 7.5 kHz)
HARMONIC DISTORTION	Less than 1.5% (50 Hz to 7.5 kHz)
FM NOISE LEVEL	—65 db maximum (ref. to 15% deviation)

## ORDERING INFORMATION

The Model 605A is supplied complete with the Model 680 exciter, crystal and oven, tubes and harmonic filter — factory tuned and tested on frequency. For stereo option specify Model 682 stereo generator — for SCA Model 683 SCA generator (specify sub-carrier frequency).

The Model 605A final amplifier further demonstrating the simplicity and uncluttered layout of the transmitter.

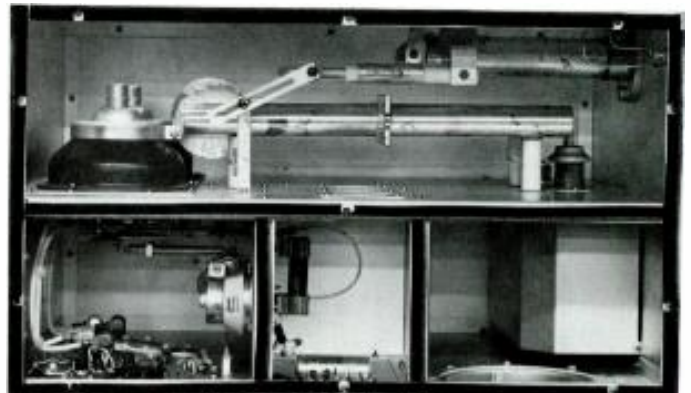

SIMPLIFIED BLOCK DIAGRAM—MODEL 605A

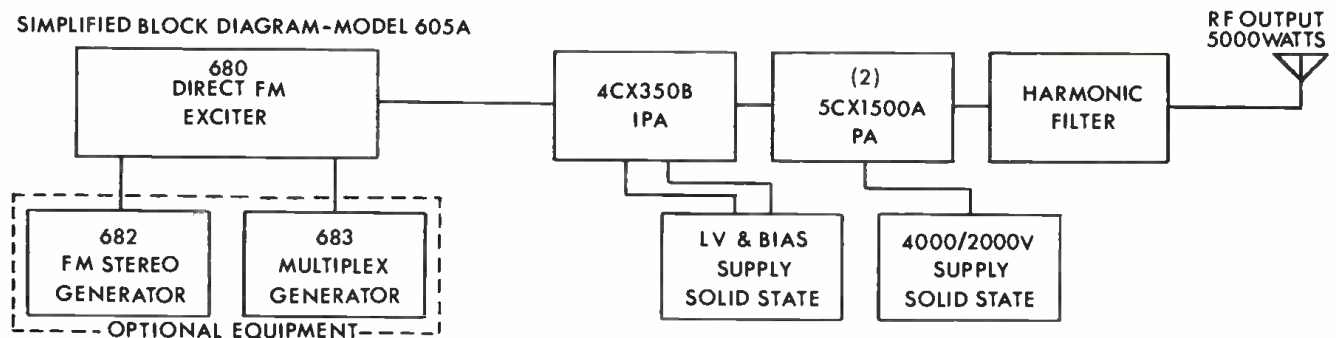

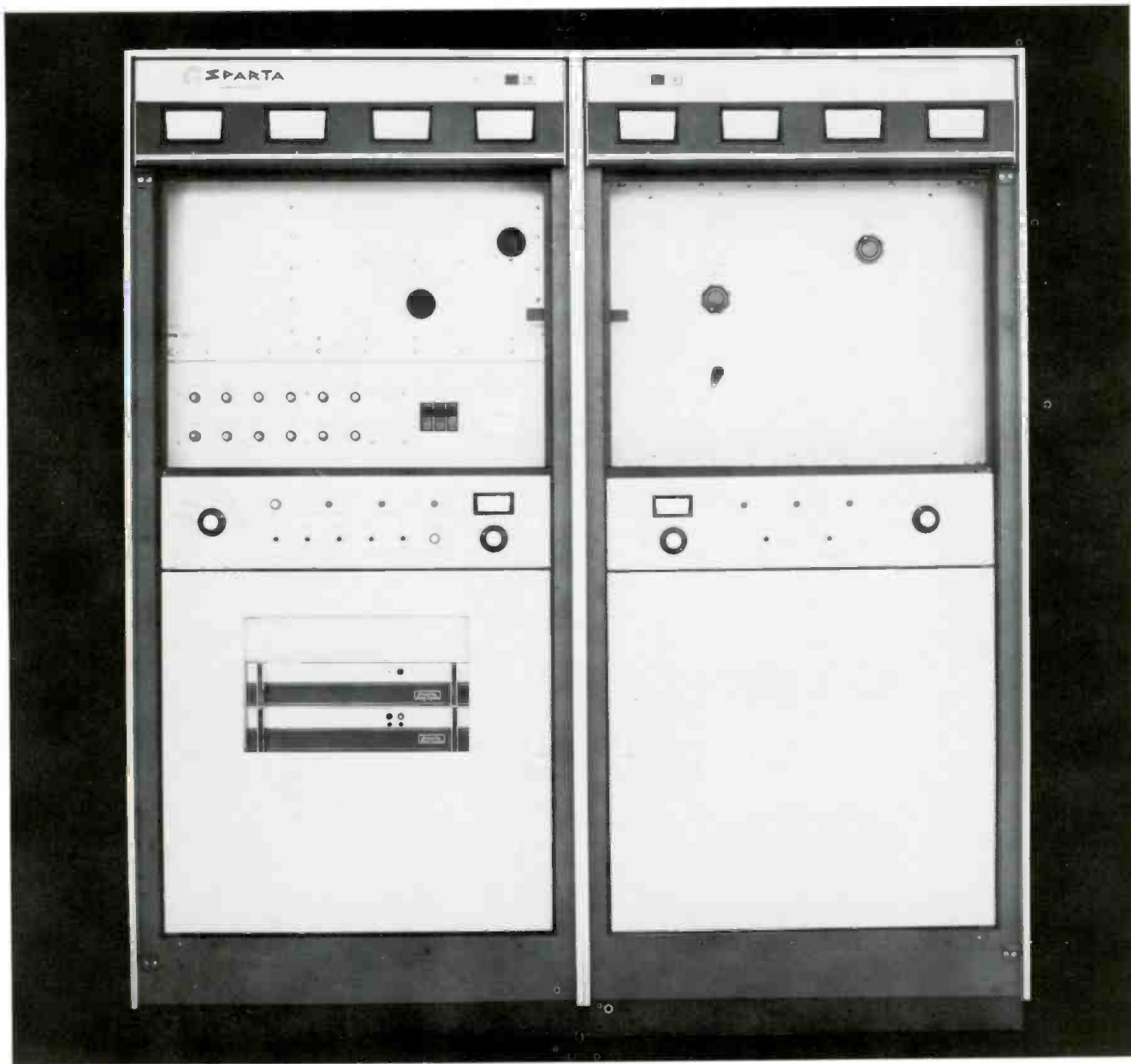

High reliability and high power output are provided in the Model 625A. The broadband, grounded grid final amplifier assures optimum performance without continual fine adjustments. The SPARTA 625A is tuned once, and stays there!

The tally-light fault locator system, that has been a popular feature on SPARTA's AM Transmitters, has been engineered into the 625A. Should there be a momentary overload, the 625A will re-cycle auto-

matically and the tally-light system will tell you where the overload occurred. The system captures information for you and keeps it on display until manually reset. Another advanced equipment design from SPARTA is Automatic Power Control guaranteeing operation within FCC tolerances, in addition to a VSWR protection system.

The trouble free SPARTA Model 680 FM Exciter gives full stereo and SCA operation, when component 682 and 683 Generators are used.

# TRANSMITTERS

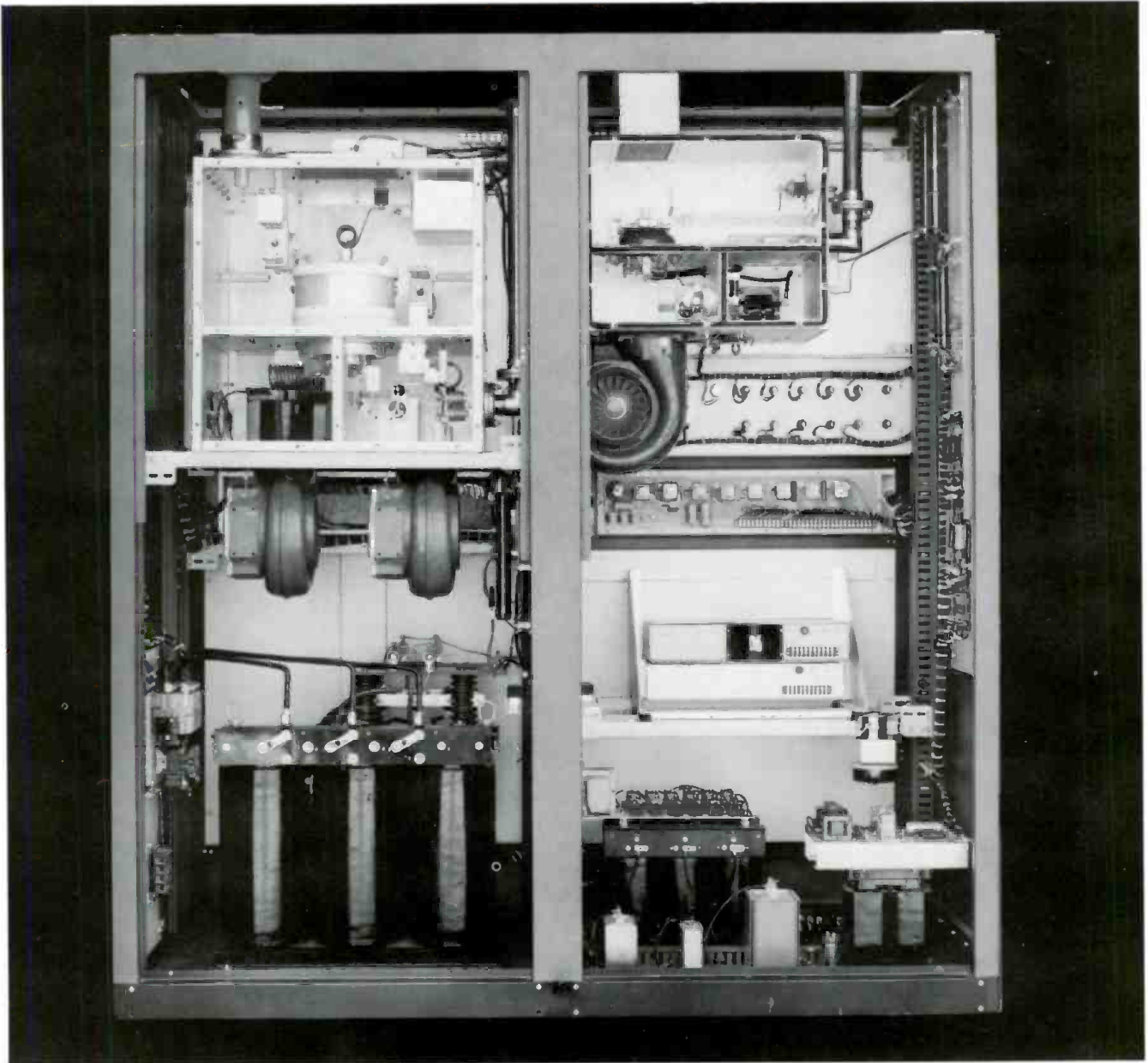

The above picture shows the roll-out high voltage power supply which is contained within the main transmitter housing. There are four heavy-duty “dolly” type casters upon which the power supply

rolls. Maintenance is a simple task in the 625A FM Transmitter because of well planned features such as these and by ease of accessibility through either front or rear doors.



## MODEL 625A

### Transmitter Specifications:

POWER OUTPUT . . . . . 25 kW  
 FREQUENCY RANGE . . . . . 88 to 108 MHz, tuned to specified operating frequency  
 RF OUTPUT IMPEDANCE . . . . . 50 ohms  
 OUTPUT TERMINATION . . . . . 3 1/8" EIA flange  
 FREQUENCY STABILITY . . . . .  $\pm 1,000$  Hz after initial warmup  
 TYPE OF MODULATION . . . . . Direct FM  
 MODULATION CAPACITY . . . . .  $\pm 95$  Hz  
 AC INPUT POWER . . . . . 200/250 V, 3-phase 60 Hz, 35 KW (50 Hz available on special order)  
 RF HARMONICS . . . . . Suppression exceeds all FCC requirements.  
 ALTITUDE . . . . . to 7,500 feet  
 AMBIENT TEMPERATURE RANGE . . . . . 0 to 50° C  
 MAXIMUM VSWR . . . . . 1.7 to 1  
 OVERALL SIZE . . . . . 68" W x 75" H x 34"  
 FINISH . . . . . Two-tone, gray  
 WEIGHT & CUBAGE . . . . . 104 cu. ft., 3000 lbs.

### MONAURAL MODE

AUDIO INPUT IMPEDANCE . . . . . 600 ohms balanced  
 AUDIO INPUT LEVEL . . . . . + 10 dBm  $\pm$  2 dB for 100% modulation at 400 Hz

### AUDIO FREQUENCY

RESPONSE . . . . . Standard 75 microsecond, FCC pre-emphasis curve +0.25 to -0.5 db, 50-15,000 Hz

DISTORTION . . . . . 0.5% or less, 50-15,000 Hz

FM NOISE . . . . . 65 dB below 100% modulation (ref. 400 Hz)

AM NOISE . . . . . 55 dB below reference carrier AM modulated 100%

SYNCHRONOUS AM . . . . . -50 dB max. (at 400 Hz) (due to 100% FM)

### STEREOPHONIC MODE

PILOT STABILITY . . . . . 19 kHz  $\pm$  1 Hz

AUDIO INPUT IMPEDANCE . . . . . (left and right) 600 ohms balanced

AUDIO INPUT LEVEL . . . . . (left and right)  $\pm$  10 dBm + 1 dB for 100% modulation at 400 Hz

### AUDIO FREQUENCY

RESPONSE . . . . . (left and right) Standard 75 micro-

second, FCC pre-emphasis curve +0.25 to -0.5 db, 50-15,000 Hz (left or right) 0.75% or less, 50-15,000 Hz  
 STEREO SEPARATION . . . . . -40 db Minimum 50-15,000 Hz or better.

### SUB-CARRIER

SUPPRESSION . . . . . -65 db below 100% modulation (main to sub-channel or sub-to main channel) 50 db below 100% modulation, 50 Hz to 15 kHz.

CROSSTALK . . . . . (main to sub-channel or sub-to main channel) 50 db below 100% modulation, 50 to 15 kHz.

### SCA SPECIFICATIONS

FREQUENCY STABILITY . . . . .  $\pm 500$  Hz  
 FREQUENCY . . . . . Between 25 and 75 kHz, 41 or 67 kHz standard

MODULATION . . . . . Direct FM

MODULATION CAPABILITY . . . . .  $\pm 15\%$

AUDIO INPUT IMPEDANCE . . . . . 600 ohms balanced

AUDIO INPUT LEVEL . . . . . + 10 dBm for 100% modulation at 400 Hz

DISTORTION . . . . . Less than 1.5%, 50-7500 Hz

FM NOISE . . . . . -65 dB maximum (ref. to 15% deviation)

CROSSTALK . . . . . (sub-channel to main channel) -60 dB or better

CROSSTALK . . . . . (Main channel to sub-channel) 50 dB below 100% Modulation (ref. 400 Hz)

AUTOMATIC MUTE LEVEL . . . . . -10 dBm at 400 Hz

MUTING DELAY . . . . . Variable from 0.6 to 4 seconds

## MODEL 610A

### Transmitter Specifications:

POWER OUTPUT . . . . . 13 kW  
 AC INPUT POWER . . . . . 21 KW at 0.9 power factor  
 TUBE COMPLEMENT . . . . . 1 ea. 4X150A, 5CX1500A, 3CX10000A7  
 WEIGHT . . . . . 2750 pounds

ALL OTHER SPECIFICATIONS MONAURAL STEREOPHONIC AND SCA, IDENTICAL WITH 625A.

SIMPLIFIED BLOCK DIAGRAM - MODEL 625A

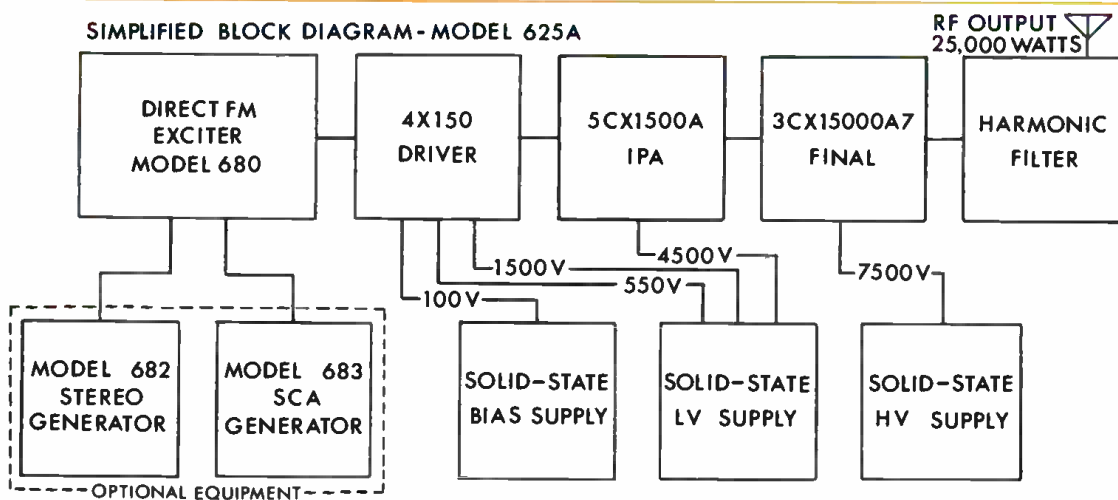

Model 610A: RF output 13,000 watts. LV supply to IPA 2600V. HV supply to final 5600V. Final tube is 3CX10000A7. All other details of block diagram are identical to Model 625A.

# ANTENNAS

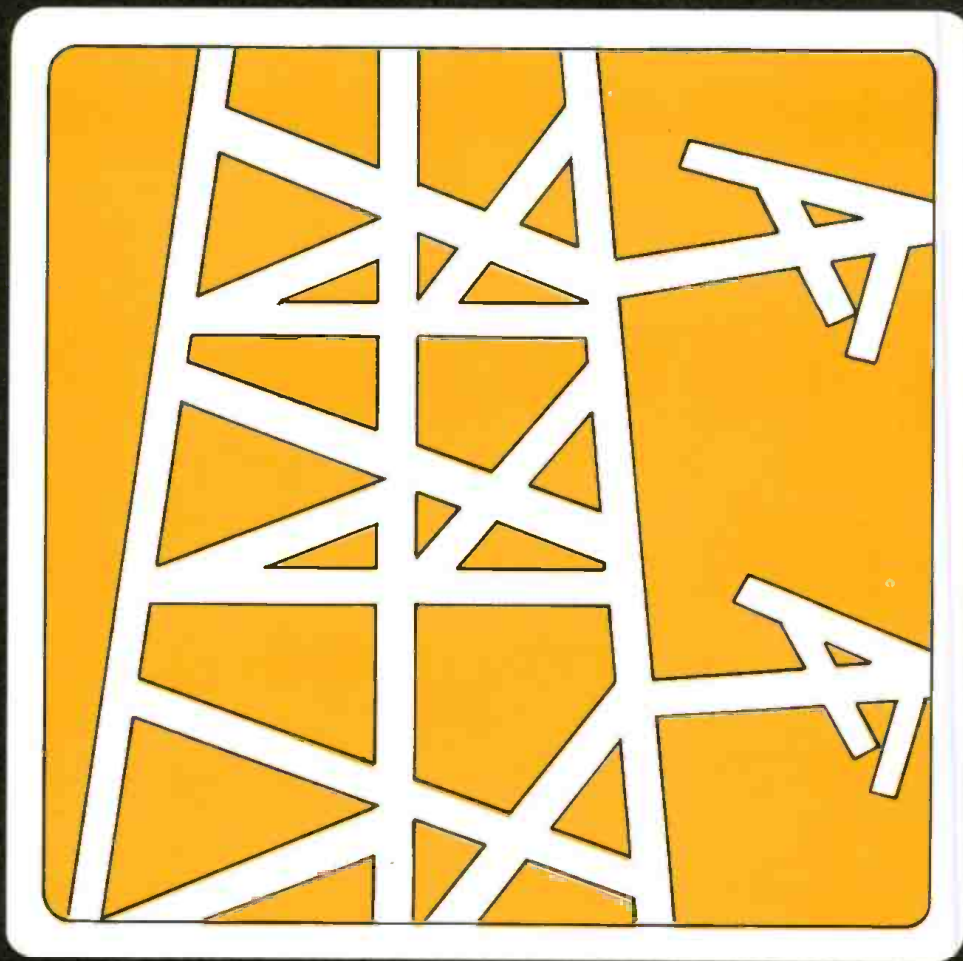



Now Class A and educational broadcasting stations can take advantage of superior quality and craftsmanship of Jampro's latest contribution to FM broadcasting.

The introduction of the "PERFORMER" JLCP series, low power and low cost antenna will allow the Class A and educational stations a quality elliptically polarized FM antenna at a cost well within

their budget.

The JLCP series is rated at 1 KW per bay and is available in models from 1 to 8 bays. Low VSWR over 200 KHz provides excellent conditions for stereo broadcasting service.

The JLCP is elliptically polarized for improved signal reception for car radios, and home receivers using built-in line cord antennas.

These PERFORMER antennas are designed for low VSWR values. Each antenna is complete with a VSWR tuner, which is adjusted for best operation after installation. The antenna is completely air tight and may be pressurized for long trouble-free service.

These JLCP series antennas are rugged! Built of thick wall copper tubing, and marine brass, they will keep their shape during installation, high winds or ice loads.

Galvanized steel mounting brackets are included with each antenna for leg mounting on uniform cross section towers. Face mounting and tapered tower mounting brackets are priced on request. Other special mounting brackets are available.

The JLCP feed system consists of a vertical 1 5/8" line, across which are shunted the various bays. The input of the antenna is a 1 5/8" EIA flange.

Deicing is available at additional cost. Each radiating bay requires 360 watts of power at 220/240 volts. They can also be operated at 110/120 volts, AC, for reduced deicing requirements. Deicers are factory installed.

**POLARIZATIONS** – The FCC permits the use of horizontally, elliptically, and circularly polarized FM broadcasting antennas. Experience has indicated that circularly polarized antennas put the most signal into a randomly polarized receiving antenna, with the elliptical antenna running a close second. Circular polarization is more difficult to achieve in a practical FM broadcasting antenna, and is thus more expensive.

**ELLIPTICAL POLARIZATION** – Like all ring-stub antennas, the PERFORMER radiates different ratios of power in different azimuthal directions. The electrical phase of the two polarizations also varies with a change of azimuth. The resulting axial ratio of the horizontally and vertically polarized components makes this an excellent elliptically polarized antenna.

## SPECIFICATIONS

- ELECTRICAL**  
**FREQUENCY RANGE** . . . . 88 to 108 MHz  
**POLARIZATION** . . . . . Elliptical, Clockwise  
**POWER GAIN**  
**HORIZONTAL** . . . . . See table below  
**VERTICAL** . . . . . Same as Horizontal  
**AZIMUTHAL PATTERN** . . ± 2.0 db in free space  
**VSWR AT INPUT** . . . . . 1.5:1 over ± 200 KHz (without field trimming)  
**POWER RATING** . . . . . 1.1:1 over ± 200 KHz (with field trimming)  
**MECHANICAL** . . . . . 1 Kilowatt per Bay  
**INPUT CONNECTION** . . . . 1 5/8" EIA flanges  
**OTHER** . . . . . See table below  
**DEICERS (each bay)**  
**MODERATE** . . . . . 90 watts @ 110-120 volts  
**HEAVY ICE** . . . . . 360 watts @ 220-240 volts

Type No. and Bays	Power Gain	Gain in DB	Field Gain	FS at 1 Mile 1 KW, MV/M	Net Weight	Safe Power Rating	Windload 50/33 PSF
JLCP-1	0.475	-3.23	0.69	94.94	12 Lbs.	1 KW	15 Lbs.
JLCP-2	0.955	- .20	0.977	134.44	51 Lbs.	2 KW	70 Lbs.
JLCP-3	1.50	1.76	1.22	167.87	71 Lbs.	3 KW	130 Lbs.
JLCP-4	2.05	3.12	1.43	196.77	90 Lbs.	4 KW	183 Lbs.
JLCP-5	2.60	4.15	1.61	221.54	107 Lbs.	5 KW	242 Lbs.
JLCP-6	3.15	4.98	1.77	243.55	132 Lbs.	6 KW	295 Lbs.
JLCP-7	3.65	5.62	1.91	262.82	153 Lbs.	7 KW	350 Lbs.
JLCP-8	4.20	6.23	2.05	282.08	174 Lbs.	8 KW	400 Lbs.

- 1) Prices include complete mounting hardware for leg mounting, guyed towers only.
- 2) Mounting brackets not included in net weight or windloading.
- 3) Windload ratings are 50/33 PSF, 110 miles per hour.
- 4) Space required on tower is 984 divided by freq. in MHz X number of bays less 1.



The best state of the art FM transmitting antenna, the JAMPRO CP produces circular polarization by a patented Jampro method.

In addition to providing the technically superior circular polarization in all directions of azimuth, the construction results in less complex installation requirements and lower wind loading and net weight.

JSCP antennas consist of four quarter wave arms, which form the four sides of a square with two hot and two cold sides. Radiation is in 90 degree phase quadrature: when the angle between the opposite corners is 45 degrees, 50% of the radiation is horizontally polarized and 50% is vertically polarized.

After rigorously controlled fabrication, the antenna system is mounted on a tower similar to that to be used by the customer. A complete instruction book containing step-by-step installation instructions, mounting sketch, de-icer wiring information, and a final measured VSWR plot, is included with each antenna system shipped.

Galvanized steel mounting brackets with stainless steel hardware are furnished.

Where regular icing conditions prevail, de-icing equipment is recommended. Electrical rod heaters are installed in the four quadrant arms, as well as in the center feed-support arm. An ice and sleet sensitive switch is part of the complete interbay wiring kit.

JAMPRO JSCP Series, circularly polarized "PENETRATOR" FM antenna.

The half power beamwidth of the vertical field is a function of the number of bays in the antenna system. It is approximately equal to 61 divided by the number of bays.

The radiation pattern for side mounted antennas is subject to azimuthal distortion by the reflection effects from the steel tower. The JAMPRO CP antenna is not greatly affected, because the basic radiator is both physically and electrically large – more than three times larger than any competitive antenna! This large illuminating source reduces the

effects of the supporting steel tower. Typical pattern circularities are  $\pm 2$  DB.

Good stereo performance requirements are met with a VSWR of 1.1 to 1 over a 400 kilocycle bandwidth! The basic element is low Q since two half waves consisting of four quarter wave arms are used. The VSWR is not affected by rain, fog, or even slight coating of ice. After installation, the elements may be trimmed for the lowest possible VSWR if desired.

## SPECIFICATIONS

JSCP TYPE – SHUNT FED SYSTEM WITH ONE VERTICAL 3 1/8" LINE

JCP TYPE – PARALLEL FEED SYSTEM WITH ALL INTERBAY CABLES

TYPE NO. AND BAYS	POWER GAIN	GAIN IN DB	FIELD GAIN	FS @ 1 MILE 1 KW, Mv/M	NET WEIGHT	SAFE POWER RATING	WINDLOAD 50/33 PSF
JSCP-1	0.46	-3.37	0.678	93.2	38.25	10.0 KW	70.5 LBS.
JCP-1	0.46	3.37	0.678	93.2	16.0	5.0 KW	57 LBS.
JSCP-2	1.0	0.0	1.0	137.6	121.5	20.0 KW	225.0 LBS.
JCP-2	1.0	0.0	1.0	137.6	80.5	10.0 KW	145.0 LBS.
JSCP-3	1.5	1.76	1.23	168.4	192.75	30.0 KW	315.0 LBS.
JCP-3	1.5	1.76	1.23	168.4	114.5	15.0 KW	223.0 LBS.
JSCP-4	2.1	3.22	1.45	199.2	264.0	40.0 KW	405.0 LBS.
JCP-4	2.1	3.22	1.45	199.2	148.0	20.0 KW	302.0 LBS.
JSCP-5	2.7	4.31	1.64	225.2	335.25	40.0 KW	495.0 LBS.
JCP-5	2.7	4.31	1.64	225.2	212.0	15.0 KW	391.0 LBS.
JSCP-6	3.2	5.05	1.79	246.0	406.5	40.0 KW	588.0 LBS.
JCP-6	3.2	5.05	1.79	246.0	251.0	30.0 KW	491.0 LBS.
JSCP-7	3.8	5.80	1.95	268.0	477.75	40.0 KW	678.0 LBS.
JCP-7	3.8	5.80	1.95	268.0	299.0	35.0 KW	592.0 LBS.
JSCP-8	4.3	6.34	2.07	285.2	549.0	40.0 KW	768.0 LBS.
JCP-8	4.3	6.34	2.07	285.2	337.0	40.0 KW	736.0 LBS.
JSCP-10	5.5	7.40	2.35	322.4	701.5	40.0 KW	948.0 LBS.
JCP-10	5.5	7.40	2.35	322.4	437.0	40.0 KW	903.0 LBS.
JSCP-12	6.6	8.20	2.57	353.2	844.2	40.0 KW	1131.0 LBS.
JCP-12	6.6	8.20	2.57	353.2	555.0	40.0 KW	1122.0 LBS.
JSCP-14	7.8	8.92	2.79	383.9	986.7	40.0 KW	1314.0 LBS.
JCP-14	7.8	8.92	2.79	383.9	671.0	40.0 KW	1348.0 LBS.
JSCP-16	8.9	9.49	2.98	410.2	1129.2	40.0 KW	1494.0 LBS.
JCP-16	8.9	9.49	2.98	410.2	831.0	40.0 KW	1930.0 LBS.
JSCP-18	10.3	10.13	3.13	4.375	1277.7	40.0 KW	1677.0 LBS.
JCP-18	10.3	10.13	3.13	4.37	914.5	40.0 KW	2090.0 LBS.
JSCP-20	11.3	10.53	3.36	4.62	1414.2	40.0 KW	1860.0 LBS.
JCP-20	11.3	10.53	3.36	4.62	982.9	40.0 KW	2395.0 LBS.

1. Power gains are for 50/50 horizontally and vertically polarized ratios. Other ratios available. 2. Antenna polarization is circular clockwise, in all directions of azimuth. 3. Prices include complete galvanized mounting hardware for leg mounting on uniform guyed towers. 4. Mounting brackets on tapered self-supporting towers, priced on request. 5. Space required on tower is 984 divided by freq. in Mhz X number of bays less 1. 6. Antenna input location on JCP series is three feet below antenna array center. 7. Windload ratings are 50/33 PSF, 110 miles per hour. 8. Antenna weights include standard mounting hardware. Add 10 Lbs/bay for deicers.

### WHEN ORDERING BE SURE TO SPECIFY

- A. Antenna type number
- B. Deicers, if any
- C. Channel, (between 88-108 Mhz)
- D. Horizontal and vertical power gains
- E. Description of Tower – make and model
- F. Beam tilt and null fill-in, if any

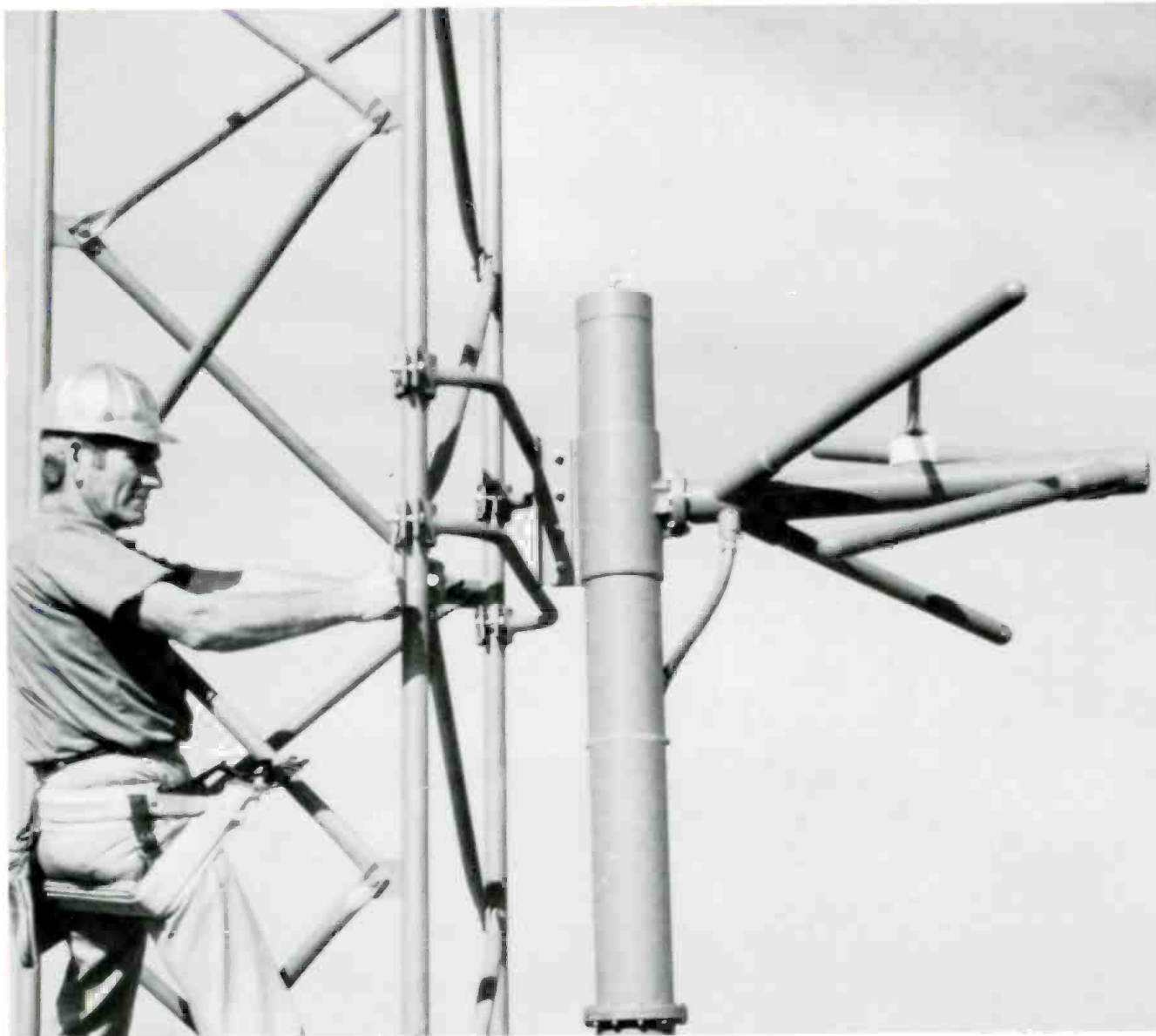

Extremely high power capacity FM antennas are now available from Jampro. These are wide band, multiple channel capability, circularly polarized antennas, of the latest patented design.

They are conservatively rated at 20 KW per bay, with an upper limit of 80 KW. This power may come from one or several combined FM stations, feeding power into one model JHCP antenna. For example, four 20 KW transmitters may be combined into one ten-bay model JHCP-10 antenna providing each station with an ERP of 100 KW.

The high power capacity is achieved by using a 6 1/8" EIA shunt fed line, with 3 1/8" individual bay feeds. Power is limited only by coax line power handling capacity.

Corona and high voltage arcing problems have been eliminated in this Jampro design. The "Q" of the radiating element has been reduced to a very low value. This lowers the surface charge density over the antenna radiating surface areas. The reduced surface charge, and other design features, have eliminated corona and arcing problems, even in rain and fog.

**VSWR BANDWIDTH** – With the unique low Q design, the antenna has a single channel bandwidth of  $\pm 200$  KHz 1.07/1 or better. Jampro's patented design makes multiple antenna resonances possible.

These antennas employ simple field adjustable tuning, for trimming VSWR during initial installation.

**DIPLEXING** – Several FM stations may be combined and operated into one JSCP antenna. FM diplexers for this purpose are available from Jampro with power ratings to 80 KW, for combining two, three or four stations. Contact Jampro for details.

**DEICING** – Electrical deicing is sufficient for all ice conditions. Factory installed, these internal ice melting heaters operate on 220 volts, using one KW of power for each bay. A complete interbay kit is furnished for wiring the deicers of the antenna. Deicer control is an accessory, and available with a high-low cold sensing thermostat, with power relay.

**RUGGED CONSTRUCTION** – Made of high-strength brass, with large diameters, these antennas will withstand the most severe weather conditions, and winds to 130 MPH. The unit construction permits easy installation. The main 6 1/8" interbay shunt feed line is supported by a heavy casting at the element location. Air bleed valves and large teflon insulators are used where required. Internal transformers insure proportional power for each bay.

**MOUNTING** – The antenna is designed for installation on the sides of existing steel towers. Face, leg or leg-skewed mounting may be used. On special order Jampro will furnish suitable steel poles for mounting these antennas, on top of towers. Leg mounting or face mounting brackets are included with each antenna. Poles and pole mounting brackets are available as accessory items.

**RADIATION PATTERNS** – The horizontal plane radiation pattern is typical of all side mounted CP polarized FM antennas. Horizontal polarization pattern circularities of  $\pm 2$  DB are normal for towers from 24 to 60 inches wide. If larger towers are to be used, Jampro pattern service is recommended.

The vertical plane pattern can be tailored to fit the service area. Beam tilt and null fill in are designed by Jampro engineers, using a computer. This service is available without cost.

**CIRCULAR POLARIZATION** – When the horizontally and vertically polarized components are nearly equal in strength in all azimuthal directions and the phase is nearly 90° quadrature, the antenna is circularly polarized. The patented JAMPRO PENETRATOR . . . and BRUTE series of FM antennas, have excellent axial ratios and are truly circularly polarized antennas.

**FEED POINT** – These antennas are bottom fed thru the 6 1/8" EIA input flange, for most models, including 6 bays. Antennas with 8, 10, 12 and 14 bays have their inputs six feet below the center of the antenna. The larger antennas have built in VSWR tuners for fine matching the antenna to the transmission line.

**SPLIT ANTENNAS** – These antennas can be supplied with an upper and lower half, in the six, eight, ten and twelve bay models. This method is currently used by nearly all European TV and FM stations. It provides 100% backup against transmitters, transmission line and antenna, permitting maintenance on one amplifier. The upper half of the antenna is fed thru its own transmission line to one 20 KW amplifier. The lower half is fed in a similar manner. When one half is inoperative, there is only a 6 DB loss in signal.

TYPE NO. AND BAYS	POWER GAIN	GAIN IN DB	FIELD GAIN	FS @ 1 MILE 1 KW, Mv/M	NET WEIGHT	SAFE POWER RATING	WINDLOAD 50/33 PSF
JHCP-3	1.6	1.98	1.25	172.	634 Lbs.	60 KW	806 Lbs.
JHCP-4	2.1	3.30	1.46	201.	1007 Lbs.	80 KW	1254 Lbs.
JHCP-5	2.7	4.35	1.65	227.	1167 Lbs.	80 KW	1460 Lbs.
JHCP-6	3.3	5.20	1.82	250.	1320 Lbs.	80 KW	1662 Lbs.
JHCP-7	3.9	5.90	1.97	271.	1540 Lbs.	80 KW	1970 Lbs.
JHCP-8	4.5	6.50	2.11	291.	1758 Lbs.	80 KW	2245 Lbs.
JHCP-10	5.7	7.53	2.38	328.	2202 Lbs.	80 KW	2827 Lbs.
JHCP-12	6.8	8.35	2.61	360.	2646 Lbs.	80 KW	3409 Lbs.
JHCP-14	8.0	9.03	2.82	388.	3089 Lbs.	80 KW	3992 Lbs.

1. Antenna polarization is circular clockwise, in all directions of azimuth; 2. Price includes complete galvanized mounting hardware for leg or face mounting on uniform cross section towers; 3. Brackets for tapered self-supporting towers are extra. Prices on request; 4. Tower space required, in feet is 984 divided by frequency in MHz x number of bays less 1; 5. Antenna input on 1 thru 6 bays at base of antenna. Inputs on 7 thru 14 bays are located six feet below the center of the antenna; 6. Windload ratings are 50/33 PSF, 110 miles per hour; 7. Antenna weights include standard mounting hardware; 8. Multi-channel antennas, add \$1500.00 for each channel.



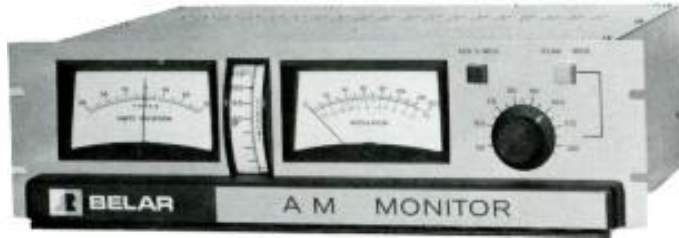

## AMM-1 FREQUENCY & MODULATION MONITORS

The AMM-1 Frequency and Modulation Monitor is the first all solid-state combination frequency and modulation monitor featuring a separate 100% negative peak indicator for absolute indication of 100% negative modulation peaks, independent of any calibration procedures.

With this state-of-the-art monitoring circuitry, the desired positive peaks may be read on the normal peak lamp and modulation meter both set to read positive peaks and the negative peaks are read on the 100% negative indicator when they exceed 99.5%. The true peak reading modulation meter responds accurately to the shortest duration program peaks commonly encountered.

### SPECIFICATIONS

RF SENSITIVITY .....	5 to 10 volts rms
RF INPUT IMPEDANCE .....	1000 ohms
RF FREQUENCY RANGE .....	260-1610 kHz
DEVIATION METER RANGE .....	±30 Hz
<b>MODULATION</b>	
METER RANGE .....	133%
CARRIER LEVEL	
METER RANGE .....	110%
<b>MODULATION METER</b>	
ACCURACY .....	2%
PEAK MODULATION	
INDICATOR .....	50 to 125%
100% NEGATIVE	
INDICATOR .....	99.5% or greater (negative modulation only)
FREQUENCY RESPONSE .....	0.5 dB, 30-15,000 Hz
DISTORTION .....	0.25% max., 30-15,000 Hz
SIGNAL-TO-NOISE RATIO .....	75 dB
REMOTE METERING .....	All meters may be remotely monitored—5000 ohms external loop resistance.
SIZE .....	5¼" H x 19" W x 10½" D
WEIGHT .....	14 lbs.

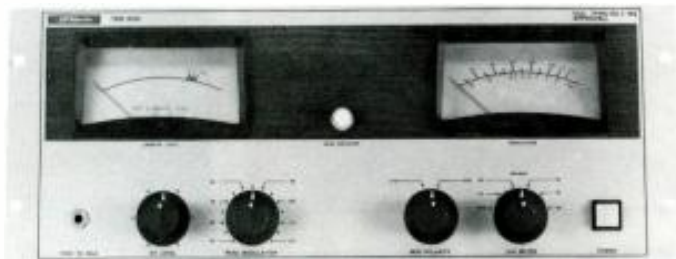

## TBM-8500 MODULATION MONITOR

The TBM-8500 employs the latest techniques in silicon, solid state circuit design. All devices are conservatively rated. Critical circuitry is on plug-in, Grade G-10 glass epoxy base, etched circuit boards.

The modulation percentage meter functions as a semi-peak reading voltmeter. When used for direct measurement of AM signal-to-noise ratio, the meter is appropriately damped to improve readability in the presence of noise.

RF input level and carrier shift are continuously monitored.

The optional remote metering kit is the Model RM-85T/R.

## TBM-8500 SPECIFICATIONS

RF FREQUENCY RANGE .....	540 to 1,600 kHz
RF INPUT SENSITIVITY .....	5 to 10 volts rms
RF INPUT IMPEDANCE .....	50 ohms unbalanced
<b>AUDIO OUTPUT (for monitoring circuits)</b>	
SOURCE IMPEDANCE .....	600 ohms balanced
LEVEL .....	+4 dBm at 100% modulation at 1 kHz
FREQUENCY RESPONSE .....	±0.5 dB, 30-15,000 Hz
DISTORTION .....	0.25% maximum, 30-15,000 Hz
<b>AUDIO OUTPUT (for distortion measurements)</b>	
IMPEDANCE .....	10K ohms, minimum
LEVEL .....	6 to 7 volts rms at 100% modulation at 1 kHz
<b>FREQUENCY RESPONSE AND DISTORTION</b>	
.....	Same as monitoring circuits
<b>PEAK FLASHER</b>	
ACCURACY .....	±2% of full scale, 30-15,000 Hz
<b>MODULATION METER (ballistics meet FCC requirements)</b>	
ACCURACY .....	+2% of full scale at 1,000 Hz modulating frequency
<b>FREQUENCY RESPONSE</b>	
SCALE .....	±0.5 dB, 30-15,000 Hz
<b>REMOTE METERING</b>	
.....	Terminations provided
DIMENSIONS .....	Rack panel 19" W x 7" H x 11" D



## TBM-8000 FREQUENCY MONITOR

The TBM-8000 provides a visual, digital readout of frequency deviation of the operating carrier of AM broadcast transmitters.

The readout is by means of seven-segment numeric display modules which afford excellent readability even in high ambient light environments. Both polarity and the frequency deviation are displayed directly.

Three modes of operation are selectable by pushbutton switching. The normal operating mode is with the "Modulated Carrier" button depressed. This mode of operation uses a 10-second gate time. Readings over the deviation range from 0 to ±39 Hertz are displayed.

With the "Unmodulated Carrier" button depressed, a 1-second gate time is employed. This position is intended primarily for transmitter frequency adjustment.

A self-adjusting RF attenuator accommodates RF input levels up to 5 watts. A front panel warning indicator is provided to detect insufficient RF input.

### SPECIFICATIONS

OPERATING RANGE .....	Any 10 kHz increment from 540 to 1600 kHz
INPUT LEVEL .....	0.5 to 5.0 watts (max.)
INPUT IMPEDANCE .....	50 ohms (UHF connector)
FREQUENCY STABILITY .....	Better than ±2 parts per million (PPM) 0 to 55°C
AM REJECTION .....	Will reject a minimum of 95% modulation and typically will reject 98%
DISPLAY .....	0 to ±39 Hertz in 1.0 Hz increments (Modulated and Unmodulated Carrier positions). 0 to ±390 Hertz in 10.0 Hz increments (Wide Range position).
ALARM INDICATORS .....	1. Low RF input; 2. Greater than 10 Hz deviation; 3. Greater than 20 Hz deviation (contact closures available when ±20 Hz has been exceeded)
POWER REQUIREMENTS .....	120, ±10 Vac or 240, ±20 Vac; 50/60 Hz, 20 watts.
DIMENSIONS .....	19" rack W x 3½" H x 9½" D
OPTIONAL ACCESSORIES .....	RM-81-T — Plug-in BCD outputs.



### TBM-3000A DIGITAL FM FREQUENCY MONITOR

The TBM-3000A FM Frequency Monitor provides digital display of either main channel carrier or 19 kHz pilot frequencies of transmitters operating in the FM broadcast band.

A special purpose, seven-segment display features excellent readability under high ambient light conditions. The TBM-3000A is specifically designed to meet the requirements of Section 73.331.

The TBM-3000A has a self-adjusting RF attenuator to accommodate RF input levels up to 5 watts, with a front panel warning indication if insufficient drive is present.

In the "Modulated Carrier" mode the data is sampled once each ten seconds. The sampling rate in the "Unmodulated Carrier" mode is five times per second. A front panel indicator light monitors proper operation of the crystal oven. Pre-calibration adjustment is not required.

### SPECIFICATIONS

OPERATING FREQUENCY	Main Carrier—88-108 MHz; Stereo Pilot—19 kHz
MAIN CARRIER:	
INPUT LEVEL	0.005 to 5 watts, maximum
INPUT IMPEDANCE	50 ohms
FREQUENCY STABILITY	±2 PPM (parts per million), (equivalent to ±200 Hz @ 100 MHz) from 0 to 55°C.
AGING RATE	Less than 2 PPM per month
STEREO PILOT:	
INPUT LEVEL	0.035 to 1.0 volts rms
INPUT IMPEDANCE	10 kohms
FREQUENCY STABILITY	±0.19 Hz from 0 to 55°C
AGING RATE	Less than 0.04 Hz per month
DISPLAY:	
MAIN CARRIER	Digital readout—zero to ±3.9 kHz in 100 Hz increments. Lamp alarm indicators—±1 and ±2 kHz deviations.
STEREO PILOT	Digital readout—zero to ±3.9 Hz in 0.1 Hz increments. Lamp alarm indicators—±1 and ±2 Hz deviations.
DIMENSIONS	Standard 19" rack panel x 3½"H x 9½"D
OPTIONAL ACCESSORIES	Analog & Digital & RF Cards



### FMS-1 STEREO FREQUENCY AND MODULATION MONITOR

The FMS-1 Stereo Monitor, when added to the FMM-1, provides complete monitoring and test functions to meet the daily requirements for stereo monitoring. FM noise, AM noise, and incidental AM are all read on the front panel meters as well as separation, crosstalk, pilot amplitude, and subcarrier suppression. A unique filter system allows the FMS-1 to be used as an inter-modulation analyzer for measuring stereo distortion directly in the frequency range of 5 to 15 KC.

The FMS-1 is calibrated with the modulation calibrator of the FMM-1.

### SPECIFICATIONS

PILOT FREQUENCY	
METER RANGE	±3 Hz
METER ACCURACY	±0.2 Hz (0.001%)

### MODULATION METER

RANGE	133% to -70 dB
ACCURACY	Better than 5% over entire scale
FREQUENCY RESPONSE (L AND R)	±0.5 dB, 50-15,000 Hz
SEPARATION	45 dB, 50-15,000 Hz. Meter range is -70 dB
CROSSTALK	60 dB (L+R) to (L-R) 60 dB (L-R) to (L+R) 66 dB SCA to (L+R), (L-R)

### OUTPUTS:

LEFT AND RIGHT CHANNEL MONITORING	600 ohms, unbalanced
LEFT AND RIGHT CHANNEL TEST	10k ohms, unbalanced
DISTORTION (EITHER CHANNEL)	0.2%

SIGNAL TO NOISE RATIO (EITHER CHANNEL)	70 dB with 75 μs de-emphasis
MONITORING MODES	(Modulation Meter Switched, 133% to -70 dB). Left Channel Audio, Right Channel Audio, L+R, L-R, 38 kHz (may be measured with modulating frequencies greater than 5 kHz), 19 kHz Pilot Injection, (12% full scale), Total Modulation, FM Noise, AM Noise, Inc. AM.
REMOTE METERING	Both pilot frequency and modulation meters may be remotely metered.

SIZE	5¼"H x 19"W x 10½"D
------	---------------------

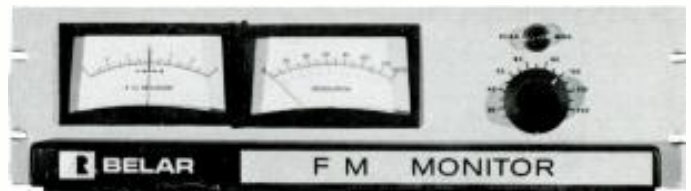

### FMM-1 FREQUENCY AND MODULATION MONITOR

The FMM-1 Frequency and Modulation Monitor is a wideband, all solid state FM monitor designed expressly to fulfill all the new requirements for monaural monitoring as well as to provide a virtually pure, distortionless demodulated signal to drive the companion FMS-1 Stereo Monitor and SCM-1 SCA Monitor for multiplex monitoring. Operational features include a total modulation meter that responds accurately to the peak amplitude of the complex waveforms encountered in today's programming. The FMM-1 peak flasher is completely independent of modulation polarity in that it samples both positive and negative peaks simultaneously and automatically selects and registers the greater amplitude if the preset level is exceeded.

### SPECIFICATIONS

RF INPUT SENSITIVITY	0.2 to 10 volts rms
RF INPUT IMPEDANCE	50 ohms
RF FREQUENCY RANGE	88-103 MHz
DEVIATION METER RANGE	±3 kHz
MODULATION METER RANGE	133% (100% at 75 kHz)
ACCURACY	Better than 5% over entire scale
PEAK MODULATION INDICATOR	50-120%
FREQUENCY RESPONSE	±0.1 dB, 50-75,000 Hz. 3 dB down at 180 kHz
DISTORTION	0.1% max., 50-75,000 Hz
STEREO SEPARATION	50 dB (at composite output jacks)
SIGNAL TO NOISE RATIO	75 dB with 75 μs de-emphasis
OUTPUTS	4 wide band isolated outputs to drive the FMS-1, and one or more SCM-1, distortion meter output, and monitoring output
REMOTE METERING	Both carrier deviation and modulation meters may be remotely metered.
SIZE	5,000 ohms external loop resistance. 5¼"H x 19"W x 10½"D

# TRANSMITTERS

# MONITORS—FM

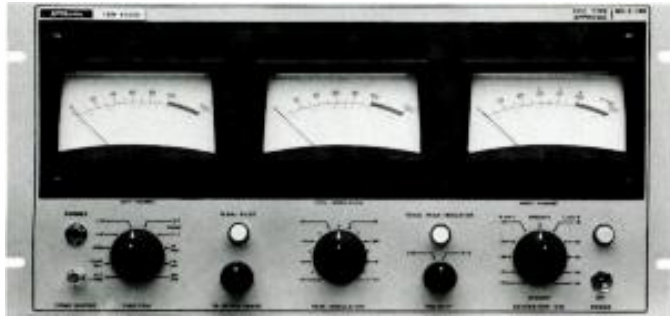

## TBM-4500A FM STEREO MOD. MONITOR

The TBM-4500A solid state monitor is a self-contained unit for all modulation of FM stereo.

Three meters feature simultaneous readings of left, right and TOTAL modulation

Pilot injection can be monitored at any time without affecting modulation metering.

The circuit design allows monitoring of stereo while transmitting SCA. "Remoting" is possible by use of the metering kit, RM-M45.

### SPECIFICATIONS

RF INPUT:	
IMPEDANCE .....	50 ohms unbalanced
SENSITIVITY .....	0.1 to 1.0 watt
COMPOSITE INPUT:	
IMPEDANCE .....	50 kohms
POWER REQUIREMENTS .....	105-125 volts ac, 50/60 Hz, 25 watts
DIMENSIONS .....	19"W x 8 1/4"H x 14"D

## TBM-4500A, TBM-2200 & TBM-3500A

### COMMON SPECIFICATIONS

SENSITIVITY .....	1.0 to 1.5 volts peak-to-peak
MODULATION METERS, LEFT, RIGHT; OR TOTAL	
ACCURACY .....	±0.5 dB
FREQUENCY RESPONSE .....	30-15,000 Hz ±0.5 dB
AUDIO OUTPUT FOR MONITORING CIRCUITS:	
SOURCE IMPEDANCE .....	600 ohms balanced
LEVEL .....	+4 dBm @100% modulation @400 Hz
DISTORTION .....	Less than 1%, 50-15,000 Hz
AUDIO OUTPUT FOR DISTORTION MEASUREMENT	
IMPEDANCE .....	10 kohm or greater
LEVEL .....	8 volts @100% modulation @400 Hz
FREQUENCY RESPONSE .....	30-15,000 Hz ±0.5 dB
DISTORTION:	
MONAURAL .....	0.25%, 30-15,000 Hz
STEREO .....	0.5%, 30-15,000 Hz
NOISE LEVEL .....	-66 dB below 100% modulation at 400 Hz
COMPOSITE OUTPUT:	
SOURCE IMPEDANCE .....	300 ohms
LEVEL .....	0.30 volts peak-to-peak
FREQUENCY RESPONSE .....	50-100,000 Hz, ±0.2 dB
PILOT INJECTION CIRCUIT:	
ACCURACY .....	±0.5%
METER INDICATION .....	6 to 12%
INDICATOR .....	Pilot lamp (operates at 6% injection or higher)
SEPARATION:	
LEFT INTO RIGHT .....	(50-15,000 Hz) 35 dB or better
RIGHT INTO LEFT .....	(50-15,000 Hz) 35 dB or better
67 kHz INTO EITHER CHANNEL .....	-60 dB or better
MEASUREMENT OF SUPPRESSED 38 kHz CARRIER .....	Modulated 100% with frequencies above 5 kHz—better than 46 dB. No modulation—better than 55 dB

CROSS TALK:	
MAIN TO STEREO SUB .....	46 dB or better
STEREO SUB CHANNEL TO MAIN .....	46 dB or better
67 kHz INTO MAIN OR STEREO .....	66 dB or better



## TBM-2200 FM STEREO MODULATION MONITOR

The solid state TBM-2200 FM Stereo Modulation Monitor is a complementary expansion unit with either a TBM-3500A or a TBM-4000S. The TBM-2200 is driven from the output from either of these monitors. Two front panel meters read left and right channel modulation percentage independently. These meters display peak values regardless of modulation waveforms.

### SPECIFICATIONS

MODULATION RANGE .....	±75 kHz deviation—100% modulation ±100 kHz deviation — 133% modulation.
COMPOSITE INPUT	
IMPEDANCE .....	10 kohms
POWER REQUIREMENTS .....	105-125 Vac, 50/60 Hz, 40 Watts
DIMENSIONS .....	19"W x 7"H x 11 1/2"D overall



## TBM-3500A FM MODULATION MONITOR

The TBM-3500A monitors the modulation characteristics of a monaural FM broadcast station, and serves as the basic unit to include SCA programming or stereophonic broadcasting, by addition of the TBM-2000A and/or the TBM-2200. The indicating meter and associated circuitry function as a semi-peak reading voltmeter, independent of waveform. A modulation polarity switch permits meter monitoring of negative or positive peaks.

### SPECIFICATIONS

OPERATING RANGE .....	88-108 MHz
MODULATION RANGE .....	±75 kHz deviation—100% mod. ±100 kHz deviation — 133% mod.
RF INPUT:	
IMPEDANCE .....	50 ohms unbalanced
SENSITIVITY .....	0.1 to 1.0 watt
COMPOSITE INPUT:	
IMPEDANCE .....	33,000 ohms
SENSITIVITY .....	1 volt peak-to-peak
POWER REQUIREMENTS .....	105-125 Vac, 50/60 Hz, 25 watts
DIMENSIONS .....	19"W x 7"H x 8"D

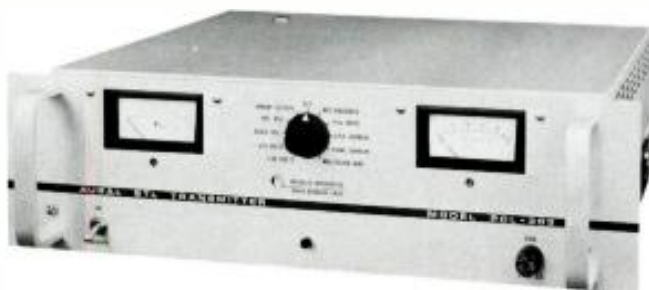

PCL-303 AURAL S.T.L. TRANSMITTER

**TRANSMITTER** – The true, direct FM principle of modulation is employed in PCL-303 STL transmitters. To ensure the required output frequency stability, an automatic frequency control (AFC) system is utilized.

An extremely stable basic oscillator is modulated with a pair of variable capacitance diodes. The frequency of the basic FM oscillator (approximately 78 MHz) is divided by 1024 using a binary divider chain.

This divided output is phase compared to the output of a reference crystal (oven-controlled) oscillator, and the resultant error voltage is used to phase lock the basic oscillator to the crystal. The phase-locked output of the direct FM basic oscillator is multiplied and power amplified; then further tripled to the output frequency with a parametric multiplying diode.

An RF cavity filter at the transmitter output attenuates spurious signals to at least 60 dB below rated power output, and an integral sampling probe feeds a panel meter to continuously monitor relative output power. A quiet, dependable, blower fan cools the final transistor power chain. The power supply is self-contained and maintains stable power output with line voltage variations from 105 VAC to 130 VAC.

An input audio filter removes unwanted program components above 17 kHz. This effectively reduces the cross talk (in all multiplex channels) which may be caused by spurious high-frequency noise in the program line. Standard 75 microsecond pre-emphasis is incorporated in the program input.

### PCL-303 TRANSMITTER SPECIFICATIONS

TYPE .....	Direct FM
RF OUTPUT .....	7 watts minimum; 8 watts maximum into nominal 50 ohm load – N-type female connector.
FREQUENCY STABILITY .....	Better than 0.001% (0-55°C); crystal mounted in temperature controlled oven.
MULTIPLICATION .....	12 times basic oscillator frequency
AM NOISE .....	Better than 75 dB below carrier reference.
DEVIATION .....	±40 kHz for 100% modulation
SPURIOUS EMISSIONS .....	More than 60 dB below carrier
AUDIO INPUT .....	600 ohms balanced; +10 dBm for 100% modulation
MULTIPLEX INPUTS .....	Two BNC connectors provided for subcarrier channels in 25-100 kHz spectrum; approximately 1.0 volt rms for 20% deviation.
SOLID STATE DEVICES .....	All-silicon: 15 transistors (JEDEC), 14 diodes, 5 varicaps, 11 IC's, 1 varactor.
POWER SUPPLY .....	Fully regulated, self-contained
COOLING .....	Convection and forced
DIMENSIONS .....	5¼" x 19" x 16"

**RECEIVER** – This is a conventional double-conversion, crystal-controlled, superhetrodyne receiver with a self-contained, regulated power supply. Signals from the antenna input are passed through a five cavity RF preselector which is used ahead of a low-noise input mixer diode (Schottky barrier type).

The first IF (72 MHz) section consists of a three-stage FET amplifier employing AGC and designed for low noise and medium bandwidth characteristics. The second IF section (10.7 MHz) is an amplifier exhibiting exceptionally sharp skirts and linear phase characteristics. These characteristics are achieved by a ten-pole active filter slightly overcoupled to give the desired response.

The audio section is a wide-band, low-noise, low-distortion type amplifier incorporating a 75 microsecond de-emphasis network. A carrier-operated squelch relay silences all output should the carrier be lost or if the power fails. Contacts for external carrier alarm use are located on the back of the chassis. A 600 ohm output-to-line transformer and a 17 kHz low-pass elliptical filter complete this section.

### PLC-303 RECEIVER SPECIFICATIONS

TYPE .....	Superhetrodyne – double conversion and crystal controlled
ANTENNA INPUT .....	Nominal 50 ohms impedance – Type N female connector
SENSITIVITY .....	Less than 3 microvolts for 20 dB quieting. Requires only 35 microvolt signal for 60 dB quieting
SELECTIVITY .....	200 kHz
AUDIO OUTPUT .....	600 ohms balanced
MULTIPLEX OUTPUTS .....	Two BNC connectors; 1.0 volt peak-to-peak per subcarrier for 20% subcarrier injection at transmitter
SOLID STATE DEVICES .....	All silicon: 19 diodes, 21 JEDEC registered transistors (18 bi-polar, 3 field effect), 1 IC
POWER SUPPLY .....	Zener regulated – self-contained
DIMENSIONS .....	5¼" x 19" x 14"

### PCL-404 SYSTEM

High-quality audio performance and increased savings characterize the Model PCL-404 Aural Studio-Transmitter Link. All solid-state circuitry and advanced techniques enable excellent performance, but pre-emphasis and de-emphasis are not standard in the PCL-404, making this STL particularly well-suited to AM applications.

Complementing the PCL-303 and PCL-303/C Aural STL equipment, the PCL-404 offers reliable performance and S.C.A. capability with a modest investment.

### PCL-404 SYSTEM SPECIFICATIONS

FREQUENCY RESPONSE .....	±1 dB, 30 Hz to 15,000 Hz
DISTORTION .....	Less than 0.8% from 50 Hz to 15,000 Hz
SIGNAL TO NOISE RATIO .....	Better than 66 dB below 100% modulation unweighted. Better than 68 dB below 100% modulation with optional weighting.
MODULATION CAPABILITY .....	One program channel and multiplex subcarrier channels.
PRIMARY POWER SOURCE .....	120/240 Vac, ±10%, 50-60 Hz.
PANEL SPACE REQUIRED .....	5¼" x 19" – transmitter or receiver

### THE MODEL PCL-202

Designed with the foreign broadcaster in mind. As such, it operates in the 300 MHz-470 MHz band. Otherwise it closely resembles the PCL-303 in performance and design, except that it is intended to operate in a 100 kHz channel assignment.

The PCL-202 offers the same benefits of direct FM and fully solid-state circuitry. Please refer to the description of the PCL-303 for a comprehensive technical description.

Present day economic factors make STL, Remote Control and Telemetry, well worth looking at, particularly for the Broadcaster who looks toward radio as an interesting and profitable future.

Wire Line Program and Control circuits have many points of possible disruption, while STL Systems require security only at the terminals. Additionally, complete control of the system is exercised by station Engineering personnel, requiring no dependency on outside sources for restoration of circuits.

The ideal of high performance, maximum reliability and sensible cost is reflected in a "Dual" channel approach to FM Stereo, whereby two transmitters and two receivers are used, each being combined into a common antenna system. This method assures two identical FM Broadcast-quality channels with 65 db. Separation, maximum Signal-To-Noise Ratio, Phase Linearity, extremely Low Distortion and Flat Frequency Response.

With a dual system, program transmission, and control circuits can be maintained, even though in a Mono mode of operation, and precious "lost air" time is no longer a consideration.

Finally, the twin-channel concept allows the Stereo Generator to remain at the FM transmitter site, preventing adjustment by uninstructed personnel and eliminating expensive interface equipment between the STL and Transmitter. In addition, such problems as Separation can be more easily diagnosed when the Stereo Generator is not combined with the STL system.

### STL-8 SYSTEM SPECIFICATIONS: AM APPLICATION

FREQUENCY RESPONSE ..... + or - 10 dB. from 50 Hz to 12,500 Hz.  
 DISTORTION ..... 1% or less, 50Hz to 12,500 Hz.  
 SIGNAL TO NOISE: ..... 60dB. or better.  
 CARRIER FREQUENCY  
 STABILITY ..... + or - .0005%  
 TEMPERATURE RANGE ..... -30 Degree C to +60 Degree C.

### FM SPECIFICATION:

FREQUENCY RESPONSE ..... + or - .5 db. from 40 Hz to 15,000 Hz.  
 DISTORTION ..... 0.6% or less, 50 Hz to 15,000 Hz.  
 SIGNAL TO NOISE: ..... -65 db. or better. Ref. 400 Hz. Mod. 100%  
 CARRIER FREQUENCY  
 STABILITY ..... + or - .0005%  
 TEMPERATURE RANGE ..... -30 Degree C to +60 Degree C.

### STL-8A TRANSMITTER SPECIFICATIONS: AM BROADCASTING

APPLICATION ..... Studio-Transmitter Link (AM) and Inter City Relay  
 CARRIER FREQUENCY RANGE ..... 942-960 MHz  
 RF POWER OUTPUT ..... Maximum Licensed power 8 watts, nominal 6 watts. Set at factory.  
 OUTPUT IMPEDANCE ..... Nominal 50 ohms  
 RF CARRIER CONNECTOR ..... UG-58A/U (Type N Female)  
 CARRIER FREQUENCY STABILITY ..... + or - .0005% -30°C +60°C (+25°C Ref.)  
 TYPE OF MODULATION ..... Direct FM 200F3. (200 F9 with remote control and/or Sub Carrier)  
 DEVIATION ..... + or - 52.5 KHz. (at 400 Hz)  
 AUDIO INPUT ..... Balanced 600 ohms, + 10DBM (+ or - 2DB) for 100% modulation.  
 MULTIPLEX INPUTS ..... Two BNC Connectors, for Remote Control and Sub Carrier inputs. .5V RMS for 20% Carrier Deviation. 50 to 600 ohms max. unbalanced.  
 AUDIO RESPONSE ..... + or - 1DB, 50 Hz - 12,500 Hz.  
 DISTORTION ..... Less than 1% THD, 50 Hz - 12,500Hz.  
 FM NOISE ..... Better than -60DB below 100% Modulation (400 Hz Ref.)  
 AM NOISE ..... Better than -55DB below carrier reference.  
 POWER REQUIREMENTS ..... 115/230 Volts 50-60 Hz. 110 watts.  
 AC POWER SUPPLY ..... Precision electronically regulated integrated circuit power supply with current limiting. Regulator circuitry contained in plug-in module.  
 SPURIOUS EMISSIONS ..... More than 60DB below carrier.  
 OUTPUT FAILURE ALARM ..... Adjustable RF output sensing pro-

vides fail-safe contact closure for alarm or automatic switching as standard equipment.

REMOTE LOCATION ..... Terminals provide for simple remote off-on control of transmitter. Built in RF sensing relay provides remote indication of transmitter status.  
 METERING ..... Precision taut-band meters for RF power and circuit testing.  
 SOLID-STATE DEVICES ..... 38 Solid-state silicon devices; 11 transistors, 3 varactor diodes, 21 diodes, 2 IC, 1 solid-state proportional temperature control oven.  
 DIMENSIONS ..... (Vertical) - Panel 7" high x 8½" wide (half rack) x 15" deep. (Horizontal) 8¾" x 19" x 8½".

### STL-8F TRANSMITTER SPECIFICATIONS FM BROADCASTING

APPLICATION ..... Studio-Transmitter Link, (FM)  
 AUDIO RESPONSE ..... + or -0.5 DB, 40HZ - 15000 Hz.  
 DISTORTION ..... Less than 6% THD, 50HZ - 15,000Hz.  
 FM NOISE ..... Better than -65DB below 100% Modulation (400 Hz Ref.)

(ALL OTHERS IDENTICAL TO STL-8A ABOVE)

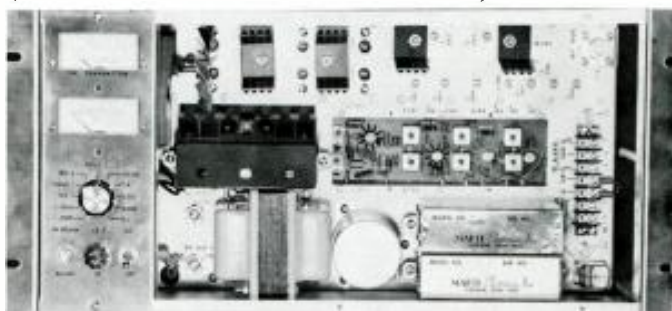

### R-200/950A RECEIVER SPECIFICATIONS AM BROADCASTING

APPLICATION ..... Crystal controlled, double conversion FM receiver for STL. Companion to STL-8A Transmitter.  
 FREQUENCY RANGE ..... 942-960 MHz  
 SENSITIVITY ..... 2uv for 20 db S/N ratio. 10uv for 50 db. 32 uv for 60 db.  
 RF INPUT IMPEDANCE ..... 50 ohms UG-58A/U (Type N Female)  
 FREQUENCY STABILITY ..... .0005% -30°C + 60°C (+25°C Ref.)  
 Solid state proportional temperature controlled ovens.  
 SELECTIVITY ..... 200 KHz for acceptance of 200 F9 modulation.  
 SPURIOUS RESPONSE ..... -70 db.  
 AUDIO OUTPUT ..... Balanced 600 ohms. +18DBM Maximum level.  
 MULTIPLEX OUTPUT ..... Two type BNC connectors for sub-carrier and/or remote control.  
 SQUELCH/FAIL SAFE/ALARM ..... Adjustable squelch provides N/O and N/C relay contacts for audio muting, fail safe shut-down and alarm circuits as required.  
 POWER REQUIREMENTS ..... 115/230 volts 50-60 Hz. 30 watts.  
 AC POWER SUPPLY ..... Precision electronically regulated integrated circuit power supply.  
 METERING ..... Precision taut-band meter with front panel test selector switch.  
 SOLID STATE DEVICES ..... 20 transistors, 23 diodes and 2 integrated circuits.  
 DIMENSIONS ..... (Vertical) - Panel 7" high x 8½" wide (half rack) x 15" deep. (Horizontal) 8¾" x 19" x 8¾".

### R-200/950F RECEIVER SPECIFICATIONS FM BROADCASTING

APPLICATION ..... Crystal controlled, double conversion FM receiver for STL. Companion to STL-8F Transmitter.

(ALL OTHER IDENTICAL TO R200/950A ABOVE)



RMC-2AX/S STUDIO UNIT

### RMC-2AX SYSTEM

Designed and approved for AM and FM Sub-Audible Telemetry, the RMC-2AX Remote Control System requires no inter-face equipment to meet the FCC Rules and Regulations, pertaining to the mixing of the sub-audible telemetry, filtering and prevention of over modulation.

The RMC-2AX is available as a 22 function system having 10 metering positions, or an optional 50 function system with 24 metering positions is available.

This same system can be used to meter an FM transmitter, except the FM 67 KHz Sub-carrier is modulated with the metering information, through a Sub-Carrier Generator, such as the SCG-8.

### SPECIFICATIONS

#### REMOTE CONTROL FUNCTIONS:

Model RMC-2AXT(10) ..... 10 Raise and Lower Commands  
 Model RMC-2AXT(25) ..... 25 Raise and Lower Commands

#### METERING:

Model RMC-2AXT(10) ..... 10 channels including calibration  
 Model RMC-2AXT(25) ..... 25 channels including calibration  
 Calibration voltage derived from double regulated Zener Diode, oven temperature controlled. Ten-turn vernier potentiometers.

#### TELEMETRY TONE

FREQUENCIES ..... 22 Hz to 28 Hz  
 TELEMETRY TONE PURITY.. Less than 2% THD at 27 Hz  
 TELFMETER ACCURACY .... ± 2% of full scale

#### TELEMETRY TONE OUTPUT

LEVEL ..... Adjustable—35 DBM to + 10 DBM  
 IMPEDANCES ..... 600 ohms  
 POWER REQUIREMENT ..... 110 volts to 125 Volts, 50/60 Hz

#### DIMENSIONS AND WEIGHT

RMC 2AXS ..... 5"H x 19"W x 6½"D. W. 14 lbs.  
 RMC-2AXT(10) ..... (2) 7"H x 19"W x 9"D. W. 26 lbs.  
 RMC-2AXT(25) ..... (1) 7"H x 19"W and (1) 10½"H x 19"W x 9"D. W. 30 lbs.



### TCR-15 A REMOTE CONTROL SYSTEM

Two versions of the TRC-15 A System are available. The interconnection requirement of the TRC-15AW is any duplex, voice-grade circuit. True wireless remote control can be accomplished with the TRC-15AR. Control subcarrier equipment is standard in this version for multiplexing control information on a Moseley Aural S.T.L. Field conversion to either configuration is possible without rewiring ... simply exchange the appropriate modules.

### TCR-15 SPECIFICATIONS

METERING FUNCTIONS ..... 15 telemetry channels, plus calibration  
 CONTROL FUNCTIONS ..... 15 RAISE, 15 LOWER (30 total)  
 CONTROL OUTPUT ..... Momentary contact closure or re-distribution up to 120V AC or DC. Max. load 50 watts non-inductive.

METER ..... 1, taut-band. Provisions for 4 external meters.  
 METERING STABILITY ..... With weekly transmitter-unit checks and daily studio-unit checks, better than 1%.

METERING ACCURACY ..... 2% or better of full scale.  
 TELEMETRY INPUT REQUIREMENTS ..... ± 1V to 10VDC for full-scale deflection. All inputs fully isolated from ground. Maximum 350V potential to ground. Input impedance 20,000 ohms.

TELEMETRY FREQUENCIES  
 AUDIBLE ..... 800–1200 Hz  
 SUBAUDIBLE ..... 20 – 30 Hz  
 CONTROL FREQUENCIES .... 300 to 400 Hz

INTERCONNECTION REQUIREMENTS  
 TRC-15AW ..... Voice-grade, data-channel phone circuit.  
 TRC-15AR  
 CONTROL CIRCUIT ..... Control subcarrier generator and detector provided internally. Studio Unit Output and Transmitter Unit input: 0.5V rms, 2,000 ohms, nominal, unbalanced. Nominal subcarrier operating frequencies 26kHz or 110 kHz.

POWER REQUIREMENTS .... 120/240 VAC, +10%, 50-60 Hz  
 Units 20 watts each.

DIMENSIONS ..... Studio and Transmitter Units Identical. 5¼"H x 19"W x 13-5/8"D.

### RC-1000 SYSTEMS

The RC-1000 Single DC Pair, pushbutton Remote Control system is designed for the operation that requires a maximum of 22 control functions and a maximum of ten (10) metering positions plus a calibrate position.

The system consists of the 1000T located at the transmitter, and the 1000C at the control point. Each unit is designed for standard rack panel mounting, requiring only 5/4 inches of vertical space. Both units are of aluminum construction with hinged front panels. Plug-in circuit boards and front panel mounted components are available from the front, with barrier terminal strips on the rear panel.

The RC-1000 control system utilizes a continuous audio frequency carrier being sent from the studio site to the transmitter site. The carrier presence at rest frequency provides the system's fail-safe circuit. Position stepping and the two control functions of each position are sent from the studio to the transmitter as frequency shift (FSK) of the carrier. At the transmitter site a stable, wideband counter discriminator detects the carrier and the various output levels are sorted to drive the appropriate circuits. In the FSK control receiver no narrow band filters are used, and full FM type limiting gives maximum rejection of line noise.

### SPECIFICATIONS

POSITION SELECTION ..... 11 Pushbutton Bank  
 CONTROL FUNCTIONS ..... 11 ON/RAISE and 11 OFF/RAISE  
 CONTROL METHOD ..... Frequency Shift Carrier

METERING ..... 10 positions plus calibrate  
 METERING INPUT ..... 1 to 5 volts DC, 10K input pot and 10K load

METERING METHOD ..... Full floating DC phone line, both sides of input switched.  
 LINE REQUIREMENTS ..... Single DC pair, p-600Hz up to 20db loss.

POWER REQUIREMENT, EACH UNIT ..... 115V AC 60HZ (adaptable for 24 VDC supply)

# TRANSMITTERS

## FIM-21 FIELD INTENSITY METER

The FIM-21 Field Intensity meter is a precision test instrument for measuring electromagnetic fields in the 535 KHz to 1605 KHz frequency spectrum. Field intensities between 10 micro-volt/m and 10 volts/m are directly indicated on the front panel meter.

A shielded RF input jack enables the instrument to be utilized as a tuned voltmeter for RF bridge measurements. Field intensity measurements requiring dynamic ranges in excess of one decade are accommodated by the FIM-21-1 in the LOG mode of operation. A logarithmic indication of field strength is displayed on the front panel meter and is also available at the recorder output. In the normal LIN mode of operation the recorder output and front panel meter provide linear indications of field strength.



### SPECIFICATIONS

FREQUENCY RANGE .....	535 kHz to 1605 kHz
FIELD INTENSITY RANGE .....	10 microvolts per meter to 10 volts per meter
ACCURACY OF CALIBRATION .....	1 percent, referenced to NBS Standard Field (calibrated to 220 millivolts per meter)
ACCURACY OF RANGE ATTENUATOR .....	2 percent over entire FI range and tuning band
SELECTIVITY: BANDWIDTH (6 dB) .....	7 kHz nominal with multi-pole hybrid filter
IF REJECTION .....	35 db minimum
IMAGE REJECTION .....	65 db minimum
ADJACENT CHANNEL REJECTION .....	50 db minimum 10 kHz above and below tuned station
PANEL METER .....	4" mirrored scale, logarithmic graduations 1 to 10, taut wire meter movement, 2% linearity
AUDIO OUTPUTS .....	Front panel loudspeaker, weather treated cone. Headphone jack
RECORDER OUTPUT .....	0.4 to 4 volts DC proportional to field intensity for each attenuator range, 2000 ohm load
BATTERIES (6 req'd) .....	Standard 1½ volt C-Zn "D" cells or Alkaline cells
BATTERY LIFE .....	Greater than 1000 FI readings
ENVIRONMENTAL .....	Continuous exposure, -10° F to +130° F; lower temperature operation practical for 'reading time' exposures.
DIMENSIONS .....	8¾"H x 11½"W x 5-1/8"D
WEIGHT .....	Approximately 11½ pounds

# TEST INSTRUMENTS

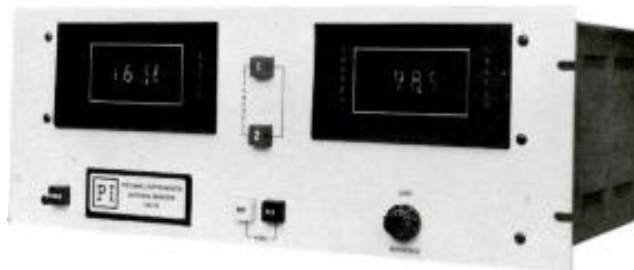

## POTOMAC INSTRUMENTS ANTENNA MONITOR

The AM-19 is designed so that it will accommodate DA-1, DA-2, and DA-3 patterns. Antenna arrays of from 2 to 12 towers with any or all of the above pattern requirements may be monitored with this device. Remote monitoring is accomplished by adding the RMP-19 remote metering panel and the RSA-19 remote switching panel (where required) to the AM-19. Outputs are available for automatic logging purposes. For application involving critical directional arrays the phase measurement readings can be resolved to 0.1 degree by connecting the PMA-19 precision monitor adaptor to the AM-19.

The AM-19-D Antenna Monitor provides for replacement of the front panel analog meters with digital panel meters and associated circuitry. A four digit numeric display provides direct readout of phase angle (Degrees) and loop current ratio (Percent).

### AM-19 SPECIFICATIONS

FREQUENCY RANGE .....	150 kHz to 2000 kHz
METERS, PHASE ANGLE AND LOOP CURRENT .....	4¾" mirrored scale, taut-band
PHASE ANGLE ACCURACY .....	±1.0 degree
PHASE RESOLUTION .....	0.5 degree
CURRENT RATIO RANGE .....	0 to 110%
RATIO ACCURACY .....	±1.5 percent
RATIO RESOLUTION .....	0.5 percent
MAXIMUM TOWERS-PATTERNS .....	Up to 12 towers, DA-1 (DA-N), DA-2 or DA-3
RF INPUT IMPEDANCE .....	50 or 72 ohms
RF INPUT LEVEL .....	0.5 to 20 volts rms
MAXIMUM INPUT FROM REFERENCE TOWER .....	2.0 volts rms for 100% loop current reference
OUTPUTS (local and remote):	
PHASE .....	0 to 5 volts DC for 0 to 180°, adj.
LOOP CURRENT .....	0 to 5 volts DC for 0 to 180%, adj.
AUDIO .....	1V rms, 50 Hz to 15 kHz ±1 dB, 1% THD, 600 ohms
REMOTE METERING CIRCUIT REFERENCE .....	11K ohms maximum
REMOTE CONTROL RELAYS .....	-24 volts DC or contact closure
LINE INPUT POWER .....	105-130 VAC, 50-60 Hz, 56 watts
ENVIRONMENTAL .....	0°C (32° F) to +50°C (122° F), 0 to 95% RH

### AM-19-D SPECIFICATIONS

NUMERIC DISPLAY, PHASE ANGLE AND LOOP CURRENT RATIO .....	4 digit nixie readout, .05% FS with error indicator for overrange.
PHASE RESOLUTION .....	0.1 degree
CURRENT RATIO RANGES .....	005.0 to 199.9 percent of reference tower
RATIO RESOLUTION .....	0.1 percent plus carrier shift with modulation
MINIMUM INPUT FOR REFERENCE TOWER .....	1.5 volts rms for 100.0% loop current reference
MAXIMUM TOWERS AND PATTERNS .....	Up to 6 towers
LINE INPUT POWER .....	105-125 VAC, 50-60 Hz, 68 VA
OPERATING ENVIRONMENT .....	+10°C (50° F) to +40°C (104° F), 0 to 95% RH

ALL OTHER SPECIFICATIONS IDENTICAL TO AM-19

# PROOF OF PERFORMANCE TRANSMITTERS

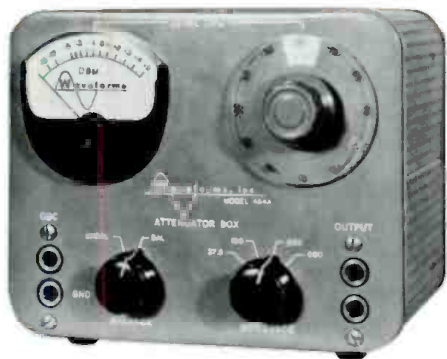

**MODEL 454A  
ATTENUATOR  
SET  
(50 Hz to 15 kHz)**

It's portable, simple, rugged – and the handiest 'box' of its type for Proof-of-Performance checks and other communi-

cations measurements. The 454A will deliver a balanced and controlled signal at any level from microphone to line at any of four impedances: 37.5Ω, 150Ω, 250Ω and 600Ω. It may be used with any oscillator, balanced or unbalanced, or any impedance.

The 454A consists of a 10 db range meter, a 10 db-per-step attenuator and a repeat coil. Binding posts receive the oscillator output, and jacks deliver the signal to the circuit under test.

Reading is direct in dbm, with no correction factors, regardless of output impedance. Reading accuracy is ±½dB. Frequency range 50 Hz to 15 kHz. Output amplitude range +15 dbm (depending on oscillator capability) down to -95 dbm. Height 6", width 7½", depth 6". Weight 6 lbs.

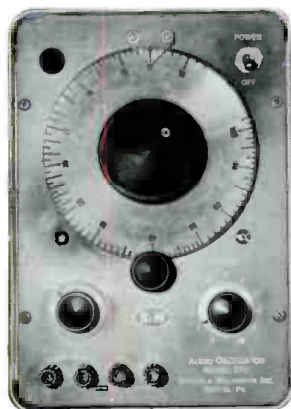

**MODEL 210  
AUDIO OSCILLATOR**

The Model 210 Audio Oscillator is a source for low distortion signals from 10 to 100,000 cycles. The circuit consists of an RC audio circuit followed by an amplifier of extremely low distortion.

The Model 210 is ideal for testing broadcast station response, filter characteristics, and laboratory set-ups which require a signal of known frequency.

**MODEL 410  
DISTORTION METER**

The Model 410 Distortion Meter measures audio distortion, noise level, audio gain or loss in db's and AC voltages.

In measuring distortion the instrument suppresses the fundamental frequency and measures the amplitude of all unwanted frequencies, including noise, as a percentage of the fundamental. The instrument includes a variable frequency Wein bridge network, calibrated attenuator and a sensitive voltmeter. Measurement of distortion, noise, decibels and AC voltages are read directly on the panel meter.



## SPECIFICATIONS

FREQUENCY RANGE	..... 10 Hz to 100 kHz
BANDS	..... x1 – 10 Hz to 100 Hz x10 – 100 Hz to 1000 Hz x100 – 1000 Hz to 10 kHz x1000 – 10 kHz to 100 kHz
FREQUENCY DIAL	..... Calibrated over 328°
FREQUENCY RESPONSE	..... ±1 db
CALIBRATION	..... ±2%, over entire range
POWER OUTPUT	..... To 10 volts into 600 ohm load
WAVEFORM DISTORTION	..... Less than .2% at 5 volt output
OUTPUT IMPEDANCE	..... 600 ohms balanced, with center tap. 600 ohms unbalanced. 150 ohms unbalanced.
HUM & NOISE LEVEL	..... 70 db down at 5 volts output
INTEGRAL POWER SUPPLY	..... 115 volts AC, 50/60 Hz, 50 W
DIMENSIONS	..... 6"W x 9"H x 12"D
WEIGHT	..... 11 lbs.

## SPECIFICATIONS

DISTORTION MEASURED	..... Fundamental frequencies from 20 to 20,000 Hz. Harmonics up to 100,000 Hz
DISTORTION LEVELS	..... Low as 0.1% can be measured
DISTORTION RANGES	..... 1% full scale, 3%, 10%, 30% and 100%
DISTORTION MEASUREMENTS	..... On signal levels of .1 volt to 30 volts rms
INPUT IMPEDANCE	..... Optimum accuracy on 600 ohms; satisfactory up to 100,000 ohms
NOISE AND DB	..... Calibrated in 1 db steps from 0 db to -15db. Additional ranges from -60 db to +50 db in 10 db steps
VOLTMETER OUTPUT TERMINALS	..... Scope monitoring, .2 volt rms for full scale reading
POWER	..... 115 volts AC, 50/60 Hz. 60 W
SIZE AND WEIGHT	..... Width 11¼", Height 9", overall weight 11 lbs.
VOLTMETER SPECIFICATIONS	..... (independent of Distortion Meter)



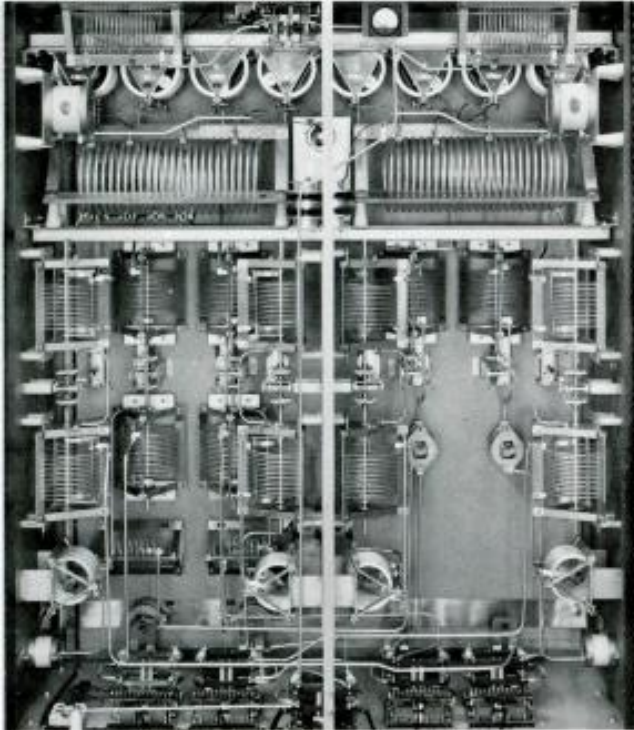

Sparta phasing equipment is custom built to meet the precise coverage patterns required. From the initial plan to the finished product, Sparta bases its design on the requirements of the station engineer and his consultant. Phasors can be built in cabinetry to match the transmitter, or panel and shelf to suit local requirements.

Sparta phasing equipment is available for all power levels and for any number of towers and patterns. Diplexers and triplexers for medium and short wave bands are also available from Sparta.



### MODEL 380 PHASE SAMPLER

The Model 380 is used in directional antenna systems where dependable phase sampling is required. Mounts inside the tuning unit away from weather induced variations. Available in several sensitivities.

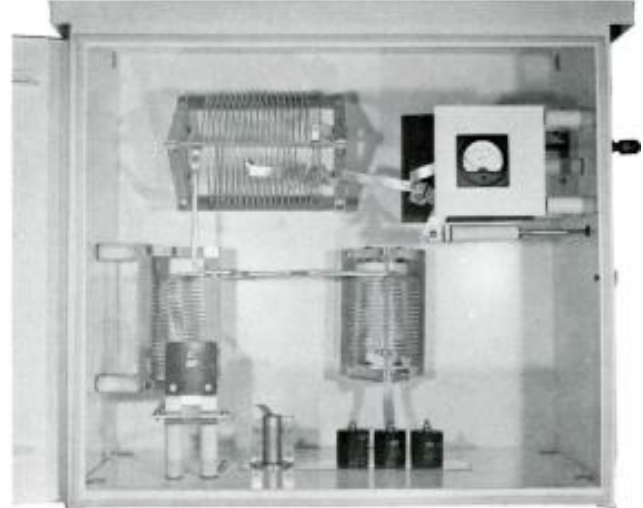

### MODEL ACU 301/305/310 ANTENNA COUPLING UNIT

Antenna coupling unit featuring full "Tee" network, input "J" plug and output meter with make-before-break switch – all components mounted in a weatherproof aluminum cabinet. Tower lighting choke and remote metering diode can be installed in ACU if required. A large antenna lead in bowl is supplied with hollow feed-thru to aid in wiring tower lights. Flanges are provided on rear of unit for either wall or pole mounting. Available in all power levels. – 3' high, 3' wide, 24" deep.

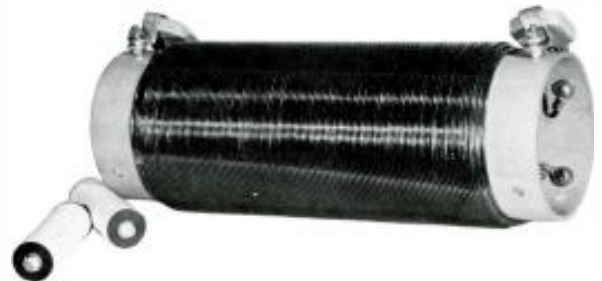

### MODEL TLC TOWER LIGHTING CHOKE

Varnished No. 10 wire wound on heavy triple-X tubing. 3 wire. Approximately 350 UH inductance.

### TOWER LIGHTING ISOLATION TRANSFORMERS

These Isolation Transformers are air insulated, capable of withstanding very high voltages between windings. The Transformer provides a highly reliable, low capacity means of supplying 60 cycle power across the base of an insulated radio tower.

### LOAD CAPACITIES

MODEL TI 2070 – 5750 WATTS  
MODEL TI 2017 – 1750 WATTS  
MODEL TI 2035 – 3500 WATTS



Typical Tower  
Installation

## ANDREW "HELIAX"® FLEXIBLE COAX (Foam Dielectric and Air Dielectric) RIGID TRANSMISSION LINES, AND "RADIAX"®

All HELIAX coaxial cables are jacketed for direct burial or for corrosive environmental conditions. Standard jacketing material is 20 year life black extruded polyethylene suitable for operation down to -65°F (-54°C) and installation down to -40°F (-40°C).

HELIAX coaxial cables are lighter weight and more flexible than smooth aluminum cables, more permanent and trouble-free than solid dielectric cables and electrically superior to either.

75 ohm and 100 ohm cables are available or can be designed for all sizes.

Teflon\* insulated cables are available in a number of sizes and impedances for high temperature or high power requirements.

Jacketed Type	Ω	Max. Freq. (GHz)	% Velocity	Peak Power (kW)	Cable Size	Diam. Over Jacket	Outer Conductor
FHJ-7-50	50	2.3	79	145	1-5/8"	2"	Cu
FLJ-7-50	50	2.3	79	145	1-5/8"	2"	Al
FHJ5-5A	50	4.4	79	44	7/8"	1.1"	Cu
FHJ5-75	75	4.9	79	29	7/8"	1.1"	Cu
FHJ5-50A	50	4.4	79	44	7/8"	1.1"	Al
FHJ4-50B	50	8.1	79	19	1/2"	.62"	Cu
FHJ4-50C	50	8.1	79	19	1/2"	.62"	Al
FHJ-4-75	75	9.1	79	12.7	1/2"	.62"	Cu

RADIAX\* is a slotted coaxial cable designed to radiate and receive RF signals. The slots in the cable allow a controlled portion of the transmitted RF signal to radiate along the length of the cable. Conversely, a signal transmitted near RADIAX will couple into and be carried along the cable. RADIAX functions as a continuous antenna.

### 50 OHM RIGID TRANSMISSION LINES

50 ohm line is offered in 7/8" to 6-1/8" sizes with bolted flanges and inner connectors compatible with EIA standard RS-225 and with IEC recommendations.



TYPE 562A

### BELDEN WIRE AND CABLE – COMMUNICATIONS CABLE

Belden offers a complete line of Communications Cables in a wide range of sizes, dimensions, shielding constructions and types of insulation.

**SHIELDING:** Braided Copper Shields have high tensile strength and are very effective at audio and radio frequencies in flexing applications. Served Copper Shields usually provide more coverage than Braided Copper Shields; they're also easier to terminate.

**Beldfoil ISO-Shield®**, unlike wire braid and served wire-shields, provides 100% coverage and adds greater effectiveness to all major shielding functions: excluding external signals, confining the transmitted signals, and minimizing cross talk.

Beldfoil ISO-Shield uses a thin layer of aluminum bonded to a polyester film. The aluminum provides the shielding while the polyester film adds a bonus insulation and increased mechanical strength.

**INSULATIONS:** Belden's Communications Cables are available in a variety of insulation materials.

Vinyl insulation resists flame, most solvents, oil, ozone and sunlight. It has a higher dielectric constant and capacitance than polyethylene and is therefore recommended for audio frequency applications.

Polyethylene insulation is lightweight and resists ozone. It has a low dielectric constant for low capacitance and provides low electrical loss and is recommended for audio and radio frequency applications.

Polypropylene insulation provides excellent heat and abrasion resistance. Because it has excellent dielectric strength and mechanical ruggedness, polypropylene insulations are widely used for miniaturization applications. Recommended for audio and radio frequencies.

## PHELPS-DODGE "CUFIL"®, "CUFLEX"®, AND RIGID TRANSMISSION LINES

Cuflex was designed for long run transmission line and for feeding high frequency antennas. This 50 ohm cable is distinguished by the corrugated copper sheath which adds to its flexibility, strength and corrosion resistance. Cuflex offers the uniform electrical properties over wide temperature variation, unlimited operating life, light weight and low cost.

### ELECTRICAL DATA

CUFLEX Catalog Number	Nominal Diam. (in.)	Velocity of Propagation (%)	Cutoff Freq. 90% fco (GHz)	Peak Power Rating (kW)
FXCC 12-50	1/2	81	7.7	19
FXCC 78-50	7/8	81	4.4	44
FXCC 158-50	1-5/8	80	2.5	145

Cufil is a copper corrugated air dielectric cable designed for antenna systems. This series is distinguished by the solid polyethylene, non-collapsible helix which completely covers the center conductor resulting in great mechanical stability.

### ELECTRICAL DATA

CUFIL Catalog Number	Nominal Diam. (in.)	Velocity of Propagation (%)	Cutoff Freq. 90% fco (GHz)	Peak Power Rating (kW)
SLCC 78-50	7/8	94	5.0	44
SLCC 158-50	1-5/8	94	2.8	145



## PRODELIN-PACIFIC "SPIR-O-LINE"®, "SPIR-O-LOK"®, AND RIGID "800" TRANSMISSION LINE

The inner conductor of Spir-O-line cable is supported by six high density polyethylene tubes which are in tangential contact. The outer aluminum sheath compresses the six polyethylene tubes to a predetermined dimension which self-centers the inner conductor and locks together all components. The intimate contact of the inner conductor, the polyethylene tubes, and the outer sheath prevents disconnections when the cable is used in a vertical position. The Spir-O-line construction enables bending with a uniform stress exhibited by all components.



### MECHANICAL AND ELECTRICAL SPECIFICATIONS PLAIN JACKETED CABLE

Catalog Number	Ω	Nominal Size (in.)	Effective Dielectric Constant	Velocity (%)	60 Hz Pk. Test Voltage (kV)	Outer Conductor		Inner Conductor		Jacket Wall
						O.D.	I.D.	O.D.	Wall	
61-875	50	7/8	1.36	85.5	3.4	.953	.837	.311	Solid	.070
64-875	50	7/8	1.36	85.5	6.0	.953	.837	.311	Solid	.070
65-875	75	7/8	1.36	85.5	6.0	.953	.837	.191	Solid	.070
66-875	75	7/8	1.36	85.5	6.0	.953	.837	.191	Solid	.070
61-1625	50	1-5/8	1.36	85.5	11.0	1.786	1.622	.606	.060	.070
64-1675	50	1-5/8	1.36	85.5	11.0	1.786	1.622	.606	.060	.070
65-1675	75	1-5/8	1.36	85.5	11.0	1.786	1.622	.372	.060	.070
66-1675	75	1-5/8	1.36	85.5	11.0	1.786	1.622	.372	.060	.070

## ROHN COMMUNICATIONS TOWERS

**TYPE 25G:** 12½" triangular; to 200' maximum (30 PSF wind loading).

**CRANK-UP #6:** 37, 54 & 71 models

**"FOLD-OVER" #25:** 48, 58 & 68 models

**"FOLD-OVER" #45:** 44, 54 & 64 models

**TYPE 45:** 18" triangular; to 300' maximum (30 PSF wind loading).

**TYPE 55G:** 18½" triangular; to 400' maximum (30 PSF wind loading).

**TYPE 65:** 26¼" triangular; to 450' maximum.

**TYPE 80-SERIES:** 41" triangular; to 800' maximum (each tower is engineered for particular job and equipment; legs 2" to 4" as required).

**TYPE 90-SERIES:** 5' nominal face

## "RIGID-TUBE" TOWERS: K.D. FOR EXPORT (TYPES D, C & J)

**D-SERIES:** 39" face; to 600' depending on antenna and wind loading. 3" O.D. Legs.

**C-SERIES:** 26½" face; to 400'; designed for 12 sq. ft. antenna at 30 PSF wind loading. 2¼" O.D. legs.

**J-SERIES:** 19½" face; to 300'; designed for 6.5 sq. ft. antenna at 30 PSF wind loading. 1½" O.D. legs.

**100SSRA:** (Self-Supporting Rigid Angle). 100' K.D. only; designed for 6 sq. ft. antenna at top, plus 8.5 sq. ft. at 70'.

**ANGLE TOWER MODEL 36:** (microwave) 30-40 PSF wind loading with ½" ice, supporting 8x12' reflector or 6' parabola.

**MODEL 48:** Up to 50 PSF wind loading with ½" ice, supporting 12x17' reflector or 15' parabola. **MODELS 36 and 48 K.D.** only, custom-designed and fabricated by ROHN at Peoria, Ill.

## STAINLESS, INC. SELF-SUPPORTING TOWERS

**Location:** Minimum space availability. (Wherever space is at a premium because of high land cost, city lot, building roofs or mountainous terrain.)

**Height:** As required.

**Loading:** Standard or special to meet requirements.

### G-25 Guyed

**Height:** From 300' to 450'

**Loading:** 30 PSF first 300' and 35 PSF above.

Stainless G-25 guyed towers are triangular in cross section of a truss type construction consisting of vertical tabular members and round bracing members. They are prefabricated in 25' sections.

### G-17 Guyed

**Height:** Up to 300 feet.

**Loading:** 30 to 50 lbs. standard

Stainless G-17 guyed towers are prefabricated in rigid 20' triangular sections.



Stainless G-4 AM/FM/TV Tower, Dayton, Ohio

### G-4 Guyed

**Height:** As required.

**Loading:** Available for any required wind or ice loading. Standard G-4 meets or exceeds EIA Specification RS-222.

Stainless G-4 towers are a full 48 inch cross section guyed triangular construction, fabricated in 25' sections for easy, fast erection. The G-4 tower is an exceptionally strong tower, a feature which is beneficial if future plans call for additional antenna to be supported on the existing tower.

### UTILITY TOWER

Utility Tower installation crews handle all the details of a package installation including lighting and ground systems.

Insulated vertical radiators are equipped with the latest Utility 3401 or 2201 pivot base insulators for positive insulation between base and ground. Utility base insulators have much higher compression rating than hollow insulators of similar size. Each is proof tested for a load approximately eight times greater than ever normally carried.

Utility Towers are easier to tune because they are built to your exact requirements and each bolted connection is tack welded after erection.

Round members and welded construction

provide smooth surfaces for easy painting and servicing. Steps are built into bracing to make entire height of tower easy for maintenance man to reach.

All Utility Tower hardware is hot dipped galvanized to prevent rust and corrosion.

**TYPE 140 AM:** 60-200'; 1.66" O.D. legs. ½" solid bracing. 30 PSF wind loading.

**TYPE 340 AM/FM:** 210-340'; 2.375" O.D. legs. .840" O.D. bracing. 30 PSF wind loading.

**TYPE 380 AM/FM:** 200-400'; 2.375" O.D. legs. .840" O.D. bracing. 30 PSF wind loading.

**TYPE 480 AM/FM:** 300-480'; 2.875" O.D. legs. 1.05" O.D. bracing. 30 PSF wind loading.

**TYPE 540 AM/FM:** 300-480'; 2.875" O.D. legs. 1.315" O.D. diagonals. 1.66" O.D. girts. 35 PSF wind loading.

**TYPE 170 (K.D.):** 140-300'; legs 2x2x1x5/32", 60° U. 30 PSF wind loading.

(AM towers to be used for FM require additional 20' fiberglass insulators.)

## WIND LOADING FACTORS

**ZONE "C":** Most of the Southern tip and East coast of Florida, coast of North Carolina.

**ZONE "B":** Western Washington State. Sacramento Valley of California. South-eastern Montana, Eastern Wyoming, Northern Nebraska and much of Southwestern South Dakota. Parts of Wisconsin, Ohio and Northern Illinois. Central Gulf Coast East to include most of Florida and coastal area north to North Carolina (those parts not Zone "C" above) and spots of the Atlantic Coast North to Maine.

**ZONE "A":** All other contiguous U.S.

(Lists of state and county zone boundaries are found in H.C.S. Thom, "Proceedings of A.S. of C.E.": April 1960)

## HEIGHT ZONE (FROM GROUND)

Tower Ht.	Zone A	Zone B	Zone C
Under 300'	30	40	50
300-650'	35	48	60
Over 650'	40	55	70

## TRUE WIND VELOCITY/IMPACT PRESSURE

WIND (MPH)	PSF	WIND (MPH)	PSF
80	25.6	115	52.9
85	28.9	120	57.6
86.6	30.0	122.5	60.0
90	32.4	125	62.5
95	36.1	130	67.6
100	40.0	132.3	70.0
105	44.1	135	72.9
110	48.4	140	78.4
111.8	50.0	141.4	80.0

# COAX FREQUENCY

## COPPER AND ALUMINUM TRANSMISSION LINE (Calculated)

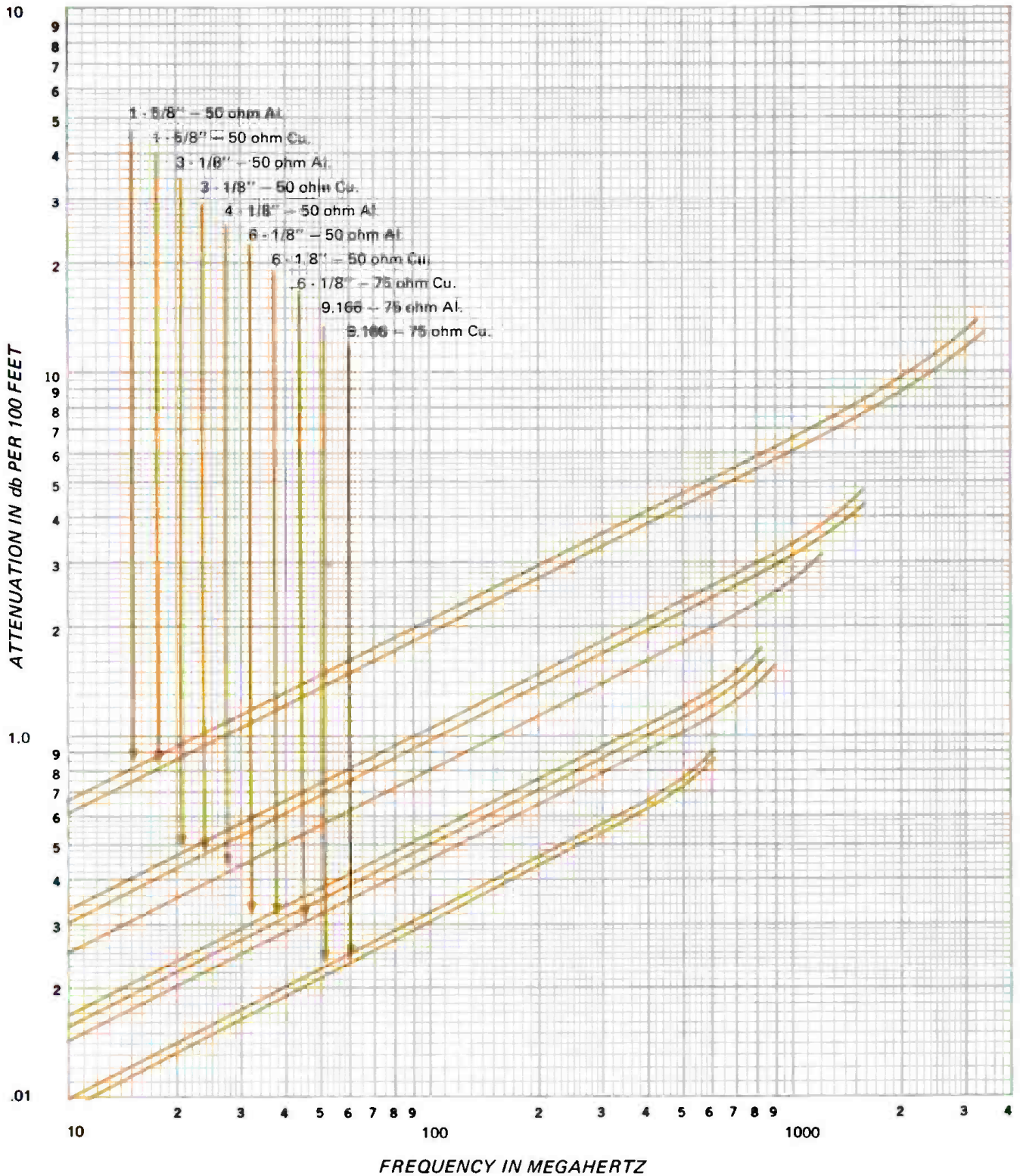

ATTENUATION: Based on 20° C ambient and unity VSWR

This chart reproduced courtesy of PRODELIN, INC. of Hightstown, New Jersey and Santa Clara, California

# WARRANTY

Sparta Electronic Corporation ("Sparta") expressly warrants products manufactured by it and bearing Sparta model numbers to be free from defective material and factory workmanship.

**THE FOREGOING EXPRESS WARRANTY IS IN LIEU OF ALL OTHER WARRANTIES, EXPRESS OR IMPLIED, IT BEING EXPRESSLY UNDERSTOOD AND AGREED THAT SPARTA DOES NOT WARRANT EITHER THE MERCHANTABILITY OF ITS PRODUCTS OR THEIR FITNESS FOR A PARTICULAR PURPOSE.**

The obligation of Sparta under the foregoing express warranty is limited to repairing any warranted product which upon Sparta's examination proves to be subject to defective material and/or factory workmanship, when such product is returned to our factory, transportation prepaid by the purchaser, within one year from the date of original purchase from Sparta. Under no circumstances shall a breach of any warranty by Sparta subject Sparta to any claim for consequential damages, the purchaser expressly assuming all risk of such consequential damages. In the case of any breach of any warranty, the liability of Sparta shall not under any circumstances exceed the cost of repair or replacement of the defective product.

High voltage transformers, modulation transformers, reactors and filter chokes carry an extended warranty of 50% of the replacement cost being allowed should failure occur during the second year.

The foregoing express warranty does not apply to any products manufactured by Sparta that have been repaired, worked upon or altered by persons not authorized by Sparta, or that have been subject to misuse, negligence or accident, or the serial number of which has been altered, effaced or removed; neither does the foregoing express warranty apply to any products of Sparta that have been connected, installed, used or adjusted otherwise than in accordance with the instructions furnished by Sparta. Accessories, allied equipment, and components supplied, but not manufactured by Sparta are not warranted, either expressly or impliedly, by Sparta, and shall carry only such warranty, if any, as is made by the manufacturer of such product.

The foregoing warranty shall be void if Sparta shall inspect any product and find it to have been modified, improperly installed or misused.

**NO PERSON, INCLUDING ANY DEALER, AGENT OR REPRESENTATIVE OF SPARTA IS AUTHORIZED TO MAKE ANY WARRANTY, WRITTEN OR ORAL, OR TO ASSUME FOR SPARTA ANY LIABILITY, EXCEPT TO REFER PURCHASER TO THE FOREGOING EXPRESS WARRANTY.**

Sparta reserves the right to make changes in design and improvements upon its products without assuming any obligation to install the same upon any of its products theretofore manufactured.

# SPARTA SALES POLICY

- I. **Conditions of Sale.** The purchaser, by accepting merchandise, consents and agrees to all of the following terms and conditions; title and right of possession to all merchandise remains with the seller until the seller has received the full purchase price thereof in cash.

If seller institutes legal action against buyer to enforce this contract or any part thereof, buyer agrees to pay such sum as the court may fix as attorney fees.

Deliveries are made subject to war, strikes, acts of God or any other cause beyond our control.

No order is binding upon SPARTA ELECTRONIC CORPORATION until accepted in writing from the SPARTA sales office, Sacramento, California.

- II. **Prices.** Prices are net f.o.b. Sacramento, California or point of shipment and subject to change without notice. Orders are filled at prices in effect at time of shipment. We reserve the right to add any federal, state or local taxes required by law. Tax exemption must be supported by an appropriate certificate at time of ordering.

- III. **Modifications.** Our policy is one of continual improvement in design and manufacture; and therefore we reserve the right to alter specifications and design without notice.

- IV. **Terms of Sale.** Purchases may be paid for as follows:

1. **CASH.** Full payment prior to shipment.
2. **C.O.D.** A 25% deposit with order and the balance collected at the time of delivery.
3. **OPEN ACCOUNT.** A 25% deposit may be required with the balance payable 30 days after invoice date. Late payments are subject to a service charge. Requests for open account terms shall be made on the SPARTA application form.
4. **SPARTA CHARGE.** This is a "revolving charge" plan similar to that offered by major retailers. See the SPARTA CHARGE application for details.

5. **FINANCE PLANS.** On major purchases, attractive lease or deferred payment plans are available. As these plans vary considerably, please contact your SPARTA Sales Representative or the SPARTA sales office for details.

- V. **Shipment.** Please specify shipping method when ordering. In the absence of such instructions, SPARTA will select the carrier and method of shipment it deems most appropriate. Usually, shipments from SPARTA or its vendors on a drop ship basis are made "Shipping Charges Collect". As such, the equipment automatically becomes the property of the purchaser when picked up by the carrier. Should damage occur during shipment, the request for inspection and claims for damage must be made by the purchaser with reimbursement paid directly to him. SPARTA will gladly assist with any necessary information required to successfully negotiate a claim.

- VI. **Returning Goods.** Do not return any merchandise without our approval. Please furnish complete details as to circumstances and reasons when requesting return of merchandise. Custom built equipment or merchandise specially ordered for you is not returnable. When return is at the request of, or for the convenience of the customer, a restocking fee of 15% will be charged. All returned merchandise must be sent freight prepaid and properly insured by the customer.

- VII. **Ordering.** Contact your SPARTA Sales Engineer or:

SPARTA ELECTRONIC CORPORATION  
5851 Florin-Perkins Road  
Sacramento, California 95828  
(916) 383-5353  
TELEX: 377-488 Sacramento, CA  
CABLE: SPARTA

Attn: Sales Department (or) Attn: International Sales Department.

# INDEX

Amplifier, Monitor System (MA-Series) .....	28	Spartamation .....	45-58
Amplifier, 1-Channel Utility (RA-1) .....	22	Including Alarm Panel, Automatic Logging	
Antenna and Tower Accessories .....	88,98	(ADP), Digital Clock, Music Makeup, Net-	
Antenna Section .....	81-88	work Joining, Oscillator, Program Controller	
Antenna, FM, Low Power .....	82	and Systems, Random Selection, Remote	
Antenna, FM, Medium Power .....	84	Control, Signal Processing, Tape Cartridge	
Antenna, FM, High Power .....	86	Handling, Time Announcer, Typical Sys-	
Antenna, FM, High Power Panel Type .....	88	tems and Components.	
Audio Products Accessories .....	34-43	Speakers and Enclosures .....	37
Automation . . . See SPARTAMATION . . .		Studio Control Center (Showcase) .....	4
Cabinets, Rack .....	43	Studio/Remote Unit, Monaural (AC155B) .....	10
Coaxial Cable and Rigid Line .....	99	Studio/Remote Unit, Stereo (ASC305B) .....	16
Coaxial Efficiency Chart .....	101	Studio-Transmitter Link .....	93
Console, 4-Channel, Remote (RA4) .....	23	<b>Tape Cartridge Accessories</b> .....	32
Console, 5-Channel, Monaural (A15B) .....	8	Tape Cartridge Head and Headmount .....	43
Console, 5-Channel, Stereo (AS30B) .....	14	Tape Cartridge Playback .....	29
Console, 5-Channel, Dual Output (A16R) .....	20	Tape Cartridge Playback, Portable .....	29
Console, 8-Channel, Monaural (A20B) .....	6	Tape Cartridge Storage .....	34
Console, 8-Channel, Stereo (AS40B) .....	12	Tape Cartridges: New, Special and Services .....	33
Console, 8-16 Channel Modular, Stereo		Tape Eraser (CE3) .....	34
or Quadraphonic .....	44	Tape Head Alignment Gauge .....	34
Console Extender Panel Cabinets .....	18	Tape Head Demagnetizer .....	34
Control Unit, Antenna Coupling .....	98	Tape Recorder, Open Reel .....	38-40
Diplexers .....	88	Test Equipment .....	96
Exciter, FM (680) .....	70	Time Delay, Tape Cartridge (CD15) .....	32
Furniture, Studio & Remote .....	4,11,15	Tone arm (ST220) .....	26
Gain Set .....	97	Tone arm Pickup Cartridges .....	26
Generator, S C A (683) .....	71	Towers .....	100
Generator, Stereo (682) .....	71	Tower Height vs Frequency Table .....	101
Limiters .....	41	Transformer, Isolation .....	98
Lighting, Tower, Accessories .....	98	Transmission Line . . . See Coaxial . . .	
Meter, Field Intensity .....	96	Transmitter Accessories .....	89-100
Microphone Stands .....	37	Transmitters, AM .....	60-69
Microphones .....	35	50 Watt (720B) .....	66
Mixers . . . See Consoles . . .		250 Watt (701B) .....	60
Monitor, Frequency & Modulation, AM .....	90	500 Watt (701B) .....	60
Monitor, Frequency & Modulation, FM .....	91	1000 Watt (701B) .....	60
Monitor, Phase .....	98	3000 Watt (703) .....	62
Phasor, Directional Antenna .....	98	5000 Watt (705) .....	64
Preamplifiers, Turntable (TEP3 Series) .....	27	10000 Watt (710) .....	64
Prefixes, Chart .....		15000 Watt (715) .....	67
Proof of Performance Equipment .....	97	25000 Watt (725) .....	67
Remote Control, Transmitter .....	95	Transmitter, FM .....	70-80
Remote Pickup/Broadcast Link .....	42	10 Watt (680 and 680/1) .....	70
		250 Watt (600A) .....	72
		1000 Watt (601A) .....	73
		2500 Watt (602A) .....	74
		5000 Watt (605A) .....	76
		10000 Watt (610A) .....	78
		25000 Watt (625A) .....	78
		Turntables (GT12) .....	26