

INSTRUCTIONS FOR INSTALLING AND OPERATION

OF

GATES EN-3H 3 KW TRANSMITTER

**217-222-8200**

800-422-2218 PARTS ONLY.

IB-832 09:01 00L  
5/4/57

21-222-8200  
Gates Radio Company  
Quincy, Illinois

## FM HARMONICS IN THE TV BAND

The sharp upsurge in FM broadcasting has in some instances developed unlooked for interference with local TV reception. In every instance this interference is in so-called fringe areas for TV reception and where the strength of the TV signal is weak enough that outside highly directional home TV antennas are necessary. ---- When this condition develops, the TV viewer quickly learns from his service man that the local FM station is the offender. ---- The FM broadcaster is immediately deluged with requests to eliminate the interference. In some instances CATV (Community Antenna Television) systems are also offended as they pick up weak distant TV stations. ----- What is the FM broadcaster's responsibility? Answer: To meet FCC rules and regulations as related to harmonic radiation of his FM equipment but not to guarantee perfect TV reception.

Below is a chart showing the picture and sound frequencies of TV stations between Channels 7-13 inclusive. Channels 2-6 are not shown. FM harmonics do not fall in these Channels. In fact, commercial FM station harmonics will affect only Channels 8 and above ----- look at the chart.

<u>TV Channel</u>	<u>Picture Frequency Band ---Mc---</u>	<u>Sound Frequency</u>
7	175.25 to 179.50	197.75
8	181.25 to 185.50	185.75
9	187.25 to 191.50	191.75
10	193.25 to 197.50	197.75
11	199.25 to 203.50	203.75
12	205.25 to 209.50	209.75
13	211.25 to 215.50	215.75

The frequency range for commercial FM broadcasting is 92.1 Mc to 107.9 Mc: --- To determine the second harmonic of your FM frequency, just multiply your frequency by 2. Example: If your frequency is 99.9 Mc, multiplied by 2 would make a second harmonic of 199.8 Mc. By consulting the above chart, you will note the second harmonic falls in the picture portion of the TV Channel 11.

### Correct FM Harmonic Radiation

The FCC stipulates that transmitters of 3000 watts power and over must have a harmonic attenuation of 80 db. For 1000 watts, 73 db., and for 250 watts, 66.9 db. All reputable manufacturers design their FM transmitters to meet or exceed these specifications.

### Fringe Area TV Strength Versus FM Harmonics

Let's take a typical FM station that radiates 70,000 microvolts per meter at 1 mile. At 80 db. harmonic attenuation (as called for by FCC), this station will radiate approximately 7 microvolts per meter at 1 mile on the second harmonic. In the case of our Channel 11 example, it is estimated that a fringe area TV station from 60 to 90 miles distance would have a signal strength of from 5 to 25 microvolts per meter. It can then be easily understood that a 7 microvolt signal, well within FCC specifications, would definitely interfere with the TV signal, yet with the FM broadcaster's equipment performing normally.

This is sometimes further aggravated by the FM station being located between the TV station and the TV receivers. In this instance the TV antennas are focussed not only on the TV station but your FM station as well. The home TV antennas are beamed at your legal second harmonic as well as the fringe TV station.

### What To Do

When interference occurs, it will develop ragged horizontal lines on the TV picture varying with the FM program content. If the TV sound portion is interfered with (usually not the case), then the FM signal will be heard in addition to the TV sound.

1. It is not up to the FM broadcaster to go on the defensive. He did not put the TV station 75 miles away nor did he select the TV Channel. ---- In most instances the condition is a natural phenomena that neither you, the TV station, nor the FCC can correct.
2. Do not adjust the FM harmonic or "T" notch filters supplied with the FM transmitter. These are factory adjusted and most FM stations do not have the expensive equipment necessary for correct adjustment. Tampering with this calibrated adjustment will probably make the condition worse.
3. Do not rely on TV service men's types of measuring equipment. They are not built to accurately measure harmonics and invariably give erroneous readings that invite the CATV or local service men's association to say "I told you so." Remember it is difficult to radiate harmonics if the equipment is built to suppress the harmonics and it is.
4. In many instances interference may be caused by overloading on the front end of the TV receiver. This problem usually occurs when the receiver is located close to the FM transmitter. This problem can be overcome by installing a trap tuned to the frequency of the FM carrier. The TV service man can and must learn how to do this. In most cases it works, while in some instances, if not properly installed or tuned, it will not completely eliminate the interference. In one case where interference of this type existed, a TV station put traps for the fundamental FM frequency on nearly every TV set in town. Not the FM transmitter.

### Summary

The FCC is well acquainted with this nation-wide problem. If TV viewers write FCC, complaining about your FM station, remember the FCC has received a few thousand similar letters. ---- It is not the obligation of the FM broadcaster to assure fringe area reception of a TV station any more than is the obligation of the TV station to assure the FM broadcaster perfect reception in his TV city.

Probably your installation will not have problems as outlined above. If they do exist, don't blame the equipment. Every transmitting device puts out a second harmonic, even the TV stations. The fact that these harmonics legally fall into the spectrum of a TV station many miles distant is coincidental, but not your fault.

Gates Radio Company

FM-3H 3 KW FM TRANSMITTER

TABLE OF CONTENTS

SECTION 1 - GENERAL DESCRIPTION	PAGE
1.1 Warranty and Safety Notice	1
1.2 Purpose of Book	1
1.3 Purpose of Equipment	1
1.4 Description	1
1.5 Technical Data	2
1.6 Vacuum Tube Table	3
 SECTION 2 - INSTALLATION	
2.1 Inspection	3
2.2 Packing Check List	3
2.3 Installation	4
2.4 Handling the 4CX5000A	5
2.5 Power Connection	6
2.6 Cooling	6
 SECTION 3 - OPERATION	
3.1 Pre-Operation (Also see Section 6)	7
3.2 Test Data	7
3.3 Adjustment	7
3.4 Maintenance	10
 SECTION 4 - CIRCUIT DESCRIPTION	
4.1 Power Amplifier	11
4.2 Intermediate Power Amplifier (IPA)	12
4.3 Exciter (Also see Section 6)	12
4.4 Power Supply	12
4.5 Control Circuits	12
4.6 Metering	13
 SECTION 5 - ADDITIONAL INFORMATION	
5.1 Remote Control	14
5.2 Stereophonic Operation	14
5.3 FM-3H Parts List	15-17
5.4 Helpful General Information	A thru E
 SECTION 6 - M-6425 FM EXCITER	
 SECTION 7 - ILLUSTRATIONS	
7.1 FM-3H Front View, Showing Operating Controls	
7.2 Floor of Transmitter (Rear View)	
7.3 RF Output Balun	
7.4 RF Cubicle	
7.5 Installation Drawing	
7.6 Graph - PA Coarse Tuning	
7.7 Block Diagram, FM-3H	
7.8 IPA & PA Simplified Block Diagram	
7.9 Graph - PA Efficiency Curve	
7.10 Overall Schematic - Transmitter	
7.11 Low Pass Filter	
7.12 2nd Harmonic Filter	

## SECTION 1 - GENERAL DESCRIPTION

### 1.1 Warranty and Safety Notice

This equipment is guaranteed under the liberal Gates Warranty, terms and conditions of which are fully set forth in the standard Gates Warranty, available upon request.

Most Gates manufactured items are guaranteed for one year, with the exception of tubes and moving parts, which are subject to specific warranties based upon hours of usage. The Warranty does not extend to "no charge" service on the field.

Switch to Safety - This equipment employs voltages which are dangerous and may prove fatal if contacted by operating personnel. Extreme caution should be exercised when working with the equipment. Observe safety regulations. Do not change tubes or make adjustments inside equipment with any voltages ON. While your Gates transmitter is fully interlocked you should not rely on the interlock switches for removing high operating voltages. It is always best to disconnect the primary power at the building wall switch and discharge all capacitors with the grounding stick provided.

### 1.2 Purpose of Book

This instruction book has been prepared to assist in the installation, operation, and maintenance of the Gates FM-3H, 3 KW, FM transmitter.

### 1.3 Purpose of Equipment

The Gates FM-3H is an FM broadcast transmitter with 3,000 watts output delivered to the transmission line. The operating frequency is 88-108 MHz with characteristics exceeding those required by the Federal Communications Commission for standard FM broadcast service. The transmitter is designed for continuous broadcast operation and consists of the exciter, intermediate power amplifier, and the power amplifier, plus their associated power supplies.

### 1.4 Description

Only one cabinet is required to house the entire transmitter. This cabinet is 42" wide x 78" high x 32 3/4" deep. All necessary metering is provided by four meters located on a meter panel at the top of the cabinet. Ready access to the complete transmitter is accomplished by removable rear door, hinged access panel, and hinged cover of the exciter unit. Front doors are provided to offer a pleasing and symmetrical front

## 1.6 Vacuum Tube Table

The following tubes are employed in the transmitter.

Symbol	Designation	Tube Type	Function
V2		4CX250B	Intermediate Power Amplifier
V1		4CX5000A	Power Amplifier

## SECTION 2 - INSTALLATION

### 2.1 Inspection

The FM-3H is carefully packed at the Gates plant to ensure safe arrival at its destination. The equipment is packed in a number of heavy cartons and wooden crates. Open the crates and cartons carefully to avoid damaging any of the contents. Remove the packing material and search for possible small items such as pilot lights, fuses, loose screws and bolts.

If damage should occur during shipment, all claims should be filed promptly with the transportation company. If a claim is to be filed, the original packing case and material must be preserved. A damage report must be filed to collect for shipping damages. Gates Radio Company is not responsible for damage occurring during shipment. Parts or components shipped to replace those damaged in transportation will be billed to the customer plus transportation expenses, the cost of which should form a portion of your claim to the transportation company.

A complete visual inspection should be made of the equipment. Determine that there are no loose connections, loose components, broken insulators, etc., that may have been damaged in shipment. Make sure all relay contacts are free and in good mechanical condition. Make sure all mechanical connections are tight. Check with a screw driver or a wrench, all mechanical and electrical connections that are mechanically bolted together. All tie downs or blocking used for shipping purposes should be removed. A good overall visual inspection may save time and trouble in placing the transmitter into operating condition.

### 2.2 Packing Check List

Certain components of the transmitter have been removed for shipment and are packed separately to ensure safe handling. These parts on the FM-3H have been kept to a bare minimum and are plug-in units and heavy components. Tubes that are not clamped down for normal operation are also removed. The following components have been removed from the transmitter for shipping purposes:

Remount the two monitor coupling loops on the exterior vertical balun.

The lower end of the inner-conductor of the balun connects to output loading capacitor C6.

Loosen the Allen set screws on the adjustable portion of the balun. The distance that this component is positioned vertically from the tube deck varies with operating frequency. Refer to your test data sheets for the proper measurement on your assigned channel. This adjustment must be accurate within 1/8" for proper operation.

The 4CX250B, ceramic chimney, and exhaust tubing are installed in the driver cubicle, figure 7.4. Place the tube in its socket, slip on the ceramic chimney, and clamp on the anode connector. Drop the exhaust tube through the opening of the upper tube deck to the top of the 4CX250B. Hold the exhaust tube in place with O rings above and below the deck surface.

Installing the 4CX5000A is simple. Handling of this tube is covered in Section 2.4. The anode connector assembly secures with a clamp to the tube and with a bolt to the plate line. Coarse frequency tuning of the plate circuit is determined by the distance of the rotary portion of the plate circuit from the 4CX5000A tube deck. This measurement is recorded in the test data for your transmitter and should be checked before operating the transmitter. Tolerance here is approximately 1/16".

Bolt the low pass filter in the transmission line between the directional coupler and antenna coax, and your basic installation is complete. The weight of the low pass filter should not be applied to the 1-5/8" coaxial components directly. Provisions should be made at the transmitter site to have at least two supports for the filter.

#### 2.4 Tube Handling and Operating Precautions, 4CX5000A

Avoid bumping this tube. Due to its large mass, bumping this tube will introduce resultant stresses which may cause internal damage.

Before operating this tube, please refer to the tune-up and operating procedure given in Section 3. It is recommended procedure to adjust the equipment for operation under heavy plate loading conditions, and with only sufficient RF drive to provide the required power output and efficiency.

Extreme care should be taken during tune-up as well as in regular service to avoid, even momentarily, operating of this tube under conditions of insufficient plate loading or excessive RF drive. These operating conditions, especially at the upper end of the VHF range, will produce excessively high seal and/or bulb temperature and will result in damage to this tube.

## 2.5 Power Connection

After the transmitter is physically in place and the components removed for shipment have been reinstalled, AC power should be brought to the transmitter. Referring to the installation drawing, Figure 7.2, the 240 V, 3 phase input enters the transmitter in the lower right hand corner and connects to the 3 phase fuse block immediately to the left. A 115 V, single phase fuse block is located at the center and to the rear of the transmitter with the input terminals for the 115 volts, single phase towards the rear of the transmitter.

The audio input line enters the base of the transmitter at the center approximately 7½" from the front. The audio line connects directly to terminal board TBI of the M-6425 exciter. Terminals 1 and 3 are the audio inputs and terminal 2 is ground or shield connection. If stereo is used, the lines are connected in accordance with the information in the M-6533 stereo generator instructions.

The power leads for the transmitter should come from a low reactance power source of either 208, 250, or 240 volts, 60 Hz, 3 phase, with approximately an 8 Kva capacity. A power source of 115 volts, 60 Hz with 500 watts capacity is also required. The conduit or wiring of the power leads should be in agreement with local electric codes and be able to carry the power requirements of the transmitter. Power leads and program leads should not be run in the same conduit or in the same wiring duct. If, due to necessity, the program leads are in close proximity to the power leads, the program leads should be separately shielded.

A good ground at these FM frequencies is mandatory in keeping RF currents in nearby audio equipment to a minimum. RF usually shows up in one of two ways - feedback or high noise, and in some cases both. It should be pointed out that even a small amount of unshielded wire makes a very efficient antenna for FM frequencies. If RF from the cabinet field is transferred to the grids of the audio equipment, it is rectified and shows up as noise or feedback. We strongly recommend a single common ground point from the transmitter base to a good grounding system such as a water pipe or actual earthing ground.

## 2.6 Cooling

*blower pumps 400 CFM*

The transmitter is air cooled and several kilowatts of heat are developed and dissipated through the air outlet in the top of the transmitter. It may be necessary to provide a means of exhausting this air from the transmitter room or enclosure. Heat is a major enemy to electronic component deterioration. A good system of removing the heated air from the transmitter and the transmitter room, and providing cool air for the air inlet of the transmitter will greatly prolong the life of the transmitter and its components. Duct work, if installed, should not provide any back pressure to the power amplifier enclosure. At no point should the duct have less of a cross sectional



area than the opening at the top of the transmitter. Sharp, right-angle bends are not permissible. Where it is necessary to turn a right-angle, a radius type bend should be used.

There are many installation possibilities. Each and every installation is somewhat different. Therefore, it is not possible to give complete detailed information on the transmitter ducting. Only general information can be supplied. As a suggestion, contact a local heating and cooling contractor for a detailed analysis of the problem.

After the transmitter has operated at full output a number of hours, a temperature rise inside the transmitter must not exceed a rise of 20° C above the ambient measured at the air intake of the blower and must not rise above 60° C under any circumstances.

## SECTION 3 -- OPERATION

### 3.1 Pre-Operation

Before placing the FM-3H into operation, check once again the points covered in Section 2. Have you mounted all components physically and made these electrical connections:

1. Primary power to the 3 phase fuse block?
2. 115 volts to the 1 phase fuse block?
3. Program line connected to the exciter?
4. 115 volts for the crystal ovens?
5. Transmitter connected to antenna or a suitable load?

If everything appears to be in order, then you may proceed.

### 3.2 Test Data

Your equipment has gone through many different kinds of tests at the Gates factory and has been operated for several hours on your assigned operating frequency. This is to ensure correct adjustment and proper setting of all controls. Refer to the test data supplied with your transmitter. This data is attached to the front of the transmitter when shipped.

### 3.3 Adjustment

<sup>21111</sup>  
Set the dial settings to those given on the test data sheet. Turn the IPA screen voltage control fully counterclockwise. Primary power may now be applied to the transmitter by pushing the filament ON button. The light behind the filament ON button should light. Next, the blower should begin to run and come up to speed. After the blower reaches maximum operating speed, air pressure in the P.A. enclosure will operate the air switch. Now run the P.A. screen voltage control to the lower position (counterclockwise) on the screen rheostat.

# TUNE UP PROCEDURE

Check the P.A. bias voltage and adjust as necessary to obtain the test data sheet measurements. During the tune-up procedure it may be necessary to increase the IPA voltage to prevent the P.A. from drawing excessive plate current. The grid bias voltage on the P.A. is a combination of the developed bias from the RF and the constant voltage from the bias supply. The bias supply is set at a compromise position to obtain the desired power output and to keep the P.A. within its dissipation ratings in case of RF failure.

Closing of the air switch will turn ON the PA filament voltage which may be read with the multimeter switch on the meter panel in the filament voltage position. Set the filament voltage for 7.5 volts. Next, place the multimeter switch on the meter panel to the driver cathode current position. (This is the UP position.) If the exciter is delivering power to the driver stage, a reading of approximately 10% will be read on the multimeter. Tune the IPA grid tuning for a maximum indication. As this meter is reading cathode current it will also read the grid current. The high voltage may now be applied by pushing the high voltage ON button. This supplies plate and screen voltage to the IPA stage simultaneously with the application of plate and screen voltage to the power amplifier stage. Bring the screen control for the driver up until the driver cathode draws approximately 50% scale reading on the multimeter. Resonate the IPA plate circuit by tuning for a dip in the IPA cathode meter reading. If the plate circuit and loading are near their operating positions, power output of the amplifier will be noticed.

Increase the screen voltage of the power amplifier by bringing the screen control lever switch to the UP position until approximately 1 ampere power amplifier plate current is indicated. Resonate the plate circuit of the power amplifier by adjusting the plate tuning (I2) for a dip in plate current. Next, check the position of the output loading by rotating the output loading control to give a maximum output indication.

The RF output meter is the farthest right-hand meter on the EM-3B. Its function is determined by the rotary switch (S1) located on the upper portion of the access door. You may read:

1. Forward power.
2. Meter calibration for maximum scale reading during VSWR measurements.
3. VSWR on the transmission line.

Set this switch to position (1). At this time, if approximately 2 to 3 kilowatts of power are measured, you should check the VSWR. If it is 1.5:1 or better, the screen voltage of the amplifier and the IPA stage may be increased until both are at maximum or near maximum. The plate tuning, output loading, and driver plate tuning should be adjusted

for the maximum output and the most overall efficient condition. To reduce the RF output, the amount of drive to the PA can be decreased by lowering the screen voltage of the IPA. Also the output can be reduced by decreasing the PA screen voltage.

The multimeter switch (S10) located on the meter panel will give an indication of the amount of drive to the grid of the PA tube. This is a relative indication and is read with the meter switch in the DOWN position. It will be noticed that maximum drive condition will be very close to the same point of the driver plate current dip. The driver plate tuning may, at some frequencies and power levels, be different for maximum output and for minimum driver plate current. A compromise should be made on the plate tuning of the driver for a driver cathode current of approximately 70% scale reading with a minimum or dip in tuning. The tuning on either side of the dip may affect PA efficiency as well as power output.

The operation of the transmitter is very simple and straightforward, and once adjusted should require only a nominal amount of touching up the tuning at regular maintenance periods. <sup>570</sup>

The overloads are set for correct operating level at the factory. The IPA plate overload is set for nearly full scale reading on the multimeter. The PA plate overload is set for approximately 1.5 amperes plate current. The adjustments for the overloads are located under a small cover plate located on the front access door. They may be referred to by symbol number on the schematic (Figure 7.10). Power output of the transmitter may be increased or decreased by three controls on the transmitter.

- (1) The first is the output loading. It is best to leave this control set for maximum loading on the amplifier as this will give more stable operation as recommended for any tetrode.
- (2) The second control is the power amplifier screen voltage. After the loading has been adjusted for maximum power output the screen voltage may be raised or lowered for the desired operating power.
- (3) The third control is the IPA screen voltage control. Reducing this to its minimum value will reduce the drive and part of the bias to the final amplifier causing it to overload and trip the plate voltage. It may be operated in its maximum position without any detrimental effects. However, to give partial control to power output and some tolerance on the power output of the IPA stage it is recommended that it be run at approximately 80% of its full scale setting.

The output of the exciter is adjusted with output control of the 10 W amplifier in the exciter and is covered in the exciter manual.

The transmitter can easily be remotely controlled. Description of the connections is covered in Section 5.

Two controls for setting the remote plate voltage and plate current for external metering are located under the cover on the hinged access door and are shown by symbol number on the schematic.

The screen voltage of the power amplifier is motor controlled and is also connected to the remote control Raise/Lower function for power output.

### 3.4 Maintenance

Maintenance of the FM-3H should consist of the following:

1. Keeping the transmitter clean.
2. Changing tubes when emission falls off.
3. Checking mechanical connections and fastenings.
4. Lubricating the blower motor.

Keeping the transmitter clean from the accumulation of dust will reduce failure resulting from arcing, dirty relay contacts, and overheating of chokes, resistors, and transformers. Electrostatic fields are "dust catchers". Support insulators in the PA enclosure and other locations are the worst offenders. They must be kept clean and free of all foreign material at all times. If not, arcing may result and the insulator shattered.

The air filters should be clean at all times. Periodically, it should be discarded and replaced with a new one. The filter is a disposable type and may be obtained at a hardware or heating supply store.

Once a month the entire transmitter should be cleaned of dust. The inside of the power amplifier should be thoroughly wiped clean of dust. A small brush, soft rag, and vacuum cleaner can be used very effectively in keeping the equipment clean.

All contactors and relays should be inspected regularly for pitting and dirt. The contacts should be barnished and cleaned if required. The overload relays are telephone type, with sealed contacts and should require little attention.

The bearings for the motor of the PA blower are sealed and normally give long trouble free operation. They are lubricated for approximately 20,000 hours of operation. After this period of operation the grease in these bearings should be changed. This is done by taking the drain plug out of the bottom of the bearing and a grease fitting attached to the upper plug on the bearing. New grease should be applied until clean grease runs out of the drain plug at the bottom. It is suggested the blower be removed for this maintenance.

The PA tube and the IPA tube should be removed once a month and the fins cleaned of dust. Air may be blown through the fins in the reverse direction or the anode cleaned with soap and water or denatured alcohol.

EXPERIENCE W/ THIS TRANSMITTER HAS SHOWN THAT IF THE FILTER IS KEPT CLEAN QUARTERLY <sup>FM-3H</sup> TUBE CLEANING IS VERY SUFFICIENT [www.americanradiohistory.com](http://www.americanradiohistory.com)

This transmitter is a precision electrical device, and as such, should be kept clean at all times and free of dust and foreign material. Dust and moisture condensation will lead to possible arc overs and short conductive paths.

A good preventive maintenance schedule is always the best assurance for trouble free transmitter operation.

#### SECTION 4 - CIRCUIT DESCRIPTION

The FM-3H circuits will be described in the following sections:

Power Amplifier	Power Supply
Intermediate Power Amplifier (IPA)	Control Circuits
Exciter	Metering

See Illustration 7.7.

##### 4.1 Power Amplifier

The power amplifier of the FM-3H employs a single 4CX5000A tetrode in a common cathode amplifier circuit. The plate circuit is inductively tuned by varying a length of inner-conductor of a transmission line within the rectangular outer-conductor. The plate line is approximately one-half wavelength long, being foreshortened by the output capacity of the tube. The large variable portion of the line is used for rough or approximate frequency setting and the end of the half-wave line is made variable for plate circuit tuning. This is controlled from the front panel. The fine frequency control covers approximately 3 MHz at the low end of the FM band and approximately 6 MHz at the higher end of the band.

Output coupling is accomplished by capacity tuning a balun. The balun inductively couples RF power from the amplifier enclosure.

The PA grid circuit is common with the IPA plate circuit. The IPA plate inductance, I-6, IPA plate tuning capacitor, C-26, and the input capacitor of the PA tube form a modified pi circuit.

Bypassing of the PA screen and filaments is accomplished by using a number of high voltage ceramic capacitors with lead lengths kept as short as possible.

In some transmitters, especially at the higher operating frequencies, there is a capacitor connected between grid and cathode of the PA. This capacitor is usually 25 pF. or 60 pF. The purpose of adding this component is to improve the overall performance of the power amplifier.

#### 4.2 IPA

The intermediate power amplifier employs a 4CX250B tetrode in a common cathode circuit. The grid circuit is capacity tuned. The plate circuit is common with the PA grid as previously explained. Screen bypassing is effected with the built-in bypass of the 4CX250B air system socket. The IPA cathode is bypassed with four ceramic button capacitors.

#### 4.3 Exciter

The FM exciter is described in detail in the exciter instruction book.

#### 4.4 Power Supply

Only one high voltage power supply is used in the FM-3H. It supplies 4.3 KV for the PA plate and 2 KV for the PA screen voltage, and the IPA plate. The basic configuration of the supply is a three phase full wave bridge. 2 KV is obtained from the center tap of the transformer to supply the IPA plate and also supply the source for the variable voltage of between 300 V. and 1500 V. for the PA screen grid. Series limiting resistor, R-47, prevents the PA screen grid from over-dissipating in case the PA has a loss of plate voltage.

The 0 to 270 Volt variable supply for the IPA screen voltage is also derived from the 2 KV center tap source. R26 is the control.

The rectifiers for the supply are molded silicon columns mounted on a panel attached to the side of the transmitter. The six columns are wired to form a three phase doubler circuit.

The PA bias supply is a single phase full wave bridge circuit using silicon rectifiers. Grid bias between 90 to 175 volts is supplied to the PA control grid. The bleeder resistor across the supply, R-41, will also provide additional bias voltage if the PA grid current due to RF drive causes grid current to flow about 40 ma with 160 volts fixed bias. R39 is the bias adjust control.

#### 4.5 Control Circuits

The control circuits of the FM-3H consist of the following:

- K1 Primary Contactor - applies voltage to the filaments, exciter, and energizes the blower.
- K2 Plate Contactor -- applies primary voltage to the plate transformer (K2 is energized after K3 closes.)

- K3 Step/Start Contactor - closes. Then K2 is energized, shorting out the contacts of K3 and the 1 ohm resistors. Step/Starting of the high voltage supply is accomplished by K3 closing first and applying voltage to the transformer primary through 1 ohm resistors, R22, R23, and R24.
- K4 Auxiliary Relay - applies holding voltage to the Step/Start contactor K3, if the air switch and door interlocks are closed.
- K5 Recycle Relay - energizes when either the PA overload or IPA overload relay is energized a number of times. The number of times is determined by control R25. The two overload relay contacts are in series across the relay circuit for K5. When either O.L. relay energizes and the contacts open, C36 starts to charge. If the contacts are open for a sufficient length of time for C36 to charge to the point that the voltage will energize K5, the contacts of K5 will break the hold circuit of K4 and the plate voltage will be switched OFF. If K5 does not operate, the overload contacts will close after an overload and the plate contactor K2 will again energize.
- K9 The Underdrive Relay -- will prevent application of plate and screen voltage to the IPA and P.A. until the grid current of the IPA reaches 8 ma. or more. K9 is located on the front access door below K4. The contacts of K9 are in series with door interlocks. In case of a plate voltage trip out due to low IPA grid current the recycle circuit will not operate. Only IPA and P.A. plate overload will operate the recycle circuit.
- S9 Air Switch - closes after the air pressure in the plenum reaches proper pressure, closing the interlock circuit and switching primary voltage to the PA filament transformer.

#### 4.6 Metering

All necessary metering of the FM-3H is accomplished with four meters located on the cabinet meter panel. A multimeter provides the following:

IPA Cathode Current  
 PA Filament Voltage  
 PA Drive

A metering rectifier circuit is calibrated at the factory to give PA filament voltage read on the multimeter. A PA drive detector, coupled to the grid circuit, provides a DC voltage to the multimeter to indicate the presence of RF in the PA grid enclosure.

The second meter reads PA plate current and is located in the Plate B<sup>+</sup> lead. The meter is properly insulated and isolated behind a protective plexiglass cover.

The third meter reads plate voltage and is located on the low potential side of the meter multiplier resistor.

The fourth meter is for indicating power output and VSWR on the transmission line. This meter works in conjunction with the directional coupler mounted in the output transmission line.

## SECTION 5 - ADDITIONAL INFORMATION

### 5.1 Remote Control

Remote control facilities are built into the FM-3H and requires only connection to either the Gates RDC-100 remote control unit or the Gates RDC-200A remote control equipment. The connections to the transmitter are made at TB-6 located in the base of the cabinet. Terminal connections for the functions are shown on the schematic Fig. 7.10.

The functions are:

1. Fail-safe, Primary ON-OFF.
2. Momentary ON-OFF for plate voltage.
3. Raise-Lower for adjusting power output.
4. Plate voltage metering.
5. Plate current metering.
6. RF power output metering.

### 5.2 Stereophonic Operation

Provision has been provided for the installation of the Gates M-6533 stereo generator in the FM exciter. Instructions for audio connections are given in the M-6425 manual. With the addition of the M-6533 stereo generator the transmitter type number becomes FMS-3H.



## 5.3 FM-3H PARTS LIST

<u>Symbol No.</u>	<u>Gates Part No.</u>	<u>Description</u>
A1		Neon Lamp .25 W (part of S4)
A2		Neon Lamp .25 W (part of S5)
B1	432 0010 000	Blower, 1/3 H.P. 3500 RPM, 115/230 V.
B2	436 0013 000	Motor, 1 RPM, Ratio 3210-1, 110 VAC
C1, C35	516 0043 000	Cap., 470 pf., 1 KV, Ceramic disc
C2, C3	516 0054 000	Cap., .001 uf., 1 KV, Ceramic disc
C6	914 1912 001	Var. Cap., 6-12 pf. (modif.)
C7	516 0233 000	HV Cap., 500 pf., 30 KV, ceramic
C8 thru C16	516 0205 000	HV Cap., 500 pf., 5 KV, ceramic
C18 thru C23	516 0206 000	Cap., 1000 pf., 5 KV, ceramic
C24	522 0071 000	Cap., 50 uf., 25 V. electrolytic
C25, C49	516 0227 000	Feedthru Cap., 500 pf., 500 V.
C26	520 0228 000	Plate Tune Cap., 0-50 pf. Var.
C27 thru C30	516 0250 000	Cap., 500 pf., 500 V. button type
C31		Cap., (part of tube socket)
C32	520 0158 000	Grid Tuning Cap., 5-30 pf. Var.
C33, C34, C48	516 0054 000	Cap., .001 uf., 1 KV, ceramic disc
C36	522 0133 000	Cap., 16 uf., 450 V. electrolytic
C37, C38, C47	516 0082 000	Cap., .01 uf., 1 KV, ceramic disc
C39	516 0200 000	Cap., 25 pf., 7.5 KV, ceramic
C42	524 0013 000	Cap., 30-30 uf., 525 V. plug-in
C45, C46	510 0510 000	Cap., 8 uf., 3 KV.
C51, C52, C53	516 0389 000	Cap., 9600 pf. 10 KV.
C54	516 0233 000	Cap., 500 pf., 30 KV.
C56	516 0210 000	Cap., 200 pf., 7.5 KV.
CR1	384 0006 000	Diode, Germanium, 1N54A
CR2, CR6	386 0016 000	Diode Zener, 10 V. 10 W. 1N2974
CR3, CR4, CR7	384 0020 000	Rectifier, Silicon, 600 PIV, 1N2071
CR5	384 0134 000	Diode, 1N914
DC1	927 3270 003	Directional Coupler, 4 KW.
F1, F2	398 0182 000	Fuse, Cartridge, 10 amp. 250 V.
F3, F4, F5	398 0319 000	Fuse, Cartridge, 35 amp. 250 V.
F6	398 0213 000	Fuse, Cartridge, 8 amp. 250 V.
F7	398 0017 000	Fuse, Cartridge, 1 amp. 250 V.
FL1	992 1600 001	Low Pass Filter
FL2	942 3928 004	Notch Filter
J1	612 0230 000	Receptacle, "ULF"
J2, J3	613 0237 000	Receptacle, "ENC" (part of FL2)
J4	612 0233 000	Receptacle "N"
K1	570 0120 000	Pri. Contactor, 4 pole, 110V. . 50/60 Hz.
K2, K3	570 0119 000	Plate/Step-Start Contactor, 4 pole. 208/220 V.
K4	574 0099 000	Control Relay. DPDT, 110 V. 60 Hz.

Symbol No.	Gates Part No.	Description
K5	574 0054 000	Recycle Relay, SPDT, 6 K ohm
K6, K7	572 0125 000	O.L. Relay, 1a, 1b, 6 VDC
K8	572 0066 000	Screen Voltage Control Relay, 20.
K9	572 0052 000	Grid Underdrive Relay
L1	913 8288 001	Variable Coupling Section
L2	942 3910 001	Plate Line & Coupling Assembly
L3	826 9569 001	Plate Choke
L4	494 0004 000	P.A. Grid RF Choke, 7 uh.
L5	913 9335 001	Drive Plate Choke Assembly
L6	913 9343 001	Drive Plate Coil (Low Band)
L6	913 9346 001	Drive Plate Coil (High Band)
L7	813 9379 001	Driver Grid Coil
L8	813 9380 001	Driver Input Coupling Coil
L13	476 0014 000	Reactor, Bias, 6 Hy.
L14	476 0186 000	Reactor, P.A. 2 Hy.
L15	476 0035 000	Reactor, Driver, 10 Hy.
M1	632 0547 002	Multimeter, 0-300 MA, 0-10 V. and 0-100 Scale
M2	632 0610 002	Meter, Plate Current, 0-3 Amp.
M3	632 0546 002	Plate Voltage Meter, 0-5 KV Scale
M4	632 0582 002	Meter, PWR, VSWR 0-200 uA.
R1, R2, R3, R4	540 0594 000	Res., 200 ohm, 2 W, 5%
R5, R17	540 0058 000	Res., 2400 ohm, 1/2 W, 5%
R6, R9, R13, R25	550 0067 000	Control, 10 K ohm.
R7	540 0070 000	Res., 7500 ohm, 1/2 W, 5%
R8	550 0029 000	VSWR Control, 10 K ohm, 2 W.
R10	542 0204 000	Res., 5 ohm, 50 W.
R11, R28, R51	550 0061 000	Control, 1 K ohm, 2 W.
R12	540 0580 000	Res., 51 ohm, 2 W, 5%
R14	540 0746 000	Res., 3300 ohm, 2 W, 10%
R15	540 0068 000	Res., 6200 ohm, 1/2 W, 5%
R16	540 0073 000	Res., 10 K ohm, 1/2 W, 5%
R18	550 0054 000	Driver Fil. Adjust Control, 50 ohm, 2W.
R22, R23, R24	542 0164 000	Res., 1 ohm, 25 W
R26	552 0807 000	Control, 20 K ohm, 50 W.
R27	542 0095 000	Res., 10 K ohm, 10 W.
R29	550 0055 000	O.L. Adjust Control, 100 ohm, 2 W.
R30	542 0058 000	Res., 50 ohm, 10 W.
R31	542 0166 000	Res., 5 ohm, 25 W.
R32	548 0167 000	Res., .16 ohm, 2 W, 1%
R33	552 0380 000	P.A. Fil. Adjust Rheostat, 10 ohm, 100 W.
R39	552 0324 000	Bias Rheostat, 5 K ohm, 25 W.
R40	540 0579 000	Res., 47 ohm, 2 W.
R41	542 0218 000	Res., 4 K ohm, 50 W.
R45	542 0224 000	Res., 10 K ohm, 50 W.
R46	552 0423 000	Screen Rheostat, 10 K ohm, 150 W.

Symbol No.	Gates Part No.	Description
R47	542 0370 000	Res., 15 K ohm, 200 W.
R48	913 3424 001	Meter Multiplier, 5 megohm
R49, R50	542 0312 000	Res., 100 K ohm, 100 W.
R52	540 0628 000	Res., 5100 ohm, 2 W, 5%
R53	540 0301 000	Res., 51 ohm, 1 W, 5%
R60, R61, R62	542 0090 000	Res., 7000 ohm, 10 W.
R63, R64	542 0309 000	Res., 50 K ohm, 100 W.
R65	542 0327 000	Res., 2000 ohm, 160 W.
S1	600 0162 000	VSWR/CAL. Rotary Switch
S2, S8	604 0196 000	Door Interlock Switch
S3	604 0284 000	Fil. OFF Pushbutton Switch N.C.
S4	604 0283 000	Fil. ON Pushbutton Switch N.O.
S5	604 0286 000	HV OFF Push Switch, N.C.
S6	604 0285 000	HV ON Push Switch, N.O.
S7	604 0032 000	Remote Local Toggle Switch DPDT
S9	604 0258 000	Air Switch, .3 to 1" W.C.
S10	602 0055 000	Multimeter Selector Switch, 2 pole, 3 Pos.
S11	602 0056 000	Bias Low/High Voltage Lever Switch, 2 pole
S12, S13	604 0052 000	Low/High Voltage Limit Switch
T1	472 0409 000	P.A. Fil. Transformer
T2	472 0090 000	Driver Fil. Transformer
T3	472 0208 000	P.A. Bias Transformer
T4	472 0535 000	HV Pwr. Transformer
TB1	614 0069 000	Terminal Board, 2 terminal
TB3	614 0071 000	Bias Supply Terminal Board, 4 terminal
TB4	614 0052 000	Motor Control Terminal Board, 8 terminal
TB5	614 0114 000	Terminal Board, 6 terminal
TB6	614 0104 000	Rmt. Ctl. Terminal Board
V1	374 0016 000	P.A. Tube, 4CX5000A
V2	374 0081 000	Driver Tube, 4CX250B
XC42	404 0016 000	Socket, Octal
(XF1, 2 & 6)	402 0015 000	Fuse Block, 3 pole
(XF3, 4 & 5)	402 0037 000	Fuse Block, 3 pole
XF7	402 0021 000	Fuseholder
XV1	404 0069 000	P.A. Tube Socket
XV2	404 0082 000	Driver Tube Socket
Z1 thru Z6	384 0235 000	Rectifier, 10 KV. >
Z7	384 0121 000	Bias Supply Rectifier

## M6425 TE-1 FM EXCITER

Gates Radio Company is supplying a 3 dB isolation pad, AT1 (992-2241-001) with the TE-1 FM Exciter. This should be installed between the RF output of the exciter and the input of following amplifier stages.

The TE-1 exciter is capable of supplying RF drive in excess of the amount needed for most transmitters. The pad provides additional isolation and de-coupling between the exciter and following amplifier stages.

When the TE-1 exciter is supplied in a Gates transmitter, the pad is already installed. If the exciter is supplied alone, the pad can be installed at any convenient point in the transmission line between the exciter output and following amplifier stage. Coaxial RF fittings are mounted on the pad for ease of installation.

PARTS LISTAT1 Isolation Pad, 3 dB -- 992-2241 001

<u>Symbol No.</u>	<u>Gates Stock No.</u>	<u>Description</u>
	612 0233 000	Receptacle, Type "N"
	612 0237 000	Receptacle, Type "BNC"
R35, R36	540 0598 000	Res., 300 ohm, 2 W.
R37, R38, R39, R40	540 0584 000	Res., 75 ohm, 2 W.

8/24/67

Gates Radio Company  
Quincy, Illinois

**INSTRUCTION MANUAL  
FOR  
M-6425 FM EXCITER  
AS USED WITH  
M-6533 STEREO GENERATOR  
AND  
M-6507 SCA GENERATOR (S)**

## INDEX

	Page
SPECIFICATIONS .....	1
EQUIPMENT DESCRIPTION .....	2
INSPECTION .....	2
INSTALLATION .....	2
OPERATION .....	2
MAINTENANCE .....	3
TROUBLESHOOTING .....	3
COMPLETE CIRCUIT DESCRIPTION & ADJUSTMENT .....	5
ELECTRICAL PARTS LIST .....	9

### SCHEMATICS & DRAWINGS

842 4885 001	Functional Block Diagram
838 2064 001	Interconnecting Diagram
838 1955 001	Schematic, Power Supply
838 2157 001	Schematic, Modulated Oscillator
827 1630 001	Schematic, 10 Watt Amplifier
842 4693 001	Schematic, AFC Unit
838 2575 001	Schematic, Audio Unit
838 2026 001	Schematic, Sub-Carrier Generator
842 4887 001	Schematic, Stereo Signal Unit

SPECIFICATIONS  
M-6425 EXCITER AS USED WITH  
M-6507 SCA AND M-6533 STEREO GENERATOR

**MECHANICAL:**

Width: 19"  
Height: 14"  
Depth: 12-1/4"  
Weight:  
(Unrated) 52 lbs. (monaural only).  
3 lbs. (SCA generator).  
6 lbs. (stereo generator).  
Finish: Beige  
Semiconductors used throughout.

All sections of exciter shipped in proper position ready to use. Remote Control Facilities Included: (see explanation on page 3).

**ELECTRICAL: (Monaural Operation).**

Frequency Range: 88 to 108 MHz.  
Power Output: 10 Watts (min.).  
RF Harmonics: Suppression meets or exceeds all FCC requirements.  
RF Output Impedance: 50 ohms (BNC connector).  
Oscillator: AFC controlled.  
Frequency Stability: .001% or better.  
Modulation Capability: Capable of  $\pm 100$  kHz ( $\pm 75$  kHz = 100% modulation).  
Audio Input Impedance: 600 ohms balanced.  
Audio Input Level: +10 dBm  $\pm 2$  dB for 100% modulation at 400 Hz.  
Audio Frequency Response: Standard 75 microsecond FCC pre-emphasis curve  $\pm 1$  dB, 30-15,000 Hz.  
Distortion: .5%, 30 to 15,000 Hz.  
FM Noise: 65 dB below 100% modulation (ref. 400 Hz).  
AM Noise: 70 db below reference carrier AM modulated 100%  
Temperature: -20° to +50° C.  
Altitude: 7,500 ft.  
Power Requirements: 117 VAC, single phase, 60 Hz, 85 watts.

**ELECTRICAL: (Stereophonic Operation).**

Pilot Oscillator: Crystal controlled.  
Pilot Stability: 19 kHz  $\pm 1$  Hz 0° to 50° C.  
Audio Input Impedance (lft & rgt): 600 ohms balanced.  
Audio Input Level (lft & rgt): +10 dBm  $\pm 1$  dB for 100% modulation at 400 Hz.  
Audio Frequency Resp. (lft & rgt): Standard 75 microsecond, FCC pre-emphases curve  $\pm 1$  dB, 30-15,000 Hz.  
Distortion (lft or rgt): 1% or less, 30-15,000 Hz.  
FM Noise (lft or rgt): 60 dB (min) below 100% modulation (ref. 400 Hz).  
Stereo Separation (lft to rgt or rgt to lft channel): 35 dB (min) 30 to 15,000 Hz.

Sub-Carrier Suppression (with or without modulation present: 42 db (min) below 90% modulation.

\*Crosstalk (main channel to sub-channel or sub-channel to main channel): 42 dB (min) below 90% modulation, 30-15,000 Hz.

Sub-Carrier 2nd Harmonic Suppression (76 kHz): 60 dB or better below 100% modulation.

Power Input: 24 V DC at 50 ma. (1.2 watts).

NOTE: Stereophonic measurements to be made from an FCC approved monitor or an equally dependable method used such as waveform measurements from a wideband, linear discriminator. A spectrum analyzer may be used in conjunction with a wideband discriminator to measure crosstalk and distortion.

**ELECTRICAL: (SCA Operation).**

Frequency: Any SCA channel between 25 and 75 kHz.  
Frequency Stability:  $\pm 500$  Hz.  
Oscillator Type: Two Colpitts heterodyned to produce desired output frequency.  
Modulation: Direct FM.  
Modulation Capability: Capable of  $\pm 7.5$  kHz ( $\pm 5$  kHz considered 100% modulation).  
Audio Input Impedance: 600 ohms balanced.  
Audio Input Level: +8 dBm,  $\pm 3$  dB for 100% modulation at 400 Hz.  
Audio Frequency Response: 41 kHz and 67 kHz, 50 microsecond, modified pre-emphasis. 67 kHz response modified for proper operation when used with stereo to conform to FCC specs.  
Distortion: 1.5% (or better) 30-15,000 Hz.  
FM Noise (main channel not modulated): 55 dB min. (ref. 100% modulation 400 Hz).  
Crosstalk (sub-channel to main channel and stereophonic sub-channel): -60 db or better.  
\*\*Crosstalk (main channel to sub-channel): 50 db below 100% modulation (ref. 400 Hz) with main channel modulated 70% by frequencies 30-15,000 Hz.

\*measurement to be made using an L=R signal for sub-channel crosstalk and an L=-R signal for main channel crosstalk.

\*\*crosstalk measurements to be made from an FCC approved monitor using 75 microsecond de-emphasis.

If FCC model not available, an equally dependable method or instrument to be used.

Power Input: 24 V DC at 40 ma. (.96 watt).

Automatic Mute Level: Variable from 0 to -40 dB below 100% modulation.

Remote Control: Exciter is internally equipped to manually or remotely switch from monaural to stereo operation. On monaural operation, normal right audio input connections are switched to the 41 kHz SCA position, if used. Remote functions are accomplished by a single set of external relay contacts (closure required for stereo operation. External relay should provide a holding function.)

### EQUIPMENT DESCRIPTION

The M-6425 exciter unit is completely self-contained. Attach it to the 117 V. AC line, connect audio input wires, and you have a complete 10 Watt FM Transmitter.

These same features are also very desirable in building up power level to the kilowatt(s) level. The exciter easily connects into the control circuitry of high power transmitters.

Silicon transistors and diodes are used throughout all circuitry, (exception Q7 and CR1, CR2 in the SCA unit only). These are greatly superior to the older germanium types because they are less sensitive to heat. Considerable transistorized equipment placed in service 15 years ago, is still running. It is felt that silicon devices will greatly increase life expectancy of transistorized equipment. This exciter is air cooled and after several hours of operation, it is difficult to detect any heat whatsoever on any part of the exciter enclosure.

### INSPECTION

All portions of the exciter are shipped in place and ready to turn on. When the unit is received, immediately inspect it for damage that may have occurred in transit. Look for loose screws and tighten them. If real damage, either concealed or obvious is determined, immediately call the transportation company that delivered the material to you and go over the damages with them. They will either note the shipping waybill which you have or give you a damage report, indicating that you may proceed with repairs. Order the necessary parts from Gates. Gates will bill these parts to you, and you in turn can bill the parts to the transportation company under the damage claim.

Remember most transportation companies like to tell you that the equipment was damaged beyond their control. All Gates equipment is shipped in approved packing containers and you are not obliged to pay for anything broken in transit, but the transportation company is.

### INSTALLATION

You will receive this equipment on one of two ways: Already mounted in a high power transmitter, or as a separate unit which may be mounted separately in a rack cabinet or as a replacement in a transmitter for an older type of ex-

citer. If the unit is already in a transmitter, interconnections to the exciter have already been made. If you receive the unit separately, refer to interconnecting diagram 838 2064 001 for proper connection to the unit. Be sure the audio input wires are shielded. Connect 50 ohm coax from J1 (RF output) on the rear of the exciter enclosure to whatever type load is to be used.

Do not physically mount the unit in a place of excessive heat or dirt. While this will probably not really damage it, you wouldn't lay a precision watch on the top of a hot and dirty amplifier.

### OPERATION

Capabilities of this equipment are far in excess of minimum FCC specifications. In addition, each exciter unit is tested on customer frequency. This insures that the unit was operating properly when it left the Gates plant. Unless the unit has been shaken up considerably in transit you should be operational by merely applying 117 volts to the proper terminals as shown on the interconnecting diagram.

Output of the exciter should be connected into either a dummy load, antenna, or a following amplifier stage. After connecting 117 V. AC to proper terminals on the exciter, power switch located on the power supply may be turned on. Observe the output frequency on a standard FM frequency monitor or by using a frequency counter. Make sure that the AFC ON-OFF switch (S1) is in the ON position.

**CAUTION** - Do not attempt to fine adjust the output frequency unless the oven heaters have been on for approximately 30 minutes. The overall exciter unit should be on for at least ten minutes before attempting to fine adjust the fine or center frequency control.

If the exciter has been turned on for the prescribed length of time the center frequency may be adjusted by center frequency adjust control R59. This should be done with no modulation applied.

Setting to obtain the proper output frequency should correspond very closely to the figure recorded by the Gates test lab when the unit was tested on customer frequency.

Output frequency should stay well within FCC specifications over long periods of time without any readjustment.

Reset drive control (R11) on the 10 watt amplifier section for the desired output level if this is necessary. A large change in this setting may affect the center frequency setting.

Apply sine wave signals to the audio input terminals for initial observation of programming if so desired. Set the proper audio input levels by observing modulation percentage on a standard FCC approved monitor. Proof of performance data using sine wave signals may then be made by proper connections of a distortion analyzer to the FM monitor.

The unit is now ready to be used as an FM transmitter or as a driver for higher power stages. Fidelity may be checked on any high quality FM receiver by listening checks.



## SCA OPERATION

Each exciter unit has provisions for two SCA units (M-6507). The exciter may come equipped with them or these may be added at a later date without changing any cabling or wiring whatsoever. Normally the SCA generators will be on either 41 or 67 kHz. The units should be placed in the slots shown on the interconnecting diagram 838 2064 001. Audio input terminals on the rear of the exciter unit will then correspond to the proper SCA unit.

With no main channel modulation on the carrier turn on the SCA time constant switch (S1) to the defeat (D) position. This will turn the SCA generator ON. Set the output level of the SCA generator (R30) to modulate the main carrier as desired. Usually 10 to 15% modulation of the main carrier is sufficient. Do not exceed 30% modulation of the main carrier by the SCA generators. This figure is the total of all SCA generators that may be employed.

Check frequency of the SCA on FCC approved monitor or by a frequency standard. If frequency needs to be re-adjusted retune L3 or L4 slightly with non-metallic tool provided. Use narrow screwdriver blade. SCA unit must be removed from cabinet to do this. SCA unit may be reconnected to proper cable plug while setting outside of cabinet.

Program the SCA generator to the proper level as read on a multiplex monitor. Set the mute switch to the desired time constant. This determines how soon after the programming stops that the sub-carrier will turn off.

Set the mute level control (R32) to the muting or quieting level as desired. This will generally be at a level approximately 30 dB below the normal 100% modulation point.

## STEREO OPERATION

This exciter has provisions for using an M-6533 composite stereo generator. This may be received with the generator mounted in position or added at a later date without changing any cabling or wiring whatsoever.

The stereo generator may be used in conjunction with either one or two SCA generators. Automatic switching is provided that allows the normal right stereo program to be changed to the second SCA generator when not in a stereo transmission mode.

A total of 16 variable adjustments are provided on the stereo generator. Eleven of these are located internally on the printed wiring board. These twelve adjustments are considered to be one time factory adjustments requiring special equipment. They should not be re-adjusted except in cases of severe trouble. Contact the Gates Service Department first.

Four controls are provided on the front panel of the stereo generator. Pilot gain, pilot phase, output level and L+R gain. Those adjustments located internally on the printed wiring board have a double underline underneath the description of control on the stereo generator schematic. Front Panel adjustments have a box drawn around them on the schematic.

In addition, a pilot defeat switch is provided on the front panel of the stereo generator for test purposes only. This must be placed in the "composite" position for normal programming.

Adjustments located on the front panel of the stereo generator will rarely, if ever, need adjusting. Adjustment should generally not be attempted unless an FCC type approved stereo monitor is available.

All of these controls were properly adjusted at the factory and do not normally drift. Set pilot gain control for 8 to 10% modulation of main carrier with no audio input applied and without any SCA modulation of main carrier.

Set output level so normal programming modulates main channel at prescribed level, 90% (+10% pilot) or if a 67 kHz SCA is being transmitted, 80% (+10% pilot +10% SCA). These are maximum figures allowed.

Set L+R gain control for equal L+R and L-R amplitude. This may be done by observing the output of the generator. The zero axis of the composite signal should have a straight line dividing the upper and lower half.

Set pilot phase control for best separation as read on stereo monitoring equipment. If none is available, connect an L-R signal to the audio inputs on rear of exciter. Set the signal generator to about 50 Hz and observe waveform on an oscilloscope connected to stereo generator output. Set pilot phase so that the corners of the "eyes" of the pattern are pointing directly at one another.

A "mono", "stereo", "remote" switch located on the audio unit picks the mode of transmission. The right stereo audio input connections are switched to the 41 kHz SCA input when not in the stereo mode. The stereo generator is then completely removed from the circuit.

Remote control equipment may be connected to appropriate terminals on back of the exciter enclosure and the stereo-mono functions performed remotely.

## MAINTENANCE

General maintenance should consist of merely keeping excessive dust out of the exciter unit. This applies particularly to the perforated metal screen over the exhaust fan. Make certain that this does not become clogged with dust and dirt.

It is not deemed necessary or advisable to remove covers from individual modules to clean them. They are well shielded and protected.

Exhaust fan (B1) should be lubricated annually. This may be done by removing plug button on ventilation screen.

## TROUBLESHOOTING

Since each individual unit is checked on customer frequency before shipment, the exciter should operate properly with a minimum amount of effort. If unit fails to operate properly, re-check to see that all plugs fit tightly into the receptacles on each individual module.

The finest of equipment will, of course, occasionally fail as there is no such thing as 100% infallibility.

If problems develop they can usually be isolated by referring to the appropriate block diagrams. Once the problem has been isolated to an individual module. That module may be checked by referring to the appropriate schematic for that particular module. Each schematic has a series of voltage or waveform measurements made on it to assist in troubleshooting.

A word of caution though, the voltage and waveform measurements are subject to some normal variation. Also, if different types of instruments are used to measure the voltages and waveforms a slightly different reading can be expected.

Complete circuit description and adjustment procedure has been included in this manual to assist in troubleshooting. A complete tune-up should not be attempted unless proper test equipment is available.

A "Cause-and-Effect" table is included in pages following to speed up the isolation of problems.

#### NO CARRIER OUTPUT

Check that power supply is providing 24 Volts DC. If pilot lamp of power supply does not light check that S1 on power supply is "ON". Check that 117 V AC is supplied to proper terminals on rear of exciter. Check 117 V fuse, F3, on power supply. Check F1 of cabinet inter-cabling. This is located on shield box behind power supply. (Refer to interconnecting diagram).

If pilot lamp on power supply lights, check 24 V. and 150 V. fuse.

If power supply is providing proper voltages, check output coax of exciter for short or open circuit.

Determine if modulated oscillator is providing output by listening to FM receiver tuned to operating frequency. Measure output level of modulated oscillator if equipment is available. This should be on the order of .5 to 1 V. RMS open circuit.

If modulated oscillator is providing power output to the 10 watt amplifier, trace the RF signal through the amplifier stages and compare AC and DC voltages with those values given on the schematic.

#### CARRIER OFF FREQUENCY

Check "locked" and "unlocked" frequency. If frequency is further away from the correct value when AFC defeat switch is on than off, fault probably lies in AFC unit. Check if fine frequency control knob has been misadjusted. Check power supply voltages.

Check that modulated oscillator oven is warm and if crystal oven of AFC unit is warm. If only the crystal oven becomes cold, total drift will only amount to a few kHz and is easily compensated for by re-adjustment of the fine frequency control. Loss of heat on the modulated oscillator circuit will cause a considerable drift of frequency. If the cause of loss of heat can not be immediately determined, modulated oscillator may be

retuned to carrier frequency and operated temporarily without an oven heater. Center frequency drift must then be observed more often and the problem should be solved swiftly.

Some types of frequency monitors will provide a nearly "on frequency" reading even though the carrier is actually several hundred kHz off frequency. The right frequency is the one where the AFC unit locks instead of kicking the frequency monitor off scale. In particular, care should be taken not to tune the modulated oscillator very far below the correct frequency or the AFC unit may lock the carrier to its image frequency which is 400 kHz below the proper frequency.

#### EXCESSIVE CARRIER SHIFT WHEN MODULATION IS APPLIED

This problem is usually caused by a defect in the AFC unit but is generally of a minor nature if the carrier stays on frequency without modulation. Check that a sufficient amount of RF sample is being fed to the input of the AFC unit. A few hundred Hz of drift is really not objectionable and may be considered normal. Also, some frequency monitors will show a carrier shift when none is present.

#### HIGH DISTORTION

Most apt to occur in the consoles or audio lines connected to the exciter. No active elements such as transistors are present in the exciter at audio frequencies. Unless there are other symptoms of improper operation, the fault will usually be somewhere else than the exciter itself.

#### HIGH NOISE

Attempt to identify noise as to type. If 120 Hz ripple, check power supply. If 60 Hz, momentarily disconnect power from oven heaters to see if it is coming from that source. Disconnect audio input wires. If noise is coming from that source, see that center tap of audio output transformer of audio console is not grounded. Check for problems with any type of isolation devices that may be present in a remote controlled system.

Disconnect plug from audio unit and any SCA generators that are used. This should isolate problem as to whether it is in the modulated oscillator or not.

#### EXCESSIVE CROSSTALK - MAIN & STEREO CHANNEL TO SCA CHANNEL

This most often is the fault of the detector and IF strip of the SCA monitor or SCA receiver. Determine if high crosstalk is present on more than one receiver. Check that crosstalk is not actually present on audio input wires.

Crosstalk may occur in improperly tuned states of either transmitter or receiver. The tuned stages of the exciter amplifier are very broad and not apt to cause trouble.

#### POOR STEREO SEPARATION

Check for proper waveform appearance at output of stereo generator and at output of monitor or receiver detector. Check if pilot is on and is modulating main carrier 8 to 10%. Check pilot phase.

## COMPLETE CIRCUIT DESCRIPTION AND ADJUSTMENT FOR EACH MODULE

(Refer to block diagram and appropriate schematic).

### POWER SUPPLY

The power supply consists of a two section unit which supplies a regulated 24 DC volts and a regulated 150 DC volts. Both sections of this supply receive AC voltage from a common power transformer. With regard to the 150 volt supply, diodes CR1 through CR4 rectify the AC voltage and the pulsating DC voltage is then applied to a filter section consisting of C1, C2, R1 and R2.

Q1 is the series regulator for this supply. A portion of the output of Q1 is sampled by reference diodes CR5 and CR13 which are temperature compensated. Transistor Q3 compares the output voltage with that supplied by reference diodes CR5 and CR13 and adjusts the gain of Q1 by means of amplifier Q2 so that the output voltage remains at a constant value as determined by voltage control R4.

With respect to the 24 volt supply, diodes CR6 through CR9 rectify the AC voltage supplied by transformer T1. This rectified voltage is applied to filter section C3, C4 and R7. Q4 is the series control transistor that actually regulates the 24 volt supply. A sample of the output voltage is compared in Q7 with a reference voltage supplied by temperature compensated diodes CR10 and CR11.

Any change in the output voltage is amplified by Q6 and Q5 which then causes series control Q4 to return the output voltage to the value set by control R11.

The output voltages will remain relatively constant over a temperature range of from -20 to +70°C. The output voltages will also remain constant as the line voltage is varied from 85 to 115% of normal 117 volt AC supply. Normal load variations will also cause no voltage change in these supplies.

For a normal AC input voltage of 110 to 125 volts, the AC input should be connected to the black and the green/blk primary leads of T1. If normal AC line voltage is very low, say 105 volts or less, the black and the white/blk primary leads of T1 should be used. If normal AC line voltage is 125 volts or more, use the black and the white primary leads.

An AC line voltage change of from 85 to 115% of normal should cause a change of no more than .05 volts on the 24 volt section. The 150 volt section should change no more than .5 volts with this same line voltage change.

Normal adjustment of this power supply is to set R4 for an output voltage of 150 volts and R11 for an output voltage of 24 volts. Power supply is then checked to see that line voltage variations or load variations do not cause a voltage variation beyond normal limits.

### MODULATED OSCILLATOR

Carrier frequency of exciter unit is generated by an emitter coupled oscillator circuit. This consists of transistors Q1 and Q2 in the modulated oscillator unit. This

circuit will oscillate anywhere in the standard FM broadcast band by adjustment of tuned transformer T1.

Transistor Q3 isolates the oscillator circuit proper from any output variations occurring in the load that may be connected to J13.

Normal monaural modulation or signals from a composite stereo generator will modulate the oscillator circuit when connected to pin 2 of J10. Modulation is accomplished by varying base bias voltages of transistors Q1 and Q2.

Frequency drift of the modulated oscillator is controlled to well within FCC specifications by first placing the entire circuit in a chamber held at a temperature of 70°C. Secondly, any drift from assigned frequency is corrected by error voltages from an automatic frequency control unit. These error signals are applied to diodes CR1 and CR2 in such a manner that they return the output frequency of the modulated oscillator to the correct frequency. CR1 and CR2 are silicon diodes biased in the reverse direction. As such, they appear as voltage variable capacitors and are directly connected into the tuned tank circuit of Q1 and Q2.

If SCA modulation is being used, it is applied to the opposite side of the voltage variable capacitors CR1 and CR2 in such a manner that it does not interfere with the frequency control characteristics or with audio or stereo modulation being applied to Q1 and Q2. By isolating the three modulation inputs as explained above, crosstalk is held to a minimum.

Power output at J13 of the modulated oscillator circuit is on the order of 15 to 20 milliwatts.

Normal adjustment of the modulated oscillator is to set it exactly on frequency with the oven warmed up and AFC defeat switch on AFC unit off. AFC defeat switch is then turned on. T1 is the only variable adjustment of the modulated oscillator and when "free-running" will tune the modulated oscillator from 88 to 108 MHz. **SEE PAGE 13A**

Normal "pull in" range of the AFC/modulated oscillator combination is about 1 kHz for every 50 to 75 kHz drift of the modulated oscillator. In other words, assume that both the "free-running" and "locked" frequency are exactly the same and no deviation from correct center frequency exists. If the "free-running" frequency of the modulated oscillator changes 50 to 75 kHz, the AFC control should return the locked frequency to within about 1 kHz.

Normal pull in is somewhat better when the modulated oscillator has drifted below normal center frequency.

### 10 WATT AMPLIFIER

The 10 watt amplifier consists of a four stage amplifier. Transistors Q1, Q2 and Q3 are single stage amplifiers while Q4 and Q5 are paralleled to obtain the desired output level.

Maximum power output of this amplifier is 10 to 15 watts. Actual power output is determined by the setting of R11 an input drive control.

Transformers T1, T2 along with associated capacitor C4 and C7 match the output impedance of these stages to the input impedance of the following stages which is very low. Inductor L1, L2 and capacitor C14 and C15 match the output impedance of Q3 to the low impedance of transistors Q4 and Q5.

The output circuit of Q4 and Q5 is a modified Pi type of circuit consisting of L5, L6 and C19 and C20.

An RF sample for the AFC unit is obtained from J12 through capacitor C22 which sets the level of the desired RF sample. This sample appears at J4 on the 10 Watt amp.

Normal adjustment of the 10 watt amplifier is to tune all adjustments for maximum power output. R11 the drive control is then set for the desired power output.

C22 is adjusted for 4 volts RMS across a 50 ohm load (located in AFC unit). This should be done with the amplifier supplying the desired power output. If the power output of the amplifier is substantially changed, C22 must be re-adjusted.

#### AFC UNIT

Output frequency of the exciter is maintained exactly on frequency by the AFC unit. A sample of the RF output is fed into J9 of the AFC unit and compared to another RF sample 200 kHz lower in frequency.

An internal RF sample is generated by a crystal controlled oscillator Q1 operating at approximately 1/3 the output frequency. Crystal Y1 is mounted in a 70°C oven for maximum stability. Q2 triples the oscillator frequency so that the RF sample obtained from L2 is 200 kHz below the operating frequency.

These two RF samples are then mixed by diodes CR1 and CR2. Low pass filter L5 and C14 and C15 filters out all but the difference of the two RF samples. Transistors Q3, Q4 and Q5 successively clip and amplify the 200 kHz signal applied to the base of Q3. This signal is further limited by transistor circuitry Q6 and Q7.

Width of the pulses obtained from limiter circuit Q6 and Q7 will vary as the 200 kHz intermediate frequency drifts upward and downward. It is the purpose of the gate circuit Q8 and Q9 to limit the width of these pulses to a pre-determined value regardless of the frequency.

The AC-DC converter circuit Q10 obtains its operating voltage from an isolated 150 volt regulated supply. Neither output terminal of the 150 volt supply is at chassis ground potential. As the duty cycle (conduction time) of Q10 is varied the average voltage appearing at the collector of Q10 will vary accordingly. This transistor is driven into conduction and saturation by the constant width pulses applied to the base of Q10 from the gate circuit. The duty cycle of Q10 is thus solely determined by the number of pulses arriving at the base of Q10. The number of pulses per second is, of course, determined by the intermediate frequency as one pulse is generated for every complete cycle of the intermediate frequency.

A reference point for the error voltage is set with respect to chassis ground by center frequency adjust control R59. The filtered DC error voltage appears at terminal 4 of J8 after being filtered by resistor R54, and capacitor C38. This DC error voltage will be exactly zero when the intermediate frequency is 200 kHz.

When the output frequency of the exciter drifts upward, the intermediate frequency will drift upward and change the duty cycle of Q10 so that a positive DC error voltage is obtained for application to the voltage variable capacitors in the modulated oscillator circuit. This error voltage causes the capacity of these diodes to increase thereby lowering the output frequency to its assigned value.

If the output frequency of the exciter attempts to drift lower in frequency the opposite action occurs.

The purpose of CR13 is to prevent a positive error voltage of over approximately 1 volt from appearing at the AFC output terminal J8 terminal 4. If this were not done a sudden positive surge such as when the exciter is initially turned on, would cause the modulated oscillator circuit to seek its image frequency because of the sudden application of a positive voltage.

Adjustment of the AFC unit consists of tuning L1 to the crystal frequency. L2 is adjusted to three times the crystal frequency. Approximately 4 VRMS is then sampled from the output of the exciter at J9 and mixed with the internally generated standard frequency to produce a 200 kHz IF frequency.

R59 is finally set in comparison with a frequency standard so that the output frequency of the exciter is correct.

R62 is sometimes varied in value to compensate for an average shift of carrier frequency when modulation is applied.

#### AUDIO UNIT

The audio unit supplies the modulated oscillator with all main channel modulation (excluding SCA). When the function switch is in the "mono" position, left audio input is filtered and pre-emphasized and applied directly to the modulated oscillator unit. The composite stereo signal including the pilot is completely removed from the modulation input of the modulated oscillator.

If the function switch is in the "stereo" position, left and right audio inputs are filtered, pre-emphasized and applied to a resistive matrix. They then connect to the stereo generator. The composite stereo signal including pilot returns through the audio unit for application to the modulation input of the modulated oscillator.

Left audio input circuitry consists of three fundamental types of circuits. First, is a 19 kHz notch filter consisting of L1 and C1.

Resistors R1 through R5 and capacitors C2, C3, C4 along with inductor L2 is a 75 microsecond pre-emphasis section.

The primary and secondary impedance of T1 is 600 ohms.

Right audio input circuitry is exactly identical to left audio input circuitry.

When selector switch S1 is in the stereo position, output of the left pre-emphasis section is connected to the primary of T1. The secondary of T1 connects into the matrix consisting of R13 through R18. At the same time, right audio input signals are routed through the right 19 kHz filter, pre-emphasis network and T2. The secondary of T2 is also connected into the resistive matrix.

Output of the matrix then produces the L-R and L+R signals for application to the signal unit of the stereo generator. At the same time the composite signal along with the 19 kHz pilot is connected through the relay to the input terminals of the modulated oscillator. The 41 kHz SCA (if used) is muted when audio is not applied.

When S1 is placed in the mono position, audio input signals connected to the left audio input, again pass through a 19 kHz notch filter and the left pre-emphasis network. There the signal terminates in R11. R11 may be adjusted to produce the desired modulation level for a given level of audio input.

Also, with S1 in the mono position the normal right stereo input terminals are connected through relay contacts K1 for application to the input of a 41 kHz sub-carrier generator unit if it is used.

The stereo generator is completely bypassed when S1 is in the mono position and no stereo signals (or pilot) can modulate the main carrier.

When S1 is in the remote position the mono to stereo functions may be performed by the contacts of a remote control relay. This relay must perform a holding function.

To adjust the audio unit, S1 is placed in the mono position. A 400 Hz signal at a level of +10 dBm is connected to the left audio input. R11 is then adjusted so the carrier is modulated 100%.

A "Left=Right" signal of 400 Hz is then connected into the left and right audio inputs and S1 is placed in the stereo mode. R18 is then adjusted for minimum 400 Hz signal level at J11-10 (L-R out).

A "Left=minus Right" signal of 400 Hz is then connected into the left and right audio inputs. With S1 in the stereo mode, R17 is adjusted for minimum 400 Hz signal level at J11-6 (L+R out).

A 19 kHz audio signal is fed into the exciter left audio input terminals and L1 is set for minimum output of 19 kHz signal at J11-6 (L+R out). The 19 kHz is then fed into the right audio input terminals and L3 is adjusted for minimum 19 kHz signal at J11-6 (L+R out).

L2 and L4 are adjusted for a 16.8 dB rise in output level at 15 kHz as compared to a 400 Hz signal. This is also measured at J11-6 (L+R out).

Finally, coils L1 through L4 are retouched slightly for minimum L+R to L-R crosstalk at 15 kHz. This is accomplished by connecting L=R and L=-R signals into the exciter input terminals and measuring output levels at the L-R and L+R terminals of the matrix.

## SUB-CARRIER GENERATOR

This unit generates the desired sub-carrier frequencies (usually 41 or 67 kHz) by utilizing two separate self-excited oscillators operating in the vicinity of 900 to 975 kHz.

Q1 and Q2 are the individual oscillators and are of a type normally known as Colpitts oscillators. Q1 is set to oscillate at 900 kHz and Q2 is set to oscillate at 941 or 967 kHz.

These two outputs are then mixed by diodes CR1 and CR2 and all but the difference frequency is filtered out by L5 and C13 and C14.

The sub-carrier frequency is then amplified by Q3 and applied to a tunable low pass filter consisting of L6, L7, L8 and C19, C20, C21 and C22. This filter removes all harmonics of the sub-carrier frequency.

Audio modulation is applied to the individual oscillators Q1 and Q2 by push-pull audio transformer T1. The audio is modulated onto the oscillators by variation of base bias voltage.

An audio shaping network is connected ahead of the primary of T1. When connected as shown the audio response will rise up several dB at 5000 cycles with respect to 400 cycles reference. Above 5000 cycles the response will then tend to roll off.

When this generator is used as a 67 kHz sub-carrier unit for use with stereo capacitor C1 and C2 are disconnected. This then functions as a sort of de-emphasis circuit rolling off frequencies above 3000 cycles so that sidebands are not generated which would interfere with the stereo signal.

A portion of the audio input is applied to a muting circuit consisting of transistor Q4, Q5, Q6 and Q7. Transistors Q4 and Q5 amplify the input audio to practically a square wave. This is then rectified by diodes CR3 and CR4 for application to transistor Q6.

When audio is applied, the DC level at the base of Q6 is such that Q6 is not conducting. This holds the bias at the base of Q7 in such a manner that Q7 is also not conducting.

When audio is removed from the input, bias from the base of Q6 disappears causing Q6 to conduct. This changes the bias at the base of Q7 causing it to conduct heavily. When this happens, the impedance from the junction of C17 and C18 to chassis ground drops to a level on the order of a few ohms. This causes the sub-carrier output to be attenuated approximately 50 or 60 dB.

The base of Q6 is connected to various capacitors through mute time constant switch S1. The value of the capacitor connected determines how long after audio disappears from the input of Q4 that the sub-carrier will shut off.

Mute level control R32 determines what level the audio must drop to before the sub-carrier is turned off.

Adjustment of the SCA generator consists first of setting the output filter properly so that there are essentially no harmonics of the sub-carrier present in the output of the SCA generator.

L6 and L8 are adjusted for maximum attenuation at the second harmonic of the SCA frequency. L7 is adjusted so that minimum attenuation or ripple exists over the sub-carrier passband. This passband is considered to be sub-carrier frequency  $\pm 15$  kHz.

L3 is adjusted for an approximate output frequency of 900 kHz and L4 is adjusted to approximately 900 kHz plus the sub-carrier frequency. This is generally 941 or 967 kHz. L3 or L4 is then "fine" tuned for the exact proper SCA frequency in comparison with a frequency standard. A non-metallic tool with narrow screwdriver type blade is necessary for this adjustment.

Output level control R30 is set to modulate the main carrier the required level.

Mute level control R32 is adjusted so the sub-carrier output turns off if the audio input signal disappears. Optimum setting is about 30 to 40 dB below 100% modulation of the sub-carrier. This is done by connecting an audio signal at 400 Hz to the proper SCA input terminals of the exciter and modulating the sub-carrier 100%. The level of audio input is then reduced 30 or 40 dB and mute level is then adjusted so that the sub-carrier output disappears.

S1 the mute delay is adjusted to whatever muting speed is desired after audio disappears from the input.

### STEREO GENERATOR

A 19 kHz pilot signal for the composite stereo signal is generated by crystal controlled oscillator Q1. Q2 isolates this signal and from the rotor of R79 a 19 kHz signal is applied to 19 kHz tuned amplifier stage Q3. The secondary of T1 is connected to a push-push doubler circuit consisting of transistors Q4 and Q5.

This stage in conjunction with transformer T2 generates a very clean 38 kHz signal.

The 38 kHz signal is applied to the balanced sub-carrier modulator circuit consisting of transformers T3, T4 and diodes CR1 through CR4.

An L-R input signal from the audio unit is also applied to the balanced sub-carrier modulator.

An L-R double sideband suppressed carrier signal appears at the output of T4. Harmonics of this signal are reduced by forwarding biasing of diodes CR1 through CR4 and by adjustment of harmonic null control R37. Sub-carrier null control R48 balances out the residual 38 kHz sub-carrier to a level of approximately -45 dB.

The L+R input signal coming from the audio unit is combined with the L-R double sideband signal at the junction of C22, R53 and R60.

The time delay of the L+R input is adjusted to agree with that experienced by the L-R circuitry. This is

accomplished by a time delay consisting of L3 through L6 and capacitor C29 and C30.

Thus a composite stereo signal appears at the junction of C22, R53 and R60 and is applied to emitter follower circuit Q12 from the rotor of R53 which is the output level control.

This signal is then amplified in transistor Q13 and applied to the base of emitter follower circuit Q14. The total composite signal along with 10% 19 kHz pilot signal appears at the emitter of Q14.

A pilot signal is obtained from terminal 4 of transformer T1 and is applied to emitter follower Q6. A phase control connected between Q6 and emitter follower Q7 allows adjustment of pilot phase for maximum separation. A pilot gain control is connected into the emitter of transistor Q7 and the pilot signal is added to the composite output by connecting the rotor of R27 to the emitter resistor of transistor Q14.

Second harmonics of the double sideband signal fall into the pass band of a normal 67 kHz SCA signal. If these second harmonic signals are not severely attenuated, crosstalk from the stereo signal will interfere or get into the sub-carrier channel.

Second harmonic signal is then amplified and inverted 180° by transistor Q9, this is obtained from R53 via Q8.

From the collector of Q9 the signal is applied to emitter follower Q10 and then back into the base circuit of amplifier Q13.

Cancellation causes any remaining crosstalk at the base of Q13 to be removed. This can be set precisely by crosstalk null control R33.

Adjustment of the stereo generator consists of setting C2 so the pilot signal is within specifications. This must be done in comparison with a frequency standard.

T1 and T2 are tuned for maximum output. Doubler balance control R20 is adjusted for minimum 19 kHz ripple on the composite output signal without a pilot signal. R79 the 19 kHz gain control is set for the desired amount of 38 kHz level to drive the balanced modulator properly. R65, L-R gain control is adjusted for the desired level of audio to drive the balanced modulator circuit.

Harmonic null control R37 is adjusted for minimum second harmonic output from the balanced modulator with R33 (crosstalk null) turned for minimum output of second harmonic signal.

Sub-carrier null control R48 is adjusted for minimum 38 kHz output. This may be observed on a type approved stereo monitor, wave analyzer or ultrasonic display. Adjustment of harmonic null control R37 is also best accomplished by observing an ultrasonic display.

L+R gain control is adjusted for correct gain relationship between the L+R and L-R portions of the composite stereo signal. L4 and L5 are adjusted for best phase relationship between the L+R and L-R portions. This is best accomplished at 15 kHz.

R53, output level control, is adjusted to modulate the main carrier 90% with a 400 Hz left or right audio input signal of +10 dBm. This level excludes the pilot.

L1 is tuned to the second harmonic of the 38 kHz double sideband signal and R33 the crosstalk null control is then turned up so it cancels out any remaining 76 kHz component remaining at the output of the stereo generator.

Pilot gain R27 is adjusted to modulate the main carrier 10%. Pilot phase R24 is adjusted for best separation as read on a stereo monitor provided all other aspects of the composite signal are proper. An alternate method involves using an L-R composite waveform and is described on page 8.

### PARTS LIST

#### CABINET ASSEMBLY - 992-1773-001

Symbol No.	Gates Part No.	Description
B1	430 0030 000	Fan, 115 V., AC, 115 CFM
C1 thru C20	516 0319 000	Cap., .001 uF, 500 V. Feedthru
F1	398 0021 000	Fuse, 4A., 250 V.
F2	398 0015 000	Fuse, .5 A, 250 V.
J1	612 0418 000	Panel Jack, BNC, UG291/U
L1 thru L6, L11 thru L20	494 0110 000	Choke, 3.3 uH.
L7 thru L10	814 4837 001	Gates Assembly
P3, P4, P9, P13 P12	620 0379 000 610 0238 000	Plug, Female Plug, BNC, UG88/U
P1, P2, P5 thru P8, P10, P11	612 0405 000	Female Plug, 15 Term.
TB1	614 0087 000	Terminal Board
TS1	614 0148 000	Tie Strip
XF1, XF2	402 0024 000	Fuseholder

#### POWER SUPPLY - 992-1726-001

A1	396 0163 000	Lamp, 3 W, 120 V.
C1, C2	524 0125 000	Cap., 200 uF, 250 V.
C3, C4	524 0104 000	Cap., 1000 uF, 50 V.
C5	524 0094 000	Capl, 500 uF, 50 V.
C6, C7	516 0043 000	Cap., 470 pF, 1kV, 10%
C8, C9, C10, C11, C12, C13, C14 C15	516 0375 000	Cap., .01 uF, 50 V.
	506 0085 000	Cap., 2 uF, 200 V.
CR1, CR2, CR3, CR4 CR5	384 0019 000 386 0043 000	Diode 1N2070 Zener Diode, 1N2767
CR6, CR7, CR8, CR9	384 0165 000	Diode 1N4720

Symbol No.	Gates Part No.	Description
CR10	386 0047 000	Zener Diode 1N3582
CR11, CR13	384 0134 000	Diode, 1N914
CR12	386 0034 000	Zener Diode, 1N3031B
F1	398 0012 000	Fuse, 3/10 A, 250 V.
F2	398 0021 000	Fuse, 4A., 250 V.
F3	398 0019 000	Fuse, 2A, 250 V.
J1	610 0419 000	Panel Connector
Q1, Q5	380 0041 000	Transistor, 2N3054
Q2	380 0045 000	Transistor, 2N4036
Q3	380 0058 000	Transistor, 2N3440
Q4	380 0043 000	Transistor, 2N3055
Q6	380 0044 000	Transistor, 40319
Q7	380 0042 000	Transistor, 2N697
R1	540 0284 000	Res., 10 ohm, 1 W, 1%
R2	540 0574 000	Res., 30 ohm, 2 W, 5%
R3	548 0189 000	Res., 2200 ohm, 3 W, 1%
R4, R11	552 0775 000	Pot., 1000 ohm, 1/2 W.
R5, R6	548 0190 000	Res., 17.5K ohm, 3 W, 1%
R7	542 0438 000	Res., 2 ohm, 25 W.
R8, R15	548 0192 000	Res., 1000 ohm, 3 W, 1%
R9	540 0583 000	Res., 68 ohm, 2 W, 5%
R13	540 0049 000	Res., 1000 ohm, 1/2 W, 5%
R14	548 0197 000	Res., 1600 ohm, 3 W, 1%
S1	604 0005 000	Toggle Switch, SPST
T1	472 0536 000	Power Transformer
XA1	406 0367 000	Lamp Socket
XQ2, XQ3, XQ6, XQ7	404 0198 000	Transipad for TO-5 Case
XF1, XF2, XF3	402 0013 000	Fuseholder

#### 10 WATT AMPLIFIER - 992-1715-001

C1, C2, C3, C5, C6, C9, C10, C18, C21	516 0054 000	Cap., .001 uF, 1kV, 10%
C4, C7, C14, C15	520 0116 000	Cap., Variable, 3.9-50 pF.
C8, C12, C17 C11	516 0082 000 506 0085 000	Cap., .01 uF, 1kV, GMV Cap., 2 uF, 200 V.
C13, C16	500 0809 000	Cap., 22 pF, 500 V, 5%
C19	500 0823 000	Cap., 82 pF, 500 V., 5%
C20	500 0812 000	Cap., 30 pF, 500 V, 5%
C22	520 0341 000	Cap., Variable, 1.5-9.1 pF.
C23, C24	516 0043 000	Cap., 470 pF, 1 kV, 10%
J2	610 0419 000	Panel Connector
J3, J4	620 0355 000	Panel Receptacle
J12	612 0403 000	Right Angle Receptacle UG1098/U
L1	814 3242 001	Inductor
L2	914 3243 001	Inductor
L3, L4	494 0164 000	RF Choke, .68 uH
L5, L6	814 3244 001	Inductor
L7	814 4837 001	Coil

Symbol No.	Gates Part No.	Description	Symbol No.	Gates Part No.	Description
Q1	380 0036 000	Transistor	C20	506 0087 000	Cap., 1 uF, 200 V.
Q2	380 0037 000	Transistor	C21	516 0043 000	Cap., 470 pF, 1 kV, 10%
Q3	380 0038 000	Transistor	C22	516 0082 000	Cap., .01 uF, 1 kV
Q4, Q5	380 0039 000	Transistor	CR1, CR2	528 0007 000	Varicap, 1N4808
R1	540 0050 000	Res., 1100 ohm, 1/2 W, 5%	HR1	914 3779 001	Oven (Modified)
R2	540 0074 000	Res., 11K ohm, 1/2 W, 5%	J10	610 0419 000	Panel Connector
R3	540 0019 000	Res., 56 ohm, 1/2 W, 5%	J13	620 0355 000	Panel Receptacle
R4, R7	540 0174 000	Res., 470 ohm, 1/2 W, 10%	L1 thru L6	494 0176 000	Choke, 3.3 uH
R5	540 0183 000	Res., 2700 ohm, 1/2 W, 10%	Q1, Q2	914 6003 001	Transistor (Gates Spec)
R6	540 0296 000	Res., 33 ohm, 1 W, 5%	Q3	380 0048 000	Transistor, 2N3118
R8	540 0182 000	Res., 2200 ohm, 1/2 W, 10%	R1	540 0928 000	Res., 4700 ohm, 1/4 W, 5%
R9, R10	540 0011 000	Res., 27 ohm, 1/2 W, 5%	R2	540 0937 000	Res., 11K ohm, 1/4 W, 5%
R11	550 0001 000	Pot., 100 ohm, 1/2 W.	R3, R4	540 0894 000	Res., 180 ohm, 1/4 W, 5%
T1	914 3246 001	Transformer	R5, R6, R7	540 0960 000	Res., 100K ohm, 1/4 W, 5%
T2	914 3247 001	Transformer	R8, R22	540 0880 000	Res., 47 ohm, 1/4 W, 5%
XQ1, XQ2	404 0196 000	Heat Sink	R9, R10	540 0881 000	Res., 51 ohm, 1/4 W, 5%
AUDIO UNIT - 992-1830-001			R11	540 0948 000	Res., 33K ohm, 1/4 W, 5%
C1, C5	508 0308 000	Cap., .025 uF, 100 V, 1%	R12	540 0933 000	Res., 7500 ohm, 1/4 W, 5%
C2, C3, C4, C6, C7, C8	508 0307 000	Cap., .03 uF, 100 V, 1%	R13	540 0042 000	Res., 510 ohm, 1/2 W, 5%
C9	522 0322 000	Cap., 100 uF, 50 V.	R14	540 0315 000	Res., 200 ohm, 1 W, 5%
CR1	384 0134 000	Diode, 1N914	R15, R16	540 0950 000	Res., 39K ohm, 1/4 W, 5%
J11	610 0419 000	Panel Connector	R17, R19	540 0937 000	Res., 11K ohm, 1/4 W, 5%
K1	572 0134 000	Relay	R18	540 0939 000	Res., 13K ohm, 1/4 W, 5%
L1, L2, L3, L4	492 0328 000	Inductor 2.7-3.3 uH	R20	540 0976 000	Res., 470K ohm, 1/4 W, 5%
R1, R2, R3, R4, R6, R7, R8, R9	548 0139 000	Res., 270 ohm, 1/2 W, 1%	R21	540 0912 000	Res., 1000 ohm, 1/4 W, 5%
R5, R10	548 0217 000	Res., 110 ohm, 1/2 W, 1%	T1	914 4247 001	RF Transformer Assembly
R11	552 0800 000	Trim Pot., 500 ohm, 1 W.	XQ1, XQ2	404 0197 000	Transipad
R12	540 0073 000	Res., 10K ohm, 1/2 W, 5%	XQ3	404 0198 000	Transipad
R13, R14	548 0218 000	Res., 600 ohm, 1/2 W, 1%	AFC UNIT - 992-1716-001		
R15, R16	540 0043 000	Res., 560 ohm, 1/2 W, 5%	C1, C13	500 0868 000	Cap., 10 pF, ±5%, 500 V.
R17, R18	552 0797 000	Trim Pot., 100 ohm, 1 W.	C2	500 0871 000	Cap., 39 pF, ±5%, 500 V.
R19	540 0046 000	Res., 750 ohm, 1/2 W, 5%	C3, C7, C8, C11	516 0054 000	Cap., .001 uF, 1 kV.
R20	540 0036 000	Res., 300 ohm, 1/2 W, 5%	C4	516 0375 000	Cap., .01 uF, 50 V.
S1	604 0336 000	Switch, SPDT, Center OFF	C5, C10	500 0869 000	Cap., 27 pF, ±5%, 500 V.
T1, T2	478 0282 000	Input Xfmr, 814 5241 001, ADC	C6	500 0872 000	Cap., 110 pF, ±5%, 500 V.
XK1	404 0209 000	Relay Socket	C9	500 0867 000	Cap., 5 pF, ±10%, 500 V.
MODULATED OSCILLATOR - 992-1772-001			C12	522 0240 000	Cap., 15 uF, 25 V.
C1, C2, C8	516 0406 000	Cap., 5.6 pF, 200 V, 10%	C14, C15	500 0877 000	Cap., 100 pF, ±5%, 500 V.
C3, C4	516 0407 000	Cap., 15 pF, 200 V, 10%	C16	506 0088 000	Cap., .1 uF, 200 V, MMW
C5	516 0410 000	Cap., 1 pF, 500 WV.	C17, C25	522 0240 000	Cap., 15 uF, 25 V.
C6, C9, C10	516 0409 000	Cap., 470 pF, 200 V, 10%	C18, C26	516 0054 000	Cap., .001 uF, 1 kV.
C7, C11	516 0408 000	Cap., 100 pF, 200 V, 10%	C19	508 0215 000	Cap., .01 uF, ±10%, 100 V.
C12	522 0244 000	Cap., 50 uF, 25 V.	C20, C21, C22, C23, C24	506 0088 000	Cap., .1 uF, 200 V.
C13, C15	516 0043 000	Cap., 470 pF, 1 kV, 10%	C27	500 0874 000	Cap., 330 pF, +5%, 100 V.
C14	522 0240 000	Cap., 15 uF, 25V.	C28	522 0240 000	Cap., 15 uF, 25 V.
C18, C19	500 0880 000	Cap., 51 pF, 500 V, 5%	C30	500 0870 000	Cap., 33 pF, ±5%, 500 V.
			C31	500 0873 000	Cap., 220 pF, ±5%, 500 V.
			C32	500 0835 000	Cap., 470 pF, ±5%, 300 V.
			C33, C34	522 0153 000	Cap., 15 uF, 3 V.
			C35, C36, C37, C39	506 0088 000	Cap., .1 uF, 200 V.



Symbol No.	Gates Part No.	Description	Symbol No.	Gates Part No.	Description
C38	506 0087 000	Cap., 1 uF, 200 V.	R34	540 0587 000	Res., 100 ohm, 2W, 5%
C40, C41	506 0085 000	Cap., 2 uF, 200 WV.	R35, R36	540 0053 000	Res., 1500 ohm, 1/2W, 5%
C43, C44, C45, C46, C47, C48, C49, C50, C51	516 0319 000	Cap., Feedthru, 1000 pF, 500 V.	R37	540 0054 000	Res., 1600 ohm, 1/2W, 5%
C52, C53	506 0088 000	Cap., .1 uF, 200 V.	R38, R47, R49	540 0055 000	Res., 1800 ohm, 1/2W, 5%
CR1, CR2	384 0134 000	Diode, Silicon 1N914	R39, R50	540 0061 000	Res., 3300 ohm, 1/2W, 5%
CR3	384 0134 000	Diode, Silicon 1N914	R40	540 0059 000	Res., 2700 ohm, 1/2W, 5%
CR4	386 0032 000	Diode, Zener 1N747A	R41, R44	540 0052 000	Res., 1300 ohm, 1/2W, 5%
CR5	386 0046 000	Diode, 6082	R42	540 0041 000	Res., 470 ohm, 1/2W, 10%
CR6, CR7, CR8, CR9, CR12	384 0134 000	Diode, Silicon 1N914	R43	540 0037 000	Res., 330 ohm, 1/2W, 5%
CR10, CR11	386 0045 000	Diode, Zener	R45, R46	540 0048 000	Res., 910 ohm, 1/2W, 5%
CR13	386 0073 000	Diode, 6046	R48	540 0064 000	Res., 4300 ohm, 1/2W, 5%
CR14	384 0166 000	Diode, Silicon 1N643	R51	540 0053 000	Res., 1500 ohm, 1/2W, 5%
CR15	386 0047 000	Diode, Zener 1N3582	R54	540 0113 000	Res., 470K ohm, 1/2W, 5%
HR1	558 0024 000	Oven, Printed Circuit, 115 V, RMS, 70° C.	R55	548 0195 000	Res., 2000 ohm, 25W, 1%
J8	610 0419 000	Receptacle	R57	540 0646 000	Res., 30K ohm, 2W, 5%
J9	620 0355 000	Panel Receptacle	R58	540 0655 000	Res., 68K ohm, 2W, 5%
L1	914 3282 001	Osc. Coil Assy, (yel. dot)	R59	552 0781 000	Pot., 20K ohm, 1-1/2 W, Clock Face
L2	914 3283 001	Trip Coil Assy, (green dot)	R60	540 0635 000	Res., 10K ohm, 2W, 5%
L3, L5	494 0112 000	RF Choke, 812 uH	R62	540 0025 000	Res., 100 ohm, 1/2W, 5%
L4	494 0151 000	RF Choke, 2.7 uH	R63	540 0071 000	Res., 8200 ohm, 1/2W, 5%
L6	494 0165 000	Choke, 2.2 uH	RT1	559 0006 000	Thermistor, 1000 ohm
L7, L8	494 0153 000	RF Choke, 300 uH	S1	604 0320 000	Switch, Toggle, DPDT
Q1, Q2, Q6, Q7, Q8, Q9	380 0046 000	Transistor, 2N708	XQ1, XQ2, XQ6, XQ7, XQ8, XQ9	404 0197 000	Transipad for TO-18 Case
Q3, Q4, Q5 Q10	380 0042 000 380 0047 000	Transistor, 2N697 Transistor, 2N3500	XQ3, XQ4, XQ5 XQ10	404 0198 000 404 0066 000	Transipad for TO-5 Case Socket, Transistor
R1, R6	540 0079 000	Res., 18K ohm, 1/2W, 5%	Y1	444 XXXX 000	Crystal (Freq. Det. by Customer Order)
R2, R7	540 0071 000	Res., 8200 ohm, 1/2W, 5%	SCA UNIT - 994-6507-001		
R3	540 0045 000	Res., 680 ohm, 1/2W, 5%	C1, C2	508 0286 000	Cap., .15 uF, ±10% Mylar 100 WVDC
R4	540 0066 000	Res., 5100 ohm, 1/2W, 5%	C3, C4, C5, C8	500 0844 000	Cap., 1000 pF, ±5%, 100V
R5, R8	540 0049 000	Res., 1000 ohm, 1/2W, 5%	C6, C9	500 0873 000	Cap., 220 pF, ±5%, 500V
R9, R11	540 0025 000	Res., 100 ohm, 1/2W, 5%	C7, C10	500 0818 000	Cap., 50 pF, ±5%, 500V
R10	540 0301 000	Res., 51 ohm, 1W, 5%	C11, C12	500 0759 000	Cap., 100 pF, ±5%, 500V
R12, R13	540 0055 000	Res., 1800 ohm, 1/2W, 5%	C13, C14	500 0878 000	Cap., 1500 pF, ±5%, 500V
R14	540 0096 000	Res., 91K ohm, 1/2W, 5%	C15	508 0278 000	Cap., .1 uF, ±10% Mylar 100 WVDC
R15	540 0056 000	Res., 2000 ohm, 1/2W, 5%	C16, C27, C29	522 0240 000	Cap., 15 uF, 25V
R16	540 0058 000	Res., 2400 ohm, 1/2W, 5%	C17, C18	508 0298 000	Cap., .01 uF, 100V, Mylar
R17, R18, R22	540 0071 000	Res., 8200 ohm, 1/2W, 5%	C19, C22	500 0831 000	Cap., 250 pF, ±5%, 500 V
R19	540 0077 000	Res., 15K ohm, 1/2W, ±5%	C20, C21	500 0874 000	Cap., 330 pF, ±5%, 100 V
R20 R24	540 0049 000	Res., 1000 ohm, 1/2W, 5%	C23	508 0298 000	Cap., .01 uF, 100 V, Mylar
R21, R25	540 0041 000	Res., 470 ohm, 1/2W, 5%	C24, C25	522 0178 000	Cap., 25 uF, 6 VDC
R23	540 0079 000	Res., 18K ohm, 1/2W, 5%	C26	522 0210 000	Cap., 100 uF, 12 VDC
R26	540 0085 000	Res., 33K ohm, 1/2W, 5%	C28	522 0233 000	Cap., 2 uF, 25 V
R27	540 0065 000	Res., 4700 ohm, 1/2W, 5%	C30	522 0242 000	Cap., 25 uF, 25 VDC
R28	540 0322 000	Res., 390 ohm, 1W, 5%	C31, C32	522 0244 000	Cap., 50 uF, 25 V
R29	540 0053 000	Res., 1500 ohm, 1/2W, 5%	C33	522 0256 000	Cap., 20 uF, 50 V
R30	540 0462 000	Res., 330 ohm, 1W, 10%	CR1, CR2	384 0006 000	Diode, Signal 1N54AS
R31	540 0050 000	Res., 1100 ohm, 1/2W, 5%	CR3, CR4	384 0018 000	Rectifier 1N2069
R32	540 0073 000	Res., 10K ohm, 1/2W, 5%	J5	610 0419 000	Receptacle
R33	540 0057 000	Res., 2200 ohm, 1/2W, 5%	L1, L2	494 0175 000	Choke 4.7 uH
			L3, L4	492 0321 000	Coil, Adj. .28 to .65 uH
			L5	494 0165 000	Choke, 2.2 uH
			L6, L8	492 0322 000	Coil, Adj. 8-20 uH

Symbol No.	Gates Part No.	Description	Symbol No.	Gates Part No.	Description
L7	492 0323 000	Coil, Adj. 15-40 uH	C5	500 0877 000	Cap., 100 pF, 500V, 5%
Q1, Q2, Q3, Q4, Q5, Q6	380 0042 000	Transistor 2N697	C7	522 0251 000	Cap., 5 uF 50V
Q7	380 0016 000	Transistor 2N1539	C9	500 0845 000	Cap., 2000 pF, 500V, 5%
R1	540 0055 000	Resistor, 1.8K ohm, 1/2 W, 5%	C14	500 0879 000	Cap., 2500 pF, 500V, 5%
R2	540 0053 000	Resistor, 1.5K ohm, 1/2 W, 5%	C16, C23, C35, C36, C39, C40, C41, C44	522 0240 000	Cap., 15 uF 25V
R3, R4	540 0035 000	Resistor, 270 ohm, 1/2 W, 5%	C17, C18, C19, C20	522 0166 000	Cap., 400 uF 3V
R5, R6, R7, R8	540 0017 000	Resistor, 47 ohm, 1/2 W, 5%	C21	522 0256 000	Cap., 20 uF 50V
R9	540 0092 000	Resistor, 62K ohm, 1/2 W, 5%	C22	522 0336 000	Cap., 250 uF 15V
R10, R17	540 0089 000	Res., 47K ohm, 1/2 W, 5%	C24, C42, C43	522 0244 000	Cap., 50 uF 25V
R11, R18	540 0097 000	Res., 100K ohm, 1/2 W, 5%	C25	522 0243 000	Cap., 35 uF 25V
R12, R19, R40	540 0095 000	Res., 82K ohm, 1/2 W, 5%	C27	506 0087 000	Cap., 1 uF, 200V
R13, R20	540 0065 000	Res., 4.7K ohm, 1/2 W, 5%	C29, C30	500 0835 000	Cap., 470 pF, 300V, 5%
R14, R21, R24, R25, R45	540 0073 000	Res., 10K ohm, 1/2 W, 5%	C31	522 0306 000	Cap., 1000 uF 25V
R15, R22	540 0049 000	Res., 1000 ohm, 1/2 W, 5%	C32	516 0054 000	Cap., 1000 pF, 1 KV 10%
R16, R23	540 0025 000	Res., 100 ohm, 1/2 W, 5%	CR1, CR2, CR3, CR4	914 4201 001	Matched Set of 4 Diodes
R26, R27, R41	540 0085 000	Res., 33K ohm, 1/2 W, 5%	J7	610 0419 000	Panel Connector
R28, R29, R35, R43	540 0056 000	Res., 2000 ohm, 1/2 W, 5%	L1, L5	492 0331 000	Adj. R.F. Coil, 1.3-3 uH
R30, R32	550 0007 000	Min. Pot., 10K ohm, 1/2 W, Linear Taper	L3, L6	494 0153 000	RF Choke, 300 uH
R31	540 0069 000	Res., 6.8K ohm, 1/2 W, 5%	L4	492 0332 000	Adj. R.F. Coil, .65-1.3 uH
R33	540 0099 000	Res., 120K ohm, 1/2 W, 5%	Q1	380 0060 000	Transistor FET
R34	540 0066 000	Res., 5.1K ohm, 1/2 W, 5%	Q2 thru Q16	380 0042 000	Transistor, 2N697
R36	540 0050 000	Res., 1.1K ohm, 1/2 W, 5%	R1	540 1001 000	Res., 511 Megohm, 1/4W, 5%
R37	540 0045 000	Res., 680 ohm, 1/2 W, 5%	R2, R10, R11, R61, R72	540 0936 000	Res., 10K ohm, 1/4W, 5%
R38	540 0042 000	Res., 510 ohm, 1/2 W, 5%	R3, R58	540 0940 000	Res., 15K ohm, 1/4W, 5%
R39	540 0078 000	Res., 16K ohm, 1/2 W, 5%	R4, R30, R50, R67, R70, R73, R76	540 0976 000	Res., 470K ohm, 1/4W, 5%
R42	540 0075 000	Res., 12K ohm, 1/2 W, 5%	R5	540 0902 000	Res., 390 ohm, 1/4W, 5%
R44	540 0061 000	Res., 3.3K ohm, 1/2 W, 5%	R6	540 0907 000	Res., 620 ohm, 1/4W, 5%
S1	600 0421 000	Switch, Type BA, 4 Pos., 1 Sect. per Gates 814 2977 001	R7	540 0934 000	Res., 8200 ohm, 1/4W, 5%
T1	478 0145 000	Input Transformer AI-10426	R8, R13, R21, R25, R28, R31, R34, R54, R64	540 0960 000	Res., 100 K ohm, 1/4W, 5%
TJ1	612 0312 000	Test Point Jack, White	R9, R49, R66, R69, R71	540 0912 000	Res., 1000 ohm, 1/4W, 5%
TJ2	612 0311 000	Test Point Jack, Black	R12, R75, R77	540 0920 000	Res., 2200 ohm, 1/4W, 5%
XQ1, XQ2	404 0066 000	Transistor Socket	R14, R15	540 0888 000	Res., 100 ohm, 1/4W, 5%
XQ3, XQ4, XQ5, XQ6	404 0198 000	Transipad for TO-5 Case	R16	540 0928 000	Res., 4700 ohm, 1/4W, 5%
STEREO GENERATOR - 994-6533-001			R17	548 0211 000	Res., 2400 ohm, 1/2W, 1%
C1, C37, C45	522 0322 000	Cap., 100 uF 50V	R18	540 0964 000	Res., 150K ohm, 1/4W, 5%
C2	520 0342 000	Cap., Var., 2-27 pF	R19, R86, R87	540 0953 000	Res., 51K ohm, 1/4W, 5%
C3	508 0291 000	Cap., .008 uF, 600V, 10%	R20	552 0795 000	Pot., 10K ohm, 1 W
C4, C6, C8 C10, C11, C12, C13, C28, C38	506 0088 000	Cap., .1 uF 200V	R22, R29, R35, R51, R57	540 0919 000	Res., 2000 ohm, 1/4W, 5%
			R23, R52, R60, R62	540 0905 000	Res., 510 ohm, 1/4W, 5%

Symbol No.	Gates Part No.	Description	Symbol No.	Gates Part No.	Description
R24	550 0009 000	Pot., 50K ohm, 1/2 W	R82, R83, R84, R85	548 0049 000	Res., 100 ohm, 1/2W, 1%
R26, R39	540 0924 000	Res., 3300 ohm, 1/4W, 5%	RT1	559 0006 000	Thermistor, 1000 ohm
R27, R53	550 0006 000	Pot., 5000 ohm, 1/2 W	S1	604 0366 000	Switch, Subminiature Toggle, SPDT
R32	540 0944 000	Res., 22K ohm, 1/4 W, 5%	T1	478 0269 000	Transformer, 19kHz
R33	552 0796 000	Pot., 5K ohm, 1W	T2	478 0270 000	Transformer, 38kHz
R36, R38	540 0895 000	Res., 200 ohm, 1/4W, 5%	T3	478 0026 000	Transformer
R37, R48	552 0797 000	Pot., 100 ohm, 1 W	T4	478 0220 000	Transformer
R40	540 0935 000	Res., 9100 ohm, 1/4W, 5%	TJ1	612 0312 000	Test Point Jack, White
R41, R42, R43, R44	548 0212 000	Res., 4700 ohm, 1/2 W, 1%	TJ2	612 0311 000	Test Point Jack, Black
R46, R47	540 0864 000	Res., 10 ohm, 1/4W, 5%	XQ1	404 0197 000	Transipad
R55, R63	540 0916 000	Res., 1500 ohm, 1/4W, 5%	XQ2 thru XQ16	404 0198 000	Transipad
R56	540 0897 000	Res., 240 ohm, 1/4W, 5%	XY1	404 0132 000	Crystal Socket
R59, R74	540 0962 000	Res., 120K ohm, 1/4W, 5%	Y1	444 1129 000	Crystal, 19KC, 30°C, Circuit 814 3270 001
R65	552 0802 000	Trim Pot., 1K ohm, 1W			
R68	550 0004 000	Pot., 1K ohm, 1/2 W			
R78	540 1008 000	Res., 10 megohm, 1/4W, 5%			
R79	552 0800 000	Pot., 500 ohm, 1W			
R80	540 0909 000	Res., 750 ohm, 1/4W, 5%			
R81	540 0936 000	Res., 10K ohm, 1/4W, 5%			

#### AFC ADJUSTMENT TO COMPENSATE FOR CIRCUIT AGING:

With AFC on, tune coarse frequency counter clockwise to raise frequency -- clockwise to lower frequency -- whichever is needed. When the right peak is noted, the "jerking" effect of the AFC unit will be obvious. There are many peaks and it is easy to get on the wrong one. When the "jerking" is seen, then tune coarse frequency control slightly counter clockwise. If frequency rises then you are in the ball park. If a counter clockwise turn lowers the frequency, then you are on the wrong side of the curve. Turn around the same peak to the other side and see if the effect of a counter clockwise turn is a rise in frequency -- if it is, then you're practically home free. Now, turn the AFC unit off and note the direction the frequency goes. If the frequency goes negative, then turn AFC back on and tune coarse frequency control counter clockwise about 500 cycles. Return to zero, with AFC vernier control; then switch off AFC again to note change. Repeat this process until frequency will remain on scale at least for a few seconds without AFC on.

#### NOTE:

When modulated oscillator and its associated AFC unit are operating properly, a counter clockwise turn of the coarse control will raise frequency and a clockwise turn will lower frequency. This is contrary to what one might think, so don't let this confuse you. The AFC vernier control is turned clockwise to raise frequency and counter clockwise to lower frequency.





VOLTAGE MEASUREMENTS  
 RMS VOLTAGE MEASURED WITH VOM  
 DC VOLTAGE MEASURED WITH VTVM  
 P-P WAVE SHAPES MEASURED WITH SCOPE

NOTE 1 - SUBJECT TO VARIATION

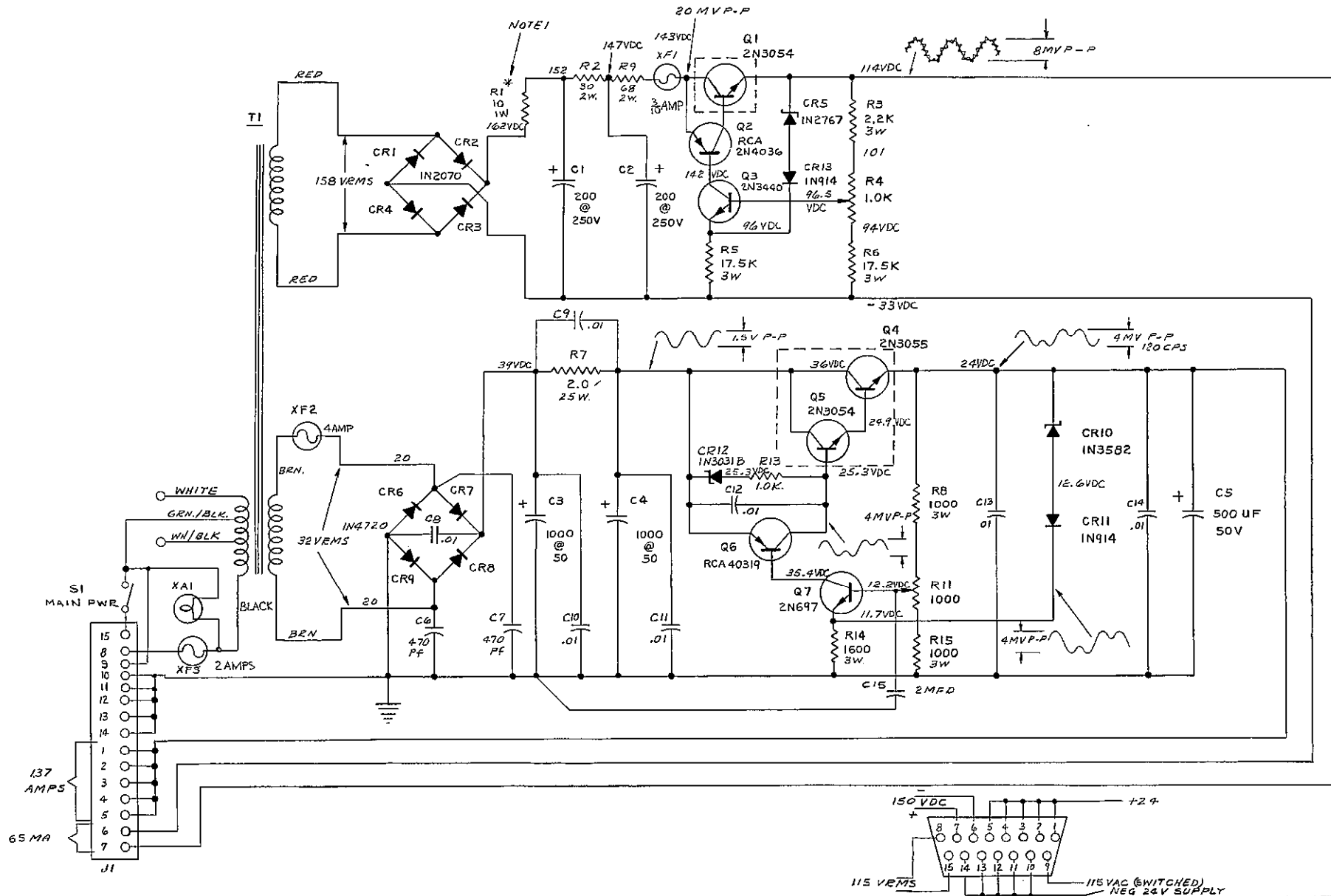

NO.	DATE	REVISION	DITM	ENG	ECN
1	12/1/64	CORRECTED DATA	AWL		
2	2/11/65	R1 WAS 100, 3W	AWL		

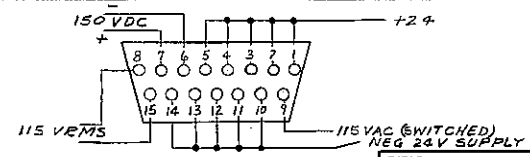

J1, VIEW FROM REAR

TITLE SCHEMATIC - POWER SUPPLY  
 M-G425 SOLID STATESMAN  
 FM EXCITER

GATES RADIO COMPANY  
 QUINCY, ILLINOIS

DR. BY DL. CH. BY ENG. 12-20-64 DWG. NO. 838-1955-001  
 DATE 8-17-65 H. Stanton

NO.	DATE	REVISION	DESN	ENG	ECN
1	8/23/66	REDRAWN	TLL		
2	9/10/66	REVISED	JCY		
3	12/4/66	REVISED <i>4 VTR</i>	AWC		
4	2/19/67	REVISED	AWC		

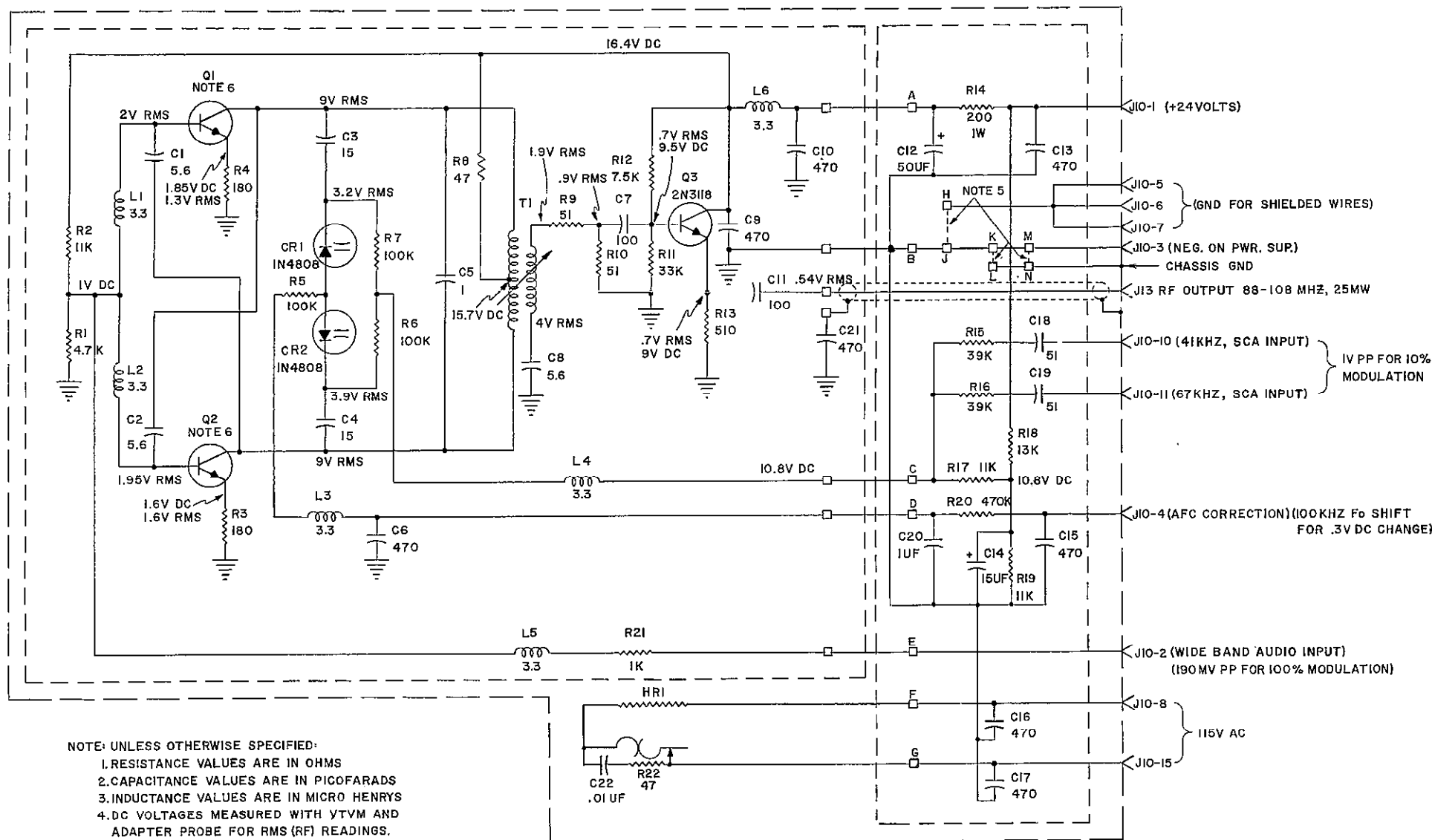

- NOTE: UNLESS OTHERWISE SPECIFIED:
1. RESISTANCE VALUES ARE IN OHMS
  2. CAPACITANCE VALUES ARE IN PICOFARADS
  3. INDUCTANCE VALUES ARE IN MICRO HENRYS
  4. DC VOLTAGES MEASURED WITH YTMV AND ADAPTER PROBE FOR RMS (RF) READINGS. (RMS READINGS MAY VARY WIDELY.)
  5. JUMPER CONNECTIONS MAY VARY PER UNIT. MOST DESIRABLE CONNECTIONS ARE DETERMINED ON FINAL TEST.
  6. GATES SPEC. 914-6003-001

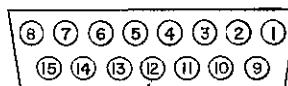

J10 (BACK VIEW)

TITLE SCHEMATIC - MOD. OSCILLATOR M6425 SOLID STATESMAN FM EXCITER			
GATES RADIO COMPANY QUINCY, ILLINOIS			
DR. BY J B	CH. BY	ENG. 12-20-66	DWG. NO.
DATE 12-26		<i>H. J. ...</i>	838-2157-001



827 1630-001

REV.	DATE	REVISION	DTM	ENG	ECN
1	12/19/66	REVISED	dwk	WF	

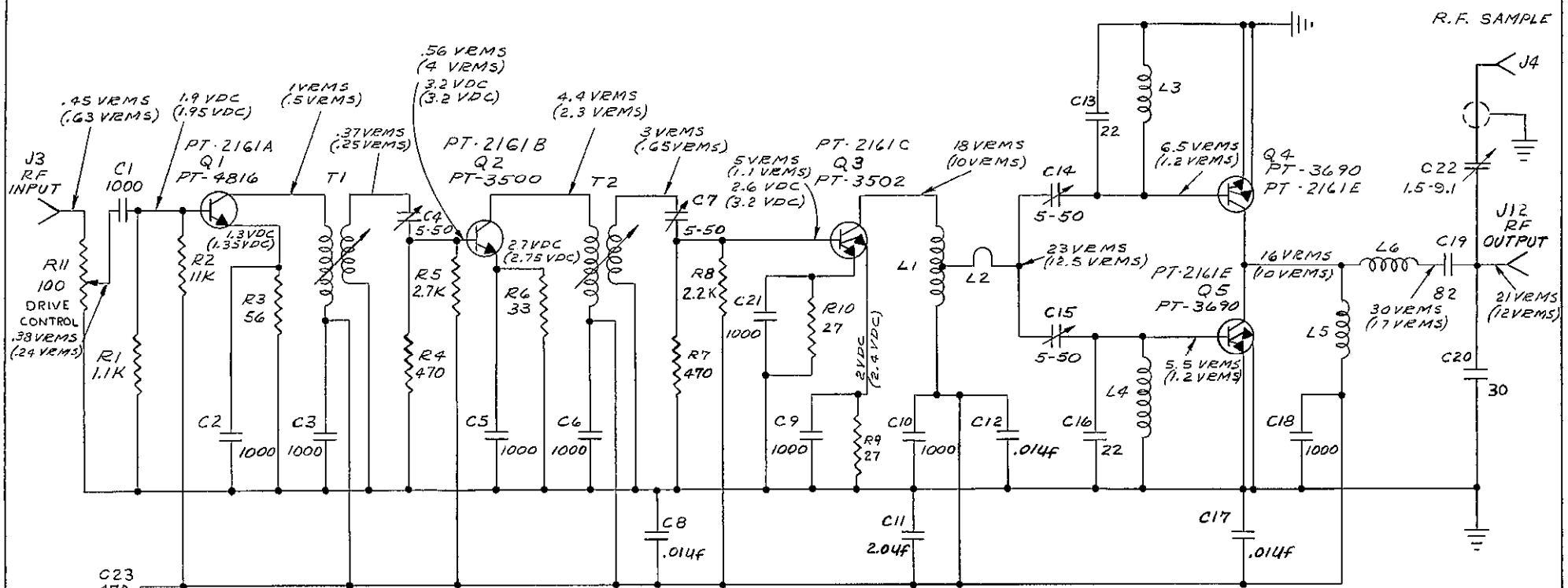

J2-3 NEG  
 J2-1 +24 V.  
 J2+24 VOLTS D.C. @ 1.0 AMPS  
 1.1A AT 10 WATT LEVEL  
 .8A AT 3.2 WATT LEVEL  
 .4A AT NO DRIVE CONDITION

NOTE: ALL CAPACITORS IN PF UNLESS OTHERWISE STATED  
 VOLTAGE MEASUREMENTS WITH HP-410B VTVM, USING  
 PROBE FOR RF, RMS VALUES. VOLTAGES IN PARENTHESIS  
 ARE AT 3 WATT OUTPUT LEVEL. OTHERWISE, 10 WATT OUTPUT

TITLE			
SCHEMATIC, 10 WATT RF AMP			
SOLID STATESMAN			
FM EXCITER M6425			
GATES RADIO COMPANY			
QUINCY, ILLINOIS			
DR. BY	CH. BY	ENG.	DWG. NO.
DATE 7/13/65		12-20-66 H. Stratman	827-1630-001

STANPAT CO. WHITESTONE, N.Y. U.S.A.

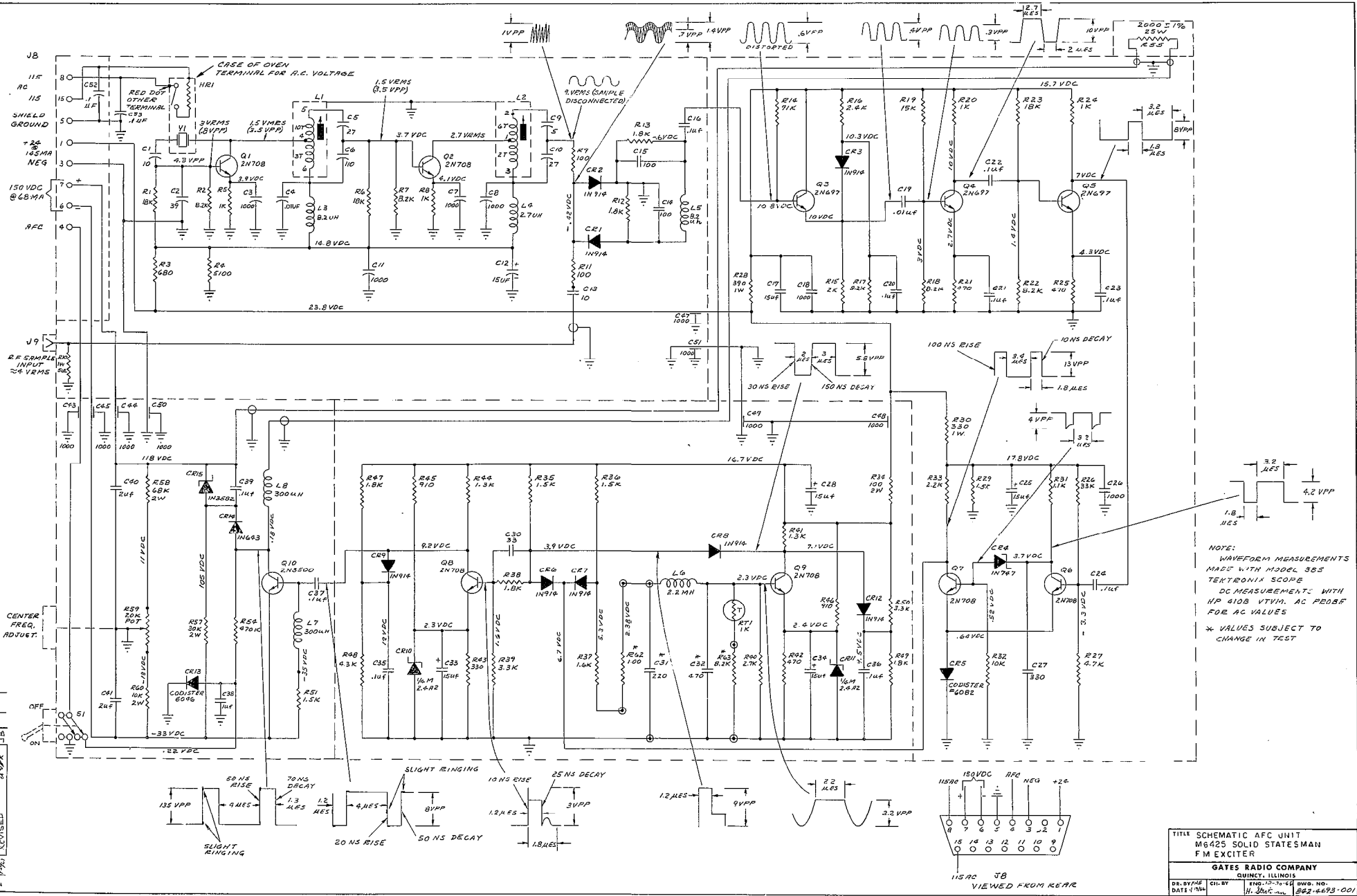

TITLE SCHEMATIC AFC UNIT  
 M6425 SOLID STATESMAN  
 FM EXCITER

GATES RADIO COMPANY  
 QUINCY, ILLINOIS

DR. BY PJE  
 DATE 4/78

CH. BY  
 H. JAC

ENG. 12-75-54  
 DWG. NO.  
 802-6693-001

NO.	DATE	REVISION	BY	CHKD.
1		DESIGNED AND DRAWN		
2		REVISED		
3		REVISED		
4		REVISED		

NO.	DATE	REVISION	BY	ENG.	ECN.
1	2/2/66	REVISED	d.v.k.	W.F.	

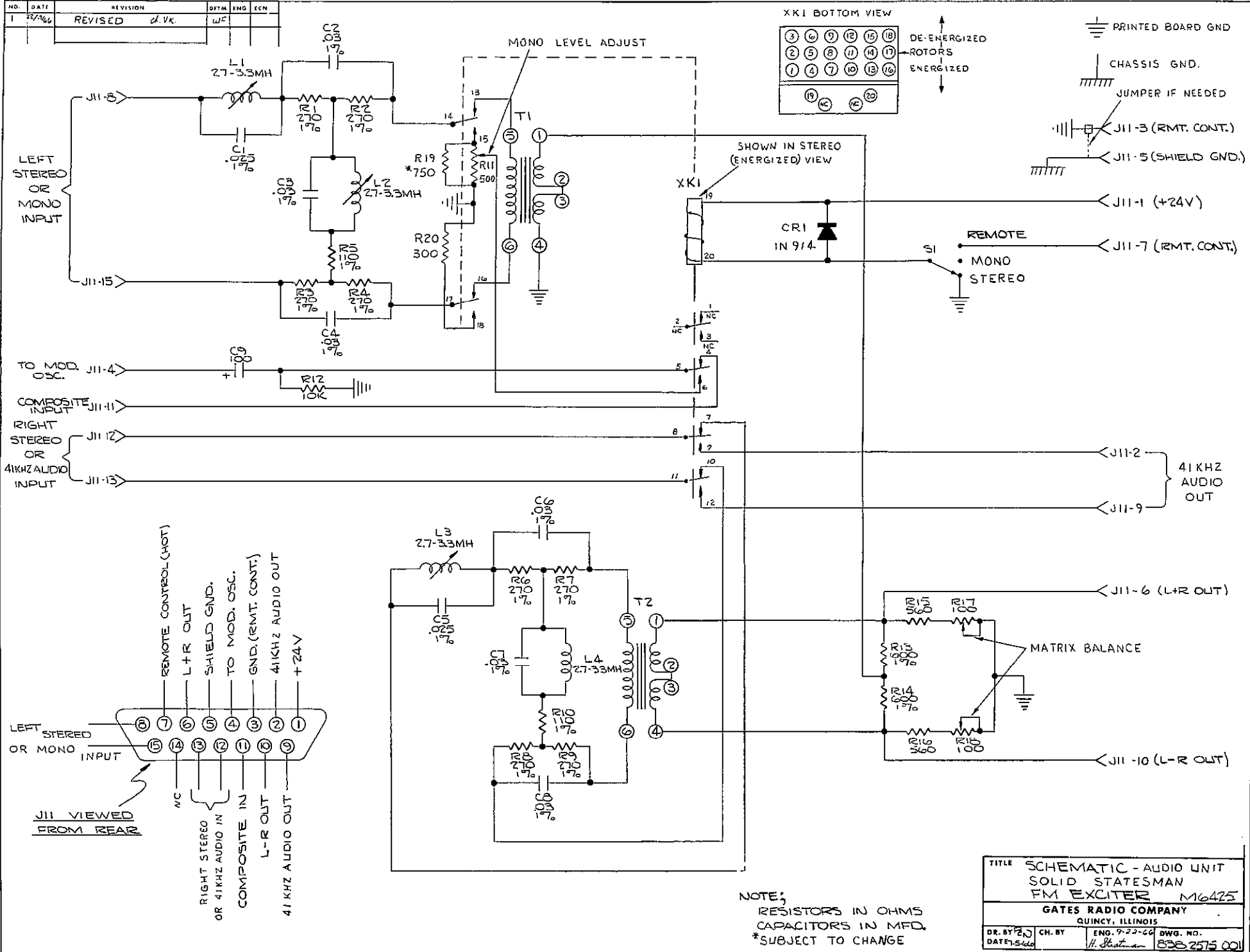

TITLE SCHEMATIC - AUDIO UNIT			
SOLID STATESMAN			
FM EXCITER M6425			
GATES RADIO COMPANY			
QUINCY, ILLINOIS			
DR. BY <i>[Signature]</i>	CH. BY	ENG. 9-22-66	DWG. NO.
DATE 7-5-66		H. St. am	838 2575 001

NO.	DATE	REVISION	DFTM	ENG	ECN
1	12/13/65	CORRECTED d.v.K.			

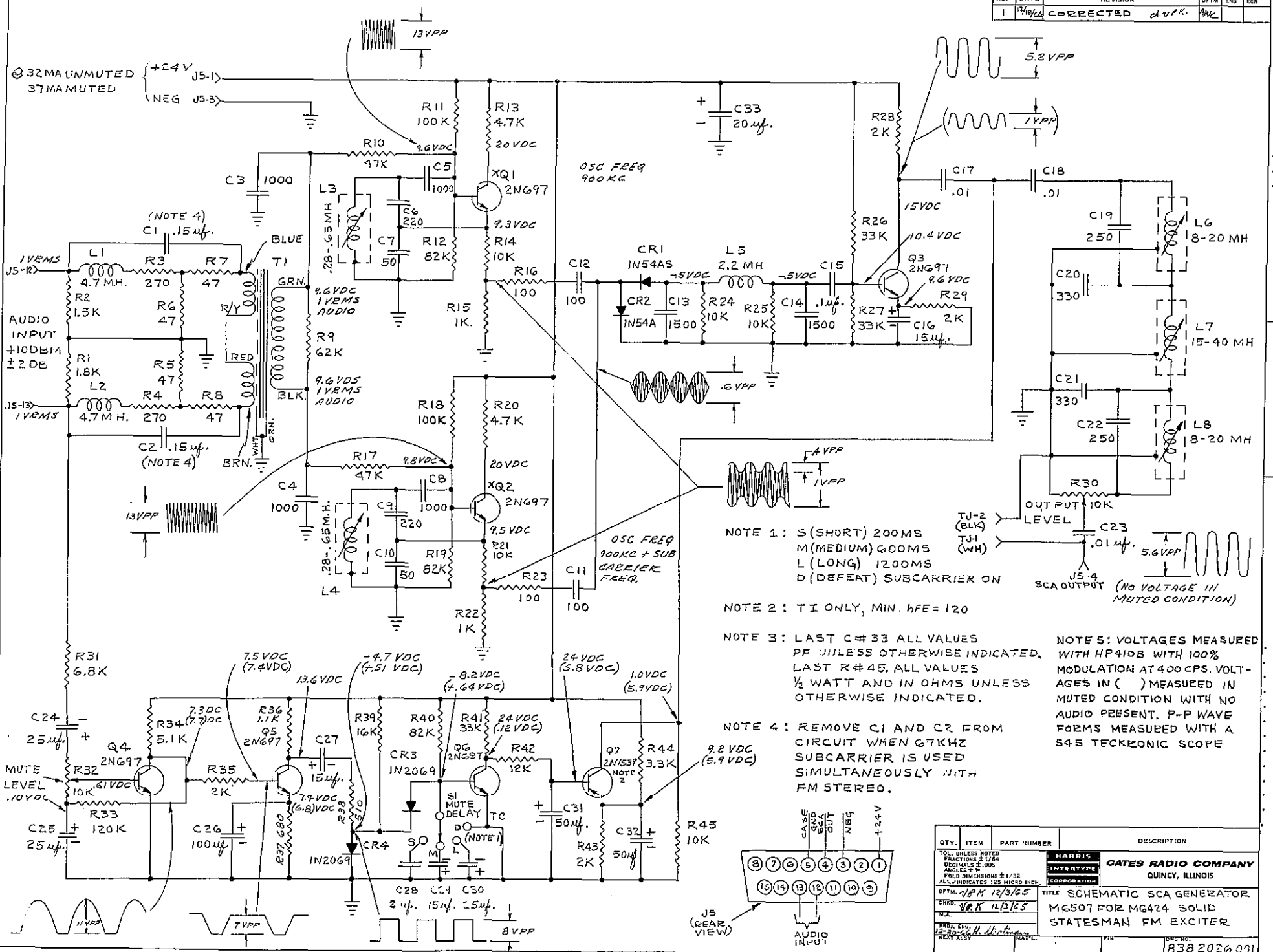

NOTE 1: S (SHORT) 200MS  
M (MEDIUM) 600MS  
L (LONG) 1200MS  
D (DEFEAT) SUBCARRIER ON

NOTE 2: T I ONLY, MIN. hFE = 120

NOTE 3: LAST C# 33 ALL VALUES  
PF UNLESS OTHERWISE INDICATED,  
LAST R# 45, ALL VALUES  
1/2 WATT AND IN OHMS UNLESS  
OTHERWISE INDICATED.

NOTE 4: REMOVE C1 AND C2 FROM  
CIRCUIT WHEN 67KHZ  
SUBCARRIER IS USED  
SIMULTANEOUSLY WITH  
FM STEREO.

NOTE 5: VOLTAGES MEASURED  
WITH HP410B WITH 100%  
MODULATION AT 400 CPS. VOLT-  
AGES IN ( ) MEASURED IN  
MUTED CONDITION WITH NO  
AUDIO PRESENT. P-P WAVE  
FORMS MEASURED WITH A  
545 TECKRONIC SCOPE

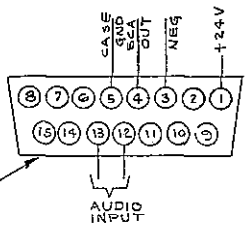

QTY.	ITEM	PART NUMBER	DESCRIPTION
TOL. UNLESS NOTED FRACTIONS 1/64 DECIMALS 0.005 ANGLES 2° HOLE DIMENSIONS ± 1/32 ALL UNDIMENSIONED 128 MICRO INCH.			
DFTM: <i>W.P.H.</i> 12/3/65		HARRIS GATES RADIO COMPANY QUINCY, ILLINOIS	
DRG: <i>W.P.H.</i> 12/13/65		INTEGRITY	
M.P.L.		CORPORATION	
PROJ. ENG. <i>W.P.H.</i>		TITLE SCHEMATIC SCA GENERATOR	
REV. ASSY		MG607 FOR MG424 SOLID STATESMAN FM EXCITER	
		DWG NO. 838 2026 001	

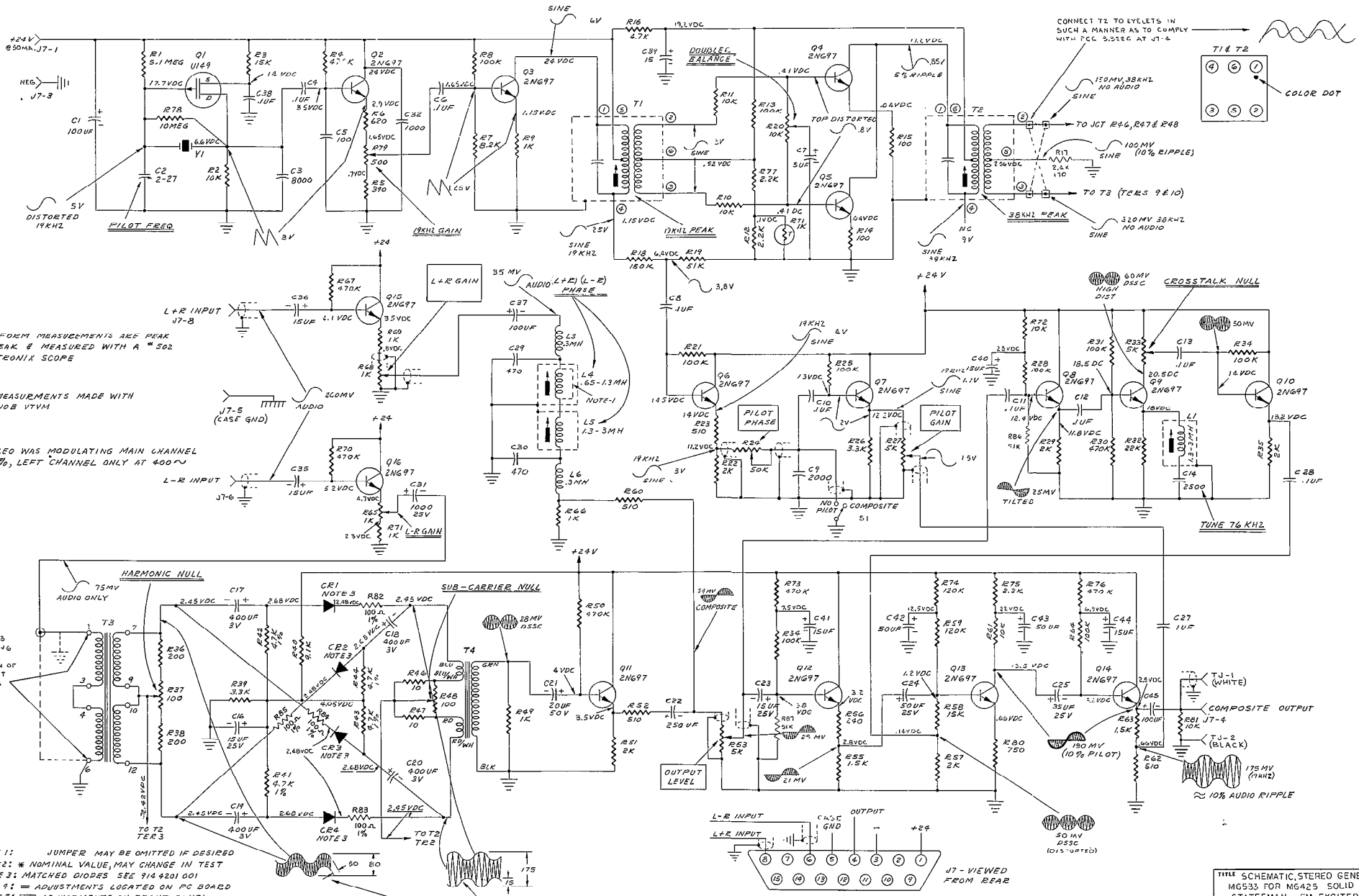

WAVEFORM MEASUREMENTS ARE PEAK TO PEAK & MEASURED WITH A \*502 TEKTRONIX SCOPE

D.C. MEASUREMENTS MADE WITH HP410B VTVM

STEREO WAS MODULATING MAIN CHANNEL 100%, LEFT CHANNEL ONLY AT 400%

NOTE 1: JUMPER MAY BE OMITTED IF DESIRED  
 NOTE 2: \* NOMINAL VALUE, MAY CHANGE IN TEST  
 NOTE 3: MATCHED DIODES 5E2 914 4201 001  
 NOTE 4: ADJUSTMENTS LOCATED ON PC BOARD  
 NOTES: □ ADJUSTMENTS ON FRONT PANEL

38KHZ IS IN PHASE AND AUDIO IS 180° OUT OF PHASE AT TWO POINTS SHOWN

TITLE SCHEMATIC, STEREO GENERATOR	
MG533 FOR MG425 SOLID	
STATESMAN FM EXCITER	
GATES RADIO COMPANY	
QUINCY, ILLINOIS	
58 BY 2702 CH. BY	ENG. 7-27-64 DWG. NO.
DATE: 6/64	N. J. L. 18424887001

SECTION 7 - ILLUSTRATIONS

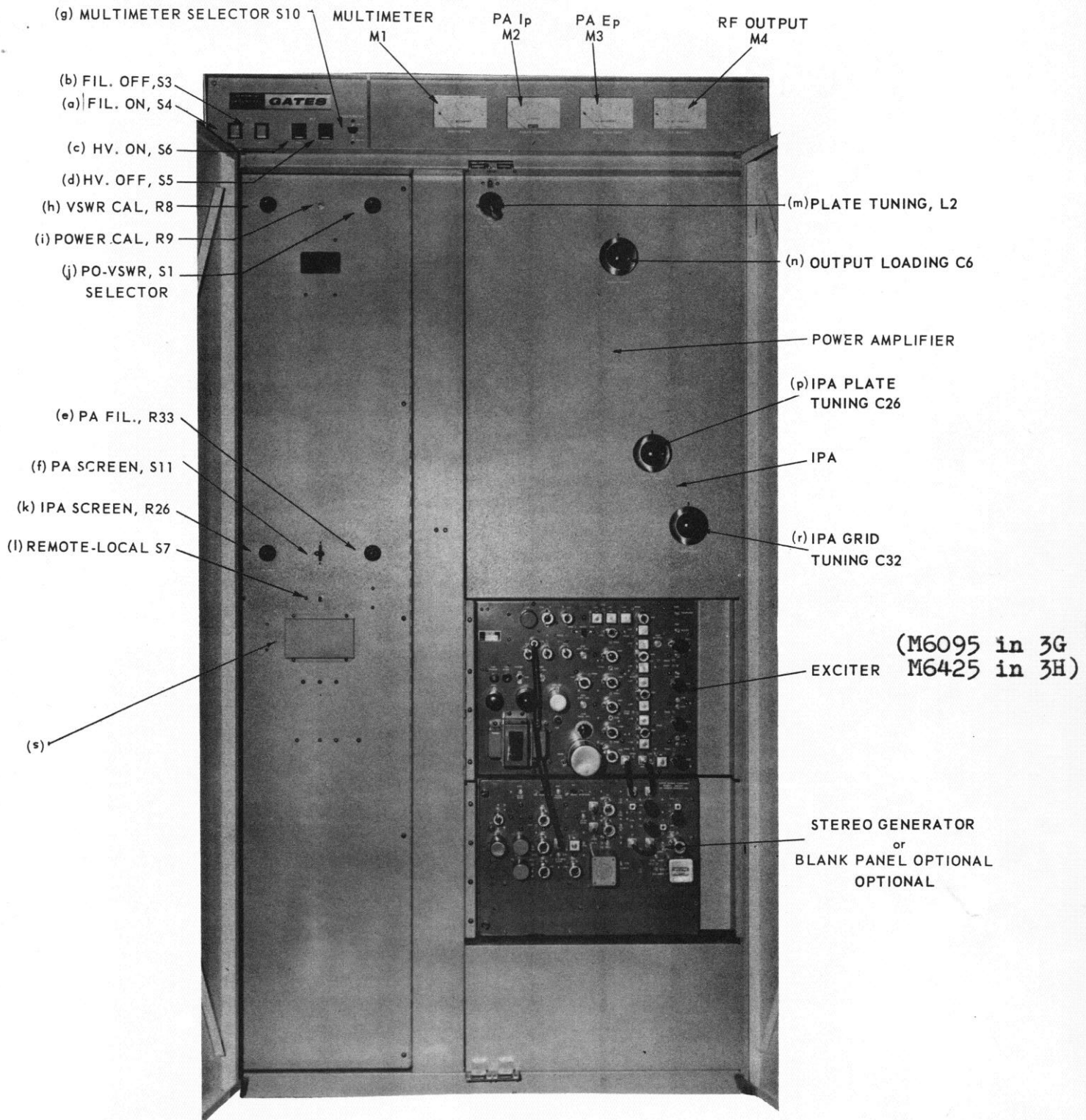

Figure 7.1  
Front View, Showing Operating Controls

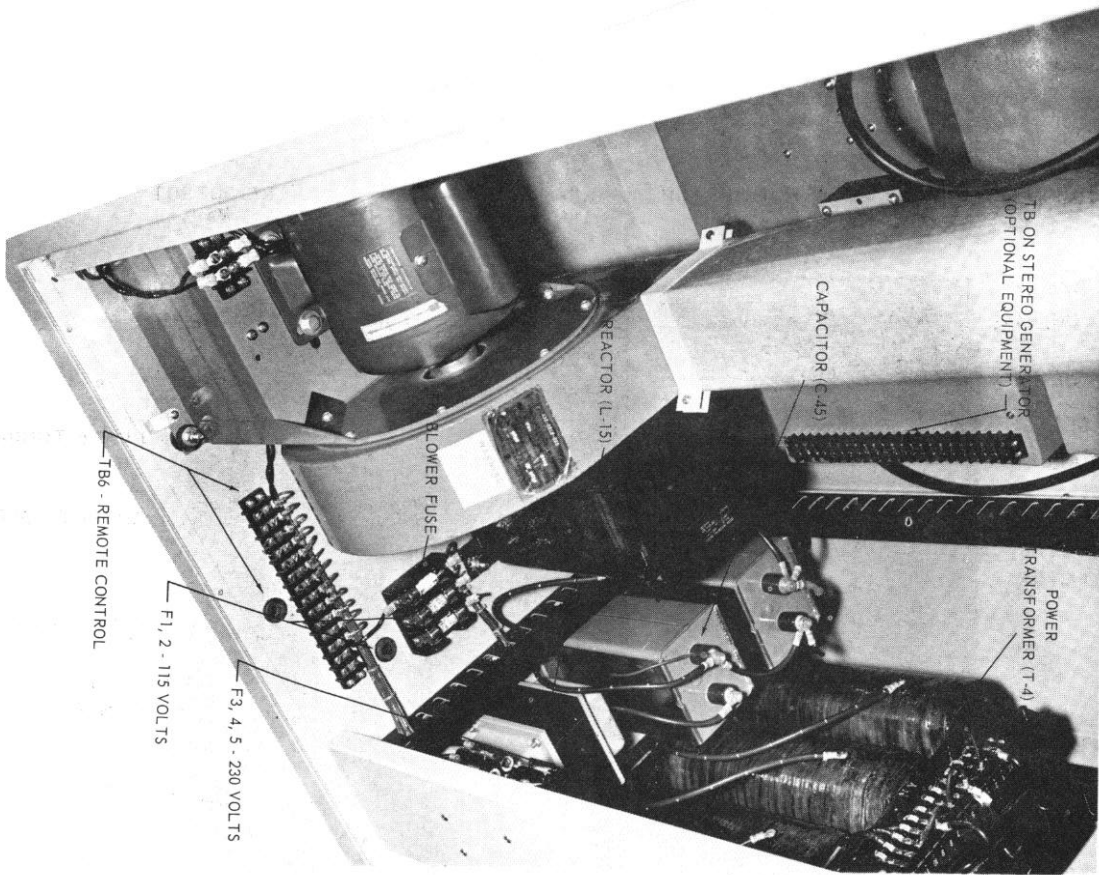

Figure 7.2  
Floor of Transmitter, (Rear View)

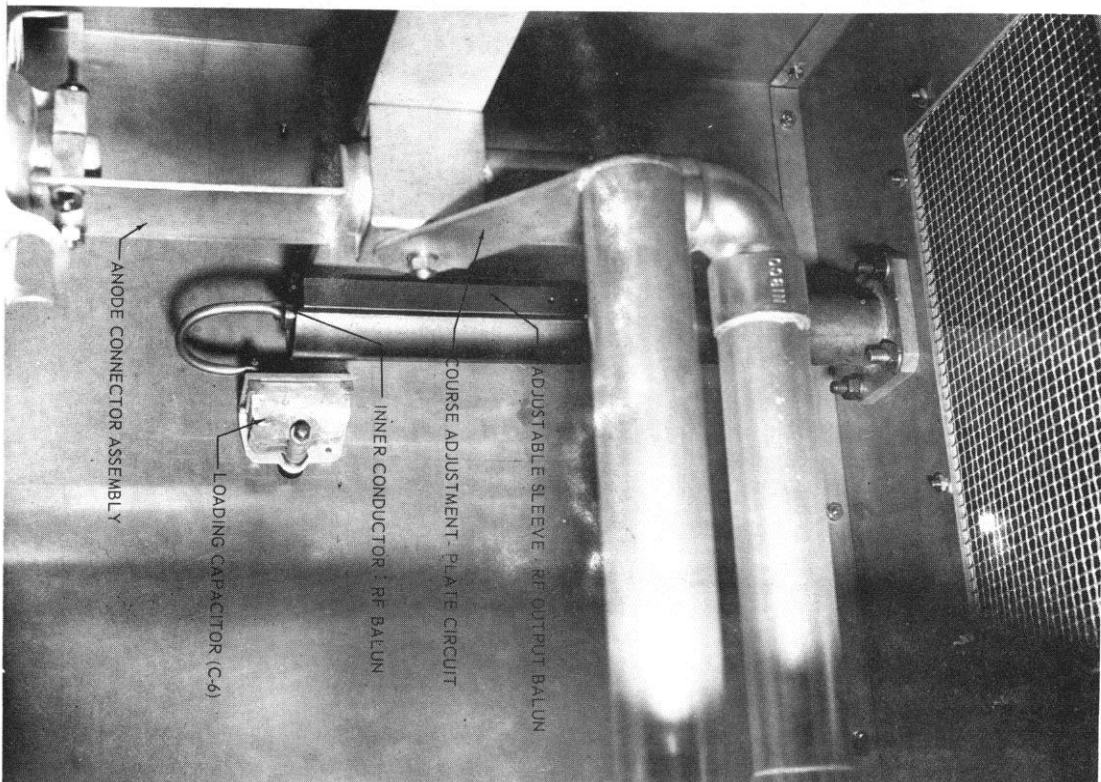
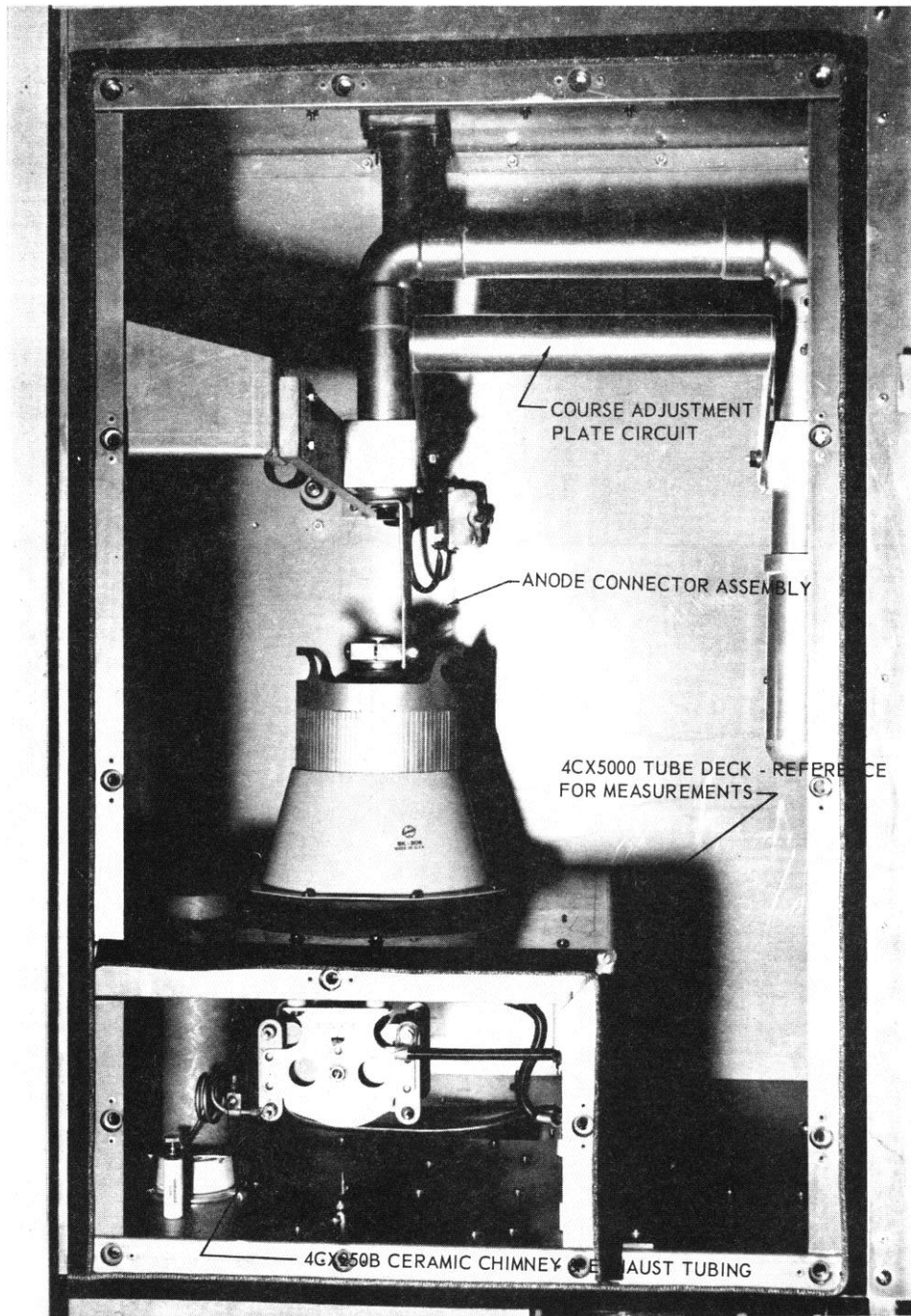

Figure 7.3  
RF Output Balun



800 571 011

Figure 7.4  
RF Cubicle





TUNING  
(INCHES FROM  
TUNING BAR  
TO PA DECK)

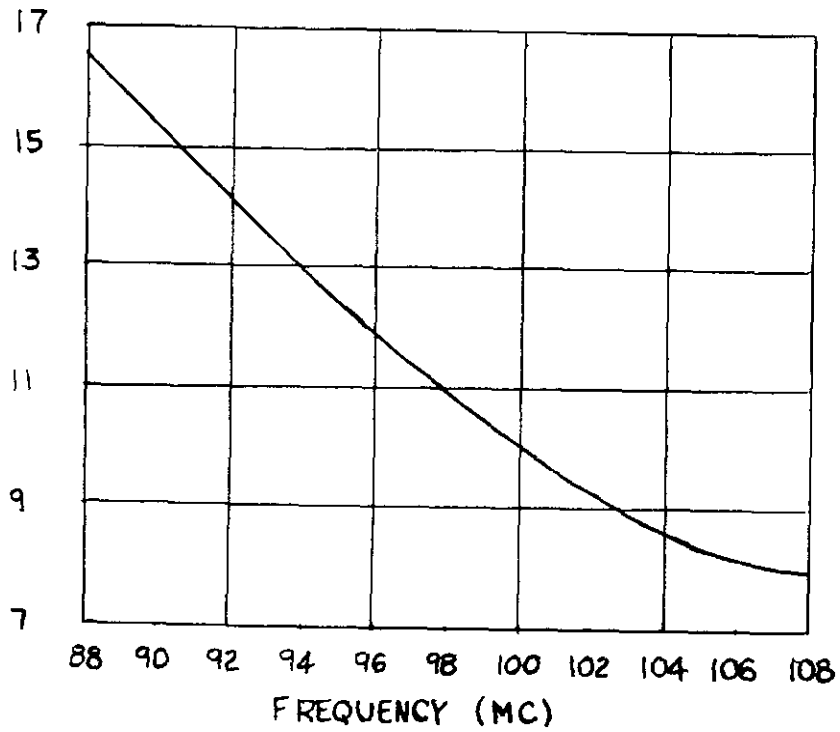

PA COARSE TUNING.

FM 3G// 3 KW FM TRANSMITTER

FIG 7.6

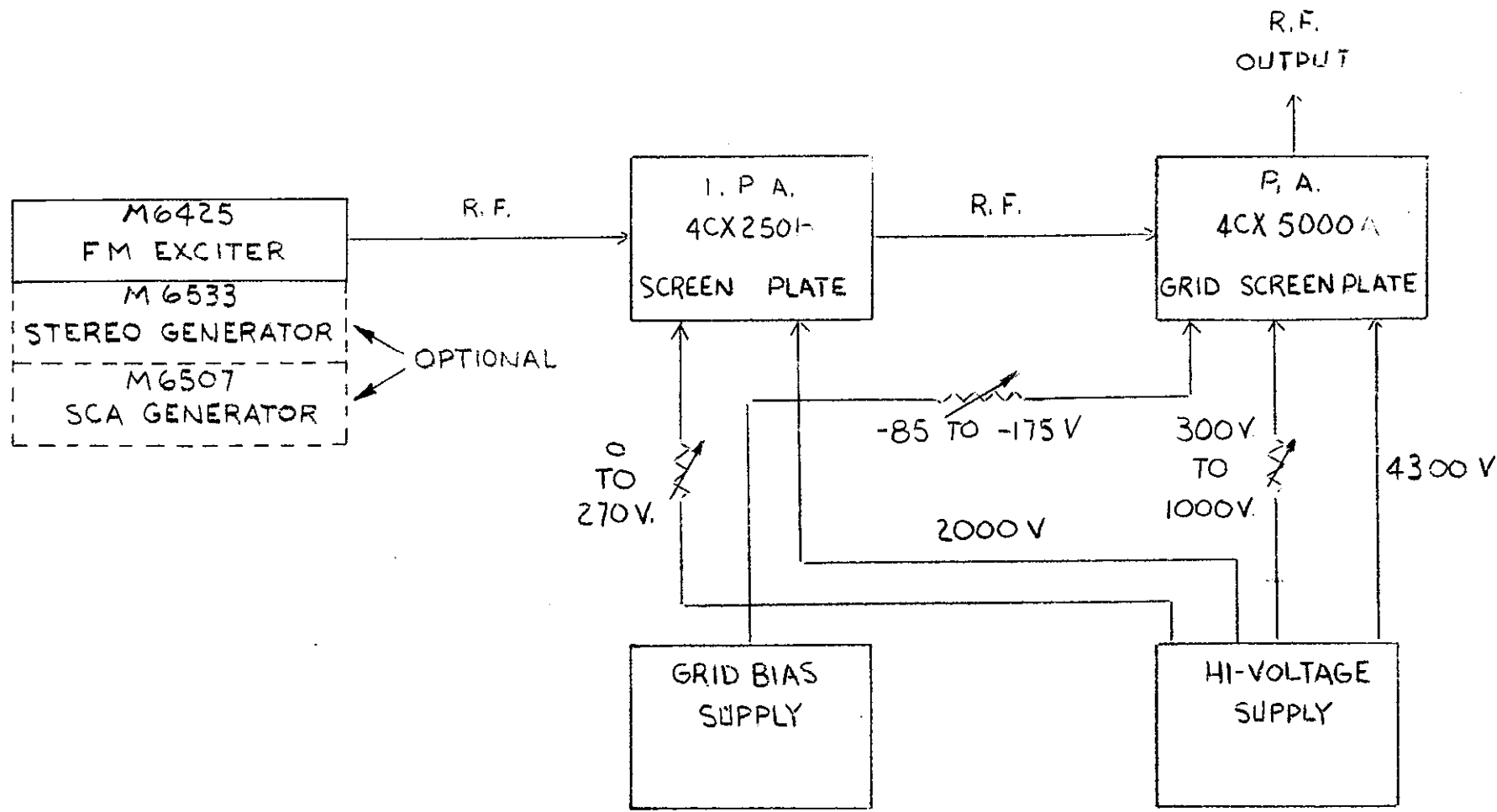

TOL. UNLESS NOTED FRACTIONS ± 1/64 DECIMALS ± .005 ANGLES ± 1° HOLE DIMENSIONS ± .002 ALL √ INDICATES 125 MICRO INCH.		<b>HARRIS</b> <b>INTERTYPE</b> <b>CORPORATION</b>		<b>GATES RADIO COMPANY</b> QUINCY, ILLINOIS	
DFTM <b>RJM 3-24-67</b>		TITLE <b>BLOCK DIAGRAM</b>			
CHKD.		<b>FM 5H FM 3H</b>			
M.E.		PRD. ENG <b>FJA 3-27-67</b>			
NEXT ASSY.		DWG. NO. <b>814-6028-001</b>			

IPA & PA SIMPLIFIED SCHEMATIC DIAGRAM  
3 KW FM TRANSMITTER

814 3175-001

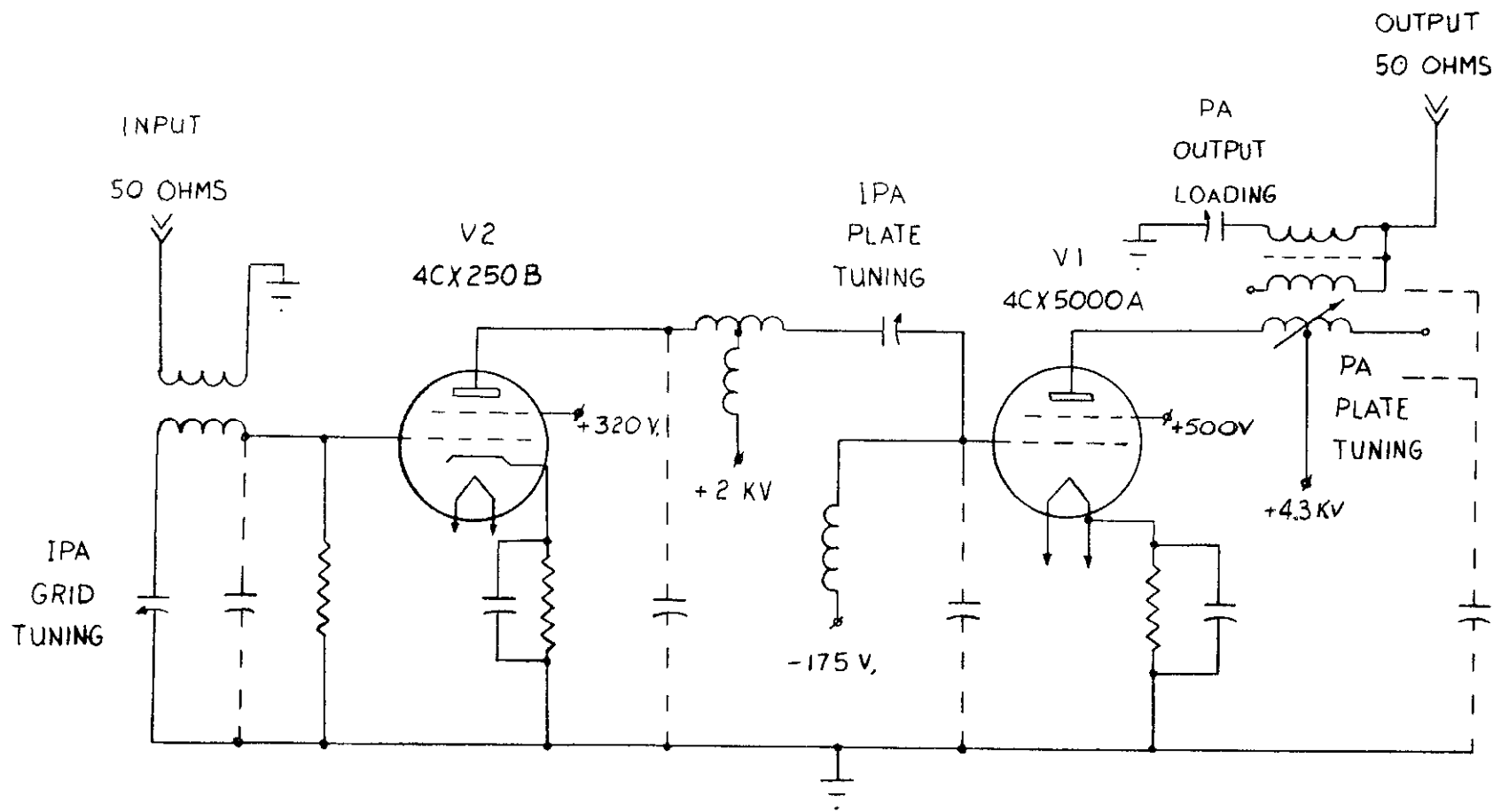

IPA & PA SIMPLIFIED SCHEMATIC DIAGRAM

FM 3G/H

FIG. 7.8

814-3175-001

2.4 kW

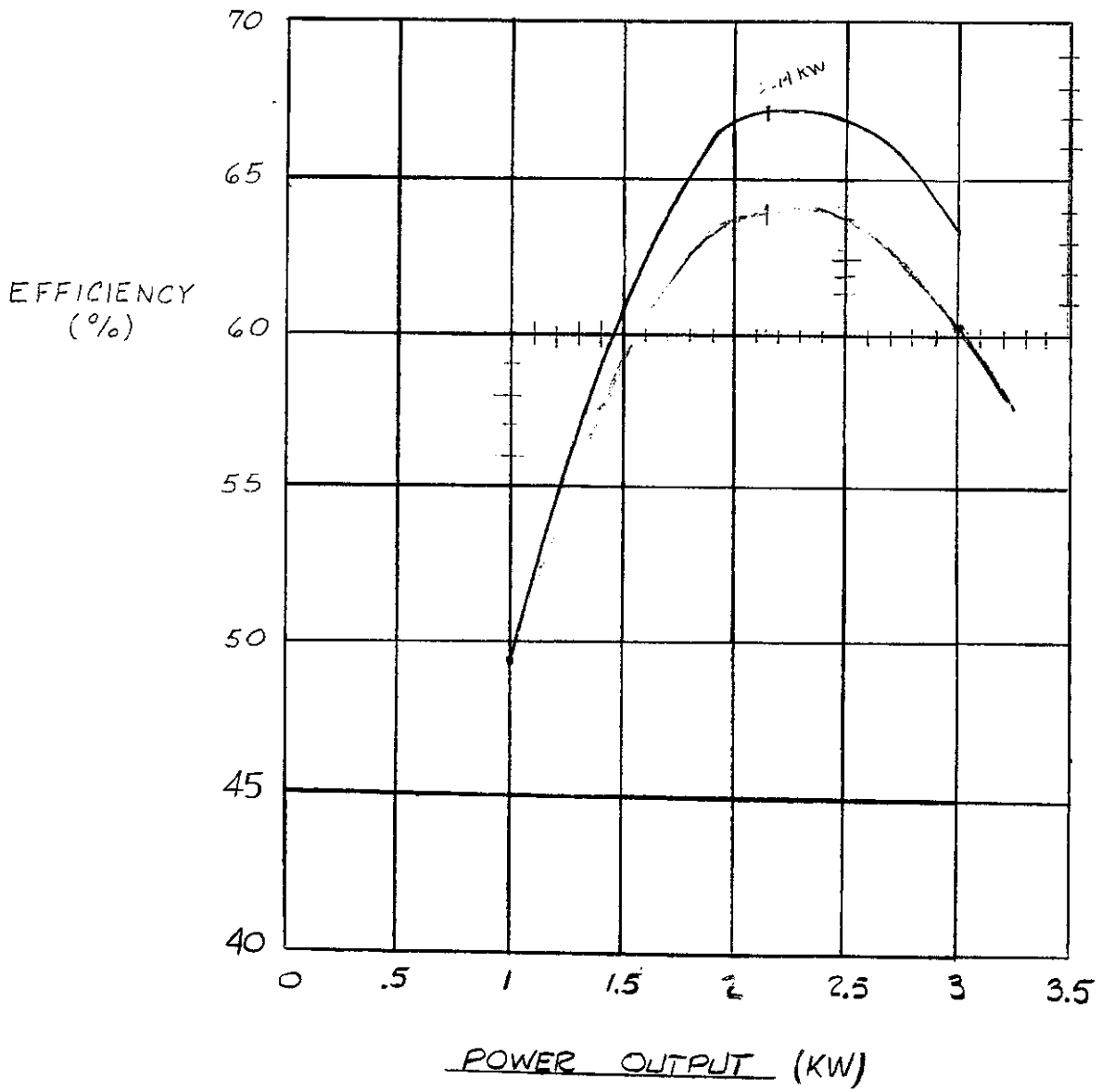
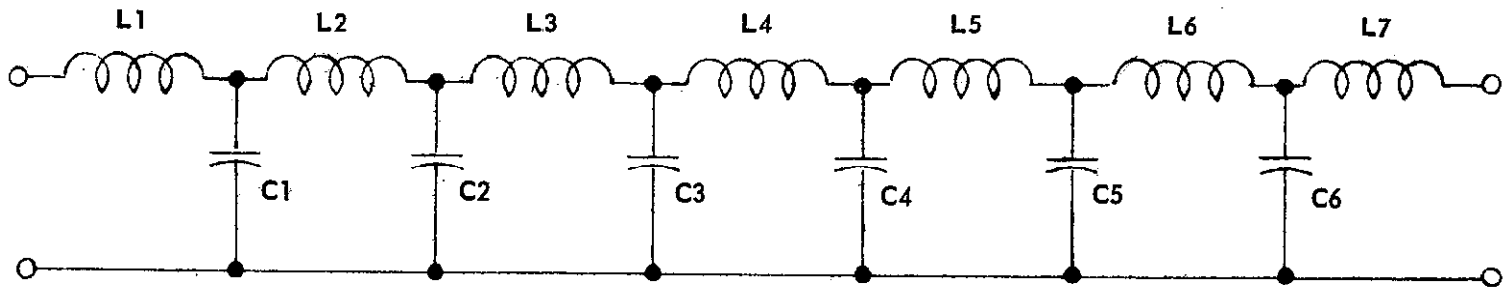
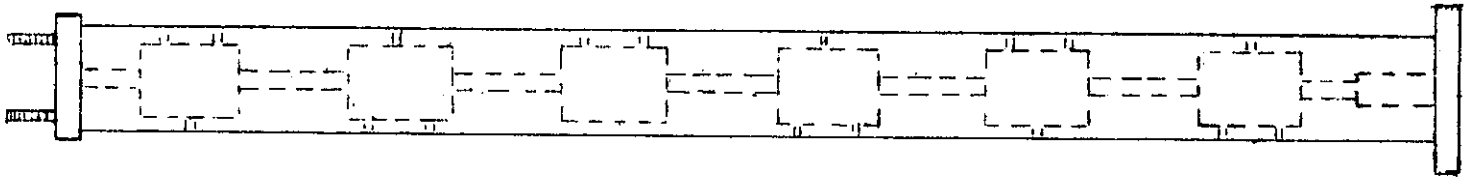

FIG 7.9

P.A. EFFICIENCY CURVE  
FM3G/μ 3 KW FM TRANSMITTER

814-3173 - 001



EQUIVALENT CIRCUIT - LOW PASS FILTER

FIGURE 7.11

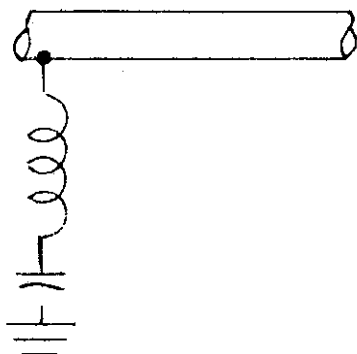
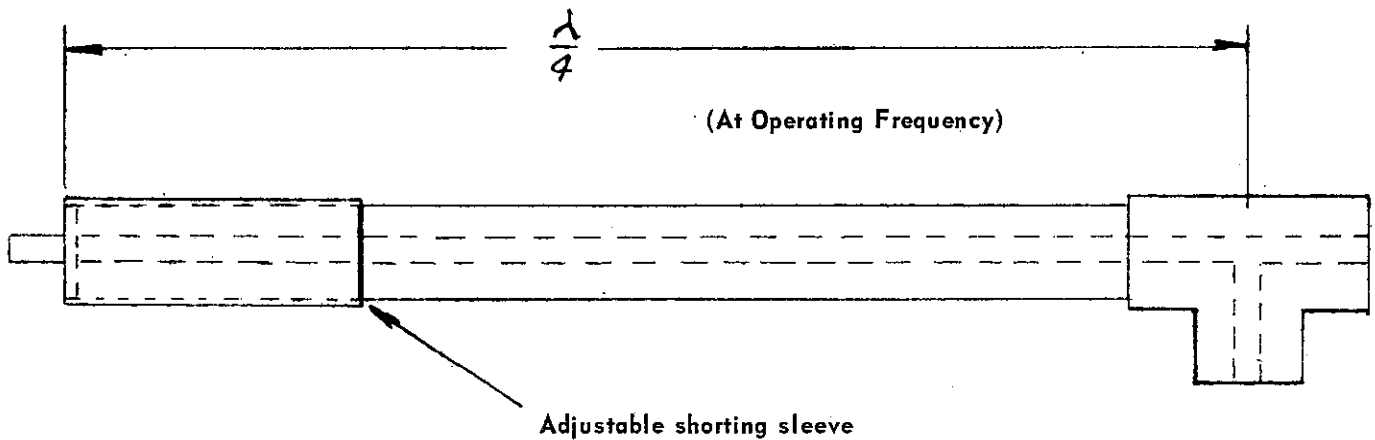

Appearance of Notch Filter at Second Harmonic

At frequencies below resonance the "Stub" appears as an inductance.

At frequencies above resonance the "Stub" appears as a capacity.

At the second harmonic frequency, the "Stub" appears as a series resonant circuit or dead short.

2nd HARMONIC FILTER

FIGURE 7.12

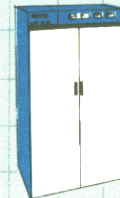
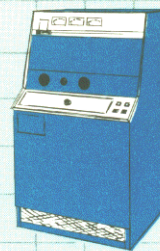
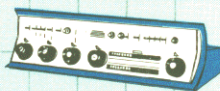

# Service Bulletin

## MAINTENANCE AND MODIFICATION DATA

Gates Radio Co., Quincy, Illinois

**Equipment:** Gates TE-1 DCFM Exciter

**Bulletin No.** FM-038MWM

**Date** May 14, 1969

**Subject:** 3 dB Isolation Network

A 3 dB pad is supplied with the Gates TE-1 exciter for isolation between the 10 watt RF amplifier and the following stage. Dissipation of this network has been found to be marginal. Failure of this pad may change the value of the load of the 10 watt RF amplifier and could cause failure of one or both of the output transistors.

A change in the 3 dB isolation network is recommended to prevent the possibility of such a failure. The present configuration of the 3 dB isolation network is as follows:

*This change made 7/69  
 R.C.M.*

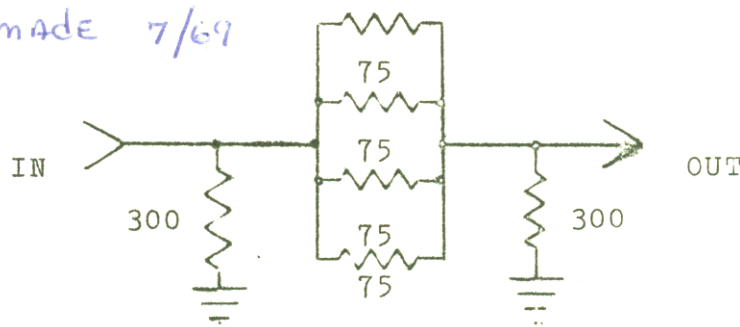

The 3 dB isolation network is contained in a 1-5/8" x 2-1/4" x 2-3/4" aluminum box mounted inside the transmitter cabinet directly behind the TE-1 output connector.

The network should be modified as follows:

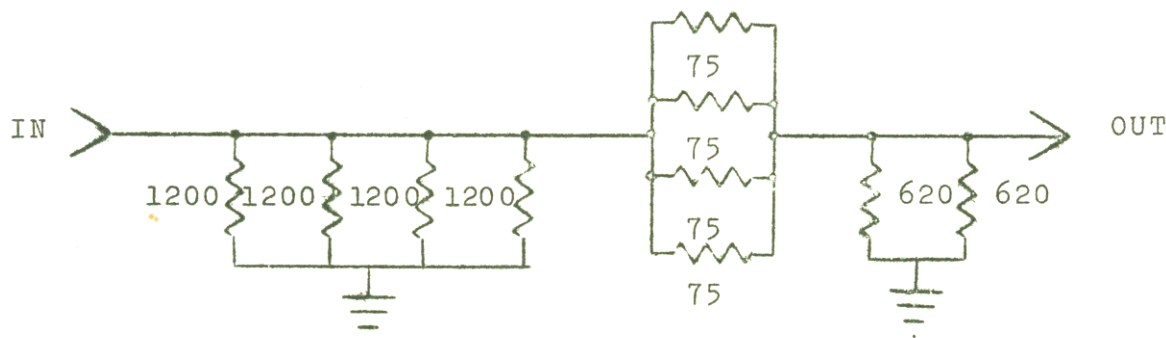

All resistors are 2 watt, 5%.

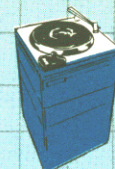
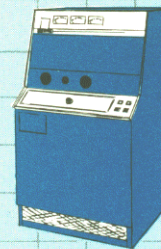
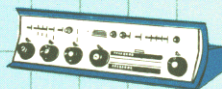

# Service Bulletin:

## MAINTENANCE AND MODIFICATION DATA Gates Radio Co., Quincy, Illinois

**Equipment:** Gates TE-1 DCFM Exciter (M-6425)

**Bulletin No.** FM-036MWM

**Date** April 24, 1969

**SUBJECT:** Service Tips on Frequency Adjustment of the TE-1

The modulated oscillator in the Gates TE-1 exciter is a free-running, slug-tuned oscillator, capable of being tuned to any frequency between 88 and 108 MHz. The automatic frequency control (AFC) module provides a nominal 200 KHz IF output which generates a DC correction voltage to maintain the desired output frequency of the modulated oscillator. Normally, the AFC unit will compensate for modulated oscillator frequency deviations of as much as  $\pm 75$  KHz.

In addition to the modulated oscillator and AFC unit, the regulated power supply and RF amplifier may affect frequency stability.

Frequency correction required falls into one of three categories:

- A. Minor Frequency Error--can be observed "on scale" on the frequency monitor, but approaches FCC limits.
- B. Major Frequency Error--gives an "off scale" indication on the frequency monitor.
- C. Extreme Frequency Error--results in loss of exciter output.

The direction and approximate magnitude of deviation from the desired frequency should be determined before making any frequency adjustment. The method of frequency adjustment depends on the amount of correction required.

### ADJUSTMENT PROCEDURES

#### A. Minor Frequency Error

1. Periodic frequency variations of several hundred Hertz can be considered normal, and no attempt should be made to adjust frequency unless FCC limits are approached. The meter scale on most frequency monitors is calibrated



+3 KHz. Frequency errors within this range should be corrected with the frequency vernier dial located on the front panel of the AFC module. The vernier dial should normally remain within one full turn of the recorded setting indicated in the factory test data. If the vernier dial does not fall within this range, proceed with Section B.

#### B. Major Frequency Error

1. Reset the AFC frequency vernier dial to the setting indicated in the test data supplied with the transmitter.
2. Adjust the coarse tuning control, located above Plug P-10 on the front panel of the modulated oscillator, very slightly. A tuning tool for this purpose is located inside the front drop-down panel of the TE-1 cabinet. This adjustment is made with the AFC function ON. Keep in mind that slight adjustment of this slug can vary the frequency several MHz.
3. If the frequency is above center frequency (high), the coarse tuning control should be turned clockwise. If the frequency is below center frequency (low), the coarse tuning control should be turned counterclockwise. Clockwise adjustment of the coarse frequency control should lower frequency and counterclockwise adjustment of this control should increase frequency. If not, see NOTE following Step 5.
4. Turn the AFC function OFF. For maximum stability, it is desirable that the observed frequency fall somewhere on the scale of the frequency monitor meter, with AFC function defeated. If the free-running frequency is not observed to be on scale, repeat Step 3 with the AFC ON. It may be necessary to repeat this step until the free-running frequency is observed to be on scale. The free-running frequency of the TE-1 exciter may appear to fluctuate as observed on the frequency monitor. This is a normal condition.
5. Turn the AFC function ON. Frequency should return to near center scale as observed on the frequency monitor. The AFC frequency vernier dial can now be readjusted for the exact frequency desired.

NOTE: The DC correction voltage supplied to the modulated oscillator is derived from mixer action in the AFC unit. It is possible to lock the modulated oscillator frequency with an "image" frequency of the AFC unit. If an "image" is affecting the output frequency, action of the coarse tuning control in the modulated oscillator will appear opposite that described in Step 3. If this situation

occurs, further adjustment of the coarse frequency control is required to determine whether the image frequency is above or below fundamental frequency. It then becomes necessary to repeat the procedures outlined in this section.

### C. Extreme Frequency Error

1. Most Gates FM transmitters are protected with an "under-drive" relay in the interlock circuit. Therefore, it may be impossible to operate the transmitter, and observe frequency on the frequency monitor without output from the exciter. Frequency errors of this magnitude should be corrected as follows:

Return the oscillator to within the bandpass of the exciter RF amplifier by monitoring grid or cathode current of the following stage. It may be impossible to determine whether the oscillator is above or below the desired operating frequency. Therefore, rotation of the coarse tuning adjustment may be required in either direction. (An alternate method would be to feed the exciter output through a wattmeter (or other RF indicating device) into a nominal 50 ohm load and adjust the modulated oscillator coarse tuning control for maximum exciter RF output.) Output of the TE-1 must be terminated at all times in a 50 ohm resistive load if not connected to the input of the following stage.

2. The IPA or final stages of the transmitter should not be retuned at this time, even though full transmitter power output may not be indicated. If, for any reason, these controls have been changed, they should be returned to the normal operating positions, or to those settings indicated in the factory test data.
3. As sufficient output is obtained from the exciter to allow operation of the transmitter, the modulation monitor can be used to permit coarse frequency correction because of its wide-band input. Observe the monitor RF input on the front panel meter and adjust the coarse tuning control of the modulated oscillator for maximum indication. This should return the frequency to within  $\pm 500$  KHz, or close enough to allow further adjustment as indicated in Section B.

This bulletin is intended as a "tuning procedure" only. Frequency deviation may be the result of component failure, in which case the methods outlined in the M-6425 instruction book, under the heading of "Troubleshooting," should be followed.

S.O. 752-74934

F.O. 24225 74934

FACTORY TEST DATA

GATES MODEL TE I FM EXCITER

(Type M6425)

CUSTOMER KTIS

SERIAL NO. \_\_\_\_\_

MINNEAPOLIS, MINN.

DATE: 10/9/67

TEST ENGR. Roy M

H. Shatman

OPERATING FREQ. 98.5 Mc.

CRYSTAL FREQ. 32.7666 Mc.

AUDIO SOURCE IMPEDANCE 600 Ohms.

CENTER FREQUENCY VERNIER SETTING 732

DISTORTION AND RESPONSE

Freq. Hz	Distortion at 100% Modulation	Frequency Response (With respect to standard 75 us pre-emphasis Curve)
30	<u>0.28</u> %	<u>-0.2</u> dB
50	<u>0.18</u> %	<u>0</u> dB
100	<u>0.18</u> %	<u>0</u> dB
400	<u>0.16</u> %	<u>0</u> dB
1000	<u>0.22</u> %	<u>0</u> dB
2500	<u>0.25</u> %	<u>+0.1</u> dB
5000	<u>0.28</u> %	<u>0</u> dB
7500	<u>0.30</u> %	<u>-0.2</u> dB
10,000	<u>0.30</u> %	<u>-0.2</u> dB
15,000	<u>0.46</u> %	<u>+0.6</u> dB

NOISE

FM noise with respect to 100% modulation at 400 Hz is -66 dB.

Input level necessary to modulate 100% at 400 Hz is +10 dBm.

AM Noise -75 dB, with respect to equivalent of 100% AM Modulation.

POWER OUTPUT

Tested at 10 Watts

Maximum 14 Watts

## HELPFUL GENERAL INFORMATION

This information, of a general nature, will be recognized by many as standard fundamental electronic information. Frequently, when problems exist, one or more of the well known fundamentals may have been overlooked. The following information, therefore, is a check list and/or a suggestion list. You will quickly note it applies to many types of installations, the fundamentals for which are all basically the same.

1. **COMPUTING EFFICIENCY.** The transmitter efficiency determines its satisfactory operation. If it is under-efficient, it will consume excess primary power, will work all components harder and tube life will be shorter. If it is over-efficient, it probably indicates either an error in a computation such as tower resistance measurements or an error in a meter. To measure efficiency in an AM transmitter, multiply the plate voltage by the plate current of the final radio frequency power amplifier. For example, if plate voltage was 2500 volts and plate current was 550 MA, we have:

$$\begin{array}{r} 2500 \\ \times .550 \\ \hline 1375.000 \end{array}$$

The above means that 1375 watts are being placed into the radio frequency power amplifier. If this power amplifier is producing 1000 watts into the antenna, it would then indicate an efficiency of 73%, or

$$\frac{1000}{1375} = 73\%$$

2. **TRANSMITTER EFFICIENCIES.** There are two types of radio frequency power amplifiers. (1) High level and (2) linear amplifiers. Normal efficiency of a high level transmitter ranges from 65 to 77% for transmitters of powers up to and including 1000 watts and 72 to 82% for transmitters having powers of 5000 watts to 10,000 watts. --- For linear amplifiers with no modulation, the normal efficiency at any power is approximately 30%. It is important to note that in a linear amplifier the efficiency increases under modulation, therefore when defining normal efficiency it must be defined without modulation.

NOTE: Variations in efficiency such as a range of 65 to 77% are expressed for reasons of: (a) transmitter used with directional antenna, which would reduce efficiency, (b) slight but not out of tolerance meter error, and (c) possible mismatch to transmission line having slightly higher than normal standing wave ratio.

If the efficiencies are within the ranges expressed, however, the installation could be considered satisfactory and of course the higher the efficiency, the better.

3. **COMPUTING POWER OUTPUT.** Power output is computed either into the radiating antenna or a known dummy antenna. In either case, the resistance measurements are known. Your consulting engineer will measure your antenna tower and give you the resistance measurement. In most Gates built AM transmitters an inbuilt dummy antenna is provided, having a resistance measurement of 50 ohms. The formula  $I^2R$  is employed. I = The current reading of your antenna meter at the tower or the meter to the dummy antenna. R = The resistance measurement of the tower or the dummy antenna. If the resistance measurement is 50 ohms and your antenna current was 4.5 amperes, then  $I^2R$  develops this result:  $4.5 \times 4.5 = 20.25$ .  $20.25 \times 50$  (the antenna resistance) = 1012.5 watts. In the foregoing you have determined that you have a direct power output reading of 1012.5 watts if your antenna current is 4.5 amperes into a 50 ohm antenna.
4. **CORRECTING LOW EFFICIENCY.** Basically a broadcast transmitter by inherent design can not produce low efficiency unless, of course, it is incorrectly tuned, or the matching load to the transmitter, which is the transmission line and antenna, is incorrect. Here the use of the dummy antenna of known resistance is of great value. Light bulbs or improvised dummy antennas are of little value in computing efficiency. By using the formula in Paragraph 3 above, it is easy to determine how efficient the transmitter is operating when it is not connected to the antenna or transmission line. If the efficiency proves satisfactory into the dummy antenna, then any inefficiency is probably in the match of the transmitter to the radiating antenna and its associated tuning unit and transmission line.

If the efficiency of the transmitter is low into the dummy antenna, check the plate volt meter and power amplifier current meter to be sure they are accurate. In rare cases they are damaged in transit. This checking can be done with another known meter such as a good quality voltohmmeter, being very careful as the voltages are lethal.

Another cause of low efficiency is a defective RF ammeter. If you suspect this, the best way is to borrow one from a nearby station. It does not have to be the exact same range as you are only interested in a comparative reading. Here an error of only .2 of an ampere can make a large difference in the efficiency. Using Paragraph 3 above, again you will note a meter reading example of 4.5 amperes was used to give us

1012.5 watts output. If this meter had read 4.4 amperes, the output would have been 968 watts. By the meter being off only 0.1 amperes, 44 watts of error or loss was determined, which is nearly 5% of the 1000 watts desired power output. ----- Most radio frequency ammeters are very carefully checked and should be accurate but here again on a sensitive item, transportation roughage can affect it and therefore be sure.

5. **ARCING.** The power developed in the transmitter must go somewhere and of course to the antenna. When it is sidetracked, frequently arcing develops. Low efficiency and arcing will often go together as all transmitters are very well insulated against arcing. Its presence would indicate one of several things:
  - Improper tuning of antenna coupler.
  - Standing wave ratios on the transmission line, usually indicated by a different current reading at each end of the line.
  - Improper ground return from the ground radials to the transmitter.
  - Incorrect resistance measurements to the tower.
  - Improper neutralization where it is required.
  - An intermittent connection such as a loose connection in the tuning unit, a loose connection in the transmission line, poor brazing of the ground system and infrequently a grounded tower light wire.
6. **TUNING ANTENNA COUPLER.** Your consultant will be of invaluable assistance in tuning up your antenna coupler correctly with a radio frequency bridge at the same time he measures your tower. It will be money well spent. Where this is not possible and a bridge is not available, then the standard cut and try procedures must be followed. The desired result, of course, is the greatest antenna current without increasing the power input to the transmitter to obtain this increased antenna current.
7. **STANDING WAVES.** This is commonly called VSWR and high standing waves are caused by improper impedance match between the output of the transmitter to the transmission line and/or the output of the transmission line to the antenna coupler and its antenna. The result will nearly always be inefficiency as it reduces the power transfer between the transmitter and the antenna. High standing waves may also be caused by a poor or no ground to the outer shield of the transmission line. This line should be grounded to the ground radials at the tower and to the transmitter at the opposite end of the transmission line. The only exception to this might be with a directional system but in all instances the outer shield of the transmission line must be grounded securely.
8. **IMPROPER GROUND.** In an AM transmitter we place at least 120 ground radials into the ground but sometimes fail to connect them securely to the transmitter. In the simplest form, the antenna and the ground can be likened to the two wires of an electric light circuit. One is as important as the other. Where the ground radials are bonded together at the tower, we suggest extending a 2" copper strap directly to the ground of the broadcast transmitter. DO NOT attach one of the outer radials closest to the transmitter as your ground system. Don't forget to ground the cabinets of the antenna coupling unit and the tower lighting chokes, and again the outer shield of the transmission line.
9. **INCORRECT TOWER MEASUREMENTS.** Your consulting engineer is provided with expensive and accurate measuring equipment for tower resistance measurements. His measurements will be accurate. It would be extremely rare to find an incorrect tower measurement by a capable consulting engineer. It has happened, however, and we include this paragraph only to point out that if all else fails for proper transmitter performance, rechecking of the tower measurements would not be amiss. Several years ago one of the world's leading consultants measured a tower incorrectly and quickly admitted it. The cause was simply one of his measuring instruments falling out of his car unbeknownst to him and upsetting the calibration of his equipment.
10. **FUSE BLOWING.** It seldom happens if the fuses are of adequate size. If it does happen, the first thing is to determine that the fuses are not overloaded. Usually overloaded fuses caused by a long period of overload of an hour or more have blackened fuse clips. Remember a very hot day and borderline fuses are trouble-makers. Also don't forget to compute the window fan, the well pump, the air-conditioner, or other items that are foolers as to power consumption.

If fuses are of adequate size and continue to blow, here are a few helpful hints:

If your transmitter has mercury vapor rectifiers, it is a cold morning and the heat in your building has gone down overnight, the mercury will likely cool at the bottom of the rectifier tubes and when high voltage is applied, cause an arc back. In such a condition, you are fortunate in blowing the fuses as an arc back can often destroy a filter reactor or power transformer. You can correct this condition by keeping adequate heat in the transmitter building or at least adjacent to the mercury vapor rectifier tubes. A light bulb placed near the rectifier tubes, to operate in cold weather when the transmitter is off, is helpful.

Dirt or scum is an evil with many results and fuse blowing caused by arc-overs is one of them. A good maintenance program prevents this.

On new transmitters, look for cable abrasions. Sometimes in transit it is possible for a wire to rub against a metal support and wear off the insulation. This is unlikely but with such a serious problem as fuses blowing, you look for everything.

If by the time you have found the trouble you have blown a number of fuses, now investigate your fuse box to be sure the clips are clean and not charred. If they are charred, fuse blowing will continue anyway and it will be necessary to replace the clips that hold the fuses.

11. UNEXPLAINED OUTAGES. This one puzzles the best of them. A transmitter that goes off the air for no reason and can be turned back on by pushing the start button brings the query, "What caused that?" If this happens very infrequently, it is probably caused by a power line dip, a jump across the arc gap at the tower base, or other normal things that activate the protective relays in the transmitter as they should.

Your transmitter always looks like the offender. It is the device with meters and it is the device that complains or quits if there is a failure anywhere in the entire system. An open or short circuit in a transmission line only reacts at the transmitter. A faulty insulator in an antenna guy wire or a bad connection in the tuning unit or ground system reacts only at the transmitter. Here again the dummy antenna is of great value. If these unexplained outages do not appear in operating into a dummy antenna, then you must look elsewhere for the problem. It is always well to remember that the transmission line tuning units and associated connections, including the tower chokes, are somewhat like the drive shaft between the automobile motor and the rear wheels. If the drive shaft fails, it does not mean that the motor is defective.

12. STEP BY STEP TROUBLE-SHOOTING. Never trouble-shoot on the basis of "it might be this or that". Instead, start from the beginning. If the transmitter was satisfactory on the dummy antenna, then the question becomes "Where is the trouble?" If a transmission line connects the transmitter to the antenna coupler, then disconnect the antenna coupler and provide a dummy antenna at the far end of the transmission line and repeat the test. If you noticed the outage at this point, then the trouble is in the transmission line. If not, reconnect it to the antenna coupler unit and put the dummy antenna at the output of the coupling unit. This is known as step by step checking to locate problems.

The same process is used in trouble-shooting the transmitter. In checking voltages, you start with the oscillator and go through to the power amplifier and with the first audio stage to the final audio stage. Other outage conditions not affecting the transmitter are listed below for your checking:

Under certain conditions, especially at higher altitudes, the guy insulators will arc, usually caused by static conditions. This will nearly always cause an outage as it changes the antenna characteristics. This is hard to find as it is hard to see. Use of field glasses at night is the best way. If it happens, the insulator should be shunted with a resistor. Write our Engineering Department for advice, giving full antenna detail when writing.

At times the arc gap at the base of the tower is set too close or has accumulated dirt. This causes an arc to ground under high modulation.

A crack in the tower base insulator is very unlikely but it should be inspected and keeping the base insulator clean is necessary. A low resistance path at this point is highly undesirable.

Look at the tower chokes. Though they are husky, they are in a vulnerable position for lightning. You might find a charred point that is causing the trouble.

Shunt fed towers or those with no base insulator are usually more sensitive to static bursts than series fed towers. The best method is to try and make the feed line to the tower equal the impedance of the transmission line. Talk to your consultant about this.

One side of the tower lighting circuit shorted to the tower itself, either permanently or intermittently, can cause trouble even though the lights may function perfectly.

13. OTHER OUTAGES. If the transmitter is the offender, such as acting improperly on a dummy antenna, the process of elimination by starting at the first and following through is preferred, unless of course the cause is actually known. The following may be helpful:

(FALL OUT) The transmitter turns off at high modulation. Possibly the overload relay is set too sensitive. The transmitter may not be properly neutralized where neutralization is required.

(HARD TO MODULATE) Cause can be either improper impedance match between transmitter and the transmission line or low grid drive to the final power amplifier. Consult the instruction book for correct grid drive. The correct match of the transmitter to load is covered in the instruction book. Usually an antenna current meter that does not move up freely with modulation indicates a mismatch between the transmitter and its loading equipment.

(BAD REGULATION) The size of the primary lines between the meter box and the transmitter is extremely important. If they are too small, bad regulation will exist. In some instances the power line has bad regulation too. This

Tube checking. Check tubes at least monthly and it is just as easy to do it each week during the periodic maintenance program. Certain tubes will become gaseous if left on the spare tube shelf too long. This type of tube should be rotated into the transmitter to prevent an emergency change to the spare tube, only to find it blowing out because of a gaseous condition.

Oiling. If the transmitter has blowers, oil them as required, but do not over-oil. Some types of turntables require oiling the motors.

Relay contacts. Burnish the contacts with an approved burnishing tool. This should be done about every six to eight weeks.

Other preventive ideas. Clean mixing attenuators if they are not the sealed type, with carbon tetrachloride, about once monthly. Every station should have a small suction type cleaner. Even your wife's Hoover with the suction attachments will do an excellent job of pulling dust from the inside of the hard to get corners of a transmitter. Take a leaf from the Navy book which says everything must at all times be sparkling clean or what is known as ship-shape.

17. **ADEQUATE TEST EQUIPMENT.** To have a maintenance program, certain capital equipment is necessary. Do not be ashamed to tell your Manager about this because he will recognize that proper maintenance is saving money and not spending money. As a minimum, you should have this equipment:

Dummy antenna (frequently supplied in Gates transmitters).

Proof of performance equipment, which includes an audio oscillator, distortion meter, gain set, and RF pickup coil or rectifier, known as the Gates SA131 proof of performance package.

A good grade of voltohmmeter.

A spare antenna current meter.

An inexpensive oscilloscope.

All of the above will cost less than \$1000.00 and will pay for itself many times through the years.

18. **THE CHIEF ENGINEER.** He has the job of keeping everybody happy - listeners, Manager, and stockholders. When trouble comes, he is under pressure. He will do his best to correct the problem as fast as he can. It is well to remember that electronic equipment has many circuits and many avenues of travel. Where problems are known, the solution is usually quick. Where the problem must be found, the solution will take time. It is well to remember that if equipment did not need maintenance, it would not need a Chief Engineer. The greatest service he renders is the insistence on a regular preventive maintenance program, which he knows will prevent most problems. If the unusual problem does arrive, causing an outage, everyone in the broadcasting should be understanding and tolerant as the problem can be solved quickest by not breathing over the Chief Engineer's shoulder.
19. **GATES ASSISTANCE TO HELP.** Gates sincerely believes that the best type of assistance it can render to the technical personnel in the radio broadcasting industry is in providing full cooperation, day or night, in solving any problem no matter how small. Gates technical people recognize that sometimes the biggest problem is solved in the most simple manner. This is part of electronics and never is fun poked at a simple solution because this is the happiest kind. It is only by asking questions of any calibre, simple or complex, of Gates people and mutually working together that the finest degree of broadcast programming is possible in your broadcasting station and the industry.

Service avenues. Unless the problem is of an emergency nature, Gates suggests that you write to the Gates Service Department about problems that you are experiencing. If you have a problem that can not wait, call the Gates Service Department during daylight hours at Area Code 217, 222-8202. Gates daylight hours are from 8 A.M. to 5 P.M., Monday thru Friday, Central Standard Time or Central Daylight Time, depending upon the period of the year. Gates nighttime service can be obtained by calling Area Code 217, 222-8202.

GATES RADIO COMPANY  
Subsidiary of Harris-Intertype Corporation  
Quincy, Illinois, U.S.A.